

**Tektronix®**

02-B-466-CE-BNCH2

1081055  
**466  
STORAGE  
OSCILLOSCOPE**  
WITH OPTION  
SERVICE

INSTRUCTION MANUAL

MANUAL  
MEETS REQUIREMENTS OF  
QSP 6-2-0

**Tektronix®**  
COMMITTED TO EXCELLENCE

## WARNING

THE FOLLOWING SERVICING INSTRUCTIONS  
ARE FOR USE BY QUALIFIED PERSONNEL ONLY.  
TO AVOID PERSONAL INJURY, DO NOT  
PERFORM ANY SERVICING OTHER THAN THAT  
CONTAINED IN OPERATING INSTRUCTIONS  
UNLESS YOU ARE QUALIFIED TO DO SO.

PLEASE CHECK FOR CHANGE INFORMATION  
AT THE REAR OF THIS MANUAL.

1061055

# 466 STORAGE OSCILLOSCOPE

WITH OPTION  
SERVICE

## INSTRUCTION MANUAL

Tektronix, Inc.  
P.O. Box 500  
Beaverton, Oregon 97077

070-1753-01  
Product Group 40

Serial Number \_\_\_\_\_

First Printing MAR 1974  
Revised NOV 1982

Copyright © 1974, 1976 Tektronix, Inc. All rights reserved.  
Contents of this publication may not be reproduced in any  
form without the written permission of Tektronix, Inc.

Products of Tektronix, Inc. and its subsidiaries are covered  
by U.S. and foreign patents and/or pending patents.

TEKTRONIX, TEK, SCOPE-MOBILE, and  are  
registered trademarks of Tektronix, Inc. TELEQUIPMENT  
is a registered trademark of Tektronix U.K. Limited.

Printed in U.S.A. Specification and price change privileges  
are reserved.

### INSTRUMENT SERIAL NUMBERS

Each instrument has a serial number on a panel insert, tag,  
or stamped on the chassis. The first number or letter  
designates the country of manufacture. The last five digits  
of the serial number are assigned sequentially and are  
unique to each instrument. Those manufactured in the  
United States have six unique digits. The country of  
manufacture is identified as follows:

B000000	Tektronix, Inc., Beaverton, Oregon, USA
100000	Tektronix Guernsey, Ltd., Channel Islands
200000	Tektronix United Kingdom, Ltd., London
300000	Sony/Tektronix, Japan
700000	Tektronix Holland, NV, Heerenveen, The Netherlands

# TABLE OF CONTENTS

	Page	SECTION 3	CIRCUIT DESCRIPTION	Page
<b>LIST OF ILLUSTRATIONS</b>	ii		Introduction	3-1
<b>LIST OF TABLES</b>	iii		Digital Logic	3-1
			<b>BLOCK DIAGRAM DESCRIPTION</b>	3-1
			Vertical Section	3-1
			Horizontal Section	3-1
			Z-Axis Amplifier	3-2
			Power Section	3-2
<b>SECTION 1 SPECIFICATION</b>			<b>DETAILED CIRCUIT DESCRIPTION</b>	3-2
Introduction	1-1		Vertical Section	3-2
Electrical Characteristics	1-1		Horizontal Section	3-9
Environmental Characteristics	1-10		Calibrator	3-15
Physical Characteristics	1-11		Low Voltage Power Supply	3-15
Standard Accessories	1-11		Fan Motor Circuit	3-16
			Z-Axis-CRT Circuit	3-16
			Storage Circuits	3-20
<b>SECTION 2 OPERATING INSTRUCTIONS</b>		<b>SECTION 4 MAINTENANCE</b>		
Operating Voltage	2-1	Introduction	4-1	
Safety Information	2-1	Cabinet Removal	4-1	
Nominal Line Voltage Range	2-1	<b>PREVENTIVE MAINTENANCE</b>	4-1	
Options	2-2	General	4-1	
<b>CONTROLS, CONNECTORS AND INDICATORS</b>	2-2	Cleaning	4-1	
Vertical	2-2	Visual Inspection	4-2	
Display and Storage	2-4	Lubrication	4-2	
Trigger	2-5	Semiconductor Checks	4-2	
Horizontal and Power	2-6	Recalibration	4-3	
Rear Panel	2-7	<b>CORRECTIVE MAINTENANCE</b>	4-3	
Right Side Panel	2-8	General	4-3	
Left Side Panel	2-8	Obtaining Replacement Parts	4-3	
P6062A 10X—1X Probe	2-8	Recalibration After Repair	4-3	
<b>BASIC DISPLAYS</b>	2-9	Instrument Repackaging	4-3	
Normal Sweep Display	2-9	Soldering Techniques	4-3	
Magnified Sweep Display	2-9	Component Replacement	4-4	
Delayed Sweep Display	2-9	Circuit Board Replacement	4-4	
Mixed Sweep Display	2-10	Low Voltage Power Transformer		
X-Y Display	2-10	Replacement	4-7	
Single Sweep Display	2-10	HV Multiplier & HV Transformer		
<b>STORAGE DISPLAYS</b>	2-10	Replacement	4-7	
Storage	2-10	CRT Replacement	4-7	
Save Storage	2-11			
Save Random Events	2-11	<b>SECTION 5 CALIBRATION</b>		
Multiple Trace Storage	2-11	Introduction	5-1	
Care of Storage Screen	2-11	Test Equipment Required	5-2	
<b>PERFORMANCE CHECK</b>	2-12	Cabinet Removal	5-5	
Purpose	2-12	A. Power Supplies and Calibrator	5-6	
Recommended Equipment	2-12	B. Display and Z-Axis	5-8	
<b>PERFORMANCE CHECK PROCEDURE</b>	2-14	C. Vertical	5-10	
A. Preliminary Procedure	2-14	D. Trigger	5-22	
B. Vertical	2-14	E. DM-Series Digital Multimeters	5-33	
C. Trigger	2-17	F. Horizontal	5-34	
D. DM-Series Digital Multimeters	2-22	G. Storage	5-45	
E. Horizontal	2-22	H. X-Y Display, Z-Axis and Gate		
F. Reduced Scan and Storage	2-28	Outputs	5-54	
G. X-Y Display, Z-Axis and Gate				
Outputs	2-32			

# TABLE OF CONTENTS (cont)

## SECTION 6 ELECTRICAL REPLACEABLE PARTS LIST

Parts Ordering Information	6-1
Special Notes and Symbols	6-1
Abbreviations	6-1
Cross Index MFG Code Number to Manufacturer	6-2
Electrical Parts List	6-3

## OPTION INFORMATION

## SECTION 7 DIAGRAMS & CIRCUIT BOARD ILLUSTRATIONS

## ADJUSTMENT LOCATIONS

## SECTION 8 MECHANICAL REPLACEABLE PARTS LIST

Parts Ordering Information	8-1
Special Notes and Symbols	8-1
Figure and Index Numbers	8-1
Indentation System	8-1
Item Name	8-1
Abbreviations	8-1
Cross Index MFR Code Number to Manufacturer	8-2
Mechanical Parts List and Figures Cabinet and Accessories	8-3

## CHANGE INFORMATION

# LIST OF ILLUSTRATIONS

Fig. No.	Description	Page No.
1-1	466 Portable Storage Oscilloscope.	Frontispiece
1-2.	Differential time measurement accuracy.	1-6
2-1.	Regulating range selector and line fuse.	2-2
2-2.	Vertical Section.	2-2
2-3.	Display and Storage Sections.	2-4
2-4.	Partial Trigger Section.	2-5
2-5.	Horizontal and Power Sections.	2-6
2-6.	Rear Panel Section.	2-7
2-6A.	Left Side Panel Controls	2-8
2-7.	P6062A Probe	2-8
3-1.	Channel 1 Preamplifier Detailed Block Diagram	3-3
3-2.	Channel 2 Preamplifier Detailed Block Diagram	3-5
3-3.	Vertical Switching Circuit Detailed Block Diagram.	3-6
3-4.	Diode Gate Conditions in Channel 1 Mode.	3-7
3-5.	A Sweep Generator Detailed Block Diagram.	3-10
3-6.	Horizontal Amplifier Detailed Block Diagram	3-14
3-7.	Z-Axis/CRT Circuit Detailed Block Diagram.	3-17
3-8A.	Shift Register and Storage Logic output.	3-20
3-8B.	Shift Register and Storage Logic Output Signals in the Fast mode.	3-20
3-9.	Erase and Timing Circuit Detailed Block Diagram.	3-22
3-10.	Storage Output Circuits Block Diagram.	3-23
3-11.	Non-Store Mode-CRT Storage Element Voltage Levels.	3-24
3-12.	Variable-Persistence Mode-CRT Storage Element Voltage Levels.	3-25
3-13.	Fast Mode-CRT Storage Element Voltage Levels.	3-25
3-14.	Multi-Fast Mode-CRT Storage Element Voltage Levels.	3-26
4-1.	Typical Rear Cabinet Frame Removal.	4-1
5-1.	Typical Rear Cabinet Frame Removal.	5-5
5-C-1	Typical display when high-frequency compensation is correctly adjusted.	5-18
5-D-1.	TRIGGER LEVEL adjusted so sweep starts 0.5 div away from 0 level (graticule center) setting.	5-29
5-F-1.	A INTEN Mode.	5-34
5-F-2.	B DLY'D Mode.	5-35
5-F-3.	Fast-rise, Low repetition-rate signals.	5-35
5-F-4.	0.2 $\mu$ s/Div Timing.	5-37
5-F-5.	0.5 $\mu$ s/Div Timing.	5-38
5-F-6.	Delay-time accuracy.	5-42
5-G-1.	(A through C.) Front Mesh Op Level (R1933) adjustment.	5-47
5-G-2.	(A through C.) Front Mesh Prep Level (R1927) adjustment (Storage Level set at 3 o'clock).	5-48
5-G-3.	(A through C.) Front Mesh Hold Level (R1935) adjustment.	5-49

# TABLE OF CONTENTS (cont)

## LIST OF ILLUSTRATIONS (cont)

Fig. No.	Description (cont)	Page No.
5-G-4.	(A through C.) Display when R1982, R1989, and STORAGE LEVEL are adjusted for Fast Storage.	5-51
5-H-1.	X-Y Phasing Check.	5-55
Option 4-1.	466 Option 4 primary winding with power-line filter.	Option 4 Page 1
Option 5-1.	464 Oscilloscope with Option 5.	Option 5 Page 1
Option 5-2.	Option 5 Block Diagram.	Option 5 Page 6
Option 5-3.	A12 TV Sync Separator & Inverter Ampl board component locations.	Option 5 Page 11
Option 5-4.	Option 5 Vertical Input changes.	Option 5 Page 11
Option 5-5.	Option 5 Trigger Switches & Trigger Pickoff.	Option 5 Page 12
Option 5-6.	Option 5 TV Sync Separator & Inverter Ampl.	Option 5 Page 13
Option 5-7.	Option 5 Trigger Holdoff circuit changes.	Option 5 Page 14
Option 7-1.	Option 7 simplified block diagram.	Option 7 Page 3
Option 7-2.	Typical battery pack discharge curves.	Option 7 Page 6
Option 7-3.	Inverter balance.	Option 7 Page 7
Option 7-4.	Circuit board layout with component locator grid.	Option 7 Page 8
Option 7-5.	466 Option 7 dc inverter.	Option 7 Page 9
Option 7-6.	Circuit board layout with test voltages.	Option 7 Page 9
Option 7-7.	466 Option 7 primary winding.	Option 7 Page 10
Option 7-8.	Typical idealized waveforms.	Option 7 Page 10
Option 7-9.	Option 7 exploded.	Option 7 Page 14
Option 1Y-1.	Lower Supply and Distribution	Option 1Y Page 1

### PULL-OUT PAGES ILLUSTRATIONS

7-1.	Semiconductor Lead configurations.
7-2.	(A through C.) A1 Attenuator and A3 Vertical Mode Switch board component locations.
7-3.	(A & B.) A2 Vertical Preamp board component locations.
7-4.	(A & B.) A6 Interface board component locations.
7-5.	(A & B.) A4 Vertical Output board component locations.
7-6.	(A & B.) A5 Trigger Generator and Sweep Logic board component locations.
7-7.	(A through C.) A7 Timing board component locations.
7-8.	(A & B.) A8 HV Multiplier board component locations.
7-9.	(A & B.) A10 Storage board component locations.
7-10.	(A & B.) A11 Fan Motor board component locations.
7-11.	(A through C.) Adjustment Locations 1.
7-12.	(A through C.) Adjustment Locations 2.
7-13.	(A through C.) Adjustment Locations 3.
7-14.	(A through C.) Adjustment Locations 4.

## LIST OF TABLES

Table No.	Title	Page No.	Table No.	Title	Page No.
1-1.	Electrical Characteristics	1-1	5-1.	Test Equipment Required	5-2
1-2.	Environmental Characteristics	1-10	5-A-1.		5-7
1-3.	Physical Characteristics	1-11	5-A-2.		5-7
2-1.	Regulating Ranges	2-1	5-A-3.		5-7
2-2.	Recommended Equipment	2-12	5-C-1.	Vertical Deflection Accuracy	5-14
2-3.	Vertical Deflection Accuracy	2-15	5-C-2.	Maximum Overshoot or Roll-Off	5-15
2-4.	Differential Time Accuracy	2-23	5-C-3.	Overshoot or Roll-off Adjustment	5-16
2-5.	B Timing Accuracy	2-24	5-C-4.	VOLTS/DIV COMPENSATION	5-17
2-6.	A Timing Accuracy	2-24	5-F-1.	Differential Time Accuracy	5-36
2-7.	A and B Magnified Accuracy	2-25	5-F-2.	B Timing Accuracy	5-39
2-8.	Differential Time Accuracy	2-26	5-F-3.	A Timing Accuracy	5-40
3-1.	Crt Cathode Voltages	3-19	5-F-4.	A and B Magnified Accuracy	5-41
			5-F-5.	Delay Time Accuracy	5-42



1753-01

THE ACCESSORY POUCH ILLUSTRATED SHOULD REMAIN ATTACHED TO THE OSCILLOSCOPE. IT IS DESIGNED TO KEEP ACCESSORIES READILY AVAILABLE AND TO AFFORD THE OSCILLOSCOPE SOME PROTECTION IN TRANSIT.

THE ADJUSTABLE CARRYING HANDLE IS DESIGNED TO OFFER CONVENIENT STABLE, OPERATING POSITIONS, SUCH AS THOSE ILLUSTRATED.

STORAGE OR OPERATION OF THE OSCILLOSCOPE ON ITS FOUR REAR FEET IS NOT DESIRABLE. THE NEXT-TO-LAST LOCKING POSITION OF THE HANDLE PROVIDES THE MOST STABLE, NEAR-UPRIGHT, OPERATING POSITION. THE MOST STABLE OPERATING POSITIONS ARE ILLUSTRATED.



1753-02

Fig. 1-1. 466 Portable Storage Oscilloscope.

# SPECIFICATION

## Introduction

The Tektronix 466 is a dual-channel portable oscilloscope. The 466 storage system provides storage for displays with a writing speed up to 3000 divisions/microsecond (in the Fast-Reduced Scan mode). Storage viewing time is greater than 15 seconds at full stored display intensity—extending to more than 6 minutes using reduced intensity in the Save mode.

The dual-channel dc-to-100 megahertz vertical system provides calibrated deflection factors from 5 millivolts to 5 volts/division. The sweep trigger circuits are capable of stable triggering over the full bandwidth capabilities of the vertical deflection system. The horizontal deflection system provides calibrated sweep rates from 0.5 seconds

to 0.05 microsecond/division along with delayed sweep features for accurate relative-time measurements. A X10 magnifier extends the calibrated sweep rate to 5 nanoseconds/division. The instrument operates over a wide variation of line voltages and frequencies. Maximum power consumption is about 100 watts.

This instrument will meet the electrical characteristics listed in the Performance Requirement column of Table 1-1 following complete calibration as given in Section 5. The performance check procedure which is given in Section 2 provides a convenient method of checking instrument performance without making internal checks or adjustments. The following electrical characteristics apply over an ambient temperature range of  $-15^{\circ}\text{C}$  to  $+55^{\circ}\text{C}$ , except as otherwise indicated. Warmup time for given accuracy is 20 minutes.

**TABLE 1-1**  
**Electrical Characteristics**

Characteristics	Performance Requirements	Supplemental Information
VERTICAL DEFLECTION SYSTEM (CH 1 and CH 2)		
Deflection Factor Calibrated Range	5 mV to 5 V/DIV in 10 steps; 1-2-5 sequence.	
Cascaded Operation (CH 1 VERT SIGNAL OUT Connected to CH 2)	Deflection Sensitivity at least 1 mV/Div. Bandwidth: Dc to at least 50 MHz.	CH 1 OUT connected to CH 2 input, ac coupled using a 50 $\Omega$ 42 inch cable terminated in 50 $\Omega$ at CH 2 input.
Uncalibrated (VAR VOLTS/DIV) Range	Provides continuously variable deflection factors between the calibrated steps. Extends maximum uncalibrated deflection factor to at least 12.5 volts per division in the 5 V/DIV position.	At least 2.5:1.
Low Frequency Linearity		0.1 division or less compression or expansion of 2 division signal at center screen positioned to the upper and lower extremes of the graticule area.
Deflection Factor Accuracy	Within 3% of indicated deflection.	With GAIN set at 5 mV/DIV.
Bandwidth	Dc to 100 MHz or greater ( $-15^{\circ}\text{C}$ to $+40^{\circ}\text{C}$ ). DC to 85 MHz ( $+40^{\circ}\text{C}$ to $+55^{\circ}\text{C}$ ).	With a 5 division, vertically centered, reference signal from a 25 $\Omega$ source and VAR VOLTS/DIV in calibrated position.



**Specification—466 Service**

**TABLE 1-1 (cont)**

Characteristics	Performance Requirements	Supplemental Information
VERTICAL DEFLECTION SYSTEM (cont)		
Risetime (calculated) <sup>1</sup>	3.5 ns or less (–15°C to +40°C). 4.15 ns or less (+40°C to +55°C).	(Same as for Bandwidth.)
AC Coupled Lower –3 dB Point	10 Hz or less with 1X probe.	1 Hz or less with 10X probe.
Bandwidth with 20 MHz BW Switch in 20 MHz Position.	Approximately 20 MHz.	–3 dB point between 15 MHz and 25 MHz.
Input Gate Current		0.5 nanoampere or less (0.1 division of deflection at 5 mV/Div) from –15°C to +30°C. 4 nanoamperes or less (0.8 division of deflection at 5 mV/Div) from +30°C to +55°C.
Input Resistance and Capacitance	1 MΩ within 2%.	Approximately 20 pf.  Aberrations 2% or less using a P6062A probe (+20°C to +30°C).
Step Response		Step Response is based on a 5 division, vertically centered, dc coupled, reference signal at all deflection factors from a 25 ohm source with VAR VOLTS/DIV control in the calibrated position, from 0°C to +40°C.
Positive-Going Step Aberrations (excluding ADD mode) (0°C to +40°C)		≤ +4%, –4%, 4% p-p, except in 1, 2, 5 V/div ranges which is ≤ +5%, –5%, 5% p-p.
Negative-Going Step		Add 2% to positive-going step aberrations.
ADD Mode		Add 5% to positive-going step aberrations.
Position Effect		Total aberrations not to exceed +5%, –5% or a total of 5% P-P.
Common-Mode Rejection Ratio (ADD Mode with CH 2 inverted)		At least 10:1 at 20 MHz for common-mode signals of 6 divisions or less with GAIN adjusted for best CMRR at 50 kHz.

<sup>1</sup>Risetime is calculated from the formula:

$$\frac{0.35}{\text{BW (In megahertz)}}$$

TABLE 1-1 (cont)

Characteristics	Performance Requirements	Supplemental Information
VERTICAL DEFLECTION SYSTEM (cont)		
Trace Shift as VAR is Rotated		Adjusts to 0.2 divisions or less.
Step Attenuator Balance		Adjustable to 0.2 division or less of trace shift when switching between adjacent deflection factor settings.
INVERT Trace Shift		Within 0.2 division when switching from normal to inverted.
Channel Isolation		At least 100:1 at 25 MHz.
Position Range		At least +12 and -12 divisions from graticule center.
Signal Delay Between CH 1 and CH 2		Approximately 120 ns.
Maximum Input Voltage	Dc coupled: 250 V (dc + peak ac) or 500 V P-P ac at 1 kHz or less.  Ac coupled: 500 V (dc + peak ac) or 500 V P-P ac at 1 kHz or less.	
Chopped Mode Repetition Rate	Approximately 250 kHz.	Within 20%.

TRIGGER SYSTEM

Sensitivity		In EXT ÷ 10, multiply requirements by 10.
DC Coupled	0.3 div internal or 50 mV external from dc to 25 MHz, increasing to 1.5 div internal or 150 mV external at 100 MHz.	
AC Coupled	0.3 div internal or 50 mV external from 30 Hz to 25 MHz, increasing to 1.5 div internal or 150 mV external at 100 MHz. Attenuates signals below about 30 Hz.	
HF REJ Coupled	0.5 div internal or 50 mV external from 30 Hz to 50 kHz. Blocks dc and attenuates signals below about 30 Hz and above about 50 kHz.	

TABLE 1-1 (cont)

Characteristics	Performance Requirements	Supplemental Information
TRIGGER SYSTEM (cont)		
LF REJ Coupled	0.5 div internal or 100 mV external from 50 kHz to 25 MHz, increasing to 1.5 div internal or 300 mV external at 100 MHz. Attenuates signals below about 50 kHz.	In EXT $\div$ 10, multiply requirements by 10.
Trigger Jitter	0.5 ns or less at 100 MHz with 5 ns/DIV sweep rate (X10 MAG on).	
External Trigger Input		
Maximum Input Voltage	250 V dc + peak ac or 250 V P-P ac (1 kHz or less).	
Input Resistance and Capacitance	1 M $\Omega$ within 10%.	20 pF within 30%.
LEVEL Control Range		
EXT	At least + and -2 V, 4 V P-P.	
EXT $\div$ 10	At least + and -20 V, 40 V P-P.	
Trigger View		
Deflection Factor		
EXT	Approximately 50 mV/div	$\pm$ 20%. Exclude LF REJ and HF REJ trigger coupling modes.
EXT $\div$ 10	Approximately 500 mV/div.	
Risetime		$\leq$ 5.0 ns over the 10% to 90% part of the fast-rise portion.
Delay Difference	$\leq$ 3 ns	With a 5 division signal having 5 ns or less risetime from a 25 $\Omega$ source, centered vertically with equal length 50 $\Omega$ cables from signal source to vertical channel and external trigger inputs, terminated in 50 $\Omega$ at each input.
Centering of Trigger Point		Adjustable to within 1.0 division of center screen.

TABLE 1-1 (cont)

Characteristics	Performance Requirements	Supplemental Information	
HORIZONTAL DEFLECTION SYSTEM			
Calibrated Sweep Range A Sweep	0.5 s/Div to 0.05 $\mu$ s/Div in 22 steps; 1-2-5 sequence. X10 MAG extends maximum sweep rate to 5 ns/Div.		
B Sweep	50 ms/Div to 0.05 $\mu$ s/Div in 19 steps; 1-2-5 sequence. X10 MAG extends maximum sweep rate to 5 ns/Div.		
Calibrated Sweep Accuracy  +20°C to +30°C  -15°C to +55°C	UNMAGNIFIED	MAGNIFIED	Accuracy specification applies over the full 10 divisions of deflection unless otherwise specified.  Exclude the first and last 50 ns of the sweep when checking magnified 5 ns, 10 ns, and 20 ns sweep rates.
	$\pm 2\%$	$\pm 3\%$	
	$\pm 3\%$	$\pm 4\%$	
Sweep Accuracy Over Any 2 Division Interval	Within 5% over any 2 division interval. Exclude first and last magnified divisions when checking 5 ns/Div and 10 ns/Div (X10 MAG on).		
Mixed Sweep Accuracy	Within 2% plus measured A Sweep error when viewing the A portion only. B Sweep portion of mixed sweep retains B Sweep accuracy.	Exclude the first 0.5 div after display start and the first 0.2 division or 0.1 $\mu$ s (whichever is greater) after the transition of A to B.	
VAR TIME/DIV Control Range (A Only)	Continuously variable between calibrated settings. Extends the slowest A sweep rate to at least 1.25 seconds per division.	At least 2.5:1.	
Sweep Length (A Only)		10.5 to 11.5 divisions.	
A Trigger Holdoff Variable	Increases A sweep holdoff time by at least a factor of 10.		
Magnified Registration		Within 0.2 division from graticule center when switching X10 magnifier from on to off (at 1 ms/Div).	
POSITION Control Range		Start of sweep must position to right of graticule center. End of sweep must position to left of graticule center.	

TABLE 1-1 (cont)

Characteristics	Performance Requirements	Supplemental Information
HORIZONTAL DEFLECTION SYSTEM (cont)		
Delay Time and Differential Time Measurement Accuracy (simplified)	+15°C to +35°C (+60°F to +95°F)	-15°C to +55°C (+5°F to +131°F)  With the A TIME/DIV switch at .5 μs/div or .2 μs/div, the differential time measurement accuracy limit is valid only for DELAY-TIME POSITION dial settings between 1.50 and 8.50.
Over One or More Major Dial Divisions	±1%	±2.5%
Over Less Than One Major Dial Division (see Fig. 1-2)	±0.01 Major Dial Division	±0.03 Major Dial Division
Delay Time and Differential Time Measurement Accuracy (detailed)	 <p style="text-align: center;">Number of Major Dial Divisions of DELAY TIME POSITION control used to make measurement. 1753-03A</p>	
Delay Time Jitter	Within 0.002% (less than one part in 50,000) of the maximum available delay time, which is 10 times the A TIME/DIV switch setting.	
Delay Range (A VAR control set to CAL)	From 0.2 μs or less to at least 5 seconds after the start of the delaying (A) sweep.	

Fig. 1-2. Differential time measurement accuracy.

TABLE 1-1 (cont)

Characteristics	Performance Requirements	Supplemental Information	
X-Y OPERATION			
		TIME/DIV switch in extreme ccw position and CH 2 or X-Y VERT MODE button depressed.	
Sensitivity  Y Axis	Same as for vertical deflection system.		
X Axis	Same as for vertical deflection system (with X10 Mag off).		
Deflection Accuracy  Y Axis	Same as for vertical deflection system.		
X Axis	Within 4%.		
Variable Range  X and Y Axis	Same as for vertical deflection system.		
Bandwidth  Y Axis	Same as for vertical deflection system.		
X Axis	Dc to at least 4 MHz.		X-Axis bandwidth measured using a 10 division reference signal.
Input Resistance and Capacitance  X and Y Axis	Same as for Vertical deflection system.		
Maximum Usable Input Voltage  X and Y Axis	Same as for vertical deflection system.		
Phase Difference between X and Y Axis Amplifiers	Within 3° from dc to 50 kHz.		

**Specification—466 Service**

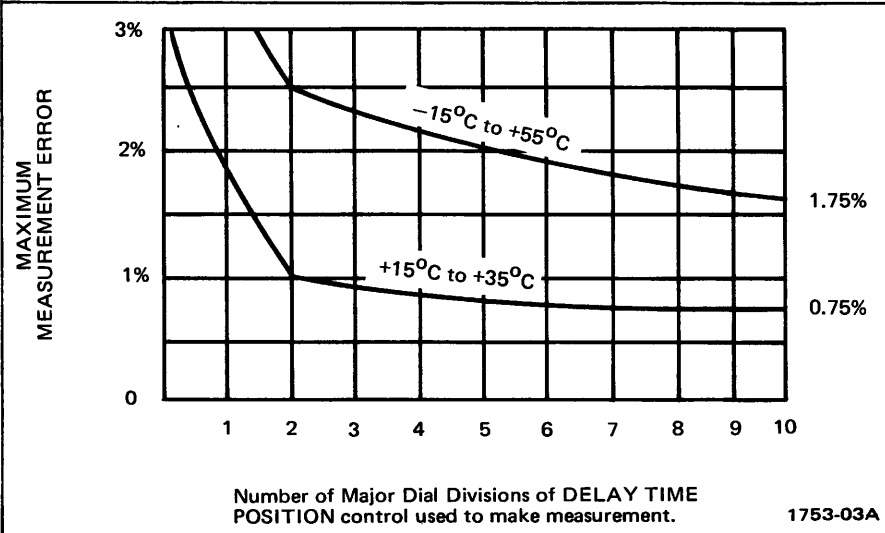
**TABLE 1-1 (cont)**

Characteristics	Performance Requirements	Supplemental Information
<b>CALIBRATOR</b>		
Output Voltage (Square Wave signal)  0°C to +40°C	300 mV within 1.0%	Adjusted to within 0.3% at 25°C, ±5°C.
-15°C to +55°C		300 mV within 1.5%.
Repetition Rate	Approximately 1 kHz.	Within 25%.
Output Resistance		Approximately 9.4 Ω.
Output Current  +20°C to +30°C  -15°C to +55°C	30 mA within 2%.	30 mA within 2.5%.
<b>Z AXIS INPUT</b>		
Sensitivity	5 V P-P signal causes noticeable modulation at normal intensity.	Positive-going signal from ground decreases intensity.
Usable Frequency Range	Dc to 50 MHz.	
Maximum Input Voltage		100 V (dc plus peak ac). 100 V P-P ac at 1 kHz or less.
<b>SIGNAL OUTPUTS</b>		
CH 1 VERT SIGNAL OUT Output Voltage  Into 1 MΩ load	One division of deflection gives at least 50 mV.	
Into 50 Ω load	One division of deflection gives at least 25 mV.	
Output Resistance		Approximately 50 Ω.
Bandwidth	DC to at least 50 MHz into 50 Ω.	
Output DC Level	Approximately 0 V.	
A and B + GATE Outputs  Output Voltage  Output Resistance	Approximately 5.5 V positive-going.	Approximately 500 Ω.

TABLE 1-1 (cont)

Characteristics	Performance Requirements	Supplemental Information
<b>POWER SOURCE</b>		
Line Voltage Ranges (AC, RMS)		
115 V		
Low	110 V, $\pm 10\%$ .	99 V to 121 V.
Medium	115 V, $\pm 10\%$ .	103.5 V to 126.5 V.
High	120 V, $\pm 10\%$ .	108 V to 132 V.
230 V		
Low	220 V, $\pm 10\%$ .	198 V to 242 V.
Medium	230 V, $\pm 10\%$ .	207 V to 253 V.
High	240 V, $\pm 10\%$ .	216 V to 264 V.
Line Frequency	48 Hz to 440 Hz.	
Maximum Power Consumption	100 watts at 115 V, 60 Hz (medium range).	
<b>CATHODE-RAY TUBE</b>		
Horizontal Resolution		At least 10 lines/division.
Vertical Resolution		At least 10 lines/division.
Display Area	8 x 10 div.	div = 0.9 cm.
Geometry		0.1 division or less of tilt or bowing.
Raster Distortion		0.1 division or less.
Normal Accelerating Potential		Approximately 8,500 volts in Normal Scan mode, or about 10,500 volts in Reduced Scan mode.
Trace Rotation Range		Adequate to align trace with horizontal center line.
Standard Phosphor	P31.	
<b>STORAGE</b>		
Stored Writing Speed		Measured with 50 V or greater drive above signal extinction (+70 V or greater at Z-axis test point, and not to exceed level where display begins to deteriorate, with visual extinction set at +20 V). It is necessary to use the STORAGE LEVEL control to reach the best compromise between writing speed and view time.
Full Scan (Center 6 X 8 div, 0.9 cm/div)		
FAST	150 div/ $\mu$ s	
VAR PERS	0.5 div/ $\mu$ s	
Reduced Scan (Center 8 X 10 div, 0.45 cm/div)		
FAST	3000 div/ $\mu$ s	
VAR PERS	3 div/ $\mu$ s	



TABLE 1-1 (cont)

Characteristics	Performance Requirements	Supplemental Information
STORAGE (cont)		
Storage View Time		These times are at full stored display intensity; they can be extended at least 40 times (>10 minutes) using reduced intensity in the SAVE Display Mode.
FAST	At least 15 seconds	
VAR PERS	At least 15 seconds	

TABLE 1-2  
Environmental Characteristics

Characteristics	Performance Requirements	Supplemental Information
Temperature		
Operating (AC)	-15°C to +55°C.	
Storage	-55°C to +75°C.	
Altitude		
Operating	To 15,000 feet. Maximum operating temperature decreased 1°C/1,000 feet above 5,000 feet.	
Storage	To 50,000 feet.	
Humidity (Operating and Storage)	5 cycles (120 hours) referenced to MIL-E-16400F.	
Vibration (Operating)	15 minutes along each of three major axes at a total displacement of 0.025 inch P-P (4 g's at 55 Hz) with frequency varied from 10 Hz to 55 Hz to 10 Hz in one minute sweeps. After sweep vibration in each axis, hold frequency steady at 55 Hz for three minutes. All major resonances must be above 55 Hz.	
Shock (Operating and Non-operating)	30 g's, 1/2 sine, 11 ms duration, 2 shocks per axis each direction for a total of 12 shocks.	
Transportation	Meets the limits of National Safe Transit Committee test procedure 1A with a 30-inch drop.	

**TABLE 1-3**  
**Physical Characteristics**

Characteristics	Information	
Construction		
Chassis	Aluminum alloy.	
Panel	Aluminum alloy with anodized finish.	
Cabinet	Blue vinyl-coated aluminum alloy.	
Circuit Boards	Glass laminate etched-wiring.	
Overall Dimension		
Height		
With Feet and Pouch	7.5 inches (19.1 cm).	
Without Pouch	6.2 inches (15.7 cm).	
Width		
With Handle	12.9 inches (32.8 cm).	
Without Handle	11.5 inches (29.2 cm).	
Depth		
Including Panel Cover	21.7 inches (55.0 cm).	
Handle Extended	23.7 inches (60.0 cm).	
Weight		
With Panel Cover, Accessories, and Accessory Pouch	30 pounds (13.6 kg).	
Without Panel Cover, Accessories, and Accessory Pouch	26 pounds (11.8 kg).	
Domestic Shipping Weight	41.5 pounds (18.8 kg).	

### Standard Accessories

Standard accessories supplied with the 466 are listed in the Mechanical Parts List in this Service manual. For optional accessories available for use with the 466, see the Tektronix, Inc. catalog.

# OPERATING INSTRUCTIONS

## Operating Voltage

This instrument operates from either a 115-volt or a 230-volt nominal line voltage source, 48 to 440 hertz.

The line voltage selector switch must indicate the applied line voltage (115 V or 230 V).

The regulating range selector (Item 52, Controls, Connectors and Indicators) must indicate the regulating range for the applied operating line voltage.

## Safety Information

The instrument is designed to operate from a single-phase power source with one of the current-carrying conductors (the Neutral Conductor) at ground (earth) potential. Operation from power sources where both current-carrying conductors are live with respect to ground (such as phase-to-phase on a three-wire system) is not recommended, since only the Line Conductor has over-current (fuse) protection within the instrument.

The instrument has a three-wire power cord with a three-terminal polarized plug for connection to the power source and safety-earth. The ground (earth) terminal of the plug is directly connected to the instrument frame. For electric-shock protection, insert this plug only in a mating outlet with a safety-earth contact.

### Power Cord Conductor Identification

Conductor	Color	Alternate Color
Ungrounded (Line)	Brown	Black
Grounded (Neutral)	Blue	White
Grounding (Earthing)	Green-Yellow	Green-Yellow

## Nominal Line Voltage Range

### CAUTION

*This instrument may be damaged if operated with the line voltage selector switch or the regulating range selector set for the wrong applied line voltage.*

To convert from one nominal line voltage range to the other, move the Line Voltage Selector switch (located on side panel) to indicate the correct nominal voltage. A 115-to-230 volt adapter may be required for the line-cord plug.

The Regulating Range Selector assembly (located on the rear panel) is set for one of the line voltage ranges shown in Table 2-1. It also contains the line fuse for overload protection.

TABLE 2-1

Regulating Ranges

Range Selector Switch Position	Regulating Range	
	115-Volts Nominal	230-Volts Nominal
LO (Switch bar in lower holes)	99 to 121 volts	198 to 242 volts
M (Switch bar in middle holes)	104 to 126 volts	207 to 253 volts
HI (Switch bar in upper holes)	108 to 132 volts	216 to 264 volts
Fuse Size	1.5 A 3AG Fast-blow	0.75 A 3AG Fast-blow

To change the regulating range:

1. Disconnect the instrument from the power source.
2. Loosen the two captive screws that hold the cover on the selector assembly; then pull to remove the cover.

## Operating Instructions—466 Service

3. Pull out the range selector switch bar (see Fig. 2-1). Select a range from Table 2-1 that is centered about the average line voltage. Slide the bar to the desired position and plug it in. Push the cover on and tighten the screws.

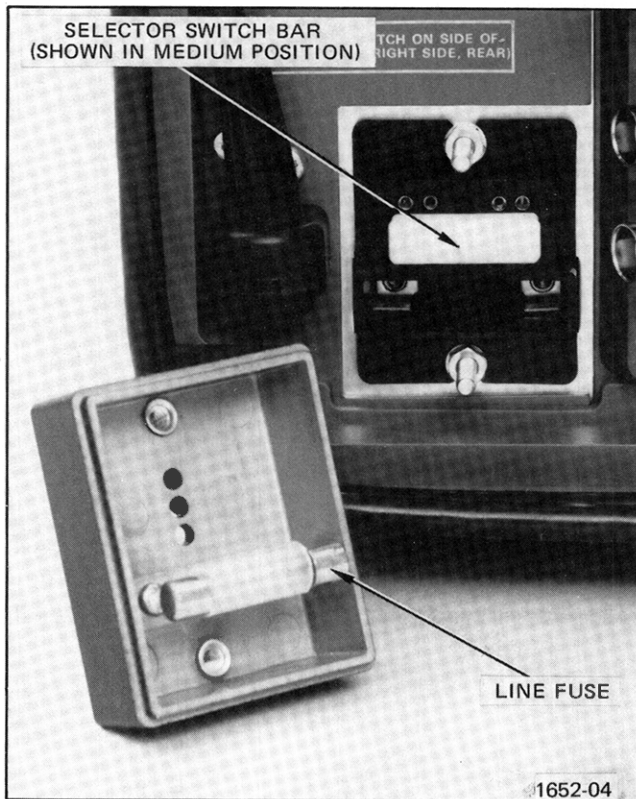

Fig. 2-1. Regulating range selector and line fuse.

### Options

Options are available that alter oscilloscope performance to meet particular applications. A number in either MOD slot (see Item 54, Controls, Connectors and Indicators) indicates a modified oscilloscope.

Refer to the Option section at the rear of this manual to find any change in operating instruction as a result of the option.

## CONTROLS, CONNECTORS AND INDICATORS

### VERTICAL

1. **CH 1 and CH 2 VOLTS/DIV** — Selects the vertical deflection factor in a 1-2-5 sequence (VARIABLE control must be in the calibrated detent for the indicated deflection factor).

2. **VOLTS/DIV READOUT** — Consists of two small lamps for each channel, located beneath the skirt of each VOLTS/DIV knob. The right lamp will light up to indicate the correct deflection factor when a 10X probe with a scale-switching connector is used. The left lamp lights up when a probe without the scale-switching connection (or no probe) is used.

3. **VAR** — Provides continuously variable uncalibrated deflection factors between the calibrated settings of the VOLTS/DIV switch, and extends the maximum vertical deflection to at least 12.5 volts per division (5 volt position).

4. **UNCAL LAMP** — Indicates when the VARIABLE VOLTS/DIV control is out of the calibrated detent and the vertical deflection factor is uncalibrated.

5. **POSITION** — Positions the display vertically. CH 2 POSITION positions the Y-Axis (vertical) display in X-Y Mode.

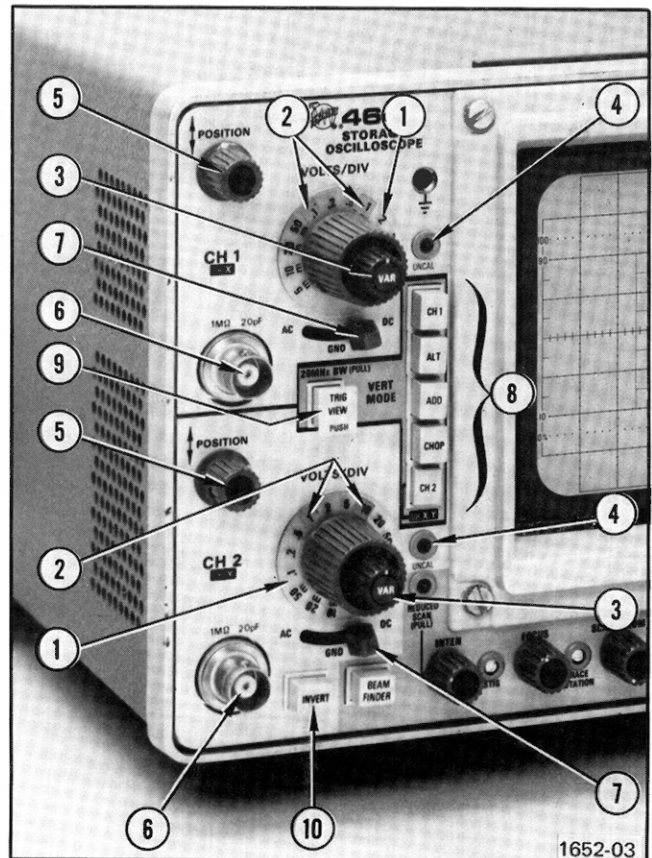

Fig. 2-2. Vertical Section.

**6. CH 1 OR X and CH 2 OR Y** — Input connectors for application of external signals to the inputs of the vertical amplifier. In the X-Y mode of operation, the signal connected to the CH 1 OR X connector provides horizontal deflection and the signal connected to the CH 2 OR Y connector provides the vertical deflection.

**7. AC—GND—DC** — Selects the method used to couple a signal to the input of the vertical amplifier. In the AC position, signals are capacitively coupled to the vertical amplifier. The dc component of the input signal is blocked. In the GND position, the input of the vertical amplifier is disconnected from the input connector and grounded to allow the input coupling capacitor to precharge. In the DC position, all components of the input signal are passed to the input amplifier.

**8. VERT MODE** — Selects mode of operation for vertical amplifier system.

CH 1: Channel 1 only is displayed.

ALT: Provides dual-trace display of the signals of both channels. Display is switched between channels at the end of each sweep. Useful at sweep rates faster than about 50 microseconds/division.

ADD: Signals applied to the CH 1 and CH 2 input connectors are algebraically added, and the algebraic sum is displayed on the crt. The INVERT switch in Channel 2 allows the display to be CH 1 plus CH 2 or CH 1 minus CH 2. Useful for common-mode rejection to remove an undesired signal or for dc offset.

CHOP: Provides dual-trace display of the signals of both channels. Display is switched between channels at a repetition rate of approximately 250 kHz. Useful at sweep rates slower than about 50 microsecond/division, or when a dual-trace, single-sweep display is required.

CH 2: Channel 2 only is displayed. It must be selected in X-Y operation.

**9. 20 MHz BW/TRIG VIEW** — Dual-purpose switch that limits the bandwidth of the vertical amplifier system to approximately 20 MHz when pulled, or when pressed, causes the signal applied to A Trigger Generator to be displayed on the crt.

**10. INVERT** — Channel 2 display is inverted in the INVERT (button in) position.

## DISPLAY AND STORAGE

**11. INTERNAL GRATICULE** — Eliminates parallax. Risetime amplitude and measurement points are indicated at the left-hand graticule edge.

**12. BEAM FINDER** — Compresses the display to within the graticule area independently of display position or applied signals; provides a visible viewing level to indicate position of display relative to crt center.

**13A. INTEN** — Controls brightness of the crt display.

**13B. REDUCED SCAN (PULL-INTEN knob)** — Reduces display to "inner" graticule with an increase in writing rate.

**13C. REDUCED SCAN LAMP** — Indicates that the REDUCED SCAN mode is in operation.

**14. ASTIG** — Used in conjunction with the FOCUS control to obtain a well-defined display. It does not require readjustment in normal use.

**15. FOCUS** — Adjusts for optimum display definition.

**16. TRACE ROTATION** — Adjusts trace to align with the horizontal graticule lines.

**17. SCALE ILLUM** — Controls graticule illumination.

**18. STORAGE LEVEL** — Varies the writing rate of the crt in the FAST and VAR PERS storage modes.

**19. SAVE** — Provides longer viewing time. It prevents accidental erasure of the stored display.

**20. SAVE INTEN** — Varies the intensity of the SAVE mode.

**21. NON STORE** — Allows operation of the instrument as a conventional oscilloscope in the NON STORE mode.

**22. VAR PERS** — Permits variable retention of the stored display.

**23. FAST** — Used for fast-writing displays. FAST mode disables the TRIG MODE switch. It automatically sequences an erase cycle, unless the VIEW TIME control is in the full clockwise detent (manual). It waits a time period determined by the VIEW TIME control, then resets the sweep in a single-sweep mode and causes READY lamp to light until the sweep is started by an applied signal. Multiple traces can be stored in this mode using the SINGL SWP button. See Storage Displays in this section.

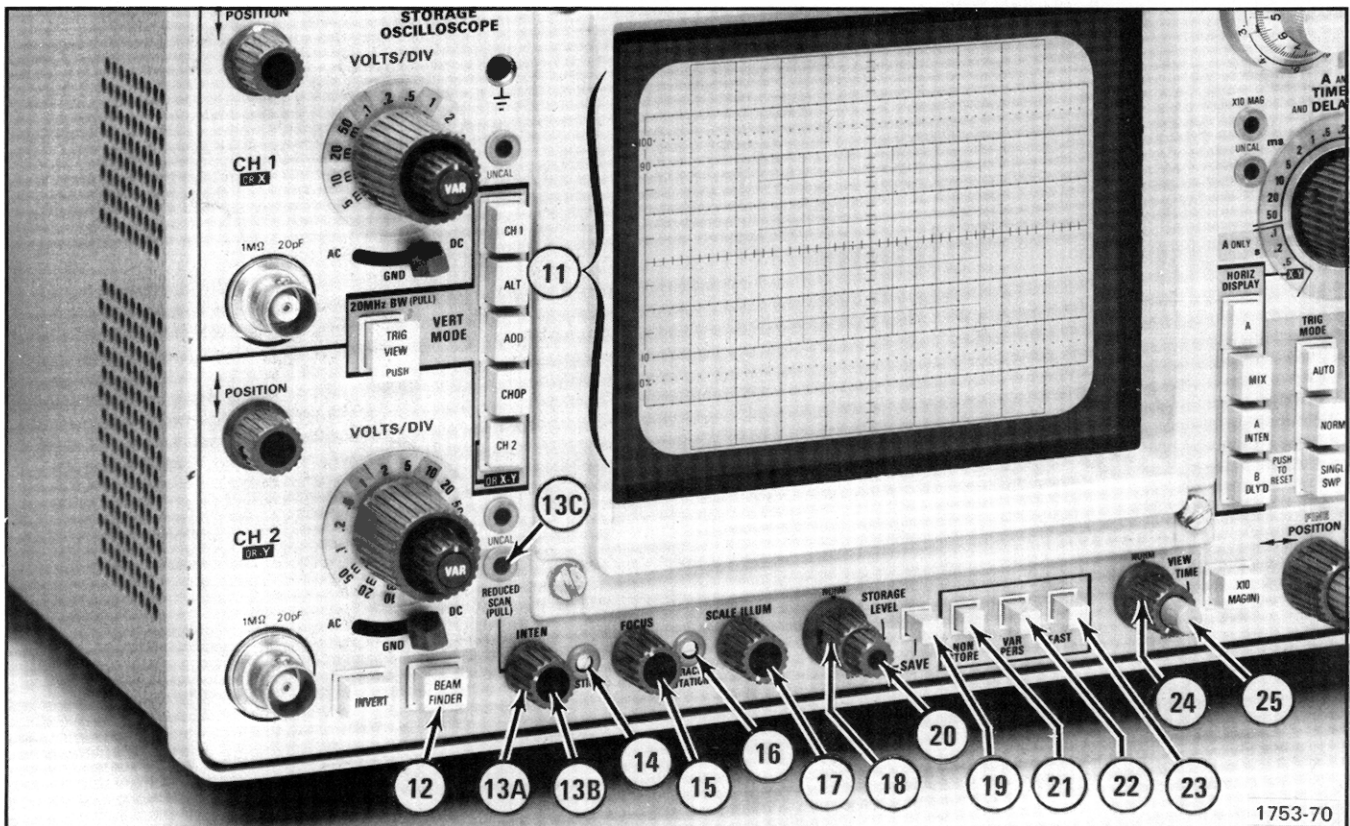

Fig. 2-3. Display and Storage Sections.

**24. VIEW TIME** — Varies the retention time (persistence) of the stored display in the VAR PERS mode. It varies the time between erase cycles in FAST mode.

**25. ERASE** — Erases the stored display, except in SAVE mode when ERASE is disabled.

## TRIGGER

### TRIG MODE

Determines the mode of trigger operation for A Sweep.

**26. AUTO** — Sweep is initiated by the applied trigger signal. In the absence of an adequate trigger signal, or if the trigger repetition rate is less than about 20 hertz, the sweep free runs and provides a bright reference trace.

**27. NORM** — Sweep is initiated by the applied trigger signal. In the absence of an adequate trigger signal, there is no trace. When the trigger rate is too low for AUTO use NORM.

**28. SINGL SWP** — When this pushbutton is pushed, the A Sweep operates in the single sweep mode. After a single sweep is displayed, further sweeps cannot be presented until the SINGLE SWP button is pushed to reset the sweep. It is useful when the signal to be displayed is not repetitive or varies in amplitude, shape or time, causing an unstable conventional display. If the SINGL SWP button is pushed while in the FAST storage mode, multiple traces can be stored. See Storage Displays in this section.

**29. READY LAMP** — Indicates A Sweep is "armed" and, upon receipt of an adequate trigger signal, will present a single-sweep display.

**30. TRIG LAMP** — Indicates that A Sweep is triggered and will produce a stable display. It is useful for setting up the trigger circuits when a trigger signal is available without a display on the crt (for example, when using external triggers).

**31. A TRIG HOLDOFF** — Provides continuous control of time between sweeps. Allows triggering on aperiodic signals (such as complex digital words). In the fully clockwise position (B ENDS A), A sweep is reset at the end of B sweep to provide the fastest possible sweep repetition rate for delayed-sweep presentations and low-repetition rate signals. Use the A trigger controls for the best possible display before using the A TRIG HOLDOFF control.

**32. COUPLING** — Determines method used to couple signals to trigger generator circuit.

AC: Signals are capacitively coupled to the input of the trigger generator. Dc is rejected and signals below about 30 Hz are attenuated.

LF REJ: Signals are capacitively coupled to the input of the trigger circuit. Dc is rejected and signals below about 50 kHz are attenuated. It is useful for providing a stable display of the high-frequency components of a complex waveform.

HF REJ: Signals are capacitively coupled to the input of trigger circuit. Dc is rejected and signals below about 30 Hz and above 50 kHz are attenuated. It is useful for providing a stable display of the low-frequency components of a complex waveform.

DC: All components of a trigger signal are coupled to the input of the trigger circuit. It is useful for providing a stable display of low-frequency or low-repetition rate signals, except the combination of ALT (dual trace) mode with the trigger SOURCE switch in NORM.

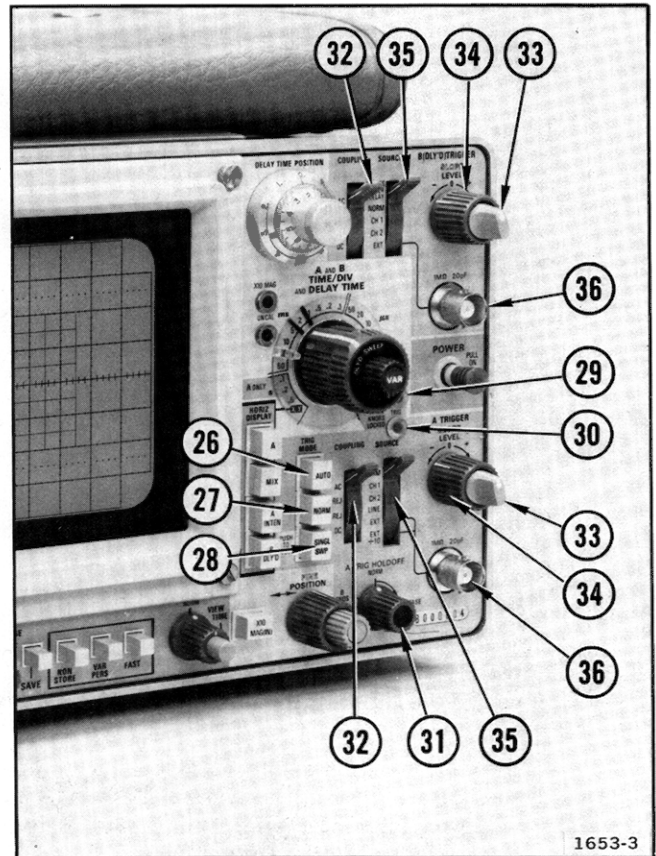

Fig. 2-4. Partial Trigger Section.

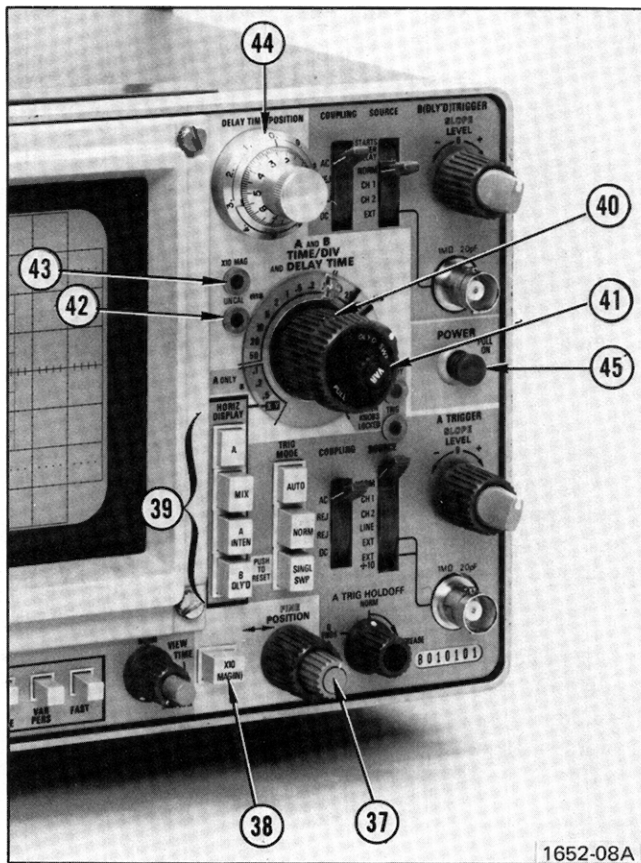

Fig. 2-5. Horizontal and Power Sections.

**33. SLOPE** — Selects the slope of the trigger signal that starts the sweep.

+: Sweep can be triggered from the positive-going portion of a trigger signal.

-: Sweep can be triggered from the negative-going portion of a trigger signal.

Correct SLOPE setting is important in obtaining a display when only a portion of a cycle is being displayed.

**34. LEVEL** — Selects the amplitude point on the trigger signal at which the sweep is triggered. It is usually adjusted for the desired display after trigger SOURCE, COUPLING and SLOPE have been selected.

**35. SOURCE** — Determines the source of the trigger signal coupled to the input of the trigger circuit.

**NORM:** Trigger source is displayed signal(s). It does not indicate time relationship between CH 1 and CH 2 signals. However, stable triggering of non-time related signals usually can be obtained by setting VERT MODE to ALT, SOURCE to NORM and COUPLING to LF REJ. Carefully adjust LEVEL for a stable display.

**EXT:** Signals connected to the External Trigger Input connectors are used for triggering. External signals must be time-related to the displayed signal for a stable display. It is useful when the internal signal is too small or contains undesired signals that could cause unstable triggering. It is useful when operating in CHOP mode.

**EXT ÷ 10 (A Trigger circuit only):** External trigger signal attenuated by a factor of 10.

**STARTS AFTER DELAY (B Trigger circuit only):** B Sweep runs immediately after the delay time selected by the DELAY-TIME POSITION dial.

**CH 1:** A sample of the signal available in Channel 1 is used as a trigger signal. CH 2 signal is unstable if it is not time-related.

**CH 2:** A sample of the signal available in Channel 2 is used as a trigger signal. CH 1 signal is unstable if it is not time-related.

**LINE:** (A Trigger circuit only): A sample of the power-line frequency is used as a trigger signal. It is useful when input signal is time-related (multiple of sub-multiple) to the line frequency or when it is desirable to provide a stable display of a line-frequency component in a complex waveform.

**36. EXTERNAL TRIGGER INPUT** — Input connector for external trigger signals.

## HORIZONTAL AND POWER

**37. FINE/POSITION** — Positions the display horizontally for A Sweep, B Sweep or the X-axis in X-Y Mode.

**38. X10 MAG** — Increases displayed sweep rate by a factor of 10. It extends fastest sweep rate to 5 nano-seconds/division. The magnified sweep is the center division of the unmagnified display (0.5 division either side of the center graticule line).

**39. HORIZ DISPLAY** — Determines mode of operation for horizontal deflection system.

**A:** Horizontal deflection provided by A Sweep at a sweep rate determined by the setting of the A TIME/DIV switch. B Sweep is inoperative.



**Mix:** First part of the horizontal sweep displayed at a rate set by the B TIME/DIV switch. Relative amounts of the display allocated to each of the two sweep rates are determined by the setting of the DELAY-TIME POSITION dial.

**A INTEN:** Sweep rate determined by the A TIME/DIV switch. An intensified portion appears on the display during the B Sweep time, which is about 10 times the B TIME/DIV switch setting. This switch position provides a check of the duration and position of the B Sweep (delayed sweep) with respect to the delaying sweep (A).

**B DLYD:** Sweep rate determined by the B TIME/DIV switch with the delay time determined by the setting of the DELAY TIME (A TIME/DIV) switch and the DELAY-TIME POSITION dial.

**40. A AND B TIME/DIV AND DELAY TIME**—A TIME/DIV switch (clear plastic skirt) selects the sweep rate of the A Sweep circuit for A Sweep only operation and selects the basic delay time (to be multiplied by DELAY TIME POSITION dial setting) for delayed sweep operation only. A VAR control must be in the calibrated detent for calibrated sweep rates. When both TIME/DIV switches are fully counterclockwise to the X-Y position, the horizontal (X-axis) display is the CH 1 input.

**41. VAR**—Provides continuously variable sweep rates between the calibrated settings of the A TIME/DIV switch. It extends the slowest A Sweep rate to at least 1.25 seconds/division. The A Sweep rate is calibrated when the control is set fully clockwise to the calibrated detent.

**42. UNCAL LAMP**—Indicates the A Sweep rate is uncalibrated (VAR control out of the calibrated detent).

**43. X10 MAGnifier LAMP**—Indicates that the X10 magnifier is on.

**44. DELAY-TIME POSITION**—Provides variable sweep delay from 0.20 to 10.20 times the delay time indicated by the A TIME/DIV switch.

**45. POWER**—Turns instrument power on and off.

**46. A +GATE**—Provides a positive-going rectangular pulse coincident with the A Sweep time, which can be used to trigger the signal source.

**47. B +GATE**—Provides a positive-going rectangular pulse coincident with the B Sweep time, which can be used to trigger the signal source after a selected delay time, providing that A Sweep is triggered internally.

**48. CH 1 VERT SIGNAL OUT**—Provides a sample of the signal applied to the CH 1 input connector.

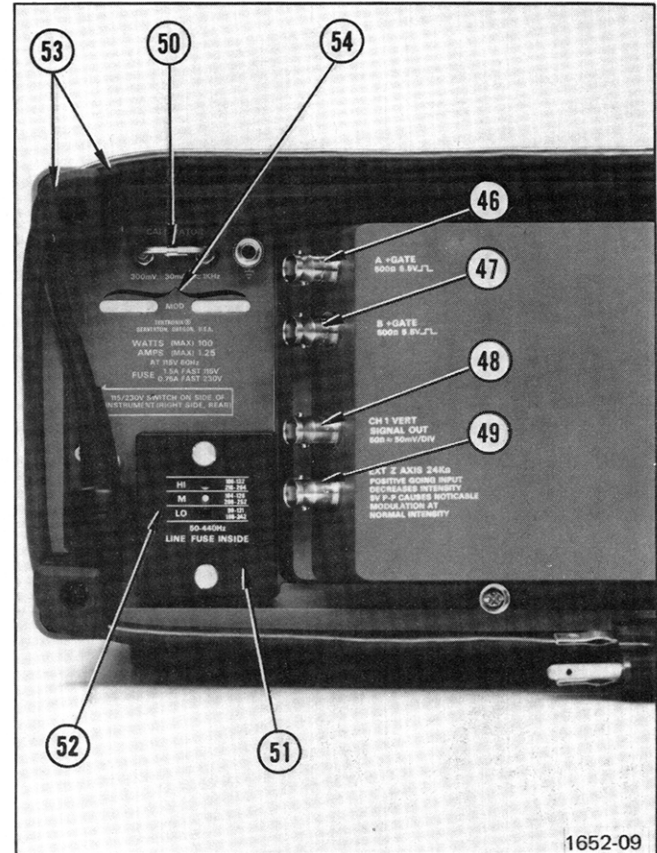

Fig. 2-6. Rear Panel Section.

**49. EXT Z-AXIS**—Permits intensity modulation of the crt display. Does not affect display waveshape. Signals with fast rise and fall provide the most abrupt intensity change. Signal must be time-related to the display for a stable display. Useful for uncalibrated modes of operation and adding time markers.

**50. CALIBRATOR**—A combination current loop/square-wave voltage output that permits the operator to compensate voltage probes and check vertical gain, current probes and oscilloscope operation. It is not intended to verify time-base calibration.

**51. LINE FUSE HOLDER**—Contains the line fuse and the regulating range selector. See Fig. 2-1 for change information.

**52. REGULATING RANGE SELECTOR**—Shown in Medium regulating range. See Fig. 2-1 for change information.

**53. LINE CORD**—May be conveniently stored by wrapping it around the feet on the rear panel or the accessory pouch.

**54. MOD Slots**—A number in either slot indicates the instrument contains an option.

## RIGHT SIDE PANEL

**55. LINE VOLTAGE SELECTOR SWITCH** (located on the right-hand side)—Selects either 115 V or 230 V nominal line voltage.

## LEFT SIDE PANEL

**56. VERTICAL GAIN CONTROLS** (accessible through left side panel)—Screwdriver adjustments to set the gain of each vertical channel.

**57. VARIABLE BALANCE CONTROLS** (accessible through left side panel)—Screwdriver adjustment to set balance of each vertical channel.

## P6062A 10X — 1X PROBE

**1. 10X—1X SLIDE SWITCH**—Selects either 10X or 1X attenuation factor. The oscilloscope VOLTS/DIV readout reflects the change in attenuation.

**2. GND REFERENCE PUSHBUTTON**—Grounds the input of the vertical amplifier. The input signal is isolated from the ground by about 9 M $\Omega$  and 11 pF, in either 1X or 10X operation. Pushbutton must be completely depressed to obtain the ground reference.

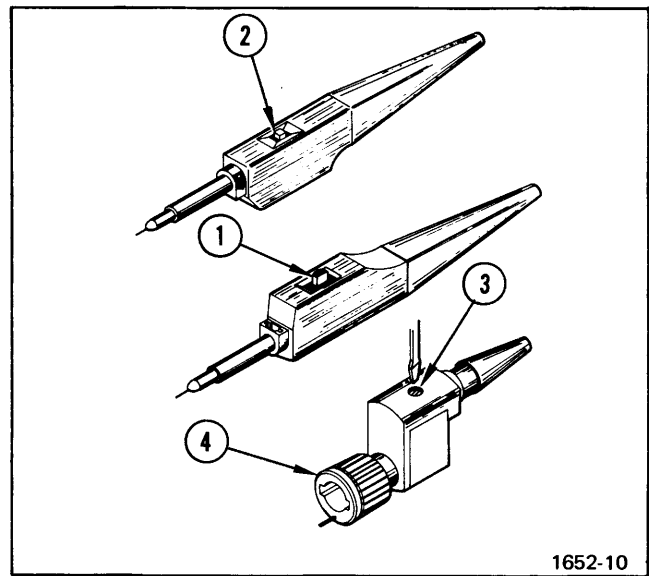

Fig. 2-7. P6062A Probe.

**3. PROBE COMPENSATION ADJUSTMENT**—Permits adjusting an individual probe to the input variations between different oscilloscopes.

**4. READOUT CONNECTOR**—Permits scale switching of the VOLTS/DIV switch when the position of 10X—1X slide switch is changed.

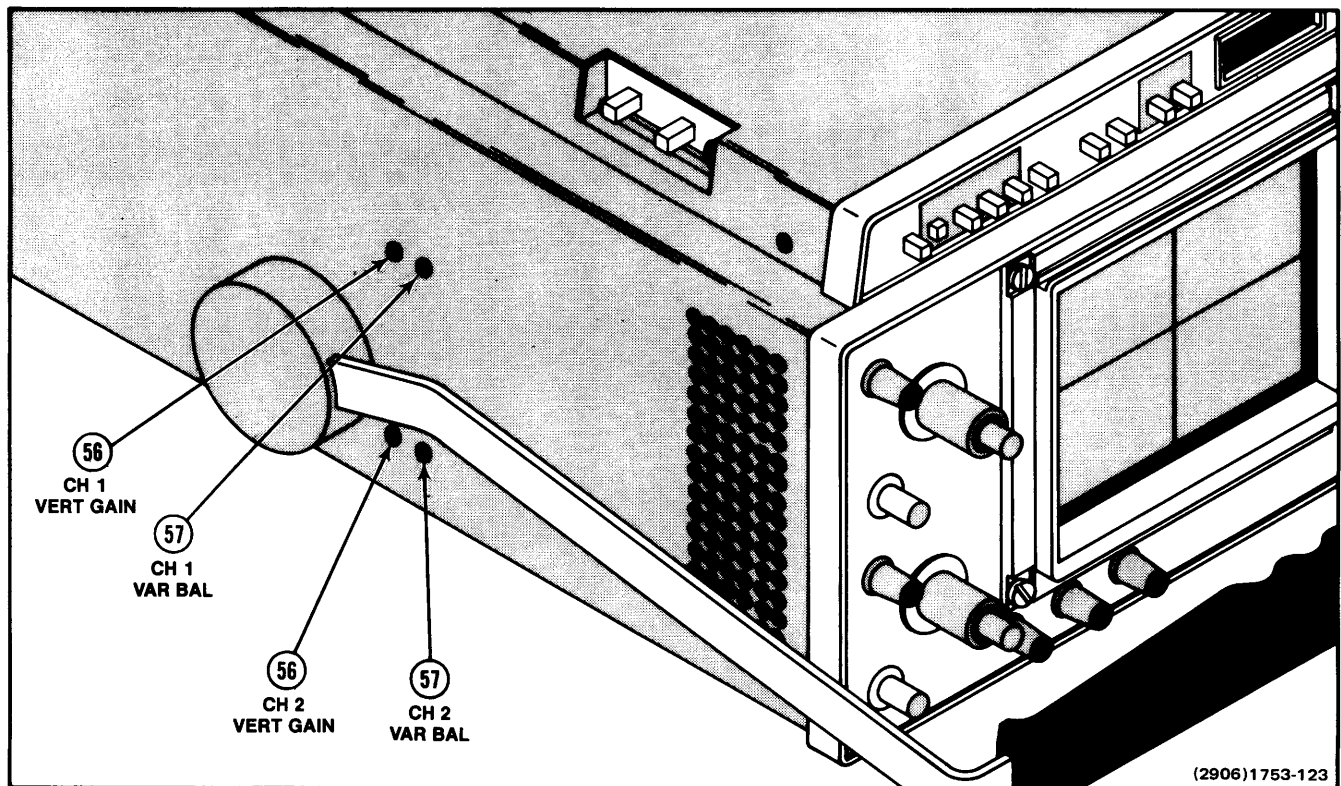

Fig 2-6A. Left Side Panel Controls.

## BASIC DISPLAYS

These instructions permit the operator to obtain the commonly used basic displays.

### Normal Sweep Display

1. Set the controls as follows:

#### VERTICAL (CH 1 and CH 2 if applicable)

VERT MODE	CH 1
VOLTS/DIV	Position determined by amplitude of signal to be applied.
VOLTS/DIV VAR	Calibrated detent
Input Coupling	AC
Vertical POSITION	Midrange
20 MHz BW	Not limited (yellow band not visible)
INVERT	Button out

#### DISPLAY

INTEN	Fully counterclockwise
REDUCED SCAN (PULL)	Pushed in
FOCUS	Midrange
SCALE ILLUM	Midrange
STORAGE LEVEL	NORM
SAVE INTEN	Fully counterclockwise
SAVE	Button out
NON STORE	Button in
VIEW TIME	NORM
VAR PERS	Button out
FAST	Button out
ERASE	Button out
BEAM FINDER	Button out
ASTIG	For well-defined display
TRACE ROTATION	To align trace with horizontal graticule line

#### TRIGGER

Trigger	(Both A and B if applicable)
SLOPE	+
LEVEL	0
SOURCE	NORM
COUPLING	AC
TRIG MODE (A only)	AUTO
A TRIG HOLDOFF	NORM

#### HORIZONTAL

TIME/DIV Switches	Locked together at 1 ms
A TIME/DIV VAR	Calibrated detent
HORIZ DISPLAY	A
X10 MAG	Off (button out)
POSITION/FINE	Midrange
DELAY-TIME POSITION	Fully counterclockwise

2. Pull the POWER switch (on) and allow several minutes for warmup. Connect the external signal to the CH 1 input connector.

3. Adjust the INTENSITY control for the desired display brightness. If the display is not visible with the INTENSITY control at midrange, press the BEAM FIND pushbutton and adjust the CH 1 VOLTS/DIV switch to reduce the vertical display size. Center the compressed display with the vertical and horizontal POSITION controls; release the BEAM FIND pushbutton. Adjust the FOCUS control for a well-defined display.

4. Set the CH 1 VOLTS/DIV switch and vertical POSITION CONTROL TO LOCATE THE DISPLAY WITHIN THE DISPLAY AREA:

5. Adjust the A Trigger LEVEL control for a stable display.

6. Set the A TIME/DIV switch and the horizontal POSITION control to locate the display within the display area.

### Magnified Sweep Display

1. Obtain a Normal Sweep Display.
2. Adjust the horizontal POSITION control to move the area to be magnified to within the center graticule division. (It may be necessary to change the TIME/DIV switch setting.)
3. Push the X10 MAG switch (on) and adjust the horizontal POSITION control for precise positioning of the magnified display. Divide the TIME/DIV setting by 10 to determine the magnified sweep rate.

### Delayed Sweep Display

1. Obtain a Normal Sweep Display.
2. Set the HORIZ DISPLAY switch to A INT and the B Trigger SOURCE switch to STARTS AFTER DELAY.
3. Pull out the B TIME/DIV switch knob and turn clockwise until the intensified zone on the display is the desired length. Adjust the INTENSITY control for the desired display brightness.
4. Adjust the DELAY-TIME POSITION dial to move the intensified zone to the portion of the display to be delayed.

## Operating Instructions—466 Service

5. Set the HORIZ DISPLAY switch to B DLY'D. The intensified zone on the display noted in steps 3 and 4 is now displayed in delayed form (change INTENSITY setting as needed). The delayed sweep rate is indicated by the dot on the B TIME/DIV switch knob.

6. For a delayed sweep display with less jitter, set the B Trigger SOURCE switch to the same position as the A Trigger SOURCE switch and adjust the B Trigger LEVEL control for a stable display. If the A Trigger SOURCE switch is in the LINE position, a sample of the line voltage will have to be supplied to the B Trigger circuit externally via the B Trigger external trigger connector.

### Mixed Sweep Display

1. Obtain a Normal Sweep Display.

2. Pull out the B TIME/DIV switch knob and turn clockwise to the desired sweep rate. Adjust the INTEN control for the desired display brightness.

3. Set the HORIZ DISPLAY switch to MIX. The display now contains more than one time factor on the horizontal axis. The first portion of the display is at the A Time Base sweep rate and the latter part is at the B Time Base sweep rate. The start of the B Time Base portion of the display can be changed by adjusting the DELAY-TIME POSITION control.

### X-Y Display

1. Preset the instrument controls as given in step 1 of Normal Sweep Display, then turn the instrument power on. Allow several minutes for instrument warm-up.

2. Set the TIME/DIV switches to X-Y and the VERT MODE to CH 2. Apply the vertical signal to the CH 2 or Y input connector and the horizontal signal to the CH 1 OR X input connector.

3. Advance the INTEN control until the display is visible. If the display is not visible with the INTEN control at midrange, press the BEAM FINDER pushbutton and adjust the CH 1 and CH 2 VOLTS/DIV switches until the display is reduced in size, both vertically and horizontally. Center the compressed display with the POSITION controls (CH 2 POSITION vertically, POSITION/FINE horizontally); release the BEAM FINDER pushbutton. Adjust the FOCUS control for a well-defined display.

### Single Sweep Display

1. Obtain a Normal Sweep Display. (For random signals, set the trigger circuit to trigger on a signal that is approximately the same amplitude and frequency as the random signal.)

2. Set the A TRIG MODE switch to SINGL SWP and press the PUSH TO RESET button. The next trigger pulse starts the sweep and displays a single trace. If no triggers are present, the READY lamp lights, indicating the A Sweep Generator circuit is set and waiting to be triggered.

3. After the sweep is complete, the circuit is "locked out" and the READY lamp is out. Press the PUSH TO RESET button to prepare the circuit for another single-sweep display.

## STORAGE DISPLAYS

### Storage

1. Set the following controls:

#### VERTICAL

VERT MODE Switch	CH 1
VOLTS/DIV Switches	Determined by amplitude of applied signal
VOLTS/DIV VAR Controls	Calibrated detent
Input Coupling Switches	AC
Vertical POSITION Controls	Midrange
20 MHz BW Switch	Not limited (yellow band not visible)
INVERT Switch	Button out

#### DISPLAY

INTEN Control	Fully counterclockwise
REDUCED SCAN (PULL)	Push in
FOCUS Control	Midrange
SCALE ILLUM Control	Midrange
STORAGE LEVEL Control	NORM
SAVE INTEN Control	Fully counterclockwise
SAVE Switch	Button out
NON STORE Switch	Button in
VIEW TIME Control	NORM

#### TRIGGER

(Both A and B if applicable)

SLOPE Switch	+
LEVEL Control	0
SOURCE Switch	NORM
COUPLING Switch	AC
TRIG MODE Switch (A only)	AUTO
A TRIG HOLDOFF Control	NORM

#### HORIZONTAL

TIME/DIV Switches	Locked together at 1 ms
A TIME/DIV VAR	Calibrated detent
HORIZ DISPLAY Switch	A
X10 MAG Switch	Off (button out)
POSITION Control	Midrange

2. Obtain a Normal Sweep Display as follows:
3. Pull the POWER switch (on) and allow several minutes for instrument warmup. Connect the external signal to the CH 1 input connector.
4. Adjust the INTEN control for the desired display brightness. If the display is not visible with the INTEN control at midrange, press the BEAM FINDER pushbutton and adjust the CH 1 VOLTS/DIV switch to reduce the vertical display size. Center the compressed display with the vertical and horizontal POSITION controls; release the BEAM FINDER pushbutton. Adjust the FOCUS control for a well-defined display.
5. Set the CH 1 VOLTS/DIV switch and CH 1 POSITION CONTROL for a display that remains in the display area vertically.
6. Adjust the A Trigger LEVEL control for a stable display.
7. Set the A TIME/DIV switch and the horizontal POSITION control for a display that remains in the display area horizontally.
8. Select either VAR PERS or FAST mode.

**NOTE**

*a. In general, better results are obtained using the VAR PERS mode for sweep speeds slower than 100  $\mu$ s/division.*

*b. When using the combination of FAST storage and B DLY'D horizontal display, set A TRIG HOLDOFF control to B ENDS A for maximum display repetition rate.*

9. Push the ERASE button. Allow a few seconds for the storage and trigger circuits to automatically provide a display.
10. Set the INTEN control for adequate display brightness. Set the STORAGE LEVEL control for optimum display (depends on the amplitude and speed of the signal to be viewed). Set the VIEW TIME control for the desired display retention (persistence) in the VAR PERS mode or for the time between erase cycles in the FAST mode.
11. Push the ERASE button. The display is erased, except in the SAVE mode, and the storage and trigger circuits are reset.

**Save Storage**

1. Obtain a Storage Display using steps 1 through 10.
2. Immediately after the event is stored, push in the SAVE button, providing a longer viewing time. The SAVE INTEN control adjusts the display brightness. Increasing the display brightness decreases the viewing time.

Pushing the SAVE button, after the event is stored, can be delayed up to several seconds (depending on the VIEW TIME setting), this reduces maximum viewing time.

Maximum viewing time occurs when the SAVE INTEN control is set fully counterclockwise, advancing the control only long enough to view the display.

3. Erase is disabled in the SAVE mode.

**Save Random Events**

1. Obtain a Storage Display using steps 1 through 10, with a test signal similar to a random event. Use the FAST mode, not VAR PERS. The FAST mode automatically disables the TRIG MODE switch and the instrument operates in a single sweep mode controlled by the storage circuitry. The READY lamp should light in the absence of a signal (random event or repetitive).

2. Set the SAVE INTEN control to maximum counterclockwise. Replace the test signal with the random event source. Push the ERASE button (or wait for the automatic erase cycle to occur). Note that the READY lamp is on. Push in the SAVE button before the random event occurs. After the event occurs and the READY lamp goes out, advance the SAVE INTEN control clockwise to view the stored display.

3. After the event is captured, the oscilloscope will automatically change to the SAVE mode.

**Multiple-Trace Storage**

1. Obtain a Storage Display using steps 1 through 10.
2. Immediately after an event is stored, press the SINGL SWP button. This will reset the sweep and the storage circuit (use the vertical or horizontal POSITION controls as desired to store successive traces on fresh crt display area). When the sweep is triggered, a new trace will be stored without erasing the previously stored display. Each time the SINGL SWP button is pressed, this cycle will be repeated until the stored traces are erased. A small amount of background will be stored each time a new trace is stored. This background can be kept to a minimum by setting the STORAGE LEVEL only as high as necessary for the particular application.

**Care of Storage Screen**

1. Use minimum beam intensity to produce a clear, well-defined display.
2. Use minimum SAVE INTEN control setting when storing a display for an extended period of time.
3. Avoid repeated use of the same area of the screen. If a particular display is being stored repeatedly, change the vertical position of the trace occasionally to use other portions of the display area.

## PERFORMANCE CHECK

### Purpose

The purpose of the performance check is for incoming inspection to determine the acceptability of newly purchased or recently recalibrated instruments. This procedure does not check every facet of the instrument calibration; rather, it is concerned primarily with those portions of the instrument essential to measurement accuracy and correct operation.

### Recommended Equipment

All equipment is assumed to be calibrated and operating within the original specifications. The

tolerances given in the performance check are for the oscilloscope under test and do not include test equipment error.

In this procedure, test equipment is named by the functional description (see Table 2-2, Description), rather than by specific front-panel nomenclature.

The accessories listed are typical bench items.

More detailed information on test equipment and accessories is located at the start of Section 5, Calibration.

### Display

Performance checks should be made with a stable, well-focused, low-intensity display. Unless otherwise noted, adjust the Intensity, Astigmatism, Focus, Trigger Level, and Position controls as needed.

**TABLE 2-2**  
**Recommended Equipment**

Description	Minimum Specifications	Example
1. Test Oscilloscope with 10X probe (10X probe should have scale-factor switching, see step B1)	Bandwidth, DC to 2 megahertz; minimum deflection factor, 5 mV/division; accuracy within 3%; dual trace.	a. Tektronix 465 Oscilloscope with included (10X) probe. b. Tektronix 475 Oscilloscope with included (10X) probe.
2. Amplitude Calibrator	Amplitude accuracy, within 0.25%; signal amplitude, 2 millivolts to 50 volts; output signal, 1 kilohertz square wave.	a. Tektronix PG 506 Calibration Generator. b. Tektronix 067-0502-01 Calibration fixture.
3. Leveled Sine-wave Generator	Frequency, 350 kilohertz to above 100 megahertz; output amplitude, variable from 0.5 to 5 volts peak-to-peak; output impedance, 50 ohms; reference frequency, 50 to 350 kilohertz; amplitude accuracy, constant within 3% of reference frequency as output frequency changes.	a. Tektronix SG 503 leveled Sine-Wave Generator <sup>1</sup> . b. Tektronix Type 191 Constant-Amplitude Signal Generator.
4. Time-Mark Generator	Marker outputs, 10 nanoseconds to 0.5 second; marker accuracy, within 0.1%; trigger output, 1 millisecond to 0.1 microsecond, time coincident with markers.	a. Tektronix TG 501 Time-Mark Generator <sup>1</sup> . b. Tektronix 2901 Time-Mark Generator.
5. Low Frequency Sine-Wave Generator	Frequency 10 hertz to 50 kilohertz; output amplitude, variable from 10 millivolts to 4 volts peak-to-peak.	a. Tektronix SG 502 Oscillator <sup>1</sup> . b. General Radio 1310A Oscillator.

<sup>1</sup>Requires a TM series power module.

**TABLE 2-2 (cont)**  
**Recommended Equipment**

Description	Minimum Specifications	Example
6. 50-Ohm Signal Pickoff	Frequency response, 50 kilohertz to 100 megahertz; impedance 50 ohms for signal input, signal output and trigger output.	a. Tektronix CT-3 signal pickoff. Part Number 017-0061-00.
7. Cable (2 Required).	Impedance, 50 ohms; Length, 42 inches; Connectors, BNC.	
8. Cable (2 Required).	Impedance, 50 ohms; Length, 18 inches; Connectors, BNC.	
9. Adapter.	Connectors, GR874 to BNC female (required with CT-3 or 106).	
10. Adapter.	Connectors, GR874 to BNC male.	
11. Adapter.	Connectors, BNC female to BNC female.	
12. Dual Input Coupler (2 Required).	Connectors, BNC female to 2 BNC male.	
13. T Connector.	Connectors, BNC.	
14. 10X Attenuator (2 Required).	Ratio, 10X; Impedance, 50 ohms; Connectors, BNC.	
15. Termination (2 Required).	Impedance, 50 ohms; Connectors, BNC.	
16. Screwdriver.	Length, three-inch shaft; Bit Size, 3/32 inch.	
17. Light Shield.	Folding viewing hood.	

<sup>1</sup>Requires a TM series power module.

## PERFORMANCE CHECK PROCEDURE

### A. PRELIMINARY PROCEDURE

1. Check that the Line Voltage Selector switch (located on side panel), indicates the correct nominal line voltage. The oscilloscope is shipped from the factory with this switch set for 115 VAC, unless otherwise specified. Verify this setting. If the line voltage is changed to 230 V line, the fuse should also be changed.

2. Set the Regulating Range Selector (located on the rear panel) to indicate the correct nominal line voltage range.

3. Set all 466 controls as specified for Normal Sweep Display under BASIC DISPLAYS in this section, except for the following:

INTEN	10 o'clock
NON STORE	Pushed in
REDUCED SCAN (PULL)	INTEN knob pushed in
CH 1 & CH 2 VOLTS/DIV	5 mV (fully clockwise)
CH 1 & CH 2 POSITION	Midrange
AC-GND-DC (both)	GND
20 MHz BW (PULL)	Full bandwidth (Push in, then release. Shows no yellow.)
VERT MODE	CH 1
INVERT	Normal (button out)
HORIZ DISPLAY	A
A and B TIME/DIV	1 ms (knobs locked)
TRIG MODE	AUTO
X10 MAG	Off (button out)

4. Connect the 466 to the correct line voltage source.

5. Pull POWER switch on. Within less than one minute, a baseline trace should appear within the display area. Allow at least 20 minutes warm up at an ambient temperature between +20°C and +30°C for checking instrument to accuracies specified.

6. Place hand over slotted hole at rear of instrument (fan plenum chamber) and check for a slight air exhaust. This verifies fan operation (fan speed varies with internal instrument temperature).

7. Adjust TRACE ROTATION control to make trace parallel to center horizontal line.

### B. VERTICAL

#### 1. Probe Indicator Lamps

a. Observe CH 1 VOLTS/DIV switch.

CHECK—Lamp is lit behind 5 mV.

b. Connect a 10X probe with a scale-factor switching connector to CH 1 input (if no scale-factor switching probe is available, an 11 kΩ resistor may be used. Touch the resistor between ground and the metal coding ring on the input connector.)

CHECK—5 mV lamp is extinguished and 50 mV lamp is on.

c. Set VERT MODE switch to CH 2 and move probe to CH 2 input.

CHECK—5 mV lamp is extinguished and 50 mV lamp is on.

d. Remove 10X probe.

CHECK—5 mV lamp is on and 50 mV lamp is extinguished.

#### 2. Alternate Mode Operation

a. Set: VERT MODE                    ALT  
A TRIGGER LEVEL                Fully clockwise

b. Position two traces about 2 divisions apart with CH 1 and CH 2 POSITION controls.

CHECK—Display alternates between vertical channels for all A TIME/DIV settings except X-Y (reduce intensity as needed at slower sweep speeds).

#### 3. Chop Mode Operation

a. Set: A TRIGGER SOURCE        NORM  
A and B TIME/DIV                1 μs (knobs locked)  
VAR TIME/DIV                    Calibrated detent  
VERT MODE                        CHOP  
A TRIGGER                         HF REJ  
COUPLING                         HF REJ

b. Position two traces about 4 divisions apart and set A TRIGGER LEVEL control for a stable display.

CHECK—Vertical Switching transients are completely blanked between horizontal chopped segments.

CHECK—Duration of each cycle is approximately 4 divisions (exact measured duration is affected by instrument timing).



**4. Beam Finder Operation**

- a. Push in BEAM FINDER button and hold.

CHECK—Trace remains entirely on screen, regardless of the setting of vertical or horizontal POSITION controls.

CHECK—INTEN control has no effect on display intensity.

- b. Release BEAM FINDER button.

**5. CH 1 VAR VOLTS/DIV Balance and VAR Indicator**

*NOTE*

*If it is necessary to make the adjustments in steps 5 through 7, insulate all of the screwdriver shaft except the tip with electrical tape or spaghetti tubing.*

- a. Set VERT MODE switch to CH 1.

- b. Position trace to center horizontal graticule line.

CHECK—CH 1 UNCAL lamp is on when VAR control is out of detent.

CHECK—Trace shift of 0.2 div or less when rotating VAR control through its range.

ADJUST—CH 1 Var Bal (R84, left side, through cabinet) for minimum trace shift while rotating CH 1 VAR control through its range.

- c. Return CH 1 VAR control to detent position.

**6. CH 2 VAR VOLTS/DIV Balance and VAR Indicator**

- a. Set VERT MODE switch to CH 2 and position trace to center horizontal line.

CHECK—CH 2 UNCAL lamp is on when VAR control is out of detent.

CHECK—Trace shift of 0.2 div or less when rotating VAR control through its range.

ADJUST—(CH 2 Var Bal) (R184, left side, through cabinet) for minimum trace shift while rotating CH 2 VAR control through its range.

- b. Return CH 2 VAR control to detent position.

**7. CH 1 & CH 2 Deflection Accuracy**

- a. Set: VERT MODE CH 1  
CH 1 AC-GND-DC DC  
A and B TIME/DIV 1 ms  
A TRIGGER  
COUPLING AC

- b. Connect 20 mV signal from amplitude calibrator (Item 2 of Recommended Equipment) to CH 1 input via 50 Ω cable.

CHECK—Display is 4 div plus or minus 0.12 div.

ADJUST—CH 1 Gain Adj (R92, left side, through cabinet) for 4 div display.

- c. Change CH 1 VOLTS/DIV and amplitude calibrator settings as shown in Table 2-3.

CHECK—Display is either 4 div plus or minus 0.12 div or 5 div plus or minus 0.15 div.

**TABLE 2-3**

**Vertical Deflection Accuracy**

Volts/Div Setting	Amplitude Calibrator Signal	Deflection in Divisions For 3% Accuracy		Reading In Divisions
		Divisions	Accuracy	
10 m	50 mV	5	±0.15	4.85 to 5.15
20 m	0.1 V	5	±0.15	4.85 to 5.15
50 m	0.2 V	4	±0.12	3.88 to 4.12
.1	0.5 V	5	±0.15	4.85 to 5.15
.2	1 V	5	±0.15	4.85 to 5.15
.5	2 V	4	±0.12	3.88 to 4.12
1	5-V	5	±0.15	4.85 to 5.15
2	10 V	5	±0.15	4.85 to 5.15
5	20 V	4	±0.12	3.88 to 4.12

- d. Set amplitude calibrator for 20 mV and apply signal to CH 2.

- e. Set: VERT MODE CH 2  
CH 1 AC-GND-DC GND  
CH 2 AC-GND-DC DC

CHECK—Display is 4 div plus or minus 0.12 div.

## Operating Instructions—466 Service

ADJUST—CH 2 Gain Adj (R192, left side, through cabinet) for 4 div display.

f. Change CH 2 VOLTS/DIV and amplitude calibrator settings as shown in Table 2-3.

CHECK—Display is either 4 div plus or minus 0.12 div or 5 div plus or minus 0.15 div.

### 8. Add Mode Operation

a. Set: VOLTS/DIV (both)	5 mV
VERT MODE	ADD
CH 1 AC-GND-DC	DC

b. Set amplitude calibrator for 10 mV signal and connect signal to both inputs via 50  $\Omega$  cable and dual-input coupler.

CHECK—Display amplitude is approximately 4 div.

### 9. CH 2 Invert Operation

a. Press INVERT pushbutton.

CHECK—Display amplitude is approximately 0 div.

### 10. CH 1 and CH 2 Var VOLTS/DIV Range

a. Set: VOLTS/DIV (both)	10 mV
VERT MODE	CH 1
INVERT	Normal (button out)

b. Set amplitude calibrator for a 5 division (50 mV) signal.

c. Rotate CH 1 VAR control fully counterclockwise.

CHECK—Display reduces to 2 div or less.

d. Set VERT MODE switch to CH 2.

e. Rotate CH 2 VAR control fully counterclockwise.

CHECK—Display reduces to 2 div or less.

f. Return both VAR controls to detent position and disconnect amplitude calibrator.

### 11. Bandwidth Limit Operation and Bandwidth

a. Set: VOLTS/DIV (both)	5 mV
A TIME/DIV	.2 ms

b. Connect about 50 kHz reference signal from leveled sine-wave generator to CH 2 input via 10X attenuator and 50  $\Omega$  termination.

c. Adjust generator for 5 div display.

d. Pull out (shows yellow) 20 MHz BW (PULL) switch.

e. Increase generator output frequency until display is 3.5 div.

CHECK—Generator output frequency is between 16 and 24 MHz.

f. Push in 20 MHz BW (PULL) switch.

g. Set generator for 100 MHz output frequency.

CHECK—Display amplitude is 3.5 div or more.

h. Set generator for 50 kHz and repeat step 11 parts c and g for 10 mV through 1 V positions of VOLTS/DIV switch (remove 10X attenuator as necessary to maintain the 5 div 50 kHz reference display).

i. Change VERT MODE to CH 1. Add 10X attenuator to test setup. Change test setup to CH 1 input.

j. Repeat step 11 parts c and g for 5 mV through 1 V positions of VOLTS/DIV switch (remove 10X attenuator as necessary to maintain a 5 div 50 kHz reference display). Disconnect leveled sine-wave generator from CH 1 input.

### 12. Cascaded Gain and Bandwidth

a. Connect CH 1 VERT SIGNAL OUT (on rear panel) to CH 2 input via 50  $\Omega$  cable and 50  $\Omega$  termination. Connect amplitude calibrator to CH 1 input via 50  $\Omega$  cable.

b. Set: VOLTS/DIV (both)	5 mV
VERT MODE	CH 2
A TIME/DIV	1 ms

c. Set amplitude calibrator for 5 mV output.

CHECK—Display is 5 div or more.

d. Disconnect test setup from CH 1 input.

e. connect about 50 kHz reference signal from leveled sine-wave generator to CH 1 input via 50  $\Omega$  cable, 10X attenuator and 50  $\Omega$  termination.

**A TRIGGER**

- f. Adjust generator for 5 div display.
- g. Set generator for 50 MHz output frequency.
- CHECK—Display amplitude is 3.5 div or more.
- h. Disconnect test setup.

SOURCE	COUPLING
NORM	AC, DC
CH 1	AC
CH 2	AC

- f. Set: CH 1 VOLTS/DIV 10 mV  
A TRIGGER COUPLING LF REJ

g. Set leveled sine-wave generator for 5 div (50 mV) display.

- h. Set CH 1 VOLTS/DIV switch to .1 V.

CHECK—Stable display, in both + and - positions of SLOPE switch for the following modes (adjust LEVEL control as needed):

**A TRIGGER SOURCE**

CH 2, CH 1, and NORM

- i. Set: A TRIGGER COUPLING HF REJ  
A TRIGGER SOURCE NORM

CHECK—No stable display.

**C. TRIGGER**

**1. A Internal 25 MHz Triggering**

- a. Set: VERT MODE CH 1
- CH 1 VOLTS/DIV 10 mV
- CH 2 VOLTS/DIV .1 V
- POSITION (CH 1 and CH 2) As needed
- 20 MHz BW (Pull) Full bandwidth (Push in, then release. Shows no yellow.)
- A and B TRIGGER COUPLING AC
- A and B TRIGGER LEVEL Midrange
- B (DLY'D) TRIGGER SOURCE NORM
- DELAY TIME Fully counter-clockwise 0.20
- POSITION
- A TRIG HOLDOFF NORM
- A and B TIME/DIV .05 μs (knobs locked)
- POSITION (Horiz) Midrange
- NON STORE Button in
- INTEN As needed

b. Connect 25 MHz signal from leveled sine-wave generator to A and B External Trigger input via 50 Ω cable, GR-to-BNC female adapter, CT-3 thru output, GR-to-BNC male adapter, 10X attenuator, 50 Ω termination and dual-input coupler.

c. Connect CT-3 Sig Out 10% signal to CH 1 and CH 2 inputs via 50 Ω cable, 50 Ω termination, and dual-input coupler.

- d. Set generator for 3 div (30 mV) display.

CHECK—TRIG lamp is lit during stable display.

- e. Set CH 1 VOLTS/DIV switch to .1 V (0.3 div display).

CHECK—Stable display, in both + and - positions of SLOPE switch for the following modes (adjust LEVEL control as needed):

**2. B Internal 25 MHz Triggering**

- a. Set: HORIZ DISPLAY B DLY'D
- CH 2 VOLTS/DIV .1 V
- CH 1 VOLTS/DIV 10 mV
- A TIME/DIV .2 μs
- B TIME/DIV .05 μs
- A & B TRIGGER COUPLING AC

b. Set leveled sine-wave generator for 3 div (30 mV), 25 MHz display.

- c. Set CH 1 VOLTS/DIV switch to .1 V (0.3 div).

CHECK—Stable display, in both + and - positions of SLOPE switch for the following modes (adjust LEVEL control as needed):

**B TRIGGER**

SOURCE	COUPLING
CH 2	AC, DC
CH 1	AC
NORM	AC

## Operating Instructions—466 Service

- d. Set: CH 1 VOLTS/DIV            10 mV  
      B TRIGGER COUPLING        LF REJ

e. Set leveled sine-wave generator for 5 div (50 mV)  
25 MHz display.

- f. Set: CH 1 VOLTS/DIV            .1 V (0.5 div)  
      B TRIGGER SOURCE            NORM

CHECK—Stable display, with both + and - slope  
(adjust LEVEL control as needed).

- g. Set: B TRIGGER COUPLING        HF REJ  
      B TRIGGER SOURCE            NORM

h. CHECK—No stable display.

### 3. B External 25 MHz Triggering

- a. Set: VOLTS/DIV (both)            10 mV  
      TRIGGER COUPLING  
      (both)                            AC  
      SOURCE (both)                 EXT  
      A TRIGGER LEVEL              Fully clockwise  
      B TRIGGER LEVEL              0

b. Set leveled sine-wave generator for 5 div (50 mV)  
display.

CHECK—Stable display, in both + and - positions of  
SLOPE switch for the following modes (adjust B LEVEL  
control as needed):

#### B TRIGGER COUPLING

AC, DC

- c. Set: CH 1 VOLTS/DIV            20 mV  
      B TRIGGER COUPLING        LF REJ

d. Adjust leveled sine-wave generator for 5 div  
(100 mV) 25 MHz display.

CHECK—Stable display in both + and - positions of B  
TRIGGER SLOPE switch (adjust B LEVEL control as  
needed).

e. Set B TRIGGER COUPLING switch to HF REJ.

CHECK—No stable display.

### 4. A External 25 MHz Triggering

- a. Set: HORIZ DISPLAY              A  
      A TIME/DIV                    .05  $\mu$ s  
      CH 1 VOLTS/DIV              10 mV  
      A TRIGGER LEVEL              0

b. Set leveled sine-wave generator for 5 div (50 mV)  
display.

CHECK—Stable display, in both + and - positions of  
SLOPE switch for the following modes (adjust LEVEL  
control as needed):

#### A TRIGGER COUPLING

AC, DC

- c. Set: CH 1 VOLTS/DIV            20 mV  
      A TRIGGER COUPLING        LF REJ

d. Set leveled sine-wave generator for 5 div, (100 mV)  
display.

CHECK—Stable display, in both + and - positions of  
SLOPE switch (adjust A TRIGGER LEVEL control as  
needed).

e. Set A TRIGGER COUPLING switch to HF REJ.

CHECK—No stable display.

f. Remove 10X attenuator from external trigger setup  
and change A TRIGGER SOURCE switch to EXT  $\div$  10.

CHECK—No stable display.

g. Set A TRIGGER COUPLING switch to LF REJ.

CHECK—Stable display, in both + and - positions of  
SLOPE switch.

- h. Set: CH 1 VOLTS/DIV            10 mV  
      A TRIGGER COUPLING        AC

i. Set leveled sine-wave generator for 5 div (50 mV),  
25 MHz display.

CHECK—Stable display, in both + and - positions of  
SLOPE switch for the following modes (adjust A TRIGGER  
LEVEL control as needed).

**A TRIGGER COUPLING**

AC, DC

j. ~~Disconnect test setup.~~

*REMOVE TEST SETUP (REMOVE dual input couplers)*

**5. A and B External 100 MHz Triggering**

a. Set: TRIGGER COUPLING (both)

A TRIGGER SOURCE	AC
CH 1 VOLTS/DIV	EXT
A TIME/DIV	50 mV
	.05 $\mu$ s

*ADD 10 attenuator to A ext input trig signal*

b. Connect 25 MHz signal from leveled sine-wave generator to A External Trigger input via 50  $\Omega$  BNC cable, GR-to-BNC female adapter, CT-3 thru output, GR-to-BNC male adapter, 10X attenuator and 50  $\Omega$  termination.

c. Connect CT-3 Sig Out 10% signal to CH 1 input via 50  $\Omega$  BNC cable and 50  $\Omega$  termination.

d. Set leveled sine-wave generator for 3 div (150 mV) 25 MHz display, then change frequency to 100 MHz. Do not readjust signal amplitude.

e. Push in X10 MAG (IN) button.

CHECK—Stable display, with 0.1 div or less jitter, in both + and - positions of SLOPE switch for the following modes (adjust A TRIGGER LEVEL control as needed):

**A TRIGGER COUPLING**

AC, DC

f. Remove 10X attenuator from External Trigger setup and change A TRIGGER SOURCE switch to EXT  $\div$  10.

CHECK—Stable display, with 0.1 div or less jitter, in both + and - positions of SLOPE switch for the following modes (adjust LEVEL control as needed):

**A TRIGGER COUPLING**

AC, DC

g. Set leveled sine-wave generator for 6 div (300 mV), 25 MHz display, then change frequency to 100 MHz. Do not readjust signal amplitude.

h. Set A TRIGGER COUPLING switch to LF REJ.

CHECK—Stable display, with 0.1 div or less jitter, in both + and - positions of SLOPE switch (adjust LEVEL control as needed).

i. Set A TRIGGER COUPLING switch to HF REJ.

CHECK—No stable display.

j. Set:	HORIZ DISPLAY	B DLY'D
	B TRIGGER MODE	LF REJ
	B TRIGGER SOURCE	EXT

k. Add 10X attenuator to external trigger setup. Move leveled sine-wave generator signal to B External Trigger input.

CHECK—Stable display, with 0.1 div or less jitter, in both + and - positions of SLOPE switch (adjust LEVEL control as needed).

**6. B Internal 100 MHz Triggering**

a. Set:	VOLTS/DIV (both)	50 mV
	TRIGGER SOURCE (both)	NORM
	TRIGGER COUPLING (both)	AC
	A TIME/DIV	.2 $\mu$ s
	B TIME/DIV	.05 $\mu$ s

b. Connect CT-3 Sig Out 10% signal to CH 1 and CH 2 inputs via 50  $\Omega$  BNC cable, 50  $\Omega$  termination, and dual-input coupler. Adjust leveled sine-wave generator for 1.5 div, 100 MHz display.

CHECK—Stable display, with 0.1 div or less jitter, in both + and - positions of SLOPE switch for the following modes:

**B TRIGGER**

SOURCE	COUPLING
NORM	AC, LF REJ, DC
CH 1	DC
CH 2	DC

c. Set B TRIGGER COUPLING switch to HF REJ.

CHECK—No stable display.

## Operating Instructions—466 Service

### 7. Internal 100 MHz Triggering

- a. Set: HORIZ DISPLAY           A  
          A TIME/DIV                 .05  $\mu$ s

CHECK—Stable display, with 0.1 div or less jitter, in both + and - positions of SLOPE switch, for the following modes:

#### A TRIGGER

SOURCE	COUPLING
NORM	AC, LF REJ, DC
CH 1	DC
CH 2	DC

- b. Set A TRIGGER COUPLING switch to HF REJ.

CHECK—No stable display.

- c. Disconnect test equipment setup.

### 8. A and B HF REJ Triggering

- a. Set: TIME/DIV (both)           10  $\mu$ s  
          X10 MAG                    Off (button out)  
          TRIGGER COUPLING  
          (bboth)                    HF REJ  
          CH 1 VOLTS/DIV           .1 V  
          CH 2 VOLTS/DIV           10 mV  
          VERT MODE                 CH 2

b. Connect 50 kHz signal from leveled sine-wave generator to CH 1 and CH 2 inputs via 50  $\Omega$  BNC cable, 50  $\Omega$  termination and dual-input coupler.

- c. Set generator for 5 div (50 mV) display in CH 2.

d. Set CH 2 VOLTS/DIV switch to .1 V. Adjust A TRIGGER LEVEL for stable display.

e. Set generator frequency for 1 MHz signal and push in X10 MAG (IN) button.

CHECK—No stable display with A TRIGGER SOURCE switch in NORM, CH 1 or CH 2.

- f. Set: A TRIGGER LEVEL         Fully clockwise  
          HORIZ DISPLAY           B DLY'D

CHECK—No stable display with B TRIGGER SOURCE switch in NORM, CH 1 or CH 2.

### 9. Single Sweep

- a. Set: A TRIGGER                   AC  
          COUPLING                   NORM  
          SOURCE                    0  
          LEVEL                      0  
          HORIZ DISPLAY            A  
          VERT MODE                 CH 1  
          X10 MAG (IN)              Off (button out)

b. Set leveled sine-wave generator for 2 div, 50 kHz display and adjust A TRIGGER LEVEL control to have sweep start about 0.5 div away from the 0 LEVEL setting.

TIME/DIV (both)           10 ms

- c. Set: CH 1 AC-GND-DC           GND  
          TRIG MODE                 SINGL SWP (push  
  in)

CHECK—READY lamp lights. If not, press SINGL SWP pushbutton again.

- d. Set CH 1 AC-GND-DC switch to DC.

CHECK—A single sweep occurs and READY lamp goes out.

- e. Press SINGL SWP button.

CHECK—A single sweep occurs each time SINGL SWP button is pressed (increase intensity setting as needed).

- f. Remove test setup.

### 10. 30 Hz Internal Triggering

- a. Set: TIME/DIV (both)           5 ms  
          A TRIG MODE              NORM  
          CH 1 VOLTS/DIV           10 mV

b. Connect 30 Hz low-frequency sine-wave generator signal to CH 1 input via 50  $\Omega$  cable, BNC tee and 50  $\Omega$  termination. From BNC tee, connect 50  $\Omega$  cable and 50  $\Omega$  termination to B EXT Input.

- c. Set generator for 3 div (30 mV) display.

- d. Set CH 1 VOLTS/DIV switch to .1 V.

CHECK—Stable display, in both + and - positions of SLOPE switch for the following modes (adjust A TRIGGER LEVEL control as needed):

**A TRIGGER COUPLING**

AC, DC

- e. Set: CH 1 VOLTS/DIV      10 mV  
           A TRIGGER COUPLING    HF REJ

f. Set generator for 5 div (50 mV) 30 Hz display, then set CH 1 VOLTS/DIV switch to .1 V.

CHECK—Stable display, in both + and – positions of SLOPE switch (adjust A TRIGGER LEVEL control as needed).

g. Set A TRIGGER COUPLING switch to LF REJ, and CH 1 VOLTS/DIV to 10 mV.

CHECK—No stable trigger.

- h. Set: A TRIG MODE            AUTO  
           A LEVEL                Fully clockwise  
           A TIME/DIV            10 ms  
           B TIME/DIV            5 ms  
           B TRIGGER SOURCE    NORM  
           B TRIGGER COUPLING HF REJ  
           HORIZ DISPLAY        B DLY'D  
           CH 1 VOLTS/DIV      .1 V

CHECK—Stable display, in both + and – positions of SLOPE switch (adjust B TRIGGER LEVEL control as needed).

- i. Set: B TRIGGER COUPLING    LF REJ  
           CH 1 VOLTS/DIV        10 mV

CHECK—No stable display.

- j. Set: B TRIG COUPLING        AC

k. Set generator for 3 div (30 mV), 30 Hz display.

l. Set CH 1 VOLTS/DIV switch to .1 V.

CHECK—Stable display, in both + and – positions of SLOPE switch for the following modes (adjust B TRIGGER LEVEL control as needed).

**B TRIGGER COUPLING**

AC, DC

**11. 30 Hz External Triggering**

- a. Set: B TRIGGER  
           COUPLING                AC  
           CH 1 VOLTS/DIV        10 mV

b. Set generator for 5 div (50 mV) display.

c. Set B TRIGGER SOURCE switch to EXT.

CHECK—Stable display, in both + and – positions of SLOPE switch for the following modes (adjust LEVEL control as needed):

**B TRIGGER COUPLING**

AC, HF REJ, DC

d. Set B TRIGGER COUPLING switch to LF REJ.

CHECK—No stable display.

e. Move test setup from B EXT Input to A EXT Input.

- f. Set: HORIZ DISPLAY        A  
           A TRIG MODE            NORM  
           A TRIGGER  
           COUPLING                AC  
           SOURCE                  EXT  
           A TRIGGER LEVEL      0

CHECK—Stable display, in both + and – positions of A TRIGGER SLOPE switch for the following modes (adjust A TRIGGER LEVEL control as needed):

**A TRIGGER COUPLING**

AC, HF REJ, DC

g. Set A TRIGGER COUPLING switch to LF REJ.

CHECK—No stable display.

h. Disconnect test setup.

**12. Line Triggers**

- a. Set: A TIME/DIV            5 ms  
           A TRIG MODE            AUTO  
           A TRIGGER SOURCE    LINE  
           SLOPE                    +  
           CH 1 VOLTS/DIV        As needed  
           A TRIGGER  
           COUPLING                AC

b. Connect 10X probe from CH 1 Input to a line-frequency source. Set CH 1 VOLTS/DIV switch as required.

CHECK—Stable display in both + and – positions of SLOPE switch.

## Operating Instructions—466 Service

c. Disconnect probe from line-frequency source, then from oscilloscope.

### 13. Trigger Level Range

a. Set:	TRIG COUPLING (both)	AC
	TRIG SOURCE (both)	EXT
	TRIGGER SLOPE (both)	+
	CH 1 VOLTS/DIV	1 V
	HORIZ DISPLAY	B DLY'D
	TIME/DIV (both)	1 ms

b. Connect 1 kHz signal from low-frequency sine-wave generator to CH 1 input and B External Trigger input via 50  $\Omega$  cable, BNC T (to B External Input) and 50  $\Omega$  cable.

c. Adjust the generator for a 4 div display.

CHECK—Display is triggered along positive slope of waveform when B TRIGGER LEVEL control is rotated, but not triggered (trace disappears) at either extreme of rotation.

d. Set B TRIG SLOPE to —.

CHECK—Display is triggered along negative slope of waveform when B TRIGGER LEVEL control is rotated, but not triggered at either extreme of rotation.

e. Move External Trigger signal to A External Input.

f. Set HORIZ DISPLAY to A.

CHECK—Display is triggered along positive slope of waveform when A TRIGGER LEVEL control is rotated, but not triggered (free-runs) at either extreme of rotation.

g. Set A TRIG SLOPE to —.

CHECK—Display is triggered along negative slope of waveform when the A TRIGGER LEVEL control is rotated, but not triggered (free-runs) at either extreme of rotation.

h. Set:	CH 1 VOLTS/DIV	5 V
	CH 1 VAR VOLTS/DIV	Fully counter-clockwise
	A TRIG SOURCE	EXT $\div$ 10
	A TRIG COUPLING	AC

i. Disconnect low-frequency sine-wave generator signal and connect 50 volt signal from amplitude calibrator to the CH 1 input and the A External Trigger input, via a 50  $\Omega$  cable, a BNC T, and a 50  $\Omega$  cable.

CHECK—Display is triggered along negative slope of waveform when A TRIG LEVEL control is rotated. (Note: The applied signal is 50 volts peak-to-peak. The range of the A LEVEL control is only  $\pm 20$ , or 40 volts peak-to-peak, or greater; therefore, untriggered operation at either extreme of rotation is not required).

j. Set A TRIG SLOPE to +.

CHECK—Display is triggered along positive slope of waveform when A TRIG LEVEL control is rotated.

### 14. Trigger View Deflection Factor

a. Set:	A TRIGGER SOURCE	EXT
	A TRIGGER LEVEL	0
	A TIME/DIV	.2 ms
	CH 1 VAR VOLTS/DIV	Calibrated detent

b. Set amplitude calibrator signal to 0.2 volts.

c. Push TRIG VIEW button and hold it in.

CHECK—Display amplitude is approximately 4 div.

d. Disconnect amplitude calibrator and set the A TRIGGER SOURCE to NORM.

## D. DM-SERIES DIGITAL MULTIMETERS

Oscilloscopes with Digital Multimeters attached, refer to the Digital Multimeter manual at this point. *RETURN TO 'F' PAGE 2-26 WHEN SECTION D IS COMPLETE*

Oscilloscopes without Digital Multimeters, continue to portion E, HORIZONTAL of performance check in Operating Instructions section.

## E. HORIZONTAL

### 1. Differential Time Linearity

a. Set:	CH 1 & CH 2 VOLTS/DIV	.5 V
	CH 1 & CH 2 VOLTS/DIV	Calibrated detent
	A TRIGGER SOURCE	NORM
	B TRIGGER SLOPE	+
	B (DLY'D) TRIGGER SOURCE	STARTS AFTER DELAY
	HORIZ DISPLAY	A INTEN
	A TIME/DIV	1 ms
	B TIME/DIV	5 $\mu$ s
	DELAY TIME POSITION (DTP)	1.00
	X10 MAG	Off (button out)

b. Connect 1 ms time marks from time-mark generator to CH 1 input via 50  $\Omega$  cable and 50  $\Omega$  termination. With the DTP control set at 1.00, check that the 2nd time mark is intensified (adjust INTEN as necessary to view the intensified time mark).



c. Set the HORIZ DISPLAY to B DLY'D and increase INTEN as necessary to view the time mark. Set Horizontal POSITION so start of sweep is within graticule area.

d. Use DTP to set second time-mark start to sweep start and note DTP reading (1.00 within 1 minor div, 0.99 to 1.01).

CHECK—Each successive time mark. See Table 2-4.

TABLE 2-4

Differential Time Accuracy

TIME MARK	DTP SETTING	
3	1.98	2.02
4	2.97	3.03
5	3.96	4.04
6	4.95	5.05
7	5.94	6.06
8	6.93	7.07
9	7.92	8.08
10	8.91	9.09
11	9.90	10.10

2. Horizontal Gain and Sweep Linearity

a. Set HORIZ DISPLAY switch to A and horizontally position 1st time mark to left edge graticule line.

CHECK—1 time mark/div, within 2% ( $\pm 0.2$  div for 11th mark).

CHECK—Linearity over any 2 div portion of sweep is within 5% of accurate timing ( $\pm 0.1$  div).

b. Push in X10 MAG (IN) button and horizontally position 1st time mark to graticule center line.

c. Release X10 MAG (IN) button.

CHECK—1st time mark should be near graticule center line, then position 1st time mark to left edge graticule line.

d. Set time-mark generator for 0.1 ms time marks.

e. Push in X10 MAG (IN) button and position nearest time mark to left edge graticule line.

CHECK—X10 MAG lamp is on when X10 MAG (IN) button is in.

CHECK—1 time mark/div, within 3% ( $\pm 0.3$  div for 11th mark).

CHECK—Sweep accuracy over any 2 div portion of magnified sweep should be within 0.1 div (5%).

f. Release X10 MAG (IN) button.

3. VAR TIME/DIV Range

a. Set: TIME/DIV (both) 2 ms  
VAR TIME/DIV Fully counter-clockwise

b. Set time-mark generator for 5 ms time marks.

CHECK—UNCAL lamp lights when VAR TIME/DIV control is out of detent.

CHECK—1 or more time mark/div.

c. Set VAR TIME/DIV control to detent (calibrated).

4. B TIME/DIV Accuracy

a. Set: DELAY TIME Fully counter-clockwise  
POSITION Fully counter-clockwise  
HORIZ DISPLAY B DLY'D  
B TRIGGER SOURCE NORM  
B TIME/DIV .05  $\mu$ s  
A TIME/DIV .5  $\mu$ s  
LEVEL (both) For triggered display  
INTEN As required

b. Set time-mark generator for 50 ns time marks.

CHECK—B Time/Div accuracy using control settings given in Table 2-5, over first 10 div of display. 1 time mark/div within 2% ( $\pm 0.2$  div for 11th mark).

TABLE 2-5

B Timing Accuracy

A and B TIME/DIV Switch Setting		Time-Mark Generator Output
A	B	
.5 $\mu$ s	.05 $\mu$ s	50 nanosecond
.5 $\mu$ s	.1 $\mu$ s	0.1 microsecond
.5 $\mu$ s	.2 $\mu$ s	0.2 microsecond
1 $\mu$ s	.5 $\mu$ s	0.5 microsecond
2 $\mu$ s	1 $\mu$ s	1 microsecond
5 $\mu$ s	2 $\mu$ s	2 microsecond
10 $\mu$ s	5 $\mu$ s	5 microsecond
20 $\mu$ s	10 $\mu$ s	10 microsecond
50 $\mu$ s	20 $\mu$ s	20 microsecond
.1 ms	50 $\mu$ s	50 microsecond
.2 ms	.1 ms	0.1 millisecond
.5 ms	.2 ms	0.2 millisecond
1 ms	.5 ms	0.5 millisecond
2 ms	1 ms	1 millisecond
5 ms	2 ms	2 millisecond
10 ms	5 ms	5 millisecond
20 ms	10 ms	10 millisecond
50 ms <sup>2</sup>	20 ms	20 millisecond
.1 s <sup>2</sup>	50 ms	50 millisecond

<sup>2</sup>Change A TRIG MODE to NORM if needed.

5. A TIME/DIV Accuracy

- a. Set: HORIZ DISPLAY           A  
           TIME/DIV (both)       .05  $\mu$ s  
           TRIG MODE            AUTO

- b. Set time-mark generator for 50 ns time marks.

CHECK—A TIME/DIV accuracy using control settings given in Table 2-6, over first 10 div of display. 1 time mark/div, within 2% ( $\pm 0.2$  div for 11th mark).

TABLE 2-6

A Timing Accuracy

A TIME/DIV Switch Setting	Time-Mark Generator Output
.05 $\mu$ s	50 nanosecond
.1 $\mu$ s	0.1 microsecond
.2 $\mu$ s	0.2 microsecond
.5 $\mu$ s	0.5 microsecond
1 $\mu$ s	1 microsecond
2 $\mu$ s	2 microsecond
5 $\mu$ s	5 microsecond
10 $\mu$ s	10 microsecond
20 $\mu$ s	20 microsecond
50 $\mu$ s	50 microsecond
.1 ms	0.1 millisecond
.2 ms	0.2 millisecond
.5 ms	0.5 millisecond
1 ms	1 millisecond
2 ms	2 millisecond
5 ms	5 millisecond
10 ms	10 millisecond
20 ms	20 millisecond
50 ms	50 millisecond
.1 s <sup>3</sup>	0.1 second
.2 s <sup>3</sup>	0.2 second
.5 s <sup>3</sup>	0.5 second

<sup>3</sup>Change A TRIG MODE to NORM and reduce intensity as needed.

6. A Magnified Accuracy

- a. Set time-mark generator for 10 ns time marks.

- b. Set: A TRIG MODE            AUTO  
           A TIME/DIV            .05  $\mu$ s  
           X10 MAG (IN)         On (button in)

CHECK—1 time mark/2 div, within 3% ( $\pm 0.3$  div for 6th mark). This applies to the full sweep length, excluding the first and last 10 divisions of magnified sweep length.

CHECK—A TIME/DIV magnified accuracy using control settings given in Table 2-7. 1 time mark/div, within 3% ( $\pm 0.3$  div for 11th mark). Exclude portions of the sweep as indicated.

**7. B Magnified Accuracy**

- a. Set: HORIZ DISPLAY            B DLY'D
- A TRIG MODE            AUTO
- A TIME/DIV                .2  $\mu$ s
- B TIME/DIV                .05  $\mu$ s

b. Set time-mark generator for 10 ns time marks. Set INTEN and both LEVEL controls as necessary to view display.

CHECK—1 time mark/2 div, within 3% (6th mark aligns with 10th graticule line  $\pm 0.3$  div). This applies to the full sweep length, excluding the first and last 10 divisions of magnified sweep length.

CHECK—B TIME/DIV accuracy using control settings given in Table 2-7. 1 time-mark/div, within 3% ( $\pm 0.3$  div for 11th mark). Exclude portions of the sweep as indicated.

**TABLE 2-7**  
**A and B Magnified Accuracy**

A and B TIME/DIV Switch Setting	Time-Mark Generator Output	Portions of total magnified sweep length to exclude from measurement
0.5 $\mu$ s .1 $\mu$ s .2 $\mu$ s	10 nanosecond 10 nanosecond 20 nanosecond	First and last 10 divisions First and last 5 divisions First and last 2 1/2 divisions
.5 $\mu$ s 1 $\mu$ s 2 $\mu$ s	50 nanosecond 0.1 microsecond 0.2 microsecond	
5 $\mu$ s 10 $\mu$ s 20 $\mu$ s	0.5 microsecond 1 microsecond 2 microsecond	
50 $\mu$ s .1 ms .2 ms	5 microsecond 10 microsecond 20 microsecond	
.5 ms 1 ms 2 ms	50 microsecond 0.1 millisecond 0.2 millisecond	
5 ms 10 ms 20 ms <sup>4</sup>	0.5 millisecond 1 millisecond 2 millisecond	
50 ms <sup>4</sup>	5 millisecond	
<b>A SWEEP ONLY</b>		
.1 s <sup>4</sup> .2 s <sup>4</sup> .5 s <sup>4</sup>	10 millisecond 20 millisecond 50 millisecond	

<sup>4</sup>Change A TRIG MODE to NORM as needed.

# Operating Instructions—466 Service

## 8. Differential Time Accuracy

a. Set time-mark generator for 0.1  $\mu$ s time marks.

b. Set: X 10 MAG (IN) Off (button out)  
 B TRIGGER SOURCE STARTS AFTER DELAY  
 A TIME/DIV .2  $\mu$ s  
 B TIME/DIV .05  $\mu$ s  
 DELAY TIME POSITION 1.50

c. Horizontally position 1st displayed marker to center vertical graticule line.

d. Set DTP control to 8.50, then move DTP control to position 1st displayed marker to center vertical line.

CHECK—DTP reading is  $8.50 \pm 0.05$  (8.45 to 8.55).

e. Set time-mark generator for .5  $\mu$ s time marks.

f. Set: DELAY TIME POSITION 1.50  
 A TIME/DIV .5  $\mu$ s

g. Position displayed marker to center vertical line.

h. Set DTP control to 8.50, then move DTP control to position displayed marker to center vertical line.

CHECK—DTP reading is  $8.50 \pm 0.05$  (8.45 to 8.55).

CHECK—Delayed sweep accuracy using control settings given in Table 2-8. Use 1.00 for 1st DTP setting and 9.00 for 2nd setting. If 1st time-mark start is not visible, use 2nd time-mark. Final DTP setting is  $9.00 \pm 0.08$  (8.92 to 9.08).

**TABLE 2-8**  
**Differential Time Accuracy**

Time-Mark Generator Output	A TIME/DIV Switch Setting	B TIME/DIV Switch Setting	DTP Setting
1 microsecond	1 $\mu$ s	.1 $\mu$ s	8.92 to 9.08 (+15°C to +35°C)  or  8.80 to 9.20 (-15°C to +55°C)
2 microsecond	2 $\mu$ s	.2 $\mu$ s	
5 microsecond	5 $\mu$ s	.5 $\mu$ s	
10 microsecond	10 $\mu$ s	1 $\mu$ s	
20 microsecond	20 $\mu$ s	2 $\mu$ s	
50 microsecond	50 $\mu$ s	5 $\mu$ s	
.1 millisecond	.1 ms	10 $\mu$ s	
.2 millisecond	.2 ms	20 $\mu$ s	
.5 millisecond	.5 ms	50 $\mu$ s	
1 millisecond	1 ms	.1 ms	
2 millisecond	2 ms	.2 ms	
5 millisecond	5 ms	.5 ms	
10 millisecond	10 ms	1 ms	
20 millisecond	20 ms <sup>5</sup>	2 ms	
50 millisecond	50 ms <sup>5</sup>	5 ms	
.1 second	.1 s <sup>5</sup>	10 ms	
.2 second	.2 s <sup>5</sup>	20 ms	
.5 second	.5 s <sup>5</sup>	50 ms	

<sup>5</sup>Change A TRIG MODE to NORM.

9. Delay Time Jitter

a. Set time-mark generator for 1 ms time marks.

b. Set: DELAY TIME 1.00  
 POSITION B DLY'D  
 HORIZ DISPLAY  
 A TRIG MODE AUTO  
 X10 MAG (IN) Off (out)  
 A TIME/DIV 1 ms  
 B TIME/DIV .2  $\mu$ s  
 B TRIGGER STARTS AFTER  
 SOURCE DELAY

c. Attach light shield to graticule housing.

CALIBRATION AID—The low repetition rate of this check makes viewing difficult. Additional intensity may be obtained by using storage.

Push in VAR PERS button and adjust INTEN, STORAGE LEVEL and VIEW TIME for a usable trace.

d. Set DTP control to position time mark to graticule center.

CHECK—Jitter is 1 div or less (60 Hertz power line) or 2.5 div or less (50 Hertz power line).

e. Set DTP control to about 9.00 to position time mark to graticule center.

CHECK—Jitter is 1 div or less (60 Hertz power line) or 2.5 div or less (50 Hertz power line).

f. Push in NON STORE button and remove light shield.

10. Mixed Sweep Accuracy

NOTE

The following portions of MIXED SWEEP mode are excluded: (1) The first 0.5 div after display start, (2) The first 0.2 div or 0.1  $\mu$ s, whichever is greater, after the transition from A Sweep to B Sweep.

a. Set: DELAY TIME Fully counter-clockwise  
 POSITION Fully counter-clockwise  
 B TRIGGER SOURCE NORM  
 B TRIGGER LEVEL Fully counter-clockwise (untriggered)  
 HORIZ DISPLAY A  
 A TIME/DIV 1 ms  
 B TIME/DIV .5 ms

b. Horizontally position 2nd time mark to left-hand graticule line and note A Sweep timing accuracy over 9 div.

c. Change HORIZ DISPLAY control to MIX and position 2nd time mark to left-hand graticule line.

CHECK—A Sweep accuracy is within 2% of accuracy noted in Step b.

d. Set B TRIGGER SOURCE switch to STARTS AFTER DELAY and position 2nd marker to 2nd graticule line (1st mark goes off screen).

CHECK—B Sweep accuracy is within 2% (7.84 to 8.16 for 8 div display).

e. Set time-mark generator for 0.2  $\mu$ s markers.

f. Set: B TRIGGER SOURCE NORM  
 HORIZ DISPLAY A  
 A TIME/DIV .2  $\mu$ s  
 B TIME/DIV .1  $\mu$ s

g. Horizontally position 2nd time mark to left-hand graticule line and note A Sweep timing accuracy over 9 div.

h. Change HORIZ DISPLAY control to MIX and position 2nd time mark to left-hand graticule line.

i. Set B TRIGGER SOURCE switch to STARTS AFTER DELAY and position 2nd marker to second graticule line (1st mark goes off screen).

CHECK—B Sweep accuracy is within 2% (7.84 to 8.16 for centered 8 div display).

j. Disconnect time-mark generator.

11. B Ends A Operation

a. Set: HORIZ DISPLAY A INTEN  
 A TIME/DIV 1 ms  
 B TIME/DIV .1 ms  
 B TRIG MODE STARTS AFTER DELAY  
 A TRIG HOLDOFF B ENDS A (clockwise detent)  
 DELAY TIME About 2.00  
 POSITION A Sweep is visible  
 INTEN

## Operating Instructions—466 Service

b. Rotate DELAY TIME POSITION control through its range.

CHECK—End of A Sweep does not extend beyond B intensified portion at any DTP setting.

### 12. A Trigger Holdoff

a. Set: HORIZ DISPLAY           A  
           A TIME/DIV            10  $\mu$ s  
           A TRIG HOLDOFF       NORM (fully  
   counterclockwise)  
           A LEVEL                Fully clockwise

b. Set test oscilloscope:  
       Vertical mode            Channel 1  
       Channel 1 Volts/Div      1 volt  
       Horiz Mode               A Sweep  
       A Trig Mode              Auto  
       Time/Div                 20  $\mu$ s

c. Connect test oscilloscope CH 1 input to +A GATE Output (on oscilloscope being calibrated) via 50  $\Omega$  cable.

d. Adjust test oscilloscope Level for triggered display and Var Time/Div so negative-portion of gate (holdoff time) is 1 div long. Adjust triggering and Position so negative gate starts at left edge graticule line on test oscilloscope.

e. Rotate A TRIG HOLDOFF control clockwise, but not into B ENDS A detent.

CHECK—Holdoff time of A GATE is increased 10 times or more.

f. Set the A TRIG HOLDOFF control to NORM.

## F. REDUCED SCAN AND STORAGE

### 1. Reduced Scan

a. Set: INTEN                   As needed  
       REDUCED SCAN (PULL)   INTEN knob  
   (push in)  
       VERT MODE                CH 1  
       CH 1 VOLTS/DIV           .1 V  
       CH 1 VAR VOLTS/DIV      Calibrated detent  
       AC-GND-DC (CH 1)        GND  
       NON STORE                On (button in)  
       STORAGE LEVEL           MAX (fully  
   clockwise)  
       INTEN (SAVE)            MAX (fully  
   clockwise)  
       SAVE                      Off (button out)  
       VIEW TIME                MAX (fully clock-  
   wise and in  
   detent)

A TRIGGER                   AC  
   COUPLING                 NORM  
   A TRIGGER SOURCE        0  
   TRIG MODE                AUTO  
   HORIZ DISPLAY            A  
   A TIME/DIV                1 ms  
   B TIME/DIV                1 ms  
   VAR TIME/DIV             Calibrated detent  
   X10 MAG                   Off (button out)

#### NOTE

*All measurements and readings in this step are referenced to the small graticule in the crt center screen unless otherwise stated.*

b. Adjust TRACE ROTATION for trace parallel to horizontal graticule line.

c. Pull INTENSITY control for Reduced Scan mode.

CHECK—REDUCED SCAN lamp lights when INTENSITY knob is pulled out.

CHECK—Trace is parallel to center horizontal graticule line.

d. Connect 0.1 ms time marks from time-mark generator to CH 1 input via 50 ohm cable and 50 ohm termination.

e. Set: X10 MAG (IN)           On (push in)  
       CH 1 AC-GND-DC         DC

CHECK—1 time mark/small div, within 2% ( $\pm 0.2$  div for 11th mark). Adjust INTEN and POSITION controls as required.

f. Vertically position display baseline 2 large div below center line (bottom line of reduced graticule) and horizontally position a time mark to center vertical graticule line.

CHECK—Time mark is parallel to center vertical graticule line.

g. Set: X10 MAG (IN)           Off (button out)  
       INTEN                    Full Scan (push in)  
       CH 1 VOLTS/DIV          .5

Set time-mark generator for 1 ms time marks and adjust INTEN, FOCUS and ASTIG controls for best focused display.

h. Set: INTEN                   Reduced Scan (pull  
   out)  
       CH 1 VOLTS/DIV          .2

CHECK—Display can be focused by adjusting FOCUS control only.

ADJUST—FOCUS for best focused display.

i. Disconnect time mark generator.

j. Connect 20 mV signal from amplitude calibrator to CH 1 input via 50 ohm cable.

k. Set CH 1 VOLTS/DIV switch to 5 mV.

CHECK—Display is 4 small div within 3% ( $\pm 0.12$  div).

l. Disconnect amplitude calibrator.

## 2. VAR PERS (Variable Persistence)

a. Set:	Storage Mode	VAR PERS (push in)
	INTEN	Minimum (fully counterclockwise), push INTEN in (full scan)
	STORAGE LEVEL	MAX (fully clockwise)

b. Push ERASE button and note intensity level of crt screen.

CHECK—Screen is flooded (bright).

c. Set STORAGE LEVEL control to minimum (fully counterclockwise) and push ERASE button.

CHECK—Entire screen erases.

## 3. Fast Mode

a. Set:	A TIME/DIV	.1 $\mu$ s
	Storage Mode	NON STORE (push in)
	INTEN	Midrange
	VIEW TIME	Minimum (fully counterclockwise)
	STORAGE LEVEL	Minimum (fully counterclockwise)
	CH 1 VOLTS/DIV	.1 V

b. Connect 9.6 MHz signal from leveled sine-wave generator to CH 1 input via 50 ohm cable and 50 ohm termination.

c. Adjust generator for 5 div display.

d. Set:	A TRIG LEVEL	Stable display
	A TIME/DIV	About 1 cycle/div
	INTEN	Off (fully counterclockwise)
	Storage Mode	Fast(push in)

e. After each erase cycle increase STORAGE LEVEL until background noise begins to store (in mid-screen). Set VIEW TIME control to MAX and A TRIG LEVEL fully counterclockwise.

f. Push ERASE button and wait 1 minute.

g. Trigger sweep by turning A TRIG LEVEL clockwise and note (brightness) level of stored information (background noise). (In this step and the rest of the Performance Check or Calibration Procedure, when instructed to turn the Trigger LEVEL control either clockwise or counterclockwise to trigger the sweep, turn the control only to the triggering point; do not turn it to the extreme of rotation.)

h. Immediately push ERASE button and trigger another sweep and compare level of stored information to that noted in part g.

CHECK—Similar level of stored information and background level.

### NOTE

*For SN below B120000, Step three, parts i, j, and k establish an intensity level that only approximates the level used to calibrate this instrument. To obtain the exact level requires that the instrument cover be removed and the calibration procedure be followed. For SN B120000 and up set INTEN to maximum (fully cw) and skip Step three, parts i, j, and k.*

i. Set:	Storage Mode	NON STORE
	A TRIG MODE	SINGL SWP

j. Rotate INTEN control until sweep start (vertical line) is visible (use Horizontal POSITION controls to place sweep start within viewing area). Then, rotate control about 30° counterclockwise from the point of extinction.

k. Set A TRIG MODE switch to AUTO and adjust FOCUS and ASTIG controls for best-focused display.

### NOTE

**DO NOT CHANGE THE INTENSITY CONTROL SETTING FOR THE REMAINDER OF STEP 3 AND ALL OF STEPS 4, 5, AND 6.**

## Operating Instructions—466 Service

l. Set: Storage Mode FAST (push in)  
VIEW TIME MAX (in detent)  
A TRIG LEVEL Fully clockwise  
STORAGE LEVEL Best display

m. Push ERASE button and wait 1 minute.

n. Trigger sweep by turning A TRIG LEVEL counterclockwise and note (brightness) level of stored trace and background level.

o. Immediately push ERASE button and trigger another sweep and compare level of stored information to that noted in part n.

CHECK—Similar intensity of stored trace.

### 4. SAVE Mode

a. Set VIEW TIME control fully counterclockwise.

b. Push SAVE button during stored display.

CHECK—Display cannot be erased by pressing ERASE button and that the display does not auto-erase.

CHECK—Display intensity turns completely off by adjusting SAVE INTEN control counterclockwise.

### 5. Full Scan Writing Rate

a. Set: SAVE Off (button out)  
Storage Mode FAST (push in)  
A TRIG LEVEL Fully clockwise

b. Set VIEW TIME control to MAX and push ERASE button, then wait 1 minute.

c. Trigger sweep by turning A TRIG LEVEL control counterclockwise.

d. Set STORAGE LEVEL control for best display.

CHECK—Trace is stored and distinguishable from background, everywhere within center 6 x 8 div, for 15 seconds or more.

e. Set: A TIME/DIV 10  $\mu$ s  
Storage Mode NON STORE

f. Adjust leveled sine-wave generator for 3.2 div, 50 kHz display (adjust A TRIG LEVEL control as needed for stable display).

g. Adjust A TIME/DIV VAR control for about 1 cycle/div.

h. Position bottom of display 3 div below center horizontal line.

i. Set: A TRIG LEVEL Fully clockwise  
A TRIG MODE SINGL SWP  
Storage Mode VAR PERS (push in)  
VIEW TIME MAX  
STORAGE LEVEL NORM

j. Push ERASE button.

k. Rotate STORAGE LEVEL control clockwise until screen starts to brighten.

l. Trigger sweep by turning A TRIG LEVEL control counterclockwise.

CHECK—Trace is stored and distinguishable from background, within center 8 horizontal div for 15 seconds or more.

m. Set A TRIG MODE switch to AUTO and position top of display 3 div above center horizontal line.

n. Set: A TRIG LEVEL Fully clockwise  
A TRIG MODE SINGL SWP

o. Push ERASE button, then trigger sweep by turning A TRIG LEVEL control counterclockwise and set STORAGE LEVEL control for best display.

CHECK—Trace is stored and distinguishable from background, everywhere within center 8 horizontal div, for 15 seconds or more.

### 6. Check REDUCED SCAN Writing Speed

#### NOTE

*All writing speeds in step 6 are referenced to the small center graticule (.45 cm = 1 div). All voltage amplitudes and TIME/DIV settings are referenced to the large graticule (0.9 cm = 1 div), even though the oscilloscope is in reduced scan mode.*

a. Set: Storage Mode NON STORE (push in)  
A TRIG MODE AUTO  
INTEN Do not rotate  
REDUCED SCAN (PULL) Pull INTEN out



## Operating Instructions—466 Service

A TIME/DIV                    5  $\mu$ s  
X10 MAG                        On (putton in)

b. Adjust leveled sine-wave generator for 1.4 large div, 350 kHz display.

c. Set A TRIG LEVEL control as needed for stable display and A TIME/DIV VAR control for about 1 cycle/large div.

d. Position center of display to top of small graticule.

e. Adjust FOCUS control for best display.

f. Set:	A TRIG LEVEL	Fully clockwise
	A TRIG MODE	SINGL SWP
	Storage Mode	VAR PERS
	STORAGE LEVEL	NORM

g. Push ERASE button.

h. Set STORAGE LEVEL control to where screen just starts to brighten.

i. Trigger sweep by turning A TRIG LEVEL control counterclockwise and set STORAGE LEVEL control for best display.

CHECK—Trace is stored and distinguishable from background, everywhere within small graticule, for 15 seconds or more.

j. Set A TRIG MODE switch to AUTO and position center of display to bottom of small graticule.

k. Set:	A TRIG LEVEL	Fully clockwise
	A TRIG MODE	SINGL SWP

l. Push ERASE button, then trigger sweep by turning A TRIG LEVEL control counterclockwise.

CHECK—Trace is stored and distinguishable from background, everywhere within small graticule, for 15 seconds or more.

m. Set A TRIG MODE switch to AUTO and position display to vertical center.

n. Set:	A TRIG LEVEL	Fully clockwise
	A TRIG MODE	SINGL SWP

o. Push ERASE button, then trigger sweep by turning A TRIG LEVEL control counterclockwise.

CHECK—Trace is stored and distinguishable from background, everywhere within small graticule, for 15 seconds or more.

p. Set:	Storage Mode	NON STORE
	A TRIG MODE	AUTO
	A TIME/DIV	.05 $\mu$ s
	VIEW TIME	Minimum (fully counterclockwise)

q. Adjust leveled sine-wave generator for 5 large div, 96 MHz display.

r. Set A TRIG LEVEL control as needed for stable display and A TIME/DIV VAR control for about 1 cycle/large div.

s. Set STORAGE MODE switch to FAST.

t. Adjust STORAGE LEVEL control for best stored display. Do not readjust STORAGE LEVEL control for rest of step 6.

u. Set VIEW TIME control to MAX (in detent).

v. Set A TRIG LEVEL control fully clockwise, push ERASE button and wait 1 minute.

w. Trigger sweep by turning A TRIG LEVEL control counterclockwise.

CHECK—Trace is stored and distinguishable from background, everywhere within small graticule for 15 seconds or more.

x. Push in NON STORE button.

y. Disconnect leveled sine-wave generator.

## G. X-Y DISPLAY, Z-AXIS AND GATE OUTPUTS

### 1. X-Axis Gain

- |                        |                        |
|------------------------|------------------------|
| a. Set: INTEN          | Fully counterclockwise |
| REDUCED SCAN (PULL)    | Push INTEN in          |
| VERT MODE              | CH 2 or X-Y            |
| POSITION (CH 1 & CH 2) | Midrange               |
| VOLTS/DIV (both)       | 5 mV                   |
| VAR VOLTS/DIV (both)   | Calibrated detent      |
| CH 1 AC-GND-DC         | AC                     |
| CH 2 AC-GND-DC         | GND                    |
| NON STORE              | On (button in)         |
| HORIZ DISPLAY          | A                      |
| A TIME/DIV             | X-Y                    |
| B TIME/DIV             | X-Y                    |
| VAR TIME/DIV           | Calibrated detent      |
| X10 MAG                | Off (button out)       |
| POSITION (Horiz)       | Midrange               |
| FINE                   | Midrange               |

b. Connect 50 mV signal from amplitude calibrator to CH 1 input via 50  $\Omega$  cable. Advance INTEN clockwise just enough to view dots in steps 1 through 3. Set Horizontal POSITION as required.

CHECK—Display is 2 dots, with dot centers 10 div apart, within 4% (9.6 to 10.4 div).

c. Adjust INTEN and FOCUS controls for best display.

d. Set amplitude calibrator for 20 mV signal.

CHECK—Display is 2 dots, with dot centers 4 div apart, within 4% ( $\pm 0.16$  div).

e. Set CH 1 AC-GND-DC switch to DC.

CHECK—Display is 2 dots, with dot centers 4 div apart, within 4% ( $\pm 0.16$  div).

f. Disconnect amplitude calibrator.

### 2. Check X-Y Phasing

a. Connect leveled sine-wave generator signal to both inputs via 50  $\Omega$  cable, 50  $\Omega$  termination, dual-input coupler to CH 1 input and CH 2 input.

b. Adjust leveled sine-wave generator for 8 div, 50 kHz signal (horizontal line 8 div long). Set Horizontal POSITION as required.

c. Set CH 2 AC-GND-DC switch to DC.

d. Adjust CH 2 POSITION control and Horizontal POSITION controls to center display.

CHECK—Opening is 0.4 div or less, measured along center graticule line.

### 3. Check X-Axis Bandwidth

a. Set CH 2 AC-GND-DC switch to GND.

b. Remove dual-input coupler and connect leveled sine-wave generator to CH 1 input via 50  $\Omega$  cable and 50  $\Omega$  termination.

c. Adjust leveled sine-wave generator for 10 div, 50 kHz display (horizontal line 10 div long). Set Horizontal POSITION as required.

d. Set leveled sine-wave generator to 4.0 MHz.

CHECK—Display is 7 div or more (set Horizontal POSITION as required).

e. Disconnect leveled sine-wave generator.

### 4. Check Z-Axis Sensitivity

a. Set: A TIME/DIV	.2 ms
A TRIG SOURCE	EXT
A TRIG MODE	AUTO

b. Connect 5 V signal from amplitude calibrator via 50  $\Omega$  cable, BNC T-connector and 50  $\Omega$  cable to EXT Z AXIS input and A EXT Trigger input.

c. Adjust A TRIG LEVEL control for triggered display (TRIG lamp is lit).

CHECK—Trace is intensity modulated at normal (and low) INTEN control settings.

d. Disconnect amplitude calibrator.

### 5. Check Z-Axis Maximum Usable Frequency

a. Set: A TIME/DIV	.05 $\mu$ s
CH 2 VOLTS/DIV	1
CH 2 AC-GND-DC	DC
CH 2	ON (IN)
CH 1	OFF (DOT)

REV. B, JAN 1976

b. Connect leveled sine-wave generator, via 50  $\Omega$  cable, BNC T-connector and 50  $\Omega$  cable to A EXT Trigger input and CH 2 input.

c. Set leveled sine-wave generator for 5 div (5 V) 50 MHz display.

d. Move cable from CH 2 input to EXT Z-AXIS input.

CHECK—Trace is intensity modulated at normal (and lower) INTEN control settings.

e. Disconnect leveled sine-wave generator.

**6. Check A and B Gates Out**

a. Set: TIME/DIV (both) 50  $\mu$ s  
 B TRIGGER SOURCE STARTS AFTER DELAY  
 DELAY TIME POSITION 0.02

b. Set test oscilloscope:  
 Vertical Mode Channel 1  
 Channel 1 Volts/Division 1 volt  
 A Time/Division 0.2 ms

c. Connect test oscilloscope input to A + GATE output via 50  $\Omega$  cable.

CHECK—Display is positive, rectangular pulse, about 5.5 V high.

d. Move 50  $\Omega$  cable to B + GATE output.

e. Set HORIZ DISPLAY switch to B DLY'D.

CHECK—Display is positive, rectangular pulse, about 5.5 V high.

f. Disconnect test oscilloscope.

**7. Check Calibrator Output**

a. Set test oscilloscope:  
 Vertical Mode Channel 1  
 Channel 1 Volts/Division 10 mV  
 A Time/Division 1 ms

b. Connect test oscilloscope to 466 calibrator loop via 10X probe. Compensate probe to calibrator waveform.

CHECK—Display is a square wave about 0.3 V (3 div) high.

*NOTE*

*See calibration procedure to check calibrator frequency and amplitude accuracy.*

c. Disconnect probe and test oscilloscope.

—END OF PROCEDURE—

# CIRCUIT DESCRIPTION

## Introduction

This section of the manual contains a description of the circuitry used in the 466 Oscilloscope. The description begins with a discussion of the instrument, using the Block Diagram pullout page in the Diagrams section. Then, each circuit is described in detail using detailed block diagrams to show the interconnections between the stages in each major circuit and the relationship of the front panel controls to the individual stages.

Complete schematics of each circuit are given in the Diagrams section. Refer to these diagrams throughout the following circuit description for electrical values and relationships.

## Digital Logic

Digital logic techniques are used to perform many functions within this instrument. The function and operation of the logic circuits are described using logic symbology and terminology. All logic functions are described using the positive logic convention. Positive logic is a system of notation where the more positive of two levels (HI) is called the true or 1 state; the more negative level (LO) is called the false or 0 state. The HI-LO method of notation is used in the logic descriptions. The specific voltages which constitute a HI or LO state vary between individual devices.

It should be noted that not all of the integrated circuit devices in this instrument are digital logic devices. The function of non-digital devices will be described individually using operating waveforms or other techniques to illustrate their function.

## BLOCK DIAGRAM DESCRIPTION

The following discussion is provided to aid in understanding the overall concept of the 466 Oscilloscope before the individual circuits are discussed in detail. Refer to the Block Diagram pullout page in the Diagrams section.

### Vertical Section

#### Preamp Circuits

Signals to be displayed on the crt are applied to the CH 1 OR X or CH 2 OR Y connectors. The input signals are

then amplified by the Preamp circuits. Each Preamp circuit includes separate vertical deflection factor, input coupling, balance, gain, and variable attenuation controls. A trigger pickoff stage in each Vertical Preamp circuit supplies a sample of the channel signals to the A trigger amplifier and B trigger amplifier circuits. A sample of the Channel 1 signal is also supplied to the CH 1 VERT SIGNAL OUT bnc connector on the instrument rear panel.

The Channel 2 Vertical Preamp circuit contains an invert feature to invert the Channel 2 signal as displayed on the crt.

#### Switching Circuits

The output of both Vertical Preamp circuits is connected to the Channel Switching Gate circuit. This circuit selects the channel to be displayed. An output signal from this circuit is connected to the Z-Axis Amplifier circuit to blank out the switching transients between channels when in the chopped mode. A trigger pickoff stage at the output of the Vertical Switching circuit provides a sample of the displayed signal(s) to the Trigger Generator circuit.

#### Output Amplifier

The Vertical Output Amplifier circuit provides the final amplification for the signal before it is connected to the crt vertical deflection plates. This circuit includes the BEAM FINDER switch which compresses the vertical and horizontal deflection to within the viewing area to aid in locating an off-screen display.

### Horizontal Section

#### Trigger Generators

The A and B Trigger Paraphase Amplifier and Tunnel Diode Driver circuits produce an output pulse that initiates the sweep signal produced by the A or B Sweep Generator circuits. The input signal to the A or B Trigger Generator circuits can be individually selected from the Channel 1 signal, Channel 2 signal, the signal(s) displayed on the crt, a signal connected to the external trigger input connectors, or (A only), a sample of the line voltage applied to the instrument. Each trigger circuit contains level, slope, coupling, and source controls.

#### A Sweep Generator

The A Sweep Generator circuit, when initiated by the A Trigger Generator circuit, produces a linear sawtooth output signal, the slope of which is controlled by the A

## Circuit Description—466 Service

TIME/DIV switch. The TRIG MODE switch controls the operating mode of the A Sweep Generator circuit. In the AUTO position, the absence of an adequate trigger signal causes the sweep to free run. In the NORM position, a horizontal sweep is presented only when correctly triggered by an adequate trigger signal. Pushing in the SINGL SWP pushbutton allows one sweep to be initiated.

### Z Axis Logic

The Z Axis Logic circuit produces an unblanking gate signal to unblank the crt so that the display can be presented. This gate signal is coincident with the sawtooth produced by the A Sweep Generator circuit. A gate signal, which is also coincident with the sawtooth, is available at the A +GATE connector on the instrument rear panel. The Z Axis Logic circuit also produces an alternate sync pulse which is connected to the Vertical Switching circuit. The pulse switches the display between channels at the end of each sweep when the VERT MODE switch is in the ALT position.

### B Sweep Generator

The B Sweep Generator circuit is basically the same as the A Sweep Generator circuit. However, this circuit only produces a sawtooth output signal after a delay time determined by the A TIME/DIV switch and the DELAY TIME POSITION dial. If the B Triggering SOURCE switch is set to the STARTS AFTER DELAY position, the B Sweep Generator begins to produce the sweep immediately following the selected delay time. If this switch is in one of the remaining positions, the B Sweep Generator circuit does not produce a sweep until it receives a trigger pulse occurring after the selected delay time.

### Horizontal Amplifier

The output of either the A or B Sweep Generator is amplified by the Horizontal Amplifier circuit to produce horizontal deflection for the crt except in the fully counterclockwise (X-Y) position of the TIME/DIV switch. A 10X magnifier in the Horizontal Amplifier circuit increases the sweep rate 10 times in any A or B TIME/DIV switch position. Other horizontal deflection signals can be connected to the horizontal amplifier by using the X-Y mode of operation. When the TIME/DIV switch is set to X-Y, the X signal is connected to the Horizontal Amplifier circuit through the Channel 1 Vertical Preamp circuit.

## Z AXIS AMPLIFIER

The Z Axis Amplifier circuit determines the crt intensity and blanking. The Z Axis Amplifier circuit sums the current inputs from the INTENSITY control, Vertical Switching circuit (chopped blanking), Z Axis Logic circuit (unblanking), and the external Z AXIS INPUT connector. The output level of the Z Axis Amplifier circuit controls the trace intensity through the CRT circuit. The CRT circuit

provides the voltages and contains the controls necessary for operation of the cathode-ray tube. The storage circuit provides clock-controlled voltage signals for operating the storage crt.

## POWER SECTION

The Power Supply circuit provides the low voltage power necessary for operation of this instrument. This voltage is distributed to all the circuits in the instrument as shown by the Power Distribution Diagram. The Calibrator circuit produces a square-wave output with accurate voltage and current amplitudes which can be used to check the calibration of the instrument and the compensation of probes. The CALIBRATOR current loop provides an accurate current source for calibration of current measuring probe systems.

## DETAILED CIRCUIT DESCRIPTION

### VERTICAL SECTION

#### Channel 1 Preamp

**General.** input signals for vertical deflection on the crt can be connected to the CH 1 OR X input connector. In the X-Y mode of operation the input signal connected to the CH 1 OR X connector provides the horizontal (X axis) deflection (TIME/DIV switch set to X-Y, VERT MODE switch set to CH 2 OR X-Y). The Channel 1 Preamp circuit provides control of input coupling, vertical deflection factor, gain and dc balance. Fig. 3-1 shows a detailed block diagram of the Channel 1 Preamp circuit. A schematic of this circuit is shown on Diagram 1 at the rear of the manual.

**Input Coupling.** Signals applied to the input connector can be ac coupled, dc coupled, or internally disconnected from the input to the Vertical Input Amplifier circuits. When the Input Coupling switch S30A is set for dc coupling, the input signal is coupled directly to the Input Attenuator stage. When ac coupled, the input signal passes through capacitor C12. This capacitor prevents the dc component of the signal from passing to the amplifier. In the GND position, S30A opens the signal path and connects the input of the amplifier to ground. This provides a ground reference without the need to disconnect the applied signal from the input connector. Resistor R14, connected across the input coupling switch, allows C12 to be pre-charged in the ground position so that the trace remains on screen when switched to the AC position.

**Input Attenuator.** The effective overall deflection factor of each channel of the 464 is determined by the appropriate VOLTS/DIV switch. The basic deflection factor of the Vertical Deflection System is 5 mV/division of crt deflection.

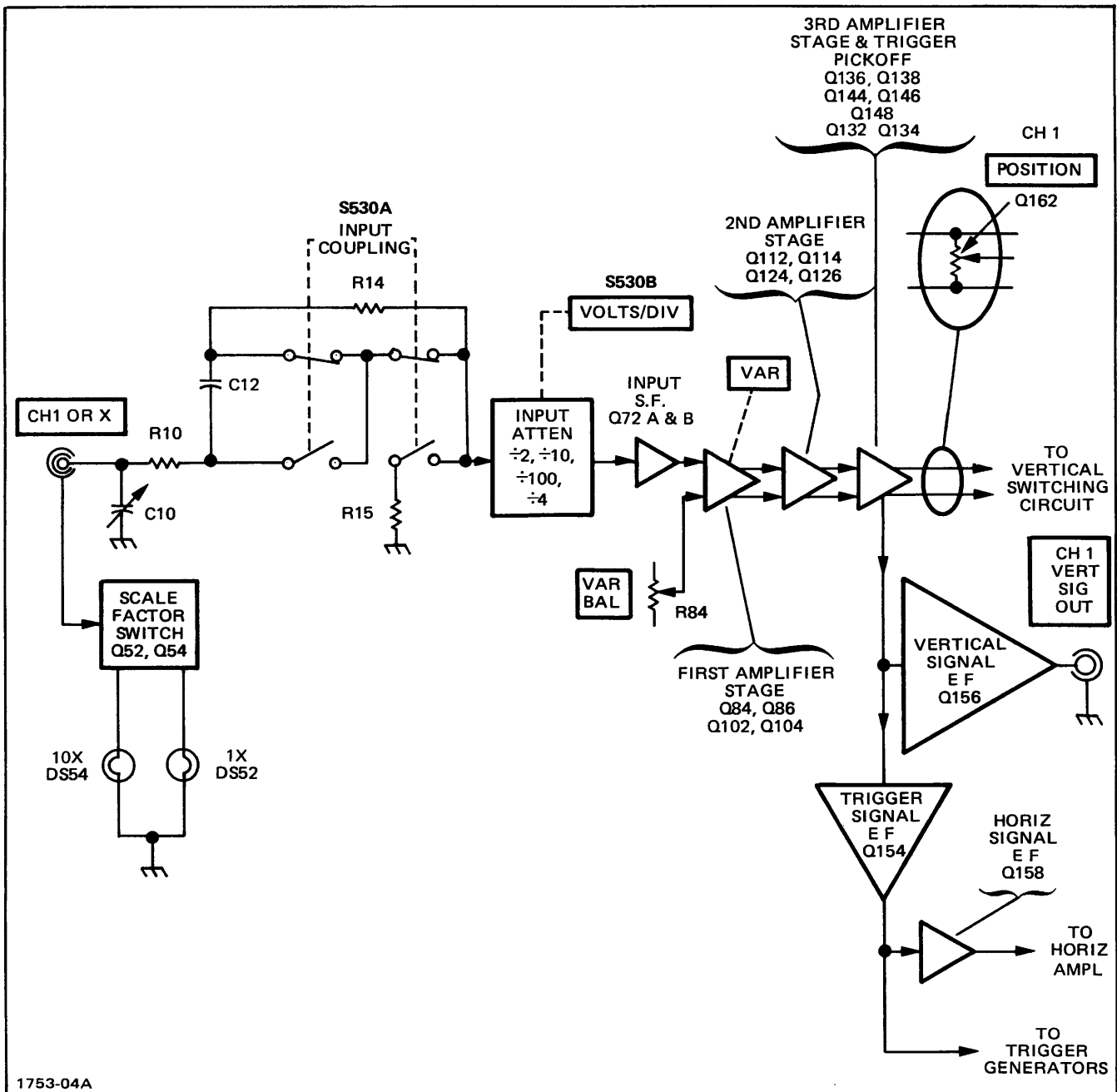

Fig. 3-1. Channel 1 Preamp Detailed Block Diagram.

For the VOLTS/DIV switch positions above 5 mV, attenuators are switched into the circuit, singly or in pairs, to help produce the vertical deflection factors indicated on the front panel. These attenuators are frequency-compensated voltage dividers. In addition to providing constant attenuation at all frequencies within the bandwidth of the instrument, the Input Attenuators are designed to maintain the same input RC characteristics (1 MΩ times approximately 20 pF) for each setting of the VOLTS/DIV switch. Each attenuator contains an adjustable series capacitor to provide correct attenuation at high frequencies and an adjustable shunt capacitor to provide correct input capacitance.

**Scale-Factor Switching Circuit.** The vertical deflection factor for each channel is indicated by back-lighting the appropriate figures on the flange of the VOLTS/DIV knob. A shorting ring at the input connector is used to determine which of the two lights will be on, depending on the probe being used.

When no probe or a 1X probe is attached to the CH 1 OR X input connector, the shorting ring remains at ≈1.2 volts. This allows Q52 base to be at +1.2 volts by way of R52, keeping Q52 and the 1X light DS52 on.

## Circuit Description—466 Service

When a 10X probe with a scale factor switching connector is attached to the CH 1 OR X input connector, the shorting ring is then grounded. This grounds the base of Q52 through R20, which turns off Q52 and the 1X light DS52 and turns on Q54 and the 10X light DS54.

**Source Follower Stage.** The Channel 1 signal from the Input Attenuator is connected to the Source Follower stage through R42, R45 and C42. R39 provides the input resistance for this stage. R42 limits the current drive to the gate of Q72A. Diode CR73 protects the circuit by clamping the gate of Q72A at about  $-8.7$  volts, if a high amplitude negative-going signal is applied to the CH 1 OR X input connector. Q72B is a relatively constant-current source for Q72A.

**First Amplifier Stage.** A paraphase cascode amplifier stage composed of Q84-Q102 and Q86-Q104 converts the single-ended input signal into a push-pull output signal. R75 and R87 provide thermal compensation; C75 and C87 compensate for Miller effect through Q84 and Q86.

Gain adjustment R92 adjusts the overall gain of the Channel 1 vertical preamplifier by adjusting the signal current into the emitters of Q102 and Q104.

The VAR control R96, when rotated out of the detent position, also adjusts the signal currents into Q102 and Q104 to provide uncalibrated deflection factors between the calibrated settings of the VOLTS/DIV switch. VAR BAL adjustment R84 adjusts for no baseline shift of the crt display when rotating the VAR control.

**Second Amplifier Stage.** Transistors Q112-Q114 and Q124-Q126 make up a push-pull cascode amplifier stage.

Q112 and Q114 convert the input signals into current signals, which are in turn converted back to voltage signals by Q124 and Q126. R111 and R118 provide thermal compensation; C111 and C118 compensate for Miller effect. C107-R107 and C108-R108 are variable high frequency compensation adjustments. CR114, CR117 and RT119 correct for changes associated with ambient temperature variations. As temperature increases, the value of RT119 decreases, resulting in a decrease in voltage across CR114 and CR117. CR114 and CR117 are voltage-variable capacitance semiconductors whose capacitance increases with a decrease in reverse voltage applied. CR114 and CR117 provide more high frequency peaking at higher temperatures.

**Third Amplifier Stage.** Q132 and Q134, in conjunction with Q304 and Q308 in the Vertical Switching circuit, form a Third Cascode Amplifier stage. The push-pull signals picked off in the emitters of Q132 and Q134 are converted to a single-ended signal by Q136, Q138, Q144 and Q146. This current signal from Q146 is converted to a voltage signal by common-base amplifier stage Q148 and applied to the bases of emitter followers Q154 and Q156. Q156 provides the output signal to the CH 1 VERT SIGNAL OUT connector located on the instrument rear panel. The output signal at the emitter of Q154 is used as the trigger signal source in the CH 1 positions of the Trigger SOURCE switches and as the signal source for emitter follower Q158. Q158 provides the X-axis signal from the Channel 1 Preamplifier to the Horizontal Amplifier in the X-Y mode. CR156, CR157, CR158 and CR159 protect the emitter circuit of Q156 in the event large signal levels are accidentally connected to the CH 1 VERT SIGNAL OUT connector. R152 adjusts the dc level of the CH 1 trigger source signal.

### Channel 2 Preamp

**General.** The Channel 2 Preamp circuit is basically the same as the Channel 1 Preamp. Only the specific differences between the two circuits are described here. Portions of this circuit not described in the following description operate in the same manner as for the Channel 1 Preamp. Fig. 3-2 shows a detailed block diagram of the Channel 2 Preamp circuit. A schematic of this circuit is shown on diagram 2 at the rear of this manual.

**Second Amplifier Stage.** Basically, the Second Amplifier Stage in Channel 2 functions as described for the second Amplifier Stage in Channel 1. However, the Channel 2 Second Amplifier Stage also contains the INVERT switching function. This allows the Channel 2 signal to be inverted as displayed on the crt. The INVERT switch, when pushed, changes the biasing on Q220-Q222 and Q224-Q226 so that Q220 and Q222 (normally inactive) will carry the signal. Since their inputs are cross-coupled from side to side, the output signal will be of the opposite polarity to that available in the normal position (pushbutton out) of the INVERT switch. The Channel 2 Invert Balance adjustment R212 adjusts the dc balance of the stage to eliminate baseline shift in the display when switching from a normal to an inverted display.

**Third Cascode Amplifier.** The trigger pickoff circuit only provides a signal to one emitter follower. This emitter follower (Q254) in turn provides the trigger signal to the Trigger Generator circuits in the CH 2 positions of the SOURCE switches.

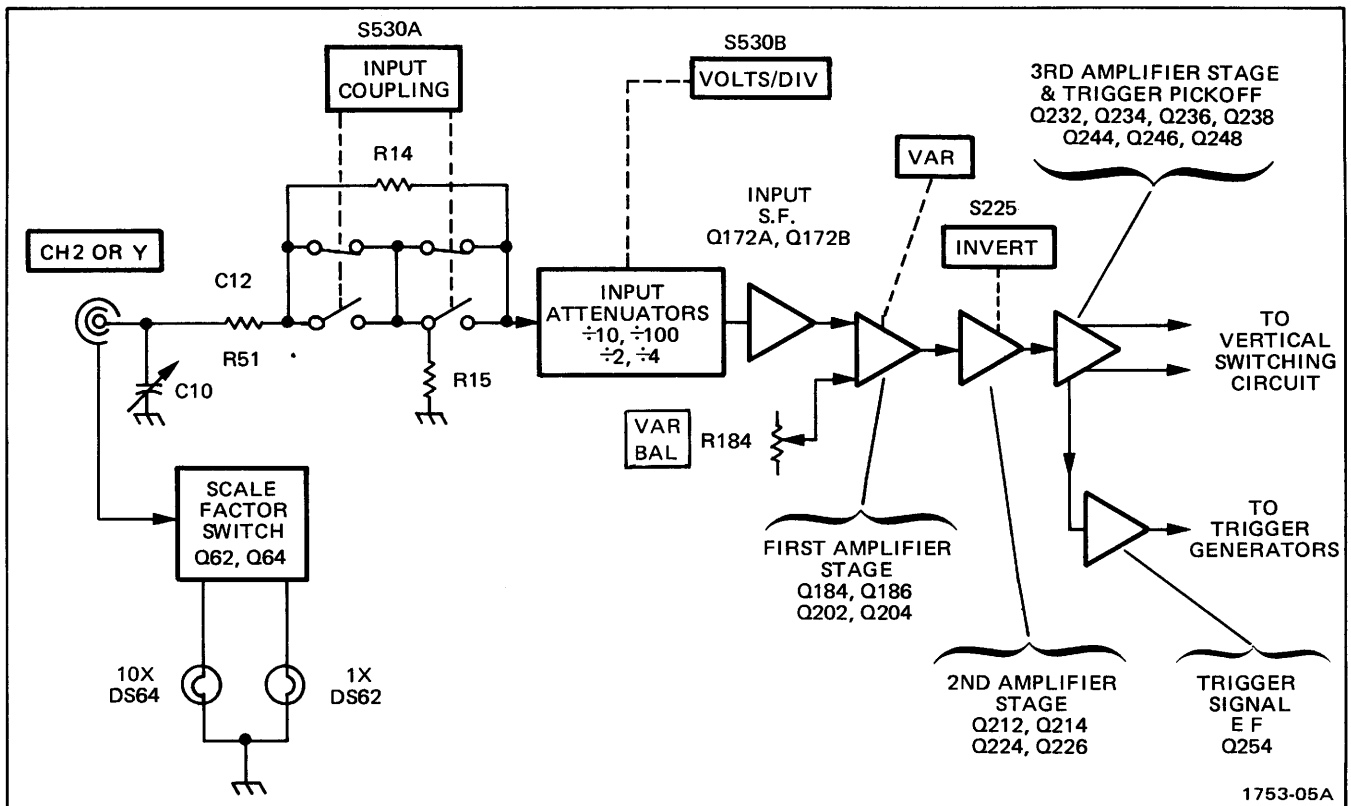

Fig. 3-2. Channel 2 Preamp Detailed Block Diagram.

### Vertical Switching Circuit

**General.** The Vertical Switching circuit determines whether the Channel 1 or Channel 2 or both signals are connected to the Vertical Output Amplifier circuit. In the alternate and chopped modes of operation both channels are alternately displayed on a shared time basis. Figure 3-3 shows a detailed block diagram of the Vertical Switching circuit. A schematic of this circuit is shown on diagram 3 at the rear of this manual.

The Diode Gates, consisting of four diodes each, can be thought of as switches which allow either of the Vertical Preamp output signals to be coupled to the Delay Line Driver and the Vertical Output Amplifier. CR304, CR305, CR307 and CR308 control the Channel 1 output and CR314, CR315, CR317 and CR318 control the Channel 2 output. These diodes are in turn controlled by the Switching Multivibrator for dual trace displays or by the VERT MODE switch for single trace displays.

**Channel 1 Only Display.** When the CH 1 pushbutton is pressed,  $-8$  volts is applied to the junction of CR315-CR317 in the Channel 2 Diode Gate through R367 (see simplified diagram in Fig. 3-4). This forward biases CR315 and CR317 and reverse biases CR314 and CR318. CR314 and CR318 block the Channel 2 signal so it cannot pass to the Delay Line Driver stage. At the same time in the Channel 1 Diode Gate, CR305 and CR307 are connected to  $+5$  volts through R371. CR305 and CR307 are held reverse-biased while CR304 and CR308 are forward biased.

Therefore, the Channel 1 signal passes to the Delay Line Driver stage.

**Channel 2 Display Only.** When the CH 2 pushbutton is pressed, the above conditions are reversed. The junction of CR305-CR307 is connected to  $-8$  volts through R377 and the junction of CR315-CR317 is connected to  $+5$  volts through R361. The Channel 1 Diode Gate blocks the Channel 1 signal and the Channel 2 Diode Gate allows the Channel 2 signal to pass to the Delay Line Driver stage.

### Switching Multivibrator.

A. ALTERNATE TRACE DISPLAY. In this mode of operation, the Switching Multivibrator operates as a bistable multivibrator. When the ALT pushbutton is pressed,  $-8$  volts is applied to the emitter of Alternate Trace Switching Amplifier stage Q352 by the VERT MODE switch. Q352 is forward biased to supply current to the "on" Switching-Multivibrator transistor through R352 and CR368 or CR378. For example, if Q374 is conducting, current is supplied to Q374 through R352 and CR378. The current flow through collector resistor R371 drops the CR305-CR307 cathode level negative so that the Channel 1 Diode Gate is blocked as for Channel 2 Only Operation. The signal passes through the Channel 2 Diode Gate to the Delay-Line Driver stage.



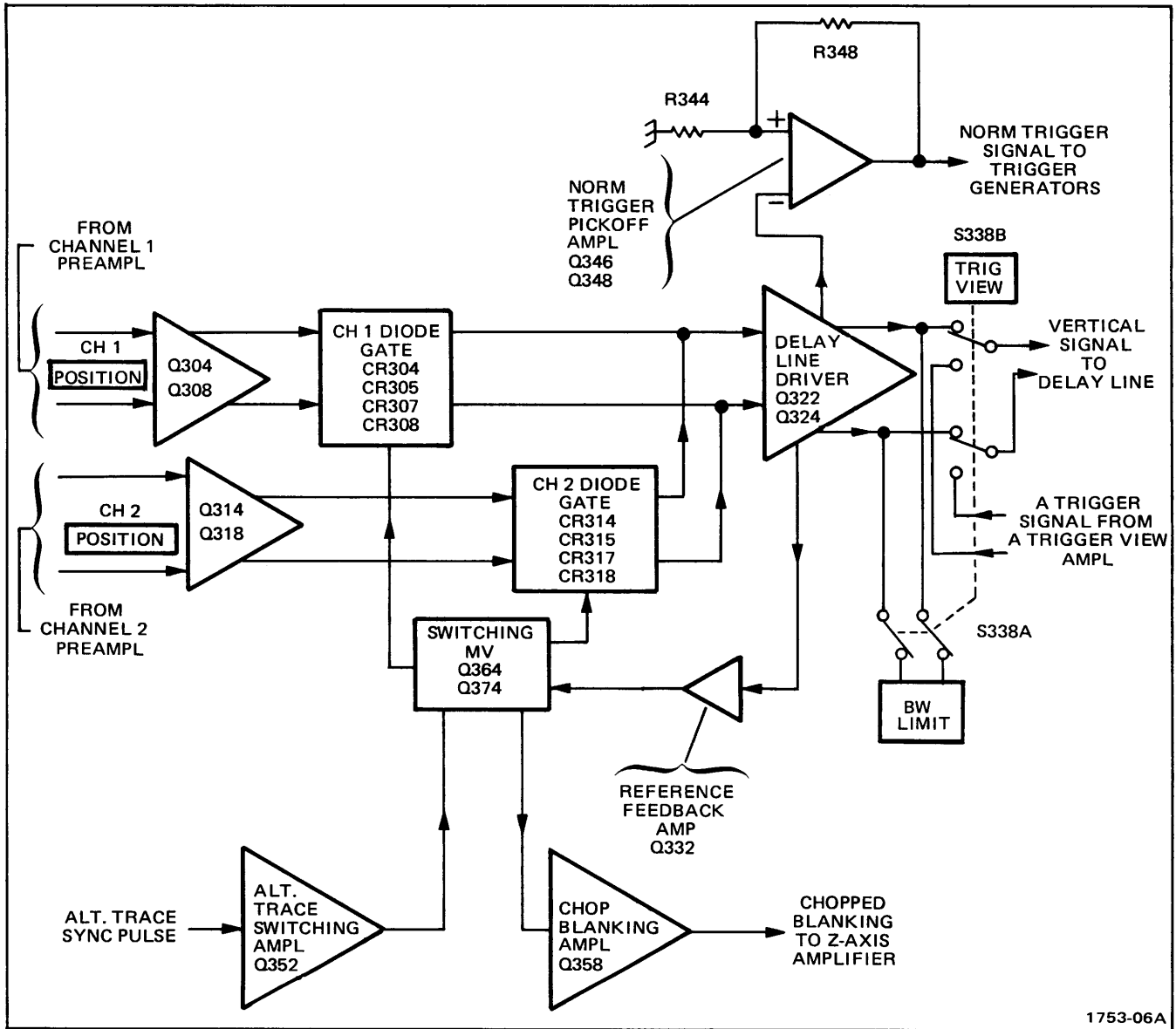

Fig. 3-3. Vertical Switching Circuit Detailed Block Diagram.

The alternate trace sync pulse is applied to the base of Q352 through C351 at the end of each sweep. This negative-going sync pulse momentarily interrupts the current through Q352 and both Q364 and Q374 are turned off. When Q352 turns on again after the alternate trace sync pulse, the charge on C368 determines whether Q364 or Q374 conducts. For example, when Q374 was conducting, C368 was charged positive on the CR378 side to the emitter level of Q374 and negatively on the CR368 side toward the negative level at the junction of CR368 and CR378. This charge is stored while Q352 is off and holds the emitter of Q364 more negative than the emitter of Q374. During the time Q364 and Q374 are turned off, the voltages at their bases become approximately equal. Now, when Q352 comes back on, the transistor with the most negative emitter conducts first, the resulting negative movement at its collector holds the other transistor off. The conditions

described previously are now reversed: now, the Channel 2 Diode Gate is reverse-biased and the Channel 1 signal passes through the Channel 1 Diode Gate.

**B. CHOPPED MODE OPERATION.** When the CHOP pushbutton is pressed, the Switching Multivibrator stage free-runs at about a 250 kHz rate. The emitters of Q364 and Q374 are connected to -8 volts through R368, R378, and the primary of transformer T354. At the time of turn-on, one of the transistors begins to conduct; for example, Q374. The negative level at the collector of Q374 forward-biases CR305 and CR307 and back-biases CR304 and CR308 preventing the Channel 1 signal from reaching the Delay-Line Driver stage. Meanwhile, the Channel 2 Diode Gate passes the Channel 2 signal to the Delay-Line Driver stage.

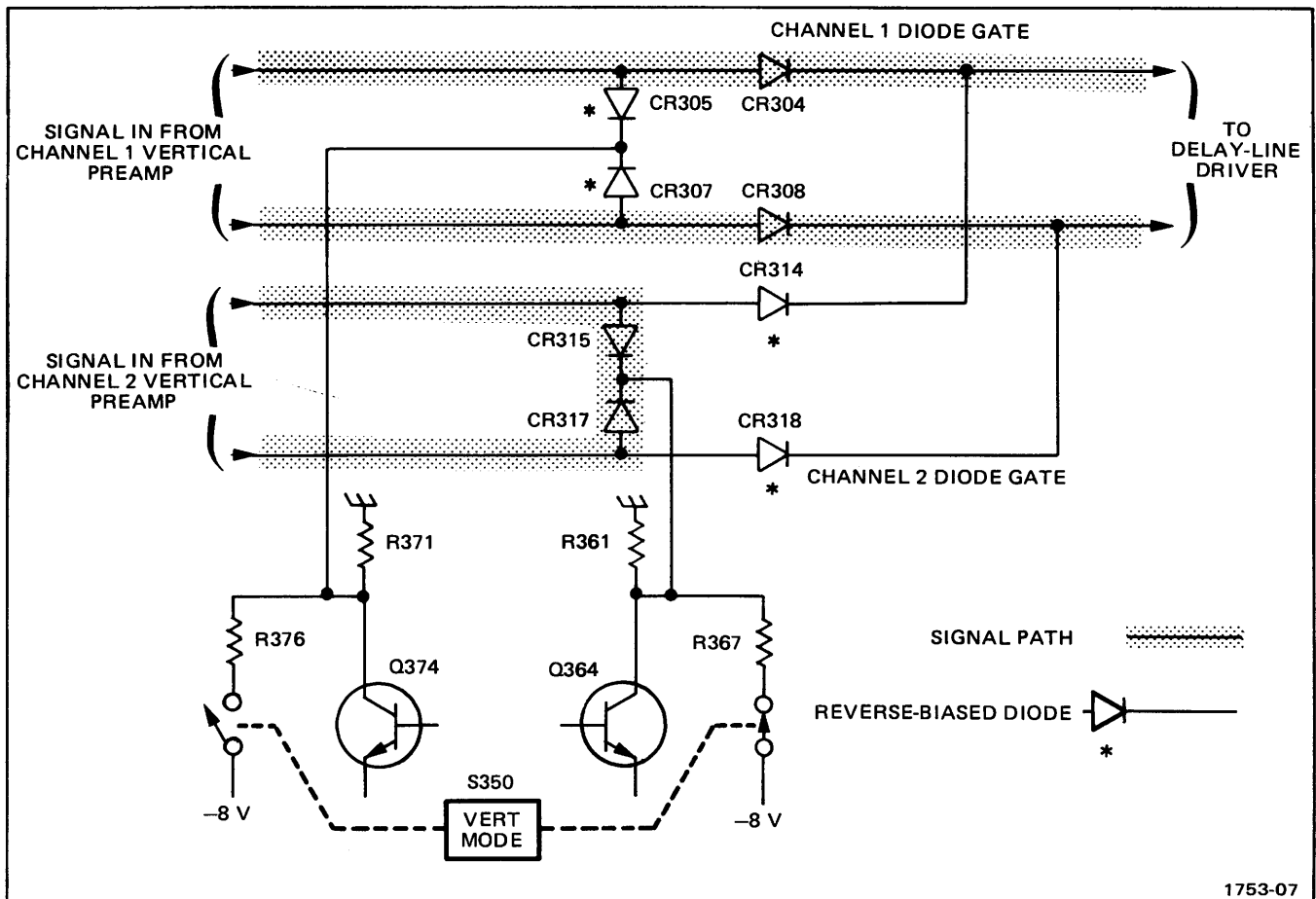

Fig. 3-4. Diode Gate Conditions in Channel 1 Mode.

The frequency-determining components in the CHOP mode are C368, R368, R370, and R378. The switching action occurs as follows: when Q374 is on, C368 attempts to charge to  $-8$  volts through R368. The emitter of Q364 slowly goes toward  $-8$  volts as C368 charges. The base of Q364 is held at a point determined by the voltage divider R365 and R374 between  $-8$  volts and the collector level of Q374. When the emitter voltage of Q364 reaches a level slightly more negative than its base, Q364 conducts. Its collector level goes negative and pulls the base of Q374 negative through divider R364-R375 to cutoff Q374. This switches the Diode Gate stages to connect the opposite channel to the Delay-Line Driver stage. Again, C368 begins to charge towards  $-8$  volts, but this time through R378. The emitter of Q374 slowly goes negative as C368 charges until Q374 turns on. Q364 is shut off and the cycle begins again.

The Chop Blanking Amplifier stage, Q358, provides an output pulse to the Z Axis Amplifier circuit which blanks out the transition between the Channel 1 and the Channel 2 traces. When the Switching Multivibrator stage changes states, the voltage across T354 momentarily increases. A negative pulse is applied to the base of Q358 to turn it off.

The width of the pulse at the base of Q358 is determined by R355 and C355. Q358 is quickly driven into cutoff and the positive going output pulse, which is coincident with trace switching, is connected to the Z Axis Amplifier circuit through R359.

C. ADDED MODE OPERATION. When the ADD pushbutton is pressed, the following occurs:

1.  $+5$  volts is applied to the cathodes of CR305 and CR307 through R371.
2.  $+5$  volts is applied to the cathodes of CR315 and CR317 through R361.
3.  $-8$  volts is applied to the junction of R321 and R322.

The first two actions enable both of the Channel Diode Gates so that the signal applied to the Delay Line Driver stage is the algebraic sum of the Channel 1 and Channel 2 signals. The  $-8$  volts applied to R321 and R322 provides sufficient current to keep both diode gates turned on without altering dc levels associated with the Delay Line Driver stage.

## Circuit Description—466 Service

**Delay-Line Driver.** The outputs from the Diode Gate stages are applied to the Delay-Line Driver stage composed of Q322 and Q324. Q322 and Q324 are connected as feedback amplifiers with R325 and R327 providing feedback from the collector to the base of their respective transistors. A sample of the signal in the collector circuit of Q322 is used for triggering in the NORM mode of trigger operation. The BW LIMIT switch S338A connects a pi filter network composed of C338, C339, L338, and L339 between the output signal lines of the Delay-Line Driver stage to reduce the upper -3 dB bandwidth limit of the Vertical Amplifier system to approximately 20 MHz. R335 and R336 provide reverse termination for the delay line. The TRIG VIEW switch S338B connects the output of the Trigger View Amplifier to the input of the Delay Line in place of the Delay-Line Driver stage. This allows viewing the trigger signal present in the A Trigger Generator circuit. The sensitivity at the input to the Delay Line is 50 mV/div p-p.

**Delay Line.** Delay Line DL339 provides approximately 120 ns delay for the vertical signal to allow the Sweep Generator circuits time to initiate a sweep before the vertical signal reaches the vertical deflection plates of the crt. This allows the instrument to display the leading edge of the signal originating the trigger pulse when using internal triggering.

**Reference Feedback Amplifier.** Reference Feedback stage Q332 provides common mode voltage feedback from the Delay-Line Driver stage to allow the diode gates to be switched with a minimum amplitude switching signal. The emitter level of Q332 is connected to the junction of the Switching Multivibrator collector resistors, R371 and R361 through CR372 or CR362. The collector level of the "on" Switching Multivibrator transistor is negative and either CR362 or CR372 is forward biased. This clamps the cathode level of the forward biased shunt diodes in the applicable Diode Gate about 0.5 volt more negative than the emitter level of Q332. The level at the emitter of Q332 follows the average voltage level at the emitters of the Delay-Line Driver stage. The shunt diodes are clamped near their switching level and therefore, can be switched very fast with a minimum amplitude switching signal. This maintains about the same current through the Diode Gate shunt diodes so that they can be switched by a minimum amplitude switching signal regardless of the deflection signal at the anodes of the shunt diodes.

**Normal Trigger Pickoff Amplifier.** The trigger signal for NORM trigger operation is obtained from the collector of Q322. Normal Trigger dc Adjustment R341 sets the dc level of the normal trigger output signal so the sweep is triggered at the 0 level of the displayed signal when the Triggering LEVEL control is set to 0. Q346 and Q348 are connected as a feedback amplifier with the signal applied to the non-inverting input and the feedback connected between the output and the inverting input. Gain of the stage is approximately 1.3 as determined by R344 and R347.

## Vertical Output Amplifier

**General.** The Vertical Output Amplifier circuit provides the final stage of amplification needed for the vertical input signal to drive the crt vertical deflection plates. A schematic diagram of this circuit is shown on diagram 4 at the back of this manual.

**Output Amplifier.** Q412-Q416 and Q422-Q426 make up the first vertical output amplifier stage. Most of the components connected between the emitters of Q412 and Q422 provide high-frequency compensation for the delay line. RT421 changes value with variations in ambient temperature to compensate for temperature-associated changes in amplifier gain. Gain Adjustment R415 adjusts the gain for the Vertical Output Amplifier.

Integrated circuit U464 is a multi-stage cascode amplifier cell. The input signal is applied push-pull between pins 1 and 5 with the inverted output signal taken from pins 9 and 12. Some of the components connected between pins 2 and 4 provide slower time constants to compensate for thermal variations. The Bias adjustment (R478) sets the dc levels within the stage to optimize the operating performance of U464. The sensitivity at the vertical deflection plates is about 3.75/Div.

**Beam Finder.** When the BEAM FINDER button is pressed, it reduces the vertical and horizontal deflection so that all signals are compressed to within the graticule area (regardless of display amplitude or position) to indicate the position of the display relative to graticule center. Also, it over-rides the action of the INTEN potentiometer and unblanking signal in the Z-Axis amplifier, and permits viewing a display that might otherwise not be visible.

Beam finder effect on the horizontal deflection is described under Gain Setting Amplifier within the Horizontal Amplifier description. The effect on the Z-Axis Amplifier is described under Z-Axis Amplifier.

In the Vertical amplifier, when the BEAM FINDER button is not pressed, the first section of S400 connects emitter resistors (R472, R473, R474, and R475) to the anode of CR1427 via P491 pin 3 and P400 pin 3. Emitter current causes CR1427 to conduct and provides a ground reference for the emitter resistors. The second section of S400 normally applies +65 volts to the vertical output final amplifier collector circuit and the vertical deflection plates via pin 1 of P400.

When the BEAM FINDER button is pressed, the second section of S400 disconnects the +65 volt source and +65 volts is applied through R498. This maintains correct average vertical deflection plate voltage to provide proper

focus of a compressed display. The first section of S400 opens the emitter resistor path to CR1427 and emitters return to ground via R471. The dynamic range and gain of the vertical output stage are thus reduced to provide a compressed, properly focused, vertical display within the graticule area, to indicate the position of the display relative to the graticule center.

## HORIZONTAL SECTION

### A and B Trigger Generators

**General.** The Trigger Generator circuits produce trigger pulses to start the Sweep Generator circuits. These trigger pulses are derived either from the internal trigger signal from the vertical deflection system, an external signal connected to the external trigger connectors, or a sample of the line voltage applied to the instrument. Controls are provided in each circuit to select trigger level, slope, coupling, and source.

An A Trigger View Amplifier is provided that amplifies the A Trigger signal for display on the crt. This provides a method of making a quick and convenient check of the signal being used to trigger the A Sweep Generator and is intended primarily for checking the signal applied to the A External Trigger Input connector.

Since the A and B Trigger Generator circuits are virtually the same, only the A Trigger Generator circuit action and the differences between the A and B Trigger Generator circuits are explained. A schematic of these circuits is shown on diagram 5 at the back of this manual.

**Trigger Source.** The Trigger SOURCE switch S610 selects the source of the trigger signal. The sources available to the A Trigger Generator circuit are the signal(s) being displayed (NORM), Channel 1 (CH 1), Channel 2 (CH 2), LINE, and EXT. The EXT  $\div$  10 (A trigger circuit only) position provides 10 times attenuation for the external trigger signal. The B Trigger SOURCE switch does not have a LINE or an EXT  $\div$  10 position, but has a STARTS AFTER DELAY position.

In the LINE mode of triggering, a sample of the power line frequency is obtained from the secondary of power transformer T1701 in the Low Voltage Power Supply circuit. To prevent unwanted attenuation of the trigger signal by the LF REJ circuit, the A Trigger COUPLING switch should not be in the LF REJ mode when using line voltage as a trigger source.

**Trigger Coupling.** The Trigger COUPLING switches offer a means of accepting or rejecting certain components of the trigger signal. In the AC, LF REJ, and HF REJ mode of trigger coupling, the dc component of the trigger signal is blocked by coupling capacitors C612 or

C611. Frequency components below about 60 Hz are attenuated when using AC or HF REJ coupling and below about 15 kHz when using LF REJ coupling. The higher frequency components of the trigger signal are passed without attenuation. In the HF REJ mode of trigger coupling, the high frequency components of the trigger signal (above about 50 kHz) are attenuated, while the lower frequency components are passed without attenuation. The dc mode of trigger coupling passes unattenuated all signals from dc to 100 MHz and above.

**Input Source Follower.** Transistor Q622 is an FET source follower. It provides a high input impedance (set primarily by R616) for the trigger signal and also provides isolation between the Trigger Generator circuit and the trigger signal source. ~~Diode CR614 provides input protection for Q622 if an excessively high amplitude negative-going input signal is present.~~ Q624 is a high-impedance, relatively constant, current source for Q622, and provides a measure of temperature compensation for Q622.

**Paraphase Amplifier.** U640 is a paraphase amplifier stage that converts the single-ended input from Source Follower Q622 into a push-pull output applied to the Tunnel Diode Driver stage. Trigger Level Centering adjustment R635 sets the level at pins 14 and 15 of U640 so that the display is correctly triggered when the LEVEL control is centered. The LEVEL control varies the level at pins 14 and 15 of U640 to select the point on a trigger signal where triggering occurs.

The slope of the input signal that triggers the Sweep Generator circuit is determined by the setting of the SLOPE switch S630. When the SLOPE switch is set to the + position, the output signal present at pin 8 of U640 is in phase with the input signal and the output signal at pin 9 is inverted with respect to the input signal. When the SLOPE switch is set to the - position, the output signal at pin 8 is inverted with respect to the input signal and the output signal at pin 9 is in phase with the input signal.

**Tunnel Diode Driver.** Q650 and Q652 are common-emitter amplifier stages that provide the signal currents necessary to switch the triggering tunnel diodes. CR650 and CR652 are 4.7 mA tunnel diodes. Quiescently, CR650 and CR652 are biased into their low voltage states. Q650 cannot provide sufficient current to switch CR650 to its high voltage state. Q652, however, can provide sufficient current to bias CR652 into its high voltage state; when Q652 next conducts triggering signal current, the anode of CR652 steps positive to approximately +0.5 volt. Since only approximately 1 mA of current is required to maintain CR652 in its high voltage state, this makes approximately 3 mA of current additionally available with which to switch CR650 to its high voltage state. Thus, the next time Q650 conducts signal current, CR650 steps to its high voltage

## Circuit Description—466 Service

state, sending a positive pulse to the logic circuit to initiate sweep action. A Trigger Sensitivity adjustment R655 adjusts the tunnel diode bias to the proper level that will not allow CR650 to be switched to its high voltage state until CR652 has been switched to its high voltage state. At the end of the sweep time and during holdoff, a negative level is applied to the anode of CR652, thereby resetting both CR650 and CR652 to their low voltage states. The reset level remains during holdoff time to ensure that a sweep gating signal will not be generated until the sweep circuit has returned to its quiescent state.

**A Trigger View Amplifier.** The amplifier consists of two emitter-coupled push-pull amplifier stages. The collector supply voltage is switched on and off by the TRIG VIEW pushbutton switch. With TRIG VIEW pushbutton not pushed, the emitter of Q672 and Q682 are returned to about  $-3$  volts, due to the voltage divider between the  $+15$  volts at R691 and the  $-8$  volts at R675. This reverse-biases the base-emitter junctions of the transistor to prevent loading the A Trigger Generator circuit.

When the TRIG VIEW pushbutton is pushed, the emitters of Q672 and Q682 are connected to  $+15$  volts through R673 and R683 to allow signal amplification. R675 adjusts for display centering.

Normally, the output of the Vertical Switching Amplifier is applied to the input of the Delay Line. When the TRIG VIEW pushbutton is pressed, the signal from the Vertical Switching Amplifier is removed and the output from the A Trigger View Amplifier is applied in its place.

### A and B Sweep Generators

**General.** The A and B Sweep Generators produce sawtooth voltages that are amplified by the Horizontal Amplifier circuit to provide horizontal deflection to the crt. These sawtooth voltages are produced on command (trigger pulses) from the Trigger Generator circuits. The Sweep Logic circuits also produce gate waveforms that are used by the Z Axis Logic circuit to unblank the crt during sweep time and produces waveforms to start and stop the sweep generator. Fig. 3-5 shows a detailed block diagram of the A Sweep Generator circuit. The B Sweep Generator circuit is very similar to the A Sweep Generator; therefore only the difference in operation associated with the B Sweep Generator will be discussed. A schematic of both circuits is shown on diagram 6 at the rear of this manual.

**Disconnect Amplifier.** After holdoff but before the next sweep, Disconnect Amplifier Q1024 conducts current

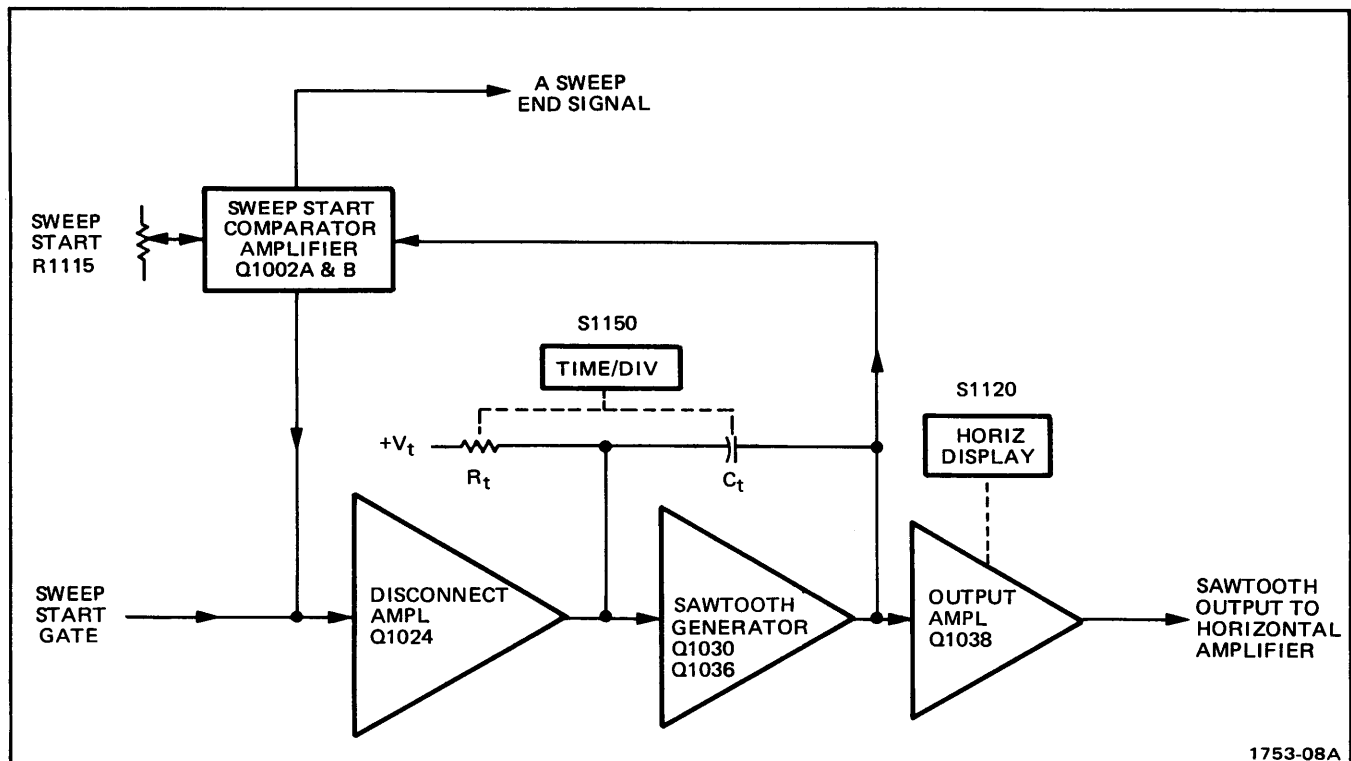

Fig. 3-5. A Sweep Generator Detailed Block Diagram.

through R1024 and the timing resistor  $R_t$ . This prevents timing current from charging the timing capacitance  $C_t$ . The positive-going sweep start gate from ~~Q1024~~ turns off Q1024 and the timing current now begins to charge the timing capacitance  $C_t$ .

CR902

**Sawtooth Sweep Generator.** Q1030 and Q1036 compose a Miller Integrator circuit. When the current flow through the Disconnect Amplifier is interrupted, the timing capacitance begins to charge through the timing resistor. The timing resistor and capacitance are selected by the A TIME/DIV switch to provide the various sweep rates listed on the instrument front panel. The output signal at the collector of Q1036 is a negative-going sawtooth waveform.

**Output Buffer Amplifier.** The Output Buffer Amplifier stage is a common-base amplifier with the signal current-driven into the emitter. It provides the output sawtooth current signal to the Horizontal Amplifier and provides a measure of isolation between the Sawtooth Generator and the Horizontal Amplifier. The HORIZ DISPLAY switch connects to this stage to control the A sawtooth output in the various horizontal modes of operation. In the A and A INTEN modes of operation, the A sweep signal passes through Q1038 to the Horizontal Amplifier. However, in the MIX and B DLY'D modes, -8 volts is connected to the emitter of Q1038 through CR1036 and R1036. This biases Q1038 off, preventing the A sawtooth signal from passing to the Horizontal Amplifier.

**Sweep Start Amplifier.** Just before the sweep starts to run down, the levels at the bases of Q1002A and B are approximately equal. When the sweep starts to run down, the base of Q1002B goes negative, which increases the forward bias on CR1004. This in turn decreases the forward bias on CR1001, which, very shortly after the start of the sweep, becomes reverse biased to interrupt the current through Q1002A. The circuit remains in this condition until after the sweep retrace is complete. When the circuit returns to quiescence, Q1002A again begins to conduct through R1024. This sets the current through Q1024, which establishes the starting point for the sweep. The Sweep Start adjustment sets the base level of Q1002A. This level is also connected to the base of Q1062A in the MIX mode of operation. This ensures that B Sweep starts at the same level as A Sweep.

**B Sweep Generator Differences.** There are three prime differences between the A and B Sweep Generators. The B Sweep Output Buffer Amplifier is prevented from passing the B Sweep signal to the Horizontal Amplifier in the A and A INTEN positions of the HORIZ DISPLAY switch. There is a transistor stage connected as a constant current source in the emitter circuit of Q1062A and B (corrects for current imbalances side-to-side in Q1062 during MIX mode operation). The Sweep Start Level connected to the base

of Q1062A is not always a fixed dc level. During MIX mode operation the A Sweep Sawtooth signal is applied to the base of the amplifier. Now, the dc level at which the B Sweep Generator will start generating its sawtooth waveform is constantly being changed by the A Sweep sawtooth. The output waveform from the B Sweep Generator takes the form of a composite sawtooth waveform, with the first and last parts occurring at a rate determined by the A Sweep Generator and the middle part occurring at a rate determined by the B Sweep Generator.

### Sweep and Z Axis Logic Circuit

**General.** The Sweep and Z Axis Logic circuit derives the logic levels necessary to control the sequence of events associated with sweep generation and crt unblanking. The +A and +B GATE signals are also generated in this circuit. Positive logic terminology and symbology are used in the following explanation of circuit operation. A schematic of this circuit is shown on diagram 8 at the rear of the manual.

**A Sweep Gate.** Q904 and Q906 compose the A Sweep Gate circuit. They form an emitter coupled stage where only one transistor can be conducting at any time. The input signal to the stage is the positive-going trigger signal from the A Firing TD in the A Trigger Generator circuit. The signal at the collector of Q904 is connected to the A Sweep Z Axis Gate circuit to control crt blanking and to generate the +A GATE signal. The signal at the collector of Q906 is connected to the emitter of the Sweep Disconnect Amplifier stage (Q1024) in the A Sweep Generator circuit to initiate A Sweep generation.

**B Sweep Gate.** Q864 and Q866 compose the B Sweep Gate circuit. They also form an emitter-coupled stage where only one transistor can be conducting at any time. The input signal to the stage is the positive-going trigger signal from the B Trigger Firing TD in the B Trigger Generator circuit. The signal at the collector of Q866 is connected to the emitter of the Sweep Disconnect Amplifier stage (Q1084) in the B Sweep Generator circuit to initiate B Sweep generation.

**Sweep Controlled Integrated Circuit.** U980 is the Sweep Control Integrated circuit. Several functions are performed in this stage, depending on the mode of operation of the instrument sweep generators. The following is a brief explanation of the function associated with each pin of the IC.

**PIN 1.** This is the positive Auto Sense input. The signal connected here comes from the A Fire Trigger TD.

**PIN 2.** This is the negative Auto Sense input. A fixed dc level established by R981 and R982 is connected here.

## Circuit Description—466 Service

PIN 3. This is the + auto gate terminal. In the AUTO mode of operation, if no trigger signals are applied to pin 1 of U980 during the  $\approx 100$  ms following the end of holdoff the gate level at pin 3 steps LO to turn Q906 on, which initiates a sweep.

PIN 4. This is the - auto gate terminal.

PIN 5. Input terminal for negative voltage supply.

PIN 6. This is the auto gate timing terminal. R944 and C944 determine the amount of time between the end of holdoff and the generation of the auto gate.

PIN 7. This terminal lights the TRIG'D light when a triggered gate has occurred.

PIN 8. This is the holdoff timing terminal. The R/C connected to this terminal (selected by the TIME/DIV switch) determines the length of holdoff time.

PIN 9. Ground terminal.

PIN 10. This is the Holdoff output terminal. The gate level present here is LO during sweep holdoff time and HI otherwise.

PIN 11. This terminal lights the READY light when operating in the single sweep mode.

PIN 12. This is the single sweep mode terminal. When +5 volts is applied to this terminal, the sweep operates in the single sweep mode; when the terminal is left open or grounded, the sweep operates in the repetitive mode.

PIN 13. This pin is used for the FAST storage mode. When +5 volts is applied here, the sweep operates in a mode similar to single sweep. However, the sweep is reset automatically when a signal from the storage circuit allows pin 18 to go LO.

PINS 14 & 15. Single sweep reset terminals. Pushing the PUSH TO RESET button prepares the single sweep circuitry to respond to the next one triggering event. Also causes the READY light to be lit.

PIN 16. This is the holdoff start input terminal. The HI sweep reset gate pulse from the sweep gen-

erators is applied here to initiate sweep hold-off.

PIN 17. This is the sweep disable output terminal. The gate level at this terminal is HI during holdoff and LO otherwise.

PIN 18. Sweep lockout input. +5 volts applied to this terminal disables all sweep action.

PIN 19. Auto mode terminal. Grounding this terminal enables auto sweep operation.

PIN 20. Input terminal to positive voltage supply.

**A Sweep Holdoff Amplifier.** Q954 is the A Sweep Holdoff Amplifier. The holdoff gate waveform is applied to the base of Q954 through R952 and C952 from pin 17 of U980. When Q954 is turned off (during holdoff time), its collector is LO and CR957 is forward biased, which resets both the Arm and Fire Trigger TD's in the A Trigger Generator. When Q954 is turned on (any time other than holdoff time), its collector level is HI and CR957 is reverse biased. This allows the trigger TD's in the A Trigger Generator to respond to the next adequate triggering signal.

**B Sweep Holdoff Amplifier.** Q844 is the B Sweep Holdoff Amplifier. Its circuit action is identical to that described for the A Sweep Holdoff Amplifier except that there are three gate signal sources that control the state of the stage. The three sources are the holdoff gate from pin 17 of U980 (through CR946), the collector of Q834 in the Delay Pickoff Comparator, and the collector of Q894 in the B Latch Multivibrator (through CR885). All three gate sources must be in their LO states for B Sweep to be triggerable; any one of the sources in its HI state will disable the B Trigger Generator TD's.

**Logic Multivibrator.** Q926 and Q924 compose a multivibrator. At quiescence, Q924 is conducting and Q926 is turned off. When the sweep starts to run, the negative-going ramp is coupled through the base of Q1002B (A and B Sweep Generator circuit) and CR1004 to the cathode of CR1011. CR1011 becomes forward biased and when the level at the anode of CR1011 falls to about +4 volts, Q926 conducts and Q924 turns off. The multivibrator remains in this state until the sweep starts to retrace and the voltage level at the anode of CR1011 rises above about +4.5 volts. The resultant pulse at the collector of Q926 is applied to Sweep Control IC U980 to terminate the sweep. The pulse at the collector of Q924 is applied to the A Sweep Z-Axis Gate to blank the crt at the end of the sweep.

**A Sweep Z-Axis Gate.** Q912 and Q914 compose the A Sweep Z-Axis Gate. They form an emitter-coupled stage where only one transistor can be conducting at any given time. The controlling signal inputs come from the collector of Q904 in the A Sweep Gate, the blanking signal from Q924 in the A Sweep Generator, and Q886 in the B Latch Multivibrator (only in the MIX mode of operation). The blanking signal for use in the Z-Axis Amplifier is taken from the collector of Q914. The collector signal of Q912 is applied to the +A GATE Emitter Follower.

In all positions of the HORIZ DISPLAY switch except for B DLY'D, -8 volts is connected to the cathode of CR896. This pulls the anode of CR895 down very close to -8 volts, causing it to be reverse biased, which in turn allows the gate signal at the collector of Q914 to pass to the Z-Axis Amplifier. In the B DLY'D position of the HORIZ DISPLAY switch, -8 volts is no longer connected to CR896. This allows CR895 to be forward biased, which blocks the A blanking signal from passing through Q914 to the Z-Axis Amplifier.

In all positions of the HORIZ DISPLAY switch except MIX, -8 volts is connected to the cathode of CR887. This keeps CR888 reverse biased and prevents the collector signal of Q886 from affecting the A Sweep Z-Axis Gate. However, in the MIX position of the HORIZ DISPLAY switch, -8 volts is no longer connected to CR887. Now, when the B Sweep ends and sets the B Sweep Latch circuit, the collector signal of Q886 (through CR888) switches the A Sweep Z-Axis Gate, causing the crt display to be completely blanked. This prevents any further display of A Sweep in the MIX mode, even though A Sweep may still be running.

**B Sweep Z-Axis Gate.** Q852 and Q854 compose the B Sweep Z-Axis Gate. They form an emitter-coupled stage where normally one transistor is on and the other is off. The controlling signal inputs come from the collector of Q864 in the B Sweep Gate and the blanking signal from Q874 in the B Sweep Generator. The blanking signal for use in the Z-Axis Amplifier is taken from the collector of Q852 (through CR894). The collector signal of Q854 is applied to the +B GATE Emitter Follower.

In the A position of the HORIZ DISPLAY switch, -8 volts is applied to the cathode of CR893, which causes CR892 to be back biased. The collector of Q852, pulled positive through R851 and CR851, back biases CR894, preventing the B Sweep Z-Axis Gate from affecting crt unblanking. In the MIX and A INTEN positions of the

HORIZ DISPLAY switch, -8 volts is removed from the cathode of CR893 and applied to the cathode of CR821. This forward biases CR892 and reverse biases CR851. CR894 is still reverse biased, but when B Sweep starts, the collector of Q852 steps negative enough to forward bias CR894 and add a slight amount of unblanking to the A Sweep unblanking already present. This provides a measure of intensification for the B Sweep portion of an A INTEN or MIX display. In the B DLY'D position of the HORIZ DISPLAY switch, -8 volts is applied to the cathodes of CR821 and CR893. This reverse biases both CR892 and CR852, which allows the full B Sweep unblanking signal to pass through CR894. Since the A Sweep Z-Axis Gate output diode CR896 is held reverse biased, the only unblanking signal present at the input to the Z-Axis Amplifier will be the B Sweep signal.

**+A Gate and +B Gate Emitter Followers.** Q916 and Q856 are emitter followers providing the +A GATE and +B GATE output signals available at the instrument rear panel. The output signals are positive-going rectangular waveforms, approximately 5.5 volts in amplitude. The amplitude is set in the collectors of Q912 and Q854. For example, when Q912 is conducting, the base of Q916 can go no more negative than approximately -0.7 volt (limited by CR914). When Q912 is not conducting, the base of Q916 rises to the decoupled +5 volt power supply level through R914. CR916, CR917, CR857, and CR858 provide protection against accidental application of damaging voltage levels to the +A GATE and +B GATE output connectors.

**B Sweep Latch.** Q882 and Q884 form the B Sweep Latch. Quiescently, (before either the A or B Sweeps have reached their maximum amplitudes) both transistors are off. Then, the sweep reset pulse from whichever sweep terminates first will be applied to the base of Q882 (A Sweep reset through CR882; B Sweep reset through CR874). The positive-going reset pulse turns on Q882 and the negative-going movement at its collector turns on Q884. The collector of Q884 in turn pulls up on the base of Q882, holding Q882 on, which causes the circuit to stay in its on or latched state. The HI at the collector of Q884 is applied to the base of the B Sweep Holdoff Amplifier (through CR885) to disable the B Trigger Tunnel Diodes. In the B ENDS A position of the A TRIG HOLDOFF control, the HI is also applied to the holdoff start input terminal of the Sweep Control IC through C947. Thus, when B Sweep ends A Sweep ends also.

The B Latch Multivibrator is reset to its quiescent state by the LO Holdoff level present at pin 10 of the Sweep Control IC during A Sweep holdoff.



**Horizontal Amplifier**

**General.** The Horizontal Amplifier circuit provides the output signals to the crt horizontal deflection plates. The signal applied to the input of the Horizontal Amplifier is determined by the TIME/DIV switch. The signal can be a sawtooth waveform generated within the instrument, or some external signal applied to the CH 1 or X input connector (X-Y mode of operation). The Horizontal Amplifier also contains the X10 magnifier, horizontal positioning, and some beam finder circuitry. Fig. 3-6 shows a detailed block diagram of the Horizontal Amplifier circuit. A schematic of this circuit is shown on diagram 9 at the rear of this manual.

**X-Axis Amplifier.** In all positions of the TIME/DIV switches except X-Y, the input signal to the base of Paraphase Amplifier Q1232 is the sawtooth waveforms from the sweep generators. In the X-Y mode, however, the sweeps are disabled and the signal applied to Q1232 comes from the Channel 1 Preamp via the X-Axis Amplifier stage. This stage includes Q1212, Q1222, and their associated circuitry.

Q1212 is connected as a feedback amplifier with R1216 as the feedback element. The input resistance is made up of R1212 and the X-Axis gain-setting adjustment R1214. When not operating in the X-Y mode, the base of Q1212 rises toward the +15 volt supply, but is clamped at approximately +4 volts by the divider action of R1218 through CR1218. This reverse biases the base-emitter junction of Q1212. The base of Q1222 also rises to approximately +4 volts. With the junction of R1205-R1222 at approximately 0 volt, Q1222 is also biased off.

When the TIME/DIV switches are set to the X-Y position (full counterclockwise), -8 volts is applied to the junction of R1215 and R1217. Also, +5 volts is applied to the emitter circuit of Q1222 through CR1205. This biases the Z-Axis Amplifier circuit into conduction. At the same time, +5 volts is applied to the Channel 1 Scale-Factor Switching Amplifier circuit (through CR1202) and to R984 on diagram 8. This enables both scale-factor indicating circuits at the same time and disables sweep generation.

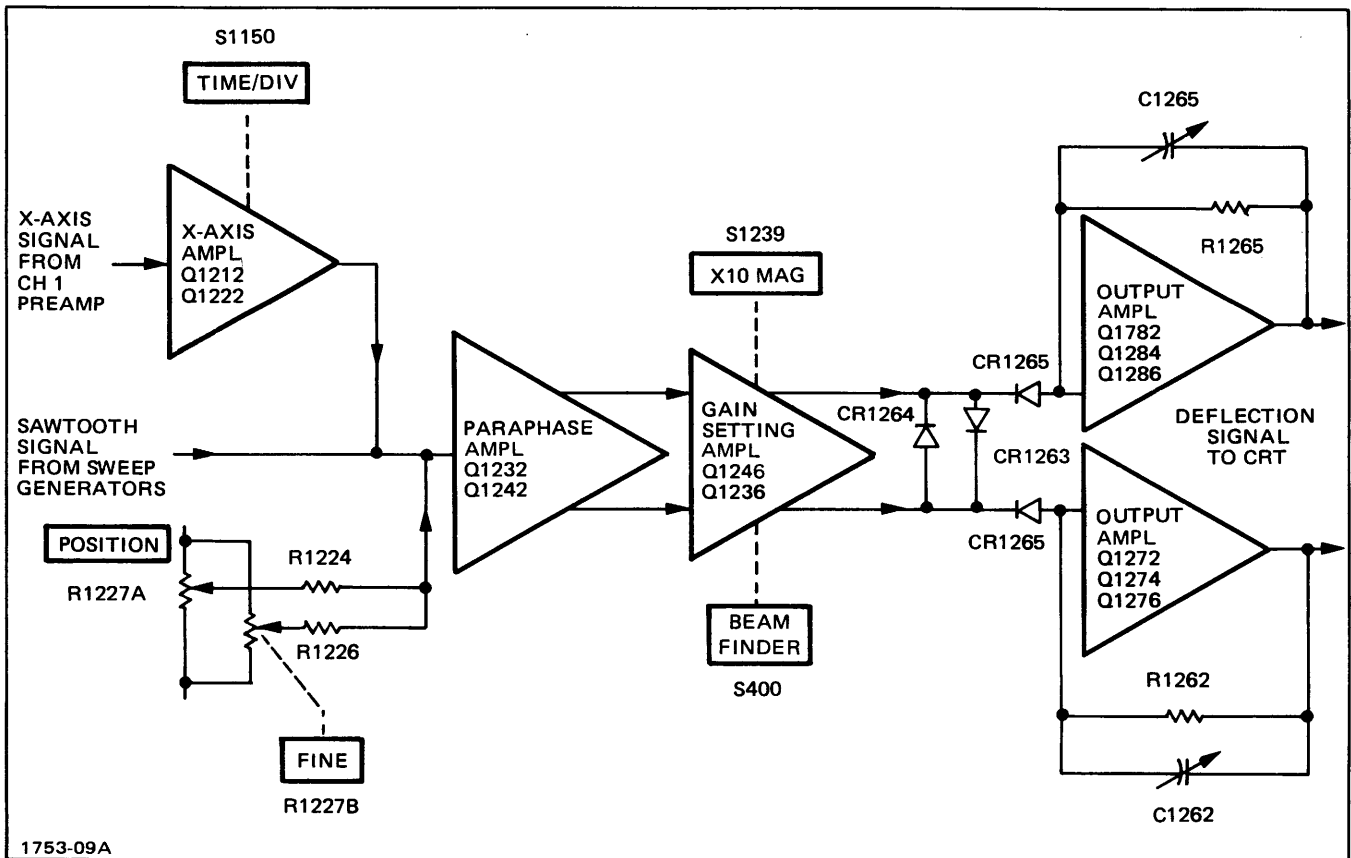

Fig. 3-6. Horizontal Amplifier Detailed Block Diagram.

**Input Paraphase Amplifier.** Q1232 and Q1242 compose the Input Paraphase Amplifier. This is an emitter-coupled amplifier stage that converts the single-ended input signal to a push-pull output signal. The signal at the collector of Q1232 is opposite in phase to the input signal. The signal at the collector of Q1242 is in phase with the input signal. Thermistor RT1243 reduces in value with increases in ambient temperature to increase the gain of the stage. This compensates for changes in amplifier gain that occur as operating temperatures vary. R1227A and R1227B are the Horizontal POSITION and FINE controls, respectively. The FINE control has approximately one-tenth the range of the POSITION control and provides fine adjustment of a magnified display.

**Gain Setting Amplifier.** Q1236 and Q1246 are an emitter coupled push-pull amplifier stage. The gain of the Horizontal Amplifier is controlled by adjusting the resistance connected between the emitters of this stage. The X1 Gain adjustment R1257 adjusts unmagnified horizontal gain and the X10 Gain adjustment R1253 adjusts magnified horizontal gain. Magnifier Registration adjustment, R1255, balances quiescent dc current in Q1236 and Q1246 so that a center screen display does not change position when the X10 Magnifier is turned on.

When the BEAM FINDER pushbutton is pressed, R1266 and R1267 are connected to +65 volts. This causes the Horizontal Amplifier to operate close to the point where signal limiting occurs, thereby ensuring that an overscanned display will remain within the crt viewing area.

**Output Amplifier.** The push-pull signal from the Gain Setting Amplifier is connected to the Output Amplifier through CR1262 and CR1265. Each half of the Output Amplifier can be considered as a single-ended feedback amplifier, which amplifies the signal current at the input to produce a voltage output to drive the horizontal deflection plates of the crt. The amplifiers have a low input impedance and require very little voltage change at the input to produce the desired output change. The Output Amplifiers are limited from overdrive by CR1263, CR1264, CR1262, and CR1265. The input diodes CR1262 and CR1265 become back-biased when the signal level at either input becomes too positive and the diodes connected back to back between the two signal paths ensure that the signal amplitude side to side will be limited to a maximum of about 0.7 volt.

Transistors Q1272 and Q1282 are inverting amplifier stages whose collector signals drive the emitter of complementary amplifiers Q1274-Q1276 and Q1284-Q1286 respectively. C1281, C1272, and C1283 provide a signal path for fast ac signal currents. R1262-R1263 and R1264-R1265 are the feedback elements in the amplifier with C1262-C1263 and C1264-C1265 providing high-

frequency compensation. The output signal from Q1274-Q1276 drives the right crt deflection plate, while the signal from Q1284-Q1286 drives the left.

## CALIBRATOR

### General

The Calibrator circuit produces a square-wave output signal with accurate voltage and current amplitudes. This output is available as a voltage or current at the CALIBRATOR current loop on the instrument rear panel.

### Multivibrator

Q1362 and Q1372 along with their associated circuitry compose an emitter-coupled astable multivibrator. The basic frequency of the multivibrator is approximately one kilohertz and is essentially determined by the RC combination of C1364, R1364 and R1372. Q1362 and Q1372 alternately conduct, producing a square-wave output signal, which is taken from the collector of Q1372.

### Output Amplifier

The output signal from the Multivibrator overdrives Output Amplifier Q1376 to produce an accurate square wave at the output. When the base of Q1376 goes positive it is cut off and the collector level drops to ground. When the base goes negative, Q1376 is biased into saturation and its collector rises positive to about +5 volts. Amplitude adjustment R1375 adjusts the resistance between the collector of Q1376 and ground to determine the amount of current allowed to flow, which in turn determines the voltage developed across R1377.

## LOW-VOLTAGE POWER SUPPLY

### General

The Low-Voltage Power Supply provides the operating voltages for the circuitry in this instrument from six regulated supplies. Electronic regulation is used to provide stable, low-ripple output voltages. A schematic of this circuit is shown on diagram 11 at the rear of this manual.

### Power Input

Power is applied to the primary of transformer T1701 through Line Fuse F1701, POWER switch S1701, Thermal Cutout S1702, Line Voltage Selector switch S1703, and the Regulating Range Selector Assembly. Line Voltage Selector switch S1703 connects the split primaries of T1701 in parallel for 115-volt nominal operation and in series for 230 V. Line Fuse F1701 should be changed to the correct value to provide the correct protection for each nominal line voltage (current rating of fuse for 230 volt operation is one-half the 1.5 A fuse rating for 115 volts).

## Circuit Description—466 Service

The vacant windings between pins 10, 11, 12, 13 and 14 of T1701 are intended for use with either a DM-series Digital Multimeter or the optional Inverter Circuit Board (Option 7). Option 7 allows the instrument to be operated from an external dc power source or an 1106 Power Supply (see Option section). The instrument cannot be equipped with Option 7 and a DM-series Digital Multimeter at the same time.

**Secondary Circuit.** The  $-8$  volt,  $+5$  volt,  $-15$  volt,  $+15$  volt and  $+65$  volt supplies are series-regulated. U1724A and B and U1762A and B are high-gain amplifier cells with differential inputs. These amplifiers monitor voltage variations in the output voltages.

The  $+65$  V supply uses zener diodes VR1726 and VR1724 as its reference and is adjustable by a calibration control, R1736. All supplies are referenced to the  $+65$  volt supply. The  $+140$  volt regulated supply is stacked on top of the  $+65$  volt supply via 75 volt zener diode VR1718.

C1743, C1744, and R1743 compose a wave-shaping circuit that provides a sample of the ac voltage present in the secondary of T1701 to the trigger circuitry for use in the LINE position of the A Trigger SOURCE switch.

## FAN MOTOR CIRCUIT

The fan motor used in the 466 is a brushless dc motor using Hall Effect devices. The fan motor control circuit varies the speed of the fan as the operating temperature changes.

Two Hall Effect devices inside the motor, and four transistors U8061A, B, C and D (U1690A-D for early SN) compose a sine-wave generator to drive the motor windings. Each of the four transistors is controlled by one-half of a Hall element to generate one-quarter of the sine-wave cycle.

As the ambient temperature increases, the value of thermistor RT8038 (RT1696 for early SN) decreases. This biases Q8067 (Q1698 for early SN) on harder to conduct more current through the Hall devices and turn the motor winding control transistor on harder.

## Z AXIS/CRT CIRCUIT

### General

The CRT circuit provides the voltage levels and control circuits necessary for operation of the cathode-ray tube except for storage functions. Fig. 3-7 shows a detailed block diagram of this circuit. The schematic of this circuit is on diagram 10 at the rear of the manual.

## High Voltage Oscillator

Q1486 and its associated circuitry compose the high-voltage oscillator that produces the drive for the high-voltage transformer, T1501. When the instrument is turned on, current through Q1484 provides forward bias for Q1486. Q1486 conducts and as its collector current increases, a voltage develops across the collector winding of T1501. This produces a corresponding voltage increase in the feedback winding of T1501, which is connected to the base of Q1486, reinforcing the drive on Q1486. Eventually, the rate of collector current increase in Q1486 becomes less than that required to maintain the voltage across the transformer winding and the output voltage drops. This turns off Q1486 by way of the feedback voltage to the base.

The voltage waveform at the collector of Q1486 is a sine wave at the resonant frequency of T1501. Q1486 remains off during the negative half cycle while the field collapses in the primary of T1501. When the field is collapsed sufficiently, the base of Q1486 becomes forward biased into conduction again, and the cycle repeats.

The amplitude of sustained oscillation depends on the average current delivered to the base of Q1486. The oscillator frequency is approximately 50 kHz. Fuse F1487 protects the  $+15$  volt supply if the High Voltage Oscillator circuit becomes shorted. C1487 and L1487 provide decoupling from the  $+15$  volt, unregulated supply.

## High-Voltage Regulator

Feedback from the crt cathode supply is applied to the base of Q1472 through R1525D. Any change in the level at the base of Q1472 produces an error signal at the collector of Q1472, which is amplified by Q1476 and Q1484 and applied to the base of Q1486 through the feedback winding of T1501.

If the output voltage at the high voltage test point (TP1443) starts to go less negative, this positive-going change is applied to the base of Q1472. Q1472 conducts harder, which in turn, causes Q1476 and Q1484 to conduct harder. This results in greater bias current to the base of Q1486 through the feedback winding of T1501. Now, Q1486 is biased closer to its conduction level so that it comes into conduction sooner to produce a larger induced voltage in the secondary of T1501. This increased voltage appears as a more negative voltage at TP1443 to correct the original positive-going change. By sampling the output from the crt cathode supply in this manner, the total output of the High-Voltage Supply is held relatively constant.

The Reduced Scan Horiz Cal (R1464), which controls Reduced Scan sweep calibration, is only effective when the REDUCED SCAN switch is pulled on. See description of Reduced Scan control circuit.

Fig. 3-7. Z-Axis/CRT Circuit Detailed Block Diagram.

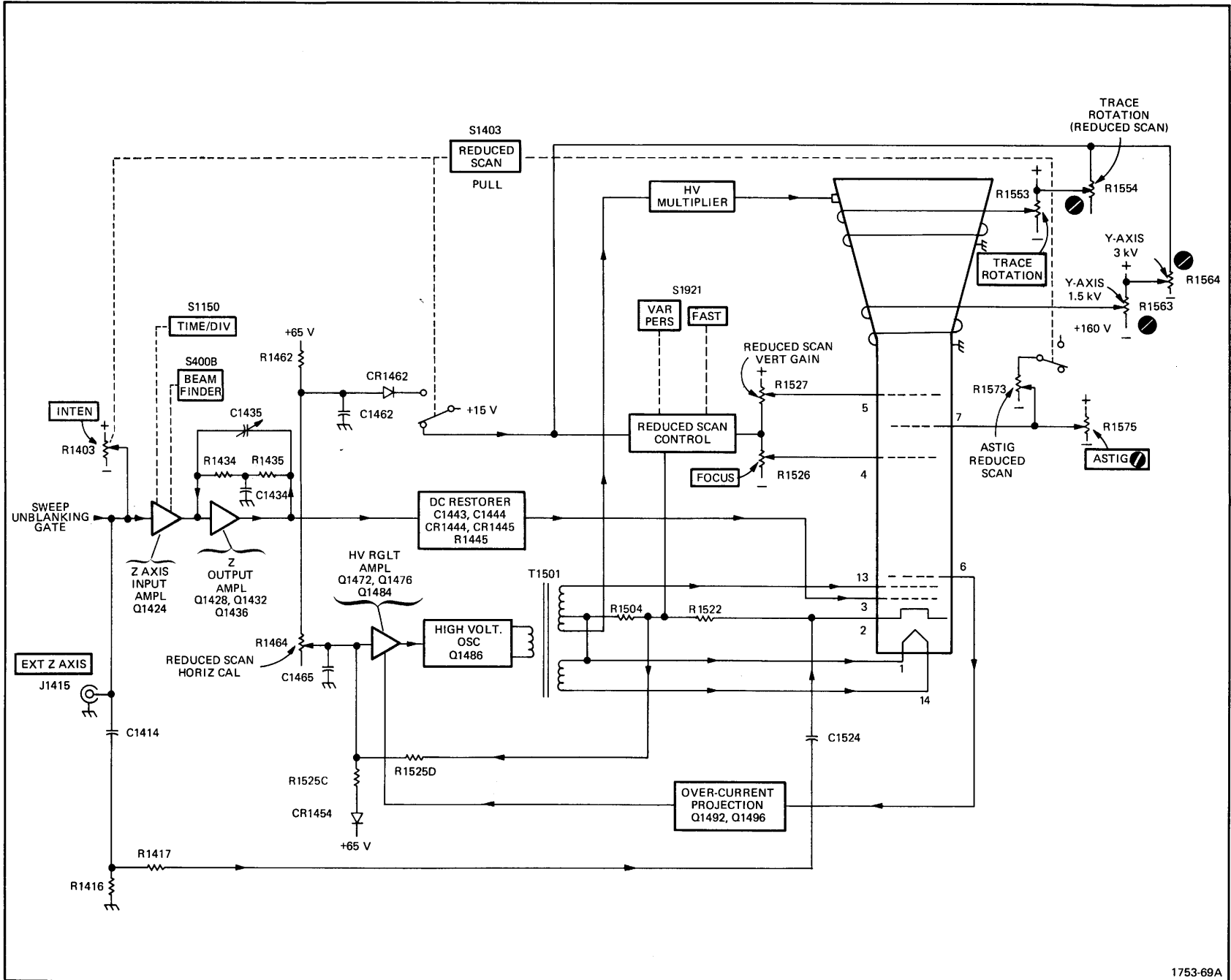

Circuit Description—466 Service

## Circuit Description—466 Service

### Over-Current Protection, Q1492 and Q1496

In some extreme cases, the crt beam current could increase enough to damage the crt meshes. The Over-current Protection circuit at pin 6 of the crt will prevent this current from going beyond about 1 mA.

The current at pin 6 of the crt represents approximately 90% of the total crt cathode current. As the current through pin 6 approaches a level representing a cathode current of approximately 1 mA, the voltage level at the base of Q1496 turns it on. Normally, Q1496 and Q1492 are biased off. When Q1496 turns on, Q1492 is biased into conduction, which starts to reduce the base drive applied to Q1484 and prevents the oscillator amplitude from increasing. This prevents the crt cathode current from increasing above approximately 1 mA.

### High-Voltage Rectifiers and Output

The high-voltage transformer, T1501 has three output windings, one for the crt filament voltage, one that provides +600 volts for the storage circuitry, and one that supplies the crt cathode and anode voltages. The filament winding is elevated to the level of the cathode supply to prevent cathode-to-filament breakdown. A zener regulated dc voltage is used for the crt filament because the high-voltage transformer secondary varies considerably due to changing loads of the storage crt. The crt grid bias voltage is derived by a dc restorer circuit that uses a sample of the signal in the high-voltage winding in conjunction with dc levels supplied by the Z-Axis Amplifier and the voltage level set by the grid bias potentiometer.

The positive accelerating potential is supplied by the High Voltage Multiplier circuit. The regulated output voltage is approximately 7000 volts.

The negative cathode potential is supplied by half-wave rectifier CR1503. The voltage output depends on which storage and scan mode is chosen. See Reduced Scan circuit description.

### Z-Axis Amplifier

The Z-Axis Amplifier circuit controls the crt intensity level from several inputs. The effect of these input signals is to either increase or decrease the trace intensity, or to completely blank portions of the display. The input transistor Q1424 is a current-driven, low input impedance amplifier. It provides termination for the input signals as well as isolation between the input signals and the following stages. The current signals from the various control sources are connected to the emitter of Q1424 and the algebraic sum of the signals determines the collector conduction level.

Q1428, Q1432, and Q1436 compose a feedback amplifier stage; R1434 and R1435 are the feedback elements. C1434 and C1435 provide high frequency compensation. Q1428 is an emitter follower providing drive to complementary amplifier Q1432-Q1436. CR1425, CR1432, and CR1439 provide protection in the event of high-voltage arcing.

In the .1 s, .2 s, .5 s, and X-Y positions of the TIME/DIV switch, +5 volts is connected to the anode of CR1401. This limits the effective range of the INTENSITY control to reduce the unblanking capabilities of the amplifier, thereby reducing the possibility of inadvertently burning the crt phosphor.

The BEAM FINDER switch has two actions on the Z-Axis circuitry. In the normal (button out) condition, the first section of S400 is open to CR1405, allowing Q1424 to conduct. The second section of S400 forward biases CR1427 by applying vertical amplifier emitter current. As a result CR1427 clamps the junction of R1425-R1427 near ground, which permits the INTEN potentiometer and the unblanking signals to set the intensity of the display.

When the BEAM FINDER button is pressed, the first section of S400 applies +65 volts to the anode of CR1405, which brings the emitter of Q1424 sufficiently positive to cut off conduction through Q1424. The second section of S400 opens, and removes the forward bias from CR1427, which opens and no longer clamps the R1425-R1427 junction. The -8 volts at the bottom of R1427 moves the Q1428 base negative, thus establishing a fixed unblanking level at the output of the Z-Axis Amplifier. The foregoing action provides a visible display even though it might otherwise be blanked or unintensified.

C1414 is a high frequency bypass to the crt cathode from the EXT Z AXIS input.

### DC Restorer Circuit

C1443, C1444, CR1442, CR1444, CR1445, CR1452, and R1445 form a dc restorer circuit. All dc levels in this circuit are referenced to the negative potential of the crt cathode. The voltage difference across R1445 approximately equals the voltage swing present at the junction of CR1442 and CR1452. The control end of R1445 is more negative than the end connected to CR1445. The amplitude of the voltage swings at the junction of CR1442 and CR1452 is determined by the voltage levels established by the Z-Axis Amplifier circuit and the CRT Bias adjustment circuit. CR1452 sets the limit of the positive excursion and CR1442 sets the limit of the negative excursion.

**CRT Control Circuits**

Focus of the crt display is controlled by FOCUS control, R1526. The Focus Tracking control, R1529, located in series with the FOCUS control, is ganged with the INTEN control to reduce focus variations when changing intensity setting. ASTIG adjustment R1575, which is used in conjunction with the FOCUS control to provide a well-defined display, varies the positive level on the astigmatism grid. Geometry adjustment R1556 varies the positive level on the horizontal deflection plate shields to control the overall geometry of the display.

The Y Axis adjustment controls the trace alignment by varying the magnetic field around the crt. R1563 controls the current through L1561, which affects the crt beam after vertical deflection, but before horizontal deflection. Therefore, it affects only the vertical (Y) components of the display. TRACE ROTATION adjustment, R1553, controls the current through L1551 and affects both vertical and horizontal rotation of the beam. R1554, Trace Rotation (Reduced Scan), R1564, Y-Axis (Reduced Scan) and R1573, Astig (Reduced Scan) become active only when in the REDUCED SCAN mode.

**Reduced Scan Control Circuit**

When the INTENSITY control is pulled for the REDUCED SCAN mode, several controls are switched in and the crt cathode supply voltage is approximately doubled.

The following calibration adjustments are active only in the REDUCED SCAN mode: R1464, Reduced Scan Horiz cal; R1527, Reduced Scan Vert Gain; R1554, Trace Rotation (Reduced Scan); R1564, Y-Axis (Reduced Scan) and R1573 Astig (Reduced Scan).

The voltage between pins 2 and 13 of the crt is kept constant when switching between Full Scan and Reduced Scan; this keeps the crt grid-voltage cutoff constant. In the Full Scan mode, pin 13 of the crt is at about +65 volts as set by CR1507 and R1507. Pin 2 of the crt is at about -1470 volts (in the NON STORE mode). When the REDUCED SCAN knob is pulled, +15 volts is applied to relay coil L1501, which closes S1501 and adds CR1506 to the rectifier circuit. This causes the voltage at pin 2 of the crt to go to approximately -3010 volts (in the NON STORE mode).

When +15 volts is applied to the cathode of CR1462, R1464 assumes control of the base of Q1472. The voltage at the top of R1464 gradually goes to +15 volts as C1462 becomes charged.

In the Full Scan mode, there is about 3 volts across R1527, established by VR1532 and VR1527. In the REDUCED SCAN mode, +15 volts is removed from the cathode of VR1532 and the lower side of R1527 is allowed to go to about -158 volts, making the Vert Cal Reduced Scan control active.

R1554 and R1564 are activated in the REDUCED SCAN mode when +15 volts is connected to them. At the same time +15 volts is removed from R1553 and R1563.

R1573 is added to the ASTIG circuit in the REDUCED SCAN mode when S1403B switches +160 volts to the top of R1573.

To keep the calibration correct when changing from NON STORE to VAR PERS or FAST storage modes, it is necessary to change the crt cathode voltage (see Table 3-1). This is accomplished by taking current out of the summing node at the base of Q1472 through R1502 from the junction of R1542 and R1543.

**TABLE 3-1**

**Crt Cathode Voltages**

	Non Store	Var Pers	Fast
Full Scan	-1470 V	-1460 V	-1445 V
Reduced Scan (approximate)	-3010 V	-2990 V	-2960 V

When switching from Full Scan to Reduced Scan, the voltage at the anode of CR1536 goes from +0.6 volt to approximately -0.6 volt in Non Store. CR1543 turns on, due to current flow through R1532, VR1533, VR1532, and R1525. When switching to VAR PERS, the voltage at the anode of CR1536 goes more negative, drawing current through R1532, R1542, and R1502. R1543 and R1547 are also drawing current through R1502. In FAST mode, -15 volts is also applied to R1543 directly, drawing current through it and through R1502.

C1462 and C1465 are in the circuit to prevent bright flashes on the crt when changing between Full Scan and REDUCED SCAN.

The voltage/temperature characteristics of CR1466 and CR1462 help you keep the high voltage constant with temperature changes.

## STORAGE CIRCUITS

### General

The Storage circuits, located on the Storage board, supply timing pulses and voltage levels to control the Image Transfer Storage crt in the Variable Persistence and Fast storage modes.

When the Fast mode is selected, the TRIG MODE switch is disabled and the instrument operates in a single sweep mode controlled by the Storage circuit. When the display is either manually or automatically erased, the Fast storage mode cycle occurs as follows:

- a. The sweep generators are disabled for approximately 1.25 seconds while the storage meshes are prepared to accept and store a display.
- b. Then, the sweeps are unlocked and a single sweep is allowed to run when a trigger is present.
- c. The waveform present during this sweep is stored on the Fast Mesh and then transferred to the Front Mesh for viewing.

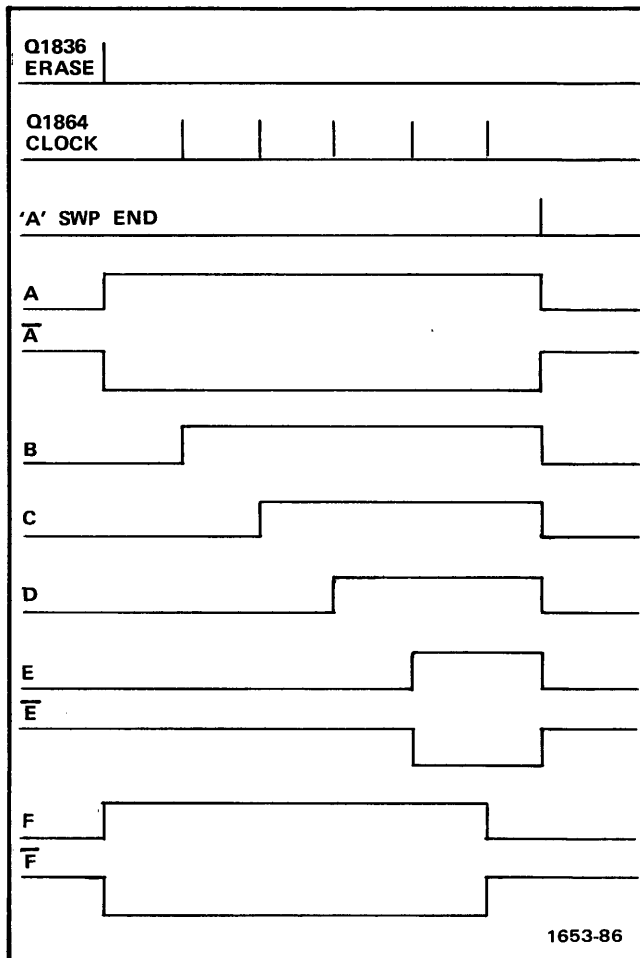

Fig. 3-8A. Shift Register and Storage Logic output.

The length of time that the stored display will remain on the screen is determined by the setting of the VIEW TIME control. In the FAST mode, this control sets the time between automatic erasures. A detent in the MAX position disables the automatic feature allowing the display to be erased only by pressing the ERASE pushbutton.

In the Variable Persistence mode, the display is stored directly on the Front Mesh for viewing. The Front Mesh is then pulsed with erase pulses. The persistence of the display is variable with the VIEW TIME control.

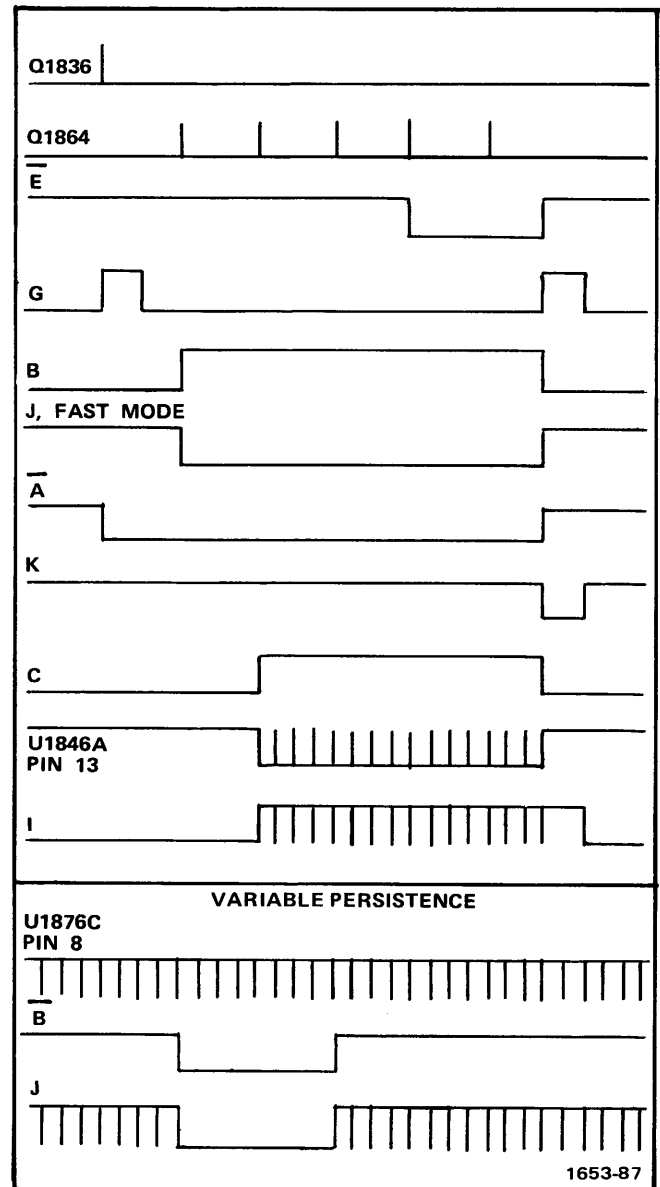

Fig. 3-8B. Shift Register and Storage Logic Output Signals in the FAST mode.

The Save mode can be used to extend the display retention capabilities of the instrument. When the SAVE pushbutton is engaged, the automatic/manual erase circuit is disabled, and the brightness of the stored display is controlled by the SAVE INTEN control. The stored viewing time is inversely proportional to save intensity and can be greatly extended when using reduced intensity in the Save mode.

Multiple traces can be stored in the Fast storage mode. After a first trace is captured and stored, pushing the SINGL SWP will initiate a second storage cycle. The second trace will simply be added to the display. This procedure can be repeated several times to obtain several traces on the screen.

### Storage Logic Circuit

Fig. 3-8A and B are timing diagrams of the signals developed by the Storage Logic circuit, Diagram 12; Fig. 3-9 is a Storage Logic block diagram.

In the following description of the Storage Logic circuitry, assume that the storage circuit is operating in the FAST mode and the automatic erase oscillator, Q1832 and Q1834, is disabled by the VIEW TIME control (fully clockwise and S1815A closed).

When the ERASE pushbutton is pushed, unijunction transistors Q1836 and Q1838 are turned on. Since C1835 is a smaller value than C1834, Q1838 turns on first and supplies a pulse that clears the shift register (U1874A, B and U1878) through U1866C. After the shift register is cleared, Q1836 supplies a pulse through U1866A and U1872C that clocks the shift register. This clock pulse causes the  $\bar{Q}$  output of U1874A to go low and turn off Q1872. When Q1872 is turned off, Q1864 (a relaxation oscillator) is permitted to turn on and supply clock pulses to the shift register at a 250 ms rate. On the fifth clock pulse from Q1864, the  $\bar{Q}$  output of U1874A goes high, turning Q1872 on, which disables the clock. When the  $\bar{Q}$  output of U1874A went high, the Q output went low; the Q output is fed back to the sweep lockout circuit to enable the sweep. When the sweep ends, pin 5 of U1866B goes high, both inputs to U1866D become low, producing a clear pulse to the shift register through U1866C. Fig. 3-8A is a timing diagram of the shift register outputs.

The outputs of the shift register are used to generate the storage logic output signals. Some of these signals correspond to the shift register outputs, others are derived from these outputs. The storage logic output signals are used to control the storage amplifiers and to enable the sweep. The following signal descriptions describe the signals that are derived from or gated with the shift register output signals (Fig. 3-8B).

**G Signal:** The G signal is generated by U1846B. U1846B is triggered by the clock pulse from Q1836 when the ERASE button is pushed, and again by the  $\bar{E}$  output when the shift register is cleared at the time the sweep ends. Each time U1846B is triggered, it generates a positive-going pulse that is 100 ms in duration.

**J Signal:** The J signal is the output of U1876B. In the FAST mode, the outputs of U1872A and U1876C remain in the high state; therefore the J signal is the same as the  $\bar{B}$  output of the shift register.

**K Signal:** The K signal is generated by the G signal being gated (by U1872D) with the  $\bar{A}$  output of the shift register. During the time of the first G pulse the  $\bar{A}$  output is low, therefore the output of U1872D remains high; at the time of the second G pulse, the  $\bar{A}$  output is high and a negative going, 100 ms pulse is generated at the output of U1872D.

**I Signal:** The I signal is formed by the K pulse and the output of U1846A being gated by U1876D. U1846A is being triggered continuously by Q1842; during the time that the shift register C output is low, CR1848 is forward biased and the timing current for U1846A is shunted away from U1846A. This causes pin 13 of U1846A to be high; since both inputs to U1876D are high, the output is low. When the C output of the shift register goes high, CR1848 is reverse biased and pin 13 of U1846A goes low; the output of U1846A is now 100 Hz, 2  $\mu$ s pulses. This signal is gated through U1876D. When the shift register is cleared, the C output goes low and forward biases CR1848, which disables the output of U1846A. At this time the K pulse goes low and extends the I signal by 100 ms.

**L Signal:** This signal is generated by Q1842, a 100 Hz oscillator.

**M Signal:** This signal is generated by Q1852, a 5 kHz oscillator. The 5 kHz oscillator is synchronized to the 100 Hz oscillator by C1842.

**VAR PERS Mode.** The shift register operates the same in the variable persistence mode as it does in the FAST mode except that it is cleared on the third clock pulse from Q1864. Pin 6 of U1866B is held high by S1921C, VAR PERS, which causes pin 12 of U1866D to be low. When the D output of the shift register goes low, the output of U1866D goes high and generates a clear pulse to the shift register.



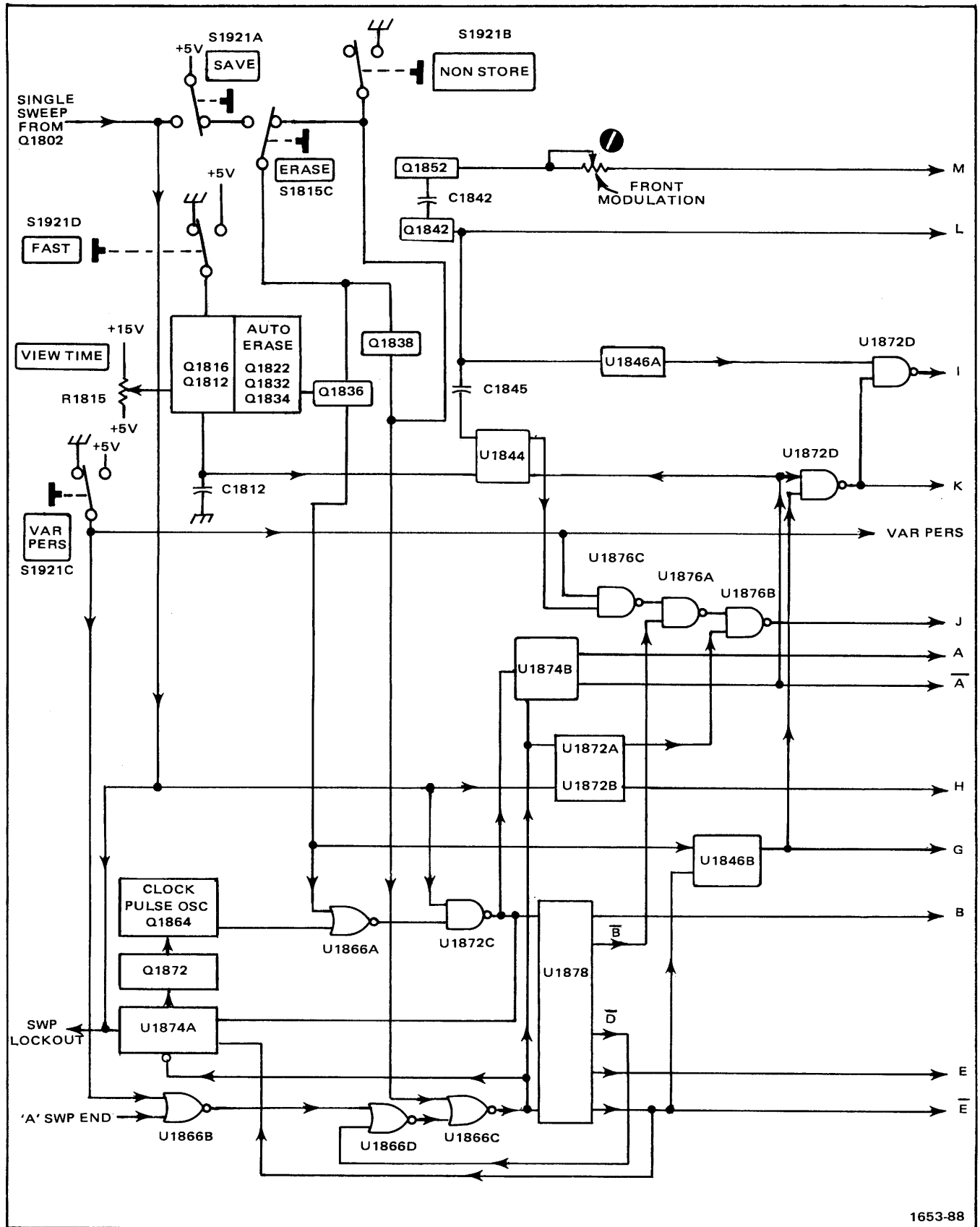

1653-88

Fig. 3-9. Erase and Timing Circuit Detailed Block Diagram.

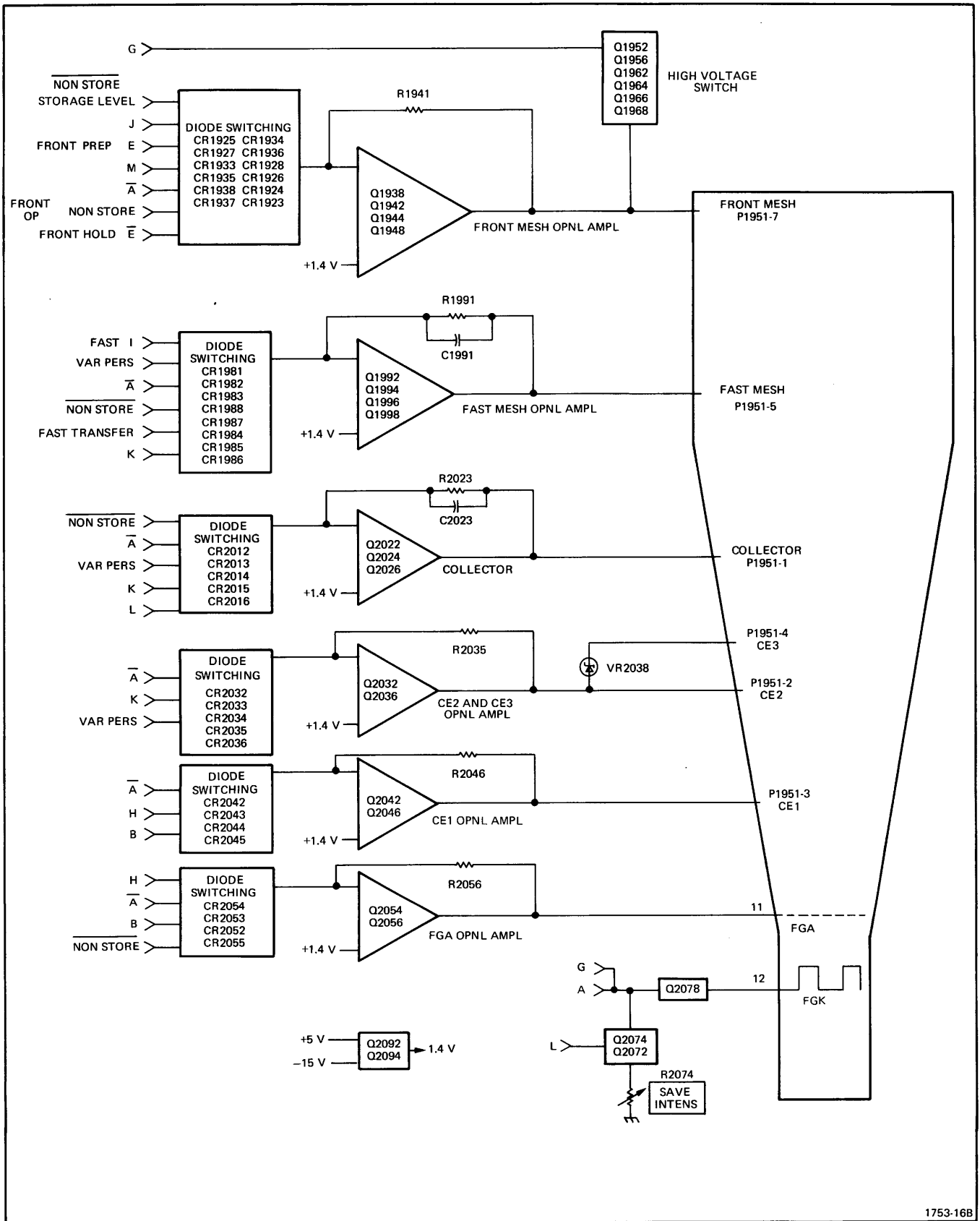

1753-16B

Fig. 3-10. Storage Output Circuits Block Diagram.

## Circuit Description—466 Service

The J output signal contains negative going pulses generated by timing circuit U1844. The timing of these pulses is controlled by the VIEW TIME control and C1812. When VAR PERS is selected, U1876C is enabled and the output of U1844 is gated through to the J signal output.

**Automatic Erase.** In the FAST mode, the automatic erase feature may be used. The automatic erase cycle time is controlled by the VIEW TIME control. If the VIEW TIME control is in any position other than fully clockwise, the erase oscillator (Q1832 and Q1834) is enabled and will provide erase pulses to U1866A.

**Multiple Trace Storage.** Multiple trace storage is accomplished by pressing the SINGL SWP pushbutton after a sweep is stored. When the SINGL SWP button is pressed, a pulse is coupled through Q1802 to flip-flop U1872A-U1872B and through U1872C to the shift register. The pulse to the flip-flop causes it to change states and disable the J signal output; the H signal output goes to the high state. The pulse is also gated through U1872C to start the shift register sequence.

### Storage Amplifier Circuit

The storage output amplifier circuits (Fig. 3-10) provide selected voltage levels for the crt storage elements to maintain proper operation in all modes of operation (Non Store, Fast, Variable Persistence).

**Flood Gun Anode and CE1 Amplifiers.** The basic circuit is a two transistor operational amplifier. The output voltage is controlled by the input current. The FGA and CE1 amplifiers operate the same, with the input currents and outputs being different. See Figures 3-11 through 3-14 for waveforms and voltage levels produced. The A pulse turns off diodes CR2054 and CR2044. When these diodes are off, current from R2053 and R2043 is added to the amplifier input through diodes CR2055 and CR2045. When the B pulse occurs, CR2053 and CR2043 are turned on, which turns off CR2055 and CR2045, removing the current through R2053 and R2043 from the input. In the FAST mode, when more than one display is stored<sup>1</sup>, diodes CR2052 and CR2042 are held on by the H input level. This maintains a 20 volt level on the FGA element and a 30 volt level on the CE1 element. When all logic inputs are LO, resistors R2054 and R2052 provide the input current which sets the output voltage of the FGA amplifier. Resistors R2044 and R2042 provide the input current which sets the output voltage of the CE1 amplifier.

<sup>1</sup>Accomplished by pressing the SINGL SWP pushbutton, while in the FAST mode.

**CE2 and CE3 Circuits.** The basic circuit is a two transistor operational amplifier. The output voltage is controlled by the input current. The A pulse turns off CR2032 and turns on CR2034, which adds the current through R2031 to the input. In the variable persistence mode, the +5 volt to CR2033 turns it on and turns off CR2034, removing the current from R2031 to the input. When the K and the A pulses are HI, both diodes CR2035 and CR2032 are turned on, turning off diodes CR2034 and CR2036. This removes the current from R2032 and R2031 from the input of the amplifier. The Zener Diode VR2038 maintains a 20 volt difference between the CE2 output and the CE3 output.

**Collector Circuit.** The basic circuit is a three transistor operational amplifier. The output voltage is controlled by the input current. When all logic inputs are LO, the input current is provided by resistors R2022 and R2012. In the Variable Persistence mode, the +5 volts connected to CR2013 by S1921C turns CR2013 on and turns CR2012 off, which removes the current through R2013 from the input. When the A and the K pulses are both HI, CR2014 and CR2016 are turned on, turning CR2015 and CR2012 off, thus removing the current through R2015 and R2013 from the input.

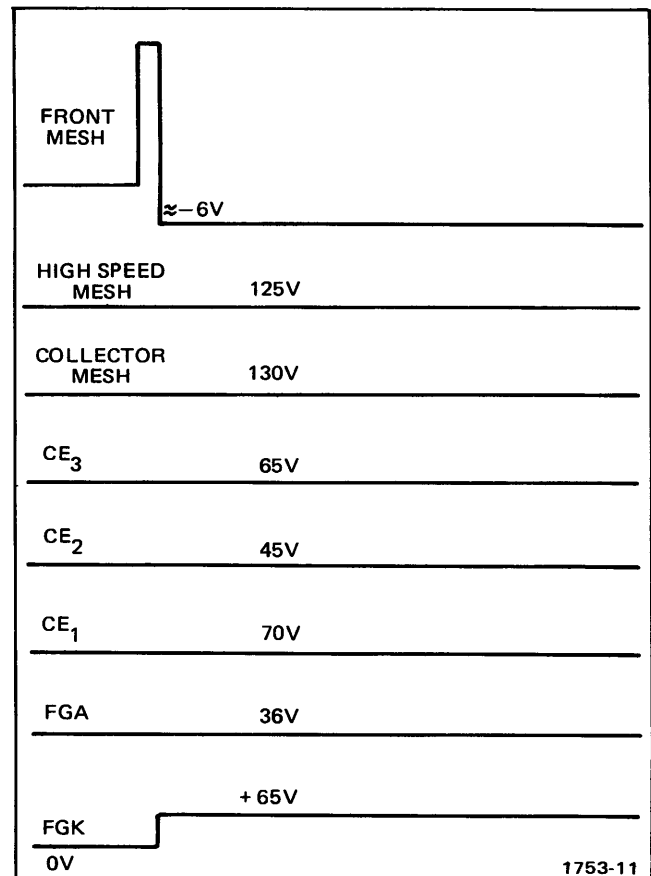

Fig. 3-11. Non-Store Mode—CRT Storage Element Voltage Levels.

**Fast Mesh Circuit.** The basic circuit is a four transistor operational amplifier. The output voltage is controlled by the input current. When all logic inputs are LO, the input current is provided by R1984 and R1988. The A pulse turns off CR1986 and turns on CR1984, thus adding the current through R1985 to the input. In the Variable Persistence mode, switch S1921C connects the +5 volts to CR1985, turning it on and turning CR1984 off, which reduces the current to the amplifier. In the Fast mode, I pulses turn on CR1982, which turns off diode CR1983, removing the current through the Fast Prep adjustment from the amplifier. When the K pulse is LO, CR1988 is turned off and CR1987 is turned on and the current through R1987 and R1989 is applied to the input circuit to provide a transfer level on the Fast Mesh.

**Front Mesh Circuit.** The basic circuit is a four transistor operational amplifier (Q1938, Q1942, Q1944 and Q1948) and a fast high voltage switch (Q1952, Q1956, Q1962/Q1964, and Q1966/Q1968). In the Non-Store mode, the

amplifiers input current is through R1925, Diodes CR1938, CR1935, and CR1927 are turned off. When A goes LO, CR1932 is turned on and CR1933 is turned off, removing the input current through CR1933. When the J pulse goes LO, CR1924 turns on and CR1925 is turned off. This removes the current through the STORAGE LEVEL control from the input. Diode CR1926 is turned off by the J pulse, which connects the current through the Front Prep adjustment to the input. When the E pulse occurs, CR1928 and CR1936 turn on, removing the current from the Front

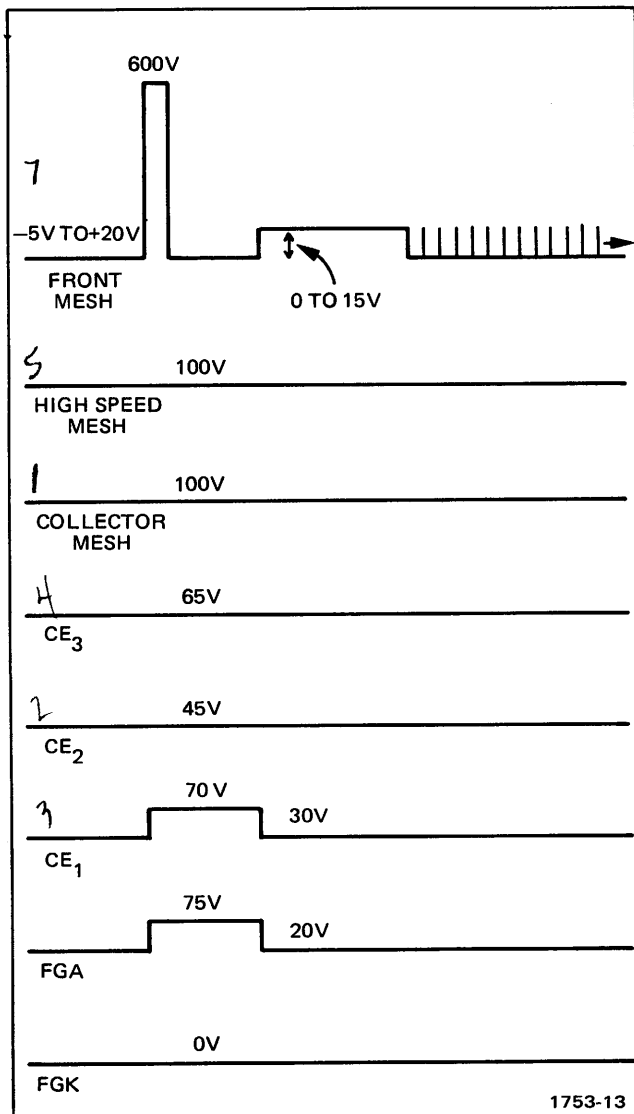

Fig. 3-12. Variable-Persistence Mode—CRT Storage Element Voltage Levels.

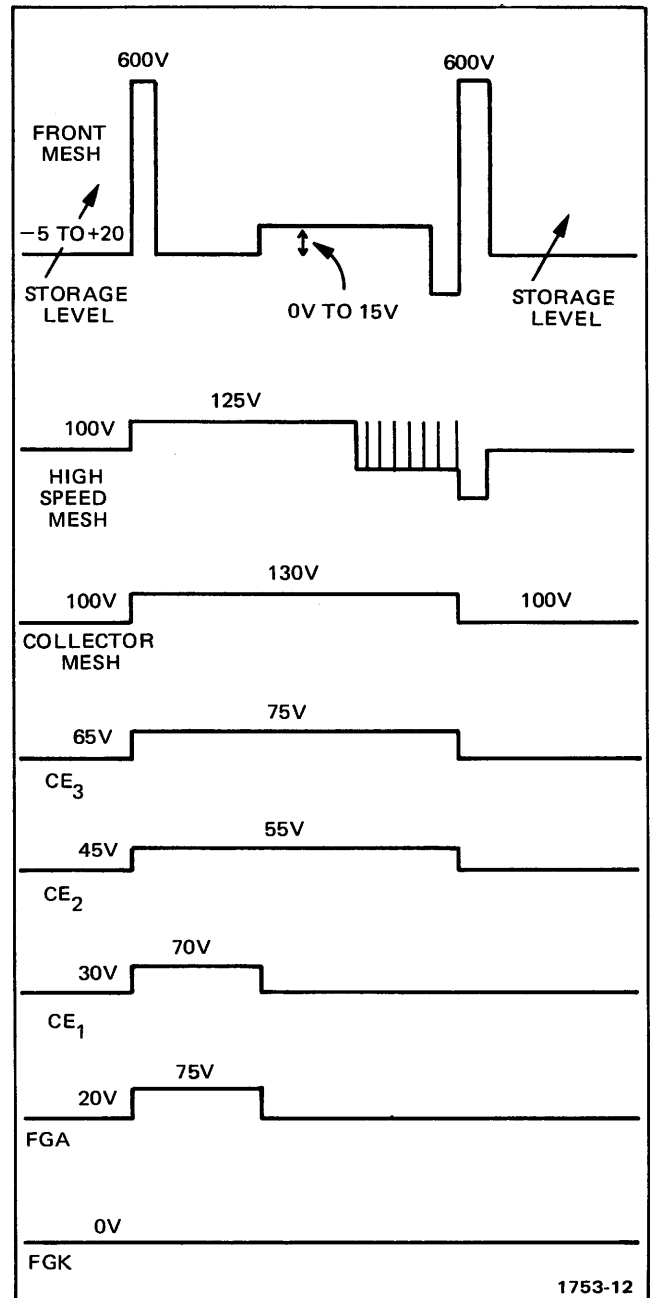

Fig. 3-13. Fast Mode—CRT Storage Element Voltage Levels.

### Circuit Description—466 Service

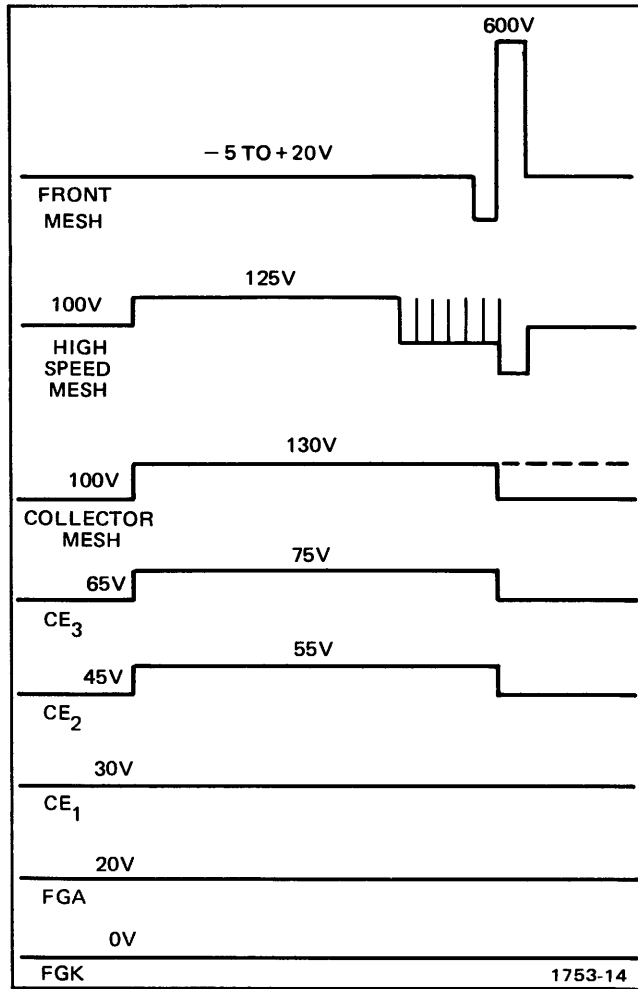

Fig. 3-14. Multi-Fast Mode—CRT Storage Element Voltage Levels.

Prep and the Front Op adjustments to the input circuit. When E goes LO, CR1937 is turned off, which allows the current through the Front Hold Adjustment to be added to the input circuit. The G pulse output is connected directly to Q1952, the input of the high voltage switch. When the G pulse goes HI, Q1952 conducts, turning Q1956 on, which turns off Q1962 and Q1964 and turns on Q1966 and Q1968, applying a 600 volts pulse to the Front Mesh. Diode CR1941 is turned off, disconnecting the operational amplifier from having any control over the Front Mesh.

# MAINTENANCE

## Introduction

This section of the manual contains information for use in preventive or corrective maintenance and troubleshooting of the 466.

## Cabinet Removal

### WARNING

*Dangerous potentials exist at several points throughout this instrument. When the instrument is operated with the cover removed, do not touch exposed connections or components. Some transistors have elevated cases. Disconnect power before cleaning the instrument or replacing parts.*

The instrument wrap-around cabinet can be removed in the following manner:

1. Unwrap the power cord from the pouch.
2. Remove the six screws indicated in Figure 4-1 and remove the rear ring assembly from the instrument.
3. With front cover in place, set instrument on its face.
4. Slide the wrap-around cabinet off the rear.

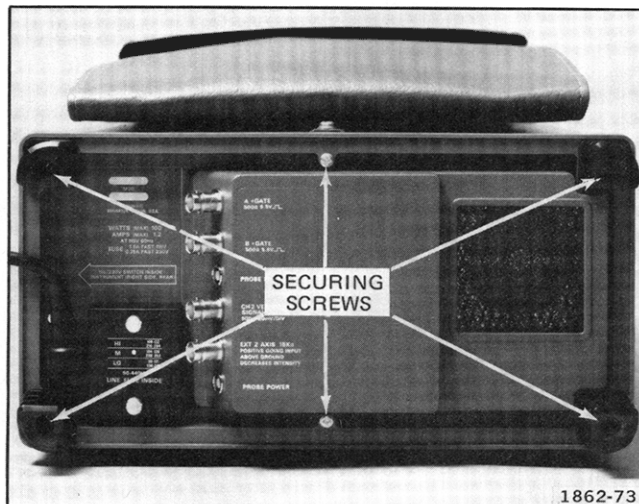

Fig. 4-1. Typical Rear Cabinet Frame Removal.

To replace the instrument in its wrap-around cabinet, reverse the removal procedure. The portable wrap-around cabinet should be installed with the carrying handle pivot points positioned toward the bottom of the instrument.

## PREVENTIVE MAINTENANCE

### General

Preventive maintenance consists primarily of cleaning and visual inspection. When performed on a regular basis, preventive maintenance can prevent instrument breakdown and will improve the reliability of this instrument. The severity of the environment to which the instrument is subjected will determine the frequency of maintenance. A convenient time to perform preventive maintenance is just prior to recalibration of the instrument.

### Cleaning

**General.** The instrument should be cleaned as often as operating conditions require. Accumulation of dirt in the instrument can cause overheating and component breakdown. Dirt on components acts as an insulating blanket and prevents efficient heat dissipation. It also provides an electrical conduction path which can result in instrument failure.

The cabinet provides protection against dust in the interior of the instrument. Operation without the cabinet in place necessitates more frequent cleaning. The front cover provides a measure of dust protection for the front panel and the crt face. The front cover should be installed when storing or transporting the instrument.

### CAUTION

*Avoid the use of chemical cleaning agents which might damage the plastics used in this instrument. Avoid chemicals which contain benzene, toluene, xylene, acetone or similar solvents. Recommended cleaning agents are isopropyl alcohol or Kelite (1 part Kelite, 20 parts water).*

## Maintenance—466 Service

**Switch Contacts.** Most of the switching in the 466 is accomplished with circuit-board mounted, cam-actuated contacts. Care must be exercised to preserve the high-frequency characteristics of these switches. Seldom is switch maintenance necessary, but if it is required, observe the following precautions.

Cleaning the switch contacts should only be done using isopropyl alcohol or a solution of one part Kelite to 20 parts water. In the absence of these cleaners, it is safe to use petroleum ether, white kerosene, or a solution of 1% dishwashing detergent and 99% water. Do not use acetone, MEK, MIBK, benzol, toluol, carbon tetrachloride, trichlene, methyl alcohol, methylene chloride, sulfuric acid, or Freon TC-TE-TF-22-TA-12.

Most spray circuit coolants and contact cleaners contain Freon 12 as a propellant. Because many Freons adversely affect the contacts, check the contents before using a spray cleaner or coolant. An acceptable contact cleaner-restorer is No Noise (Electronic Chemical). The only recommended circuit coolants are dry ice or isopropyl alcohol. There are three recommended switch lubricants. They are Silicone Versilube (General Electric Co.), Rykon R (Standard Oil), and WD-40 (Rocket Chemical Co.).

**Exterior.** Loose dust accumulated on the outside of the 466 can be removed with a soft cloth or small paint brush. The paint brush is particularly useful for dislodging dirt on and around the front-panel controls. Dirt which remains can be removed with a soft cloth dampened in a mild detergent and water solution. Abrasive cleaners should not be used.

**Crt.** Clean the blue and clear plastic light filters and the crt face with a soft, lint-free cloth dampened with denatured alcohol or a mild detergent and water solution. The optional crt mesh filter can be cleaned in the following manner.

1. Hold the filter in a vertical position and brush lightly with a soft brush to remove light coatings of dust and lint.
2. Greasy residues or dried-on dirt can be removed with a solution of warm water and neutral pH liquid detergent. Use the brush to lightly scrub the filter.
3. Rinse the filter thoroughly in clean water and allow to air dry.

4. If any lint or dirt remains, use clean low-pressure (9 psi is adequate) air to remove. Do not use tweezers or other hard cleaning tools on the filter; the special finish may be damaged.

5. When not in use, store the mesh filter in a lint-free dust-proof container such as a plastic bag.

**Interior.** Dust in the interior of the instrument should be removed occasionally due to its electrical conductivity under high-humidity conditions. The best way to clean the interior is to blow off the accumulated dust with dry, low-pressure air. Remove any dirt that remains with a soft paint brush or a cloth dampened with a mild detergent and water solution. A cotton-tipped applicator is useful for cleaning in narrow spaces or for cleaning circuit boards.

### Visual Inspection

The instrument should be inspected occasionally for such defects as broken connections, broken or damaged ceramic strips, improperly seated semiconductors, damaged or improperly installed circuit boards, and heat-damaged parts.

The corrective procedure for most visible defects is obvious; however, particular care must be taken if heat-damaged components are found. Overheating usually indicates other trouble in the instrument: therefore, it is important that the cause of overheating be corrected to prevent recurrence of the damage.

### Lubrication

The fan motor and most of the potentiometers used in the 466 are permanently sealed and generally do not require periodic lubrication. The switches, both cam- and lever-type, are installed with proper lubrication applied where necessary and will only rarely require any additional lubrication. It is recommended that a regular periodic lubrication program not be performed on any of the components used in the 466.

### Semiconductor Checks

Periodic checks of the transistors and other semiconductors are not recommended. The best check of semiconductor performance is actual operation in the instrument.

### Recalibration

To ensure accurate measurements, check instrument calibration after each 1000 hours of operation or every six months if used infrequently. In addition, replacement of components may necessitate recalibration of the affected circuits. Complete calibration instructions are given in the Calibration section.

The calibration procedure can also be helpful in localizing certain troubles in the instrument. In some cases, minor troubles may be revealed or corrected by recalibration.

## CORRECTIVE MAINTENANCE

### General

Corrective maintenance consists of component replacement and instrument repair. Special techniques required to replace components in this instrument are given here.

### Obtaining Replacement Parts

**Standard Parts.** All electrical and mechanical part replacements for the 466 can be obtained through your local Tektronix Field Office or representative. However, many of the standard electronic components can be obtained locally in less time than is required to order them from Tektronix, Inc. Before purchasing or ordering replacement parts, check the parts list for value, tolerance, rating, and description.

#### NOTE

*Physical size and shape of a component may affect instrument performance, particularly at high frequencies. Always use direct-replacement components, unless it is known that a substitute will not degrade instrument performance.*

**Special Parts.** In addition to the standard electronic components, some special components are used in the 466. These components are manufactured or selected by Tektronix, Inc. to meet specific performance requirements, or are manufactured for Tektronix, Inc., in accordance with our specifications. Most of the mechanical parts used in this instrument have been manufactured by Tektronix, Inc. Order all special parts directly from your local Tektronix Field Office or representative.

**Ordering Parts.** When ordering replacement parts from Tektronix, Inc., it is imperative that all of the following information be included in the order to ensure receiving the proper parts.

1. Instrument type (include mod or option numbers).
2. Instrument serial number.
3. A description of the part (if electrical, include the circuit number).
4. Tektronix Part number.

### Recalibration After Repair

After any electrical component has been replaced, the calibration of that particular circuit should be checked, as well as the calibration of other closely related circuits. Since the power supply affects all circuits, calibration of the entire instrument should be checked if work has been done in the power supply or if the transformer has been replaced.

### Instrument Repackaging

If the Tektronix instrument is to be shipped to a Tektronix Service Center for service or repair, attach a tag showing: owner (with address) and the name of an individual at your firm that can be contacted, complete instrument serial number and a description of the service required.

Save and re-use the package in which your instrument was shipped. If the original packaging is unfit for use or not available, repackage the instrument as follows:

1. Obtain a carton of corrugated cardboard having inside dimensions of no less than six inches more than the instrument dimensions; this will allow for cushioning. Refer to the following table for carton test strength requirements.
2. Surround the instrument with polyethylene sheeting to protect the finish of the instrument.
3. Cushion the instrument on all sides by tightly packing dunnage or urethane foam between carton and instrument, allowing three inches on all sides.
4. Seal carton with shipping tape or industrial stapler.

#### SHIPPING CARTON TEST STRENGTH

Gross Weight (lb)	Carton Test Strength (lb)
0-10	200
10-30	275
30-120	375
120-140	500
140-160	600

### Soldering Techniques

#### WARNING

*Always disconnect the instrument from the power source before soldering.*

Ordinary 60/40 solder and a 35- to 40-watt pencil-type soldering iron can be used to accomplish the majority of the soldering. If a higher wattage-rating soldering iron is used on the etched circuit boards, excessive heat can cause the etched circuit wiring to separate from the board base material.



**CAUTION**

*The Vertical Preamplifier Attenuator circuit boards are made of material easily damaged by excessive heat. When soldering to these boards, do not use a soldering iron with a rating of more than approximately 15 watts. Avoid prolonged applications of heat to circuit-board connections. Use only isopropyl alcohol when cleaning this circuit board.*

When soldering to the ceramic strips in the instrument, a slightly larger soldering iron can be used. It is recommended that a solder containing about 3% silver be used when soldering to these strips to avoid destroying the bond to the ceramic material. This bond can be broken by repeated use of ordinary tin-lead solder or by the application of too much heat; however, occasional use of ordinary solder will not break the bond if excessive heat is not applied.

If it becomes necessary to solder in the general area of any of the high-frequency contacts in the instrument, clean the contacts immediately after soldering. Refer to the section entitled Switch Contacts under Preventive Maintenance for recommended cleaners and procedures.

### Component Replacement

**WARNING**

*Always disconnect the instrument from the power source before replacing components.*

**Semiconductor Replacement.** Semiconductors should not be replaced unless actually defective. If removed from their sockets during routine maintenance, return them to their original sockets. Unnecessary replacement of semiconductors may affect the calibration of this instrument. When semiconductors are replaced, check the operation of the part of the instrument which may be affected.

Replacement semiconductors should be of the original type or a direct replacement. Lead configuration of the semiconductors used in this instrument are shown in the pullout pages. Some plastic case transistors have lead configurations which do not agree with those shown there. If a replacement transistor is made by a different manufacturer than the original, check the manufacturer's

basing diagram for correct basing. All transistor sockets in this instrument are wired for the standard basing as used for metal-cased transistors. Transistors which have heat radiators or are mounted on the chassis use silicone grease to increase heat transfer. Replace the silicone grease when replacing these transistors.

**WARNING**

*Handle silicone grease with care. Avoid getting silicone grease in the eyes. Wash hands thoroughly after use.*

An extracting tool should be used to remove the 14, 16, and 20 pin integrated circuits to prevent damage to the pins. This tool is available from Tektronix, Inc. Order Tektronix Part No. 003-0619-00. If an extracting tool is not available when removing one of these integrated circuits, pull slowly and evenly on both ends of the device. Try to avoid having one end of the integrated circuit disengage from the socket before the other, since this may damage the pins.

### Circuit Board Replacement

Occasionally it may be necessary to gain access to the reverse side of the circuit board or to remove one circuit board to gain access to another. The following procedures outline the necessary steps to facilitate instrument disassembly. Most of the connections to the circuit boards in the instrument are made with pin connectors. However, some connections are soldered to the board. Observe the soldering precautions given under Soldering Techniques in this section.

**Vertical Preamp Board.** Remove and replace as follows:

1. Disconnect and remove the following control extension shafts (held to switch or potentiometer shafts with .050" Allen set screws):
  - a. Two vertical POSITION shafts.
  - b. Two VAR VOLTS/DIV shafts.
  - c. TRIG VIEW pushbutton shaft.
2. Disconnect the INVERT pushbutton extension shaft from the INVERT switch shaft. Insert a scribe or similar tool between the end of the white plastic switch shaft and the inside of the black plastic extension shaft and pry gently.

3. Remove the CH 1 and CH 2 attenuator shields (each is held with five screws and washers).

4. Unsolder the two resistors that connect the Vertical Preamp board to the Attenuator boards.

5. Unplug P350 from the Vertical Mode Switching board.

6. Unplug nine coaxial cable connections from the board. Note cable color code and location to facilitate reinstallation.

7. Unplug the delay-line leads (one lead soldered) from the rear of the board.

8. Unsolder the red-brown wire from the rear end of the board. Note location for reinstallation.

9. Unsolder the bare wire ground connection between the Preamp board and the Interface board, near the Geometry control.

10. Remove the five screws holding the board and remove the board from the instrument.

11. To replace the Vertical Preamp board, reverse the removal steps.

**Vertical Mode Switch and Attenuator.** Remove and replace as follows:

1. Remove the Vertical Preamp board according to the preceding procedure.

2. Remove the two VOLTS/DIV knobs.

3. Remove AC-GND-DC lever switch knobs (pull straight off).

4. Remove the two UNCAL and REDUCED SCAN light lenses. Pry them away from the front panel with fingernails and pull straight out.

5. Unplug P53 and P63 from the Vertical Mode Switch board (P53 and P63 are connected to wires from the VOLTS/DIV sensitivity lights on the front panel).

6. Unplug all remaining connectors from the Vertical Mode Switch board. Note wire color codes to facilitate correct reinstallation.

7. Remove the securing screw and hex securing post from the rear of the Vertical Mode Switch board.

8. Remove the four nuts that secure the attenuator assemblies to the front casting.

9. Remove the Vertical Mode Switch board from the instrument.

10. To reinstall the Vertical Mode Switch board, reverse the order of removal steps. To align the VERT MODE switch pushbuttons, hold the assembly in place with a slight forward pressure and use a small tool to reach through the front panel to align the buttons. Install the remaining parts in the reverse order of removal. Do not tighten the circuit board securing screws until the securing nuts at the front of the attenuator chassis are tight and the circuit board is aligned properly.

**Trigger Generator and Sweep Logic Board.** Remove and replace as follows:

1. Remove the READY and TRIG light lenses from the front panel. Pry them away from the front panel with fingernails and pull straight out.

2. Disconnect eight coaxial cables (five on the front and three on the back). Unsolder the red-brown wire from the top of the board. Note cable color-codes and locations to ensure proper installation during reassembly.

3. Unsolder the two wires (white-red and white-yellow) from the bottom of the circuit board, that come from the Timing board and DELAY TIME POSITION control. Note wire color codes and locations to ensure proper installation during reassembly.

4. Remove the A TRIGGER and B TRIGGER SLOPE/LEVEL knobs and the A TRIG HOLDOFF knob.

5. Remove the nuts and washers from the SLOPE/LEVEL potentiometers.

## Maintenance—466 Service

6. Remove the POWER switch actuator rod from the plastic holder on the switch. Pry the rod out of the holder with a small flat-bladed screwdriver.

7. If the circuit board is being completely replaced, remove the POWER switch bracket from the circuit board. It is held with two nuts and two flat washers.

8. Remove three mounting screws from the circuit board (two at rear, and one at center-top; pozidrive screwdriver required).

9. Unplug the Trigger Generator and Sweep Logic circuit board from the Interface Board by forcing the Trigger board away from the two white interboard connectors at the bottom edge of the Trigger board. Use screwdriver to pry loose.

10. Move the Trigger board to the rear until the Trigger switches clear the front casting and then remove the assembly from the instrument. Exercise caution to avoid damaging the connector pins on the Interface board.

11. To reinstall the Trigger Generator and Sweep Logic circuit board, reverse the order of the removal steps. If the indexing of the Trigger switches was disturbed, a series of trial-and-error installation-removal-adjustment steps will be necessary to return them to correct alignment.

**Sweep Timing Circuit Board.** Remove and replace as follows:

1. Remove the Trigger Generator and Sweep Logic circuit boards as outlined above to facilitate the Timing Board removal.

2. Unsolder four wires from the Timing circuit board. Make note of wire color-codes to ensure proper installation during reassembly.

3. Remove the knobs from the VAR TIME/DIV control and the A AND B TIME/DIV switches (1/16" Allen wrench required). Be careful not to lose the plastic bushing behind the knobs.

4. Remove the X10 MAG and the UNCAL light lenses. Pry them away from the instrument front panel with fingernails and pull straight out.

5. Remove the two (2) board mounting screws and the hex rod from the Sweep Timing circuit board (3/16" wrench or nutdriver required).

6. Use a flat blade screwdriver and pry the Timing board away from the Interface board. Gently pull away the corner of the Interface board near the B External Trigger Input connector and simultaneously lift up on the Timing board near the rear to fully disengage connector pins from the Interface board.

7. To reinstall the Timing board, reverse the order of the removal steps.

**Storage Board.** Remove and replace as follows:

1. Remove the INVERT, BEAM FINDER, and X10 MAG (IN) extension shafts. Remove by prying with a scribe or similar tool between the end of the white plastic switch shaft and the inside end of the extension shaft.

2. Remove the INTEN, ASTIG, FOCUS, TRACE ROTATION, and SCALE ILLUM extension shafts. (Use .050" Allen wrench to remove shafts from shaft coupling.)

3. Remove the STORAGE LEVEL/INTEN, VIEW TIME/ERASE and POSITION/FINE knobs. Use .050" and 1/16" Allen wrenches. The ERASE knob is removed by pulling straight off.

4. Remove the SAVE, NON STORE, VAR PERS and FAST pushbuttons by pulling them straight off.

5. Unplug P1951 from the Storage board.

6. Unsolder the white-gray wire from the +600 V point on the Storage board.

7. Remove the four board mounting screws.

8. Carefully move the board straight forward to disconnect the interconnecting pins from the Main Interface board.

9. To install the Storage board, reverse the order of the removal steps.

### Low-Voltage Power Transformer Replacement

1. Remove the fuse block cover from the rear of the instrument.
2. Remove the calibrator loop. Unsolder the white-red and white-brown wires. Remove the nuts, flat washers and insulating washers.
3. Remove the ground post.
4. Remove the blue cover plate from the rear of the instrument.
5. Remove the screw holding the top outside transformer mounting bar.
6. Remove the transformer mounting bolts to free the transformer.
7. Unsolder the transformer leads from the Interface board and the solder lug on the rear subpanel. Note the wire color-codes to facilitate correct reinstallation.
8. Remove the transformer leads from the fuse block. It will be necessary to use a special pin removing tool available under Tektronix Part Number 003-0707-00. It is necessary to use this tool to remove the transformer leads from the fuse block. The leads can be reinstalled by simply pushing them into place. Note wire color codes and locations to facilitate correct reinstallation.
9. Option 7 only—Unsolder the five wires from transformer terminals. Note wire color codes and locations to facilitate reinstallation.
10. Remove the POWER switch mounting bracket from the Trigger board.
11. Remove the thermal cutout switch mounted on the main chassis. It is held with two self-tapping screws.
12. Remove the transformer assembly from the instrument.
13. Remove the thermal cutout and POWER switch assembly from the old transformer and install on the new transformer. Note wire color codes and locations to facilitate correct installation.

14. Install the new transformer assembly in the instrument by reversing the order of the removal steps.

### HV Multiplier and HV Transformer Replacement

1. Remove the high-voltage shield on the right side behind the Vertical Preamp board (held with two screws on the outside of the shield and one screw under the rear of the Vertical Preamp board).
2. Remove the plastic cover from the HV Multiplier.
3. Discharge the crt anode lead to the chassis and unsolder it from the HV Multiplier board.
4. Unsolder the HV Transformer center lead and remove the HV Multiplier board.
5. To remove the HV Transformer:
  - a. Remove the top HV shield (held with four screws).
  - b. Unsolder the two high-voltage diodes from the HV Transformer lead that projects through the Interface board.
  - c. Unsolder the remaining HV Transformer leads from the Interface board, while removing HV Transformer. (Use a solder-removing tool.) Note wire locations to facilitate reinstallation.
6. To install the HV Multiplier or HV Transformer, reverse the order of the removal steps.

### CRT Replacement

**WARNING**

*Handle the crt carefully. Rough handling or scratching can cause the crt to implode.*

#### Removal.

1. Remove the gray plastic bezel and filter from the front of the crt (held with four screws).
2. Remove the plastic rear cover from the rear of the instrument (held with two flat-head screws). Do not unsolder wires.

## Maintenance—466 Service

3. Remove the bell-shaped cover to expose the crt socket (held with two screws). It will be necessary to remove one screw, loosen one screw and swivel the plate under the fan impeller to gain access to one of the cover mounting screws.

4. Unplug the crt socket.

5. Set the instrument on its left side.

6. Unplug the vertical deflection plate leads from the left side of the crt neck.

7. Unplug the horizontal deflection plate leads from the bottom side of the crt neck.

8. Unplug the storage plug (P1951) from the Storage board.

9. Disconnect the crt anode connector and discharge the connector pin to the instrument chassis.

10. Holding one hand on the crt face, push forward (slowly) on the crt base with the other hand. Guide the anode connector and the storage plug through crt shield openings while slowly pulling the crt out of the instrument. The plastic corner pads may fall loose when the crt is removed; save them for reinstallation. Also, the white plastic centering bracket should remain inside the crt shield.

Set the crt on a soft material to prevent scratching.

### Installation.

1. Make sure the plastic centering bracket is in place inside the shield and that the black plastic corner pads are in place at the front corners of the crt opening.

2. Insert a wire or string through the hole in the upper right rear corner of the crt shield, to facilitate installation of the anode lead. Be sure to dress the wire or string across the upper right opening of the plastic centering bracket.

3. Connect the wire or string to crt anode lead connector and add tape to hold it firmly.

4. Insert the neck of the crt part way into the crt shield and into the plastic centering bracket. Orient the crt with the anode lead towards the top of the instrument.

5. While holding the front of the crt with one hand, carefully insert the storage plug through the grommet hole in the bottom of the crt shield. Be sure to pull wires through while inserting crt.

6. Draw the anode lead through the hole in the shield.

7. While still holding the crt with one hand, make sure the plastic centering bracket is in place on the crt neck.

8. Slowly push the crt the rest of the way into the crt shield. If the crt does not go in all the way, pull it out part way and move the plastic centering bracket farther up on the crt neck.

9. Install the bezel filter on the front of the crt.

10. Make the following crt connections:

a. Crt anode lead.

b. Crt base socket

c. Storage plug (P1951). Be sure to match arrows.

d. Horizontal deflection plate leads to neck pins. (White-green wire to right pin and white-red wire to left pin.)

e. Vertical deflection plate leads to neck pins. (White-blue to upper pin and white-brown to lower pin.)

11. Install bell-shaped crt socket cover (two screws).

12. Secure plate under fan impeller.

13. Install plastic rear cover (two flat-head screws—see crt replacement, Step 3).

14. Check the calibration of the instrument.

# CALIBRATION

## INTRODUCTION

### Purpose

The purpose of the calibration procedure is to provide a calibration sequence for adjustments, run a functional check of all modes prior to calibration and correct all defects found.

Where possible, instrument performance is checked before an adjustment is made. Steps containing adjustments and checks are titled Check/Adjust steps. Those with only checks are titled Check steps. A total check of all characteristics is possible by going through the calibration procedure and performing each step only through the CHECK portion.

### Limits And Tolerances

All limits and tolerances given in this procedure are calibration guides and should not be interpreted as instrument specifications unless they are also found in the Specifications section of this manual.

Tolerances given are for the oscilloscope under test and do not include test equipment error.

### Line Voltage Selection

This procedure is for 115 V ac line, medium range. If a different range is to be used, set the Regulating Range Selector and Line Voltage Selector for the available line voltage.

### Internal Adjustments

Do not preset internal controls or move the +65 Volt Supply adjustment as this typically will require complete recalibration.

### Display

Adjustments should be made with a stable, well-focused, low-intensity display. Unless otherwise noted, adjust the Intensity, Astigmatism, Focus, Position and Trigger Level controls as needed.

### Externally Accessible Adjustments

The following internal calibration adjustments can be made without cabinet removal (review the appropriate portion of the calibration procedure before making adjustments):

Adjustment	Location	Calibration
CH 1 Var Bal (R84)	Left-hand side panel	Vertical
CH 1 Gain (R92)	Left-hand side panel	Vertical
CH 2 Var Bal (R184)	Left-hand side panel	Vertical
CH 2 Gain (R192)	Left-hand side panel	Vertical
Fine Fast Transfer Level (R1989)	Bottom panel	Storage

## TEST EQUIPMENT REQUIRED

The test equipment listed in Table 5-1, or equivalent, is required for complete calibration of the 466. Specifications given for the equipment are the minimum necessary for accurate calibration. Therefore, the equipment used must meet or exceed the listed specifications. Detailed operating instructions for the test equipment are not given in this procedure. Refer to the appropriate instruction manual if more information is needed.

If only a Performance Check is to be performed, not all of the listed test equipment is required. Items used only for calibration are indicated by footnote 1. The remaining pieces of equipment are common to both procedures.

### Special Calibration Fixtures

Special calibration fixtures are used only where they facilitate instrument calibration. These fixtures are available from Tektronix, Inc. Order by part number through your local Tektronix Field Office or representative.

### Calibration Equipment Alternatives

All of the listed equipment is required to completely check and calibrate this instrument. However, complete checking or calibration may not always be necessary or desirable. The user may be satisfied with checking only

selected characteristics, thereby reducing the amount of test equipment actually required.

The Performance Check and Calibration procedures are based on the first item of equipment given as an example. When other equipment is substituted, control settings, calibration setup, or choice of accessories might need to be altered. If the exact item of equipment given as an example in the Test Equipment list is not available, first check the specifications column carefully to see if any other equipment might suffice. Then check the Usage column to see what this item is used for. If used for a check or adjustment that is of little or no importance to your measurement requirements, the item and corresponding step(s) can be deleted.

In this procedure, test equipment is named by the functional description (see Table 5-1, Description), rather than by specific front-panel nomenclature.

The following procedures are written to completely check and adjust the 466 to the Performance Requirements listed in the Specifications section and in the Operators manual. If the applications for which you will use the 466 do not require the full available performance from the 466, the procedures and the required equipment list can be shortened accordingly. For example, the basic measurement capabilities of this instrument can be verified by just checking vertical deflection accuracy and basic horizontal timing and calibrator signal.

**TABLE 5-1**  
Test Equipment Required

DESCRIPTION	MINIMUM SPECIFICATIONS	USAGE	EXAMPLES
1. Variable Autotransformer <sup>1</sup>	Output, 1.2 amperes over a range of 103.5 to 126.5 volts.	Power supply regulation check.	General Radio W8MT3VM Variac Autotransformer
2. Digital Multimeter <sup>1</sup>	Range, 0 to 150 volts; dc voltage accuracy, within 0.1%; display, 4 1/2 digits.	Low-voltage power supply checks and adjustment; crt grid bias check; vertical and horizontal centering adjustments; calibrator output voltage adjustment.	a. Tektronix DM 501 Digital Multimeter <sup>2</sup> . b. Any digital voltmeter that meets minimum specifications.
3. DC Voltmeter <sup>1</sup>	Range, 0 to 1500 volts; calibrated to 1% accuracy at -1470 volts.	High-voltage power supply check.	a. Triplet Model 630-NA. b. Simpson Model 262.

<sup>1</sup>Used for calibration procedure only.

<sup>2</sup>Requires a TM 500 series power module.

TABLE 5-1 (cont)

DESCRIPTION	MINIMUM SPECIFICATIONS	USAGE	EXAMPLES
4. Test Oscilloscope with 2 10X probes and a 1X probe	Bandwidth, dc to 100 megahertz; minimum deflection factor, 5 mV/division; accuracy within 3%; dual trace. (One 10X probe should have Scale-Factor switching, but an 11 kΩ resistor may be substituted in subsection C VERTICAL, Step 1, part a.)	Power Supply ripple; crt Z-axis compensation; Vertical gain adjustment; A Trigger Holdoff check; High-speed timing adjustment; Storage checks and adjustments; A and B + GATE output signals check.	a. Tektronix 465 Oscilloscope with 2 included (10X) probes. b. Tektronix 475 Oscilloscope with 2 included (10X) probes. c. 2 P6062A (10X or 1X) probes are supplied as standard accessories for the 466.
5. Amplitude Calibrator	Amplitude accuracy, within 0.25%; signal amplitude, 2 millivolts to 50 volts; output signal, 1 kilohertz square wave.	Vertical checks and adjustments; Trigger View gain check; Storage checks and adjustments; X Gain adjustment; External Z-axis check.	a. Tektronix PG 506 Calibration Generator. <sup>2</sup> b. Tektronix 067-0502-01 calibration fixture.
6. Leveled Sine-Wave Generator	Frequency, 350 kilohertz to above 100 megahertz; output amplitude, variable from 0.5 to 5 volts peak-to-peak; output impedance, 50 ohms; reference frequency, 50 to 350 kilohertz; amplitude accuracy, constant within 3% of reference frequency as output frequency changes.	Vertical centering, bandwidth and isolation checks; Trigger checks and adjustments; Storage check and adjustments; X-Y phase difference adjustment; X-Y bandwidth check.	a. Tektronix SG 503 Leveled Sine-Wave Generator. <sup>2</sup> b. Tektronix Type 191 Constant-Amplitude Signal Generator.
7. Time-Mark Generator	Marker outputs, 10 nanoseconds to 0.5 second; marker accuracy, within 0.1%; trigger output, 1 millisecond to 0.1 microsecond, time coincident with markers.	Crt Y-axis and geometry adjustments; Auto trigger check; Horizontal timing checks and adjustments. Storage checks and adjustments.	a. Tektronix TG 501 Time-Mark Generator. <sup>2</sup> b. Tektronix 2901 Time-Mark Generator.
8. Low-Frequency Sine-Wave Generator	Frequency, 10 hertz to 50 kilohertz; output amplitude, variable from 10 millivolts to 4 volts peak-to-peak.	Low-frequency trigger checks.	a. Tektronix SG 502 Oscillator. <sup>2</sup> b. General Radio 1310A Oscillator.
9. Square-Wave Generator	Repetition rate, 1 kHz to 1 MHz; risetime, 1 nanosecond or less from fast-rise ± outputs; output amplitude, at least 60 volt pulse from High-amplitude output; aberrations, within 2% from fast-rise output.	Vertical compensation.	a. Tektronix PG 506 Calibration Generator. <sup>1/2</sup> b. Tektronix Type 106 Square Wave Generator.

<sup>1</sup>Used for calibration procedure only.

<sup>2</sup>Requires a TM 500 series power module.



TABLE 5-1 (cont)

DESCRIPTION	MINIMUM SPECIFICATIONS	USAGE	EXAMPLES
10. 50-Ohm Signal Pickoff	Frequency response, 50 kilohertz to 100 megahertz; impedance 50 ohms for signal input, signal output and trigger output.	Trigger checks and adjustments.	Tektronix CT-3 signal pick-off. Part Number 017-0061-00.
11. Cable (2 required)	Impedance, 50 ohms; Length, 42 inches; Connectors, BNC.	Signal interconnection.	Tektronix Part Number 012-0057-01.
12. Cable (2 required)	Impedance, 50 ohms; Length, 18 inches; Connectors, BNC.	Signal interconnection.	Tektronix Part Number 012-0076-00.
13. Adapter	Connectors, GR874 to BNC female.	Vertical compensation: Trigger adjustments. (Required with CT-3 or 106.)	Tektronix Part Number 017-0063-00.
14. Adapter	Connectors, GR874 to BNC male.	Trigger adjustment; signal interconnection.	Tektronix Part Number 017-0064-00.
15. Adapter	Connectors, BNC female to BNC female.	Signal interconnection.	Tektronix Part Number 103-0028-00.
16. Dual-Input Coupler <sup>3</sup> (2 required)	Connectors, BNC female to 2 BNC male.	Vertical checks, trigger checks and adjustments, X-Y Phase check.	Tektronix Part Number 067-0525-01.
17. T Connector	Connectors, BNC.	Signal interconnection.	Tektronix Part Number 103-0030-00.
18. 10X Attenuator (2 required)	Ratio, 10X; impedance 50 ohms; connectors, BNC.	Vertical compensation; Vertical bandwidth check; Trigger adjustments.	Tektronix Part Number 011-0059-02.
19. 5X Attenuator	Ratio, 5X; impedance 50 ohms; connectors, BNC.	Vertical system compensation adjustments; Trigger adjustments.	Tektronix Part Number 011-0060-02.
20. 2X Attenuator	Ratio, 2X; impedance, 50 ohms; connectors, BNC.	Vertical system compensation.	Tektronix Part Number 011-0069-02.
21. Termination (2 required)	Impedance, 50 ohms; connectors, BNC.	Signal termination.	Tektronix Part Number 011-0049-01.

<sup>3</sup>The dual-input couplers (Item in the Equipment Required List) are needed for common-mode and X-Y checks. They also permit faster trigger calibration and checking. A direct substitute can easily be made by connecting two short, 50 ohm, BNC cables and a BNC female-to-female adapter to a BNC T connector.

Description	Tektronix Part Number
2—50 ohm BNC cables, 8 inches long	012-0118-00
1—BNC female-to-female adapter	103-0028-00
1—BNC T connector	103-0030-00

TABLE 5-1 (cont)

DESCRIPTION	MINIMUM SPECIFICATIONS	USAGE	EXAMPLES
22. Adapter	Connectors, BNC male to miniature probe tip.	Vertical input attenuator compensation.	Tektronix Part Number 013-0084-01
23. Screwdriver	Length, three-inch shaft; bit size, 3/32 inch.	Adjust variable resistors.	Xcelite R-3323.
24. Low-Capacitance Screwdriver	Length, 1-inch shaft; bit size, 3/32 inch.	Adjust all variable capacitors.	J.F.D. Electronics Corp. Adjustment Tool, Number 5284
25. Light Shield	Folding viewing hood.	Horizontal, delay-time jitter.	Tektronix Part Number 016-0592-00. (Standard Accessory for the 466.)
26. Shorting Strap		Calibrator adjustment.	Two-inch length of #20 or larger insulated wire with alligator clip attached to each end.

**Cabinet Removal**

**WARNING**

*High voltages exist at several points throughout this instrument. Disconnect power before cleaning the instrument or replacing parts. When the instrument is operated with the cover removed, do not touch exposed connections or components. Some transistors may have elevated cases.*

The instrument wrap-around cabinet can be removed in the following manner:

1. Install dust cover and set instrument face on a flat surface.
2. Unwrap the power cord from the instrument feet.
3. Remove the six screws indicated in Figure 5-1 and remove the instrument feet and rear cabinet assembly from the instrument.

4. Slide the wrap-around cabinet up and over the back to remove the oscilloscope. To replace the instrument in its wrap-around cabinet, reverse the removal procedure.

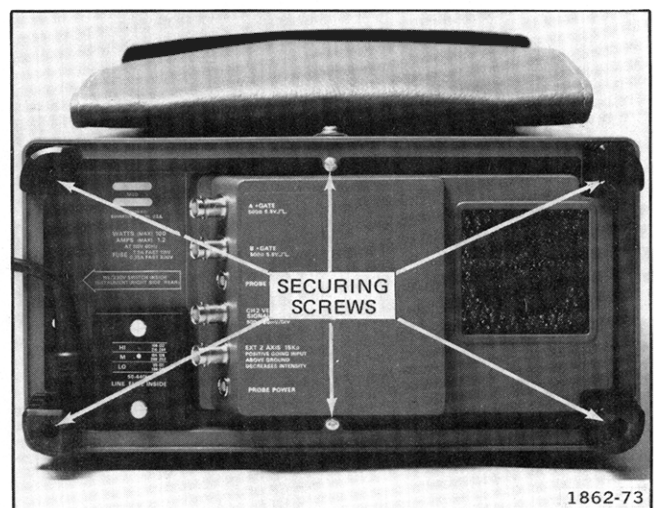

Fig. 5-1. Typical Rear Cabinet Frame Removal.

## A. POWER SUPPLIES AND CALIBRATOR

### Equipment Required

- |  |                           |
|--|---------------------------|
| 1. Digital Multimeter                              | 4. Autotransformer        |
| 2. DC Voltmeter                                    | 5. Three-Inch Screwdriver |
| 3. Test Oscilloscope (with 10X probe and 1X probe) | 6. Shorting Strap         |

See **ADJUSTMENT LOCATIONS 1** pull-out page for adjustments and test points (TP).

### 466 Control Settings:

#### Power

Regulating Range Selector Medium  
 Line Voltage Selector 115 V  
 POWER ON

A TRIGGER SOURCE	NORM
B (DLY'D) TRIGGER SOURCE	STARTS AFTER DELAY
TRIG MODE	AUTO
A TRIG HOLDOFF	NORM

#### Display

REDUCED SCAN (PULL) Push INTEN in  
 INTEN Midrange  
 FOCUS Midrange  
 SCALE ILLUM As desired  
 ASTIG Best defined trace

#### Sweep (A and B)

HORIZ DISPLAY	A
A TIME/DIV	1 ms
B TIME/DIV	1 ms
VAR TIME/DIV	Calibrated detent
DELAY TIME POSITION	Fully counterclockwise
X10 MAG	Off (button out)
POSITION (horizontal)	Midrange
FINE	Midrange

#### Vertical (CH 1 and CH 2)

VERT MODE CH 1  
 POSITION Midrange  
 VOLTS/DIV 5 mV  
 VAR VOLTS/DIV Calibrated detent  
 AC-GND-DC DC  
 INVERT Normal (button out)  
 20 MHz BW (PULL) Full bandwidth (Push in, then release. Shows no yellow)

#### Preliminary

a. Check that the Line Voltage Selector switch (located on side panel), indicates the correct nominal line voltage. The oscilloscope is shipped from the factory with this switch set for 115 Vac, unless otherwise specified. Verify this setting. If the line voltage is changed to 230 V line, the fuse should also be changed. (See parts list for correct value.)

#### Storage

NON STORE On (button in)  
 STORAGE LEVEL NORM  
 SAVE INTEN Midrange  
 SAVE Off (button out)  
 VIEW TIME NORM

b. Set the Regulating Range Selector (located on the rear panel) to indicate the correct nominal line voltage range.

c. Connect the 466 to the correct line voltage source.

#### Trigger (A and B)

COUPLING AC  
 LEVEL Midrange  
 SLOPE +

d. Pull POWER switch on. Within less than one minute, a baseline trace should appear within the display area. Allow at least 20 minutes warmup at an ambient temperature between +20°C and +30°C for checking instrument to accuracies specified.

**1. Check/Adjust Power Supply DC Levels And Ripple**

**NOTE**

Review the important information at the beginning of the Calibration section before starting calibration.

- a. Connect digital multimeter between test point given in Table 5-A-1 and ground on interface board.

CHECK—

**TABLE 5-A-1**

Power Supply	Test Point	Tolerance	Reading
+65 Volt	+65 V	±0.5%	+64.67 to +65.33
+15 Volt	+15 V	±1.5%	+14.77 to +15.23
+5 Volt	+5 V	±1.5%	+4.92 to +5.08
-8 Volt	-8 V	±1.5%	-7.88 to -8.12
-15 Volt	-15 V	±1.5%	-14.77 to -15.23
+140 Volt	+140 V	±5.0%	+133 to +147

**NOTE**

If the adjustment in step 1b is made, the oscilloscope will require complete recalibration.

- b. Connect digital multimeter between +65 Volt test-point and ground on interface board.

ADJUST—+65 Volt Supply (R1736) for +65.00 volts. Recheck the power supplies to the tolerances listed in Table 5-A-2.

CHECK—

**TABLE 5-A-2**

Power Supply	Test Point	Tolerance	Reading
+65 Volt	+65 V	±0.1%	+64.93 to +65.07
+15 Volt	+15 V	±0.7%	+14.89 to +15.11
+5 Volt	+5 V	±0.7%	+4.96 to +5.04
-8 Volt	-8 V	±0.7%	-7.88 to -8.12
-15 Volt	-15 V	±0.7%	-14.89 to -15.11
+140 Volt	+140 V	±5.0%	+133 to +147

- c. Disconnect digital multimeter and connect test oscilloscope to +65 Volt test point and ground on interface board. Check ripple amplitude while varying autotransformer between 103.5 to 126.5 Vac.

CHECK—

**TABLE 5-A-3**

Power Supply	Test Point	Typical Ripple (Peak-to-peak)
+65 Volt	+65 V	4 mV
+15 Volt	+15 V	2 mV
+5 Volt	+5 V	2 mV
-8 Volt	-8 V	2 mV
-15 Volt	-15 V	2 mV
+140 Volt	+140 V	300 mV

- d. Return line voltage to 115 volts and disconnect test oscilloscope.

**2. Check High Voltage**

- a. Verify NON STORE button is pushed in and INTEN-REDUCED SCAN (PULL) button is pushed in.

- b. Connect dc voltmeter between TP1501 and ground on interface board.

CHECK—Crt cathode voltage is -1470 V, within 2% (-1440 V to -1500 V).

- c. Disconnect dc voltmeter.

**3. Check/Adjust Calibrator Accuracy**

- a. Connect shorting strap from TP1367 to TP1372.

- b. Connect digital multimeter between ground and CALIBRATOR current loop.

CHECK—Calibrator dc level is 300 mV, within 0.3% from +20°C to +30°C (299.1 to 300.9 mV) or 1.0% from 0°C to +40°C (297 to 303 mV) or 1.5% from -15°C to +55°C (295.5 to 304.5 mV).

ADJUST—Amplitude (R1375) for 300 mV.

- c. Remove shorting strap.

- d. Disconnect digital multimeter.

- e. Set test oscilloscope:

Volts/Div                    10 mV  
Time/Div                    0.2 ms

- f. Connect 10X probe to CALIBRATOR current loop.

CHECK—Calibrator frequency is 1 kHz within 25%; 0.8 ms (4 div) to 1.33 ms (6.65 div) per cycle.

- g. Remove 10X probe.

## B. DISPLAY AND Z-AXIS

### Equipment Required

- |                        |                                |
|------------------------|--------------------------------|
| 1. Digital Multimeter  | 5. 50 Ohm BNC Cable            |
| 2. Time-Mark Generator | 6. 50 Ohm BNC Termination      |
| 3. Test Oscilloscope   | 7. Three-inch Screwdriver      |
| 4. 10X Probe           | 8. Low-Capacitance Screwdriver |

See **ADJUSTMENT LOCATIONS 1** pull-out page for adjustments and test points (TP).

### 466 Control Settings (\*Indicates changes from the previous step)

POWER ON

B (DLY'D) TRIGGER SOURCE STARTS AFTER DELAY  
 TRIG MODE AUTO  
 A TRIG HOLD OFF NORM

### Display

REDUCED SCAN (PULL) Push INTEN in  
 \*INTEN \*Fully counterclockwise  
 FOCUS Midrange  
 SCALE ILLUM As desired  
 ASTIG Best defined trace

### Sweep (A and B)

\*A TIME/DIV \*X-Y  
 \*B TIME/DIV \*X-Y  
 VAR TIME/DIV Calibrated detent  
 DELAY TIME POSITION Fully counterclockwise  
 HORIZ DISPLAY A  
 X10 MAG Off (button out)  
 POSITION (horizontal) Midrange  
 FINE Midrange

### Vertical (CH 1 and CH 2)

VERT MODE CH 1  
 POSITION Midrange  
 VOLTS/DIV 5 mV  
 VAR VOLTS/DIV Calibrated detent  
 \*AC-GND-DC \*GND  
 INVERT Normal (button out)  
 20 MHz BW (PULL) Full bandwidth (push in, then release. Shows no yellow)

### 1. Adjust Crt Grid Bias

a. Connect digital multimeter between TP1443 and ground.

b. Set INTEN control for +20 V and SCALE ILLUM to off (fully counterclockwise).

CHECK—Crt display for well-defined, low-intensity dot, using FOCUS and ASTIG controls as needed.

ADJUST—Crt Grid Bias (R1454) for dimmest, visible dot.

c. Disconnect digital multimeter.

### Storage

NON STORE On (button in)  
 STORAGE LEVEL NORM  
 INTEN (SAVE) Midrange  
 SAVE Off (button out)  
 VIEW TIME NORM

### Trigger (A and B)

COUPLING AC  
 LEVEL Midrange  
 SLOPE +  
 A TRIGGER SOURCE NORM

**2. Adjust Trace Alignment**

a. Set:

A TIME/DIV	.5 ms
INTEN	Midrange

b. Position trace to center horizontal graticule line.

CHECK—Trace is parallel with center horizontal line.

ADJUST—TRACE ROTATION (front-panel adjustment) to make trace parallel to center horizontal line.

**3. Adjust Display Controls, Y-Axis Alignment and Geometry**

a. Set:

CH 1 AC-GND-DC	DC
CH 1 VOLTS/DIV	0.1 V

b. Connect 1 ms time marks from time-mark generator to CH 1 Input connector via 50 ohm cable and 50 ohm termination.

c. Adjust VAR TIME/DIV control for 1 time mark/major div, then set time-mark generator for .1 ms (10 time marks/large div).

CHECK—Center time-mark tilt is 0.1 div or less, when compared to center vertical graticule line.

ADJUST—Y-Axis Alignment (R1563) to align center time mark with center vertical graticule line.

INTERACTION—Y-Axis Alignment and TRACE ROTATION adjustments. Readjust until there is minimum interaction.

CHECK—Vertical curvature of time marks across graticule area is 0.1 div or less.

ADJUST—Geometry (R1556) for minimum curvature of time marks.

d. Remove time-marks from CH 1 Input.

CHECK—Trace curvature is 0.1 div or less, when positioned from graticule top to bottom.

INTERACTION—Geometry (R1556) and Y-Axis Alignment (R1563) adjustments. Adjust both for optimum response.

**4. Adjust Z-Axis Compensation**

a. Connect test oscilloscope 10X probe to TP1443. Set test oscilloscope vertical input to ac, Volts/div to 5 V (with probe), Time/div to 1  $\mu$ s. Adjust trigger, intensity and position controls to center signal in display area.

b. Set oscilloscope under test A TIME/DIV switch to .05  $\mu$ s, VAR TIME/DIV to calibrated detent, and INTEN control to produce a 15 volt display on the test oscilloscope.

c. Set test oscilloscope Time/div to .2  $\mu$ s and center the unblanking gate signal within the display area.

CHECK—Display for best square corner on unblanking gate signal.

ADJUST—Z-Axis Compensation (C1435), using low capacitance screwdriver, for best square corner on unblanking gate signal.

d. Disconnect test equipment setup.

## C. VERTICAL

### Equipment Required

- |   |  |
|---|--|
| <ol style="list-style-type: none"> <li>1. Amplitude Calibrator</li> <li>2. Test Oscilloscope (only if gain requires complete recalibration)</li> <li>3. Square-Wave Generator</li> <li>4. Leveled Sine-Wave Generator</li> <li>5. 2 10X Probes (one should have Scale-Factor Switching, however an 11 kΩ resistor may be substituted in step 1, part a).</li> <li>6. 50 Ohm BNC Cable (2 required)</li> </ol> | <ol style="list-style-type: none"> <li>7. Dual-Input Coupler</li> <li>8. 2X or 5X BNC Attenuator</li> <li>9. 10X BNC Attenuator (2 required)</li> <li>10. 50 Ohm BNC Termination (2 required)</li> <li>11. Low-Capacitance Screwdriver</li> <li>12. Screwdriver</li> <li>13. BNC-to-probe tip adapter</li> </ol> |
|---|--|

See **ADJUSTMENT LOCATIONS 2** pull-out page for adjustments and test points (TP).

### 466 Control Settings: (\*Indicates changes from the previous step)

POWER	ON
<b>Display</b>	
REDUCED SCAN (PULL)	OFF (push INTEN in)
INTEN	As desired
FOCUS	For optimum definition
SCALE ILLUM	As desired
ASTIG	Best defined trace

### Vertical (CH 1 and CH 2)

VERT MODE	CH 1
POSITION	Midrange
*VOLTS/DIV	*5 mV
VAR VOLTS/DIV	Calibrated detent
*AC-GND-DC	*DC
INVERT	Normal (button out)
20 MHz BW (PULL)	Full bandwidth (push in, then release. Shows no yellow)

### Storage

NON STORE	On (button in)
STORAGE LEVEL	NORM
SAVE INTEN	Midrange
SAVE	Off (button out)
VIEW TIME	NORM

### Trigger (A and B)

COUPLING	AC
LEVEL	As needed for stable display
SLOPE	+
A TRIGGER SOURCE	NORM
B (DLY'D) TRIGGER SOURCE	STARTS AFTER DELAY
TRIG MODE	AUTO
A TRIG HOLD OFF	NORM

### Sweep (A and B)

HORIZ DISPLAY	A
*A TIME/DIV	*1 ms
*B TIME/DIV	*1 ms
*VAR TIME/DIV	*Calibrated detent
DELAY TIME POSITION	Fully counterclockwise
X10 MAG	Off (button out)
POSITION (horizontal)	Midrange
FINE	Midrange

### 1. Check Probe Indicator Lamps

a. Connect a 10X probe with a scale-factor switching connector to CH 1 input (if no scale-factor switching probe is available, an 11 kΩ resistor may be used. Connect the resistor between ground and the metal coding ring on the input connector).

CHECK—5 mV lamp is extinguished and 50 mV lamp is on.

b. Set VERT MODE switch to CH 2 and move probe to CH 2 input.

CHECK—5 mV lamp is extinguished and 50 mV lamp is on.

c. Remove 10X probe.

## 2. Check Input Coupling Switches

a. Connect 20 mV standard amplitude signal from calibration generator to CH 2 input via 50  $\Omega$  cable.

b. Position bottom of display to center horizontal graticule line and set CH 2 AC-GND-DC switch to GND.

CHECK—No vertical deflection; trace is at center horizontal graticule line.

c. Set CH 2 Input coupling to AC.

CHECK—Display is centered about center horizontal graticule line.

d. Set VERT MODE switch to CH 1 and move test signal to CH 1.

e. Position bottom of display to center horizontal graticule line.

f. Set CH 1 AC-GND-DC switch to GND.

CHECK—No vertical deflection; trace is at center horizontal graticule line.

g. Set CH 1 AC-GND-DC switch to AC.

CHECK—Display is centered about center horizontal graticule line.

h. Disconnect square-wave signal.

## 3. Check Alternate Mode

a. Set:

VERT MODE	ALT
A TRIGGER LEVEL	Fully clockwise

b. Position two traces about 2 divisions apart.

CHECK—Sweeps alternate for all A TIME/DIV settings except X-Y.

## 4. Check Chop Mode

a. Set:

A TIME/DIV	1 $\mu$ s
VERT MODE	CHOP
AC-GND-DC (both)	GND
A TRIGGER COUPLING	HF REJ
A TRIGGER LEVEL	As needed for stable display

b. Position two traces about 4 divisions apart and set A TRIGGER LEVEL control for a stable display.

CHECK—Vertical Switching transients are completely blanked between horizontal chopped segments.

CHECK—Duration of each cycle is about 4 divisions (exact measured duration is affected by instrument timing).

c. Set:

VERT MODE	CH 1
AC-GND-DC (both)	DC
CH 1 VOLTS/DIV	.2 V
A TRIGGER COUPLING	AC

## 5. Adjust Output Amplifier Bias

### NOTE

*The final adjustment of R478 (Bias Adj) should achieve a compromise between maximum signal amplitude, optimum transient response, and minimum position effect. R478 adjustment is covered in Step 5, part b and later steps in this procedure. Severe misadjustment of R478 may result in loss of gain, or excessive aberrations when display is in some vertical positions.*



## Calibration—466 Service

*RECALIBRATION—Do not adjust at this time—instead, move to Step 6 and complete the checks or adjustments in Steps 6 through 26. For calibration after repair or replacement of vertical components—do Step 5.*

*If calibration requirements are met, there is no need to make this adjustment. If position effect, aberrations and risetime requirements are not met, then make this adjustment.*

*After the adjustment, do Steps 6 through 26. If calibration requirements are still not met, the setting of bias adjustment may be compromised to meet position effect, aberrations and risetime.*

a. Connect 100 MHz signal from leveled sine-wave generator to CH 1 input via 50  $\Omega$  cable and 50  $\Omega$  termination. Adjust generator for approximately 4 div of signal display.

b. ADJUST—Bias Adj (R478) for maximum signal.

c. Disconnect test equipment.

### 6. Check Beam Finder

a. Push in BEAM FINDER button and hold.

CHECK—Trace remains entirely on screen, regardless of the setting of vertical or horizontal POSITION controls.

b. Release BEAM FINDER button.

### 7. Check/Adjust CH 1 Var Volts/Div Balance And Var Indicator

a. Position trace to center horizontal graticule line.

CHECK—CH 1 UNCAL lamp is on when VAR control is out of detent.

CHECK—Trace shift of 0.2 div or less when rotating VAR control through its range.

ADJUST—CH 1 Var Bal (R84) for minimum trace shift while rotating CH 1 VAR control through its range.

b. Return CH 1 VAR control to detent position.

### 8. Check/Adjust CH 1 Position Centering

a. Connect about 50 kHz signal from leveled sine-wave generator to CH 1 input via 50  $\Omega$  cable and 50  $\Omega$  termination.

b. Set:

CH 1 VOLTS/DIV	.2 V
CH 1 AC-GND-DC	AC
A TIME/DIV	1 ms

c. Adjust generator for 2.4 div display,—then change CH 1 VOLTS/DIV switch to 20 mV without moving the VAR control.

CHECK—Top of display positions down to center horizontal graticule line or below, bottom of display positions up to center horizontal graticule line or above.

ADJUST—CH 1 Pos Ctr (R166) so display positions same distance above and below graticule center line.

d. Disconnect generator.

### 9. Check/Adjust CH 2 Var Volts/Div Balance And Var Indicator

a. Set VERT MODE switch to CH 2 and position trace to center horizontal graticule line.

CHECK—CH 2 UNCAL lamp is on when VAR control is out of detent.

CHECK—Trace shift if 0.2 div or less when rotating VAR control through its range.

ADJUST—CH 2 Var Bal (R184) for minimum trace shift while rotating CH 2 VAR control through its range.

b. Return CH 2 VAR control to detent position.

### 10. Check/Adjust CH 2 Invert Balance

a. Set CH 2 AC-GND-DC to GND.

b. Position trace to center horizontal graticule line and push INVERT button.

CHECK—Trace shift is .2 div or less when switching from normal to inverted.

ADJUST—Invert Bal (R212) for minimum trace shift.

INTERACTION—Invert Bal (R212) and Var Bal (R184). Readjust as needed for no visible interaction.

### 11. Check/Adjust CH 2 Position Centering

a. Connect about 50 kHz signal from leveled sine-wave generator to CH 2 input via 50 Ω cable and 50 Ω termination.

b. Set:

INVERT	Normal (button out)
CH 2 VOLTS/DIV	.2 V
CH 2 AC-GND-DC	AC
A TRIG LEVEL	Fully clockwise

c. Adjust generator for 2.4 div display—then change CH 2 VOLTS/DIV switch to 20 mV without moving VAR control.

CHECK—Top of display positions down to center horizontal graticule line or below, bottom of display positions up to center horizontal graticule line or above.

ADJUST—CH 2 Pos Ctr (R266) so display positions same distance above and below graticule line.

d. Disconnect generator.

### 12. Check CH 2 and CH 1 Gate Current

a. Set:

AC-GND-DC (both)	GND
VOLTS/DIV (both)	5 mV

b. Position trace to graticule center and change AC-GND-DC switch to DC.

CHECK—Trace shift is 0.1 div or less, when switching between GND and DC.

c. Change VERT MODE to CH 1, position trace to graticule center and change AC-GND-DC switch to DC.

CHECK—Trace shift is 0.1 div or less, when switching between GND and DC.

d. Set both AC-GND-DC switches to DC.

### 13. Check/Adjust Gain

#### NOTE

*It is not always necessary to do a complete recalibration to meet instrument gain specifications. Use following sequence to determine needed adjustments.*

a. CHECK—Step 13 parts (a), (b), and (f). Note CH 1 5 mV/DIV accuracy.

b. CHECK—Step 13 parts (g) and (h). Note CH 2 5 mV/DIV accuracy.

(1). If both channels are within 3%, continue with parts (i) through (k) and remainder of procedure.

(2). If error exceeds 3% and both channels have an error of the same polarity (for example—CH 1 is +4% and CH 2 is +2%) adjust the smaller error to zero using Output Gain Adj R415 then adjust either CH 1 Gain Adj (R92) or CH 2 Gain Adj (R192) to remove the remaining error (for example—CH 1 error is +4% and CH 2 is +2%. Adjust Output Gain Adj to change the error for CH 2 to 0% and CH 1 to +2%. Then adjust CH 1 Gain Adj to reduce CH 1 error to 0%).

(3). If error exceeds 3% and the channels have an error of opposite polarity (for example—CH 1 is +4% and CH 2 is -2%) adjust the larger error to match the lesser error, using either CH 1 Gain Adj (R92) or CH 2 Gain Adj (R192) then adjust Output Gain Adj R415 to remove the remaining error (for example—CH 1 error is +4% and CH 2 is -2%. Adjust CH 1 Gain Adj to change the error of CH 1 to -2%. Then adjust Output Gain Adj to reduce CH 1 and Ch 2 errors to 0%).

c. If any gain adjustment has insufficient adjustment range, a complete gain recalibration is needed. Start with Step 13 part (a) and continue. This establishes a typical CH 1 output used as a reference for setting output gain.

(a). Set:

VERT MODE	CH 1
CH 1 VOLTS/DIV	5 mV
CH 1 AC-GND-DC	DC

## Calibration—466 Service

(b). Connect 20 mV standard amplitude signal from calibration generator to CH 1 input via 50  $\Omega$  cable.

(c). Set:

### Test Oscilloscope Controls

Vertical mode	Add
Channel 2	Invert
Volts/Div (both)	.1 V (with 10X probe)
Triggering	For free-running sweep

(d). Connect two 10X probes from test oscilloscope to TP322 and TP324 on preamp board.

CHECK—Signal between TP322 and TP324 is 400 mV peak-to-peak (4 div).

ADJUST—CH 1 Gain Adj (R92) for 400 mV peak-to-peak. (NOTE: This is a nominal value for this adjustment. It may be reset to obtain correct CH 1 input-to-display gain.)

(e). Remove 10X probes from TP322 and TP324.

(f). Observe crt display.

CHECK—Display is 4 div within 3% ( $\pm 0.12$  div).

ADJUST—Output Gain Adj R415 for 4 div display.

(g). Set:

VERT MODE	CH 2
CH 2 VOLTS/DIV	5 mV
CH 2 AC-GND-DC	DC

(h). Connect 20 mV standard amplitude signal from amplitude calibrator to CH 2 input via 50  $\Omega$  cable.

CHECK—Display is 4 div within 3% ( $\pm 0.12$  div).

ADJUST—CH 2 Gain Adj (R192) for 4 div display.

(i). Change VOLTS/DIV and calibration generator settings as shown in Table 5-C-1.

CHECK—Display is either 5 div  $\pm 0.15$  div or 4 div  $\pm 0.12$  div.

(j). Set:

VERT MODE	CH 1
CH 1 VOLTS/DIV	5 mV
CH 1 AC-GND-DC	DC

(k). Connect 20 mV standard amplitude signal from the amplitude calibrator to CH 1 input via 50  $\Omega$  cable.

CHECK—Display is either 5 div  $\pm 0.15$  div. or 4 div  $\pm 0.12$  div. Check All VOLTS/DIV settings. See Table 5-C-1.

TABLE 5-C-1

### Vertical Deflection Accuracy

VOLTS/DIV SETTING	AMPLITUDE CALIBRATOR SIGNAL	DEFLECTION IN DIV FOR 3% ACCURACY		READING IN DIV
		DIVISIONS	ACCURACY	
10 m	50 mV	5	$\pm 0.15$ div	4.85 to 5.15
20 m	0.1 V	5	$\pm 0.15$ div	4.85 to 5.15
50 m	0.2 V	4	$\pm 0.12$ div	3.88 to 4.12
.1	0.5 V	5	$\pm 0.15$ div	4.85 to 5.15
.2	1 V	5	$\pm 0.15$ div	4.85 to 5.15
.5	2 V	4	$\pm 0.12$ div	3.88 to 4.12
1	5 V	5	$\pm 0.15$ div	4.85 to 5.15
2	10 V	5	$\pm 0.15$ div	4.85 to 5.15
5	20 V	4	$\pm 0.12$ div	3.88 to 4.12

**14. Check CH 1 and CH 2 Var Volts/Div Range**

a. Set both VOLTS/DIV switches to 10 mV and amplitude calibrator for 50 mV signal.

b. Rotate CH 1 VAR control fully counterclockwise.

CHECK—Display reduces to 2 div or less.

c. Move signal to CH 2 Input connector and set VERT MODE switch to CH 2.

d. Rotate CH 2 VAR control fully counterclockwise.

CHECK—Display reduces to 2 div or less.

e. Return both VAR controls to detent position.

**15. Check Add Mode**

a. Set:

VOLTS/DIV (both)	5 mV
VERT MODE	ADD
INVERT	Normal (button out)

b. Connect 10 mV standard amplitude signal from amplitude calibrator to both inputs via 50 Ω cables and dual-input coupler.

CHECK—Display of 4 div, ±3%, if gain adjustments in Step 13 were not changed, or 4 div, ±1%, if gain adjustments in Step 13 were changed.

**16. Check Compression And Expansion**

a. Set:

CH 2 AC-GND-DC	GND
VERT MODE	CH 1

b. Adjust CH 1 VAR control for 2 div display centered about center horizontal graticule line.

c. Position top of display to top graticule line.

CHECK—Display compression or expansion is 0.1 div or less.

d. Position bottom of display to bottom graticule line.

CHECK—Display compression or expansion is 0.1 div or less.

e. Set CH 1 VAR control to detent position.

f. Disconnect amplitude calibrator and dual-input coupler.

**17. Check/Adjust Output Low-Frequency Compensation**

a. Set:

A TIME/DIV	0.2 ms
VERT MODE	CH 1
AC-GND-DC (both)	DC
VOLTS/DIV (both)	5 mV
A TRIG LEVEL	As needed for stable display.

b. Connect fast-rise, + output of square-wave generator to CH 1 via a 50 Ω cable, 10X attenuator, and 50 Ω termination.

c. Adjust square-wave generator to maintain 5 div display throughout Step 17.

d. Adjust square-wave generator for signal indicated in Table 5-C-2.

**TABLE 5-C-2**

**Maximum Overshoot or Roll-Off**

Square-Wave Generator Signal	A TIME/DIV Setting	Maximum Overshoot Or Roll-off in div
100 Hz	2 ms	4.85 to 5.15
1 kHz	.2 ms	4.85 to 5.15
10 kHz	20 μs	4.85 to 5.15
100 kHz	2 μs	4.85 to 5.15

CHECK—Display overshoot or roll-off is within 3% (5 div ±0.15 div).

e. If above checks are within 3%, proceed to Step 18.

**Calibration—466 Service**

f. If not, make following adjustments for best flat-top waveform.

ADJUST—

**TABLE 5-C-3**

**Overshoot or Roll-off Adjustment**

Square-Wave Generator Signal	A TIME/DIV Setting	Output Adjustment
100 Hz	2 ms	R444
1 kHz	.2 ms	R445
10 kHz	20 $\mu$ s	R446
100 kHz	2 $\mu$ s	R453, R107, C107

INTERACTION—R444, R445, R446, R453, R107 and C107. Readjust as needed for best overall response within 3% (C108 and R108 may also require adjustment at this time if severe mis-adjustment or repairs have been made to the associated circuitry).

- g. Set VERT MODE switch to CH 2.
- h. Connect square-wave generator to CH 2 input.

CHECK—Display overshoot or roll-off is within 3% (5 div  $\pm$ 0.15 div) using Table 5-C-2.

ADJUST—R207, C207 for best flat-top waveform, using 100 kHz square-wave generator signal (C208 and R208 may also require adjustment at this time if severe mis-adjustment or repairs have been made to the associated circuitry).

**NOTE**

*It may be necessary to compromise the adjustments in Step 17, parts d through h to obtain the best reponse between CH 1 and CH 2.*

- i. Disconnect square-wave generator from CH 2 input.

**18. Check/Adjust CH 1 Volts/Div Compensation**

**NOTE**

*C10, in the CH 1 Preamp, is set at the factory to give C10, in the CH 2 Preamp, enough range to match CH 2 input capacitance with CH 1 input capacitance. Unless there is a circuit malfunction, the CH 1 C10 should not need readjustment. When adjusting either C10, or other adjustments in this section, if the low-capacity screwdriver contains a metal bit, the metal may affect the adjustment. Check adjustment after the screwdriver is removed, and re-adjust as necessary.*

a. Set:

VOLTS/DIV (both)	5 mV (see note)
VERT MODE	CH 1
A TIME/DIV	.2 ms (see note)
20 MHz BW (PULL)	Pull out (shows yellow)

**NOTE**

*In steps 18 and 19, all VOLTS/DIV settings assume the use of a 10X probe with Scale-Factor switching (preferably the probe supplied as a standard accessory with the oscilloscope you are calibrating). If it is necessary to use a 10X probe without Scale-Factor switching, set the VOLTS/DIV knob to indicate one tenth of the setting listed (5 mV instead of 50 mV, etc). When adjusting compensation, one adjustment will affect the waveform front corner, and another will affect the flat top. Ignore the front corner when making the flat top adjustment and vice-versa. The A TIME/DIV should be set to 1 ms for the flat top, and to .2 ms for front corner checks and adjustments.*

b. Connect a 10X probe to the CH 1 input (note that the VOLTS/DIV Scale-Factor switching will now indicate 50 mV).

c. Connect the square-wave generator high-amplitude output to either a 2X, 5X, or 10X BNC attenuator (depending on generator amplitude), to a 50  $\Omega$  BNC termination, to a BNC-to-probetip adapter, to the tip of the 10X probe.

d. Adjust the square-wave generator for a 5 division, 1 kilohertz display and add or remove attenuators and termination as needed to maintain a 5 division display throughout steps 18 and 19.

e. Adjust the probe compensation adjustment for the best flat-top waveform. Do not re-adjust probe compensation throughout the remainder of steps 18 and 19.

f. Set VOLTS/DIV to .1 V.

g. CHECK—Compensation for all VOLTS/DIV settings listed in Table 5-C-4 for display overshoot, roll-off, and flat-top within 2% (5 div  $\pm$ 0.1 div). If all settings are within 2%, skip part h, otherwise perform part h.

h. ADJUST—Any adjustment pair (see Table 5-C-4) as necessary so compensation for all settings is within 2%.

**19. Adjust CH 2 Volts/Div Compensation**

a. Set:

VERT MODE                      CH 2

b. Transfer the 10X probe from the CH 1 input to the CH 2 input.

c. Adjust the square-wave generator for a 5 division, 1 kilohertz display and add or remove attenuators and termination as needed to maintain a 5 division display throughout the remainder of this step.

d. CHECK—The display for a flat-top waveform within 2%.

e. ADJUST—C10 in the CH 2 preamp for the best flat-top waveform using a low-capacitance screwdriver.

f. Repeat Step 18, parts f through h for CH 2.

g. Disconnect test setup.

**TABLE 5-C-4**

**VOLTS/DIV COMPENSATION**

VOLTS/DIV Setting (10X Scale-Factor)	Adjust	
	(T/Div 1 ms) Flat	(T/Div .2 ms) Corner
.1V	C37	C36
.2V	C35	C34
.5V	C33	C32
1V	Check	Check
2V	Check	Check
5V	C31	C30

**NOTE**

*If the oscilloscope is to be used primarily with a 50 ohm signal source, more accurate reproduction of the waveform front corner may be achieved by calibrating with a 50 ohm system. To accomplish this, substitute a properly terminated 50 ohm cable for the 10X probe while making the corner adjustments listed in Table 5-C-4.*

## Calibration—466 Service

### 20. Check/Adjust CH 2 and Output High-Frequency Compensation

a. Set:

VOLTS/DIV (both)	5 mV
A TRIGGER SLOPE	+
20 MHz BW (PULL)	Full bandwidth (push in, then release; shows no yellow)

b. Connect fast-rise, + output of square-wave generator to CH 2 input via 50  $\Omega$  cable, 10X attenuator and 50  $\Omega$  termination.

#### NOTE

*Adjustments in Steps 20 through 26 interact. Perform all the checks, but not the adjustments, in these steps before making any adjustments (unless calibration is being performed after repair or replacement of vertical components).*

*If all checks are within the given limits, proceed to Step 27.*

*If not, perform checks and adjustments in Steps 20 through 26, using low-capacitance screwdriver.*

*If still not within the given limits:—Perform Steps 6 through 26.*

*If still not within the given limits:—Compromise the adjustment of Vertical Output Bias (R478), setting it to minimize the aberrations in Step 21 parts a and d. (See NOTE preceding Step 5 part a.)*

c. Adjust square-wave generator for 100 kHz to 1 MHz display, 5 div high.

d. Set A TIME/DIV to about 0.2  $\mu$ s.

CHECK—Flat-top display with aberrations typically within 4% (5 div  $\pm$ 0.2 div). See Fig. 5-C-1 for typical display.

ADJUST—C409, C428, R428, C455, R455, C233, C208, R208, C312 and R312, in the order given, for best flat-top waveform with fastest risetime. *also C207 & R207*

e. Connect test setup to fast-rise, -output of square-wave generator.

f. Set A TRIGGER SLOPE to -.

CHECK—Flat-bottom display with aberrations within 5% (5 div  $\pm$ 0.25 div).

INTERACTION—Adjustments in Step 20d affect negative-step aberrations. Optimize risetime and minimum aberrations on both positive- and negative-going displays in Steps 20d and f.

### 21. Check CH 2 Position Effect

a. Position bottom of display to top graticule line.

CHECK—Display aberrations are within 7% (5 div  $\pm$ 0.35 div).

b. Set A TRIGGER SLOPE control to +.

c. Connect test setup to fast-rise, + output of square-wave generator.

d. Position top of display to bottom graticule line.

CHECK—Display aberrations are within 5% (5 div  $\pm$ 0.25 div).

### 22. Check/Adjust CH 1 High-Frequency Compensation

a. Set VERT MODE switch to CH 1.

b. Move test signal from CH 2 input to CH 1 input.

CHECK—Flat-top display with aberrations within 3% (5 div  $\pm$ 0.15 div). See Fig. 5-C-1 for typical display.

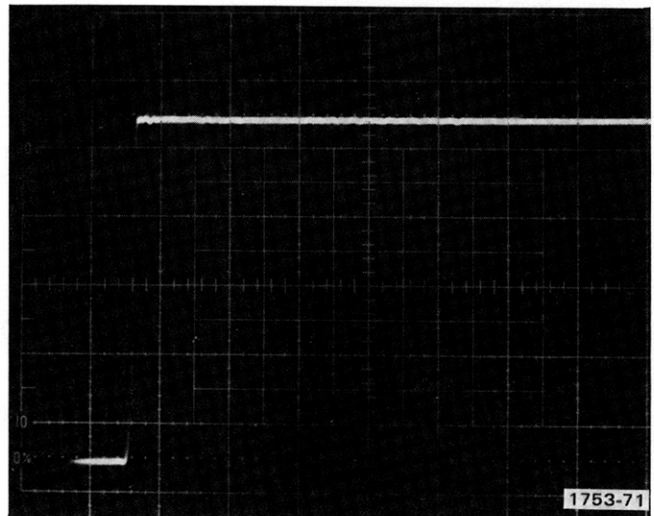

Fig. 5-C-1. Typical display when high-frequency compensation is correctly adjusted.

ADJUST—C133, C108, R108, C302 and R302, in the order given, for best flat-top display. *also C107 + R107*

c. Connect test setup to fast-rise, —output of square-wave generator.

d. Set A TRIGGER SLOPE to —.

CHECK—Flat-bottom display with aberrations within 5% (5 div  $\pm 0.25$  div).

INTERACTION—Adjustments in Step 22 part b affect negative step. Optimize risetime and minimum aberrations on both positive- and negative-going displays in Step 22 parts b and d.

**23. Check CH 1 Position Effect**

a. Position bottom of display to top graticule line.

CHECK—Display aberrations are within 7% (5 div  $\pm 0.35$  div).

b. Set A TRIGGER SLOPE control to +.

c. Connect test setup to fast-rise, positive output of square-wave generator.

d. Position top of display to bottom graticule line.

CHECK—Display aberrations are within 5% (5 div  $\pm 0.25$  div).

**24. Check CH 1 Transient Response**

a. Set A TRIGGER LEVEL to +.

b. Connect output of fast-rise, + output of square-wave generator to CH 1 input via 50  $\Omega$  cable, 10X attenuator and 50  $\Omega$  termination.

c. Adjust generator and add or remove attenuators to maintain a 5 div display through the 5 mV, 10 mV, 20 mV and 50 mV positions of CH 1 VOLTS/DIV switch.

**NOTE**

*It is possible to obtain more signal intensity. Set Storage Mode switch to VAR PERS and adjust STORAGE LEVEL, VIEW TIME and INTEN controls for most usable trace.*

CHECK—Display flat-top and aberrations are within 3% (5 div  $\pm 0.15$  div).

**25. Check CH 2 Transient Response**

a. Set VERT MODE to CH 2.

b. Move test setup to CH 2.

c. Adjust generator and add or remove attenuator to maintain a 5 div display through the 5 mV, 10 mV, 20 mV and 50 mV positions of CH 1 VOLTS/DIV switch.

CHECK—Display flat-top and aberrations are within 3% (5 div  $\pm 0.15$  div).

d. Remove test setup.

**26. Check Bandwidth**

a. Set:

A TIME/DIV	.2 ms
CH 2 VOLTS/DIV	5 mv

b. Connect about 50 kHz reference signal from leveled sine-wave generator to CH 2 input via 10X attenuator and 50  $\Omega$  termination.

c. Adjust generator for 5 div display.

d. Set generator for 100 MHz output frequency.

CHECK—Display amplitude is 3.5 div or more.

e. Repeat Step 26 parts c and d for 10 mV through 1 V positions of VOLTS/DIV switch.

f. Change VERT MODE to CH 1. Change test setup to CH 1 input.

g. Repeat Step 26 parts c and d for 5 mV through 1 V positions of VOLTS/DIV switch.

h. Disconnect test setup.



## Calibration—466 Service

### 27. Check Cascaded Gain And Bandwidth

a. Set:

VOLTS/DIV (both)	5 mV
AC-GND-DC (both)	AC
VERT MODE	CH 2
A TIME/DIV	1 ms

b. Connect CH 1 VERT SIGNAL OUT (on rear panel) to CH 2 input via 50  $\Omega$  cable and 50  $\Omega$  termination.

c. Connect 5 mV signal from amplitude calibrator to CH 1 input via 50  $\Omega$  cable.

CHECK—Display is 5 div or more.

d. Remove test setup from CH 1 input.

e. Connect about 50 kHz reference signal from leveled sine-wave generator to CH 1 input via 50  $\Omega$  cable, 10X attenuator and 50  $\Omega$  termination.

f. Adjust generator for 5 div display.

g. Set generator for 50 MHz output frequency.

CHECK—Display amplitude is 3.5 div or more.

h. Disconnect test setup.

### 28. Check Channel Isolation

a. Set:

CH 2 VOLTS/DIV	.2 V
VERT MODE	CH 2
CH 1 AC-GND-DC	GND

b. Connect 25 MHz signal from leveled sine-wave generator to CH 2 input via 50  $\Omega$  cable and 50  $\Omega$  termination.

c. Adjust generator for 2 div display.

d. Set:

VOLTS/DIV (both)	20 mV
VERT MODE	CH 1

CHECK—Display amplitude is 0.2 div or less.

e. Move test setup from CH 2 input to CH 1.

f. Set:

CH 1 AC-GND-DC	DC
CH 2 AC-GND-DC	GND

g. Set VERT MODE switch to CH 2.

CHECK—Display amplitude is 0.2 div or less.

h. Disconnect test setup.

### 29. Check Common-Mode Rejection Ratio

a. Set:

VOLTS/DIV (both)	5 mV
AC-GND-DC (both)	DC
VERT MODE	CH 1
CH 2 INVERT	Invert (pushed in)

b. Connect 20 MHz signal from leveled sine-wave generator to CH 1 and CH 2 inputs via 50  $\Omega$  cable, 10X attenuator, 50  $\Omega$  termination and dual-input coupler.

c. Set generator for 6 div display.

d. Set VERT MODE switch to ADD.

CHECK—Display is 0.6 div or less (indicates CMRR of at least 10:1 at 20 MHz).

e. Proceed to Step 29 part j if CHECK meets requirement.

f. Set VERT MODE switch to CH 1.

g. Set generator for 6 div display of 50 kHz reference signal.

h. Set VERT MODE switch to ADD.

ADJUST—CH 2 Gain Adj (R192) for minimum display (best CMRR).

i. Set generator for 20 MHz output frequency.

CHECK—Display is 0.6 div or less (indicates CMRR of at least 10:1 at 20 MHz).

j. Release CH 2 INVERT switch and disconnect test setup.

### 30. Check Bandwidth Limit Operation

a. Set:

20 MHz BW (PULL)	Pull out (shows yellow)
CH 1 AC-GND-DC	DC
VERT MODE	CH 1

b. Connect about 50 kHz reference signal from leveled sine-wave generator to CH 1 input via 50  $\Omega$  cable and 50  $\Omega$  termination.

c. Set generator for 6 div display.

d. Increase generator output frequency until display is 4.2 div.

CHECK—Generator output frequency is between 16 and 24 MHz.

e. Disconnect test setup.

## D. TRIGGER

<b>Equipment Required</b>	
1. Leveled Sine-Wave Generator	9. GR-to-BNC Female Adapter
2. Low-Frequency Sine-Wave Generator	10. 10X BNC Attenuator
3. Time-Mark Generator	11. 50-Ohm BNC Termination (2 required)
4. Amplitude Calibrator	12. Dual-Input Coupler (2 required)
5. Square-Wave Generator	13. BNC-T Connector
6. 50-Ohm Signal Pickoff Unit (Type CT-3)	14. 18-inch 50-Ohm BNC Cable (2 required)
7. 10X Probe	15. GR-to-BNC Male Adapter
8. 42-inch 50-Ohm BNC Cable (2 required)	16. Female-to-Female BNC Adapter
	17. Screwdriver

See **ADJUSTMENT LOCATIONS 3** pull-out pages for adjustments and test points (TP).

**466 Control Settings (\*Indicates change from previous step)**

POWER	ON
<b>Display</b>	
REDUCED SCAN (PULL)	Push INTEN in
INTEN	As desired
FOCUS	As desired
SCALE ILLUM	As desired
ASTIG	Best defined trace
<b>Vertical (CH 1 and CH 2)</b>	
VERT MODE	CH 1
POSITION	Midrange
*CH 1 VOLTS/DIV	*10 mV
*CH 2 VOLTS/DIV	*.1 V
VAR VOLTS/DIV	Calibrated detent
AC-GND-DC	DC
INVERT	Off (button out)
*20 MHz BW (PULL)	*Full bandwidth (push in, then release; shows no yellow)
<b>Storage</b>	
NON STORE	On (button in)
STORAGE LEVEL	NORM
SAVE INTEN	Midrange
SAVE	Off (button out)
VIEW TIME	NORM

**Trigger (A and B)**

COUPLING	AC
LEVEL	Midrange
SLOPE	+
A TRIGGER SOURCE	NORM
*B (DLY'D) TRIGGER SOURCE	*NORM
TRIG MODE	AUTO
A TRIG HOLDOFF	NORM

**Sweep (A and B)**

HORIZ DISPLAY	A
*A TIME/DIV	*.05 $\mu$ s
*B TIME/DIV	*.05 $\mu$ s
VAR TIME/DIV	Calibrated detent
DELAY TIME POSITION	Fully counterclockwise (0.2 $\mu$ s)
X10 MAG (IN)	Off (button out)
POSITION (horizontal)	Midrange
FINE	Midrange

**1. Check/Adjust A Trigger Sensitivity And Trig Lamp**

a. Connect 25 MHz signal from leveled sine-wave generator to A and B External Trigger inputs via 50  $\Omega$  cable, GR to BNC female adapter, CT-3 thru output, GR-to-BNC male adapter, 10X Attenuator, 50  $\Omega$  termination and dual-input coupler.

b. Connect CT-3 Sig Out 10% signal to CH 1 and CH 2 inputs via 50 Ω cable, 50 Ω termination and dual-input coupler.

c. Set generator for 3 div display.

d. Set CH 1 VOLTS/DIV switch to .1 V (0.3 div display).

CHECK—Stable triggered display obtained by rotating A TRIGGER LEVEL control with SLOPE set to both + and −.

CHECK—TRIG lamp is lit during stable display.

e. Set CH 1 VOLTS/DIV switch to .2 V (0.15 div display).

CHECK—No stable triggered display is obtained by rotating A TRIGGER LEVEL control with SLOPE set to both + and −.

f. If CHECKS in parts d and e meet the requirements, move to Step 2.

g. Set CH 1 VOLTS/DIV switch to 10 mV and adjust generator for 2.5 div display.

h. Set CH 1 VOLTS/DIV switch to .1 V.

ADJUST—A Trig. Sens (R655) so stable triggered display is just obtained by rotating A TRIGGER LEVEL control in both + and − slopes.

i. Set CH 1 VOLTS/DIV switch to 10 mV and adjust generator for 3 div display.

j. Set CH 1 VOLTS/DIV switch to .2 V.

CHECK—No stable triggered display is obtained by rotating A TRIGGER LEVEL control. If a stable triggered display is obtained, the trigger is too sensitive. Readjust A Trig. Sens (R655) for a stable triggered display with a 0.3 div display but no stable triggered display with a 0.15 div display (see parts d and e).

## 2. Check/Adjust B Trigger Sensitivity

a. Set:

HORIZ DISPLAY	B DLY'D
CH 1 VOLTS/DIV	10 mV
A TRIGGER LEVEL	Fully clockwise

b. Set leveled sine-wave generator for 3 div display.

c. Set CH 1 VOLTS/DIV switch to .1 V (0.3 div display).

CHECK—Stable triggered display obtained by rotating B TRIGGER LEVEL control with SLOPE set to both + and −.

d. Set CH 1 VOLTS/DIV switch to .2 V (0.15 div display).

CHECK—No stable triggered display is obtained by rotating B TRIGGER LEVEL control.

e. If CHECKS in parts c and d meet requirements, move to Step 3.

f. Set CH 1 VOLTS/DIV switch to 10 mV and adjust generator for 2.5 div display.

g. Set CH 1 VOLTS/DIV switch to .1 V.

ADJUST—B Trig Sens (R555) so stable triggered display is just obtained by rotating B TRIGGER LEVEL control with SLOPE set to both + and −.

h. Set CH 1 VOLTS/DIV switch to 10 mV and adjust generator for 3 div display.

i. Set CH 1 VOLTS/DIV switch to .2 V.

CHECK—No stable triggered display is obtained by rotating B TRIGGER LEVEL control. If a stable triggered display is obtained, the trigger is too sensitive. Readjust B Trig Sens (R555) for a stable triggered display with a 0.3 div display but no stable triggered display with a 0.15 div display (see parts d and e).

## 3. Check/Adjust B Trigger Slope And Level Centering

a. Set:

TIME/DIV (both)	10 μs
B TRIGGER LEVEL	0
CH 1 VOLTS/DIV	10 mV

b. Set leveled sine-wave generator for 4 div, 50 kHz display.

## Calibration—466 Service

c. Vertically center display about center horizontal graticule line. Horizontally move display as needed to view sweep start.

d. Switch B TRIGGER SLOPE switch between + and -.

CHECK—Display begins at the same vertical point on the center horizontal graticule line, in both + and - slopes.

ADJUST—B Trig Slope (R545) for + and - sine-wave portions to start at same point on sine wave.

ADJUST—B Trig Level (R535) for starting point of display to be at graticule center.

### 4. Check/Adjust A Trigger Slope And Level Centering

a. Set:

HORIZ DISPLAY	A
A TRIGGER LEVEL	0

b. Switch A TRIGGER SLOPE switch between + and -.

CHECK—Display begins at the same vertical point on the center horizontal graticule line, in both + and - slopes.

ADJUST—A Trig Slope (R645) for + and - sine-wave portions to start at same point on sine wave.

ADJUST—A Trig Level (R635) for starting point of display to be at graticule center.

### 5. Check/Adjust A Trigger DC Levels

a. Set leveled sine-wave generator for 5 div (50 mV) display.

b. Set CH 1 VOLTS/DIV switch to 50 mV and vertically center display about center horizontal graticule line.

c. Adjust A TRIGGER LEVEL control for stable display with both + and - slopes.

### NOTE

For parts d, e, and f: A TRIGGER LEVEL control must remain at 0 for proper adjustment. To check or reset the control, change A TRIGGER COUPLING to AC and adjust A TRIGGER LEVEL control for a stable display with both + and - slopes. Return trigger to dc-coupled mode. For all steps: when SOURCE is set to NORM and COUPLING is set to DC, display must be centered vertically on graticule with vertical POSITION control.

d. Set A TRIGGER COUPLING switch to DC.

CHECK—Stable display, starting at graticule center line, with both + and - slopes.

ADJUST—Norm DC Trig Bal (R341) for stable display, starting at graticule center line, with both + and - slopes.

e. Set A TRIGGER SOURCE switch to CH 1.

CHECK—Stable display, starting at center graticule line, with both + and - slopes.

ADJUST—CH 1 DC Trig Bal (R152) for stable display, starting at graticule center with both + and - slopes.

f. Set:

A TRIGGER SOURCE	CH 2
VERT MODE	CH 2
CH 2 VOLTS/DIV	50 mV

CHECK—Stable display, vertically centered, starting at center graticule line, with both + and - slopes.

ADJUST—CH 2 DC Trig Bal (R252) for stable display, starting at graticule center with both + and - slopes.

### 6. Check B Trigger DC Levels

a. Set:

HORIZ DISPLAY	B DLY'D
VERT MODE	CH 1
A TRIGGER LEVEL	Fully clockwise
B TRIGGER LEVEL	0
COUPLING (both)	DC
SOURCE (both)	NORM

b. Use vertical POSITION controls as needed.

CHECK—Stable triggering when display is positioned within 0.5 div of graticule center, and SLOPE is set to + and -, for the following modes:

**B TRIGGER**

SOURCE	VERT MODE	POSITION CONTROL
NORM	CH 1	Moves display away from triggering point.
CH 1	CH 1	Does not affect triggering.
CH 2	CH 2	Does not affect triggering.

c. Set: B TRIGGER SOURCE switch to NORM and use CH 2 POSITION control as needed.

CHECK—Stable triggering when display is positioned within 1 div of graticule center and SLOPE is set to + and -.

**7. Check B Internal 25 MHz Triggering**

a. Set:

VERT MODE	CH 1
TRIGGER COUPLING (both)	AC
CH 1 VOLTS/DIV	10 mV
CH 2 VOLTS/DIV	.1 V
A TIME/DIV	.2 $\mu$ s } ?
B TIME/DIV	.5 $\mu$ s }

b. Set leveled sine-wave generator for 3 div (30 mV), 25 MHz display.

c. Set CH 1 VOLTS/DIV switch to .1 V.

d. Use B TRIGGER LEVEL control as needed.

CHECK—Stable display, with both + and - slopes for these modes:

**B TRIGGER**

SOURCE	COUPLING
CH 2	AC, DC
CH 1	DC, AC
NORM	AC, DC

e. Set:

CH 1 VOLTS/DIV	10 mV
B TRIGGER COUPLING	LF REJ

f. Set leveled sine-wave generator for 5 div (50 mV) 25 MHz display.

g. Set CH 1 VOLTS/DIV switch to .1 V (0.5 div).

h. Use B TRIGGER LEVEL as needed.

CHECK—Stable display, for both + and - slopes with B TRIGGER SOURCE set to NORM, CH 1, and CH 2.

i. Set B TRIGGER COUPLING switch to HF REJ.

CHECK—No stable display with B TRIGGER SOURCE set to CH 2, CH 1, and NORM.

**8. Check A Internal 25 MHz Triggering**

a. Set:

HORIZ DISPLAY	A
A TIME/DIV	.05
A TRIG LEVEL	0
CH 1 VOLTS/DIV	10 mV

b. Set leveled sine-wave generator for 3 div (30 mV), 25 MHz display.

c. Set CH 1 VOLTS/DIV switch to .1 V.

d. Use A TRIGGER LEVEL control as needed.

CHECK—Stable display, with both + and - slopes for these modes:

**A TRIGGER**

SOURCE	COUPLING
NORM	AC, DC
CH 1	DC, AC
CH 2	AC, DC

e. Set:

CH 1 VOLTS/DIV	10 mV
A TRIGGER COUPLING	LF REJ

## Calibration—466 Service

f. Set leveled sine-wave generator for 5 div (50 mV) 25 MHz display.

g. Set CH 1 VOLTS/DIV switch to .1 V.

h. Use A TRIGGER LEVEL as needed.

CHECK—Stable display, for both + and - slopes with A TRIGGER SOURCE set to CH 2, CH 1, and NORM.

i. Set A TRIGGER COUPLING switch to HF REJ.

CHECK—No stable display with A TRIGGER SOURCE set to NORM, CH 1, and CH 2.

### 9. Check A External 25 MHz Triggering

a. Set:

VOLTS/DIV (both)	10 mV
TRIGGER COUPLING (both)	AC
SOURCE (both)	EXT
A TRIGGER LEVEL	As needed

b. Set leveled sine-wave generator to maintain 5 div (50 mV) display throughout Steps 9 and 10.

CHECK—Stable display, for both + and - slopes with A TRIGGER COUPLING set to AC and DC.

c. Set:

CH 1 VOLTS/DIV	20 mV
A TRIGGER COUPLING	LF REJ

d. Set leveled sine-wave generator for 5 div (100 mV), 25 MHz display.

e. Use A TRIGGER LEVEL control as needed.

CHECK—Stable display, with + and - slopes.

f. Set A TRIGGER COUPLING switch to HF REJ.

CHECK—No stable display.

g. Remove 10X attenuator from external trigger setup and change A TRIGGER SOURCE switch to EXT ÷ 10.

CHECK—No stable display.

h. Set A TRIGGER COUPLING switch to LF REJ.

CHECK—Stable display, with both + and - slopes.

i. Set:

CH 1 VOLTS/DIV	10 mV
A TRIGGER COUPLING	AC

j. Set leveled sine-wave generator for 5 div (50 mV), 25 MHz display (0.5 V at external trigger input).

CHECK—Stable display, for both + and - slopes with A TRIGGER COUPLING set to AC and DC.

### 10. Check B External 25 MHz Triggering

a. Set:

HORIZ DISPLAY	B DLY'D
A TIME/DIV	.2 $\mu$ s
B TIME/DIV	.05 $\mu$ s

b. Add 10X attenuator to the external trigger setup.

CHECK—Stable display, for both + and - slopes with B TRIGGER COUPLING set to AC and DC.

c. Set CH 1 VOLTS/DIV switch to 20 mV.

d. Adjust leveled sine-wave generator for 5 div (100 mV) 25 MHz display.

e. Set B TRIGGER COUPLING switch to LF REJ and use B TRIGGER LEVEL control as needed.

CHECK—Stable display, with both + and - slopes.

f. Set B TRIGGER COUPLING switch to HF REJ.

CHECK—No stable display.

**11. Check B and A External 100 MHz Triggering**

a. Set:

TRIGGER COUPLING	
(both)	AC
CH 1 VOLTS/DIV	50 mV
B TRIGGER LEVEL	As needed

b. Connect 25 MHz signal from leveled sine-wave generator to B External Trigger input via 50 Ω BNC cable, GR-to-BNC female adapter, CT-3 through output, GR-to-BNC male adapter, 10X attenuator and 50 Ω termination (remove dual input connector).

c. Connect CT-3 Sig Out 10% signal to CH 1 input via 50 Ω BNC cable and 50 Ω termination (remove dual input connector).

d. Set leveled sine-wave generator for 3 div (150 mV) 25 MHz display, then change frequency to 100 MHz. Do not readjust signal amplitude.

e. Push in X10 MAG (IN) button and use B TRIGGER LEVEL control as needed.

CHECK—Stable display, with 0.1 div or less jitter, for + and – slopes with B TRIGGER COUPLING set to AC and DC.

f. Set leveled sine-wave generator for 6 div (300 mV), 25 MHz display, then change frequency to 100 MHz. Do not readjust signal amplitude.

g. Set B TRIGGER COUPLING switch to LF REJ and use B TRIGGER LEVEL control as needed.

CHECK—Stable display, with 0.1 div or less jitter, with both + and – slopes.

h. Set B TRIGGER COUPLING switch to HF REJ.

CHECK—No stable display.

i. Set:

HORIZ DISPLAY	A
A TIME/DIV	.05 μs
A TRIGGER MODE	LF REJ
A TRIGGER SOURCE	EXT

j. Move leveled sine-wave generator signal from B External input to A External Trigger input.

k. Use A TRIGGER LEVEL control as needed.

CHECK—Stable display, with 0.1 div or less jitter, with both + and – slopes.

l. Set A TRIGGER COUPLING to HF REJ.

CHECK—No stable display.

m. Set A TRIGGER COUPLING switch to AC.

n. Set leveled sine-wave generator for 3 div (150 mV) 25 MHz display, then change frequency to 100 MHz. Do not readjust signal amplitude.

o. Use A TRIGGER LEVEL control as needed.

CHECK—Stable display, with 0.1 div or less jitter, for both + and – slopes with A TRIGGER COUPLING set to AC and DC.

p. Remove 10X attenuator from External trigger setup and change A TRIGGER SOURCE switch to EXT ÷ 10.

q. Use A TRIGGER LEVEL control as needed.

CHECK—Stable display, with 0.1 div or less jitter, for both + and – slopes with A TRIGGER COUPLING set to DC and AC.

r. Set leveled sine-wave generator for 6 div (300 mV) 25 MHz display, then change frequency to 100 MHz. Do not readjust signal amplitude.

s. Set A TRIGGER COUPLING to LF REJ and use A TRIGGER LEVEL as needed.

CHECK—Stable display, with 0.1 div or less jitter, with both + and – slopes.

t. Set A TRIGGER COUPLING to HF REJ.

CHECK—No stable display.

u. Disconnect test setup.



**12. Check A Internal 100 MHz Triggering**

a. Set:

VOLTS/DIV (both)	50 mV
TRIGGER SOURCE (both)	NORM
TRIGGER COUPLING (both)	AC

b. Connect leveled sine-wave generator signal to CH 1 and CH 2 inputs via 50 ohm BNC cable, 50 ohm termination and dual-input coupler. Adjust leveled sine-wave generator for 1.5 div 100 MHz display.

CHECK—Stable display, with 0.1 div or less jitter, for + and – slope, for these modes (adjust A TRIGGER LEVEL as needed):

**A TRIGGER**

SOURCE	COUPLING
NORM	AC, LF REJ, DC
CH 1	DC, LF REJ, AC
CH 2	AC, LF REJ, DC

c. Set A TRIGGER COUPLING switch to HF REJ.

CHECK—No stable display.

**13. Check B Internal 100 MHz Triggering**

a. Set:

HORIZ DISPLAY	B DLY'D
A TIME/DIV	.2 $\mu$ s
B TIME/DIV	.05 $\mu$ s

CHECK—Stable display, with 0.1 div or less jitter, for + and – slope, for these modes (adjust B TRIGGER LEVEL as needed):

**B TRIGGER**

SOURCE	COUPLING
NORM	AC, LF REJ, DC
CH 1	DC, LF REJ, AC
CH 2	AC, LF REJ, DC

b. Set B TRIGGER COUPLING switch to HF REJ.

CHECK—No stable display.

**14. Check A and B HF REJ (High Frequency Reject) Triggering**

a. Set:

HORIZ DISPLAY	A
TIME/DIV (both)	10 $\mu$ s
X10 MAG	Off (button out)
TRIGGER COUPLING (both)	HF REJ
CH 1 VOLTS/DIV	.1 V
CH 2 VOLTS/DIV	10 mV
VERT MODE	CH 2
TRIGGER SOURCE (both)	CH 2
POSITION (horizontal)	As needed

b. Set leveled sine-wave generator to 50 kHz.

c. Set generator for 5 div (50 mV) display in CH 2.

d. Set CH 2 VOLTS/DIV switch to .1 V. Adjust A TRIGGER LEVEL for stable display, with both + and – slopes.

e. Set generator frequency for 1 MHz signal and push in X10 MAG (IN) button.

CHECK—No stable display with A TRIGGER SOURCE switch in CH 2, CH 1, and NORM.

f. Set:

A TRIGGER LEVEL	Fully clockwise
HORIZ DISPLAY	B DLY'D

CHECK—No stable display with B TRIGGER SOURCE switch in CH 1, CH 2, and NORM.

**15. Check Single Sweep**

a. Set:

A TRIGGER COUPLING	AC
SOURCE (A)	NORM
LEVEL (A)	0
HORIZ DISPLAY	A
VERT MODE	CH 1
X10 MAG (IN)	Off (button out)

b. Set leveled sine-wave generator for 2 div 50 kHz display. Use horizontal POSITION to move start of sweep within viewing area. Adjust the A TRIGGER LEVEL control

to move the start of the sweep vertically about 0.5 div from its position when the A TRIGGER LEVEL was set to 0 (see Fig. 5-D-1).

c. Set:

TIME/DIV (both)	10 ms
CH 1 AC-GND-DC	GND
TRIG MODE	SINGL SWP (push in)

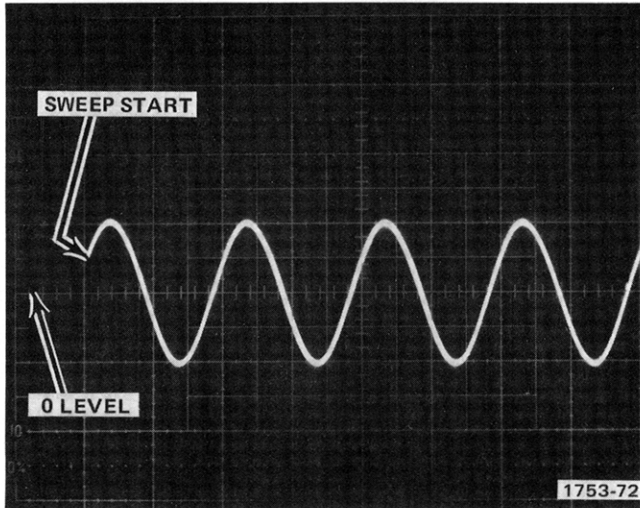

Fig. 5-D-1. TRIGGER LEVEL adjusted so sweep starts 0.5 div away from 0 level (graticule center) setting.

CHECK—Ready lamp lights.

d. Set CH 1 AC-GND-DC switch to DC.

CHECK—A single sweep occurs and READY lamp goes out.

e. Press SINGL SWP button.

CHECK—A single sweep occurs each time SINGL SWP button is pressed.

f. Remove test setup.

### 16. Check 30 Hz Internal Triggering

a. Set:

TIME/DIV (both)	5 ms
A TRIGGER MODE	NORM
CH 1 VOLTS/DIV	10 mV

b. Connect 30 Hz low-frequency generator signal to CH 1 input via 50 Ω cable, BNC T and 50 Ω termination.

From BNC T, connect 50 Ω cable and 50 Ω termination to B EXT Input.

c. Set low-frequency generator for 3 div (30 mV) vertically centered display.

d. Set CH 1 VOLTS/DIV switch to .1 V.

CHECK—Stable display, for both + and - slopes with A TRIGGER COUPLING set to AC and DC. (Set A TRIGGER LEVEL as needed.)

e. Set:

CH 1 VOLTS/DIV	10 mV
A TRIGGER COUPLING	HF REJ

f. Set low-frequency generator for 5 div (50 mV) 30 Hz display.

g. Set CH 1 VOLTS/DIV switch to .1 V (0.5 div) and use A TRIGGER LEVEL as needed.

CHECK—Stable display, with both + and - slopes.

h. Set A TRIGGER COUPLING switch to LF REJ.

CHECK—No stable display.

i. Set:

A TRIG MODE	AUTO
LEVEL (A)	Fully clockwise
A TIME/DIV	10 ms
B TIME/DIV	5 ms
B TRIGGER SOURCE	NORM
B TRIGGER COUPLING	HF REJ
HORIZ DISPLAY	B DLY'D
CH 1 VOLTS/DIV	.1 V
LEVEL (B)	As needed

CHECK—Stable display, with both + and - slopes.

j. Set B TRIGGER COUPLING switch to LF REJ.

CHECK—No stable display.

## Calibration—466 Service

k. Set:

CH 1 VOLTS/DIV	10 mV
B TRIG COUPLING	AC

l. Set low-frequency generator for 3 div (30 mV) 30 Hz display.

m. Set CH 1 VOLTS/DIV switch to .1 V and use B TRIGGER LEVEL control as needed.

CHECK—Stable display, for both + and - slopes with B TRIGGER COUPLING set to AC and DC.

### 17. Check 30 Hz External Triggering

a. Set:

B TRIGGER COUPLING	AC
CH 1 VOLTS/DIV	10 mV

b. Set low-frequency generator for 5 div (50 mV) display.

c. Set B TRIGGER SOURCE switch to EXT.

CHECK—Stable display, for both + and - slopes with B TRIGGER COUPLING set to AC, HF REJ and DC.

d. Set B TRIGGER COUPLING switch to LF REJ.

CHECK—No stable display.

e. Move test setup from B EXT Input to A EXT Input.

f. Set:

HORIZ DISPLAY	A
A TRIGGER COUPLING	AC
A TRIG MODE	NORM
SOURCE (A)	EXT
TRIGGER LEVEL (A)	As needed

CHECK—Stable display, for both + and - slopes with A TRIGGER COUPLING set to AC, HF REJ, and DC.

g. Set A TRIGGER COUPLING switch to LF REJ.

CHECK—No stable display.

h. Disconnect test setup.

### 18. Check Line Triggers

a. Set:

A TIME/DIV	5 ms
A TRIG MODE	AUTO
A TRIG COUPLING	AC
A TRIGGER SOURCE	LINE
SLOPE (A)	+
CH 1 VOLTS/DIV	As required

b. Connect 10X probe from CH 1 input to a line-frequency source.

CHECK—Stable display, starting on positive-going slope.

c. Set A TRIGGER SLOPE switch to -.

CHECK—Stable display, starting on negative-going slope.

d. Disconnect probe from line-frequency source, then from oscilloscope.

### 19. Check Trigger Level Range

a. Set:

TRIG COUPLING (both)	AC
TRIG SOURCE (both)	EXT
TRIGGER SLOPE (both)	+
VERT MODE	CH 1
CH 1 VOLTS/DIV	1 V
HORIZ DISPLAY	B DLY'D
TIME/DIV (both)	1 ms

b. Connect 1 kHz signal from low-frequency generator to CH 1 input and B External Trigger input via 50  $\Omega$  cable, BNC T (to B External input) and 50  $\Omega$  cable.

c. Adjust the generator for a 4 div display.

CHECK—Display is triggered along positive slope of waveform when B TRIGGER LEVEL control is rotated, but not triggered (trace disappears) at either extreme of rotation.

d. Set B TRIG SLOPE to -.

CHECK—Display is triggered along negative slope of waveform when B TRIGGER LEVEL is rotated, but not triggered at either extreme of rotation.

e. Move External Trigger signal to A External input.

f. Set HORIZ DISPLAY to A.

CHECK—Display is triggered along positive slope of waveform when A TRIGGER LEVEL control is rotated, but not triggered (free-runs) at either extreme of rotation.

g. Set A TRIG SLOPE to —.

CHECK—Display is triggered along negative slope of waveform when A TRIGGER LEVEL control is rotated, but not triggered at either extreme of rotation.

h. Set:

CH 1 VOLTS/DIV	5 V
A TRIG SOURCE	EXT ÷ 10
A TRIG COUPLING	AC

i. Disconnect low-frequency generator signal and connect 50 volt standard amplitude signal from calibration generator via 50 Ω cable.

**NOTE**

*In the remainder of this step, adjust CH 1 VAR VOLTS/DIV as needed to get top and bottom of display on screen.*

CHECK—Display is triggered along negative slope of waveform when A TRIG LEVEL control is rotated. (NOTE—The applied signal is 50 volts peak-to-peak. The range of the A LEVEL control is only ± 20 volts, or 40 volts peak-to-peak, or greater; therefore, untriggered operation at either extreme of rotation is not required.)

j. Set A TRIG SLOPE to +.

CHECK—Display is triggered along positive slope of waveform when A TRIG LEVEL control is rotated (the note for step i applies to step j).

k. Disconnect calibration generator signal.

**20. Check A Normal Mode**

a. Set:

A TIME/DIV	1 ms
A TRIG SOURCE	NORM
A TRIG COUPLING	DC
A TRIG MODE	AUTO
CH 1 VOLTS/DIV	.5 V
CH 1 VAR VOLTS/DIV	Calibrated detent
LEVEL (A)	As needed

b. Connect .1 s time marks from time-mark generator to CH 1 input via 50 Ω cable and 50 Ω termination.

CHECK—Display is triggered.

c. Set A TRIG MODE switch to NORM.

CHECK—Display is triggered.

d. Set CH 1 AC-GND-DC switch to GND.

CHECK—Display is not triggered.

**21. Check Automatic Recovery Time**

a. Set:

CH 1 AC-GND-DC	DC
A TRIG MODE	AUTO

CHECK—Display is triggered.

b. Set time-mark generator for .5 s time marks.

CHECK—Display is not triggered.

c. Disconnect time-mark generator.

**22. Check/Adjust Trigger View Centering**

a. Set:

TRIG COUPLING (A)	AC
SOURCE (A)	EXT
SLOPE (A)	+
LEVEL (A)	0
A TIME/DIV	.2 ms

## Calibration—466 Service

b. Connect 0.2 volt standard amplitude signal from calibration generator to A External Trigger Input via 50  $\Omega$  cable.

c. Push TRIG VIEW button and hold it in for remainder of step 22.

CHECK—Display triggers symmetrically within 1 div of graticule center line when A TRIGGER SLOPE is switched between + and -.

ADJUST—Trig View Centering (R675) for symmetrical triggering about graticule center line.

d. Rotate A TRIGGER LEVEL control (with TRIG VIEW pushed in).

CHECK—That display is triggered when the A TRIGGER LEVEL control rotation moves the waveform bottom down to within 1 division of graticule center.

CHECK—That display is triggered when the A TRIGGER LEVEL control rotation moves the waveform top up to within 1 division of graticule center.

e. Set A TRIG COUPLING switch to DC.

CHECK—Display top and bottom are triggered within 1 div of graticule center line.

### 23. Check Trigger View Gain

a. Push TRIG VIEW button and hold it in.

CHECK—Display amplitude is 3.2 to 4.8 div.

b. Disconnect calibration generator.

### 24. Check Trigger View Risetime

a. Set:

A TIME/DIV	1 $\mu$ s
A TRIG SLOPE	+

b. Connect 100 kHz fast-rise, + output signal from square-wave generator to A External Trigger input via 50  $\Omega$  cable and 50  $\Omega$  termination.

c. Push TRIG VIEW button and hold it in. Use A TRIGGER LEVEL control to position top of display to 100% graticule line. Adjust generator so bottom of display is at 0% graticule line.

d. Set:

A TIME/DIV	.05 $\mu$ s
X10 MAG (IN)	On (button in)
POSITION (horizontal)	As needed

CHECK—Risetime between 10% and 90% point of display is 1 div or less (5 ns or less).

### 25. Check Trigger View Delay Difference

a. Set:

CH 1 VOLTS/DIV	50 mV
X10 MAG (IN)	Off (button out)

b. Connect 100 kHz fast-rise, + output signal from square-wave generator to CH 1 input and A External Trigger input via 50  $\Omega$  cable, female-to-female BNC adapter, BNC-T connector and 2 equal-length, 50  $\Omega$  cables—each terminated into 50  $\Omega$ .

c. Push TRIG VIEW button and hold it in. Adjust square-wave generator for 4 div display. Use A TRIGGER LEVEL and POSITION (horizontal) controls to center leading edge of display.

d. Release TRIG VIEW button.

e. Adjust CH 1 VAR VOLTS/DIV control for a 4 div display and CH 1 POSITION to vertically center display.

CHECK—Time difference, along horizontal graticule center line, between TRIG VIEW display and CH 1 display is 0.6 div or less (3 ns or less).

f. Disconnect square-wave generator.

## E. DM-SERIES DIGITAL MULTIMETERS

*FOR OSCILLOSCOPES WITH DIGITAL MULTIMETERS ATTACHED, REFER TO THE CALIBRATION SECTION OF THE DIGITAL MULTIMETER MANUAL AT THIS POINT.*

*FOR CALIBRATION OF OSCILLOSCOPES WITHOUT DIGITAL MULTIMETERS, CONTINUE TO PART F.*

## F. HORIZONTAL

### Equipment Required

- |                                  |  |
|----------------------------------|--|
| 1. Test oscilloscope             | 4. 50-Ohm BNC termination                            |
| 2. Time-mark generator           | 5. Screwdriver                                       |
| 3. 50-Ohm BNC cable (2 required) | 6. Low-capacitance screwdriver                       |
|                                  | 7. Light shield—for Delay-Time Jitter only (step 15) |

See

**ADJUSTMENT LOCATIONS 4**

pull-out page for adjustments and test points (TP).

### 466 Control Settings (\*Indicates changes from previous step)

POWER	ON
<b>Display</b>	
REDUCED SCAN (PULL)	Off (push INTEN in)
INTEN	As desired
FOCUS	As desired
SCALE ILLUM	As desired
ASTIG	Best defined trace
<b>Vertical (CH 1 and CH 2)</b>	
VERT MODE	CH 1
POSITION	Midrange
*VOLTS/DIV	*.5 V
*VAR VOLTS/DIV	*Calibrated detent
AC-GND-DC	DC
INVERT	Normal (button out)
20 MHz BW (PULL)	Full bandwidth (push in, then release; shows no yellow)

### Storage

NON STORE	On (button in)
STORAGE LEVEL	NORM
SAVE INTEN	Midrange
SAVE	Off (button out)
VIEW TIME	NORM

### Trigger (A and B)

*COUPLING LEVEL	*AC As needed for triggered display
SLOPE	+
A TRIGGER SOURCE	NORM
*B (DLY'D) TRIGGER SOURCE	*STARTS AFTER DELAY
TRIG MODE	AUTO
A TRIG HOLDOFF	NORM

### Sweep (A and B)

*HORIZ DISPLAY	*A INTEN
*A TIME/DIV	*1 ms
*B TIME/DIV	*5 $\mu$ s
VAR TIME/DIV	Calibrated detent
*DELAY TIME POSITION (DTP)	*1.00
X10 MAG	Off (button out)
POSITION (horizontal)	As needed
FINE	As needed

### Timing Checks and Adjustments

**A INTEN Mode.** The A INTEN mode verifies which time mark (or other timing signal) will be seen in B DLY'D mode. Adjust intensity and focus to permit observation of the intensified portion of the display. See Fig. 5-F-1.

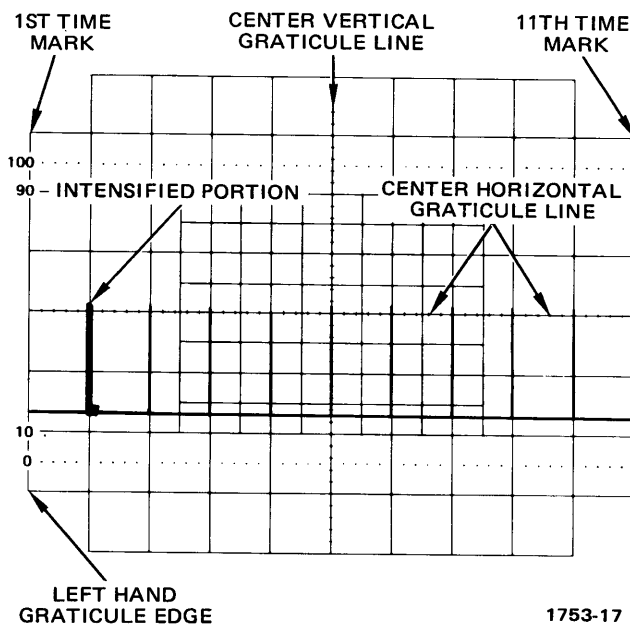
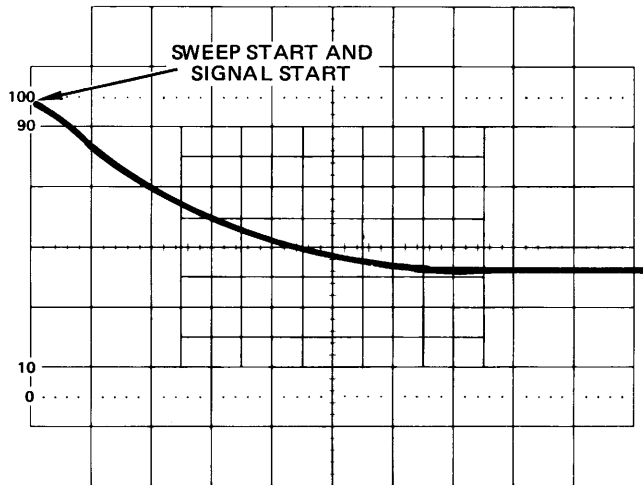

Fig. 5-F-1. A INTEN Mode.

**B DLY'D Mode.** The B DLY'D mode establishes the most accurate point for making checks and adjustments. Position the time mark (or other timing signal) so it begins at the left-hand edge (sweep start) of the trace—do this with the DTP control when checking and when doing the calibration adjustment during calibration. Optimum intensity and focus settings for this mode are different from A INTEN mode. See Fig. 5-F-2.



1753-18

Fig. 5-F-2. B DLY'D Mode.

Timing is checked and adjusted after a stable display is obtained and is referenced along the center horizontal graticule line.

Lowest usable intensity settings reduce the error contributed by trace thickness.

When a CHECK is indicated, use the A INTEN mode to identify the correct signal. Switch to B DLY'D and set the signal start at the left-hand edge (sweep start) using the DELAY TIME POSITION (DTP) control, then make the measurement.

When an ADJUST is indicated, set the DELAY TIME POSITION (DTP) control to the required setting (for example—1.00 in step 1 parts a and b), then make the adjustment (in the same example—Sweep Start, R1115) to have the signal start at the sweep start.

**Fast-Rise, Low Repetition-Rate Signals.** It may be difficult—because of high light levels, etc., to observe the starting point of some signals. Use the sweep starting point just before the signal start.

In step 1 parts a and b, for example, if the signal start was set to start 0.5 minor divisions after the sweep start, the baseline beginning would appear as a small dot. See Fig. 5-F-3.

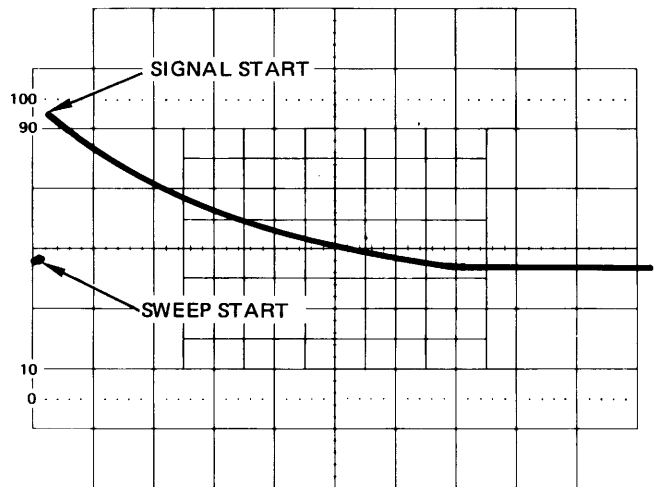

1753-19

Fig. 5-F-3. Fast-rise, Low Repetition-rate signals.

The error in this method is small, as long as B Sweep is 100 or more times faster than A Sweep. For example, with A TIME/DIV switch set to 1 ms and B TIME/DIV to 5  $\mu$ s, the B DLY'D mode resolution is 5% per major graticule division. The use of the 0.5 minor division spot is 1/10 of that, or 0.05%.

**1. Check/Adjust Sweep Start and A Sweep Timing**

a. Connect 1 ms time marks from time-mark generator to CH 1 input via 50  $\Omega$  cable and 50  $\Omega$  termination.

b. Note 2nd time mark is intensified. Change HORIZ DISPLAY to B DLY'D and set signal start to sweep start with DTP.

CHECK—DTP control reads 1.00.

c. Set HORIZ DISPLAY to A INTEN, use DTP to move intensified portion to 10th time mark.

d. Change HORIZ DISPLAY to B DLY'D and set signal start to sweep start with DTP.

CHECK—DTP control reads 9.00.

ADJUST—A Swp Cal (R1145) for signal start at sweep start.



## Calibration—466 Service

- e. Set DTP control to 1.00.

CHECK—Signal starts at sweep start.

ADJUST—Swp Start (R1115) for signal start at sweep start.

INTERACTION—A Swp Cal (R1145) and Swp Start (R1115) adjustments. Adjust both alternately until 2nd mark starts exactly at 1.00 and 10th mark starts exactly at 9.00.

### 2. Check Differential Time Accuracy

- a. Use DTP to set second time mark start to sweep start and note DTP reading (1.00 within 1 minor div, 0.99 to 1.01).

CHECK—Each successive time mark.

**TABLE 5-F-1**  
Differential Time Accuracy

TIME MARK	DTP SETTING			
	+15°C to +35°C		-15°C to +55°C	
3	1.98	2.02	1.95	2.05
4	2.97	3.03	2.92	3.08
5	3.96	4.04	3.90	4.10
6	4.95	5.05	4.87	5.13
7	5.94 to	6.06	5.85 to	6.15
8	6.93	7.07	6.82	7.18
9	7.92	8.08	7.80	8.20
10	8.91	9.09	8.77	9.23
11	9.90	10.10	9.75	10.25

### 3. Check/Adjust Horizontal Gain and Sweep Linearity

- a. Set HORIZ DISPLAY switch to A and horizontally position display to have 1st time mark under left-hand graticule edge.

CHECK—1 time mark/div, within 2% ( $\pm 0.2$  div for 11th mark,  $+20^{\circ}\text{C}$  to  $+30^{\circ}\text{C}$ ), or within 3% ( $\pm 0.3$  div for 11th mark,  $-15^{\circ}\text{C}$  to  $+55^{\circ}\text{C}$ ).

ADJUST—X1 Gain (R1257) for exactly 1 time mark/div over full 10 div.

- b. Set time-mark generator for 0.1 ms time marks.

- c. Push in X10 MAG (IN) button.

CHECK—X10 MAG lamp is on when X10 MAG (IN) button is in.

CHECK—1 time mark/div, within 3% ( $\pm 0.3$  div for 11th mark,  $+20^{\circ}\text{C}$  to  $+30^{\circ}\text{C}$ ), or within 4% ( $\pm 0.4$  div for 11th mark,  $-15^{\circ}\text{C}$  to  $+55^{\circ}\text{C}$ ).

ADJUST—X10 Gain (R1253) for exactly 1 time mark/div over full 10 div.

CHECK—Sweep accuracy over any 2 div portion of 10 div sweep is within 0.1 div (5%).

- d. Release X10 MAG (IN) button.

- e. Set time-mark generator for 1 ms time marks.

CHECK—Linearity over any 2 div portion of sweep is within 5% of accurate timing ( $\pm 0.1$  div).

### 4. Check/Adjust Magnifier Registration

- a. Push in X10 MAG (IN) button.

b. Set time-mark generator for 5 ms time marks and position middle time mark to start at center vertical graticule line.

- c. Release X10 MAG (IN) button.

CHECK—Middle time mark starts at center line, within 0.2 div.

ADJUST—Mag Reg (R1255) so middle time mark starts at center line. Repeat parts a through c until there is no display shift between magnifier on and off.

### 5. Check/Adjust B Sweep Timing

- a. Set time-mark generator for 1 ms time marks.

- b. Set:

DELAY TIME POSITION	Fully CCW
B TRIGGER SOURCE	Normal
B TIME/DIV	1 ms
HORIZ DISPLAY	B DLY'D

CHECK—1 time mark/div, within 2% ( $\pm 0.2$  div for 11th mark,  $+20^{\circ}\text{C}$  to  $+30^{\circ}\text{C}$ ), or within 3% ( $\pm 0.3$  div for 11th mark,  $-15^{\circ}\text{C}$  to  $+55^{\circ}\text{C}$ ).

ADJUST—B Swp Cal (R1175) for exactly 1 time mark/div over full 10 div.

**6. Check A Sweep Length**

- a. Set HORIZ DISPLAY switch to A.
- b. Set time-mark generator for 5 ms time marks and position 3rd time mark to center vertical graticule line.

CHECK—Sweep continues past center, 0.5 to 1.5 div (10.5 to 11.5 total sweep length).

**7. Check Var Time/Div Range**

- a. Set:
 

A TIME/DIV	2 ms
VAR TIME/DIV	Fully counterclockwise
POSITION (horizontal)	As needed

CHECK—UNCAL lamp lights when VAR TIME/DIV control is out of detent.

CHECK—1 time mark/div or more.

- b. Set VAR TIME/DIV control to detent (calibrated).

**8. Check Horizontal Position Range**

- a. Set FINE and POSITION controls fully clockwise.

CHECK—Sweep starts to right of center vertical graticule line.

- b. Set FINE and POSITION controls fully counterclockwise.

CHECK—Sweep ends to left of center vertical graticule line.

**9. Check/Adjust A Sweep High Speed Timing**

**NOTE**

Step 9, parts a through l do not apply to instruments below serial number B010300.

- a. Set time-mark generator for  $5.0 \mu\text{s}$  time marks.

- b. Set:

DELAY TIME POSITION	1.00
B TRIGGER SOURCE	STARTS AFTER DELAY
A TIME/DIV	$5 \mu\text{s}$
B TIME/DIV	$.2 \mu\text{s}$
HORIZ DISPLAY	A
POSITION (horizontal)	As needed
FINE	As needed

CHECK—1 time mark/div, within 2% ( $\pm 0.2$  div for 11th mark,  $+20^{\circ}\text{C}$  to  $+30^{\circ}\text{C}$ ), or within 3% ( $\pm 0.3$  div for 11th mark,  $-15^{\circ}\text{C}$  to  $+55^{\circ}\text{C}$ ).

- c. Set time-mark generator for  $2.0 \mu\text{s}$  time marks.

- d. Set A TIME/DIV switch to  $2 \mu\text{s}$ .

CHECK—1 time mark/div, within 2% ( $\pm 0.2$  div for 11th time mark,  $+20^{\circ}\text{C}$  to  $+30^{\circ}\text{C}$ ) or within 3% ( $\pm 0.3$  div for 11th time mark,  $-15^{\circ}\text{C}$  to  $+55^{\circ}\text{C}$ ).

- e. If parts b and d requirements are met, proceed to part m.

- f. Adjust C1136 for 1 time mark/div, using low-capacitance screwdriver.

- g. Set HORIZ DISPLAY switch to B DLY'D (A TIME/DIV,  $2 \mu\text{s}$ ; B TIME/DIV,  $0.2 \mu\text{s}$ ) and horizontally position the displayed time mark to cross center vertical graticule line. See Point A, Fig. 5-F-4.

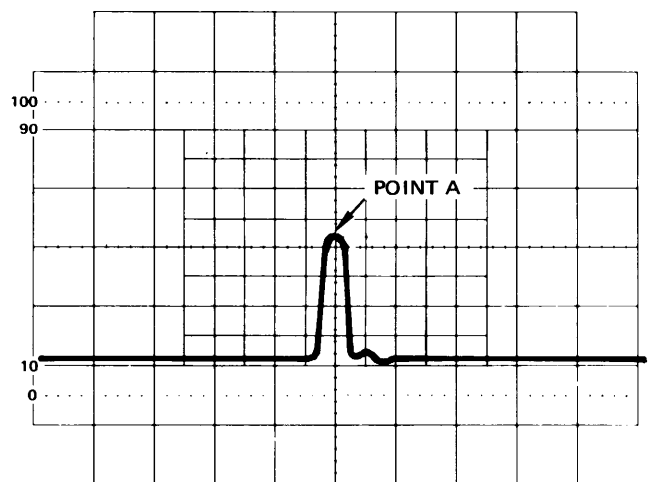

Fig. 5-F-4.  $0.2 \mu\text{s}/\text{Div}$  Timing.

1753-20

## Calibration—466 Service

h. Set DTP control to 9.00.

ADJUST—C1136 to position the displayed time mark to cross center line.

INTERACTION—C1136 and the 1.00 and 9.00 DTP settings. Set DTP control to 1.00 and repeat parts g and h until there is no visible interaction.

i. Set:

A TIME/DIV	5 $\mu$ s
DELAY TIME POSITION	1.00
HORIZ DISPLAY	A
B TIME/DIV	1 $\mu$ s

j. Set time-mark generator for 5  $\mu$ s time marks and note 1 time mark/div (set horizontal POSITION as needed).

k. Set HORIZ DISPLAY switch to B DLY'D and horizontally position the displayed time mark to cross center vertical graticule line. See Point A, Fig. 5-F-5.

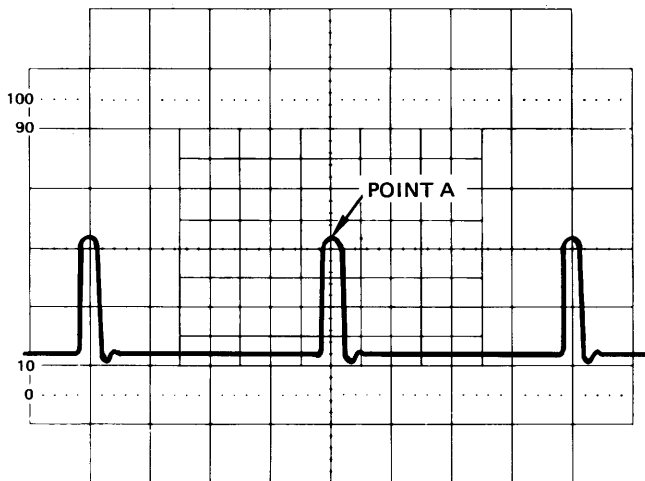

1753-21

Fig. 5-F-5. 0.5  $\mu$ s/Div Timing.

l. Set DTP control to 9.00. Note that there is a time mark crossing center vertical line between an 8.94 to 9.06 DTP control setting. If not, repeat parts f through k adjusting C1136 to get both the 2  $\mu$ s range and 5  $\mu$ s range within a DTP reading of 8.94 to 9.06.

m. Set time-mark generator for 0.5  $\mu$ s time marks.

n. Set:

DELAY TIME POSITION	1.50
B TRIGGER SOURCE	STARTS AFTER DELAY
A TIME/DIV	.5 $\mu$ s
B TIME/DIV	.05 $\mu$ s
HORIZ DISPLAY	A

CHECK—1 time mark/div, within 2% ( $\pm 0.2$  div for 11th mark,  $+20^{\circ}\text{C}$  to  $+30^{\circ}\text{C}$ ), or within 3% ( $\pm 0.3$  div for 11th mark,  $-15^{\circ}\text{C}$  to  $+55^{\circ}\text{C}$ ).

o. Set time-mark generator for 0.2  $\mu$ s time marks.

p. Set A TIME/DIV switch to .2  $\mu$ s.

CHECK—1 time mark/div, within 2% ( $\pm 0.2$  div for 11th mark,  $+20^{\circ}\text{C}$  to  $+30^{\circ}\text{C}$ ), or within 3% ( $\pm 0.3$  div for 11th mark,  $-15^{\circ}\text{C}$  to  $+55^{\circ}\text{C}$ ).

q. If parts n and p requirements are met, proceed to step 10.

r. Set time-mark generator for 0.5  $\mu$ s time marks.

s. Set A TIME/DIV switch to .5  $\mu$ s and adjust C1137 for 1 time mark/div, using low-capacitance screwdriver.

t. Set HORIZ DISPLAY switch to B DLY'D and horizontally position the displayed time mark to cross center vertical graticule line. See Point A, Fig. 5-F-4.

u. Set DTP control to 8.50.

ADJUST—C1137 to position the displayed time mark to cross center line.

INTERACTION—C1137 and the 1.50 and 8.50 DTP settings. Set DTP control to 1.50 and repeat parts t and u until there is no visible interaction.

v. Set:

A TIME/DIV	.2 $\mu$ s
DELAY TIME POSITION	1.50
HORIZ DISPLAY	A

w. Set time-mark generator for 0.2  $\mu$ s time marks and note 1 time mark/div.

x. Set HORIZ display switch to B DLY'D (verify B TIME/DIV is set to 0.5  $\mu$ s) and horizontally position the 2nd displayed time mark to cross center vertical graticule line. See Point A, Fig. 5-F-5.

y. Set DTP control to 8.50. Observe a time mark crossing center vertical line between 8.45 to 8.55 DTP control setting. If not, repeat parts r through x, adjusting C1137 to get both the .2  $\mu$ s range and the .5  $\mu$ s range within a DTP reading of 8.45 to 8.55.

**10. Check/Adjust B Sweep High Speed Timing**

a. Set:

DELAY TIME POSITION Fully counterclockwise  
 HORIZ DISPLAY B DLY'D  
 B TRIGGER SOURCE NORM  
 A TIME/DIV 1  $\mu$ s  
 B TIME/DIV .5  $\mu$ s

b. Set time-mark generator for 0.5  $\mu$ s time marks.

CHECK—1 time mark/div, within 2% ( $\pm 0.2$  div for 11th mark, +20°C to 30°C) or within 3% ( $\pm 0.3$  div for 11th mark, -15°C to +55°C).

ADJUST—C1167 for 1 time mark/div.

**11. Check B and A Time/Div Accuracy**

a. Set:

B TIME/DIV .05  $\mu$ s  
 A TIME/DIV .5  $\mu$ s

b. Set time-mark generator for 50 ns time marks.

CHECK—B Time/Div accuracy using control settings given in Table 5-F-2, over first 10 div of display, 1 time mark/div within 2% ( $\pm 0.2$  div for 11th mark, +20°C to +30°C) or within 3% ( $\pm 0.3$  div for 11th mark, -15°C to +55°C).

c. Set:

HORIZ DISPLAY A  
 A TIME/DIV .05  $\mu$ s  
 TRIG MODE AUTO

**TABLE 5-F-2**

**B Timing Accuracy**

A and B TIME/DIV Switch Setting		Time-Mark Generator Output
A	B	
.5 $\mu$ s	.05 $\mu$ s	50 nanosecond
.5 $\mu$ s	.1 $\mu$ s	0.1 microsecond
.5 $\mu$ s	.2 $\mu$ s	0.2 microsecond
1 $\mu$ s	.5 $\mu$ s	0.5 microsecond
2 $\mu$ s	1 $\mu$ s	1 microsecond
5 $\mu$ s	2 $\mu$ s	2 microsecond
10 $\mu$ s	5 $\mu$ s	5 microsecond
20 $\mu$ s	10 $\mu$ s	10 microsecond
50 $\mu$ s	20 $\mu$ s	20 microsecond
.1 ms	50 $\mu$ s	50 microsecond
.2 ms	.1 ms	0.1 millisecond
.5 ms	.2 ms	0.2 millisecond
1 ms	.5 ms	0.5 millisecond
2 ms	1 ms	1 millisecond
5 ms	2 ms	2 millisecond
10 ms	5 ms	5 millisecond
20 ms	10 ms	10 millisecond
50 ms	20 ms	*20 millisecond
50 ms	50 ms	*50 millisecond

\*Change A TRIG MODE to NORM if needed.

d. Set time-mark generator for 50 ns time marks.

CHECK—A TIME/DIV accuracy using control settings given in Table 5-F-3 over first 10 div of display, 1 time mark/div, within 2% ( $\pm 0.2$  div for 11th mark, +20°C to +30°C) or within 3% ( $\pm 0.3$  div for 11th mark, -15°C to +55°C).

**12. Check/Adjust High Speed Magnified Timing**

a. Set time-mark generator for 10 ns time marks.

b. Set:

A TRIG MODE AUTO  
 A TIME/DIV .05  $\mu$ s  
 X10 MAG (IN) On (button in)  
 INTEN As needed

CHECK—1 time mark/2 div, within 3% (6th mark aligns with 10th graticule line  $\pm 0.3$  div, +20°C to +30°C) or within 4% (6th mark aligns with 10th graticule line  $\pm 0.4$  div, -15°C to +55°C). This applies to the full sweep length, excluding the first and last 10 divisions of magnified sweep length.

**TABLE 5-F-3**  
**A Timing Accuracy**

<b>A TIME/DIV Switch Setting</b>	<b>Time-Mark Generator Output</b>
.05 $\mu$ s	50 nanosecond
.1 $\mu$ s	0.1 microsecond
.2 $\mu$ s	0.2 microsecond
.5 $\mu$ s	0.5 microsecond
1 $\mu$ s	1 microsecond
2 $\mu$ s	2 microsecond
5 $\mu$ s	5 microsecond
10 $\mu$ s	10 microsecond
20 $\mu$ s	20 microsecond
50 $\mu$ s	50 microsecond
.1 ms	0.1 millisecond
.2 ms	0.2 millisecond
.5 ms	0.5 millisecond
1 ms	1 millisecond
2 ms	2 millisecond
5 ms	5 millisecond
10 ms	10 millisecond
20 ms	20 millisecond
50 ms	50 millisecond
.1 s	*0.1 second
.2 s	*0.2 second
.5 s	*0.5 second

\*Change A TRIG MODE to NORM and reduce intensity as needed.

To determine the first portion to be excluded, release X10 MAG (IN) button. Position sweep start 1.5 div left of center vertical graticule line. Push in X10 MAG (IN) button—the first 10 div of sweep is magnified to the left and is off screen.

To determine the last portion to be excluded on the 0.5  $\mu$ s/div range, release X10 MAG (IN) button. Position sweep stop 1.5 div right of center vertical graticule line. Push in X10 MAG (IN) button—the last 50 ns of sweep is magnified to the right and is off screen.

ADJUST—C1262 and C1265 for 1 cycle/2 div, with low-capacitance screwdriver, excluding the first and last 10 div (which are off screen).

**13. Check A and B Magnified Accuracy**

- a. Push in X10 MAG (IN) button.

CHECK—A TIME/DIV accuracy using control settings given in Table 5-F-4. 1 time mark/div, within 3% ( $\pm 0.3$  div for 11th mark, +20°C to +30°C) or within 4% ( $\pm 0.4$  div for 11th mark, -15°C to +55°C). Exclude portions of the sweep as indicated.

**TABLE 5-F-4**  
**A and B Magnified Accuracy**

A and B TIME/DIV Switch Setting	Time-Mark Generator Output	Portions of total magnified sweep length to exclude from measurement
.05 $\mu$ s	10 nanosecond	First and last 10 divisions
.1 $\mu$ s	10 nanosecond	
.2 $\mu$ s	20 nanosecond	First and last 5 divisions
.5 $\mu$ s	50 nanosecond	First and last 2 1/2 divisions
1 $\mu$ s	0.1 microsecond	
2 $\mu$ s	0.2 microsecond	
5 $\mu$ s	0.5 microsecond	
10 $\mu$ s	1 microsecond	
20 $\mu$ s	2 microsecond	
50 $\mu$ s	5 microsecond	
.1 ms	10 microsecond	
.2 ms	20 microsecond	
.5 ms	50 microsecond	
1 ms	0.1 millisecond	
2 ms	0.2 millisecond	
5 ms	0.5 millisecond	
10 ms	1 millisecond	
20 ms	*2 millisecond	
50 ms	*5 millisecond	
<b>A SWEEP ONLY</b>		
.1 s	*10 millisecond	
.2 s	*20 millisecond	
.5 s	*50 millisecond	

\*Change A TRIG MODE to NORM.

b. Set:

HORIZ DISPLAY            B DLY'D  
A TRIG MODE            AUTO

CHECK—B TIME/DIV accuracy using control settings given in Table 5-F-4. 1 time mark/div, within 3% ( $\pm 0.3$  div for 11th mark,  $+20^{\circ}\text{C}$  to  $+30^{\circ}\text{C}$ ) or within 4% ( $\pm 0.4$  div for 11th mark,  $-15^{\circ}\text{C}$  to  $+55^{\circ}\text{C}$ ). Exclude portions of the sweep as indicated.

c. Set time-mark generator for 10 ns time marks.

CHECK—1 time mark/2 div, within 3% (6th mark aligns with 10th graticule line  $\pm 0.3$  div,  $+20^{\circ}\text{C}$  to  $+30^{\circ}\text{C}$ ) or within 4% (6th mark aligns with 10th graticule line  $\pm 0.4$  div,  $-15^{\circ}\text{C}$  to  $+55^{\circ}\text{C}$ ). This applies to the full sweep length, excluding the first and last 10 divisions of magnified sweep length.

d. Set DTP fully counterclockwise, A TIME/DIV to .2  $\mu$ s, and B TIME/DIV to .05  $\mu$ s.

**14. Check Delay Time Accuracy**

a. Set time-mark generator for 0.1  $\mu$ s time marks.

b. Set:

X10 MAG (IN)	Off (button out)
B TRIGGER SOURCE	STARTS AFTER DELAY
A TIME/DIV	.2 $\mu$ s
B TIME/DIV	.05 $\mu$ s
DELAY TIME POSITION	1.50

## Calibration—466 Service

c. Horizontally position 1st displayed marker to center vertical graticule line. See Fig. 5-F-6.

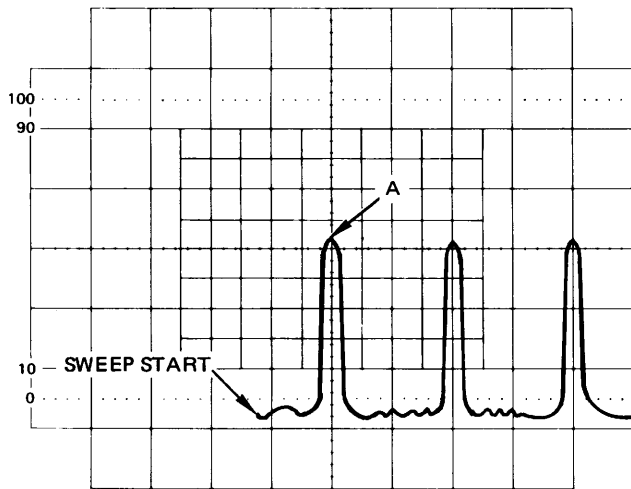

1753-22

Fig. 5-F-6. Delay-time Accuracy.

d. Set DTP control to 8.50, then move DTP control to position 1st displayed marker to center vertical line.

CHECK—DTP reading is  $8.50 \pm 0.05$  (8.45 to 8.55,  $+15^\circ\text{C}$  to  $+35^\circ\text{C}$ ), or  $8.50 \pm 0.12$  (8.35 to 8.62,  $-15^\circ\text{C}$  to  $+55^\circ\text{C}$ ).

e. Set time-mark generator for  $.5 \mu\text{s}$  time marks.

f. Set:

DELAY TIME POSITION 1.50  
A TIME/DIV  $.5 \mu\text{s}$

g. Position displayed marker to center vertical line with horizontal POSITION control.

h. Set DTP control to 8.50, then move DTP control to position displayed marker to center vertical line.

CHECK—DTP reading is  $8.50 \pm 0.05$  (8.45 to 8.55,  $+15^\circ\text{C}$  to  $+35^\circ\text{C}$ ), or  $8.50 \pm 0.12$  (8.38 to 8.62,  $-15^\circ\text{C}$  to  $+55^\circ\text{C}$ ).

CHECK—Delayed sweep accuracy using control settings given in Table 5-F-5. Use 1.00 for 1st DTP setting and 9.00 for 2nd setting (set DTP to 1.00 and use horizontal POSITION control to align time mark to center graticule reference line, then set DTP to 9.00 and move DTP so nearest time mark aligns with center graticule reference line—read amount of error from DTP dial). If 1st time mark is not visible, use 2nd time mark. Final DTP setting should read  $9.00 \pm 0.08$  (8.92 to 9.08,  $+15^\circ\text{C}$  to  $+35^\circ\text{C}$ ) or  $9.00 \pm 0.20$  (8.80 to 9.20,  $-15^\circ\text{C}$  to  $+55^\circ\text{C}$ ).

TABLE 5-F-5

Delay Time Accuracy

Time-Mark Generator Output	A TIME/DIV Switch Setting	B TIME/DIV Switch Setting	DTP Setting
1 microsecond	$1 \mu\text{s}$	$.1 \mu\text{s}$	8.92 to 9.08 ( $+15^\circ\text{C}$ to $+35^\circ\text{C}$ )  or  8.80 to 9.20 ( $-15^\circ\text{C}$ to $+55^\circ\text{C}$ )
2 microsecond	$2 \mu\text{s}$	$.2 \mu\text{s}$	
5 microsecond	$5 \mu\text{s}$	$.5 \mu\text{s}$	
10 microsecond	$10 \mu\text{s}$	$1 \mu\text{s}$	
20 microsecond	$20 \mu\text{s}$	$2 \mu\text{s}$	
50 microsecond	$50 \mu\text{s}$	$5 \mu\text{s}$	
.1 millisecond	.1 ms	$10 \mu\text{s}$	
.2 millisecond	.2 ms	$20 \mu\text{s}$	
.5 millisecond	.5 ms	$50 \mu\text{s}$	
1 millisecond	1 ms	.1 ms	
2 millisecond	2 ms	.2 ms	
5 millisecond	5 ms	.5 ms	
10 millisecond	10 ms	1 ms	
20 millisecond	20 ms	*2 ms	
50 millisecond	50 ms	*5 ms	
.1 second	.1 s	*10 ms	
.2 second	.2 s	*20 ms	
.5 second	.5 s	*50 ms	

\*Change A TRIG MODE to NORM.

**15. Check Delay Time Jitter**

a. Set time-mark generator for 1 ms time marks.

b. Set:

DELAY TIME POSITION	1.00
A TRIG MODE	AUTO
A TIME/DIV	1 ms
B TIME/DIV	.2 $\mu$ s

c. Attach light shield to graticule housing.

CALIBRATION AID—The low repetition rate of this check makes viewing difficult. Additional intensity may be obtained by using storage.

Push in VAR PERS button and adjust INTEN, STORAGE LEVEL and VIEW TIME for a usable trace.

d. Set DTP control to position time mark to graticule center.

CHECK—Jitter is 1 div or less (60 Hertz power line) or 2.5 div or less (50 Hertz power line).

e. Set DTP control to about 9.00 to position time mark to graticule center.

CHECK—Jitter is 1 div or less (60 Hertz power line) or 2.5 div or less (50 Hertz power line).

f. Push in NON STORE button and remove light shield.

**16. Check Mixed Sweep Accuracy**

*NOTE*

*The following portions of MIXED SWEEP mode are excluded: (1) The first 0.5 div after display start, (2) The first 0.2 div or 0.1  $\mu$ s, whichever is greater, after the transition from A Sweep to B Sweep.*

a. Set:

DELAY TIME POSITION	Fully counterclockwise
B TRIGGER SOURCE	NORMAL
LEVEL (B)	Fully counterclockwise (untriggered)
HORIZ DISPLAY	A
A TIME/DIV	1 ms
B TIME/DIV	.5 ms
A TRIGGER LEVEL	As needed for triggered sweep

b. Horizontally position 2nd time mark to left-hand graticule line and note A Sweep timing accuracy over 9 div.

c. Change HORIZ DISPLAY control to MIX and position 2nd time mark to left-hand graticule line.

CHECK—A sweep accuracy is within 2% of accuracy noted in part b.

d. Set B TRIGGER SOURCE switch to STARTS AFTER DELAY and position 2nd marker to 2nd graticule line (1st mark goes off screen).

CHECK—B Sweep accuracy is within 2% (8 div display  $\pm 0.16$  div from 2nd to 10th graticule lines).

e. Set time-mark generator for 0.2  $\mu$ s markers.

f. Set:

B TRIGGER SOURCE	NORMAL
HORIZ DISPLAY	A
A TIME/DIV	.2 $\mu$ s
B TIME/DIV	.1 $\mu$ s

g. horizontally position 2nd time mark to left-hand graticule line and note A Sweep timing accuracy over 9 div (from 1st to 10th graticule lines).

h. Change HORIZ DISPLAY control to MIX and position 2nd time mark to left-hand graticule line.

CHECK—A sweep error is within 2% of accuracy noted in part g.

i. Set B TRIGGER SOURCE switch to STARTS AFTER DELAY and position 2nd marker to left-hand graticule line (1st mark goes off screen).

CHECK—B Sweep accuracy is within 2% (centered 8 div display  $\pm 0.16$  div from 2nd to 10th graticule lines).

**17. Check B Ends A Operation**

a. Set:

HORIZ DISPLAY	A INTEN
A TIME/DIV	1 ms
B TIME/DIV	.1 ms
B TRIG MODE	STARTS AFTER DELAY
A TRIG HOLDOFF	B ENDS A (clockwise detent)
DELAY TIME POSITION	About 2.00
INTEN	A Sweep is visible



## Calibration—466 Service

b. Rotate DELAY TIME POSITION control through its range.

CHECK—End of A Sweep does not extend beyond B intensified portion at any DTP setting.

### 18. Check A Trigger Holdoff

a. Set:

HORIZ DISPLAY	A
A TIME/DIV	10 $\mu$ s
A TRIG HOLDOFF	NORM (fully counter-clockwise)
LEVEL (A)	Fully clockwise

b. Set test oscilloscope:

Vertical mode	Channel 1
Channel 1 Volts/Div	1 Volt
Horizontal mode	A Sweep
A Trig Slope	—
A Trig Mode	AUTO

c. Connect test oscilloscope CH 1 input to A +GATE Output (on oscilloscope being calibrated) via 50  $\Omega$  cable.

d. Adjust test oscilloscope Time/Div, Var Time/Div, and Triggering so negative portion of gate (holdoff time) is 1 div long and position waveform between 1st and 2nd vertical graticule lines.

e. Rotate A TRIG HOLDOFF control clockwise, but not into A ENDS B detent.

CHECK—Holdoff time of A GATE is increased 10 times or more.

f. Set the A TRIG HOLDOFF control to NORM.

g. Disconnect time-mark generator and test oscilloscope.

## G. REDUCED SCAN AND STORAGE

### Equipment Required

- |                                |                                |
|--------------------------------|--------------------------------|
| 1. Leveled Sine-Wave Generator | 5. 10X Probe                   |
| 2. Amplitude Calibrator        | 6. 42-inch 50-ohm BNC Cable    |
| 3. Time-Mark Generator         | 7. 50-Ohm BNC Termination      |
| 4. Test Oscilloscope           | 8. Three-inch screwdriver      |
|                                | 9. Low-Capacitance screwdriver |

See

**ADJUSTMENT LOCATIONS 1**

pull-out page for adjustments and test points (TP).

### 466 Control Settings (\*Indicates changes from the previous step)

POWER ON

#### Display

REDUCED SCAN (PULL) Push INTEN in  
 INTEN As desired  
 FOCUS Best focused trace  
 SCALE ILLUM As desired  
 ASTIG Best defined trace

#### Vertical (CH 1 and CH 2)

VERT MODE CH 1  
 POSITION Midrange  
 \*VOLTS/DIV \*.1 V  
 VAR VOLTS/DIV Calibrated detent  
 AC-GND-DC \*GND  
 INVERT Normal (button out)  
 20 MHz BW (PULL) Full bandwidth (push in,  
 then release; shows  
 no yellow)

#### Storage

NON STORE ON (button in)  
 STORAGE LEVEL MAX (fully clockwise)  
 SAVE INTEN MAX (fully clockwise)  
 SAVE Off (button out)  
 VIEW TIME MAX (fully clockwise and  
 in detent)

#### Trigger (A and B)

COUPLING AC  
 LEVEL As needed for triggered  
 display  
 SLOPE +  
 A TRIGGER SOURCE NORM  
 B (DLY'D TRIGGER SOURCE STARTS AFTER DELAY  
 TRIG MODE AUTO  
 A TRIG HOLDOFF NORM

### Sweep (A and B)

HORIZ DISPLAY	A
*A TIME/DIV	*1 ms
*B TIME/DIV	*1 ms
VAR TIME/DIV	Calibrated detent
DELAY TIME POSITION	Fully counterclockwise
X10 MAG	Off (button out)
POSITION (horizontal)	Midrange
FINE	Midrange

### 1. Check/Adjust Reduced Scan

#### NOTE

All measurements and readings in this step are referenced to the small graticule in the crt center screen unless otherwise stated.

- a. Pull INTENSITY control for Reduced Scan mode.

CHECK—REDUCED SCAN lamp lights when INTENSITY knob is pulled out.

CHECK—Trace is parallel to center horizontal graticule line.

ADJUST—Trace Rot R1554 (Reduced Scan Trace Rotation) for trace parallel to graticule line.

#### NOTE

If adjustment range is insufficient, remove, reverse, and reinstall P1551. Readjust Full Scan Trace rotation (Front Panel) and then Reduced Scan Trace rotation (R1554).

## Calibration—466 Service

b. Connect 0.1 ms time marks from time-mark generator to CH 1 input via 50 ohm cable and 50 ohm termination.

c. Set:

X10 MAG (IN)	On (push in)
CH 1 AC-GND-DC	DC

d. CHECK—1 time mark/div, within 2% (9.8 to 10.2 for 11th mark, +20°C to +30°C), or within 3% (9.7 to 10.3 for 11th mark, -15°C to +55°C).

ADJUST—R1464 for 1 time mark/(small) div.

e. Vertically position display baseline 2 large div below center line (bottom line of reduced graticule) and horizontally position a time mark to center vertical graticule line.

CHECK—Time mark is parallel to center vertical graticule line.

ADJUST—3 kV Y-Axis (R1564) for time mark parallel to graticule line.

### NOTE

*If range is insufficient, remove, reverse, and reinstall P1561. Adjust Full Scan Y-Axis (R1563—see B. DISPLAY AND Z-AXIS, Step 3, part c) then reduced scan (R1564).*

f. Set:

X10 MAG (IN)	Off (button out)
REDUCED SCAN (PULL)	Full Scan (push INTEN in)
CH 1 VOLTS/DIV	.5

Set time-mark generator for 1 ms time marks and adjust INTEN, FOCUS, and ASTIG controls for best focused display.

g. Set:

REDUCED SCAN (PULL)	Reduced Scan (pull INTEN out)
CH 1 VOLTS/DIV	.2

CHECK—Display can be focused by adjusting FOCUS control only.

ADJUST—Reduced Scan Astigmatism (R1573) and FOCUS, for best focused display.

h. Disconnect time-mark generator.

i. Connect 20 mV signal from amplitude calibrator to CH 1 input via 50 ohm cable.

j. Set CH 1 VOLTS/DIV switch to 5 mV.

CHECK—Display is 4 div within 3% (3.88 to 4.12 div).

ADJUST—R1527 for 4 (small) div.

INTERACTION—Reduced Scan Astigmatism (R1573) and R1527. Readjust as needed for optimum results.

k. Disconnect amplitude calibrator.

l. See NOTE following Step four, part l. For SN B120000 and up, perform Step one, parts m through q below. For SN below B120000, proceed to Step two.

m. Set:

INTEN	Maximum (fully cw)
A TIME/DIV	.05 $\mu$ s
X10 MAG	On (button in)

n. Connect a 96 MHz signal from the leveled sine-wave generator to CH 1 input via 50 ohm cable and 50 ohm termination.

o. Adjust generator for a 5 large-division display.

p. ADJUST—Intensity Limit (1406) for maximum usable intensity with minimum defocusing or blooming. Adjust FOCUS control as necessary while adjusting R1406.

q. Disconnect Sine-wave generator; Set A TIME/DIV to 1 ms, and X10 MAG to off (button out).

## 2. Pre-Adjust Storage Controls

a. Set:

A TRIG LEVEL	Fully clockwise
INTEN	Minimum (fully counter-clockwise)
Storage Mode	FAST (push in)
REDUCED SCAN (Pull)	Push INTEN in

### NOTE

*If Storage board or crt have been changed, or misadjustments have been made (or suspected to have been made), perform the following pre-adjustments. If the circuit is operating normally, no parts have been replaced and adjustments have not been tampered with, then proceed to Step 3.*

b. Pre-set Front Mesh Prep (R1927), Coarse Fast Mesh Transfer (R1989), and Front Operating Level (R1933), fully counterclockwise.

c. Set test oscilloscope vertical mode to channel 1, and channel 1 volts/div for 2 V/div sensitivity (including 10X probe attenuation).

d. Connect the 10X probe from the test oscilloscope to P1951 pin 7 (Front Mesh) and connect the probe ground lead to the 466 circuit ground. Press the ERASE button and verify that the READY lamp illuminates. Adjust R1935 Fast Mesh Hold Level for a reading of approximately  $-6\text{ V}$  on the test oscilloscope.

e. Connect the test oscilloscope 10X probe to P1951 pin 5, and probe ground to 466 circuit ground.

*NOTE Press erase before measurement.*

f. Pre-adjust Fast Prep (R1982) for a reading of approximately  $+5\text{ V}$  on the test oscilloscope.

g. Move the 10X probe to P1951 pin 7.

### 3. Adjust/Check Var Pers

a. Set:

Storage Mode	VAR PERS (push in)
INTEN	Minimum (fully counter-clockwise)
VIEW TIME	NORM (fully counter-clockwise)

b. Press ERASE button and note intensity of crt screen. Set STORAGE LEVEL to minimum (fully counterclockwise).

c. ADJUST—Front Mesh Operating Level (R1933) for a complete ramp waveform test oscilloscope display of approximately  $2.5\text{ V}$  amplitude and a repetition rate of approximately one cycle per  $.2\text{ ms}$ . This should produce a 466 display that is just brighter than the display that is produced when R1933 is set so the display sides begin to darken. See Fig. 5-G-1A through C. Then disconnect the test oscilloscope 10X probe and ground lead from the 466.

#### NOTE

*This sets STORAGE LEVEL maximum range. If set too high, screen fades positive (grows brighter). If set too low, maximum writing speed may not be achieved.*

d. Push ERASE button and note intensity level of crt screen. Set STORAGE LEVEL control to approximately 3 o'clock.

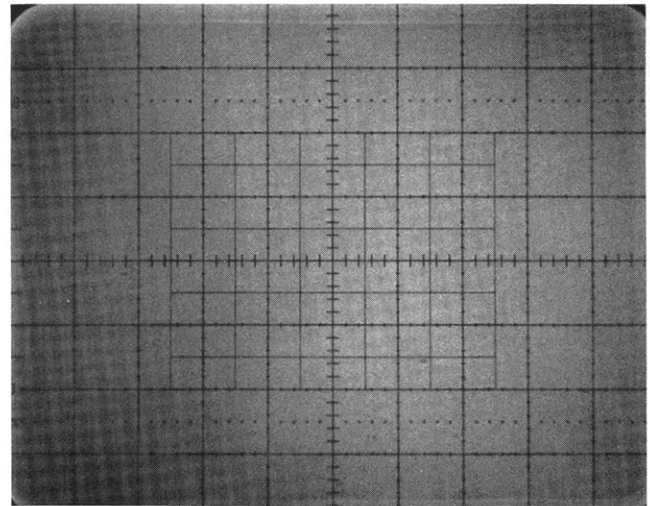

A. Incorrect R1933 adjustment (too far counter-clockwise).

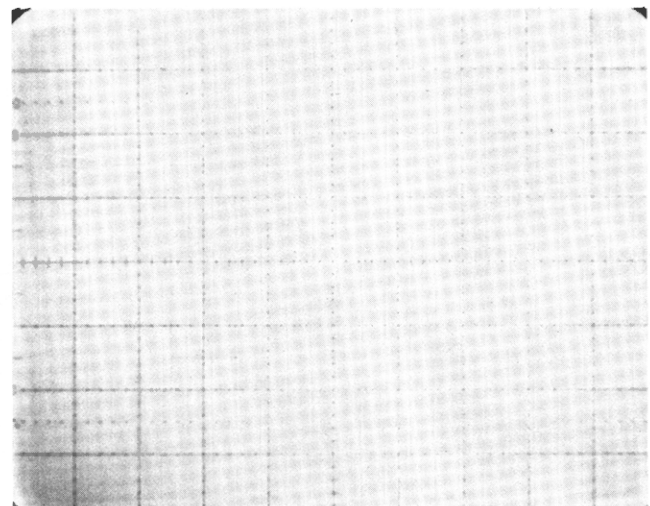

B. Incorrect R1933 adjustment (too far clockwise).

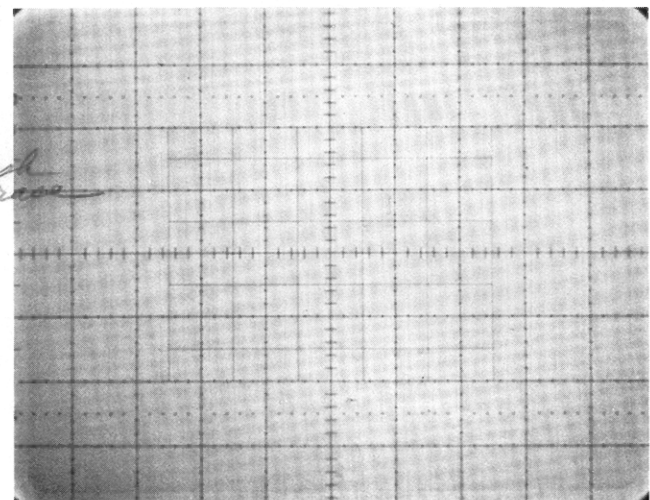

C. Correct R1933 adjustment (typical optimum display).

1753-76

Fig. 5-G-1 A-C. Front Mesh Op Level (R1933) adjustment.

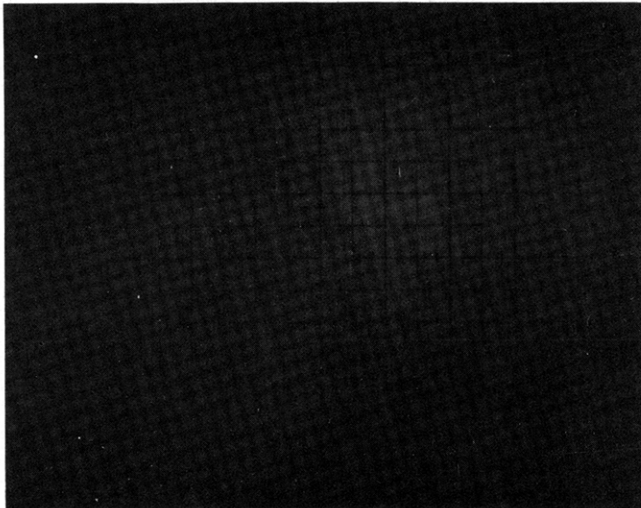

A. Incorrect R1927 adjustment (background level too low).

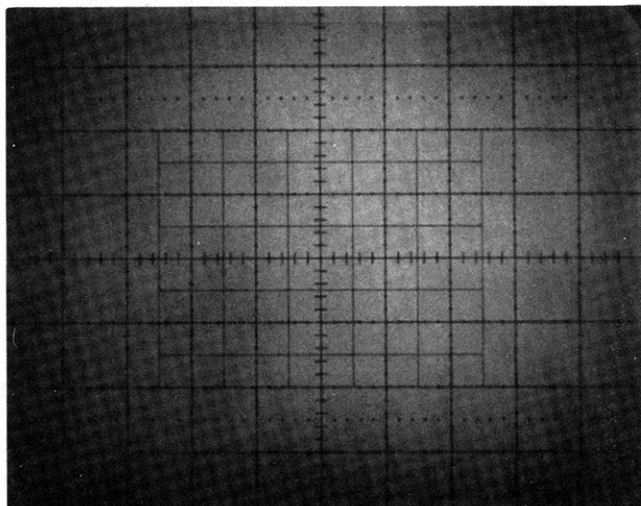

B. Incorrect R1927 adjustment (background level too high).

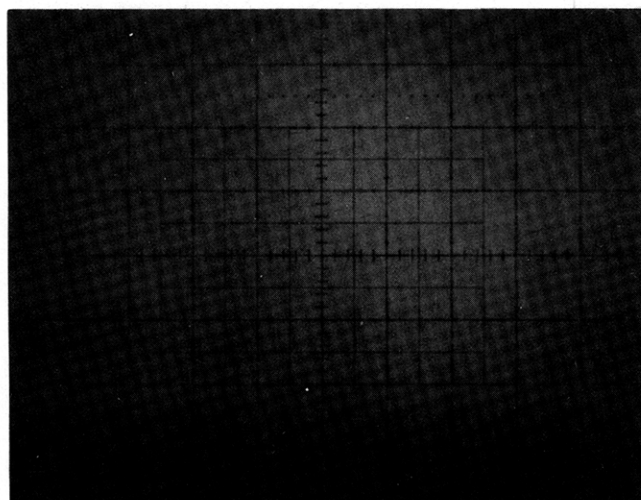

C. Correct R1927 adjustment (typical optimum background level display). 1753-77

Fig. 5-G-2 A-C. Front Mesh Prep Level (R1927) adjustment (Storage Level set at 3 o'clock).

e. ADJUST—Front Mesh Prep Level (R1927) until about 1 division on edges of crt screen begin to darken. Push ERASE button after each adjustment of R1927. Adjust R1927 for most uniform light background with darker edges. Depending upon the crt, this often occurs just above the point where two large light spots begin to appear on each side of graticule center. See Fig. 5-G-2A through C.

f. Set STORAGE LEVEL control to minimum (fully counterclockwise) and push ERASE button.

g. CHECK—Entire screen erases. (Failure to erase completely indicates Front Mesh Prep Level, R1927, is set too high.) Repeat Step 3, parts d and e as necessary.

#### 4. Adjust Fast Mode

a. Set:

A TIME/DIV	.1 $\mu$ s
Storage Mode	NON STORE (push in)
INTEN	Midrange
VIEW TIME	Minimum (fully counterclockwise)
STORAGE LEVEL	Minimum (fully counterclockwise)

b. Connect 9.6 MHz signal from leveled sine-wave generator to CH 1 input via 50 ohm cable and 50 ohm termination.

c. Adjust generator for 5 div display.

d. Set:

A TRIG LEVEL	Stable display
INTEN	Off (fully counterclockwise)
Storage Mode	FAST (push in)

e. After each automatic erase cycle, increase STORAGE LEVEL until a small amount of background noise can be seen. Set VIEW TIME control to MAX (in detent) and A TRIG LEVEL fully counterclockwise.

f. Push ERASE button and wait 15 seconds.

g. Turn A TRIG LEVEL clockwise just enough to trigger the sweep, and note brightness level of stored information (background noise).

NOTE

*In this step and the rest of the Performance Check or Calibration Procedure, when instructed to turn the Trigger LEVEL control either clockwise or counterclockwise to trigger the sweep, turn the control only to the triggering point; do not turn it to the extreme of rotation.*

h. Immediately push ERASE button and trigger another sweep and compare level of stored information to that noted in part g.

CHECK—Minimum fade-up or fade-down (brightening or dimming).

ADJUST—Front Mesh Hold Level (R1935) for no fade-up or fade-down after 15 seconds. If display in part g fades up, turn R1935 clockwise. Set A TRIG LEVEL fully counterclockwise. Repeat parts f through h as necessary. See Fig. 5-G-3A through C.

i. Push ERASE button and wait 1 minute.

j. Trigger sweep by turning A TRIG LEVEL clockwise and note brightness level of stored information (background noise).

k. Immediately push ERASE button, trigger another sweep, and compare level of stored information to the previous level. Fine-adjust R1935 as necessary for minimum fade-up or fade-down after 1 minute. Repeat parts i through k as necessary to achieve minimum fade-up and fade-down after 1 minute.

l. Set storage mode to NON STORE mode.

NOTE

*For SN B120000 and up, writing speed checks are made with intensity set at maximum (INTEN fully clockwise). For SN below B120000, writing speed checks are made at or near maximum usable intensity. Increase intensity setting until display begins to bloom and can no longer be properly focused, then reduce intensity setting until display can be focused for a reasonably well-defined presentation. This should occur with the INTEN control at approximately 1 o'clock. If this condition is difficult to achieve, perform parts m, n, and o; otherwise, proceed to part p. Whichever method is used, after the reference setting is made, DO NOT CHANGE INTEN CONTROL SETTING FOR REMAINDER OF STEP 4 THROUGH STEP 6.*

m. Set test oscilloscope vertical sensitivity for 20 V/div (including 10X probe attenuation) and connect 10X probe to TP1443 (Z-Axis).

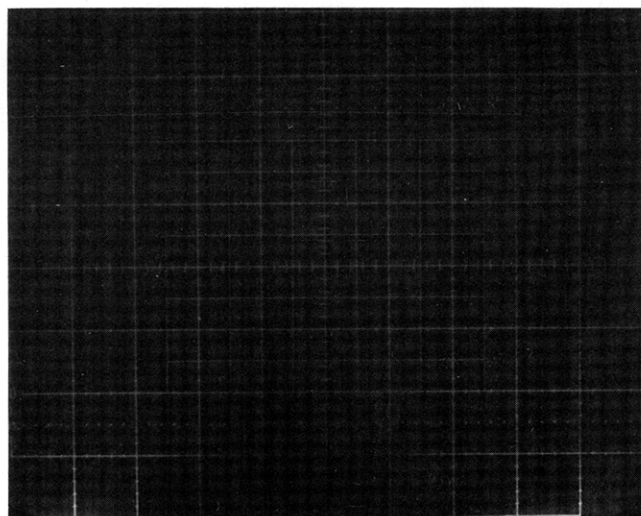

A. Incorrect R1935 adjustment (display fading negative).

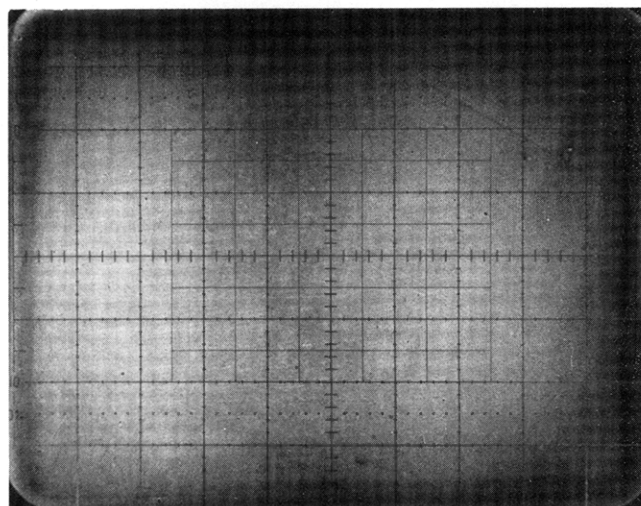

B. Incorrect R1935 adjustment (display fading positive).

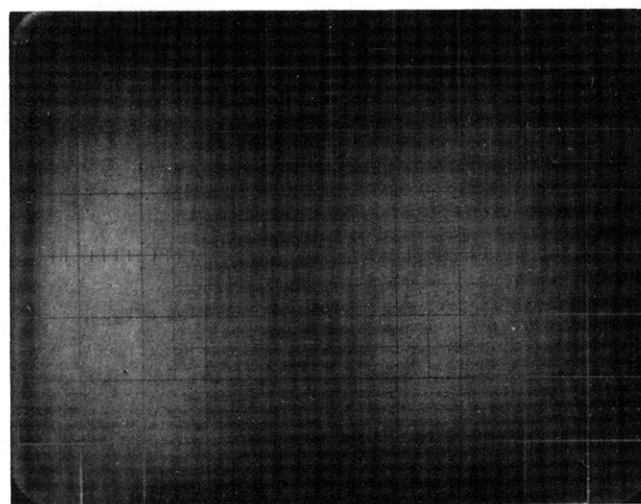

C. Correct R1935 adjustment (typical optimum display).

1753-78

Fig. 5-G-3 A-C. Front Mesh Hold Level (R1935) adjustment.

## Calibration—466 Service

n. Adjust INTEN control for +70 V level from dc reference to top of waveform (50 V grid drive). DO NOT CHANGE INTEN CONTROL SETTING FOR REMAINDER OF STEP 4 THROUGH STEP 6. Obtain best-focused triggered display.

o. Disconnect 10X probe.

p. Set:

Storage Mode	FAST (push in)
VIEW TIME	Minimum (fully counterclockwise)
Fine Fast Transfer Level (R1987)	Midrange

q. Wait several automatic erase cycles.

ADJUST—Coarse Fast Transfer Level (R1989) for well-defined display with small amount of background storage. (Adjust STORAGE LEVEL as necessary.)

r. Set:

VIEW TIME	MAX (in detent)
A TRIG LEVEL	Fully clockwise

s. Push ERASE button and wait 15 seconds.

t. Trigger sweep by turning A TRIG LEVEL counterclockwise (just to the triggering point) and note brightness level of stored trace and background level.

u. Immediately push ERASE button and trigger another sweep and compare level of stored information to that noted in part t.

CHECK—Minimum fade-up or fade-down of well-defined stored trace.

ADJUST—Fast Prep (R1982) for minimum fade-up or fade-down, after 15 seconds. (If 1st display fades up, turn R1982 counterclockwise.)

INTERACTION—Fast Prep (R1982) and Front Mesh Hold (R1935). Re-adjust R1935 and R1989 (see part x) as needed to maintain minimum fade-up or fade-down of background in parts s and t. Adjust STORAGE LEVEL control as needed to maintain background level of part u. Turn A TRIG LEVEL fully clockwise.

v. Push ERASE button and wait 1 minute.

w. Trigger sweep by turning A TRIG LEVEL counterclockwise and note brightness of stored information.

x. Immediately push ERASE button and compare level of stored information to that noted in part w.

CHECK—Minimum fade-up or fade-down.

ADJUST—Fast Prep (R1982) for minimum fade-up or fade-down. (If 1st display fades up, turn R1982 counterclockwise.)

INTERACTION—Fast Prep (R1982) and Fast Transfer Level (R1989). Readjust R1989 as needed to maintain display transfer level (well-defined, stored trace).

y. Set:

A TRIGGER LEVEL	0
VIEW TIME	Minimum (fully counterclockwise)

CHECK—Best trace transfer.

ADJUST—Fast Transfer Level (R1989) and STORAGE LEVEL control for best stored display. See Fig. 5-G-4.

## 5. Adjust Front Mesh Modulation (Below SN B092810 only)

a. Push ERASE button to trigger a new sweep.

b. Push SAVE button.

ADJUST—Front Modulation (R1858) midrange, and check for most even brightness of stored display. Fine adjust R1858 if necessary for most even brightness.

CHECK—Display does not auto erase.

CHECK—Display intensity turns completely off by adjusting SAVE INTEN control counterclockwise.

### NOTE

All writing speed checks are made with approximately +70 volt unblanking level. Once the STORAGE LEVEL control is set, do not change it. Obtaining maximum writing speed may require readjustment of the fine transfer level (R1987), then repeat Step 4 part q.

c. Set SAVE button to off (out).

**6. Check Full Scan Storage Writing Rate**

a. Set:

Storage Mode	FAST (push in)
A TRIG LEVEL	Fully clockwise

b. Set VIEW TIME control to MAX (in detent) and push ERASE button and wait 1 minute.

c. Trigger sweep by turning A TRIG LEVEL control counterclockwise.

CHECK—Trace is stored and distinguishable from background, everywhere within center 8 x 6 div, for 15 seconds or more.

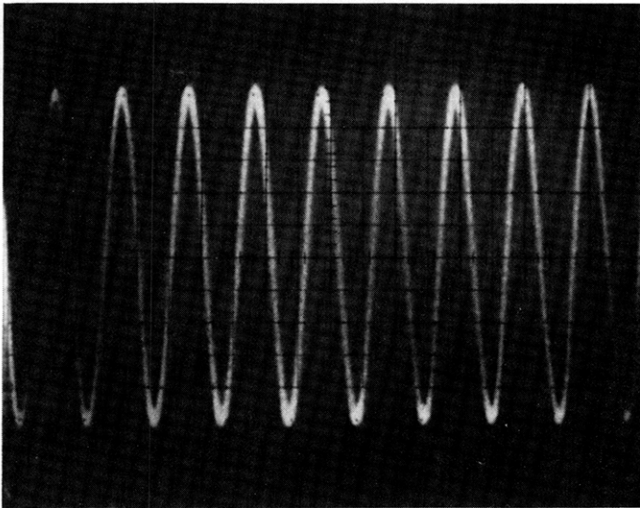

**A. Incorrect Adjustment (fading negative).**

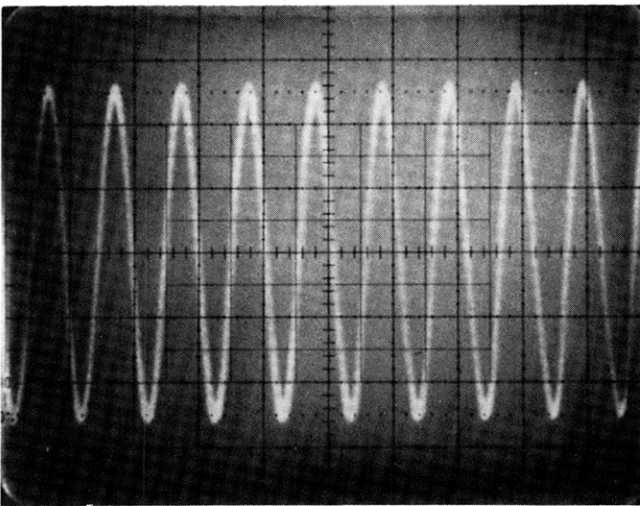

**B. Incorrect adjustment (fading positive).**

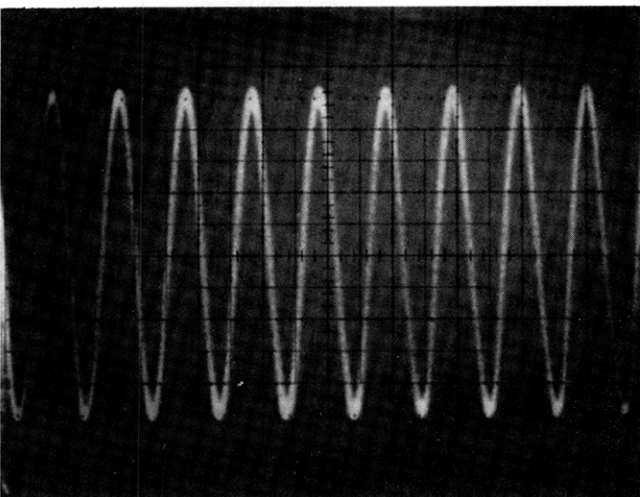

**C. Correct adjustment.**

1753-79

**Fig. 5-G-4 A-C. Display when R1982, R1989, and STORAGE LEVEL are adjusted for Fast Storage.**

d. Set:

Storage Mode	NON STORE (push in)
A TIME/DIV VAR	Fully counterclockwise

e. Adjust leveled sine-wave generator for 5 div, 3.2 MHz display. (Adjust A TRIG LEVEL control as necessary for a triggered display.)

f. Adjust FOCUS and ASTIG controls for best display.

g. Set:

Storage Mode	FAST (push in)
VIEW TIME	Minimum (fully counterclockwise)
STORAGE LEVEL	Best display

h. Set:

VIEW TIME	MAX (in detent)
A TRIG LEVEL	Fully clockwise

i. Push ERASE button several times to ensure meshes are stable, then wait 3 minutes.

j. Trigger sweep by turning A TRIG LEVEL control counterclockwise.

CHECK—Trace is stored and distinguishable from background, everywhere within center 8 x 6 div, for 15 seconds or more.



## Calibration—466 Service

k. Set:

A TIME/DIV	10 $\mu$ s
Storage Mode	NON STORE

l. Adjust leveled sine-wave generator for 3.2 div, 50 kHz display (adjust A TRIG LEVEL control as needed for stable display).

m. Adjust A TIME/DIV VAR control for about 1 cycle/div.

n. Position bottom of display 3 div below center horizontal line.

o. Set:

A TRIG LEVEL	Fully clockwise
A TRIG MODE	SINGL SWP
Storage Mode	VAR PERS (push in)
VIEW TIME	MAX (in detent)
STORAGE LEVEL	NORM

p. Push ERASE button.

q. Rotate STORAGE LEVEL control clockwise until screen starts to brighten.

r. Trigger sweep by turning A TRIG LEVEL control counterclockwise.

CHECK—Trace is stored and distinguishable from background, within center 8 horizontal div, for 15 seconds or more.

s. Set A TRIG MODE switch to AUTO and position top of display 3 div above center horizontal line.

t. Set:

A TRIG LEVEL	Fully clockwise
A TRIG MODE	SINGL SWP

u. Push ERASE button, then trigger sweep by turning A TRIG LEVEL control counterclockwise.

CHECK—Trace is stored and distinguishable from background, everywhere within center 8 horizontal div, for 15 seconds or more.

## 7. Check Reduced Scan Writing Speed

### NOTE

*All writing speeds in step 7 are referenced to the small center graticule (.45 cm = 1 div). All voltage amplitudes and TIME/DIV settings are referenced to the large graticule (0.9 cm = 1 div) even though the oscilloscope is in Reduced Scan mode.*

a. Set:

Storage Mode	NON STORE (push in)
A TRIG MODE	AUTO
INTEN	Do not rotate
REDUCED SCAN (PULL)	Pull
A TIME/DIV	5 $\mu$ s
X10 MAG	On (button in)

b. Adjust leveled sine-wave generator for 1.4 large div, 350 kHz display.

c. Set A TRIG LEVEL control as needed for stable display and A TIME/DIV VAR control for about 1 cycle/large div.

d. Position center of display to top of small graticule.

ADJUST—FOCUS and ASTIG controls for best display.

e. Set:

A TRIG LEVEL	Fully clockwise
A TRIG MODE	SINGL SWP
Storage Mode	VAR PERS
STORAGE LEVEL	NORM

f. Push ERASE button.

g. Set STORAGE LEVEL control to where screen just starts to brighten.

h. Trigger sweep by turning A TRIG LEVEL control counterclockwise.

CHECK—Trace is stored and distinguishable from background, everywhere within small graticule, for 15 seconds or more.

i. Set A TRIG MODE switch to AUTO and position center of display to bottom of small graticule.

j. Set:

A TRIG LEVEL	Fully clockwise
A TRIG MODE	SINGL SWP

k. Push ERASE button, then trigger sweep by turning A TRIG LEVEL control counterclockwise.

CHECK—Trace is stored and distinguishable from background, everywhere within small graticule, for 15 seconds or more.

l. Set A TRIG MODE to AUTO and position display to vertical center.

m. Set:

A TRIG LEVEL	Fully clockwise
A TRIG MODE	SINGL SWP

n. Push ERASE button, then trigger sweep by turning A TRIG LEVEL control counterclockwise.

CHECK—Trace is stored and distinguishable from background, everywhere within small graticule, for 15 seconds or more.

o. Set:

Storage Mode	NON STORE
A TRIG MODE	AUTO
A TIME/DIV	.05 $\mu$ s
VIEW TIME	Minimum (fully counter-clockwise)

p. Adjust leveled sine-wave generator for 5 large div, 96 MHz display.

q. Set A TRIG LEVEL control as needed for stable display and A TIME/DIV VAR control to cal (in detent).

r. Set STORAGE MODE switch to FAST.

s. Adjust STORAGE LEVEL control for best stored display. Do not readjust STORAGE LEVEL control for rest of Step 7.

t. Set VIEW TIME control to MAX (in detent).

u. Set A TRIG LEVEL control fully clockwise, push ERASE button and wait 1 minute.

v. Trigger sweep by turning A TRIG LEVEL control counterclockwise.

CHECK—Trace is stored and distinguishable from background, everywhere within small graticule for 15 seconds or more.

w. Set:

Storage Mode	NON STORE (push in)
A TRIG LEVEL	Stable display
A TIME/DIV	.1 $\mu$ s

x. Adjust leveled sine-wave generator for 5 large div, 32 MHz display.

y. Adjust A TIME/DIV VAR control for about 1 cycle/large div.

z. Set A TRIG LEVEL control fully clockwise, Storage Mode switch to FAST, push ERASE button several times and wait 3 minutes.

aa. Trigger sweep by turning A TRIG LEVEL control counterclockwise.

CHECK—Trace is stored and distinguishable from background, everywhere within small graticule, for 15 seconds or more.

ab. Disconnect leveled sine-wave generator.

ac. Push in NON STORE button, set VAR TIME/DIV to cal.

## H. X-Y DISPLAY, Z-AXIS AND GATE OUTPUTS

### Equipment Required

- |   |                           |
|---|---------------------------|
| 1. Amplitude Calibrator                   | 5. 50 Ohm BNC Termination |
| 2. Leveled Sine-Wave Generator            | 6. Dual-Input Coupler     |
| 3. Test Oscilloscope                      | 7. BNC T Connector        |
| 4. 42 inch 50 Ohm BNC Cable (2 required). | 8. Three-inch screwdriver |

See

**ADJUSTMENT LOCATIONS 1**

pull-out page for adjustments and test points (TP).

### 466 Control Settings (\*Indicates changes from the previous step):

POWER	ON
<b>Display</b>	
*REDUCED SCAN (PULL)	*Push INTEN in
INTEN	As needed
FOCUS	As needed for focused display
SCALE ILLUM	As desired
ASTIG	Best defined trace

### Vertical (CH 1 and CH 2)

*VERT MODE	*CH 2 or X-Y
POSITION	Midrange
*VOLTS/DIV	*5 mV
VAR VOLTS/DIV	Calibrated detent
*CH 1 AC-GND-DC	*AC
CH 2 AC-GND-DC	GND
INVERT	Normal (button out)
20 MHz BW (PULL)	Full bandwidth (push in, then release; shows no yellow)

### Storage

*NON STORE	*On (button in)
*STORAGE LEVEL	*NORM
*SAVE INTEN	*Midrange
SAVE	Off (button out)
*VIEW TIME	*NORM

### Trigger (A and B)

COUPLING	AC
*LEVEL	*Midrange
SLOPE	+
A TRIGGER SOURCE	NORM
B (DLY'D) TRIGGER SOURCE	STARTS AFTER DELAY
*TRIG MODE	*AUTO
A TRIG HOLDOFF	NORM

### Sweep (A and B)

HORIZ DISPLAY	A
*A TIME/DIV	*X-Y
*B TIME/DIV	*X-Y
*VAR TIME/DIV	*Calibrated detent
X10 MAG	Off (button out)
POSITION (horizontal)	Midrange
FINE	Midrange

### 1. Check/Adjust X GAIN

a. Connect 20 mV signal from amplitude calibrator to CH 1 input via 50 ohm cable.

CHECK—Display is 2 dots, with dot centers 4 div apart, within 4% (4 div  $\pm 0.16$  div).

ADJUST—X-Axis Gain (R1214) for 2 dot display, with dot centers 4 div apart.

b. Set amplitude calibrator for 50 mV signal.

CHECK—Display is 2 dots, with dot centers 10 div apart, within 4% (10 div  $\pm 0.4$  div).

c. Set CH 1 AC-GND-DC switch to DC.

CHECK—Display is 2 dots, with dot centers 10 div apart, within 4% (10 div  $\pm 0.4$  div).

d. Disconnect amplitude calibrator.

### 2. Check X-Y Phasing

a. Connect leveled sine-wave generator signal to both inputs via 50 ohm cable, 50 ohm termination, dual-input coupler to CH 1 and CH 2 inputs.

b. Adjust leveled sine-wave generator for 8 div, 50 kHz signal.

c. Set CH 2 AC-GND-DC switch to DC.

d. Adjust CH 2 POSITION control and horizontal POSITION controls to center display (see Fig. 5-H-1).

CHECK—Opening is 0.4 div or less, measured along center graticule line (see Fig. 5-H-1).

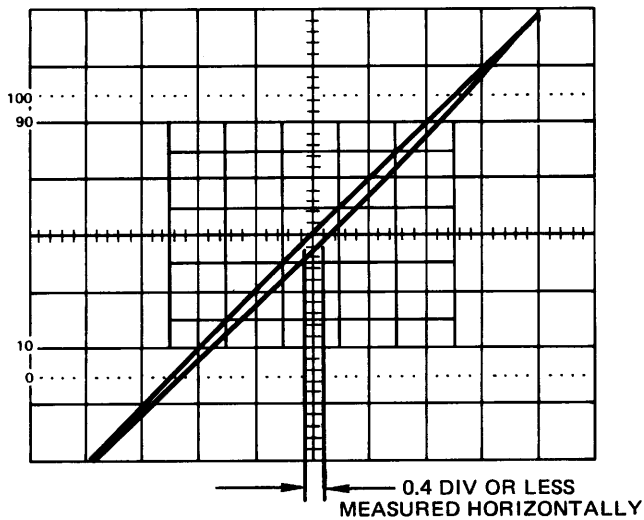

1753-23

Fig. 5-H-1. X-Y Phasing Check.

### 3. Check X-Axis Bandwidth

a. Set CH 2 AC-GND-DC switch to GND.

b. Remove dual-input coupler and connect leveled sine-wave generator to CH 1 input via 50 ohm cable and 50 ohm termination.

c. Adjust leveled sine-wave generator for 10 div, 50 kHz display.

d. Adjust leveled sine-wave generator to 4.0 MHz.

CHECK—Display is 7 div or more.

e. Disconnect leveled sine-wave generator.

### 4. Check Z-Axis Sensitivity

a. Set:

A TIME/DIV	.2 ms
A TRIG SOURCE	EXT

b. Connect 5 V signal from amplitude calibrator via 50 ohm cable, BNC T-connector and 50 ohm cable to EXT Z-AXIS input and A EXT Trigger input.

c. Adjust A TRIG LEVEL control for triggered display (TRIG lamp is lit).

CHECK—Trace is intensity modulated at normal (and lower) INTEN control settings.

d. Disconnect amplitude calibrator.

### 5. Check Z-Axis Maximum Usable Frequency

a. Set:

A TIME/DIV	.05 $\mu$ s
CH 2 VOLTS/DIV	1
CH 2 AC-GND-DC	DC

b. Connect leveled sine-wave generator, via 50 ohm cable and BNC T-connector to A EXT Trigger input then through 50 ohm cable to CH 2 input.

c. Set leveled sine-wave generator for 5 div (5 V) 50 MHz display.

d. Move cable from CH 2 input to EXT Z-AXIS input.

CHECK—Trace is intensity modulated at normal (and lower) INTEN control settings.

e. Disconnect leveled sine-wave generator, cables, and connector.

### 6. Check A and B Gates Out

a. Set:

TIME/DIV (both)	50 $\mu$ s
B TRIGGER SOURCE	STARTS AFTER DELAY
DELAY TIME POSITION	Fully counterclockwise

## Calibration—466 Service

b. Set:                    Test Oscilloscope Controls

Vertical Mode	Channel 1
Channel 1 Volts/Division	1 volt
A Time/Division	0.2 ms

c. Connect test oscilloscope input to A + GATE output via 50 ohm cable.

CHECK—Display is positive, rectangular pulse, about 5.5 V high.

d. Move 50 ohm cable to B + GATE output.

e. Set HORIZ DISPLAY switch to B DLY'D.

CHECK—Display is positive, rectangular pulse, about 5.5 V high.

f. Disconnect test oscilloscope.

# REPLACEABLE ELECTRICAL PARTS

## PARTS ORDERING INFORMATION

Replacement parts are available from or through your local Tektronix, Inc. Field Office or representative.

Changes to Tektronix instruments are sometimes made to accommodate improved components as they become available, and to give you the benefit of the latest circuit improvements developed in our engineering department. It is therefore important, when ordering parts, to include the following information in your order: Part number, instrument type or number, serial number, and modification number if applicable.

If a part you have ordered has been replaced with a new or improved part, your local Tektronix, Inc. Field Office or representative will contact you concerning any change in part number.

Change information, if any, is located at the rear of this manual.

## SPECIAL NOTES AND SYMBOLS

X000 Part first added at this serial number  
00X Part removed after this serial number

## ITEM NAME

In the Parts List, an Item Name is separated from the description by a colon (:). Because of space limitations, an Item Name may sometimes appear as incomplete. For further Item Name identification, the U.S. Federal Cataloging Handbook H6-1 can be utilized where possible.

## ABBREVIATIONS

ACTR	ACTUATOR	PLSTC	PLASTIC
ASSY	ASSEMBLY	QTZ	QUARTZ
CAP	CAPACITOR	RECP	RECEPTACLE
CER	CERAMIC	RES	RESISTOR
CKT	CIRCUIT	RF	RADIO FREQUENCY
COMP	COMPOSITION	SEL	SELECTED
CONN	CONNECTOR	SEMICOND	SEMICONDUCTOR
ELCTLT	ELECTROLYTIC	SENS	SENSITIVE
ELEC	ELECTRICAL	VAR	VARIABLE
INCAND	INCANDESCENT	WW	WIREWOUND
LED	LIGHT EMITTING DIODE	XFMR	TRANSFORMER
NONWIR	NON WIREWOUND	XTAL	CRYSTAL

CROSS INDEX—MFR. CODE NUMBER TO MANUFACTURER

Mfr. Code	Manufacturer	Address	City, State, Zip
0000M	SONY/TEKTRONIX CORPORATION	P O BOX 14, HANEDA AIRPORT	TOKYO 149, JAPAN
00779	AMP, INC.	P O BOX 3608	HARRISBURG, PA 17105
00853	SANGAMO ELECTRIC CO., S. CAROLINA DIV.	P O BOX 128	PICKENS, SC 29671
01121	ALLEN-BRADLEY COMPANY	1201 2ND STREET SOUTH	MILWAUKEE, WI 53204
01295	TEXAS INSTRUMENTS, INC., SEMICONDUCTOR GROUP	P O BOX 5012, 13500 N CENTRAL EXPRESSWAY	DALLAS, TX 75222
01963	CHERRY ELECTRICAL PRODUCTS CORPORATION	3600 SUNSET AVENUE	WAUKEGAN, IL 60085
02111	SPECTROL ELECTRONICS CORPORATION	17070 EAST GALE AVENUE	CITY OF INDUSTRY, CA 91745
02735	RCA CORPORATION, SOLID STATE DIVISION	ROUTE 202	SOMERVILLE, NY 08876
03508	GENERAL ELECTRIC COMPANY, SEMI-CONDUCTOR PRODUCTS DEPARTMENT	ELECTRONICS PARK	SYRACUSE, NY 13201
03888	KDI PYROFILM CORPORATION	60 S JEFFERSON ROAD	WHIPPANY, NJ 07981
04222	AVX CERAMICS, DIVISION OF AVX CORP.	P O BOX 867, 19TH AVE. SOUTH	MYRTLE BEACH, SC 29577
04713	MOTOROLA, INC., SEMICONDUCTOR PROD. DIV.	5005 E MCDOWELL RD, PO BOX 20923	PHOENIX, AZ 85036
05397	UNION CARBIDE CORPORATION, MATERIALS SYSTEMS DIVISION	11901 MADISON AVENUE	CLEVELAND, OH 44101
05828	GENERAL INSTRUMENT CORP ELECTRONIC SYSTEMS DIV.	600 W JOHN ST.	HICKSVILLE LI, NY 11802
07263	FAIRCHILD SEMICONDUCTOR, A DIV. OF FAIRCHILD CAMERA AND INSTRUMENT CORP.	464 ELLIS STREET	MOUNTAIN VIEW, CA 94042
07716	TRW ELECTRONIC COMPONENTS, IRC FIXED RESISTORS, BURLINGTON DIV.	2850 MT. PLEASANT	BURLINGTON, IA 52601
08806	GENERAL ELECTRIC CO., MINIATURE LAMP PRODUCTS DEPARTMENT	NELA PARK	CLEVELAND, OH 44112
09353	C AND K COMPONENTS, INC.	103 MORSE STREET	WATERTOWN, MA 02172
12617	HAMLIN, INC.	GROVE & LAKE STS.	LAKE MILLS, WI 53551
12697	CLAROSTAT MFG. CO., INC.	LOWER WASHINGTON STREET	DOVER, NH 03820
12954	SIEMENS CORPORATION, COMPONENTS GROUP	8700 E THOMAS RD, P O BOX 1390	SCOTTSDALE, AZ 85252
12969	UNITRODE CORPORATION	580 PLEASANT STREET	WATERTOWN, MA 02172
13511	AMPHENOL CARDRE DIV., BUNKER RAMO CORP.		LOS GATOS, CA 95030
14193	CAL-R, INC.	1601 OLYMPIC BLVD.	SANTA MONICA, CA 90404
14433	ITT SEMICONDUCTORS	3301 ELECTRONICS WAY P O BOX 3049	WEST PALM BEACH, FL 33402
14552	MICRO SEMICONDUCTOR CORP.	2830 E FAIRVIEW ST.	SANTA ANA, CA 92704
15238	ITT SEMICONDUCTORS, A DIVISION OF INTER NATIONAL TELEPHONE AND TELEGRAPH CORP.		
15454	RODAN INDUSTRIES, INC.	P.O. BOX 168, 500 BROADWAY	LAWRENCE, MA 01841
16299	CORNING GLASS WORKS, ELECTRONIC COMPONENTS DIVISION	2905 BLUE STAR ST.	ANAHEIM, CA 92806
16546	GLOBE UNION INC. USCC/CENTRALAB ELECTRONICS DIV.	3900 ELECTRONICS DR.	RALEIGH, NC 27604
17856	SILICONIX, INC.	4561 COLORADO	LOS ANGELES, CA 90039
18324	SIGNETICS CORP.	2201 LAURELWOOD DRIVE	SANTA CLARA, CA 95054
19396	ILLINOIS TOOL WORKS, INC. PAKTRON DIV.	811 E. ARQUES	SUNNYVALE, CA 94086
22526	BERG ELECTRONICS, INC.	900 FOLLIN LANE, SE	VIENNA, VA 22180
24546	CORNING GLASS WORKS, ELECTRONIC COMPONENTS DIVISION	YOUK EXPRESSWAY	NEW CUMBERLAND, PA 17070
24931	SPECIALITY CONNECTOR CO., INC.	550 HIGH STREET	BRADFORD, PA 16701
25088	SIEMENS CORP.	2620 ENDRESS PLACE	GREENWOOD, IN 46142
27014	NATIONAL SEMICONDUCTOR CORP.	186 WOOD AVE. S	ISELIN, NJ 08830
32293	INTERSIL, INC.	2900 SEMICONDUCTOR DR.	SANTA CLARA, CA 95051
32997	BOURNS, INC., TRIMPOT PRODUCTS DIV.	10900 N. TANTAU AVE.	CUPERTINO, CA 95014
33096	COLORADO CRYSTAL CORPORATION	1200 COLUMBIA AVE.	RIVERSIDE, CA 92507
50157	MIDWEST COMPONENTS INC.	2303 W 8TH STREET P. O. BOX 787	LOVELAND, CO 80537
50434	HEWLETT-PACKARD COMPANY	1981 PORT CITY BLVD.	MUSKEGON, MI 49443
51406	MURATA CORPORATION OF AMERICA	640 PAGE MILL ROAD	PALO ALTO, CA 94304
53944	ELT INC., GLOW LITE DIVISION	2 WESTCHESTER PLAZA	ELMSFORD, NY 10523
56289	SPRAGUE ELECTRIC CO.	BOX 698	PAULS VALLEY, OK 73075
57668	R-OHM CORP.	87 MARSHALL ST.	NORTH ADAMS, MA 01247
59660	TUSONIX INC.	16931 MILLIKEN AVE.	IRVINE, CA 92713
71400	BUSSMAN MFG., DIVISION OF MCGRAW-EDISON CO.	2155 N FORBES BLVD	TUCSON, AZ 85705
71707	COTO COIL CO., INC.	2536 W. UNIVERSITY ST.	ST. LOUIS, MO 63107
72982	ERIE TECHNOLOGICAL PRODUCTS, INC.	65 PAVILION AVE.	PROVIDENCE, RI 02905
73138	BECKMAN INSTRUMENTS, INC., HELIPOT DIV.	644 W. 12TH ST. 2500 HARBOR BLVD.	ERIE, PA 16512 FULLERTON, CA 92634

CROSS INDEX—MFR. CODE NUMBER TO MANUFACTURER

Mfr. Code	Manufacturer	Address	City, State, Zip
73803	TEXAS INSTRUMENTS, INC., METALLURGICAL MATERIALS DIV.	34 FOREST STREET	ATTLEBORO, MA 02703
74276	SIGNALITE DIV., GENERAL INSTRUMENT CORP.	1933 HECK AVE.	NEPTUNE, NJ 07753
74970	JOHNSON, E. F., CO.	299 10TH AVE. S. W.	WASECA, MN 56093
75042	TRW ELECTRONIC COMPONENTS, IRC FIXED RESISTORS, PHILADELPHIA DIVISION	401 N. BROAD ST.	PHILADELPHIA, PA 19108
76493	BELL INDUSTRIES, INC., MILLER, J. W., DIV.	19070 REYES AVE., P O BOX 5825	COMPTON, CA 90224
80009	TEKTRONIX, INC.	P O BOX 500	BEAVERTON, OR 97077
80031	ELECTRA-MIDLAND CORP., MEPCO DIV.	22 COLUMBIA ROAD	MORRISTOWN, NJ 07960
81439	THERM-O-DISC, INC.	1320 S MAIN, P O BOX 1538	MANSFIELD, OH 44907
82389	SWITCHCRAFT, INC.	5555 N. ELSTON AVE.	CHICAGO, IL 60630
83003	VARO, INC.	P O BOX 411, 2203 WALNUT STREET	GARLAND, TX 75040
84411	TRW ELECTRONIC COMPONENTS, TRW CAPACITORS	112 W. FIRST ST.	OGALLALA, NE 69153
90201	MALLORY CAPACITOR CO., DIV. OF P. R. MALLORY AND CO., INC.	3029 E. WASHINGTON STREET P. O. BOX 372	INDIANAPOLIS, IN 46206
91418	RADIO MATERIALS COMPANY, DIV. OF P. R. MALLORY AND COMPANY, INC.	4242 W BRYN MAWR P. O. BOX 609	CHICAGO, IL 60646 COLUMBUS, NE 68601
91637	DALE ELECTRONICS, INC.		
92966	SYLVANIA MINIATURE LIGHTING PRODUCTS, INC., SUB OF GTE SYLVANIA, LIGHT. PROD.	526 ELM STREET	KEARNY, NJ 07032



Replaceable Electrical Parts—466 Service

Ckt No.	Tektronix Part No.	Serial/Model No. Eff	Dscont	Name & Description	Mfr Code	Mfr Part Number
A1	670-3254-00	B010100	B113349	CKT BOARD ASSY:ATTENUATOR	80009	670-3254-00
A1	670-3254-01	B113350		CKT BOARD ASSY:ATTENUATOR (SEE DM MANUAL FOR ALTERNATE VERSION)	80009	670-3254-01
A2	670-2810-00	B010100	B138374	CKT BOARD ASSY:VERTICAL PREAMP	80009	670-2810-00
A2	670-2810-01	B138375	B149849	CKT BOARD ASSY:VERTICAL PREAMP	80009	670-2810-01
A2	670-2810-02	B149850		CKT BOARD ASSY:VERTICAL PREAMP	80009	670-2810-02
A3	670-2809-00			CKT BOARD ASSY:VERTICAL MODE SWITCH	80009	670-2809-00
A4	670-2811-00	B010100	B071669	CKT BOARD ASSY:VERTICAL OUTPUT	80009	670-2811-00
A4	670-2811-01	B071670	B150754	CKT BOARD ASSY:VERTICAL OUTPUT	80009	670-2811-01
A4	670-2811-03	B150755		CKT BOARD ASSY:VERTICAL OUTPUT	80009	670-2811-03
A5	670-3324-00			CKT BOARD ASSY:TRIGGER GEN & SWEEP LOGIC (SEE DM MANUAL FOR ALTERNATE VERSION) (SEE OPTION 5)	80009	670-3324-00
A6	670-2805-00	B010100	B010134	CKT BOARD ASSY:INTERFACE	80009	670-2805-00
A6	670-2805-01	B010135	B059999	CKT BOARD ASSY:INTERFACE	80009	670-2805-01
A6	670-2805-03	B060000	B079999	CKT BOARD ASSY:INTERFACE	80009	670-2805-03
A6	670-2805-05	B080000	B119999	CKT BOARD ASSY:INTERFACE	80009	670-2805-05
A6	670-2805-07	B120000	B129999	CKT BOARD ASSY:INTERFACE	80009	670-2805-07
A6	670-2805-09	B130000	B138194	CKT BOARD ASSY:INTERFACE	80009	670-2805-09
A6	670-2805-11	B138195	B149443	CKT BOARD ASSY:INTERFACE	80009	670-2805-11
A6	670-2805-15	B149444	B152499	CKT BOARD ASSY:INTERFACE	80009	670-2805-15
A6	670-2805-21	B152500		CKT BOARD ASSY:INTERFACE	80009	670-2805-21
A7	670-2807-00	B010100	B010291	CKT BOARD ASSY:TIMING	80009	670-2807-00
A7	670-3466-00	B010292		CKT BOARD ASSY:TIMING (SEE DM MANUAL FOR ALTERNATE VERSION)	80009	670-3466-00
A8	670-2754-00	B010100	B102829	CKT BOARD ASSY:HIGH VOLTAGE MULTIPLIER	80009	670-2754-00
A8	670-2754-01	B102830		CKT BOARD ASSY:HIGH VOLTAGE MULTIPLIER	80009	670-2754-01
A9	670-2279-01			CKT BOARD ASSY:CRT SCALE ILLUMINATION	80009	670-2279-01
A10	670-2808-00			CKT BOARD ASSY:STORAGE & LOGIC	80009	670-2808-00
A11	670-2245-00	B010100	B138089	CKT BOARD ASSY:FAN MOTOR	80009	670-2245-00
A11	670-6002-01	B138090		CKT BOARD ASSY:FAN MOTOR	80009	670-6002-01
A12	-----			(SEE OPTION 5)		
A13	-----			(SEE OPTION 7)		
B1690	147-0035-00	B010100	B138089X	MOTOR, DC: BRUSHLESS, 10-15VDC, 145MA	25088	1AD3001-0A
B8045	147-0035-00	XB138090		MOTOR, DC: BRUSHLESS, 10-15VDC, 145MA	25088	1AD3001-0A
C9	-----			(SEE DM MANUAL FOR ALTERNATE VERSION)		
C10(2)	281-0064-00			CAP., VAR, PLSTC: 0.25-1.5PF, 600V	74970	273-0001-101
C12(2)	285-0816-01			CAP., FXD, PLSTC: 0.019UF, 10%, 600V (SEE DM MANUAL FOR ALTERNATE VERSION)	80009	285-0816-01
C20(2)	283-0000-00			CAP., FXD, CER DI: 0.001UF, +100-0%, 500V	59660	831-519-Y5P-102P
C21(2)	283-0000-00			CAP., FXD, CER DI: 0.001UF, +100-0%, 500V	59660	831-519-Y5P-102P
C30(2)	307-1014-01			ATTENUATOR, FXD: 100X	80009	307-1014-01
C31						
C32(2)	307-1013-01			ATTENUATOR, FXD: 10X	80009	307-1013-01
C33						
C34(2)	307-1011-00			ATTENUATOR, FXD: 4X	80009	307-1011-00
C35						
C36(2)	307-1010-01			ATTENUATOR, FXD: 2X	80009	307-1010-01
C37						
C42(2)	283-0156-00			CAP., FXD, CER DI: 1000PF, +100-0%, 200V	72982	8111A208Z5U0102Z
C72	281-0547-00			CAP., FXD, CER DI: 2.7PF, 10%, 500V	04222	7001-1321
C73	283-0004-00			CAP., FXD, CER DI: 0.02UF, +80-20%, 150V	91418	SP203Z151-4R9
C74	290-0517-00			CAP., FXD, ELCTLT: 6.8UF, 20%, 35V	56289	196D685X0035KA1
C75	281-0536-00			CAP., FXD, CER DI: 1000PF, 10%, 500V	72982	301000 X 5P0102K
C76	-----	B010100	B050749	(ADDED WHEN NECESSARY)		
C76	283-0004-00	B050750		CAP., FXD, CER DI: 0.02UF, +80-20%, 150V	91418	SP203Z151-4R9
C82	283-0198-00			CAP., FXD, CER DI: 0.22UF, 20%, 50V	56289	1C10Z5U223M050B

Ckt No.	Tektronix Part No.	Serial/Model No. Eff	Dscont	Name & Description	Mfr Code	Mfr Part Number
C87	281-0536-00			CAP., FXD, CER DI: 1000PF, 10%, 500V	72982	301000 X 5P0102K
C107	281-0167-00			CAP., VAR, CER DI: 9-45PF, 200V	59660	538-011D9-45
C108	281-0207-00			CAP., VAR, PLSTC: 2-18PF, 100V	80031	2807C00218MH02F0
C111	281-0525-00			CAP., FXD, CER DI: 470PF, +/-94PF, 500V	04222	7001-1364
C118	281-0525-00			CAP., FXD, CER DI: 470PF, +/-94PF, 500V	04222	7001-1364
C133	281-0207-00			CAP., VAR, PLSTC: 2-18PF, 100V	80031	2807C00218MH02F0
C142	283-0067-00			CAP., FXD, CER DI: 0.001UF, 10%, 200V	59660	835-515-Z5D0102K
C144	281-0512-00			CAP., FXD, CER DI: 27PF, +/-2.7PF, 500V	59660	308-000C0G0270K
C147	281-0525-00			CAP., FXD, CER DI: 470PF, +/-94PF, 500V	04222	7001-1364
C148	283-0004-00			CAP., FXD, CER DI: 0.02UF, +80-20%, 150V	91418	SP203Z151-4R9
C155	281-0540-00			CAP., FXD, CER DI: 51PF, 5%, 500V	59660	301-000U2J0510J
C157	283-0004-00			CAP., FXD, CER DI: 0.02UF, +80-20%, 150V	91418	SP203Z151-4R9
C158	281-0518-00	B010100	B010139X	CAP., FXD, CER DI: 47PF, +/-9.4PF, 500V	59660	301-000U2J0470M
C161	281-0536-00			CAP., FXD, CER DI: 1000PF, 10%, 500V	72982	301000 X 5P0102K
C162	281-0536-00			CAP., FXD, CER DI: 1000PF, 10%, 500V	72982	301000 X 5P0102K
C172	281-0547-00			CAP., FXD, CER DI: 2.7PF, 10%, 500V	04222	7001-1321
C173	283-0004-00			CAP., FXD, CER DI: 0.02UF, +80-20%, 150V	91418	SP203Z151-4R9
C174	290-0517-00			CAP., FXD, ELCTLT: 6.8UF, 20%, 35V	56289	196D685X0035KA1
C175	281-0536-00			CAP., FXD, CER DI: 1000PF, 10%, 500V	72982	301000 X 5P0102K
	-----			(ADDED WHEN NECESSARY)		
C176	283-0004-00	XB050750		CAP., FXD, CER DI: 0.02UF, +80-20%, 150V	91418	SP203Z151-4R9
C182	283-0198-00			CAP., FXD, CER DI: 0.22UF, 20%, 50V	56289	1C10Z5U223M050B
C187	281-0536-00			CAP., FXD, CER DI: 1000PF, 10%, 500V	72982	301000 X 5P0102K
C207	281-0167-00			CAP., VAR, CER DI: 9-45PF, 200V	59660	538-011D9-45
C208	281-0207-00			CAP., VAR, PLSTC: 2-18PF, 100V	80031	2807C00218MH02F0
C211	281-0525-00			CAP., FXD, CER DI: 470PF, +/-94PF, 500V	04222	7001-1364
C218	281-0525-00			CAP., FXD, CER DI: 470PF, +/-94PF, 500V	04222	7001-1364
C233	281-0207-00			CAP., VAR, PLSTC: 2-18PF, 100V	80031	2807C00218MH02F0
C238	283-0004-00			CAP., FXD, CER DI: 0.02UF, +80-20%, 150V	91418	SP203Z151-4R9
C242	283-0067-00			CAP., FXD, CER DI: 0.001UF, 10%, 200V	59660	835-515-Z5D0102K
C244	281-0579-00			CAP., FXD, CER DI: 21PF, 5%, 500V	59660	301-050C0G0210J
C247	281-0525-00			CAP., FXD, CER DI: 470PF, +/-94PF, 500V	04222	7001-1364
C248	283-0004-00			CAP., FXD, CER DI: 0.02UF, +80-20%, 150V	91418	SP203Z151-4R9
C253	290-0517-00			CAP., FXD, ELCTLT: 6.8UF, 20%, 35V	56289	196D685X0035KA1
C255	281-0540-00			CAP., FXD, CER DI: 51PF, 5%, 500V	59660	301-000U2J0510J
C261	281-0536-00			CAP., FXD, CER DI: 1000PF, 10%, 500V	72982	301000 X 5P0102K
C262	281-0536-00			CAP., FXD, CER DI: 1000PF, 10%, 500V	72982	301000 X 5P0102K
C302	281-0122-00			CAP., VAR, CER DI: 2.5-9PF, 100V	59660	518-000A2.5-9
C312	281-0122-00			CAP., VAR, CER DI: 2.5-9PF, 100V	59660	518-000A2.5-9
C321	283-0004-00			CAP., FXD, CER DI: 0.02UF, +80-20%, 150V	91418	SP203Z151-4R9
C328	281-0525-00			CAP., FXD, CER DI: 470PF, +/-94PF, 500V	04222	7001-1364
C329	281-0525-00			CAP., FXD, CER DI: 470PF, +/-94PF, 500V	04222	7001-1364
C331	290-0517-00			CAP., FXD, ELCTLT: 6.8UF, 20%, 35V	56289	196D685X0035KA1
C334	283-0004-00			CAP., FXD, CER DI: 0.02UF, +80-20%, 150V	91418	SP203Z151-4R9
C338	281-0579-00			CAP., FXD, CER DI: 21PF, 5%, 500V	59660	301-050C0G0210J
C339	281-0589-00			CAP., FXD, CER DI: 170PF, 5%, 500V	72982	301000Z5D0171J
C348	290-0517-00			CAP., FXD, ELCTLT: 6.8UF, 20%, 35V	56289	196D685X0035KA1
C351	281-0549-00			CAP., FXD, CER DI: 68PF, 10%, 500V	59660	301-000U2J0680K
C352	290-0517-00			CAP., FXD, ELCTLT: 6.8UF, 20%, 35V	56289	196D685X0035KA1
C354	290-0517-00			CAP., FXD, ELCTLT: 6.8UF, 20%, 35V	56289	196D685X0035KA1
C355	281-0549-00			CAP., FXD, CER DI: 68PF, 10%, 500V	59660	301-000U2J0680K
C357	290-0517-00			CAP., FXD, ELCTLT: 6.8UF, 20%, 35V	56289	196D685X0035KA1
C364	281-0511-00			CAP., FXD, CER DI: 22PF, +/-2.2PF, 500V	59660	301-000C0G0220K
C368	283-0058-00			CAP., FXD, CER DI: 0.02UF, 10%, 100V	56289	273C17
C374	281-0511-00			CAP., FXD, CER DI: 22PF, +/-2.2PF, 500V	59660	301-000C0G0220K
C375	290-0517-00			CAP., FXD, ELCTLT: 6.8UF, 20%, 35V	56289	196D685X0035KA1
C382	290-0517-00			CAP., FXD, ELCTLT: 6.8UF, 20%, 35V	56289	196D685X0035KA1

Replaceable Electrical Parts—466 Service

Ckt No.	Tektronix Part No.	Serial/Model No. Eff	Dscont	Name & Description	Mfr Code	Mfr Part Number
C383	290-0517-00			CAP., FXD, ELCLTLT: 6.8UF, 20%, 35V	56289	196D685X0035KA1
C384	290-0517-00			CAP., FXD, ELCLTLT: 6.8UF, 20%, 35V	56289	196D685X0035KA1
C385	283-0004-00			CAP., FXD, CER DI: 0.02UF, +80-20%, 150V	91418	SP203Z151-4R9
C392	283-0004-00			CAP., FXD, CER DI: 0.02UF, +80-20%, 150V	91418	SP203Z151-4R9
C402	283-0023-00			CAP., FXD, CER DI: 0.1UF, +80-20%, 12V	91418	MX0104Z1205R5
C404	281-0546-00			CAP., FXD, CER DI: 330PF, 10%, 500V	04222	7001-1380
C405	283-0618-00			CAP., FXD, MICA D: 130PF, 2%, 400V	00853	D155F131G0
C406	281-0602-00			CAP., FXD, CER DI: 68PF, 5%, 500V	59660	308-000P2G0680J
C409	281-0096-00			CAP., VAR, AIR DI: 5.5-18PF, 350V	59660	538-006-A5.5-18
C413	283-0067-00			CAP., FXD, CER DI: 0.001UF, 10%, 200V	59660	835-515-Z5D0102K
C416	281-0576-00			CAP., FXD, CER DI: 11PF, 5%, 500V	59660	301-000COG0110J
C417	283-0081-00			CAP., FXD, CER DI: 0.1UF, +80-20%, 25V	91418	MX104Z2504R0
C423	283-0067-00			CAP., FXD, CER DI: 0.001UF, 10%, 200V	59660	835-515-Z5D0102K
C426	281-0576-00			CAP., FXD, CER DI: 11PF, 5%, 500V	59660	301-000COG0110J
C428	281-0097-00			CAP., VAR, CER DI: 9-35PF, 200V	72982	538-006-D9-35
C437	283-0067-00			CAP., FXD, CER DI: 0.001UF, 10%, 200V	59660	835-515-Z5D0102K
C438	283-0067-00			CAP., FXD, CER DI: 0.001UF, 10%, 200V	59660	835-515-Z5D0102K
C444	283-0268-00			CAP., FXD, CER DI: 0.015UF, 10%, 50V	56289	1C20X7R153K050B
C445	283-0083-00			CAP., FXD, CER DI: 0.0047UF, 20%, 500V	72982	811-565C471J
C446	283-0116-00			CAP., FXD, CER DI: 820PF, 5%, 500V	72982	801-547B821J
C447	283-0054-00			CAP., FXD, CER DI: 150PF, 5%, 200V	59660	855-535U2J0 151J
C453	283-0331-00			CAP., FXD, CER DI: 43PF, 2%, 100V	72982	805-505A430G
C455	281-0089-00	B010100	B071669	CAP., VAR, CER DI: 2-8PF, 350V	59660	538-006-A2-8
C455	281-0096-00	B071670		CAP., VAR, AIR DI: 5.5-18PF, 350V	59660	538-006-A5.5-18
C457	283-0260-00	B010100	B071669X	CAP., FXD, CER DI: 5.6PF, 5%, 200V	72982	811B200C0G569C
C462	281-0611-00			CAP., FXD, CER DI: 2.7PF, +/-0.25PF, 200V	59660	374-018C0J0279C
C472	283-0023-00			CAP., FXD, CER DI: 0.1UF, +80-20%, 12V	91418	MX0104Z1205R5
C475	283-0023-00			CAP., FXD, CER DI: 0.1UF, +80-20%, 12V	91418	MX0104Z1205R5
C476	283-0000-00			CAP., FXD, CER DI: 0.001UF, +100-0%, 500V	59660	831-519-Y5P-102P
C491	283-0178-00			CAP., FXD, CER DI: 0.1UF, +80-20%, 100V	72982	8131N145651 104Z
C492	283-0081-00			CAP., FXD, CER DI: 0.1UF, +80-20%, 25V	91418	MX104Z2504R0
C493	283-0081-00			CAP., FXD, CER DI: 0.1UF, +80-20%, 25V	91418	MX104Z2504R0
C494	283-0023-00			CAP., FXD, CER DI: 0.1UF, +80-20%, 12V	91418	MX0104Z1205R5
C495	283-0003-00			CAP., FXD, CER DI: 0.01UF, +80-20%, 150V	91418	SP103Z151-4R9
C496	283-0003-00			CAP., FXD, CER DI: 0.01UF, +80-20%, 150V	91418	SP103Z151-4R9
C502	281-0579-00			CAP., FXD, CER DI: 21PF, 5%, 500V	59660	301-050C0G0210J
C503	281-0603-00			CAP., FXD, CER DI: 39PF, 5%, 500V	59660	308-000C0G0390J
C504	-----			(SEE OPTION 5)		
C511	281-0523-00			CAP., FXD, CER DI: 100PF, +/-20PF, 500V	72982	301-000U2M0101M
C512	283-0004-00			CAP., FXD, CER DI: 0.02UF, +80-20%, 150V	91418	SP203Z151-4R9
C515	281-0511-00			CAP., FXD, CER DI: 22PF, +/-2.2PF, 500V	59660	301-000COG0220K
C522	283-0003-00			CAP., FXD, CER DI: 0.01UF, +80-20%, 150V	91418	SP103Z151-4R9
C525	283-0003-00			CAP., FXD, CER DI: 0.01UF, +80-20%, 150V	91418	SP103Z151-4R9
C528	281-0511-00			CAP., FXD, CER DI: 22PF, +/-2.2PF, 500V	59660	301-000COG0220K
C531	283-0003-00			CAP., FXD, CER DI: 0.01UF, +80-20%, 150V	91418	SP103Z151-4R9
C549	283-0003-00			CAP., FXD, CER DI: 0.01UF, +80-20%, 150V	91418	SP103Z151-4R9
C550	283-0023-00	XB010275		CAP., FXD, CER DI: 0.1UF, +80-20%, 12V	91418	MX0104Z1205R5
C552	283-0023-00	XB010275		CAP., FXD, CER DI: 0.1UF, +80-20%, 12V	91418	MX0104Z1205R5
C582	290-0527-00			CAP., FXD, ELCLTLT: 15UF, 20%, 20V	90201	TDC156M020FL
C583	290-0527-00			CAP., FXD, ELCLTLT: 15UF, 20%, 20V	90201	TDC156M020FL
C584	290-0527-00			CAP., FXD, ELCLTLT: 15UF, 20%, 20V	90201	TDC156M020FL
C585	290-0527-00			CAP., FXD, ELCLTLT: 15UF, 20%, 20V	90201	TDC156M020FL
C601	283-0023-00			CAP., FXD, CER DI: 0.1UF, +80-20%, 12V	91418	MX0104Z1205R5
C602	-----			(SEE OPTION 5)		
C603	281-0529-00			CAP., FXD, CER DI: 1.5PF, +/-0.25PF, 500V	04222	7001-1315
C604	281-0523-00			CAP., FXD, CER DI: 100PF, +/-20PF, 500V	72982	301-000U2M0101M
	-----			(SEE OPTION 5)		

Replaceable Electrical Parts—466 Service

Ckt No.	Tektronix Part No.	Serial/Model No. Eff	Dscont	Name & Description	Mfr Code	Mfr Part Number
C606	281-0578-00			CAP., FXD, CER DI: 18PF, 5%, 500V	59660	301-050C0G0180J
C607	281-0620-00			CAP., FXD, CER DI: 21PF, 1%, 500V	59660	301-000C0G0210F
	-----			(SEE OPTION 5)		
C610	-----			(SEE OPTION 5)		
C611	281-0523-00			CAP., FXD, CER DI: 100PF, +/-20PF, 500V	72982	301-000U2M0101M
C612	283-0004-00			CAP., FXD, CER DI: 0.02UF, +80-20%, 150V	91418	SP203Z151-4R9
	-----			(SEE OPTION 5)		
C615	281-0511-00			CAP., FXD, CER DI: 22PF, +/-2.2PF, 500V	59660	301-000C0G0220K
C622	283-0003-00			CAP., FXD, CER DI: 0.01UF, +80-20%, 150V	91418	SP103Z151-4R9
C625	283-0003-00			CAP., FXD, CER DI: 0.01UF, +80-20%, 150V	91418	SP103Z151-4R9
C628	281-0511-00			CAP., FXD, CER DI: 22PF, +/-2.2PF, 500V	59660	301-000C0G0220K
C631	283-0003-00			CAP., FXD, CER DI: 0.01UF, +80-20%, 150V	91418	SP103Z151-4R9
C649	283-0003-00			CAP., FXD, CER DI: 0.01UF, +80-20%, 150V	91418	SP103Z151-4R9
C650	283-0023-00	XB010275		CAP., FXD, CER DI: 0.1UF, +80-20%, 12V	91418	MX0104Z1205R5
C652	283-0023-00	XB010275		CAP., FXD, CER DI: 0.1UF, +80-20%, 12V	91418	MX0104Z1205R5
C676	281-0513-00			CAP., FXD, CER DI: 22PF, +/-5.4PF, 500V	59660	301-055P2G0270M
C691	290-0517-00			CAP., FXD, ELCTLT: 6.8UF, 20%, 35V	56289	196D685X0035KA1
C822	283-0067-00	B010100	B010169	CAP., FXD, CER DI: 0.001UF, 10%, 200V	59660	835-515-25D0102K
C822	290-0534-00	B010170		CAP., FXD, ELCTLT: 1UF, 20%, 35V	56289	196D105X0035HA1
	-----			(NOT USED WITH DM44)		
C843	281-0577-00			CAP., FXD, CER DI: 14PF, 5%, 500V	59660	301-050C0G0140J
C845	290-0527-00			CAP., FXD, ELCTLT: 15UF, 20%, 20V	90201	TDC156M020FL
C874	281-0511-00			CAP., FXD, CER DI: 22PF, +/-2.2PF, 500V	59660	301-000C0G0220K
C882	281-0511-00			CAP., FXD, CER DI: 22PF, +/-2.2PF, 500V	59660	301-000C0G0220K
C885	290-0529-00			CAP., FXD, ELCTLT: 47UF, 20%, 20V	05397	T368C476M020AZ
C887	283-0003-00			CAP., FXD, CER DI: 0.01UF, +80-20%, 150V	91418	SP103Z151-4R9
C895	283-0003-00			CAP., FXD, CER DI: 0.01UF, +80-20%, 150V	91418	SP103Z151-4R9
C897	283-0023-00			CAP., FXD, CER DI: 0.1UF, +80-20%, 12V	91418	MX0104Z1205R5
C922	281-0500-00			CAP., FXD, CER DI: 2.2PF, +/-0.5PF, 500V	04222	7001-1092
C925	281-0511-00			CAP., FXD, CER DI: 22PF, +/-2.2PF, 500V	59660	301-000C0G0220K
C942	290-0527-00			CAP., FXD, ELCTLT: 15UF, 20%, 20V	90201	TDC156M020FL
C943	281-0508-00			CAP., FXD, CER DI: 12PF, +/-0.6PF, 500V	59660	301-000C0G0120J
C944	290-0522-00			CAP., FXD, ELCTLT: 1UF, 20%, 50V	56289	196D105X0050HA1
C945	281-0524-00			CAP., FXD, CER DI: 150PF, +/-30PF, 500V	04222	7001-1381
C947	281-0543-00			CAP., FXD, CER DI: 270PF, 10%, 500V	72982	301055X5P271K
C952	281-0518-00			CAP., FXD, CER DI: 47PF, +/-9.4PF, 500V	59660	301-000U2J0470M
	-----			(SEE OPTION 5)		
C955	-----			(SEE OPTION 5)		
C956	283-0024-00			CAP., FXD, CER DI: 0.1UF, +80-20%, 50V	72982	8121N083Z5U0104Z
	-----			(SEE OPTION 5)		
C958	290-0527-00			CAP., FXD, ELCTLT: 15UF, 20%, 20V	90201	TDC156M020FL
	-----			(SEE OPTION 5)		
C965	290-0527-00			CAP., FXD, ELCTLT: 15UF, 20%, 20V	90201	TDC156M020FL
C967	290-0527-00			CAP., FXD, ELCTLT: 15UF, 20%, 20V	90201	TDC156M020FL
C968	290-0527-00			CAP., FXD, ELCTLT: 15UF, 20%, 20V	90201	TDC156M020FL
C987	290-0536-00			CAP., FXD, ELCTLT: 10UF, 20%, 25V	90201	TDC106M025FL
C992	283-0081-00			CAP., FXD, CER DI: 0.1UF, +80-20%, 25V	91418	MX104Z2504R0
C993	283-0023-00			CAP., FXD, CER DI: 0.1UF, +80-20%, 12V	91418	MX0104Z1205R5
C994	283-0023-00			CAP., FXD, CER DI: 0.1UF, +80-20%, 12V	91418	MX0104Z1205R5
C1000	283-0004-00			CAP., FXD, CER DI: 0.02UF, +80-20%, 150V	91418	SP203Z151-4R9
C1002	283-0178-00			CAP., FXD, CER DI: 0.1UF, +80-20%, 100V	72982	8131N145651 104Z
C1003	281-0637-00			CAP., FXD, CER DI: 91PF, 5%, 500V	72982	301000Z5D910J
C1008	283-0003-00			CAP., FXD, CER DI: 0.01UF, +80-20%, 150V	91418	SP103Z151-4R9
C1021	283-0004-00	B010100	B135184	CAP., FXD, CER DI: 0.02UF, +80-20%, 150V	91418	SP203Z151-4R9
C1021	283-0104-00	B135185		CAP., FXD, CER DI: 2000PF, 5%, 500V	72982	811-565B202J
C1024	290-0527-00			CAP., FXD, ELCTLT: 15UF, 20%, 20V	90201	TDC156M020FL

Replaceable Electrical Parts—466 Service

Ckt No.	Tektronix Part No.	Serial/Model No. Eff	Dscont	Name & Description	Mfr Code	Mfr Part Number
C1026	281-0523-00			CAP., FXD, CER DI: 100PF, +/-20PF, 500V	72982	301-000U2M0101M
C1030	281-0662-00			CAP., FXD, CER DI: 10PF, +/-0.5PF, 500V	59660	301-000H3M0100D
C1031	283-0004-00			CAP., FXD, CER DI: 0.02UF, +80-20%, 150V	91418	SP203Z151-4R9
C1036	283-0023-00			CAP., FXD, CER DI: 0.1UF, +80-20%, 12V	91418	MX0104Z1205R5
C1038	290-0527-00			CAP., FXD, ELCTLT: 15UF, 20%, 20V	90201	TDC156M020FL
C1062	283-0178-00			CAP., FXD, CER DI: 0.1UF, +80-20%, 100V	72982	8131N145651 104Z
C1063	281-0637-00			CAP., FXD, CER DI: 91PF, 5%, 500V	72982	301000Z5D910J
C1081	283-0004-00			CAP., FXD, CER DI: 0.02UF, +80-20%, 150V	91418	SP203Z151-4R9
C1084	290-0527-00			CAP., FXD, ELCTLT: 15UF, 20%, 20V	90201	TDC156M020FL
C1086	281-0523-00			CAP., FXD, CER DI: 100PF, +/-20PF, 500V	72982	301-000U2M0101M
C1091	283-0004-00			CAP., FXD, CER DI: 0.02UF, +80-20%, 150V	91418	SP203Z151-4R9
C1095	281-0662-00			CAP., FXD, CER DI: 10PF, +/-0.5PF, 500V	59660	301-000H3M0100D
C1112	283-0080-00			CAP., FXD, CER DI: 0.022UF, +80-20%, 25V	91418	MX223Z2504R0
C1115	290-0519-00			CAP., FXD, ELCTLT: 100UF, 20%, 20V	90201	TDC107M020WLD
C1131	295-0160-00	B010100	B010291	CAP. SET, MATCHED: 9.95UF, 0.1UF, 998PF (C1131, C1133 AND C1135 ARE FURN AS A UNIT)	80009	295-0160-00
C1131	295-0175-00	B010292		CAP., SET, MTCHD: 0.1UF, 9.95UF, 985PF, 0.2% (C1131, C1133 AND C1135 ARE FURN AS A UNIT)	80009	295-0175-00
C1132	281-0523-00			CAP., FXD, CER DI: 100PF, +/-20PF, 500V	72982	301-000U2M0101M
C1133	295-0160-00	B010100	B010291	CAP. SET, MATCHED: 9.95UF, 0.1UF, 998PF (C1131, C1133 AND C1135 ARE FURN AS A UNIT)	80009	295-0160-00
C1135	-----					
C1133	295-0175-00	B010292		CAP., SET, MTCHD: 0.1UF, 9.95UF, 985PF, 0.2% (C1131, C1133 AND C1135 ARE FURN AS A UNIT)	80009	295-0175-00
C1135	-----					
C1136	281-0096-00	XB010300		CAP., VAR, AIR DI: 5.5-18PF, 350V	59660	538-006-A5.5-18
C1137	281-0089-00			CAP., VAR, CER DI: 2-8PF, 350V	59660	538-006-A2-8
C1138	283-0331-00			CAP., FXD, CER DI: 43PF, 2%, 100V	72982	805-505A430G
C1144	283-0003-00			CAP., FXD, CER DI: 0.01UF, +80-20%, 150V	91418	SP103Z151-4R9
C1151	283-0268-00			CAP., FXD, CER DI: 0.015UF, 10%, 50V	56289	1C20X7R153K050B
C1152	290-0245-00			CAP., FXD, ELCTLT: 1.5UF, 10%, 10V	56289	150D155X9010A2
C1153	283-0645-00			CAP., FXD, MICA D: 790PF, 1%, 100V	00853	D151E791F0
C1161	295-0157-00			CAP., SET, MTCHD: 0.1UF, 1UF, 998PF (C1161, C1163 AND C1165 ARE FURN AS A UNIT)	80009	295-0157-00
C1162	281-0523-00			CAP., FXD, CER DI: 100PF, +/-20PF, 500V	72982	301-000U2M0101M
C1163	295-0157-00			CAP., SET, MTCHD: 0.1UF, 1UF, 998PF (C1161, C1163 AND C1165 ARE FURN AS A UNIT)	80009	295-0157-00
C1165	-----					
C1167	281-0089-00			CAP., VAR, CER DI: 2-8PF, 350V	59660	538-006-A2-8
C1168	283-0331-00			CAP., FXD, CER DI: 43PF, 2%, 100V	72982	805-505A430G
C1171	283-0003-00			CAP., FXD, CER DI: 0.01UF, +80-20%, 150V	91418	SP103Z151-4R9
C1203	283-0023-00			CAP., FXD, CER DI: 0.1UF, +80-20%, 12V	91418	MX0104Z1205R5
C1223	283-0004-00	B010100	B151079	CAP., FXD, CER DI: 0.02UF, +80-20%, 150V	91418	SP203Z151-4R9
C1223	283-0104-00	B151080		CAP., FXD, CER DI: 2000PF, 5%, 500V	72982	811-565B202J
C1237	290-0650-00			CAP., FXD, ELCTLT: 1000UF, 20%, 10V	56289	109D108X0010T2
C1239	283-0006-00			CAP., FXD, CER DI: 0.02UF, +80-20%, 500V	72982	0841545Z5V00203Z
C1246	290-0215-00			CAP., FXD, ELCTLT: 100UF, +75-10%, 25V	56289	30D107G025DD9
C1262	281-0064-00			CAP., VAR, PLSTC: 0.25-1.5PF, 600V	74970	273-0001-101
C1263	281-0526-00			CAP., FXD, CER DI: 1.5PF, +/-0.5PF, 500V	04222	7001-1313
C1264	281-0526-00			CAP., FXD, CER DI: 1.5PF, +/-0.5PF, 500V	04222	7001-1313
C1265	281-0064-00			CAP., VAR, PLSTC: 0.25-1.5PF, 600V	74970	273-0001-101
C1272	283-0092-00	B010100	B134619	CAP., FXD, CER DI: 0.03UF, +80-20%, 200V	59660	845-534Z5U0303Z
C1272	283-0328-00	B134620		CAP., FXD, CER DI: 0.03UF, +80-20%, 200V	72982	8131N225Z5U0303Z
C1275	283-0003-00	B010100	B010179	CAP., FXD, CER DI: 0.01UF, +80-20%, 150V	91418	SP103Z151-4R9
C1275	283-0002-00	B010180		CAP., FXD, CER DI: 0.01UF, +80-20%, 500V	91418	SM103Z5014R9
C1276	283-0003-00			CAP., FXD, CER DI: 0.01UF, +80-20%, 150V	91418	SP103Z151-4R9
C1281	283-0024-00			CAP., FXD, CER DI: 0.1UF, +80-20%, 50V	72982	8121N083Z5U0104Z
C1282	283-0024-00			CAP., FXD, CER DI: 0.1UF, +80-20%, 50V	72982	8121N083Z5U0104Z
C1283	283-0092-00	B010100	B134619	CAP., FXD, CER DI: 0.03UF, +80-20%, 200V	59660	845-534Z5U0303Z
C1283	283-0328-00	B134620		CAP., FXD, CER DI: 0.03UF, +80-20%, 200V	72982	8131N225Z5U0303Z

Ckt No.	Tektronix Part No.	Serial/Model No. Eff	Dscont	Name & Description	Mfr Code	Mfr Part Number
C1286	283-0003-00			CAP., FXD, CER DI: 0.01UF, +80-20%, 150V	91418	SP103Z151-4R9
C1288	283-0003-00	B010100	B010179	CAP., FXD, CER DI: 0.01UF, +80-20%, 150V	91418	SP103Z151-4R9
C1288	283-0002-00	B010180		CAP., FXD, CER DI: 0.01UF, +80-20%, 500V	91418	SM103Z5014R9
C1364	285-0686-00			CAP., FXD, PLSTC: 0.068UF, 10%, 100V	56289	192P68392
C1373	281-0551-00			CAP., FXD, CER DI: 390PF, 10%, 500V	04222	7001-1363
C1374	290-0532-00			CAP., FXD, ELCTLT: 150UF, 20%, 6V	90201	TDC157M006WLC
C1375	281-0513-00			CAP., FXD, CER DI: 27PF, +/-5.4PF, 500V	59660	301-055P2G0270M
C1414	281-0580-00			CAP., FXD, CER DI: 470PF, 10%, 500V	04222	7001-1374
C1423	283-0000-00			CAP., FXD, CER DI: 0.001UF, +100-0%, 500V	59660	831-519-Y5P-102P
C1432	283-0000-00			CAP., FXD, CER DI: 0.001UF, +100-0%, 500V	59660	831-519-Y5P-102P
C1433	290-0534-00			CAP., FXD, ELCTLT: 1UF, 20%, 35V	56289	196D105X0035HA1
C1434	281-0661-00			CAP., FXD, CER DI: 0.8PF, +/-0.1PF, 500V	04222	7001-1268
C1435	281-0064-00			CAP., VAR, PLSTC: 0.25-1.5PF, 600V	74970	273-0001-101
C1437	283-0057-00			CAP., FXD, CER DI: 0.1UF, +80-20%, 200V	56289	2C20Z5U104Z200B
C1443	283-0071-00	B010100	B138194	CAP., FXD, CER DI: 0.0068UF, +80-30%, 5000V	59660	3905SF602Y5S682Z
C1443	285-0509-01	B138195		CAP., FXD, PPR DI: 0.0068UF, 20%, 5000V	56289	430P507
C1444	285-1040-00			CAP., FXD, PLSTC: 0.0012UF, 10%, 4000V	56289	430P522
C1452	290-0164-00	B010100	B135794	CAP., FXD, ELCTLT: 1UF, +50-10%, 150V	56289	500D105F150BA7
C1452	283-0057-00	B135795		CAP., FXD, CER DI: 0.1UF, +80-20%, 200V	56289	2C20Z5U104Z200B
C1455	290-0194-00			CAP., FXD, ELCTLT: 10UF, +50-10%, 100V	56289	30D106F100C9
C1462	290-0527-00			CAP., FXD, ELCTLT: 15UF, 20%, 20V	90201	TDC156M020FL
C1465	285-0894-00	B010100	B050469	CAP., FXD, PLSTC: 5UF, 5%, 50V	56289	LP66A1A505J002
C1465	285-0913-00	B050470		CAP., FXD, PLSTC: 3UF, 5%, 50V	84411	TEK34-3055R5
C1472	283-0059-00			CAP., FXD, CER DI: 1UF, +80-20%, 50V	72982	8131N031Z5U0105Z
C1473	285-0598-00			CAP., FXD, PLSTC: 0.01UF, 5%, 100V	19396	DU490B103J
C1483	283-0010-00			CAP., FXD, CER DI: 0.05UF, +100-20%, 50V	56289	273C20
C1487	290-0316-00			CAP., FXD, ELCTLT: 47UF, 20%, 35V	56289	150D476X0035S2
C1494	290-0523-00			CAP., FXD, ELCTLT: 2.2UF, 20%, 20V	56289	196D225X0020HA1
C1498	283-0003-00			CAP., FXD, CER DI: 0.01UF, +80-20%, 150V	91418	SP103Z151-4R9
C1499	283-0004-00			CAP., FXD, CER DI: 0.02UF, +80-20%, 150V	91418	SP203Z151-4R9
C1503	283-0071-00	B010100	B138194	CAP., FXD, CER DI: 0.0068UF, +80-30%, 5000V	59660	3905SF602Y5S682Z
C1503	285-0509-01	B138195		CAP., FXD, PPR DI: 0.0068UF, 20%, 5000V	56289	430P507
C1504	283-0071-00	B010100	B138194	CAP., FXD, CER DI: 0.0068UF, +80-30%, 5000V	59660	3905SF602Y5S682Z
C1504	285-0509-01	B138195		CAP., FXD, PPR DI: 0.0068UF, 20%, 5000V	56289	430P507
C1505	283-0004-00			CAP., FXD, CER DI: 0.02UF, +80-20%, 150V	91418	SP203Z151-4R9
C1506	283-0043-00			CAP., FXD, CER DI: 0.0068UF, 3000V	59660	3903BW416Z5U682P
C1507	283-0004-00			CAP., FXD, CER DI: 0.02UF, +80-20%, 150V	91418	SP203Z151-4R9
C1508	283-0043-00			CAP., FXD, CER DI: 0.0068UF, 3000V	59660	3903BW416Z5U682P
C1512	283-0013-00			CAP., FXD, CER DI: 0.01UF, +100-0%, 1000V	56289	33C29A7
C1514	290-0531-00	B010100	B129999X	CAP., FXD, ELCTLT: 100UF, 20%, 10V	90201	TDC107M010WLC
C1517	283-0126-00			CAP., FXD, CER DI: 82PF, 5%, 1000V	56289	33C180
C1524	285-1040-00			CAP., FXD, PLSTC: 0.0012UF, 10%, 4000V	56289	430P522
C1526	285-1040-00			CAP., FXD, PLSTC: 0.0012UF, 10%, 4000V	56289	430P522
C1527	283-0003-00			CAP., FXD, CER DI: 0.01UF, +80-20%, 150V	91418	SP103Z151-4R9
C1556	283-0003-00			CAP., FXD, CER DI: 0.01UF, +80-20%, 150V	91418	SP103Z151-4R9
C1557	283-0004-00			CAP., FXD, CER DI: 0.02UF, +80-20%, 150V	91418	SP203Z151-4R9
C1574	283-0003-00	B010100	B010234	CAP., FXD, CER DI: 0.01UF, +80-20%, 150V	91418	SP103Z151-4R9
C1574	283-0002-00	B010235		CAP., FXD, CER DI: 0.01UF, +80-20%, 500V	91418	SM103Z5014R9
C1582	283-0345-00	B010100	B099999	CAP., FXD, CER DI: 1000PF, 10%, 10,000V	72982	3910BW324X5R102Z
C1582	283-0368-00	B100000		CAP., FXD, CER DI: 0.001UF, 20%, 12,000V	51406	DHR18Y5F102M12KV
C1583	283-0345-00	B010100	B099999	CAP., FXD, CER DI: 1000PF, 10%, 10,000V	72982	3910BW324X5R102Z
C1583	283-0368-00	B100000		CAP., FXD, CER DI: 0.001UF, 20%, 12,000V	51406	DHR18Y5F102M12KV
C1585	283-0345-00	B010100	B099999	CAP., FXD, CER DI: 1000PF, 10%, 10,000V	72982	3910BW324X5R102Z
C1585	283-0368-00	B100000		CAP., FXD, CER DI: 0.001UF, 20%, 12,000V	51406	DHR18Y5F102M12KV
C1601	-----			(SEE OPTION 7)		
C1603	-----			(SEE OPTION 7)		
C1605	-----			(SEE OPTION 7)		
C1609	-----			(SEE OPTION 7)		

# Replaceable Electrical Parts—466 Service

Ckt No.	Tektronix Part No.	Serial/Model No. Eff	Dscont	Name & Description	Mfr Code	Mfr Part Number
C1614	-----			(SEE OPTION 7)		
C1622	-----			(SEE OPTION 7)		
C1626	-----			(SEE OPTION 7)		
C1652	-----			(SEE OPTION 7)		
C1654	-----			(SEE OPTION 7)		
C1662	-----			(SEE OPTION 7)		
C1664	-----			(SEE OPTION 7)		
C1671	-----			(SEE OPTION 7)		
C1698	290-0536-00	B010100	B138089X	CAP., FXD, ELCTLT: 10UF, 20%, 25V	90201	TDC106M025FL
C1710	-----			(SEE OPTION 4 AND OPTION 7)		
C1712	290-0560-00			CAP., FXD, ELCTLT: 47UF, 20%, 25V	90201	TDC476M025DL
C1713	290-0560-00			CAP., FXD, ELCTLT: 47UF, 20%, 25V	90201	TDC476M025DL
C1718	283-0004-00	B010100	B082639	CAP., FXD, CER DI: 0.02UF, +80-20%, 150V	91418	SP203Z151-4R9
C1718	283-0006-00	B082640		CAP., FXD, CER DI: 0.02UF, +80-20%, 500V	72982	0841545Z5V00203Z
C1720	-----			(SEE OPTION 4 AND 7)		
C1721	-----			(SEE OPTION 4 AND 7)		
C1722	290-0468-00			CAP., FXD, ELCTLT: 250UF, +75-10%, 150V	56289	68D10470
C1723	290-0638-00			CAP., FXD, ELCTLT: 1200UF, +75-10%, 100V	56289	68D10529
C1724	283-0178-00			CAP., FXD, CER DI: 0.1UF, +80-20%, 100V	72982	8131N145651 104Z
C1725	283-0004-00			CAP., FXD, CER DI: 0.02UF, +80-20%, 150V	91418	SP203Z151-4R9
C1735	281-0623-00			CAP., FXD, CER DI: 650PF, 5%, 500V	04222	7001-1362
C1737	290-0392-00			CAP., FXD, ELCTLT: 3.6UF, 10%, 125V	90201	TL5365K125B1A
C1743	281-0580-00			CAP., FXD, CER DI: 470PF, 10%, 500V	04222	7001-1374
C1744	283-0057-00			CAP., FXD, CER DI: 0.1UF, +80-20%, 200V	56289	2C20Z5U104Z200B
C1750	-----			(SEE OPTION 4 AND 7)		
C1751	290-0584-00			CAP., FXD, ELCTLT: 5500UF, +100-10%, 30V	90201	FFP552GN4A3P2
C1757	290-0536-00			CAP., FXD, ELCTLT: 10UF, 20%, 25V	90201	TDC106M025FL
C1760	-----			(SEE OPTION 4 AND 7)		
C1761	290-0584-00			CAP., FXD, ELCTLT: 5500UF, +100-10%, 30V	90201	FFP552GN4A3P2
C1767	290-0535-00			CAP., FXD, ELCTLT: 33UF, 20%, 10V	56289	196D336X0010KA1
C1768	283-0003-00			CAP., FXD, CER DI: 0.01UF, +80-20%, 150V	91418	SP103Z151-4R9
C1770	-----			(SEE OPTION 4 AND 7)		
C1771	290-0584-00			CAP., FXD, ELCTLT: 5500UF, +100-10%, 30V	90201	FFP552GN4A3P2
C1772	-----			(SEE OPTION 7)		
C1773	-----			(SEE OPTION 7)		
C1777	290-0535-00			CAP., FXD, ELCTLT: 33UF, 20%, 10V	56289	196D336X0010KA1
C1778	283-0267-00			CAP., FXD, CER DI: 0.01UF, 20%, 500V	72982	0841546X5500103M
C1780	-----			(SEE OPTION 4 AND 7)		
C1781	290-0570-00			CAP., FXD, ELCTLT: 500UF, +75-10%, 50V	90201	FFP20-36042
C1787	290-0528-00			CAP., FXD, ELCTLT: 15UF, 20%, 50V	90201	TDC156M050WLC
C1802	283-0003-00			CAP., FXD, CER DI: 0.01UF, +80-20%, 150V	91418	SP103Z151-4R9
C1812	283-0150-00			CAP., FXD, CER DI: 650PF, 5%, 200V	59660	835-515B651J
C1826	290-0535-00			CAP., FXD, ELCTLT: 33UF, 20%, 10V	56289	196D336X0010KA1
C1831	290-0114-00			CAP., FXD, ELCTLT: 47UF, 20%, 6V	56289	150D476X0006B2
C1834	290-0524-00			CAP., FXD, ELCTLT: 4.7UF, 20%, 10V	90201	TDC475M010EL
C1835	290-0534-00			CAP., FXD, ELCTLT: 1UF, 20%, 35V	56289	196D105X0035HA1
C1842	283-0198-00			CAP., FXD, CER DI: 0.22UF, 20%, 50V	56289	1C10Z5U223M050B
C1845	283-0054-00	B010100	B137527	CAP., FXD, CER DI: 150PF, 5%, 200V	59660	855-535U2J0 151J
C1845	283-0087-00	B137528		CAP., FXD, CER DI: 300PF, 10%, 1000V	56289	403637
C1846	290-0527-00			CAP., FXD, ELCTLT: 15UF, 20%, 20V	90201	TDC156M020FL
C1847	290-0527-00			CAP., FXD, ELCTLT: 15UF, 20%, 20V	90201	TDC156M020FL
C1848	283-0150-00			CAP., FXD, CER DI: 650PF, 5%, 200V	59660	835-515B651J
C1855	283-0220-00			CAP., FXD, CER DI: 0.01UF, 20%, 50V	72982	8121N075X7R0103M
C1862	290-0246-00			CAP., FXD, ELCTLT: 3.3UF, 10%, 15V	56289	162D335X9015CD2
C1869	290-0531-00			CAP., FXD, ELCTLT: 100UF, 20%, 10V	90201	TDC107M010WLC
C1933	281-0523-00	XB092810		CAP., FXD, CER DI: 100PF, +/-20PF, 500V	72982	301-000U2M0101M
C1942	283-0003-00			CAP., FXD, CER DI: 0.01UF, +80-20%, 150V	91418	SP103Z151-4R9
C1945	283-0081-00			CAP., FXD, CER DI: 0.1UF, +80-20%, 25V	91418	MX104Z22504R0

Ckt No.	Tektronix Part No.	Serial/Model No. Eff	Dscont	Name & Description	Mfr Code	Mfr Part Number
C1947	283-0003-00			CAP., FXD, CER DI: 0.01UF, +80-20%, 150V	91418	SP103Z151-4R9
C1962	281-0637-00			CAP., FXD, CER DI: 91PF, 5%, 500V	72982	301000Z5D910J
C1964	281-0637-00			CAP., FXD, CER DI: 91PF, 5%, 500V	72982	301000Z5D910J
C1967	290-0164-00			CAP., FXD, ELCTLT: 1UF, +50-10%, 150V	56289	500D105F150BA7
C1968	283-0013-00	XB010290		CAP., FXD, CER DI: 0.01UF, +100-0%, 1000V	56289	33C29A7
C1991	-----	-----		(PART OF CIRCUIT BOARD)		
C1992	283-0003-00			CAP., FXD, CER DI: 0.01UF, +80-20%, 150V	91418	SP103Z151-4R9
C1995	290-0534-00			CAP., FXD, ELCTLT: 1UF, 20%, 35V	56289	196D105X0035HA1
C1996	283-0067-00			CAP., FXD, CER DI: 0.001UF, 10%, 200V	59660	835-515-Z5D0102K
C1998	283-0092-00			CAP., FXD, CER DI: 0.03UF, +80-20%, 200V	59660	845-534Z5U0303Z
C2023	283-0067-00			CAP., FXD, CER DI: 0.001UF, 10%, 200V	59660	835-515-Z5D0102K
C2025	283-0150-00			CAP., FXD, CER DI: 650PF, 5%, 200V	59660	835-515B651J
C2074	283-0003-00			CAP., FXD, CER DI: 0.01UF, +80-20%, 150V	91418	SP103Z151-4R9
C2077	283-0004-00	XB124210		CAP., FXD, CER DI: 0.02UF, +80-20%, 150V	91418	SP203Z151-4R9
C2079	283-0000-00			CAP., FXD, CER DI: 0.001UF, +100-0%, 500V	59660	831-519-Y5P-102P
C2094	290-0526-00			CAP., FXD, ELCTLT: 6.8UF, 20%, 6V	90201	TDC685M00NLE
C2095	290-0517-00			CAP., FXD, ELCTLT: 6.8UF, 20%, 35V	56289	196D685X0035KA1
C2096	290-0535-00			CAP., FXD, ELCTLT: 33UF, 20%, 10V	56289	196D336X0010KA1
C2097	290-0517-00			CAP., FXD, ELCTLT: 6.8UF, 20%, 35V	56289	196D685X0035KA1
C2099	283-0081-00			CAP., FXD, CER DI: 0.1UF, +80-20%, 25V	91418	MX104Z2504R0
C2802	-----	-----		(SEE OPTION 5)		
C2803	-----	-----		(SEE OPTION 5)		
C2804	-----	-----		(SEE OPTION 5)		
C2805	-----	-----		(SEE OPTION 5)		
C2812	-----	-----		(SEE OPTION 5)		
C2827	-----	-----		(SEE OPTION 5)		
C2854	-----	-----		(SEE OPTION 5)		
C2856	-----	-----		(SEE OPTION 5)		
C2860	-----	-----		(SEE OPTION 5)		
C2861	-----	-----		(SEE OPTION 5)		
C2865	-----	-----		(SEE OPTION 5)		
C2866	-----	-----		(SEE OPTION 5)		
C2879	-----	-----		(SEE OPTION 5)		
C8064	290-0536-00	XB138090		CAP., FXD, ELCTLT: 10UF, 20%, 25V	90201	TDC106M025FL
CR72	152-0323-00			SEMICONV DEVICE: SILICON, 35V, 0.1A	80009	152-0323-00
CR73	152-0323-00			SEMICONV DEVICE: SILICON, 35V, 0.1A	80009	152-0323-00
CR75	152-0141-02	B010100	B089999X	SEMICONV DEVICE: SILICON, 30V, 150MA (REPLACED WITH W75)	01295	1N4152R
CR76	152-0153-00	B010100	B149849	SEMICONV DEVICE: SILICON, 15V, 50MA	07263	FD7003
CR76	152-0141-02	B149850		SEMICONV DEVICE: SILICON, 30V, 150MA	01295	1N4152R
CR114	152-0422-00			SEMICONV DEVICE: SILICON, 4V, 7PF	04713	SMV1264
CR117	152-0422-00			SEMICONV DEVICE: SILICON, 4V, 7PF	04713	SMV1264
CR148	152-0141-02			SEMICONV DEVICE: SILICON, 30V, 150MA	01295	1N4152R
CR156	152-0141-02			SEMICONV DEVICE: SILICON, 30V, 150MA	01295	1N4152R
CR157	152-0141-02			SEMICONV DEVICE: SILICON, 30V, 150MA	01295	1N4152R
CR158	152-0141-02			SEMICONV DEVICE: SILICON, 30V, 150MA	01295	1N4152R
CR159	152-0141-02			SEMICONV DEVICE: SILICON, 30V, 150MA	01295	1N4152R
CR172	152-0323-00			SEMICONV DEVICE: SILICON, 35V, 0.1A	80009	152-0323-00
CR173	152-0323-00			SEMICONV DEVICE: SILICON, 35V, 0.1A	80009	152-0323-00
CR175	152-0141-02	B010100	B089999X	SEMICONV DEVICE: SILICON, 30V, 150MA (REPLACED WITH W175)	01295	1N4152R
CR176	152-0153-00	B010100	B149849	SEMICONV DEVICE: SILICON, 15V, 50MA	07263	FD7003
CR176	152-0141-02	B149850		SEMICONV DEVICE: SILICON, 30V, 150MA	01295	1N4152R
CR214	152-0422-00			SEMICONV DEVICE: SILICON, 4V, 7PF	04713	SMV1264
CR217	152-0422-00			SEMICONV DEVICE: SILICON, 4V, 7PF	04713	SMV1264
CR248	152-0141-02			SEMICONV DEVICE: SILICON, 30V, 150MA	01295	1N4152R
CR304	152-0153-00	B010100	B149849	SEMICONV DEVICE: SILICON, 15V, 50MA	07263	FD7003
CR304	152-0322-00	B149850		SEMICONV DEVICE: SILICON, 15V, HOT CARRIER	50434	5082-2672



Replaceable Electrical Parts—466 Service

Ckt No.	Tektronix Part No.	Serial/Model No. Eff	Dscont	Name & Description	Mfr Code	Mfr Part Number
CR305	152-0153-00	B010100	B149849	SEMICON D DEVICE: SILICON, 15V, 50MA	07263	FD7003
CR305	152-0322-00	B149850		SEMICON D DEVICE: SILICON, 15V, HOT CARRIER	50434	5082-2672
CR307	152-0153-00	B010100	B149849	SEMICON D DEVICE: SILICON, 15V, 50MA	07263	FD7003
CR307	152-0322-00	B149850		SEMICON D DEVICE: SILICON, 15V, HOT CARRIER	50434	5082-2672
CR308	152-0153-00	B010100	B149849	SEMICON D DEVICE: SILICON, 15V, 50MA	07263	FD7003
CR308	152-0322-00	B149850		SEMICON D DEVICE: SILICON, 15V, HOT CARRIER	50434	5082-2672
CR314	152-0153-00	B010100	B149849	SEMICON D DEVICE: SILICON, 15V, 50MA	07263	FD7003
CR314	152-0322-00	B149850		SEMICON D DEVICE: SILICON, 15V, HOT CARRIER	50434	5082-2672
CR315	152-0153-00	B010100	B149849	SEMICON D DEVICE: SILICON, 15V, 50MA	07263	FD7003
CR315	152-0322-00	B149850		SEMICON D DEVICE: SILICON, 15V, HOT CARRIER	50434	5082-2672
CR317	152-0153-00	B010100	B149849	SEMICON D DEVICE: SILICON, 15V, 50MA	07263	FD7003
CR317	152-0322-00	B149850		SEMICON D DEVICE: SILICON, 15V, HOT CARRIER	50434	5082-2672
CR318	152-0153-00	B010100	B149849	SEMICON D DEVICE: SILICON, 15V, 50MA	07263	FD7003
CR318	152-0322-00	B149850		SEMICON D DEVICE: SILICON, 15V, HOT CARRIER	50434	5082-2672
CR342	152-0141-02			SEMICON D DEVICE: SILICON, 30V, 150MA	01295	1N4152R
CR358	152-0075-00	XB138375		SEMICON D DEVICE: GE, 25V, 40MA	14433	G866
CR362	152-0141-02			SEMICON D DEVICE: SILICON, 30V, 150MA	01295	1N4152R
CR368	152-0141-02			SEMICON D DEVICE: SILICON, 30V, 150MA	01295	1N4152R
CR372	152-0141-02			SEMICON D DEVICE: SILICON, 30V, 150MA	01295	1N4152R
CR378	152-0141-02			SEMICON D DEVICE: SILICON, 30V, 150MA	01295	1N4152R
CR517	152-0246-00			SEMICON D DEVICE: SW, SI, 40V, 200MA	03508	DE140
CR550	152-0125-00	B010100	B050962	SEMICON D DEVICE: TUNNEL, 15PF, 4.7MA	03508	STD704
CR550	152-0125-01	B050963		SEMICON D DEVICE: TUNNEL, 4.7MA, 18PF	03508	STD704
CR552	152-0125-00	B010100	B050962	SEMICON D DEVICE: TUNNEL, 15PF, 4.7MA	03508	STD704
CR552	152-0125-01	B050963		SEMICON D DEVICE: TUNNEL, 4.7MA, 18PF	03508	STD704
CR553	152-0141-02			SEMICON D DEVICE: SILICON, 30V, 150MA	01295	1N4152R
CR554	152-0141-02			SEMICON D DEVICE: SILICON, 30V, 150MA	01295	1N4152R
CR610	-----			(SEE OPTION 5)		
CR617	152-0246-00			SEMICON D DEVICE: SW, SI, 40V, 200MA	03508	DE140
CR650	152-0125-00	B010100	B050962	SEMICON D DEVICE: TUNNEL, 15PF, 4.7MA	03508	STD704
CR650	152-0125-01	B050963		SEMICON D DEVICE: TUNNEL, 4.7MA, 18PF	03508	STD704
CR652	152-0125-00	B010100	B050962	SEMICON D DEVICE: TUNNEL, 15PF, 4.7MA	03508	STD704
CR652	152-0125-01	B050963		SEMICON D DEVICE: TUNNEL, 4.7MA, 18PF	03508	STD704
CR821	152-0141-02			SEMICON D DEVICE: SILICON, 30V, 150MA	01295	1N4152R
CR822	152-0141-02			SEMICON D DEVICE: SILICON, 30V, 150MA	01295	1N4152R
CR823	152-0141-02			SEMICON D DEVICE: SILICON, 30V, 150MA	01295	1N4152R
CR824	152-0141-02			SEMICON D DEVICE: SILICON, 30V, 150MA	01295	1N4152R
CR834	152-0141-02			SEMICON D DEVICE: SILICON, 30V, 150MA	01295	1N4152R
CR846	152-0322-00			SEMICON D DEVICE: SILICON, 15V, HOT CARRIER	50434	5082-2672
CR851	152-0141-02			SEMICON D DEVICE: SILICON, 30V, 150MA	01295	1N4152R
CR852	152-0141-02			SEMICON D DEVICE: SILICON, 30V, 150MA	01295	1N4152R
CR853	152-0141-02			SEMICON D DEVICE: SILICON, 30V, 150MA	01295	1N4152R
CR857	152-0141-02			SEMICON D DEVICE: SILICON, 30V, 150MA	01295	1N4152R
CR858	152-0141-02			SEMICON D DEVICE: SILICON, 30V, 150MA	01295	1N4152R
CR865	152-0141-02			SEMICON D DEVICE: SILICON, 30V, 150MA	01295	1N4152R
CR874	152-0141-02			SEMICON D DEVICE: SILICON, 30V, 150MA	01295	1N4152R
CR882	152-0141-02			SEMICON D DEVICE: SILICON, 30V, 150MA	01295	1N4152R
CR884	152-0141-02			SEMICON D DEVICE: SILICON, 30V, 150MA	01295	1N4152R
CR885	152-0141-02			SEMICON D DEVICE: SILICON, 30V, 150MA	01295	1N4152R
CR887	152-0141-02			SEMICON D DEVICE: SILICON, 30V, 150MA	01295	1N4152R
CR888	152-0141-02			SEMICON D DEVICE: SILICON, 30V, 150MA	01295	1N4152R
CR892	152-0141-02			SEMICON D DEVICE: SILICON, 30V, 150MA	01295	1N4152R
CR893	152-0141-02			SEMICON D DEVICE: SILICON, 30V, 150MA	01295	1N4152R
CR894	152-0141-02			SEMICON D DEVICE: SILICON, 30V, 150MA	01295	1N4152R
CR895	152-0141-02			SEMICON D DEVICE: SILICON, 30V, 150MA	01295	1N4152R
CR896	152-0141-02			SEMICON D DEVICE: SILICON, 30V, 150MA	01295	1N4152R
CR897	152-0141-02			SEMICON D DEVICE: SILICON, 30V, 150MA	01295	1N4152R

Replaceable Electrical Parts—466 Service

Ckt No.	Tektronix Part No.	Serial/Model No. Eff	Dscont	Name & Description	Mfr Code	Mfr Part Number
CR908	152-0141-02			SEMICON D DEVICE: SILICON, 30V, 150MA	01295	1N4152R
CR914	152-0141-02			SEMICON D DEVICE: SILICON, 30V, 150MA	01295	1N4152R
CR916	152-0141-02			SEMICON D DEVICE: SILICON, 30V, 150MA	01295	1N4152R
CR917	152-0141-02			SEMICON D DEVICE: SILICON, 30V, 150MA	01295	1N4152R
CR943	152-0141-02			SEMICON D DEVICE: SILICON, 30V, 150MA	01295	1N4152R
CR945	152-0141-02			SEMICON D DEVICE: SILICON, 30V, 150MA	01295	1N4152R
CR946	152-0141-02			SEMICON D DEVICE: SILICON, 30V, 150MA	01295	1N4152R
CR948	152-0333-00			SEMICON D DEVICE: SILICON, 55V, 200MA	07263	FDH-6012
CR949	152-0141-02	XB082300		SEMICON D DEVICE: SILICON, 30V, 150MA (SEE OPTION 5)	01295	1N4152R
CR957	152-0322-00			SEMICON D DEVICE: SILICON, 15V, HOT CARRIER (SEE OPTION 5)	50434	5082-2672
CR962	152-0141-02			SEMICON D DEVICE: SILICON, 30V, 150MA	01295	1N4152R
CR986	152-0141-02			SEMICON D DEVICE: SILICON, 30V, 150MA	01295	1N4152R
CR987	152-0141-02			SEMICON D DEVICE: SILICON, 30V, 150MA	01295	1N4152R
CR989	152-0141-02			SEMICON D DEVICE: SILICON, 30V, 150MA	01295	1N4152R
CR1001	152-0141-02			SEMICON D DEVICE: SILICON, 30V, 150MA	01295	1N4152R
CR1004	152-0141-02			SEMICON D DEVICE: SILICON, 30V, 150MA	01295	1N4152R
CR1011	152-0141-02			SEMICON D DEVICE: SILICON, 30V, 150MA	01295	1N4152R
CR1024	152-0141-02			SEMICON D DEVICE: SILICON, 30V, 150MA	01295	1N4152R
CR1035	152-0141-02			SEMICON D DEVICE: SILICON, 30V, 150MA	01295	1N4152R
CR1036	152-0141-02			SEMICON D DEVICE: SILICON, 30V, 150MA	01295	1N4152R
CR1061	152-0141-02			SEMICON D DEVICE: SILICON, 30V, 150MA	01295	1N4152R
CR1062	152-0141-02			SEMICON D DEVICE: SILICON, 30V, 150MA	01295	1N4152R
CR1064	152-0141-02			SEMICON D DEVICE: SILICON, 30V, 150MA	01295	1N4152R
CR1068	152-0141-02			SEMICON D DEVICE: SILICON, 30V, 150MA	01295	1N4152R
CR1095	152-0141-02			SEMICON D DEVICE: SILICON, 30V, 150MA	01295	1N4152R
CR1098	152-0141-02			SEMICON D DEVICE: SILICON, 30V, 150MA	01295	1N4152R
CR1099	152-0141-02			SEMICON D DEVICE: SILICON, 30V, 150MA	01295	1N4152R
CR1153	152-0141-02	XB124370		SEMICON D DEVICE: SILICON, 30V, 150MA	01295	1N4152R
CR1202	152-0141-02			SEMICON D DEVICE: SILICON, 30V, 150MA	01295	1N4152R
CR1205	152-0141-02			SEMICON D DEVICE: SILICON, 30V, 150MA	01295	1N4152R
CR1218	152-0141-02			SEMICON D DEVICE: SILICON, 30V, 150MA	01295	1N4152R
CR1262	152-0322-00			SEMICON D DEVICE: SILICON, 15V, HOT CARRIER	50434	5082-2672
CR1263	152-0153-00	B010100	B149443	SEMICON D DEVICE: SILICON, 15V, 50MA	07263	FD7003
CR1263	152-0322-00	B149444	B152499	SEMICON D DEVICE: SILICON, 15V, HOT CARRIER	50434	5082-2672
CR1263	152-0153-00	B152500		SEMICON D DEVICE: SILICON, 15V, 50MA	07263	FD7003
CR1264	152-0153-00	B010100	B149443	SEMICON D DEVICE: SILICON, 15V, 50MA	07263	FD7003
CR1264	152-0322-00	B149444	B152499	SEMICON D DEVICE: SILICON, 15V, HOT CARRIER	50434	5082-2672
CR1264	152-0153-00	B152500		SEMICON D DEVICE: SILICON, 15V, 50MA	07263	FD7003
CR1265	152-0322-00			SEMICON D DEVICE: SILICON, 15V, HOT CARRIER	50434	5082-2672
CR1271	152-0141-02			SEMICON D DEVICE: SILICON, 30V, 150MA	01295	1N4152R
CR1281	152-0141-02			SEMICON D DEVICE: SILICON, 30V, 150MA	01295	1N4152R
CR1285	152-0141-02			SEMICON D DEVICE: SILICON, 30V, 150MA	01295	1N4152R
CR1364	152-0141-02			SEMICON D DEVICE: SILICON, 30V, 150MA	01295	1N4152R
CR1372	152-0141-02			SEMICON D DEVICE: SILICON, 30V, 150MA	01295	1N4152R
CR1401	152-0141-02			SEMICON D DEVICE: SILICON, 30V, 150MA	01295	1N4152R
CR1405	152-0333-00			SEMICON D DEVICE: SILICON, 55V, 200MA	07263	FDH-6012
CR1411	152-0141-02			SEMICON D DEVICE: SILICON, 30V, 150MA	01295	1N4152R
CR1412	152-0153-00	B010100	B149443	SEMICON D DEVICE: SILICON, 15V, 50MA	07263	FD7003
CR1412	152-0141-02	B149444	B152499	SEMICON D DEVICE: SILICON, 30V, 150MA	01295	1N4152R
CR1412	152-0153-00	B152500		SEMICON D DEVICE: SILICON, 15V, 50MA	07263	FD7003
CR1413	152-0141-02			SEMICON D DEVICE: SILICON, 30V, 150MA	01295	1N4152R
CR1425	152-0141-02			SEMICON D DEVICE: SILICON, 30V, 150MA	01295	1N4152R
CR1427	152-0333-00			SEMICON D DEVICE: SILICON, 55V, 200MA	07263	FDH-6012
CR1432	152-0141-02	B010100	B059999	SEMICON D DEVICE: SILICON, 30V, 150MA	01295	1N4152R
CR1432	152-0061-00	B060000		SEMICON D DEVICE: SILICON, 175V, 100MA	07263	FDH2161

# Replaceable Electrical Parts—466 Service

Ckt No.	Tektronix Part No.	Serial/Model No. Eff	Dscont	Name & Description	Mfr Code	Mfr Part Number
CR1439	152-0061-00			SEMICON D DEVICE: SILICON, 175V, 100MA	07263	FDH2161
CR1442	152-0061-00			SEMICON D DEVICE: SILICON, 175V, 100MA	07263	FDH2161
CR1444	152-0242-00			SEMICON D DEVICE: SILICON, 225V, 200MA	07263	FDH5004
CR1445	152-0242-00			SEMICON D DEVICE: SILICON, 225V, 200MA	07263	FDH5004
CR1452	152-0061-00			SEMICON D DEVICE: SILICON, 175V, 100MA	07263	FDH2161
CR1454	152-0061-00			SEMICON D DEVICE: SILICON, 175V, 100MA	07263	FDH2161
CR1461	152-0141-02			SEMICON D DEVICE: SILICON, 30V, 150MA	01295	1N4152R
CR1462	152-0075-00			SEMICON D DEVICE: GE, 25V, 40MA	14433	G866
CR1466	152-0141-02			SEMICON D DEVICE: SILICON, 30V, 150MA	01295	1N4152R
CR1477	152-0141-02			SEMICON D DEVICE: SILICON, 30V, 150MA	01295	1N4152R
CR1482	152-0141-02			SEMICON D DEVICE: SILICON, 30V, 150MA	01295	1N4152R
CR1486	152-0333-00			SEMICON D DEVICE: SILICON, 55V, 200MA	07263	FDH-6012
CR1497	152-0141-02			SEMICON D DEVICE: SILICON, 30V, 150MA	01295	1N4152R
CR1503	152-0409-00			SEMICON D DEVICE: SILICON, 12,000V, 5MA	83003	VG12X-1
CR1506	152-0409-00			SEMICON D DEVICE: SILICON, 12,000V, 5MA	83003	VG12X-1
CR1507	152-0409-00			SEMICON D DEVICE: SILICON, 12,000V, 5MA	83003	VG12X-1
CR1512	152-0331-00			SEMICON D DEVICE: SILICON, 800V, 25MA	0000M	152-0331-00
CR1514	152-0413-00	B010100	B129999X	SEMICON D DEVICE: SILICON, 400V, 750MA	12969	UTR307
CR1533	152-0061-00			SEMICON D DEVICE: SILICON, 175V, 100MA	07263	FDH2161
CR1535	152-0246-00			SEMICON D DEVICE: SW, SI, 40V, 200MA	03508	DE140
CR1536	152-0246-00			SEMICON D DEVICE: SW, SI, 40V, 200MA	03508	DE140
CR1543	152-0246-00			SEMICON D DEVICE: SW, SI, 40V, 200MA	03508	DE140
CR1552	152-0061-00			SEMICON D DEVICE: SILICON, 175V, 100MA	07263	FDH2161
CR1554	152-0141-02			SEMICON D DEVICE: SILICON, 30V, 150MA	01295	1N4152R
CR1562	152-0061-00			SEMICON D DEVICE: SILICON, 175V, 100MA	07263	FDH2161
CR1564	152-0141-02			SEMICON D DEVICE: SILICON, 30V, 150MA	01295	1N4152R
CR1573	152-0061-00			SEMICON D DEVICE: SILICON, 175V, 100MA	07263	FDH2161
CR1582	152-0409-00			SEMICON D DEVICE: SILICON, 12,000V, 5MA	83003	VG12X-1
CR1583	152-0409-00			SEMICON D DEVICE: SILICON, 12,000V, 5MA	83003	VG12X-1
CR1601	-----			(SEE OPTION 7)		
CR1624	-----			(SEE OPTION 7)		
CR1625	-----			(SEE OPTION 7)		
CR1626	-----			(SEE OPTION 7)		
CR1627	-----			(SEE OPTION 7)		
CR1628	-----			(SEE OPTION 7)		
CR1632	-----			(SEE OPTION 7)		
CR1634	-----			(SEE OPTION 7)		
CR1643	-----			(SEE OPTION 7)		
CR1691	152-0141-02	B010100	B138089X	SEMICON D DEVICE: SILICON, 30V, 150MA	01295	1N4152R
CR1692	152-0141-02	B010100	B138089X	SEMICON D DEVICE: SILICON, 30V, 150MA	01295	1N4152R
CR1694	152-0141-02	B010100	B138089X	SEMICON D DEVICE: SILICON, 30V, 150MA	01295	1N4152R
CR1696	152-0141-02	B010100	B138089X	SEMICON D DEVICE: SILICON, 30V, 150MA	01295	1N4152R
CR1699	152-0141-02	B010100	B138089X	SEMICON D DEVICE: SILICON, 30V, 150MA	01295	1N4152R
CR1711	152-0107-00			SEMICON D DEVICE: SILICON, 400V, 400MA	01295	G727
CR1712	152-0107-00			SEMICON D DEVICE: SILICON, 400V, 400MA	01295	G727
CR1717	152-0107-00			SEMICON D DEVICE: SILICON, 400V, 400MA	01295	G727
CR1718	152-0066-00			SEMICON D DEVICE: SILICON, 400V, 750MA	14433	LG4016
CR1719	152-0066-00			SEMICON D DEVICE: SILICON, 400V, 750MA	14433	LG4016
CR1721	152-0497-00			SEMICON D DEVICE: SILICON, 600V, 1.5A	80009	152-0497-00
CR1723	152-0061-00			SEMICON D DEVICE: SILICON, 175V, 100MA	07263	FDH2161
CR1724	152-0141-02			SEMICON D DEVICE: SILICON, 30V, 150MA	01295	1N4152R
CR1732	152-0141-02			SEMICON D DEVICE: SILICON, 30V, 150MA	01295	1N4152R
CR1733	152-0141-02			SEMICON D DEVICE: SILICON, 30V, 150MA	01295	1N4152R
CR1734	152-0066-00			SEMICON D DEVICE: SILICON, 400V, 750MA	14433	LG4016
CR1737	152-0066-00			SEMICON D DEVICE: SILICON, 400V, 750MA	14433	LG4016
CR1751	152-0556-00			SEMICON D DEVICE: BRIDGE, 50V, 2.5A	05828	KBL005-8
CR1757	152-0066-00			SEMICON D DEVICE: SILICON, 400V, 750MA	14433	LG4016
CR1761	152-0488-00			SEMICON D DEVICE: SILICON, 200V, 1500MA	04713	SDA317

Kct No.	Tektronix Part No.	Serial/Model No. Eff	Dscont	Name & Description	Mfr Code	Mfr Part Number
CR1767	152-0066-00			SEMICON D DEVICE: SILICON, 400V, 750MA	14433	LG4016
CR1771	152-0488-00			SEMICON D DEVICE: SILICON, 200V, 1500MA	04713	SDA317
CR1777	152-0066-00			SEMICON D DEVICE: SILICON, 400V, 750MA	14433	LG4016
CR1781	152-0488-00			SEMICON D DEVICE: SILICON, 200V, 1500MA	04713	SDA317
CR1787	152-0066-00			SEMICON D DEVICE: SILICON, 400V, 750MA	14433	LG4016
CR1814	152-0141-02			SEMICON D DEVICE: SILICON, 30V, 150MA	01295	1N4152R
CR1815	152-0141-02			SEMICON D DEVICE: SILICON, 30V, 150MA	01295	1N4152R
CR1822	152-0141-02			SEMICON D DEVICE: SILICON, 30V, 150MA	01295	1N4152R
CR1825	152-0141-02			SEMICON D DEVICE: SILICON, 30V, 150MA	01295	1N4152R
CR1835	152-0061-00			SEMICON D DEVICE: SILICON, 175V, 100MA	07263	FDH2161
CR1845	152-0061-00			SEMICON D DEVICE: SILICON, 175V, 100MA	07263	FDH2161
CR1848	152-0061-00			SEMICON D DEVICE: SILICON, 175V, 100MA	07263	FDH2161
CR1866	152-0141-02			SEMICON D DEVICE: SILICON, 30V, 150MA	01295	1N4152R
CR1869	152-0141-02			SEMICON D DEVICE: SILICON, 30V, 150MA	01295	1N4152R
CR1875	152-0141-02			SEMICON D DEVICE: SILICON, 30V, 150MA	01295	1N4152R
CR1876	152-0141-02			SEMICON D DEVICE: SILICON, 30V, 150MA	01295	1N4152R
CR1877	152-0141-02			SEMICON D DEVICE: SILICON, 30V, 150MA	01295	1N4152R
CR1923	152-0141-02			SEMICON D DEVICE: SILICON, 30V, 150MA	01295	1N4152R
CR1924	152-0141-02			SEMICON D DEVICE: SILICON, 30V, 150MA	01295	1N4152R
CR1925	152-0141-02			SEMICON D DEVICE: SILICON, 30V, 150MA	01295	1N4152R
CR1926	152-0141-02			SEMICON D DEVICE: SILICON, 30V, 150MA	01295	1N4152R
CR1927	152-0141-02			SEMICON D DEVICE: SILICON, 30V, 150MA	01295	1N4152R
CR1928	152-0141-02			SEMICON D DEVICE: SILICON, 30V, 150MA	01295	1N4152R
CR1932	152-0141-02			SEMICON D DEVICE: SILICON, 30V, 150MA	01295	1N4152R
CR1933	152-0141-02			SEMICON D DEVICE: SILICON, 30V, 150MA	01295	1N4152R
CR1934	152-0141-02			SEMICON D DEVICE: SILICON, 30V, 150MA	01295	1N4152R
CR1935	152-0141-02			SEMICON D DEVICE: SILICON, 30V, 150MA	01295	1N4152R
CR1936	152-0141-02			SEMICON D DEVICE: SILICON, 30V, 150MA	01295	1N4152R
CR1937	152-0141-02			SEMICON D DEVICE: SILICON, 30V, 150MA	01295	1N4152R
CR1938	152-0141-02			SEMICON D DEVICE: SILICON, 30V, 150MA	01295	1N4152R
CR1941	152-0040-00	B010100	B092809	SEMICON D DEVICE: SILICON, 600V, 1A	15238	LG109
CR1941	152-0331-00	B092810		SEMICON D DEVICE: SILICON, 800V, 25MA	0000M	152-0331-00
CR1944	152-0141-02	XB070000	B079999X	SEMICON D DEVICE: SILICON, 30V, 150MA	01295	1N4152R
CR1947	152-0141-02			SEMICON D DEVICE: SILICON, 30V, 150MA	01295	1N4152R
CR1962	152-0141-02			SEMICON D DEVICE: SILICON, 30V, 150MA	01295	1N4152R
CR1963	152-0040-00			SEMICON D DEVICE: SILICON, 600V, 1A	15238	LG109
CR1965	152-0040-00			SEMICON D DEVICE: SILICON, 600V, 1A	15238	LG109
CR1966	152-0061-00			SEMICON D DEVICE: SILICON, 175V, 100MA	07263	FDH2161
CR1981	152-0141-02			SEMICON D DEVICE: SILICON, 30V, 150MA	01295	1N4152R
CR1982	152-0141-02			SEMICON D DEVICE: SILICON, 30V, 150MA	01295	1N4152R
CR1983	152-0141-02			SEMICON D DEVICE: SILICON, 30V, 150MA	01295	1N4152R
CR1984	152-0141-02			SEMICON D DEVICE: SILICON, 30V, 150MA	01295	1N4152R
CR1985	152-0141-02			SEMICON D DEVICE: SILICON, 30V, 150MA	01295	1N4152R
CR1986	152-0141-02			SEMICON D DEVICE: SILICON, 30V, 150MA	01295	1N4152R
CR1987	152-0141-02			SEMICON D DEVICE: SILICON, 30V, 150MA	01295	1N4152R
CR1988	152-0141-02			SEMICON D DEVICE: SILICON, 30V, 150MA	01295	1N4152R
CR1996	152-0141-02			SEMICON D DEVICE: SILICON, 30V, 150MA	01295	1N4152R
CR2012	152-0141-02			SEMICON D DEVICE: SILICON, 30V, 150MA	01295	1N4152R
CR2013	152-0141-02			SEMICON D DEVICE: SILICON, 30V, 150MA	01295	1N4152R
CR2014	152-0141-02			SEMICON D DEVICE: SILICON, 30V, 150MA	01295	1N4152R
CR2015	152-0141-02			SEMICON D DEVICE: SILICON, 30V, 150MA	01295	1N4152R
CR2016	152-0141-02			SEMICON D DEVICE: SILICON, 30V, 150MA	01295	1N4152R
CR2026	152-0141-02			SEMICON D DEVICE: SILICON, 30V, 150MA	01295	1N4152R
CR2032	152-0141-02			SEMICON D DEVICE: SILICON, 30V, 150MA	01295	1N4152R
CR2033	152-0141-02			SEMICON D DEVICE: SILICON, 30V, 150MA	01295	1N4152R
CR2034	152-0141-02			SEMICON D DEVICE: SILICON, 30V, 150MA	01295	1N4152R
CR2035	152-0141-02			SEMICON D DEVICE: SILICON, 30V, 150MA	01295	1N4152R

Replaceable Electrical Parts—466 Service

Ckt No.	Tektronix Part No.	Serial/Model No. Eff	Dscont	Name & Description	Mfr Code	Mfr Part Number
CR2036	152-0141-02			SEMICON D DEVICE: SILICON, 30V, 150MA	01295	1N4152R
CR2042	152-0141-02			SEMICON D DEVICE: SILICON, 30V, 150MA	01295	1N4152R
CR2043	152-0141-02			SEMICON D DEVICE: SILICON, 30V, 150MA	01295	1N4152R
CR2044	152-0141-02			SEMICON D DEVICE: SILICON, 30V, 150MA	01295	1N4152R
CR2045	152-0141-02			SEMICON D DEVICE: SILICON, 30V, 150MA	01295	1N4152R
CR2052	152-0141-02			SEMICON D DEVICE: SILICON, 30V, 150MA	01295	1N4152R
CR2053	152-0141-02			SEMICON D DEVICE: SILICON, 30V, 150MA	01295	1N4152R
CR2054	152-0141-02			SEMICON D DEVICE: SILICON, 30V, 150MA	01295	1N4152R
CR2055	152-0141-02			SEMICON D DEVICE: SILICON, 30V, 150MA	01295	1N4152R
CR2807	-----			(SEE OPTION 5)		
CR2809	-----			(SEE OPTION 5)		
CR2818	-----			(SEE OPTION 5)		
CR2824	-----			(SEE OPTION 5)		
CR2825	-----			(SEE OPTION 5)		
CR2826	-----			(SEE OPTION 5)		
CR2828	-----			(SEE OPTION 5)		
CR2831	-----			(SEE OPTION 5)		
CR2865	-----			(SEE OPTION 5)		
CR8042	152-0141-02	XB138090		SEMICON D DEVICE: SILICON, 30V, 150MA	01295	1N4152R
CR8044	152-0141-02	XB138090		SEMICON D DEVICE: SILICON, 30V, 150MA	01295	1N4152R
CR8046	152-0141-02	XB138090		SEMICON D DEVICE: SILICON, 30V, 150MA	01295	1N4152R
CR8048	152-0141-02	XB138090		SEMICON D DEVICE: SILICON, 30V, 150MA	01295	1N4152R
CR8066	152-0141-02	XB138090		SEMICON D DEVICE: SILICON, 30V, 150MA	01295	1N4152R
DL339	119-0481-00			DELAY LINE, ELEC: 120NS, 100 OHM	80009	119-0481-00
DS52	150-0130-00			LAMP, INCAND: 5V, 60MA	92966	34254-TINNED
DS54	150-0130-00			LAMP, INCAND: 5V, 60MA	92966	34254-TINNED
DS58	150-0035-00			LAMP, GLOW: 90V, 0.3MA	53944	A1B-3
DS62	150-0130-00			LAMP, INCAND: 5V, 60MA	92966	34254-TINNED
DS64	150-0130-00			LAMP, INCAND: 5V, 60MA	92966	34254-TINNED
DS68	150-0035-00			LAMP, GLOW: 90V, 0.3MA	53944	A1B-3
DS965	150-0130-00			LAMP, INCAND: 5V, 60MA	92966	34254-TINNED
DS967	150-0130-00			LAMP, INCAND: 5V, 60MA	92966	34254-TINNED
DS1140	150-0035-00			LAMP, GLOW: 90V, 0.3MA	53944	A1B-3
DS1239	150-0035-00			LAMP, GLOW: 90V, 0.3MA	53944	A1B-3
DS1524	150-0002-00			LAMP, GLOW: 0.5 MA 60/125V	74276	NE-2T(T2)
DS1525	150-0002-00			LAMP, GLOW: 0.5 MA 60/125V	74276	NE-2T(T2)
DS1572	150-0035-00			LAMP, GLOW: 90V, 0.3MA	53944	A1B-3
DS1792	150-0129-00			LAMP, INCAND: 6.3V, 200MA	08806	2112D
DS1794	150-0129-00			LAMP, INCAND: 6.3V, 200MA	08806	2112D
E437	276-0543-00	XB150755		SHLD BEAD, ELEK: FERRITE	80009	276-0543-00
E438	276-0543-00	XB150755		SHLD BEAD, ELEK: FERRITE	80009	276-0543-00
F1487	159-0016-00			FUSE, CARTRIDGE: 3AG, 1.5A, 250V, FAST-BLOW	71400	AGC 1 1/2
F1601	-----			(SEE OPTION 7)		
F1701	159-0016-00			FUSE, CARTRIDGE: 3AG, 1.5A, 250V, FAST-BLOW	71400	AGC 1 1/2
F1701	159-0042-00	XB151620		FUSE, CARTRIDGE: 3AG, 0.75A, 250V, FAST-BLOW	71400	AGC 3/4
F1702	159-0172-00	XB151620		(OPTION A1, A2, A3, A4)		
F1702	-----			FUSE, CARTRIDGE: TYPE C, 13 AMP	33096	PB1267
F1702	-----			(OPTION A2 ONLY)		
FL1701	-----			(SEE OPTION 4)		
J1	136-0499-14			CONNECTOR, RCPT, :14 CONTACT	00779	4-380949-4
J2	136-0499-16			CONNECTOR, RCPT, :16 CONTACT	00779	4-380949-6

Replaceable Electrical Parts—466 Service

Ckt No.	Tektronix Part No.	Serial/Model No. Eff	Dscont	Name & Description	Mfr Code	Mfr Part Number
J5	136-0499-12			CONNECTOR, RCPT, : 12 CONTACT	00779	4-380949-2
J6	136-0499-12			CONNECTOR, RCPT, : 12 CONTACT	00779	4-380949-2
J8	136-0577-00			CONNECTOR, RCPT, : 6 CONTACT	22526	65001-015
J10(2)	131-0679-02			CONNECTOR, RCPT, : BNC, MALE, 3 CONTACT	24931	28JR270-1
J145	131-0955-00			CONN, RCPT, ELEC: BNC, FEMALE (SEE OPTION 4)	13511	31-279
J154	131-1003-00			CONN, RCPT, ELEC: CKT BD MT, 3 PRONG	80009	131-1003-00
J155	131-1003-00			CONN, RCPT, ELEC: CKT BD MT, 3 PRONG	80009	131-1003-00
J158	131-1003-00			CONN, RCPT, ELEC: CKT BD MT, 3 PRONG	80009	131-1003-00
J159	131-0955-00			CONN, RCPT, ELEC: BNC, FEMALE (SEE OPTION 4)	13511	31-279
J255	131-1003-00			CONN, RCPT, ELEC: CKT BD MT, 3 PRONG	80009	131-1003-00
J338	131-1003-00			CONN, RCPT, ELEC: CKT BD MT, 3 PRONG	80009	131-1003-00
J339	131-1003-00			CONN, RCPT, ELEC: CKT BD MT, 3 PRONG	80009	131-1003-00
J349	131-1003-00			CONN, RCPT, ELEC: CKT BD MT, 3 PRONG	80009	131-1003-00
J351	131-1003-00			CONN, RCPT, ELEC: CKT BD MT, 3 PRONG	80009	131-1003-00
J359	131-1003-00			CONN, RCPT, ELEC: CKT BD MT, 3 PRONG	80009	131-1003-00
J500	131-0352-02			CONNECTOR, RCPT, : BNC, FEMALE	24931	28JR166-1
J571	131-1003-00			CONN, RCPT, ELEC: CKT BD MT, 3 PRONG	80009	131-1003-00
J573	131-1003-00			CONN, RCPT, ELEC: CKT BD MT, 3 PRONG	80009	131-1003-00
J575	131-1003-00			CONN, RCPT, ELEC: CKT BD MT, 3 PRONG	80009	131-1003-00
J600	131-0352-02			CONNECTOR, RCPT, : BNC, FEMALE	24931	28JR166-1
J678	131-1003-00			CONN, RCPT, ELEC: CKT BD MT, 3 PRONG	80009	131-1003-00
J688	131-1003-00			CONN, RCPT, ELEC: CKT BD MT, 3 PRONG	80009	131-1003-00
J858	131-1003-00			CONN, RCPT, ELEC: CKT BD MT, 3 PRONG	80009	131-1003-00
J859	131-0955-00			CONN, RCPT, ELEC: BNC, FEMALE (SEE OPTION 4)	13511	31-279
J917	131-1003-00			CONN, RCPT, ELEC: CKT BD MT, 3 PRONG	80009	131-1003-00
J918	131-0955-00			CONN, RCPT, ELEC: BNC, FEMALE (SEE OPTION 4)	13511	31-279
J919	131-1003-00			CONN, RCPT, ELEC: CKT BD MT, 3 PRONG	80009	131-1003-00
K1501	108-0663-00			COIL, REED SW: 12V, 20MA	71707	SP-12-P
L302	108-0181-01			COIL, RF: 0. 2UH	80009	108-0181-01
L312	108-0181-01			COIL, RF: 0. 2UH	80009	108-0181-01
L338	108-0182-00			COIL, RF: 0. 3UH	80009	108-0182-00
L339	108-0182-00			COIL, RF: 0. 3UH	80009	108-0182-00
L428	108-0370-00			COIL, RF: 0. 14UH	80009	108-0370-00
L463	108-0557-00	B010100	B071669X	COIL, RF: 35NH	80009	108-0557-00
L464	108-0557-00	B010100	B071669X	COIL, RF: 35NH	80009	108-0557-00
L471	108-0538-00			COIL, RF: 2. 7UH	76493	JWM#B7059
L483	108-0740-00	B010100	B150754X	TRANSFORMER, RF: 225NH	80009	108-0740-00
L486	108-0740-00	B010100	B150754X	TRANSFORMER, RF: 225NH	80009	108-0740-00
L491	108-0538-00			COIL, RF: 2. 7UH	76493	JWM#B7059
L492	108-0538-00			COIL, RF: 2. 7UH	76493	JWM#B7059
L494	108-0538-00			COIL, RF: 2. 7UH	76493	JWM#B7059
L546	108-0370-00			COIL, RF: 0. 14UH	80009	108-0370-00
L547	108-0370-00			COIL, RF: 0. 14UH	80009	108-0370-00
L582	108-0538-00			COIL, RF: 2. 7UH	76493	JWM#B7059
L584	108-0538-00			COIL, RF: 2. 7UH	76493	JWM#B7059
L585	108-0538-00			COIL, RF: 2. 7UH	76493	JWM#B7059
L646	108-0370-00			COIL, RF: 0. 14UH	80009	108-0370-00
L647	108-0370-00			COIL, RF: 0. 14UH	80009	108-0370-00
L942	108-0538-00			COIL, RF: 2. 7UH	76493	JWM#B7059
L1374	108-0245-00			COIL, RF: 3. 9UH	76493	B6310-1
L1487	108-0422-00			COIL, RF: FIXED, 82UH	80009	108-0422-00
L1551	108-0779-00			COIL, TUBE DEFLE: TRACE ROTATOR	80009	108-0779-00

Replaceable Electrical Parts—466 Service

Ckt No.	Tektronix Part No.	Serial/Model No. Eff	Dscont	Name & Description	Mfr Code	Mfr Part Number
L1561	108-0714-00			COIL,TUBE DEFLE:Y AXIS ALIGNMENT	80009	108-0714-00
L2095	108-0538-00			COIL,RF:2.7UH	76493	JWM#B7059
L2096	108-0538-00			COIL,RF:2.7UH	76493	JWM#B7059
L2097	108-0538-00			COIL,RF:2.7UH	76493	JWM#B7059
L2099	108-0538-00			COIL,RF:2.7UH	76493	JWM#B7059
LR482	108-0284-00	B010100	B150754	COIL,RF:0.1UH	80009	108-0284-00
LR482	108-0729-00	B150755		COIL,RF:195NH	80009	108-0729-00
LR484	108-0284-00	B010100	B150754	COIL,RF:0.1UH	80009	108-0284-00
LR484	108-0729-00	B150755		COIL,RF:195NH	80009	108-0729-00
P1601	-----			(SEE OPTION 7)		
Q52	151-0281-00			TRANSISTOR:SILICON,NPN	03508	X16P4039
Q54	151-0302-00			TRANSISTOR:SILICON,NPN	07263	S038487
Q62	151-0281-00			TRANSISTOR:SILICON,NPN	03508	X16P4039
Q64	151-0302-00			TRANSISTOR:SILICON,NPN	07263	S038487
Q72A,B	151-1032-00			TRANSISTOR:SILICON,FET,DUAL	17856	DN399
Q84	151-0441-00			TRANSISTOR:SILICON,NPN	04713	SRF501
Q86	151-0441-00			TRANSISTOR:SILICON,NPN	04713	SRF501
Q102	153-0597-00			SEMICON DVC SE:SILICON,PNP	80009	153-0597-00
Q104						
Q112	151-0441-00			TRANSISTOR:SILICON,NPN	04713	SRF501
Q114	151-0441-00			TRANSISTOR:SILICON,NPN	04713	SRF501
Q124	151-0198-00			TRANSISTOR:SILICON,NPN,SEL FROM MPS918	04713	SPS8802-1
Q126	151-0198-00			TRANSISTOR:SILICON,NPN,SEL FROM MPS918	04713	SPS8802-1
Q132	151-0434-00			TRANSISTOR:SILICON,PNP	04713	SS7144
Q134	151-0434-00			TRANSISTOR:SILICON,PNP	04713	SS7144
Q136	151-0221-00			TRANSISTOR:SILICON,PNP	04713	SPS246
Q138	151-0221-00			TRANSISTOR:SILICON,PNP	04713	SPS246
Q144	151-0434-00			TRANSISTOR:SILICON,PNP	04713	SS7144
Q146	151-0434-00			TRANSISTOR:SILICON,PNP	04713	SS7144
Q148	151-0434-00			TRANSISTOR:SILICON,PNP	04713	SS7144
Q154	151-0221-00			TRANSISTOR:SILICON,PNP	04713	SPS246
Q156	151-0221-00			TRANSISTOR:SILICON,PNP	04713	SPS246
Q158	151-0190-00			TRANSISTOR:SILICON,NPN	07263	S032677
Q162	151-0190-00			TRANSISTOR:SILICON,NPN	07263	S032677
Q172A,B	151-1032-00			TRANSISTOR:SILICON,FET,DUAL	17856	DN399
Q184	151-0441-00			TRANSISTOR:SILICON,NPN	04713	SRF501
Q186	151-0441-00			TRANSISTOR:SILICON,NPN	04713	SRF501
Q202	153-0597-00			SEMICON DVC SE:SILICON,PNP	80009	153-0597-00
Q204						
Q212	151-0441-00			TRANSISTOR:SILICON,NPN	04713	SRF501
Q214	151-0441-00			TRANSISTOR:SILICON,NPN	04713	SRF501
Q220	153-0547-00			SEMICON DVC SE:SILICON,NPN,MATCHED (Q220 AND Q224 FURN AS A MATCHED PAIR)	80009	153-0547-00
Q222	153-0547-00			SEMICON DVC SE:SILICON,NPN,MATCHED (Q222 AND Q226 FURN AS A MATCHED PAIR)	80009	153-0547-00
Q224	153-0547-00			SEMICON DVC SE:SILICON,NPN,MATCHED (Q224 AND Q220 FURN AS A MATCHED PAIR)	80009	153-0547-00

Ckt No.	Tektronix Part No.	Serial/Model No. Eff	Dscont	Name & Description	Mfr Code	Mfr Part Number
Q226	153-0547-00			SEMICON DVC SE:SILICON,NPN,MATCHED (Q226 AND Q222 FURN AS A MATCHED PAIR)	80009	153-0547-00
Q232	151-0434-00			TRANSISTOR:SILICON,PNP	04713	SS7144
Q234	151-0434-00			TRANSISTOR:SILICON,PNP	04713	SS7144
Q236	151-0221-00			TRANSISTOR:SILICON,PNP	04713	SPS246
Q238	151-0221-00			TRANSISTOR:SILICON,PNP	04713	SPS246
Q244	151-0434-00			TRANSISTOR:SILICON,PNP	04713	SS7144
Q246	151-0434-00			TRANSISTOR:SILICON,PNP	04713	SS7144
Q248	151-0434-00			TRANSISTOR:SILICON,PNP	04713	SS7144
Q254	151-0221-00			TRANSISTOR:SILICON,PNP	04713	SPS246
Q262	151-0190-00			TRANSISTOR:SILICON,NPN	07263	S032677
Q304	151-0221-00			TRANSISTOR:SILICON,PNP	04713	SPS246
Q308	151-0221-00			TRANSISTOR:SILICON,PNP	04713	SPS246
Q314	151-0221-00			TRANSISTOR:SILICON,PNP	04713	SPS246
Q318	151-0221-00			TRANSISTOR:SILICON,PNP	04713	SPS246
Q322	151-0442-00	B010100	B010139	TRANSISTOR:SILICON,NPN	80009	151-0442-00
Q322	151-0212-00	B010140		TRANSISTOR:SILICON,NPN	04713	SRF 518
Q324	151-0442-00	B010100	B010139	TRANSISTOR:SILICON,NPN	80009	151-0442-00
Q324	151-0212-00	B010140		TRANSISTOR:SILICON,NPN	04713	SRF 518
Q332	151-0188-00			TRANSISTOR:SILICON,PNP	04713	SPS6868K
Q346	151-0198-00			TRANSISTOR:SILICON,NPN,SEL FROM MPS918	04713	SPS8802-1
Q348	151-0221-00	B010100	B089999	TRANSISTOR:SILICON,PNP	04713	SPS246
Q348	151-0220-03	B090000		TRANSISTOR:SILICON,PNP,SEL	04713	SPS6915
Q352	151-0223-00	B010100	B138374	TRANSISTOR:SILICON,NPN	04713	SPS8026
Q352	151-0190-00	B138375		TRANSISTOR:SILICON,NPN	07263	S032677
Q358	151-0223-00	B010100	B138374	TRANSISTOR:SILICON,NPN	04713	SPS8026
Q358	151-0190-00	B138375		TRANSISTOR:SILICON,NPN	07263	S032677
Q364	151-0190-00			TRANSISTOR:SILICON,NPN	07263	S032677
Q374	151-0190-00			TRANSISTOR:SILICON,NPN	07263	S032677
Q412	151-0441-00			TRANSISTOR:SILICON,NPN	04713	SRF501
Q416	151-0221-00			TRANSISTOR:SILICON,PNP	04713	SPS246
Q422	151-0441-00			TRANSISTOR:SILICON,NPN	04713	SRF501
Q426	151-0221-00			TRANSISTOR:SILICON,PNP	04713	SPS246
Q522	151-1042-00			SEMICON DVC SE:MATCHED PAIR FET	01295	SKA5390
Q524						
Q550	151-0221-00			TRANSISTOR:SILICON,PNP	04713	SPS246
Q552	151-0221-00			TRANSISTOR:SILICON,PNP	04713	SPS246
Q610	-----			(SEE OPTION 5)		
Q612	-----			(SEE OPTION 5)		
Q622	151-1042-00			SEMICON DVC SE:MATCHED PAIR FET	01295	SKA5390
Q624						
Q650	151-0221-00			TRANSISTOR:SILICON,PNP	04713	SPS246
Q652	151-0221-00			TRANSISTOR:SILICON,PNP	04713	SPS246
Q672	151-0221-00			TRANSISTOR:SILICON,PNP	04713	SPS246
Q678	151-0223-00	B010100	B138374	TRANSISTOR:SILICON,NPN	04713	SPS8026
Q678	151-0190-00	B138375		TRANSISTOR:SILICON,NPN	07263	S032677
Q682	151-0221-00			TRANSISTOR:SILICON,PNP	04713	SPS246
Q688	151-0223-00	B010100	B138374	TRANSISTOR:SILICON,NPN	04713	SPS8026
Q688	151-0190-00	B138375		TRANSISTOR:SILICON,NPN	07263	S032677
Q820A,B	151-0232-00			TRANSISTOR:SILICON,NPN,DUAL	07263	SP12141
Q822	151-0190-00			TRANSISTOR:SILICON,NPN	07263	S032677
Q824	151-0220-00			TRANSISTOR:SILICON,PNP	07263	S036228
Q834	151-0220-00			TRANSISTOR:SILICON,PNP	07263	S036228
Q844	151-0220-03			TRANSISTOR:SILICON,PNP,SEL	04713	SPS6915
Q852	151-0190-00			TRANSISTOR:SILICON,NPN	07263	S032677
Q854	151-0190-00			TRANSISTOR:SILICON,NPN	07263	S032677
Q856	151-0220-00			TRANSISTOR:SILICON,PNP	07263	S036228



Replaceable Electrical Parts—466 Service

Ckt No.	Tektronix Part No.	Serial/Model No. Eff	Dscont	Name & Description	Mfr Code	Mfr Part Number
Q864	151-0220-03			TRANSISTOR: SILICON, PNP, SEL	04713	SPS6915
Q866	151-0220-03			TRANSISTOR: SILICON, PNP, SEL	04713	SPS6915
Q872	151-0220-00			TRANSISTOR: SILICON, PNP	07263	S036228
Q874	151-0220-00			TRANSISTOR: SILICON, PNP	07263	S036228
Q882	151-0190-00			TRANSISTOR: SILICON, NPN	07263	S032677
Q884	151-0220-00			TRANSISTOR: SILICON, PNP	07263	S036228
Q886	151-0220-00	B010100	B102859X	TRANSISTOR: SILICON, PNP	07263	S036228
Q904	151-0220-03			TRANSISTOR: SILICON, PNP, SEL	04713	SPS6915
Q906	151-0220-03			TRANSISTOR: SILICON, PNP, SEL	04713	SPS6915
Q912	151-0190-00			TRANSISTOR: SILICON, NPN	07263	S032677
Q914	151-0190-00			TRANSISTOR: SILICON, NPN	07263	S032677
Q916	151-0220-00			TRANSISTOR: SILICON, PNP	07263	S036228
Q924	151-0220-00			TRANSISTOR: SILICON, PNP	07263	S036228
Q926	151-0220-00			TRANSISTOR: SILICON, PNP	07263	S036228
Q954	151-0220-00	B010100	B150549	TRANSISTOR: SILICON, PNP	07263	S036228
Q954	151-0220-03	B150550		TRANSISTOR: SILICON, PNP, SEL	04713	SPS6915
	-----			(SEE OPTION 5)		
Q964	151-0190-00			TRANSISTOR: SILICON, NPN	07263	S032677
Q982	151-0190-00			TRANSISTOR: SILICON, NPN	07263	S032677
Q984	151-0188-00			TRANSISTOR: SILICON, PNP	04713	SPS6868K
Q986	151-0188-00			TRANSISTOR: SILICON, PNP	04713	SPS6868K
Q1002A, B	151-0354-00			TRANSISTOR: SILICON, PNP, DUAL	32293	ITS1200A
Q1006	151-0220-00			TRANSISTOR: SILICON, PNP	07263	S036228
Q1024	151-0283-00			TRANSISTOR: SILICON, NPN	07263	S032790
Q1030	151-1025-00			TRANSISTOR: SILICON, JFE, N-CHANNEL	01295	SFB8129
Q1036	151-0127-00			TRANSISTOR: SILICON, NPN	07263	S006075
Q1038	151-0188-00			TRANSISTOR: SILICON, PNP	04713	SPS6868K
Q1062A, B	151-0354-00			TRANSISTOR: SILICON, PNP, DUAL	32293	ITS1200A
Q1064	151-0188-00			TRANSISTOR: SILICON, PNP	04713	SPS6868K
Q1066	151-0220-00			TRANSISTOR: SILICON, PNP	07263	S036228
Q1084	151-0283-00			TRANSISTOR: SILICON, NPN	07263	S032790
Q1090	151-1025-00			TRANSISTOR: SILICON, JFE, N-CHANNEL	01295	SFB8129
Q1096	151-0127-00			TRANSISTOR: SILICON, NPN	07263	S006075
Q1098	151-0188-00			TRANSISTOR: SILICON, PNP	04713	SPS6868K
Q1140	151-0302-00			TRANSISTOR: SILICON, NPN	07263	S038487
Q1170	151-0302-00			TRANSISTOR: SILICON, NPN	07263	S038487
Q1212	151-0220-00			TRANSISTOR: SILICON, PNP	07263	S036228
Q1222	151-0410-00			TRANSISTOR: SILICON, PNP	80009	151-0410-00
Q1232	151-0190-02			TRANSISTOR: SILICON, NPN	04713	SM7706
Q1236	151-0188-00			TRANSISTOR: SILICON, PNP	04713	SPS6868K
Q1242	151-0190-02			TRANSISTOR: SILICON, NPN	04713	SM7706
Q1246	151-0188-00			TRANSISTOR: SILICON, PNP	04713	SPS6868K
Q1272	151-0220-00			TRANSISTOR: SILICON, PNP	07263	S036228
Q1274	151-0406-00			TRANSISTOR: SILICON, PNP	04713	OBD
Q1276	151-0407-00			TRANSISTOR: SILICON, NPN	04713	SS2456
Q1282	151-0223-00	B010100	B138374	TRANSISTOR: SILICON, NPN	04713	SPS8026
Q1282	151-0190-00	B138375	B152499	TRANSISTOR: SILICON, NPN	07263	S032677
Q1282	151-0223-00	B152500		TRANSISTOR: SILICON, NPN	04713	SPS8026
Q1284	151-0407-00			TRANSISTOR: SILICON, NPN	04713	SS2456
Q1286	151-0406-00			TRANSISTOR: SILICON, PNP	04713	OBD
Q1362	151-0342-00			TRANSISTOR: SILICON, PNP	07263	S035928
Q1372	151-0342-00			TRANSISTOR: SILICON, PNP	07263	S035928
Q1376	151-0164-00			TRANSISTOR: SILICON, PNP	01295	SKB3334
Q1424	151-0223-00	B010100	B138374	TRANSISTOR: SILICON, NPN	04713	SPS8026
Q1424	151-0190-00	B138375	B152499	TRANSISTOR: SILICON, NPN	07263	S032677
Q1424	151-0223-00	B152500		TRANSISTOR: SILICON, NPN	04713	SPS8026
Q1428	151-0188-00			TRANSISTOR: SILICON, PNP	04713	SPS6868K

Replaceable Electrical Parts—466 Service

Ckt No.	Tektronix Part No.	Serial/Model No. Eff	Dscont	Name & Description	Mfr Code	Mfr Part Number
Q1432	151-0407-00			TRANSISTOR: SILICON, NPN	04713	SS2456
Q1436	151-0406-00			TRANSISTOR: SILICON, PNP	04713	0BD
Q1472	151-0126-00			TRANSISTOR: SILICON, NPN	04713	ST1046
Q1476	151-0301-00			TRANSISTOR: SILICON, PNP	27014	2N2907A
Q1484	151-0136-00			TRANSISTOR: SILICON, NPN	02735	35495
Q1486	151-0140-00			TRANSISTOR: SILICON, NPN	02735	36568
Q1492	151-0302-00			TRANSISTOR: SILICON, NPN	07263	S038487
Q1496	151-0301-00			TRANSISTOR: SILICON, PNP	27014	2N2907A
Q1606	-----			(SEE OPTION 7)		
Q1608	-----			(SEE OPTION 7)		
Q1622	-----			(SEE OPTION 7)		
Q1626	-----			(SEE OPTION 7)		
Q1642	-----			(SEE OPTION 7)		
Q1644	-----			(SEE OPTION 7)		
Q1652	-----			(SEE OPTION 7)		
Q1654	-----			(SEE OPTION 7)		
Q1662	-----			(SEE OPTION 7)		
Q1664	-----			(SEE OPTION 7)		
Q1698	151-0301-00	B010100	B138089X	TRANSISTOR: SILICON, PNP	27014	2N2907A
Q1716	151-0311-01			TRANSISTOR: SILICON, NPN	04713	SJE908
Q1718	151-0347-00			TRANSISTOR: SILICON, NPN	56289	2N5551
Q1732	151-0347-00			TRANSISTOR: SILICON, NPN	56289	2N5551
Q1734	151-0476-00			TRANSISTOR: SILICON, NPN	02735	68430
Q1736	151-0347-00			TRANSISTOR: SILICON, NPN	56289	2N5551
Q1752	151-0302-00	B010100	B081689	TRANSISTOR: SILICON, NPN	07263	S038487
Q1752	151-0136-00	B081690		TRANSISTOR: SILICON, NPN	02735	35495
Q1754	151-0302-00			TRANSISTOR: SILICON, NPN	07263	S038487
Q1756	151-0477-00			TRANSISTOR: SILICON, NPN	04713	SJE374
Q1762	151-0302-00			TRANSISTOR: SILICON, NPN	07263	S038487
Q1764	151-0302-00			TRANSISTOR: SILICON, NPN	07263	S038487
Q1766	151-0478-00			TRANSISTOR: SILICON, NPN	04713	SJE410
Q1772	151-0302-00			TRANSISTOR: SILICON, NPN	07263	S038487
Q1774	151-0302-00			TRANSISTOR: SILICON, NPN	07263	S038487
Q1776	151-0478-00			TRANSISTOR: SILICON, NPN	04713	SJE410
Q1780	151-0341-00			TRANSISTOR: SILICON, NPN	07263	S040065
Q1782	151-0341-00			TRANSISTOR: SILICON, NPN	07263	S040065
Q1784	151-0302-00			TRANSISTOR: SILICON, NPN	07263	S038487
Q1786	151-0302-00			TRANSISTOR: SILICON, NPN	07263	S038487
Q1788	151-0478-00			TRANSISTOR: SILICON, NPN	04713	SJE410 - \$1.15 (4/96)
Q1792	151-0390-00			TRANSISTOR: SILICON, NPN	04713	SPS3414
Q1802	151-0190-00			TRANSISTOR: SILICON, NPN	07263	S032677
Q1812	151-0188-00			TRANSISTOR: SILICON, PNP	04713	SPS6868K
Q1816	151-0188-00			TRANSISTOR: SILICON, PNP	04713	SPS6868K
Q1822	151-0190-00			TRANSISTOR: SILICON, NPN	07263	S032677
Q1832	151-0188-00			TRANSISTOR: SILICON, PNP	04713	SPS6868K
Q1834	151-0190-00			TRANSISTOR: SILICON, NPN	07263	S032677
Q1836	151-0508-00			TRANSISTOR: UJT, SI, 2N6027, TO-98	03508	2N6027
Q1838	151-0508-00			TRANSISTOR: UJT, SI, 2N6027, TO-98	03508	2N6027
Q1842	151-0508-00			TRANSISTOR: UJT, SI, 2N6027, TO-98	03508	2N6027
Q1852	151-0508-00			TRANSISTOR: UJT, SI, 2N6027, TO-98	03508	2N6027
Q1864	151-0508-00			TRANSISTOR: UJT, SI, 2N6027, TO-98	03508	2N6027
Q1872	151-0190-00			TRANSISTOR: SILICON, NPN	07263	S032677
Q1938	151-0410-00			TRANSISTOR: SILICON, PNP	80009	151-0410-00
Q1942	151-0410-00			TRANSISTOR: SILICON, PNP	80009	151-0410-00
Q1944	151-0347-00	B010100	B092809	TRANSISTOR: SILICON, NPN	56289	2N5551
Q1944	151-0292-00	B092810		TRANSISTOR: SILICON, NPN	01295	A5T5058
Q1948	151-0347-00	B010100	B092809	TRANSISTOR: SILICON, NPN	56289	2N5551
Q1948	151-0292-00	B092810		TRANSISTOR: SILICON, NPN	01295	A5T5058

Replaceable Electrical Parts—466 Service

Ckt No.	Tektronix Part No.	Serial/Model No. Eff	Dscont	Name & Description	Mfr Code	Mfr Part Number
Q1952	151-0188-00			TRANSISTOR: SILICON, PNP	04713	SPS6868K
Q1956	151-0347-00	B010100	B092809	TRANSISTOR: SILICON, NPN	56289	2N5551
Q1956	151-0292-00	B092810		TRANSISTOR: SILICON, NPN	01295	A5T5058
Q1962	151-0444-00			TRANSISTOR: SILICON, NPN	80009	151-0444-00
Q1964	151-0444-00			TRANSISTOR: SILICON, NPN	80009	151-0444-00
Q1966	151-0444-00			TRANSISTOR: SILICON, NPN	80009	151-0444-00
Q1968	151-0444-00			TRANSISTOR: SILICON, NPN	80009	151-0444-00
Q1992	151-0410-00			TRANSISTOR: SILICON, PNP	80009	151-0410-00
Q1994	151-0410-00			TRANSISTOR: SILICON, PNP	80009	151-0410-00
Q1996	151-0347-00	B010100	B092809	TRANSISTOR: SILICON, NPN	56289	2N5551
Q1996	151-0292-00	B092810		TRANSISTOR: SILICON, NPN	01295	A5T5058
Q1998	151-0347-00	B010100	B092809	TRANSISTOR: SILICON, NPN	56289	2N5551
Q1998	151-0292-00	B092810		TRANSISTOR: SILICON, NPN	01295	A5T5058
Q2022	151-0410-00			TRANSISTOR: SILICON, PNP	80009	151-0410-00
Q2024	151-0347-00	B010100	B092809	TRANSISTOR: SILICON, NPN	56289	2N5551
Q2024	151-0292-00	B092810		TRANSISTOR: SILICON, NPN	01295	A5T5058
Q2026	151-0347-00	B010100	B092809	TRANSISTOR: SILICON, NPN	56289	2N5551
Q2026	151-0292-00	B092810		TRANSISTOR: SILICON, NPN	01295	A5T5058
Q2032	151-0410-00			TRANSISTOR: SILICON, PNP	80009	151-0410-00
Q2036	151-0347-00			TRANSISTOR: SILICON, NPN	56289	2N5551
Q2042	151-0410-00			TRANSISTOR: SILICON, PNP	80009	151-0410-00
Q2046	151-0347-00			TRANSISTOR: SILICON, NPN	56289	2N5551
Q2054	151-0410-00			TRANSISTOR: SILICON, PNP	80009	151-0410-00
Q2056	151-0347-00			TRANSISTOR: SILICON, NPN	56289	2N5551
Q2072	151-0190-00			TRANSISTOR: SILICON, NPN	07263	S032677
Q2074	151-0410-00			TRANSISTOR: SILICON, PNP	80009	151-0410-00
Q2078	151-0347-00			TRANSISTOR: SILICON, NPN	56289	2N5551
Q2092	151-0190-00			TRANSISTOR: SILICON, NPN	07263	S032677
Q2094	151-0188-00			TRANSISTOR: SILICON, PNP	04713	SPS6868K
Q2802	-----			(SEE OPTION 5)		
Q2803	-----			(SEE OPTION 5)		
Q2813	-----			(SEE OPTION 5)		
Q2824	-----			(SEE OPTION 5)		
Q2834	-----			(SEE OPTION 5)		
Q2854	-----			(SEE OPTION 5)		
Q2863	-----			(SEE OPTION 5)		
Q8067	151-0301-00	XB138090		TRANSISTOR: SILICON, PNP	27014	2N2907A
R10(2)	315-0750-00			RES., FXD, CMPSN: 75 OHM, 5%, 0.25W	01121	CB7505
R12	-----			(SEE OPTION 5)		
R14	315-0105-00			RES., FXD, CMPSN: 1M OHM, 5%, 0.25W	01121	CB1055
R15	315-0220-00			RES., FXD, CMPSN: 22 OHM, 5%, 0.25W	01121	CB2205
R20(2)	315-0101-00			RES., FXD, CMPSN: 100 OHM, 5%, 0.25W	01121	CB1015
R31(2)	317-0100-00	XB113350		RES., FXD, CMPSN: 10 OHM, 5%, 0.125W (NOMINAL VALUE, SELECTED)	01121	BB1005
R32(2)	315-0360-00	XB113350		RES., FXD, CMPSN: 36 OHM, 5%, 0.25W (NOMINAL VALUE, SELECTED)	01121	CB3605
R33(2)	317-0220-00	XB113350		RES., FXD, CMPSN: 22 OHM, 5%, 0.125W (NOMINAL VALUE, SELECTED)	01121	BB2205
R34(2)	SELECTED	XB113350				
R36(2)	317-0100-00	XB113350		RES., FXD, CMPSN: 10 OHM, 5%, 0.125W (NOMINAL VALUE, SELECTED)	01121	BB1005
R39	321-0481-00			RES., FXD, FILM: 1M OHM, 1%, 0.125W	24546	NA4D1004F
R42(2)	317-0474-00			RES., FXD, CMPSN: 470K OHM, 5%, 0.125W	01121	BB4745
R45(2)	315-0300-00			RES., FXD, CMPSN: 30 OHM, 5%, 0.25W	01121	CB3005
R52	315-0823-00			RES., FXD, CMPSN: 82K OHM, 5%, 0.25W	01121	CB8235
R53	315-0202-00			RES., FXD, CMPSN: 2K OHM, 5%, 0.25W	01121	CB2025
R54	315-0681-00			RES., FXD, CMPSN: 680 OHM, 5%, 0.25W	01121	CB6815

Ckt No.	Tektronix Part No.	Serial/Model No. Eff	Discont	Name & Description	Mfr Code	Mfr Part Number
R55	315-0100-00			RES., FXD, CMPSN: 10 OHM, 5%, 0.25W	01121	CB1005
R58	315-0154-00			RES., FXD, CMPSN: 150K OHM, 5%, 0.25W	01121	CB1545
R62	315-0823-00			RES., FXD, CMPSN: 82K OHM, 5%, 0.25W	01121	CB8235
R63	315-0202-00			RES., FXD, CMPSN: 2K OHM, 5%, 0.25W	01121	CB2025
R64	315-0681-00			RES., FXD, CMPSN: 680 OHM, 5%, 0.25W	01121	CB6815
R65	315-0100-00			RES., FXD, CMPSN: 10 OHM, 5%, 0.25W	01121	CB1005
R68	315-0154-00			RES., FXD, CMPSN: 150K OHM, 5%, 0.25W	01121	CB1545
R72	315-0301-00			RES., FXD, CMPSN: 300 OHM, 5%, 0.25W	01121	CB3015
R73	321-0030-00			RES., FXD, FILM: 20 OHM, 1%, 0.125W	91637	MFF1816G20R00F
R74	321-0030-00			RES., FXD, FILM: 20 OHM, 1%, 0.125W	91637	MFF1816G20R00F
R75	315-0112-00			RES., FXD, CMPSN: 1.1K OHM, 5%, 0.25W	01121	CB1125
R76	321-0229-00			RES., FXD, FILM: 2.37K OHM, 1%, 0.125W	91637	MFF1816G23700F
R78	321-0078-00	B010100	B148915	RES., FXD, FILM: 63.4 OHM, 1%, 0.125W	91637	MFF1816G63R40F
R78	321-0070-00	B148916		RES., FXD, FILM: 52.3 OHM, 1%, 0.125W (NOMINAL VALUE, SELECTED)	16299	NA55D52R3F
R82	315-0512-00			RES., FXD, CMPSN: 5.1K OHM, 5%, 0.25W	01121	CB5125
R83	321-0229-00			RES., FXD, FILM: 2.37K OHM, 1%, 0.125W	91637	MFF1816G23700F
R84	311-1555-00			RES., VAR, NONWIR: 100K OHM, 20%, 0.5W	73138	91-77-0
R85	315-0123-00			RES., FXD, CMPSN: 12K OHM, 5%, 0.25W	01121	CB1235
R86	315-0151-00			RES., FXD, CMPSN: 150 OHM, 5%, 0.25W	01121	CB1515
R87	315-0112-00			RES., FXD, CMPSN: 1.1K OHM, 5%, 0.25W	01121	CB1125
R91	321-0085-00			RES., FXD, FILM: 75 OHM, 1%, 0.125W	91637	MFF1816G75R00F
R92	311-1225-00			RES., VAR, NONWIR: 1K OHM, 20%, 0.50W	32997	3386F-T04-102
R93	321-0085-00			RES., FXD, FILM: 75 OHM, 1%, 0.125W	91637	MFF1816G75R00F
R94	321-0064-00			RES., FXD, FILM: 45.3 OHM, 1%, 0.125W	91637	MFF1816G45R30F
R95	321-0026-00			RES., FXD, FILM: 18.2 OHM, 1%, 0.125W	91637	MFF1816G18R20F
R96	311-1364-00			RES., VAR, NONWIR: 1K OHM, 10%, 0.50W (FURNISHED AS A UNIT WITH S96)	01121	10M821
R97	321-0026-00			RES., FXD, FILM: 18.2 OHM, 1%, 0.125W	91637	MFF1816G18R20F
R98	321-0064-00			RES., FXD, FILM: 45.3 OHM, 1%, 0.125W	91637	MFF1816G45R30F
R102	321-0199-00			RES., FXD, FILM: 1.15K OHM, 1%, 0.125W	91637	MFF1816G11500F
R103	321-0199-00			RES., FXD, FILM: 1.15K OHM, 1%, 0.125W	91637	MFF1816G11500F
R104	321-0109-00			RES., FXD, FILM: 133 OHM, 1%, 0.125W	91637	MFF1816G133R0F
R105	321-0109-00			RES., FXD, FILM: 133 OHM, 1%, 0.125W	91637	MFF1816G133R0F
R106	315-0101-00			RES., FXD, CMPSN: 100 OHM, 5%, 0.25W	01121	CB1015
R107	311-1267-00			RES., VAR, NONWIR: 5K OHM, 10%, 0.50W	32997	3329P-L58-502
R108	311-1466-00			RES., VAR, NONWIR: 2K OHM, 20%, 0.50W	73138	72-39-0
R111	315-0301-00			RES., FXD, CMPSN: 300 OHM, 5%, 0.25W	01121	CB3015
R114	321-0068-00			RES., FXD, FILM: 49.9 OHM, 1%, 0.125W	91637	MFF1816G49R90F
R115	321-0132-00			RES., FXD, FILM: 232 OHM, 1%, 0.125W	91637	MFF1816G232R0F
R116	321-0132-00			RES., FXD, FILM: 232 OHM, 1%, 0.125W	91637	MFF1816G232R0F
R117	321-0068-00			RES., FXD, FILM: 49.9 OHM, 1%, 0.125W	91637	MFF1816G49R90F
R118	315-0301-00			RES., FXD, CMPSN: 300 OHM, 5%, 0.25W	01121	CB3015
R119	315-0274-00			RES., FXD, CMPSN: 270K OHM, 5%, 0.25W	01121	CB2745
R124	315-0182-00			RES., FXD, CMPSN: 1.8K OHM, 5%, 0.25W	01121	CB1825
R126	315-0151-00			RES., FXD, CMPSN: 150 OHM, 5%, 0.25W	01121	CB1515
R128	321-0114-00			RES., FXD, FILM: 150 OHM, 1%, 0.125W	91637	MFF1816G150R0F
R129	321-0114-00			RES., FXD, FILM: 150 OHM, 1%, 0.125W	91637	MFF1816G150R0F
R132	321-0172-00			RES., FXD, FILM: 604 OHM, 1%, 0.125W	91637	MFF1816G604R0F
R133	321-0089-00			RES., FXD, FILM: 82.5 OHM, 1%, 0.125W	91637	MFF1816G82R50F
R134	321-0172-00			RES., FXD, FILM: 604 OHM, 1%, 0.125W	91637	MFF1816G604R0F
R136	315-0222-00			RES., FXD, CMPSN: 2.2K OHM, 5%, 0.25W	01121	CB2225
R137	315-0101-00			RES., FXD, CMPSN: 100 OHM, 5%, 0.25W	01121	CB1015
R138	315-0222-00			RES., FXD, CMPSN: 2.2K OHM, 5%, 0.25W	01121	CB2225
R141	315-0390-00			RES., FXD, CMPSN: 39 OHM, 5%, 0.25W	01121	CB3905
R142	315-0431-00			RES., FXD, CMPSN: 430 OHM, 5%, 0.25W	01121	CB4315
R143	321-0195-00			RES., FXD, FILM: 1.05K OHM, 1%, 0.125W	91637	MFF1816G10500F

Replaceable Electrical Parts—466 Service

Ckt No.	Tektronix Part No.	Serial/Model No. Eff	Dscont	Name & Description	Mfr Code	Mfr Part Number
R144	321-0087-00			RES., FXD, FILM: 78.7 OHM, 1%, 0.125W	91637	MFF1816G78R70F
R145	321-0195-00			RES., FXD, FILM: 1.05K OHM, 1%, 0.125W	91637	MFF1816G10500F
R146	315-0390-00			RES., FXD, CMPSN: 39 OHM, 5%, 0.25W	01121	CB3905
R147	315-0331-00			RES., FXD, CMPSN: 330 OHM, 5%, 0.25W	01121	CB3315
R148	321-0149-00			RES., FXD, FILM: 348 OHM, 1%, 0.125W	91637	MFF1816G348R0F
R151	321-0201-00			RES., FXD, FILM: 1.21K OHM, 1%, 0.125W	91637	MFF1816G12100F
R152	311-1224-00			RES., VAR, NONWIR: 500 OHM, 20%, 0.50W	32997	3386F-T04-501
R153	315-0331-00			RES., FXD, CMPSN: 330 OHM, 5%, 0.25W	01121	CB3315
R154	315-0101-00			RES., FXD, CMPSN: 100 OHM, 5%, 0.25W	01121	CB1015
R155	321-0064-00			RES., FXD, FILM: 45.3 OHM, 1%, 0.125W	91637	MFF1816G45R30F
R156	315-0751-00			RES., FXD, CMPSN: 750 OHM, 5%, 0.25W	01121	CB7515
R157	315-0331-00			RES., FXD, CMPSN: 330 OHM, 5%, 0.25W	01121	CB3315
R158	321-0064-00			RES., FXD, FILM: 45.3 OHM, 1%, 0.125W	91637	MFF1816G45R30F
R161	315-0271-00			RES., FXD, CMPSN: 270 OHM, 5%, 0.25W	01121	CB2715
R162	315-0271-00			RES., FXD, CMPSN: 270 OHM, 5%, 0.25W	01121	CB2715
R163	311-1311-00			RES., VAR, NONWIR: 1K OHM, 20%, 1W	01121	73M4G048L102M
R164	321-0190-00			RES., FXD, FILM: 931 OHM, 1%, 0.125W	91637	MFF1816G931R0F
R165	315-0392-00			RES., FXD, CMPSN: 3.9K OHM, 5%, 0.25W	01121	CB3925
R166	311-1559-00			RES., VAR, NONWIR: 10K OHM, 20%, 0.50W	73138	91-81-0
R167	315-0392-00			RES., FXD, CMPSN: 3.9K OHM, 5%, 0.25W	01121	CB3925
R172	315-0301-00			RES., FXD, CMPSN: 300 OHM, 5%, 0.25W	01121	CB3015
R173	321-0030-00			RES., FXD, FILM: 20 OHM, 1%, 0.125W	91637	MFF1816G20R00F
R174	321-0030-00			RES., FXD, FILM: 20 OHM, 1%, 0.125W	91637	MFF1816G20R00F
R175	315-0112-00			RES., FXD, CMPSN: 1.1K OHM, 5%, 0.25W	01121	CB1125
R176	321-0229-00			RES., FXD, FILM: 2.37K OHM, 1%, 0.125W	91637	MFF1816G23700F
R178	321-0078-00	B010100	B148915	RES., FXD, FILM: 63.4 OHM, 1%, 0.125W	91637	MFF1816G63R40F
R178	321-0070-00	B148916		RES., FXD, FILM: 52.3 OHM, 1%, 0.125W (NOMINAL VALUE, SELECTED)	16299	NA55D52R3F
R182	315-0512-00			RES., FXD, CMPSN: 5.1K OHM, 5%, 0.25W	01121	CB5125
R183	321-0229-00			RES., FXD, FILM: 2.37K OHM, 1%, 0.125W	91637	MFF1816G23700F
R184	311-1555-00			RES., VAR, NONWIR: 100K OHM, 20%, 0.5W	73138	91-77-0
R185	315-0123-00			RES., FXD, CMPSN: 12K OHM, 5%, 0.25W	01121	CB1235
R186	315-0151-00			RES., FXD, CMPSN: 150 OHM, 5%, 0.25W	01121	CB1515
R187	315-0112-00			RES., FXD, CMPSN: 1.1K OHM, 5%, 0.25W	01121	CB1125
R191	321-0085-00			RES., FXD, FILM: 75 OHM, 1%, 0.125W	91637	MFF1816G75R00F
R192	311-1225-00			RES., VAR, NONWIR: 1K OHM, 20%, 0.50W	32997	3386F-T04-102
R193	321-0085-00			RES., FXD, FILM: 75 OHM, 1%, 0.125W	91637	MFF1816G75R00F
R194	321-0064-00			RES., FXD, FILM: 45.3 OHM, 1%, 0.125W	91637	MFF1816G45R30F
R195	321-0026-00			RES., FXD, FILM: 18.2 OHM, 1%, 0.125W	91637	MFF1816G18R20F
R196	311-1364-00			RES., VAR, NONWIR: 1K OHM, 10%, 0.50W (FURNISHED AS A UNIT WITH S196)	01121	10M821
R197	321-0026-00			RES., FXD, FILM: 18.2 OHM, 1%, 0.125W	91637	MFF1816G18R20F
R198	321-0064-00			RES., FXD, FILM: 45.3 OHM, 1%, 0.125W	91637	MFF1816G45R30F
R202	321-0199-00			RES., FXD, FILM: 1.15K OHM, 1%, 0.125W	91637	MFF1816G11500F
R203	321-0199-00			RES., FXD, FILM: 1.15K OHM, 1%, 0.125W	91637	MFF1816G11500F
R204	321-0109-00			RES., FXD, FILM: 133 OHM, 1%, 0.125W	91637	MFF1816G133R0F
R205	321-0109-00			RES., FXD, FILM: 133 OHM, 1%, 0.125W	91637	MFF1816G133R0F
R206	315-0101-00			RES., FXD, CMPSN: 100 OHM, 5%, 0.25W	01121	CB1015
R207	311-1267-00			RES., VAR, NONWIR: 5K OHM, 10%, 0.50W	32997	3329P-L58-502
R208	311-1466-00			RES., VAR, NONWIR: 2K OHM, 20%, 0.50W	73138	72-39-0
R211	315-0301-00			RES., FXD, CMPSN: 300 OHM, 5%, 0.25W	01121	CB3015
R212	311-1559-00			RES., VAR, NONWIR: 10K OHM, 20%, 0.50W	73138	91-81-0
R213	315-0103-00			RES., FXD, CMPSN: 10K OHM, 5%, 0.25W	01121	CB1035
R214	321-0068-00			RES., FXD, FILM: 49.9 OHM, 1%, 0.125W	91637	MFF1816G49R90F
R215	321-0132-00			RES., FXD, FILM: 232 OHM, 1%, 0.125W	91637	MFF1816G232R0F
R216	321-0132-00			RES., FXD, FILM: 232 OHM, 1%, 0.125W	91637	MFF1816G232R0F
R217	321-0068-00			RES., FXD, FILM: 49.9 OHM, 1%, 0.125W	91637	MFF1816G49R90F

Ckt No.	Tektronix Part No.	Serial/Model No. Eff	Dscont	Name & Description	Mfr Code	Mfr Part Number
R218	315-0301-00			RES., FXD, CMPSN: 300 OHM, 5%, 0.25W	01121	CB3015
R219	315-0274-00			RES., FXD, CMPSN: 270K OHM, 5%, 0.25W	01121	CB2745
R220	315-0101-00			RES., FXD, CMPSN: 100 OHM, 5%, 0.25W	01121	CB1015
R221	315-0751-00			RES., FXD, CMPSN: 750 OHM, 5%, 0.25W	01121	CB7515
R222	315-0101-00			RES., FXD, CMPSN: 100 OHM, 5%, 0.25W	01121	CB1015
R223	315-0182-00			RES., FXD, CMPSN: 1.8K OHM, 5%, 0.25W	01121	CB1825
R224	315-0181-00			RES., FXD, CMPSN: 180 OHM, 5%, 0.25W	01121	CB1815
R225	315-0101-00			RES., FXD, CMPSN: 100 OHM, 5%, 0.25W	01121	CB1015
R226	315-0181-00			RES., FXD, CMPSN: 180 OHM, 5%, 0.25W	01121	CB1815
R227	315-0182-00			RES., FXD, CMPSN: 1.8K OHM, 5%, 0.25W	01121	CB1825
R228	321-0114-00			RES., FXD, FILM: 150 OHM, 1%, 0.125W	91637	MFF1816G150ROF
R229	321-0114-00			RES., FXD, FILM: 150 OHM, 1%, 0.125W	91637	MFF1816G150ROF
R232	321-0172-00			RES., FXD, FILM: 604 OHM, 1%, 0.125W	91637	MFF1816G604ROF
R233	321-0089-00			RES., FXD, FILM: 82.5 OHM, 1%, 0.125W	91637	MFF1816G82R50F
R234	321-0172-00			RES., FXD, FILM: 604 OHM, 1%, 0.125W	91637	MFF1816G604ROF
R236	315-0222-00			RES., FXD, CMPSN: 2.2K OHM, 5%, 0.25W	01121	CB2225
R237	315-0101-00			RES., FXD, CMPSN: 100 OHM, 5%, 0.25W	01121	CB1015
R238	315-0222-00			RES., FXD, CMPSN: 2.2K OHM, 5%, 0.25W	01121	CB2225
R241	315-0390-00			RES., FXD, CMPSN: 39 OHM, 5%, 0.25W	01121	CB3905
R242	315-0431-00			RES., FXD, CMPSN: 430 OHM, 5%, 0.25W	01121	CB4315
R243	321-0195-00			RES., FXD, FILM: 1.05K OHM, 1%, 0.125W	91637	MFF1816G10500F
R244	321-0087-00			RES., FXD, FILM: 78.7 OHM, 1%, 0.125W	91637	MFF1816G78R70F
R245	321-0195-00			RES., FXD, FILM: 1.05K OHM, 1%, 0.125W	91637	MFF1816G10500F
R246	315-0390-00			RES., FXD, CMPSN: 39 OHM, 5%, 0.25W	01121	CB3905
R247	315-0331-00			RES., FXD, CMPSN: 330 OHM, 5%, 0.25W	01121	CB3315
R248	321-0149-00			RES., FXD, FILM: 348 OHM, 1%, 0.125W	91637	MFF1816G348ROF
R251	321-0201-00			RES., FXD, FILM: 1.21K OHM, 1%, 0.125W	91637	MFF1816G12100F
R252	311-1224-00			RES., VAR, NONWIR: 500 OHM, 20%, 0.50W	32997	3386F-T04-501
R253	315-0751-00			RES., FXD, CMPSN: 750 OHM, 5%, 0.25W	01121	CB7515
R255	321-0064-00			RES., FXD, FILM: 45.3 OHM, 1%, 0.125W	91637	MFF1816G45R30F
R261	315-0271-00			RES., FXD, CMPSN: 270 OHM, 5%, 0.25W	01121	CB2715
R262	315-0271-00			RES., FXD, CMPSN: 270 OHM, 5%, 0.25W	01121	CB2715
R263	311-1311-00			RES., VAR, NONWIR: 1K OHM, 20%, 1W	01121	73M4G048L102M
R264	321-0190-00			RES., FXD, FILM: 931 OHM, 1%, 0.125W	91637	MFF1816G931ROF
R265	315-0392-00			RES., FXD, CMPSN: 3.9K OHM, 5%, 0.25W	01121	CB3925
R266	311-1559-00			RES., VAR, NONWIR: 10K OHM, 20%, 0.50W	73138	91-81-0
R267	315-0392-00			RES., FXD, CMPSN: 3.9K OHM, 5%, 0.25W	01121	CB3925
R302	311-1263-00			RES., VAR, NONWIR: 1K OHM, 10%, 0.50W	32997	3329P-L58-102
R304	315-0751-00			RES., FXD, CMPSN: 750 OHM, 5%, 0.25W	01121	CB7515
R308	315-0511-00			RES., FXD, CMPSN: 510 OHM, 5%, 0.25W	01121	CB5115
R312	311-1263-00			RES., VAR, NONWIR: 1K OHM, 10%, 0.50W	32997	3329P-L58-102
R314	315-0751-00			RES., FXD, CMPSN: 750 OHM, 5%, 0.25W	01121	CB7515
R318	315-0511-00			RES., FXD, CMPSN: 510 OHM, 5%, 0.25W	01121	CB5115
R321	321-0193-00			RES., FXD, FILM: 1K OHM, 1%, 0.125W	91637	MFF1816G10000F
R322	321-0193-00			RES., FXD, FILM: 1K OHM, 1%, 0.125W	91637	MFF1816G10000F
R323	321-0134-00			RES., FXD, FILM: 243 OHM, 1%, 0.125W	91637	MFF1816G243ROF
R324	321-0134-00			RES., FXD, FILM: 243 OHM, 1%, 0.125W	91637	MFF1816G243ROF
R325	321-0126-00			RES., FXD, FILM: 200 OHM, 1%, 0.125W	91637	MFF1816G200ROF
R326	323-0161-00			RES., FXD, FILM: 464 OHM, 1%, 0.50W	75042	CECT0-4640F
R327	321-0126-00			RES., FXD, FILM: 200 OHM, 1%, 0.125W	91637	MFF1816G200ROF
R328	315-0750-00			RES., FXD, CMPSN: 75 OHM, 5%, 0.25W	01121	CB7505
R329	315-0750-00			RES., FXD, CMPSN: 75 OHM, 5%, 0.25W	01121	CB7505
R331	323-0106-00			RES., FXD, FILM: 124 OHM, 1%, 0.50W	91637	MFF1226G124ROF
R332	315-0101-00			RES., FXD, CMPSN: 100 OHM, 5%, 0.25W	01121	CB1015
R334	315-0821-00			RES., FXD, CMPSN: 820 OHM, 5%, 0.25W	01121	CB8215
R335	321-0065-00			RES., FXD, FILM: 46.4 OHM, 1%, 0.125W	91637	MFF1816G46R40F
R336	321-0065-00			RES., FXD, FILM: 46.4 OHM, 1%, 0.125W	91637	MFF1816G46R40F

Replaceable Electrical Parts—466 Service

Ckt No.	Tektronix Part No.	Serial/Model No. Eff	Dscont	Name & Description	Mfr Code	Mfr Part Number
R341	311-1224-00			RES., VAR, NONWIR: 500 OHM, 20%, 0.50W	32997	3386F-T04-501
R342	321-0049-00			RES., FXD, FILM: 31.6 OHM, 1%, 0.125W	91637	MFF1816G31R60F
R343	315-0271-00			RES., FXD, CMPSN: 270 OHM, 5%, 0.25W	01121	CB2715
R344	321-0177-00			RES., FXD, FILM: 681 OHM, 1%, 0.125W	91637	MFF1816G681R0F
R345	321-0206-00			RES., FXD, FILM: 1.37K OHM, 1%, 0.125W	91637	MFF1816G13700F
R346	323-0156-00			RES., FXD, FILM: 412 OHM, 1%, 0.50W	75042	CECTO-4120F
R347	321-0126-00			RES., FXD, FILM: 200 OHM, 1%, 0.125W	91637	MFF1816G200R0F
R348	315-0511-00			RES., FXD, CMPSN: 510 OHM, 5%, 0.25W	01121	CB5115
R349	321-0068-00			RES., FXD, FILM: 49.9 OHM, 1%, 0.125W	91637	MFF1816G49R90F
R351	315-0752-00			RES., FXD, CMPSN: 7.5K OHM, 5%, 0.25W	01121	CB7525
R352	321-0057-00			RES., FXD, FILM: 38.3 OHM, 1%, 0.125W	91637	MFF1816G38R30F
R355	315-0683-00			RES., FXD, CMPSN: 68K OHM, 5%, 0.25W	01121	CB6835
R356	315-0101-00			RES., FXD, CMPSN: 100 OHM, 5%, 0.25W	01121	CB1015
R357	315-0101-00			RES., FXD, CMPSN: 100 OHM, 5%, 0.25W	01121	CB1015
R358	315-0202-00			RES., FXD, CMPSN: 2K OHM, 5%, 0.25W	01121	CB2025
R359	315-0272-00			RES., FXD, CMPSN: 2.7K OHM, 5%, 0.25W	01121	CB2725
R361	321-0193-00			RES., FXD, FILM: 1K OHM, 1%, 0.125W	91637	MFF1816G10000F
R362	321-0135-00			RES., FXD, FILM: 249 OHM, 1%, 0.125W	91637	MFF1816G249R0F
R364	321-0211-00			RES., FXD, FILM: 1.54K OHM, 1%, 0.125W	91637	MFF1816G15400F
R365	321-0210-00			RES., FXD, FILM: 1.5K OHM, 1%, 0.125W	91637	MFF1816G15000F
R367	315-0151-00			RES., FXD, CMPSN: 150 OHM, 5%, 0.25W	01121	CB1515
R368	321-0117-00			RES., FXD, FILM: 162 OHM, 1%, 0.125W	91637	MFF1816G162R0F
R370	315-0622-00			RES., FXD, CMPSN: 6.2K OHM, 5%, 0.25W	01121	CB6225
R371	321-0193-00			RES., FXD, FILM: 1K OHM, 1%, 0.125W	91637	MFF1816G10000F
R372	321-0135-00			RES., FXD, FILM: 249 OHM, 1%, 0.125W	91637	MFF1816G249R0F
R374	321-0211-00			RES., FXD, FILM: 1.54K OHM, 1%, 0.125W	91637	MFF1816G15400F
R375	321-0210-00			RES., FXD, FILM: 1.5K OHM, 1%, 0.125W	91637	MFF1816G15000F
R377	315-0151-00			RES., FXD, CMPSN: 150 OHM, 5%, 0.25W	01121	CB1515
R378	321-0117-00			RES., FXD, FILM: 162 OHM, 1%, 0.125W	91637	MFF1816G162R0F
R402	321-0176-00			RES., FXD, FILM: 665 OHM, 1%, 0.125W	91637	MFF1816G665R0F
R403	321-0176-00			RES., FXD, FILM: 665 OHM, 1%, 0.125W	91637	MFF1816G665R0F
R404	315-0242-00	B010100	B136059	RES., FXD, CMPSN: 2.4K OHM, 5%, 0.25W	01121	CB2425
R404	315-0512-00	B136060		RES., FXD, CMPSN: 5.1K OHM, 5%, 0.25W (NOM VALUE, SELECTED. 2.4K OHM MIN., 10K OHM MAX)	01121	CB5125
R405	321-0209-00			RES., FXD, FILM: 1.47K OHM, 1%, 0.125W	91637	MFF1816G14700F
R406	321-0134-00			RES., FXD, FILM: 243 OHM, 1%, 0.125W	91637	MFF1816G243R0F
R407	321-0075-00			RES., FXD, FILM: 59 OHM, 1%, 0.125W	91637	MFF1816G59R00F
R408	321-0075-00			RES., FXD, FILM: 59 OHM, 1%, 0.125W	91637	MFF1816G59R00F
R409	321-0162-00			RES., FXD, FILM: 475 OHM, 1%, 0.125W	91637	MFF1816G475R0F
R411	321-0087-00			RES., FXD, FILM: 78.7 OHM, 1%, 0.125W	91637	MFF1816G78R70F
R412	321-0068-00			RES., FXD, FILM: 49.9 OHM, 1%, 0.125W	91637	MFF1816G49R90F
R413	315-0391-00			RES., FXD, CMPSN: 390 OHM, 5%, 0.25W	01121	CB3915
R414	321-0076-00			RES., FXD, FILM: 60.4 OHM, 1%, 0.125W	91637	MFF1816G60R40F
R415	311-1248-00			RES., VAR, NONWIR: 500 OHM, 10%, 0.50W	73138	72-23-0
R416	321-0058-00			RES., FXD, FILM: 39.2 OHM, 1%, 0.125W	91637	MFF1816G39R20F
R417	321-0157-00			RES., FXD, FILM: 422 OHM, 1%, 0.125W	91637	MFF1816G422R0F
R418	315-0270-00			RES., FXD, CMPSN: 27 OHM, 5%, 0.25W	01121	CB2705
R421	315-0911-00			RES., FXD, CMPSN: 910 OHM, 5%, 0.25W	01121	CB9115
R422	321-0068-00			RES., FXD, FILM: 49.9 OHM, 1%, 0.125W	91637	MFF1816G49R90F
R423	315-0391-00			RES., FXD, CMPSN: 390 OHM, 5%, 0.25W	01121	CB3915
R424	321-0076-00			RES., FXD, FILM: 60.4 OHM, 1%, 0.125W	91637	MFF1816G60R40F
R425	315-0270-00			RES., FXD, CMPSN: 27 OHM, 5%, 0.25W	01121	CB2705
R426	321-0058-00			RES., FXD, FILM: 39.2 OHM, 1%, 0.125W	91637	MFF1816G39R20F
R427	321-0157-00			RES., FXD, FILM: 422 OHM, 1%, 0.125W	91637	MFF1816G422R0F
R428	311-1248-00			RES., VAR, NONWIR: 500 OHM, 10%, 0.50W	73138	72-23-0
R433	315-0201-00			RES., FXD, CMPSN: 200 OHM, 5%, 0.25W	01121	CB2015
R434	315-0392-00			RES., FXD, CMPSN: 3.9K OHM, 5%, 0.25W	01121	CB3925

Ckt No.	Tektronix Part No.	Serial/Model No. Eff	Dscont	Name & Description	Mfr Code	Mfr Part Number
R435	321-0068-00			RES., FXD, FILM: 49.9 OHM, 1%, 0.125W	91637	MFF1816G49R90F
R436	321-0068-00			RES., FXD, FILM: 49.9 OHM, 1%, 0.125W	91637	MFF1816G49R90F
R437	315-0621-00			RES., FXD, CMPSN: 620 OHM, 5%, 0.25W	01121	CB6215
R438	315-0621-00			RES., FXD, CMPSN: 620 OHM, 5%, 0.25W	01121	CB6215
R442	321-0178-00			RES., FXD, FILM: 698 OHM, 1%, 0.125W	91637	MFF1816G698ROF
R443	321-0178-00			RES., FXD, FILM: 698 OHM, 1%, 0.125W	91637	MFF1816G698ROF
R444	311-1230-00			RES., VAR, NONWIR: 20K OHM, 20%, 0.50W	32997	3386F-T04-203
R445	311-1227-00			RES., VAR, NONWIR: 5K OHM, 20%, 0.50W	32997	3386F-T04-502
R446	311-1227-00	B010100	B010139	RES., VAR, NONWIR: 5K OHM, 20%, 0.50W	32997	3386F-T04-502
R446	311-1228-00	B010140		RES., VAR, NONWIR: 10K OHM, 20%, 0.50W	32997	3386F-T04-103
R447	315-0472-00	B010100	B071669	RES., FXD, CMPSN: 4.7K OHM, 5%, 0.25W	01121	CB4725
R447	315-0103-00	B071670		RES., FXD, CMPSN: 10K OHM, 5%, 0.25W	01121	CB1035
R453	311-1227-00			RES., VAR, NONWIR: 5K OHM, 20%, 0.50W	32997	3386F-T04-502
R454	321-0073-00			RES., FXD, FILM: 56.2 OHM, 1%, 0.125W	91637	MFF1816G56R20F
R455	311-1244-00	B010100	B071669	RES., VAR, NONWIR: 100 OHM, 10%, 0.50W	32997	3386X-T07-101
R455	311-1236-00	B071670		RES., VAR, NONWIR: 250 OHM, 10%, 0.50W	73138	72-22-0
R456	321-0073-00			RES., FXD, FILM: 56.2 OHM, 1%, 0.125W	91637	MFF1816G56R20F
R457	321-0113-00			RES., FXD, FILM: 147 OHM, 1%, 0.125W	91637	MFF1816G147ROF
R462	315-0360-00			RES., FXD, CMPSN: 36 OHM, 5%, 0.25W	01121	CB3605
R463	321-0052-00			RES., FXD, FILM: 34 OHM, 1%, 0.125W	91637	MFF1816G34R00F
R464	321-0052-00			RES., FXD, FILM: 34 OHM, 1%, 0.125W	91637	MFF1816G34R00F
R465	321-0080-00			RES., FXD, FILM: 66.5 OHM, 1%, 0.125W	91637	MFF1816G66R50F
R466	321-0175-00			RES., FXD, FILM: 649 OHM, 1%, 0.125W	91637	MFF1816G649ROF
R467	323-0127-00			RES., FXD, FILM: 205 OHM, 1%, 0.50W	91637	MFF1226G205ROF
R471	315-0301-00			RES., FXD, CMPSN: 300 OHM, 5%, 0.25W	01121	CB3015
R472	323-0144-00			RES., FXD, FILM: 309 OHM, 1%, 0.50W	75042	CECT0-3090F
R473	323-0144-00			RES., FXD, FILM: 309 OHM, 1%, 0.50W	75042	CECT0-3090F
R474	323-0144-00			RES., FXD, FILM: 309 OHM, 1%, 0.50W	75042	CECT0-3090F
R475	323-0144-00			RES., FXD, FILM: 309 OHM, 1%, 0.50W	75042	CECT0-3090F
R476	321-0121-00			RES., FXD, FILM: 178 OHM, 1%, 0.125W	91637	MFF1816G178ROF
R477	321-0172-00			RES., FXD, FILM: 604 OHM, 1%, 0.125W	91637	MFF1816G604ROF
R478	311-1138-00			RES., VAR, NONWIR: 1K OHM, 20%, 0.50W	73138	72XW-44-0-102M
R482	317-0101-00	B010100	B071669	RES., FXD, CMPSN: 100 OHM, 5%, 0.125W	01121	BB1015
R482	317-0100-00	B071670	B150754X	RES., FXD, CMPSN: 10 OHM, 5%, 0.125W	01121	BB1005
R483	308-0758-00			RES., FXD, WW: 430 OHM, 1%, 7W	14193	SP1151S-430ROF
R484	315-0201-00			RES., FXD, CMPSN: 200 OHM, 5%, 0.25W	01121	CB2015
R485	317-0101-00	B010100	B071669	RES., FXD, CMPSN: 100 OHM, 5%, 0.125W	01121	BB1015
R485	317-0100-00	B071670	B150754X	RES., FXD, CMPSN: 10 OHM, 5%, 0.125W	01121	BB1005
R486	308-0758-00			RES., FXD, WW: 430 OHM, 1%, 7W	14193	SP1151S-430ROF
R493	323-0049-00			RES., FXD, FILM: 31.6 OHM, 1%, 0.50W	91637	MFF1226G31R60F
R498	301-0751-00			RES., FXD, CMPSN: 750 OHM, 5%, 0.50W	01121	EB7515
R502	315-0754-00			RES., FXD, CMPSN: 750K OHM, 5%, 0.25W	01121	CB7545
R503	315-0334-00			RES., FXD, CMPSN: 330K OHM, 5%, 0.25W	01121	CB3345
R507	321-0068-00			RES., FXD, FILM: 49.9 OHM, 1%, 0.125W	91637	MFF1816G49R90F
R508	321-0068-00			RES., FXD, FILM: 49.9 OHM, 1%, 0.125W	91637	MFF1816G49R90F
R509	321-0068-00			RES., FXD, FILM: 49.9 OHM, 1%, 0.125W	91637	MFF1816G49R90F
R511	315-0104-00			RES., FXD, CMPSN: 100K OHM, 5%, 0.25W	01121	CB1045
R512	315-0563-00			RES., FXD, CMPSN: 56K OHM, 5%, 0.25W	01121	CB5635
R516	321-0481-00			RES., FXD, FILM: 1M OHM, 1%, 0.125W	24546	NA4D1004F
R517	315-0101-00			RES., FXD, CMPSN: 100 OHM, 5%, 0.25W	01121	CB1015
R518	315-0101-00			RES., FXD, CMPSN: 100 OHM, 5%, 0.25W	01121	CB1015
R522	315-0101-00			RES., FXD, CMPSN: 100 OHM, 5%, 0.25W	01121	CB1015
R523	315-0150-00			RES., FXD, CMPSN: 15 OHM, 5%, 0.25W	01121	CB1505
R524	315-0150-00			RES., FXD, CMPSN: 15 OHM, 5%, 0.25W	01121	CB1505
R525	315-0101-00			RES., FXD, CMPSN: 100 OHM, 5%, 0.25W	01121	CB1015
R526	317-0102-00	XB113370	B152699X	RES., FXD, CMPSN: 1K OHM, 5%, 0.125W	01121	BB1025
R527	321-0209-00			RES., FXD, FILM: 1.47K OHM, 1%, 0.125W	91637	MFF1816G14700F



Replaceable Electrical Parts—466 Service

Ckt No.	Tektronix Part No.	Serial/Model No. Eff	Dscont	Name & Description	Mfr Code	Mfr Part Number
R528	315-0390-00			RES., FXD, CMPSN: 39 OHM, 5%, 0.25W	01121	CB3905
R529	321-0209-00			RES., FXD, FILM: 1.47K OHM, 1%, 0.125W	91637	MFF1816G14700F
R530	311-1647-00			RES., VAR, NONWIR: PNL, 10K OHM, 1W, W/SW (FURNISHED AS A UNIT WITH S530)	12697	381-CM40354
R531	315-0681-00			RES., FXD, CMPSN: 680 OHM, 5%, 0.25W	01121	CB6815
R535	311-1558-00			RES., VAR, NONWIR: 20K OHM, 20%, 0.50W	73138	91-80-0
R536	315-0202-00			RES., FXD, CMPSN: 2K OHM, 5%, 0.25W	01121	CB2025
R537	315-0560-00			RES., FXD, CMPSN: 56 OHM, 5%, 0.25W	01121	CB5605
R538	315-0362-00			RES., FXD, CMPSN: 3.6K OHM, 5%, 0.25W	01121	CB3625
R539	315-0222-00			RES., FXD, CMPSN: 2.2K OHM, 5%, 0.25W	01121	CB2225
R540	315-0222-00	B010100	B082299	RES., FXD, CMPSN: 2.2K OHM, 5%, 0.25W	01121	CB2225
R540	315-0182-00	B082300		RES., FXD, CMPSN: 1.8K OHM, 5%, 0.25W	01121	CB1825
R541	315-0682-00			RES., FXD, CMPSN: 6.8K OHM, 5%, 0.25W	01121	CB6825
R542	315-0182-00			RES., FXD, CMPSN: 1.8K OHM, 5%, 0.25W	01121	CB1825
R544	315-0103-00			RES., FXD, CMPSN: 10K OHM, 5%, 0.25W	01121	CB1035
R545	311-1558-00			RES., VAR, NONWIR: 20K OHM, 20%, 0.50W	73138	91-80-0
R546	315-0101-00			RES., FXD, CMPSN: 100 OHM, 5%, 0.25W	01121	CB1015
R547	315-0101-00			RES., FXD, CMPSN: 100 OHM, 5%, 0.25W	01121	CB1015
R549	315-0331-00			RES., FXD, CMPSN: 330 OHM, 5%, 0.25W	01121	CB3315
R550	315-0330-00			RES., FXD, CMPSN: 33 OHM, 5%, 0.25W	01121	CB3305
R551	323-0313-00	B010100	B010274	RES., FXD, FILM: 17.8K OHM, 1%, 0.50W	75042	CECTO-1782F
R551	323-0318-00	B010275		RES., FXD, FILM: 20K OHM, 1%, 0.50W	91637	MFF1226D20001F
R552	315-0330-00			RES., FXD, CMPSN: 33 OHM, 5%, 0.25W	01121	CB3305
R553	315-0183-00			RES., FXD, CMPSN: 18K OHM, 5%, 0.25W	01121	CB1835
R554	315-0104-00			RES., FXD, CMPSN: 100K OHM, 5%, 0.25W	01121	CB1045
R555	311-1558-00			RES., VAR, NONWIR: 20K OHM, 20%, 0.50W	73138	91-80-0
R556	315-0562-00			RES., FXD, CMPSN: 5.6K OHM, 5%, 0.25W	01121	CB5625
R557	321-0097-00			RES., FXD, FILM: 100 OHM, 1%, 0.125W	91637	MFF1816G100ROF
R558	321-0258-00			RES., FXD, FILM: 4.75K OHM, 1%, 0.125W	91637	MFF1816G47500F
R560	315-0304-00	XB010210		RES., FXD, CMPSN: 300K OHM, 5%, 0.25W	01121	CB3045
R562	315-0304-00	XB010210		RES., FXD, CMPSN: 300K OHM, 5%, 0.25W	01121	CB3045
R602	315-0470-00			RES., FXD, CMPSN: 47 OHM, 5%, 0.25W (SEE OPTION 5)	01121	CB4705
R603	325-0073-00			RES., FXD, FILM: 3.57M OHM, 1%, 0.50W	03888	PME70-G35703F
R604	321-0385-00			RES., FXD, FILM: 100K OHM, 1%, 0.125W (SEE OPTION 5)	91637	MFF1816G10002F
R605	-----					
R606	323-0480-00			RES., FXD, FILM: 976K OHM, 1%, 0.50W	91637	MFF1226G97602F
R607	321-0451-00			RES., FXD, FILM: 487K OHM, 1%, 0.125W	91637	MFF1816G48702F
R608	-----			(SEE OPTION 5)		
R609	315-0274-00			RES., FXD, CMPSN: 270K OHM, 5%, 0.25W (SEE OPTION 5)	01121	CB2745
R610	-----					
R611	315-0104-00			RES., FXD, CMPSN: 100K OHM, 5%, 0.25W	01121	CB1045
R612	315-0563-00			RES., FXD, CMPSN: 56K OHM, 5%, 0.25W (SEE OPTION 5)	01121	CB5635
R613	-----			(SEE OPTION 5)		
R614	-----			(SEE OPTION 5)		
R615	-----			(SEE OPTION 5)		
R616	321-0481-00			RES., FXD, FILM: 1M OHM, 1%, 0.125W (SEE OPTION 5)	24546	NA4D1004F
R617	315-0101-00			RES., FXD, CMPSN: 100 OHM, 5%, 0.25W	01121	CB1015
R618	315-0101-00			RES., FXD, CMPSN: 100 OHM, 5%, 0.25W	01121	CB1015
R619	-----			(SEE OPTION 5)		
R620	-----			(SEE OPTION 5)		
R622	315-0101-00			RES., FXD, CMPSN: 100 OHM, 5%, 0.25W	01121	CB1015
R623	315-0150-00			RES., FXD, CMPSN: 15 OHM, 5%, 0.25W	01121	CB1505
R624	315-0150-00			RES., FXD, CMPSN: 15 OHM, 5%, 0.25W	01121	CB1505
R625	315-0101-00			RES., FXD, CMPSN: 100 OHM, 5%, 0.25W	01121	CB1015
R626	317-0102-00	XB113370	B152699X	RES., FXD, CMPSN: 1K OHM, 5%, 0.125W	01121	BB1025

Replaceable Electrical Parts—466 Service

Ckt No.	Tektronix Part No.	Serial/Model No. Eff	Dscont	Name & Description	Mfr Code	Mfr Part Number
R627	321-0209-00			RES., FXD, FILM: 1.47K OHM, 1%, 0.125W	91637	MFF1816G14700F
R628	315-0390-00			RES., FXD, CMPSN: 39 OHM, 5%, 0.25W	01121	CB3905
R629	321-0209-00			RES., FXD, FILM: 1.47K OHM, 1%, 0.125W	91637	MFF1816G14700F
R630	311-1647-00			RES., VAR, NONWIR: PNL, 10K OHM, 1W, W/SW (FURNISHED AS A UNIT WITH S630)	12697	381-CM40354
R631	315-0681-00			RES., FXD, CMPSN: 680 OHM, 5%, 0.25W	01121	CB6815
R635	311-1558-00			RES., VAR, NONWIR: 20K OHM, 20%, 0.50W	73138	91-80-0
R636	315-0202-00			RES., FXD, CMPSN: 2K OHM, 5%, 0.25W	01121	CB2025
R637	315-0560-00			RES., FXD, CMPSN: 56 OHM, 5%, 0.25W	01121	CB5605
R638	315-0362-00			RES., FXD, CMPSN: 3.6K OHM, 5%, 0.25W	01121	CB3625
R639	315-0222-00			RES., FXD, CMPSN: 2.2K OHM, 5%, 0.25W	01121	CB2225
R640	315-0222-00	B010100	B082299	RES., FXD, CMPSN: 2.2K OHM, 5%, 0.25W	01121	CB2225
R640	315-0182-00	B082300		RES., FXD, CMPSN: 1.8K OHM, 5%, 0.25W	01121	CB1825
R641	315-0682-00			RES., FXD, CMPSN: 6.8K OHM, 5%, 0.25W	01121	CB6825
R642	315-0182-00			RES., FXD, CMPSN: 1.8K OHM, 5%, 0.25W	01121	CB1825
R644	315-0103-00			RES., FXD, CMPSN: 10K OHM, 5%, 0.25W	01121	CB1035
R645	311-1558-00			RES., VAR, NONWIR: 20K OHM, 20%, 0.50W	73138	91-80-0
R646	315-0101-00			RES., FXD, CMPSN: 100 OHM, 5%, 0.25W	01121	CB1015
R647	315-0101-00			RES., FXD, CMPSN: 100 OHM, 5%, 0.25W	01121	CB1015
R649	315-0331-00			RES., FXD, CMPSN: 330 OHM, 5%, 0.25W	01121	CB3315
R650	315-0330-00			RES., FXD, CMPSN: 33 OHM, 5%, 0.25W	01121	CB3305
R651	323-0313-00	B010100	B010274	RES., FXD, FILM: 17.8K OHM, 1%, 0.50W	75042	CECT0-1782F
R651	323-0318-00	B010275		RES., FXD, FILM: 20K OHM, 1%, 0.50W	91637	MFF1226D20001F
R652	315-0330-00			RES., FXD, CMPSN: 33 OHM, 5%, 0.25W	01121	CB3305
R655	311-1558-00			RES., VAR, NONWIR: 20K OHM, 20%, 0.50W	73138	91-80-0
R656	315-0562-00			RES., FXD, CMPSN: 5.6K OHM, 5%, 0.25W	01121	CB5625
R657	321-0097-00			RES., FXD, FILM: 100 OHM, 1%, 0.125W	91637	MFF1816G100R0F
R658	321-0258-00			RES., FXD, FILM: 4.75K OHM, 1%, 0.125W (SEE OPTION 5)	91637	MFF1816G47500F
R660	315-0304-00	XB010210		RES., FXD, CMPSN: 300K OHM, 5%, 0.25W	01121	CB3045
R662	315-0304-00	XB010210		RES., FXD, CMPSN: 300K OHM, 5%, 0.25W	01121	CB3045
R672	315-0100-00			RES., FXD, CMPSN: 10 OHM, 5%, 0.25W	01121	CB1005
R673	315-0362-00			RES., FXD, CMPSN: 3.6K OHM, 5%, 0.25W	01121	CB3625
R674	315-0361-00			RES., FXD, CMPSN: 360 OHM, 5%, 0.25W	01121	CB3615
R675	311-1566-00			RES., VAR, NONWIR: 200 OHM, 20%, 0.50W	73138	91-88-0
R676	315-0330-00			RES., FXD, CMPSN: 33 OHM, 5%, 0.25W	01121	CB3305
R677	301-0821-00			RES., FXD, CMPSN: 820 OHM, 5%, 0.50W	01121	EB8215
R678	315-0430-00			RES., FXD, CMPSN: 43 OHM, 5%, 0.25W	01121	CB4305
R679	315-0681-00			RES., FXD, CMPSN: 680 OHM, 5%, 0.25W	01121	CB6815
R682	315-0100-00			RES., FXD, CMPSN: 10 OHM, 5%, 0.25W	01121	CB1005
R683	315-0362-00			RES., FXD, CMPSN: 3.6K OHM, 5%, 0.25W	01121	CB3625
R684	315-0361-00			RES., FXD, CMPSN: 360 OHM, 5%, 0.25W	01121	CB3615
R687	301-0821-00			RES., FXD, CMPSN: 820 OHM, 5%, 0.50W	01121	EB8215
R688	315-0430-00			RES., FXD, CMPSN: 43 OHM, 5%, 0.25W	01121	CB4305
R689	315-0681-00			RES., FXD, CMPSN: 680 OHM, 5%, 0.25W	01121	CB6815
R691	315-0302-00			RES., FXD, CMPSN: 3K OHM, 5%, 0.25W	01121	CB3025
R694	301-0221-00			RES., FXD, CMPSN: 220 OHM, 5%, 0.50W	01121	EB2215
R822	315-0101-00			RES., FXD, CMPSN: 100 OHM, 5%, 0.25W	01121	CB1015
R823	321-0227-00			RES., FXD, FILM: 2.26K OHM, 1%, 0.125W	91637	MFF1816G22600F
R824	315-0431-00			RES., FXD, CMPSN: 430 OHM, 5%, 0.25W	01121	CB4315
R825	315-0104-00			RES., FXD, CMPSN: 100K OHM, 5%, 0.25W	01121	CB1045
R826	315-0202-00			RES., FXD, CMPSN: 2K OHM, 5%, 0.25W	01121	CB2025
R827	315-0101-00			RES., FXD, CMPSN: 100 OHM, 5%, 0.25W	01121	CB1015
R832	301-0822-00			RES., FXD, CMPSN: 8.2K OHM, 5%, 0.50W	01121	EB8225
R833	315-0104-00			RES., FXD, CMPSN: 100K OHM, 5%, 0.25W	01121	CB1045
R834	315-0241-00			RES., FXD, CMPSN: 240 OHM, 5%, 0.25W	01121	CB2415
R835	315-0561-00			RES., FXD, CMPSN: 560 OHM, 5%, 0.25W	01121	CB5615

Replaceable Electrical Parts—466 Service

Ckt No.	Tektronix Part No.	Serial/Model No. Eff	Dscont	Name & Description	Mfr Code	Mfr Part Number
R836	315-0112-00			RES., FXD, CMPSN: 1.1K OHM, 5%, 0.25W	01121	CB1125
R837	315-0183-00	B010100	B082299	RES., FXD, CMPSN: 18K OHM, 5%, 0.25W	01121	CB1835
R837	315-0123-00	B082300		RES., FXD, CMPSN: 12K OHM, 5%, 0.25W	01121	CB1235
R842	315-0132-00			RES., FXD, CMPSN: 1.3K OHM, 5%, 0.25W	01121	CB1325
R843	321-0206-00			RES., FXD, FILM: 1.37K OHM, 1%, 0.125W	91637	MFF1816G13700F
R844	321-0243-00			RES., FXD, FILM: 3.32K OHM, 1%, 0.125W	91637	MFF1816G33200F
R845	315-0220-00			RES., FXD, CMPSN: 22 OHM, 5%, 0.25W	01121	CB2205
R846	315-0391-00			RES., FXD, CMPSN: 390 OHM, 5%, 0.25W	01121	CB3915
R847	321-0186-00			RES., FXD, FILM: 845 OHM, 1%, 0.125W	91637	MFF1816G845R0F
R851	315-0112-00			RES., FXD, CMPSN: 1.1K OHM, 5%, 0.25W	01121	CB1125
R852	321-0209-00			RES., FXD, FILM: 1.47K OHM, 1%, 0.125W	91637	MFF1816G14700F
R853	315-0472-00			RES., FXD, CMPSN: 4.7K OHM, 5%, 0.25W	01121	CB4725
R854	321-0160-00			RES., FXD, FILM: 453 OHM, 1%, 0.125W	91637	MFF1816G453R0F
R855	315-0221-00			RES., FXD, CMPSN: 220 OHM, 5%, 0.25W	01121	CB2215
R856	321-0160-00			RES., FXD, FILM: 453 OHM, 1%, 0.125W	91637	MFF1816G453R0F
R857	315-0911-00			RES., FXD, CMPSN: 910 OHM, 5%, 0.25W	01121	CB9115
R858	301-0471-00			RES., FXD, CMPSN: 470 OHM, 5%, 0.50W	01121	EB4715
R862	315-0390-00			RES., FXD, CMPSN: 39 OHM, 5%, 0.25W	01121	CB3905
R863	321-0211-00			RES., FXD, FILM: 1.54K OHM, 1%, 0.125W	91637	MFF1816G15400F
R864	315-0681-00			RES., FXD, CMPSN: 680 OHM, 5%, 0.25W	01121	CB6815
R865	315-0681-00			RES., FXD, CMPSN: 680 OHM, 5%, 0.25W	01121	CB6815
R866	315-0332-00			RES., FXD, CMPSN: 3.3K OHM, 5%, 0.25W	01121	CB3325
R867	315-0151-00			RES., FXD, CMPSN: 150 OHM, 5%, 0.25W	01121	CB1515
R872	315-0103-00			RES., FXD, CMPSN: 10K OHM, 5%, 0.25W	01121	CB1035
R873	321-0164-00			RES., FXD, FILM: 499 OHM, 1%, 0.125W	91637	MFF1816G499R0F
R874	321-0250-00			RES., FXD, FILM: 3.92K OHM, 1%, 0.125W	91637	MFF1816G39200F
R875	321-0195-00			RES., FXD, FILM: 1.05K OHM, 1%, 0.125W	91637	MFF1816G10500F
R876	321-0228-00	B010100	B150549	RES., FXD, FILM: 2.32K OHM, 1%, 0.125W	91637	MFF1816G23200F
R876	321-0230-00	B150550		RES., FXD, FILM: 2.43K OHM, 1%, 0.125W	91637	MFF1816G24300F
R877	321-0171-00			RES., FXD, FILM: 590 OHM, 1%, 0.125W	91637	MFF1816G590R0F
R878	321-0192-00			RES., FXD, FILM: 976 OHM, 1%, 0.125W	91637	MFF1816G976R0F
R882	315-0103-00			RES., FXD, CMPSN: 10K OHM, 5%, 0.25W	01121	CB1035
R883	315-0153-00			RES., FXD, CMPSN: 15K OHM, 5%, 0.25W	01121	CB1535
R884	315-0103-00			RES., FXD, CMPSN: 10K OHM, 5%, 0.25W	01121	CB1035
R885	315-0220-00			RES., FXD, CMPSN: 22 OHM, 5%, 0.25W	01121	CB2205
R886	315-0102-00			RES., FXD, CMPSN: 1K OHM, 5%, 0.25W	01121	CB1025
R887	315-0102-00			RES., FXD, CMPSN: 1K OHM, 5%, 0.25W	01121	CB1025
R888	315-0102-00			RES., FXD, CMPSN: 1K OHM, 5%, 0.25W	01121	CB1025
R889	315-0104-00	B010100	B010137X	RES., FXD, CMPSN: 100K OHM, 5%, 0.25W	01121	CB1045
R892	315-0202-00	B010100	B010249	RES., FXD, CMPSN: 2K OHM, 5%, 0.25W	01121	CB2025
R892	315-0182-00	B010250		RES., FXD, CMPSN: 1.8K OHM, 5%, 0.25W	01121	CB1825
R895	321-0210-00			RES., FXD, FILM: 1.5K OHM, 1%, 0.125W	91637	MFF1816G15000F
R901	315-0390-00			RES., FXD, CMPSN: 39 OHM, 5%, 0.25W	01121	CB3905
R902	315-0471-00			RES., FXD, CMPSN: 470 OHM, 5%, 0.25W	01121	CB4715
R903	321-0160-00			RES., FXD, FILM: 453 OHM, 1%, 0.125W	91637	MFF1816G453R0F
R904	321-0160-00			RES., FXD, FILM: 453 OHM, 1%, 0.125W	91637	MFF1816G453R0F
R905	321-0209-00			RES., FXD, FILM: 1.47K OHM, 1%, 0.125W	91637	MFF1816G14700F
R906	315-0332-00			RES., FXD, CMPSN: 3.3K OHM, 5%, 0.25W	01121	CB3325
R907	315-0151-00			RES., FXD, CMPSN: 150 OHM, 5%, 0.25W	01121	CB1515
R908	315-0103-00			RES., FXD, CMPSN: 10K OHM, 5%, 0.25W	01121	CB1035
R912	321-0209-00			RES., FXD, FILM: 1.47K OHM, 1%, 0.125W	91637	MFF1816G14700F
R913	321-0150-00			RES., FXD, FILM: 357 OHM, 1%, 0.125W	91637	MFF1816G357R0F
R914	315-0472-00			RES., FXD, CMPSN: 4.7K OHM, 5%, 0.25W	01121	CB4725
R915	315-0221-00			RES., FXD, CMPSN: 220 OHM, 5%, 0.25W	01121	CB2215
R916	315-0911-00			RES., FXD, CMPSN: 910 OHM, 5%, 0.25W	01121	CB9115
R917	301-0471-00			RES., FXD, CMPSN: 470 OHM, 5%, 0.50W	01121	EB4715
R918	-----			(SEE DM44 MANUAL)		

Ckt No.	Tektronix Part No.	Serial/Model No. Eff	Dscont	Name & Description	Mfr Code	Mfr Part Number
R922	321-0129-00			RES., FXD, FILM: 215 OHM, 1%, 0.125W	91637	MFF1816G215ROF
R923	321-0187-00			RES., FXD, FILM: 866 OHM, 1%, 0.125W	91637	MFF1816G866ROF
R924	321-0227-00			RES., FXD, FILM: 2.26K OHM, 1%, 0.125W	91637	MFF1816G22600F
R925	321-0284-00			RES., FXD, FILM: 8.87K OHM, 1%, 0.125W	91637	MFF1816G88700F
R926	321-0126-00			RES., FXD, FILM: 200 OHM, 1%, 0.125W	91637	MFF1816G200ROF
R927	315-0103-00			RES., FXD, CMPSN: 10K OHM, 5%, 0.25W	01121	CB1035
R943	315-0102-00			RES., FXD, CMPSN: 1K OHM, 5%, 0.25W	01121	CB1025
R944	315-0274-00	B010100	B082299	RES., FXD, CMPSN: 270K OHM, 5%, 0.25W	01121	CB2745
R944	315-0334-00	B082300		RES., FXD, CMPSN: 330K OHM, 5%, 0.25W	01121	CB3345
R945	315-0101-00			RES., FXD, CMPSN: 100 OHM, 5%, 0.25W	01121	CB1015
R948	311-1666-00			RES., VAR, NONWIR: PNL, 20K OHM, 1W, W/SW (FURNISHED AS A UNIT WITH S948)	01121	12M293
R949	315-0361-00	XB082300		RES., FXD, CMPSN: 360 OHM, 5%, 0.25W (SEE OPTION 5)	01121	CB3615
R952	321-0201-00			RES., FXD, FILM: 1.21K OHM, 1%, 0.125W (SEE OPTION 5)	91637	MFF1816G12100F
R953	321-0243-00			RES., FXD, FILM: 3.32K OHM, 1%, 0.125W (SEE OPTION 5)	91637	MFF1816G33200F
R954	315-0132-00			RES., FXD, CMPSN: 1.3K OHM, 5%, 0.25W (SEE OPTION 5)	01121	CB1325
R955	315-0270-00			RES., FXD, CMPSN: 27 OHM, 5%, 0.25W (SEE OPTION 5)	01121	CB2705
R956	321-0195-00			RES., FXD, FILM: 1.05K OHM, 1%, 0.125W (SEE OPTION 5)	91637	MFF1816G10500F
R957	315-0431-00			RES., FXD, CMPSN: 430 OHM, 5%, 0.25W (SEE OPTION 5)	01121	CB4315
R958	315-0220-00			RES., FXD, CMPSN: 22 OHM, 5%, 0.25W (SEE OPTION 5)	01121	CB2205
R962	315-0682-00			RES., FXD, CMPSN: 6.8K OHM, 5%, 0.25W	01121	CB6825
R965	315-0100-00			RES., FXD, CMPSN: 10 OHM, 5%, 0.25W	01121	CB1005
R967	315-0100-00			RES., FXD, CMPSN: 10 OHM, 5%, 0.25W	01121	CB1005
R981	315-0472-00			RES., FXD, CMPSN: 4.7K OHM, 5%, 0.25W	01121	CB4725
R982	315-0241-00			RES., FXD, CMPSN: 240 OHM, 5%, 0.25W	01121	CB2415
R983	315-0102-00			RES., FXD, CMPSN: 1K OHM, 5%, 0.25W	01121	CB1025
R984	315-0122-00			RES., FXD, CMPSN: 1.2K OHM, 5%, 0.25W	01121	CB1225
R985	315-0122-00			RES., FXD, CMPSN: 1.2K OHM, 5%, 0.25W	01121	CB1225
R986	315-0103-00			RES., FXD, CMPSN: 10K OHM, 5%, 0.25W	01121	CB1035
R987	315-0102-00			RES., FXD, CMPSN: 1K OHM, 5%, 0.25W	01121	CB1025
R988	315-0392-00			RES., FXD, CMPSN: 3.9K OHM, 5%, 0.25W	01121	CB3925
R989	315-0682-00			RES., FXD, CMPSN: 6.8K OHM, 5%, 0.25W	01121	CB6825
R992	315-0220-00			RES., FXD, CMPSN: 22 OHM, 5%, 0.25W	01121	CB2205
R993	315-0220-00			RES., FXD, CMPSN: 22 OHM, 5%, 0.25W	01121	CB2205
R994	315-0220-00			RES., FXD, CMPSN: 22 OHM, 5%, 0.25W	01121	CB2205
R1001	315-0360-00			RES., FXD, CMPSN: 36 OHM, 5%, 0.25W	01121	CB3605
R1002	303-0562-00			RES., FXD, CMPSN: 5.6K OHM, 5%, 1W	01121	GB5625
R1003	315-0101-00			RES., FXD, CMPSN: 100 OHM, 5%, 0.25W	01121	CB1015
R1004	315-0360-00			RES., FXD, CMPSN: 36 OHM, 5%, 0.25W	01121	CB3605
R1005	315-0220-00			RES., FXD, CMPSN: 22 OHM, 5%, 0.25W	01121	CB2205
R1006	315-0560-00			RES., FXD, CMPSN: 56 OHM, 5%, 0.25W	01121	CB5605
R1008	321-0270-00	B010100	B010139	RES., FXD, FILM: 6.34K OHM, 1%, 0.125W	91637	MFF1816G63400F
R1008	321-0223-00	B010140		RES., FXD, FILM: 2.05K OHM, 1%, 0.125W	91637	MFF1816G20500F
R1021	321-0193-00			RES., FXD, FILM: 1K OHM, 1%, 0.125W	91637	MFF1816G10000F
R1022	321-0193-00			RES., FXD, FILM: 1K OHM, 1%, 0.125W	91637	MFF1816G10000F
R1024	321-0165-00			RES., FXD, FILM: 511 OHM, 1%, 0.125W	91637	MFF1816G511ROF
R1026	315-0181-00			RES., FXD, CMPSN: 180 OHM, 5%, 0.25W	01121	CB1815
R1029	315-0101-00			RES., FXD, CMPSN: 100 OHM, 5%, 0.25W	01121	CB1015
R1031	315-0470-00			RES., FXD, CMPSN: 47 OHM, 5%, 0.25W	01121	CB4705

Replaceable Electrical Parts—466 Service

Ckt No.	Tektronix Part No.	Serial/Model No. Eff	Dscont	Name & Description	Mfr Code	Mfr Part Number
R1032	315-0101-00			RES., FXD, CMPSN: 100 OHM, 5%, 0.25W	01121	CB1015
R1033	321-0256-00			RES., FXD, FILM: 4.53K OHM, 1%, 0.125W	91637	MFF1816G45300F
R1035	315-0101-00			RES., FXD, CMPSN: 100 OHM, 5%, 0.25W	01121	CB1015
R1036	315-0561-00			RES., FXD, CMPSN: 560 OHM, 5%, 0.25W	01121	CB5615
R1037	321-0251-01			RES., FXD, FILM: 4.02K OHM, 0.5%, 0.125W	91637	MFF1816G40200D
R1038	315-0470-00			RES., FXD, CMPSN: 47 OHM, 5%, 0.25W	01121	CB4705
R1039	321-0228-00			RES., FXD, FILM: 2.32K OHM, 1%, 0.125W	91637	MFF1816G23200F
R1060	315-0101-00			RES., FXD, CMPSN: 100 OHM, 5%, 0.25W	01121	CB1015
R1061	315-0360-00			RES., FXD, CMPSN: 36 OHM, 5%, 0.25W	01121	CB3605
R1062	301-0562-00			RES., FXD, CMPSN: 5.6K OHM, 5%, 0.50W	01121	EB5625
R1063	315-0101-00			RES., FXD, CMPSN: 100 OHM, 5%, 0.25W	01121	CB1015
R1064	315-0360-00			RES., FXD, CMPSN: 36 OHM, 5%, 0.25W	01121	CB3605
R1065	315-0220-00			RES., FXD, CMPSN: 22 OHM, 5%, 0.25W	01121	CB2205
R1066	315-0560-00			RES., FXD, CMPSN: 56 OHM, 5%, 0.25W	01121	CB5605
R1067	315-0101-00			RES., FXD, CMPSN: 100 OHM, 5%, 0.25W	01121	CB1015
R1068	315-0561-00	B010100	B010139	RES., FXD, CMPSN: 560 OHM, 5%, 0.25W	01121	CB5615
R1068	315-0181-00	B010140		RES., FXD, CMPSN: 180 OHM, 5%, 0.25W	01121	CB1815
R1081	321-0193-00			RES., FXD, FILM: 1K OHM, 1%, 0.125W	91637	MFF1816G10000F
R1082	321-0193-00			RES., FXD, FILM: 1K OHM, 1%, 0.125W	91637	MFF1816G10000F
R1084	321-0165-00			RES., FXD, FILM: 511 OHM, 1%, 0.125W	91637	MFF1816G511R0F
R1086	315-0181-00			RES., FXD, CMPSN: 180 OHM, 5%, 0.25W	01121	CB1815
R1089	315-0101-00			RES., FXD, CMPSN: 100 OHM, 5%, 0.25W	01121	CB1015
R1091	315-0470-00			RES., FXD, CMPSN: 47 OHM, 5%, 0.25W	01121	CB4705
R1092	315-0101-00			RES., FXD, CMPSN: 100 OHM, 5%, 0.25W	01121	CB1015
R1093	321-0256-00			RES., FXD, FILM: 4.53K OHM, 1%, 0.125W	91637	MFF1816G45300F
R1095	315-0101-00			RES., FXD, CMPSN: 100 OHM, 5%, 0.25W	01121	CB1015
R1097	321-0251-01			RES., FXD, FILM: 4.02K OHM, 0.5%, 0.125W	91637	MFF1816G40200D
R1098	321-0229-00			RES., FXD, FILM: 2.37K OHM, 1%, 0.125W	91637	MFF1816G23700F
R1099	315-0561-00			RES., FXD, CMPSN: 560 OHM, 5%, 0.25W	01121	CB5615
R1112	321-0125-00			RES., FXD, FILM: 196 OHM, 1%, 0.125W (SEE DM SERIES MNL FOR ALTN VALUES)	91637	MFF1816G196R0F
R1113	321-0068-00			RES., FXD, FILM: 49.9 OHM, 1%, 0.125W (SEE DM SERIES MNL FOR ALTN VALUES)	91637	MFF1816G49R90F
R1114	321-0231-00			RES., FXD, FILM: 2.49K OHM, 1%, 0.125W	91637	MFF1816G24900F
R1115	311-1244-00			RES., VAR, NONWIR: 100 OHM, 10%, 0.50W	32997	3386X-T07-101
R1116	311-1464-00			RES., VAR, WW: 2K OHM, 5%, 2W (SEE DM SERIES MNL FOR ALTN VALUES)	02111	534-264
R1117	321-0169-00			RES., FXD, FILM: 562 OHM, 1%, 0.125W (SEE DM SERIES MNL FOR ALTN VALUES)	91637	MFF1816G562R0F
R1131	323-0498-04			RES., FXD, FILM: 1.5M OHM, 0.1%, 0.50W	91637	HFF129D15003B
R1132	315-0101-00			RES., FXD, CMPSN: 100 OHM, 5%, 0.25W	01121	CB1015
R1133	323-0481-04			RES., FXD, FILM: 1M OHM, 0.1%, 0.50W	91637	MFF1226D10003B
R1134	321-0648-04			RES., FXD, FILM: 500K OHM, 0.1%, 0.125W	91637	CMF110216D50002B
R1135	321-0618-04			RES., FXD, FILM: 250K OHM, 0.1%, 0.125W	07716	0BD
R1136	321-0414-04			RES., FXD, FILM: 200K OHM, 0.1%, 0.125W	91637	MFF1816D20002B
R1137	321-0385-04			RES., FXD, FILM: 100K OHM, 0.1%, 0.125W	91637	MFF1816D10002B
R1138	321-0756-04			RES., FXD, FILM: 50K OHM, 0.1%, 0.125W	91637	MFF1816D50001B
R1140	311-1374-00	B010100	B010291	RES., VAR, NONWIR: 50K OHM, 20%, 1W (FURNISHED AS A UNIT WITH S1140)	01121	10M329A
R1140	311-1701-00	B010292		RES., VAR, NONWIR: PNL, 50K OHM, 1W, W/SW (FURNISHED AS A UNIT WITH S1140)	01121	18M655
R1141	315-0154-00			RES., FXD, CMPSN: 150K OHM, 5%, 0.25W	01121	CB1545
R1142	-----			(SEE DM SERIES MANUAL FOR ALTN VALUES)		
R1143	-----			(SEE DM SERIES MANUAL FOR ALTN VALUES)		
R1144	321-0212-00			RES., FXD, FILM: 1.58K OHM, 1%, 0.125W	91637	MFF1816G15800F
R1145	311-1245-00			RES., VAR, NONWIR: 10K OHM, 10%, 0.50W	73138	72-28-0
R1146	322-0258-00	B010100	B010291	RES., FXD, FILM: 4.75K OHM, 1%, 0.25W	75042	CEBT0-4751F

## Replaceable Electrical Parts—466 Service

Ckt No.	Tektronix Part No.	Serial/Model No. Eff Dscont	Name & Description	Mfr Code	Mfr Part Number
R1146	315-0472-00	B010292	RES., FXD, CMPSN: 4.7K OHM, 5%, 0.25W	01121	CB4725
R1147	-----		(SEE DM SERIES MANUAL FOR ALTN VALUES)		
R1151	321-0436-00		RES., FXD, FILM: 340K OHM, 1%, 0.125W	91637	MFF1816G34002F
R1153	321-0345-00		RES., FXD, FILM: 38.3K OHM, 1%, 0.125W	91637	MFF1816G38301F
R1161	323-0498-04		RES., FXD, FILM: 1.5M OHM, 0.1%, 0.50W	91637	HFF129D15003B
R1162	315-0101-00		RES., FXD, CMPSN: 100 OHM, 5%, 0.25W	01121	CB1015
R1163	323-0481-04		RES., FXD, FILM: 1M OHM, 0.1%, 0.50W	91637	MFF1226D10003B
R1164	321-0648-00		RES., FXD, FILM: 500K OHM, 0.1%, 0.125W	91637	CMF110216D50002B
R1165	321-0618-04		RES., FXD, FILM: 250K OHM, 0.1%, 0.125W	07716	OBD
R1166	321-0414-04		RES., FXD, FILM: 200K OHM, 0.1%, 0.125W	91637	MFF1816D20002B
R1167	321-0385-04		RES., FXD, FILM: 100K OHM, 0.1%, 0.125W	91637	MFF1816D10002B
R1168	321-0756-04		RES., FXD, FILM: 50K OHM, 0.1%, 0.125W	91637	MFF1816D50001B
R1170	315-0473-00		RES., FXD, CMPSN: 47K OHM, 5%, 0.25W	01121	CB4735
R1175	311-1245-00		RES., VAR, NONWIR: 10K OHM, 10%, 0.50W	73138	72-28-0
R1203	315-0471-00		RES., FXD, CMPSN: 470 OHM, 5%, 0.25W	01121	CB4715
R1205	321-0212-00		RES., FXD, FILM: 1.58K OHM, 1%, 0.125W	91637	MFF1816G15800F
R1212	321-0126-00		RES., FXD, FILM: 200 OHM, 1%, 0.125W	91637	MFF1816G200ROF
R1213	321-0264-00		RES., FXD, FILM: 5.49K OHM, 1%, 0.125W	91637	MFF1816G54900F
R1214	311-1222-00		RES., VAR, NONWIR: 100 OHM, 20%, 0.50W	32997	3386F-T04-101
R1215	315-0102-00		RES., FXD, CMPSN: 1K OHM, 5%, 0.25W	01121	CB1025
R1216	321-0174-00		RES., FXD, FILM: 634 OHM, 1%, 0.125W	91637	MFF1816G634ROF
R1217	321-0147-00		RES., FXD, FILM: 332 OHM, 1%, 0.125W	91637	MFF1816G332ROF
R1218	315-0821-00		RES., FXD, CMPSN: 820 OHM, 5%, 0.25W	01121	CB8215
R1222	321-0164-00		RES., FXD, FILM: 499 OHM, 1%, 0.125W	91637	MFF1816G499ROF
R1223	315-0332-00		RES., FXD, CMPSN: 3.3K OHM, 5%, 0.25W	01121	CB3325
R1224	315-0512-00		RES., FXD, CMPSN: 5.1K OHM, 5%, 0.25W	01121	CB5125
R1226	315-0823-00		RES., FXD, CMPSN: 82K OHM, 5%, 0.25W	01121	CB8235
R1227A, B	311-1670-00		RES., VAR, NONWIR: PNL, 10K X 100K OHM, 0.5W	01121	18M408
R1232	321-0178-00		RES., FXD, FILM: 698 OHM, 1%, 0.125W	91637	MFF1816G698ROF
R1233	321-0184-00		RES., FXD, FILM: 806 OHM, 1%, 0.125W	91637	MFF1816G806ROF
R1234	322-0184-00		RES., FXD, FILM: 806 OHM, 1%, 0.25W	75042	CEBTO-8060F
R1236	323-0158-00		RES., FXD, FILM: 432 OHM, 1%, 0.50W	75042	CECTO-4320F
R1237	307-0106-00		RES., FXD, CMPSN: 4.7 OHM, 5%, 0.25W	01121	CB47G5
R1238	321-0228-00		RES., FXD, FILM: 2.32K OHM, 1%, 0.125W	91637	MFF1816G23200F
R1239	315-0154-00		RES., FXD, CMPSN: 150K OHM, 5%, 0.25W	01121	CB1545
R1242	321-0225-00		RES., FXD, FILM: 2.15K OHM, 1%, 0.125W	91637	MFF1816G21500F
R1243	315-0270-00		RES., FXD, CMPSN: 27 OHM, 5%, 0.25W	01121	CB2705
R1244	321-0184-00		RES., FXD, FILM: 806 OHM, 1%, 0.125W	91637	MFF1816G806ROF
R1245	322-0184-00		RES., FXD, FILM: 806 OHM, 1%, 0.25W	75042	CEBTO-8060F
R1246	321-0097-00		RES., FXD, FILM: 100 OHM, 1%, 0.125W	91637	MFF1816G100ROF
R1247	321-0228-00		RES., FXD, FILM: 2.32K OHM, 1%, 0.125W	91637	MFF1816G23200F
R1252	321-0210-00		RES., FXD, FILM: 1.5K OHM, 1%, 0.125W	91637	MFF1816G15000F
R1253	311-1222-00		RES., VAR, NONWIR: 100 OHM, 20%, 0.50W	32997	3386F-T04-101
R1254	323-0303-00		RES., FXD, FILM: 14K OHM, 1%, 0.50W	75042	CECTO-1402F
R1255	311-1226-00		RES., VAR, NONWIR: 2.5K OHM, 20%, 0.50W	32997	3386F-T04-252
R1256	323-0303-00		RES., FXD, FILM: 14K OHM, 1%, 0.50W	75042	CECTO-1402F
R1257	311-1225-00		RES., VAR, NONWIR: 1K OHM, 20%, 0.50W	32997	3386F-T04-102
R1258	321-0111-00		RES., FXD, FILM: 140 OHM, 1%, 0.125W	91637	MFF1816G140ROF
R1262	323-0309-00		RES., FXD, FILM: 16.2K OHM, 1%, 0.50W	75042	CECTO-1622F
R1263	322-0280-00		RES., FXD, FILM: 8.06K OHM, 1%, 0.25W	75042	CEBTO-8061F
R1264	322-0280-00		RES., FXD, FILM: 8.06K OHM, 1%, 0.25W	75042	CEBTO-8061F
R1265	323-0309-00		RES., FXD, FILM: 16.2K OHM, 1%, 0.50W	75042	CECTO-1622F
R1266	315-0333-00		RES., FXD, CMPSN: 33K OHM, 5%, 0.25W	01121	CB3335
R1267	315-0333-00		RES., FXD, CMPSN: 33K OHM, 5%, 0.25W	01121	CB3335
R1268	321-0347-00		RES., FXD, FILM: 40.2K OHM, 1%, 0.125W	91637	MFF1816G40201F
R1271	315-0301-00		RES., FXD, CMPSN: 300 OHM, 5%, 0.25W	01121	CB3015
R1272	301-0393-00		RES., FXD, CMPSN: 39K OHM, 5%, 0.50W	01121	EB3935

Replaceable Electrical Parts—466 Service

Ckt No.	Tektronix Part No.	Serial/Model No. Eff	Dscont	Name & Description	Mfr Code	Mfr Part Number
R1273	315-0621-00			RES., FXD, CMPSN: 620 OHM, 5%, 0.25W	01121	CB6215
R1274	321-0179-00	B010100	B059999	RES., FXD, FILM: 715 OHM, 1%, 0.125W	91637	MFF1816G715ROF
R1274	317-0911-00	B060000		RES., FXD, CMPSN: 910 OHM, 5%, 0.125W	01121	BB9115
R1275	315-0470-00			RES., FXD, CMPSN: 47 OHM, 5%, 0.25W	01121	CB4705
R1276	315-0470-00			RES., FXD, CMPSN: 47 OHM, 5%, 0.25W	01121	CB4705
R1277	315-0101-00			RES., FXD, CMPSN: 100 OHM, 5%, 0.25W	01121	CB1015
R1278	321-0370-00	B010100	B059999	RES., FXD, FILM: 69.8K OHM, 1%, 0.125W	91637	MFF1816G69801F
R1278	315-0333-00	B060000		RES., FXD, CMPSN: 33K OHM, 5%, 0.25W	01121	CB3335
R1281	301-0471-00			RES., FXD, CMPSN: 470 OHM, 5%, 0.50W	01121	EB4715
R1282	315-0751-00			RES., FXD, CMPSN: 750 OHM, 5%, 0.25W	01121	CB7515
R1283	301-0393-00			RES., FXD, CMPSN: 39K OHM, 5%, 0.50W	01121	EB3935
R1284	321-0179-00	B010100	B059999	RES., FXD, FILM: 715 OHM, 1%, 0.125W	91637	MFF1816G715ROF
R1284	317-0911-00	B060000		RES., FXD, CMPSN: 910 OHM, 5%, 0.125W	01121	BB9115
R1285	315-0621-00			RES., FXD, CMPSN: 620 OHM, 5%, 0.25W	01121	CB6215
R1286	315-0470-00			RES., FXD, CMPSN: 47 OHM, 5%, 0.25W	01121	CB4705
R1287	315-0101-00			RES., FXD, CMPSN: 100 OHM, 5%, 0.25W	01121	CB1015
R1288	315-0470-00			RES., FXD, CMPSN: 47 OHM, 5%, 0.25W	01121	CB4705
R1289	321-0260-00	B010100	B059999X	RES., FXD, FILM: 4.99K OHM, 1%, 0.125W	91637	MFF1816G49900F
R1362	315-0512-00			RES., FXD, CMPSN: 5.1K OHM, 5%, 0.25W	01121	CB5125
R1363	315-0273-00			RES., FXD, CMPSN: 27K OHM, 5%, 0.25W	01121	CB2735
R1364	315-0913-00			RES., FXD, CMPSN: 91K OHM, 5%, 0.25W	01121	CB9135
R1365	315-0752-00			RES., FXD, CMPSN: 7.5K OHM, 5%, 0.25W	01121	CB7525
R1367	315-0912-00			RES., FXD, CMPSN: 9.1K OHM, 5%, 0.25W	01121	CB9125
R1372	315-0913-00			RES., FXD, CMPSN: 91K OHM, 5%, 0.25W	01121	CB9135
R1373	315-0512-00			RES., FXD, CMPSN: 5.1K OHM, 5%, 0.25W	01121	CB5125
R1375	311-1221-00			RES., VAR, NONWIR: 50 OHM, 20%, 0.50W	32997	3386F-T04-500
R1376	321-0107-00			RES., FXD, FILM: 127 OHM, 1%, 0.125W	91637	MFF1816G127ROF
R1377	321-0001-00			RES., FXD, FILM: 10 OHM, 1%, 0.125W	75042	CEATO-10R00F
R1402	315-0162-00	B010100	B119999	RES., FXD, CMPSN: 1.6K OHM, 5%, 0.25W	01121	CB1625
R1402	315-0332-00	B120000	B135184	RES., FXD, CMPSN: 3.3K OHM, 5%, 0.25W	01121	CB3325
R1402	315-0272-00	B135185		RES., FXD, CMPSN: 2.7K OHM, 5%, 0.25W	01121	CB2725
R1403	311-1718-00			RES., VAR, NONWIR: 5K OHM, 20%, 1W, W/SW (FURNISHED AS A UNIT WITH S1403A, B)	01121	12M970
R1404	315-0332-00	XB120000		RES., FXD, CMPSN: 3.3K OHM, 5%, 0.25W	01121	CB3325
R1405	301-0752-00			RES., FXD, CMPSN: 7.5K OHM, 5%, 0.50W	01121	EB7525
R1406	311-1245-00	XB120000		RES., VAR, NONWIR: 10K OHM, 10%, 0.50W	73138	72-28-0
R1407	315-0202-00			RES., FXD, CMPSN: 2K OHM, 5%, 0.25W	01121	CB2025
R1413	315-0302-00			RES., FXD, CMPSN: 3K OHM, 5%, 0.25W	01121	CB3025
R1414	301-0243-00			RES., FXD, CMPSN: 24K OHM, 5%, 0.50W	01121	EB2435
R1416	315-0221-00			RES., FXD, CMPSN: 220 OHM, 5%, 0.25W	01121	CB2215
R1417	315-0470-00			RES., FXD, CMPSN: 47 OHM, 5%, 0.25W	01121	CB4705
R1422	321-0262-00			RES., FXD, FILM: 5.23K OHM, 1%, 0.125W	91637	MFF1816G52300F
R1423	321-0210-00			RES., FXD, FILM: 1.5K OHM, 1%, 0.125W	91637	MFF1816G15000F
R1424	315-0153-00			RES., FXD, CMPSN: 15K OHM, 5%, 0.25W	01121	CB1535
R1425	321-0297-00			RES., FXD, FILM: 12.1K OHM, 1%, 0.125W	91637	MFF1816G12101F
R1427	315-0102-00			RES., FXD, CMPSN: 1K OHM, 5%, 0.25W	01121	CB1025
R1428	315-0101-00			RES., FXD, CMPSN: 100 OHM, 5%, 0.25W	01121	CB1015
R1431	315-0391-00			RES., FXD, CMPSN: 390 OHM, 5%, 0.25W	01121	CB3915
R1432	315-0102-00	B010100	B059999	RES., FXD, CMPSN: 1K OHM, 5%, 0.25W	01121	CB1025
R1432	317-0102-00	B060000		RES., FXD, CMPSN: 1K OHM, 5%, 0.125W	01121	BB1025
R1433	315-0101-00	B010100	B059999	RES., FXD, CMPSN: 100 OHM, 5%, 0.25W	01121	CB1015
R1433	317-0101-00	B060000		RES., FXD, CMPSN: 100 OHM, 5%, 0.125W	01121	BB1015
R1434	321-0249-00			RES., FXD, FILM: 3.83K OHM, 1%, 0.125W	91637	MFF1816G38300F
R1435	323-0322-00			RES., FXD, FILM: 22.1K OHM, 1%, 0.50W	75042	CECTO-2212F
R1436	315-0102-00			RES., FXD, CMPSN: 1K OHM, 5%, 0.25W	01121	CB1025
R1437	321-0179-00	B010100	B059999	RES., FXD, FILM: 715 OHM, 1%, 0.125W	91637	MFF1816G715ROF
R1437	317-0911-00	B060000		RES., FXD, CMPSN: 910 OHM, 5%, 0.125W	01121	BB9115

Kct No.	Tektronix Part No.	Serial/Model No. Eff	Dscont	Name & Description	Mfr Code	Mfr Part Number
R1439	301-0393-00			RES., FXD, CMPSN: 39K OHM, 5%, 0.50W	01121	EB3935
R1442	315-0102-00	B010100	B124364	RES., FXD, CMPSN: 1K OHM, 5%, 0.25W	01121	CB1025
R1442	315-0102-03	B124365		RES., FXD, CMPSN: 1K OHM, 5%, 0.25W	01121	CB1025
R1443	315-0221-00			RES., FXD, CMPSN: 220 OHM, 5%, 0.25W	01121	CB2215
R1444	315-0102-00	B010100	B124364	RES., FXD, CMPSN: 1K OHM, 5%, 0.25W	01121	CB1025
R1444	315-0102-03	B124365		RES., FXD, CMPSN: 1K OHM, 5%, 0.25W	01121	CB1025
R1445	315-0226-00			RES., FXD, CMPSN: 22M OHM, 5%, 0.25W	01121	CB2265
R1446	315-0103-00	B010100	B124364	RES., FXD, CMPSN: 10K OHM, 5%, 0.25W	01121	CB1035
R1446	315-0103-03	B124365		RES., FXD, CMPSN: 10K OHM, 5%, 0.25W	01121	CB1035
R1453	315-0103-00			RES., FXD, CMPSN: 10K OHM, 5%, 0.25W	01121	CB1035
R1454	311-1554-00			RES., VAR, NONWIR: 200K OHM, 20%, 0.50W	73138	91-76-0
R1455	315-0102-00			RES., FXD, CMPSN: 1K OHM, 5%, 0.25W	01121	CB1025
R1462	315-0124-00			RES., FXD, CMPSN: 120K OHM, 5%, 0.25W	01121	CB1245
R1463	321-0365-00			RES., FXD, FILM: 61.9K OHM, 1%, 0.125W	91637	MFF1816G61901F
R1464	311-1555-00			RES., VAR, NONWIR: 100K OHM, 20%, 0.5W	73138	91-77-0
R1465	321-0433-00			RES., FXD, FILM: 316K OHM, 1%, 0.125W	91637	MFF1816G31602F
R1466	315-0103-00			RES., FXD, CMPSN: 10K OHM, 5%, 0.25W	01121	CB1035
R1467	321-0414-00			RES., FXD, FILM: 200K OHM, 1%, 0.125W	91637	MFF1816G20002F
R1472	315-0272-00			RES., FXD, CMPSN: 2.7K OHM, 5%, 0.25W	01121	CB2725
R1473	315-0103-00			RES., FXD, CMPSN: 10K OHM, 5%, 0.25W	01121	CB1035
R1474	315-0102-00			RES., FXD, CMPSN: 1K OHM, 5%, 0.25W	01121	CB1025
R1475	315-0683-00			RES., FXD, CMPSN: 68K OHM, 5%, 0.25W	01121	CB6835
R1477	315-0122-00			RES., FXD, CMPSN: 1.2K OHM, 5%, 0.25W	01121	CB1225
R1482	315-0104-00			RES., FXD, CMPSN: 100K OHM, 5%, 0.25W	01121	CB1045
R1483	315-0562-00			RES., FXD, CMPSN: 5.6K OHM, 5%, 0.25W	01121	CB5625
R1486	315-0472-00			RES., FXD, CMPSN: 4.7K OHM, 5%, 0.25W	01121	CB4725
R1492	315-0271-00			RES., FXD, CMPSN: 270 OHM, 5%, 0.25W	01121	CB2715
R1493	315-0223-00			RES., FXD, CMPSN: 22K OHM, 5%, 0.25W	01121	CB2235
R1494	315-0103-00			RES., FXD, CMPSN: 10K OHM, 5%, 0.25W	01121	CB1035
R1495	315-0102-00			RES., FXD, CMPSN: 1K OHM, 5%, 0.25W	01121	CB1025
R1496	321-0284-00			RES., FXD, FILM: 8.87K OHM, 1%, 0.125W	91637	MFF1816G88700F
R1497	321-0289-00			RES., FXD, FILM: 10K OHM, 1%, 0.125W	91637	MFF1816G10001F
R1498	321-0297-00			RES., FXD, FILM: 12.1K OHM, 1%, 0.125W	91637	MFF1816G12101F
R1501	315-0104-00			RES., FXD, CMPSN: 100K OHM, 5%, 0.25W	01121	CB1045
R1502	315-0205-00			RES., FXD, CMPSN: 2M OHM, 5%, 0.25W	01121	CB2055
R1504	315-0103-00	B010100	B124364	RES., FXD, CMPSN: 10K OHM, 5%, 0.25W	01121	CB1035
R1504	315-0103-03	B124365		RES., FXD, CMPSN: 10K OHM, 5%, 0.25W	01121	CB1035
R1505	315-0203-00			RES., FXD, CMPSN: 20K OHM, 5%, 0.25W	01121	CB2035
R1507	315-0102-00			RES., FXD, CMPSN: 1K OHM, 5%, 0.25W	01121	CB1025
R1508	315-0103-00	B010100	B124364	RES., FXD, CMPSN: 10K OHM, 5%, 0.25W	01121	CB1035
R1508	315-0103-03	B124365		RES., FXD, CMPSN: 10K OHM, 5%, 0.25W	01121	CB1035
R1512	315-0102-00			RES., FXD, CMPSN: 1K OHM, 5%, 0.25W	01121	CB1025
R1514	307-0061-00			RES., FXD, CMPSN: 7.5 OHM, 5%, 0.50W	01121	EB75G5
R1517	315-0754-00			RES., FXD, CMPSN: 750K OHM, 5%, 0.25W	01121	CB7545
R1518	315-0754-00			RES., FXD, CMPSN: 750K OHM, 5%, 0.25W	01121	CB7545
R1522	315-0103-00	B010100	B124364	RES., FXD, CMPSN: 10K OHM, 5%, 0.25W	01121	CB1035
R1522	315-0103-03	B124365		RES., FXD, CMPSN: 10K OHM, 5%, 0.25W	01121	CB1035
R1525A, B)	307-0431-01			RES., FXD, FILM: HI VOLT FOCUS& REG	80009	307-0431-01
R1525C, D)						
R1526	311-1717-00			RES., VAR, NONWIR: 2.5M OHM, 10%, 1W	12697	CM40403
R1527	311-1550-00			RES., VAR, NONWIR: 2M OHM, 20%, 0.50W	73138	91-72-0
R1529	311-1716-00			RES., VAR, NONWIR: PNL, 1.5MEG OHM, 1W	16546	BA201-010
R1530	315-0225-00	XB120000		RES., FXD, CMPSN: 2.2M OHM, 5%, 0.25W	01121	CB2255
R1532	315-0625-00			RES., FXD, CMPSN: 6.2M OHM, 5%, 0.25W	01121	CB6255
R1533	315-0124-00			RES., FXD, CMPSN: 120K OHM, 5%, 0.25W	01121	CB1245
R1542	315-0106-00			RES., FXD, CMPSN: 10M OHM, 5%, 0.25W	01121	CB1065
R1543	315-0136-01			RES., FXD, CMPSN: 13M OHM, 5%, 0.25W	01121	CB1365



Replaceable Electrical Parts—466 Service

Ckt No.	Tektronix Part No.	Serial/Model No. Eff	Dscont	Name & Description	Mfr Code	Mfr Part Number
R1545	315-0395-00			RES., FXD, CMPSN: 3.9M OHM, 5%, 0.25W	01121	CB3955
R1547	315-0206-01			RES., FXD, CMPSN: 20M OHM, 5%, 0.25W	01121	CB2065
R1552	315-0361-00			RES., FXD, CMPSN: 360 OHM, 5%, 0.25W	01121	CB3615
R1553	311-1313-00			RES., VAR, NONWIR: 2K OHM, 20%, 1W	01121	73M4G048L202M
R1554	311-1561-00			RES., VAR, NONWIR: 2.5K OHM, 20%, 0.50W	73138	91-83-0
R1556	311-1554-00			RES., VAR, NONWIR: 200K OHM, 20%, 0.50W	73138	91-76-0
R1562	301-0301-00			RES., FXD, CMPSN: 300 OHM, 5%, 0.50W	01121	EB3015
R1563	311-1561-00			RES., VAR, NONWIR: 2.5K OHM, 20%, 0.50W	73138	91-83-0
R1564	311-1561-00			RES., VAR, NONWIR: 2.5K OHM, 20%, 0.50W	73138	91-83-0
R1572	315-0204-00			RES., FXD, CMPSN: 200K OHM, 5%, 0.25W	01121	CB2045
R1573	311-1552-00			RES., VAR, NONWIR: 500K OHM, 20%, 0.50W	73138	91-74-0
R1574	315-0683-00			RES., FXD, CMPSN: 68K OHM, 5%, 0.25W	01121	CB6835
R1575	311-1372-00			RES., VAR, NONWIR: 100K OHM, 20%, 1W	01121	73M1G040L104M
R1583	301-0305-00			RES., FXD, CMPSN: 3M OHM, 5%, 0.50W	01121	EB3055
R1584	301-0305-00			RES., FXD, CMPSN: 3M OHM, 5%, 0.50W	01121	EB3055
R1585	301-0305-00			RES., FXD, CMPSN: 3M OHM, 5%, 0.50W	01121	EB3055
R1586	301-0305-00			RES., FXD, CMPSN: 3M OHM, 5%, 0.50W	01121	EB3055
R1587	301-0305-00			RES., FXD, CMPSN: 3M OHM, 5%, 0.50W	01121	EB3055
R1604	-----			(SEE OPTION 7)		
R1605	-----			(SEE OPTION 7)		
R1607	-----			(SEE OPTION 7)		
R1609	-----			(SEE OPTION 7)		
R1611	-----			(SEE OPTION 7)		
R1613	-----			(SEE OPTION 7)		
R1614	-----			(SEE OPTION 7)		
R1617	-----			(SEE OPTION 7)		
R1618	-----			(SEE OPTION 7)		
R1622	-----			(SEE OPTION 7)		
R1623	-----			(SEE OPTION 7)		
R1624	-----			(SEE OPTION 7)		
R1625	-----			(SEE OPTION 7)		
R1626	-----			(SEE OPTION 7)		
R1631	-----			(SEE OPTION 7)		
R1633	-----			(SEE OPTION 7)		
R1639	-----			(SEE OPTION 7)		
R1640	-----			(SEE OPTION 7)		
R1641	-----			(SEE OPTION 7)		
R1642	-----			(SEE OPTION 7)		
R1645	-----			(SEE OPTION 7)		
R1652	-----			(SEE OPTION 7)		
R1654	-----			(SEE OPTION 7)		
R1662	-----			(SEE OPTION 7)		
R1664	-----			(SEE OPTION 7)		
R1671	-----			(SEE OPTION 7)		
R1691	303-0150-00	B010100	B138089X	RES., FXD, CMPSN: 15 OHM, 5%, 1W	01121	GB1505
R1692	321-0062-00	B010100	B138089X	RES., FXD, FILM: 43.2 OHM, 1%, 0.125W	91637	CMF55-116G43R20F
R1693	323-0140-00	B010100	B138089X	RES., FXD, FILM: 280 OHM, 1%, 0.50W	75042	CECT0-2800F
R1694	323-0140-00	B010100	B138089X	RES., FXD, FILM: 280 OHM, 1%, 0.50W	75042	CECT0-2800F
R1695	321-0228-00	B010100	B138089X	RES., FXD, FILM: 2.32K OHM, 1%, 0.125W	91637	MFF1816G23200F
R1697	321-0201-00	B010100	B138089X	RES., FXD, FILM: 1.21K OHM, 1%, 0.125W	91637	MFF1816G12100F
R1698	315-0363-00	B010100	B138089X	RES., FXD, CMPSN: 36K OHM, 5%, 0.25W	01121	CB3635
R1712	315-0272-00			RES., FXD, CMPSN: 2.7K OHM, 5%, 0.25W	01121	CB2725
R1715	315-0392-00			RES., FXD, CMPSN: 3.9K OHM, 5%, 0.25W	01121	CB3925
R1716	307-0107-00	B010100	B149443	RES., FXD, CMPSN: 5.6 OHM, 5%, 0.25W	01121	CB56G5
R1716	307-0116-00	B149444		RES., FXD, CMPSN: 9.1 OHM, 5%, 0.25W	01121	CB91G5
R1717	321-0172-00			RES., FXD, FILM: 604 OHM, 1%, 0.125W	91637	MFF1816G604R0F
R1718	321-0369-00			RES., FXD, FILM: 68.1K OHM, 1%, 0.125W	91637	MFF1816G68101F
R1722	303-0333-00			RES., FXD, CMPSN: 33K OHM, 5%, 1W	01121	GB3335
R1723	315-0153-00			RES., FXD, CMPSN: 15K OHM, 5%, 0.25W	01121	CB1535
R1724	315-0102-00			RES., FXD, CMPSN: 1K OHM, 5%, 0.25W	01121	CB1025
R1725	321-0280-00			RES., FXD, FILM: 8.06K OHM, 1%, 0.125W	91637	MFF1816G80600F

Replaceable Electrical Parts—466 Service

Ckt No.	Tektronix Part No.	Serial/Model No. Eff	Dscont	Name & Description	Mfr Code	Mfr Part Number
R1726	321-0277-00	B010100	B050451	RES., FXD, FILM: 7.5K OHM, 1%, 0.125W (FOR SOME S/N, R1726 WILL CONSIST OF TWO 15K OHM, 0.25W RESISTORS IN PARALLEL. REPL WITH A SINGLE 323-0277-00)	91637	MFF1816G75000F
R1726	323-0277-00	B050452		RES., FXD, FILM: 7.5K OHM, 1%, 0.50W (SEE FOOTNOTE ON R1726)	75042	CECT0-7501F
R1727	303-0682-00	XB010135		RES., FXD, CMPSN: 6.8K OHM, 5%, 1W	01121	GB6825
R1732	315-0331-00			RES., FXD, CMPSN: 330 OHM, 5%, 0.25W	01121	CB3315
R1733	315-0243-00			RES., FXD, CMPSN: 24K OHM, 5%, 0.25W	01121	CB2435
R1734	307-0052-00			RES., FXD, CMPSN: 3 OHM, 5%, 0.50W	01121	EB30G5
R1735	321-0362-00			RES., FXD, FILM: 57.6K OHM, 1%, 0.125W	91637	MFF1816G57601F
R1736	311-1226-00			RES., VAR, NONWIR: 2.5K OHM, 20%, 0.50W	32997	3386F-T04-252
R1737	321-0284-00			RES., FXD, FILM: 8.87K OHM, 1%, 0.125W	91637	MFF1816G88700F
R1743	315-0103-00			RES., FXD, CMPSN: 10K OHM, 5%, 0.25W	01121	CB1035
R1744	315-0103-00			RES., FXD, CMPSN: 10K OHM, 5%, 0.25W	01121	CB1035
R1752	321-0756-03			RES., FXD, FILM: 50K OHM, 0.25%, 0.125W	91637	MFF1816D50001C
R1753	321-0603-00			RES., FXD, FILM: 15K OHM, 0.25%, 0.125W	91637	MFF1816D15001C
R1754	315-0681-00	B010100	B079999	RES., FXD, CMPSN: 680 OHM, 5%, 0.25W	01121	CB6815
R1754	315-0911-00	B080000	B081689	RES., FXD, CMPSN: 910 OHM, 5%, 0.25W	01121	CB9115
R1754	315-0122-00	B081690		RES., FXD, CMPSN: 1.2K OHM, 5%, 0.25W	01121	CB1225
R1756	315-0163-00			RES., FXD, CMPSN: 16K OHM, 5%, 0.25W	01121	CB1635
R1757	308-0245-00			RES., FXD, WW: 0.6 OHM, 5%, 2W	91637	CW2B30 0.60HM 5%
R1762	321-0720-03			RES., FXD, FILM: 60K OHM, 0.25%, 0.125W	91637	MFF1816D60001C
R1763	321-0816-03			RES., FXD, FILM: 5K OHM, 0.25%, 0.125W	91637	MFF1816D50000C
R1765	315-0471-00			RES., FXD, CMPSN: 470 OHM, 5%, 0.25W	01121	CB4715
R1766	315-0472-00			RES., FXD, CMPSN: 4.7K OHM, 5%, 0.25W	01121	CB4725
R1767	308-0245-00			RES., FXD, WW: 0.6 OHM, 5%, 2W	91637	CW2B30 0.60HM 5%
R1772	321-0755-03			RES., FXD, FILM: 65K OHM, 0.25%, 0.125W	91637	MFF1816D65001C
R1773	321-0962-03			RES., FXD, FILM: 8K OHM, 0.25%, 0.125W	91637	MFF1816D80000C
R1774	321-0275-00			RES., FXD, FILM: 7.15K OHM, 1%, 0.125W	91637	MFF1816G71500F
R1775	315-0152-00			RES., FXD, CMPSN: 1.5K OHM, 5%, 0.25W	01121	CB1525
R1776	315-0163-00			RES., FXD, CMPSN: 16K OHM, 5%, 0.25W	01121	CB1635
R1777	308-0245-00			RES., FXD, WW: 0.6 OHM, 5%, 2W	91637	CW2B30 0.60HM 5%
R1778	315-0101-00			RES., FXD, CMPSN: 100 OHM, 5%, 0.25W	01121	CB1015
R1781	321-0622-00			RES., FXD, FILM: 37.96K OHM, 0.25%, 0.125W	91637	MFF1816D37961C
R1782	315-0332-00			RES., FXD, CMPSN: 3.3K OHM, 5%, 0.25W	01121	CB3325
R1783	321-1283-03			RES., FXD, FILM: 8.76K OHM, 0.25%, 0.125W	91637	MFF1816D87600C
R1784	315-0332-00			RES., FXD, CMPSN: 3.3K OHM, 5%, 0.25W	01121	CB3325
R1785	315-0682-00			RES., FXD, CMPSN: 6.8K OHM, 5%, 0.25W	01121	CB6825
R1786	315-0301-00			RES., FXD, CMPSN: 300 OHM, 5%, 0.25W	01121	CB3015
R1787	315-0163-00			RES., FXD, CMPSN: 16K OHM, 5%, 0.25W	01121	CB1635
R1788	307-0052-00			RES., FXD, CMPSN: 3 OHM, 5%, 0.50W	01121	EB30G5
R1792	315-0392-00	B010100	B010134	RES., FXD, CMPSN: 3.9K OHM, 5%, 0.25W	01121	CB3925
R1792	315-0302-00	B010135		RES., FXD, CMPSN: 3K OHM, 5%, 0.25W	01121	CB3025
R1794	311-1373-00			RES., VAR, NONWIR: 5K OHM, 20%, 1W	01121	73U4G04OL502M
R1802	315-0202-00			RES., FXD, CMPSN: 2K OHM, 5%, 0.25W	01121	CB2025
R1803	315-0302-00			RES., FXD, CMPSN: 3K OHM, 5%, 0.25W	01121	CB3025
R1812	315-0104-00			RES., FXD, CMPSN: 100K OHM, 5%, 0.25W	01121	CB1045
R1813	315-0204-00			RES., FXD, CMPSN: 200K OHM, 5%, 0.25W	01121	CB2045
R1814	315-0334-00			RES., FXD, CMPSN: 330K OHM, 5%, 0.25W	01121	CB3345
R1815	311-1669-00	B010100	B071809	RES., VAR, NONWIR (FURNISHED AS A UNIT WITH S1815A, B, C)	01121	12M458
R1815	311-1864-00	B071810		RES., VAR, NONWIR: PNL, 10K OHM, 1.0W, 2PST (FURNISHED AS A UNIT WITH S1815A, B, C)	01121	14M445
R1816	315-0152-00			RES., FXD, CMPSN: 1.5K OHM, 5%, 0.25W	01121	CB1525
R1817	315-0124-00			RES., FXD, CMPSN: 120K OHM, 5%, 0.25W	Q1121	CB1245
R1818	315-0203-00			RES., FXD, CMPSN: 20K OHM, 5%, 0.25W	01121	CB2035

Replaceable Electrical Parts—466 Service

Ckt No.	Tektronix Part No.	Serial/Model No. Eff	Dscont	Name & Description	Mfr Code	Mfr Part Number
R1823	315-0103-00			RES., FXD, CMPSN: 10K OHM, 5%, 0.25W	01121	CB1035
R1824	315-0103-00			RES., FXD, CMPSN: 10K OHM, 5%, 0.25W	01121	CB1035
R1825	315-0161-00			RES., FXD, CMPSN: 160 OHM, 5%, 0.25W	01121	CB1615
R1826	315-0150-00			RES., FXD, CMPSN: 15 OHM, 5%, 0.25W	01121	CB1505
R1827	315-0132-00			RES., FXD, CMPSN: 1.3K OHM, 5%, 0.25W	01121	CB1325
R1831	315-0822-00			RES., FXD, CMPSN: 8.2K OHM, 5%, 0.25W	01121	CB8225
R1832	315-0153-00			RES., FXD, CMPSN: 15K OHM, 5%, 0.25W	01121	CB1535
R1833	315-0221-00			RES., FXD, CMPSN: 220 OHM, 5%, 0.25W	01121	CB2215
R1834	315-0222-00			RES., FXD, CMPSN: 2.2K OHM, 5%, 0.25W	01121	CB2225
R1835	315-0222-00			RES., FXD, CMPSN: 2.2K OHM, 5%, 0.25W	01121	CB2225
R1836	315-0822-00			RES., FXD, CMPSN: 8.2K OHM, 5%, 0.25W	01121	CB8225
R1837	315-0153-00			RES., FXD, CMPSN: 15K OHM, 5%, 0.25W	01121	CB1535
R1838	315-0221-00			RES., FXD, CMPSN: 220 OHM, 5%, 0.25W	01121	CB2215
R1842	315-0433-00			RES., FXD, CMPSN: 43K OHM, 5%, 0.25W	01121	CB4335
R1843	315-0182-00			RES., FXD, CMPSN: 1.8K OHM, 5%, 0.25W	01121	CB1825
R1844	315-0272-00			RES., FXD, CMPSN: 2.7K OHM, 5%, 0.25W	01121	CB2725
R1845	315-0103-00			RES., FXD, CMPSN: 10K OHM, 5%, 0.25W	01121	CB1035
R1846	315-0103-00			RES., FXD, CMPSN: 10K OHM, 5%, 0.25W	01121	CB1035
R1847	315-0203-00			RES., FXD, CMPSN: 20K OHM, 5%, 0.25W	01121	CB2035
R1848	315-0113-00			RES., FXD, CMPSN: 11K OHM, 5%, 0.25W	01121	CB1135
R1852	307-0106-00			RES., FXD, CMPSN: 4.7 OHM, 5%, 0.25W	01121	CB47G5
R1853	315-0241-00			RES., FXD, CMPSN: 240 OHM, 5%, 0.25W	01121	CB2415
R1855	315-0473-00			RES., FXD, CMPSN: 47K OHM, 5%, 0.25W	01121	CB4735
R1856	315-0204-00	B010100	B092809	RES., FXD, CMPSN: 200K OHM, 5%, 0.25W	01121	CB2045
R1856	315-0474-00	B092810		RES., FXD, CMPSN: 470K OHM, 5%, 0.25W	01121	CB4745
R1858	311-1254-00	B010100	B092809X	RES., VAR, NONWIR: 1M OHM, 20%, 0.50W	73138	72-18-0
R1862	315-0154-00			RES., FXD, CMPSN: 150K OHM, 5%, 0.25W	01121	CB1545
R1863	315-0471-00			RES., FXD, CMPSN: 470 OHM, 5%, 0.25W	01121	CB4715
R1864	315-0272-00			RES., FXD, CMPSN: 2.7K OHM, 5%, 0.25W	01121	CB2725
R1867	315-0272-00			RES., FXD, CMPSN: 2.7K OHM, 5%, 0.25W	01121	CB2725
R1869	315-0103-00			RES., FXD, CMPSN: 10K OHM, 5%, 0.25W	01121	CB1035
R1872	315-0221-00			RES., FXD, CMPSN: 220 OHM, 5%, 0.25W	01121	CB2215
R1874	315-0911-00			RES., FXD, CMPSN: 910 OHM, 5%, 0.25W	01121	CB9115
R1875	315-0103-00			RES., FXD, CMPSN: 10K OHM, 5%, 0.25W	01121	CB1035
R1922	315-0334-00			RES., FXD, CMPSN: 330K OHM, 5%, 0.25W	01121	CB3345
R1923	311-1668-00			RES., VAR, NONWIR: PNL, 2 X 10K OHM, 0.5W	01121	16M142
	-----			(FURNISHED AS A UNIT WITH R2074)		
R1924	315-0132-00			RES., FXD, CMPSN: 1.3K OHM, 5%, 0.25W	01121	CB1325
R1925	321-0411-00			RES., FXD, FILM: 187K OHM, 1%, 0.125W	91637	MFF1816G18702F
R1926	321-0414-00			RES., FXD, FILM: 200K OHM, 1%, 0.125W	91637	MFF1816G20002F
R1927	311-1229-00			RES., VAR, NONWIR: 15K OHM, 20%, 0.50W	32997	3386F-T04-153
R1928	315-0332-00			RES., FXD, CMPSN: 3.3K OHM, 5%, 0.25W	01121	CB3325
R1932	315-0823-00			RES., FXD, CMPSN: 82K OHM, 5%, 0.25W	01121	CB8235
R1933	311-1252-00			RES., VAR, NONWIR: 500K OHM, 20%, 0.50W	32997	3386F-T04-504
R1934	321-0373-00			RES., FXD, FILM: 75K OHM, 1%, 0.125W	91637	MFF1816G75001F
R1935	311-1319-00			RES., VAR, NONWIR: 10K OHM, 10%, 0.75W	73138	89-126-1
R1941	321-0414-00			RES., FXD, FILM: 200K OHM, 1%, 0.125W	91637	MFF1816G20002F
R1942	315-0153-00			RES., FXD, CMPSN: 15K OHM, 5%, 0.25W	01121	CB1535
R1943	315-0391-00			RES., FXD, CMPSN: 390 OHM, 5%, 0.25W	01121	CB3915
R1944	315-0163-00			RES., FXD, CMPSN: 16K OHM, 5%, 0.25W	01121	CB1635
R1945	315-0221-00	B010100	B069999	RES., FXD, CMPSN: 220 OHM, 5%, 0.25W	01121	CB2215
R1945	315-0220-00	B070000	B079999	RES., FXD, CMPSN: 22 OHM, 5%, 0.25W	01121	CB2205
R1945	315-0221-00	B080000		RES., FXD, CMPSN: 220 OHM, 5%, 0.25W	01121	CB2215
R1946	315-0154-00			RES., FXD, CMPSN: 150K OHM, 5%, 0.25W	01121	CB1545
R1947	315-0102-00			RES., FXD, CMPSN: 1K OHM, 5%, 0.25W	01121	CB1025
R1952	315-0332-00			RES., FXD, CMPSN: 3.3K OHM, 5%, 0.25W	01121	CB3325
R1953	315-0303-00	B010100	B124209	RES., FXD, CMPSN: 30K OHM, 5%, 0.25W	01121	CB3035

Ckt No.	Tektronix Part No.	Serial/Model No. Eff	Dscont	Name & Description	Mfr Code	Mfr Part Number
R1953	315-0153-00	B124210		RES., FXD, CMPSN: 15K OHM, 5%, 0.25W	01121	CB1535
R1954	315-0153-00			RES., FXD, CMPSN: 15K OHM, 5%, 0.25W	01121	CB1535
R1955	315-0202-00	B010100	B069999	RES., FXD, CMPSN: 2K OHM, 5%, 0.25W	01121	CB2025
R1955	315-0201-00	B070000	B079999	RES., FXD, CMPSN: 20K OHM, 5%, 0.25W	01121	CB2015
R1955	315-0202-00	B080000		RES., FXD, CMPSN: 2K OHM, 5%, 0.25W	01121	CB2025
R1956	315-0133-00	B010100	B069999X	RES., FXD, CMPSN: 13K OHM, 5%, 0.25W	01121	CB1335
R1956	315-0133-00	XB080000		RES., FXD, CMPSN: 13K OHM, 5%, 0.25W	01121	CB1335
R1957	315-0124-00			RES., FXD, CMPSN: 120K OHM, 5%, 0.25W	01121	CB1245
R1962	315-0335-00			RES., FXD, CMPSN: 3.3M OHM, 5%, 0.25W	01121	CB3355
R1963	315-0753-00			RES., FXD, CMPSN: 75K OHM, 5%, 0.25W	01121	CB7535
R1964	315-0335-00			RES., FXD, CMPSN: 3.3M OHM, 5%, 0.25W	01121	CB3355
R1965	315-0334-00			RES., FXD, CMPSN: 330K OHM, 5%, 0.25W	01121	CB3345
R1966	315-0125-00	B010100	B010289	RES., FXD, CMPSN: 1.2M OHM, 5%, 0.25W	01121	CB1255
R1966	315-0155-00	B010290		RES., FXD, CMPSN: 1.5M OHM, 5%, 0.25W	01121	CB1555
R1967	315-0155-00	B010100	B010289	RES., FXD, CMPSN: 1.5M OHM, 5%, 0.25W	01121	CB1555
R1967	315-0185-00	B010290		RES., FXD, CMPSN: 1.8M OHM, 5%, 0.25W	01121	CB1855
R1968	315-0335-00			RES., FXD, CMPSN: 3.3M OHM, 5%, 0.25W	01121	CB3355
R1982	311-1339-00	B010100	B010169	RES., VAR, NONWIR: 5K OHM, 10%, 0.50W	73138	89-131-1
R1982	311-1319-00	B010170		RES., VAR, NONWIR: 10K OHM, 10%, 0.75W	73138	89-126-1
R1983	321-0355-00	B010100	B010169	RES., FXD, FILM: 48.7K OHM, 1%, 0.125W	91637	MFF1816G48701F
R1983	321-0357-00	B010170		RES., FXD, FILM: 51.1K OHM, 1%, 0.125W	91637	MFF1816G51101F
R1984	321-0364-00			RES., FXD, FILM: 60.4K OHM, 1%, 0.125W	91637	MFF1816G60401F
R1985	321-0366-00			RES., FXD, FILM: 63.4K OHM, 1%, 0.125W	91637	MFF1816G63401F
R1986	321-0365-00			RES., FXD, FILM: 61.9K OHM, 1%, 0.125W	91637	MFF1816G61901F
R1987	311-1229-00	B010100	B010139	RES., VAR, NONWIR: 15K OHM, 20%, 0.50W	32997	3386F-T04-153
R1987	311-1225-00	B010140		RES., VAR, NONWIR: 1K OHM, 20%, 0.50W	32997	3386F-T04-102
R1988	321-0302-00			RES., FXD, FILM: 13.7K OHM, 1%, 0.125W	91637	MFF1816G13701F
R1989	311-1225-00	B010100	B010139	RES., VAR, NONWIR: 1K OHM, 20%, 0.50W	32997	3386F-T04-102
R1989	311-1229-00	B010140		RES., VAR, NONWIR: 15K OHM, 20%, 0.50W	32997	3386F-T04-153
R1991	321-0385-00			RES., FXD, FILM: 100K OHM, 1%, 0.125W	91637	MFF1816G10002F
R1992	315-0752-00			RES., FXD, CMPSN: 7.5K OHM, 5%, 0.25W	01121	CB7525
R1993	315-0391-00			RES., FXD, CMPSN: 390 OHM, 5%, 0.25W	01121	CB3915
R1994	315-0822-00			RES., FXD, CMPSN: 8.2K OHM, 5%, 0.25W	01121	CB8225
R1995	315-0201-00			RES., FXD, CMPSN: 200 OHM, 5%, 0.25W	01121	CB2015
R1996	315-0103-00			RES., FXD, CMPSN: 10K OHM, 5%, 0.25W	01121	CB1035
R1997	301-0203-00			RES., FXD, CMPSN: 20K OHM, 5%, 0.50W	01121	EB2035
R1998	315-0102-00			RES., FXD, CMPSN: 1K OHM, 5%, 0.25W	01121	CB1025
R1999	315-0471-00			RES., FXD, CMPSN: 470 OHM, 5%, 0.25W	01121	CB4715
R2012	321-0394-00			RES., FXD, FILM: 124K OHM, 1%, 0.125W	91637	MFF1816G12402F
R2013	321-0396-00			RES., FXD, FILM: 130K OHM, 1%, 0.125W	91637	MFF1816G13002F
R2015	321-0396-00			RES., FXD, FILM: 130K OHM, 1%, 0.125W	91637	MFF1816G13002F
R2022	321-0337-00			RES., FXD, FILM: 31.6K OHM, 1%, 0.125W	91637	MFF1816G31601F
R2023	321-0423-00			RES., FXD, FILM: 249K OHM, 1%, 0.125W	91637	MFF1816G24902F
R2024	315-0223-00			RES., FXD, CMPSN: 22K OHM, 5%, 0.25W	01121	CB2235
R2025	315-0753-00			RES., FXD, CMPSN: 75K OHM, 5%, 0.25W	01121	CB7535
R2026	315-0471-00			RES., FXD, CMPSN: 470 OHM, 5%, 0.25W	01121	CB4715
R2031	321-0452-00			RES., FXD, FILM: 499K OHM, 1%, 0.125W	91637	MFF1816G49902F
R2032	321-0452-00			RES., FXD, FILM: 499K OHM, 1%, 0.125W	91637	MFF1816G49902F
R2033	321-0392-00			RES., FXD, FILM: 118K OHM, 1%, 0.125W	91637	MFF1816G11802F
R2034	315-0104-00			RES., FXD, CMPSN: 100K OHM, 5%, 0.25W	01121	CB1045
R2035	321-0433-00			RES., FXD, FILM: 316K OHM, 1%, 0.125W	91637	MFF1816G31602F
R2037	315-0222-00			RES., FXD, CMPSN: 2.2K OHM, 5%, 0.25W	01121	CB2225
R2038	315-0393-00			RES., FXD, CMPSN: 39K OHM, 5%, 0.25W	01121	CB3935
R2042	321-0411-00			RES., FXD, FILM: 187K OHM, 1%, 0.125W	91637	MFF1816G18702F
R2043	321-0414-00			RES., FXD, FILM: 200K OHM, 1%, 0.125W	91637	MFF1816G20002F
R2044	321-0395-00			RES., FXD, FILM: 127K OHM, 1%, 0.125W	91637	MFF1816G12702F
R2045	315-0104-00			RES., FXD, CMPSN: 100K OHM, 5%, 0.25W	01121	CB1045

Replaceable Electrical Parts—466 Service

Ckt No.	Tektronix Part No.	Serial/Model No. Eff	Dscont	Name & Description	Mfr Code	Mfr Part Number
R2046	321-0452-00			RES., FXD, FILM:499K OHM, 1%, 0.125W	91637	MFF1816G49902F
R2047	301-0473-00			RES., FXD, CMPSN:47K OHM, 5%, 0.50W	01121	EB4735
R2048	315-0222-00			RES., FXD, CMPSN:2.2K OHM, 5%, 0.25W	01121	CB2225
R2052	321-0449-00			RES., FXD, FILM:464K OHM, 1%, 0.125W	91637	MFF1816G46402F
R2053	321-0400-00			RES., FXD, FILM:143K OHM, 1%, 0.125W	91637	MFF1816G14302F
R2054	321-0422-00			RES., FXD, FILM:243K OHM, 1%, 0.125W	91637	MFF1816G24302F
R2055	315-0104-00			RES., FXD, CMPSN:100K OHM, 5%, 0.25W	01121	CB1045
R2056	321-0452-00			RES., FXD, FILM:499K OHM, 1%, 0.125W	91637	MFF1816G49902F
R2057	301-0473-00			RES., FXD, CMPSN:47K OHM, 5%, 0.50W	01121	EB4735
R2058	315-0102-00			RES., FXD, CMPSN:1K OHM, 5%, 0.25W	01121	CB1025
R2072	315-0103-00			RES., FXD, CMPSN:10K OHM, 5%, 0.25W	01121	CB1035
R2073	315-0103-00			RES., FXD, CMPSN:10K OHM, 5%, 0.25W	01121	CB1035
R2074	311-1668-00			RES., VAR, NONWIR:PNL, 2 X 10K OHM, 0.5W (R2074 FURN AS A UNIT WITH R1923)	01121	16M142
R2075	315-0204-00			RES., FXD, CMPSN:200K OHM, 5%, 0.25W	01121	CB2045
R2076	315-0103-00			RES., FXD, CMPSN:10K OHM, 5%, 0.25W	01121	CB1035
R2077	315-0303-00	B010100	B092809	RES., FXD, CMPSN:30K OHM, 5%, 0.25W	01121	CB3035
R2077	315-0153-00	B092810		RES., FXD, CMPSN:15K OHM, 5%, 0.25W	01121	CB1535
R2078	315-0243-00			RES., FXD, CMPSN:24K OHM, 5%, 0.25W	01121	CB2435
R2079	315-0393-00	B010100	B069999	RES., FXD, CMPSN:39K OHM, 5%, 0.25W	01121	CB3935
R2079	315-0103-00	B070000	B079999	RES., FXD, CMPSN:10K OHM, 5%, 0.25W	01121	CB1035
R2079	315-0393-00	B080000		RES., FXD, CMPSN:39K OHM, 5%, 0.25W	01121	CB3935
R2092	321-0189-00			RES., FXD, FILM:909 OHM, 1%, 0.125W	91637	MFF1816G909R0F
R2093	321-0150-00			RES., FXD, FILM:357 OHM, 1%, 0.125W	91637	MFF1816G357R0F
R2094	315-0103-00			RES., FXD, CMPSN:10K OHM, 5%, 0.25W	01121	CB1035
R2099	301-0220-00	B010100	B079999	RES., FXD, CMPSN:22 OHM, 5%, 0.50W	01121	EB2205
R2099	308-0290-00	B080000		RES., FXD, WW:8 OHM, 5%, 5W	91637	CW2A-8R000J
R2801	-----			(SEE OPTION 5)		
R2802	-----			(SEE OPTION 5)		
R2803	-----			(SEE OPTION 5)		
R2804	-----			(SEE OPTION 5)		
R2805	-----			(SEE OPTION 5)		
R2807	-----			(SEE OPTION 5)		
R2809	-----			(SEE OPTION 5)		
R2810	-----			(SEE OPTION 5)		
R2811	-----			(SEE OPTION 5)		
R2812	-----			(SEE OPTION 5)		
R2813	-----			(SEE OPTION 5)		
R2814	-----			(SEE OPTION 5)		
R2816	-----			(SEE OPTION 5)		
R2818	-----			(SEE OPTION 5)		
R2820	-----			(SEE OPTION 5)		
R2824	-----			(SEE OPTION 5)		
R2825	-----			(SEE OPTION 5)		
R2826	-----			(SEE OPTION 5)		
R2827	-----			(SEE OPTION 5)		
R2830	-----			(SEE OPTION 5)		
R2833	-----			(SEE OPTION 5)		
R2834	-----			(SEE OPTION 5)		
R2850	-----			(SEE OPTION 5)		
R2854	-----			(SEE OPTION 5)		
R2856	-----			(SEE OPTION 5)		
R2860	-----			(SEE OPTION 5)		
R2861	-----			(SEE OPTION 5)		
R2863	-----			(SEE OPTION 5)		
R2875	-----			(SEE OPTION 5)		
R2879	-----			(SEE OPTION 5)		
R8033	321-0228-00	XB138090		RES., FXD, FILM:2.32K OHM, 1%, 0.125W	91637	MFF1816G23200F
R8035	321-0201-00	XB138090		RES., FXD, FILM:1.21K OHM, 1%, 0.125W	91637	MFF1816G12100F
R8036	315-0363-00	XB138090		RES., FXD, CMPSN:36K OHM, 5%, 0.25W	01121	CB3635
R8054	323-0140-00	XB138090		RES., FXD, FILM:280 OHM, 1%, 0.50W	75042	CECTO-2800F

Ckt No.	Tektronix Part No.	Serial/Model No. Eff	Dscont	Name & Description	Mfr Code	Mfr Part Number
R8056	323-0140-00	XB138090		RES., FXD, FILM: 280 OHM, 1%, 0.50W	75042	CECT0-2800F
R8058	303-0150-00	XB138090		RES., FXD, CMPSN: 15 OHM, 5%, 1W	01121	GB1505
R8065	321-0062-00	XB138090		RES., FXD, FILM: 43.2 OHM, 1%, 0.125W	91637	CMF55-116G43R20F
RT119	307-0181-00			RES., THERMAL: 100K OHM, 10%, 4MW/DEG C	15454	1DE104-K-220EC
RT219	307-0181-00			RES., THERMAL: 100K OHM, 10%, 4MW/DEG C	15454	1DE104-K-220EC
RT421	307-0124-00			RES., THERMAL: 5K OHM, 10%	50157	1D1618
RT557	307-0124-00			RES., THERMAL: 5K OHM, 10%	50157	1D1618
RT657	307-0124-00			RES., THERMAL: 5K OHM, 10%	50157	1D1618
RT1243	307-0122-00			RES., THERMAL: 50 OHM, 10%	50157	3D1515
RT1423	307-0181-00			RES., THERMAL: 100K OHM, 10%, 4MW/DEG C	15454	1DE104-K-220EC
RT1696	307-0124-00	B010100	B138089X	RES., THERMAL: 5K OHM, 10%	50157	1D1618
RT8038	307-0124-00	XB138090		RES., THERMAL: 5K OHM, 10%	50157	1D1618
S30A	105-0521-00			ACTUATOR, CAM SW: ATTN	80009	105-0521-00
S30B	105-0282-01			ACTUATOR, CAM SW: DC, GND, AC	80009	105-0282-01
S96	-----			(FURNISHED AS A UNIT WITH R96)		
S196	-----			(FURNISHED AS A UNIT WITH R196)		
S225	260-1208-00			SWITCH, PUSH: DPDT, 28VDC, PUSH-PUSH	80009	260-1208-00
S338A	105-0423-00			ACTUATOR, SWITCH: BANDWIDTH LIMIT	80009	105-0423-00
S338B	105-0421-00			ACTUATOR, SWITCH: MOMENTARY	80009	105-0421-00
S350	260-1424-01			SWITCH, PUSH: 5 STA, 2 POLE INTERLOCK	80009	260-1424-01
S400	260-1421-00			SWITCH, PUSH: 1 STA, MOMENTARY, NON-SHORT	80009	260-1421-00
S510A, B	105-0572-01			ACTUATOR, SL SW: 5 OF 6 POS. W/CONT	80009	105-0572-01
S510	-----			(SEE OPTION 5)		
S515	105-0570-01			ACTUATOR, SL SW: 4 OF 5 POSITION W/CONT	80009	105-0570-01
S530	-----			(FURNISHED AS A UNIT WITH R530)		
S610	105-0571-01			ACTUATOR, SL SW: 6 OF 6 POSITION	80009	105-0571-01
S615	105-0570-01			ACTUATOR, SL SW: 4 OF 5 POSITION W/CONT	80009	105-0570-01
S630	-----			(FURNISHED AS A UNIT WITH R630)		
S948	-----			(FURNISHED AS A UNIT WITH R948)		
S1100	260-1422-00			SWITCH, PUSH: 3 STA, INTERLOCK	80009	260-1422-00
S1120	260-1423-00			SWITCH, PUSH: 4 STA, INTERLOCK, NON-SHORT	80009	260-1423-00
S1140	-----			(FURNISHED AS A UNIT WITH R1140)		
S1150	263-1066-00	B010100	B010291	SW CAM ACTR AS: TIME/CM	80009	263-1066-00
S1150	263-1092-01	B010292		SW CAM ACTR AS: TIME/CM	80009	263-1092-01
S1150	263-1092-01			SW CAM ACTR AS: TIME/CM (DM SERIES)	80009	263-1092-01
S1239	260-1208-00			SWITCH, PUSH: DPDT, 28VDC, PUSH-PUSH	80009	260-1208-00
S1403	-----			(FURNISHED AS A UNIT WITH R1403)		
S1501	260-1726-00			SWITCH, REED: 3A, 5W, V=3.5KV, 50W	12617	DRVT-5
S1601	-----			(SEE OPTION 7)		
S1701	260-0834-00			SWITCH, TOGGLE: DPDT, 5A, 125VAC, 0.25-40 THD	09353	U21-SHZQE
S1702	260-0413-01	B010100	B079999	SWITCH, THRMSTC: NC, 79.4 OPEN, 68.3, 10A, 240V	73803	20700L63-253
S1702	260-0551-00	B080000		SW, THERMOSTATIC: NC, 10A, 240VAC	81439	36 T 21 3780
S1703	260-1300-01			SWITCH, SLIDE: DPDT, 3A, 125V	82389	46206LFE
S1703	260-1300-03			SWITCH, SLIDE: DPDT, 3A, 125V, PAINTED	80009	260-1300-03
S1703	-----			(OPTION 1Y ONLY)		
S1765	-----			(SEE OPTION 7)		
S1765A	-----			(SEE OPTION 7)		
S1765B	-----			(SEE OPTION 7)		
S1765C	-----			(SEE OPTION 7)		
S1765D	-----			(SEE OPTION 7)		
S1765E	-----			(SEE OPTION 7)		
S1765F	-----			(SEE OPTION 7)		
S1815A,	-----			(FURNISHED AS A UNIT WITH R1815)		
S1815B, C						
S1921A, B	260-1603-00			SWITCH, PUSH: 4 STA, 2 POLE, W/LOCKOUT	80009	260-1603-00
S1921C, D						

Replaceable Electrical Parts—466 Service

Ckt No.	Tektronix Part No.	Serial/Model No. Eff	Dscont	Name & Description	Mfr Code	Mfr Part Number
T354	120-0366-00			XFMR, TOROID: 2 WINDINGS	80009	120-0366-00
T1501	120-0909-00	B010100	B109999	XFMR, PWR, STU:HV	80009	120-0909-00
T1501	120-0909-01	B110000		XFMR, PWR, SDN&SU: HIGH VOLTAGE	80009	120-0909-01
T1601	-----			(SEE OPTION 7)		
T1631	-----			(SEE OPTION 7)		
T1701	120-0908-00			XFMR, PWR, STPDN:	80009	120-0908-00
T1701	120-1407-00			XFMR, PWR, SDN&SU: ASIA LINE VOLTAGE	80009	120-1407-00
	-----			(OPTION 1Y ONLY)		
U464	155-0115-00			MICROCIRCUIT, LI: CRT VERT DEFLECTION DRIVER	80009	155-0115-00
	-----			(155-0077-01 MAY BE USED)		
U540	155-0032-01	B010100	B150706	MICROCIRCUIT, LI: MONOLITHIC, INPUT PRE-AMPL	80009	155-0032-01
U540	155-0217-00	B150707		MICROCIRCUIT, LI: PLRT INV & TRIG PICK OFF	PL 80009	155-0217-00
U640	155-0032-01	B010100	B150706	MICROCIRCUIT, LI: MONOLITHIC, INPUT PRE-AMPL	80009	155-0032-01
U640	155-0217-00	B150707		MICROCIRCUIT, LI: PLRT INV & TRIG PICK OFF	PL 80009	155-0217-00
U980	155-0049-01	B010100	B135174	MICROCIRCUIT, DI: MONOLITHIC, SWEEP CONTROL	80009	155-0049-01
U980	155-0049-02	B135175		MICROCIRCUIT, DI: SWEEP CONTROL, W/LOCKOUT	80009	155-0049-02
U1690	156-0281-00	B010100	B138089X	MICROCIRCUIT, LI: 4 TRANSISTOR ARRAY	02735	CA3725
U1724	156-0158-00			MICROCIRCUIT, LI: DUAL OPERATIONAL AMPLIFIER	18324	MC1458N
U1762	156-0158-00			MICROCIRCUIT, LI: DUAL OPERATIONAL AMPLIFIER	18324	MC1458N
U1844	156-0402-00			MICROCIRCUIT, LI: TIMER	27014	LM555CN
U1846	156-0172-00			MICROCIRCUIT, DI: DUAL RETRIG ONE-SHOT W/CLR	80009	156-0172-00
U1866	156-0043-00			MICROCIRCUIT, DI: QUAD 2-INPUT POS NOR GATE	80009	156-0043-00
U1872	156-0371-00			MICROCIRCUIT, DI: QUAD 2-INPUT NAND ST	80009	156-0371-00
U1874	156-0041-00			MICROCIRCUIT, DI: DUAL D-TYPE FLIP-FLOP	27014	DM7474N
U1876	156-0030-00			MICROCIRCUIT, DI: QUAD 2-INPUT NAND GATE	01295	SN7400(N OR J)
U1878	156-0221-00			MICROCIRCUIT, DI: QUAD LATCH	01295	SN74175N
U2810	-----			(SEE OPTION 5)		
U8061	156-0281-00	XB138090		MICROCIRCUIT, LI: 4 TRANSISTOR ARRAY	02735	CA3725
V1555	154-0708-00	B010100	B079999	ELECTRON TUBE: CRT	80009	154-0708-00
V1555	154-0750-00	B080000		ELECTRON TUBE: CRT, T4640-0	80009	154-0750-00
VR75	152-0166-00			SEMICONV DEVICE: ZENER, 0.4W, 6.2V, 5%	04713	SZ11738
VR128	152-0166-00			SEMICONV DEVICE: ZENER, 0.4W, 6.2V, 5%	04713	SZ11738
VR175	152-0166-00			SEMICONV DEVICE: ZENER, 0.4W, 6.2V, 5%	04713	SZ11738
VR228	152-0166-00			SEMICONV DEVICE: ZENER, 0.4W, 6.2V, 5%	04713	SZ11738
VR434	152-0127-00			SEMICONV DEVICE: ZENER, 0.4W, 7.5V, 5%	04713	SZG35009K2
VR550	152-0175-00	XB010210		SEMICONV DEVICE: ZENER, 0.4W, 5.6V, 5%	04713	SZG35008
VR552	152-0175-00	XB010210		SEMICONV DEVICE: ZENER, 0.4W, 5.6V, 5%	04713	SZG35008
VR583	152-0227-00			SEMICONV DEVICE: ZENER, 0.4W, 6.2V, 5%	04713	SZ13903
VR650	152-0175-00	XB010210		SEMICONV DEVICE: ZENER, 0.4W, 5.6V, 5%	04713	SZG35008
VR652	152-0175-00	XB010210		SEMICONV DEVICE: ZENER, 0.4W, 5.6V, 5%	04713	SZG35008
VR948	152-0278-00			SEMICONV DEVICE: ZENER, 0.4W, 3V, 5%	04713	SZG35009K20
VR958	-----			(SEE OPTION 5)		
VR987	152-0278-00			SEMICONV DEVICE: ZENER, 0.4W, 3V, 5%	04713	SZG35009K20
VR1145	152-0395-00			SEMICONV DEVICE: ZENER, 0.4W, 4.3V, 5%	14552	TD332317
VR1146	152-0166-00			SEMICONV DEVICE: ZENER, 0.4W, 6.2V, 5%	04713	SZ11738
VR1282	152-0168-00			SEMICONV DEVICE: ZENER, 0.4W, 12V, 5%	04713	SZG35009K4
VR1289	152-0166-00	XB060000		SEMICONV DEVICE: ZENER, 0.4W, 6.2V, 5%	04713	SZ11738
VR1514	152-0280-00	B010100	B129999X	SEMICONV DEVICE: ZENER, 0.4W, 6.2V, 5%	80009	152-0280-00
VR1527	152-0149-00			SEMICONV DEVICE: ZENER, 0.4W, 10V, 5%	04713	SZG35009K3
VR1532	152-0283-00			SEMICONV DEVICE: ZENER, 0.4W, 43V, 5%	12954	DZ750903B1N976B
VR1533	152-0427-00			SEMICONV DEVICE: ZENER, 0.4W, 100V, 5%	80009	152-0427-00
VR1604	-----			(SEE OPTION 5)		
VR1605	-----			(SEE OPTION 5)		
VR1622	-----			(SEE OPTION 5)		

Replaceable Electrical Parts—466 Service

Ckt No.	Tektronix Part No.	Serial/Model No. Eff	Dscont	Name & Description	Mfr Code	Mfr Part Number
VR1639	-----			(SEE OPTION 5)		
VR1641	-----			(SEE OPTION 5)		
VR1712	152-0304-00			SEMICONV DEVICE:ZENER,0.4W,20V,5%	15238	Z5411
VR1718	152-0580-00			SEMICONV DEVICE:ZENER,0.4W,75V,2%	80009	152-0580-00
VR1722	152-0304-00			SEMICONV DEVICE:ZENER,0.4W,20V,5%	15238	Z5411
VR1724	152-0268-00			SEMICONV DEVICE:ZENER,0.4W,56V,5%	80009	152-0268-00
VR1725	152-0294-00	B010100	B010134	SEMICONV DEVICE:ZENER,1W,36V,5%	04713	1N3033B
VR1725	152-0281-00	B010135		SEMICONV DEVICE:ZENER,0.4W,22V,5%	12954	1N969B
VR1726	152-0411-00			SEMICONV DEVICE:ZENER,0.25W,9V,5%	04713	SZ12483KRL
VR1772	152-0279-00	XB010135		SEMICONV DEVICE:ZENER,0.4W,5.1V,5%	04713	SZG35010RL
VR1794	152-0127-00	XB010135		SEMICONV DEVICE:ZENER,0.4W,7.5V,5%	04713	SZG35009K2
VR1945	152-0166-00	B010100	B069999X	SEMICONV DEVICE:ZENER,0.4W,6.2V,5%	04713	SZ11738
VR1945	152-0166-00	XB080000		SEMICONV DEVICE:ZENER,0.4W,6.2V,5%	04713	SZ11738
VR1995	152-0166-00			SEMICONV DEVICE:ZENER,0.4W,6.2V,5%	04713	SZ11738
VR2038	152-0304-00			SEMICONV DEVICE:ZENER,0.4W,20V,5%	15238	Z5411
VR2077	152-0149-00	XB081800		SEMICONV DEVICE:ZENER,0.4W,10V,5%	04713	SZG35009K3
VR2827	-----			(SEE OPTION 5)		
VR2832	-----			(SEE OPTION 5)		
W75	131-0566-00	XB090000		BUS CONDUCTOR:DUMMY RES,2.375,22 AWG	57668	JWW-0200E0
W175	131-0566-00	XB090000		BUS CONDUCTOR:DUMMY RES,2.375,22 AWG	57668	JWW-0200E0
W1514	131-0566-00	XB130000		BUS CONDUCTOR:DUMMY RES,2.375,22 AWG	57668	JWW-0200E0



# OPTION INFORMATION

Your instrument may be equipped with one or more options. This section describes those options, or directs the reader to where the option is documented.

Option 01	Deletes DM44 Temperature Probe	
Option 04	EMI Environmental:	Described in this section
Option 05 <sup>1</sup>	TV Sync Separator:	Described in this section
Option 07 <sup>2</sup>	EXT DC Operation:	Described in this section
Option 10 <sup>1</sup>	Third Channel Trigger	Described in 464/466 Option 10 Service Supplement (Tektronix Part Number 061-2172-00)
Option 1Y	100V Power Input Operation	Described in this section

<sup>1</sup> Options 05 and 10 cannot be installed in the same instrument.

<sup>2</sup> Option 07 cannot be installed in instruments equipped with DM-Series Digital Multimeters.

## NOTE

*The combination 466 and DM-Series Digital Multimeter is considered a separate instrument and not an option. Information about the DM-Series Digital Multimeter portion of the combination instrument is described in a separate manual for each DM version as follows:*

*DM43-DM40  
DM44*

*Described in manual 070-1779-00  
Described in manual 070-2036-01*

## OPTION 4

## INTRODUCTION

This section describes the features of Option 4 as it pertains to the 466 Oscilloscope. This circuitry modifies the instrument to meet additional conducted and radiated interference requirements over the frequency range of 150 kHz to 25 MHz (conducted) and 150 kHz to 1 GHz (radiated).

The following additions and changes were made to the standard circuitry to meet the specification requirements:

EMI filter (FL1701) added in series with the input power cord.

Cathode ray tube mesh filter installed to minimize crt faceplate radiation.

Four signal-output bnc connectors on the rear plenum chamber changed to a type that improves shielding of the connected signal leads.

Capacitors added across the transformer secondary supplies.

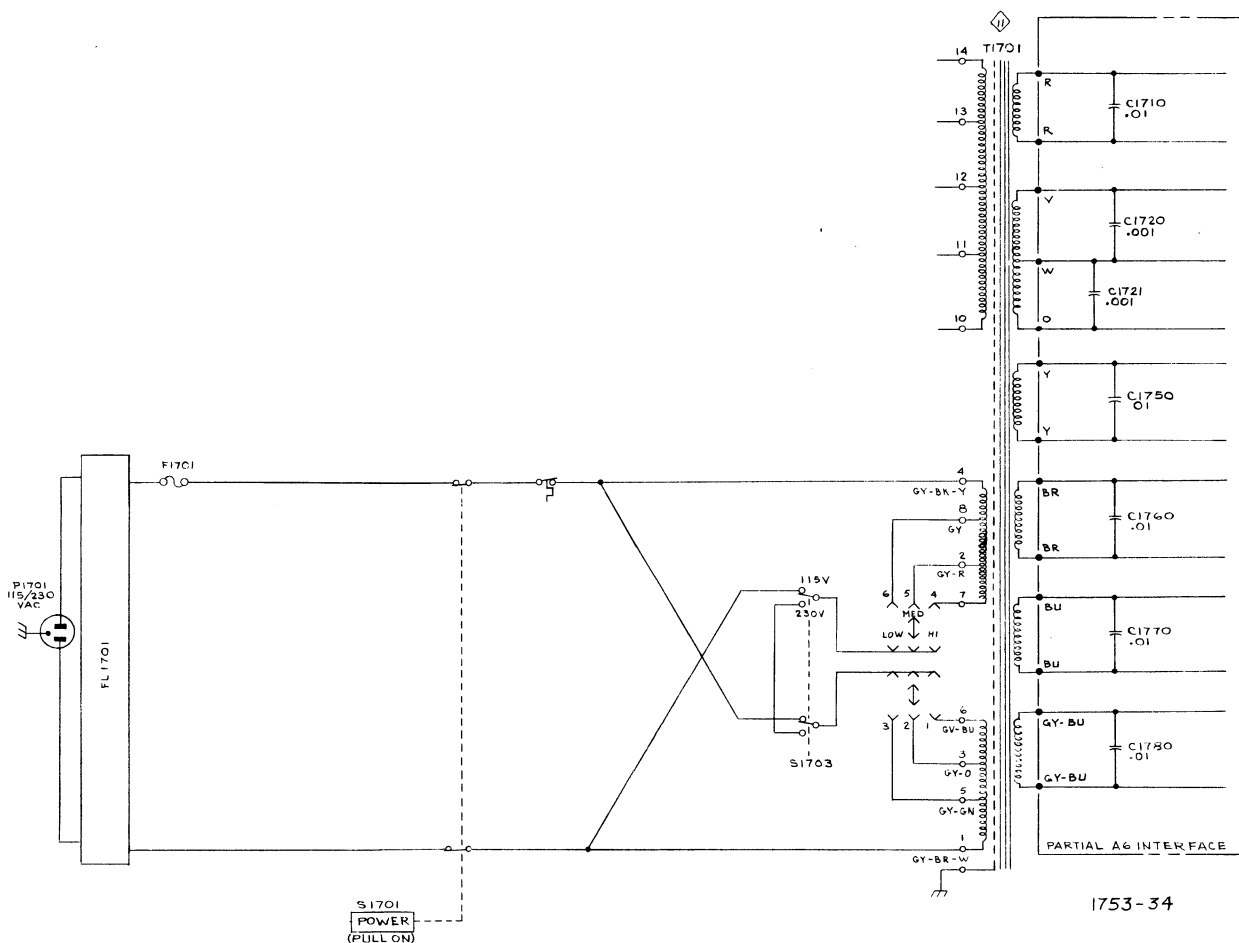

Figure Option 4-1. 466 Option 4 primary winding with power-line filter.

**REPLACEABLE ELECTRICAL PARTS  
OPTION 4**

Ckt No.	Tektronix Part No.	Serial/Model No. Eff	Dscont	Name & Description	Mfr Code	Mfr Part Number
C1710	283-0003-00			CAP., FXD, CER DI:0.01UF,+80-20%,150V (WHEN INSTRUMENT IS EQUIPPED WITH BOTH OPT 4 AND OPT 7, ONLY ONE SET OF THESE CAPACITORS IN USED)	72982	855-558Z5U-103Z
C1720	283-0000-00			CAP., FXD, CER DI:0.001UF,+100-0%,500V (SEE FOOTNOTE ON C1710)	72982	831-516E102P
C1721	283-0000-00			CAP., FXD, CER DI:0.001UF,+100-0%,500V (SEE FOOTNOTE ON C1710)	72982	831-516E102P
C1750	283-0003-00			CAP., FXD, CER DI:0.01UF,+80-20%,150V (SEE FOOTNOTE ON C1710)	72982	855-558Z5U-103Z
C1760	283-0003-00			CAP., FXD, CER DI:0.01UF,+80-20%,150V (SEE FOOTNOTE ON C1710)	72982	855-558Z5U-103Z
C1770	283-0003-00			CAP., FXD, CER DI:0.01UF,+80-20%,150V (SEE FOOTNOTE ON C1710)	72982	855-558Z5U-103Z
C1780	283-0003-00			CAP., FXD, CER DI:0.01UF,+80-20%,150V (SEE FOOTNOTE ON C1710)	72982	855-558Z5U-103Z
FL1701	119-0376-01			FILTER,RAD INT:2 X 3A,250V,400 HZ	80009	119-0376-01
J145	131-1315-00			CONN,RCPT,ELEC:BNC,FEMALE	24931	28JR235-1
J159	131-1315-00			CONN,RCPT,ELEC:BNC,FEMALE	24931	28JR235-1
J859	131-1315-00			CONN,RCPT,ELEC:BNC,FEMALE	24931	28JR235-1
J918	131-1315-00			CONN,RCPT,ELEC:BNC,FEMALE	24931	28JR235-1

**REPLACEABLE MECHANICAL PARTS**

Fig. & Index No.	Tektronix Part No.	Serial/Model No. Eff	Dscont	Qty	1	2	3	4	5	Name & Description	Mfr Code	Mfr Part Number
				1						FILTER,RAD INT:2 X 3A,250V,400 HZ (ATTACHING PARTS)	80009	119-0376-01
	211-0038-00			1						SCREW,MACHINE:4-40 X 0.312,FLH,100 DEG	83385	OBD
	210-0586-00			1						NUT,PL,ASSEM WA:4-40 X 0.25,STL CD PL	83385	OBD
										* - - - -		
	131-0707-00			1						CONNECTOR,TERM.:22-26 AWG,BRS& CU BE GOLD	22526	47439
	131-0708-00			1						CONTACT,ELEC:0.48"L,28-32 AWG WIRE	22526	47437
	131-1310-00			1						CONTACT,ELEC:MESH FILTER GROUND	80009	131-1310-00
				4						CONNECTOR,RCPT,: (SEE T145,T159,T859,T918 REPL)		
	179-2162-00			1						WIRING HARNESS:OPTION NO.4	80009	179-2162-00
	210-0774-00			2						EYELET,METALLIC:0.152 OD X 0.245 INCH L,BRS	80009	210-0774-00
	210-0775-00			2						EYELET,METALLIC:0.126 OD X 0.23 INCH L,BRS	80009	210-0775-00
	378-0726-00			1						FILTER,MESH:EMI	80009	378-0726-00
	348-0239-00	XB149173		1						GROMMET,PLASTIC:DK GRAY,U-SHAPE,0.27 ID	80009	348-0239-00

# 466 and 464

## OPTION 5 TV SYNC SEPARATOR

### Introduction

Option 5, when installed in the 466 or 464 Oscilloscope, adds a TV Sync Separator and other changes to provide stable sweep triggering from composite video waveforms. Two positions are added to the A Trigger COUPLING switch; TV FIELD and TV LINE. When these positions are selected, the A Sweep may be triggered at the Field or Line rate with the A trigger LEVEL control. A TV LINE position is added to the B trigger SOURCE switch. In this position, the B Sweep may be triggered at the line rate. The option 5 circuitry accepts sync-positive or sync-negative video from Channel 1, Channel 2, or external input. Recognition circuits accommodate 405-525-625 line 50 or 60 Hz field rate broadcast systems, and are compatible with closed circuit systems with up to 1201 line 60 Hz field rates.

### General Information

Option 5 provides the instrument with front-panel selection of additional processing of trigger signals, to facilitate observation and measurement of composite video and related television waveforms. Added circuits provide amplification, selectable polarity inversion, clip-

ping, and vertical-sync recognition. Outputs of vertical and horizontal (field and line rate) triggers are connected to the A Sweep trigger COUPLING switch, and horizontal (line rate) triggers are connected to the B Sweep trigger SOURCE switch.

When the A Trigger COUPLING switch is set to TV FIELD or TV LINE positions, the A Sweep Trigger SOURCE switch selects the source of signals to be processed in the sync separator. This includes NORM (composite vertical signal), CH 1, CH 2, EXT, or EXT ÷ 10 (LINE source is not a usable function with TV FIELD or TV LINE coupling).

The Option 5 circuitry may be operated from normal sync-negative composite video (with the A Sweep trigger SLOPE switch at -); or inverted video (SLOPE switch set to +), for most standard broadcast systems using from 405 to 819 lines, 50 or 60 Hz field rates, or for closed-circuit systems using up to 1201 lines and 60 Hz field.

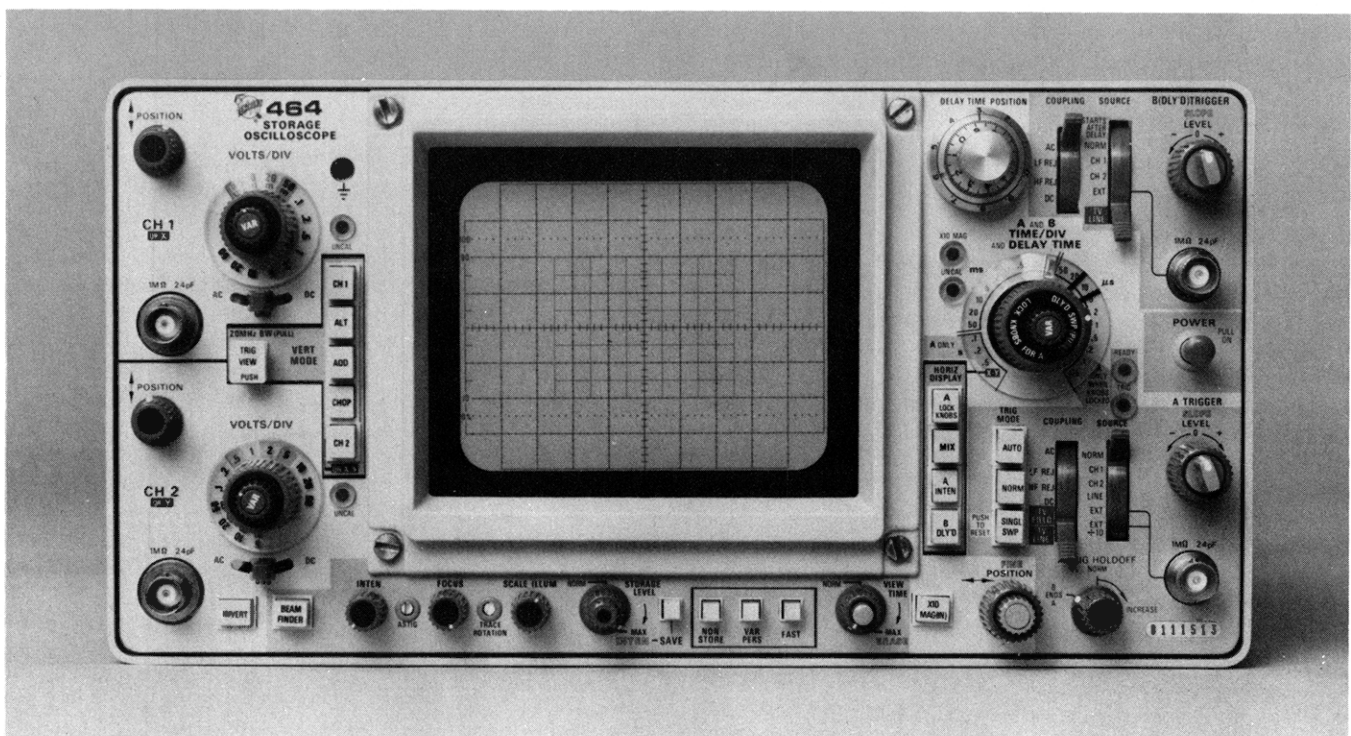

Fig. Option 5-1. 464 Oscilloscope with Option 5.

## Options—466 Service

When the A Sweep trigger COUPLING switch is set to TV FIELD or TV LINE, the output of the Sync Separator is automatically applied to the A Sweep trigger circuits, and only this signal may be used for triggering the A Sweep. For B Sweep, the horizontal sync signal (line-rate sync) from the Separator is fed only to the TV LINE position on the B Sweep trigger SOURCE switch, which may be selected at the option of the user.

To optimize video measurements, the vertical amplifier AC input coupling capacitors are increased from .02 to 0.2  $\mu$ F. The larger physical size of these capacitors increases the input shunt capacitance, which is normalized at 24 pF.

This description includes the characteristics, operation, and maintenance of the added features of Option 5. For all other information concerning the 466 or 464 Oscilloscopes, refer to the appropriate Operators and Service manual sections.

### Characteristics

Characteristics as listed in Section 1 apply except as noted below:

#### Input Characteristics

Resistance	1 M $\Omega$ $\pm$ 2%
Capacitance	24 pF, $\pm$ 2%
Time Constant	24 $\mu$ s $\pm$ 2%

#### AC Input Coupling

Low Frequency -3 dB	
Direct	$\leq$ 1 Hz
Via 10X Passive Probe	$\leq$ 0.1 Hz
Tilt, 10 ms wide pulse	
Direct	$\leq$ 2.5%
Via 10X Passive Probe	$\leq$ 0.25%

#### Triggering

Sync Separation	Stable video rejection and sync separation from sync-positive or sync-negative composite video, 405 to 819 line, 50 or 60 Hz field rate, or for closed-circuit systems using up to 1201 lines on a 60 Hz field.
-----------------	---

Amplitude Requirement (p-p)		Min	Max
Internal	Composite Video (nominal) <sup>1</sup>	1.2 div	20 div
	Composite sync	0.5 div	20 div
External	Composite video (nominal)	225 mV	4V
	Composite sync	75 mV	4V
Ext $\div$ 10	Composite video (nominal)	2.25 V	40 V
	Composite sync	750 mV	40 V

<sup>1</sup>Peak video  $\approx$  7/3 sync amplitude.

### Furnished Accessories

Add:

- 1 Graticule, NTSC (CCIR System M), -40 to +100 units, with 7.5 unit setup line; horizontal divisions along "0" line. Tektronix Part Number 337-1674-08.
- 1 Graticule, CCIR (CCIR System B), 0 to +100 units, 35 unit setup line; horizontal divisions along "30" line. Tektronix Part Number 337-1674-09.

### Operating Information

The following instructions pertain primarily to use of Option 5 in TV applications. For general operating and application information, see the Operator's Manual.

**Installation of Video Graticule.** To install a video graticule, loosen (about 6 turns) the four captive screws holding the crt bezel in place, and remove the bezel. Remove the light filter from the two bosses on the bezel, and install the desired graticule on these bosses, with the marking on the outside.

The extended tab at the bottom of the graticule mates with the slightly wider (bottom) margin of the graticule cover.

The graticule can be moved slightly horizontally to line up the external graticule and mask with the crt graticule and viewing area. Reinstall the bezel.

When the video graticule is installed, the ten horizontal divisions along the "0" line correspond to the internal graticule divisions, and the TIME/DIV calibration of the oscilloscope is correct. However, the vertical divisions represent only proportions of the 100-unit (CCIR) or 140-unit (NTSC) video waveform, and the vertical "VOLTS/DIV" calibration is inapplicable.

To calibrate for a standard 1 V (nominal) studio video signal, apply the 300 mV CALIBRATOR waveform to the Vertical input and adjust the VOLTS/DIV and VARIABLE controls so that the displayed waveform occupies just 30 units (CCIR graticule) or 42 units (NTSC graticule). This adjustment may be performed with a free-running sweep.

**Operation of the Sync Separator.** To trigger the 466 or 464 on a video signal, perform the following three steps:

a. Set the A Sweep COUPLING switch to TV FIELD or TV LINE.

b. Provide the A Trigger input circuit with a suitable Composite Sync or Composite Video waveform.

#### NOTE

*Composite Sync is combined Vertical and Horizontal sync as a single waveform, but without video (picture) waveforms; Composite Video is the picture waveform complete with Vertical and Horizontal blanking and sync.*

For special considerations in Dual Trace modes (ALT and CHOP), see "Vertical Operating Modes—Special Considerations." For internal triggering, the sync portion of the displayed waveform should be at least 10 units, or 0.5 division on the CCIR graticule; 14 units, or about 0.75 division on the NTSC graticule. For external triggering, the sync portion of the waveform should be at least 75 mV in amplitude, or 0.75 V in the "EXT ÷ 10" mode. Do not exceed the indicated maximum amplitudes (20 div for internal triggering, 40 volts for external triggering), to avoid circuit overloads and partial or complete loss of sync.

c. Select the proper polarity for the video waveform applied. For normal video with sync at the negative peak and positive-going picture information, the A Sweep Trigger SLOPE switch should be set to minus (–); for inverted video having sync at the positive peaks and peak video (white) at the negative peaks, the SLOPE switch should be set to plus (+). The A Sweep SLOPE switch controls an inverting/non-inverting signal preamplifier ahead of the sync separator.

**Triggering the Sweep.** The output of the Sync Separator is fed directly to the A Sweep Trigger circuit; all that is required for triggering, is the proper setting of the A Sweep Trigger LEVEL control. To trigger the B Sweep from the Line-rate trigger output, perform the following steps:

a. Make sure the A Sweep is running.

#### NOTE

*The B Sweep cannot be operated independently, and cannot run more than once per operation of the A Sweep. For "Composite line" displays, see "Special Measurements" in the following text.*

b. Set the B Sweep Trigger SOURCE switch to TV LINE.

c. Set the B Sweep Trigger LEVEL control for a stable triggered sweep.

#### Vertical Operating Modes—Special Considerations.

a. **Dual Trace Modes:** For dual trace operation, the Sync Separator input must be taken from CH 1, CH 2, or an external source. (When only one trace is displayed, the NORM position of the A Sweep SOURCE switch may be used.) The Sync Separator is not capable of correct processing of the switched (composite vertical deflection) waveforms present on the NORM bus in the Alternate and Chopped modes; it is therefore not possible to obtain stable simultaneous displays of two independent video signals that are not gen-locked together.

b. **Single Channel Triggering:** When triggering from Channel 1 or Channel 2, the waveform fed to the Sync Separator is the same (except for positioning) as that displayed on-screen when the channel is turned on. If the VOLTS/DIV VAR control is used to reduce displayed amplitude, the signal to the Sync Separator is also reduced. When the Channel 2 INVERT switch is pushed in, the CH 2 signal to the A Sweep Trigger SOURCE switch is also inverted. Therefore, in selecting the position of the A Sweep SLOPE switch in Internal triggering, it is only necessary to note the polarity of the displayed waveform, disregarding its actual polarity as applied to the Vertical INPUT connector. For external triggering, the actual applied polarity will determine the necessary SLOPE setting.

It is not necessary to display Channel 1 or Channel 2 to obtain CH1 or CH2 triggering. Whenever the AC-GND-DC switch for the channel is not in GND, the input amplifier and trigger channel are active, regardless of the selection of VERT MODE pushbuttons.

c. **Add Mode:** A single-channel trigger signal amplitude is not affected by the contribution of the other channel to an ADD mode display. When the ADD mode with CH2 inverted is used to compare two video waveforms by subtraction, the CH1 or CH2 signal to the Sync Separator will be adequate for stable triggering providing the individual channel signal (when displayed alone) meets the signal requirements.

## Options—466 Service

When the ADD mode is used to display a signal from two sides of a balanced line, the A Sweep SOURCE switch NORM (composite vertical) position may be used if neither Channel signal alone is of sufficient amplitude for stable sync separation and triggering.

**Typical Operation.** In a typical operating mode for the Option 5 instrument, the A Sweep establishes the basic frame and field presentation, and the B Sweep allows detailed observation and measurement of various portions of the video waveform.

To obtain stable displays free of interlace jitter (for systems which have 2:1 interlace), the A Sweep TIME/DIV switch should be set to display an odd number of fields plus a fraction of a field, in the unmagnified display. For 50 and 60 Hz field rates, the 2 ms/div setting is usually selected, though for some PAL system observations, a setting of 5 ms/div (approx. 2 1/2 field display) with the A TRIGGER HOLDOFF control set to approximately 4 o'clock (additional 1 field holdoff) may be desirable to maintain a stable display relationship to the four-field PAL burst-blanking sequence. All detail measurements are then made with B Sweep, using the B DLY'd or MIX mode, with the B Sweep SOURCE switch set to either STARTS AFTER DELAY (continuously variable B Sweep start point), or to TV LINE (B Sweep starts after the leading edge of the next horizontal sync pulse following the delay interval set by the DELAY TIME POSITION control and the A Sweep TIME/DIV setting).

Because the leading edge of the sync pulse will not be displayed; the typical B TIME/DIV setting for width measurements on front porch, back porch and horizontal blanking intervals, horizontal sync, serration, and equalizing pulses will be 10  $\mu$ s/div, to allow display of two consecutive pulses. Use the 10X Magnifier to display the second pulse at 1  $\mu$ s/div.

For rise and fall time measurements on blanking and sync waveforms, trigger the A or B Sweep directly from the displayed waveform (avoiding the processing delay of the sync separator). This permits viewing the triggering edge at sweep rates from .5 to .05  $\mu$ s/div.

### Selecting an Individual Line.

#### NOTE

*For field and line identification systems, see "Identifying Fields, Frames, & Lines in 525/60 and 625/50 TV Systems" at the end of this Operating Information text.*

The Sync Separator circuit does not differentiate between the two fields of an interlaced frame, or among the four fields of the PAL color frame sequence. However, if a 1 1/2 or 3 1/2 field basic A Sweep cycle is used, the sweep will remain stably locked to a given display until the signal is interrupted.

a. One Frame Cycle: To display an entire vertical blanking interval and locate a specific line (e.g., one of the lines containing a specific VIT waveform), set the A Sweep to 2 ms/div and the B Sweep TIME/DIV switch (pull to unlock from A) to 10  $\mu$ s/div. Use the POSITION control to center the second vertical blanking interval to center-screen, and depress the 10X MAG pushbutton. This will provide sufficient resolution to identify the field. Adjust the A TRIG HOLDOFF as necessary.

If the displayed field is not the desired one; rotate the A Sweep SLOPE control momentarily to the opposite polarity, then back again until the start of the desired field is displayed.

Press A INTEN, and use the DELAY TIME POSITION control to position the intensified zone (B Sweep) on the desired line. Pressing the B DLY'D button will then display the desired line.

b. Two-Frame Cycle: If PAL burst blanking is to be checked, an A Sweep 3 1/2 field cycle (5 ms/div, with the A TRIGGER HOLDOFF at about 4 o'clock) is required, using B Sweep (MIX mode recommended) to identify fields and lines. At 5 ms/div, only two and a fraction fields will be displayed, with a full field covered by the trigger holdoff interval. To put a specific field on-screen in a particular location will typically require several operations of the SLOPE switch.

### Special Measurements.

a. Overscanned Displays: For various video measurements, it may be desirable to magnify the video waveform vertically beyond the limits of the screen. Under these circumstances, the trigger amplifiers or Sync Separator may be overloaded, blocking out some sync pulses in the vicinity of strong video transitions, or losing sync pulses altogether. To avoid overload problems, use External sync, or use the other vertical channel to supply a constant amplitude signal to the Sync Separator while the overscanned observations are being made. Note, however, that transient-response aberrations in the main vertical amplifier will be increased when the signal is driven offscreen, becoming relatively serious if the amplifier is driven to saturation and cutoff.

b. Horizontal Sync Pulse Measurements: Rise and fall times and width of horizontal sync pulses may be measured while using the Sync Separator to determine whether part or all of the lines or groups of lines appear to be abnormal. A bright display of all horizontal sync pulses is obtained when the A Sweep COUPLING switch is set to TV LINE.

c. RF Interference: Operation in the vicinity of some FM and TV transmitters may show objectionable amounts of RF signal energy in the display, even when coaxial input connections are used. The front-panel 20 MHz BW Switch will usually eliminate such interference from the display, but will not affect the signal reaching the Sync Separator. Where the RF interferes with Sync Separator operation, external filters will be required. Use of probes designed for 10-30 MHz oscilloscopes will provide 6 to 10 dB attenuation in the 50-100 MHz range, and may be beneficial in reducing interference.

### Identifying Fields, Frames & Lines in 525/60 and 625/50 TV Systems

**NTSC (CCIR System M).** Field 1 is defined as the field whose first equalizing pulse is one full H interval (63.5  $\mu$ s) from the preceding horizontal sync pulse. The Field 1 picture starts with a full line of video.

Field 1 lines are numbered 1 through 263, starting with the leading edge of the first equalizing pulse. The first regular horizontal sync pulse after the second equalizing interval is the start of line 10.

Field 2 starts with an equalizing pulse a half-line interval from the preceding horizontal sync pulse. The Field 2 picture starts with a half line of video.

Field 2 lines are numbered 1 through 262, starting with the leading edge of the second equalizing pulse. After the second equalizing interval, the first full line is line 9.

**CCIR System B and Similar 625/50 Systems (including PAL).** In most 625-line, 50 Hz field-rate systems, identification of parts of the picture relies primarily on continuous line numbering rather than on field-and-line identification, except for PAL systems.

The CCIR frame starts with the first (wide) vertical sync pulse following a field which ends with a half-line of video. The first line after the second equalizing interval is line 6; the first picture line is line 23 (half-line of video). The first field of the frame contains lines 1 through the first half of line 313, the picture ending with a full line of video (line 310).

The second field of the frame commences with the leading edge of the first (wide) vertical sync pulse (middle of "line" 313), and runs through line 625 (end of equalizing interval). The first full line after the equalizing interval is line 318; the picture starts on line 336 (full line).

The first field is referred to as "odd," the second field as "even." Note that the identification systems for System M and System B are reversed.

In the four-field PAL sequence with Bruch Sequence Color-burst blanking, the fields are identified as follows:

Field 1: Field that follows a field ending in a half-line of video, when preceding field has color burst on the last full line. Field 1 lines are 1 through 312 and half of line 313. Color burst starts on line 7 of Field 1; a half-line of video appears on line 23.

Field 2: Field that follows a field ending in a full line which does not carry color burst. Field 2 lines are the last half of line 313 through line 625. Color burst starts on line 319 (one line without burst following the last equalizing pulse); a full line of video appears at line 336.

Field 3: Field that follows a field ending in a half line when preceding field has no color burst on its last full line. Field 3 lines are 1 through the first half of line 313. Burst starts on line 6 (immediately following the last equalizing pulse); a half-line of video appears on line 23.

Field 4: Field that follows a field ending in a full line carrying color burst. Field 4 lines are the second half of line 313 through line 625. Color burst for Field 4 starts on line 320 (two full lines without burst follow the last equalizing pulse); video starts with a full line on line 336.



## CIRCUIT DESCRIPTION

### Introduction

This section describes circuitry unique to Option 5. Refer to the Circuit Description section of this manual for information concerning those portions of the circuitry that are unchanged by Option 5.

Figure Option 5-2 shows the circuit stages for those circuits added or changed by Option 5. This discussion is limited to a general description of those stages. Refer to the schematic diagrams and component location figures at the end of this Option 5 description for a more detailed examination of individual components.

### Switching

The added TV FIELD and TV LINE positions of the A trigger COUPLING switch open the conventional signal path to the A trigger circuitry. The TV FIELD and TV LINE positions also couple the appropriate output of the Sync Separator stage to the conventional A trigger generator circuitry.

The Option 5 TV LINE position on the B trigger SOURCE switch couples line rate trigger signals from the Sync Separator output to the conventional B trigger generator circuitry.

With Option 5, the A trigger SLOPE switch adds connections through P2834 to provide inverting or non-inverting control of the Trigger Amplifier and Inverter stage.

### Trigger Pickoff

This stage consists of Q610, a source follower, and Q612, an emitter follower. The stage provides isolation, impedance match to the Trigger Amplifier and Inverter, and minimum loading to the input signal. Gain of the trigger pickoff stage is slightly less than unity. The video trigger signal (internal or external) from the A trigger SOURCE switch is coupled to the input of Q610, while the output of the Trigger Pickoff stage (Q612 emitter) is fed through P612 and P2810 to the Trigger Amplifier and Inverter stages (Q2802, Q2803, & U2810). CR610 protects the input of Q610 from damage when high amplitude negative signals are present.

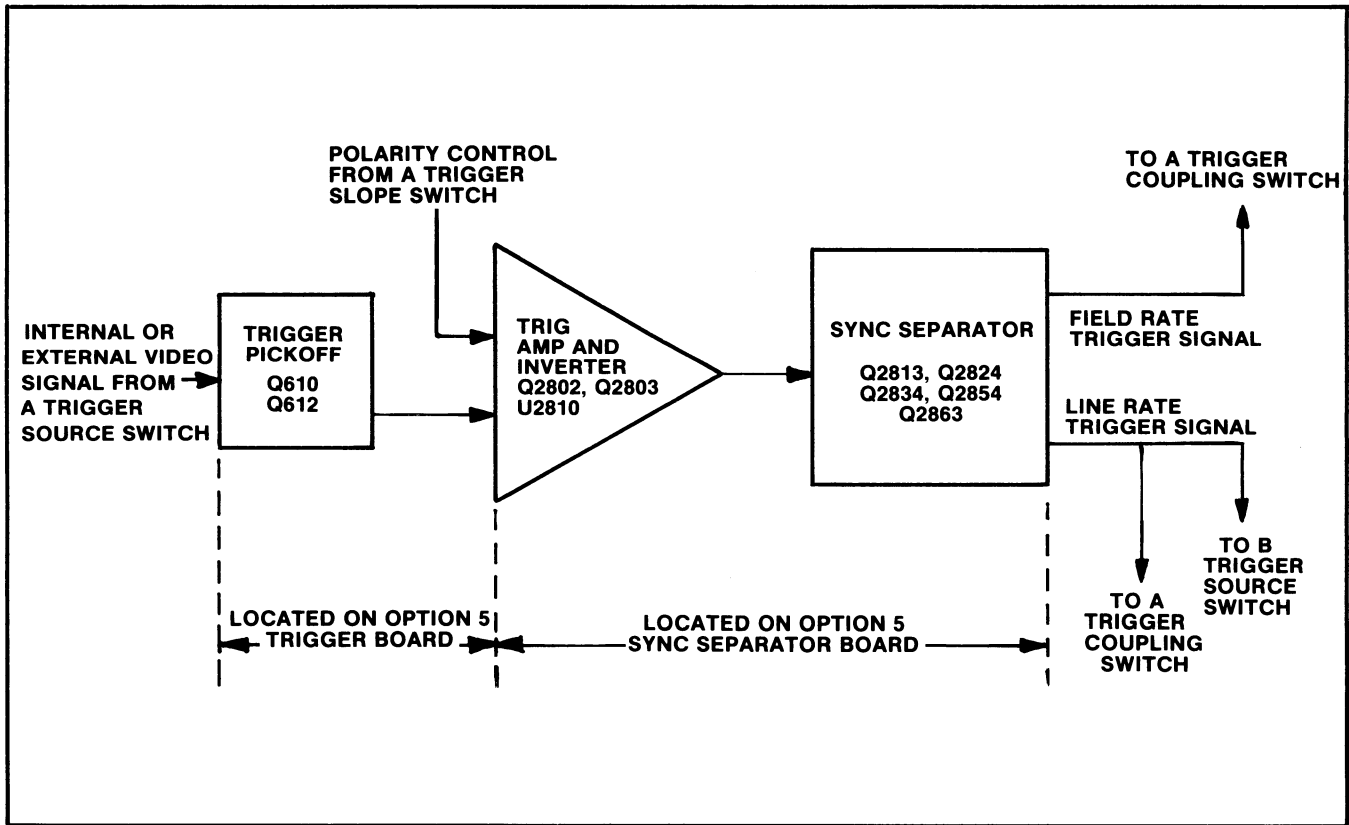

Fig. Option 5-2. Option 5 Block Diagram.

### Trigger Amplifier and Inverter

This stage consists of Q2802, Q2803, and U2810, and is designed to provide adequate drive and correct polarity for the following Sync Separator stage, which accepts only negative sync (positive-going video). Signal is applied to the Trigger Amplifier and Inverter from the Trigger Pickoff via P2810. Polarity control is applied from the A trigger SLOPE switch through P2834. Output from the stage is fed to Q2813, the Sync Separator input.

When the A trigger SLOPE switch is in the plus position, this stage inverts the signal it receives from the Trigger Pickoff. When the minus SLOPE is selected, the signal is not inverted. Only one transistor, Q2802 or Q2803, conducts at a time. Feedback resistor R2807 controls Operational Amplifier U2810 gain for low amplitude signals, while R2809, CR2807, CR2809 control the gain for higher amplitude signals.

### Sync Separator

The Sync Separator strips off the video (picture) information from the incoming sync-negative video output of U2810, amplifies the resulting composite sync for use as horizontal (TV line) sync by A and B sweep triggers, and processes the composite sync to provide vertical (field rate) sync to the A Sweep trigger circuits.

Video Stripper, Q2813 and Q2824, form a limited-swing feedback amplifier which amplifies only the negative peaks of the incoming waveform. The base of Q2813 rests at an equilibrium point of approximately +9.0 V, which is affected slightly by the Clipping Level adjustment R2826. The emitter of Q2824 is held at approximately +10.1 V, and the collector rests at approximately +9 V.

With sync-negative video applied to Q2813, the negative-going peaks (sync) are clamped at the +9 V level. The positive-going portions of the input waveform generate increasing amounts of feedback current via R2818 until Q2824 reaches its negative-swing limit. Beyond this point, further positive input cuts off Q2813, and has negligible effect on the output. When Q2813 is driven positive, the negative excursion at the collector of Q2824 is stopped at approximately +7.6 V. By not permitting Q2824 to be cut off when Q2813 is cut off the output to Q2834 is relatively unaffected by input video excursions. The maximum signal swing at the Q2824 collector for any magnitude of input signal above about 100 mV p-p is about 2 V p-p, with active response confined to the most negative parts of the input signal. The divider R2824-R2825-R2826 sets the bias level for Q2824.

Diodes CR2824-CR2825 provide thermal compensation for Q2834, and have no other circuit function. Q2834 provides TV LINE (horizontal) composite sync output to the A & B Sweep Trigger SOURCE switches to serve as TV LINE sync, and drive to the Vertical Sync Recognizer Q2854-Q2863. In the quiescent state, Q2834 is cut off, its emitter held at +5.1 V and its base below the turn-on level of +5.7 V. The collector is at +10.1 V, prevented from rising further above the +9.6 V supply by CR2828. When negative-going sync pulses arrive at Q2813, they are inverted by Q2824 and provide sufficient base current to saturate Q2834. Q2834 is driven between saturation and cutoff, and generates approximately 4.9 V p-p of sync signal, attenuated to approximately 0.1 V, suitable for A and B sweep triggering, and is ac coupled to the A and B sweep trigger circuitry.

The Vertical Sync Recognizer, Q2854 and Q2863, recognizes the various forms of TV Vertical (Field Rate) sync pulses by providing an output signal proportional in amplitude to the duration (width) of a preceding negative-going pulse. The output signal occurs on the trailing edge of the input pulse. In most TV systems using sync-negative video, a Vertical sync pulse consists of a train of negative-going pulses about 5 times wider than horizontal sync pulses, and separated by narrow intervals (serrations) of about the same width as horizontal sync pulses. In these systems, the recognizer produces a train of narrow output pulses, one for each serration of the sync pulse. In some 405/50 and 819/50 broadcast systems and in many closed circuit TV systems, the vertical sync pulse is a single negative-going (sync-negative) pulse having a duration of several full horizontal lines. In these systems, the recognizer puts out a single narrow pulse at the end of the sync pulse.

Q2854 is driven by the Q2834 Sync Amplifier with a 4.9 V signal, with the negative portion of the signal representing the sync portion of the incoming waveform. In the absence of sync pulses, the collector of Q2834 is high and CR2831 holds the base of Q2854 at about +9.6 volts. When the Q2834 collector steps negative with a sync pulse, Q2834 is cut off and its collector steps positive by about 350 mV. The output stage network sets the emitter of Q2863 near +10.2 volts and provides Q2854 with a collector voltage of around +12.2 volts. The 60  $\mu$ A collector current of Q2854 (set by approximately 9.0 volts drop across R2856) generates around 0.35 volts drop in the equivalent 5.5 K $\Omega$  collector load. This sets the base voltage of Q2863 at +11.9 volts nominal, ensuring that Q2863 is cut off.

## Options—466 Service

When Q2854 is cut off, C2856 discharges toward ground on a 30 microsecond time-constant, starting at a rate of about  $-300$  mV per microsecond. The Q2854 emitter runs down 0.5 to 2.0 volts in the negative direction for the duration of a 2 to 6 microsecond wide horizontal sync or vertical equalizing pulse. For the longer duration vertical sync pulses, the emitter runs down 4 volts (typical for 819/50 system with serrations) to 5.5 volts (run-down stops when the emitter reaches  $+4.2$  volts since the base is held at  $+4.7$  volts).

When the collector of the Q2834 Sync Amplifier steps positive at the end of the pulse, a negative-going output pulse is generated at the collector of Q2854 that is proportional to the amount of emitter rundown. The exact magnitude of this output pulse is a complex function of the rate-of-rise of the positive transition from Q2834, the value of C2856, the collector-to-base capacitance of Q2854 (including C2854) and the collector-to-ground capacitance of Q2854. The output pulse at the Q2854 collector is approximately 80% of the amount of emitter run-down.

The positive-going trailing edge of the differentiated Q2854 collector output pulse, which is coupled back to the base by C2854 and the Q2854 collector capacitance, creates an overshoot at the base of Q2854. This drives the base about 1.5 V above the quiescent level at the end of a Vertical sync pulse (this overshoot does not appear on the Q2834 collector bus). The Q2854 collector waveform stays negative during the time the base is being driven positive; when the base stops at the quiescent level, the collector voltage rises rapidly, coupling an apparent overshoot into the base waveform. This condition tends to reduce the amount of usable rundown for Vertical serrations following the first one, but is otherwise insignificant.

The output stage bias network, keeping Q2863 cut off in the quiescent state, inhibits the output of Q2854 collector pulses of less than about 2 V peak (negative) amplitude. The larger pulses corresponding to the trailing edge of vertical sync pulses are large enough to turn on Q2863, and provide output signals of 1 to 2.5 V at the input end of C2865. Because of the short risetime of the generated pulses, the output stage responds a small amount, even during cutoff, due to base-emitter capacitance in Q2863; this is particularly noticeable when the load is removed.

With the load disconnected, the negative-going output pulses are 2 to 2.5 V in amplitude (somewhat smaller in 819/50 systems with serrated sync pulses), with a risetime of about 25 ns and a width of about 150 ns. Because they are so narrow, with a low repetition rate, they are hard to locate in an oscilloscope display. They are frequently misinterpreted as to their presence or absence, their amplitude, and even polarity (a small trailing-edge overshoot is often mistaken for the pulse itself).

The output stage is diode-connected to limit positive-going peaks in the output. Output coupling capacitor C2865 attenuates the signal, providing a proper level to the A Trigger circuits, to permit correct trigger LEVEL control action.

## CALIBRATION PROCEDURE

### Introduction

This procedure ensures proper calibration and performance of the TV Sync Separator circuitry included in Option 5, and is based on the 525/60 line and field system. If your Option 5 instrument is calibrated with the equipment prescribed for the 525/60 system, it should perform satisfactorily with other line and field systems.

Before starting this procedure, make sure the rest of your instrument meets all the specifications covered by the Performance Check or Calibration Procedure in the main portion of this manual. For Option 5 instruments, during the main Performance Check or Calibration Procedure, use the 24 picofarad Normalizer (067-0539-00) for vertical attenuator input compensation. Refer to the "Test Equipment Required" Table in this Option 5 description for complete information on the Normalizer.

### Preliminary Procedure for Sync Separator Calibration

1. Refer to the instructions in the main portion of this manual and remove the front cover and cabinet from your Option 5 instrument.
2. Set the controls as stated under Preliminary Control Settings in this Option 5 description.
3. Connect the Option 5 instrument to a power source within the range of its overall voltage and frequency specifications.
4. Refer to the Performance Temperature Specifications in the Performance Check or Calibration Procedure in the main portion of this manual.
5. Allow at least 20 minutes warm-up before proceeding.

**Table 1**  
**TEST EQUIPMENT REQUIRED**

Description	Minimum Specifications	Examples
Television Test Signal Generator	Composite Video Output with 525/60 and 1201/60 line and field rate; Output 350 mV to 1 V into 75 $\Omega$ termination.	Tektronix Part Number 067-0601-00 Calibration Fixture with 067-5002-00 (525/60) and 067-5010-00 (1201/60) plug-in units.
Test Oscilloscope with 10X probe	Bandwidth, dc to 20 MHz; minimum deflection factor, 5 mV/division at 20 MHz; Accuracy within 3%.	Tektronix 465 Oscilloscope with included 10X probe.
Termination	Impedance, 75 $\Omega$ ; Connectors, bnc.	Tektronix Part Number 011-0055-00.
Cable, Coaxial (two required)	Impedance, 75 $\Omega$ (not critical, 50 $\Omega$ may be substituted); length 42 inches; Connectors, bnc.	Tektronix Part Number 012-0074-00.
Input Normalizer	RC Time Constant, 24 pF times one M $\Omega$ (used during Vertical Input Compensation in main Performance Check and Calibration Procedure).	Tektronix Part Number 067-0539-00.

**Preliminary Control Settings for Option 5 Calibration**  
(unlisted controls may be left at any position)

**Sweep Controls**

HORIZ DISPLAY	A
A AND B TIME/DIV	20 $\mu$ s

**Power Controls**

Regulating Range Selector	At center of range of available power source.
Line Voltage Selector	As specified for available power source.
POWER	ON (pull)

**CRT Controls**

INTENSITY	Midrange (for viewable trace)
FOCUS	Midrange (for focused trace)
SCALE ILLUM	Midrange
BEAM FINDER	Out (off)

**Vertical Controls**

VERT MODE	CH 2
CH 2 VOLTS/DIV	.1 V
CH 2 Input Coupling	AC
INVERT	Out (Normal)
20 MHz BW (PULL)	In (full bandwidth)

**Triggering Controls**

TRIG MODE	AUTO
A LEVEL	11 o'clock
B LEVEL	0 (12 o'clock)
A & B SLOPE	Minus (-)
A COUPLING	TV FIELD
B COUPLING	AC
A SOURCE	NORM
B SOURCE	TV LINE

**Procedure**

**1. Clipping Level Adjustment (R2826 on Sync Separator Board)**

a. Connect the Television Test Signal Generator (with the 525/60 067-5002-00 plug-in installed) Composite Video Output to the CH 2 input via a 75 ohm cable and 75 ohm termination.

b. Adjust the Average Picture Level fully counter-clockwise and the Composite Video Amplitude for a 3 division display.

## Options—466 Service

- c. Set the CH 2 VOLTS/DIV to .5 V/DIV.
- d. Adjust the Average Picture Level for a 2 division display. Set CH 2 VOLTS/DIV to 2.
- e. Connect a 10X probe from the test oscilloscope (Vertical Volts/Div set for .2 V) to TP 2865 (see Fig. Option 5-3).
- f. Connect the generator rear panel Field Rate Trigger Output through a coaxial cable to the Test Oscilloscope External Trigger input. Set Test Oscilloscope Trigger Source to Ext, Time/Div to 1.0 ms, and Trigger Level for a stable triggered display.
- g. ADJUST—R2826. Starting at the counter-clockwise stop, adjust in a clockwise direction until the test oscilloscope display consists of a sequence of 6 narrow—6 wide—6 narrow pulses (for systems other than 525/60 the number and shape of pulses will differ). Adjust until top of displayed pulses are clean and free of any distortion (disregard bottom of pulses). Set Test Oscilloscope Volts/Div to .5 V.
- h. Set the Option 5 instrument CH 2 VOLTS/DIV to .5, .2, and .1 (volts), and 50 mV/DIV, and check at each setting for a test oscilloscope display with top and bottom of waveform clean and free of distortion. If any distortion is noted, repeat parts a through h.
- i. Switch the Option 5 A TRIGGER SLOPE to plus (+) and depress the INVERT button (in).
- j. Repeat part h.
- k. Replace the Test Signal Generator 525/60 plug-in with the 067-5010-00 (1201/60) plug-in; set the Option 5 instrument A Trigger SLOPE to minus (-); release the INVERT button (out), and repeat parts h through j.
- l. Disconnect the Test Oscilloscope probe and external trigger cable.

## 2. A and B Sweep TV Line Trigger Check

- a. Replace the Television Test Signal Generator 1201/60 plug-in with the 525/60 plug-in.
- b. Set the Option 5 instrument VOLTS/DIV to 1.0 V, the A TIME/DIV to 20  $\mu$ s/Div, and the A TRIGGER COUPLING to TV LINE.
- c. CHECK—That stable TV line triggering can be achieved by adjusting the A TRIGGER LEVEL control (disregard field pulses moving through the display).
- d. Set the Option 5 instrument A Trigger COUPLING switch to TV FIELD: Set the A TIME/DIV to 2 ms, B TIME/DIV to 0.1 ms, and adjust the A TRIGGER LEVEL for a stable triggered display.
- e. Depress the HORIZ DISPLAY A INTEN button and adjust the B TRIGGER LEVEL control to display the intensified portion of the trace.
- f. Rotate the DELAY TIME POSITION dial to position the start of the intensified portion of the trace just to the left of the 2nd displayed field pulse.
- g. Depress the HORIZ DISPLAY B DLY'D button and adjust the B TRIGGER LEVEL control for a stable display.
- h. Rotate the DELAY TIME POSITION dial and check that a stable display can be obtained for any sync pulse that is positioned on top of the field pulse (display should jump from one sync pulse to the next as the DELAY TIME POSITION dial is rotated).
- i. Disconnect the test equipment, remove the power plug from the power source, and replace the cabinet on the Option 5 instrument.

This completes the Calibration Procedure and check of the Option 5 portion of the instrument.

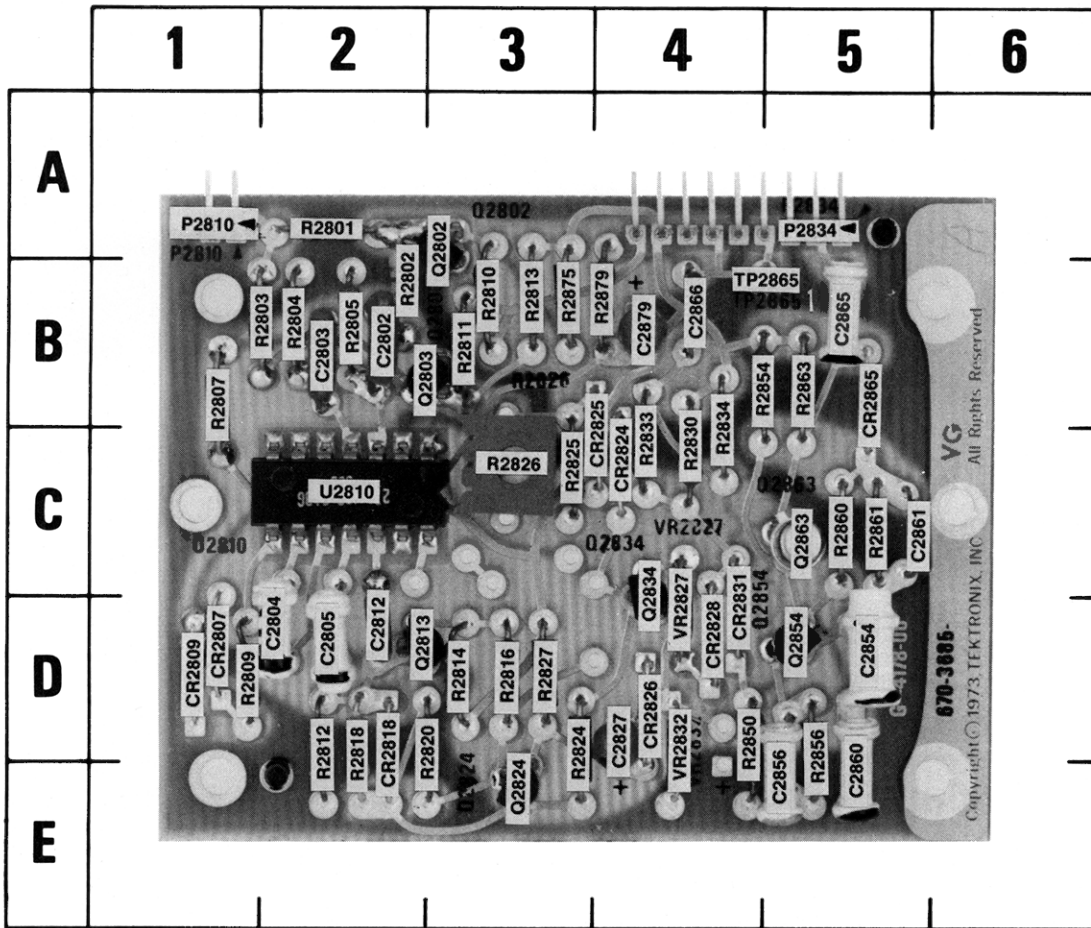

Fig. Option 5-3. A12 TV Sync Separator & Inverter Ampl board component locations.

CKT NO	GRID LOC	CKT NO	GRID LOC	CKT NO	GRID LOC	CKT NO	GRID LOC	CKT NO	GRID LOC	CKT NO	GRID LOC	CKT NO	GRID LOC
C2802	2B	C2861	5C	CR2825	4C	Q2824	3E	R2801	2A	R2812	2E	R2827	3D
C2803	2B	C2865	5B	CR2826	4D	Q2834	4D	R2802	2B	R2813	3B	R2830	4C
C2804	2D	C2866	4B	CR2828	4D	Q2854	5D	R2803	2B	R2814	3D	R2833	4C
C2805	2D	C2879	4B	CR2831	4D	Q2863	5C	R2804	2B	R2816	3D	R2834	4C
C2812	2D			CR2865	5B			R2805	2B	R2818	2E	R2850	4D
C2827	4D	CR2807	1D			P2810	1A	R2807	1B	R2820	3E	R2854	5B
C2854	5D	CR2809	1D	Q2802	3A	P2834	4A	R2809	1D	R2824	3E	R2856	5E
C2856	5E	CR2818	2E	Q2803	3B	P2833	4C	R2810	3B	R2825	3C	R2860	5C
C2860	5E	CR2824	4C	Q2813	3D	P2863	1A	R2811	3B	R2826	3C	R2861	5C
													VR2827
													VR2832
													VR2832

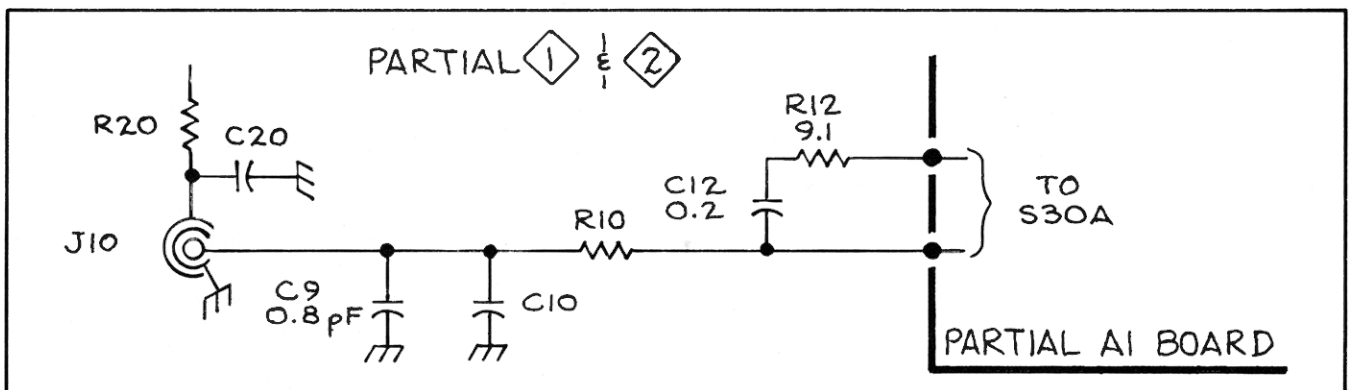
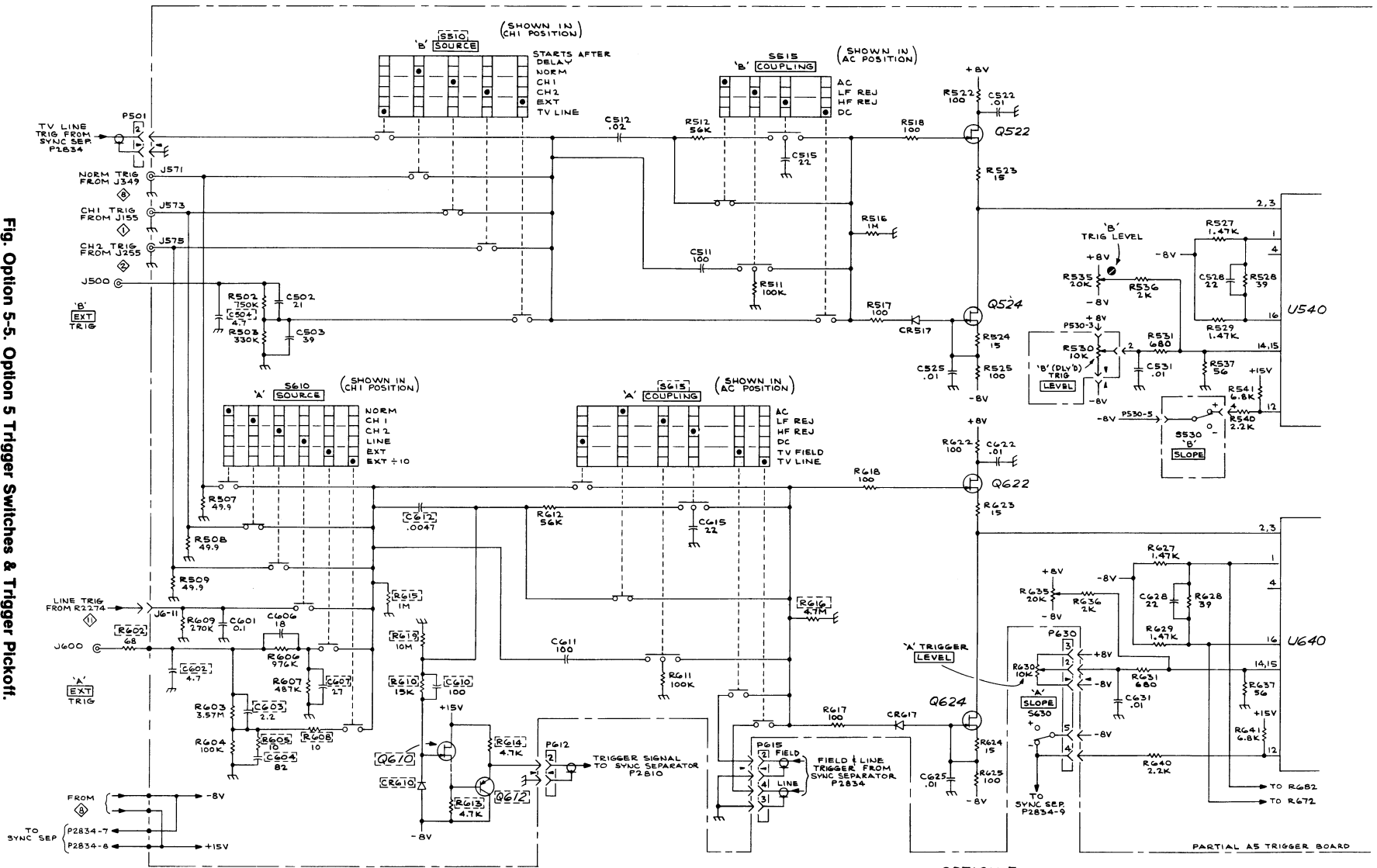

Fig. Option 5-4. Option 5 Vertical Input changes.

Fig. Option 5-5. Option 5 Trigger Switches & Trigger Pickoff.



466/464

OPTION 5  
TRIGGER SWITCHES & TRIGGER PICKOFF AL 275

Fig. Option 5-6. Option 5 TV Sync Separator & Inverter Ampl.

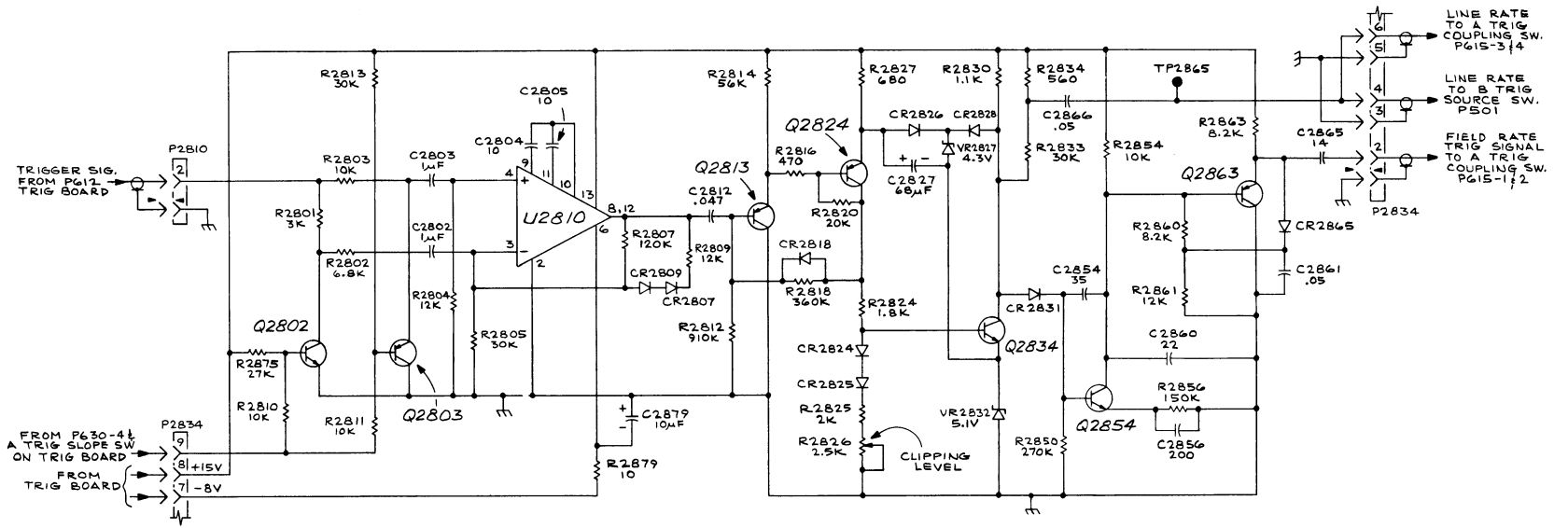

466/464

OPTION 5  
TV SYNC SEPARATOR & INVERTOR AMP

275  
FL



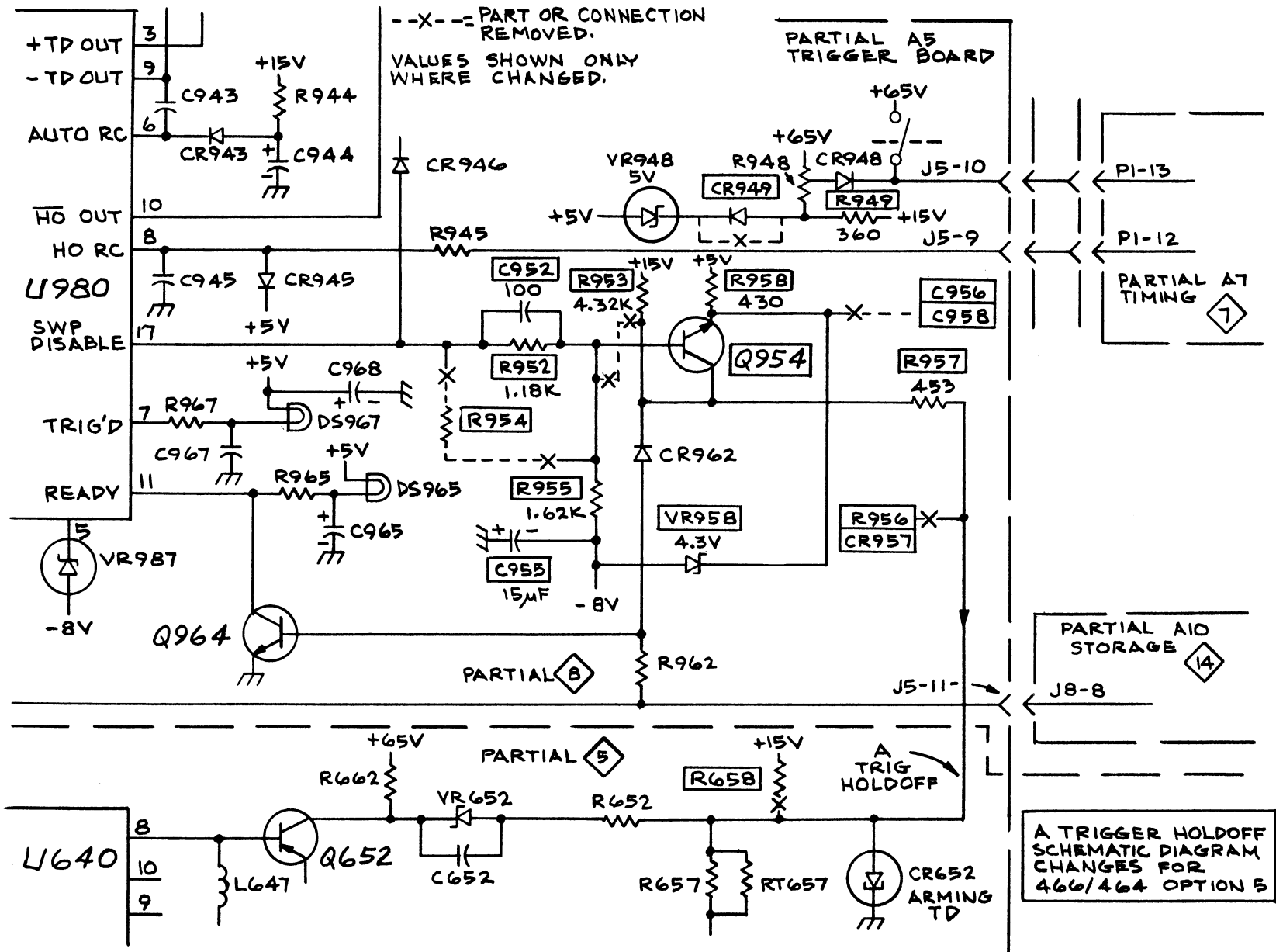

Fig. Option 5-7. Option 5 Trigger Holdoff circuit changes.

## REPLACEABLE ELECTRICAL PARTS OPTION 5

Ckt No.	Tektronix Part No.	Serial/Model No. Eff	Dscont	Name & Description	Mfr Code	Mfr Part Number
CHANGE TO:						
A1	672-0553-01			CKT BOARD ASSY:ATTENUATOR	80009	672-0553-01
C12	285-1055-00			CAP.,FXD,PLSTC:0.2UF,10%,400V	80009	285-1055-00
ADD:						
C9	281-0661-00			CAP.,FXD,CER DI:0.8PF,+/-0.1PF,500V	72982	301-000C0K0808B
R12	307-0116-00			RES.,FXD,CMPSN:9.1 OHM,5%,0.25W	01121	CB91G5
CHANGE TO:						
A5	670-3324-01			CKT BOARD ASSY:TRIGGER GEN &SWEEP LOGIC	80009	670-3324-01
C603	281-0610-00			CAP.,FXD,CER DI:2.2PF,+/-0.1PF,500V	72982	374001C0J0229B
C604	281-0528-00			CAP.,FXD,CER DI:82PF,+/-8.2PF,500V	72982	301-000U2M0820K
C607	281-0513-00			CAP.,FXD,CER DI:27PF,+/-5.4PF,500V	72982	301-000P2G0270M
C612	283-0083-00			CAP.,FXD,CER DI:0.0047UF,20%,500V	72982	811-565C472J
C952	281-0523-00			CAP.,FXD,CER DI:100PF,+/-20PF,500V	72982	301-000U2M0101M
Q954	151-0190-00			TRANSISTOR:SILICON,NPN	07263	S032677
R602	315-0680-00			RES.,FXD,CMPSN:68 OHM,5%,0.25W	01121	CB6805
R616	315-0475-00			RES.,FXD,CMPSN:4.7M OHM,5%,0.25W	01121	CB4755
R952	321-0200-00			RES.,FXD,FILM:1.18K OHM,1%,0.125W	91637	MFF1816G11800F
R953	321-0254-00			RES.,FXD,FILM:4.32K OHM,1%,0.125W	91637	MFF1816G43200F
R955	321-0213-00			RES.,FXD,FILM:1.62K OHM,1%,0.125W	91637	MFF1816G16200F
R957	321-0160-00			RES.,FXD,FILM:453 OHM,1%,0.125W	91637	MFF1816G453R0F
R958	315-0431-00			RES.,FXD,CMPSN:430 OHM,5%,0.25W	01121	CB4315
S510	105-0571-01			ACTUATOR,SL SW:6 OF 6 POSITION	80009	105-0571-01
S615	105-0571-01			ACTUATOR,SL SW:6 OF 6 POSITION	80009	105-0571-01
ADD:						
C504	281-0592-00			CAP.,FXD,CER DI:4.7PF,+/-0.5PF,500V	72982	301-023C0H0479D
C602	281-0592-00			CAP.,FXD,CER DI:4.7PF,+/-0.5PF,500V	72982	301-023C0H0479D
C610	281-0584-00			CAP.,FXD,CER DI:100PF,5%,500V	72982	0301000Y5E0101J
C955	290-0527-00			CAP.,FXD,ELCTLT:15UF,20%,20V	90201	TDC156M020FL
CR610	152-0246-00			SEMICONV DEVICE:SW,SI,40V,200MA	03508	DE140
CR949	152-0141-02			SEMICONV DEVICE:SILICON,30V,150MA	01295	1N4152R
Q610	151-1005-00			TRANSISTOR:SILICON,JFE,N-CHANNEL	80009	151-1005-00
Q612	151-0220-03			TRANSISTOR:SILICON,PNP,SEL	80009	151-0220-03
R605	315-0100-00			RES.,FXD,CMPSN:10 OHM,5%,0.25W	01121	CB1005
R608	315-0100-00			RES.,FXD,CMPSN:10 OHM,5%,0.25W	01121	CB1005
R610	315-0153-00			RES.,FXD,CMPSN:15K OHM,5%,0.25W	01121	CB1535
R613	315-0472-00			RES.,FXD,CMPSN:4.7K OHM,5%,0.25W	01121	CB4725
R614	315-0472-00			RES.,FXD,CMPSN:4.7K OHM,5%,0.25W	01121	CB4725
R615	321-0481-00			RES.,FXD,FILM:1M OHM,1%,0.125W	24546	NA4D1004F
R619	315-0106-00			RES.,FXD,CMPSN:10M OHM,5%,0.25W	01121	CB1065
R620	315-0470-00			RES.,FXD,CMPSN:47 OHM,5%,0.25W	01121	CB4705
R949	315-0361-00			RES.,FXD,CMPSN:360 OHM,5%,0.25W	01121	CB3615
VR958	152-0395-00			SEMICONV DEVICE:ZENER,0.4W,4.3V,5%	14552	TD332317
REMOVE:						
C956	283-0024-00			CAP.,FXD,CER DI:0.1UF,+80-20%,50V	72982	8121N08325U0104Z
C958	290-0527-00			CAP.,FXD,ELCTLT:15UF,20%,20V	90201	TDC156M020FL
CR957	152-0322-00			SEMICONV DEVICE:SILICON,15V,HOT CARRIER	50434	5082-2672

**REPLACEABLE ELECTRICAL PARTS  
OPTION 5**

Ckt No.	Tektronix Part No.	Serial/Model No. Eff	Dscont	Name & Description	Mfr Code	Mfr Part Number
R658	321-0258-00			RES., FXD, FILM: 4.75K OHM, 1%, 0.125W	91637	MFF1816G47500F
R954	315-0132-00			RES., FXD, CMPSN: 1.3K OHM, 5%, 0.25W	01121	CB1325
R956	321-0195-00			RES., FXD, FILM: 1.05K OHM, 1%, 0.125W	91637	MFF1816G10500F
ADD:						
A12	670-3685-00			CKT BOARD ASSY: TV SYNC SEPARATOR	80009	670-3685-00
C2802	283-0059-00			CAP., FXD, CER DI: 1UF, +80-20%, 25V	72982	8131N03125U0105Z
C2803	283-0059-00			CAP., FXD, CER DI: 1UF, +80-20%, 25V	72982	8131N03125U0105Z
C2804	281-0504-00			CAP., FXD, CER DI: 10PF, +/-1PF, 500V	72982	301-055C0G0100F
C2805	281-0504-00			CAP., FXD, CER DI: 10PF, +/-1PF, 500V	72982	301-055C0G0100F
C2812	283-0341-00			CAP., FXD, CER DI: 0.047UF, 10%, 100V	72982	8121N153X7R0473K
C2827	290-0530-00			CAP., FXD, ELCTLT: 68UF, 20%, 6V	90201	TDC686M006NLF
C2854	281-0632-00			CAP., FXD, CER DI: 35PF, 1%, 500V	72982	308-000C0G0350F
C2856	281-0605-00			CAP., FXD, CER DI: 200PF, 10%, 500V	04222	7001-1375
C2860	281-0511-00			CAP., FXD, CER DI: 22PF, +/-2.2PF, 500V	72982	301-000C0G0220K
C2861	283-0010-00			CAP., FXD, CER DI: 0.05UF, +100-20%, 50V	56289	273C20
C2865	281-0577-00			CAP., FXD, CER DI: 14PF, 5%, 500V	72982	301-050C0G0140J
C2866	283-0010-00			CAP., FXD, CER DI: 0.05UF, +100-20%, 50V	56289	273C20
C2879	290-0536-00			CAP., FXD, ELCTLT: 10UF, 20%, 25V	90201	TDC106M025FL
CR2807	152-0141-02			SEMICONV DEVICE: SILICON, 30V, 150MA	01295	1N4152R
CR2809	152-0141-02			SEMICONV DEVICE: SILICON, 30V, 150MA	01295	1N4152R
CR2818	152-0141-02			SEMICONV DEVICE: SILICON, 30V, 150MA	01295	1N4152R
CR2824	152-0141-02			SEMICONV DEVICE: SILICON, 30V, 150MA	01295	1N4152R
CR2825	152-0141-02			SEMICONV DEVICE: SILICON, 30V, 150MA	01295	1N4152R
CR2826	152-0141-02			SEMICONV DEVICE: SILICON, 30V, 150MA	01295	1N4152R
CR2828	152-0141-02			SEMICONV DEVICE: SILICON, 30V, 150MA	01295	1N4152R
CR2831	152-0141-02			SEMICONV DEVICE: SILICON, 30V, 150MA	01295	1N4152R
CR2865	152-0141-02			SEMICONV DEVICE: SILICON, 30V, 150MA	01295	1N4152R
Q2802	151-0190-00			TRANSISTOR: SILICON, NPN	07263	S032677
Q2803	151-0220-00			TRANSISTOR: SILICON, PNP	07263	S036228
Q2813	151-0188-00			TRANSISTOR: SILICON, PNP	04713	SPS6868K
Q2824	151-0188-00			TRANSISTOR: SILICON, PNP	04713	SPS6868K
Q2834	151-0192-00			TRANSISTOR: SILICON, NPN, SEL FROM MPS6521	04713	SPS8801
Q2854	151-0192-00			TRANSISTOR: SILICON, NPN, SEL FROM MPS6521	04713	SPS8801
Q2863	151-0188-00			TRANSISTOR: SILICON, PNP	04713	SPS6868K
R2801	315-0302-00			RES., FXD, CMPSN: 3K OHM, 5%, 0.25W	01121	CB3025
R2802	315-0682-00			RES., FXD, CMPSN: 6.8K OHM, 5%, 0.25W	01121	CB6825
R2803	315-0103-00			RES., FXD, CMPSN: 10K OHM, 5%, 0.25W	01121	CB1035
R2804	315-0123-00			RES., FXD, CMPSN: 12K OHM, 5%, 0.25W	01121	CB1235
R2805	315-0303-00			RES., FXD, CMPSN: 30K OHM, 5%, 0.25W	01121	CB3035
R2807	315-0124-00			RES., FXD, CMPSN: 120K OHM, 5%, 0.25W	01121	CB1245
R2809	315-0123-00			RES., FXD, CMPSN: 12K OHM, 5%, 0.25W	01121	CB1235
R2810	315-0103-00			RES., FXD, CMPSN: 10K OHM, 5%, 0.25W	01121	CB1035
R2811	315-0103-00			RES., FXD, CMPSN: 10K OHM, 5%, 0.25W	01121	CB1035
R2812	315-0914-00			RES., FXD, CMPSN: 910K OHM, 5%, 0.25W	01121	CB9145
R2813	315-0303-00			RES., FXD, CMPSN: 30K OHM, 5%, 0.25W	01121	CB3035
R2814	315-0563-00			RES., FXD, CMPSN: 56K OHM, 5%, 0.25W	01121	CB5635
R2816	315-0471-00			RES., FXD, CMPSN: 470 OHM, 5%, 0.25W	01121	CB4715
R2818	315-0364-00			RES., FXD, CMPSN: 360K OHM, 5%, 0.25W	01121	CB3645
R2820	315-0203-00			RES., FXD, CMPSN: 20K OHM, 5%, 0.25W	01121	CB2035
R2824	315-0182-00			RES., FXD, CMPSN: 1.8K OHM, 5%, 0.25W	01121	CB1825
R2825	315-0202-00			RES., FXD, CMPSN: 2K OHM, 5%, 0.25W	01121	CB2025
R2826	311-1226-00			RES., VAR, NONWIR: 2.5K OHM, 20%, 0.50W	32997	3386F-T04-252

### REPLACEABLE ELECTRICAL PARTS OPTION 5

Ckt No.	Tektronix Part No.	Serial/Model No.		Name & Description	Mfr	
		Eff	Dscont		Code	Mfr Part Number
R2827	315-0681-00			RES., FXD, CMPSN: 680 OHM, 5%, 0.25W	01121	CB6815
R2830	315-0112-00			RES., FXD, CMPSN: 1.1K OHM, 5%, 0.25W	01121	CB1125
R2833	315-0303-00			RES., FXD, CMPSN: 30K OHM, 5%, 0.25W	01121	CB3035
R2834	315-0561-00			RES., FXD, CMPSN: 560 OHM, 5%, 0.25W	01121	CB5615
R2850	315-0274-00			RES., FXD, CMPSN: 270K OHM, 5%, 0.25W	01121	CB2745
R2854	315-0103-00			RES., FXD, CMPSN: 10K OHM, 5%, 0.25W	01121	CB1035
R2856	315-0154-00			RES., FXD, CMPSN: 150K OHM, 5%, 0.25W	01121	CB1545
R2860	315-0822-00			RES., FXD, CMPSN: 8.2K OHM, 5%, 0.25W	01121	CB8225
R2861	315-0123-00			RES., FXD, CMPSN: 12K OHM, 5%, 0.25W	01121	CB1235
R2863	315-0822-00			RES., FXD, CMPSN: 8.2K OHM, 5%, 0.25W	01121	CB8225
R2875	315-0273-00			RES., FXD, CMPSN: 27K OHM, 5%, 0.25W	01121	CB2735
R2879	315-0100-00			RES., FXD, CMPSN: 10 OHM, 5%, 0.25W	01121	CB1005
U2810	156-0136-00			MICROCIRCUIT, LI: OPERATIONAL AMPLIFIER	80009	156-0136-00
VR2827	152-0395-00			SEMICONV DEVICE: ZENER, 0.4W, 4.3V, 5%	04713	1N749A
VR2832	152-0195-00			SEMICONV DEVICE: ZENER, 0.4W, 5.1V, 5%	80009	152-0195-00

### REPLACEABLE MECHANICAL PARTS

Fig. & Index No.	Tektronix Part No.	Serial/Model No.		Qty	1	2	3	4	5	Name & Description	Mfr	
		Eff	Dscont								Code	Mfr Part Number
CHANGE TO:												
1-3	337-1674-08			1						SHLD, IMPLOSION: FILTER, MKD FOR NTSC	80009	337-1674-08
	337-1674-09			1						SHLD, IMPLOSION: FILTER, MKD FOR CCIR	80009	337-1674-09
-132	333-1810-01	B010100	B152299	1						PANEL, FRONT:	80009	333-1810-01
	333-1810-03	B152300		1						PANEL, FRONT:	80009	333-1810-03
	179-2194-00			1						WIRING HARNESS:	80009	179-2194-00
	198-2318-00			1						WIRE SET, ELEC:	80009	198-2318-00
	441-1205-00			1						CHASSIS, SCOPE: SYNC SEPARATOR	80009	441-1205-00

## OPTION 7

### INTRODUCTION

Option 7 is a dc to ac inverter that permits Tektronix Oscilloscopes to operate on 12 or 24 V dc with no performance deterioration. Circuitry is provided to protect against damage due to connection of 24 V when in the 12 V mode of operation.

The 24-volt external input permits use with conventional dc power (marine and aircraft).

Option 7 is an integral part of the oscilloscope. The modified oscilloscope has a three-position voltage input selection slide switch (visible through the right-hand side panel) at the rear of the line voltage selector switch. A dc input connector is located below the fan cover on the rear panel.

### SPECIFICATIONS

#### AC Requirements

No increase in ac requirements over those of oscilloscopes not having Option 7.

#### DC Requirements

11.5 to 14 volts or 22 to 28 volts. 11.5-volt operation excludes graticule light operation, probe power use and Option 5. Operating range may be extended to 15 volts or 30 volts with a series dropping resistor. Maximum elevation for + or – power lead is 60 V with respect to oscilloscope chassis ground.

#### Temperature

The same operating and non-operating range as the oscilloscope without Option 7.

### SAFETY CONSIDERATIONS

Option 7 becomes a part of the modified instrument. The safety considerations for the unmodified instrument apply.

### FUNCTION OF CONTROLS AND CONNECTORS

#### Mode Switch<sup>1</sup>

- |       |   |
|-------|---|
| AC    | Applies ac power to the oscilloscope power switch.  |
| DC 12 | Permits 12 V operation of the instrument from an external 12 V source.  |
| DC 24 | Permits 24 V operation of the instrument from either an external 24 V power source or from the 1106 Power Supply, which may be mechanically attached to the oscilloscope. |

#### Dc Input Connector

Option 7 mode switch and dc input connector are located on the modified oscilloscope.

<sup>1</sup> Be sure that the 1106 Line Selector switch is set to the correct line voltage for proper battery charging.

**OPERATION AND INSPECTION**

Set the oscilloscope and Option 7 for the power source available as listed.

TABLE OPTION 7-1

Power Source	Oscilloscope Line Selector	Option 7 Mode Switch
115 V AC	115	AC
230 V AC	230	AC
12 V DC	—	12
24 V DC	—	24
1106 <sup>1</sup>	—	24

Turn the oscilloscope on. Check that the oscilloscope operates properly on any of the listed power sources that may be available.

Connect the oscilloscope frame to a ground (earth) reference before using.

**CIRCUIT DESCRIPTION**

Option 7 is a dc to ac inverter. It operates on 12 or 24 V dc. The circuit description is for 24 V operation unless noted otherwise. Refer to the schematic diagram in Section 6 throughout the detailed circuit description.

The operating frequency of the inverter is approximately 400 Hz.

**Simplified Block Diagram**

See Figure Option 7-1. The dc source is applied to the turn-off level circuit, the start circuit and the primary of T1701. If the dc source is above the level set by Turn-Off Level Adjustment R1613, the turn-off circuit does not operate.

The start circuit provides a large current surge through T1631 secondary to the bases of Q1652, Q1662, Q1654 and Q1664. This starts the inverter.

The turn-off circuit is activated in two ways. In 24 V operation, Q1622 is turned on by the source voltage dropping below 22 V. In 12 V mode of operation, Q1626 is turned on by the accidental application of 24 V dc.

**Turn-Off Level Circuit**

The voltage reference for the base of Q1606 is set by R1604, VR1604 and VR1605 for about 9.1 V. This establishes the junction of R1607 and the emitters of Q1606 and Q1608 at about 9.7 V. C1605 helps to hold the 9.1 V level, preventing inverter transients from activating the turn-off circuit and prevents Q1608 from turning on when the inverter is started. This allows the power source time to recover after providing the initial-start surge.

Source voltages higher than 22 V dc cause increased current through R1607, Q1606 and R1609. Q1608 is kept cut off by the increased voltage across R1609 and the resulting change across divider R1611-R1613-R1614. This permits no current through R1617. Since R1617 furnishes bias to Q1622, the transistor is cut off. This permits the collector of Q1622 and the rest of the turn-off circuit to rise to a voltage determined by the inverter circuit and the dc source voltage. The collector of Q1622 may be about 24 V (with respect to—dc) with a 12 V dc source and about 36 V with a 24 V dc source.

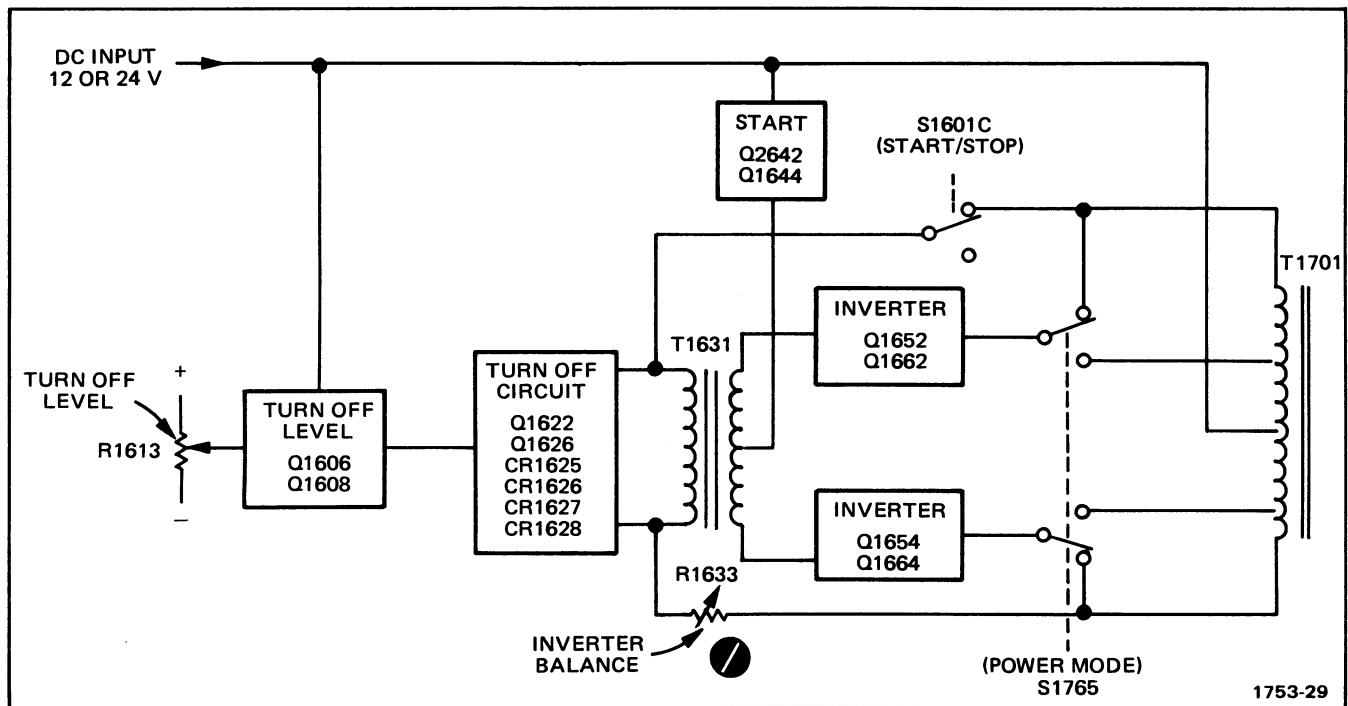

Figure Option 7-1. Option 7 simplified block diagram.

If the dc source voltage drops to less than 22 V, the current through divider R1609, R1611, R1613 and R1614 is decreased. Q1608 conducts, taking current from Q1606, and causing less drop across R1609. This makes Q1608 conduct more and Q1606 is cut off. Current flow through R1617 turns Q1622 on. Q1622 saturates, dropping its collector voltage to about 0.2 V. R1618 limits the maximum base current of Q1622.

During 12 V dc operation, there is no current flow through VR1604 and VR1605, since their series rating, about 18 volts, exceeds the applied voltage. The base current of Q1606, through R1605, turns Q1606 on enough to take all the current through R1607, which causes Q1608 to be cut off.

### Turn-Off Circuit

Q1622 is off under normal operating conditions until the dc source drops below 22 V and causes Q1622 to conduct. Q1622 does not conduct during 12 V dc operation, since the turn-off level circuit is disabled. CR1625, CR1626, CR1627, and CR1628 form a bridge rectifier. The inverter waveform is rectified to provide operating power for the turn-off circuit. C1626 filters the inverter spokes to keep them from firing Q1626 (scr). R1623 prevents C1626 from charging to the peak-to-peak inverter spikes.

Q1622 saturates when it is turned on. C1622 provides the high current path for feedback current via CR1625 or CR1626. Once the inverter is shut down, R1622 establishes a path to discharge C1622.

If 24 V dc is accidentally applied when the mode switch is in the 12 V position, the inverter transformer T1701 attempts to produce two times the correct feedback. This is sufficient to cause VR1622 to conduct. VR1622 provides the firing current for the scr, Q1626. Q1626 fires and shorts out the bridge rectifier and the primary of T1631, stopping the inverter. R1625 prevents Q1626 from being fired by inverter noise. R1624 and C1626 provide holding current for Q1626, keeping it conducting until the surge currents created by the over-voltage conditions have terminated. CR1624 permits rapid charging of C1626.

### Start Circuit

When S1601 is closed, the external dc source is applied to C1614, VR1641, and R1645. The initial surge is coupled to Q1642 through C1614, VR1639, and R1641. Q1642 saturates until C1614 charges through R1639 to the value determined by VR1639 and the base-emitter junction of Q1642 (about 5.7 volts), then Q1642 is cut off. R1641 limits the base current in Q1642. VR1639, once C1614 is charged, makes Q1642 insensitive to input variations. R1642 limits Q1642 collector current. Q1644, R1645, and VR1641 provide a constant current during the time Q1642 is saturated, regardless of the dc source voltage. CR1643 is reverse biased by this starting current. The starting current is applied to the inverter transistors through T1631.

### Inverter Circuit

The starting surge is applied to the bases of Q1652, Q1662, Q1654, and Q1664 through T1631, R1652, R1662, R1654, and R1664. Since the transistors do not have identical parameters, one pair will conduct before the other, and start the inverter. Operating base current is provided through CR1643.

R1626, R1631, and T1631 primary and secondary are the main frequency-determining components for the inverter. Four base resistors, R1652, R1662, R1654, and R1664, distribute the drive evenly between the four transistors. C1652, C1662, C1654 and C1664 degenerate the high frequency response and reduce transients.

Feedback to maintain inverter operation is provided from T1701 primary to T1631 primary through R1626, R1631, R1633, CR1632 and CR1634. R1626 and R1631 provide frequency stability and current limiting. R1633, CR1632, and CR1634 compensate for differences in transistors and components. CR1632 and CR1634 conduct during different inverter half-cycles and permit R1633 to balance the drive to T1701.

C1710, C1720, C1721, C1750, C1760, C1770 and C1780 are added with Option 7 to provide optimum reduction of transients during inverter operation.

### DC Input

External power is applied through P1601. CR1601 is normally reverse biased. If the wrong polarity external power is applied, CR1601 becomes forward biased and blows fuse F1601. Low-pass network T1601, C1601, C1603, and C1609 is a filter to reduce transients to the dc source.

### Start-Stop Switch

S1601, Section A in the off (stop) position discharges the capacitors in the turn-off and start circuits. This ensures the correct time constants when S1601 is changed to the on (start) position. In the start position, the dc input is applied to the inverter circuitry by S1601, Section A. At the same time S1601, section B is closed, completing the feedback loop for the inverter transistors. S1601, section B stops the inverter in the off position by opening the feedback loop between T1701 and T1631.

### Power-Mode Switch

Sections A and F connect filter C1671 and R1671 to T1701 during 12 or 24 V operation to reduce converter transients. Sections C and D select either transformer terminals 11 and 13 or 12 and 14, to provide the same secondary output when operating on 12 or 24 V. Sections B and E connect transformer terminals 10 and 14 to S1765, C and D and to the inverter feedback circuit during 12 or 24 V operation.



## MAINTENANCE

### Obtaining Replacement Parts

**STANDARD PARTS.** All electrical and mechanical part replacements for Option 7 can be obtained through your local Tektronix Field Office or representative. However, many of the standard electronic components can be obtained locally in less time than is required to order them from Tektronix, Inc. Before purchasing or ordering replacements parts, check the parts list for value, tolerance, rating and description.

**SPECIAL PARTS.** In addition to the standard electronic components, some special components are used in Option 7. These components are manufactured or selected by Tektronix, Inc., to meet specific performance requirements, or are manufactured for Tektronix, Inc., in accordance with our specifications. Most of the mechanical parts used in this instrument have been manufactured by Tektronix, Inc. Order all special parts directly from your local Tektronix Field Office or representative.

**ORDERING PARTS.** When ordering replacement parts from Tektronix, Inc., include the following information:

1. Instrument type.
2. Instrument serial number.
3. A description of the part (if electrical, include the circuit number).
4. Tektronix part number.

### Circuit Board Chassis Removal

The circuit board is mounted on a small chassis located between the power transformer and the crt shield. To remove the chassis, remove three screws. Two thread-forming screws are located at the top of the chassis. One screw is at the bottom of the chassis and is removed from the right-hand side by going just below the power transformer.

## CALIBRATION

Option 7 may be calibrated without removing it from the oscilloscope.

The reference letters (A), (B), etc., refer to points indicated on the schematic and circuit board illustrations.

### Equipment Required

**DC POWER SOURCE.** Voltage from 22 V to 28 V and from 11.5 V to 14 V. A source voltage of less than 22 volts will turn off Option 7 when it is operating in the 24 V mode. Starting current in 24 V mode is approximately 4 to 10 A. The dc source must be capable of handling this surge without dropping to 22 V or less. The 12 V starting surge is approximately 15 A.

**DC VOLTMETER.** 22 V to 28 V.

**TEST OSCILLOSCOPE.** Used to verify the inverter balance adjustment. If the instrument under test and Option 7 are operational and the power source has a negative ground, they may be used as the test oscilloscope for this check.

## NOTE

Option 7 is calibrated at the factory using a power supply (having the specifications listed first under the equipment required list). This permits the most accurate setting of the turn-off volts and inverter balance adjustments. Because this type of power supply may not be available, several alternate possibilities are given. The alternate power supplies have drawbacks, including voltage stability vs. time with high discharge rates, see Figure Option 7-2.

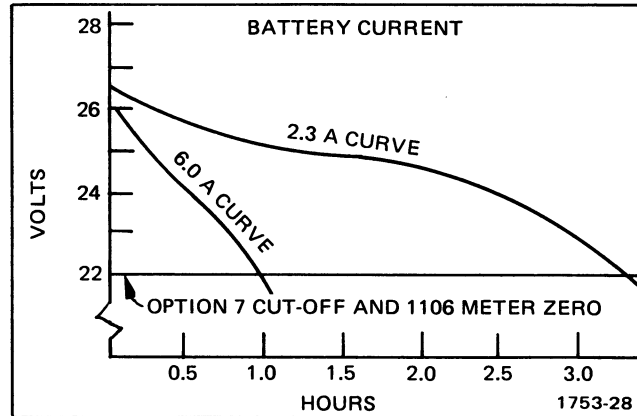

Figure Option 7-2. Typical battery pack discharge curves.

1. Variable power supply with the aforementioned capabilities.
2. Variable power supply with an adequate current rating, in series with items 4 or 5.
3. 1106 Power Supply battery pack.<sup>2</sup>
4. Two 12-volt wet-cell storage batteries, in series, tapped at 20, 22, or 24 V.<sup>3</sup>
5. 18 to 23 Ni Cd cells, 4.0 amp hr (D cells) or greater, furnishing 20 to 28 V.<sup>3</sup>

## CAUTION

*This procedure is for an external dc source with the negative lead at ground potential (negative ground system).*

<sup>2</sup> To set the turn-off level, the battery is charged above the cut-off point (22 V). An oscilloscope is connected and the battery allowed to discharge while its voltage is being monitored. As it reaches 22 V the turn-off point is set to cut off Option 7. The turn-off point on Option 7 approximately coincides with the meter zero on the 1106.

<sup>3</sup> This does not permit accurate adjustment of the turn-off level. Ni Cd batteries can be used, following the technique used for item 3.

### Operating Range

- a. Connect the dc source to the oscilloscope equipped with Option 7. Operate the oscilloscope in the 24 V mode. Connect the voltmeter between fuse, F1601 (B) and the common negative return (A). Vary the dc source from 28 V to 22 V.

CHECK—Oscilloscope should operate over the voltage range.

- b. Change the dc source to 12 V. Operate the oscilloscope in the 12 V mode. Vary the dc source from 14 V to 11.5 V.

CHECK—Oscilloscope should operate over the voltage range.

### Inverter Balance

#### NOTE

If the major oscilloscope use is with a 12-volt source, do this step while operating the oscilloscope and dc source on 12 volts.

Operate the oscilloscope in the 24 V mode. Set the dc source to 24 V. Connect the test oscilloscope between C1601 (C) and the common negative return (A).

CHECK—Signal should be flat. See Figure Option 7-3.

ADJUST—Inverter Balance (R1633) for the flattest signal.

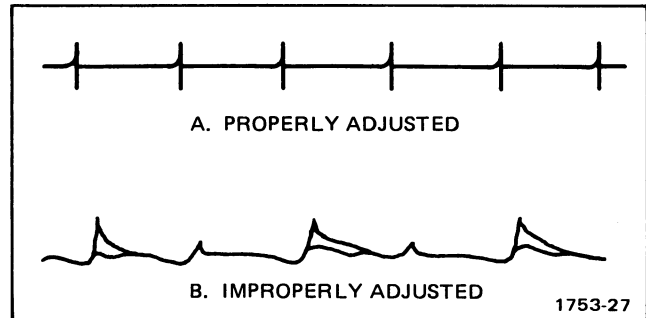

Figure Option 7-3. Inverter balance.

#### NOTE

There is a slow drift (about a second) after the inverter balance adjustment has been moved. This is due to transistor characteristics and will require a slight Inverter Balance readjustment.

A very close approximation of the preceding method can be obtained by setting the inverter balance control for the minimum sound coming from the inverter.

### Turn-Off Level

Set the dc source for 21.8 V.

ADJUST—Turn-Off Level (R1613) slowly until Option 7 turns off.

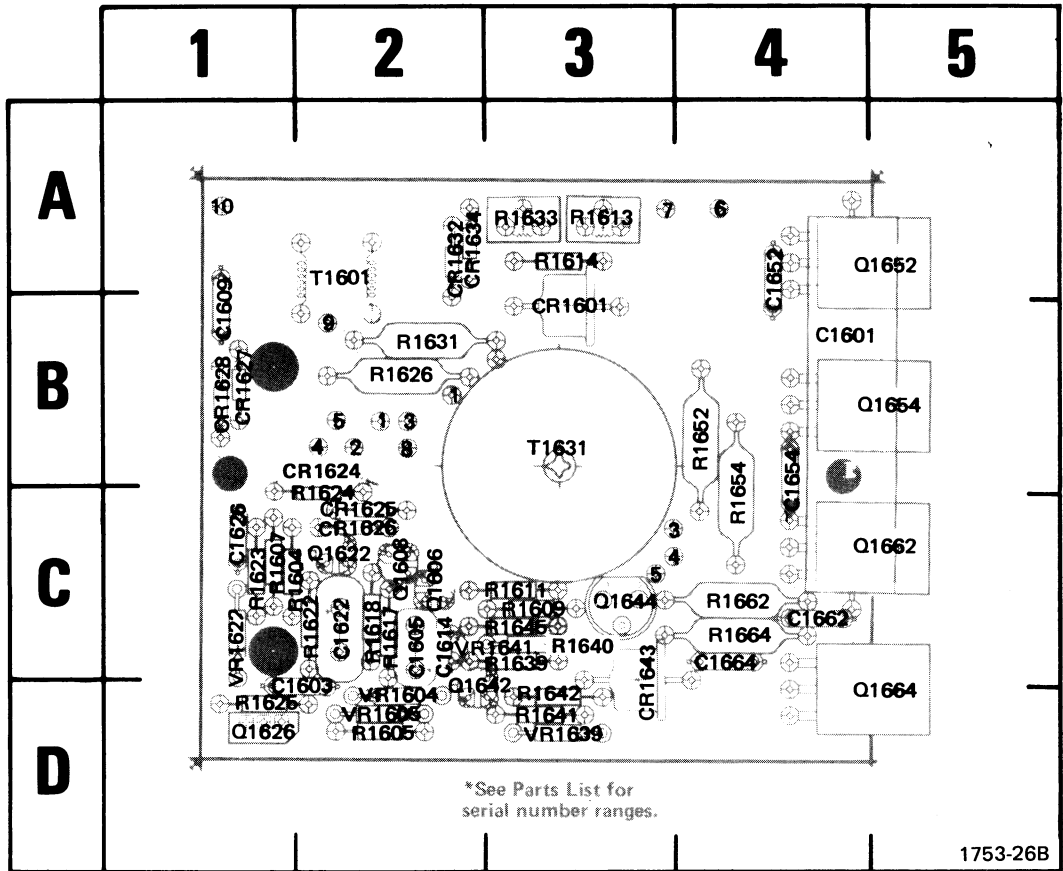

CKT NO	GRID LOC	CKT NO	GRID LOC	CKT NO	GRID LOC	CKT NO	GRID LOC
C1601	4B	CR1628	1B	R1605	2D	R1641	3D
C1603	2D	CR1632	2A	R1607	1C	R1642	3D
C1605	2C	CR1634	2A	R1609	3C	R1645	3C
C1609	1B	CR1643	3D	R1611	3C	R1652	4B
C1614	2C			R1613	3A	R1654	4B
C1622	2C	Q1606	2C	R1614	3A	R1662	4C
C1626	1C	Q1608	2C	R1617	2C	R1664	4C
C1652	4A	Q1622	2C	R1618	2C		
C1654	4B	Q1626	1D	R1622	2C	T1601	2A
C1662	4C	Q1642	2D	R1623	1C	T1631	3B
C1664	4C	Q1644	3C	R1624	2C		
		Q1652	5A	R1625	1D	VR1604	2D
		Q1654	5B	R1626	2B	VR1605	2D
CR1601	3B	Q1662	5C			VR1622	1C
CR1624	2B	Q1664	5D	R1631	2B	VR1639	3D
CR1625	2C			R1633	3A	VR1641	3C
CR1626	2C	R1604	1C	R1639	3C		
CR1627	1B			R1640	3C		

Fig. Option 7-4. Circuit board layout with component locator grid.

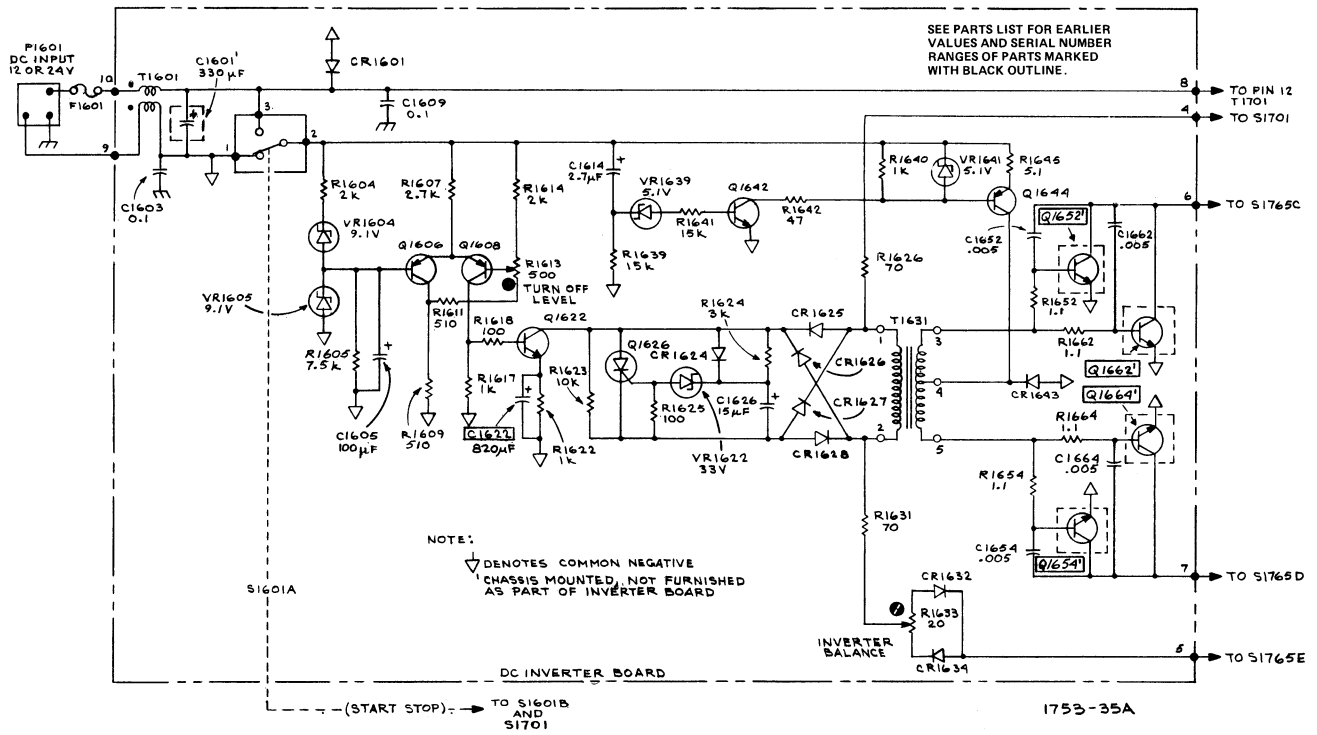

Fig. Option 7-5. 464 Option 7 dc inverter.

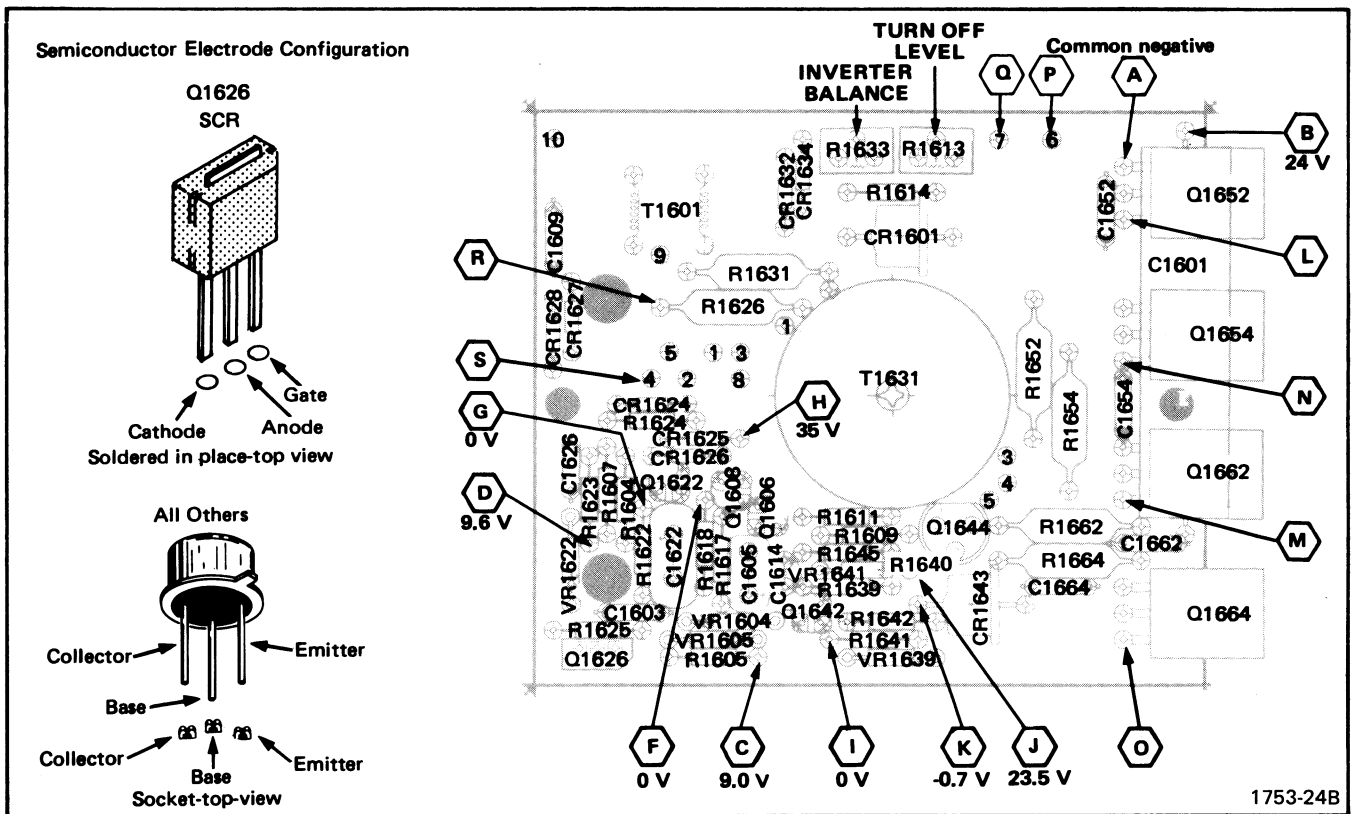

Fig. Option 7-6. Circuit board layout with test voltages

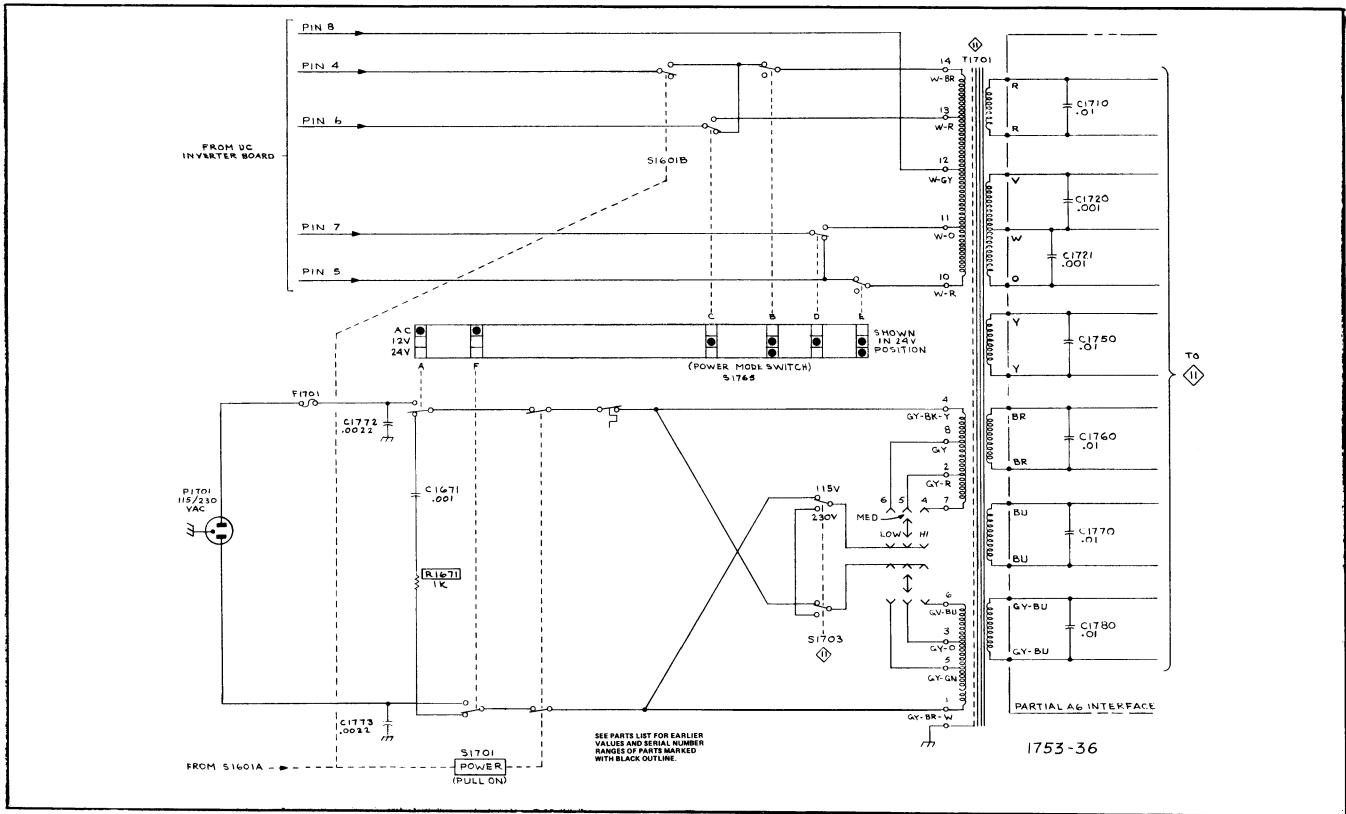

Figure Option 7-7. 466 Option 7 primary winding.

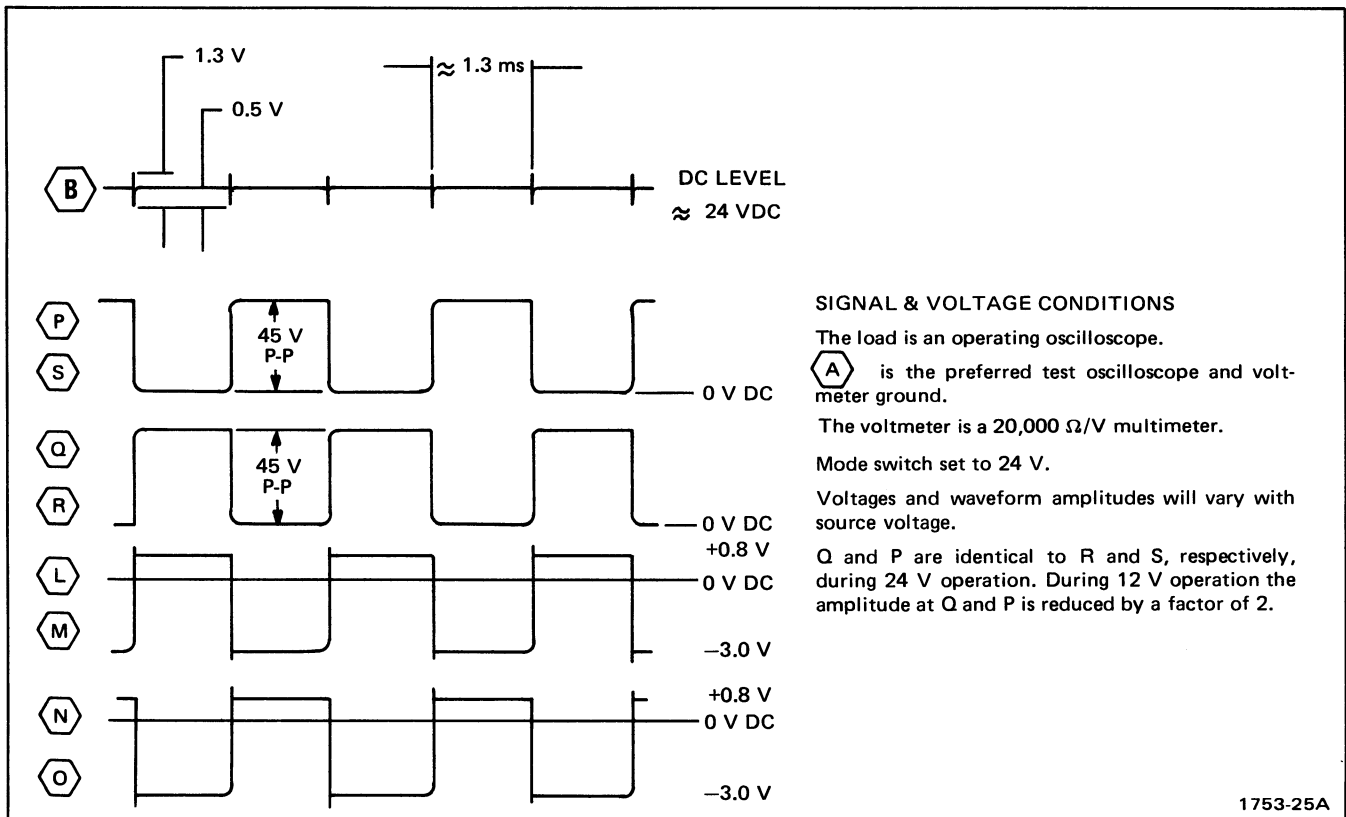

Figure Option 7-8. Typical idealized waveforms.

**REPLACEABLE ELECTRICAL PARTS  
OPTION 7**

Ckt No.	Tektronix Part No.	Serial/Model No. Eff	Dscont	Name & Description	Mfr Code	Mfr Part Number
ADDITIONAL PARTS ADDED TO STANDARD 466						
C1601	290-0667-00			CAP., FXD, ELCTLT: 330UF, +75-10%, 50V	56289	500D158
C1671	283-0000-00			CAP., FXD, CER DI: 0.001UF, +100-0%, 500V	72982	831-516E102P
C1710	283-0003-00			CAP., FXD, CER DI: 0.01UF, +80-20%, 150V	72982	855-558Z5U-103Z
	-----			(WHEN INSTRUMENT IS EQUIPPED WITH BOTH OPTION 4 AND OPTION 7, ONLY ONE SET OF THESE CAPACITORS IS USED)		
C1720	283-0000-00			CAP., FXD, CER DI: 0.001UF, +100-0%, 500V (SEE FOOTNOTE ON C1710)	72982	831-516E102P
C1721	283-0000-00			CAP., FXD, CER DI: 0.001UF, +100-0%, 500V (SEE FOOTNOTE ON C1710)	72982	831-516E102P
C1750	283-0003-00			CAP., FXD, CER DI: 0.01UF, +80-20%, 150V (SEE FOOTNOTE ON C1710)	72982	855-558Z5U-103Z
C1760	283-0003-00			CAP., FXD, CER DI: 0.01UF, +80-20%, 150V (SEE FOOTNOTE ON C1710)	72982	855-558Z5U-103Z
C1770	283-0003-00			CAP., FXD, CER DI: 0.01UF, +80-20%, 150V (SEE FOOTNOTE ON C1710)	72982	855-558Z5U-103Z
C1772	283-0263-00			CAP., FXD, CER DI: 0.0022UF, 20%, 3000V (MOUNTED ON REAR PANEL OF 466. NOT USED WHEN INSTR IS EQUIPPED WITH BOTH OPT 4 AND OPT 7)	56289	33C319
C1773	283-0263-00			CAP., FXD, CER DI: 0.0022UF, 20%, 3000V (SEE FOOTNOTE ON C1772)	56289	33C319
C1780	283-0003-00			CAP., FXD, CER DI: 0.01UF, +80-20%, 150V (SEE FOOTNOTE ON C1710)	72982	855-558Z5U-103Z
F1601	159-0038-00			FUSE, CARTRIDGE: 3AG, 15A, 32V, FAST-BLOW	71400	MDL 15A
P1601	131-1556-00			CONN, RCPT, ELEC: PWR, MALE, 125VAC, 15A	80009	131-1556-00
Q1652	151-0436-00	B010100	B082629	TRANSISTOR: SILICON, NPN	80009	151-0436-00
Q1652	153-0636-00	B082630		TRANSISTOR: SILICON, NPN, SELECTED	80009	153-0636-00
Q1654	151-0436-00	B010100	B082629	TRANSISTOR: SILICON, NPN	80009	151-0436-00
Q1654	153-0636-00	B082630		TRANSISTOR: SILICON, NPN, SELECTED	80009	153-0636-00
Q1662	151-0436-00	B010100	B082629	TRANSISTOR: SILICON, NPN	80009	151-0436-00
Q1662	153-0636-00	B082630		TRANSISTOR: SILICON, NPN, SELECTED	80009	153-0636-00
Q1664	151-0436-00	B010100	B082629	TRANSISTOR: SILICON, NPN	80009	151-0436-00
Q1664	153-0636-00	B082630		TRANSISTOR: SILICON, NPN, SELECTED	80009	153-0636-00
R1671	302-0102-00	B010100	B051019	RES., FXD, CMPSN: 1K OHM, 10%, 0.50W	01121	EB1021
R1671	308-0077-00	B051020		RES., FXD, WW: 1K OHM, 5%, 3W	14193	SA301001J
S1601	260-0834-00			SWITCH, TOGGLE: DPDT, 5A, 125VAC, 0.25-40 THD	09353	U21-SHZQE
S1765	105-0479-00			ACTUATOR, SWITCH: SLIDE, INVERTER	80009	105-0479-00
S1765A	260-0760-00			SWITCH, SENS: 10A, 250V, SPDT, SNAP ACTION	01963	E62-10A
S1765B	260-0760-00			SWITCH, SENS: 10A, 250V, SPDT, SNAP ACTION	01963	E62-10A
S1765C	260-0760-00			SWITCH, SENS: 10A, 250V, SPDT, SNAP ACTION	01963	E62-10A
S1765D	260-0760-00			SWITCH, SENS: 10A, 250V, SPDT, SNAP ACTION	01963	E62-10A
S1765E	260-0760-00			SWITCH, SENS: 10A, 250V, SPDT, SNAP ACTION	01963	E62-10A
S1765F	260-0760-00			SWITCH, SENS: 10A, 250V, SPDT, SNAP ACTION	01963	E62-10A

## REPLACEABLE ELECTRICAL PARTS OPTION 7

Ckt No.	Tektronix Part No.	Serial/Model No. Eff	Dscont	Name & Description	Mfr Code	Mfr Part Number
A13	670-2744-01	B010100	B082418	CKT BOARD ASSY: INVERTER	80009	670-2744-01
A13	670-2744-02	B082419		CKT BOARD ASSY: INVERTER	80009	670-2744-02
C1603	283-0178-00			CAP., FXD, CER DI: 0.1UF, +80-20%, 100V	72982	8131N145651 104Z
C1605	290-0531-00			CAP., FXD, ELCTLT: 100UF, 20%, 10V	90201	TDC107M010WLC
C1609	283-0178-00			CAP., FXD, CER DI: 0.1UF, +80-20%, 100V	72982	8131N145651 104Z
C1614	290-0573-00			CAP., FXD, ELCTLT: 2.7UF, 20%, 50V	56289	196D275X0050JA1
C1622	290-0533-00	B010100	B082418	CAP., FXD, ELCTLT: 330UF, 20%, 6V	90201	TDC337M006WLD
C1622	290-0708-00	B082419		CAP., FXD, ELCTLT: 820UF, 20%, 6V	56289	109D827X0006F2
C1626	290-0528-00			CAP., FXD, ELCTLT: 15UF, 20%, 50V	90201	TDC156M050WLC
C1652	283-0110-00			CAP., FXD, CER DI: 0.005UF, +80-20%, 150V	56289	19C242B
C1654	283-0110-00			CAP., FXD, CER DI: 0.005UF, +80-20%, 150V	56289	19C242B
C1662	283-0110-00			CAP., FXD, CER DI: 0.005UF, +80-20%, 150V	56289	19C242B
C1664	283-0110-00			CAP., FXD, CER DI: 0.005UF, +80-20%, 150V	56289	19C242B
CR1601	152-0198-00			SEMICONV DEVICE: SILICON, 200V, 3A	03508	1N5624
CR1624	152-0333-00			SEMICONV DEVICE: SILICON, 55V, 200MA	07263	FDH-6012
CR1625	152-0107-00			SEMICONV DEVICE: SILICON, 400V, 400MA	01295	G727
CR1626	152-0107-00			SEMICONV DEVICE: SILICON, 400V, 400MA	01295	G727
CR1627	152-0107-00			SEMICONV DEVICE: SILICON, 400V, 400MA	01295	G727
CR1628	152-0107-00			SEMICONV DEVICE: SILICON, 400V, 400MA	01295	G727
CR1632	152-0333-00			SEMICONV DEVICE: SILICON, 55V, 200MA	07263	FDH-6012
CR1634	152-0333-00			SEMICONV DEVICE: SILICON, 55V, 200MA	07263	FDH-6012
CR1643	152-0198-00			SEMICONV DEVICE: SILICON, 200V, 3A	03508	1N5624
Q1606	151-0301-00			TRANSISTOR: SILICON, PNP	27014	2N2907A
Q1608	151-0301-00			TRANSISTOR: SILICON, PNP	27014	2N2907A
Q1622	151-0302-00			TRANSISTOR: SILICON, NPN	07263	S038487
Q1626	151-0506-00			SCR: SILICON	03508	C106B2X283
Q1642	151-0302-00			TRANSISTOR: SILICON, NPN	07263	S038487
Q1644	151-0335-00			TRANSISTOR: SILICON, PNP	04713	SJE917
R1604	315-0202-00			RES., FXD, CMPSN: 2K OHM, 5%, 0.25W	01121	CB2025
R1605	315-0752-00			RES., FXD, CMPSN: 7.5K OHM, 5%, 0.25W	01121	CB7525
R1607	315-0272-00			RES., FXD, CMPSN: 2.7K OHM, 5%, 0.25W	01121	CB2725
R1609	315-0511-00			RES., FXD, CMPSN: 510 OHM, 5%, 0.25W	01121	CB5115
R1611	315-0511-00			RES., FXD, CMPSN: 510 OHM, 5%, 0.25W	01121	CB5115
R1613	311-1248-00			RES., VAR, NONWIR: 500 OHM, 10%, 0.50W	73138	72-23-0
R1614	315-0202-00			RES., FXD, CMPSN: 2K OHM, 5%, 0.25W	01121	CB2025
R1617	315-0102-00			RES., FXD, CMPSN: 1K OHM, 5%, 0.25W	01121	CB1025
R1618	315-0101-00			RES., FXD, CMPSN: 100 OHM, 5%, 0.25W	01121	CB1015
R1622	315-0102-00			RES., FXD, CMPSN: 1K OHM, 5%, 0.25W	01121	CB1025
R1623	316-0103-00			RES., FXD, CMPSN: 10K OHM, 10%, 0.25W	01121	CB1031
R1624	315-0302-00			RES., FXD, CMPSN: 3K OHM, 5%, 0.25W	01121	CB3025
R1625	316-0101-00			RES., FXD, CMPSN: 100 OHM, 10%, 0.25W	01121	CB1011
R1626	308-0450-00			RES., FXD, WW: 70 OHM, 1%, 3W	91637	RS2B-B70ROOF
R1631	308-0450-00			RES., FXD, WW: 70 OHM, 1%, 3W	91637	RS2B-B70ROOF
R1633	311-1501-00			RES., VAR, NONWIR: 20 OHM, 10%, 0.50W	73138	72-37-0
R1639	315-0153-00			RES., FXD, CMPSN: 15K OHM, 5%, 0.25W	01121	CB1535
R1640	315-0102-00			RES., FXD, CMPSN: 1K OHM, 5%, 0.25W	01121	CB1025
R1641	315-0153-00			RES., FXD, CMPSN: 15K OHM, 5%, 0.25W	01121	CB1535
R1642	315-0470-00			RES., FXD, CMPSN: 47 OHM, 5%, 0.25W	01121	CB4705
R1645	307-0113-00			RES., FXD, CMPSN: 5.1 OHM, 5%, 0.25W	01121	CB51G5
R1652	308-0459-00			RES., FXD, WW: 1.1 OHM, 5%, 3W	91637	CW2B-1R100J
R1654	308-0459-00			RES., FXD, WW: 1.1 OHM, 5%, 3W	91637	CW2B-1R100J
R1662	308-0459-00			RES., FXD, WW: 1.1 OHM, 5%, 3W	91637	CW2B-1R100J
R1664	308-0459-00			RES., FXD, WW: 1.1 OHM, 5%, 3W	91637	CW2B-1R100J
T1601	120-0637-00			XFMR, TOROID: 5 TURNS BIFILAR	80009	120-0637-00
T1631	120-0852-00			XFMR, TOROID: 2 WINDINGS	80009	120-0852-00
VR1604	152-0306-00			SEMICONV DEVICE: ZENER, 0.4W, 9.1V, 5%	15238	Z5409
VR1605	152-0306-00			SEMICONV DEVICE: ZENER, 0.4W, 9.1V, 5%	15238	Z5409
VR1622	152-0241-00			SEMICONV DEVICE: ZENER, 0.4W, 33V, 5%	80009	152-0241-00
VR1639	152-0279-00			SEMICONV DEVICE: ZENER, 0.4W, 5.1V, 5%	04713	SZG35010RL
VR1641	152-0279-00			SEMICONV DEVICE: ZENER, 0.4W, 5.1V, 5%	04713	SZG35010RL



## REPLACEABLE MECHANICAL PARTS OPTION 7

Fig. & Index No.	Tektronix Part No.	Serial/Model No.		Qty	1 2 3 4 5	Name & Description	Mfr	
		Eff	Dscont				Code	Mfr Part Number
7-9-1	441-1171-00			1		CHASSIS,SCOPE:INVERTER	80009	441-1171-00
	211-0008-00			2		SCREW,MACHINE:4-40 X 0.25 INCH,PNH STL	83385	OBD
	210-0994-00			2		WASHER,FLAT:0.125 ID X 0.25" OD,STL	86928	5702-201-20
						- - - * - - -		
-2	-----			1		CKT BOARD ASSY:INVERTER(SEE A13 REPL) (ATTACHING PARTS)		
-3	211-0116-00	B010100	B150754	2		SCR,ASSEM WSHR:4-40 X 0.312 INCH,PNH BRS	83385	OBD
	211-0292-00	B150755		2		SCR,ASSEM WSHR:4-40 X 0.29, BRS NI PL	78189	OBD
						- - - * - - -		
	-----			-		. CKT BOARD ASSY INCLUDES:		
-4	136-0252-07			12		. SOCKET,PIN CONN:W/O DIMPLE	22526	75060-012
-5	-----			1		. XFMR,TOROID:(SEE T1601 REPL) (ATTACHING PARTS)		
-6	343-0443-00			1		. RETAINER,XFMR:	80009	343-0443-00
-7	212-0011-00			1		. SCREW,MACHINE:8-32 X 0.750 INCH,FLH STL	83385	OBD
-8	210-0409-00			1		. NUT,PLAIN,HEX.:8-32 X 0.312 INCH,BRS	73743	3046-402
						- - - * - - -		
-9	-----			4		TRANSISTOR:(SEE Q1652,Q1654,Q1662,Q1664 REPL) (ATTACHING PARTS)		
-10	210-0586-00			3		NUT,PL,ASSEM WA:4-40 X 0.25,STL CD PL	83385	OBD
-11	343-0451-00			1		RETAINER,XSTR:	80009	343-0451-00
						- - - * - - -		
-12	342-0195-00			1		INSULATOR,PLATE:0.70 X 3 INCHES LONG	08530	OBD
-13	348-0141-00			1		GROMMET,PLASTIC:U-SHP,0.625 XO.658 INCH	80009	348-0141-00
-14	348-0055-00			1		GROMMET,PLASTIC:0.25 INCH DIA	80009	348-0055-00
-15	352-0031-00			1		FUSEHOLDER:3AG FUSE	75915	357001
						(ATTACHING PARTS)		
-16	211-0507-00			1		SCREW,MACHINE:6-32 X 0.312 INCH,PNH STL	83385	OBD
-17	210-0006-00			1		WASHER,LOCK:#6 INTL,0.018THK,STL CD PL	78189	1206-00-00-0541C
-18	210-0407-00			1		NUT,PLAIN,HEX.:6-32 X 0.25 INCH,BRS	73743	3038-0228-402
						- - - * - - -		
-19	407-1341-00			1		BRACKET,ELEC SW:ALUMINUM	80009	407-1341-00
-20	260-0760-00			6		SWITCH,SENS:10A,250V,SPDT,SNAP ACTION	01963	E62-10A
-21	105-0479-00			1		ACTUATOR,SWITCH:SLIDE,INVERTER (ATTACHING PARTS)	80009	105-0479-00
-22	211-0212-00			2		SCREW,MACHINE:2-56 X 1.75 INCH,PNH STL	83385	OBD
-23	210-0405-00			2		NUT,PLAIN,HEX.:2-56 X 0.188 INCH,BRS	73743	2X12157-402
						- - - * - - -		
	214-1925-00			1		SPRING,SW ACT:POWER SOURCE	80009	214-1925-00
-24	386-2649-00			1		PL,ACTR GUIDE:INVERTER	80009	386-2649-00
-25	260-0834-00			1		SWITCH,TOGGLE:DPDT,5A,125VAC,0.25-40 THD (ATTACHING PARTS)	09353	U21-SHZQE
-26	210-0562-00			1		NUT,PLAIN,HEX.:0.25-40 X 0.312 INCH,BBS	73743	2X20224-402
-27	210-0046-00			1		WASHER,LOCK:0.261 ID,INTL,0.018 THK,BRS	78189	1214-05-00-0541C
						- - - * - - -		
	131-1556-00			1		CONN,RCPT,ELEC:PWR,MALE,125VAC,15A (ATTACHING PARTS)	80009	131-1556-00
	211-0101-00			2		SCREW,MACHINE:4-40 X 0.25" 100 DEG,FLH STL	83385	OBD
						- - - * - - -		
	179-2145-00			1		WIRING HARNESS:	80009	179-2145-00
	348-0056-00			1		GROMMET,PLASTIC:0.375 INCH DIA	80009	348-0056-00
	200-1634-00			1		COVER SCOPE:REAR	80009	200-1634-00
	210-0204-00			1		TERMINAL,LUG:0.146 INCH DIA DE,45 DEG BEND	78189	2157-06-01-2520N
	334-2268-00			1		MARKER,IDENT:	80009	334-2268-00
	348-0365-00			4		FOOT,CABINET:PLASTIC,W/LATCH GROOVE	80009	348-0365-00
						(ATTACHING PARTS)		
						ACCESSORIES		
	161-0094-00			1		CABLE ASSY,PWR,:3 WIRE,36 INCHES LONG	16428	KH7667

# OPTION 7 EXPLODED

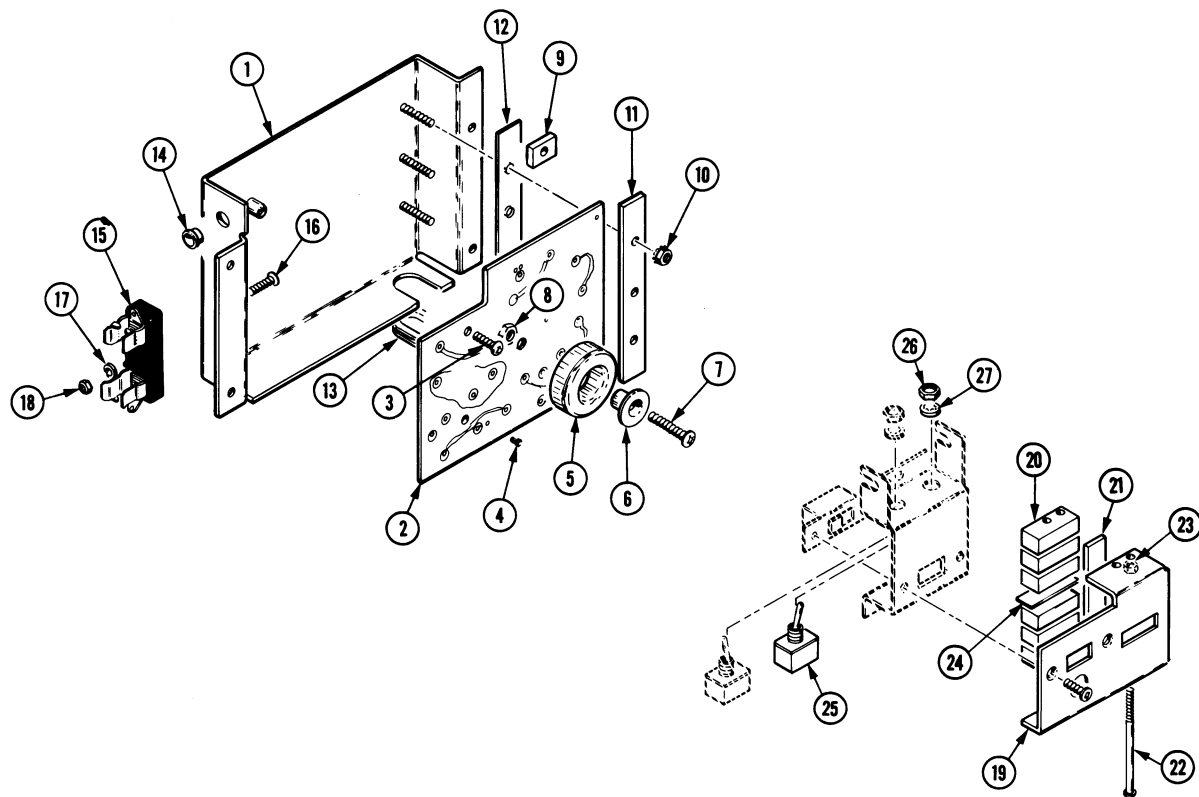

Fig. Option 7-9

## OPTION 1Y

### 100 Volt Power Input Operation

The 464 or 466 equipped with Option 1Y will operate from a nominal power input voltage of 100 volts ac or 200 volts ac depending on the setting of Line Voltage Selector switch S1703. The HI, MED, LO Regulating Range Selector function is removed, and a different power transformer, fuse-holder cover, S1703 switch (100 V/200 V), and cabinet assembly (with new power-input-voltage nomenclature) are among the changes for Option 1Y. Maximum 464 or 466 Option 1Y power consumption is 125 watts at 100 V 60 Hz.

Electrical and mechanical replaceable parts of Option 1Y are integrated into the standard Replaceable Parts lists.

### AC Regulating Ranges

	100 V/200 V Switch Setting	
	100 V	200 V
Regulating Range	90 V to 100 V rms	180 V to 220 V rms

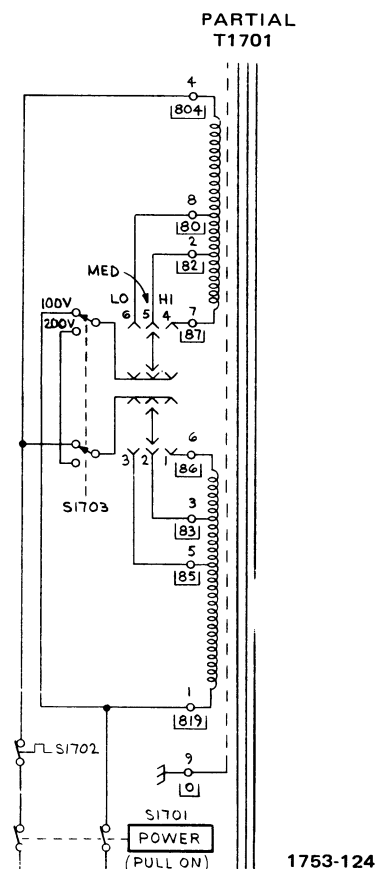

PARTIAL POWER SUPPLY & DISTRIBUTION

11

Fig. Option 1Y-1. Lower Supply and Distribution

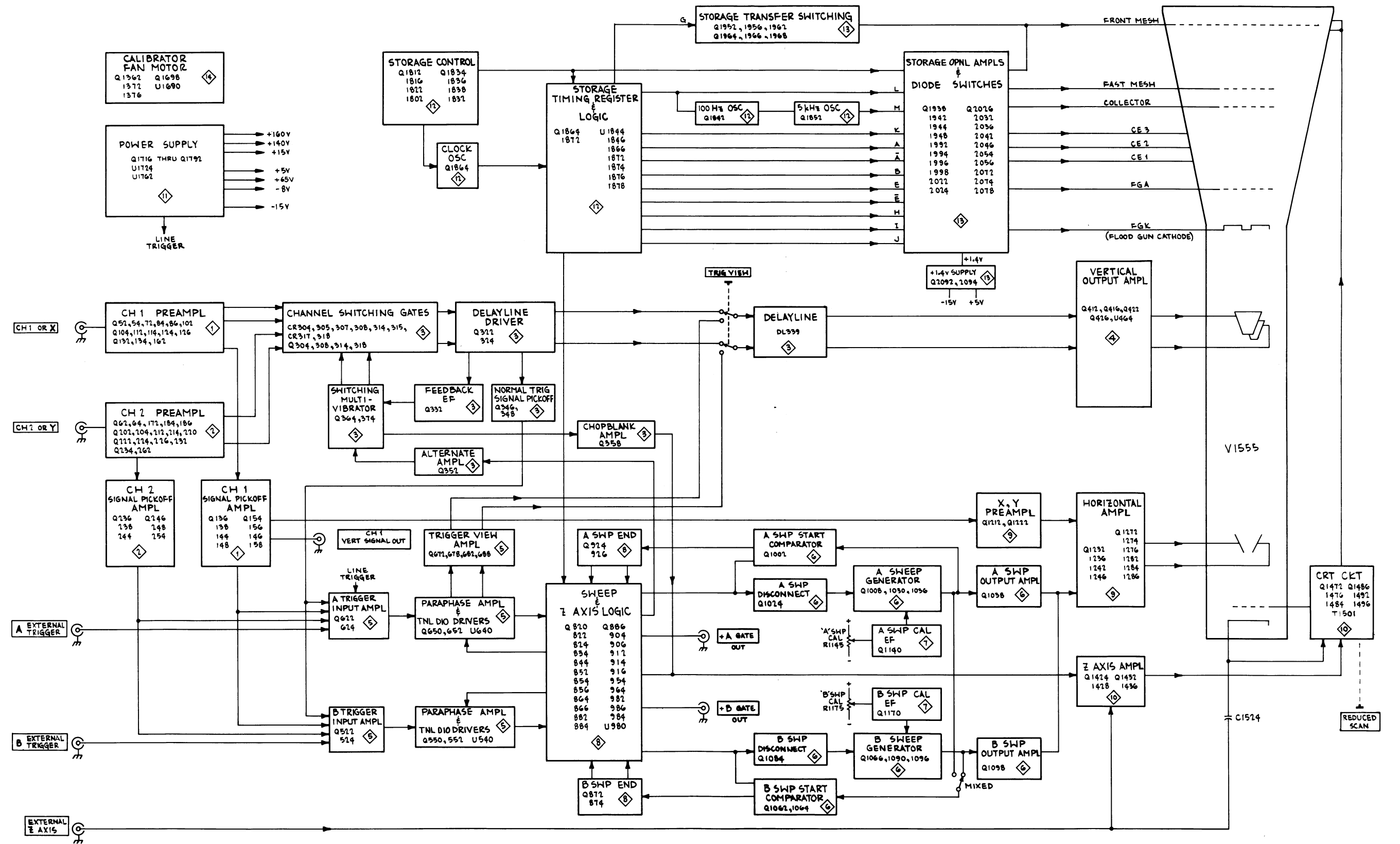



### VOLTAGE AND WAVEFORM CONDITIONS

Voltages and waveforms similar to those shown on this diagram can be obtained by using the recommended test equipment and test set-ups listed below.

#### RECOMMENDED TEST EQUIPMENT

ITEM	SPECIFICATIONS	RECOMMENDED TYPE
OSCILLOSCOPE	Bandwidth DC to 100 MHz Minimum Deflection Factor 5 mV/div Input Impedance 1 MΩ/20 pF	TEKTRONIX 465 Oscilloscope with P6065 or P6062A 10X probe.
DIGITAL MULTIMETER (For voltage up to 1 kV)	Input Impedance 10 MΩ Range 0 - 1 kV	TEKTRONIX DM 501.
DC VOLTMETER (For voltages above 1 kV)	Input Impedance 20,000Ω/volt Range 0 to 6 kV	TRIPLETT Model 630NA

Voltages and waveforms on this diagram were obtained under the following 466 conditions, unless noted otherwise.

#### POWER & CRT CONTROLS

POWER	ON (pulled out)
INTENSITY	Midrange (pushed in, Full Scan)
FOCUS	Adjusted for focused trace
SCALE ILLUM	Midrange
Storage Mode	NON STORE (pushed in)
VIEWTIME	NORM
VERTICAL CONTROLS (BOTH CHANNELS)	
VOLTS/DIV	5 mV
VAR	CAL
POSITION	Centered
AC-DC-GND	DC
VERT MODE	CH 1
INVERT	Out
20 MHz BW	In (full bandwidth)

#### B TRIGGER CONTROLS

SOURCE	STARTS AFTER DELAY
COUPLING	AC
LEVEL	0
SLOPE	+
SWEEP CONTROLS	
X10 MAG	Out
POSITION	Midrange
FINE	Midrange
HORIZ DISPLAY	A
DELAY TIME POSITION	0.02
A AND B TIME/DIV and DELAY TIME (Knobs Locked)	.2 ms

#### Signal Applied (For Waveforms Only)

The 466 Calibrator signal is applied to the CH 1 input through a compensated 10X probe.

Test Oscilloscope Vertical input is ac coupled unless noted otherwise by a 0 volt reference on the waveform drawing.

#### A TRIGGER CONTROLS

A TRIG HOLDOFF	NORM
TRIG MODE	AUTO
COUPLING	AC
SOURCE	NORM
LEVEL	0
SLOPE	+

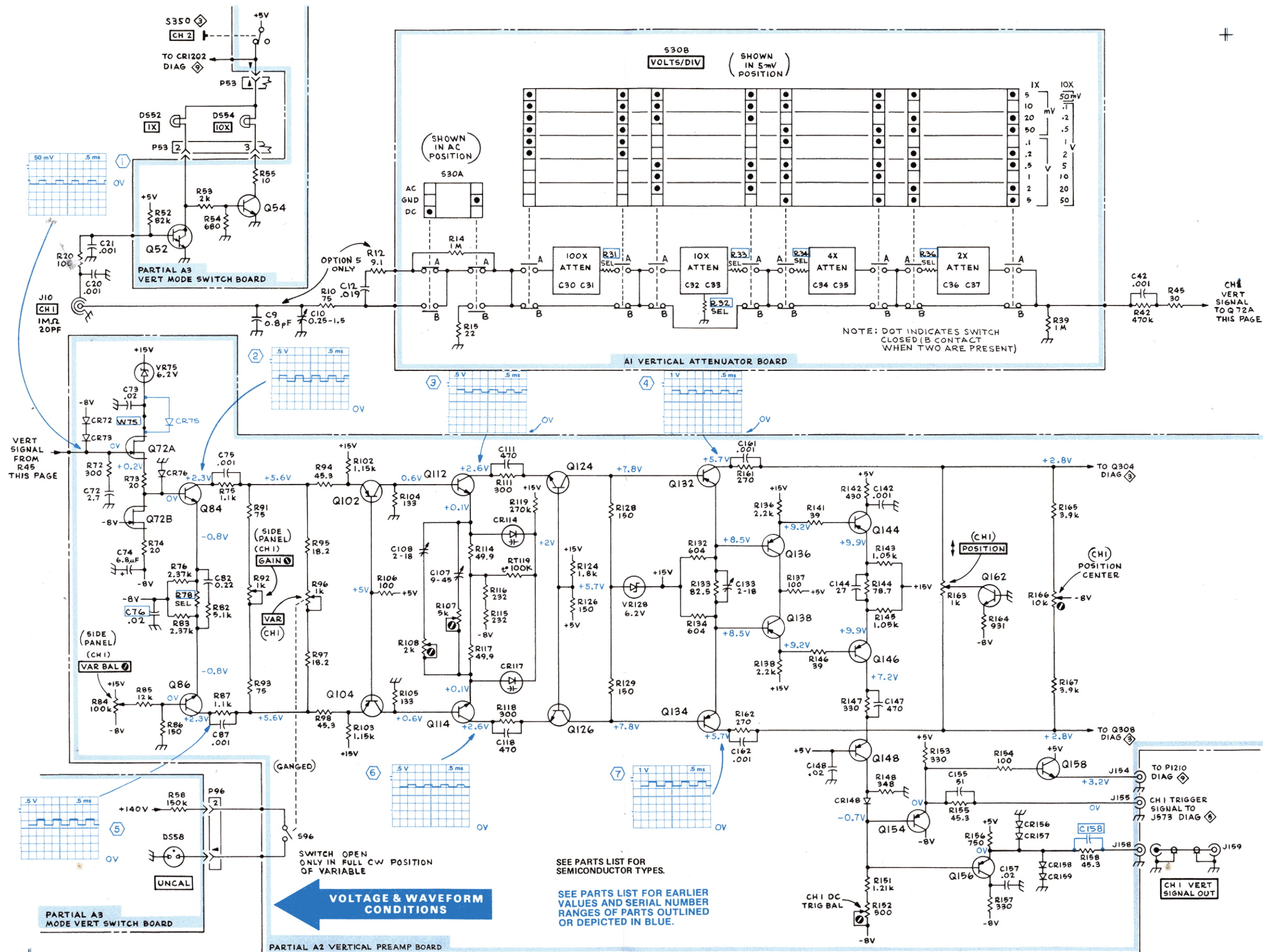

### VOLTAGE AND WAVEFORM CONDITIONS

Voltages and waveforms similar to those shown on this diagram can be obtained by using the recommended test equipment and test set-ups listed below.

#### RECOMMENDED TEST EQUIPMENT

ITEM	SPECIFICATIONS	RECOMMENDED TYPE
OSCILLOSCOPE	Bandwidth DC to 100 MHz Minimum Deflection Factor 5 mV/div Input Impedance 1 MΩ/20 pF	TEKTRONIX 466 Oscilloscope with P6065 or P6062A 10X probe.
DIGITAL MULTIMETER (For voltage up to 1 kV)	Input Impedance 10 MΩ Range 0 - 1 kV	TEKTRONIX DM 501.
DC VOLTMETER (For voltages above 1 kV)	Input Impedance 20,000Ω/volt Range 0 to 6 kV	TRIPLETT Model 630NA

Voltages and waveforms on this diagram were obtained under the following 466 conditions, unless noted otherwise.

#### POWER & CRT CONTROLS

POWER	ON (pulled out)
INTENSITY	Midrange (pushed in, Full Scan)
FOCUS	Adjusted for focused trace
SCALE ILLUM	Midrange
Storage Mode	NON STORE (pushed in)
VIEWTIME	NORM
VERTICAL CONTROLS (BOTH CHANNELS)	
VOLTS/DIV	5 mV
VAR	CAL
POSITION	Centered
AC-DC-GND	DC
VERT MODE	CH 1
INVERT	Out
20 MHz BW	In (full bandwidth)

#### B TRIGGER CONTROLS

SOURCE	STARTS AFTER DELAY
COUPLING	AC
LEVEL	0
SLOPE	+

#### SWEEP CONTROLS

X10 MAG	Out
POSITION	Midrange
FINE	Midrange
HORIZ DISPLAY	A
DELAY TIME POSITION	0.02

#### Signal Applied (For Waveforms Only)

The 466 Calibrator signal is applied to the CH 1 input through a compensated 10X probe.

Test Oscilloscope Vertical input is ac coupled unless noted otherwise by a 0 volt reference on the waveform drawing.

#### A TRIGGER CONTROLS

A TRIG HOLDOFF	NORM
TRIG MODE	AUTO
COUPLING	AC
SOURCE	NORM
LEVEL	0
SLOPE	+

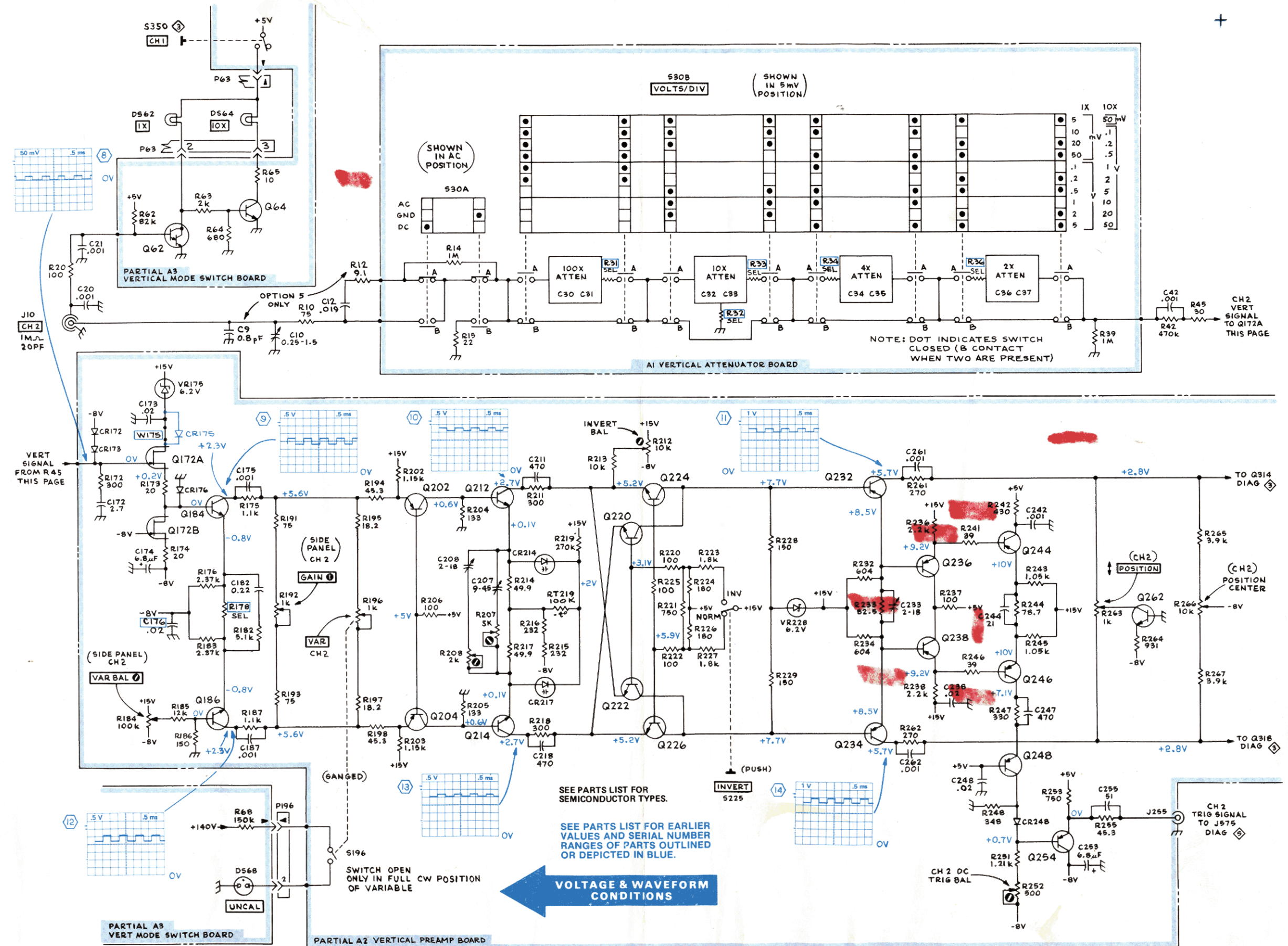





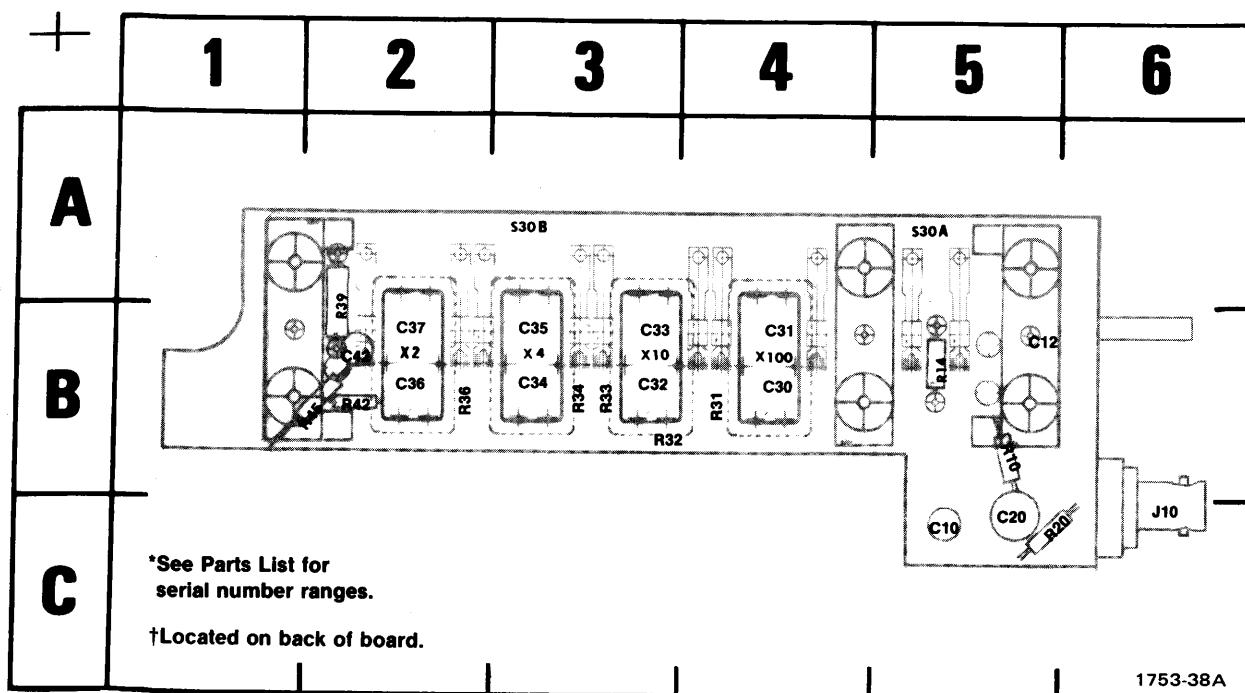

(A) A1 Attenuator circuit board.

CKT NO	GRID LOC	CKT NO	GRID LOC
C10	5C	R31*	4B
C12	5B	R32*	3B
C20	5C	R33*	3B
C30	4B	R34*	3B
C31	4B	R36*	2B
C32	3B	R39	2A
C33	3B	R42	2B
C34	3B	R45	2B
C35	3B	S30A	5A
C36	2B	S30B	3A
C37	2B	X2	2B
C42	2B	X4	3B
J10	6C	X10	3B
R10	5B	X100	4B
R14	5B		
R15†			
R20†	5C		

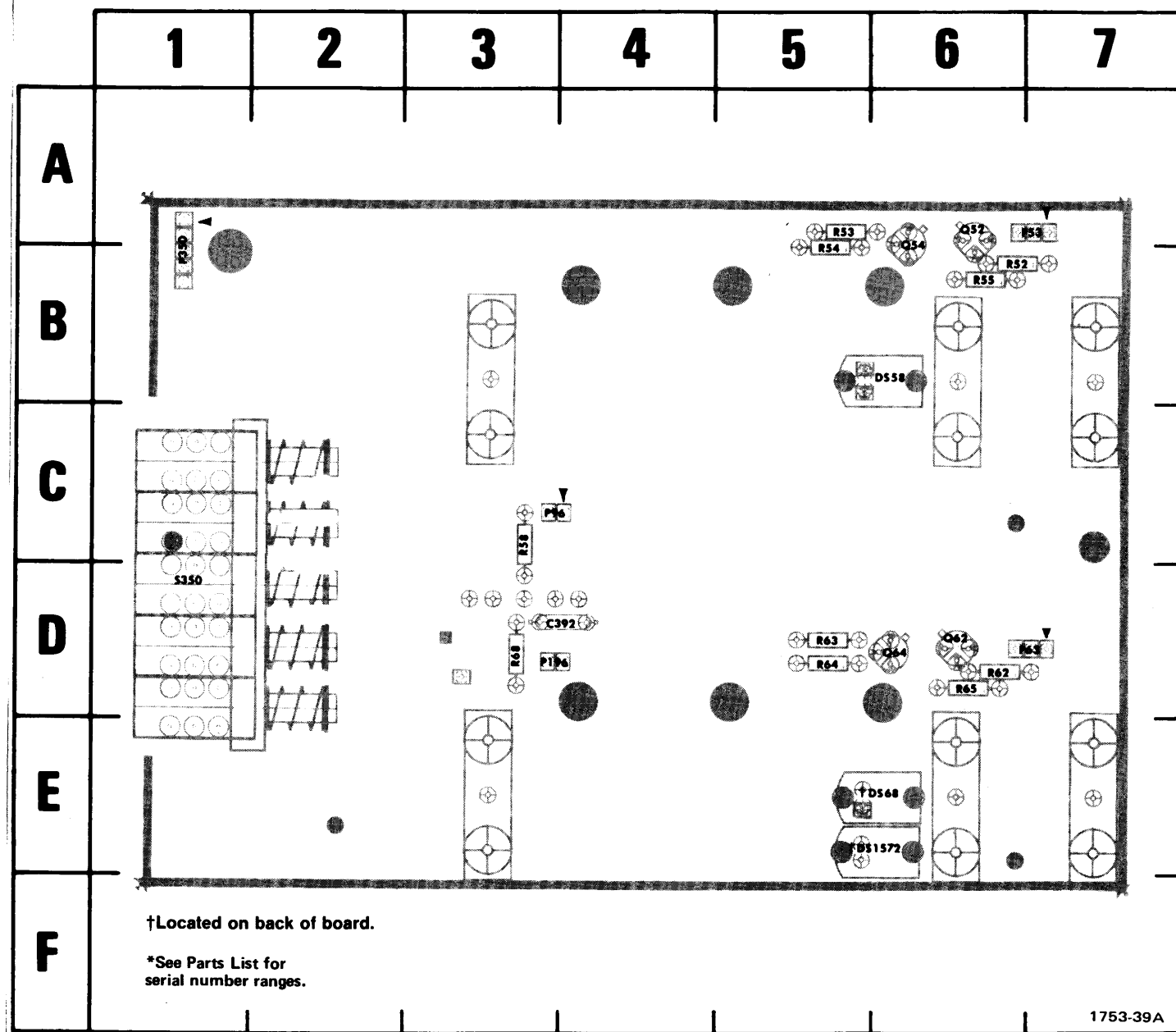

(B) A3 Vertical Mode Switch circuit board.

CKT NO	GRID LOC	CKT NO	GRID LOC
C392	4D	Q62	6D
DS58	6B	Q54	6D
†DS68	6E	R52	6B
†DS1572	6E	R53	5A
		R54	5B
		R55	6B
P53	7A	R58	3C
P63	7D	R62	6D
P96	4C	R63	5D
P196	4D	R64	5D
P350	1B	R65	6D
		R68	3D
Q52	6A	S350	1D
Q54	6A		

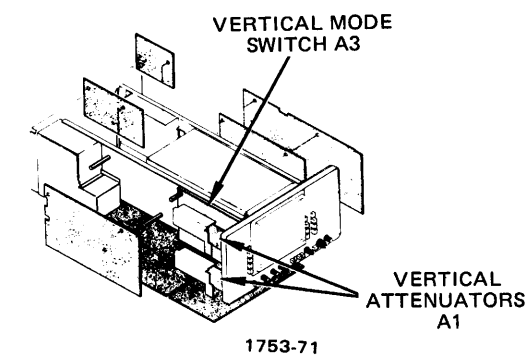

(C) Board locations.

Fig. 7-2 (A) through (C). A1 & A3 Board component locations.

## DIAGRAMS AND CIRCUIT BOARD ILLUSTRATIONS

### Symbols and Reference Designators

Electrical components shown on the diagrams are in the following units unless noted otherwise:

- Capacitors = Values one or greater are in picofarads (pF).  
Values less than one are in microfarads (μF).
- Resistors = Ohms (Ω).

Symbols used on the diagrams are based on USA Standard Y32.2-1967.

Logic symbology is based on MIL-STD-806B in terms of positive logic. Logic symbols depict the logic function performed and may differ from the manufacturer's data.

The following prefix letters are used as reference designators to identify components or assemblies on the diagrams.

A	Assembly, separable or repairable (circuit board, etc.)	H	Heat dissipating device (heat sink, heat radiator, etc.)	RT	Thermistor
AT	Attenuator, fixed or variable	HR	Heater	S	Switch
B	Motor	HY	Hybrid circuit	T	Transformer
BT	Battery	J	Connector, stationary portion	TC	Thermocouple
C	Capacitor, fixed or variable	K	Relay	TP	Test point
CB	Circuit breaker	L	Inductor, fixed or variable	U	Assembly, inseparable or non-repairable (integrated circuit, etc.)
CR	Diode, signal or rectifier	LR	Inductor/resistor combination	V	Electron tube
DL	Delay line	M	Meter	VR	Voltage regulator (zener diode, etc.)
DS	Indicating device (lamp)	P	Connector, movable portion	Y	Crystal
E	Spark Gap	Q	Transistor or silicon-controlled rectifier	Z	Phase shifter
F	Fuse	R	Resistor, fixed or variable		
FL	Filter				

The following special symbols are used on the diagrams:

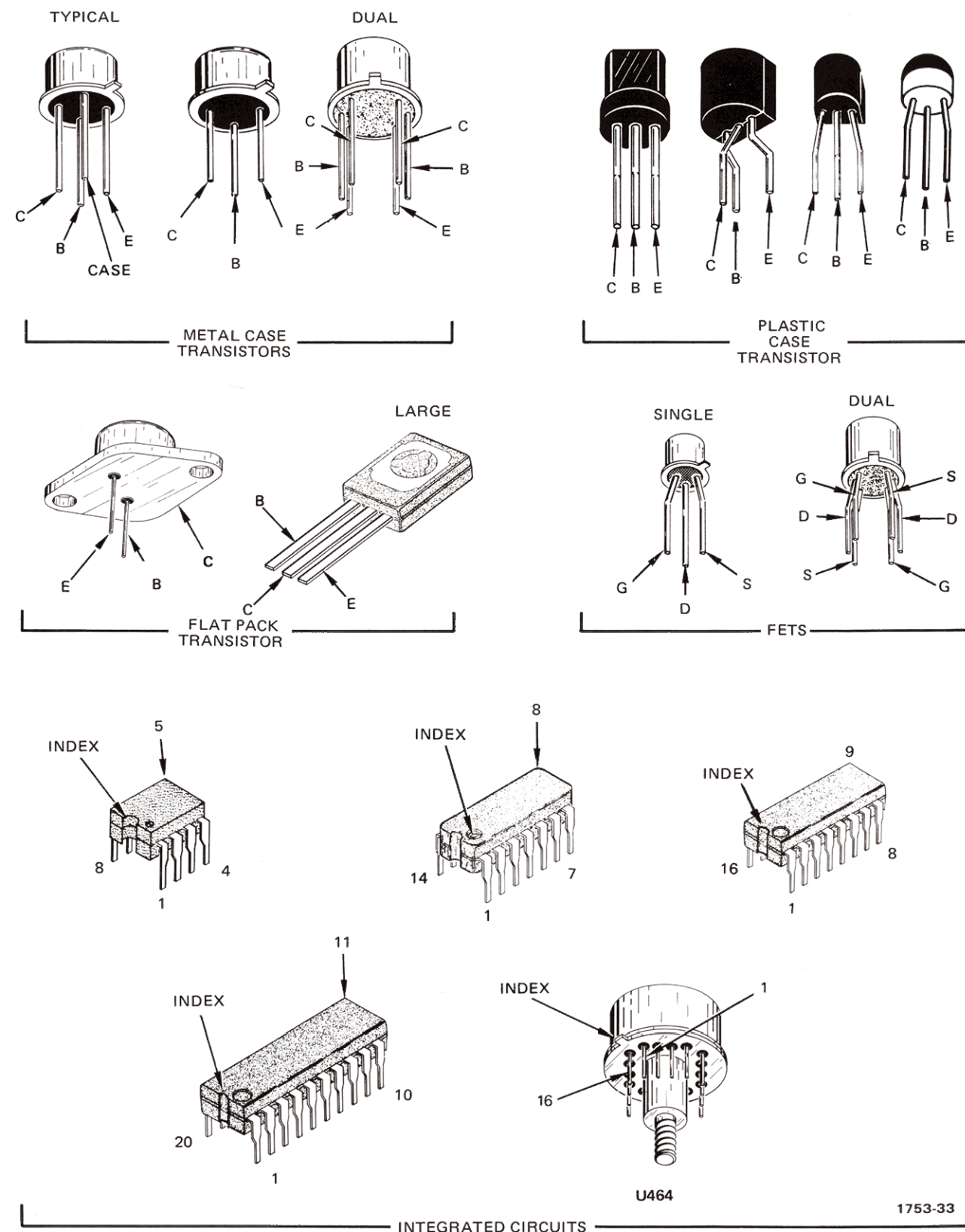
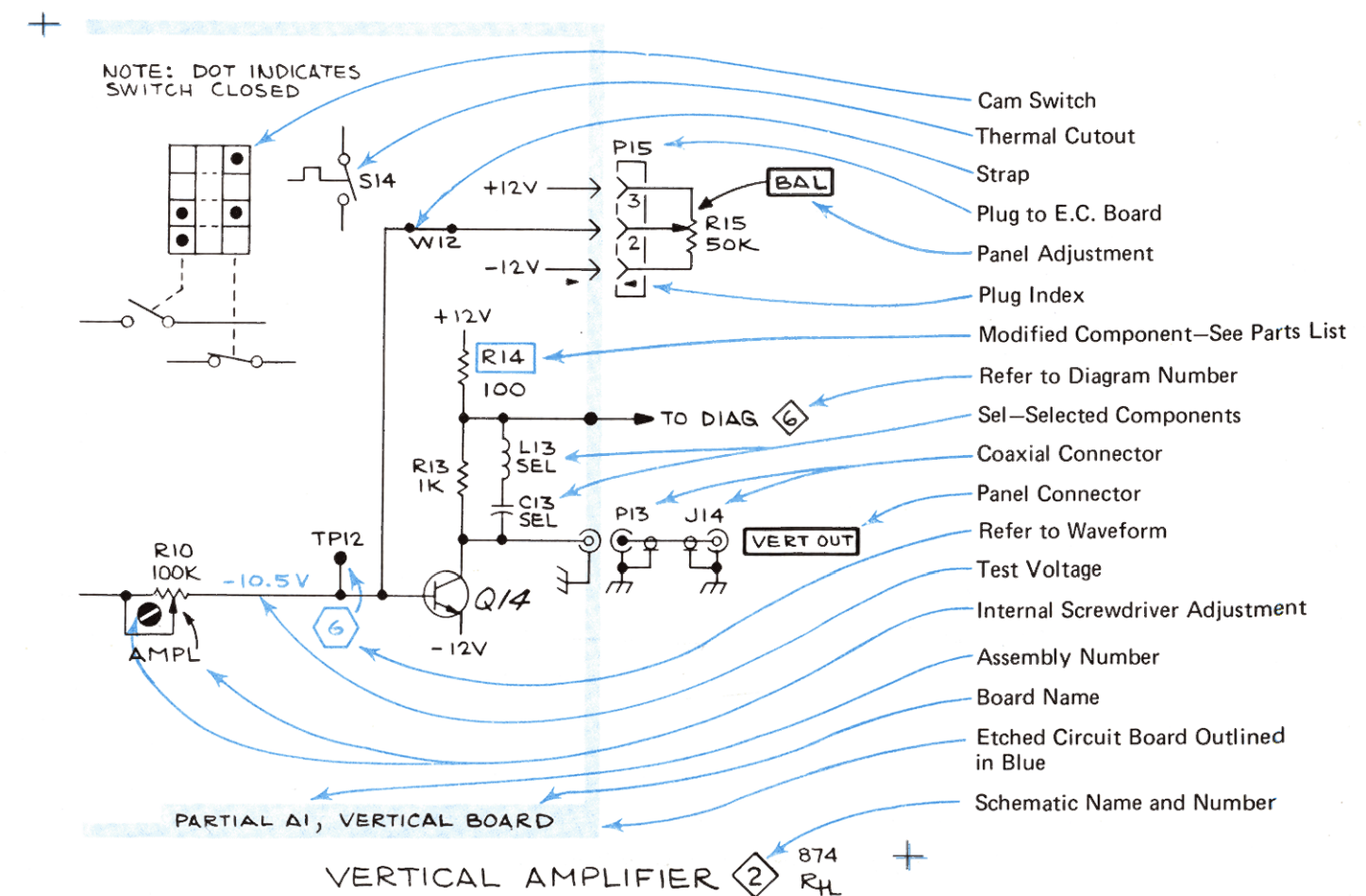

Fig. 7-1. Semiconductor Lead configurations.

### VOLTAGE AND WAVEFORM CONDITIONS

Voltages and waveforms similar to those shown on this diagram can be obtained by using the recommended test equipment and test set-ups listed below.

#### RECOMMENDED TEST EQUIPMENT

ITEM	SPECIFICATIONS	RECOMMENDED TYPE
OSCILLOSCOPE	Bandwidth DC to 100 MHz Minimum Deflection Factor 5 mV/div Input Impedance 1 MΩ/20 pF	TEKTRONIX 465 Oscilloscope with P6065 or P6062A 10X probe.
DIGITAL MULTIMETER (For voltage up to 1 kV)	Input Impedance 10 MΩ Range 0 - 1 kV	TEKTRONIX DM 501.
DC VOLTMETER (For voltages above 1 kV)	Input Impedance 20,000Ω/volt Range 0 to 6 kV	TRIPLETT Model 630NA

Voltages and waveforms on this diagram were obtained under the following 466 conditions, unless noted otherwise.

#### POWER & CRT CONTROLS

POWER	ON (pulled out)
INTENSITY	Midrange (pushed in, Full Scan)
FOCUS	Adjusted for focused trace
SCALE ILLUM	Midrange
Storage Mode	NON STORE (pushed in)
VIEWTIME	NORM
VERTICAL CONTROLS (BOTH CHANNELS)	
VOLTS/DIV	5 mV
VAR	CAL
POSITION	Centered
AC-DC-GND	DC
VERT MODE	CH 1
INVERT	Out
20 MHz BW	In (full bandwidth)

#### B TRIGGER CONTROLS

SOURCE	STARTS AFTER DELAY
COUPLING	AC
LEVEL	0
SLOPE	+

#### SWEEP CONTROLS

X10 MAG	Out
POSITION	Midrange
FINE	Midrange
HORIZ DISPLAY	A
DELAY TIME POSITION	0.02

#### Signal Applied (For Waveforms Only)

The 466 Calibrator signal is applied to the CH 1 input through a compensated 10X probe.

Test Oscilloscope Vertical input is ac coupled unless noted otherwise by a 0 volt reference on the waveform drawing.

#### A TRIGGER CONTROLS

A TRIG HOLDOFF	NORM
TRIG MODE	AUTO
COUPLING	AC
SOURCE	NORM
LEVEL	0
SLOPE	+

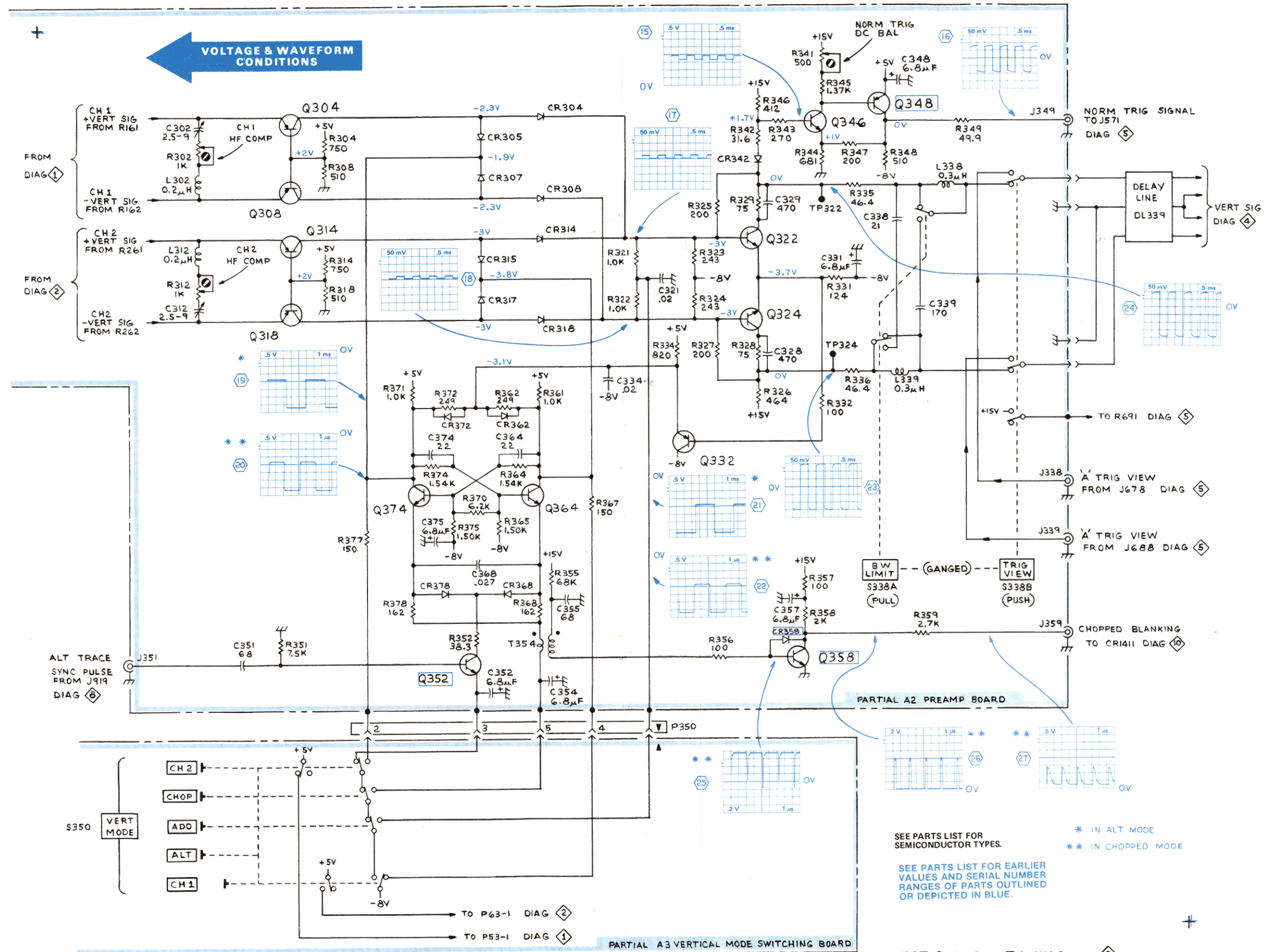

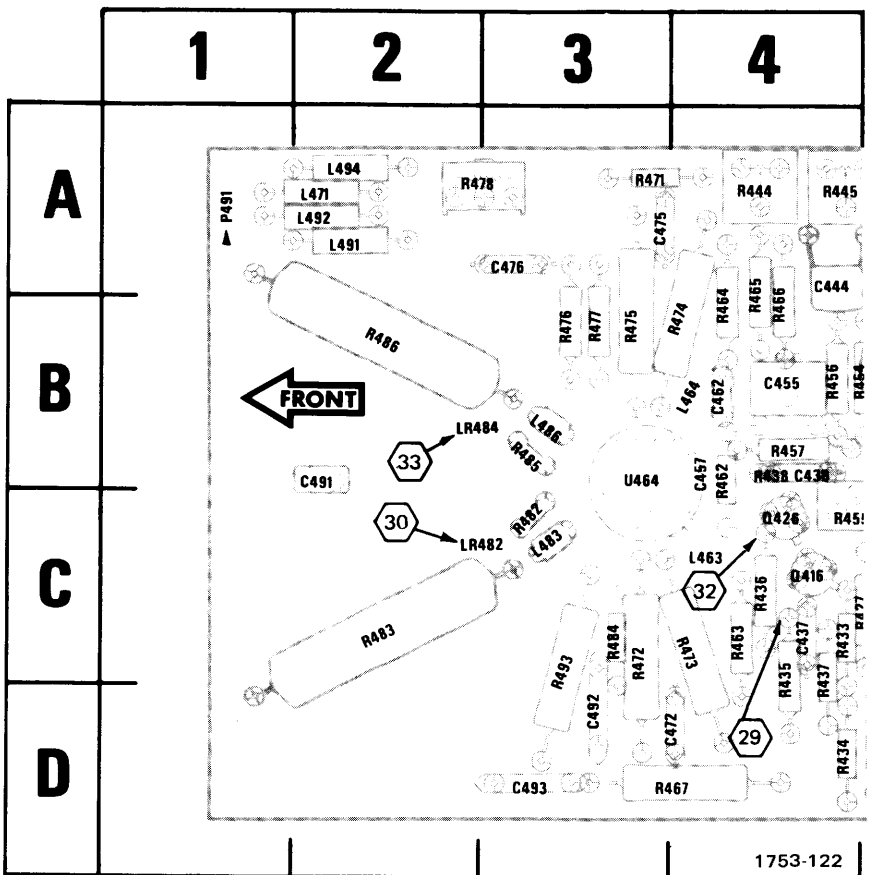
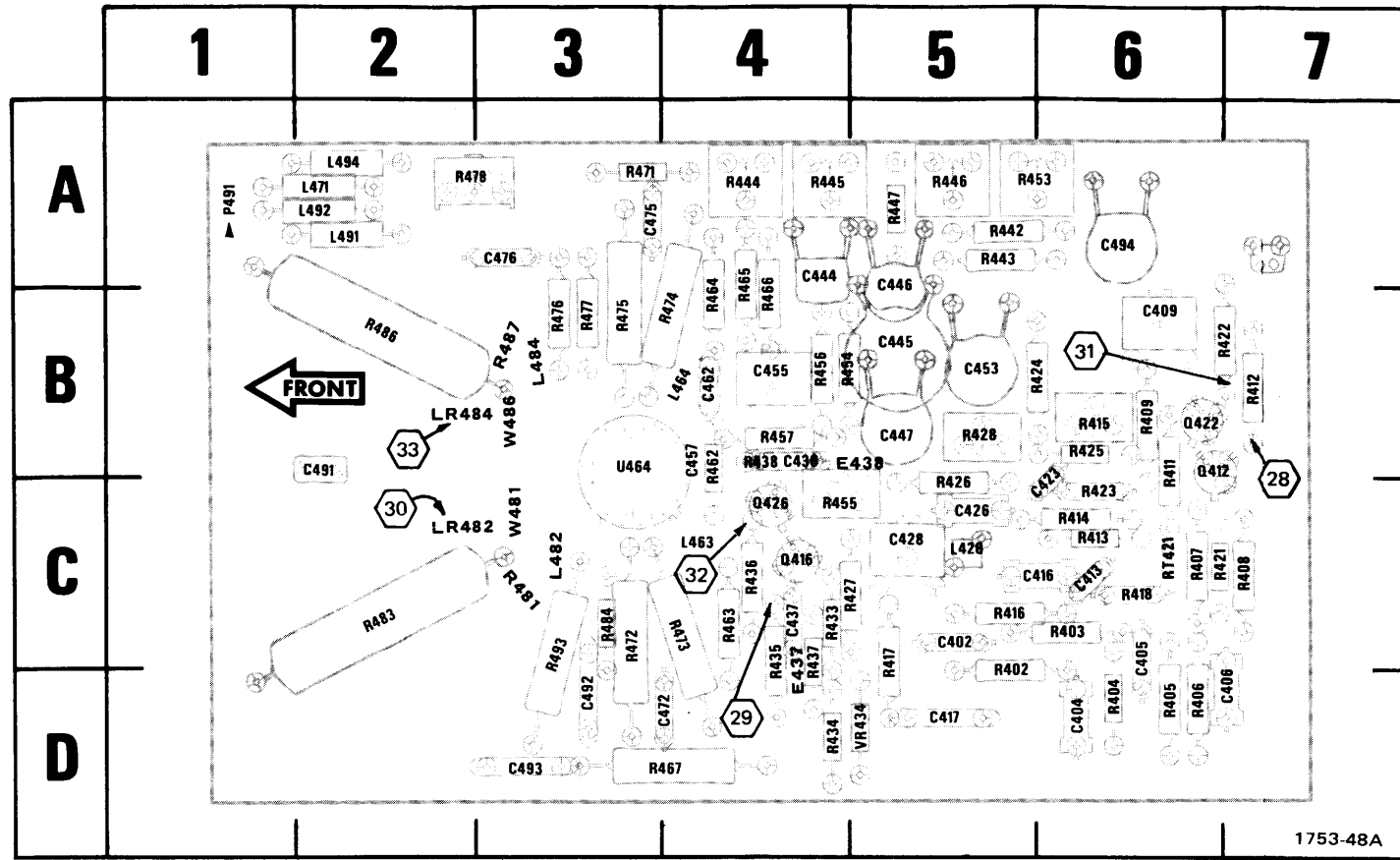

\*See Parts List for serial number ranges.

(A) A4 Vertical Output circuit board (SN B150755-up).

(C) Partial A4 Vertical Output circuit board (SN B150754 & below).

CKT NO	GRID LOC	CKT NO	GRID LOC	CKT NO	GRID LOC	CKT NO	GRID LOC	CKT NO	GRID LOC
C402	5C	C493	3D	R402	5D	R435	4C	R475	3B
C404	6D	C494	6A	R403	6C	R436	4C	R476	3B
C405	6C			R404	6D	R437	4C	R477	3B
C406	7D	E437*	4D	R405	6D	R438	4B	R478	2A
C409	6B	E438*	5B	R406	6D	R442	5A	R481*	3C
C413	6C			R407	6C	R443	5A	R482	3C
C416	6C			R408	7C	R444	4A	R483	2C
C417	5D	L428	5C	R409	6B	R445	4A	R484	3C
C423	6C	L463*	4C	R411	6B	R446	5A	R485	3B
C426	5C	L464*	4B	R412	7B	R447	5A	R486	2B
C428	5C	R471	2A	R413	6C	R453	5A	R487*	3B
C437	4C	L483	3C	R414	6C	R454	4B	R493	3C
C438	4B	L486	3B	R415	6B	R455	4C		
C444	4A	L491	2A	R416	5C	R456	4B		
C445	5B	L492	2A	R417	5C	R457	4B		
C446	5A	L494	2A	R418	6C	R462	4B		
C447	5B			R421	6C	R463	4C		
C453	5B	LR482*	3C	R422	6B	R464	4B		
C455	4B	LR484*	2B	R423	6C	R465	4A		
C457*	4B			R424	5B	R466	4B		
C462	4B	P491	1A	R425	6B	R467	4D		
C472	4D			R426	5C	R471	3A		
C475	3A	Q412	6B	R427	4C	R472	3C	W481*	3C
C476	3A	Q416	4C	R428	5B	R473	4C	W486*	3B
C491	2B	Q422	6B	R433	4C	R474	4B		
C492	3D	Q426	4C	R434	4D				

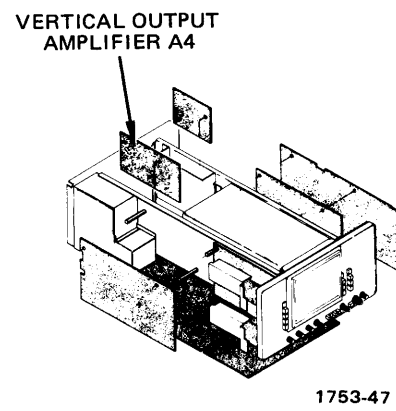

(B) Board location.

Fig. 7-5 (A), (B) & (C). Vertical Output board component locations.

### VOLTAGE AND WAVEFORM CONDITIONS

Voltages and waveforms similar to those shown on this diagram can be obtained by using the recommended test equipment and test set-ups listed below.

#### RECOMMENDED TEST EQUIPMENT

ITEM	SPECIFICATIONS	RECOMMENDED TYPE
OSCILLOSCOPE	Bandwidth DC to 100 MHz Minimum Deflection Factor 5 mV/div Input Impedance 1 MΩ/20 pF	TEKTRONIX 465 Oscilloscope with P6065 or P6062A 10X probe.
DIGITAL MULTIMETER (For voltage up to 1 kV)	Input Impedance 10 MΩ Range 0 - 1 kV	TEKTRONIX DM 501.
DC VOLTMETER (For voltages above 1 kV)	Input Impedance 20,000Ω/volt Range 0 to 6 kV	TRIPLETT Model 630NA

Voltages and waveforms on this diagram were obtained under the following 466 conditions, unless noted otherwise.

#### POWER & CRT CONTROLS

POWER	ON (pulled out)
INTENSITY	Midrange (pushed in, Full Scan)
FOCUS	Adjusted for focused trace
SCALE ILLUM	Midrange
Storage Mode	NON STORE (pushed in)
VIEWTIME	NORM
VERTICAL CONTROLS (BOTH CHANNELS)	
VOLTS/DIV	5 mV
VAR	CAL
POSITION	Centered
AC-DC-GND	DC
VERT MODE	CH 1
INVERT	Out
20 MHz BW	In (full bandwidth)

#### B TRIGGER CONTROLS

SOURCE	STARTS AFTER DELAY
COUPLING	AC
LEVEL	0
SLOPE	+

#### SWEEP CONTROLS

X10 MAG	Out
POSITION	Midrange
FINE	Midrange
HORIZ DISPLAY	A
DELAY TIME POSITION	0.02
A AND B TIME/DIV and DELAY TIME (Knobs Locked)	.2 ms

#### Signal Applied (For Waveforms Only)

The 466 Calibrator signal is applied to the CH 1 input through a compensated 10X probe.

Test Oscilloscope Vertical input is ac coupled unless noted otherwise by a 0 volt reference on the waveform drawing.

#### A TRIGGER CONTROLS

A TRIG HOLDOFF	NORM
TRIG MODE	AUTO
COUPLING	AC
SOURCE	NORM
LEVEL	0
SLOPE	+

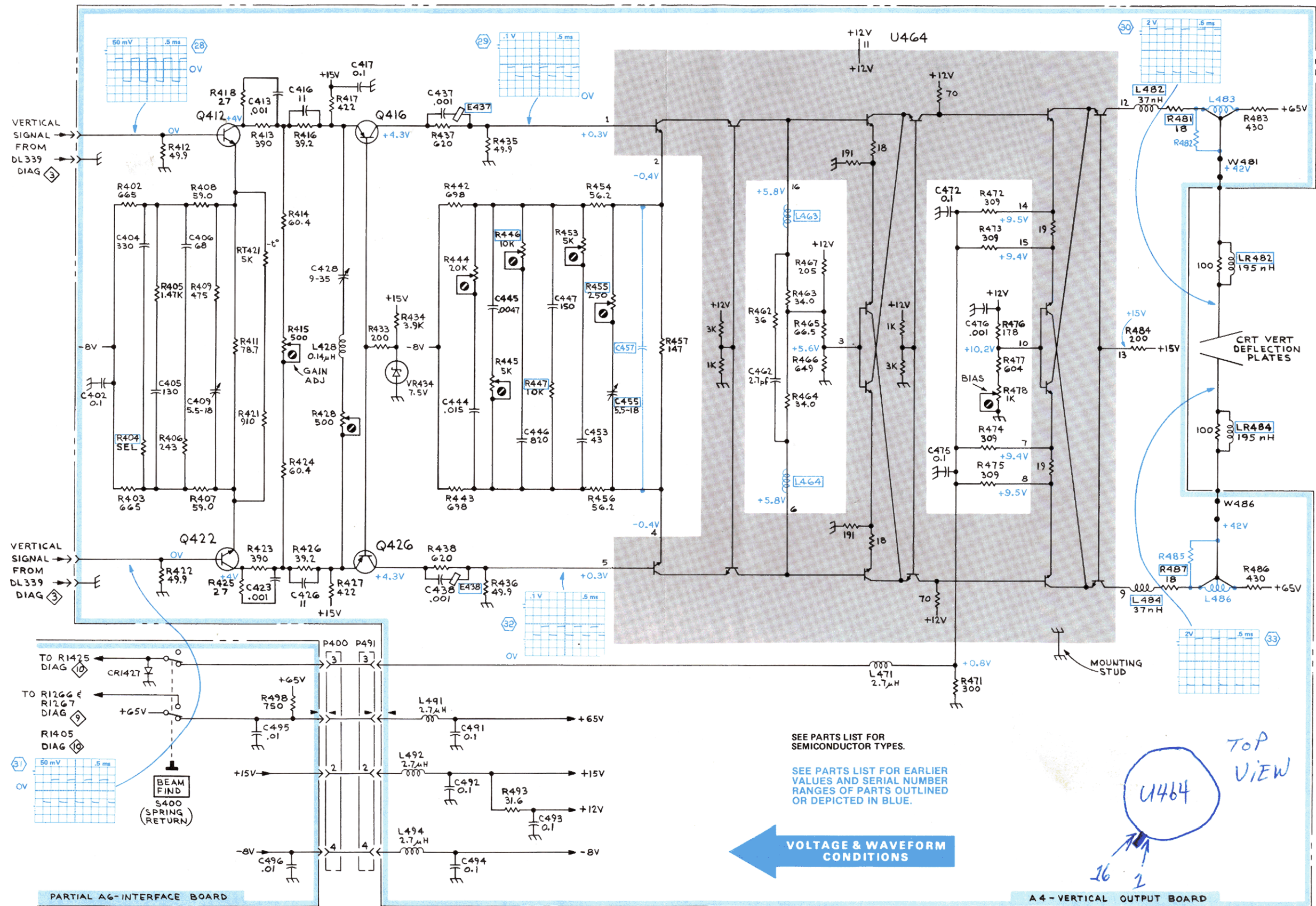



### VOLTAGE AND WAVEFORM CONDITIONS

Voltages and waveforms similar to those shown on this diagram can be obtained by using the recommended test equipment and test set-ups listed below.

#### RECOMMENDED TEST EQUIPMENT

ITEM	SPECIFICATIONS	RECOMMENDED TYPE
OSCILLOSCOPE	Bandwidth DC to 100 MHz Minimum Deflection Factor 5 mV/div Input Impedance 1 MΩ/20 pF	TEKTRONIX 465 Oscilloscope with P6065 or P6062A 10X probe.
DIGITAL MULTIMETER (For voltage up to 1 kV)	Input Impedance 10 MΩ Range 0 - 1 kV	TEKTRONIX DM 501.
DC VOLTMETER (For voltages above 1 kV)	Input Impedance 20,000Ω/volt Range 0 to 6 kV	TRIPLETT Model 630NA

Voltages and waveforms on this diagram were obtained under the following 466 conditions, unless noted otherwise.

#### POWER & CRT CONTROLS

POWER	ON (pulled out)
INTENSITY	Midrange (pushed in, Full Scan)
FOCUS	Adjusted for focused trace
SCALE ILLUM	Midrange
Storage Mode	NON STORE (pushed in)
VIEWTIME	NORM
VERTICAL CONTROLS (BOTH CHANNELS)	
VOLTS/DIV	5 mV
VAR	CAL
POSITION	Centered
AC-DC-GND	DC
VERT MODE	CH 1
INVERT	Out
20 MHz BW	In (full bandwidth)

#### A TRIGGER CONTROLS

A TRIG HOLDOFF	NORM
TRIG MODE	AUTO
COUPLING	AC
SOURCE	NORM
LEVEL	0
SLOPE	+

#### B TRIGGER CONTROLS

SOURCE	STARTS AFTER DELAY
COUPLING	AC
LEVEL	0
SLOPE	+

#### SWEEP CONTROLS

X10 MAG	Out
POSITION	Midrange
FINE	Midrange
HORIZ DISPLAY	A
DELAY TIME POSITION	0.02
A AND B TIME/DIV and DELAY TIME (Knobs Locked)	.2 ms

#### Signal Applied (For Waveforms Only)

The 466 Calibrator signal is applied to the CH 1 input through a compensated 10X probe.  
Test Oscilloscope Vertical input is ac coupled unless noted otherwise by a 0 volt reference on the waveform drawing.

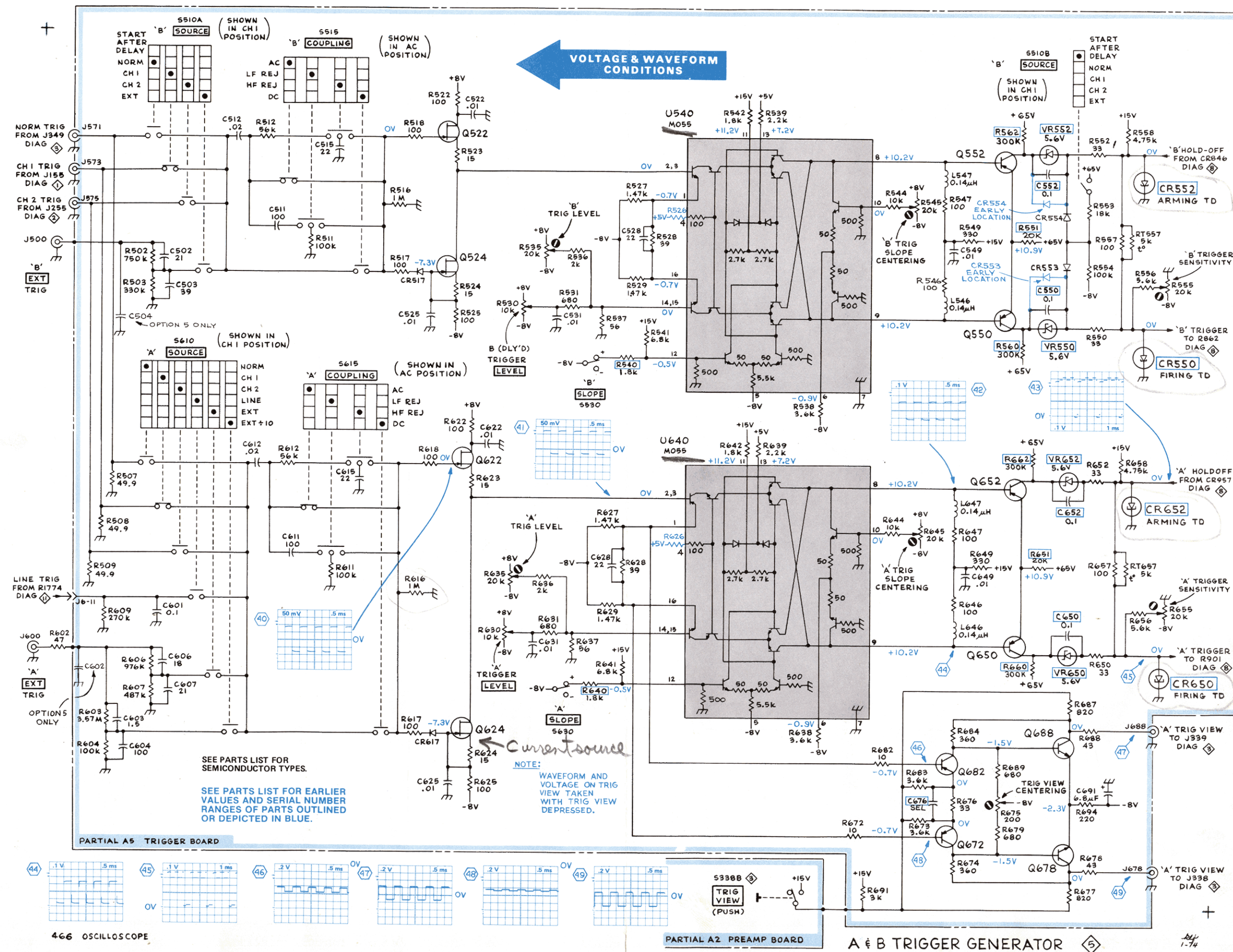

466 OSCILLOSCOPE

PARTIAL A2 PREAMP BOARD

A & B TRIGGER GENERATOR

### VOLTAGE AND WAVEFORM CONDITIONS

Voltages and waveforms similar to those shown on this diagram can be obtained by using the recommended test equipment and test set-ups listed below.

#### RECOMMENDED TEST EQUIPMENT

ITEM	SPECIFICATIONS	RECOMMENDED TYPE
OSCILLOSCOPE	Bandwidth DC to 100 MHz Minimum Deflection Factor 5 mV/div Input Impedance 1 MΩ/20 pF	TEKTRONIX 465 Oscilloscope with P6065 or P6062A 10X probe.
DIGITAL MULTIMETER (For voltage up to 1 kV)	Input Impedance 10 MΩ Range 0 - 1 kV	TEKTRONIX DM 501.
DC VOLTMETER (For voltages above 1 kV)	Input Impedance 20,000Ω/volt Range 0 to 6 kV	TRIPLETT Model 630NA

Voltages and waveforms on this diagram were obtained under the following 466 conditions, unless noted otherwise.

#### POWER & CRT CONTROLS

POWER	ON (pulled out)
INTENSITY	Midrange (pushed in, Full Scan)
FOCUS	Adjusted for focused trace
SCALE ILLUM	Midrange
Storage Mode	NON STORE (pushed in)
VIEWTIME	NORM
VERTICAL CONTROLS (BOTH CHANNELS)	
VOLTS/DIV	5 mV
VAR	CAL
POSITION	Centered
AC-DC-GND	DC
VERT MODE	CH 1
INVERT	Out
20 MHz BW	In (full bandwidth)

#### A TRIGGER CONTROLS

A TRIG HOLDOFF	NORM
TRIG MODE	AUTO
COUPLING	AC
SOURCE	NORM
LEVEL	0
SLOPE	+

#### B TRIGGER CONTROLS

SOURCE	STARTS AFTER DELAY
COUPLING	AC
LEVEL	0
SLOPE	+

#### SWEEP CONTROLS

X10 MAG	Out
POSITION	Midrange
FINE	Midrange
DELAY TIME POSITION	0.02

A AND B TIME/DIV and DELAY TIME (Knobs Locked)

#### Signal Applied (For Waveforms Only)

The 466 Calibrator signal is applied to the CH 1 input through a compensated 10X probe.

Test Oscilloscope Vertical input is ac coupled unless noted otherwise by a 0 volt reference on the waveform drawing.

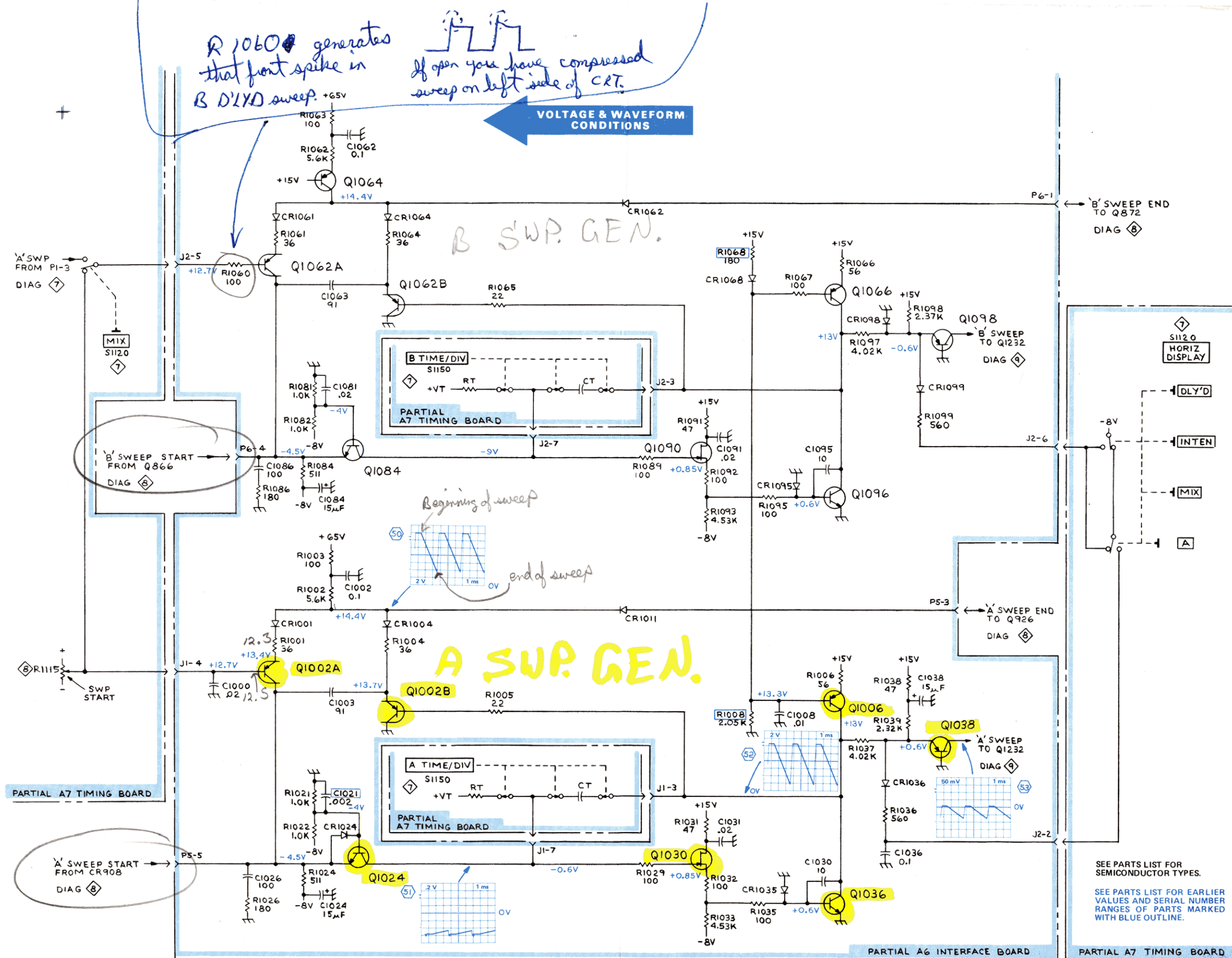





### VOLTAGE AND WAVEFORM CONDITIONS

Voltages and waveforms similar to those shown on this diagram can be obtained by using the recommended test equipment and test set-ups listed below.

#### RECOMMENDED TEST EQUIPMENT

ITEM	SPECIFICATIONS	RECOMMENDED TYPE
OSCILLOSCOPE	Bandwidth DC to 100 MHz Minimum Deflection Factor 5 mV/div Input Impedance 1 MΩ/20 pF	TEKTRONIX 465 Oscilloscope with P6065 or P6062A 10X probe.
DIGITAL MULTIMETER (For voltage up to 1 kV)	Input Impedance 10 MΩ Range 0 - 1 kV	TEKTRONIX DM 501.
DC VOLTMETER (For voltages above 1 kV)	Input Impedance 20,000Ω/volt Range 0 to 6 kV	TRIPLETT Model 630NA

Voltages and waveforms on this diagram were obtained under the following 466 conditions, unless noted otherwise.

#### POWER & CRT CONTROLS

POWER	ON (pulled out)
INTENSITY	Midrange (pushed in, Full Scan)
FOCUS	Adjusted for focused trace
SCALE ILLUM	Midrange
Storage Mode	NON STORE (pushed in)
VIEWTIME	NORM
VERTICAL CONTROLS (BOTH CHANNELS)	
VOLTS/DIV	5 mV
VAR	CAL
POSITION	Centered
AC-DC-GND	DC
VERT MODE	CH 1
INVERT	Out
20 MHz BW	In (full bandwidth)

#### B TRIGGER CONTROLS

SOURCE	STARTS AFTER DELAY
COUPLING	AC
LEVEL	0
SLOPE	+

#### SWEEP CONTROLS

X10 MAG	Out
POSITION	Midrange
FINE	Midrange
HORIZ DISPLAY	A
DELAY TIME POSITION	0.02
A AND B TIME/DIV AND DELAY TIME (Knobs Locked)	.2 ms

#### Signal Applied (For Waveforms Only)

The 466 Calibrator signal is applied to the CH 1 input through a compensated 10X probe.

#### A TRIGGER CONTROLS

A TRIG HOLDOFF	NORM
TRIG MODE	AUTO
COUPLING	AC
SOURCE	NORM
LEVEL	0
SLOPE	+

Test Oscilloscope Vertical input is ac coupled unless noted otherwise by a 0 volt reference on the waveform drawing.

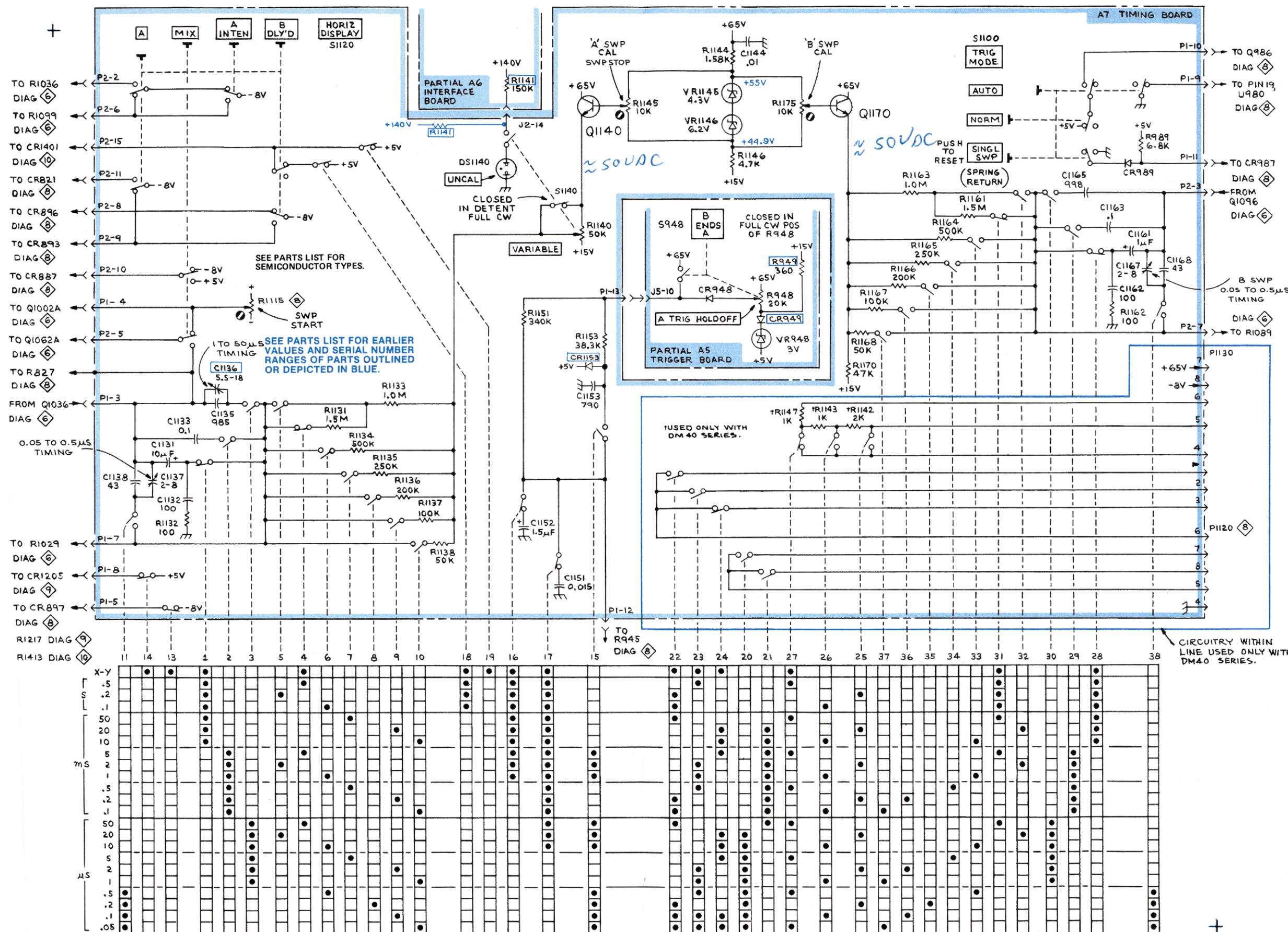

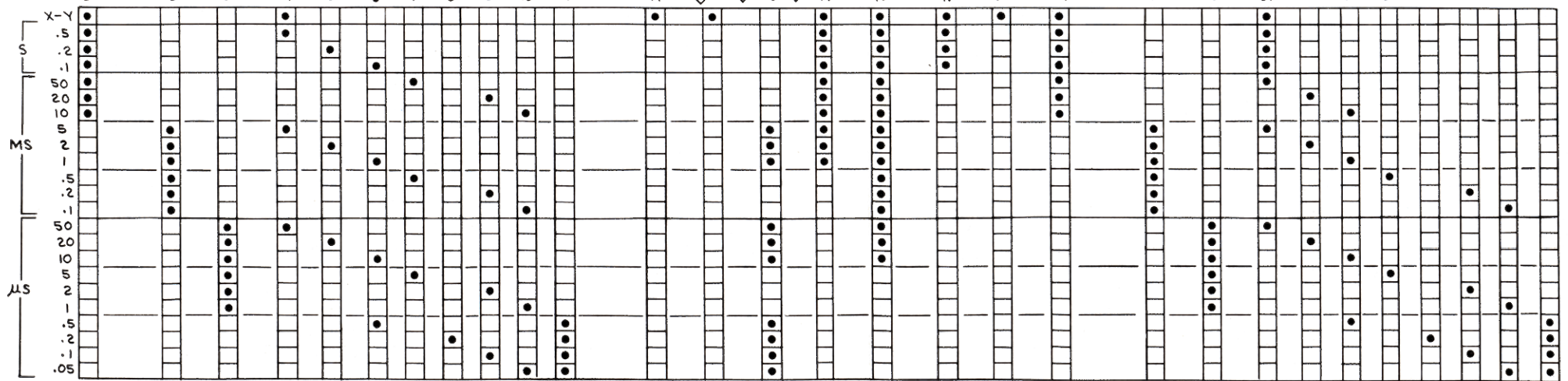
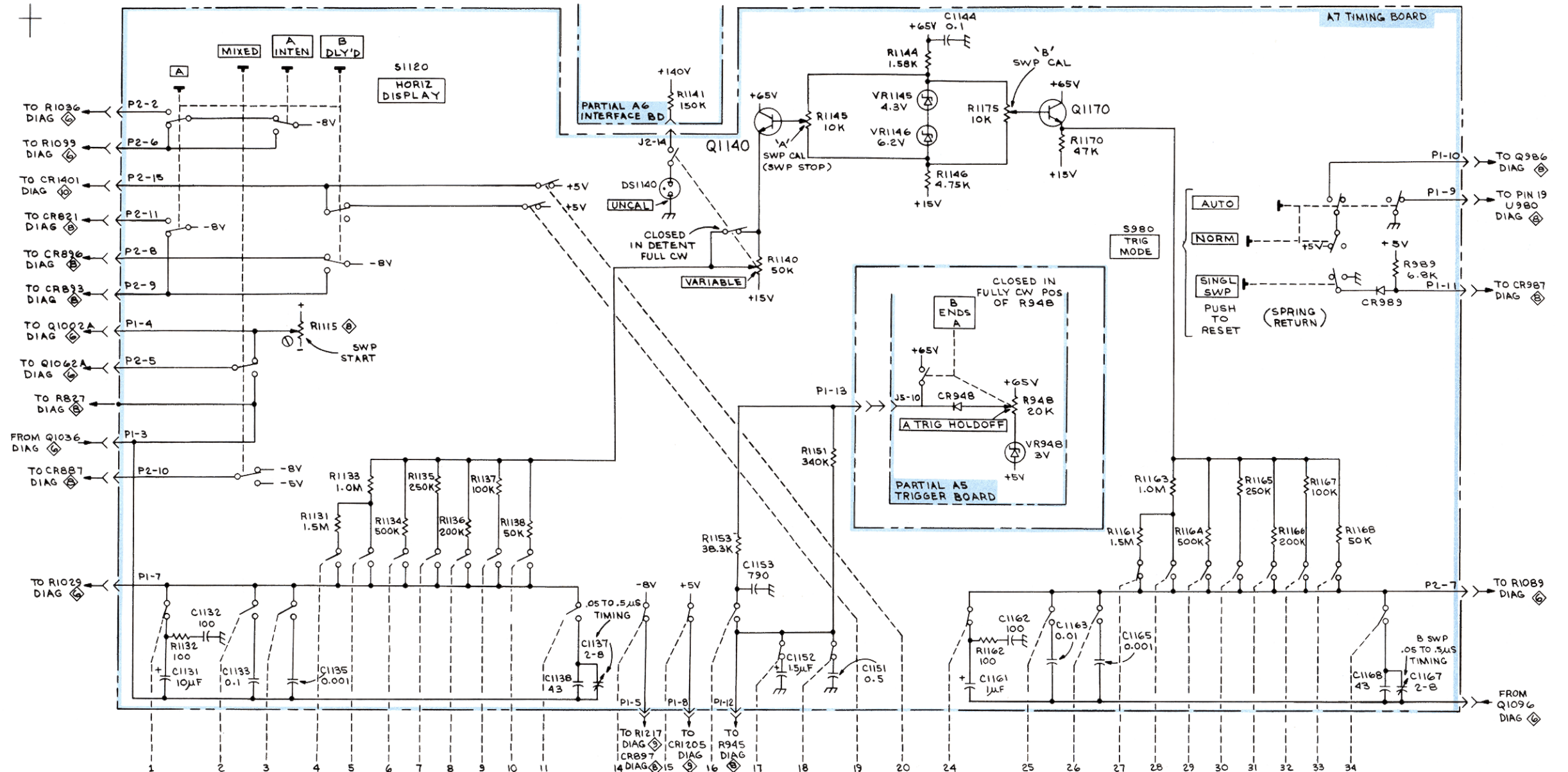

51150  
 'A' AND 'B'  
 TIME/DIV AND  
 DELAY TIME  
 (SWITCH SHOWN  
 IN X-Y POSITION)



### VOLTAGE AND WAVEFORM CONDITIONS

Voltages and waveforms similar to those shown on this diagram can be obtained by using the recommended test equipment and test set-ups listed below.

#### RECOMMENDED TEST EQUIPMENT

ITEM	SPECIFICATIONS	RECOMMENDED TYPE
OSCILLOSCOPE	Bandwidth DC to 100 MHz Minimum Deflection Factor 5 mV/div Input Impedance 1 MΩ/20 pF	TEKTRONIX 465 Oscilloscope with P6065 or P6062A 10X probe.
DIGITAL MULTIMETER (For voltage up to 1 kV)	Input Impedance 10 MΩ Range 0 - 1 kV	TEKTRONIX DM 501.
DC VOLTMETER (For voltages above 1 kV)	Input Impedance 20,000Ω/volt Range 0 to 6 kV	TRIPLETT Model 630NA

Voltages and waveforms on this diagram were obtained under the following 466 conditions, unless noted otherwise.

#### POWER & CRT CONTROLS

POWER	ON (pulled out)
INTENSITY	Midrange (pushed in, Full Scan)
FOCUS	Adjusted for focused trace
SCALE ILLUM	Midrange
Storage Mode	NON STORE (pushed in)
VIEWTIME	NORM
VERTICAL CONTROLS (BOTH CHANNELS)	
VOLTS/DIV	5 mV
VAR	CAL
POSITION	Centered
AC-DC-GND	DC
VERT MODE	CH 1
INVERT	Out
20 MHz BW	In (full bandwidth)

#### A TRIGGER CONTROLS

A TRIG HOLDOFF	NORM
TRIG MODE	AUTO
COUPLING	AC
SOURCE	NORM
LEVEL	0
SLOPE	+

#### B TRIGGER CONTROLS

SOURCE	STARTS AFTER DELAY
COUPLING	AC
LEVEL	0
SLOPE	+

#### SWEEP CONTROLS

X10 MAG	Out
POSITION	Midrange
FINE	Midrange
HORIZ DISPLAY	A
DELAY TIME POSITION	0.02

#### Signal Applied (For Waveforms Only)

The 466 Calibrator signal is applied to the CH 1 input through a compensated 10X probe.

Test Oscilloscope Vertical input is ac coupled unless noted otherwise by a 0 volt reference on the waveform drawing.

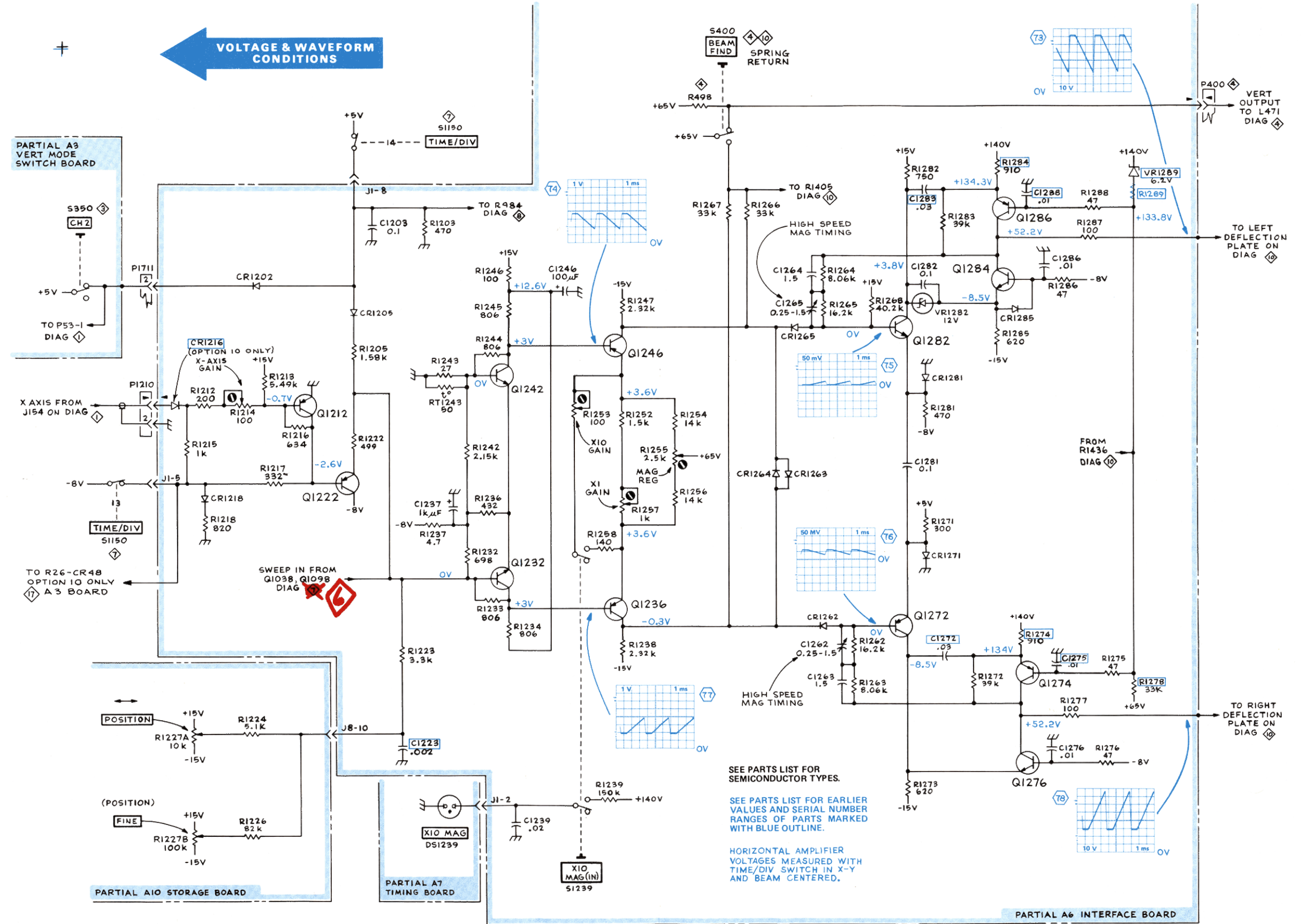

SEE PARTS LIST FOR SEMICONDUCTOR TYPES.  
SEE PARTS LIST FOR EARLIER VALUES AND SERIAL NUMBER RANGES OF PARTS MARKED WITH BLUE OUTLINE.

HORIZONTAL AMPLIFIER VOLTAGES MEASURED WITH TIME/DIV SWITCH IN X-Y AND BEAM CENTERED.



### VOLTAGE AND WAVEFORM CONDITIONS

Voltages and waveforms similar to those shown on this diagram can be obtained by using the recommended test equipment and test set-ups listed below.

#### RECOMMENDED TEST EQUIPMENT

ITEM	SPECIFICATIONS	RECOMMENDED TYPE
OSCILLOSCOPE	Bandwidth DC to 100 MHz Minimum Deflection Factor 5 mV/div Input Impedance 1 MΩ/20 pF	TEKTRONIX 466 Oscilloscope with P6065 or P6062A 10X probe.
DIGITAL MULTIMETER (For voltage up to 1 kV)	Input Impedance 10 MΩ Range 0 - 1 kV	TEKTRONIX DM 501.
DC VOLTMETER (For voltages above 1 kV)	Input Impedance 20,000Ω/volt Range 0 to 6 kV	TRIPLETT Model 630NA

Voltages and waveforms on this diagram were obtained under the following 466 conditions, unless noted otherwise.

#### POWER & CRT CONTROLS

POWER	ON (pulled out)
INTENSITY	Midrange (pushed in, Full Scan)
FOCUS	Adjusted for focused trace
SCALE ILLUM	Midrange
Storage Mode	NON STORE (pushed in)
VIEWTIME	NORM
VERTICAL CONTROLS (BOTH CHANNELS)	
VOLTS/DIV	5 mV
VAR	CAL
POSITION	Centered
AC-DC-GND	DC
VERT MODE	CH 1
INVERT	Out
20 MHz BW	In (full bandwidth)

#### A TRIGGER CONTROLS

A TRIG HOLDOFF	NORM
TRIG MODE	AUTO
COUPLING	AC
SOURCE	NORM
LEVEL	0
SLOPE	+

#### B TRIGGER CONTROLS

SOURCE	STARTS AFTER DELAY
COUPLING	AC
LEVEL	0 Tek 466
SLOPE	+
SWEEP CONTROLS	
X10 MAG	Out
POSITION	Midrange
FINE	Midrange
HORIZ DISPLAY	A
DELAY TIME POSITION	0.02
A AND B TIME/DIV and DELAY TIME (Knobs Locked)	.2 ms

#### Signal Applied (For Waveforms Only)

The 466 Calibrator signal is applied to the CH 1 input through a compensated 10X probe.

Test Oscilloscope Vertical input is ac coupled unless noted otherwise by a 0 volt reference on the waveform drawing.

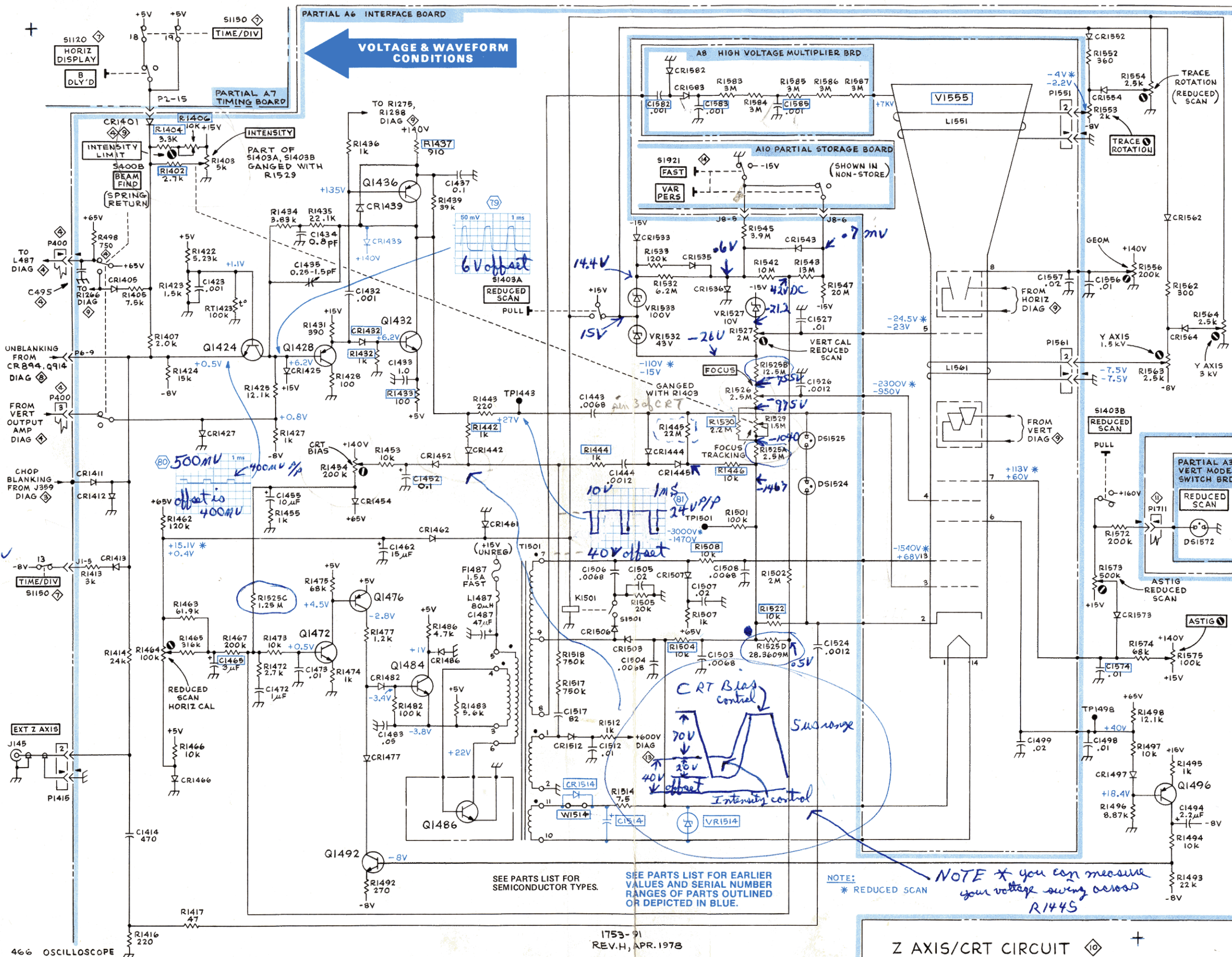

Z AXIS/CRT CIRCUIT

### VOLTAGE AND WAVEFORM CONDITIONS

Voltages and waveforms similar to those shown on this diagram can be obtained by using the recommended test equipment and test set-ups listed below.

#### RECOMMENDED TEST EQUIPMENT

ITEM	SPECIFICATIONS	RECOMMENDED TYPE
OSCILLOSCOPE	Bandwidth DC to 100 MHz Minimum Deflection Factor 5 mV/div Input Impedance 1 MΩ/20 pF	TEKTRONIX 465 Oscilloscope with P6065 or P6062A 10X probe.
DIGITAL MULTIMETER (For voltage up to 1 kV)	Input Impedance 10 MΩ Range 0 - 1 kV	TEKTRONIX DM 501.
DC VOLTMETER (For voltages above 1 kV)	Input Impedance 20,000Ω/volt Range 0 to 6 kV	TRIPLETT Model 630NA

Voltages and waveforms on this diagram were obtained under the following 466 conditions, unless noted otherwise.

#### POWER & CRT CONTROLS

POWER	ON (pulled out)
INTENSITY	Midrange (pushed in, Full Scan)
FOCUS	Adjusted for focused trace
SCALE ILLUM	Midrange
Storage Mode	NON STORE (pushed in)
VIEWTIME	NORM
VERTICAL CONTROLS (BOTH CHANNELS)	
VOLTS/DIV	5 mV
VAR	CAL
POSITION	Centered
AC-DC-GND	DC
VERT MODE	CH 1
INVERT	Out
20 MHz BW	In (full bandwidth)

#### A TRIGGER CONTROLS

A TRIG HOLDOFF	NORM
TRIG MODE	AUTO
COUPLING	AC
SOURCE	NORM
LEVEL	0
SLOPE	+

#### B TRIGGER CONTROLS

SOURCE	STARTS AFTER DELAY
COUPLING	AC
LEVEL	0
SLOPE	+

#### SWEEP CONTROLS

X10 MAG	Out
POSITION	Midrange
FINE	Midrange
HORIZ DISPLAY	A
DELAY TIME POSITION	0.02
A AND B TIME/DIV and DELAY TIME (Knobs Locked)	.2 ms

#### Signal Applied (For Waveforms Only)

The 466 Calibrator signal is applied to the CH 1 input through a compensated 10X probe.

Test Oscilloscope Vertical input is ac coupled unless noted otherwise by a 0 volt reference on the waveform drawing.

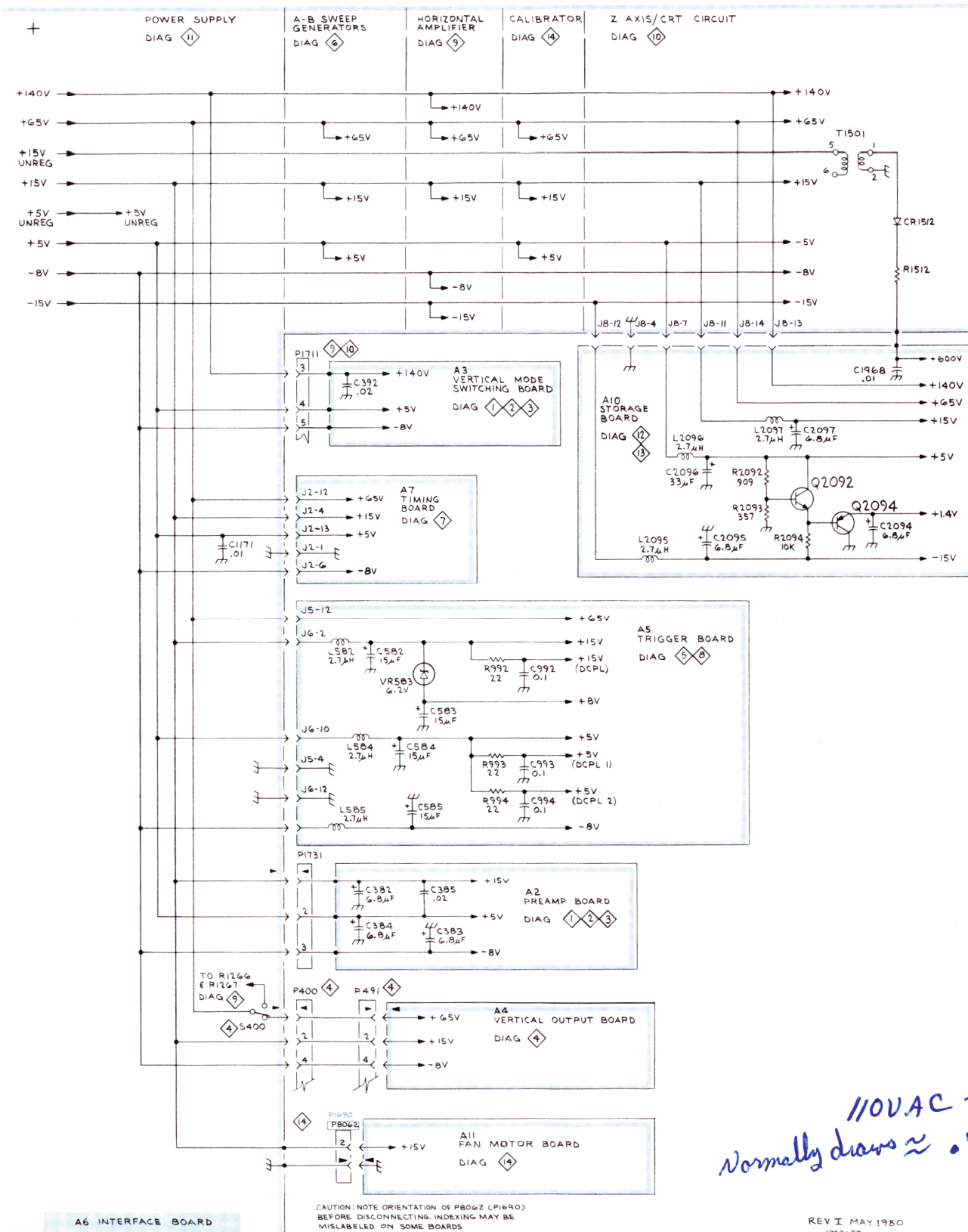

466 OSCILLOSCOPE

REV I MAY 1960  
1763-92

*110V AC  
Normally draws ~ 0.7 Amps*

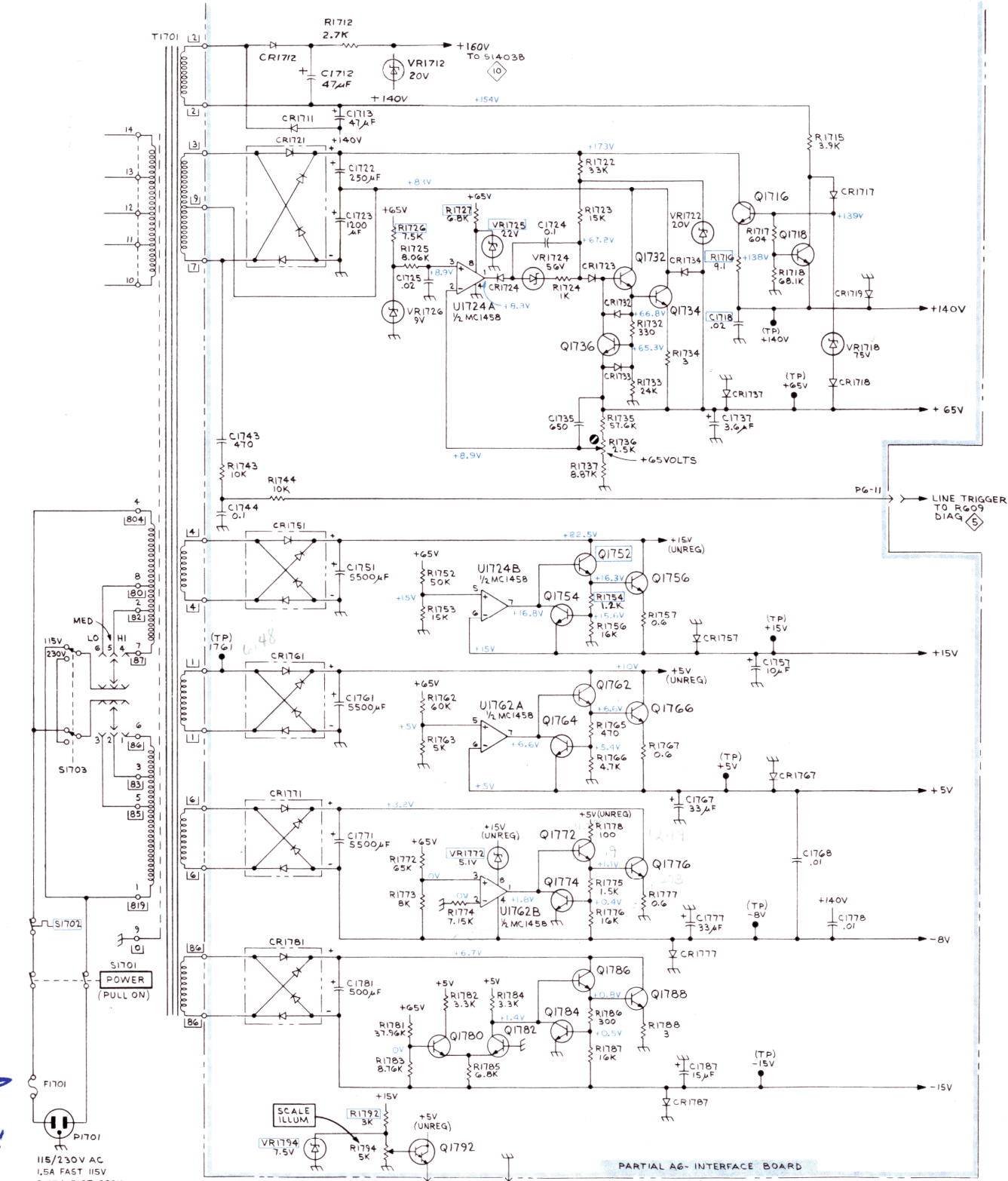

#### VOLTAGE & WAVEFORM CONDITIONS

SEE PARTS LIST FOR SEMICONDUCTOR TYPES.  
NOTE: VOLTAGES TAKEN WITH LINE SET TO 10V RMS MED LINE.

POWER SUPPLY & DISTRIBUTION



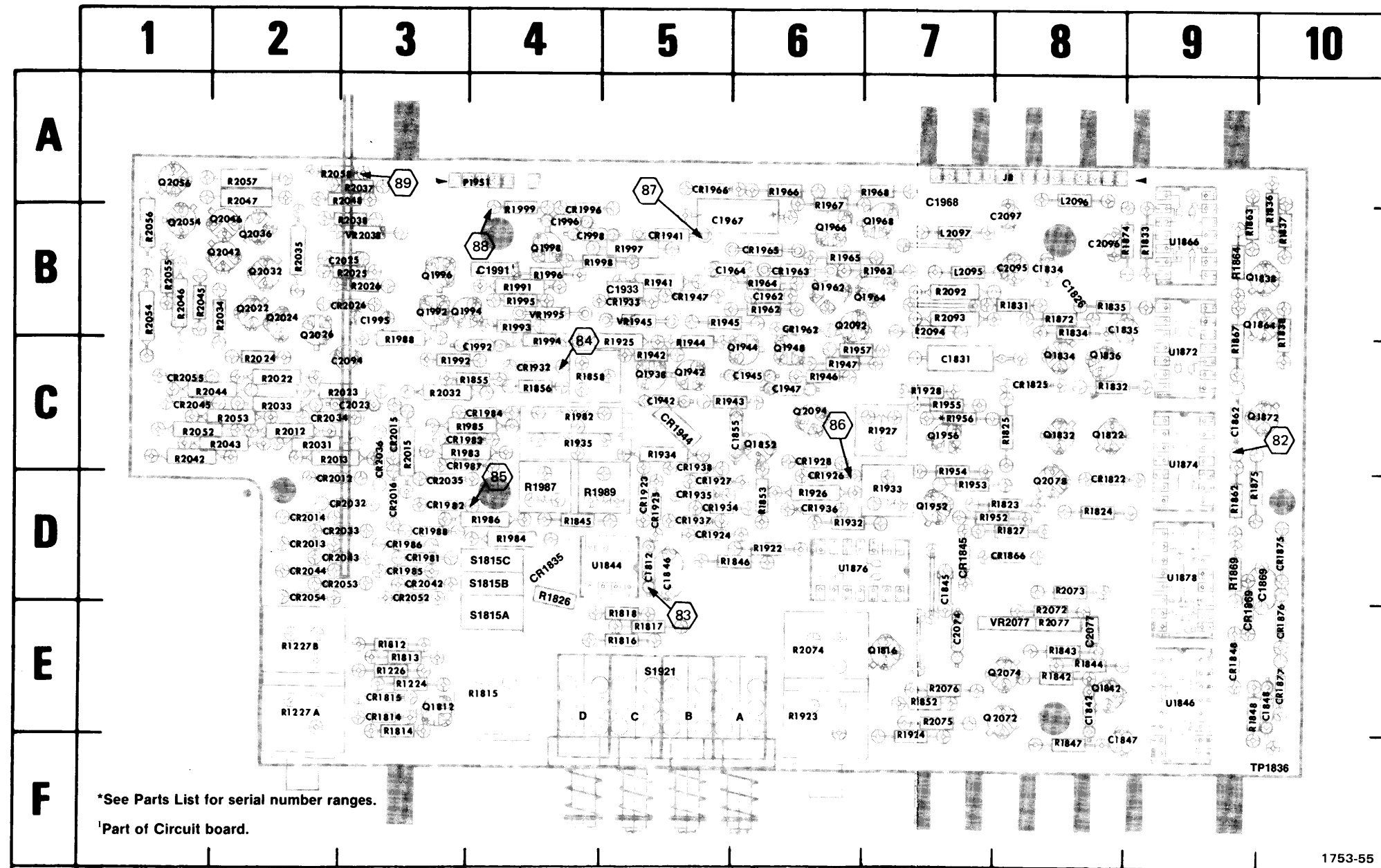

(A) A10 Storage board.

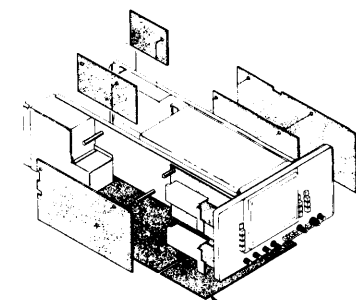

1753-56  
STORAGE A10  
(B) Board location.

CKT NO	GRID LOC	CKT NO	GRID LOC	CKT NO	GRID LOC	CKT NO	GRID LOC	CKT NO	GRID LOC	CKT NO	GRID LOC	CKT NO	GRID LOC	CKT NO	GRID LOC	CKT NO	GRID LOC	CKT NO	GRID LOC		
C1812	5D	C1962	6B	CR1814	3E	CR1927	5D	CR1981	3D	CR2033	3D	L2096	8A	Q1938	5C	Q2026	2B	R1227B	2E	R1834	8B
C1826	8B	C1964	5B	CR1815	3E	CR1928	6C	CR1982	3D	CR2034	2C	L2097	7B	Q1942	5C	Q2032	2B	R1812	3E	R1835	8B
C1831	7C	C1967	5B	CR1822	8D	CR1932	4C	CR1983	4C	CR2035	3D			Q1944	6C	Q2036	2B	R1813	3E	R1836	10B
C1834	8B	C1968*	7A	CR1825	8C	CR1933	5B	CR1984	4C	CR2036	3C	P1951	4A	Q1948	6C	Q2042	2B	R1814	3E	R1837	10B
C1835	8B	C1991	4B	CR1835	4D	CR1934	5D	CR1985	3D	CR2042	3D			Q1952	7D	Q2046	2B	R1815	4E	R1838	10B
C1842	8E	C1992	4C	CR1845	7D	CR1935	5D	CR1986	3D	CR2043	3D	Q1812	3E	Q1956	7C	Q2054	1B	R1816	5E	R1842	8E
C1845	7D	C1995	3B	CR1848	9E	CR1936	6D	CR1987	4C	CR2044	2D	Q1816	7E	Q1962	6B	Q2056	1A	R1817	5E	R1843	8E
C1846	5D	C1996	4B	CR1866	8D	CR1937	5D	CR1988	3D	CR2045	1C	Q1822	8C	Q1964	7B	Q2072	8E	R1818	5E	R1844	8E
C1847	9F	C1998	4B	CR1869	9E	CR1938	5C	CR1996	4B	CR2052	3D	Q1832	8C	Q1966	6B	Q2074	8E	R1823	8D	R1845	4D
C1848	10E	C2023	3C	CR1875	10D	CR1941	5B	CR2012	2D	CR2053	3D	Q1834	8C	Q1968	7B	Q2074	8E	R1824	8D	R1846	6D
C1855	6C	C2025	3B	CR1876	10E	CR1944*	5C	CR2013	2D	CR2054	2D	Q1836	8C	Q1992	3B	Q2078	8D	R1825	8C	R1847	8F
C1862	9C	C2074	7E	CR1877	10E	CR1947	5B	CR2014	2D	CR2055	1C	Q1838	10B	Q1994	3B	Q2092	6B	R1826	4D	R1848	9E
C1869	10D	C2077*	8E	CR1923	5D	CR1962	6B	CR2015	3C			Q1842	8E	Q1996	3B	Q2094	6C	R1827	8D	R1852	7E
C1933*	5B	C2094	3C	CR1924	5D	CR1963	6B	CR2016	3D	J8	8A	Q1852	6C	Q1998	4B			R1827	4D	R1853	6D
C1942	5C	C2095	8B	CR1925	5D	CR1965	6B	CR2026	3B			Q1864	10B	Q2022	2B	R1224	3E	R1831	8B	R1853	6D
C1945	6C	C2096	8B	CR1926	6D	CR1966	5A	CR2032	3D	L2095	7B	Q1872	10C	Q2024	2B	R1226	3E	R1832	8C	R1855	4C
C1947	6C	C2097	8B													R1227A	2E	R1833	9B	R1856	4C

CKT NO	GRID LOC	CKT NO	GRID LOC	CKT NO	GRID LOC
R1858*	4C	R1997	5B	U1876	6D
R1862	9D	R1998	4B	U1878	9D
R1863	9B	R1999	4B		
R1864	9B	R2012	2C	VR1945*	5B
R1867	9B	R2013	2C	VR1995	4B
R1869	9D	R2015	3C	VR2038	3B
R1872	8B	R2022	2C	VR2077*	8E
R1874	9B	R2023	3C		
R1875	9D	R2024	2C		
R1922	6D	R2025	3B		
R1923	6E	R2026	3B		
R1924	7E	R2031	2C		
R1925	5C	R2032	3C		
R1926	6D	R2033	2C		
R1927	7C	R2034	2B		
R1928	7C	R2035	2B		
R1932	6D	R2037	3A		
R1933	7D	R2038	3B		
R1934	5C	R2042	1C		
R1935	4C	R2043	2C		
R1941	5B	R2044	2C		
R1942	5C	R2045	1B		
R1943	5C	R2046	1B		
R1944	5C	R2047	2A		
R1945	6B	R2048	3A		
R1946	6C	R2052	1C		
R1947	6C	R2053	2C		
R1952	8D	R2054	1B		
R1953	7D	R2055	1B		
R1954	7C	R2056	1B		
R1955	7C	R2057	2A		
R1956*	7C	R2058	2A		
R1957	6C	R2072	8E		
R1962	6B	R2073	8D		
R1963	7B	R2074	6E		
R1964	6B	R2075	7E		
R1965	6B	R2076	7E		
R1966	6A	R2077	8E		
R1967	6B	R2092	7B		
R1968	7A	R2093	7B		
R1982	4C	R2094	7B		
R1983	4C				
R1984	4D	S1815A	4E		
R1985	4C	S1815B	4D		
R1986	4D	S1815C	4D		
R1987	4D	S1921	5E		
R1989	4D				
R1988	3C	TP1836	10F		
R1991	4B				
R1992	3C	U1844	5D		
R1993	4B	U1846	9E		
R1994	4C	U1866	9B		
R1995	4B	U1872	9C		
R1996	4B	U1874	9C		

### VOLTAGE AND WAVEFORM CONDITIONS

Voltages and waveforms similar to those shown on this diagram can be obtained by using the recommended test equipment and test set-ups listed below.

#### RECOMMENDED TEST EQUIPMENT

ITEM	SPECIFICATIONS	RECOMMENDED TYPE
OSCILLOSCOPE	Bandwidth DC to 100 MHz Minimum Deflection Factor 5 mV/div Input Impedance 1 MΩ/20 pF	TEKTRONIX 465 Oscilloscope with P6065 or P6062A 10X probe.
DIGITAL MULTIMETER (For voltage up to 1 kV)	Input Impedance 10 MΩ Range 0 - 1 kV	TEKTRONIX DM 501.
DC VOLTMETER (For voltages above 1 kV)	Input Impedance 20,000Ω/volt Range 0 to 6 kV	TRIPLETT Model 630NA

Voltages and waveforms on this diagram were obtained under the following 466 conditions, unless noted otherwise.

#### POWER & CRT CONTROLS

POWER	ON (pulled out)
INTENSITY	Midrange (pushed in, Full Scan)
FOCUS	Adjusted for focused trace
SCALE ILLUM	Midrange
Storage Mode	NON STORE (pushed in)
VIEWTIME	NORM
VERTICAL CONTROLS (BOTH CHANNELS)	
VOLTS/DIV	5 mV
VAR	CAL
POSITION	Centered
AC-DC-GND	DC
VERT MODE	CH 1
INVERT	Out
20 MHz BW	In (full bandwidth)

#### B TRIGGER CONTROLS

SOURCE	STARTS AFTER DELAY
COUPLING	AC
LEVEL	0
SLOPE	+

#### SWEEP CONTROLS

X10 MAG	Out
POSITION	Midrange
FINE	Midrange
HORIZ DISPLAY	A
DELAY TIME POSITION	0.02
A AND B TIME/DIV and DELAY TIME (Knobs Locked)	.2 ms

#### Signal Applied (For Waveforms Only)

The 466 Calibrator signal is applied to the CH 1 input through a compensated 10X probe.

Test Oscilloscope Vertical input is ac coupled unless noted otherwise by a 0 volt reference on the waveform drawing.

#### A TRIGGER CONTROLS

A TRIG HOLDOFF	NORM
TRIG MODE	AUTO
COUPLING	AC
SOURCE	NORM
LEVEL	0
SLOPE	+

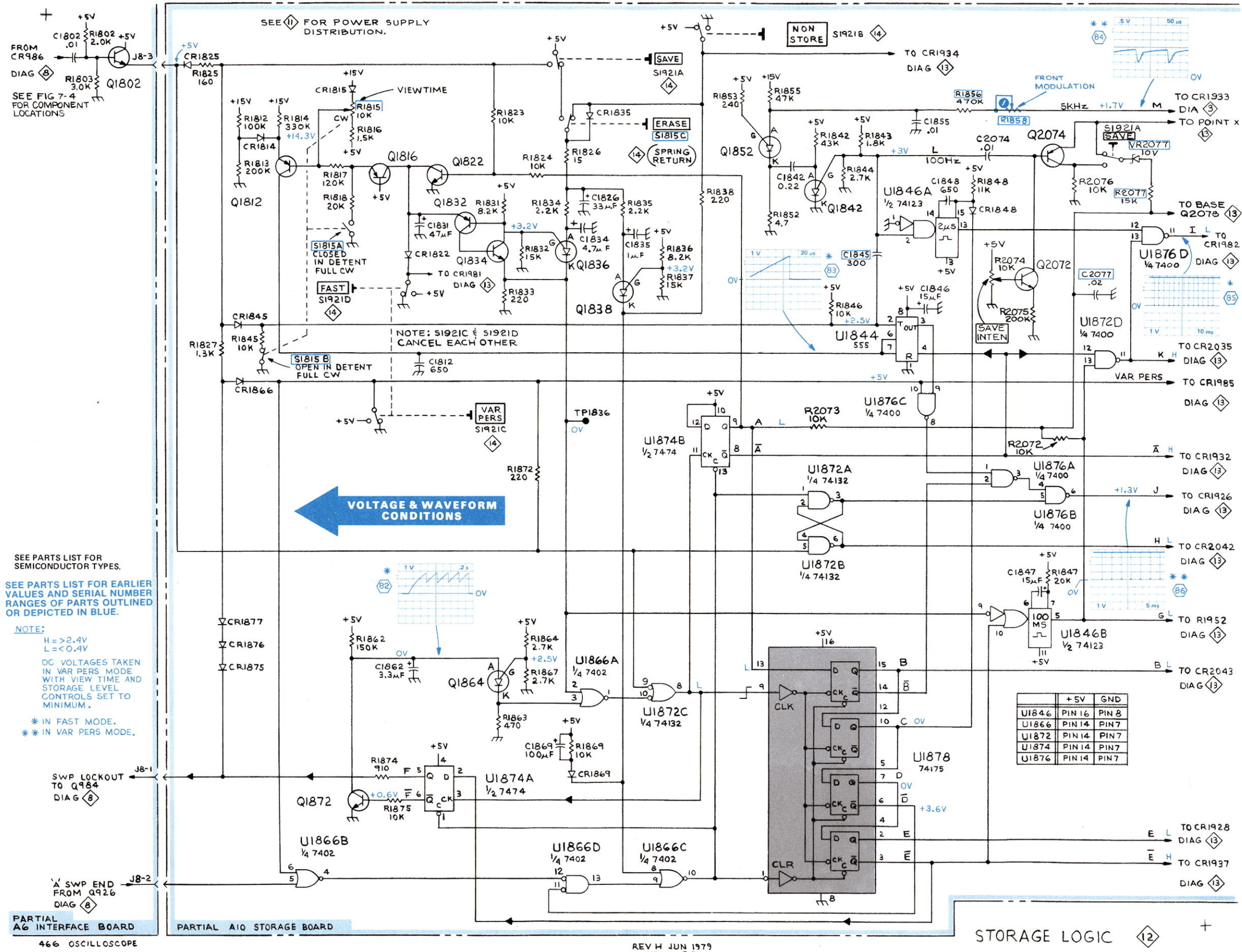

SEE PARTS LIST FOR SEMICONDUCTOR TYPES.  
SEE PARTS LIST FOR EARLIER VALUES AND SERIAL NUMBER RANGES OF PARTS OUTLINED OR DEPICTED IN BLUE.  
NOTE:  
H > 2.4V  
L < 0.4V  
DC VOLTAGES TAKEN IN VAR PERS MODE WITH VIEW TIME AND STORAGE LEVEL CONTROLS SET TO MINIMUM.  
\* IN FAST MODE.  
\* \* IN VAR PERS MODE.

PARTIAL A10 STORAGE BOARD  
466 OSCILLOSCOPE

REV H JUN 1979  
1753-93

STORAGE LOGIC 12

**VOLTAGE AND WAVEFORM CONDITIONS**

Voltages and waveforms similar to those shown on this diagram can be obtained by using the recommended test equipment and test set-ups listed below.

**RECOMMENDED TEST EQUIPMENT**

ITEM	SPECIFICATIONS	RECOMMENDED TYPE
OSCILLOSCOPE	Bandwidth DC to 100 MHz Minimum Deflection Factor 5 mV/div Input Impedance 1 MΩ/20 pF	TEKTRONIX 465 Oscilloscope with P6065 or P6062A 10X probe.
DIGITAL MULTIMETER (For voltage up to 1 kV)	Input Impedance 10 MΩ Range 0 - 1 kV	TEKTRONIX DM 501.
DC VOLTMETER (For voltages above 1 kV)	Input Impedance 20,000Ω/volt Range 0 to 6 kV	TRIPLETT Model 630NA

Voltages and waveforms on this diagram were obtained under the following 466 conditions, unless noted otherwise.

**POWER & CRT CONTROLS**

POWER	ON (pulled out)
INTENSITY	Midrange (pushed in, Full Scan)
FOCUS	Adjusted for focused trace
SCALE ILLUM	Midrange
Storage Mode	NON STORE (pushed in)
VIEWTIME	NORM
VERTICAL CONTROLS (BOTH CHANNELS)	
VOLTS/DIV	5 mV
VAR	CAL
POSITION	Centered
AC-DC-GND	DC
VERT MODE	CH 1
INVERT	Out
20 MHz BW	In (full bandwidth)

**A TRIGGER CONTROLS**

A TRIG HOLDOFF	NORM
TRIG MODE	AUTO
COUPLING	AC
SOURCE	NORM
LEVEL	0
SLOPE	+

**B TRIGGER CONTROLS**

SOURCE	STARTS AFTER DELAY
COUPLING	AC
LEVEL	0
SLOPE	+

**SWEEP CONTROLS**

X10 MAG	Out
POSITION	Midrange
FINE	Midrange
HORIZ DISPLAY	A
DELAY TIME POSITION	0.02
A AND B TIME/DIV and DELAY TIME (Knobs Locked)	.2 ms

**Signal Applied (For Waveforms Only)**

The 466 Calibrator signal is applied to the CH 1 input through a compensated 10X probe.

Test Oscilloscope Vertical input is ac coupled unless noted otherwise by a 0 volt reference on the waveform drawing.

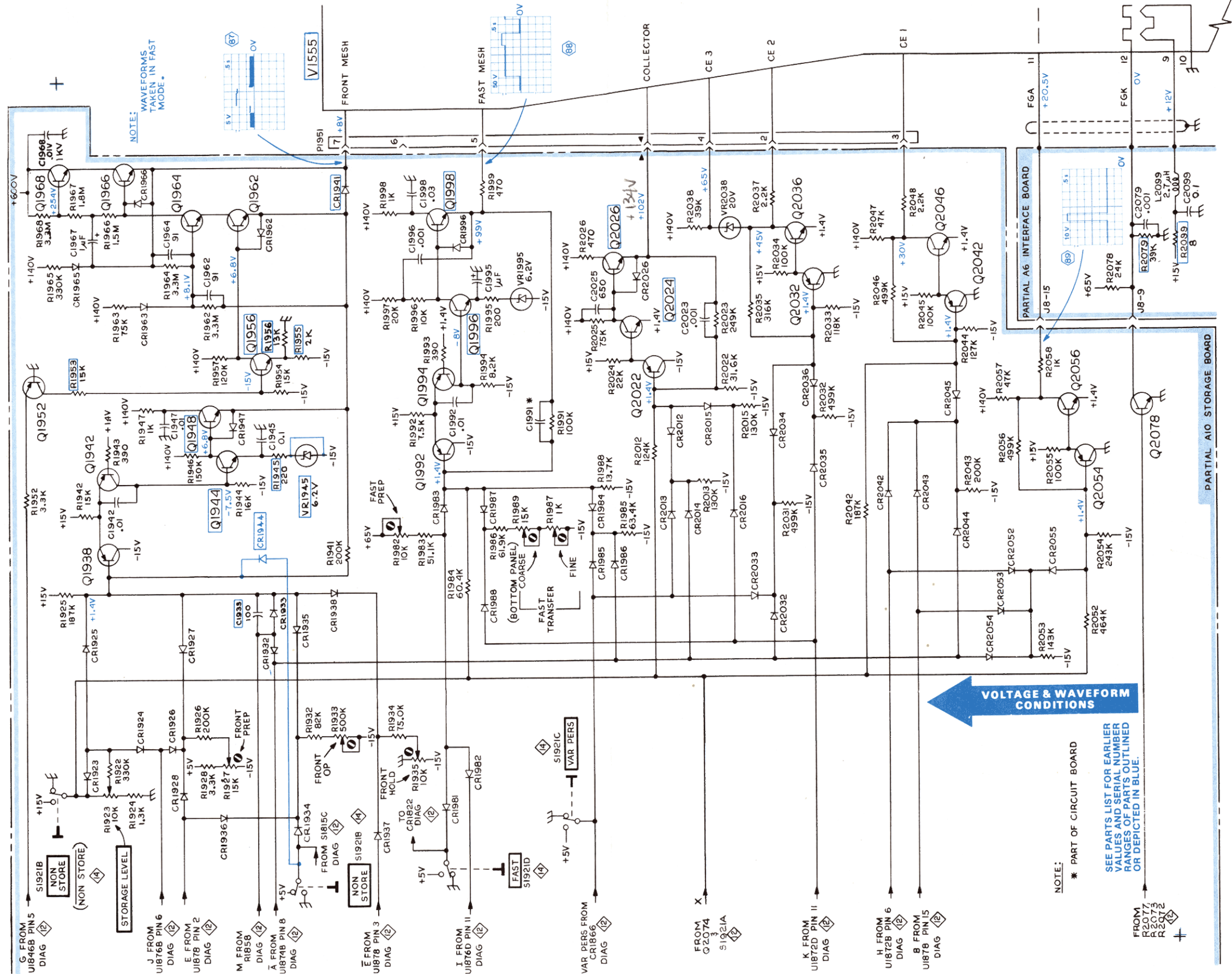

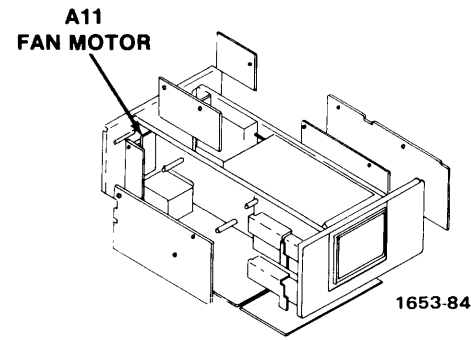

(B) Board locations.

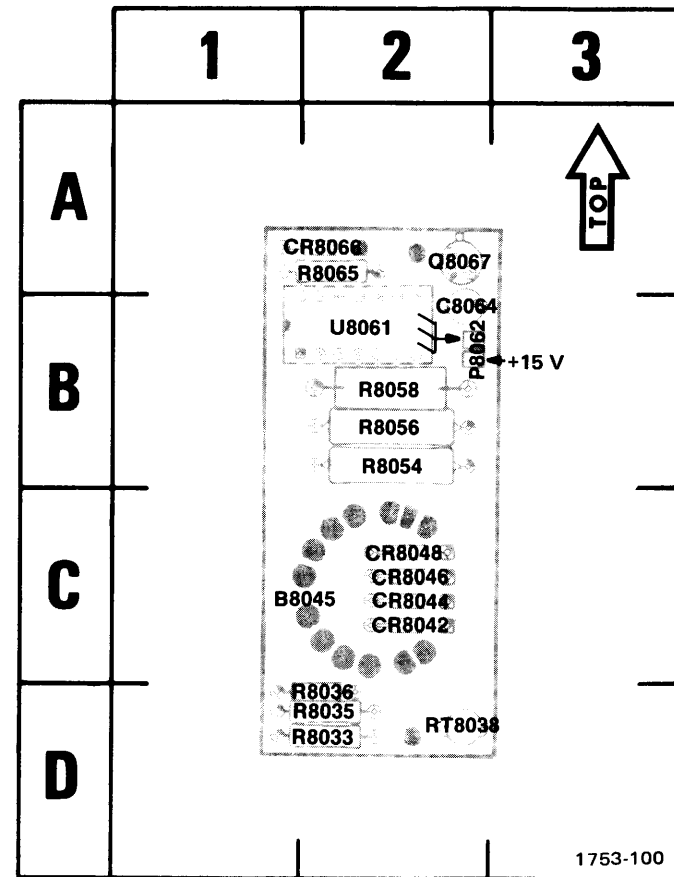

(A) A11 Fan Motor board (SN B138090 & up).

CKT NO	GRID LOC	CKT NO	GRID LOC
B8045	1C	R8033	2D
		R8035	2D
C8064	2B	R8036	2D
		R8054	2B
CR8042	2C	R8056	2B
CR8044	2C	R8058	2B
CR8046	2C	R8065	2A
CR8048	2C		
CR8066	2A	RT8038	2D
P8062	2B	U8061	2B
Q8067	2A		

**CAUTION**  
Observe and note orientation of P8062 before disconnecting it from A11 board. Index mark may be incorrect on some boards.

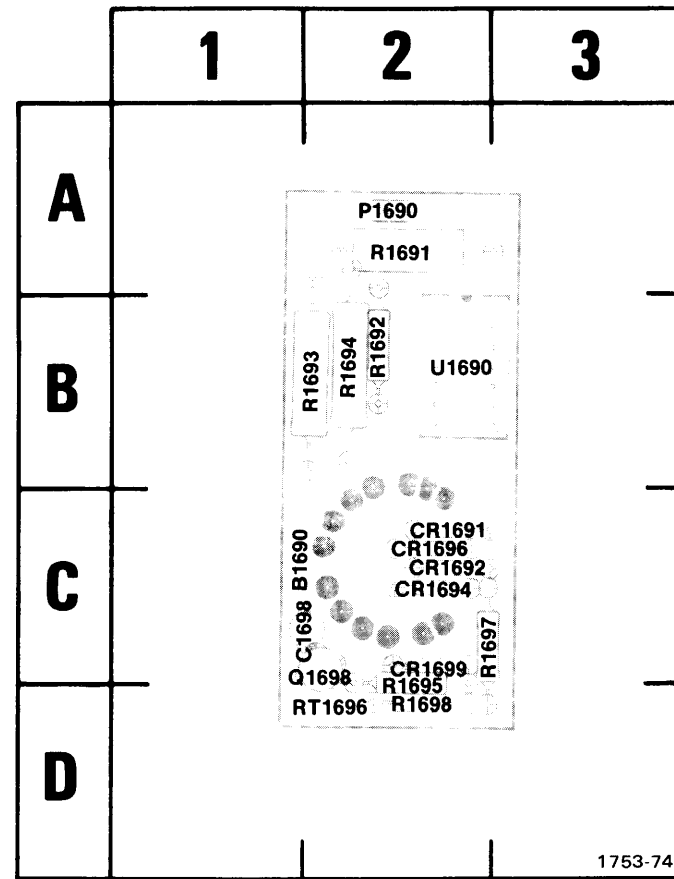

(C) A11 Fan Motor board (SN below B138090).

CKT NO	GRID LOC	CKT NO	GRID LOC
B1690	1C	R1691	2A
		R1692	2B
C1698	2C	R1693	2B
		R1694	2B
CR1691	2C	R1695	2D
CR1692	2C	R1697	2C
CR1694	2C	R1698	2D
CR1696	2C		
CR1699	2C	RT1696	2D
P1690	2A	U1690	2B
Q1698	2C		

Fig. 7-10 (A) (B) & (C). A11 Fan Motor board component locations.

A11 BOARD COMPONENT LOCATIONS

### VOLTAGE AND WAVEFORM CONDITIONS

Voltages and waveforms similar to those shown on this diagram can be obtained by using the recommended test equipment and test set-ups listed below.

RECOMMENDED TEST EQUIPMENT		
ITEM	SPECIFICATIONS	RECOMMENDED TYPE
OSCILLOSCOPE	Bandwidth DC to 100 MHz Minimum Deflection Factor 5 mV/div Input Impedance 1 MΩ/20 pF	TEKTRONIX 465 Oscilloscope with P6065 or P6062A 10X probe.
DIGITAL MULTIMETER (For voltage up to 1 kV)	Input Impedance 10 MΩ Range 0 - 1 kV	TEKTRONIX DM 501.
DC VOLTMETER (For voltages above 1 kV)	Input Impedance 20,000Ω/volt Range 0 to 6 kV	TRIPLETT Model 630NA

Voltages and waveforms on this diagram were obtained under the following 466 conditions, unless noted otherwise.

#### POWER & CRT CONTROLS

POWER	ON (pulled out)
INTENSITY	Midrange (pushed in, Full Scan)
FOCUS	Adjusted for focused trace
SCALE ILLUM	Midrange
Storage Mode	NON STORE (pushed in)
VIEWTIME	NORM
<b>VERTICAL CONTROLS (BOTH CHANNELS)</b>	
VOLTS/DIV	5 mV
VAR	CAL
POSITION	Centered
AC-DC-GND	DC
VERT MODE	CH 1
INVERT	Out
20 MHz BW	In (full bandwidth)

#### A TRIGGER CONTROLS

A TRIG HOLDOFF	NORM
TRIG MODE	AUTO
COUPLING	AC
SOURCE	NORM
LEVEL	0
SLOPE	+

#### B TRIGGER CONTROLS

SOURCE	STARTS AFTER DELAY
COUPLING	AC
LEVEL	0
SLOPE	+

#### SWEEP CONTROLS

X10 MAG	Out
POSITION	Midrange
FINE	Midrange
HORIZ DISPLAY	A
DELAY TIME POSITION	0.02
A AND B TIME/DIV and DELAY TIME (Knobs Locked)	.2 ms

#### Signal Applied (For Waveforms Only)

The 466 Calibrator signal is applied to the CH 1 input through a compensated 10X probe.

Test Oscilloscope Vertical input is ac coupled unless noted otherwise by a 0 volt reference on the waveform drawing.

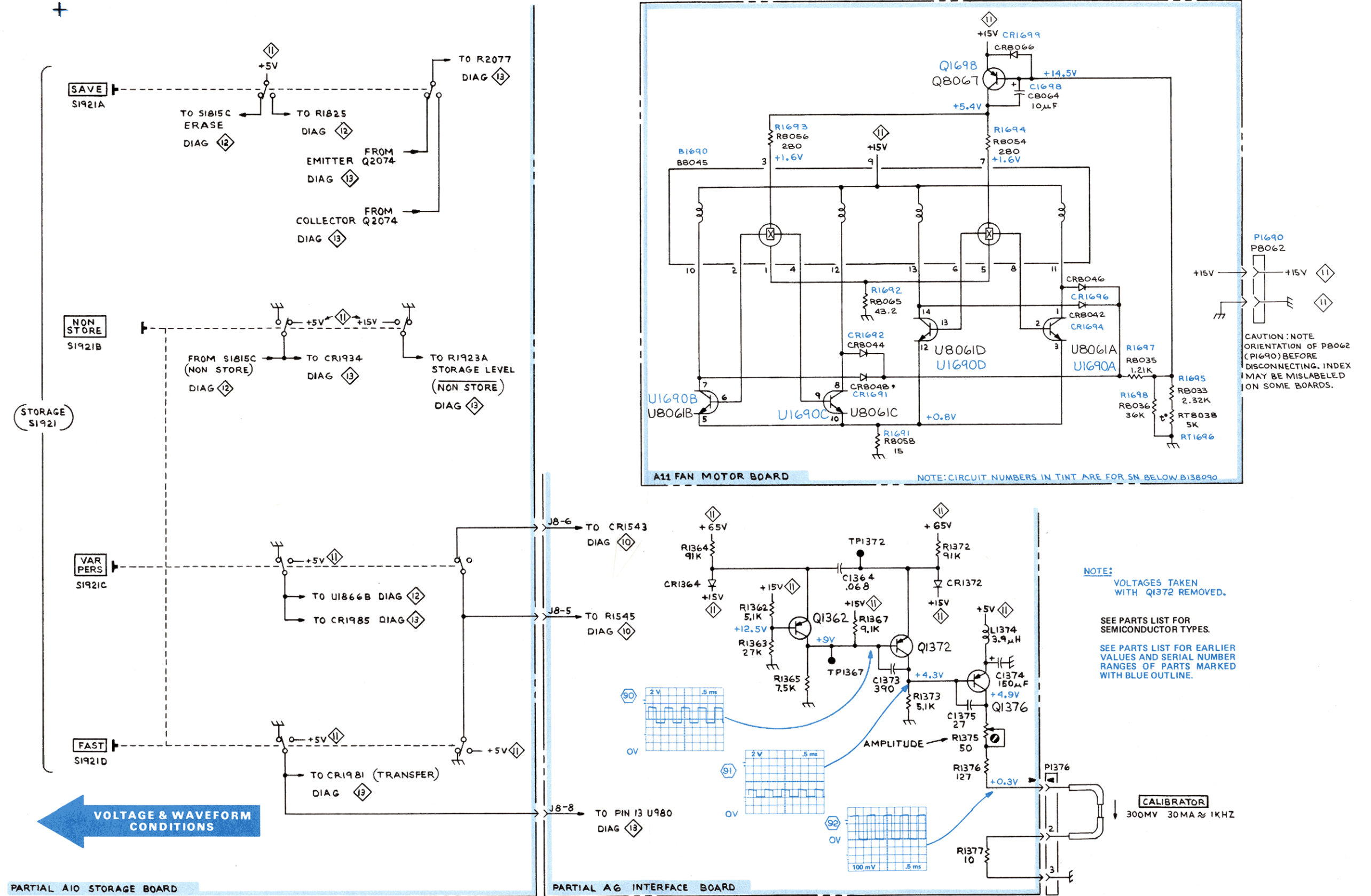

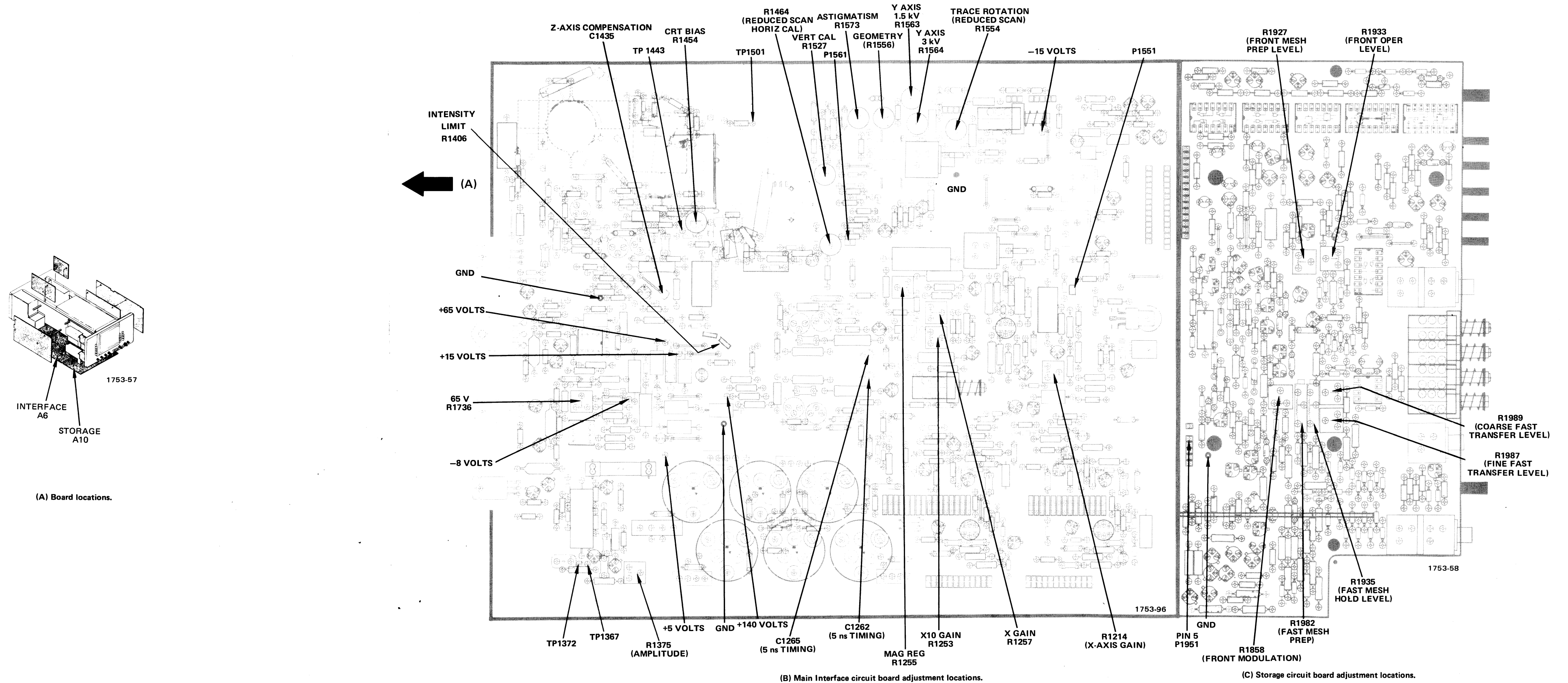
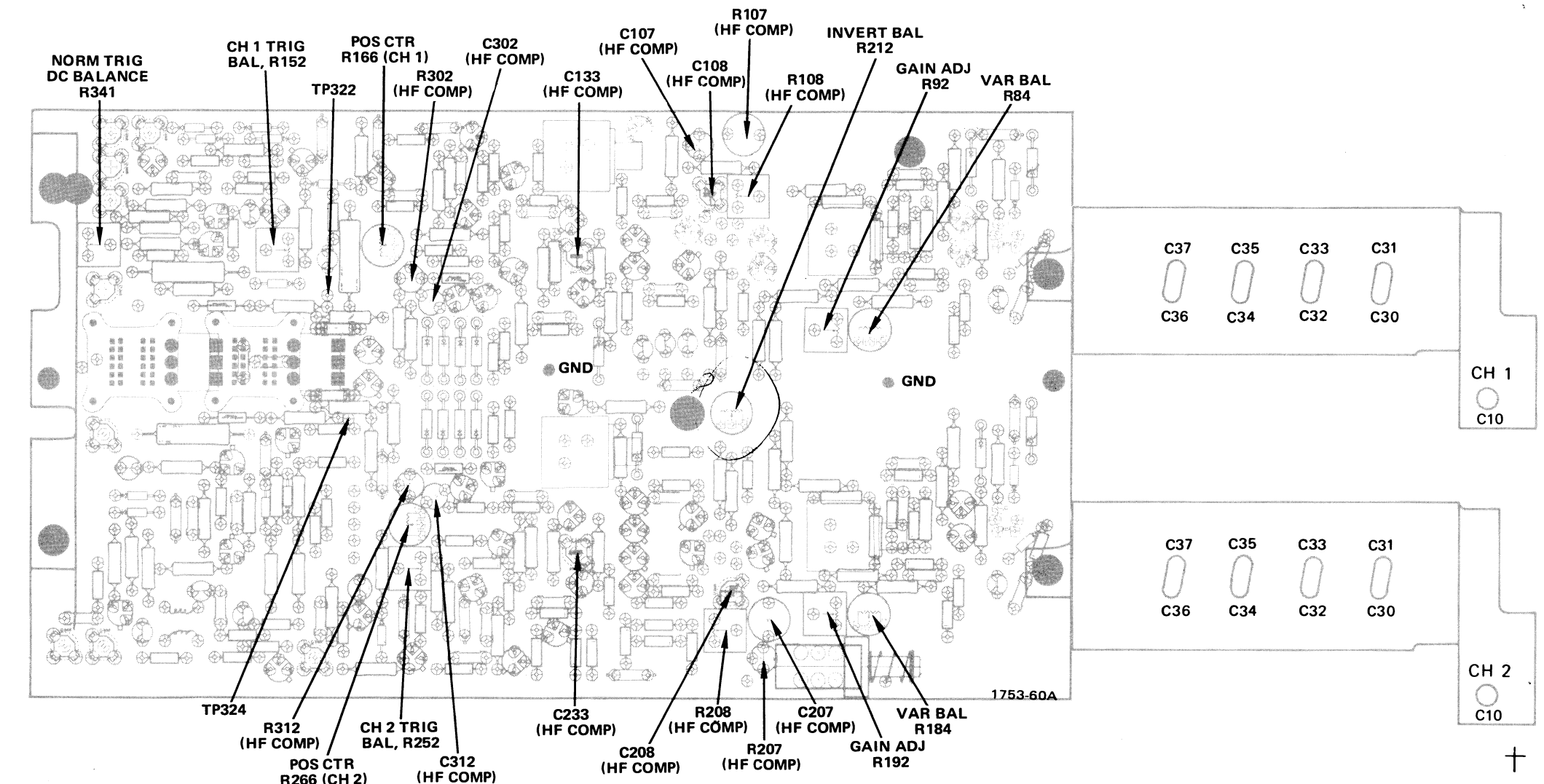
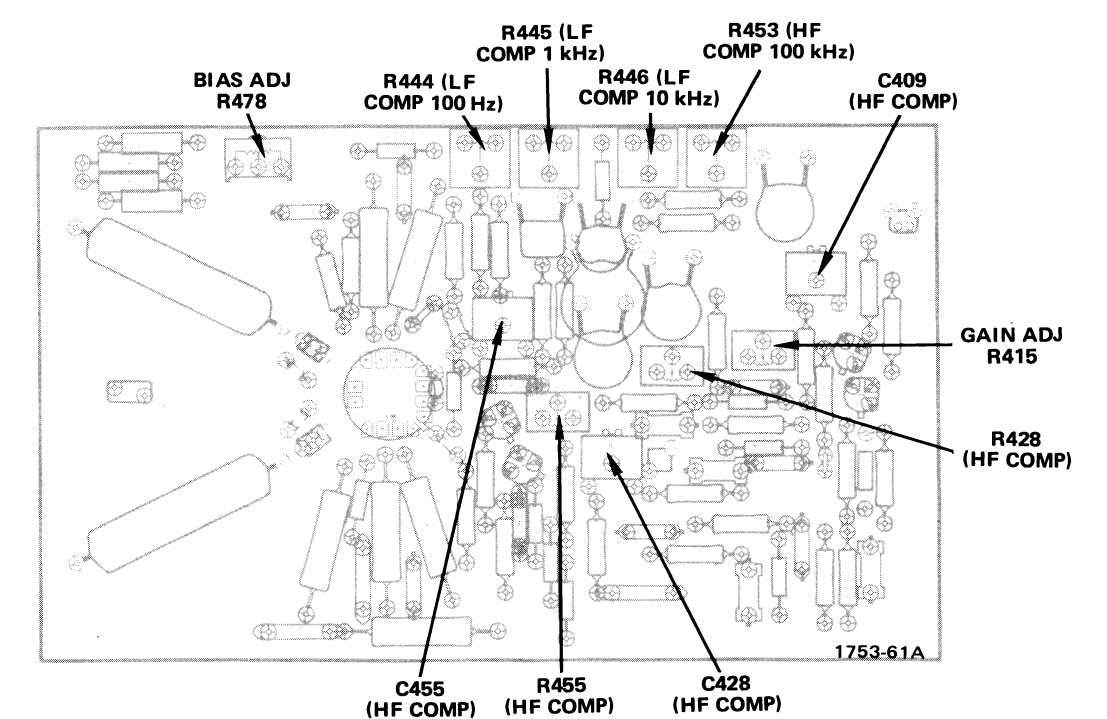

Fig. 7-11(A) through (C). Adjustment locations 1.



(C) Preamp circuit board adjustment locations.



(B) Vertical Output circuit board adjustment locations.

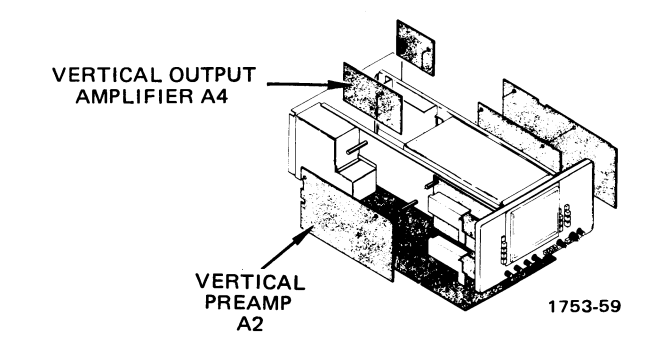

(A) Board locations

Fig. 7-12(A) through (C). Adjustment locations 2.

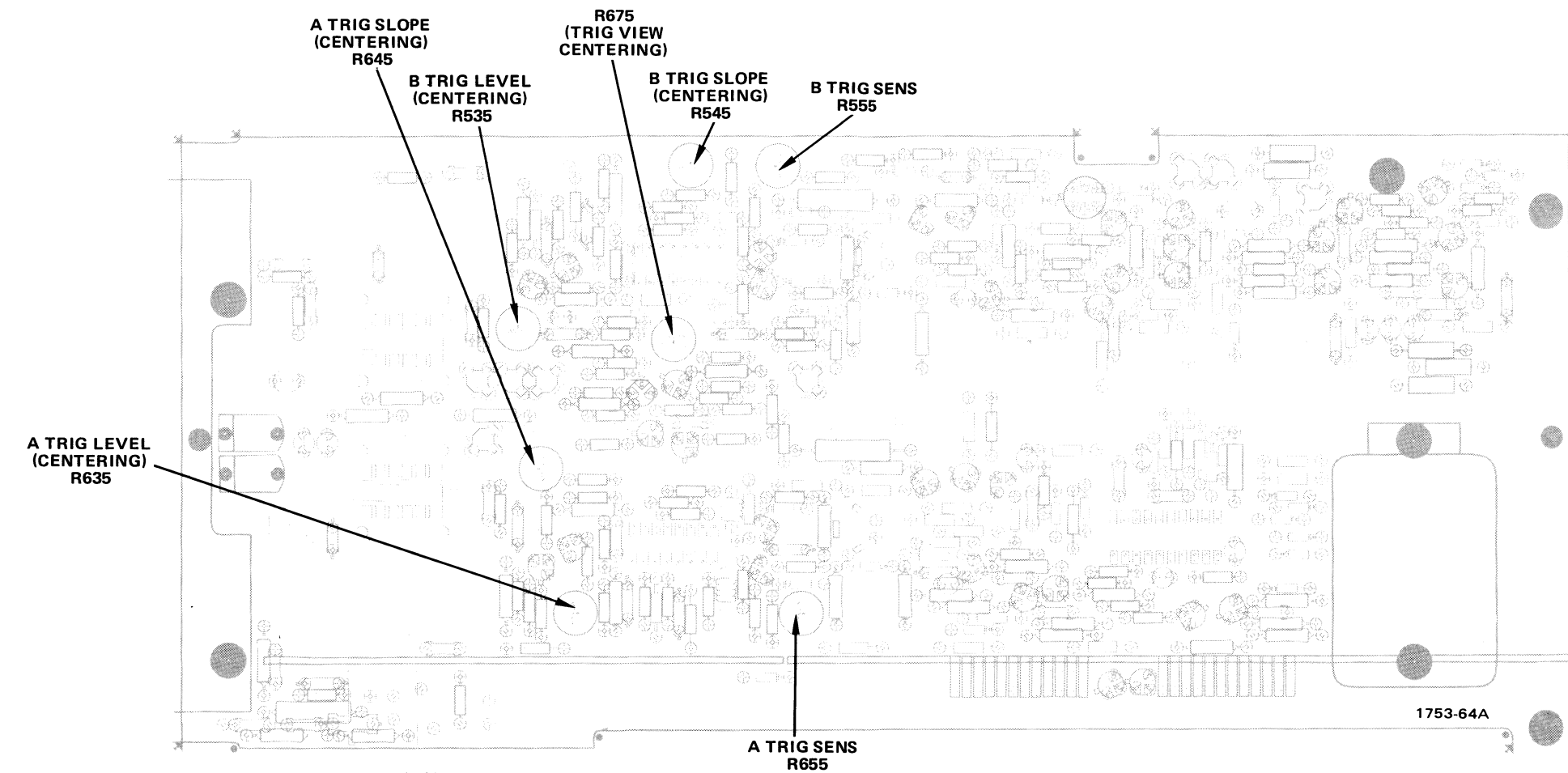

(C) Trigger circuit board adjustment locations.

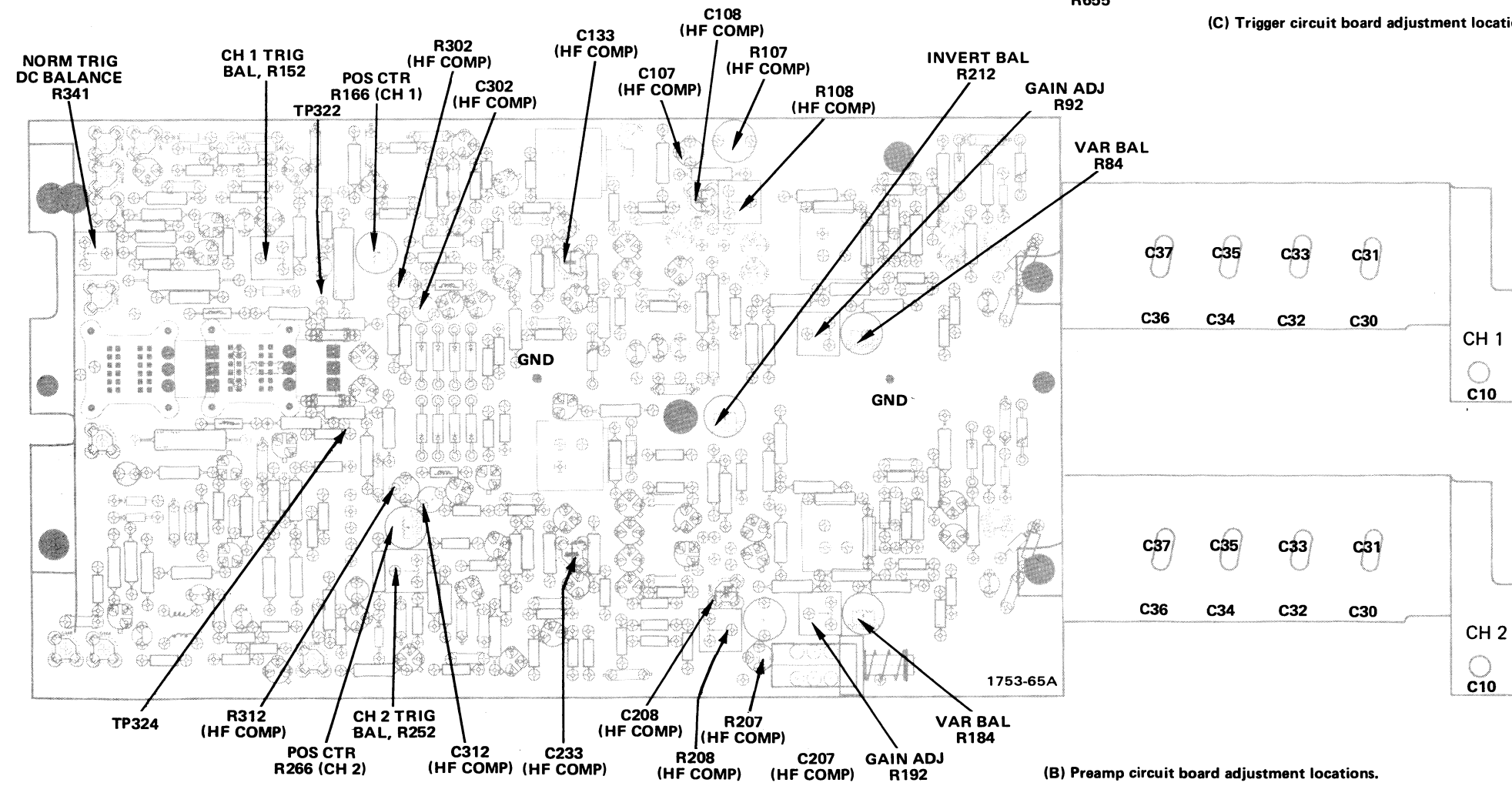

(B) Preamp circuit board adjustment locations.

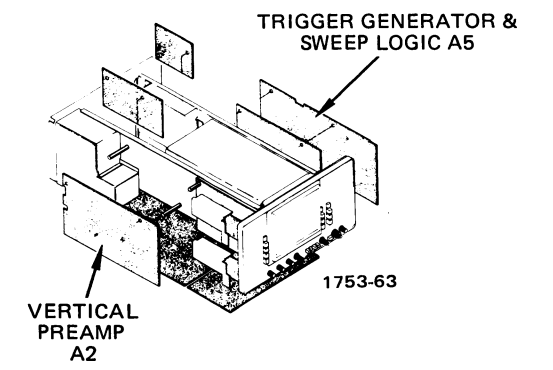

(A) Board locations.

Fig. 7-13(A) through (C). Adjustment locations 3.



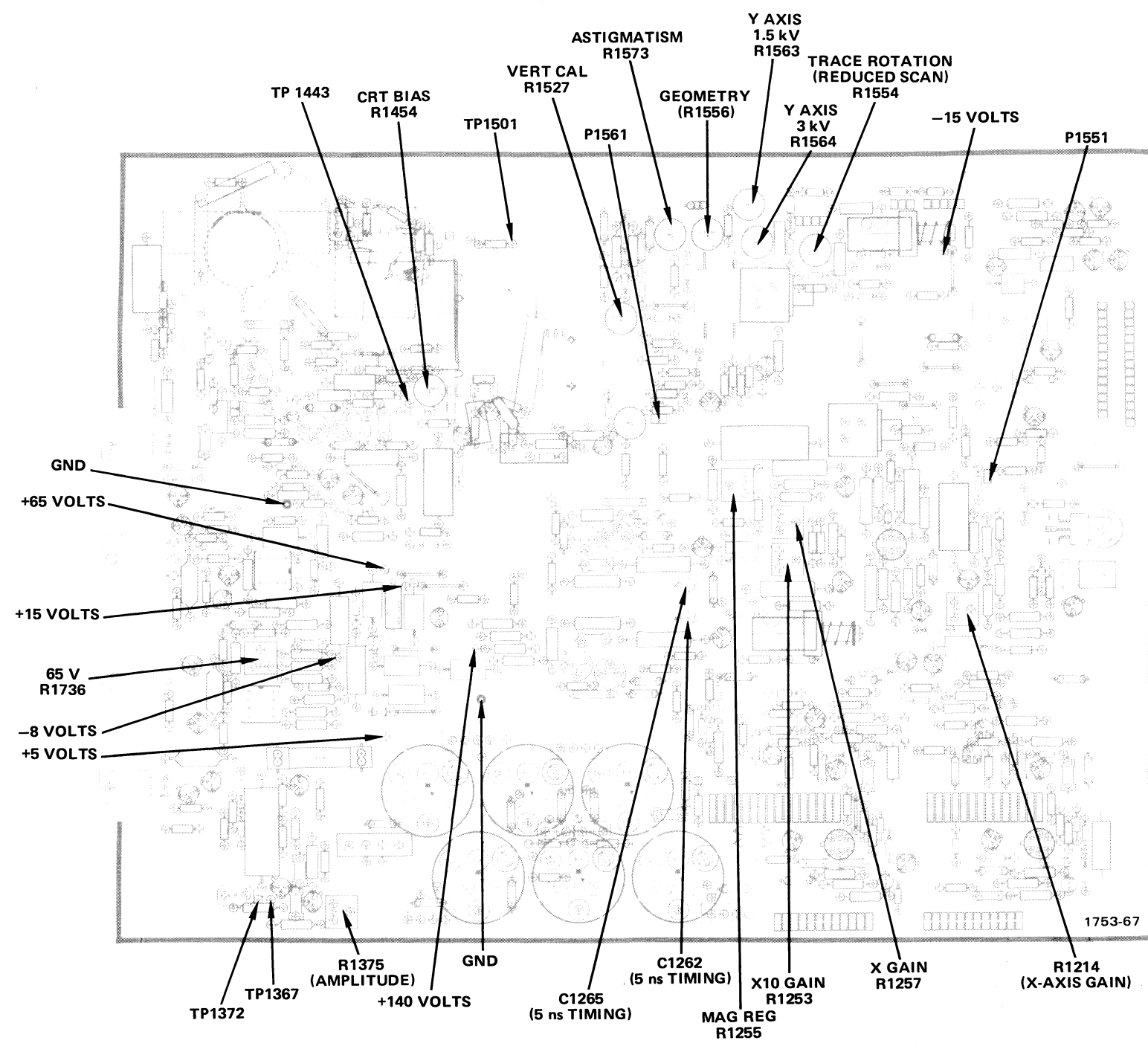

(B) Main Interface circuit board adjustment locations.

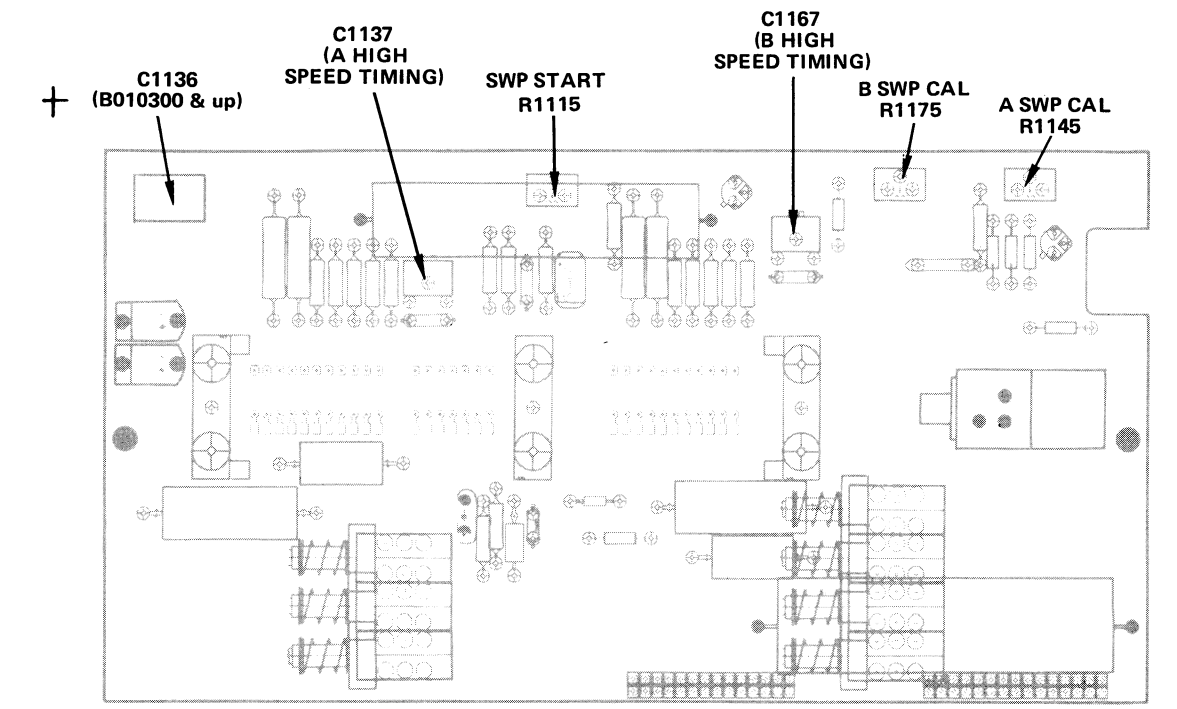

(C) Timing circuit board adjustment locations.

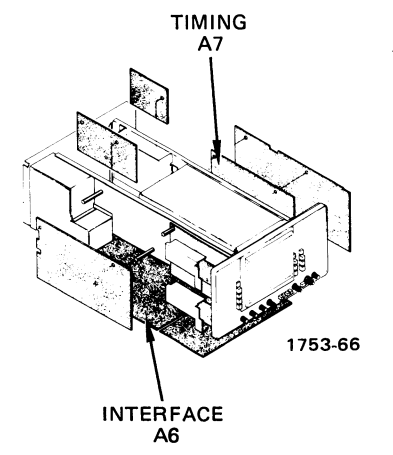

(A) Board locations.

Fig. 7-14(A) through(C). Adjustment locations 4.

**8-8 not in original**

# REPLACEABLE MECHANICAL PARTS

## PARTS ORDERING INFORMATION

Replacement parts are available from or through your local Tektronix, Inc. Field Office or representative.

Changes to Tektronix instruments are sometimes made to accommodate improved components as they become available, and to give you the benefit of the latest circuit improvements developed in our engineering department. It is therefore important, when ordering parts, to include the following information in your order: Part number, instrument type or number, serial number, and modification number if applicable.

If a part you have ordered has been replaced with a new or improved part, your local Tektronix, Inc. Field Office or representative will contact you concerning any change in part number.

Change information, if any, is located at the rear of this manual.

## SPECIAL NOTES AND SYMBOLS

X000 Part first added at this serial number  
00X Part removed after this serial number

## FIGURE AND INDEX NUMBERS

Items in this section are referenced by figure and index numbers to the illustrations.

## INDENTATION SYSTEM

This mechanical parts list is indented to indicate item relationships. Following is an example of the indentation system used in the description column.

```

1 2 3 4 5           Name & Description
Assembly and/or Component
Attaching parts for Assembly and/or Component
-----*-----
Detail Part of Assembly and/or Component
Attaching parts for Detail Part
-----*-----
Parts of Detail Part
Attaching parts for Parts of Detail Part
-----*-----

```

Attaching Parts always appear in the same indentation as the item it mounts, while the detail parts are indented to the right. Indented items are part of, and included with, the next higher indentation. The separation symbol ---\*--- indicates the end of attaching parts.

**Attaching parts must be purchased separately, unless otherwise specified.**

## ITEM NAME

In the Parts List, an Item Name is separated from the description by a colon (:). Because of space limitations, an Item Name may sometimes appear as incomplete. For further Item Name identification, the U.S. Federal Cataloging Handbook H6-1 can be utilized where possible.

## ABBREVIATIONS

#	INCH	ELECTRN	ELECTRON	IN	INCH	SE	SINGLE END
ADPTR	NUMBER SIZE	ELEC	ELECTRICAL	INCAND	INCANDESCENT	SECT	SECTION
ALIGN	ACTUATOR	ELECTLT	ELECTROLYTIC	INSUL	INSULATOR	SEMICOND	SEMICONDUCTOR
AL	ADAPTER	ELEM	ELEMENT	INTL	INTERNAL	SHLD	SHIELD
ASSEM	ALIGNMENT	EPL	ELECTRICAL PARTS LIST	LPHLDR	LAMPHOLDER	SHLDR	SHOULDERED
ASSY	ALUMINUM	EQPT	EQUIPMENT	MACH	MACHINE	SKT	SOCKET
ATTEN	ASSEMBLED	EXT	EXTERNAL	MECH	MECHANICAL	SL	SLIDE
AWG	ASSEMBLY	FIL	FILLISTER HEAD	MTG	MOUNTING	SLFLKG	SELF-LOCKING
BD	ATTENUATOR	FLEX	FLEXIBLE	NIP	NIPPLE	SLVG	SLEEVING
BRKT	AMERICAN WIRE GAGE	FLH	FLAT HEAD	NON WIRE	NOT WIRE WOUND	SPR	SPRING
BRS	BOARD	FLTR	FILTER	OBD	ORDER BY DESCRIPTION	SQ	SQUARE
BRZ	BRACKET	FR	FRAME or FRONT	OD	OUTSIDE DIAMETER	SST	STAINLESS STEEL
BSHG	BRASS	FSTNR	FASTENER	OVH	OVAL HEAD	STL	STEEL
CAB	BRONZE	FT	FOOT	PH BRZ	PHOSPHOR BRONZE	SW	SWITCH
CAP	BUSHING	FXD	FIXED	PL	PLAIN or PLATE	T	TUBE
CER	CABINET	GSKT	GASKET	PLSTC	PLASTIC	TERM	TERMINAL
CHAS	CAPACITOR	HDL	HANDLE	PN	PART NUMBER	THD	THREAD
CKT	CERAMIC	HEX	HEXAGON	PNH	PAN HEAD	THK	THICK
COMP	CHASSIS	HEX HD	HEXAGONAL HEAD	PWR	POWER	TNSN	TENSION
CONN	CIRCUIT	HEX SOC	HEXAGONAL SOCKET	RCPT	RECEPTACLE	TPG	TAPPING
COV	COMPOSITION	HLCPS	HELICAL COMPRESSION	RES	RESISTOR	TRH	TRUSS HEAD
CPLG	CONNECTOR	HLEXT	HELICAL EXTENSION	RGD	RIGID	V	VOLTAGE
CRT	COVER	HV	HIGH VOLTAGE	RLF	RELIEF	VAR	VARIABLE
DEG	COUPLING	IC	INTEGRATED CIRCUIT	RTNR	RETAINER	W/	WITH
DWR	CATHODE RAY TUBE	ID	INSIDE DIAMETER	SCH	SOCKET HEAD	WSHR	WASHER
	DEGREE	IDNT	IDENTIFICATION	SCOPE	OSCILLOSCOPE	XFMR	TRANSFORMER
	DRAWER	IMPLR	IMPELLER	SCR	SCREW	XSTR	TRANSISTOR

CROSS INDEX—MFR. CODE NUMBER TO MANUFACTURER

Mfr. Code	Manufacturer	Address	City, State, Zip
S3109	FELLER ASA ADOLF AG., C/O PANEL COMPONENTS CORP.	355 TESCONI CIRCLE	SANTA ROSA, CA 95401
000BK	STAUFFER SUPPLY	105 SE TAYLOR	PORTLAND, OR 97214
000CY	NORTHWEST FASTENER SALES, INC.	7923 SW CIRRRUS DRIVE	BEAVERTON, OR 97005
000DX	KADEE QUALITY PRODUCTS COMPANY	720 S GRAPE	MEDFORD, OR 97501
000EX	O'HARA METAL PRODUCT COMPANY	542 BRANNAN STREET	SAN FRANCISCO, CA 94107
00779	AMP, INC.	P O BOX 3608	HARRISBURG, PA 17105
01009	ALDEN PRODUCTS CO.	117 N. MAIN ST., P.O. BOX 860	BROCKTON, MA 02403
01963	CHERRY ELECTRICAL PRODUCTS CORPORATION	3600 SUNSET AVENUE	WAUKEGAN, IL 60085
04811	PRECISION COIL SPRING COMPANY	P O BOX 5450, 10107 ROSE ST.	EL MONTE, CA 91734
05006	TWENTIETH CENTURY PLASTICS, INC.	415 E WASHINGTON BLVD.	LOS ANGELES, CA 90015
05129	KILO ENGINEERING COMPANY	2015 D	LA VERNE, CA 91750
05820	WAKEFIELD ENGINEERING, INC.	AUDUBON ROAD	WAKEFIELD, MA 01880
07700	TECHNICAL WIRE AND PRODUCTS, INC.	129 DERMODY ST.	CRANFORD, NJ 07016
08261	SPECTRA-STRIP CORP.	7100 LAMPSON AVE.	GARDEN GROVE, CA 92642
08530	RELIANCE MICA CORP.	342-39TH ST.	BROOKLYN, NY 11232
09353	C AND K COMPONENTS, INC.	103 MORSE STREET	WATERTOWN, MA 02172
12014	CHICAGO RIVET AND MACHINE CO.	950 S. 25TH AVENUE	BELLWOOD, IL 60104
12327	FREEWAY CORPORATION	9301 ALLEN DRIVE	CLEVELAND, OH 44125
12360	ALBANY PRODUCTS CO., DIV. OF PNEUMO DYNAMICS CORPORATION	145 WOODWARD AVENUE	SOUTH NORWALK, CT 06586
16428	BELDEN CORP.	P. O. BOX 1331	RICHMOND, IN 47374
22526	BERG ELECTRONICS, INC.	YOUK EXPRESSWAY	NEW CUMBERLAND, PA 17070
22670	G.M. NAMEPLATE, INC.	2040 15TH AVENUE WEST	SEATTLE, WA 98119
24011	ELECTRONIZED CHEMICALS CORPORATION	S BEDFORD STREET	BURLINGTON, MA 01803
24931	SPECIALITY CONNECTOR CO., INC.	2620 ENDRESS PLACE	GREENWOOD, IN 46142
25088	SIEMENS CORP.	186 WOOD AVE. S	ISELIN, NJ 08830
26233	USM CORP NYLOC FASTENER DIV.	1501 W SEPULVEDA BLVD. P.O. BOX 3158	TORRANCE, CA 90510
27143	ATLAS SPRING AND MFG. CO.	1805 N. SPAULDING AVE.	CHICAGO, IL 60647
28520	HEYMAN MFG. CO.	147 N. MICHIGAN AVE.	KENILWORTH, NJ 07033
28817	CAL-METEX CORP., SUBSIDIARY OF METEX CORP.	509 HINDRY AVE.	INGLEWOOD, CA 90301
42838	NATIONAL RIVET AND MFG. CO.	1-21 EAST JEFFERSON ST.	WAUPUN, WI 53963
51316	ANGELUS WASHER AND STAMPING CO.	1411 ESPERANZA ST.	LOS ANGELES, CA 90023
57668	R-OHM CORP.	16931 MILLIKEN AVE.	IRVINE, CA 92713
70276	ALLEN MFG. CO.	P. O. DRAWER 570	HARTFORD, CT 06101
70278	ALLIED STEEL AND CONVEYORS, DIV. OF SPARTON CORP.	17333 HEALY	DETROIT, MI 48212
70318	ALLMETAL SCREW PRODUCTS CO., INC.	821 STEWART AVE.	GARDEN CITY, NY 11530
70485	ATLANTIC INDIA RUBBER WORKS, INC.	571 W. POLK ST.	CHICAGO, IL 60607
70903	BELDEN CORP.	2000 S BATAVIA AVENUE	GENEVA, IL 60134
71279	CAMBRIDGE THERMIONIC CORP.	445 CONCORD AVE.	CAMBRIDGE, MA 02138
71400	BUSSMAN MFG., DIVISION OF MCGRAW- EDISON CO.	2536 W. UNIVERSITY ST.	ST. LOUIS, MO 63107
71590	CENTRALAB ELECTRONICS, DIV. OF GLOBE-UNION, INC.	P O BOX 858	FORT DODGE, IA 50501
71785	TRW, CINCH CONNECTORS	1501 MORSE AVENUE	ELK GROVE VILLAGE, IL 60007
73743	FISCHER SPECIAL MFG. CO.	446 MORGAN ST.	CINCINNATI, OH 45206
73803	TEXAS INSTRUMENTS, INC., METALLURGICAL MATERIALS DIV.	34 FOREST STREET	ATTLEBORO, MA 02703
74445	HOLO-KROME CO.	31 BROOK ST. WEST	HARTFORD, CT 06110
75497	LAMSON AND SESSIONS CO.	5000 TIEDEMAN ROAD	CLEVELAND, OH 44144
75915	LITTELFUSE, INC.	800 E. NORTHWEST HWY	DES PLAINES, IL 60016
78189	ILLINOIS TOOL WORKS, INC. SHAKEPROOF DIVISION	ST. CHARLES ROAD	ELGIN, IL 60120
79136	WALDES, KOHINOOR, INC.	47-16 AUSTEL PLACE	LONG ISLAND CITY, NY 11101
79807	WROUGHT WASHER MFG. CO.	2100 S. O BAY ST.	MILWAUKEE, WI 53207
80009	TEKTRONIX, INC.	P O BOX 500	BEAVERTON, OR 97077
80126	PACIFIC ELECTRICORD CO.	747 W. REDONDO BEACH, P O BOX 10	GARDENA, CA 90247
83294	ARROW FASTENER CO., INC.	271 MAYHILL ST.	SADDLE BROOK, NJ 07662
83385	CENTRAL SCREW CO.	2530 CRESCENT DR.	BROADVIEW, IL 60153
86445	PENN FIBRE AND SPECIALTY CO., INC.	2032 E. WESTMORELAND ST.	PHILADELPHIA, PA 19134
86928	SEASTROM MFG. COMPANY, INC.	701 SONORA AVENUE	GLENDALE, CA 91201
87308	N. L. INDUSTRIES, INC., SOUTHERN SCREW DIV.	P. O. BOX 1360	STATESVILLE, NC 28677
89663	REESE, J. RAMSEY, INC.	71 MURRAY STREET	NEW YORK, NY 10007
91260	CONNOR SPRING AND MFG. CO.	1729 JUNCTION AVE.	SAN JOSE, CA 95112
93907	TEXTRON INC. CAMCAR DIV	600 18TH AVE	ROCKFORD, IL 61101
97464	INDUSTRIAL RETAINING RING CO.	57 CORDIER ST.	IRVINGTON, NJ 07111
98291	SEAELECTRO CORP.	225 HOYT	MAMARONECK, NY 10544

Fig. & Index No.	Tektronix Part No.	Serial/Model No.		Qty	1	2	3	4	5	Name & Description	Mfr Code	Mfr Part Number
		Eff	Dscont									
1-1	200-1411-00			1						RTNR,IMPLOSION:5.422 X 4.743X 0.441,GRAY	80009	200-1411-00
-2	213-0313-00			4						. THUMBSCREW:4-40 X 0.45 INCH,KNURLED	80009	213-0313-00
	337-1674-00	B010100	B050599	1						SHLD,ELCTRN TUB:CRT	80009	337-1674-00
-3	337-1674-07	B050600		1						SHLD,IMPLOSION:SMOKE GRAY	80009	337-1674-07
-4	366-0494-00			2						KNOB:GRAY WITH SETSCREW	80009	366-0494-00
	213-0153-00			1						. SETSCREW:5-40 X 0.125,STL BK OXD,HEX SKT	000CY	OBD
-5	366-1031-02			2						KNOB:RED,VAR,0.127ID X 0.392 OD	80009	366-1031-02
	213-0153-00			1						. SETSCREW:5-40 X 0.125,STL BK OXD,HEX SKT	000CY	OBD
-6	366-1426-00			2						KNOB:GRAY	80009	366-1426-00
	213-0153-00			2						. SETSCREW:5-40 X 0.125,STL BK OXD,HEX SKT	000CY	OBD
-7	366-0215-02			2						KNOB:LEVER SWITCH	80009	366-0215-02
-8	366-1023-01			3						KNOB:GY,0.127 ID X0.392 OD X 0.531 H	80009	366-1023-01
	213-0153-00			1						. SETSCREW:5-40 X 0.125,STL BK OXD,HEX SKT	000CY	OBD
-9	366-1319-00			1						KNOB:GRAY	80009	366-1319-00
	213-0140-00			1						. SETSCREW:2-56 X 0.94 INCH,HEX SOC STL	70276	OBD
-10	366-1215-00			1						KNOB:GRAY	80009	366-1215-00
	213-0153-00			1						. SETSCREW:5-40 X 0.125,STL BK OXD,HEX SKT	000CY	OBD
-11	366-1059-00			1						PUSH BUTTON:GRAY	80009	366-1059-00
-12	366-1215-00	B010100	B153899	1						KNOB:GRAY	80009	366-1215-00
	366-1215-03	B153900		1						KNOB:GY,0.127 ID X 0.5 OD X 0.531 H	80009	366-1215-03
	213-0153-00			1						. SETSCREW:5-40 X 0.125,STL BK OXD,HEX SKT	000CY	OBD
-13	331-0328-00			1						DIAL,CONTROL:10 TURN FOR 0.25 DIA SHAFT	05129	461-S-70
	213-0048-00			1						. SETSCREW:4-40 X 0.125 INCH,HEX SOC STL	74445	OBD
-14	366-1346-02			1						KNOB:RED	80009	366-1346-00
	213-0153-00			1						. SETSCREW:5-40 X 0.125,STL BK OXD,HEX SKT	000CY	OBD
-15	366-1219-01			1						KNOB:GRAY--DLYD SWP	80009	366-1219-01
	213-0890-00			2						. SETSCREW:6-32 X 0.25 L,STL BLK OXD	83294	OBD
-16	354-0442-01			1						RING,KNOB SKIRT:CLEAR,1.45 OD	80009	354-0442-01
	213-0153-00			1						. SETSCREW:5-40 X 0.125,STL BK OXD,HEX SKT	000CY	OBD
	213-0005-00			1						. SETSCREW:8-32 X 1.25 INCH,HEX SOC STL	74445	OBD
-17	401-0080-00			1						BRG,KNOB SKIRT:0.789 ID X 0.866"OD PLASTIC	80009	401-0080-00
-18	366-1327-00			1						KNOB:GRAY	80009	366-1327-00
	213-0153-00			1						. SETSCREW:5-40 X 0.125,STL BK OXD,HEX SKT	000CY	OBD
-19	366-1280-00			1						KNOB:GRAY	80009	366-1278-00
	213-0153-00			1						. SETSCREW:5-40 X 0.125,STL BK OXD,HEX SKT	000CY	OBD
-20	366-0494-00			1						KNOB:GRAY WITH SETSCREW	80009	366-0494-00
	213-0153-00			1						. SETSCREW:5-40 X 0.125,STL BK OXD,HEX SKT	000CY	OBD
-21	366-1278-00			2						KNOB:GRAY	80009	366-1278-00
	213-0153-00			1						. SETSCREW:5-40 X 0.125,STL BK OXD,HEX SKT	000CY	OBD
-22	366-1280-00			2						KNOB:GRAY	80009	366-1278-00
	213-0153-00			1						. SETSCREW:5-40 X 0.125,STL BK OXD,HEX SKT	000CY	OBD
-23	378-0803-01			3						LENS,LIGHT:CLEAR,ATTENUATOR	80009	378-0803-01
-24	378-0745-00			2						LENS,LIGHT:CLEAR,TIMING	80009	378-0745-00
-25	378-0803-00			2						LENS,LIGHT:CLEAR	80009	378-0803-00
-26	426-0681-00			16						FR,PUSH BUTTON:GRAY PLASTIC	80009	426-0681-00
-27	426-1072-00			4						FRAME,PUSH BTN:PLASTIC	80009	426-1072-00
-28	358-0378-01	B010100	B010274	18						BUSHING,SLEEVE:0.250 OD X 0.131 ID,PRESS MT	80009	358-0378-01
	358-0378-01	B010275	B136449	14						BUSHING,SLEEVE:0.250 OD X 0.131 ID,PRESS MT	80009	358-0378-01
	358-0378-01	B136450		11						BUSHING,SLEEVE:0.250 OD X 0.131 ID,PRESS MT	80009	358-0378-01
	358-0599-00	XB136450		3						BUSHING,SLEEVE:0.125 ID X 0.234 THK,PLSTC	28520	B-187-125
	358-0540-00	XB010275		2						BSHG,MACH.THD:0.25-32 X 0.128 ID X 0.24" L (ATTACHING PARTS)	80009	358-0540-00
	210-0583-00	XB010275		2						NUT,PLAIN,HEX:0.25-32 X 0.312 INCH,BRS	73743	2X20317-402
	210-0940-00	XB010275		2						WASHER,FLAT:0.25 ID X 0.375 INCH OD,STL - - - * - - -	79807	OBD
	358-0539-00	XB010275		2						BSHG,MACH THD:HEX,0.375 DIA X 0.247" L (ATTACHING PARTS)	80009	358-0539-00
	210-0583-00	XB010275		1						NUT,PLAIN,HEX:0.25-32 X 0.312 INCH,BRS	73743	2X20317-402
	210-0940-00	XB010275		2						WASHER,FLAT:0.25 ID X 0.375 INCH OD,STL	79807	OBD
	129-0532-00	XB010275	B070809	1						POST,ELEC-MECH:HEX,0.25-32 X 0.90 INCH L	80009	129-0532-00
	129-0213-00	B070810		1						SPACER,POST:1,156 L,W/0.25-32 THD - - - * - - -	80009	129-0213-00
-29	358-0216-01			2						GROMMET,PLASTIC:	80009	358-0216-01
-30	358-0216-00			1						BUSHING,PLASTIC:0.257 ID X 0.412 INCH OD	80009	358-0216-00
-31	378-0635-00			4						LENS,LIGHT:WHITE	80009	378-0635-00

Replaceable Mechanical Parts—466 Service

Fig. & Index No.	Tektronix Part No.	Serial/Model No.		Qty	1 2 3 4 5	Name & Description	Mfr Code	Mfr Part Number
		Eff	Dscont					
1-32	333-1810-00	B010100	B152299	1		PANEL,FRONT:	80009	333-1810-00
	333-1810-02	B152300		1		PANEL,FRONT:	80009	333-1810-02
-33	352-0340-00			2		LAMPHOLDER:SCALE FACTOR	80009	352-0340-00
	-----			1		CKT BOARD ASSY:CRT SCALE ILLUM(SEE A9 REPL)		
-34	352-0329-00			1		. LAMPHOLDER:SCALE ILLUMINATION	80009	352-0329-00
-35	378-0728-00			1		. REFLECTOR,LIGHT:SCALE ILLUMINATION	80009	378-0728-00
-36	175-0825-00			FT		. WIRE,ELECTRICAL:2 WIRE RIBBON	80009	175-0825-00
-37	131-0707-00			2		. CONNECTOR,TERM:22-26 AWG,BRS& CU BE GOLD	22526	47439
-38	352-0169-00			1		. HLDR,TERM CONN:2 WIRE BLACK	80009	352-0169-00
-39	348-0276-00			FT		SHLD,GSKT,ELEK:0.026 OD NPRNW/WIRE NET CO	28817	01-0404-3719
-40	386-2801-00	B010100	B152299	1		SUBPANEL,FRONT:	80009	386-2801-00
	386-2801-01	B152300		1		SUBPANEL,FRONT:	80009	386-2801-01
						(ATTACHING PARTS)		
-41	213-0107-00			7		SCR,TPG,THD FOR:4-40 X 0.25 INCH,FLH STL	93907	OBD
						-----*		
-42	386-2340-00			4		SUPPORT,CRT:FRONT	80009	386-2340-00
-43	342-0184-00			1		INSULATOR,FILM:CRT,MYLAR	80009	342-0184-00
-44	426-0926-02			1		FRAME SECT,CAB:FRONT	80009	426-0926-02
						(ATTACHING PARTS)		
-45	213-0183-00			4		SCR,TPG,THD FOR:6-20 X 0.5 TYPE B,PNH,STL	83385	OBD
						-----*		
-46	386-2876-00			1		SUPPORT,CRT:CENTER	80009	386-2876-00
-47	-----			1		COIL,TUBE DEFLE:TRACE ROTATION(SEE L1551 REPL)		
-48	441-1202-01			1		CHASSIS,SCOPE:MAIN W/BRACKETS	80009	441-1202-01
-49	337-2081-00			1		. SHIELD,CRT:FRONT	80009	337-2081-00
-50	-----			1		TRANSISTOR:(SEE Q1486 REPL)		
						(ATTACHING PARTS)		
-51	211-0012-00			2		SCREW,MACHINE:4-40 X 0.375,PNH STL CD PL	83385	OBD
-52	358-0214-00			2		INSULATOR,BSHG:0.25 DIA X 0.188 INCH L	24011	OBD
-53	210-0201-00			1		TERMINAL,LUG:0.12 ID,LOCKING,BRZ TIN PL	86928	OBD
						-----*		
-54	214-1610-00			1		HEAT SINK,ELEC:TRANSISTOR	80009	214-1610-00
-55	407-1153-00			1		BRACKET,XSTR:ALUMINUM	80009	407-1153-00
						(ATTACHING PARTS)		
-56	210-0586-00			2		NUT,PL,ASSEM WA:4-40 X 0.25,STL	83385	OBD
						-----*		
-57	337-2000-00			1		SHIELD,ELEC:HV MULTIPLIER	80009	337-2000-00
						(ATTACHING PARTS)		
-58	211-0503-00	B010100	B150184	2		SCREW,MACHINE:6-32 X 0.188 INCH,PNH STL	83385	OBD
	211-0661-00	B150185		2		SCREW,MACHINE:4-40 X 0.25 INCH,PNH,STL	78189	OBD
-59	211-0008-00	B010100	B150184	1		SCREW,MACHINE:4-40 X 0.250,PNH,STL,CD PL	83385	OBD
	211-0661-00	B150185		1		SCREW,MACHINE:4-40 X 0.25 INCH,PNH,STL	78189	OBD
						-----*		
-60	342-0225-00			1		INSUL,CKT BOARD:POLYCARBONATE	80009	342-0225-00
-61	343-0088-00			1		CLAMP,LOOP:0.062 INCH DIA	80009	343-0088-00
-62	-----			1		CKT BOARD ASSY:HV MULTIPLIER(SEE A8 REPL)		
						(ATTACHING PARTS)		
-63	211-0601-00			1		SCR,ASSEM WSHR:6-32 X 0.312,DOUBLE SEMS	83385	OBD
-64	211-0207-00	B010100	B149333	1		SCR,ASSEM WSHR:4-40 X 0.312 DOUBLE SEMS	83385	OBD
	211-0244-00	B149334		1		SCR,ASSEM WSHR:4-40 X 0.312 INCH,PNH STL	78189	OBD
						-----*		
-65	426-0781-00			1		MOUNT,MOTOR:	80009	426-0781-00
						(ATTACHING PARTS)		
-66	213-0088-00			2		SCR,TPG,THD CTG:4-24 X 0.25 INCH,PNH STL	83385	OBD
						-----*		
-67	337-1762-00			1		SHLD,ELECTRICAL:FAN MOTOR	80009	337-1762-00
-68	-----			1		CKT BOARD ASSY:FAN MOTOR(SEE A11 REPL)		
						(ATTACHING PARTS)		
-69	213-0044-00			2		SCR,TPG,THD FOR:5-32 X 0.188 INCH,PNH STL	83385	OBD
						-----*		
	-----			-		CKT BOARD ASSY INCLUDES:		
-70	131-0608-00			2		. TERMINAL,PIN:0.365 L X 0.025 PH BRZ GOLD	22526	47357
-71	136-0252-07			3		. SOCKET,PIN CONN:W/O DIMPLE	22526	75060-012
-72	136-0269-02	B010100	B138090X	1		. SKT,PL-IN ELEK:MICROCIRCUIT,14 DIP,LOW CLE	73803	CS9002-14

Fig. & Index No.	Tektronix Part No.	Serial/Model No. Eff	Dscont	Qty	1	2	3	4	5	Name & Description	Mfr Code	Mfr Part Number
1-73	147-0035-00			1	.	MOTOR,DC:BRUSHLESS,10-15VDC,145MA					25088	1AD3001-0A
-74	426-0781-00			1	.	MOUNT,MOTOR:					80009	426-0781-00
-75	385-0060-00			1	SPACER,POST:1.75 L W/6-32THD EA END,NYL						80009	385-0060-00
-76	385-0125-00			2	SPACER,POST:2.343 L W/6-32 THD EA END						80009	385-0125-00
-77	348-0253-00			1	GROMMET,PLASTIC:BLACK,OBLONG,3.OXO.925						80009	348-0253-00
	343-0089-00	XB010300		1	CLAMP,LOOP:LARGE						80009	343-0089-00
-78	348-0299-00	B010100	B139999	4	PAD,CAB.FOOT:BLACK POLYURETHANE						80009	348-0299-00
	348-0339-00	B140000		4	FOOT,CABINET:W/CORD WRAP						80009	348-0339-00
					(ATTACHING PARTS)							
-79	213-0183-00	B010100	B139999X	4	SCR,TPG,THD FOR:6-20 X 0.5 TYPE B,PNH,STL						83385	OBD
	212-0033-00	B010100	B139999	4	SCREW,MACHINE:8-32 X 0.750 INCH,PNH,STL						83385	OBD
	212-0020-00	B140000		4	SCREW,MACHINE:8-32 X 1.0 INCH,PNH,STL						93907	OBD
					-----*-----							
-80	348-0349-00			FT	SHLD GSKT,ELEC:0.187 INCH DIA,2.75 FT L						07700	2143951
-81	426-1152-00	B010100	B139999	1	FRAME SECT,CAB:REAR						80009	426-1152-00
	426-0970-00	B140000		1	FR SECT.,CAB.:REAR						80009	426-0970-00
					(ATTACHING PARTS)							
-82	211-0544-00	B010100	B139999	2	SCREW,MACHINE:6-32 X 0.750,TRH,STL						83385	OBD
	211-0516-00	B140000		2	SCREW,MACHINE:6-32 X 0.875 INCH,PNH,STL						83385	OBD
					-----*-----							
-83	-----			4	CONNECTOR,RCPT,:(SEE J145,J159,J859,J918 REPL)							
-84	210-0255-00			4	TERMINAL,LUG:0.391 ID,LOCKING,BRS CD PL						80009	210-0255-00
-85	386-2408-00			1	PLATE,CONN MTC:ALUMINUM						80009	386-2408-00
-86	200-1634-00			1	COVER SCOPE:REAR						80009	200-1634-00
					(ATTACHING PARTS)							
-87	211-0101-00			2	SCREW,MACHINE:4-40 X 0.25,100 DEG,FLH,STL						83385	OBD
					-----*-----							
-88	200-1635-00			1	COVER,FAN IMPLR:ALUMINUM						80009	200-1635-00
					(ATTACHING PARTS)							
-89	211-0507-00			2	SCREW,MACHINE:6-32 X 0.312 INCH,PNH,STL						83385	OBD
					-----*-----							
-90	369-0038-00	B010100	B137672	1	IMPLR,FAN,CENTR:						80009	369-0038-00
	369-0038-02	B137673		1	IMPLR,FAN,CENTR:						80009	369-0038-02
	213-0075-00			1	. SETSCREW:4-40 X 0.094,STL BK OXD,HEX SKT						000BK	OBD
-91	200-1459-00			1	COVER,CRT:REAR						80009	200-1459-00
					(ATTACHING PARTS)							
-92	211-0008-00			2	SCREW,MACHINE:4-40 X 0.250,PNH,STL,CD PL						83385	OBD
					-----*-----							
	136-0581-00			1	SKT,PL-IN ELEK:ELCTR N TUBE,14 CONT W/LEADS						80009	136-0581-00
-93	136-0202-01			1	. SOCKET,PLUG-IN:14 PIN						80009	136-0202-01
-94	214-0464-00			14	. CONTACT,ELEC:CRT						80009	214-0464-00
-95	348-0145-00			1	GROMMET,PLASTIC:U-SHP,1.0 X 0.42 INCH						80009	348-0145-00
-96	407-1128-00			1	BRKT,CRT SHIELD:REAR,NYLON						80009	407-1128-00
					(ATTACHING PARTS)							
-97	211-0507-00			3	SCREW,MACHINE:6-32 X 0.312 INCH,PNH,STL						83385	OBD
-98	210-0202-00			3	TERMINAL,LUG:0.146 ID,LOCKING,BRZ TINNED						78189	2104-06-00-2520N
-99	210-0802-00			1	WASHER,FLAT:0.15 ID X 0.312 INCH OD						12327	OBD
-100	220-0419-00			2	NUT,PLAIN,SQ:6-32 X 0.312 INCH,STL						83385	OBD
-101	210-0457-00			1	NUT,PL,ASSEM WA:6-32 X 0.312,STL CD PL						83385	OBD
					-----*-----							
-102	386-2246-00			1	SUPPORT,CRT:REAR						80009	386-2246-00
-103	-----			1	COIL,RF:Y AXIS(SEE L1561 REPL)							
					(ATTACHING PARTS)							
-104	343-0217-00			1	CLAMP,COIL:Y-AXIS						80009	343-0217-00
-105	211-0147-00			2	SCREW,MACHINE:4-40 X 0.25 INCH,PNH,STL						83385	OBD
-106	210-0201-00			1	TERMINAL,LUG:0.12 ID,LOCKING,BRZ TIN PL						86928	OBD
	176-0047-00			FT	BRAID,WIRE:0.156 W,FLAT						70903	8660
-107	210-0938-00	B010100	B010249	1	WASHER,FLAT:0.109 ID X 0.25 INCH OD,STL						75497	AN960-3
	210-0938-00	B010250		2	WASHER,FLAT:0.109 ID X 0.25 INCH OD,STL						75497	AN960-3
					-----*-----							
-108	337-1971-00			1	SHIELD,CRT:REAR						80009	337-1971-00
-109	-----			1	DELAY LINE,ELEC:(SEE DL339 REPL)							
					(ATTACHING PARTS)							
-110	407-1138-00			1	BRKT,DELAY LINE:ALUMINUM						80009	407-1138-00
-111	210-0457-00			1	NUT,PL,ASSEM WA:6-32 X 0.312,STL CD PL						83385	OBD
					-----*-----							

Replaceable Mechanical Parts—466 Service

Fig. & Index No.	Tektronix Part No.	Serial/Model No. Eff	Dscont	Qty	1	2	3	4	5	Name & Description	Mfr Code	Mfr Part Number
1-112	129-0419-00			1						POST,ELEC-MECH:HEX.,0.588 INCH LONG	80009	129-0419-00
-113	348-0064-00			4						GROMMET,PLASTIC:0.625 INCH DIA	80009	348-0064-00
-114	386-2889-00			1						SUPPORT,CAP.: (ATTACHING PARTS)	80009	386-2889-00
-115	211-0507-00			1						SCREW,MACHINE:6-32 X 0.312 INCH,PNH STL	83385	OBD
-116	220-0444-00			1						NUT,PLAIN,SQ:6-32 X 0.250 INCH,STL - - - * - - -	70318	OBD
-117	-----			1						SW,THERMOSTATIC:(SEE S1702 REPL) (ATTACHING PARTS)		
-118	213-0044-00	B010100	B149569	2						SCR,TPG,THD FOR:5-32 X 0.188 INCH,PNH STL	83385	OBD
	213-0138-00	B149570		2						SCR,TPG,TF:4-24 X 0.188 INCH,PNH STL - - - * - - -	83385	OBD
-119	348-0067-00			1						GROMMET,PLASTIC:0.312 INCH DIA	80009	348-0067-00
-120	200-1445-01			1						COV ASSY,LINE V:	80009	200-1445-01
	200-1445-15			1						COV,LINE V SEL: (OPTION 1Y ONLY)	80009	200-1445-15
-121	352-0102-00			1						. FUSEHOLDER:0.262"ID TUBE FOR CRTG FUSE (ATTACHING PARTS)	80009	352-0102-00
-122	213-0717-00			2						. SCREW,TPG,TF:4-20 X 0.312 PNH,STL,CD PL	93907	OBD
	214-0773-03			2						. NUT,PLAIN:6-32 X 0.324 DIA,BRS CD PL - - - * - - -	80009	214-0773-03
-123	204-0549-01	B010100	B148529	1						BODY ASSY,LINE:	80009	204-0549-01
	204-0549-03	B148530		1						BODY ASSY,LINE: (ATTACHING PARTS)	80009	204-0549-03
-124	210-0407-00			2						NUT,PLAIN,HEX.:6-32 X 0.25 INCH,BRS	73743	3038-0228-402
-125	210-0006-00			2						WASHER,LOCK:#6 INTL,0.018THK,STL CD PL - - - * - - -	78189	1206-00-00-0541C
	-----			-						BODY ASSY,LINE INCLUDES:		
	131-1318-01			2						. BUS CONDUCTOR:	80009	131-1318-01
	210-0666-00			2						. RIVET,TUBULAR:0.188 L X 0.125 OD,BRS	12014	3329-3-16LONG
	214-0778-00	B010100	B148529	1						. CONT ASSY,ELEC:LINE V SEL,LOW/MED/HI	80009	214-0778-00
	214-0778-01	B148530		1						. CONTACT ASSY,EL:LINE V SEL,LOW/MED/HI	80009	214-0778-01
	344-0135-00			2						. CLIP,ELECTRICAL:FUSE,CU BE ALBALOY PL	80009	344-0135-00
-126	-----			1						CABLE ASSY,PWR:3 WIRE,92 IN L(SEE P701 REPL)		
	161-0033-07			1						CABLE ASSY,PWR:,3 WIRE,92 INCH LONG	16428	KH8389
	161-0033-35	B151620		1						CABLE ASSY,PWR:3,0.75MM SQ,220V,91.0 L (OPTION A1)	80126	OBD
	161-0033-36	B151620		1						CABLE ASSY,PWR:3,0.75MM SQ,240V,91.0 L (OPTION A2)	80126	OBD
	161-0033-37	B151620		1						CABLE ASSY,PWR:3,0.75MM,240V,91.0 L (OPTION A3)	S3109	OBD
	161-0033-38	B151620		1						CABLE ASSY,PWR:3,18 AWG,240V,91.0 L (OPTION A4)	80126	OBD
-127	358-0371-00	B010100	B010299X	1						BSHG,STRAIN RLF:90 DEG,0.25 INCH DIA HOLE (ATTACHING PARTS)	80009	358-0371-00
-128	358-0372-00	B010100	B010299	1						BSHG,STRAIN RLF:180 DEG,0.156" DIA HOLE	80009	358-0372-00
	358-0323-00	B010300		1						BSHG,STRAIN RLF:90 DEG,0.515 DIA HOLE - - - * - - -	28520	SR-15-1
	334-1529-00	XB151620		1						PLATE,IDENT:BLANK (OPT A1,A2,A3,A4)	80009	334-1529-00
-129	200-1004-00	B010100	B010299X	1						CABLE,NIP.,ELEC:0.265 ID X 0.38"OD W/FLG	80009	200-1004-00
-130	-----			1						TRANSFORMER:POWER(SEE T1701 REPL) (ATTACHING PARTS)		
-131	212-0511-00			4						SCREW,MACHINE:10-32 X 3" LONG,HEX HD STL	83385	OBD
-132	166-0228-00			4						INS SLV,ELEC:0.187 ID X 2.75 INCH LONG	80009	166-0228-00
-133	220-0410-00			2						NUT,EXTENDED WA:10-32 X 0.375 INCH,STL	83385	OBD
-134	361-0609-00	B010100	B153449	2						SPACER,XFMR:0.479 X 0.6 X 2.8,AL	80009	361-0609-00
	361-0609-01	B153450		2						SPACER,XFMR:0.479 X 0.6 X 2.8,AL - - - * - - -	80009	361-0609-01
-135	343-0475-00			2						RETAINER,XFMR:ALUMINUM (ATTACHING PARTS)	80009	343-0475-00
	211-0559-00			1						SCREW,MACHINE:6-32 X 0.375"100 DEG,FLH STL	83385	OBD
	211-0510-00			1						SCREW,MACHINE:6-32 X 0.375,PNH,STL,CD PL - - - * - - -	83385	OBD



Fig. & Index No.	Tektronix Part No.	Serial/Model No. Eff Dscont	Qty	1	2	3	4	5	Name & Description	Mfr Code	Mfr Part Number
1-136	200-0103-00		1						NUT,PLAIN,KNURL:0.25-28 X 0.375" OD,BRASS	80009	200-0103-00
-137	355-0507-00		1						STUD,SHOULDERED:BINDING POST (ATTACHING PARTS)	80009	355-0507-00
-138	210-0455-00		1						NUT,PLAIN,HEX.:0.25-28 X 0.375 INCH,BRASS	73743	3089-402
-139	210-0011-00		1						WASHER,LOCK:0.25 ID,INTL,0.025 THK STL - - - * - - -	000BK	OBD
-140	119-0373-00		1						COIL,CAL: (ATTACHING PARTS)	80009	119-0373-00
-141	210-0442-00		2						NUT,PLAIN,HEX.:3-48 X 0.187 INCH,CD PL BRS	73743	3014-402
-142	210-0201-00		2						TERMINAL,LUG:0.12 ID,LOCKING,BRZ TIN PL	86928	OBD
-143	210-0851-00		2						WASHER,FLAT:0.119 ID X 0.375 INCH OD,STL	12327	OBD
-144	210-0811-00		2						WSHR,SHOULDERED:0.125 ID X 0.50 INCH OD	86928	5604-47
-145	210-0593-00		2						NUT,FINISHING:0.25 HEX X 0.312" LONG,BRS - - - * - - -	80009	210-0593-00
-146	361-0059-01		1						INSULATOR,PLATE:1.093 X 0.343 X 0.125 INCH	80009	361-0059-01
-147	386-2748-01		1						PANEL,REAR:	80009	386-2748-01
	386-2748-03		1						PANEL,REAR: (OPTION 1Y ONLY)	80009	386-2748-03
	-----								(ATTACHING PARTS FOR EACH PANEL)		
-148	211-0038-00		1						SCREW,MACHINE:4-40 X 0.312,FLH,100 DEG	83385	OBD
-149	210-0201-00		1						TERMINAL,LUG:0.12 ID,LOCKING,BRZ TIN PL	86928	OBD
-150	210-0586-00		1						NUT,PL,ASSEM WA:4-40 X 0.25,STL - - - * - - -	83385	OBD
-151	210-0201-00		1						TERMINAL,LUG:0.12 ID,LOCKING,BRZ TIN PL (ATTACHING PARTS)	86928	OBD
-152	210-0586-00		1						NUT,PL,ASSEM WA:4-40 X 0.25,STL - - - * - - -	83385	OBD
	211-0114-00		1						SCREW,MACHINE:4-40 X 0.438 INCH,FLH STL	83385	OBD
	-----								(OPTION 7 ONLY)		
	210-0551-00		1						NUT,PLAIN,HEX.:4-40 X 0.25 INCH,STL	000BK	OBD
	-----								(OPTION 7 ONLY)		

Replaceable Mechanical Parts—466 Service

Fig. & Index No.	Tektronix Part No.	Serial/Model No. Eff Dscont	Qty	1 2 3 4 5	Name & Description	Mfr Code	Mfr Part Number
2-1	384-0442-00	B010100 B010274	2		EXTENSION SHAFT:0.125 OD X 8.452 INCH LONG	80009	384-0442-00
	384-1007-00	B010275 B081849	2		EXTENSION SHAFT:8.328 L X 0.123 OD	80009	384-1007-00
	384-1007-01	B081850	2		EXTENSION SHAFT:8.428 L X 0.124 OD PLSTC	80009	384-1007-01
-2	376-0051-01		1		CPLG,SHAFT,FLEX:0.127 ID X 0.375 OD	80009	376-0051-01
	213-0048-00		4		. SETSCREW:4-40 X 0.125 INCH,HEX SOC STL	74445	OBD
-3	376-0051-00	B010100 B050399	1		CPLG,SHAFT,FLEX:0.127 ID X 0.375 ID DELRIN	80009	376-0051-00
	376-0051-01	B050400	1		CPLG,SHAFT,FLEX:0.127 ID X 0.375 OD	80009	376-0051-01
	213-0022-00	B010100 B050399	4		. SETSCREW:4-40 X 0.188 INCH,HEX SOC STL	74445	OBD
	213-0048-00	B050400	4		. SETSCREW:4-40 X 0.125 INCH,HEX SOC STL	74445	OBD
-4	384-1149-00		2		EXTENSION SHAFT:7.0 INCH LONG	80009	384-1149-00
-5	376-0051-00		2		CPLG,SHAFT,FLEX:0.127 ID X 0.375 ID DELRIN	80009	376-0051-00
	213-0022-00		8		. SETSCREW:4-40 X 0.188 INCH,HEX SOC STL	74445	OBD
-6	366-1402-31		1		PUSH BUTTON:GRAY--INVERT	80009	366-1402-31
-7	384-1100-00		1		EXTENSION SHAFT:0.13 SQ X 6.215" LONG,PLSTC	80009	384-1100-00
-8	343-0213-00		1		CLAMP,LOOP:0.2 ID,PLASTIC	80009	343-0213-00
-9	386-2833-00		1		SUPPORT,SHAFT:PLASTIC	80009	386-2833-00
-10	384-1233-01		1		KNOB:12.2 L X 0.125 OD	80009	384-1233-01
	131-1428-00	XB050400	3		CONTACT,ELEC:GROUNDING CLIP	80009	131-1428-00
					(ATTACHING PARTS)		
	211-0207-00	B010100 B149333	3		SCR,ASSEM WSHR:4-40 X 0.312 DOUBLE SEMS	83385	OBD
	211-0244-00	B149334	3		SCR,ASSEM WSHR:4-40 X 0.312 INCH,PNH STL	78189	OBD
					- - - * - - -		
-11	-----		1		CKT BOARD ASSY:VERTICAL PRE AMPL(SEE A2 REPL)		
					(ATTACHING PARTS)		
-12	211-0207-00	B010100 B149333	5		SCR,ASSEM WSHR:4-40 X 0.312 DOUBLE SEMS	83385	OBD
	211-0244-00	B149334	5		SCR,ASSEM WSHR:4-40 X 0.312 INCH,PNH STL	78189	OBD
	129-0413-01	XB050400	1		SPACER,POST:0.538 L,W/4-40 TAP 1 END	80009	129-0413-01
	210-0994-00	XB050400	1		WASHER,FLAT:0.125 ID X 0.25" OD,STL	86928	5702-201-20
					- - - * - - -		
					CKT BOARD ASSY INCLUDES:		
			1		. ACTUATOR,SWITCH:TRIG VIEW,(SEE S338B REPL)		
-13	105-0420-00		1		. . ACTUATOR,SWITCH:MOMENTARY	80009	105-0420-00
-14	214-1779-00		1		. . SPRING,HLCPS:0.156 OD X 0.844 INCH LONG	04811	OBD
-15	351-0359-00		1		. . GUIDE,SLIDE SW:	80009	351-0359-00
			1		. ACTUATOR,SWITCH:BW LIMIT,(SEE S338A REPL)		
-16	376-0146-00		1		. . CPLG,SHAFT,RGD:FOR 0.125 INCH DIA SHAFT	80009	376-0146-00
	213-0048-00		1		. . . SETSCREW:4-40 X 0.125 INCH,HEX SOC STL	74445	OBD
-17	105-0422-00		1		. . ACTUATOR,SWITCH:BANDWIDTH LIMIT	80009	105-0422-00
-18	214-1126-01		2		. . SPRING,FLAT:0.7 X 0.125,CU BE GRN CLR	80009	214-1126-01
-19	214-1127-00		2		. . ROLLER,DETENT:0.125 DIA X 0.125,SST	80009	214-1127-00
-29	351-0355-00		1		. . GUIDE,SLIDE SW:	80009	351-0355-00
	131-1030-00		4		. CONT ASSY,ELEC:CAM SWITCH,BOTTOM	80009	131-1030-00
	131-1031-00		5		. CONTACT ASSY,EL:CAM SWITCH,TOP	80009	131-1031-00
					(ATTACHING PARTS)		
	210-0779-00	B010100 B137739	5		. RIVET,TUBULAR:0.051 OD X 0.115 INCH LONG	42838	RA-29952715
	210-3082-00	B137740	5		. EYELET,METALLIC:0.047 OD X 0.133 L,BRASS	80009	210-3082-00
					- - - * - - -		
-21	-----		2		. RES.,VARIABLE:(SEE R96,R196 REPL)		
-22	361-0515-00		2		. SPACER,SWITCH:PLASTIC	80009	361-0515-00
-23	-----		1		. SWITCH,PUSH:INVERT(SEE S225 REPL)		
-24	361-0411-00		2		. SPACER,PUSH SW:0.13 W X 0.375 INCH L,PLSTC	71590	J64285-00
-25	131-0157-00		2		. TERMINAL,PIN:0.25 L X 0.04OD,BRS	98291	013-1001-000-479
-26	214-0579-00	B010100 B148915	5		. TERM,TEST POINT:BRN CD PL	80009	214-0579-00
	214-0579-02	B148916	5		. TERM,TEST POINT:BRASS	80009	214-0579-02
-27	200-1673-00	B010100 B103099	4		. COVER,XSTR:TEMP STAB,S-SHAPED	05820	OBD
	200-0945-00	B103100	6		. COVER,HALF XSTR:DUAL TO-18,ALUMINUM	80009	200-0945-00
	200-0945-01	XB103100	6		. COVER,HALF XSTR:DUAL TO-18,W/2-56 THD	80009	200-0945-01
	211-0001-00	XB103100	6		. SCREW,MACHINE:2-56 X 0.25 INCH,PNH STL	87308	OBD
-28	352-0134-00		1		. HOLDER,COIL:TOROIDAL,0.472 X 0.417 INCH	80009	352-0134-00
-29	214-0506-00		1		. CONTACT,ELEC:0.045 SQ X 0.375 INCH L	80009	214-0506-00
-30	131-1003-00		9		. CONN,RCPT,ELEC:CKT BD MT,3 PRONG	80009	131-1003-00
-31	136-0252-04	B010100 B113334	169		. SOCKET,PIN TERM:U/W 0.016-0.018 DIA PINS	22526	75060-007
	136-0252-07	B113335 B152699	149		. SOCKET,PIN CONN:W/O DIMPLE	22526	75060-012
	136-0252-07	B152700	43		. SOCKET,PIN CONN:W/O DIMPLE	22526	75060-012
	136-0634-00	XB113335	1		. SOCKET,PLUG-IN:20 LEAD DIP,CKT BD MTG	73803	CS9002-20

Replaceable Mechanical Parts—466 Service

Fig. & Index No.	Tektronix Part No.	Serial/Model No. Eff Dscont	Qty	1	2	3	4	5	Name & Description	Mfr Code	Mfr Part Number
2-	136-0252-00		2						. SOCKET, PIN TERM:0.145 INCH LONG	00779	2-330808-7
-32	129-0385-00		2						SPACER, POST:1.77 L, W/6-32& 4-40 THD ENDS	80009	129-0385-00
-33	366-1257-19		1						PUSH BUTTON: SIL GY, CH 1	80009	366-1257-19
-34	366-1402-36		1						PUSH BUTTON: GRAY--ALT	80009	366-1402-36
-35	366-1257-16		1						PUSH BUTTON: GRAY--ADD	80009	366-1257-16
-36	366-1402-37		1						PUSH BUTTON: GRAY--CHOP	80009	366-1402-37
-37	366-1257-20		1						PUSH BUTTON: GRAY--CH2	80009	366-1257-20
-38	384-1129-00		5						EXTENSION SHAFT: 5.607 INCH LONG	80009	384-1129-00
	672-0428-00	B010100 B113349	1						CKT BOARD ASSY: ATTENUATOR	80009	672-0428-00
	672-0428-01	B113350	1						CKT BOARD ASSY: ATTENUATOR	80009	672-0428-01
									(ATTACHING PARTS)		
-39	129-0457-00		1						SPACER, POST: 1.07L, W/4-40 TAP 1 END	80009	129-0457-00
-40	210-0938-00		1						WASHER, FLAT: 0.109 ID X 0.25 INCH OD, STL	75497	AN960-3
	211-0207-00	B010100 B149333	1						SCR, ASSEM WSHR: 4-40 X 0.312 DOUBLE SEMS	83385	OBD
	211-0244-00	B149334	1						SCR, ASSEM WSHR: 4-40 X 0.312 INCH, PNH STL	78189	OBD
	210-0586-00		4						NUT, PL, ASSEM WA: 4-40 X 0.25, STL	83385	OBD
									- - - - *		
									ATTENUATOR ASSY INCLUDES:		
-40.1	200-1760-00		2						. COVER, ATTEN: CLEAR PLASTIC	80009	200-1760-00
-41	200-1439-00		2						. COVER, CHASSIS: ATTENUATOR	80009	200-1439-00
									(ATTACHING PARTS)		
-42	213-0055-00		2						. SCR, TPG, THD FOR: 2-32 X 0.188 INCH, PNH STL	93907	OBD
-43	210-0938-00		2						. WASHER, FLAT: 0.109 ID X 0.25 INCH OD, STL	75497	AN960-3
-44	211-0008-00	B010100 B150184	8						. SCREW, MACHINE: 4-40 X 0.250, PNH, STL, CD PL	83385	OBD
	211-0661-00	B150185	8						. SCREW, MACHINE: 4-40 X 0.25 INCH, PNH, STL	78189	OBD
-45	210-0851-00	B010100 B148614	8						. WASHER, FLAT: 0.119 ID X 0.375 INCH OD, STL	12327	OBD
	210-1307-00	B148615	8						. WASHER, LOCK: 0.115 ID, SPLIT, 0.025 THK	86928	A384-25N
									- - - - *		
	166-0030-00		2						. SPACER, SLEEVE: 0.25 OD X 0.188 INCH LONG	80009	166-0030-00
	211-0012-00		2						. SCREW, MACHINE: 4-40 X 0.375, PNH STL CD PL	83385	OBD
-46	131-0679-02		2						. CONNECTOR, RCPT, :BNC, MALE, 3 CONTACT	24931	28JR270-1
									(ATTACHING PARTS)		
-47	220-0695-00		2						. NUT, PLAIN, DODEC: 0.500-28 X 0.90 INCH, BRS	73743	OBD
-48	210-0845-00		2						. WASHER, FLAT: 0.500 ID X 0.625 INCH OD, STL	89663	634-R
	210-1039-00		2						. WASHER, LOCK: INT, 0.521 ID X 0.625 INCH OD	24931	OBD
									- - - - *		
-49	441-1058-00		2						. CHASSIS, SCOPE: ATTENUATOR	80009	441-1058-00
									(ATTACHING PARTS)		
-50	129-0299-00		8						. POST, ELEC-MECH: HEX, 0.333 INCH LONG	80009	129-0299-00
-51	210-0004-00		8						. WASHER, LOCK: #4 INTL, 0.015THK, STL CD PL	000BK	OBD
-52	211-0097-00		4						. SCREW, MACHINE: 4-40 X 0.312 INCH, PNH STL	83385	OBD
-53	210-0004-00		4						. WASHER, LOCK: #4 INTL, 0.015THK, STL CD PL	000BK	OBD
-54	211-0001-00		4						. SCREW, MACHINE: 2-56 X 0.25 INCH, PNH STL	87308	OBD
-55	210-0053-00		4						. WASHER, LOCK: INTL, 0.092 ID X 0.175"OD, STL	83385	OBD
-56	210-1008-00		4						. WASHER, FLAT: 0.09 ID X 0.188" OD, BRS	12360	OBD
-57	210-0405-00		4						. NUT, PLAIN, HEX: 2-56 X 0.188 INCH, BRS	73743	12157-50
									- - - - *		
-58			2						. CKT BOARD ASSY: ATTENUATOR (SEE A1 REPL)		
	131-1030-00		10						. . CONT ASSY, ELEC: CAM SWITCH, BOTTOM	80009	131-1030-00
	131-1031-00		10						. . CONTACT ASSY, EL: CAM SWITCH, TOP	80009	131-1031-00
-59	136-0252-01		8						. . CONTACT, ELEC: 0.178 INCH LONG	00779	1-332095-2
	136-0252-07	XB113350	12						. . SOCKET, PIN CONN: W/O DIMPLE	22526	75060-012
	136-0333-00		2						. . SOCKET, PIN TERM: U/W 0.03 DIA PINS	00779	1-331677-4
-60	337-1406-00		1						. . SHLD, ELECTRICAL: CAM CONTACTS	80009	337-1406-00
-61	105-0243-00		2						. ACTUATOR, SWITCH: AC, DC	80009	105-0243-00
									(ATTACHING PARTS)		
-62	213-0214-00		2						. SCREW, CAP SCH: 2-56 X 0.375" HEX HD STL	70278	OBD
									- - - - *		
	263-1065-00		2						. SW CAM ACTR AS: VOLTS/DIV	80009	263-1065-00
									(ATTACHING PARTS)		
-63	211-0116-00	B010100 B150754	12						. SCR, ASSEM WSHR: 4-40 X 0.312 INCH, PNH BRS	83385	OBD
	211-0292-00	B150755	12						. SCR, ASSEM WSHR: 4-40 X 0.29, BRS NI PL	78189	OBD
									- - - - *		

Fig. & Index No.	Tektronix Part No.	Serial/Model No. Eff Dscont	Qty	1 2 3 4 5	Name & Description	Mfr Code	Mfr Part Number
2-	-----		-		. EACH ACTUATOR ASSY INCLUDES:		
-64	131-0963-00		2		. . CONTACT,ELEC:GROUNDING	000EX	OBD
-65	210-0406-00		2		. . NUT,PLAIN,HEX.:4-40 X 0.188 INCH,BRS	73743	12161-50
-66	214-1139-03		2		. . SPRING,FLAT:RED COLORED	80009	214-1139-03
-67	214-1752-00		2		. . ROLLER,DETENT:	80009	214-1752-00
-68	401-0180-00		1		. . BEARING,CAM SW:FRONT & REAR (ATTACHING PARTS)	80009	401-0180-00
-69	354-0390-00		1		. . RING,RETAINING:0.338 ID X 0.025" THK,STL -----*	79136	5100-37MD
-70	384-0878-02		1		. . SHAFT,CAM SW:	80009	384-0878-02
-71	105-0282-01		1		. . ACTUATOR,CAM SW:DC,GND,AC	80009	105-0282-01
-72	210-0406-00		4		. . NUT,PLAIN,HEX.:4-40 X 0.188 INCH,BRS	73743	12161-50
-73	401-0178-00		1		. . BEARING,CAM SW:CENTER (ATTACHING PARTS)	80009	401-0178-00
-74	354-0443-00		1		. . RING,RETAINING:0.328 FREE IDX 0.448 OD -----*	97464	200-37
-75	210-1189-00		1		. . WASHER,FLAT:0.195 ID X 0.367 INCH OD,BRS	51316	OBD
-76	214-2043-00		1		. . SPRING,HLCPS:CONICAL,0.20 INCH LONG	80009	214-2043-00
-77	105-0521-00		1		. . ACTUATOR,CAM SW:ATTEN	80009	105-0521-00
-78	384-0880-00		1		. . SHAFT,CAM SW:REAR	80009	384-0880-00
-79	210-0406-00		4		. . NUT,PLAIN,HEX.:4-40 X 0.188 INCH,BRS	73743	12161-50
-80	214-1139-02		1		. . SPRING,FLAT:GREEN COLORED	80009	214-1139-02
	214-1139-00		1		. . SPRING,FLAT:0.885 X 0.156CU BE GLD CLR	80009	214-1139-00
-81	214-1752-00		2		. . ROLLER,DETENT:	80009	214-1752-00
-82	401-0180-00		1		. . BEARING,CAM SW:FRONT & REAR	80009	401-0180-00
-83	337-1418-01	B010100 B138051	2		. SHIELD,ELEC:CAM SWITCH CASTING	80009	337-1418-01
	337-1418-02	B138052	2		. SHIELD,ELEC:CIRCUIT BOARD (ATTACHING PARTS)	80009	337-1418-02
-84	211-0001-00		6		. SCREW,MACHINE:2-56 X 0.25 INCH,PNH STL	87308	OBD
-85	210-0053-00		6		. WASHER,LOCK:INTL,0.092 ID X 0.175"OD,STL	83385	OBD
-86	210-1134-00		6		. WASHER,FLAT:0.09 ID X 0.25 INCH OD,BRS -----*	12327	OBD
-87	-----		1		. CKT BOARD ASSY:VERTICAL MODE SW(SEE A3 REPL)		
-88	131-0608-00		15		. . TERMINAL,PIN:0.365 L X 0.025 PH BRZ GOLD	22526	47357
-89	136-0252-07		12		. . SOCKET,PIN CONN:W/O DIMPLE	22526	75060-012
-90	-----		1		. . SWITCH,PUSH:VERT MODE(SEE S350 REPL)		
-91	361-0411-00		4		. . SPACER,PUSH SW:0.13 W X 0.375 INCH L,PLSTC	71590	J64285-00
-92	352-0331-00		3		. . LAMPHOLDER:	80009	352-0331-00
-93	384-1159-00		1		EXTENSION SHAFT:10.384 INCH LONG,W/KNOB	80009	384-1159-00
-94	214-1756-00		1		ACTUATOR,SWITCH:POWER	80009	214-1756-00
-95	-----		1		SWITCH,TOGGLE:POWER ON(SEE S1701 REPL) (ATTACHING PARTS)		
-96	210-0562-00		1		NUT,PLAIN,HEX.:0.25-40 X 0.312 INCH,BBS	73743	2X20224-402
-97	210-0046-00		1		WASHER,LOCK:0.261 ID,INTL,0.018 THK,BRS -----*	78189	1214-05-00-0541C
-98	-----		1		SWITCH,SLIDE:LINE SELECT(SEE S1703 REPL) (ATTACHING PARTS)		
-99	211-0101-00		2		SCREW,MACHINE:4-40 X 0.25,100 DEG,FLH STL -----*	83385	OBD
-100	200-1526-00		1		CON,INV SW HOLE:	80009	200-1526-00
-101	407-1133-00		1		BRACKET,ELEC SW:ALUMINUM (ATTACHING PARTS)	80009	407-1133-00
-102	210-0406-00		2		NUT,PLAIN,HEX.:4-40 X 0.188 INCH,BRS	73743	12161-50
-103	210-0938-00		2		WASHER,FLAT:0.109 ID X 0.25 INCH OD,STL -----*	75497	AN960-3
-104	343-0213-00		1		CLAMP,LOOP:0.2 ID,PLASTIC	80009	343-0213-00
-105	384-1238-00		1		EXTENSION SHAFT:1.375 L X 0.125 OD AL	80009	384-1238-00
-106	376-0051-00		1		CPLG,SHAFT,FLEX:0.127 ID X 0.375 ID DELRIN	80009	376-0051-00
	213-0022-00		4		. SETSCREW:4-40 X 0.188 INCH,HEX SOC STL	74445	OBD
-107	-----		1		CKT BOARD ASSY:TRIG GEN/SWP LGC(SEE A5 REPL) (ATTACHING PARTS)		
-108	210-0583-00		2		NUT,PLAIN,HEX:0.25-32 X 0.312 INCH,BRS	73743	2X20317-402
-109	210-0940-00		2		WASHER,FLAT:0.25 ID X 0.375 INCH OD,STL	79807	OBD
-110	211-0207-00	B010100 B149333	3		SCR,ASSEM WSHR:4-40 X 0.312 DOUBLE SEMS	83385	OBD
	211-0244-00	B149334	3		SCR,ASSEM WSHR:4-40 X 0.312 INCH,PNH STL -----*	78189	OBD

Replaceable Mechanical Parts—466 Service

Fig. & Index No.	Tektronix Part No.	Serial/Model No. Eff	Discont	Qty	1	2	3	4	5	Name & Description	Mfr Code	Mfr Part Number
2-	-----			-						CKT BOARD ASSY INCLUDES:		
-111	384-1160-00			4						. EXTENSION SHAFT:3.05 INCH LONG	91260	OBD
-112	376-0142-00			4						. ADPT,SHAFT,CPLG:SLIDE TO SHAFT	80009	376-0142-00
	213-0048-00			1						. . SETSCREW:4-40 X 0.125 INCH,HEX SOC STL	74445	OBD
-113	-----			2						. ACTUATOR,SL SW:A,B CPLG(SEE S515,S615 REPL)		
-114	-----			1						. ACTUATOR,SL SW:A SOURCE(SEE S610 REPL)		
-115	-----			1						. ACTUATOR,SL SW:B SOURCE(SEE S510A,B REPL)		
-116	351-0355-01			4						. GUIDE,SLIDE SW:W/SPRINGS AND ROLLERS	80009	351-0355-01
-117	214-1127-00			2						. . ROLLER,DETENT:0.125 DIA X 0.125,SST	80009	214-1127-00
-118	214-1126-00			2						. . SPRING,FLAT:GOLD COLORED	80009	214-1126-00
-119	214-1770-00			4						. LEVER,SLIDE SW: (ATTACHING PARTS)	80009	214-1770-00
-120	354-0165-00			2						. RING,RETAINING:0.114 FREE IDX 0.025 INCH - - - * - - -	97464	1000-15
-121	-----			2						. CONNECTOR,RCPT:BNC,W/HDWR(SEE J500,600 REPL) (ATTACHING PARTS)		
-122	210-0012-00			2						. WASHER,LOCK:INTL,0.375 ID X 0.50" OD STL - - - * - - -	78189	1220-02-00-0541C
-123	131-1003-00			8						. CONN,RCPT,ELEC:CKT BD MT,3 PRONG	80009	131-1003-00
-124	136-0252-04	B010100	B010289	177						. SOCKET,PIN TERM:U/W 0.016-0.018 DIA PINS	22526	75060-007
	136-0252-04	B010290	B102859	185						. SOCKET,PIN TERM:U/W 0.016-0.018 DIA PINS	22526	75060-007
	136-0252-07	B102860	B152699	182						. SOCKET,PIN CONN:W/O DIMPLE	22526	75060-012
	136-0252-07	B152700		48						. SOCKET,PIN CONN:W/O DIMPLE	22526	75060-012
-125	136-0499-12			2						. CONNECTOR,RCPT,:12 CONTACT	00779	4-380949-2
-126	200-1167-00	B010100	B082399	2						. COVER,XSTR:TEMP STAB FOR 2 TO-18 CS STYLE	80009	200-1167-00
	200-1673-00	B082400	B113344	2						. COVER,XSTR:TEMP STAB,S-SHAPED	05820	OBD
	200-0945-00	B113345		2						. COVER,HALF XSTR:DUAL TO-18,ALUMINUM	80009	200-0945-00
	200-0945-01	XB113345		2						. COVER,HALF XSTR:DUAL TO-18,W/2-56 THD	80009	200-0945-01
	211-0062-00	XB113345		2						. SCREW,MACHINE:2-56 X 0.312,PNH,STL	83385	OBD
-127	214-0579-00			3						. TERM,TEST POINT:BRS CD PL	80009	214-0579-00
-128	-----			2						. RES.,VAR,NONWIR:TRIGGER(SEE R530,R630 REPL)		
-129	407-1442-00			1						. BRACET,CRT BD: (ATTACHING PARTS)	80009	407-1442-00
-130	211-0207-00	B010100	B149333	2						. SCR,ASSEM WSHR:4-40 X 0.312 DOUBLE SEMS	83385	OBD
	211-0244-00	B149334		2						. SCR,ASSEM WSHR:4-40 X 0.312 INCH,PNH STL - - - * - - -	78189	OBD
-131	352-0331-00			2						. LAMPHOLDER:	80009	352-0331-00
-132	-----			1						. RES.,VARIABLE:(SEE R948 REPL)		
-133	361-0515-00			1						. SPACER,SWITCH:PLASTIC	80009	361-0515-00
-134	366-1402-34	B010100	B010349	1						PUSH BUTTON:GRAY--A	80009	366-1402-34
	366-1489-36	B010350		1						PUSH BUTTON:GRAY--A LOCK KNOBS	80009	366-1489-36
	366-1402-29			1						PUSH BUTTON:GRAY--MIX	80009	366-1402-29
	366-1402-44			1						PUSH BUTTON:GRAY--A INTEN	80009	366-1402-44
	366-1402-35			1						PUSH BUTTON:GRAY--B DLY'D	80009	366-1402-35
-135	384-1058-00			4						EXTENSION SHAFT:8.157 INCH LONG	80009	384-1058-00
-136	366-1402-38			1						PUSH BUTTON:GRAY--AUTO	80009	366-1402-38
	366-1402-39			1						PUSH BUTTON:GRAY--NORM	80009	366-1402-39
	366-1257-29			1						PUSH BUTTON:SIL GY,SINGL SWP	80009	366-1257-29
	131-0993-00			1						BUS,CONDUCTOR:2 WIRE BLACK	00779	850100-01
-137	384-1101-00			3						EXTENSION SHAFT:4.14 INCH LONG	80009	384-1101-00
	672-0438-00	B010100	B010291	1						CKT BOARD ASSY:TIME/CM	80009	672-0438-00
	672-0460-00	B010292	B136769	1						CKT BOARD ASSY:TIME/DIV	80009	672-0460-00
	672-0460-01	B136770		1						CKT BOARD ASSY:TIME/DIV	80009	672-0460-01
	672-0472-00	B010100	B136769	1						CKT BOARD ASSY:TIMING (DM40/DM43 VERSION ONLY)	80009	672-0472-00
	672-0472-02	B136770		1						CKT BOARD ASSY:TIMING (DM40/DM43 VERSION ONLY)	80009	672-0472-02
	672-0472-01	B010100	B136769	1						CKT BOARD ASSY:TIMING (DM44 VERSION ONLY)	80009	672-0472-01
	672-0472-03	B136770		1						CKT BOARD ASSY:TIMING (DM44 VERSION ONLY)	80009	672-0472-03
-138	129-0386-00			2						POST,ELEC-MECH:HEX,1.593 INCH LONG - - - * - - -	80009	129-0386-00

Replaceable Mechanical Parts—466 Service

Fig. & Index No.	Tektronix Part No.	Serial/Model No. Eff Dscont	Qty	1	2	3	4	5	Name & Description	Mfr Code	Mfr Part Number
2-	-----		-	TIMING BOARD ASSY INCLUDES:							
	131-0963-00	XB136770	1	. CONTACT,ELEC:GROUNDING					000EX	OBD	
-139	384-1234-00	B010100 B010291	1	. EXTENSION SHAFT:0.081 OD X 10.025 INCH LONG					80009	384-1234-00	
	384-1279-00	B010292	1	. EXTENSION SHAFT:0.081 DIA X 10.275 INCH LG					80009	384-1279-00	
	263-1066-00	B010100 B010291	1	. SW CAM ACTR AS:TIME/CM					80009	263-1066-00	
	263-1092-00	B010292 B136769	1	. SW CAM ACTR AS:TIME/CM					80009	263-1092-00	
	263-1092-01	B136770	1	. SW CAM ACTR AS:TIME/CM					80009	263-1092-01	
	263-1092-01		1	. SW CAM ACTR AS:TIME/CM					80009	263-1092-01	
	-----		-	(DM40/DM43/DM44 VERSION ONLY)							
				(ATTACHING PARTS)							
-140	211-0116-00	B010100 B010291	6	. SCR,ASSEM WSHR:4-40 X 0.312 INCH,PNH BRS					83385	OBD	
	211-0116-00	B010292 B136769	8	. SCR,ASSEM WSHR:4-40 X 0.312 INCH,PNH BRS					83385	OBD	
	211-0244-00	B136770	8	. SCR,ASSEM WSHR:4-40 X 0.312 INCH,PNH STL					78189	OBD	
	-----		-	. ACTUATOR ASSY INCLUDES:							
-141	200-1419-00	B010100 B010291	1	. . COVER,CAM SW:20 & 16 ELEMENTS					80009	200-1419-00	
	200-1747-00	B010292	1	. . COVER, CAM SW:11 & 27 ELEMENTS					80009	200-1747-00	
				(ATTACHING PARTS)							
-142	211-0008-00	B010100 B010291	6	. . SCREW,MACHINE:4-40 X 0.250,PNH,STL,CD PL					83385	OBD	
	211-0008-00	B010292	8	. . SCREW,MACHINE:4-40 X 0.250,PNH,STL,CD PL					83385	OBD	
-143	210-0004-00	B010100 B010291	6	. . WASHER,LOCK:#4 INTL,0.015THK,STL CD PL					000BK	OBD	
	210-0004-00	B010292	8	. . WASHER,LOCK:#4 INTL,0.015THK,STL CD PL					000BK	OBD	
	-----		-	. . CONTACT,ELEC:GROUNDING					000EX	OBD	
-144	131-0963-00	B010100 B136769	2	. . CONTACT,ELEC:GROUNDING					000EX	OBD	
	131-0963-00	B136770	1	. . CONTACT,ELEC:GROUNDING					000EX	OBD	
-145	210-0406-00		2	. NUT,PLAIN,HEX.:4-40 X 0.188 INCH,BRS					73743	12161-50	
-146	214-1139-02		1	. . SPRING,FLAT:GREEN COLORED					80009	214-1139-02	
	214-1139-03		1	. . SPRING,FLAT:RED COLORED					80009	214-1139-03	
-147	214-1752-00	B010100 B010291	2	. . ROLLER,DETENT:					80009	214-1752-00	
	214-1127-00	B010292	2	. . ROLLER,DETENT:0.125 DIA X 0.125,SST					80009	214-1127-00	
-148	401-0180-00	B010100 B010291	1	. . BEARING,CAM SW:FRONT & REAR					80009	401-0180-00	
	401-0081-02	B010292 B136769	1	. . BEARING,CAM SW:FRONT					80009	401-0081-02	
	401-0180-00	B136770	1	. . BEARING,CAM SW:FRONT & REAR					80009	401-0180-00	
				(ATTACHING PARTS)							
-149	354-0390-00	B010100 B010291	1	. . RING,RETAINING:0.338 ID X 0.025" THK,STL					79136	5100-37MD	
	354-0391-00	B010292 B136769	1	. . RING,RETAINING:0.395"FREE ID X 0.025" STL					97464	3100-43-CD	
	354-0390-00	B136770	1	. . RING,RETAINING:0.338 ID X 0.025" THK,STL					79136	5100-37MD	
	-----		-	. . SHAFT,CAM SW:3.779 L X 0.248 OD					80009	384-0878-03	
-150	384-0878-03	B010100 B010291X	1	. . ACTUATOR,CAM SW:TIME/CM,FRONT					80009	105-0365-01	
-151	105-0365-01	B010100 B010291	1	. . ACTUATOR,CAM SW:TIME/CM,FRONT					80009	105-0626-00	
	105-0626-00	B010292 B136769	1	. . ACTUATOR,CAM SW:TIME/CM,FRONT					80009	105-0626-01	
	105-0626-01	B136770	1	. . ACTUATOR,CAM SW:TIME/CM,FRONT					80009	105-0626-01	
	210-0406-00	XB010292	4	. . NUT,PLAIN,HEX.:4-40 X 0.188 INCH,BRS					73743	12161-50	
	407-1199-00	XB010292	1	. . BRACKET,COVER:ABS					80009	407-1199-00	
-152	210-0406-00		4	. . NUT,PLAIN,HEX.:4-40 X 0.188 INCH,BRS					73743	12161-50	
-153	401-0177-00	B010100 B010291	1	. . BEARING,CAM SW:CENTER & REAR,0.80 & 0.83					80009	401-0177-00	
	401-0115-00	B010292 B136769	1	. . BEARING,CAM SW:CENTER					80009	401-0115-00	
	401-0178-00	B136770	1	. . BEARING,CAM SW:CENTER					80009	401-0178-00	
-154	210-1160-00	B010100 B010291X	1	. . WASHER,FLAT:0.129 ID X 0.031 THK,TEFLON					86928	5612-32-31	
-155	361-0538-00	B010100 B010291X	1	. . SPACER,SLEEVE:0.248 OD X 1.355 INCH LONG					80009	361-0538-00	
-156	214-1416-00	B010100 B010291X	1	. . SPRING,HLCPS:0.176 OD X 0.835 INCH LONG					27143	OBD	
-157	105-0364-01	B010100 B010291	1	. . ACTUATOR,CAM SW:TIME/CM,REAR					80009	105-0364-01	
	105-0627-00	B010292 B136769	1	. . ACTUATOR,CAM SW:TIME/CM,REAR					80009	105-0627-00	
	105-0627-01	B136770	1	. . ACTUATOR,CAM SW:TIME/CM,REAR					80009	105-0627-01	
				(ATTACHING PARTS)							
-158	384-0882-01	B010100 B010291	1	. . SHAFT,CAM SW:9.00 L X 0.125 OD,INNER					80009	384-0882-01	
	384-0882-04	B010292	1	. . SHAFT,CAM SW:9.325 L,0.125OD INTMD CNCT					80009	384-0882-04	
-159	354-0445-00	B010100 B010291	1	. . RING,RETAINING:0.225 ID X 0.25 INCH,STL					97464	3100-25-ST	
	354-0391-00	B010292 B136769	1	. . RING,RETAINING:0.395"FREE ID X 0.025" STL					97464	3100-43-CD	
	354-0390-00	B136770	1	. . RING,RETAINING:0.338 ID X 0.025" THK,STL					79136	5100-37MD	
	-----		-	. . SPRING,HLCPS:0.176 OD X 0.835 INCH LONG					27143	OBD	
	214-1416-00	XB136770	1	. . RING,RETAINING:0.225 ID X 0.25 INCH,STL					97464	3100-25-ST	
	354-0445-00	XB136770	1	. . WASHER,FLAT:0.129 ID X 0.031 THK,TEFLON					86928	5612-32-31	
	210-1160-00	XB136770	1	. . NUT,PLAIN,HEX.:4-40 X 0.188 INCH,BRS					73743	12161-50	
-160	210-0406-00		4	. . NUT,PLAIN,HEX.:4-40 X 0.188 INCH,BRS					73743	12161-50	

Replaceable Mechanical Parts—466 Service

Fig. & Index No.	Tektronix Part No.	Serial/Model No. Eff	Dscont	Qty	1 2 3 4 5	Name & Description	Mfr Code	Mfr Part Number
2-161	214-1139-02			1	.	SPRING,FLAT:GREEN COLORED	80009	214-1139-02
	214-1139-03			1	.	SPRING,FLAT:RED COLORED	80009	214-1139-03
-162	214-1752-00	B010100	B010291	2	.	ROLLER,DETENT:	80009	214-1752-00
	214-1127-00	B010292		2	.	ROLLER,DETENT:0.125 DIA X 0.125,SST	80009	214-1127-00
-163	401-0204-01	B010100	B010291	1	.	BEARING,CAM SW:W/INSERT	80009	401-0204-01
	401-0081-04	B010292	B136769	1	.	BEARING,CAM SW:W/INSERT	80009	401-0081-04
	401-0204-01	B136770		1	.	BEARING,CAM SW:W/INSERT	80009	401-0204-01
	351-0366-00			1	.	STOP,SLIDE:	80009	351-0366-00
	105-0449-00	B010100	B010291	1	.	STOP SHAFT,CAM:CAM SWITCH ACTUATOR	80009	105-0449-00
	105-0410-00	B010292	B136769	1	.	STOP,RTRY SHAFT:CAM SW DRUM	80009	105-0410-00
	105-0449-00	B136770		1	.	STOP ASSY,CAM:CAM SWITCH ACTUATOR	80009	105-0449-00
-164	352-0349-00			1	.	HOLDER,STOP PIN:ZAMAK	000DX	OBD
-165	105-0409-00			1	.	STOP,SHAFT,CAM SW DRUM	80009	105-0409-00
-166	361-0535-00			1	.	SPACER,RING:0.130 ID X 0.18 INCH OD	80009	361-0535-00
-167	354-0291-00			1	.	RING,RETAINING:	97464	2000-12CD
-168	214-1812-00			1	.	SPR,HLCL,TRSN:0.832 OD,LOOPENDS,MUW	80009	214-1812-00
-169	376-0039-00			1	.	ADPT,SHAFT,CPLG:0.128 AND 0.082"DIA SHAFT	80009	376-0039-00
	213-0022-00			2	.	SETSCREW:4-40 X 0.188 INCH,HEX SOC STL	74445	OBD
-170	-----			1	.	RES.,VARIABLE:(SEE R1140/S1140 REPL)		
-171	361-0515-00			1	.	SPACER,SWITCH:PLASTIC	80009	361-0515-00
-172	-----			1	.	CKT BOARD ASSY:TIMING(SEE A7 REPL)		
	131-0604-00	B010100	B010291	29	.	CONTACT,ELEC:CKT BD SW,SPR,CU BE	80009	131-0604-00
	131-0604-00	B010292		37	.	CONTACT,ELEC:CKT BD SW,SPR,CU BE	80009	131-0604-00
-173	131-0566-00	B010100	B010291X	1	.	BUS CONDUCTOR:DUMMY RES,2.375,22 AWG	57668	JWW-0200E0
-174	131-1261-00			29	.	CONTACT,ELEC:F-SHAPED	00779	1-380953-0
-175	136-0252-07	B010100	B152699X	6	.	SOCKET,PIN CONN:W/O DIMPLE	22526	75060-012
-176	352-0331-00			2	.	LAMPHOLDER:	80009	352-0331-00
-177	-----			1	.	SWITCH,PUSH:TRIGGER MODE (SEE S980 REPL)		
-178	361-0542-00			4	.	SPACER,SWITCH:PLASTIC	71590	J-64281
-179	-----			1	.	SWITCH,PUSH:HORIZ DISPLAY(SEE S1120 REPL)		
-180	361-0385-00			4	.	SPACER,PB SW:0.164 INCH LONG	80009	361-0385-00
-181	129-0419-00			1	.	POST,ELEC-MECH:HEX.,0.588 INCH LONG	80009	129-0419-00
	131-0761-00			2	.	TERMINAL STUD:SCREW MTG,FLAT TAB	71279	572-4897-01-0516
	210-0202-00			2	.	TERMINAL,LUG:0.146 ID,LOCKING,BRZ TINNED	78189	2104-06-00-2520N
-182	-----			1	.	CKT BOARD ASSY:VERT OUTPUT(SEE A4 REPL) (ATTACHING PARTS)		
-183	211-0207-00	B010100	B149333	2	.	SCR,ASSEM WSHR:4-40 X 0.312 DOUBLE SEMS	83385	OBD
	211-0244-00	B149334		2	.	SCR,ASSEM WSHR:4-40 X 0.312 INCH,PNH STL	78189	OBD
-184	220-0456-00			1	.	NUT,PLAIN,HEX.:6-32 X 0.25 INCH,STL	73743	9038
-185	210-1092-00			1	.	WASHER,FLAT:0.147 ID X 0.312" OD,BRS	12327	OBD
	-----			-	.	CKT BOARD ASSY INCLUDES:		
-186	131-0608-00			3	.	TERMINAL,PIN:0.365 L X 0.025 PH BRZ GOLD	22526	47357
-187	136-0252-07	B010100	B152699	15	.	SOCKET,PIN CONN:W/O DIMPLE	22526	75060-012
	136-0252-07	B152700		3	.	SOCKET,PIN CONN:W/O DIMPLE	22526	75060-012
	136-0252-01			16	.	CONTACT,ELEC:0.178 INCH LONG	00779	1-332095-2
-188	214-0579-00			1	.	TERM,TEST POINT:BRZ CD PL	80009	214-0579-00
-189	407-1149-00			1	.	BRACKET,GND:MICROCIRCUIT,BRASS	80009	407-1149-00
-190	361-0008-00			3	.	SPACER,SLEEVE:0.11 ID X 0.25 OD X 0.28"H	80009	361-0008-00
	131-0773-00	B010100	B010124	1	.	LEAD,ELECTRICAL:18.0 INCH LONG	01009	8111LFD
-191	131-1141-00	B010125		1	.	LEAD,ELECTRICAL:MV,RIGHT ANGLE CONN,18.0 L	01009	8111LF-90
	348-0067-00	B010100	B010124	1	.	GROMMET,PLASTIC:0.312 INCH DIA	80009	348-0067-00
-192	348-0063-00	B010125		1	.	GROMMET,PLASTIC:0.50 INCH DIA	80009	348-0063-00
-193	366-1402-33			1	.	PUSH BUTTON:GRAY--X10	80009	366-1402-33
-194	384-1236-00	B010100	B081849	1	.	EXTENSION SHAFT:9.04 L W/OFFSET	80009	384-1236-00
	384-1236-01	B081850		1	.	EXTENSION SHAFT:9.055 L,PLSTC	80009	384-1236-01
-195	366-1512-00			4	.	PUSH BUTTON:GRAY,0.18 SQ X 0.83 INCH LG	80009	366-1512-00
-196	366-1402-42			1	.	PUSH BUTTON:--BEAM FINDER	80009	366-1402-42
-197	384-1060-00			1	.	EXTENSION SHAFT:7.831 INCH LONG	80009	384-1060-00
-198	386-2834-00			1	.	SUPPORT,SHAFT:PLASTIC	80009	386-2834-00
-199	384-1179-00			1	.	EXTENSION SHAFT:9.312 INCH LONG	80009	384-1179-00
-200	384-0376-00			2	.	EXTENSION SHAFT:0.124 OD X 6.238 INCH LONG	80009	384-0376-00
-201	384-1233-00			1	.	EXTENSION SHAFT:0.124 OD X 12.15 INCH LONG	80009	384-1233-00
-202	376-0029-00			4	.	CPLG,SHAFT,RGD:0.128 ID X 0.312 OD X 0.5"L	80009	376-0029-00
	213-0022-00			2	.	SETSCREW:4-40 X 0.188 INCH,HEX SOC STL	74445	OBD

Fig. & Index No.	Tektronix Part No.	Serial/Model No. Eff Dscont	Qty	1 2 3 4 5	Name & Description	Mfr Code	Mfr Part Number
2-203	384-1007-00		1		EXTENSION SHAFT:8.328 L X 0.123 OD	80009	384-1007-00
-204	376-0051-00		1		CPLG,SHAFT,FLEX:0.127 ID X 0.375 ID DELRIN	80009	376-0051-00
	213-0022-00		4		. SETSCREW:4-40 X 0.188 INCH,HEX SOC STL	74445	OBD
-205	-----		1		CKT BOARD ASSY:STORAGE & LOGIC(SEE A10 REPL) (ATTACHING PARTS)		
-206	211-0207-00	B010100 B149333	4		SCR,ASSEM WSHR:4-40 X 0.312 DOUBLE SEMS	83385	OBD
	211-0244-00	B149334	4		SCR,ASSEM WSHR:4-40 X 0.312 INCH,PNH STL	78189	OBD
	-----		-		CKT BOARD ASSY INCLUDES:		
-207	131-0566-00		3		. BUS CONDUCTOR:DUMMY RES,2.375,22 AWG	57668	JWW-0200EO
-208	131-0608-00		6		. TERMINAL,PIN:0.365 L X 0.025 PH BRZ GOLD	22526	47357
-209	131-0787-00		15		. CONTACT,ELEC:0.64 INCH LONG	22526	47359
-210	136-0252-07	B010100 B152699	117		. SOCKET,PIN CONN:W/O DIMPLE	22526	75060-012
	136-0252-07	B152700	28		. SOCKET,PIN CONN:W/O DIMPLE	22526	75060-012
-211	136-0260-02		2		. SKT,PL-IN ELEC:MICROCIRCUIT,16 DIP,LOW CLE	71785	133-51-92-008
	136-0269-02		4		. SKT,PL-IN ELEC:MICROCIRCUIT,14 DIP,LOW CLE	73803	CS9002-14
	136-0514-00		1		. SKT,PL-IN ELEC:MICROCIRCUIT,8 DIP	73803	CS9002-8
-212	214-0579-00		3		. TERM,TEST POINT:BR3 CD PL	80009	214-0579-00
-213	-----		1		. SWITCH,PUSH:STORAGE(SEE S1921A,B REPL)		
-214	361-0608-00		4		. SPACER,PUSH SW:PLASTIC	80009	361-0608-00
-215	407-1481-00		1		BRACKET,ANGLE:CKT BOARD,ALUMINUM (ATTACHING PARTS)	80009	407-1481-00
-216	210-0586-00		1		NUT,PL,ASSEM WA:4-40 X 0.25,STL	83385	OBD
	210-0810-00		1		WASHER,FLAT:0.125 ID X 0.50 INCH OD,FIBER	86445	OBD
-217	337-1999-00		1		SHLD,ELECTRICAL:HI VOLTAGE (ATTACHING PARTS)	80009	337-1999-00
-218	211-0008-00	B010100 B010179	4		SCREW,MACHINE:4-40 X 0.250,PNH,STL,CD PL	83385	OBD
	211-0008-00	B010180	3		SCREW,MACHINE:4-40 X 0.250,PNH,STL,CD PL	83385	OBD
	131-1428-00	XB010180	1		CONTACT,ELEC:GROUNDING CLIP	80009	131-1428-00
	211-0110-00	XB010180	1		SCREW,MACHINE:4-40 X 0.312 INCH,PHB STL	83385	OBD
	210-0001-00	XB010180	1		WASHER,LOCK:INTL,0.092 ID X 0.18"OD,STL	78189	1202-00-00-0541C
-219	342-0222-00		1		INSULATOR,PLATE:HIGH VOLTAGE,POLYESTER	80009	342-0222-00
-220	343-0088-00		1		CLAMP,LOOP:0.062 INCH DIA	80009	343-0088-00
	343-0213-00		2		CLAMP,LOOP:0.2 ID,PLASTIC	80009	343-0213-00
-221	-----		4		TRANSISTOR:(SEE Q1734,Q1756,Q1766,Q1776 REPL) (ATTACHING PARTS)		
-222	343-0473-00		1		RETAINER,XSTR:ALUMINUM	80009	343-0473-00
-223	210-0457-00		3		NUT,PL,ASSEM WA:6-32 X 0.312,STL CD PL	83385	OBD
-224	342-0214-00		1		INSULATOR,PLSTC:TRANSISTOR	80009	342-0214-00
-225	-----		1		TRANSISTOR:(SEE Q1716 REPL) (ATTACHING PARTS)		
-226	211-0097-00		1		SCREW,MACHINE:4-40 X 0.312 INCH,PNH STL	83385	OBD
-227	210-1122-00		1		WASHER,LOCK:0.12 ID,DISHED,0.025 THK	86928	OBD
-228	342-0224-00		1		INSULATOR,PLATE:TRANSISTOR	80009	342-0224-00
-229	-----		1		TRANSISTOR:(SEE Q1792 REPL) (ATTACHING PARTS)		
-230	211-0180-00		1		SCR,ASSEM WSHR:2-56 X 0.25 INCH,PNH BR3	83385	OBD
-231	210-1156-00		1		WASHER,SHLDR:0.09 ID X 0.085 D,NYL,0.2 OD	80009	210-1156-00
-232	342-0166-00		1		INSULATOR,PLATE:TRANSISTOR	80009	342-0166-00
-233	214-1979-00		1		HEAT SINK,XSTR:1 EA 2-56 & 4-40 THD (ATTACHING PARTS)	80009	214-1979-00
-234	210-0586-00		2		NUT,PL,ASSEM WA:4-40 X 0.25,STL	83385	OBD
-235	-----		1		CKT BOARD ASSY:INTERFACE(SEE A6 REPL) (ATTACHING PARTS)		
-236	129-0413-01		2		SPACER,POST:0.538 L,W/4-40 TAP 1 END	80009	129-0413-01
-237	210-0938-00		2		WASHER,FLAT:0.109 ID X 0.25 INCH OD,STL	75497	AN960-3
-238	211-0207-00	B010100 B149333	6		SCR,ASSEM WSHR:4-40 X 0.312 DOUBLE SEMS	83385	OBD
	211-0244-00	B149334	6		SCR,ASSEM WSHR:4-40 X 0.312 INCH,PNH STL	78189	OBD



**Replaceable Mechanical Parts—466 Service**

Fig. & Index No.	Tektronix Part No.	Serial/Model No. Eff Dscont	Qty	1 2 3 4 5	Name & Description	Mfr Code	Mfr Part Number
2-	-----				CKT BOARD ASSY INCLUDES:		
-239	136-0514-00	XB152500	2		. SKT,PL-IN ELEC:MICROCIRCUIT,8 DIP	73803	CS9002-8
	129-0413-00		1		. POST,ELEC-MECH:0.538 INCH L (ATTACHING PARTS)	80009	129-0413-00
-240	210-0938-00		1		. WASHER,FLAT:0.109 ID X 0.25 INCH OD,STL	75497	AN960-3
-241	210-0586-00		1		. NUT,PL,ASSEM WA:4-40 X 0.25,STL -----*	83385	OBD
-242	385-0149-00		1		. SPACER,POST:0.625 L W/4-40 THD EA END,NYL (ATTACHING PARTS)	80009	385-0149-00
-243	211-0207-00	B010100 B149333	1		. SCR,ASSEM WSHR:4-40 X 0.312 DOUBLE SEMS	83385	OBD
	211-0244-00	B149334	1		. SCR,ASSEM WSHR:4-40 X 0.312 INCH,PNH STL	78189	OBD
-244	210-0938-00		1		. WASHER,FLAT:0.109 ID X 0.25 INCH OD,STL -----*	75497	AN960-3
-245	131-0382-00		1		. TERMINAL,STUD:0.812 L,INSULATED (ATTACHING PARTS)	71279	572-4822-01-05-1
-246	210-0586-00		1		. NUT,PL,ASSEM WA:4-40 X 0.25,STL -----*	83385	OBD
-247	131-0566-00	B010100 B129999	17		. BUS CONDUCTOR:DUMMY RES,2.375,22 AWG	57668	JWW-0200E0
	131-0566-00	B130000	18		. BUS CONDUCTOR:DUMMY RES,2.375,22 AWG	57668	JWW-0200E0
-248	136-0577-00		1		. CONNECTOR,RCPT,:6 CONTACT	22526	65001-015
-249	136-0499-14		1		. CONNECTOR,RCPT,:14 CONTACT	00779	4-380949-4
	136-0499-16		1		. CONNECTOR,RCPT,:16 CONTACT	00779	4-380949-6
-250	136-0252-07		177		. SOCKET,PIN CONN:W/O DIMPLE	22526	75060-012
-251	124-0119-00	B010100 B081949	1		. TERMINAL BOARD:2 NOTCH,CERAMIC,CLIP MTD	80009	124-0119-00
	124-0175-01	B081950	1		. TERMINAL BOARD:2 NOTCH,CERAMIC,STUD MTD (ATTACHING PARTS)	80009	124-0175-01
-252	361-0007-00		1		. SPACER,SLEEVE:0.250 INCH DIA,PLASTIC -----*	80009	361-0007-00
-253	131-0608-00		25		. TERMINAL,PIN:0.365 L X 0.025 PH BRZ GOLD	22526	47357
-254	131-1261-00		24		. CONTACT,ELEC:F-SHAPED	00779	1-380953-0
-255	-----		1		. SWITCH,PUSH:X10 MAG(SEE S1239 REPL)		
-256	361-0385-00		2		. SPACER,PB SW:0.164 INCH LONG	80009	361-0385-00
-257	-----		1		. SWITCH,PUSH:BEAM FIND(SEE S400 REPL)		
-258	361-0385-00		2		. SPACER,PB SW:0.164 INCH LONG	80009	361-0385-00
-259	376-0073-00	B010100 B010249	2		. CPLG HALF,SHAFT:0.375 INCH OD,PLSTC	80009	376-0073-00
	376-0072-00	B010250	2		. CPLG HALF,SHAFT:0.562 INCH OD,PLSTC	80009	376-0072-00
	213-0048-00		1		. SETSCREW:4-40 X 0.125 INCH,HEX SOC STL	74445	OBD
-260	-----		2		. RES.,VARIABLE:(SEE R1526,R1529 REPL) (ATTACHING PARTS)		
-261	210-0583-00		2		. NUT,PLAIN,HEX:0.25-32 X 0.312 INCH,BRS	73743	2X20317-402
-262	210-0940-00		2		. WASHER,FLAT:0.25 ID X 0.375 INCH OD,STL	79807	OBD
	210-0046-00		2		. WASHER,LOCK:0.261 ID,INTL,0.018 THK,BRS -----*	78189	1214-05-00-0541C
-263	342-0242-00		1		. INSUL,VAR RES:0.700 X 0.500POLY	80009	342-0242-00
-264	386-2433-00		2		. SUPPORT,VAR RES:CIRCUIT BOARDMOUNTING	80009	386-2433-00
-265	214-0579-00		19		. TERM,TEST POINT:BRS CD PL	80009	214-0579-00
-266	214-0973-00		1		. HEAT SINK,ELEC:0.28 X 0.18 OVAL X 0.187"H	80009	214-0973-00
-267	344-0154-00		2		. CLIP,ELECTRICAL:FUSE,CKT BD MT	80009	344-0154-00
-268	342-0221-00		1		. INSULATOR FILM:MAIN CHASSIS,MYLAR	80009	342-0221-00
-269	179-2143-00		1		. WIRING HARNESS:MAIN	80009	179-2143-00
-270	210-0774-00		16		. EYELET,METALLIC:0.152 OD X 0.245 INCH L,BRS	80009	210-0774-00
-271	210-0775-00		16		. EYELET,METALLIC:0.126 OD X 0.23 INCH L,BRS	80009	210-0775-00
	179-2169-00		1		. WIRING HARNESS:POWER ON	80009	179-2169-00
-272	175-0825-00		FT		. WIRE,ELECTRICAL:2 WIRE RIBBON	80009	175-0825-00
-273	175-0826-00		FT		. WIRE,ELECTRICAL:3 WIRE RIBBON	80009	175-0826-00
-274	175-0827-00		FT		. CABLE,SP,ELEC:4,26 AWG,STRD.PVC JKT,RBN	08261	SS04267(1061)0C
-275	175-0828-00		FT		. WIRE,ELECTRICAL:5 WIRE RIBBON	08261	SS-0526-710610C
-276	131-0707-00		36		. CONNECTOR,TERM:22-26 AWG,BRS& CU BE GOLD	22526	47439
-277	131-1538-00		4		. CONTACT,ELEC:CRIMP-ON,22-26 AWG WIRE (CONTACTS FOR DEFLECTION LEADS)	22526	75369-002
-278	352-0169-00		5		. HLDR,TERM CONN:2 WIRE BLACK	80009	352-0169-00
-279	352-0161-00		4		. HLDR,TERM CONN:3 WIRE,BLACK	80009	352-0161-00
-280	352-0162-00		2		. HLDR,TERM CONN:4 WIRE BLACK	80009	352-0162-00
-281	352-0163-00		2		. CONN BODY,PL,EL:5 WIRE BLACK	80009	352-0163-00
	210-0774-00		1		. EYELET,METALLIC:0.152 OD X 0.245 INCH L,BRS	80009	210-0774-00
	210-0775-00		1		. EYELET,METALLIC:0.126 OD X 0.23 INCH L,BRS	80009	210-0775-00

Replaceable Mechanical Parts—466 Service

Fig. & Index No.	Tektronix Part No.	Serial/Model No. Eff	Dscont	Qty	1 2 3 4 5	Name & Description	Mfr Code	Mfr Part Number
3-1	200-1412-00			1		COVER,SCOPE:FRONT	80009	200-1412-00
	200-1723-00			1		COVER,SCOPE:FRONT	80009	200-1723-00
	367-0172-03			1		HANDLE,CARRYING:12.722 L,BLACK VINYL,W/HDW	80009	367-0172-03
-2	334-2320-00			1		. PLATE,IDENT:MKD 466 OSCILLOSCOPE	22670	OBD
-3	200-0602-00			2		. COVER,HDL LATCH:2.12 DIA X 0.7,ACETAL	80009	200-0602-00
-4	367-0172-00			1		. HANDLE,CARRYING:12.722 L,BLACK VINYL (ATTACHING PARTS)	80009	367-0172-00
-5	213-0227-00			4		. SCR,TPG,THD FOR:6-32 X 0.50 DEG,FLH ST - - - * - - -	83385	OBD
-6	214-0516-00			2		. SPRING,HLCPS:0.959 DIA X 1.250 INCH LONG	80009	214-0516-00
-7	214-1987-00			2		. INDEX,HDL RING:	80009	214-1987-00
-8	214-0515-02			2		. HUB,HDL INDEX:1.42 DIA X 0.565 THK,AL CD (ATTACHING PARTS)	80009	214-0515-02
-9	210-1182-00	B010100	B150999	2		. WSHR,SPR TNSN:0.218 ID X 0.69 INCH OD	80009	210-1182-00
	210-0805-00	B151000		2		. WASHER,FLAT:0.204 ID X 0.438 INCH OD,STL	12327	OBD
-10	213-0139-01			2		. SCREW,SLFLKG:10-24 X 0.375,HEX HD,STL - - - * - - -	26233	P38AS 1024 6C
-11	437-0169-00			1		CABINET,SCOPE:	80009	437-0169-00
	437-0169-02			1		CABINET,SCOPE: (OPTION 1Y ONLY)	80009	437-0169-02
-12	348-0015-00	XB010125	B010194X	4		. BUMPER,RUBBER:BLACK,0.4375 INCH DIA	70485	1732
-13	348-0080-01	B010100	B010124	4		. FOOT,CABINET:BOTTOM	80009	348-0080-01
	348-0014-00	B010125	B010194	4		. FOOT,CABINET:BLACK PLASTIC	80009	348-0014-00
	348-0080-01	B010195		4		. FOOT,CABINET:BOTTOM (ATTACHING PARTS)	80009	348-0080-01
-14	129-0496-00	XB010125	B010194X	4		. SPACER POST:0.20 L,W/6-32THD THRU - - - * - - -	80009	129-0496-00
	437-0176-00			1		CABINET,SCOPE:	80009	437-0176-00
	437-0176-01			1		CABINET,SCOPE: (OPTION 1Y ONLY)	80009	437-0176-01
-15	352-0263-00	B010100	B151684	1		. HLDR,POUCH ASSY:TEK BLUE POLYCARBONATE	80009	352-0263-00
	352-0263-01	B151685		1		. HLDR,POUCH ASSY:TEK BLUE POLYCARBONATE	80009	352-0263-01
	-----			-		. (SUBPART OF STANDARD 437-0169-00 CABINET ONLY)		

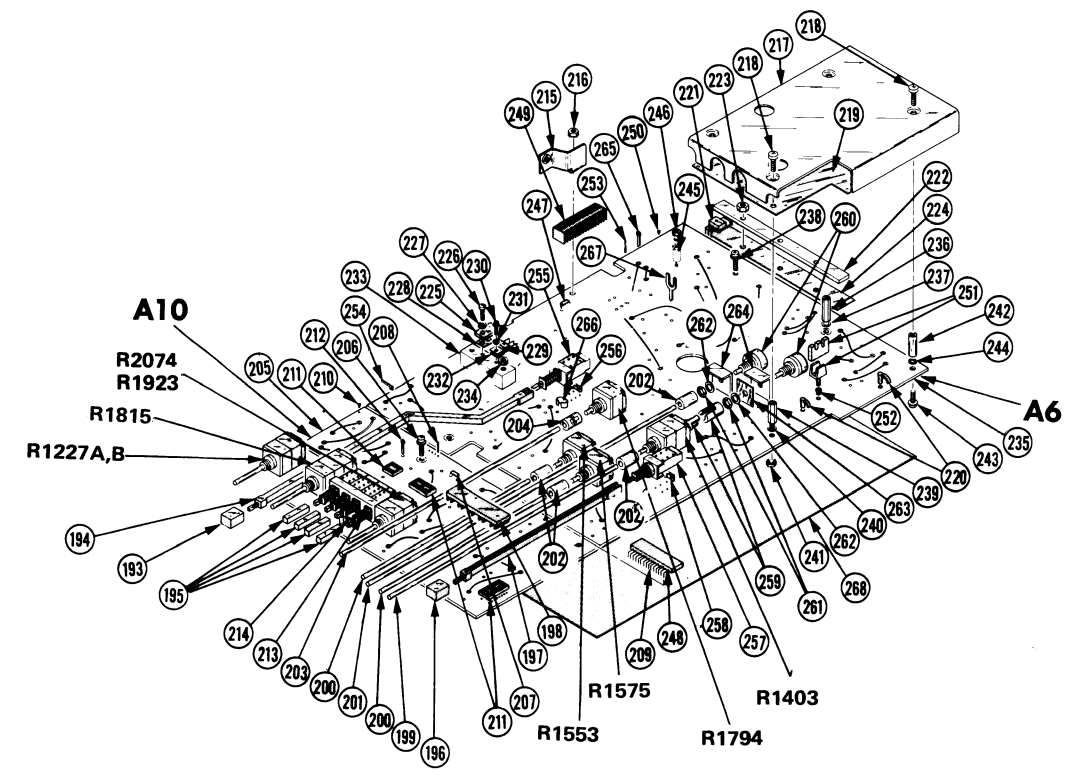
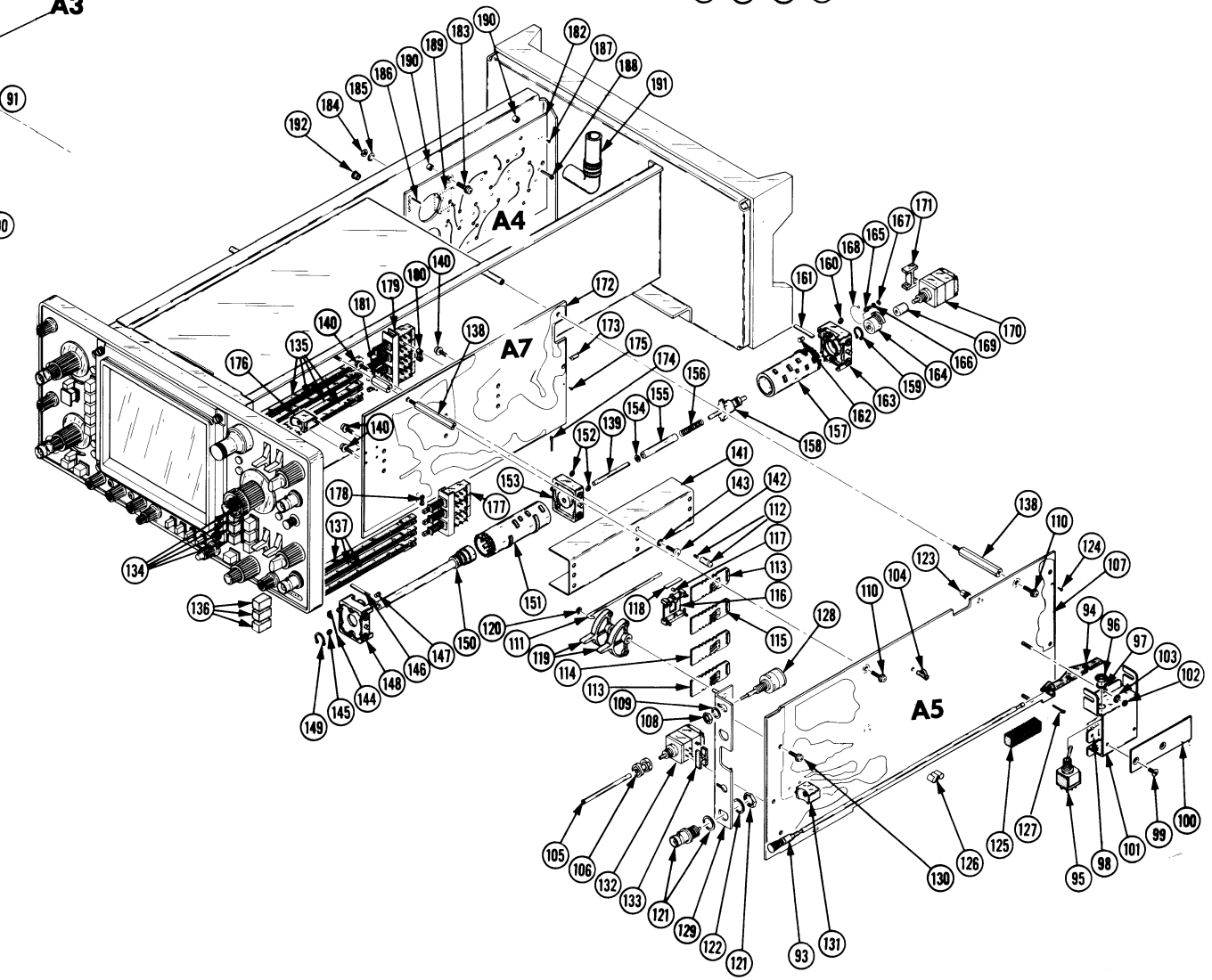
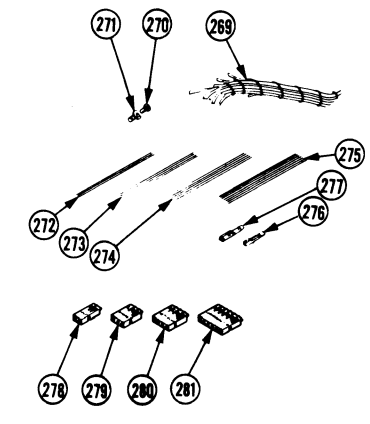
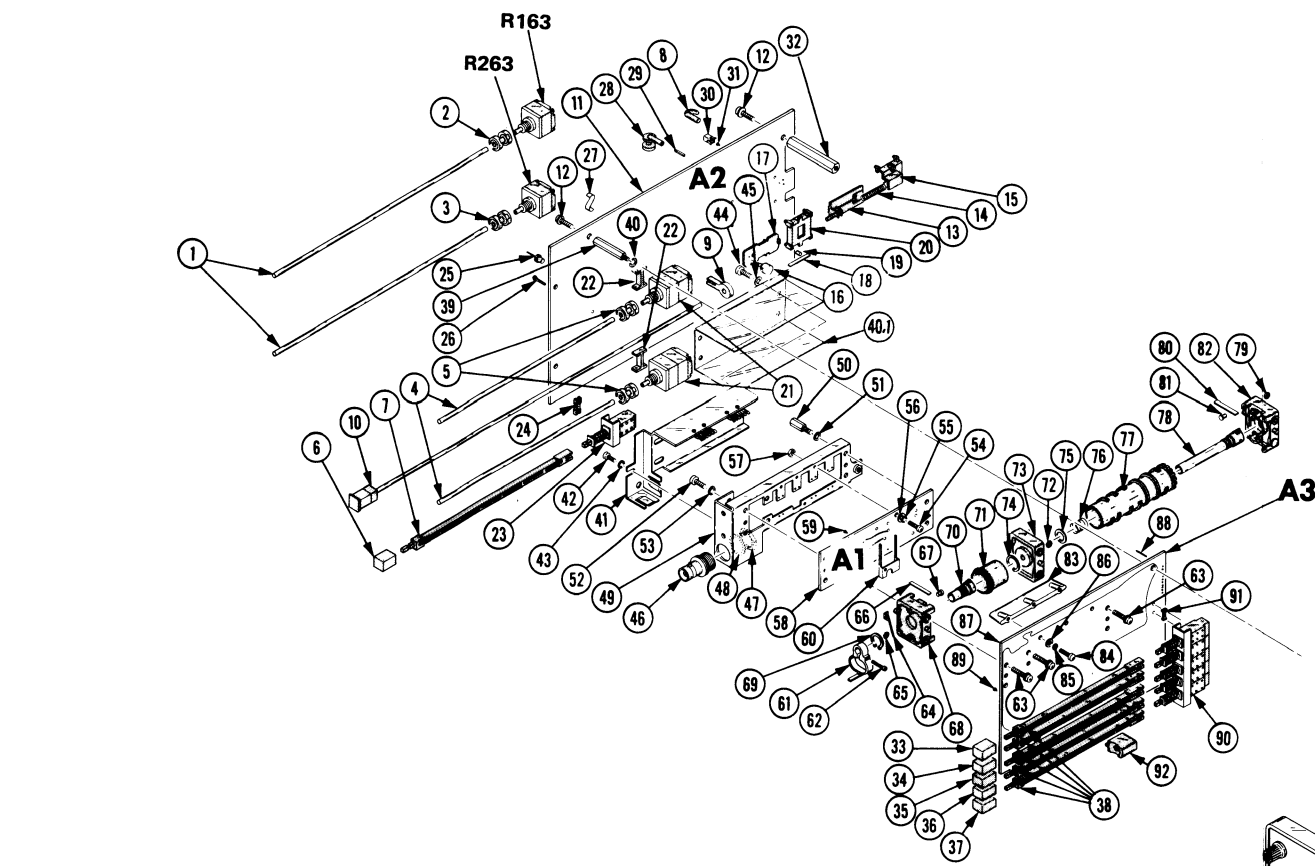

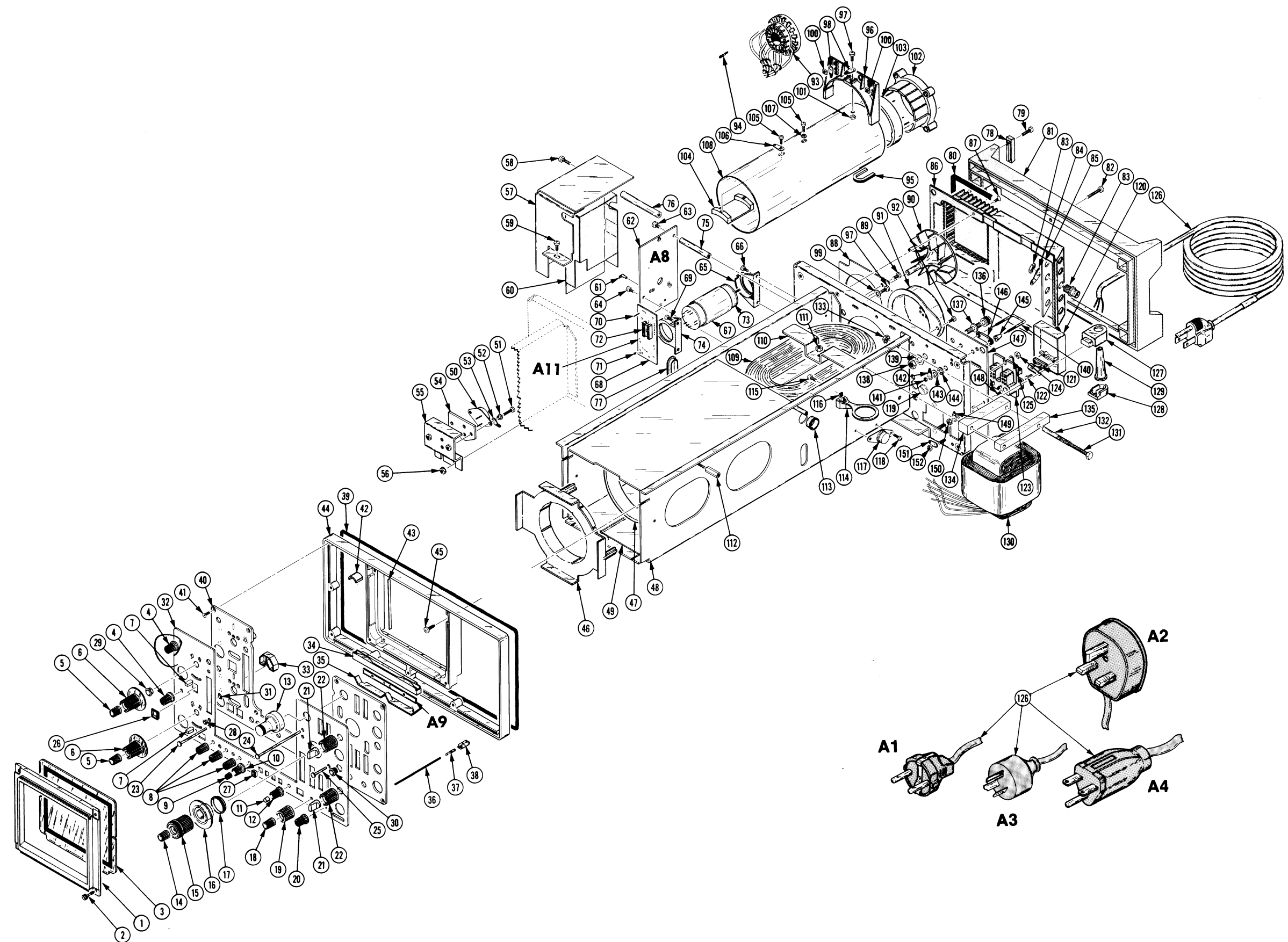

REV FEB 1982

466 OSCILLOSCOPE

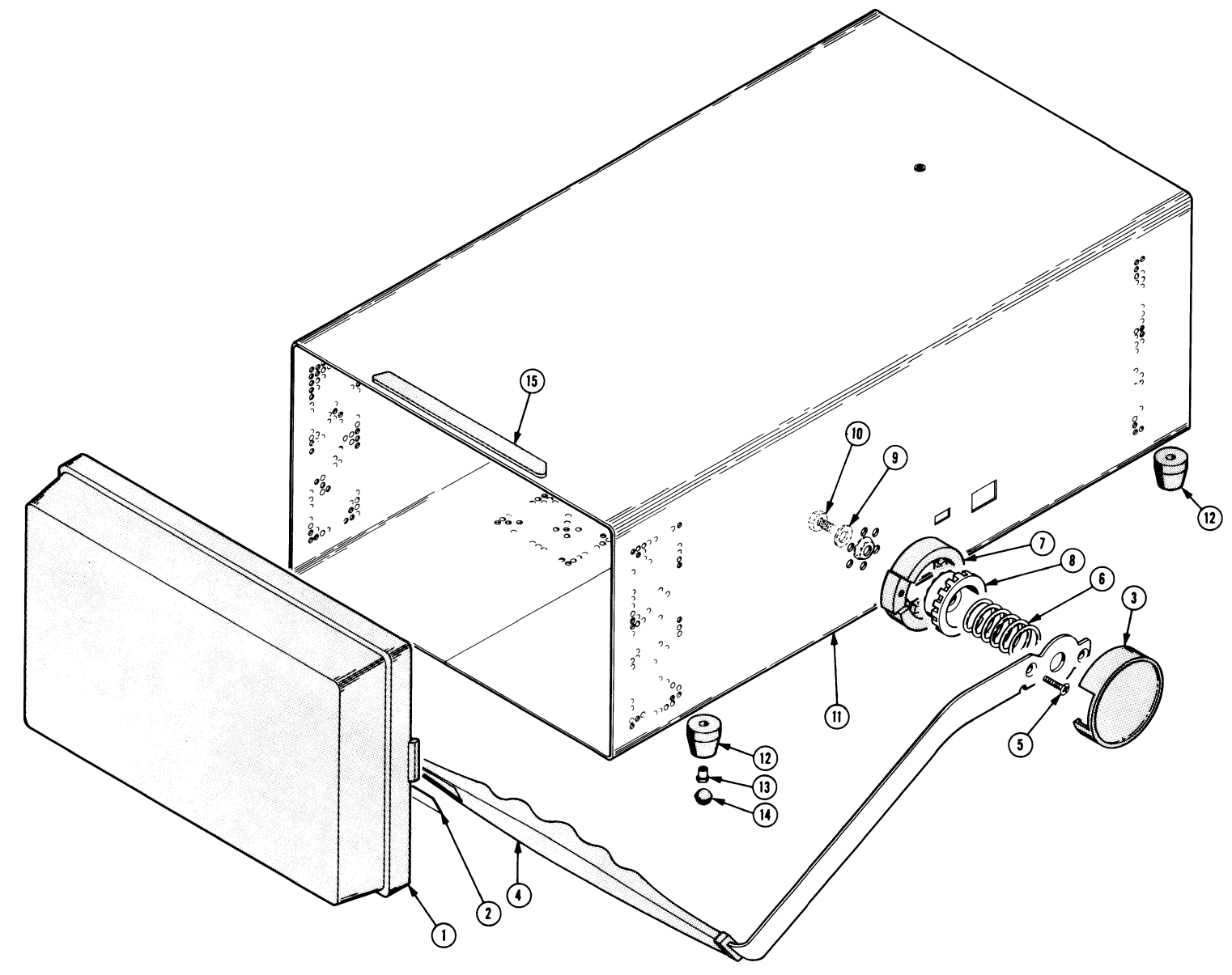

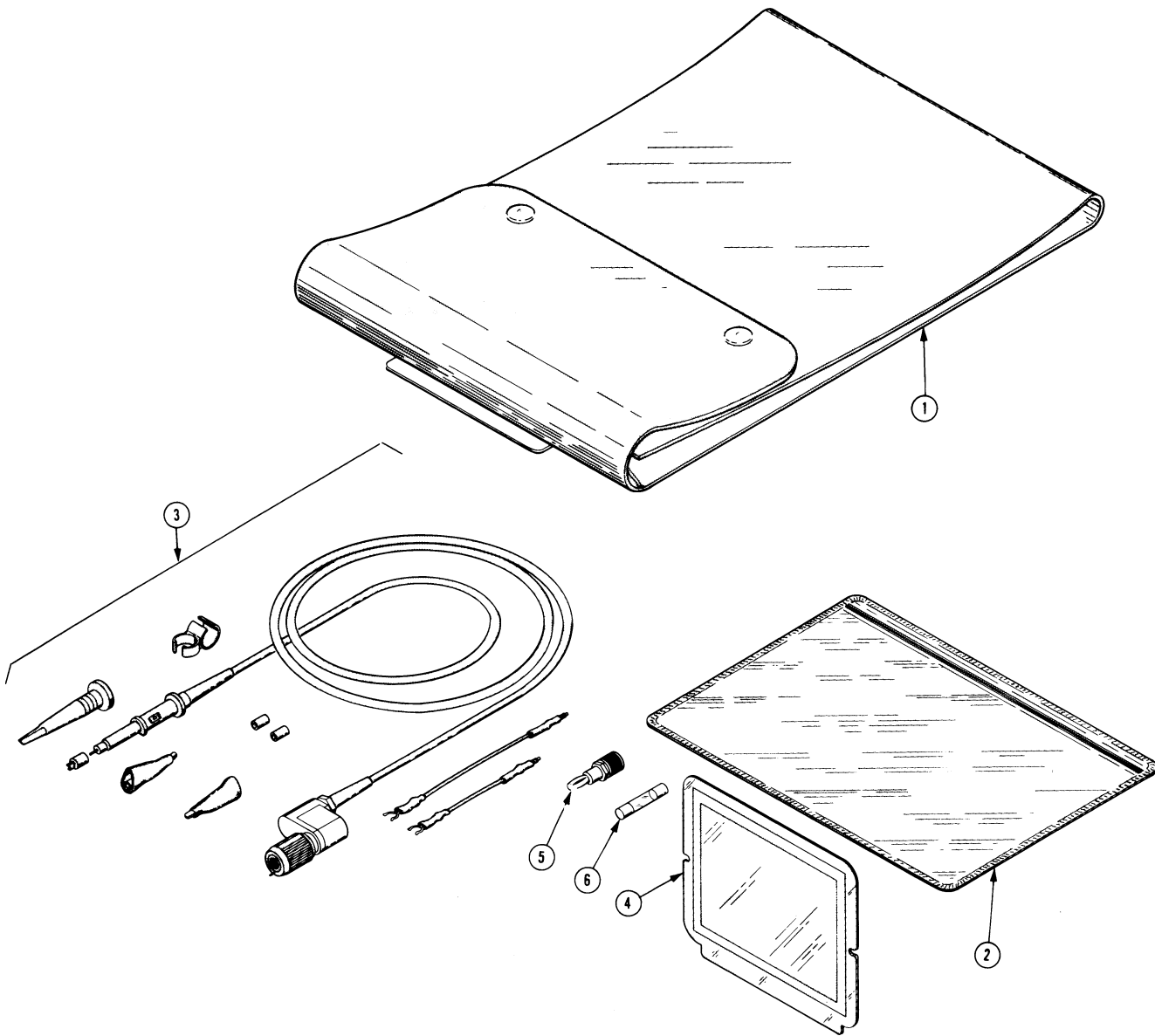

ACCESSORIES

Fig. & Index No.	Tektronix Part No.	Serial/Model No.		Qty	1	2	3	4	5	Name & Description	Mfr Code	Mfr Part Number
		Eff	Dscont									
-1	016-0535-02			1						POUCH,ACCESSORY:W/HARDWARE,STANDARD	80009	016-0535-02
	016-0594-00			1						POUCH,ACCESSORY:W/HARDWARE(W/DM)	80009	016-0594-00
-2	016-0537-00			1						POUCH,ACCESSORY:VINYL,W/ZIPPER	05006	ZIP-6X91D
-3	010-6062-03	B010100	B134726	2						PROBE,VOLTAGE:72.0 L,1 X & 10 X,/ACCESS	80009	010-6062-03
	010-6062-13	B134727		2						LEAD,TEST:72.0 L,W/ACCESSORIES	80009	010-6062-13
	010-6430-00			1						PROBE,TEMP:1.5 METER L,W/ACCESSORIES	80009	010-6430-00
-4	337-1674-07			1						SHLD,IMPLOSION:SMOKE GRAY	80009	337-1674-07
-5	134-0016-01			1						PLUG,TIP:W/BINDING POST	80009	134-0016-01
	003-0120-00			1						LEAD,TEST:PAIR	80009	003-0120-00
-6	159-0016-00			2						FUSE,CARTRIDGE:3AG,1.5A,250V,FAST-BLOW (FOR 115V OPERATION)	71400	AGC 1 1/2
	159-0042-00			2						FUSE,CARTRIDGE:3AG,0.75A,250V,FAST-BLOW (FOR 230V OPERATION)	71400	AGC 3/4
	016-0592-00			1						VISOR,CRT:	80009	016-0592-00
	070-1753-01			1						MANUAL,TECH:SERVICE	80009	070-1753-01
	070-1737-00			1						MANUAL,TECH:OPERATORS	80009	070-1737-00
	070-1779-00			1						MANUAL,TECH:SERVICE,DM40/DM43	80009	070-1779-00
	070-2036-01			1						MANUAL,TECH:SERVICE	80009	070-2036-01

REV NOV 1982

466 OSCILLOSCOPE

## **MANUAL CHANGE INFORMATION**

At Tektronix, we continually strive to keep up with latest electronic developments by adding circuit and component improvements to our instruments as soon as they are developed and tested.

Sometimes, due to printing and shipping requirements, we can't get these changes immediately into printed manuals. Hence, your manual may contain new change information on following pages.

A single change may affect several sections. Since the change information sheets are carried in the manual until all changes are permanently entered, some duplication may occur. If no such change pages appear following this page, your manual is correct as printed.

DESCRIPTION

EFF SN: B153450 (M46555, M46860, M47423)

M46555

REPLACEABLE MECHANICAL PARTS LIST CHANGES

A6 INTERFACE Board

REMOVE: sockets for....

U1724

U1762

PN: 136-0514-00 2 SKT, PL-IN ELEC: MICROCKT, 8 DIP

A10 STORAGE & LOGIC Board

REMOVE: sockets for....

U1846

U1878

PN: 136-0260-02 2 SKT, PL-IN ELEC: MICROCKT, 16 DIP, LOW CLE

U1866

U1872

U1874

U1876

PN: 136-0269-02 4 SKT, PL-IN ELEC: MICROCKT, 14 DIP, LOW CLE

U1844

PN: 136-0514-00 1 SKT, PL-IN ELEC: MICROCKT, 8 DIP

A5 TRIG GEN/SWP LOGIC Board

REMOVE: sockets for....

U540

U640

PN: 136-0260-02 2 SKT, PL-IN ELEC: MICROCKT, 16 DIP, LOW CLE

CHANGE: socket for....

U980

PN: 136-0752-00 1 SKT, PL-IN ELEC: MICROCKT, 20 DIP

M46860

REPLACEABLE MECHANICAL PARTS LIST CHANGES

CHANGE: Fig 1-134

PN: 361-0609-01 2 SPACER, XFMR: 0.479 X 0.6 X 2.8, AL

M47423

REPLACEABLE ELECTRICAL PARTS LIST CHANGES

CHANGE:

R31 317-0150-00 RES, FXD, CMPSN: 15 OHM, 5%, 0.125W