

**Bellcore**

---

SPECIAL REPORT  
SR-2275  
ISSUE 3, DECEMBER 1997

# Bellcore Notes on the Networks

*Bellcore*



**BELLCORE  
DOCUMENTATION PRODUCTION AND CONTROL  
NOTICE OF DOCUMENTATION UPDATE**

Project Name \_\_\_\_\_

<p>Type of Update</p> <p>( ) Initial Release of New Document</p> <p>( ) Maintenance Release to Existing Document</p>
--

<p>Documentation Title <u>Bellcore Notes on the Networks</u></p> <p>Documentation Identification <u>SR-2275</u></p> <p>Issue/Revision, Date <u>Issue 3, December 1997</u></p> <p>First/Current Compatible System Release/Version _____</p> <p>Date Required at Destination _____</p>
--

Reason For Update/Comments; Associated MRs:	
<p>_____</p> <p>Supervisor Initials/Date</p>	<p>_____</p> <p>Originator Initials/Date</p>

_____	_____
Project Approval	Date



---

SPECIAL REPORT  
SR-2275  
ISSUE 3, DECEMBER 1997

# Bellcore Notes on the Networks

Prepared for Bellcore by:  
Information Infrastructure, Standards, and Forum Department

For further information, please contact:

A.L. Carey

J.C. Staats

Copyright © 1994, 1997 Bellcore.

All rights reserved.

---



---

## SPECIAL REPORT NOTICE OF DISCLAIMER

This Special Report is published by Bell Communications Research, Inc. (Bellcore) to inform the industry of topics discussed in *Bellcore Notes on the Networks*.

Bellcore reserves the right to revise this document for any reason, including but not limited to, conformity with standards promulgated by various agencies, utilization of advances in the state of the technical arts, or the reflection of changes in the design of any equipment, techniques, or procedures described or referred to herein.

BELLCORE MAKES NO REPRESENTATION OR WARRANTY, EXPRESS OR IMPLIED, WITH RESPECT TO THE SUFFICIENCY, ACCURACY, OR UTILITY OF ANY INFORMATION OR OPINION CONTAINED HEREIN. BELLCORE EXPRESSLY ADVISES THAT ANY USE OF OR RELIANCE UPON SAID INFORMATION OR OPINION IS AT THE RISK OF THE USER AND THAT BELLCORE SHALL NOT BE LIABLE FOR ANY DAMAGE OR INJURY INCURRED BY ANY PERSON ARISING OUT OF THE SUFFICIENCY, ACCURACY, OR UTILITY OF ANY INFORMATION OR OPINION CONTAINED HEREIN.

This document is not to be construed as a suggestion to any manufacturer to modify or change any of its products, nor does this document represent any commitment by Bellcore or any Local Exchange Carrier (LEC) or service provider to purchase any product, whether or not it provides the described characteristics.

Readers are specifically advised that each LEC may have requirements or specifications different from the generic descriptions herein. Therefore, any vendors or manufacturers of products should communicate directly with a LEC or service provider to ascertain that company's needs, specifications and actual requirements.

Nothing contained herein shall be construed as conferring by implication, estoppel or otherwise any license or right under any patent, whether or not the use of any information herein necessarily employs an invention of any existing or later issued patent.

Bellcore does not recommend products and nothing contained herein is intended as a recommendation of any product to anyone.

If further information is required, please contact:

Senior Consultant  
Bellcore  
3 Corporate Place, Room PYA 2F-241  
Piscataway, NJ 08854-4199  
732-699-6927

For general information about this or any other Bellcore documents, please contact:

Bellcore Customer Services  
8 Corporate Place, Room 3A-184  
Piscataway, NJ 08854  
1-800-521-2673 (US & Canada)  
732-699-5800 (all other)  
732-336-2559 (FAX)

or visit

[www.bellcore.com](http://www.bellcore.com)

## Trademark Acknowledgments

Appletalk is a registered trademark of **Apple Computer, Inc.**

CLASS is a service mark of **Bellcore.**

CLCI, CLEI, CLFI, CLLI, ISCP, NMA, SEAS, are trademarks of **Bellcore.**

COMMON LANGUAGE, SPACE, TELEGATE, and TIRKS are registered trademarks of **Bellcore.**

DECNet is a trademark of **Digital Equipment Corporation.**

APPN and IBM 3270 are registered trademarks of **International Business Machines Corporation.**

1/1AESS, 4ESS, 5ESS, Dataphone, and SLC are registered trademarks of **Lucent Technologies, Inc.**

NEAX-61E is a trademark of **NEC America, Inc.**

DMS-10, DMS-100F, DATAPATH, and TOPS are trademarks of **Nortel.**

DMS-100 is a registered trademark of **Nortel.**

EWSD is a registered trademark of **Siemens AG.**



---

## Bellcore Notes on the Networks

### Contents

Foreword.....	Foreword-1
1. Overview .....	1-1
2. Local Access and Transport Areas.....	2-1
2.1 LATA Design Requirements.....	2-1
2.2 Design Exceptions.....	2-2
2.3 LEC Relationship with Other Exchange Companies .....	2-3
2.4 LEC, Offshore, International, and Independent LATA Assignments .....	2-4
3. Numbering Plan and Dialing Procedures.....	3-1
3.1 NANP Number Structure .....	3-2
3.2 Numbering Plan Areas .....	3-2
3.3 Easily Recognizable Codes .....	3-3
3.4 N11 Service Codes.....	3-5
3.5 Central Office Codes.....	3-6
3.6 Line Numbers.....	3-7
3.7 Dialing Procedures .....	3-8
3.8 Dialing Prefixes for Carrier Selection.....	3-13
3.9 Operator Assistance .....	3-13
3.10 International Direct Distance Dialing .....	3-13
3.11 OXX and IXX Codes .....	3-14
3.12 Special Characters (#) and (*).....	3-15
3.13 Vertical Service Codes.....	3-15
3.14 Automatic Number Identification II Digit Assignments.....	3-16
3.15 Local Number Portability.....	3-16
3.16 Number Pooling .....	3-17
3.17 Assignment of 555 Numbers.....	3-17
4. Network Design and Configuration .....	4-1
4.1 Introduction.....	4-1
4.2 Operator Services Systems.....	4-10
4.3 Network Design Considerations .....	4-18
4.4 Blocking Probabilities.....	4-23
4.5 LATA Network Configurations .....	4-24
4.6 Reliability of Equipment and Systems.....	4-42
5. Billing, Customer Data, and Control .....	5-1
5.1 Automatic Message Accounting .....	5-1
5.2 Network Service Evaluation .....	5-8
5.3 Customer Network Services.....	5-9

---

---

5.4	Customer Network Management .....	5-11
6.	Signaling .....	6-1
6.1	Introduction.....	6-1
6.2	Analog Access Line Signaling.....	6-2
6.3	Switching System Interfaces to Access Lines.....	6-23
6.4	Interoffice In-Band Analog Signaling.....	6-31
6.5	On- and Off-Hook Signals .....	6-35
6.6	Controlled Outpulsing.....	6-48
6.7	Loop Signaling.....	6-62
6.8	E&M Signaling .....	6-67
6.9	Duplex Signaling.....	6-86
6.10	Dial Pulsing .....	6-88
6.11	Single-Frequency Signaling .....	6-99
6.12	Multifrequency (MF) Signaling .....	6-110
6.13	Dual-Tone Multifrequency Signaling .....	6-118
6.14	Calling Number Delivery .....	6-136
6.15	LATA Access.....	6-142
6.16	Special Tandem Signaling (CAMA, OSPS, and TOPS Offices).....	6-166
6.17	Signaling From End Offices to Operator Services Systems .....	6-173
6.18	Signaling to Automatic Intercept System .....	6-212
6.19	Carrier Group Alarm .....	6-214
6.20	Call Progress Tones (Audible Tone Signals).....	6-218
6.21	Other Miscellaneous Signals.....	6-230
6.22	Register Timing and Effect on Signaling.....	6-253
6.23	Common Channel Signaling .....	6-254
7.	Transmission.....	7-1
7.1	Introduction.....	7-1
7.2	Network Architecture.....	7-1
7.3	Objectives and Limits .....	7-3
7.4	Voice Transmission Impairments and their Control .....	7-5
7.5	Voiceband Data Transmission Impairments and Their Control .....	7-17
7.6	Digital Transmission.....	7-21
7.7	Digital Data Transmission.....	7-24
7.8	Transmission Aspects of Switches.....	7-27
7.9	Adaptive Differential Pulse-Code Modulation Technology .....	7-31
7.10	Asynchronous Transfer Mode Technology.....	7-32
7.11	End-to-End Performance.....	7-36
7.12	Network Transmission Design.....	7-44
7.13	Operator Services Transmission .....	7-58
7.14	Transmission Limits — IntraLATA Networks.....	7-62
7.15	Loop Transmission — Design and Characterization .....	7-68
7.16	Interoperation with Other Networks .....	7-75
8.	Operations and Maintenance.....	8-1

---

---

8.1	Introduction .....	8-1
8.2	Trunk Maintenance .....	8-2
8.3	Common Channel Signaling .....	8-29
8.4	Switch Diagnostics .....	8-40
8.5	Switching System Maintenance .....	8-47
8.6	Memory Administration .....	8-49
8.7	Facility Maintenance .....	8-50
8.8	Transport System Maintenance .....	8-50
8.9	Loop Maintenance .....	8-55
8.10	Planned Long-Term Network Advancement .....	8-57
8.11	Digital Testing Parameters .....	8-61
9.	Common Systems .....	9-1
9.1	Introduction .....	9-1
9.2	Cross-Connect Systems .....	9-2
9.3	Power Systems .....	9-19
9.4	Network Equipment-Building System .....	9-25
10.	Surveillance and Control .....	10-1
10.1	Network Traffic Management .....	10-2
10.2	Network Service Center (NSC) .....	10-28
11.	Synchronization .....	11-1
11.1	Introduction .....	11-1
11.2	Synchronization Background .....	11-1
11.3	Hierarchical Method of Synchronization .....	11-3
11.4	Internodal Synchronization .....	11-4
11.5	Intranodal Synchronization .....	11-9
11.6	Reliability and Performance .....	11-11
11.7	Interconnection with Other Networks .....	11-12
11.8	Administration .....	11-13
11.9	Synchronization Network Operations .....	11-14
11.10	Synchronization Network Testing .....	11-15
12.	Distribution .....	12-1
12.1	Introduction .....	12-1
12.2	Metallic Loop Conditioning .....	12-5
12.3	BOC Loop Surveys .....	12-7
12.4	Voice-Frequency Channel Terminating Equipment .....	12-19
12.5	Analog Loop Carrier .....	12-20
12.6	Universal Digital Loop Carrier .....	12-20
12.7	Integrated Digital Loop Carrier .....	12-25
12.8	Basic Exchange Radio System .....	12-29
12.9	Integrated Service Digital Network .....	12-32
12.10	Universal Digital Channel .....	12-43
12.11	Distribution Network Physical Structures .....	12-45

---

---

12.12 New Technology .....	12-46
13. Terminal Equipment and Premises Wiring Interconnection.....	13-1
13.1 Introduction.....	13-1
13.2 Scope .....	13-2
13.3 Terminal Equipment Connections.....	13-7
13.4 Grandfather Requirements .....	13-11
13.5 Interface Specifications.....	13-13
13.6 Incidence of Harm.....	13-15
13.7 Compatibility Requirements .....	13-18
13.8 Testing and Maintenance .....	13-19
14. Network Architectures and Services.....	14-1
14.1 Introduction.....	14-1
14.2 Common Channel Signaling .....	14-2
14.3 CLASS Services.....	14-14
14.4 Service Enabling Technologies — Simplifying the User Interface .....	14-22
14.5 Line Information Database Services .....	14-29
14.6 Toll-Free Database Service .....	14-41
14.7 Advanced Intelligent Network.....	14-58
14.8 Integrated Service Control Point.....	14-71
14.9 Integrated Services Digital Network.....	14-87
14.10 Public Switched Digital Service.....	14-117
14.11 Public Packet Switched Service.....	14-127
14.12 Asynchronous Transfer Mode (ATM)-Based Broadband Integrated Services Digital Network (B-ISDN).....	14-142
14.13 Frame Relay .....	14-178
14.14 Switched Multi-megabit Data Service .....	14-184
14.15 Synchronous Optical Network.....	14-190
15. Exchange Access.....	15-1
15.1 Points of Presence .....	15-1
15.2 Expanded Interconnection.....	15-1
15.3 Switched-Access Service .....	15-2
15.4 Special-Access Service .....	15-12
15.5 Other Network Services .....	15-15
15.6 Interconnecting Entities .....	15-17
15.7 Transmission .....	15-18
15.8 Signaling .....	15-18
15.9 Automatic Message Accounting Measurement Requirements .....	15-19
16. Mobile Services Interconnection .....	16-1
16.1 Wireless Services Providers.....	16-1
16.2 Interconnection Types.....	16-3
16.3 Optional Features .....	16-33
16.4 Conventional 2-Way Mobile Service.....	16-33

---



---

16.5	Land-to-Mobile Calls .....	16-37
16.6	Transmission and Signaling Requirements .....	16-37
16.7	Common-Carrier Paging Systems .....	16-40
16.8	FCC Part 90 Private Carriers.....	16-44
16.9	CT2 Concept .....	16-45
16.10	Personal Communications Services .....	16-45
17.	Open Network Architecture .....	17-1
17.1	Common ONA Model.....	17-1
17.2	Basic Serving Arrangement Categories .....	17-3
17.3	Regulatory Background .....	17-21
18.	Industry Forums and Standards Committees .....	18-1
18.1	Overview .....	18-1
18.2	Asynchronous Transfer Mode (ATM) Forum.....	18-1
18.3	Internet Engineering Task Force (IETF).....	18-2
18.4	Intelligent Network Forum (IN Forum) .....	18-2
18.5	Digital Audio-Visual Council (DAVIC).....	18-3
18.6	International Telecommunications Union - Telecommunications (ITU-T)..	18-3
18.7	International Telecommunications Advisory Committee -Telecommunications (ITAC-T) .....	18-6
18.8	Telecommunications Industry Association (TIA).....	18-7
18.9	Alliance for Telecommunications Industry Solutions.....	18-9
19.	Interexchange Access/Local Exchange Services Ordering.....	19-1
19.1	Access Service Ordering .....	19-1
19.2	Local Exchange Access Ordering .....	19-2
19.3	Access Service Ordering Guidelines (ASOG) .....	19-3
19.4	Local Service Ordering Guidelines (LSOG).....	19-7
	.....Glossary-1	
	References .....	References-1

---



---

## Foreword

*Bellcore Notes on the Networks*, Issue 3, replaces all previous issues. The subjects discussed in this document have been updated to reflect changes in the industry since the 1994 issue of the document. Regulatory rulings, the Telecommunications Act, judicial decisions, and industry standards and forum activities have contributed to the changes.

*Notes* is a Special Report published by Bellcore to provide its view of technical topics related to *typical* LEC switched network characteristics. It is not a generic requirements document. No part of the text constitutes or suggests a requirement on the part of any LEC or entity. Attempts have been made to ensure that information contained herein is recent and reliable. However, due to the constant evolution in technology and its associated documentation, the most current information available regarding topics of interest should be sought.

Requirements and specifications for the various components that constitute LEC networks are generally contained in Bellcore generic requirements publications (GRs) or standards documents where actual requirements are clearly identified and described. Where possible, specific references have been included in this document. To adequately explain the technical attributes and operating functions of various parts of the networks, it has been necessary in some cases to refer to specific manufacturers' equipment or systems currently in widespread use. These references do not constitute a recommendation of the specific equipment or their manufacturers by Bellcore. Throughout this document, the reader is referred to numerous sources for additional information on the topics presented.

*Notes* contains technical material of interest to engineering and planning groups, as well as descriptions of the characteristics and background of these subjects in layman's terms. This issue of *Notes* provides an overview of some of the typical technical characteristics and basic operating principles of switched access and transport networks. New technologies, systems, and network services that have evolved since the 1994 issue and that are available and commonly deployed as of mid-year 1997 have been included. Interconnection arrangements between LECs and other entities that currently exist in some or all of the LEC switched networks are also covered. Experimental, local-application, or individual-case basis arrangements are not covered in this document.

Readers familiar with previous issues of *Notes* will find a new section, *Interexchange Access/Local Exchange Access Ordering*, as well as changes in format and content designed to make the material useful regardless of the readers' technical background. Changes to the placement of text were minimized because many readers have become familiar with the way this document has been arranged. Section 1, *Overview*, explains text organization and content in further detail.

---

To ensure that telecommunications entities are referred to in a manner consistent with legal, regulatory, and industry conventions, it is necessary to use a variety of terms (and acronyms) to differentiate between types of LECs. These are explained as follows:

- LEC — Local Exchange Carrier refers to any and all exchange carriers that provide telecommunications exchange and exchange-access service.
- BOC — Bell Operating Company refers to a LEC that was part of the former Bell System.
- Independent LEC — Independent Local Exchange Carrier refers to a LEC that was not part of the former Bell System.
- Competitive LEC — Competitive Local Exchange Carrier refers to a LEC that operates within the same geographic territory previously the purview of another LEC.

All LEC switched networks are composed of integrated parts that consist of transmission and switching systems, control and signaling processes, and associated operational support systems that are engineered, owned, and managed by each LEC independently. With these networks, the LECs provide, administer, and maintain telecommunications services and offer facilities arrangements to other entities that also provide telecommunications services.

These networks provide two primary functions. One function is an on-demand communication path to connect any two customers' points of termination within the LATA or market area. The other function is to connect these points of termination to the point of termination of another entity providing telecommunications services to its end users for the purpose of exchanging information.

Each LEC has an individual business plan that guides its deployment and operations activities, so many of the characteristics described may not apply to a particular LEC network. These plans vary greatly between companies, and obviously affect individual company purchasing and deployment decisions. Current network technology permits LECs to offer a wide variety of service offerings. These offerings vary widely from LEC to LEC, and, at times, within a particular LEC. A virtually identical service may be offered by several LECs under different names, prices, and/or arrangements. Availability and compatibility information changes almost daily. The serving LEC has the most current, detailed, and specific information about its individual offerings, deployment status, and specifications.

Joint planning between the LECs (wherever practical and appropriate) contributes to the provisioning of least-cost telecommunications services. To encourage such efforts, much of the information contained in this issue was reviewed by subject-matter experts of Bellcore, the BOCs, the United States Telephone Association (USTA), the National

---

Telephone Cooperative Association (NTCA), and the Organization for the Protection and Advancement of Small Telephone Companies (OPASTCO).

Individual differences between LECs, the effects of state regulatory bodies, and other factors are beyond the scope and technical focus of this issue. *Notes* does, however, furnish much of the information needed by the telecommunications industry, regulators, consultants, and vendors, to maintain and/or interact with the LEC networks.

This document, although broad in scope, cannot cover all of the detailed technical characteristics of each LEC's continually evolving switched network. For details of specific capabilities or services offered in any particular area, contact the carriers or service providers serving that area. Both Bellcore and individual LECs may also have more detailed material available.



---

## Section 1 Overview Contents

1. Overview .....	1-1
Section 2 — Local Access and Transport Areas.....	1-1
Section 3 — Numbering Plan and Dialing Procedures.....	1-2
Section 4 — Network Design and Configuration .....	1-2
Section 5 — Billing, Customer Data, and Control .....	1-2
Section 6 — Signaling .....	1-2
Section 7 — Transmission .....	1-3
Section 8 — Operations and Maintenance.....	1-3
Section 9 — Common Systems .....	1-3
Section 10 — Surveillance and Control.....	1-3
Section 11 — Synchronization .....	1-3
Section 12 — Distribution .....	1-4
Section 13 — Terminal Equipment and Premises Wiring Interconnection.....	1-4
Section 14 — Network Architectures and Services.....	1-4
Section 15 — Exchange Access.....	1-5
Section 16 — Mobile Services Interconnection .....	1-5
Section 17 — Open Network Architecture .....	1-5
Section 18 — Industry Forums and Standards Committees .....	1-5
Section 19 — Interexchange Access/Local Exchange Services Ordering.....	1-5





---

## 1. Overview

*Bellcore Notes on the Networks*, Issue 3, is a widely recognized telecommunications primer presenting an encyclopedia-style overview of numerous technologies and topics regarding today's Local Exchange Carrier (LEC) networks. *Notes* deals with complex, highly technical subjects, but presents the information in a way that makes it accessible and understandable to a variety of readers. *Notes* has been written with two audiences in mind; the technical and non-technical reader. While it provides sufficient detail to serve as a reference document for the technical reader, and it also was written to distill technical concepts in such a way that they are understandable to the non-technical audience.

The Table of Contents is comprehensive, and probably will be most useful to the technical reader. This is a reference document, and section titles that are useful to the technical reader may not be very useful to a non-technical reader. For that reason, this overview has been provided along with introductory material at the beginning of each section. The following paragraphs provide a very brief description of the purpose of each section. These will help guide non-technical readers to those sections of *Notes* that contain the needed information. Once there, introductory material in each section provides more specific information.

The last section of *Notes* is the Glossary, which contains acronyms, abbreviations, definitions, and symbols. The telecommunications industry, like any other highly technical and growing industry, has its own language. Any reader may, from time to time, encounter words or phrases that are not familiar, so the Glossary is included as a guide to meaning and usage. An Index has also been provided for easier access to a particular subject.

*Notes* is not a comprehensive document, nor is it a requirements document. Further, each LEC designs and implements its network based on its own individual business plans. Therefore, the parameters and configurations of some networks are not covered in this document. Special services, experimental services, and services not yet commonly deployed are not discussed.

## Section 2 — Local Access and Transport Areas

Local Access and Transport Areas (LATAs) define a geographic location based on a number of non-geographic considerations. Most LECs recognize the LATA as the boundary of a service area, and *Notes* only addresses the parts of messages (e.g., voice, data, signaling) that originate and complete within these boundaries. Listed by region is each LATA and the associated Numbering Plan Areas (NPAs).

### **Section 3 — Numbering Plan and Dialing Procedures**

In order to be delivered, messages must be uniformly addressed via a unique telephone number and routed. The calling customer supplies much of the address, and the network adds the remainder of the address and usually defines call routing. There are many networks and geographic destinations, so standardization of the telephone numbering plan and dialing procedures is critical to ensure that telecommunication within and between networks can occur. The growth in the number of messages and the advent of Local Number Portability have necessitated expansions and changes in the numbering plan and dialing procedures, as well as the process for routing telephone calls.

### **Section 4 — Network Design and Configuration**

Networks are configured based on a variety of economic, statistical, and other principles. Network configuration and its designed routing determines how a message travels to its destination. While most messages are dialed by the customer and handled within the LEC networks, additional entities or services (interexchange carriers or operator assistance) are available. The customer expects reliability from the telecommunications networks, which are regularly evaluated to ensure a high level of end-to-end service.

### **Section 5 — Billing, Custom Data, and Control**

Message information is recorded, usually in the early stages of the call, for accounting, billing, or routing purposes. Customers who require additional message detail and/or control of their network configuration can purchase LEC services (where available) that allow access to private call detail and/or customer management of limited parts of the customer network serving arrangement.

### **Section 6 — Signaling**

Signaling refers to the sending and receiving of control information between the parts of a telecommunications network handling a message. These signals determine message status, routing, handling, control functions, billing, and access capability to other networks. Each network part must have consistent signaling protocols to handle messages within and between networks. This information is carried either on the routes or channels controlled (circuit-associated signaling), or it travels on a separate shared (common) channel used to convey this information. Due to the almost overwhelming number of potential combinations of terminal equipment, switching systems, operations systems, and other network parts, a vast amount of information must be available to address message delivery possibilities.

---

---

## Section 7 — Transmission

Any message is subject to a variety of conditions that will improve or impair its transmission. Network architecture describes the various necessary parts that provide end-to-end message connectivity. Each network part has a set of conditions to which it is vulnerable, and that must be considered as messages are passed through LEC networks.

## Section 8 — Operations and Maintenance

Virtually every message must physically travel through one or more switching systems in at least one network before reaching its destination. Therefore, an effective overall maintenance plan to provide high-quality service at a reasonable cost is imperative. Because switching and support systems are closely related within and between networks, inadequate maintenance in any one system can affect any other related system. Continued automation, necessitated by the rapid growth in number and complexity of messages, requires highly evolved diagnostic and maintenance plans.

## Section 9 — Common Systems

While there are many types of switching systems, there are features common to almost every type. These common systems include the building systems for the physical switch location, systems that provide power to the switching equipment, and the cross-connect systems that perform multiple functions in addition to acting as the point where the line or channel connects to the switching system.

## Section 10 — Surveillance and Control

To ensure the economical use of networks and to maintain vital telecommunications services, networks are commonly equipped with surveillance and control capabilities. These capabilities allow for network traffic management, network servicing, and service evaluation. Network surveillance and control also ensure maintenance of a high level of network elements utilization, minimize the effect of network overloads, and support the LEC commitments to National Security/Emergency Preparedness (NS/EP).

## Section 11 — Synchronization

Relying solely on its internal timing source, a stand-alone unit of digital equipment may function adequately. However, when two or more units are connected via digital facilities, synchronized clock sources or timing is required. Without synchronization, messages are lost or erroneously repeated.

---

## **Section 12 — Distribution**

The distribution network is where the network connects to individual customers. In descending size order, which coincides to the order in which the facility extends from the switching system to the customer, the typical distribution network order is feeder plant, distribution plant, and the loop that connects the customer to the network. The distribution network can be composed of metallic cable, fiber-optic cable, radio, or a combination of the three, and frequently includes electronic or cross-connect equipment.

## **Section 13 — Terminal Equipment and Premises Wiring Interconnection**

In addition to network access via a loop, terminal equipment such as a telephone, data terminal, or private switching equipment must be connected with the Public Switched Telephone Network (PSTN). Federal Communications Commission (FCC) rules exist regarding terminal equipment manufacture, shipping tolerances, and interconnection characteristics to protect the public network from potential harm. Compatibility requirements are specified, and respective responsibilities of the customer and the LEC are defined. This section contains general information on the FCC registration program and the demarcation point specifications.

## **Section 14 — Network Architectures and Services**

Many customers require additional capabilities to meet their telecommunications needs. These services provide specialized features but generally still use part or all of the public network. These architectures and the services they enable are relatively new and actively evolving. The services presented in this section include CLASS services, Alternate Billing Service (ABS), 800 Data Base Service, Advanced Intelligent Network (AIN), Integrated Service Control Point (ISCP), Integrated Services Digital Network (ISDN), Asynchronous Transfer Mode (ATM) based Broadband Integrated Services Digital Network (BISDN), Public Switched Digital Service (PSDS), Public Packet Switched Service (PPSS), Frame Relay (FR), Switched Multi-megabit Data Service (SMDS), and Synchronous Optical Network (SONET). Common Channel Signaling (CCS) is a basic building block of the first seven of the services listed above. PSDS, PPSS, SMDS, FR, and SONET are new high speed transport services or architectures and are also included in this section. Other service enabling technologies designed to simplify the user interface are also described, and include the Analog Display Services Interface (ADSI), Voice Activated Dialing (VAD), and Voice Activated Network Control (VANC).

---

---

## Section 15 — Exchange Access

In most cases, LECs are precluded from providing network services that extend beyond their boundaries. Exchange access is provided to interconnecting entities (such as interexchange carriers) by LECs so that these entities can provide telecommunication services between LATAs (interLATA) to end-user customers.

## Section 16 — Mobile Services Interconnection

Wireless Services Providers (WSPs) offer services using radio as their transmission medium under FCC license. WSPs require interconnection with the LEC networks, and mobile (wireless carrier) interconnection alternatives and capabilities are addressed in this section.

## Section 17 — Open Network Architecture

Open Network Architecture (ONA) is a regulatory concept created by the FCC to further the FCC's goals of bringing the full benefits of the "Information Age" to the American public. The FCC requires the LECs to offer unbundled Basic Serving Arrangements (BSAs) and Basic Service Elements (BSEs) under tariff so Enhanced Service Providers (ESPs) can access them to provide enhanced services. This section defines the elements and arrangements.

## Section 18 — Industry Forums and Standards Committees

There are many industry forums, standards bodies and associations that operate in the United States and internationally that address various issues related to interconnection, technical standards, reliability and operations in the telecommunications industry. A sampling of the more prominent bodies are described in this section, including the Alliance for Telecommunications Industry Solutions (ATIS), the ATM Forum, the International Telecommunications Union, and others. Information is provided that describes the functions of the organization and its organizational structure, and lists contacts for further information and participation.

## Section 19 — Interexchange Access/Local Exchange Access Ordering

This is a new section added to *Notes* for this issue, and contains information that has been developed to facilitate the ordering of interconnection facilities between interexchange and local exchange carriers. Much of this ordering process has generally been developed at the industry's Ordering and Billing Forum (OBF) of ATIS. The information relates to specific

---

procedures and processes that are necessary to provide the proper ordering, billing, provisioning, and exchange of information between the customer and provider of access services. Industry guidelines for ordering are explained, and various forms that would be used for ordering specific exchange or interexchange access services listed and discussed.

## Section 2 Local Access and Transport Areas Contents

2.	Local Access and Transport Areas.....	2-1
2.1	LATA Design Requirements.....	2-1
2.2	Design Exceptions.....	2-2
2.3	LEC Relationship with Other Exchange Companies .....	2-3
2.4	LEC, Offshore, International, and Independent LATA Assignments.....	2-4

---

## List of Tables

Table 2-1.	Numerical LATA Assignments — NYNEX .....	2-5
Table 2-2.	Numerical LATA Assignments — Bell Atlantic .....	2-6
Table 2-3.	Numerical LATA Assignments — Ameritech .....	2-7
Table 2-4.	Numerical LATA Assignments — BellSouth .....	2-8
Table 2-5.	Numerical LATA Assignments — Southwestern Bell Telephone.....	2-11
Table 2-6.	Numerical LATA Assignments — U S WEST .....	2-12
Table 2-7.	Numerical LATA Assignments — Pacific Bell .....	2-13
Table 2-8.	Numerical LATA Assignments — Others .....	2-14
Table 2-9.	Numerical LATA Assignments — Independents.....	2-16



---

## 2. Local Access and Transport Areas

As part of the divestiture of the Local Exchange Companies (LECs), the Modification of Final Judgment (MFJ) called for the separation of *exchange* and *interexchange* telecommunications functions. Exchange services can be provided by LECs; interexchange services are to be provided by other than LEC entities.

New service territories called Local Access and Transport Areas (LATAs), also referred to as *service areas* by some LECs, were created in response to the MFJ exchange-area requirements. LATAs serve the following two basic purposes:

- They provide a method for delineating the area within which the LECs may offer services
- They provided a basis for determining how the assets of the former Bell System were to be divided between the LECs and AT&T at divestiture.

Appendix B of the MFJ requires each LEC to offer equal access through LEC end offices in a LATA to all Interexchange Carriers (ICs). All carriers must be provided services that are equal in type, quality, and price to those provided to AT&T. In general, such services include, but are not limited to, providing network-control signaling, answer supervision, automatic calling-number identification, Carrier Access Codes (CACs), directory services, testing and maintenance of facilities, and billing data.

### 2.1 LATA Design Requirements

The MFJ, Section IV, 9.1-4, contains specific guidelines for the establishment of LATAs. These Court-approved requirements are listed below.

- Any area may encompass one or more contiguous local exchanges serving common social, economic, and other purposes — even where such configuration transcends municipal or other local-government boundaries.
- Every point served by a LEC within a state will be included within an exchange area. Any area that includes part or all of one Standard Metropolitan Statistical Area (SMSA),<sup>1</sup> or a Standard Consolidated Statistical Area (SCSA) in the case of densely populated states, needs Court approval to include a substantial part of any other SMSA or SCSA.
- Except with Court approval, no exchange area located in one state may include any point located within another state.

---

1. An SMSA is a geographic area defined by the United States Government for the purpose of gathering and reporting federal statistics.

SMSAs became the new basis for LEC service areas. A large-population nucleus (for example, a city) and its adjacent communities have a high degree of economic and social integration and, therefore, have a need to communicate with each other. SMSAs provide the boundaries within which federal agencies compile information on population, housing, industry, trade, employment, and a wide range of other subjects. SCSAs are combinations of two or more related SMSAs.

SMSAs are designated and defined according to published specifications. Under current guidelines, an area qualifies for recognition as an SMSA if it contains a city of at least 50,000 people, or if it contains an urbanized area with a population of 50,000 that is part of a total metropolitan-area population of at least 100,000. The federal government had previously designated a total of 323 SMSAs nationwide, and 50 of the SMSAs were combined to form 17 SCSAs. As a result of the latest review process, both the number of and terminology for statistical areas have changed.

On June 30, 1990, there were 263 Metropolitan Statistical Areas (MSAs) and 20 Consolidated Metropolitan Statistical Areas (CMSAs). These are roughly equivalent to SMSAs and SCSAs, respectively. However, CMSAs are composed of 71 areas called Primary Metropolitan Statistical Areas. LECs are the predominant service providers in 220 of the MSAs and 17 of the CMSAs. But in some cases (for example, Los Angeles), other LECs also serve significant numbers of subscribers.

Several characteristics of MSAs have an impact on LATA design. By definition, MSAs designate only metropolitan areas, and therefore do not cover all areas served by the LECs. MSAs are sometimes contiguous, making the identification of separate communities-of-interest difficult from a telecommunications perspective. MSAs follow county boundaries that frequently do not coincide with local exchange or wire center boundaries. For these and other reasons, LATAs do not directly overlay MSAs. However, the MFJ relies heavily on the use of MSAs in the configuration of LATAs. There are several reasons for this:

- MSAs were defined by the federal government
- MSAs have become a widely accepted method of defining meaningful population groups
- Using MSAs allows areas with a high community-of-interest to remain intact.

Based on the guidelines provided by the MFJ, the LECs designed LATAs to encompass all areas now served by the LECs. Tables 2-1 through 2-7 list the 164 LEC LATAs approved by the Court.

## **2.2 Design Exceptions**

The Court recognized the need for flexibility in determining LATA boundaries and provided for a waiver process. In each case where a waiver was requested, the responsible LEC provided the Court with a detailed description of the factors underlying the request.

---

---

Economic factors and customer considerations determined the type of exception requested. Specific exceptions were granted where the Court was convinced that there were compelling economic or service reasons. In most cases, permanent exceptions from MFJ guidelines were requested and approved. In other cases, the exceptions applied for were temporary in nature.

Generally, permanent exceptions were sought where LATA configurations, if forced into MFJ guidelines, would have created negative social and economic consequences. In each case, care was taken to ensure that the exceptions did not contradict the spirit and purpose of the MFJ. Exceptions were requested to accomplish the following:

- Continue existing service arrangements such as flat-rate, Extended-Area Service (EAS), and privileged-business
- Include nonsubstantial markets
- Preserve existing wire center boundaries
- Preserve existing communities-of-interest
- Minimize disruption to end office toll trunking
- Minimize impact on customers
- Include a tandem arrangement.

Permanent exceptions were requested for LATAs that did not fully meet the boundary requirements contained in Section 2.1, and LATAs were approved with boundaries crossing state lines and containing substantial parts of more than one MSA/CMSA. Some LATAs required exceptions for both reasons.

In some instances, exceptions were requested to permit the LECs to provide certain types of interLATA services. Permission to continue existing long-standing LEC local-calling arrangements and EAS across LATA boundaries were granted by the Court. In addition, *limited corridor* exceptions were required to preserve traditional direct LEC interstate serving arrangements. These exceptions called for LEC-to-LEC, interLATA trunking between, for example, portions of the New Jersey LATAs, and between portions of the Philadelphia LATA and portions of the Delaware Valley (NJ) LATA.

A number of LATAs were approved that contained one MSA/CMSA and a *nonsubstantial* part of another MSA/CMSA. No exceptions were required in these cases.

### 2.3 LEC Relationship with Other Exchange Companies

The MFJ does not impose *equal access* obligation on other LECs, restrict the lines of business in which they may engage, nor restrict the types of services they may provide. Furthermore, there is no deadline on the decision by independent LECs regarding the interexchange of traffic to or from LEC LATAs and associated areas. Under Federal

---

Communications Commission (FCC) rules, independent LECs are also required to provide equal access upon receipt of a bona fide request, when that request does not present an undue implementation burden to the independent LEC.

Analysis of traffic between independent LEC-served areas and LEC LATAs was necessary to determine the nature of the traffic (interLATA versus intraLATA) for the purpose of asset assignment, and to clearly delineate the areas the LECs could serve. The Department of Justice (DOJ) defined the proper approach under the decree as, in general, treating the territory served by an independent company *as if* it were served by a LEC. Thus, if the traffic or facility arrangement would not violate the decree if the territory at issue were served by a LEC, it would not be deemed in violation of the decree by the DOJ if served by an independent company. In addition, guidelines to assist in the classification of traffic were also provided by the DOJ.

The Court has approved the associations of independent LEC exchanges as proposed by the LECs and modified by the DOJ. However, because the independent LECs and LECs must negotiate the business arrangements needed to implement the association, changes can result. In the future, a LEC can petition the Court for a revised classification of particular LEC/independent LEC traffic.

## **2.4 LEC, Offshore, International, and Independent LATA Assignments**

Tables 2-1 through 2-9 provide the LATA assignments for LECs, offshore and international companies, and independent companies. These assignments are also contained in the *Local Exchange Routing Guide (LERG)* which is issued quarterly on paper, and monthly in several soft media, including data tape, CD-ROM, and NDM (a high-speed data transfer over private lines). LATAs in the 8xx series were not used by the Court. They have been assigned by the Traffic Routing Administration (TRA) to identify points in Canada, the Atlantic and the Caribbean.

**Table 2-1.** Numerical LATA Assignments — NYNEX

LATA	LATA Name	NPA1 <sup>a</sup>	NPA2	NPA3	NPA4	NPA5	NPA6
120	Maine	207					
122	New Hampshire	603					
124	Vermont	802					
126	Western Massachusetts	413					
128	Eastern Massachusetts	508	617	781	978		
130	Rhode Island	401					
132	New York Metro, New York	516	212	914	203	718	917
133	Poughkeepsie, New York	914	717				
134	Albany, New York	518	413				
136	Syracuse, New York	315	607				
138	Binghamton, New York	607	717				
140	Buffalo, New York	716	814				

- a. An NPA is a specific geographical area identified by a unique NPA code. The boundaries of an NPA code are normally within a state, province, or subdivision of another country within the North American Numbering Plan (NANP).

**Table 2-2.** Numerical LATA Assignments — Bell Atlantic

LATA	LATA Name	NPA1	NPA2	NPA3	NPA4	NPA5
220	Atlantic Coastal, New Jersey	609				
222	Delaware Valley, New Jersey	609				
224	North Jersey, New Jersey	201	732	908	973	
226	Capitol, Pennsylvania	215	610	717	814	
228	Philadelphia, Pennsylvania	215	302	610		
230	Altoona, Pennsylvania	814				
232	Northeast Pennsylvania	717	814	908		
234	Pittsburgh, Pennsylvania	412	724			
236	Washington, DC	202	301	410	540	703
238	Baltimore, Maryland	301	410			
240	Hagerstown, Maryland	301	410			
242	Salisbury, Maryland	301	410			
244	Roanoke, Virginia	540	615	703		
246	Culpeper, Virginia	540	703			
248	Richmond, Virginia	540	703	804		
250	Lynchburg, Virginia	804	910	919		
252	Norfolk, Virginia	757	804	919		
254	Charleston, West Virginia	304	540	703		
256	Clarksburg, West Virginia	202	304	412		

**Table 2-3.** Numerical LATA Assignments — Ameritech

LATA	LATA Name	NPA1	NPA2	NPA3	NPA4	NPA5	NPA6	NPA7
320	Cleveland, Ohio	216	440					
322	Youngstown, Ohio	216	330	412	440			
324	Columbus, Ohio	614	740					
325	Akron, Ohio	216	330					
326	Toledo, Ohio	313	317	419	765			
328	Dayton, Ohio	513	937					
330	Evansville, Indiana	812						
332	South Bend, Indiana	219						
334	Auburn-Huntington, Indiana	219	419					
336	Indianapolis, Indiana	217	219	317	765			
338	Bloomington, Indiana	618	812					
340	Detroit, Michigan	248	313	517	734	810		
342	Upper Peninsula, Michigan	715	906					
344	Saginaw, Michigan	517						
346	Lansing, Michigan	517						
348	Grand Rapids, Michigan	517	616					
350	Northeastern Wisconsin	414	715	906	920			
352	Northwestern Wisconsin	715	612					
354	Southwestern Wisconsin	608	815					
356	Southeastern Wisconsin	414	608	715	815	920		
358	Chicago, Illinois	312	414	815	219	708	630	847
360	Rockford, Illinois	608	815					
362	Cairo, Illinois	618						
364	Sterling, Illinois	815						
366	Forrest, Illinois	217	309	815				
368	Peoria, Illinois	217	309	618	815			
370	Champaign, Illinois	217						
374	Springfield, Illinois	217						
376	Quincy, Illinois	217						

**Table 2-4.** Numerical LATA Assignments — BellSouth

LATA	Sub-LATA	LATA Name	NPA1	NPA2	NPA3	NPA4	NPA5	NPA6
420		Asheville, North Carolina	704					
422		Charlotte, North Carolina	704	803	864			
424		Greensboro, North Carolina	704	910	919			
426		Raleigh, North Carolina	919					
428		Wilmington, North Carolina	803	843	910	919		
430		Greenville, South Carolina	704	803	864			
432		Florence, South Carolina	803	843				
434		Columbia, South Carolina	803					
436		Charleston, South Carolina	803	843				
438		Atlanta, Georgia	205	334	404	706	770	
440		Savannah, Georgia	803	843	912			
442		Augusta, Georgia	404	706	803	912		
444		Albany, Georgia	912					
446		Macon, Georgia	912					
448		Pensacola, Florida	904	205	334			
448	13	Pensacola, Florida WA-EA*	205	334	850	904		
448	14	Pensacola, Florida CR-EA*	205	334	850	904		
448	15	Pensacola, Florida FW-EA*	850	904				
450		Panama City, Florida	904	912				
450	09	Panama City, Florida PC-EA*	850	904				

\* In Florida only, 5-digit LATA numbers exist, which represent Equal-Access Exchange Areas (EAEAs). Based on Florida Public Service Commission Order 13750, Docket 820537-TP of October 5, 1984: "EAEAs are geographic areas, configured based on 1987 planned toll center/access tandem areas, in which the (Telephone) Company is responsible for providing equal access to both carriers and end users in the most economically efficient manner. In an EAEA, ICs (interexchange carriers) and resellers may have one or more points of presence so long as any additional costs incurred by the Company in providing such alternate or additional point of presence be paid by the party choosing such location as primary point of connection will be provided by the Company in each EAEA."



**Table 2-4. Numerical LATA Assignments — BellSouth (Continued)**

LATA	Sub-LATA	LATA Name	NPA1	NPA2	NPA3	NPA4
450	10	Panama City, Florida SJ-EA*	850	904	912	
450	11	Panama City, Florida QC-EA*	850	904		
450	12	Panama City, Florida MR-EA*	850	904		
452		Jacksonville, Florida	904			
452	04	Jacksonville, Florida CL-EA*	904			
452	05	Jacksonville, Florida LO-EA*	904			
454		Gainesville, Florida	904			
454	02	Gainesville, Florida NW-EA*	352	904		
454	03	Gainesville, Florida OL-EA*	904	352		
456		Daytona Beach, Florida	904			
456	01	Daytona Beach, Florida PO-EA*	904			
458		Orlando, Florida	305	407	904	
458	06	Orlando, Florida OR-EA*	305	407		
458	07	Orlando, Florida LB-EA*	407			
458	08	Orlando, Florida WI-EA*	904	407		
460		Southeastern Florida	305	407	561	954
460	17	Southeastern Florida* GG-EA	305	954		
460	18	Southeastern Florida* GR-EA	407	561		
462		Louisville, Kentucky	502	812		
464		Owensboro, Kentucky	502	615	901	931
466		Winchester, Kentucky	423	502	606	615

\* In Florida only, 5-digit LATA numbers exist, which represent Equal-Access Exchange Areas (EAEAs). Based on Florida Public Service Commission Order 13750, Docket 820537-TP of October 5, 1984: "EAEAs are geographic areas, configured based on 1987 planned toll center/access tandem areas, in which the (Telephone) Company is responsible for providing equal access to both carriers and endusers in the most economically efficient manner. In an EAEA, ICs (interexchange carriers) and resellers may have one or more points of presence so long as any additional costs incurred by the Company in providing such alternate or additional point of presence be paid by the party choosing such location as primary point of connection will be provided by the Company in each EAEA."

**Table 2-4. Numerical LATA Assignments — BellSouth (Continued)**

LATA	LATA Name	NPA1	NPA2	NPA3	NPA4	NPA5	NPA6
468	Memphis, Tennessee	901	502	601			
470	Nashville, Tennessee	205	423	502	615	931	
472	Chattanooga, Tennessee	615	205	404	704	706	423
474	Knoxville, Tennessee	606	704	423			
476	Birmingham, Alabama	205					
477	Huntsville, Alabama	205	601				
478	Montgomery, Alabama	205	912	334			
480	Mobile, Alabama	205	228	334	601	850	904
482	Jackson, Mississippi	205	318	334	504	601	901
484	Biloxi, Mississippi	228	504	601			
486	Shreveport, Louisiana	318	501	870	903		
488	Lafayette, Louisiana	318					
490	New Orleans, Louisiana	504	601				
492	Baton Rouge, Louisiana	504					

**Table 2-5.** Numerical LATA Assignments — Southwestern Bell Telephone

LATA	LATA Name	NPA1	NPA2	NPA3	NPA4	NPA5	NPA6	NPA7
520	St. Louis, Missouri	314	573	618				
521	Westphalia, Missouri	314	573					
522	Springfield, Missouri	316	417	501	870	918		
524	Kansas City, Missouri	417	660	712	785	816	913	
526	Fort Smith, Arkansas	501	417	918				
528	Little Rock, Arkansas	314	501	573	870	918		
530	Pine Bluff, Arkansas	318	501	870				
532	Wichita, Kansas	316	405	417	719	918		
534	Topeka, Kansas	303	308	402	785	913		
536	Oklahoma City, Oklahoma	405	806					
538	Tulsa, Oklahoma	316	918					
540	El Paso, Texas	505	915					
542	Midland, Texas	915						
544	Lubbock, Texas	806						
546	Amarillo, Texas	405	505	719	806			
548	Wichita Falls, Texas	817	940					
550	Abilene, Texas	915						
552	Dallas, Texas	214	254	817	903	940	972	
554	Longview, Texas	214	501	870	903	972		
556	Waco, Texas	254	817					
558	Austin, Texas	512						
560	Houston, Texas	281	409	713				
562	Beaumont, Texas	409						
564	Corpus Christi, Texas	512						
566	San Antonio, Texas	210	512	830	956			
568	Brownsville, Texas	210	830	956				
570	Hearne, Texas	409						

**Table 2-6.** Numerical LATA Assignments — U S WEST

LATA	LATA Name	NPA1	NPA2	NPA3	NPA4	NPA5	NPA6	NPA7
620	Rochester, Minnesota	507	319	605	712	515		
624	Duluth, Minnesota	218	715					
626	St. Cloud, Minnesota	612	605	218	320			
628	Minneapolis, Minnesota	612	218	507	320			
630	Sioux City, Iowa	712	402	605	507			
632	Des Moines, Iowa	319	507	515	660	712	816	
634	Davenport, Iowa	309	319	608	660	815	816	
635	Cedar Rapids, Iowa	319	507					
636	Brainerd-Fargo, North Dakota	701	218	605				
638	Bismark, North Dakota	701	406	605				
640	South Dakota	605	307	308	402	406	507	701
644	Omaha, Nebraska	308	402	660	712	816		
646	Grand Island, Nebraska	303	307	308	605	785	913	970
648	Great Falls, Montana	406	208					
650	Billings, Montana	406	307	701				
652	Idaho	208	307	435	503	509	541	702
654	Wyoming	208	303	307	308	406	435	605
656	Denver, Colorado	303	307	308	435	970		
658	Colorado Springs, Colorado	303	719					
660	Utah	208	307	406	435	520	602	702
664	New Mexico	505	915					
666	Phoenix, Arizona	435	520	602	619	702	760	801
668	Tucson, Arizona	602	505	520				
670	Eugene, Oregon	503	530	541	916			
672	Portland, Oregon	206	253	360	425	503	509	541
674	Seattle, Washington	206	253	360	425			
676	Spokane, Washington	208	503	509	541			

**Table 2-7.** Numerical LATA Assignments — Pacific Bell

LATA	LATA Name	NPA1	NPA2	NPA3	NPA4	NPA5	NPA6	NPA7
720	Reno, Nevada	530	541	702	916			
721	Pahrump, Nevada	702						
722	San Francisco, California	408	415	510	650	707		
724	Chico, California	530	916					
726	Sacramento, California	530	707	916				
728	Fresno, California	209						
730	Los Angeles, California	213	310	520	562	602	619	626
732	San Diego, California	619	760					
734	Bakersfield, California	805						
736	Monterey, California	408						
738	Stockton, California	209						
740	San Luis Obispo, California	805						

**Table 2-8.** Numerical LATA Assignments — Others

LATA	LATA Name	NPA1	NPA2	NPA3	NPA4	NPA5	NPA6	NPA7
821	Anguilla	264						
823	Antigua	268						
825	Barbados	246						
827	Bermuda	441						
829	British Virgin Island	284						
841	Cayman Islands	345						
842	Dominica	767						
843	Grenada	473						
844	Montserrat	664						
845	St. Kitts & Nevis	869						
846	St. Lucia	758						
847	St. Vincent	784						
848	Trinidad & Tobago	868						
849	Turks & Caicos	649						
820	Puerto Rico	787						
822	Virgin Islands	340						
824	Bahamas	242						
826	Jamaica	876						
828	Dominican Republic	809						
832	Alaska	907						
834	Hawaii	808						
836	Midway-Wake	808						
838	Mexico	521	881	882	883	885		
850	On Qc Ab	418	514	613	705	807	819	905
851	Ontario	416	418	514	519	613	705	807
870	No. Mariana Islands	670						
871	Guam	671						
881	Alberta	403	902					
882	British Columbia	250	604					
883	Quebec	418						
884	Alberta	403	889					
885	Newfoundland	709						

**Table 2-8.** Numerical LATA Assignments — Others

---

LATA	LATA Name	NPA1	NPA2	NPA3	NPA4	NPA5	NPA6	NPA7
886	British Columbia	250	403	604				
887	NS & Prince Ed Island	902						
888	Manitoba	204						
889	NS & Prince Ed Island	902						
890	New Brunswick	506						
891	Saskatchewan	306						
892	Ab & YT	250	403	604	819	867	889	

---

**Table 2-9.** Numerical LATA Assignments — Independents

LATA	Sub-LATA	LATA Name	NPA1	NPA2	NPA3	NPA4	NPA5	NPA6	NPA7
920		Connecticut	203	860					
921		Fishers Island, New York	516						
922		Cincinnati, Ohio	513	606	812	937			
923		Lima-Mansfield, Ohio	216	330	419	513	614	740	937
924		Erie, Pennsylvania	814						
927		Harrisonburg, Virginia	703	540					
928		Charlottesville, Virginia	703	804					
929		Edinburg, Virginia	703	540					
930		Eppes Fork, Virginia	804						
932		Bluefield, West Virginia	304	703	540				
937		Richmond, Indiana	317	513	765	937			
938		Terre Haute, Indiana	217	812					
939		Ft. Myers, Florida	813	941					
939	01	Avon Park, EA FL	813	941					
939	02	Ft. Myers, EA FL	813	941					
949		Fayetteville, North Carolina	919	910					
951		Rocky Mount, North Carolina	919	804					
952		Tampa, Florida	813	941					
953		Tallahassee, Florida	850	904					
956		Bristol-Johnson City, Tennessee	615	703	540	423			
958		Lincoln, Nebraska	402	712	785	913			
960		Couer D'Alene, Idaho	208	509	406				
961		San Angelo, Texas	915						
963		Kalispell, Montana	406						
973		Palm Springs, California	619	760					
974		Rochester, New York	716						
976		Mattoon, Illinois	217						
977		Macomb, Illinois	309	217					
978		Olney, Illinois	618						
980		Navajo Territory, Arizona	602	520					
981		Navajo Territory, Utah	435	801					
999		Reserved for svcs	900	500	504				



---

## Section 3 Numbering Plan and Dialing Procedures Contents

3.	Numbering Plan and Dialing Procedures.....	3-1
3.1	NANP Number Structure .....	3-2
3.2	Numbering Plan Areas .....	3-2
3.2.1	NPA Code Format and Capacity.....	3-2
3.2.2	NPA Code Assignment .....	3-3
3.3	Easily Recognizable Codes .....	3-3
3.3.1	Media Representation of Easily Recognizable Codes .....	3-4
3.4	N11 Service Codes .....	3-5
3.4.1	Unassigned Service Codes .....	3-5
3.4.2	Universal Emergency Number.....	3-5
3.4.3	N99 Codes.....	3-6
3.5	Central Office Codes.....	3-6
3.5.1	Central Office Code Format and Capacity.....	3-6
3.5.2	Central Office Code Assignments.....	3-6
3.5.3	Code Conservation and Relief .....	3-6
3.6	Line Numbers.....	3-7
3.6.1	Line Number Format and Capacity.....	3-7
3.6.2	Line Number Assignments.....	3-7
3.6.3	Coin Station Numbering .....	3-8
3.7	Dialing Procedures .....	3-8
3.8	Dialing Prefixes for Carrier Selection.....	3-13
3.9	Operator Assistance .....	3-13
3.10	International Direct Distance Dialing .....	3-13
3.11	0XX and 1XX Codes .....	3-14
3.12	Special Characters (#) and (*).....	3-15
3.13	Vertical Service Codes.....	3-15
3.14	Automatic Number Identification II Digit Assignments.....	3-16
3.15	Local Number Portability.....	3-16
3.16	Number Pooling .....	3-17
3.17	Assignment of 555 Numbers.....	3-17

---

## List of Figures

Figure 3-1.	International Telephone Number Format .....	3-1
-------------	---	-----

## List of Tables

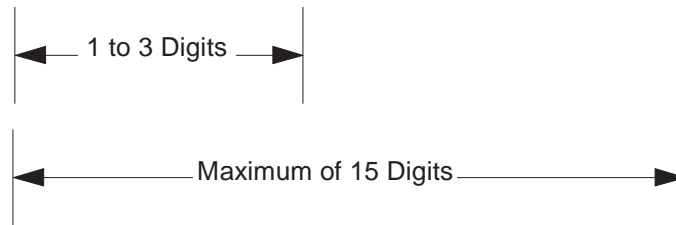
Table 3-1.	NANP Telephone Number Format.....	3-2
Table 3-2.	Service Code Assignments .....	3-5
Table 3-3.	Major Dialing Options.....	3-8
Table 3-4.	Recommended Dialing Procedure for Directory Assistance Under Feature Group D .....	3-10
Table 3-5.	Treatment of 0 and 00 Dialed Calls from Equal-Access End Offices .....	3-11
Table 3-6.	Dialing Procedures Available with Feature Group D.....	3-12
Table 3-7.	NPA Codes in Alphabetical Order (as of September 1997).....	3-19
Table 3-8.	NPA Codes in Numerical Order (as of September 1997) .....	3-21

---

### 3. Numbering Plan and Dialing Procedures

All domestic telecommunications numbering plans for public networks conform to the major aspects of standards established by the International Telecommunication Union—Telecommunication Standardization Sector (ITU-T).<sup>1</sup> Recommendation E.164, revised in 1977, defines international telephone numbers to be in the format shown in Figure 3-1.

Country Code (CC) + National (Significant) Number (N(S)N)



**Figure 3-1.** International Telephone Number Format

Country codes, which may be 1, 2, or 3 digits in length, are assigned by the ITU-T and reported in an annex to Recommendation E.164. Within the geographic area designated for each country code, the local administration may define its own national numbering plan. The combined length of the country code and national (significant) number cannot exceed 15 digits.

Country code “1” is shared by 18 countries in North America. Within this area, national numbers are formatted according to the North American Numbering Plan (NANP).

---

1. Formerly the International Telegraph and Telephone Consultative Committee (CCITT).

---

### 3.1 NANP Number Structure

The NANP is based on a destination code principle where each main telephone in the NANP has a specific address assigned to it. NANP numbers are in the 10-digit functional format shown in Table 3-1.

**Table 3-1.** NANP Telephone Number Format

3-Digit Numbering Plan Area (NPA) Code	+	3-Digit Central Office Code	+	4-Digit Station Number
---	---	--------------------------------------	---	------------------------------

NANP numbers may be geographic or non-geographic. Geographic NANP numbers define a hierarchy. The area served by the NANP is divided into distinct geographic areas, called Numbering Plan Areas (NPAs), each of which is assigned a NPA code.

Certain NPA codes identify services rather than geographic areas. The functions of these non-geographic codes are explained in Sections 3.3 and 3.4 below.

Central office (NXX) codes are typically assigned to switching entities/points of interconnection that provide basic switching functions within each NPA. Each central office code can serve as many as 10,000 subscriber lines or station numbers. The subsections that follow describe NPAs, central office codes, and station numbers in more detail.

### 3.2 Numbering Plan Areas

Most NPA codes, also called area codes, identify a geographic area. Tables 3-7 and 3-8 at the end of this section list the NPA codes assigned through September 1997. Updated assignment data is available from the NANP administrator.

#### 3.2.1 NPA Code Format and Capacity

NPA codes are in the following format.

**NXX**

where N is any digit 2 through 9

X is any digit 0 through 9.

---

This NXX format provides a total of 792 NPA codes, calculated as follows:

Maximum NPA codes available with NXX format (8*10*10)	800
Less reserved codes of N11 format (see Section 3.4)	8
Total NPA codes available for assignment	792

### 3.2.2 NPA Code Assignment

NPA codes are assigned by the NANP administrator in accordance with guidelines developed by the Industry Numbering Committee (INC). The document is entitled INC 96-0308-011, *NPA Allocation Plan and Assignment Guidelines*. Documents developed and maintained by the INC may be downloaded from the home page of the Alliance for Telecommunications Industry Solutions (ATIS) at [www.atis.org](http://www.atis.org).

NPAs were created and designed in ways that maximize caller understanding while minimizing both dialing effort and equipment cost. There are several principles to be considered in planning NPA boundary changes due to either the introduction of new NPAs or the realignment of existing NPA boundaries. These principles are included in INC 97-0404-016, *NPA Code Relief Planning and Notification Guidelines*.

### 3.3 Easily Recognizable Codes

NPA codes in the format NZZ, where ZZ = 00, 22, 33, ... 88 are called Easily Recognizable Codes (ERCs). These non-geographic codes are reserved and allocated to provide caller access to specific services. Currently assigned ERCs include 500, 600, 700, 800, 877, 888, and 900.

Numbers in the 500 ERC are used for “follow-me” personal communications services. These services are defined in document INC-95-0407-009, *Personal Communications Services N00 NXX Code Assignment Guidelines*, which also explains how these codes are administered.

The 600 ERC is a mixed service code uniquely for Canada. The 600 ERC is administered by the Canadian Number Administrator in conjunction with the Canadian Steering Committee on Numbering (CSCN). 600-NXX codes are available to any Canadian carrier that meets assignment criteria established by the CSCN.

The entire range of central office codes and line numbers associated with the 700 ERC has been assigned for unrestricted use by Interexchange Carriers (ICs) to provide network-based services. Each IC has access to the full complement of codes and numbers within the 700 ERC. Therefore, these codes and numbers are not centrally administered.

---

Telephone numbers within the 800, 888, and 877 ERCs are used to provide a service - freephone - in which the called party, rather than the calling party, is charged for the call. Since May 1, 1993, Service Provider Portability (SPP) has been mandatory for these numbers in the United States and its territories, and now in Canada as well. End users interested in obtaining an 800, 888, or 877 number can contact one of the many responsible organizations that have access to the Service Management System (SMS/800) for number assignment.

Telephone numbers within the 900 ERC are used to provide various special services - premium rate - to callers. Information services, polling, and fund-raising are among the many services provided. Typically these services involve call charges established by each 900 service provided to the caller. Following industry-developed guidelines documented in INC 97-0404-012, *900 NXX Code Assignment Guidelines*, the NANP administrator assigns 900 NXX codes to common carriers who wish to provide such services to the public. A list of currently assigned 900 NXX codes may be obtained from the NANP administrator or from Volume 8, Section 4.9 of the *Local Exchange Routing Guide (LERG)*, TR-EOP-000092. The *LERG* contains information about local routing data obtained from the Routing Database System (RDBS). This information reflects the current network configuration and scheduled network changes for all entities originating or terminating within the NANP, excluding Canada. For more information on the *LERG*, contact Bellcore Traffic Routing Administration at 732-699-6700.

A few NPA codes not in ERC format have also been assigned to designate non-geographic services. These codes include 456, 710, 880, and 881.

Numbers in the 456 NPA are used to identify specific carrier networks on calls placed from outside the area served by the NANP and terminating inside a NANP country, or calls from one NANP country to another, but not within a NANP country. These numbers are described in document INC-94-0826-003.

Numbers in the 710 NPA are used by the U.S. Government for purposes of national security and emergency preparedness. More information can be found in Bellcore Letter IL-94-01-002.

Numbers in the 880 and 881 NPAs are used to provide foreign-billed 800-type service, i.e., calls originating from one NANP country and terminating in another NANP country, for which the international portion of the call is paid for by the caller, and the terminating domestic portion of the call is free to the calling party. Numbers in the 880 NPA correspond to numbers in the 800 NPA, and numbers in the 881 NPA correspond to numbers in the 888 NPA. Further details are in Bellcore Letter IL-96-03-001.

### **3.3.1 Media Representation of Easily Recognizable Codes**

ERCs must always be dialed in connection with their respective services. Whenever these ERCs are shown in any type of media, they should *not* appear in parentheses because

---

parentheses imply that dialing the code is optional. Media advertising that includes ERCs should show them preceded by the prefix digit “1” (for example, 1+ 800 + NXX-XXXX).

### 3.4 N11 Service Codes

Service codes serve various special functions. Some are no longer in use, others are in limited use, and some are standard almost everywhere. Table 3-2 shows service code assignments currently used in many LEC networks. These codes are not available for assignment as geographic NPA codes nor as ERCs.

**Table 3-2.** Service Code Assignments

Code	Assignment
211	Unassigned
311	Non-Emergency Access to Police, etc.
411	Local Directory Assistance
511	Unassigned
611	Telco Repair Service
711	Telecom Relay Service
811	Telco Business Office
911	Emergency

#### 3.4.1 Unassigned Service Codes

Any unassigned service codes that are phased out of service, including 611 and 811, will be kept available for future assignment by the NANP administrator. Service codes may be used locally if their assignment and use can be discontinued on short notice.

#### 3.4.2 Universal Emergency Number

Where it has been implemented, public emergency service should be universally accessible by dialing 911. A requirement for callers to dial a 1 (or any other) prefix with the digits 911 is strongly discouraged. Enhanced 911 service should not be referred to or shown as “E911” to avoid the possible misconception that the “E” could or should be dialed. Enhanced 911 service differs from 911 in that with Enhanced 911 the telephone number and the location (address) of the caller are available to the emergency center.

### 3.4.3 N99 Codes

NPA codes in the format N99 are reserved for potential use in the future expansion of the three-digit NPA code format. The INC is studying both the potential for expansion and the need for these codes to support the transition to the expanded format.

## 3.5 Central Office Codes

This section describes central office codes.

### 3.5.1 Central Office Code Format and Capacity

Central office codes are in the following format.

**NXX**  
where N is any digit 2 through 9, and  
X is any digit 0 through 9.

This NXX format provides a total of 792 central office codes.

Central office codes available in NXX format	800
Less reserved codes in N11 format	8
Central office codes available for assignment	792

### 3.5.2 Central Office Code Assignments

Central office code assignments are made in accordance with the document INC 95-0407-008, *Central Office Code (NXX) Assignment Guidelines*.

### 3.5.3 Code Conservation and Relief

The continuing growth in telephone number assignments has made code conservation and code relief an important consideration. Central office code conservation is discussed in Section 8 of the above-referenced assignment guidelines. Relief planning principles are discussed in INC 97-0404-016, *NPA Code Relief Planning and Notification Guidelines*.



---

## 3.6 Line Numbers

### 3.6.1 Line Number Format and Capacity

Line numbers are in the following format.

**XXXX**

where X is any digit 0 through 9.

### 3.6.2 Line Number Assignments

Telephone number assignments are outside the scope of this document. However, in the absence of specific line number assignment guidelines, the following are specific considerations for such assignments.

Some patterns of dialing irregularities, coupled with the existence of various *high-volume* numbers (for example, NPA-555-1212), can lead to large quantities of *wrong number* calls being directed toward certain station numbers in the Direct Distance Dialing (DDD) network. Wrong numbers due to dialing mistakes, when spread randomly through the network, are largely unavoidable but tolerable to most customers who receive an occasional “wrong number” call. However, when high-volume numbers are involved, even a very small dialing error rate can result in a significant volume of wrong numbers being directed to a few customers. Such a situation can be intolerable to the recipients. Therefore, it is appropriate to take steps to avoid such situations.

The following are some of the known dialing irregularities.

- a. Dialing that starts before dial tone is received results in the loss of Dual-Tone Multifrequency (DTMF) dialed digit(s) or the first few pulses (digits) of a dial-pulsed (rotary dialed) call. Slow dial tone aggravates this irregularity.
- b. Omitting the prefix digit “1” when required preceding a 10-digit call.
- c. Dialing one digit too high or too low anywhere in the call address. This is generally more prevalent with rotary dials than with touch-tone dialing.
- d. Omitting the 800 or 888 ERC when customers know that the call terminates in their own NPA.

To avoid problems resulting from these irregularities, the following guidelines are recommended.

- Leave the numbers NX5-5512 unassigned. This prevents error (b).
- Leave the numbers NXX-555X unassigned, or use them for internal purposes only. This prevents error (c).

- Any central office using codes 255, 355, or 455 should leave station number 1212 unassigned. This is to guard against error (a) in the rotary dial case. The assumption is that once a caller places a finger in the wrong position on the dial he/she will dial all three central office code digits without removing the dialing finger each time. Similar logic could be applied to 222-, 444-, 666- and 888-1212 for touch-tone dialing, but such errors seem less prevalent than the rotary dial case.
- Any central office using a code in the form N91 should avoid placing subscribers who are likely to receive a high volume of calls in the N91-1XXX station number to prevent misdialing to 911. This prevents error (a).

### 3.6.3 Coin Station Numbering

It has been recommended that public and semipublic stations be assigned line numbers in the 9000 series (for example, NXX-9XXX). Generally, current operating practices include a check for public/semipublic telephones on collect or third-number calls to 9000 series numbers only.

Many public/semipublic telephones meet the requirements for an automated check. In those cases where the automated public/semipublic station check can be applied, there is no need to have the called public station numbered in the 9XXX series.

However, there are still many situations in which the 9XXX line number is the only indication of a public/semipublic station. Therefore, it is still suggested that companies assign public/semipublic stations in this 9XXX line number series when possible.

## 3.7 Dialing Procedures

Dialing refers to the *use* of certain digits or special characters as prefixes or appendixes to the number address as defined by the NANP. In the U.S., dialing is regulated by local public utility commissions, and as a result, dialing patterns vary from one jurisdiction to another. For example, the digit “1” is used in the NANP to indicate that the full 10-digit NANP number will follow. The prefix “1” is also used in many areas of the NANP to indicate that a call within the “home” NPA will incur a toll charge. In such a use, the “1” is part of the dialing plan. Table 3-3 illustrates the major dialing options in use.

**Table 3-3.** Major Dialing Options

	<b>Option I</b>	<b>Option II</b>	<b>Option III</b>
Local call within home NPA	7 digits	7 digits	7 digits
Toll call within home NPA	7 digits	1 + 10 digits	1 + 10 digits
Local call across NPA boundary	1 + 10 digits	10 digits	1 + 10 digits
Toll call across NPA boundary	1 + 10 digits	1 + 10 digits	1 + 10 digits

In all options, 7-digit local calling is permitted for calls within the home NPA, except in areas where NPA overlays have been implemented. In these areas, all calls must be dialed on a 10-digit basis as directed by the FCC in its Second Report and Order in CC Docket 96-98.

Several different dialing arrangements are in use for local calls that cross NPA boundaries. In some locations these calls may be dialed on a 10-digit basis, without the prefix "1." In other locations, 7-digit dialing to foreign NPAs is retained through the use of "protected" NXX codes. The use of protected codes is discouraged because it uses central office codes inefficiently and may contribute to the premature exhaust of an NPA.

Because dialing patterns vary in the NANP, the industry felt it was important to develop and recommend a uniform dialing plan. The resulting document, INC 97-0131-017, *Industry Numbering Committee Uniform Dialing Plan*, recommends that all calls be dialed on a uniform 10-digit basis, eliminating the use of the prefix "1" as a toll indicator. If required, however, toll indication could be provided in another manner such as a tone indicating that the caller will incur additional charges. Although the industry has made its recommendation, no decisions have been made on implementation.

Tables 3-4 through 3-6 show additional details of dialing procedures available for use with FGD.

**Table 3-4.** Recommended Dialing Procedure for Directory Assistance Under Feature Group D

Type of Call	Dialing Procedure	Operator Reached
<b>IntraLATA</b>		
HNPA*	411 or 555-1212	LEC
FNPA	1+ NPA-555-1212	LEC
HNPA**	101XXXX-555-1212	IntraLATA Carrier
FNPA**	101XXXX-1+NPA-555-1212	IntraLATA Carrier
<b>InterLATA</b>		
HNPA*	555-1212	LEC
FNPA	1 + NPA-555-1212	IC†
HNPA	101XXXX-555-1212	IC†
FNPA	101XXXX-1+NPA-555-1212	IC†

**Legend:**

FNPA = Foreign Numbering Plan Area

HNPA = Home Numbering Plan Area

IC = Interexchange Carrier

LATA = Local Access and Transport Area

LEC = Local Exchange Carrier

NPA = Numbering Plan Area

\* Use of the prefix 1 is acceptable in areas where Centralized Automatic Message Accounting (CAMA) access is required.

\*\* Only applies in those areas where intraLATA competition is allowed.

† Presubscription applies to interLATA directory assistance calls. The call will be handed off to the IC, but the IC business arrangement with a LEC to provide directory assistance may result in reaching a LEC operator.

**Table 3-5.** Treatment of 0 and 00 Dialed Calls from Equal-Access End Offices

Dialing Format	Suggested Disposition Equal-Access End Office
0	LEC
00	IC*
101XXXX + 0	IC
101XXXX + 00	IC**
101XXXX + 0+7/10D	IntraLATA - IC, if permitted†
00 + 7/10D	IntraLATA - LEC‡ IntraLATA - IC‡

**Legend:**

IC = Interexchange Carrier

LATA = Local Access and Transport Area

LEC = Local Exchange Carrier

X = Any digit 0 through 9

D = Digits

\* Assumes subscriber is presubscribed.

\*\* While this is not a NANP dialing standard, to avoid customer confusion 101XXXX + 00 dialed calls should be processed and routed to the IC operator facility.

† Because regulatory treatment of IntraLATA competition varies widely, this section does not specifically address dialed 0+ 7/10D where such competition is allowed.

‡ 00 + 7/10D and 101XXXX + 00 + 7/10D dialed calls are not defined in the NANP. Upon completion of dialing 00, the call would generally be routed to the IC operator facility, and subsequent digits would be acknowledged. This may only apply to subscribers with DTMF telephones; calls of this type generated by rotary dial customers may not be processed.

**Table 3-6.** Dialing Procedures Available with Feature Group D

Dialing Format	Destination
101XXXX + (1) + (NPA) + NXX + XXXX 101XXXX + 011 + CC + NN + (#)**	Carrier specified by 101XXXX.
011 + CC + NN + (#)**	Presubscribed carrier.
01 + CC + NN + (#)**	Presubscribed carrier operator function.
(1) + (NPA) + NXX + XXXX (InterLATA)	Presubscribed carrier
(1) + (NPA) + NXX + XXXX (IntraLATA)	LEC
(0) + (NPA) + NXX + XXXX (InterLATA)	Presubscribed carrier operator function.
(0) + (NPA) + NXX + XXXX (IntraLATA)	LEC operator function.
101XXXX + 0+ (NPA) + NXX + XXXX 101XXXX + 01 + CC + NN + (#)†	Operator function of carrier specified by 101XXX.
0	LEC operator.
00	Presubscribed carrier operator function.
101XXXX + 0	Operator of carrier specified by 101XXX.
1 + ERC+ NXX + XXXX	Carrier determined by 6-digit or 10-digit translation of ERC+ NXX.
101XXXX + (0/1) + SAC + NXX + XXXX	Carrier specified by 101XXXX.
101XXXX + #‡	Carrier specified by 101XXXX.

**Legend:**

CC = Country Code  
 ERC = Easily recognized code  
 N = Any digit 2 through 9  
 NPA = Numbering Plan Area code  
 X = Any digit 0 through 9

\*\* ( ) indicates optional dialing digits.

† (#) indicates that dialing the character # (on DTMF touch-tone telephones) at the end of an international address is desirable but not required. If used, it eliminates the need for timing in some cases.

‡ # indicates that the character # at the end of a dialed Carrier Access Code (CAC) is required.

---

### 3.8 Dialing Prefixes for Carrier Selection

As a result of the Modification of Final Judgment (MFJ), the GTE consent decree, and the implementation of access change plans in state as well as federal jurisdictions, many callers are required to select an IC for calls that cross LATA boundaries. ICs connect their facilities to many LEC networks using several different access arrangements. The most common access arrangements are Feature Group B (FGB) and Feature Group D (FGD).

FGB callers reach an IC's facility by dialing 950-XXXX. The XXXX digits in the 950 number identify the IC and are called the Carrier Identification Code (CIC). CICs are assigned in accordance with industry-approved guidelines documented in INC 95-0127-006, *CIC Administrative Guidelines*. When the call is "cut through," the IC switching equipment provides a second dial tone indicating that the caller must dial a Personal Identification Number (PIN) plus the number to be called.

FGD permits callers to *presubscribe* to or *select* a specific IC on a per-call basis. If the caller wants to use the presubscribed carrier, only the called number need be dialed. FGD also allows the caller to override prescription on a per-call basis and choose an alternate IC by dialing 101XXXX + 0/1 + 10 digits. The 101XXXX dialing prefix is called the Carrier Access Code (CAC). The last four digits of the 101XXXX CAC are the CIC.

Note that CICs for FGB and FGD access are assigned from separate pools.

### 3.9 Operator Assistance

Callers reach the LEC operator by dialing 0 (zero). To reach the presubscribed IC operator, 00 (zero zero) is dialed, where available. A presubscribed customer should also be able to dial 101XXXX + 0 to reach an alternate IC operator facility. In non-equal access end offices, 00 can be routed either to the LEC operator facility, to a single IC's operator facility, or it can be blocked.

### 3.10 International Direct Distance Dialing

There are three major types of carriers involved in international calling.

- *International Carriers (INCs)* provide call transport between a United States gateway and a foreign country's gateway where the international carrier connects to the foreign terminating network.
- *Interexchange Carriers (ICs)* provide call transport between the originating LATA and the IC's gateway office.
- *Interexchange/International Carriers (IC/INCs)* provide transport between the originating LATA and a foreign country's gateway.

Most international calls are handled by INCs. On some international calls, however, both ICs and INCs are involved, which implies that two carriers are selected by a single CAC - the INC indirectly.

- A single carrier (IC/INC) provides both interLATA and international transport, and uses a single CAC that includes both.
- An IC and an INC, having separate CACs, can agree to handle each other's traffic. A customer placing an International Direct Distance Dialing (IDDD) call could use either carrier's CAC. The interLATA portion would be handled by the IC and the international portion would be handled by the INC. An IDDD caller is not able to independently specify both an IC and an INC for an international call. Except in the case of a carrier that provides both functions, the caller will specify either the IC or INC of choice. The other carrier (INC or IC, respectively) involved will be the result of a prearranged business agreement.

When an international call is dialed by a customer in a national network, the local switching system must be able to recognize that it is receiving an international address. In the NANP, a local switching system with IDDD capability is alerted to the fact that an international number is being dialed by use of a special prefix code. The following dialing patterns are used for IDDD in the NANP.

For station-paid direct-dialed calls:   011 + country code + national number

For operator-assisted calls:           01 + country code + national number

The list of current country code assignments can be found in Section 1.10 of the *LERG*.

### 3.11 0XX and 1XX Codes

Within the NANP there are two series of 3-digit codes — 0XX and 1XX — that are not used as NPA or central office codes but are used for various specialized interoffice purposes. End offices or their associated Centralized Automatic Message Accounting (CAMA) offices will not accept a 7-digit or 10-digit address having a 0XX or 1XX code in the NPA or central office code field. Although not subscriber-dialable, such codes are accepted and routed by switching systems when received via an intermachine trunk or a source authorized to generate them (for example, a testboard). In the past, 0XX codes were typically used as a pseudo-central office code to route special calls to a switching office that did not have a normal central office code assigned (for example, a toll office). These codes were also used to route special calls to a switching office termination that a LEC did not want dialed using a normal address. When 0XX codes serve a pseudo-central office code function, they are used in conjunction with an NPA code so most of the codes can be reused in each NPA.

---



---

By contrast, 1XX codes are frequently used as pseudo-NPA codes. For example, some codes in the form 18X are used to direct international calls to the proper gateway office.

0XX and 1XX codes are not administered centrally. The selection of the specific 0XX or 1XX code to be used for a routing or billing function is the responsibility of the carrier implementing its use. If the 0XX or 1XX code will be used to route calls between a LEC and an IC, the code selection should be made by mutual agreement to avoid code conflicts. Section 1.4 of the *LERG* lists the 1XX codes that have universal routing assignments.

### 3.12 Special Characters (#) and (\*)

The advent of new services and special dialing procedures creates an increasing need to make use of the (#) and (\*) characters for special functions.

To minimize the amount of confusion experienced by callers using these characters, there is an effort to standardize their use. It is also important that consistent terminology be known and used when referring to these characters. The (#) and the (\*) should be called the number sign and the star, respectively. The terms number sign and star have been internationally agreed upon. Use of the terms asterisk for (\*) and pound sign for (#) should *not* be used in documentation dealing with dialing procedures.

Currently, the characters (#) and (\*) have the following general applications:

1. The first use of the number sign (#) is as an end-of-dialing or conclude the present action and proceed to the next action indicator. This end-of-dialing use exists today and avoids a timing period (for example, IDDD) using certain types of switching systems. The *conclude-and-proceed* use also occurs in some telephone credit card services where the customer wants to indicate that the present call is over and a new call is about to be placed (for example, sequence calling). The latter use is expected to become more common as services with extended dialing sequences become more prevalent.
2. The second use of the number sign (#) is as the first character when dialing a call that is a wideband or other data call requiring special treatment. In certain types of data calls, both an initial and concluding (#) may be required. Functionally, this is similar in many respects to the KP + (address) + ST format used by operators.
3. The first use of the star (\*) is as a prefix when dialing a Vertical Service Code (VSC) (for example, call forwarding) of the form \*XX. In this application, the (\*) indicates to the switching system that the digits following specify a certain desired feature/service. Section 3.13 discusses VSCs.

### 3.13 Vertical Service Codes

VSCs are customer-dialed codes in the \*XX (or \*2XX) dialing format for touch-tone phones and 11XX (or 112XX) dialing format for rotary phones. They are used to provide

---

customer access to features and services (for example, Call Forwarding, Automatic Callback) provided by LECs, ICs, and Cellular Mobile Radio Telecommunications Service (CMRS) providers. For example, Call Forwarding is activated by dialing \*72 or 1172.

VSCs are assigned to features or services to enable consistent accessibility throughout the Public Switched Telephone Network (PSTN). The purpose of common/standard VSCs is to minimize customer confusion and provide a standard service access approach for features and services within the following:

- Multiple individual networks (multi-network applications)
- Across and/or among two or more networks on an internetwork basis (internetwork applications) where multiple networks must act on a VSC in a consistent manner on a given call.

VSC assignments are to be made using the same VSC resource, but multi-networks and internetwork applications will be identified separately.

VSCs are assigned and administered by the NANP administrator using industry-approved guidelines. INC 96-0802-015, *Vertical Service Code Assignment Guidelines*, provides information on assignment principles and criteria, responsibilities of code applicants and the code administrator, and code application procedures. Current VSC assignments can be obtained from the NANP administrator or from Section 1.6 of the *LERG*.

Although VSCs are assigned centrally by the NANP administrator, it is recognized that many service providers have used these codes for purposes that do not correspond to those for which the codes were assigned. Accordingly, the assignment of a VSC does not guarantee ubiquitous access throughout the NANP area.

### **3.14 Automatic Number Identification II Digit Assignments**

Automatic Number Identification (ANI) "II" digits are two digits that are sent with the originating telephone number identifying the type of originating station (for example, Plain Old Telephone Service [POTS] [00], Hotel/Motel [06]). Assignment of new ANI II digit pairs are made through industry consensus at INC. The NANP administrator is responsible for tracking the assignments. Listings of ANI II digit pairs can be obtained from the administrator or from Section 1.8 of the *LERG*.

### **3.15 Local Number Portability**

Local Number Portability (LNP) allows telephone subscribers to retain their numbers in situations in which number changes are usually required. Service Provider Portability (SPP) allows subscribers to retain their numbers when changing from one local service provider to another. Location Portability (LP) allows subscribers to retain their numbers when physically moving from one location to another. The FCC has ordered, in Docket 96-

---

---

98, that SPP shall be implemented in the U.S. under a defined set of circumstances in specified areas of the country. The FCC has identified 100 Metropolitan Statistical Areas (MSAs) in which SPP will be implemented initially. The FCC also indicated that LP should be accommodated, but was not specific about when this must be accomplished. In response to the SPP order, the telecommunications industry has developed the architecture and systems to provide SPP, which will rely on the existing Signaling System 7 (SS7) network and an interconnecting arrangement of routing and rating databases. Impacts to many systems are under investigation, including SS7, service provisioning, operations support systems, operator services, emergency services, and number administration.

### 3.16 Number Pooling

Geographic NANP numbers are currently assigned to service providers at the NXX level, i.e., in blocks of 10,000 numbers. The increased demand for new services such as cellular, paging, and internet access, combined with the needs of carriers participating in local competition, has depleted the supply of NXX codes in many areas, resulting in a dramatic increase in the need for new NPA codes. In many cases, NXX codes are being assigned to meet current rating and routing requirements, often resulting in inefficient number usage. The public, service providers, and regulators are all concerned about the accelerated exhaust of NPAs, and the industry has focused on number pooling as a way to reduce the demand for NXX codes while continuing to encourage and foster local competition.

Number pooling refers, basically, to a number administration and assignment process in which geographic numbers in a local environment are allocated to a shared reservoir associated with a designated geographic area. The numbers in the shared reservoir could be available to service providers in blocks or as individual numbers. Factors under consideration include the geographic size of the area in which pooling occurs (e.g., rate center, NPA, or state) and which numbers will be included in the reservoir (e.g., embedded or growth numbers). The industry is studying the most effective way to introduce number pooling, given the urgent need, the costs involved, and the impact on the network, operations support systems, and assignment procedures. No decisions have been made as of the publication date of this document.

### 3.17 Assignment of 555 Numbers

The central office code “555” has traditionally been used only for the provision of directory assistance, which callers reach by dialing NPA-555-1212. To increase the use of this valuable resource, 555 numbers are now available for a wide variety of information services, including directory assistance. The industry has developed assignment guidelines (INC 94-0429-002, *555 NXX Assignment Guidelines*) for this resource. A companion document, ICCF 96-0411-014, *555 Technical Service Interconnection Arrangements*, describes suggested access arrangements that may be used for 555 numbers. 555 numbers

---

such as 555-1212, previously used for various directory assistance purposes, have been “grandfathered” and will not be assigned for any other purpose.

555 numbers have been used in magazines, films, books, etc., to avoid calls to active numbers. Opening up the 555 numbers eliminates this source of “fictitious” numbers and increases the possibility of completed calls if 555 numbers continue to be used by the media. To mitigate this possibility in the future, a small block of 555 numbers, 555-0100 to 555-0199, have been set aside for media use as fictitious numbers. These numbers will be reserved permanently, and will not be assigned by the administrator. In addition, 800-555-0199 has been reserved for media use and will not be available from the SMS/800 system for assignment.

**Table 3-7. NPA Codes in Alphabetical Order (as of September 1997)**

STATE/PROVINCE OR OTHER SPECIAL USE	AREA CODE	STATE/PROVINCE OR OTHER SPECIAL USE	AREA CODE	STATE/PROVINCE OR OTHER SPECIAL USE	AREA CODE
800 Service	800	Colorado	303	Kentucky	502
800 Svc. Expansion	888	Colorado	719	Kentucky	606
888 Svc. Expansion	877	Colorado	970	Louisiana	318
900 Service	900	Connecticut	203	Louisiana	504
Alabama	205	Connecticut	860	Maine	207
Alabama	334	Delaware	302	Manitoba	204
Alaska	907	Dist. of Columbia	202	Maryland	240
Alberta	403	Dominica	767	Maryland	301
Alberta	780	Florida	305	Maryland	410
Anguilla	264	Florida	352	Maryland	443
Antigua/Barbuda	268	Florida	407	Massachusetts	413
Arizona	520	Florida	561	Massachusetts	508
Arizona	602	Florida	813	Massachusetts	617
Arkansas	501	Florida	850	Massachusetts	781
Arkansas	870	Florida	904	Massachusetts	978
Bahamas	242	Florida	941	Michigan	248
Barbados	246	Florida	954	Michigan	313
Bermuda	441	Georgia	404	Michigan	517
British Columbia	250	Georgia	706	Michigan	616
British Columbia	604	Georgia	770	Michigan	734
British Virgin Is.	284	Georgia	912	Michigan	810
Califomia	209	Grenada	473	Michigan	906
Califomia	213	Guam	671	Minnesota	218
Califomia	310	Hawaii	808	Minnesota	320
Califomia	323	IC Services	700	Minnesota	507
Califomia	408	Idaho	208	Minnesota	612
Califomia	415	Illinois	217	Mississippi	228
Califomia	510	Illinois	309	Mississippi	601
Califomia	530	Illinois	312	Missouri	314
Califomia	562	Illinois	618	Missouri	417
Califomia	619	Illinois	630	Missouri	573
Califomia	626	Illinois	708	Missouri	660
Califomia	650	Illinois	773	Missouri	816
Califomia	707	Illinois	815	Montana	406
Califomia	714	Illinois	847	Montserrat	664
Califomia	760	Inbound International	456	Nebraska	308
Califomia	805	Indiana	219	Nebraska	402
Califomia	818	Indiana	317	Nevada	702
Califomia	831	Indiana	765	New Brunswick	506
Califomia	909	Indiana	812	New Hampshire	603
Califomia	916	Iowa	319	New Jersey	201
Califomia	925	Iowa	515	New Jersey	609
Califomia	949	Iowa	712	New Jersey	732
Canada (Services)	600	Jamaica	876	New Jersey	908
Caribbean Islands	809	Kansas	316	New Jersey	973
Cayman Islands	345	Kansas	785	New Mexico	505
CNMI	670	Kansas	913	New York	212

**Table 3-7. NPA Codes in Alphabetical Order (as of September 1997)**

STATE/PROVINCE OR OTHER SPECIAL USE	AREA CODE	STATE/PROVINCE OR OTHER SPECIAL USE	AREA CODE	STATE/PROVINCE OR OTHER SPECIAL USE	AREA CODE
New York	315	Oregon	541	Texas	512
New York	516	PAID-800 Serv.	880	Texas	713
New York	518	PAID-888 Serv.	881	Texas	806
New York	607	Pennsylvania	215	Texas	817
New York	716	Pennsylvania	412	Texas	830
New York	718	Pennsylvania	610	Texas	903
New York	914	Pennsylvania	717	Texas	915
New York	917	Pennsylvania	724	Texas	940
Newfoundland	709	Pennsylvania	814	Texas	956
North Carolina	704	Personal Comm. Svcs.	500	Texas	972
North Carolina	910	Puerto Rico	787	Trinidad and Tobago	868
North Carolina	919	Quebec	418	Turks & Caicos Is.	649
North Dakota	701	Quebec	450	U.S. Government	710
Nova Scotia	902	Quebec	514	US Virgin Islands	340
Ohio	216	Quebec	819	Utah	435
Ohio	330	Rhode Island	401	Utah	801
Ohio	419	Saskatchewan	306	Vermont	802
Ohio	440	South Carolina	803	Virginia	540
Ohio	513	South Carolina	843	Virginia	703
Ohio	614	South Carolina	864	Virginia	757
Ohio	740	South Dakota	605	Virginia	804
Ohio	937	St. Kitts & Nevis	869	Washington	206
Oklahoma	405	St. Lucia	758	Washington	253
Oklahoma	580	St. Vincent & Gren.	784	Washington	360
Oklahoma	918	Tennessee	423	Washington	425
Ontario	416	Tennessee	615	Washington	509
Ontario	519	Tennessee	901	West Virginia	304
Ontario	613	Tennessee	931	Wisconsin	414
Ontario	647	Texas	210	Wisconsin	608
Ontario	705	Texas	214	Wisconsin	715
Ontario	807	Texas	254	Wisconsin	920
Ontario	905	Texas	281	Wyoming	307
Oregon	503	Texas	409	Yukon & NW Terr.	867

**Table 3-8. NPA Codes in Numerical Order (as of September 1997)**

NPA	Location/Use	NPA	Location/Use	NPA	Location/Use
201	New Jersey	312	Illinois	450	Quebec
202	Dist. of Columbia	313	Michigan	456	Inbound International
203	Connecticut	314	Missouri	473	Grenada
204	Manitoba	315	New York	500	Personal Comm. Svcs.
205	Alabama	316	Kansas	501	Arkansas
206	Washington	317	Indiana	502	Kentucky
207	Maine	318	Louisiana	503	Oregon
208	Idaho	319	Iowa	504	Louisiana
209	California	320	Minnesota	505	New Mexico
210	Texas	323	California	506	New Brunswick
212	New York	330	Ohio	507	Minnesota
213	California	334	Alabama	508	Massachusetts
214	Texas	340	US Virgin Islands	509	Washington
215	Pennsylvania	345	Cayman Islands	510	California
216	Ohio	352	Florida	512	Texas
217	Illinois	360	Washington	513	Ohio
218	Minnesota	401	Rhode Island	514	Quebec
219	Indiana	402	Nebraska	515	Iowa
228	Mississippi	403	Alberta	516	New York
240	Maryland	404	Georgia	517	Michigan
242	Bahamas	405	Oklahoma	518	New York
246	Barbados	406	Montana	519	Ontario
248	Michigan	407	Florida	520	Arizona
250	British Columbia	408	California	530	California
253	Washington	409	Texas	540	Virginia
254	Texas	410	Maryland	541	Oregon
264	Anguilla	412	Pennsylvania	561	Florida
268	Antigua/Barbuda	413	Massachusetts	562	California
281	Texas	414	Wisconsin	573	Missouri
284	British Virgin Is.	415	California	580	Oklahoma
301	Maryland	416	Ontario	600	Canada (Services)
302	Delaware	417	Missouri	601	Mississippi
303	Colorado	418	Quebec	602	Arizona
304	West Virginia	419	Ohio	603	New Hampshire
305	Florida	423	Tennessee	604	British Columbia
306	Saskatchewan	425	Washington	605	South Dakota
307	Wyoming	435	Utah	606	Kentucky
308	Nebraska	440	Ohio	607	New York
309	Illinois	441	Bermuda	608	Wisconsin
310	California	443	Maryland	609	New Jersey

**Table 3-8. NPA Codes in Numerical Order (as of September 1997)**

NPA	Location/Use	NPA	Location/Use	NPA	Location/Use
610	Pennsylvania	740	Ohio	868	Trinidad and Tobago
612	Minnesota	757	Virginia	869	St. Kitts & Nevis
613	Ontario	758	St. Lucia	870	Arkansas
614	Ohio	760	California	876	Jamaica
615	Tennessee	765	Indiana	877	888 Svc. Expansion
616	Michigan	767	Dominica	880	PAID-800 Serv.
617	Massachusetts	770	Georgia	881	PAID-888 Serv.
618	Illinois	773	Illinois	888	800 Svc. Expansion
619	California	780	Alberta	900	900 Service
626	California	781	Massachusetts	901	Tennessee
630	Illinois	784	St. Vincent & Gren.	902	Nova Scotia
647	Ontario	785	Kansas	903	Texas
649	Turks & Caicos Is.	787	Puerto Rico	904	Florida
650	California	800	800 Service	905	Ontario
660	Missouri	801	Utah	906	Michigan
664	Montserrat	802	Vermont	907	Alaska
670	CNMI	803	South Carolina	908	New Jersey
671	Guam	804	Virginia	909	California
700	IC Services	805	California	910	North Carolina
701	North Dakota	806	Texas	912	Georgia
702	Nevada	807	Ontario	913	Kansas
703	Virginia	808	Hawaii	914	New York
704	North Carolina	809	Caribbean Islands	915	Texas
705	Ontario	810	Michigan	916	California
706	Georgia	812	Indiana	917	New York
707	California	813	Florida	918	Oklahoma
708	Illinois	814	Pennsylvania	919	North Carolina
709	Newfoundland	815	Illinois	920	Wisconsin
710	U.S. Government	816	Missouri	925	California
712	Iowa	817	Texas	931	Tennessee
713	Texas	818	California	937	Ohio
714	California	819	Quebec	940	Texas
715	Wisconsin	830	Texas	941	Florida
716	New York	831	California	949	California
717	Pennsylvania	843	South Carolina	954	Florida
718	New York	847	Illinois	956	Texas
719	Colorado	850	Florida	970	Colorado
724	Pennsylvania	860	Connecticut	972	Texas
732	New Jersey	864	South Carolina	973	New Jersey
734	Michigan	867	Yukon & NW Terr.	978	Massachusetts



---

## Section 4

### Network Design and Configuration Control

4.	Network Design and Configuration .....	4-1
4.1	Introduction .....	4-1
4.1.1	Terminal Equipment .....	4-1
4.1.2	Network Configurations.....	4-3
4.1.3	Switching Equipment.....	4-4
4.1.3.1	End Office Switching Systems .....	4-5
4.1.3.2	Host/Remote Switching Unit and Remote Terminals .....	4-5
4.1.3.3	Tandem Switching Systems.....	4-6
4.1.3.4	Dynamic Routing Switching Systems .....	4-8
4.1.3.5	Combined Systems .....	4-8
4.1.3.6	Digit Utilization and Translation .....	4-8
4.1.3.7	Trunk Circuits .....	4-9
4.1.3.8	Call Control .....	4-10
4.1.4	Interexchange Carrier Points of Presence .....	4-10
4.2	Operator Services Systems.....	4-10
4.2.1	Existing Architecture .....	4-11
4.2.2	Future Architecture .....	4-11
4.2.3	OSS Switching Environment .....	4-12
4.2.4	Position in the Network.....	4-13
4.2.5	Call Handling .....	4-13
4.2.6	OSS Subsystems .....	4-13
4.2.7	Features .....	4-14
4.2.7.1	Basic OSS Features.....	4-14
4.2.7.2	Customer Access Features.....	4-15
4.2.7.3	Customer Listing Information Features.....	4-15
4.2.7.4	Service Specific Call Handling Features .....	4-16
4.2.7.5	Special Billing Features .....	4-16
4.2.8	Telecommunications Relay Service.....	4-17
4.3	Network Design Considerations .....	4-18
4.3.1	Fundamentals of Hierarchical Routing .....	4-18
4.3.2	Application of Alternate Routing.....	4-21
4.3.3	Fundamentals of Dynamic Routing Technique .....	4-22
4.4	Blocking Probabilities .....	4-23
4.5	LATA Network Configurations .....	4-24
4.5.1	IntraLATA Configurations .....	4-25
4.5.1.1	Routing .....	4-25
4.5.1.2	Blocking.....	4-26
4.5.1.3	Configurations .....	4-26

---

---

4.5.2	Dynamic Routing Configuration.....	4-29
4.5.3	LATA-Access Configurations .....	4-31
4.5.3.1	Equal Access (Feature Group D).....	4-31
4.5.3.2	Other Access (Feature Groups A, B, and C) .....	4-36
4.5.3.3	Feature Group A .....	4-36
4.5.3.4	Feature Group B .....	4-37
4.5.3.5	Feature Group C .....	4-37
4.5.3.6	Operator Services.....	4-38
4.5.4	Combined Configurations .....	4-39
4.6	Reliability of Equipment and Systems .....	4-42
4.6.1	Local Exchange Network Hypothetical Reference Connection .....	4-43
4.6.2	End-to-End Network Availability Objective .....	4-44
4.6.3	Network Segment Availability Objectives .....	4-45
4.6.3.1	Distribution Network Segment.....	4-45
4.6.3.2	Circuit Switch .....	4-46
4.6.3.3	ISDN Switch.....	4-47
4.6.3.4	Facility-Entrance Network Segment.....	4-48
4.6.3.5	Interoffice Network Segment .....	4-48
4.6.4	CCS Network Reliability and Unavailability (Downtime) Objectives.....	4-50

---

---

## List of Figures

Figure 4-1.	Hypothetical Local Network (within a Single LATA).....	4-7
Figure 4-2.	Existing Operator Services Systems (OSSs) .....	4-12
Figure 4-3.	Alternate Routing Arrangement .....	4-20
Figure 4-4.	Relationships Involved in Alternate Routing Arrangement .....	4-20
Figure 4-5.	Example of Nonhierarchical Routing Using the DR-T Routing Scheme.....	4-23
Figure 4-6.	Single Tandem with Alternate Routing .....	4-27
Figure 4-7.	Combined Sector-Tandem Configuration with Multistage Alternate Routing .....	4-28
Figure 4-8.	Three-Level IntraLATA Network .....	4-30
Figure 4-9.	Dynamic Routing Sequence for A-B Traffic.....	4-30
Figure 4-10.	Basic Interexchange Carrier LATA-Access Routing Options .....	4-33
Figure 4-11.	Service Prefix Routing.....	4-33
Figure 4-12.	Sectored Routing .....	4-34
Figure 4-13.	Alternate Routing .....	4-35
Figure 4-14.	Terminating Routing.....	4-35
Figure 4-15.	Out-Of-LATA Routing.....	4-35
Figure 4-16.	Single Tandem/Access Tandem .....	4-40
Figure 4-17.	Combined Sector Tandem/Access Tandem.....	4-40
Figure 4-18.	Restricting DRT to Two-Link Paths.....	4-42
Figure 4-19.	Local Exchange Network Hypothetical Reference Connection .....	4-44
Figure 4-20.	End-to-End Network Availability Objective .....	4-45
Figure 4-21.	Distribution Network Segment Unavailability Objective .....	4-46
Figure 4-22.	Switch Network Segment Unavailability Objective (Through Path) .....	4-47
Figure 4-23.	Facility-Entrance Network Segment Availability .....	4-49
Figure 4-24.	Interoffice Network Segment Unavailability Objective.....	4-49
Figure 4-25.	ANSI (T1.111.6) Downtime Objectives for CCS Basic Mesh Network Segments (MTP Only).....	4-51
Figure 4-26.	Example Case: One Trunk Group with Its Terminating CCSSOs) .....	4-52

## List of Tables

Table 4-1.	Comparison of Typical Blocking Probabilities .....	4-24
------------	--	------

---



---

## 4. Network Design and Configuration

### 4.1 Introduction

The equipment arrangements and features that this section describes for originating and terminating calls in a Local Access and Transport Area (LATA) are based on equipment that exists in some or all intraLATA networks. All arrangements described in this section are intended to operate within these LATA boundaries.

#### 4.1.1 Terminal Equipment

Although terminal equipment is not a part of intraLATA networks, the general descriptions included here are provided to show the relationships to and use of the associated demarcation points. Terminal equipment consists of apparatus provided on the customer premises that permits a user to originate and/or receive communications over the telecommunications network. This equipment generally provides incoming and outgoing signaling and 2-way communications, but is not limited solely to these functions.

Customer premises terminal equipment must comply with the requirements specified in Part 68 of the Federal Communications Commission (FCC) Rules and Regulations as a prerequisite for connecting to the network. Terminal equipment registered with the FCC in accordance with the requirements in Part 68 can be connected directly to the telecommunications network for those services covered by the FCC Rules and Regulations.

Detailed information describing the electrical interfaces between switching equipment and customer premises terminal equipment can be found in FR-64, *LATA Switching Systems Generic Requirements (LSSGR)*, and in Section 6 of this publication. General information is contained in this section.

An *individual* central office line serves only one customer. Several terminal equipment items can be bridged across the line, but they are for use by a single customer.

A *multiparty* line is a central office line that serves more than one customer. Since the line has one set of equipment at the central office, only one customer can use the line at a time. Each customer can be selectively signaled using superimposed ringing systems. Selectivity is obtained by ringing to ground from either side of the telephone line and by using polarized ringers.<sup>1</sup> Terminal equipment arranged for outgoing signaling generates supervisory off- or on-hook signals and either dial pulses or Dual-Tone Multifrequency (DTMF) pulses. This arrangement enables the central office or Private Branch Exchange

---

1. Multifrequency ringing systems are commonly used by independent Local Exchange Carriers (LECs) to provide selective ringing for party-line subscribers. These ringers can be connected across the two sides of the line, rather than from one side of the line to ground, as long as the number of parties does not exceed the available frequencies.

(PBX) equipment to initially establish the routing of the call through the Local Exchange Carrier (LEC) or other switched networks to its destination.

Rotary dials, or an electronic equivalent, are used to generate dial pulses (alternate opens and closures of a dc loop) that are transmitted on a central office or PBX line. A DTMF keyset is used to generate tones needed to operate central office or PBX equipment. The keyset is arranged to generate a pair of specific frequencies for each dialed digit.

Terminal equipment can be divided into various categories. Following is a general description of three basic categories:

- Terminals such as telephone sets, data modems, facsimile machines, and ancillary devices (for example, answering sets and automatic dialers)
- Key Telephone Systems (KTSs)
- PBXs.

A telephone set, or its equivalent, is used to communicate by voice over the telecommunications network. A telephone set is a terminal instrument that permits 2-way, real-time voice communications over the network. The set converts voice and voiceband acoustic signals into electrical signals suitable for transmission over the network and, conversely, converts received electrical signals into acoustic signals. A telephone set usually generates the control signals required to initiate a call on the network and the alerting signal in response to an incoming call. A telephone set generally consists of a transmitter, receiver, induction coil (hybrid), switch-hook, dial, and ringer or electronic sounder. Direct current and ringing current are usually supplied from the central office (or from the PBX when a telephone set is connected to a PBX).

A KTS is an arrangement of multiline telephone-station apparatus and associated equipment that usually allows a user to selectively answer, originate, or hold calls over a specific central office or PBX line. Lines are selected or held by operating buttons (or keys) that are mounted either external or internal to the station apparatus. Visual indicators usually display line status such as line select, busy, idle, hold, and ringing. Audible alerting, generated internally or externally to the station apparatus, is normally provided. Other features, such as intercom capability, toll restriction, exclusion, and conferencing, are also sometimes provided.

A PBX is an assembly of equipment that allows individuals within a community of users to communicate with each other. It also provides access to and from the network by means of trunks between the PBX and the serving central office. Connections with the PBX are made by the PBX equipment in response to user dialing action. Outgoing calls to a central office can also be made by dialing through the PBX switching equipment, or sometimes by placing them through the PBX attendant. An access code is usually dialed and the PBX station is terminated to a trunk in a central office, thereby gaining access to the network.

After the second dial tone, address information of the called party is dialed, resulting in a network connection to the called station. An attendant position can be provided for

---

---

answering incoming calls and for user assistance. The attendant also completes incoming calls to PBX stations except when the PBX provides Direct Inward Dialing (DID) service. With PBX DID service, a central office call can be completed to the PBX station without operator assistance. This can be done since the dial PBX equipment interprets digits forwarded from the central office equipment and routes the call directly to the station.

Hybrid PBXs/KTSs are systems that can be arranged through the common equipment to perform automatic PBX and KTS functions. In particular, a PBX/KTS is an assembly of equipment that allows an individual within a community of users to originate or answer calls to or from the public network or other users (PBX line) within the community. In addition, a PBX/KTS allows a user to selectively answer, originate, or hold calls over a specific central office line. A detailed description of the signaling interface can be found in Section 6 of this document.

#### 4.1.2 Network Configurations

This section describes the network configurations and design considerations applicable to intraLATA networks. The symbols used are defined in the Glossary provided at the end of this document.

Switching systems in a LATA are interconnected by a network of trunks providing the necessary capabilities for handling a variety of customer services. The interconnections provide for both intraLATA and interLATA services. For interLATA services, trunks connect most LEC networks to the networks of the Interexchange Carriers (ICs). A particular arrangement of switching systems and interconnecting trunks is referred to as a network configuration. A number of different configurations are possible, depending on the number and type of switching systems employed.

The number and placement of switching systems in a particular configuration is largely dependent on the economic trade-off between trunking and switching. Economic studies show that large volumes of traffic between two points are most economically handled when served over direct trunks. Conversely, when the volume of traffic between two points is small, it is ordinarily more economical to aggregate the demand at intermediate switching systems. End-to-end connections can involve several switching systems if the originating and terminating points are a significant distance apart.

The basic routing arrangements required for the systematic and efficient handling of message traffic are defined in a network plan. Currently, these plans nearly always specify a hierarchical network configuration and automatic alternate routing to provide rapid connections while making efficient use of the deployed equipment. A network configuration must provide for the collection and distribution of traffic for all points. With automatic alternate routing, a call that encounters an *all trunks busy* condition on the first route tested is automatically *route-advanced*, and offered in sequence to one or more alternate routes for completion until it reaches a final route.

---

### 4.1.3 Switching Equipment

Stored Program Control (SPC) is the most common type of switching equipment used at end offices and tandem offices. These systems use either analog or digital switching. However, there are locations that continue to be served by electromechanical (Step-by-Step [SXS] and crossbar) systems. The switching system used must have the capability to send, receive, and be actuated by the signals discussed in Section 6.

Each "callable" customer terminal in World Zone 1 (North America and the Caribbean) is assigned a unique 10-digit address. Routing between terminals is based upon this address. Proper routing of calls may require dialing additional digits. The details of these considerations are found in Section 3 of this document.

Signaling between switching systems may use either inband or out-of-band signaling. Examples of inband signaling are multifrequency and dial pulse. An example of out-of-band signaling is Common Channel Signaling (CCS). With multifrequency and dial pulse signaling, the number of digits actually passed at each stage of the call is usually the minimum required to advance the call toward its destination. For incoming calls, end office switching systems are arranged to receive a minimum of 4 digits. End offices serving more than one central office code need to receive 5 or more address digits on incoming calls.

When Signaling System 7 (SS7) CCS is used, a unique SS7 24-bit routing label is used to route the signaling information associated with the call. It contains an 8-bit Destination Point Code (DPC) that identifies the terminating office, an 8-bit Originating Point Code (OPC) that identifies the message originating point (the originating office), and a Signaling Link Selection (SLS) field that is used to perform load sharing on the signaling links used to route the message. Other information about the call, such as the bearer capability (connection type), carrier identification, identification of unlisted calling number, etc. is also sent with the routing label.

Most SPC offices can accept and process Carrier Access Codes (CACs), including 10XXX. Offices with this capability are referred to as Equal-Access End Offices (EAEOs) and support Feature Group D (FGD) calling. In the 1994/1995 time frame, FGD CAC format will be 101XXXX (that is, the CAC will be expanded from 5 to 7 digits). Most SPC offices should accept and process the new CACs.

Some end offices are not equipped to accept a carrier 10XXX/101XXXX access code for routing (for example, SXS offices). However, these end offices can handle 950-XXXX for Feature Group B (FGB) access and Feature Group A (FGA) access numbers.

Connections established through the network from an originating customer's point of termination to a terminating customer's point of termination are generally controlled by the originating (or calling) terminal. Control signals including hook switch status and digits dialed (passed to the originating end office by the Integrated Services Digital Network [ISDN] D-channel or by loop closure and either DTMF or dial pulse signaling) will initiate the call. This, in turn, will connect the customer to the network and provide a transmission path between the originating and terminating points. The network, specifically the various

---



---

switching systems, will provide the necessary call-progress signals to the originating terminal equipment (indicating call progress) and an alerting signal to the terminating terminal equipment (indicating that a call is waiting).

#### 4.1.3.1 End Office Switching Systems

End office switching systems provide access to the Message Telecommunications Service (MTS) or packet network. A telephone user can originate or receive communications to or from the network via an end office. The basic function of the network is to provide communication paths between originating-customer terminal equipment and terminating-customer terminal equipment. If both originating and terminating customers are served by the same switching system, the communications path is through the one switching system only. If the customers are served by different switching systems in the same LATA, the communications path is established via the intraLATA network. If the customers are served by Local Exchange Company (LEC) switching systems in different LATAs, the path is established through the interLATA network via an IC.<sup>2</sup>

The traffic network design is based on the capabilities of the end office to selectively route traffic according to the called number. If the end office is capable of alternate routing (generally the case for common-control systems), traffic to a distant office can first be routed on one trunk group. When all trunks in that group are busy, the office can alternate route the overflow to another office. For noncommon-control (or direct control) systems, all the traffic for a destination must be routed over an only-route trunk group. The introduction of SPC capabilities in end office switching systems expands their ability to selectively route traffic. Thus, the ultimate network configuration of trunks and switching systems is dependent on the capabilities of the mix of end offices.

The signaling used depends both on the route chosen and the type of call. Distinctly different signaling patterns are used for intraLATA, interLATA direct, interLATA via tandem, international, and operator-assisted calls. The network can accommodate a mixture of CCS and multifrequency signaling on the various legs of a tandem-switched call.

#### 4.1.3.2 Host/Remote Switching Unit and Remote Terminals

SPC switching technology also offers the potential to serve a group of customers remotely using a Remote Switching Unit (RSU), which is connected to a controlling (host) SPC switching system by a data link and interconnecting facilities (Figure 4-1). The remote unit operates primarily as an extension of the host SPC switching system. Commands are issued to the remote unit via the data link from the host. At the remote unit, a processor interprets these commands and performs the requested functions. In addition, the microprocessor scans the network and line appearances in the remote terminal for changes of state and

---

2. InterLATA calls may be handled differently by some independent LECs.

reports these changes, via the data link, to the host switching system (Figure 4-1). The data link connecting the host and remote unit is part of the trunk group connecting the two units. Ordinarily, this trunk group is the only one allowed for switched calls from an RSU office; however, some current host/remote designs have the capability to trunk directly from the remote unit to other offices without routing through the host. Also, some RSUs have the capability to allow calling among customers served by the RSU should the data link fail between the RSU and the host switch. This can be an advantage where the RSU serves an isolated community. A single, host, electronic switching system can control multiple RSUs. For some RSUs there may exist a host office without lines, for example, a host office equipped with trunks only and no lines.

The RSU is a smaller and more cost-effective system than traditional stand-alone switching entities (Figure 4-1). One of the attributes of the host/remote distributed system is the ability to start new wire centers at a smaller size than is economically feasible for larger, stand-alone systems, while still providing the customers in the serving area with all the features of the SPC host system. Remote switching has a number of applications, including Community Dial Office (CDO) replacement or capping, new small wire-center formation, and extension of new features or services to electromechanical wire centers.

Remote terminals are available in small (96 lines) or large (2000+ lines) and can be used in remote switching digital applications. Generic requirements for remote terminal capabilities are contained in TR-TSY-000008 and GR-303-CORE, respectively.

#### 4.1.3.3 Tandem Switching Systems

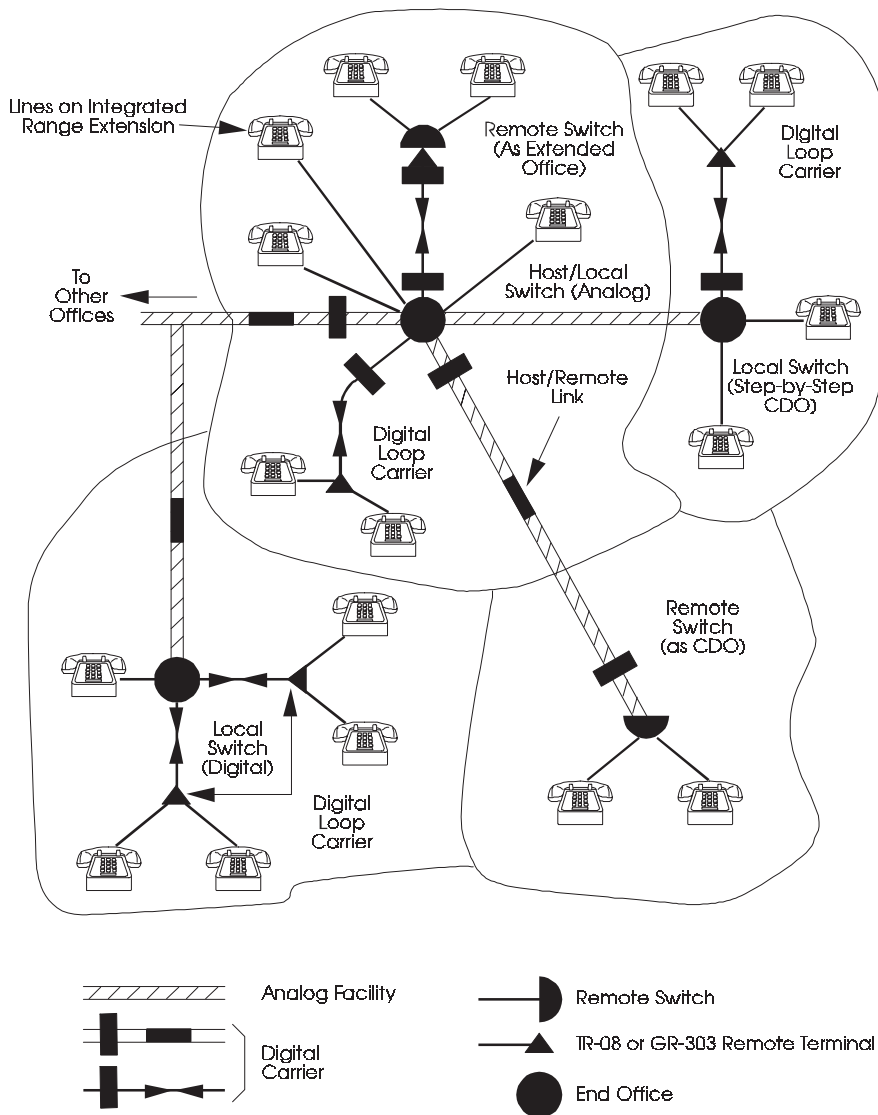
Tandem switching systems are used to interconnect end offices when direct trunk groups are *not* economically justified, or when the network configuration indicates alternate routing *is* economically justified. Tandem offices provide the ability to configure the network economically, act as buffers between different systems, and centralize functions such as billing (which may not be available in all end offices). LEC tandem switching systems perform some or all of the following functions:

- Interconnect end offices
- Connect to other tandems
- Serve as Centralized Automatic Message Accounting (CAMA) points for end offices
- Provide access to ICs
- Provide access to operator positions.

In other words, tandem switching systems perform trunk-to-trunk switching (customer lines are not ordinarily connected to tandems) and generally provide two basic network functions — traffic concentration and centralization of services. As traffic concentrators, tandems allow the traffic of groups of end offices to be economically gathered for delivery between the end offices or to distant points. Also, with tandems, call recording, LATA

---

access, operator services, and signaling conversion functions can be centralized and made economically available to groups of end offices. Proper deployment of tandems is based on the blending of the functional needs and the economics of traffic concentration according to the technical capabilities of the tandems being deployed.



Note: All possible configurations are not shown.

**Figure 4-1.** Hypothetical Local Network (within a Single LATA)

Tandem switching systems can be 2- or 4-wire, analog or digital, depending on the transmission plan for the networks to which the tandem switches have access and the distance between offices. Both 2- and 4-wire trunk facilities can be terminated on analog tandem switches. Digital switches are inherently 4-wire switching systems but may contain 2-wire analog interfaces.

#### 4.1.3.4 Dynamic Routing Switching Systems

Dynamic Routing Switching Systems, commonly called “via” nodes, are used to interconnect end offices when a direct trunk group is unavailable. Via nodes provide the ability to configure the network economically by reducing the total network trunk requirements. A via node interconnects end offices in the same way as a tandem switching system, but is also used as an end office, thus utilizing idle trunks in the network. Proper use of a via node is determined by a collection of current network data at a centralized controller. Dynamic Routing Switching Systems must be SPC.

#### 4.1.3.5 Combined Systems

Recognizing that dedicated tandems serving rural or other low-volume areas may not necessarily be cost effective, tandem capabilities have been added to a variety of end office technologies. The combined systems share portions of the hardware and software as an efficient compromise to meet both customer service needs and network requirements.

#### 4.1.3.6 Digit Utilization and Translation

Routing within an intraLATA network is done sequentially by each switching system as a call progresses. To do this, each office must be able to examine the destination-code digits received to select an outgoing route and determine the proper signaling to pass to the next switching system.

The dialing plan for geographic numbers employs the principle of destination-code routing. Each customer terminal in World Zone 1 is assigned a unique 10-digit number that consists of a 3-digit area code, a 3-digit central office code, and a 4-digit station number.

Several methods are commonly used for treating the address digits of a call. When an intraLATA Foreign Numbering Plan Area (FNPA) can be reached by more than one route, the first 6 digits (area code and central office code) of the 10-digit number of each call to an FNPA are examined by the originating switching system to determine the preferred outgoing route. In addition, all or part of the 6 digits can be *deleted*, other digits can be *prefixed*, or the digits can be *converted* to other digits, depending on the requirements of the switching system to which the address information must be forwarded. This process is called 6-digit translation.

---

---

Digit deletion is used for various purposes including the following:

- To drop an area code when pulsing into that area
- To drop an area code or central office code when other digits are to be substituted for them (this is called code conversion)
- To drop part or all of a central office code when the remaining code digits are all that are necessary to route the call to that office (delete 1, 2, or 3 digits).

The number of digits that can be deleted is independent of the number of digits used for selecting the outgoing route. Digit deletion always begins with the first digit received.

One to six digits can be prefixed to the received digits, depending upon the type of switch. An example is the prefixing of the Home Numbering Plan Area (HNPA) code to the central office code and station number received.

Code conversion is a capability in some systems, which permits the substitution of digits for some or all of the digits received. This feature provides flexibility in meeting numbering plan requirements by furnishing routing digits for certain switching systems in the network (for example, to establish a call through an SXS system that requires routing digits different from those provided by the 7-digit address). The last preceding tandem office can delete some of the 7 digits and furnish digits that fit the switching pattern of the SXS system. Another example is the converting of the dialed digits 911 to a 7- or 10-digit telephone number for routing.

#### 4.1.3.7 Trunk Circuits

Trunks between switching systems are most commonly carried on channels of digital carrier systems (Digital Signal level 1 [DS1] and higher-order multiplexes). However, some individual analog circuits on copper cable pairs and some Frequency Division Multiplex (FDM) and Code Division Multiplex (CDM) carrier systems are employed.

Analog SPC and electromechanical switching systems must treat each trunk as an individual analog circuit. Digital SPC systems usually treat full DS1s (or higher-order multiplexes) and switch the digital contents of the channel without conversion to analog.

The following paragraphs describe the relationship between trunk types and the connection types that are supported.

Voiceband or 3-kHz connections may use either analog or digital trunk channels and either multifrequency or CCS signaling. Data connections at 56 kbps must use digital trunk channels and may use either multifrequency or CCS signaling. However, the use of multifrequency signaling may limit the flexibility of use of that channel.

Digital trunk channels designed to carry 7 kHz or 64 kbps require Clear-Channel Capability (CCC) and thus require out-of-band signaling such as CCS for interoffice signaling.

---

Detailed requirements for trunk signaling are contained in FR-64, *LATA Switching Systems Generic Requirements (LSSGR)*.

#### 4.1.3.8 Call Control

Recorded announcements and various tones are used to advise the calling customer of call progress. On most calls, the calling party will receive either a recorded announcement or a call progress tone. Control of the connection is achieved as follows.

- On *customer-dialed calls*, the connection is usually under the immediate control of the calling customer and under delayed control (timed disconnect) of the called customer. The range of disconnect timing intervals for various switching systems is shown in Table 6-8 in Section 6 of this document.
- On *operator-dialed calls*, the connection between the operator and the calling customer is under joint control except where the operator performs actions to have sole control of the call.

#### 4.1.4 Interexchange Carrier Points of Presence

A Point of Presence (POP) is a location within a LATA that has been designated by an IC for the connection of its facilities with those of a LEC. Typically, a POP will be at a building that houses an IC's switching system or facility node, and it must be located within the LATA that the IC serves. An IC may have more than one POP within a LATA, and a POP may be for public and private, switched and nonswitched services. One location may serve as a POP for several service types.

The IC is required to designate at each POP a physical Point of Termination (POT), consistent with the technical and operational characteristics specified by the LEC. The POT provides a clear demarcation between the LEC's exchange-access functions and the IC's interLATA functions, and enables the LEC to meet its tariff obligations. This POT generally will be a distributing frame or other item of equipment at which the LEC's access lines terminate, and where cross-connection, testing, and service verification can occur. The IC can also have a multiplexed (Time-Division Multiplexing [TDM], Frequency Division Multiplex [FDM], etc.) POT interface, which requires a special testing procedure.

## 4.2 Operator Services Systems

Although the vast majority of calls that are placed through the telecommunications network are established directly by the customer, there are many situations and/or services that require an operator. There are also certain functions or services that previously required an

---

---

operator that are now fully automated. Both access to operators and some automated functionality are provided to the customer via the Operator Services System (OSS).

Services provided via the OSS may be grouped into two broad categories: Assistance and Information.

- *Assistance operators and automated functionality* assist customers in the completion of calls and in special or alternate billing of services. Operators may also be trained to provide assistance on the proper use of optional services or capabilities available to the customer.
- *Information (or Directory Assistance) operators* provide customer listing information (telephone numbers, address information, etc.) via a database accessible by the operator or, in some cases, directly accessible by the customer. Intercept is also included in this category.

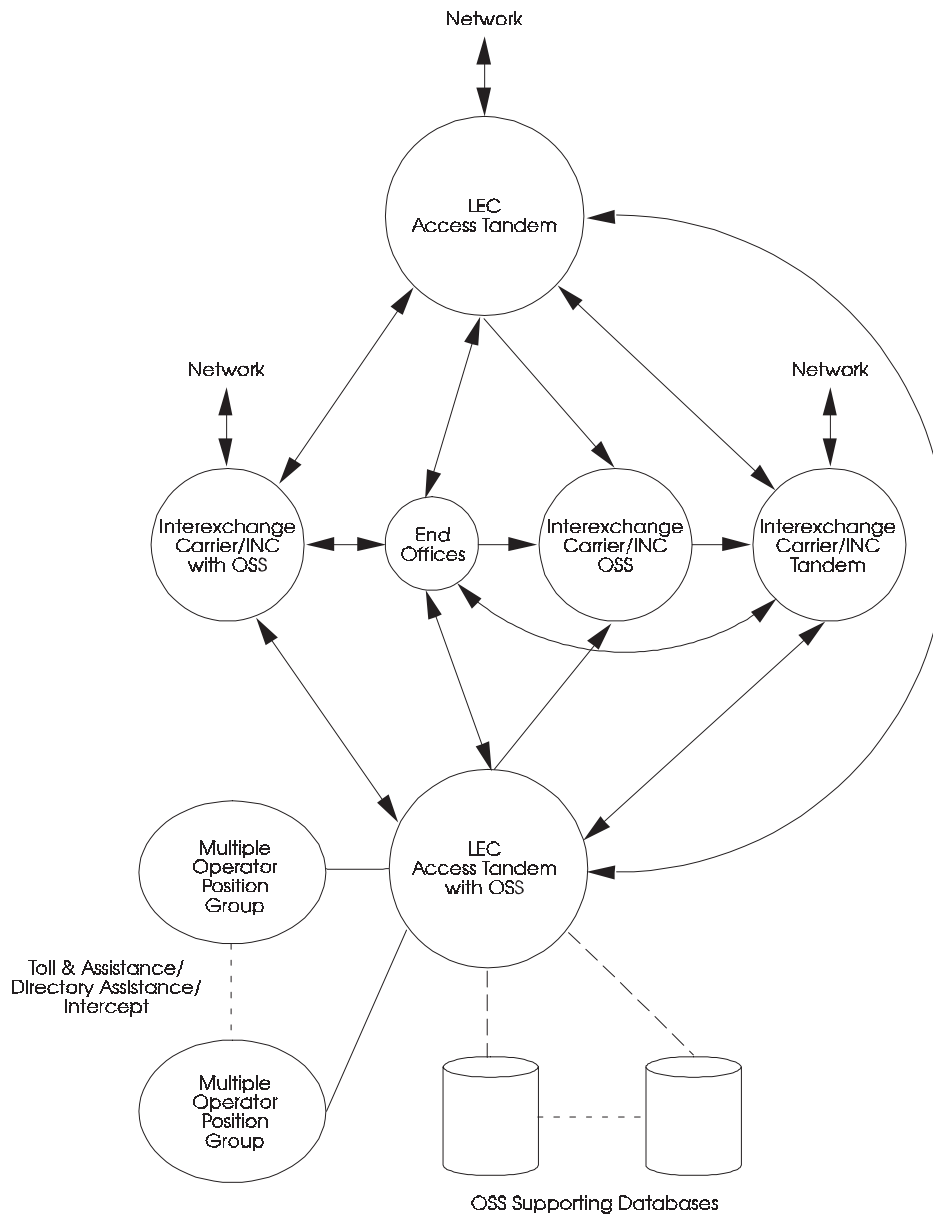
The OSS serves as a call-processing switching system from which customers may access operators or automated functionality in order to complete calls or gain access to information. Some additional functions accomplished by the OSS include automatic call distribution, recording of billing details, and information retrieval. Additional information may be found in Bellcore's FR-271, *Operator Services Systems Generic Requirements (OSSGR)*.

#### **4.2.1 Existing Architecture**

A generic view of the existing OSS architecture is shown in Figure 4-2. This figure shows that an OSS may have access to operator positions, databases, end offices, tandem offices, and other OSSs. The OSS may also serve as a platform from which new technology such as speech recognition can be applied to existing services or functions. The OSS is capable of identifying the requested service based on service codes, dialing patterns, trunk groups and/or signaling information. The system is capable of distributing calls to attendant positions or automated peripherals based on these identified service needs.

#### **4.2.2 Future Architecture**

The future OSS architecture will be based on the evolution of the existing architecture. Emphasis is being placed on the flexibility of the OSS to allow new services, to provide operator or automated functionality to calls. Advanced Intelligent Network concepts, such as service creation and migration of intelligence to external systems, are expected to be used within the OSS architecture. Furthermore, the communication between OSSs and other network elements and systems (for example, AIN network elements and systems) is expected to increase as the network evolves. For example, SS7 signaling may be used in the future to pass additional information from offices to OSSs,



**Figure 4-2.** Existing Operator Services Systems (OSSs)

**4.2.3 OSS Switching Environment**

An OSS is a tandem switching system with special operator services capabilities. Some OSSs serve only operator services traffic in a stand-alone environment (in other words, tandem functions are not provided). Others reside on Access Tandem (AT) switches that



---

also serve nonoperator services traffic. Additional hardware and software is necessary for a switching system to be capable of providing operator services.

#### 4.2.4 Position in the Network

The OSS receives calls from end offices, from LEC tandems, and from other operator systems (both LEC and IC). An OSS is capable of completing calls to LEC end offices and routing calls to an IC's POP. The OSS may also route calls to other OSSs. Some OSS-provided services terminate at the system, such as some listing service calls. OSSs normally receive operator and automated service call types combined on end office trunk groups. The OSS sorts the traffic by call type and distributes each call to the resource needed for call processing.

#### 4.2.5 Call Handling

After recognizing a request for service, an OSS will begin initial call processing to determine call type. This initial processing may also determine originating station restrictions if applicable to the requested service. If the service is intraLATA, the OSS will either serve the call or pass it to another system that can provide the requested service on the LEC's behalf. If the call (or service) is interLATA in nature, the preferred IC is determined and the call is either served by the LEC OSS on behalf of that carrier (prearranged service contracts must be in place) or the call is passed to the IC for handling.

#### 4.2.6 OSS Subsystems

To accomplish the provision of operator services, the OSS depends on the core switching capabilities of the OSS and numerous subsystems and databases that are accessed at the direction of the core. The various components that make up the subsystems and databases are frequently developed and provided by multiple suppliers. To promote an environment in which this arrangement can function efficiently, open non-proprietary interfaces between the components are strongly recommended. Many of these non-proprietary interfaces are specified in Bellcore's FR-271, *Operator Services Systems Generic Requirements (OSSGR)*.

Some examples of subsystems and databases that may be used by an OSS are listed below.

- *Position Subsystem* — This subsystem provides the means by which the core switch can attach an attendant to a call. The position equipment may consist of terminals simply displaying information provided by the core. Recently deployed intelligent workstations can be equipped with a software layer that provides additional displays or attaches additional call processing resources based on the basic core-provided call details.

- *Databases* — Databases are used to store information that is needed for call processing and to provide listing-information-based services to customers. An individual database may be accessed directly or indirectly by the core as part of call processing, by the position subsystem at the direction of an attendant, or as directed by other OSS subsystems. Examples of these databases include the following:
  - Line Information Database (LIDB)
  - Listing Services Database (LSDB)
  - Intercept database
  - Operator Reference Database (ORDB)
  - Real Time Rating System (RTRS).
- *Announcement Subsystem* — This subsystem provides audio information to system users on an automated basis. Recent applications have implemented speech recognition and speech processing capabilities for use in interactive functionality between the customer and fully automated services.
- *Report Subsystem* — This subsystem prepares reports for system administrators and/or provides data for downstream processing and report generation.

#### 4.2.7 Features

The features provided at the OSS may be divided into several categories: those common to the basic OSS functionality, customer access, access to customer listing information, service specific call-handling, and special billing.

##### 4.2.7.1 Basic OSS Features

Features common to the basic OSS include determination of calling, called, and billed number. This capability enables an operator or the system itself to enter selected call details. This functionality includes basic validity and format checks.

- *Service Determination and Handling Methods* allow an operator to enter, or the system to determine, the specific service and the handling method requested by the caller.
  - *Initial Call Processing* provides the capability for the OSS to determine customer-dialed digits and to request and interpret post-seizure dialing information.
  - *IntraLATA/InterLATA Check* provides the capability to determine whether a request for call completion is intraLATA or interLATA.
  - *IC Code Processing* allows the OSS to offer service on behalf of or to direct calls to ICs.
-

- 
- *Sequence Call Processing* allows a customer to request further action/services while connected to the OSS.
  - *Terminating Inward Service* provides the capability to receive requests from other OSSs for service on various calls including emergency assistance, call completion, busy-line verification, operator interrupt, and other operator-handled services.

#### 4.2.7.2 Customer Access Features

Customer access features provide the capability for a customer to access an operator in order to obtain information relating to services, dialing instructions, or general assistance traditionally provided by the operator.

- *Rate Information* allows the operator to provide a customer with information about charges for specific services.
- *CAMA* allows an operator to be bridged onto a 1+ call in order to obtain the calling (billing) number from the customer.
- *Credit Recording* provides the capability for an operator to enter customer credit requests for calls that encountered a wrong number or network trouble.
- *Trouble Reporting* provides the capability for an operator to report customer-encountered network difficulties by keying trouble codes and details into the OSS.

#### 4.2.7.3 Customer Listing Information Features

Customer listing information features allow customers to obtain information through the OSS, either from an operator or via an announcement machine. Examples are listed below.

- *Directory Assistance* provides the capability for a customer to obtain the listed telephone number for a given name and address.
- *Customer Name and Address Service* allows a customer to obtain the mailing address associated with a given telephone number.
- *Area Business Listings* allow a customer to obtain business listings based on a given geographic area and the business category or trade name.

Data associated with these and other listing services are not retained in the OSS but in databases that are accessible by the OSS.

#### 4.2.7.4 Service Specific Call Handling Features

The OSS can provide functionality or automation specific to certain services or classes of services. **Note:** These services may or may not be optional in their offering or pricing.

- *Message Delivery* is a feature that allows a customer to record a message to be delivered to a specified station by the OSS.
- *Busy-Line Verification* is feature that provides the capability for a calling customer to request that an operator verify the current status of a given line.
- *Operator Interrupt* provides the capability for an operator, at customer direction, to interrupt an established connection.
- *Conferencing* is a feature that allows three or more customer's stations to be bridged together on a single call.

OSS call handling for specialized attendant groups uses the ACD functionality of the OSS to distribute incoming calls to specialized attendant groups that provide services unique to the caller's service code or other identifying characteristic of the originating call.

#### 4.2.7.5 Special Billing Features

Special billing functions enable the OSS to provide alternate billing (that is, calling card, collect and third number billing). Common to all of these billing methods is the capability of the OSS to verify the billed number via access to the LIDB in which the billed number resides. This validation process is provided via data messages launched and replied to on the existing SS7 network.

- *Calling Card Billing* allows a customer to place a call and have the charges associated with that call billed to a valid calling card.
  - *Collect Billing* enables the calling customer's capability to bill the charges associated with a call to the called customer. This billing method requires verbal acceptance from the called party.
  - *Third Number Billing* allows a customer to bill a call to a valid telephone number that is neither the called nor the calling number.
  - *Originating Line Number Screening* is the OSS feature that queries the LIDB to determine what billing or service restrictions (if any) are associated with the calling station.
-

---

#### 4.2.8 Telecommunications Relay Service

Telecommunications Relay Service (TRS) is a telephone transmission service that provides the ability for an individual who has a hearing or speech disability to engage in communication with a hearing individual in a manner that is functionally equivalent to the ability of an individual who does not have a hearing impairment or speech impairment. TRS includes services that enable 2-way communication between an individual who uses a Text Telephone (TT) or other nonvoice terminal and an individual who does not use such a device.

Several regulatory and legislative actions have mandated that TRS be made available. Most significant of these actions is the Americans with Disabilities Act (ADA), which prescribes that

“Each common carrier shall provide TRS, individually, through designees, through a competitively selected vendor, or in concert with other carriers.”

In addition, the ADA directed the FCC to prescribe regulations establishing functional requirements, guidelines, and operations procedures for TRS. In the FCC Docket No. 90-571, the Commission provided such regulations. Key among them is a technical standard that prescribes equal or equivalent access to ICs. Specifically, it is stated that

“TRS users shall have access to their chosen interexchange carrier through TRS, and to all other operator services, to the same extent that such access is provided to voice users.”

In each state, TRS is provided, after a selection/certification bidding process, by a single carrier, either an IC, a LEC, or other (usually nonprofit) organization.

The regulation prescribing equal access for TRS has been interpreted to require that the TRS provider offer the TRS user the ability to designate the carrier to transport the call by using Feature Group D (FGD) signaling to the LEC access tandem. Accordingly, the TRS provider must establish the technical capability and the administrative procedures to route the call to the designated transport carrier. Similarly, the transport carrier must be able to recognize the TRS call, complete the call to its destination, and obtain sufficient call detail information to accurately rate and bill the call. With such an arrangement, the established connection will link the calling party to the called party, through the TRS platform and the facilities of the transport carrier.

To provide the technical capability as specified in the FCC Docket and meet the requirements of the ADA, a workshop was established under the auspices of the Industry Carriers Compatibility Forum (ICCF) to develop and propose the necessary technical arrangements to accommodate TRS. The final output of the TRS Workshop entitled *TRS — Technical Needs*, ICCF #93-0729-008, presents the current industry understanding of network technical issues associated with the implementation of TRS. The document, which should be considered the product of industry consensus, also proposes the technical arrangements and the ultimate network solution to the stated issues.

---

---

### 4.3 Network Design Considerations

The successful completion of traffic dialed by customers and operators depends upon a trunking network in which no-circuit conditions are rarely encountered under expected conditions. Alternate or dynamic routing and selection of appropriate blocking probabilities make this possible with reasonable trunk efficiency. This section discusses network design considerations for intraLATA services that may not apply to LATA access services. See SR-TAP-000191, *Trunk Traffic Engineering Concepts and Applications*, for a detailed discussion.

The principle of alternate routing is applied to telephone traffic by providing a first-choice, high-usage route for a given item of traffic, and a second-choice, alternate route when calls fail to find an idle trunk on the first-choice route. Additional alternate routes can be provided subject to routing restrictions.

The principle of dynamic routing is applied to telephone traffic by updating routing patterns on a real-time or short-time interval on the basis of trunk group measurements collected by a network central controller.

#### 4.3.1 Fundamentals of Hierarchical Routing

Alternate routing is advantageous because it provides the opportunity to minimize the cost per unit of carried traffic. With alternate routing, the load is allocated to high-usage and final routes in the most economical manner. Alternate routing also permits the meshing of traffic streams that have differing busy hours or seasons.

Figure 4-3 illustrates a 1-way, high-usage trunk group from end office A to end office B, with an alternate (final) route via a tandem. In general, the direct or high-usage route is shorter and less expensive than the alternate-route path. However, because each leg of the alternate route is used by other calls, a number of traffic items can be combined for improved efficiency on that route. The basic engineering problem then, is to minimize the cost of carrying the offered load (that is, to determine how much of the offered load should be carried on the direct route and how much should be overflowed to the alternate route).

Figure 4-4 shows the relationships involved. The graph shows, as a function of the number of trunks in the high-usage trunk group, the cost of the direct route, the cost of the alternate route, and total cost for serving the given offered load. The high-usage trunk group cost, of course, increases in direct proportion to the number of high-usage trunks. If there are no high-usage trunks, all of the offered traffic must be carried on the alternate route, so the incremental alternate-route cost is high. As trunks are added to the high-usage trunk group, less offered traffic is overflowed to the alternate route so that the incremental alternate-route cost decreases. This cost decreases very rapidly as the first trunks are added to the high-usage trunk group. This is due to the efficiency of each of these trunks, which relieves a substantial amount of load from the alternate route. As more high-usage trunks are added, each successive high-usage trunk carries less traffic,<sup>3</sup> while each alternate-route trunk

---

continues to carry a significant amount of traffic. Eventually it becomes undesirable to add any more high-usage trunks. The point at which this threshold occurs is where the total cost (the sum of the two curves) is minimized. This point is designated as N in Figure 4-4.

A method commonly used to determine N is called Economic Hundred Call Seconds (ECCS) engineering. This method determines the maximum number of high-usage trunks for which the cost per hundred call seconds (CCS) carried on the “last” trunk of the high-usage trunk group is less than or equal to the cost per CCS on an additional alternate route trunk.

This relationship can be expressed by the following equation and is the basis of ECCS engineering.

$$\frac{\text{CALT}}{\text{CHU}} = \frac{28}{\text{ECCS}}$$

Where:    CALT =    Cost of a path on the alternate route.  
               CHU =    Cost of a trunk on the high-usage route.  
               28 =    Capacity in CCS added to the alternate route  
                           by the addition of an incremental trunk  
                           (path).

The equation is solved for the ECCS — the load to be carried by the “last” or least-efficient trunk in the high-usage trunk group. Given the ECCS and the offered load, standard trunking tables can be entered to determine the number of trunks required and the estimated amount of overflow. This is the largest number of trunks for which the load carried on the last trunk is not less than the ECCS.

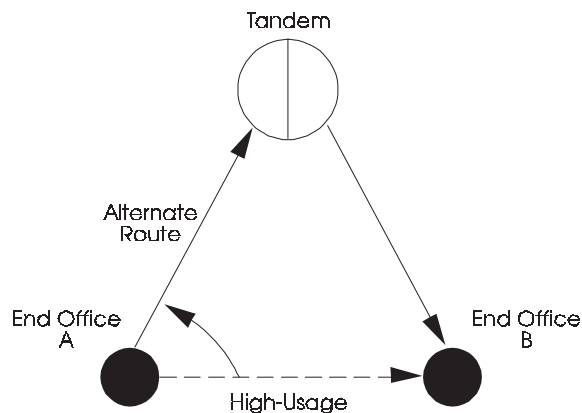
Since the equation is solved for the ECCS, the other elements of the equation must be known. The left portion of the equation (CALT/CHU) is the cost ratio, or the relationship of the cost of a path on the alternate route to the cost of a trunk on the direct route. Cost ratios used for alternate-route engineering are always greater than unity (1).

The “28” shown in the equation is the incremental capacity of the alternate route (the capacity that would be added to the alternate route by the addition of one path). This value is usually assumed to be a constant of 28 CCS, thereby permitting calculation of the ECCS as a function of a single variable, the cost ratio.

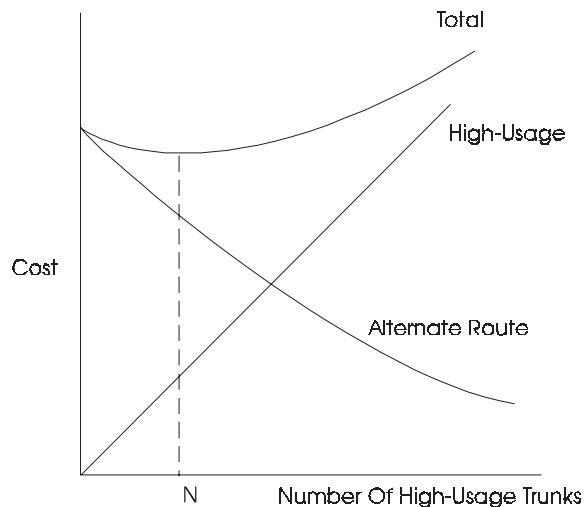
Thus it can be seen that with low cost ratios, the ECCS will be high and fewer high-usage trunks will be provided. Conversely, a low ECCS would result from a high cost ratio and a

- 
3. This principle can be illustrated with an SXS switching system offering a call to a group of ten 1-way outgoing trunks. Tested in order, trunk No. 1 will be selected first, reselected when idle, and thus be kept busy most of the time. Trunk No. 2 will be slightly less busy, and trunk No. 3 will be used less than No. 2. This pattern will continue to the tenth trunk, which is called into use only when all prior trunks are busy.
-

greater number of high-usage trunks will be provided. Simply, the more expensive the alternate route relative to the high-usage trunk group, the less traffic that will be overflowed to it.



**Figure 4-3.** Alternate Routing Arrangement



**Figure 4-4.** Relationships Involved in Alternate Routing Arrangement

The total cost curve is rather flat near the minimum. As a result, errors in ECCS that might result from minor cost ratio or incremental CCS errors will not have a significant impact on network cost.

The number of high-usage trunks to be provided in a group depends not only on the ECCS and offered load, but on the variability of the offered load as well. This variability can be either within the hour (usually peakedness), or day to day. Such variability can be the result



---

of traffic patterns as in the case of day-to-day variations, or it can be system-induced as is usually the case with peakedness. In either event, the effect of such variability is a reduction of the capacity of a group of trunks. Where such variability is present, equivalent random-engineering techniques are required for the high-usage groups, and Neal-Wilkinson capacity tables are used to size grade-of-service engineered final trunk groups.

Traffic volumes reach peaks during certain hours. Trunks are usually provided to care for average-time consistent busy-hour loads in the busy season of the year. Where only one outlet (trunk group) is available, trunks must be provided for the group busy-hour load. If two routes (a direct and an alternate route) are available, however, the busy hours on each of the two routes will frequently be different. Where this is the case, trunks only need to be provided on the direct route to care for that portion of busy-hour offered load that cannot be carried on idle trunks in the alternate route. The alternate route may be sized for a different busy hour and thus is not fully loaded in the busy hour of the direct route.

Often there are two or more potential first-choice alternate routes for a high-usage group. The selection of alternate routes can be based on a routing discipline if overall cost differences are not significant, or the choice can be based on the economics of each individual case (that is, selection of the least expensive alternate route). In general, the overall network economics are not highly sensitive to variation in alternate-route costs.

New high-usage trunk groups are ordinarily established when offered loads are large enough to justify them. Using cost-ratio techniques alone, trunk groups with as few as one trunk can be economically justified. However, other factors, such as administrative costs, traffic measurement variability, modular trunk engineering, and the cost of certain central office equipment should be considered in establishing a minimum trunk group size. The deployment of digital switching systems, digital trunk interfaces, and digital transmission facilities provides the opportunity for modularization of trunk groups to achieve equipment and administrative cost savings. The specific modularity rules are given in SR-TAP-000191, *Trunk Traffic Engineering Concepts and Applications*.

#### **4.3.2 Application of Alternate Routing**

The principle of alternate routing is basic to the design of the network and is used extensively to provide economic and service advantages. Switching equipment automatically seeks alternate routes. Calls can be offered in succession to a series of alternate routes via one or more tandems. At each switching system, all of the high-usage trunk groups to which a call can be offered are kept very busy with a portion of the traffic overflowing to another route. The final trunk groups are fewer in number and have low blocking so that the engineered level of service is good. The overall chance of completing a call is improved by the fact that it can be offered to more than one trunk group. Switching equipment operates rapidly and the change in speed of service between the selection of direct and alternate routes is not significant.

---

In an emergency situation of limited impact and extent, such as a localized equipment failure, the ability to use an alternate route adds another measure of protection to service. However, if there is a heavy surge of traffic over an entire area (for example, during a major disaster such as a hurricane), there is little margin to absorb such surges in load, and service may not be as immediately available as it would be with an only-route-type network.

In addition to the final trunk groups that connect end offices to their home tandem, high-usage trunk groups are provided from end offices to other end offices and tandems when justified by economics and traffic volumes. The traffic items that should be considered when evaluating traffic volumes for the purpose of proving-in new high-usage groups are subject to the rules of the network hierarchy.

There are, in many cases, no direct routes for calls to low-volume points. Calls between end offices not directly connected are completed over two or more trunk groups in tandem. A tandem switch in a hierarchical network will always be involved in multilink (two or more trunks) connections.

Since every end office is connected to a tandem, the tandem network can be used to provide an alternate route for each of the high-usage groups. Therefore, fewer high-usage trunks are required. Furthermore, with the ability to alternate route via a tandem, it generally becomes economical to accommodate growth by establishing new high-usage groups of small size.

### **4.3.3 Fundamentals of Dynamic Routing Technique**

A Dynamic Routing Technique (DRT) is a traffic routing method in which one or more central controllers determine near real-time routes for a switched network, based on the state of network congestion measured as trunk group busy/idle status and switch congestion. The choice of traffic routes in a hierarchical network is static (preplanned and fixed) over time, other than the manual or automated controls performed by Network Traffic Management (NTM) in response to localized or general network overload.

Using DRT, network traffic can be more efficiently distributed over the network trunk groups and switches than traffic routed on the hierarchical network. Based on near real-time network traffic congestion, DRT selects routes that provide lower blocking than today's fixed routes can attain. Consequently, DRT can reduce the level of demand servicing and react more easily to relieve problems associated with forecast errors. Also, networks using DRT can carry significantly more traffic if a switch or fiber link fails than networks using hierarchical routing.

DRT differs from current routing operations in at least two important areas: (1) the frequency of traffic data collection and (2) application of this data to the selection of routes. This dynamic routing algorithm, commonly called DR-T, can use traffic data collected about every T minutes to change routes after each data update, where T is fixed from near zero to about five minutes.

---

Routing using the DR-T scheme is illustrated in Figure 4-5, where any node can originate traffic and also act as a via node. The choice of routes can change in the next T-minute period.

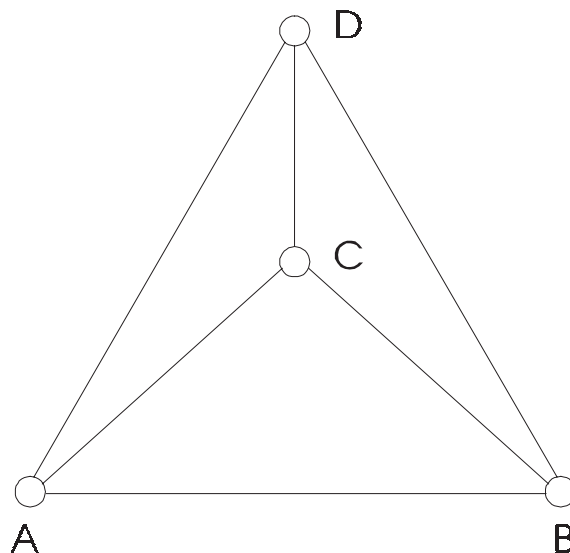
In nonhierarchical routing, switches could originate and terminate traffic and also be used for via traffic.

At the beginning of the update interval of length T (for example,  $T = 5$  minutes), the ordered routes for first-offered traffic from switches A to B determined by the DR-T algorithm could be:

1. A - B
2. A - C - B

The ordered routes from switches C to B could be:

1. C - D - B
2. C - B



**Figure 4-5.** Example of Nonhierarchical Routing Using the DR-T Routing Scheme

#### 4.4 Blocking Probabilities

Trunking service objectives are expressed in terms of the percent of calls blocked on final and only-route groups in the average time consistent busy hour of the busy season. With a given load, the degree of blocking is a function of the amount of trunk idle time available. When the idle time is low, there is little capacity available to handle new calls and the

blocking rate is high. When the idle time is high, there is capacity available to handle new calls and the blocking rate is low. For example, with a random offered load of 406 CCS, the different trunk capacities and idle times required to achieve B.01 and B.02 blocking (according to the Neal-Wilkinson theory) are shown in Table 4-1.

**Table 4-1.** Comparison of Typical Blocking Probabilities

<b>Blocking</b>	<b>Offered Load (CCS)</b>	<b>Peakedness of Offered Load</b>	<b>Trunks Required</b>	<b>Percent Occupancy</b>	<b>Percent Idle</b>
B.01	406	1.0	20	56	44
B.02	406	1.0	18	63	37

It should be noted that there is more idle time with B.01 service than with B.02 service. Trunk groups engineered on a B.01 basis, therefore, do not react as severely to overloads as when higher blocking probabilities are used. This applies to all levels of offered load.

A B.01 objective for engineering a trunk group does not necessarily mean 1-percent overall (or point-to-point) blocking. If the group is an only-route group, B.01 blocking can be expected in the average time consistent busy hour of the busy season. At other periods of the year or during other hours of the day, probability of blocking is substantially lower. If the B.01 objective is used on an alternate-route final group, the blocking in the network that it is part of is expected to be considerably lower, even in the average time consistent busy hour of the busy season. For example, if 50 percent of the calls were first offered to high-usage groups within the network, only 1 percent of those overflowing to the final group as an alternate group would be subject to trunk blocking. In such a case, the average blocking in the total network would be closer to B.005 than to B.01. In other words, blocking within alternate-route networks is always substantially less than the blocking objective for final groups.

Trunks are provided in such quantities that the probability of blocking (including switching equipment blocking) in the chain of connection constitutes a satisfactory overall Grade of Service (GOS). This requires careful consideration of all factors involved in meeting the objective of balanced service and cost. Based on the expected number of links per connection and the relative numbers of trunks in high-usage and final groups, the use of B.01 as the quality-of-service objective for final groups produces, in theory, overall trunking service in the B.01-to-B.02 range under average conditions.

## 4.5 LATA Network Configurations

LEC intraLATA networks serve both intraLATA and LATA-access traffic. Configurations for intraLATA traffic are discussed first, and then LATA-access configurations are discussed in Section 4.5.2.

---

### 4.5.1 IntraLATA Configurations

LATAs vary in shape and size, as well as in population density and distribution. Within a given LATA, configurations for the distribution of intraLATA traffic can be characterized as metropolitan (high-volume, short-distance) and nonmetropolitan (low-volume, long-distance). LATAs can be served by a variety of configurations.

Metropolitan local-tandem networks, because of the high degree of direct trunking, have in the past served less as a point of concentration and more as a means to convert incompatible electromechanical end office signaling schemes. The evolution to SPC end offices reduces the reliance on local tandems for both signal conversion and traffic concentration and provides a smooth transition to DRTs. The availability of large digital tandems provides the opportunity to replace several electromechanical tandems with a single digital tandem. This combination and deployment in metropolitan networks has the following advantages.

- Growth follows an orderly modernization pattern from electromechanical to electronic tandems.
- A lower total network cost can be achieved, that is, the number of tandems can be stabilized by replacing an existing smaller tandem with a larger system that better absorbs network growth or by reducing the number of tandems by employing a dynamic routing scheme.
- Transmission performance is improved.

In some metropolitan networks intraLATA and interLATA traffic remained combined, and was carried by the same network components, for a permitted transitional period following divestiture. However, the required separation of the networks has now been largely realized, and intraLATA and interLATA traffic is combined only at access tandems and on end office-to-access tandem trunk groups as discussed in Section 4.5.3.

In nonmetropolitan areas, several electromechanical Community Dial Offices (CDOs) may be clustered around a larger office serving a larger community. The interoffice traffic is handled by using the tandem capabilities of the larger and more modern centralized end office. As the CDOs are replaced by SPC systems, direct high-usage trunk groups can be economically built between these systems to reduce the tandem load. The conversion to host/remote systems also reduces tandem requirements.

#### 4.5.1.1 Routing

The routing rules for the intraLATA network are based on the alternate route network design principles discussed in Section 4.3. The provision of high-usage trunk groups is dependent on the offered loads and design parameters. With SPC switching systems, the practicality of establishing 2-way trunk groups increases the opportunity for more high-usage groups than would be possible on a 1-way basis. Also, for given directional loads, a single 2-way group is more efficient than a pair of 1-way groups sized for the directional

---

loads. Another advantage of 2-way groups is that they can automatically adjust to changes in the direction of the offered load.

With some older end office switching equipment, some traffic cannot be routed directly from end office-to-end office on high-usage or only-route trunk groups, even though there is sufficient load to support such groups and the end offices are capable of direct routing. This traffic, and traffic from less capable offices, must be tandem-routed for the following reasons.

- *CAMA Recording* — Any traffic requiring detail billing must be routed to a tandem for CAMA recording for end offices that have no capability for Local Automatic Message Accounting (LAMA) recording.
- *Pulse Conversion* — Some end offices do not have trunk circuit pulsing that is compatible with all other offices and must use a tandem for pulse conversion.
- *Six-Digit Translation* — Some end offices do not have 6-digit translation capability or capacity for certain number services (for example, 800 or 900 Service) and must use a tandem for translation or concentration.

#### 4.5.1.2 Blocking

The design of the intraLATA network is generally based on a blocking probability criteria of B.01.

#### 4.5.1.3 Configurations

When considering the design of an intraLATA network, different configurations may be appropriate, depending on the traffic demand and end office capabilities within the LATA. Three configurations will be discussed: single-tandem, two-level networks; multitandem, two-level networks; and three-level networks.

In an environment of common control and SPC end offices, the *single-tandem two-level network* with alternate routing is the logical choice for many LATAs. The single-tandem network is a two-level configuration in which overflow from all high-usage trunk groups is routed via the single tandem. First-routed traffic is also routed via the tandem where high-usage trunk groups between end offices are not justified, or where certain tandem functions are required.

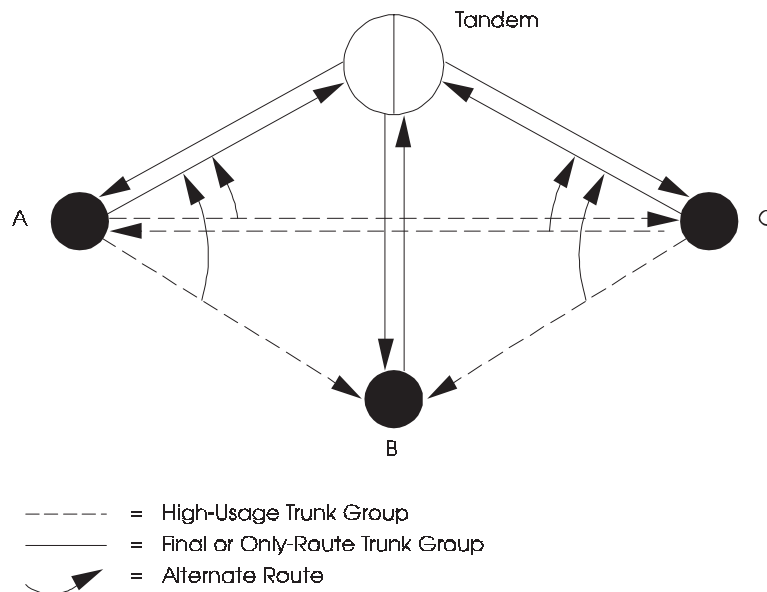
Figure 4-6 is an example of a single-tandem configuration. The tandem provides the overflow route for high-usage groups A-B, A-C, C-B, and C-A and the first route for B-A and B-C traffic. In this example, all trunk groups are shown as 1-way, although 2-way groups should be established as permitted by economics and equipment types for the previously stated reasons. It should be noted that only final-trunk groups are terminated at

---

the tandem. The high-usage trunk groups connect end offices. First-routed and overflow traffic are merged on the tandem trunk groups to effect trunk economies.

The single-tandem alternate-routing configuration offers the advantage of greater flexibility and lower cost when compared to nonalternate-route configurations. Two possible routes are available for any call offered first to a high-usage group. Unanticipated loads between end offices can often take advantage of temporarily idle capacity on the tandem route.

In any network where the tandem provides the overflow route for traffic first-routed on high-usage trunk groups, the tandem is subject to congestion from overload. Small increases in the load offered to the high-usage trunk groups can result in large increases in the load overflowed from those groups and then offered to the tandem. The sensitivity of the tandem to network overloads is a function of the size of the trunk groups incoming to the tandem. Larger trunk groups, because of their higher occupancy, saturate sooner and protect the tandem by blocking calls at the originating switching system. Network controls, usually consisting of alternate-route cancellation at subtending offices, will ordinarily ensure that the tandem can continue to function effectively during overloads.

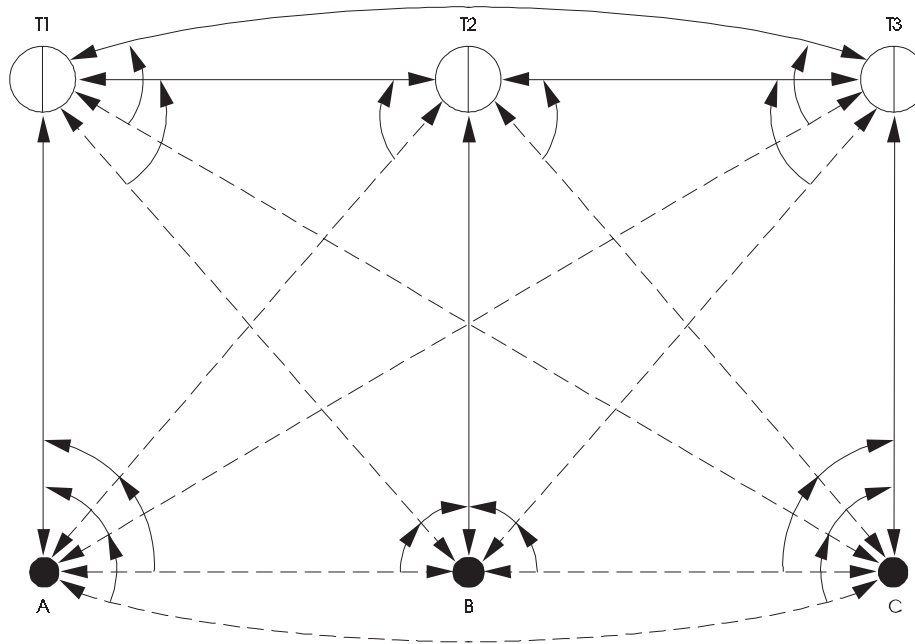


**Figure 4-6.** Single Tandem with Alternate Routing

When growth causes the tandem requirements in a metropolitan area or LATA to exceed the capacity of a single tandem, an additional tandem or tandems must be added. This is done by sectoring the area, with each tandem serving a sector, resulting in a *multitandem, two-level network*.

The combined sector tandem configuration is a two-level, Multialternate Route (MAR) arrangement that provides a maximum of four routes between any two end offices, depending on the number of high-usage trunk groups that are justified.

Figure 4-7 depicts a three-sector arrangement with a full complement of trunk groups. The first-choice route between A and B end offices is the high-usage group, A-B; the second-choice route from A to B is via the *distant* tandem, A-T2-B; the third-choice route is via the home-sector tandem, A-T1-B; and the last-choice route is via the intertandem final trunk group, A-T1-T2-B.



SECTOR	SECTOR	SECTOR
A	B	C
<u>Route</u>	<u>A → B</u>	<u>A → C</u>
First	A-B	A-C
Second	A-T2-B	A-T3-C
Third	A-T1-B	A-T1-C
Fourth	A-T1-T2-B	A-T1-T3-C

Note: All Trunk Groups Can Be 1- or 2-Way. Trunk Groups in This Illustration Are Shown 2-Way For Simplification.

- = High-Usage Trunk Group
- = Final Trunk Group
- ↪ = Alternate Route

**Figure 4-7.** Combined Sector-Tandem Configuration with Multistage Alternate Routing



---

The three-sector configuration depicted in Figure 4-7 can be expanded to four or more sectors by interconnecting all sector tandems with final trunk groups using these same routing patterns. All features of the combined sector-tandem configuration are retained with this arrangement.

High-usage trunk groups in the combined sector-tandem configuration can be either 1- or 2-way. The final route to and from an end office is via its own sector tandem. High-usage trunk groups are established in accordance with the criteria for load accumulation and trunk-group sizing.

The combined sector-tandem configuration, so named because both incoming and outgoing traffic for a sector are combined on the same tandem, is preferable over directional tandem configurations. It provides the greatest flexibility because of its extensive alternate-routing capability and its ability to adjust to changing traffic patterns and load conditions.

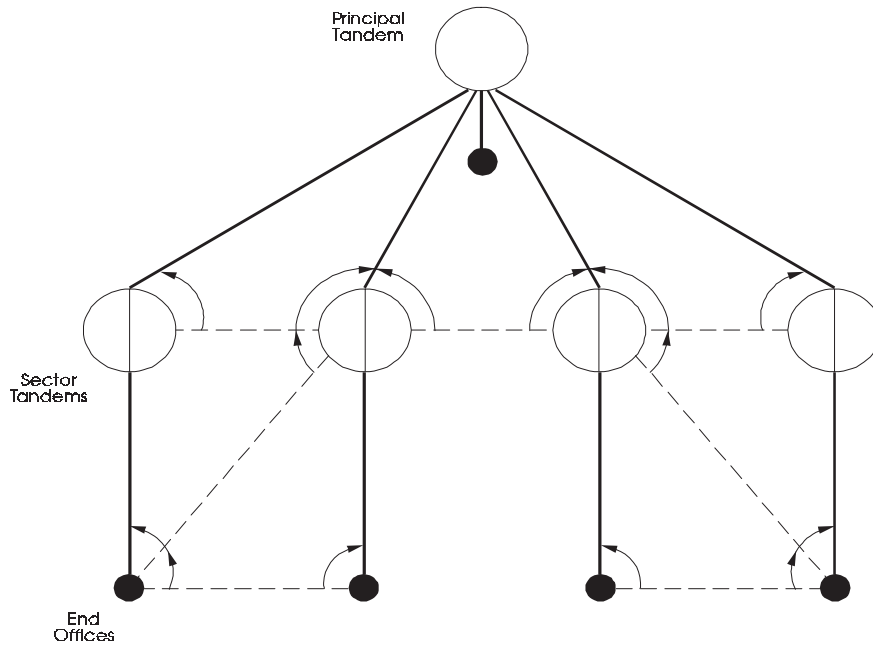
Several sectors or individual two-level networks within a LATA may be interconnected by establishing intertandem trunks between all pairs of tandems to form one large two-level network. However, it may be more economical to designate one or more tandems as a “principal” tandem, thus creating a *three-level network*.

Figure 4-8 shows that the second-level (or sector) tandems would be interconnected by high-usage groups with the overflow routed to the principal tandem. (Not all possible high-usage groups are shown.) Where high-usage intertandem groups are not justified, the traffic would be routed to the principal tandem. End offices could have high-usage groups to the principal tandem, but only for its sector tandem function. In LATAs with multiple-principal tandems, sector tandems could establish high-usage groups to a distant principal tandem based on economics. A sector tandem would “home” or final-route to only one principal tandem.

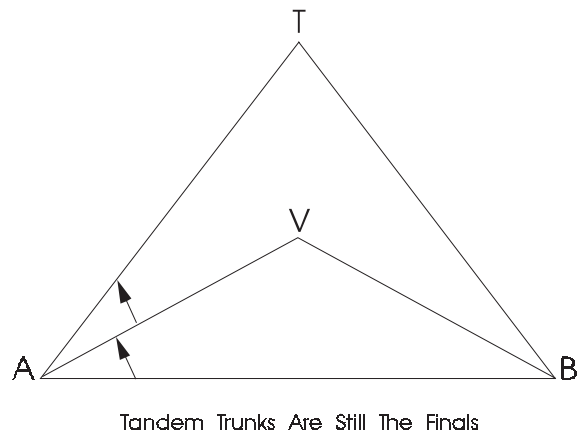
#### 4.5.2 Dynamic Routing Configuration

For every designated period and for every pair of switches A and B in the Dynamic Routing network, the controller computes the following routing sequence for A-to-B traffic (Figure 4-9):

1. *Direct path* — The first choice path in the routing sequence is AB.
  2. *Alternate path* — The next path in the routing sequence is a nonhierarchical path, that is, a path of the form AVB, where V is a DRT network switch used as the via node. A DRT routing sequence may or may not include an alternate AVB path, depending on whether the central controller can find a suitable via node V.
  3. *Tandem path* — If AB is a high-usage trunk group, then the last path in the DRT routing sequence will be ATB, where T is the homing tandem of the switches A and B. If AB is a direct final, then the DRT routing sequence will not include the tandem path ATB.
-



**Figure 4-8.** Three-Level IntraLATA Network



The controller will not recommend the intermediate path AVB if no suitable path via node V is available.

**Figure 4-9.** Dynamic Routing Sequence for A-B Traffic

---

Thus, a path in a dynamic routing sequence will have either one or two links. When the controller computes a nonhierarchical alternate path AVB, the dynamic routing sequence will be AB-AVB-ATB, if AB is a high-usage trunk group. If AB is a direct final, the routing sequence will be AB-AVB.

### 4.5.3 LATA-Access Configurations

Access for ICs to telephone subscribers within a LATA is provided by most LECs as either equal access for conforming end offices or by several other forms of access for nonconforming end offices.

#### 4.5.3.1 Equal Access (Feature Group D)

Each LEC must, within the terms of the Modification of Final Judgment (MFJ) and/or FCC rules, provide equal LATA access to all ICs upon receipt of a bona fide request.

This section discusses the conditions under which access is provided and the network configurations for the access services. The transmission plan is described in Section 7 of this document.

LATA access is provided through the end offices serving the telephone customer. Originating equal-access (FGD) service requires the following:

- A trunk-type termination affording call supervision to an IC
- A uniform access code (accomplished using a 10XXX prefix, to be expanded due to a 1988 industry consensus to a 101XXXX prefix, dialed by the customer that selects the desired IC)
- Calling-party identification (by forwarding Automatic Number Identification [ANI] available as an option to the IC)
- Recording access-charge billing details
- Presubscription to a customer-specified IC
- Overlap outpulsing.

These features can be provided only in SPC-type switching systems, and are available with the vendor products used for illustrative purpose in Section 6 of this document.

Terminating equal access requires a trunk termination to afford call supervision. It also requires some form of terminating message recording for proper access-usage billing to the IC.

It is required that equal access for terminating traffic be provided coincident with the provision of originating equal access, but it may be provided earlier at the discretion of the LEC.

The MFJ allows the LECs to provide access via a switching system above the end office level. This switching system or FGD access tandem allows small volumes of traffic to various ICs to be economically gathered at the tandem until direct groups (with or without overflow to the tandem) can be justified between an end office and an IC.

Tandem access is designed to provide service (transmission and call-blocking probability) equal to that of direct end office-POP connections. The location of the access tandem is a LEC option and is based on economic studies. While an access tandem generally will be located in the LATA it serves, it is permissible to serve a LATA from a tandem located in another LATA.

The equal-access multifrequency signaling format consists of the calling number and 7- or 10-digit address information. The calling number, which includes expanded ANI information digits, is transmitted first, followed by the address digits. See Section 6 of this document for details.

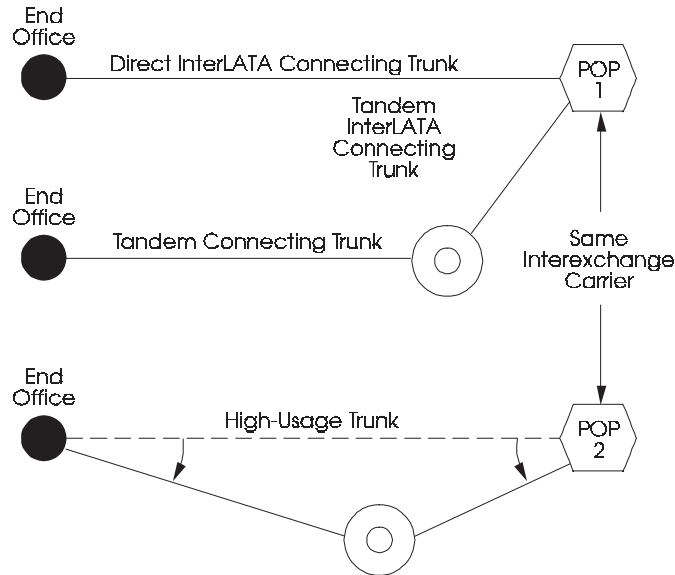
FGD access service between an end office and an IC POP will be ordered by the IC. The service will be provided in cooperation with the IC, on an only-route group between the end office and the POP; on a tandem connecting group between the access tandem and POP; or on a high-usage group between the end office and POP with overflow to the access tandem (see Figure 4-10). FGD service does not allow more than one access tandem in a connection between an end office and a POP.

If an IC has multiple POPs in a LATA, it is assumed that the IC will elect to serve a designated set of end offices from each POP. An access tandem serving multiple IC and/or POPs may need to be able to route to an IC based on the incoming end office trunk group, as well as by the CAC. IC traffic may not be routed from an end office to more than one POP based on destination address or IC-designated load allocation, but may be alternate routed as described later. A LEC cannot route originating LATA-access traffic to a POP other than the one designated by the IC.

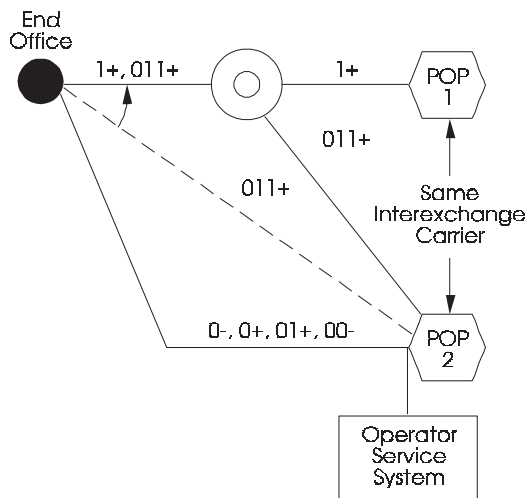
An IC (with either presubscription or 10XXX/101XXXX access code dialing) can specify that a LEC route LATA-access traffic from an end office to more than one POP, or on separate trunk groups to the same POP, according to a customer-dialed service prefix indicator (0-, 0+, 1+, 01+, 011+, 00-) or the originating line class of service (multiparty, coin, hotel/motel). (See Figure 4-11.) Such routing is dependent on screening performed by the equal-access end office.

The IC will designate that special routing is required by providing an order for each type of traffic from the end office to the designated POP. This type of special routing only applies to originating traffic. Depending on the IC order, a separate routing pattern may have to be developed for each type of traffic. Trunk requirements will then be developed for each trunk group based on the combination of traffic types to be routed over it.

---



**Figure 4-10.** Basic Interexchange Carrier LATA-Access Routing Options

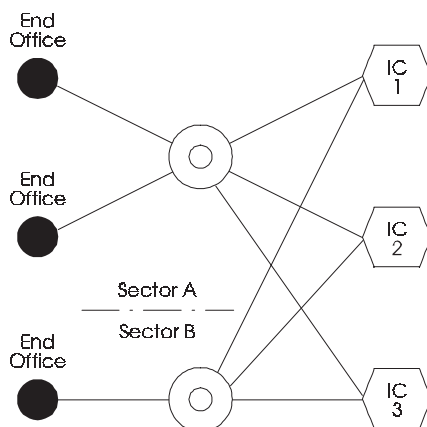


**Figure 4-11.** Service Prefix Routing

LATA access between a given end office and the POPs for all ICs that do not have an only-route trunk group to the end office will be final routed through a single LEC-designated access tandem. One of the advantages of tandem routing is that it reduces trunking and routing changes that may occur because of potential shifts of traffic between different ICs. In some LATAs, due to geographic considerations, access tandem capacity limitations, facility availability, or economic justification, the LEC can elect to sector the LATA into geographic territories, each served by a separate access tandem (Figure 4-12). Each sector

would consist of the territory served by the end offices that are subtending an access tandem for the final routing of terminating LATA-access traffic. Likewise, end offices should be sectored on a single tandem for originating traffic, but different tandems can be used according to service prefix routing requirements. Access tandem sectoring is independent of the homing plan chosen by the ICs for their POPs.

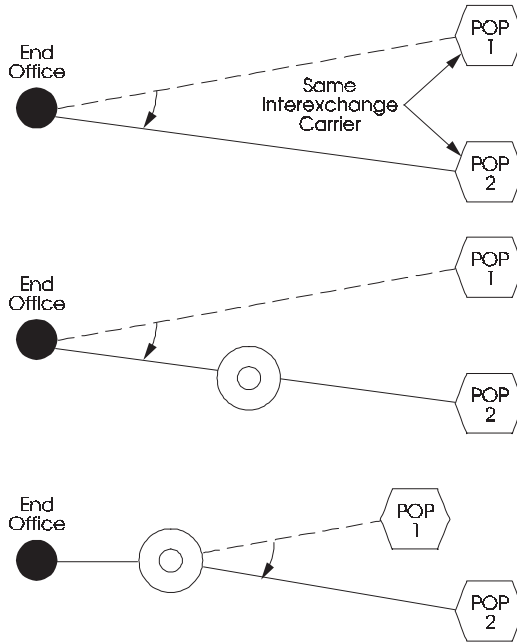
At the request of an IC, a LEC may first-route all of any type of originating equal-access traffic, as defined by a service prefix indicator, service access code, or originating line class of service, to a POP designated by an IC, and alternate-route overflow traffic to a second POP. The LEC will determine whether this alternate-routing option will be performed at the end office or the access tandem and specify the trunk quantities (Figure 4-13).



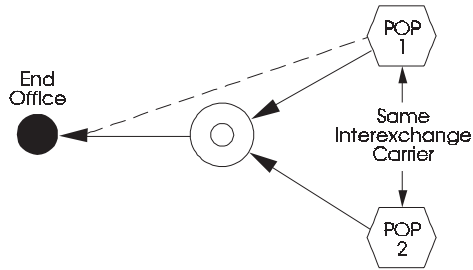
**Figure 4-12.** Sectored Routing

A LEC will accept an individual IC's terminating traffic destined for a single end office from more than one POP. As with the alternate routing for originating LATA-access traffic, this permits the IC to route to more than one POP for service protection. It also eliminates the necessity for an IC to shuttle traffic inefficiently from one POP to another for completion to an end office (Figure 4-14).

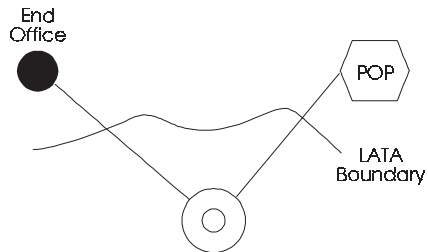
There will be LATAs or areas within a LATA where there is either no tandem technically capable of performing the access-tandem function, or no tandem at all. In such a case, the LEC can identify a tandem in another LATA to provide the access tandem function (Figure 4-15). The network economics, access tandem capacity, and facility availability will determine the selection of this type of arrangement.



**Figure 4-13.** Alternate Routing



**Figure 4-14.** Terminating Routing



**Figure 4-15.** Out-Of-LATA Routing

---

If a LATA does not have an access tandem and uses a tandem in another LATA for access traffic, the tandem interLATA connecting trunk groups must be connected to the IC's POP in the LATA to be served (i.e., the originating LATA). That traffic cannot be routed to an IC's POP located in the same LATA as the access tandem. LECs can also use a tandem in an adjacent LATA to perform intraLATA switching, although it is *not* a LATA-access function. The design blocking objective for FGD LATA access service applies to the Grade of Service (GOS) between the end office and the IC's POP irrespective of the routing configuration used. The design blocking objective is specified in tariffs filed and is typically B.01.

If access is provided by an only-route trunk group (direct interLATA connecting) between the end office and the IC POP, that group is designed to the blocking objective specified in the tariff, for example B.01. If access is provided via an access tandem, both the end office-access tandem (tandem connecting) group and the access tandem-POP (tandem interLATA connecting) group are engineered to B.005 to meet the overall end office-POP objective of B.01. The provision of a high-usage group between the end office and the IC POP does not change these blocking objectives on the tandem route.

High-usage trunk groups can be established between the end office and the POP in cooperation with the IC when traffic volumes justify them. Standard engineering procedures should be followed to prove in high-usage group candidates and to determine the ECCS to be used in trunk-group sizing. The tandem-connecting group serves as the final group for all LATA-access traffic into and out of the end office. It will be shared by all the ICs except those that have direct interLATA connecting groups. IntraLATA traffic between the end office and the access tandem also can be carried on this group based on economics. The tandem interLATA connecting group serves as the final route for an IC's LATA-access traffic between its POP and the end offices served by the tandem.

#### 4.5.3.2 Other Access (Feature Groups A, B, and C)

Equal-access service (FGD) is based on particular dialing, signaling, routing, and transmission capabilities at conforming end offices and access tandems. Because some end offices do not have the capabilities that permit FGD service to be offered, and because some ICs may not need all the capabilities provided with FGD, other access services are also offered. These services are offered as Feature Groups A, B, or C as discussed in the following subsections. Transmission plans for these services are discussed in Section 7 of this document.

#### 4.5.3.3 Feature Group A

Feature Group A (FGA) service provides line-side access. With this service, a customer dials an assigned telephone number that connects to a specific IC. That IC then returns a tone or announcement to signal the caller to input additional tone-generated digits of the

---



---

called number. Calls can be completed to the called number by the IC seizing an access line in the called LATA and dialing the number (generally on a local-call basis). Traffic to and from the FGA serving office is completed over augmented local-network trunk groups, often via a intraLATA tandem.

#### 4.5.3.4 Feature Group B

Feature Group B (FGB) service is trunk-side access where a subscriber currently dials a 950-0/1XXXX access code to reach the IC. This service is available from selected end offices that must be capable of 7-digit translation in order to route the call to the proper XXXX-identified trunk group to the selected IC. As with FGA, upon reaching the IC, address digits (that is, the called number) are provided as specified by the IC.

While optional rotary dial service and ANI are also available for direct trunking to an IC, they may not be available in every office capable of 7-digit translation. Direct terminating access is available to designated end offices with proper call-recording capability. Customers in all types of offices can access an IC or be accessed by an IC via an FGB access tandem that provides the translation and call-recording function for the end office. However, customers in certain end offices (for example, SXS) may need to dial 1+950+0/1XXXX for access or 1+950+XXXX.

The combination of high-usage direct trunking with overflow to the access tandem is available to an IC for those end offices capable of direct termination service. An intermediate tandem subtending the FGB access tandem can be employed as an alternative to extending FGB access to end offices by either establishing additional access tandems or by rehoming end offices to existing access tandems.

The transmission plan performance objectives are less stringent than for equal access, and are provided in Section 7 of this document.

#### 4.5.3.5 Feature Group C

Feature Group C (FGC) is the post-divestiture equivalent of the nonequal-access predivestiture arrangement provided to AT&T, as well as “default carriers” or “carriers of last resort”. It retains the predivestiture routing that generally is on a direct basis between each end office and an AT&T switching system. In those cases where the AT&T switching system is in the LATA, it will be a POP. If the AT&T switching system is in an adjacent or remote LATA, AT&T has established a facility POP and the LEC will route from the end office only to the facility POP. The LEC may desire to route traffic via an FGC access tandem on a high-usage/final-route basis or first-route basis via the access tandem rather than routing all the traffic directly. Alternate routing of originating traffic takes into account end office capabilities and any technical limitations of interLATA billing data (Automatic Message Accounting [AMA]) recording through an access tandem. AT&T must convert

---

their access service to FGD when an end office is converted to equal access. Most end offices have now been converted so the use of FGC is nearly non-existent.

#### 4.5.3.6 Operator Services

Operator services are provided on those customer calls that require operator handling to complete the connection (for example, 0-, 00-, collect, third-number billing, manual credit card calls, and manual sent-paid coin), and on calls that require operator or automated assistance for billing after the customer has dialed the called number (for example, automated credit card and local coin).

In general, intraLATA operator billing and assistance services are handled on LEC operator systems. These operator systems are integrated in tandem switching systems that are available from various vendors. The integration allows operator traffic to be combined with intraLATA message traffic on tandem connecting trunks between the end office and the access tandem. These systems technically allow the LECs to provide FGC and FGD operator services for ICs as well as for themselves. In addition, these tandems, with or without the operator function, are capable of switching operator traffic to those ICs wishing to provide their own operator services. In any case, the system design provides network economies because normally low volume and inefficiently trunked operator traffic can be efficiently concentrated at a tandem. Directory assistance and intercept arrangements are described in Section 5 of this document.

Sent-paid coin traffic originating from LEC public and semipublic coin stations can be served by a LEC operator system for intraLATA toll calls. InterLATA sent-paid coin traffic originating at LEC coin stations is presubscribed to an IC. Customer-Owned Coin-Operated Telephones (COCOTs) do not receive coin box accounting functions from LEC equipment.

The trunk facilities between the end office and the OSS are equipped with inband, expanded inband, or multiwink signaling to provide coin collect, coin return, and other controls between the LEC operator systems and/or AT&T equipment and the coin box. If the coin box control signals are to be tandemmed through a LEC tandem, the tandem must meet the signaling and transmission objectives described in Sections 6 and 7 of this document.

FGC traffic, identified by a 0-, 0+, or 01+ service prefix indicator, is predominantly handled by LEC operator system equipment, either by operators or by automated means. For those end offices that can sort out intraLATA and interLATA traffic, the operator services equipment may be bridged on both IC and LEC tandems so that the IC traffic need not route via the LEC tandem. Some LECs may utilize 00- or 10XXX(101XXXX)-00- to allow separation between IC and LEC 0-operator traffic.

Within some independent areas (such as Alaska), LECs do not and have not provided operator services. Within these select areas, intraLATA operator billing and assistance services are handled via IC operator systems. Ordinarily, 0-, collect, third-number billing,

---

---

manual credit card calls, and manual sent-paid coin, or calls that require operator assistance are routed to the IC of "last resort." It is intended that intraLATA 0- traffic is the responsibility of the LEC and is therefore routed to an Operator Service Provider (OSP) chosen by the LEC. All ICs served via an independent area's Equal-Access End Office (EAEO) or tandem are accessed by presubscribed customers dialing 00- or 10XXX-00-.

Operator services traffic can be combined with 1+ and 011+, and with sent-paid coin. However, if combined on one trunk group, inband signaling requirements will be increased and all trunks will have to be equipped for operator access. This requires special trunk circuits and could impact operator system capacity. Combined operation should occur only where the added costs of equipping trunks and the effect on operator system capacity can be offset by reduced trunk requirements. Ordinarily this will occur only where small trunk groups can handle the total traffic volume.

Public and semipublic coin station non sent-paid coin (for example, credit card service), and all non coin-station operator services FGD traffic (0-, 0+, 01+) can be routed to any IC including AT&T, based on the 10XXX access code or presubscription. Both operator services and Direct Distance Dialing (DDD) calls (with or without the ANI option) can be routed directly or via the access tandem. However, operator assistance-type calls that are dialed by a patron to an IC that has not requested this service may be screened and blocked at the originating end office. In some end offices, customer stations presubscribed to an IC can obtain operator assistance from the IC by dialing 00.

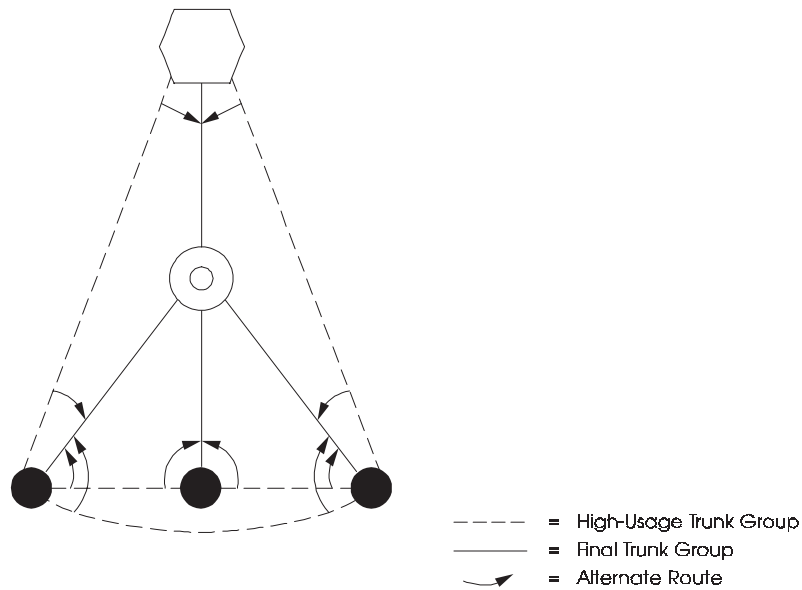
#### 4.5.4 Combined Configurations

IntraLATA and interLATA access can be treated as separate network configurations. While such segregation is possible for SPC end offices capable of providing equal-access service, there is also the potential to combine the switching and trunking to the extent that network economies can be achieved. The following paragraphs discuss typical combined network configurations.

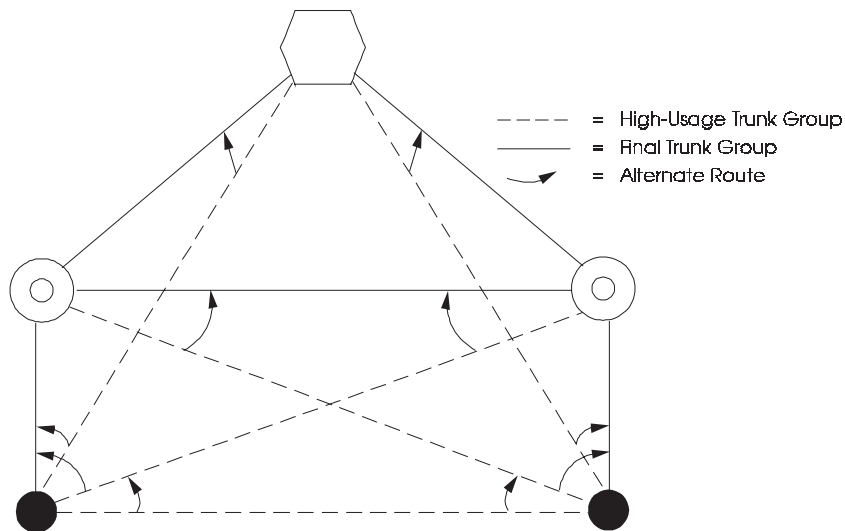
In LATAs with a single access tandem, that tandem can also serve as a local (intraLATA) tandem as shown in Figure 4-16. IntraLATA and interLATA traffic are combined on the tandem connecting trunk groups, while the end office-to-end office high-usage groups carry only intraLATA traffic, and the end office-IC POP groups carry only interLATA traffic. IntraLATA routing is the same as with a segregated single-tandem network.

Where two or more access tandems are required, the tandems can also serve as local tandems in a combined sector-tandem configuration as shown in Figure 4-17. As with the single tandem case described above, the tandem connecting final groups carry both intraLATA and interLATA traffic. The end office-to-end office and end office-distant tandem high-usage groups, and the intertandem final group carry only intraLATA traffic routed as with a segregated, combined sector-tandem configuration.

---



**Figure 4-16.** Single Tandem/Access Tandem



**Figure 4-17.** Combined Sector Tandem/Access Tandem

It is feasible to have two access tandems in a LATA with only one of them needed as a tandem for intraLATA traffic. However, this arrangement will normally evolve to the combined sector-tandem configuration as soon as the trunking rearrangements can be made to take advantage of the flexibility and multiple alternate routes offered by the two-tandem arrangement. Similarly, it is possible that two tandems could be required for intraLATA

---

traffic but only one required as an access tandem. With only one access tandem, trunking penalties will result from the need to segregate intraLATA and interLATA traffic to avoid a second tandem switch on interLATA calls. This can be avoided by equipping both tandems as access tandems and routing the traffic as shown on Figure 4-17.

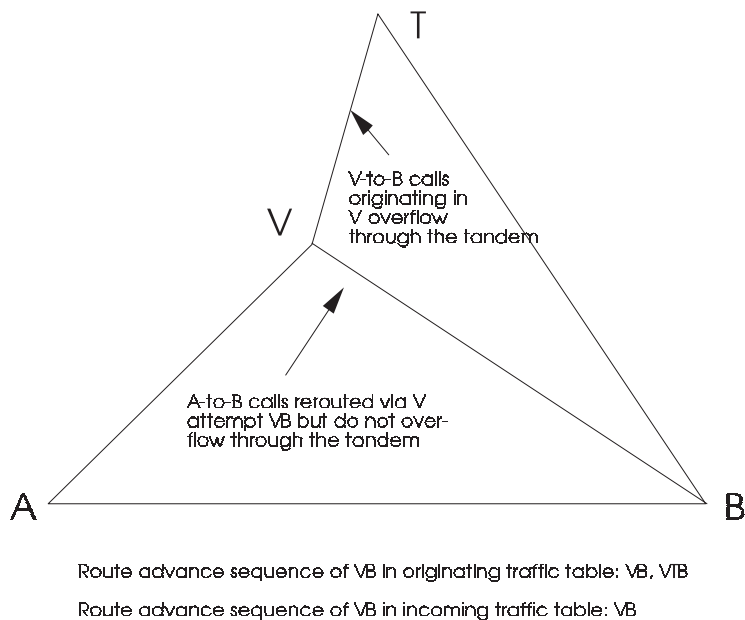
The three-level principal tandem arrangement shown in Figure 4-8 may also be used for intraLATA traffic. With this arrangement, the sector tandems would be equipped as access tandems and the principal tandem would function only as a tandem for intraLATA traffic.

In LATAs with Dynamic Routing, the via nodes serve as tandems and end offices for intraLATA traffic. Due to the one tandem link rule, Dynamic Routing cannot currently be used for interLATA traffic.

When the Dynamic Routing algorithm recommends a two-link path, the probability is very high that both links will have excess capacity to complete the overflow calls; however, there is a small probability that one of the two links may not have any spare capacity to complete the call. If the first link is busy, the call will overflow to the tandem and be completed in the same way as it would in a hierarchical network. However, if the second leg is busy and the A-B call is allowed to overflow from the via node V to the tandem T, then the A-B call will be carried on the three-link path (AV, VT, TB). (See Figure 4-18.) The three-link path, however, will not cause transmission problems in the network because the combined transmission loss for links VT and TB (or VT, TT, and TB when the offices A and B home on different tandems T and T) is not greater than that for the link VB alone. The tandem trunks and tandem switches are normally designed to make up for the extra transmission loss.

Occurrence of such three-link paths can be prevented in the DRT implementation as follows: Two routing tables can be set up in each end office switch, one for originating traffic and one for incoming traffic. In switch V, the originating traffic table should consist of two paths for V-to-B calls: VB, VTB. The incoming traffic routing table should consist of only one route: VB. Thus, A-B calls, which are rerouted from the direct route AB and reach V, will attempt VB, but if VB is busy they will not overflow to the VT link. The incoming traffic routing table will prevent such overflow. On the other hand, V-B calls originating in V will attempt VB and, if VB is busy they will attempt the VTB path. (See Figure 4-18.)

Separate Routing Tables in Via Switches for Originating and Incoming Traffic

**Figure 4-18.** Restricting DRT to Two-Link Paths

## 4.6 Reliability of Equipment and Systems

Local exchange telecommunication networks providing services such as Plain Old Telephone Service (POTS), Integrated Services Digital Network (ISDN) capabilities, or future telecommunications services must be highly dependable. The customer has come to expect a high level of network dependability based on the performance levels that have been experienced for POTS, and on the levels that are continuing to be observed for new services such as ISDN.

As new technology, functionality, and services are integrated into the network, objectives have been set that, at a minimum, preserve the expected levels of dependability for these existing services.

A primary characteristic of local exchange network dependability is its availability. Availability is strictly defined as the ability of an item to be in a state to perform a required function at a given instant of time, or at a desired instant of time within a given time interval. This assumes that the external resources, if required, are provided.

However, for the intraLATA networks, availability is generally interpreted as the long-term fraction of time that the network performs its function as intended (for example, when the network successfully provides a communications path from one customer to another).

---

There are four major factors influencing the availability of the intraLATA network as seen by the customer:

- Network topology
- Equipment architectures
- Equipment reliability
- Telephone company maintenance practices.

Each of these factors must be considered during equipment and system design, as well as during network planning and design, to ensure that an acceptable level of service dependability is provided to customers.

To ensure adequate equipment and systems reliability, the *service dependability management* process is followed. This process includes the following:

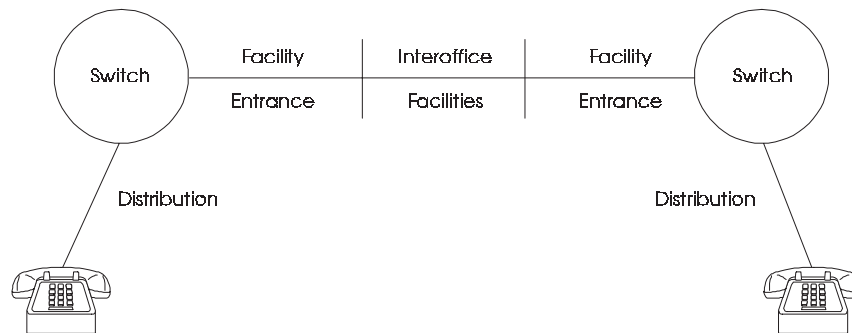
- Establishment of service-level dependability objectives
- Development of reference network architectures
- Allocation of the dependability objectives to various (facility, interoffice, etc.) network equipment and systems.

Baseline service-level objectives on the availability of a local exchange network have been developed for network engineering purposes and are presented in this section. These *end-to-end* network objectives are derived from long-established network-availability objectives, observed network-availability performance, and projected availability needs of the network. A reference network architecture is presented and allocations to network segments and network elements are given.

These resulting availability objectives for segments, equipment, and systems are primarily used during network architecture studies, product conception engineering studies, design reliability evaluations, and customer reliability analyses where reliability modeling techniques are used to estimate performance for comparison to objectives. In addition, they are also used as baseline performance objectives for comparison to actual field performance.

#### **4.6.1 Local Exchange Network Hypothetical Reference Connection**

The service dependability management process requires a reference network architecture, or local exchange network Hypothetical Reference Connection (HRC). The network architecture used as the local exchange network HRC is shown in Figure 4-19.



**Figure 4-19.** Local Exchange Network Hypothetical Reference Connection

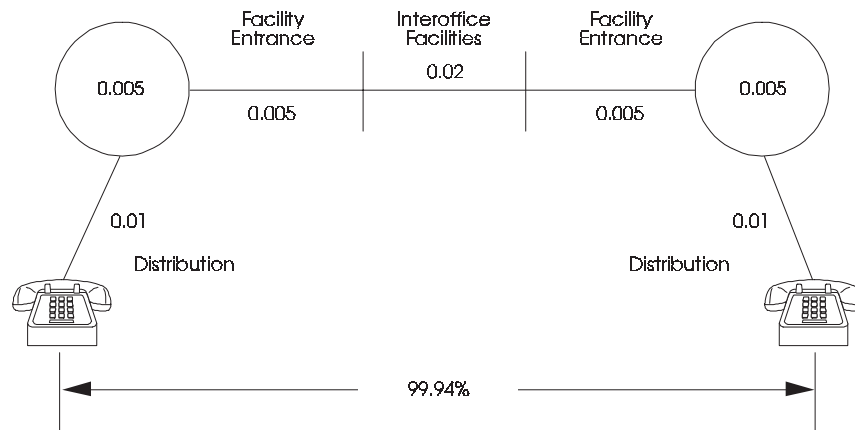
Figure 4-19 is a simple model of the existing intraLATA POTS network, including the major network segments needed to connect two telephone subscribers served by different central office switches. There are four network segments used in the HRC:

- *Distribution* — consisting of two distribution network segments related to each subscriber (customer premises equipment, which is not part of the telephone company network, is not considered here)
- *Switch* — the two central office switches
- *Facility Entrance* — a facility-entrance network segment including equipment such as analog-to-digital converters (channel banks), multiplexers, automated digital terminals, etc.
- *Interoffice* — the interoffice transmission facility segment used to transmit calls from one central office switch to the other.

#### 4.6.2 End-to-End Network Availability Objective

Since it is important from the customer's view that there be a high probability of obtaining a path through the network, a high level of end-to-end network availability is desirable. This section addresses only the availability of a path through the network due to failures of the equipment and not the effects of blocking due to traffic congestion. All segments in the network are independent and each network segment contributes directly to the unavailability or downtime of any path. The hypothetical reference circuit shown in Figure 4-20 has a derived end-to-end availability of 99.94 percent. This is approximately 315 minutes per year or one minute per day of unavailability.





**Figure 4-20.** End-to-End Network Availability Objective

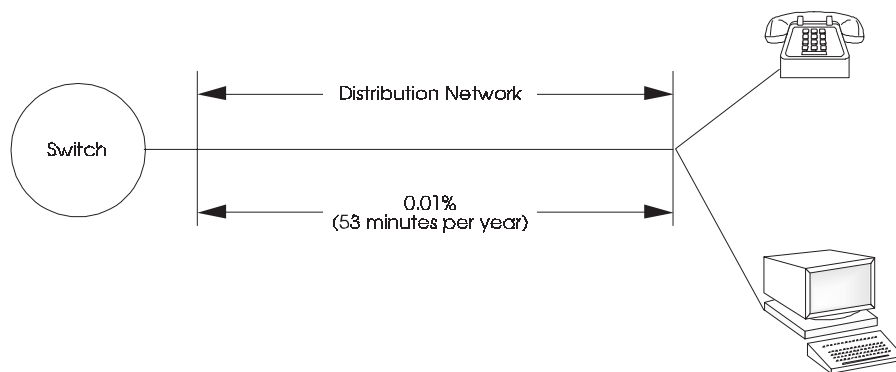
### 4.6.3 Network Segment Availability Objectives

Switching and transmission services and equipment availability objectives are traditionally stated in terms of line or channel availability. Each contributes directly to the end-to-end network path availability. Therefore, these parameters indicate the ability of the equipment in the network segment to perform its function (for example, distribution, switching, facility entrance or interoffice transmission) when needed for a customer's call. Bellcore has investigated the availability of the equipment in each of the network segments shown, and end-to-end objectives have been proposed to help ensure the dependability of the services provided over these networks. Availability is affected by many factors, such as equipment failures (for example, resulting from hardware reliability failures, software bugs, or procedural errors), equipment and system architectures, maintainability and repair strategies and uncontrollable factors such as cable cuts/dig-ups, storms, etc. Each factor must be considered in designing and maintaining dependable equipment and a dependable network. The network segment objectives discussed are based on long-standing performance objectives, on observed field performance, and a summation of the objectives for the equipment in the segment. Each network segment is discussed in detail in the following sections.

#### 4.6.3.1 Distribution Network Segment

The distribution network segment, as used here, includes both the feeder and the loop from the switch to the customer's home/office, excluding customer premises equipment. Two distribution segments, one associated with each subscriber, are included in the local exchange network HRC. In the distribution network, availability is essential from the telephone customers' view since they have come to expect access to the network virtually

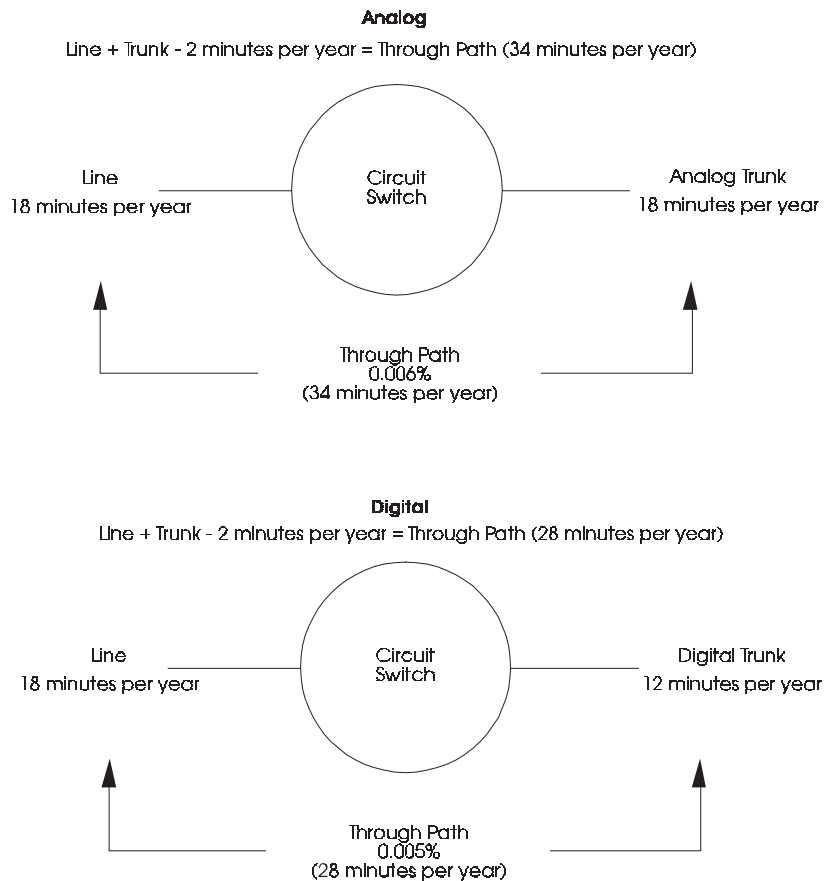
upon demand. The objective on the level of the *distribution* segment availability that is suggested for engineering existing and new services is 99.99 percent [see GR-499-CORE, *Transport Systems Generic Requirements (TSGR): Common Requirements*]. This would give a maximum unavailability objective of 0.01 percent, which equates to a maximum downtime objective of approximately 53 minutes per year per customer line (Figure 4-21). Availability objectives are sometimes expressed in terms of the complement of availability, unavailability, or downtime. Each is discussed in the remainder of this section, which is devoted to the switch network segment.



**Figure 4-21.** Distribution Network Segment Unavailability Objective

#### 4.6.3.2 Circuit Switch

The switching systems in the HRC perform interconnection of subscriber lines to trunks to form the end-to-end transmission path. The best objective known is the total switch downtime objective of 2 minutes per year, which is described in GR-512-CORE, LSSGR: *Reliability, Section 12*. In addition, objectives also exist for individual lines (18 minutes per year) and for individual trunks (also 18 minutes per year for analog trunks and 12 minutes per year for digital trunks). For a through transmission path transversing the switch from a line to a trunk, the maximum unavailability objective is the sum of the line and trunk unavailabilities minus 2 minutes per year, since the total outage objective is included in both the line and trunk objectives and need only be considered once on a through path. This results in a through-path objective (line to analog trunk) of 34 minutes per year or 0.006 percent and (line to digital trunk) of 28 minutes per year or 0.005 percent. Figure 4-22 shows switch unavailability.



**Figure 4-22.** Switch Network Segment Unavailability Objective (Through Path)

Additional dependability objectives have been developed for circuit switches in the following areas and are contained in the *LSSGR*.

- Cutoff calls
- Ineffective machine attempts
- Failure rates
- Service life.

#### 4.6.3.3 ISDN Switch

Reliability objectives for ISDN switching systems have been developed to help ensure that the dependability of ISDN services is similar to that of POTS. ISDN introduces the concept of multiple services (such as circuit-switched voice and packet-switched data) integrated onto the same physical interface. Thus, the definition of a line failure becomes more

---

difficult. Therefore, parameters that address the numerous partial line outage modes have been developed in addition to objectives of the *LSSGR*. For Basic Rate Access (BRA), reliability objectives have been developed to be consistent with Figure 4-22 and the *LSSGR*. Following are examples of new availability (downtime) parameters:

- Accumulated B-channel circuit mode downtime
- Accumulated B-channel packet mode downtime
- D-channel packet data downtime
- Total ISDN circuit switching capability downtime
- Total ISDN packet switching capability downtime.

Similar parameters have been developed for Primary Rate Access (PRA). The objectives can be found in GR-512-CORE.

#### 4.6.3.4 Facility-Entrance Network Segment

For purposes of reliability modeling, the *facility-entrance* network segment is defined as the portion of the network that performs functions (such as analog-to-digital and digital-to-analog conversion, framing, digital channel cross-connection, multiplexing, demultiplexing, etc.) before channels are put onto the interoffice transmission facilities to be sent to the receiving-end central office. At the receiving-end central office, it is assumed that the facility-entrance equipment is replicated to perform reverse functions such as demultiplexing. Figure 4-23 illustrates a representative configuration of typical digital terminal equipment contained in the facility-entrance network. The facility-entrance segment is allocated 0.005 percent unavailability at each end or a total of 0.01 percent for both. See TR-TSY-000009, *Asynchronous Digital Multiplexes Requirements and Objectives*, and TR-NWT-000418, *Generic Reliability Assurance Requirements for Fiber Optic Transport Systems*, for more information.

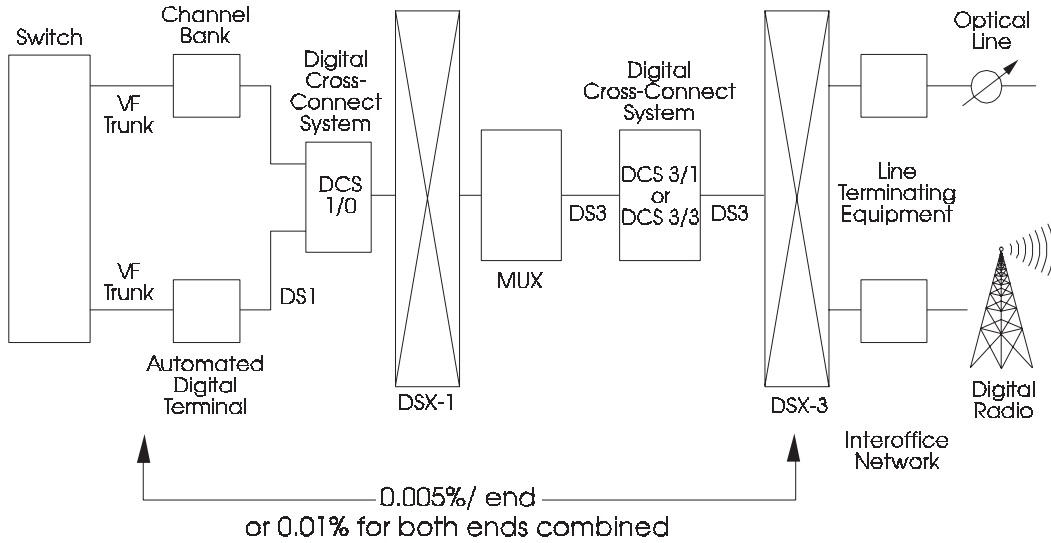
#### 4.6.3.5 Interoffice Network Segment

The origin of the availability objective for the LEC's *interoffice* transmission network is the former "Short-Haul Availability Objective," which has its origin in early microwave radio applications.

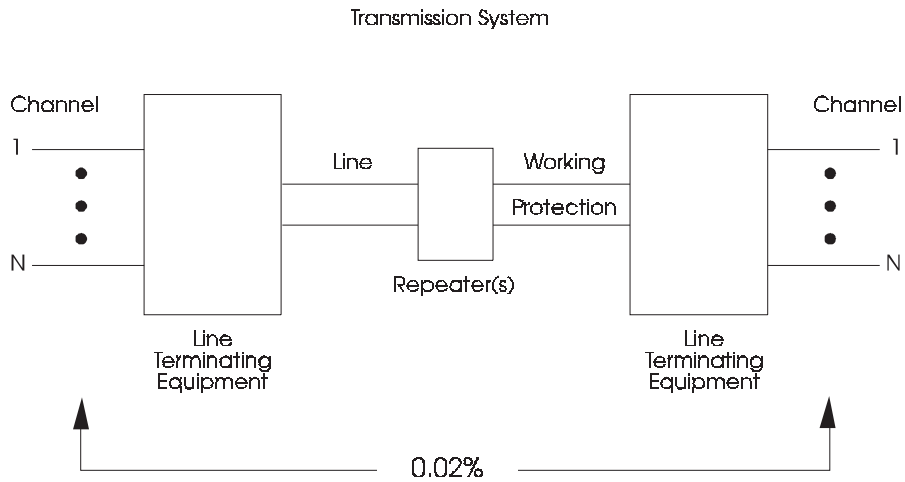
The suggested short-haul, 2-way transmission, minimum availability objective for a LEC transmission channel is 99.98 percent (0.9998 availability) at 250 miles. A full statement of the numeric values of the objective is a plot of unavailability linearly prorated by route length. However, only the maximum objective will be used here. Figure 4-24 is a model showing the generic application of the short-haul availability objective to a transmission system in the interoffice transmission segment of the network. The short-haul availability

---

objective has been widely applied to LEC transmission systems in the past (such as fiber-optic systems) (see GR-499-CORE and TR-NWT-000418).



**Figure 4-23.** Facility-Entrance Network Segment Availability



**Figure 4-24.** Interoffice Network Segment Unavailability Objective

---

#### 4.6.4 CCS Network Reliability and Unavailability (Downtime) Objectives

The integration of out-of-band signaling with intraLATA networks, via Common Channel Signaling (CCS) networks, is an important factor in overall network reliability. This is because failures in signaling will prevent completion of calls and will be viewed by customers as failures of the network. Following is a brief discussion of CCS network unavailability (downtime) objectives and four potential alternatives to achieve software diversity in the CCS network.

Unavailability (downtime) objectives are intended to control the amount of time a CCS network (or a segment thereof) is unable to perform its required signaling functions. They can be represented by a single number equal to the long-term percentage of time a CCS network, or segments thereof, are expected to be “down.” As such, downtime objectives can significantly influence end-user perception of service quality. The expected percentage of downtime for a network element can be interpreted either as

- The average downtime over many years for this network element, or as
- The average downtime over one year for a population of the network elements.

According to ANSI T1.111, *American National Standard for Telecommunications — SS7 — MTP*, T1.111.6, Section 5.1.2, the Message Transfer Part (MTP) downtime objective for the CCS basic mesh network shown in Figure 4-25 corresponds to (an average of)<sup>4</sup> no more than 10 minutes downtime per year for the signaling paths between two Signaling End Points (SEPs)<sup>5</sup> and is broken down as follows:

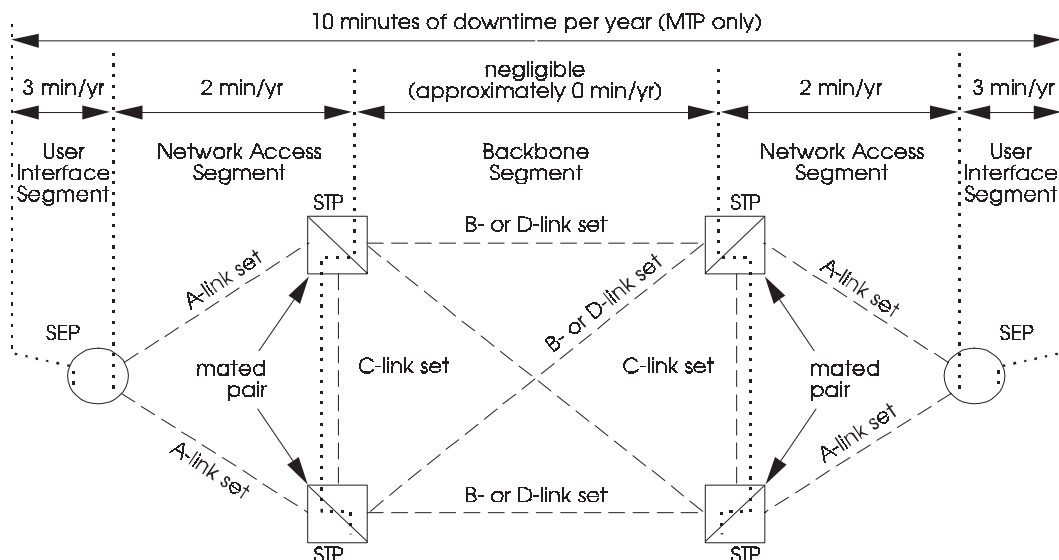
- Each user interface segment should be down (an average of) no more than 3 minutes per year,
- Each network access segment should be down (an average of) no more than 2 minutes per year, and
- The backbone network segment should be down a negligible amount of time (that is, close to 0 minutes downtime per year). Note that downtime for this segment includes failures that prevent use of the backbone segment but do not by themselves disable any other segment(s).

The above allocation assumes an ANSI-based (Recommendation T1.111.5 in ANSI T1.111-1988, Section 7.2.1) reference architecture with two-way diversity for the A-link sets and three-way diversity for the B-/D-link sets. If three-way diversity is not achievable in the backbone segment, the downtime of that segment may no longer be negligible. Hence, the 10-minute end-to-end objective may no longer be achievable.

---

4. The original text in the *American National Standard for Telecommunications — SS7 — MTP* refers to “nominal requirements” that have been interpreted in GR-246-CORE, *Bell Communications Research Specification of Signaling System Number 7*, as “average downtime numbers”; thus the text in the parentheses represents Bellcore's interpretation of this ANSI downtime objective.

5. Examples of SEPs are Service Control Points (SCPs) and switches.



**Figure 4-25.** ANSI (T1.111.6) Downtime Objectives for CCS Basic Mesh Network Segments (MTP Only)

A backbone network segment failure may cause the switches on each Signaling Transfer Point (STP) pair to lose communication with the switches on the remote STP pair, but the switches can still communicate with the other switches homed on the same STP pair. It occurs when

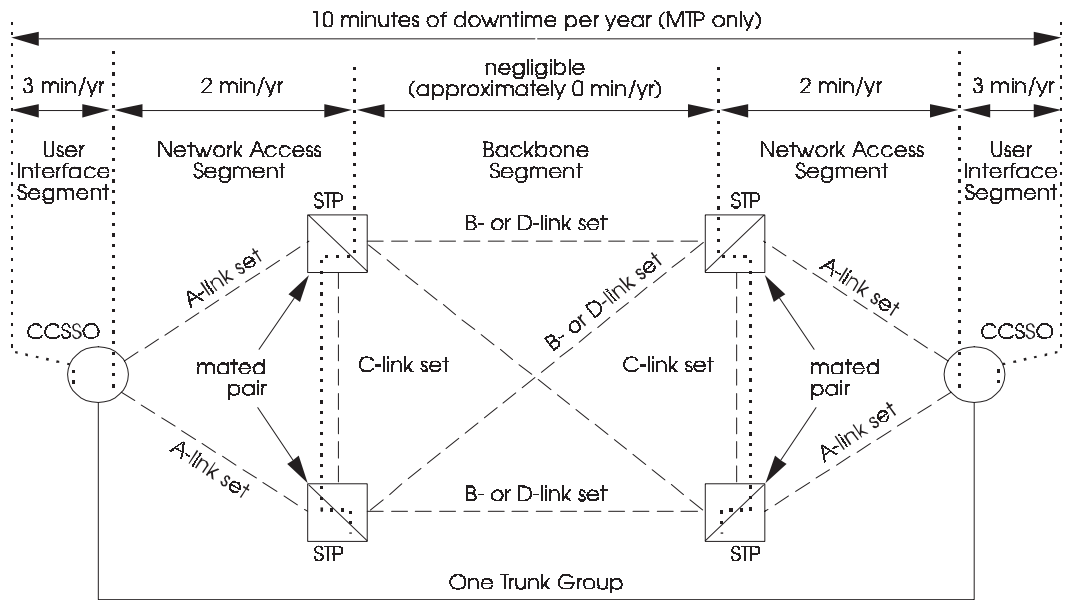
- The entire B-/D-link set quad fails,
- One of the STPs in either mated pair and the B-/D-link set pair of the other STP in the mated pair fail, or
- A-link set to one of the STPs in either mated pair and its C-link set and the B-/D-link set pair of the other STP in the mated pair fail.

When the SEPs in Figure 4-25 are both CCS Switching Offices (CCSSOs),<sup>6</sup> the 10-minute end-to-end downtime objective and the above allocation to network segments correspond to a *single* trunk group with its terminating CCSSOs interconnected using the ANSI-based reference architecture (see Figure 4-26).

It also applies when instead of CCSSOs there are Service Switching Points (SSPs)<sup>7</sup> or SCPs.

6. A CCSSO is a switch equipped with the ISDN User Part (ISUP) of SS7 for call setup.

7. An SSP is a switch equipped to halt call progress, launch an SS7 query to obtain additional information from an SCP, and route or treat the call based on the information received in the SCP's response. SSPs can be End Offices (EOs) or tandem switches. SSPs interact with databases to provide services and routing.



**Figure 4-26.** Example Case: One Trunk Group with Its Terminating CCSOs)

Detailed information on CCS network element reliability objectives can be found in GR-82-CORE, *Signaling Transfer Point (STP) Generic Requirements*; TR-NWT-000029, *Service Control Point Node Generic Requirements for IN1*; GR-1241-CORE, *Supplemental Service Control Point (SCP) Generic Requirements*; TR-NWT-000533, *Service Switching Points, FSD 31-01-0000*; and GR-512-CORE.



---

## Section 5

### Billing, Customer Data, and Control

#### Contents

5.	Billing, Customer Data, and Control .....	5-1
5.1	Automatic Message Accounting .....	5-1
5.1.1	Data Generation .....	5-2
5.1.1.1	Flat-Rate Calls .....	5-3
5.1.1.2	Measured-Rate Calls.....	5-3
5.1.1.3	Toll Calls .....	5-4
5.1.1.4	InterLATA Carrier Interconnection.....	5-4
5.1.1.5	LEC-to-LEC Interconnection .....	5-6
5.1.1.6	Advanced Intelligent Network Automatic Message Accounting.....	5-7
5.1.1.7	Centralized Automatic Message Accounting .....	5-7
5.2	Network Service Evaluation .....	5-8
5.3	Customer Network Services.....	5-9
5.3.1	Message Detail Recording .....	5-9
5.3.1.1	MDR via RAO .....	5-10
5.3.1.2	MDR to Customer Premises .....	5-10
5.4	Customer Network Management .....	5-11
5.4.1	Configuration Management .....	5-12
5.4.2	Performance Management .....	5-13
5.4.3	Fault Management.....	5-14
5.4.4	Accounting Management .....	5-16
5.4.5	Security Management .....	5-17



---

## 5. Billing, Customer Data, and Control

This section discusses the many features that define and maintain billing, customer data, and control.

### 5.1 Automatic Message Accounting

Automatic Message Accounting (AMA) is the process used by circuit-switching systems, packet-switching systems, and other network elements to provide billing usage measurements data. This data is needed either to permit charging the customer for use of network services or to permit charging other carriers (including Interexchange Carriers [ICs] and other Local Exchange Carriers [LECs]) for assistance in placing call connections. The specific data items needed for customer billing are determined by a complex interaction between the customer's service request, the customer's service permissions, and local tariffs.

In general, network personnel create and maintain the databases about customer service permissions and charging in response to service orders issued when a customer requests new or changed service. In today's network, such requests involve interaction between the customer and a LEC service representative. Special direct interactions between the customer and network elements and/or Operations-Support Systems (OSSs) could commonly initiate service changes in the future.

Network elements determine what service to provide by using a customer's service request (for example, dialed digits) and the network's database information about the customer's service permissions. Then, by using AMA call processing, these elements determine whether usage information must be generated for billing and other purposes. If AMA data is generated, the network element outputs the data in a form suitable for processing by a Revenue Accounting Office (RAO).

The AMA data output from the network element is transported to the RAO by AMA teleprocessing, data networking, or via magnetic tapes. When magnetic tapes are used, the tapes are carried between the network element and the RAO. A network element that is provided with an AMA teleprocessing feature transmits AMA data on a store, poll, and forward basis to a central point for input into the RAO message billing process. The teleprocessing feature is implemented at the network element via hardware and software, which, as a package, is called an AMA Transmitter (AMAT). An AMAT is connected to a central collector through data-transmission facilities to form an AMA Teleprocessing System (AMATPS). [For more information, see TR-TSY-000385, *Automatic Message Accounting Teleprocessing System (AMATPS) Generic Requirements*.]

AMA data networking, like AMATPS, allows transmission of AMA data to a central point for input to the RAO. AMA data networking distinguishes itself from AMATPS by taking advantage of emerging data services and file transfer protocols for the information transport. AMA Data Networking System (AMADNS) supports the transfer, processing,

and management mechanisms required to supply data applications with AMA data. AMADNS is able to manage higher AMA data volumes and supports access to AMA data by new applications, for example, fraud detection and market data systems. Some of these applications are expected to have special needs, such as specialized data processing, and *near-real-time* and *on-demand access* to AMA data. In addition, the value of given AMA data may vary widely (due to the use of data aggregation, for example), thereby requiring the capability to treat different AMA data in a different manner. AMADNS is designed to support the special needs of multiple applications while retaining the high degree of quality, availability, and security required for AMA data. (See GR-1343-CORE, *Generic Requirements for the Automatic Message Accounting Data Networking System (AMADNS)*, for more information.)

The AMA data records received in an accounting office are edited and subjected to various integrity checks. The Customer Record Information System (CRIS) processes records that are needed for end-user billing. The first major step in this processing is to calculate a monetary price, based on applicable tariffs, for each billable occurrence of customer usage. The corresponding customer account is recognized, and the priced usage transactions are posted for customer billing at regular intervals. Records that are needed for carrier access billing are sent to the Carrier Access Billing System (CABS), which calculates monetary prices based on applicable tariffs, posts the resulting charges to the carriers' accounts, and bills the carriers on a regular basis. CRIS and CABS are generic terms used to describe specific types of billing systems. There are currently many system types that are based on the CRIS and CABS general functionality, but have different names. The names of the billing systems may be different, but they all perform basically the same function.

In addition to using the AMA data for actual billing purposes, the data is also used for such ancillary functions as maintenance, network operations, and surveillance. For these functions, the data received by the RAO in the normal AMA data stream is "spun-off" for dissemination to the organization requesting the data.

Because of the tremendous volume of AMA data that typical LEC accounting offices must process each day and the business requirement for very high integrity billing processes, it is beneficial that a universal AMA data format be used by all network elements and for all services. For most LECs, the format used is the Bellcore AMA Format (BAF). The generic requirements of BAF for all services are set forth in GR-1100-CORE, *Bellcore Automatic Message Accounting Format (BAF) Requirements*. Similar generic requirements for other services are documented in Bellcore documents for the specific service.

For LECs using formats other than BAF, the AMA data generated by LEC networks is often referred to as Call Detail Recording (CDR).

### **5.1.1 Data Generation**

Every line and/or trunk that can originate a LEC service is assigned a charge class. This charge class, in conjunction with other supplementary data, determines the service requests

---

---

that can be originated from the line and/or trunk. The charge class is also a factor in determining whether or not an AMA data record is to be generated for a given service request, and in determining the content and format of AMA data generated for the service request.

For each occurrence of service use, AMA data is generated if that use is billable or if the data is required for one of the ancillary AMA data-usage functions. The AMA data is always provided under the premise that all usage of resources associated with the service may be billable. Therefore, in addition to data input that is common to all AMA data records (for example, the identification of the user of the service, the user's service requests, dialed digits, the time and duration of such use), the record for specific network service use contains data specific to that use and the features of the customer's line or trunk that provide access to the service.

The following sections discuss AMA data generation strategies for several services and technologies. These sections do not cover all types of recordings; see GR-1100-CORE for a complete list.

#### 5.1.1.1 Flat-Rate Calls

A flat-rate area is defined by a group of destination codes (called NXX or NPA-NXX) and usually includes all the destination codes within a geographic boundary. Flat-rate service permits non-coin line customers having the appropriate charge class to make, for a fixed monthly charge, an unlimited number of network uses of services or calls to destinations within a flat-rate area.

For calls originated from lines having the flat-rate charge class, AMA data is normally not required for a call to a destination within the originator's flat-rate area. However, for individual and multi-party lines, capability is provided to generate detailed AMA data for special studies and for billable features that may apply.

Note: The potential introduction of Local Number Portability (LNP) outside of the rate center will impact the flat-rate billing model. For more information, see the LNP generic requirements in GR-2936-CORE, *Local Number Portability Capability Specification*.

#### 5.1.1.2 Measured-Rate Calls

Measured-rate service provides to customers, who have the appropriate charge class, a limited amount of call usage to destinations within a defined message-rate area for a basic monthly charge. All usage for calls to destinations within the defined area that exceeds the limit is additionally charged. Computation of the allowed and additional usage may be based upon any combination of the following factors: distance called, call duration, time of day, day of the week, and/or date.

---

The data generated for local message-rate calls is formatted into a message-rate call type. The call type to be used for recording the AMA billing data for a particular call is a function of the data that is necessary for the billing tariffs that determine the charges for that call.

#### 5.1.1.3 Toll Calls

Calls to destination codes outside the originating customer's flat-rate and/or message-rate area are chargeable mainly on the basis of the call destination, the call duration, the day, the date, and the time of the day. For nonoperator-handled calls originated by 1- and 2-party non-coin lines, the AMA data record is generally generated in the switching office serving the originating customer. The actual form of the record is a function of how the call is to be carried, for example, via the LEC facilities or those of an IC (domestic carrier or International Carrier [INC]). For calls that originate from 4- or 8-party lines, the call must be routed to a centralized point for identification of the calling station. The AMA data record for these calls is made at that point.

#### 5.1.1.4 InterLATA Carrier Interconnection

Per-call AMA data records are generated at each LATA for all IC/INC calls originating from or terminating to that LATA. This includes calls routed to an operator-service facility and test calls made by an IC/INC to a LATA.

##### 5.1.1.4.1 *Originating-LATA Recording of Interexchange Carrier/International Carrier Calls*

The following describes two types of records, per-call AMA data records and originating-LATA overflow records.

- *Per-Call AMA Data Records* — In a multifrequency signaling environment, an originating-call AMA record is made for all calls that progress to the stage where the carrier-connect signal is received from the IC/INC. The time at which the leading edge of this carrier-connect signal is received from the IC/INC is used as the carrier-connect time for the originating LATA.

For Common Channel Signaling/Signaling System 7 (CCS/SS7), the Initial Address Message (IAM) is sent directly from the Signaling Point/Service Switching Point (SP/SSP) end office to the IC/INC to start timing. If an access tandem switch is involved in the call, then the Exit Message (EXM) sent from the access tandem to the end office SP/SSP indicates that the call setup information has actually been sent to the IC/INC.

In either the multifrequency or the CCS/SS7 case, the AMA data record contains a called-party answer time as well as the carrier-connect time. In addition, the AMA data

---

---

record contains the identity of the carrier that is dialed or the presubscribed carrier. The elapsed time from answer time to disconnect is used for billing the customer for the call; the elapsed time from carrier-connect time to disconnect is used for billing the IC/INC access charges.

Calls to an IC/INC operator-service facility are handled differently. An access record is generated at the Equal-Access End Office (EAE0) for calls routed directly to an IC/INC operator-service facility. Since called-party supervision is not passed back to the EAE0, these calls generate unanswered call records whereby the call disconnect time for carrier-connect elapsed-time calculations is determined at the time of operator release.

- *Originating-LATA Overflow Record* — AMA data records are generated for calls that reach the point where the carrier-connect signal is received. AMA records are also generated to provide a count of the number of calls that cannot be delivered to the IC/INC because an outgoing trunk is not available.

This overflow record is generated every hour and is output only at the originating LATA. For an IC/INC with only a direct connection from the EAE0, the overflow count is incremented whenever a call cannot be delivered to the IC/INC because an outgoing trunk is not available. For an IC/INC with both a direct connection from the EAE0 and an overflow connection to the access tandem, no count of calls that overflow to the access tandem or calls that are blocked (direct and tandem-connection busy) is made at the EAE0. An overflow count is incremented in the hourly record generated at the IC/INC access tandem for calls that do not complete because an outgoing trunk is not available from the access tandem to the IC/INC.

The generation of this record is based on the premise that the LECs will be handling the intraLATA call. Since competition for intraLATA call traffic has increased, the LECs will not be the only carriers. There may be other carriers of intraLATA traffic that do not require this record. It should be noted, that another type of record(s) may be needed to address the new intraLATA carriers.

#### 5.1.1.4.2 *Terminating-LATA Recording of Interexchange Carrier/International Carrier Calls*

The switching system at which the call enters the LATA generates the terminating AMA access record. A per-call access record may be made for all calls that progress to the stage where an incoming-trunk seizure signal from the IC/INC has been recognized. In all records, the leading edge of this seizure signal is used to determine the recorded carrier-connect time for the terminating LATA. However, only the elapsed time from called-party off-hook time to call disconnect time is used for billing the IC/INC access charges.

The generation of this record is based on the premise that the LECs will be handling the intraLATA call. Since competition for intraLATA call traffic has increased, the LECs will

---

not be the only carriers. There may be other carriers of intraLATA traffic that do not require this record. It should be noted, that another type of record(s) may be needed to address the new intraLATA carriers.

#### 5.1.1.5 LEC-to-LEC Interconnection

The usage measurement recording performed on call connections between local exchange carriers depends on the type of network interconnection being used. Common forms of LEC-to-LEC interconnection are

- A. Standard trunk connections – In this case, LEC-to-LEC interconnection is achieved using the same type of trunk arrangements used for calls completed within a LEC network. These trunks are not designed for interconnection or exchange access usage measurement recording, but may be used in situations where interconnecting carriers agree to “bill and keep (revenue)” for calls originating within their networks. The “bill and keep” arrangement avoids the need for intercarrier compensation for calls involving multiple LECs. If the interconnecting trunks use Common Channel Signaling (CCS), a Link Monitoring System (LMS) may be used to monitor and record usage on the internetwork facilities.
  - B. Feature Group D exchange access connections – With this interconnection arrangement, the same type of facilities used for LEC-to-IC connections are used for LEC-to-LEC connections. The Feature Group D connections support usage recording for both originating and terminating access, but there is no distinction made in the AMA recording for LEC-to-IC interconnections versus LEC-to-LEC interconnections. This means the billing systems processing Feature Group D AMA records must closely examine each record received to determine whether the call involved an inter-LATA or intra-LATA connection. The intercarrier compensation for LEC-to-IC connections (in which the IC is assumed to be the carrier billing the end user) is fundamentally different than intercarrier compensation for LEC-to-LEC interconnections (in which the originating LEC is assumed to be the carrier billing the end user).
  - C. Wireless Service Provider (WSP) interconnection – In this case, the network interconnections originally designed for access between a LEC and a wireless carrier are used for LEC-to-LEC interconnections. The WSP interconnections consist of Type 1 (line side), Type 2A (trunk side/tandem) and Type 2B (trunk side/end office). The WSP interconnections provide AMA recordings for originating calls, but do not completely support AMA recording for calls terminating to an LEC.
  - D. Connecting Network Access Recording (CNAR) trunks – This mode of interconnection was originally designed to address AMA recording needs for Local Number Portability (LNP). Of the LEC-to-LEC interconnection options listed here, the CNAR interconnections provide the most extensive AMA recording for both originating and terminating LEC interconnection. The AMA records for CNAR trunks
-



---

are expected to capture Service Provider Identification and other carrier information which will facilitate billing system processing of the interconnection usage measurements.

#### 5.1.1.6 Advanced Intelligent Network Automatic Message Accounting

With the advent of Advanced Intelligent Network (AIN) the traditional forms of AMA data will change to some degree. This change will come in the form of enhanced services that will allow the SSP end office to generate AMA records for new services without needing a generic update for the new feature. This is accomplished by the AIN Expanded Call Model (ECM), which allows the LECs to design a new feature and specify the desired AMA data format to be generated by the SSP end office. This flexibility allows the LECs to customize the billing of the new feature based on the LECs' current billing formats and applicable tariffs. This method expedites the previous method in which the LEC would go to the supplier and request the design of a new feature. The supplier would in turn design the AMA data format to Bellcore's or the supplier's own specifications, and then return the completed feature to the LEC for approval. The requesting LEC had very little control over the design and AMA data format of the new feature. With AIN AMA, the requesting LEC has complete control, utilizing the AIN ECM to design the AMA data format to its unique specifications.

AIN performs its functions via the CCS/SS7 network. When an AIN feature is activated, the SSP end office sends a database query to the Service Control Point (SCP), which in turn looks up the requested information in its database, and sends a reply message back to the SSP. The SSP then decodes the message, processes the call, and performs any SCP indicated function (in this case, the appropriate AMA data is generated). In summary, the SCP is typically the main source of information, not the SSP. This allows for greater AMA data format flexibility for the design and implementation of new customer-focused features.

#### 5.1.1.7 Centralized Automatic Message Accounting

The AMA data for certain calls is controlled, collected, and recorded at a Centralized Automatic Message Accounting (CAMA) recording location. These calls may originate from a local switching system that does not have the Local Automatic Message Accounting (LAMA) feature. Or, these calls may originate from those lines of a local switching system that has the LAMA feature but cannot automatically identify the directory number of the originator (for example, those calls originated by 4- and 8-party lines served by the local switching system). Hence, the calls must be connected to an operator for manual identification and input of the originating-station directory number.

The switching system having the CAMA recording function is typically a tandem switching system, which is equipped with the AMA features. The tandem switching system is also

---

---

equipped with the Automatic Number Identification (ANI) and Operator Number Identification (ONI) features. For operation with CAMA, the local Stored Program Control System (SPCS) should be capable of outpulsing the calling-line identity of lines requiring ANI of the originating number. AMA data recorded at a CAMA recording location is, in general, identical to that recorded at a LAMA recording location.

## 5.2 Network Service Evaluation

The Service Evaluation System (SES) is an operations system that provides statistical indicators that can be used to evaluate the quality of the telecommunications network under all types of service conditions. Evaluation consists of monitoring selected call attempts to determine the disposition of the call (for example, completed, busy, no answer, equipment blockages, and failures). Service evaluation data is used to provide both quality assessment of network service delivered to the customer and to direct quality control activities. The service evaluation process, as used by the LECs, is defined in more detail in GR-2932-CORE, *Database Functionalities*, of FR-64, *LATA Switching Systems Generic Requirements (LSSGR)*.

Service evaluations are random samples of telephone service obtained from the evaluation of calls originated by telephone users. Since “dropping” of this function during times of switch overload would defeat the intent of service evaluation (namely, to assess the customer perspective of service during times when the customer is most likely to be adversely affected), service evaluation is considered a nondeferrable function. The samples are taken by such means, in such quantities, and so distributed as to be uniform throughout a LEC network.

Historically, certain switches supported service evaluation interfaces based on the frequent rotation of bridging arrangements among customer lines. However, these arrangements are undesirable because they raise concerns about privacy, are costly due to the need for manual rotations, cannot provide a truly random sample, and provide a very limited sample size for fault identification. Newer switching systems provide some type of a common-point monitoring interface for random sampling.

The bridging arrangement or monitoring interface consists of a voice link and a data link. The voice link permits audible monitoring of the call-setup process, and the data link permits the passing of data signals between the switching system and the SES.

Network service performance evaluations in use by the LECs are completely automated through the use of the No. 2 SES.<sup>1</sup> The No. 2 SES obtains Dial-Line Service Evaluation (DLSE) and Incoming-Trunk Service Evaluation (ITSE) measurements without human monitoring (see TR-TSY-000742, *No. 2 Service Evaluation System Interface*).

---

1. *No. 1 SES*, the first computer-based system for service evaluation, automated earlier methods of manual evaluation and allowed for centralized operation and automatic record keeping. No. 1 SES remains in service to evaluate operator-assisted calls.

---

## 5.3 Customer Network Services

Customer network services provide data to customers concerning the customers' use of the LEC facilities and services. This data may be used by the customer for such purposes as cost allocation and private telecommunications network management. Although large business and government customers are the typical users, these services are not restricted to such customers; the services may also be used by other business and residential customers.

Currently, only one service, Message Detail Recording (MDR), defined as a customer network service, is widely deployed. However, to meet the customers' needs for additional data concerning the customers' use of LEC facilities and services, other services may be offered on a local basis now or widely in the future.

### 5.3.1 Message Detail Recording

The MDR feature provides detailed data on a customer's calls. The primary user of MDR information is the business customer. As required by the MDR customer, the switch may provide MDR call data for calls *originated* by the MDR customer (for example, from the customer's line, private facility trunk, attendant, etc.) and/or calls *terminating* to the MDR customer's facilities (for example, private facility trunk, attendant, etc.). The MDR customer typically uses the call data records for cost allocation and/or telecommunications system management. MDR has evolved to become an umbrella term to describe the recording of usage information for features such as account or authorization codes, queuing, automatic route selection, facility restriction, private facility access, etc. In the past, the MDR feature was broadly termed Station Message Detail Recording (SMDR).

Various features in currently deployed switching systems provide the capability for the switching office to provide records of call details to a customer. However, GR-610-CORE, *Message Detail Recording (MDR)*, specifies two basic methods for providing MDR data.

One method, the MDR via the Revenue Accounting Office (RAO) feature, provides a capability for transmitting MDR information to the LEC RAO in the same data stream that transmits AMA data records for the switching system. As the RAO processes the received data stream, the MDR AMA information is separated from all the AMA data records and forwarded to the customer.

An alternative method provides MDR to the customer's premises, whereby the switching system that serves the call forwards the MDR data for the call to the customer on a data link or its equivalent.

### 5.3.1.1 MDR via RAO

Two methods are available to transport the customer's MDR data as a part of the AMA file. With the first method, MDR data is derived by RAO processes (generally from the AMA data for a call). The source of the data is the actual AMA record in the case where an AMA data record is generated for billing purposes. This AMA data record serves a dual role — for billing the call and for MDR purposes. Therefore, the RAO processing has to recognize from the AMA record data itself (for example, originating number, etc.) that MDR data must be derived from AMA data. However, if no AMA data record is generated for the call, such as when a call uses only private customer facilities, the switching system generates a special record that is used for MDR data purposes only. These special records are recorded in the switching system's AMA file along with all other AMA data records.

The second method for transmitting the MDR data to the customer via the RAO generates a separate MDR data record whenever MDR data is to be provided for a call. Therefore, if the call is chargeable, two separate records are generated for the call — the AMA data record and the MDR data record. This arrangement has limited use only and is not consistent with GR-610-CORE generic requirements. These MDR-data-only records are also inserted into the AMA data record stream for transport to the RAO.

The BAF modular concept supports a more efficient method of providing MDR data via the RAO. Instead of creating two records for an MDR customer's calls (an MDR record and an AMA data record), one record can be used for both purposes. MDR data modules (defined in GR-610-CORE) are added to existing AMA data records to record information (needed for MDR data purposes only) that is not otherwise a part of the AMA data record.

Regardless of which method provides MDR data via the RAO, the MDR data is output from the network element in the AMA data stream. This data is transported to the LEC RAO either by magnetic tapes that are hand-carried between the network element and the RAO or via AMA teleprocessing. AMA teleprocessing is a switching system feature to transmit AMA data on a store, poll, and forward basis to a central point for input into the RAO message billing process. RAO processes separate the MDR customer-required data from the AMA call data (whether the MDR data is in the same record as the call data or in a separate record), reformat the MDR data into the form required by the customer (for example, magnetic tape, printed reports, etc.), and forward the MDR data to the MDR customer.

### 5.3.1.2 MDR to Customer Premises

If the customer MDR data is to be transmitted by the switch to the customer premises, currently deployed switching systems must generate two different data record types to provide both MDR data to the customer as well as AMA data to the RAO. One type transmits the AMA data in the AMA file (if the call is billable or otherwise requires an AMA data record) and another type transmits the MDR data directly to the customer.

---

---

To further simplify the MDR data generation, whether for MDR via RAO or for MDR to customer premises, the modular record is designated for transmission of the MDR data in either case. By using the modular AMA data record for MDR purposes, the AMA data record, enhanced with the MDR-specific data modules, forms the MDR data record. As previously stated, in those cases where the MDR data is to be transported to the customer via the RAO, the MDR data modules are included in the AMA data record that is transmitted to the RAO. However, if the MDR data is to be transmitted to the customer in some manner outside of the MDR-via-RAO stream (for example, MDR to customer premises), the MDR data modules are included only in the MDR data record sent to the customer; the normal AMA data record (if required for the call) is transmitted to the RAO without the MDR data-specific modules.

The MDR-to-customer-premises data record generated at the switching system is transmitted from the switching system toward the MDR customer's Customer Premises Equipment (CPE). The MDR data flow is entirely from the switching system toward the CPE; however, control messages may be exchanged between the CPE and the switching system. The transmission facility is provided by a LEC-offered service that may be analog private line, message telephone service (using a dial-in/dial-back arrangement for security purposes), a digital data system channel, Public Packet-Switched Service (PPSS), or Integrated Services Digital Network (ISDN) access [GR-499-CORE, *Transport Systems Generic Requirements (TSGR): Common Requirements*].

## 5.4 Customer Network Management

The telecommunications Service Providers (SPs)/Network Operators (NOs) offer a variety of Customer Service Management/Customer Network Management (CSM/CNM) services for the exchange and exchange-access networks. These services provide customers access to and control over the SP facilities and services that they use. Large businesses, government customers, and ICs are typical users of these services.

CSM/CNM supports five major management functions:

1. Configuration management
2. Performance management
3. Fault management
4. Accounting management
5. Security management.

Each SP uses a variety of systems, often developed (by Bellcore and/or third-party vendors), to support its marketing strategy. Therefore, not all of these functions are available in all SPs.

### 5.4.1 Configuration Management

Configuration management applies to a variety of network services including, but not limited to, switched voice, switched data, and packet data. The following examples illustrate some of these functions:

- **Centrex Reconfiguration** — A customer can modify Centrex/station features (such as the capability to remotely pick up another station's incoming call) or rearrange Centrex lists (also known as "swap telephone numbers"), which allows the customer to change station numbers.
- **Private-line Reconfiguration** — Allows customers to allocate resources by reserving lines, verifying resources, combining bandwidth across contiguous channels, and defining special days for temporary reconfigurations. These functions may apply to analog private lines, Digital Signal level 0 (DS0) and below, or DS1 and above.

A customer may also review routing information or current routes, past routing changes, and scheduled routing changes.

A customer has four routing controls:

1. Change routing for a specific duration or until further notice
  2. Manage routing preferences
  3. Rename routes
  4. Take routes out of service and restore them to service.
- **Service Order Management** — A customer can perform the following six functions:
    1. Initiating a service order - allows a customer to submit a service order.
    2. Checking a service order status - enables a customer to request information about the status of a service order, which may include the following: service order receipts, the planned completion date, actual completion date, and price quotes.
    3. Receiving notification - permits the management system to notify the customer proactively when information becomes available (for example, when the order is completed).
    4. Modifying a service order - allows a customer to access a pending service order and modify it.
    5. Canceling a service order - permits a customer to request that a pending service order request be canceled.
    6. Cross-referencing related service order numbers - lets a customer look up which service orders are related to one another.
  - **Directory Number Hunt Groups (DNHGs)** — A customer may control the existence and membership of DNHGs by four specific functions:
-

- 
1. Creating or deleting a DNHG
  2. Adding or removing a DNHG member
  3. Examining the current status of a DNHG
  4. Cross-referencing all DNHGs and Centrex lines.
- Network Planning Access Information — A customer may acquire information about available facilities, the capacity of facilities, and the compatibility of facilities.
  - Service Information — This portion of configuration management provides information to a customer. For example, a customer may request a list of circuits and telephone numbers that describes their services. A customer may also use this function to find the name of a trouble circuit for reporting purposes, verify service information before taking further actions such as entering a trouble, and check the consistency of information between the customer's records and the actual network.

#### **5.4.2 Performance Management**

Performance management consists of traffic-measurement reporting and performance monitoring.

Traffic-measurement reporting comprises seven functions.

1. Receive Scheduled Traffic-Measurement Report — A customer may access traffic-measurement reports that have been previously scheduled (as they become available).
  2. Request and Receive On-Demand Traffic-Measurement Report — A customer may request on-demand traffic-measurement reports and access them when they become available.
  3. List All Requested Reports — A customer may receive a listing of outstanding traffic reports.
  4. Create and Modify Schedule for Traffic-Measurement Reports — A customer may set the schedule that determines when traffic measurements are taken (for example, each day, at midnight, every 12 hours).
  5. Create and Modify Traffic-Report Definition — A customer may initiate a traffic-report request by defining the information that the report should provide (for example, traffic over a half-hour period).
  6. Modify Filters for Traffic-Report Delivery — A customer may set filter criteria to control which requested reports are actually delivered or when they are delivered.
  7. Cancel Traffic-Measurement Request — A customer may cancel a previously requested on-demand or scheduled report.
-



The second part of performance management, performance monitoring, is similar to fault management (described below). The two differ in that fault management is concerned with managing failures and persistent performance degradations that affect a customer's service, while performance monitoring refers to functions that allow customers to obtain, evaluate, and report on network performance parameters, and identify performance degradations. Some of these functions are described below:

- **Real-Time Performance Monitoring** — Performance information passes through a filter of criteria to determine what events and data should be sent to the customer. Events are exception notifications that are sent to the customer as quickly as normal system processing permits. Routine performance data is sent to the customer on a periodic schedule.
- **Real-Time Performance Criteria Modification** — A customer may modify the criteria that are used to filter performance information.
- **Performance Data Logging** — Performance information may be placed into a log file for customer access. The specific data that is recorded in this log is determined by a second filter that contains criteria that may be different from those used in the filter for real-time performance monitoring.
- **Performance Data Logging Criteria Modification** — A customer may modify the criteria that are used to filter performance data for the log file.
- **Performance Log Retrieval** — A customer may request (in whole or in part) a performance log. For example, a customer may request all logged performance data for a specific circuit in a specific time period.

### 5.4.3 Fault Management

Fault management comprises alarm surveillance, testing, and trouble administration. Alarm surveillance is concerned with managing information about service affecting failures and persistent performance degradations.

- **Real-Time Alarm Reporting** — Alarm information passes through a filter of criteria to determine what alarms should be sent to the customer. Information is sent to the customer as quickly as normal system processing permits.
  - **Real-Time Alarm Criteria Modification** — A customer may modify the criteria that are used to filter alarm information.
  - **Alarm Logging** — Alarm information may be placed in a log file for customer access. The specific alarms that are recorded in this log are determined by a second filter that contains criteria that may be different from those used in the filter for real-time alarms.
  - **Alarm Logging Criteria Modification** — A customer may modify the criteria that are used to filter alarms for the alarm log file.
-



- 
- Alarm Log Retrieval — A customer may request (in whole or in part) an alarm log. For example, a customer may request all logged alarms for a specific circuit in a specific time period.
  - Current Status Request — A customer may request on-demand status reports for facilities and access them when they become available.
  - Scheduled Status Report Retrieval — A customer may access previously scheduled status reports for facilities when they become available.
  - All Requested Reports — A customer may receive a listing of all outstanding status reports.
    - Schedule Creation and Modification — A customer may create, view, and update the schedule for recurring scheduled status reports.
    - Parameters Creation and Modification — A customer may create, view, and update parameters controlling the content of a scheduled status report.
    - Status Request Cancellation — A customer may cancel a previously requested on-demand or scheduled report.

Testing applies to analog and digital interfaces. The seven functions that follow describe aspects of testing:

1. Request Scheduled Test — A customer may request that a test be done at some point in the future or at regular intervals at a certain time. This function allows customers to execute intrusive tests of analog facilities that would otherwise interrupt their service.
  2. List All Scheduled Tests — A customer may request a list of all tests scheduled for a given facility or facilities.
  3. Modify Schedule of Test — A customer may access and modify a request for a scheduled test.
  4. Request On-Demand Test — A customer may request that a test be performed as soon as possible.
  5. Request Test Cancellation — A customer may request that a scheduled or on-demand test be canceled. Because of information-processing delays by the network provider, a cancellation request does not necessarily mean that the test will actually be canceled.
  6. Receive Test Results — A customer may be notified that a test is complete. This notification may be accompanied by test results, or the customer may be required to take specific action to receive the results. This function applies both to scheduled and on-demand tests.
  7. Set Test Type — A customer may request that a specific test be performed. The customer may also be permitted to set parameters for the requested test. In some cases, the customer may not be given the option of setting test type or parameters. These may be automatically assigned according to the facility being tested.
-

The last area of fault management is trouble administration. Trouble administration also has seven functions:

1. Enter Trouble — A customer may request that a trouble report be created with the appropriate information.
2. Add Trouble Information — A customer may provide additional descriptive tests for an open trouble report. This additional information will be appended to the description provided when the trouble was originally entered.
3. Cancel Trouble — A customer may attempt to close out a trouble report. Typically, the customer has resolved the trouble and wants to abort the trouble report.
4. Check Trouble Status — A customer may request status information on an open or closed customer trouble report.
5. Review Circuit Trouble History — A customer may request information about past troubles reported for a particular service or circuit.
6. Report Trouble Status Change — A customer may be notified proactively of changes in the trouble status.
7. Request Trouble Report Format — A customer may request information on what conditional package of attributes applies to trouble reports for a particular circuit or service.

#### **5.4.4 Accounting Management**

A customer may access two classes of accounting information:

1. “As rendered” (for example, as they appeared on the bill)
2. Current (information based upon the current billing period).

Accounting management has six functions:

1. Get Billing Information — A customer may request accounting information. This request may be defined for the current or a rendered billing period, for one or more billing details, or as a summary of billing information.
  2. Reconcile Billing Concerns — A customer may request that an accounting item be verified for accuracy.
  3. Manage Billing Information — For example, billing numbers, telephone numbers, cross-references, limits.
  4. Notice of Exceeded Limits — A customer may be notified if a monetary limit has been exceeded. This limit may be prespecified by the customer or network provider and may pertain to a single user or group of users.
-

5. Bill Payment — A customer may provide information in support of bill payment.
6. Usage Data — A customer may access information on service usage (for example, Switched Multi-megabit Data Service [SMDS] reports).

#### **5.4.5 Security Management**

Security regarding access to and control of a customer's services and facilities is ensured through seven functions:

1. Authentication — Customers should verify their identities to gain entry to access and control mechanisms.
  2. Authorization/Access Control — A customer may not be permitted to manipulate services and facilities that are servicing other customers.
  3. Data Integrity — A customer's data is protected from unauthorized changes.
  4. Data Confidentiality — A customer's data is protected from eavesdropping.
  5. Intrusion Detection and Recovery — Methods are provided to detect intrusion and undo any unauthorized changes.
  6. Administration — The customer may share responsibility for determining security levels and user permissions.
  7. Reporting — The customer may receive reports of unauthorized or suspicious activities.
-



## Section 6 Signaling Contents

6.	Signaling .....	6-1
6.1	Introduction .....	6-1
6.2	Analog Access Line Signaling .....	6-2
6.2.1	Loop-Start Signaling .....	6-3
6.2.2	Ground-Start Signaling .....	6-7
6.2.2.1	Start-Dial Signal in Ground-Start .....	6-9
6.2.2.2	Recognition of a New Call .....	6-10
6.2.2.3	Prevention of Unauthorized Calls.....	6-11
6.2.3	Open Switching Intervals on Loop-Start-Start and Ground-Start Access Lines .....	6-12
6.2.4	Maintenance Tests Performed on Loop-Start and Ground-Start Access Line During the Idle State.....	6-13
6.2.5	Tests Made in the Process of Connecting or Disconnecting a Call .....	6-14
6.2.5.1	Power Cross Test .....	6-14
6.2.5.2	Low Line Resistance Test.....	6-15
6.2.5.3	PBX Loop Test .....	6-15
6.2.5.4	Restore and Verify Test.....	6-16
6.2.5.5	Call Sequences.....	6-17
6.2.6	Coin Collect and Coin Return .....	6-20
6.2.7	Showering .....	6-20
6.2.8	Direct Inward Dialing .....	6-21
6.3	Switching System Interfaces to Access Lines.....	6-23
6.4	Interoffice In-Band Analog Signaling.....	6-29
6.5	On- and Off-Hook Signals .....	6-33
6.5.1	Connect (Seizure).....	6-35
6.5.2	Answer (Off-Hook).....	6-35
6.5.2.1	Charge Delay .....	6-35
6.5.2.2	Answer Signals on Calls to Directory Assistance .....	6-35
6.5.2.3	Cross-Office Transfer Time for Answer Signals.....	6-35
6.5.3	Control of Disconnect .....	6-36
6.5.3.1	Calling-Customer Control of Disconnect .....	6-36
6.5.3.2	Calling-Customer Control of Disconnect with Forced Disconnect .....	6-38
6.5.3.3	Operator Control of Disconnect.....	6-38
6.5.4	Guard Time .....	6-39
6.5.5	Immediate-Dial .....	6-43
6.5.6	Signaling Integrity Check .....	6-43

---

6.5.7	Reverse Make-Busy (Off-Hook Make-Busy) .....	6-44
6.6	Controlled Outpulsing .....	6-46
6.6.1	Delay-Dial Without Signaling Integrity Check .....	6-46
6.6.2	Delay-Dial with Integrity Check .....	6-50
6.6.3	Generation of Delay-Dial Signals .....	6-51
6.6.4	Wink-Start .....	6-52
6.6.5	Glare .....	6-54
6.6.5.1	Glare Resolution in Electronic Switching Offices .....	6-55
6.6.5.2	Trunk Hunting — Method to Minimize Glare .....	6-56
6.6.6	Start-Dial (Start-Pulsing) .....	6-57
6.6.7	Unexpected Stop .....	6-58
6.6.8	Dynamic Overload Control .....	6-59
6.7	Loop Signaling .....	6-60
6.7.1	Loop Reverse-Battery Signaling .....	6-60
6.7.2	Battery-and-Ground Signaling .....	6-61
6.7.3	Idle Circuit Terminations and Trunk Capacitance .....	6-64
6.8	E&M Signaling .....	6-65
6.8.1	Type I Interface .....	6-66
6.8.2	Type II Interface .....	6-66
6.8.3	Type III Interface .....	6-67
6.8.4	Type IV Interface .....	6-68
6.8.5	Type V Interface .....	6-69
6.8.6	Signaling State Summary .....	6-69
6.8.7	Switching Methods .....	6-70
6.8.7.1	Relay Contacts .....	6-70
6.8.7.2	Solid-State Switches .....	6-70
6.8.8	Transient Suppression .....	6-72
6.8.8.1	Type I and III M Leads .....	6-72
6.8.8.2	All E Leads .....	6-72
6.8.8.3	Type II, IV, and V M Leads .....	6-73
6.8.9	E&M Lead Current Limits .....	6-73
6.8.10	Current Limiters .....	6-73
6.8.10.1	Type I M Lead .....	6-74
6.8.10.2	Type II SB Lead .....	6-74
6.8.10.3	Type III SB Lead .....	6-74
6.8.11	Compatibility .....	6-75
6.8.12	Interface Conversion .....	6-76
6.8.13	Back-to-Back Connections .....	6-76
6.8.14	60-Hz Immunity Requirements .....	6-78
6.8.15	Working Range .....	6-78
6.8.16	Relative Merits .....	6-78
6.8.16.1	Type I Interface .....	6-78
6.8.16.2	Type II Interface .....	6-78
6.8.16.3	Type III Interface .....	6-79

---

---

6.8.16.4	Type IV Interface.....	6-79
6.8.16.5	Type V Interface.....	6-79
6.8.17	E&M Lead Connection to Testboards .....	6-79
6.8.18	List of Service Trunks.....	6-79
6.8.19	E&M Signaling for Customer Installation Equipment .....	6-81
6.8.19.1	Differences Between Customer Installation E&M Signaling and Central Office E&M Signaling.....	6-81
6.8.19.2	E&M Lead Interfaces at the NI .....	6-81
6.8.19.3	E&M Signaling Standards for Customer Installation Equipment.....	6-81
6.9	Duplex Signaling.....	6-84
6.10	Dial Pulsing .....	6-86
6.10.1	Dial-Pulse Generation .....	6-86
6.10.2	Loop and Leak .....	6-88
6.10.3	Dial-Pulsing Limits .....	6-89
6.10.3.1	Pulse Waveform Criteria .....	6-90
6.10.3.2	Maximum Number of Dial-Pulse Repetitions Without Pulse Correction .....	6-95
6.10.3.3	Pulse Links and Converters .....	6-95
6.10.3.4	Maximum Number of Dial-Pulse Repetitions with Pulse Correction .....	6-95
6.10.4	Interdigital Time .....	6-95
6.11	Single-Frequency Signaling .....	6-97
6.11.1	Single-Frequency Transmitter.....	6-101
6.11.2	Single-Frequency Receiver .....	6-102
6.11.3	Voice Path Cuts and 2600-Hz Band Elimination Filter Insertion.....	6-104
6.11.4	Signaling Delay.....	6-104
6.11.5	Continuous Tones .....	6-105
6.11.6	Foreign Exchange Line Signaling.....	6-105
6.12	Multifrequency (MF) Signaling .....	6-108
6.12.1	Tones Sent by the Calling Station after Dialing .....	6-110
6.12.2	Multifrequency Transmitter .....	6-110
6.12.2.1	Digit Duration.....	6-110
6.12.2.2	KP Duration.....	6-110
6.12.2.3	Transmitter Tone Level, Frequency, and Timing Limits .....	6-111
6.12.2.4	Transmitter Impedance .....	6-112
6.12.2.5	Tests of Multifrequency Transmitters .....	6-112
6.12.3	Multifrequency Receiver.....	6-112
6.12.3.1	Receiver Limits.....	6-112
6.12.3.2	Maximum Impairment.....	6-115
6.13	Dual-Tone Multifrequency Signaling .....	6-116
6.13.1	DTMF Signaling Frequencies.....	6-117

---

---

6.13.2	DTMF Central Office Receiver Operation .....	6-117
6.13.2.1	Input Impedance and Longitudinal Balance .....	6-117
6.13.2.2	Registration of DTMF Signals Without Noise .....	6-117
6.13.2.3	Digits Registered in Presence of Gaussian Noise .....	6-119
6.13.3	DTMF Receiver Test Circuit Operation .....	6-122
6.13.3.1	Automatic Tests in 1/1A ESS Switching System .....	6-122
6.13.3.2	Low-Level Test.....	6-123
6.13.4	DTMF Station Test Receiver Operation .....	6-123
6.13.4.1	Input Impedance .....	6-123
6.13.4.2	Edge Band Frequencies .....	6-123
6.13.4.3	Effective Sensitivity.....	6-123
6.13.4.4	Limiting Pulsing Speed And Pulse Duration.....	6-124
6.13.5	In-Service Receivers and Transmitters .....	6-124
6.13.5.1	Use of # (Number Sign).....	6-124
6.13.5.2	DTMF Receiver Start Dialing Signal .....	6-124
6.13.5.3	DTMF Transmitters in Electronic Switching Systems .....	6-125
6.13.6	Barriers to End-to-End DTMF Signaling.....	6-125
6.13.6.1	Polarity Guard.....	6-126
6.13.6.2	Enabling DTMF Signaling in Single-Slot Coin Telephones.....	6-126
6.13.6.3	Effects of Time Assignment Speech Interpolation.....	6-126
6.13.6.4	Effect of Echo Suppressors and Dial Tone .....	6-127
6.13.7	Increased Sensitivity DTMF Receiver for End-to-End Signaling .....	6-128
6.13.8	Out-of-Band Signaling — Digital Carrier and Digital Switching Systems .....	6-129
6.14	Calling Number Delivery .....	6-134
6.14.1	Customer Premises Equipment (CPE) Considerations .....	6-134
6.14.2	LEC Network Considerations .....	6-135
6.14.3	Data Interface .....	6-135
6.14.3.1	Data Parameters .....	6-135
6.14.3.2	Data Protocol .....	6-136
6.14.3.3	Data Timing .....	6-139
6.15	LATA Access.....	6-140
6.15.1	Carrier Classification .....	6-140
6.15.2	Feature Group A.....	6-141
6.15.3	Feature Group B.....	6-142
6.15.4	Feature Group C.....	6-147
6.15.5	Feature Group D — Equal Access .....	6-147
6.15.5.1	Equal Access End Office .....	6-148
6.15.5.2	Signaling for Calls Not Requiring Special Operator Services Signaling .....	6-148
6.15.5.3	Signaling North American Dialing Plan.....	6-150

---



---

	6.15.5.4	Routing .....	6-157
	6.15.5.5	International Carriers .....	6-158
	6.15.5.6	North American World Zone 1 Calls.....	6-163
	6.15.5.7	Supervision .....	6-163
6.16		Special Tandem Signaling (CAMA, OSPS, and TOPS Offices) .....	6-164
	6.16.1	Signaling to CAMA .....	6-165
	6.16.1.1	Types of Switching Systems used as CAMA Offices.....	6-165
	6.16.1.2	Called-Number Outpulsing Format in CAMA .....	6-165
	6.16.1.3	Overlap Outpulsing from CAMA .....	6-165
	6.16.1.4	CAMA Outpulsing Formats .....	6-166
	6.16.1.5	CAMA ANI Pulsing Format.....	6-166
	6.16.1.6	CAMA Permanent Signal and Partial Dial Timing .....	6-166
	6.16.2	Time from Request for ANI to ANI Failure in CAMA .....	6-167
	6.16.3	CAMA Transfer .....	6-167
6.17		Signaling From End Offices to Operator Services Systems .....	6-170
	6.17.1	“Operator Services” or Bell II” Signaling to Operator Services Systems.....	6-170
	6.17.2	“Bell I” Signaling to Operator Services Systems.....	6-174
	6.17.2.1	Outpulsing Format.....	6-174
	6.17.2.2	Trunking Plans.....	6-174
	6.17.2.3	ANI Information Digits .....	6-179
	6.17.3	Coin Control Signaling .....	6-180
	6.17.3.1	Inband Coin Control .....	6-181
	6.17.3.2	Multiwink Coin Control .....	6-182
	6.17.3.3	EIS Coin Control .....	6-183
	6.17.3.4	Impacts on Coin Stations of Automatic Coin Toll Service (ACTS) and Calling Card Service .....	6-184
	6.17.4	Combined Coin and Non-coin Operator Services Switch Interface .....	6-202
	6.17.5	Selective Class of Call Screening Code Assignments in Operator Services Systems.....	6-203
	6.17.6	Charge-a-Call Public Telephone Service .....	6-204
	6.17.6.1	Charge-a-Call Service Dialing Restrictions.....	6-204
	6.17.6.2	Charge-a-Call Trunking Arrangements .....	6-205
	6.17.7	Post-Pay Coin.....	6-205
	6.17.7.1	Trunking Alternatives.....	6-205
	6.17.7.2	Restrictions .....	6-206
	6.17.7.3	Signaling .....	6-206
	6.17.7.4	Providing Ringback .....	6-207
	6.17.7.5	Trunking Plans and Pulsing Formats .....	6-207
	6.17.8	Smart/Intelligent (non-network controlled) Coin Station .....	6-208
6.18		Signaling to Automatic Intercept System .....	6-209
	6.18.1	Interoffice Signaling with ANI .....	6-210

---

---

6.18.2	Interoffice Signaling with ONI or Operator Assistance.....	6-210
6.19	Carrier Group Alarm .....	6-211
6.19.1	Call Processing Between Carrier Failure and Trunk Conditioning.....	6-211
6.19.2	Trunk Conditioning.....	6-212
6.19.3	Carrier Restoral.....	6-214
6.20	Call Progress Tones (Audible Tone Signals).....	6-215
6.20.1	Precise Tone Plan.....	6-219
6.20.2	Nonprecise Tones.....	6-220
6.20.3	Call Progress Tones .....	6-220
6.20.4	Receiver Off-Hook Tone .....	6-222
6.20.5	102 Test Trunk.....	6-223
6.21	Other Miscellaneous Signals.....	6-225
6.21.1	Ringng.....	6-225
6.21.1.1	Ring Forward (Re-ring).....	6-225
6.21.1.2	Ringback.....	6-225
6.21.2	Tones and Announcements .....	6-226
6.21.2.1	Special Information Tones.....	6-226
6.21.2.2	Equipment Operation.....	6-230
6.21.2.3	SITs, Tones, and Announcements used in the Network .....	6-230
6.22	Register Timing and Effect on Signaling.....	6-248
6.23	Common Channel Signaling .....	6-249
6.23.1	CCS Architecture .....	6-250
6.23.2	Description of SS7 Protocol Parts.....	6-252
6.23.2.1	SS7 Structure .....	6-252
6.23.3	Description of ANSI-Standardized Protocol Parts.....	6-252
6.23.3.1	Overview of SS7 (T1.110).....	6-252
6.23.3.2	Message Transfer Part — MTP (T1.111.x).....	6-252
6.23.3.3	Signaling Connection Control Part — SCCP (T1.112.x).....	6-254
6.23.3.4	Integrated Services Digital Network User Part — ISUP (T1.113.x).....	6-255
6.23.3.5	Transaction Capabilities Application Part — TCAP (T1.114.x).....	6-257
6.23.3.6	Operations, Maintenance, and Administration Part — OMAP (T1.116.x).....	6-258
6.23.3.7	Interworking Specification — (T1.609).....	6-258
6.23.4	SS7 Network-Layer Protocol and Performance.....	6-259
6.23.4.1	Network-Layer Protocol.....	6-259
6.23.4.2	Functions and Performance of the SS7 Network Layer.....	6-260
6.23.5	Message Transfer Part.....	6-263
6.23.5.1	Link-Layer Protocol.....	6-265

---

---

6.23.5.2	Signal Unit Delimitation and Length.....	6-265
6.23.5.3	Error Detection and Correction .....	6-265
6.23.5.4	Sequence Control.....	6-265
6.23.5.5	Link Status Signal Unit.....	6-265
6.23.5.6	Unique Functions of T1.111.3 .....	6-265
6.23.6	Signaling Connection Control Part .....	6-266
6.23.6.1	SCCP Routing Principles.....	6-266
6.23.7	Global Title Addressing.....	6-268
6.23.7.1	Guidelines for Using Global Title-Translation.....	6-269
6.23.7.2	Procedures for Translation.....	6-270
6.23.8	ISDN User Part .....	6-271
6.23.8.1	Services Supported by the ISUP.....	6-271
6.23.8.2	Services Required by the ISUP.....	6-272
6.23.8.3	Signaling Procedures .....	6-272
6.23.8.4	Trunk-Management Procedures.....	6-272
6.23.9	Transaction Capabilities Application Part .....	6-274
6.23.9.1	General Description .....	6-275
6.23.9.2	Normal Procedures .....	6-277
6.23.10	Operations, Maintenance, and Administration Part.....	6-278
6.23.10.1	Services Based on Common Management Information Protocol.....	6-278
6.23.10.2	TCAP Formats .....	6-279
6.23.10.3	MTP Routing Verification Test Procedure .....	6-279
6.23.10.4	SCCP Routing Verification Test Procedure .....	6-280
6.23.10.5	Link Equipment Failure Procedure.....	6-280
6.23.10.6	Link Fault Sectionalization Procedure.....	6-281
6.23.10.7	Circuit Validation Test (CVT).....	6-282

---

---

## List of Figures

Figure 6-1.	Principle of Operations of Loop-Start Signaling .....	6-4
Figure 6-2.	Loop-Start Operation on a PBX Trunk (Rockwell).....	6-6
Figure 6-3.	Principle of Operation of Ground-Start Signaling.....	6-8
Figure 6-4.	Ground Start Operation on a PBX Trunk .....	6-9
Figure 6-5.	Coin Collect and Return Circuit .....	6-20
Figure 6-6.	Loop Reverse-Battery Signaling for DID.....	6-22
Figure 6-7.	5ESS GDX Line Unit, Battery Feed, and Supervision.....	6-23
Figure 6-8.	Loop Voltage Versus Current, 5ESS Line Circuit .....	6-24
Figure 6-9.	DMS-100 Switching System Loop-Start Line, Battery Feed, and Supervision .....	6-26
Figure 6-10.	DMS-100 Switching System Loop- and Ground-Start Line, Battery Feed, and Supervision.....	6-27
Figure 6-11.	EWSD Switching System — Single-Party Line Circuit .....	6-27
Figure 6-12.	NEAX-61E Line Card, Eight Loop-Start Lines .....	6-28
Figure 6-13.	Controlled-Outpulsing Formats for 1/1A ESS Systems .....	6-52
Figure 6-14.	Reverse-Battery Signaling.....	6-62
Figure 6-15.	Battery-and-Ground Pulsing, Loop Supervision .....	6-63
Figure 6-16.	E&M Lead Control Status .....	6-65
Figure 6-17.	Type I Interface .....	6-66
Figure 6-18.	Type II Interface .....	6-67
Figure 6-19.	Type III Interface.....	6-68
Figure 6-20.	Type IV Interface.....	6-68
Figure 6-21.	Type V Interface .....	6-69
Figure 6-22.	Type III-to-Type I Conversion (Normal Range) .....	6-75
Figure 6-23.	Type II-to-Type I Conversion.....	6-76
Figure 6-24.	Trunk Circuit to Trunk Circuit via Auxiliary Trunk Link Repeater.....	6-77
Figure 6-25.	Trunk Circuits Back-to-Back — Type II.....	6-77
Figure 6-26.	Type I — Customer Installation Originates on the M Lead .....	6-82
Figure 6-27.	Type I — Customer Installation Originates on the E Lead .....	6-82
Figure 6-28.	Type II — Customer Installation Originates on the M Lead.....	6-83
Figure 6-29.	Type II — Customer Installation Originates on the E Lead.....	6-83
Figure 6-30.	DX Signaling Circuit .....	6-84
Figure 6-31.	Dial-Pulse Signaling.....	6-87
Figure 6-32.	Leaks for Dial-Pulse Testing.....	6-88
Figure 6-33.	Test Circuit for Dial-Pulse Templates .....	6-91
Figure 6-34.	Dial-Pulse Template for Noninductive Test.....	6-92
Figure 6-35.	Inductor for Inductive Dial-Pulse Test Circuit .....	6-93
Figure 6-36.	Dial Pulse Template for Inductive Test.....	6-94
Figure 6-37.	E&M 4-Wire 2600-Hz SF Signaling System .....	6-101
Figure 6-38.	DTMF Digit Source.....	6-119
Figure 6-39.	Gaussian Noise Source .....	6-119

---

---

Figure 6-40.	Gaussian Noise Test of DTMF Receiver.....	6-120
Figure 6-41.	Impulse Noise Source .....	6-120
Figure 6-42.	Impulse Noise Test — DTMF Receiver.....	6-121
Figure 6-43.	Single and Multiple Data Message Formats.....	6-137
Figure 6-44.	Originating Signaling Sequence — Without ANI Direct Connection — FGB .....	6-142
Figure 6-45.	Originating Signaling Sequence — With ANI Direct Connection — FGB .....	6-143
Figure 6-46.	Originating Signaling Sequence — EO Tandem Connection — FGB .....	6-144
Figure 6-47.	Terminating Signaling Sequence — Tandem — FGB .....	6-145
Figure 6-48.	Direct IC/INC Connection — FGD.....	6-148
Figure 6-49.	Tandem IC/INC Connection — FGD.....	6-149
Figure 6-50.	Combined Direct and Tandem IC/INC Connection — FGD .....	6-149
Figure 6-51.	Originating Signaling Sequence — Via Access Tandem — FGD.....	6-152
Figure 6-52.	Terminating Sequence — Access Tandem Through an Access Tandem — FGD .....	6-153
Figure 6-53.	Terminating Sequence — Direct From IC to EAEO Tandem — FGD .....	6-154
Figure 6-54.	INC Interconnection — Indirect — Originating LATA — FGD.....	6-159
Figure 6-55.	INC Interconnection — Indirect — Terminating LATA — FGD .....	6-159
Figure 6-56.	International Call - Originating Signaling Sequence at Connection to INC (or via IC) — FGD .....	6-162
Figure 6-57.	Originating Signaling Sequence, Operator Services, InterLATA or IntraLATA — “Bell II” Signaling.....	6-171
Figure 6-58.	Originating Signaling Sequence .....	6-181
Figure 6-59.	Coin Deposit Signals .....	6-187
Figure 6-60.	Illustrative Digital 102 Test Trunk and Tone Generator .....	6-224
Figure 6-61.	Reorder Condition .....	6-227
Figure 6-62.	No-Circuit Condition .....	6-228
Figure 6-63.	Typical SS7 Network Architecture.....	6-251
Figure 6-64.	SS7 Protocol Architecture .....	6-253
Figure 6-65.	Basic Message Structure.....	6-263
Figure 6-66.	Procedure for Message Processing.....	6-264
Figure 6-67.	ISUP — Message Format.....	6-273
Figure 6-68.	ISUP — Information Element Format.....	6-274
Figure 6-69.	Detailed TCAP Message Structure with an Invoke Component .....	6-276

---

---

## List of Tables

Table 6-1.	5ESS Switching System Loop-Start Originating Call Sequence.....	6-17
Table 6-2.	5ESS Switching System Ground-Start Originating Call Sequence.....	6-18
Table 6-3.	5ESS Switching System Terminating Call Sequence.....	6-19
Table 6-4.	Battery Supply — 5ESS Switching System .....	6-24
Table 6-5.	Battery Connections in Call Processing — 5ESS System.....	6-25
Table 6-6.	Signals Required in Dialing Through the Network .....	6-30
Table 6-7.	Signals Used in Dialing Through the Network .....	6-34
Table 6-8.	Disconnect Timing .....	6-37
Table 6-9.	Actual Guard Time for Various Switching Systems .....	6-40
Table 6-10.	Time to Restore Trunk Circuit to Idle after Disconnect.....	6-41
Table 6-11.	Off-Hook Make-Busy Provisions .....	6-45
Table 6-12.	Available Controlled-Outpulsing Methods .....	6-48
Table 6-13.	Delay from Connect to Delay-Dial.....	6-54
Table 6-14.	Signal States Sent .....	6-70
Table 6-15.	Service Trunks .....	6-80
Table 6-16.	On- and Off-Hook Conditions .....	6-98
Table 6-17.	Typical Single-Frequency Signaling Characteristics .....	6-99
Table 6-18.	Typical Transmission Characteristics.....	6-103
Table 6-19.	Typical Single-Frequency Signaling Delays .....	6-105
Table 6-20.	Multifrequency Codes .....	6-109
Table 6-21.	MF Sender Pulse and Interdigital Intervals .....	6-111
Table 6-22.	Minimum Digit Timing (seconds).....	6-114
Table 6-23.	DTMF Frequency Pairs .....	6-117
Table 6-24.	ABCD Codes, Locally Switched Circuits, IDT to RDT.....	6-132
Table 6-25.	ABCD Codes, Locally Switched Circuits, RDT to IDT.....	6-133
Table 6-26.	Availability of Feature Groups .....	6-140
Table 6-27.	FGD Controlled-Outpulsing Default Timing .....	6-151
Table 6-28.	Supervisory Signal Exchange Between Operator Providing ONI and CAMA (Continued) .....	6-169
Table 6-29.	Pulsing Format from End Office to Operator Service InterLATA and IntraLATA Calls Using “Bell II” Signaling .....	6-172
Table 6-30.	Pulsing Format from End Office to Operator Service System- International Calls and Test Calls Using “Bell II” Signaling .....	6-173
Table 6-31.	Pulsing Format from an End Office to an OSPS or TOPS Office with ANI Supercombined Coin and Non-coin Trunk Group Using “Bell I” Signaling .....	6-176
Table 6-32.	Pulsing Format — End Office to OSPS or TOPS Office with ANI Combined Coin or Combined Non-coin Trunk Group Using “Bell I” Signaling .....	6-177
Table 6-33.	Pulsing Format — End Office to OSPS or TOPS Office with ANI Using “Bell I” Signaling.....	6-178

---

---

Table 6-34.	Pulsing Format — Non-conforming End Office to an OSPS or TOPS Office without ANI.....	6-179
Table 6-35.	Information Digit I.....	6-180
Table 6-36.	Multiwink Signals and Their Functions .....	6-182
Table 6-37.	Intercept-Class Signals Transmitted to Automatic Intercept Center.....	6-209
Table 6-38.	Call Progress Tones .....	6-215
Table 6-39.	Glossary of Call Progress Tones .....	6-217
Table 6-40.	Precise Tones .....	6-219
Table 6-41.	Nonprecise Tones .....	6-220
Table 6-42.	Current Call Progress Tones.....	6-220
Table 6-43.	Rarely Used Call Progress Tones .....	6-221
Table 6-44.	Encoding Scheme for Special Information Tones.....	6-228
Table 6-45.	Frequencies for Use in SITs .....	6-229
Table 6-46.	Tolerances for Announcement Machines .....	6-230
Table 6-47.	Treatment Applied for Incompleted Call Attempts.....	6-232
Table 6-48.	Typical Global Title Translations.....	6-270

---





---

## 6. Signaling

### 6.1 Introduction

This section covers signaling on access lines and interoffice trunks within Local Access and Transport Area (LATA) networks, including signaling on some special-service circuits.

As stated in the Foreword, *Notes* presents a snapshot view of switched intraLATA networks. Most of the installed switched network elements are from Lucent or Nortel. However, equipment manufactured by Ericsson, NEC America, Alcatel (Rockwell), and Siemens Stromberg-Carlson can be found in one or more intraLATA networks.

To explain existing network-signaling characteristics and illustrate network configurations, it is necessary to refer to these manufacturers' equipment. These references do *not* constitute a recommendation of these products or their manufacturers by the Local Exchange Carriers (LECs) or Bellcore. Moreover, the illustrative use of specific manufacturers' products does not imply that similarly equipped products of other manufacturers cannot be used in intraLATA networks.

There are variances among the characteristics of different manufacturers' switching systems. The variances depicted in many of the tables in this section show the operational bounds of existing systems in the intraLATA networks. FR-64, *LATA Switching Systems Generic Requirements (LSSGR)*, presents Bellcore's view of the proposed generic requirements of new LATA switching systems for analysis.

While the *LSSGR* addresses generic requirements for switching systems, *Notes* presents a "how it works" approach. It contains considerable information from the *LSSGR* and standards, intended as examples of how the various switching systems meet or do not meet the requirements at the time of publication, not as another source of standards. Because the *LSSGR* is published more frequently than *Notes*, the material in *Notes* may be out of date the first time any module of the *LSSGR* is republished.

With circuit-associated signaling, the signals are carried on the same facility as the voice path. This is in contrast to Common Channel Signaling (CCS), where the signaling and voice path are carried on separate facilities. Circuit-associated signaling on physical facilities uses metallic conductors to transmit the signals. Circuit-associated signaling on carrier facilities uses inband or out-of-band signaling systems. Inband signaling shares the channel with voice. Single-frequency, Dual-Tone Multifrequency (DTMF), and multifrequency (MF) signaling are all examples of inband signaling. Out-of-band signaling shares the voice channel on the carrier system, but without invading its analog frequency spectrum. Digital carrier is a good example of out-of-band (or, more properly, out-of-slot) signaling. In this case, most of the bits in the bit stream are reserved for voice transmission, while others are shared for signaling.

Access lines connect customer installation (terminal) equipment to a switching system. The access lines can use metallic cable or carrier facilities. Network facilities used to provide

---

---

access lines are described in Section 12. Trunks connect one switching system to another switching system. Trunks also can use metallic cable or carrier facilities.

## 6.2 Analog Access Line Signaling

An analog access line is a 2-wire or 4-wire interface between a customer installation demarcation point or network interface and a switching system (network) across which are transmitted common-battery loop supervision, loop dial-pulse or DTMF address signaling, alerting signals, and voiceband electrical energy. Five classes of signals are used on access lines.

- Call progress signals — These are audible tones or announcements that inform the network customer of call progress.
- Supervisory signals — These signals are the means by which a customer initiates a request for service, holds a connection, or releases a connection. The supervisory signal is also used to initiate and terminate charges for the call. With loop-start operation, the on-hook or off-hook condition of the terminal is detected by the network. There is normally no supervision of the network state (on- or off-hook) at the terminal. With ground-start, however, supervision is maintained in both directions between the terminal equipment and the network to avoid simultaneous seizures of the access line from both ends.
- Control signals — These are used for auxiliary functions associated with equipment connections to the Point of Termination (POT) or demarcation point. Examples are toll diversion and party identification.
- Address signals — These provide information to the network concerning the desired destination of the call (usually the called number).
- Alerting signals — These are supplied by the network to alert the terminal equipment of an incoming call.

An access line usually consists of two conductors called the tip lead and the ring lead. In the idle state, the ring lead is usually negative with respect to the tip lead at the switching system. In the various call states, the switching system may interchange the voltages on these leads. Maintenance activities may also interchange the voltages on these leads temporarily. Connection of a given lead (tip or ring) to the positive or negative side of the battery cannot be ensured at the demarcation point.

Technical requirements of the line interface are detailed in the following documents:

- GR-506-CORE, *LSSGR: Signaling for Analog Interfaces*
- TR-TSY-000222, *InterLATA Dial Pulsing Requirements*, which covers interLATA and intraLATA dial-pulsing (includes single-frequency signaling requirements that are not covered elsewhere)

- 
- TA-NPL-000912, *Compatibility Information for Telephone Exchange Service*
  - ANSI T1.401-1993, *American National Standard for Telecommunications — Interface Between Carriers and Customer Installations — Analog Voicegrade Switched Access Lines Using Loop-Start and Ground-Start Signaling*
  - ANSI T1.405-1996, *American National Standard for Telecommunications — Network-to-Customer Installation Interfaces — Direct-Inward-Dialing Analog Voicegrade Switched Access Using Loop Reverse-Battery Signaling*
  - EIA/TIA 464-B-1996, *Private Branch Exchange (PBX) Switching Equipment for Voiceband Application*
  - ANSI/EIA 470-A-1987, *Telephone Instruments with Loop Signaling.*

### 6.2.1 Loop-Start Signaling

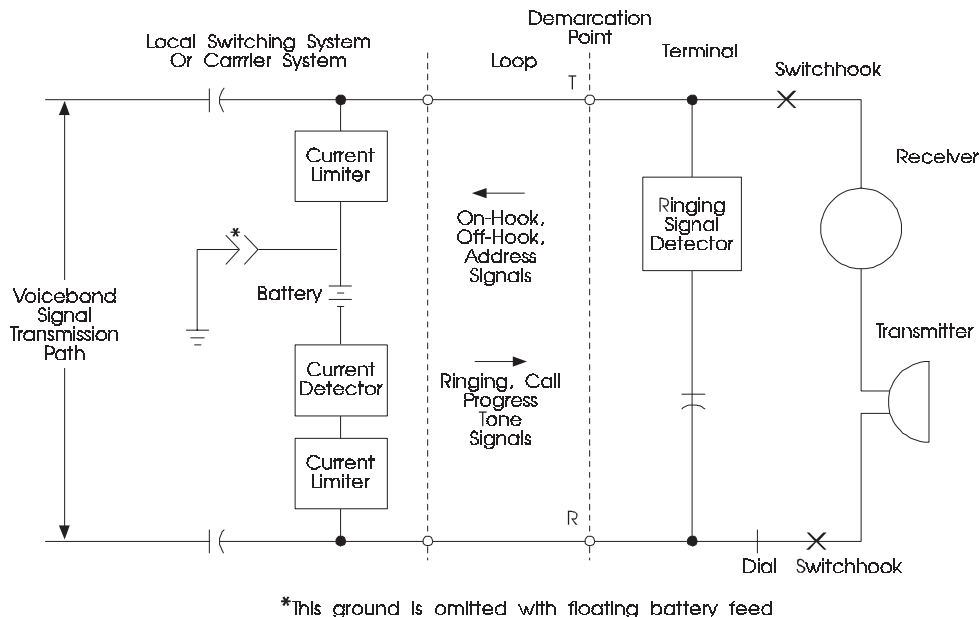
Loop-start signaling is the most common signaling method used on access lines in the public switched network. It is used to provide the following 2-way services:

- Message Telecommunications Service (MTS) for residence and business;
- Public Telephone Service (PTS);
- Data or facsimile service;
- One-way incoming service to an attendant at a Private Branch Exchange (PBX) or Automatic Call Distributor (ACD).

In the loop-start idle or on-hook state of the terminal, the network usually connects the tip conductor to the positive end, and the ring conductor to the negative end of a voltage supply. The positive end may or may not be grounded. For example, the 5ESS switching system uses a floating line supply in some stages of a call, whereas most other switches employ a grounded supply. Digital Loop Carrier (DLC) systems between the switch and the network interface may also use either floating or grounded battery supply.

Figure 6-1 shows the principle of operation of loop-start signaling. The most common voltage on the line is called 48 Volts. 48 Volts is the historical nominal voltage of the network power system that supplied this voltage. Because of the evolution in the design of network power systems, the nominal voltage of a modern 48-V power systems is greater than 48 Volts. Depending on the operating state of the network power system, a 48-V power system may vary between 42.75V and 56.7V. Depending on the network equipment used to provide the access line, the idle state line voltage can be as high as 105V and as low as 0V. The higher voltages are generally from range-extension equipment. Low voltages on the line at the demarcation point during the idle state can be caused by devices inserted in the line to isolate the customers' equipment during the idle state. These devices are known as Maintenance Terminating Units (MTUs). The isolation permits testing the loop without physically removing the connection to the terminal.

In modern LEC networks, the voltage applied to an access line during the idle state will generally be greater than 19V (unless MTUs are used) and less than 80V.



**Figure 6-1.** Principle of Operations of Loop-Start Signaling

When loop-start signaling is used, the terminal appears as a very high resistance to the network during on-hook; hence, an open-circuit condition exists. To initiate a call, the terminal sends an off-hook signal by closing the loop, lowering the tip-to-ring dc resistance<sup>1</sup> and drawing a dc current from the network. The network detects the current as a seizure signal. This process of monitoring the terminal status by the network is called dc loop supervision. The request for service initiated at the calling end is termed a seizure. The response of the network is the application of an ac dial-tone signal superimposed on the dc loop current flowing in the circuit. Dial tone is discussed with other call progress signals in Section 6.20. During failure of primary ac at the serving switching system, the current may drop to 18 mA.

After receiving dial tone, the terminal originating the call will send the address of the called party by either DTMF or dial-pulse signaling.<sup>2</sup> A short description of dial-pulse characteristics is provided in Section 6.10. DTMF is covered in Section 6.13.

1. See ANSI T1.401-1993 or EIA/TIA/464-B-1996 for exact current/voltage characteristic of a terminal. The highest dc resistance that will meet the requirements of ANSI T1.401-1993 or EIA/TIA/464-B-1996 for an off-hook is 330Ω with 20 mA flowing.
2. See ANSI T1.401-1993 or EIA/TIA/464-B-1996 for DTMF and dial-pulse signaling requirements.

---

Most switching systems in the network monitor the time from the beginning of dial tone until the detection of the first address information character. If no address character is received in 5 to 40 seconds, the loop may be connected first to an announcement, then to a Receiver Off-Hook (ROH) tone, and then to an open-circuit condition for up to 1.2 seconds. Some switching systems, like EWSD, open the loop for 800 ms before connecting the line to a recorded announcement. ROH tone is applied after the announcement. The second procedure is specified in the *LSSGR*. If an on-hook signal is received at any time from the terminal and if the terminal remains on-hook, it will eventually be restored to a normal idle state.

The network has historically provided no standard release signal on loop-start lines. Even in switching systems that interrupt loop current as part of permanent signal treatment, range-extension equipment may block this signal from reaching the terminal. Therefore, a terminal for loop-start service should not be designed to solely depend on loop current interrupts in permanent signal treatment as primary disconnect signals. Modern Digital Loop Carrier (DLC) systems do repeat the interruption of loop current. As DLC systems replace older range extension equipment, the interruption of loop current will become a more dependable disconnect signal.

After sending the called-address information, the calling party may hear call progress tones as the call completes to the called terminal. Audible ringing would indicate a successful connection, while tones or announcements would indicate other conditions. Section 6.2.0 discusses call-progress signals.

The called terminal is alerted by a ringing signal, which for one-party service is an 84- to 104-Vrms, 20-Hz, superimposed on 48-V nominal dc voltage. There are also other forms of ringing used in the telephone industry. In these, the ringing frequency can vary from approximately 15 to 70 Hz, with the ac ringing voltage and the dc supervisory voltage varying widely. The ringing and superimposed dc voltage can appear on either tip or ring. The ringing can be tip-to-ring, tip-to-ground, or ring-to-ground. However, the predominate ringing frequency used on one-party lines in modern LEC networks is 20 Hz and the other ringing frequencies are mainly confined to multi-party lines as described in the next paragraph.

Selective ringing (ringing only one party on a multi-party line) is accomplished in two ways. The first method is to change the superimposed voltage from positive to negative. By ringing on the tip or the ring and using positive or negative superimposed voltage, four selective ringing codes can be obtained. This method is used by many of the independent LECs and is the predominant method used in the former Bell Operating Company (BOC) intraLATA networks. The second method is to use several ringing frequencies. Ringing-to-ground can be used. Since 60 Hz is a frequency in one of the ringing systems, this type of ringing is usually applied tip-to-ring in a balanced fashion to prevent false operation of the 60-Hz ringer. Frequency-selective ringing is used in only a few BOCs and in several other LECs.

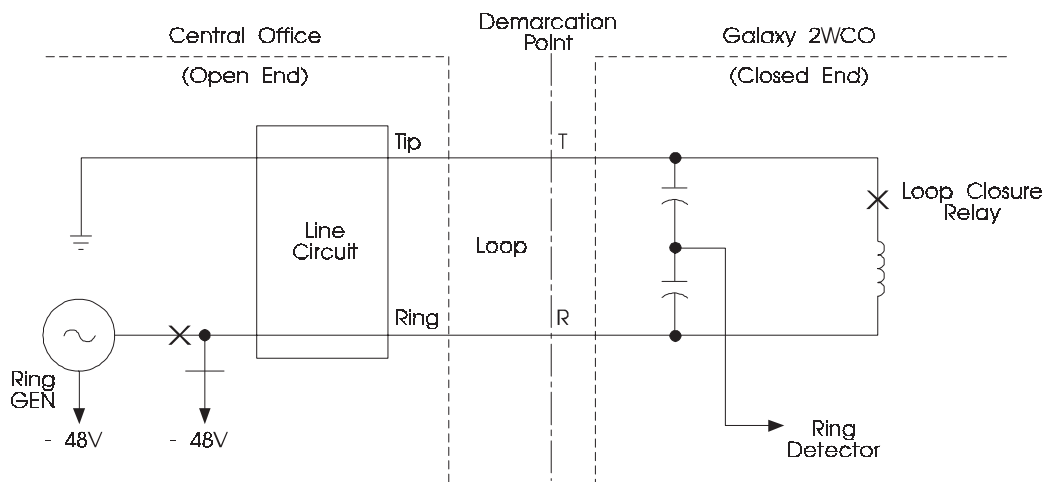
With superimposed-voltage ringing, the ringing signal is applied between tip and ring for most one-party lines. Usually the ringing and superimposed dc voltage are on the ring lead with the tip lead grounded. However, selective 2- or 4-party and semi-selective 4-party or 8-party lines have ringing on either tip- or ring-to-ground.

The ringing signal generally consists of a ringing interval followed by a silent period. The typical silent interval is 4 seconds. As a result, a central office line can be seized for as long as 4 seconds before seizure can be recognized at the station. The person at the station may attempt to originate a call during this interval. This is not normally a problem because the person originating the call from the station end is usually the person to whom the call is being directed. However, ground-start would give a dc signal as soon as the line was seized. This is an important difference between loop-start signaling and ground-start signaling.

The called party answers the ringing signal by going off-hook. This trips (removes) the ringing signal and activates the talking path. The tripping interval is usually less than 200 ms.

A call is ended by the calling or called terminal, or both, going on-hook. This action is called disconnect; it brings the terminal to the idle state when little or no dc loop current flows in the circuit. There is no signal sent from the network to either the called or the calling terminal at disconnect. Section 6.5.3 covers the various methods of control of disconnect.

An example of the terminal end when using loop-start signaling is shown in Figure 6-2. This is the arrangement for a central office PBX trunk (central office line) in a Rockwell Galaxy system.



**Figure 6-2.** Loop-Start Operation on a PBX Trunk (Rockwell)

---

## 6.2.2 Ground-Start Signaling

Ground-start signaling for 2-way dial facilities was introduced in the early 1920s. Its purpose is to reduce the likelihood of seizure of the facility by both ends of the circuit during the silent interval between rings.

Ground-start signaling is typically used on 2-way PBX central office trunks with Direct Outward Dialing (DOD) and attendant-handled incoming-call service. In addition, ground-start signaling is typically used on ACD service and for automatically originated data service.

The ground-start line conductors transmit common battery-loop supervision, DTMF address signaling or loop dial pulses, alerting signals, and voiceband electrical energy. Ground-start lines are often used rather than loop-start for the following reasons.

- They provide a signal that can act as a start-dial signal. It is not necessary to detect dial tone in most situations. (See Section 6.2.2.1.)
- They provide a positive indication of a new call.
- They help prevent unauthorized calls.
- They provide indication to calling or called party of distant-end disconnect under normal operation.

In the idle state, the network applies a negative dc voltage to the ring conductor and keeps the tip conductor open. As Figure 6-3 shows, an office with conventional battery would permanently ground the battery. An office with floating battery would temporarily ground the positive side of the battery supply.

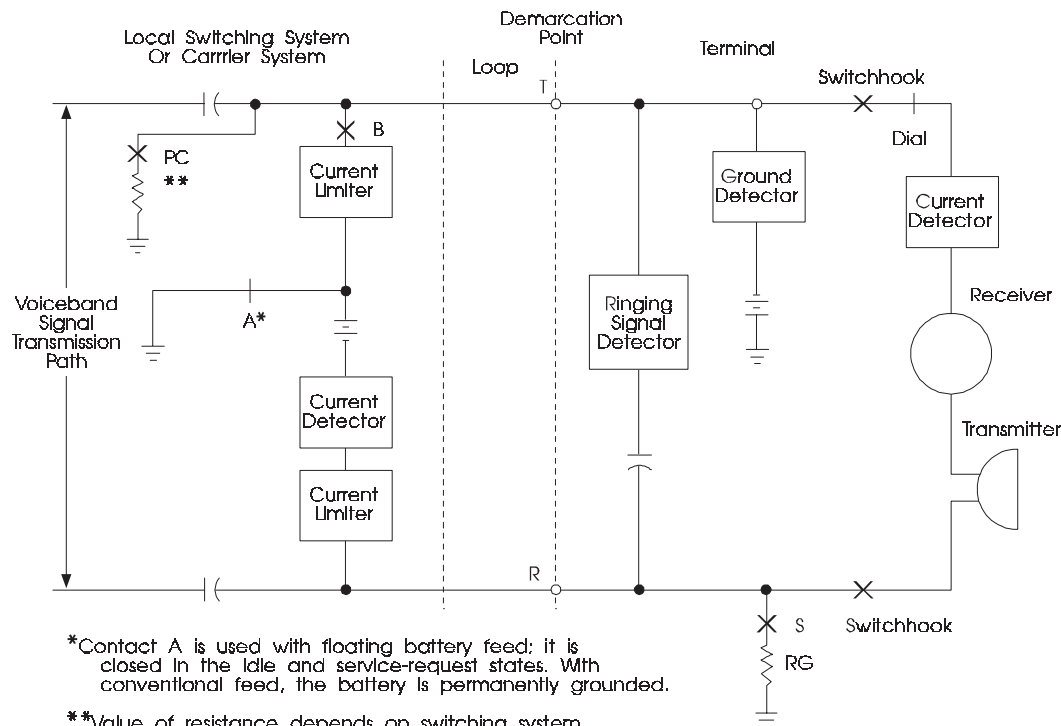
In the idle state, the terminal presents an open circuit tip-to-ring and ring-to-ground. The terminal has a detector connected tip-to-battery to detect a seizure (off-hook) from the network. A typical detector has a resistance of 10,000 to 20,000  $\Omega$ .

To initiate a call, the terminal grounds the ring conductor of the line by operating contact S. The resultant current in the ring conductor is detected by the network. In turn, the network applies dial tone and applies the positive side of the battery to the tip conductor and in switching systems with floating battery, removes ground from the battery supply.

The result is that in switching systems with a conventional battery, the tip is grounded. In switching systems with floating battery, there is a voltage between tip and ring, with ring the more negative, until the line becomes idle again. The terminal will detect the ground on the tip or voltage between tip and ring and close the switchhook contacts and open contact S. This places the terminal in the loop mode.

The terminal stays in the loop mode for addressing, call processing, and communication states. The line reverts to the ground-start mode only after the terminal or network goes on-hook. All actions of the network and terminal described in Section 6.2.1 for a loop-start line apply when a ground-start line is in the loop mode.

---



**Figure 6-3.** Principle of Operation of Ground-Start Signaling

At disconnect, four different combinations can occur. The network or terminal can disconnect first, and the line can have conventional battery supply or floating battery supply. The possible disconnect sequences are as follows.

- When the *network disconnects first* on a line with *conventional battery*, the network removes ground from the tip, which removes current from the line. The terminal waits about 350 ms to determine that the open is a disconnect and not an Open Switching Interval (OSI). It then idles the line in preparation for a new call. Most switching systems guard the line during the disconnect interval; however, some do not, before returning to idle (ready for a new call).
- When the *network disconnects first* on a line with *floating battery*, the network removes battery from tip and ring, which in turn removes current from the line. The network waits a guard time of about 600 ms minimum before returning to idle. The terminal waits about 350 ms to determine that the open is a disconnect and not an OSI. It then starts a line disconnect procedure. The terminal may or may not have a guard time between detecting a disconnect and making the line idle.
- When the *terminal disconnects first* on a line with *conventional battery*, the terminal opens the loop. The terminal holds the line busy until the ground is removed from the

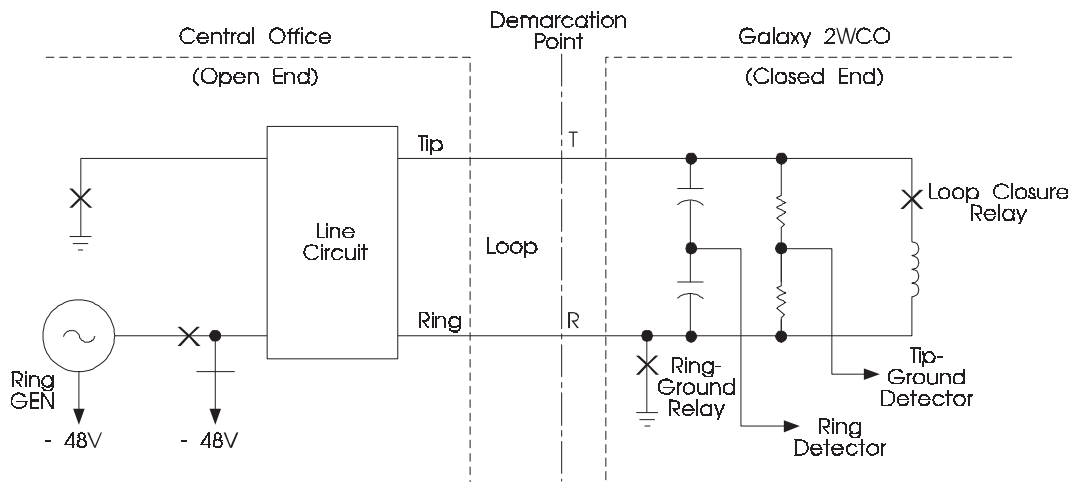


tip. To prevent noise on the line from prematurely idling the line, the terminal may hold the open before returning the line to idle.

- When the *terminal disconnects first* on a line with *floating battery*, the terminal opens the loop. The terminal may hold the line busy for a guard time. The network reapplies ground to the tip conductor within 50 ms of the loop open and then removes the ground from the tip conductor to indicate that the network has returned to the idle state.

To initiate a call to the terminal, the network connects a ringing circuit to the line. This applies ground to tip and negative battery with 20-Hz ringing to ring. Because ringing may or may not be present when the call is initiated, the ground on the tip lead will make the line busy at the terminal. Ringing is used as an alerting signal at the terminal. The terminal answers the call by closing the switchhook contact (Figure 6-4). The network responds by tripping the ringing signal and activating the talking path. The battery supply, as before, may be either conventional or floating. Disconnect is identical to that described for calls originated by the terminal.

An example of the terminal end when using ground-start signaling is shown in Figure 6-4, the arrangement for a 2-wire PBX trunk (central office line) in a Rockwell Galaxy system.



**Figure 6-4.** Ground Start Operation on a PBX Trunk

#### 6.2.2.1 Start-Dial Signal in Ground-Start

There is no single dc signal that can act as a start-dial signal in ground-start without the necessity of detecting dial tone. There are, however, dc signals in each of the switching systems that can perform this function. The first signal is ground on the tip, the oldest of the dc start-dialing signals. It can be used with 5ESS (with restrictions due to floating battery), DMS-10, DMS-100F, and NEAX-61E switching systems. The power cross test in 1/1AESS and 2ESS switching systems causes ground to be connected to the tip before dial

---

tone. Ground on the ring lead from these systems cannot be used as a start-dial signal. However, a second method, a dc voltage between tip and ring can be used as a start-dial signal from these systems. DC voltage between tip and ring can be used as an indication that all network switching systems will be ready to accept address signals within 70 ms.

Dialing can begin 70 ms after the start of dial tone. In some situations ground on tip or ring, dc voltage on both tip and ring, or dc voltage between tip and ring occur simultaneously with dial tone, as follows.

- Ground on tip
  - 5ESS switching system (ground is on the tip for only about 250 ms after the start of dial tone, then is removed for the rest of the call)
  - DMS-10 and DMS-100F systems;
  - EWSD system;
  - NEAX-61E system;
  - DCO system.
- A dc voltage between tip and ring
  - DMS-10 and DMS-100F switching systems;
  - 1/1AESS system;
  - 2ESS system;
  - 5ESS system;
  - EWSD system;
  - DCO system;
  - NEAX-61E system.

A dc test plus timing can be used on all systems in any intraLATA network. Dialing can begin 275 ms after voltage is applied between tip and ring on a ground-start line.

#### 6.2.2.2 Recognition of a New Call

A new terminating call can always be recognized on a ground-start line because there is an off-hook<sup>1</sup> indication from the network and ringing is present on the line. Not all terminal equipment detects the combination of off-hook and ringing from the network as the start of a new call. Some use only the on-hook to off-hook transition of the network. This simpler method is equally effective on lines with floating-battery supply because the network

---

1. Ground on tip and battery on ring on lines with conventional battery feed and voltage between tip (+) and ring (-) on lines with floating battery.

---

guards the line for 600 ms after a disconnect. This provides a guaranteed on-hook interval much longer than any possible OSI for the terminal to recognize. However, there is no guarantee of an on-hook interval on lines with conventional battery supply.<sup>1</sup>

The line can be seized in less than 50 ms after disconnect in switching systems without guard time.<sup>2</sup> Failure to recognize a new call at the terminal causes a call failure known as ring-no-answer. With this failure, the called party hears audible ringing, but the attendant never answers the call.

### 6.2.2.3 Prevention of Unauthorized Calls

Ground-start can prevent unauthorized calls. This is described as follows.

#### 6.2.2.3.1 *Restricted Station*

A restricted station may be connected to a central office by the attendant. The attendant may dial for the station or may allow through-dialing by the station. When the station remains off-hook after the called party disconnects, the station cannot get central office dial tone at the end of the called-party disconnect timing sequence if ground-start operation is used. This occurs because the central office has reverted to the ground-start mode. It requires a ground on the ring conductor to activate the service request sensor (current detector or line furred), whereas the station can provide only a loop closure.

#### 6.2.2.3.2 *Toll-Diversion Signal*

The toll-diversion signal is a reversal of the loop voltage. During the originating call setup period, the battery polarity supplied to the terminal is -48V on ring and ground on tip. The toll-diversion signal is -48V on tip and ground on ring. Most range-extension equipment,

- 
1. The 1/1AESS switching system has a 2-second guard time between calls on ground-start lines when the system that originated the call disconnects first. It does not have guard time between calls when the terminal originates the call or when the terminal disconnects first. The 2/2BESS switching system has a 1-second guard time on disconnect of either ground-start or loop-start lines when the line is marked with a PBX class of service.
  2. A feature in the 1/1AESS and DMS-100 switching systems, Uniform Call Distribution (UCD), helps the recognition of new calls. This feature advances the first-choice selection through the hunting group after each terminating call. For example, if the last call was placed on ground-start line 6, the next hunt for idle ground-start lines will start with line 7, continue to the end of the group, and start over at line 1, if necessary. This action spreads the calls throughout the hunting group. As a result, the probability of placing a new call on a ground-start line just disconnected in the central office but not yet disconnected at the terminal is less than if the group were always hunted from the highest preference to the lowest. This advantage disappears when only one trunk in the group is idle or when ringing is used to recognize a new call.
-

---

including carrier systems, does not repeat the toll-diversion signal. Consequently, toll restriction that does not require a central office signal must be used when range-extension equipment is in the facility.

For toll-diversion purposes, most central office switching systems can be arranged to provide a momentary battery reversal (50-150 ms long) to a dial PBX if a prefix or area code involving toll charges is dialed. This reversal is also sent if the numeral 0 is dialed because the station could request the operator to place a long-distance call.

Toll-diversion as a network service has decreased because modern digital PBXs can be programmed to perform the toll-diversion feature.

### **6.2.3 Open Switching Intervals on Loop-Start-Start and Ground-Start Access Lines**

OSIs may be generated on lines by switching systems as the call is switched from one call state to another. An OSI removes battery and ground from the line (or line voltage in systems that have a floating line voltage supply) for a period of time without meaning a network disconnect of a call. OSIs occur on both loop-start and ground-start services. Generally, OSIs are less than 350 ms, with more than 100 ms between OSIs.

In general, network switching systems can be classified as three types: analog switching systems that use a different circuit to monitor the status of an access line during the idle state than during the communications state (such as the 1A ESS), digital switching systems that use a different circuit to monitor the status of an access line during the idle state than during the communications state (such as the 5 ESS), and digital switching systems that use the same circuit to monitor the status of an access line during all call states.

For analog switching systems that use a different circuit to monitor the status of an access line during the idle state than during the communications state, OSIs can occur upon:

- Connection of calling line to dial tone;
- Completion of sending called-address information by calling line;
- Completion of sending called-address information by originating switching system;
- Change from ringing to silent interval or silent to ringing interval;
- Start and removal (tripping) of ringing;
- Switching a call to a 3-way bridge for custom-calling services, or returning from the 3-way bridge to a normal (talking) condition;
- Switching to call-waiting tone;
- Transferring a call;
- Placing a call on hold;

- 
- Using a 3- or 6-port conference bridge.

On an intraoffice call, the other line or lines connected to the line using the custom-calling services (such as call waiting) will also experience an OSI.

For digital switching systems that use a different circuit to monitor the status of an access line during the idle state than during the communications state, OSIs can occur upon:

- Connection of calling line to dial tone;
- Change from ringing to silent interval or silent to ringing interval;
- Start and removal (tripping) of ringing

For digital switching systems that use the same circuit to monitor the status of an access line during all call states, OSIs can occur upon the:

- Change from ringing to silent interval or silent to ringing interval;
- Start and removal (tripping) of ringing

As stated above, OSIs are less than 350 ms in duration and do not mean network disconnect. In modern LEC networks, most switching systems use an interruption of loop current greater than 600 ms as an indication of network disconnect during the permanent signal disconnect process.

#### **6.2.4 Maintenance Tests Performed on Loop-Start and Ground-Start Access Line During the Idle State**

To maintain the network properly, test signals are periodically applied to an access line at the central office. These tests are performed on loop-start and ground-start signaling access lines. The voltage applied to the terminal equipment in the on-hook state can be up to a maximum of 202 Vdc between the tip and ring conductors, or between either conductor and ground. Maintenance testing signals of up to 45 Vac rms from tip-to-ring, tip-to-ground, and ring-to-ground in the frequency range of 5 to 3800 Hz may also be applied when the equipment is in the on-hook state.

These network maintenance tests are as follows:

- ac signals of less than 10V rms or signals of 24 Hz or 30 Hz superimposed on -70 to +70 Vdc on tip (with ring grounded), on ring (with tip grounded), or on both tip and ring (with respect to ground)
  - ac signals of 10V rms or less, tip-to-ring or tip-to-ground and ring-to-ground at any frequency from 5 to 1000 Hz
  - ground on tip or ring
  - dc voltages from 0 to  $\pm 202V$ , tip-to-ring, or on tip with ring grounded, or on ring with tip grounded, or on both tip and ring with respect to ground
-

- 
- ac signals of 3V rms or less, tip-to-ring, at any frequency from 1000 to 2000 Hz. It is desirable that the customer premises equipment not respond to ac signals of 5V rms or less, tip-to-ring, at any frequency from 1000 to 5000 Hz.

These conditions may be applied during testing. Such tests are applied sequentially; the series of tests may last up to 12 seconds. See ANSI T1.401 for additional information.

### 6.2.5 Tests Made in the Process of Connecting or Disconnecting a Call

Three tests made in the process of connecting or disconnecting a call cause a detectable condition outside the switching system. The tests are made, for the most part, by the 1/1AESS switching system. Not all switching systems use similar tests. Where other systems are intended, they will be specifically mentioned. The 5ESS switching system is discussed separately. The tests can occur on loop-start and ground-start, but not on Direct Inward Dialing (DID) service.

#### 6.2.5.1 Power Cross Test

The power cross test is made before originating and terminating calls. Generally, a power cross test is performed by switching systems that use a different circuit to monitor the status of an access line during the idle state than during the communications state. The 1/1AESS, 2/2BESS, and 5ESS switching systems have a power cross test of the type described. DMS-100F systems do not have such a test. In the NEAX-61E system, the need for the power cross test is eliminated because the system continually scans the line circuits for loop trouble conditions, and removes lines with detected problems from service.

In the 1/1AESS switching system power cross test, an OSI of about 25 to 50 ms precedes the test. The test detects ac or positive dc voltages over 16V as a power cross on loop-start or ground-start lines. To make this test, detectors are placed tip-to-ground and ring-to-ground. The input resistance of each detector is about 18 k $\Omega$  on calls originating from the line. For calls terminating to the line, the ring detector resistance is about 18 k $\Omega$ , while the tip detector resistance is about 36 k $\Omega$ . The test lasts about 50 to 100 ms. Dial tone, battery on the ring, and ground on the tip are connected to the line immediately after the power cross test. The test has caused call failures on calls originating from ground-start lines where the terminal recognizes the 18-k $\Omega$  input resistance of the detector as a grounded tip and proceeds as if dial tone were present.

The power cross test in the 2ESS switching system is the same in loop-start and ground-start lines. The test first places a 632- $\Omega$  resistor tip-to-ring for about 10 to 20 ms. A ground-start terminal connects ground to the ring to start the call. This ground passes through the 632- $\Omega$  resistor to the tip side of the line, grounding the tip side. The test then opens the line with an OSI of 100 to 150 ms. Dial tone, battery on the ring, and ground on the tip are

---

connected to the line immediately after the OSI. As with the 1/1A ESS, this test has caused call failures on originating calls from ground-start lines.

The power cross test in the 5ESS switching system differs between ground-start and loop-start. In loop-start, ground is connected to both tip and ring before dial tone. In addition, OSIs occur. Since these conditions should not cause call failures, they will not be discussed further. In ground-start, OSIs occur before dial tone but there is no connection of either battery or ground to tip or ring. Dial tone, floating battery, and ground on the tip are connected to the line at the same time. The ground on the tip is removed about 250 ms after the start of dial tone. For more details, see Table 6-2.

The EWSD system continuously monitors for ac power cross by means of the loop detector. If a cross is detected, the line is isolated from the line circuit by the Z (disconnect) relay. Automatic retesting occurs periodically at short intervals, and the line is automatically restored to service if it is verified that the power cross fault has been removed.

#### 6.2.5.2 Low Line Resistance Test

The low line resistance test is designed to prevent false charging where irregularities exist in the called line. A check is performed in all switching systems (for example, 1/1AESS, 2/2BESS, 5ESS, DMS-10, and DMS-100F) to ensure that tip-to-ring resistance is high enough to avoid immediate ring trip upon application of ringing. The test is performed prior to ringing in the terminating call sequence. In the 1/1AESS switching system on loop-start lines, the test is made by applying approximately a 250- $\Omega$  ground to the tip and approximately 250  $\Omega$  from battery to the ring. On ground-start lines, the battery and ground are reversed. In other systems, this test on ground-start lines is known as PBX loop test. The PBX loop test is discussed in more detail in Section 6.2.5.3. This test in the 1/1AESS switching system will see a resistance below 6.3 k $\Omega$  as a failure and may see resistances below 17 k $\Omega$  as a failure.

In the EWSD system, the loop detector is more sensitive than the ring trip detector and therefore no special ring pretrip test is required. A false seizure will be detected; the line will end up in the permanent-signal state and therefore appear busy when a terminating call is attempted.

#### 6.2.5.3 PBX Loop Test

The PBX loop test is made on calls to ground-start lines by all network switching systems. It prevents attaching a new call to a terminal before the loop at the terminal is opened. Without this test, a call connected by the network could fail. If the call failed, the calling party would not hear an audible ring because the ringing would be tripped by the closed loop at the terminal. In addition, the calling party would be charged for the call even though it was not completed. This type of failure is called a no-ring no-answer.

---



---

The following is a typical test. Ground is placed on the ring of the line. A detector in series with battery is placed on the tip. If a high resistance (open loop) is detected, the call is completed. If a low resistance is detected, that circuit to the terminal is released and a second circuit is selected. The PBX loop test is made on the second circuit. Any call failing the second test is routed to reorder tone.

The way most central offices select ground-start lines in a hunting group is incompatible with some maintenance or traffic-control activities. The central office generally selects a ground-start line from the most preferred to the least preferred. This means that many more attempts will be made on the most preferred ground-start line than on the least preferred. If the terminal removes several of the most preferred lines from service by placing a low resistance tip-to-ring, these will look idle to the central office but will fail the PBX loop test. Where the second trial locates a line without a tip-to-ring short, calls to the terminal will complete normally. However, as the number of ground-start lines placed out of service by closing tip-to-ring is increased, the number of calls failing both the first and the second trial also increases. Eventually, as the removal of circuits from service continues, all traffic to the terminal will be blocked. To remove a ground-start line in a hunting group from service, a call should be placed from or to that line.

Where range-extension equipment is used in the network, the loop test is not effective. Calls from the network over range-extension equipment, which would have experienced a second trial without range-extension equipment, give no-ring no-answer failures. Such calls are reduced in the 1/1AESS and DMS-100 switching systems when Uniform Call Distribution (UCD) is used.

#### 6.2.5.4 Restore and Verify Test

Generally, a restore and verify test is performed by switching systems that use a different circuit to monitor the status of an access line during the idle state than during the communications state. The restore and verify test is made in 1/1AESS, 2/2BESS, and 5ESS switching systems. It is not made in DMS-10 or DMS-100F systems. Where performed, it is automatically made on a line after the line is involved in a network connection and before it is idled. This test determines if supervision has been returned to the line and if the cutoff contact has been closed. The restore and verify test procedure differs between loop-start and ground-start lines. The 1/1AESS system places a 1000- or 2000- $\Omega$  resistor from the tip to the ring for a loop-start line or between ring and ground for a ground-start line. The test takes about 50 to 100 ms. With loop-start service, the resistance of the line ferrod being tested is approximately 660  $\Omega$  to battery on the ring side of the line, and 660  $\Omega$  to ground on the tip side. With ground-start service, the resistance of the line ferrod is approximately 1320  $\Omega$  to battery on the ring side of the line. The tip side of the line is open.

The restore and verify test is not made in the EWSD switching system because the battery feed is never removed from the line unless the line circuit is faulty. There is no cutoff relay in the loop-start line circuit.

---



### 6.2.5.5 Call Sequences

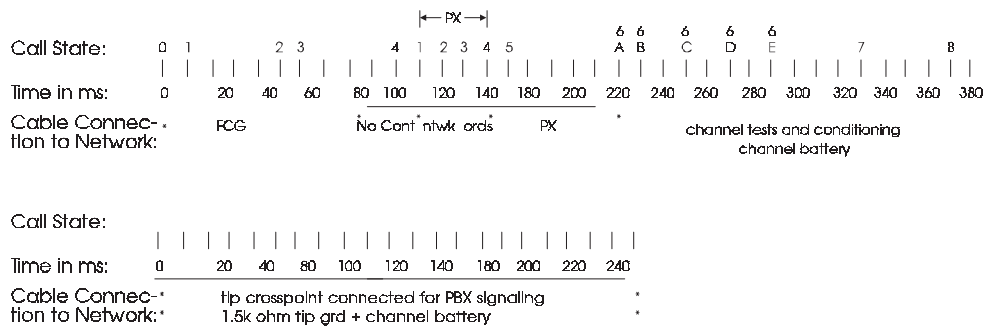
Table 6-1 illustrates the call sequence for an originating loop-start call, using the 5ESS system as an example, from customer off-hook, through line testing, application of dial tone, and testing after dial-tone application. Table 6-2 covers the call sequence of an originating ground-start call through the same stages as the loop-start call, plus the application of ground to the tip of the line for 250 ms after the start of dial tone. Table 6-3 covers the call sequence of a terminating call on either ground-start or loop-start.

**Table 6-1. 5ESS Switching System Loop-Start Originating Call Sequence**

Call State:	0	1	2	3	4	5	6A	6B	7	8	9					
Time in ms:	0	20	40	60	80	100	120	140	160	180	200	220	240	260	280	300
Cable Connection to Network:	*	FCG				No Cont <sup>+</sup> ntwk orders <sup>*</sup>								channel tests <sup>*</sup>		channel battery <sup>*</sup>

#### Call State Details:

- 0: Connect High-Level Service Circuit (HLSC) Gated Diode Crosspoint (GDX) access; close Stage 2 (access) GDX crosspoint; delay 10 ms.
- 1: Perform False Cross Ground (FCG) test; delay 40 ms.
- 2: Read results of first FCG test; delay 10 ms.
- 3: Perform No Continuity test; delay 40 ms.
- 4: Get results of No Continuity test; close first-stage GDX crosspoints; open scan crosspoints; close tip crosspoint if line is served through DLC or is a PBX and class of DLC or PBX requires ground on tip or if Coin First; delay 80 ms.
- 5: Verify scan-crosspoint order; verify scan on-hook; start Loop Start (LS) Power Cross (PX) test; power-up channel (GDX not connected to network yet); delay 50 ms.
- 6A: Get PX results; verify channel on-hook; delay 10 ms.
- 6B: Close Stage 0 GDX crosspoints; delay 10 ms.
- 7: Apply loop bridge (619  $\Omega$  tip-to-ring); delay 40 ms.
- 8: Verify channel off-hook; remove loop bridge; release HLSC GDX access; delay 20 ms.
- 9: Idle HLSC memory; test phone off-hook; enable supervisory scan.

**Table 6-2. 5ESS Switching System Ground-Start Originating Call Sequence****Call State Details:**

- 0: Connect HLSC GDX access; close second stage (access); delay 10 ms.
- 1: Perform FCG test; delay 40 ms.
- 2: Read results of FCG test; delay 10 ms.
- 3: Perform No Continuity test; delay 40 ms.
- 4: Get results of No Continuity test; close first-stage GDX crosspoints; open ring-scan crosspoints; set HLSC start of GS power-cross (PX) test; delay 10 ms.
- PX: Set values for PX test and connect HLSC relay access.
- 5: Verify scan-crosspoint orders; verify scan on-hook; activate GS PX test; power-up channel (channel not connected to GDX network yet); delay 50 ms.
- 6A: Begin channel discharge; open first-stage GDX crosspoint; disconnect HLSC GDX access; get PX results; verify channel on-hook; power-down channel but keep break circuit closed; set HLSC; delay 10 ms.
- 6B: Close Stage 0 GDX crosspoints; close HLSC GDX crosspoints; delay 20 ms.
- 6C: Add 618-Ω bridge for faster channel discharge; delay 20 ms.
- 6D: Open channel-break circuit; set HLSC tip voltage.
- 6E: Remove HLSC; delay 40 ms.
- 7: Open HLSC relays; apply loop bridge; delay 40 ms.
- 8: Remove loop-bridge order; disconnect HLSC GDX access; delay 20 ms.
- 9: Idle HLSC memory; enable supervisory scan; close first-stage GDX crosspoints.

Subsequent to completion of the process, another process will power-up the channel, connect the tip-scan crosspoint (signal the PBX to convert from ring-ground to loop supervision), connect a digit receiver, and apply dial tone. The tip-scan crosspoint remains connected for 250 ms, during which time the PBX is expected to convert to loop supervision. The 5ESS switching system will accept digits from the PBX 70 ms after the tip ground is applied.

**Table 6-3. 5ESS Switching System Terminating Call Sequence**

Call State:	1	2	3	4	5	6	7	8										
Time in ms:	0	20	40	80	100	120	140	160	180	200	220	240	260					
Cable Connection to Network:		FCG		*No Cont*	*N		PX		*H*	Low Line Resistance								
									*L*	(LLR) test; -40 V R grd								
									*S*	200Ω 6mA Ring								
									*C*****	delay								
									*****									
Call State:							9	10	11	12	13	14						
Time in ms:							280	300	320	340	360	380	400	420	440	460	480	500
Cable Connection to Network:							Low Line Resistance							channel tests			*	
							test continued							channel battery			*	
																	*	

**Call State Details:**

- 1: Connect HLSC GDX access; close second stage (access) GDX crosspoint.
- 2: Perform FCG test; delay 40 ms.
- 3: Read results of first FCG test; delay 10 ms.
- 4: Perform No Continuity test; delay 40 ms.
- 5: Get results of No Continuity test; close first-stage GDX crosspoints; open scan crosspoints except for tip if line is served through DLC or is a PBX and class of DLC or PBX requires ground on tip; delay 10 ms.
- 6: Verify scan crosspoint orders; start PX test; delay 50 ms.
- 7: Check PX results; delay 10 ms.
- 8: Start pre-trip test; delay 170 ms.
- 9: Check pre-trip results; power-up channel (not yet connected to network); delay 40 ms.
- 10: Verify channel is on-hook; connect channel to GDX access network; delay 10 ms.
- 11: Connect loop bridge; delay 40 ms.
- 12: Verify channel is off-hook; open channel break circuit and power-down; delay 30 ms.
- 13: Remove loop bridge; open channel GDX access crosspoints; if GS or line is served through DLC or is a PBX and class of DLC or PBX requires ground on tip, open tip; delay 20 ms.
- 14: Select ringing configuration and start ringing.

### 6.2.6 Coin Collect and Coin Return

Coin collect usually uses +130 V negative-grounded potential, and coin return uses -130 V positive-grounded. However, there are a few locations using -130 for coin collect and +130 for coin return. The circuit (in simplified form) for collecting and returning coins over a customer's line is shown in Figure 6-5. Where  $\pm 130$  V is used, a current limiter or series dropping resistor is added to the circuit. The value of the resistor is chosen so there is approximately a 20-V drop across it when collecting or returning coins.

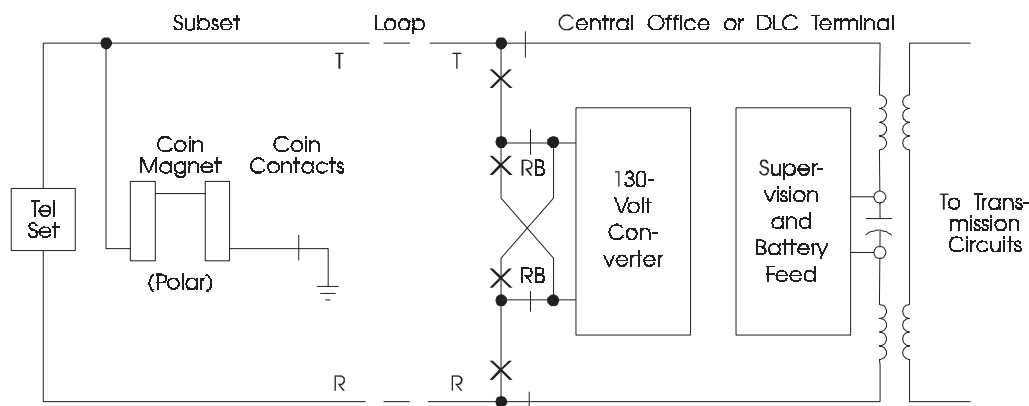


Figure 6-5. Coin Collect and Return Circuit

The coin mechanism is polarized and diverts the coins in one direction to collect and in the other to return. Contacts connect the coin magnets to ground when a coin is deposited. Operation of a coin return signal from an operator-services system or automated coin-service system disconnects the talking battery and connects T to -130V. A coin-collect signal connects +110 V to T. The collect or return signals are applied for a minimum of 350 ms. The minimum current required to operate a coin relay is 41 mA.

Carrier facilities normally are used between the operator and the serving office. The methods of transmitting these signals on carrier facilities are described in the sections on Operator Services Position System (OSPS) and the TOPS systems, coin control signals (Section 6.17). OSPS is a feature of the 5ESS switching system, while the TOPS system is a feature of the DMS-100/200F system.

### 6.2.7 Showering

Showering is a condition that occurs when the line current is of such a magnitude that it is sufficient to operate the line current sensor, but insufficient to operate the customer dial-pulse register current sensor (register relay or ferrod). The condition occurs because the line leakage resistance is too low, or terminal equipment draws more current than it should in the on-hook condition. The result is that the control circuits continue to attempt to connect

---

the line to the dial-pulse register while the dial-pulse register repeatedly releases the line as if the call were abandoned.

Showering lines are a problem in all switching systems that use line current sensors for call recognition and then switch to sensors in the dial-pulse register to supervise during the dialing interval. In electronic systems, the switching system will automatically remove the line from service. The EWSD system, among others, solves the showering problem by using the same loop current sensor throughout the call setup.

### 6.2.8 Direct Inward Dialing

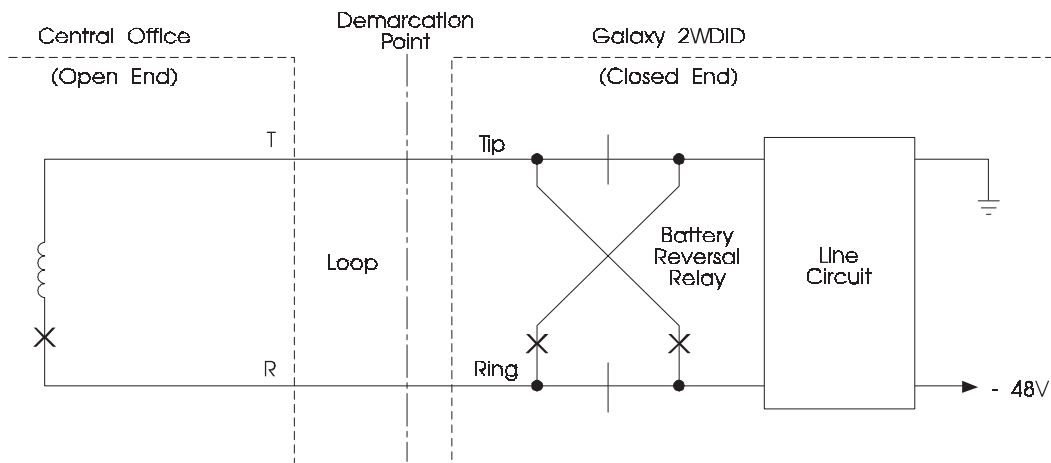
DID provides for direct-dial access to PBX stations (or radio paging or voice mail systems, etc.) from public network stations. DID requires transmission of address signals from the network to the terminal. Wink-start or delay-dial supervisory control of address signals can be used, depending on the serving switching office. In addition, loop reverse-battery supervision is used. While either loop or battery-and-ground dial pulsing is used for address signals, other forms of signaling such as multifrequency or DTMF are available. DTMF signaling to a PBX is a feature of the 1/1AESS, DMS-10, and DMS-100F switching systems. The DMS-10 system, Generic 301.80 or later, allows for multifrequency and DTMF address signaling if the DTMF IN-OUT pulsing option has been provided. The DMS-200-type systems cannot be upgraded to provide this feature. The EWSD system provides DID using dial-pulse or DTMF signaling. The NEAX-61E system provides DID using dial-pulse, multifrequency or DTMF address signaling and loop or E&M supervisory signaling. Although DID is considered line signaling, DID uses signaling identical to that of a 1-way outgoing trunk. In fact, most DID circuits connect to the trunk side of the switching system. The principles used in DID signaling are covered in the following sections.

Section	Title
6.5.5	Immediate-Dial
6.6.1 - 6.6.3	Delay-Dial
6.6.4	Wink-Start
6.7	Loop Signaling
6.7.1	Reverse-Battery Signaling
6.7.2	Battery-and-Ground Signaling
6.10	Dial-Pulsing

Any switching system that can provide tandem connections can provide DID service. This includes 1/1AESS, 4ESS, 5ESS, DMS-10, DMS-100F, EWSD, and NEAX-61E switching systems. A feature for making DID trunks busy automatically is available for 1/1AESS and 2ESS switching systems. All require a control circuit from the PBX to the central office to

---

signal when a local power failure or PBX processor failure occurs. The PBX connects the tip and ring of the pair together when conditions are normal, but the 5ESS, DMS-10, DMS-100, and EWSD systems do not have this feature. However, all have off-hook make-busy, which can be used to busy-out DID trunks from the PBX. An example of the terminal end when using loop reverse-battery signaling is shown in Figure 6-6. This is the arrangement for a DID circuit in a Rockwell Galaxy system.



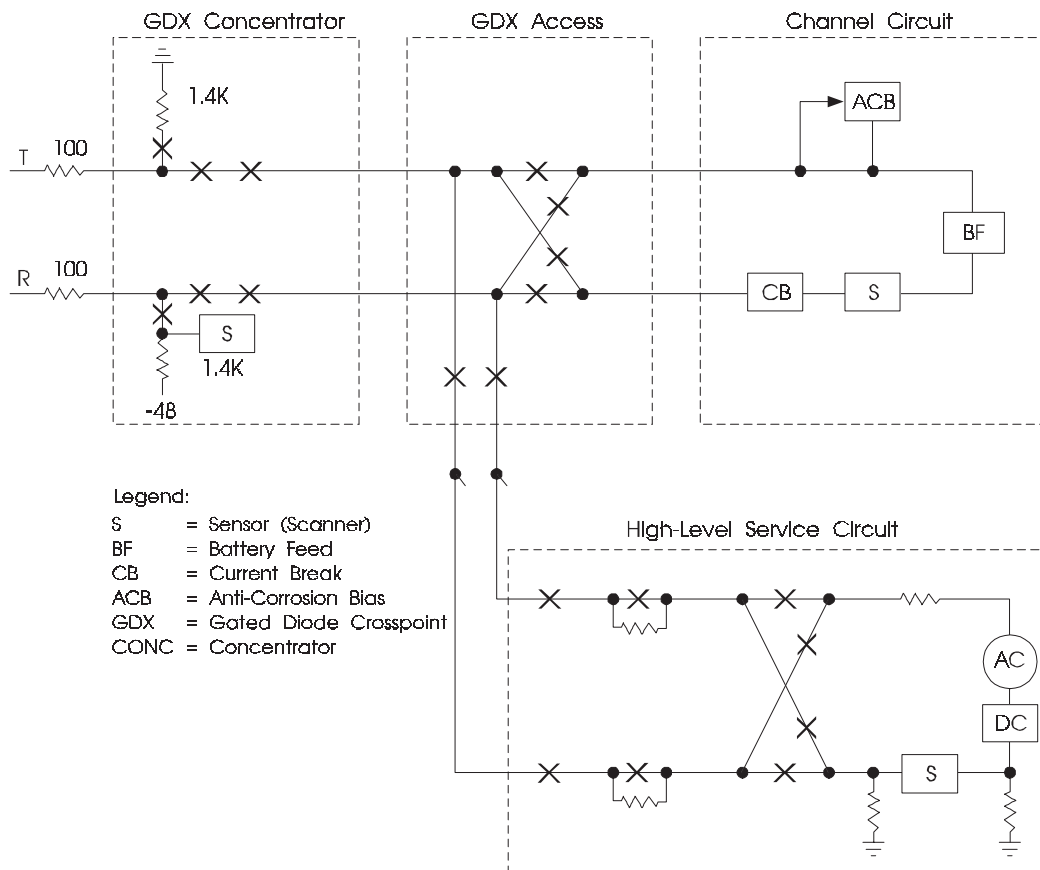
**Figure 6-6.** Loop Reverse-Battery Signaling for DID

DID also provides direct-dial access to Centrex stations from the public network. In this case the traffic is carried to the Centrex on network trunks. The supervision and address signaling use any of the methods offered by the offices involved.

### 6.3 Switching System Interfaces to Access Lines

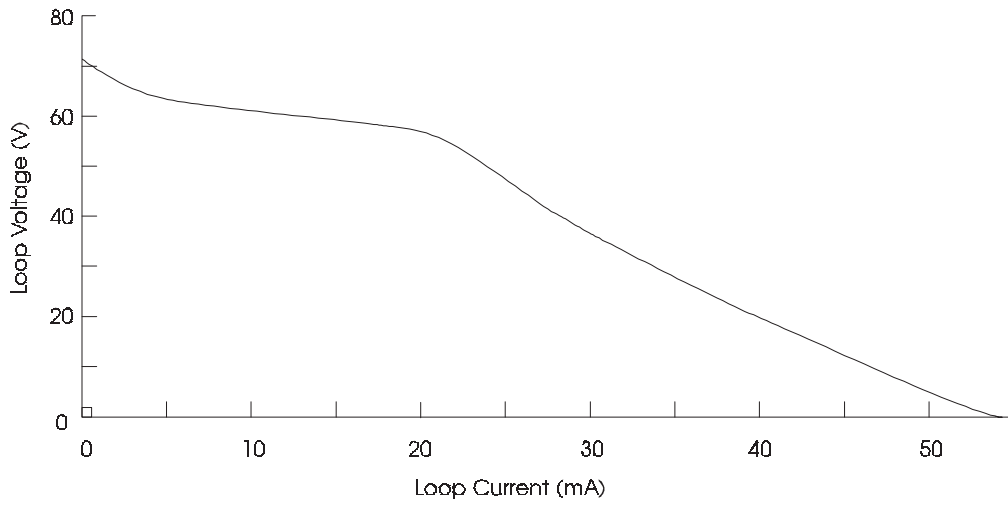
This section provides several examples of switching system interfaces to loop-start and ground-start access lines.

Figure 6-7 shows a 5ESS switching system Gated Diode Crosspoint (GDX) line-unit battery feed and supervision arrangement. The GDX concentrator contains the line concentrator, the line scanner, and the battery supply for the line scanner.



**Figure 6-7.** 5ESS GDX Line Unit, Battery Feed, and Supervision

The 1.4-k $\Omega$  resistor in this circuit is the ground applied during the first 250 ms of dial tone on a ground-start call. The battery for the GDX concentrator is a grounded supply. The High-Level Service Circuit (HLSC) also uses a grounded battery for ringing and testing. The channel circuit supplies floating battery for talking, dialing, supervision, and testing. Figure 6-8 shows voltage versus current characteristic for the 5ESS channel circuit. It shows the voltage measured at the main distributing frame with a battery voltage of -52.5V. The channel circuit has a line current supply in the talking condition with an anticorrosion circuit that will sink up to 15mA to hold the tip lead 0 to -5V with respect to ground.



**Figure 6-8.** Loop Voltage Versus Current, 5ESS Line Circuit



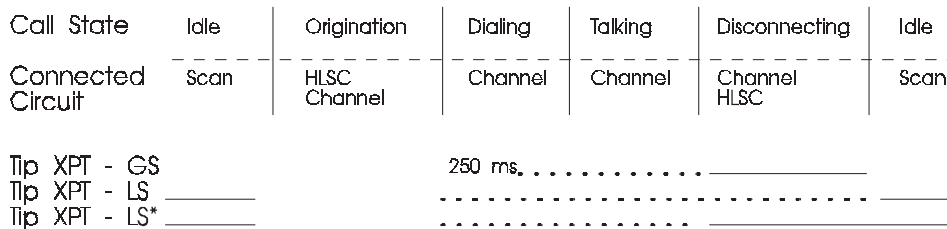
Tables 6-4 and 6-5 show which portion of the 5ESS switching system line unit is supplying battery at the various stages of the call.

**Table 6-4. Battery Supply — 5ESS Switching System**

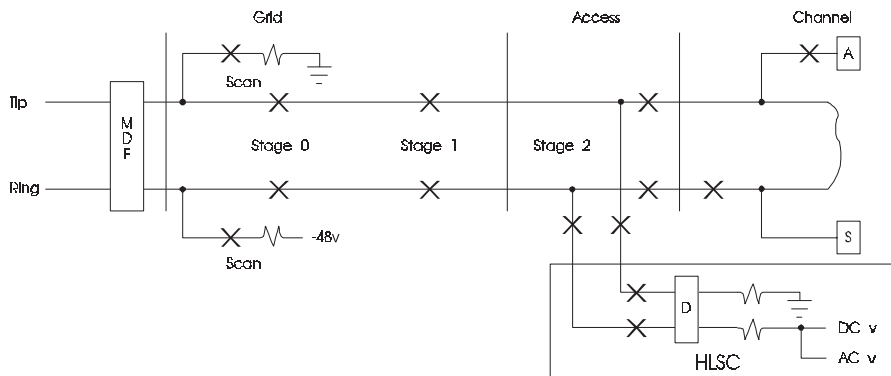
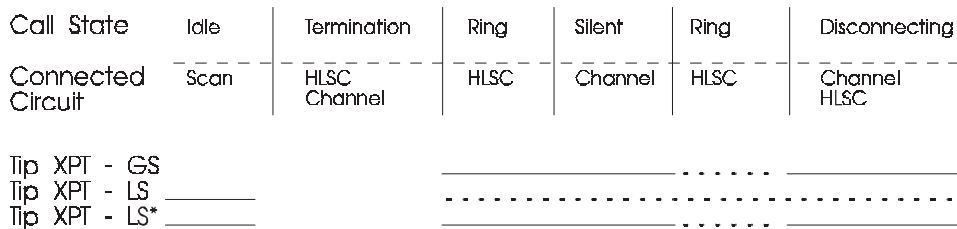
Scanner	Channel	High-Level Service Circuit
Idle Line	Dialing	FCG Tests
PBX Signaling	Talking	Power Cross (PX) Tests
Permanent Signal	Disconnect Timing	Per-Call Channel Tests
Line Test	Line Flash	Ring Pre-trip Tests
	Line Test	Ringing Generator
		Ringing Continuity
		Party Tests
		Coin Functions
		Restore and Verify Test
		Channel Diagnostics
		Fabric Exercise
		Office-to-Office Tests

**Table 6-5.** Battery Connections in Call Processing — 5ESS System

ORIGINATION SEQUENCE



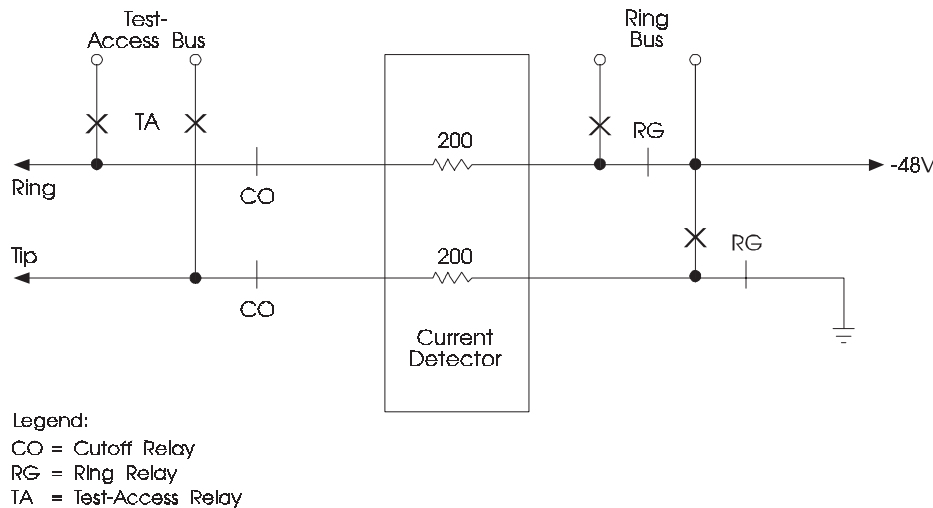
TERMINATION SEQUENCE



Legend:

- A = Anticorrosion Bias
- D = Current Threshold Detector
- FCG = False Cross and Ground
- GDX = Gated Diode Crosspoint
- GS = Ground Start
- HLSC = High-Level Service Circuit
- LS = Loop-Start
- PX = Power Cross
- S = Supervisory Detector
- XPT = Crosspoint
- \_\_\_\_\_ = Tip crosspoint closed
- = Tip crosspoint closed if ground on tip during dialing and talking
- \* = Service Class PBX

Figures 6-9 and 6-10 show DMS-100 10-line circuit cards. Figure 6-9 shows a line card for a loop-start line. The line card illustrated in Figure 6-10 is for a combination loop- or ground-start line that may be used for coin or other special applications (note option switch). Another line card with +48 V loop- or ground-start adds a “+48 V” relay to the circuit of Figure 6-10. When operated, it transfers the ring battery feed from -48 V to ground, and shifts the tip battery feed from ground to +48 V. Analog-to-digital (A/D) and digital-to-analog (D/A) conversion are contained in the line circuit chip. The circuit loss is software-adjustable.

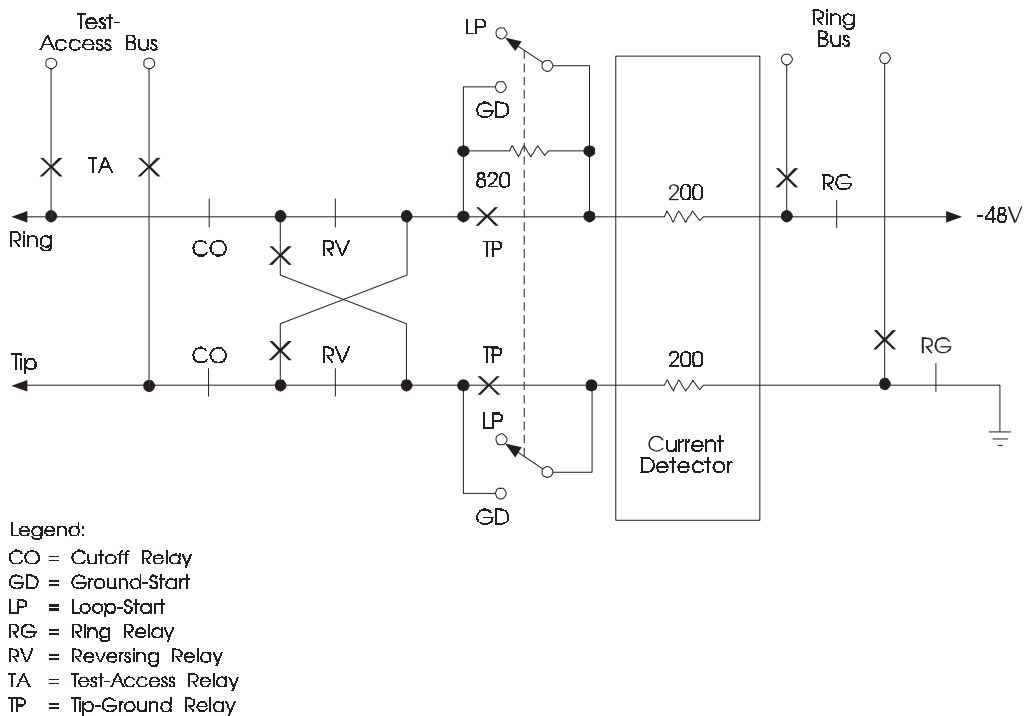


**Figure 6-9.** DMS-100 Switching System Loop-Start Line, Battery Feed, and Supervision

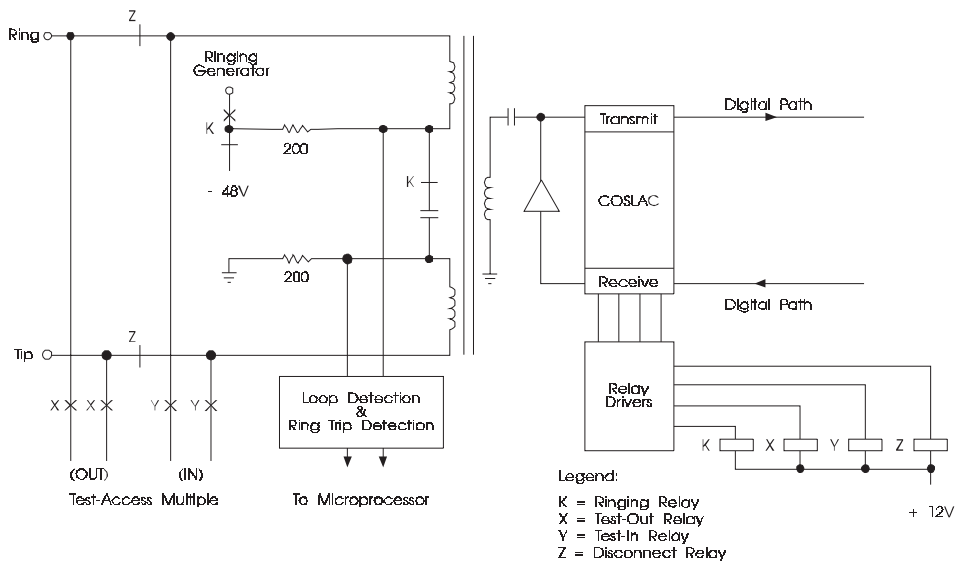
Figure 6-11 shows a simplified schematic diagram of the analog line circuit for single-party lines that is part of the Siemens EWSD switching system. Other line circuit designs are available for such special functions as 2-party, coin, or ground-start lines. These have battery-feed arrangements similar to that of the single-party line circuit.

A/D and D/A conversion of speech is done by a Siemens' Customer Optimized Subscriber Audio Processing (COSLAC) chip, which is programmable for such functions as transmit level, receive level, time slot assignment, hybrid balance, etc. Other chip outputs control relay drivers for such functions as ringing application, test-access switching, or line disconnection.

As seen in Figure 6-11, the battery-feed resistors are connected to the subscriber line tip and ring conductors at all times except when the line is purposely disconnected from the line circuit (that is, the line circuit is in a *precutover* state or the line circuit is isolated from a foreign potential present on the line). This single-source battery-feed arrangement eliminates most of the Open Switching Intervals (OSIs) described in Section 6.2.3.



**Figure 6-10.** DMS-100 Switching System Loop- and Ground-Start Line, Battery Feed, and Supervision



**Figure 6-11.** EWSD Switching System — Single-Party Line Circuit

Figure 6-12 shows the NEC NEAX-61E switching system 8-circuit line card. It provides A/D and D/A conversion, test access and ringing, overvoltage protection, padding, loop balance and 2- to 4-wire conversion. The 8LC is used for ordinary loop-start service, while a more complex 4-circuit card (4LC) is used for coin, ground-start, or other special circuit applications. The 4LC adds a polarity-reversing relay, a  $\pm 130V$  coin-control feed on the tip lead, a relay feeding +48V on the tip in place of ground and simultaneously charging the feed to the ring from -48V to ground, and +48V and -48V ground detectors.

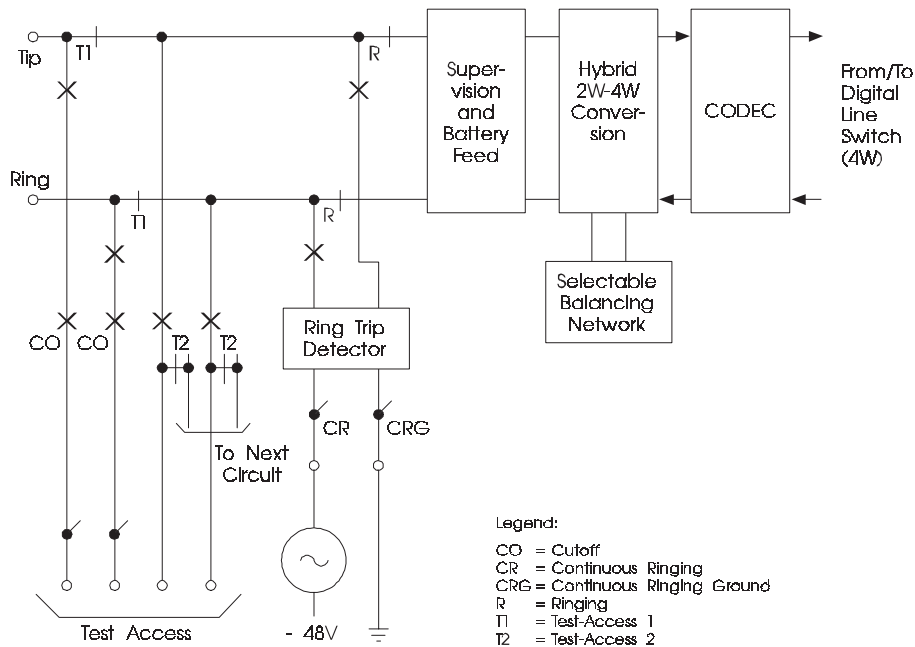


Figure 6-12. NEAX-61E Line Card, Eight Loop-Start Lines

---

## 6.4 Interoffice In-Band Analog Signaling

This section describes in-band analog interoffice signaling for operator and customer call setup.

The use of circuit-associated interoffice in-band analog signaling call-completion and call-supervision methods and techniques covered in Sections 6.5 and 6.6 have almost become obsolete in modern LEC interoffice networks. Their use has been replaced by Common Channel Signaling (CCS) methods described in Section 6.23. In general, in-band analog signaling call-supervision methods are encountered only in special applications, such as operator system trunks, E911 trunks, and busy-verification trunks. In addition, the physical dc-signaling interfaces described in Sections 6.7 through 6.9 are also almost non-existent in modern LEC interoffice networks. They have been replaced by direct digital interfaces to switching systems and other network elements. In general, the dc-signaling physical interfaces will only be encountered on connections to small step-by-step switching systems that may still be present in LEC networks. The ac call-progress signals (such as line busy signals) are still used, but in most cases, they are applied by the originating office rather than traversing the interoffice network from the terminating office.

The names given for the various signals (see Table 6-6) are those that are well established by general use. A few alternative terms having considerable use are shown in parentheses in the table. The direction of each signal, the indication given to the customer or operator, and the on- or off-hook classification of the signal are shown where applicable.

**Table 6-6. Signals Required in Dialing Through the Network**

Name of Signal	On-Hook	Off-Hook	Direction		Use or Meaning	Indication		See Note
			Calling End	Called End		To Customer	To Operator	
Connect (Seizure)		√	→	→	Requests service and holds connection			
Dial Tone			←	←	Equipment ready for dialing	Steady tone	Steady tone	
Disconnect	√		→	→	No service desired Message completed Release connection		Calling supervisory lamp lighted	
Answer (Off-Hook)		√	←	←	Called party answered. Charge timing begins and depends on this signal.		Called supervisory lamp dark	
Hang Up	√		←	←	Called party releases. Message completed			
Delay-Dial (Delay Pulsing)		√	←	←	Called end not ready for digits		Start-dial or KP forward lamp dark	
Wink		√	←	←	Called end not ready for digits		Start-dial or KP forward lamp dark	
Start-Dial (Start Pulsing)	√		←	←	Called end ready for digits		Start-dial or KP forward lamp lighted	
Dial Pulsing (DP)	√	√	←	→	Indicates called number			
Dual-Tone Multifrequency Pulsing			→	→	Indicates called number			
Multifrequency Pulsing (MF) Keypulse (KP)			→	→	Prepares receiver for digits			
Digits			→	→	Indicates called number			
Start (ST)			→	→	Indicates that all necessary digits have been sent			
Start Identification (Automatic Number Identification (ANI))		√	←	←	Indicates that Centralized Automatic Message Accounting (CAMA) sender is ready to receive calling number			
ANI Outpulsing Keypulse (KP)			→	→	Prepares CAMA sender for digits			
Identification Digits			→	→	Indicates if service-observed, whether identification is automatic or operator, ANI failure, hotel/motel, mobile, coinless public telephone, etc.			
Digits			→	→	Indicates calling number, if sent			1
Start Pulse			→	→	Indicates all digits sent			
Line-Busy Tone			←	←	Called line busy	60-Interruptions per min (IPM)	60-IPM tone	
Reorder Tone and No Circuit (All Trunks Busy)			←	←	All paths busy All trunks busy Blockage in equipment Incomplete registration of digits	120-IPM tone	120-IPM tone	2
Ringing			→	→	Alerts called customer to incoming call	Bell rings or other alerting signal		3



**Table 6-6.** Signals Required in Dialing Through the Network (Continued)

Name of Signal	On-Hook	Off-Hook	Direction		Use or Meaning	Indication		See Note
			Calling End	Called End		To Customer	To Operator	
Audible Ringing			←		Called station being rung or awaiting operator answer			
Ring Forward (Timed Wink)	√			→	Recalls operator forward to connection		Steady or flashing lamp	4
Ringback (Untimed)	√		←		Recalls operator backward to connection		Lighted lamp for duration of ring	
Ringing Start				→	Starts ringing when terminating equipment is of controlled ringing type			
Wink-Off	√		←		Release customer from operator trunk			
Reverse Make-busy		√	←		Make busy from far end of trunk			
Coin Collect			←		To collect coins deposited in coin box			
Calling Card Service Tone			←		Indicates caller may dial billing number			5
Coin Collect Tone			→	←	Indicates coin collect signal is being sent to coin box		Low tone or no tone	
Coin Return			←		To return coins deposited in coin box			
Coin-Return Tone			→	←	Indicates coin return signal is being sent to coin box		High tone or no tone	
Coin-Denomination Tone			→		Indicates numbers and values of coins deposited in box		Tones from gongs or oscillator in coin box	
Class-of-Service Tone			→		Indicates to operator class of service of calling customer's line		High, low or no tone	
Recorder Warning Tone			→	←	Indicates telephone conversation being recorded		1400-Hz tone of 0.5-second duration applied every 15 seconds	
Alerting Tone			←		Indicates that operator has come on line (emergency interrupt on a busy line verification call)		440-Hz tone for 2 seconds followed by 1/2 second of tone every 10 seconds	
Recall (Customer Flashing)	√	√	→	←	Manually recalls operator to connection		Flashing lamp	

**Note 1.** — A Start Signal (ST) pulse may not be sent on calls by multiparty customers or in the case of identification failure.

**Note 2.** — Conditions producing a 120-Impulses Per Minute (IPM) tone signal apply to facilities that are engineered relatively liberally; hence, the probability of an immediate subsequent attempt succeeding is good.

**Note 3.** — Ringing of the called station should be started automatically upon seizure of the called terminal.

**Note 4.** — No effect unless inward operator is at terminating end of the connection.

**Note 5.** — 60 ms of 941 + 1477 Hz (number tone) and 940 ms of 350 + 440 Hz (dial tone). This signal decays exponentially with a time constant of 200 ms.

Applications of several of these signals are listed in Table 6-7 for a dialed connection switched through two intermediate offices in addition to the originating and terminating offices. Calls can, of course, be switched through more or fewer offices.

Section 6.5 describes on- and off-hook signals from a technical viewpoint, and how they are used in signaling systems. This section also includes the requirements for sender and register timing intervals.

The signaling, carrier, and switching systems referred to in this section are manufactured by Lucent, NEC, Nortel, Alcatel, Ericsson, and Siemens Stromberg-Carlson. There are many systems of other manufacturers in use throughout the industry. Some of these differ appreciably in design, but are comparable with the equipment described in this section.

Digital carrier systems (for example, T1) have an integral signaling system that makes use of one of the code bits associated with each channel for trunk signaling. These systems can interconnect with E&M lead, loop reverse-battery, and foreign-exchange signaling. They can also connect directly with switching systems that have a digital carrier trunk feature.

---

## 6.5 On- and Off-Hook Signals

A number of interoffice signals are classified as on-hook, off-hook, or a sequential combination of the two. The terms were derived from the position of an early telephone receiver in relation to the mounting (hook) provided for it. If the station is on-hook, the conductor loop between the station and end central office is open and no current is flowing. For the off-hook condition, there is a dc shunt across the line and current is flowing in the loop. For more information on interoffice signaling see GR-506-CORE, *LSSGR: Signaling for Analog Interfaces*.

These terms are also convenient to designate the two signaling conditions of a trunk. Usually, if a trunk is not in use, the offices at both ends are sending an on-hook signal. Seizure of the trunk at the calling end sends an off-hook signal toward the called end. If a trunk is awaiting an answer from the called end, the called end is signaling on-hook toward the calling end. Answer of the call sends an off-hook signal back toward the calling end. However, one-way trunks using delay-dial operation with loop reverse-battery signaling can send off-hook toward the originating office when idle.

Both off- and on-hook signals, when not used to convey address information, are often referred to as supervisory signals or simply as *supervision*. A sequence of alternating on- and off-hook signals (dial pulses) occurring within a specific time duration may be used to convey address information.

The various on- or off-hook signals are shown in Table 6-6. The direction of transmission of each signal is also shown. The following factors help in determining the significance of a signal in addition to information in the table.

- Duration — The on-hook interval of a dial pulse is shorter than an on-hook disconnect signal transmitted in the same direction.
- Relative time of occurrence — A delay-dial, off-hook signal occurs before any digits have been sent, while the answer off-hook signal occurs after all digits have been sent. Although both signals are transmitted in the same direction and both are off-hook, they are distinguished by the relative time of their occurrence.

**Table 6-7. Signals Used in Dialing Through the Network**

Name of Signal	Calling Station	Originating End Office	Originating Tandem Office	Terminating Tandem Office	Terminating End Office	Called Station	Notes/Remarks
Connect (Seizure)	→	→	→	→	→	→	1
Disconnect	→	→	→	→	→	→	1, 2
Answer (Off-Hook)		←	←	←	←	←	2, 3, 4
Hang-Up (On-Hook)		←	←	←	←	←	2, 4
Delay-Dial (Delay Pulsing)		←	←	←	←		As required
Start-Dial (Start Pulsing)		←	←	←	←		
Wink-Start		←	←	←	←		
Dial Tone	←						
Called-Station Identity	→						
DTMF Pulsing	→	→	→	→	→		5
Dial Pulsing (DP)	→	→	→	→	→		5
Multifrequency (MF) Pulsing	→	→	→	→	→		
Calling-Station Identity (CAMA) Verbal (Interim) MF Pulsed Digits		→	→	→	→		Operator Identification Automatic Identification } CAMA
Line Busy	←						
Reorder (Tone & SIT)	←						6
No Circuit (NC Tone & SIT) (Intertandem)	←		←				6
Ringing						→	
Audible Ringing	←						
Ringing Start				→	→		As required
Recorder Warning Tone						→	As required
Announcements	←						6, 7

**Note 1.** — In ground-start operation, the connect and disconnect signals extend to the called station. In loop-start, these signals extend only to the terminating end office.

**Note 2.** — This signal is relayed from office to office.

**Note 3.** — Used in charging control.

**Note 4.** — Answer supervision must be returned to the office where charging is located. It is desirable to return real or simulated answer supervision to the originating office in all cases.

**Note 5.** — Connection must be established before remaining or regenerated digits are sent ahead.

**Note 6.** — May originate at any one of the indicated offices.

**Note 7.** — Announcement may be by machine (recorded announcement) or operator.

---

### 6.5.1 Connect (Seizure)

A connect signal is a sustained off-hook signal sent toward the called end of a trunk following its seizure. This signal is the means by which the calling end requests service. The signal continues as long as the connection is held. Momentary interruptions in the connect signal caused by dial pulses are ignored as far as the connect and disconnect functions are concerned. To avoid double seizures (that is, simultaneous seizure from both ends), a connect signal must be sent immediately upon seizure of a 2-way trunk to make it busy at the other end. Simultaneous seizure of a 2-way trunk from both ends is called *glare*.

### 6.5.2 Answer (Off-Hook)

#### 6.5.2.1 Charge Delay

When the called customer answers, an off-hook signal is sent toward the calling end to the office where automatic charging takes place. For charging purposes, the answer off-hook signal is distinguished from off-hook signals of shorter duration by the requirement that it be continuous for a minimum interval ranging from 2 to 5 seconds. The minimum value stated in the *LSSGR* for an off-hook signal that should be recognized as an answer signal for charging and supervision purposes is 2 seconds.

Most trunks when idle, and all trunks when awaiting the customer's answer, transmit an on-hook signal from the called end to the calling end. Most trunks return to the on-hook state when the called station hangs up.

#### 6.5.2.2 Answer Signals on Calls to Directory Assistance

To provide proper billing, answer supervision should be returned on all 555-1212 and NPA + 555-1212 calls for direct-dialed directory assistance. Where operator directory assistance (131) trunks are used jointly to complete customer-dialed 555 calls and operator-placed 131 calls, they should be arranged to return answer supervision. Where the 131 trunks handle only operator-dialed traffic, the return of answer supervision is optional.

#### 6.5.2.3 Cross-Office Transfer Time for Answer Signals

Since individual switching offices contribute directly to network effects, it is important to establish performance objectives that recognize those parameters to which the network is most sensitive. Cross-office delay in transfer of the answer signal is one such parameter. Long-term priorities seek to avoid loss of revenue attributable to slow transfer of the answer signal that governs the start of charging.

---

Return of an answer signal should be performed with dispatch. Figures ranging from 5 to 25 ms are being achieved and are preferred. In the absence of economic options to achieve higher speeds, figures on the order of 50 ms (average) for normal tandem offices appear acceptable.

### 6.5.3 Control of Disconnect

#### 6.5.3.1 Calling-Customer Control of Disconnect

Calling-customer control of disconnect, also known as forward control of disconnect, forward disconnect, or calling-party control, is the means by which the calling end notifies the called end that the established connection is no longer needed and should be released. Forward disconnect is an on-hook signal sent toward the called end. As long as the customer remains off-hook, the connection will remain up. When the calling customer goes on-hook for a period longer than the disconnect time, the connection is released. This allows the caller to disconnect at any time by hanging up.

To distinguish an on-hook signal intended as a disconnect signal from other on-hook signal indications, the forward disconnect signal should exceed about 150 to 400 ms. To ensure that ring-forward signals do not cause false disconnects, incoming trunk equipment to operators must not release during a minimum on-hook interval of 140 ms (a maximum 130-ms ring-forward pulse plus a 10-ms safety margin). In general, any trunk circuit connected to inband signaling equipment must also be arranged so that it will not release during an on-hook interval of less than 140 ms.

Calling-customer control is usually modified by the end office to prevent connecting the called party to dial tone as soon as the caller goes on-hook, and to prevent locking the caller to the connection as long as the caller is off-hook. Table 6-8 lists disconnect timing that occurs in various telephone connections when the calling party hangs up and the called party remains off-hook, and when the called party hangs up and the caller remains off-hook.

Calling-customer control of disconnect is also modified by the Automatic Message Accounting (AMA) location (local AMA, Centralized Automatic Message Accounting [CAMA], OSPS or TOPS system) and by some tandem switching systems. If the called party goes on-hook for a period of time, after at least 2 seconds of answer, a timed disconnect will occur. Current arrangements for Local Automatic Message Accounting (LAMA), CAMA, operator-services systems, and some tandem switching systems require an on-hook from the called party of 10 to 12 seconds to cause a timed disconnect.

---

**Table 6-8. Disconnect Timing**

(For non-coin, direct-dialed calls; no operator handling)

Central Office Switching System	Timed Delay in Terminating Office, from Incoming Disconnect to Restoral of Called Line to Idle State	Timed Delay in Originating Office, From Incoming Disconnect to Restoral of Calling Line to Idle State
1/1AESS	2 to 3 seconds (ground-start) 10 to 11 seconds (loop-start)	Immediate (ground-start outgoing trunk) 10 to 11 seconds (loop-start)
2/2B and 5ESS	10 to 11 seconds	10 to 11 seconds
DMS-10	11 seconds*	11 seconds*
DMS-100	10 seconds**	10 seconds**
EWSD	10 seconds (software adjustable)†	10 seconds†
NEAX-61E	10 seconds	10 seconds
LSSGR	10 to 12 seconds	10 to 12 seconds

\* From 128 ms to 155 seconds in 128-ms steps, software-adjustable.

\*\* From 1 to 40.8 seconds in 10-ms steps, software-adjustable.

† From 10 to 12 seconds in 0.1-second steps, software-adjustable

Overload conditions will reduce the timed disconnect period to 5 seconds in the 1/1AESS switching system. The disconnect releases all equipment from the LAMA, CAMA, operator-services system, or tandem switching location to the called party. The portion of the connection from the calling party to the AMA location or tandem switching system may remain connected or may be disconnected as covered in this section.

The disconnect timing in LAMA, CAMA, operator-services systems, and tandem switching for the *called* party going on-hook should be much longer than the disconnect timing for the *calling* party going on-hook. This is because many short on-hook signals are generated in the network in the backward (called-to-calling) direction. There is no plan to reduce the disconnect timing for called-party disconnect below the present 10 to 12 seconds. This form of disconnect releases the calling party and stops charging when a carrier facility used in the connection fails.

Hold forward (no timed disconnect) after a 2-second answer is no longer required. This means that test positions can no longer hold forward on calls that have been answered. However, it is still possible to hold forward on calls that are not answered.

### 6.5.3.2 Calling-Customer Control of Disconnect with Forced Disconnect

In addition to the features discussed above, calling-customer control of disconnect can include a forced disconnect feature. The addition of this feature is a distinguishing characteristic of outgoing CAMA and Automatic Intercept System (AIS) end office trunk circuits. The calling customer may disconnect at any time but is automatically disconnected (winked off)<sup>1</sup> when an on-hook signal is received from the CAMA or AIS. The timing of partial dial, permanent signal, and other disconnect sequences is performed by the CAMA or AIS trunk to avoid holding trunks out of service. If the terminating end reverts to off-hook, the outgoing trunk circuit is automatically made busy (reverse make-busy).

The forced disconnect described in the previous sections is timed by the CAMA or operator-services office. For example, on a called-party disconnect, OSPS times 10 seconds on non-coin calls, the TOPS system as a CAMA is adjustable but the default is 16 seconds, and the 4ESS switching system as a CAMA times 10 seconds, before returning an on-hook signal to the originating and terminating offices. The originating office should eliminate the disconnect timing, per Table 6-8, when the CAMA or operator-services system goes on-hook first. The originating office must, however, time long enough before disconnect to prevent accidental disconnection. Minimum disconnect timing of 150 ms is long enough for CAMA trunks. Operator-services trunks that use multiwink coin control or expanded-inband coin control would require longer disconnect times. Many originating offices use 190 to 425 ms disconnect timing. The on-hook wink used in expanded-inband coin control is 300 to 450 ms when received. This requires a disconnect time of more than 500 ms.

### 6.5.3.3 Operator Control of Disconnect

Operator control of disconnect is used on outgoing trunks to operator-services systems. The end office trunks are designed to have calling-customer control of disconnect until the operator office returns off-hook supervision (Automatic Number Identification [ANI] request) to the end office to indicate that the operator office is ready to receive the calling number. This off-hook signal remains for the duration of the call, locking the calling customer to the operator office. At the end of the call, the operator office, recognizing an on-hook from the calling (or called) party, provides necessary timing and then reverts to on-hook toward the end office. This causes a forced disconnect of the calling customer. If the terminating end reverts to off-hook, the trunk circuit is automatically made busy.

---

1. Wink off and winked off are popular terms for a forced disconnect from a CAMA, AIS, or operator-services system. Actually the off- to on-hook transition, not a wink, causes the disconnect.

---



---

#### 6.5.4 Guard Time

Generally, two methods are used to guarantee the minimum disconnect interval necessary between calls. In the first method, the trunk is held busy at the calling end for an interval after its release. This prevents a new connect signal from being sent forward until sufficient time has elapsed to effect the release of the equipment at the called end. The second method permits the trunk to be reseized immediately; but the sending of the connect signal is delayed by common-control equipment either for a measured interval, or until a test of the trunk indicates that disconnection has taken effect. The second method cannot be used for 2-way trunks because, as explained in Section 6.5.1, the connect signal must be sent immediately.

The timed interval used to ensure trunk release before reseizure is called *guard time*. The disconnect time averages 360 ms. Therefore, typical guard times are 700 ms. Minimum guard times for senders are chosen to be longer than the average disconnect times plus round-trip signaling time for the incoming office, but generally not as long as the maximum possible disconnect interval. A guard time less than the maximum possible disconnect interval is used to save sender holding time. This can be done without an appreciable effect on service because trunks do not usually take the maximum time to release, a new call is not usually connected in the minimum time, and signaling distortion is not normally at its most adverse limit.

The actual guard times for the various switching systems are in Table 6-9. The table includes guard times for use on terrestrial facilities, and for use on trunks routed through an earth satellite where the switching systems can work with such facilities. The 1/1A ESS, 1/1A ESS HILO,<sup>1</sup> 4ESS, and 5ESS, DMS-10 and DMS-100F switching systems have options to operate with satellite facilities.

---

1. HILO is a feature of the 1/1A ESS switching system for toll use. It provides two electrically independent transmission paths through the switching network, and thus provides 4-wire transmission in a 2-wire switch.

---

**Table 6-9.** Actual Guard Time for Various Switching Systems

Switching System	Guard Time in Milliseconds	
	Terrestrial Facilities	Satellite Facilities
1/1A ESS and 1/1A ESS HILO	800 to 1000	1600 to 1800
2/2B ESS	750 min *	—
4ESS	1050 to 1200	1050 to 1200
5ESS	800 to 1000	None
DMS-10	128 to 3968 **	128 to 3968 **
DMS-100F	10 to 2550 †	10 to 2550 †
EWSD	752, 1000 ‡	752, 1000 ‡
NEAX-61E	1000	None
<i>LSSGR</i>	750 to 1000	None

\* Except when a timing list entry is not available; guard time is then 0 ms.

\*\* Adjustable per trunk group in 128-ms steps.

† Adjustable per trunk group in 10-ms steps.

‡ 1000 ms for immediate-dial, 752 ms for the rest.

Switching systems (using guard timing) do *not* require an on-hook from the far end between an outgoing call and an incoming call on a 2-way trunk. Switching systems in the network should hold a 2-way trunk busy to another outgoing call for a period of time (guard time) after the disconnect (on-hook) signal is sent to the far office. This permits the far switching system to restore to the idle condition. The far office does not have a guard time after the release of an incoming call. As a result, the far office can originate a new call before the guard time has ended in the outgoing office. The effects of this are that the two offices tend to alternate originating calls on a given trunk during peak traffic periods, and glare (the simultaneous seizure of both ends of a 2-way trunk) is reduced. Switching systems are blind to the supervisory state during guard timing. Therefore, it is not necessary to see an on-hook between an outgoing and an incoming call. If an off-hook is present when the switching system completes guard timing, the off-hook should be treated as a new call.

An important factor in establishing a compatible guard time is the interval required to restore the incoming trunk circuit to the idle condition (force an on-hook toward the calling end if the called end is still off-hook) after the disconnect signal is received by the incoming trunk. Electronic switching systems, in general, have disconnect intervals that can become

very long for heavy traffic conditions. The time required to restore the trunk circuit to idle, after the disconnect timing has elapsed, is shown in Table 6-10.

**Table 6-10.** Time to Restore Trunk Circuit to Idle after Disconnect

Switching System	Light Traffic (ms)	Heavy Traffic (ms)
1/1A ESS	175 to 275	450
2/2B ESS	400	None
4ESS ring forward allowed	175 to 240	270
4ESS ring forward not allowed	175 to 320	350
5ESS	100	180 at 95% level - 250 max
DMS-10	200	200 to 300
DMS-100F	100	180 at 95% level - 250 max
EWSD	50	300 max
<i>LSSGR</i>	None	None

The guard time discussed in the last few paragraphs is the time that the 2-way trunk is held idle after disconnect. This guard time historically was not applied when digits were not received after the connect signal. The common control of trunks in electronic switching systems rather than control in the individual trunks increased the switching circuit delay. Single-frequency signaling and earth satellites increased the facility delay. With the increases in these delays, pumping was experienced on 2-way trunks. As a result, it was necessary to apply guard time on all disconnects to prevent pumping.

Pumping on 2-way trunks is started by the disconnect of a call or by a facility condition that causes a signaling hit on an idle trunk. The pumping is sustained by the recognition of a delay-dial or wink-start signal as a new connect signal, long delays in the signaling path, and no guard time after a connect signal when no digits are received. An example of two offices follows.

1. Off-hook signaling hit to office A.

Office A sees signaling hit as a connect signal; sends a wink-start signal to office B.

2. Office B sees the wink-start signal as a connect signal.

2. Signaling hit ends.

Office A restores trunk to idle.

Office B sends a wink-start signal to Office A.

3. Office A sees the wink-start as a connect signal.

Wink-start signal from Office B ends.

Office B restores trunk to idle.

Office A sends office B a wink-start signal.

4. Office B sees the wink-start signal as a connect signal.

At this point, the pumping will continue indefinitely with offices A and B sending each other wink-start signals.

This application of guard time causes the trunk circuit to ignore a new connect signal for a period of time after the release of an incoming call. The guard time should be as long as the round-trip signaling time of the facility to be completely effective. The 1/1A ESS and 4ESS systems have effective guard times when an incoming call is released. The 1/1A ESS switching system guards only after an incoming off-hook/disconnect sequence where no digits are received. The guard time used is equal to the guard time for the disconnect of an outgoing call.

The 4ESS, DMS-10, and DMS-100F switching systems provide the same guard time when an incoming call is released as when an outgoing call is released. See Table 6-9 for details. Not all switching systems provide an effective guard time for new connect signals after the

---

release of an incoming call. However, guard times much shorter than optimum often stop pumping. Moreover, a short guard time can be obtained in some systems by switching from delay-dial to wink-start operation. As indicated in Table 6-13, the return of a wink-start signal is much slower than the return of a delay-dial signal in many systems. This often prevents pumping on circuits that pump when operated delay-dial.

### 6.5.5 Immediate-Dial

Trunk groups employing common receiving equipment (such as registers) may be equipped at the called end with fast links (or bylinks), with both the links and the common receiving equipment liberally engineered to minimize delays. Such groups are normally ready to receive pulsing about 120 ms after receipt of the connect signal. Immediate-dial is used with these trunks. The NEAX-61E system is ready to receive pulses 65 ms after seizure. Advantage is realized, however, if delay-dial is employed for signaling-integrity-check purposes. Senders are informed by translations whether they are operating with this type of trunk, or with trunks requiring either a delay-dial or wink-start signal prior to the start-dial indication.

As a minimum interval between seizure and outpulsing on immediate-dial circuits, the 1/1A ESS switching system is using 170 ms, the 4ESS switching system 210 ms, and the 5ESS switching system 150 ms. The NEAX-61E system waits 192 ms before sending pulses and the EWSD switching system delays 200 ms. The DMS-10 and DMS-100F switching systems have an adjustable predial delay that can be set to 150 ms or higher. The Galaxy System terminal equipment has a minimum of 150 ms predial delay.

### 6.5.6 Signaling Integrity Check

Signaling integrity check is a per-call test made by an office during the initial call setup. It is used as an indication of the ability of the trunk to transmit signals. The test is associated with detection, identification, and recording of trunk/facility troubles, as well as with a second attempt at call completion if the switching system has this capability. The ability to detect trunk/facility troubles lessens the probability that customers will be left high and dry (for example, circuit held out of service with no battery or ground on tip or ring) and improves the call completion rate when the switching system has second-attempt capability. The ability to identify and record trunk/facility troubles greatly assists maintenance. Therefore, the integrity check feature is recommended on intertandem and tandem connecting trunks.

The exact nature of the check varies between switching systems. However, there are two general types of signaling integrity checks. The first and most complete check requires a response from the incoming office in the form of a delay-dial or wink-start signal, and is called an integrity check. The second check, for wire trunks only, requires circuit continuity

---

and the correct polarity on the tip and ring of the trunk, and is called a continuity and polarity check.

The 4ESS, 1/1A ESS, DMS-10, and DMS-100F switching systems provide the continuity and polarity test check on immediate-dial calls over physical facilities using loop reverse-battery supervision.

Trunks using immediate-dial (not equipped for integrity check) over carrier do not have any form of signaling-integrity check. Under these circumstances, the switching machine outpulses blindly on the trunk. If there is a trunk trouble, it generally goes undetected by the equipment (no trouble record) and the customer usually ends up high and dry.

The 4ESS, 1/1A ESS, DMS-10, and DMS-100F switching systems can provide signaling integrity check on all outgoing calls using the delay-dial or wink-start method of operation, with multifrequency pulsing and loop reverse-battery or E&M supervision. This method can also be employed with dial-pulsing and E&M supervision, provided the distant office uses an incoming trunk circuit that will return a stop-dial/start-dial signal. The Galaxy System terminal equipment can provide signaling integrity check on all outgoing calls using delay-dial or wink-start.

### **6.5.7 Reverse Make-Busy (Off-Hook Make-Busy)**

Outgoing trunk make-busy by means of off-hook supervision received from the terminating end is a feature of outgoing CAMA, operator-services system, and AIS trunks in all local switching systems. Other types of outgoing trunks, especially loop signaling trunks with customer control of disconnect, require an applique circuit to make the trunk automatically appear busy when idle and while receiving off-hook supervision from the terminating end.

Provisions for off-hook make-busy for trunks other than operator-services system and AIS when an outgoing trunk circuit is used, or other techniques that accomplish the same result with or without an outgoing trunk circuit, are summarized in Table 6-11.

**Table 6-11. Off-Hook Make-Busy Provisions**

(For trunks other than operator-services and Automatic Intercept System [AIS])

Office	Supervision	Off-Hook Make-Busy	Provision of Off-Hook Make-Busy
1/1A ESS	Loop	No	None Available
	E&M	No	Substitute 2-way trunk circuit
2/2B ESS	Loop or E&M	No	Substitute 2-way trunk circuit
4ESS	E&M	No	Substitute 2-way trunk circuit
5ESS system	Loop, E&M, digital	Yes	Always available
DMS-10	Loop, E&M, digital	Yes	Always available
DMS-100F	Loop, E&M, digital single-frequency	Yes	Always available
EWSD	Loop, E&M, digital	Yes	Always available
NEAX-61E	Loop, E&M, digital	Yes	Always available

---

## 6.6 Controlled Outpulsing

Controlled outpulsing is used between offices and between operator-services systems and offices. Controlled outpulsing permits the use of slower links and results in a more efficient use of registers. With controlled outpulsing, the originating office seizes the trunk and sends a connect signal to the terminating office, just as in immediate-dial outpulsing. However, if the idle state of the called office is an on-hook indication, the terminating office returns an immediate off-hook signal (or is off-hook idle) followed by an on-hook signal to the originating office. The exact timing of the on-, off-, on-hook (or off-, on-hook) signaling sequence constitutes the differences between the delay-dial and wink-start methods of controlled outpulsing. For more on controlled outpulsing see GR-506-CORE, *LSSGR: Signaling for Analog Interfaces*.

These differences are described in Sections 6.6.1 through 6.6.4. Whether delay-dial or wink-start, the originating office will wait a short period after receiving the on-, off-, on-hook (or off-, on-hook) signaling sequence and then begin outpulsing. Either dial-pulse or multifrequency address signaling can use controlled outpulsing. Wink-start is the preferred method of operation when controlled outpulsing is used in modern LEC networks and essentially all new trunks being added to the network that require controlled outpulsing use the wink-start signal.

To describe the operation of the various switching systems for signaling-compatibility purposes properly, it is necessary to define the signal *sent* by the terminating office and the signal *expected* by the originating office. Generally, the signal *sent* by the terminating office is the same as the signal *expected* by the originating office. However, this may not always be the case. In addition, in specific situations, there are advantages in not having the *sent* and *expected* signals identical. For example, glare resolution in the 1/1A ESS switching system (Section 6.6.5) uses different *sent* and *expected* signals to resolve the glare in the “wink-start mode.” When two 1/1A ESS switching system offices interconnect, both can *send* wink-start but both do not *expect* wink-start. The office selected to back out of the connection (glare situation) *expects* a wink-start signal and, therefore, times the wink. Any wink-start signal over 500 ms is detected as glare. The office selected to remain on the trunk *expects* delay-dial and does not time the signal received (other than the 18- to 20-second interval timing) and, therefore, remains in control of the trunk. Another factor is the difference in the definition used by the various systems for delay-dial and wink-start. Table 6-12 covers the design capabilities of the various systems, the systems' ability to use the various methods, and the preferred method of controlled outpulsing.

### 6.6.1 Delay-Dial Without Signaling Integrity Check

Delay-dial without signaling integrity check is the oldest method of controlled outpulsing. It is also the least satisfactory method from a maintenance standpoint. Consequently, it should be used only when wink-start or delay-dial with integrity check is not available.



---

In this method, the originating office seizes the trunk circuit, which sends a connect signal toward the called office. After a timing interval of at least 300 ms on some trunks and 75 ms on others, the calling office then looks at the supervision from the called office. If the supervision is on-hook, the originating office starts outpulsing procedures. If the supervision is off-hook, the calling office waits until the supervision from the called office goes on-hook (start-dial), then starts outpulsing. The called office sends a delay-dial (off-hook) signal from the incoming trunk circuit as soon as the connect signal is recognized. The called office maintains the delay-dial signal until a register is attached to the incoming trunk. When the register is ready to receive pulses, the start-dial (on-hook) signal is sent to the calling office.

In this method of controlled outpulsing, there is no minimum time requirement for the delay-dial (off-hook) signal. In fact, no delay-dial signal is needed if the called office is ready to receive pulses.

If the called office is not ready to receive pulses, the speed with which the called office returns the delay-dial signal is especially important. Where signaling integrity check is not used, the failure to receive a delay-dial signal may permit the sender to outpulse before the register is attached at the called end. This can cause the call to be routed to reorder or left high and dry, depending on the exact conditions involved.

The trunk circuits that use E&M leads for signaling in the delay-dial method of operation are on-hook at both ends when idle. E&M signaling trunks should receive the delay-dial signal less than 300 ms after seizure; otherwise, the originating end will interpret the on-hook signal (or lack of off-hook signal) as a start-dial signal and begin outpulsing prematurely. The 300 ms must include all delays in signaling units and transmission facility, as well as the delay within the terminating trunk circuit. These conditions obviously preclude using transmission facilities derived from a synchronous satellite that has a round-trip transmission time of over 300 ms.

Some loop signaling trunks using the delay-dial method of controlled outpulsing must receive the delay-dial signal within 75 ms of trunk seizure. With this method of operation, the incoming trunk is in the off-hook state when idle to meet the timing requirements. Other loop signaling trunks using the delay-dial method must receive the signal in less than 300 ms after seizure. With this operation, the incoming trunks can be either off- or on-hook when idle. The off-hook when idle trunk circuits could be used with synchronous satellite-derived facilities; however, the use of such trunks on satellite facilities is remote since the 2-wire loop trunk circuits are generally used for tandem connecting, and there is no suitable signaling unit to interface with the 4-wire loop trunk circuits. The 5ESS digital switching system does not provide off-hook when idle.

**Table 6-12.** Available Controlled-Outpulsing Methods

Switching System	Type of Call	Delay-Dial			Delay-Dial With Integrity Check	Wink-Start	
		Expect	Sent			Expect	Sent
			Hardware	Software			
1/1A ESS (End Office)	Non-toll 2-way group	NAN	NNN	NNN	NAN	PAG	PAN
	Tandem connecting — incoming	—	NAN	NAN	—	—	PAN
	Tandem connecting — outgoing	—	—	—	NAN	PAN	—
	CAMA — outgoing	—	—	—	NAN	PAN	—
1/1A ESS (Tandem)	2-way intertandem	—	NNN	NNN	NAN	PAG	PAN
	Tandem connecting — incoming	—	NNN	—	—	—	PAN
	Tandem connecting — outgoing	—	—	—	NAN	PAN	—
1/1A ESS HILO	2-way intertandem	—	—	NAN	NAN	PAG	PAN
	Tandem connecting — incoming	—	—	NAN	—	—	PAN
	Tandem connecting — outgoing	—	—	—	NAN	PAN	—
	CAMA — incoming	—	—	—	—	—	PAN
2/2B ESS	Non-toll — incoming	—	NNN	—	—	—	PAN
	Non-toll — outgoing	—	—	—	NAN	PAN	—
	Tandem connecting — incoming	—	—	—	—	—	PAN
	Tandem connecting — outgoing	—	—	—	NAN	PAN	—
	CAMA — outgoing	—	—	—	NAN	PAN	—
4ESS	2-way intertandem	—	—	NNN	NAN	PAG	PAN
	Tandem connecting — incoming	—	—	NNN	—	—	PAN
	Tandem connecting — outgoing	—	—	—	NAN	PAN	—
	CAMA	—	—	NNN	—	—	PAN
5ESS system (End Office)	2-way Non-toll	—	—	NNN	NAN	PAG	PAN
	Tandem connecting — incoming	—	—	NAN	—	—	PAN
	Tandem connecting — outgoing	—	—	—	NAN	PAN	—

(See legend at end of table.)

**Table 6-12.** Available Controlled-Outpulsing Methods (Continued)

Switching System	Type of Call	Delay-Dial			Delay-Dial With Integrity Check	Wink-Start	
		Expect	Sent			Expect	Sent
			Hardware	Software	Expect		
5ESS system (Tandem)	2-way intertandem	—	—	NAN	NAN	PAG	PAN
	Tandem connecting — incoming	—	—	NAN	—	—	PAN
	Tandem connecting — outgoing	—	—	—	NAN	PAN	—
	CAMA	—	—	—	—	—	PAN
DMS-10 and DMS-100F	2-way Non-toll	—	—	NAN	NAN	PAG	PAN
	Tandem connecting — incoming	—	—	NAN	—	—	PAN
	Tandem connecting — outgoing	—	—	—	NAN	PAN	—
	2-way intertandem	—	—	NAN	NAN	PAG	PAN
	CAMA — incoming	—	—	NAN	—	—	PAN
	CAMA — outgoing	—	—	—	NAN	PAN	—
EWSD (End Office)	Non-toll 2-way	—	—	NAN	NAN	PAG	PAN
	Tandem connecting — incoming	—	—	NAN	—	—	PAN
	Tandem connecting — outgoing	—	—	—	NAN	PAN	—
	CAMA — outgoing	—	—	—	—	—	PAN
NEAX-61E (End Office)	2-way non-toll	—	—	NAN	NAN	PAG	PAN
	Toll connecting — incoming	—	—	NAN	—	—	PAN
	Toll connecting — outgoing	—	—	—	NAN	PAN	—
	CAMA	—	—	—	—	—	—
NEAX-61E (Tandem)	2-way intertandem	—	—	NAN	NAN	PAG	PAN
	Tandem connecting — incoming	—	—	NAN	—	—	PAN
	Tandem connecting — outgoing	—	—	—	NAN	PAN	—
	CAMA	—	—	—	—	—	PAN

**Legend:**

First Character: P — Preferred method  
N — Not preferred method

Second Character: A — Always Available  
N — Not always available

Third Character: G — Preferred method used when trunk will back-out of glare conditions.  
Not used when trunk does not back-out.  
N — No glare resolution consideration.

---

When the originating office *expects* a delay-dial signal (without integrity check), the terminating office may or may not *send* a delay-dial signal. The 1/1A ESS, 1/1A ESS HILO, 2/2B ESS, 4ESS, DMS-10, and DMS-100F switching systems can send a delay-dial signal. These switching systems and OSPS never operate in the *expect* delay-dial (without integrity check) mode.

Delay-dial is often referred to as an off-hook, on-hook signaling sequence. The delay-dial signal is the off-hook interval and the start-dial is the on-hook interval. ESS switching systems do not check for an on-hook before the delay-dial signal. The DMS-10 and DMS-100F switching systems have a reverse (off-hook) make-busy feature. They both check for an on-hook before seizure.

### 6.6.2 Delay-Dial with Integrity Check

With integrity check, the originating office will not outpulse until a delay-dial (off-hook) signal followed by a start-dial (on-hook) signal has been detected at the originating office. This method is very much like wink-start operation. The 5ESS switching system always provides delay-dial with integrity check. Electronic switching systems do have differences between delay-dial *expected* and wink-start *expected*.

In the delay-dial with integrity check method of controlled outpulsing, seizure of the trunk by the originating office causes the distant office to return a delay-dial signal. However, the delay-dial signal does not have to be returned within a given interval (that is, 300 ms). It can be delayed for a longer period since the originating office will not begin outpulsing until it has received an off-hook (delay-dial) signal followed by an on-hook (start-dial) signal. Performance of this positive signaling sequence from on-hook to off-hook to on-hook verifies the *integrity* of the trunk.

The delay-dial signal in this method of controlled outpulsing must meet the following requirements.

- The off-hook must be a minimum of 140 ms in duration.
- The off-hook to on-hook transition (start-dial) must not occur until 210 ms after the connect signal is received and the register is ready to receive pulses.

It is desirable to minimize the post-dialing delay by sending the off-hook to on-hook transition as soon as possible after the above requirements are met. The signaling system used with the transmission facility will distort the off-hook (delay-dial) signal as it is transmitted between offices. As a result, the originating office must recognize an off-hook as short as 100 ms as a delay-dial signal.

It was not originally necessary to specify a 210-ms delay from the reception of the connect signal at the terminating office to the sending of the start-dial signal because it was inherent to the operation of the 1 ESS switching system. However, with the advent of faster systems, it would be possible to complete sending the 140-ms minimum delay-dial signal before the

---

originating office was in a position to receive the delay-dial signal. There is a period of time after the 1/1A ESS switching system sends the connect signal forward on a 1- or 2-way trunk during which the system is blind to signaling from the far end. A start-dial signal occurring within 210 ms of the connect signal can be missed. The 5ESS, EWSD, DMS-10, and DMS-100F digital switching systems have no blind interval.

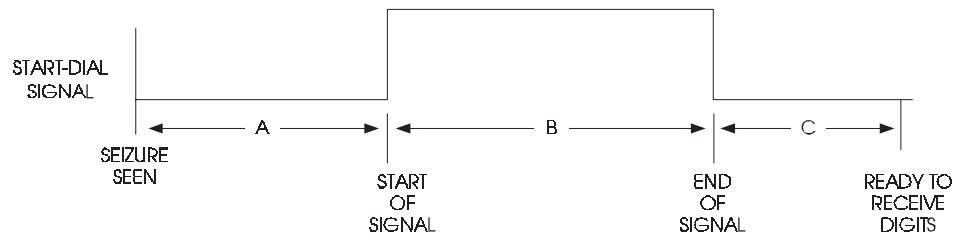
Electronic switching systems 1/1A ESS, 1/1AESS HILO, 2/2B ESS, 4ESS, 5ESS, DMS-10, and DMS-100F can *expect* delay-dial with integrity check. There is a difference between *expect* wink-start and *expect* delay-dial with integrity check. *Expect* delay-dial with integrity check operation has no time limit for the delay-dial signal in most systems, except a 4-second limit when glare detection is used (Section 6.6.5), while wink-start has a shorter time-out interval of 500 to 600 ms for the 1/1A ESS switching system. See Section 6.5.5 for the time-out interval for other systems. The 2/2B ESS system times 8 seconds ( $\pm 10$  percent) for an off-hook, and then up to 16 seconds ( $\pm 10$  percent) for an on-hook.

Delay-dial with integrity check can be on-, off-, on-hook like wink-start or an off-hook, on-hook signaling sequence like delay-dial. All E&M trunks are on-hook when idle. The loop trunks can be off- or on-hook when idle per Section 6.6.1. The originating office would have to restrict interconnection to on-, off-, on-hook sequence trunks to make use of all three signaling intervals. However, 1/1A ESS, 1/1A ESS HILO, 2/2B ESS, 4ESS, and 5ESS equipment does not detect the original on-hook. DMS-10 and DMS-100F systems do check for the original on-hook.

### 6.6.3 Generation of Delay-Dial Signals

In some switching systems, the delay-dial signal is generated in the individual incoming trunk circuits. Such signals are suitable for use with switching systems that either *expect* delay-dial without integrity check, or delay-dial with integrity check. This operation is known as hardware generation of the delay-dial signal.

In other equipment, such as the 1/1A ESS HILO, 4ESS, 5ESS, DMS-10, and DMS-100F switching systems, the delay-dial signal is generated by the common-control equipment associated with the trunk equipment. This operation is known as software generation of the delay-dial signal. This method permits the return of the delay-dial signal as long as 5 seconds after the connect (seizure) signal. In Figure 6-13, the information for the 1/1A ESS HILO switching system indicates that the delay-dial signal will be returned in less than 5 seconds. This means that software generation of the delay-dial signal is completely compatible only with switching systems that *expect* delay-dial with signaling integrity check.



	Minimum*			Typical*			Heavy Traffic*			Maximum*		
	A	B	C	A	B	C	A	B	C	A	B	C
Hardware Delay Dial:												
Loop Signaling	5	280	45	10	350	50	10	500	75	15	>16 sec	100
E&M	5	330	45	10	400	50	10	550	75	15	>16 sec	100
HILO Delay-Dial:												
Loop and E&M	15	280	45	75	350	50	150	500	75	<5 sec	0	100
Wink:												
Loop	110	140	45	200	155	50	300	175	75	>16 sec	200	100
E&M	160	140	45	250	155	50	350	175	75	>16 sec	200	100

\* Times in milliseconds unless noted.

**Figure 6-13.** Controlled-Outpulsing Formats for 1/1A ESS Systems

#### 6.6.4 Wink-Start

With wink-start operation, the trunk equipment signals on-hook at each end when in the idle condition. On receipt of a connect signal, the called office initiates a request for a register, but does not immediately return an off-hook (delay-dial) signal to the calling office. The on-hook signal to the calling office is maintained until the register is attached at the called office, at which time the called office sends a wink-start signal. The wink-start signal must meet the following requirements:

- The off-hook must be 140 to 290 ms long.
- The off-hook to on-hook transition (start-dial) must not occur until 210 ms after the connect signal is received.

It is desirable to minimize post-dialing delay by sending the on-hook transition as soon as possible after the above requirements are met. The nominal wink-start signal is 150 ms for the 1/1A ESS, 250 ms for 4ESS, 220 ms for the 5ESS, and 180 ms for the EWSD switching systems. It is about 200 ms for DMS-10 switching systems and 10 to 2550 ms in 10-ms steps (150-ms default value) for DMS-100F systems. The Galaxy System terminal equipment sends a 140 ms minimum and 200 ms nominal wink-start signal. The 1/1A ESS switching system delays returning the wink-start signal for slightly more than 100 ms. This is the minimum time required to attach a register/receiver to the incoming trunk after the connect signal is received. The 4ESS switching system usually returns the wink-start signal

---

within a few ms of the receipt of the connect signal. The DMS-10 system usually returns the wink-start signal within 60 ms of the receipt of the connect signal. The DMS-100F system returns the wink-start signal 10 to 2550 ms (100 ms default) after the receipt of the connect signal. In DMS-100F systems, the length of the wink-start signal is adjustable per office in 10-ms steps. The transitions from on- to off- to on-hook, with the duration of off-hook constrained as indicated, constitute the wink.

The signal transmission system will generally distort the wink. As a result, the calling office must recognize an off-hook signal in the range of 100 to 350 ms as a wink-start signal. Off-hook signals exceeding 350 ms can be treated as glare on 2-way wink-start trunks (Section 6.6.5). All wink-start trunks operate in the same manner, whether using E&M or loop reverse-battery signaling.

The 210-ms minimum delay between reception of the connect signal and completion of the wink-start signal is inherent to the operation of the 1/1A ESS switching system. Additional details concerning this subject are provided in Section 6.6.2.

Wink-start operation requires a 210-ms delay between reception of the connect signal and the completion of the wink-start signal. This timing ensures that there is at least 100 ms of off-hook (wink) signal at a time that the signal can be recognized by 1/1AESS switching systems. The timing also permits wink-start signals to go off-hook as soon as the trunk is seized, as is the case with 4ESS and 5ESS systems. These requirements are compatible with all known network arrangements.

The capability of various switching systems to *expect* or *send* wink-start is covered in Table 6-13. In the case of *expect* wink-start, Lucent and Nortel switching systems time the received off-hook signal. On 2-way trunks, a wink-start signal longer than a predetermined length of time is interpreted as a glare condition and initiates the start of a glare sequence.

The list below covers these times for the different switching systems. On 1-way trunks, a wink-start signal longer than a predetermined length of time causes the following maintenance activity:

- 1/1A ESS — A 500- to 600-ms or longer wink-start signal causes the call to be routed to reorder and maintenance activity started.
- 5ESS switching system — A 350-ms or longer wink-start signal causes a retrial of the call on first failure and routes the call to reorder on the second failure.
- DMS-10 system — A 400-ms or longer wink-start signal is interpreted as a reverse (off-hook) make-busy and another trunk is selected to route the call. If on the second trial a 400-ms or longer wink-start signal is encountered, the call is routed to reorder.
- DMS-100 system — Allows selectable timing from 10 to 2550 ms in 10-ms steps, with a default of 350 ms.
- EWSD system — Wink-start signals longer than 420 ms for nonequal-access trunks, 752 ms for interLATA carrier trunks, and 1500 ms for International Carrier (INC) trunks cause the call to be routed to another trunk and maintenance activity started.

All present CAMA systems *send* wink-start.

The delay introduced by various switching systems from receipt of a seizure (connect) signal to the return of a delay-dial or wink-start signal is shown in Table 6-13 and Figure 6-13.

Wink-start operation is also used for Direct-Inward-Dialing (DID) service between the network and PBXs. The requirements for DID service are contained in:

- ANSI T1.405-1996, *American National Standard for Telecommunications — Network-to-Customer Installation Interfaces — Direct-Inward-Dialing Analog Voicegrade Switched Access Using Loop Reverse-Battery Signaling*
- EIA/TIA-464-B-1996, *Private Branch Exchange (PBX) Switching Equipment for Voiceband Application*.

**Table 6-13.** Delay from Connect to Delay-Dial

Switching System	Delay in Milliseconds from Connect Signal to:		
	Wink	Delay-Dial	
		Hardware	Software
1/1AESS		See Figure 6-13	
1/1AESS HILO		See Figure 6-13	
2/2BESS	50 to 450	10 to 30	NA *
4ESS	50	NA	50
5ESS system	100 to 200	NA	10 to 60
DMS-10	50 (minimum)	NA	50 (minimum)
DMS-100F	100**	NA	100**
EWSD	56	NA	56
LSSGR		No requirement	

\* NA = Not applicable.

\*\* Default value (adjustable from 10 to 2550 ms per office in 10-ms steps).

### 6.6.5 Glare

Two-way trunks are subject to occasional simultaneous seizures at both ends because of the unguarded interval between the seizure of the trunk at one end and the consequent making busy of the trunk at the other end, giving *glare*. These simultaneous seizures cause each end of the trunk to receive a sustained off-hook signal.

Equipment at each end should be arranged to

- Prevent the off-hook signal from reaching the charging control equipment



- Disengage from this mutually blocking condition.

Dependent upon the switching systems involved, various techniques are used to reduce ineffective attempts and long time-out intervals due to glare. The 1/1AESS, 2/2BESS, 4ESS, 5ESS, DMS-10, and DMS-100F switching systems use a method to detect and resolve glare on both wink-start and delay-dial controlled-outpulsing conditions that saves both originating calls.

#### 6.6.5.1 Glare Resolution in Electronic Switching Offices

Electronic switching systems detect glare by timing the incoming wink-start or delay-dial signal. Where the maximum time for the appropriate controlled-outpulsing signal is exceeded, glare is assumed. The office detecting the glare condition holds the off-hook toward the other office until it can back out of the connection, attach a register to the connection, and go on-hook toward the other office as a start-dial signal. The call incoming to the office detecting glare will be completed on the original trunk. The call outgoing from the office detecting glare will be retried on another trunk. Thus both calls are saved.

Any wink-start signal over 350 ms can be treated as glare. The actual glare detection times for the various switching equipment are as follows:

- 1/1AESS switching system, 500 to 600 ms;
- 2/2BESS switching system, 450 to 550 ms;
- 4ESS switching system, 350 to 500 ms;
- 5ESS switching system, 400 to 500 ms;
- DMS-10 switching system, 400 to 500 ms;
- DMS-100F switching system, 350 ms (software adjustable, 10 to 2550 ms per office in 10-ms steps);
- EWSD switching system, 420 ms for nonequal-access trunks, 752 ms for interLATA carrier trunks, and 1500 ms for INC trunks;
- Galaxy System terminal equipment, 350 ms;
- NEAX-61E switching system, 350 ms;
- *LSSGR* specifies 350 ms.

Delay-dial to start-dial intervals that exceed 4 seconds may be considered glare. The 1/1AESS switching system normally has 6-second timing. The actual glare detection times when expecting delay-dial for various switching equipment are as follows:

- 1/1AESS switching system: 4  $\pm$ 0.1 seconds with 4 to 8 seconds overall timing (optional); 6  $\pm$ 0.1 seconds with 16 to 20 seconds overall timing (normally used);

- 
- 2/2BESS system: Glare resolution with wink-start only;
  - 4ESS system:  $4 \pm 0.1$  seconds, intertandem;  $5 \pm 0.1$  seconds, tandem connecting; 10 seconds, second trial, intertandem and tandem connecting;
  - 5ESS system: 4 to 4.2 seconds, first trial; 10 to 10.2 seconds, second trial
  - DMS-10 system: 0 to 50 seconds, software-adjustable in 128-ms steps per trunk group;
  - DMS-100F system: 160 ms to 40 seconds software-adjustable per office, with 5 seconds as a default value;
  - EWSD system: 4.0 seconds;
  - Galaxy System terminal equipment: 5 seconds;
  - NEAX-61E system: 4 to 5 seconds each, first and second trials;
  - The *LSSGR* specifies 4 seconds.

In all systems, a failure on a retried call will route the call to reorder.

Wink-start sent is the preferred controlled-outpulsing method on 2-way trunks. (See Table 6-12.) Wink-start permits less expensive trunk circuits in electronic switching systems when hardware is used to generate the delay-dial signal, and quicker detection of glare for either hardware- or software-generated delay-dial. The following protocols are used:

- IntraLATA: The lower-ranked office (for example, end office) should back out (give up control) of glare situations in favor of the higher-ranked office (for example, tandem), thereby allowing the greatest chance of completion to a call that has traversed the network and is completing rather than one that is just starting. If the offices are of equal rank, the offices are often given control in accordance with their alphabetical order in the CLLI code listings;
- InterLATA: The office that backs out and the office that remains on the connection in the case of glare are chosen by agreement of the LEC and the Interexchange Carrier (IC).

#### 6.6.5.2 Trunk Hunting — Method to Minimize Glare

The strategy of selecting idle trunks, as well as the number of seizures per trunk per unit of time, has an effect on glare. Opposite-order trunk hunting gives lowest glare. In this method, one office selects from low- to high-numbered trunks, while the other office selects from high- to low-numbered<sup>1</sup> trunks. In this selection method, glare is possible only when all but one trunk in the group is busy. The greater the number of seizures per trunk per unit of time, the greater the glare problem. When glare is an issue, consideration should be given

---

1. Characteristically, between two offices (A and Z), the Z office will use the reverse hunting feature. The A and Z office designations should be determined by CLLI codes.

---

to adding more trunks to the group or to replacing a single group of 2-way trunks with two groups of 1-way trunks.

### 6.6.6 Start-Dial (Start-Pulsing)

Start-dial is an on-hook signal from the called office to the calling office. It occurs when the receiving office is ready to accept digits. However, a momentary delay of a minimum of 70 ms after receipt of the start-dial signal should be introduced before dial pulsing is started. This delay is necessary because dial pulse receivers are sometimes momentarily disabled at the instant of the sending of the start-dial signal to prevent the registration of a false reflected pulse. Good practice also suggests that dial-pulse receivers at the called end be disabled for 30 to 70 ms after the start-dial signal is sent. There is no standard delay between the start-dial signal and multifrequency outpulsing for existing switching systems. The delay can be 0 to 200 ms, depending on the multifrequency sender used.

Experimental data indicate that the start-dial signal generates transient noise at the sending central office that lasts about 20 ms in electronic offices. This transient noise can mask the keypulse (KP) signal long enough to prevent recognition by the multifrequency receiver, thereby causing a call failure. No Lucent-, Nortel-, or NEC-manufactured switching system will accept a multifrequency-pulsed address signal unless it begins with KP (and ends with ST [start]). The nominal transmitted KP signal is from 90 to 120 ms and the multifrequency receiver will recognize a KP signal of 55 ms minimum. NEC switches wait for 72 ms after the start-dial signal before transmitting the KP. It is good practice to introduce a minimum delay of 50 ms between the receipt of the start-dial signal and the beginning of outpulsing. Actual delays introduced between the reception of the start-dial signal and the beginning of the KP signal are shown in milliseconds as follows:

- 1/1AESS switching system, 100 to 150;
- 4ESS system; 20, 80, or 200 (selectable per trunk group);
- 5ESS system, 70;
- DMS-10 system, 70;
- DMS-100F system, 70 default value (software adjustable per office, 10 to 2550 ms with 10-ms steps);
- EWSD system, 92;
- NEAX-61E system, 72.

The *LSSGR* has the following minimum requirements: 50 ms under normal conditions, and 200 ms on 2-way trunks without glare control.

### 6.6.7 Unexpected Stop

An unexpected stop is a spurious off-hook (stop) signal detected by the sender before or during outpulsing. The detection of an unexpected-stop signal is used as a trouble condition. However, prudent use of this test is required because it is possible for many circuits to produce unexpected-stop signals when there is no trouble. To prevent taking unnecessary trouble records and falsely sending calls to reorder, the Lucent-made switching machines use different methods to avoid detecting nonproductive, unexpected-stop signals.

Tandem switching systems can look for unexpected stops during multifrequency outpulsing on intertandem circuits. However, no Lucent-made switching system looks for unexpected stops after outpulsing is completed, that is, after the last dial pulse when dialpulsing or after the ST pulse when multifrequency pulsing.

Switching systems test for unexpected stops during multifrequency outpulsing as follows.

- The 1/1AESS switching system looks for an unexpected stop before outpulsing and in an interval between the tens and units digits on intertandem, tandem connecting, and local trunks.
- The 4ESS system looks for an unexpected stop after receipt of the start-dial indication to the completion of the ST pulse on intertandem calls and on tandem connecting calls before outpulsing starts to the hundreds digit for 10-digit outpulsing, to the ST pulse on 7-digit outpulsing, to the tens digit on 5-digit outpulsing, and to the units digit on 4-digit outpulsing.
- The 5ESS system looks for an unexpected stop during outpulsing after receipt of the start-dial signal to the completion of the ST signal on intertandem trunks. On tandem completing trunks, it looks for unexpected stops until finished sending the tens digit of the line number and is blind to them thereafter.
- The DMS-10 system, after receipt of the start-dial signal, will ignore all unexpected stops that are less than 200 ms; if an unexpected stop signal greater than 200 ms occurs before the end of outpulsing, the call will be disconnected.
- The DMS-100F system looks for unexpected stops between the tens and the units digits.
- The EWSD system looks for unexpected stops during outpulsing from the validation of the start-dial signal to the completion of the ST pulse.
- The *LSSGR* has no requirement.

Switching systems test for unexpected stops during dial-pulse outpulsing as follows.

- The 5ESS switching system with stop-go operation allowed looks for an unexpected stop after the hundreds digit or any second stop. The 5ESS system without stop-go operation treats any stop as unexpected.
-

- 
- The DMS-10 system, after receipt of the start-dial signal, ignores all unexpected stops that are less than 200 ms; if an unexpected-stop signal greater than 200 ms occurs before the end of outpulsing, the call is disconnected. The DMS-10 system does not operate stop-go.
  - The DMS-100F system checks for stop signals after each digit and accepts up to three stops per call. The number accepted is adjustable per trunk group.
  - The *LSSGR* has no requirement.

### 6.6.8 Dynamic Overload Control

Dynamic Overload Control (DOC) equipment is available for use in electronic switching offices and is used to send signals to distant offices, requesting that they limit the amount of traffic sent to the electronic office. The DOC signals are sent because of a shortage of real time, a shortage of receivers, or a lack of capability to switch calls. The DOC control console at the switching office contains lamps indicating the types of signals being sent. It is also network management's practice to carefully monitor traffic in expected overload situations (for example, during Mother's Day).

---

## 6.7 Loop Signaling

Historically, many different types of loop signaling methods have been used in LEC networks. In modern LEC networks, only two methods survive: loop-start signaling and loop reverse-battery signaling (also known as just reverse-battery signaling). This section describes loop reverse-battery signaling. Section 6.2.1 describes loop-start signaling. Loop-start signaling provides access lines and loop reverse-battery signaling is used to provide one-way interoffice trunks or to provide DID service to a PBX (see Section 6.2.8).

### 6.7.1 Loop Reverse-Battery Signaling

Figure 6-14 shows a basic application of reverse-battery signaling. For clarity, the interoffice trunk is shown using cable pairs and electromechanical components. In SPC switching systems, equivalent electronic implementations are used. SPC switching systems can connect to loop reverse-battery circuits provided by cable pairs, by digital carrier systems or by a direct digital interface to a digital carrier system.

In loop reverse-battery signaling, the calling office uses loop open and loop closure to indicate on-hook and off-hook to the called office. The called office sends a change from on-hook to off-hook by reversing battery and ground on the tip and ring conductors. Normal battery (ring negative with respect to tip) indicates on-hook and reverse battery (tip negative with respect to ring) indicates off-hook.

In the idle or on-hook condition, all current sensors in Figure 6-14 (electronic, ferrod, or relay) are unoperated and the switch (SW) contacts are open. Upon seizure of the outgoing trunk by the calling office (trunk group selection based on the office code dialed by the calling customer), the following will occur.

- SW1 and SW2 contacts close, thereby closing the loop to called office and causing the A relay to operate.
- Operation of the A relay signals off-hook (connect) to called office.
- Upon completion of pulsing between offices, SW3 contacts close and the called customer is alerted. When the called customer answers, the S2 relay is operated.
- Operation of the S2 relay results in operating the T relay, which reverses the voltage polarity on the loop signaling off-hook to the calling end.
- The voltage polarity causes the CS relay to operate, sending an off-hook (answer) signal to the processor in the calling office.

When the calling party hangs up, disconnect timing per Section 6.5.3 (150 to 400 ms) is started. After the timing is completed, SW1 and SW2 contacts are released in the calling office. This opens the loop to the A relay in the called office and releases the calling party. (The calling party is free to place another call.) Disconnect timing is started in the called

---

---

office as soon as the A relay releases. When the disconnect timing is completed, the following will occur.

- If the called party has returned to on-hook, SW3 contacts will release. The called party is free to place another call.
- If the called party is still off-hook, disconnect timing per Table 6-8 is started in the called office. On the completion of the timed interval, SW3 contacts will open. The called customer will be returned to dial tone. If the trunk is seized again from the calling office during the disconnect timing, the disconnect timing is terminated and the called party is returned to dial tone. The new call would be completed without interference from the previous call.

When the called party hangs up, the CS relay in the calling office releases. Then the following occurs.

- If the calling party has also hung up, disconnection takes place as described above.
- If the calling party is still off-hook, disconnect timing per Table 6-8 is started. On the completion of the disconnect timing, SW1 and SW2 contacts are opened. This returns the calling party to dial tone and de-energizes the A relay in the called office. The calling party is free to place a new call at this time. After the disconnect timing (150 to 400 ms), the SW3 contacts are released which, in turn, releases the called party. The called party can place a new call at this time.

### 6.7.2 Battery-and-Ground Signaling

The range of loop signaling on wire trunks can be increased by employing battery-and-ground signaling. This is accomplished by applying battery and ground (opposite polarity of that applied at the called office) during the loop closure portion of a dial pulse. This doubles the effective voltage available for signaling. Between digits and at the completion of pulsing, a bridge supervisory relay may be substituted for the pulsing battery and ground to detect the backward signals. This arrangement is sometimes called “battery-and-ground pulsing — loop supervision.” When maximum range is required, “battery-and-ground pulsing, battery-and-ground supervision” may be employed. Caution should be observed in using battery-and-ground signaling since, in some cases, it may result in impulse noise with adverse effects on data service. Figure 6-15 shows a circuit using battery-and-ground pulsing with loop holding. This technique, widely used at one time, has become rare in the presence of digital carrier facilities. It may be found on some DID trunks provided by cable pairs.

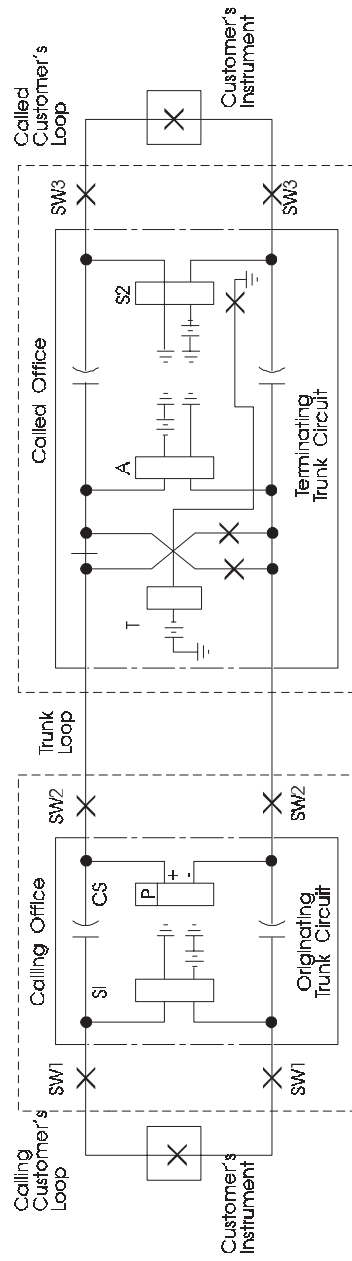


Figure 6-14. Reverse-Battery Signaling



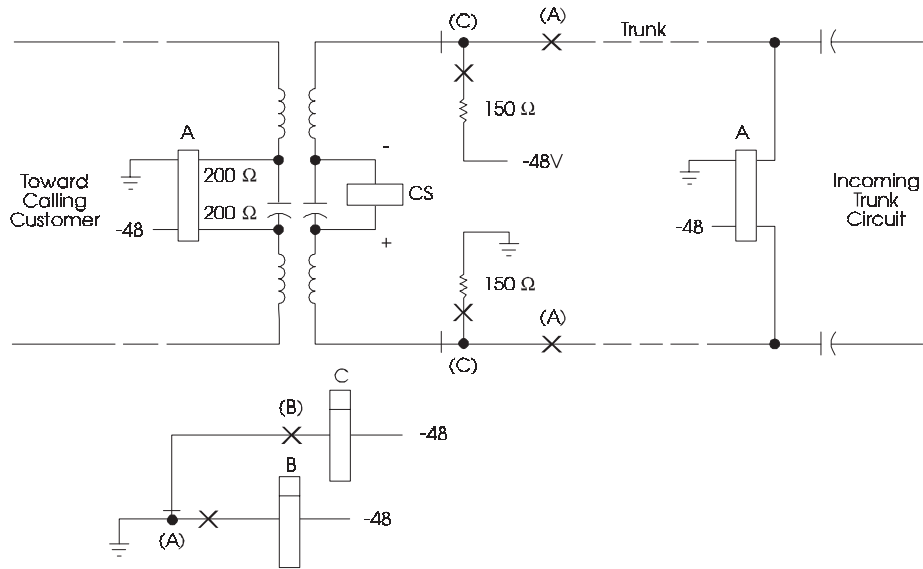


Figure 6-15. Battery-and-Ground Pulsing, Loop Supervision

### 6.7.3 Idle Circuit Terminations and Trunk Capacitance

Idle circuit terminations do not affect signaling on E&M trunks because the T and R leads are not in the dc signaling path. Idle circuit terminations, such as the typical transmission value of 2.16  $\mu\text{F}$  in series with 900  $\Omega$ , may therefore be used.

Idle circuit terminations connected to signaling leads have a substantial effect on signaling. In the idle condition, the termination toward the called end presented by an outgoing trunk circuit or incoming trunk signaling, or channel unit using loop signaling should not exceed 0.5  $\mu\text{F}$  capacitance. This capacitance limit includes all shunt capacitances including transmission capacitors, contact-protector capacitors, and idle circuit termination capacitors.

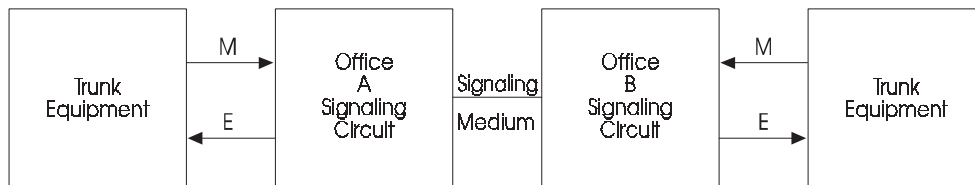
The total trunk capacitance in the on-hook state, including the idle circuit termination in the outgoing loop trunk circuit, the cable, any transmission repeaters, and the on-hook terminating channel unit, should not exceed 2  $\mu\text{F}$  for trunks with a 2000- $\Omega$  specified conductor range, or 4  $\mu\text{F}$  for trunks with a 4000- $\Omega$  specified conductor range.

## 6.8 E&M Signaling

E&M signaling was first used on trunk circuits from switchboards. The trunk circuits connected to various wire-line signaling circuits. Later, carrier systems were introduced for these circuits. Single-frequency signaling was used to transmit the E&M lead information to the far end. Even with the advent of digital carrier, E&M trunk circuits stayed in place because the carrier did not replace the trunk circuit function. However, when electronic switching systems combined the functions of the trunk circuit, the signaling circuit and the digital carrier terminal in a single package, the use of E&M signaling began to wane. Common Channel Signaling (CCS), in turn, has replaced most trunk signaling systems in intraLATA networks. However, some use of E&M signaling may continue for some time where trunk groups are not large enough for more modern methods (Centrex tie lines, trunks from Centrex for private networks, and a multitude of private line applications).

Type I, Type II, and Type III E&M signaling interfaces are essentially the only E&M arrangements that were used in North American intraLATA networks. The Type III interface is found only in offices with older 1 ESS and 2 ESS switching systems and is probably obsolete. Type I and Type II interfaces are covered in GR-506-CORE, *LSSGR: Signaling for Analog Interfaces*.

Most signaling systems, other than loop-signaling, are separate from the trunk equipment and functionally are located between the trunk equipment and the line facility. The E&M signaling systems derive their name from historical designations of the signaling leads on the circuit drawings covering these systems. Traditionally, the E&M signaling interface consisted of two leads between the switching (trunk) equipment and the signaling equipment: the M lead that carries signals from the trunk equipment to the signaling equipment, and the E lead that carries signals from signaling equipment to the trunk equipment. As a result, signals from office A to office B leave on the M lead of the trunk circuit in office A, and arrive on the E lead in office B. In the same manner, signals from office B leave on the M lead, and arrive on the E lead of office A. The flow of signals between two offices using E&M lead signaling is shown in Figure 6-16.



**Figure 6-16.** E&M Lead Control Status

Type I E&M signaling circuits use only one lead for each direction of signaling with a common ground return. This means that the signaling leads had a greater noise influence than if the leads were balanced (2-wire) as are transmission circuits. While Type I E&M signaling circuits operated satisfactorily in electromechanical systems, they were not satisfactory for electronic systems that required separation of the switching system power

supply from the power supply serving other central office equipment. As a result, several new E&M interfaces were introduced. The traditional Type I interface and the newer interfaces are described below.

### 6.8.1 Type I Interface

The Type I interface (Figure 6-17) is the original E&M signaling arrangement. Signaling from the trunk circuit to the signaling facility is over the M lead using nominal -48 V for off-hook and local ground for on-hook. Signaling in the other direction is over the E lead using local ground for off-hook and open for on-hook. The trunk circuit sensor on the E lead should use nominal -48 V, and essentially the full voltage should appear on the E lead during the on-hook state.

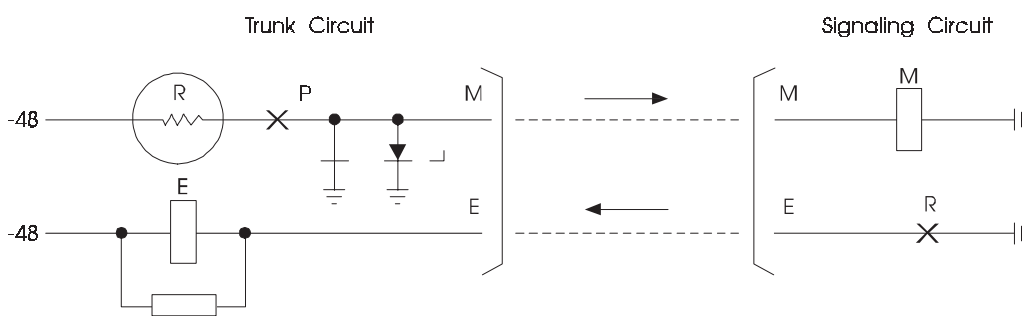


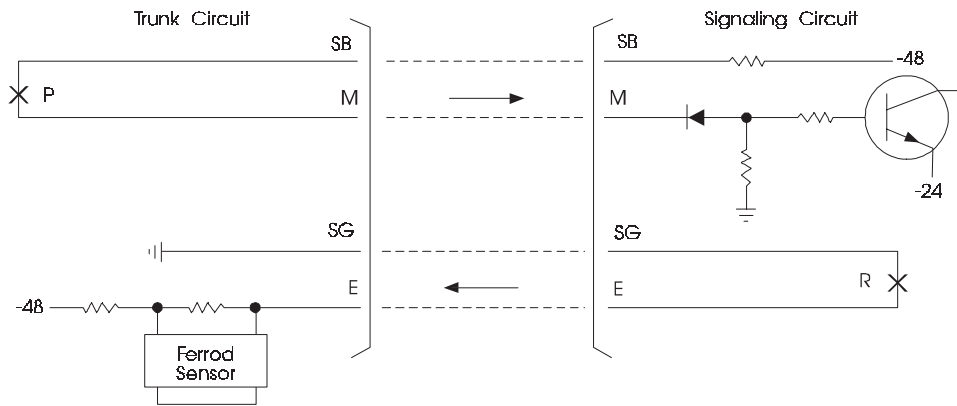
Figure 6-17. Type I Interface

The battery supply to the M lead for the off-hook state may be applied through a current limiter to prevent circuit damage in case the M lead is accidentally grounded. In any case, the voltage should not drop more than 5V with 85 mA in the M lead. The current limiter for the M lead is described in Section 6.8.10. In the on-hook state, the potential drop from M lead to ground at the trunk circuit should not exceed 1 V when an external -50V source is connected to the M lead through 1000  $\Omega$ .

### 6.8.2 Type II Interface

The Type II interface (Figure 6-18) is a 4-wire, fully looped but nonsymmetric arrangement. Signaling from the trunk circuit to the signaling facility is by means of opens and closures across the paired M and SB (signal battery) leads for on-hook and off-hook, respectively. Since the signaling facility supplies nominal -48 V to the SB lead, the effect is to signal on the M lead with battery for off-hook and open for on-hook. Signaling in the reverse direction is by means of opens and closures across the paired E and SG (signal ground) leads for on-hook and off-hook, respectively. Since the trunk circuit grounds the

SG lead, the effect is to signal on the E lead. The signaling facility supplies nominal -48 V to the SB lead through a current limiter.



**Figure 6-18.** Type II Interface

The trunk circuit sensor on the E lead should be biased with nominal -48V, except that if considerable loss of compatibility with test equipment can be tolerated, the voltage may be between -48V and -21V. In any case, in the on-hook state, essentially the full sensor voltage should be present on the E lead.

The sensor on the M lead in the signaling facility may be biased with a voltage in the range of +10V to -24V. When a negative bias or reference is used, it is desirable that a blocking diode be used to prevent the voltage from appearing on the M lead during the on-hook state. This is required if the voltage is more negative than -24 V.

### 6.8.3 Type III Interface

The Type III interface (Figure 6-19) is a compromise; a partially looped, 4-wire E&M lead arrangement. It is essentially a Type I interface except that the battery and ground for signaling on the M lead are supplied by the signaling facility over the SB and SG leads, respectively. The E lead is identical to the Type I E lead, except that the expected current is significantly lower because of the high-resistance E lead detectors used in electronic switching systems to replace relays.

The signaling facility supplies its local ground to the SG lead and feeds nominal -48 V to the SB lead through a current limiter. The M lead sensor should meet the same characteristics as in the Type II interface except that the blocking diode may be omitted.

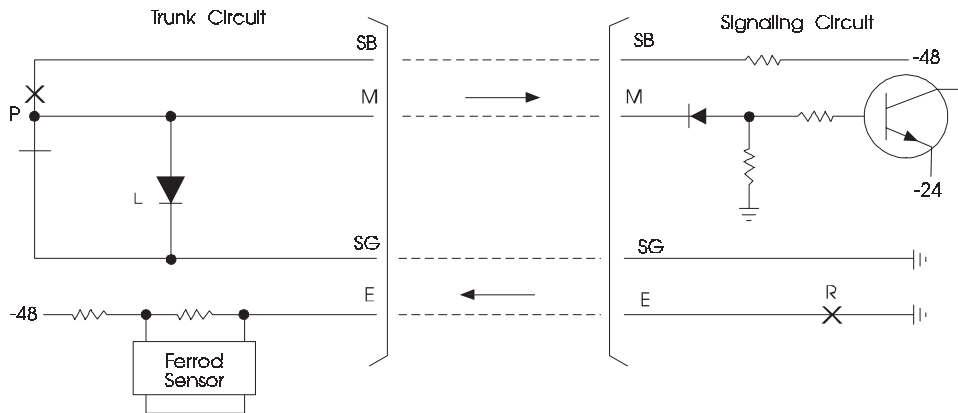


Figure 6-19. Type III Interface

### 6.8.4 Type IV Interface

The Type IV interface (Figure 6-20) is a symmetric, 4-wire looped E&M lead arrangement. Signaling from the trunk circuit to the signaling facility is by means of opens and closures across the M and SB leads for on-hook and off-hook, respectively. Signaling in the reverse direction is identical except that it is across the E and SG leads. Since the trunk circuit grounds the SG lead and the signaling facility grounds the SB lead, the signaling over both the E&M leads is by means of open for on-hook and ground for off-hook. The Type II interface in trunk circuits is identical to the Type IV interface, as are the characteristics for both trunk circuits and signaling facilities.

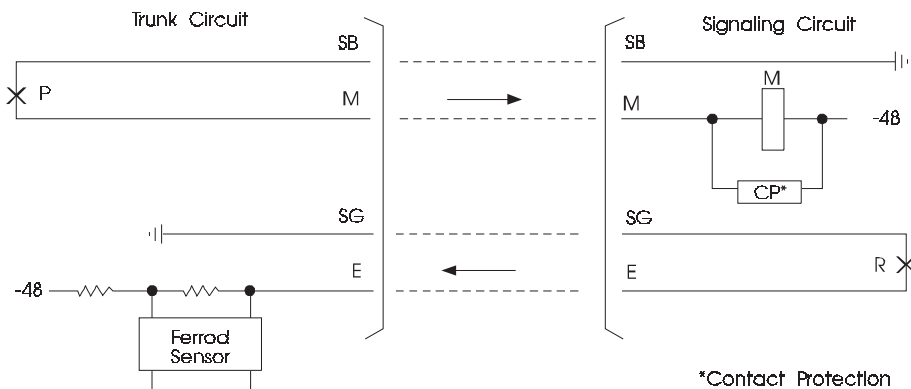
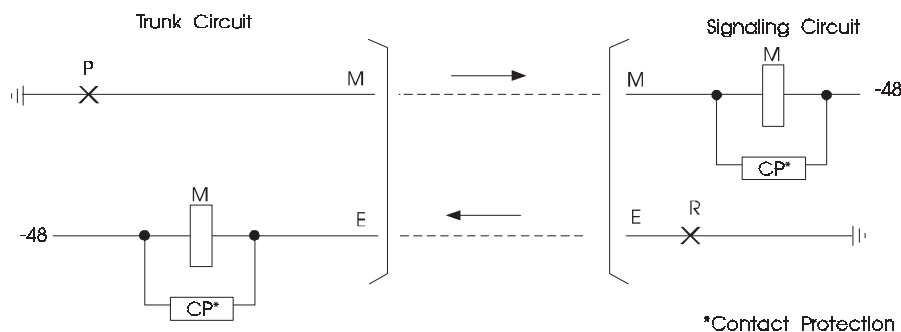


Figure 6-20. Type IV Interface

### 6.8.5 Type V Interface

The Type V interface (Figure 6-21) is a symmetric, 2-wire E&M lead arrangement that signals in both directions by means of open for on-hook and ground for off-hook. Signaling from the trunk circuit to the signaling facility is over the M lead; signaling in the reverse direction is over the E lead. This interface is essentially the unbalanced version of the Type IV interface in which local ground is used for off-hook instead of the ground obtained over the SB or SG lead.



**Figure 6-21.** Type V Interface

The Type V interface is widely used outside North America. However, *Type V interface* is nomenclature used only in North America. A variety of other lead designations are in use besides E&M. The known corresponding sets are E, SZ1, Sa, and SR and M, SZ2, Sb, and SS.

At present, an upper limit of 50 mA on the E or M leads is used for new designs. With the possible exception of maximum current, the design characteristics covered herein should provide for complete functional compatibility with other systems.

The E&M lead sensors are biased with nominal -48V and, in the on-hook state, essentially the full voltage appears on the leads. The sensor resistance is high enough to limit the signaling lead currents to 50 mA.

Most E&M lead test sets used in North America are not fully compatible with either Type IV or V interfaces. The use of -48V on E&M lead sensors will help in the standardizing of E&M test sets.

### 6.8.6 Signaling State Summary

Table 6-14 summarizes the signaling states with respect to the sending end. It should be noted that a bridged examination of all E leads will show essentially nominal -48V (or -21V for the 4ESS switching system) on the leads during the on-hook state. For M leads, any

voltage between +10 and -52.5 V for either on- or off-hook states may be found. Table 6-14 indicates the signal sent, not what a bridged measurement might indicate.

**Table 6-14.** Signal States Sent

Type	Trunk-to-Signaling Circuit			Signaling-to-Trunk Circuit		
	Lead	On-Hook	Off-Hook	Lead	On-Hook	Off-Hook
I	M	Ground	Battery	E	Open	Ground
II	M	Open	Battery	E	Open	Ground
III	M	Ground	Battery	E	Open	Ground
IV	M	Open	Ground	E	Open	Ground
V	M	Open	Ground	E	Open	Ground

## 6.8.7 Switching Methods

### 6.8.7.1 Relay Contacts

The simplest switching means for E&M signaling is a relay contact. Transfer contacts are required for sending on the Type I and III M leads. To lengthen contact life and reduce current surges, a break-before-make transfer should be used and is desirable to keep the open interval during transfer to a maximum of 1 or 2 ms. A longer transfer time may introduce distortion (increase in percent break) to dial pulsing with certain signaling facilities.

### 6.8.7.2 Solid-State Switches

To maintain signaling compatibility and interoperate with the probable variety of E&M lead test equipment, the following characteristics need to be considered.

**Type I M Lead:** In the on-hook state, the potential drop from M lead to local ground should not exceed 1 V when -50 V are connected externally through 1000  $\Omega$  to the M lead.

**Type II M Lead:** If the switch is polarized, reversing means should be provided. In the off-hook state, the potential drop from the M lead to SB lead should not exceed 2 V with 50 mA in the M lead. The current in the SB lead should equal the M lead current  $\pm 10$  percent. Any difference between the two lead currents implies incomplete separation of signaling and trunk circuit power systems, a condition contrary to the intent of the Type II interface arrangement. Unless opto-isolators (or equivalent) are used, it appears that perfect separation cannot be achieved, hence the  $\pm 10$  percent allowance given above. In the on-hook state, little leakage is permitted. If the M lead is grounded, the M lead current should not exceed 100  $\mu$ A whether the SB lead is open or connected to -50 V. If a grounded source



---

of  $\pm 12$  V is connected to the M lead while the SB lead is open, the M lead current should not exceed 24  $\mu$ A.

The switch should operate properly when connected to a signaling facility applying nominal +12 or -42.5 to -52.5 V on the SB lead. The switch should be reversible if it is polarized since the battery may sometimes be supplied on the M lead instead of the SB lead. Normal M lead current is well under 50 mA, but the M lead may be grounded accidentally. Three types of current limiter are in use on the SB leads, leading to three fault current characteristics. Most commonly, a resistor will limit the current to a steady maximum of 175 mA. Another limiter, a Positive Temperature Coefficient (PTC) thermistor, will permit a maximum current of 1.7 A, which drops 75 percent within about 0.5 second and stabilizes at about 30 mA. The third limiter, a 13 A resistance lamp or equivalent, will permit a peak of 3 to 4 A, which will drop to 0.8 A within 10 ms and stabilize at a maximum of about 360 mA within 50 ms.

Additional details concerning fault currents are provided in Section 6.8.10.

**Type III M Lead:** The requirements will be similar to those for the Type II M lead switch, except +12 V will not be found on the SB lead and the leakage requirements for the on-hook state will not apply. When -50 V is connected externally through 1000  $\Omega$  to the M lead, the potential drop between the M and SG leads should not exceed 1 V in the on-hook state.

**Type IV M Lead:** The Type IV and II interfaces appear identical in trunk circuits when relay contacts are used. The difference is in the signaling facility in that it supplies battery to the SB lead for Type II operation or ground for Type IV operation. The M lead signaling formats are battery and open for Type II and ground and open for Type IV. The significance of switch leakage in the on-hook states is different. For Type II, the requirements given are for effective switch leakage to battery or ground to be at least 500 k $\Omega$ . For Type IV operation only, the leakage to ground may be as low as 100 k $\Omega$  in the on-hook state. Also, there are no expected fault currents for the Type IV M lead. Therefore, if a trunk circuit is to be used exclusively for Type IV, the switch requirements are relaxed. If the trunk circuit may be used optionally for either Type II or IV, the switch should be designed to the Type II arrangements.

**Type V M Lead:** The characteristics of the Type V switch are the same as those for the Type IV switch, with additional provisional consideration that the M lead current should be no greater than 50 mA.

**Type I E Lead:** The Type I E lead switch should supply local ground to the E lead in the off-hook state which should not exceed 2 V potential drop across the switch when the E lead current is 250 mA. The potential supplied to the switch will be between -42.5 and -52.5 V in the on-hook state. In the off-hook state, the E lead current is commonly about 50 mA; there has been no limit on the current and it may be as high as 250 mA. The effective resistance of the switch in the on-hook state should be at least 100 k $\Omega$ .

**Type II E Lead:** The Type II E lead switch should supply a closure across the E and SG leads for off-hook. The potential drop across the switch should not exceed 2 V with 50 mA

---

in the E lead. In the on-hook state, the effective resistance of the switch should be at least 500 k $\Omega$ . If the switch is polarized, a reversing means is required. The voltage supplied to the switch on the E lead is in the range of -21 to -52.5 V and the SG lead is grounded. In some trunk configurations, the battery may be supplied on the SG lead, and the E lead may connect to resistance ground or a voltage in the range of +10 to -24 V.

When the SG lead connects to nominal -50 V in the connecting circuit, it is possible for a fault ground on the E lead to cause a surge of up to 1.7 A, falling to about 175 mA within 1 second and stabilizing at about 30 mA after many seconds, or the fault may cause a steady current of up to 175 mA. Normal E lead currents are well under 50 mA.

**Type III E Lead:** The characteristics of the Type III E lead switch are the same as those for the Type I E lead switch, except that the maximum current should not exceed 50 mA. The 2-V potential drop limit is at 50 mA instead of 250 mA.

**Type IV E Lead:** Since the Type IV arrangement is symmetric, the characteristics of the E lead switch are identical to those of the Type IV M lead switch.

**Type V E Lead:** Since the Type V arrangement is symmetrical, switching is the same for both the E lead and the M lead. (See the M lead for Type V, above.)

## 6.8.8 Transient Suppression

Under certain circumstances, surge or transient suppression circuitry is required.

### 6.8.8.1 Type I and III M Leads

Although it appears abnormal, past design placed the surge suppression for Type I and Type III M leads in the trunk circuit. In early circuits, this was done by wiring a 1000- $\Omega$  resistor from the M lead to ground in the trunk circuit. High-wattage resistors were required since they dissipate about 2.5W in the off-hook state. Later, a zener diode in series with a 1000- $\Omega$ , 0.5-W resistor was used as a general replacement for the higher-power resistor. However, the resistor may be omitted. The present requirement is that the trunk circuit should include a 65-V  $\pm$ 10 percent zener diode between the M lead and ground with the anode connected to the M lead. The diode should be able to dissipate at least 500 mW.

### 6.8.8.2 All E Leads

In all interface types, if the E lead sensor is inductive, the sensor should be equipped with a transient suppressor. The requirements for it are that, when the E lead changes from off-hook to on-hook, the voltage rise should not exceed 300V and the rate of rise should not exceed 1V per  $\mu$ s. The voltage surge should not exceed 80V for more than 10 ms. For

---

---

normal relays with at least 500- $\Omega$  windings, a network consisting of 470  $\Omega$  in series with 0.13  $\mu$ F will be satisfactory.

It is permissible for the signaling facility also to provide a network consisting of 470  $\Omega$  in series with 0.13  $\mu$ F across its E lead switch. Accordingly, the design of the E lead sensor should tolerate this capacitance, plus its own capacitance and that of the E lead.

### 6.8.8.3 Type II, IV, and V M Leads

If the M lead sensor (except the Type I and III interfaces) is inductive, it should be provided with a transient suppressor meeting the E-lead requirements above.

In Type II and IV interfaces, it is not permissible to also provide a capacitor-type transient suppressor across the M lead switch in the trunk circuit if the trunk sends dial pulses or other pulses with timing requirements equivalent to those of dial pulses. If the switch requires greater protection than that given by the signaling facilities, it must be by means other than a capacitor network.

## 6.8.9 E&M Lead Current Limits

No lower limit is set for off-hook currents in E or M leads. From a practical standpoint, the lowest usable currents are approximately 1 or 2 mA. If sensor resistance is higher, the resistance-capacitance time constant will cause excessive pulse distortion. Since there is no lower limit for currents, it is not permissible to use current sensors in any E or M lead except for the one at the end of the lead.

In the past, no upper limit was established for E or M lead currents. The maximum known M lead current to signaling facilities is approximately 85 mA into E-type single-frequency units, with the next highest being about 55 mA into duplex (DX) signaling circuits. See Section 6.8.10 for M lead fault currents. The highest known E lead current was into No. 5 crossbar circuits where it could reach 250 mA or slightly over. Most electromechanical systems used relays with currents in the 50-mA range. Electronic systems usually draw much lower currents. It is desirable that all E&M lead currents be limited to a maximum of 50 mA in new circuit designs for normal circuit operation.

## 6.8.10 Current Limiters

For all E leads and Type IV and V M leads, the current limits are established by the supply voltage and the sensor resistance. In the case of Type I, II, and III M leads, the current limiting is done at both ends of the leads. Having to supply battery to a signaling lead is a major defect in these three interfaces. The following sections discuss limiters in the battery feed to M or SB leads.

---

#### 6.8.10.1 Type I M Lead

The trunk circuit signals off-hook by supplying nominal -48 V to the M lead. In the earlier E&M lead circuits, a resistance lamp was provided in the battery feed to the M lead switch. These lamps are satisfactory in most respects and are still used. A resistance lamp used as a current limiter in the battery supply of the Type I M lead represents less than 10  $\Omega$  cold.

To avoid using resistance lamps, several circuit designs have been introduced. One design uses one fuse per M lead. Some circuits use PTC thermistors, and others use a 1000- $\Omega$  resistor. If thermistors or resistors are used, the resulting circuit should meet the Type I interface characteristics.

The desired characteristic for Type I M lead current limiters is that the potential drop in the trunk circuit should not exceed 5 V at 85 mA of M lead current plus any internal current.

#### 6.8.10.2 Type II SB Lead

The signaling circuit with the Type II interface supplies battery, usually -48V, to the SB lead. As in the Type I interface, a current limiter is necessary in this battery feed. Three types of limiters are used: lamps, PTC thermistors, and fixed resistors. The known fixed resistor limiters are in the range of nominal 316 to 1000  $\Omega$ . The worst-case fault current is a steady 175 mA. To maintain maximum compatibility, the resistor should not exceed 1000  $\Omega$ , or 500  $\Omega$  if the circuit may optionally provide a Type III interface. Resistors under 316  $\Omega$  may be used, but must be large power types. The resistor should never be under 150  $\Omega$ .

A resistance lamp with a rating of 28V, 169 mA is used in one DX circuit to limit the SB lead current. A ground fault on the SB or M lead can cause a current peak of 3 to 4A, which drops to 800 mA within 10 ms and stabilizes at about 360 mA within 50 ms.

The third limiter is a PTC thermistor used in the G-type single-frequency signaling units. The cold resistance range is 40 to 90  $\Omega$  at 25°C. Until the thermistor reaches about 50°C, it exhibits a small negative temperature coefficient. Thereafter, the coefficient becomes positive at and above the switching or Curie temperature. The initial fault current will be about 1.6A, which may rise slightly for approximately 100 ms and then decay to a few hundred mA within 0.5 to 1 second. Eventually, the current will stabilize under 50 mA if there is little or no series resistance to the ground fault. Series resistance limits the peak current and slows the decay after the device switches.

#### 6.8.10.3 Type III SB Lead

The same current limiters are used for Type III SB leads as for Type II, except that there are three circuits known to use the resistance lamp, two DX circuits and the E&M applique. All the problems and characteristics are the same as for the Type II interface, except that

---

during normal service, the resistance of the limiter should not exceed  $500\ \Omega$  if the signaling circuit or signaling interface converter furnishes the SB lead and detects the M lead signal. Where the SB lead is furnished by one circuit and the M lead detector is in another circuit, as is the case in a Type III-to-Type I conversion (Figure 6-22), the current limiter for the SB lead must not cause a voltage drop of more than 5 V with 85 mA flowing. Many trunk circuits with the Type III interface use  $975\text{-}\Omega$  surge-suppression resistors from the M lead to the SG lead; the resultant voltage divider effect will reduce the M lead voltage to such a low value that some common test sets cannot detect the off-hook state if over  $500\ \Omega$  is used in the SB lead.

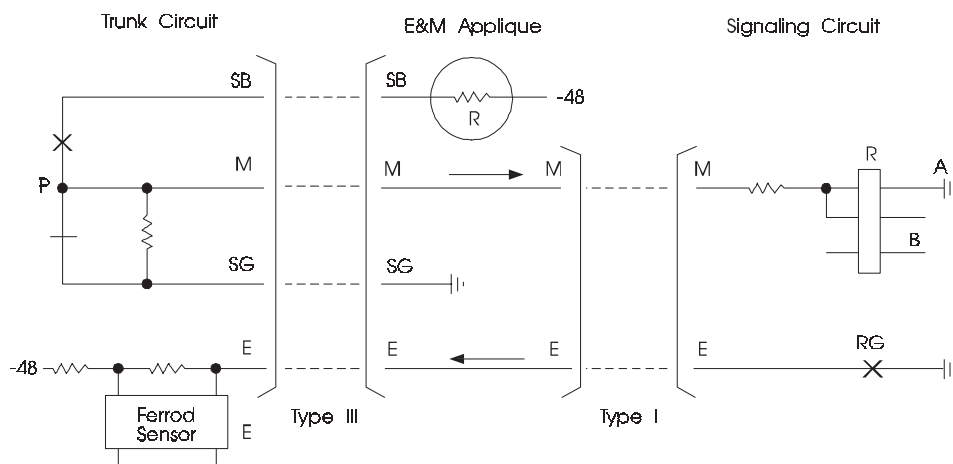


Figure 6-22. Type III-to-Type I Conversion (Normal Range)

### 6.8.11 Compatibility

When trunk and signaling circuits conform to the characteristics for standard E&M lead interfaces, there will be completely functional dc signaling compatibility between any trunk circuit and any signaling circuit of the same interface type. Except for any options to provide the particular interface type, no other option is required for this assured compatibility.

The characteristics for the Type I interface also ensure compatibility with all known E&M lead testing equipment and status indicators. The absence of ground for on-hook makes the Type II M lead incompatible with several status indicators and test sets. The low voltage for off-hook on Type III M leads when the trunk circuit uses resistance surge suppression causes incompatibility with some indicators and test equipment. The use of other than nominal  $-48\text{ V}$  for SB leads or sensors on E leads may lead to moderate or even complete incompatibility with test facilities. Therefore, even where the interface characteristics permit using other than  $48\text{ V}$ , there should be a sound technical reason for doing so.

### 6.8.12 Interface Conversion

It is possible to use older signaling facilities having only the Type I interface with trunk circuits having the Type II or III interface. This connection requires the use of a conversion circuit, the E&M applique. This circuit has options for converting Type II or Type III to Type I. Figures 6-22 and 6-23 show these conversions. Figure 6-22 is for normal-range resistance limits. For greater range, a more involved applique circuit has been used in which an M-lead relay repeats the signal on the M-lead toward the signaling circuit.

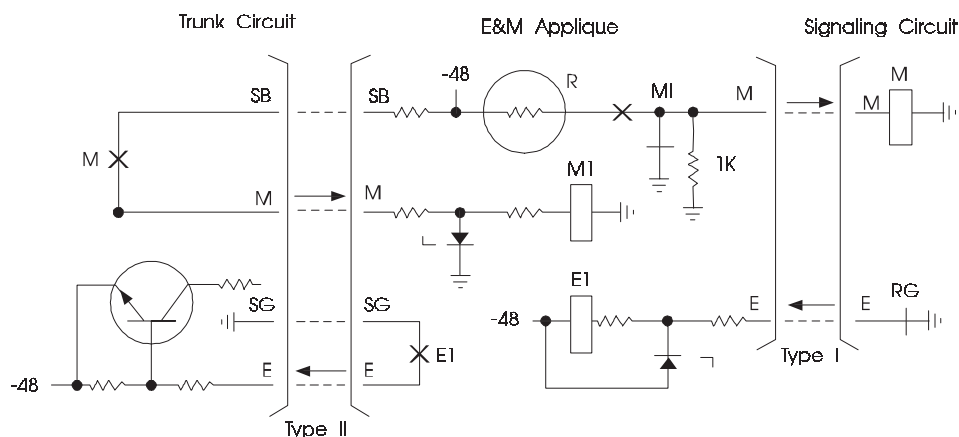


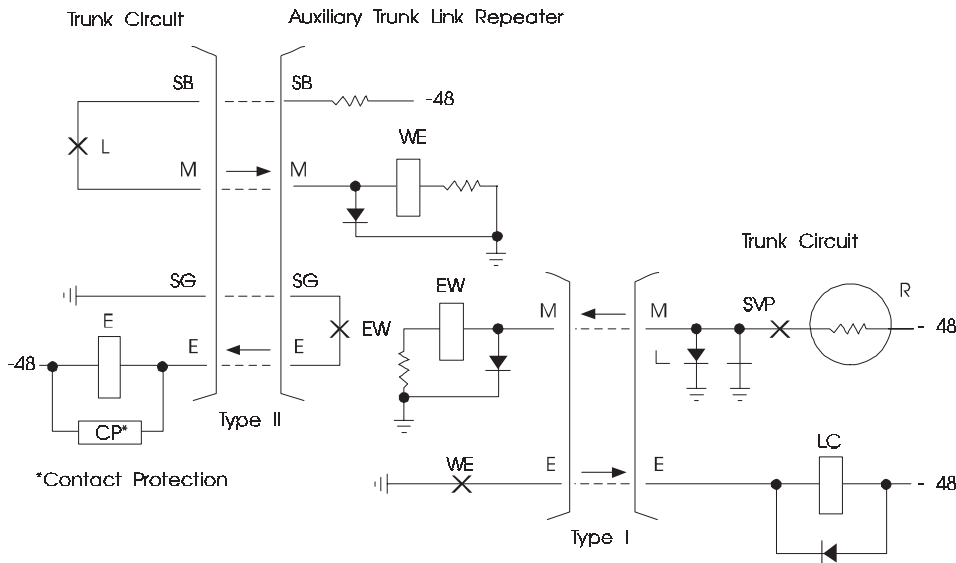
Figure 6-23. Type II-to-Type I Conversion

### 6.8.13 Back-to-Back Connections

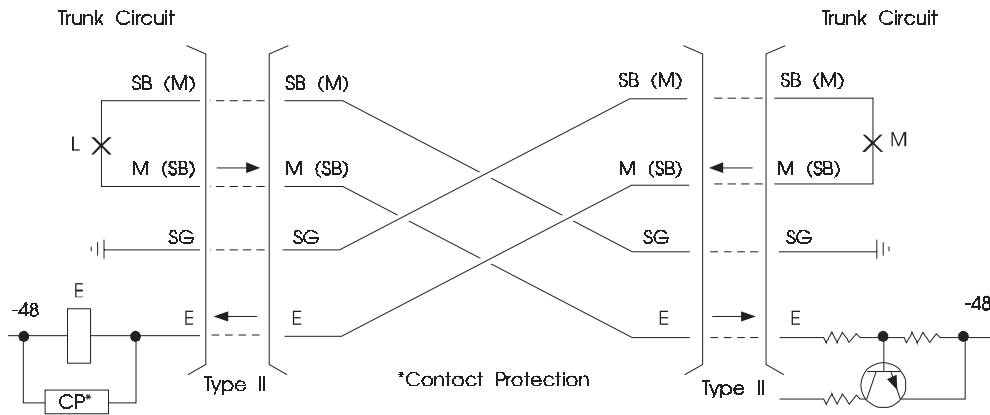
Sometimes it is desirable to connect a trunk circuit of one switching system to a trunk circuit of another system in the same building. Built-up trunks sometimes make use of signaling facilities interconnected within the same building. These back-to-back connections can sometimes be made directly; otherwise, they are made through auxiliary link circuits, depending upon the interface type.

Circuits with Type I or III interfaces must use an auxiliary link for back-to-back connections. This is illustrated in as Figure 6-24 for a Type I interface. Type I interfaces can be connected back-to-back through an auxiliary pulse-link circuit which interchanges the signaling conditions of the E and M leads. Circuits with Type II, IV, or V interfaces may be interconnected metallically by connecting leads SB, M, SG, and E of one, to leads SG, E, SB, and M (respectively) of the other. (The SB and SG leads are omitted for Type V.) Back-to-back connections are shown in Figure 6-25. The back-to-back interconnection shown in Figure 6-25 is used in the 1/1A ESS switching system. For earlier systems, two lead designators are reversed: the lead labeled M becomes SB, and SB becomes M.

When two like circuits with Type II interfaces are connected back to back, they form a symmetric arrangement. When signaling circuits are interconnected, battery and open are



**Figure 6-24.** Trunk Circuit to Trunk Circuit via Auxiliary Trunk Link Repeater



**Figure 6-25.** Trunk Circuits Back-to-Back — Type II

used for the signaling states in both directions. Circuits with Type V interfaces are connected back to back by simply wiring the E lead of one to the M lead of the other, and vice versa.

Where trunk circuits are interconnected, ground and open are used for the signaling states in both directions. Most E&M lead test facilities are made for the usual asymmetric interfaces; therefore, improvisation is necessary to do some of the testing. If this is considered to be a serious problem, the trunk circuits may be interconnected by using an auxiliary circuit.

#### **6.8.14 60-Hz Immunity Requirements**

E&M leads should remain within a building or, at most, pass between adjacent buildings with a common ground system. They are therefore not exposed to significant 60-Hz induction or lightning and have no requirements in this regard.

#### **6.8.15 Working Range**

The sensors on the E&M leads should be sensitive enough to permit each conductor, including SB and SG leads, to have a resistance of at least 150  $\Omega$ . This means at least 300  $\Omega$  on a loop basis where applicable. The sensitivity should be low enough that -50 V or ground through 20,000  $\Omega$  bridged onto either M or E leads, respectively, will not be seen as an off-hook state. The sensor on the Type III M lead should accommodate a 900- $\Omega$  surge-suppression resistor from the M lead to the SG lead in the trunk circuit.

#### **6.8.16 Relative Merits**

##### **6.8.16.1 Type I Interface**

In the Type I interface, battery is supplied at the trunk circuit for both the E&M leads. This causes high return current through the office grounding system. In some offices where the trunk circuits are on one floor and the signaling facilities are on another floor, special equalizing jumpers have to be added between the ground systems of the two floors to maintain the required 0.5-V maximum potential between the two floors with large numbers of E&M leads in use. More importantly, it violates the integrity of the office grounding scheme.

##### **6.8.16.2 Type II Interface**

The Type II interface provides nearly complete or complete separation between switching and signaling power systems. It is least likely (along with Type IV) to cause interference to other circuits in sensitive environments. Metallic back-to-back interconnection of like circuits is possible.

On the negative side, when a trunk circuit connects to a signaling facility having only the Type I or V interface, the interface conversion circuit adds to the installed cost of the trunk.



### 6.8.16.3 Type III Interface

The Type III interface is used in 1/1A ESS, and 2/2B ESS switching systems. It provides complete separation of power systems for the M lead and allows the trunk circuit to establish the level of E lead current. The conversion to Type I is cheaper than from Type II to Type I.

Drawbacks to the Type III interface are its inability to use simple back-to-back interconnection of like circuits and the fact that it does not return the current from the E lead to the trunk circuit.

### 6.8.16.4 Type IV Interface

The Type IV interface has all the advantages of the Type II interface and, in addition, has no battery feed problem. It is the ideal E&M lead interface where single-lead signaling is considered a hazard or where separation of power systems is required.

### 6.8.16.5 Type V Interface

The Type V interface has no battery feed problem. Although it does not provide separation of power systems, there tends to be no return ground current between power systems when the circuit is on- or off-hook in both directions. It is the standard outside of North America.

## 6.8.17 E&M Lead Connection to Testboards

When the signaling leads of any E&M interface appear on jacks at testboards, only the E&M leads appear on jacks for testing. The E lead is on the tip and the M lead is on the ring of the jack.

## 6.8.18 List of Service Trunks

A list of service trunks using E&M signaling and the various loop-signaling arrangements is shown in Table 6-15.

Table 6-15. Service Trunks

Function	Type of Equipment	Location	Direction	Supervision	Start	Address of Called Party	Address of Calling Party	Coin Control (Note 1)	Ringling (Note 2)	Other Signals
OSPS—Coin 1+ Some or all combined Dial 0, 00, 0+, 1+ Dial 0, 00 Dedicated 00	OSPS	Remote Building	To OSPS	Loop Reverse-Battery, High-Low	Wink	MF**	MF**	Inband	Inband*	ANI Request Signal from OSPS — Reverse Make Busy†
					Wink	MF**	MF**	Multiwink or EIS	Multiwink or EIS	
				E&M	Wink	MF**	MF**	Inband	Inband	ANI Request Signal from OSPS — Reverse Make Busy
					Wink	MF**	MF**	Multiwink or EIS	Multiwink or EIS	
OSPS—Non-coin 1+ Some or all combined (Dial 0, 00, 0+, 1+) 0+ Dial 0, 00 Dedicated 00	OSPS	Remote Building	To OSPS	Loop Reverse-Battery High-Low	Wink	MF**	MF**	None	Inband—Wink Only or Wink and MFT EIS	ANI Request Signal from OSPS — Reverse Make Busy
				E&M	Wink	MF**	MF**	None	Inband—Wink Only or Wink and MFT EIS	ANI Request Signal from OSPS — Reverse Make Busy
OSPS—Coin and Non-coin Combined Some or all Combined (Dial 0, 00, 0+, 1+)	OSPS	Remote Building	To OSPS	Loop Reverse-Battery, High-Low	Wink	MF**	MF**	Inband	Inband	ANI Request Signal from OSPS — Reverse Make Busy
					Wink	MF**	MF**	Multiwink or EIS	Multiwink or EIS	
				E&M	Wink	MF**	MF**	Inband	Inband	ANI Request Signal from OSPS — Reverse Make Busy
					Wink	MF**	MF**	Multiwink or EIS	Multiwink or EIS	
Intercept - Combined, (Regular, Trouble and Machine)	No. 6A Announcement System	Same or Remote Building	To System	Loop Reverse-Battery, High-Low	None	None	None	None	None	Signal to Announcement System Accompanying Seizure to Indicate Regular, Trouble, and Machine
Combined (Regular Trouble, and Machine)	Automatic Intercept Center (AIC)	Same or Remote Building	To System	Loop Reverse-Battery, High-Low	Wink	MF**	None	None	None	Reverse Make-Busy
				E&M	Wink	MF**	None	None	None	None

**Note 1:** Coin control consists of two signals; coin collect and coin return.

**Note 2:** Ringling the customer.

**Legend:**

MF Multifrequency

\* The inband signals will be preceded by a wink.

\*\* Special format.

† Also operator-attached and operator-released signals when multiwink or expanded-inband signaling is used.

---

### 6.8.19 E&M Signaling for Customer Installation Equipment

E&M signaling is often used on tie trunks to a PBX. The tie trunks between the LEC and the customer are terminated at the demarcation point. Tie trunks can use all the signaling protocols and signaling systems used for interoffice trunks as covered in Sections 6.4 through 6.6 and Sections 6.10 through 6.13.

#### 6.8.19.1 Differences Between Customer Installation E&M Signaling and Central Office E&M Signaling

E&M signaling at the network interface to end-users is usually identical to central office trunk signaling. That is, the signals from the customer are sent on the M lead (originate on the M lead) and received on the E lead.

However, some E&M signaling from the customer uses the E lead (originates on the E lead) to send signals and the M lead to receive signals.

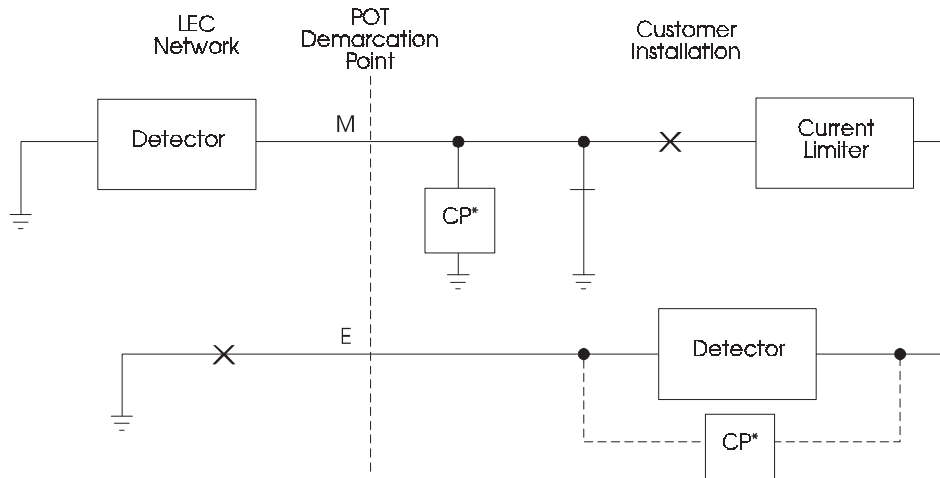
#### 6.8.19.2 E&M Lead Interfaces at the NI

The customer uses both Type I and Type II signaling interfaces. Originating on the M lead, the interfaces look and operate identically with the Type I and Type II interfaces described earlier. However, when the customer originates on the E lead, the Type I and Type II interfaces look and operate quite differently. The figures showing the four customer premises interfaces are as follows:

Type I	Customer installation originates on the M lead	Figure 6-26
Type I	Customer installation originates on the E lead	Figure 6-27
Type II	Customer installation originates on the M lead	Figure 6-28
Type II	Customer installation originates on the E lead	Figure 6-29

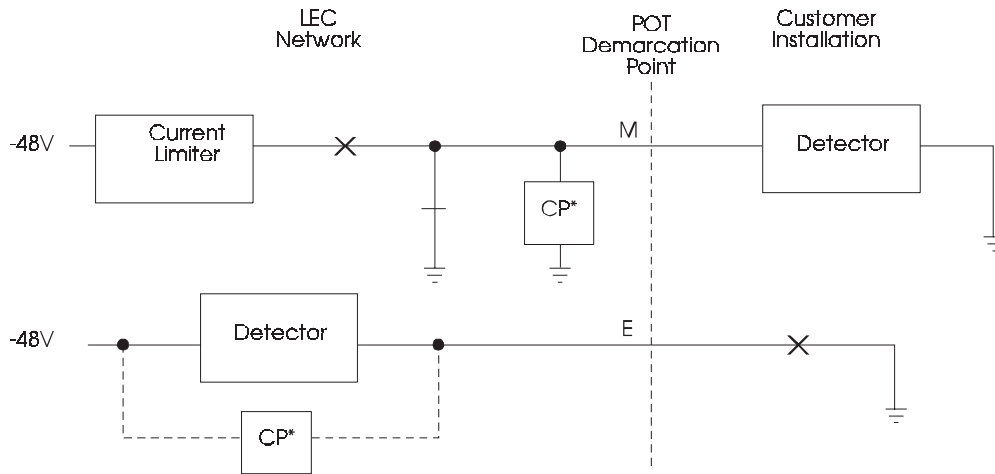
#### 6.8.19.3 E&M Signaling Standards for Customer Installation Equipment

The Type I and Type II interfaces and protocols for a customer installation that originates on the M lead are covered in EIA/TIA 464-B-1996, *Private Branch Exchange (PBX) Switching Equipment for Voiceband Application*. ANSI T1.409-1996, *American National Standard for Telecommunications — Network-to-Customer Installation Interfaces— Analog Voicegrade Special Access Lines Using E&M Signaling* covers all four of the interfaces described above.



\* Contact protection required if the detector is inductive.

**Figure 6-26.** Type I — Customer Installation Originates on the M Lead



\*Contact protection required if the detector is inductive.

**Figure 6-27.** Type I — Customer Installation Originates on the E Lead

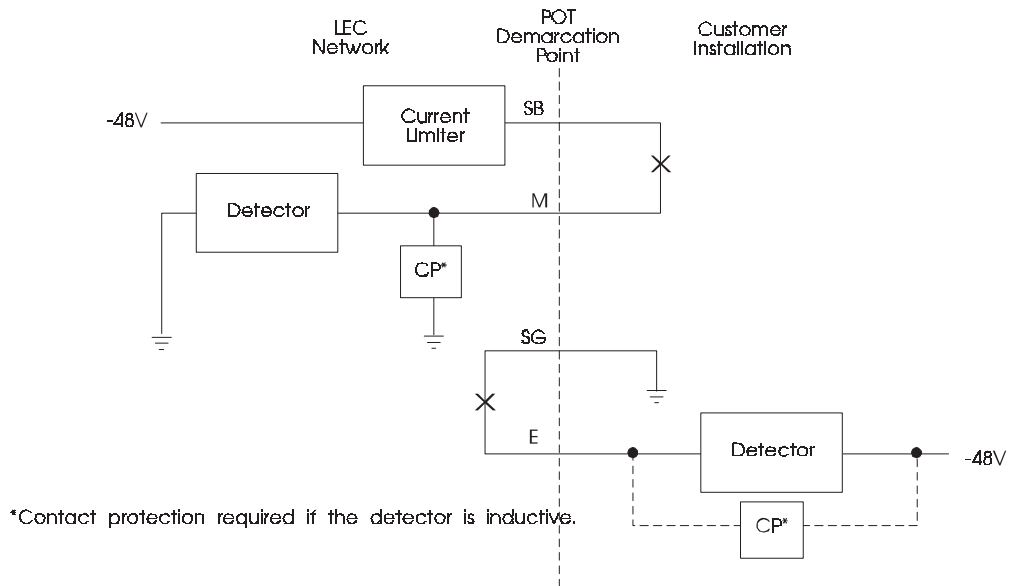


Figure 6-28. Type II — Customer Installation Originates on the M Lead

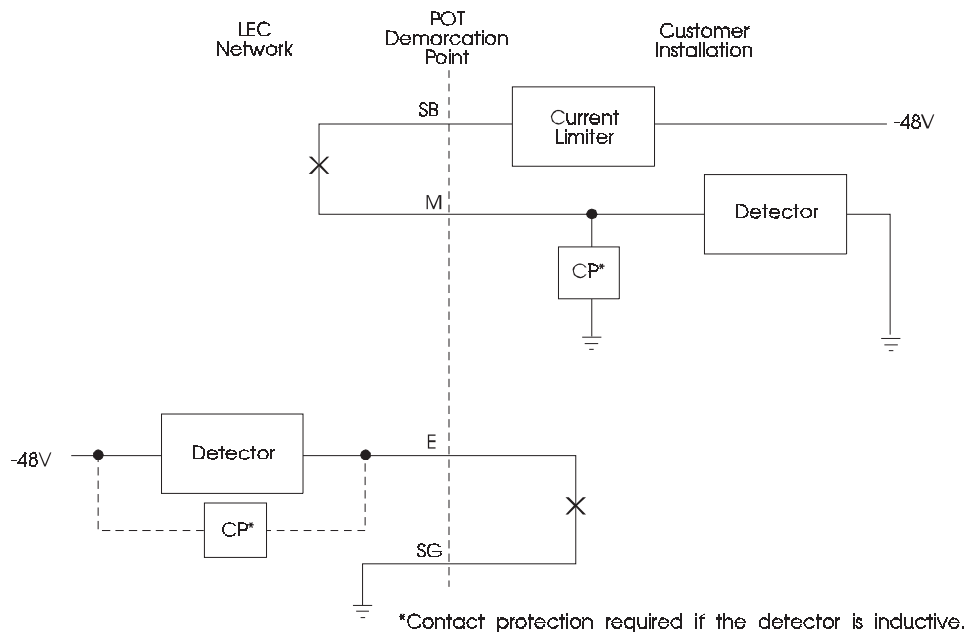


Figure 6-29. Type II — Customer Installation Originates on the E Lead

## 6.9 Duplex Signaling

Duplex (DX) signaling is probably obsolete in modern LEC networks. If found at all, it will be in the last signaling link between the serving office and a PBX or ACD using E&M signaling over an access line provided by cable pair facilities.

DX signaling was developed to provide dc signaling and dial pulsing beyond the range of loop-signaling methods. DX signaling is duplex in operation; that is, it provides simultaneous 2-way signaling paths. A sensitive polar relay or semiconductor detector at each end of the line receives signals from the distant end. Balancing networks are provided and must be adjusted for each circuit according to the resistance of the line conductors.

DX signaling is based upon a balanced and symmetrical circuit that is identical at both ends. Figure 6-30 shows a trunk using this method. The signaling circuit uses the same conductors as the talking path. Introducing the signaling current into the midpoints of the repeating coils does not require a filter to separate the signaling frequencies from the voice transmission. One conductor in the DX system carries the supervisory and pulsing signals. Both conductors individually carry currents resulting from differences in terminal ground potentials and battery supply voltages so that current in the second wire can cancel the effect of this unwanted current in the first wire. This arrangement gives self-compensation against differences in ground potential and ac induction, and partial compensation for battery supply variations.

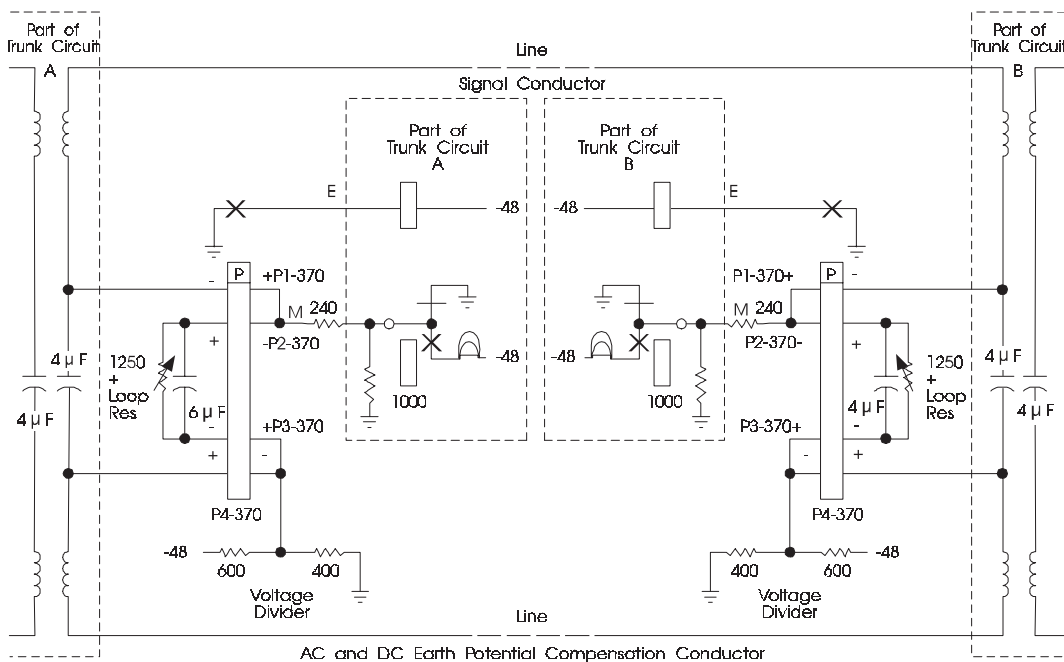


Figure 6-30. DX Signaling Circuit

---

With proper balancing network adjustment, DX signaling circuits will repeat 12 pulses per second (pps) of 58-percent break with a distortion not exceeding  $\pm 4$  percent break. This performance is better than for most loop-signaling arrangements. A single DX signaling section is limited to a maximum loop resistance of 5000  $\Omega$ .

Sometimes it is necessary to extend signaling circuit E and M leads beyond their normal limitations. For this purpose, signal lead-extension circuits are used to secure adequate range. In effect, this circuit consists of a DX signaling circuit with an additional relay. This circuit, often designated DX2, converts signals from signaling circuit E lead conditions to signaling circuit M lead conditions. Usually, however, the DX2 function is built into a channel unit for a digital carrier system.

DX signaling equipment must be balanced for proper operation. A static or dc balance is required as well as a transient balance. The dc balance is achieved by adjusting a resistor in the balancing network of the DX1 or DX2 to 1250  $\Omega$  plus resistance of the loop.

To obtain a satisfactory transient balance of the R relay, use a simple balancing network consisting of the line balancing resistance shunted by an experimentally determined capacitance. All trunk arrangements can be balanced using 6  $\mu\text{F}$  in the balancing network if 4  $\mu\text{F}$  is used at the repeat coil midpoints of a 2-wire line, or if 4  $\mu\text{F}$  is used across the simplexes of a 4-wire line.

When a change of signaling state is sent over a DX signaling facility, the time it takes that signal to arrive at the terminating circuit ranges between 2 and 25 ms. This delay time is dependent primarily on the total trunk capacitance including the repeat coil midpoint capacitor, cable capacitance, and capacitance of any repeaters in the trunk. The conductor resistance is significant only insofar as it represents greater mileage and, therefore, more cable capacitance. The battery voltage and balancing network capacitor are not significant factors.

---

## 6.10 Dial Pulsing

Dial-pulsing requirements have changed little over the years. The tendency has been to provide longer range (more resistance in the loop) and more margin for satisfactory pulse reception with the same pulsing limits. In all switching systems, loop range and pulsing limits can be traded for each other without changing the physical equipment.

The three standards below cover customer installation equipment requirements for dial pulses and range limits that are satisfactory for all existing switching systems.

- ANSI T1.401-1993, *American National Standard for Telecommunications — Interface Between Carriers and Customer Installations — Analog Voicegrade Switched Access Lines Using Loop-Start and Ground-Start Signaling*;
- EIA/TIA 464-B-1996, *Private Branch Exchange (PBX) Switching Equipment for Voiceband Application*;
- EIA 470-A-1987, *Telephone Instruments with Loop Signaling*;
- GR-506-CORE, *LSSGR: Signaling for Analog Interfaces*.

The *LSSGR* requires that new switching systems receive pulses at higher and lower pulsing speeds and at longer range with the same number of ringers and with the same percent break at the terminal.

### 6.10.1 Dial-Pulse Generation

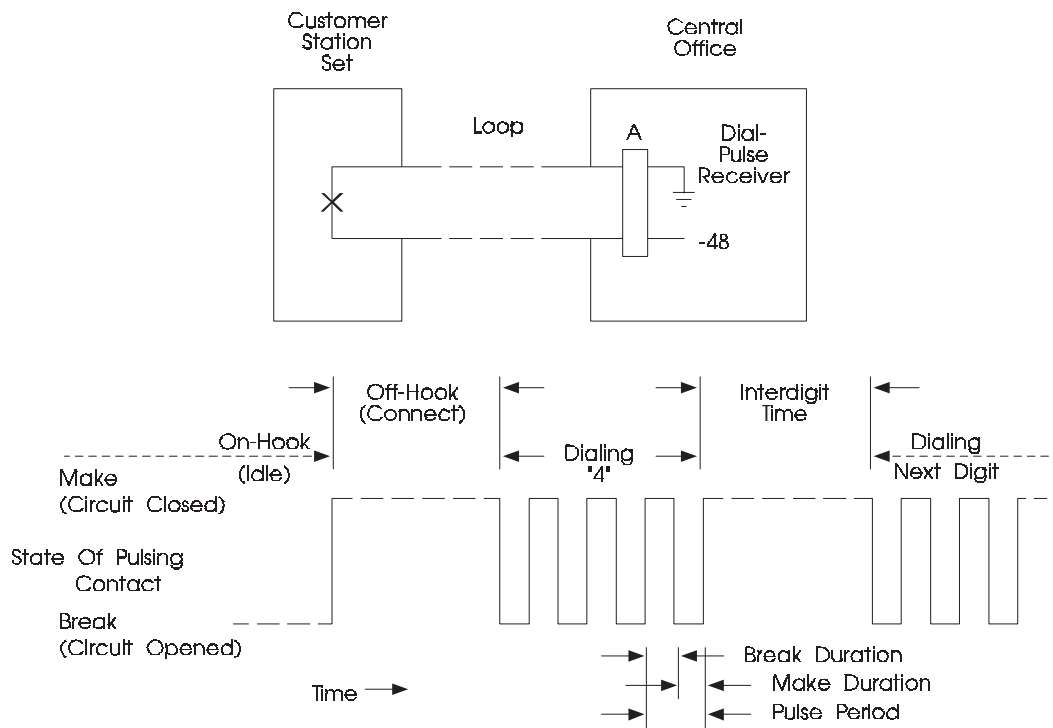
Dial pulsing is a means of transmitting address digit information from a customer's dial (or electronic pulse generator) to the central office equipment. Dial pulses are momentary openings of the loop that are detected in the switching equipment. Senders that accept dial pulses from interoffice trunks are available, as well as senders that will dial-pulse outward.

With dial pulsing, the numeric value of each digit is represented by the number of on-hook intervals in a train of pulses. The on-hook intervals of each digit are separated by short off-hook intervals, while the digits themselves are separated by relatively long off-hook intervals. The on-hook signals are not interpreted as disconnect signals since they are considerably less than the minimum disconnect times given in Section 6.5.3. The off-hook interval between digits is distinguished from the off-hook between pulses by a timing circuit. The end of a digit is recognized when the off-hook signal is in the order of 75 to 210 ms.

Dial-pulse signaling ideally is originated at a *pulsing speed* of approximately 10 pps at approximately 61-percent break. Pulsing speed is maintained as close to the nominal 10 pps as economic considerations warrant. The break ratio is deliberately changed away from 50-percent break to compensate for the characteristics of pulse-receiving equipment and signal transmission systems, which differ substantially, and to make the most advantageous use of circuit conditions occurring during the break and make time intervals.



Figure 6-31 illustrates dial pulsing. It shows a typical pulse generator (which may be the electronic switch in an electronic dial, the cam-operated contact in a rotary dial or the *make* contact of a pulse-repeating relay in a signaling circuit as shown); these switches or contacts open and close a dc circuit a number of times equal to the digit being dialed. (Electronic switches have taken the place of most contacts in new equipment. Within the context of this document the words “electronic switch” are interchangeable with “dial contact” or “relay contact.”) The pulse generator may also be a keyer operating on the signaling bits in a digital bitstream. The figure illustrates some of the terms employed in describing dial-pulse signaling circuits.



Legend:

Pulsing Period = Break Duration + Make Duration (ms)

Pulsing Speed = Pulse Per Second =  $1000 \div$  Pulsing Period (ms)

Percent Break =  $100 \times$  Break Ratio

**Figure 6-31.** Dial-Pulse Signaling

Dial pulses are measured at a contact or switch in normal practice. This can be the dial contact or electronic switch. In the standard listed below, one of the proposed detectors (slope detector) measures the opens and closures of the dial contact or electronic switch remotely by sensing the abrupt changes in voltage as the contact opens and closes. It can also be a relay contact or electronic switch in a pulse-receiving circuit.

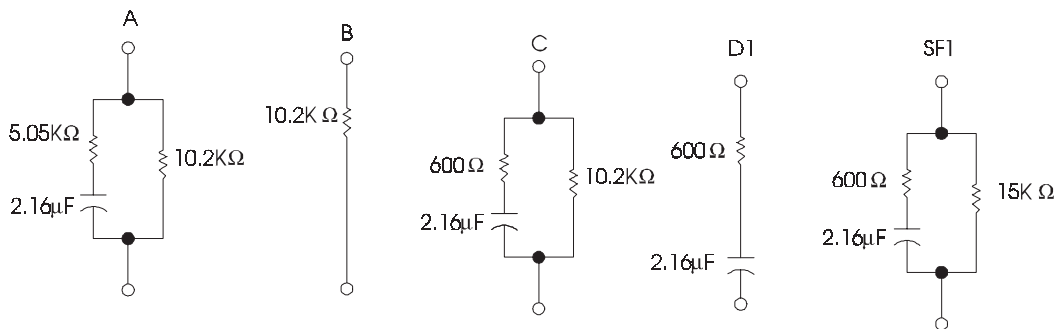
Methods and equipment for measuring dial pulses are covered in IEEE Standard 753-1983, *IEEE Standard Functional Methods and Equipment for Measuring the Performance of Dial-Pulse (DP) Address Signaling Systems*. The standard calls for two different pulse receivers. The first is a relay detector; the second is an electronic detector (“quasi A-relay”). A method is available to measure the waveforms of dial pulses with a test circuit and an oscilloscope. This method is presented later in this section.

### 6.10.2 Loop and Leak

In a dial-pulse receiver using a relay, series resistance in the circuit connecting the pulsing contact with the relay winding reduces the maximum current that can flow and the rate at which the current increases from zero to maximum. The net effect of adding series resistance is the same as increasing the percent break at the pulsing contact. Shunt capacitance and shunt resistance have the opposite effect. Instead of ceasing abruptly when the pulsing contact is opened, relay winding current continues flowing at a steady rate through the shunt resistance, and then at an exponentially decreasing rate until the capacitance is charged to the signaling voltage.

In certain pulsing tests, series resistance is added to roughly simulate the effect of a long loop in increasing the break ratio. The test condition is then known as the *loop* condition, with the amount of resistance usually stated. Various defined combinations of resistance and capacitance are often shunted across the test circuit to simulate the tendency of ringers, ringing bridges, and other equipment to reduce the break ratio. The conditions are known as *leak* conditions.

The various leak conditions are shown in Figure 6-32.



**Figure 6-32.** Leaks for Dial-Pulse Testing

- **Leak A** — A 10,200-Ω  $\pm 1$ -percent resistor is connected in parallel with a series combination of a 2.16-μF  $\pm 2$ -percent capacitor and 5050-Ω  $\pm 1$ -percent resistor across the pulsing contact. This leak is the equivalent of a customer line located next to the central office equipped with five C4A ringers and a 15,000-Ω leak on the drop wire.

---

This leak is a rough substitute for electronic ringers, which comprise primarily resistance and capacitance in series;

- Leak B — A resistor of  $10,200\ \Omega \pm 1$  percent parallels the pulsing contact. This leak condition represents a line-insulation leak of  $10,200\ \Omega$  on a 2-party subscriber line, where ringers are connected to ground and do not significantly affect dial pulsing;
- Leak C — A  $2.16\text{-}\mu\text{F} \pm 2$ -percent capacitor in series with  $600\text{-}\Omega \pm 1$ -percent resistor is connected in parallel with  $10,200\text{-}\Omega \pm 1$ -percent resistor across the pulsing contact. This network simulates a dial-pulse transmitter with a  $10,200\text{-}\Omega$  leak across the loop conductors;
- Leak D1 — A  $2.16\text{-}\mu\text{F} \pm 2$ -percent capacitor in series with  $600\text{-}\Omega \pm 1$ -percent resistor is connected across the pulsing contact. This network simulates dial-pulse sender circuits on long loop trunks;
- Leak SF1 — A  $2.16\text{-}\mu\text{F} \pm 2$ -percent capacitor in series with  $600\text{-}\Omega \pm 1$ -percent resistor is connected in parallel with  $15,000\text{-}\Omega \pm 1$ -percent resistor across the pulsing contact. This leak condition is primarily used with pulsing tests designed to check the operation of a single-frequency signaling system.

In a purely nonreactive dc circuit, the flow of current would correspond exactly to the changing state of the pulsing contact. In practice, however, relay-based circuits do have considerable inductance and capacitance, so that the flow of current in the relay winding does not correspond exactly to the instantaneous state of the pulsing contact. Furthermore, relays cannot exactly translate change of current in their windings into changes of state of their own contacts. The important consideration, however, is the state of the contact that controls all subsequent activity in the circuit. For this reason, the terms and definitions in Figure 6-31 refer to states of the pulsing contact and not to current flow or any other feature of the circuit. The terms *break ratio* and *percent break* always imply the presence of a switch or relay contact at the point where the break ratio is specified. The terms have no meaning apart from such a contact.

In most cases, the contact of the signaling circuit at which a break ratio is specified is accessible for the connection of a signaling test set. Where it is not accessible, an “A relay” as part of the test set is substituted for the regular relay, solely for the purpose of providing an accessible contact for testing. The relay is a specific type representative of relays originally used to terminate dial-pulse signaling circuits. Pulsing test requirements are then identified with the test relay, not with the relay in the signaling circuit for which it is substituted.

### 6.10.3 Dial-Pulsing Limits

Mechanical dials were typically designed to a break ratio of 58 to 64 percent, made with an objective accuracy of  $10 \pm 0.5$  pps, and operated under normal service conditions between 8 and 11 pps during any portion of the rundown. The objective output for modern dial-pulse

---

senders using E&M, loop, or battery-and-ground pulsing is  $10 \pm 0.2$  pps with 60.0  $\pm 2$ -percent break. The majority of senders in service will outpulse  $10 \pm 1$  pps within the following limits for percent break:

E&M pulsing	56.0 to 60.0
Loop pulsing	59.5 to 67.5
Battery-and-ground	48.5 to 66.0

Many automatic dialers are designed for fixed make and break times rather than for fixed speed and percent break. The central values would then be 61-ms break time and 39-ms make time. Allowing for tolerances of  $\pm 10$  percent from these central values will produce the following time values in milliseconds:

Make Time	35.1 to 42.9
Break Time	54.9 to 67.1

Percent break requirements for the various signaling, trunk, and pulse-repeater circuits differ since the percent break may be shifted in passing through various circuits. Signaling circuits are designed to shift the break ratio of received dial pulses, if necessary, to a value better suited to the circuit to which they deliver those pulses.

In general, dial-pulse receivers, such as the registers of switching systems, must have capabilities broader than the requirements of the pulse generators and repeating devices to provide a margin for normal variations in break ratio and pulsing speed. However, switching systems generate short on-hook signals that could be mistaken for dial pulses. These signals occur before the start of pulsing, during the interdigital interval, and shortly after the completion of outpulsing. As a result, it is recommended that dial-pulse receivers ignore on-hook signals shorter than 10 ms and accept on-hook signals greater than 25 ms.

At one time it was common for dial pulses originating from the customer line to be repeated into a trunk to a second central office, then repeated over a trunk to a third. The percent break of the pulses could increase or decrease with each link in the connection, placing severe limits on the dial-pulse receiver in the last office. Today, however, such cases have essentially disappeared.

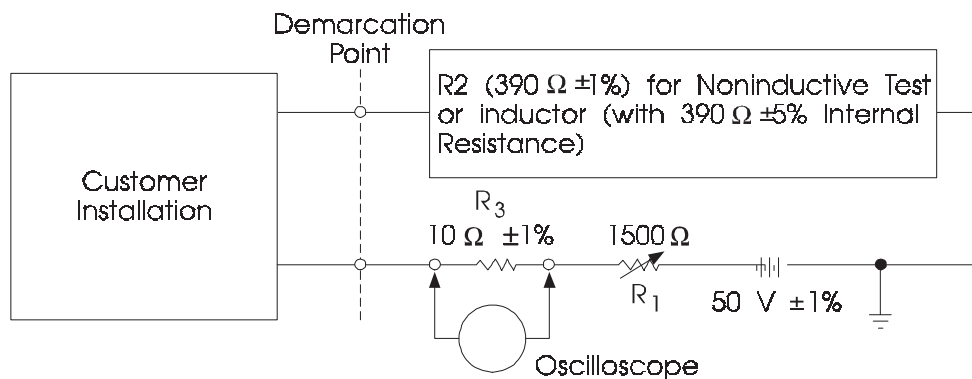
#### 6.10.3.1 Pulse Waveform Criteria

ANSI T1.401-1993, *American National Standard for Telecommunications — Interface Between Carriers and Customer Installations — Analog Voicegrade Switched Access Lines Using Loop-Start and Ground-Start Signaling* contains a different type of dial-pulsing test that was devised through the cooperation of all segments of the telephone industry. The requirements are summarized as follows:

**Network Requirements:** The network will accept pulses at a rate of 8 to 11 pulses per second that have from 58- to 64-percent break, with the equivalent of up to five C4A type ringers on the line.

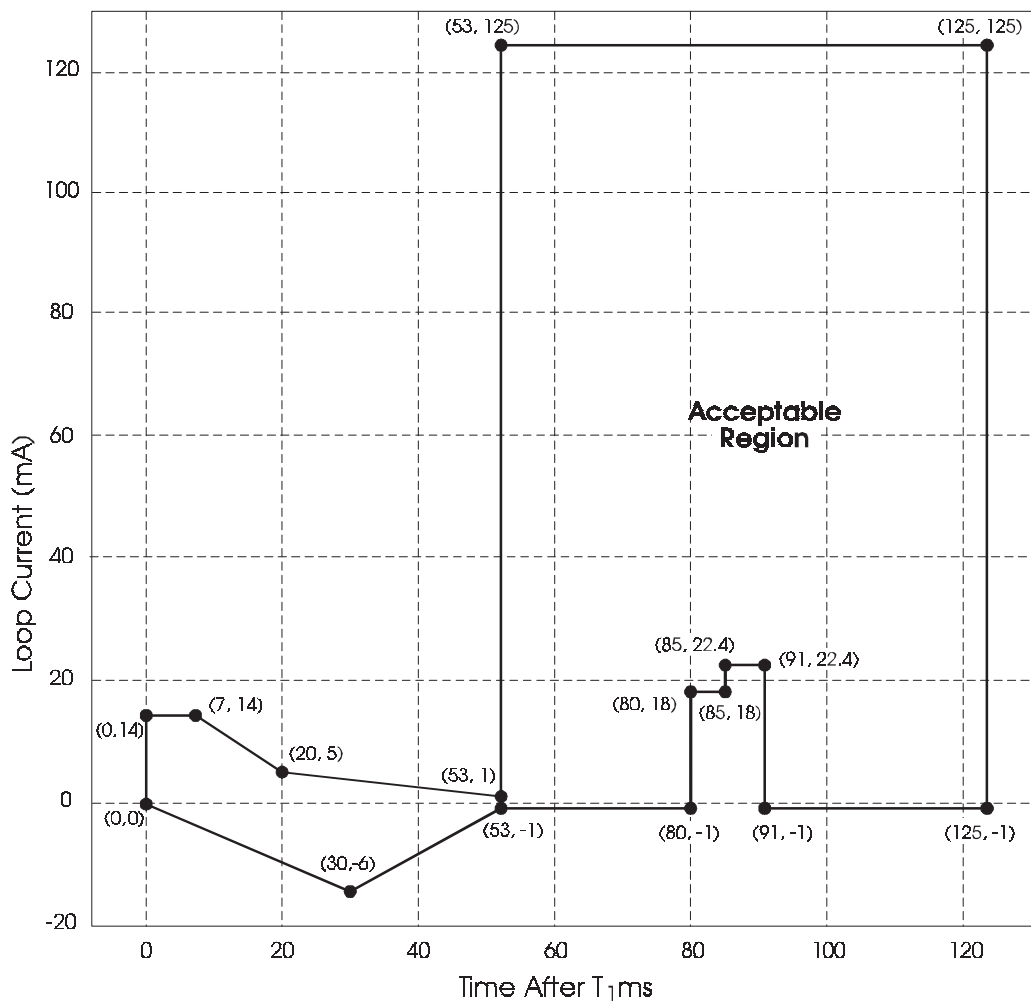
**Customer Installation Requirements:** The customer installation requirements use pulse waveform criteria. The waveform is required to lie within a template when the customer installation pulses into a test circuit. Two test circuits are specified: a noninductive and an inductive circuit, together with their corresponding templates. The dial pulses are required to pass both tests. (The tests have been simplified for this presentation.)

- The noninductive test circuit is shown in Figure 6-33. The value of  $R_1$  is varied from 0 to  $1500\Omega$  during this test.



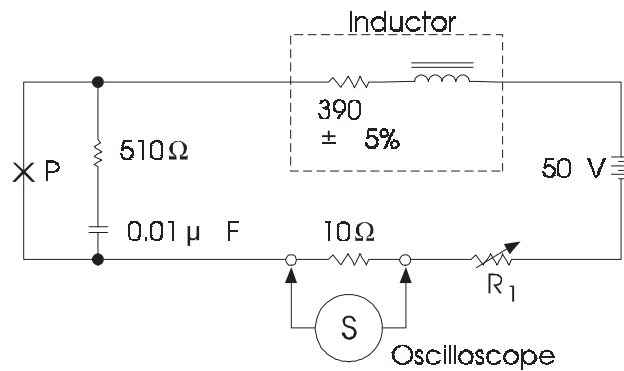
**Figure 6-33.** Test Circuit for Dial-Pulse Templates

- The noninductive template is shown in Figure 6-34.
  - $T_1$  is the time that the current drops below 14 mA during the break interval of each pulse;
  - $T_2$  is the time that the current increases to 14 mA during the make interval;
  - $T_3$  is the time that the current drops below 14 mA during the break interval of the next pulse.  $T_3$  does not apply to the last dial pulse in a pulse train;
  - The ratio of the break time ( $T_2 - T_1$ ) to the period ( $T_3 - T_1$ ) should be 0.58 to 0.64.



**Figure 6-34.** Dial-Pulse Template for Noninductive Test

- The inductive test circuit is shown in Figure 6-35, with an inductor substituted for the resistor. Specifications for the inductor are in Figure 6-35. For all values of  $R_1$  from 0 to  $1500 \Omega$ , the current in the test circuit should be within the template of Figure 6-36 during the test. In addition, to reduce the possibility of error in detecting dial pulses, the current in the test set should not enter the shaded area;
- $T_{01}$  is the time that the current drops below 20 mA during the break interval of each pulse.



P: Mercury-wetted contacts; 75 ±1 ms open, 50 ±1 ms closed, continuous pulsing.  
 $R_1$ : Adjust to 2100 Ω, 1270 Ω, and 100 Ω, as specified below.  
 Tolerances are ±1% except as noted.

During each loop closure the current shall rise to within ±5% of the values listed below:

Time from Start of Closure (ms)	Instantaneous Loop Current in mA		
	$R_1 = 2100 \text{ W}$	$R_1 = 1270 \text{ W}$	$R_1 = 100 \text{ W}$
2	7.0	7.9	8.5
5	10.6	12.1	14.0
10	14.0	17.2	24.5
15	16.1	20.9	35.0
20	17.3	23.5	45.0
25	18.2	25.5	56.0
30	18.8	27.0	67.0
35	19.1	28.0	76.5
40	19.3	28.7	86.0
45	19.5	29.1	92.0
50	19.6	29.3	96.0

Figure 6-35. Inductor for Inductive Dial-Pulse Test Circuit

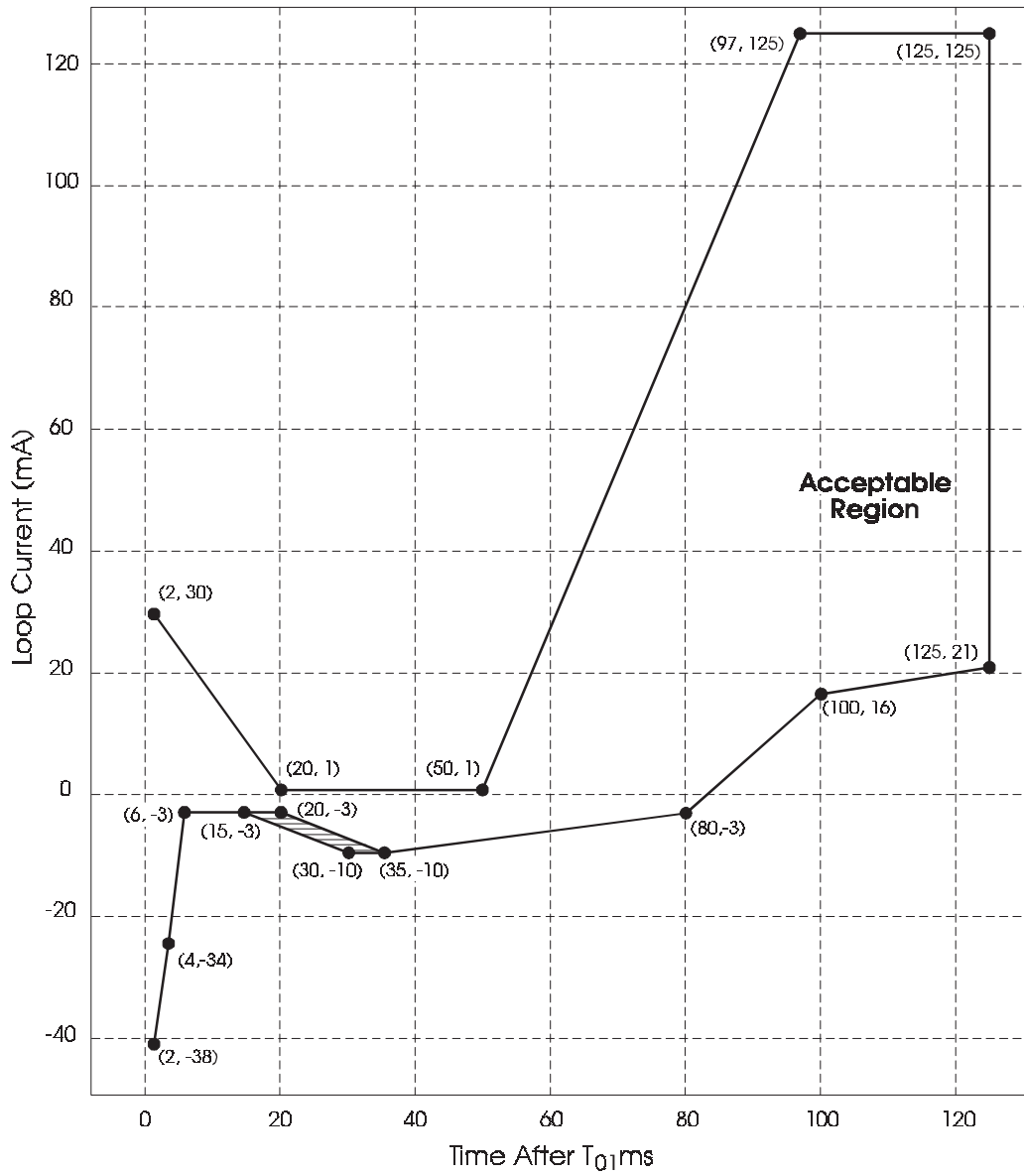


Figure 6-36. Dial Pulse Template for Inductive Test



---

### 6.10.3.2 Maximum Number of Dial-Pulse Repetitions Without Pulse Correction

The discussion in this section is applicable to all loop or battery-and-ground dial pulsing, including the use of dial pulsing to terminal equipment receiving DID. The values of 42- to 84-percent break at 8 to 12 pps represent a limiting condition for pulse receivers. These limits are as applicable for electronic pulse detectors as they are for relay types formulated on the use of a 221A relay, or its equivalent, as a pulse detector.

### 6.10.3.3 Pulse Links and Converters

A trunk may be made up of two or more signaling sections connected in tandem using the same, or different, types of signaling systems. If two adjacent sections have E&M signaling arrangements, an auxiliary pulse link is usually provided to repeat the signals. If the two sections are different, converters are provided. For example, if a trunk circuit employing loop signaling is connected to a trunk facility using signaling with E&M lead control, a converter is used to convert loop signaling to E&M signaling and vice versa. Where digital carrier systems are connected back-to-back, the signaling paths of the individual channels are usually connected by use of a digital cross-connection system or “tandem” channel units. Both approaches eliminate the use of extra equipment at the point of connection.

### 6.10.3.4 Maximum Number of Dial-Pulse Repetitions with Pulse Correction

The total objective round-trip signaling delay for terrestrial facilities should not exceed 300 ms. In the case of delay-dial without integrity check, the 300 ms must also include time for the far-end switching system to return delay-dial. Because of the time delay inherent in single-frequency signaling, two signaling sections of single-frequency signaling should not be used in applications where delay is important, such as delay-dial without integrity check or stop-go operation.

## 6.10.4 Interdigital Time

The interdigital time is the interval from the end of the last on-hook pulse of one digit train of dial pulses to the beginning of the first on-hook pulse of the next digit train (see Figure 6-31). A timer or slow-release relay which ignores the digit pulses but releases between pulse trains, is used to condition the receiving equipment for the next digit. For customer dialing, the interdigital time depends on the user.

The interdigital time delivered by a sender depends on the availability of the succeeding digit. When the next digit is immediately available, the sender must control the minimum interdigital interval. The requirement for the minimum interval is 300 ms. A previous

recommendation was 700 ms, based on outpulsing to step-by-step equipment with its slow response time.

1/1AESS, 2/2BESS, 5ESS, DMS-10, DMS-100F, and EWSD switching systems have always had the ability to transmit a 700-ms interdigital interval. This feature has been added to the 4ESS switching system. The 1/1AESS system has an office option for an interdigital interval of 600 to 1000 ms. The default value is 600 ms. The DMS-10 system can send a 700-ms interdigital interval and, with the use of a different hardware pack, can transmit a per trunk group software adjustable interval between 200 to 900 ms. The DMS-100F system has a software adjustable interval of 70 to 1000 ms. The Galaxy System terminal equipment has always had the ability to send a 700 ms interval.

Although senders and registers can recognize interdigital intervals as short as 300 ms, senders have not in the past used interdigital intervals of less than 500 ms when outpulsing; shorter intervals approaching the 300-ms minimum may be used in the future. An accuracy of  $\pm 5$  percent is considered satisfactory for timing this interval.

---

## 6.11 Single-Frequency Signaling

Single-frequency signaling systems are ac signaling systems that were designed to convey supervision and dial-pulsing addressing functions over interoffice trunks. They were used over network trunks where dc signaling was not feasible or economical. Single-frequency signaling systems are basically two-state ac signaling that can handle trunk supervision and dial pulsing. With more complicated signaling protocols, single-frequency signaling was also used for three-state ac signaling that was needed for ground-start and loop-start foreign exchange private lines.

Single-frequency signaling is not used in modern LEC networks. At one time, there were a great many interoffice trunks and foreign exchange facilities using single-frequency signaling. Single-frequency signaling was replaced by the digital bitstream signaling of digital carrier systems, which in turn, has been replaced by CCS systems.

For further information on single-frequency signaling and measurements on single-frequency signaling, see IEEE STD 752-1986, *IEEE Standard for Functional Requirements for Methods and Equipment for Measuring the Performance of Tone Address Signaling Systems*.

One of the chief problems with inband ac signaling is prevention of mutual interference between voice transmission and signaling. Single-frequency signals are audible and, consequently, signaling should not take place during the time the channel is used for conversation. Because single-frequency signal-receiving equipment must remain on the channel during conversation to respond to supervision changes, false operation from voice sounds that resemble the tones used for signaling can occur. Protection against voice interference can be accomplished in a number of ways:

- Signal tones of a character not likely to occur in normal speech may be used;
- Timing for sustained signaling tones may be used to prevent false operation due to voice frequencies occurring in the signaling band;
- Voice-frequency energy, other than the signaling frequency, may be detected and used to prevent false operation of the signaling receiver.

Single-frequency signaling systems pass the necessary signals for network trunks over voice-frequency line facilities without impairing the normal use of these facilities for speech. These systems deliver and accept dc signals to and from the switching trunk equipment in the form of loop or E&M lead controls. The dc signals are transformed to ac on the line side and vice versa.

Single-frequency signaling uses 2600 Hz for signaling on the transmission facility in both directions. Consequently, it may be applied to any voice-grade channel of any length and makeup, provided that it is 4-wire from end to end.

The on- and off-hook conditions for basic single-frequency signaling systems are shown in Table 6-16.

---

**Table 6-16.** On- and Off-Hook Conditions

Signal	Tone	Direction	Lead	Condition
On-hook	On	Sending	M	Ground
		Receiving	E	Open
Off-hook	Off	Sending	M	Battery
		Receiving	E	Ground

Because the single-frequency signaling system uses a tone on the 4-wire voice path, its characteristics are quite different from those of dc systems. The major differences are as follows:

- Single-frequency signaling systems have a longer delay in signaling time;
- They may distort on-hook or off-hook signals. This is particularly true of foreign exchange units;
- They have a lower pulsing speed and a narrower percent break range for incoming dc pulses. Pulse correctors are included to bring the incoming pulses within the percent break range that the single-frequency signaling can accept;
- They interrupt the voice path during and after transitions between on- and off-hook;
- Continuous tones can cause them to malfunction.

Single-frequency signaling equipment can provide for 2- and 4-wire E&M signaling, 2-wire loop signaling, and 2- and 4-wire foreign exchange line signaling (either loop- or ground-start). The characteristics of typical single-frequency signaling units are covered in Table 6-17. Figure 6-37 is a block diagram illustrating the basic features of a four-wire E&M signaling unit.

**Table 6-17.** Typical Single-Frequency Signaling Characteristics

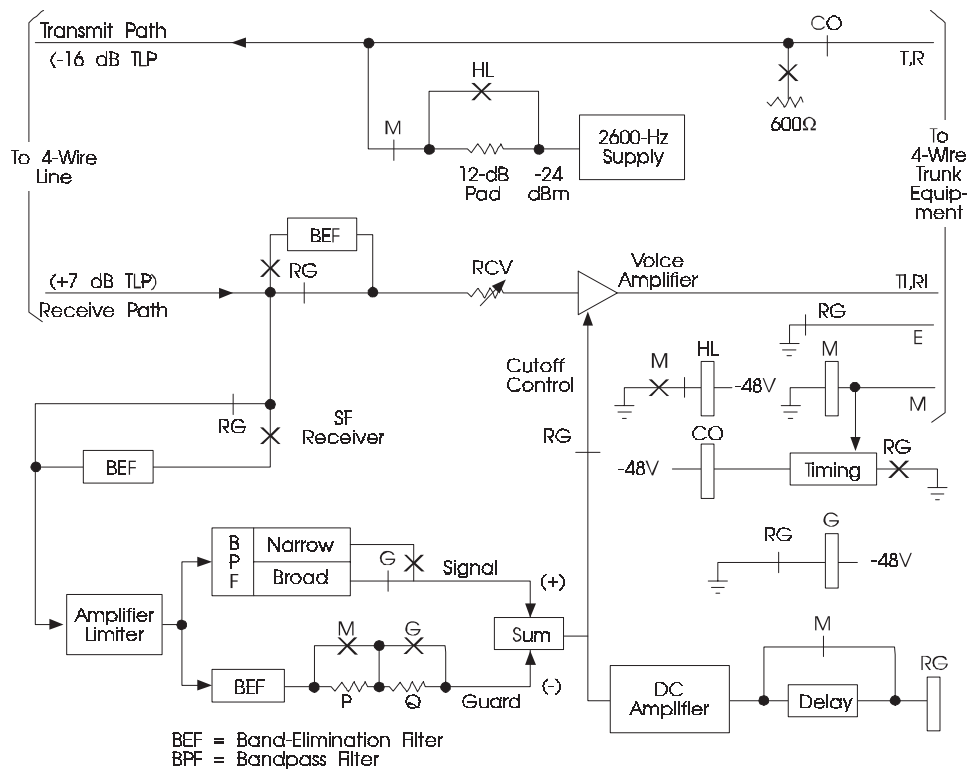
<b>(A) General:</b>	
(a) Signaling frequency (tone)	2600 Hz
(b) Idle-state transmission	Cut
(c) Idle/break	Tone
Busy/make	No tone
<b>(B) Receiver</b>	
(a) Detector bandwidth	$\pm 50$ Hz at -7 dBm (early) $\pm 30$ Hz at -7 dBm (later)
(b) Detector sensitivity	-24 dBm (-31 dBm0)
(c) Detector nonoperate	-30 dBm (-37 dBm0)
(d) Detector overload	+6 dBm (-1 dBm0)
(e) Band elimination filter:	
(1) Insertion loss	45 dB
(2) Insertion time	13 ms
(3) Release Time	300 ms
(f) Pulsing rate	7.5 to 12 pps
(g) E&M unit:	
(1) Minimum time for on-hook	33 ms
(2) Minimum no tone for off-hook	55 ms
(3) Input percent break (tone)	38 to 85 (10 pps)
(4) E lead	Open when idle
(h) Originating (loop reverse-battery) unit:	
(1) Minimum tone for idle	40 ms
(2) Minimum no tone for off-hook	43 ms
(3) Minimum output for on-hook	69 ms
(4) Voltages on transmission leads	
-48 V on ring and ground on tip	On-hook
-48 V on tip and ground on ring	Off-hook
(i) Terminating (loop reverse-battery) unit:	
(1) Minimum tone for on-hook	90 ms
(2) Minimum no tone for off-hook	60 ms
(3) Minimum output (tone-on)	56 ms
(4) Loop open	On-hook

**Table 6-17.** Typical Single-Frequency Signaling Characteristics (Continued)

<b>(C) Transmitter:</b>	
(a) Low-level tone	-36 dBm (-20 dBm0)
(b) High-level tone	-24 dBm (-8 dBm0)
(c) High-level tone duration	400 ms
(d) Predict	8 ms
(e) Holdover cut	125 ms
(f) Crosscut and on-hook cut	625 ms
(g) E&M unit:	
(1) Voltage on M lead	Off-hook (no tone)
(2) Minimum ground on M lead	11-21 ms
Minimum voltage on M lead	19-21 ms
(3) Minimum output tone	21-51 ms
Minimum no tone	21-26 ms
(h) Originating (loop reverse-battery) unit:	
(1) Loop current to no tone or no loop current to tone	19 ms
(2) Minimum input for tone out	20 ms
(3) Minimum input for no tone out	14 ms
(4) Minimum tone out	51 ms
(5) Minimum no tone out	26 ms
(6) Loop open	On-hook
(i) Terminating (loop) unit:	
(1) Reverse-battery to no tone, or normal battery to tone	19 ms
(2) Minimum battery for tone out	20-25 ms
(3) Minimum reverse-battery for no tone	14 ms
(4) Minimum tone out	51 ms
(5) Minimum no tone out	26 ms
(6) Battery on R lead (-48 V on ring and ground on tip)	On-hook

### 6.11.1 Single-Frequency Transmitter

The keyer relay (M) (Figure 6-37) is operated and released by signals on the M lead and removes or applies 2600 Hz to the transmit line of the facility. The M relay operates the HL relay to remove the 12-dB pad in order to permit a high-level initial signal to secure an improved signal-to-noise operating environment. The HL relay is slow to release; hence, dial pulses that operate the M relay are transmitted at an augmented level. In addition, a cutoff relay operates to block any noise that may be present from the office side of the circuit.



**Figure 6-37.** E&M 4-Wire 2600-Hz SF Signaling System

Typical single-frequency signaling units will accept and transmit dial pulses at speeds from 8 to 12 pps with 56 to 69 percent break. If the range of percent break presented to the M lead is outside these limits, means must be provided to bring the range within these limits. In general, this is done with an M lead pulse corrector.

Limitations in percent break for loop-type units are overcome by the built-in transmitting pulse corrector.

---

When using single-frequency signaling without pulse correction, the percent break range is limited to sender outpulsing. In addition, because of the pulse-shaping methods in the sender, most loop dial-pulsing units also require built-in pulse correction.

The pulse correction lengthens the short pulses and ensures a minimum interpulse interval. A typical pulse corrector lengthens any pulse greater than 17 ms to an output of at least 46 ms. In addition, the pulse corrector guarantees an interval of at least 23 ms between pulses. The distortion from M lead to tone in later units is +1 ms.

### 6.11.2 Single-Frequency Receiver

The receiving portions of the single-frequency unit include an amplifier, band elimination networks, and a signal detector. The amplifier's primary function is to block any noise or speech present in the office equipment from interfering with operation of the signal detector and also to make up for the insertion loss of the signaling unit in the receive speech path. The signal detector circuit includes an amplitude limiter, a signal-guard network, rectifiers, a dc amplifier, and a pulse-correcting circuit, the output of which operates a relay to repeat signals to the E lead of the trunk equipment. Typical transmission characteristics are shown in Table 6-18.

The receiver sensitivity is -29 dBm or less at a zero Transmission Level Point (TLP). The signal-guard network provides the necessary frequency discrimination to separate signal and non-signal (guard) voltages. By combining the voltage outputs of the signal and guard detectors in opposing polarity, protection against false operation from speech and noise is secured. The guard feature efficiency is changed between the dialing and talking conditions to secure optimum overall operation.

An incoming signal is separated into signal and guard components by the signal and guard detectors. The bandwidth of the signal component is approximately 100 Hz, centering on 2600 Hz. The guard component is all other frequencies in the voiceband. These components produce opposing voltages with a resultant net voltage in the signal detector. In the talking condition (tone off in both directions), the guard detector sensitivity requires almost a pure 2600-Hz tone to operate the receiver since non-signal frequencies will produce a voltage opposing its operation. The guard principle is an important feature in avoiding signaling imitation by speech. It is, however, insufficient to ensure that a speech-simulated signal will not cause false operation of the receiver (talk-off). An additional time delay is therefore provided, so that during the dialing condition the receiver will just operate the RG relay on a tone pulse of 35 ms for E-type units. When the RG relay operates, it causes a slow relay (G) to release, greatly decreasing the sensitivity of the guard channel and making the signaling channel responsive to a wider band of frequencies. This slow release reduces talk-off. Early-vintage units can receive dial pulsing only when sending on-hook to the originating end. Later units can receive dial pulsing regardless of supervisory state.



**Table 6-18.** Typical Transmission Characteristics

<b>• Line Receiver:</b>	
— Level (Transmission Level Point [TLP])	+7 dB TLP, 600 $\Omega$
<b>• Line Transmit:</b>	
— Level	-16 dB TLP, 600 $\Omega$
— Overload level	-6 dBm (-22 dBm0)
<b>• Equipment Transmit:</b>	
— Maximum TLP, 4-wire	+6.5 dB, 600 $\Omega$
— Maximum transmit TLP, 2-wire	+3 dB
— Minimum receive TLP, 2-wire	-12 dB
— Impedance, 2-wire	600/900 $\Omega$ +2.16 $\mu$ F
— Hybrid loss, 2-wire	4.2 dB
— Trans-hybrid loss (properly terminated)	47 dB
<b>• Equipment Receive:</b>	
— Maximum TLP, 4-wire	0 dB, 600 $\Omega$
<b>• Attenuation:</b>	0 to 16.5 dB, 0.1 dB steps
<b>• Insertion Loss:</b>	
— 1 kHz, 2-wire	4.2 dB (Ref)
— 4-wire	0.5 dB (Ref)
— 1 kHz transmit cut	(Ref) +69 dB
— 2.6 kHz (Band Elimination Filter [BEF] in)	(Ref) +40 dB
— 200 Hz, 2-wire	(Ref) +1 dB
— 4-wire	(Ref) $\pm$ 0.15 dB
— 3 kHz	(Ref) $\pm$ 0.3 dB
<b>• Delay Distortion, 500 Hz to 3 kHz</b>	180 $\mu$ s

### 6.11.3 Voice Path Cuts and 2600-Hz Band Elimination Filter Insertion

Single-frequency signaling units interrupt the transmit voice path to improve signaling margins. A 2600-Hz Band Elimination Filter (BEF) is inserted in the receive path whenever the unit receives a 2600-Hz tone. The filter blocks the tone but permits audible ring, busy, and other call progress signals to be heard by the calling party without the signaling tone. In addition, the filter prevents the single-frequency tone from entering the next signaling link. The typical filter insertion time is 13 ms. The early-vintage units use a relay to insert the filter. They delay inserting the filter for about 100 ms. To prevent excessive single-frequency tone from entering the next link, the units employ an electronic cut (in the amplifier) in the receive path. The cut limits the single-frequency tone leak to a maximum of about 30 ms. The sequence is to operate the cut, insert the filter, and restore the receive voice path. The cut is controlled to minimize thump. The later units use only the filter to limit the duration of the 2600-Hz tone that can enter the next signaling link. An electronic switch is used to insert the filter over a period of time. The gradual insertion nearly eliminates any thump that would be associated with the filter insertion.

Cut circuits break and terminate the transmitting voice path when both ends are on-hook for all units, and also momentarily after most changes in signaling state. The duration of this cut must be considered when tones are sent from the switching equipment after a change in signaling state.

The various signaling units do not have identical cut times, but the following is typical of the transmission cut timing in a sender dial-pulse or multifrequency pulse unit. The unit has the transmitting path continuously cut when both ends are on-hook; when the near end goes off-hook, the transmitting path at the near end is reestablished in nominally 125 ms. At the far end, the transmitting path is reestablished nominally in 625 ms. If the far end goes off-hook during this interval, the cut timing is changed to the shorter interval.

If both ends are off-hook and the near end goes on-hook, the transmitting voice path is cut and then reestablished nominally in 625 ms. Most units have the transmit path cut feature.

Multifrequency pulsing is not affected by these cuts because the signaling delay of the single-frequency system plus the time required to attach a register is in excess of the cut timing.

### 6.11.4 Signaling Delay

The signaling delay through a single-frequency system consists of the delay from the change of state of the dc input to application or removal of signaling tone, the transit time of the transmission facility, and the response time of the distant unit.

The transmission delay is the 1-way delay of the transmission facilities between two network locations. This delay applies to either a forward or return signal. It depends on the transmission facility types, their links, and any multiplexing delays. Average delays are

---

about 0.4 ms per pair of D4 channel banks, 0.0084 ms per route mile of fiber facility (which excludes channel banks), and 0.082 ms per route mile of voice-frequency facility. This type of delay is very short compared with other system delays. For an extreme intraLATA case of 600 carrier miles, 2 pairs of channel banks and 15 loop miles at each end, the total transmission delay is about 8 ms. The transmission facility delays of most trunks are much less than this.

With late-vintage E&M lead units without built-in pulse correction that are suitable for senderized dial pulsing, the nominal delay from off-hook to on-hook is 21 ms from the time the M lead is changed from battery to ground until tone is transmitted plus the transit time of the facility plus a nominal 55 ms for recognition of tone presence and removal of ground from the E lead (a nominal total of 76 ms plus transit time).

The typical 1-way delay times for single-frequency signaling between two network locations are shown in Table 6-19.

**Table 6-19.** Typical Single-Frequency Signaling Delays

	Seizure	Disconnect
E&M	76 ms	44-54 ms
Originating to Terminating	79 ms	109 ms
Terminating to Originating	NA	59 ms

### 6.11.5 Continuous Tones

Continuous tones can interfere with the proper operation of single-frequency signaling. It is obvious that a pure tone near 2600 Hz will cause the far-end (receiving) unit to go on-hook. It is also true that continuous tones that are not 2600 Hz will act as guard signals and keep the signaling units off-hook, even though 2600 Hz is also present. Continuous tones can also hold a unit on-hook after the signaling tone is removed.

Most signaling units have the cut circuits, described in this section, that permit use with continuous tones. However, a few do not. As a result, provision must be made to interrupt tone sources on a periodic basis or when a supervisory state is changed. The 102 test line, for instance, would not give accurate results if the test tone and off-hook were applied at the same time because the tone would hold some single-frequency units on-hook and keep the 2600-Hz filter in the circuit. For this reason, the tone on the 102 test line should be applied 300 ms after the off-hook for proper operation.

### 6.11.6 Foreign Exchange Line Signaling

There are similarities and differences between access line and trunk single-frequency signaling equipment that will help in understanding the basic operation and compatibility

---

of access line signaling equipment without the detail covered previously for trunk signaling equipment.

There are two types of signaling on access lines — *loop-start* and *ground-start*. Access line signaling is described in Section 6.2 and its associated references.

Loop-start is used for ordinary telephone key systems and similar services. Ground-start is used for PBX and other services that must have a dc signal to indicate when dial tone is applied by the serving switching system or is used to avoid glare.

This discussion assumes that the network uses a conventional battery supply with battery on a line lead (usually the ring) and ground on the other line lead (usually the tip). Floating battery supplies as discussed in Section 6.2.1 are not considered in this discussion, although they are generally compatible with the line single-frequency signaling units discussed here.

Single-frequency signaling units used for line signaling have the same general characteristics as those for trunk signaling. These similarities are as follows:

- There is 2- or 4-wire transmission on the output side of the signaling units;
- There is 4-wire transmission between signaling units;
- The transmit level is at -16 dB TLP;
- The receive level is at +7 dB TLP;
- Supervision and dial pulsing from the customer interface are identical to loop signaling on trunks;
- The nominal 2600-Hz tone level is -20 dBm0;
- Tone-on is on-hook; tone-off is off-hook, but with exceptions covered below.

The access line signaling units do the following differently from the trunk units.

- The loop-start Foreign Exchange Office (FXO) signaling unit (central office end) does not send a supervisory signal to the Foreign Exchange Station (FXS) unit (station end);
  - The ground-start FXO unit removes tone to the FXS whenever the tip is grounded. The ground-start FXS grounds the tip toward the station (terminal) whenever 2600 Hz is absent;
  - The ground-start FXS unit converts a ground on the ring to 2600-Hz tone toward the FXO unit. The FXO converts tone from the FXS to ground on the ring;
  - The ground-start FXO unit recognizes ground on the tip and no tone from the FXS as a signal to convert to the loop signaling mode;
  - The ground-start FXS recognizes removal of 2600 Hz from the FXO and a closed loop at the station as a signal to convert to the loop signaling mode.;
-

- 
- The FXO unit receives ringing from the switching system and converts the 20-Hz signal to a 2600-Hz tone signal. With loop-start, ringing is converted to pure 2600-Hz tone. With ground-start, ringing is converted to 2600-Hz tone modulated by 20 Hz;
  - The FXS converts the tone ringing signal to a 20-Hz ringing signal superimposed on a 50-V supervisory signal;
  - For ground-start cases only, when the central office disconnects first, ground is removed from the tip. This causes application of 2600 Hz toward the FXS. The FXS does four things:
    1. It applies tone toward the FXO;
    2. It converts to the ground-start mode.;
    3. It removes ground from the tip toward the station, opening loop current. Removal of tip ground causes the station to release;
    4. It applies 2600 Hz toward the FXO. This returns the FXO to the ground-start mode and removes the loop closure toward the central office.

With all these actions complete, the circuit returns to the idle condition.

- When the station disconnects first, the station opens the loop to the FXS. The FXS applies 2600 Hz toward the FXO. Tone toward the FXO causes it to open the loop to the central office. For the ground-start case only, when the central office disconnects, ground is removed from the tip to the FXO. The FXO restores to the ground-start mode and applies 2600 Hz toward the FXS. The FXS restores to the ground-start mode and removes ground from the tip of the line to the station. The station releases. With all these actions complete, the line returns to the idle condition.

The signaling delays from input at an FXO to the output at the FXS loop-start single-frequency signaling units are longer than in trunk units. These delays of 100 to 500 ms do not affect the basic service from a line. They may, however, affect a machine-controlled device that operates satisfactorily on a wire line. The signaling delay from an input to an FXS to output at an FXO is about the same as with single-frequency trunk signaling units. In addition, the signaling unit removes changes in dc voltage/current from the network. For example, Open Switching Intervals (OSIs) (see Section 6.2.3) and the open circuit condition used in many switching systems to release lines on hold are blocked by the signaling units.

There are much longer signaling delays from input at an FXO to the output at the FXS ground-start units than in trunk signaling units. In addition, signaling distortion is introduced in these signals from the FXO to the FXS. The distortion occurs because delay for disconnect signals from the FXO to the FXS is longer for the disconnect signal (remove ground from tip) than for the seizure signal (ground on the tip). A typical signal distortion is 150 ms although individual signaling distortions can go from 300 to 500 ms. The delay and distortion are in both units, which reduces the lengths of OSIs, and negates the PBX loop test described in Section 6.2.5.3.

---

## 6.12 Multifrequency (MF) Signaling

Multifrequency signaling is an ac tone signaling method used to transmit address information and other information over voice-frequency transmission facilities. MF signaling is used on interoffice transmission facilities and in some cases for DID service. Multifrequency signaling uses two combinations (and only two) of six frequencies in the voiceband. The six frequencies are

- 700 Hz;
- 900 Hz;
- 1100 Hz;
- 1300 Hz;
- 1500 Hz;
- 1700 Hz.

As Table 6-20 shows, the 15 possible frequency combinations are used to represent the digits zero through nine and several special control or information signals.

MF signaling is used for the following applications:

- Transmission of the called number from one switching system to another switching system;
- Transmission of the calling number (ANI information from a switching system to an operator system or other network equipment that requires calling number information);
- Control of public coin-operated telephones from operator systems.

**Table 6-20.** Multifrequency Codes

Frequencies In Hz	Signals			
	Digit and Control	Inband and Expanded Inband	CCITT System 5	Interexchange and Operator System Signaling
700 + 900	1			
700 + 1100	2	Coin Collect		
700 + 1300	4			
700 + 1500	7			
700 + 1700		Ringback	Code 11	KP''' & ST'''
900 + 1100	3			
900 + 1300	5			
900 + 1500	8	Operator Released*		
900 + 1700			Code 12	KP' & ST'
1100 + 1300	6			
1100 + 1500	9			
1100 + 1700	KP	Coin Return	KP1	
1300 + 1500	0	Operator Attached*		
1300 + 1700			KP2	KP'' & ST''
1500 + 1700	ST	Coin Collect and Operator Released*		ST

\* Expanded inband only.

The principal advantages of multifrequency signaling are speed, accuracy, and range. Multifrequency senders transmit more rapidly than dial-pulse senders. Consequently, multifrequency signaling requires less holding time per call. As a result, a relatively small number of senders or registers are used as common equipment for a large number of trunks.

Standards on multifrequency signaling are covered in GR-506-CORE, *LSSGR: Signaling for Analog Interfaces*; TR-NWT-000507, *Transmission, Section 7*; IEEE STD 752-1986, *IEEE Standard for Functional Requirements for Methods and Equipment for Measuring the Performance of Tone Address Signaling Systems*; and ANSI T1.405-1996, *American National Standard for Telecommunications — Network-to-Customer Installation Interfaces — Direct-Inward-Dialing Analog Voicegrade Switched Access Using Loop Reverse-Battery Signaling*.

### 6.12.1 Tones Sent by the Calling Station after Dialing

Tone signals sent by the *calling* station after dialing but before the *called* party answers can interfere with multifrequency pulsing. As a result, data or other tone signals should not be sent by the *calling* station before the *called* station answers. Any tone handshake signals should originate from the *called* station, not from the *calling* station.

### 6.12.2 Multifrequency Transmitter

A typical interoffice use of multifrequency signaling begins when the originating office gives a connect signal to the distant end, which returns off-hook supervision to delay signaling until a register is attached. When the terminating office has attached a MF receiver, it changes the supervision to on-hook as a *start-dial* signal. The originating office then sends a KP signal followed by the address digit codes and an ST signal.

At the distant end, the KP signal prepares the multifrequency receiver for MF signals. Besides informing the distant end that no more pulses are to be expected, the ST signal begins call processing in the distant office.

#### 6.12.2.1 Digit Duration

Multifrequency signals are sent by transmitters in Stored-Program Control (SPC) offices, including those that serve as hosts for operator-services systems. The transmitters receive numbers from customers or from operators or other network equipment by multifrequency pulsing, DTMF pulsing, or dial pulsing. The tones are generated by discrete oscillators in analog offices or read from read-only memory in digital offices. The multifrequency senders associated with the 1/1A ESS switching system output pulse with signals and interdigital periods of  $60 \pm 0.5$  ms each (a rate of approximately 8.3 digits per second). This rate is increased to 10 pps for intercontinental dialing using CCITT Signaling System No. 5. The present multifrequency pulsing rates as stated in the *LSSGR* are 58 to 75 ms for pulses and interdigital intervals. Other pulse and interdigital intervals are shown in Table 6-21.

#### 6.12.2.2 KP Duration

The KP signal duration is 90 to 120 ms. The receivers are designed to accept a KP signal of 55 ms minimum, but it is good practice for MF transmitters to send KP signals near 120 ms to provide margin against transmission impairments such as delay distortion and Time Assignment Speech Interpolation (TASI) clipping. The duration of the KP signal is given in Table 6-21.

---



**Table 6-21.** MF Sender Pulse and Interdigital Intervals

Switching System	Pulse and Interdigital-Intervals (ms)		KP Signal Duration (ms)
	Normal	Optional	
1/1A ESS	60 ±0.5	50 ±0.5	120 ±0.5
1/1A ESS HILO	60 ±0.5	50 ±0.5	
2/2B ESS	75	50	100
4ESS	70	50	
5ESS	70	None	110
DMS-10	68 ±7	70	100 ±10
DMS-100	70	70*	100
EWSD	68	None	100
NEAX-61E	64 ±3		96 ±3
<i>LSSGR</i>	58 - 75	None	90 - 120

\* Adjustable in 10-ms steps from 10 to 2550 ms per trunk group.

### 6.12.2.3 Transmitter Tone Level, Frequency, and Timing Limits

The normal power output of multifrequency presently used is -6 to -8 dBm per frequency at 0 TLP. The frequencies of the oscillators are within ±1.5 percent of nominal. The levels of the two tones of a digit should be within 1 dB. The older equipment transmits -6 dBm0 per frequency and the new equipment sends the LEC standard of -7 dBm0 per frequency. However, there is no plan to change equipment using -6 dBm0 to the new level.

The multifrequency tone leakage limit when no signal is being sent is -58 dBm0. When signals are sent, the total extraneous frequency components should be at least 30 dB below the level of either of the two signal frequencies when measured over a 3-kHz band.

Most senders used in LEC switching systems are arranged so that under normal conditions, the two tones comprising a multifrequency signal are applied to the trunk simultaneously and neither tone is transmitted if either tone source should fail. The *LSSGR* requires that the transmitter start and end the two tones within 1 ms of each other. Multifrequency receivers, however, will recognize a pulse as a valid signal if the two tones arrive within 4 ms of each other.

#### 6.12.2.4 Transmitter Impedance

It is an *LSSGR* requirement for the transmitter to have the same nominal impedance as the office in which it is used, that is, 600 or 900  $\Omega$  in series with 2.16  $\mu\text{F}$ . When connected to a 4-wire carrier channel or to the 4-wire port of a terminating set, the impedance should be 600  $\Omega$  nonreactive. The transmitter should have a longitudinal balance to ground and a return loss at least equal to that required for voice transmission.

#### 6.12.2.5 Tests of Multifrequency Transmitters

Multifrequency senders in electronic offices, such as the 1/1A ESS switching system, are tested by the receivers in the same office with a circuit known as the multifrequency test environment circuit. Each transmitter is tested against each receiver in the office, as explained in Section 6.12.3 on receivers.

### 6.12.3 Multifrequency Receiver

An MF receiver is connected to a trunk as part of a register, as required. It does not respond to voice-frequency signals until it receives the KP signal. The unit can then receive and pass on the number codes and the ST signal to its associated equipment. A basic receiver design includes a level-limiting amplifier feeding a series of bandpass filters, one for each of the six tones. The output of each filter is rectified and used to trigger a flip-flop indicating that the particular tone is present. The tone pairs are then decoded into digits. Before this occurs, however, a “signal present” filter and detector inhibit all the individual tone detectors unless a signal of proper general frequency and level is present. The same functions, of course, can be done by digital signal processing.

#### 6.12.3.1 Receiver Limits

Existing multifrequency receivers generally meet the *LSSGR* requirements below.

**Impedance:** The impedance of an analog receiver should match that of the end switching system, that is, 600 or 900  $\Omega$  in series with 2.16  $\mu\text{F}$ . When connected to a 4-wire carrier channel or the 4-wire port of a terminating set, it should be 600  $\Omega$  nonreactive. The longitudinal balance to ground should be at least equal to that required for voice transmission.

**Tone Level:** The receiver should respond to signal levels between 0 and -25 dBm per frequency or their digital equivalent. Existing receivers may have a sensitivity of only -22 dBm, but new circuits should meet the -25 dBm requirement. The receiver should not respond if the signal levels drop below -35 dBm per frequency.

---

---

**Receipt of KP:** The receiver should not respond to address signals before being *unlocked* by receipt of a KP signal. Simulation of the KP signal by speech or other signals or noise should not cause more than one lost call per 2500 calls. If two or more consecutive KP signals are received, all except the first should be ignored. Once unlocked, the receiver should remain unlocked until it receives the start signal (ST, ST', ST'', or ST'''). In applications not using KP and ST signals, the switching system should provide a means of locking and unlocking the receiver.

**Digit Duration:** The receiver should respond to signals in which each frequency component duration is at least 30 ms. The receiver should respond to a KP signal that is at least 55 ms long and may respond if the KP signal is from 30 to 54 ms long. The two frequency components may be shifted in time relative to each other by as much as 4 ms due to Envelope Delay Distortion (EDD) in the transmission facility (an extreme example taken from analog undersea cable facilities with 3-kHz channelization; more typically 0.3 ms or less in an intraLATA network). It is desirable that the receiver not respond to signals shorter than the requirements in the preceding part, and it is required that it not respond to signals in which the two components are not coincident for more than 10 ms. The receiver should recognize interpulse intervals as short as 25 ms. This interval is defined as the time during which no signal frequency component is above -35 dBm. It is desirable that the receiver bridge interruptions as long as possible, consistent with meeting the interpulse requirement. It is required that it bridge interruptions up to 10 ms long after the minimum length signal has been received. The receiver should accept up to 10 pulses per second.

**Two and Only Two Frequencies:** The receiver should check for the presence of only two valid frequency components in each pulse. If a pulse fails to meet this requirement, the call should receive reorder treatment. As an example of an alternative technique, the DMS-100F switching system 6X92BB multifrequency receiver checks for all six valid frequency components in a multifrequency pulse. The two highest-level components are selected as the value of the pulse.

**Level Difference Between the Two Frequencies:** The receiver should tolerate pulses in which there may be as much as a 6-dB difference in power levels of the two frequency components. It is desirable that even greater level differences be tolerated. Existing receivers more than meet this requirement. Multifrequency receivers in the 1/A ESS switching system are tested with 6.25-dB difference in power levels of the two frequency components.

**Maximum Length of Multifrequency Digits:** In Lucent-made switching systems, the only limit on the length of time that multifrequency signals can be sent or received is the

time-out interval of the multifrequency receiver. Table 6-22 shows information on minimum digit timing.

**Table 6-22.** Minimum Digit Timing (seconds)

	1 ESS		DMS-10†		DMS-100‡		LSSGR Objective	
	DP	MF	DP	MF	DP	MF	DP	MF
First digit must be received in less than _____ seconds from seizure.	16 10*		16	—	2-30	2-30	16-24	5-10
Each digit must be received within _____ seconds after previous digit.			16	—	2-30	2-30	16-24	5-10
Second and third digits must each be received in less than _____ seconds from registration of previous digit.	16 5*							
Fourth digit must be received in less than _____ seconds from registration of third digit.	16 5*							
Each digit after fourth digit must be received in less than _____ seconds from registration of previous digit.	16 5*							
All digits must be received in less than _____ seconds from seizure.		16 10*	—	16	2-30	2-30		20 30**
<b>Note:</b> Includes both 3- and 10-digit register operation.								
* Under overload conditions								
** Optional								
† All times shown are software settable from 1 second to 155 second in 1-second increments								
‡ 1-second increments								

**Types and Levels of Noise:** The following types and levels of noise should be tolerated with an error rate of not more than one in 2500 10-digit calls:

- Message Circuit Noise — Signal-to-noise ratio 20 dB;
- Impulse Noise — Signal-to-noise ratio -12 dB (test with impulse noise tape 201). The digital noise tape is covered in TR-TSY-000763, *Digit Simulation Test Tape*;
- Power Line Induction — 60 Hz, 81 dBrnc0; 180 Hz, 68 dBrnc0.

The limits for impulse noise power represent levels that are exceeded not more than 15 times in 15 minutes.

**Tolerate Intermodulation Products:** The receiver should tolerate 2A-B and 2B-A intermodulation products (where the A and B frequencies represent the digit being transmitted) caused by transmission of multifrequency pulses over facilities. The power

---

sum of these modulation products is expected to be at least 28 dB below each frequency component of the signals.

**Frequencies Accepted:** The receiver should accept 700-, 900-, 1100-, 1300-, 1500-, and 1700-Hz signals within the limits of +1.5 percent +5 Hz and -1.5 percent -5 Hz.

**Receiver Tests:** In some electronic switching offices, each multifrequency receiver is tested with each multifrequency transmitter through an environmental test circuit. The following tests are made.

- Flat Loss Test — A resistive pad is inserted between the transmitter and receiver circuits. This tests transmitter output level and receiver sensitivity;
- Twist Test — A network that attenuates the 1500-Hz signal 6.25 dB more than the 700-Hz signal is inserted between the transmitter and receiver. This tests the ability of the receiver to respond to two multifrequency tones when one is at a level appreciably different from the other;
- Double Keying Test — A third frequency is generated in this circuit and applied to the receiver at a level 6 dB higher than the tone pair from the transmitter. This simulates the type of signal produced when two multifrequency digits are sent simultaneously. The receiver should respond to all three tones and the receiver should reject the signal as invalid;
- Modulation Products Test — A third frequency is generated in this circuit and applied to the receiver at a level 15 dB below the level of either tone in the pair from the transmitter. This simulates 2A-B intermodulation products produced by trunk facilities. The receiver should respond only to the two tones from the transmitter when a digit is being sent and should reject the third frequency. When the two tones from the transmitter are absent, however, the individual channel detector (although not the signal present indicator) should be operated by the third frequency.

The DMS-100F switching system does not provide an environmental test circuit between the transmitter and receiver to mutilate the tones from the transmitter as they are looped to the receiver.

#### 6.12.3.2 Maximum Impairment

The multifrequency receiver should correctly detect valid digits and reject nonvalid tone or tones (digits) when all operating parameters are at their worst. That is, for valid digits the frequencies of both tones can be as far from normal (high or low) as allowed, the tone level can be as high or low as allowed, the twist can be at its maximum, and noise as high as allowed and still detect valid digits.

---

### 6.13 Dual-Tone Multifrequency Signaling

Dual-Tone Multifrequency (DTMF) signaling provides a method for address signaling from customer installations using the voice transmission path. This system provides 16 distinct signals. Each signal is composed of two voiceband frequencies, one from each of two mutually exclusive frequency groups of four frequencies each. The signal frequencies are geometrically spaced and are not harmonically related.

The requirements for DTMF signaling in the intraLATA networks including customer installation equipment<sup>1</sup> using DTMF are covered in the following standards:

- LEC intraLATA Networks — GR-506-CORE, *LSSGR: Signaling for Analog Interfaces*;
- LEC intraLATA Networks — TA-NPL-000912, *Compatibility Information For Telephone Exchange Service*;
- LEC intraLATA Networks — TR-TSY-000181, *Dual-Tone Multifrequency Receiver Generic Requirements for End-to-End Signaling Over Tandem-Switched Voice Links*;
- Measurements of DTMF signaling — IEEE STD 752-1986, *IEEE Standard for Functional Requirements for Methods and Equipment for Measuring the Performance of Tone Address Signaling Systems*;
- Telephone — ANSI/EIA 470-A-1987, *Telephone Instruments with Loop Signaling*;
- CPE using loop-start and ground-start signaling — ANSI T1.401-1993, *American National Standard for Telecommunications — Interface Between Carriers and Customer Installations — Analog Voicegrade Switched Access Lines Using Loop-Start and Ground-Start Signaling*;
- CPE using loop reverse-battery signaling — ANSI T1.405-1996, *American National Standard for Telecommunications — Network-to-Customer Installation Interfaces — Direct-Inward-Dialing Analog Voicegrade Switched Access Using Loop Reverse-Battery Signaling*;
- PBXs — ANSI/EIA/TIA 464-B-1996, *Private Branch Exchange (PBX) Switching Equipment for Voiceband Application (and inclusion of ANSI/EIA 464-1)*.

---

1. See ANSI T1.401-1993 or ANSI/EIA/TIA/464-B-1996 for the exact current/voltage characteristics of a terminal during DTMF signaling and in the communications state. The highest dc resistance that will meet the requirements of ANSI T1.401-1993 or ANSI/EIA/TIA/464-B-1996 for an off-hook is 430  $\Omega$  with 20 mA flowing. During power failure at the serving switching system, the current will drop to 18 mA.

### 6.13.1 DTMF Signaling Frequencies

Table 6-23 shows the frequency pairs assigned for DTMF signaling.

**Table 6-23.** DTMF Frequency Pairs

	High-Group Frequencies (Hz)				
		1209	1336	1477	1633
<b>Low Group</b>	697	1	2	3	A
<b>Frequencies</b>	770	4	5	6	B
<b>(Hz)</b>	852	7	8	9	C
	941	*	0	#	D

The \* and # symbols are for network provided services. At present, the # is an optional end-of-dialing signal on some calls (for example, International Direct Distance Dialing [IDDD]) to avoid timing when address lengths are variable. The standard for custom-calling services uses the format \*XX(X) for customer activation and control of custom-calling services. The characters A through D are not used in public LEC networks.

### 6.13.2 DTMF Central Office Receiver Operation

Operation of a switching system DTMF receiver is described in the following sections.

#### 6.13.2.1 Input Impedance and Longitudinal Balance

**Minimum Input Impedance:** If a DTMF receiver is bridged from tip to ring the minimum input impedance for the DTMF receiver is 40,000  $\Omega$  from dc to 4 kHz. Otherwise, a switching system must meet the transmission requirements of TR-NWT-000507, *LSSGR: Transmission, Section 7* while receiving DTMF signals;

**Minimum Longitudinal Balance:** The minimum longitudinal balance for a DTMF receiver is 50 dB (TR-NWT-000507, *LSSGR: Transmission, Section 7*). A test in IEEE STD 455-1985, *IEEE Standard Test Procedure for Measuring Longitudinal Balance of Telephone Equipment Operating in the Voice Band*, can be used to verify the return loss.

#### 6.13.2.2 Registration of DTMF Signals Without Noise

**Valid Tone Check:** The DTMF receiver checks that two of the tones listed above are present and that one is from each group of four. The receiver should ignore a single DTMF tone.

**Simultaneously Operating Two Pushbuttons:** The receiver should ignore the result of operating two DTMF telephone pushbuttons simultaneously. Most DTMF telephones will send a single valid DTMF tone, or none, when two buttons are pushed simultaneously.

**Tone Frequency Limits:** The receiver should register the digit if the frequencies are within  $\pm 1.5$  percent of their nominal values, but ignore it if the deviation of either frequency is greater than  $\pm 3.5$  percent. The DMS-100F Universal Tone Receiver (UTR) will not totally reject digits whose frequencies deviate more than  $\pm 3.5$  percent.

**Tone and Interdigital Time Limits:** The receiver should register DTMF digits as short as 40 ms (transients can be present in the first 5 ms of the digit) and should recognize interdigital intervals as short as 40 ms. The shortest cycle time (tone-on plus tone-off interval) that must be accepted is 93 ms. Digits less than 23 ms long should be rejected.

**Transients:** Transients are defined as short-duration amplitude changes exceeding 1 dB deviation from the steady-state signal level. Any such transient should be restricted to the first 5 ms of the tone-on interval. The maximum transient peak should not exceed 12 dB above the steady-state peak amplitude of the composite signal.

**Gaps in Tone:** There is no requirement for bridging a gap in tone. However, the receiver must recognize 40 ms of no tone as an interdigital interval. Some receivers will recognize 20 ms or more of no tone as an interdigital interval.

**Tone-Level Limits:** The receiver should register DTMF digits with a power per frequency of -25 to 0 dBm and with the high-frequency tone power of +4 to -8 dB relative to that of the low-frequency tone as measured with a 900- $\Omega$  termination bridged across the receiver. The overload level value of 0 dBm assumes a termination of 900  $\Omega$ . The receiver should not respond if either frequency component of the signal is below -55 dBm into 900  $\Omega$ . In electronic switching offices, the termination is 900  $\Omega$ .

**Digit Registration with Echoes:** DTMF digits should be accurately registered in the presence of signal echoes that are delayed up to 20 ms and reduced in level by at least 16 dB with respect to the primary signal.

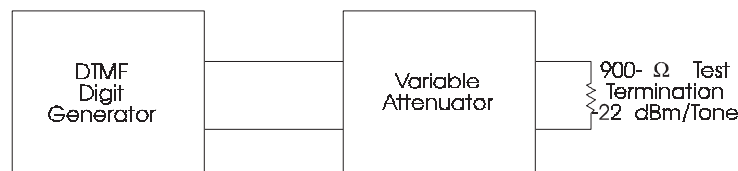
**Dial Tone:** DTMF digits should be registered in the presence of central office precise dial tone. The level of the dial tone is nominally -10 dBm (-13 dBm per frequency) at the point of application when a 900- $\Omega$  test termination is substituted for the customer line. The worst case would be 1.5 dB for tolerance in tone level or -8.5 dBm for both tones at the source. Line impedance mismatch for a 2-wire office may increase the dial tone another 3 dB. The worst case for a 2-wire office is -5.5 dBm for both tones at the receiver. In 4-wire and digital offices, the trans-hybrid loss reduces the dial-tone level at the receiver. Thus, 4-wire and digital offices should be able to register DTMF signals in the presence of dial tone at -13.5 dBm.



### 6.13.2.3 Digits Registered in Presence of Gaussian Noise

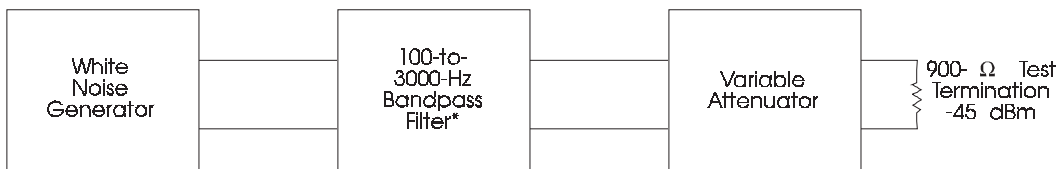
Low-level DTMF digits should be registered with a low error rate in the presence of Gaussian noise. Details of this test are as follows.

- Error rate should be less than one error in 10,000 pulses with a DTMF pulsing rate of 10 pps with a 50-ms tone-on time, and a 50-ms interdigital interval. All DTMF digits should be included in the test sequence;
- Each DTMF should be at a nominal value and at a level of -22 dBm into a 900- $\Omega$  test termination.<sup>2</sup> Figure 6-38 shows the method of measuring the tone levels.



**Figure 6-38.** DTMF Digit Source

- Figure 6-39 shows the noise source for the tests. The noise generator produces a noise level of -45 dBm of flat-weighted 3-kHz band-limited Gaussian noise as measured in a 900- $\Omega$  test termination;

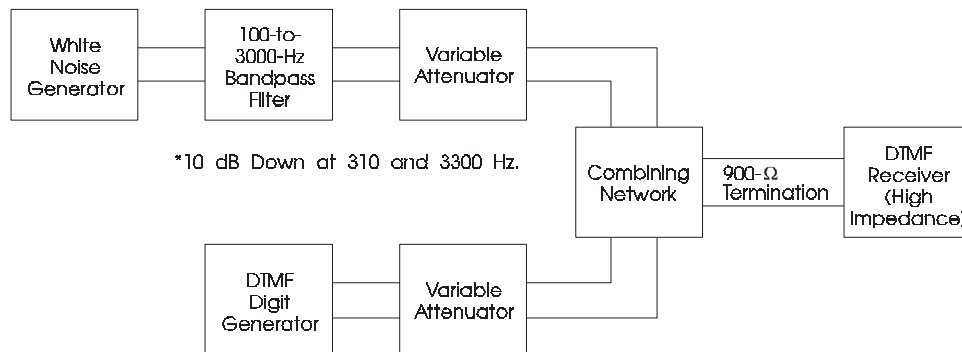


\*10 dB Down at 310 and 3300 Hz

**Figure 6-39.** Gaussian Noise Source

- The test DTMF receiver is connected to the digit and noise sources as shown in Figure 6-40. The DTMF receiver is across a 900- $\Omega$  test termination during the test. The levels of tone in Figure 6-38 and of Gaussian noise in Figure 6-39 assume a 0-dB loss in the combining network of Figure 6-40. Where the combining network has loss, the levels of the tone and noise should be increased to compensate for the loss. The level of the DTMF signals should be -22 dBm per tone and the noise should be -45 dBm at the receiver.

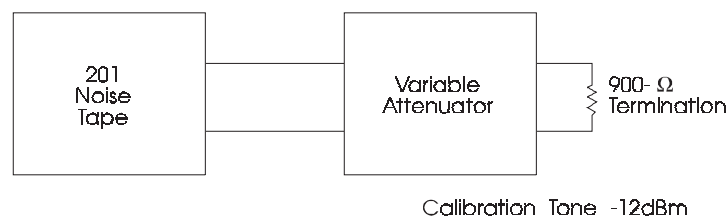
2. For other than 900- $\Omega$  applications, an appropriate adjustment in voltage levels should be made.



**Figure 6-40.** Gaussian Noise Test of DTMF Receiver

**Digits Registered in Presence of Impulse Noise:** Low-level DTMF digits should be registered with a low error rate in the presence of impulse noise. Details of the test are as follows:

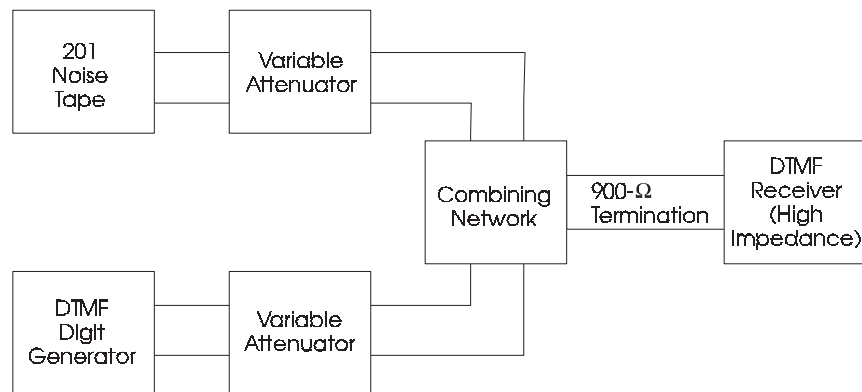
- The DTMF pulsing rate should be 10 pps with a 50-ms tone-on time and a 50-ms interdigital interval. All DTMF digits should be incorporated in the sequence of pulses;
- Each DTMF should be at a nominal value and at a level of -22 dBm into a 900- $\Omega$  test termination. The method of measuring the tone levels is shown in Figure 6-38;
- The noise level is set to a signal-to-noise ratio of -12 dB (noise at a higher level than the signal). The impulse noise source for the tests should be the 201 noise tape described in TR-TSY-000762, *Impulse Noise Tape No. 201* and shown in Figure 6-41. At this level, there should be no more than 14 errors in 10,000 pulses (16.7 minutes);



**Figure 6-41.** Impulse Noise Source

- Impulse noise tape No. 201 is a recording of an N1 carrier channel not equipped with companders. The tape has a running time of approximately 30 minutes. By varying the playback level of the tape, a wide range of line noise can be simulated. A 1000-Hz calibration tone at the start of the tape simplifies the noise level adjustment;
- The test DTMF receiver is connected to the digit and noise sources as shown in Figure 6-42. This arrangement places the DTMF receiver across a 900- $\Omega$  termination during the test. The level of tone in Figure 6-38 and of impulse noise in Figure 6-41 assume a 0-dB loss in the combining network of Figure 6-42. Where the combining network has

loss, the levels of the tone and noise should be increased to compensate for the loss. The DTMF signals should be at -22 dBm per tone and the calibration tone on the noise tape should be -12 dBm at the receiver.



**Figure 6-42.** Impulse Noise Test — DTMF Receiver

**Double-Digit Registration with Impulse Noise:** Double-digit registration of a single DTMF digit should not occur often in the presence of impulse noise. Details of this test are as follows:

- The DTMF pulsing rate should be 4 pps with a 180-ms tone-on time and a 70-ms interdigital interval. All DTMF digits should be incorporated in the sequence of pulses;
- All other conditions for this test are the same as in this section.

**Extraneous Frequency Components:** The primary source of nonlinear distortion in the DTMF signal is the DTMF telephone. However, facilities like single-channel loop carrier systems may also introduce distortion. Nonlinear distortion produces extraneous frequencies that accompany the DTMF signal and may interfere with receiver operation. The nonlinear distortion requirement for DTMF receivers is defined as the total power of these extraneous frequencies that must be tolerated in the voiceband above 500 Hz, relative to the power level of a DTMF signal. The requirement is expressed as follows: the receiver should tolerate a signal-to-distortion ratio of 20 dB relative to the two-tone power level of a DTMF signal, and a ratio of 16 dB with respect to any single DTMF tone (from EIA 470-A-1987, *Telephone Instruments with Loop Signaling*).

**Digit Simulation:** The average rate of digit simulation by speech, room noise, etc., prior to DTMF signaling and during interdigital intervals, should be less than one occurrence in 3000 calls for digits 0 through 9; one occurrence in 2000 calls for digits 0 through 9 plus \* and #; and one occurrence in 1500 calls for all 16 combinations.

The above data was collected from actual 7-digit calls. Because the facilities to make such a test are not widely available, a digit simulation test tape and technical description of the tape are available as TR-TSY-000763, *Digit Simulation Test Tape*, to replace testing on actual calls. When this tape is played back through a band-pass filter that is 10 dB down at

300 Hz and 3000 Hz and at a calibration level of -20 dBm into the same type of receiver as was used to collect this data, the following numbers were developed. There should be no more than 670 total simulations of the 16 DTMF tone pairs; of this total, not more than 330 simulations of the digits 0-9, and no more than 170 total simulations of the signals \* or #.

### 6.13.3 DTMF Receiver Test Circuit Operation

The DTMF receiver test circuit operation is described in the following sections.

#### 6.13.3.1 Automatic Tests in 1/1A ESS Switching System

Automatic tests of the DTMF receiver in the 1/1A ESS switching system are made as follows.

**High Band Edge and Low Band Edge Tests:** The receiver must correctly receive digits.

- Level-per-tone, -22 dBm (900  $\Omega$ )
- Frequencies, 1.5 percent above nominal and 1.5 percent below nominal
- Digit length, 40 ms
- Interdigit length, 40 ms or greater.

**Overload Test:** The receiver must correctly receive digits.

- Level-per-tone, 0 dBm (900  $\Omega$ )
- Frequencies, 1.5 percent below nominal
- Digit length, 40 ms
- Interdigit length, 40 ms or greater.

**Out-of-Band Test:** The receiver must ignore the following:

- Level-per-tone, 0 dBm (900  $\Omega$ )
- Frequencies, 3.5 percent below nominal
- Digit length, 70 ms
- Interdigit length, 70 ms.

**Third-Frequency Test:** The receiver must ignore the following:

- Level-per-tone, -10 dBm (900  $\Omega$ )
  - Frequencies, nominal
  - Digit length, 70 ms
-

- Interdigit length, 70 ms
- Third frequency, 2000 Hz
- Third frequency level, -10 dBm (900  $\Omega$ ).

**Low-Group Only and High-Group Only Test:** The receiver must ignore the following:

- Single-frequency tone (2600 Hz)
- Level, -10 dBm
- Frequency, nominal
- Digit length, 70 ms
- Interdigit length, 70 ms.

#### 6.13.3.2 Low-Level Test

Low-level test of DTMF receivers in offices without automatic testing can be made with a source of DTMF digits adjusted to send -22 dBm  $\pm$ 1 dB into a 900- $\Omega$  test termination.

### 6.13.4 DTMF Station Test Receiver Operation

Operation of the DTMF station test receiver is described in the following sections.

#### 6.13.4.1 Input Impedance

The station test receiver should have an input impedance identical to, and if appropriate, be bridged across the loop termination at the same point as the service receiver of the particular central office.

#### 6.13.4.2 Edge Band Frequencies

The edge band frequencies of the test receiver should be centered at  $\pm$ 1.5 percent of the nominal DTMF and held to a tolerance of  $\pm$ 0.2 percent.

#### 6.13.4.3 Effective Sensitivity

The effective sensitivity should be 1  $\pm$ 1 dB more restrictive than the service receiver and should tolerate the same range of twist as the service receiver; that is, it should tolerate a

---

difference in the high-frequency level with respect to the low-frequency level of +4 to -8 dB.

#### 6.13.4.4 Limiting Pulsing Speed And Pulse Duration

The limiting pulsing speed and pulse duration that will be accepted by a test receiver when working in conjunction with a speed test circuit for DTMF automatic dialers are as follows:

- Signals of 48 ms or more should be accepted and signals shorter than 43 ms should be rejected.
- Interpulse intervals of 45 ms or more should be accepted and intervals shorter than 40 ms should be rejected.
- Cycle time of 97 ms or more should be accepted and cycle times less than 93 ms should be rejected.

### 6.13.5 In-Service Receivers and Transmitters

#### 6.13.5.1 Use of # (Number Sign)

Some DTMF receivers, like those used in 1/1A ESS, DMS-100, DMS-10, EWSD and NEAX61E switching systems will interpret the DTMF digit # (number sign) as an end-of-dialing signal. In this case, the number sign can be used to eliminate a time-out when a variable number of digits can be expected. Operator-services offices send the DTMF digit # as part of the Calling Card Service prompt tone to release any DTMF to dial-pulse converters in the connection.

#### 6.13.5.2 DTMF Receiver Start Dialing Signal

**Customer Dial-Pulse and DTMF Receiver:** The 1/1A ESS switching system receiver on lines does not provide any start signal (wink-start or delay-dial) except dial tone.

**Private Network DTMF Receiver:** There is a DTMF receiver used in the 1/1A ESS switching system that sends controlled-outpulsing start signals (wink-start or software delay-dial). It is used on private network signaling and Direct Outward Dialing (DOD). However, the receiver is not found in all offices. It connects to trunks with trunk features. The receiver has the following characteristics.

- It meets the requirements for a central office receiver (see Section 6.13.2).
  - Both common-control and manual DTMF outpulsing are received.
-

- 
- The receiver will provide either dial tone, wink-start, or software delay-dial signal to the connected trunk when ready to receive information. However, a given trunk cannot send both dial tone and a wink-start signal.

#### 6.13.5.3 DTMF Transmitters in Electronic Switching Systems

The 1/1A ESS, DMS-10, DMS-100, EWSD and NEAX61E switching systems can provide a DTMF transmitter for outpulsing to a PBX, Centrex, or other location. The transmitter always connects to a trunk circuit that has either line or trunk functions. A trunk circuit with line functions is used when a line is the connecting circuit at the distant end, and a trunk circuit with trunk functions is used when a trunk is the connecting circuit. The conditions for the transmitter are as follows:

- The tone level is  $-7 \text{ dBm}_0 \pm 1.0 \text{ dB}$  per frequency.
- The frequency tolerance of individual frequencies is  $\pm 1.5$  percent.
- When a DTMF digit is being sent, the total extraneous frequency components should be at least 30 dB below the level of either of the two signal frequencies when measured over a 3-kHz band.
- The tone leakage limit when no DTMF digit is being sent is  $-58 \text{ dBm}_0$ .
- The DTMF transmitter applies both tones of the DTMF digit to the trunk or line simultaneously, and neither tone is sent if either tone source fails.
- The DTMF transmitter is arranged to delay the first pulse at least 70 ms after the start-dial signal or 70 ms after seizure if there is no start-dial signal.
- The digits are greater than 50 ms and the interdigital interval is greater than 45 ms.
- The transmitter operates wink-start or delay-dial expected to trunks; it operates ground-start lines.
- There is no option to operate dial-tone start to either lines or trunks.
- The transmitter can operate immediate-start on lines or trunks.
- In DTMF signaling, there are no equivalents of the KP and ST signals used in multifrequency pulsing. However, the # can be sent as a last signal to systems that will accept it as an end-of-dialing signal.

#### 6.13.6 Barriers to End-to-End DTMF Signaling

In modern LEC networks, almost all barriers to end-to-end DTMF signaling have been removed because banking services, voice mail systems, paging services, answering machines, and many more services depend upon end-to-end DTMF signaling. Most DTMF

---

telephone sets have polarity guards, DTMF has been enabled for dial-tone-first public telephones. Time Assignment Speech Interpolation (TASI) systems are very rarely used or are no longer used, and echo suppressors have been replaced by echo cancellers. The following discussion is included as mainly historical information, but some of these barriers to end-to-end DTMF may still be encountered in telephone networks.

There are several barriers to end-to-end DTMF signaling. First, some switching systems reverse the polarity on the line during the call. This can disable the DTMF pad unless a telephone set contains a polarity-guard circuit. Second, to permit proper coin totalizer operation and to prevent fraud in many single-slot coin telephones, the normal negative battery supply from the end office is replaced with a positive battery supply. This disables the DTMF pad. Third, echo suppressors, where still found, can attenuate the DTMF signals enough to cause signaling failures if dial-tone start is used.

#### 6.13.6.1 Polarity Guard

To enable DTMF signaling in a telephone attached to a switching system that changes line polarity during a call, a polarity guard can be designed into the telephone. This provides proper polarity to the telephone regardless of the line polarity.

#### 6.13.6.2 Enabling DTMF Signaling in Single-Slot Coin Telephones

Enabling DTMF signaling in single-slot coin telephones has many ramifications. Briefly, complete DTMF signaling enablement in some switching systems, while preserving proper coin totalizer operation and fraud prevention, requires one of two things:

- A polarity guard in the coin station and Automated Coin Toll Service (ACTS) features in the operator-services offices;
- Dial-tone-first features in the end office switching systems and Calling Card Service features in the operator-services offices. Dial-tone-first is covered in Section 6.17. Calling Card Service is covered in FR-271, *Operator Service Systems Generic Requirements, OSSGR*.

#### 6.13.6.3 Effects of Time Assignment Speech Interpolation

During busy traffic periods, TASI systems switch a call to a facility only when speech is present. This means that at least the first few milliseconds of speech or signaling are clipped when switching is necessary to provide a path through the system. For information on which talker or signal is switched to which facility, an internal signaling system is used. When traffic is heavy, the internal signaling system may not keep up with the necessary changes and, in fact, there may not be a voice channel available for the speech or signaling.

---



---

TASI originally was used only on overseas calls. Now it can be found on interLATA carriers and private networks. The result is shortened signaling digits on end-to-end signaling. Where signaling failures occur due to TASI, longer DTMF digits should cure the problem.

#### 6.13.6.4 Effect of Echo Suppressors and Dial Tone

The effects of echo suppressors used by the various ICs and in the non-LEC networks that can be connected to LEC networks are unknown. In general, the makeup of these networks is unknown to the LEC. In the past, multifrequency pulsing (see Section 6.12) was universally used by the ICs. This meant that multifrequency pulsing had to pass through the various links of the network. As a result, end-to-end pulsing that used the levels and timing of multifrequency signaling would have an excellent chance of working. However, multifrequency address signaling is giving way to CCS. In addition, before SPC switching systems, echo suppressors were always part of the transmission facility. As a result, multifrequency address signaling had to pass through the echo suppressors. Now many of the echo suppressors are part of the switching system. Even if multifrequency signaling is used, the multifrequency signals may not pass through the echo suppressors. Fortunately, echo suppressors have widely been replaced by echo cancellers, which are much less troublesome.

There is no guarantee that end-to-end DTMF signaling with dial tone present will always work over facilities using echo suppressors. When DTMF signaling is transmitted over facilities using echo suppressors and dial tone is sent from the switching system, there is some risk that the first DTMF signal will be attenuated over the entire digit or over the first portion of the digit as follows:

- The attenuation varies from zero loss to complete blockage of tone depending on the relative DTMF and dial-tone levels at the echo-suppressor location. Under adverse conditions, typical loss for an echo suppressor is 6 dB. The Echo Suppressor Terminal (EST) used in the 4 ESS digital switching system introduces 0 to 15 dB of loss, depending on the tone levels at the EST (using split operation).
- In many of these unfavorable circumstances, the attenuation will occur over only the first portion of the pulse. The attenuated portion of the pulse can be as long as 64 ms.

One solution is to use DTMF-to-dial-pulse converters when pulsing over facilities using echo suppressors and dial tone must be used as a start signal. This assumes that dial-pulse signals can be used end-to-end and that the DTMF-to-dial-pulse converter is always on the line. Those assumptions restrict this solution to private networks. In situations where the dial tone can be reduced in level or eliminated (by using a zip tone or an announcement), link-by-link or end-to-end DTMF signaling can be sent successfully.

---

Another approach is to place an echo-suppressor disabler tone (2125 Hz) on the circuit just before dial tone is applied. If the dial tone is applied while the disabler tone is present and the tone is then removed, the suppressor will remain disabled until the dial tone is removed.

If the DTMF-tone signals originate in transmitters that time the pulses rather than telephones that generally do not time the DTMF signals, a first digit of near 120 ms can reduce failures caused by echo suppressors and TASI systems.

### 6.13.7 Increased Sensitivity DTMF Receiver for End-to-End Signaling

In many cases, it is not possible to use DTMF-to-dial-pulse converters or to alter the dial tone to permit end-to-end signaling. Another look at the problem has produced the following possible solution. The suggested receiver concepts have been tried, and they work. However, presently there is no known commercial receiver that meets these requirements. The method will not be effective, however, if the call is cut-through to another dial tone and normal sensitivity receiver (for example, in tie-line or dial-9 access situations). It also will not be effective if the DTMF tones are about -3 dB with respect to the dial tone and the 4ESS switching system EST is used. In this case, the EST will completely suppress the DTMF signals.

The complete requirements for this receiver are in TR-TSY-000181, *Dual-Tone Multifrequency Receiver Generic Requirements for End-to-End Signaling Over Tandem-Switched Voice Links*. Briefly, these requirements increase the sensitivity of the DTMF receiver from -25 dBm per frequency to -36 dBm per frequency. This 11-dB increase in sensitivity permits receiving DTMF digits when the echo suppressor is in the double-talk mode. The double-talk mode adds up to 15 dB of attenuation to the circuit in both directions, depending on the tone levels at the echo suppressor. The increased sensitivity DTMF receiver uses many of the same requirements as the central office receiver. However, the other requirements are more stringent, as follows:

- Echo — The receiver must tolerate the same signal-to-echo requirement at 20-ms echo delay as the central office receiver and add a new requirement of 24-dB signal-to-echo ratio at 45-ms echo delay.
- Gaussian Noise — The receiver signal-to-noise ratio stays the same (23 dB); the pulse signal level is reduced to 3 dB above the minimum accept level (-33 dBm per tone). The error rate stays the same.
- Impulse Noise — The signal-to-noise ratio of -12 dB (noise higher than signal) remains the same while the pulse signal level is reduced to 3 dB above the minimum accept level (-33 dBm). The error rate remains the same (14 errors in 10,000 digits).
- Adaptive Sensitivity — The receiver may use adaptive sensitivity to minimize false digits from echoes and speech. When the first pulse is received, the sensitivity threshold of the receiver would be raised instantly to 9 dB below the received level of

---

the first pulse. In most situations, this new sensitivity would be satisfactory for the rest of the digits on this call.

### 6.13.8 Out-of-Band Signaling — Digital Carrier and Digital Switching Systems

The channel units of digital transmission systems have built-in signaling functions and employ out-of-band signaling. The eighth bit of a time slot normally used for the transmission of speech is used for indicating the on-hook state during a signaling sequence. This is done in a manner analogous to the transmission of 2600-Hz tone, representing the on-hook state for inband signaling. The eighth bit may be used exclusively for signaling (in the obsolete D1A and D1B channel banks) or only every sixth frame (in all modern systems). The channel units contain the circuitry for converting between the signal on the digital transmission line and the form of signal (loop, E&M, ground-start, etc.) required by the terminating or switching equipment. In respect to signaling features, D-channel bank units resemble single-frequency signaling units. However, the signal delay and distortion of the D-channel banks are far less. Signaling distortion is below  $\pm 5$  ms. The signaling range is 8 to 12 pps at 10- to 90-percent break. The end-to-end signaling delay for E&M channel units in channel banks is 0.2 ms (D1A), 0.6 ms (D1B), 1.6 ms (D1D, D2, D3, D4), and 7 ms (D5). When digital switches are connected directly by digital lines, there are no channel banks to introduce delay or pulse distortion.

One of the problems with the signaling associated with D-channel banks is the accuracy with which the system transmits pulses. A split pulse is a single pulse that has been divided in two by a false off-hook. It is usually associated with pulses detected by a pulse-repeating relay. However, electronic pulse detectors can also detect split pulses. The condition is usually caused by mechanical/electrical oscillations in the circuit. Many metallic loop signaling circuits have momentary splits in the pulses. These are not always seen at the far end of the circuit because the characteristics of the wire pair smooth out these signals. However, the signaling of the D-channel bank does not provide this smoothing and the split pulse can arrive at the far office where it can cause wrong numbers or other problems.

Digital transmission facilities have 1-way transmission delays as follows.

- A pair of D-channel banks of types used for message trunks has a delay of about 0.35 ms.
- The T-carrier line has a delay of 0.0079 ms (including repeaters) per mile.
- Fiber line facilities have a delay of 0.0084 ms per mile.
- The 4ESS switching system has a delay of 1 ms.
- The Echo Suppressor Terminal (EST) associated with the 4ESS system has a delay of 0.2 ms.

- 
- The 5ESS system has a nominal delay of 0.44 ms. Delay is less than 0.56 ms 99 percent of the time.
  - The DMS-10 system has nominal 1-way outgoing and incoming transmission delays of 0.19 and 0.35 ms, respectively.

MDP-326-140, *Digital Channel Bank Requirements and Objectives*, includes the signaling characteristics of channel units. These include the following:

- Sleeve ground Dial-Pulse Originating (SDPO) channel unit
- Dial-Pulse Originating (DPO) (2-wire) channel unit
- Dial-Pulse Terminating (DPT) (2-wire) channel unit
- E&M channel units
- Foreign exchange channel unit — Station End (FXS)
- Foreign exchange channel unit — Office End (FXO)
- Multifrequency Signaling Originating (MFO) (2-wire) channel unit.

Most signaling on trunks requires only a single signaling path in each direction. The time-sharing of the least significant speech bit, one frame out of six, gives a 1333-bps path that is highly satisfactory for this purpose. For some foreign-exchange circuits, two paths are needed toward the distant station, for example, to alert the station and to send forward-disconnect signals. In this case, the shared signaling bit is further subdivided into “A” and “B” signaling bits, each at a rate of 666 2/3 bps.

By contrast, in DLC systems a much more complex set of signaling conditions must be provided. GR-303-CORE, *Integrated Digital Loop Carrier System Generic Requirements, Objectives, and Interface*, defines the four signaling bits A, B, C, and D for transmission of signaling between the Integrated Digital Terminal (IDT) of the switching system and the Remote Digital Terminal (RDT) of the carrier system.

These ABCD bits are the least significant bit of each channel in the 6th, 12th, 18th, and 24th frames of the 24-frame extended superframe. Signaling is accomplished by replacing the bits (located in these positions) of the originally encoded byte with signaling bits. The replacement bits typically relate to the call state of the subscriber line as, for example, on-hook and off-hook states.

The ABCD bits allow a maximum of 16 possible states per channel. Functionally, these bits comprise per-channel data-links operating at a rate of 333.3 bps. Signaling information is refreshed every 3 ms and conveys signaling/supervision information related to the associated channel.

The use of these data-links depends on the specific line terminating equipment. Alternate means of conveying equivalent information may be available and, thus, this form of signaling will not always be used. For example, to provide a clear 64 kbps capability on all DS0s, a separate signaling channel is required.

---

---

Table 6-24 gives the ABCD-bit codes for locally switched services, from IDT to RDT. Table 6-25 gives the corresponding codes for the RDT-to-IDT direction. GR-303-CORE, *Integrated Digital Loop Carrier System Generic Requirements, Objectives, and Interface*, gives additional ABCD codes for non-locally-switched circuits such as foreign exchange.

**Table 6-24.** ABCD Codes, Locally Switched Circuits, IDT to RDT

ABCD Code	Loop Start	Ground Start	Loop Reverse Battery	Coin		Multi- Party
				CF	DTF	
0000	-R ringing	-R ringing		-R ringing	-R ringing	-R ringing
0001						
0010	DS0 AIS	DS0 AIS	DS0 AIS	DS0 AIS	DS0 AIS	DS0 AIS
0011						
0100	RLCF	RLCF		RLCF	RLCF	
0101	LCF	LCF	LO	LCF	LCF	LCF
0110						
0111	DS0 RAI	DS0 RAI	DS0 RAI	DS0 RAI	DS0 RAI	DS0 RAI
1000	<i>Reserved</i>	<i>Reserved</i>	<i>Reserved</i>	<i>Reserved</i>	<i>Reserved</i>	<i>Reserved</i>
1001						
1010				Pos. Coin Check	Pos. Coin Check	+R ringing
1011				Neg Coin Check	Neg. Coin Check	Tip Party Test
1100				Pos. Coin Control	Pos. Coin Control	+T ringing
1101	<i>Reserved</i>	<i>Reserved</i>	<i>Reserved</i>	<i>Reserved</i>	<i>Reserved</i>	<i>Reserved</i>
1110				Neg. Coin Control	Neg. Coin Control	-T ringing
1111	LCFO	LCFO	LC	LCFO	LCFO	LCFO

**Legend:**

AIS	Alarm Indication Signal
CF	Current Feed
DTF	Dial-Tone First
LC	Loop Closure
LO	Loop Open
LCF	Loop Current Feed
RLCF	Reverse Loop Current Feed
LCFO	Loop Current Feed Open
<i>Reserved</i>	for superframe-to-extended superframe translation

**Table 6-25.** ABCD Codes, Locally Switched Circuits, RDT to IDT

ABCD Code	Loop Start	Ground Start	Loop Reverse Battery	Coin		Multi- Party
				CF	DTF	
0000		Ring Ground				
0001						
0010	DS0 AIS	DS0 AIS	DS0 AIS	DS0 AIS	DS0 AIS	DS0 AIS
0011						
0100			RLCF			
0101	LO	LO	LCF	LO	LO	LO
0110						
0111	DS0 RAI	DS0 RAI	DS0 RAI	DS0 RAI	DS0 RAI	DS0 RAI
1000	<i>Reserved</i>	<i>Reserved</i>	<i>Reserved</i>	<i>Reserved</i>	<i>Reserved</i>	<i>Reserved</i>
1001						
1010						
1011						
1100						
1101	<i>Reserved</i>	<i>Reserved</i>	<i>Reserved</i>	<i>Reserved</i>	<i>Reserved</i>	<i>Reserved</i>
1110				Coin Ground	Coin Ground	Tip Party Ground
1111	LC	LC		LC	LC	LC

(See Table 6-24 for legend.)

---

## 6.14 Calling Number Delivery

This feature delivers the calling customer's directory number to the called Customer Premises Equipment (CPE) over the tip-and-ring of the line. Along with the directory number, the information received by the customer contains the date and time of the call. This information is delivered after the first full ring of the call. If the call is answered before or during the data transmission, the normal ringing trip occurs and the customer may not receive the data.

The CND feature can be offered to users on a subscription basis and/or on a usage sensitive basis. This is a LEC option. While the majority of CND activations are via subscription, usage sensitive customers can activate/deactivate the feature by going off-hook, receiving dial tone, and then dialing an appropriate code. Once on, the feature stays on until the customer turns it off. The control method is as follows:

- The first character is (\*) for DTMF and (11) for dial-pulse telephones.
- The suggested activation code is (\*65) for DTMF and (1165) for dial-pulse telephones.
- The suggested deactivation code is (\*85) for DTMF and (1185) for dial-pulse telephones.

A caller may choose to block the presentation of their number by a method covered in TR-NWT-000391, *CLASS<sup>SM</sup> Feature: Calling Identity Delivery Blocking Features*. When the calling number is blocked (or made “anonymous”), a “privacy” indication is displayed in place of the calling number. When the calling number is not available, an “out of area/unavailable” indication is displayed in place of the calling number.

The CND feature is described in TR-NWT-000031, *CLASS<sup>SM</sup> Feature - Calling Number Delivery*, while the data interface is described in GR-30-CORE, *Voiceband Data Transmission Interface*.

### 6.14.1 Customer Premises Equipment (CPE) Considerations

To receive data from the SPCS, the customer needs a CPE with special signaling capabilities. Type 1 CPE supports on-hook signaling for features such as CND. Type 1 CPE must be able to detect the CND data during the long silent interval of the first ringing cycle. CND data may also be delivered during the first long silent interval of a distinctive ringing pattern, if the silent interval is long enough for the transmission of the data.

SR-TSV-002476, *Customer Premises Equipment Compatibility Considerations for the Voiceband Data Transmission Interface*, discusses compatibility aspects and recommendations on CPE characteristics such as sensitivity, frequency and baud rate variations, tolerance to twist and received Signal-to-Noise characteristics. It encourages the design of CPE receivers with enough sensitivity to operate on all types of loops.



The general electrical characteristics of CPE connected to the LEC networks is covered in TA-NPL-000912, *Compatibility Information For Telephone Exchange Service*.

### 6.14.2 LEC Network Considerations

This service can be offered in a Stored Program Control (SPC) office for calls local to that switch. For interswitch calls, CCS is required to send the calling number from the originating switching system or billing point to the terminating SPC switching system.

Once the Calling Number information is available, the SPC switching system formulates and transmits the data to the customer via Frequency Shift Keying (FSK). The central office transmitter must meet the requirements in GR-30-CORE, *Voiceband Data Transmission Interface*.

FSK is a modulation scheme used by the CND feature and other on-hook and off-hook features.

### 6.14.3 Data Interface

The serving SPC switching system transmits information to the called end, but the called end does not transmit information to the central office. Two frequencies (1200 Hz, mark or "1," and 2200 Hz, space or "0") are used to transmit the information at a rate of 1200 baud.

#### 6.14.3.1 Data Parameters

The parameters of the data interface are as follows:

Modulation Type	Continuous-phase binary frequency-shift-keying (BFSK)
Mark (Logic 1)	1200 ± 12 Hz
Space (Logic 0)	2200 ± 22 Hz
Carrier Level	-13.5 dBm ± 1.5 dB at the point of application to the loop facility into a standard 900 ohm test termination
Carrier Purity	Total power of all extraneous signals in the voiceband (0-4KHz), including products of nonlinear or quantizing distortion, shall be at least 30 dB below the power of each carrier frequency, measured at the point of application to the loop facility into a 900-ohm test termination.
Source Impedance	900 ohms + 2.16 µF nominal, with a return loss that satisfies the requirements for voice transmission input impedance as described in TR-NWT-000507, Table 7.4.2.

---

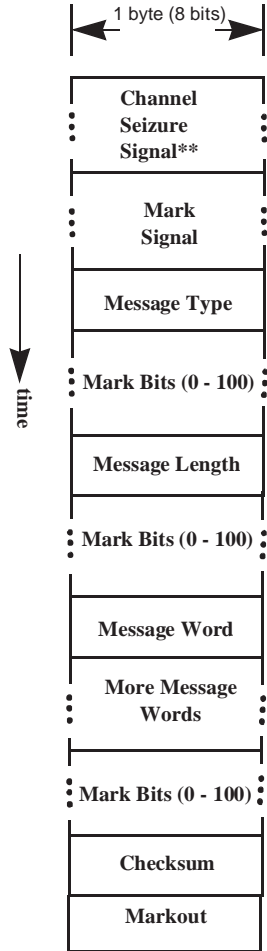
Longitudinal Balance	Impedance balance to ground shall conform to the requirements in TR-NWT-000507, Section 7.4.9, for voice transmission.
Transmission Rate	1200 $\pm$ 12 baud
Application of Data	Serial, binary, asynchronous
Bit Error Rate	BER < 10 <sup>-7</sup>

#### 6.14.3.2 Data Protocol

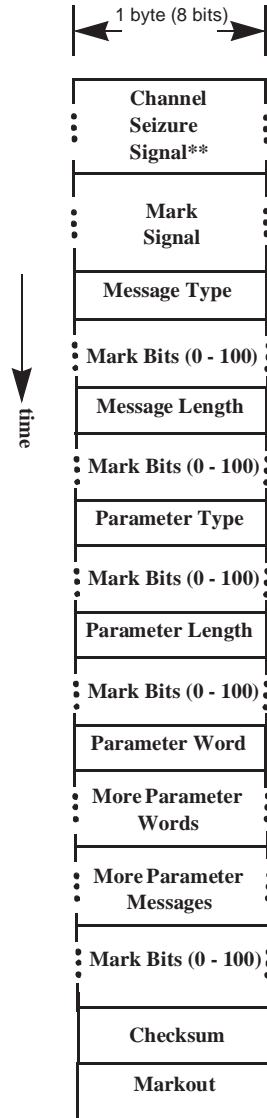
The CND data may be sent in the Single Data Message Format (SDMF) or Multiple Data Message Format (MDMF) as shown in Figure 6-43. The asynchronous protocol used in this interface provides data transmission and error checking as follows:

- The protocol uses words that are 8-bit data bytes each. Each word is preceded by a start bit (space = logical 0) and followed by a stop bit (mark = logical 1). The bytes are sent with the least significant bit first.
- Message type, message length, and error detection (checksum word) are each a single word. The value of the byte is encoded in binary as follows:
  - Message type for CND [= 4 (00000100) for SDMF, or 128 (10000000) for MDMF]
  - Message length is the number, in binary, of the data words sent
  - Checksum word is the two's complement of the modulo 256 of the binary representation sum of all the other words in the message (i.e., message type, message length and message data words for the SDMF; message type, message length, all parameter type words, all parameter length words and all parameter data words for the MDMF). The CPE calculates it based on the received words and if a match occurs between the result of its calculated “checksum” and the received checksum word, the message is deemed correct. Otherwise, an Error message is displayed.

**Single Data Message Frame Format**



**Multiple Data Message Frame Format**



\*\* for on-hook transmission only

**Figure 6-43.** Single and Multiple Data Message Formats

- The message and parameter words are encoded in ASCII characters to permit alphabetic as well as numeric characters to be sent. ASCII characters are covered by ANSI X3.4-1986, *Coded Character Set — 7-bit American National Code for Information Exchange*.

**When Using Single Data Message Format (SDMF)**, the meanings of the various message words are as follows:

- The first two words are the month (for example, March would be 03)
- The third and fourth words are the day of the month
- The fifth and sixth words are the hour of the day in 24-hour time (for example, 1:00 PM is 1300)
- The seventh and eighth words are the minute of the hour
- The remaining words are the calling party's dialing number (DN).

**When Using Multiple Data Message Format**

- The SPCS provides the following message type word parameter associated with CND when using the MDMF:

Message type word	Meaning
10000000	Call setup

- The SPCS provides the following parameters when using the MDMF:
  - the date and time (month, day, hour and minutes)
  - the calling line DN if available and able to be displayed
  - or
  - “P” if an anonymous indication is to be delivered in lieu of the calling line DN as reason for absence of DN
  - or
  - “O” if an out-of-area/unavailable indication is to be delivered in lieu of the calling line DN as reason for absence of DN.

The SPCS uses the following binary values and formats for the above parameters:

Parameter type value	Parameter
00000001	Date/time
00000010	Calling line DN
00000100	Reason for absence of DN

### 6.14.3.3 Data Timing

- Data transmission (including Channel Seizure, Mark Signal, and any inter-word delays) takes place in the first long silent interval, that is, signaling should not begin until a silent interval of at least 500 ms has elapsed after the end of the first power ringing pattern, and ends at least 200 ms before the start of the second power ringing pattern.
- Data transmission begins no later than 1.5 seconds after the end of the first power ringing pattern.
- The Channel Seizure Signal consists of a block of 300 continuous bits of alternating “0”s and “1”s. The first bit to be transmitted is a “0.” The last bit to be transmitted is a “1.”
- Following the channel seizure signal, 180 bits of mark are sent. This signal is shown as Mark Signal in Figure 6-43.

After the Mark Signal, the data signals for message type word, message length word, and Message or Parameter word(s) are sent. There should be no more than 10 stuffed mark bits between the data words.

## 6.15 LATA Access

The following sections cover the signaling from an end office to an IC or an INC, and signaling to an end office from a interexchange carrier or INC. Detailed information on LATA access (network design and configurations) is discussed in Section 4. Table 6-26 compares the various feature groups for providing methods of LATA access.

**Table 6-26.** Availability of Feature Groups

Switching System	Feature Group					
	A	B		C	D	
		EO	AT		EAEO*	AT
1A ESS	Yes	Yes	Yes	Yes	Yes	Yes
1A ESS HILO	Yes	Yes	NA	Yes	NA	Yes
2 ESS	Yes	Yes	NA	Yes	NA	NA
2B ESS	Yes	Yes	NA	Yes	Yes	NA
4 ESS	NA	NA	Yes	Yes	NA	Yes
5ESS system	Yes	Yes	Yes	Yes	Yes	Yes
DMS-10, -100F	Yes	Yes	Yes	Yes	Yes	Yes
EWSD	Yes	Yes	NA	Yes	Yes	NA
NEAX61E	Yes	Yes	Yes	Yes	Yes	Yes

NA = Not Applicable.

\* When signaling between EAEO and an interexchange carrier is multifrequency in one link and SS7 in the other, some limitations apply

Generic requirements that apply to LATA access are as follows:

- FR-271, *Operator Services Systems Generic Requirements (OSSGR)*
- GR-505-CORE, *Call Processing*
- GR-506-CORE, *LSSGR: Signaling for Analog Interfaces*
- FR-64, *LATA Switching Systems Generic Requirements (LSSGR)*

### 6.15.1 Carrier Classification

It is appropriate to classify the carrier handling the various calls because the use of certain protocols is associated with the type of carrier handling the call. Carriers may be classified as follows:

- 
- *Interexchange Carrier (IC)* — These are carriers providing connections between LATAs and serving areas where the calling and called customers are in World Zone 1.
  - *International Carrier (INC)* — These are carriers that generally provide connections between a customer located in the contiguous 48 United States and a customer located outside World Zone 1. INCs may also provide connections between a customer located in the contiguous 48 United States and a customer located in World Zone 1 outside the contiguous United States.
  - *Consolidated Carrier (IC and INC)* — These are carriers that provide connections as described in both of the above.

### 6.15.2 Feature Group A

Feature Group A (FGA) is a line-side access that includes foreign exchange service and interLATA Off-Network Access Line (ONAL) service from private networks. FGA can be arranged for originating-calling-only, terminating-calling-only, or 2-way calling. All end office switching systems used by the LECs can provide FGA. The line supervisory signaling for FGA may use ground-start or loop-start, as stated in Section 6.2 on access line signaling.

Access to an IC is made by placing a call to the 7-digit Plain Old Telephone Service (POTS) number of the carrier. The connection to the carrier is no different from any other local or toll call in the LATA. The call can be made from a coin or non-coin line, and may involve an operator. The call from the originator to the IC must be paid for by the originator to the LEC.

After the originator is connected to the IC/INC, signaling from the originator to the carrier must be by an inband method such as DTMF for both the called number and identity of the calling party. The format of the signaling for the called and calling number is the responsibility of the IC/INC. The carrier will bill the originator for the interLATA portion of the call.

Calls from an IC/INC into a LATA are connected to a POTS line. The telephone number of the called party is entered by dial-pulse or DTMF signaling. The signaling protocol is no different than on any other call to a POTS line. As in the case of the call originating within the LATA, all of this section applies.

The call will be controlled by calling-customer control of disconnect as described in Section 6.4.3. The IC/INC does not receive answer supervision from either the called or the calling line. If the carrier uses ground-start lines to connect to the originating and terminating LATAs, the IC may get an on-hook signal after the appropriate disconnect timing (Table 6-8).

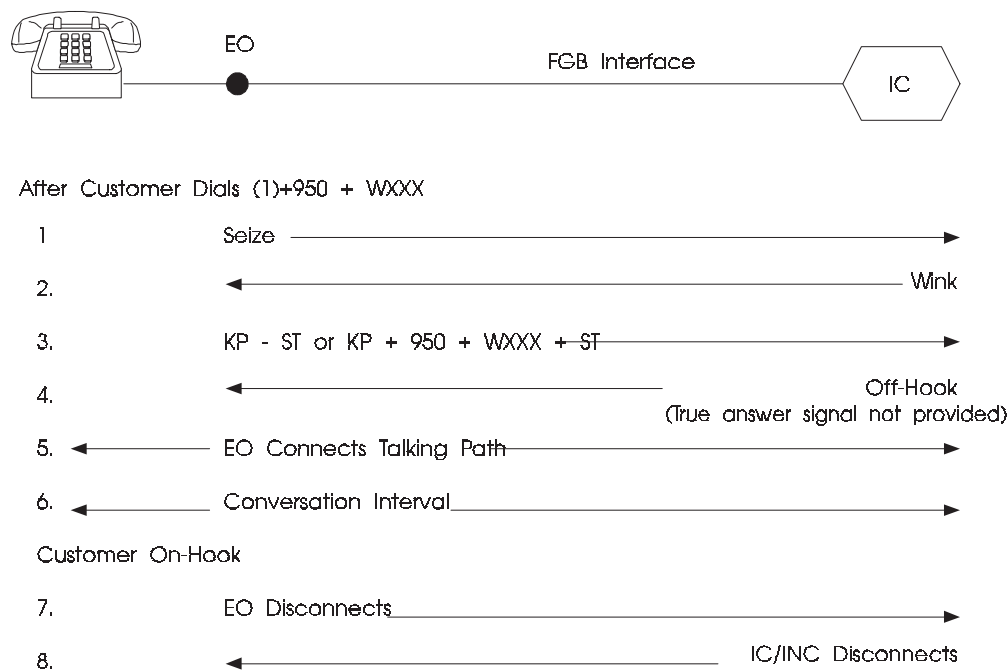
More information on FGA is available in the following documents:

- TR-TSY-000697, *Feature Group A, FSD 20-24-0200*

- GR-505-CORE, *Call Processing*
- GR-506-CORE, *LSSGR: Signaling for Analog Interfaces*
- All of the above documents are modules of FR-64, *LATA Switching Systems Generic Requirements (LSSGR)*.

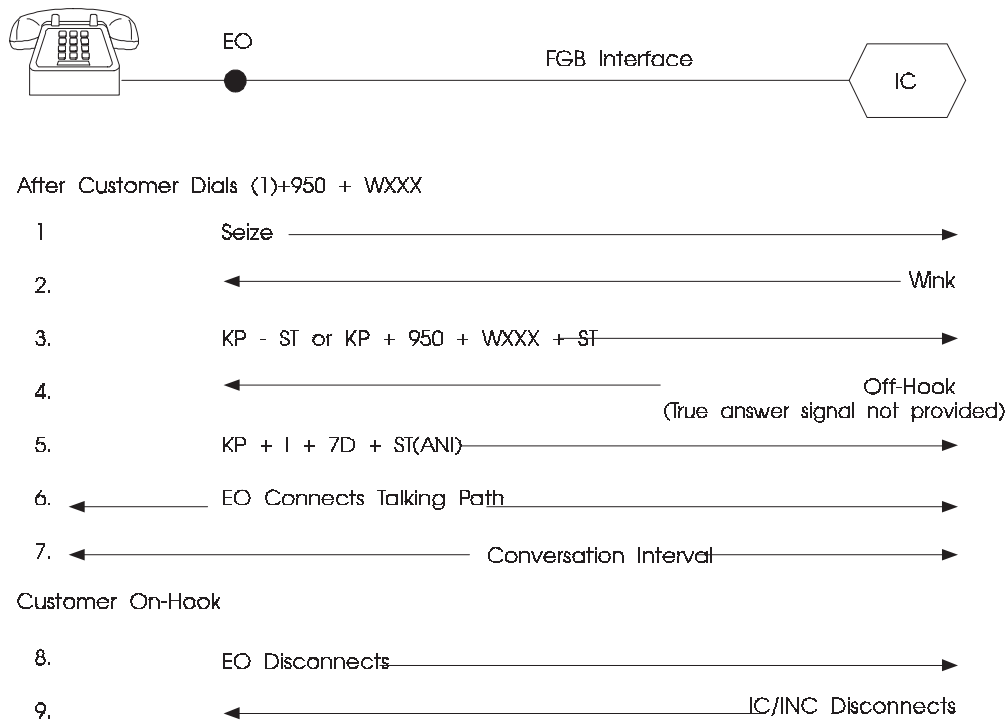
### 6.15.3 Feature Group B

Feature Group B (FGB) is a trunk-side access arrangement. Calls to the IC/INC use the telephone number 950-WXXX, where W equals 0 or 1. The call may go directly from the end office or be tandemed through a second office known as an access tandem to reach the carrier. The access tandem may serve only FGB functions or may provide multiple functions. Calls from the IC/INC can go directly to the end office or can be switched through the access tandem to reach it. ANI can be furnished optionally on most direct connections between the end office and the carrier. ANI information cannot currently be furnished on tandem connections. The signaling format used in calls from the end office to the carrier without ANI is shown in Figure 6-44; from the end office to the carrier with ANI is shown in Figure 6-45; from an end office, tandemed through the access tandem, to the carrier is shown in Figure 6-46; and from the carrier through an access tandem to the end office is shown in Figure 6-47.

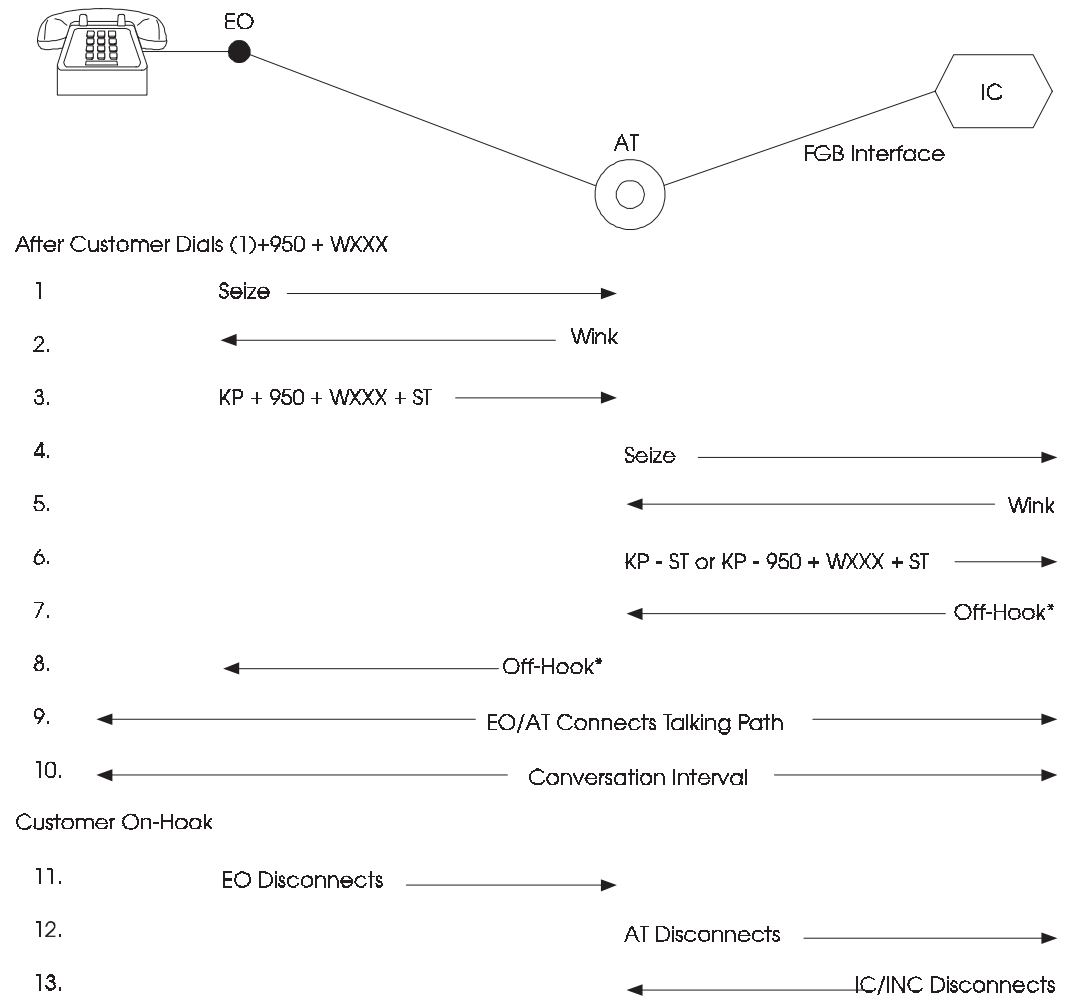


**Figure 6-44.** Originating Signaling Sequence — Without ANI Direct Connection — FGB



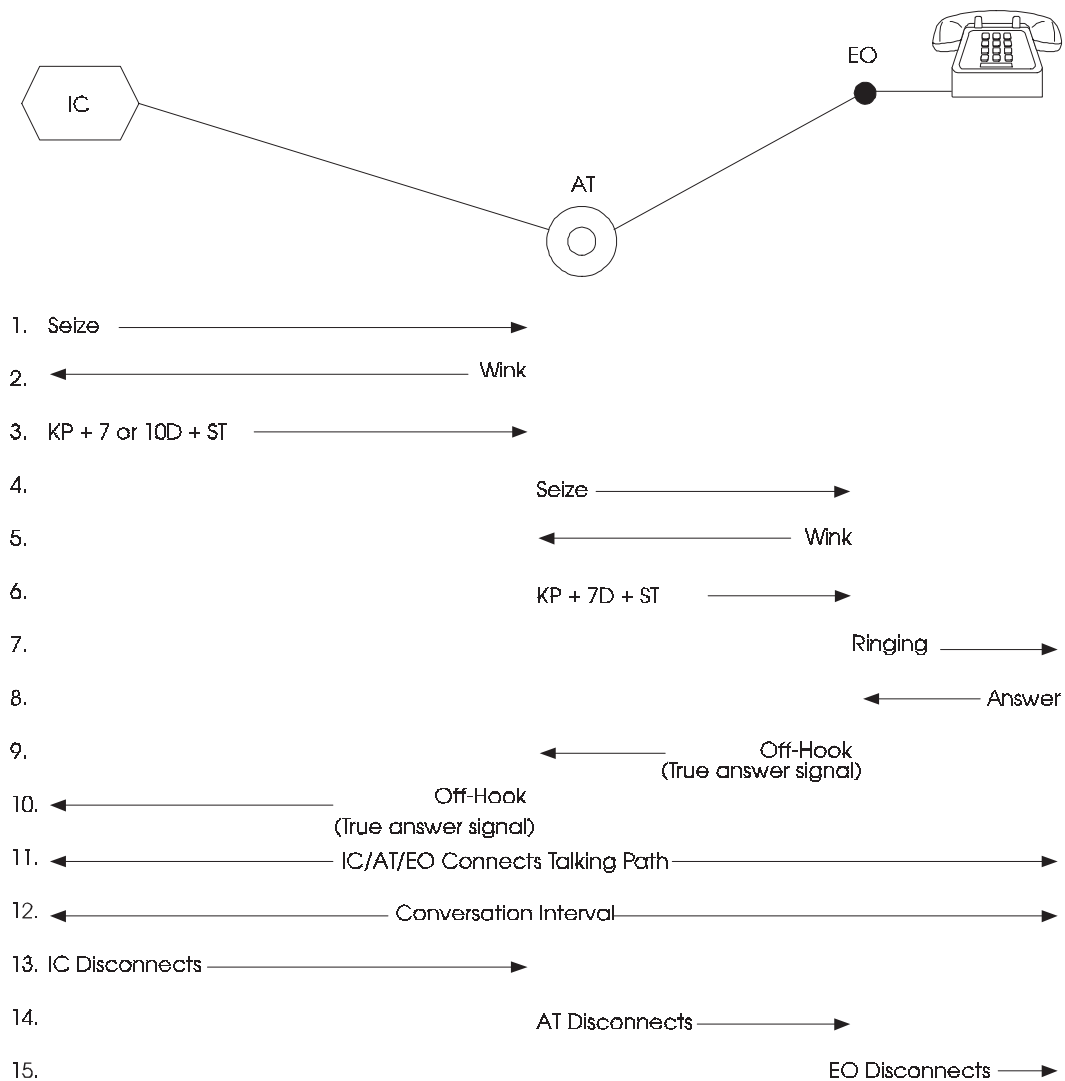


**Figure 6-45. Originating Signaling Sequence — With ANI Direct Connection — FGB**



\*True answer signal not provided

**Figure 6-46.** Originating Signaling Sequence — EO Tandem Connection — FGB



**Figure 6-47.** Terminating Signaling Sequence — Tandem — FGB

Any switching system can be used as an FGB end office as long as the calls are routed through an access tandem. In fact, any switching system can be used as an end office that connects directly to a carrier if the office can translate the seven dialed digits on outgoing calls and provide AMA records on both incoming and outgoing calls. With these restrictions, end offices that can connect directly to a carrier are usually limited by practical reasons to SPC switching systems such as 1/1A ESS, 5ESS, DMS-10, DMS-100F, and NEAX-61E. For all the same reasons, the access tandems are usually limited to 1/1A ESS, 4ESS, 5ESS, DMS-100F, and NEAX-61E switching systems. Table 6-26 shows the FGB arrangements currently available.

The protocol for interLATA calls involves signaling sequences and times between signals that do not exist in intraLATA calls as follows:

- Calls from an end office or access tandem
  - The carrier returns a wink signal within 4 seconds of trunk seizure.
  - The carrier returns an off-hook signal within 5 seconds of completion of the address outpulsing.
- Calls from a carrier to an end office or access tandem
  - The end office or access tandem returns the wink-start signal within 8 seconds of trunk seizure.
  - The carrier starts outpulsing the address within 3.5 seconds of the wink.
  - The carrier completes sending the address sequence within 20 seconds.

Supervisory signaling between the end office and carrier or access tandem and carrier can be any of the types mentioned in this section for interoffice calls. However, loop or E&M signaling is usually used on 1-way trunks, and E&M signaling is usually used on 2-way trunks where individual trunks are used. In addition, direct connection of the switching system to digital carrier can be made at one or both ends.

Address signaling from the calling party to the carrier is usually voice-frequency signaling such as DTMF for both the called number and identity of the calling party. However, dial-pulse signaling can be used from suitably equipped end offices. Address signaling from the carrier to the end office depends upon the exchange. Either dial-pulse or multifrequency signaling may be necessary. In addition, delay-dial or wink-start outpulsing control may be used.

On outgoing calls from a LATA, the call will be controlled by the calling party. The IC/INC will receive calling-party disconnect supervision, but not flashing or other on-hook signals shorter than disconnect.

On outgoing calls from a LATA, the end office or access tandem does not receive true answer supervision from the carrier. The IC/INC sends an off-hook before the called number or calling-party identity is accepted.

On incoming calls to the LATA, the carrier will receive supervision from the calling party to the called party. It will also receive flashing and other on-hook signals.

On incoming calls to the LATA, the end office or access tandem will receive off-hook supervision from the IC/INC. This supervision may or may not be true supervision from the calling party. To prevent false disconnects from the on-hook signals seen by an incoming office, the LECs use a disconnect time of at least 10 to 12 seconds.

Further information on FGB is available in the following documents:

- TR-TSY-000698, *Feature Group B, FSD 20-24-0300*
-

- 
- GR-505-CORE, *Call Processing*
  - GR-506-CORE, *LSSGR: Signaling for Analog Interfaces*
  - All of the above documents are modules of FR-64, *LATA Switching Systems Generic Requirements (LSSGR)*
  - TR-NPL-000175, *Compatibility Information for Feature Group B Switched Access Service*.

#### 6.15.4 Feature Group C

Feature Group C (FGC) contains the arrangements originally used between the LEC and AT&T for provision of switched-access services. It includes the arrangements used to provide Direct Distance Dialing (DDD) discussed in this section and certain operator system calls. It can be interfaced as indicated in Table 6-26. Originally it was thought that FGC would be used only until equal access was implemented under Feature Group D. However, the plans in many LEC intraLATA networks have changed. Many LECs now plan to leave FGC in place until CCS is available in the LATA.

Other information on FGC is available in the following documents.

- SR-504, *SPCS Capabilities and Features*
- GR-505-CORE, *Call Processing*
- GR-506-CORE, *LSSGR: Signaling for Analog Interfaces*
- All of the above references are modules of FR-64, *LATA Switching Systems Generic Requirements (LSSGR)*
- FR-271, *Operator Services Systems Generic Requirements (OSSGR)*.

#### 6.15.5 Feature Group D — Equal Access

Feature Group D (FGD) consists of Equal Access End Office (EAEO)-to-IC/INC, EAEO-to-access tandem, and access tandem-to-carrier interconnection arrangements. Most switching equipment, such as 1/1A ESS, 5ESS, DMS-10, DMS-100F, EWSD, and NEAX-61E, provides EAEO features. Dial-pulse signaling as well as DTMF can be used from the calling telephone.

In EAEOs, the customer dials an access code of 10XXX to identify the desired carrier. FGD has a presubscription feature that eliminates the need for a presubscribed caller to dial the 10XXX carrier access code. (See Section 3 for dialing procedures.) The desired carrier is identified by XXX, the carrier identification code. FGD is covered in detail in the following documents:

- GR-690-CORE, *Exchange Access Interconnection, FSD 20-24-0000*
- TR-NPL-000258, *Compatibility Information for Feature Group D Switched Access Service.*

In addition to regular message service, FGD is used for exchange access for such digital applications as switched 56 kbps service, 64 clear access, and ISDN.

#### 6.15.5.1 Equal Access End Office

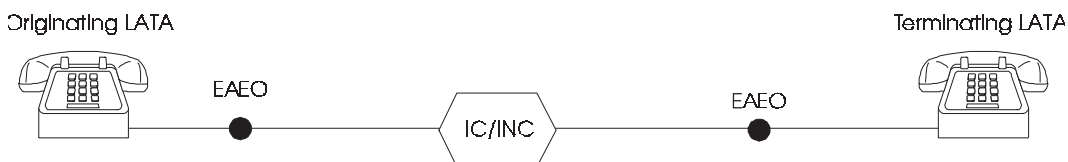
In an EAEO, the calling party enters all the address information as usual. If not presubscribed to a carrier, the calling party can rotary-dial or DTMF the access-code 10XXX. This is followed by 0 or 1 (if 1 is required in this area) to indicate whether the call requires operator assistance (0) or does not need it (1). Then, the 7- or 10-digit telephone number of the called party is dialed.

Signaling from the EAEO depends on whether the carrier needs special operator services signaling. This provides operator features such as operator hold, operator recall, ringback, and coin control signals. It is limited to direct trunk groups between the EAEO and the carrier's operator system. When operator services signaling is not needed, a second signaling method is used that permits direct trunk groups from an EAEO to an IC/INC or trunk groups from an access tandem to the carrier. With the second method of signaling, calls to an operator can be made, but the operator system features of operator services signaling will not be available.

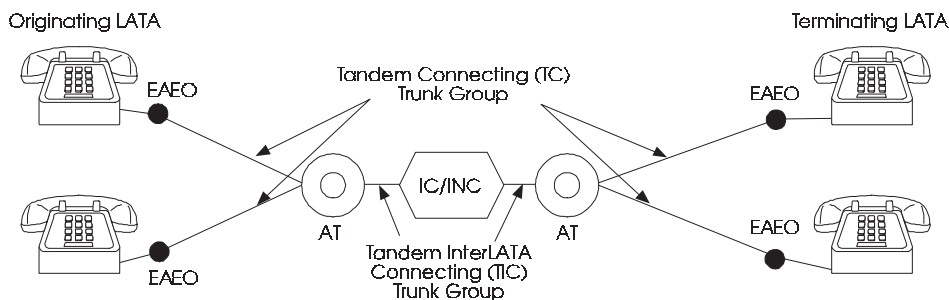
#### 6.15.5.2 Signaling for Calls Not Requiring Special Operator Services Signaling

The equal-access arrangement for calls not requiring the special operator signaling provided by OSS is available in 1/1A ESS, 5ESS, DMS-10, DMS-100F, and NEAX-61E switching systems.

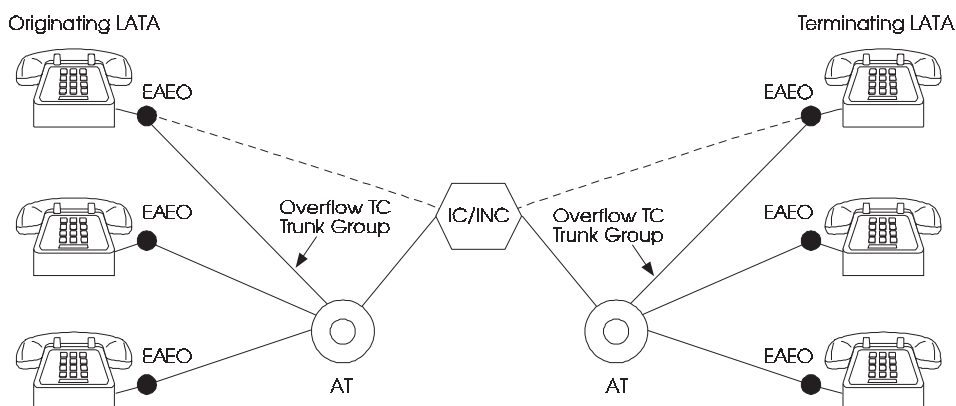
Calls from an EAEO can be routed directly or through an access tandem to the IC/INC. Figure 6-48 shows the direct connection between an EAEO and the carrier, while Figure 6-49 shows an access tandem being used to route calls from an EAEO to the carrier. A given EAEO can use both the direct and tandem arrangements for a single carrier as shown in Figure 6-50.



**Figure 6-48.** Direct IC/INC Connection — FGD



**Figure 6-49.** Tandem IC/INC Connection — FGD



**Figure 6-50.** Combined Direct and Tandem IC/INC Connection — FGD

IntraLATA, interLATA, and international calls can be routed to an appropriate carrier. All three types of traffic can be carried on a single trunk group if transmission requirements permit. The transmission requirements for intraLATA trunks differ from those for tandem-connecting trunks. In some cases, segregated intraLATA trunk groups may be desirable.

All trunks from the EAEO to the access tandem and from the access tandem to the IC/INC can be 1- or 2-way trunks. Trunk groups from the access tandem to the carrier will necessarily carry traffic for only that carrier. Trunk groups from the EAEO to the access tandem can carry traffic from several ICs/INCs and for the LEC. The generic programs for various manufacturers' equipment that support FGD are shown in Table 6-26.

There are major changes in the signaling format sent from the EAEO. Changes for connection directly to the IC/INC follow.

- ANI calling number information is 10 rather than 7 digits.
- A second information digit is added to the ANI outpulsing.
- The ANI information is sent first, followed by the called number, with no controlled-outpulsing signal (wink) between the two pieces of information.

- The carrier sends an acknowledgment wink after receiving all pulses.

Some of the additional changes in signaling format that occur when a call passes through an access tandem are listed below.

- Two-stage outpulsing is used.
- The first stage of outpulsing is sent to the access tandem. It identifies the carrier and type of call.
- The second stage of outpulsing is controlled by a wink-start signal sent from the IC/INC and repeated by the access tandem.
- The second stage of outpulsing is end-to-end outpulsed from the end office to the carrier.
- The acknowledgment wink is sent from the IC/INC and repeated by the access tandem.
- Answer supervision is received by the EAEO.

**Trunk Terminology:** Trunk terminology (as shown in Figures 6-49 and 6-50) is listed below.

- The trunk from an EAEO directly to an IC is a Direct InterLATA Connecting (DIC) trunk.
- The trunk from an EAEO to an access tandem is a tandem-connecting trunk.
- The trunk from an access tandem to an IC is a Tandem InterLATA Connecting (TIC) trunk.

**Dialing Plan:** The current dialing plan is based on the 10XXX (to be expanded to 101XXXX effective January 1, 1998) carrier access code, in lieu of presubscription, where XXX serves to identify the specific carrier. (See Section 3 for dialing procedures.) The dialing sequence is 10XXX + (0/1) + 7/10 digits, where X can be any digit from 0 to 9. The 7/10 digits dialed must conform to the North American Numbering Plan (NANP).

The NANP allows the calling party to dial the access code followed immediately by the called party's telephone number without requiring a second dial tone from the IC/INC. The EAEO receives all of the dialed digits, determines the carrier, and establishes a connection to that carrier.

Because the EAEO receives the customer's complete dialing sequence directly, any DTMF requirement is eliminated. As a result, either pushbutton or rotary-dial telephones can be used to access a carrier.

### 6.15.5.3 Signaling North American Dialing Plan

To minimize setup time on calls to an IC/INC, an overlapped outpulsing format with the capability for two-stage outpulsing on connections via an access tandem is used. Details of



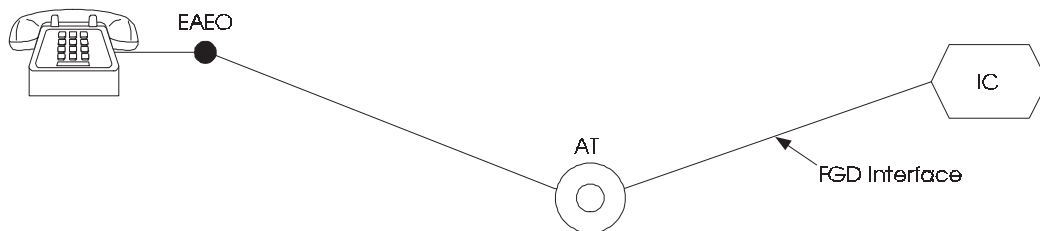
the full-feature signaling format for the equal-access North American dialing plan follow and are illustrated in Figures 6-51 through 6-53.

**Originating Direct Connection from EAEO to IC:** After the customer dials 10XXX + (0/1) + (NPA) + NXX

1. The EAEO seizes an outgoing trunk to the appropriate IC.
2. The carrier responds with a wink-start signal.
3. After receiving the wink-start signal, the EAEO delays 40 to 200 ms before outpulsing. If the carrier has requested ANI, the EAEO outpulses KP + II + ANI (10 digits) + ST. Otherwise it sends KP + ST.
4. After the customer has completed dialing XXXX, the EAEO outpulses KP + (0) + 7/10 digits + ST.
5. The IC returns an acknowledgment wink, which has the same requirements as a wink-start signal.
6. The carrier returns true called-party answer supervision from the far end.
7. Default timing for this signaling sequence is in Table 6-27.

**Table 6-27.** FGD Controlled-Outpulsing Default Timing

Type of Call	Time in Seconds an EAEO Will Wait		
	After Seizure for a Wink-Start Signal from the Carrier or AT	After the First Stage of Outpulsing is Completed for a Wink-Start Signal from the Carrier to Start the Second Stage of Outpulsing	After Outpulsing is Completed from an Acknowledgment Wink from the Carrier to Show that Pulsing has Been Received from the EAEO
InterLATA Not via an AT	4	Not Applicable	4
InterLATA via an AT	4	12	4
International	4	20	8



After Customer Dials (T0XXX) + (0/1) + (NPA) + NXX

1. Seize →
2. ← Wink
3. KP + OZZ + XXX + ST →
4. Seize →
5. ← Wink  
\*
6. ← Wink
7. KP + II + ANI + ST or KP - ST →

After Customer has Completed Dialing XXXX

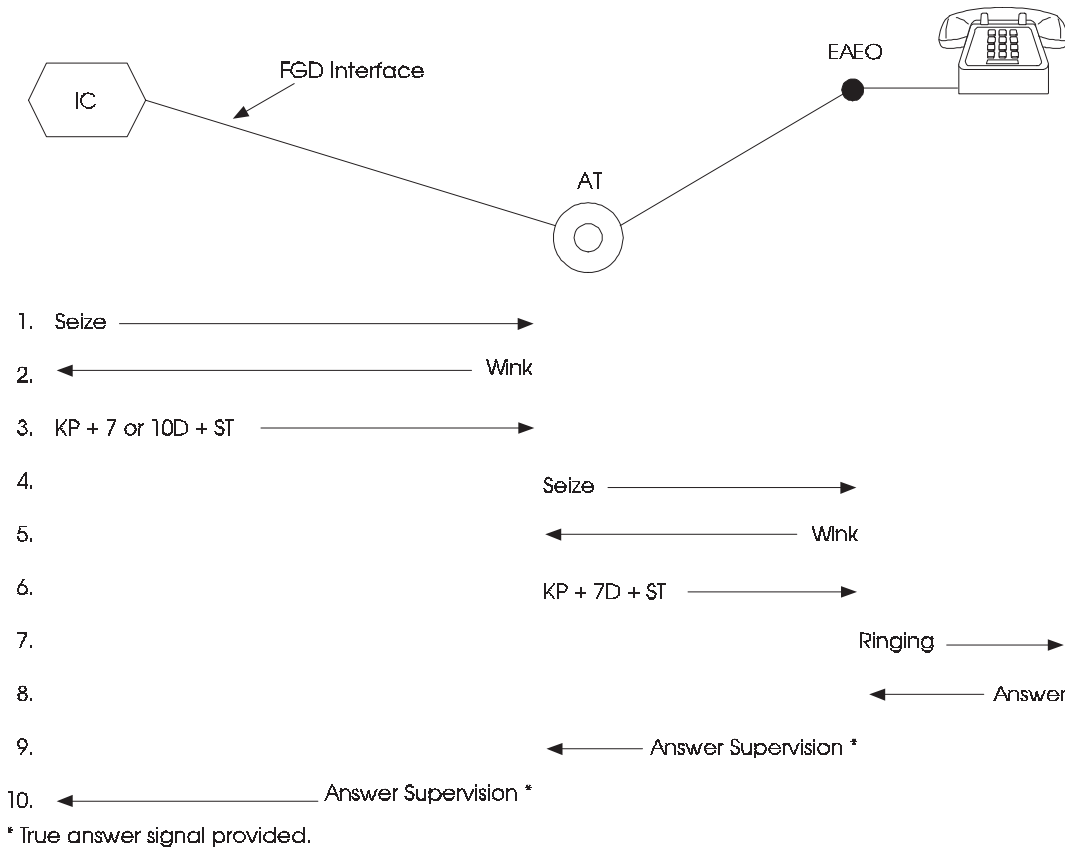
8. KP + (0) + 7/10D + ST →
9. ← Acknowledge Wink  
\*\*
10. ← Acknowledge Wink
11. ← Answer Supervision †
12. ← Answer Supervision †

\* This wink is timed in tandem for both time of arrival and length of wink to end office.

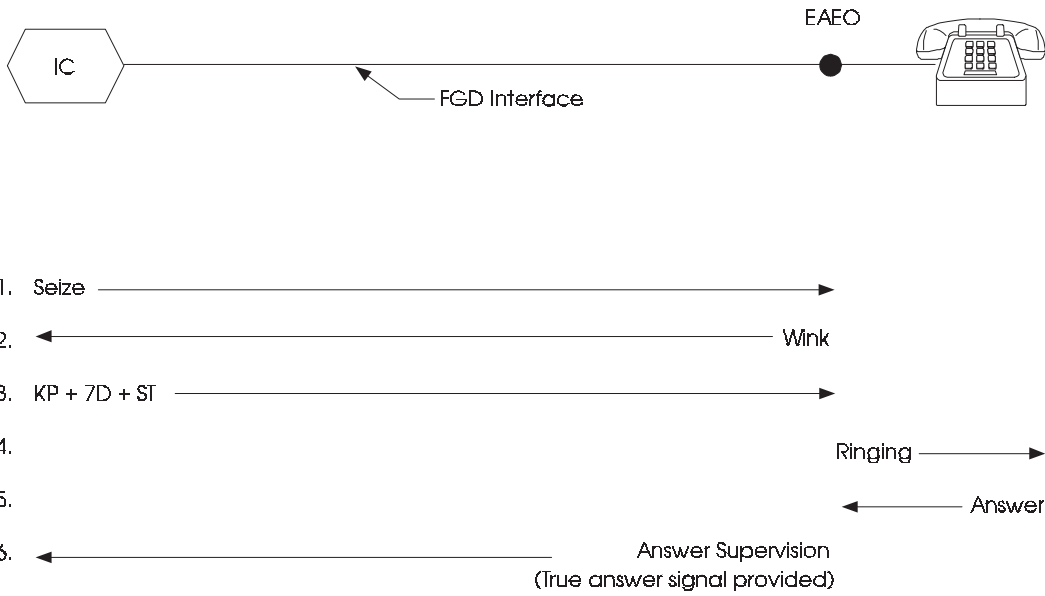
\*\*This wink is not timed in tandem.

† True answer supervision may or may not be provided.

**Figure 6-51.** Originating Signaling Sequence — Via Access Tandem — FGD



**Figure 6-52.** Terminating Sequence — Access Tandem Through an Access Tandem — FGD



**Figure 6-53.** Terminating Sequence — Direct From IC to EAE0 Tandem — FGD

Disconnect signaling can then be passed in either direction between the LEC and IC. The access tandem to carrier signaling sequence for customers collocated at an access tandem (that is, with the access tandem also serving an end-office function) is the same as the signaling between an EAEO and IC, as previously described. The ANI information digits (II) are defined in the *Local Exchange Routing Guide (LERG)*. They are assigned as shown below:

00	—	Identified POTS Line, no special treatment
01	—	Operator Number Identification (ONI) (Multiparty)
02	—	ANI Failure
06	—	Hotel/Motel Without Room Identification (to obtain ONI of the room)
07	—	Special Operator Handling (Coinless, Hospital, Inmate, etc.)
10	—	(Not assignable - conflicts with 10X test code)
12-19	—	(Not assignable - conflict with international outpulsing code)
20	—	Automatically Identified Outward-Dialing (AIOD), Listed DN Sent
23	—	Coin or Non-coin Line Status Unknown
24	—	800 Service Call
27	—	Code 27 identifies a line connected to a pay station that uses network provided coin control signaling. II 27 is used to identify this type of pay station irrespective of whether the pay station is provided by a LEC or a non-LEC. II 27 is transmitted from the originating end office on all calls made from these lines.
29	—	Code 29 is used to identify lines serving a confinement/detention facility that are intended for inmate/detainee use and require outward call screening (e.g., 0+ collect only service). As per Section 276(d) of the Telecom Act, inmate telephone service is considered to be included in the general category of payphone service. Accordingly, lines identified with ANI II 29 include both prison/inmate phones and payphones.
30	—	Intercept (blank) - for calls to an unassigned number
31	—	Intercept (trouble) - for lines in trouble-busy state
32	—	Intercept (regular) - for calls to recently changed numbers
34	—	Telco Operator Handled Call
40-49	—	Unrestricted Use - locally determined by carrier
52	—	Outward WATS
61	—	Cellular Service - Type 1 - for calls originating from cellular carrier via Type 1 trunks and forwarded to the 1C - ANI identifies only the cellular system

---

62	—	Cellular Service - Type 2 - for calls originating from a cellular carrier via Type 2 trunks and tandem-switched through the LEC to the IC - ANI identifies the mobile directory number
63	—	Cellular Service - Roaming - for calls originating from a cellular carrier when routing traffic forwarded to a cellular subscriber
70	—	Code 70 identifies a line connected to a pay station (including both coin and coinless stations) that does not use network provided coin control signaling. II 70 is used to identify this type pay station line irrespective of whether the pay station is provided by a LEC or a non-LEC. II 70 is transmitted from the originating end office on all calls made from these lines.
93	—	Access for Private Virtual Network types of service
95	—	Unassignable - conflict with Test Codes 958 and 959.

**Originating Connection Via Access Tandem:** The two-stage overlapped outpulsing format is necessary on calls via the access tandem to minimize call setup time. Since the access tandem needs information in the first stage of outpulsing to identify the proper carrier and associated routing information, the first state of outpulsing must include

- Identification of this as an IC call
- Identification of the carrier
- The type of call routing required, as described later in this section

The first stage of outpulsing from the EAEO to the access tandem has the format KP + 0ZZ + XXX + ST, where:

0ZZ = spare tandem center codes, one for each type of call routing, where 0 is the digit zero and Z is any digit from 0 to 9. The initial 0 identifies the call as an interexchange call and ZZ identifies the carrier. A maximum of four codes are available; one for each of the maximum of four trunk groups between the access tandem and the carrier.

XXX = dialed (or presubscribed) IC/INC.

The signaling sequence on an IC call via an access tandem after the customer dials (10XXX) + (0/1) + (NPA) + NXX is as follows:

1. EAEO seizes trunk to access tandem.
  2. Access tandem responds with wink.
  3. EAEO outpulses KP + 0ZZ + XXX + ST.
  4. Access tandem seizes trunk to appropriate IC.
  5. IC responds with wink.
  6. Access tandem cuts through the talking path and repeats the wink.
-

---

From this point on, the processing of the call by the LEC and carrier is identical to the direct connection case, except that all winks, address digits, and other signaling pass through the access tandem. The EAEO should recognize an off-hook of 100 to 500 ms as a wink. Default timing for this signaling sequence is in Table 6-27.

There is signaling incompatibility when an originating connection via an access tandem has one link using circuit-associated signaling and the other using CCS such as SS7. The incompatibility is caused by the fact that the second stage of outpulsing using circuit-associated signaling is not repeated to the IC. At present there is no standard for this mixed signaling. One or both of the signaling protocols will have to be changed before the carrier can receive the second stage of outpulsing.

**Terminating:** Termination of an IC call is a straightforward operation consisting of the following:

1. IC seizes trunk to EAEO (or access tandem).
2. EAEO (or access tandem) responds with wink.
3. IC outpulses KP + 7/10 digits + ST.
4. EAEO (or access tandem) completes the call to the appropriate station and returns called-party answer supervision.

Answer supervision is returned on all calls, including calls to free lines. Disconnect signaling can then be passed in either direction between the LEC and the carrier.

#### 6.15.5.4 Routing

**Originating Calls:** If an IC call is placed from an EAEO and there is a DIC trunk from that EAEO, the call will be routed first over a DIC trunk. If there is no available DIC trunk and there are tandem-connecting trunks, then the call can be alternate-routed to an EAEO tandem-connecting trunk group for completion via the access tandem. On an IC call originating from a station whose office is collocated with an access tandem, the access tandem will route the call to the IC over the TIC trunk group used for calls from subtending EAEOs.

More than one trunk group may be provided to a carrier from an EAEO or access tandem. The carrier can specify the particular trunk group to be used for different types of traffic; for example, 0+ calls may be placed on one group and 1+ calls on another.

For calls routed from an EAEO via an access tandem, the trunk group to be selected from the access tandem to the IC will be indicated in the first stage of outpulsing from the EAEO in the 0ZZ code.

The access tandem can also route to different outgoing TIC trunk groups based upon the incoming trunk groups. That is, calls to a carrier from one EAEO can be routed on different outgoing TIC trunk groups than calls from other EAEOs.

---

---

Routing for INC calls follows the same rules as for IC calls. When a call is routed using INC signaling, the same capability for splitting traffic among trunk groups is provided. The INX codes (operator-assisted and nonoperator-assisted calls) will be assigned for the different types of traffic and will be the same whether the traffic goes direct or via an access tandem, and whether a carrier is involved or not.

**Terminating Calls:** When an IC/INC terminates a call to a LATA, it will seize a trunk to the appropriate EAEO or access tandem and outpulse via multifrequency signaling 7 or 10 digits to the access tandem or 7 digits to the EAEO to complete the call to the called station. Calls directed through the access tandem will be routed to the called station via the station's serving EAEO. In some network configurations, the terminating switching machine serves the combined functions of an access tandem and EAEO. In these instances, trunk treatment is provided as discussed in this section.

**Trunk Circuits:** All IC/INC trunks will be loop or E&M, multifrequency, wink signaling, 2-wire or 4-wire facilities. They generally use digital facilities and interface the carrier's POT on a Digital Signal level 1 (DS1) or DS3 basis. Tandem-connecting trunks between the EAEO and the access tandem or DIC trunks between the EAEO and the IC/INC are tandem-connecting grade. Trunks between the access tandem and the IC/INC are 4-wire intertandem grade with 0 dB loss. Switchable pad-type trunks are used at a 2-wire analog access tandem, if it serves combined access tandem and EAEO functions.

#### 6.15.5.5 International Carriers

**Points of Interconnection:** The carrier interconnection plan includes LATA access features for INCs. This arrangement is described below and utilizes the dialing plan of IDDD and currently the 10XXX access prefix.

An INC desiring to serve a LATA can interface with the LEC network directly or indirectly. In this case, the INC establishes a Point of Presence (POP) in a LATA and interfaces with the LEC directly via an EAEO or an access tandem.

Figures 6-53 and 6-54 illustrate the indirect interface arrangement. In this case the INC establishes gateway offices, and an IC provides the domestic network to/from these INC gateway offices. The following sections describe a typical LEC originating interface to the IC or INC for international calls. The terminating interface is the same as for IC calls.

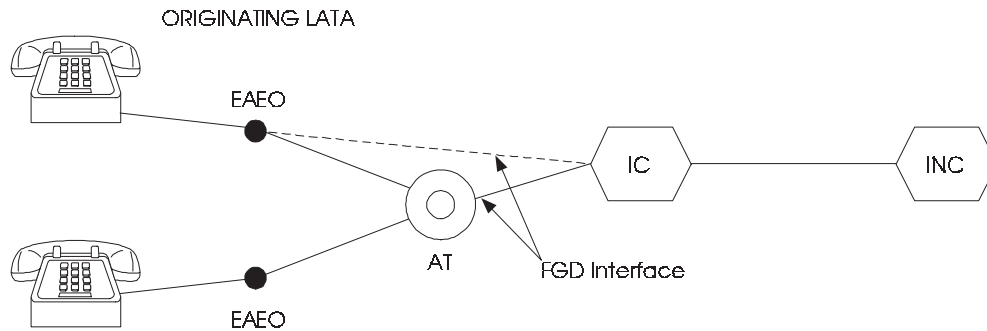
**Dialing Plan:** Direct-dial calls to countries outside the NANP area<sup>1</sup> from EAEOs are dialed as (10XXX) + 011 + CC + NN, where CC is the country code and NN is the telephone number within the country. The optional (10XXX) prefix indicates that a given customer line has dialed for or may be presubscribed to either an INC or integrated carrier.

Operator assistance calls will be dialed as (10XXX) + 01 + CC + NN.

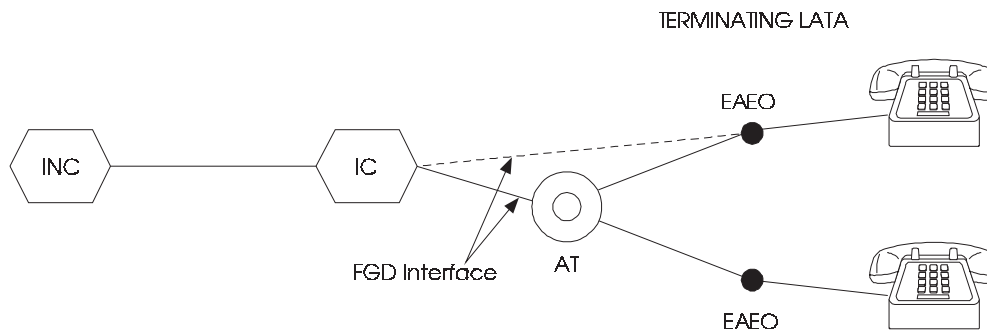
---

1. The North American Numbering Plan (NANP) is used in World Zone 1, which includes the United States, Canada, Puerto Rico, the U.S. Virgin Islands, Bermuda, and other Caribbean Islands.





**Figure 6-54.** INC Interconnection — Indirect — Originating LATA — FGD



**Figure 6-55.** INC Interconnection — Indirect — Terminating LATA — FGD

Calls from any remaining non-equal-access office will continue to use the same dialing and routing plans as before 1984.

**Routing and Signaling:** To minimize call setup time on international calls, a two-stage overlapped outpulsing format is used. This is consistent with both the present handling of IDDD calls and the signaling for LATA access in general. Access tandems need information in the first stage of outpulsing to identify the proper carrier. ICs need to know which country code was dialed; hence, which INC, and which gateway of that INC, to connect to. ICs and INCs also need to know the type of call routing required. The first stage of outpulsing includes the following information:

- Identification of the call as an international call
- Identification of the INC (or integrated carrier) that was dialed
- Identification of the country code dialed
- The type of call routing required (for example, operator).

The existing format of KP + 011 + CCC + ST used in first-stage IDDD signaling today cannot carry all this information. Therefore, a new format has been designed:

KP + 1NX + XXX + CCC + ST where

1NX = International system routing codes, one for each type of call routing

XXX = Dialed (or presubscribed) carrier

CCC = Country code (padded with leading "0," if needed).

Consistent with the LATA-access signaling formats for domestic calls, the signaling sequences on an international call are as follows (Figure 6-56).

• **Connection from EAEO Directly to IC (Indirectly to INC)** After Customer Dials (10XXX) + 011 (or 01) + CC:

1. EAEO seizes trunk to appropriate IC.
2. Carrier responds with wink.
3. EAEO outputs KP + 1NX + XXX + CCC + ST to carrier.

The carrier can then either return a wink to signify its readiness to receive more digits or process the connection through to the appropriate INC gateway, which then returns a wink to the originating end. Therefore,

1. IC returns wink to EAEO.
2. EAEO outputs KP + II + ANI (3/10 digits) + ST.

After the customer has completed dialing "NN,"

1. EAEO outputs KP + CC + NN + ST.
2. IC returns an acknowledgment wink.
3. IC returns called-party answer supervision.
4. Default timing for this signaling sequence is in Table 6-30.

Disconnect signaling can then be passed in either direction between the LEC and IC.

• **Connection via Access Tandem to IC (Indirectly to INC)** After Customer Dials (10XXX) + 011 (or 01) + CC:

1. EAEO seizes trunk to access tandem.
2. Access tandem responds with wink.
3. EAEO outputs KP + 1NX + XXX + CCC + ST to access tandem.
4. Access tandem seizes trunk to appropriate IC.
5. IC responds with wink.
6. Access tandem outputs KP + 1NX + XXX + CCC + ST to carrier.
7. IC or INC responds with wink.

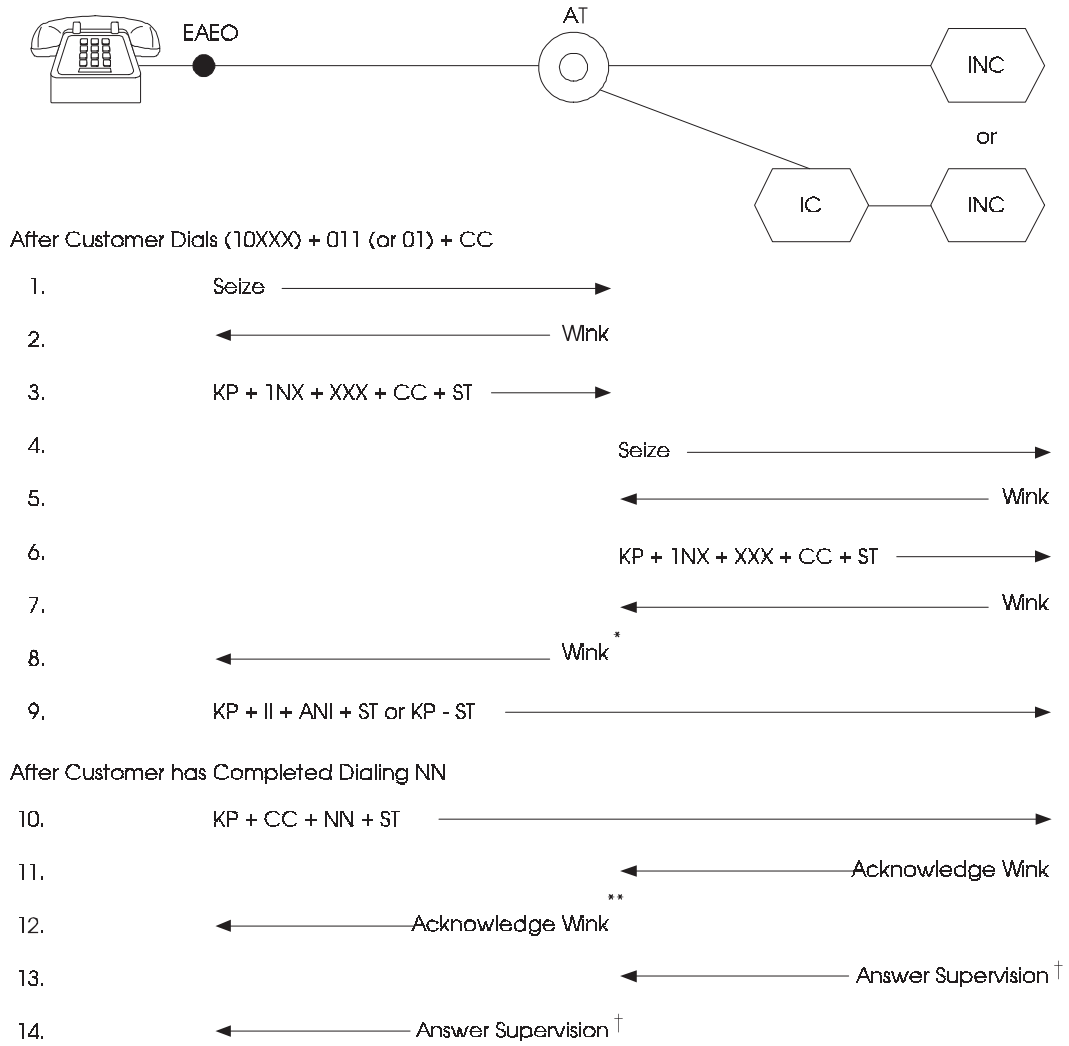
---

8. Access tandem cuts through the talking path and repeats the wink.

9. EAEO outpulses KP + II + ANI (3/10 digits) + ST.

From this point on, the processing of the call by the LEC and IC is identical to the direct-connection case, except that all winks, address digits, and other signaling are passed through the access tandem.

- **Connection Directly to INC:** When the INC establishes its own POP within the LATA, the INC can interconnect directly to the LEC, rather than via an IC. Either direct or tandem access is possible. Routing and signaling are exactly as stated above, with the IC being replaced by the INC.



\* This wink is timed in tandem for both time of arrival and length of wink to end office.

\*\*This wink is not timed in tandem.

† True answer supervision may or may not be provided.

**Figure 6-56.** International Call - Originating Signaling Sequence at Connection to INC (or via IC) — FGD

---

#### 6.15.5.6 North American World Zone 1 Calls

The processing of a call to a North American address outside the United States depends on whether the carrier designated by the originating customer is an IC, INC, or consolidated carrier. North American World Zone 1 calls are dialed (10XXX) (+1) + 10D. The (10XXX) is the carrier identification code and the (+1) is required wherever it is normally required to signify a distant NPA. All World Zone 1 calls to domestic and consolidated carriers are processed in the same manner as calls within the United States. Such calls are handled as international calls, with a first stage of the form

KP + 1NX + XXX + 01R + ST.

The 01R identifies one of ten North American *regions*, to distinguish among calls to various regions (based on NPAs) outside the continental United States, but in World Zone 1, to assist in routing the call to an appropriate INC gateway.

#### 6.15.5.7 Supervision

The supervisory control for equal access is calling-customer control of disconnect with forced disconnect (see Section 6.4.3). The typical switching system, as an EAEO or as an access tandem, will disconnect 10 to 11 seconds after the called party disconnects (Table 6-8).

The LECs use 10XXX+ access dialing, similar to that used for domestic ICs. International Record Carriers (IRCs) are assigned their own 10XXX codes. Routing to multiple IRC gateway locations is provided through the interLATA network by selecting the appropriate gateway office. The gateway is chosen on the basis of originating location and destination country code.

The carrier interconnection plan includes LATA-access features for IRCs. This arrangement uses the dialing plan of IDDD and currently has the 10XXX access prefix.

---

## 6.16 Special Tandem Signaling (CAMA, OSPS, and TOPS Offices)

The arrangements discussed in this section reflect signaling provided under FGC. Section 6.15 shows the arrangements for all the feature groups (A, B, C, and D).

Section 6.17 describes signaling specific to operator services systems such as SPS and TOPS.

CAMA, OSPS, and TOPS offices can record call details for customer billing. CAMA offices handle non-coin direct-dialed calls; the OSPS and TOPS offices are arranged to handle long-distance calls from non-coin and coin stations requiring operator assistance and can also operate as CAMA offices.

The CAMA equipment records the called number as it is pulsed from the end office. It also records the calling number pulsed from the end office providing it has ANI. An operator is temporarily connected to the call to record the calling number if ANI equipment is not available at the end office, if the caller is on a 4-party or multiparty line, or if there is an identification failure at the end office. This method of operation is called Operator Number Identification (ONI).

The primary information categories transmitted from an end office to a CAMA, OSPS, or TOPS office are the called number and the calling number. The called number is sent on either an immediate-dial basis for dial-pulse calls or on a wink-start basis for multifrequency pulsing calls. On dial-pulse calls, the CAMA, OSPS, or TOPS office goes off-hook toward the end office after the end of dialing has been recognized by a suitable timing interval. On multifrequency pulsing calls to electronic CAMA (1/1A ESS or 4ESS switching systems), OSPS, or TOPS offices, the off-hook can be returned to the end office as soon as the ST pulse is recognized by the CAMA, OSPS, or TOPS system. As a result, the off-hook can arrive at the end office while the ST pulse is still being sent.<sup>1</sup> This off-hook indication signals the end office to start outputting the ANI information. There is no requirement for a delay between the receipt of the off-hook start-dial by the end office and sending of the KP of the ANI information. However, it is good practice to have a minimum delay of 50 ms between these two signals to permit the transients associated with the off-hook start-dial signal to dissipate before the first multifrequency pulse is sent. (See Section 6.5.6 for information on a similar situation with the on-hook start-dial signal used to send address information.) Multifrequency pulsing is always used to send the ANI information.

The pulsing characteristics between the CAMA, OSPS, or TOPS office and the end and distant offices for the called and calling number are the same as the characteristics for normal pulsing on the network. (See Sections 6.6 and 6.12.1 through 6.12.3.) However, for the ANI case, the signaling formats are somewhat different from those in network pulsing. The signaling formats for the called and calling numbers are covered in Section 6.16.4.

---

1. In LEC end offices, the senders do not recognize the return of an off-hook signal while the ST pulse is being sent because they are blind to the supervisory state during and after outputting of the ST pulse. For information concerning unexpected stops, see Section 6.5.7.

---

On ONI calls, the CAMA, OSPS, or TOPS incoming trunk goes off-hook toward the end office in the same manner as described above, after the called number has been received. This off-hook signal indicates to the originating office that the call is being processed satisfactorily. Once the trunk has gone off-hook for either an ANI or an ONI call, it will remain off-hook for the rest of the call except for wink signals associated with coin control and re-ringing.

The trunk may be forced off-hook toward the end office for maintenance reasons. This off-hook should make the end-office end of the trunk busy. This feature is known as reverse make-busy. There is no guarantee, however, that the end office will always receive an off-hook on every call to a CAMA or operator services office. Certain calling sequences, such as permanent signal, partial dial, or vacant code, may not result in an off-hook toward the end office.

Control of disconnect in CAMA or operator services offices is covered in Section 6.4.3.

### **6.16.1 Signaling to CAMA**

#### **6.16.1.1 Types of Switching Systems used as CAMA Offices**

The following Lucent, Nortel, and NEC switching systems may be arranged as CAMA serving offices: 1/1A ESS, 4ESS, and 5ESS switching systems; Operator Services Position System (OSPS); DMS-10 and DMS-200 switching systems; and NEAX-61E.

#### **6.16.1.2 Called-Number Outpulsing Format in CAMA**

CAMA offices have three called-number outpulsing formats. These differences are important because they impose different permanent signal and partial dial timing requirements on the connected switching systems. The CAMA systems do not always outpulse all the called number digits at one time. Outpulsing can start

- As soon as sufficient digits are available to advance the call toward its destination
- When the first digit of the calling number is received
- When all digits of the calling number are received.

#### **6.16.1.3 Overlap Outpulsing from CAMA**

Overlap outpulsing is a method of outpulsing developed to minimize post-dialing delay. With overlap outpulsing, the call is advanced toward its destination as soon as sufficient address information is available. Once a call is advanced, each succeeding digit is sent

---

forward as soon as it is received. Thus, with overlap pulsing, the timing of the pulses from the CAMA office can be maintained to the end office serving the called line.

#### 6.16.1.4 CAMA Outpulsing Formats

These are the CAMA outpulsing formats.

- Nonimmediate-start (multifrequency or dial-pulse) does not begin outpulsing until the first digit of the calling number is received. This format is used for calls from 1/1A ESS switching systems and OSPS (CAMA) or TOPS (CAMA) offices.
- The 4ESS system does not outpulse the called number until the complete calling number is recorded.
- The DMS-100 system provides the ability for overlap outpulsing for line to trunk/trunk to trunk.
- The DMS-10 system can provide optional overlap outpulsing for dial-pulse signaling on CAMA, OSPS, and Extended Area Service (EAS) routes, and for multifrequency signaling on equal-access and operator service routes.

Once enough digits have been collected to determine the internal route to a trunk group (usually all but the last 4 digits), outpulsing will start.

#### 6.16.1.5 CAMA ANI Pulsing Format

The CAMA ANI pulsing format, with controlled outpulsing, is KP + 7 or 10 digits + ST for the called number, followed by KP+ I +7 digits +ST for the calling number. The meanings of the (single) ANI digits are in Table 6-35. This procedure is the preferred method; but on Operator Identification (OI) and Identification Failure (IF) calls, calling number digits are not available and the ST is optional.

#### 6.16.1.6 CAMA Permanent Signal and Partial Dial Timing

The end office or tandem permanent signal and partial-dial timing on trunks is 5 to 10 seconds for permanent signal or partial-dial and 20 to 30 seconds overall. A permanent-signal or partial-dial timing of 16 to 21 seconds has been used on immediate-start pulsing. In the absence of crossbar tandems in the network, the immediate-start recommendation can be reconsidered and possibly dropped. These times do not affect the permanent signal and partial dial timing in succeeding offices.

---



---

### 6.16.2 Time from Request for ANI to ANI Failure in CAMA

The following shows the time intervals from request for ANI until the call is offered to an operator because ANI information was not received.

- 1/1A ESS switching system, 1.0 to 8.0 seconds
- 2/2B ESS switching system, not applicable
- OSPS, 6 seconds
- 4ESS system, 8.0 seconds to receive Information (I) digit, 5.0 seconds from I digit to all remaining digits
- 5ESS system, 11.0 seconds
- DMS-10 system, software adjustable per office from 0 to 155 seconds with a 128-ms step
- DMS-200 system, software adjustable per trunk group from 2 to 30 seconds.

### 6.16.3 CAMA Transfer

The operators who perform the ONI function can be CAMA, OSPS, or TOPS office operators. When these operators perform the ONI function for a separate CAMA office, the arrangement is known as CAMA transfer. With this arrangement, two voice-frequency circuits are required between the CAMA office and the OSPS or TOPS office: (1) the *talking path* over which call-defining zip tones are received from the CAMA office and over which the operator can converse with the customer, and (2) the *keypulse path* over which multifrequency calling number signals are returned to the CAMA office as keyed by the operator. Table 6-28 indicates the exchange sequence of supervisory signals passed over these circuits between the CAMA office and the OSPS or TOPS office for loop and E&M signaling. The following explains the various conditions for each sequence.

- Out-of-Service — The OSPS office is not prepared to accept traffic from the CAMA office and will ignore seizures from it. The CAMA office should recognize this state and not request service.
  - Position Occupied — The OSPS or TOPS office is prepared to receive traffic from the CAMA office.
  - Position Seizure — The CAMA office requests service from the OSPS or TOPS office.
  - Position Busy — After a 700- to 900-ms delay, the OSPS or TOPS office reacts to the seizure by the CAMA office. This signals it to send the call identity signals.
  - Call Identity Signals — A 1- or 2-pulse order tone signal is sent by the CAMA office indicating whether the calling number is required as the result of an ANI failure or for a call that is normally operator identified (ONI).
-

- **Sender Attached** — A sender-attached signal is sent by the CAMA office to indicate that it is prepared to receive multifrequency calling number signals.
- **Position Attached** — A position-attached signal is sent by the OSPS or TOPS office to indicate when an operator is actually attached to the trunk and ready to serve the customer. Position attached may occur before sender attached when the operator services office is lightly loaded. The CAMA office should be insensitive to this sequence.
- **Multifrequency Calling Number Signals** — Multifrequency tones are sent to the CAMA office identifying the calling number.
- **Reorder** — If the CAMA office cannot recognize the calling number signals as meaningful, it will send a reorder signal. The operator will recognize this signal and key the reset signal (KP BACK in OSPS or TOPS offices), which should prepare the CAMA office to receive the calling number again. The operator will again key the calling number. Should the number remain unacceptable to the CAMA office, the reorder signal will again be sent to the OSPS or TOPS office. If the operator decides that continuing the process will not salvage the call, the operator sends the position disconnect signal to the CAMA office.
- **CAMA Release** — If the calling number is acceptable to the CAMA office, it sends the release signal to the OSPS or TOPS office.
- **The OSPS or TOPS Releases** — The OSPS or TOPS office will respond to the CAMA release by returning to the position-occupied condition.
- **Position Disconnect** — At any point in the signaling sequence, the OSPS or TOPS office can terminate the call by sending the position-disconnect signal. The CAMA office will respond with CAMA release.

**Table 6-28.** Supervisory Signal Exchange Between Operator Providing ONI and

CAMA (Continued)

Sequence State	System	Signal	E&M Signaling			
			OSPS or TOPS		CAMA	
			Talk	KP	Talk	KP
a	OSPS TOPS	Out of Service	On-Hook	Off-Hook	X	X
	CAMA	Not Requesting Service	X	X	On-Hook	On-Hook
b	OSPS TOPS	Position Occupied	On-Hook	On-Hook	On-Hook	On-Hook
c	CAMA	Position Seizure	On-Hook	On-Hook	Off-Hook	On-Hook
d	OSPS TOPS	Position Busy	On-Hook	Off-Hook	Off-Hook	On-Hook
e	CAMA	Call Identity Signals	—	—	(Zip Tones*)	—
f	CAMA	Sender Attached	On-Hook	Off-Hook	Off-Hook	Off-Hook
g	OSPS TOPS	Position Attached	Off-Hook	Off-Hook	Off-Hook	Off-Hook
h	OSPS TOPS	MF Calling No. Signals	—	(MF Signals)	—	—
i	CAMA		Off-Hook	Off-Hook	Off-Hook	On-Hook
	OSPS TOPS		—	(Reset Tone**)	—	—
j	CAMA	CAMA Released	Off-Hook	Off-Hook	On-Hook	On-Hook
k	OSPS TOPS	OSPS or TOPS Release	On-Hook	On-Hook	On-Hook	On-Hook
l	OSPS TOPS	Position Disconnect	Off-Hook (100ms) On-Hook	—	—	—

\* Call Identity Signal (Zip Tones):

Tone — 480 Hz at a minimum of 0.062-V rms (-24 dBm, 900W bridging)

Timing — ANI Failure 0.420 to 1.380 Tone  
 — ONI (2 Tones) 0.050 to 0.175 Tone  
 0.050 to 0.175 Silence  
 0.050 to 0.175 Tone

\*\* Reset Tone: 700 and 1700 Hz (ST3P).

---

## 6.17 Signaling From End Offices to Operator Services Systems

Services routed through operator services systems include the following:

- Calls from non-coin lines for person-to-person, calling card, collect, third number and other types of calls
- Calls requiring screening to prevent fraud
- Calls from various types of coin stations
- Calls from Charge-a-Call telephones
- International dialed calls (where applicable).

See Section 14.5 for a description of some of these services. More information on all of the services is available in FR-271, *Operator Services Systems Generic Requirements*, GR-528-CORE, *LSSGR: Public Telecommunications Services, FSD 10-01-0000*, and GR-506-CORE, *LSSGR: Signaling for Analog Interfaces*. GR-528-CORE and GR-506-CORE are modules of FR-64, *LATA Switching Systems Generic Requirements (LSSGR)*.

### 6.17.1 “Operator Services” or Bell II” Signaling to Operator Services Systems

Operator services (Bell II) signaling features are available in all TOPS offices and in OSPS offices with generic 5E4.2 or later. In the EAEO, these features are available in 1 ESS, 5ESS, DMS-10, and DMS-100 switching systems.

Operator services signaling is very similar to other multifrequency signaling used to signal OSPS or TOPS, referred to as “Bell I” signaling (see Section 6.17.2). The differences are as follows:

- Two information digits are used in the ANI information sequence, rather than the one in “Bell I” signaling.
- The multifrequency signaling start digit on the ANI information can be either ST (interLATA calls) or STP (intraLATA calls). This permits identification of interLATA versus intraLATA calls without translating the dialed digits at the operator services system. Previously, only the start signal ST was used with ANI information.

Like the operator services systems, operator services signaling can support direct-dialed traffic (1+) as well as assistance traffic (0-) and toll-and-assistance traffic (0+). Operator services signaling can handle and identify intraLATA, interLATA, and international traffic. OSPS and TOPS trunks are usually 2-way.

On calls to be routed to an operator services system, the following will occur:

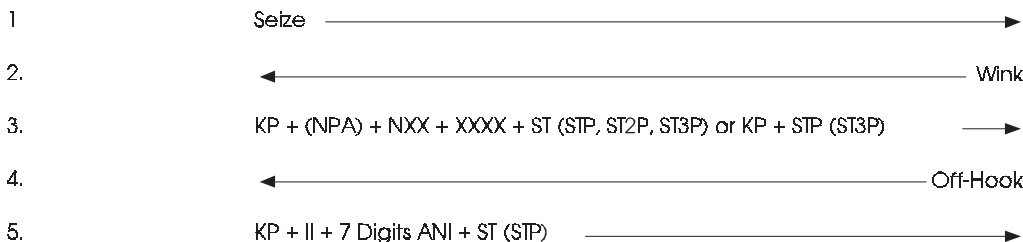
1. The customer dials 10XXX + (1) + 7 or 10, or 10XXX + 0 + 7 or 10, (Table 6-29).

2. The end office seizes an outgoing trunk.
3. The operator service facility responds with a standard wink.
4. The end office outpulses the called number after a delay of 40 to 200 ms. The outpulsing is KP + 7/10 digits + ST (STP, ST2P, ST3P).
5. Any time after the start of the ST pulse, the operator services system will come off-hook to indicate readiness to receive ANI information.
6. The end office outpulses the ANI information after a delay of 40 to 200 ms. The outpulsing is KP + II + 7 digits + ST (STP). On ANI failures, KP + 02 + ST (STP) will be sent. Operator Services Signaling always includes ANI.

See Figure 6-57 for the signaling format for interLATA or intraLATA calls to operator systems. All timing intervals are exactly the same as used for signaling to operator services systems.



After Customer has Completed Dialing (10XXX) + (0/1) + (NPA) + NXX + XXXX OR (10XXX) + 0



**Figure 6-57.** Originating Signaling Sequence, Operator Services, InterLATA or IntraLATA — “Bell II” Signaling

**Table 6-29.** Pulsing Format from End Office to Operator Service InterLATA and IntraLATA Calls Using "Bell II" Signaling

0-, 0+, 1+ Coin; 0-, 0+, 1+ Non-coin; and 0-, 0+, 1+ Screened Traffic			
Type of Call	Customer Dials	Multifrequency-Pulsed Called Number	ANI Calling Number
<i>Non-coin:</i>			
Direct dialed			
Predesignated Carrier	(1) + 7 or 10 digits	KP-7 or 10 digits-ST2P	KP-II-7 digits-ST*
Override Predesignation	10XXX + (1) + 7 or 10 digits	KP-7 or 10 digits-ST2P	KP-II-7 digits-ST*
Operator assistance (0-)			
Predesignated carrier	00	KP-ST3P	KP-II-7 digits-ST*
Override Predesignation	10XXX + 0	KP-ST3P	KP-II-7 digits-ST*
Operator assistance (0+)			
Override Predesignation	10XXX + 0 + 7 or 10 digits	KP-7 or 10 digits-ST3P	KP-II-7 digits-ST*
<i>Coin:</i>			
Direct dialed	10XXX + (1) + 7 or 10 digits	KP-7 or 10 digits-ST	KP-II-7 digits-ST*
Operator assistance (0-)	10XXX + 0 (zero)	KP-STP	KP-II-7 digits-ST*
Operator assistance (0+)	10XXX + 0 + 7 or 10 digits	KP-7 or 10 digits-STP	KP-II-7 digits-ST*

\*ST for interLATA calls; STP for intraLATA.

If a time-out occurs waiting for the start-pulsing wink or the ANI request off-hook signal, a reorder announcement is connected. If all trunks to the IC/INC are busy, a no-circuit announcement is connected. If a trunk cannot be seized for any other reason, reorder tone should be returned.

Customer flashes are repeated to the operator system. Ringback, coin-control, operator-attached, and operator-released signals sent from the operator system should also function as usual, and normal operator services disconnect procedures should be followed. Operator system hold continues, as does wink off. If an OSPS or TOPS office is acting as an access tandem for the intraLATA to the interLATA, it is transparent to the interLATA call.

Tables 6-29 and 6-30 show the various outpulsing formats for pulsing between an end office and operator system. There is great similarity between Table 6-29 and Table 6-33 (Pulsing Format - End Office to OSPS or TOPS Office with ANI using "Bell I" Signaling) for OSPS or TOPS systems. In both cases, supercombined 0-, 0+, and 1+ coin; 0-, 0+, and 1+ non-coin; and 0-, 0+, and 1+ screened traffic can be routed over a single trunk group. Post-pay coin cannot be routed on the same trunk group as prepay coin.

All trunk groups between an EAEO and an operator system can always use the supercombined format. However, the operator system can also use pulsing formats analogous to those in Tables 6-32, 6-33, and 6-34 for the OSPS or TOPS systems when used for FGC if the LEC and IC agree. International and test call dialing are covered in Table 6-30.

The three special ANI information digit pairs (II) 08, 68, and 78 (explained below) are required for the operator system to handle calls from interLATA-restricted lines. These information digit pairs are sent only on calls to the operator system serving the carrier for which interLATA restriction applies. Other ANI pairs (II) used with this signaling are as shown later in this section.

To aid the transition from existing operator services signaling, this and any future type of signaling should initially be available at the end office and the operator services system. The type of signaling at the operator services system is available on a trunk group basis so that the end offices can be converted office-by-office.

Other information is available on OSS in FR-271, *Operator Services Systems Generic Requirements*.

**Table 6-30.** Pulsing Format from End Office to Operator Service System-  
International Calls and Test Calls Using "Bell II" Signaling

0-, 0+, 1+, Coin — 0-, 0+, 1+ Non-coin — and 0-, 0+, 1+ Screened Traffic			
International Calls			
Type of Call	Customer Dials	Multifrequency-Pulsed Called Number	ANI Calling Number*
<i>Non-coin</i>			
Direct dialed			
Predesignated Carrier	011 + CC + NN	KP + 1 + CC + NN-ST2P	KP-II-7 digits-ST
Override Predesignation	10XXX + 011 + CC + NN	KP + 1 + CC + NN-ST2P	KP-II-7 digits-ST
Operator assistance (0-)			
Predesignated carrier	00 (zero minus)	KP + 0 + ST	KP-II-7 digits-ST
Override Predesignation	10XXX + 0	KP + 0 + ST	KP-II-7 digits-ST
Operator assistance (0+)			
Predesignated carrier	01 + CC + NN	KP + 1 + CC + NN-ST3P	KP-II-7 digits-ST
Override Predesignation	10XXX + 01 + CC + NN	KP + 1 + CC + NN-ST3P	KP-II-7 digits-ST
<i>Coin</i>			
Direct dialed	10XXX + 011 + CC + NN	KP + 1 + CC + NN-ST	KP-II-7 digits-ST
Special toll handling	10XXX + 01 + CC + NN	KP + 1 + CC + NN-STP	KP-II-7 digits-STP
Typical Test Calls			
Type of Call	Tester Dials	Multifrequency-Pulsed Called Number	ANI Calling Number*
Test	10X	KP-10X-ST	—
Test	958 + XXXX	KP-958 + XXXX-ST	—
Test	959 + XXXX	KP-959 + XXXX-ST	—

\* Refer to Section 6.15.5.3 for the meaning of the ANI information digits II.



---

## 6.17.2 “Bell I” Signaling to Operator Services Systems

Although a pre-divestiture scheme, this signaling still exists between end offices and operator services systems in some locations. It is similar to the “Bell II” signaling described in Section 6.17.1, but uses just one ANI Information Digit and a non-variable ST signal on the multifrequency ANI information.

### 6.17.2.1 Outpulsing Format

The end office identifies the type of call to operator services systems by using four different multifrequency start signals. On calls where the end office uses multifrequency pulsing for the called number, the appropriate start signal is sent with the called number. On calls where the end office uses dial pulsing, the appropriate start signal is sent with the ANI information. In addition, timing is used to identify the type of call. For example, when it is desired to reach an operator (0 call), 0 is dialed. When special toll handling is desired (for example, collect, person-to-person, credit card, etc. [0+ call]), 0 followed by the called number is dialed. The 0 and 0+ calls use the same ST pulse for identification. As a result, other means have to be used to separate these two categories of calls. In customer-originated calls, OSPS and TOPS offices consider a dialing pause of over 4 to 5 seconds<sup>1</sup> after dialing 0 to be a 0- call. In multifrequency pulsing calls, KP followed by a start signal of STP or ST3P, depending on the trunking plan, but with no called number, is outpulsed to identify a 0 call.

OSPS or TOPS offices currently initiate timing following the receipt of a leading 0 dial-pulse digit to determine if additional digits follow. Timing is performed by the operator services OSPS or TOPS processor and is not terminated until a *complete* digit (consisting of two to nine pulses) is registered by a dial-pulse receiver and reported to the processor. The time interval is 4 to 5 seconds for receipt of a complete digit. This change will allow the 0+ customer a minimum of approximately 3 seconds to *begin* dialing a second digit, while requiring the 0- customer to wait no longer than 5 seconds. When it is determined that the call is a 0- call, the operator services office returns the off-hook ANI request signal.

### 6.17.2.2 Trunking Plans

The OSPS or TOPS office can have a variety of trunking plans. It can

- Combine all coin and non-coin traffic on one supercombined trunk group. The pulsing format for this arrangement with ANI is shown in Table 6-31.
- Combine all coin traffic on one trunk group and all non-coin traffic on another. The pulsing format for this arrangement with ANI is shown in Table 6-32.

---

1. The TOPS system is adjustable from 2 to 30 seconds.

- 
- Combine all 0-, 0+ coin traffic on one trunk group and all 0-, 0+ non-coin traffic on another. The pulsing format for this arrangement with ANI is shown in Table 6-33. The 1+ coin and 1+ non-coin traffic would be handled on two additional trunk groups also shown in Table 6-33.
  - Use six individual trunk groups for 0-, 0+, 1+ coin and 0-, 0+, 1+ non-coin traffic. The pulsing format for this arrangement with ANI is shown in Table 6-34 and without ANI in Table 6-34.

In each case where more than one type of traffic is carried on a single trunk group, the type of call is identified by distinctive multifrequency ST digits or information (I) digits transmitted from the end office with the called/calling number. For dial-pulsing calls, the identifying ST pulse is associated with the ANI information. For multifrequency pulsing calls, the identifying ST pulse is associated with the address information. For both multifrequency and dial-pulsing calls, the information digit is with the ANI information. To separate traffic, a different information digit is used with each call to indicate whether it has been subject to local service observing and also whether it was processed by automatic identification, operator identification, or identification failure procedures. Tables 6-31 through 6-34 show this information. Figure 6-60 shows a typical outpulsing format for multifrequency address signaling.

**Table 6-31.** Pulsing Format from an End Office to an OSPS or TOPS Office with ANI Supercombined Coin and Non-coin Trunk Group Using "Bell I" Signaling

0-, 0+, 1+ Coin; 0-, 0+, 1+ Non-coin; and 0-, 0+, 1+ Screened Traffic			
Multifrequency Pulsing			
Type of Call	Customer Dials	Multifrequency-Pulsed Called Number	ANI Calling Number
<i>Non-coin</i>			
Direct dialed	(1) + 7 or 10 digits	KP-7 or 10 digits-ST2P	KP-I-7 digits-ST
Operator assistance	0 (zero)	KP-ST3P	KP-I-7 digits-ST
Special toll	0 + 7 or 10 digits	KP-7 or 10 digits-ST3P	KP-I-7 digits-ST
<i>Coin</i>			
Direct dialed	(1) + 7 or 10 digits	KP-7 or 10 digits-ST	KP-I-7 digits-ST
Operator assistance	0 (zero)	KP-STP	KP-I-7 digits-ST
Special toll	0 + 7 or 10 digits	KP-7 or 10 digits-STP	KP-I-7 digits-ST
Dial Pulsing			
Type of Call	Customer Dials	Dial-Pulsed Called Number	ANI Calling Number
<i>Non-coin</i>			
Direct dialed	(1) + 7 or 10 digits	7 or 10 digits	KP-I-7 digits-ST2P
Operator assistance	0 (zero)	Seizure no digits	KP-I-7 digits-ST3P
Special toll	0 + 7 or 10 digits	7 or 10 digits	KP-I-7 digits-ST3P
<i>Coin</i>			
Direct dialed	(1) + 7 or 10 digits	7 or 10 digits	KP-I-7 digits-ST
Operator assistance	0 (zero)	Seizure no digits	KP-I-7 digits-STP
Special toll	0 + 7 or 10 digits	7 or 10 digits	KP-I-7 digits-STP

**Note:** See Table 6-35 for meaning of information digit I.

**Table 6-32.** Pulsing Format — End Office to OSPS or TOPS Office with ANI Combined Coin or Combined Non-coin Trunk Group Using “Bell I” Signaling

<i>Combined Coin</i> 0-, 0+, & 1+ Coin			
<i>Combined Non-coin</i> 0-, 0+, & 1+ Non-coin			
0-, 0+, & 1+ Post-pay coin			
0-, 0+, & 1+ Screened traffic			
0-, 0+, & 1+ Non-coin combined with 0-, 0+, & 1+ post-pay coin and/or 0-, 0+, & 1+ screened traffic			
<b>Multifrequency Pulsing</b>			
Type of Call	Customer Dials	Multifrequency-Pulsed Called Number	ANI Calling Number
Direct dialed	(1) + 7 or 10 digits	KP-7 or 10 digits-ST	KP-I-7 digits-ST
Operator assistance	0 (zero)	KP-STP	KP-I-7 digits-ST
Special toll	0 + 7 or 10 digits	KP-7 or 10 digits-STP	KP-I-7 digits-ST
<b>Dial Pulsing</b>			
Type of Call	Customer Dials	Dial-Pulsed Called Number	ANI Calling Number
Direct dialed	(1) + 7 or 10 digits	7 or 10 digits	KP-I-7 digits-ST
Operator assistance	0 (zero)	Seizure-no digits	KP-I-7 digits-STP
Special toll	0 + 7 or 10 digits	7 or 10 digits	KP-I-7 digits-STP

**Note:** See Table 6-35 for meaning of information digit I.

**Table 6-33. Pulsing Format — End Office to OSPS or TOPS Office with ANI Using "Bell I" Signaling**

<i>Individual</i>			
0-, 0+, & 1+ Coin			
0-, 0+, & 1+ Non-coin			
0-, 0+, & 1+ Post-pay coin			
0-, 0+, & 1+ Screened traffic			
<i>Combined</i>			
0- & 0+ Coin			
0- & 0+ Non-coin			
0- & 0+ Post-pay coin			
0- & 0+ Screened traffic			
0- & 0+ Non-coin combined with 0- & 0+ post-pay coin and/or 0- & 0+ screened traffic			
1+ Non-coin combined with 1+ post-pay coin and/or 1+ screened traffic			
<b>Multifrequency Pulsing</b>			
Type of Call	Customer Dials	Multifrequency-Pulsed Called Number	ANI Calling Number
Direct dialed	(1) + 7 or 10 digits	KP-7 or 10 digits-ST	KP-I-7 digits-ST
Operator assistance	0 (zero)	KP-ST	KP-I-7 digits-ST
Special toll	0 (zero)	Seizure-no digits	KP-I-7 digits-ST
	0 + 7 or 10 digits	KP-7 or 10 digits-ST	KP-I-7 digits-ST
<b>Dial Pulsing</b>			
Type of Call	Customer Dials	Dial-Pulsed Called Number	ANI Calling Number
Direct dialed	(1) + 7 or 10 digits	7 or 10 digits	KP-I-7 digits-ST
Operator assistance	0 (zero)	Seizure-no digits	KP-I-7 digits-ST
Special toll	0 + 7 or 10 digits	7 or 10 digits	KP-I-7 digits-ST

**Note:** See Table 6-35 for meaning of information digit I.

**Table 6-34.** Pulsing Format — Non-conforming End Office to an OSPS or TOPS Office without ANI

<i>Individual Trunk Groups</i>		
0-, 0+, & 1+ Coin		
0-, 0+, & 1+ Non-coin		
0-, 0+, & 1+ Post-pay coin		
0-, 0+, & 1+ Screened traffic		
<i>Combined Trunk Groups</i>		
0- & 0+ Coin		
0- & 0+ Non-coin		
0- & 0+ Post-pay coin		
0- & 0+ Non-coin and		
0- & 0+ post-pay coin with service tone identification		
<b>Multifrequency Pulsing</b>		
Type of Call	Customer Dials	Multifrequency-Pulsed Called Number
Direct dialed	(1) + 7 or 10 digits	KP-7 or 10 digits-ST*
Operator assistance	0 (zero)	Seizure-no digits
Special toll	0 (zero)	KP-ST**
	0 + 7 or 10 digits	KP-7 or 10 digits-ST*
<b>Dial Pulsing</b>		
Type of Call	Customer Dials	Dial-Pulsed Called Number
Direct dialed	(1) + 7 or 10 digits	7 or 10 digits
Operator assistance	0 (zero)	Seizure-no digits
Special toll	0 + 7 or 10 digits	7 or 10 digits

\* ST indicates that any of the usable ST signals will be accepted.

Because the identifying ST pulse is associated with the called number, each of the above multifrequency pulsing formats can be used without ANI from the end office. The only usable situation under which the dial-pulsing format without ANI could be used is when an individual trunk group is used for each type of service.

### 6.17.2.3 ANI Information Digits

A single ANI information digit is used for an operator services system call using Bell I signaling. Tables 6-31 through 6-34 cover the operator services system application.

The information in this section covers operation with OSPS and TOPS offices. Some exchange carriers will continue to use this mode of operation indefinitely, as will some

switching systems in the LECs. Note that a dual information digit format is associated with equal access, "Bell II" signaling described in Section 6.17.1.

Information digits 0, 1, 2, 3, 4, and 5 are used with the same meaning in the CAMA, OSPS, and TOPS systems. Digits 0, 1, and 2 identify nonobserved calls while digits 3, 4, and 5 identify observed calls. These information digits (see Table 6-35) will continue to be used. Note that the information digits for equal access are now standard (see Section 6.15.5.3).

**Table 6-35. Information Digit I**

Service	Nonobserved	Observed
Automatic Identification (AI)	0	3
Operator Identified (OI)	1	4
Identification Failure (IF)	2	5
Hotel/Motel	6	6
Special Screening (for example, Charge-a-Call)	7	7

### 6.17.3 Coin Control Signaling

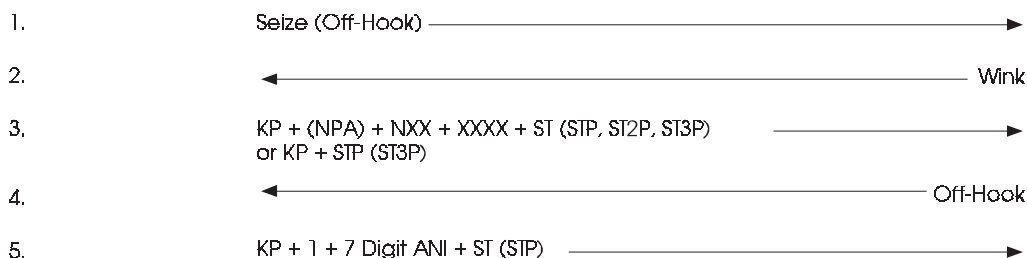
Over the years, several different methods of coin control have evolved to meet changing needs. In addition to coin collect, coin return, and ringback, the multiwink and expanded inband methods provide signals to control the polarity of the battery applied to the coin telephone by the end office.

There are three different methods of coin control signaling used from the OSPS or TOPS system to the end office. They are inband, multiwink, and Expanded Inband Signaling (EIS) coin control. All can be used from host or remote local exchange company locations and can be used with E&M lead signaling on either physical or carrier facilities. All three types of coin control can be used with 2-wire physical facilities employing loop signaling. However, with Calling Card Service, only multiwink and EIS coin control provide DTMF pad and totalizer control without station set modifications. A typical outpulsing format for end office to operator services system is shown in Figure 6-58.

Coin-control signaling is covered in GR-528-CORE, *LSSGR: Public Telecommunications Services, FSD 10-01-0000*.



After Customer has Completed Dialing (0/1) + (NPA) + NXX + XXXX OR 0 (zero)



**Figure 6-58.** Originating Signaling Sequence

### 6.17.3.1 Inband Coin Control

#### 6.17.3.1.1 Signals

Inband coin control uses multifrequency signals to control coins and ring back the coin station as covered under “collect,” “return,” and “ringback” in Table 6-33.

An on-hook wink (off-, on-, off-hook) of 70 to 130 ms is sent (50 to 150 ms in duration when received) from the operator services system to alert the end office to prepare a receiver for the multifrequency signal that begins 95 to 195 ms after the end of the wink. The multifrequency signal will persist for approximately 1 second for collect and return and 2 seconds for ringback.

#### 6.17.3.1.2 Ringback Protocol

The OSPS or TOPS office sends one ringback signal. The end office applies standard ringing (2 seconds on, 4 seconds off) to the station and audible ring toward the operator services office until the station answers or the operator services office release is received. The operator services office times for 30 to 36 seconds waiting for answer. If answer is not received, it releases back. The end office performs a coin return before releasing the coin station. If answer is received and a coin-control signal sent, release-back will not occur until at least 300 ms after completion of the signal.



### 6.17.3.2 Multiwink Coin Control

Multiwink coin control uses multiple on-hook wink signals sent from an operator services office to an end office. It is used in 5ESS, DMS-10, DMS-100F and EWSD systems. In addition to coin collect, coin return, and ringback signals, this signaling format provides signals called operator-attached and operator-released.

The operator-attached signal is used with dial-tone-first coin telephones to instruct the end office to change the mode of the coin totalizer or coin signaling priority to the toll mode by application of positive battery to the coin telephone. It is not sent the first time a coin call is forwarded to the OSPS or TOPS office because the end office is expected to connect a coin call to the operator services office in the operator-attached condition. However, the operator-attached signal is sent before each subsequent operator services office attachment requiring a coin deposit. The operator-released signal (negative battery supplied to the coin telephone) restores the coin totalizer or coin signaling priority to the local mode and enables the DTMF pad on certain coin telephones. The operator-released signal is sent whenever the operator services office releases from a connection having positive battery applied to the coin telephone. It is also sent upon initial connection to a 0+ coin call on a dial-tone-first trunk when the trunk provides for Calling Card Service.

#### 6.17.3.2.1 Signals

The multiwink signaling format employs a series of one to five supervisory on-hook winks from the OSPS or TOPS office to the end office outgoing trunks (as shown in Table 6-36).

**Table 6-36.** Multiwink Signals and Their Functions

Number of On-Hook Winks	Function	Subsequent OSPS or TOPS Guard Interval (Minimum)	End Office Work Time (Maximum)
1	Operator-Released	500 ms	380 ms
2	Operator-Attached	500 ms	380 ms
3	Coin Collect	1.1 seconds	880 ms
4	Coin Return	1.1 seconds	880 ms
5	Ringback	2.4 seconds	2.1 seconds

The wink on-hook intervals, as sent by the operator services office, are 70 to 130 ms and the wink off-hook intervals are 95 to 150 ms. To allow for pulse distortion, the end office trunk circuit should be capable of operating with on-hook intervals from 50 to 150 ms spaced from 75 to 185 ms apart when received.

At the end of a wink signal, the operator services office will allow time for the end office to complete detection and application of the signal before sending a new signal. The

minimum interval after sending a signal by the operator services office and the maximum time in which the end office must detect and apply the signal are shown in Table 6-36.

#### 6.17.3.2.2 Ringback Protocol

See Section 6.17.3.1.2.

#### 6.17.3.3 EIS Coin Control

As with inband coin control, EIS coin control employs an on-hook wink to alert the end office that multifrequency tones will be sent. It is used in 1/1A ESS, 2/2B ESS, 5ESS, DMS-100F, and EWSD switching systems. With EIS, the wink is extended to produce an on-hook of between 325 and 425 ms (300 and 450 ms when received). In addition, the interval between the end of the wink signal and the start of the multifrequency tones is lengthened to between 770 and 850 ms, while the duration of the tones is reduced to between 480 and 700 ms.

##### 6.17.3.3.1 Signals

OSPS and TOPS offices are able to work with EIS. EIS provides operator-attached and operator-released signals as does multiwink coin control. However, in EIS a coin station initiating a 0+, 0- or nonchargeable call on a trunk providing Calling Card Service is initially connected to the operator services office with negative battery applied to the station. As with the other signaling methods, 1+ calls are initially connected with positive battery applied. The operator-attached signal is sent whenever the operator services office is connected for a coin deposit, and the operator-released signal is sent whenever the operator services office is released from a connection having positive battery applied to the coin station. A signal, not available with multiwink, is combined coin-collect and operator-released. This signal, which causes the end office to collect coins and then apply negative battery to the coin station, is currently used for interim overtime collections on calls still in the talking state.

The guard intervals following the operator-released and operator-attached signals are 600 ms. Guard intervals following the other signals are 2 seconds.

##### 6.17.3.3.2 Ringback Protocol

See Section 6.17.3.1.2.

---

---

#### 6.17.3.4 Impacts on Coin Stations of Automatic Coin Toll Service (ACTS) and Calling Card Service

The ACTS and Calling Card Service features of the operator services offices make use of the additional signals. The signals for coin control are described in Sections 6.17.3.1, 6.17.3.2, and 6.17.3.3. The sequences of these signals and other signals are described in this section. In some cases, two back-to-back signals spaced by a guard interval (to give the end office time to respond) are used. Guard intervals are also necessary between coin control signals, machine-generated announcements, and certain other supervisory signals. The following sections supply the signaling protocol and timing information on these more complex interfaces.

However, before going into ACTS and Calling Card Service, Section 6.17.3.4.1 describes the DTMF and coin totalizer control in the two types of coin telephones in common use in the LECs and Section 6.17.3.4.2 describes the interface before these features existed. Coin-control signaling and charge-a-call is covered in GR-528-CORE, *LSSGR: Public Telecommunications Services, FSD 10-01-0000*.

##### 6.17.3.4.1 Coin Telephone DTMF Pad and Coin Totalizer Control

There are two different types of coin telephones in service in the LEC networks used for prepaid coin service. The older is coin-first; the newer is dial-tone-first. These are discussed in the following sections.

###### 1. Coin-First

These coin telephones use a negative battery supply (usually -48 V on the ring and ground on the tip but possibly other voltages, for example, when range-extenders are used) from the end office. They do not require positive battery supply (+48 V on the ring and ground on the tip). If equipped with DTMF, the DTMF pad is disabled unless an initial deposit equal to the local rate has been made. When the deposit is collected or returned, the pad is again disabled. A feature called coin retention has been provided for DTMF pad enablement with coin-first telephones and is required for Calling Card Service.

###### 2. Dial-Tone-First

These coin telephones initially have the DTMF pad enabled and a negative battery supplied as with the coin-first telephones. However, the negative battery places the coin totalizer in the C-series sets in the local mode; that is, the readout does not occur until an amount equal to the initial rate is deposited. This can result in composite coin signals, which may not be recognized by operators or ACTS. In the D-series sets, the negative battery gives the pad priority over the coin signals. Thus, pad operation during a coin deposit may result in coin signaling errors at the operator services office.

---

A positive battery supply is needed from the end office when a coin deposit is requested by the operator services office. The positive battery supply changes the coin totalizer in the C-series sets to the toll mode so that coin deposits of any denomination cause an immediate readout, which can be detected by an operator or by ACTS equipment. In the D-series sets, it gives priority to the coin deposits, preventing DTMF pad interference. The positive battery supply also disables the pad on all but D-type of dial-tone-first coin telephones. Disabling the pad during coin deposit prior to ACTS was desirable to prevent simulation of coin tones with the pad. However, with ACTS the coin tone receivers used at operator services offices will not respond to DTMF signals so the pad-disabling function is no longer necessary. By way of reference, if a positive battery were supplied to an early-model (A-series) coin-first telephone, the DTMF pad and the coin totalizer would fail to function.

#### 6.17.3.4.2 Interface Prior to Calling Card Service

##### 1. Coin-First Operator Services System Interface prior to Calling Card Service Introduction

The coin-first operator services system interface is as follows.

- Coin collect, coin return, and ringback are the only coin-control signals required. Inband coin control is generally used on trunks handling coin traffic. Multiwink and EIS can be used, but the additional signals (operator-attached, operator-released, and EIS coin-collect/operator-released) are not functional.
- Single-slot coin telephones with a totalizer sending the coin denomination tones or the traditional three-slot coin telephones with the bell and gong can be used. However, with the latter an operator must supervise the coin deposit since the bell and gong are not compatible with ACTS.
- Originally, the initial deposit was retained. However, an end office operating in a non-Calling Card Service environment returns the deposit before connecting the coin call to an operator services office.
- The end office battery supply to the coin telephone is negative. The end office may interchange the voltage on tip and ring of the line during the course of the call, but positive battery supply is not used.
- DTMF pad enablement depends upon the deposit of the initial local rate. When the initial rate is present in the hopper, the pad is enabled. Collection or return of the coins disables the pad.

##### 2. Dial-Tone-First Operator Services System Interface prior to Calling Card Service Introduction

The introduction of dial-tone-first coin telephones required one major change in the operator services interface. The coin totalizer used in most single-slot dial-tone-first

---

---

telephones requires a positive battery supply from the end office to place it in the toll mode so that coin deposits cause an immediate readout. The D-series requires positive battery to give coin signals priority over DTMF signals. The following describes the dial-tone-first operator services interface.

- Any of the coin-control signaling methods can be used. Inband operation is the same as with coin-first (see first bullet in previous section). If multiwink or EIS is used, the additional signals may be used to control battery polarity.
- The coin telephones are single slot or multislot (same as coin-first). Early production single-slot sets, the A-series, cannot be used with dial-tone-first; nor can they be used as coin-first in an end office serving both coin-first and dial-tone-first because the positive battery disables the set.
- Any initial deposit is returned by the end office (same as coin-first).
- Negative battery supply to the coin station from the end office is normal for dial-tone-first coin telephones in the origination and dialing stages of a call. However, when the station is connected through the outgoing trunk to the operator services system, the end office replaces the negative battery supply with positive. The positive supply changes the coin totalizer or signaling priority mode in single-slot coin telephones as mentioned above. This positive supply remains connected until the call is disconnected by the operator services office unless multiwink or EIS is provided with the additional signals functional to control battery polarity.
- The DTMF pads in some coin telephones are disabled during any call through an operator services office, which has positive battery applied continuously. The pad in the D-series set is not affected by battery polarity. Pad enablement does not depend on the presence of coins in the hopper.

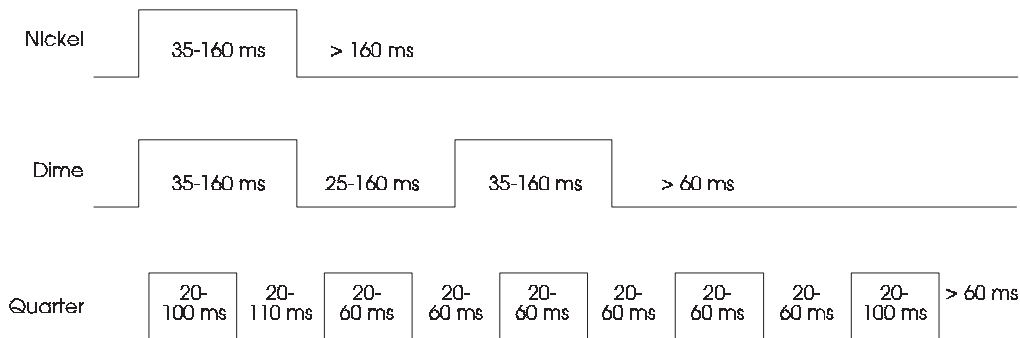
#### 6.17.3.4.3 ACTS and Operator Services System Interface

ACTS provides coin tone detectors in the operator services offices, permitting automatic coin deposit counting to be used. The requirements for either type of coin service remain the same, except that coin telephones must provide dual-frequency coin deposit signals. These signals must consist of two simultaneous tones of 1700 and 2200 Hz or 1537 and 2200 Hz at a power level between -24.8 dBm and +3 dBm (into 600  $\Omega$ ) for each frequency as received by the operator services office. The tone pairs are changed each time the coin box is collected. A minimum of 6 ms of tone is needed to recognize a coin signal. After detection, the coin detectors should bridge no-tone intervals of 10 ms in the coin tone.

The tone burst representing a nickel must be 35- to 160-ms long and must be followed by a silent interval of at least 160 ms before another coin signal is detected. A dime is represented by two bursts 35 to 160 ms long spaced by 25 to 160 ms. The silent interval after a dime signal must exceed 60 ms. A quarter is denoted by five bursts. The first and

---

fifth may be 20 to 100 ms long. The second, third, and fourth are 20 to 60 ms. The first and second may be spaced by 20 to 110 ms; the remaining by 20 to 60 ms. The end of a quarter sequence is followed by a 60-ms silent interval. The times given above are shown graphically in Figure 6-59.



**Figure 6-59.** Coin Deposit Signals

The coin-tone detectors will not recognize DTMF signals as a coin deposit. Therefore, DTMF pad disablement is not necessary when ACTS is used.

Here are the default values for various ACTS parameters.

- Initial Timeout — Timeout for initial ACTS contacts. Default value is 5.5 seconds.
- Charge Due Timeout — Timeout for charge-due contacts. Default value is 8 seconds.
- Initial Announcement Delay — Amount of time between initial announcements. Default value is 8 seconds.
- Charge Due Announcement Delay — Amount of time between charge-due announcements. Default value is 8 seconds.
- Time and Charge (TAC) Announcement Delay — Amount of time between two TAC announcements. Default value is 3 seconds.
- Ring Back Time — The amount of time that ACTS should ring back the telephone on a calling-party disconnect with charges due. Default value is 30 seconds.
- Ring Back Answer Delay — Amount of delay needed for the customer to bring the receiver to his/her ear on a ringback answer. Default value is 2 seconds.
- Collect Time — Maximum amount of coin collection time allowed on a recalled ACTS call. Default value is 32 seconds.

---

#### 6.17.3.4.4 Calling Card Service Operator Services System Interface

Calling Card Service permits customers to dial billing information without the assistance of an operator. The billing information is sent from the coin or non-coin calling telephone via DTMF signaling. As a result, the DTMF pads must be enabled. Both coin-first and dial-tone-first coin telephones can be used with Calling Card Service. However, dial-tone-first is preferred because the end office can continue to return any initial deposit, and the pad on coin telephones arranged for Calling Card Service will remain enabled throughout a call for end-to-end signaling. Because of the additional complications to the interfaces due to coin retention and Calling Card Service, the details of coin control for both ACTS and Calling Card Service calls are given in this section.

##### 1. Dial-Tone-First

Multiwink and EIS coin control enable DTMF pads in dial-tone-first coin telephones. Inband coin control may be used with Calling Card Service. C-series stations require modification for pad enablement when operating in the dial-tone-first mode. Signaling protocols are similar with multiwink and EIS methods. There are, however, three important differences.

A. Multiwink — All calls are connected to operator services offices with positive battery applied to the station to place the totalizer in the toll mode. If the operator services office determines that a 0+ call from a coin telephone is to receive Calling Card Service treatment, an operator-released signal must be sent immediately to enable the DTMF pad. If it is subsequently determined that the call is to be sent-paid, the operator office sends an operator-attached signal when the *paid* key is depressed. With EIS 1+ and no dialed prefix, calls arrive at the operator office with positive battery. The same applies to multiwink. However, 0-, 0+ and nonchargeable number calls arrive with negative battery applied, eliminating the need for the initial operator-released signal. As with multiwink, an operator-attached signal is sent when the *paid* key is depressed if the call is subsequently determined to be sent-paid.

B. Interim Overtime Seizures — EIS uses a combined coin-collect/operator-released signal after the seizure. With multiwink, separate signals are used.

C. Ringback Protocol — This is described in Section 6.17.3.1.2.

With both types of coin control, the pad is enabled on coin telephones except during intervals when coin deposits are being made. Coin control with Calling Card Service and dial-tone-first is discussed in the following sections.

**1+ ACTS Call With Multiwink Signaling and Dial-Tone-First:** The end office applies positive battery to the coin station immediately before connecting to the operator services office. The ACTS equipment is connected and the initial deposit requested. If a problem is encountered, an operator is also connected. When the initial charge has been satisfied, the ACTS equipment (and operator, if attached) is released

---

---

and an operator-released signal transmitted to the end office to enable the DTMF pad. If the call does not complete (for example, reaches intercept, reorder, busy, or no answer), a coin return is sent prior to releasing back. When the call completes but terminates during the initial period, a coin collect is sent prior to releasing back. If the initial period expires and the call is still in the talking state, a coin collect is sent approximately 7 seconds before the end of the initial period. This is followed by an announcement at the end of the period. Should an interim overtime seizure be required, an operator-attached signal is sent before the ACTS equipment is connected.

A coin-collect signal may be needed after a partial deposit on a large charge call. When the deposit is complete, an operator-released signal is sent, followed by a coin collect. On calls that terminate with charges due, an operator-attached signal is sent, followed by a ringback if the calling party has gone on-hook. After the charges are satisfied, a coin collect is sent, followed by release back. An operator-released signal is not sent at the end of a call. The following listing shows the sequence of a typical call with pertinent minimum timing information. The sequence begins with completion of the ANI digits.

1. +48 V to station (DTMF pad disabled)
  2. ANI start signal complete
  3. 2.2-second delay
  4. ACTS announcement
  5. Coin deposits
  6. Operator-released sent (enabled)
  - 7. (Conversation interval)**
  8. Coin collect approximately 7 seconds before end of initial period (at end of initial period for OSPS)
  9. Announcement at end of initial period (1.8 seconds after initial period for OSPS)
  - 10. (Conversation interval)**
  11. Announcement
  12. Operator-attached signal sent for interim overtime seizure (DTMF pad disabled)  
(Operator-attached signal sent 600 ms after announcement for OSPS)
  13. Coin deposits
  14. Coin collect, if large charge
  15. Coin deposits
  16. Operator-released signal sent (pad enabled)
  17. 0.6-second delay
-



- 
18. Coin-collect signal sent
  - 19. (Conversation interval)**
  20. Calling-party on-hook
  21. Operator-attached signal sent (DTMF pad disabled)
  22. 1.6-second delay
  23. Ringback
  24. Calling-party answer
  25. 2.0-second delay
  26. Announcement
  27. Coin deposits
  28. Coin collect sent
  29. 1.2-second delay (1.1-second for OSPS)
  30. Release-back.

**0+ ACTS Test Call with Multiwink Signaling and Dial-Tone-First:** The ACTS test call is used by the craftsperson to verify correct operation of a station with ACTS equipment. An announcement stating the detected coin denomination is given after each deposit. The coins are returned at the end of the call. The following listing shows the sequence of a typical call with pertinent minimum timing information. The sequence begins with completion of the ANI digits.

1. +48 V to station (DTMF pad disabled)
2. ANI start signal complete
3. 2.2-second delay
4. Announcement
5. Coin deposits and responses
6. Calling-party on-hook
7. Coin return sent
8. 1.2-second delay (1.1-second for OSPS)
9. Release-back.

**0+ Calling Card Service with Multiwink Signaling and Dial-Tone-First:** This type of call comes to OSPS in the same state as a 1+ ACTS call, that is, +48 V to the station placing the totalizer or signaling priority in the toll mode and possibly disabling the DTMF pad. OSPS determines from trunk group information or a Local Originating

---

---

Station Treatment (LOST) or Originating Station Treatment (OST) query that the call is eligible for Calling Card Service. An operator-released signal is then sent to enable the pad. The Calling Card Service announcement follows. The calling party may enter the calling card number at this time. If a valid number is received, the call progresses without any additional coin-control signaling. If the caller chooses to talk to an operator, an operator may be reached by dialing "0," flashing the switchhook, or doing nothing for approximately 5 seconds, at which time an operator is automatically attached. No signal is sent prior to the attachment. If the caller chooses to place the call sent-paid, an operator-attached signal is sent when the *paid* key is depressed on the position. From this point the call is treated as a normal sent-paid coin call. The following listing shows the sequence for a typical call with pertinent minimum timing information. The timing information in the listing does not include the time taken by the LOST or OST query. The query time adds to the stated delay.

1. +48 V to station (DTMF pad disabled)
2. ANI start signal complete
3. 0.75-second delay (1.55 seconds for OSPS)
4. Operator-released signal sent (pad enabled)
5. 0.6-second delay
6. Calling Card Service announcement
7. Valid number entered
8. Operator attached; no additional signaling
9. Customer requests sent-paid
10. *Paid* key pressed
11. Operator-attached signal sent (pad disabled)
12. Coin deposit
13. Operator-released signal sent (pad enabled)
- 14. (Conversation interval)**
15. Normal sent-paid treatment.

**ANI Failure/ONI Call with Multiwink Signaling and Dial-Tone-First:** Since this call comes to OSPS with the totalizer in the toll mode and the DTMF pad is not needed while the operator is attached, no additional signaling is required by the Calling Card Service interface.

**1+ ACTS Call with EIS and Dial-Tone-First:** The 1+ ACTS call with EIS is the same as with multiwink except for a few of the coin-control signals. After the coin deposit during an interim overtime seizure, a combined coin-collect/operator-released signal is

---

---

sent instead of a separate signal for each function. The following listing shows the sequence of a typical call with pertinent minimum timing information.

1. +48 V to station (DTMF pad disabled)
  2. ANI start signal complete
  3. 2.2-second delay
  4. ACTS announcement
  5. Coin deposits
  6. Operator-released sent (pad enabled)
  - 7. (Conversation interval)**
  8. Coin collect approximately 7 seconds before end of initial period (at end of initial period for OSPS)
  9. Announcement at end of initial period (1.8 seconds after initial period for OSPS)
  - 10. (Conversation interval)**
  11. Announcement
  12. Operator-attached signal sent for interim overtime seizure (DTMF pad disabled)  
(Operator-attached signal sent 600 ms after announcement for OSPS)
  13. Coin deposits
  14. Coin collect, if large charge
  15. Coin deposits
  16. Combined coin-collect/operator-released signal sent (pad enabled)
  - 17. (Conversation interval)**
  18. Calling-party on-hook
  19. Operator-attached signal sent (pad disabled)
  20. 1.0-second delay
  21. Ringback
  22. Calling-party answer
  23. 2.0-second delay
  24. Announcement
  25. Coin deposits
  26. Coin collect sent
-

27. 0.3-second delay

28. Release-back.

**0+ ACTS Test Call with EIS and Dial-Tone-First:** End offices using EIS connect 0+ calls to OSPS with negative battery applied to the station for DTMF pad enablement in anticipation of a Calling Card Service. Since this places the totalizer or signaling priority in the local mode, an operator-attached signal must be sent at the beginning of the test call to switch to the toll mode. The rest of the call is the same as with multiwink signaling. The following list summarizes the sequence:

1. -48 V to station (DTMF pad enabled)
2. ANI start signal complete
3. 1.6-second delay
4. Operator-attached signal sent (pad disabled)
5. 0.5-second delay (1-second for OSPS)
6. Announcement
7. Coin deposits and responses
8. Calling-party on-hook
9. Coin return sent
10. 0.3-second delay
11. Release-back.

**0+ Calling Card Service Call with EIS and Dial-Tone-First:** As stated in the section above, this call comes to OSPS with the DTMF pad enabled. Thus, there is no need to send an initial operator-released signal as with multiwink signaling. In fact, unless the caller chooses to talk to an operator and to place the call on a sent-paid basis, no coin signaling is required at any time. OSPS must still determine if the call is to receive Calling Card Service treatment via trunk group information or LOST/OST query. The following listing shows a typical call flow:

1. -48 V to station (DTMF pad enabled)
  2. ANI start signal complete
  3. 0.6-second delay (1.2-seconds for OSPS)
  4. Calling Card Service announcement
  5. Valid number entered
  6. Operator attached; no additional signaling
  7. Customer requests sent-paid
-

8. *Paid* key pressed
9. Operator-attached signal sent (DTMF pad disabled)
10. Coin deposit
11. Operator-released signal sent (DTMF pad enabled)

**12. (Conversation interval)**

13. Normal sent-paid treatment.

**ANI Failure/ONI Call with EIS and Dial-Tone-First:** When the call has been identified via the operator-entered calling number as coming from a coin station eligible for Calling Card Service, it is not known whether it was dialed 1+ or 0+. Thus, if the operator indicates sent-paid by pressing the *paid* key, an operator-attached signal is sent to ensure that the totalizer or signaling priority is in the toll mode. If the *paid* key is pressed before the calling number is entered, the signal is sent after the calling number is entered. Otherwise, it is sent when the key is pressed. The call then proceeds as a normal sent-paid call.

**2. Coin-First**

As stated in Section 6.18.1, a coin-first telephone receives negative battery from the end office. For the DTMF pad to be operational, a coin deposit equal to the initial rate must be present in the hopper. If the coins are returned or collected, the pad is disabled until a deposit equal to the initial rate has been made again. A feature called *coin retention* was developed to provide pad enablement for Calling Card Service without additional deposits. An end office operating with coin retention does not return the coins on calls routed to OSPS. Instead, OSPS assumes the responsibility to return the coins as soon as they are no longer needed.

OSPS will return the coins immediately after receipt of the calling number on all but 0+ calls. The coins are also returned on 0+ calls if the caller does not enter a valid calling card number within the allotted time interval. If a valid number is entered, the coins are retained until calling-party disconnect is detected so the pad will be available for sequence calls. Thus, the pad is enabled for end-to-end signaling only on 0+ Calling Card Service calls and 1+ sent-paid calls during the initial period when the deposit exceeds the initial rate.

All three types of coin control may be used with strictly coin-first operation (combined coin-first and dial-tone-first is covered in later in this section). However, when multiwink or EIS is used on coin-first trunk groups, the operator-attached, operator-released, and combined coin-collect/operator-released signals are not sent.

**1+ ACTS Call with Multiwink or EIS and Coin-First:** Coin-first operation is functionally the same with both types of signaling. Immediately after ANI is completed, OSPS sends a coin return signal to return the initial deposit (the DTMF pad is disabled at this time). From this point on, the call is similar to dial-tone-first except

---

that no operator-attached or operator-released signal is sent. The following listing shows a typical call sequence.

1. -48 V to station — coins retained (DTMF pad enabled)
  2. ANI start signal complete
  3. 0.75-second delay
  4. Coin return sent (pad disabled)
  5. Delay: 1.8 seconds (multiwink); 2.4 seconds (EIS)
  6. ACTS announcement
  7. Coin deposits (pad enabled if greater than initial rate)
  - 8. (Conversation interval)**
  9. Coin collect approximately 7 seconds before end of initial period (pad disabled) (at end of initial period for OSPS)
  10. Announcement at end of initial period (1.8 seconds after initial period for OSPS)
  - 11. (Conversation interval)**
  12. Announcement at interim overtime seizure
  13. Coin deposits
  14. Coin collect, if large charge
  15. Coin deposits
  16. Coin-collect signal sent
  - 17. (Conversation interval)**
  18. Calling-party on-hook
  19. Ringback
  20. Calling-party answer
  21. 2.0-second delay
  22. Announcement
  23. Coin deposits
  24. Coin collect sent
  25. Delay: 1.2 seconds (multiwink); 1.1 seconds (multiwink with OSPS); 0.3 second (EIS)
  26. Release-back.
-

---

**0+ ACTS Test Call with Multiwink or EIS and Coin-First:** Except for the initial coin return, this call is the same as dial-tone-first operation with multiwink signaling. With EIS, the operator-attached is replaced by the coin return. The following listing shows a typical sequence:

1. -48 V to station — coins retained (DTMF pad enabled)
2. ANI start signal complete
3. 0.6-second delay (1.2 seconds for OSPS)
4. Coin return sent (pad disabled)
5. Delay: 2.8 seconds (multiwink); 1.6 seconds (EIS)
6. Announcement
7. Coin deposits and responses
8. Calling-party on-hook
9. Coin return sent
10. Delay: 1.2 seconds (multiwink); 1.1 seconds (multiwink with OSPS); 0.3 second (EIS)
11. Release-back.

**0+ Calling Card Service Call with Multiwink or EIS and Coin-First:** On a Calling Card Service call, the initial deposit is retained until the calling party has completed the call (and the following sequence calls, if applicable). There is no coin signaling throughout. If the caller chooses to be connected to an operator, the coins are returned before the operator is attached. The following listing shows a typical sequence:

1. -48 V to station — coins retained (DTMF pad enabled)
  2. ANI start signal complete
  3. 0.6-second delay (1.2 seconds for OSPS)
  4. Calling Card Service announcement
  5. Valid number entered
  6. Coin return sent (pad disabled)
  7. Calling-party on-hook
  8. Operator attached
  9. Coin return sent
  10. If not sent-paid, no additional signaling
  11. Delay: 1.2 seconds (multiwink); 0.3 second (EIS)
-

12. If sent-paid, normal sent-paid treatment
13. (Multiwink 1.1-second delay for OSPS)
14. Release back.

**ANI Failure/ONI Call with Multiwink or EIS and Coin-First:** This call comes to OSPS with the coins retained. When the operator has entered the back (calling) number and OSPS determines the call is from a coin-first telephone on a trunk group marked for coin retention, a coin return signal is sent to the end office. The call then proceeds as a normal operator-handled call.

### 3. Combined Dial-Tone-First and Coin-First

The combined dial-tone-first/coin-first mode of operation is a temporary arrangement to facilitate the conversion from coin-first to dial-tone-first. Since there are hardware restrictions on its use, it is not applicable to some end offices. Both the C- and D-series sets require positive battery to place the totalizer or signaling priority in the toll mode for immediate readout of all deposits. The A-series coin-first coin telephones will not function with positive battery. Therefore, the combined mode cannot be used with A-series sets. Also, the positive battery disables the DTMF pad in C-series sets operating as either coin-first or dial-tone-first. A station modification can be made to dial-tone-first C-Series stations to enable the pad regardless of battery polarity. However, the modification does not work on coin-first sets. Coin-first telephones require negative battery for pad enablement. Thus, the combined dial-tone-first/coin-first mode cannot be used unless battery polarity control is provided by either multiwink or EIS signaling.

When the combined mode is used, the operator services system applies both treatments to the incoming trunk on every call identified as eligible for Calling Card Service. Neither treatment adversely affects the stations operating in the other mode. Each coin telephone responds to its required signals as described in these sections. The following listing shows the sequence of the coin control signals and timing information.

In the listing below, since the type of telephone is not known when the call comes in, the first line stating battery polarity or coin status is deleted. For the same reason, the DTMF pad state is also deleted.

#### **1+ ACTS Call — Multiwink, Coin-First, and Dial-Tone-First:**

1. ANI start signal complete
2. 0.75-second delay (1.55 seconds for OSPS)
3. Coin return sent
4. 1.8-second delay
5. ACTS announcement
6. Coin deposits



---

7. Operator-released signal sent

**8. (Conversation interval)**

9. Coin collect approximately 7 seconds before end of initial period (at end of initial period for OSPS)

10. Announcement at end of initial period (1.8 seconds after initial period for OSPS)

**11. (Conversation interval)**

12. Announcement

13. Operator-attached signal sent for interim overtime seizure (operator-attached signal sent 600 ms after announcement for OSPS)

14. Coin deposits

15. Coin collect, if large charge

16. Coin deposits

17. Operator-released signal sent

18. 0.6-second delay

19. Coin-collect signal sent

**20. (Conversation interval)**

21. Calling-party on-hook

22. Operator-attached signal sent

23. 1.6-second delay

24. Ringback

25. Calling party answers

26. 2.0-second delay

27. Announcement

28. Coin deposits

29. Coin collect sent

30. 1.2-second delay (1.1 seconds for OSPS)

31. Release-back.

**0+ ACTS Test Call — Multiwink, Coin-First, and Dial-Tone-First:**

1. ANI start signal complete

2. 0.6-second delay (1.2 seconds for OSPS)

---

3. Coin return sent
4. 2.8-second delay
5. Announcement
6. Coin deposits and responses
7. Calling-party on-hook
8. Coin return sent
9. 1.2-second delay (1.1 seconds for OSPS)
10. Release-back.

**0+ Calling Card Service Call — Multiwink, Coin-First, and Dial-Tone-First:**

1. ANI start signal complete
2. 0.75-second delay (1 second for OSPS)
3. Operator-released signal sent
4. 0.6-second delay
5. Calling Card Service announcement
6. Valid number entered
7. Coin return sent
8. Calling party on-hook
9. Operator attached
10. Coin return sent
11. Customer requests sent-paid
12. 1.2-second delay (1.1 seconds for OSPS)
13. *Paid* key pressed
14. Release-back.
15. Operator-attached signal sent
16. Coin deposit
17. Operator-released signal sent
18. Normal sent-paid treatment.

**ANI Failure/ONI Call — Multiwink, Coin-First, and Dial-Tone-First:**

1. Operator attached
-

- 
2. Calling number entered
  3. Customer requests sent-paid
  4. Coin return sent
  5. *Paid* key pressed
  6. If not sent-paid, no additional signaling
  7. Calling number entered
  8. If sent-paid, normal sent-paid treatment
  9. Coin return sent
  10. Normal sent-paid treatment.

**1+ ACTS Call — EIS, Coin-First, and Dial-Tone-First:**

1. ANI start signal complete
  2. 0.75-second delay (1.55 seconds for OSPS)
  3. Coin return sent
  4. 2.4-second delay
  5. ACTS announcement
  6. Coin deposits
  7. Operator-released signal sent
  - 8. (Conversation interval)**
  9. Coin collect approximately 7 seconds before end of initial period (at end for OSPS)
  10. Announcement at end of initial period (1.8 seconds after initial period for OSPS)
  - 11. (Conversation interval)**
  12. Announcement
  13. Operator-attached signal sent for interim overtime seizure (operator-attached signal sent 600 ms after announcement for OSPS)
  14. Coin deposits
  15. Coin collect, if large charge
  16. Coin deposits
  17. Combined coin-collect/operator-released signal sent
  - 18. (Conversation interval)**
-

19. Calling-party on-hook
20. Operator-attached signal sent
21. 1.0-second delay
22. Ringback
23. Calling party answers
24. 2.0-second delay
25. Announcement
26. Coin deposits
27. Coin collect sent
28. 0.3-second delay
29. Release-back.

**0+ ACTS Test Call — EIS, Coin-First, and Dial-Tone-First:**

1. ANI start signal complete
2. 0.6-second delay (1.2 seconds for OSPS)
3. Coin return sent
4. 2.0-second delay
5. Operator-attached signal sent
6. 0.5-second delay
7. Announcement
8. Coin deposits and responses
9. Calling party on-hook
10. Coin return sent
11. 0.3-second delay
12. Release-back.

**0+ Calling Card Service Call — EIS, Coin-First, and Dial-Tone-First:**

1. ANI start signal complete
  2. 0.6-second delay (1.2 seconds for OSPS)
  3. Calling Card Service announcement
  4. Valid number entered                      **or**    4. Coin return sent
-

- 
- |                                   |                                    |
|-----------------------------------|------------------------------------|
| 5. Calling-party on-hook          | 5. Operator attached               |
| 6. Coin return sent               | 6. Customer requests sent-paid     |
| 7. 0.3-second delay               | 7. <i>Paid</i> key pressed         |
| 8. Release-back                   | 8. Operator-attached signal sent   |
| 9. <b>(Conversation interval)</b> | 9. Coin deposit                    |
| 10. Normal sent-paid treatment    | 10. Operator-released signal sent. |

**ANI Failure/ONI Call — EIS, Coin-First, and Dial-Tone-First:**

- |                                  |           |                                  |
|----------------------------------|-----------|----------------------------------|
| 1. Operator attached             |           | 2. Customer requests sent-paid   |
| 2. Calling number entered        | <b>or</b> | 3. <i>Paid</i> key pressed       |
| 3. Coin return sent              |           | 4. Calling number entered        |
| 4. Customer requests sent-paid   |           | 5. Operator-attached signal sent |
| 5. <i>Paid</i> key pressed       |           | 6. 1.0-second delay              |
| 6. Operator-attached signal sent |           | 7. Coin return sent              |
| 7. Coin deposits                 |           | 8. Coin deposits                 |
| 8. Operator-released signal sent |           | 9. Operator-released signal sent |
| 9. Normal sent-paid treatment    |           | 10. Normal sent-paid treatment.  |

**6.17.4 Combined Coin and Non-coin Operator Services Switch Interface**

Non-coin telephones may be connected to operator services switch offices over trunks in trunk groups dedicated to non-coin traffic. However, combined (that is, both coin and non-coin traffic) trunk groups are also used. Since non-coin telephones require negative battery supply to enable the DTMF pads for dialing and end-to-end signaling, the design of combined groups should always provide negative battery to non-coin lines. This requirement can limit the use of combined trunk groups in some end offices. For example, a 1/1A ESS switching system not equipped with outgoing trunks that are designed for Calling Card Service has no control of battery polarity to the station connected to the operator services switch office. Trunks carrying coin traffic always provide positive battery to place the totalizer in the toll mode. Thus, non-coin traffic cannot be routed to the operator services switch office over these trunks. Installation or retrofit of trunk circuits compatible with Calling Card Service and EIS permits a 1/1A ESS switching system to control battery polarity so combined coin and non-coin groups can be used.

---

### 6.17.5 Selective Class of Call Screening Code Assignments in Operator Services Systems

Selective screening of ANI-identified calls to an operator services switch is possible. Information digit 7 or 07 is used to identify a call requiring special screening. Candidates for special screening are calls from such locations as coinless public telephones (including inmate calling), post-pay coin telephones, hospitals, and other public institutions such as college dormitories.

Another method of screening originating calls is via Originating Line Number Screening (OLNS) information from a Line Information Database (LIDB) (see Section 14.5 for a discussion of this capability).

Telephones using selective screening should be grouped in a single band or possibly two bands of numbers for easy identification by checking the upper and lower limits of the bands.

The billing for screened calls can be restricted to the following categories.

- Locally Assigned — Assigned to meet local conditions
  - Single Allowed Class
    - Sent-Paid Only
    - Credit Card Only
    - Special Billing Number Only
    - Collect Only
  - Double Allowed Classes
    - Credit Card and Special Billing Number Only
    - Sent-Paid and Collect Only
    - Collect and Special Called Only
  - Multiple Allowed Classes
    - Sent-Paid, Credit Card, and Special Billing Number Only
    - Sent-Paid, Collect, and Special Called Only
    - Credit Card, Special Billing Number, Bill to Third, Collect, and Special Called
    - Screened Hotel/Motel.
-

### 6.17.6 Charge-a-Call Public Telephone Service

A Charge-a-Call public telephone is served by a single party, non-coin loop-start line with no extensions and no custom-calling features. It can only be used for originating calls. This prevents fraudulent collect calls. Charge-a-Call was originally known as Coinless Public Telephone (CPT) service.

#### 6.17.6.1 Charge-a-Call Service Dialing Restrictions

The following is a list of Not Sent-Paid (NSP) or free calls that may be made from all coinless phones:

- (1) + N11 (local directory assistance, repair, and emergency calls)
- 0 + 7 or 10 digits
- 01 + 7 to 12 digits (overseas NSP)
- 0-
- (1)<sup>1</sup> + 800 + XXX + XXXX (800 Service calls)
- (1) + NPA + 555 + 1212 (directory assistance in a foreign NPA).

The Charge-a-Call customer can make NSP person-to-person calls, request notify or a time and charge quotation, and make a call charged to the called party's billing number. However, as is the case with coin lines and hotel lines, OSPS will not accept a special billing number (0XX/1XX +XXXX+RAO<sup>2</sup>) from the calling customer on a coinless call.

Where tariffs so provide, the customer may call

- 0 + NXX + XXXX (local NSP).

In addition, where available locally, the Charge-a-Call customer can dial

- 411 or (1) + 555 + 1212 (directory assistance in the home NPA).

A Charge-a-Call customer is *not* permitted to make the following types of calls:

- (1) + NXX + XXXX (sent-paid, local, or toll)
- (1) + NPA + NXX + XXXX (toll sent-paid)
- 011 + 7 to 12 digits (overseas sent-paid).

Because the Charge-a-Call telephone cannot receive calls, the operator will not leave word for a callback. If the central office can ring back non-coin lines, the operator may use that

1. The parentheses indicate that the prefix is required in some areas but not in others.
2. Revenue Accounting Office.

capability to ring an on-hook customer to give a time and charge quote. (The Charge-a-Call telephone has a ringer.) Otherwise, the operator cannot contact an on-hook customer who expects time and charges. (Ordinarily, the operator would call the non-coin customer back via a delayed call trunk.)

#### 6.17.6.2 Charge-a-Call Trunking Arrangements

Where the Charge-a-Call line is identified by ANI, the call can be routed over the following:

- Individual 0- or 0+ non-coin trunk group
- Combined 0- and 0+ non-coin trunk group
- Combined 1+, 0-, 0+ non-coin trunk group
- Supercombined 1+, 0-, 0+ coin and non-coin trunk group.

The Charge-a-Call call is screened by using information digit 7 and a lookup table of restricted lines in OSPS. See Section 6.17.5 for details on selective screening.

Where the Charge-a-Call line is not identified by ANI, the call must be routed over a dedicated trunk group for screened traffic.

#### 6.17.7 Post-Pay Coin

A post-pay coin telephone is a coin telephone that can accept coin deposits but is not equipped to return coins. This mode is rare in LECs.

##### 6.17.7.1 Trunking Alternatives

There are three alternatives for handling post-pay coin:

- Dedicated post-pay coin trunk groups that will carry only post-pay traffic
- Combined post-pay coin and non-coin groups with ANI screening where the kind of call will be determined by table lookup.
- Combined post-pay coin and non-coin groups where a post-pay coin call will be identified by a service tone that follows the position-attached zip tone.

ANI screening should be used wherever possible on combined post-pay coin and non-coin groups. Post-pay coin station numbers are grouped together in bands for easy identification by checking the upper and lower limits of the bands.

---



---

Where the end office has no ANI capability, it is possible to use service tone identification of post-pay calls on combined trunk groups. The traffic is divided into at least three trunk groups:

- Combined 0- 0+ non-coin and 0- 0+ post-pay coin group
- 1+ non-coin group
- 1+ post-pay coin group.

Where the end office has no ANI or service tone capability, two dedicated post-pay trunk groups must be used:

- 0- 0+ post-pay
- 1+ post-pay.

#### 6.17.7.2 Restrictions

Planners consider the following restrictions when planning end office trunks for post-pay use.

- Post-pay and prepay cannot be combined on the same trunk group.
- When a combined group carries non-coin traffic identified by ANI, then the post-pay traffic on that group must also be identified by ANI.
- On trunks using service tone identification, if 1+ post-pay coin is provided, it cannot be combined with 1+ non-coin traffic. This is because 1+ non-coin ONI calls result in a nonloop seizure, and the operator would be unable to use keys required to identify post-pay calls.

In addition, 1+ (non-coin or post-pay coin) ONI calls cannot share a trunk group with 0- 0+ traffic. Therefore, 1+ non-coin and 1+ post-pay coin must be served by a dedicated trunk group when service tone identification is used. The trunk must be compatible; that is, it must have hold, reverse make-busy, release guard, and unrestricted re-ring (re-ring into on- or off-hook supervision from the station).

#### 6.17.7.3 Signaling

Where ANI screening is used to identify post-pay coin calls in combined trunk groups or where dedicated trunk groups are used for post-pay coin calls, the signaling format remains the same as for non-coin calls. However, for trunks that use service tones to identify post-pay coin calls, the operator services system sends an off-hook to the end office 400 to 500 ms after the operator has been connected to the trunk serving the post-pay coin call. This delay will separate the zip tone and service tone about 200 ms. This prevents operator confusion by the two tones (order tone followed by service tone). The end office starts to

---

---

send the service tone identification when the off-hook is received. The service tone is approximately 700 ms long. Precise high tone or precise low tone is used.

#### 6.17.7.4 Providing Ringback

To provide ringback on post-pay coin calls, the end office should be equipped with the following.

- Polar marginal coin control (+130 V on the tip and -48 V on the ring for 50 to 100 ms alternating with -48 V on the tip and +130 V on the ring for 50 to 100 ms for the duration of the ringback key operation).
- Ability to respond to a single on-hook wink of 75 ms (+50, -5 ms) sent and 50 to 150 ms received.

#### 6.17.7.5 Trunking Plans and Pulsing Formats

Here are the trunking plans many LECs use for post-pay coin. With ANI:

- Combine all post-pay coin and non-coin traffic on one combined trunk group. The pulsing format for this arrangement with ANI is shown in Table 6-32.
- Combine all post-pay coin traffic on one trunk group and all non-coin traffic on a second trunk group. The pulsing format for this arrangement with ANI is shown in Table 6-32.
- Combine all 0-, 0+ post-pay traffic and all 0-, 0+ non-coin traffic on one trunk group. Combine all 1+ post-pay traffic and all 1+ non-coin traffic on one trunk group. The pulsing format for this arrangement is shown in Table 6-33.
- Use six individual trunk groups for 0-, 0+, 1+ coin; 0-, 0+, 1+ non-coin traffic, or 0-, 0+, 1+ post-pay coin. The pulsing format for this arrangement with ANI is shown in Table 6-33.

Without ANI (Service Tone Identification):

- Combine all 0-, 0+ post-pay coin traffic on one trunk group and all 0-, 0+ non-coin traffic on a second trunk group. The pulsing format for this arrangement without ANI is shown in Table 6-34. The 1+ coin and 1+ non-coin traffic would be handled on two additional trunk groups as described below.
- Use six individual trunk groups for 0-, 0+, 1+ post-pay coin and 0-, 0+, 1+ non-coin traffic. The pulsing format for this arrangement is shown in Table 6-34. Service tone is not required.

### **6.17.8 Smart/Intelligent (non-network controlled) Coin Station**

A smart/intelligent (non-network controlled) public telephone uses a line with attributes similar in most ways to those of the conventional POTS, measured-usage lines. The smart/intelligent public telephone performs all the coin functionality provided by the standard coin interface within the telephone terminal; therefore, no signaling is needed from the end office.

## 6.18 Signaling to Automatic Intercept System

The Automatic Intercept System (AIS) serves end offices and works with either the ANI or ONI of the called number. The AIS is covered in both TR-NWT-000505, *Call Processing, Section 5*, and GR-506-CORE, *LSSGR: Signaling for Analog Interfaces*.

Table 6-37 shows the signaling formats used for ANI and ONI. Numbers disconnected, in trouble, or not equipped are translated in the end office to route incoming calls reaching these numbers to outgoing intercept trunks. The intercept trunks can be arranged to identify the type of intercept and to transmit the information to the AIS. The AIS does not generate a unique disconnect signal. The disconnect is under control of the calling party. The end office trunk must be held busy a minimum of 450 ms before reseizure to allow time for the AIS to restore to the idle state. The features required in the trunks and interoffice signals follow. **Note:** End office E&M outgoing trunks are converted to *loop* at the Automatic Intercept Center (AIC).

**Table 6-37.** Intercept-Class Signals Transmitted to Automatic Intercept Center

Class	End Office				Trunk Concentrator
	ANI	ONI		E&M Signaling	MF
	MF Signaling	Loop Signaling			
		Tip	Ring		
Regular	KP + 3 + 7d + ST	Battery	Ground	One pulse	KP + 6 + ST
Trouble	KP + 1 + 7d + ST or KP + 1 + ST	Ground	Battery	Two pulses	KP + 8 + ST
Blank or unassigned number	KP + 0 + 7d + ST or KP + 0 + ST	Brief +130 V on tip and ring followed by battery on tip, ground on ring		Three pulses	KP + 7 + ST
Failure to identify line number	KP + 2 + ST				

**Note 1:** If an announcement is given to the customer before the call is completed to the AIC, KP + 5 + ST is transmitted to the AIC.

**Note 2:** Information digits and KP signals are optional.

### 6.18.1 Interoffice Signaling with ANI

- Battery-and-ground signaling with reverse-battery answer supervision
- Reverse make-busy feature to make the end office outgoing trunk busy from the AIC
- Idle condition (on-hook with battery on ring and ground on tip).

### 6.18.2 Interoffice Signaling with ONI or Operator Assistance

- One class (single class of intercept traffic on one trunk)
  - With or without supervision
  - Supervision could be high-low, bridge, or dc signaling
  - No reverse make-busy feature
  - Idle condition same as ANI trunk.
- Three classes (three classes of intercept traffic on one trunk)
  - DC signaling or dial-pulse signaling (see Table 6-38)
  - No reverse make-busy feature
  - Idle condition same as ANI trunk.

---

## 6.19 Carrier Group Alarm

Carrier Group Alarm (CGA) is used to minimize the effects of carrier failures on switching systems and on service. A CGA system should

- Release customers from the failed circuits
- Stop charging
- Busy out the failed circuits
- Prevent false charging
- Prevent the failed circuits from seizing the central office equipment.

These objectives are effected by the CGA equipment operating on the trunk equipment. This process is referred to as *CGA trunk conditioning*. Several vintages of CGA systems exist. Some are for use with E&M signaling only. Other CGA systems handle loop reverse-battery signaling as well as E&M signaling, or are included in the DS1 trunk terminations of digital switches.

The operation of a CGA system can be divided into three parts:

1. Detection of the carrier failure
2. Conditioning the failed trunk
3. Reaction of the switching equipment to the processing of the failure.

The carrier failure-detection circuit is generally in the carrier terminal. With some switching systems, the software has the capability to detect carrier failure. SPC systems perform at least part of the trunk-conditioning process within the switching machine.

The CGA equipment can be collocated with or, where calling-party control is used, remote from the switching system. Where there is more than one link of signaling equipment in a facility, CGA equipment can be collocated with the switching system and at one or more locations remote from the switching system. These several CGAs would perform the CGA trunk processing for a trunk into a switching machine. Each CGA equipment would perform the trunk processing where the associated carrier link failed.

The next few sections discuss CGA actions, features, and limitations in the order they would occur when a carrier system fails and then restores.

### 6.19.1 Call Processing Between Carrier Failure and Trunk Conditioning

After a carrier failure occurs (for example, loss of synchronization in a digital carrier system) but before CGA trunk conditioning begins, it is desirable to maintain the same supervisory state on each trunk as existed before the failure. If the carrier cannot be restored in a reasonable time (for example, 2.5 seconds), trunk processing should be initiated to

---

---

remove the trunks from service. The time should be long enough to maximize the possibility of restoring the carrier before trunk processing begins, but short enough so that the customers using the facility are not more annoyed by the affects caused by the delay in processing the failure than they are by the affects of the carrier failure.

This method of maintaining the previous supervisory state after failure is designed into D4 channel banks and other similar digroup terminations. Its advantage lies in its capability to maintain connections even though signaling may be lost due to bursts of errors with digital carrier or due to the time required to perform carrier protection. This method not only saves calls on short failures, it also prevents massive seizures of circuits that were idle at the time of failure and prevents false charging before trunk processing begins.

Single-frequency signaling units have a natural tendency to remain in the same supervisory state after the failure as they were in before the failure. However, all single-frequency units and D1 and D2 channel banks can fail off-hook, on-hook, or alternating between off-and on-hook.

### 6.19.2 Trunk Conditioning

There are two methods of accomplishing trunk conditioning. The first controls supervisory signals associated with the signaling systems, and the second uses auxiliary signals forwarded directly to the trunk circuit or to the central control of an electronic switching system.

- Where trunk conditioning is accomplished through the control of supervisory signals, the associated signaling systems are forced on-hook. If the affected trunk is an incoming circuit or a 2-way trunk circuit used in the incoming mode, the on-hook will force the release of the associated switching system, thereby disconnecting established calls. The on-hook toward an outgoing trunk has no effect in systems with calling-party control because the calling party can always release from the connection. Where joint hold or operator control is used, the on-hook permits the calling party to release.

As will be seen in the sections that follow, if supervisory conditioning is the only trunk conditioning used, a subsequent off-hook would trap the customer on the trunk for the duration of the carrier failure. As a result, joint-hold trunks should be used with auxiliary trunk conditioning signals to busy out the trunk during carrier failure.

- About 10 seconds after the failure is detected by the CGA equipment, an auxiliary signal from the carrier terminal is applied to the trunk circuits of all outgoing and 2-way trunks with calling-party control. This auxiliary signal forces them off-hook, thereby making them appear busy to the switching system. The 1-way incoming and joint-hold circuits remain on-hook.

The disadvantage of the supervisory busy-out for 2-way trunk circuits is that, in the failed condition, a permanent signal is presented to the switching system. A large failure can tie up the office for a short period of time. In the absence of this kind of carrier-failure trunk

---

---

conditioning, however, repeated seizures on the trunks can occur throughout the period of the carrier failure.

Supervisory conditioning can be applied at the switching system or at a remote location for calling-party control. The only requirement for remote trunk conditioning is that provisions are made to control the supervisory state of the signaling during the failure of the carrier system. Supervisory conditioning can be the sole method of trunk conditioning for calling-party control. Incoming trunks and trunks using joint-hold control remain on-hook during the carrier failure.

Where the trunk conditioning is accomplished using auxiliary signals, the trunk circuit is made busy by closing a contact between two auxiliary signaling leads. This auxiliary signal is applied at the time the trunk processing begins and remains until the carrier is restored. Since these auxiliary leads usually have rather short resistance ranges, this method is usually limited to situations where the CGA and switching equipment are collocated. The auxiliary signals for 1/1A ESS and 4ESS switching systems are for a carrier group rather than a single circuit. Except for the 4ESS switching system, the auxiliary signal makes the trunk circuit busy for any future usage but does not disconnect the call presently using the trunk.

Joint-hold or operator-control circuits require the use of an auxiliary signal to busy out the trunk during the carrier failure. The signal is required because the supervision must remain on-hook during the failure to prevent locking a customer to the trunk circuit. When the carrier failure ends, all supervisory signals are restored to normal.

The following sections discuss the ways that CGA, with supervisory conditioning techniques, can be applied to various types of signaling.

- CGA on trunks equipped with E&M lead signaling with supervisory conditioning as the busy-out method is the most frequently used arrangement on intertandem and tandem connecting trunks. It has the advantage that the carrier terminal and the switching system do not have to be collocated. All E&M lead incoming and 2-way trunk circuits having calling-party control will operate in this mode. Many E&M 1-way outgoing trunk circuits will also function in this mode. Where 1-way outgoing circuits with this make-busy mode are not available, 2-way trunk circuits can be used.

The disadvantage of this mode of make-busy is that the 2-way trunks are seized on carrier failure. This can cause a shortage of common equipment until the permanent signal arrangements clear the condition.

This make-busy method should not be used with joint-hold or operator-control trunks.

- CGA on loop reverse-battery signaling trunks with supervisory conditioning as the busy-out mode is a method of trunk conditioning. Since only 1-way trunks are available, there is no false seizure of switching equipment. Use of this method requires a reverse make-busy feature in the outgoing trunk circuit. These trunk circuits are limited to CAMA and TOPS trunks at present. Since the TOPS trunk circuits are



---

operator-control supervision, only CAMA and LAMA trunks are available for this method.

CGA on trunks to 4ESS or 1/1A ESS switching systems uses central control for part of the processing. The carrier system furnishes a loop closure on two auxiliary signaling leads to these electronic switching systems for the duration of the carrier failure. The loop closure causes the start of trunk processing within the switching system on a carrier group of 24 trunks. The 4ESS system does all trunk processing. The 1/1A ESS switching system requires on-hook supervision from the failed incoming or 2-way trunks to process the failure properly. In addition to the CGA trunk processing, the 4ESS switching system also has a software CGA trunk-processing capability that does not require either trunk conditioning from the carrier equipment or auxiliary signaling leads.

### 6.19.3 Carrier Restoral

As soon as the carrier failure is over, processing to restore the affected trunks begins. The exact procedure is individual to each carrier system. However, the net result, where the carrier system has direct or indirect control over trunk processing, is to return trunks to idle state in a matter of seconds. Where the carrier system does not control the CGA process (for example, the 4ESS switching system), manual intervention may be required to restore trunks to service.

Carrier failure involving a operator-services system can occur on either the end office or the tandem side of the operator-services system. The failed trunks are processed by the carrier and signaling systems when the failure is between the end office and the operator-services switch office. When the carrier failure is between the operator-services switch office and the tandem office, the operator-services switch office takes indirect maintenance action to place the trunks out of service after two call-attempt failures.

## 6.20 Call Progress Tones (Audible Tone Signals)

Call progress signals are audible tone signals that are used to inform the originating customer or an operator of the progress or disposition of a call. Call progress signals are usually applied to the originating access line by the switching system serving the access line, but they also may come from other switching systems (such as PBXs) via inter-switching-system transmission facilities. Two general types of call progress tones have been used in LEC networks. These two types are referred to as precise tone plan signals and nonprecise tone signals. Almost all LEC network equipment currently use precise tone plan signals. Nonprecise tone signals have become obsolete. The only circumstance where they might be encountered is when the call progress tones originated in one of the few small Step-by-Step systems that may still be present in LEC networks. Details on the precise tone plan are presented in Section 6.20.1 and details on nonprecise tones are presented in Section 6.20.2.

Table 6-38 gives a brief description of tones currently used in the LEC networks that are heard by telecommunications network users or operator services systems. Table 6-39 gives a brief description of tones heard by telecommunications network users, operators or operator services systems that have been used in LEC networks but are now rarely encountered. Many of the tones in Table 6-39 have been replaced by announcements or operator services systems.

**Table 6-38. Call Progress Tones**

Name	Description
1. Dial Tone	This tone is sent to a customer or operator to indicate that the network is ready to receive DTMF signals or dial pulses. It is used in all types of switching systems. Normally dial tone means that the entire wanted number may be dialed; however, there are some cases where the calling party must await a second dial tone or where an operator, after dialing an initial group of digits, must wait for a second dial tone before the rest of the number can be dialed.
2. Recall Dial Tone	Recall dial tone is sometimes referred to as stutter dial tone. Recall dial tone is used to indicate that a switching system is ready to accept address information or other information from an access line. It is used by network services such as three-way calling.
3. Message-Waiting Indicator Tone	Message-waiting indicator tone is used with message-waiting services. It also indicates that a switching system is ready to accept address information or other information from an access line.

**Table 6-38. Call Progress Tones (Continued)**

Name	Description
4. Confirmation Tone	Confirmation tone is used to indicate that the network has received information from an access line or has processed a request received from an access line. One example is the activation or deactivation of network features such as call forwarding.
5. Call Waiting Tone	Call Waiting is a network service that allows a busy line to answer a second incoming call by flashing the switchhook. Audible ringing (instead of line busy) is applied to the calling line, and the Call Waiting tone is applied to the called line. (So that only the <i>called</i> party hears the tone, the connection is momentarily broken, and the other party to that connection experiences a moment of silence.) Flashing the switchhook places the existing connection on hold and connects the customer to the waiting call.
6. Audible Ring Tone	Audible ringing is applied to the originating end user's access line to indicate that the called access line is being alerted.
7. Line Busy Tone	Line busy tone is applied to the originating end user's access line when the called access lines is off-hook or already being alerted.
8. Reorder	Reorder tone is applied to the originating end user's access line when network equipment or facilities needed to complete a call are unavailable.
9. Reverting Tone	The same type of signal as line busy tone is used for reverting tone in all systems. The reverting signal informs the calling multiparty subscriber that the called party is on the same line and to hang up while the line is being rung.
10. Receiver Off-Hook Tone	This tone is used to cause off-hook customers to replace the receiver (go on-hook) on an access line in permanent signal and to signal a non-PBX off-hook line when ringing key is operated by an operator.
11. Busy Verification Tone (Centrex, operator-services)	Busy verification allows the Centrex attendant or operator-services operator to call and be connected to a busy line. The busy-verification tone is applied to both parties of the connection to inform them of the intrusion by the attendant or operator. No tone is applied if the station called for busy verification is idle.
12. Calling Card Service — Prompt Tone	This tone is used to inform the customer that credit card information must be keyed in. The first 60 ms of this composite tone is 941 Hz and 1477 Hz, which is the DTMF digit #. This tone will release any DTMF to dial-pulse converter in the connection.

**Table 6-38. Call Progress Tones (Continued)**

Name	Description
13. Recorder Warning Tone	When recording equipment is used, this tone is connected to the line to inform the distant party that the conversation is being recorded. The tone source is located within the recording equipment and cannot be controlled by the party applying the recorder to the line. This tone is required by FCC Rules (with exceptions) and is recorded along with the speech. See NOTE.
14. Coin Denomination Tones	These tones enable an operator services system or a network operator to determine the amount deposited in coin telephones.
NOTE: A warning tone is not always required with recording equipment. See the FCC Rules, <i>Code of Federal Regulations</i> 47, Part 64, Subpart E, para. 64.501(c).	

**Table 6-39.** Glossary of Call Progress Tones

Name	Description
1. Recorder Connected Tone	This tone is used to inform the customer his/her call has completed to a recording machine and to proceed to leave a message, dictate, etc. It is to be distinguished from the recorder warning tone, which warns the customer that the conversation is being recorded.
2. Deposit Coin Tone	This tone, sent to a post-pay coin telephone, informs the calling party that the called party has answered and that the coin should be deposited.
3. Partial Dial Tone	High tone is used to notify the calling party that he/she has not begun dialing within a preallotted time, measured after receipt of dial tone (permanent signal condition), or that he/she has not dialed enough digits (partial dial condition). This is a signal to hang up and dial again.
4. No Such Number	This signal tells the calling party to hang up, check the called number, and dial again. Calls to unassigned or discontinued numbers may also be routed to intercepting operators or preferably to a machine announcement system that verbally supplies the required message. In some offices, reorder tone is returned in this condition.
5. Indication of Camp-On	Attendant camp-on service allows a Centrex attendant to hold incoming calls to busy lines. Each time the attendant releases his/her talking connection from the loop involved in the camped-on call the <i>indication of camp-on tone</i> is heard by the called customer, if the customer has subscribed to the indication of camp-on option. The customer may get this tone several times as the attendant reconnects and releases from the loop in response to timed reminders from the console.
6. Data Set Answer-Back Tone	This tone is heard by customers when manually initiating a data call. It normally occurs shortly after the onset of audible ringing and means that the remote data set has answered. The data set at the calling end should then be put into the data mode.
7. Order Tones	High tones sent over end office or tandem trunks indicate: (1) to the originating operator that the order should be passed, and (2) to the receiving operator that an order is about to be passed.
8. Coin Collected Tone	Low tone over a coin recording-completing trunk informs the originating toll operator that the coin-control circuit has collected the charge.

**Table 6-39.** Glossary of Call Progress Tones (Continued)

Name	Description
9. Coin Returned Tone	High tone over a coin recording-completing trunk informs the originating toll operator that the coin control circuit has returned the charge when the connection is not completed (also called coin-refund tone).
10. Coin Return (Test) Tone	High tone is used to tell an operator that a tester has completed a call to his/her position over a coin trunk.
11. Permanent Signal Tone	An end user's access line, not in use, that exhibits a steady off-hook is routed to a permanent signal trunk. High tone, superimposed on battery, is supplied through a resistance lamp to the ring lead of the trunk. The tone informs an operator or tester making a verification test that the line is temporarily out of service. An intermittent ground may also be applied to the ring lead of a line left in the "hold" condition. Typical reasons for the line condition are: (a) no dialing within the allowed waiting interval, (b) a telephone is off-hook, (c) low insulation resistance or other line trouble.
12. Service Observing Tone	This tone indicates that the trunk to which it is applied is being service-observed.
13. Proceed to Send Tone (IDDD)	This tone informs the operator that an overseas sender has been seized and the address information (KP-CC-NN-ST) should be transmitted.
14. Centralized Intercept Bureau Order Tone	This tone tells the centralized intercept bureau operator that a call has reached the position.
15. ONI Order Tone	This tone tells the ONI operator that a call has reached the position.

### 6.20.1 Precise Tone Plan

The precise tone plan has always been used in the 1/1A ESS, 2/2B ESS, 4ESS, 5ESS (including OSPS), DMS-10, DMS-100F (including TOPS), EWSD, and NEAX-61E switching systems. The precise tone plan was developed to provide uniform call progress signals that are easily distinguishable by end-users and network operators and that are easily detectable by network and customer telecommunications equipment. The precise tone plan uses four frequencies: 350, 440, 480, and 620 Hz. The frequencies are held to  $\pm 1.5$ -dB amplitude variation and  $\pm 0.5$ -percent frequency variation. The total power of harmonics and other extraneous frequencies is at least 30 dB below the signal level measured where the tone is applied to the voice transmission path. The tones are used individually or in pairs (added not modulated) to form standard audible tone signals. Some call progress signals, such as dial tone, are steadily applied to an access line while others are applied with a distinctive cadence (e.g., busy signal). The five current audible tones that

are the basis of precise call progress signals, the power of the tones where applied to an access line and the traditional names of the tones are shown in Table 6-40. For more detailed information on precise call progress tones, see GR-506, *LSSGR: Signaling for Analog Interfaces*.

**Table 6-40.** Precise Tones

Traditional Name	Power per Frequency (dBm)			
	350 Hz	440 Hz	480 Hz	620 Hz
Call Interrupt		-13		
High Tone			-17	
Dial Tone	-13	-13		
Audible Ringing		-19	-19	
Low Tone			-24	-24
<p>The difference in frequency of 90 Hz of dial tone's two frequencies gives dial tone its buzzing sound.</p> <p>Low tone received its name from the characteristic of the 140 Hz beat frequency produced by its two frequency components.</p> <p>The signal power is measured at the point the signal is applied to a access line with a termination equal to the office impedance.</p>				

## 6.20.2 Nonprecise Tones

Nonprecise call progress tones were mainly generated by electromechanical switching systems and are rarely encountered in modern LEC networks. There were no requirements for nonprecise tones; thus, the frequency content and power level of all nonprecise tones that have been used in the network are not documented. Table 6-41 gives some known nonprecise tones that were used in LEC networks. Others may also have been used.

**Table 6-41.** Nonprecise Tones

Traditional Name	Frequency (Hz)	Approximate Level
Call Interrupt	Not Used	Not Used
High Tone	400 or 500	61 to 71 dBmC
Dial Tone	Same As Low Tone	61 to 71 dBmC
Audible Ringing	420 modulated by 480 420 modulated by 40 500 modulated by 40	61 to 71 dBmC
Low Tone	600 modulated by 120 600 modulated by 133 600 modulated by 140 600 modulated by 160	61 to 71 dBmC

### 6.20.3 Call Progress Tones

Table 6-42 lists tones currently used in the LEC networks. Table 6-43 lists tones that have been used in LEC networks but are now rarely encountered.

**Table 6-42. Current Call Progress Tones**

Name (See Note)	Tone Applied	Cadence
1. Dial Tone	Dial Tone	Steady
2. Recall Dial Tone	Dial Tone	100 ms on, 100 ms off three times then steady on
3. Message Waiting Indicator Tone	Dial Tone	100 ms on, 100 ms off ten times then steady on
4. Confirmation Tone	Dial Tone	100 ms on, 100 ms off three times then steady off
5. Call Waiting Tone	Call Interrupt	0.3 seconds on, repeated once after 10 seconds. Other cadences are also used.
6. Audible Ring Tone	Audible Ringing	Continuously repeating 2 seconds on, 4 seconds off
7. Line Busy Tone	Low Tone	Continuously repeating 0.5 second on, 0.5 second off
8. Reorder Tone	Low Tone	Continuously repeating 0.25 second on, 0.25 second off
9. Reverting Tone	Low Tone	Continuously repeating 0.5 second on, 0.5 second off
10. Receiver Off-Hook	1400+2060+2450+2600 Hz See Section 6.20.4	Continuously repeating 0.1 second on, 0.1 second off
11. Busy Verification Tone (Centrex)	Call Interrupt	Initial 1.5 seconds followed by 0.3 second every 7.5 to 10 seconds (6 seconds in No. 1/1A ESS)
12. Calling Card Service-Prompt Tone	DTMF # Character followed immediately by Dial Tone	60 milliseconds of DTMF # 940 milliseconds of dial tone (exponentially decaying at time constant of 200 milliseconds)
13. Recorder Warning	1400 Hz	0.5-second burst every 15 seconds
14. Coin Denomination	See GR-528-CORE or GR-506-CORE	
5¢		one <i>beep</i>
10¢		two <i>beeps</i>
25¢		five <i>beeps</i>



---

**Table 6-42. Current Call Progress Tones (Continued)**

Name (See Note)	Tone Applied	Cadence
NOTE: Tones 1 through 13 are heard by end users; tone 14 is heard by operators or detected by operator services systems.		

**Table 6-43.** Rarely Used Call Progress Tones

Name (See Note)	Tone Applied	Cadence
1. Recorder Connected	Call Interrupt	0.5-second burst every 5 seconds
2. Deposit Coin Tone	Low Tone	Steady
3. Partial Dial Tone	High Tone	Steady
4. No Such Number	200 to 400 Hz	Frequency modulated at 1 Hz, interrupted every 6 seconds for 0.5 second
5. Indication of Camp-On	Call Interrupt	1 second every time attendant releases from loop
6. Data Set Answer-Back	2025 Hz	Steady
7. Order Tones	High Tone	One to four short spurts
8. Coin Collected Tone	Low Tone	Steady
9. Coin Returned Tone	High Tone	0.5 to 1 second once
10. Coin Return (Test) Tone	High Tone	0.5 to 1 second once
11. Permanent Signal	High Tone	Steady
12. Service Observing Tone	135 Hz	Steady
13. Proceed to Send Tone (IDDD)	High Tone	Steady
14. Centralized Intercept Bureau Order Tone	1850 Hz	500 milliseconds
15. ONI Order Tone	700 + 1100 Hz	95 to 250 milliseconds

NOTE: Tones 1 through 6 were heard by end users; tones 7 through 15 were heard by operators.

#### 6.20.4 Receiver Off-Hook Tone

The Receiver Off-Hook (ROH) tone alerts the customer that a receiver has been left off-hook and is used to call the customer back to the telephone (Enhanced 911, pay telephones, etc.). Studies in the 1960s showed an ROH tone level of +5 Volume Units (VU) was preferred. (See IEEE STD 152-1991, *IEEE Standard for Audio Program Level Measurement* for Volume Units.)

---

When digital switching appeared, the switches could not pass the required ROH tone level. There was a large advantage, however, in how these switches handled permanent signals. The lines that remained off-hook after timing-out are not placed back in service to time-out again; rather they are held out of service until the line returns to on-hook. A new study showed that much lower tone levels were nearly as effective as the old levels. So a new standard of +3 to -6 dBm was adopted for new digital offices. Because the alerting action of the tone increases with the power level, it is desirable to provide ROH at the highest permissible level within these limits. Studies indicate that the customer response rate increases 0.5 percent per dB as tone power is increased over this range. Estimates are that this improved customer response results in an additional 1,000 completed calls and one less customer trouble report per dB of increased power annually in a 10,000 line office.

In the DMS-10 switching system, the ROH tone (as well as all other tones and digits) is generated by Pulse-Code Modulation (PCM) samples stored in memory on the Tone & Digit Sender circuit pack. PCM samples of the composite signal, generated by combining 1400 Hz, 2060 Hz, 2450 Hz, and 2600 Hz at -6 dBm each, are stored in memory. Under direction of the main Central Processing Unit (CPU), the PCM samples are read out as required and processed through the line card Digital-to-Analog (D/A) circuitry to produce the ROH tone at 0 dBm.

ROH tone is not a signal used in the tandem network and is never placed on trunks. In some cases, the tone is applied to foreign exchange lines using carrier facilities. However, digital carrier is immune to overload from the relatively high power level of the ROH tone.

In some cases, ROH tone is applied, either automatically or manually, to lines that could be connected to an attendant headset. Several switching systems (1/1A ESS, 2/2B ESS, 5ESS, and EWSD) have facilities to prevent automatic application of ROH tone.

Tests of ROH tone on actual telephone connections showed the Sound Pressure Levels (SPLs) varied from 109 to 110 dBA and 108 to 109 dB SPL (0 dB SPL is 0.0002 dynes per square centimeter).

The current ROH tone is a combination of 1400 Hz, 2060 Hz, 2450 Hz, and 2600 Hz tones added together. The tone frequencies should be within  $\pm 2.0$  percent of their nominal values and the total power of harmonics and other extraneous frequencies, including quantizing distortion, should be at least 15 dB below the total ROH signal level. Each frequency component of the ROH tone should be at a level within 3 dB of the other components and within the range of +3.0 to -6.0 dBm per frequency.

### **6.20.5 102 Test Trunk**

In a modern office, either a digital tone or a quiet termination is provided for maintenance applications. The type of tone provided is dependent on the contents of a Read-Only Memory (ROM). For maintenance applications, it forms a highly stable common office milliwatt supply for general testing and calibration. From the Code 102 test trunk, the tone

---

or quiet termination is available to the test position, and is available for automatic trunk and line testing. Connection of the test circuit and application of tests are under software control.

Access to the digital tone stored in the ROM is controlled by the Maintenance Trunk Module (MTM) controller via the Trunk Logic Circuits (TLC-1 and TLC-2). (Refer to Figure 6-60.) The TLCs serve as communication buffers for control and data signals between the MTM and the tone generator. The tone generator is connected to the following inputs and outputs:

- Data Reception (RDAT) Bus — for receiving data
- Transmit Data (XDAT) Bus — for sending data
- Enable A and B — to activate the respective TLC at the appropriate time slot for the required test.

The first enable signal to arrive at one of the TLCs activates the address counters to cycle the ROM via OR gate U1 and the channel controller. The ROM address is incremented once per frame time (125 ms) via the channel controller. The card frame time is synchronized with the first enable signal by the channel controller, which controls reset of the flip-flop. The 8-bit parallel output of the ROM, representing the tone, is applied to the output buffer, which converts the parallel PCM data to serial PCM form. The output of PCM data is controlled by the X Enable (XE) output from either of the TLCs and by the status of a Signal Distributor (SD) from either TLC. If  $SD_o = 1$ , the PCM is presented to the XDAT bus. If  $SD_o = 0$ , the flow of the data to XDAT is interrupted, and the quiet termination condition exists.

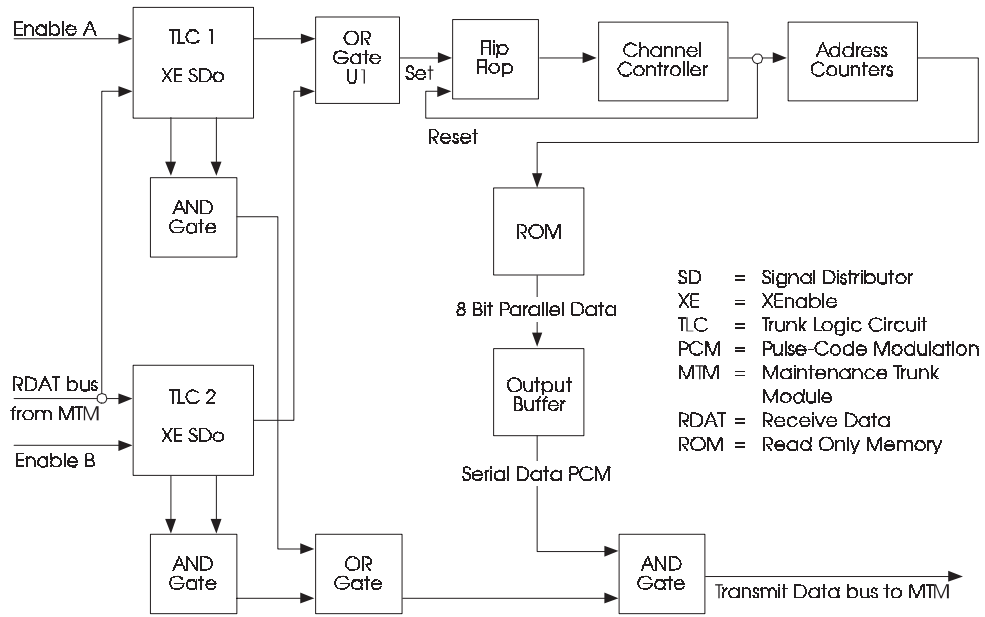


Figure 6-60. Illustrative Digital 102 Test Trunk and Tone Generator

---

## 6.21 Other Miscellaneous Signals

### 6.21.1 Ringing

#### 6.21.1.1 Ring Forward (Re-ring)

This is a signal used by an operator at the calling end to recall an operator at the called end on an established connection. It is originated by means of a ringing key. On trunks with E&M lead signaling, the outgoing trunk equipment generates a single on-hook pulse for each activation of the ringing key. As applied to tandem dialing circuits, ring forward is a momentary on-hook of  $100 \pm 30$  ms transmitted toward the called end (50 to 140 ms received), which is converted at the destination office to a recall signal.

On metallic trunks arranged for loop signaling, a dc-simplex +130-V ring-forward signal may be sent for  $100 \pm 30$  ms.

#### 6.21.1.2 Ringback

Ringback is a signal used by an operator at the called end of an established connection to recall the originating operator. The operation of the called operator's ringing key sends an on-hook pulse back to the calling end that is converted to a recall signal on the originating operator's console. Ringback continues as long as the called operator's ringing key is operated. Ringback is also used by an operator to recall a customer or to alert the calling customer.

Operator-controlled ringing (ringback) is required on all coin lines to ring the telephone when the calling customer hangs up after the call is completed, to alert the customer when an overtime deposit is necessary. It is also used to summon a customer who has requested a time and charge quote but has hung up. Ringback has also been used to identify the calling line on emergency calls, on other than 4- or 8-party lines, if the caller inadvertently hangs up before identifying the location of the emergency.

If a 4- or 8-party line customer has made an emergency call and then hung up, the calling number will not be available at the operator-services office. For emergency calls to a 2/2B ESS switching system, a special emergency key is required at the operator-services office in addition to the regular ringback key.

Interoffice coin or post-pay coin trunks with the ringback feature can be arranged for unrestricted ringback or restricted ringback. With the former, ringing is applied whether the station is on- or off-hook. In some cases, ROH tone is applied instead of ringing when the station is off-hook. With the latter, ringing is applied only if the station is on-hook. Unrestricted ringback is provided for all coin and single-party lines. Restricted ringback is

---

---

used to guard against annoying a customer if the operator should attempt to ring back against a party line and rings the wrong party.

With loop trunks to the end office, 20-Hz ringing or reverse-battery can be used as the ringback signal. Non-coin trunks can use a single wink, while coin trunks can use multifrequency tones or multiwink, as described later, as a ringback signal. See Section 6.17.3.1.2 for ringback protocol.

## 6.21.2 Tones and Announcements

Tones and announcements are used to inform customers and operators of various conditions encountered on dialed calls. They are also required for service analysis of conditions that result in failure to complete dialed calls. Analysis data are used to evaluate administrative, engineering, and maintenance efforts to improve service.

Tones are used primarily to identify the condition of called lines and network blockage or failure conditions. Generally, a low tone interrupted at 60 Impulse Per Minute (IPM) indicates that the called customer's line has been reached but is busy. A low tone interrupted at 120 IPM indicates that the end or tandem switching or transmission paths to the office or equipment serving the called customer are busy.

Announcements are used when the condition encountered requires explanation for either customers or operators. Announcements explain the type and severity of the condition and suggest the appropriate action to be taken.

With the widespread use of direct distance dialing, a variety of tones or announcements for the same condition can be confusing to the customer, the service evaluator, or the automatic call-detection devices that make use of tone and announcement information.

Nonuniformity makes it impossible to analyze performance results with any degree of accuracy. The use of standard prerecorded announcements allows service evaluators to identify each type of announcement by certain key words in the announcement. Automated call-detection devices identify calls terminating in announcement systems by use of prerecorded Special Information Tones (SITs). SITs are covered in detail in CB 154, *Specifications for Special Information Tones (SIT) for Encoding Recorded Announcements*.

### 6.21.2.1 Special Information Tones

SITs permit mechanized call detectors and classifiers to classify calls that reach recorded announcements resulting from network conditions to Reorder (RO), Vacant Code (VC), No Circuit (NC), Intercept (IC), and Ineffective Other (IO). Five encoded SITs (RO' SIT, VC, NC' SIT, IC, and IO) are intended for use by the LECs to indicate network conditions encountered in the intraLATA networks. Two separate encoded SITs (RO" SIT and NC" SIT) are intended to indicate network conditions encountered in the exchange access or

---

InterLATA networks. Figures 6-61 and 6-62 provide further clarity in the use of SITs in the LEC intraLATA and the interchange carrier interLATA networks. In addition, one tone has been designated for future use.

An SIT, as defined by the International Telecommunication Union—Telecommunication Standardization Sector (ITU-T), consists of a sequence of three precise tone segments with frequencies of  $950 \pm 50$  Hz,  $1400 \pm 50$  Hz, and  $1800 \pm 50$  Hz, sent in that order. Each segment is allowed a duration of  $330 \pm 70$  ms with a silent interval of up to 30 ms between segments. The nominal tone level is  $-24$  dBm0\*<sup>1</sup> with limits of  $\pm 1.5$  dB measured with continuous tone. The difference in level between any two segments is required to be less than 3 dB. The above requirements apply at the point at which tones are applied to the network. The first and second tone segments have a short or long duration, and the frequency state is assigned to the lower or higher part of the frequency band allowed by ITU-T. The third tone segment may be of long or short duration but is limited to the lower frequency state. For this initial application, the third tone segment has been assigned both a fixed long duration and a fixed lower frequency. These fixed assignments provide reference or calibration points for detection devices.

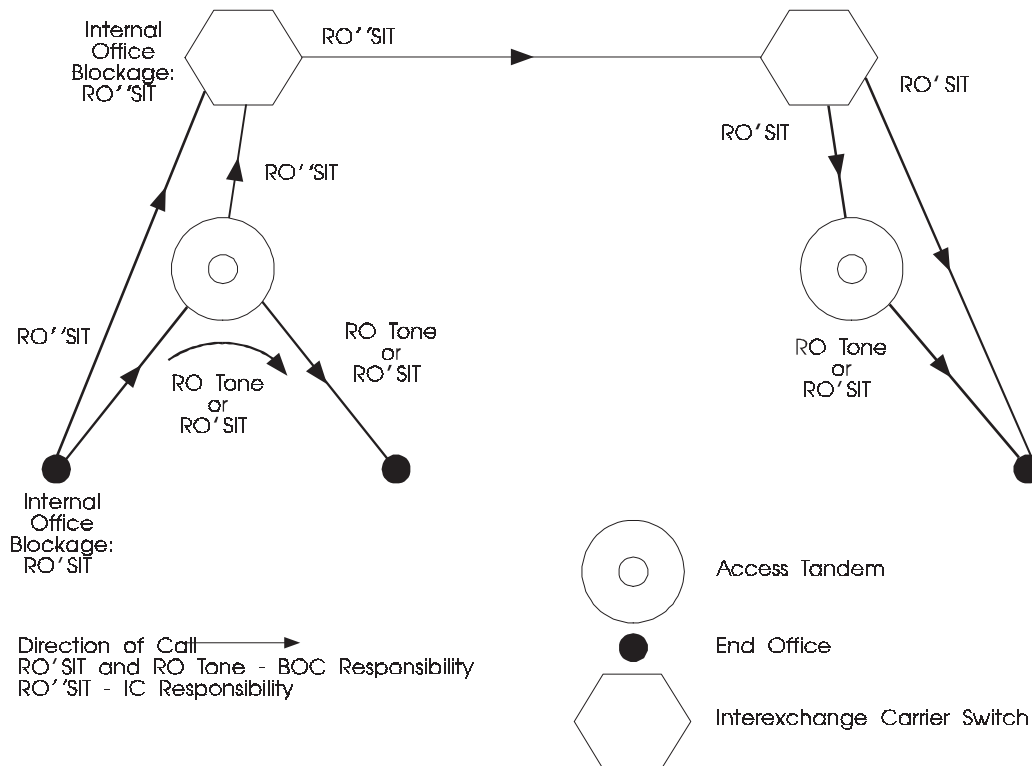
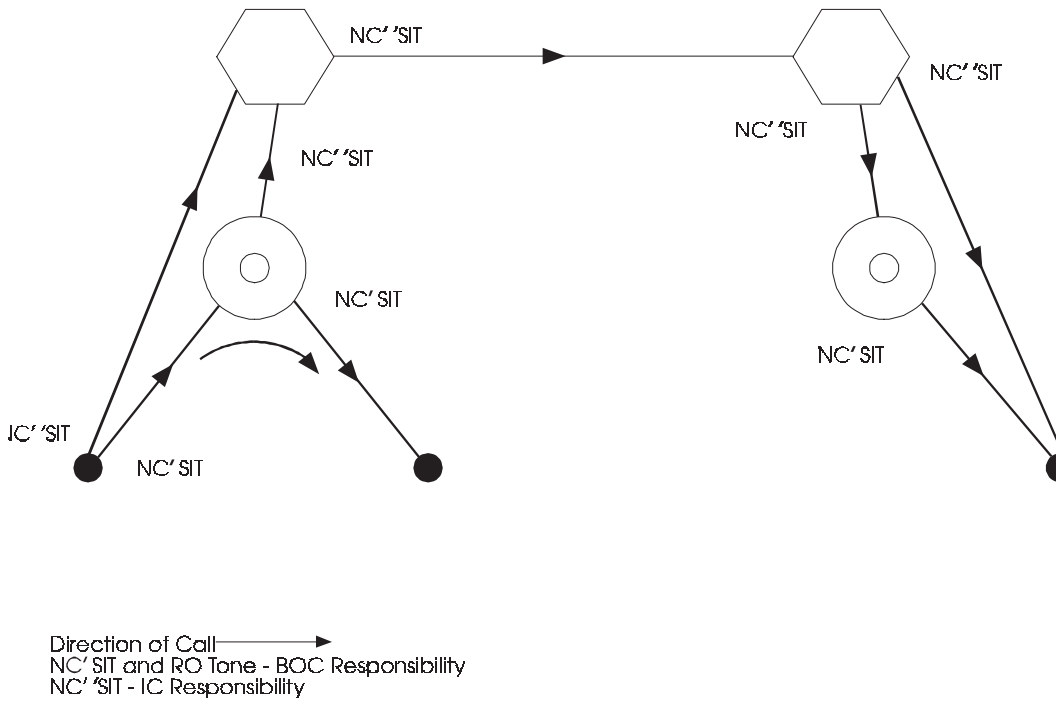


Figure 6-61. Reorder Condition

1. dBm0 = decibels (dB) relative to 1 mW measured at the 0 dB TLP.





**Figure 6-62.** No-Circuit Condition

The encoding scheme for the eight categories is in Table 6-44. The duration encoding is represented by short (S) and long (L) designations, and the frequency encoding is represented by high (h) and low (l) designations.

**Table 6-44.** Encoding Scheme for Special Information Tones

Category	Duration	Frequency
RO' SIT	SLL	lhl
VC SIT	LSL	hll
NC' SIT	LLL	hhl
IC SIT	SSL	lll
RO" SIT	SLL	hll
NC" SIT	LLL	lll
IO-SIT	LSL	lhl
Future	SSL	hhl

The frequencies assigned for use in the SIT encoding method are shown in Table 6-45.

**Table 6-45.** Frequencies for Use in SITs

First Segment	Second Segment	Third Segment
(l) 913.8 Hz	(l) 1370.6 Hz	(l) 1776.7 Hz
(h) 985.2 Hz	(h) 1428.5 Hz	(l) 1776.7 Hz

Application of SIT tones starting with the 985.2-Hz frequency may cause false detection by automatic trunk-testing equipment because this frequency is close to the milliwatt transmission test tone. Since the access of trunk-testing equipment to SITs (for example, No-Circuit Announcement) is a relatively rare occurrence, the false-detection problem is not expected to be a significant impairment to trunk testing.

The duration of each segment assigned for use in SIT encoding is as follows:

- Short duration (S) 274 ms
- Long duration (L) 380 ms.

The defined frequency states lie within ITU-T tolerances. They are designed to be stable to within  $\pm 1.5$  percent of nominal values, and the duration states are stable to within  $\pm 5$  percent of nominal.

The interval between the segments of SITs is between 0 and 4 ms. Interruption within a segment is less than 1 ms. To minimize the number of customers who may abandon without listening to the standard announcement, the nominal time gap between the third tone segment and the beginning of the announcement is set as close to zero as possible, with an allowed maximum of 100 ms for prerecorded standard announcements. Frequency flutter is limited to  $\pm 0.2$  percent in cassette recordings of an announcement and  $\pm 1$  percent at the point of application to the network. The total harmonics and other distortion products are at least 25 dB below the total tone power at the point of application.

**Exceptions:** The ITU-T tolerances for the duration states are satisfied on all current announcement systems. Frequency states as implemented through 13A or equivalent digital announcement systems also satisfy ITU-T tolerances. However, due to the imprecision of electromechanical announcement systems, the ITU-T frequency tolerances may be exceeded by these older-generation machines. As older systems are replaced, full ITU-T compliance will be attained.

The nominal tone levels for SITs are set at -24 dBm0 with a tolerance of  $\pm 1.5$  dB. This tone level was selected to reduce the tone level differential with respect to the recorded announcement (-22 VU). These levels and stability requirements set the absolute level of each tone segment and fulfill the ITU-T requirement that the tone level difference between any two segments be less than 3 dB. This tolerance will be satisfied with the digital machines, but for older-generation machines, a tone level difference of up to 4.5 dB may be realized. Table 6-46 displays the expected components of error for SIT application to the

network and indicates the expected tolerances for digital and electromechanical announcement systems.

**Table 6-46.** Tolerances for Announcement Machines

Condition	Duration	Frequency
Cassette Generation	±1.0%	±1.0%
Portable Playback	±0.5%	±0.5%
Electromechanical Announcement Machine	±3.0%	±3.0%
Digital Announcement Machine		±0.0%
Totals	±4.5%	±1.5%

**Special Announcements:** Some situations or locations require special announcements. These announcements are not prerecorded and are prepared locally using blank cassettes that contain the appropriate prerecorded SIT.

#### 6.21.2.2 Equipment Operation

Announcement trunks should be equipped for delayed cut-through so that an announcement will be heard from the start of the message. There is an audible ring during the interval before the start of the announcement, and the interval should be as short as possible. Announcements are brief and carefully prepared. Announcement facilities should be well maintained to ensure the quality of announcements. Announcement systems used for intercepted numbers are arranged for operator cut-through.

#### 6.21.2.3 SITs, Tones, and Announcements used in the Network

Table 6-47 provides a list of treatments, along with the typical announcements, applied for incompleting call attempts for the various conditions encountered. See CB 154, *Specifications for Special Information Tones (SIT) for Encoding Recorded Announcements*, for additional information. The reorder call disposition generally results from the following four network conditions.

1. An internal office blockage, for example, failure to match. In intraLATA switching systems, the generic disposition is currently reorder tone (120 IPM). In interLATA switching systems, a disposition of reorder announcement equipped with RO" SIT should be the normal response.
2. Failure to provide a wink on an interoffice call attempt. Call attempts between two intraLATA switching systems encountering a no-wink condition should be provided

---

with either reorder tone or an announcement equipped with RO" SIT (see Figure 6-61). Call attempts encountering a no-wink condition from an intraLATA switching system directly connected to an interLATA switching system are routed to an announcement equipped with RO" SIT.

3. Insufficient digits.
4. All announcement trunks are busy.

NC call dispositions result from the following two conditions.

1. Failure to find an available interoffice trunk. In an intraLATA switching system when an intraLATA call attempt is originated or through-switched and fails to obtain an interoffice trunk, the appropriate disposition is either an announcement equipped with NC' SIT or reorder tone. In intraLATA switching systems when a call attempt is being originated on interLATA access trunks or through-switched via an access tandem to an Interexchange Carrier (IC) and no trunk is available, the appropriate response should be an announcement equipped with NC" SIT. Likewise, in an interLATA switching system or to an intraLATA switching system, the disposition is an announcement equipped with NC" SIT.
2. Calls affected by the application of network-management controls. If controls are activated by the exchange carrier and disposition of calls blocked by those controls is an NC announcement, that announcement is encoded with NC' SIT. If similar controls are activated by an IC, the disposition is an announcement equipped with NC" SIT.

A primary use of the recorded announcement machines is to provide an intercepting message to calls reaching vacant or disconnected customer numbers. One such machine provides a single channel with an announcement interval that is usually fixed for a particular installation. It may be set to one of six intervals ranging from 11 to 36 seconds. Means are provided to connect a trunk at the beginning of an announcement interval and repeat from one to nine announcements (two or three is the usual number) and then to connect to an intercept operator. Two machines are usually provided, one for service and one for automatic standby. In multioffice cities, the machines are provided in a central location, and intercept trunks may be brought into the center or to subcenters to which the announcements are transmitted.

A smaller machine is used in small offices where the larger intercept machines cannot be economically justified. In this use, changed numbers, vacant thousands and hundreds levels, as well as all vacant or disconnected numbers, are routed to the machine. Normally, only one machine is provided. This machine operates on a stop-start basis. When started, all subsequent calls requiring intercept in the announcement interval are cut in immediately to the machine at any stage of the announcement cycle. Provision can be made for subsequent transfers to an operator.

Direct-dialed calls will reach these machines when required. The announcements give the customer the proper action to be taken. Also, it is desirable to inform the customer that the

---

announcement is recorded. Connections to announcement machines should not return off-hook (answer) supervision.

Table 6-47 contains some of the tones and announcements used by the LECs.

**Table 6-47.** Treatment Applied for Incompleted Call Attempts

Encountered Condition	Returned Treatment	Applied at (Note 1)	Announcement	Reportable Condition (Note 2)
<b>IntraLATA Call Handling</b>				
<b>General Categories:</b>				
Signal-to-Start Dialing	Dial Tone	EO		
Connected to Called Line or to Operator Trunk	Audible Ringing Tone	EO		
Receiver Off-Hook (ROH)	Announcement or ROH Tone	EO		
Line Busy	60 IPM Tone	EO		
Trunk Group Overflow	120 IPM Tone	EO/T		
Announcement Overflow	120 IPM Tone	EO/T		
Direct Inward				
Dialing Trunk Group Overflow	60 IPM Tone	EO/T		
All Trunks Busy	Announcement or 120 IPM Tone	EO/T	We're sorry, all circuits are busy now. Will you please try your call again later.	NC SIT†

(See Notes at end of table)

**Table 6-47.** Treatment Applied for Incompleted Call Attempts (Continued)

Encountered Condition	Returned Treatment	Applied at (Note 1)	Announcement	Reportable Condition (Note 2)
<b>IntraLATA Call Handling (Cont'd)</b> <b>Switching Blockages:</b> No Dial Tone Situations  Internal Office Failure; No Wink Received EO/LT; or Partial Digits Received.	Announcement or Quiet  Announcement or 120 IPM Tone	EO  EO/T	We're sorry, due to heavy calling, we cannot complete your call at this time. Will you please hang up and try your call later. If your call is urgent, please try again now.  We're sorry, your call did not go through. Will you please try your call again.	RO SIT
Sender or Transmitter Overload  <b>Special Network Conditions:</b> Disaster  Network-Management Control	Announcement or 120 IPM Tone  Announcement (to be recorded locally using a prerecorded SIT cassette)  Announcement	EO/T  EO/T  EO/T	We're sorry, all circuits are busy now. Will you please try your call again later.  (With flexibility due to situation) We're sorry, (storm, flood, tornadoes, etc.) damage in (or near) (city) has blocked your call. Emergency calls may be placed through your operator.  We're sorry, all circuits are busy now. Will you please try your call again later.	NC SIT  NC SIT  NC SIT

**Table 6-47.** Treatment Applied for Incompleted Call Attempts (Continued)

Encountered Condition	Returned Treatment	Applied at (Note 1)	Announcement	Reportable Condition (Note 2)
<b>IntraLATA Call Handling (Cont'd)</b> <b>Special Network Conditions: (Cont'd)</b>				
Work Stoppage	Announcement	EO	We're sorry, because of a work stoppage, the operator will be delayed in helping you. If your call is urgent, stay on the line and the operator will answer as soon as possible.	
Emergency Announcement	Announcement	EO/T	We're sorry, due to telephone company facility trouble, your call cannot be completed at this time. Will you try your call again later.	NC SIT
Network Management 7- or 10-digit code Controls	60 IPM Tone Recording on Emergency Announcement Arranged for Immediate Cut-Through	EO/T		
Network-Management 7- or 10-Digit Code Controls (Switches Equipped with CCS)	Announcement	EO/T	We're sorry, all circuits are busy now. Will you please try your call again later.	NC SIT
Vacant Number Intercept or Vacant Levels in Small Offices with Only One Announcement Channel	Announcement	EO	We're sorry, your call cannot be completed as dialed or the number has been disconnected. Please check the number and dial again.	IC SIT

**Table 6-47.** Treatment Applied for Incompleted Call Attempts (Continued)

Encountered Condition	Returned Treatment	Applied at (Note 1)	Announcement	Reportable Condition (Note 2)
<b>IntraLATA Call Handling (Cont'd)</b> <b>Misdialing:</b> Prefix Code (Access Code) Dialed in Error  Prefix Not Dialed; Prefix "1" Not Dialed; Prefix "0" Not Dialed	Announcement  Announcement	EO  EO	We're sorry, it is not necessary to dial a "1" or "0" when calling this number. Will you please hang up and try your call again.  We're sorry, you must first dial a "1" or "0" when calling this number. Will you please hang up and try your call again.	IO SIT  IO SIT
Vacant Code; Unauthorized CAMA (UCA) ("1" or "0" Plus Unauthorized Code)  Nonworking 911  <b>Numbers Intercepted:</b> Vacant or Disconnected Number (Includes Vacant Thousands and Hundreds or Numbers with Denied Terminating Service)	Announcement  Announcement  Announcement	EO/T  EO/T  EO	We're sorry, your call cannot be completed as dialed. Please check the number and dial again.  911 is not a working emergency number for your area. For emergencies, hang up a moment and dial your operator.  We're sorry, you have reached a number that has been disconnected or is no longer in service. If you feel you have reached this recording in error, please check the number and try your call again.	VC SIT  VC SIT  IC SIT



**Table 6-47.** Treatment Applied for Incompleted Call Attempts (Continued)

Encountered Condition	Returned Treatment	Applied at (Note 1)	Announcement	Reportable Condition (Note 2)
<b>IntraLATA Call Handling (Cont'd)</b> <b>Numbers Intercepted: (Cont'd)</b> Centrex Nonworking Stations (First Choice)  (Second Choice)  Intra-PBX Calls Served by Centrex Offices for Unassigned or Restricted Codes	Announcement (to be recorded locally using a prerecorded SIT cassette)  Announcement (to be recorded locally using a prerecorded SIT cassette)  Announcement	EO  EO  EO	We're sorry, the number you have reached is not in service. If you are calling the (ABC Co.), please dial (XXX XXXX).  We're sorry, the number you have reached is not in service. Please dial the main listed number for the company you are calling.  We're sorry, your call cannot be completed as dialed. Please check the number and try again, or call your attendant to help you.	IC SIT  IC SIT  IO SIT
High-Volume Customer Number Change  Receiver Off-Hook	Announcement (to be recorded locally using a prerecorded SIT cassette)  Announcement	EO  EO	Telephone numbers at the (ABC Co.) have been changed. For their new numbers, please dial (NXX- XXXX).  If you'd like to make a call, please hang up and try again. If you need help, hang up and then dial your operator.	IC SIT

**Table 6-47.** Treatment Applied for Incompleted Call Attempts (Continued)

<b>Encountered Condition</b>	<b>Returned Treatment</b>	<b>Applied at (Note 1)</b>	<b>Announcement</b>	<b>Reportable Condition (Note 2)</b>
<b>IntraLATA Call Handling (Cont'd)</b> <b>Local Coin:</b> Initial Coin Deposit	Announcement (to be recorded locally using a blank tape)	EO	The call you have made requires a (initial rate) deposit. Please hang up momentarily, listen for dial tone, deposit (initial rate), and dial your call again.	IO SIT
Deposit Required for Overtime  <b>Screened Line:</b> Prefix Dialing Error Screened Intercept	Announcement (to be recorded locally using a blank tape)  Announcement	EO  EO	(Alerting tone) (Pause) Excuse me, please deposit (5) cents for the next (N) minutes. If (5) cents is not deposited within 25 seconds, your call will be automatically terminated.  We're sorry, your call cannot be completed as dialed from the phone you are using. Please read the instruction card and dial again.	IO SIT

**Table 6-47.** Treatment Applied for Incompleted Call Attempts (Continued)

Encountered Condition	Returned Treatment	Applied at (Note 1)	Announcement	Reportable Condition (Note 2)
<b>IntraLATA Call Handling (Cont'd)</b> <b>Coinless Public Telephone Service:</b> Customer Dialing Sent-Paid Call  <b>800 Service:</b> Out-of-Band  Out-of-Band (Second Choice)	Announcement   Announcement  Announcement	EO   OSO  OSO	We're sorry, your call cannot be completed as dialed from the phone you are using. Please read the instruction card and dial again.  We're sorry, you have dialed a number that cannot be reached from your calling area.  We're sorry, your call cannot be completed as dialed. Please check the number and dial again.	IO SIT   VC SIT  VC SIT

**Table 6-47.** Treatment Applied for Incompleted Call Attempts (Continued)

Encountered Condition	Returned Treatment	Applied at (Note 1)	Announcement	Reportable Condition (Note 2)
<b>IntraLATA Call Handling (Cont'd)</b> <b>Remote Switching System (RSS/RSM)</b> Local Service Only	Announcement (to be recorded locally using a prerecorded SIT cassette)	RSS/RSM	(With flexibility as appropriate) We're sorry, due to telephone company facility trouble, only calls to numbers in the NXX exchange and 911 can be completed at this time.	NC SIT
Voice or Data Channel Failure	Announcement	EO	We're sorry, due to telephone company facility trouble, your call cannot be completed at this time. Will you try your call again later.	NC SIT
<b>Custom Calling:</b> Custom-Calling Feature	Announcement	EO	We're sorry, your call cannot be completed as dialed. Please check your instruction manual or call the Business Office for assistance.	IO SIT
Custom-Calling Feature	Announcement	EO	We're sorry, your call cannot be completed as dialed. Please check your instruction manual or call Repair Service for assistance.	IO SIT

**Table 6-47.** Treatment Applied for Incompleted Call Attempts (Continued)

Encountered Condition	Returned Treatment	Applied at (Note 1)	Announcement	Reportable Condition (Note 2)
<b>IntraLATA Call Handling (Cont'd)</b>				
<b>Custom Calling: (Cont'd)</b>				
Speed-Calling List Full	Announcement	EO	We're sorry, additional Speed-Calling numbers cannot be entered at this time. Will you try again later, please.	
Custom-Calling List Full	Announcement	EO	We're sorry, we cannot process your custom-calling request at this time. Will you try again later, please.	RO SIT
<b>Other:</b>				
Temporarily Denied Service	Announcement	EO	We're sorry, the telephone you are calling from is not in service at this time.	IC SIT
Flexible Incoming Call Restriction	Announcement (to be recorded using a pre-recorded SIT cassette)	EO	We're sorry, the number you are calling cannot receive calls at this time. Please call again later.	IC SIT
Customer-Controlled Incoming Call Restriction	Announcement (to be recorded using a pre-recorded SIT cassette)	EO	We're sorry, the number you are calling cannot receive calls at this time. Please call again later.	IC SIT

**Table 6-47.** Treatment Applied for Incompleted Call Attempts (Continued)

<b>Encountered Condition</b>	<b>Returned Treatment</b>	<b>Applied at (Note 1)</b>	<b>Announcement</b>	<b>Reportable Condition (Note 2)</b>
<b>InterLATA Call Handling (Cont'd)</b>				
10XXX, XXX Not Valid	Announcement	EAE0	We're sorry, your call cannot be completed with the access code you dialed. Please check the code and try again or call your long- distance company for assistance.	IO SIT
10XXX dialed, Interexchange Carrier Temporarily Out of Service	Announcement	EAE0	We're sorry, the long- distance company you have dialed is experiencing a temporary service problem. Please try your call again later.	NC SIT
950-WXXX, XXX Not Valid	Announcement	EO/T	We're sorry, your call cannot be completed with the access code you dialed. Please check the code and dial again or ask your long- distance company for assistance.	IO SIT
10XXX, Should be 950-WXXX	Announcement	EAE0	We're sorry, the long- distance company access code you dialed must be preceded by the digits 950. Please hang up and try your call again.	IO SIT

**Table 6-47.** Treatment Applied for Incompleted Call Attempts (Continued)

<b>Encountered Condition</b>	<b>Returned Treatment</b>	<b>Applied at (Note 1)</b>	<b>Announcement</b>	<b>Reportable Condition (Note 2)</b>
<b>InterLATA Call Handling (Cont'd)</b>				
950-WXXX, Should be 10XXX	Announcement	EAE0	We're sorry, it is not necessary to dial the digits 950 before the long-distance company access code. Please hang up and try your call again.	IO SIT
10XXX Omitted When Required (First Choice)	Announcement	EAE0	We're sorry, a long-distance company access code is required for the number you have dialed. Please dial your call with the access code.	IO SIT
(Second Choice)	Announcement	EAE0	We're sorry, your call cannot be completed as dialed. Please check the number and dial again.	VC SIT
Toll Restriction or Diversion; InterLATA Restriction; 10XXX from Restricted Line; 10XXX from WATS Line	Announcement	EAE0	We're sorry, your call cannot be completed as dialed from the phone you are using. Please read the instruction card and dial again.	IO SIT

**Table 6-47.** Treatment Applied for Incompleted Call Attempts (Continued)

Encountered Condition	Returned Treatment	Applied at (Note 1)	Announcement	Reportable Condition (Note 2)
<b>InterLATA Call Handling (Cont'd)</b>				
10XXX+1, NO AD1 for XXX	Announcement	EAEO/AT	We're sorry, your call cannot be completed with the access code you dialed. Please check the code and dial again or call your long-distance company for assistance.	IO SIT
10XXX+(Prefix 1 Not Dialed)	Announcement	EAEO	We're sorry, you must dial a "1" before the area code when dialing this number. Will you please hang up and try your call again.	IO SIT
10XXX+IntraLATA, XXX Restricted	Announcement	EAEO	We're sorry, it is not necessary to dial a long-distance company access code for the number you have dialed. Please hang up and try your call again.	IO SIT
10XXX+International, XXX Domestic; 10XXX+Domestic, XXX International	Announcement	EAEO	We're sorry, your call cannot be completed with the access code you dialed. Please check the code and try again or call your long-distance company for assistance.	IO SIT



**Table 6-47.** Treatment Applied for Incompleted Call Attempts (Continued)

<b>Encountered Condition</b>	<b>Returned Treatment</b>	<b>Applied at (Note 1)</b>	<b>Announcement</b>	<b>Reportable Condition (Note 2)</b>
<b>InterLATA Call Handling (Cont'd)</b>				
10XXX+SAC or N11 (911 should not be blocked)	Announcement	EAE0	We're sorry, it is not necessary to dial a long-distance company access code for the number you have dialed. Please hang up and try your call again.	IO SIT
EAE0 All Trunks Busy to AT	Announcement	EAE0	We're sorry, all circuits are busy now. Will you please try your call again later.	NC SIT
EAE0 Does Not Get Wink From AT; EAE0/AT Intraoffice Failure	Announcement or 120 IPM Tone	EAE0	We're sorry, your call did not go through. Will you please try your call again.	RO SIT
EAE0/AT Does Not Get Wink(s) from Interexchange Carrier	Announcement	EAE0/AT	We're sorry, due to network difficulties, your long-distance call cannot be completed at this time. Please try your call again later.	RO SIT

**Table 6-47.** Treatment Applied for Incompleted Call Attempts (Continued)

<b>Encountered Condition</b>	<b>Returned Treatment</b>	<b>Applied at (Note 1)</b>	<b>Announcement</b>	<b>Reportable Condition (Note 2)</b>
<b>InterLATA Call Handling (Cont'd)</b>				
EAE0/AT All Trunks Busy to Interexchange Carrier	Announcement	EAE0/AT	We're sorry, all circuits are busy now. Will you please try your call again later.	NC SIT
Interexchange Carrier Intraoffice Failure	Announcement	IC/INC	We're sorry, the long-distance company you have selected is unable to complete your call at this time. Please try your call again.	RO SIT
All Trunks Busy Within Interexchange Carrier Network; Interexchange Carrier All Trunks Busy to EAE0/AT	Announcement	IC/INC	We're sorry, all circuits are busy now. Will you please try again later.	NC SIT
Interexchange Carrier Not in Service	Announcement (Or To Be Recorded Locally)	EO/AT	We're sorry, the long-distance company you have selected is unable to complete your call at this time. Please contact your long-distance company for assistance.	NC SIT

**Table 6-47.** Treatment Applied for Incompleted Call Attempts (Continued)

<b>Encountered Condition</b>	<b>Returned Treatment</b>	<b>Applied at (Note 1)</b>	<b>Announcement</b>	<b>Reportable Condition (Note 2)</b>
<b>InterLATA Call Handling (Cont'd)</b>				
All Channels Busy Within Cellular Carrier	Announcement (To Be Recorded Locally)	Cellular Carrier	We're sorry, all channels are busy now. Please try your call again later.	NC SIT
Interexchange Carrier Does Not Get Wink From EAEO/AT	Announcement	IC/INC	We're sorry, your call did not go through. Will you please try your call again.	RO SIT
EAEO/AT Receives Incorrect No. of Digits from IC/INC	Announcement	EAEO/AT	We're sorry, the long-distance company you have selected is unable to complete your call at this time. Please try your call again.	RO SIT
EAEO/AT Gets Digits for Nonsubtend Station	Announcement	EAEO/AT	We're sorry, your call cannot be completed as dialed. Please check the number and dial again.	VC SIT
Operator System Overloads (0 Plus)	Announcement	EAEO/AT	We're sorry, due to heavy calling, we cannot complete your call at this time. Will you please hang up and try your call again later.	NC SIT

**Table 6-47.** Treatment Applied for Incompleted Call Attempts (Continued)

Encountered Condition	Returned Treatment	Applied at (Note 1)	Announcement	Reportable Condition (Note 2)
<b>InterLATA Call Handling (Cont'd)</b> (0 Minus)	Announcement	EAEO/AT	We're sorry, due to heavy calling, the operator will be delayed in assisting you. If your call is urgent, stay on the line and an operator will answer as soon as possible.	NC SIT

**LEGEND:****Note 1:** Applied at

- AT - Access Tandem
- EAEO - Equal-Access End Office
- EO - End Office and/or Equal Access End Office
- T - Sector, Principal, and/or Access Tandem
- IC - Interexchange Carrier (Long-Distance Company)
- INC - International Carrier (Long-Distance Company)
- OSO - Originating Screening Office (800 Service).
- RSS/RSM - Remote Switching System/Remote Switching Module

**Note 2:** Conditions reportable by the Service Evaluation Bureau. Reportable conditions that require announcements also require SIT.

IC SIT - Intercept Special Information Tone (See Section 6.21.2.1 for description of other SITs).

† The NC and RO SITs are applied by LECs, while the NC and RO SITs are applied by Interexchange Carriers. Subject: Part 1

## 6.22 Register Timing and Effect on Signaling

The software controlling registers in switches have timing functions to prevent their being held too long. The intervals allowed for the registration of digits and for a distant sender or register to be attached have an effect on signaling. If any of the intervals allowed for digit registration are exceeded, the distant office will route the call to reorder and release.

The limits for digit pulsing that result from digit registration timing are given for the various switching systems in Table 6-22. Delays exceeding these intervals do not always result in reorder routing since these limits are necessarily based on minimum timing in the sender and registers. Some of the intervals are automatically reduced during periods of heavy traffic to conserve equipment.

The limits for the speed of attachment of a register following receipt of a connect signal from the calling office is typically 16 seconds in normal traffic (1A ESS system), reducing to 4 seconds in heavy traffic. This measure minimizes the effect that delays in one office may have on other offices. Without reduced intervals, mutual delays between offices during periods of heavy traffic can pyramid, seriously impairing service.

---

## 6.23 Common Channel Signaling

Telephone signaling has been defined as “basically a matter of transferring information between machines, and between humans and machines” (“Signaling Systems for Control of Telephone Switching,” *Bell System Technical Journal*). A current definition of signaling is the exchange of control information between elements of a telecommunications network. Such information includes supervisory signaling used to initiate and terminate connections and to indicate status, general-purpose information transactions, and network management. The elements of today's networks include switches, databases, and operations centers.

Common Channel Signaling (CCS) is a signaling method in which the signals are no longer carried over the circuits/channels being controlled (as is done with inband analog signaling, for example). Instead, a separate shared (common) channel (signaling link) is used to convey the signaling information. Thus, CCS is really special-purpose data communications, capable of using available data protocols and network technology.

Signaling System 7 (SS7) is the latest protocol in use for signaling among switches and databases. It was initially specified by the CCITT<sup>1</sup> in the 1980 *Yellow Book* recommendations, with updates in the 1984 *Red Book*, 1988 *Blue Book*, and 1993 *White Book*. The equivalent standard for United States networks is given in the American National Standards Institute (ANSI) standards.<sup>2</sup> A full Bellcore specification is given in GR-246-CORE, *Bellcore Specification of Signaling System Number 7*.

SS7 protocol features help ensure reliable, high-performance transfer of signaling information in the face of network disturbances and failures. Also, application-level procedures support call control for both Integrated Services Digital Network (ISDN) and non-ISDN calls, services associated with ISDN and non-ISDN calls, call control for ATM connections, generalized transaction-oriented information transfer, and management and operations signaling.

In the words of the CCITT specification, “The overall objective of Signaling System No. 7 is to provide an internationally standardized general purpose CCS system:

- optimized for operation in digital telecommunications networks in conjunction with stored-program controlled exchanges;
- that can meet present and future requirements of information transfer for inter-processor transactions within telecommunications networks for call control, remote control, network database access, and management and maintenance signaling;
- that provides a reliable means of information transfer in correct sequence, without loss or duplication.”

---

1. The CCITT is now called the International Telecommunication Union—Telecommunication Standardization Sector (ITU-T).

2. The Bellcore specification is based on the current view of the ANSI standard.

---

The Bellcore specification currently consists of six parts:

- Message Transfer Part (MTP) — a three-level protocol providing connectionless message transfer
- Signaling Connection Control Part (SCCP) — providing sophisticated database management and Open Systems Interconnection (OSI) network-service compatibility
- ISDN User Part (ISUP or ISDNUP) — providing ISDN call setup and control, harmonized to work with ISDN access protocol<sup>1</sup>
- Transaction Capabilities Application Part (TCAP) — designed for transaction-type information transfer, and patterned after remote-operations protocol
- Operations, Maintenance, and Administration Part (OMAP) — providing SS7 messages and procedures for CCS management functions
- B-ISDN User Part (BISUP) — providing ATM broadband ISDN call control.

### 6.23.1 CCS Architecture

The SS7 network model consists of network nodes, termed Signaling Points (SPs), interconnected by point-to-point signaling links, with all the links between two SPs called a link set. When this model is applied to a physical network, most commonly there is a one-to-one correspondence between physical nodes and logical entities. But when there is a need (for example, a physical gateway node needs to be a member of more than one network), a physical network node may be logically divided into more than one SP, or a logical SP may be distributed over more than one physical node. These artifices require careful administration to ensure that management procedures within the protocol work correctly.

Messages between two SPs may be routed over a link set directly connecting the two points; this is referred to as the associated mode of signaling. Messages may also be routed via one or more intermediate SPs that relay the messages at the network layer; this is called the nonassociated mode of signaling. SS7 supports only a special case of nonassociated routing, called quasi-associated mode, in which routing is static except for relatively infrequent changes in response to events such as link failures or addition of new SPs. SS7 does not include sufficient procedures to maintain in-sequence delivery of information if routing were to change completely on a packet-by-packet basis.

The function of relaying messages at the network layer (purists restrict this further to MTP relaying) is called the Signaling Transfer Point (STP) function. Though this practice results in some confusion, the logical and physical network nodes at which this function is performed are frequently called STPs, even though they may provide other functions as well. A crucial part of designing an SS7 network is including sufficient equipment

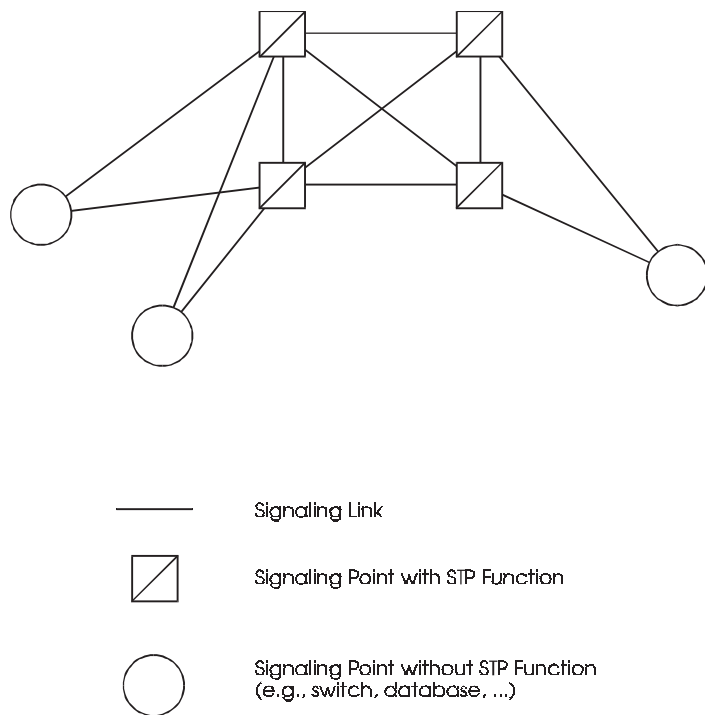
---

1. The ISUP has been designed to also be used for POTS call setup and control.

redundancy and physical-route diversity so that the stringent availability objectives are met. This design is largely a matter of locating signaling links and SPs with the STP function, so that performance objectives can be met for the projected traffic loads at a minimum cost.

Currently, most networks deploying SS7 networks have chosen to employ a physical network structure similar to that modeled in Figure 6-63. The STP function is concentrated in a relatively small number of nodes that are essentially dedicated to that function. The STPs are paired or *mated*, and pairs of STPs are interconnected with the *quad* configuration of signaling links. This has proved to be an extremely reliable backbone network. Other nodes, such as switching systems and Service Control Points (SCPs), are typically homed on one of the mated pairs of STPs with one or more links to each of the mates, depending on traffic volumes.

In Figure 6-63, an SS7 link from an SP to an STP is designated as an “A-Link.” Similarly, an SS7 link from an STP to its mate STP is designated as a “C-Link” and an SS7 link from an STP to an STP other than its mate is designated as a “B-Link.”



**Figure 6-63.** Typical SS7 Network Architecture



---

## 6.23.2 Description of SS7 Protocol Parts

### 6.23.2.1 SS7 Structure

To help ensure flexibility for diverse applications and for future evolution, the signaling protocol consists of functional modules patterned after the OSI reference model (CCITT *Blue Book*).

The major functional modules of SS7 are the MTP, SCCP, ISUP, TCAP, and OMAP. Figure 6-64 shows the SS7 architecture as it currently exists. Some application parts have interfaces to both SCCP and MTP. For example, the ISUP could utilize the SCCP to support end-to-end interactions, such as a request for information from the terminating exchange to the originating exchange in the call, but utilize the MTP directly for transport of most circuit control messages. (**Note:** Although the ISUP-to-SCCP interface has been standardized, there are no current ISUP services that make use of this interface. Further ISUP standards work would be required to make any use of this capability.) The MTP, which provides a highly reliable connectionless sequenced transport service, consists of three layers: a physical/electrical layer, a data-link layer, and a network layer.

## 6.23.3 Description of ANSI-Standardized Protocol Parts

### 6.23.3.1 Overview of SS7 (T1.110)

This document provides an overall description of the SS7 protocol and architecture (ANSI *American National Standards for Telecommunications — Signaling System No. 7*).

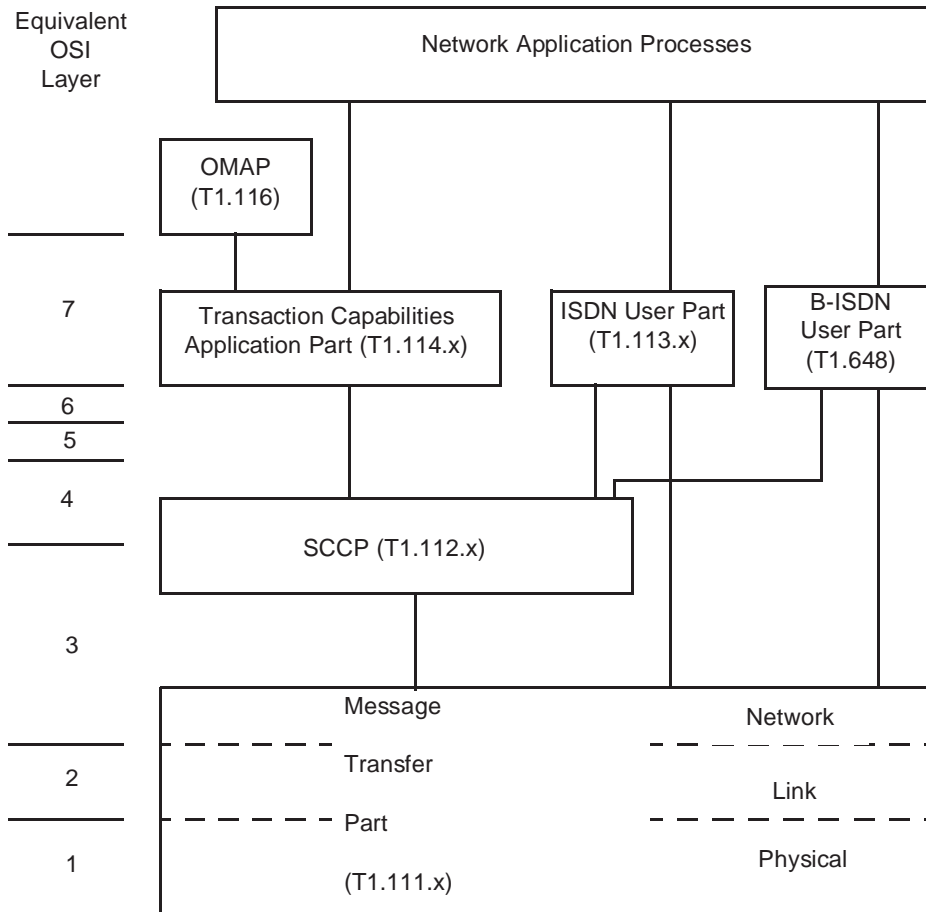
Throughout this section, you will see references in parentheses of the form T1.11x.y. These references also appear in GR-246-CORE and are included to facilitate cross-referencing.

### 6.23.3.2 Message Transfer Part — MTP (T1.111.x)

The MTP is intended to provide a connectionless transport system providing reliable transfer of signaling messages between the locations of communicating user functions. It is specified in Recommendations T1.111.1 through T1.111.8.

**T1.111.1** — *Functional Description of the Message Transfer Part* — This is an overall description of the signaling system and the division of functions and interactions between the MTP and the other parts.

**T1.111.2** — *Signaling Data Link* — This specifies the physical, electrical, and functional characteristics (level 1) of a signaling data link and the means to access it.



**Legend:**

- ISDN = Integrated Services Digital Network
- OSI = Open Systems Interconnection
- SCCP = Signaling Connection Control Part

**Figure 6-64.** SS7 Protocol Architecture

- 
- T1.111.3** — *Signaling Link* — This level-2 protocol specifies the use of flags for signal delimitation, an error-monitoring and link-acceptance procedure, and a basic method of error detection and correction using a 16-bit Cyclic Redundancy Check (CRC) code, along with positive and negative signal acknowledgments and retransmission in the case of error. A forward error correction scheme is also specified for links with long delays (for example, satellites).
- T1.111.4** — *Signaling Network Functions and Messages* — These level-3 signaling network functions and procedures include transfer of messages from origination to destination on the signaling network, with sequencing provided by consistently used signaling link-selection codes, reconfiguration of routes due to failures, sending management information about abnormal situations in the signaling network, and controlling traffic in the event of congestion.
- T1.111.5** — *Signaling Network Structure* — This section presents network architecture considerations and numerous examples demonstrating the procedures of T1.111.4 for a sample mesh network.
- T1.111.6** — *MTP Signaling Performance* — Performance considerations and requirements are presented here, including availability, errors, delays (queuing and cross-office), and capacities.
- T1.111.7** — *Testing and Maintenance* — A limited capability for testing the signaling links and the network routing is provided here.
- T1.111.8** — *Numbering of Signaling Point Codes* — This recommendation describes the allocation of network identification codes to networks in the national SS7 environment.

### 6.23.3.3 Signaling Connection Control Part — SCCP (T1.112.x)

The SCCP modifies the connectionless sequenced transport service provided by the MTP for those user parts requiring enriched connectionless or connection-oriented service to transfer signaling (and other) information between nodes. User-part interfaces consistent with that of the OSI network layer (for example, primitives of the form N-CONNECT or N-DATA) are used at the user/SCCP interface. Also, a subaddress called the Subsystem Number (SSN) is used to identify users of the SCCP.

The protocol used by the SCCP to provide network services is divided into four protocol classes defined as follows:

- 0 Basic connectionless
- 1 Sequenced (MTP) connectionless
- 2 Basic connection-oriented
- 3 Flow-control connection-oriented.

---

To date, Classes 0, 1, 2, and 3 have been fully specified by ITU-T. Only Classes 0 and 1 are currently included in the Bellcore (or ANSI) description of SCCP; connection-oriented procedures for North America have not been developed.

In addition, the SCCP provides specialized services such as global title translation, where an address specified by the user as a global title (a logical address different from the physical network address) is translated into a corresponding point code and subsystem number. The SCCP also provides functions to manage equivalent or identical applications at multiple SPs using global title translation.

**T1.112.1** — *Functional Description of the SCCP* — This recommendation contains a general description of the functions within the SCCP, the services provided to users and assumed from the MTP, and the primitives for interlayer services.

**T1.112.2** — *Definitions and Functions of SCCP Messages* — This defines the meaning of each message and of the various information elements contained in each message and the mapping of elements to messages.

**T1.112.3** — *SCCP Formats and Codes* — The SCCP messages consist of the following:

- One octet mandatory message-type code that uniquely defines the function and format of each message
- Fixed mandatory part containing the values of a set of predefined, sequenced, fixed-length parameters for that message type
- Variable mandatory part consisting of pointers to parameters; the parameter length; and the value of a set of predefined, sequenced, variable-length parameters for that message type
- Optional part consisting of name, length, and value of a set of optional parameters.

**T1.112.4** — *SCCP Procedures* — This recommendation details the procedure for SCCP connectionless transport services, for SCCP connection-oriented transport service, for specialized addressing and routing by the SCCP, and for management of multiple translation points and end point/databases.

**T1.112.5** — *SCCP Performances* — This chapter defines Quality of Service (QoS) parameters as seen by the user of the SCCP. It also defines internal parameters, not seen by the SCCP user, which contribute to a QoS parameter. Connectionless SCCP and connection-oriented SCCP parameters are described and values are specified for internal parameters.

#### 6.23.3.4 Integrated Services Digital Network User Part — ISUP (T1.113.x)

The ISUP is a user part of SS7 that provides connection-related services for control of ISDN and non-ISDN circuits. These include control of digital and analog circuit-switched

---

---

network connections between exchanges, and the provision of related services such as calling- and called-party identification, call redirection, and operator services. ISUP also provides some network management capabilities for control of the ISDN interoffice network. The network management capabilities include allowing one exchange to block calls on a trunk or trunk group basis (in case of failure, for example) and detecting and releasing call setup attempts requiring an excessive number of trunks (due to routing table errors creating loops, for example). Because of its role in connection control, there is a correspondence between many of the capabilities of ISUP and the specification of D-channel access signaling protocol for ISDN.

The ISUP uses the transport capabilities of the MTP and SCCP to carry messages from exchange to exchange:<sup>1</sup>

**T1.113.1** — *Functional Description of the ISDN User Part* — This gives an overview of the signaling functions provided by the ISUP.

**T1.113.2** — *General Function of Messages and Signals* — This recommendation describes the messages and elements of signaling information and their functionality as employed by the ISUP.

**T1.113.3** — *Formats and Codes* — The encoding of signaling information elements and the format of the messages in which they are conveyed. ISUP messages are specified here and consist of the following:

- Two octets (14 bits) of Circuit-Identification Code (CIC) to reference a particular circuit
- One octet mandatory message-type code, which uniquely defines the function and format of each message
- Fixed mandatory part containing the values of a set of predefined, sequenced, fixed-length parameters for that message type
- Variable mandatory part consisting of pointers to parameters, the parameter length, and the value of a set of predefined, sequenced, variable-length parameters for that message type
- Optional part consisting of name, length, and value of a set of optional parameters.

**T1.113.4** — *ISDN User Part Signaling Procedures* — This recommendation details the procedures for basic call control and for providing a variety of other services with the ISUP.

---

1. The SCCP would be used when messages are intended to be end-to-end (that is, when they do not pass through all exchanges in a connection, but may be sent directly from end exchange to end exchange). No ISUP services that use SCCP transport have been standardized.

---

---

**T1.113.5** — *Performance Objectives in the ISDN Application* — Availability, dependability, and cross-exchange delay objectives are presented in this recommendation.

#### 6.23.3.5 Transaction Capabilities Application Part — TCAP (T1.114.x)

The TCAP of SS7 supports non-circuit-related information transfer between signaling nodes. It provides a generic framework protocol based on the OSI protocol for remote operations (which can be used to invoke functions and procedures at remote nodes), and an SS7-specific transaction-level protocol (which serves to associate operation requests together as a transaction) (CCITT *Blue Book*). TCAP leaves the detailed definition of the operations themselves and accompanying data to be service-specific except where operations and parameters are clearly applicable to a wide variety of services. The initial specification is intended to support services requiring transactions among exchanges and databases, such as number translation and billing verification. These existing procedures use connectionless network (SCCP) service only.

**T1.114.1** — *Functional Description of Transaction Capabilities* — This gives an overview of the functions provided by TCAP and of the layered architecture modeling interactions within TCAP and with TCAP users.

**T1.114.2** — *Transaction Capabilities Definitions and Functions* — This recommendation describes the messages and parameters that have been standardized for use in TCAP.

**T1.114.3** — *Transaction Capabilities Formats and Codes* — This describes the detailed formats and codes used for messages and parameters in TCAP. The coding of messages and parameters follows an OSI coding methodology. Each message consists of the following portions:

- Transaction portion with package type and transaction IDs
- Dialogue portion<sup>1</sup> containing protocol version, application context, and other information applicable to the conversation between two peer applications.
- Component portion containing component type, component IDs, operations, and parameters.

**T1.114.4** — *Transaction Capabilities Procedures* — This section gives the detailed procedures for transaction-level interaction and component-level interactions between signaling nodes.

**T1.114.5** — *Definitions and Functions of Transaction Capabilities Operations, Parameters, and Error Codes* — This section standardizes the encodings for specific

---

1. The dialogue and component portions are optional. However, either the dialogue or component portion or both must be present. In practice, the dialogue portion is usually treated as optional and the component portion as mandatory.

---

transaction capabilities operations (and their related parameters) used by a variety of applications. Error codes for common errors detected by applications are also listed.

#### 6.23.3.6 Operations, Maintenance, and Administration Part — OMAP (T1.116.x)

OMAP specifies the protocol for managing the CCS network using SS7 to transport information between signaling points. Architecturally, OMAP lies above TCAP in the SS7 protocol stack, using the remote operations service of TCAP to communicate between OMAP applications.

OMAP specifies the following five procedures:

1. *MTP Routing Verification Test (MRVT)* - verifies MTP routing data for a network node.
2. *SCCP Routing Verification Test (SRVT)* - verifies SCCP routing data for a global title address.
3. *Link Equipment Failure (LEF)* - notifies a signaling point of a signaling terminal or interface equipment failure at the far end of a signaling link.
4. *Link Fault Sectionalization (LFS)* - identifies the failed component on a signaling link.
5. *Circuit Validation Test (CVT)* - verifies that two exchanges have sufficient and consistent translations data for placing a call on a specific circuit of an interexchange circuit group.

The OMAP specification describes detailed application-level procedures and message formats for each procedure.

#### 6.23.3.7 Interworking Specification — (T1.609)

This specification,<sup>1</sup> while not precisely part of the SS7 specifications, defines the interworking of SS7 and ISDN access protocol (Q.931) for the control of basic calls. It is based on a model of call processing that has the individual protocol-processing blocks for SS7 ISUP and Q.931 protocols interacting with a higher-level call-control block. This block contains functions such as routing of the call and through-connection of the information path. The interworking specification contains sections defining successful call setup, normal call release, unsuccessful call release, and suspend/resume, each of which has the following format:

- *Arrow diagrams* showing message flows in typical call sequences, such as successful setup using enbloc address signaling, and successful setup using overlap addressing in the originating Q.931 access.

---

1. This specification is not currently included within GR-246-CORE. However, other Bellcore GRs address ISUP-Q.931 protocol interworking.

- 
- *Parameter tables* showing the relationship of parameters in matching messages from ISUP and Q.931 such as the mapping of parameters in the setup and initial address messages.
  - *Parameter mappings* showing the detailed mapping of parameter values in cases where this is somewhat complex.

## 6.23.4 SS7 Network-Layer Protocol and Performance

### 6.23.4.1 Network-Layer Protocol

The MTP, which is itself layered and includes layers (levels in SS7 terminology) corresponding to the physical, data-link, and network layers, provides a connectionless network service to its users. The MTP routes a message to the proper SP (node) within the network and delivers it to the correct MTP user at that point. There are a limited number of direct MTP users. Three of these direct users are of interest in U.S. networks:

1. MTP signaling-network management, an entity which performs management of the signaling network itself
2. ISUP, which is an application-layer protocol used by call-processing applications to control bearer connections
3. SCCP, which uses the MTP on its own behalf for some management interactions, but predominantly uses the MTP as an agent for SCCP users, which are termed subsystems.

The initial design of SS7 did not include the SCCP. The SCCP was added to meet the need for additional services beyond those provided by MTP. These services include routing of messages on the basis of global titles,<sup>1</sup> transparent management of routing to applications that have been duplicated on more than one physical node for reliability or capacity, and connection-oriented data transfer. Existing direct users of the MTP (that is, ISUP) retained a direct interface to the MTP.

Since SS7 currently does not include a transport layer, the network layer must directly provide the quality of service required by the applications. An extensive set of management procedures to route traffic around failures of network components is provided in the MTP and SCCP. These procedures, in combination with a network design that includes sufficient spare capacity and physical diversity of routes, enable a very high-quality network service to be provided. Note that the SCCP is not used to improve the quality of service offered by the MTP, but to provide additional functions, such as segmentation and reassembly, and

---

1. A global title is an address, such as customer-dialed digits, that does not explicitly contain information that would allow routing in the signaling network. This allows an application to specify a logical address for the message rather than having to provide the explicit physical location of the destination node.



---

logical addressing. A message is acted upon by the MTP at every SP through which it passes. It is acted upon by the SCCP, however, only at those points at which the additional functions provided by the SCCP are needed (perhaps only at the origination and destination points).

The underlying SS7 network service is connectionless, with connections built above the connectionless service in case they are needed. Today, almost all interactions of applications over the signaling network (for example, the exchange of messages to set up a call) involve a small number of messages, and connection establishment and disconnection would add significant overhead. A possible way to use connections and avoid the overhead problem would be to maintain permanent or quasi-permanent connections among the applications that interact frequently.

This solution, however, has a number of inherent problems. Signaling links fail with non-negligible frequency, and management procedures to maintain or reestablish all the connections using the failed link would be more complex than those used to update connectionless routing tables to bypass the failure. Also, balancing traffic loads across parallel links within the network by distributing messages appears to be much simpler than balancing load by distributing connections among the parallel links.

Thus, the needs of the applications and ease of network operation both seem to point in the direction of connectionless data transfer. Nonetheless, there is one feature usually associated with connection-oriented transfer that is frequently needed by signaling applications, namely, in-sequence delivery of information (out-of-order control messages can be hazardous to network operation). However, the MTP is able to maintain message sequencing with very high probability despite its connectionless operation. The MTP user generates a value for a Signaling Link Selection (SLS) field as a parameter for each message. As the message is routed through the network, wherever there is a choice between alternative links, the selection is made based on the SLS value in the message. Thus, when in-sequence delivery of several messages is required, the user must simply give the same SLS parameter for all of them. They will follow the same path through the network and be delivered in order. Even if a link fails in the middle of the sequence, the management procedures that reroute traffic around the failure will maintain the sequencing with high probability.

To date, standardization work in the U.S. on connection-oriented services within the SCCP has diminished due to a lack of immediate need. Therefore, the basic choice of connectionless operation for the foundation of the network layer seems justified at present.

#### 6.23.4.2 Functions and Performance of the SS7 Network Layer

This section gives important functions and performance characteristics of the SS7 network-layer service as seen by users of that service. These *users* are typically applications within network nodes. There are five network-layer functions:

- 
- *Data Transfer* — The SS7 network layer offers both connectionless and connection-oriented data-transfer services. Direct users of the MTP receive connectionless service,<sup>1</sup> although they can obtain in-sequence delivery of information by requesting the appropriate class of connectionless or connection-oriented service. The connection-oriented classes offer message segmentation and reassembly, and the more powerful class offers flow control and other additional functions to implement the OSI network-layer service.
  - *Addressing Options* — Direct MTP users address their peers with a point code, which labels the destination SP; and a service indicator, which directs the message to the proper MTP user at that SP. SCCP users can address a peer with the point code of the SP plus a subsystem number that identifies the user at that point. Alternately, the SCCP user can address a peer via a logical address, termed a global title. SCCP functions translate the global title into a point code plus subsystem number in order to deliver the information. The use of a global title to reach an application (for example, 800-number translation), permits the application to be moved among the physical nodes of the network without having to inform every entity that needs to talk to the application. The protocol itself gives essentially no restrictions on what information can be used as a global title, although most current users use some form of telephone number.
  - *Routing* — The MTP bases its routing of a message on the message's destination, which is identified by the Destination Point Code (DPC). When SCCP logical addressing is used, the SCCP translation function derives a DPC for use by the MTP.
  - *Message Priorities* — Each message is assigned one of four congestion priorities (0 through 3, with 3 being the highest). This is done so that the least important traffic can be shed first in the event of network congestion.
  - *Management Feedback* — Users are given information on the inaccessibility/unavailability of peers and on the congestion status of route sets to the peer (for example, what is the lowest priority message that can get through?). Users are expected to respond to this information and stop generating undeliverable traffic, although the network can protect itself even if the user ignores the information.

Network-layer performance objectives are taken from Section T1.111.6:

- *Unavailability* — Any signaling route set (the union of all paths through the signaling network between two SPs that need to communicate) should be unavailable no more than 10 minutes per year, on the average. Today this objective is about the best that can be obtained with 2-way facility diversity for signaling links, and is also comparable to the unavailability objective for switching systems.
- *Message Loss* — Not more than 1 in  $10^7$  messages should be lost. This objective follows from an objective that signaling error results in the failure of not more than 1

---

1. The service is connectionless at layer 3 even though there may be a connection at layer 2 (for example, a signaling link, between the origination and destination SPs).

---

in  $10^4$  circuit-connection attempts, plus the fact that a circuit-connection attempt may involve several pairs of SPs and at least four to six messages between each pair of SPs.

- *Mis-sequenced Messages* — A stringent objective is set that not more than 1 in  $10^{10}$  messages be duplicated or delivered out of sequence. It is not clear precisely how the 1 in  $10^{10}$  number was arrived at beyond the fact that, in general, out-of-sequence control messages are more troublesome to deal with than a missing one, which usually can be covered by a timeout. Therefore, the objective for out-of-sequence delivery was made much more stringent than the objective for dropped messages.
- *Errored Message Delivery* — The probability of delivery of a message with an undetected error should be less than 1 in  $10^9$ . In today's transmission facility network, raw error rates in the vicinity of one errored message per thousand must be tolerated. The error-detecting power of the 16-bit CRC in the current data-link layer protocol results in a residual rate of about 1 in  $10^9$ .
- *Delay* — Although there are delay objectives for specific services or uses of the SS7 protocol, SS7 itself does not specify any end-to-end delay objectives. However, there are objectives for some components of the end-to-end delay, and others can be calculated. Therefore, given a network configuration, the delay between any two specific SPs can be estimated. This delay will be the sum of queuing, emission, and propagation delays on the links and network layer relaying delays at the STPs (if any) that messages must traverse between the two points.

Links are engineered so that the mean queuing delay on a link is approximately 0.5 of the mean message emission time on the link. In situations where alternative links have failed and additional traffic has been rerouted onto the link, mean delays may reach two to three times the message-emission time (mean message emission time is the mean message length divided by the link speed).

The mean time to relay a message through an STP at the MTP level — exclusive of link queuing and emission delays — is approximately 20 ms at normal loads and about 45 ms when the mate STP is unavailable and the load on the STP is doubled. The STP relay times are approximately doubled if SCCP global-title translation processing is required. These figures are obtained from GR-82-CORE, *Signaling Transfer Point (STP) Generic Requirements*.

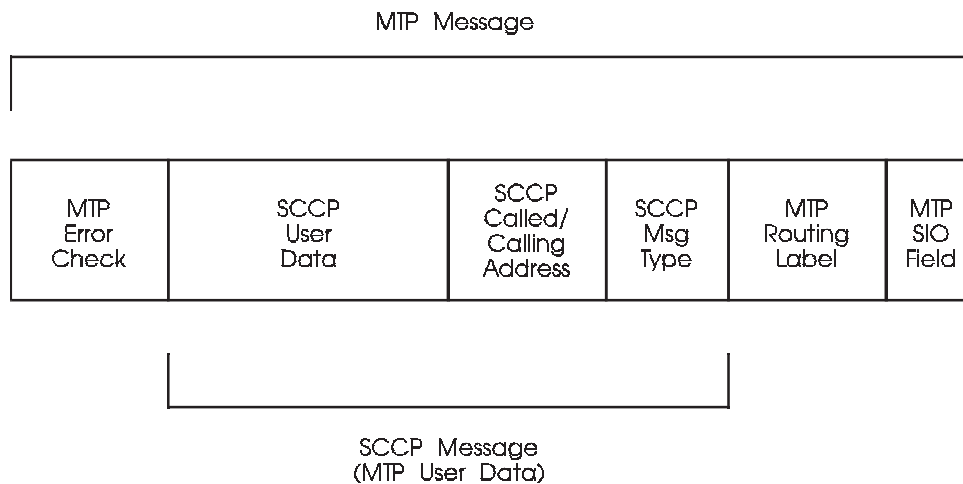
- *Throughput* — Although the protocol for higher-speed links has been specified, typical SS7 networks use 56/64 kbps links. If more traffic capacity is needed between two points, additional parallel links can be installed to a maximum of 16. As links are engineered to about 40-percent occupancy, the maximum capacity between adjacent points with 56 kb links is about 360 kbps.
  - *Maximum Message Size* — To allow space for the MTP routing label, a direct user of the MTP can place up to 264 octets in each message. In the SCCP connectionless data classes, user data cannot exceed 255 octets per message. In addition, the user data plus
-

the SCCP protocol-control information must fit within the 264-octet limit for MTP user data.

### 6.23.5 Message Transfer Part

The SS7 protocol is divided into several functional parts (see Figure 6-64). The MTP (which consists of three levels: physical, link, and network) provides the basic functions of routing messages between nodes of the signaling network and is implemented in all nodes of the network. Routing is based on an address allocated to each node in the network, known as a point code. Each node can be located by at least one unique point code. However, a node may be assigned multiple point codes, where some point codes are used to refer to a mated pair of nodes rather than a single node. This *alias* point code, or *capability code*, may then be used to distribute traffic dynamically to the mated pair.

The MTP acts upon the parts of the message known as the routing label and Signaling Information Octet (SIO). The routing label contains the point codes of the originating and destination nodes, and the SLS field to select a specific outgoing link from among a group of links to the same destination. The SIO identifies the MTP user that has generated the message, and specifies which MTP user should receive the message at the destination node. Information for protocol layers above the MTP is carried in a user data parameter within the MTP. Figure 6-65 shows the basic message structure.



**Legend:**

MTP = Message Transfer Part  
 SCCP = Signaling Connection Control Part  
 SIO = Signaling Information Octet

**Figure 6-65.** Basic Message Structure

When a message is received by a node, it uses the DPC in the routing label to determine if it is the destination intended for the message. If not, the message is sent out on an outgoing signaling link determined by routing tables in the node. If the node is itself the destination of the message, then the information in the user-data field of the MTP is passed to an MTP-user specified in the SIO (this may be the SCCP or ISUP). Figure 6-66 shows the procedure for message processing.

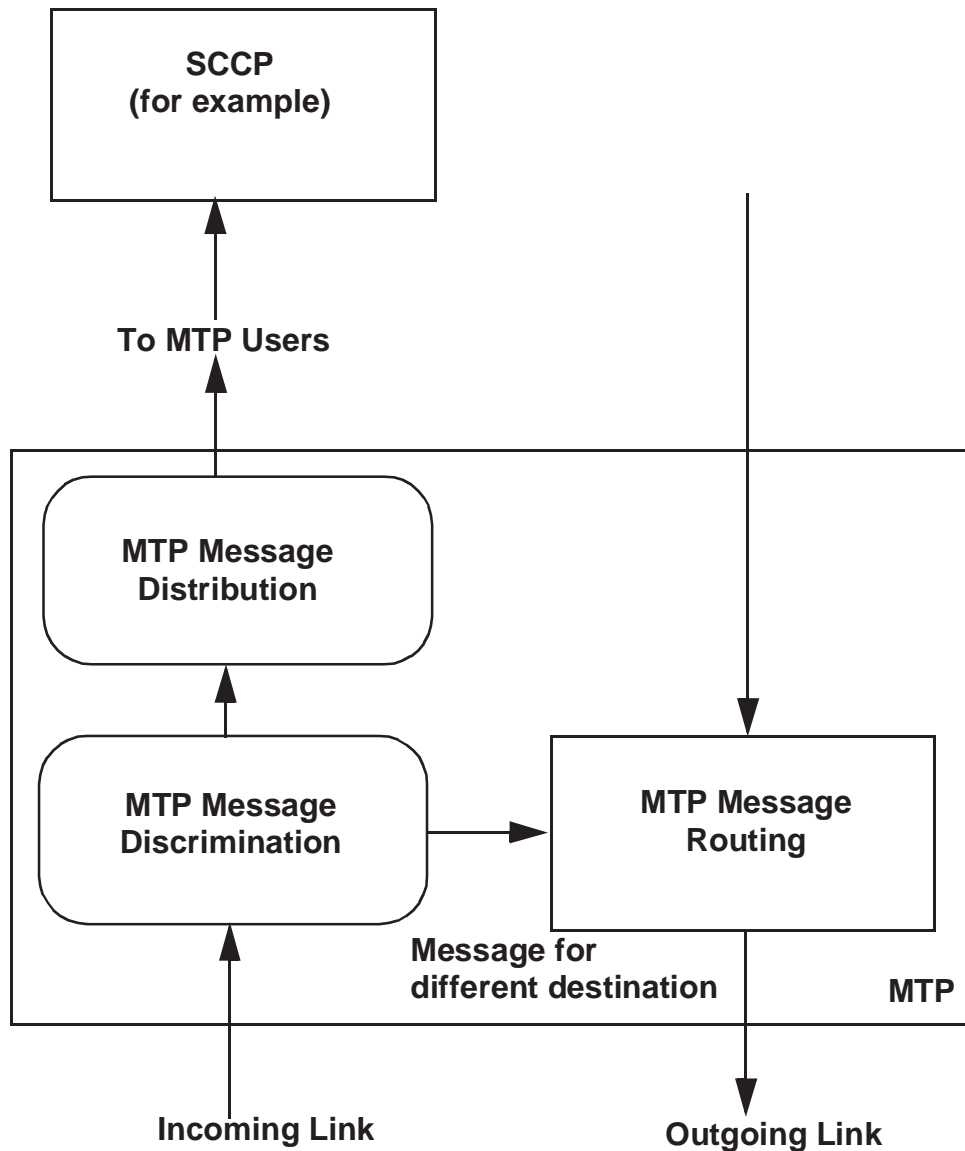


Figure 6-66. Procedure for Message Processing

#### 6.23.5.1 Link-Layer Protocol

This section examines the characteristics of the layer-2 operation for SS7. The SS7 layer-2 specification is found in T1.111.3.

The purpose of T1.111.3 is to convey layer-3 information between adjacent network-signaling nodes. Each link operates at 56 or 64 kbps. Errors in network signaling could have a significant impact on network operation. Therefore, T1.111.3 also provides error detection and correction to compensate for any physical-layer errors.

#### 6.23.5.2 Signal Unit Delimitation and Length

The beginning and end of a signal unit is indicated by a unique 8-bit stuffing pattern, called the “flag.” A bit-stuffing technique is used on the user data to ensure that the flag pattern is not imitated elsewhere in the signal unit. The default maximum number of octets in the information field for T1.111.3 is 272 octets.

#### 6.23.5.3 Error Detection and Correction

Detection and correction of layer-2 errors provide for a reliable information transfer of layer-3 information. In T1.111.3, error detection is accomplished using a CRC-16.

Two forms of signal unit error correction are provided. The “basic method” and the “preventive cyclic retransmission method.”

#### 6.23.5.4 Sequence Control

The protocol uses a transmitter-based sliding-window mechanism for sequence and error control. The sliding window operates in a modulo 128 mode.

#### 6.23.5.5 Link Status Signal Unit

In T1.111.3, layer-management information is sent using the Link Status Signal Unit (LSSU). This function is not used to provide a service to the next higher layer. It is only used for link-layer management.

#### 6.23.5.6 Unique Functions of T1.111.3

T1.111.3 provides two unique functions: a link *proving-in* period and error monitoring. The proving-in period serves to verify that the link is operating with an acceptable error rate

---

---

before data transfer can occur. Repeated failure to obtain acceptable service during proving-in will result in the link being removed from service. Two different proving-in time periods are defined — normal and emergency. The normal proving-in period typically lasts a couple of seconds, and the emergency period is about one-half of a second.

The other function provided by T1.111.3 is error monitoring during data transfer. During normal operation, errors are counted with a *leaky bucket* monitor that triggers the link's removal from service if an error-rate threshold is exceeded. No special messages are required for this monitoring function.

### 6.23.6 Signaling Connection Control Part

The SCCP of SS7 protocol provides additional network routing and management services. The SCCP is used when sending signaling traffic that is not directly related to the control of circuits (for example, queries and responses exchanged between switches or from switch to database). It is also used for circuit-related messages that can be sent end-to-end, that is, which affect only the originating and terminating SPs. This section describes the use of addressing in the SCCP, providing information on basic SCCP routing procedures and on the use of global-title addresses.

The SCCP is a user of the MTP, identified by a particular value of the SIO in the MTP. The SCCP provides several additional network-layer functions, such as the ability to identify specific application processes within a node (for example, 800 service or calling-card verification applications); additional management procedures to support the use of replicated databases; and the ability to support virtual connection service over the MTP, which is purely connectionless. The SCCP provides an OSI-like interface to higher-layer protocols in order to simplify the development of applications using SCCP.

SCCP may not be implemented in all nodes of a network, as some nodes may only need the MTP functionality. The SCCP is implemented in those nodes where non-circuit-related signaling or end-to-end signaling is originated and terminated, and those STPs involved in SCCP address translation and database management.

#### 6.23.6.1 SCCP Routing Principles

SCCP routing procedures for connectionless service are based on the SCCP called-party address parameters carried in the Unitdata and Unitdata Service messages. Recently, Extended Unitdata and Extended Unitdata Service messages have added the capability to base SCCP routing on the optional Intermediate Signaling Network Identification (ISNI) parameter. Once the intermediate networks listed in the SCCP ISNI parameter have been transited, SCCP routing reverts to the standard or established procedures based on the SCCP called-party address.

The SCCP called-party address is analyzed to determine routing of the SCCP message. Two forms of address information may be used in the SCCP called-party address:

1. The address may consist of an SSN explicitly identifying the application within the receiving node that should receive the information carried within the message.
2. The address may consist of a global title, in which case the SCCP must refer to a translation table to determine whether the message should be processed locally or passed to another node, and what the outgoing address should be. If it must be sent out, the message is passed back down to the MTP with a new DPC determined from the translation.

The address parameter contains indicators that identify what address information is present, such as the following:

- Whether the address contains point code, SSN, or global title
- Whether SSN or global title is to be used as the basis for routing
- What the global title format is.

For certain applications, both SSN and global title may be present in the address. The routing indicator in the address indicator field identifies if the global title is present for routing purposes or is supplied for information only.

Point codes are not normally included in the SCCP called-party address, since this duplicates information found in the MTP routing label. Therefore, the SCCP routing procedures currently ignore any point code found in the Point Code field of the SCCP called-party address. An exception to this general rule is the “Global Title equals Point Code” Translation Type, the definition of which was prompted by development of the ISNI network capability. In this case, the Global Title field (not the Point Code field) of an SCCP address is populated with a point code to facilitate SCCP routing based on ISNI information. When any required ISNI-based routing is complete, the point code is passed to the MTP to complete routing of the message.

The SCCP calling-party address serves a different purpose. It indicates where a message originates, and is used to identify where to route the response to the message or where to return undeliverable messages. The information contained in the SCCP calling-party address is used by the application when creating the MTP routing label and the SCCP called-party address in a response message. It is also used in the Unitdata Service message when the original message cannot be delivered and the message-return service has been requested. The SCCP calling-party address may contain a point code, an SSN or a global title, or some combination of these.

When a global title translation is expected or ISNI routing or identification functions are required by the SCCP, the inclusion of a point code or global title in the SCCP calling-party address becomes necessary since intermediate processing of the message above the MTP level, such as global title translation, will result in a change to the MTP Originating Point Code (OPC) of the message.

---



---

In cases where no translation is necessary (the message is routed directly to its destination using the routing label alone), the OPC from the routing label may be used to identify routing of the response. In this case, the SCCP calling-party address may consist of a subsystem number only. In general, however, it is preferable to include a point code or global title in the SCCP calling-party address for all cases.

### 6.23.7 Global Title Addressing

A global title is an address, such as customer-dialed digits, that does not explicitly contain information that would allow routing in the signaling networks. This allows an application to specify a logical address for the message rather than having to provide the explicit physical location of the destination node. The SCCP function at the source must then send the message to a node that will provide the global title-translation function, using the translator node's point code in the MTP routing label, and the global title in the SCCP called-party address. The translator node performs a translation on the global title to determine further routing information and sends the message with a new routing label (including the translator's point code as the OPC) and a new called-party address.

The intent of global title capability is to reduce the amount of information that the source node is required to know about locations of applications in the network and their status. A source exchange is not required to know the physical location of an application and does not need to maintain knowledge of location changes due to failure or the introduction of new equipment into the network. Instead, the translator node maintains any information about physical locations in the network. Any SS7 node could, in principle, perform translation, but translation typically occurs in an STP. The administrative task of updating translation tables is then limited to the STPs performing translation, typically a much smaller task than updating tables in each of the exchanges that may create a message.

The use of global titles is incorporated into SCCP management procedures. The management procedures allow databases to be provided in a primary/secondary configuration, such that the primary database handles queries under normal conditions, while the secondary database will take over traffic gracefully in the event of a failure or maintenance outage of the primary. The procedures operate by requiring that translator nodes be notified in the event of a node or subsystem failure, so that the global title-translation tables are updated to send traffic to the backup system. The procedure is transparent to the source nodes and requires no action on their part. The SCCP management procedures also allow a configuration with multiple replicated databases based on priorities.

The SCCP management has been extended to allow SCCP loadsharing of GT routed messages among a group of databases. The databases are assigned equal priority and the adjacent STPs use an implementation-dependent scheme to distribute the traffic among the databases.

---

### 6.23.7.1 Guidelines for Using Global Title-Translation

Global titles should be used when the application involved is supported by replicated databases. Global titles may also be used in other arrangements if they simplify the amount of administration that must take place at the exchange. However, there is a significant impact on STP capacity caused by the global title-translation function, which differs from implementation to implementation. The advantages of using global title translation are summarized below.

- *Administrative Advantages* — Locations of functions in the network (for example, 800-number translation) can be changed more easily based on the growth of traffic or introduction of new technology. These changes do not require administration of tables in the switch.
- *Management* — Translations allow the STP to manage response to failures in the network, and the exchange to be ignorant of such failures. The exchange is not required to store the status of subsystems in the network or to perform status tests when a failure has taken place.
- *Security* — For internetworking, the use of global titles may provide a measure of security in the network, since the global title does not contain explicit information about the location of functions in the network. In practice, this must be weighed against the additional processing that is required to do global-title rather than explicit addressing.
- *Flexibility* — Global titles are, by design, not restrictive in structure. Although the typical current global title is part of a directory number, in theory any kind of number can be used, such as a point code, or a number referring to a particular service.

There are also disadvantages to using global titles. They are based largely on performance. These disadvantages are summarized below.

- *Added Processing* — In some current STP implementations, global-title translation can be a bottleneck, as the throughput for messages using global title addressing may be a third to a half of the throughput for explicit MTP routing. The reduction in throughput varies depending on the architecture of a particular STP.

Translation may also add delay to message-processing time in some implementations, although the additional delay appears to be minor.

- *Management* — Since the use of global titles removes knowledge of physical location from the exchange, the exchange may be unable to take action to decrease traffic if the database function fails completely. If the message-return service has been used, the exchange will be informed via the Unitdata Service message that a particular address is unavailable due to node or subsystem failure. An individual address may not be sufficient to identify what subsequent traffic should be canceled, however, since the address does not correspond to a physical location. Information that translation of a particular 800 number cannot be done may not be sufficient to indicate that all 800

queries cannot be processed (for example, if 800 queries are processed by multiple pairs of SCPs).

Moreover, after a message undergoes global-title translation, the translating node becomes the *originator* of the message at the MTP level (its OPC is used in the routing label). Any subsequent MTP congestion information is sent to the translator rather than the source node.

Therefore, no procedures have been developed on receipt of the Unitdata Service message at an exchange when global titles are used. Any procedures would be difficult to generalize due to the flexibility in use of global-title addressing.

This type of management action becomes necessary only when both primary and secondary have failed, and some action is necessary to maintain service. Most services to date have defined default actions when no response has been received to a query, and they do not generate additional traffic in the network when this occurs.

#### 6.23.7.2 Procedures for Translation

A global title indicator field indicates the format of the global title. Global title format for indicator value 2 has been specified for use in US networks. In addition, the global title may include subfields, such as a numbering plan and encoding scheme, as well as the global-title value itself.

The receiving node uses the specified translation table to translate the global-title value to new address information. The organization of translation tables is not specified in the protocol and is left to network administration.

The protocol allows the results of translation to be any combination of point code, subsystem number, or new global title. Table 6-48 shows some typical possibilities.

**Table 6-48.** Typical Global Title Translations

Translating Node	Received SCCP Address	Translation	New SCCP Address
STP	GT*	GT-->PC**+SSN	SSN PC used in routing label
STP	GT+SSN	GT-->PC	SSN PC used in routing label
STP	GT	GT-->PC+GT	GT PC used in routing label
Endpoint	GT	GT-->SSN	None, message terminates

\* Global Title

\*\* Point Code

The global title is currently retained after translation. This provides additional routing information if the message must be returned due to routing failure, and allows generation

of the outgoing message without altering the length indicators and pointers. Two examples of global-title use follow.

- In 800 service, global titles are used to route queries to the correct database for translation of the 800 number. The global-title value is the first six digits of the 800 number, and the translation type is network-specific. For more information, see TR-NWT-000533, *Service Switching Points*.
- In Alternate Billing Service (ABS), global titles may be used to route queries for calling-card verification. The global title used consists of the first six digits of the ANI or billing number of the calling customer, as described in FR-271, *Operator Services Systems Generic Requirements*.

### 6.23.8 ISDN User Part

The ISUP protocol defines the functions, procedures, and interexchange signaling information flows that enable voice and nonvoice calls over circuit-switched connections between ISDN access points to be set up, supervised, and released. Non-ISDN connections also use ISUP for call setup. ISUP was developed on the basis of the requirements imposed by existing voice and nonvoice services and the need for a flexible design to accommodate future ISDN capabilities for new services and new connection types. A further important consideration was the need to interwork with the D-channel protocol that was under development at the time.

The following sections present a general description of the ISUP protocol in terms of its principal capabilities, procedures, and signaling-information flows.

#### 6.23.8.1 Services Supported by the ISUP

The ISUP supports three types of service: basic service, supplementary service, and end-to-end signaling. The basic service provided by the ISUP protocol is the setup and release of a simple call involving a single circuit-switched connection between the exchange terminations of two subscriber-access lines.

For circuit-switched data calls over 64-kbps transparent connections, the protocol permits the selection of any one of the data bit rates that are internationally specified by the user classes for the synchronous-terminal operating mode in public data networks.

In addition to basic service, the ISUP protocol supports supplementary services, such as user access to calling-party address identification, redirection of calls, operator services, and malicious-call identification. The last type of service is end-to-end signaling. End-to-end signaling may be regarded as the transfer of information that, although related to a call, is not directly related to the control of a circuit. Typically, an information transfer such as this may occur between the originating and terminating local exchanges to request, or to

---

---

respond to a request for, supplementary information related to an existing call between the two exchanges.

The service provided by the ISUP protocol to support end-to-end signaling is implemented by the so-called pass-along procedure. As the name implies, information pertaining to a given call is passed along the route of transit exchanges during which the circuits involved in the call are interconnected. The only action taken by a transit exchange is the readdressing of received pass-along information, so that it may be forwarded to the next exchange in the chain. An alternative to this method of end-to-end signaling is mentioned in the following section.

#### 6.23.8.2 Services Required by the ISUP

ISUP information to be passed from one exchange to another is packaged in accordance with a prescribed format. Each of the message types that have been standardized so far serves a specific purpose. Thus, the initial address message is used to initiate call setup and contains the address of the called party, the identification of the requested connection type, and other information required to establish a connection. For the transport of these messages to other exchanges, the ISUP relies on the services provided by the MTP. Figures 6-67 and 6-68 depict the ISUP message and information element formats, respectively.

As already mentioned, end-to-end signaling may be accomplished by using the pass-along service of the ISUP protocol. An alternative method makes use of the services of the SCCP of SS7. This method is universally applicable and, unlike pass-along, is independent of the presence/absence of a circuit connection between the exchanges originating and terminating the message.

#### 6.23.8.3 Signaling Procedures

The ISUP protocol defines the procedures associated with the transfer of signaling information and the exchange functions that process the received information. As a consequence, this protocol may invoke further information transfers. The protocol describes, for instance, the procedure that selects an outgoing circuit based on received called-party-address information and on the signaling procedure that causes the subsequent sending of the identity of the selected circuit to a succeeding exchange.

#### 6.23.8.4 Trunk-Management Procedures

Certain procedures are specified in the ISUP protocol that permit circuits or groups of circuits to be blocked (that is, removed from use for regular traffic); unblocked; or reset, where resetting allows the alignment of the circuit state in the two exchanges on which it

---

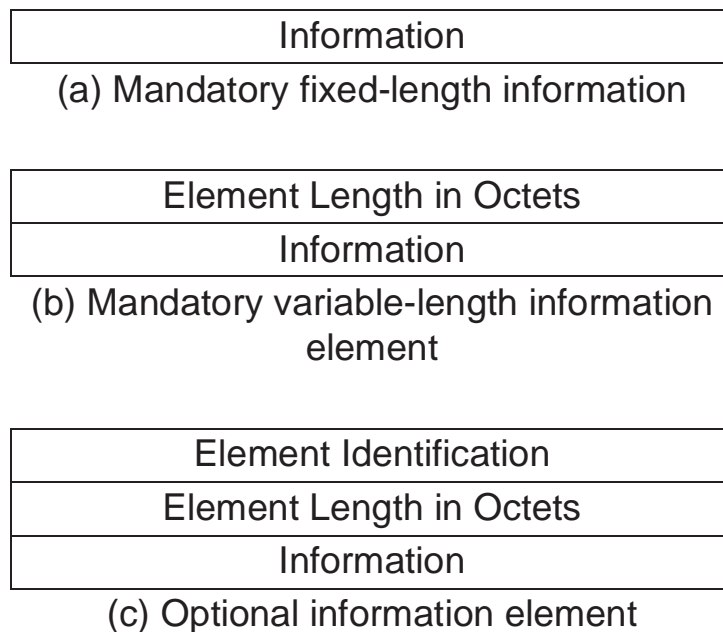
terminates. The set of messages provided in the protocol for the purpose of circuit control includes the following:

- Blocking and blocking acknowledgment messages
- Unblocking and unblocking acknowledgment messages
- Circuit-group blocking, circuit-group unblocking, circuit-group blocking acknowledgment, and circuit-group unblocking acknowledgment messages
- Reset circuit messages
- Circuit-group reset and circuit-group reset acknowledgment messages.

In general, the messages related to a single circuit (for example, blocking) contain the identity of the concerned circuit, while circuit-group-related messages include a range of circuits and an indication of the circuits within that range that are affected (for example, need to be blocked in the case of a circuit-group blocking message).

8	7	6	5	4	3	2	1
Routing Label							
Circuit Identification Code							
Message Type							
Mandatory Fixed-Length Information Elements							
Pointers to Mandatory Variable- Length Information Elements							
Mandatory Variable-Length Information Elements							
Optional Information Elements							

**Figure 6-67.** ISUP — Message Format



**Figure 6-68.** ISUP — Information Element Format

### 6.23.9 Transaction Capabilities Application Part

TCAP protocol defines the functions, procedures, and signaling for controlling noncircuit-related information flows between SS7 nodes. TCAP was developed to support signaling among exchanges, Service Control Points (SCPs), databases, and Operation, Administration and Maintenance (OA&M) centers. Based on the Remote Operations of CCITT Recommendation X.299 (Message Handling Systems: Remote Operations and Reliable Transfer Server) for foreseen services, TCAP provides six Operation Protocol Data Units (OPDUs) as components:

- Invoke Last
- Invoke Not Last<sup>1</sup>
- Return Result Last

---

1. These components represent an extension to the CCITT version of TCAP and to CCITT Remote Operations.

- 
- Return Result Not Last<sup>1</sup>
  - Return Error
  - Reject.

#### 6.23.9.1 General Description

Following is a general description of the TCAP protocol in terms of the principal capabilities, procedures, and signaling information flows of its two portions: the transaction portion and the component portion. Figure 6-69 shows the detailed message structure of a TCAP message with an invoke component. The return-result component does not include operation information, the return-error component replaces operation-code information with error-code information, and the reject component replaces operation-code information with problem-code information.

The transaction portion of TCAP identifies whether the transaction between the two nodes is expected to consist of a single message or multiple messages. This allows a query to be linked to its response and identifies the context to help interpret a broader group of components contained in one or more TCAP messages. The TCAP message is one of the following *package types*:

- Query
- Conversation
- Response
- Unidirectional
- Abort.

A query or conversation message may be sent either *with permission* or *without permission*, indicating (respectively) that the receiving node may or may not end the TCAP transaction (that is, that the sending application is not, or is, expecting to send further messages as part of this transaction). Messages with a transaction portion package-type of *unidirectional* (sending information in only one direction) or *response* do not allow continuation of the transaction. A message with the abort package type informs the destination node that the sending node has terminated an established TCAP transaction.

---

1. These components represent an extension to the CCITT version of TCAP and to CCITT Remote Operations.

---



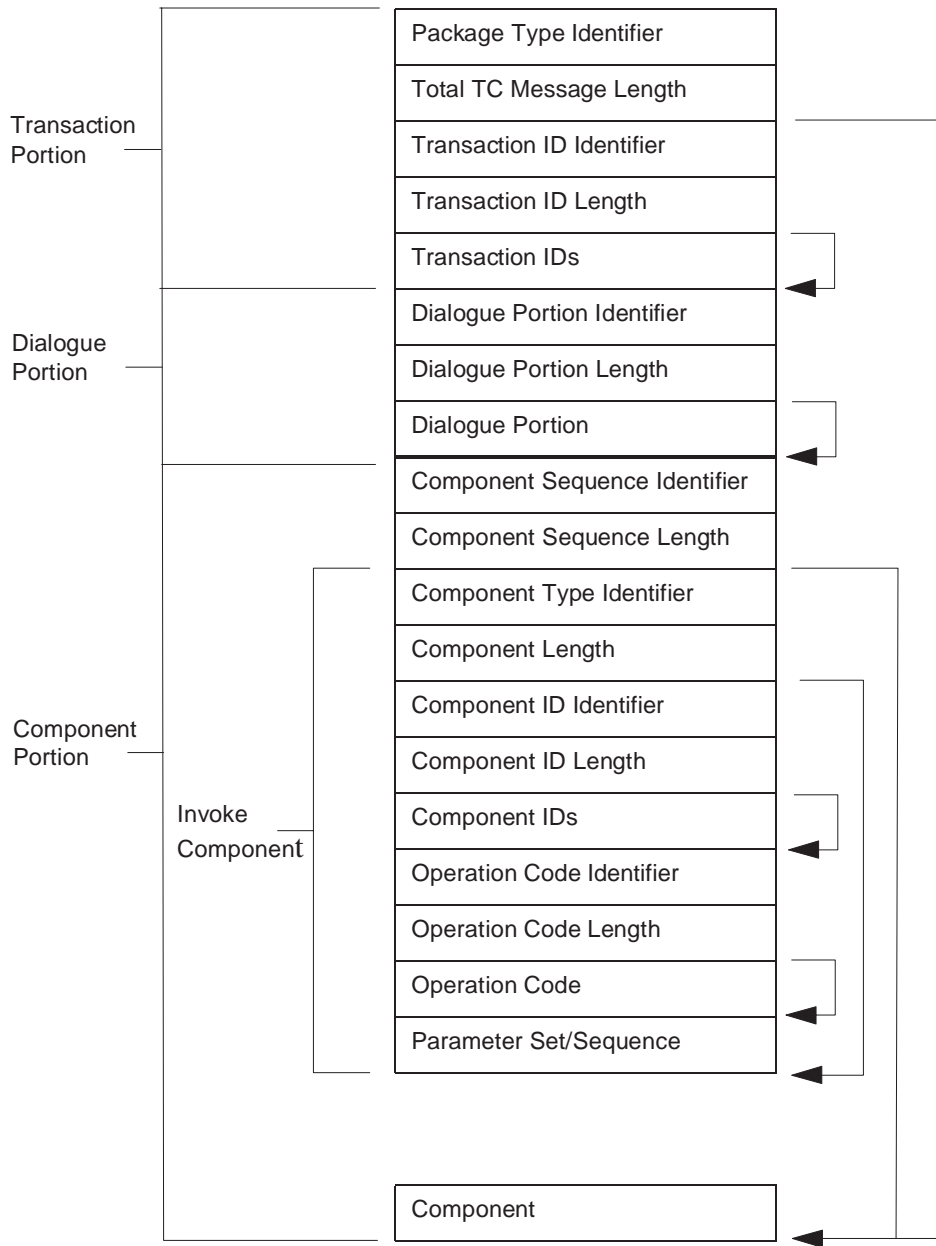


Figure 6-69. Detailed TCAP Message Structure with an Invoke Component

The dialogue portion carries information that applies for the duration of the transaction such as application context (defining the allowed operations, parameters, and errors) and certain security information (such as public key information if the component portion is encrypted).

The component portion of TCAP consists of one or more components and carries the desired information either from one application process to another application process, or from TCAP to TCAP. Each component corresponds to one Operation Protocol Data Unit (OPDU). For national use, operations within the components have been grouped into nine standardized families. Operations specifiers and parameters provide the additional granularity needed to meet the varied needs of the many services that make use of TCAP signaling. For normal operation, application processes send and receive only invoke and return-result components.

#### 6.23.9.2 Normal Procedures

In the transaction portion, the unidirectional package type is specified when an application process has to send a TCAP message to another application process but does not need to set up a TCAP transaction to correlate the components of this message with components in another message. No response by the receiving application process is required. When a TCAP transaction is required, the first message is one of the two query package types (with or without permission to release).

If the application process initiating a TCAP transaction expects to send more components to be treated as part of the same transaction, Query Without Permission is sent. The receiving application process establishes a transaction from its perspective and replies using one of the conversation package types (with or without permission to release).

If the application process initiating a TCAP transaction does not expect to send more components in this transaction, Query With Permission is sent. If the receiving application process determines that it wishes to establish a transaction from its perspective, it replies using one of the conversation package types (with or without permission to release). If the receiving application process does not wish to establish a transaction, it replies using the response package type. Therefore, permission to release the transaction is not a request that the other application terminate the transaction, but rather it is an indication that further information from the sending application would not be interrupted by termination of the transaction.

A single TCAP message can carry any mix of components. In the component portion, the initiating application process provides all the elements needed to construct each component. For example, for an invoke component, the application process provides the component-type identifier (*invoke* the component-ID identifier [standardized as 15]), the operation-code identifier (0 if national TCAP is being used, otherwise 1), the operation code (operation family and operation specifier), and parameters.

---

---

TCAP has extended the ITU-T Remote Operations procedures to allow an application process to respond to an invoke with one or more invoke or return-result messages. The return-result component may also be sent when no explicit invoke has been received (for example, to support periodic polling of an application process).

### 6.23.10 Operations, Maintenance, and Administration Part

The OMAP protocol specifications are based on the OSI-defined Common Management Information Protocol (CMIP) and are implemented using TCAP. The following sections on CMIP-Based Services and on TCAP Messages describe the common protocol and message formats used by OMAP. Sections on the MRVT, SRVT, LEF, and LFS procedures then describe the individual protocols for each.

#### 6.23.10.1 Services Based on Common Management Information Protocol

OMAP uses two services that are based on services provided by CMIP: Confirmed-Action and Event-Report.

The Confirmed-Action service is used by an OMAP application to request an OMAP application in another signaling point to perform a specific action. The OMAP application receiving the request performs the action, if possible, and in any case responds to the requesting OMAP application with the result of the action performed. A request for a Confirmed-Action always contains the following parameters:

- *Resource class* — The type of object on which the action is to be performed
- *Resource instance* — The particular object on which the action is to be performed
- *Action value* — The particular action to be performed
- *Action arguments* — Additional parameters specific to the Action value.

A response to a Confirmed-Action request either indicates success or the particular error encountered. The particular error reported may also be supplemented by additional parameter information.

The Event-Report service is used by an OMAP application to report the occurrence of an event to another OMAP application. An Event-Report indication always contains the following information:

- *Resource class* — The type of object for which this event is defined
  - *Resource instance* — The particular object for which the event occurred
  - *Event value* — The particular event being reported
  - *Event information* — Additional information pertaining to the event being reported.
-

### 6.23.10.2 TCAP Formats

The TCAP format of an OMAP message is determined by its role in providing the Confirmed-Action and Event-Report services. The CMIP/OMAP messages used to provide these services are the Confirmed-Action request message, the Confirmed-Action “success” response message, Confirmed-Action “failure” response message, and the Event-Report message. The TCAP information contained in these messages is described below.

- *Confirmed-Action request message* is carried by a TCAP Query with Permission. The Invoke (Last) component is used with an operation code assigned by OMAP for Confirmed Action. This operation includes a sequence of parameters indicating the Resource Class, the Resource Instance, the Action Value, and the Action arguments (depending on Action Value).
- *“Success” response message to a Confirmed-Action request* is carried by a TCAP Response. The Return Result (Last) component uses the component identifier from the Confirmed-Action request to connect the response with the request. No parameters are sent in this message.
- *“Failure” response message to a Confirmed-Action request* is also carried by a TCAP Response. In this case, a Return Error component is sent with an error code and associated error parameters (if any) specified by OMAP. As with a success message, the component identifier from the Confirmed-Action request connects the response with the request.
- *Event-Report message* is carried by a TCAP Query with Permission. The Invoke (Last) component is used with an operation code assigned by OMAP to report an event. This operation includes a sequence of parameters indicating the Resource Class, the Resource Instance, the Event Value, and the Event Information (depending on Event Value).

### 6.23.10.3 MTP Routing Verification Test Procedure

The MRVT procedure verifies the consistency of MTP routing data for a particular Destination Point Code (DPC). Examples of problems it can uncover are routing loops and STPs which do not recognize a particular DPC. Any error uncovered is accompanied by information indicating where the error occurred. The initiator of an MRVT may also request trace information on the signaling points traversed on each path to the DPC if the test result is “success.”

The MRVT operates recursively as follows.

- The SP initiating the MRVT procedure sends an MRVT message to each SP its routing data indicates as a possible route for the DPC under test. This initiating SP then waits to receive test results via MTP Routing Verification Acknowledgment (MRVA) messages.
-

- 
- If an SP receives an MRVT message, it forwards MRVT messages on the possible routes seen and summarizes the results received (via MRVA messages) in a new MRVA message that is returned to the SP from which it received the MRVT message.
  - If an MRVT message arrives at the DPC under test, OMAP at that node acknowledges receipt with an MRVA message.
  - Errors encountered in this process are reported in MRVA messages and also in MTP Routing Verification Result (MRVR) messages sent directly to the SP which initiated the MRVT procedure. (MRVR messages are also used to indicate trace information to locate the error.)

In terms of the CMIP model described above, the Resource Class is “MTP Routing Tables” and the Resource Instance is the DPC under test. The MRVT message indicates a “Test Route” Confirmed-Action request. The MRVA message indicates either a “success” or “failure” response for the “Test Route” action. The MRVR message indicates a “Route Trace” Event-Report and Event Information indicating “success” or the particular error encountered.

#### 6.23.10.4 SCCP Routing Verification Test Procedure

The SRVT performs the same consistency check for SCCP routing data that the MRVT performs for MTP routing data. The SRVT checks the consistency of SCCP routing data for a particular SCCP global title address (that is, a Global Title Indicator and SCCP Address).

The SRVT procedure employs the same recursive procedure as the MRVT described above. For the SRVT procedure, SRVT, SCCP Routing Verification Acknowledgment (SRVA), and SCCP Routing Verification Result (SRVR) messages perform the roles played by the MRVT, MRVA, and MRVR messages, respectively, in the MRVT procedure. Where the MRVT procedure forwards MRVT messages through SPs which perform the MTP relay function (in other words, STPs doing MTP routing), the SRVT procedure forwards SRVT messages through SPs which perform an SCCP relay function (in other words, STPs doing SCCP routing).

The SRVT procedure also allows an SCCP Relay Point to verify a global title translation at two mated STPs.

In the CMIP model, the Resource Class employed is “SCCP Routing Tables” and the Resource Instance is the global title address under test.

#### 6.23.10.5 Link Equipment Failure Procedure

The LEF procedure is a simple procedure used by a SP to inform another SP that it has detected a local signaling terminal or interface equipment failure. This information allows

---

the receiving SP to deduce that a Level 1 failure on a signaling link is not the result of failed interface equipment at its own end of the signaling link.

Two messages are used by the LEF procedure:

- *Link Equipment Unavailable (LEU) Message* — indicates that a local signaling terminal or interface equipment has failed.
- *Link Equipment Available (LEA) Message* — indicates that the failure has cleared and the signaling link is available and ready for alignment.

In the CMIP model, the Resource Class is “Link Information” and the Resource Instance is the point code of the SP sending the LEU or LEA message. The LEU and LEA messages are Event-Reports respectively indicating “Link Unavailable” and “Link Available” information for a “Link Status” event value. Both messages identify the involved signaling link by its signaling link code.

#### 6.23.10.6 Link Fault Sectionalization Procedure

The Link Fault Sectionalization (LFS) procedure identifies a faulty component on a signaling link by supervising the Level 1 Loopback test described in Section 2.1 of chapter T1.111.7.

The LFS procedure operates as follows:

- The SP initiating the LFS procedure (called the controlling SP) begins by sending a Facility Test Underway (FTU) message to the SP at the other end of the link to be tested (called the controlled SP).
- The controlling SP then runs the Level 1 loopback test for each component on the signaling link (DS0 dataport, Data Service Unit, Office Channel Unit, etc.) until a component fails the test or all components pass.
- When the controlling SP completes its testing, it sends the results of the test to the controlled SP in a Facility Test Results (FTR) message.
- If the remote link interface at the controlled SP has the ability to echo incoming data, then the controlling SP can send a Facility Test Loopback (FTL) message to the controlled SP to request the operation of the loopback for the link interface.
- The controlled SP indicates whether it successfully initiated the loopback with a Facility Test Acknowledgment (FTA) message.

In the CMIP model, the Resource Class indicated is “Link Information” and the Resource Instance is the point code of the controlling SP. The FTU and FTR messages are Event-Reports for “Link Test” and “Link Test Results” events, respectively. The FTL message indicates a “Loop Request” Confirmed-Action request and the FTA message indicates either a “success” or “failure” response for the “Loop Request” action.

---

#### 6.23.10.7 Circuit Validation Test (CVT)

The CVT is used to ensure that two exchanges have sufficient and consistent translation data for placing a call on a specific circuit of an interexchange circuit group.





## Section 7 Transmission Contents

7.	Transmission .....	7-1
7.1	Introduction .....	7-1
7.2	Network Architecture .....	7-1
7.2.1	End-to-End Connections .....	7-1
7.2.1.1	Customer Premises Equipment .....	7-1
7.2.1.2	Subscriber Loops .....	7-2
7.2.1.3	Switches .....	7-2
7.2.1.4	Trunks .....	7-2
7.2.1.5	Local Exchange Carriers .....	7-2
7.2.1.6	Interexchange Carriers .....	7-2
7.2.1.7	End Office-to-End Office Connections .....	7-3
7.2.1.8	Connections to Other Networks .....	7-3
7.3	Objectives and Limits .....	7-3
7.4	Voice Transmission Impairments and their Control .....	7-5
7.4.1	Loss .....	7-5
7.4.2	Message Circuit Noise .....	7-6
7.4.3	Crosstalk .....	7-7
7.4.4	Echo and Singing .....	7-8
7.4.5	Slope .....	7-16
7.4.6	Influence of CPE on Perceived Voice Quality .....	7-17
7.5	Voiceband Data Transmission Impairments and Their Control .....	7-17
7.5.1	Impulse Noise .....	7-17
7.5.2	Envelope Delay Distortion .....	7-18
7.5.3	Phase Jitter .....	7-18
7.5.4	Nonlinear (Intermodulation) Distortion .....	7-19
7.5.5	C-Notched Noise .....	7-19
7.5.6	Slips .....	7-20
7.5.7	Frequency Shift .....	7-20
7.5.8	Slope .....	7-20
7.5.9	Customer Premises Equipment .....	7-21
7.6	Digital Transmission .....	7-21
7.6.1	Synchronization .....	7-21
7.6.2	Characteristics of Digital Transmission .....	7-22
7.6.2.1	Error-Free Seconds .....	7-22
7.6.2.2	Bit Error Ratio .....	7-22
7.6.2.3	Severely Errored Seconds .....	7-22
7.6.2.4	Slips .....	7-22
7.6.2.5	Phase Hits .....	7-22

---

	7.6.2.6	Timing Jitter.....	7-23
	7.6.3	Bit Integrity .....	7-23
	7.6.4	Clear-Channel Capability.....	7-23
7.7		Digital Data Transmission.....	7-24
	7.7.1	Dedicated Digital Services.....	7-24
	7.7.2	Switched 56-kbps Services .....	7-24
	7.7.2.1	Type I PSDS Access.....	7-25
	7.7.2.2	Circuit-Switched Digital Capability .....	7-25
	7.7.2.3	DATAPATH Service.....	7-26
	7.7.2.4	Interworking of PSDS Technologies.....	7-26
	7.7.2.5	Switched 56 kbps as an ISDN Bearer Service.....	7-26
	7.7.2.6	Interworking Between PSDS and ISDN Switched 56-kbps Data.....	7-27
	7.7.3	Switched 64-kbps Service .....	7-27
	7.7.4	ISDN Switched DS1/Switched Fractional DS1 .....	7-27
	7.7.5	Switched Digital Services Performance.....	7-27
7.8		Transmission Aspects of Switches.....	7-27
	7.8.1	Comparison of Analog and Digital Switches.....	7-27
	7.8.2	Digital Switch Distortion Performance.....	7-30
7.9		Adaptive Differential Pulse-Code Modulation Technology .....	7-31
7.10		Asynchronous Transfer Mode Technology.....	7-32
	7.10.1	ATM Cells.....	7-32
	7.10.2	ATM Cell Assembly and Disassembly .....	7-32
	7.10.3	ATM Switching.....	7-33
	7.10.4	ATM Transport .....	7-34
	7.10.5	ATM Delay .....	7-35
	7.10.5.1	Delay Associated with Cell Assembly and Disassembly.....	7-35
	7.10.5.2	Delay Associated with SONET Rate Conversion .....	7-35
	7.10.5.3	Delay Associated with Jitter Removal.....	7-35
	7.10.5.4	Total ATM Delay .....	7-36
	7.10.6	Transmission Errors and Cell Loss .....	7-36
7.11		End-to-End Performance.....	7-36
	7.11.1	Grade of Service.....	7-37
	7.11.2	Customer Opinion .....	7-37
	7.11.2.1	Perception of Loss .....	7-37
	7.11.2.2	Loss/Noise .....	7-40
	7.11.2.3	Talker Echo.....	7-40
	7.11.2.4	Loss/Noise/Talker Echo.....	7-41
	7.11.2.5	Listener Echo .....	7-41
	7.11.3	Network Performance .....	7-41
7.12		Network Transmission Design.....	7-44
	7.12.1	Network Transmission Plans .....	7-44
	7.12.1.1	Via Net-Loss Plan.....	7-44

---

---

7.12.1.2	Fixed-Loss Plan .....	7-45
7.12.1.3	Metropolitan Area and Long-Distance Plans .....	7-46
7.12.1.4	Loss Plan for Evolving Digital Networks.....	7-49
7.12.2	Loss Implementation.....	7-50
7.12.2.1	Trunk Types.....	7-50
7.12.2.2	Signal Level Conventions and Definitions — Analog ....	7-52
7.12.2.3	Loss Implementation for Analog Trunks.....	7-54
7.12.2.4	Signal Level Conventions and Definitions — Digital ....	7-55
7.12.2.5	Loss Implementation for Combination Trunks.....	7-56
7.12.2.6	Loss Implementation for Digital Trunks .....	7-56
7.13	Operator Services Transmission .....	7-58
7.13.1	Transmission Objectives .....	7-58
7.13.2	Directory Assistance and Intercept Service .....	7-58
7.13.3	IntraLATA Long-Distance and Assistance Service.....	7-60
7.13.4	Operator Services Transmission Plan .....	7-60
7.14	Transmission Limits — IntraLATA Networks .....	7-62
7.14.1	Trunk Loss Limits .....	7-63
7.14.1.1	Test Tones.....	7-63
7.14.2	C-Message Noise Limits.....	7-63
7.14.3	Impulse Noise Requirements .....	7-64
7.14.4	Balance Limits .....	7-64
7.14.5	Loop Noise .....	7-66
7.14.6	Central Office Noise .....	7-66
7.14.6.1	Cross-Office Noise .....	7-67
7.14.6.2	Impulse Noise .....	7-68
7.15	Loop Transmission — Design and Characterization .....	7-68
7.15.1	Revised Resistance Design .....	7-68
7.15.2	Modified Long-Route Design .....	7-69
7.15.3	Concentrated Range Extender with Gain.....	7-69
7.15.4	Performance of RRD and MLRD Loops .....	7-70
7.15.5	The Carrier Serving Area Concept.....	7-71
7.15.6	Digital Subscriber Line .....	7-71
7.15.7	Spectrum Management in Loop Plant.....	7-74
7.15.8	Loop Surveys .....	7-74
7.15.9	Basic Exchange Telecommunications Radio Service/Basic Exchange Radio Service .....	7-75
7.16	Interoperation with Other Networks .....	7-75
7.16.1	Switched Exchange Access.....	7-75
7.16.1.1	Access Connections .....	7-75
7.16.1.2	WATS Access Lines.....	7-82
7.16.1.3	Transmission Performance Limits.....	7-83
7.16.1.4	InterLATA Directory Assistance.....	7-83
7.16.2	Interconnection with Private Networks.....	7-84
7.16.3	Interconnection with Cellular Mobile Radio Networks .....	7-85

---

---

## List of Figures

Figure 7-1.	IntraLATA Connections .....	7-4
Figure 7-2.	Comparison of Noise Weighting .....	7-7
Figure 7-3.	Reflection Points and Echo Paths in a Telephone Connection.....	7-9
Figure 7-4.	Switching of 4-Wire Trunks at a 2-Wire Switching Office.....	7-13
Figure 7-5.	Terminal Balance Arrangements .....	7-14
Figure 7-6.	Echo Canceler Application.....	7-16
Figure 7-7.	Probable Numbers of Coding Bits Used.....	7-30
Figure 7-8.	Combining CBR and VBR Traffic Using Cell Switching.....	7-33
Figure 7-9.	Customer Perception of End Office-to-End Office Loss — Analog Network .....	7-38
Figure 7-10.	Customer Perception of End Office-to-End Office Loss — Digital Network .....	7-39
Figure 7-11.	Loss/Noise Grade of Service .....	7-40
Figure 7-12.	Loss/Noise/Echo Grade of Service.....	7-42
Figure 7-13.	Grade-of-Service Distributions.....	7-43
Figure 7-14.	intraLATA Trunks.....	7-47
Figure 7-15.	Trunk Types.....	7-51
Figure 7-16.	Analog Trunk Transmission Level Points .....	7-52
Figure 7-17.	Analog End Office to Analog Tandem.....	7-54
Figure 7-18.	Analog End Office to Digital Tandem .....	7-57
Figure 7-19.	Digital End Office to Digital Tandem .....	7-57
Figure 7-20.	Typical Automatic Intercept System Trunks.....	7-60
Figure 7-21.	Operator Services System Plan.....	7-61
Figure 7-22.	Basic Digital Transmission Plan — Operator Service .....	7-61
Figure 7-23.	Objective Loudness Ratings — RRD .....	7-72
Figure 7-24.	Maximum Length of CSA Loop.....	7-73
Figure 7-25.	Exchange-Access Connections.....	7-77
Figure 7-26.	Feature Group A .....	7-78
Figure 7-27.	Feature Group B .....	7-79
Figure 7-28.	Feature Group C .....	7-80
Figure 7-29.	Feature Group D .....	7-81
Figure 7-30.	WAL Service Configurations .....	7-82
Figure 7-31.	InterLATA Directory Assistance.....	7-84

---

---

## List of Tables

Table 7-1.	IntraLATA Office Balance Limits .....	7-13
Table 7-2.	Transmission Characteristics — Analog vs. Digital End Offices .....	7-29
Table 7-3.	Bandwidths for SONET Transport (Mbps) .....	7-34
Table 7-4.	VNL and ICL Values for Trunks on Carrier Facilities.....	7-44
Table 7-5.	IntraLATA Trunk Losses (ICL) .....	7-48
Table 7-6.	Loss Objectives — Operator Services.....	7-59
Table 7-7.	C-Message Noise Limits .....	7-63
Table 7-8.	Impulse Noise Limits.....	7-65
Table 7-9.	Loop Noise Objectives and Requirements .....	7-66
Table 7-10.	End Office Noise Requirements .....	7-67
Table 7-11.	Loop Design Plans.....	7-70
Table 7-12.	FGD Design Loss .....	7-82



---

## 7. Transmission

### 7.1 Introduction

The subject of transmission covers a broad range of performance considerations related to the physical facilities that compose the network architecture.

Network architecture includes the numerous items that provide end-to-end connections. Performance considerations include voice and voiceband-data impairments, customer opinion and Grade of Service (GOS), transmission plans, and methods for meeting loss objectives and test limits.

This section describes these aspects of transmission, as well as operator services, loop transmission, switched exchange access, and interconnection to cellular mobile radio and private networks.

### 7.2 Network Architecture

#### 7.2.1 End-to-End Connections

Customers making telephone calls use an integrated communications path in which entities providing portions of end-to-end, intraLATA service are the exchange carriers and the providers of Customer Premises Equipment (CPE) at each end of the connection. For interLATA calls, there is the additional presence of one or more Interexchange Carriers (ICs). The following subsections discuss each part of an end-to-end connection.

##### 7.2.1.1 Customer Premises Equipment

A wide variety of CPE manufactured and sold by many sources can be connected to the customer's side of the demarcation point.<sup>1</sup> The efficiency of this equipment in converting an acoustic signal into an electric signal (and the reverse) is an important consideration in the development of any transmission plan. The efficiency of the equipment affects the loudness, noise, and echo performance of the overall connection. All CPE must meet the requirements of Part 68 of the FCC Rules and Regulations (Section 13). In the discussion that follows, CPE is assumed to be a telephone set that also meets American National Standards Institute (ANSI) Standard EIA 470-A-1987.

---

1. The FCC, in its ruling associated with Docket 88-57, has adopted the term "demarcation point" in place of network interface.

#### 7.2.1.2 Subscriber Loops

The effect of subscriber loops on end-to-end performance is also important. Most of today's Local Exchange Carrier (LEC) loops conform to Revised Resistance Design (RRD) rules.<sup>2</sup> RRD rules apply to loops with up to 1500  $\Omega$  resistance and 24 kft in length. New loops up to 24 kft are implemented using the Digital Loop Carrier (DLC) as first choice. DLC rules require that no loop should have more than 8 dB of loss at 1 kHz.

#### 7.2.1.3 Switches

The loop serving the customer connects to a switch in the serving end office. End office switches may be analog (electronic, Step-by-Step [SXS], or crossbar technology, in sharply decreasing order of likelihood) or digital units. Interoffice calls involving complex routing pass through one or more intermediate offices called tandems. Tandems may be analog, but they are usually, and ever increasingly, digital.

#### 7.2.1.4 Trunks

Switches located in the same or different central office buildings are joined by trunks. These trunks generally use digital facilities, although a (rapidly declining) number of analog wire-pair facilities are used for distances of a few miles or less. Analog carrier facilities are deployed in some rural areas.

#### 7.2.1.5 Local Exchange Carriers

LECs provide service within a Local Access and Transport Area (LATA) and furnish exchange-access service for the origination or termination of interLATA calls. Exchange access requires an access connection from the end office to the IC Point of Termination (POT). This connection consists of either a direct end office-to-POT segment, or links connected via one or more tandems to concentrate traffic.

#### 7.2.1.6 Interexchange Carriers

One or more ICs provide a transmission path between LEC access networks. An IC network connection can use a single direct trunk or multiple tandem-switched links. The IC switch serving the LATA may be several hundred miles away. The IC network may be configured with multiple paths between POTs to permit concentration and alternate routing. The IC

---

2. Some independent LECs and other entities, particularly those associated with the Rural Electrification Administration (REA), may use different design criteria.

---



---

may use a dynamic method of routing where the path of a call depends on available facilities and traffic volume.

#### 7.2.1.7 End Office-to-End Office Connections

Figure 7-1 shows the various connections that can occur in intraLATA networks. These connections include the following:

- A connection between Customers A and B, both served by end office #1.
- A connection joining Customer A (served by end office #1) and Customer C (served by end office #2). The end offices are linked via an Inter-end Office Trunk (IOT).
- A connection joining Customer C (served by end office #2) and Customer D (served by end office #3). The two end offices are joined via Tandem Connecting Trunks (TCTs) to sector tandems that are part of a tandem-switching network. The sector tandems are connected via an Intertandem Trunk (ITT) or via two ITTs if a principal tandem is used.

#### 7.2.1.8 Connections to Other Networks

Other networks may be involved in a “built-up” connection. There may be access trunking from an end office or a tandem to a cellular mobile carrier interface.

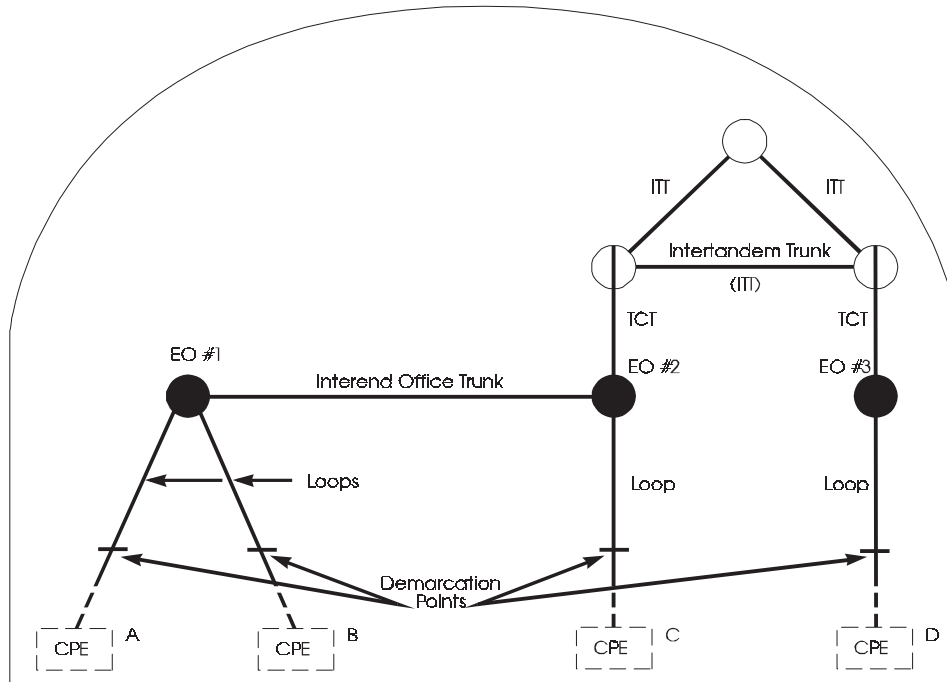
Lines or trunks from an end office or a tandem may provide connections to a private network. The owner of a private network may function as an IC, either for the owner’s use or for use by other firms. Thus, on any given call, numerous possibilities exist for joining multiple networks.

### 7.3 Objectives and Limits

Transmission criteria fall into the following two major categories.

- *Objectives* are goals that are classified by their intended use. For example, one classification is the time frame in which the objective is to be met (current, near-term, or long-range). Objectives may apply to trunks, loops, transmission facilities, switching systems, or to overall connections. They may be stated separately for the design criteria, the initial (turn-up) performance, or the in-service performance of a piece of equipment or a trunk. There can be separate objectives for the performance of elements (such as trunks) that are provisioned with newer versus embedded technologies.
- *Limits* are established to provide a practical means for meeting objectives. Limits are set on the performance of an individual circuit or a small population of circuits,

whereas objectives are typically established for a large population. (Specific types of test limits such as pre-service, acceptance, maintenance, and immediate action, are discussed in Sections 7.14 and 7.16.1.)



- CPE = Customer Premises Equipment
- = End Office (EO)
- = Principal Tandem
- ◕ = Sector Tandem
- TCT = Tandem Connecting Trunk

**Figure 7-1.** IntraLATA Connections

Objectives for initial and in-service performance are typically expressed as a distribution, although limits also may be specified to ensure that performance is within reasonable bounds.

Performance objectives are goals for network performance. Most objectives are current. However, a long-range objective is often stated as the performance distribution that telephone plant should achieve based on trends in technology, economics, and customer

---

expectations. Requirements for new designs are usually based on satisfying such long-term objectives.

As telecommunications technology evolves, transmission performance is reviewed, and the objectives and limits are updated. Voice transmission performance is analyzed through field surveys, laboratory tests, and computer models that relate transmission impairments to customers' opinions of transmission quality. These models are based on surveys of telephone plant performance to characterize the level of performance in the network and on subjective tests that relate transmission impairments to customer opinion (see Section 7.11).

Transmission performance for analog data communication is assessed through computer models based on laboratory and field analyses of error characteristics of modems. The computer simulations use modem models appropriate for each particular transmission evaluation. For digital data communication, Bit Error Ratio (BER) models are used.

## 7.4 Voice Transmission Impairments and their Control

Significant impairments to voice transmission performance are loss, noise, echo, singing, near-singing, crosstalk, and slope. Other impairments, which also affect voice transmission but have more critical impact on voiceband analog data transmission, are discussed later.

Where the same end office serves the calling and called customers, transmission quality depends primarily on loss and noise. If the end office is digital, near-singing also needs to be considered. On intraLATA routes of less than 200 mi, singing, crosstalk, and slope are additional potential impairments. On routes of approximately 200 mi or more, or where delay is introduced by digital processing, echo becomes a consideration.

### 7.4.1 Loss

Loss refers to the decrease in power level of a signal traversing a communication path.

Acoustic-to-acoustic loss of an overall connection is the fundamental parameter for voice communication. Measurements of acoustic-to-acoustic loss are obtained using acoustic sources and terminations that simulate human mouths and ears. However, because telephone transmission plans consider both the overall connection and the elements that make up the connection, acoustic-to-electric, electric-to-electric, and electric-to-acoustic characteristics should also be considered.

Acoustic loss can be expressed in terms of either a loss-frequency characteristic or a number that reflects averaging across the frequency band of interest. ANSI/IEEE STD 661 specifies the latter technique, which involves the concept of loudness loss as perceived by telephone listeners.

---

Loudness loss for a connection is affected by telephone set efficiency, loop loss, and trunk loss. Thus, the design of telephone sets (see Section 7.4.6) and loops (see Section 7.15) at both ends of a connection are as important to the quality of a connection as the design of trunks.

The sending loudness efficiency of the telephone set/loop combination is described in terms of the Transmitting Objective Loudness Rating (TOLR). TOLR is a measure (in decibels) of the efficiency with which the telephone set/loop combination converts an acoustic-pressure input at the telephone transmitter to an electric-voltage output measured at the end office. Pressure and voltage are stated in loudness terms as defined in ANSI/IEEE STD 661.<sup>3</sup>

The receiving loudness efficiency of the telephone set/loop combination is described in terms of the Receiving Objective Loudness Rating (ROLR). ROLR is a measure (in decibels) of the efficiency with which the combination converts an electric voltage input at the end office to an acoustic pressure output measured at the telephone set receiver.

For telephone connections involving calling and called customers served by the *same* end office, the overall connection loudness loss is roughly the sum of TOLR and ROLR. For telephone connections involving customers served by *different* end offices, the connection loudness loss is close to the sum of TOLR, ROLR, and the 1-kHz end office-to-end office electrical loss (see Section 7.12).

## 7.4.2 Message Circuit Noise

Noise is any unwanted signal present in a communication channel. The unwanted signals in a voiceband channel, referred to as message circuit noise, can originate from components of the transmission channel (for example, thermal noise), from outside electrical interference (power induction), or from interference produced by one transmission channel being coupled to another (crosstalk). These unwanted signals can be annoying to the telephone user, regardless of their nature or origin. Thus, noise should be controlled to satisfactory limits.

The usual message circuit noise measurement is a frequency-weighted average of the noise on a voice circuit using a voiceband noise measuring set (as specified in ANSI/IEEE Std 743. C-message weighting is normally used. A plot of this weighting is shown in Figure 7-2 along with the psophometric (noise-meter) weighting of the International

---

3. In 1996, in an effort to harmonize telecommunications standards for North American with international standards, U. S. National standards bodies agreed to adopt international definitions and measurement methods for telephone loudness ratings. The international terms “sending loudness rating (SLR)” and “receive loudness rating (RLR)” correspond to TOLR and ROLR, respectively. The method of calculation for SLR and RLR can be found in ITU-T Recommendation P.79. Approximate conversion between the two sets of values can be accomplished using the relationships  $SLR (P.79) = TOLR (IEEE) + 57 \text{ dB}$  and  $RLR (P.79) = ROLR - 51 \text{ dB}$ .

Telecommunication Union—Telecommunication Standardization Sector (ITU-T) (formerly CCITT). Measurements are expressed in dB above reference noise (dBrnC). The reference for the measuring set is a 0-dBrnC reading, which results from a 1004-Hz tone at a power of -90 dBm. White noise of 0-dBm total power from 0 to 3 kHz is equivalent to 88 dBrnC. (Figure 7-2 also shows a plot for the C-notched weighting. Section 7.5.5 discusses C-notched noise.)

Thermal and interference noise are primarily design-controlled. Techniques such as limits on applied channel load, design limits on coders and decoders, and the layout of outside plant provides this control. Noise control in repeated voice and carrier systems requires care in repeater and terminal placement, inclusion of suppression devices to nullify disturbances, and coordination with other telephone systems as well as power companies and radio services. Voice-frequency systems and subscriber loops require good longitudinal balance to ensure low noise.

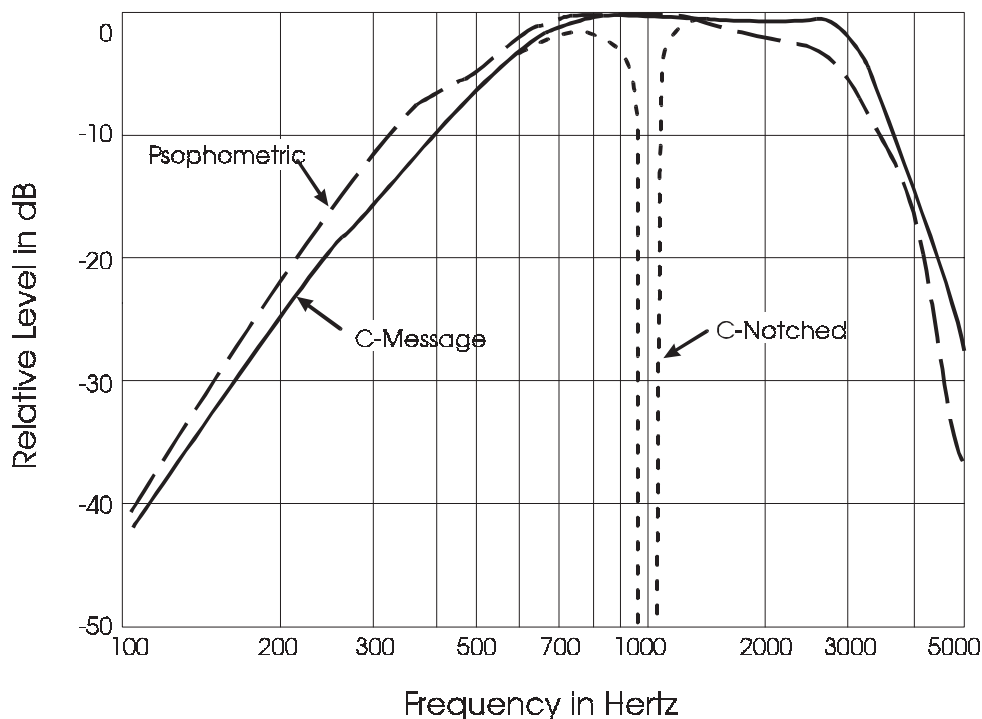


Figure 7-2. Comparison of Noise Weighting

### 7.4.3 Crosstalk

Crosstalk is a form of noise. Intelligible crosstalk is a speech signal that is transferred from one voice channel to another and is understandable under ambient circuit- and room-noise conditions. Thus, intelligible crosstalk not only causes a certain amount of annoyance but

---

also violates caller privacy. The annoyance to the disturbed customer may be heightened by doubts as to the privacy of his/her own conversation. Intelligible crosstalk can result from inter-channel interference within a transmission system or between systems that are physically isolated. There are three basic causes of crosstalk in today's networks:

1. *Energy coupling* between adjacent Pulse-Amplitude Modulation (PAM) samples when a shared codec (coder/decoder) is used in a Pulse-Code Modulation (PCM) system
2. *Coupling* between transmission media (for example, cable pairs)
3. *Use of a common battery source with insufficient decoupling* between circuits.

Crosstalk may not be intelligible but may have the syllabic characteristic that indicates the source is speech. Because this type of crosstalk does not generally violate privacy, limits need not be as stringent as for intelligible crosstalk; however, the attention of disturbed parties is more likely to be diverted than when an equal amount of ordinary noise is present. Therefore, limits for unintelligible crosstalk are more stringent than for other forms of noise.

PCM coders or decoders can be a source of unintelligible crosstalk. An ideal coder is biased exactly half-way between the smallest positive and smallest negative decision values. This means that an input signal need exceed only one half of a small step size to change the transmitted code. In real coders the bias can drift. If a PCM coder is biased very close to a decision level, minute amounts of noise or crosstalk in the analog signal can reach or exceed the decision value, causing an output signal that corresponds to a full step. This is equivalent to one-bit coding of the interfering signal. The resulting crosstalk may not be intelligible, but there is syllabic content.

“Babble” is a form of unintelligible crosstalk. It is a conglomeration of multiple crosstalk signals that is speech-related; however, little or no conversation is understandable.

#### 7.4.4 Echo and Singing

Echo is the signal, at any point in a circuit, that results from power being reflected from the primary speech path. This reflection of signal can occur either at a 4- to 2-wire junction in a circuit or at an impedance irregularity in a 2-wire circuit. The reflected signal can cause talker echo, listener echo (near singing), and singing.

Figure 7-3(A) shows a generic end-to-end telephone connection. The primary speech (signal) path is shown in Figure 7-3(B). The 2-wire path at each end includes the customer loop and may also include 2-wire switches and trunks.

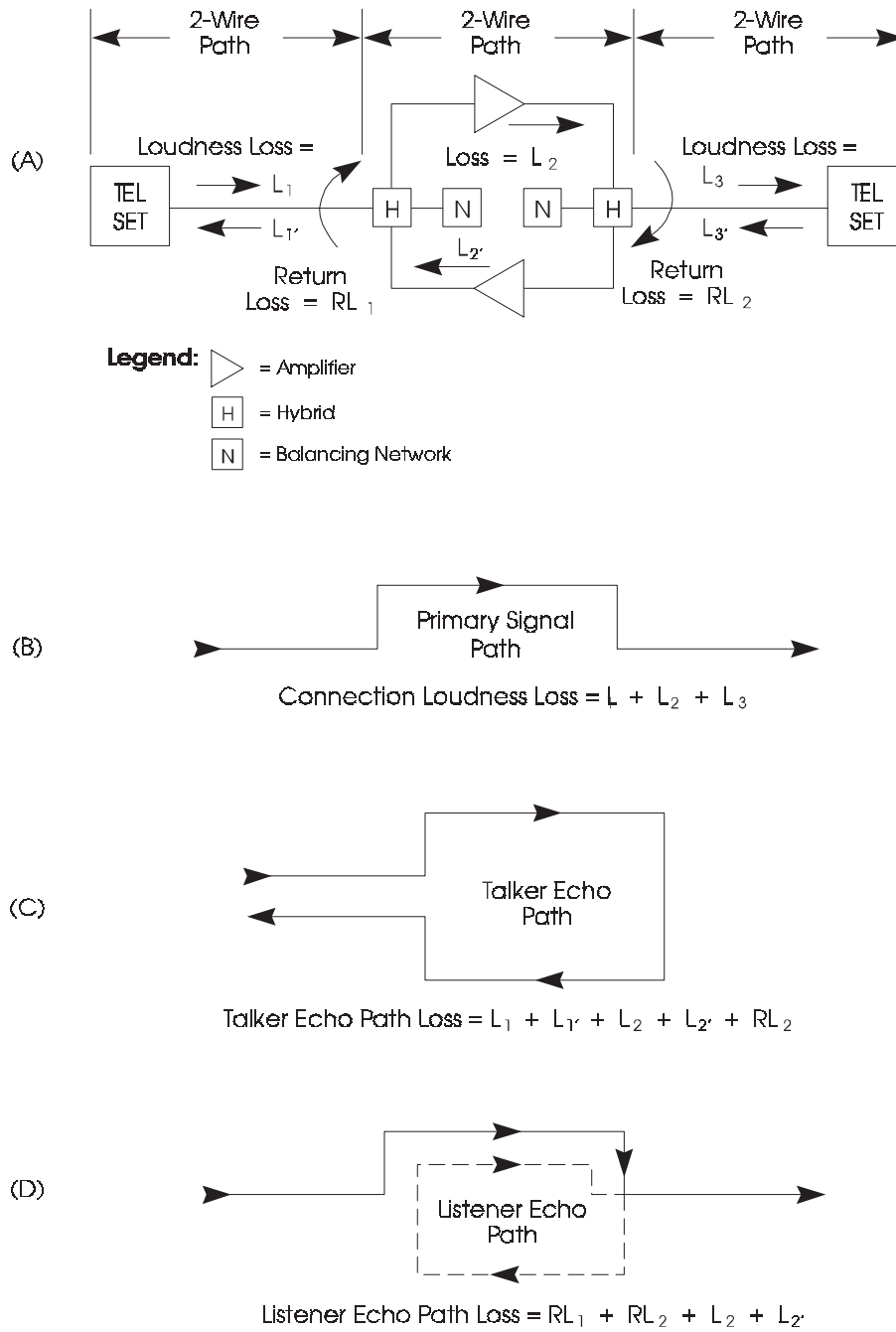


Figure 7-3. Reflection Points and Echo Paths in a Telephone Connection

---

The 4-wire path may include 4-wire trunks and switches or may consist of a single 4-wire digital end office. The 4-wire path is connected to the 2-wire path at each end by a “hybrid.” Since the impedance ( $Z$ ) of the balancing network in the hybrid does not precisely match the impedance of the 2-wire path, some of the power arriving in the 4-wire path will be reflected. Multiple echoes can occur on connections that have multiple reflection points, but a single echo usually predominates on such connections.

The fraction of power reflected at a 2-wire junction depends on the impedance mismatch. It is expressed in terms of return loss.

$$\text{Return Loss} = 20 \log |(Z_1 + Z_2) / (Z_1 - Z_2)|$$

This formula applies for any two impedances,  $Z_1$  and  $Z_2$ . It is approximately correct for the echo reflected into the 4-wire path at a hybrid, where  $Z_1$  represents the impedance of the balancing network and  $Z_2$  represents the impedance of the 2-wire path as seen from the hybrid. Return loss varies with frequency.

The three types of echo-related interference that can occur in the transmission path are described below.

### 1. Talker Echo

Figure 7-3 includes a diagram of the talker-echo path, in the generic connection. Talker echo occurs when primary speech reflected at the far end returns to the talker along the talker-echo path, as Figure 7-3(C) shows. The talking customer hears his/her own voice delayed by the round-trip delay of the echo path. Talker echo is annoying and can interfere with the talker’s speech process. The amount of annoyance depends of the amplitude and delay of the echo (see Section 7.11).

Loss insertion and echo cancelers are used to attenuate talker-echo signals in the transmission path. Balance techniques are used to minimize the amount of signal that is returned at reflection points.

Echo Return Loss (ERL) is a quantitative measure of echo path loss over the middle portion of the voiceband where signal energy perceived as echo is most likely to be found. ERL is defined in ANSI/IEEE STD 743 as the weighted average of the return losses, measured with a Return Loss Measuring Set (RLMS) using bandpass-filtered noise with 3-dB points at 560 Hz and 1965 Hz.

### 2. Listener Echo

If the talker’s speech reflected from the far end is again reflected at a near-end impedance mismatch, the listener hears it twice. The listener-echo path, shown by the broken line in Figure 7-3(D), includes the ERL at both ends of the 4-wire path and the round-trip electrical loss between the reflection points. It can be seen that any provision to control talker echo will also reduce listener echo. Thus, listener echo is usually not a concern on long connections where talker echo has been considered.

---



---

Listener echo (also referred to as near-singing distortion) causes the listener to perceive a hollowness, as if the talker were speaking into an empty barrel. Listener echo performance is judged on the basis of a measure called Weighted Echo Path Loss (WEPL). WEPL is the reciprocal (expressed in dB) of the average magnitude of the voltage gain of the (closed) listener echo path over the band from 200 to 3400 Hz.<sup>4</sup>

Digital end offices and host-remote links are potential sources of listener echo on connections between two local subscribers, due to the low loss of the equivalent 4-wire path and the potential for poor balance at each loop hybrid. For this reason, WEPL objectives have been formulated for the design of this type of equipment. Since WEPL is a closed-path parameter, the requirements are stated in terms of a distribution of connections rather than a distribution of lines.

WEPL is a calculated quantity, and the requirements apply to every possible connection that an end office can provide. Hybrid balance objectives have been derived that, if met, will ensure that WEPL objectives are met (provided that the delay and loss of listener echo paths are controlled). To meet balance objectives in digital end offices, the population of metallic loops is divided into two subpopulations, loaded and nonloaded, with provision for separate hybrid balance networks. Return loss specifications apply to loop hybrids when they are terminated in impedances that represent the two types of loops. Loop-hybrid balance is discussed later in this section.

WEPL, as well as requirements for both WEPL and hybrid balance, are discussed in TR-NWT-000507.

### 3. Singing

Singing is caused by power circulating in a transmission path. It occurs in the same manner as listener-echo and results in a sustained loud tone on the connection. Singing occurs if the gains in line repeaters, carrier channels, or digital end offices are high enough and the return losses low enough so that the round-trip path gain at some frequency has magnitude greater than unity with phase shift equal to 0 or some multiple of 360 degrees.

Singing normally occurs at frequencies near the upper or lower edge of the voiceband where impedances are not well matched. To measure the return loss at the band edges, measuring sets transmit a shaped spectrum of noise in two narrow bands. The 3-dB points of the Singing Return Loss (SRL) low spectrum are 260 Hz and 500 Hz. For SRL high, the 3-dB points are 2200 Hz and 3400 Hz.

The singing margin of a connection is equal to the amount of gain that, added to the listener-echo path, would just initiate singing. As discussed previously, the "hollow" condition that occurs just before actual singing is called near-singing.

---

4. In conjunction with the adoption of international methods of specifying loudness ratings for telephone sets<sup>3</sup>, the use of WEPL is being replaced with Weighted Terminal Coupling Loss ( $TCL_W$ ). Details of the use and measurement of  $TCL_W$  are contained in the latest revision of ANSI EIA/TIA-579 (anticipated publication of this revision is during the first quarter of 1998).

---

Control of echo and singing may involve the following methodologies (in addition to insertion of loss in the transmission path):

- Through balance
- Terminal balance
- Hybrid balance
- Balance in Remote Switching Units (RSUs)
- Echo-control devices.

### **Through Balance**

The use of 4-wire facilities for intertandem trunks in the intraLATA network helps to minimize intermediate echoes. Through balance is used to control echo at 4- to 2-wire conversions in analog (2-wire) switching systems that connect intertandem trunks where intraLATA end-to-end connections may exceed approximately 200 miles. (Few LATAs exceed the 200-mile figure, and 2-wire tandems are no longer common.) The amount of echo reflected at these 4- to 2-wire conversions depends largely on the impedance connected to the 2-wire side of the hybrid (see Figure 7-4). Office cabling-length restrictions limit the range of these impedances to some degree, and optimum balance is achieved for each hybrid using through-balance procedures. Each trunk that is to be balanced is connected through the switching system to a test termination. (The half path from the center of the switch to the test termination has been built-out so that its impedance is equal to the median of the impedances of all half paths in the office.) The Network Build-Out Resistor and Capacitor (NBOR and NBOC) of the trunk hybrid are then adjusted to obtain the required balance. Because of the office cabling restrictions, an acceptable level of through balance can be assured on all switched connections. Through balance requirements, Pre-Service Limits (PSLs) and Immediate-Action Limits (IALs), are given in Table 7-1.

### **Terminal Balance**

Terminal balance procedures control the echo at a 2-wire long-distance tandem office where an intertandem trunk is connected to a Tandem Connecting Trunk (TCT). Terminal balance measurements are performed at the tandem office with the TCT connected to a quiet termination at the end office. Figure 7-5 shows the possible combinations of 2- and 4-wire facilities involved in terminal balance measurements. If the end office and the tandem office are both equivalent 4-wire facilities, no balance measurement is necessary (or possible) from the tandem office unless there is a 2-wire facility between them. Terminal balance requirements are given in Table 7-1.

---

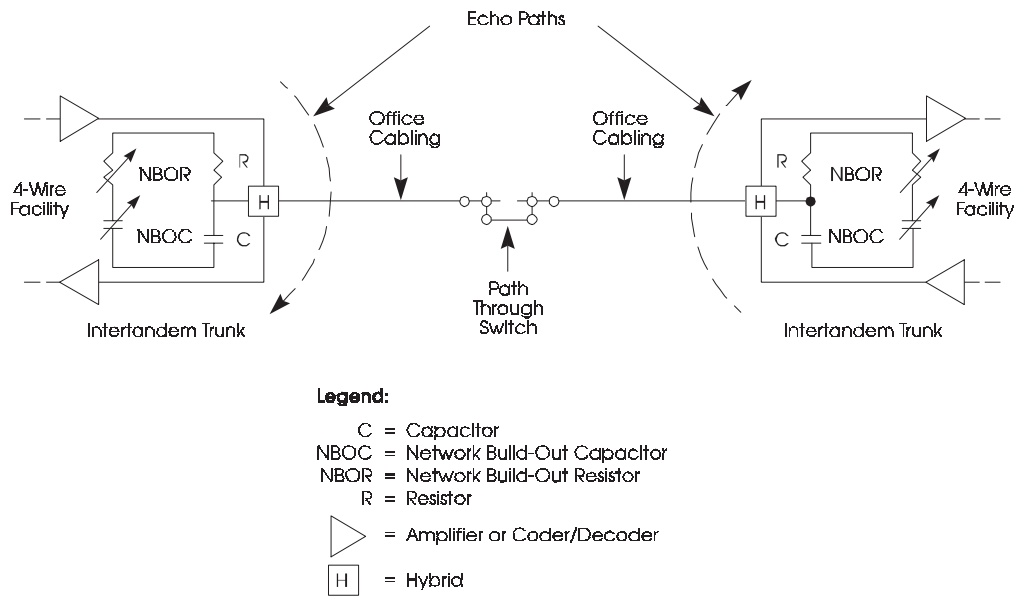


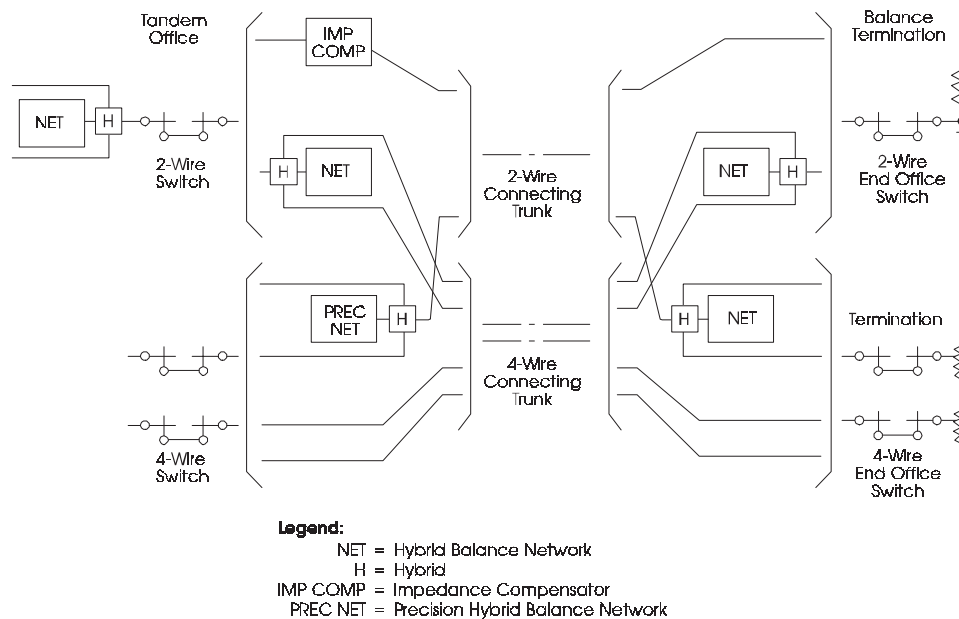
Figure 7-4. Switching of 4-Wire Trunks at a 2-Wire Switching Office

Table 7-1. IntraLATA Office Balance Limits

Measurement	ERL (dB)		SRL (dB)	
	PSL <sup>a</sup>	IAL <sup>b</sup>	PSL	IAL
<b>Terminal Balance</b>				
Analog switch				
2-wire facilities				
(interbuilding)	18	13	10	6
(intrabuilding)	22	16	14	10
4-wire facilities	22	16	15	11
Digital switch				
2-wire facilities				
(interbuilding)	18	16	13	11
(intrabuilding)	22	16	15	11
4-wire facilities	22	16	15	11
<b>Through Balance</b>	27	21	20	14

a. PSL = Pre-Service Limit

b. IAL = Immediate-Action Limit



**Figure 7-5.** Terminal Balance Arrangements

### Hybrid Balance

Because digital end offices provide a 4-wire-equivalent transmission path, subscriber line circuits must:

- Convert PCM-coded signals to analog signals and vice-versa
- Provide 4-wire to 2-wire conversion
- Minimize signal coupling from the 4-wire receive path to the 4-wire transmit path.

Conversion from 4-wire to 2-wire is accomplished with a hybrid circuit. However, control of echo and singing requires balance procedures that are more flexible than those used at TCT hybrids. Traditional hybrid circuits, with multiple balance networks can be used. However, hybrids with adaptive balance circuits, based on echo canceler technology, are becoming more common.

The important methods for improving hybrid balance are as follows:

- Adherence to the loop design plans, as discussed later in this section
- Segregation between loaded loops, non-loaded loops, and treated loops (those equipped with transmission equipment such as repeaters or Subscriber Loop Carrier [SLC]), with provision for automatic balance selection in the off-hook mode
- Use of hybrids with adaptive (self-balancing) circuits.

---

Improved line-circuit balance is obtained by requiring that line circuits meet performance specifications when connected to three specific test terminations. Nonloaded loops are represented by 800  $\Omega$  resistance in parallel with a series combination of 0.05- $\mu$ F capacitance and 100- $\Omega$  resistance. For loaded loops, 1650- $\Omega$  resistance in parallel with a series combination of 0.005- $\mu$ F capacitance and 100- $\Omega$  resistance is used. Finally, treated lines are represented by 900- $\Omega$  resistance in parallel with 2.16- $\mu$ F capacitance.

Application of the proper balance network, or adaptive balancing of the hybrid, is a function of the end-office switch. Provision is sometimes made to add loss, when necessary, in the 4-wire portion of line circuits. This is normally an interim measure to avoid singing when a loop has a severely deficient SRL.

### **Balance in Remote Switching Units**

A Remote Switching Unit (RSU) or Remote Switching Module (RSM) controlled by an end office is considered to be part of its host office for transmission purposes. The link between the remote and host has zero loss, and in conjunction with the remote time-slot interchanger, may contribute appreciable delay. A listener-echo path is formed, since this link is provided on a 4-wire facility. To meet WEPL objectives on this path, loop segregation with balance networks as previously discussed or adaptive hybrids should be used at the RSU/RSM.

### **Echo-Control Devices**

Echo-control devices (normally cancelers) are used in conjunction with impedance-balance procedures and transmission-path loss to control echo in the message network. They are used in cases of high, end-to-end, echo-path delay where loss values large enough to satisfy talker-echo objectives would result in unacceptable performance (see Section 7.11). Generally, cancelers are required on long terrestrial trunks and on all trunks routed via satellite transmission facilities. Cancelers also can be used to increase the return-loss performance in digital switch line cards.

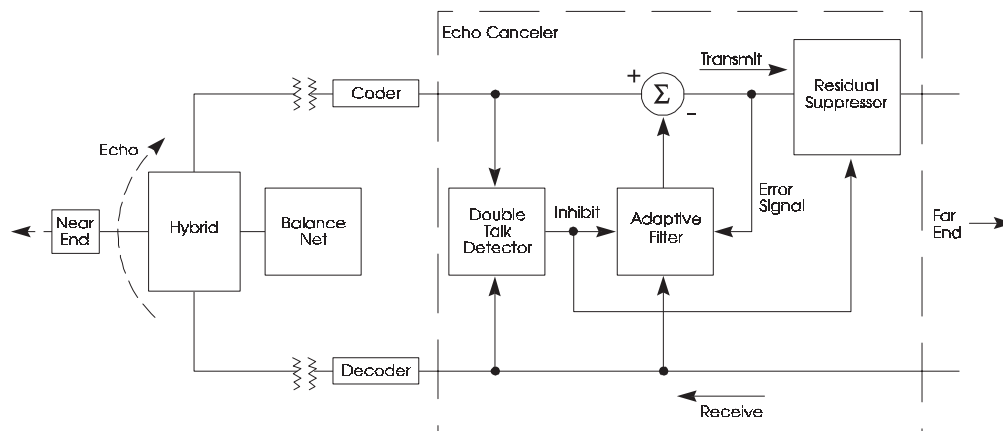
An echo canceler (see Figure 7-6) uses an adaptive filter to model the near-end echo path (tail circuit) and predict the echo that will result from the reflection of far-end signal in the tail circuit. A replica of the predicted signal is subtracted from the actual echo signal and, through an iterative process, the canceler converges toward full cancellation.

Because only the echo signal replica is subtracted in the sending direction, signals originating at the near end pass through the canceler unimpeded.

An important component in an echo canceler is a detector that recognizes when near- and far-end signals are occurring simultaneously. This “double-talk” detector inhibits the adaptive filter so that the near-end signal is not interpreted as an error signal. Otherwise, inappropriate adjustments would be made to the echo-path model.

A return loss of as much as 6 dB may be required in the tail circuit so that the canceler can distinguish between returned echo and near-end signal, thus permitting convergence to occur.

---



**Figure 7-6.** Echo Canceled Application

Adaptive filters cannot achieve full cancellation, and very small echo signals may not be canceled. This can be due to nonlinear elements in the tail circuit. A residual suppressor (typically a center clipper) is used to remove signals below a specified threshold. This suppressor may be inhibited during periods of double-talking so that the near-end signal is not modified.

Echo cancelers can adapt only when signal is present. There is a “training” time (typically 250-500 ms) initiated by the first received signal. During this interval, echo will be returned to the far end. The ability to converge is dependent on the amount of round-trip transmission delay in the tail circuit. A typical limit is 28 ms, but longer options are available. Accommodation of long tail-circuit delay can result in increased noise and convergence time. Therefore, it is advisable to position the canceler within 28 ms of the 4- to 2-wire conversion point.

Echo cancelers use digital techniques and are most efficiently used where signals are transmitted via digroups (24 channels). Because the canceler processes the signal, bit integrity (see Section 7.6.3) is not maintained. Therefore, provision should be made to disable cancelers whenever digital data signals are being transmitted.<sup>5</sup>

#### 7.4.5 Slope

Some slope is desirable to provide margin against circuit instability (singing) at the edges of the voiceband. Slope is less of an impairment to voice transmission than to voiceband

5. Users of the telephone network for the transmission of digital data signals are cautioned that as a result of the introduction, by some service providers, of digital signal processing techniques to enhance the sound of speech over the telephone network, disabling of the echo cancelers in a connection may not ensure that bit integrity is maintained.

---

data. However, low-frequency slope affects voice quality, and excessive, high-frequency slope reduces intelligibility of speech.

Slope is determined by measuring the loss of a channel at several frequencies, usually 404, 1004, and 2804 Hz. This is known as a three-tone slope measurement. Any increase or decrease in loss at 404 or 2804 Hz versus 1004 Hz is called slope. Negative slope occurs if the loss at 404 or 2804 Hz is less than the loss at 1004 Hz.

The slope of an end office-to-end office connection is determined primarily by the characteristics of the filters used in carrier channel banks, digital remote terminals, and digital switches. The performance of these circuit elements is, for the most part, under the control of the equipment designer. The slope contribution from subscriber loops (excessive lengths of nonloaded cable pairs or bridged taps) is under control of the outside-plant engineer.

#### **7.4.6 Influence of CPE on Perceived Voice Quality**

The quality of an overall connection is dependent on the performance of the CPE at each end of the connection. Low transmitter sensitivity, excess receive gain, distortion at high volumes, uneven frequency response or excessive slope, and other factors can result in poor performance. ANSI EIA 470 specifies minimum standards for such equipment.

### **7.5 Voiceband Data Transmission Impairments and Their Control**

Voiceband data performance depends on proper control of the impairments previously discussed, as well as those covered in the following paragraphs.

#### **7.5.1 Impulse Noise**

Impulse noise is defined as any excursion of the noise waveform on a channel that exceeds a specified threshold level within a certain time interval. To minimize contributions due to the high ratio of peak to root mean square (rms) power that is characteristic of message-circuit noise, the threshold is set 12 to 18 dB above the rms value of the noise. The impulse-noise level is designated to be that threshold at which the average counting rate is equal to five per 5 minutes.

Since most impulse noise originates as transients from the operation of relays and other electromechanical switches, engineering rules and mitigative measures are aimed at shielding low-level carrier signals from the radiation of these transients. Carrier-only cables, shortened spans between repeaters, and contact arc-suppression networks are some of the techniques used. Electronic and digital central offices are relatively free of this impairment.

---

## 7.5.2 Envelope Delay Distortion

Envelope Delay Distortion (EDD) is associated with distortion of a received signal, caused by the unequal transit times of the signal's separate frequency components through a transmission channel. EDD gives rise to intersymbol interference in data transmission, which causes increased sensitivity to background noise.

An ideal channel would have a phase versus frequency characteristic that is linear. For such a channel, envelope delay, which is defined as the slope of the phase/frequency characteristic, would have a constant value. The performance of actual systems is evaluated by comparing envelope delay values throughout the frequency band.

Envelope delay is approximated using a difference measurement. Test sets may use various frequency widths for this difference, but the common value (IEEE STD 743-1984) is 166-2/3 Hz. Other widths give varying resolution of ripples in the envelope delay characteristic. Narrower widths yield higher resolution, but there is reduced accuracy.

EDD, sometimes called Relative Envelope Delay (RED) is the difference in envelope delay at a given frequency compared to the envelope delay at a reference frequency. Minimum envelope delay in telecommunications channels occurs in the vicinity of 1700 Hz. Therefore, envelope delay measurements are usually normalized to zero at a reference frequency of 1700 Hz.

In the network, EDD is controlled in the design of codec filters and other apparatus and especially by the use of digital trunks connected directly to digital switches. Its importance has declined as analog trunk facilities and switches have become less common. In data modems, EDD effects are minimized by the use of fixed or automatic equalizers.

## 7.5.3 Phase Jitter

Phase jitter is unwanted angular modulation of a transmitted signal. It displaces the zero crossings of the signal.

Phase jitter impairs voiceband data transmission by reducing the data-receiver margin against other impairments. This impairment is controlled by the design of transmission equipment. The end-to-end, phase-jitter objective for intraLATA data connections is no more than 10 degrees peak-to-peak in the frequency band of 20 to 300 Hz, and 15 degrees peak-to-peak in the band of 4 to 300 Hz. Individual digital carrier terminals are allotted 1.3 degrees. Since phase jitter historically arose mainly in the carrier supplies of single-sideband Frequency Division Multiplex (FDM) carrier systems, its incidence has declined with the near-disappearance of such systems.

Noise, which can also perturb zero crossings, can cause readings on a phase-jitter measuring set even though no incidental modulation is present. The design of a test set can guard against this type of erroneous reading.



---

#### 7.5.4 Nonlinear (Intermodulation) Distortion

Nonlinear elements in transmission equipment give rise to nonlinear distortion. Nonlinear distortion occurs when components generated from the transmitted signal add, usually in an undesirable manner, to that signal. The primary concern is for nonlinear distortion within an individual voice channel as generated mainly in the PCM coding/decoding process.

Nonlinear distortion specifications are usually stated in terms of intermodulation distortion. Intermodulation products arising from nonlinear distortion interfere with the desired signal much as noise does. However, intermodulation distortion is more damaging than noise. It reduces the error margin of a data receiver and affects the accuracy of automated speech-recognition systems.

The common method for measuring nonlinear distortion is called the 4-tone method. Four equal-level tones are transmitted at a composite signal power level of -13 dBm<sub>0</sub> (data level). Two tones are 6 Hz apart, centered at 860 Hz. The other tones are 16 Hz apart, centered at 1380 Hz. The resulting test signal has an amplitude-density function similar to that of a data signal. At the receiving end, the power averages of the second- and third-order intermodulation products are each compared to the composite 4-tone signal. The ratios of the composite power to those of the products are called R<sub>2</sub> and R<sub>3</sub>, respectively. Care must be taken when measured values of R<sub>2</sub> and R<sub>3</sub> are large to ensure that noise does not cause false readings. Procedures exist to determine the noise-only contributions so that readings can be corrected to indicate true distortion levels.

Nonlinear distortion is controlled primarily in the design of equipment.

#### 7.5.5 C-Notched Noise

For voice transmission, the noise that is heard during the quiet intervals of speech is most important. This noise is the impairment that is quantified in the standard, message-circuit noise measurement. Transmission systems using compandors or quantizers exhibit increased noise in the presence of a signal. For voiceband data transmission, the noise on the channel during active transmission and the corresponding signal-to-noise ratio are relevant.

The effect of noise on data-modem performance depends on the level of the noise relative to the level of the data signal. The regulating amplifiers that are used in data sets to bring incoming data signals to an optimum level raise signal and noise equally. Thus, it is the signal-to-C-notched noise ratio of the incoming signal that determines data performance.

To measure C-notched noise, a test (holding) tone at or near 1004 Hz is transmitted from the far end of the channel under test and then filtered out ahead of the noise-measuring set. The level of the holding tone has traditionally been specified at two levels: -16 dBm<sub>0</sub> for voice and -13 dBm<sub>0</sub> for data circuits. The holding tone is removed by a narrow-notch filter,

centered at the frequency of the tone, hence the name “C-notched noise.” This type of measurement is also referred to as “noise-with-tone.”

Figure 7-2 illustrates a typical C-notched filter response.

A signal-to-C-notched noise ratio of at least 24 dB should be maintained on an end-to-end intraLATA data connection.

### 7.5.6 Slips

As explained later, under Section 7.6.2.4, an impairment known as a “slip” may occur if digital equipment is not synchronized. The result of a slip will be the deletion or repetition of one full frame (193 bits) of information. This can affect voiceband signals being carried on a digital channel.

A slip is rarely noticeable in voice transmission, but it is likely to impair data transmission because it causes discrete jumps in the phase of the received signal. For example, the time interval occupied by a slipped frame is exactly 125 microseconds. For a data carrier frequency of 2000 Hz with a period equal to 500 microseconds, the resulting phase step would be  $125/500$  of a full cycle or 90 degrees — a sizable jump.

### 7.5.7 Frequency Shift

If a tone experiences a change in frequency when it is transmitted over a channel, the channel is said to give frequency shift or offset. The shift can be measured by using a precise frequency source at one end of a channel and a frequency counter at the receiving end. Any difference is the frequency shift.

Frequency shift is important in systems that use narrow-band receiving filters. Frequency shift cannot occur in digital facilities or switches but can take place in analog facilities that use single-sideband, suppressed-carrier transmission. Frequency shift is controlled by maintaining precise pilot signals and carrier frequencies on these systems.

### 7.5.8 Slope

Slope has always been more important to voiceband data transmission than to voice transmission. Slope affects data and facsimile transmission, but its role as an impairment has decreased with the wide use of automatically equalized data sets.

---

---

### 7.5.9 Customer Premises Equipment

Data modems may cause service degradation if their signal power is excessive. Therefore, this equipment should conform to an average long-term power requirement of -16 dBm<sub>0</sub> per channel. However, in applying this requirement, it is possible to permit the idle periods between calls to compensate for somewhat higher power on a channel during active periods. It has been established that the signal power during an actual call should not exceed -13 dBm<sub>0</sub> averaged over any 3-second interval.

## 7.6 Digital Transmission

In the analog network, the fundamental transmission path is a 4-kHz baseband voice channel. For digital transmission, voiceband signals are encoded according to the  $\mu = 255$  law into 8-bit words at a rate of 8000 words per second (wps). Each voiceband channel is contained in one of twenty-four 64-kbps Digital Signal level 0 (DS0) channels (a digroup) that comprise the 1.544-Mbps Digital Signal level 1 (DS1) bit stream. DS1 signals are commonly multiplexed into higher-rate signals in the digital hierarchy.

Digital elements in the telecommunications network include transmission facilities, switching systems, PCM channel banks, Digital Cross-Connect Systems (DCSs), and multiplexers. Maintenance of digital channels is simplified by the use of automatic error monitoring on digital facilities and by the ability to test the digroup rather than each channel.

Substantial savings can be realized by terminating digital transmission facilities directly onto digital switches in digroups. This normally requires dedication of digroups to message trunk service with all (unswitched) special-services circuits being assigned to other digroups.

Alternatively, use of the “nail-up” function in the digital switch for special services would allow a mixed digroup to be terminated directly. Another possibility is to separate the special-services circuits from the mixed digroup by means of a DCS prior to termination on the switch.

### 7.6.1 Synchronization

Synchronization ensures that the bit streams between digital equipment in the network operate at the same frequency and are phase-aligned. DS1 facilities within a synchronization network sector (usually corresponding to a LATA) are synchronized to a centralized timing source. Synchronization within a building is accomplished by timing all digital equipment from one source, the Building-Integrated Timing Supply (BITS). A complete description of intraLATA digital synchronization is contained in Section 11.

## 7.6.2 Characteristics of Digital Transmission

### 7.6.2.1 Error-Free Seconds

An Error-Free Second (EFS) is any 1-second interval that does not contain any bit errors.

### 7.6.2.2 Bit Error Ratio

The Bit Error Ratio (BER), sometimes referred to as Bit Error Rate, is the fraction of errored bits relative to total bits received in the transmitted digital stream.

### 7.6.2.3 Severely Errored Seconds

A Severely Errored Second (SES) is a 1-second interval during which the BER is greater than or equal to  $10^{-3}$  at DS0 or DS1 transmission rates. This corresponds to greater than 64 bit errors over a 1-second period at the DS0 rate or greater than 1,544 bit errors at the DS1 rate.

### 7.6.2.4 Slips

A transmission impairment known as a “slip” (also called a “controlled slip”) can occur if digital equipment is not synchronized. As an example, suppose a digital switch receives DS1 signals that differ in frequency from the internal rate of the switch; in other words, a “frequency offset” exists. An overflow or underflow of information will eventually occur. This results in a slip, which is the deletion or repetition of one entire frame (193 bits) of information. These modifications to the digital stream can cause significant errors in digital data transmission.

### 7.6.2.5 Phase Hits

The switching of digital transmission facilities or multiplex equipment (for example, from a working to a standby element) can cause a rapid change in phase (called a “hit”) on the transmitted signal. Receiving synchronizing equipment is designed to buffer changes in incoming phase. However, the switching of transmission facilities may cause a hit directly on the transmitted signal as a result of a difference in phase between the working and standby facilities.

---

---

#### 7.6.2.6 Timing Jitter

The random accumulation of small timing errors in the clock circuits of a string of digital regenerators can lead to variations in the timing of a digital signal. This “timing jitter” can cause digital errors and, in the extreme, introduce distortion into the voice signals carried on the digital channels.

#### 7.6.3 Bit Integrity

The capability of transmitting bit streams through the network without any change (preserving bit integrity) is a benefit of end-to-end digital connections. To avoid intermediate digital processing (which destroys bit integrity), loss is inserted on all-digital connections at the receiving end only where digital-to-analog conversion occurs. Devices, such as echo cancelers, that use digital processing need to have the capability of being disabled, when necessary, to preserve bit integrity.

#### 7.6.4 Clear-Channel Capability

With conventional digital transmission, the eighth bit of every sixth word is “robbed” for purposes of transmitting signaling information. Where signaling is carried by other means, such as with Common Channel Signaling (CCS), a bit rate of 64 kbps is available for Integrated Services Digital Network (ISDN) services. This is referred to as DS0 Clear-Channel Capability (DS0 CCC).

In order to obtain transparency in a DS1 signal (DS1 CCC), it is necessary to take into account the “ones-density” requirement. This requirement is imposed by the clock-recovery circuits in digital line repeaters and other regenerators. Two methods (coding plans) are used to replace a string of eight successive “zeroes” with another string that provides sufficient “ones.” These methods are Bipolar with 8-Zero Substitution (B8ZS) and Zero-Byte Time-Slot Interchange (ZBTISI).

In the B8ZS method, eight successive zeroes are replaced with a unique pattern of ones containing Bipolar Violations (BPVs). (The normal bipolar coding rule, sometimes referred to as Alternate Mark Inversion [AMI] requires a positive pulse to be followed by a negative pulse and vice-versa. There may be zeroes between the pulses.) At the receiving end, the unique pattern of BPVs is detected, triggering restoration of the original group of eight zeroes. A consideration with this method is that associated digital equipment must be “optioned” to recognize the unique pattern and not treat it as BPVs caused by errors.

The ZBTISI method involves buffering the bit stream and searching for all-zero octets (words) that, in combination with their adjacent words, result in a violation of the ones-density requirement. When this condition is found, the all-zero octet is flagged and replaced by an inserted address code containing sufficient ones to meet the requirement. At the

---

---

receiving end, the flag and code are recognized, and the word is restored to its original all-zero state.

An advantage of the ZBTSI method is that it does not interfere with error detection techniques that are based on the presence of bipolar violations. A disadvantage is increased transmission delay, caused by the necessary buffering. Delay considerations are responsible for B8ZS being the preferred method in long-term network plans.

## **7.7 Digital Data Transmission**

Digital data can be transmitted at various speeds over both dedicated (private line) and switched facilities. These capabilities, which are offered for intraLATA service as well as for LATA access, are discussed in the following paragraphs.

### **7.7.1 Dedicated Digital Services**

Digital Data Special Access Service provides baseband data transmission via dedicated facilities. Full duplex, synchronous digital transmission at bit rates of 2.4, 4.8, 9.6, 19.2, 56, and 64 kbps is available. An additional, lower-speed secondary channel may also be provided along with all but the 64-kbps rate. These channels operate in parallel with the primary data channel and are used by the customer to control or monitor his/her own network.

High-Capacity Digital Special Access Service provides digital transmission at rates of 1.544 Mbps and higher. The DS3 rate (44.736 Mbps) is the most commonly used higher rate although DS1C (3.152 Mbps), DS2 (6.312 Mbps), and DS4NA (139.264 Mbps) are available in some instances.

LECs offer these digital services under various trade names. The performance specifications are provided in local tariffs. Where LATA access is involved, performance criteria for the access portion of the connection are in Bellcore generic requirements. Transmission parameter limits for Digital Data Special Access Service (64 kbps and under) can be found in TR-NWT-000341. For High-Capacity Digital Service, requirements are contained in GR-342-CORE.

### **7.7.2 Switched 56-kbps Services**

Switched 56-kbps services provide a circuit-switched transport capability for end-to-end, full-duplex, 56-kbps digital transmission. For some time, this service has been provided using end-to-end digital connections under the umbrella name of Public Switched Digital Service (PSDS). More recently, the service is being provided as one of the ISDN "bearer services."

---

---

Generic feature requirements for PSDS are contained in TR-TSY-000534.

Three end-user interface arrangements for PSDS are defined in ANSI TIA/EIA-596:

- 4-wire access using AMI digital transmission, at a line (loop) rate of 56 kbps. The interface for this access technology is designated “Type I” in ANSI TIA/EIA-596.
- 2-wire access using Time-Compression Multiplexing (TCM),<sup>6</sup> at a line rate of 144 kbps. The interface for this access technology is designated “Type II.”
- 2-wire access using TCM, at a line rate of 160 kbps. This access technology uses a “Type III” interface.

In addition to defining the three types of interfaces, ANSI TIA/EIA-596 provides technical and functional requirements for Network Channel Terminating Equipment (NCTE), specifications for interfaces between NCTE and Data Terminal Equipment (DTE), and end-to-end compatibility and maintenance requirements for connection to PSDS. The three access arrangements are described briefly in the following paragraphs. Section 14 contains more information on PSDS architectures.

#### 7.7.2.1 Type I PSDS Access

This access arrangement is similar to that used for Digital Data Special Access Service. An early application provided PSDS connection via a 1A ESS analog switch. Later applications allow PSDS connections via various manufacturers’ digital switches.

#### 7.7.2.2 Circuit-Switched Digital Capability

Circuit-Switched Digital Capability (CSDC) is a feature offering that provides PSDS capability, via a 2-wire (Type II) access, for customers served by the 1A ESS switch. Data is transmitted, using AMI coding, in 200-bit bursts at a bit rate of 144 kbps. Loops are limited in length (delay considerations) and loss at 72 kHz (the half-bit rate). Both the loss of the loop and the effects of bridged taps must be taken into account.

Special line terminating equipment is required at the 1A ESS end office to provide a full duplex path through the switch to the trunk side. On the trunk side, the data signal is placed on a DS0 channel of a DS1 (or higher) facility. End-to-end routing is via digital trunks and tandem offices. The integrity of the 7 data-carrying bits of each byte must be maintained to the far end. This is accomplished by disabling echo cancelers and avoiding digital pads or other forms of digital processing.

---

6. In TCM, bursts of digital signal are transmitted, alternately, in each direction. Sufficient time is allowed between bursts to ensure that the signal has been received, prior to transmittal of a burst in the other direction. Use of a line rate that is significantly higher than 56 kbps allows for full-duplex operation at 56 kbps.

In addition to the Type II interface information contained in ANSI TIA/EIA-596, information on CSDC service can be found in TR-880-22135-84-01.

#### 7.7.2.3 DATAPATH Service

DATAPATH service is similar to CSDC in that TCM is utilized on a two-wire loop to provide access (Type III) to the end office. In this case, however, the TCM bit rate is 160 kbps and the service is provided via a Nortel DMS-100 digital switch. The 160-kbps TCM rate provides a full 64-kbps data channel with an 8-kbps signal channel for control and maintenance functions. (It should be noted, however, that end-to-end transmission of 64-kbps data signals is not possible without clear-channel transmission facilities in the network. Such facilities are not provided for PSDS.) In addition to the Type III interface information contained in ANSI TIA/EIA-596, information on DATAPATH service can be found in TR-EOP-000277.

#### 7.7.2.4 Interworking of PSDS Technologies

The end-user equipment for PSDS must be compatible with the protocol used by the serving switch. However, there are no restrictions on calls between end-user equipment that employ any of these technologies. As noted above, end-to-end connections must consist solely of digital facilities and switches. Where inband signaling is used, PSDS calls must be routed via dedicated trunk groups consisting only of digital trunks terminating on digital switches. This is because there is no unique traveling class mark to identify a PSDS call throughout the network, to ensure routing by digital facilities. With deployment of Signaling System 7 (SS7), PSDS call routing will not require dedicated trunk groups.

#### 7.7.2.5 Switched 56 kbps as an ISDN Bearer Service

One of the circuit-mode bearer services defined for both the ISDN Basic Rate and Primary Rate Interfaces is "Unrestricted Digital Information Rate Adapted from 56 kbps." The 56 kbps of user data is carried within a 64-kbps B-channel. The ISDN end-user equipment provides rate adaption which ensures that the all-zero octet is not transmitted. Although the network may employ digital facilities without CCC, the received bit stream of user data at the terminating end is identical (within performance limitations) to the transmitted bit stream at the originating end, in other words, the end-to-end connection maintains bit integrity.



---

#### 7.7.2.6 Interworking Between PSDS and ISDN Switched 56-kbps Data

With the conversion of trunk signaling from multifrequency to SS7, it will be possible to route PSDS and ISDN 56-kbps calls over shared SS7-supported trunk groups and these calls will be able to interwork. SR-NWT-002598 provides references to various Bellcore documents that provide the requirements that will allow this interworking to take place.

#### 7.7.3 Switched 64-kbps Service

Another ISDN bearer service, defined for both Basic Rate and Primary Rate Interfaces is “Unrestricted Digital Information, 64-kbps CCC.” The essential characteristics of the service are that there are no restrictions on the user’s 64-kbps data stream, and the received bit stream is identical (within performance limitations) to the transmitted stream at the originating demarcation point. That is, bit integrity is maintained.

#### 7.7.4 ISDN Switched DS1/Switched Fractional DS1

Switched Fractional DS1 (SWF-DS1) is a family of multirate services that provides the ISDN end user with the ability to obtain CCC for bandwidth on demand. Speeds of 64 kbps to 1536 kbps can be accessed. SWF-DS1 is offered to the end user at rates of  $N \times 64$  kbps, where  $2 \leq N \leq 24$ . **NOTE:** For  $N=6$  (384 kbps),  $N=23$  (1472 kbps), and  $N=24$  (1536 kbps), channels are designated H0, H10, and H11, respectively.

#### 7.7.5 Switched Digital Services Performance

As with Digital Data Services (DDSs), performance specifications for intraLATA switched digital services are provided in local tariffs. Where LATA access is involved, performance specifications for the access portion can be found in Bellcore technical references. Transmission parameter limits for ISDN-based switched DDSs can be found in GR-334-CORE.

### 7.8 Transmission Aspects of Switches

#### 7.8.1 Comparison of Analog and Digital Switches

Although analog and digital end offices provide the same basic functions, there are fundamental differences in their designs. Table 7-2 compares features that relate to transmission and signaling performance of the two types of switches. Some of the

---

differences are specific to a particular manufacturer's switch, for example, the use of a floating ground versus a ground-referenced battery supply.

**Table 7-2. Transmission Characteristics — Analog vs. Digital End Offices**

Parameter	Analog Office	Digital Office
<b>Loop Battery Supply</b>		
Battery Feed	Ground-Referenced	Ground-Referenced or Floating
Limiting of Loop Current	Simple Resistor	Simple Resistor or Current Regulator
Open Switch Intervals	Many and Long	Few and Short, or None
Loop Limit	1500-1600 $\Omega$	1600-2000 $\Omega$
Loop Limited by	Signaling & Supervision	Current to CPE
<b>Transmission Aspects</b>		
Cross-Office Loss	0.3-1.5 dB, not controlled	0-7 dB (set via translations; analog or digital padding)
Test Access Loss	0.3-0.6 dB	0 dB
Frequency Response	High loss < 200 Hz	High loss <200 Hz and >3.4 kHz
Envelope Delay Distortion	Minor, < 300 Hz	Some, <500 and >2000 Hz
Noise, Message	-5 to 5 dBrnC, highly variable	16-19 dBrnC, constant
Signal-to-CNN Ratio	Very high, approx. 60 dB	approx. 35 dB
Impulse Noise	SXS: 59 dBrnC	42 dBrnC
(Threshold for 5 Counts in 5 min)	Crossbar: 54 dBrnC Electronic: 47 dBrnC	
Frequency Shift	None Possible: Metallic Path	None Possible: Digital Path
Phase Hits	None Possible	Possible on Interentity Calls if Sync Net Fails
Overload Point	approx. +20 dBm - Saturation in Inductors	+3.17 dBm0 - Coder Overload
Echo Delay	0.2 ms, fixed	1.5 ms, variable
Pad Control in Centrex Networks	Analog Pad, Controlled by Class of Service or Translations	Digital Pad and/or Variable Analog Amplifier, Controlled by Translations
<b>General</b>		
DLC Interface	Tip & Ring	Tip & Ring or Integrated (OS1)
Cross-Office Path	Physical (Wire Contacts, Repeat Coils, Relays)	Electronic (Hybrid, Coder, Decoder, Hybrid)
Tone Sources	Analog Oscillators	Read-Only Memories
Tone Receivers	Analog Filters and Rectifiers	Digital Signal Processors
Ringing Sources	Common Generator	Per-Frame Inverters
Metallic Test Access for Loop Test System	Yes	Yes
Trunk Interfaces: VF	Yes	Not in Some Designs
DS-1	Only with DCT Frame	Yes
“Nail-Up” of Special Services	No	In Some

## 7.8.2 Digital Switch Distortion Performance

Bit robbing, discussed in Section 7.6.4, results in a  $7-5/6$  bit code that gives a signal-to-distortion ratio approximately 1.8 dB lower than that for a full 8-bit signal. It is typical on a call switched through a digital tandem office for signaling on the outgoing bit stream to use the eighth bit-position of a frame that differs from the frame used on the incoming bit stream. (This can also occur on a digital trunk that passes through a DCS or an echo canceler.) It is likely that the output will be a  $7-4/6$  bit code. With this disassociated bit borrowing, the result after five tandem switching stages could be equivalent to coding with 7 bits (never fewer). This would cause an additional 4.2-dB degradation of signal-to-distortion performance.

In practice, the chance of only seven bits being used is relatively small, given a reasonable number of switching stages. Figure 7-7 shows the relative probabilities of various numbers of coding bits being used versus the number of intermediate bit-borrowing stages. For example, with three stages of switching, the relative chances are:  $7-5/6$  bits, 3 percent;  $7-4/6$  bits, 40 percent; and  $7-3/6$  bits, 57 percent. It should be noted that with DS0 CCC transmission, this problem will not exist.

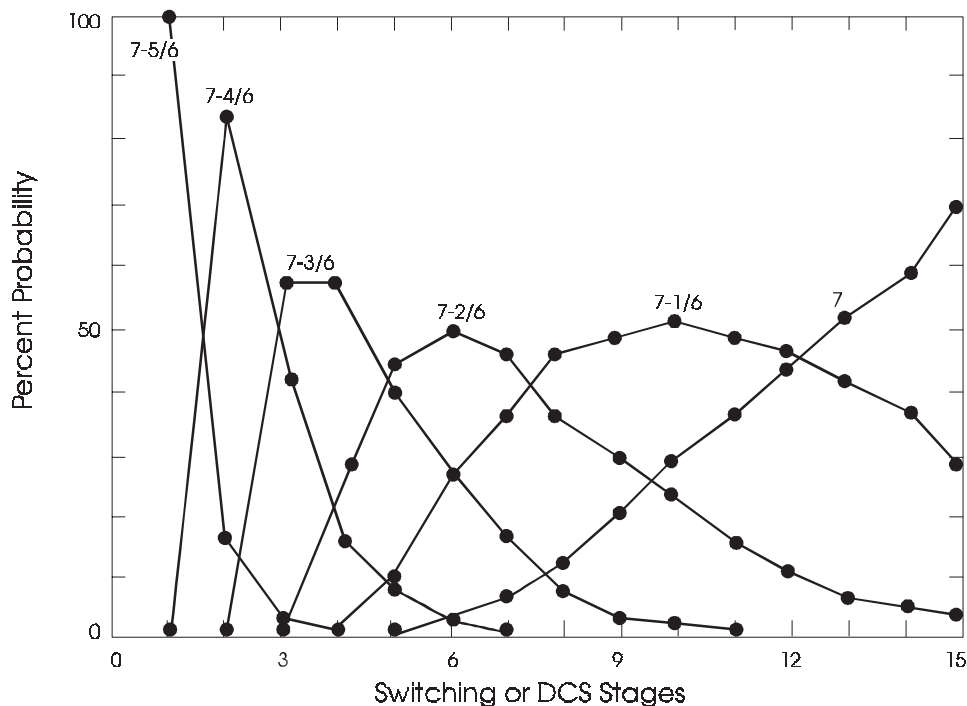


Figure 7-7. Probable Numbers of Coding Bits Used

---

## 7.9 Adaptive Differential Pulse-Code Modulation Technology

Adaptive Differential Pulse-Code Modulation (ADPCM) is a method for digital encoding of analog signals that requires fewer bits per channel than PCM.

With ADPCM, only a 4-bit error signal is sent, denoting the difference between a predicted value and the actual value of a signal. The international standard ADPCM system uses 32 kbps per voice channel, as compared to 64 kbps for PCM. ADPCM is not used widely in exchange carrier networks but is quite common in international trunks and private networks.

A transcoder converts signals digitally between PCM and ADPCM. This makes ADPCM transmission compatible with PCM terminals such as digital switches and channel banks. Typically, the transcoder interfaces with two PCM-DS1 lines on one side and one ADPCM-DS1 line on the other. In some transcoders, only 44 of the 48 PCM channels are available. The remaining time slots are used for signaling and maintenance information.

The performance of ADPCM for speech is only slightly less in comparison with PCM. The presence of ADPCM cannot be detected with ordinary test equipment that measures bandwidth, idle noise, C-notched noise, or slope. However, fewer tandem ADPCM encodings can be tolerated as compared to PCM encodings.

Application rules limiting the number of ADPCM encodings that may be encountered in the network are provided in ANSI T1.501.

Since the ADPCM algorithm is based on characteristics of voice signals, performance is somewhat poorer for voiceband data. Normal applications of multifrequency, Dual-Tone Multifrequency (DTMF), or single-frequency signaling are not affected, but all modem signals are degraded to some extent. Many voiceband data modems and digital facsimile terminals operating at data rates of up to 33.6 kbps (14.4 kbps for facsimile) operate poorly or not at all over ADPCM. The general rule is to limit the number of asynchronous tandem encodings to three. An asynchronous tandem ADPCM encoding occurs when the connection is analog (when the signal must pass through an analog switch, for example). A limit of three ADPCM encodings allows some margin for impairment from other factors. As recommended by the ITU-T (formerly the CCITT), the international limit is four.

To pass through a digital switch, it is necessary only to convert the ADPCM to PCM; no analog connection is required. The standard ADPCM algorithm contains a synchronous coding adjustment such that no penalty occurs when the ADPCM signal is converted to PCM and back without an analog interface.

However, this assumes that the ADPCM and PCM bit streams are not disturbed by errors, bit-robbing for signaling, or by digital signal processing such as digital loss. Such a connection would be rare in the United States in a pre-ISDN environment, since most digital switches interface with bit-shared PCM. A digital tandem without bit integrity will generally give an ADPCM degradation ranging between negligible and that of an

---

asynchronous connection. The penalty is small for bit-shared PCM but equal to that of an asynchronous encoding if digital loss is used.

## 7.10 Asynchronous Transfer Mode Technology

Asynchronous Transfer Mode (ATM) is a flexible digital transmission method that allows different kinds of services to be carried in one network, without need for overlay networks for each service. This is accomplished by putting the digitized voice, data, or video signal into standard, fixed-length packets of bytes, called cells. Cells are assembled from the bit stream of the source call or service. These cells may be intermixed with cells from other services. Cells are routed through the network at ATM switching points. At the destination, the cells for each service are sorted, collected, and disassembled into a bit stream appropriate to each service.

Each cell is independent of other cells, even those of the same call. However, cells for a given call are routed over the same path, as discussed later. There are no assigned time slots, as there are in synchronous systems such as Time Division Multiplex (TDM). Hence the name *Asynchronous* Transfer Mode.

### 7.10.1 ATM Cells

An ATM cell, as standardized by the ITU-T (formerly the CCITT), consists of 53 bytes. Each cell is partitioned into a 5-byte header and a 48-byte information field. The header contains overhead information for functions such as routing. The information field may also contain some overhead. The advantages of fixed-length cells over variable-length cells are (1) smaller cell delay variation and (2) simpler hardware and software for cell processing at sources, nodes, and destinations. The 53-byte cell is a compromise between long cells, which are more efficient for video and data, and short cells which have less delay for voice.

### 7.10.2 ATM Cell Assembly and Disassembly

Cell assembly consists of loading the source bit stream into ATM cells. Cell disassembly consists of unloading the cells into the destination bit stream. Figure 7-8 illustrates cell assembly where two types of service, Constant Bit Rate (CBR) and Variable Bit Rate (VBR) are combined over a DS3 connection. CBR services, such as voice transmission, require cells to be created at a fixed rate, while VBR services, which transmit data in bursts, do not. In the example, one CBR cell is created, followed by three non-CBR cells. Access algorithms can be used to ensure that delay-sensitive CBR services will always get a cell when data is ready. VBR services are generally more delay-tolerant, and can be permitted to wait if a cell is not immediately available. VBR services can use all of the cells that are

---

not being used by the CBR service. In this example, the VBR service has transmitted a burst of data requiring only two cells. Unused (empty) cells maintain periodicity of the CBR cells.<sup>1</sup>

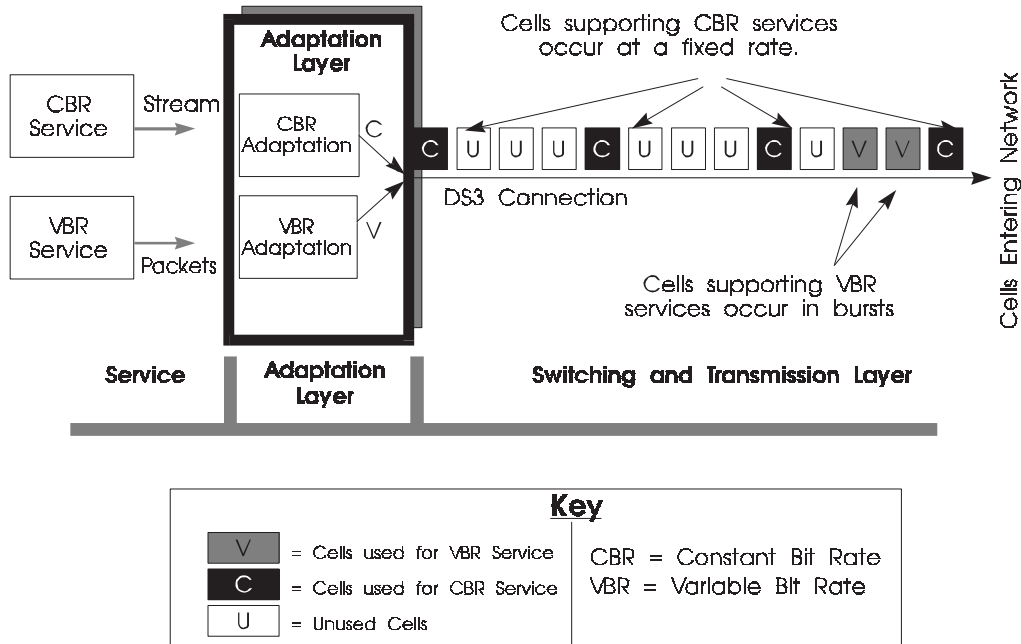


Figure 7-8. Combining CBR and VBR Traffic Using Cell Switching

### 7.10.3 ATM Switching

The switching methodology for ATM cells differs from those used in analog and digital switches:

- Analog switches reserve and nail up a physical path through the switch for a given call, for the duration of the call. Digital switches reserve a path through the switch in the form of a designated time slot. In either case, the path must have fixed bandwidth capability equal to the highest bandwidth to be switched. Thus, if a switch can switch broadband signals, it is inefficient for narrowband signals. If a switch is efficient for narrowband signals, it cannot readily switch broadband signals.
- ATM switches route cells independently according to their header address. However, once a path is determined for a given call, all subsequent cells for that call follow the same path. Services of all bandwidths may share the same physical connection. A service can use whatever bandwidth it needs and dynamically vary it. Cells from

1. These unused cells could be used to carry other VBR services.

various routes are queued and merged or routed when they reach the front of the queue in a process called statistical multiplexing.

ATM does not provide "dedicated" connections for calls. Rather, ATM provides virtual connections on virtual paths and on virtual channels.

#### 7.10.4 ATM Transport

Between ATM switching nodes, ATM cells may be carried on DS1, DS3, or Synchronous Optical Network (SONET) facilities (see Section 14.15). Table 7-3 shows the raw bandwidth of SONET channels, the bandwidth available to ATM, and the bandwidth available to ATM cell information fields ("payload"), that is, available to application layers above the cell layer. (Bandwidth is synonymous with bit rate or speed.)

**Table 7-3.** Bandwidths for SONET Transport (Mbps)

Facility	Line Rate	Available Rate for ATM cells	Available Rate for Applications
STS-1	51.84	49.536	44.863
STS-3	155.52	149.76	135.632
STS-12	622.08	600.896	544.208

Following are illustrations of how different bandwidths are accommodated in ATM transport:

- A single 64-kbps voice or voiceband data channel can be loaded into cells that occur with an approximate period of 6 ms, or at a rate of about 167 cells per second in the ATM cell stream.
- A 1.544 Mbps DS1 can be loaded into cells that occur with an approximate period of 1/4 ms, or at a rate of about 4000 cells per second in the ATM cell stream.
- A 44.736 Mbps DS3 can be loaded into cells that occur with an approximate period of 8.6  $\mu$ s or at a rate of about 116,000 cells per second in the ATM cell stream.

In any of these cases, the intervening intervals are available for cells of other calls or services. **NOTE:** Cells for CBR services occur in the ATM cell stream with a cell period approximately equal to the cell assembly/disassembly delay, which is discussed below.



---

## 7.10.5 ATM Delay

### 7.10.5.1 Delay Associated with Cell Assembly and Disassembly

Since the source bit stream is at a lower bit rate than the SONET Synchronous Transport Signal level N (STS-N) bit stream, the cell assembly process introduces delay. The assembler cannot form a cell until 48 bytes have arrived. Similarly, the disassembler can only emit bytes at a rate that is compatible with the lower bit rate of the destination bit stream.

For example, for DS0 64-kbps voice or voiceband data as the source, the one-way delay for loading 48 bytes into cells is about 6 ms:

$$48 \text{ bytes} \times 8 \text{ bits/byte} \div 64 \text{ kbps} = 6 \text{ ms.}$$

As another example, for DS1 circuit emulation as the source, that is, the carrying of DS1 on ATM cells, the one-way delay for loading 48 bytes into cells is about 1/4 ms:

$$48 \text{ bytes} \times 8 \text{ bits/byte} \div 1.544 \text{ Mbps} = 1/4 \text{ ms.}$$

Finally, for DS3 circuit emulation as the source, that is, the carrying of DS3 on ATM cells, the one-way delay for loading 48 bytes into cells is about 8.6  $\mu$ s:

$$48 \text{ bytes} \times 8 \text{ bits/byte} \div 44.736 \text{ Mbps} = 8.6 \mu\text{s.}$$

### 7.10.5.2 Delay Associated with SONET Rate Conversion

There is a similar delay mechanism when STS-1 cells are converted to STS-3 cells and back again, or when STS-3 cells are converted to STS-12 cells and back again, but the amount of delay has negligible effect on performance. The delay for conversion between STS-1 and STS-3 is about 7.4  $\mu$ s:

$$48 \text{ bytes} \times 8 \text{ bits/byte} \div 51.84 \text{ Mbps} = 7.4 \mu\text{s.}$$

The delay for conversion between STS-3 and STS-12 is about 2.5  $\mu$ s:

$$48 \text{ bytes} \times 8 \text{ bits/byte} \div 155.52 \text{ Mbps} = 2.5 \mu\text{s.}$$

### 7.10.5.3 Delay Associated with Jitter Removal

Due to contention at queues, accompanying such functions as merging of bit streams at cell concentrators and cell switches, the cells for a given source get randomly jittered with respect to their original positions in time. The spread of the jitter depends on several factors including the number of such queues and the amount of traffic that a cell must contend with at each queue.

---

CBR services require restoration of the periodicity of the bytes, while VBR services do not. Restoration of CBR services is accomplished by means of a jitter removal buffer just prior to, or in conjunction with, cell disassembly. The jitter removal buffer introduces delay equal to the buffer length which, by design, is approximately equal to the width of the delay variation distribution.

#### 7.10.5.4 Total ATM Delay

The assembly/disassembly delay and jitter removal buffer delay in ATM transport are in addition to the delay of digital systems. The ATM contribution to echo path delay is twice the one-way assembly/disassembly delay (12 ms total for 64-kbps voice, for example) plus the sum of jitter removal buffer delays at each end (this can be several ms). This is a significant increase in delay which will necessitate additional echo control for voice transport on ATM. A method for echo control in the ATM domain has not yet been standardized.

#### 7.10.6 Transmission Errors and Cell Loss

Transmission errors in the underlying SONET transport facility layer will introduce errors into a cell header or into the cell information field (or perhaps both, in the case of burst errors). The effect of header errors and information field errors is different. An information field error will result directly in a single error in the decoded bit stream. A header error may result in lost or misrouted cells and a 48-byte long discontinuity in the decoded bit stream, similar to a frame insertion or omission slip in TDM systems.

Cell loss can also result from buffer overflow at queues at ATM switching nodes, due to contention among cells of various calls or services at times of high traffic. In addition, cell loss can result from buffer overflow at a jitter removal buffer when cell delay variation (delay jitter) exceeds the buffer capacity. The design of the buffers is a trade-off between cell loss, cell delay, and buffer memory requirements.

### 7.11 End-to-End Performance

Customer perception of the transmission quality of a telephone call is based on an assessment of end-to-end performance. This performance is a composite of the performance of each portion of the end-to-end connection (described in Section 7.2.1). Moreover, voice performance parameters (for example, loss, noise, and echo) are interrelated in a complex manner. The following paragraphs describe the methodology used to arrive at performance estimates for connections in existing networks or in new architectures where the changes may be relatively minor or global.

---

---

### 7.11.1 Grade of Service

Estimates of end-to-end performance are obtained in terms of customer opinion by means of modeling techniques. Two types of models are involved: one characterizing the performance of the network being studied, the other relating customer opinion to the presence/magnitude of various performance impairments. Customer opinion models are based on subjective tests, conducted in the field or laboratory, in which combinations of impairments with controlled magnitude are presented to subjects. These subjects judge the quality of each combination by placing it in one of five categories: excellent, good, fair, poor, or unsatisfactory.

Grade of Service (GOS) combines the distribution of customer opinions with the distribution of telephone plant performance parameters, to obtain the expected percentage of customer opinions in each of the five categories. It is common practice to combine the "good" and "excellent" percentages to arrive at a "Percent Good Or Better" (% GOB) rating. Alternatively, the "Percent Poor Or Worse" (% POW) rating, which combines the "poor" and "unsatisfactory" categories, is sometimes used. These terms are also used for customer opinion models as discussed in the following paragraphs.

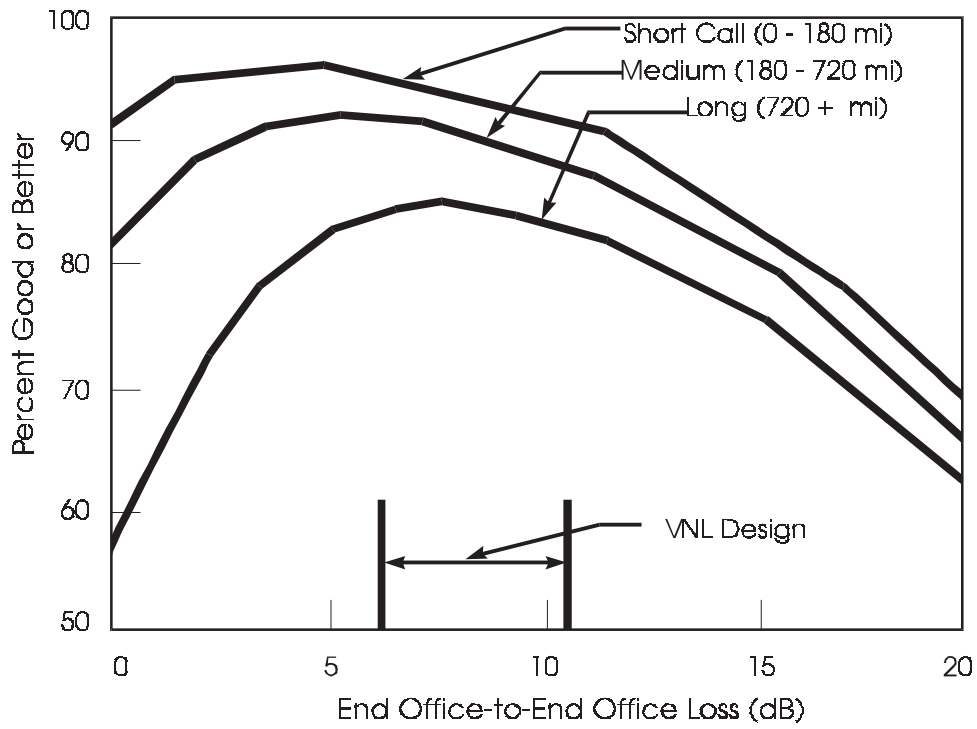
### 7.11.2 Customer Opinion

The effects of loss, noise, talker echo, and listener echo on customer opinion of telephone connections are discussed in this section.

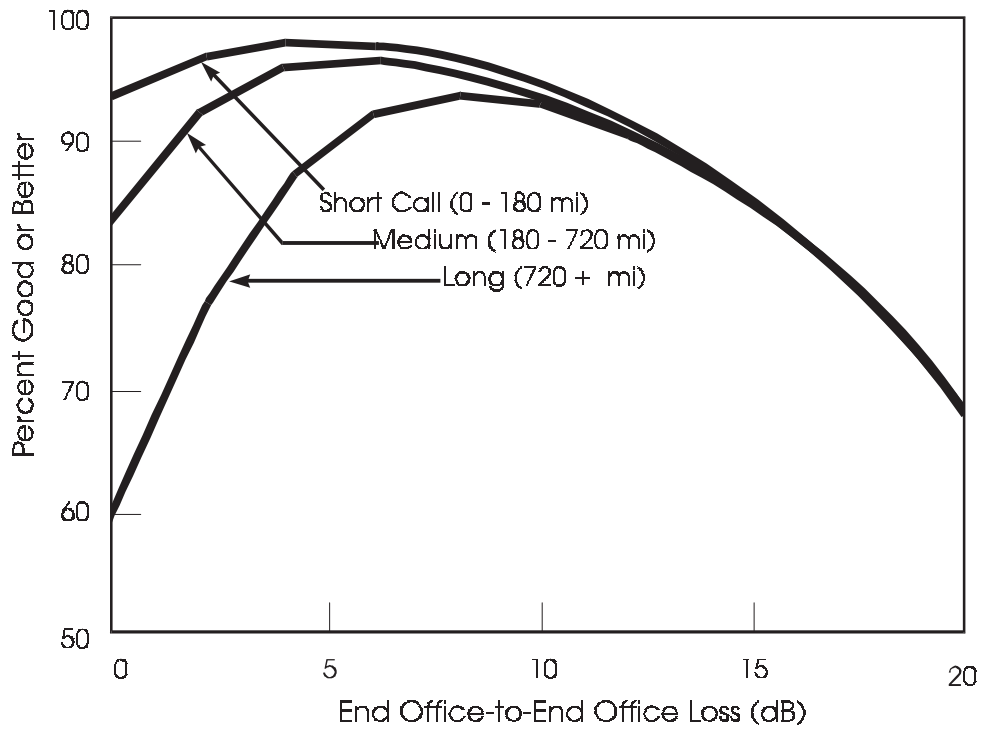
#### 7.11.2.1 Perception of Loss

Figure 7-9 shows the effect of loss on customer opinion for an analog network. In this study, the end office-to-end office loss was varied over a range of 20 dB for short-, medium-, and long-mileage calls. Customer %-GOB ratings are plotted as a function of this loss. It can be seen that customer opinion improves with increased loss up to a maximum value, and then declines as the loss continues to increase. The maximum values are approximately 4, 6, and 8 dB, respectively, for the three categories of calls. Also indicated is the range of losses that resulted from application of the Via Net-Loss (VNL) Plan to analog networks (see Section 7.12.1.1).

Study results for a digital network are shown in Figure 7-10. The curves have similar shapes, again indicating an optimum value of loss for each category of call. The factors that cause the curves to differ from those for an analog network are discussed in Section 7.12.



**Figure 7-9.** Customer Perception of End Office-to-End Office Loss — Analog Network



**Figure 7-10.** Customer Perception of End Office-to-End Office Loss — Digital Network

## 7.11.2.2 Loss/Noise

The effects of connection-loudness loss and message-circuit noise are estimated by means of loss/noise, subjective-opinion models. Contours of constant % GOB are shown in Figure 7-11 for a specific set of loss/noise subjective tests. For low values of noise, the model indicates that the percentage of calls rated good or better is controlled primarily by loss. For higher values of noise, both loss and noise affect the rating.

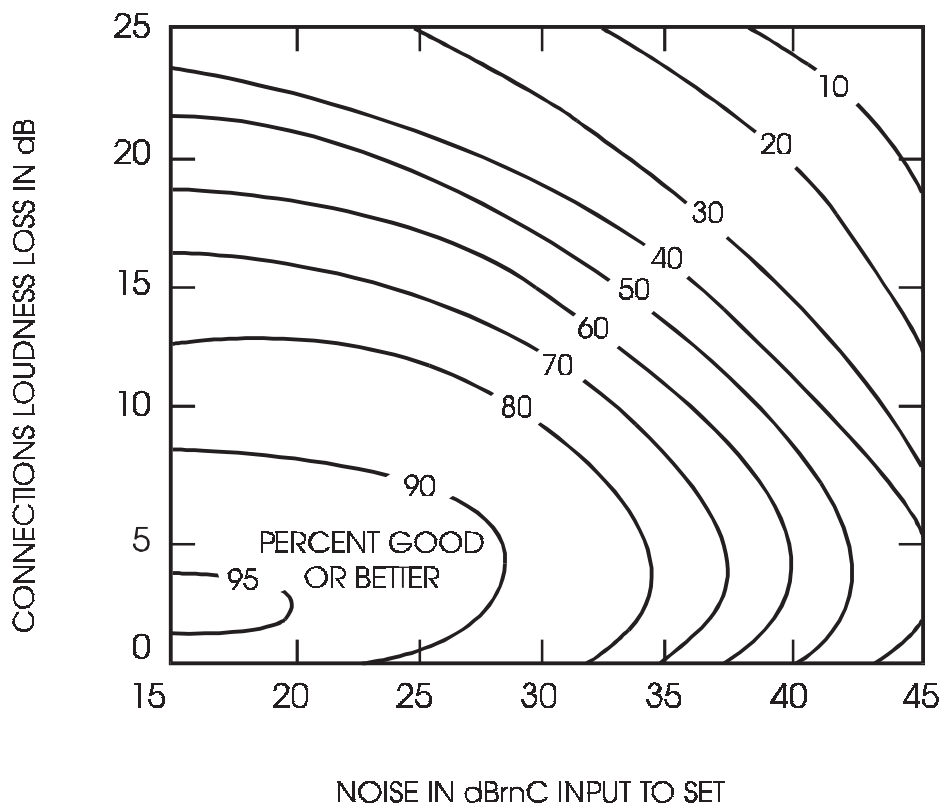


Figure 7-11. Loss/Noise Grade of Service

## 7.11.2.3 Talker Echo

The amount of annoyance caused by talker echo depends on the amplitude and delay of the echo. Figure 7-12 (A) shows a talker-echo opinion model. It can be seen that the amount of echo path loss needed to achieve a given talker-echo rating rises with increased echo delay. The acoustic echo path loss includes the TOLR and ROLR (see Section 7.4.1) of the telephone set/loop, the electrical loss from the loop to the reflection point and back, and the ERL at the reflection point. For loops with a 500-type telephone set, the sum of the TOLR and ROLR has a mean of about 4 dB and a standard deviation of about 3.5 dB.

---

#### 7.11.2.4 Loss/Noise/Talker Echo

A combined loss/noise/talker echo opinion model is shown in Figure 7-12 (B). These results are for a specific combination of loss and noise. However, just as in Figure 7-12 (A), as the acoustic echo path loss of a connection decreases and/or the echo path delay increases, a decrease occurs in the percentage of customers rating the connection good or better.

#### 7.11.2.5 Listener Echo

Figures 7-12 (C) and (D) show opinion models for listener echo alone and combined loss/noise/listener echo, respectively. The ratings are plotted as a function of WEPL (see Section 7.4.4). The effects of changing the echo path loss and/or the echo path delay are similar to those for talker echo.

### 7.11.3 Network Performance

Estimated performance for intra-end office connections (connections involving customers served by the same end office) is shown in Figure 7-13. The estimates were obtained by determining the distribution of loudness losses for connections via analog end offices, that is, assuming a fixed value of noise and applying the subjective opinion model to the loss/noise values.

Performance estimated for inter end office connections designed under the VNL Plan is also shown in Figure 7-13. A fixed value of 7 dB of loss was added to the loudness-loss distribution that was used for the intra end office connections to obtain a loudness-loss distribution applicable to inter end office connections. The approximate average end office-to-end office loss for non-metropolitan connections in the older analog network was 7 dB.

The performance curves in Figure 7-13 are results of a particular subjective opinion database and connection performance models based on loss/noise assumptions for a specific type of network. Use of a different opinion database would probably result in different values of % GOB for this network. However, it would be expected that the shape and relative placement of the performance curves would remain about the same. The point is that in evaluating the performance of two or more architectures a common opinion model is used. The resulting differences in performance values are the relevant rather than the absolute values obtained.

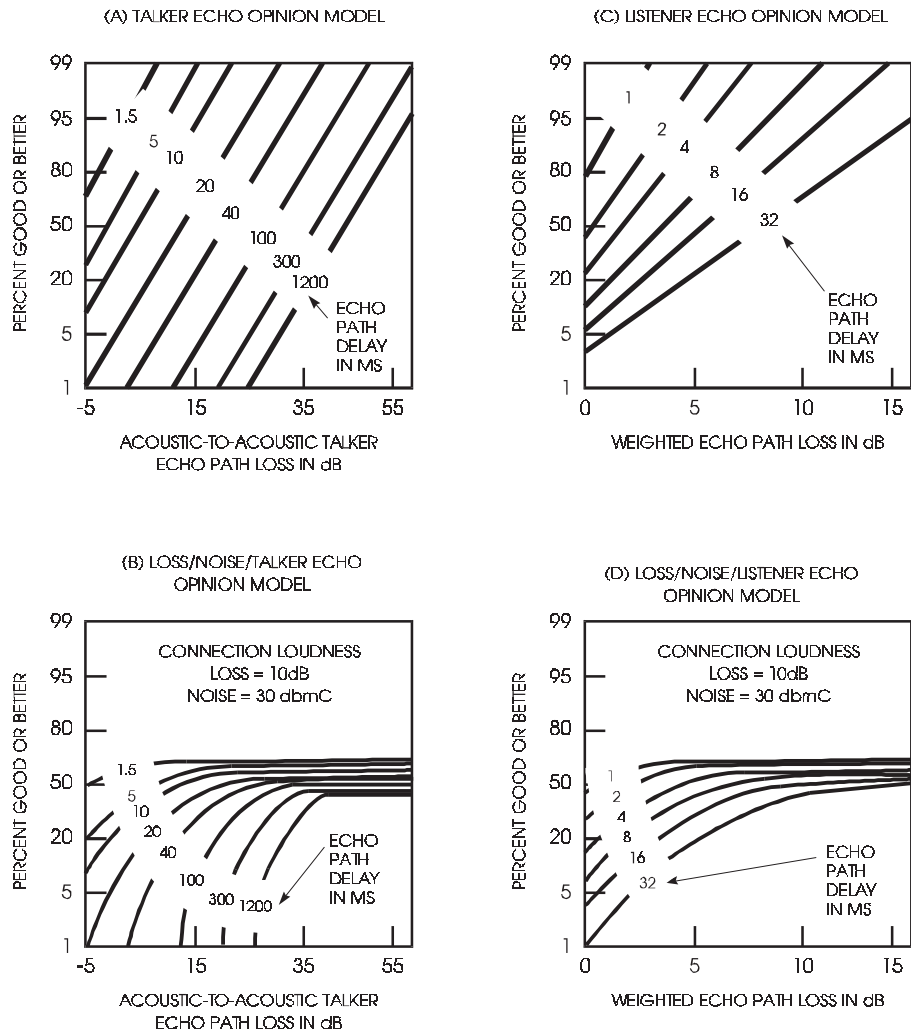


Figure 7-12. Loss/Noise/Echo Grade of Service



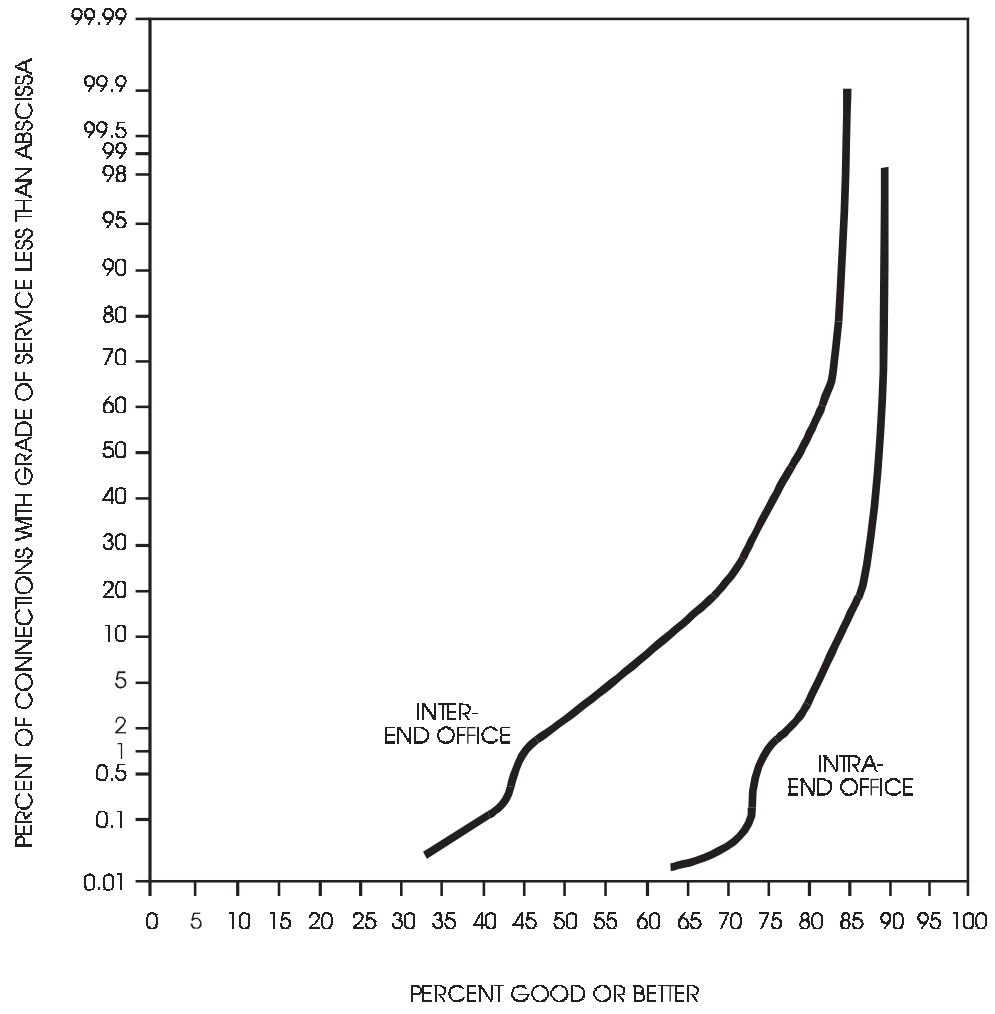


Figure 7-13. Grade-of-Service Distributions

## 7.12 Network Transmission Design

The various transmission loss plans that relate to intraLATA networks, as well as the methods for implementing the desired loss, are discussed in this section.

### 7.12.1 Network Transmission Plans

As the telephone network has evolved, various transmission plans have been developed with the purpose of providing the best possible transmission performance on the largest majority of telephone calls within appropriate economic constraints. These plans are discussed in the following paragraphs.

#### 7.12.1.1 Via Net-Loss Plan

The VNL Plan was developed in the early 1950s for a nationwide, totally analog network. The objective was to provide the lowest possible loss in each connection, commensurate with satisfactory talker-echo performance. The plan was developed using the results of studies indicating user tolerance to talker echo. It took into account the number of trunks in a connection, the expected random deviations in trunk losses from design values, and the expected ERL at the distant end office.

The VNL Plan assigned loss to a trunk based on the amount of round-trip delay the trunk was expected to contribute. Since delay is a function of the type of facility as well as the trunk length, both of these characteristics were taken into account. To ensure a minimum value of loss on all connections, each toll-connecting trunk (similar to a tandem-connecting trunk) was assigned a loss of 2.5 dB in addition to the applicable VNL. A maximum connection loss of approximately 11 dB was permitted for round-trip delays approaching 45 ms. For greater delays, echo suppressors/cancelers were deployed. The VNL Plan is rarely used, as more recent loss plans are more easily administered in modern networks see Section 7.12.1.2. Table 7-4 gives VNL values for carrier trunks used in intraLATA applications.

**Table 7-4.** VNL and ICL Values for Trunks on Carrier Facilities

Trunk Length (mi)	ICL = VNL dB <sup>a</sup>
0-165	0.5
166-365	0.8
366-565	1.1
Any length with echo canceler	0.0

- a.  $(0.0015 \times \text{Average Length} + 0.4)$  dB  
 VNL = Via Net Loss  
 ICL = Inserted Connection Loss.

---

The VNL Plan is not well suited to an all-digital network because of the requirement that loss be inserted into each trunk. Satisfying this requirement would entail

- Decoding of the digital signal followed by analog loss insertion and recoding, or
- Use of digital "pads" to lower the ultimate analog signal level.

In addition to increasing the cost of facilities, both of these techniques introduce transmission impairments. Decoding and encoding add quantizing noise to the signal while digital processing to insert loss in the analog signal adds noise and decreases the signal-to-distortion ratio. With either technique, bit integrity (see Section 7.6.3) is lost. The Fixed-Loss Plan, described in Section 7.12.1.2, overcomes these deficiencies.

#### 7.12.1.2 Fixed-Loss Plan

The Fixed-Loss Plan was developed to address the needs of an evolving digital network. It specified end-to-end loss values of 0, 3, or 6 dB for intraoffice calls, interoffice calls less than 200 miles, and interoffice calls greater than 200 miles, respectively. This loss was to be inserted in the receive path at the end office, either by digital processing before decoding or by analog padding after decoding.

The selection of a fixed-loss value for interoffice calls greater than 200 miles was based on echo and noise considerations. Some improvement in talker-echo performance could be expected due to the increased use of digital (4-wire equivalent) trunks to the end offices. However, on calls approaching 1850 miles (where it was assumed echo control would be deployed) any loss less than the value specified by the VNL Plan lowers echo performance. Noise in an all-digital network is less than in an analog network and is constant for all connection lengths. Assuming a fixed loss of 6 dB on these connections, the small decrease in overall echo performance is more than offset by the accompanying increase in loss-noise GOS.

The Fixed-Loss Plan is also compatible with a network that is only partially digital. The desired end office-to-end office loss value is achieved by allocating losses to analog trunks. "Lossless" digital facilities and digital switch paths are maintained at digital reference level. This means that the equivalent power level of a signal at any digital point in a connection is the same as the power of the original analog signal (assuming a 0-level encoder). If the final digital-to-analog decoding point is at a tandem office, a -3 decode level should be used; thus, on a connection to an analog TCT with a loss of 3 dB, the combined loss to the end office will be 6 dB. If the final decoding point is at the end office, a -6 decode level provides the desired end office-to-end office loss of 6 dB.

**NOTE:** Terms and concepts relating to digital transmission are discussed in Section 7.12.2.

---

### 7.12.1.3 Metropolitan Area and Long-Distance Plans

First, the VNL Plan principles and later, the Fixed-Loss plan principles were applied to the design of a transmission plan for use in metropolitan networks. These networks were designed so that all possible end office-to-end office connections are less than 200 route miles. This ensures that round-trip delay rarely exceeds 10 ms, thus obviating the need for special echo-control measures. Since successive calls can be trunked either directly or via tandem offices, differences in loss from one call to the next are minimized by specifying modest losses on tandem trunks and near-zero losses on intertandem trunks.

IntraLATA service is provided using a metropolitan network or a long-distance network. Figure 7-14 shows an architecture that could apply to either type of network or both simultaneously. Tandems are called sector tandems in metropolitan networks and long-distance tandems in the long-distance network. A principal tandem connects sector tandems or long-distance tandems via intertandem trunks. Tandems can be multifunctional--acting as a sector tandem for metropolitan traffic, as a long-distance tandem, and even as an access tandem (see Section 7.16.1) for interLATA traffic.

As Figure 7-14 shows, three types of trunks are used to carry intraLATA traffic:

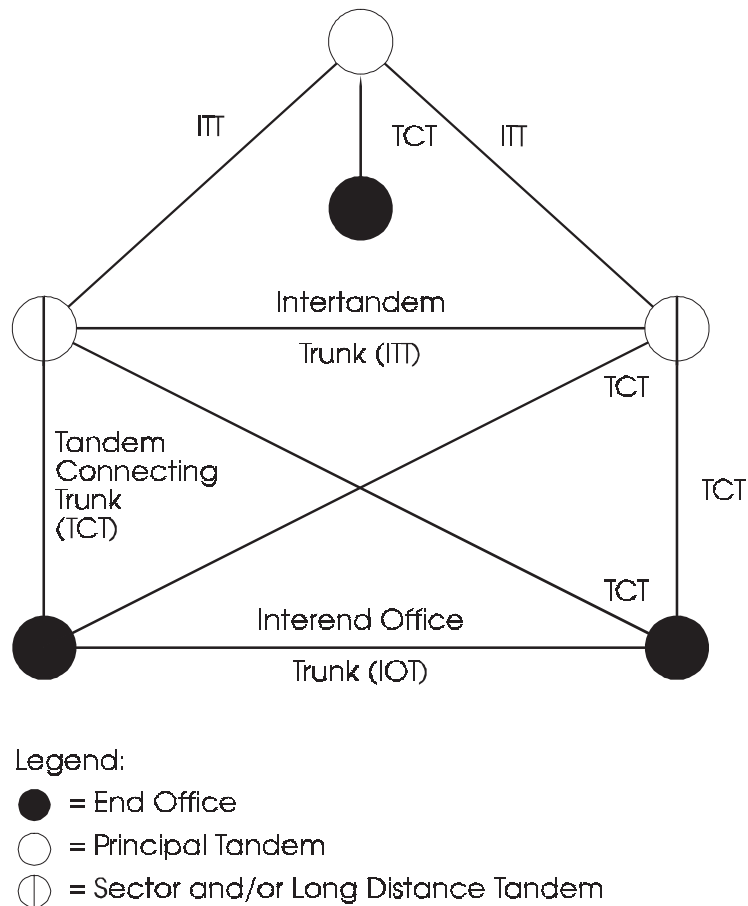
- IOTs, which connect any two end offices
- TCTs, which connect end offices to sector tandems or long-distance tandems
- ITTs, which connect any two sector tandems or long-distance tandems or either a sector or long-distance tandem to a principal tandem.

To implement a metropolitan plan, the area is divided into geographic sectors. A sector comprises the serving areas of a number of end offices. These areas are not necessarily contiguous, but the end offices offer a blend of traffic to take advantage of the noncoincidence of busy-hour traffic loads. Each sector is served by a sector tandem that forms an intermediate switching point for traffic between end offices. It also commonly provides end office switching functions.

The loss plan adopted for metropolitan networks allows for a loss of 3 dB for an inter-end office connection (see Table 7-5). (The facilities for which a loss of up to 5 dB was allowed are no longer used.) A loss objective of 1.5 dB applies to analog ITTs unless one or both ends terminates in a principal tandem that meets through-balance requirements or in a sector tandem that also serves as a long-distance or access tandem. In these cases, the loss design objective becomes 0.5 dB. The loss from end office-to-end office via one or more tandem offices is 6 dB for an all-digital connection. It will fall between 6 and 9 dB when analog and combination facilities are used.

Following are characteristics of the long-distance plan (see Table 7-5):

1. For an individual trunk shorter than 200 miles, the loss objectives are similar to those for metropolitan networks.



**Figure 7-14.** intraLATA Trunks

2. Analog trunks longer than 200 miles (rarely used now) are designed for a specific loss plus VNL.
3. All trunks (other than IOTs of less than 200 miles) have balance objectives.

Where a trunk or trunk group is used for both metropolitan and long-distance traffic, the more stringent long-distance requirements apply.

Table 7-5. IntraLATA Trunk Losses (ICL)

Trunk	Network	Loss (dB)		Notes
		Objective	Max.	
<b>Interend Office (IOT)</b>				
Analog	Metro*	3.0	5.0	1, 2
	LD > 200 mi	VNL + 6.0	8.9	4
Digital or Combination	Metro*	3.0	-	-
	LD > 200 mi	6.0	-	4
<b>Tandem Connecting (TCT)</b>				
Analog	Metro*	3.0	4.0	1, 3
	LD > 200 mi	VNL + 2.5	5.4	4
Digital or Combination	Metro	3.0	-	-
	LD	3.0	-	4
<b>Intertandem (ITT)</b>				
Analog				
ST to ST	Metro	1.5	-	-
ST to PT	Metro	0.5	-	4
General	LD	VNL	1.4	4, 5
Digital				
	Metro	0.0	-	-
	LD	0.0	-	4
Combination				
	Metro	1.0	-	-
	LD	1.0	-	4, 5
<b>Notes:</b>				
* Or LD < 200 miles				
1. Maximum applies only when gain is supplied by negative-impedance repeaters.				
2. 0.0 to 3.0 dB permitted without gain.				
3. 0.0 to 4.0 dB permitted without gain (Metro); 2.0 to 4.0 dB (LD < 200 miles).				
4. Balance required.				
5. Facilities must be 4-wire.				

---

#### 7.12.1.4 Loss Plan for Evolving Digital Networks

##### **Introduction and Background**

ANSI T1.508 provides recommended design values and application rules for network loss for Public Switched Telephone Network (PSTN) connections that are all-digital between demarcation points or that are all-digital from end office-to-end office. The standard also provides echo control and connection delay guidelines. The recommended loss values, planning rules, and application guidelines are intended to accommodate the evolution of the PSTN to handle all-digital services, such as those of ISDN (see Section 14), while maintaining compatibility with the current analog and digital U. S./North American transmission loss/level plans. Additionally, the standard provides guidelines to promote the correct and easy interconnection of LEC networks with:

1. IC networks,
2. terminal equipment, and
3. interconnecting networks for which compatible standards have been developed.

ANSI T1.508 was developed with the intent that recommendations be implemented in a manner that is consistent with the physical evolution of the all-digital network, as opposed to retroactive application to existing facilities, architectures, or services.

The achievement of satisfactory echo performance and preservation of bit integrity in all-digital connections were key considerations in the development of the standard:

- The increase in round-trip transmission delay caused by the inherent processing delay of digital elements (for example, digital switches, digital facility multiplexers, and DCSs) is a source of echo performance degradation that is manifested as talker echo. (See Section 7.4.4 for a discussion of talker echo.)
- As discussed in Section 7.6.3, digital signal processing (such as digital-to-analog conversion or the insertion of digital loss), precludes the transmission of unmodified bit streams across the network. The maintenance of bit integrity is necessary so that customers who use the network to transmit digital data can expect a signal to arrive at the terminating demarcation point without modification. To accomplish this, the standard recommends the insertion of network loss, where required, as near to the end-user terminal as possible. A goal, when the connection is all-digital from end-user terminal to end-user terminal, is to migrate the control of loss insertion to the end-user terminal. Until that time, loss values that are dependent on the type of connection are usually administered at the point of switching nearest the end-user terminal. Loss values that are not dependent on the type of connection can be inserted at the final digital-to-analog conversion point (for example, DLC remote terminal) or at the last point of switching.

## Network Loss Recommendations

When the connection is all-digital (including the end-user terminals), and the control of loss insertion has migrated to the terminals, the terminals should comply with the requirements of ANSI EIA/TIA-579. This will ensure that each terminal will provide sufficient talker echo control to preclude the need for network-based echo control measures.

For digital connections terminated in analog access lines, the standard provides loss values that are dependent on the connection architecture:

- For interLATA or interconnecting network connections, the requirement is 6 dB.
- For intraLATA connections involving different LECs, 6 dB is the preferred value, although 3 dB may apply to connections not involving a tandem office.
- For intraLATA connections involving the same LEC, guidelines are:

0 to 6 dB (Typically 0 dB, 3 dB or 6 dB).

As indicated in the standard, the choice of network loss value depends on performance considerations, administrative simplicity, and current network design.

### 7.12.2 Loss Implementation

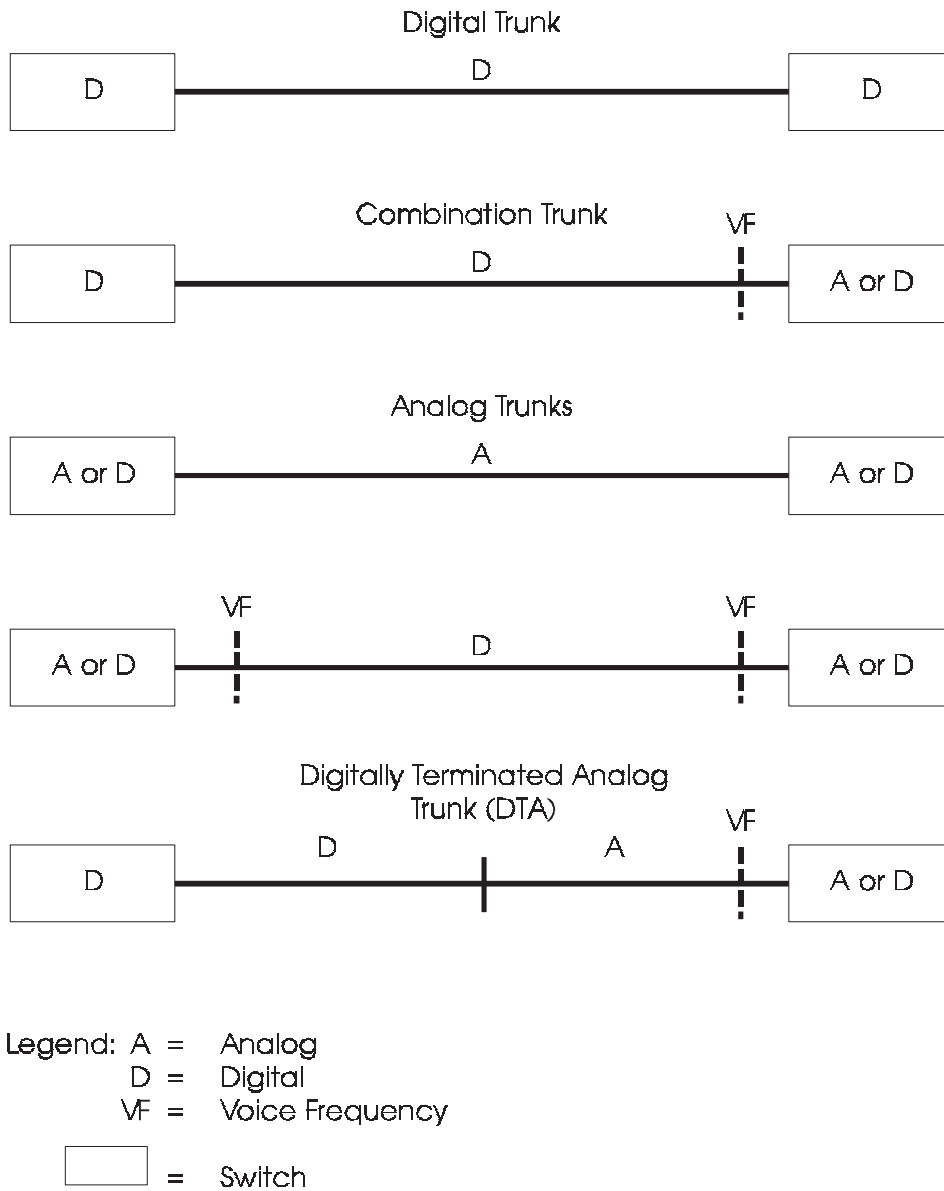
Loss implementation methods are dependent on the type of trunk.

#### 7.12.2.1 Trunk Types

The various types of trunks shown in Figure 7-15 are categorized as follows.

- Digital trunks use only digital transmission facilities and interface digitally with digital switching systems at each end.
  - Combination trunks use only digital transmission facilities and interface digitally with a digital switching system at one end and interface at voice frequency with any type of switching system at the other end.
  - Trunks that use analog facilities, wholly or in part, are treated as analog trunks, regardless of the switching systems and the manner of interface. Trunks that use only digital facilities but interface at voice frequency at both ends are treated as analog, regardless of the switching systems.
  - Trunks that use both analog and digital facilities and interface digitally with a digital switching system at one end and interface at voice frequency with any type of switching system at the other end are called Digitally Terminated Analog (DTA) trunks and are treated as analog trunks.
-





**Figure 7-15.** Trunk Types

## 7.12.2.2 Signal Level Conventions and Definitions — Analog

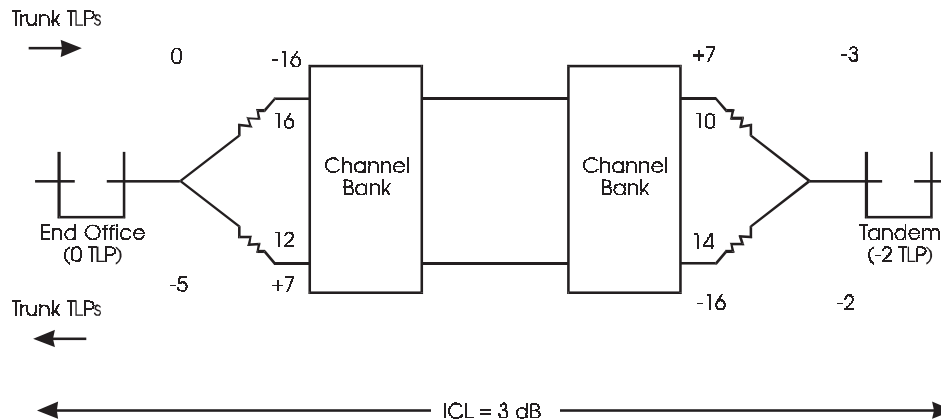
**Transmission Level Points:** Transmission Level Points (TLPs) are points in a circuit where TLP values are assigned. The TLP value is the ratio expressed in dB of a signal power at that point to the power of the same signal at a reference point called a zero Transmission Level Point (0 TLP). A point where the TLP value is “x” is generally referred to as an x Transmission Level Point (x TLP).

TLPs are defined for individual trunks in each direction of transmission. TLPs are normally defined only at points where voice-frequency analog signals are expected.

By referring all signal levels to a common reference point, the TLP concept enables losses in analog circuits to be conveniently provisioned and maintained. In addition, TLPs facilitate the evaluation of interference signals in relation to the desired signal.

The initial TLP of a trunk in the transmitting direction is equal to the TLP of the switching office. Historically, end offices have been assigned a TLP value of 0 and analog tandem offices a TLP value of -2. In addition, standard TLP values have been assigned to input and output test points of repeaters and carrier systems.

Figure 7-16 illustrates the application of TLPs in a tandem connecting trunk utilizing an analog carrier system. In the transmitting direction, the trunk assumes the 0 TLP of the end office. A loss of 16 dB (represented by a pad) is required to interface the standard -16 TLP at the carrier system input. A 10 dB loss lowers the TLP from +7 at the carrier system output to -3 at the far end of the trunk. The difference between initial and final TLPs indicates the loss of the trunk. As is generally the case, the final TLP differs from the TLP of the office at the receiving end.



Note: Pad values shown include hybrid and other transmission path losses

**Figure 7-16.** Analog Trunk Transmission Level Points

---

The analysis of the TLPs in the opposite direction (tandem to end office) is similar. Again, the initial and final TLPs (-2 and -5, respectively) indicate the loss of the trunk. Different pad loss values are required to interface the input/output TLPs of the carrier system in this direction of transmission.

TLPs are not defined at interim points in a digital switch or connection. Considerable confusion has arisen from attempts to assign TLP values to digital switches when they are used as tandems. As noted previously, TLPs are defined only at points where voice-frequency analog signals are expected. Any analog signal must be digitally encoded before digital switching and/or transmission takes place. Similarly, decoding of the digital signal must take place in order to obtain an analog signal. New concepts, discussed later, are required to analyze digital connections.

**Reference Level:** At any point in an analog circuit, reference level is the power level (in dBm) that is numerically equal to the TLP value at that point. Thus a signal having a power level equal to the TLP value is said to be at reference level and is normally referred to as a "0 dBm0 signal," since it would have a power level of 0 dBm at a 0 TLP. Voice and voiceband data signals are normally 10 to 30 dB below reference level.

**Inserted Connection Loss:** The Inserted Connection Loss (ICL) of a trunk is the 1004-Hz transducer loss of the circuit referenced to the nominal impedances of the offices (600 or 900  $\Omega$ ) that it interconnects. The ICL reflects all of the gains and/or losses from the outgoing appearance at the originating switch through the circuit to a termination at the outgoing side of the terminating office.

The definition of ICL applies equally well for voice-frequency, analog carrier, or digital-carrier trunk facilities, provided that the appearances mentioned above are at voice frequency. However, if either or both switches are digital, these voice-frequency appearances do not exist. In these cases, ICL cannot be defined in the traditional manner and level measurements can be performed only at analog test points.

**Test Pads:** Test pads are fixed-value attenuators that reduce the standard milliwatt (0 dBm) test signal to the circuit TLP value at the point where the test signal is to be applied. Analog tandem offices were normally equipped with 2 dB test pads (TP2). End offices do not have test pads (TP0). Test pads are generally not associated with digital switches.

**Expected Measured Loss:** The Expected Measured Loss (EML) of a trunk is the 1004-Hz loss that is expected to be measured under specified test conditions. This loss is calculated by summing all gains and losses of the trunk in the specified measuring configuration. It is used as a reference for comparison with actual measurements.

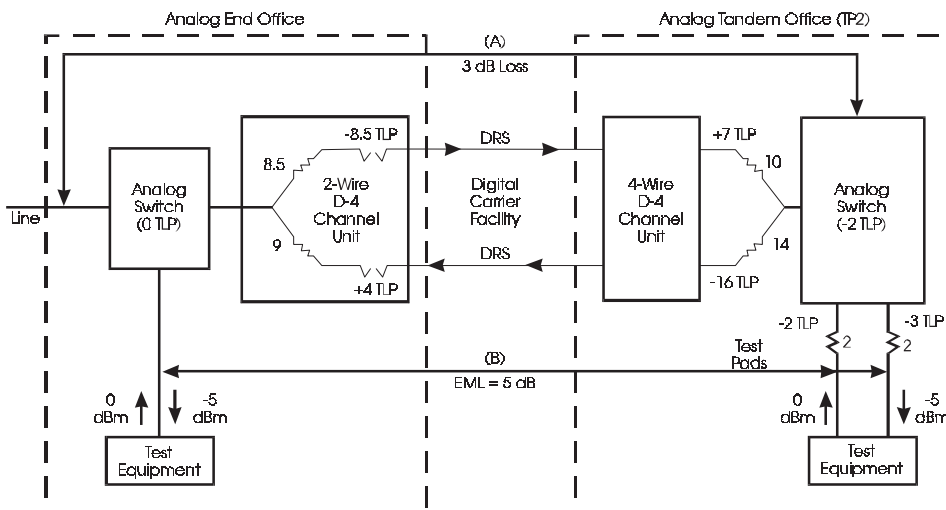
The EML includes test access losses for the connection of both automatic and manually operated measuring equipment. If test access loss is negligible, EML is essentially the same as ICL. Losses caused by test pads and office wiring can cause EML to differ significantly from ICL.

---

**Actual Measured Loss:** The 1004-Hz loss of a trunk that is actually measured with the trunk in its specified state using the specified measuring configuration is called Actual Measured Loss (AML). AML is compared with EML to determine loss performance.

### 7.12.2.3 Loss Implementation for Analog Trunks

Figure 7-17 shows an analog tandem office (TP2) connected to an analog end office via a digital carrier facility. The type of facility is not important for this analysis; however, the trunk is classed as an analog trunk. A trunk with an ICL of 3 dB is illustrated. Ignoring any wiring or trunk circuit losses, the loss between the center of the tandem switch and the end office line appearance is 3 dB as indicated (A). The test level received at both offices is -5 dBm because of the 2-dB test pads at the tandem office. Thus, the EML of this trunk (B) is 5 dB.



DRS = Digital Reference Signal

Note: Pad values shown include hybrid and other transmission path losses

**Figure 7-17.** Analog End Office to Analog Tandem

---

#### 7.12.2.4 Signal Level Conventions and Definitions — Digital

**Digital Milliwatt:** An important concept relating to signals in digital facilities is Digital Milliwatt (DMW). A DMW is a digital representation of a 0-dBm, 1000-Hz (analog) sine wave. A representation consisting of eight 8-bit words has been adopted by the ITU-T (formerly the CCITT) for a DMW that is encoded according to the  $\mu = 255$  encoding law.

The DMW is not recommended for transmission over DS1 facilities, because the bit pattern duplicates the framing sequence of D-type channel banks. Under certain conditions, the bank can frame on the DMW sequence, causing frame misalignment without any accompanying alarm condition. However, the DMW can be used internally in digital switching systems, because these systems do not operate at the DS1 rate.

In addition, it is not advisable to inject a 1000 Hz signal into a DS1 system because of the harmonic relation to the 8000 Hz sampling rate. Interference signals can result in erroneous loss measurements when these frequencies are mixed.

**Digital Reference Signal:** The Digital Reference Signal (DRS) is an encoded analog signal which, by current international convention, is a sine wave in the frequency range of 1013 Hz to 1022 Hz, having a power of 0 dBm  $\pm 0.03$  dB. ITU-T (formerly the CCITT) and ANSI are considering adoption of a specific encoded signal which uses a 797-byte repetitive pattern and has a frequency of a 1013.801756 ... Hz. The avoidance of the DMW sequence means that these DRSs do not have the limitations of the DMW and can be transmitted over the network. For reference level purposes, DRS is equivalent to the analog milliwatt signal in analog facilities.

**Digital Pads:** Digital pads are used to insert loss before decoding. When a signal is in digital (PCM) form, gain or loss can be applied directly to the bit stream without first converting it to analog. A simple look-up table can be used to convert from one code set to the other; or the nonlinear PCM can be converted to linear code, multiplied by the gain or loss desired, and converted back to nonlinear PCM. This avoids the cost of digital-to-analog-to-digital conversion but does not avoid signal impairment, since approximately the same amount of quantizing noise is added in either case.

Digital level control always reduces the signal-to-quantizing noise ratio because of round-off errors in mapping between code sets. This differs from analog gain adjustment, which seldom affects signal-to-noise ratio.

To provide a nearly constant ratio of signal-to-quantizing noise over a signal range from -40 to +3 dBm<sub>0</sub>, non-linear  $\mu = 255$  PCM coding is used. This range closely approximates the range of talker levels to be found at end offices and tandems and assures optimum quality for almost all talkers. Digital loss or gain pushes speech power toward one end or the other of this range by the amount of the loss or gain inserted. It reduces the code set used, since the maximum output signal will be x dB below the maximum code (for x dB loss) or the minimum will be y dB above the minimum code (for y dB gain).

---

---

**Encoders:** Encoders convert analog signals into digital signals for transmission through digital facilities such as trunks and switches. If a sinusoidal signal of "e" dBm at an encoder input results in a DRS at the encoder output, the encoder is said to have an encode level of "e" and is called an "e-level encoder." The input side of the encoder is said to be an "e Encode Level Point" (e ELP).

For  $\mu = 255$  encoders, overload (clipping) begins to occur at an input power level that is 3.17 dB higher than the power level of a sinusoid that would produce a DRS at the encoder output. Thus, the overload level of an e-level encoder is  $(e + 3.17)$  dBm.

**Decoders:** Decoders convert digital signals into analog signals. If a DRS at a decoder input results in a sinusoidal signal of "d" dBm at the decoder output, the decoder is said to have a decode level of "d" and is called a "d-level decoder." The output side of the decoder is said to be a "d Decode Level Point" (d DLP).

**Equivalent Power Level:** Equivalent Power Level is a term used to denote the power level of an analog signal that is encoded into a digital bit stream. Equivalent power should not be confused with the actual power of the digital signal. The equivalent power can be measured indirectly by mapping the digital signal to the output of a 0-level decoder. The power of the decoded signal can, of course, be measured directly with analog measuring equipment. The equivalent power is sometimes referred to as "power relative to a 0-level decoder."

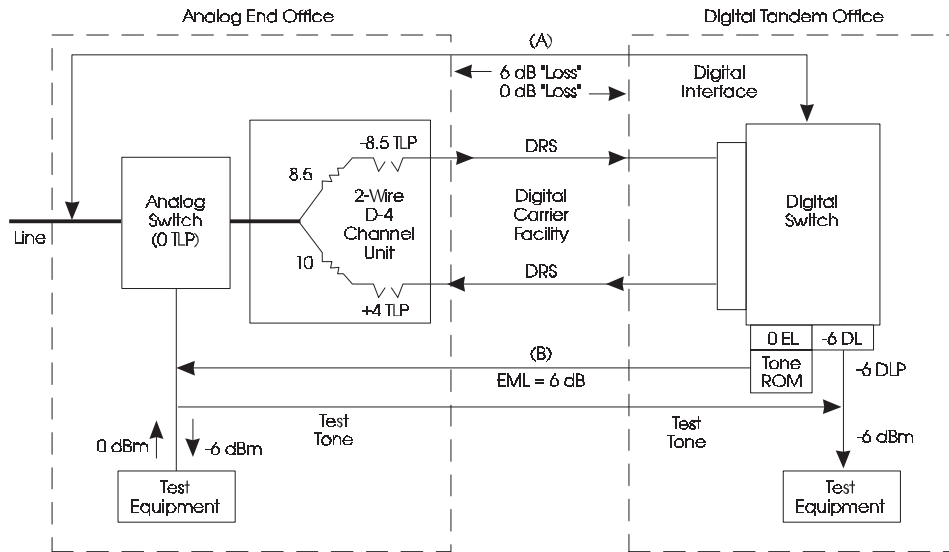
#### 7.12.2.5 Loss Implementation for Combination Trunks

Figure 7-18 shows a digital tandem office connected to an analog end office via a digital carrier facility. Because the interface is digital at the digital switch, the digital carrier facility is considered a combination trunk (as discussed earlier in this Section). Using the concept of equivalent power at the center of the digital switch, a loss of 6 dB is indicated from the tandem to the end office line appearance and 0 dB loss is indicated in the opposite direction (A). It is apparent that an ICL cannot be assigned to this trunk. However, with the tandem office encode and decode levels of 0 and -6, respectively, the test level received at both offices is -6 dBm; thus, the EML of this trunk is 6 dB in both directions (B).

#### 7.12.2.6 Loss Implementation for Digital Trunks

Figure 7-19 shows a digital tandem connected to a digital end office via a digital carrier facility. As discussed earlier in this Section, this connection is a digital trunk. Using the concept of equivalent power, it can be seen that there is no loss between the two switches. ICL has no meaning with respect to this trunk. Both switches encode at 0 and decode at -6. Thus, the loss is 6 dB from the tandem to the end office line appearance and 0 dB in the opposite direction (A). The EML of the trunk is 6 dB in both directions (B).

---



Note: Pad values shown include hybrid and other transmission path losses.

Figure 7-18. Analog End Office to Digital Tandem

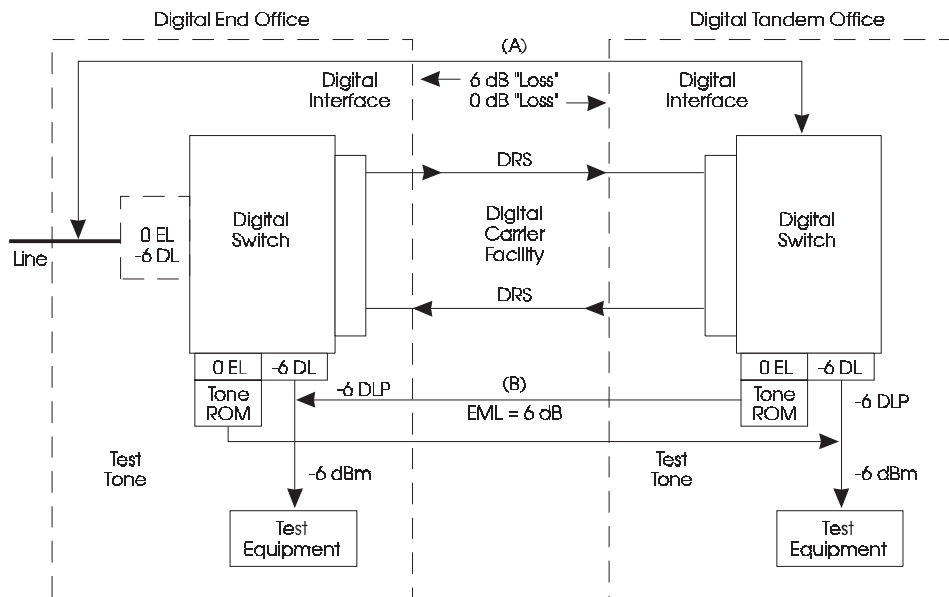


Figure 7-19. Digital End Office to Digital Tandem

As mentioned previously, the Fixed-Loss Plan and the Loss Plan for Evolving Digital Networks both provide for loss insertion to be external to a digital path. Under the Fixed-Loss Plan, the loss is inserted in the receive channel at each end office. The Loss Plan for Evolving Digital Networks makes provision for loss insertion in the receive channel at each end office or at the digital-to-analog conversion point. Thus, a connection from end office-to-end office with analog loops at each end begins with a 0-level encoder and ends with a -6-level decoder. The equivalent signal level undergoes no change between the encoder output and the decoder input.

## **7.13 Operator Services Transmission**

Operator services are provided by personnel in centrally located position groups. These services include intraLATA long-distance assistance, directory assistance, intercept, and special services such as mobile communications. Depending on the type of traffic being served, the position groups home on tandem switches, digital Automatic Call Distributors (ACDs), or Automatic Intercept Systems (AISs). Operator centers are often located hundreds of miles from the customers being served and are normally connected to switching centers by digital facilities.

### **7.13.1 Transmission Objectives**

The general transmission objective for the customer-to-customer portion of an operator-assisted call is a loss-noise-echo GOS, that is, essentially the same as for an unassisted call over the same distance (see Section 7.11). The transmission performance for the connection between the operator and the calling customer should be equivalent to that on a short, direct-dial connection. Between the operator and the called customer, the performance should be equivalent to that on the final customer-to-customer connection. The intent of these objectives is to ensure nearly equal voice level for all participants of a conference call.

Operators are influenced by environmental factors such as noise in the operating room. The objective for the acoustic signal-to-noise ratio is 29 dB. For over-the-ear headsets, this translates into a room-noise requirement of 55 dBA average (Sound Pressure Level [SPL] using an "A" weighting network) and 62 dBA peak at the operator position. The corresponding values for in-the-ear headsets are 52 and 59 dBA, respectively. The quoted noise levels are referenced to a level of 20 micropascals. Attention to placement of adjacent consoles and sound treatment of the room are required to meet these objectives.

### **7.13.2 Directory Assistance and Intercept Service**

Many LECs provide directory assistance and intercept services, known collectively as "number services," using ACDs to forward calls to operator groups. The ACD network is

---



basically similar to the regular message network. For example, local directory assistance or intercept service is configured so that the ACD functions as a tandem office. Directory assistance service for interLATA traffic is discussed in Section 7.16.1.4. As with other operator services, the personnel are often located at a considerable distance from the customer being served.

The transmission objective for number services is to provide quality on local service that is equivalent to that of a short long-distance call, and on long-distance service, quality that is equivalent to a normal call between the same areas. The volume level from an automated voice-response unit should be comparable to that of a live operator. Digital ACDs with digital trunking are typically lossless. For an analog ACD network, the ICL objective is 3 dB between the end office originating the call and the ACD switch. Concentrators or tandem offices may occur in the routing with an additional 0.8 dB allowed for the concentrator trunk. The loss-design objectives for analog number services are summarized in Table 7-6.

**Table 7-6. Loss Objectives — Operator Services**

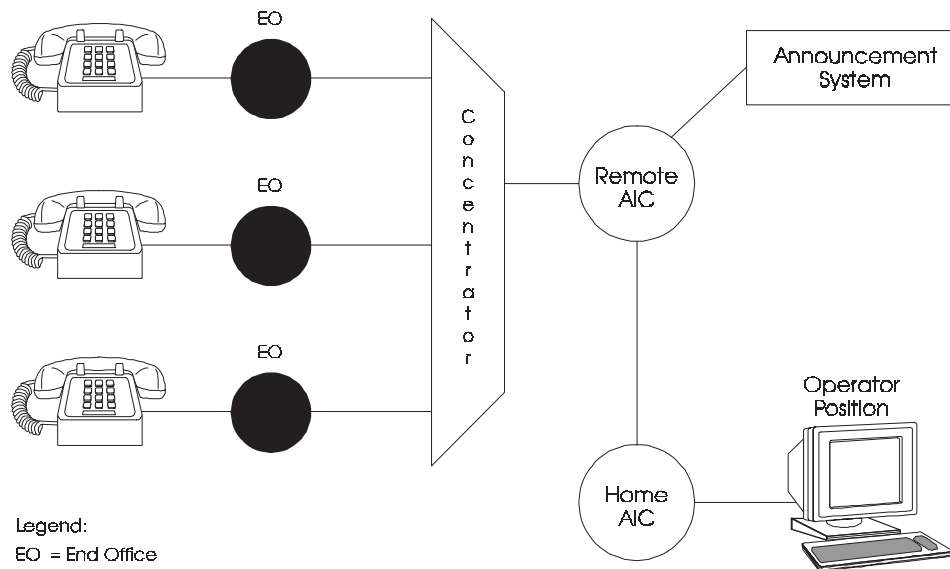
Trunk Type		Equivalent Trunk	Nominal ICL (dB)
ACD	Local DA End Office-ACD	Tandem Connecting	3.0
	End Office-Concentrator	Tandem Connecting	3.0 <sup>a</sup>
	Tandem-ACD	Intertandem	0.5 <sup>a</sup>
	Concentrator-ACD	Intertandem	0.8 <sup>a</sup>
AIS and ACD Intercept	End Office-ACD	AIS	3.0
	End Office-Concentrator	AIS	3.0 <sup>a</sup>
	Concentrator-ACD or AIS	Intertandem	0.8 <sup>a</sup>

a. Unless gain transfer is used (No. 1 Trunk Concentrator only).

A mechanized intercept service is provided by the recorded, voice-answer feature of the AIS shown in Figure 7-20.

Routine announcements are provided at the remote Automatic Intercept Center (AIC). A customer requiring further information can then be connected to an operator at the home AIC.

The AIS transmission plan is similar to the intercept portion of the ACD plan. The AIS switches should meet long-distance, tandem office transmission requirements.



**Figure 7-20.** Typical Automatic Intercept System Trunks

### 7.13.3 IntraLATA Long-Distance and Assistance Service

Proposed generic requirements relating to operator services equipment can be found in FR-271.

The system plan for operator services is shown in Figure 7-21. The calling party (end office A) and called party (end office B) are connected to the operator through a bridge via the voice-data links. These links are used only while the operator is needed. When the operator functions are complete, the bridge is dropped, and the tandems are connected via an intertandem trunk. If this were an interLATA call, the tandems would be connected via the tandem interLATA connecting trunks (by an IC) upon release of the operator (see Section 7.16.1.4 for terms related to interLATA calling).

### 7.13.4 Operator Services Transmission Plan

The basic, digital, operator services transmission plan is shown in Figure 7-22. The ELP and DLP shown at the end office are the same as in the Fixed-Loss Plan. In an all-digital environment, the analog signal is encoded at the end office and switched by the end office and tandem offices without additional signal processing. The required transmission loss is inserted by an analog pad (after decoding) in the operator subsystem. The operator's voice signal is encoded in the subsystem and transported to the end office, also without further processing. Loss is inserted in the end office receive path by digital padding before decoding or by analog loss after decoding.

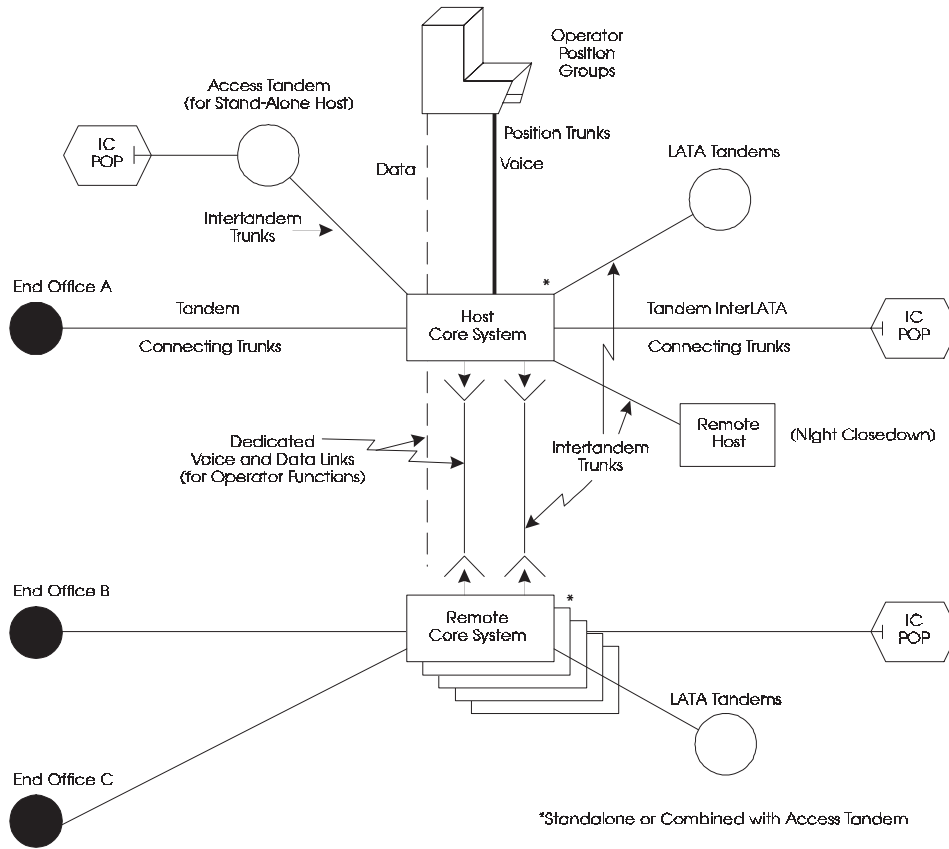


Figure 7-21. Operator Services System Plan

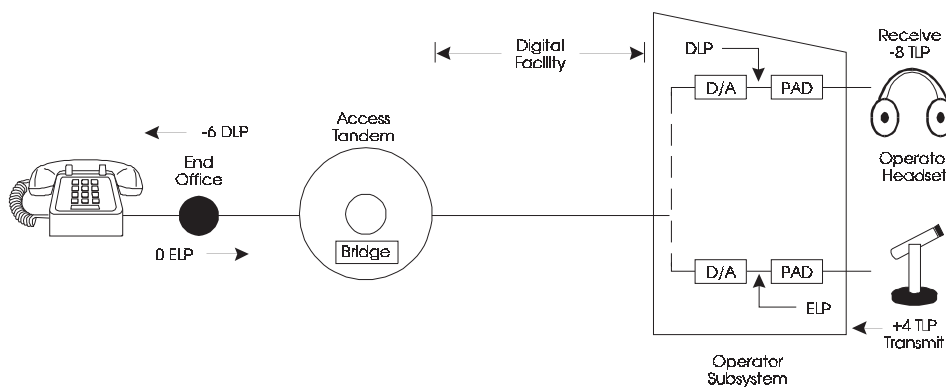


Figure 7-22. Basic Digital Transmission Plan — Operator Service

---

To meet transmission objectives, the operator-speech signal (or synthesized speech from, for example, an Automated Coin Toll Service [ACTS] system) should appear at the host switch at a level nearly equal to the average level of speech arriving at that point from local customers (that is, equivalent to a 1004-Hz tone of -21 dBm).

The headset-jack TLPs that are derived in the following paragraphs are based on the use of headsets conforming to specifications in GR-314-CORE. Operator services equipment should allow for an adjustment of these TLPs by  $\pm 6$  dB so that objectives can be met with headsets exhibiting different transmit and/or receive efficiencies.

Assuming an average speech input of 88 dB SPL (relative to 20 micropascals), conforming headsets should produce a -17 dBm power level at the transmit jack. To meet the -21 dBm0 objective, the TLP at the transmit jack is specified as +4. For headsets having 10 dB lower TOLR, a TLP of -6 may be used instead.

The objective for the receive channel is to deliver as high a voice-signal level as possible without exceeding Occupational Safety and Health Administration (OSHA) acoustic limits for work environments. For conforming headsets, an incoming signal of -29 dBm will be converted to the desired level of 87 dB SPL. To meet the -21 dBm0 objective, the receive jack TLP is set at -8.

As stated previously, operator systems may be located at a considerable distance from customers. Connections may consist of large amounts of fiber facilities that have relatively low propagation velocity, and transmission delay may become significant. Network layouts involving more than 8 or 9 ms of echo-path delay require echo cancellation or voice-switched attenuators to assure a good loss-noise-echo GOS as perceived by the operator.

## 7.14 Transmission Limits — IntraLATA Networks

To ensure that networks provide satisfactory performance objectives, requirements are set for trunks, loops, and switching offices. Trunk loss, C-message noise, impulse noise, balance limits, loop-noise objectives/requirements, and end office noise requirements are discussed here.

For some parameters, two categories are used for assigning test limits. "Digital" refers to facilities using D2-equivalent or later channel banks with cable extensions of one mile or less. (This category also applies to cable of one mile or less.) All other facilities are considered to be in the "analog" category.

The requirements for most intraLATA trunk transmission parameters are given in terms of Pre-Service Limits (PSLs), Immediate Action Limits (IALs), and maintenance limits. PSLs represent a maximum (or range) of a parameter that is allowed prior to turn-up of a service. IALs are thresholds beyond which performance of an in-service circuit is deemed unsatisfactory, and immediate corrective action is necessary. Maintenance limits lie between PSLs and IALs and are used to flag trunks that should be scheduled for corrective action.

---

### 7.14.1 Trunk Loss Limits

For pre-service measurements, a deviation of the AML from the EML of up to 0.5 dB is allowed. The IAL is  $\pm 2.0$  dB for digital trunks and 2.5 dB for analog trunks. Individual exchange carriers may use more stringent values for IALs. As stated above, maintenance limits lie between the PSLs and IALs. The specific maintenance limits are determined by each exchange carrier.

#### 7.14.1.1 Test Tones

Test tones, used for short-term tests, are currently allowed to be at 0 dBm0. Tones for long-term tests operate at -10 dBm0.

### 7.14.2 C-Message Noise Limits

Noise must be kept within defined limits to provide good service. Table 7-7 gives the C-message-noise PSLs and IALs for message trunks. These limits are given in terms of dB<sub>BrnC0</sub>, which means that the TLP, at the point of measurement, should be subtracted from the measured noise level to obtain a corrected result. The limits for analog trunks are mileage dependent. The digital category includes trunks on voice-frequency cable with lengths of 15 miles or less. Again, individual exchange carriers may use more stringent IALs. Maintenance limits are determined by the individual exchange carriers and lie between PSLs and IALs.

**Table 7-7. C-Message Noise Limits**

Limit Type	Facility Type	Limit Values (dB <sub>BrnC0</sub> ) <sup>a</sup>				
		Facility Length (mi)				
		0-50	51-100	101-200	201-400	401-1000
Pre-service	Analog	29	31	33	36	38
	Digital	26	26	26	26	26
Immediate Action	Analog	34	36	38	41	43
	Digital	30	30	30	30	30

- a. For voice-frequency cable facilities, or for cable extensions of digital facilities, the digital limits are applicable if the cable length is 15 mi or less. If the cable is longer than 15 mi, add 3 dB to the digital limit.

### 7.14.3 Impulse Noise Requirements

Impulse noise is important on channels used for voiceband data or facsimile transmission. Where digital facilities are involved, high impulse noise usually results from a high error ratio on a DS1 system, which affects all 24 circuits in the digroup. Where Bipolar with 8-Zero Substitution (B8ZS) coding is involved, bit errors will be introduced by high-capacity digital multiplexers and other terminals if they are optioned for ordinary bipolar operation (Section 7.6.4). The same can occur if equipment on a bipolar facility is unintentionally optioned for B8ZS.

Because impulse noise occurs sporadically, measurement requires relatively long time periods. Measurement of a single channel normally requires a 15-minute period. Time can be saved in the evaluation of complete trunk groups that share common facilities by using sampling techniques and a shorter measurement period of 5 minutes. Sampling is feasible, because trunks in a common route are assumed to share a similar impulse noise exposure.

Impulse noise limits for trunks, facilities, and connections are given in Table 7-8. The requirement on a trunk group is that no more than 50 percent of measurements should display an impulse noise level in excess of a specified value. The measurement is performed by adjusting the impulse counter threshold to the specified level and noting whether the count at the end of 5 minutes is 5 or less (acceptable), or 6 or more (unacceptable).

### 7.14.4 Balance Limits

Through-balance procedures are necessary to control echo at 4- to 2-wire conversions at any 2-wire tandem switch in the long-distance intraLATA network. Through-balance limits at a 2-wire, switching point are shown in Table 7-1. The office terminal-balance limits apply at a long-distance tandem office as explained in Sections 7.4.4 and 7.12.1.

TCTs in the long-distance intraLATA network should meet the terminal-balance limits in Table 7-1. "Digital switch" applies to all types of TCT connected to a digital tandem switch. This higher return loss is needed, because the Fixed-Loss and the Loss Plan for Evolving Digital Networks use reduced loss for control of talker echo. The analog limits apply to all other TCTs.

To meet echo-control objectives, a long-distance tandem office should have at least 50 percent of all trunks meeting or exceeding the PSLs and none below the IALs for ERL or SRL. For initial installation, no trunk should be turned-up for service below the PSL limit. On subsequent testing, any trunk measuring below the IAL should be removed from service and repaired.

---

**Table 7-8. Impulse Noise Limits**

Measurement	Limits	Level	
Connections	15 counts in 15 minutes on at least 85% of calls	6 dB below signal	
Loops	15 counts in 15 minutes on all loops	59 dBrnC <sup>a</sup>	
Switching Offices	5 counts in 5 minutes on 50% of trunks in group IAL: 20 counts in 5 minutes	Crossbar	54 dBrnC
		Step-by-Step	59 dBrnC
		Electronic or Digital	47 dBrnC
Trunks	5 counts in 5 minutes on 50% of trunks in group IAL: 20 counts in 5 minutes	Voice Frequency	54 dBrnC <sub>0</sub>
		Compandored or Mixed	66 dBrnC <sub>0</sub> <sup>b</sup>
		Digital	62 dBrnC <sub>0</sub> <sup>c</sup>
		Non-compandored	
0 - 125 mi		58 dBrnC <sub>0</sub>	
126 - 1000 mi		59 dBrnC <sub>0</sub>	
Facilities	5 counts in 5 minutes on 50% of channels IAL: 20 counts in 5 minutes	Voice Frequency	52 dBrnC <sub>0</sub>
		Compandored or Mixed	64 dBrnC <sub>0</sub> <sup>b</sup>
		Digital	62 dBrnC <sub>0</sub> <sup>c</sup>
		Non-compandored	
0 - 125 mi		56 dBrnC <sub>0</sub>	
126 - 1000 mi		57 dBrnC <sub>0</sub>	

- a. Level at Central Office (CO), or referred to CO through 0-dB, 1004 Hz loss.
- b. With -13 dBm<sub>0</sub> holding tone.
- c. Holding tone not required; if holding tone is used, the level is 67 dBrnC<sub>0</sub>.

Two-wire, long-distance tandem offices are surveyed periodically to determine whether the office continues to meet echo-control objectives. These surveys can be done using a sampling technique in which ERL and SRL measurements are made on a small percentage of circuits in each trunk group. Results of such a sample survey would be expected to have a distribution with at least half the measurements equal to or greater than PSLs and none less than IALs.

Periodically, testing trunk groups on a routine basis can produce more reliable data than the small-sample survey technique.

The return-loss values obtained for terminal balance are highly dependent on proper design and installation of the TCTs. On 2-wire paths, this includes the use of pads in short metallic trunks and impedance compensators in loaded metallic trunks.

#### 7.14.5 Loop Noise

Table 7-9 lists the objective for noise measured on subscriber loops at customer demarcation points and indicates recommended action for loops exceeding that limit. Impulse noise limits for loops are given in Table 7-8.

As DLC and RSU technologies are introduced, loop noise performance is subject to change. Long metallic loops, with their significant exposure to noise induced by power lines, become relatively uncommon. However, modern electronic circuits can be susceptible to saturation due to induced low-frequency longitudinal currents. The resulting harmonics can be a source of noise. The noise at the demarcation point for loops served via Universal Digital Loop Carrier (UDLC) (Section 7.15) is a combination of the noise at the central office terminal and the (approximately) 18 dBrnC0 of noise contributed by the remote terminal decoder. The result is that cases of relatively high noise, approaching the 30-dBrnC limit, become less common, although noise levels rise on average.

**Table 7-9.** Loop Noise Objectives and Requirements

<b>NMS<sup>a</sup> Reading (dBrnC)</b>	<b>Significance</b>	<b>Action Recommended</b>
<20	Objective for all loops	None
21 to 30	Loop noise marginal as 30 dBrnC approached	Further analysis and investigation
>30	Unacceptable	Immediate investigation

a. Noise Measuring Set

For loops served via Integrated Digital Loop Carrier (IDLC) and RSUs, the remote terminal decoder becomes the only source of noise and demarcation point noise levels are somewhat lower than for loops served by UDLC.

#### 7.14.6 Central Office Noise

The types of noise that affect transmission through a central office are discussed in this section.



#### 7.14.6.1 Cross-Office Noise

Noise generated in the serving end office is largely cross-office noise. This includes the net sum of all noise sources on a connection between any two line appearances. Excessive battery noise, marginal codec chips, and corrosion or wear of switching equipment are some of the sources of cross-office noise. Except for per-line codecs in digital offices, the nature of noise sources is such that excessive noise occurs on random connections rather than on all connections. If these random occurrences become too frequent, the noise performance at the average end-user terminal will become unsatisfactory. Therefore, noise in the serving end office must be kept within defined limits.

The cross-office noise test consists of measurements of steady-state noise and average-peak noise. The reading of the position of the digital display or the regular location of the meter needle of a noise-measuring set is the steady-state noise measurement. The average-peak measurements are made by observing the noise-measuring set and averaging the peak readings over a few minutes. During the measurement, the far end of the connection should be properly terminated.

The condition of the office is judged by measurements of 20 randomly selected, cross-office connections. An office is considered satisfactory if none of the measurements of either type exceeds the applicable lower limits shown in Table 7-10.

**Table 7-10. End Office Noise Requirements**

Office Type	Steady-State Noise (dBrnC)		Average Peak Noise (dBrnC) (Meter Damped)	
	Lower Limit	Upper Limit	Lower Limit	Upper Limit
Analog	18	22	26	30
Digital	21	25	29	33

An office is considered unsatisfactory if four or more steady-state or average-peak measurements exceed the lower limits or if any single measurement of either type exceeds the upper limits. In this case, corrective action should be taken.

If one, two, or three measurements of both types exceed the lower but not the upper limits, the condition of the office is considered doubtful. In such cases, another 20 connections are tested to improve the sample accuracy. If no more than 3 of the 40 readings exceed the lower limits, the office is now acceptable. On the other hand, if 4 or more of the 40 measurements exceed the lower limits, the office is unacceptable and needs corrective action.

An RSU is a switching entity controlled by and classified as part of a host electronic switching system. In many respects, such a remote is analogous to a peripheral frame within the host switch. The RSU should be transparent to a subscriber served by it. Hence, the

---

GOS for the RSU-served customer should be equivalent to that of a user served by the host. From a noise-impairment point of view, loops from the subscriber to the remote should satisfy the usual loop requirements. The combination of the remote, the connecting channel, and the host switching system is considered as a single unit, even though the link channel is a normal carrier facility. To maintain the necessary GOS, the noise level of the channel must be kept below 20 dBmC.

#### 7.14.6.2 Impulse Noise

In digital switches, impulse noise can come from defective circuit packs in the time-slot interchange, which cause bit errors. Impulse noise limits for switching offices are given in Table 7-8.

### 7.15 Loop Transmission — Design and Characterization

The loop between the demarcation point at the customer location and the end office is an important link in any telephone connection. Satisfactory design of the loop is as important to overall transmission performance as the design of a trunk or switch. Loss objectives for loops are not explicitly stated; instead, loop loss is controlled by the use of design rules.

Before 1980, almost all loops were designed according to resistance design (96 percent) or long-route design (3 percent). The success of DLC made possible a third design plan, the carrier serving area concept. Fundamental to all three plans is the notion that designing loop facilities on an individual basis would be prohibitively expensive and extremely difficult to administer. Instead, loops are laid out on a global basis through rules designed to help ensure the following:

1. No loop exceeds the office signaling range
2. All customers receive at least 20 mA of loop current into an assumed station resistance of 430  $\Omega$
3. The distribution of loop transmission losses is satisfactory.

#### 7.15.1 Revised Resistance Design

Revised Resistance Design (RRD) is the current, urban/suburban design plan replacing resistance design. RRD rules apply to loops with resistance of 1500  $\Omega$  or less and length of 24 kft or less. RRD is an outside-plant design that is consistent, economical, operationally simple, and most importantly, capable of providing improved loop transmission performance.

---

---

The major differences between this plan and resistance design are that RRD allows a higher, maximum loop resistance for loaded loops (1500  $\Omega$  instead of 1300, central office range permitting) and reduces the amount of bridged-tap allowed. The maximum length of 18 kft for nonloaded loops is the same in both plans, except that in RRD the maximum length includes the length of any bridged-tap. The rule changes result in transmission improvements and outside-plant savings. Under some circumstances, the RRD plan reduces dc signaling margins because of the increase in maximum loaded-loop resistance to 1500  $\Omega$ . However, few modern switches have loop ranges below 1600  $\Omega$ . Table 7-11 summarizes the RRD plan rules.

### 7.15.2 Modified Long-Route Design

Loops longer than 24 kft, typically found in rural areas, are designed using DLC as first choice, or Modified Long-Route Design (MLRD). MLRD, also summarized in Table 7-11, was introduced in 1980 to provide for loops range-extended on a per-line basis. Under this plan, the 1500- to 2000- $\Omega$  range is designated as Resistance Zone 18 (RZ 18) with additional gain (3 dB) required. The 2000- to 2800- $\Omega$  range (RZ 28) requires 6 dB of gain.

When a wire center is totally equipped with newer range extenders (which automatically switch their net-gain settings from 3 to 6 dB, as required), it is not necessary to maintain and administer separate transmission zones in that wire center. Therefore, all loops under MLRD can be considered to be in a single range-extended zone. However, some companies that administer ringing range limitations by zone or have a large number of older range-extension circuits may still use RZ 18 and RZ 28 zoning.

MLRD is not limited to long rural loops and can be applied anywhere it is economically justified. While existing loops need not be rebuilt to conform to the new plan, the gain application rules indicated here are used for new loop designs that utilize existing cable.

### 7.15.3 Concentrated Range Extender with Gain

Some analog electronic wire centers use Concentrated Range Extender with Gain (CREG) design. This plan allows increased use of fine-gauge facilities in the outside plant by providing repeaters, each associated with a stage of switching concentration. The CREG design is compatible with the loading arrangements in both the RRD and MLRD plans.

Table 7-11. Loop Design Plans

Design Parameter	Carrier Serving Area	Revised Resistance Design	Modified Long-Route Design
Loop Resistance ( $\Omega$ ) <sup>a</sup>	N/A (limited by loss)	0-18 kft: 1300 max. 18-24 kft: 1500 max.	1501-2800
Loading	None <sup>b</sup>	Full H88 > 18 kft	Full H88
Cable Gauging	Two gauges, except stubs and fuse cables (max. lengths including BT): <ul style="list-style-type: none"> <li>• 24-, 22-, and/or 19-gauge: 12 kft</li> <li>• 26-gauge: 9 kft<sup>c</sup></li> </ul>	Two-gauge combinations (22-, 24-, 26-gauge) preferred	
Bridged Tap (BT) and End Section (ES)	Total BT 2.5 kft max. No single BT > 2 kft	Nonloaded cable & BT: 18 kft max. Total BT: 6 kft max.	ES & BT: 3 to 12 kft
		Loaded: ES & BT, 3 to 12 kft	
Transmission Limitations	None; supports ISDN DSL, 56-kb data, and “despecialized” special services	Compatible with ISDN DSL. No digital services > 18 kft.	No digital services. Needs range extender with gain if > 1500 $\Omega$ .

- a. Includes (only) the resistances of the cable and loading coils.
- b. At least one exchange carrier uses an “extended Carrier Serving Area (CSA)” in some rural areas. This variant allows loading but does not accommodate digital services.
- c. Multigauge designs incorporating 26 gauge are restricted in total length to  $12 - [3L_{26}/9 - BT]$  kft, where  $L_{26}$  is the total length of the 26-gauge and BT is the sum of bridged taps of all gauges.

#### 7.15.4 Performance of RRD and MLRD Loops

The RRD and MLRD plans employ similar loading schemes, have the same end-section and bridged-tap rules, and are compatible with any combination of cable gauges. These plans offer improved transmission performance over older plans and give approximately the same minimum loop ratings, that is, TOLR and ROLR (see Section 7.4.1).

Figure 7-23 shows the TOLR and ROLR for maximum-loss RRD loops as a function of loop length. The figure applies in the worst case with maximum cable resistance, bridged-tap, and end section. Dashed lines show the design limit objectives for TOLR and ROLR.

---

The RRD plan results in improved ratings over the resistance design plan in the 12- to 18-kft region (where maximum loss occurs) and comes closer to meeting the design limit objectives in this zone. Performance offered by the long-route design on MLRD plans differs primarily in the 1500- to 1600- $\Omega$  resistance range where the MLRD plan provides gain, resulting in better performance.

### 7.15.5 The Carrier Serving Area Concept

The evolution to a network that can readily provide digital services via loop facilities led to the Carrier Serving Area (CSA) concept. A CSA is an area that is or may be served by DLC. DLC may be either stand-alone (UDLC) or integrated into the end office switch (IDLC). All loops within a CSA are nonloaded. They are capable of providing on a nondesigned-basis conventional, voice-grade message service; digital data service up to 64 kbps; Digital Subscriber Lines (DSLs) for ISDN; and most locally switched, 2-wire, voice-grade special services. Ordinary channels (pair-gain pairs) on the DLC system have a loss of 2 dB or less, thus allowing for attenuation in the physical cable within the CSA. Loop length in the CSA is limited by attenuation, not by dc resistance. Bridged-tap lengths are controlled to preserve capability for high-speed, digital operation. CSA design is now used for most loop growth.

The CSA design plan is summarized in Table 7-11. The table indicates that within the CSA the maximum allowable loop length involving 26-gauge cable is dependent on the length of bridged-tap. This dependency is illustrated in Figure 7-24.

### 7.15.6 Digital Subscriber Line

The DSL for ISDN Basic Rate Access (BRA) transmits 160 kbps in both directions simultaneously on a nonloaded cable pair. The DSL is intended to operate with cable loss of up to 42 dB at 40 kHz. To minimize crosstalk between DSLs in the same cable binder group, the signal is recoded into 2 Binary 1 Quaternary (2B1Q) form, that is, two binary pulses become one quaternary pulse on the line (see Section 12). Almost all loops designed to resistance design criteria, whether RRD or its predecessors, will transmit a DSL signal out to 18 kft. The customer provides a Network Termination 1 (NT1) device on the customer side of the demarcation point to operate into the DSL transceiver in the central office. With suitable channel units, a DSL can be extended out to a CSA on DLC facilities.

Other emerging loop technologies are Fiber in the Loop (FITL) and High Bit-Rate Digital Subscriber Line (HDSL). These are discussed in Section 12.

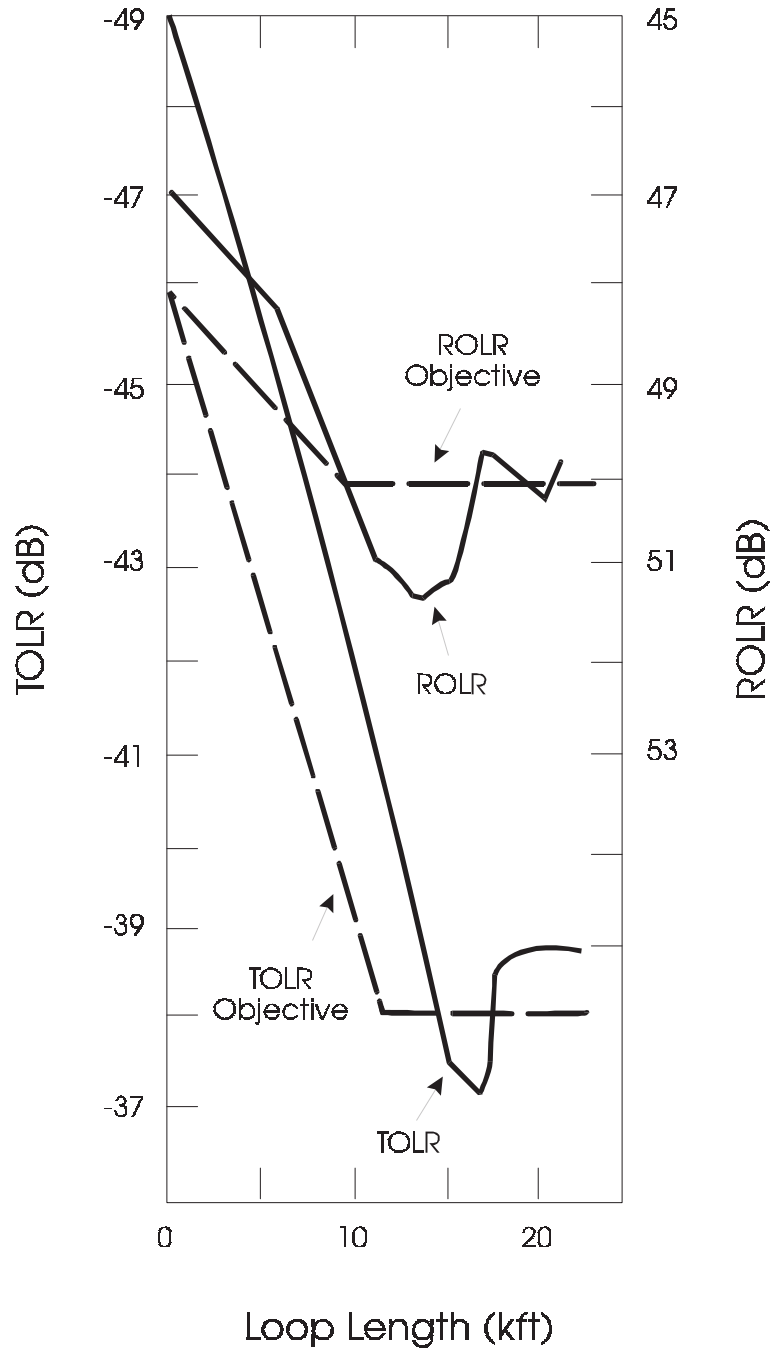
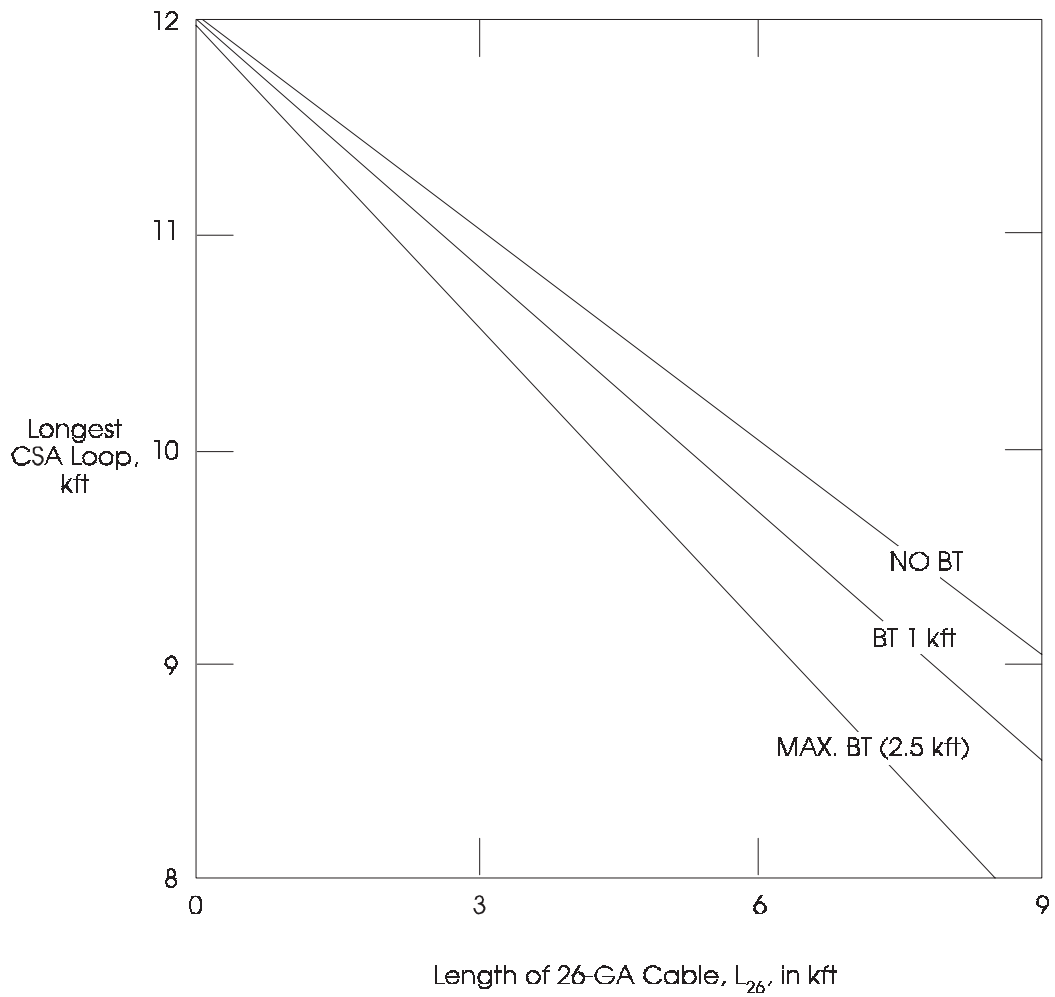


Figure 7-23. Objective Loudness Ratings — RRD



Legend:

- BT = Bridged Tap
- CSA = Carrier Serving Area
- GA = Gauge

Figure 7-24. Maximum Length of CSA Loop

---

### 7.15.7 Spectrum Management in Loop Plant

Loops are used for transmission of a wide variety of signals other than voice:

- Voiceband data
- Analog program material
- Local Area Data-Channel (LADC) traffic
- Public Switched Digital Service (PSDS) 56-kbps signals
- Data-above-voice operation
- ISDN BRA and Primary Rate Access (PRA) signals
- DS1 high-capacity services
- Digital data services of 2.4- through 64-kbps speeds.

Loops for most of these services coordinate satisfactorily with one another, with voiceband circuits, and with the T1 carrier spans used in loop plant; however, data signals may cause excessive interference with 15-kHz program circuits. Single-channel, analog loop-carrier systems are uniquely exposed to 56-kbps data. When interference occurs, it becomes a special coordination problem. The level of the disturbing signal may have to be reduced, coupling losses increased, or amplitude raised on the disturbed circuit. It may be necessary to reassign service to different cable pairs or substitute DLC facilities.

A wide variety of proprietary formats exist for data-above-voice systems. The use of a 2B1Q line-code standard for ISDN BRA is intended to control the effects of ISDN-to-ISDN, near-end crosstalk, which would be more severe if a code with greater high-frequency content were used; however, ISDN BRA currently also involves at least two prestandard line formats. If present in the same binder group, these signals can reduce each other's error margins. Studies have resulted in spectrum-management tables that indicate maximum loop ranges to ensure coordination of combinations of these systems. Thus, for technologies in use today, observance of these maximum ranges avoids crosstalk problems.

### 7.15.8 Loop Surveys

Studies have been made to quantify the characteristics of subscriber loops. The latest one, taken by the Bell Operating Companies in 1983, provided data from which the median, 1-kHz, 900- $\Omega$  insertion loss from the Main Distributing Frame (MDF) in the end office to the demarcation points, was calculated to be 3.6 dB. This value did not differ significantly from the results of surveys taken in 1964 and 1973. In practice, loops are normally measured for loss between a dial-up, 900- $\Omega$ , tone source in the serving end office and a test set at the demarcation point. Such measurements include losses due to office wiring, as well as the minor impedance mismatch that occurs when the test-set termination is 600  $\Omega$  instead of 900; thus, these measurement results may differ from calculated values.



---

A 1980 survey restricted to long loops found that approximately 4 percent of the measured losses exceeded 8.5 dB and that 2 percent exceeded 10 dB. With the design rules in effect at that time, a small percentage of loops was expected in the range of 8.5 to 10 dB with none greater than 10 dB. Under RRD rules, no properly designed loop should have more than 8.5 dB of loss at 1 kHz. According to the 1983 survey results, about 98 percent of all nonloaded loops are usable for the standard ISDN DSL. Details of the 1983 survey are contained in ST-TSY-000041.

### 7.15.9 Basic Exchange Telecommunications Radio Service/Basic Exchange Radio Service

Radio systems have been used, in the past, for special loop applications. In recent years, the FCC has established frequency allocations to be used by radio systems to provide loop facilities to isolated customer locations that would be too costly to serve by conventional wire, DLC, or radio methods. As referred to by the FCC, Basic Exchange Telecommunications Radio Service (BETRS) is also known as Basic Exchange Radio (BEXR) service.

## 7.16 Interoperation with Other Networks

### 7.16.1 Switched Exchange Access

Switched exchange-access arrangements are provided for originating or terminating interLATA telecommunications. They interface with an IC at a POT<sup>2</sup> and can route to an end office either directly or via an access tandem.

LECs offer several switched-access arrangements called *feature groups*. Feature groups differ in transmission performance and signaling capabilities and are ordered by the ICs or other users according to user needs. LECs also provide Wide Area Telecommunications Service (WATS) Access Lines (WALs). Transmission considerations for Feature Groups A through D and WALs are discussed in the following paragraphs.

#### 7.16.1.1 Access Connections

The following exchange-access connections are shown in Figure 7-25:

---

2. For the purposes of this section, the Point of Termination (POT) is considered to be collocated with the Interexchange Carrier's Point of Presence (POP) shown in Figures 7-25 through Figure 7-29.

- 
- A connection from end office #1 to the IC POT provided by a Direct InterLATA Connecting (DIC) trunk. This connection, provided under Feature Groups B, C, or D, offers trunk-side access at the end office.
  - Connections from end office #1 and end office #2 to the IC POT via an access tandem. In both cases, trunk-side access is provided at the end office to a TCT that connects to the access tandem. A Tandem InterLATA Connecting (TIC) trunk connects the access tandem to the IC POT. This overall connection can be provided under Feature Groups B, C, or D.
  - A connection from the line side of end office #2 to the IC POT, provided under Feature Group A.
  - A connection from the trunk side of end office #2 to the IC POT via a sector tandem and an access tandem. In this case, a TCT connects the end office to the sector tandem and an ITT connects the two tandems. This arrangement would be provided under Feature Group B when direct TCTs to the access tandem are not available.

Four transmission types describe the characteristics of switched exchange-access services. Type C provides a 2-wire interface at the IC POT and has the least stringent parameter limits. Type B involves either a 2- or a 4-wire, IC interface and has transmission limits that are generally more stringent than Type C. Type B1 is similar to B but with higher performance. Type A1 involves a 4-wire interface and has the highest requirements.

Several 4-wire interfaces at the IC POT are offered:

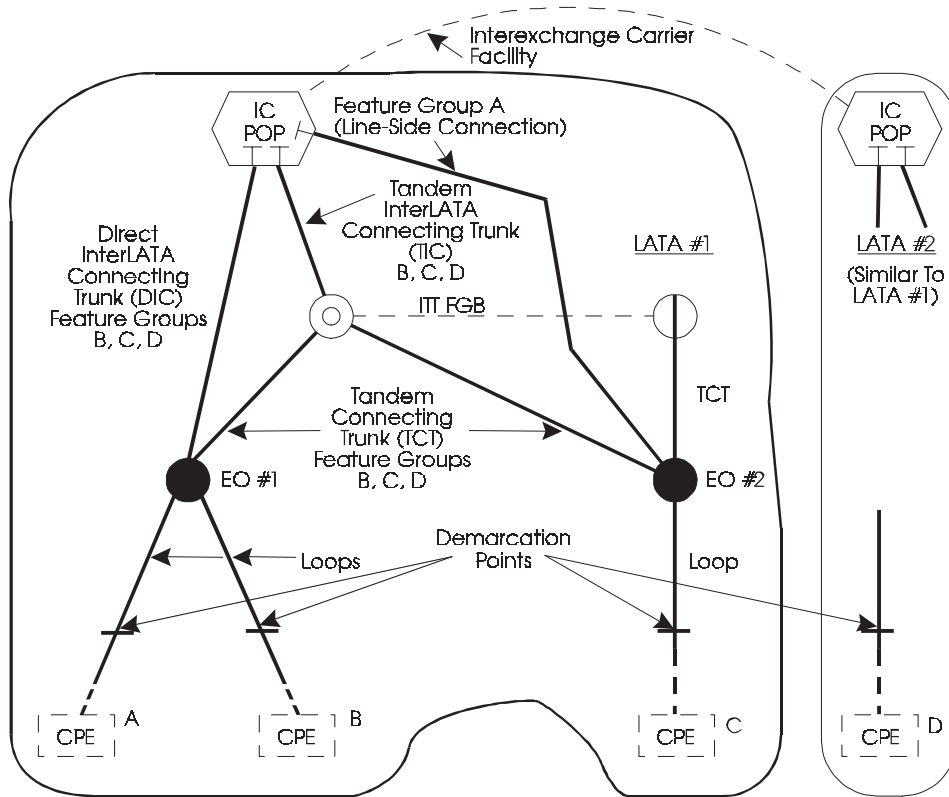
- Voice frequency
- Digital at DS1, DS1C, DS2, DS3, or DS4, and fiber rates
- Analog carrier at the group, supergroup, or master group levels.

Of these, the voice-frequency, DS2, DS4, and analog-carrier interfaces are mainly of historical interest. Note that provision of these transmission types is dependent upon the following factors:

1. The particular feature group
2. Interface type
3. Availability of exchange-carrier facilities.

In the following paragraphs, typical ICLs are given for various switch-to-switch connections. With some exceptions in Feature Group B and C services, the IC designs are within these objectives. Actual requirements are in the form of allowable ranges of levels at the POT and the end office. In the case of Feature Group D, it is the responsibility of the IC to design to ensure equality of access. In all cases, however, the responsibility of the exchange carrier in meeting these objectives ends at the IC POT.

---



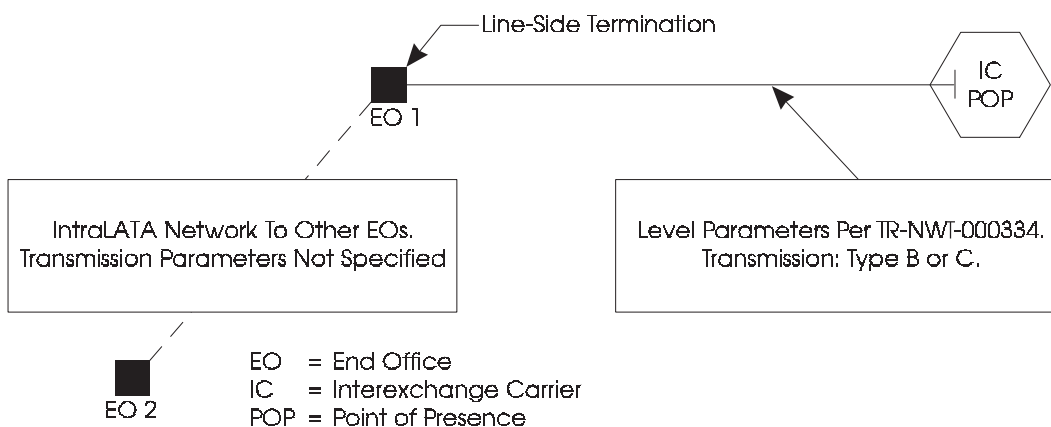
**Legend:**

- ⊙ = Access Tandem
- CPE = Customer-Premises Equipment
- = End Office (EO)
- IC = Interexchange Carrier
- ITT = Intertandem Trunk
- POP = Point of Presence
- ⊖ = Sector Tandem

**Figure 7-25. Exchange-Access Connections**

## 1. Feature Group A (FGA)

Exchange access under FGA provides a voice transmission path between the IC POT and the line side of an end office. The end office constitutes the First Point Of Switching (FPOS) in the LATA. Switched connections may be made directly to an end user served by the same end office or via the intraLATA network to an end user served by another end office in the LATA. These connections are illustrated in Figure 7-26. FGA is commonly used to support foreign exchange and similar services. Transmission parameter limits are specified to the FPOS.



**Figure 7-26.** Feature Group A

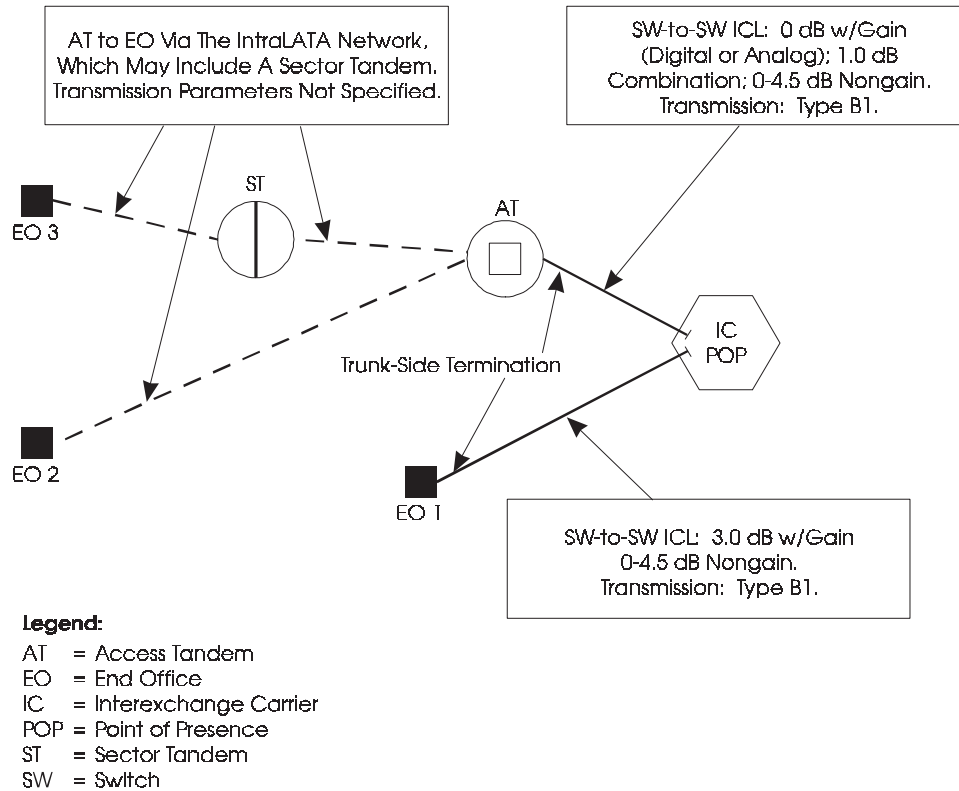
## 2. Feature Group B (FGB)

Exchange access under FGB provides a voice transmission path between the IC POT and the trunk side of the FPOS within a LATA. Access is gained to end user connections either directly or, if the FPOS acts as a tandem, through subtending end offices via the intraLATA network. For example, Figure 7-27 shows that FGB could be provided by connecting the IC POT to end office #1 directly, to end office #2 via an access tandem, or to end office #3 via an access tandem and sector tandem.

FGB is provided with type-B1 transmission. The parameters are specified from the IC POT to the FPOS with the exception of an overall balance requirement to the end office for connections via a tandem switch. The nominal loss is 3 dB for direct connections between the FGB end office and the IC switch. The nominal loss is 0 dB for connections between the FGB access tandem and the IC switch. Exceptions to these loss values may be necessary in cases where non-gain, voice-frequency facilities or combination trunks are used or where the IC requests them.

Transmission parameter specifications for FGB (as well as FGC and FGD) are split into two tiers based on the type of facility used. More stringent limits are placed on facilities using newer-type digital systems (D2 through D5 channel banks or equivalent). These facilities may include voice frequency cable extensions of one mile or less. All other

facilities, including those with cable extensions of greater than one mile, carry less stringent limits. Note that the type of facility used is dependent upon availability from the exchange carrier.



**Figure 7-27. Feature Group B**

### 3. Feature Group C (FGC)

FGC access is provided only to AT&T from a particular end office until FGD (equal access) is available, at which time FGC is discontinued. Consequently, use of this offering has declined substantially in recent years.

Exchange access under FGC provides a voice transmission path between an AT&T POT and an end office. As shown in Figure 7-28, access is provided through trunk-side switching at an end office or an access tandem. All segments of FGC connections are provided with Type-B1 transmission.

Because of the limited application of FGC, facility loss objectives are not included in this document. Loss specifications can be found in GR-334-CORE.

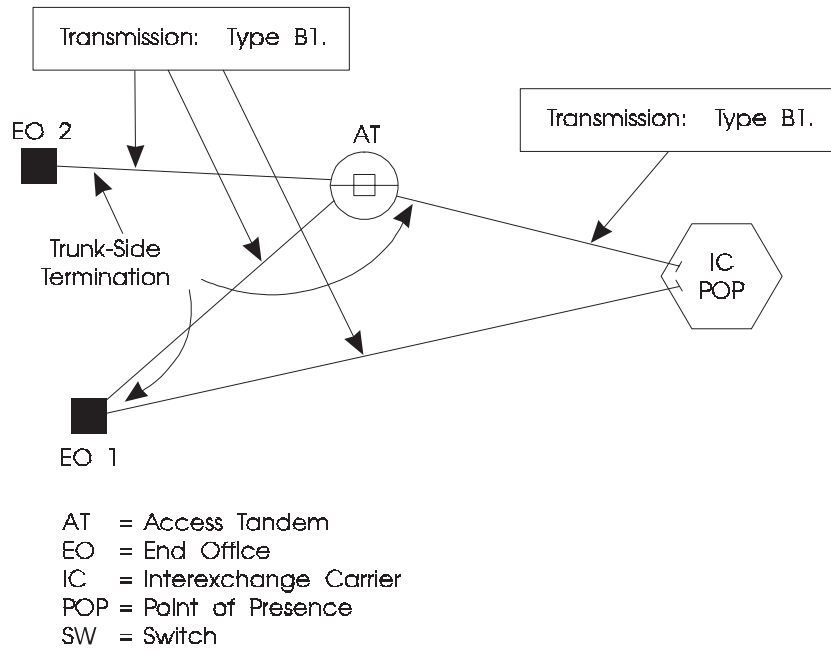
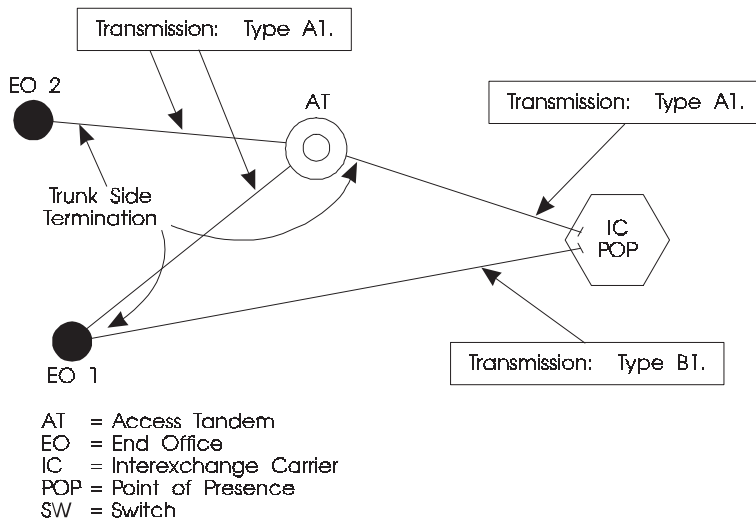


Figure 7-28. Feature Group C

## 4. Feature Group D (FGD)

Exchange access under FGD provides transmission between an IC POT and an end office. As shown in Figure 7-29, LATA access is provided through trunk-side switching at an end office or access tandem. If access to an end office is provided via an access tandem, Type-A1 transmission is provided on both segments of the connection. Direct access to an end office is provided with Type-B1 transmission.



**Figure 7-29.** Feature Group D

FGD provides the equal-access arrangement to all ICs. The transmission and maintenance plans are intended to ensure that the quality (loss, noise, and echo performance) furnished to all ICs by a LEC will be perceived by the end user to be equal, regardless of whether access is provided directly or via an access tandem.

The equal-access requirement of FGD necessitates a loss plan such that the transmission loss from the end office to the IC switch via an access tandem is equal to the loss via a direct path. Equal transmission is achieved when trunks are designed as specified in Table 7-12. Additional design specifications are provided in GR-334-CORE

**Table 7-12. FGD Design Loss**

IC Switch Type	Loss (dB) <sup>a, b</sup>	
	EO to IC	IC to EO
Digital	0	6
Analog (TP0)	0	6
Analog (TP2)	3	3

- a. These losses are between the end office (EO) access line (loop) interface and the center of the IC switch.
- b. If a cable facility without gain is used in the access connection, the loss can vary by  $\pm 1$  dB.

#### 7.16.1.2 WATS Access Lines

WAL service provides a voice transmission path between a customer's demarcation point or a Centrex switch and a WATS central office switch capable of performing screening functions for WATS. As shown in Figure 7-30, it is offered only in connection with FGC or FGD. WAL service is arranged for originating calling (WATS-type service), terminating calling (800-type service), or 2-way calling.

At the demarcation point, a WAL is provided with a 2- or a 4-wire interface at the option of the IC. At the WATS central office, a line termination is provided except when the following options that require a trunk termination are ordered: dialed number-identification services, answer supervision, or E&M supervisory signaling.

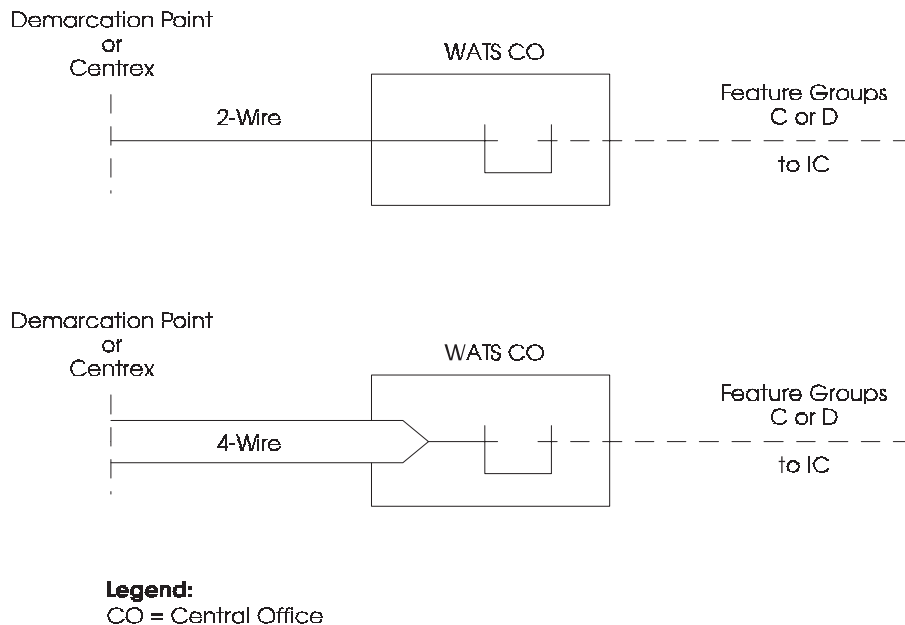
WALs are provided with three transmission types: standard 2-wire, improved 2-wire, and 4-wire. Standard 2-wire WALs have a maximum loss of 7.5 dB. Improved 2-wire WALs have a maximum loss of 4.5 dB. Improved 2-wire WALs also provide improved attenuation distortion and (optionally) improved echo performance.

Four-wire WALs offer further improved attenuation distortion and echo performance, and they allow the IC some flexibility in determining circuit loss. The nominal loss value for 4-wire WALs is 4 dB.

#### 7.16.1.3 Transmission Performance Limits

Transmission limits for access services are specified in GR-334-CORE. The parameters that are defined for voice transmission include loss deviation, attenuation distortion (slope), C-message noise, C-notched noise, and echo. Separate limits are given for transmission types A1, B1, B, C, and for each of the facility-dependent tiers where applicable.





**Figure 7-30.** WAL Service Configurations

Transmission limits in GR-334-CORE are given as acceptance limits and IALs. Comparable to a PSL an acceptance limit is the maximum value of, or deviation from, a design parameter that is allowed at service turnup or IC acceptance. An IAL is the bound of acceptable performance and the threshold beyond which immediate corrective action should be taken.

GR-334-CORE also provides ranges for expected transmission levels at the IC POT and at the LEC switch. These ranges depend on the particular interface code, the transmission type, and the feature group.

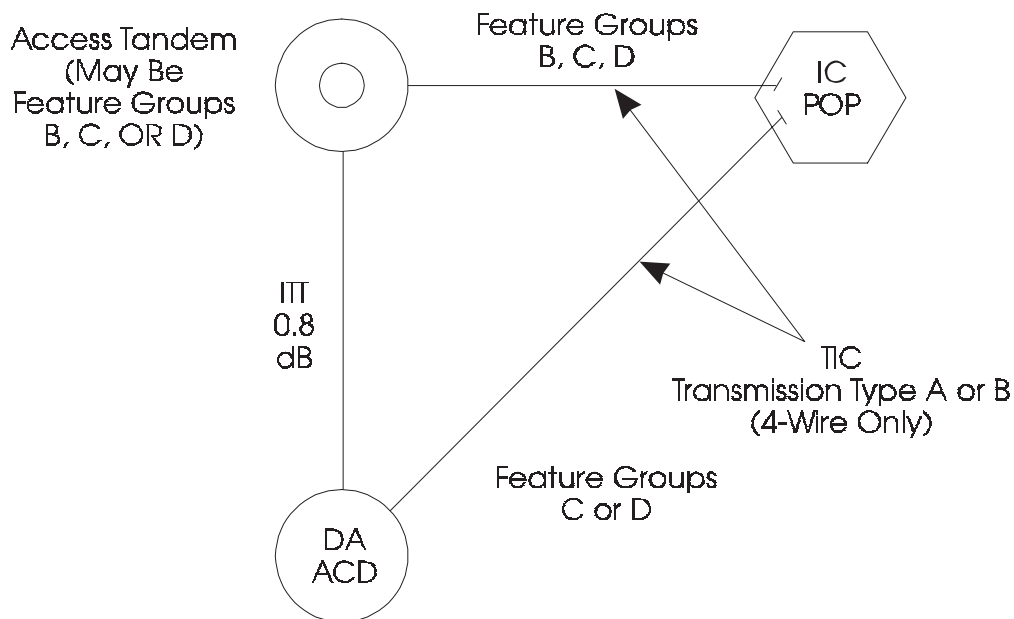
Finally, GR-334-CORE specifies analog parameters that affect data transmission. These include signal-to-C-notched noise ratio (at data level), Envelope Delay Distortion (EDD), impulse noise, intermodulation distortion, and phase jitter.

LECs may elect to establish and support technical standards that differ from those provided in GR-334-CORE.

#### 7.16.1.4 InterLATA Directory Assistance

Directory assistance for interLATA traffic is shown in Figure 7-31.

Connection from the IC POT to an ACD can be made by a direct path or via an access tandem. This service can be provided with FGC and FGD. Directory-assistance traffic incoming to an access tandem can also be provided via FGB. However, only transmission



ACD = Automatic Call Distributor  
 DA = Directory Assistance  
 IC = Interexchange Carrier  
 ITT = Intertandem Trunk  
 POP = Point of Presence  
 TIC = Tandem InterLATA Connecting (Trunk)

**Figure 7-31.** InterLATA Directory Assistance

Type B (4-wire) is used, since Type C (2-wire) cannot provide the desired quality and will present the operator with contrast between intra- and interLATA directory assistance calls.

Requirements for the TICs are provided in GR-334-CORE. Provision of directory assistance via FGB is at the option of the LECs and depends on the availability of facilities and switching capability.

### 7.16.2 Interconnection with Private Networks

Large customers often operate their own networks consisting of Private Branch Exchanges (PBXs) interconnected by tie trunks. These trunks may use facilities supplied by LECs and/or ICs or privately owned facilities. The PBXs may be customer-owned or, alternatively, the PBX functions may involve Centrex service provided by an exchange carrier switching office.

---

Private network connections to intraLATA networks are made via traditional PBX central office trunks that are line-side connections at the end office and provide either 1-way or 2-way service. In addition, trunk-side connections to the end office are provided for Direct Inward Dialing (DID) applications. Increasingly, provision is being made for connection to PBXs on a DS1 (24-circuit) basis.

The Telecommunications Industry Association (TIA) has developed a loss plan for  $\mu$  PBXs, that is, PBXs that use  $\mu$ -law interfaces to connect to digital facilities. The plan is contained in ANSI TIA/EIA-464. It should be noted that this loss plan specifies losses to be placed between the ports of a PBX for the various available port-to-port connections.

Facility losses are determined, in part, by the customer and are based on factors such as network architecture. FCC Part 68 Rules (see Section 13) apply to PBXs connecting to public facilities. Detailed specifications for facilities provided by exchange carriers to private network customers are contained in TR-NWT-000965 (intraLATA) and TR-NWT-000335 (exchange access).

### **7.16.3 Interconnection with Cellular Mobile Radio Networks**

Wireless Services Providers (WSPs) provide end-link telephone service to their customers via radio links from a WSP Wireless Switching Center (WSC). The WSC is interconnected to the LEC network to reach regular telephone customers. Details are given in Section 16.



---

## Section 8

### Operations and Maintenance

### Contents

8.	Operations and Maintenance.....	8-1
8.1	Introduction.....	8-1
8.1.1	Maintenance Objective .....	8-1
8.1.2	Network Evolution.....	8-1
8.2	Trunk Maintenance .....	8-2
8.2.1	Digital Trunk.....	8-3
8.2.2	Trunk Types .....	8-3
8.2.3	Steps for Effective Trunk Maintenance .....	8-3
8.2.3.1	Trouble Detection .....	8-3
8.2.3.2	Service Protection.....	8-4
8.2.3.3	Trouble Verification .....	8-5
8.2.3.4	Sectionalization.....	8-6
8.2.3.5	Repair.....	8-6
8.2.3.6	Repair Verification .....	8-6
8.2.3.7	Restore to Normal.....	8-6
8.2.4	Test Positions .....	8-7
8.2.4.1	Operational Tests .....	8-7
8.2.4.2	Transmission Tests .....	8-7
8.2.5	Test Lines.....	8-8
8.2.5.1	Transmission Test Lines.....	8-9
8.2.5.2	Operational Test Lines.....	8-21
8.2.6	CAROT System .....	8-24
8.3	Common Channel Signaling .....	8-29
8.3.1	CCS Maintenance Plan .....	8-29
8.3.2	Node Maintenance .....	8-30
8.3.3	Signaling Link Maintenance .....	8-30
8.3.4	CCS Interface.....	8-30
8.3.5	Present Link Testing Strategy.....	8-36
8.3.6	Link Circuit Parameters .....	8-39
8.3.7	Data Service Unit Test .....	8-39
8.3.8	Network Maintenance .....	8-40
8.3.9	Link Maintenance Flow .....	8-40
8.4	Switch Diagnostics.....	8-40
8.4.1	Digital Systems .....	8-42
8.4.2	Digital Switch Alarms.....	8-43
8.4.3	Network Synchronization .....	8-43
8.4.4	Automatic Operational Trunk Testing .....	8-44
8.4.5	Performance Monitoring .....	8-44

---

---

8.4.6	Transitional Strategies.....	8-45
8.4.6.1	Switch Surveillance .....	8-45
8.4.6.2	CAROT .....	8-46
8.4.6.3	Miscellaneous Arrangements.....	8-46
8.5	Switching System Maintenance .....	8-47
8.5.1	Switching Control Center.....	8-47
8.5.2	Electronic Systems Assistance Center .....	8-48
8.5.3	SCC Operations Systems .....	8-48
8.6	Memory Administration.....	8-49
8.6.1	Provisioning-Driven Memory Administration (PDMA).....	8-49
8.6.2	System Administration.....	8-49
8.6.3	Memory Backup and Restoration .....	8-49
8.7	Facility Maintenance .....	8-50
8.7.1	Facility Maintenance and Administration Center .....	8-50
8.7.2	Operations Support Systems .....	8-50
8.8	Transport System Maintenance.....	8-50
8.8.1	Integrated Services Digital Network Basic Access Maintenance .....	8-51
8.8.2	Public Packet Switched Network Maintenance .....	8-51
8.8.3	Synchronous Optical Network Maintenance .....	8-52
8.9	Loop Maintenance.....	8-55
8.9.1	Automatic Repair Service Bureau.....	8-56
8.9.2	Loop Maintenance Operations System .....	8-56
8.9.3	Mechanized Loop Testing System .....	8-56
8.9.4	Loop Cable Maintenance Operations System .....	8-56
8.10	Planned Long-Term Network Advancement .....	8-57
8.10.1	Bit Error Ratio.....	8-58
8.10.2	Assignment of Bits in DS1 Superframe Format Signals.....	8-59
8.10.3	Assignment of Bits in DS1 Extended Superframe Format Signals .....	8-60
8.11	Digital Testing Parameters .....	8-61

---

---

## List of Figures

Figure 8-1.	Test Line Arrangements for IntraLATA Trunk Testing.....	8-11
Figure 8-2.	900-W Quiet Termination .....	8-12
Figure 8-3.	600-W Quiet Termination .....	8-13
Figure 8-4.	1/1A ESS Switching System Quiet Termination - Tandem State .....	8-13
Figure 8-5.	1/1A ESS Switching System Quiet Termination — Local State.....	8-14
Figure 8-6.	The CAROT System.....	8-25
Figure 8-7.	Near-End, Far-End, and Common CAROT Testing Functions of Equipment within an End Office for Three Types of Test Equipment ..	8-28
Figure 8-8.	National Signaling Network .....	8-31
Figure 8-9.	Access Links — Database Access .....	8-32
Figure 8-10.	Bridge Links .....	8-32
Figure 8-11.	Cross Links — Regional STPs .....	8-33
Figure 8-12.	Cross Links .....	8-33
Figure 8-13.	Diagonal Links .....	8-34
Figure 8-14.	Fully Associated Links .....	8-34
Figure 8-15.	Signaling Data Links Summary.....	8-35
Figure 8-16.	CCS Test Access via SMAS/SARTS .....	8-36
Figure 8-17.	Test Access via Digital Cross-Connect System .....	8-37
Figure 8-18.	DS0A Testing Arrangement .....	8-38
Figure 8-19.	Example of Link Maintenance Flow .....	8-41

## List of Tables

Table 8-1.	Trunk Types.....	8-3
Table 8-2.	Test Requirements for A and B Digital Link Circuits.....	8-39
Table 8-3.	Data Service Unit Test.....	8-39
Table 8-4.	Digital Switch Alarms .....	8-43
Table 8-5.	Bit Error Ratio .....	8-58
Table 8-6.	Assignment of Bits in DS1 Superframe Format Signals .....	8-59
Table 8-7.	Assignment of Bits in DS1 Extended Superframe Format Signals .....	8-60

---





---

## 8. Operations and Maintenance

### 8.1 Introduction

#### 8.1.1 Maintenance Objective

The objective of an effective overall maintenance plan is to provide high-quality service on the network at a reasonable cost. To accomplish this, a maintenance program must take advantage of the accuracy and speed afforded by modern automated Operations Support Systems (OSSs) as well as the efficiencies possible from consolidation of skilled communications technicians at centralized work locations.

Maintenance plans for most Local Exchange Carrier (LEC) networks have evolved to a centralized method of operational and administrative control. Centralized databases and work forces make it possible to effectively maintain the precision and stability required for the current public switched network.

The sophistication of switching systems and of the network as a whole is growing. This, together with the deployment of digital switching systems with trouble detection and analysis capabilities, requires maintenance plans and methods that can take advantage of the advanced network element capabilities.

Inadequate maintenance at one switching office or center can cause excessive trouble at that location and create an adverse reaction elsewhere in the network. The switch-connecting network has become increasingly larger in bandwidth. Outages, therefore, have a much greater effect on the overall network.

To preserve the network integrity, a well-organized maintenance plan is essential. Intercompany cooperation is necessary for coordinated maintenance of the North American integrated network. Company maintenance plans that clearly define the responsibilities assigned to each work position and control center facilitate the cooperative maintenance of the switched network.

#### 8.1.2 Network Evolution

The continued evolution of maintenance procedures is stimulated by the implementation of advanced technology built into OSSs and by the continued growth of the communications network, both in size and capabilities. The following factors contribute to that evolution:

- Increased use of automated procedures and self-alarming arrangements that automatically indicate troubles in the switching and transmission networks
- More widespread use of digital switching systems with trouble detection and analysis capabilities

- Formation of control centers that have responsibilities for maintenance as well as other operations for trunks and facilities associated with a group of central offices
- Interconnection of the centralized OSSs to create an intelligent operations support network

The creation of control centers has permitted personnel to retain a high level of expertise because of greater exposure to various and difficult maintenance problems. In addition, personnel at the centers are afforded a broader view of the network, which can be beneficial in detecting and repairing troubles that affect a number of elements in the network.

Many LECs have organized maintenance efforts so that centralized trunk and switching system maintenance functions are the responsibilities of the Switching Control Center (SCC) in the exchange environment. Personnel at the work centers are organized into work positions and teams. Each work position is assigned a particular set of maintenance functions and is generally supported by an automated system.

- Trunk-related problems are handled by a Trunk Work Station (TWS) where technicians perform manual and routine tests on circuits to correct problems. A Trunk Operations Support Center (TOSC) is responsible for trunk transmission problem identification and administration of corrective action.
- Facility maintenance may be monitored, directed, and administered from centralized locations. In areas with a high concentration of T-carrier facilities, a Facility Maintenance and Administration Center (FMAC) directs and coordinates the activities associated with restoration of service using spare facilities.

In addition, Network Operations Centers (NOCs) are becoming more widespread using support groups such as the Electronic Systems Assistance Center (ESAC) and the Network Management Center (NMC). These centers typically perform surveillance functions on transport and network elements and are more centralized than SCCs.

As the network continues to evolve toward a fully digital environment with planned self-checking and self-healing capabilities, changes in the network workplaces may become necessary to take full economic and technological advantage of the new environment.

## **8.2 Trunk Maintenance**

The trunk maintenance process ensures that trunks are accessible to traffic, that they function properly during call setup and termination, and that they provide a proper transmission path during the call.

Trunk maintenance procedures may involve manual operations conducted from a test position, as well as fully mechanized testing via the Centralized Automatic Reporting On Trunks (CAROT) system and switch diagnostics. In these instances, test lines provide far-end test termination functions.

---

## 8.2.1 Digital Trunk

The increase in the number of digital switches in the network, combined with a heavy concentration of digital facilities, has made it necessary to define a "digital trunk" and to examine existing trunk maintenance plans to ensure that the digital trunks are properly monitored and tested. The increased use of the switched-message network to transmit data has demanded new methods and operating procedures for trunk maintenance. Trunk maintenance plans must ensure that the switched-message network will support low-speed data as well as voice transmission.

A digital trunk is defined as an interoffice switched-message trunk originating and terminating in digital switches connected by a digital facility with no analog/digital conversion.

## 8.2.2 Trunk Types

Table 8-1 illustrates the trunk types that exist in the network.

**Table 8-1.** Trunk Types

Trunk Types	Orig. Office	Facility	Term. Office
Analog	A <sup>a</sup>	A	A
" "	D <sup>b</sup>	A	A
" "	A	A	D
" "	D	A	D
Combined	A	D	A
" "	D	D	A
" "	A	D	D
Digital	D	D	D

a. A = Analog

b. D = Digital

## 8.2.3 Steps for Effective Trunk Maintenance

### 8.2.3.1 Trouble Detection

Trouble detection for message trunks requires both the detection of trouble and reference to the responsible maintenance organization. Service goals mandate identification of

troubles as soon as they occur. Digital Facility performance monitoring may provide immediate detection capabilities; however, routine CAROT testing is still required to detect analog-trunk troubles and to provide C-notched noise results on digital trunks until performance monitoring is improved and deployed with end-to-end capability.

Digital and combination trunks are maintained by the following activities:

- Performance monitoring is used where available.
- Routine testing (CAROT) continues.

Performance monitoring capabilities exist in network elements and OSSs. Examples of network elements that have some performance monitoring capability are

- Digital switches
- Digital Carrier Terminals (DCTs)
- Digital multiplexers.

A number of vendors manufacture performance monitoring devices that can be attached to digital facilities with monitoring results available through an operations system.

The trunk maintenance organization needs all available performance monitoring results to assist in the trunk maintenance effort. Often the required performance monitoring information is not directed to them. More interaction between the trunk maintenance, switch maintenance, and facilities maintenance organizations is dictated by the merging of technologies.

Analog trunks continue to be maintained by all CAROT routine testing and administrative operations. It is anticipated that as the transition to a fully digital network environment continues, the number of analog trunks will be decreased to a small fraction of total trunks. This will begin the age of all-digital trunks and of trunk maintenance based on network performance monitoring.

#### 8.2.3.2 Service Protection

Service protection requires that a failed or degraded trunk be taken out of service. Service protection for digital and combination trunks is handled as follows:

- Automatic removal from service for an indication of a red or yellow alarm
- Manual removal from service based on referral from other maintenance organizations, such as FMAC.

Failure of a trunk facility (1.544-Mbps DS1) system, as determined by a red or yellow alarm, will automatically remove from service the affected switched message trunks.

---

---

Red alarms are initiated by a Carrier Group Alarm (CGA) either from a channel bank or as calculated by the digital switch. Some switches may have the capability to remove trunks from service based on Out-of-Frame (OOF) counts and/or an excessive number of slips.

Each LEC must be aware of the capabilities of the digital switches deployed and use the available parameters.

While a CGA will affect both voice and data, slips and OOFs may have a minimal effect on voice while affecting data transmission. Slips, however, may cause customer line cutoffs.

CGAs are provided to notify maintenance personnel of a Carrier Failure Alarm (CFA) and to allow trunk conditioning. Trunk conditioning involves terminating in-place calls to stop billing and then taking the trunk out of service to prevent customers from accessing trunks served by a failed or degraded facility.

Trunk conditioning should occur when a CFA is detected in either direction of transmission. This is accomplished by giving the appropriate indication per trunk group. Trunks should automatically be restored to service when the CGA has cleared.

In analog Stored Program Control (SPC) switches, several conditions must be correct for trunk conditioning to take place properly:

- The CGA on the channel bank must be cross-connected to a master scanner point in the switch
- The master scanner point must be translated in the switch to correspond to a CGA number
- The Trunk Network Numbers (TNNs) must be translated in the switch to correspond to the CGA number.

#### 8.2.3.3 Trouble Verification

Trouble verification is a validation that a trunk trouble exists. A retest of the suspicious trunk or trunks is made before manually removing it from service.

Trouble verification for digital, combination, and analog trunks is handled as follows:

- Perform CAROT tests to verify transmission and access troubles
- Perform manual digital or voice-grade data tests to verify switched data impairments.

Tests are conducted to verify marginal troubles and/or hard failures. CAROT provides a mechanized test but is limited to analog impairments and access problems (with the exception of the C-notched-noise parameters, which may indicate digital impairment). Troubles that are reported to be affecting switched data should be verified by performing manual digital testing.

---

#### 8.2.3.4 Sectionalization

The first step in sectionalization is to determine if the trouble is switch- or facility-related. Once this has been determined, the trouble may be referred to the proper maintenance force for further sectionalization.

Sectionalization for digital and combination trunks is handled as follows:

- Use OSS information to indicate network troubles
- Perform demand tests and pattern results.

OSS testing capability can dramatically aid in sectionalizing trunk troubles. Systems such as Bellcore's NMA system and Northern Telecom's Digital Facilities Management System (DFMS) are examples of OSSs designed for this capability. Again, close interaction is needed between the trunk maintenance organization and the facilities organization.

Demand testing via CAROT can be useful for pointing to a digital facility or switch trouble on a particular trunk or trunk group. All trunks on a given facility can be tested. If they all fail, a facility problem is indicated. If only one individual trunk is failing, a switch or channel problem is indicated.

Switching machine sectionalization for analog trunks is handled by performing demand tests and patterning results.

#### 8.2.3.5 Repair

Repair of a switched-message trunk demands that the trouble, once sectionalized, be referred to the proper maintenance group for further isolation and repair. This requires interaction and coordination between more than one organization and/or location. For digital, combination, and analog trunks, the procedure will depend on the operational and administrative organizations of the LEC.

#### 8.2.3.6 Repair Verification

The same procedures are used here as for trouble verification.

#### 8.2.3.7 Restore to Normal

When repair verification is complete, the affected trunks may be manually returned to service. Additional monitoring may be required to confirm that the trouble condition has been cleared.

---

---

## 8.2.4 Test Positions

Test positions provide an assortment of capabilities associated with manual trunk testing. The capabilities vary substantially in their level of sophistication and features provided, depending on the type and vintage of the switching system and local practices. The fundamental functions of a test position are to provide access to trunks for transmission and operational testing and to control the maintenance state (that is, availability for service) of the trunks. Test positions are normally located at the “ends” of trunks or at a centralized control location.

Test positions have the capability to talk over or monitor the trunks being tested and to perform certain transmission, operational, and signaling tests. Tests may be conducted between two different test positions or between a test position and a test line. The maintenance state of the trunk may be controlled at a trunk test position. For example, a trunk may be made “active” or available for service, or it may be placed in an out-of-service state.

In addition, access to control the signaling on a trunk from a test position is generally provided. The outgoing supervision (on- or off-hook) can be controlled and monitored, and the incoming supervision may also be monitored. In addition, the ability to outpulse (multifrequency pulsing, dial pulsing, and dual-tone multifrequency signaling) is provided. Stress-signaling test conditions may be applied to the near end, while the signals received at the far end are compared with expected results to detect marginal troubles. Trunks that do not pass this pulsing test are subjected to further analysis and repair. Measurements of dc trunk characteristics (resistance, capacitance, and voltage) of trunks can be performed by switching systems that connect trunks through conducting paths to test positions.

### 8.2.4.1 Operational Tests

Operational testing features are provided at test positions. The ring-forward function on trunks is tested by a termination at a supervisory and signaling test circuit (103-type test line). Ringing, tripping, and supervisory functions on incoming trunks are tested via synchronous and nonsynchronous test lines.

### 8.2.4.2 Transmission Tests

For transmission testing of trunks, test signals can be originated and controlled by the test position. These originating test signals include 1004 Hz at 0, -10, or -16 dBm0, 404 Hz at -16 dBm0, and 2804 Hz at -16 dBm0. Transmission measurements performed at a receiving-end test position should include all of those tests specified in GR-334-CORE, *Switched Access Service: Transmission Parameter Limits and Interface Combinations*. Transmission tests may be conducted between one test position and another (particularly for trouble sectionalization) or from a test position to a far-end test line.

---

On-site trunk test positions provide most or all of the above capabilities for each type of central office. For certain types of offices, there are associated remote trunk maintenance positions at centralized locations that provide many of the testing functions found at the on-site positions.

### 8.2.5 Test Lines

Test lines are part of the basic plan for the maintenance of trunks. Test lines range in complexity from those providing simple tones and terminations to those providing the relatively complex functions of applying marginal signaling tests and transmission tests and recognizing and replying to specific signals received.

All of the test lines discussed in the following paragraphs can be accessed from manual test positions, although some might require control features not found in all positions. The following descriptions are generally limited to more modern implementations of each test-line type.

Test lines are currently accessed by the following:

- Tandem office, intertandem trunks — A 3-digit 10X code corresponding to the specific type of test line
- Tandem office, intertandem connecting trunks — A 3-digit end office code (NXX) assigned from the spare NXX codes available in a Numbering Plan Area (NPA)
- End offices — A 7-digit subscriber number.

For transmission test lines, the digits received (and in some machines, the incoming trunk class) are used by the switching system to

- Connect to the proper type of test line
- Choose a line of the proper signaling type, impedance, and transmission-level point
- Place the incoming trunk unit in the correct state to simulate a local-terminating or through-switched call.

Two exchange number (NNX) codes, 958 and 959, are reserved for testing purposes. The code 958 is typically used for communications between switching offices. This code can be used to provide access to a test line that terminates on a test frame or switchperson's desk. These test locations are provided with the means for both originating and terminating calls for handling intermachine troubles. Calls are directed by outputting up to nine digits that include the NPA and a 0XX code (NPA + 0XX + 958), or the NPA and an X thousands digit followed by the test line code (958-1XXX).

Currently, the code 959 plus three or four additional digits is assigned for access to office test lines in Local Exchange Carrier (LEC) and Interexchange Carrier (IC) offices.

---



---

Test lines should not be seized until the originating office has completed pulsing. Following seizure or ring trip, off-hook supervision is provided unless off-hook supervision is a part of the test sequence. Following off-hook supervision, test lines that send tones provide a quiet period of 300 ms to permit the single-frequency signaling units to change supervisory state (refer to Section 6 of this document).

In many cases, periods of on-hook supervision are applied at timed intervals to facilitate taking down the connection once the originating end has disconnected. Most test lines can be optioned to remove tone during these periods to ensure proper single-frequency signaling unit operation.

To provide supervision, test lines typically have supervisory control circuits (for example, holding coil and relay) that may be in the transmission path. These control circuits are designed to have a negligible effect on the transmission specifications in the voiceband.

The stated frequencies of test-line tones include an additional 4 Hz above the nominal frequency to avoid the modulation byproducts that may be produced in a Pulse-Code Modulation (PCM)-type carrier.

#### 8.2.5.1 Transmission Test Lines

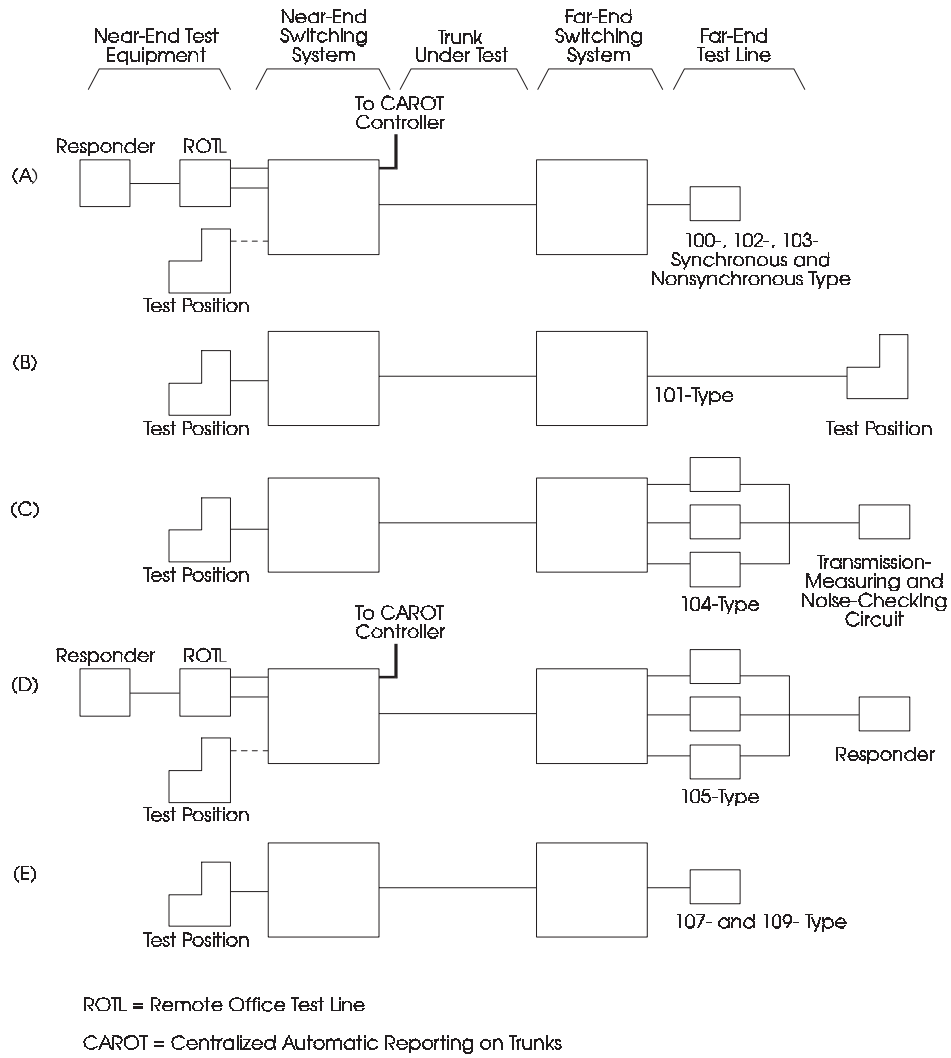
**100 Test Line:** The 100 test line is in industry-wide use to facilitate connection to a termination for balance and noise testing [see Part (A) of Figure 8-1]. There are two general versions of the 100-type test line. The early version provides only a quiet termination for balance and noise testing. The later version, in addition to the quiet termination, also provides a 1-kHz tone for 1-way loss measurements. The parameters of the quiet termination and 1-kHz tone are as follows:

1. Quiet termination — The quiet termination typically provides a termination consisting of 900 or 600  $\Omega$  (depending on office impedance) in series with a 2.16- $\mu$ F capacitor (see Figures 8-2 and 8-3). In some cases, this termination is built out of the nominal office capacitance with a build-out capacitor. Exceptions are the following:
  - a. In 4-wire analog offices, the quiet termination is a 4-wire, 600- $\Omega$  termination.
  - b. In digital offices, the office provides the equivalent of a 600- $\Omega$ , 4-wire quiet termination.
  - c. The 1/1A ESS offices have two versions of quiet termination. The older version consists of a 900- $\Omega$  resistor in series with a 2.16- $\mu$ F capacitor (see Figure 8-2), as described above. The newer version is more complex with two states, tandem and local.
    - The tandem state provides a termination consisting of an 887- $\Omega$  resistor in series with a 2.16- $\mu$ F capacitor. In some cases, this termination may be built out to the equivalent of 400 ft of office cabling (juncture grouping frame to the termination) with a build-out resistor and a build-out capacitor (Figure 8-4).

- The local state provides a complex impedance designed to simulate a typical local loop. Figure 8-5 shows a simplified schematic of this termination. In some cases, the termination may be built out to the equivalent of 400 ft of office cable.

## 2. 1-kHz test tones

- a. Frequency — Several versions of mW-tone supplies exist. The older version provides 1000-Hz  $\pm$ 10-Hz tone. The newer version provides 1004-Hz  $\pm$ 1-Hz tone.
- b. Level — These tones are adjusted to either 0.0  $\pm$  0.03 dBm (Test Pad [TP] 0 office), -2.0  $\pm$ 0.03 dBm (TP 2 office), or -3.0  $\pm$ 0.03 dBm (TP 3 office) as measured at the center of the switching machine (for example, trunk or line distribution frame and junctor grouping frame).
- c. Impedance — Nominal impedance of the tone source is either 600 or 900  $\Omega$ , depending on the nominal impedance of the office.
- d. Exception — Digital offices may provide a 0.0-dBm0 synthesized 1004-Hz digital signal (digital mW). For more information on the digital mW, see FR-64, *LATA Switching Systems Generic Requirements (LSSGR)*.



**Figure 8-1.** Test Line Arrangements for IntraLATA Trunk Testing

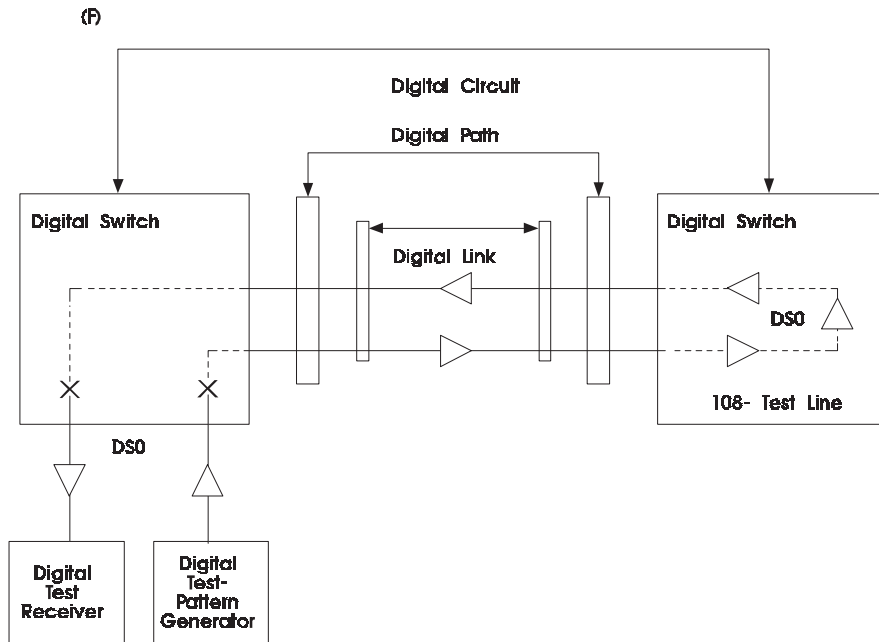


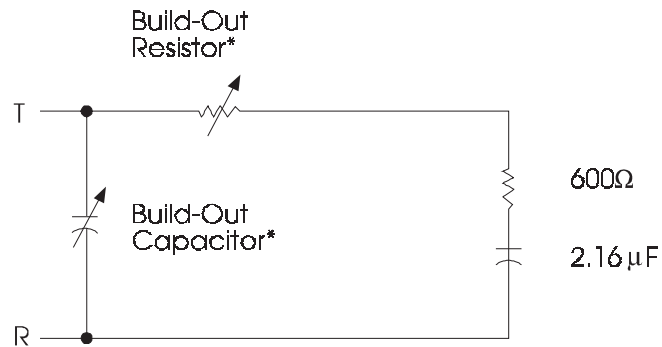
Figure 8-1. Test Line Arrangements for IntraLATA Trunk Testing (Continued)



Figure 8-2. 900-Ω Quiet Termination

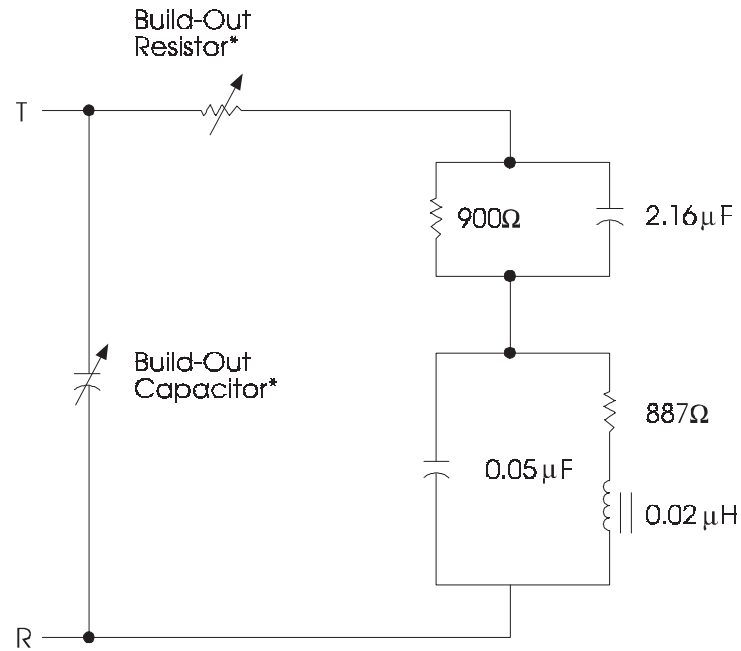


**Figure 8-3.** 600-Ω Quiet Termination



\* In some cases, the build-out resistor and the build-out capacitor may be adjusted to build out the termination to a total of 400 ft of office cable from the connecting frame (for example, the junctor grouping frame).

**Figure 8-4.** 1/1A ESS Switching System Quiet Termination - Tandem State



\* In some cases, the build-out resistor and the build-out capacitor may be adjusted to build out the termination to a total of 400 ft of office cable from the connecting frame (for example, the junctor grouping frame).

**Figure 8-5.** 1/1A ESS Switching System Quiet Termination — Local State

---

### 3. Operational Parameters

- a. The older version of the 100-type test lines provides only a quiet termination. Upon seizure of the test line, the operational sequences are as follows:
  - Off-hook (answer) supervision is returned, and quiet termination is placed across circuit
  - Some versions return a short interval (approximately 1 second) of on-hook (disconnect) supervision every 11 seconds, starting approximately 11 seconds after the initial connection.
- b. The newer versions of the 100-type test lines provide a 1-kHz tone followed by a quiet termination. Upon seizure of the test line, the operational sequences are as follows:
  - Off-hook (answer) supervision is returned
  - After approximately a 300-ms delay, a 1-kHz tone is applied for approximately  $5.5 \pm 0.5$  seconds.
  - After the tone is disconnected, a quiet termination is applied until the caller disconnects
  - Certain types may return a 1-, 2-, or 3-second on-hook (disconnect) signal approximately 11 seconds after the quiet termination has been applied
  - Others may return a series of 1-, 2-, or 3-second on-hook (disconnect) signals approximately every 30 seconds after the quiet termination has been applied.

**101 Test Line:** The 101 test line provides a communication and test line into a testboard or test position that can be reached over any trunk incoming to the switching system served by that test position [see Part (B) of Figure 8-1]. It is used for reporting troubles, making transmission tests, etc.

**102 Test Line:** Milliwatt (102-type) provides a 1000- or 1004-Hz tone for 1-way loss measurements [see Part (A) of Figure 8-1]. The features of this termination are given below.

1. Transmission parameters — 1000- or 1004-Hz tone
    - a. Frequency — Several versions of mW-tone supplies exist. The older version provides a 1000-Hz  $\pm 10$ -Hz tone. The newer version provides a 1004-Hz ( $\pm 1$ -Hz) tone.
    - b. Level — These tones are adjusted to either  $0.0 \pm 0.03$  dBm (TP 0 office),  $-2.0 \pm 0.03$  dBm (TP 2 office), or  $-3.0 \pm 0.030$  dBm (TP 3 office) as measured at the center of the switching machine (for example, trunk or line distribution frame and junctor grouping frame).
-

- 
- c. Impedance — Nominal impedance of the tone source is either 600 or 9000  $\Omega$  and depends on the nominal impedance of the office.
  - d. Exception — Digital offices may provide a 0.0-dBm0 synthesized 1004-Hz digital signal (digital mW). For more information on the digital mW, see FR-64, *LATA Switching Systems Generic Requirements (LSSGR)*.
2. Operational parameters — Upon seizure of the test line, the operational sequences are as follows:
    - a. Off-hook (answer) supervision is returned.
    - b. After a delay of approximately 300 ms (minimum 200 ms for a 1/1A ESS office), a 1-kHz tone is applied.

Note: One older version may be optioned for a 175-ms delay.
    - c. The test line may be installed to provide, at regular intervals ranging between 9 and 12 seconds, either a 1-, 2-, or 3-second interruption of tone. Some of the test lines may also provide on-hook (disconnect) supervision during this no-tone interval.

Note: One older version may be optioned for a 2-second interruption every 2 minutes.

**104 Test Line:** Transmission measuring and noise checking (104 type) provides a test termination for 2-way transmission testing and 2-way noise checking. This termination may be used to test trunks from offices equipped with automatic trunk test frames but cannot be used by the CAROT system. It may also be used for manual 1-person 2-way transmission measurements from a testboard or maintenance center [see Part (C) of Figure 8-1]. The 104-type test termination does the following:

1. Provides test pads as required by the office in which it is located
  2. Provides off-hook supervision
  3. Measures the 1000-Hz loss of the trunk from originating end to far end
  4. Adjusts a transmitting pad to equal the trunk loss measured in (3). If this loss exceeds 10 dB, the transmitting pad value is reduced by 10 dB and a subsequent “wink” signal indicates this fact to the originating end.
  5. Performs two self-checks to determine if the pad has been properly adjusted. In case of failure in either of these checks, a repetition of the measurement is requested.
  6. Applies 1000-Hz test power directly to the trunk to permit a receiving measurement at the originating end.
  7. After a timed interval, sends 1000-Hz test power through the transmitting pad adjusted in (4), preceded by a “wink” signal if it has been reduced by 100 dB. The difference between the levels of the two tones received at the originating end (adjusted by 10 dB, if necessary) equates to the loss measured in (3).
-



8. Provides a quiet termination for 5 seconds so that the noise measurement can be made at the originating end.
9. At the same time, makes a noise measurement at the test termination. If the noise exceeds the threshold (41 dBmC), an alternating on-hook, off-hook disconnect signal is returned. Otherwise, a steady on-hook signal is returned.

**105 Test Line:** Automatic transmission measuring test line (105 type) provides far-end access to a responder and permits 2-way loss and noise measurements to be made on trunks from a near-end office equipped with a Remote Office Test Line (ROTL) and responder. Up to 15 105-type test lines may be associated with one common responder. The test lines act as parking circuits for calls awaiting connection to the responder [see Part (D) of Figure 8-1]. The near-end ROTL and responder are directed by a CAROT controller or equivalent or a manually operated ROTL control unit. In an integrated 105-type test line/responder unit, the 105-type test line performs the responder functions in addition to its normal functions.

The waiting calls are served, one at a time, on a cyclic preferential basis. As each call from a 105-type test line is connected, the test line provides the proper supervision and impedance conversion between the trunks to be tested and the responder.

The 105-type test lines provide indications to the responder regarding the impedance at which the measurement is to be made (600 or 900  $\Omega$ ) and the TP required (TP 0, TP 2, or TP 3).

When the 105-type test line is seized, the timing functions are initiated and an off-hook supervisory signal and test-progress tone are returned to the originating office. (Test-progress tone equals 2225 Hz  $\pm$ 25 Hz at -10 dBm0  $\pm$ 0.5 dB.) If the responder is idle, the chain-circuit relays operate cut-through relays that connect the test line to the responder and remove the test-progress tone. If the responder is busy and/or other test lines in preferential positions in the chain circuit have already been seized, the test-progress tone continues to be sent back to the originating end to indicate that the call is parked and awaiting cut-through to the responder. When the chain circuit has progressed to the test line under consideration, the test line is cut through and the test-progress tone is removed.

Prior to connecting to a responder, the 105-type test line requires two or three timing intervals, depending upon the type of trunks being served. These timing intervals are provided by a timing circuit incorporated in the test line. The first timing interval of 150 ms is required in some offices to allow the marker to perform continuity tests prior to cut-through. The second timing interval of 150 ms is required to allow single-frequency signaling units to stabilize.

The third timing interval of 900-ms minimum is provided by all 105-type test lines. A test-progress tone is returned to the originating end, indicating that a test line has been seized. If at the end of this third timing period the 105-type test line has not seized a responder, the test-progress tone remains on the line until the connection is made or until the originating end releases the connection.

After the testing sequence has been completed, the responder signals the 105-type test line to release. A just-released 105-type test line remains connected to the trunk until the originating end disconnects or until the office time-out feature causes it to be disconnected. On 105-type test lines used in end offices, the test line also returns an on-hook signal to the originating office. When the test line has been released from the trunk, it restores to normal and is ready to receive another test call.

Several types of responders exist. The 51B-type can be used in conjunction with the 105-type test line. The 51B is capable of making 2-way loss and noise measurements. The 52-type responder provides additional testing capability. The 56A-type responder is designed for small end offices, community dial offices, and Private Branch Exchanges (PBXs). The 51B-type responders are no longer being manufactured. The responder testing capabilities are as follows:

1. 51B-type responder
  - a. Loss
  - b. C-message noise
2. 52-type responder
  - a. Loss
  - b. C-message noise
  - c. C-notched noise
  - d. Gainslope
  - e. Return loss (balance)
    - Measure and terminate “three-card option”
    - Terminate only “one-card option”
3. 56A-type mini-responder<sup>1</sup>
  - a. Loss
  - b. C-message noise
  - c. C-notched noise
  - d. Gainslope
  - e. Return loss (balance) — terminal only

---

1. The mini-responder provides an additional manual sequence in which 1-way (far-to-near) measurements of loss, gainslope, and C-message noise can be made by personnel at the near end. The mini-responder combines the function of a single 105-type test line and responder.

---

- 
4. Remote Trunk Test Unit (RTTU) — all 52-type capabilities, including balance measurements and terminations.

**107 Test Line:** Data-transmission test line (107-type) provides connection to a signal source that provides test signals for 1-way testing of data and voice transmission parameters [see Part (E) of Figure 8-1]. The test line provides a Peak-to-Average Ratio (P/AR) signal, gainslope frequencies, quiet termination, and intermodulation-distortion test signals. The test line also allows measurements of return loss, frequency shift, phase jitter, C-notched noise, impulse noise, gain hits, phase hits, and dropouts.

The P/AR signal, having a spectrum similar to many high-speed data sets, permits a rapid check of the quality of a facility for data transmission. The P/AR signal is particularly sensitive to envelope-delay distortion. The three gainslope frequencies (1004 Hz, 404 Hz, and 2804 Hz) at -16 dBm0 permit measurement of the trunk frequency characteristics. A 1004-Hz, -16-dBm0 tone permits measurement of frequency shift, phase jitter, C-notched noise, impulse noise, gain hits, phase hits, and dropouts.

**108 Test Line:** Code 108 test line once provided a looparound termination for in-service testing of far-end echo suppressors. Code 108, however, has been reassigned to a digital circuit loopback test line, as defined in American National Standards Institute (ANSI) T1.206-1988, *Digital Exchanges and PBXs — Digital Circuit Loopback Test Line* and FR-476, *OTGR Section 6: Network Maintenance: Access and Testing*. This test line originally provides a loopback at the Digital Signal level 0 (DS0) (64 kbps), of a digital circuit for analysis and repair purposes. The definition of the 108 test line has been broadened to provide a loopback at higher rates than 64 kbps.

Part (F) of Figure 8-1 shows the architecture and application of the 108 test line.

This test line is needed to verify the overall performance of switched digital circuits for the following reasons:

1. For analysis of customer reports of degraded data service on switched circuits
2. For repair verification of a switched circuit's digital error performance prior to returning the circuit to service
3. As a preservice check to ensure proper implementation of DS0/DS1 options
4. To establish performance benchmarks in the digital environment.

The Digital Test Receiver and Digital Test Pattern Generator may reside in the switch as an adjunct to the switch similar to the ROTL or in an OSS.

A standard interface from operating system to network equipment or system is needed to allow flexibility in the implementation of automated digital (DS0) testing of switched message trunks.

**109 Test Line:** Echo canceler test line (109-type) [see Part (E) of Figure 8-1] provides loopback arrangements for in-service testing of far-end echo cancelers. Upon access, the test line returns off-hook supervision and, after a 2-second delay, returns a nominal 1000-

---

Hz (or 1004-Hz) tone at -10 dBm0 for approximately 8 seconds. After an on-hook flash, a connection is made to a quiet termination. Measurements made at the near end with a Return Loss Measuring Set (RLMS) should indicate a very high reading for this condition.

After approximately 16 seconds, another on-hook flash is followed by a 16-second interval in which the trunk is looped back with no attenuation. The RLMS should indicate a very low reading since the echo canceler cannot function with less than 6 dB of return loss.

Finally, after a third on-hook flash, the trunk is looped through a 10-dB pad for 16 seconds. The echo canceler should now function, and a high level of return loss will be measured. The near-end canceler has no effect on these tests and must be checked with a similar test performed with the functions reversed at each end on the trunk.

At any time after the first interval of 1000-Hz tone, a ring forward (re-ring) signal will cause all timing to stop in the test line. Each subsequent ring-forward signal will cause the line to advance to the next state.

Note: The four-step sequence (tone followed by three loopback conditions) is repeated until disconnect, whether the test line is timed or manually controlled.

The looparound test line enables one person in a distant office to make 2-way transmission tests. Test calls directed to this test line are manually originated. This test line is used to measure the near-to-far loss of 4-wire or equivalent trunks and has two terminations, each reached by means of separate directory numbers. After measuring the far- to near-end loss of all trunks in the group (using a 102-type test line), one trunk is selected as a reference trunk. Using the reference trunk, one termination of this test line is dialed. Taking each of the remaining trunks in turn, the other termination of the test line is then dialed and test power is sent over the trunk under test and received on the reference trunk. By knowing the far- to near-end loss of the reference trunk and the overall measurement of the two trunks, the near- to far-end loss is calculated by subtraction.

Note: This test line may be equipped with a security callback feature.

The looparound connection is made by means of a control unit. Early models of this unit allow the two circuits to be connected if a tone of between 980 and 1020 Hz and a level greater than -15 dBm is detected on one of the circuits. The presence of signals outside of this 40-Hz range causes the two circuits to be disconnected. In the current design, incoming signals within the above requirements are regenerated at the same frequency and within  $\pm 0.1$  dB of the received level and applied to the reference line or trunk for transmittal to the distant end. The following modes of operation exist, depending on the type of test line equipment:

- Two circuits are looped together when the two test appearances are seized, one after the other.
  - A mW tone is connected to the first circuit to be seized. When the second circuit is seized, the mW tone is disconnected and the circuits are connected.
-

- 
- A mW tone is provided on one test-line appearance and a balance termination provided on the other (if they are accessed individually). If both are accessed, the incoming circuits are connected.
  - A combined mW-balance test line is provided on one appearance. This circuit is similar to the new 100-type test line described in the beginning of Section 8.2.5.1. When the second appearance is seized, the two incoming circuits are connected.

In all cases where mW tone is applied, a 300-ms delay takes place before a connection is made. Off-hook supervision is returned upon seizure or ring-tip. The mW tones and balance terminations may be interrupted by 1-, 2-, or 3-second on-hook intervals as discussed under 100- and 102-type test lines. Similarly, the looparound connection may be interrupted at approximately 11-second intervals for 1, 2, or 3 seconds.

The 4ESS digital loopback/complement test line (606-type) provides operational and digital testing capability for switched digital (56-kbps) trunks. This test line is used by the 1A ESS switching system for diagnostic (routine and demand) tests on 1A ESS-to-4ESS trunks and by the 4ESS trunk maintenance technicians for 4ESS-to-4ESS digital trunks. A digital loopback is provided with circuitry to alter the received bit stream before retransmission. The bit stream must be modified (inverted) to prevent errors due to reflections from a hybrid at the 1A ESS locations. Operational tests (such as access in voice mode, automatic balance, transfer to digital, transfer to voice, or disconnect) and digital tests (such as bit errors, block errors, or errored seconds) are performed by the 1A ESS maintenance circuit.

- Manual tests are performed by the 4ESS trunk maintenance technicians in both loopback and straightaway<sup>2</sup> modes. A one-person test can be performed in a loopback mode by originating a data-test call via a Circuit Maintenance System (CMS) to the test line. The data-test call assigned is 959606. After the 4ESS has set up a call to the test line, the technician will use a digital test set to perform tests.
- A two-person straightaway test is used to sectionalize a problem to the transmit or receive direction of the digital trunk. The 4ESS switching system will set up a no-outpulse connection via a CMS at the direction of the technician. Communications are then established with the far-end technician to verify that a similar connection has been set up. The appropriate digital tests will be performed by the two technicians.

### 8.2.5.2 Operational Test Lines

**103 Test Line:** Signal-supervisory test line (103-type) [see Part (A) of Figure 8-1] provides a connection to a supervisory and signaling test circuit for overall testing of these features on intertoll trunks equipped with ring-forward (re-ring) features that can be reached by an

---

2. Straightaway tests are made by two people, one at each end of the circuit or by one person testing into a test circuit at the distant end.

---

automatic trunk test frame or by dialing manually. The features of the 103-type connection are as follows:

- On seizure, the test trunk returns an off-hook signal
- On receipt of a ring-forward (re-ring) signal, the test trunk returns an on-hook signal
- On receipt of a second ring-forward (re-ring) signal, the test trunk returns a 120-Interruptions-Per-Minute (IPM) flash.

Synchronous test lines are required for offices (usually in connection with crossbar offices) where ringing, tripping, and supervisory features are in the incoming trunk relay equipment. Marginal tests of the supervisory and tripping functions are provided. Tests may be originated on either a manual or automatic basis [see Part (A) of Figure 8-1]. In SPC offices, an equivalent program-controlled test-line operation is provided to satisfy the requirements of the originating-office test frames. The test line is required to perform the functions as follows:

1. Test for application of the ringing signal
  2. Test for pretripping of machine ringing during the silent interval
  3. Provide interrupted audible ringing tone for approximately 2 seconds, followed by a test for tripping the machine ringing during a 3- to 4-second silent interval. On some earlier test lines, this sequence may be repeated once. On certain toll versions, a single 2-second interval of test progress tone is applied instead of the interrupted audible ringing tone.
  4. Provide the following supervisory tests:
    - a. An off-hook signal of approximately 1.3-second duration for synchronizing with automatic progression test equipment in originating offices is returned. During the off-hook period, soak current is applied to supervisory relays
    - b. Return 0.2 second of on-hook supervision; release current is applied to the supervisory relays
    - c. Return 0.3 second of off-hook supervision; soak current is applied to the supervisory relays
    - d. Return 0.2 second of off-hook supervision; release current is applied to the supervisory relays
    - e. Return 0.3 second of off-hook supervision; soak current is applied to the supervisory relays
    - f. Return 0.2 second of on-hook supervision; release current is applied to the supervisory relays
    - g. Return 1.3 seconds of off-hook supervision; operate current is applied to the supervisory relays
-

- 
- h. Return 0.2 second of on-hook supervision; open circuit condition presented to the supervisory relays
  - i. Return 0.3 second of off-hook supervision; operate current is applied to the supervisory relays
  - j. Return 0.2 second of on-hook supervision; open circuit presented to the supervisory relays
  - k. Return 0.3 second of off-hook supervision; operate current is applied to the supervisory relays
  - l. Return continuous on-hook supervision and provide an audible signal. Audible signal may be “tick-stock” at 120 IPM, interrupted dial tone, test progress tone, or high tone.
5. Send tone signals to the originating office as follows:
- a. Send audible ringing tone for 0.3-second intervals interrupted for 0.2 second as an indication that the trunk-circuit-tripping features operated falsely on the pretripping test
  - b. The incoming trunk circuit returns the regular audible ring to indicate a tripping failure occurred.

A nonsynchronous test line provides an operational test that is not as complete as the synchronous test but can be performed more rapidly [see Part (A) of Figure 8-1]. The nonsynchronous test is the only type required for electromechanical offices where marginal-type tests cannot be applied directly to the incoming trunk circuit, as is frequently the case with step-by-step systems. However, test terminations provided for application of marginal-type tests to circuits (such as connectors in step-by-step offices) generally meet the minimum requirements for nonsynchronous incoming trunk-test lines and are frequently used for this purpose. In some instances, connector test terminations can be used to apply marginal tests to such circuits as toll transmission selectors. The minimum requirements for a nonsynchronous test line are as follows:

1. Starts to function under control of ringing signal
2. Permits audible ringing signal to be returned for a minimum of 0.5 second to originating office
3. Causes ringing to trip
4. After ringing is tripped, returns the 60-IPM line-busy signal that consists of alternate 0.5-second off- and on-hook signals with low tone applied during each off-hook period until disconnection.

The nonsynchronous test line, used in many step-by-step offices for application of marginal tests to connector circuits, operates as follows:

1. Starts to function under control of the ringing signal
-



2. Permits audible ringing signal to be returned for 1 to 1.5 seconds
3. Returns an initial off-hook signal of 1- to 1.5-second duration, during which time ringing is tripped
4. Provides the following supervisory signals sequentially after the initial off-hook tests are applied:
  - a. 0.5 second on-hook
  - b. 1 to 1.5 seconds off-hook
  - c. 0.2 second on-hook
  - d. 0.3 second off-hook
  - e. 0.2 second on-hook
  - f. 0.3 second off-hook
  - g. 0.2 second on-hook
  - h. 0.3 second off-hook
  - i. 2-second on-hook period to permit disconnection from the test line
  - j. Alternate 5.5-second off-hook and 2-second on-hook intervals are repeated until disconnection takes place. The first two 5.5-second intervals are provided to facilitate testing of the ring-forward (re-ring) and control features provided on some operator-selected trunks to end offices and are desirable where these features are provided.

### **8.2.6 CAROT System**

The CAROT system performs end-to-end routine or demand transmission and operational tests on trunks within a defined geographical area. The system consists of a minicomputer-based CAROT controller that performs mechanized administrative and control functions and an ROTL in most central offices. The system seizes and places test calls over specified outgoing trunks. Test calls received on incoming trunks are terminated to 105 type test lines and/or responders. In more recent designs, the ROTL, test lines, and responder-equipment functions can be combined in a single circuit. Similarly, the test line and responder functions can be combined into single circuits that do not contain an ROTL function. Without the ROTL function, 1-way outgoing trunks cannot be accessed for testing via the CAROT system. Figure 8-6 shows a functional diagram of the CAROT system.

---



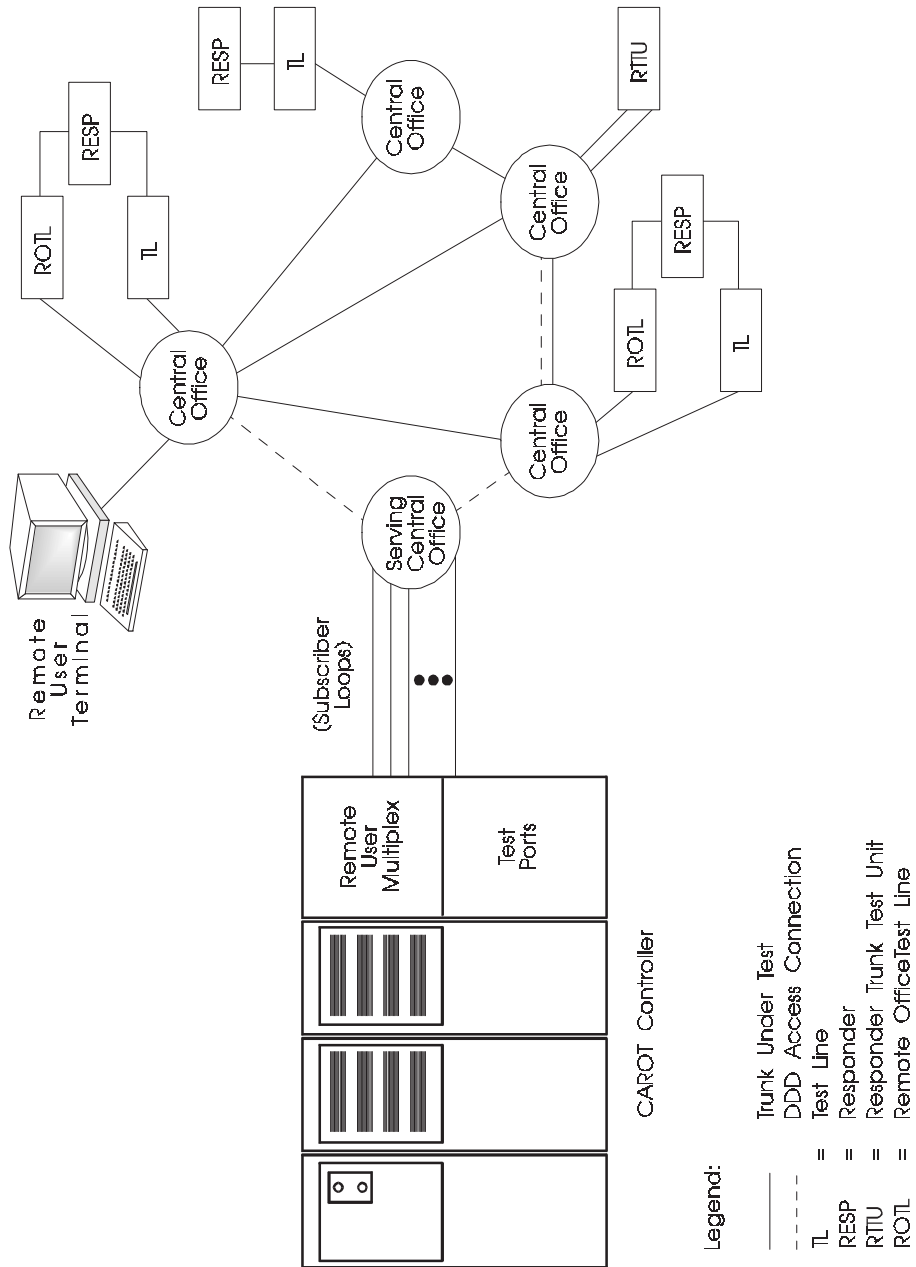


Figure 8-6. The CAROT System

The CAROT controller has the capability of

- Causing seizure of trunks by the ROTL
- Causing test equipment (for example, responder and test lines) to be connected to each end of the trunks seized
- Causing the test equipment to perform measurements on trunks
- Receiving and storing results of measurements
- Analyzing test results and comparing with test limits contained in the database
- Reporting trouble indications and compiling statistics on test schedule and trunk performance.

The ROTLs provide the means for remote access of trunks over the network. Access is provided to all outgoing and 2-way trunks in an office, with the exception of operator trunks. Access is provided to idle trunks and, if desired for a particular test call, to maintenance-busied trunks in SPC offices.

The ROTLs associated with SPC switches and other specially equipped ROTLs can control the maintenance state of trunks under the direction of a ROTL control unit at a manual-test position. Idle trunks may be made maintenance-busy, and maintenance-busied trunks may be restored to service. A verification of the completion of either action is returned to the test positions.

Remote manual access to and testing from an ROTL are provided by means of an interrogator or a responder/ROTL control unit at a test position. This allows communications technicians to conduct the same transmission tests that are conducted on an automatic basis, that is, calls to 100-, 102-, and 105-type test lines on a demand basis.

Conventional ROTLs (including expanded ROTLs and small ROTLs) have functions separate from test lines and responders. Mini-ROTLs are single-microprocessor units that incorporate the functions of the conventional ROTL, 105-type test line, and 52A responder. Mini-responders are microprocessor-controlled units that incorporate the functions of the 105-type test line and 52A responder. The CAROT system conducts routine automatic testing by commanding a near-end ROTL to access a far-end test line over the trunk to be tested. For transmission testing, 100-, 102-, and 105-type test lines are called; for operational testing from electromechanical ROTLs, 103, synchronous, and nonsynchronous types are used.

The basic sequence of operation of the CAROT system can be illustrated with the case of the conventional ROTL. The CAROT controller has access to an ROTL via switched dial-up connections. Under the direction of the CAROT controller, a ROTL seizes a particular trunk and sets up a test call to a test line with a given directory number. When the far-end connection is set up, the ROTL seizes the near-end responder. The controller then commands the ROTL responder and far-end responder to perform tests. Test signals are

---

---

exchanged and measured, and the results are reported to the controller. The ROTL is then commanded to release the trunk and responder.

The three basic CAROT end office test-equipment arrangements shown in Figure 8-6 are illustrated in more functional detail in Figure 8-7. Central office A is equipped with a conventional ROTL with separate responder and 105-type test line (an arrangement that can be used with most types of switching systems). When central office A is used as a near end, the CAROT controller dials up the ROTL, which connects to the responder through the access circuit. The ROTL then connects the responder with the outgoing trunk to be tested, and measurements are made. When central office A is used as a far end, the 105-type test line is dialed up on an incoming trunk by the originating (distant) end. The 105-type test line can be parked on until it gains access to the responder. The responder is then connected to the incoming trunk and testing begins under the direction of the originating end. The responder is the only equipment common to both near- and far-end testing functions.

Central office B, equipped with a mini-ROTL, is also capable of both near- and far-end CAROT testing. In this case, the mini-ROTL performs the combined functions of the conventional ROTL, 105-type test line, and responder, except for performing the terminal-balance measurement. Mini-ROTLs are typically used in end offices and are equipped to provide a termination enabling balance measurements to be made from other end offices.

Central office C is equipped with a combined 105-type test line/responder (mini-responder). Since there is no ROTL, central office C can only function as a far-end test termination. Central offices that contain test lines separate from the responder also can fulfill only the far-end function.

CAROT is the primary resource currently in use for switched message trunk maintenance. In addition to the analog trunk testing functions, CAROT also provides a record of trunk orders due and past due. Trunk orders are tested prior to turn up and, if all tests pass, are placed in the routine testing database.

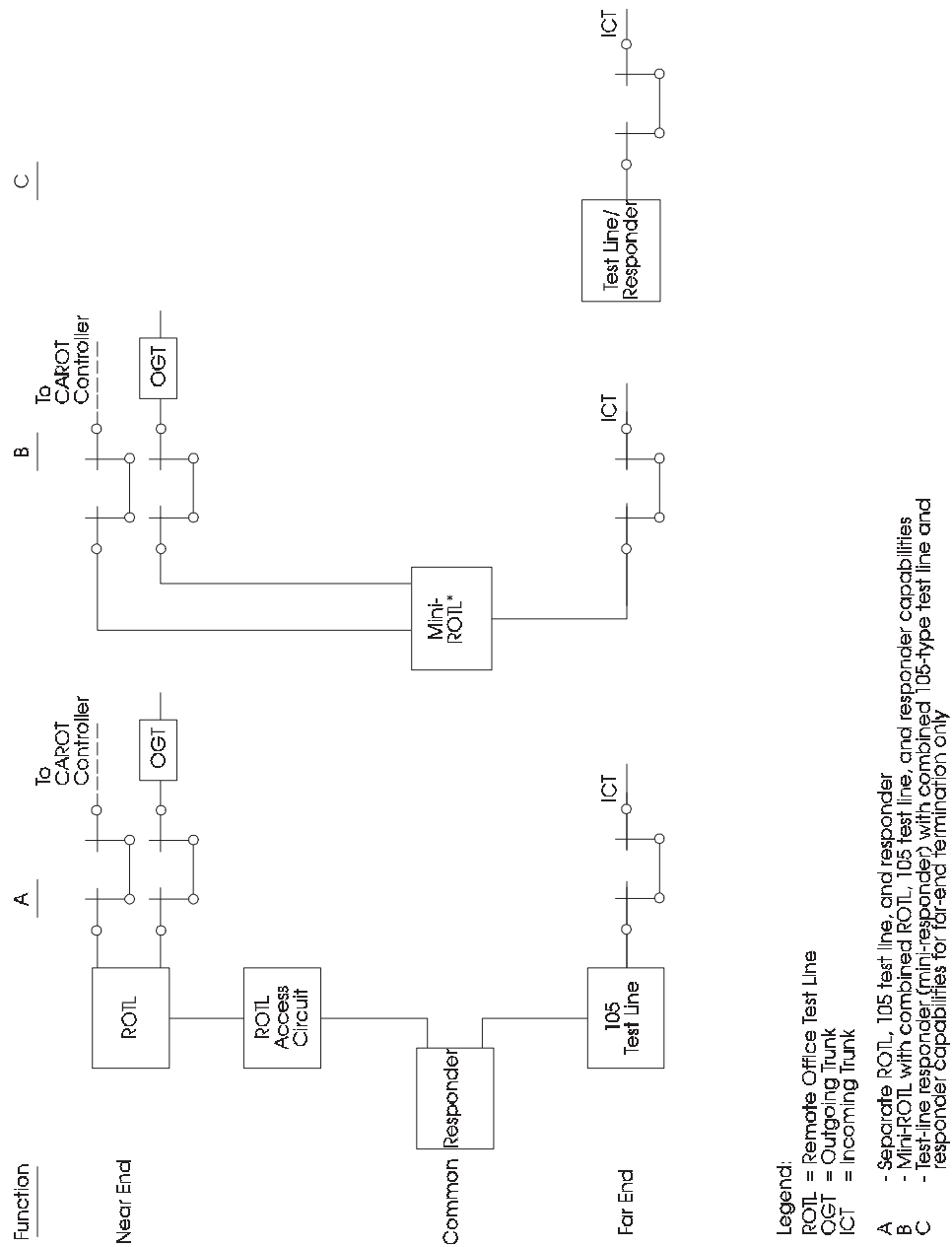
CAROT has two databases. One provides the routine testing information required to schedule and test all of the trunks for a specified area. This routine testing database has a capacity of about 100,000 trunks. The other CAROT database is the Circuit Order Test and Completion (COTC) database. The COTC provides the means to pre-test circuit orders and also provides reports on circuit order activity.

The CAROT databases are maintained either by manual input from the TIRKS system or through direct input via a CAROT/TIRKS interface.

CAROT is a mature system, dating from the mid-seventies. It has served as the primary analog trunk testing system for the LECs since deployment.

The disposition of CAROT as an active testing operations system in a fully digital network environment is the LECs' long-term focal point.

---



**Figure 8-7.** Near-End, Far-End, and Common CAROT Testing Functions of Equipment within an End Office for Three Types of Test Equipment

### 8.3 Common Channel Signaling

For maintenance purposes, it is important to understand the differences in circuit-associated signaling (per-trunk signaling) and Common Channel Signaling (CCS).

- With circuit-associated signaling, all signaling information is carried on the same facility as the voice path. Since voice and signaling share the same path, it is necessary to limit signaling to periods when no voice transmission occurs. In general, this limits signaling to the setup time before called-party answer. Circuit-associated signaling also dictates that multilink connections be established one link at a time. Each succeeding link must be established before signaling to the next office can begin. This increases the total call setup time.
- With CCS, the voice and signaling are carried on separate facilities over different routes:
  - The voice channels are dedicated for voice, voice-band data, and information-type signals only (tones, announcements, etc.)
  - The signaling channels are in a separate network from the voice channels and carry the control, address, and supervisory signals
  - The signaling network is common to many voice channels.

#### 8.3.1 CCS Maintenance Plan

The suggested maintenance philosophy of the CCS network is to ensure that service interruptions are minimal and that service is restored as quickly as possible.

Because of the redundancy in the network architecture and capacity engineering, the unavailability objective for the individual link is

A/C Link	$\frac{\text{unavailability}}{\text{(availability)}}$	= 788.4 min/yr
		= 99.850%
B/D Link	$\frac{\text{unavailability}}{\text{(availability)}}$	= 1103.8 min/yr
		= 99.789%

Figure 8-8 shows this redundancy and capacity engineering in the national signaling network. Figures 8-9 through 8-15 depict the various types on CCS links. CCS maintenance can be divided into three processes:

- Node maintenance
- Signaling link maintenance
- Network maintenance.

### 8.3.2 Node Maintenance

CCS node maintenance is designed to detect hardware or software problems and quickly repair them.

As soon as trouble is verified, the CCS node must take steps to reconfigure to ensure a working CCS network. Appropriate alarms, status indications, and output messages alert maintenance personnel and identify the location and the nature of the trouble.

The node-maintenance strategy includes five tests:

- Continuous, automatic tests
- Per-operation or per-message automatic tests
- Periodic, automatic tests
- Semiautomatic tests
- Manual routine tests.

### 8.3.3 Signaling Link Maintenance

A signaling link is composed of a transmission link and two signaling-link terminals.

The SS7 protocol allows the CCS network elements, such as the Signaling Transfer Point (STP), Service Switching Point (SSP), or Service Control Point (SCP), to perform link monitoring, automatic link turndown, and trouble sectionalization. There are four trouble detection routines:

- Signaling unit error-rate monitor
- Acknowledgment time-out indicator
- Unexpected backward sequence number received
- Unexpected forward indicator bits.

### 8.3.4 CCS Interface

The CCS node should be able to provide either of the following physical-level interfaces:

- CCITT Recommendation V.35 describes a 34-pin connector that connects the terminal equipment to the transmission link. The transmission link provides Data Service Unit (DSU), Channel Service Unit (CSU), and Office Channel Unit (OCU) functions.
  - The DS0A interface is a 4-wire interface that connects the signaling terminal equipment to the transmission link. The signaling terminal equipment provides the necessary DSU, CSU, and OCU functions.
-

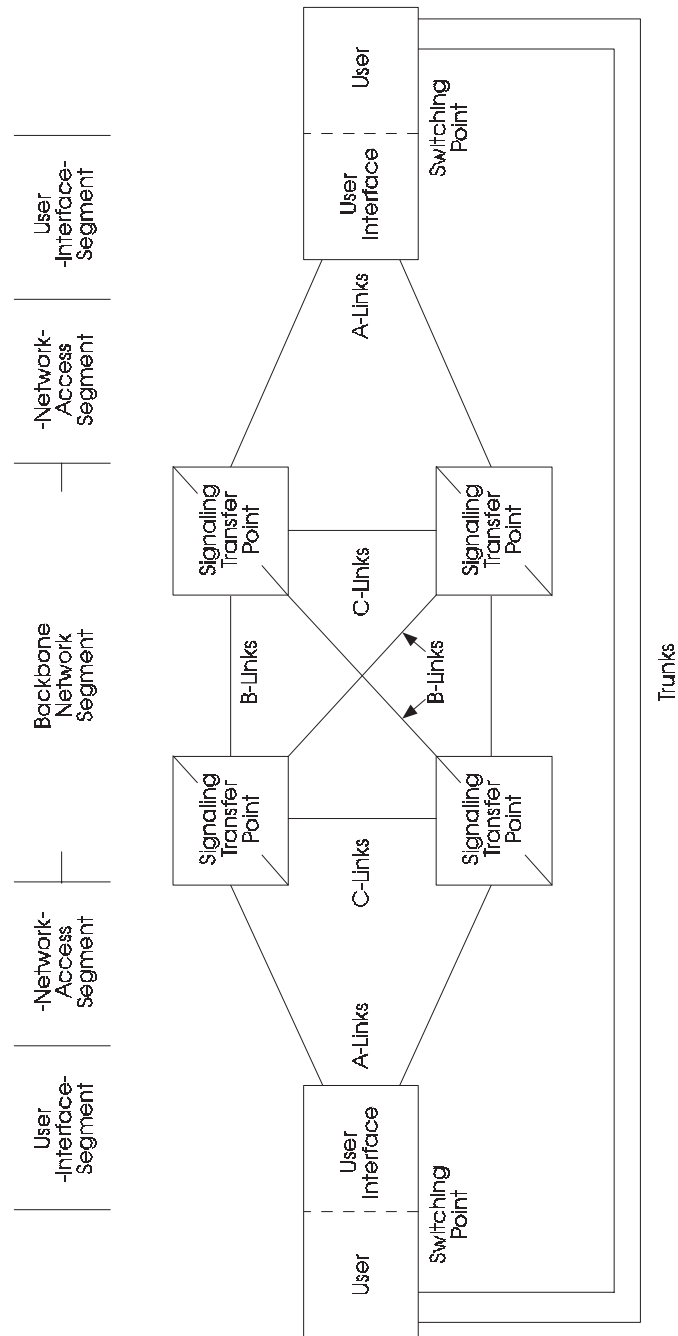
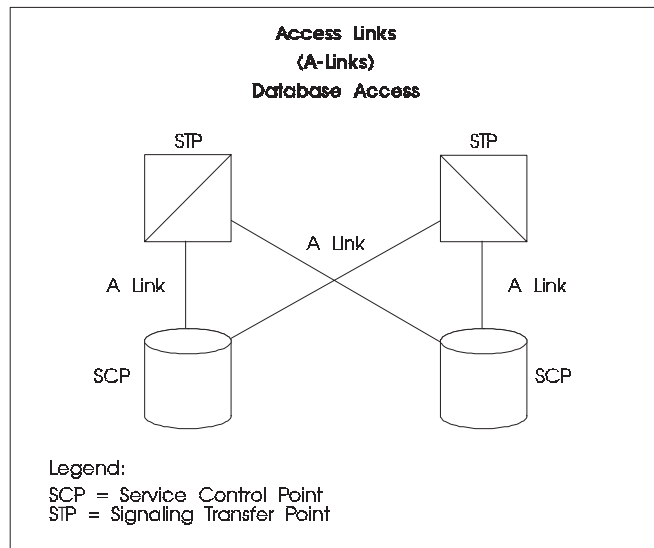
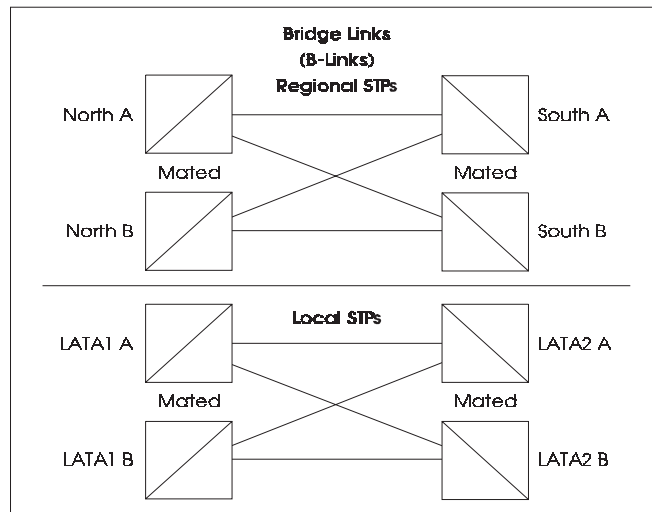


Figure 8-8. National Signaling Network



Note: Links that connect SCPs to STPs are also called access links.

**Figure 8-9.** Access Links — Database Access

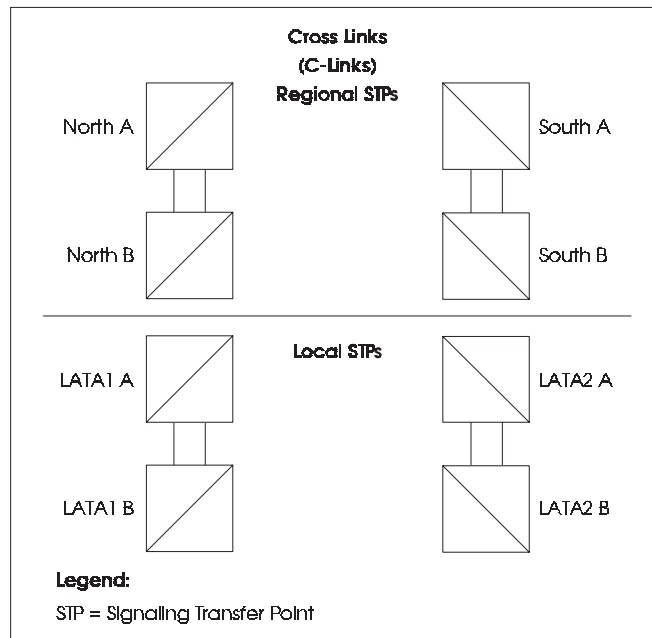


Note: Links that connect mated STPs to other mated STPs at the same hierarchical level (LSTP to LSTP or RSTP to RSTP) are called bridge links.

Bridge links are deployed in a quad arrangement for 3-way path diversity. Each B-link set can have a maximum of 8 links for implementations using a 5-bit Signalling Line Selection (SLS) code, or 16 links for implementations using an 8-bit SLS code.

**Figure 8-10.** Bridge Links

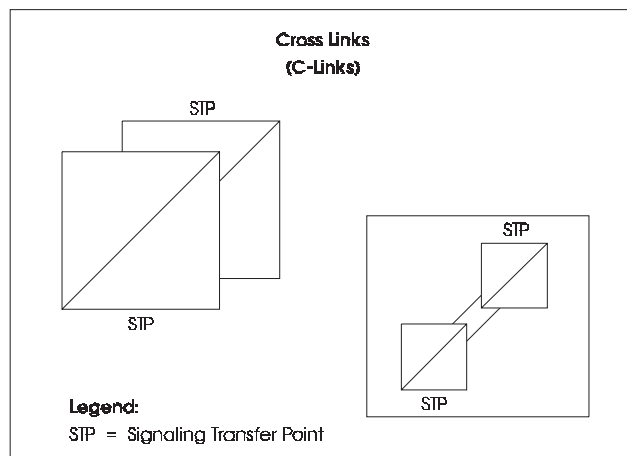




Note: Links that connect-mated STPs together are called cross links.

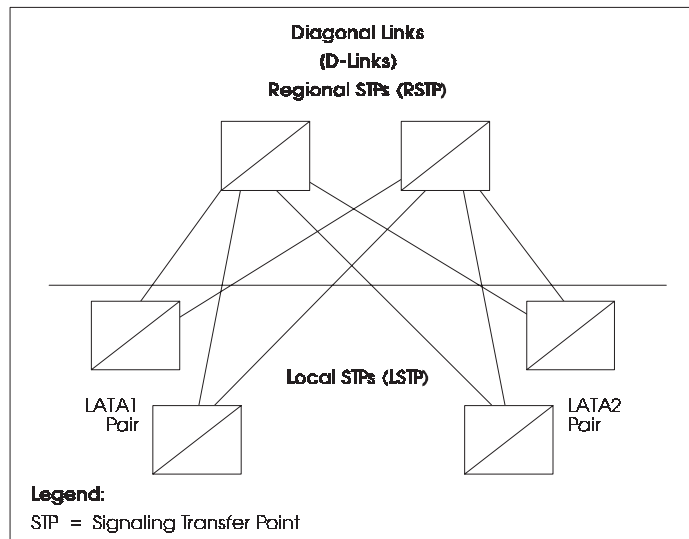
Cross links are deployed for additional path diversity and for passing network-management messages between mated STPs. C-link sizing is dependent on A-link deployment. There can be up to 16 links in a single link set.

**Figure 8-11.** Cross Links — Regional STPs



Note: This symbol refers to mated STP pairs that are separated geographically for reliability. Cross links are not shown, but are implied.

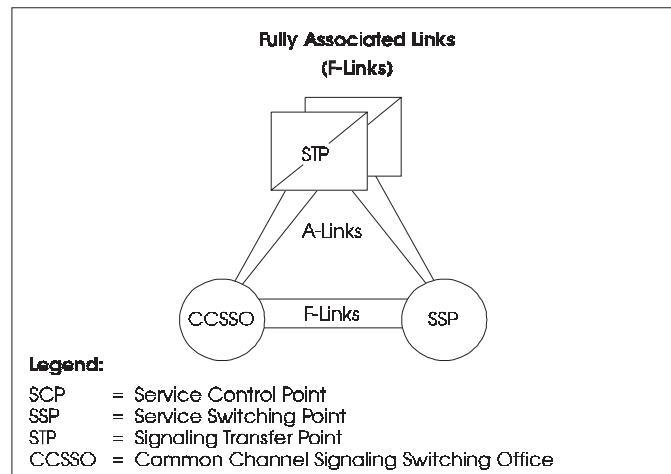
**Figure 8-12.** Cross Links



Note: Links that connect STPs of different hierarchical levels (LSTPs to RSTPs) are called diagonal links.

Diagonal links are deployed in a quad arrangement for three-way path diversity. The link set is sized at a maximum of eight links.

**Figure 8-13.** Diagonal Links

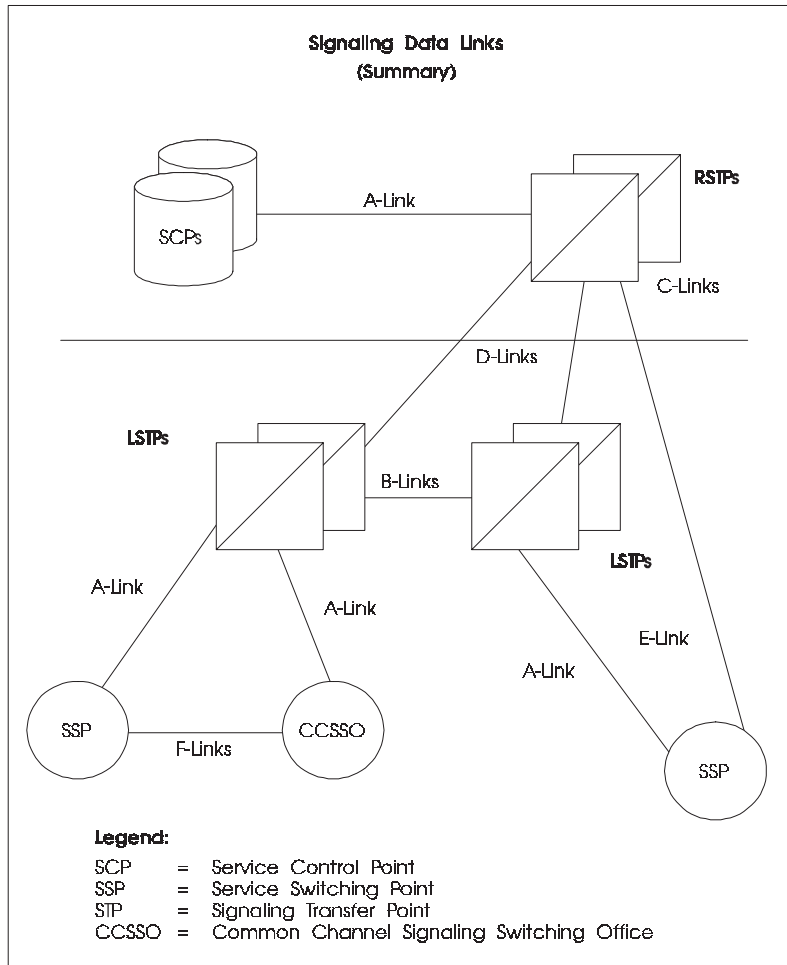


Note: Links that connect CCSSOs and/or SSPs directly together (that is, not via STPs) are called fully associated links.

These links could be deployed in a community of interest where no STPs would be available for trunk signaling CLASS services. The maximum link-set size is 16.

**Figure 8-14.** Fully Associated Links

Summary



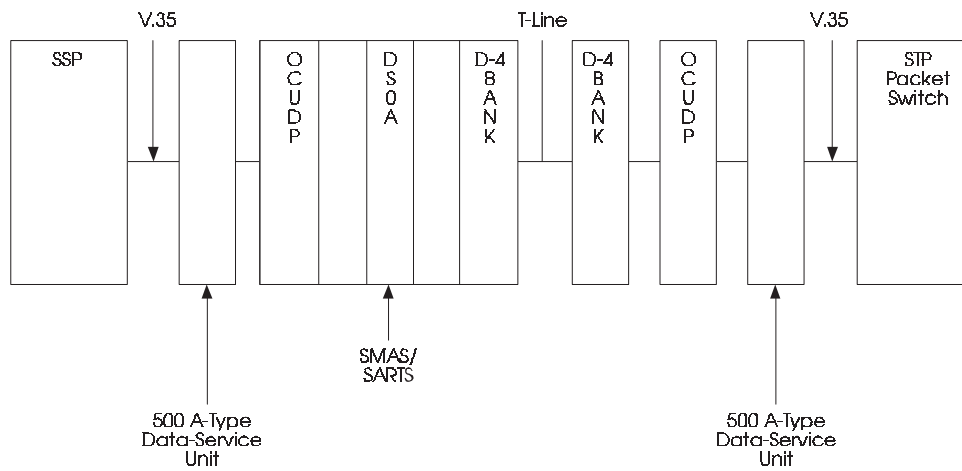
Note: The above visual depicts a two-level CCS network architecture that includes a summary of possible link deployment. Extended links (E-Links) are utilized to interconnect an SSP to a non-mated pair of STPs.

**Figure 8-15.** Signaling Data Links Summary

### 8.3.5 Present Link Testing Strategy

There are various strategies for link testing.

- Figure 8-16 shows CCS test access via Switched Maintenance Access System/ Switched Access Remote Test Systems (SMAS/SARTS) (a typical A-Link 56-kbps circuit). This is the present link-testing strategy. The figure shows the SMAS/SARTS with wired-in-access for loopback testing.
- Figure 8-17 shows digital test access via the Digital Cross-Connect System (DCS). This is also a present strategy.
- Figure 8-18 shows the DS0A link testing arrangement which provides an opportunity for in-depth maintenance testing of the links used in the CCS network. A series of data port-type channel units (DS0-DP) connects the CCS network elements. At the SSP, the V.35 interface is used.

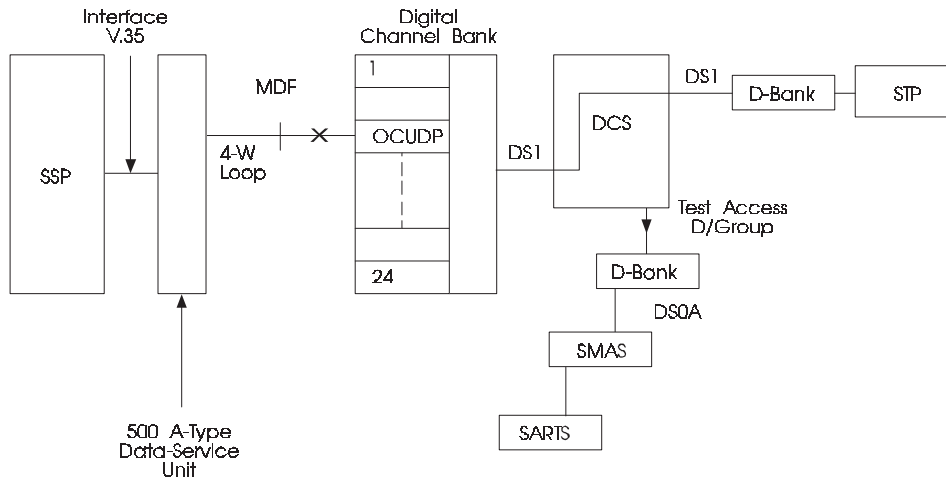


**Legend:**

DS0A = Digital Signal Zero  
 OCUDP = Office Channel Unit Data Port  
 SARTS\* = Switched Access Remote Test Systems  
 SMAS\* = Switched Maintenance Access System  
 SSP = Service Switching Point  
 STP = Signaling Transfer Point

\* AT&T-manufactured systems used to access and test special service circuits from a remote location

**Figure 8-16.** CCS Test Access via SMAS/SARTS

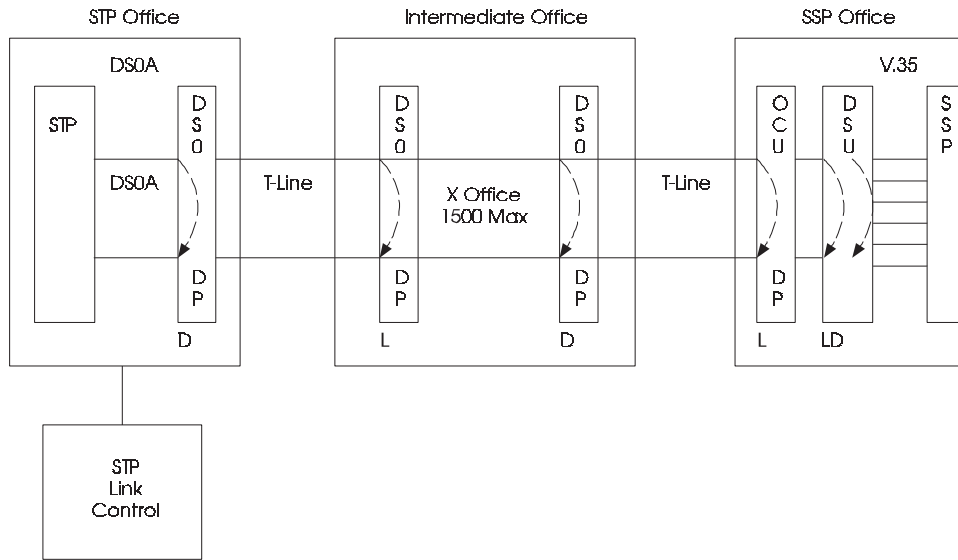


**Legend:**

- DCS = Digital Cross-Connect System
- DS0A = Digital Signal Zero
- MDF = Main Distributing Frame
- OCUDP = Office Channel Unit Data Port
- SARTS\* = Switched Access Remote Test Systems
- SMAS\* = Switched Maintenance Access System
- SSP = Service Switching Point
- STP = Signaling Transfer Point

\* AT&T-manufactured systems used to access and test special service circuits from a remote location

**Figure 8-17.** Test Access via Digital Cross-Connect System



**Legend:**

- DS0A = Digital Signal Zero
- DSU = Data Service Unit
- OCU = Office Channel Unit
- SSP = Service Switching Point
- STP = Signaling Transfer Point
  
- L = Line Loopback
- D = Drop Loopback

**Figure 8-18.** DS0A Testing Arrangement

### 8.3.6 Link Circuit Parameters

Test requirements for provisioning and maintenance of the A and B digital link circuits include link circuits using data port and 500-type data service units. Table 8-2 lists the test requirements.

**Table 8-2.** Test Requirements for A and B Digital Link Circuits

A Link	Channel Loopback	0 Error 10 Min.
B Link	Straightaway End-to-End	0 Error 10 Min.

Circuits using data port with data service units require channel loopback or end-to-end tests using standard equipment (e.g., a KS-20909 transmitter and KS-20908 receiver or equivalent). The requirement is for 0 errors in 10 minutes.

### 8.3.7 Data Service Unit Test

Tests performed from the V.35 interface of the DSU at one end of the link and the test DSU at the other end should be within the values Table 8-3 lists.

**Table 8-3.** Data Service Unit Test

A Link	Local test (LL)	0 error 10 min
B Link	DSU functional test	0 Error 10 min
C Link	Straightaway digital test	Maximum 3 bit errors in 15 min in both directions
D Link	Loopback to distant end	Maximum 6 bit errors in 15 min

### 8.3.8 Network Maintenance

Failures and overloads in the CCS network are detected by the software or through the receipt of Signaling System 7 (SS7) messages.

The following real-time network problems are reported to the local and remote maintenance forces:

- Start (or end) of signaling link congestion
- Start (or end) of signaling link overflow
- Near-end manual changeover or changeback
- Signaling link declared failure
- Far-end processor outage
- Node isolation.

### 8.3.9 Link Maintenance Flow

The flowchart in Figure 8-19 shows the usual sequence of maintenance activities that occur in the event of link failure.

## 8.4 Switch Diagnostics

SPC switching systems are designed to conduct routine automatic operational tests and to analyze trunk faults. In addition, per-call tests are made. Application of these programs can result in error messages indicating possible trunk troubles. In certain cases, the switching system will automatically take equipment out of service.

Automatic progression testing is the primary mode of routine testing. Under program control, the diagnostic is performed on trunks and other equipment with trunk-network appearances. Depending on the type of trunk and its operational record, various standard tests are initiated. Trunks are not necessarily tested daily.

An automatic continuity and polarity test is run daily or on a scheduled basis for each outgoing trunk. This test is to check that the correct voltages appear on the tip and ring of the trunk. The test does not require placing a call to a distant office.

Trunks that fail either routine tests or per-call tests are placed on a trunk-maintenance list for further testing and analysis. Trunks that do not pass tests at this point may be removed from service, depending on the number of trunks already out of service.

---



The results of tests conducted by the switch are transmitted to the appropriate work center, that is, SCC or TOSC. The work center may then undertake more thorough tests of the trunk.

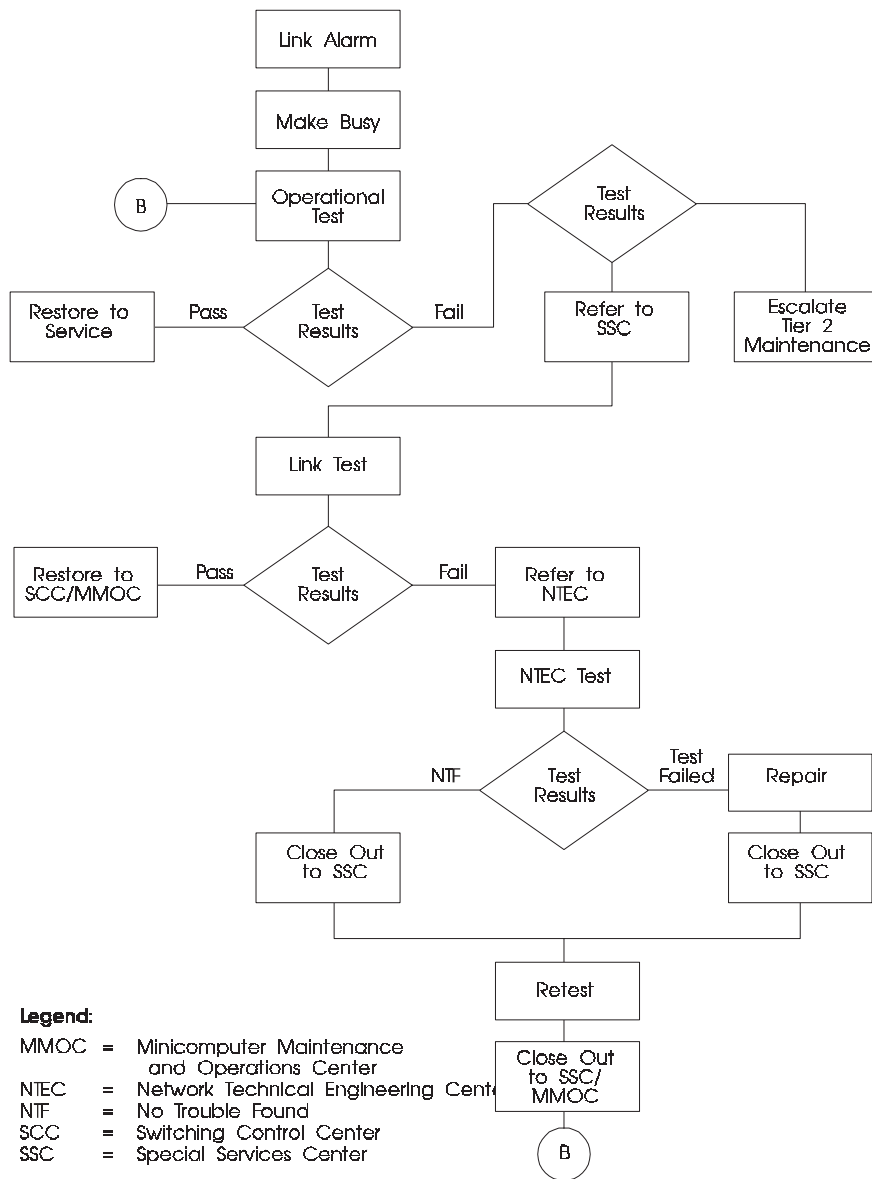


Figure 8-19. Example of Link Maintenance Flow

In exchange offices with electromechanical switching systems, similar testing functions may be performed by the machine under the control of a paper-tape reader. Test results are punched out on cards at the central office by the switch. In electromechanical offices equipped with an automatic trunk-analysis system, test results are transmitted to a central data processor. The central processor performs analysis, generates trouble reports, and gives summaries of central office activity. This information is transmitted over data links to workstations at SCCs.

In offices with electromechanical switching systems equipped with an expanded ROTL or mini-ROTL, automatic operational tests can be conducted under control of the CAROT system if the appropriate optional equipment is installed. These advanced operational trunk tests provide all the operational testing capabilities that are provided by automatic progression tests, except for certain types of trunks in end offices and in Common-Control Switching Arrangement (CCSA) offices.

#### **8.4.1 Digital Systems**

Digital switching systems are capable of analyzing and reporting slips, Bipolar Violations (BPVs), and OOF conditions as an aid to network maintenance. These methods are dependable where the facility is entirely at the same bit rate as the interface to the switching machine. Where any part of the facility is multiplexed to another bit rate or is provided with automatic protection switching, the facility cannot be effectively monitored for BPVs because they are removed by the multiplexers and automatic protection switches.

The digital switch provides surveillance and performance-monitoring capabilities not available in the analog switching world.

Administrative procedures associated with switch maintenance must include an analysis of the parameters that may indicate network degradation. Each digital switch manufacturer provides a specific set of network performance-monitoring or surveillance capabilities. These capabilities have several basic functions in common:

- To indicate the failure of an interfacing T1 system by reporting a CGA. The CGA is activated when a preset parameter for Bit Error Ratio (BER) is exceeded. The BER is derived by the switch from the count of BPVs received on the incoming Digital Signal level 1 (DS1) (1.544 Mbps) bit stream.
  - To automatically remove from service the trunks associated with a T1 system with a reported CGA and to return those trunks to service when the BER reaches a preset acceptable parameter.
  - To provide a report of timing errors on the interfacing digital network by counting the number of slips received in a 24-hour period and reporting when that count exceeds the set parameters.
-

- To provide a report when the switch is unable to maintain frame alignment with the incoming bit stream (OOF) and unable to reframe for a specific period of time.

### 8.4.2 Digital Switch Alarms

Table 8-4 lists the various types of digital switch alarms and related data.

**Table 8-4.** Digital Switch Alarms

Parameter	Threshold	Time Window	Alarm
Loss of Signal	Red Condition	2.5 seconds	Major (CGA)
BER <sup>a</sup>	10 <sup>-6</sup> (Low)	Few minutes to 1 hour	Minor
	10 <sup>-3</sup> (High)	Few seconds	Major (CGA)
OOF Count	17 (Low)	24 h	Minor
	511 (High)	24 h	Major
Slip Count	4 (Low)	24 h	Minor
	255 (High)	24 h	Major

- a. It is important to be aware that the BER parameter is based on a count of BPVs received at the switch. As discussed elsewhere in this document, multiplexing on the network removes the BPVs, thus negating the switch's capability to detect a trouble via this parameter.

### 8.4.3 Network Synchronization

Digital network synchronization is a vital resource for the switched trunking network. Digital network maintenance should begin with a properly synchronized network. The proliferation of digital PBXs and the different varieties of switch manufacturers in the network have highlighted this important requirement. Synchronization problems will cause slips on the network.

A *slip* is defined as the deletion or repetition of one frame of DS1 (1.544 Mbps) data (193 bits) due to frequency differences between the transmit and receive clocks of a transmission path. Some of the effects of slips on voice and data transmission are as follows:

- Audible clicks on the line for voice transmission. Clicking noise increases as the slip rate increases.

- Signal errors, loss of frame, and loss of data for voiceband data. Depending on the rate of slips and error correction capability of the transmission media, data may be required to be resent.
- Errors, loss of data, and an increase in throughput time due to resends.

The significance of network synchronization cannot be overemphasized and should be a primary concern in any network maintenance plan. Each LEC has a synchronization coordinator assigned to investigate and resolve slip indications.

#### **8.4.4 Automatic Operational Trunk Testing**

Both the analog SPC switch and the digital switch have the capability to run programmed automatic operational tests on trunks. These tests are usually run at night and perform continuity and signaling tests. Trunks that fail are taken out of service and reported on a Trunk Out-of-Service list for maintenance.

#### **8.4.5 Performance Monitoring**

Performance monitoring is the continuous collection and reporting of transmission performance information. Although performance monitoring has been in place to varying degrees for some time, the capabilities have changed significantly. Initial performance monitoring functions included monitoring simple framing and coding aspects. More recent systems have incorporated more advanced techniques as detailed in GR-820-CORE, *OTGR Section 5.1: Generic Transmission Surveillance*, for DS1 and DS3, or GR-253-CORE, *Synchronous Optical Network (SONET): Common Generic Criteria*, for SONET (or T1.231-1993 and its revision, T1.231-1997 for DS1, DS3, and SONET).

Performance information is derived from primitives detected in the monitored signal, e.g., a bipolar violation in a DS1 line signal or a CRC-6 code violation in a DS1 ESF signal. Such primitives are combined with others to develop performance parameters such as Errored Seconds (ES) and Severely Errored Seconds (SES). Some digital signals provide the capability to report received performance primitives to the far end, enabling the near end to develop a measure of performance received at the far end. Performance data is accumulated for periods of 15 minutes and one day, and sufficient periods are retained so that several hours or several days of data is available.

Threshold values can be set for most performance parameters, which will cause an alert to be generated when crossed.

Performance monitoring parameters are defined according to a layered arrangement to help sectionalize problems to a specific layer. For DS1, the layered entities are *line* and *path*.

A DS1 line provides digital transport at the nominal rate of 1.544 Mbps. A DS1 line is a metallic transmission medium that employs Alternate Mark Inversion (AMI) or bipolar 8-

---

---

zero substitution (B8ZS) coding, characteristics of which are used for performance monitoring at the line layer.

A DS1 path is a framed digital signal between two points at a nominal rate of 1.544 Mbps. The DS1 path representation is independent of the specific transmission equipment.

The DS1 path is characterized by its framing. DS1 paths exist in two general frame formats: the superframe format (SF) and the extended superframe format (ESF).

Similar layering is provided for DS3. SONET is more complex, with five layers, all with performance monitoring capabilities defined.

The basic performance parameters measured at each level are ES, SES, and Unavailable Seconds (UAS). Other parameters are defined for specific technologies and layers to help analyze or sectionalize an impairment.

#### **8.4.6 Transitional Strategies**

One strategy for switched message trunk maintenance is to migrate from the mode of maintenance that relies on routine testing of analog transmission parameters for voice-quality and carrier-system failures or customer reports for indications of data transmission quality to an integrated voice/data trunk maintenance mode. This integrated maintenance mode is based on performance monitoring of the digital bit stream and takes economic advantage of available technology to detect, sectionalize, and repair trunks that do not support voice or are degrading the digital bit stream to the point that data transmission is impaired.

Transitional strategies are needed to help ensure that the embedded analog portion of the switched message network, as well as the digital portion, continue to be maintained at a high quality for voice and data transmission throughout the transition to a fully digital network. During this period, operational deployments and administrative procedures will be migrating toward the long-term performance-monitoring-based maintenance mode.

##### **8.4.6.1 Switch Surveillance**

One potential transitional strategy is to integrate digital switch surveillance results into the overall trunk trouble-detection process and to concentrate surveillance efforts in SCCs serving digital central offices.

Slip, BPVs, and OOF reports would be analyzed and treated as primary indicators of digital trunk or facility problems. However, due to the function of multiplexers that effectively remove BPVs, the switch surveillance of BPVs is restricted to those violations that occur between the switch and the nearest multiplexer. The removal of BPVs by the multiplexer is due to a conversion to unipolar for transmission through the multiplexer and then back

---

---

to bipolar to continue on the DS1 or higher speed path. There are two points associated with this multiplexed scenario that are of strategic importance.

- Although the function of the multiplexer removes any BPVs, it does not correct the error. The result is that no error condition (BPV) is reported to the switch, but if there are BPVs present up to the multiplexer, then the digital message received is altered. This only affects voice traffic if the BPV rate is very high, but the effect on data transmission is obvious (message received not the same as message sent).
- The BER parameter in the digital switch activates the CGA at a preset low of  $10^{-3}$ . The CGA will remove the affected trunks from service. The BER is derived in the switch from a count of the BPVs received. Thus, if there are BPVs that are degrading a digital path but pass through a multiplexer prior to termination at the switch, the switch's capability to detect the problem and to remove the trouble trunks from service is negated.

With these points in mind, an analysis of switch surveillance parameters can and should be used in the overall trunk trouble-detection process. Programs can be written in No. 2 Switching Control Center System (No. 2SCCS) to filter and report these exceeded parameters to the work group responsible for repair.

#### 8.4.6.2 CAROT

During the transitional period, CAROT should continue to test all interoffice message trunks for circuit-order turnup and routine scheduled transmission testing. It would be advisable to identify the digital trunks in the CAROT database to ensure that the C-notched noise parameter is applied and used in trouble analysis as well as to provide an inventory of digital trunks that will prove useful throughout the transition to the long-term performance mode of operation.

#### 8.4.6.3 Miscellaneous Arrangements

Primary testboard positions are used to terminate certain types of cable pairs. The primary jacks, usually of the four-jack-per-circuit type, permit ready access to line conductors to facilitate testing them and determining the type and location of any existing trouble. These jacks also permit patching toll terminating equipment. The test equipment consists of test and talk cords, a test battery, a voltmeter, and a Wheatstone bridge.

Secondary testboard positions are used for monitoring, talking, and signaling on circuits as desired and for patching or making operational tests on drop circuits and ringer equipment. The facilities consist of test multiples with or without patching-jack bays. The test multiple is usually a single appearance of two jacks per trunk. One jack is a multiple of the switch appearance (and/or multiple of the switchboard) that permits overall testing, including monitoring and tests toward the line of carrier facilities. The other jack is provided to make

the trunk test busy to the near-end switching system. (It still may be accessed from the distant end of a 2-way circuit.)

Current arrangements for SPC and digital switches provide the capabilities on a *dialed-up* basis using test connector switches or the switching machine itself to provide maintenance access to the trunks.

Other miscellaneous arrangements include

- Testing jacks — used with electromechanical signaling equipment, carrier terminal equipment, etc.
- Pulsing test sets — used for pulsing over circuits
- Transmission test equipment — designed to be portable
- Carrier alarm facilities — designed to release all connections to a faulty facility, make carrier channels busy, and provide alarms as an aid to trunk maintenance
- Personal computer/workstation-based Bit Error Ratio Testing (BERT) on randomly selected switched message trunks.

## 8.5 Switching System Maintenance

Switching system maintenance involves surveillance, control, analysis, and repair of equipment to ensure a high quality of service.

Switching system maintenance includes

- Preventive maintenance — scheduled routine testing of switching equipment
- Corrective maintenance — the detection, verification, sectionalization, and repair of switching troubles.

In switching maintenance, centralization is the key concept. Centralization advantages are maximized by switching machines that have the ability to send their alarms to centralized maintenance centers and support systems.

Centralization allows central offices to be unstaffed for certain periods and concentrates expertise in a single location. Several centers and operations systems have been developed for centralized switch maintenance and are discussed briefly here.

### 8.5.1 Switching Control Center

The SCC is the focal point of switching system maintenance. Each SCC oversees the maintenance of a group of central offices. Employees in the SCCs are usually organized into work positions such as surveillance, analysis, force management, administration, and trunk maintenance.

---

SPC-SCCs receive diagnostic printouts at the time of fault detection and, periodically, the results of automated checks for hardware and software errors. The printouts provide an indication of the overall health of the system.

When an alarm is received at the SCC, immediate action is taken to protect service. If the problem is not easily solved, it is given to an analyst for in-depth analysis. Once the cause of the trouble has been pinpointed, the analyst may correct the problem from the SCC. If hands-on work is required at a central office, the work is scheduled and assigned to a specific craftsperson who may be dispatched to the office. The progress of the job is tracked and the completion noted.

### **8.5.2 Electronic Systems Assistance Center**

Complex switching troubles requiring assistance may be escalated to the Electronic Systems Assistance Center (ESAC), a LEC-wide center for support of all electronic switches.

### **8.5.3 SCC Operations Systems**

Different companies use various operations systems, such as the following:

- No. 2SCCS — The No. 2SCCS supports SPC-SCCs by providing remote alarms and logging and analysis of trouble indicators. It permits remote control of the switch from the SCC.
  - Centralized Automatic Trouble Locating and Analysis System (CATLAS) — CATLAS assists personnel at SPC-SCCs by providing a list of suspected faulty components based on a comparison of input data from the switch and all known failure data for AT&T equipment.
  - Customer Services Computer Access Network Standards (CSCANS) — CSCANS provides access to up-to-date changes in software for various switching systems and distributes the changes to the central office through the No. 2SCCS. CSCANS interfaces with vendor systems such as AT&T's Software Change Administration and Notification System (SCANS), Northern Telecom's Customer Service Computer Access Network (C-SCANS), and Siemens Stromberg-Carlson's Siemens Customer Access Network (SIESCAN).
  - WFA— WFA is a Bellcore-developed system designed to price, load, and track all control center and dispatched work activities.
  - NMA— The NMA system is a Bellcore product designed to monitor switching and transport networks, including receiving and analyzing messages from network elements.
-



## 8.6 Memory Administration

Memory administration in a central office refers to the adding, altering, deleting, and querying of data stored in the switching system database. Data contained in a switching system needs to carry out operations functions that are essential for providing services and maintaining the quality of those services. Thus, memory administration is vital to provisioning and maintenance as well as system administration functions necessary to support these areas. For more detail see FR-472, *OTGR Section 2: Network Element (NE) Memory Administration*.

In general, memory administration functions are driven by three types of activity:

- Provisioning
- System Administration
- Memory Backup and Restoration.

### 8.6.1 Provisioning-Driven Memory Administration (PDMA)

Service demands for network changes may originate from customers or trunk, facility, or other work orders requesting additions, deletions, or changes in switching system data. Database changes that alter transmission parameters, performance parameters, and rate and route parameters may also be categorized as provision-driven. Input commands that request software changes originating from these work orders have traditionally been known as Recent Change Messages.

### 8.6.2 System Administration

System administration functions include tasks performed to support various operations activities. These activities may include enforcement and management of security on Input/Output (I/O) messages, scheduling of administrative reports, and modification of site-dependent data contained in the switching system.

### 8.6.3 Memory Backup and Restoration

Memory backups provide the capability to recover from the loss of switching system data due to factors such as human error, software bugs, etc. The backup process requires that working data be copied into one or more non-volatile memories. In the memory restoration process, data is copied back into the working memory from the backup memory after data loss or data corruption has occurred. Because backup memory becomes increasingly outdated as each Recent Change Message or data update is input into the working memory, timely updates of backup memory are necessary to maintain integrity of the copy of backup

---

memory. Determination of when to update local backup memory is made after considering the number of changes that have occurred since the last update, the elapsed time since the last update, and other parameters.

## 8.7 Facility Maintenance

### 8.7.1 Facility Maintenance and Administration Center

An FMAC controls facility maintenance and administration within a LATA that has a sufficiently high density of carrier networks (metropolitan areas). The FMAC has control over all facility networks within the LATA, including T-carrier and fiber systems. The maintenance actions are categorized as either preventive or corrective.

Preventive maintenance responsibilities of the FMAC include scheduling all routine maintenance, performing all line routines for digital carrier facilities, and analyzing maintenance activity results to enhance carrier network performance. Corrective maintenance actions include detection and verification of facility troubles, outage notification to the appropriate center, sectionalization and repair of troubles, and repair verification.

### 8.7.2 Operations Support Systems

Various operations systems are in use by different companies to support facility maintenance. An example system that is widely used is Bellcore's NMA system.

The NMA system provides around-the-clock network surveillance, and end-to-end surveillance at the carrier's telecommunications network. The NMA system receives and analyzes messages from network elements to determine the causes of network outages.

## 8.8 Transport System Maintenance

Transport system maintenance is accomplished primarily on access and testing activities supplemented by surveillance functions. However, in the case of all-digital services such as Integrated Services Digital Network (ISDN) and Synchronous Optical Network (SONET), maintenance may rely primarily on surveillance capabilities with less reliance on access and testing.

Transport system maintenance includes the following:

- *Trouble Detection* — Troubles are detected through continuous monitoring, routing tests, per-call tests, or periodic tests.

- 
- *Service Recovery* — Recovery is accomplished through the use of redundant design, backup equipment, and spare facilities.
  - *Trouble Notification* — Notification to an Operations System (OS) allows personnel to initiate isolation and repair procedures.
  - *Trouble Verification* — The corrective maintenance activity that verifies if a reported trouble still exists.
  - *Trouble Isolation* — Sectionalizing the trouble occurs after trouble detection, verification, and service recovery have taken place.
  - *Repair* — The trouble has been isolated to a minimum number of replaceable elements. Additional manual verification normally occurs prior to repair.
  - *Repair Verification and Return to Service* — After verification that the trouble has been cleared, the repaired element is then returned to its normal operating state.

### 8.8.1 Integrated Services Digital Network Basic Access Maintenance

Maintenance of ISDN Basic Access lines is accomplished by performance monitoring and testing.

Portions of the access lines that are carried by DS1 or higher rate carrier systems are monitored for transmission quality. The Digital Subscriber Line (DSL) portion is monitored using features built into the digital line signal. Cyclic Redundancy Check (CRC) errors and Far End Block Errors (FEBE) use the Embedded Operations Channel (EOC) to compare to threshold values. Exceeding the threshold causes an alert to be sent to the OS.

Some access lines, such as those routed over existing carrier systems, and some situations, such as customer requests for on-site trouble sectionalization, may require testing. Testing needs are satisfied with loopback test capabilities and OS-based testing, switch-based testing, or portable test sets. Metallic tests of loop facilities are used to further isolate troubles caused by grounds, shorts, crosses, and opens.

The performance monitoring and testing schemes described above, along with a network termination self-test capability, provides the ability to determine if the trouble is likely to be in the network or in the customer provided equipment.

### 8.8.2 Public Packet Switched Network Maintenance

Public Packet Switched Network (PPSN) links connect a Packet Switch (PS) to an Access Concentrator (AC) or to another PS. Using high-speed access lines (up to 56 kbps), Data Terminal Equipment (DTE) and Signaling Terminal Equipment (STE) are connected to a PS. High speed access lines are also referred to as links. For maintenance purposes, PS links

consist of a transmission link with PS link termination equipment at each end (except for customer-provided high-speed access lines).

PPSN maintenance strategy includes:

- *Trouble Detection* — PPSN nodes detect hard troubles and marginal performance conditions on links through parameter measuring and threshold comparisons. Hard faults may be detected by the percentage of frames received in error, the percentage of frames retransmitted, and the number of times retransmission has exceeded the threshold. Marginal performance is determined using the same parameters in addition to the number of times a link has been removed and restored automatically without a hard fault detected.
- *Service Protection* — PPSN nodes, upon detecting a hard fault, automatically remove the link from service. Packets waiting for retransmission on the faulty link as well as any new packets are redirected to another active link.
- *Trouble Verification* — The PPSN system automatically verifies the trouble by attempting to reactivate the failed link.
- *Trouble Notification* — Link troubles are categorized by alarm levels depending on their severity. Critical alarms are used to indicate node isolation, major alarms indicate a link failure, and minor alarms generally indicate marginal troubles.
- *Trouble Isolation* — After a hard trouble has been verified on a link, the PPSN node runs diagnostics on the near-end link termination.

### 8.8.3 Synchronous Optical Network Maintenance

SONET standardizes the way information is transported in Network Elements (NEs) that use optical fiber. The standards addressed with deploying this transport include the following:

- Signal Rates and Formats
- Multiplexing Schemes
- NE Functions
- Synchronous Network Operation
- Single Mode Optical Interface.

SONET synchronous multiplexing refers to combining low speed digital signals (DS1, DS1C, CEPT E1,<sup>3</sup> DS2, and DS3) in a high speed format that allows easy extraction of the low speed components from the high speed line. SONET's major attribute is its ability to transport many different (asynchronous or synchronous) digital signals using a standard

---

3. CEPT is the European Conference of Post and Telecommunication.

---

Synchronous Transport Signal (STS) format. These digital signals (payload) are mapped into an STS through the use of Virtual Tributaries (VTs) and payload pointers. The pointers allow for flexible alignment of payload within the transport signal by indicating where the synchronous or asynchronous payload begins.

SONET maintenance strategy includes alarm surveillance, performance monitoring, testing, and use of control features described below.

- *Alarm Surveillance* — Deals with the detection and reporting of the following:
    - *Loss of Signal (LOS)* — All incoming SONET signals are monitored for the loss of physical layer signal (optical and electrical). The detection of LOS must be timely for fast restoration of transport payloads.
    - *Loss of Frame (LOF)* — LOF is detected when an Out-of-Frame (OOF) on the incoming signal persists for 3 ms.
    - *Loss of Pointer (LOP)* — SONET equipment enters an LOP state when a valid pointer cannot be obtained by using pre-determined pointer interpretation rules. The LOP state can also be created when a number of consecutive pointers with the New Data Flag (NDF) set to “1001,” but not indicating concatenation, is received. Under normal operation, the NDF would be set only once to indicate pointer value change. When set continuously in a concatenation indicator, consecutive NDFs would indicate pointer processor failure (for example, stuck bits).
    - *Equipment Failures* — This condition results in alarms if a failure condition is detected including, but not limited to, fuse or power circuit failures, synchronization equipment failure, CPU failure, local backup memory failure, receiver/transmitter failure, terminating equipment failure, etc. Alarms associated with equipment failures are categorized as critical, major, or minor, depending on their severity and impact on service.
    - *Trouble on the Automatic Protection Switching (APS) Channel* — Three failure conditions are monitored regarding the APS Channel:
      1. Protection Switching Byte Failure is detected by monitoring the incoming K1 byte.
      2. Channel Match Failure is detected by monitoring the channel number information in the incoming K2 byte (bits 1-4).
      3. APS Mode Mismatch is detected by monitoring the architecture and mode of operation indicators in the incoming K2 byte (bits 5-8).
    - *Failure of Embedded Operations Channel (EOC)* — An EOC failure is defined as either a failure of the Data Communications Channel (DCC) or a failure of the line carrying the EOC.
-

- 
- *Payload Label Mismatch* — If a received VT signal or a received STS does not equal either the locally provisioned value or the equipped non-specific code, it is considered mismatched.
  - *Unequipped* — An unequipped failure is declared if a received VT or STS contains all zeros in specific overhead bits (C2 byte for STS, bits 5, 6, and 7 of the V5 byte for VT). This indicates that the far-end terminal is not equipped to provide the STS or VT.
  - *Alarm Indication Signals (AIS)* — AIS is used in the digital network to alert downstream equipment that an upstream failure has been detected. SONET signal formats provide different AISs for various layers of functionality. Types of AIS indications include DS $n$  AIS, VT Path AIS, STS AIS, and Line AIS.
  - *RFI Failure* — A remote failure indication failure is declared when there is a significant period of continuous indication that the signal received at the far-end was defective, reported via the Remote Defect Indication (RDI). If the newer enhanced RDI is used, the failure can delineate between remote failures based on transmission defects (called the “server” type of RFI failure), remote failures based on unequipped or trace identifier mismatch (called the “connectivity” type of RFI failure), or remote failures based on payload label mismatch (called the “payload” type of RFI failure).
  - *Performance Monitoring (PM)* — Is required according to the level of functionality provided in the NE. SONET provides the capability to gather PM data based on overhead bits, such as Bit Interleaved Parity (BIP) bits, at the Section, Line, and Path layers. The principles of performance monitoring described in Section 8.4.6 apply to SONET as well as DS1 and DS3. SONET primitives measured include BIP, pointer justifications, and defects that contribute to the failures listed above. From these primitives, ES, SES, UAS, and several other parameters are developed for the Physical, Section, Line, STS-path, and VT-path layers.
  - *Testing Process* — Testing deals with the procedures that result in isolation of a failure to a replaceable or repairable unit. The tools used in a SONET environment to accomplish this, in addition to tools in the SONET signal format, are test access, diagnostics, and loopbacks. Testing activities include:
    - Analysis of alarms, PM data, and maintenance signals
    - Execution of diagnostics
    - Execution of controls, such as switching to protection
    - Activation of loopbacks
    - Access for testing signal measurements.

Each of these activities requires access through either a local interface or the remote operations interface.

---

- 
- *Control Features* — Control features are necessary to maintain the SONET NE. The NE should notify the surveillance OS when any control function is executed. Control features include:
    - *Reinitialize system* — A hard boot to reload the operating system. This may affect the state of memory of the NE as well as other resources.
    - *Restart system* — A soft boot that reloads an application onto the system. This should not affect nonvolatile memory or other resources.
    - *Restoration of a failed unit to service* — This involves temporary restorations when an entity has failed, such as rerouting a facility when a facility fails.
    - *Remove entity from service for test* — Traffic is switched off the entity for the entity to be tested.
    - *Inhibit/Allow alarmed and non-alarmed indicators* — This allows for suppression and restart of messages from the OS.
    - *Check equipment status/configuration* — Status and configuration of equipment should be retrievable.
    - *Protection switch capabilities* — The ability to simultaneously switch all affected signals from one multiplexer, optical unit, and/or channel to another.
    - *Manual switch from active to standby* — Used for any redundant hardware or software.
    - *Manual switch between synchronization sources* — The ability to switch between timing sources, both internal and external.

## 8.9 Loop Maintenance

Many of the trouble conditions occurring in the network (such as those affecting the switching systems or the interconnecting trunks and facilities) are detected by means of automatic alarm indicators or as a result of a routine testing operation.

Trouble conditions occurring in the customer's terminal equipment or on the loop facility connecting the customer's terminal equipment with the serving central office are detected by automated, scheduled loop tests, switching machine tests made prior to establishing the connections to the loop, or by the customer reporting the condition to the Centralized Repair Service Attendant Bureau (CRSAB), usually by dialing "611" or a special 7-digit or 800 number.



### **8.9.1 Automatic Repair Service Bureau**

The ARSB provides mechanized repair service administration, recordkeeping, trouble analysis, and testing. It is composed of the Loop Maintenance Operations System (LMOS), Mechanized Loop Testing (MLT) System, and Loop Cable Maintenance Operations System (LCAMOS). The major objectives of the ARSB are to

- Improve maintenance center efficiency and reduce the cost of repair operations
- Improve customer service by more rapid detection, location, and repair of troubles
- Improve customer contact handling by providing the RSA with timely customer-oriented information.

### **8.9.2 Loop Maintenance Operations System**

LMOS mechanizes customer line records and produces basic management and trouble history reports. Specific primary functions include trouble report processing, online management reports, control of automated testing, and analysis of past trouble reports via the Trouble Report Evaluation and Analysis Tool (TREAT) or a similar measurement and analysis system. The system acts on data derived from trouble report status entries (customer calls or employee originated) relative to open troubles and trouble history. A secondary function of LMOS is to feed inventory systems that provide management reports (for example, equipment use reports).

### **8.9.3 Mechanized Loop Testing System**

The MLT system is an automated testing system that works with LMOS. The MLT system accesses a customer's loop using either no-test trunks to the switch serving the loop or trunks to test shoes at the distribution frame on which the loop is terminated. The MLT system then performs a series of adaptive tests under computer control. LMOS line record information is fed into the test algorithms so that each test series is custom-tailored to the expected electrical characteristics of the line. MLT outputs include pass/fail indications, analog-measurement results, and recommended actions, depending upon the transaction selected and the user. MLT and LMOS are designed to work with pair-gain configurations as well as standard cable pair arrangements. Other test sets may be utilized by central office and cable technicians to enhance MLT test results when necessary.

### **8.9.4 Loop Cable Maintenance Operations System**

LCAMOS, which is integrated with LMOS/MLT, provides for the prediction, tracking, and analysis of cable troubles. The Cable Repair Administrative System (CRAS) is one module

---



---

of the three that will compose LCAMOS. CRAS helps the distribution plant maintenance organization schedule repair forces efficiently and locate trouble-prone outside-plant facilities that need the most rehabilitation. These facilities are identified by analyzing a history of past trouble reports.

The LCAMOS tracker is used to track customer troubles that are outside plant related, correlate multiple customer troubles into a related trouble, and track this item as a Cable Trouble Ticket (CTT). Upon completion of the repair, the tracker will transmit data to CRAS for further analysis.

## 8.10 Planned Long-Term Network Advancement

There are OSSs planned and, in some cases, deployed (for example, the NMA system), that will detect digital network degradation through performance monitoring of the switch, facility, and all network elements on an end-to-end basis.

There are also advanced facility formats (such as DS1, ESF, and SONET rings) that will provide advanced monitoring and protection capabilities.

The transition to an enhanced network that is self-checking and self-healing requires interim measures and procedures that take advantage of the embedded technology while preparing to economically deploy and fully utilize the new technology.

Three network advancements that may have a direct strategic impact on the operating telephone companies' switched message trunk-maintenance plans are as follows.

- NMA system — This Bellcore system provides an end-to-end view of the network. The NMA system conducts performance monitoring of the digital facility and integrates digital switch performance monitoring results for the total end-to-end view.
- Integrated Test System (ITS) — This Bellcore system provides test access from an integrated workstation for special-service, ISDN, and switched circuits.
- ESF T1 Format — This provides efficient path-level monitoring of the digital facility and allows NEs to report degradation and failures. The CRC is not affected by multiplexing in the network, as is the BPV count in the digital switch.

These advancements, once fully developed and deployed, will affect the trunk maintenance process and lead further toward the implementation of performance-monitoring-based trunk maintenance plans.

**8.10.1 Bit Error Ratio**

Table 8-5 shows the DS1 BER (error ratio, meaning, and conversion to errors per second).

**Table 8-5.** Bit Error Ratio

<b>Error Ratio</b>	<b>Meaning</b>	<b>Equal To</b>
$10^{-4}$	1 Error in 10,000	154 Errors in a second
$10^{-5}$	1 " " " 100,000	15.4 " " "
$10^{-6}$	1 " " " 1,000,000	1.5 " " "
$10^{-7}$	1 " " " 10,000,000	1 Error every 6.5 seconds

### 8.10.2 Assignment of Bits in DS1 Superframe Format Signals

Table 8-6 shows the DS1 Superframe format signals. Note that the sequence is repetitive. Frames 6 and 12 are signaling frames.

**Table 8-6.** Assignment of Bits in DS1 Superframe Format Signals

Frame No.	Terminal Framing	Signaling Framing	Coding Bits	Signaling Bit	Signaling Channel
1	1	-	1-8	-	
2	-	0	1-8	-	
3	0	-	1-8	-	
4	-	0	1-8	-	
5	1	-	1-8	-	
6	-	1	1-7	8	A
7	0	-	1-8	-	
8	-	1	1-8	-	
9	1	-	1-8	-	
10	-	1	1-8	-	
11	0	-	1-8	-	
12	-	0	1-7	8	B

**8.10.3 Assignment of Bits in DS1 Extended Superframe Format Signals**

Table 8-7 shows the assignment of bits in DS1 ESF signals.

**Table 8-7.** Assignment of Bits in DS1 Extended Superframe Format Signals

Frame No.	Bit No.	FPS*	FDL**	CRC†	Traffic Bits	Signaling Bits
1	0	-	M	-	1-8	
2	193	-	-	C1	1-8	
3	386	-	M	-	1-8	
4	579	0	-	-	1-8	
5	772	-	M	-	1-8	
6	965	-	-	C2	1-7	8
7	1158	-	M	-	1-8	
8	1351	0	-	-	1-8	
9	1544	-	M	-	1-8	
10	1737	-	-	C3	1-8	
11	1930	-	M	-	1-8	
12	2123	1	-	-	1-7	8
13	2316	-	M	-	1-8	
14	2509	-	-	C4	1-8	
15	2702	-	M	-	1-8	
16	2895	0	-	-	1-8	
17	3088	-	M	-	1-8	
18	3281	-	-	C5	1-7	8
19	3474	-	M	-	1-8	
20	3667	1	-	-	1-8	
21	3860	-	M	-	1-8	
22	4053	-	-	C6	1-8	
23	4246	-	M	-	1-8	
24	4439	1	-	-	1-7	8

\* FPS = Framing Pattern Sequence

\*\* FDL = 4-kbps Facility Data Link (M = message bits)

† CRC = CRC-6 Bits C1-C6

---

## 8.11 Digital Testing Parameters

The test parameters described in this section are parameters that have been defined for measuring digital links and sections by the Institute of Electrical and Electronics Engineers (IEEE) document, P1007, *Methods and Equipment Standard for Measuring the Transmission Characteristics of PCM Telecommunications Circuits and Systems*.

- Line-code violations — Line-code violations are not end-to-end parameters, but must be measured at each line terminating equipment. The functions of multiplexing in the network limit these parameters to be indicative of specific line troubles only, and they are often transparent to the switch.
- BPV — A BPV occurs when two consecutive non-zero signal elements of the same polarity occur in a bipolar signal. A BPV is a code violation if it occurs
  - in an AMI signal or
  - in a Bipolar n Zero Substitution (BnZS) signal separate from a zero substitution code.

The above violations indicate transmission errors. The BPVs are usually expressed as a ratio to the total number of bits; that is  $(1 \times 10^{-6}) = 1$  bit error in a million bits transmitted.

The most commonly deployed DS1 signal format is AMI, although Bipolar with 8 Zero Substitution (B8ZS) is being used for clear-channel applications.

- BnZS violation — A BnZS occurs when a string of consecutive zeros of length  $n$  is received in a BnZS signal.
- Pulse Density Violation (PDV) — A PDV occurs if
  - an uninterrupted string of zeros is received that is longer than is allowed in the code or
  - the % ones density averaged over a specified number of bits is less than allowed in the code.
- Path-code violations — Path-code violations are end-to-end measurable parameters.
  - CRC violation — A CRC code (usually stated with the number of bits, for example, CRC-6, CRC-9, CRC-16) is defined for some digital transmission formats. The CRC is the result of a calculation carried out on the set of transmitted bits by the transmitter. The CRC is encoded into the transmitted signal with the data. At the receiver, the calculation creating the CRC is repeated and the result compared to the one encoded in the signal. If the CRC codes calculated at the transmitter and the receiver are not identical, a CRC violation has occurred, indicating transmission errors.

The CRC violation information may be used to approximate BER.

- 
- Parity violation — Some digital transmission formats define a parity bit. If the received parity and the parity calculation on the data do not agree, a parity violation has occurred, indicating transmission errors.
  - Framing bit errors — Framing BER may be counted to detect transmission path errors. Errors in the framing bit pattern indicate average BER of the transmission path.
  - Severely Errored Frame (SEF) — A severely errored frame occurs when two or more frame errors occur in a 3-ms time period.
  - BER — The ratio of the number of digital errors received in a specified time period to the total number of bits received in the same time period. BER may be measured directly by generating a known signal and detecting errors in that signal, or it may be approximated, based on a count of code violations or framing bit errors.

The digital switches in the current network approximate BER by counting the bipolar violations received.

- Errored second — An errored second is a second during which one or more errors occur in a digital bit stream.
- Severely Errored Second (SES) — A severely errored second is a second during which the BER is  $1 \times 10^{-3}$  or greater.
- Error-Free Second (EFS) — An EFS is a second during which no errors occur.
- Available time and unavailable time — Available and unavailable time is measured in units of time, that is, seconds. Both may also be expressed as a percentage of a fixed time period.

Unavailable time is a measure of the time that transmission is unusable. It begins with 10 consecutive SESs and ends when 10 consecutive seconds occur that are not SESs.

- Synchronization parameters
    - Controlled slip — A controlled slip is the loss or gain of a set of consecutive digit positions in a digital signal, in which both the magnitude and instant of that loss or gain are controlled to enable the signal to be in accord with a signal rate different from its own.
    - Uncontrolled slip — An uncontrolled slip is the loss or gain of a digit position or a set of consecutive digit positions in a digital signal resulting from an uncontrolled aberration of the timing processes associated with the transmission or switching of that signal.
    - Loop timing — Loop timing is the difference between the bit rates of the signals in the two directions of a link. Loop timing is reported in parts per million (ppm).
-

- Disturbance parameters
    - Timing jitter — Timing jitter is the short-term variations of the significant instants of a digital signal from their ideal positions in time. The term jitter applies to variations of 10 Hz and higher.
    - Wander — Wander is the long-term variation of the significant instants of a digital signal from their ideal positions in time. Long-term implies that these variations are of low frequency, that is, less than 10 Hz.
    - Delay — Delay is the time elapsed between the transmission of a signal and the reception of that signal.
  - Interface parameters — Interface parameters are characteristics of the electrical signals at the Digital System Cross-Connect (DSX) access to a link or section.
    - Line rate — The line rate, or binary digit rate, is the number of digits per unit of time. The line rate is measured in bits per second with the appropriate scale applied, that is, 1000 bps = 1 kbps.
    - Pulse shape — The pulse shape of a signal is a plot of voltage versus time. Templates and pulse envelopes have been defined for standard interface points.
    - Power level — The power level is the rms power received, expressed in mW.
    - Pulse imbalance — Pulse imbalance is the ratio of the height of the positive pulses to the height of the negative pulses in a given signal.
    - Signal-to-noise ratio — The signal-to-noise ratio is the ratio of a signal power to noise power at the test point.
-





## Section 9

### Common Systems

### Contents

9.	Common Systems .....	9-1
9.1	Introduction .....	9-1
9.2	Cross-Connect Systems .....	9-2
9.2.1	Benefits of Properly Deployed Cross-Connect Systems .....	9-2
9.2.2	Distributing Frame .....	9-3
9.2.2.1	Conventional Frames .....	9-4
9.2.2.2	Modular Frames .....	9-5
9.2.2.3	Distributing Frame Network Elements .....	9-5
9.2.3	Digital Signal Cross-Connect Systems .....	9-7
9.2.3.1	DSX Functions .....	9-8
9.2.4	Digital Interface Systems (DISs) .....	9-8
9.2.5	Automated Cross-Connect Systems .....	9-9
9.2.5.1	Digital Cross-Connect System (DCS) .....	9-10
9.2.6	Fiber-Optic Cross-Connects .....	9-12
9.2.6.1	Optical Fiber System Advantages .....	9-13
9.2.6.2	Fiber Distributing Frame .....	9-13
9.2.6.3	Optical DSX (ODSX) and Optical Interface Systems (OIS) ...	9-15
9.2.7	Other Cross-Connect Systems .....	9-16
9.2.7.1	Feeder Distribution Interfaces .....	9-16
9.2.7.2	Fiber Demarcation Boxes .....	9-16
9.2.8	Cross-Connect Automation .....	9-17
9.2.9	Cross-Connects in a Network .....	9-18
9.3	Power Systems .....	9-19
9.3.1	Supported Equipment .....	9-21
9.3.1.1	Battery-Plant Voltage Limits .....	9-21
9.3.2	A/B Distribution .....	9-22
9.3.3	Rectifiers .....	9-22
9.3.4	Noise-Voltage Objectives .....	9-23
9.3.4.1	Voice .....	9-23
9.3.4.2	Broadband .....	9-23
9.3.5	Protection .....	9-23
9.3.6	Grounding .....	9-24
9.3.7	Batteries .....	9-24
9.3.8	Uninterruptible Power Systems .....	9-24
9.3.9	DC-to-DC Converters .....	9-25
9.3.10	DC-to-AC Inverters .....	9-25
9.4	Network Equipment-Building System .....	9-25

---

9.4.1	Equipment .....	9-26
9.4.2	Buildings .....	9-26
9.4.3	Fire Resistance .....	9-26
9.4.4	Cable-Entrance Facility.....	9-27

## List of Figures

Figure 9-1.	Common System Elements.....	9-1
Figure 9-2.	Distributing Frame Components .....	9-4
Figure 9-3.	Conventional Distributing Frame .....	9-5
Figure 9-4.	Modular Distributing Frame .....	9-6
Figure 9-5.	Interconnection Hierarchy .....	9-7
Figure 9-6.	Central Office Cross-Connect Network .....	9-18
Figure 9-7.	Cross-Connect Systems in a Telecommunications Network.....	9-19
Figure 9-8.	DC Power Plant .....	9-20
Figure 9-9.	Standby AC Power System.....	9-20
Figure 9-10.	Duplex Cable-Entrance Facility .....	9-28

## List of Tables

Table 9-1.	Synchronous Optical Network (SONET) Optical Rates).....	9-11
Table 9-2.	-48 V Power Plant Limits .....	9-21
Table 9-3.	24-V, 130-V, and 140-V Power Plant Limits .....	9-22
Table 9-4.	Voice-Frequency Plant Noise-Voltage Limits .....	9-23

---

## 9. Common Systems

### 9.1 Introduction

Local Exchange Carrier (LEC) networks require a variety of specialized generic equipment to support network elements. This shared equipment is referred to as *common systems*. The interrelationship among these common systems is illustrated in Figure 9-1. Common systems include cross-connect systems such as distributing frames, power systems, and the Network Equipment-Building System (NEBS) that provides space and environmental support for network elements. These systems are located in central offices and remote building locations.

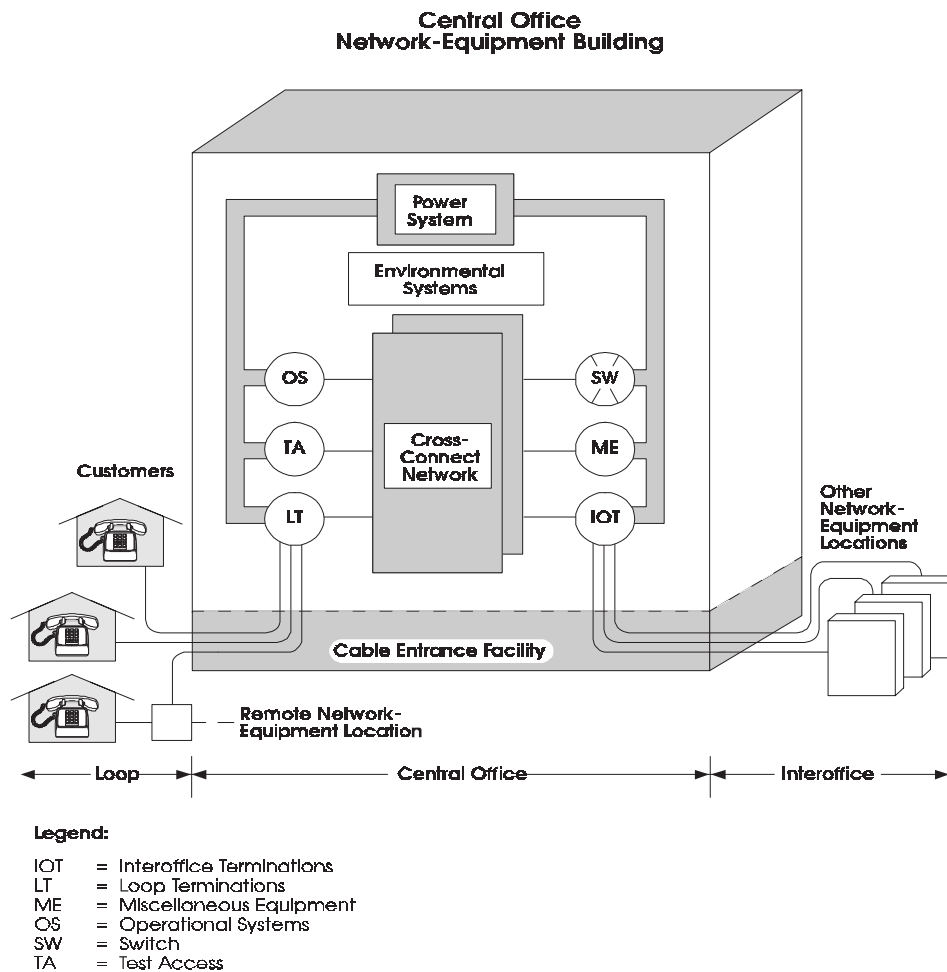


Figure 9-1. Common System Elements

## 9.2 Cross-Connect Systems

Cross-connect systems provide a physical termination point for physical cables and individual conductors. They can be manual or automated, metallic or optical. Cross-connect systems, such as distributing frames, Digital Signal Cross-connects (DSXs), and Fiber Distributing Frames (FDFs), provide the following basic functions: cross-connection of network distribution facilities and equipment in the central office, electrical protection for conductive media, test access, temporary disconnection, and termination points for facilities and equipment. The rapid introduction of new, high bit-rate digital services has placed new requirements on existing distributing frames, DSXs, and FDFs. Many applications require specially shielded cross-connects, while certain high bit-rate digital loop, bridged alarm and metering services require substantially more cross-connections than traditional services.

Cross-connect systems usually include not only distributing frames, FDFs, and DSXs, but also Feeder Distribution Interfaces (FDIs), Digital Cross-connect Systems (DCSs), Electronic DSXs (EDSXs), Optical Interface Systems (OISs), and Optical DSXs (ODSXs). Distributing frames, DSXs, and FDIs are widely deployed and typically are manually operated devices used for cross-connecting metallic-wire, media-transporting, analog/digital signals. DCSs and EDSXs, first deployed in 1981, are automated digital cross-connect devices whose applications include network reconfiguration and the elimination of digital channel banks and multiplexers. Synchronous Optical Network (SONET) DCSs are expected to accommodate optical terminations (for example, Optical Carrier level 3 [OC-3]) as well as electrical terminations (for example, Synchronous Transport Signal level 1 [STS-1]). FDFs are currently deployed and are expected to meet the potential needs of optical fiber cross-connects. OISs and ODSXs are expected to find some specialized applications in the future but are not likely to replace the FDF.

### 9.2.1 Benefits of Properly Deployed Cross-Connect Systems

Ideally, when deployed in the proper architecture, cross-connect systems provide the following:

- **Physical connections**

Cross-connect systems provide physical links between equipment and facilities.

- **Standard interfaces**

Cross-connect systems provide standard interfaces for many different types of connections.

---

- **Decoupling of major network components**

Cross-connect systems decouple loop facilities, interoffice facilities, transmission equipment, and switching equipment to enhance planning, engineering, and operations activities.

- **Flexibility for repair and growth**

The number of fibers deployed, particularly for loop fibers, must be larger than the number in service. This ensures that capacity is available to replace failed fibers and provide service to new customers quickly. Cross-connect systems provide quick access to this spare capacity.

- **Economic efficiency**

Cross-connect systems support the concentration of customers onto expensive equipment modules. This keeps equipment utilization high and reduces capital costs.

- **Evolution**

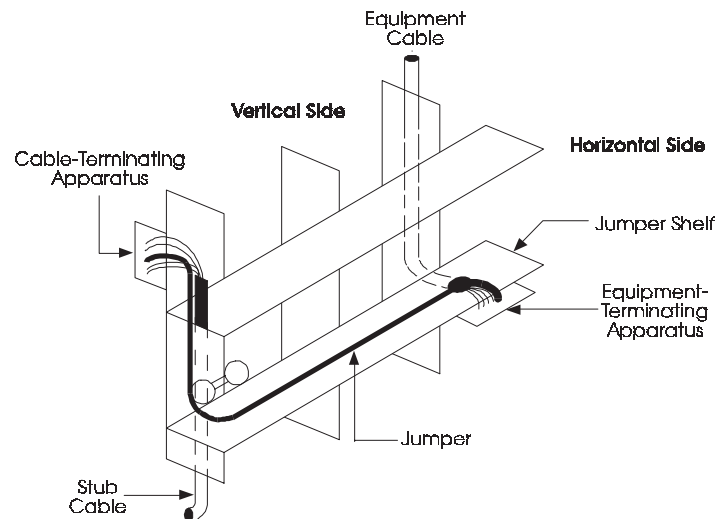
Cross-connect systems provide the flexibility required to evolve the network technologically and architecturally. Without cross-connects, network components are (by definition) hardwired. Evolution would then require wholesale disruption of service to existing customers as components are removed from service and replaced with newer equipment.

### 9.2.2 Distributing Frame

The distributing frame provides the termination point for virtually all voice-grade and voice-grade compatible facilities and equipment in a central office. It is composed of protectors, connectors, and terminal strips or blocks. Distributing frames are categorized as either conventional or modular, as described in the following text.

Figure 9-2 illustrates the basic components of a typical distributing frame: framework, termination apparatus, and jumper wire. Frameworks are steel structures that provide wire-carrying shelves and mounting positions for connecting apparatus. Terminal blocks are termination apparatus mounted on the frameworks. Terminal blocks are used for permanent termination of cables from equipment. Connecting apparatus (connectors) for distribution plant cables may include removable protector units. Jumpers are typically twisted pairs of insulated wire terminated on connectors and terminal blocks interconnecting the distribution pairs and equipment.

---



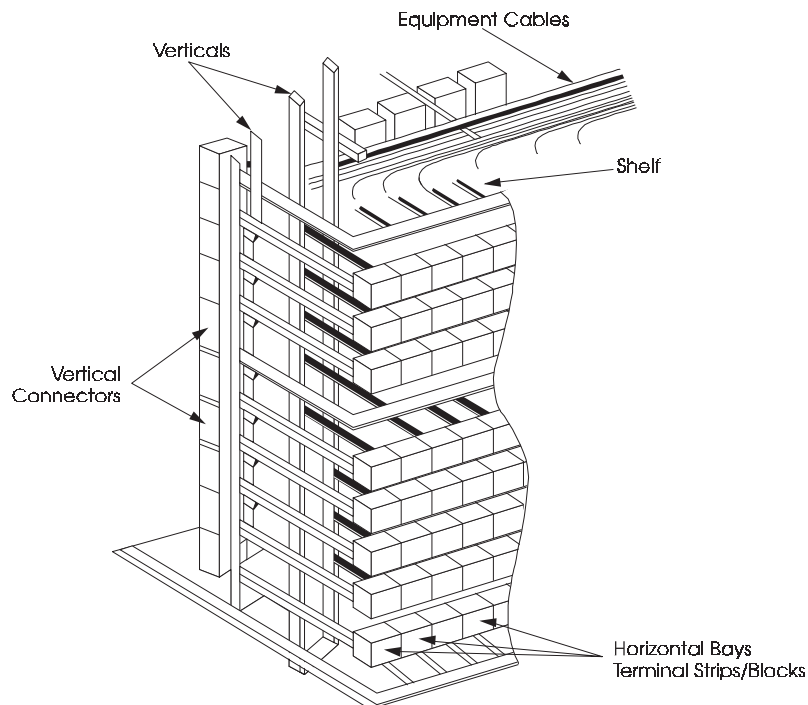
**Figure 9-2.** Distributing Frame Components

#### 9.2.2.1 Conventional Frames

A common type of distributing frame in use is the double-sided conventional distributing frame (Figure 9-3). This design features a structure of horizontal wire-carrying shelves backed by vertical uprights.

Conventional frames have total allocation flexibility (that is, they can be used to terminate all types of voice-grade and voice-grade compatible facilities and equipment) and are of three basic types.

- *Tall conventional distributing frames* are older designs of various heights, widths, and horizontal shelf separations. The largest applications are approximately 15 feet tall and several hundred feet long. Approximately two dozen variations of conventional framework designs are in use.
- *Low-Profile Conventional Distribution Frames (LPCDFs)* are approximately 8 feet tall and are compatible with the NEBS requirements discussed in Section 9.4.
- *Conventional protector frames* are separate protector frames sometimes used to mount protector-equipped connectors. These connectors are interconnected via cables to higher-density terminal blocks mounted on the vertical side of the distributing frame.



**Figure 9-3.** Conventional Distributing Frame

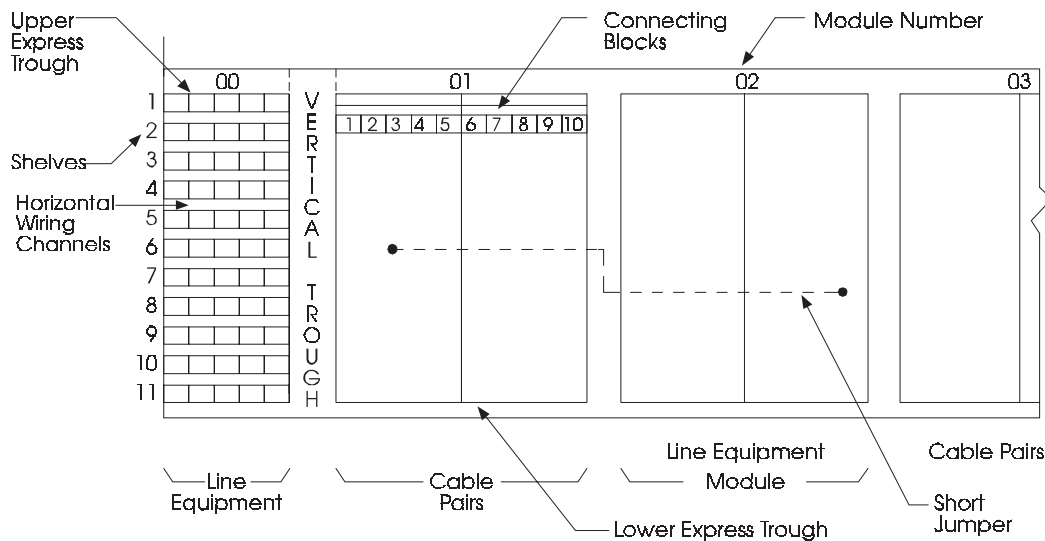
#### 9.2.2.2 Modular Frames

Modular frames are generally single-sided, low-height units compatible with GR-63-CORE, *Network Equipment-Building System (NEBS) Requirements: Physical Protection*, developed for greater labor efficiency. Cables are hardwired to a specific module area. Figure 9-4 illustrates a typical modular frame. Typically, a modular frame consists of alternating modules of line equipment and cable pairs that allow the use of short jumpers between adjacent modules.

#### 9.2.2.3 Distributing Frame Network Elements

Distributing frame networks are configurations of one or more frames identified by functional cross-connect applications for specific facility/equipment systems. There are four elements in distributing frame networks: functional frames, physical hardware, termination allocations, and tie pairs.

Functional frames are defined by the classes of distribution plant cable and terminated switching equipment they serve.



**Figure 9-4. Modular Distributing Frame**

- *Combined Main Distributing Frame (CMDf)* terminates both subscriber cable and line equipment as well as trunk cable and line equipment (also called Main Distributing Frame [MDF]).
- *Subscriber Main Distributing Frame (SMDF)* terminates subscriber cable and line equipment, but not trunk cable or trunk equipment.
- *Trunk Main Distributing Frame (TMDF)* terminates trunk cable and trunk equipment, but not subscriber cable or line equipment.
- *Intermediate Distributing Frame (IDF)* has no direct outside-plant termination. An IDF used exclusively to terminate tie pairs that interconnect two or more frames is called a Tie-Pair Distributing Frame (TPDF).

TPDFs that terminate tie pairs from only a specific functional frame are regarded as part of the supported functional frame. Protector frames are also considered an integral part of the associated functional frame.

Functional frames can be implemented with variations in physical hardware. For example, an SMDF functional frame could use a low-profile conventional frame, a tall conventional frame, or a modular frame to provide the SMDF function.

Termination allocation is the placement of all required facilities and equipment terminations on a specific frame within the network. Distribution cable and switch terminations require allocation to a specific functional frame. Other facility and equipment terminations that require allocation are test-access equipment, miscellaneous equipment, and pair-gain and carrier systems.



### 9.2.3 Digital Signal Cross-Connect Systems

DSX system frames are manually operated cross-connect devices used within central offices and at remote offices. These frames provide a convenient central facility for cross-connect, circuit-rearrangement, patching, and testing purposes. Any digital equipment (for example, digital channel banks, digital switch interfaces, or digital transmission facilities) may be terminated at an equal-signal-level cross-connect. The DSX system accommodates equipment and facilities used for both switched and special-access service.

Digital systems are being deployed in the LECs with associated DSX cross-connect frame systems. Each Digital Signal level 1 (DS1) signal can transport up to 24 DS0 voiceband circuits, while DS3 signals can transport up to 672 DS0 circuits.

Networks within Local Access and Transport Areas (LATAs) transport a variety of digital signals. Digital carrier systems operate at different bit rates, as Figure 9-5 shows. The cross-connects are designated DSX-N, where N indicates the level of the digital network interconnected at that cross-connect system. The DS1 signal at 1.544 Mbps is the lowest *carrier* level in the digital hierarchy. Thus, DS1 equipment is interconnected at the DSX-1 cross-connect system, and DS1C equipment (3.152 Mbps) is interconnected at the DSX-1C cross-connect system, etc.

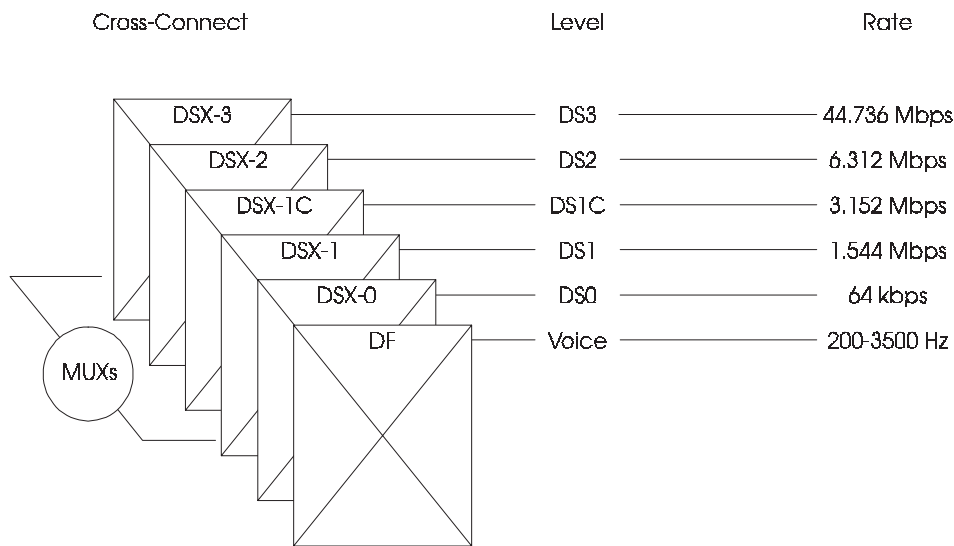


Figure 9-5. Interconnection Hierarchy

### 9.2.3.1 DSX Functions

DSXs provide several specific functions.

- DSXs provide facilities/equipment termination of cables from office repeater bays, carrier terminals, channel banks, and multiplexers, which are generally terminated by cable pairs onto jack sets on DSX panels.
- Cross-connection of equipment and facilities on DSX frames is accomplished with *jumpers*. Depending on the type of DSX in use, jumpers are multiple twisted-insulated wires for DSX-1 or coaxial cable for DSX-3. Jumpers are run on the shelves (troughs) of the framework.
- Test access is provided on DSX frames for digital circuit testing. Monitoring access is provided with or without opening the circuit. Opening the circuit can simultaneously affect many constituent circuits. Therefore, virtually all DSX termination points constitute bridged test-access points for a given terminated facility/equipment.
- Jacks on the DSX permit a circuit to be moved without removing cross-connections and with only momentary loss of service known as *rolling*. This is done through coordination with a distant office.

### 9.2.4 Digital Interface Systems (DISs)

A DIS is a termination, test access, and rearrangement point for digital and analog equipment at a single signal rate. A DIS must have the capability to provide rearrangeable connections between any two equipment terminations or appearances; bridged access, whereby equipment can be connected in parallel with a transmission signal path; and series access, whereby a transmitted signal can be split. These capabilities enable a DIS to provide several operational functions, including equipment interconnection, test access, and patching. A DIS provides the same functions as a DSX but at a lower cost per termination. This because a DIS achieves some of its functionality by using reusable external modules or smart patch cords.

A DIS can handle electrical signals, both analog and digital, in the frequency range from 4 kHz to 1.2 GHz. Applications could include electrical signals Voice Frequency (VF), DSO, ISDN, Asymmetrical Digital Subscriber Line (ADSL), High bit-rate Digital Subscriber Line (HDSL), DS1, DS1C, DS2, DS3, SONET STS-1, and STS-3, and analog video and digital video.

DISs can be deployed in either of two modes of operation: interconnect or cross-connect. Interconnect arrangements work best in small installations (less than 1000 terminations) when the connected equipment is close to the DIS, has little or no growth, and there is not a frequent need to upgrade or change equipment. For larger installations that are growing rapidly, with frequent need for rearrangements and upgrades of equipment, a cross-connect solution is more practical and economical.

---

---

In the interconnect mode, the DIS would be typically installed close to the electronic cross-connect system as an intermediary termination and connection (splice) point between the electronic cross-connect equipment and the other central-office equipment.

The cross-connect mode of operation provides an extremely convenient, cost-effective, and flexible method to connect all compatible equipment terminations to electronic cross-connect systems. The DIS would be installed centrally in the equipment area. Equipment cables at the same digital rate would be terminated from both the electronic cross-connect system and other network equipment that may be interconnected.

More information on DISs can be found in GR-2875-CORE, *Generic Requirements for Digital Interface Systems*.

### 9.2.5 Automated Cross-Connect Systems

Automated cross-connect systems are software-controlled intelligent network elements that are used to provide logical cross-connect functions. There are two types of automated cross-connect systems that are commonly deployed in telecommunications networks. They are generically called Electronic Digital Signal Cross-connect (EDSX) systems and Digital Cross-connect Systems (DCSs).

EDSXs are software-controlled alternatives to the manual DSX. These devices can have the added capabilities of intelligent network elements similar to digital cross-connect systems except that EDSXs do not provide access to the constituent subrate signals. The EDSX provides for interconnection of digital transport facilities/equipment and allows remote provisioning, test-access, automatic protection, and service-monitoring capabilities. Because of their lower functionality compared to DCSs, EDSXs are somewhat less expensive per digital port and are also capable of having large numbers of ports per system. An EDSX is considered to be a special case of the more general designation of DCS.

DCSs are software-controlled devices considered to be intelligent network elements because they can provide the following features:

- Remote provisioning and rearrangement of the digital interconnections
- Continuous service monitoring
- Automatic equipment and facilities protection (self-healing capabilities)
- Remote test access.

DCSs can provide for the logical cross-connection of the constituent subrate digital signals of any associated higher-level input-to-output digital signals. For example, a DCS 1/0 can cross-connect any DS0 signal on a DS1 input to any other available DS0 time slot on a DS1 output. Similarly, a DCS 3/1 can cross-connect any DS1 signal on a DS3 input to any available DS1 time slot on a DS3 output.

---

### 9.2.5.1 Digital Cross-Connect System (DCS)

A DCS terminates standard digital signals and facilities operating at a standard digital signal rate, and automatically cross-connects constituent (tributary) signals according to an electronically alterable memory map. The list below describes several types of DCSs used in today's network.

- **N-DCS** - The Narrowband Digital Cross-connect System (N-DCS) cross-connects DS0 signals and terminates DS1 signals. It is also known as a DCS 1/0. Some terminate higher rate signals such as DS3.
- **W-DCS** - The Wideband Digital Cross-connect System (W-DCS) cross-connects DS1 signals, and/or VT1.5 signals and terminates DS3, STS-1, STS-3, and/or OC-N signals.
- **SONET W-DCS** - The SONET W-DCS cross-connects at the VT1.5<sup>1</sup> rate and provides SONET signal multiplexing and termination. They can also carry asynchronous signals. The SONET W-DCS also provides transport gateway functions by providing any one or all of the following interfaces: DS3, DS2, DS1C, and DS1<sup>2</sup>.
- **DCS 3/1** - The DCS 3/1 is a non-SONET (that is, asynchronous) W-DCS that cross-connects DS1s, and provides the ability to terminate DS1s and asynchronous DS3s. The DS1 bit stream is cross-connected without any change, regardless of the DS1 format.
- **EDSX-1** - The EDSX-1 is a non-SONET W-DCS with no multiplexing functions that cross-connects only DS1 signals. It only cross-connects any incoming signal to any other outgoing signal of the same rate. It does not terminate constituent tributaries of incoming signals, and does not provide multiplexing functions.
- **B-DCS** - The Broadband Digital Cross-connect System (B-DCS) cross-connects DS3, STS-1, and STS-3c signals, and terminates DS3, STS-1, STS-3, and OC-N signals.
- **SONET B-DCS** - A B-DCS cross-connects at the STS-1<sup>3</sup> signal rate. It provides transport gateway functions by providing DS3, OC-3, OC-3C, and OC-12 interfaces and the capability of cross-connecting any incoming signal to any outgoing signal.
- **EDSX-3** - The EDSX-3 is a non-SONET B-DCS with no multiplexing functions that cross-connects and terminates only DS3 signals.
- **EDSX STS-N** - The EDSX STS-N is a B-DCS that cross-connects at the STS-N rate with all the SONET overhead and payload unaltered.

- 
1. The Virtual Tributary (VT) structure is designed to transport sub-STS-1 rates using the SONET network. VT1.5 is used for signals at rates of 1.728 Mb/s or less.
  2. In some regions, W-DCSs also will have OC-3 and OC-12 interfaces.
  3. STS-1 is the basic building block of the SONET hierarchy. It is an electrical signal with a bit rate of 51.84 Mb/s, and is scrambled and converted to an optical signal to obtain an OC-1 signal. Higher rate signals are obtained from STS-1 signals.
-

### 9.2.5.1.1 SONET Digital Cross-Connect Systems

A SONET DCS cross-connects digital signals in the formats defined by the SONET<sup>4</sup> signal hierarchy as shown in Table 9-1.

**Table 9-1.** Synchronous Optical Network (SONET) Optical Rates)

OC Level	Line Rate (Mb/s)	Line Rate (Gb/s)
OC-1	51.840	
OC-3	155.520	
OC-9	466.560	
OC-12	622.080	
OC-18	933.120	
OC-24	1244.160	1.24
OC-36	1866.240	1.86
OC-48	2488.320	2.48
OC-192	9953.280	9.95

SONET DCSs provide SONET signal multiplexing and termination. They can also carry asynchronous signals such as DS3, DS2, DS1C, and DS1. SONET DCSs were introduced to provide the same functionality in SONET networks, that is, in the new synchronous digital hierarchy, as the pre-SONET DCSs did in the asynchronous digital hierarchy. Most of them can also provide transport gateway functions for the interconnection of DSC and SONET networks. Only two classes of DCSs apply for SONET, the W-DCS and the B-DCS. More information on SONET DCSs may be found in GR-2891, *SONET Digital Cross-Connect Systems with ATM Functionality-Generic Criteria*.

### 9.2.5.1.2 DCS Functions

The main functions performed by a DCS are grooming, add/drop, broadcast, facility rolling, performance monitoring, test access, and remote configuration. The following is a short summary of these functions; TR-NWT-000233, *Wideband and Broadband Digital Cross-connect Systems Generic Criteria*, contains more detail.

**Grooming** is a function that allows efficient use of both incoming and outgoing facilities by the cross-connection of tributaries. Grooming includes consolidation and segregation.

4. The basic building block used in the SONET) is the 51.840 Mb/s Optical Carrier level 1 (OC-1) bit rate defined in GR-253-CORE, *Synchronous Optical Network (SONET): Common Generic Criteria*. This SONET standard defines a family of optical transmission signals with a progressive hierarchy of signals.

An **add/drop** function is provided by DCSs with a multiplexing function, allowing access to incoming and outgoing tributaries embedded within terminating high-speed facility. Such tributaries may then be added and dropped. This is the same function provided by an Add/Drop Multiplexer.

The **broadcast** function is the capability of providing a one-way cross-connection from an incoming digital signal source (from an interface port or tributary) to more than one outgoing interface port, or to tributaries within one or more outgoing high-speed digital signals.

The **facility rolling** function allows the transfer of traffic from one facility to another without service interruption. Facility rolling can be performed on unidirectional or bidirectional traffic. Some applications are transport facility upgrades and digital switch cutovers without service interruptions.

The **performance monitoring** function allows the detection of performance anomalies for transmission entities that terminate or pass through the DCS.

The **monitoring test access** function allows for non-intrusive in-service testing of signals that pass through the DCS by tapping interface ports or tributaries, using the broadcast function, for connection via test port to monitoring test equipment.

The **remote configuration** function allows the reconfiguration of networks to accommodate changes in service demands and to restore traffic after a failure has occurred, both under control from an operations system.

### 9.2.6 Fiber-Optic Cross-Connects

High bit-rate frames have experienced substantial growth in large central offices. Optical cross-connect technology can potentially minimize metallic cabling and jumper limitations while performing better than metallic frames. Optical cross-connects may also facilitate the support of a variety of transmission rates on the same functional hardware (for example, frames, connectors, cables, and jumpers).

An optical-fiber transmission system consists of the facilities and equipment used to transmit voice, data, video, and other communications services between two or more points in the telecommunications network, with optical fiber as the transmission medium. These points could include customer locations, central offices, or points of interface with Interexchange Carriers (ICs), Competitive Local Exchange Carriers (CLECs) or Alternate Access Providers (AAPs). Optical-fiber transmission systems operate either over two fibers, one for each transmission direction, or with bidirectional transmission, where the same fiber is used for transmission in both directions.

Optical fiber transmission systems were initially introduced in telecommunications networks in the interoffice transmission plant. Interest in expanding the use of fiber

---

---

facilities has accelerated fiber system deployment in the loop plant. As the number of these systems increases, the need for optical cross-connect systems becomes apparent.

#### 9.2.6.1 Optical Fiber System Advantages

For many years, LECs have used digital carrier systems to multiplex analog or low bit-rate signals onto higher bit-rate digital transmission systems. Typically, copper cable has been used to carry these digital signals. However, applications in recent years have proven optical fiber cable to be a much more effective means of transmission than copper cable.

- **Economics**

Optical fiber cable offers economic advantages over both shared feeder and dedicated copper cable approaches to providing digital lines. Economic studies have shown that optical fiber systems are less expensive than copper facilities with similar characteristics when system capacity exceeds 150 equivalent DS3 circuits and transmission distances are greater than 8 kft.

- **Structure**

Compared to traditional copper cable, optical fiber cable is lighter, smaller, and free from external electromagnetic interference. These structural advantages translate to reduced costs in shipping, installation, and maintenance.

#### 9.2.6.2 Fiber Distributing Frame

An FDF is a centralized termination point for optical fiber facilities and equipment. An FDF can provide rearrangeable connections between any two terminations or appearances and limited series test access to split an optical fiber path.<sup>5</sup>

Current FDF designs are based on existing modular distributing frame designs.

GR-449-CORE, *Generic Requirements and Design Considerations for Fiber Distributing Frames*, contains additional information on FDFs.

FDFs will be needed in central offices and in remote offices. FDFs also may be installed at large customer locations. Furthermore, an FDF may serve as the point of interface between a local operating company and an IC.

---

5. Although the FDF can provide limited series test access to an optical fiber transmission system by removing the cross-connection fiber jumper, test access is not a major FDF function.



#### 9.2.6.2.1 FDF Physical Appearance

Today, most FDF designs are based on single-sided modular distributing frame designs and built to fit standard 7-foot high, 23-inch wide equipment racks conforming to TA-EOP-000345, *Equipment Framework Generic Requirements*. Typically, these designs provide 648 fiber terminations in 8 or 9 shelves per 7-foot high and 23-inch wide rack. Higher density designs are also available and are discussed in [Section 9.2.6.2.4](#). Some newer designs are based on double-sided conventional distributing frame designs.

#### 9.2.6.2.2 FDF Nomenclature

- *FDF bay* - a supporting structure, also called an equipment rack (this is a historical term that first referred to central office relay racks), and all the FDF apparatus mounted on it. The term *equipment rack* should not be confused with the cable racks and pathways that run along the ceilings of central offices and remote sites. Sometimes the term *module* may be preferable to the term *bay* to emphasize the similarities of function and engineering between the FDF and other modular cross-connect frames.
- *FDF* - one or more FDF bays with the capability to do all required FDF functions. These bays may be associated via internal cabling, or may be contiguous. Bays joined by external cabling, such as tie cables, are not considered a frame. A *single frame* is at least the minimal set of FDF bays required to do all FDF functions.
- *FDF network* - one or more FDF frames at a single location, such as a central office, that are interlinked to provide the FDF functions in common. These links are provided with external cabling.
- *FDF system* - an FDF network with its support services, including required planning, engineering, records, assignment, and operations support, and all FDF documentation including user quids.

#### 9.2.6.2.3 FDF Location

FDFs are needed in small and large central offices.

FDFs also may be placed in remote offices. These remote sites, typically small, are extensions of a central office, set up to serve a specific population center. Their use may be motivated by a lack of space in the central office or by high growth of digital facilities in a concentrated geographical area. These remote offices often experience high growth and are often unstaffed.

FDFs also may be installed at large customer locations. An FDF may also serve as the point of interface between a local exchange carrier and an IC.

---



---

#### 9.2.6.2.4 High Density Fiber Distributing Frame (HD-FDF)

In the past, fiber transmission systems were used mostly for interoffice applications. Now, fiber is being deployed in the loop in applications such as Fiber-In-The-Loop (FITL) and Fiber-To-The-Curb (FTTC). Consequently, the number of fibers that will terminate in central offices and at Controlled Environment Vaults (CEVs) will increase. There will also be a need to terminate fibers at customer premises.

HD-FDFs have been developed to meet the need to terminate a larger number of fibers using the same amount of floor space. GR-449-CORE classify FDFs according to their termination density into the following categories:

- Low-density or conventional-density FDF: up to 648 terminations per 7-foot bay
- HD-FDF: between 648 and 1440 terminations per 7-foot bay
- Very-High-Density FDF (VHD-FDF): over 1440 terminations per 7-foot bay.

The HD-FDF is intended for applications where large fiber counts are to be managed in a small amount of space. They will be used in central offices, CEVs, and at customer premises where space is limited.

#### 9.2.6.3 Optical DSX (ODSX) and Optical Interface Systems (OIS)

Central offices with all-fiber transport between central office equipment generally do not exist today. Most intra-office connections are still installed using metallic media, either wire pairs or coaxial cable. However, many central offices are in transition. Increasingly, central office equipment is becoming available with optical interfaces. The result is an ever-increasing number of intra-office fiber cables and associated terminations that need to be managed.

The traditional all-copper networks are rapidly evolving toward all-fiber networks. New transport technologies such as Synchronous Optical Network (SONET), Asynchronous Transfer Mode (ATM), and Wavelength Division Multiplexing (WDM) are evolving to support these demands with an increasing numbers of intra-office fiber facilities connecting equipment with optical interfaces. The desire is to minimize the number of optical-to-electrical and electrical-to-optical conversions within the central office to reduce capital costs as well as transmission performance delays. Therefore, the number of intra-office fiber terminations is expected to grow rapidly over the next few years.

Initially, Bellcore's view was that an optical equivalent to a metallic DSX—an Optical DSX (ODSX), such as that described in TA-NPL-000464 – could be the solution. The successful operation of a laboratory model of an ODSX has been demonstrated by Bellcore. Bellcore's efforts included participation in an optical signal interface development in the T1X1.4 Committee.

An ODSX was planned as a manually operated device that provides for the interconnection of optical terminal equipment in a wire center. The ODSX was expected to be the optical functional equivalent of a metallic DSX. This means that, in addition to the cross-connect functions of the FDF, the ODSX would provide test access and circuit rolling capabilities.

With the advent of intelligent network elements that provide remote cross-connection and test access capabilities, such as DCSs and Add/Drop Multiplexers (ADMs), it was thought that most or all of these intra-office facilities and their associated connections could be managed on the FDF, or if need be, on a separate intra-office FDF dedicated for this purpose. However, recent developments have shown the need for a device that can provide for nonobtrusive test access and non-service-affecting rearrangement and cutover flexibility. Bellcore's term for such a device is an Optical Interface System (OIS). Conceptually, an OIS would have the same functionality as an ODSX but at a lower cost per fiber termination. This is because an OIS achieves some of its functionality by the use of reusable external modules and/or smart patch cords similar to a DIS in metallic applications as described in [Section 9.2.4](#).

## 9.2.7 Other Cross-Connect Systems

The Feeder Distribution Interface (FDI) cross-connect and fiber demarcation boxes device is not usually considered to be common systems but is included for completeness.

### 9.2.7.1 Feeder Distribution Interfaces

FDIs are located in the outside-plant environment for interconnection of cable feeder pairs with subscriber-premises cable distribution pairs. The FDI is used typically for cross-connection of metallic wire, but an Optical Feeder Distribution Interface (OFDI) is available for optical cross-connection.

### 9.2.7.2 Fiber Demarcation Boxes

Fiber demarcation boxes are used to provide an interface between the telecommunication provider's network and individual customer cables. Fiber demarcation boxes are typically located on the customer's premises in controlled environments such as building basements or telecommunication equipment closets. GR-2898-CORE, *Generic Requirements for Fiber Demarcation Boxes*, addresses fiber demarcation box requirements.

---

### 9.2.8 Cross-Connect Automation

New cross-connect system design concepts, using new and existing technologies with a variety of innovative approaches, could automate a substantial part of the cross-connect function and address the limitations of manual technology. Plans for new network technologies are changing the view of how cross-connect systems should interact and what functions they should perform. Cross-connect automation is a popular goal of cross-connect system planners and network architects.

A cross-connect architecture describes the essential arrangements, configurations, and interconnections between various cross-connect systems in a central office and at remote locations in the loop network. A number of devices exist today that are capable of providing automated cross-connections using electronic components (for example, EDSX, DCS). These devices should be configured to provide appropriate capacity and should meet network-interface requirements when used to automate cross-connect functions.

As the number of fiber facilities grows, coherent and well thought-out strategies must be developed to manage large concentrations of fibers at hubs such as central offices, remote terminals, and building entrances.

The physical fiber optic media and the associated physical connections that are needed to provide broadband and other fiber-based services to customers are typically managed by FDFs. Automated Optical Cross-connects (AOXs) might permit quicker capacity and broadband service provisioning and remote access. It is hoped their future deployment would improve cross-connect efficiency by lowering costs and increasing service responsiveness.

Three factors are driving the need for the AOX.

- New Digital Technologies
- New Broadband Networks
- SONET Deployment.

An AOX system terminates standard optical signals and facilities and automatically cross-connects them and perhaps constituent (tributary) signals (these could be different wavelengths) according to an electronically alterable memory map. It is the optical analog of a DCS or an EDSX if no subrate or tributary cross-connections are provided. It could also function as an automated ODSX, if DSX test access was provided, but this may not be provided by most AOX systems.

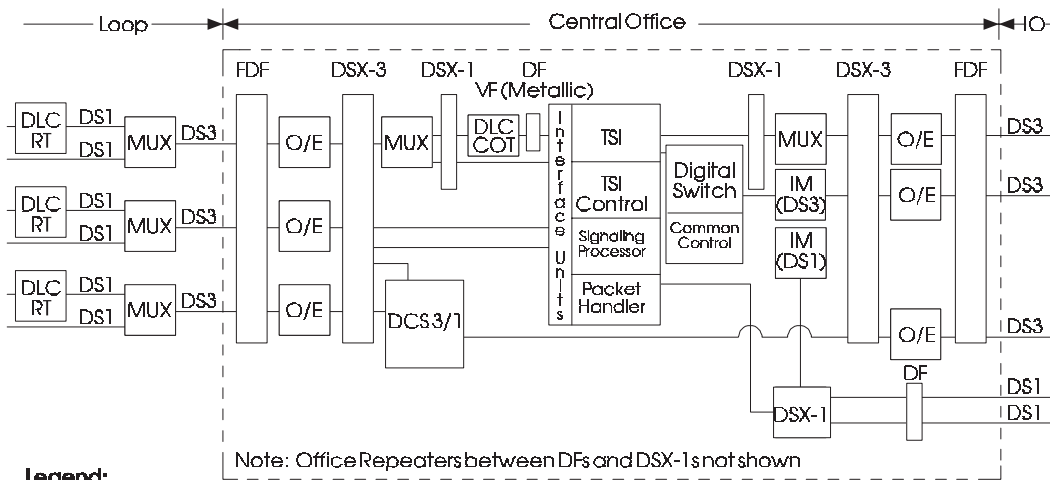
The term AOX system is used to distinguish these devices from manual cross-connect systems (e.g., FDFs). Along with other functions, an AOX can automatically cross-connect signals according to an electronically alterable memory map.

---

### 9.2.9 Cross-Connects in a Network

Cross-connect devices are located throughout the intraLATA networks. Figure 9-6 illustrates the cross-connect system devices discussed above. Planning organizations typically plan for the long-term evolution of the cross-connect network. An integral part of the plan usually involves traditional cross-connect systems shown in Figure 9-6. Figure 9-7 shows the use of various cross-connect systems that have been traditionally used in a central office network.

The impact of growth in services and the orderly expansion on the cross-connect system are factors important to the planning process. The plan choice should consider network flexibility, operational system support, and the ability to support new services.



**Legend:**

- COT = Central Office Terminal
- DCS = Digital Cross-connect System
- DF = Distributing Frame
- DLC = Digital Loop Carrier
- IM = Interface Module
- MUX = Multiplexer/Demultiplexer
- RT = Remote Terminal
- TSI = Time-Slot Interchange
- FDF = Fiber Distributing Frame
- O/E = Optical/Electronic Converter
- IO = Interoffice

Note: See Section 9.2.2 and Figure 9-5 for further information on DSX-3 and DSX-1.

**Figure 9-6.** Central Office Cross-Connect Network

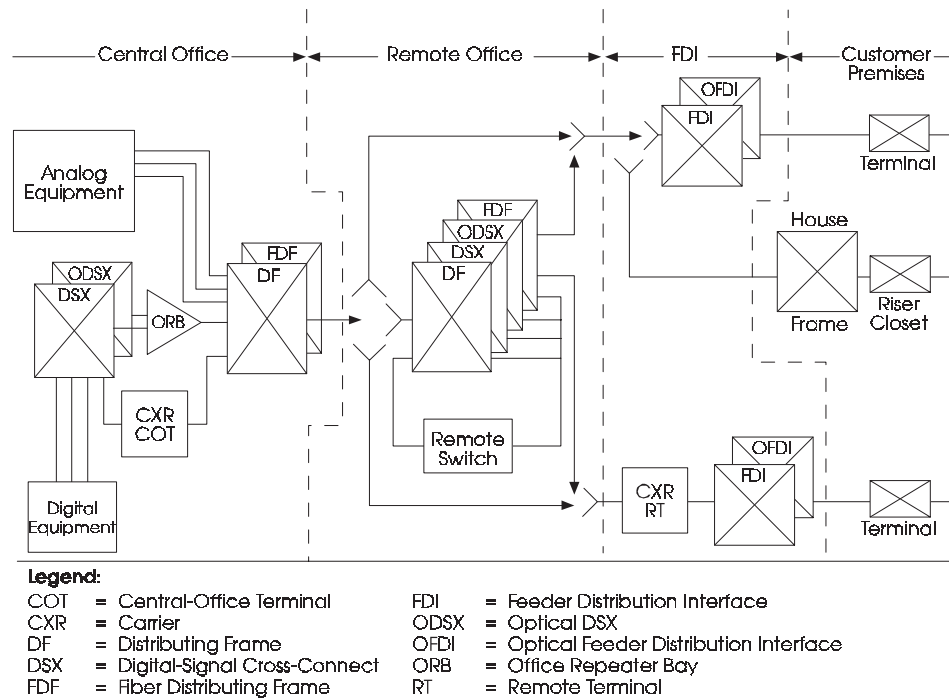


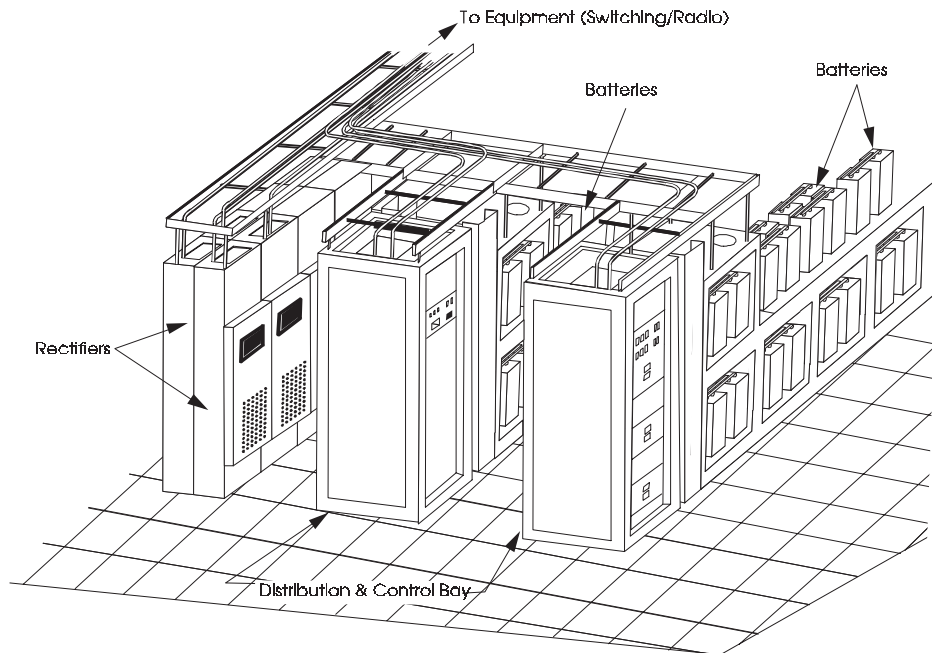
Figure 9-7. Cross-Connect Systems in a Telecommunications Network

### 9.3 Power Systems

Power systems provide two principal functions: the conversion of the commercial ac power source to dc voltages required by the network equipment, and the generation of emergency (reserve) power when the commercial power is interrupted. Because power systems have long operational lives, the existing plant contains a great variety of equipment and systems.

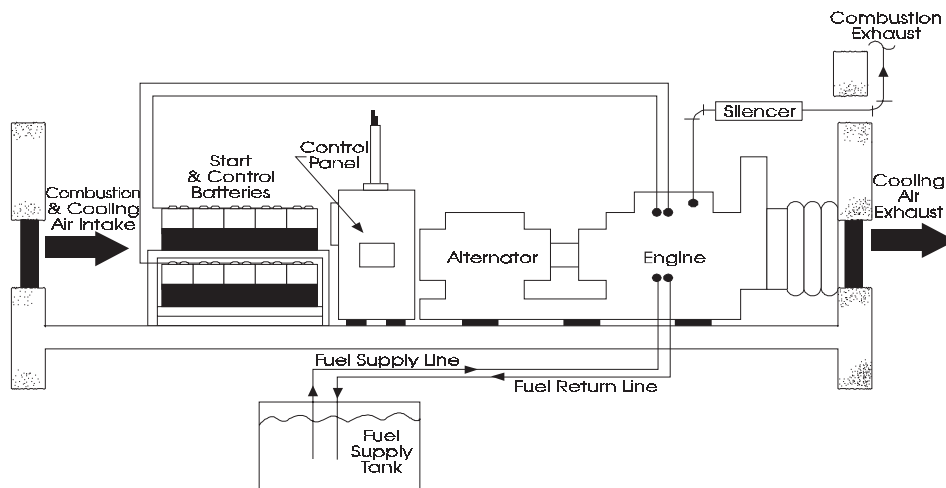
Figure 9-8 illustrates a typical central office bulk dc power equipment area. A centralized or bulk power plant used in confined locations has similar equipment and is usually mounted on no more than three frames. Confined locations are usually defined as areas with limited floor space or fixed enclosure locations. These locations are unattended and may have entrances that require the use of ladders. Examples of confined locations are electronic environmental enclosures and huts.

Reliability requirements of power system hardware equipment, overcurrent protection devices, and wire and cable are controlled by the system powered. Generic requirements for hardware reliability, including redundancy, are given in Section 3.3.3 of TR-NWT-000474, *OTGR Section 4: Network Maintenance: Alarm and Control — Network Element*.



**Figure 9-8.** DC Power Plant

The primary ac energy source is usually the public electric utility, although other sources, such as solar energy, have been used in unusual circumstances in inaccessible sites such as mountain tops. Emergency or reserve energy sources include, for example, electrochemical cells and alternator sets. The electrochemical cells are usually flooded and valve-regulated lead-acid batteries, while the alternator sets are usually powered by diesel engines or turbines. Figure 9-9 provides a view of a typical emergency or reserve ac power system.



**Figure 9-9.** Standby AC Power System

### 9.3.1 Supported Equipment

Equipment supported by power systems includes virtually all the active circuit components in central offices and confined locations. In addition to the active network circuit elements, the energy system may support mechanical equipment such as air-conditioning and ac-operated computer systems where the operations systems reside.

Network power requirements range from 10 kW to several megawatts in central offices and from 2.5 kW to 24 kW at remote sites. Typical dc voltages required by various equipment in the central office range from  $\pm 24$  V to +140 V. The most frequent voltage found in central offices is -48 V.

Confined locations have power plants with *only* -48 V. These confined-location power plants are called bulk power plants.<sup>6</sup> The equipment in a central office derives subvoltages from these base values as required by embedded power-conversion circuits. Where -48 V power plants are the only source of power available and other voltage values are needed such as  $\pm 130$  V or +24 V, these voltages are provided by bulk dc-to-dc converter plants.

Components of a power system include rectifiers, distribution (including overcurrent-protection devices), batteries, standby ac plants, dc-to-dc voltage converters, and dc-to-ac inverters for use by ac-operated equipment within the network or for ancillary equipment.

#### 9.3.1.1 Battery-Plant Voltage Limits

Existing power plants with 24 V, -48 V, 130 V, and +140 V have been engineered to provide the voltages shown in Tables 9-2 and 9-3 at the power distribution frame (board). These values may vary depending on the engineered distribution voltage drop. (For more information about 24-cell, valve-regulated batteries, refer to TA-NWT-000406, *DC Bulk Power System for Confined Locations*.)

**Table 9-2. -48 V Power Plant Limits**

State	24-Cell Battery- Only Plant* (dc V)
Normal	-55.0 to -50.8
Emergency	-60.0 to -43.75
Transient**	-62

\* This range includes the voltage levels required for 24-cell, valve-regulated batteries.

\*\* The duration of the transient voltage shall not exceed 300 ms.

6. If power sources are embedded within the equipment, for example in digital loop-carrier equipment, the power is called *dedicated*. These sources are not general-purpose power sources.

**Table 9-3.** 24-V, 130-V, and 140-V Power Plant Limits

State	24-V Battery Plant (dc V)	130-V Battery Plant (dc V)	140-V Battery Plant (dc V)
Normal	25.4 to 27.5	133.50 to 134.00	158.75 to 156.25
Emergency	22.25 to 30.0	103.25 to 148.8	120.0 to 160.0
Transient*	32	Not Applicable	160

\* The duration of the transient voltage shall not exceed 300 ms.

**Note:** Transient voltage limits described above are the short-term voltage levels that equipment operating from the power plant must withstand (without self-destruction) while maintaining the expected operating limits of the equipment.

### 9.3.2 A/B Distribution

Distribution systems today contain feeders from the battery discharge circuit to the first or primary overcurrent and distribution system. From the primary distribution system, many systems rely on two feeders to prevent loss of power for call processing, and are independently overcurrent-protected. If the protection device should fail or a fault should occur on one of the feeders, the alternate feeder provides power to the load. Each overcurrent-protection device and feeder are engineered for the current and voltage drop required to power all the equipment from one feeder. This arrangement is called an A/B distribution system.

### 9.3.3 Rectifiers

Commercial ac power is channeled through two or more rectifiers connected in parallel that float-charge the batteries and supply power to the network equipment. Most rectifiers in use today have power ratings in the 5- to 40-kW range for central offices and in the 1.25- to 2.5-kW range for confined locations. Typical rectifiers maintain the dc output voltages to within  $\pm 0.5$  percent of the nominal float-voltage value to promote longer battery life.

The output voltage is filtered to smooth the dc voltage provided to the network equipment. Additional filtering is provided on equipment to reduce audible noise on subscriber lines (talk power) if the power for the subscriber lines is not converted within the switching equipment.



### 9.3.4 Noise-Voltage Objectives

#### 9.3.4.1 Voice

Table 9-4 shows the voice noise-voltage limits for the different power plants. The noise-voltage instrument set measures noise voltages for an input impedance of 600  $\Omega$ .

**Table 9-4.** Voice-Frequency Plant Noise-Voltage Limits

Plant Type	Value	Units
24 V	56	dBrnc
48 V	56	dBrnc
130 V	70	dBrnf (3 kHz Flat)
140 V	92	dBrnf (3 kHz Flat)

#### 9.3.4.2 Broadband

The broadband noise-voltage objective for 24-, 48-, and 140-V power plants is a limit of 100 mV rms in any 3-kHz band between 10 kHz and 20 MHz. *The noise limit for the 130-V power plant is 3.67 mV in any 3-kHz band between 10 kHz and 550 kHz.* **Note:** Historically, this requirement was given as 50 dBrnf with a 7A Noise Measuring Set (NMS) at 135  $\Omega$ .

### 9.3.5 Protection

The power system also has voltage detectors that can shut down defective rectifiers to avoid damage. Low-voltage disconnects are provided in some power plants to protect equipment from low-input voltage damage and to prevent individual cell damage within battery strings. Overcurrent protection is provided, with fuses or circuit breakers, for the distribution wire and cable. These overcurrent-protection devices help to prevent catastrophic events, such as fires, during short circuits or overloads in the electronic power distribution cabinets or distribution systems.

Controllers with electromechanical or microprocessor control are employed to provide plant shutdown controls, to measure plant current and voltage, and to provide alarms if the plant voltage or current values are not within limits. Microprocessor controllers provide data acquisition and limited diagnostic capability. They also permit remote access to obtain the status of the plant's operating conditions and alarms.

### 9.3.6 Grounding

Both ac and dc grounding systems at central offices and confined locations must adhere to operational and safety requirements. These requirements are for conductors, bonding, fault-current paths, and low-impedance paths between grounding points. All of the requirements are aimed at helping to prevent hazardous conditions, electrical shocks, electrical fires, electrical interference, and system deterioration.

Grounding requirements are controlled for three types of systems. One type is ac systems, as discussed in the *National Electrical Code (Article 250)*. The other types are dc power and communication systems, which are explained in the following three documents:

- FR-64, *LATA Switching Systems Generic Requirements (LSSGR)*
- TR-NWT-000295, *Isolated Ground Planes: Definition and Application to Telephone Central Offices*
- GR-63-CORE.

### 9.3.7 Batteries

When commercial power is lost, all critical equipment operating from the dc power sources contained within the central office or remote location receives power from the batteries. If ac input equipment is contained in the site and must function during ac power outages, then dc-to-ac inverters are provided, with their input voltage obtained from the battery in the dc power plant. Batteries provided in these applications usually have the capacity to supply energy to the load equipment for a minimum of 3 hours to a maximum of 8 hours.

### 9.3.8 Uninterruptible Power Systems

When special protection is required for ac-powered systems supporting network or ancillary functions, such as the Emergency 911 computer system or Automatic Message Accounting (AMA) equipment, then Uninterruptible Power Systems (UPSs) are provided. Usually these UPSs have dedicated rectifiers and batteries and do not operate from the dc battery plant powering the network equipment. Batteries provided in these applications have the capacity to supply energy to the load equipment for a minimum of 5 minutes to a maximum of 8 hours, depending on the local equipment's function in the network. If an orderly shutdown of the equipment is needed, then the 5- to 15-minute reserve time is provided. If the equipment must be kept online to serve the network, a longer reserve time is provided.

With a standby stationary alternator set (Figure 9-9), energy for the network can be supplied for an extended period (from hours to weeks).

---

Confined locations normally *do not* contain standby stationary alternator sets. These sites usually rely on the movement of portable alternator sets to the site to provide power when the outage is expected to last more than the battery reserve time allocated.

### 9.3.9 DC-to-DC Converters

Depending on total load requirements and the sensitivity of specific components to voltage levels, a dc-to-dc converter may be located directly on the circuit pack it serves. Otherwise, dc-to-dc converters, commonly called *embedded converters*, convert the bulk dc battery voltage to the voltage necessary to operate the electronics in a shelf or frame. Multiple embedded converters can be provided to obtain redundancy for availability (reliability). Multiple converters are sometimes provided when the individual converter's power rating is not sufficient to power the load equipment. Then the converters are grouped to power loads on a shelf or on multiple shelves.

### 9.3.10 DC-to-AC Inverters

AMA and ancillary equipment supporting network systems that affect service are examples of equipment requiring an uninterruptible power source. Dc-to-ac inverters driven directly from the bulk power plant are often used. Dedicated UPSs are often provided when the ac load equipment needs conditioned ac power. These systems also provide the battery for powering the load during ac power outages. *The battery voltage in UPSs may not be -48 V, but may be dc voltages of up to 450 V.*

## 9.4 Network Equipment-Building System

A telephone central office building with its mechanical, electrical, and structural systems provides a protected environment for the network equipment. Similar protection may be provided at confined electronic equipment locations (for example, enclosures above or below ground, or in leased commercial spaces). Central office or remote network equipment and the associated enclosure are strongly interrelated and are major components of the NEBS. Coordinated design and implementation of the equipment and building subsystems are essential to manage space utilization, temperature, humidity, air quality, acoustic noise, illumination quality, electromagnetic compatibility, electrostatic discharge, electrical protection and safety, fire prevention and protection, earthquake protection, and office vibrations.

---

### **9.4.1 Equipment**

The network equipment includes switching, transmission, power, cross-connect, and operations systems, together with their associated cabling, cable racks, frame-and-aisle lighting, and equipment-support subsystems such as raised floors and overhead bracing, where required. GR-63-CORE provides spatial and environmental requirements for the equipment. Spatial requirements address framework dimensions, line-up conformity, framework interfaces with cable racks and floors, floor loading, and vertical space allocations. Environmental requirements address ambient temperature and humidity, heat dissipation, fire resistance, handling and transportation, earthquake and office vibration, airborne contaminants, grounding, acoustic noise, illumination, electromagnetic compatibility, electrostatic discharge, loop electrical environment, electrical safety, and corrosion.

GR-63-CORE provides requirements for the assembly of equipment and cable racks within the central office building. It also addresses the relationships between the network equipment and the building subsystems, such as smoke detection and cooling air distribution.

### **9.4.2 Buildings**

In addition to providing shelter from inclement weather, the buildings that house network equipment provide essential environmental control, commercial power distribution, structural support, and physical protection. The building's air-conditioning and filtration plants control equipment temperature, humidity, and air quality. With some exceptions as noted in Section 9.3, commercial ac power feeds the building systems and the battery plants that supply dc power to the network equipment. Building floors, columns, and ceilings, the design of which is governed by local and state building codes, support the equipment weight and provide resistance to seismic and other lateral forces. Electrical grounding systems reduce circuit crosstalk and impulse noise and also protect the network equipment from electrical faults and lightning strikes.

### **9.4.3 Fire Resistance**

Detection, alarm, and air-handling systems, together with structures that control the spread of fire and smoke, protect the network equipment from damage and disruption of service due to fire. All new central office equipment systems and retrofit to existing equipment systems must meet the fire-resistant requirements defined in Section 4.2 of GR-63-CORE. Any cables, components, or other material that does not meet these specifications must submit to special fire tests.

---

#### 9.4.4 Cable-Entrance Facility

The Cable-Entrance Facility (CEF), once termed the *cable vault*, is the interface between the central office and the distribution network. There are three types of CEFs: *above-surface* (in vaultless offices), *subsurface* (in cable vaults), and *duplex* (in multistory offices). The CEF serves five functions.

1. Common entrance for feeder, interoffice, and toll cables
2. Cable pressurization point for the distribution cable network
3. Space where cable corrosion protection measures are applied
4. Location for routing riser cables and bridging feeder cables
5. Location for splicing feeder and riser cables and terminating-connector stub cables.

The subsurface CEF is generally located directly under one or more distributing frames. The above-surface CEF is often adjacent to the terminating frame and located on the first level of the central office building. With the exception of the auxiliary CEF, both types are enclosed. To comply with the NEBS fire-resistance recommendation, an enclosed CEF is surrounded on all sides by walls, partitions, or other fire protection isolating structural elements to separate this space from adjacent building spaces.

Duplex CEFs combine the design features of both the above-surface and the subsurface CEFs. A duplex system is often used whenever several terminating frames are required on more than one level in the same central office building (Figure 9-10).

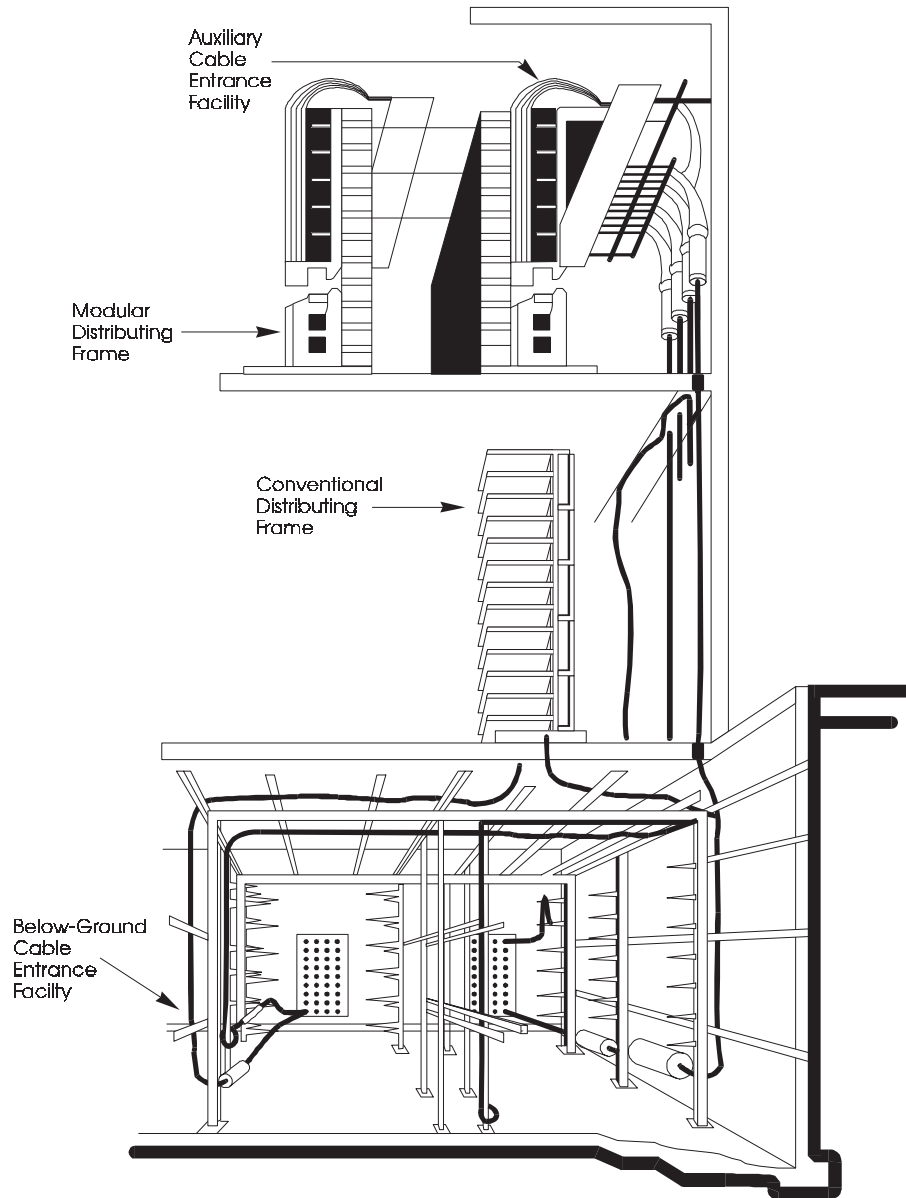


Figure 9-10. Duplex Cable-Entrance Facility

---

## Section 10

### Surveillance and Control

### Contents

10. Surveillance and Control.....	10-1
10.1 Network Traffic Management.....	10-2
10.1.1 Network Traffic Management Principles.....	10-4
10.1.2 Network Traffic Management Functions.....	10-5
10.1.3 Network Traffic Management Technology.....	10-8
10.1.3.1 Circuit-Switched Operations Support.....	10-8
10.1.3.2 CCSN Operations Support.....	10-10
10.1.4 Network Traffic Management Controls.....	10-10
10.1.4.1 Circuit-Switched Network Controls .....	10-10
10.1.4.2 Common Channel Signaling Network Controls .....	10-15
10.1.4.3 Network Traffic Management Methods .....	10-24
10.1.4.4 Summary of Network Traffic Management Controls.....	10-27
10.2 Network Service Center (NSC).....	10-28
10.2.1 Network Service Center Functions .....	10-28
10.2.1.1 Intercompany Technical Coordination and Liaison Process .....	10-29
10.2.1.2 Network Service Evaluation Process.....	10-29
10.2.1.3 Network Trouble Localization Process .....	10-30
10.2.1.4 Summary of Network Service Center Functions .....	10-30
10.2.2 NSC Interfaces and Applications.....	10-31
10.2.3 NSC Analysis and Evaluation Methods.....	10-32
10.2.3.1 Trouble Reports .....	10-32
10.2.3.2 Intercompany Technical Coordination and Liaison .....	10-32
10.2.3.3 Interaction with ICs and Small Independent LECs .....	10-33
10.2.3.4 Summary of Analysis and Evaluation Methods .....	10-33

---

---

## List of Figures

Figure 10-1. Network Performance at Overload Condition .....	10-6
Figure 10-2. Network Congestion .....	10-7
Figure 10-3. Current NTMOS Interfaces .....	10-9
Figure 10-4. Cancel From (CANF) .....	10-12
Figure 10-5. Cancel To (CANT) .....	10-12
Figure 10-6. Skip (SK) .....	10-13
Figure 10-7. Selective Incoming Load Control (SILC) .....	10-15
Figure 10-8. Typical CCS Network .....	10-16
Figure 10-9. General Structure of Signaling System Functions/Levels .....	10-18

## List of Tables

Table 10-1. External Network Service Center Inputs .....	10-31
Table 10-2. External Network Service Center Outputs .....	10-31



---

## 10. Surveillance and Control

The major objectives of the Local Exchange Carrier (LEC) Network Surveillance and Control Organizations are to maintain a high level of network element utilization, minimize the effect of network overloads, and support the LECs' National Security/Emergency Preparedness (NS/EP) commitment. The following important functions that contribute to attaining these objectives are:

- Network Traffic Management (NTM)
- Network service.

An overview of each of these functions follows. Section 10.1 describes NTM, and Section 10.2 describes network service.

*General:* The definition of a modern telephone network is changing as customer needs change. The telephone network is evolving into subnetworks, the combination of which makes up the modern network. These subnetworks include, but are not limited to, the following:

- Plain Old Telephone Service (POTS)
- Public Packet Switched Network (PPSN)
- Common Channel Signaling Network (CCSN).

Some of these subnetworks (such as CCSN) have dynamic NTM control intelligence built directly into their protocol, for example, Signaling System Number 7 (SS7). Many new services (for example, Toll Free Database Service) that are part of the CCSN also contain dynamic NTM control capabilities. While these controls are an important part of the CCSN, they do not replace the manual controls already in place.

*Network Traffic Management Center:* LEC NTM organizations provide real-time surveillance and control of message traffic in the Local Access and Transport Area (LATA) networks. Their goal is to increase call completions and optimize the use of available trunks and switching equipment. Several dedicated Operations Support Systems (OSSs) aid them in achieving this goal by accumulating information on both the flow of traffic and the manual and automatic/dynamic control capabilities provided in LEC switching elements. Using this information and control capability, network traffic managers can optimize call-carrying capacity in their networks. The OSSs also enable network traffic managers to interact with the network to minimize the adverse effects of traffic overloads and machine and/or facility failures.

Because of its role in ensuring the performance of the total network, NTM also plays a role in NS/EP planning.

The Bellcore family of systems called Customer Network Management (CNM) systems focuses on the customer's desire to manage and control the activities associated with operations systems, switching systems, and their private network facilities. Even though

---

these systems are associated with the term “network management,” they are not directly associated with LEC intraLATA NTM and, therefore, will not be discussed in this section. CNM is discussed in Section 5.

*Network Service Center:* Many LECs have organized a Network Service Center (NSC) to help ensure that high-quality network service is provided. The LEC NSC initiates appropriate maintenance efforts to help provide a high grade of access service to and from Interexchange Carriers (ICs), independent LECs, and other entities. It is important to correct in a timely manner any problems that could cause unsatisfactory network service. This effort, by necessity, involves all interconnected networks and requires the coordinated involvement of the LEC, ICs, independent LECs, and other interconnected entities.

*Service Evaluation Center:* A third group organized by many LECs is the Service Evaluation Center (SEC). The SEC provides corporate-level quality assessment of end-to-end network service. The focus of the SEC is the availability, suitability, and billing integrity of both the customers’ contact services (calls to operators, calls to repair service, and calls to the business offices) and the total network Message Telecommunications Services (MTSs) that are provided automatically by network equipment.

## 10.1 Network Traffic Management

Most LEC networks are engineered and equipped to provide acceptable levels of service during normal traffic-load periods. When customer demands or equipment malfunctions cause a deviation from the engineered requirements or when heavier than normal calling occurs, modern networks can become congested and network throughput can be adversely affected. NTM provides a means to improve the performance of the network during these situations.

LEC NTM organizations oversee the performance of the circuit-switched network and control the flow of traffic, when necessary, to obtain the maximum use of network capacity. Circuit-switched trunk signaling may be conventional or via the CCSN.

The CCSN SS7 protocol contains an extensive set of automatic network management procedures. These procedures deal with congestion and failures in the signaling network and help the protocol support highly reliable low-delay transport of signaling information. As a result, signaling traffic is automatically rerouted around failed routes if alternate routes exist and is stopped as close to the point of origination as possible in the case of congestion.

Because humans cannot respond fast enough to deal with overload situations that might occur in high-speed packet networks of this type, there are no direct manual controls for signaling traffic that would be analogous to the manual code or trunk-group controls of the circuit-switched network. The automatic signaling network management procedures, combined with the manual and automatic controls in the circuit-switched network, are generally sufficient to maximize the performance of the overall network.

---

---

The LEC OSSs used to perform this function are primarily the Network Data Collection Operations System (NDCOS), the Network Traffic Management Operations System (NTMOS), the SEAS system, and the Service Management System (SMS). The LEC NTM personnel using these OSSs may be in one LEC organization or several different organizations, each responsible for NTM of a particular subnetwork (for example, POTS or CCSN).

Maximizing network performance requires planning for anticipated peak periods; developing contingency plans for unexpected events such as storms, floods, and civil disturbances; and implementing control actions where required. Many LEC Network Management Centers (NMCs) use the following work functions to manage the network:

- Monitor the flow of traffic in the network on a real-time basis
- Collect and analyze network performance data
- Identify abnormal network situations
- Investigate and determine the reasons for network traffic-flow problems
- Activate network controls or other corrective action
- Cooperate with ICs, other LECs, and other LECs exchanging information on matters of common interest in planning for interconnection
- Coordinate activities with facility and switching system maintenance personnel to minimize the impact of outages.

The ultimate objective of NTM is to complete as many calls as possible (over existing facilities). The NMC provides for the surveillance and control of the traffic flow to and from the IC Point of Termination (POT) and for network service within the LATA. The NMC activities include active surveillance of LATA and interLATA access trunking and switching systems and taking the appropriate measures to protect the intraLATA network from congestion and failure.

NTM maintains a high level of service to the customer. By diligently monitoring the individual network components and total network performance, NTM can ensure the most efficient use of existing network capacity. This has the following five significant results:

- Increased number of completed calls
- Higher return on network capital investment
- Improved customer service
- Protected essential services, such as 911, during abnormal network situations
- Reduced cost from reduced customer reports.

The existence of an NTM capability does not eliminate the need to engineer the network adequately to provide sufficient network capacity for satisfactory service under normal load conditions. It is NTM's responsibility to institute temporary measures to compensate

---

for network problems during overload and/or failure conditions as well as temporary equipment shortages due to pending switch additions, facility additions, transitions, and conversions.

### 10.1.1 Network Traffic Management Principles

NTM decisions are generally guided by four principles, which apply regardless of switching technology, network structure, signaling characteristics, or routing techniques. All NTM control actions should be based upon at least one of the following principles.

1. *Keep all trunks filled with messages.*<sup>1</sup> Since the network is normally trunk-limited, it is important to optimize the ratio of messages to nonmessages<sup>2</sup> on any trunk group. When unusual conditions occur in the network and cause increased short holding-time calls (nonmessages), the number of carried messages decreases because nonmessage traffic is occupying a larger percentage of network capacity.

NTM controls are designed to reduce nonmessage traffic and allow more call completions. This results in higher customer satisfaction and increased revenues from the network.

2. *Give priority to single-link connections.* In a network designed to automatically alternate route calls, the most efficient use of available trunking occurs when traffic loads are at or below normal engineered values. When the engineered traffic load is exceeded, more calls are alternate-routed and, therefore, must use more than one link to complete a call. During overload situations, the use of more than one link to complete a call occurs more often, and the possibility of a multilink call blocking other call attempts is greatly increased. Thus, in some cases it becomes necessary to limit alternate routing to give first-routed traffic a reasonable chance to complete. Some NTM controls block a portion or all of alternate-routed calls to give preference to first-routed traffic.
3. *Use all available trunking.* The network is normally engineered to accommodate Average Business Day (ABD) busy-hour calling requirements. Focused overloads (storms, floods, and civil disturbances) and holiday calling often result in greatly increased calling and drastic changes from the calling patterns for which the network is engineered. This aberration can also be caused by facility failures and switching system outages. In these cases, some trunk groups are greatly overloaded, while others may be virtually idle. NTM controls can be activated in some of these cases to use the temporarily idle capacity in the network. These controls are known as reroutes.

---

1. A message is a successfully completed call.

2. A nonmessage is a call that does not complete to the number dialed and is typically an ineffective attempt.

---

---

It must be noted that reroutes have become more complex in the intraLATA network with the provision of new network services. Each service or Feature Group has unique characteristics that the network traffic manager must take into consideration when rerouting. Billing, transmission, and translation issues all require careful planning before implementation.

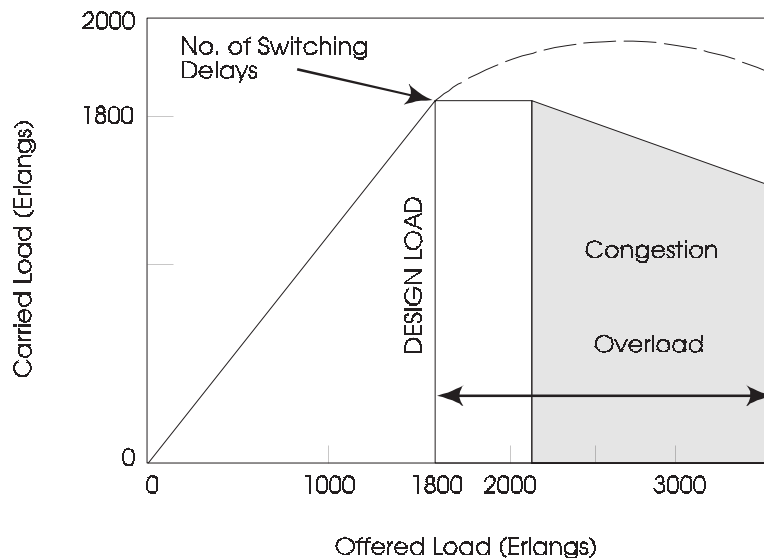
4. *Inhibit switching congestion.* A switching system is engineered to handle the expected number of attempts generated over its trunk groups with little or no service degradation. However, large numbers of ineffective attempts that exceed the engineered capacity of the switching system can result in switching congestion. If this switching congestion is not relieved, it not only affects potential messages within the congested switching system, but it can also cause connected switching systems to become congested. Therefore, NTM controls are available that can remove the ineffective attempts to a congested switching system. These controls result in inhibiting the switching congestion and preventing its spread to adjacent switching systems and networks.

### 10.1.2 Network Traffic Management Functions

The need for NTM is apparent considering the various types of overloads that can occur in the network and in its individual components. The following are several types of overloads for which network traffic management controls can provide complete or partial relief.

- *A general network overload* is caused by changes in traffic patterns and/or increased traffic load. These changes may be generated by a reduced business week (heavier calling before and after an extended weekend), holiday traffic, local or seasonal changes such as an increase in tourist traffic, unanticipated growth, and disasters. In cases of general network overload, a large amount of the network capacity may be used to switch calls that have a poor chance of completing. These calls are often regenerated many times by both the calling customers and switching systems before they are completed. This results in contention between the “poor completers” and those calls having a better chance of completing. Because of the volume of regeneration to the poor completers, much of the available trunking and switching capacity is used in switching these calls to an overflow route or announcement.

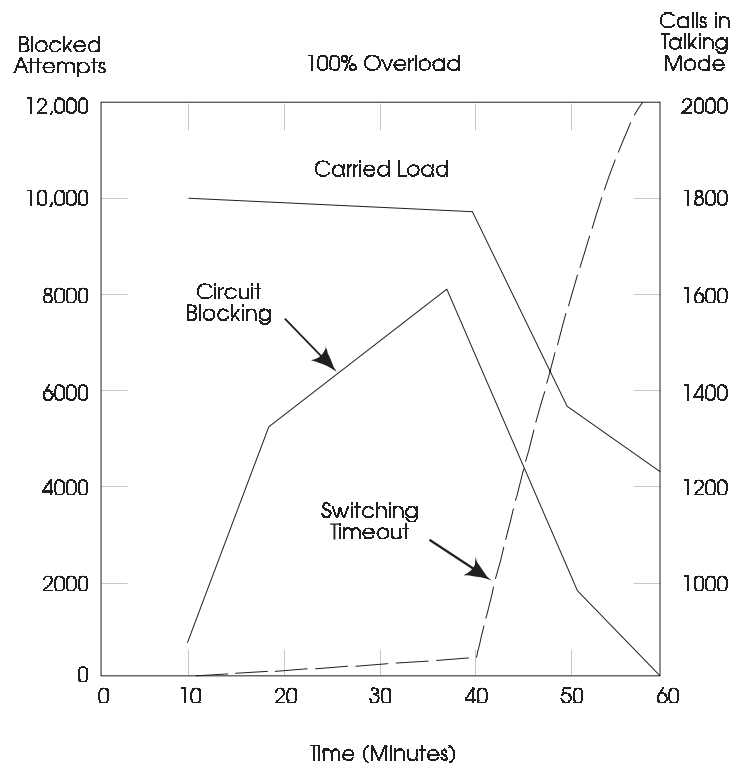
As NTM personnel identify poor completers, appropriate measures are instituted, when necessary, to control congestion and remove some or all of these calls from the network. This is done by using code-blocking, call-gapping, and protective trunk-group controls. The control of poor completers can greatly increase the number of messages handled by the network. Figure 10-1 depicts the typical network performance under a general overload. This figure indicates the reduction of completed traffic when the offered load exceeds engineered capacity and congestion is present and the increased number of calls encountering switching delay.



**Figure 10-1.** Network Performance at Overload Condition

- A *focused overload* is generally directed toward a particular location and may result from media stimulation (news programs, advertising, call-in contests, telethons) or events that cause mass calling to government or public-service agencies, weather bureaus, or public utilities. Without the application of appropriate network controls, the effects of these types of overloads could spread throughout the network. Focused overloads are normally managed using code controls or, if anticipated, trunk-limited or choke networks.
- A *switching system overload* occurs because each individual switching system is engineered to handle a specific load volume known as engineered capacity. The engineered capacity is usually less than the total switching capacity. When the load is at or below engineered capacity, the switching system handles calls in an efficient and reliable manner. However, when the load increases beyond the engineered capacity, delays can occur within the switching system's internal components, causing one piece of equipment or software to wait for a succeeding component. The resulting internal congestion can also cause connected systems to wait for start-dial indications. This can also cause internal congestion in connected switching systems.

Figure 10-2 demonstrates the buildup of switching delay over time and its effects on the carried load for a model network designed to carry about 1600 erlangs of simultaneous calls. This model network was subjected to a 100-percent overload (that is, a load twice that of the design load). The left ordinates of Figure 10-2 indicate the number of attempts lost due to circuit blocking or switching-delay timeouts.



**Figure 10-2.** Network Congestion

At the onset of the overload, also known as circuit shortage, the dominant cause for customer blockage is the failure to find an idle circuit. Circuit blocking alone limits the number of extra calls that can be completed but does not cause a significant loss in the call-carrying capacity of the network below its maximum. As the overload persists and the network enters a congested state, regenerated-calling pressure changes customer blockage from circuit shortage to switching delays.

Switching delays cause timeout conditions during call setup and occur when switching systems become severely overloaded. Timeouts are designed into switching systems to release common-control components after excessively long delay periods and provide the customer with a signal indicating call-attempt failure. Switching-congestion timeouts with short holding-time attempts on circuit groups replace normal holding-time calls. Switching delays spread quickly throughout the network.

- A *trunk-group overload* usually occurs during general or focused overloads and/or atypical busy hours. Some of the overload causes not discussed above are facility outages, inadequate trunk provisioning, and routing errors. The results of a trunk-group overload can be essentially the same as those previously discussed for general



overloads. However, the adverse effects are usually confined to the particular trunk group or the apex area formed by the trunk group and those groups' alternate-routing to the overloaded trunk group. Trunk-group overload problems can often be minimized or handled completely by the temporary use of NTM reroute controls until a more permanent solution can be provided.

NTM groups are equipped to identify network overload situations rapidly and take appropriate action to inhibit congestion and prevent its spread before service degradation occurs.

### **10.1.3 Network Traffic Management Technology**

NMCs can continuously monitor and control a large variety of switching systems within their areas. Information is passed from each equipped switching system, usually via an NDCOS, to an NTMOS that provides NTM personnel with timely information in predetermined intervals on the use of switching system resources. If a problem develops in the NTM-controlled cluster of offices, the network traffic manager can activate the appropriate NTM controls.

#### **10.1.3.1 Circuit-Switched Operations Support**

Widely deployed among the LECs, the typical NTMOS provides 30-second and 5-minute data. Data from these switching systems can be arranged in the NTMOS database to be displayed by LATA. The system can serve a number of LATAs from one location. Network traffic managers can monitor and control up to several hundred switching systems from one NTMOS-supported NMC. The NTMOS employs a computer and peripherals to provide centralized surveillance and control of switching systems and trunk groups. To accomplish this, the NTMOS does the following:

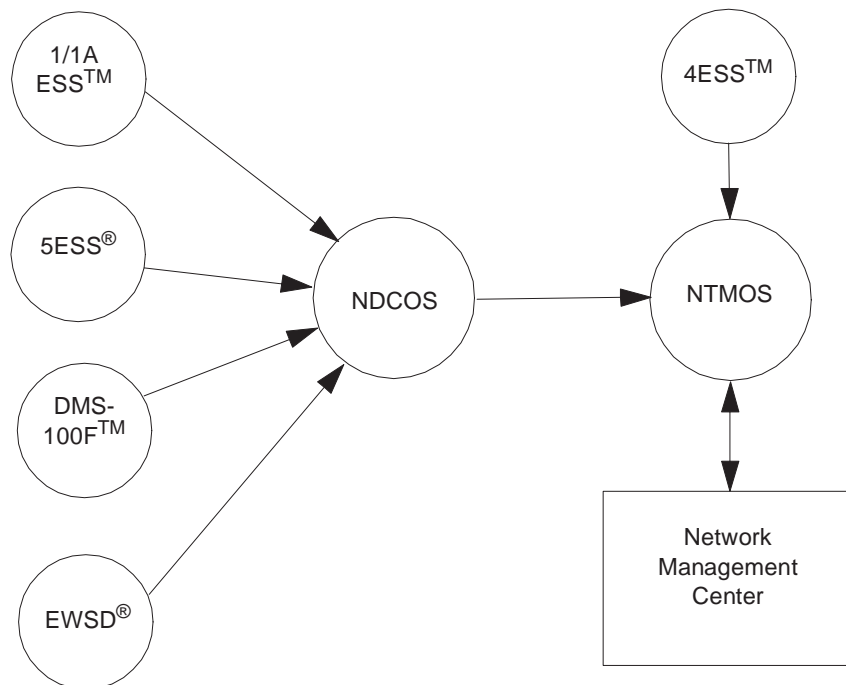
- Gathers network data and performs calculations every 5 minutes. The results of these calculations are matched against preset thresholds in the database. Results that equal or violate these thresholds cause the computer to activate indicators on the display and produce hard-copy exception printouts.
- Receives an update of discretets (off-on status conditions) every 30 seconds from switching systems that update indicator displays. These discretets alert the network traffic manager to a variety of potential network problems. Individual discretets are available to indicate overload program activation, control implementation, receive Automatic Congestion Control (ACC) signals, etc.
- Updates a display system organized to depict the relationships between the different switching systems that supply data to the system, which provides a visual indication of network conditions violating preset thresholds (for example, trunk-group attempt exceptions, switching system performance indicators, and trunk-group overflow



conditions). Each exception displayed can be investigated in detail through the use of a computer terminal and screens specifically designed for NTMOS. The screens are arranged so that the network traffic manager can move from a gross indication of a network problem to a more finite analysis.

- Provides indicators to the network traffic manager to activate manual controls and provides signals to override automatic controls in switching systems through interactive screen pages at the direction of network traffic managers. Control commands are usually communicated to the switching system by the NTMOS over the same interface through which data is collected from the system.
- Provides administrative reports concerning final trunk-group no-circuit conditions, trunk-network conditions, machine attempts, individual common-control usage and attempts data, and call-delay information. Several of these reports can also be helpful to the NSC in analyzing network problem areas.

Several of the switching systems are connected to the NTMOS (see Figure 10-3) through an intermediate computer-based NDCOS. The 4ESS switching system has its own DCOSs and interface with the NTMOS via direct data links.



**Figure 10-3.** Current NTMOS Interfaces

### 10.1.3.2 CCSN Operations Support

To take control action on the CCSN when appropriate, the network traffic manager needs surveillance data. Even though the network traffic manager does not generally augment the Common Control Signaling (CCS) automatic controls with manual controls, the network traffic manager should be aware of problems in the CCSN. Otherwise, the network traffic manager who sees the effects of a CCS-related problem in the circuit-switched network but is unaware of the specific cause may take inappropriate action in response.

## 10.1.4 Network Traffic Management Controls

This section describes the various types of controls that are available for NTM.

### 10.1.4.1 Circuit-Switched Network Controls

There are two broad categories of NTM controls.

- *Protective controls* — These controls remove traffic from the network during overload conditions. This traffic is usually removed as close as possible to its origin, thus making more of the network available to other traffic with higher probability of completion.
- *Expansive controls* — These controls reroute traffic from routes experiencing overflows or failures to other parts of the network that are lightly loaded with traffic because of noncoincident trunk and switching system busy hours.

Implementation of either type of control can be accomplished on a manual or automatic basis; for example, manual controls are activated by network traffic managers, and automatic controls are activated by network components. In some switching systems, these controls are implemented on a planned control-response basis that is preprogrammed into the switching system. In other systems, controls are available on a flexible basis, whereby any control can be assigned to any trunk group on a real-time basis.

The availability of any specific control, its allowable control percentages, and the method of operation can vary with the specific type of switching system and is discussed in greater detail later in this section. In many instances, these network controls can be activated with variable percentages of traffic affected (for example, 25, 50, 75, or 100 percent) to fine-tune the control to match the magnitude of the problem. Some switching systems also allow further control selectivity by the use of Hard-To-Reach (HTR) code-determination algorithms or specification of alternate-routed traffic, direct-routed traffic, or combined direct- and alternate-routed traffic-control choices. The most common manual controls are described below.

- *Cancel controls* consist of two variations (see Figures 10-4 and 10-5). “Cancel From” (CANF) potentially prevents overflow traffic from a selected trunk group from
-

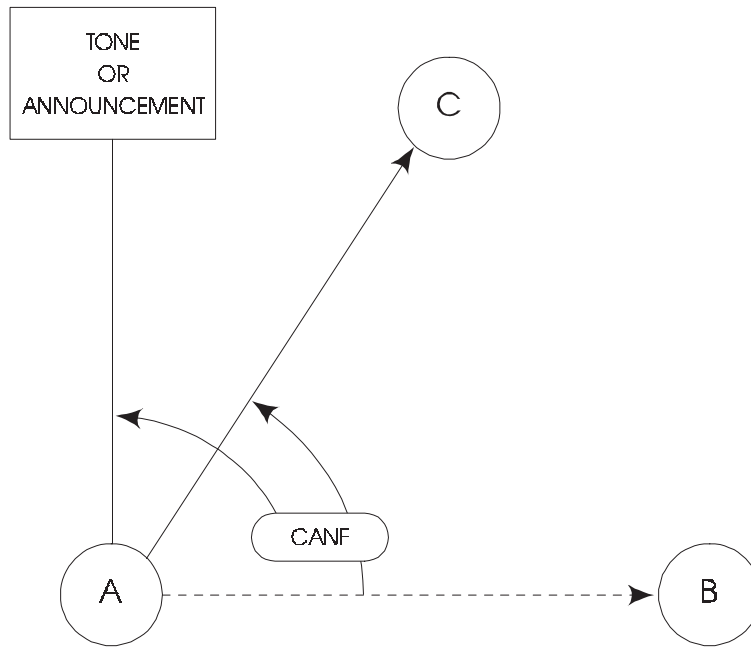
---

advancing to any alternate route. “Cancel To” (CANT) potentially prevents all sources of traffic from accessing a specific route. Some control arrangements permit CANF and CANT to be applied to alternate-routed or direct-routed traffic or both. All cancel controls are implemented on a percentage-of-traffic basis.

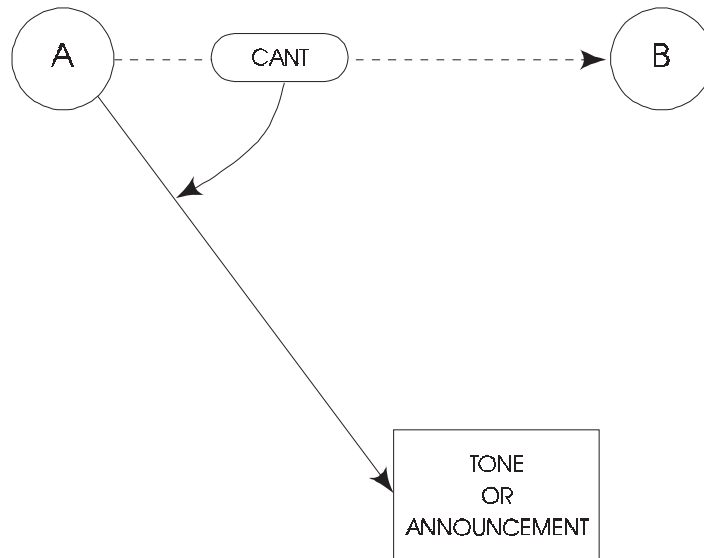
- *Skip control* directs a percentage of traffic to bypass a specific circuit group on a prehunt basis and advance to the next route in its normal routing pattern (see Figure 10-6). The control can be arranged to affect alternate-routed or direct-routed traffic or both.
- *Code-block control* blocks a percentage of calls routing to a specific destination code. In most cases, a code-block control can also be specified to include the called-station address digits.
- *Call-gapping control*, like code-block control, limits routing to a specific code or station address. Call gapping is more effective in controlling mass calling situations than the code-block control. Call gapping consists of an adjustable timer that stops all calls to a specified code for a time interval selected from 16 different time intervals. After the expiration of the time interval, one call to the specified code or address is allowed access to the network, after which the call-gapping procedure is recycled for another time interval.
- *Circuit-directionalization control* changes 2-way circuits to 1-way operation.
- *Circuit-turndown control* removes 1- or 2-way circuits from service.
- *Reroute controls* serve in a variety of ways to redirect traffic from congested or failed routes to other circuit groups not normally included in the route advance chain but that have temporary idle capacity. Reroutes override the normal routing algorithms in switching systems. Reroutes can be used on a planned basis, such as on a recurring peak-calling day, or in response to unexpected overloads or failures. “Regular Reroute” affects traffic overflowing a trunk group. “Immediate Reroute” (IRR) affects traffic before hunting the trunk group for an idle circuit. Reroute controls may redirect traffic to a single or multiple routes. The multiple option is referred to as a “Spray Reroute.” :

Stored Program Control (SPC) switches may include the following types of automatic controls

- Selective Dynamic Overload Control (SDOC)
- Selective Trunk Reservation (STR)
- DOC
- Trunk Reservation
- Selective Incoming Load Control (SILC).

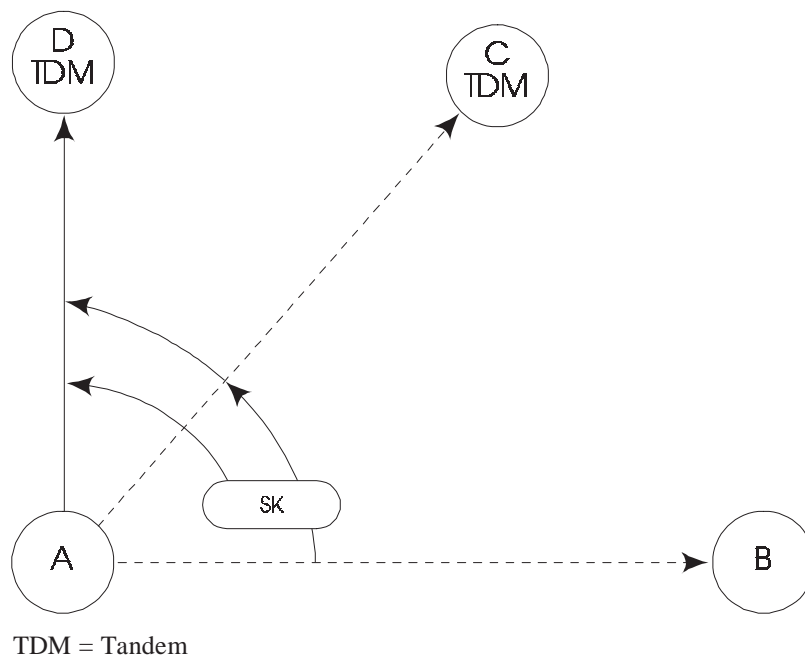


**Figure 10-4.** Cancel From (CANF)



**Figure 10-5.** Cancel To (CANT)

---



**Figure 10-6.** Skip (SK)

SDOC and STR are considered “selective” protective controls because they can selectively control traffic to HTR points more severely than other traffic. (HTR points are 3- or 6-digit destination codes to which calls have a very small chance of completing.) If the probability of completing through the network is very low and the outgoing trunk groups or connected switching systems are overloaded, selective protective controls can prevent the wasted usage of these overloaded network resources for traffic to HTR points. SDOC responds to switching congestion by dynamically controlling the amount and type of traffic offered to an overloaded or failed switching system. STR, conversely, responds to trunk congestion in the outgoing trunking field and is triggered on a particular trunk group when less than a certain number of circuits are idle in that group.

SDOC and STR are two-level control systems. The first level indicates less congestion than the second level. The first-level response is typically limited to control of traffic destined for HTR points, whereas the second level applies controls to both HTR points and other traffic, typically alternate-routed traffic. HTR traffic can also be manually enabled.

HTR traffic is automatically detected by the AT&T 4ESS switch based on an analysis of destination-code completion statistics. This analysis is performed on a 3- and 6-digit basis every 5 minutes. In the Northern Telecom DMS-100 and DMS-200 switches, HTR codes can also be manually selected and enabled.

Automatic controls, such as SDOC and STR, are intended to be activated by a switching system within a matter of seconds in response to a switching system or trunk-group overload. These controls provide rapid protection for the network and, by their code-selective basis, attempt to restrict traffic that has a low probability of completion. When automatic controls trigger, network traffic managers monitor their operations and adjust system parameters to deal with the particular network condition, whether it is a general overload, a mass call-in, a natural disaster, or a major network-component failure. Among these parameters are call-completion determinations that designate a code "HTR" and control-response options that designate the amount of traffic to be controlled or trunks to be reserved at each triggering level. Since the optimum control response depends on the severity, geographical distribution, and type of overload, maximizing the calls carried by the network requires the coordination and combination of automatic and manual control responses.

Automatic controls for the Northern Telecom DMS-100F switches include the following:

- Internal Dynamic Overload Control (IDOC)
- SDOC
- SILC
- Automatic Out-of-Chain Reroute (AOCR).

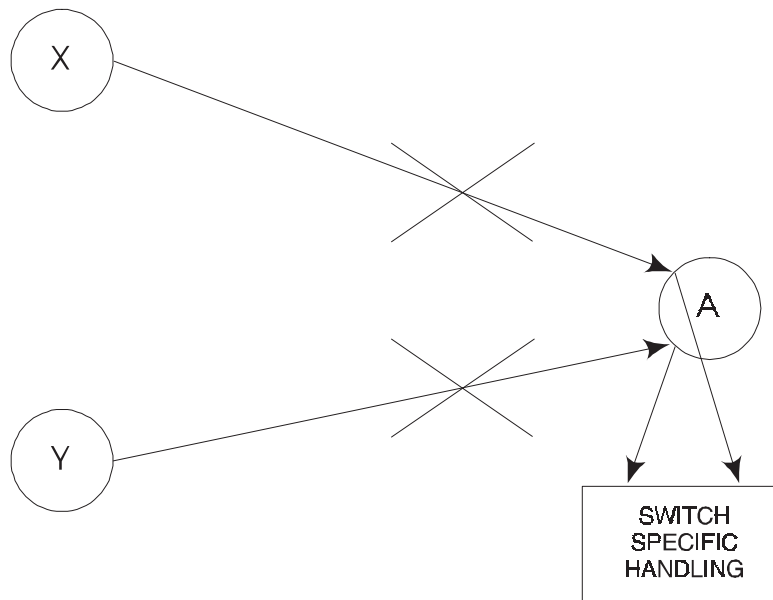
IDOC is an automatic control that reacts to impending internal overload conditions. There are three levels of IDOC activation.

- Level 1 is activated when the number of incoming multifrequency calls waiting for a receiver exceeds the predetermined threshold.
- Level 2 is activated when the percentage of time devoted to call processing is greater than the predetermined threshold.
- Level 3 is activated if the switch loses call-processing ability.

SDOC is the method of activating a control strategy upon receipt of a CCS congestion message.

SILC is an automatic control that blocks selected incoming calls to reduce the amount of traffic that is accepted by the switch (see Figure 10-7). There are two thresholds for SILC controls similar to the IDOC thresholds 1 and 2. Each threshold has two modes of call blocking — by percentage or time-interval gap — but only one may be used at a time.

AOCR provides extended routing for calls that overflow their in-chain final trunk groups. As the last in-chain trunk group is occupied, AOCR is triggered to use a specified alternate route as long as capacity exists in the alternate route.



**Figure 10-7.** Selective Incoming Load Control (SILC)

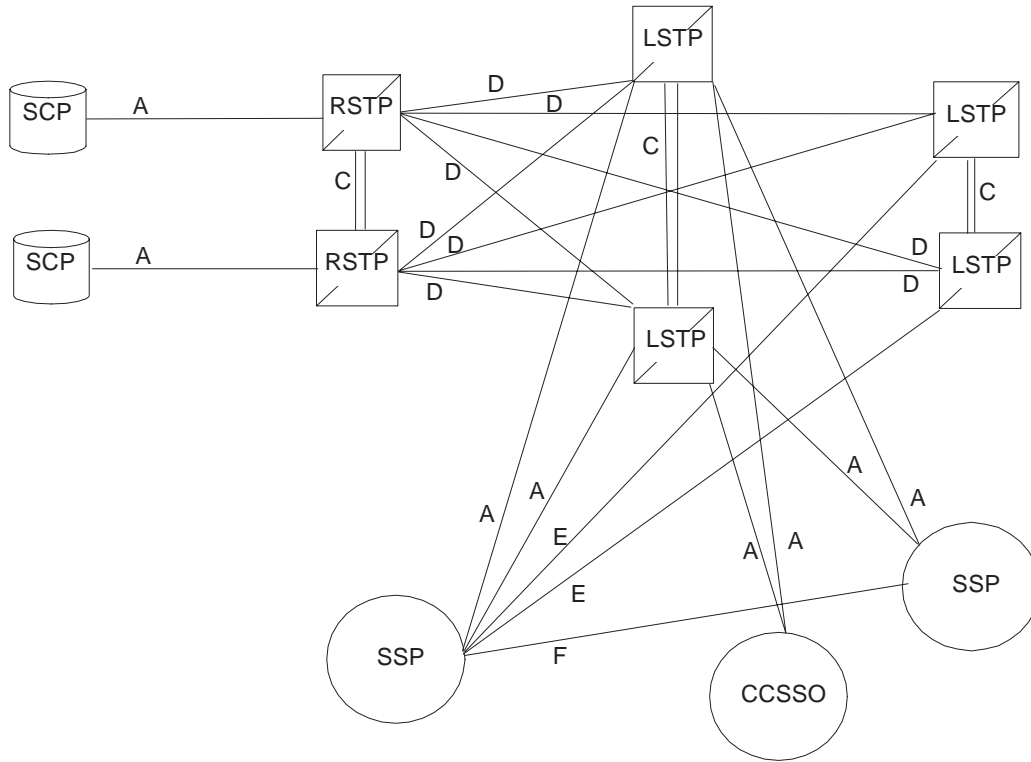
*Trunk reservation* makes it possible to reserve a specified number of trunks in a trunk group. When control is enabled, it automatically limits the number of attempts offered to a trunk group when fewer than the specified number of trunks remain available. The following two controls may be provided on a trunk group.

1. *Protectional Reservation of Equipment (PRE)* threshold is useful in reserving facilities for first-routed traffic. If the PRE threshold is exceeded, all traffic alternate-routed to this trunk group is inhibited from searching for an idle trunk in that group and is routed to an announcement.
2. *Directional Reservation of Equipment (DRE)* threshold is useful in reserving facilities for incoming traffic on 2-way trunk groups. If the DRE threshold is exceeded, all outgoing traffic to this trunk group is inhibited from searching for an idle trunk in that group and is routed to an announcement.

#### 10.1.4.2 Common Channel Signaling Network Controls

This section is an overview of the LEC CCS-NTM architecture, considering the overall network, the nodes, and the links.

Figure 10-8 represents a typical CCS network architecture with both regional and local Signaling Transfer Points (STPs) and sample nodes and links. Nodes and links are discussed below.



- Legend:**
- CCSSO = Common Channel Signaling Switching Office
  - LSTP = Local Signaling Transfer Point
  - RSTP = Regional Signaling Transfer Point
  - SCP = Service Control Point
  - SSP = Service Switching Point

**Note:** Single alphabetical characters (A, C, D, E, and F) represent links.

**Figure 10-8.** Typical CCS Network



---

**CCS Nodes:** CCS nodes in the CCS network are called Signaling Points (SPs). There are three types of CCS nodes or SPs.

1. Switching offices are tandems or end offices that have CCS capabilities. Each switching office can be one of two types.
  - A Common Channel Signaling Switching Office (CCSSO) is equipped for call-setup messages *only*; it cannot transport call-services information. Requests for call-services information are routed to Service Switching Point (SSP) offices for access to the CCS network.
  - The SSP may be equipped for *both* call-setup messages and call-services information. The SSP interacts with databases (such as the Service Control Point [SCP]) to execute requests for call-services information. Access tandems and equal-access end offices may be used as SSPs.
2. STPs are packet switches that provide CCS message routing. The STP routes messages to the appropriate destination signaling point, using both the CCS messages and information stored in its memory.

Within the CCS network structure, STPs are either Local STPs (LSTPs) or Regional STPs (RSTPs).

- LSTPs provide the message routing functions for call setup.
  - RSTPs may provide call-setup and regional access to the SCP database for services such as Toll Free Service and Alternate Billing Service (ABS).
3. SCPs, connected to STPs, are associated with applications that consist of service-specific software and a database of customer-related information. SCPs may operate either in mated pairs (for increased reliability) or as stand-alone units. The network database required for Toll Free Service is the first SCP application. The network database required for ABS is the Line Information Database (LIDB).

Each SP has its own unique network address that is called a *point code*. Every Signaling System Number 7 (SS7) message has a routing label that contains the point codes for the origination and destination of the message, plus the Signaling Link Selection (SLS) code.

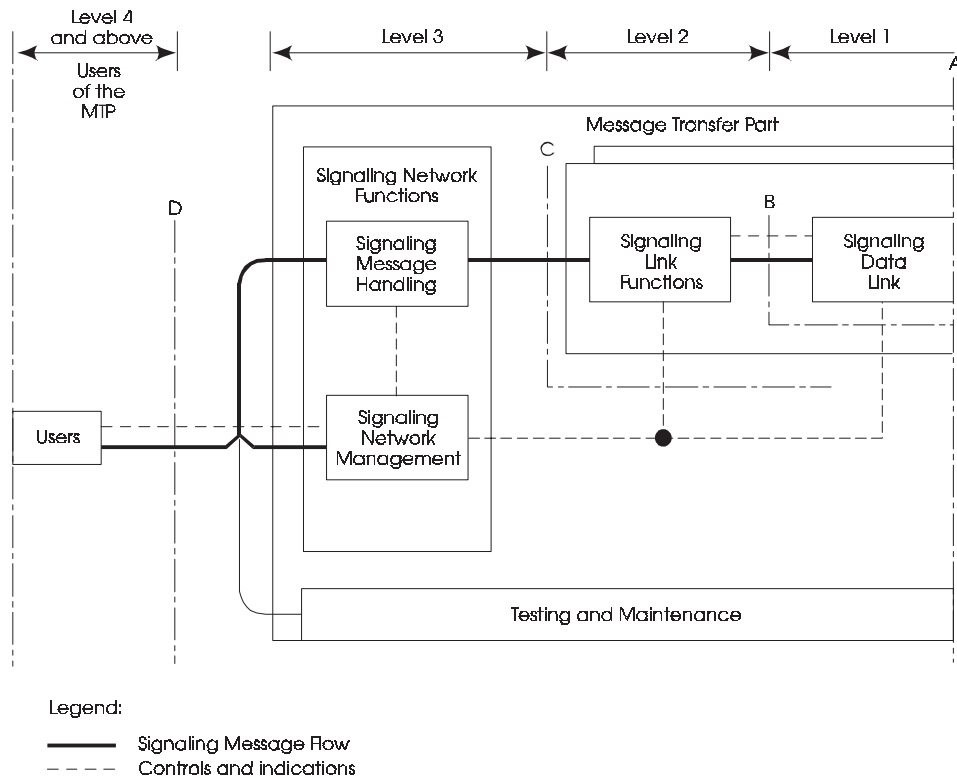
**CCS Links:** The communication path between two adjacent nodes in the CCS Network is called a *link*. It is identified in SS7 messages by Signaling Link Codes (SLCs). The links that connect a pair of adjacent nodes are grouped into a *link set*.

Link sets may be either a direct path to the destination signaling point or the first leg in an indirect route to that destination (for example, intermediate signaling points and link sets). A Combined Link Set (CLS) is a collection of outgoing link sets that share traffic to a given-destination signaling point.

There are six different types of links that differ in their connection to CCS network elements.

- A-Link (Access link) — connects a switching office, SP, SSP, or SCP to an STP
- B-Link (Bridge link) — connects two STPs on the same hierarchical level (for example, an RSTP to an RSTP)
- C-Link (Cross link) — connects mated pairs of STPs to each other
- D-Link (Diagonal link) — connects an STP on one hierarchical level to an STP on another level (for example, an LSTP to an RSTP)
- E-Link (Extended link) — connects a CCSSO, SSP, or SCP to an STP that is different than its associated (A-link connected) STP
- F-Link (Fully associated link) — directly connects two CCSSO/SSPs without going through an STP.

**Automatic Controls:** This section briefly describes the automatic controls that are designed into the SS7 protocol. Figure 10-9 shows the general structure of the signaling system functions (levels).



**Figure 10-9.** General Structure of Signaling System Functions/Levels

---

Direct control of signaling traffic within the CCS network is performed exclusively by automatic control procedures within the SS7 protocol. The Message Transfer Part (MTP) of the protocol, in particular Levels 2 and 3, contains a fairly comprehensive set of controls for dealing with congestion and failures in the signaling network. Level 4 contains some controls. The following briefly describes the four functions (levels) included in the protocol.

*Signaling Data-Link Functions (Level 1):* Level 1 defines the physical, electrical, and functional characteristics of a signaling data link and the means to access it. The Level-1 element provides a bearer for a signaling link. In a digital environment, 56- or 64-kbps digital paths will normally be used for the signaling data link.

*Signaling Link Functions (Level 2):* Level 2 defines the functions and procedures for transferring signaling messages over one individual signaling data link. A signaling data link, as a bearer, provides a signaling path for reliable transfer of signaling messages between two points. Level-2 procedures on each signaling link help ensure that message signal units are delivered from one end of the link to the other sequentially and essentially error-free and also that Level 3 is notified when such delivery is not possible.

The following Level-2 procedures are related most directly to network management.

- *Error Correction and Monitoring* — Link performance is continuously monitored. Indications of link failures are promptly reported to Level 3 so that traffic may be diverted to alternate links.
- *Processor Outage* — Level 2 transmits link-status units indicating processor outage when it loses communication with Level 3 at its own end of the link. Such loss of communication may imply a major failure at the node; hence, receipt of processor-outage status units will be reported promptly to the CCS operations support system (and in the future, possibly to the NTMOS). Processor-outage status units are also transmitted briefly on command of Level 3 as part of the management inhibit procedure. Unfortunately in this case, the processor-outage status units do not indicate any problem. If adopted, the NTMOS should not report the receipt of processor-outage status units to a network traffic manager until the receipt has persisted long enough to indicate that an inhibiting procedure exists.
- *Level-2 Flow Control* — When the receiving end of a signaling link detects congestion, it withholds acknowledgments and periodically transmits link-status units indicating “busy” so that the other end knows that the delay of acknowledgments is caused by congestion, not link failure. This procedure permits the congested end to “catch up” after conditions such as a temporary traffic surge or a temporary capacity reduction due to maintenance activity. It is not in itself sufficient to deal with a sustained traffic overload. Level-3 flow control (discussed below) actually stops transmission of traffic at its source and is required for sustained traffic overloads.

*Signaling Network Functions (Level 3):* Level 3, in principle, defines those transport functions and procedures that are common to, but independent of, the operation of

---

individual signaling links. These functions fall into two major categories: signaling message handling and signaling network management.

- *Signaling Message-Handling Functions* — At the actual transfer of a message, signaling message-handling functions direct the message to the proper signaling link or higher-level function.
- *Signaling Network Management Functions* — On the basis of predetermined data and information about the status of the signaling network, signaling network management functions control the current message routing and the configuration of signaling network facilities. The functions contain a number of control procedures to divert traffic to alternate routes in case of failures within the signaling network and to reduce signaling traffic temporarily in case of congestion. If, despite all the control procedures, the MTP at a node cannot deliver messages to certain destinations, it notifies both the MTP used at that node and MTP network management at adjacent nodes.

The three types of signaling network management (link, traffic, and route management) are briefly explained below.

#### *1. Signaling Link Management*

Signaling link management provides procedures to activate and deactivate signaling links and to restore them automatically after failure. (These procedures are closer to what has traditionally been called maintenance rather than network management.) The SS7 protocol includes some optional procedures to automatically allocate signaling terminals, or both signaling terminals and signaling data links, to particular signaling links. It is expected that in LEC networks these optional procedures will not be used and that each signaling link will consist of a predetermined signaling data link with a predetermined signaling terminal at each end. The following specific procedures are included in signaling link management.

- *Signaling Link Activation:* When the decision is made to activate an inactive signaling link, initial alignment is attempted. If the alignment is successful, an optional signaling link test may be performed before the link is opened to user traffic. If, after 8 minutes (480- to 600-second range) of repeated attempts, initial alignment is not possible, local maintenance is notified by the CCS operations support system and through other local maintenance users.
  - *Signaling Link Restoration:* When a signaling link failure is detected, automatic attempts are made to bring the link back in alignment. If the link cannot be restored automatically within 8 minutes (480- to 600-second range), maintenance is notified so that manual intervention can be initiated.
  - *Signaling Link Deactivation:* Once signaling traffic is removed from a link, the link may be deactivated, and the signaling terminals taken out of service.
-

- 
- *Link-Set Activation*: A link-set activation procedure starts a signaling link set that does not have any signaling links in service. The two alternative link-set activation procedures are link-set normal activation and link-set emergency restart. Each procedure consists of performing a signaling-link activation on as many of the links in the link set as possible in parallel. In link-set emergency restart, the shorter (emergency) prove-in periods and timeouts are used in the initial alignment procedures until at least one link is placed in service. The protocol recommendations do not specify the conditions for choosing one procedure or the other. However, it is expected that the emergency restart procedures would be used, for example, when a link-set failure leaves some destinations inaccessible.

## 2. Signaling Traffic Management

- Signaling traffic management consists of the Level-3 procedures that actually divert traffic or notify local users to stop sending traffic in cases of failure or congestion. The following are some of the specific procedures:
  - *Changeover*: Traffic is diverted to alternative signaling links when a signaling link becomes unavailable. This procedure includes three major points.
    - When a signaling point recognizes that a signaling link has become unavailable, it stops transmitting and accepting message-signal units on the concerned signaling link and also determines if any route is still available to the SP at the remote end of the link. If it is still possible to communicate with the SP at the remote end of the link, the near-end SP sends a changeover-order message that contains the sequence number of the last message-signal unit accepted on the unavailable link. The far-end SP will respond with a changeover-acknowledgment message that contains the sequence number of the last message-signal unit accepted at that end. Upon receipt of a changeover order or acknowledgment, a SP sends all message-signal units, following the one acknowledged in the order of acknowledgment, on alternate links.
    - Alternate links are chosen in accordance with the routing defined for each destination. Traffic to different destinations may be diverted to one or more links. If there is no alternate link for a destination, messages for that destination are discarded, local users (if any) are notified of the destination's inaccessibility, and transfer-prohibited messages are sent to adjacent nodes on a broadcast or response basis.
    - If communication with the far-end signaling point is impossible, new traffic for the unavailable link is diverted to alternate links after a brief delay. This time delay reduces the probability that any diverted message will reach its destination before a message that was sent to the same destination over the unavailable link, just before it became unavailable.
-

- *Changeback*: Changeback is the inverse of changeover. It diverts traffic *back* to a signaling link when a link becomes available. Traffic diversions can be performed at the discretion of the SP that initiates changeback, as follows:
    - On a destination basis (individually for each traffic flow)
    - For all destinations previously diverted on that alternative link (individually for each alternative signaling link)
    - At the same time for a number (or all) of the alternative signaling links.
    - If the SP at the other end of the link that has become available is accessible via a link from which traffic is to be diverted
    - A changeback declaration is sent to that node via the link from which traffic is to be diverted
    - Traffic is restarted on the now available link with the receipt of a changeback acknowledgment.
    - Each changeback acknowledgment is associated with its corresponding declaration through changeback codes contained in the messages.
    - The only time this sequence-control procedure ensures sequencing of messages is when both links involved in the procedure connect the same two SPs. If a changeback declaration cannot be sent, the traffic to be diverted to the newly available link is held in a changeback buffer for a time period (provisional value = 1 second) to reduce the probability of out-of-sequence delivery.
  - *Forced Rerouting*: Forced rerouting diverts traffic from a route that has become unavailable because of receipt of a transfer-prohibited message to an alternative route if one is available. When a transfer-prohibited message is received, the following procedures occur.
    - Transmission of signaling traffic toward the subject destination on the link sets pertaining to the unavailable route is immediately stopped, and such traffic is stored in a forced-rerouting buffer.
    - The alternative route is determined. If no alternative route is available, the actions specified above for a changeover when no alternative link is available are applicable.
    - If an alternative route is available, the subject signaling traffic is restarted on a link set pertaining to the alternative route, starting with the content of the forced-rerouting buffer. A transfer-prohibited message is sent along the alternate route if it is not currently carrying traffic for the subject destination.
-

- *Controlled Rerouting*: The controlled-rerouting procedure is used to divert traffic to a newly available route when a transfer-allowed message is received or to an alternate route when a transfer-restricted message is received. The procedure is essentially the same as forced rerouting except that traffic is held in a controlled-rerouting buffer for a period of time before it is diverted to reduce the probability of out-of-sequence delivery.

### 3. Signaling Route Management

Signaling route management is a function that relates only to the quasi-associated mode of signaling. Its task is to transfer information about changes in the availability or congestion status of signaling routes in the signaling network to enable remote SPs to take appropriate signaling traffic management actions. For example, an STP may send messages indicating inaccessibility of a particular SP via that STP, thereby enabling other SPs to stop routing messages into an incomplete route.

*User Function (Level 4 and Above)*: Levels 4 and above relate to the different users of the MTP. Users define the functions and procedures they need for the particular signaling system. The following are some examples of users of the MTP:

- Integrated Services Digital Network (ISDN)
- Toll Free Service
- ABS Calling Card Service.

Service-specific automatic network management controls are also applicable here.

**Manual Controls**: This section describes how manual controls can be used to influence CCS traffic.

CCS NTM relies heavily on automatic controls. Manual intervention is limited primarily to adjusting parameters used in the automatic control process. Surveillance data is provided so that the network traffic manager can monitor the performance of the automatic controls and coordinate NTM action in the CCS and circuit-switched networks when appropriate.

Any manual control of calls in the switched network that generates the signaling may be an appropriate response to some CCS network overload and failure situations. For example, a network traffic manager can apply code controls, cancel calls, and reduce the load on the CCS network if congestion is sufficiently severe and persistent. As long as non-CCS trunk groups remain in the network, it may be possible to mitigate the effects of CCS network failure by rerouting calls to non-CCS trunk groups.

A series of commands allow network personnel to adjust parameters manually for automatic SS7 network management controls.

While there are no traditional real-time manual controls that apply to traffic management in the SS7-based CCS networks, automatic traffic management procedures, defined for the SS7 protocol's MTP as implemented at the STP, rely on such parameters to manage traffic



flow properly and to trigger reroutes of traffic under conditions of failure in real-time. Included in this set of parameters are nine link-transmit congestion thresholds and currently 28 distinct timer parameters.

While it is unlikely that modifications to these parameters would be used as manual real-time traffic controls, network managers and/or network engineers will probably have to adjust the values of these parameters to optimize traffic flow and network performance as network loads grow and the network configuration and/or types of network transmission facilities used for signaling links change over time. Also, the values used for these parameters, even at initial provisioning of signaling links, will likely need different settings for different link speeds. Therefore, there is a need to control these parameters.

#### 10.1.4.3 Network Traffic Management Methods

This section describes some of the methods used to perform NTM.

**IntraLATA:** The LEC NMC will be constantly apprised of the condition of the intraLATA network through the use of near real-time data provided by the NTMOS.

LEC NMC personnel use detailed trunk-group and switching system data to make NTM decisions concerning the application of restrictive and/or expansive controls affecting intraLATA traffic. All NTM control actions are based on one or more of the principles discussed earlier in this section.

The methods used include the application of appropriate NTM controls to ensure the most efficient use of network capacity and to prevent the spread of network congestion. These controls will generally be implemented through the NTMOS.

To effect reroutes in the LATA network, 7- or 10-digit outpulsing and digit reception are required between offices used for the reroute. The conversion to 7- or 10-digit outpulsing and reception between offices in a LATA allows the flexibility needed for cutovers and transitions and establishes the capability to reroute intraLATA traffic within the LATA to sustain a high level of customer service.

**Exchange Access:** The LEC NTM personnel also monitor LATA-access traffic flow to help ensure the provision of acceptable exchange-access service levels. Network conditions adversely affecting the company's ability to provide efficient and effective use of its network may require the implementation of appropriate NTM controls. Generally, LATA-access network controls will be protective in nature, for example, preventing the onset and spread of network congestion in LEC switching systems. LECs maintain the right to apply protective controls on any traffic that they handle, including an IC's exchange-access traffic when it is determined that an IC's traffic is affecting the levels of service provided to other ICs and/or service provided within the LATA. One NTM control applicable for that purpose is call gapping on the carrier access code assigned to the carrier.

---



---

SILC may be used in LEC switching systems where the distant office furnishing incoming traffic is not equipped to respond to LEC overloads.

**Cooperation with Independent LECs and ICs:** LEC NTM personnel make many decisions each day regarding the flow of traffic. These decisions require timely reactions and consideration of the health of the entire network as well as of individual network segments and specific carriers. It is this global outlook that has made this function effective in the past, and with mutual cooperation effective NTM will continue.

Fulfillment of LEC NTM responsibilities requires a broad industry commitment to maximize completed messages over time. This maximization best serves the interests of the public, the nation, and the industry. Effective use of the network under all operating conditions aids in ensuring that the public will have high-quality network service and also benefits the ICs, independent LECs, and the LECs economically.

Effective NTM depends on the following:

- The prompt availability of network data indicating when and where a problem exists
- A trained organization working under a cooperative arrangement that crosses organization and corporate boundaries
- The authority to implement controls.

Cooperation, coordination, and control are the essential ingredients in the successful NTM of telecommunications networks.

Cooperation between the LEC NMC and organizations in the independent LECs and the ICs is needed to preserve network integrity. The LEC and other NTM forces need to confer on the following actions:

- Inhibiting switching congestion in the local and other networks to ensure the viability of all network services and providers
- Establishing expansive controls to optimize network use
- Preplanning for network overloads and interruptions
- Recommending capacity adjustments to all affected parties
- Assisting with cutover transitions to minimize service impact and to ensure continuity of service
- Responding to overloads and interruptions by taking appropriate action to protect the LEC and/or other networks.

**Planning:** Planning to anticipate and minimize the impact of network congestion is a basic function of NTM.

Experience has shown that planning for peak calling periods has a beneficial effect on overall NTM effectiveness. The timely application of preplanned control strategies can be instrumental in reducing switching and circuit-group congestion.

---

It is also desirable, from a network-protection standpoint, for all ICs and LECs to establish an NTM function for their own networks. With these capabilities in place, the spread of network congestion will be minimized by real-time and cooperative interactions among the involved service providers.

**Evaluation:** Comprehensive analysis and evaluation of the results of NTM control actions are crucial to understanding how the network reacts to an overload situation. This understanding guides the NTM organizations in the LECs, independent LECs, and ICs when planning how to deal with future overload situations in the network.

**Data Sharing and Controls:** Interfaces between NTM organizations may exist for the exchange of near real-time surveillance data necessary to accurately determine control implementation strategies.

**Network Service Protection:** The failure of a switching system has an adverse effect on all systems connected to that system. The LEC NMC is concerned with failures of all systems that could affect the delivery of LATA traffic.

LEC switching system outages affect both the LECs and the other telecommunication services. The degree of service degradation will vary based on the following factors:

- Size of the failed switching system
- Time of day
- Position of the system in the network architecture
- Resiliency of overload control characteristics of the interconnected systems
- Length of the outage
- Extent that NTM is able to minimize the effect of the switching system outages through the timely activation of network traffic controls.

Service outages affect telecommunication services provided by the failed system (for example, end offices) and also result in network congestion of interconnected systems. The primary causes are customer reattempts resulting in increased dial-tone demands, second-trial attempt algorithms resident in switching systems, and delays and timeouts caused by the loss of connectivity between switching systems. Network congestion resulting from a switching system outage affects the overall efficiency of the network to such an extent that some calls will fail even though they are not directed toward the affected system. This is due to network resources that are being overused to process ineffective attempts rather than completed messages.

NMCs have been provided with the capability of keeping abreast of the viability of switching systems within their area. Information passed directly from each equipped switching system through a data-collection device to an NTMOS provides NTM personnel with timely (30-second and 5-minute) information on the use of switching system resources. If a problem develops in the NTM-controlled cluster of offices, it can be dealt

---

---

with by the NMC with the activation of the appropriate NTM controls (cancel, skip, reroute, etc.).

**Consequences of IC Switch Failure:** Failure of an IC's switching system is also of primary concern to the LECs. The loss of a system will result in a reduction of multiple POTs, or a complete loss with a single POT, of the capability of that carrier to receive and transmit calls from and to all entities in the LATA. This may result in LEC network congestion.

An uncontrolled failure of an IC's switching system could also have a negative effect on traffic to other ICs. With the onset of network congestion, LEC switching system resources (for example, dial tone and senders/transmitters) will be used to process ineffective attempts to the failed switching system. Customer reattempts will aggravate the situation to the point that the calls to other ICs may be affected.

A third important consequence of an untimely or uncontrolled reaction to an IC failure could be adverse effects on intraLATA network efficiency and the degradation of that network to the point where emergency intraLATA calls (fire, police, etc.) may be affected.

#### 10.1.4.4 Summary of Network Traffic Management Controls

NTM is the term used to describe a variety of activities associated with improving network traffic flow and customer service when abnormal conditions (unusual traffic patterns or equipment failures) may have resulted in a congested, inefficient network. These activities include the application of appropriate network controls, when and where necessary, and planning the means by which the impact of network overloads can be minimized.

Effective NTM is based on the use of near real-time trunk-group and switching system data and the ability to implement the required NTM controls in an expeditious manner. The NTMOS serves this data-gathering and control-implementation need.

Each LEC NMC is concerned with completing as many calls as possible within the intraLATA network and providing equal treatment for the traffic flow to and from all ICs. Each LEC NMC is organized to fulfill the following NTM responsibilities:

- Provide a means to help ensure that near real-time control actions can be used to prevent a failure to one IC from adversely affecting the traffic of another IC
  - Address the needs of individual machine- and/or facility-failure planning
  - Provide a focal point for NS/EP concerns
  - Provide an operations interface with ICs and independent LECs
  - Plan the installation, operation, and testing of automatic and manual controls to monitor that they function as designed
  - Provide short-term trunk and switch relief through the implementation of local reroutes
-

- Provide upper management with a focal point for current network operations to aid in restoration efforts
- Provide real-time surveillance and control of significant LATA switching entities during normal operation, abnormal situations, cutovers, transitions, etc.

## 10.2 Network Service Center (NSC)

An NSC has been organized in many LECs to serve as a focal point for actions that help ensure that the customer continues to receive quality network service. Through the use of comprehensive reports, which include customer feedback, operator reports, and machine-detected problems, NSC personnel perform an essential role in initiating appropriate corrective action on network problems that, in most cases, are not readily discernible through local maintenance tools. This results in improved customer satisfaction and increased revenues due to the timely elimination of network-completion obstacles. Through the NSC's analysis and report generation, upper management is apprised of network performance and problem areas. This information aids upper management in making resource-deployment decisions by indicating areas requiring special attention. The NSC also serves as a vehicle for obtaining network information requested by regulatory agencies, network planning organizations, etc.

### 10.2.1 Network Service Center Functions

Network service is defined as that service provided by the telephone network after the caller (customer or operator) has received the signal to start dialing. It includes connection availability (whether the customer attempt is successfully completed to the dialed destination with an acceptable speed-of-service), connection suitability (the quality, sustainability, and integrity of established connections), and usage accounting (accurate call billing). The role of the NSC is that of an overseer of the network service provided to customers within its assigned network segment.

Many LECs have assigned the following functions to the NSC:

- Provide the primary interface between ICs/small independent LECs, other LECs, and recently, Competitive LECs (CLECs) for intra/intercompany technical coordination, serving as a principal point of contact between the LECs and all other entities to resolve noncircuit-specific service-related issues and to escalate service complaints not resolved through normal maintenance channels. This technical coordination spans virtually all types of equipment.
  - Keep management informed about the quality and trends of network service.
  - Identify and investigate cases of substandard service (weak-spot analysis) and make recommendations for improvement.
-

- 
- Identify and refer troubles not readily seen by local systems and processes.

The LEC NSC organizations are equipped and staffed to fulfill these responsibilities and to respond to regulatory, customer, and industry demands for the provision of quality service by the LECs.

Some small independent LECs, CLECs, and ICs maintain organizations that perform similar activities for the segments of the network for which they have responsibility. Some small independent LECs may directly participate in LEC NSCs. The LEC NSC typically serves as a focal point for most LEC network service-improvement activities and is usually responsible for the following:

- Establishing and maintaining effective interface arrangements with appropriate ICs and/or centers or maintenance organizations for noncircuit-specific trouble referral, escalation, and resolution of intraLATA and exchange service problems
- Performing service improvement/service evaluation functions within the intraLATA networks
- Tracking and trending intraLATA service levels to identify potential network weak spots
- Providing pattern analysis and referral of trouble conditions within the LEC intraLATA networks.

Many LECs have delegated the following three network service and performance surveillance processes to the NSC:

- Intercompany coordination and liaison
- Network service evaluation
- Network trouble localization.

#### 10.2.1.1 Intercompany Technical Coordination and Liaison Process

The intercompany technical coordination and liaison process involves the handling of both internal and external noncircuit-specific service referrals and complaints. In this process, the NSC serves as one of the primary points of contact for all exchange carriers and ICs to resolve network service-related issues and for the escalation of network service complaints not resolved through normal maintenance channels.

#### 10.2.1.2 Network Service Evaluation Process

The network service evaluation process involves those centers and systems that interact to perform service quality assurance and service improvement activities. In this process, the NSC tracks and analyzes overall company measurement indicators and other results on a

---

daily, weekly, and monthly basis in an effort to ensure that quality intraLATA service is provided to customers.

#### 10.2.1.3 Network Trouble Localization Process

The network trouble localization process uses call-failure data and Operator Trouble Reports (OTRs) collected from several sources to identify network-trouble conditions that are not readily detectable by local maintenance systems and processes. In this process, the NSC receives trouble-pattern information and associated administrative summaries, performs analysis, and refers troubles to the centers responsible for repair.

Characteristic work functions performed in the NSC include the following:

- Network trouble analysis
- Network service evaluation
- Call-attempt analysis
- NSC administration
- Intercompany technical coordination and liaison
- Special investigations and testing
- New services and service improvement.

Specific trouble referrals related to the following points are typically handled by the NSC:

- Availability of dial tone
- Completion of call to desired number
- Ability to hear well and to be heard well
- Privacy of conversation
- Proper termination and billing of calls
- Ability to receive incoming calls.

#### 10.2.1.4 Summary of Network Service Center Functions

NSCs provide a common point of contact between LECs, between LECs and ICs, between LECs and CLECs, and between LECs and small independent LECs. Through their coordinated efforts, the NSCs facilitate the vital flow of technical information between the various organizations and companies responsible for providing quality telephone service at a reasonable cost.

---

## 10.2.2 NSC Interfaces and Applications

The NSC interfaces with a number of work groups and centers within the LEC, as well as with a number of operations systems. The NSC also interfaces with ICs and small independent LECs.

Table 10-1 lists the major interfaces that provide input to the NSC and the type of input received, that is, trouble referrals, reports, etc. The major interfaces that receive outputs from the NSC are listed in Table 10-2, including the type of outputs sent.

**Table 10-1.** External Network Service Center Inputs

Interface	Input Received
InterLATA carrier	Assistance requests and referrals
Other NSCs (LECs, ICs, CLECs, and small independent LECs)	Assistance requests and referrals

**Table 10-2.** External Network Service Center Outputs

Interface	Output Sent
InterLATA carriers	Trouble referrals
Other NSCs (LECs, ICs, CLECs, and small independent LECs)	Network performance data and trouble referrals

The LEC NSC is responsible for network service in the intraLATA network and for directing the necessary maintenance effort to ensure equal quality exchange access for ICs and independent LECs. In this context, the NSC actively pursues its roles in the following processes that were described earlier:

- Intercompany coordination and liaison
- Network service evaluation
- Network trouble localization.

Using these processes, the NSC stays informed of the condition of the LEC network and keeps upper management apprised of the quality and level of service for their area of responsibility.

### 10.2.3 NSC Analysis and Evaluation Methods

This section describes some of the analysis and evaluation methods used by the NSC.

#### 10.2.3.1 Trouble Reports

Two major trouble report categories for the NSC are MLI and MDII. These are discussed in the following paragraphs.

**MLI:** This is a report that describes a failure on a multilink call (for example, a call on which there were alternate routes) between the originating point and the terminating point. Because the actual route the call took cannot be identified, the MLI provides a general description of the trouble that occurred (for example, reorder, no ring, no answer, wrong number, noise, or crosstalk). It does not identify the route or where on that route the call failed. Possible sources for MLI reports are as follows:

- Operator reports
- Dial-Line Service Evaluation (DLSE)
- Incoming-Trunk Service Evaluation (ITSE)
- End-user reports (public, employee, regulatory, etc.).

**MDII:** This is a trouble report that details an ineffective switching attempt that was detected by a reporting office for the NSC. The reporting office can be either the originating or the terminating office involved in the call. Because an MDII reports a trouble on a single-link call (for example, a call on which there are dedicated trunks between the originating and the terminating office), details provided by the MDII about the trouble are specific. Sources for MDII reports are the switches and OSs that monitor them.

#### 10.2.3.2 Intercompany Technical Coordination and Liaison

The NSC's responsibility for monitoring the quality of network service provided by its assigned network segment includes tracking service trends relating to the provision of quality LATA access for ICs and independent LECs.

The intercompany technical coordination and liaison function includes activities that provide for provision of service to ICs and independent LECs. These activities include the handling of related service requests, referrals, and complaints; the forwarding of related disposition information; and data collection for studies involving related problems affecting termination.

---



### 10.2.3.3 Interaction with ICs and Small Independent LECs

Many LECs have given the responsibility for intraLATA end-to-end service to the NSC. To fulfill that responsibility, a comprehensive process is required to handle both internal and external service referrals and complaints in an expeditious and effective manner. The LEC NSC serves as the focal point for service evaluation requests, reception of service referrals, and the resulting output of clearance disposition information to the ICs and independent LECs. The LEC NSC serves as the primary point of contact for matters relating to LEC service quality assurance and quality control.

Service complaints and referrals from various ICs and customer/regulatory organizations, both internal and external to the LEC, are input to the LEC NSC for disposition and resolution. Following resolution, the appropriate organizations are notified of the action taken.

### 10.2.3.4 Summary of Analysis and Evaluation Methods

The LEC NSC is a key point in a cooperative industry effort to provide quality telephone service to the customer in the most cost-effective manner. This is accomplished through the detailed analysis of customer, operator, and machine-detected reports of network problems. Through the use of near real-time information, the LEC NSC provides comprehensive analysis and service monitoring support for the intraLATA network and helps ensure quality access service between the LEC, ICs, CLECs, and small independent LECs.

The LEC NSC establishes an efficient channel for the flow of technical information between LECs, ICs, and CLECs. This coordinated effort by the LEC NSC results in the timely elimination of network problems. The LEC NSC serves as a primary point of contact with appropriate LEC maintenance organizations for trouble referral, escalation, and resolution intraexchange and exchange-access problems.



---

## Section 11 Synchronization Contents

11. Synchronization .....	11-1
11.1 Introduction .....	11-1
11.2 Synchronization Background .....	11-1
11.3 Hierarchical Method of Synchronization .....	11-3
11.4 Internodal Synchronization .....	11-4
11.4.1 Timing Source .....	11-4
11.4.2 Clock Strata Requirements .....	11-5
11.4.3 Primary Reference Source .....	11-5
11.4.4 Facility Selection .....	11-7
11.4.5 Timing Loops .....	11-8
11.4.6 Implementation Strategy .....	11-8
11.5 Intranodal Synchronization .....	11-9
11.5.1 Building-Integrated Timing Supply .....	11-9
11.5.2 Composite Clock .....	11-9
11.5.3 BITS Advantages .....	11-9
11.5.4 BITS Implementation .....	11-10
11.6 Reliability and Performance .....	11-11
11.6.1 Jitter and Wander .....	11-11
11.6.2 Slip Performance .....	11-11
11.7 Interconnection with Other Networks .....	11-12
11.7.1 Asynchronous Operation .....	11-12
11.7.2 Plesiochronous Operation .....	11-12
11.8 Administration .....	11-13
11.9 Synchronization Network Operations .....	11-14
11.9.1 Detection of Impaired Synchronization .....	11-14
11.9.2 Restoration of the Synchronization Network .....	11-14
11.9.2.1 Internodal Failure .....	11-15
11.9.2.2 Intranodal Failure .....	11-15
11.10 Synchronization Network Testing .....	11-15
11.10.1 Cutover Coordination .....	11-15
11.10.2 Synchronization Tests .....	11-16
11.10.3 Test Configurations .....	11-16

---

---

## List of Figures

Figure 11-1. Two-Frame Circular Buffer (1.544 Mbps) after Framing is Extracted .....	11-2
Figure 11-2. Hierarchical Network Synchronization .....	11-4
Figure 11-3. Recommended BITS Implementation .....	11-10
Figure 11-4. Plesiochronous Operation.....	11-13
Figure 11-5. Synchronization Test Configuration.....	11-17

## List of Tables

Table 11-1. Clock Strata Requirements .....	11-6
Table 11-2. Stratum-3 Slip Conditions .....	11-12

---

## 11. Synchronization

### 11.1 Introduction

This section summarizes the Digital Synchronization Network Plan that supports Local Exchange Carriers (LECs). The plan is consistent with the specifications in American National Standards Institute (ANSI) T1.101-1987, *Synchronization Interface Standards for Digital Networks*. A more detailed explanation of the plan is published in GR-436-CORE, *Digital Network Synchronization Plan*.

### 11.2 Synchronization Background

A stand-alone unit of digital equipment may perform its functions well with its internal clock changing speed arbitrarily. However, when two or more of these units are connected with all-digital transport systems, they require synchronized clock rates.<sup>1</sup> Different clock rates can cause portions of the bit streams to be lost (or repeated) in transmission as a result of buffer slip. The resulting service impairment is generally more serious for data customers than for voice customers. However, analog data and facsimile transmissions are also seriously affected.

The Local Access and Transport Area (LATA) networks are evolving toward all-digital networks consisting of interconnected digital-switching and transport equipment. Synchronization is necessary to control slips in the Digital Signal level 1 (DS1) network and to control pointer adjustments, which can cause errors due to jitter, in the Synchronous Optical Network (SONET). This section provides an overview of the synchronization considerations that need to be addressed when developing a synchronization network that meets established performance objectives. This section emphasizes the currently predominant signals (DS1 and Composite Clock [CC]) in use to transport timing, but future synchronization distribution using SONET Optical Carrier level N (OC-N) signals are also discussed.

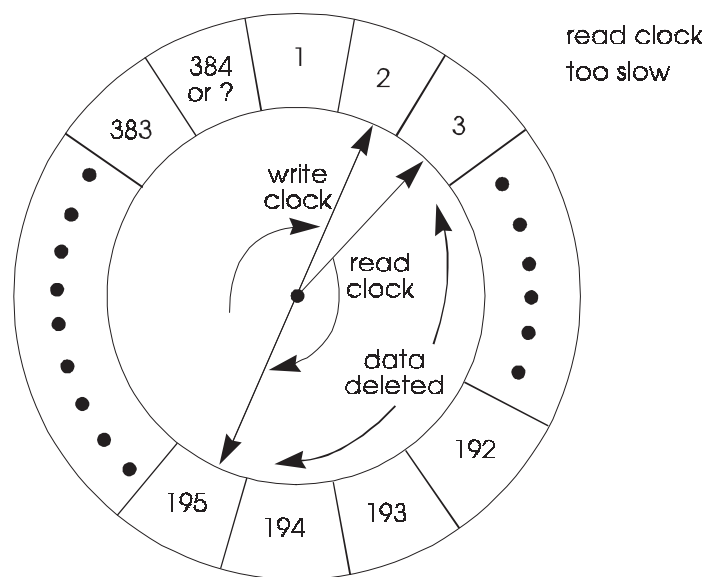
Since the early 1960s, the application of digital technology in the design of transport, network management, and switching systems has been expanding. The T1-carrier system, in which 24 voice channels are combined into a stream of 1.544 Mbps, is an example of a digital transmission facility. For analog voice channelizing applications, each channel is represented in the line bit stream as a time slot containing an 8-bit encoded voice sample. If a buffer should slip in analog voice applications, losing one sample (the receiver processes 8000 samples per second for each time slot), not much is lost. However, if the

---

1. *Synchronization*, as used here, refers to an arrangement for operating digital systems at a common clock rate (frequency synchronization).

eight bits in each time slot represent customer data (digital or analog), usable customer information is lost.

Figure 11-1 illustrates a frame slip in a receive buffer. If the *read* process (controlled by the system clock) is slower than the *write* process (controlled by the received bit stream), a slip will occur, eliminating one frame of data (controlled frame slip). If the *read* process is faster than the *write* process, a slip will occur in the other direction, repeating one frame of data. The framing pattern is not affected by a controlled slip.



Read clock derived from system clock  
Write clock derived from incoming data stream

**Figure 11-1.** Two-Frame Circular Buffer (1.544 Mbps) after Framing is Extracted

The intent of the buffer is to compensate for small variations, such as changes caused by temperature and humidity, between the internal clock and the received bit-stream speed. Such small variations tend to change direction, often avoiding a buffer slip threshold (random slips due to phase wander). However, a slight difference in clock rates causes slips that occur periodically due to the frequency error.

Buffer slips are avoided when all interconnected digital-equipment clocks run at a common rate. A common rate becomes possible when controlling reference signals have a common source. Synchronization is usually accomplished by a hierarchical method of providing, for every digital node in a network, a traceable path to a highly accurate source of timing known as a Primary Reference Source (PRS).

---

SONET has a different scheme that uses payload pointers for accommodating frequency differences and wander between SONET Network Elements (NEs). These pointers are three bytes in the SONET overhead that contain the number of bytes offset between the pointer byte and the beginning of the Synchronous Payload Envelope (SPE). When frequency differences or wander are experienced in a SONET network this pointer value is adjusted. Unlike a slip, the pointer adjustment does not result in any loss of data. However, the adjustment is done at the byte level, creating an eight-Unit Interval (UI) phase step on the payload (DSn) output. This phase step is played out by a desynchronizer circuit so that the amount of jitter it creates is controlled. However, if pointer adjustments occur at too great a rate, the jitter may accumulate and lead to data errors. Pointer adjustments accommodate a much smaller amount of wander than do slips. This has placed an emphasis on “short-term stability” performance of the synchronization network, in addition to frequency accuracy.

### 11.3 Hierarchical Method of Synchronization

The hierarchical method of synchronization establishes a *master-slave* relationship between nodes (the slave receives timing from the upstream master) in a star-like architecture. Each network is configured so that every node has a reliable path of clock reference traceable to a common source.

In the hierarchical method, the PRS is the most accurate clock and the source of timing reference for every node in the network. Reference signals are extended from the PRS through stratum levels of nodes controlled by clocks that meet less stringent accuracy requirements. Each successive node in the hierarchy distributes reference signals to a smaller portion of the network.

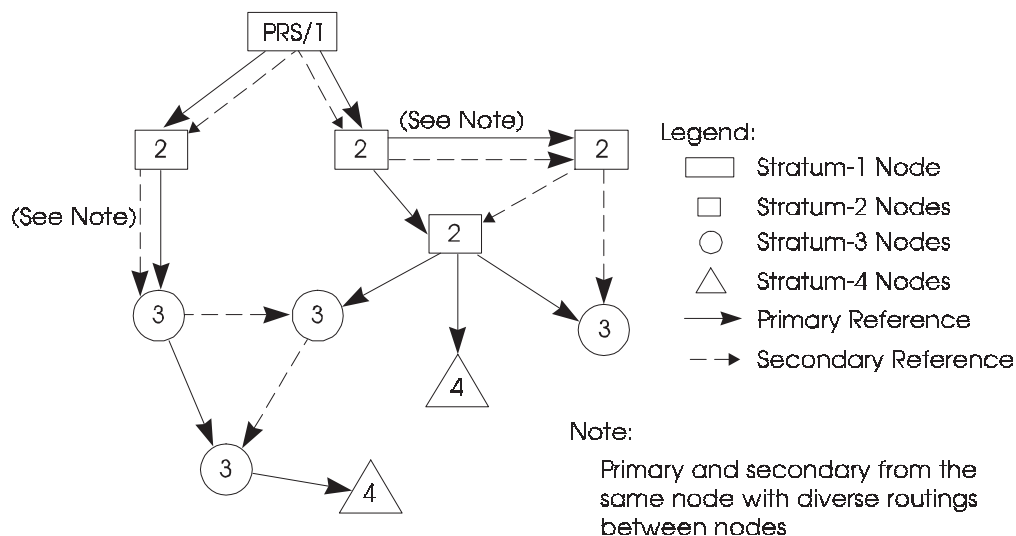
Each node in the hierarchy may receive timing reference from a node of an equal or higher stratum level. A reference that has degraded to a level that is lower than the stratum level of the node receiving it may be rejected (declared unavailable) by that node.

Figure 11-2 shows an example of a four-level hierarchy with the highest level called stratum 1. This represents the PRS for the network, which may be all-inclusive within a LATA or may cross company lines of several telecommunications carriers plus some private networks.

With all nodes interconnected properly and no impairments on reference spans or within a node that passes timing on to another node, the accuracy and stability of the reference signal at every node is very close to the quality of the PRS signal. Appropriate buffering arrangements are employed on some T1-carrier terminal equipment to effectively absorb the slight effects of daily variations.

Each node that receives a PRS-traceable reference signal and generates a new output reference signal for another node in the timing chain is an intervening clock for the downstream nodes. The quantity of intervening clocks that are permissible is limited only

by the stability of the regenerated and transported DS1 signals that are selected for use to pass timing (synchronization). However, if the most direct paths are assigned, the number of intervening clocks is minimized, as well as the opportunity for impairment to the timing signal. The most direct, most stable paths are selected for reference transport between nodes.



**Figure 11-2.** Hierarchical Network Synchronization

## 11.4 Internodal Synchronization

This section discusses considerations for developing a hierarchical synchronization strategy. Properly designed networks minimize the possibility of slips and ensure that timing loops are not created. Important considerations when developing an internal synchronization network plan are discussed in the following sections. In most cases, *internodal* may also refer to *interbuilding*. Exceptions could occur where more than one digital node shares the same physical structure or where a single digital node comprises multiple structures.

### 11.4.1 Timing Source

The synchronization network is made up of a hierarchy of digital-system clocks. These clocks ultimately derive synchronization reference from a stratum-1 clock. The hierarchy uses selected digital facilities as synchronization links, which provide paths that are traceable back to a PRS. These digital facilities often are the same systems that provide customer service. Clocks can derive synchronization reference from other clocks that are



---

higher or equally positioned in the synchronization hierarchy, but never from a clock (node) that is lower in the hierarchy.

#### 11.4.2 Clock Strata Requirements

Clocks are grouped into four strata levels with each level, except stratum 1, having an enhanced category. However, only the stratum 3E is included in Table 11-1. Stratum 1 is the highest performance clock and stratum 4 is the lowest performance clock in the hierarchy. Stratum-1 clocks are *sources* that have no network input reference and no holdover mode (refer to GR-1244-CORE, *Clocks for the Synchronized Network: Common Generic Criteria*, for information about holdover). Stratum-4 clocks do not provide holdover, and therefore enter free-run when they lose their references. For this reason they are not used to distribute timing to other nodes. The SONET Minimum Clock (SMC) is a classification designated by Bellcore in GR-253-CORE, *Synchronous Optical Network (SONET) Transport System: Common Generic Criteria*. The SMC designation specifies a clock with the significant phase noise filtering that is required in SONET applications. Another classification with enhanced filtering is the Stratum 3E, which is a classification Bellcore designated in GR-1244-CORE and will also be included in the next revision of ANSI T1.101. Stratum-3E clocks are fully compatible with existing stratum-3 clocks because they have the full stratum-3 pull-in/hold-in range. The filtering specification requires that the 3E clock be able to accept an input with high levels of wander, and generate an output with low levels of wander. Furthermore, the 3E is required to provide significantly better holdover than stratum 3. All stratum level clocks must meet a series of specifications to be classified into a stratum level. The primary specifications that must be met cover accuracy, holdover stability, and pull-in. Individual network clocks must meet all of the requirements of a particular stratum to be classified into that stratum. Clocks that cannot meet these requirements are considered non-stratifiable and must be administered on an *ad hoc* basis. Table 11-1 shows the clock strata requirements as set forth in ANSI T1.101-1994.

#### 11.4.3 Primary Reference Source

The source of timing information for a network that has digital connectivity with any other network should meet stratum-1 performance requirements. Known as a PRS, a stratum-1 clock is usually collocated with a stratum-2 clock. There are currently three technologies being used as PRSs in the network: Cesium beam references, LOnG RAnge Navigation-C (LORAN-C), and Global Positioning System (GPS). At divestiture, there were few PRSs deployed in the LEC networks. PRS deployment has grown in recent years and is expected to continue growing. The main reasons for this are as follows:

- *Better performance* — as more PRSs are deployed, the length of timing chains is minimized so performance is improved

- *Less Administration* — as more PRSs are deployed synchronization networks become easier to plan, administer, and maintain.

**Table 11-1.** Clock Strata Requirements

Stratum	Minimum Accuracy*	Holdover Stability**	Pull-In Range†
1	$\pm 1 \times 10^{-11}$	Not applicable	None
2	$\pm 1.6 \times 10^{-8}$ ( $\pm 0.025$ Hz @ 1.544 MHz)	$\pm 1 \times 10^{-10}$ /day	Must be capable of synchronizing to clock with accuracy of $\pm 1.6 \times 10^{-8}$
3E	$\pm 4.6 \times 10^{-6}$ ( $\pm 7$ Hz @ 1.544 MHz)	$1 \times 10^{-8}$ day 1 $0.5 \times 10^{-9}$ /day past day 1	Must be capable of synchronizing to clock with accuracy of $\pm 4.6 \times 10^{-6}$ (stratum 3)
3	$\pm 4.6 \times 10^{-6}$ ( $\pm 7$ Hz @ 1.544 MHz)	< 255 slips on any connecting link during the initial 24 hours of Holdover.	Must be capable of synchronizing to clock with accuracy of $\pm 4.6 \times 10^{-6}$
SONET Minimum Clock (SMC)	$\pm 20 \times 10^{-6}$ ( $\pm 31$ Hz @ 1.544 MHz)	Under Study	Must be capable of synchronizing to clock with accuracy of $\pm 20 \times 10^{-6}$
4	$\pm 32 \times 10^{-6}$ ( $\pm 50$ Hz @ 1.544 MHz)	Not applicable	Must be capable of synchronizing to clock with accuracy of $\pm 32 \times 10^{-6}$

\* Minimum accuracy represents the maximum long-term (20-year) deviation from the nominal frequency with no external frequency reference (Free-Run Mode).

\*\* Minimum stability represents the maximum rate of change of the clock frequency with respect to time upon loss of all frequency references (Holdover Mode).

† Pull-in range is a measure of the maximum input frequency deviation from the nominal clock rate that can be overcome by a clock to pull itself into synchronization with a reference signal.

---

#### 11.4.4 Facility Selection

Two important considerations in the choice of the primary and secondary reference facilities and routings are given below.

- Nodal position in the hierarchy is designed so that a loop is never formed.
- The synchronization facilities are chosen to maximize the reliability and survivability of the synchronization network.

Identifying digital transmission facilities that have the best overall availability is the major objective in selecting primary or secondary synchronization links. Availability is defined in terms of the absence of long outages and the absence of numerous short-term outages. Outages may be caused by equipment failures, craft activity, or natural disruptions. Instabilities in the network, such as reframes and line errors, suggest an unsuitable system and can be used as a criterion to reject a link as a candidate or to assign a replacement for one already selected.

Characteristics that primarily determine the availability of a digital transmission facility include the following:

- Historical troubles
- Provisioning activity
- Facility length
- System type (cable carrier, digital microwave, or lightwave systems)
- Protection switching (frequent switching activity may be a negative factor)
- Physical type (underground, buried, or aerial paired cable, coaxial cable, fiber-optic cable, radio or satellite link)
- Number and types of regenerative repeaters
- Number of multiplexers and other intermediate office equipment, if any
- Dedicated or nondedicated cables (cable with carrier and voice-frequency pairs)
- Cable cross-section.

Currently, nearly all transmission media have been found to be suitable for the transport of timing (stable synchronization reference frequency). Exceptions are satellite links and SONET Virtual Tributary 1.5 (VT1.5). Some other multiplexed systems, such as T1-C carrier systems, frequently exhibit wander and jitter that is within specifications, but should be avoided as timing transport facilities.

Satellite links are deemed unsuitable due to excessive wander (path delay variations) characteristics. SONET is a synchronous transport system that uses a scheme of byte-stuffing known as *pointer adjustments* for frequency justification. Pointers can be deployed at the virtual-tributary level (DS1 payload) which may generate excessive wander that

---

could disqualify this mode of operation as a medium to pass synchronization reference signals.

GR-253-CORE defines the requirements for SONET NEs to provide an output DS1 signal for timing distribution purposes that would provide an alternate means for synchronization distribution. This signal is derived directly from the OC-N signal, carries no traffic, and is required to have very low levels of wander. It is expected that the synchronization network will evolve to OC-N based timing distribution for the following reasons:

- DS1 payload signals carried on SONET are not recommended for network synchronization distribution due to the degradation of short-term stability and the phase hits that SONET introduces.
- OC-N signals have tighter short-term stability requirements than DS1 signals, so they should provide for better overall network performance.
- OC-N signals are expected to be rearranged less frequently than DS1 signals.

#### 11.4.5 Timing Loops

The use of secondary timing references in the synchronization network increases the possibility of inadvertently creating timing loops. That is, a timed clock could receive timing from itself via a chain of other clocks, forming a loop. Timing loops are undesirable for at least two reasons. First, all the clocks in the timing loop become isolated from the primary timing source (i.e., a timing path does not exist back to a PRS). Second, frequency instabilities are likely to arise because of the timing reference feedback. Therefore, avoiding the creation of timing loops is an important concern during the configuration process.

#### 11.4.6 Implementation Strategy

Synchronization of the Local Exchange Carrier (LEC) digital networks is accomplished by adhering to the following rules.

- Rule 1

A node can receive synchronization reference signals only from other nodes that contain clocks of equal or higher strata. In general, the node under consideration will receive synchronization directly from the upstream node containing the strata-quality clock.

- Rule 2

References to nodes must be configured so that timing loops are never formed. GR-436-CORE provides a methodology for ensuring that no timing loops exist in a network.

---

- Rule 3

The most reliable facilities are selected as primary and secondary synchronization facilities.

- Rule 4

Where possible, primary and secondary synchronization facilities are diverse, and synchronization facilities within the same cable are minimized.

- Rule 5

The total number of nodes in series from the stratum-1 source should be minimized (most direct PRS-traceable path).

## 11.5 Intranodal Synchronization

### 11.5.1 Building-Integrated Timing Supply

Each node has a single master timing supply. This master clock (and its ancillary equipment), called the Building-Integrated Timing Supply (BITS), is the most accurate and stable clock in the node.

### 11.5.2 Composite Clock

The BITS supplies DS1/DS0 timing to all other clocks in the building according to service needs. DS0 interconnections require phase synchronization at both the bit level and byte level. This phase synchronization is provided by the Composite Clock (CC) signal. The CC signal is a 64-kHz, 5/8-duty-cycle, Return-to-Zero, bipolar signal with a Bipolar Violation (BPV) every eighth bit. Bit synchronization is achieved by having data transmitted on the leading edge of the CC signal and sampled on the trailing edge of the CC signal. Byte synchronization is achieved by the BPV in the CC signal, which indicates byte boundaries. Because of this scheme, it is necessary that DS0 transmitter and receiver be synchronized to phase aligned CC signals, and that cabling distances, which introduce delay, be limited to 1500 feet. Because of these restrictions, DS0 interconnections are used for intraoffice applications only.

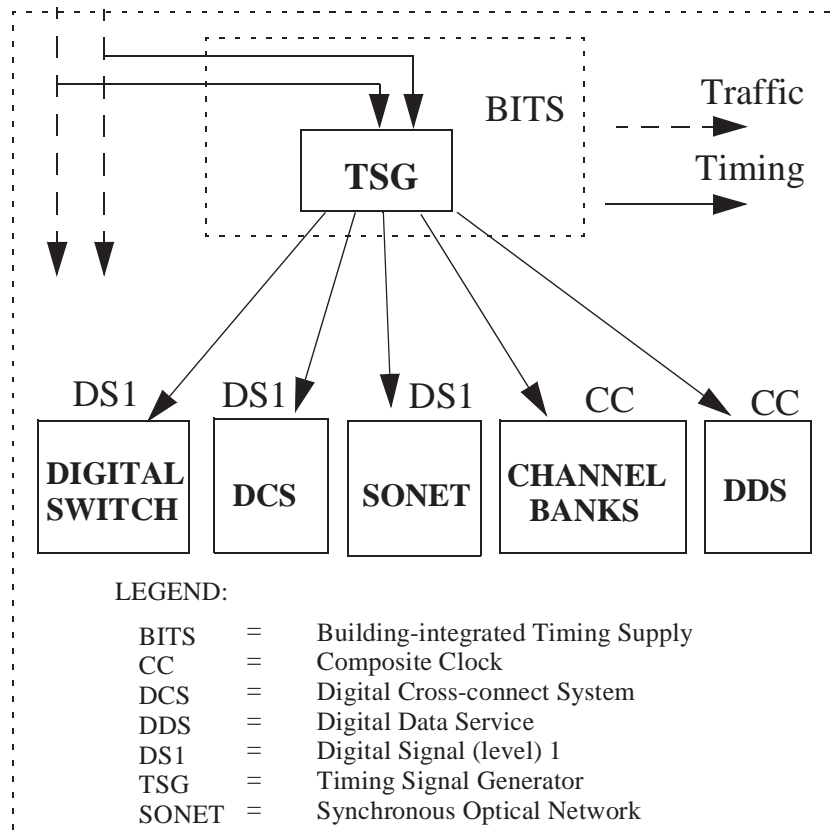
### 11.5.3 BITS Advantages

The advantages of implementing the BITS concept can be separated into three major areas: performance, use of resources, and operations. In the area of performance, the designation of a master timing supply per node improves reliability and availability of timing

distribution. The BITS concept minimizes the number of synchronization links entering an office, since only the BITS will be timed from an external reference. In the area of resources, BITS allows shared use of equipment among services within the office. In the area of operations, the key feature is that the BITS is location-dependent, not service-dependent. This makes record-keeping for provisioning and maintenance purposes considerably easier as new digital services are introduced. Thus, instead of a different intranodal synchronization network for each service (grooming), there is only one with the BITS.

#### 11.5.4 BITS Implementation

The Bellcore recommended BITS implementation is to use a Timing Signal Generator (TSG) as the BITS (See Figure 11-3). The TSG is timed by using a bridging repeater or bridging resistors on an incoming DS1 signal to provide an input. When SONET-based timing distribution is used, the TSG is timed by the derived DS1 from the SONET terminal. All other synchronous equipment in the office then derives timing from the TSG.



**Figure 11-3.** Recommended BITS Implementation

---

## 11.6 Reliability and Performance

Reliable operation is a crucial ingredient for an effective synchronization network. For this reason, the synchronization network is designed with redundancy, such as primary and secondary (backup) synchronization reference facilities. In addition, each stratum-2 and stratum-3 digital node is equipped with dual clocks, each able to bridge short disruptions of the synchronization references. The active clock normally follows the synchronization reference. Should all external reference be lost, the clock frequency drifts at a rate determined by its holdover characteristics (see Table 11-1). For example, a stratum-2 entity has a clock with a holdover drift rate of less than one part in  $10^{-10}$  per day. Therefore, the first slip due to clock drift would occur in about 14.3 days.

### 11.6.1 Jitter and Wander

The slip rate between two digital nodes is affected by the difference in clock rates and by phase error due to other causes (such as phase hits, noise, or jitter on a received reference signal). Individually or in combination, these impairments may trigger a slip, depending on buffer fill.

Timing jitter and wander are impairments of a digital signal caused by transmission facilities and equipment in the digital network. Timing jitter is the short-term variation of the significant instances of a digital signal from their ideal positions in time (phase oscillations with frequency greater than or equal to 10 Hz), while timing wander is the long-term variations (less than 10 Hz).

Both timing jitter and wander can contribute to producing slips in digital networks; however, jitter is effectively filtered at the BITS, which is a key element where many impairments can be absorbed at each node. The amount of wander that is removed by the BITS is determined by the filtering characteristics of the clock incorporated in the TSG. The stratum 2 clock provides the most filtering of all clocks and will remove the most wander.

### 11.6.2 Slip Performance

Most nodes in today's networks have stratum-3 clocks. Table 11-2 summarizes the stratum-3 slip rates under various operating conditions. During trouble-free conditions, the nominal stratum-3 slip rate is zero. Should there be trouble on the primary reference, the clock will switch to a secondary reference. The transition may generate a slight phase error at the clock output. A possibility exists that some connecting links could experience buffer fill coincident with the generated phase error, and a single slip may result. During the most extreme trouble conditions, such as the loss of all frequency references, the nominal clock drift will cause no more than 255 slips on any connected trunk in the first 24 hours. This is assured by an average frequency deviation from other referenced nodes of less than 3.7

---

parts in  $10^7$ , and is intended to avoid exceeding maintenance limits and causing the systems to turn down trunks to those entities. Under similar conditions, a stratum-2 clock will drift a maximum of 1 part in  $10^{10}$ .

**Table 11-2.** Stratum-3 Slip Conditions

Trouble Condition	Description
Trouble-free	Nominal clock slip rate = 0.
Primary reference trouble	Maximum of one slip on any trunk will result from a switched reference or any other rearrangement.
Loss of all references	Maximum slips = 255 slips the first day for any trunk. This occurs when the stratum-3 clock drifts a maximum of 0.37 parts per million from its referenced frequency.

## 11.7 Interconnection with Other Networks

As the synchronization network evolves, intraLATA digital networks can interact directly or indirectly with ICs, other exchange carriers, Wireless Services Providers (WSPs), or private networks. Direct interaction occurs when a portion of a network either accepts a PRS-traceable reference from another network or passes a PRS-traceable reference to another network. Indirect interaction occurs when a timing reference is not accepted/passed between networks. In all cases, digital connectivity is the basis for any interaction related to synchronization.

### 11.7.1 Asynchronous Operation

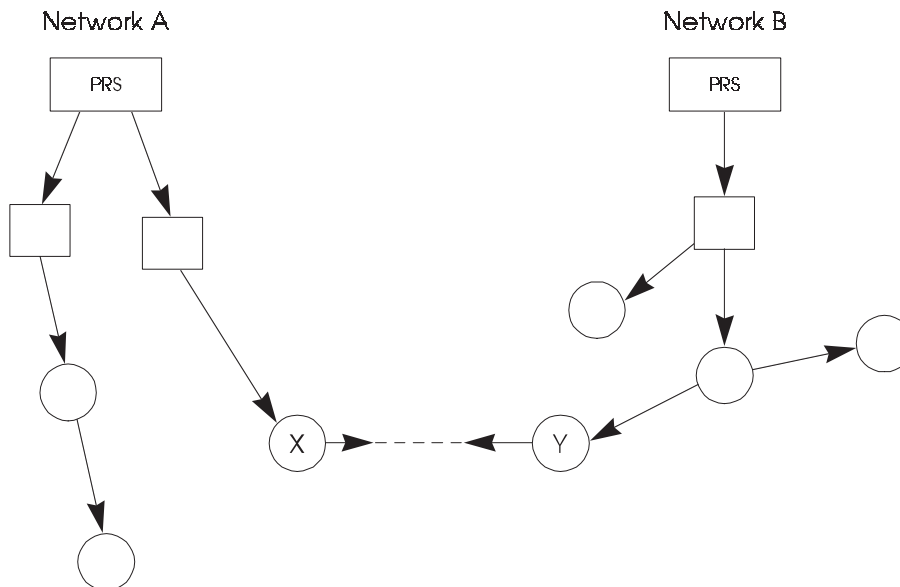
Asynchronous operation occurs when one of the connecting networks does not have its own primary frequency standard and does not accept stratum-1 traceable timing from another network. Slips can occur whenever digital connectivity exists, whether the connectivity exists directly between two nodes of separate connecting networks or indirectly through a third network node.

### 11.7.2 Plesiochronous Operation

Figure 11-4 is an example of plesiochronous operation between networks. It occurs when each network is timed from an independent and physically discrete frequency reference



(stratum-1 clock). Although these networks are digitally connected, no timing reference is passed between them. The output frequency of each stratum-1 clock is so close to the output frequency of other stratum-1 clocks that virtually slip-free performance will be experienced by the interconnecting links between networks.



Facility X-Y has each direction timed from a different source.

**Figure 11-4.** Plesiochronous Operation

## 11.8 Administration

Each network is locally administered by the responsible company. Synchronization coordinators have been established in many LECs to plan and administer their networks.

The functions of the synchronization coordinator are generally as follows.

- Maintaining a synchronization network sector map that shows the primary and secondary synchronization facility connections between all digital nodes within the company boundaries and known connections with other networks. The synchronization map is updated on an ongoing basis.
- Maintaining a node plan to document the distribution of timing signals within each node.
- Ensuring the integrity of synchronization. To accomplish this, internal coordination of the following activities should occur on a project-management basis.

- 
- Engineering, ordering, installing, testing, and cutting over of synchronization facilities and equipment
  - Planning and implementing operations systems (alarm reporting, network analysis, administration)
  - Documenting synchronization network sector maps and node-timing distribution plans, including updating mechanized record-keeping systems and facility-engineering systems.

## 11.9 Synchronization Network Operations

Maintenance activities involve the detection of synchronization network degradation and failures and the restoration of quality timing distribution. Ideally, corrective action is completed before services are seriously affected.

### 11.9.1 Detection of Impaired Synchronization

In general, there are two ways of detecting a failure in the synchronization network (a failure means that there has been some disruption in the distribution of timing). One method is to monitor the synchronization network facilities and equipment for impairments, and the other method is to monitor the synchronized transmission facilities for slips.

Since much of the internodal synchronization network is composed of equipment that is primarily used to provide customer services, this equipment will have monitoring capability. If a digital transmission facility fails (or is degraded sufficiently in performance), alarms, such as Carrier Group Alarms (CGAs), are generated and processed by an alarm operations system. A decision is frequently made to remove the facility from service for maintenance action. Often, a spare facility will be patched into the network to restore service and timing distribution.

If a clock fails, a clock-failure alarm is generated and sent to an operations system for maintenance action. However, total clock failure is unlikely due to redundancy in design. Rather, a clock is more likely to be unable to derive timing from its primary link. In this case, it will switch automatically to its secondary link and generate an alarm. Maintenance action will be taken to restore the primary link.

### 11.9.2 Restoration of the Synchronization Network

When the cause of slips in the synchronization network has been located, it is necessary to restore the distribution of timing to those isolated parts of the network. Because of the duplication of timing links into many nodes, restoration following an internodal failure can often be achieved by selectively switching to secondary links for certain nodes. However,

---

---

the same extent of redundancy might not exist for some equipment in the intranodal network. Where no redundancy exists, restoration must be achieved by repairing the failed equipment. Essentially, the major goals of network restoration are to distribute timing to as many network elements as possible and to minimize the number of timing islands and spanning facilities that are affected.

#### 11.9.2.1 Internodal Failure

If the primary link for a clock has failed, timing is restored by switching to the secondary link (when provided) for that clock. If both the primary and secondary links for a clock have failed, timing cannot be restored to that clock unless a third link is temporarily made available or one of the failed links is repaired. With the loss of all external references, stratum-2, stratum-3E, stratum-3, and SMC clocks will enter the holdover mode of operation, which uses stored data to attempt to maintain a stable output.

#### 11.9.2.2 Intranodal Failure

For clocks in the intranodal subnetwork that have both primary and secondary timing links, restoration of a link failure can be achieved with switching. For those clocks without redundant timing links, restoration of a link failure involves repairing the failed link itself or provisioning a new link. Failure of the BITS clock itself is a relatively unlikely occurrence due to design redundancy. In the event of a TSG failure, restoration can be achieved only by repairing the unit itself.

### 11.10 Synchronization Network Testing

There are unscheduled tests where monitoring for slips and analyzing impairment and alarm reports are suggested to isolate and correct a fault. This section discusses planned (scheduled) testing.

Planned tests can be divided into two types: operational and certification. Operational tests ensure the user that the Equipment Under Test (EUT) is properly integrated into the existing network and is performing as expected (that is, for cutover applications). Certification tests qualify the EUT, verifying that published performance specifications and existing standards and objectives are met.

#### 11.10.1 Cutover Coordination

As new timing entities (such as digital cross-connect systems and switches) are introduced into the network, synchronization tests should be included within the pre-cutover test

---

---

procedures. A synchronization coordinator typically will interface with the organizations involved in the cutover process to ensure that all appropriate parties are aware of the synchronization requirements associated with the cutover.

The extent of synchronization testing for a new entity may be adjusted to fit the role in the hierarchy of the new entity. A new BITS clock may require more extensive tests than a non-BITS clock. In addition, the cutover method or procedure for a BITS entity will require special consideration.

### 11.10.2 Synchronization Tests

Pre-service synchronization tests include

- Switching of references and switching-control features
- Reference impairment detection, alarms, and reports
- Switching of SYNC UNITS (clocks) and diagnostics
- Wander tolerance/generation
- Jitter tolerance/generation
- Pull-in/hold-in to a reference frequency offset
- Stability during rearrangements/transitions
- Drift (phase error) in normal and holdover modes.

Signals should be compared to a standard, such as a cesium beam oscillator, for certification tests. A bridged network signal (with PRS traceability) is adequate for operational tests. Observation periods may vary to fit the need.

### 11.10.3 Test Configurations

Figure 11-5 shows a test configuration for many synchronization tests. With this arrangement, the input reference signals can be controlled to stress the EUT while output signals are compared with a standard, and the results are recorded. This is a complex setup and is necessary only for certification-type tests. A computer program is often used to control the test sets and collect data on phase-comparison samples.

Many simpler test-set configurations may be used for fault-isolation tests as well as planned operational tests. The simplest form would be the visual comparison two signals using an oscilloscope, in effect duplicating the function of a slip-detector test set.

Most planned tests are performed with the EUT out of service. In-service, non-intrusive tests are often conducted using Digital Signal Cross-Connect — Digital Signal level 1 (DSX-1) monitor jacks to detect and isolate timing troubles. However, network analysis is

---

required because the source of a degradation in the synchronization network could be far removed from the point where a timing problem is first detected.

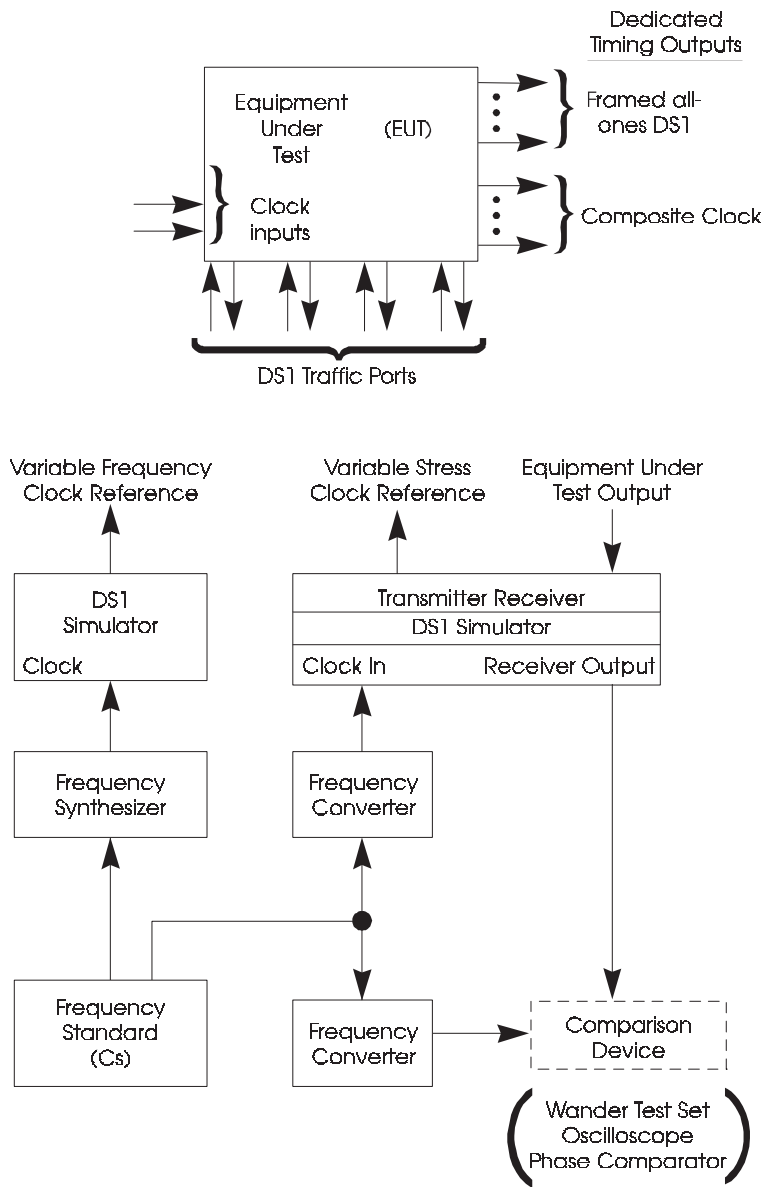


Figure 11-5. Synchronization Test Configuration



## Section 12

### Distribution

### Contents

12. Distribution .....	12-1
12.1 Introduction .....	12-1
12.1.1 Feeder and Distribution Plants .....	12-1
12.1.1.1 Feeder Plant .....	12-1
12.1.1.2 Distribution Plant .....	12-3
12.1.2 Multiple, Dedicated, and Interfaced Plant .....	12-3
12.1.3 Distribution Network Design .....	12-4
12.1.4 Carrier Serving Areas .....	12-5
12.2 Metallic Loop Conditioning .....	12-5
12.3 BOC Loop Surveys .....	12-7
12.3.1 1983 BOC Survey Results .....	12-7
12.3.1.1 Composite .....	12-8
12.3.1.2 Residence .....	12-13
12.3.1.3 Business .....	12-15
12.3.2 1987 to 1990 BOC Digital Access Survey .....	12-17
12.3.2.1 Digital Loop Carrier Study .....	12-17
12.3.2.2 Potential Broadband Study .....	12-18
12.4 Voice-Frequency Channel Terminating Equipment .....	12-19
12.5 Analog Loop Carrier .....	12-20
12.6 Universal Digital Loop Carrier .....	12-20
12.7 Integrated Digital Loop Carrier .....	12-25
12.7.1 TR-TSY-000008 Interface .....	12-26
12.7.2 TR-TSY-000303/GR-303-CORE Interface .....	12-27
12.8 Basic Exchange Radio System .....	12-29
12.9 Integrated Service Digital Network .....	12-32
12.9.1 Basic Rate Access Interface .....	12-32
12.9.1.1 Digital Subscriber Lines .....	12-32
12.9.1.2 Access Architectures .....	12-34
12.9.1.3 Maintenance .....	12-37
12.9.2 Primary Rate Access Interface .....	12-37
12.9.3 Broadband Access .....	12-41
12.10 Universal Digital Channel .....	12-42
12.10.1 System Description .....	12-42
12.10.2 DSL Transmission Technology .....	12-43
12.10.3 Customer-Usable Data Rate .....	12-43
12.10.4 Transport over Carrier Systems .....	12-44
12.11 Distribution Network Physical Structures .....	12-44
12.12 New Technology .....	12-45

---

12.12.1 Fiber-in-the-Loop.....	12-46
12.12.2 High Speed Digital Subscriber Lines.....	12-48
12.12.2.1 High Bit-Rate Digital Subscriber Line .....	12-48
12.12.2.2 Asymmetric Digital Subscriber Line .....	12-49

## List of Figures

Figure 12-1. Feeder and Distribution Plants .....	12-2
Figure 12-2. Carrier Serving Areas .....	12-6
Figure 12-3. Representation of Loop .....	12-8
Figure 12-4. Total Length Distribution .....	12-9
Figure 12-5. Working Length Distribution .....	12-10
Figure 12-6. Bridged-Tap Length Distribution .....	12-10
Figure 12-7. Cable Gauge Distribution (Not Including Bridged-Taps) .....	12-12
Figure 12-8. Cable Construction Distribution (Not Including Bridged-Taps).....	12-12
Figure 12-9. Total Length Distribution Residence Loops.....	12-13
Figure 12-10. Working-Length Distribution Residence Loops.....	12-14
Figure 12-11. Bridged-Tap Length Distribution Residence Loops.....	12-14
Figure 12-12. Total Length Distribution Business Loops.....	12-15
Figure 12-13. Working-Length Distribution Business Loops.....	12-16
Figure 12-14. Bridged-Tap Length Distribution Business Loops.....	12-16
Figure 12-15. Distribution Network — Digital Loop Carrier .....	12-21
Figure 12-16. Universal Digital Loop Carrier Configuration .....	12-22
Figure 12-17. UDLC Over Fiber .....	12-24
Figure 12-18. IDLC Generic Interface .....	12-26
Figure 12-19. Digital BEXR System.....	12-30
Figure 12-20. ISDN Basic Rate Access Configuration.....	12-33
Figure 12-21. DSL Line Code — 2B1Q .....	12-34
Figure 12-22. ISDN Basic Rate Access Transport Architecture.....	12-36
Figure 12-23. Primary Rate Access Architecture.....	12-38
Figure 12-24. Other ISDN Primary Rate Access Architectures.....	12-39
Figure 12-25. Other ISDN Primary Rate Access Architectures.....	12-40
Figure 12-26. Universal Digital Channel .....	12-43
Figure 12-27. Generic Fiber-in-the-Loop (FTTC) System .....	12-47
Figure 12-28. Repeaterless DS1 Access Architecture Using HDSL.....	12-49

---



---

## List of Tables

Table 12-1.	1983 Loop Survey — Length Statistics.....	12-9
Table 12-2.	Loop Surveys — Comparison of Lengths .....	12-11
Table 12-3.	1983 Loop Survey — Residence Length Statistics .....	12-13
Table 12-4.	1983 Loop Survey — Business Length Statistics .....	12-15
Table 12-5.	DLC System-Related Elements .....	12-23
Table 12-6.	UDLC Services.....	12-24



---

## 12. Distribution

### 12.1 Introduction

The distribution network is the part of the overall telephone network that connects the switched and interoffice networks with individual customers. An integral part of the distribution network is the loop, which connects the customer to the local central office (CO), thus providing access to the interoffice network.

#### 12.1.1 Feeder and Distribution Plants

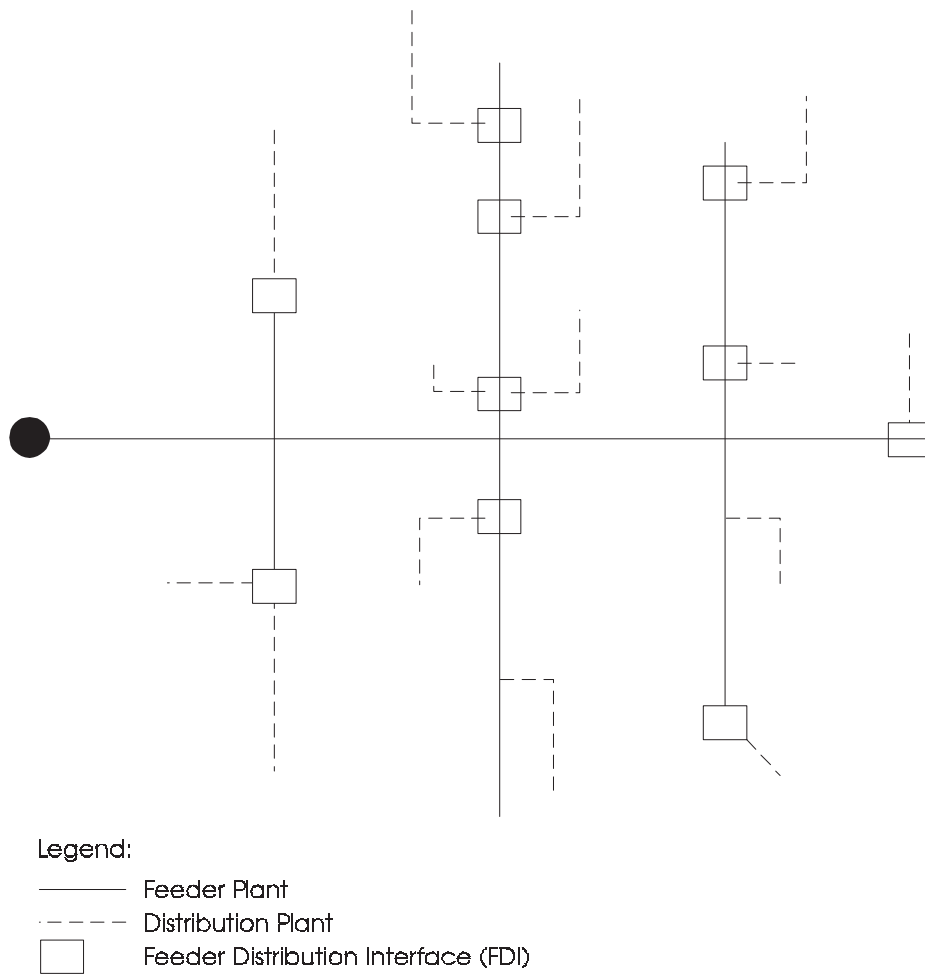
The distribution network is divided into two major parts: feeder and distribution plants. Figure 12-1 shows a simplified schematic representation of the feeder route, its branch or subsidiary feeder routes, and distribution routes.

##### 12.1.1.1 Feeder Plant

The feeder portion of the present Local Exchange Carrier (LEC) network is composed of fiber-optic cables, various gauges of copper cables, T1-carrier lines, and radio. It can transport analog and digital signals that are multiplexed together to derive high bit rates, which characterize the modern feeder network. Analog-to-digital conversion is achieved through Digital Loop Carrier (DLC) systems, described in detail in Sections 12.6 and 12.7, which are also the first step in the multiplexing process. Both the DLC and multiplexer systems are strategically placed in proximity to the Feeder Distribution Interface (FDI).

The cable pair or channel capacity of the feeder plant decreases (tapers) as its distance from the local central office increases. As the feeder distributes facilities along the way between the local central office and the customers, the cable pair capacity decreases. The feeder routes provide large numbers of cable pairs or channels from the central office to strategic remote locations called serving areas, part of the Serving Area Concept (SAC). These serving areas include cross-connect points in the network between the feeder plant and the distribution plant, at the FDI.

To meet future service needs, sections of the feeder plant are designed to be augmented periodically. Typical relief time periods for feeder plants vary between four and fifteen years, depending on individual company needs and practices. Local geography and customer or facilities locations determine the placement of feeder routes, including below-ground or aerial facilities. Many feeder routes parallel major traffic highways. Multiple connecting subfeeders, or branch feeder routes, are derived from a relatively small number of main feeder routes leaving a local central office. Because of the high number of cables involved, and the need for periodic addition of cables, most below-ground feeder plants are in underground conduit structures for ease of placement and replacement.



**Figure 12-1.** Feeder and Distribution Plants

---

### 12.1.1.2 Distribution Plant

The distribution plant consists of small cables/systems that cross-connect the feeder plant to the customer. This plant is designed to meet the greatest expected customer demand in an area for the life of the plant. In the distribution facilities copper cables of 26, 24, 22 (and rarely 19) gauge predominate. Distribution network design requires more distribution pairs than feeder pairs; distribution networks contain more distribution cables than feeder cables. Most distribution plants include either direct-buried or aerial cable, with the ultimate needs installed initially.

### 12.1.2 Multiple, Dedicated, and Interfaced Plant

Distribution plant design treats loops on an aggregate instead of an individual basis, so large composite cross-sections of facilities are designed with similar transmission characteristics. This simplifies distribution network design, especially when several gauges of cable are used.

The major distribution network designs that have been used by the LECs include multiple, dedicated, and interfaced plant. Carrier Serving Area (CSA) design is discussed later in this section.

Multiple plant design extended the number of customers that could be served by a feeder pair through multipling (splicing two or more distribution pairs to a single feeder pair). This procedure has the advantage of providing flexibility to accommodate future assignments by providing multiple appearances of the same loop pair at several distribution points. However, adding new feeder cables causes line and station transfers and cable-pair transfers to relieve the distribution cables. Multiple plant design was largely replaced by dedicated plant design because of the labor intensity of adding to or changing existing plant and customer demands to convert from multiple-party line to single-party line service.

Dedicated plant provides a permanently assigned cable pair from the central office Main Distributing Frame (MDF) to each customer. Dedicated plant largely eliminates expensive transfers of lines, stations, and cable pairs. Because of customer demand for additional service, the use of dedicated plant design for new construction has, in turn, been generally superseded by interfaced plant.

Interfaced plant uses a manual cross-connect and demarcation point, the FDI, between the feeder plant and distribution plant. The cross-connect, or interface, allows any feeder pair to be connected to any distribution pair. This increases flexibility and reduces outside plant deployment and labor costs. Compared to both multiple and dedicated plant, interfaced plant provides greater flexibility in the network and represents the present conventional (metallic pair) distribution plant design philosophy.

---

### 12.1.3 Distribution Network Design

To help achieve acceptable transmission in the distribution network, design rules are used to control loop transmission performance. Loops are designed on a global basis to guarantee that loop transmission loss is statistically distributed and that no single loop in the distribution network exceeds the signaling range of the central office.

Prior to 1980, loops were usually designed using one of the following design plans: Resistance Design (RD), Long-Route Design (LRD), or Unigauge Design (UG). The most common current design plans applied only on a forward-going basis (retroactive redesign is not generally deployed) are the following: Revised Resistance Design (RRD), Modified Long-Route Design (MLRD), and Concentrated Range Extender with Gain (CREG).<sup>1</sup>

RRD guidelines recommend that loops 18 kft in length or less, including bridged-tap<sup>2</sup>, should be nonloaded and have loop resistances of 1300  $\Omega$  or less; loops 18 kft to 24 kft in length (including bridged-tap) should be loaded and have loop resistances less than or equal to 1500  $\Omega$ ; loops longer than 24 kft should be implemented using Digital Loop Carrier (DLC) as first choice, or by CREG or MLRD as second choices.

RRD limits bridged-tap to less than 6 kft for nonloaded cable. For loaded cable, the end section plus bridged-tap must be greater than 3 kft but less than 12 kft.

MLRD applies to the design of loops having loop resistances greater than 1500  $\Omega$  but less than or equal to 2800  $\Omega$ . All cables should be loaded, and MLRD recommends that two cable gauges be used along with the required range extension and gain. The bridged-tap and end-section requirements are compatible with RRD for loaded cable.

The CREG plan allows for increased use of finer gauge cable facilities by providing a repeater behind a stage of switching concentration in the central office. In this way, the range-extension circuitry is shared rather than dedicated in each loop. CREG design applies to loops having loop resistances of 0 to 2800  $\Omega$ . Its loading, bridged-tap, and end-section requirements are compatible with RRD and MLRD, unlike the UG plan that it replaces.

Current design plans offer improved transmission performance over the old plans, while all plans provide approximately the same minimum loop transmission loudness ratings.

- 
1. See Section 7, "Transmission", for additional information regarding the design rules for these plans.
  2. A bridged-tap is any branch or extension of a cable pair beyond the point where it is used and in which no direct current flows when a station set is connected to the pair in use.
-

---

#### 12.1.4 Carrier Serving Areas

The evolution of the network that can provide digital services using distribution plant facilities has led to the development of the CSA concept. A CSA is a geographical area that is, or could be served by, a DLC from a single remote terminal site and within which all loops, without any conditioning or design, are capable of providing conventional voice-grade message service, digital data service up to 64 kbps, and some 2-wire, locally switched voice-grade special services (see Figure 12-2). The maximum loop length in a CSA is 12 kft for 19-, 22-, or 24-gauge cables and 9 kft for 26-gauge cables. These lengths include any bridged-tap that may be present. The maximum allowable bridged-tap is 2.5 kft, with no single bridged-tap longer than 2.0 kft. All CSA loops must be unloaded and should not consist of more than two gauges of cable.

The area around the serving central office within a distance of 9 kft for 26-gauge cable and 12 kft for 19-, 22-, and 24-gauge cables, although not a CSA, is compatible with the CSA concept in terms of achievable transmission performance and supported services.

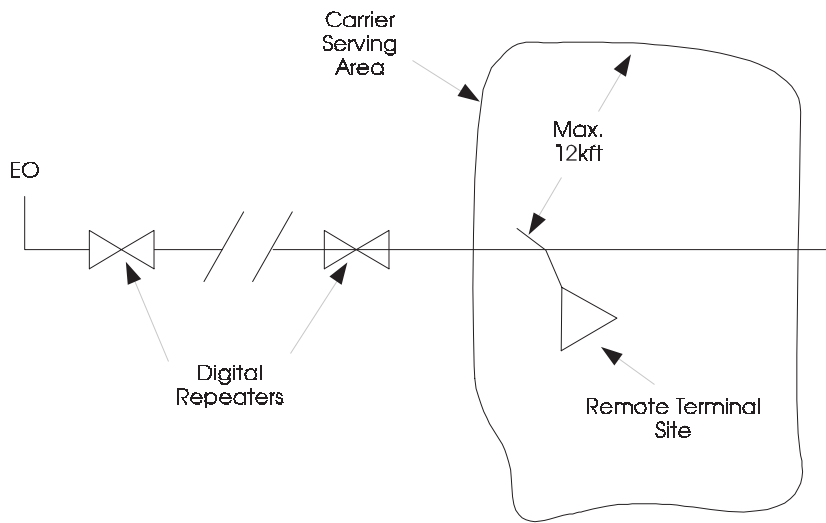
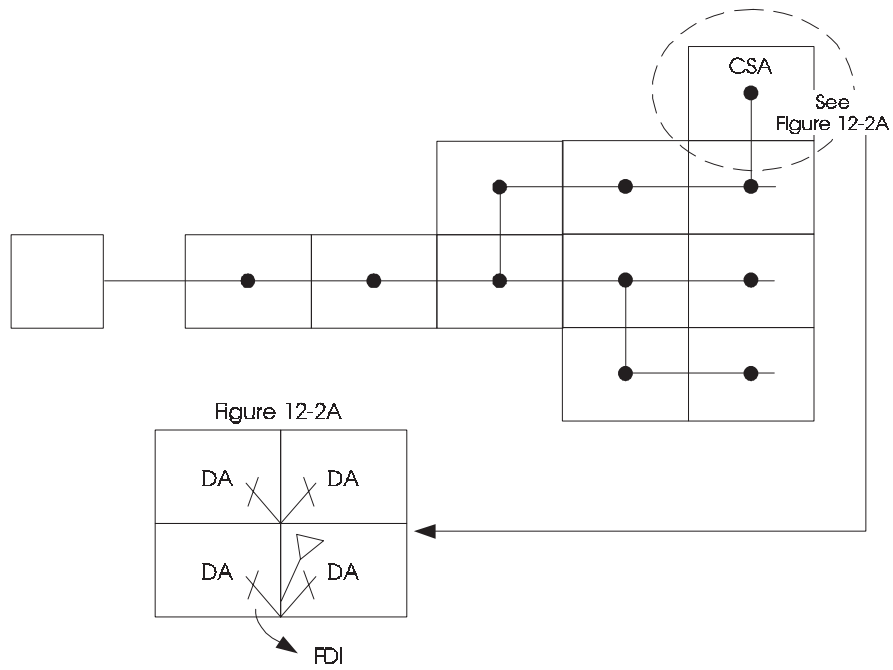
In addition to the CSA concept, the LECs also use the Serving Area Concept described above.

#### 12.2 Metallic Loop Conditioning

The transport of digital signals carrying 56 kbps or more bandwidth may require additional design considerations. Restrictions on loss and bridged-tap, removal of build-out capacitors, introduction of echo cancelers and line equalizers, and coordination with other services in the same cable may be required.

New digital signal-processing techniques, such as those used in the Integrated Services Digital Network (ISDN) Basic Rate Access (BRA) Digital Subscriber Line (DSL), permit the deployment of 160 kbps signals on most nonloaded loops ( $\leq 1300 \Omega$ ) without any conditioning.

Copper cables are the most widely deployed transmission media today. However, fiber-optic cables are usually the media of choice in the feeder plant for deployment of DLC. Fiber cables in the distribution plant may also be needed to handle the increasing bandwidth required for future services (Section 12.12). Radio transport is also used in selected routes.



- Legend:**
- CSA = Carrier Serving Area
  - DA = Distribution Area
  - EO = End Office
  - FDI = Feeder Distribution Interface

**Figure 12-2. Carrier Serving Areas**



---

## 12.3 BOC Loop Surveys

Three major surveys of BOC subscriber loops have been conducted in the last 20 years.<sup>3</sup> The first survey was made in 1964, the second in 1973, and the third in 1983. A fourth, the 1987 to 1990 Digital Access Survey (DAS), obtained more specialized information about DLC loops, and loops in potential broadband wire centers. (A potential broadband wire center is a wire center serving an area containing establishments that have high potential to use new loop technologies for subscribing to future broadband services; i.e., wire centers serving large business customers.) Results obtained from these surveys continue to be of value for planning and network management. Recent technological advances and the increasing number and types of services, coupled with the introduction of electronics (particularly digital carrier technology and fiber-optics) into the loop plant, have a significant impact on the assumptions that distribution network planners and engineers use to improve the network. This section describes the principal results of the 1983 Loop Survey, as well as the objectives of the 1987 to 1990 DAS and a summary of the corresponding results. This information provides a statistical profile of the loop network to aid the planning and engineering process.

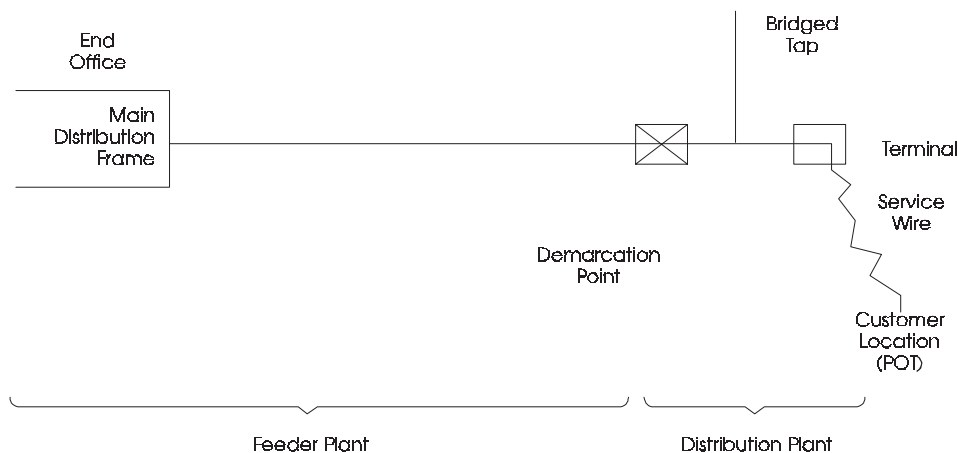
### 12.3.1 1983 BOC Survey Results

The following terms are used in the 1983 BOC survey results. Figure 12-3 illustrates terms describing the distribution plant.

- *Total length* of the loop is the sum of all cable segment lengths, including all the bridged-taps.
- *Working length* of the loop is the sum of all cable segment lengths from the central office to the customer's Point of Termination (POT). Working length must be less than or equal to the *total length* of the loop.
- *Service* refers to the type of service provided by the sampled pair (business or residence service and whether residence or business service is a special service).
- *Drop (or service wire) length* is an estimate of the total entrance wire length from an outside terminal location to the customer.

---

3. Other entities conduct similar surveys. The methodologies and results of these surveys may differ from the BOC surveys discussed herein.



**Figure 12-3.** Representation of Loop

#### 12.3.1.1 Composite

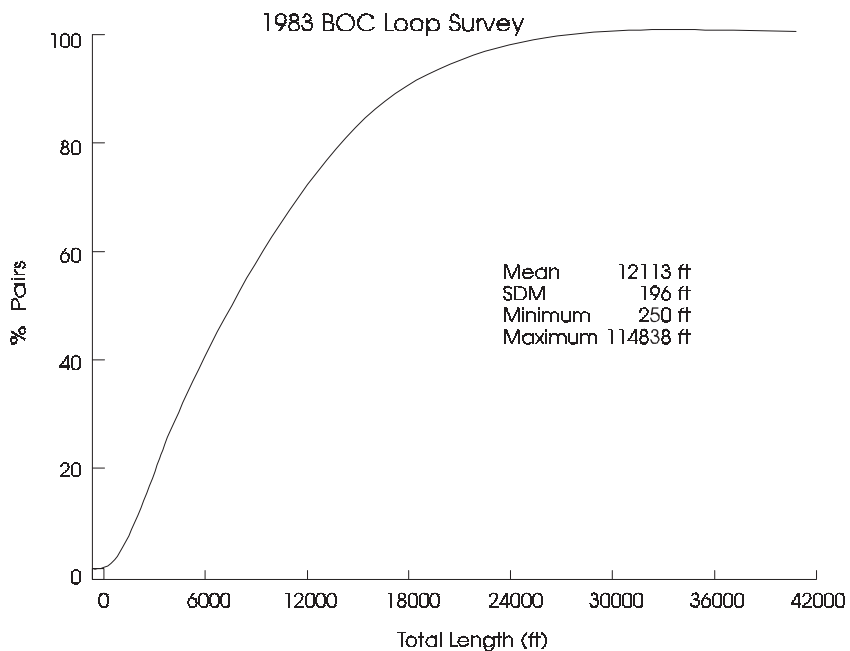
Table 12-1 contains the summary statistics of lengths for all the sampled working pairs. In this discussion, average and mean are synonymous. The average total length for the sampled pairs is 12,113 ft; average working length 10,787 ft; average bridged-tap length 1,299 ft. The average airline distance is 7,692 ft; average drop or service wire length 73 ft; and average planned ultimate route length 29,850 ft. These last three values are not shown in the table.

Table 12-1 also contains the standard errors in the estimation of means for each of these statistics. To calculate a 90-percent confidence interval for the sample, multiply 196 (the Standard Error of Mean [SDM] for total length from Table 12-1) by 1.645 (the 90-percent confidence coefficient). The resulting 90-percent confidence interval for the sample mean of the total length is  $12,113 \pm 322$  ft. This is interpreted to mean that, with a probability of 0.9, the mean total length of all working pairs lies in this interval. The confidence coefficient for the 99-percent confidence interval is 2.58, and for the 80-percent interval, 1.28. These coefficients can be used to determine the desired confidence interval. Figures 12-4, 12-5, and 12-6 present the distribution of total, working, and bridged-tap lengths as determined by the 1983 survey.

**Table 12-1.** 1983 Loop Survey — Length Statistics

(Sample Size 2,290)				
	Minimum ft	Maximum ft	Mean ft	SDM* ft
Total Length	250	114,838	12,113	196
Working Length	186	114,103	10,787	188
Total Bridged-Tap	0	18,374	1,299	34

\*SDM (Standard Error of Mean)



**Figure 12-4.** Total Length Distribution

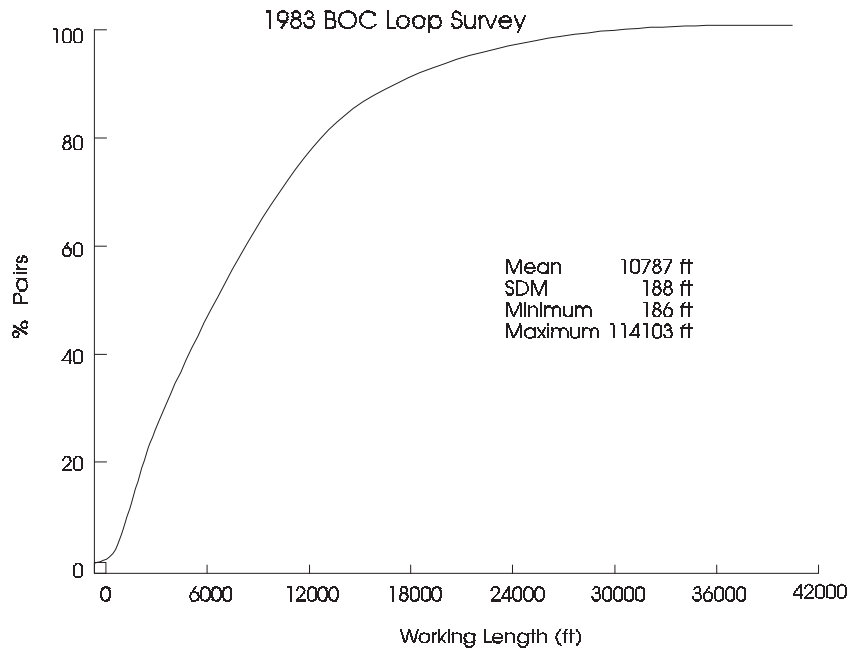


Figure 12-5. Working Length Distribution

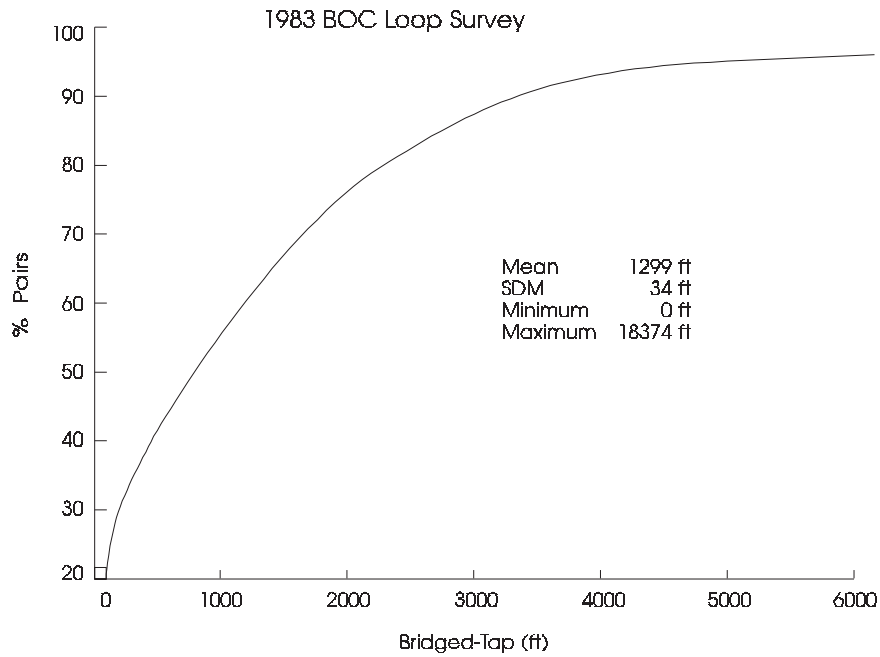


Figure 12-6. Bridged-Tap Length Distribution

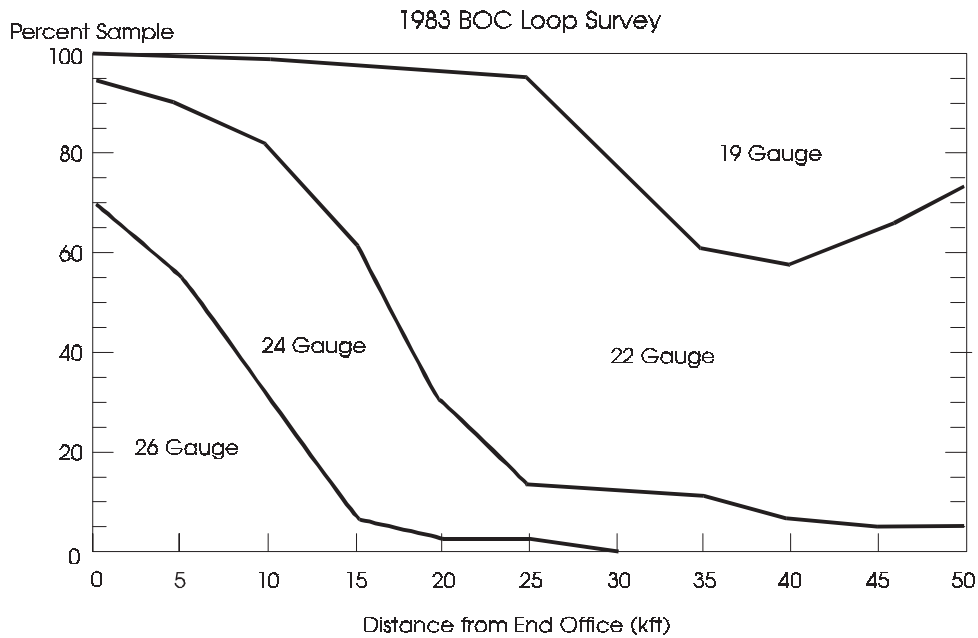
Table 12-2 shows a comparison between the working-loop lengths of working pairs from 1964, 1973, and 1983 BOC loop surveys. Residence pairs from the 1983 survey are compared to the total sample results from the earlier surveys. This comparison is made because earlier surveys emphasized residential main stations. Working-loop lengths show an increasing trend while an averaged bridged-tap length shows a decreasing trend over these years.

**Table 12-2.** Loop Surveys — Comparison of Lengths

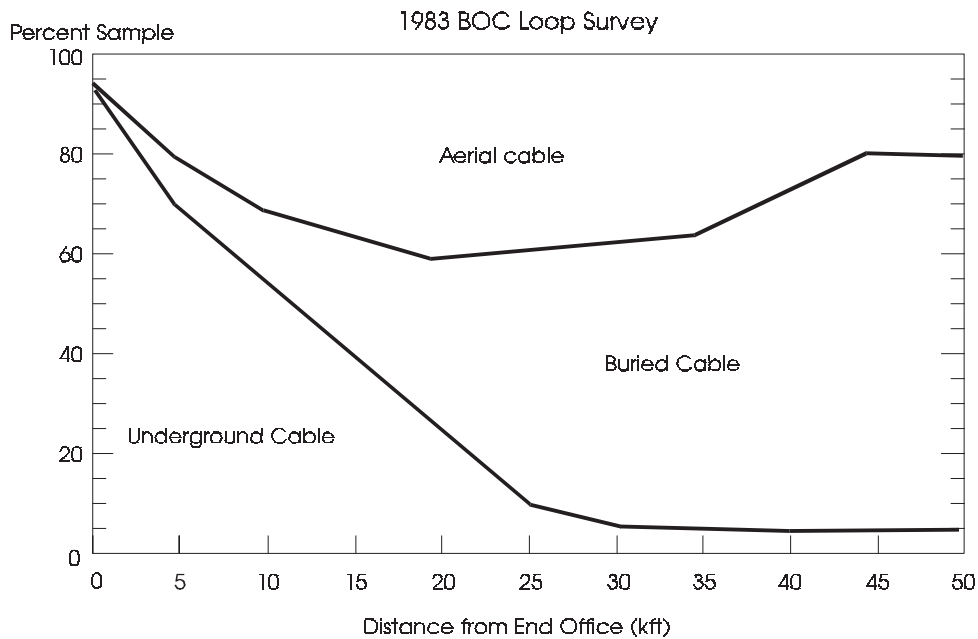
	<b>Total</b>	<b>Total</b>	<b>Residence</b>
Year of Survey	1964	1973	1983
Average Working Length	10,613 ft	11,413 ft	11,723 ft
Average Total Bridged-Tap	2,478	1,821	1,490
Average Airline Distance	7,758	8,410	8,387

Figure 12-7 shows the cumulative percent of the cable gauges all the way from the central office. The statistics are given as a function of distance from the central office. The gauge distribution in Figure 12-7 was derived by determining the gauge of each working pair sampled at 500-ft intervals from the central office. This figure shows that as one moves away from the central office, the gauge becomes more and more coarse. For example, at a distance of 10 kft from the central office the approximate cable mix is 30 percent for 26 gauge, 51 percent for 24 gauge, 18 percent for 22 gauge, and 1 percent for 19 gauge.

Figure 12-8 shows the cable structure distribution as a function of distance from the central office. This information was also derived by determining the structure type at 500-ft intervals from the central office. Aerial cable is mounted on utility poles, underground cable is in conduits, and buried cable is placed directly in the ground. This figure shows that more than 85 percent of the cable structure is underground close to the central office. It also shows that the farther the distance from the central office, the more buried and aerial facilities predominate. For example, at a distance of 10 kft from the central office, about 53 percent of the structure is underground, 16 percent is buried, and 31 percent is aerial.



**Figure 12-7.** Cable Gauge Distribution (Not Including Bridged-Taps)



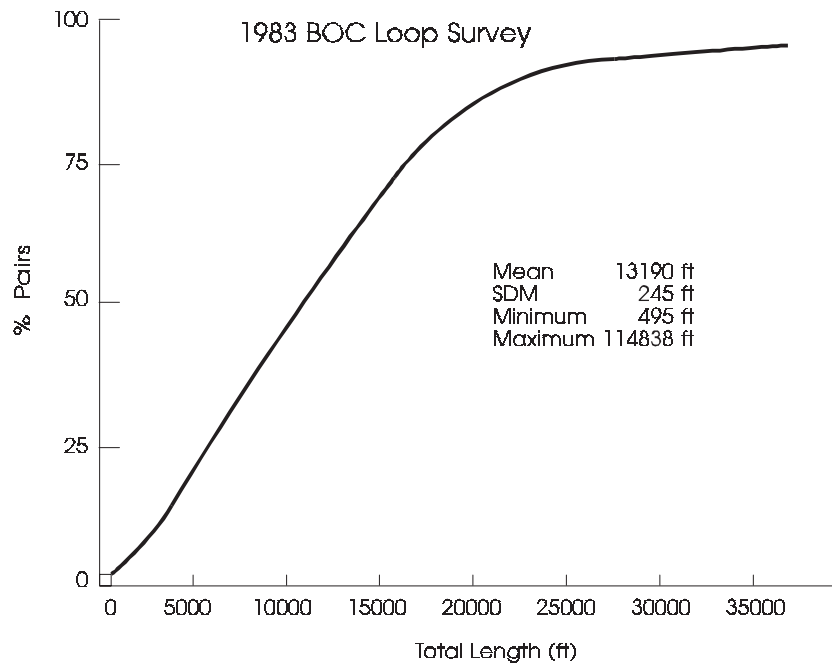
**Figure 12-8.** Cable Construction Distribution (Not Including Bridged-Taps)

12.3.1.2 Residence

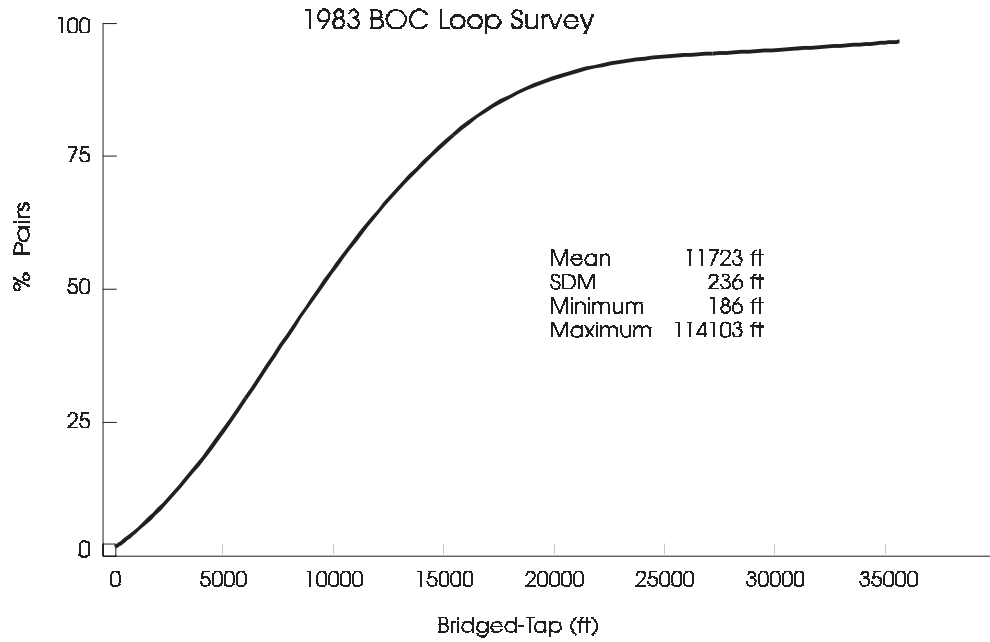
Table 12-3 contains summary statistics of lengths of sampled residence working pairs. Sampled residence pairs have an average total length of 13,190 ft and an average working length of 11,723 ft. The average bridged-tap length is 1,490 ft. Figures 12-9 through 12-11 present cumulative distribution plots for these statistics.

**Table 12-3.** 1983 Loop Survey — Residence Length Statistics

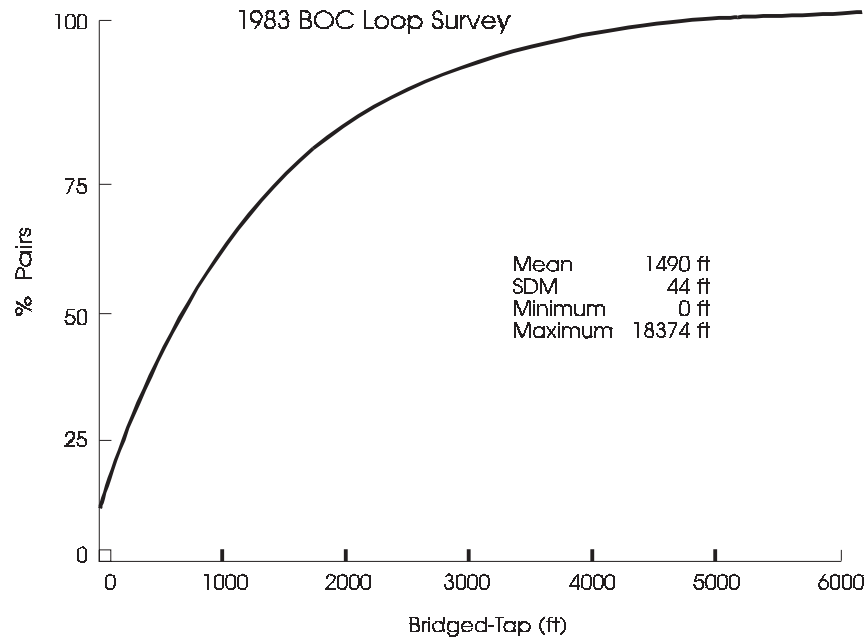
	Minimum ft	Maximum ft	Mean ft	SDM ft
Total Length	495	114,838	13,190	245
Working Length	186	114,103	11,723	236
Total Bridged-Tap	0	18,374	1,490	44



**Figure 12-9.** Total Length Distribution Residence Loops



**Figure 12-10.** Working-Length Distribution Residence Loops



**Figure 12-11.** Bridged-Tap Length Distribution Residence Loops

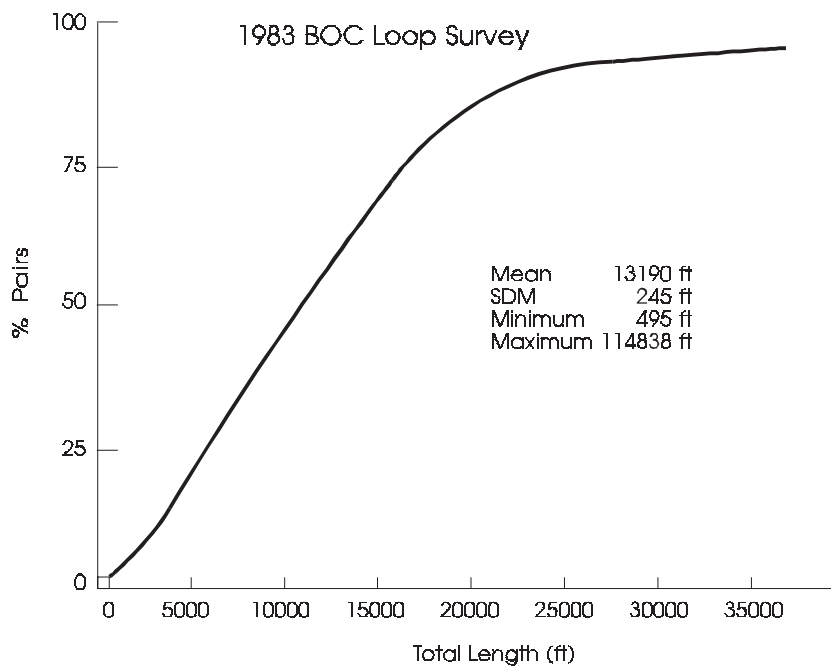


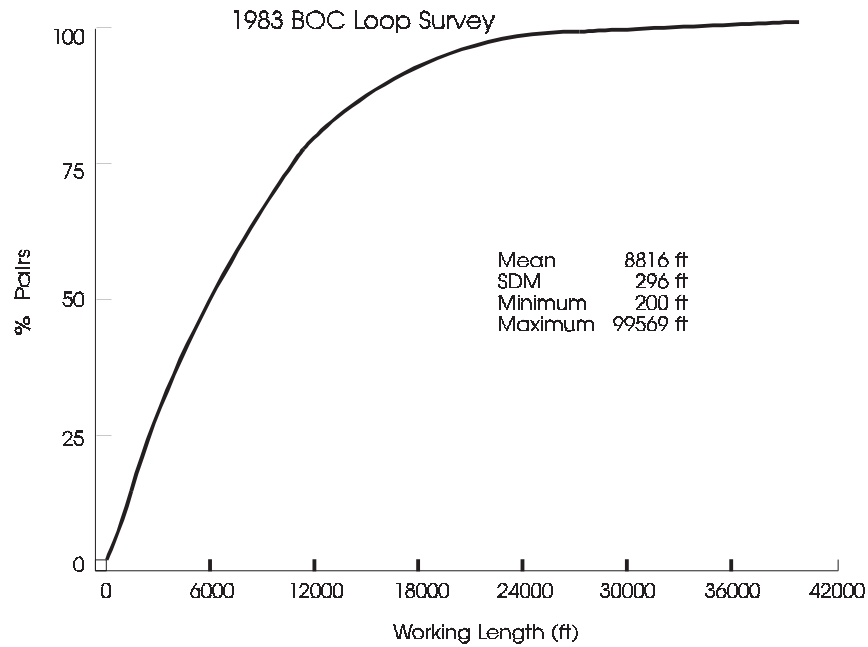
## 12.3.1.3 Business

Table 12-4 contains summary statistics of lengths of sampled business working pairs. Business pairs have an average total length of 9,840 ft, an average working length of 8,816 ft, and an average bridged-tap length of 894 ft. Figures 12-12 through 12-14 present cumulative distribution plots for these statistics. The average working-loop length for a business service is about 30-percent shorter than the average working-loop length for a residence service.

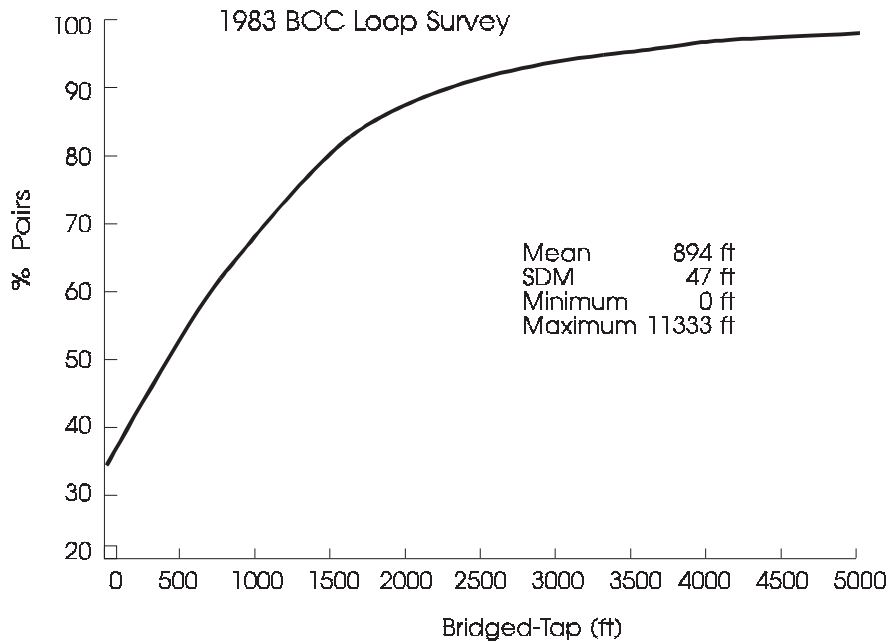
**Table 12-4.** 1983 Loop Survey — Business Length Statistics

	Minimum ft	Maximum ft	Mean ft	SDM ft
Total Length	250	100,613	9,840	302
Working Length	200	99,569	8,816	296
Total Bridged-Tap	0	11,333	894	47

**Figure 12-12.** Total Length Distribution Business Loops



**Figure 12-13.** Working-Length Distribution Business Loops



**Figure 12-14.** Bridged-Tap Length Distribution Business Loops

---

### 12.3.2 1987 to 1990 BOC Digital Access Survey

The DAS consists of two major parts:

1. A study of wire center characteristics
2. Transmission and physical characteristics of the loop

First, the survey looked at loops served by DLC systems. Second, the survey studied loops served from the potential broadband (PBB) wire centers serving large business customers. Five of the seven existing BOCs participated in the DAS study.

#### 12.3.2.1 Digital Loop Carrier Study

A total of 686 DLC subscriber loops were sampled in the five participating Regions. These loops are served from 126 wire centers. The primary conclusions, based upon the 1987 - 1990 data, are:

- In 1987, about 5% of all sampled circuits were provided by DLC systems (growth rate of 20%), corresponding to only 9% of the circuits several years later (i.e., by the end of 1991). These results illustrate the large magnitude of the embedded wire center and loop plant base, such that a considerable time is required before a significant penetration may be achieved in any conversion effort.
  - A considerable amount of optical fiber had already been placed into the feeder portion of the DLC plant, corresponding to approximately one-quarter of all DLC loops. In contrast, there was no evidence of fiber in the distribution plant (see Section 12.12.1, Fiber-in-the-Loop). In addition, a large fraction of non-working fiber is terminated in the wire centers. This available fiber is an indication of a well-planned approach to serve future DLC and/or broadband services.
  - Integrated DLC (Section 12.7) represented more than one-quarter of the DLC loops, eliminating the Central Office Terminal (COT). This corresponds to a significant cost savings and improved positioning for providing future digital services.
  - More than two-thirds of the DLC loops meet CSA guidelines (Section 12.1). This indicates that much of the loop is able to provide digital services through the use of ISDN, HDSL, ADSL, and other new loop technologies (See later sections). A large percentage (42%) of the DLC loops contain 22-gauge copper in the distribution portion. Since the CSA guidelines are developed around 24- and 26-gauge cable, which restricts the CSA to 9 kft and 12 kft, respectively, the large use of 22-gauge cable may allow the extension of the guidelines beyond the presently recommended distances.
  - Cable sheath age results indicate that the vast majority (98%) of the in-place copper serving DLC loops had not yet been in place sufficiently long to be fully depreciated. Over two-thirds had been installed in the preceding 15 years.
-

- 
- Cable sheath sizes less than 100 pairs dominate the loop feeder plant beyond 6,000 ft. Thus, the recommended separation of the transmit and receive pairs of the T1 may not be possible. Since such separation is not an issue for HDSL technology, the latter represents a cost-effective alternative for metallic feeder lines to the Remote Terminal (RT).

Some pertinent statistics derived from the data for the DLC wire centers and loop plant are:

- More than two-thirds (67.3%) of the loops are compatible with CSA guidelines. The main reason for incompatibility of the balance is excessive bridged-tap.
- The average working length of the DLC loop plant is 35,238 ft, with a COT to RT length of 29,746 ft, RT to FDI of 1,283 ft (almost one-third of the sampled loops have the RT co-located with the FDI), and a distribution length of 4,209 ft. The average service wire (drop) length for DLC loops is 154 ft, well within present FITL (Fiber To The Curb [FTTC]) requirements (Section 12.12), based upon 500 ft maximum. Indeed, over 90% of all service wires lengths (aerial and buried) are less than 218 ft.
- Approximately one-quarter (24.8%) of all DLC loops were served by fiber feeder, carrying transmission rates ranging from 6 Mbps to 560 Mbps. The large majority (approximately two-thirds, or 67.4%) are at 45 Mbps.
- Twenty seven percent of all the DLC loops were integrated directly into the switch.
- More than one-tenth (11.5%) of the loops are loaded in the distribution portion, and are therefore restricted to voiceband services. Bridged-taps are found on 56% of the distribution portions.
- Almost three-quarters (73.3%) of DLC lines serve residential subscribers.
- The loop plant distribution structure of DLC loops consists of one-third aerial (36.8%), half buried (50.7%), and one-eighth (12.5%) underground plant.

### 12.3.2.2 Potential Broadband Study

A total of 559 loops serving large business locations were sampled in the same 5 participating Regions, selected from 101 wire centers. The primary conclusions are:

- The feeder plant is only in an early positioning stage for providing future broadband services; i.e., optical fiber was beginning to be terminated in potential broadband wire centers but did not yet provide direct service to a significant number of large customer sites. In addition, half of the PBB wire centers had no digital switching machines. However, conversion to digital switching is a major objective and has been progressing well.
  - The PBB serving area is well positioned to take advantage of the ISDN Digital Subscriber Line (DSL) and other high bit-rate technologies; i.e., spare copper pairs are
-

---

available at the wire centers and major customer sites. Approximately half of the loops serving large business sites meet CSA guidelines and will support DSL rates. The copper is relatively new and will be available for many years to support advanced copper-based technologies.

- Those loops not consistent with CSA guidelines are compromised by the presence of load coils and bridged-taps. Most of the loading and bridged-taps are located in the feeder portions because relatively few of these business loops have a distribution section.

Some pertinent statistics derived from the PBB data are:

- Approximately one-eighth (13%) of all PBB wire centers have a high potential to provide future broadband services. These wire centers serve more than 43% of all working circuits in the 5 Regions.
- More than three-quarters (76.6%) of the loops serving large business sites terminate the feeder directly at the customer's premises; i.e., there is no distribution portion.
- The average working length from the CO to the customer's building entrance facility, for a large business located within a PBB serving area, is 13,092 ft, including an average feeder section of 12,634 ft and distribution section of 458 ft. Excluding those loops without any distribution segment (zero length), the average distribution section is 2,057 ft.
- Approximately 8% of the loops were served by fiber feeder. Thus, 92% were served entirely by metallic facilities at the time of the survey.
- Twelve percent of the loops were served by DLC systems (fiber or copper feeder).
- A large majority of the loops to large business customers are in underground conduit, with limited spare duct capacity.
- Only 3% of the large business sites are served by optical fiber, with an average cable size of 12 fibers. Considerably more fiber is available in the feeder plant but is not directly connected to the customer.
- The loop plant serving large business locations is comprised of 10% aerial, 6% buried, and 84% underground plant.
- The PBB loop plant contains approximately 22% of 22-gauge, 40% of 24-gauge and 38% of 26-gauge copper cable. Negligible 19-gauge is present.

## 12.4 Voice-Frequency Channel Terminating Equipment

Voice-frequency terminating equipment is available to meet the wide range of transmission (Section 7), signaling (Section 6), test requirements for Message Telephone Services

---

---

(MTS), and special access over metallic facilities. Terminal equipment at the end office may provide the necessary interface between 2-wire and 4-wire facilities and can provide transmission only, signaling only, or both, in single units. At present, when central office equipment is not sufficient or adequate, Network Channel Terminating Equipment (NCTE) is needed at the customer location for terminating special-access lines or trunks.

Since there are a variety of serving arrangements, a different NCTE unit is usually needed for each. However, some units are multifunctional and can be used for more than one serving arrangement. Serving arrangements include 2-wire, 4-wire, and 6-wire arrangements; loop signaling, duplex (DX) and single-frequency (SF) signaling; impedance compensation; and 4-wire loopback arrangements.

## 12.5 Analog Loop Carrier

Analog carrier systems, both single channel and multichannel, have been available for loop applications for about 30 years. The single-channel systems provide an additional channel (called an "add-on" channel) by using a frequency spectrum above the voice-frequency band. These systems are usually used as an interior arrangement in congested areas to defer new cable or drop installations.

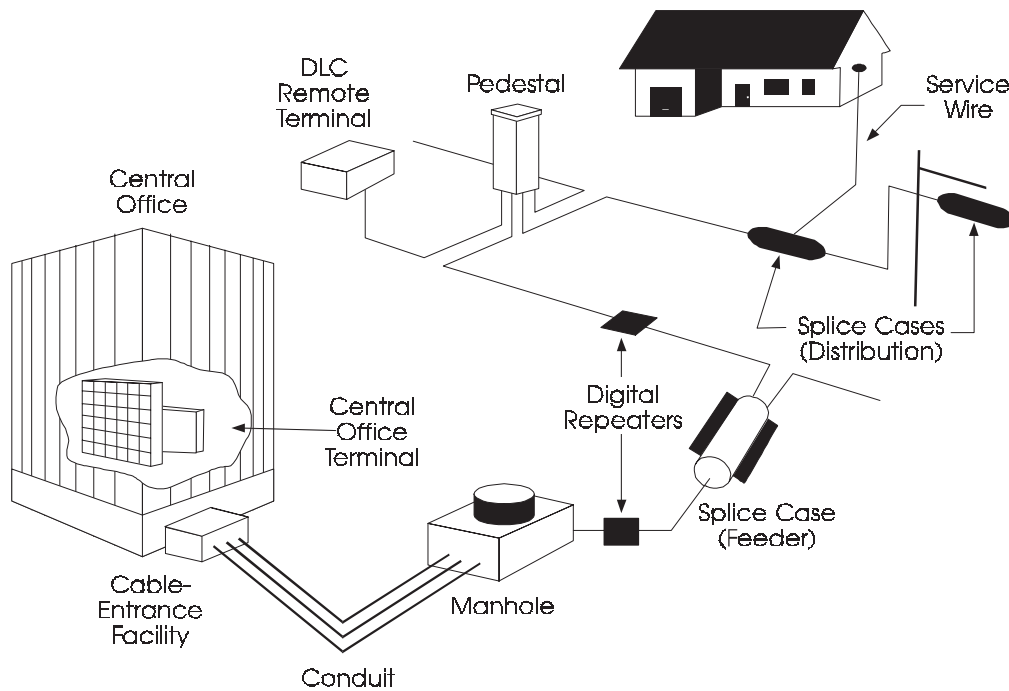
The multichannel systems generally provide four to eight channels on a single cable pair. Unlike the single-channel systems, no voice frequency channel is provided. Multichannel analog loop-carrier systems provide either a lumped (or "concentrated") remote terminal where all customer connections are made or a distributed remote terminal arrangement where one or more customer connections are made in several locations on the same system. The multichannel systems are used in low-growth areas, typically on long loops.

Some analog carrier systems may be affected by ISDN BRA DSL (Section 12.9) and other digital services. Spectrum management (see Section 7) concerns have caused some BOCs to stop deploying these systems. Furthermore, many analog systems are being removed in areas where ISDN or new digital services are planned or forecast. Universal Digital Channel (UDC) systems are being deployed to avoid spectrum incompatibility (Section 12.10).

## 12.6 Universal Digital Loop Carrier

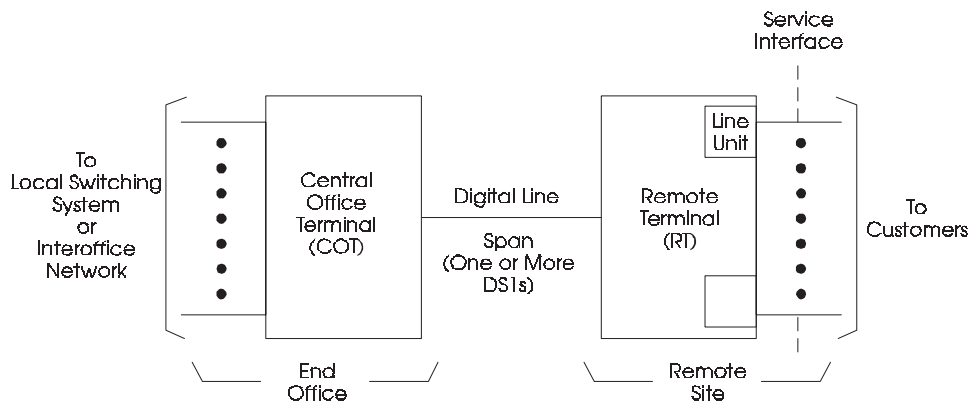
Universal Digital Loop Carrier (UDLC) systems were introduced in the early 1970s as an economical alternative to metallic facilities for long feeder routes (see Figure 12-15). As the cost of UDLC systems decreased and their service capabilities increased, they began to be used in suburban and urban areas with greater frequency. The decreased cost permitted the systems to become an economic substitute for cable at increasingly shorter loop lengths, and the improved service capabilities opened new applications for UDLC systems.

---



**Figure 12-15.** Distribution Network — Digital Loop Carrier

UDLC systems consist of a Central Office Terminal (COT) located near the switching system, a Remote Terminal (RT) located near the customer to be served, and a digital transmission facility connecting the COT to the RT (see Figure 12-16). TR-NWT-000057, *Functional Criteria for Digital Loop Carrier Systems*, treats UDLC systems as complete systems consisting of a COT and an RT. This document describes the interfaces between the COT and the local switching system and between the RT and the customer, but it does not specify the interface between the COT and the RT. Individual communications circuits (such as POTS and Foreign Exchange [FX]) are accepted as separate inputs at the COT (RT), time-division multiplexed by the UDLC system, and reproduced at the RT (COT). There is an analog-to-digital (A/D) conversion of analog inputs to the UDLC, and these signals, which are carried digitally within the UDLC, undergo a digital-to-analog (D/A) conversion when output at the COT or RT. In addition, some new UDLC systems offer optional features, such as high-speed, digitally multiplexed output ports and DS0 digital cross-connect functionality.



**Figure 12-16.** Universal Digital Loop Carrier Configuration

The digital transmission facility used by a UDLC system may be repeated metallic cable pairs, or optical fibers. Either or both of the facilities are combined with digital multiplexers or other appropriate media. TR-NWT-000057 requirements assume the use of a digital facility operating at a DS1 rate.

UDLC systems have extensive operations features allowing single-ended maintenance from either the COT or the RT. Among the features are automatic protection switching for digital facility failures, remote alarm capabilities, and remote testing of digital facilities and the distribution plant. In addition to the digital facility, the COT and the RT, a UDLC system, rely on other elements to permit maintenance and overall operation (see Table 12-5).

UDLC circuit maintenance is generally accomplished by the use of the Pair-Gain Test Controller (PGTC) and a bypass pair to provide metallic test access to the distribution pairs. The PGTC interface is described in TR-TSY-000465, *Interface Between Loop Carrier Systems and Loop Testing Systems*. When the distance is too large for the bypass pair to provide meaningful readings, a Remote Test Unit (RTU) is installed within the remote terminal site to allow metallic test access. In addition, RTUs are also installed in remote terminal sites where their use can be cost-justified.

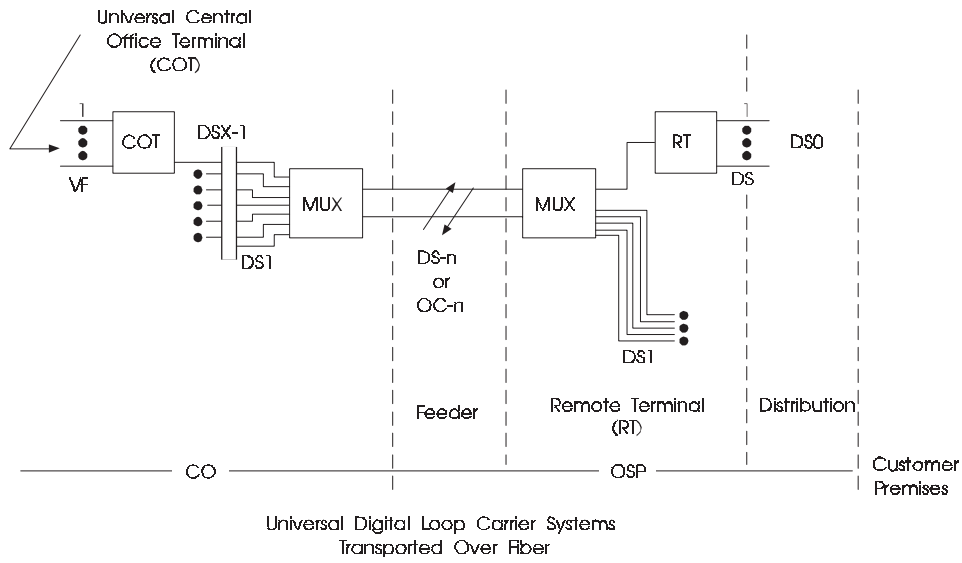
Large multiple remote terminal sites have permitted the use of higher-rate digital transmission facilities (such as optical fibers and multiplexers) between COTs and remote terminals (see Figure 12-17). In some cases, optical fibers are the only transmission media available between the central office and the multiple remote terminal site.



**Table 12-5. DLC System-Related Elements**

<b>DLC System-Related Elements</b>
<p><b>Feeder Plant</b></p> <ul style="list-style-type: none"> <li>Remote test units</li> <li>Remote terminal</li> <li>Digital line (T-lines or optical fibers)</li> <li>Structure (poles or conduit)</li> <li>Manholes, apparatus cases, repeaters, splice cases</li> <li>Lightguide Interconnection Terminal (LIT)</li> <li>Multiplexers</li> <li>Remote terminal housings (controlled environmental vault/huts/cabinets)</li> <li>Land for remote terminal housings</li> <li>Environmental alarms</li> </ul>
<p><b>Central Office</b></p> <ul style="list-style-type: none"> <li>Main Distributing Frame (MDF)</li> <li>Interior cabling</li> <li>Digital Signal Cross-connect (DSX)</li> <li>Central Office Terminal (COT)</li> <li>Lightguide Interconnection Equipment (LIE)</li> <li>Multiplexers</li> <li>Office Repeater and Bays (ORB)</li> <li>Line interface modules</li> <li>Central office support systems (power, space, operations interface, etc.)</li> </ul>

The increasing use of large multiple-system remote terminal sites and the increased ability of UDLC systems to provide services in addition to conventional Message Telephone Service (MTS or POTS) call for a more systematic approach to deploying UDLC systems. A systematic UDLC deployment would allow cost reduction associated with custom loop conditioning often required for digital data services and voice-frequency special-service circuits, and the ability to offer new access services. UDLC systems can support a wide range of different services. Single-party and multiparty POTS service still represents the majority of circuits being transported over UDLC; however, a large number of coin services, voice-frequency special services, and other circuits are also supported via UDLC. Table 12-6 presents a list of some available service applications.



**Legend:**

- DS-n = Digital Signal -n
- DSX = Digital Signal Cross-Connect
- MUX = Multiplexer
- OC-n = Optical Carrier -n
- OSP = Outside Plant
- RT = Remote Terminal
- VF = Voice Frequency

**Figure 12-17. UDLC Over Fiber**

**Table 12-6. UDLC Services**

UDLC Services
Message telephone service (POTS)
Coin
Multiparty
Centrex
Private Branch Exchange - Central Office (PBX-CO) trunks
Local WATS
Foreign exchange (FX)
Voice-grade private line
Digital Data Service (DDS) ( $\leq 64$ kbps)
ISDN basic rate access (144 kbps)

Large remote terminals providing hundreds of circuits allow more automated capabilities such as remote service provisioning and remote equipment inventory. Remote terminal-based, digital cross-connect functions, and digital test access become cost effective when large remote terminals are used. In general, operations functions (such as monitoring, testing, provisioning, and taking inventory) become extremely cost effective when integrated within a UDLC system.

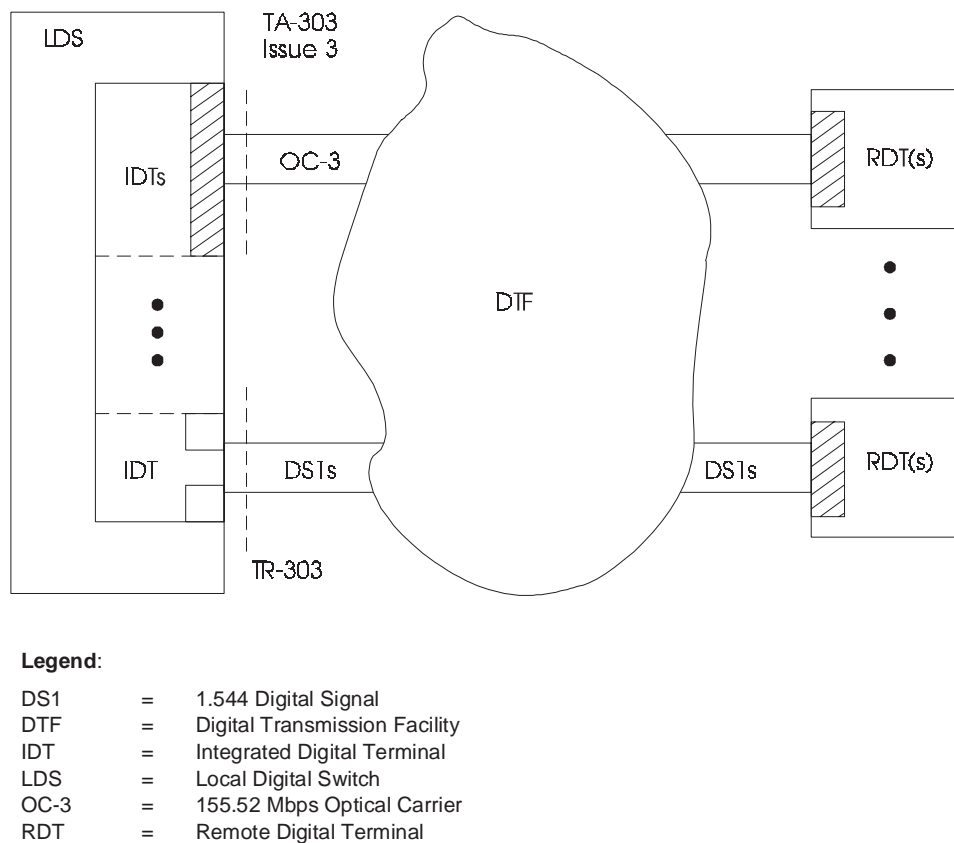
## 12.7 Integrated Digital Loop Carrier

DLC systems discussed in the previous section can be used with any switching system because the interface presented to the switching system by a circuit carried within the DLC system is the same as if the circuit were carried on a metallic pair of wires. The introduction of digital switching systems has made it possible for the DLC COT to be eliminated by integrating many of the COT functions into the switching system. The A/D and D/A conversions that are done in a DLC COT for analog signals are not required at the switching system interface; instead, the signals are switched in their digital form, and conversions are done elsewhere in the telephone network, when needed.

In an Integrated Digital Loop Carrier (IDLC) system, the Remote Digital Terminal (RDT) has a direct interface to the digital switching system. The switching system provides all the functionality associated with terminating the digital facilities. These digital facilities may be a DS1 or higher-rate digital facility on a metallic or optical fiber transmission medium. The switching system also provides capabilities for an IDLC system to interface external systems or equipment for surveillance, provisioning, and maintenance operations.

The interface between the switching system and the RDT may be proprietary; that is, the switching system and the RDT are provided by the same supplier, or a switching system supplier and an RDT supplier have reached an agreement as to the interface. At divestiture

in 1984, there was a large embedded base of SLC<sup>®</sup>-96 IDLC systems. Bellcore has described the SLC-96 interface in TR-TSY-000008, *Digital Interface Between the SLC<sup>®</sup>-96 Digital Loop Carrier System and a Local Digital Switch*. Bellcore has also defined the requirements for an IDLC system and a generic IDLC interface in TR-TSY-000303 and GR-303-CORE, *Integrated Digital Loop Carrier System Generic Requirements, Objectives, and Interface*. (See Figure 12-18.) These interfaces are briefly described in the following sections.



**Figure 12-18.** IDLC Generic Interface

SLC is a registered trademark of AT&T.

---

### 12.7.1 TR-TSY-000008 Interface

TR-TSY-000008 describes the requirements necessary for a Local Digital Switching (LDS) system to connect to an SLC-96 RDT across a digital interface at the T1 rate of 1.544 Mbps. However, TR-TSY-000008 is now recognized as a generic interface that provides a multivendor environment with mix-and-match capabilities between switching systems and DLC systems. This technical reference also describes the interface requirements that will allow an RDT to mimic the SLC-96 RDT in order to interface an LDS that provides an interface meeting the requirements of TR-TSY-000008. However, TR-TSY-000008 does not describe system requirements or requirements for the RDT-to-customer interface.

The digital interface between the LDS and RDT is specified at the DSX-1 level. The DS1s from the RDT pass through an Office Repeater Bay (ORB) and are terminated on a DSX-1 frame. The DS1s are then cross-connected at the DSX-1 frame to the LDS. The interface supports from two to four DS1s per RDT without facility Automatic Protection Switching (APS) and from three to five DS1s with facility APS. The LDS can interface the RDT in MODE I, no concentration; MODE II, 48 circuits concentrated on 24 DS1 time-slots; and MODE III, 24 special-service circuits on 24 DS1 time-slots.

The DS1s use a format in which 12 DS1 frames are grouped together to form a superframe. The signaling and supervision information is carried between the RDT and LDS using a method called *robbed* (stolen) bit signaling. The least-significant digit in a circuit's DS1 time-slot is robbed every sixth (A bit) and twelfth (B bit) frame to generate a per-circuit signaling channel. By toggling the A and B bits, nine signaling codes can be defined from the two bits. This per-circuit signaling channel is used to carry signaling and supervision information, such as on-hook, off-hook, ringing, and coin-control signals between the LDS and RDT. The channel also carries a channel-test initiate signal for those channels that can be tested using the PGTC discussed in the DLC section.

The superframe framing bits are split between a DS1 framing sequence and a signaling frame on two of the DS1s between the LDS and RDT. Of the 36 signaling frame bits available every 9 ms, 24 are used to derive four operations channels, while the remaining 12 are used to resynchronize the four operations channels. On one of the DS1s, a concentrator channel, maintenance channel, alarm channel, and protection line switch channel are derived. If the RDT needs a second concentrator channel for MODE II operation, the second DS1 will have a concentrator channel; otherwise, there are no operations channels on the second DS1. The concentrator channel is used to control activity requests and time-slot assignments for a MODE II RDT. The maintenance channel is used to control channel and distribution pair (drop) testing. The alarm channel is used to exchange alarm data between the LDS and RDT. The protection line switch channel is used to control facility APS when a system is equipped with a protection DS1.

The interface supports an RDT that terminates up to 96 subscriber lines. The RDT can provide single-party, multiparty, coin, and other locally switched circuits. If non-locally switched circuits are provided by the RDT, the circuits must be groomed in the field onto a DS1 that does not terminate on the LDS, or the LDS must provide the capability to bring

---

---

the circuits out of the switch to an interoffice facility. As a third option, some switching systems may allow the *nail-up* of circuit in capable switches.

### 12.7.2 TR-TSY-000303/GR-303-CORE Interface

In September 1986, Bellcore first published *Integrated Digital Loop Carrier System Generic Requirements, Objectives, and Interface*, TR-TSY-000303. This technical reference describes the overall generic requirements for an IDLC system as well as a generic IDLC interface between an LDS and an RDT. The IDLC system described in Issue 1 of TR-TSY-000303 consists of an Integrated Digital Terminal (IDT) in the LDS, an RDT that terminates on the IDT (see Figure 12-18), and 2 to 28 DS1 facilities connecting the IDT and RDT. The IDT is a logic device in the LDS that consists of all the resources of an LDS that are needed to terminate one RDT. The DS1s between the LDS and RDT use Extended Superframe Format (ESF).

The key feature of TR-TSY-000303 is the generic IDLC interface between the LDS and RDT. The generic IDLC interface allows the LECs to mix and match LDSs and RDTs from different suppliers. The generic IDLC interface uses a DS0 as an Embedded Operations Channel (EOC) between the RDT and LDS. The LDS provides a network-layer or application-layer mediation function that allows operating systems and RDTs to communicate with each other over the EOC. The messages that cross the EOC are based on the Common-Management Information Services (CMIS), Remote Operations Service (ROS), and Abstract Syntax Notation One (ASN.1) defined by the International Standards Organization (ISO) and the International Telecommunication Union—Telecommunication Standardization Sector (ITU-T).<sup>4</sup> The management information model for DS1-based IDLC systems is described in TR-TSY-000303, Revision 3, Supplement 3, published in March 1990. The Link Access Procedure on the D-channel (LAPD) is used as the data-link layer protocol on the EOC.

An IDLC RDT can support a rich set of operations messages over the EOC. This allows the RDT to provide capabilities such as a digital cross-connect and maintenance functions that are managed over the EOC.

The generic IDLC interface also supports two different call-processing techniques. The first is called *hybrid signaling*. In hybrid signaling, ABCD codes are used for call supervision (for example, on-/off-hook detection) while a time-slot is assigned to a line unit. Per-call time-slot assignment is accomplished over a 64-kbps Time-slot Management Channel (TMC) that carries messages between the LDS and the RDT. These messages are used to make and break time-slot assignments between line units and DS0s on a per-call basis.<sup>5</sup> The second call-processing technique is *out-of-band signaling*. It consists solely of

---

4. Formerly the International Telegraph and Telephone Consultative Committee (CCITT).

5. RDTs that do not have a per-call time-slot assignment capability do not require a TMC since no time-slot assignment messages need to be exchanged between the LDS and RDT.

---

a 64-kbps channel, the Common Signaling Channel (CSC). The CSC carries messages for making time-slot assignments and for call supervision. RDTs that use a CSC may use it only for call supervision, not to perform time-slot assignments on a per-call basis.

Both the TMC and CSC employ the LAPD protocol that is used on ISDN D-channels. The TMC and CSC messages are based on the CCITT Q.931 standard, *ISDN-User Network Interface Layer 3 Specification*, and are largely consistent with the ISDN call control requirements in TR-TSY-000268, *ISDN Access Call Control Switching and Signaling Requirements*. In this way, technology developed to support ISDN basic and primary rate access can be adapted for call processing across the generic IDLC interface.

To enable connection with different RDTs serving a wide range of applications, the LDS must accommodate both call-processing techniques, but not simultaneously for any one RDT.

The generic IDLC interface supports the transport of ISDN BRA (Section 12.9) lines using a method called "4:1 time-division multiplexing." For ISDN DSLs that terminate on the RDT, the B-channels are transported in DS0s while the D-channel of the DSL is time-division multiplexed with up to 3 D-channels from other DSLs for transport to the LDS. This method provides an economical transport mechanism for ISDN BRA lines. The RDT will also translate messages received over the EOC into DSL-embedded operations channel messages for ISDN DSLs.

TR-TSY-000303, Supplement 2, issued in October 1989, describes a generic IDLC interface based on the Synchronous Optical Network (SONET). The major changes occur at the physical layer where the physical layer is provided as a SONET signal carried on fibers rather than DS1 signals carried on metallic facilities. The SONET-based generic IDLC interface uses a DS0 EOC, as does the DS1, but supports only the CSC call-processing technique. Other than the changes in the performance monitoring requirements and the use of the CSC for call processing, DS1 and SONET-based IDLC systems must meet the same requirements.

Various cumulative changes and additions to IDLC requirements, as well as an upgrade to the GR format, are provided in GR-303-CORE, issued in September 1995.

## 12.8 Basic Exchange Radio System

In providing telecommunications services in rural areas with low population density, both the initial capital cost and the ongoing maintenance cost can be very high if long cables or long open wires are used to reach the scattered subscribers in very remote locations. Basic Exchange Radio (BEXR) systems are economically attractive in providing rural telecommunications services because of recent advances in micro-electronics, digital radio, and voice-coding technologies. Both capital and maintenance savings are possible.

A digital BEXR system is a point-to-multipoint wireless DLC system. It is used in subscriber loops to provide economical basic telecommunications services to fixed

---

---

subscriber locations. The frequency plans for BEXR systems in the United States are the same as those for land-mobile radio systems in 150-MHz and 450-MHz bands. However, in the 800-MHz frequency band, only a subset of the channels for land-mobile radio systems is assigned for BEXR. The channel spacing is 25 kHz in 450-MHz and 800-MHz bands and is 30 kHz in 150-MHz bands. The same frequency plan is shared by land-mobile radio and BEXR on a co-primary basis as authorized by the Federal Communications Commission (FCC) in December 1987. The land-mobile radio is used primarily in or near metropolitan areas whereas BEXR is used reasonably far away from metropolitan areas. The geographic separation between these two different applications allows sharing of the same frequency bands.

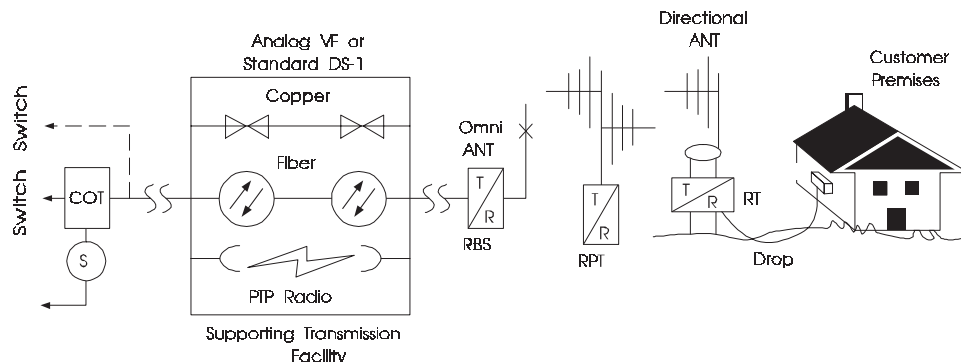
Figure 12-19 shows a functional block diagram of the digital BEXR system. The basic functional modules of the digital BEXR system are the COT that interfaces with the local exchange switch, the Radio Base Station (RBS) acting with the COT as the multiplexer and the main radio distribution point, and the Remote Terminal (RT) relating directly between the customer line and RBS. The COT is usually located near the local exchange switch. The RBS is usually located either with the COT or remotely at a site with high elevation to optimize the point-to-multipoint radio transmissions to cover many scattered subscribers. The RT is located near the subscriber location. The transmission facilities between the COT and the RBS can be voice-frequency cable pairs or standard digital transmission facilities such as T1-carrier, digital microwave radio or optical fiber systems. In some situations, a radio repeater may be used if there is no direct line-of-sight between an RT and the RBS.

Each RT receives and transmits on a pair of Radio Frequency (RF) channels in both Frequency-Division Multiple Access (FDMA) and Time-Division Multiplexing (TDM) or Time-Division Multiple Access (TDMA) modes.

For example, in the 450-MHz band, the 650 kHz of total allocated frequency bandwidth for one direction of transmission is divided into 26 RF channels with 25-kHz channel separation using FDMA. Digital signals from multiple subscribers may be multiplexed on each 25-kHz RF channel by either TDM or TDMA. Voice-coding techniques may be used to compress the bit rate of the digitized voice signal of an individual subscriber. The RBS concentrates and compresses the digital baseband voice signals from the COT, multiplexes them into channel groups, and broadcasts these multiplexed channels to the subscriber community. The radio signal is modulated with an optimum digital modulation scheme as determined by the class and quality of service desired. Additionally, the modulation levels may vary from subscriber to subscriber as necessary to improve system gain and to overcome poor propagation conditions encountered on certain difficult radio paths. By using a Demand Assignment Multiple Access technique, each RT can access any of the 26 RF channels in the 450-MHz band and any of the individual voice circuits multiplexed within an RF channel. The total number of subscribers that can be served from a particular system depends on the quality of service desired and the modulation technique employed. For example, the maximum number of subscribers that can be served by an available BEXR product is 570 in the 450-MHz frequency band alone. If 150-MHz and 800-MHz bands are also available at the same serving area, the maximum number of BEXR subscribers can be

---



**Legend:**

ANT	=	Antenna (type varies)
COT	=	Central Office Terminal
Customer premises	=	mounting arrangement
Drop	=	LEC standard copper facility
PTP Radio	=	any point-to-point radio external to the system
RBS	=	Radio Base Station
RPT	=	Radio Repeater
RT	=	Remote Terminal
S	=	Standard operations system interface
SDP	=	Standard Demarcation Point
Switch	=	any local exchange office
T/R	=	Transmit/Receive (connections vary)

**Figure 12-19.** Digital BEXR System

considerably larger. The number of BEXR channel pairs in the 150-MHz, 450-MHz, and 800-MHz bands is 18, 26, and 50, respectively.

The RBS normally employs an omni-directional antenna. The RT usually uses a Yagi antenna with about 10-dB gain. A system gain of 130 dB or more is employed to ensure adequate and reliable coverage for this type of system. Additionally, techniques such as Automatic Power Control (APC) may be used to increase system gain and to equalize the RBS-received power levels from various RTs. The typical coverage area of an RBS is about 60-kilometer radius under good propagation conditions. An ITU handbook titled *Rural Telecommunications*, CCIR<sup>6</sup> Report 380-2 (MOD F), and CCIR Report 1057 (MOD F) provide additional information on point-to-multipoint TDMA digital radio systems for rural telecommunications services.

The BEXR systems also contain many features to meet the functional requirements of DLC systems such as signaling, supervision, and maintenance.

6. The International Radio Consultative Committee (CCIR) is now called the International Telecommunication Union—Radiocommunication Sector (ITU-R).

In addition to rural telecommunications services, BEXR systems are also being used for the following applications:

- To provide services to areas with temporary or seasonal needs or with uncertain future growth. Examples are oil exploration, construction sites, mining sites, conventions, visiting ships, etc.
- To provide emergency telephone services during a disaster. Examples are hurricane, earthquake, crash site of a large commercial airplane, etc.
- To bring telephone services to off-shore islands or over swamp areas
- To upgrade services for subscribers from multiparty line to single-party service
- To defer the high construction cost of a new cable route to meet a small amount of new demand; i.e., instances where growth has resulted in the exhaustion of current facilities and expensive, new cable construction may be necessary to meet a small amount of new demand.

With the addition of a digital encryption feature, the BEXR system can also be used as an overlay backup secure communications system. A very recent technical breakthrough, and the encouragement of the FCC to utilize the radio spectrum to hasten competition in the exchange area, have led to aggressive explorations by potential carriers of the use of higher frequency bands (e.g., 2-30 GHz for the one-way distribution of wideband and broadband information and for two-way loop access). Currently there are a few in-service systems and a limited number of technology trials focusing largely on interference issues. Applications, market, and technology issues are still under exploration.

## 12.9 Integrated Service Digital Network

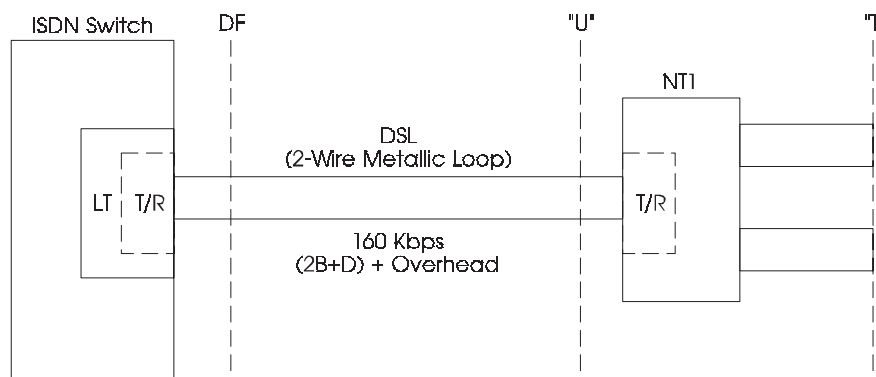
Integrated Service Digital Network (ISDN) is an end-to-end digital network serving voice and nonvoice services. It uses an intelligent signaling network and a small set of user-network interfaces. ISDN will allow the existing telephone (voice-data) network to evolve gradually into an integrated network capable of handling voice, data, video, text, and graphics.

Three ISDN standard interfaces have been identified:

- Basic Rate Access (BRA)
- Primary Rate Access (PRA)
- Broadband access.

### 12.9.1 Basic Rate Access Interface

The BRA interface makes use of the Digital Subscriber Line (DSL), as described in TR-NWT-000393, *Generic Requirements for ISDN Basic Access Digital Subscriber Lines*, to deliver 144 kbps of bidirectional customer data, information rate, plus one bidirectional channel of 16 kbps to support provisioning and maintenance, including performance monitoring and framing. This makes the total data rate of 160 kbps in each of the two directions of transmission (see Figure 12-20).



**Legend:**

DF	=	Distribution Frame
DSL	=	Digital Subscriber Line
LT	=	Line Termination
NT1	=	Network Termination 1
"T"	=	"T" Reference Point (4-wire)
T/R	=	DSL Transceiver
"U"	=	"U" Reference Point (2-wire)
B	=	64 kbps
D	=	16 kbps

**Figure 12-20.** ISDN Basic Rate Access Configuration

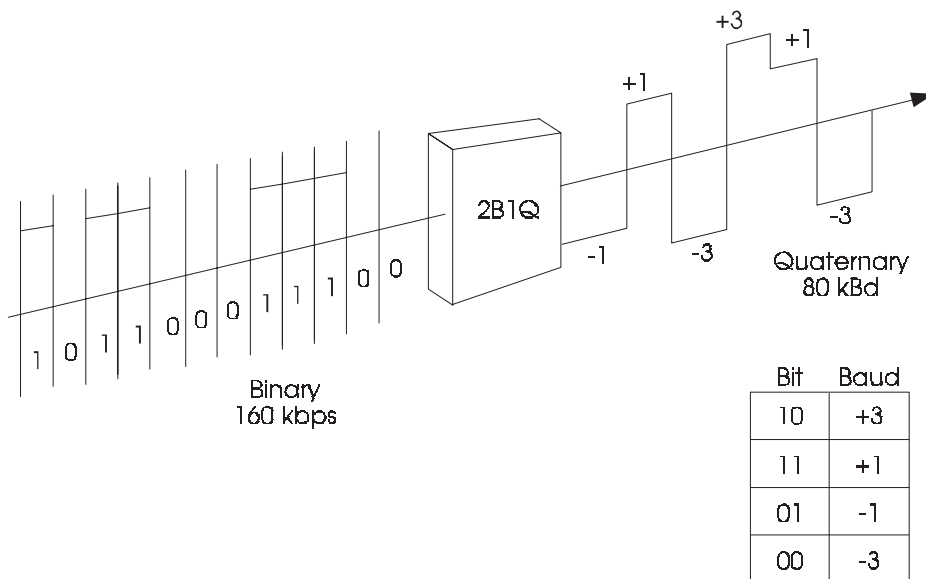
#### 12.9.1.1 Digital Subscriber Lines

The DSL consists of a master digital transmitter/receiver (transceiver) and a slave digital transceiver, connected by a 2-wire metallic loop. Timing and control information are provided by the master to the slave. The DSL uses the Echo Cancelers with Hybrid (ECH) principle to provide full-duplex signal transmission over a 2-wire nonloaded loop. The echo canceler technique is used to remove echoes of the transmitted signal that have mixed with the received signal. The echoes are reflections of the transmitted signal from discontinuities, such as bridged-taps and gauge changes, or from line impedance

mismatches and transformer hybrid leakage. This permits a weakly received signal to be accurately detected and provides the means for avoiding the use of separate pairs of wires for each direction of transmission.

Once the transceivers are powered and joined by a 2-wire loop, they establish communications automatically without field adjustments. These transceivers operate over metallic nonloaded loops originally installed for voice-frequency transmission. These loops do not require plant conditioning or pair selection. They may be aerial, buried, or underground cables with a variety of gauges, pair counts, splices, and bridged-taps. The DSL system is intended to operate on nearly all nonloaded loops 18 kft or less in length and meeting 1300  $\Omega$  resistance design rules, based on results of the 1983 loop survey described earlier in this section.

The maximum signal power loss (at a frequency of 40 kHz) is about 42 dB. The DSL uses a 4-level Pulse-Amplitude Modulation (PAM) code without redundancy. This line code is commonly referred to as 2B1Q (2 Binary, 1 Quaternary). Figure 12-21 illustrates the quaternary symbols and the 2B1Q line code. The average power of a 2B1Q transmitted signal is between 13.0 and 14.0 dBm over a frequency band from 0 Hz to 80 kHz, with a nominal peak of the largest pulse being 2.5V. As discussed earlier, the DSL binary information rate is 160 kbps, but the baud rate on the line is 80 kBd  $\pm 5$  parts per million.



**Figure 12-21.** DSL Line Code — 2B1Q

---

### 12.9.1.2 Access Architectures

Digital transceivers are embedded in equipment that provides for functions such as powering and network operations support. The master transceiver is in the Line Termination (LT) located in the local switch, and the slave transceiver is in the Network Termination (NT) located at the customer's end. The term NT refers to network termination functions whether it is an NT1, as shown in Figure 12-20, and/or an NT2 or any other equipment. The NT terminates the DSL on the customer side of the interface shown on Figure 12-20. TR-NWT-000397, *ISDN Basic Access Transport System Requirements*, specifies the ISDN BRA transport system generic requirements. These requirements include provision for *sealing current* on the 2-wire loop, in-service digital error-performance monitoring, metallic and digital testing features, an EOC for LT-NT communications and interfaces to support systems.

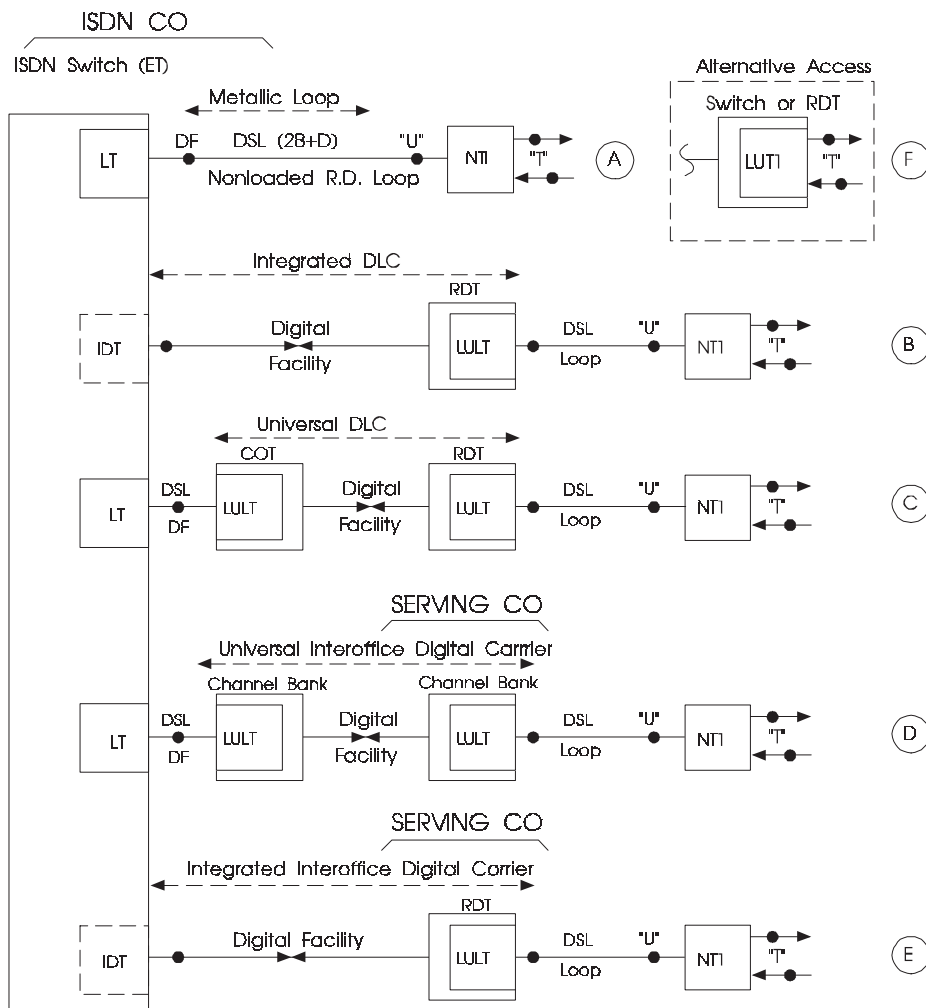
Figure 12-20 also shows the location of the interface of the access line with the NT, which is commonly called the "U" interface point. A standard electrical interface has been internationally established at the "T" reference point. The "T" reference point is a 4-wire interface intended for customer inside wiring, which supports the ISDN BRA service capability and is independent of the transmission technique chosen for the 2-wire loop.

The customer has access to as many as three channels: none, one, or two 64-kbps B (bearer) channels, plus one 16-kbps D channel. The ISDN BRA interface is commonly referred to as 2B+D. These channels provide *clear* transport in the sense that there are no constraints in the transmission of logical information. For instance, there is no limit in the number of consecutive zeros being transmitted. The D channel contains signaling and routing data for the B channels and, possibly, customer packet data. Other than transmission delay (queuing delays), there is no delay to which D channels will be subjected by transport systems over the access path (line segment). In general, the two B channels are transported as independent, byte-oriented 64-kbps channels, without regard for time relationships between the two channels.

Figure 12-22 shows the ISDN BRA architectures, supported in TR-NWT-000397, using the DSL system. The most prevalent architecture is expected to be (A), which consists of a DSL system in which a nonloaded RD loop exists between the LT located at a local ISDN switch and the NT1 located at the customer's premises. The remaining architectures in Figure 12-22 involve the multiplexing of BRA DSLs onto DLC systems or interoffice carrier systems.

TR-NWT-000397 describes two methods of multiplexing and transporting ISDN BRA DSLs over DS1s or higher-rate facilities: 3-DS0 TDM and 4:1 TDM. A 3-DS0 TDM is very simple to implement in carrier systems, as it requires only three *nailed-up* DS0 channels. The ISDN channels (2B+D) are transported transparently in three DS0s. The DSL overhead (16 kbps) is contained in the third DS0 with the D channel. The second method, *4:1 TDM*, is intended for more efficient use of bandwidth in more advanced carrier systems. B channels are assigned DS0s, possibly in real-time upon demand. Up to four D channels share a DS0 on a full-time nonconcentrated basis. The information content of the DSL

---



**Legend:**

- COT = Central Office Terminal
- DF = Distribution Frame
- DLC = Digital Loop Carrier
- ET = Exchange Termination
- IDT = Integrated Digital Terminal
- LT = Line Termination
- LULT = Line Unit "LT"
- LUNT = Line Unit "NT"
- LUT1 = Line Unit "T" Interface
- LNT1 = Network Termination 1
- R.D. = Resistance Design
- "T" = T Reference Point
- "U" = U Reference Point

**Figure 12-22.** ISDN Basic Rate Access Transport Architecture

---

overhead must be converted for transport to the ISDN switch and operations support systems via the carrier system EOC.

Architectures (B) and (C) in Figure 12-22 illustrate two local BRA architectures involving DLC systems. Architecture (B) shows a DLC system integrated (IDLC) at a DS1 or higher rate with the ISDN switch, and (C) shows a UDLC system multiplexing and transporting BRA DSLs. IDLC access would be the preferred arrangement over UDLC for any significant ISDN demand that cannot be served by simple DSLs directly from the local ISDN switch.

---

It is unlikely that initial customer demand will necessitate installation of ISDN switching capabilities in every central office, nor is it likely that the network providers would be able to make such a capital investment. Thus, until deployment of ISDN-capable switches is ubiquitous, there will be a need to provide remote access over interoffice carrier systems as shown in access architectures (D) and (E). Interoffice carrier systems can be either universal or integrated like DLC systems.

Other remote access architectures are possible. For example, Remote Switching Units (RSUs) could be hosted in a remote wire center (from an ISDN switch). Also, back-to-back interoffice and loop-carrier systems, interfacing via DSLs across the (non-ISDN) serving central office, could be deployed.

Where cable plant and distance limitations permit, BRA may be provided to a customer via the 4-wire "T" interface. It is also possible that a customer-provided loop regenerator (repeater) may be employed to extend the range of the DSL (for example, customer campus environments).

#### 12.9.1.3 Maintenance

The maintenance approach for ISDN BRA lines is based primarily on in-service performance monitoring. The objective of performance monitoring is to ensure that ISDN BRA lines have high levels of availability and quality. This continuous monitoring of the DSL transmission system allows for trouble detection and potential repair of ISDN BRA lines before the customer reports a problem. In-service performance monitoring data aids in verifying and sectionalizing troubles, thereby leading to efficient trouble clearance. Trouble isolation will be done by a combination of standard and ISDN DSL-specific out-of-service maintenance techniques that complement the capabilities of performance monitoring. The out-of-service maintenance techniques include metallic and digital remote-test access.

#### 12.9.2 Primary Rate Access Interface

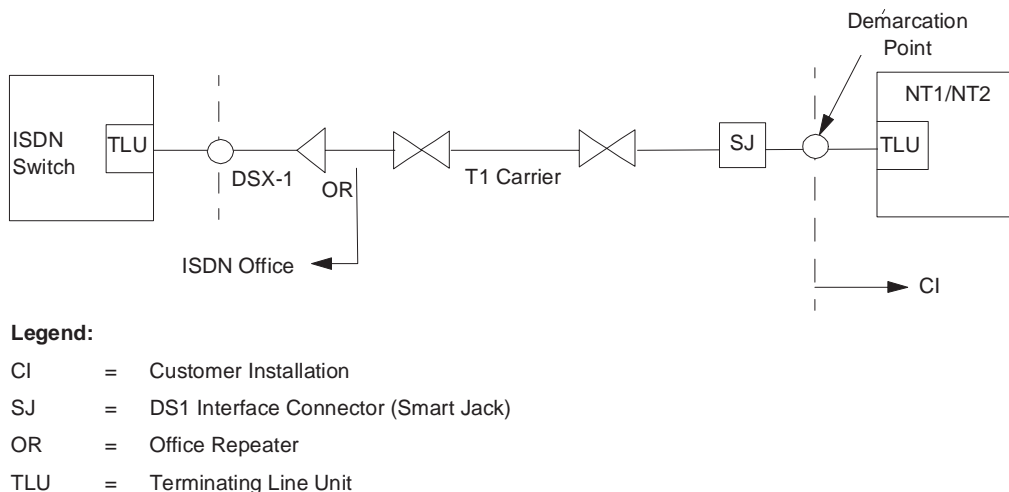
TR-TSY-000754, *ISDN Primary Rate Access Transport System Requirements*, contains detailed transport requirements for the ISDN PRA interface. The PRA interface is a 4-wire, full-duplex DS1 service interface at 1.544 Mbps to be met at the demarcation point. PRA provides digital network access at the DS1 rate (see Figure 12-23). The PRA interface supports only point-to-point equipment configurations. There is either a transmitter or a receiver for each direction of transmission. The PRA interface uses the ESF for DS1s. The ESF provides for embedded operations channel communications and single-ended performance monitoring capabilities. The framing bit, or 193rd bit in each DS1 superframe, is time-division multiplexed to provide a 4-kbps EOC, a 2-kbps Cyclic Redundancy Check (CRC), and a 2-kbps Framing Pattern Sequence (FPS). If instead of using Bipolar with 8-Zero Substitution (B8ZS), one uses Zero-Byte Time-Slot Interchange (ZBTISI) to provide

---



64-kbps clear-channel capability, the EOC is reduced to a minimum of 2 kbps. The EOC is used by the service provider to manage and maintain the network.

Figure 12-23 shows the T1-carrier architecture, which is the most common access arrangement in the near term. Figures 12-24 and 12-25 illustrate other transport architectures.

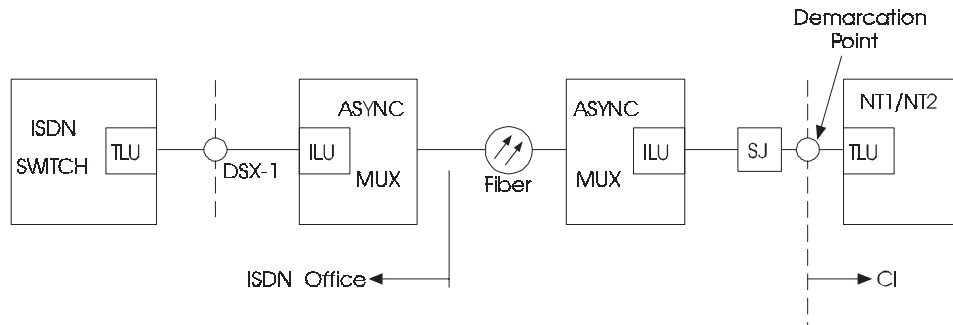


**Figure 12-23.** Primary Rate Access Architecture

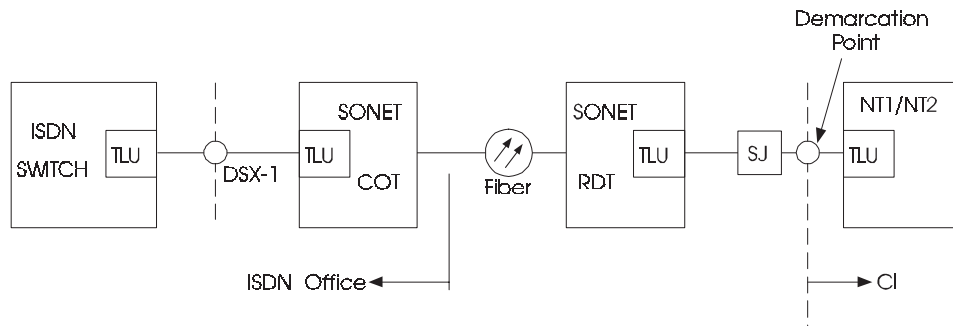
PRA service access capability is provided full-duplex within one or more 1.536-Mbps DS1 information payloads. Each DS1 payload is channelized into 24 separate byte-oriented 64-kbps time slots. The most common channelization for PRA will be 23B+D. Since one D channel may provide control and signaling for more than twenty-three B channels, additional DS1 facility accesses may be provided in the form of 24B. Thus, a given PRA service capability is defined by the D-channel span of control with the channelization possibly occupying the 24th time slot of a PRA facility. The B channels can support virtually any type of service (circuit-switched, packet-switched, or channel-switched).

PRA may be channelized to handle greater information capacity, such as the 384-kbps H0 channel. A PRA with H0-channel capabilities may be provisioned in various combinations with 64-kbps B and D channels on one or more DS1 facilities. Thus, a given PRA may have the form  $mB+nH0+D$  (where  $m$  and  $n$  represent arbitrary numbers).

The entire 1.536-Mbps information capacity need not be used in providing a given PRA service capability. Any remaining bandwidth may be used to assign non-ISDN services.



A) Asynchronous Multiplexer System or SONET UDLC System/Asynchronous DS1 Mapping or SONET ADM System/Asynchronous DS1 Mapping

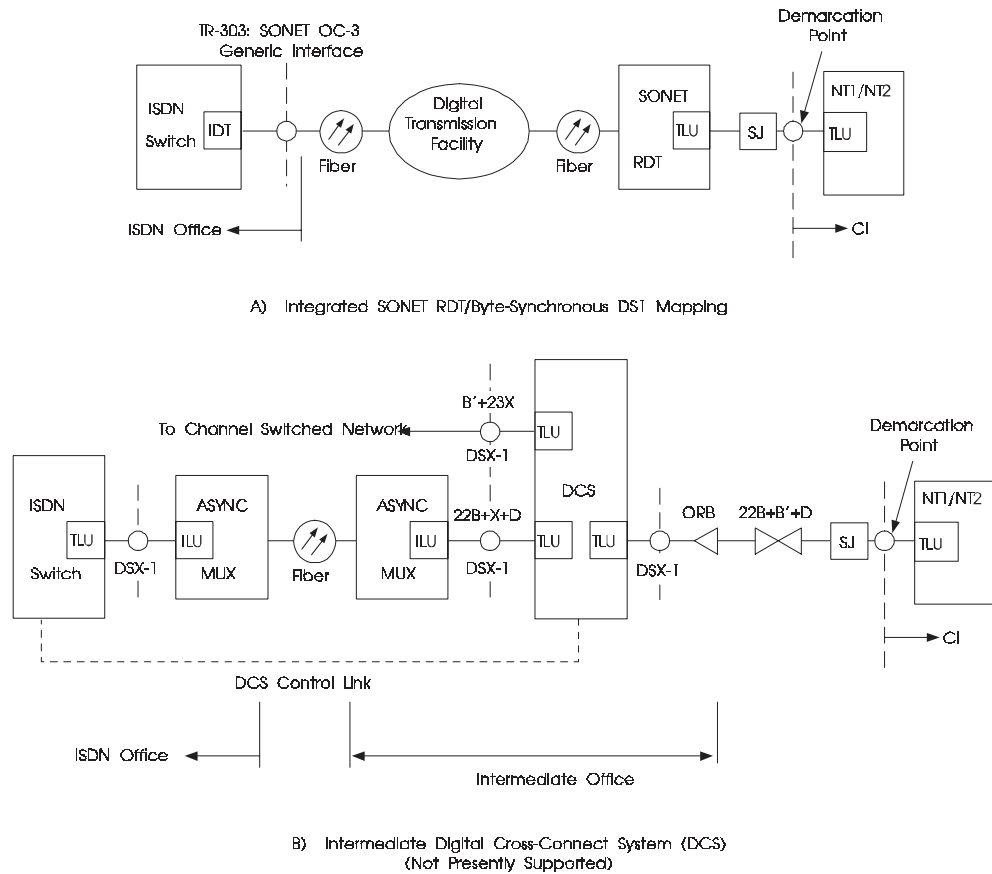


B) SONET UDLC System/Byte-Synchronous DS1 Mapping (Not Recommended)

**Legend:**

- ADM = Add-Drop Multiplexer
- DSX-1 = Digital Signal Cross-Connect (DS1 Rate)
- ILU = Intermediate Line Unit
- MUX = Multiplexer
- RDT = Remote Digital Terminal
- SJ = Smart Jack
- TLU = Terminating Line Unit

**Figure 12-24.** Other ISDN Primary Rate Access Architectures



**Legend:**

- CI = Customer Installation
- DCS = Digital Cross-connect System
- DSX-1 = Digital Signal Cross-Connect (DS1 Rate)
- IDT = Integrated Digital Terminal
- ILU = Intermediate Line Unit
- ISDN = Integrated Services Digital Network
- MUX = Multiplexer
- ORB = Office Repeater Bay
- RDT = Remote Digital Terminal
- SJ = Smart Jack
- SONET = Synchronous Optical Network
- TLU = Terminating Line Unit

**Figure 12-25. Other ISDN Primary Rate Access Architectures**

---

In addition to the 23B+D and the H0-channel applications, the entire information capacity of a DS1 facility (1.536 Mbps) may be used by one single channel, termed an H11 channel. A PRA with H11-channel capabilities would need a D channel (for control and signaling) on a second DS1 facility or perhaps a basic access service capability. When only one DS1 facility is desired by the customer, a reduced version of the H11 channel, called H10, is used. The H10 channel occupies 1.472 Mbps of the available 1.536 Mbps. This permits the 64-kbps D channel signaling and control functions within the same DS1 facility.

### 12.9.3 Broadband Access

Whereas ISDN BRA and PRA are designed to operate over the copper plant, Broadband ISDN (BISDN) relies mainly on transport over optical fiber facilities. BISDN will provide services and data rates orders of magnitude greater than that of PRA, such as video telephony and very high speed data. International standards groups (ITU-T) have determined that the Asynchronous Transfer Mode (ATM) shall be the vehicle for the delivery of BISDN services. Although the related efforts of the ITU-T primarily focus on developing such ATM standards for BISDN for the public network, it is presently anticipated that ATM will first emerge in the private, business, and corporate environments. Thus, in 1991, the ATM Forum was created to accelerate the development and deployment of ATM products and services in the private environment.

There are currently 3 options defined for public BISDN transmission:

- Full duplex at 155.52 Mbps
- User to network at 155.52 and network to user at 622.08 Mbps
- Full duplex at 622.08 Mbps.

The ITU-T defines 2 service areas to be provided by BISDN: Interactive Services and Distribution Services.

Interactive services include:

- Broadband video telephony (e.g., video conferencing, video surveillance)
- High speed unrestricted data and information transmission (e.g., Internet)
- Messaging (e.g., video email)
- Retrieval (e.g., medical information, video files)

Distribution services include those with presentation control and those without control. In the former, the centrally located services are transmitted periodically but the customer can control the start and order of the presentation. An example would be for education or training purposes.

Distribution services without presentation control would include broadcast video, characterized by very high quality, high resolution.

---

Technical Advisory TA-TSV-001238, *Generic Requirements for SMDS on the 155.520 MBPS Multi-Services Broadband ISDN Inter-Carrier Interface (B-ICI)*, was issued in 1992, followed by several generic requirements documents covering broadband switching, signaling, and interfaces, as well as related ATM protocols and network elements; e.g., GR-1110-CORE, *Broadband Switching System (BSS) Generic Requirements*, and GR-1113-CORE, *Asynchronous Transfer Mode (ATM) Adaptation Layer (AAL) Protocols*, both first issued in 1994.

Commercial deployment of ATM and BISDN has been initiated within several areas of the United States, particularly for high speed data.

## 12.10 Universal Digital Channel

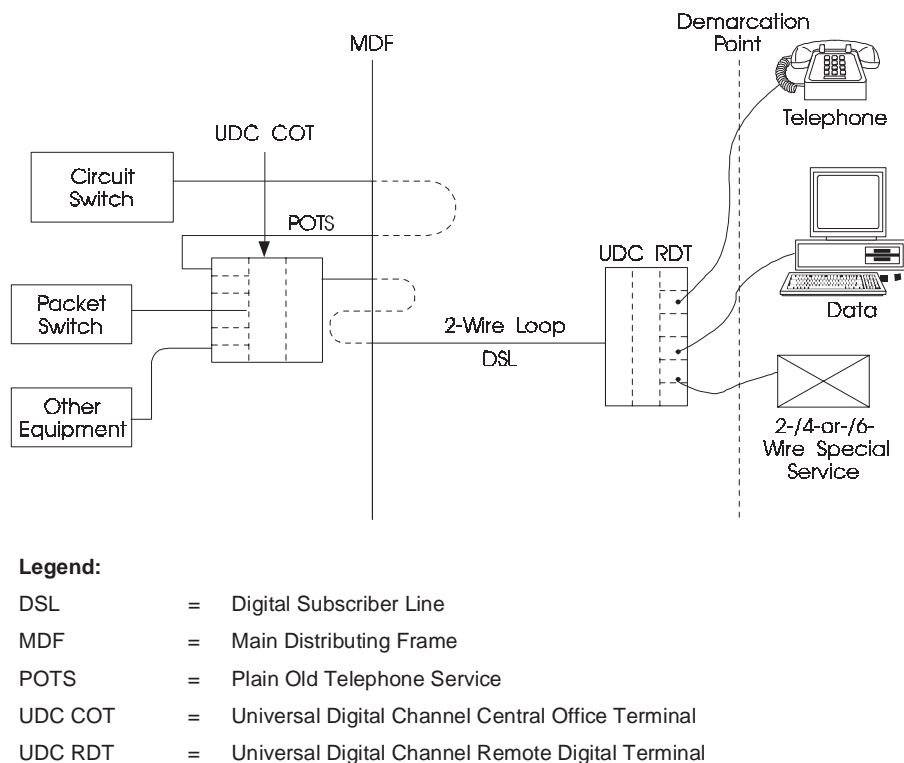
Functionally, the Universal Digital Channel (UDC) is a small Digital Loop Carrier (DLC) system. It uses the 2-wire DSL transmission technology developed for ISDN BRA (Section 12.9). UDC systems may be deployed by a LEC to deliver multiple services over a single metallic pair (loop). UDC system requirements and objectives appear in TR-TSY-000398, *Universal Digital Channel (UDC) Generic Requirements and Objectives*.

### 12.10.1 System Description

A UDC system (see Figure 12-26) consists of a COT, an RDT, and the DSL transport facility. Both the RDT and COT contain the following functional blocks: a DSL transceiver, a channel multiplexer, and as many as six Service Definition Modules (SDMs).

The DSL transceiver develops the electrical interface with the loop and presents to and accepts from the channel multiplexer the transmit and receive data streams. Both UDC terminals have matching DSL transceivers that provide 2-wire, full-duplex transmission. The SDMs in the RDT provide the service interfaces to Customer Premises Equipment (CPE). At the central office, corresponding SDMs provide the interfaces to switching systems and/or other transmission systems. The channel multiplexer allocates the bits in the DSL data streams to the services delivered by each SDM and at the central office. It may also provide the interface to network operations systems. Several COTs may be combined in a bay (central terminal) to share an operations interface module for integrated testing, performance monitoring, and provisioning.

Although each of the UDC functional blocks may be implemented as an independent module, most systems have integrated functions and interfaces to minimize system cost and to present a plug-in free environment. Minimization of system cost is of paramount importance. Although some applications may be best suited to a system with plug-ins, the requirements are written to facilitate integration of these functional components within an RDT or COT.



**Figure 12-26.** Universal Digital Channel

### 12.10.2 DSL Transmission Technology

The DSL described in TR-NWT-000393 was selected for the UDC to maximize loop coverage, to ease provisioning of the UDC transport facility, to reduce transport equipment costs, and to maximize spectrum compatibility. The DSL can be deployed at up to 18 kft on a nonloaded resistance-designed ( $1300 \Omega$  or less) plant. DSL technology can be deployed anywhere within a CSA.

UDC has no relationship to ISDN BRA service capability or interface standards (other than a common transport technology).

### 12.10.3 Customer-Usable Data Rate

The ISDN BRA DSL provides capacity for two 64-kbps channels and one 16-kbps channel. The 144-kbps total bandwidth of these channels is potentially available for transport of services and could be allocated in various ways. A maximum of six circuits has been

---

proposed for a single UDC system to help simplify system administration. These circuits may be 2-wire, 4-wire, or 6-wire, and either analog or digital.

#### 12.10.4 Transport over Carrier Systems

UDC has been designed to be transportable over any carrier system that meets Bellcore requirements (as specified in TR-NWT-000397) for carrier transport of ISDN BRA. This technical reference places requirements on carrier line units and carrier system features to help ensure that the ISDN carrier transport alternative, termed *3-DS0 TDM*, can be used for UDC.

### 12.11 Distribution Network Physical Structures

Physical structures support telephone transmission media. These physical structures include poles, towers, conduits, manholes, equipment enclosures such as huts, and even the ground when cable is directly buried.

The most common cable structure is still the pole line. Buried cable is now used wherever feasible, but pole lines remain an important structure in today's environment.

Pole lines carrying critical services are designed with a high strength-to-load ratio, as appropriate for their application environment. Factors such as weather (the frequency, severity, and damaging effects of ice and wind storms) and critical services that may be routed over a pole line determine its design.

According to the load carried and terrain features, poles from 25 to 125 ft are used. Guys or braces support poles where there are unbalanced tensions or changes in the direction of pull. Several kinds of wood (such as southern pine) and preservative treatments are used in the manufacture of "telephone" or utility poles. Suspension strand, used to support cables, has varying breaking strengths from a minimum of 2400 lb to a maximum of 25,000 lb. Self-supporting cable uses built-in strand and requires no separate strand. This simplifies the placing operation.

In rural or suburban areas, cables are often buried directly in the ground. Buried cables generally have a waterproof filling to prevent water intrusion. Splices may be made in the ground or above ground in pedestals. The depth of buried feeder or distribution cables can vary depending upon location, governmental regulations, and the possibility of future excavations such as road widenings or new fences but is usually from 2 to 4 ft. Service wires or drops are buried relatively shallow, preferably at a minimum of 12 inches. The use of direct-buried innerduct (semi-flexible high density polyethylene duct, HDPE, typically 1-2 in. diameter) has been encouraged recently to provide physical protection and facilitate maintenance and upgrades for the distribution and drop media.

In more congested areas, cables are placed in conduit, and manholes are used for splicing. Conduits have a hierarchy: there are main, subsidiary, and branch conduits. Main conduit provides protection for and link feeder sections of plant. Subsidiary conduit links the feeder route to a customer location or distribution plant. Branch conduit links the underground feeder route to the plant (feeder or distribution) that is aerial, attached to a building, or directly buried.

A major advantage of using conduit is the ability to reuse cable spaces without costly excavation by removing smaller, older cables and replacing them with larger cables or fiber facilities. Some companies reserve vacant ducts for maintenance purposes. With the increasing use of relatively small diameter fiber-optic cables, several innerducts are pulled into existing conduit, thus increasing the capacity of the conduit. Thus, several cables may be used within a single conduit.

The length of a conduit section is based on several factors, including the location of intersecting conduits and ancillary equipment such as repeaters or loading coils, the length of cable reels, anticipated pulling tension, and physical obstructions. Conduit sections typically range from 350 to 700 ft in length. Pulling tension is determined by the weight of the cable, the coefficient of friction, and the geometry of the duct run. Plastic conduit has a lower coefficient of friction than does concrete or fiberglass conduit and thus allows longer cable pulls. HDPE innerduct plus lubrication may be used to obtain particularly low frictional values. New placement methods, such as blown-cable techniques, may be effectively used for placing fiber-optic cables relatively long distances within innerduct that is installed within conduit or direct-buried.

When land routing of cables is impractical or impossible, submarine cable is used. Although it is heavily armored, protective material is generally placed on the outside of submarine cable, especially in shallow water. Clamps are used near the water's edge to anchor the cable from the action of currents.

As loop electronics enters the distribution network, equipment enclosures are becoming more widespread. These enclosures are designed to house repeaters, remote terminals, and other loop electronic equipment. They may or may not have a controlled environment to regulate temperature and humidity. Prefabricated or custom-built huts and housings or cabinets are used in remote areas. In congested areas, or where right of way is difficult to obtain, the underground Controlled Environmental Vault (CEV) provides a dry, temperate underground location for electronic equipment.

## 12.12 New Technology

Fiber-in-the-Loop (FITL) in various forms and high speed digital subscriber lines for convenient implementation in the loop distribution plant are complementary maturing loop technologies presently being deployed in the distribution network for providing advanced services.

---



---

### 12.12.1 Fiber-in-the-Loop

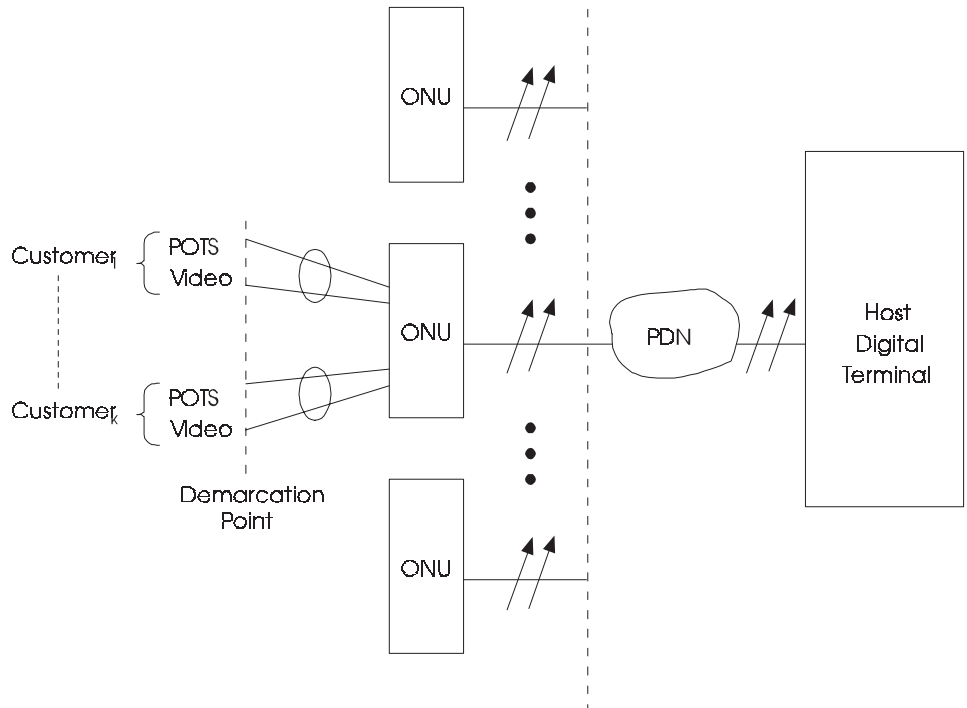
FITL represents a transport technology that not only provides end-to-end digital connectivity, but also lowers provisioning costs for existing services and allows the gradual introduction of new broadband services, such as video services. FITL includes Fiber-to-the-Curb (FTTC) as well as Fiber-to-the-Home (FTTH) and other variations.

Requirements for FTTC systems are contained in TR-NWT-000909 and TA-NWT-000909, *Generic Requirements and Objectives for Fiber in the Loop Systems*, including video requirements in addition to narrowband service requirements. Initially, FTTC systems will be treated as *black boxes*. The interior of the black box is described in terms of functional requirements, while its interfaces to customers and to the remainder of the local access network will be specified in detail. As the technology matures, optical interfaces may be defined to attain a mix-and-match capability among different manufacturers. This approach to generic requirements allows service providers to deploy FTTC systems independently of other systems present in the serving central office.

The FTTC system consists of an Optical Network Unit (ONU), an optical fiber Passive Distribution Network (PDN), and a Host Digital Terminal (HDT) (see Figure 12-27). The ONU is a network element that serves several living units, and provides existing service interfaces to residential and small business customers. The ONU is connected to the individual living units by service lines or drops consisting of metallic twisted pairs and coaxial cable. The optical fiber distribution network connects the ONU to the HDT, which provides concentration, grooming of services, signaling, and operations functions. The HDT may be located in a central office, in the feeder, or in the distribution segments of the access network. FTTC systems are being commercially deployed in several parts of the country, primarily in growth areas.

FTTH is similar to FTTC, but utilizes an Optical Network Terminal (ONT) located at the residence, allowing complete elimination of metallic media from the loop distribution plant. Cost-effective technologies for implementing FTTH are being developed and investigated for deployment in the near future.

An additional architecture currently in common use is that of Hybrid Fiber-Coax (HFC), which incorporates coaxial distribution cable and line extenders. The coaxial cable is used as the primary transmission medium connecting an Optical/Electrical Node (O/E N), serving a community, to terminals serving several living units each and connected to the individual residences by coaxial drops. An arrangement presently being deployed in some areas is the parallel installation of FTTC and HFC. In this case, the FTTC network provides narrowband services and the HFC network provides broadcast video.



**Legend:**

- ONU = Optical Network Unit
- PDN = Passive Distribution Network
- POTS = Plain Old Telephone Service

**Figure 12-27.** Generic Fiber-in-the-Loop (FTTC) System

---

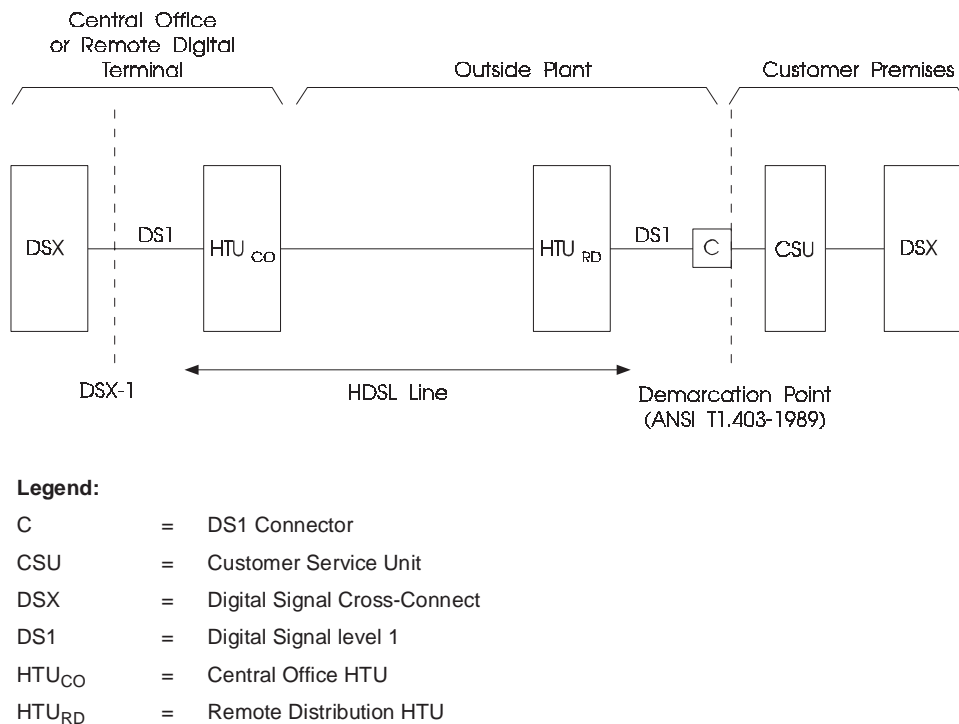
## 12.12.2 High Speed Digital Subscriber Lines

Advances in digital signal-processing techniques have been made to extend the capability of the embedded copper plant. The development of the High Bit-Rate Digital Subscriber Line (HDSL) and the Asymmetric Digital Subscriber Line (ADSL) expands the capability of the twisted cable pair, so that it is possible to transport signals in excess of 1.5 Mbps over nonrepeated, POTS-like (nonconditioned) unloaded loops out to CSA ranges.

### 12.12.2.1 High Bit-Rate Digital Subscriber Line

An HDSL system represents a robust network-provided transparent alternative for a T1 line, so that the customer does not have to effect any change to maintain the existing service. It may be represented by a pair of High Bit-Rate Transmission Units (HTUs), known as central office HTU (HTU subcentral office) and a Remote Distribution HTU (HTU subRD), and two twisted-wire pairs connecting them (see Figure 12-28). The robustness of HDSL allows its use without bridged-tap removal, without binder group separation or strict shielding requirements such as typically required for T1 lines, and without repeaters up to 12,000 ft. An HDSL line consists of two bi-directional pairs; each pair transmits half of the DS1 rate. Preliminary requirements for HDSL transmission technology and associated operations have been provided in TA-NWT-001210, *Generic Requirements for High-Bit-Rate Digital Subscriber Lines*, and FA-NWT-001211, *Generic Network Operations Requirements for High-Bit-Rate Digital Subscriber Lines*, respectively.

HDSL is presently being deployed as an alternative to T1 lines and providing DS1 service to subscribers.



**Figure 12-28.** Repeaterless DS1 Access Architecture Using HDSL

### 12.12.2.2 Asymmetric Digital Subscriber Line

ADSL technology utilizes a single non-loaded copper pair that conforms to RRD rules (Section 12.1) to transport a uni-directional high bit-rate channel (1.544 Mbps and higher), bi-directional lower bit-rate channel(s), and a POTS line. The target range for ADSL is 18,000 ft.

ADSL-1 technology limits the high bit-rate to 1.544 Mbps, whereas ADSL-3 technology make it possible to transport higher bit-rates. Thus, ADSL-1 provides a 1.544 Mbps channel to the subscriber, a 16.0 Kbps bi-directional low bit-rate channel, and a POTS line. ADSL-3 uses techniques in adaptive filtering, parallel processing, channel coding, and Very Large Scale Integration (VLSI) to transmit higher bit-rates over twisted pairs than previously possible. It provides a composite 6.312 Mbps unidirectional video signal from the Central Office to the customer, a 64 kbps bi-directional control signal, a 160 kbps bi-directional ISDN BRA signal, a 384 kbps bi-directional ISDN PRA H0 signal, and a POTS line. ADSL-3 is designed to build on SONET standards.

The ADSL equipment consists of ADSL Terminal Units (ATUs) connected by a single non-loaded twisted pair. The ATU terminal located at the CO is designated as the ATU-C

---

and the one at or near the customer is the ATU-R. These terminals multiplex/demultiplex the various signals for transport over the copper line.

ADSL technology provides the LECs the capability to offer a variety of new services to customers by using the embedded copper plant. It will enable them to enter a strategically important market that includes Pay-Per-View and Video-on-Demand applications for the residential subscribers. For business customers, ADSL technology will help the LECs to provide services such as targeted advertising, home shopping, high quality audio, interactive data, and multimedia applications. In general, ADSL is expected to stimulate the demand for high bit-rate services, which new revenues can be used to help drive fiber deployment and thus further stimulate growth of broadband services. Early preliminary requirements for ADSL transmission technology and associated operations are provided in FA-NWT-001307, *Framework Generic Requirements for Asymmetric Digital Subscriber Lines*, and FA-NWT-001308, *Framework Generic Network Operations Requirements for Asymmetric Digital Subscriber Lines*, respectively.

ADSL is currently being field trailed in anticipation of wide commercial deployment.



---

## Section 13

### Terminal Equipment and Premises Wiring Interconnection

### Contents

13.	Terminal Equipment and Premises Wiring Interconnection.....	13-1
13.1	Introduction.....	13-1
13.2	Scope.....	13-2
13.2.1	Message Telecommunications Service and Wide Area Telecommunications Service.....	13-2
13.2.2	Two-Wire Interfaces.....	13-3
13.2.3	Four-Wire Interfaces.....	13-4
13.2.4	Premises Wiring.....	13-5
13.2.4.1	Non-System Simple Customer Premises Wiring.....	13-5
13.2.4.2	System Premises Wiring.....	13-6
13.2.5	Digital Services.....	13-6
13.2.6	ISDN and PSDS Services.....	13-6
13.2.7	Coin Services.....	13-7
13.3	Terminal Equipment Connections.....	13-7
13.3.1	FCC Registration Requirements.....	13-7
13.3.2	Registration Function Codes.....	13-8
13.3.3	Terminal Systems.....	13-9
13.3.3.1	Fully Protected Systems.....	13-9
13.3.3.2	Partially Protected Systems.....	13-10
13.3.3.3	Unprotected Systems.....	13-10
13.3.3.4	Totally Protected Systems.....	13-10
13.3.3.5	Ringer Equivalence.....	13-10
13.3.4	Notification Requirements.....	13-11
13.4	Grandfather Requirements.....	13-11
13.4.1	Grandfather Concept.....	13-11
13.4.2	Register-Only.....	13-12
13.4.3	Grandfather and Register-Only Dates.....	13-12
13.4.4	Notification Requirements.....	13-13
13.5	Interface Specifications.....	13-13
13.5.1	Demarcation Point.....	13-13
13.5.2	Single Unit Installations.....	13-14
13.5.3	Multiunit Installations.....	13-14
13.5.4	Means of Connection.....	13-14
13.5.5	Plugs and Jacks.....	13-14
13.5.6	Hard Wiring of Grandfathered Equipment.....	13-15
13.6	Incidence of Harm.....	13-15
13.6.1	Telephone Company Responsibilities.....	13-17

---

---

13.6.2	Customer Responsibilities.....	13-18
13.7	Compatibility Requirements .....	13-18
13.8	Testing and Maintenance .....	13-19
13.8.1	Telephone Company Responsibilities.....	13-19
13.8.2	Customer Responsibilities.....	13-20

## List of Figures

Figure 13-1.	Principle of Operation for Loop-Start Signaling .....	13-4
Figure 13-2.	Schematic of a 4-Wire Demarcation Point Arrangement.....	13-5
Figure 13-3.	Typical Terminal Equipment Registration Number .....	13-9



---

## 13. Terminal Equipment and Premises Wiring Interconnection

### 13.1 Introduction

This section presents information about the interconnection of terminal equipment with the Public Switched Telephone Network (PSTN). Information is also presented on the interconnection of premises wiring to the network and the interconnection of terminal equipment to subrate and 1.544-Mbps digital, ISDN, Public Switched Digital Service (PSDS), and coin services. This section contains general information on the Federal Communications Commission (FCC) registration program and the demarcation point specifications.

The FCC registration program allows certain kinds of terminal equipment and premises wiring to be directly connected to the PSTN without telephone company-supplied protective connecting arrangements. The technical standards and procedures whereby telephone subscribers, both business and residential, can directly connect terminal equipment and premises wiring to the PSTN appear in Part 68 of the FCC Rules and Regulations.

The technical requirements of Part 68 are not concerned with performance characteristics, but rather with protecting the network from harm from terminal equipment and premises wiring directly connected to the network. The program makes use of a manufacturer's attestation concept, in which the applicant is responsible for demonstrating that the equipment complies with and will continue to comply with Part 68 requirements.

The technical standards outlined in Part 68 require the terminal equipment to be capable of withstanding normal handling and shipping. Consequently, the standards involve environmental simulations that include shock, vibration, temperature, and humidity tests. Leakage-current limitations are met through the use of 1,000-V dielectrics in the network interface circuitry and 1500-V dielectrics in all power transformers. In some instances, required tests for demonstrating hazardous-voltage protection can prove destructive in demonstrating the fail-safe features of the circuit.

The rules also contain limitations on inband (100 to 4000 Hz) and out-of-band (up to 1 MHz) signal power and limitations on longitudinal balance to minimize the probability of crosstalk.

Signal-power rules for digital services primarily concern limitations on maximum signal strengths expressed in voltages. The rules are intended to protect against crosstalk interference into analog carriers in adjacent binder groups as well as unacceptable noise and interferences caused by excessive voltage in the network.

The on-hook impedance limitations address both ac and dc conditions. The ac conditions relate to ringer-power requirements of the terminal equipment when connected to the

---

telephone company's central office. The dc requirements relate to the loading effects of the terminal equipment on the telephone company's loop-maintenance measurements.

Techniques are provided for measuring the ringer equivalence in both ac and dc formats in relationship to the loading effects of a standard telephone ringer. The typical telephone loop is capable of handling up to four or five standard ringers; consequently, the ringer equivalence number of a device is used to determine whether the ringing capability of a given loop will be overloaded when additional terminal devices are added.

A billing-protection feature ensures that data equipment will not transmit for a period of two seconds after the device goes off-hook to help ensure proper operation of the telephone company's billing equipment.

Hearing-aid compatibility for telephones is also required by the FCC. Effective August 16, 1989 every telephone manufactured in the United States, or imported for use in the United States, had to be hearing-aid compatible. Effective August 16, 1991 every cordless telephone manufactured in the United States, or imported into the United States had to be hearing-aid compatible. All telephones manufactured or imported for use in the United States after January 1, 2000 must contain a volume control feature.

Procedures have been established whereby manufacturers must attest by letter to the FCC that their non-system inside wiring meets Part 68 requirements (for example, the 1500-V insulation standard). The telephone companies are expected to maintain an up-to-date list of approved wire. The FCC periodically publishes a list of attestation registrants.

*The National Electric Code*, 1996 Edition, requires that communications equipment which connects to the telephone network be listed by a national recognized testing laboratory such as Underwriters Laboratories (UL). The applicable standards for telephone equipment are provided in UL 1950, 3rd Edition.

## **13.2 Scope**

### **13.2.1 Message Telecommunications Service and Wide Area Telecommunications Service**

The FCC registration program applies to the direct connection of terminal equipment and premises wiring to the PSTN in conjunction with all services other than party-line service. Message Telecommunications Service (MTS) uses, in whole or in part, the PSTN. Wide Area Telecommunications Service (WATS) permits customers to make outgoing voice or data calls, and 800 Service permits customers to receive voice or data calls that are billed on a bulk rather than individual-call basis. The service is provided within selected service areas or bands by special access to the PSTN via WATS-equipped central offices.

The FCC Rules covering MTS and WATS allow a network connection to two broad categories of terminal equipment — registered equipment or grandfathered equipment

---

---

legally and directly connected by tariff prior to October 17, 1977. Either category of terminal equipment can be used in conjunction with MTS and WATS.

Criteria have been established for interconnection of equipment to the PSTN at specific defined interfaces to protect the network from possible harm from improperly designed or maintained terminal equipment. Harm, as defined by the FCC, is considered to be electrical hazards to telephone company personnel, damage to telephone company equipment, malfunction of telephone company billing equipment, and degradation of service to persons other than the user of the subject terminal equipment (that is, the calling or called party).

The demarcation point is the point of demarcation and/or interconnection between telephone company communications facilities and terminal equipment, protective apparatus or wiring at a subscriber's premises. Connections to the telephone network at the demarcation point are made to wires commonly called tip and ring leads. In 4-wire connections, leads are designated tip, ring, tip-1, and ring-1. Leads designated tip and ring at the interface are for transmitting voice frequencies toward the network, and leads designated tip-1 and ring-1 at the interface are for receiving voice frequencies from the network.

For purposes of this section, the PSTN is referred to as the network, and the interface between the terminal equipment or premises wiring and the network is referred to as the demarcation point. The term Point of Termination (POT) is commonly used in the tariffs to denote the demarcation point. To maintain consistency in terminology throughout this section, only the term demarcation point will be used. Additional detail related to demarcation point specifications is provided in Section 13.5.

### **13.2.2 Two-Wire Interfaces**

Loop-start is the most commonly used signaling scheme in the network and is usually a 2-wire interface at the demarcation point. Loop start is typically used to provide 2-way service for residence or business customers to the MTS. Figure 13-1 provides an example of typical loop-start signaling. To initiate a call, the terminal sends an off-hook signal by lowering the tip-to-ring resistance (closing the switchhook contact) and drawing direct current from the network. It is the detection of dc loop current by the network that determines the terminal's off-hook state, hence the name loop-start signaling.

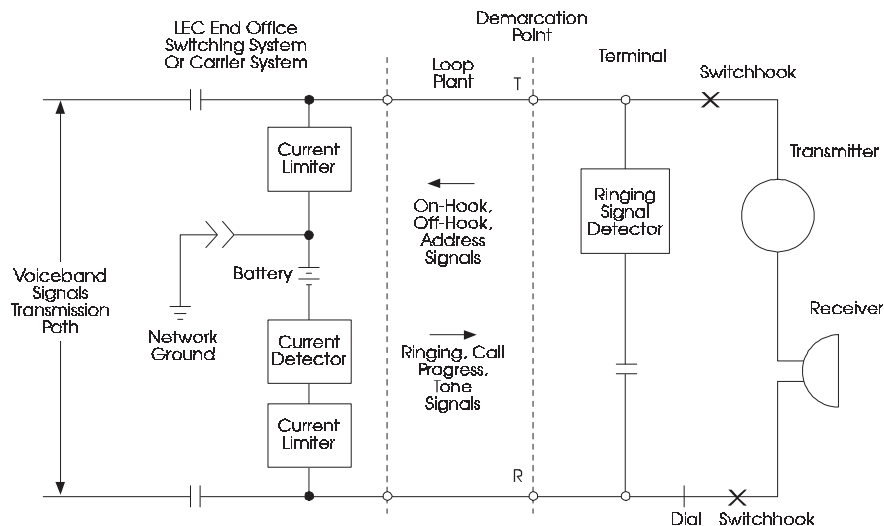
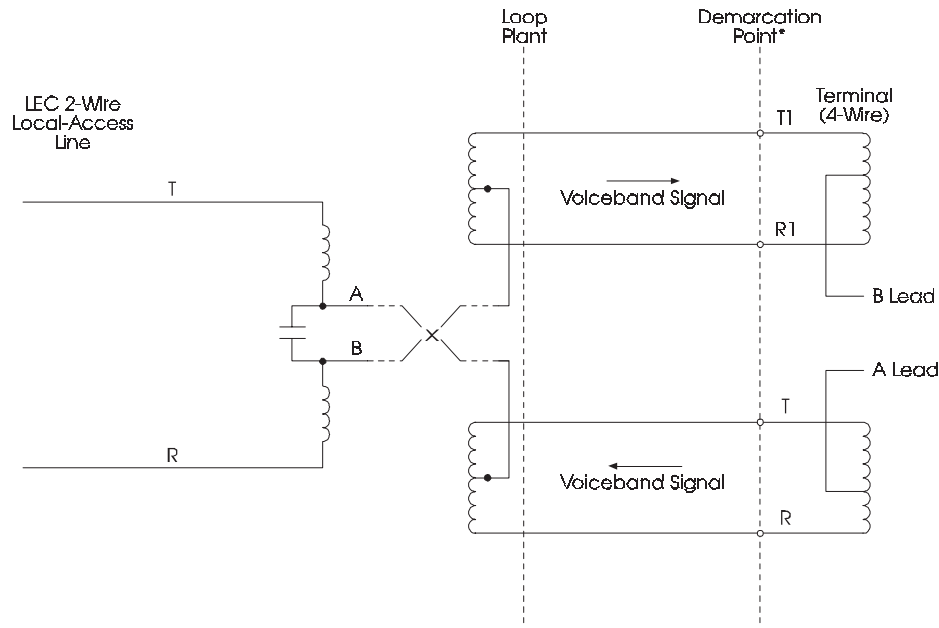


Figure 13-1. Principle of Operation for Loop-Start Signaling

### 13.2.3 Four-Wire Interfaces

In addition to 2-wire demarcation points, FCC rules cover 4-wire demarcation points. The 4-wire demarcation point lead designations and their electrical functions are illustrated in Figure 13-2 and are defined as follows.

- The leads designated T and R at the demarcation point are for transmitting voiceband signals toward the network.
- The leads designated T1 and R1 at the demarcation point are for receiving voiceband signals from the network.
- The lead derived by the terminal from the T-and-R pair must provide the same electrical function as the tip lead for 2-wire demarcation points and is commonly designated the A lead.
- The lead derived by the terminal from the T1-and-R1 pair must provide the same electrical function as the ring lead for 2-wire demarcation points and is commonly designated the B lead.



\* Lead designations at the Demarcation Point are specified in FCC Rules and Regulations, Part 68, Subpart A.

**Figure 13-2.** Schematic of a 4-Wire Demarcation Point Arrangement

## 13.2.4 Premises Wiring

### 13.2.4.1 Non-System Simple Customer Premises Wiring

Non-system simple customer premises wiring is used with up to four-line business and residence services located at the customer premises on the customer's side of the demarcation point. Parties other than telephone companies are permitted to provide and install up to four-line non-system simple customer premises wiring.

Responsibility for proper telephone-company protector grounding and access to the protector remains solely with the telephone company. Responsibility for any additional protectors that might be installed as part of the customer premises wiring and associated bonding of those devices to other systems (for example, CATV, ac power, TV antenna, etc.) rests with the customer. Special qualifications for installers are not required for non-system simple customer premises inside wiring installations. The registration program requires the use of FCC-attested wire for the non-system simple customer premises inside-wiring activity. The telephone company is not responsible for premises wiring on the customer's side of the demarcation point; however, telephone companies do offer premises-wiring maintenance agreements.

#### 13.2.4.2 System Premises Wiring

System premises wiring connects separately-housed equipment entities or system components to one another, or connects an equipment entity or system component with the telephone network interface located at the customer premises. Operations associated with the installation, connection, reconfiguration and removal of system premises wiring shall be performed in accordance with FCC Part 68 Rules and Regulations and under the supervision and control of a responsible supervisor.

#### 13.2.5 Digital Services

The FCC registration program includes terminal equipment connected to subrate or to 1.544-Mbps digital services. Terminal equipment connected to these services is generically referred to as Network Channel Terminating Equipment (NCTE). Subrate and 1.544-Mbps digital services include, for example, Dataphone digital service and Terrestrial Digital Circuits (TDCs). The Dataphone digital service is offered at rates (speeds) of 2.4, 4.8, 9.6, and 56 kbps. TDC operates at a speed of 1.544 Mbps and is also referred to as DS1 or High-Capacity Circuits (HCCs). The FCC additionally envisions that voluntary industry organizations such as the Alliance for Telecommunications Industry Solutions (ATIS)<sup>1</sup> will continue to develop uniform compatibility standards for new digital services, including Integrated Services Digital Network (ISDN).

New terminal equipment was permitted to be connected to subrate and 1.544-Mbps digital services until March 31, 1987 without a requirement for registration, provided the connection requirements described in the grandfather section of the Part 68 Rules were met. Under an FCC decision, the Local Exchange Carriers (LECs) are not obligated to provide line power on 1.544-Mbps service. Also, terminal-equipment manufacturers are not required to provide NCTE keep-alive or minimum-pulse density capability as a condition of Part 68 registration.

Definitions for subrate and 1.544-Mbps digital interfaces are contained in Part 68. Descriptions of these interfaces are included in GR-54-CORE, DS1 High-Capacity Digital Service End User Metallic Interface Specifications, ANSI T1.403-1994, *Carrier-to-Customer Installation - DS1 Metallic Interface*, and ANSI T1.410-1992, *Carrier-to-Customer Metallic Interface - Digital Data at 64 Kbs and Subrates*.

#### 13.2.6 ISDN and PSDS Services

Part 68 includes terminal equipment connected to the 2-wire Basic Rate Access (BRA) interface and the 4-wire Primary Rate Access (PRA) interface associated with ISDN. Terminal equipment for PSDS is also included in the Commission's registration program.

---

1. Formerly the Exchange Carriers Standards Association (ECSA).

---

---

The Commission established grandfather dates for connection to ISDN BRA or PRA and PSDS (Types I, II, or III) as follows. Terminal equipment, including its premises wiring directly connected to ISDN or PSDS on or before November 13, 1996, may remain connected for service life without registration, unless subsequently modified. New installation of terminal equipment, including its premises wiring, may occur until May 13, 1998, without registration of any terminal equipment involved, provided the terminal equipment is of a type directly connected to ISDN or PSDS as of November 13, 1996.

The FCC requires the use of eight-position connectors for ISDN and PSDS services under Part 68. Domestic and international standards organizations specify an eight-position non-keyed jack for ISDN. Domestically, industry consensus supporting the eight-position jack for ISDN BRA is reflected in ANSI specification T1.601-1993, and for ISDN PRA in ANSI T1.408-1990. Consensus has further been reached on eight-position jack requirements in PSDS as set forth in ANSI/TIA/EIA specification 596-92. Internationally, eight-position jacks are specified in the interconnection standards of the International Standards Organization (ISO)/International Electrotechnical Commission (IEC) 8877 and Canadian Standard, CS-03, Part III.

### 13.2.7 Coin Services

Central-office and instrument-implemented coin payphones must be registered under Part 68. Central-office implemented telephones execute coin acceptance requiring coin service signaling from the central office. Instrument-implemented telephones contain all circuitry required to execute coin acceptance and related functions within the instrument itself and not requiring coin service signaling from the central office. A general description of the electrical characteristics of the network interface for payphones that use central office services is contained in TR-TSY-000456, *Public Terminals Generic Requirements*.

## 13.3 Terminal Equipment Connections

### 13.3.1 FCC Registration Requirements

The FCC registration program has evolved to permit a wide variety of optional techniques to achieve compliance. The program requires terminal equipment or systems to be registered or grandfathered unless they are connected to the network via *totally*<sup>1</sup> protective circuitry (that is, circuitry that ensures compliance with all Part 68 requirements, including signal-power limiting).

The technical requirements of Part 68 establish limiting values for certain electrical parameters to prevent harm to the network. In addition, administrative procedures have been established by Part 68 and the FCC staff in various orders, public notices, and in the instructions for preparing Form 730 (the registration application form). These

administrative procedures apply to the registration and use, under appropriate conditions, of protective circuitry, terminal equipment, systems, and components.

In general, all telephone and data-terminal equipment located on customer premises is required to be registered with the FCC if it is directly connected to the PSTN. Terminal equipment directly connected to subrate or to 1.544-Mbps digital ISDN, PSDS, and coin services also requires registration. Exceptions to this are as follows.

- Terminal equipment connected to party lines — The FCC was not able to establish uniform national standards for party-line terminal equipment because of great differences in the design of party lines within and among telephone companies.
- Equipment located at the Local Exchange Carrier's (LEC's) Central Office (CO), or the office of a Competitive Local Exchange Carrier (CLEC)<sup>2</sup>, does not require registration.
- Equipment furnished as a part of the loop plant, even if located on customer premises, does not require registration.
- Certain classes of test equipment do not require registration.

### 13.3.2 Registration Function Codes

The 14-character FCC registration number appearing on all registered terminal equipment devices is made up of the following components:

- Three alphanumeric characters identifying the grantee of the registration
- Three alphanumeric characters identifying the manufacturer of the device (1976 to 1989) or country of origin (1989 - ongoing)
- Five numerals that make the registration number unique
- Two alphabetical characters identifying the terminal equipment device type (that is, its function)
- A single alphabetical character identifying the type of network signaling (that is, tone-type or dial-pulse), if any, employed by the device.

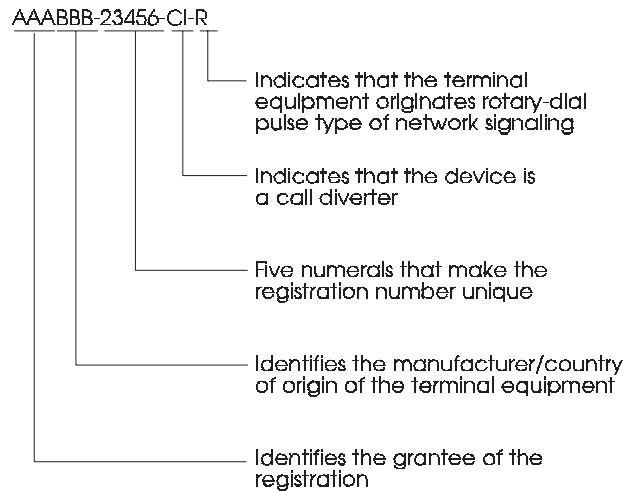
Figure 13-3 shows a typical registration number as it would appear on a terminal equipment device and as it would be reported by the customer.

---

2. The CLEC equipment is exempt only from registration if the CLEC has conformed to all LEC collocation requirements.

---





**Figure 13-3.** Typical Terminal Equipment Registration Number

The FCC has assigned two-character registration function codes to identify the type of equipment, for example, CD (Call Distributors), DM (Data Modems), etc. Equipment is classified as devices, systems, protective circuits, and adjuncts. Devices are considered to be equipment requiring not more than four central office lines; systems are equipment such as Key Telephone Systems (KTSs) and Private Branch Exchanges (PBXs) that require five or more central office lines; and adjuncts are entities intended to be used with host equipment and generally do not connect directly to the network. Most terminal equipment is a single discrete entity. Some equipment has connections for separately registered devices. For example, data modems and facsimile equipment can provide jacks for the connection of telephones.

### 13.3.3 Terminal Systems

Terminal systems represent common terminal equipment interfacing with the PSTN under the access tariff and applicable local tariffs, and they have ports for the connection of either registered or nonregistered ancillary devices or systems. Automatic call distributors (11 or more lines) are registered as PBXs. PBX consoles and multiline KTS telephones may be registered as a part of the system; however, they also may be registered separately as components of systems (PBX components as PX, key system components as KX, etc.).

#### 13.3.3.1 Fully Protected Systems

Fully protected systems provide full Part 68 compliance when installed under the fully protected systems premises-wiring procedures identified in Part 68. Connection of

nonregistered equipment, such as Customer-Provided Communication Systems (CPCSs), can require the use of appropriate signal-limiter circuits.

#### 13.3.3.2 Partially Protected Systems

Partially protected systems provide specific protection from hazardous voltages on the network. Installation is in accordance with Part 68 wiring procedures.

#### 13.3.3.3 Unprotected Systems

Unprotected systems typically provide a metallic connection directly from the station equipment to the central office; consequently, the installation must be made in accordance with the requirements of Part 68, unprotected systems premises-wiring procedures.

#### 13.3.3.4 Totally Protected Systems

The totally protected-systems registration option permits the registration of equipment providing total Part 68 compliance for all system operational states, including signal-power limitation (fully protected systems premises-wiring procedures).

#### 13.3.3.5 Ringer Equivalence

A number of factors determine the ringer-equivalence number, such as the electrical characteristics of the customer's equipment and the number of ringers that the registered device is equal to or contains. Each central office line has a maximum number of ringers that can be connected without causing a malfunction. When the number of ringers connected to a central office line exceeds the maximum for that central office line, the ringers can fail to operate properly. This is known as exceeding the ringing-bridge limitation.

The ringer-equivalence number is the actual ringer equivalence, expressed in units and tenths, followed by a letter. This letter indicates the ringing frequency at which the indicated ringer equivalence was determined.

The letter A or B appears as a suffix indicating the ringing frequency that will function properly with the telephone company network lines and trunks. Terminal-equipment devices that do not include a ringer-equivalence number with the letter A or B as a suffix are not permitted to be connected to the telephone company facilities. An exception can exist when the ringer equivalence is zero. If the ringer equivalence is zero, it is possible that

---

- A letter suffix may not appear on the terminal equipment device, or
- The letter X may appear as the suffix to the ringer equivalence.

Such zero-ringer-equivalence devices are not excluded from use on telephone company facilities merely because no ringer-equivalence suffix letter appears on the device or because the suffix is X. The suffix X will appear only when the ringer equivalence is zero. In all cases where both the letters A and B appear as a suffix, the number containing the letter A will be used for computation of the ringer equivalence.

The following are examples of ringer-equivalence numbers:

- 0.5B — Indicates a ringer equivalence of  $\frac{1}{2}$  in a device designed to be used with the B-ringing frequency
- 1.5A — Indicates a ringer equivalence of  $1\frac{1}{2}$  in a device designed to be used with the A-ringing frequency.

### 13.3.4 Notification Requirements

Customers connecting terminal equipment or protective circuitry to the telephone network shall, upon request of the telephone company, inform the telephone company of the particular line(s) to which such connection is made, the FCC registration number, and the ringer-equivalence number of the registered terminal equipment or registered protective circuitry.

## 13.4 Grandfather Requirements

### 13.4.1 Grandfather Concept

The grandfather provisions contained in Part 68 of the FCC Rules cover an alternative whereby certain nonregistered telephone terminal equipment can be connected to the telephone network. The primary purpose of this alternative is to afford proper recognition to the millions of terminal-equipment items produced by manufacturers that had been directly connected to the network prior to the adoption of Part 68 with no evidence of having caused harm.

The FCC established the grandfather transition period to allow manufacturers time to deplete their existing nonregistered inventory prior to the register-only date. Any equipment within the scope of the program that was directly connected as of the grandfather date is eligible for connection under the grandfather provision of the program. Any equipment identical to a grandfather device is eligible for grandfathering if it was directly connected prior to the register-only date, and it may be disconnected and reconnected for its equipment life.

### 13.4.2 Register-Only

The FCC registration program permits the direct connection of two classifications of approved terminal equipment — registered and grandfathered.

- *Registered equipment* complies with Part 68 of the FCC Rules and Regulations and has been granted a registration number by the FCC.
- *Grandfathered equipment* is nonregistered equipment that meets the following requirements:
  - Was directly connected to the telecommunications network without a telephone company-provided Protective Connecting Arrangement/Data Access Arrangement (PCA/DAA), in accordance with telephone company tariffs (Bell Operating Companies [BOCs], Interexchange Carriers [ICs], or non-BOC exchange carriers) as of the *grandfather eligibility* date
  - Is *of a type* that was directly connected as of the *grandfather eligibility* date and has been directly connected for the first time between the *grandfather eligibility* date and the *register-only* date.

Any nonregistered equipment (even though identical to a grandfathered device) that was not connected to the network by the register-only date may be connected through a customer-provided grandfathered protective circuitry that was connected to the network prior to the register-only date or through FCC-registered protective circuitry. Thus, new equipment intended for direct connection after the register-only date, whether or not it is identical to equipment previously grandfathered, must be registered.

### 13.4.3 Grandfather and Register-Only Dates

The grandfather eligibility date is October 17, 1977, and the register-only date is July 1, 1979, for equipment directly connected to the network that consists of non-key telephone sets, data sets, ancillary devices, and protective circuitry for such equipment. PBX and key systems and their associated protective circuitry that are directly connected to the network have a grandfather eligibility date of June 1, 1978, and a register-only date of January 1, 1980. PBX (or similar) systems directly connected to private-line-type service (Tie-Trunk Type Interfaces, Off-Premises Station Lines, Automatic Identified Outward Dialing [AIOD], and Message Registration) have a grandfather eligibility date of April 30, 1980 and a register-only date of May 1, 1983. Terminal equipment, including premises wiring and protective apparatus directly connected to subrate or to 1.544-Mbps digital services, has a grandfather eligibility date of December 15, 1985, and a register-only date of March 31, 1987. Terminal equipment, including premises wiring directly connected to ISDN BRA or PRA, or PSDS (Type I, II, or III), has a grandfather eligibility date of November 13, 1996, and a register-only date of May 13, 1998.

---

---

Once an item of equipment is grandfathered by connection prior to the register-only date, it retains that status regardless of disconnection or reconnection at the same or another premises. Grandfathered status is also retained regardless of repair operations that restore equipment to the same functional operation it had before the failure that resulted in the repair operation. The phrase *Unless subsequently modified*, as contained in the grandfather provision of Part 68, is not intended to limit routine repairs of this nature. The provision intends to cause loss of grandfather status if components in previously grandfathered equipment are replaced during a repair operation with components that are not comparable to the original ones. Grandfathered status might also be lost due to modifications that significantly change the functions of the original equipment.

#### **13.4.4 Notification Requirements**

The customer is obligated to notify the telephone company, upon request, of intended connections of grandfathered equipment and to provide sufficient identifying information (for example, manufacturer's name, model, and serial numbers) so the telephone company can determine whether the equipment is of a type that has been grandfathered.

To simplify the determination of whether a certain type of nonregistered terminal equipment is grandfathered, the FCC maintains a list of all terminal equipment that is eligible for grandfathering. This list was compiled from lists that the telephone companies were required to furnish to the FCC. The list must contain sufficient descriptive information to identify all terminal equipment that was directly connected to the telephone network as of the grandfather eligibility date. The composite list serves as the basis for determining the grandfather status of the terminal equipment.

### **13.5 Interface Specifications**

Terminal equipment, including its physical and electrical components, is subject to the FCC registration program, which requires that compliance with FCC Part 68 Rules be met at the demarcation point.

#### **13.5.1 Demarcation Point**

The demarcation point is the point of demarcation and/or interconnection between telephone company communications facilities and terminal equipment, protective apparatus or wiring at a subscriber's premises. Carrier-installed facilities at, or constituting, the demarcation point shall consist of wire or a jack conforming to Subpart F of the Part 68 Rules and Regulations.

### **13.5.2 Single Unit Installations**

For single unit installations existing as of August 13, 1990, and installations installed after that date, the demarcation point shall be a point within 12 inches of the protector or, where there is no protector, within 12 inches of where the telephone wire enters the customer's premises.

### **13.5.3 Multiunit Installations**

In multiunit premises existing as of August 13, 1990, the demarcation point shall be determined in accordance with the local carrier's reasonable and nondiscriminatory standard operating practices. In multiunit premises in which wiring is installed after August 13, 1990, the telephone company may establish a reasonable and nondiscriminatory practice of placing the demarcation point at the minimum point of entry. If the telephone company does not elect to establish a practice of placing the demarcation point at the minimum point of entry, the multiunit premises owner shall determine the location of the demarcation point or points. The minimum point of entry shall be either the closest practicable point to where the wiring crosses a property line or the closest practicable point to where the wiring enters a multiunit building or buildings. The telephone company's reasonable and nondiscriminatory standard operating practices shall determine which apply.

### **13.5.4 Means of Connection**

Registered equipment is required to be connected to the telephone network through the means of connection specified in Part 68 Rules. Both registered and grandfathered terminal equipment must be accorded the rights of connection specified in Part 68. Any jack installed by the telephone company at, or constituting, the demarcation point shall conform to Subpart F of the Part 68 rules. Subject to the requirements of Part 68 section 68.213, connection of wiring and terminal equipment to the telephone network may be made through a jack conforming to Subpart F or by direct attachment to carrier-installed wiring including, but not limited to, splicing, bridging, twisting and soldering. Connection to the network of wiring subject to Section 68.215 and terminal equipment used therewith shall be through telephone company-provided jacks conforming to Subpart F, in such a manner as to allow for easy and immediate disconnection.

### **13.5.5 Plugs and Jacks**

Telephone company-provided jacks at the demarcation point allow a ready means of connecting and disconnecting registered/grandfathered equipment and premises wiring to and from the network. These jacks are arranged to allow a connected mating plug to be

---

---

withdrawn without interfering with the operation of other terminal equipment that remains connected to the telephone network.

Telephone company-provided jacks generally provide a bridged or series connection to the tip-and-ring conductors of a telephone line. The jacks are located at the demarcation point on the customer premises.

Several types of jacks have been standardized through industry agreement, and these are detailed in Subpart F of Part 68. As an alternative to the description in Subpart F of Part 68, connections to the telephone network may be made through standard plugs and standard telephone company-provided jacks or the equivalent described in nationwide telephone tariffs. Essentially, these jacks are miniature-modular, miniature-ribbon, and data jacks. When a customer wants to connect data equipment that has been registered, the telephone company is notified as to which lines the customer intends to connect with such equipment. The telephone company determines the attenuation of each line between the interface and the telephone company central office. During the telephone company installation, connections are made in each data jack that affect maximum signal power delivered by the data equipment to the central office. Maximum allowable signal power permitted at the central office must not be exceeded.

Registered data equipment that is arranged to transmit at a fixed level not greater than -9 dBm permissive data can use voice or data jacks.

### **13.5.6 Hard Wiring of Grandfathered Equipment**

The FCC order dealing with grandfathered equipment requires that grandfathered equipment must be accorded the rights of connection through a standard telephone company-installed jack. If such means are not available, the telephone company will negotiate to provide the connection through alternative means. The order specifies that such means may be a nonstandard plug and jack, an adapter, or hard wiring. Thus, grandfathered equipment connections are not restricted to standard plugs and jacks. Whenever practical, such devices are installed on a plug-and-jack basis.

## **13.6 Incidence of Harm**

The FCC registration program attempts to control harm by providing technical requirements for terminal equipment. Network harms are usually classified under the following categories:

- Hazardous voltage
- Excessive signal power
- Longitudinal imbalance

- Improper network-control signaling.

Voltage levels in a telephone plant are considered hazardous to telephone company employees when they exceed the following levels for more than 1 second:

- 70-V peak or 50-V rms for continuous ac voltages
- 135 V to ground for continuous dc voltages.

The Hazardous Voltage Limitations Section of Part 68 covers voltage limitations in detail.

Terminal equipment transmitting excessive signal power can induce either noise or crosstalk in other pairs in the same cable sheath. This adversely interferes with the service of other pairs and degrades the quality of service provided over the network. Excessive signal power in the network can cause broadband carrier system overloads and failures. In addition, excessive signal power and longitudinal imbalances can affect network control signaling, including signals originating in equipment on customer premises.

Signal power is considered excessive when, for switched-network data services averaged over any 3-second interval, it exceeds -12 dBm at the mainframe of the end office. The following are indicators that excessive signal power can exist:

- Broadband carrier failures
- Noise and crosstalk reports
- Abnormally loud tones on the line.

The signal-power rules for digital services are concerned primarily with limitations on maximum signal strengths expressed in voltages. These rules are intended to protect against crosstalk interference into analog carriers in adjacent binder groups and unacceptable noise and interferences caused by excessive voltages in the network. Specific restrictions are placed on maximum output pulses, average power, and, depending on the particular service involved, pulse amplitudes. Limitations are also placed on *encoded-analog content*, which is essentially a digitally encoded representation of an analog signal. These limitations apply where digital terminal equipment for connection to digital services contains an analog-to-digital converter or where signals in digital form are converted into voiceband analog signals in the network. These limitations are applied by means of a zero-level decoder testing function that decodes the digital signal and tests its analog signal against acceptable levels. Minimum pulse-density requirements that ensure continuity of the output signals are also in the rules to prevent self-oscillation of line repeaters should the digital information stream from the customer's terminal equipment fall below minimum density requirements.

Crosstalk is the transfer of an electrical signal from one pair of wires to another pair of wires, where it might cause noise or interference with signals on the second pair. This coupling between the wire pairs in a cable is controlled by electrically balancing the two wires of each pair with respect to all other wires in a cable. The objective is to provide, as nearly as possible, identical exposure to interfering signals for each wire of a pair. Balancing tends to eliminate undesirable signals without interfering with normal

---



---

transmission. This is called longitudinal balancing. If the terminal equipment connected to the loop is not properly balanced to provide identical electrical terminations to ground for both wires of the pair, longitudinal imbalance results.

All combinations of terminal equipment and premises wiring must have a high degree of longitudinal balance. When one of the conductors in a pair has a fault to ground of less than 25,000  $\Omega$ , a substantial imbalance exists.

The following are examples of conditions that can cause an imbalance:

- Faults to ground
- Crosses to other pairs in the cable
- Improper splices
- Improperly grounded ringers
- Improper terminal equipment.

Other conditions can also cause longitudinal imbalance. However, the condition most readily measured is the imbalance caused by faults to ground with loop-start terminal equipment in the on-hook state.

Network-control signaling directs the operation of switching machines in the network including initiating a call, dialing the desired number, ringing the called station, completing the connection to the called station, disconnecting when the conversation is finished, and charging properly for the call. Network-control signals are exchanged between interoffice switching facilities as well as between terminal equipment and the serving end office.

The following conditions can indicate cases of improper network-control signaling:

- Pretrip
- No answer
- Wrong numbers caused by mutilated digits
- Improper billing that includes no billing
- Improper tip-party identification associated with an unauthorized extension
- Data calls less than 2 seconds.

### **13.6.1 Telephone Company Responsibilities**

The telephone company will, where practical, advise customers that they must disconnect the terminal equipment, premises wiring, plugs and jacks, or protective circuitry causing the harm at the point of connection to the telephone company facilities and leave it disconnected until it is repaired. However, where prior notice is not practical or the customer refuses to disconnect the terminal equipment, the telephone company may

---

temporarily discontinue service, if such action is reasonable under the circumstances. In cases of temporary discontinuance, the telephone company will take action as follows:

- Notify the customer promptly
- Give the customer the opportunity to correct the situation that gave rise to the temporary discontinuance
- Inform the customer of the right to bring a complaint to the FCC.

### **13.6.2 Customer Responsibilities**

If the terminal equipment or the premises wiring causes harm to the telephone network, immediate action can be required if one of the following conditions exists:

- Electrical hazards to telephone company personnel are present
- A circuit imbalance or excessive signal power causes degradation of service to persons other than the user of the subject terminal equipment or his/her calling or called party
- Malfunction of telephone company billing equipment exists
- Damage to telephone company equipment has occurred.

When trouble is experienced on a telephone line with the terminal equipment, the customer is responsible for disconnecting the terminal equipment from the line to determine if it is malfunctioning. If it is subsequently determined that the terminal equipment is malfunctioning, the use of this equipment must be discontinued until the problem has been corrected.

## **13.7 Compatibility Requirements**

Part 68 Rules require that telephone companies notify, in writing, customers who have registered or grandfathered equipment connected to telephone company facilities of any changes in facilities, equipment, operations, or procedures that can render the customer's terminal equipment incompatible with the telephone company facilities. This written notification must be provided with adequate time to allow the customer the opportunity to maintain uninterrupted service.

Upon request, the telephone company will provide interface information. The telephone company will provide technical information concerning interface parameters, including the number of ringers that can be connected to a particular telephone line. This is needed to permit terminal equipment to operate in a manner compatible with telephone company communications facilities.

---

## 13.8 Testing and Maintenance

### 13.8.1 Telephone Company Responsibilities

The telephone company is responsible for properly testing the telephone company interface for noise, continuity, ability to originate and receive calls, tip-and-ring polarity, and the other operations associated with the connection arrangement and the customer's requirements.

Under the FCC registration program, industry-wide agreements have been reached regarding the specific electrical characteristics appearing on the individual contacts of standard jacks. The telephone company is responsible for ensuring that these standards are met.

After the standard interconnection jacks at the customer premises are installed, the telephone company tests the jacks for dial tone, audible noise, ringback, and proper tip-and-ring polarity. Series-type jacks are tested for proper mechanical-contact closure to verify that telephone company-provided equipment connected on the network side of the series connection will operate properly with or without the terminal equipment connected to the standard jack. The telephone company is not responsible if the terminal equipment fails to maintain continuity through the series connection, thus causing the telephone company-provided equipment to malfunction.

If the telephone or ancillary device is readily available during the telephone company installation visit and can be easily connected by the customer, the telephone company will request that the customer connect the devices and verify that the jack and terminal equipment work properly. If, for any reason, the request cannot be accommodated or if no problem is encountered, the installation is considered complete. If there is a problem other than ringing, the telephone company will advise the customer to disconnect the terminal equipment, to verify with the manufacturer or supplier whether the correct standard jack has been ordered, and to follow the manufacturer's recommended repair procedures.

If there is trouble with the ringing, it may be directly caused by the customer's telephone or because the bridged-ringer limitation for the line has been exceeded. If the ringing problem is specifically caused by the customer's telephone and the bridged-ringer limitation has not been exceeded, the customer is advised to refer the problem to the manufacturer or vendor before reconnecting the device to the network.

A Maintenance of Service Charge (MSC) is billed by the telephone company when the telephone company receives a trouble report, visits the premises, and finds that the trouble is caused by equipment or facilities other than those provided by the telephone company. The following are examples of trouble reports:

- Improper dialing from a terminal-equipment device
- Terminal equipment giving an erroneous off-hook condition

- Failure of commercial ac power, power plug removed, or circuit breaker operated when only the terminal equipment was affected
- Failure to disconnect because of trouble in the terminal equipment
- Improper operation of the terminal equipment
- Improper programs or methods used by customers regarding the terminal equipment
- Nonstandard customer-provided premises wiring.

The MSC applies for any telephone company visit required because of a service difficulty resulting from the use of terminal equipment; it does not apply if the service difficulty results from telephone company-owned equipment. For purposes of MSC billing, telephone company-provided plugs installed on grandfathered ancillary devices should be treated as telephone company-owned. If trouble occurs in the plug, the telephone company repairs or replaces the plug at no cost to the customer.

### **13.8.2 Customer Responsibilities**

The customer is responsible for disconnecting the registered terminal equipment from the telephone company line if the customer detects that the equipment is defective or, alternatively, if the telephone company notifies the customer that the equipment is causing harm to the telephone network. The terminal equipment must remain disconnected until the defect is corrected. It must also remain disconnected if the equipment becomes deregistered as a result of FCC action.

---

## Section 14

### Network Architectures and Services

### Contents

14. Network Architectures and Services.....	14-1
14.1 Introduction.....	14-1
14.2 Common Channel Signaling .....	14-2
14.2.1 CCS Network Architecture .....	14-2
14.2.1.1 Switches.....	14-3
14.2.1.2 Signaling Transfer Point.....	14-4
14.2.1.3 Service Control Point.....	14-4
14.2.1.4 Signaling Links.....	14-4
14.2.2 SS7 Protocol.....	14-7
14.2.2.1 Message Transfer Part .....	14-7
14.2.2.2 ISDN User Part.....	14-7
14.2.2.3 Signaling Connection Control Part.....	14-9
14.2.2.4 Transaction Capabilities Application Part.....	14-9
14.2.2.5 Operations, Maintenance, and Administration Part.....	14-10
14.2.3 CCS Call Setup .....	14-11
14.3 CLASS Services.....	14-14
14.3.1 Network Architecture.....	14-20
14.3.2 Service Characteristics.....	14-20
14.3.3 Call Processing.....	14-21
14.4 Service Enabling Technologies — Simplifying the User Interface .....	14-22
14.4.1 Analog Display Services Interface (ADSI).....	14-22
14.4.1.1 Definition.....	14-23
14.4.1.2 Server Display Control .....	14-23
14.4.1.3 Feature Download.....	14-24
14.4.1.4 Illustrative Example.....	14-25
14.4.1.5 Network Capabilities .....	14-27
14.4.2 Voice Activated Services .....	14-27
14.5 Line Information Database Services .....	14-29
14.5.1 LIDB Services Overview .....	14-30
14.5.1.1 ABS.....	14-30
14.5.1.2 Originating Line Number Screening (OLNS) .....	14-31
14.5.1.3 GetData .....	14-32
14.5.1.4 Calling Name (CNAM) .....	14-33
14.5.2 Network Architecture.....	14-33
14.5.2.1 Line Information Database .....	14-35
14.5.2.2 Signaling Transfer Point .....	14-35
14.5.2.3 Operator Services System.....	14-35
14.5.2.4 LIDB Administrative System .....	14-36

---

---

14.5.3	LIDB Modification of Final Judgment Waiver.....	14-36
14.5.4	Call Processing.....	14-36
14.5.5	Calling Card Formats.....	14-38
14.5.6	Deployment Status.....	14-39
14.5.7	Regulatory Developments.....	14-39
14.6	Toll-Free Database Service.....	14-41
14.6.1	Background.....	14-41
14.6.2	Network Architecture.....	14-42
14.6.2.1	Local Network.....	14-42
14.6.2.2	SSP.....	14-43
14.6.2.3	CCS Network.....	14-43
14.6.2.4	SCP.....	14-45
14.6.2.5	SMS/800.....	14-45
14.6.3	Service Characteristics.....	14-46
14.6.3.1	Toll-Free Access Service.....	14-46
14.6.3.2	Basic Toll-Free Database Service.....	14-47
14.6.3.3	Optional Toll-Free Database Service Capabilities.....	14-47
14.6.3.4	Vertical Features.....	14-48
14.6.4	Call Processing.....	14-49
14.6.4.1	Dialing Plan Background.....	14-49
14.6.4.2	Toll-Free Access with Calling Station NPA.....	14-50
14.6.4.3	Toll-Free Access with Automatic Number Identification.....	14-50
14.6.4.4	SSP Functionality.....	14-53
14.6.5	Regulatory Developments.....	14-55
14.6.6	Deployment Status.....	14-56
14.7	Advanced Intelligent Network.....	14-58
14.7.1	Introduction.....	14-58
14.7.2	Architecture.....	14-58
14.7.3	Services.....	14-60
14.7.4	The AIN Call Model.....	14-61
14.7.4.1	The Originating Basic Call Model.....	14-61
14.7.4.2	The Terminating Basic Call Model.....	14-63
14.7.5	Call Processing.....	14-65
14.7.5.1	Trigger Detection Points.....	14-65
14.7.5.2	Event Detection Points (EDPs).....	14-66
14.7.6	Service Illustration.....	14-68
14.8	Integrated Service Control Point.....	14-70
14.8.1	Toll Free Service.....	14-71
14.8.1.1	Bellcore INS Solution.....	14-72
14.8.1.2	Toll Free Service Interfaces.....	14-74
14.8.2	LIDB Services.....	14-75
14.8.2.1	Alternate Billing Service (ABS).....	14-75
14.8.2.2	Calling Name.....	14-77

---

---

14.8.2.3	Originating Line Number Screening (OLNS) .....	14-78
14.8.2.4	GetData Services .....	14-79
14.8.3	AIN Services .....	14-80
14.8.3.1	The ASMS System .....	14-81
14.8.3.2	The ISCP Family of Systems.....	14-82
14.8.3.3	The Intelligent Services Peripheral (ISP) .....	14-83
14.8.3.4	The TELEGATE Internet Gateway (TIG) System .....	14-83
14.8.4	Local Number Portability.....	14-83
14.9	Integrated Services Digital Network.....	14-86
14.9.1	Types of Service.....	14-86
14.9.2	The Local Loop.....	14-87
14.9.3	Central Office Equipment .....	14-87
14.9.4	SS7 .....	14-88
14.9.5	Service Characteristics .....	14-88
14.9.5.1	BRA ISDN.....	14-88
14.9.5.2	PRA ISDN .....	14-88
14.9.5.3	Call-Processing Numbering Plan.....	14-89
14.9.6	National ISDN.....	14-89
14.9.6.1	National ISDN-1 .....	14-89
14.9.6.2	National ISDN-2.....	14-94
14.9.6.3	National ISDN-3 and National ISDN 1995, 1996, 1997, and 1998.....	14-98
14.9.7	Customer Premises Equipment .....	14-113
14.9.7.1	BRA ISDN Configuration .....	14-113
14.9.7.2	Reference Points for BRA ISDN .....	14-114
14.9.7.3	PRA ISDN Configuration.....	14-114
14.9.7.4	Reference Points for PRA.....	14-115
14.10	Public Switched Digital Service.....	14-116
14.10.1	Network Architecture.....	14-117
14.10.1.1	Type I Architecture.....	14-117
14.10.1.2	Type II Architecture .....	14-118
14.10.1.3	Type III Architecture .....	14-120
14.10.2	Service Characteristics .....	14-122
14.10.2.1	Transmission Characteristics .....	14-122
14.10.2.2	Signaling Characteristics .....	14-122
14.10.2.3	Routing Characteristics.....	14-123
14.10.3	Call Processing.....	14-123
14.10.3.1	Type I Call Establishment .....	14-123
14.10.3.2	Type II Call Establishment .....	14-124
14.10.3.3	Type III Call Establishment.....	14-124
14.10.4	Interoperability Issues .....	14-124
14.11	Public Packet Switched Service .....	14-126
14.11.1	Service Description .....	14-126
14.11.2	Network Elements .....	14-127

---

---

14.11.3 Service Applications .....	14-127
14.11.4 Network Architecture.....	14-127
14.11.5 PPSN Topology.....	14-128
14.11.6 Physical-Access Interfaces.....	14-129
14.11.7 Dial Access .....	14-129
14.11.8 Dedicated Access .....	14-131
14.11.9 Access Protocols .....	14-131
14.11.9.1 Dedicated Packet .....	14-131
14.11.9.2 Dial-Up Packets .....	14-132
14.11.9.3 Asynchronous and Proprietary Protocols .....	14-133
14.11.10 Internetwork and Intranetwork Interfaces .....	14-133
14.11.11 Service Characteristics .....	14-134
14.11.11.1 Standard Packet Facilities .....	14-135
14.11.11.2 PPSS-Specific Facilities.....	14-136
14.11.11.3 Protocol Conversion.....	14-136
14.11.12 Call Processing.....	14-137
14.11.13 Interoperability Issues .....	14-139
14.11.13.1 National PPSN Compatibility .....	14-140
14.12 Asynchronous Transfer Mode (ATM)-Based Broadband Integrated Services Digital Network (B-ISDN) .....	14-141
14.12.1 B-ISDN Principles .....	14-141
14.12.1.1 What is B-ISDN?.....	14-142
14.12.1.2 B-ISDN Protocol Reference Model.....	14-143
14.12.2 ATM Concepts .....	14-146
14.12.2.1 ATM Cell.....	14-146
14.12.2.2 Virtual Path and Virtual Channel Concept.....	14-148
14.12.2.3 ATM Layer Processing.....	14-149
14.12.2.4 Connection Setup.....	14-151
14.12.3 ATM Adaptation Layers (AAL) .....	14-153
14.12.4 Benefits of ATM .....	14-156
14.12.5 Broadband Services.....	14-157
14.12.5.1 Permanent Virtual Connections (PVCs).....	14-157
14.12.5.2 Switched Virtual Connections (SVCs) .....	14-158
14.12.6 ATM-based BISDN Architecture .....	14-170
14.12.6.1 User Access Interfaces.....	14-172
14.12.6.2 LEC Intra-Network Interfaces .....	14-172
14.12.6.3 Inter-Carrier Interfaces .....	14-174
14.12.7 Multiservice ATM-based BISDN Architecture .....	14-175
14.13 Frame Relay .....	14-177
14.13.1 Overview .....	14-177
14.13.2 LEC Frame Relay Service Deployment.....	14-181
14.13.2.1 Common LEC Frame Relay Service Features.....	14-181
14.13.2.2 Emerging Features .....	14-181

---



---

14.13.2.3 Recently Completed and Ongoing Standardization Work .....	14-182
14.14 Switched Multi-megabit Data Service .....	14-183
14.14.1 Service Description .....	14-183
14.14.2 Service Architecture.....	14-184
14.14.3 Supporting Requirements for SMDS .....	14-186
14.14.3.1 Access .....	14-186
14.14.3.2 Interconnection .....	14-186
14.14.3.3 Customer Network Management.....	14-187
14.14.3.4 Operations Interconnection.....	14-187
14.14.3.5 Usage Measurements .....	14-187
14.14.3.6 Operations (Using OSI) .....	14-187
14.15 Synchronous Optical Network .....	14-189
14.15.1 Motivation for SONET .....	14-189
14.15.1.1 Standardized Optical Transmission .....	14-190
14.15.1.2 Single-Ended Operations and Network Management .....	14-190
14.15.1.3 Cost Reduction.....	14-191
14.15.1.4 Survivability and Availability.....	14-191
14.15.1.5 Customer Network Management.....	14-191
14.15.1.6 High Speed Services .....	14-191
14.15.2 Rates and Format .....	14-192
14.15.2.1 Synchronous Hierarchical Rates.....	14-192
14.15.2.2 Layered Overhead and Transport Functions.....	14-198
14.15.2.3 Operations Capabilities of the Signal Format.....	14-203
14.15.2.4 Performance Monitoring.....	14-203
14.15.2.5 Embedded Operations Channel .....	14-204
14.15.2.6 Simplified Multiplexing.....	14-204
14.15.2.7 Integrated Optical Terminations .....	14-204
14.15.2.8 Mappings .....	14-205
14.15.2.9 Protection Switching.....	14-205
14.15.2.10 Network Synchronization .....	14-206
14.15.3 Network Architecture.....	14-206
14.15.3.1 Point-to-Point.....	14-207
14.15.3.2 Linear and Tree.....	14-207
14.15.3.3 Ring: UPSR .....	14-208
14.15.3.4 Ring: 2-Fiber BLSR.....	14-210
14.15.3.5 4-Fiber BLSR.....	14-212
14.15.3.6 Hubbing .....	14-213
14.15.3.7 DCS Ring and DCS Mesh .....	14-215
14.15.4 Higher Bandwidth Evolution .....	14-216
14.15.4.1 SONET OC-192 Systems .....	14-217
14.15.4.2 WDM Systems.....	14-218
14.15.5 SONET and ATM Network Integration.....	14-219

---

---

14.15.6 SONET Operations Communications Network.....	14-222
14.15.6.1 Operations Communications Architecture Overview.....	14-222

## List of Figures

Figure 14-1. CCS Network Architecture.....	14-3
Figure 14-2. SS7 Network Architecture.....	14-5
Figure 14-3. SS7 Protocol .....	14-8
Figure 14-4. CCS IntraLATA Call Setup.....	14-12
Figure 14-5. Sample Initialization Screen.....	14-25
Figure 14-6. Sample Connection Screen.....	14-26
Figure 14-7. Sample Call Waiting Deluxe Screen .....	14-27
Figure 14-5. LIDB Architecture.....	14-34
Figure 14-6. Toll-Free Database Service — Basic System Architecture.....	14-44
Figure 14-7. Toll-Free Access with ANI.....	14-51
Figure 14-8. Toll-Free Access from End Offices not Equipped for Equal Access.....	14-52
Figure 14-9. Current Toll-Free Network Configuration .....	14-54
Figure 14-10. Advanced Intelligent Network Architecture.....	14-60
Figure 14-11. Originating BCM .....	14-62
Figure 14-12. Terminating BCM.....	14-64
Figure 14-13. Toll Usage Control Service Example .....	14-69
Figure 14-14. IN/AIN Network Configuration for Toll Free Service.....	14-73
Figure 14-15. Interconnection of LEC/IXC Networks in Support of LIDB Alternate Billing Services.....	14-76
Figure 14-16. CNAM Solutions Supporting Both IN and AIN Network Protocols .....	14-78
Figure 14-17. Elements of AIN .....	14-82
Figure 14-18. Bellcore INS Solution for Number Portability .....	14-85
Figure 14-19. ISDN Network Architecture .....	14-87
Figure 14-20. ISDN BRA Configuration .....	14-114
Figure 14-21. ISDN PRA Configuration.....	14-115
Figure 14-22. Type I Technology Architecture.....	14-118
Figure 14-23. Type II Technology Architecture .....	14-119
Figure 14-24. Type III Technology Architecture .....	14-121
Figure 14-25. PPSN Architecture.....	14-128
Figure 14-26. PPSN Access Interfaces.....	14-130
Figure 14-27. Simple Protocol Stack .....	14-144
Figure 14-28. B-ISDN Protocol Reference Model.....	14-144
Figure 14-29. ATM Cell Formats.....	14-147
Figure 14-30. Virtual Path and Virtual Channels.....	14-149

---

---

Figure 14-31. ATM Layer Processing.....	14-150
Figure 14-32. Switching Virtual Channels.....	14-151
Figure 14-33. Connection Setup.....	14-153
Figure 14-34. Mapping User Data Into ATM Cells.....	14-154
Figure 14-35. ATM Service Classes and Corresponding AAL Protocols.....	14-155
Figure 14-36. LANE Components.....	14-162
Figure 14-37. Campus/Enterprise Environment.....	14-165
Figure 14-38. Private/Public ATM Interconnection Architectures.....	14-167
Figure 14-39. Multiple Service-specific Networks Evolve Toward a Broadband Network.....	14-168
Figure 14-40. Interworking among ATM Networks.....	14-170
Figure 14-41. Schematic of ATM-based Broadband Switching System Interfaces.....	14-171
Figure 14-42. Structure of a Broadband Network.....	14-176
Figure 14-43. Example LEC IntraLATA Network Supporting FR PVC Service.....	14-178
Figure 14-31. Example of Networks in Support of SMDS.....	14-185
Figure 14-32. A SONET Analogy.....	14-189
Figure 14-33. STS-1 Frame.....	14-194
Figure 14-34. Synchronous Payload Envelope.....	14-195
Figure 14-35. STS-1 Frame.....	14-196
Figure 14-36. Sub-DS3 Payloads.....	14-197
Figure 14-37. VT Sizes.....	14-199
Figure 14-38. Simplified Diagram Depicting SONET Section, Line, and Path Definitions.....	14-200
Figure 14-39. Optical Interface Layers.....	14-201
Figure 14-40. Point-to-Point Architecture.....	14-208
Figure 14-41. Linear Architecture.....	14-208
Figure 14-42. Tree Architecture.....	14-209
Figure 14-43. Unidirectional Self-Healing Ring Architecture.....	14-210
Figure 14-44. 2-Fiber Bidirectional Line Switched Ring Architecture.....	14-211
Figure 14-45. 4-Fiber Bidirectional Line Switched Ring Architecture.....	14-213
Figure 14-46. Hubbing Architectures.....	14-214
Figure 14-47. DCS Ring Architecture (Single Homing).....	14-216
Figure 14-48. N-wavelength Point-to-Point WDM System.....	14-218
Figure 14-49. Example of WDM-ADM Function.....	14-219
Figure 14-50. Conventional SONET and ATM Network.....	14-220
Figure 14-51. Hybrid SONET/ATM NEs in an Example Network.....	14-221
Figure 14-52. Three Ways of Combining STM and ATM Traffic.....	14-221
Figure 14-53. SONET Operations Communication: Example NE and Interface Types.....	14-223
Figure 14-54. Example SONET Operations Communications Architecture.....	14-224
Figure 14-55. Interactive Protocol Stacks for SONET Operations Communications.....	14-225
Figure 14-56. Example Intra-site LAN and Point-to-Point DCC.....	14-226

---

---

Figure 14-57. Example Operations Communications Network for a Survivable Ring .....	14-226
Figure 14-58. Operations Communications Functions.....	14-227

## List of Tables

Table 14-1. BRI Access, Call Control, and Signaling .....	14-99
Table 14-2. Uniform Interface Configurations for BRI.....	14-100
Table 14-3. BRI Features .....	14-100
Table 14-4. PRI Access, Call Control and Signaling.....	14-107
Table 14-5. PRI Features .....	14-108
Table 14-6. Packet Data Features and Capabilities.....	14-109
Table 14-7. Operations Capabilities.....	14-110
Table 14-8. Cross-Platform Capabilities.....	14-111
Table 14-9. Operations Capabilities - Availability Matrix .....	14-112
Table 14-10. User-Network BSS Interfaces .....	14-173
Table 14-11. LEC Intra-Network Interfaces .....	14-174
Table 14-12. Inter-Carrier Interfaces .....	14-174
Table 14-13. Line Rates for the Allowable OC-N Signals .....	14-193
Table 14-14. VT Sizes .....	14-198
Table 14-15. Mappings into SONET .....	14-205

---

## 14. Network Architectures and Services

### 14.1 Introduction

This section discusses architectures and services within Local Access and Transport Areas (LATAs). These architectures, and the services they enable, are relatively new and are actively evolving. Presently, there are twelve of these new architecture-based services:

- CLASS services
- Alternate Billing Service (ABS)
- 800 Data Base Service
- Advanced Intelligent Network (AIN)
- Integrated Service Control Point (ISCP)
- Integrated Services Digital Network (ISDN)
- Public Switched Digital Service (PSDS)
- Public Packet Switched Service (PPSS)
- Asynchronous Transfer Mode (ATM) based Broadband Integrated Services Digital Network (BISDN)
- Frame Relay (FR)
- Switched Multi-megabit Data Service (SMDS)
- Synchronous Optical Network (SONET).

Common Channel Signaling (CCS) is a basic building block of seven of these services: CLASS, ABS, 800 Data Base Service, AIN, ISDN, ATM-based BISDN, and ISCP. The role of CCS in some of these services is presented in Section 6 of this document.

Service enabling technologies, some based on CCS, are described in subsection 14.4. These evolving technologies, designed to simplify the user interface, include the Analog Display Services Interface (ADSI), Voice Activated Dialing (VAD), and Voice Activated Network Control (VANC).

PSDS, PPSS, SMDS, FR, and SONET, while not based on CCS, are new services or architectures and are discussed at the end of this section.

## 14.2 Common Channel Signaling

Common Channel Signaling (CCS) is currently being deployed in most Local Exchange Carrier (LEC) networks. Telecommunications technology has shifted toward distributed processing of network functions requiring a more efficient and reliable means of transporting control information switch-to-switch, and between switches and databases. This more efficient means of control is provided by CCS using the Signaling System 7 (SS7) protocol.

The CCS network is a separate *overlay* network used to transport signaling messages between network nodes using specialized signaling links. SS7 is the network protocol that has been designed to meet the needs of the digital telecommunications environment by providing high-speed, high-volume, low-delay transport of control information. SS7 provides a richer set of capabilities than the previous multifrequency inband signaling systems.

CCS is a critical component of the emerging, and still evolving, intelligent network architecture. SS7 is an out-of-band packet switched communication protocol that has been specified by the International Telecommunication Union—Telecommunication Standardization Sector (ITU-T),<sup>1</sup> the American National Standards Institute (ANSI), and Bellcore. The Bellcore specification of SS7 can be found in GR-246-CORE, *Bellcore Specification of Signaling System Number 7*. The protocol defines how the information that governs call control and services based on CCS will be communicated across the network.

SS7 message packets contain information ranging from the most basic call connect and disconnect functions to sophisticated query and response transactions between network switches and databases. Databases can be used to provide the intelligence governing call disposition of 800 Data Base Service, Alternate Billing Service (ABS), Calling Name Delivery (CNAM), automated registration and routing information for Personal Communications Services (PCS), and to support emerging Intelligent Network services and new functionality such as Local Number Portability.

### 14.2.1 CCS Network Architecture

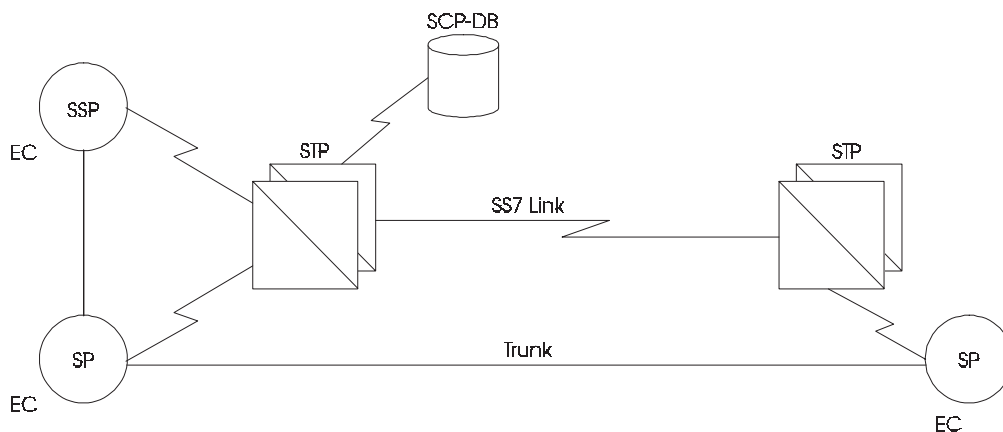
The basic components of the CCS network are switches, Signaling Transfer Points (STPs), signaling links, and Service Control Point (SCP) databases. An SS7 architectural model is shown in Figure 14-1.

All CCS nodes equipped with CCS signaling links, and able to communicate with other CCS nodes using the SS7 protocol, are globally referred to as Signaling Points (SPs). When an SP originates, or is the end destination for an SS7 message, it may also be referred to as a Signaling End Point (SEP).

---

1. Formerly the International Telegraph and Telephone Consultative Committee (CCITT).

---

**Legend:**

DB	=	Database
EC	=	Exchange Carrier
SCP	=	Service Control Point
SP	=	Signaling Point
SSP	=	Service Switching Point
STP	=	Signaling Transfer Point

**Figure 14-1.** CCS Network Architecture

## 14.2.1.1 Switches

A switch is an SP/SEP that can switch end user voice or data calls. Several possible switch capabilities exist, and any given switch may support one or more capabilities. These include:

- *Common Channel Signaling Switching Office (CCSSO)* — A CCSSO is an analog or digital switch equipped with the ISDN User Part (ISDNUP or ISUP) of the SS7 protocol, which supports voice and/or data call set-up. The CCSSO capability may be deployed in end offices, tandems, or access tandems.
- *Service Switching Point (SSP)* — An SSP is a SP/SEP that can halt call progress, launch an SS7 query to obtain additional information from an SCP, and then route or treat the call based on the information received in the SCP's response. SSPs use the SS7 Transaction Capabilities Application Part (TCAP) for database queries and responses. SSPs can be end offices, tandems, or access tandems. SSP and CCSSO functionality are complementary and commonly available in the same network node.
- *Operator Services System (OSS)* — An OSS is a SP/SEP equipped to provide operator assistance to end users. Today, the operator service call setup capabilities of these OSSs

are based on multifrequency trunks, but the OSS is also equipped to make SS7 TCAP inquiries to databases for call processing information such as credit card validation.

#### 14.2.1.2 Signaling Transfer Point

An STP is a specialized routing SP. It is an SS7-based packet switch that transfers SS7 messages to and from other SPs and is always deployed in mated pairs for reliability. The STP uses the Message Transfer Part (MTP) and the Signaling Connection Control Part (SCCP) of the SS7 protocol to screen and route messages destined for other nodes in the SS7 network. It functions as an SS7 network routing hub, interfacing with SPs only through SS7 links and not voice or data trunks. Within the LEC CCS network structure, STPs are architecturally referred to as either Local STPs (LSTPs) or Regional STPs (RSTPs). A detailed SS7 network architecture model is shown in Figure 14-2.

LSTPs provide the immediate message routing function for the SEPs. They typically are used to support local call set-up and CLASS features. They also function as message routers out of the local network to other local networks, or higher levels within the same network, or to fully exit the LEC network to another LEC, Interexchange Carrier (IC), cellular, or private CCS network.

Each signaling point has its own unique network address that is called a point code. Every SS7 message has a routing label that contains the point codes for the origination and destination of the message, plus the Signaling Link Selection (SLS) code.

#### 14.2.1.3 Service Control Point

The SCP is an SP/SEP that functions as a database to provide information to another SCP or SSP. TCAP queries and responses are used to communicate with the SCP as is done for 800 Data Base Service and ABS. SCPs may support one or more services per SCP, and SCPs may be deployed singularly as stand-alone nodes, as mated pairs, or as multiple replicates (more than 2) to increase their availability.

#### 14.2.1.4 Signaling Links

The communication path between adjacent nodes in the CCS network is called a link. Links must be provided on physically diverse routes if optimum network performance, including availability, is to be maintained. Links in the CCS network are currently optimized for 56 kbps.

Six different link designations have been established to distinguish their use in the CCS network architecture.

---



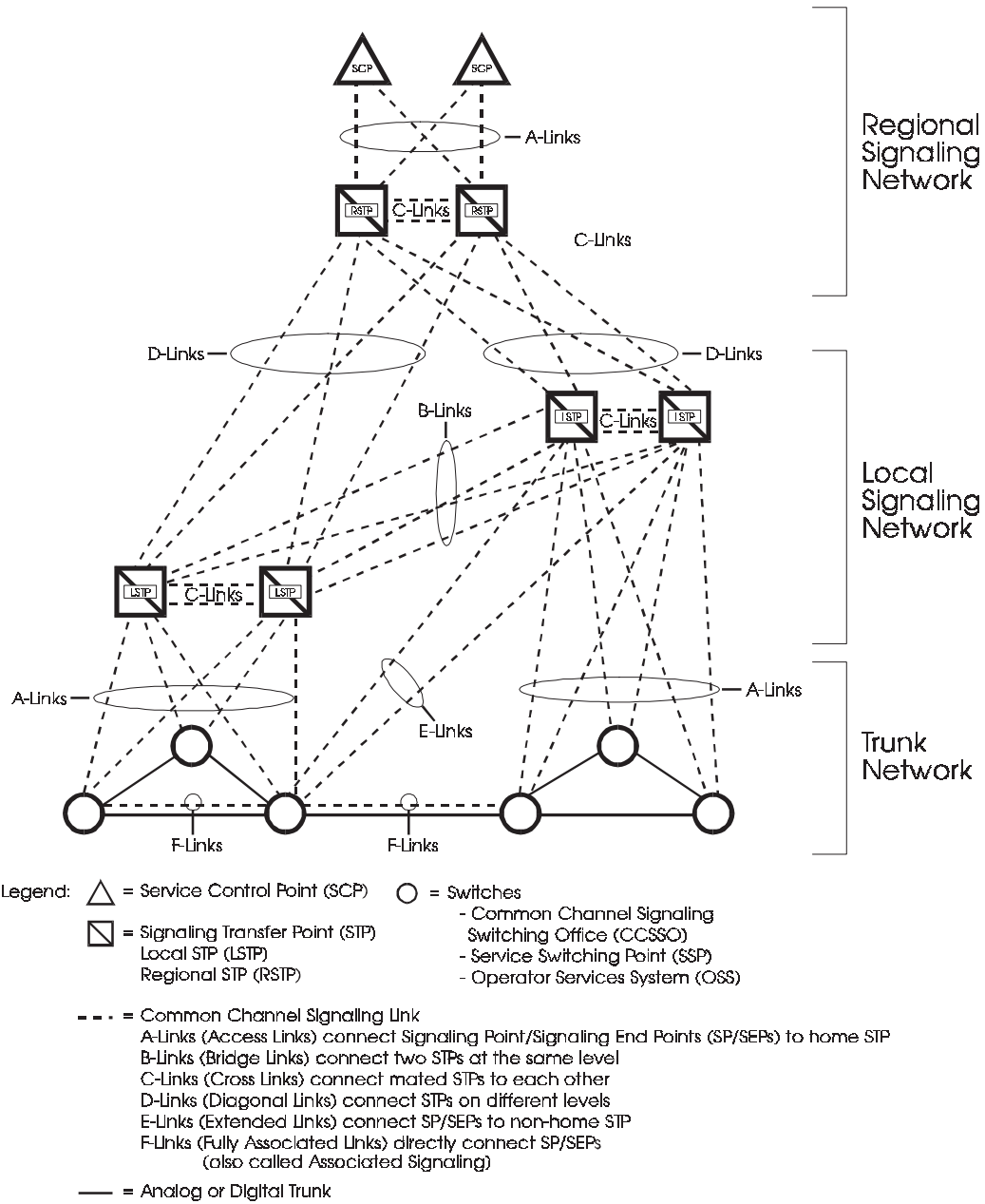


Figure 14-2. SS7 Network Architecture

- A-Links (Access Links) — Connect SP/SEPs to an STP pair which is considered to be its home STP pair.
- B-Links (Bridge Links) — Connect two STP pairs on the same hierarchical level, such as between LSTPs.
- C-Links (Cross Links) — Connect STPs together to form mated pairs.
- D-Links (Diagonal Links) — Connect STP pair on one hierarchical level to an STP pair on another level, such as from an LSTP pair to an RSTP pair.
- E-Links (Extended Links) — Connect an SP/SEP to an STP pair that is not its home STP pair.
- F-Links (Fully Associated Links) — Connect two CCS/SS7 SPs when there is a high community of interest between them (also called Associated Signaling).

The LEC CCS network architecture can be viewed as paralleling the voice switched network it supports. Local SEPs (switches and OSSs) are linked to their LSTP pair using A-links. The LSTP pair is cross-connected using C-links. LSTP pairs are interconnected using B-links. An LSTP pair is connected to the RSTP pair using D-links. Because STPs, either LSTP or RSTP, are paired nodes, the B or D links sets used to interconnect them are often referred to as quad link sets. For quad link sets, a minimum of 3-way diversity is recommended for reliability and availability.

The number of LSTPs in a network is influenced by

- Number of SPs to interconnect
- Signaling traffic volumes
- Distance between SPs and STP sites
- Cost of STPs
- Cost of link facilities
- Network and service performance objectives
- Regulatory requirements.

RSTPs are deployed as higher level network signaling concentrators to facilitate regional access to SCPs providing network-based services such as 800 and ABS.

Throughout this section, CCS node functionalities are described as independent capabilities. However, the CCS model does not preclude two or more CCS network functionalities from being physically combined, but logically separated, within an SP node, such as CCSSO, SSP, and even STP functionalities.

---

---

## 14.2.2 SS7 Protocol

SS7 is the layered protocol used by national and international telecommunications networks to provide highly reliable information transfer with low delay and without loss or duplication of messages. SS7 protocol in the United States is defined by the ANSI T1S1.3 Technical Subcommittee of Committee T1-Telecommunications and is largely aligned with the ITU-T specification of SS7 for international use. Figure 14-3 shows the SS7 protocol as implemented in LEC networks. The major protocol components of SS7 are the Message Transfer Part (MTP), the Signaling Connection Control Part (SCCP), the ISDN User Part (ISDNUP or ISUP), the Transaction Capabilities Application Part (TCAP), and the Operations, Maintenance, and Administration Part (OMAP).

### 14.2.2.1 Message Transfer Part

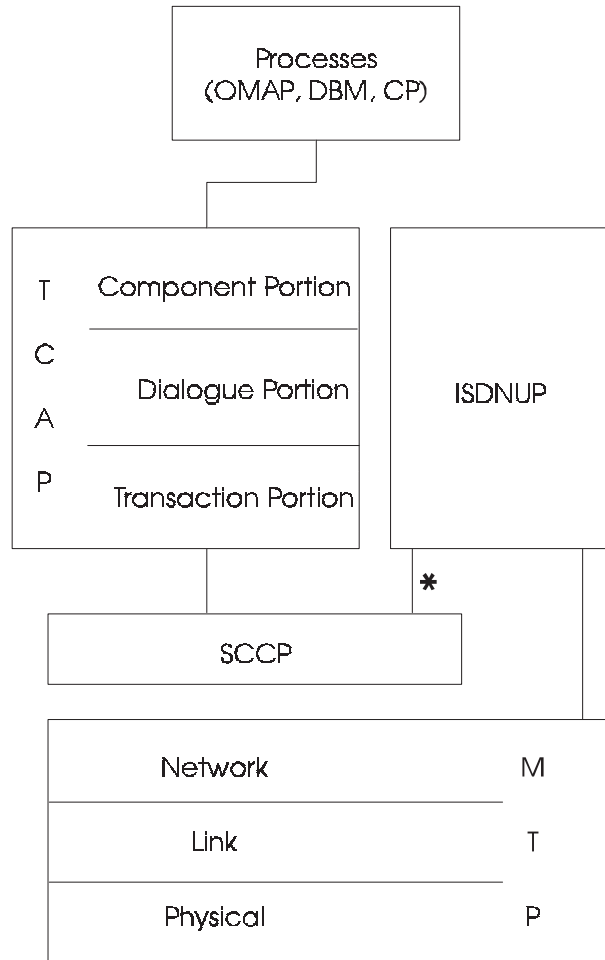
The overall function of the MTP layer of the protocol is to serve as a connectionless transport system, in which each message takes its own route and no *connection* is set up for the transport of subsequent packets. This transport system provides reliable transfer of signaling messages between the locations of communicating users or application functions. The term *user* in this context refers to any functional entity that uses the basic transport capability provided by the MTP, such as the ISDNUP or the SCCP portions of the protocol.

The MTP portion of the SS7 protocol consists of three levels: physical, link, and network levels. MTP functions include specifying the signaling link physical characteristics, signaling error detection and recovery, CCS network routing, and management and flow control.

### 14.2.2.2 ISDN User Part

The ISDNUP layer of the protocol provides circuit-related functions for both ISDN and non-ISDN calls. The call-processing applications in the end office switches use ISDNUP to set up and release message trunks used for call connections. In this respect, SS7 replaces inband signaling on those interoffice trunks.

The call-processing applications use ISDNUP to relay supervisory signaling information needed for call establishment and disconnect, and for billing functions. The CCS network performs these traditional functions better and faster than its predecessors and improves network performance by providing better utilization of message trunks, faster call setup, and fraud prevention. The ISDNUP is used to provide interexchange signaling to support analog or digital circuit control and ISDN access signaling.



\* Currently not being supported in LEC networks.

**Legend:**

- CP = Call Processing
- DBM = Database Management
- ISDNUP = ISDN User Part
- MTP = Message Transfer Part
- OMAP = Operations, Maintenance, and Administration Part
- SCCP = Signaling Connection Control Part
- TCAP = Transaction Capabilities Application Part

**Figure 14-3. SS7 Protocol**

Another benefit of using CCS for call setup is that the additional information can be passed along as part of the basic messages that provide call setup functions. This information can be used by applications in terminating switches to provide new types of services. An example of this is the Calling Party Number (CPN) used by the CLASS services.

Although not always associated with a specific call, certain ISDNUP messages can be associated with circuits and provide a set of network-management functions for a switched network of interoffice trunks. The use of circuit-related procedures requires the establishment of an interoffice circuit connection either prior to or simultaneously with signaling communication between switching machines. The procedure for establishing and disconnecting calls requires a link-by-link method of signaling; signaling messages are passed from switch to switch, controlling the circuits on each leg of the connection.

#### 14.2.2.3 Signaling Connection Control Part

The SCCP layer of the protocol provides special message-transport capabilities for noncircuit-related information exchange between the applications in network nodes. SCCP messages are used to provide services for the signaling network itself, or to transport some type of information on an end-to-end basis. SCCP messages are used by applications to access data at a remote location without sending a call there. These messages are used when there is no circuit-switched communication occurring between the nodes. Therefore, noncircuit-related SCCP messages perform functions that were not possible in earlier, inband signaling systems.

Because of the end-to-end nature of noncircuit-related signaling functions, the routing procedures were optimized to provide fast, efficient, and reliable transport between network nodes without the sequential node-to-node procedures needed for trunk setup in ISDNUP call control. SCCP messages traverse the SS7 network from the originating network node to the destination network node by routing through STPs only.

#### 14.2.2.4 Transaction Capabilities Application Part

The TCAP layer of the protocol provides the ability to exchange information between SEPs to support services or to maintain and administer the network. TCAP uses the SCCP layer for transport.

TCAP is designed to support database access by switches. Applications in switching machines can use TCAP to access centrally stored call-processing and routing instructions, or customer information. For example, ABS, 800 Data Base, and Calling Name Delivery (CNAM) use TCAP to access information stored in other SPs including SCPs.

In addition to allowing telephone company switches to access databases, TCAP provides the internodal communication needed to modernize networks through distributed processing techniques. Distributed processing allows shared use of network resources by

---

multiple entities in the network. This provides faster, more efficient introduction of future changes to the network.

Other capabilities of TCAP provide functions that can be used by applications in end offices to enable new exchange services.

- End offices can send query and response messages to edit customer-programmable lists for the CLASS features such as Distinctive Ringing/Call Waiting (DRCW).
- ISDN switches can query remote ISDN switches to determine whether the telephone number to which a customer wishes to forward calls is capable of receiving calls for that type of service.
- End offices can send busy/idle queries to check the status of distant telephone lines without establishing a trunk connection. This enables services such as Automatic Callback (AC) to monitor for an idle condition and establish calls after a customer's initial attempt encounters a busy line. This end office service prevents repetitive call attempts to reach distant busy lines, reducing inefficient use of circuits.
- TCAP supports cellular switching functions such as automated user registration.
- There is an ability to protect the transfer of TCAP information against a variety of security threats, as needed.

#### 14.2.2.5 Operations, Maintenance, and Administration Part

OMAP is the layer of the SS7 protocol that is specified for managing the CCS network by using SS7 to transport operation and maintenance information between SPs.

Architecturally, OMAP lies above TCAP in the SS7 protocol stack and uses the remote operations service of TCAP to communicate between OMAP applications. OMAP functions include network monitoring, routing updates, signaling network management, automatic call gapping, and consolidation of Operations, Administration, and Maintenance (OA&M) information. OMAP currently performs these functions through the following procedures:

- MTP Routing Verification Test (MRVT) — verifies MTP routing data for a Destination Point Code (DPC).
  - SCCP Routing Verification Test (SRVT) — verifies SCCP routing data for a global title address.
  - Link Equipment Failure (LEF) — notifies an SP of a signaling terminal or interface equipment failure at the far end of a signaling link.
  - Link Fault Sectionalization (LFS) — identifies the failed component on a signaling link.
-

- Circuit Validation Test (CVT) — ensures that two exchanges have sufficient and consistent translation data for placing a call on a specific circuit of an interexchange circuit group.

More details on the SS7 protocol can be found in Section 6 of this document and in GR-246-CORE.

### 14.2.3 CCS Call Setup

An example of basic intraLATA Plain Old Telephone Service (POTS) call setup using CCS is described in this section along with additional information on interLATA and ISDN calls.

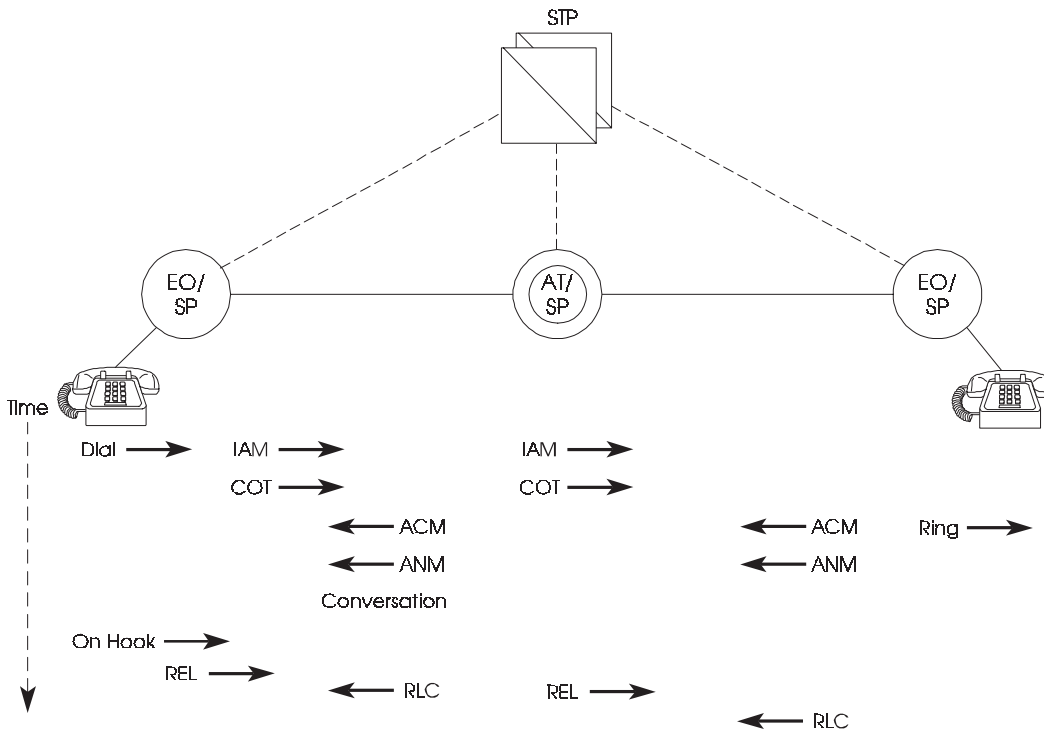
The ISDNUP portion of the SS7 protocol is used to support call setup. The Initial Address Message (IAM) is a mandatory message sent in the forward direction to initiate seizure of an outgoing circuit and to transmit address and other information relating to the routing and handling of a call. The Address Complete Message (ACM) is a message sent in the backward direction indicating that all the address signals required for routing the call to the called party have been received. The Answer Message (ANM) is a message sent in the backward direction indicating that the call has been answered. The Release Message (REL) is a message sent in either direction indicating that the circuit identified in the message is being released due to the reason (cause) supplied and is ready to be put in the idle state on receipt of the Release Complete Message (RLC). The RLC is a message sent in either direction in response to the receipt of an REL.

The following is a description of how these messages are used for setup of an intraLATA interoffice call. This call scenario is for an intraLATA call switched through an Access Tandem (AT) where a Continuity Check Message (COT) is required. Refer to Figure 14-4 for a diagram of the scenario.

When the customer dials an intraLATA interoffice call, the originating office sends an IAM over the SS7 signaling link to the AT via the STP pair. The AT then sends an IAM to the terminating office indicating the circuit to be used for the call between the AT and the terminating office. When the terminating office receives the IAM and the COT, it sends an ACM to the AT and applies power ringing to the called party's line. When the AT receives the ACM, it sends an ACM to the originating end office. When the called party goes off-hook, an ANM is sent from the terminating end office to the AT. When the AT receives the ANM, it sends an ANM to the originating end office. After the calling and called party finish their conversation, one party will go on-hook. If the calling party goes on-hook, the originating end office sends an REL to the AT. When the access tandem receives the REL, it sends an RLC to the originating office, and sends an REL to the terminating office. When the terminating office receives the REL, it sends an RLC to the AT.

CCS based POTS call set-up to ICs uses the same switch-to-switch message flow as described above for an intraLATA call. For calls routed to ICs, however, additional

optional parameters may be included in the IAM depending on which IC has been selected. Examples of these additional optional parameters include Charge Number (containing Automatic Number Identification [ANI]), Carrier Identification Parameter (containing the 3- or 4-digit carrier identification code for the call), and Calling Party Number (CPN).



**Legend:**

- ACM = Address Complete Message
- ANM = Answer Message
- AT = Access Tandem
- COT = Continuity Check Message
- EO = End Office
- IAM = Initial Address Message
- REL = Release Message
- RLC = Release Complete Message
- SP = Signaling Point
- STP = Signaling Transfer Point

**Figure 14-4.** CCS IntraLATA Call Setup



---

ISDN call set-up is basically the same, from a message flow standpoint, as POTS call set-up. The key differences are in the bearer capabilities that can be requested (such as 64 clear channel) and additional information that can be sent as part of call set-up (such as high-layer and low-layer compatibility).

More information on CCS call setup can be found in GR-317-CORE, *Switching System Generic Requirements for Call Control Using the Integrated Services Digital Network User Part (ISDNUP)*; GR-394-CORE, *Switching System Generic Requirements for Interexchange Carrier Interconnection Using the Integrated Services Digital Network User Part (ISDNUP)*; TR-NWT-000444, *Switching System Generic Requirements Supporting ISDN Access Using the ISDN User Part*; and GR-905-CORE, *Common Channel Signaling (CCS) Network Interface Specification (CCSNIS) Supporting Network Interconnection, Message Transfer Part (MTP), and Integrated Services Digital Network User Part (ISDNUP)*. Descriptions of CCS-based services such as CLASS service, ISDN, ABS, 800 Data Base Service, AIN, and ISCP, and examples of call processing for those services will be given in Sections 14.3 through 14.9.

---

### 14.3 CLASS Services

CLASS features provide capabilities beyond existing call-management services, such as Custom Calling services, since many of the CLASS features are based on the transport of the Calling Party Number (CPN). Most of the CLASS services do not require the use of specialized Customer Premises Equipment (CPE). The CLASS Calling Identity Delivery (CID) services that do require some form of specialized CPE are Calling Number Delivery (CND), Calling Name Delivery (CNAM), Calling Identity Delivery on Call Waiting (CIDCW), Call Waiting Deluxe (CWD), and Bulk Calling Line Identification (BCLID). The interface between the switch and the customer's CPE display device is described in GR-30-CORE, *Voiceband Data Transmission Interface Generic Requirements*.

CLASS features have been tariffed for use by residence and small-business customers since 1987. The availability of the features varies among LECs, individual regulatory jurisdictions, and exchange serving areas. Some of the features, such as Automatic Callback (AC), require the customer to dial a vertical service code (for AC, the code is \*66). Other CLASS features, such as the CID features described above, do not require any special dialing by the customer. Vertical service codes are administered by the North American Numbering Plan (NANP). Increasingly, LECs are offering selected CLASS features and Custom Calling services on a pay-per-use as well as a subscription basis.

CLASS features can be used by customers with dial pulse (rotary) and Dual-Tone Multifrequency (DTMF) telephone sets. Rotary customers typically dial "11" instead of the "\*", which is not available on rotary dials. With the convenience and screening capabilities the CLASS features provide, customers are afforded greater control over their calls. The provision of these services depends on the installation of the CLASS feature hardware and software in the end offices and Common Channel Signaling (CCS) in the end offices and all intervening switches. While CLASS features initially worked only on intra-network calls, many CCS network providers are in the process of interconnecting. The ability of some CLASS features to work on inter-network calls has either recently occurred (e.g., CND) or is expected to occur in the near future (e.g., AC and Automatic Recall [AR]).

The CLASS features (listed in alphabetical order) and their respective vertical service codes are discussed below.

- *Anonymous Call Rejection (ACR)* (described in TR-NWT-000567, *CLASS<sup>SM</sup> Feature: Anonymous Call Rejection, FSD 01-02-1060*) is a CLASS feature that allows ACR customers to automatically reject calls whose presentation status would prevent delivery of the calling party number to their CPE.

When ACR is activated on a line, incoming calls are checked to see whether presentation of the calling party's telephone number is allowed or denied. If allowed, the call is completed to the called party, and if he/she is assigned a CID feature such as CND, the calling party number is also delivered. If presentation of CID information is denied, the call is routed to a network announcement and the ACR customer receives no alerting for that call. The LEC-programmable announcement informs the caller that

---

the person he/she is trying to reach does not accept calls whose calling number is marked anonymous. To complete the call, the caller must re-originate the call, ensuring the presentation of the calling number is allowed.

Incoming calls are checked for acceptance or rejection by ACR regardless of the current state of the ACR customer's line (that is, busy or idle), and regardless of the assignment of a CID feature on the customer's line.

The suggested activation code for ACR is \*77, or 1177 for dial-pulse rotary sets; the suggested ACR de-activation code is \*87, or 1187 for dial-pulse rotary sets.

- *Automatic Callback (AC)* (described in TR-NWT-000215, *CLASS<sup>SM</sup> Feature: Automatic Callback, FSD 01-02-1250*) enables the user to redial the last outgoing call automatically. If the number is busy, the called line is automatically monitored until the line becomes idle, or until the AC monitoring period expires (usually 30 minutes). The customer can deactivate AC monitoring, before the call back is complete, by dialing the AC deactivation code.

The suggested activation code for AC is \*66, or 1166 for dial-pulse rotary sets. The suggested deactivation code for AC is \*86, or 1186 for dial-pulse rotary sets.

- *Automatic Recall (AR)* (described in TR-NWT-000227, *CLASS<sup>SM</sup> Feature: Automatic Recall, FSD 01-02-1260*) lets the user return the last incoming call automatically, whether or not the call was answered. This feature operates in a similar manner to AC. If the number is busy, the called line is automatically monitored until the line becomes idle, or until the AR monitoring period expires (usually 30 minutes).

The suggested activation code for AR is \*69, or 1169 for dial-pulse rotary sets. The suggested deactivation code for AR is \*89, or 1189 for dial-pulse rotary sets.

- *Bulk Calling Line Identification (BCLID)* (described in TR-NWT-000032, *CLASS<sup>SM</sup> Feature: Bulk Calling Line Identification, FSD 02-02-1280*) is a CID feature that allows a Centrex, Multiline Hunt Group (MLHG), or Private Branch Exchange (PBX) customer to receive call-related information, such as calling-party number, called-party number, time of call, on calls received from outside the Centrex, MLHG, or PBX. The CPE receives this information from the central office over a dedicated data link. Activation and deactivation codes are not required.

- *Call Waiting Deluxe (CWD)* (described in GR-416-CORE, *Call Waiting Deluxe Feature, FSD 01-02-1215*) enables a customer, on viewing CIDCW information for a second incoming call (that is, the waited call), to choose how the call should be treated. The types of treatment that a customer may select for the waited call include the following:

- Answering the call, while putting the existing call on hold (ANSWER)
  - Answering the call and disconnecting the existing call (DROP)
  - Forwarding the call (for example, to voicemail) (FORWARD)
-

- 
- Connecting the call to an announcement (ANNOUNCEMENT)
  - Putting the call on hold (HOLD)
  - Conferencing the existing call and the incoming call (CONFERENCE).

The customer is provided with the option to alternate between a held call and an existing call, or to disconnect from one party while remaining connected to the other (DROP FIRST and DROP LAST). The customer is also provided with a default treatment that either forwards the incoming call to another number (e.g., to voice mail or another number) or continues in a ringing state until a specified timeout period.

CWD is offered to customers with Analog Display Services Interface (ADSI)-compatible CPE and other types of CPE that can emulate an ADSI CPE. Customers using CWD with non-ADSI compatible CPE might only be able to use a subset of the available CWD options. Activation and Deactivation codes are not required.

- *Calling Identity Delivery Blocking (CIDB)* (described in TR-NWT-000391, *CLASS<sup>SM</sup> Feature: Calling Identity Delivery Blocking Features, FSD 01-02-1053*) allows callers to control the presentation of their names and numbers on a permanent basis (the feature is activated for every outgoing call), or on a temporary basis (the feature is activated on an individual, per-call basis).

The CIDB features that allow callers to control the presentation of calling identity items on a permanent basis enable these callers to specify a permanent default value of “public” or “anonymous” in regard to the availability of their numbers and names to called parties. There are no feature access codes for permanent CIDB features. The customer must request this feature from their LEC.

The per-call CIDB features are CLASS features that allow callers to control the availability of their numbers and/or names to called parties on a per-call basis by first dialing a feature access code before making the call. These per-call CIDB features are as follows:

- Calling Number Delivery Blocking (CNDB)
- Caller Identity Delivery and Suppression (CIDS).

The FCC ruled in 1995 that \*67 (or 1167 for dial-pulse rotary sets) should be used to block CID information, and that \*82 (or 1182 for dial-pulse rotary sets) should be used to unblock CID information (on call from lines with permanent blocking), and that the blocking and/or unblocking shall apply to both calling party name and number.

When the status of the calling party CID information is “anonymous,” the CID information will not be delivered to the CPE of a CID customer. An anonymous caller indication will be delivered instead. (The CPN is still delivered to the terminating office, so that the rest of the CLASS features function properly.) When the status of the calling CID information is “public,” the CID information is delivered to the CPE of a CID customer.

---

- 
- *Calling Identity Delivery On Call Waiting (CIDCW)* (described in TR-NWT-000575, *CLASS<sup>SM</sup> Feature: Caller Identity Delivery On Call Waiting, FSD 01-02-1090*) is a CID service that allows a customer, while off-hook on an existing call, to receive information about a calling party on a waited call. The transmission occurs almost immediately after the customer is alerted to the new call so he/she can use this information to decide whether to take the new call. The switch temporarily breaks the talking path during the transmission of the CID information to the CPE, and mutes the near end (that is, the CIDCW customer), so that neither party hears the data transmission. The subscriber may have CND, CNAM, CIDCW, or all three CID services active on the line at the same time.
  - *Calling Name Delivery (CNAM)* (described in TR-NWT-001188, *CLASS<sup>SM</sup> Feature: Calling Name Delivery Generic Requirements, FSD 01-02-1070*) is a CID service that allows the subscriber to receive the calling party's name and the date and time of the call on a specialized display device before the call is answered. The calling party name and number may both be delivered if the user subscribes to both CID services, CNAM and CND.

CNAM is only available on a subscription basis. The calling party name information is retrieved from a Service Control Point (SCP) database accessible by the terminating central office switch via the CCS network, using non-call-associated signaling (e.g., SS7/Transaction Capabilities Application Part [TCAP]).

- *Calling Number Delivery (CND)* (described in TR-NWT-000031, *CLASS<sup>SM</sup> Feature: Calling Number Delivery, FSD 01-02-1051*) is a CID service that enables the user to receive the telephone number, date, and time of an incoming call on a specialized CPE display device before the call is answered. The information is transmitted by the terminating switch to the device between the first and second ringing cycle.
- *Customer Originated Trace (COT)* (described in TR-TSY-000216, *CLASS<sup>SM</sup> Feature: Customer Originated Trace, FSD 01-02-1052*) enables the user to request that a record of the last incoming call be generated and provided to an authorized organization, such as the LEC or a law enforcement agency. Call details include the calling party number, date/time of the call, and the date/ time the record was created. COT is billed on a per-activation basis.

The suggested activation code for COT is \*57, or 1157 for dial-pulse rotary sets.

- *Distinctive Ringing/Call Waiting (DRCW)* (described in TR-TSY-000219, *CLASS<sup>SM</sup> Feature: Distinctive Ringing/Call Waiting, FSD 01-01-1110*) alerts the user by a special ring or special call-waiting tone when a call is received from any of a pre-specified list of telephone numbers. The procedures for creating and updating this list are described in TR-NWT-000220, *CLASS<sup>SM</sup> Feature: Screening List Editing, FSD 30-28-0000*.

The suggested activation code for DRCW is \*61, or 1161 for dial-pulse rotary set. The suggested deactivation code is \*81, or 1181 for dial-pulse rotary sets.

---

- 
- *Numbering Plan Area Split Management* (described in TR-NWT-001251, *CLASS<sup>SM</sup> Feature: Numbering Plan Area Split Management, FSD 30-29-0000*) allows customers to use their CLASS features with the dialing arrangements that are allowed during a permissive dialing period before a Numbering Plan Area (NPA) split.

During the permissive dialing period of an NPA split, customers have a choice of dialing arrangements they may use to complete calls to lines in the new NPA.

Customers may view this as different telephone numbers representing the same line. CLASS features only recognize a single telephone number as representing a line, and therefore experience problems when a customer attempts to use the dialing arrangements allowed during a permissive dialing period.

The following are the CLASS features that the NPA Split Management feature affects:

- AC and AR
- SLE
- Screening list services, such as DRCW, Selective Call Acceptance (SCA), Selective Call Forwarding (SCF), and Selective Call Rejection (SCR).

The LEC controls the effects of the NPA Split Management feature on the above CLASS features by populating it with NPA values and control options associated with the specific CLASS feature functionality. For the services above, the NPA Split Management feature allows these services to function using either the old or new NPA.

- *Screening List Editing (SLE)* (described in TR-NWT-000220, *CLASS<sup>SM</sup> Feature: Screening List Editing, FSD 30-28-0000*) provides customers a way to create and update a list of numbers to be used with features such as SCA, SCF, SCR, and DRCW. The maximum list size can be specified by the LEC, with the largest allowable value being 31.

The activation code for SLE is the same as that of the feature for which the customer is building the list (for example, the SCF activation code would be \*63, or 1163 for dial-pulse rotary sets).

- *Selective Call Acceptance (SCA)* (described in TA-TSY-001034, *CLASS<sup>SM</sup> Feature: Selective Call Acceptance*) allows a customer to accept voice calls only from calling parties whose telephone numbers match entries on a pre-specified list of telephone numbers. If the calling number is not on the SCA screening list, the call receives a denial announcement or is routed to an alternative telephone number, depending on subscriber's selection at activation time. The denial announcement is determined by the LEC and the terminating station is not alerted. The procedures for creating and updating this list are described in TR-NWT-000220.

The suggested access code for activating/deactivating, modifying or obtaining a status report for SCA is \*64, or 1164 for dial-pulse rotary sets.



- 
- *Selective Call Forwarding (SCF)* (described in TR-TSY-000217, *CLASS<sup>SM</sup> Feature: Selective Call Forwarding, FSD 01-02-1410*) allows a customer to have forwarded only those calls from calling parties whose telephone numbers match a pre-specified list established by the subscriber. The procedures for creating and updating this list are described in TR-NWT-000220.

The suggested activation code for SCF is \*63, or 1163 for dial-pulse rotary sets. The suggested deactivation code is \*83, or 1183 for dial-pulse rotary sets.

- *Selective Call Rejection (SCR)* (described in TR-TSY-000218, *CLASS<sup>SM</sup> Feature: Selective Call Rejection, FSD 01-02-0760*) enables the user to deny incoming calls when a call is received from any of a pre-specified list of telephone numbers. The denied callers receive an appropriate network announcement. All other incoming calls receive normal call treatment. The procedures for creating the list of telephone numbers are described in TR-NWT-000220.

The suggested activation code for SCR is \*60 or 1160 for dial-pulse rotary sets. The suggested deactivation code is \*80, or 1180 for dial-pulse rotary sets.

- *Visual Message Waiting Indicator (VMWI)* (described in TR-NWT-001401, *Visual Message Waiting Indicator Generic Requirements*) allows LECs to alert end users via a visual indicator, such as a lamp on the CPE, that a message or messages are waiting for retrieval. The visual indicator could supplement or replace the current method of customer notification - the stutter dial tone. VMWI requires that activation and deactivation messages be sent from the service provider (who receives and stores the original messages intended for the end user) to the network in the same manner as currently employed for stutter dial tone. When received from the service provider, the network sends appropriate activation and deactivation messages to the end user's CPE to control the VMWI.
  - *Visual Screening List Editing (VSLE)* (described in TR-NWT-001436-CORE, *CLASS<sup>SM</sup> Feature: Visual Screening List Editing, FSD 30-28-0100*) allows customers to activate and deactivate features that use lists, administer operation (for example, designating the number to which calls should be forwarded), and create and modify lists of Directory Numbers (DNs). Each list is associated with a particular feature to identify those telephone calls that should be given special treatment. This feature differs from SLE only in its use of the ADSI to support visual administration of the screening list. It is otherwise functionally identical to SLE.
-

### 14.3.1 Network Architecture

The network architecture for CLASS services is the network architecture for CCS described in Section 6. This architecture consists of end offices equipped with the CLASS feature hardware and software, and with CCS/SS7 signaling links to mated Signaling Transfer Point (STP) pairs, which can connect to SCPs and other CCS end offices.

### 14.3.2 Service Characteristics

The provision of CLASS services on an interoffice basis depends on the installation of CCS for call setup in the end offices and all intervening switches. Most CLASS features, with a few exceptions such as AC, depend on the transmission of the CPN from the originating office to the terminating office for interoffice calls. This CPN is carried as part of the Initial Address Message (IAM) of the SS7 call setup messages. In addition, the AC, AR, and SLE features rely on the transmission of TCAP messages between the originating office and terminating office for interoffice calls. If the central office is CLASS feature-capable but does not have SS7 connectivity with other central offices, the CLASS features work on intraoffice calls only.

The services also depend on the installation of the CLASS feature software and hardware in the end offices. The software residing in the switch enables the terminating end office to match the calling number passed over the CCS network to instructions associated with the called-party's line. For example, the switch checks to see if the customer has a list feature active and has programmed the calling number onto this list. The switch then handles the call appropriately by either providing normal call treatment, providing special ringing, forwarding the call, or rejecting the call. If the called-party has subscribed to a CID feature, the switch delivers the appropriate CID information or an anonymous caller indicator to the called-party's CPE display device.

CLASS feature deployment requires the following:

- Feature-specific CLASS software
- Programmable announcement, tone, and digit collection equipment
- Central office to CPE transmission equipment, if CID services are supported
- Signaling link equipment to connect with the CCS network
- CCS/SS7 basic hardware and software for interoffice operation.



---

### 14.3.3 Call Processing

For illustrative purposes, this section describes call processing for the CLASS features CND, CNDB, and AR.

*Calling Number Delivery (CND).* If customers subscribe to CND, they must obtain the appropriate CPE to display the CPN. The terminating central office transmits the CPN, date, and time of the call to the customer's CPE between the first and second ringing cycle. The transmission employs 1200-baud Frequency Shift Key (FSK) signaling according to Bell 202 modem specifications. If customers pick up the handset before the completion of transmission of this information (that is, the start of the second ringing cycle), they will not receive all of the information.

*Calling Number Delivery Blocking (CNDB).* Before normal dialing, the customer dials a service code to either

- block the CPN from being displayed on the called party's CPE, or
- unblock the number (i.e., the Calling Party Number is displayed on the called party's CPE).

The originating central office changes the presentation status indicator of the CID information from "public" to "anonymous" in the first case and from "anonymous" to "public" in the second case. The terminating central office acts on this information accordingly, either transmitting the information to the CPE or withholding it.

*Automatic Recall.* The AR customer can return the last call received at his or her phone by going off-hook, waiting for dial tone, and dialing \*69 (or 1169), the AR feature activation code. After the customer completes this activation procedure, the switch checks the busy/idle status and class of service of the called line. If the call is an interswitch call, an SS7 TCAP message is sent to the terminating switch requesting information on the busy/idle status and class of service of the called line. In either the intraswitch or interswitch case, if the line is idle and the class of service is allowed, call setup is attempted. If the call cannot be completed immediately due to a busy line, call completion is attempted when both stations are idle. In the meantime, the customer is instructed to hang up after being advised that the called line will be monitored for the next 30 minutes.

The busy/idle status of both lines is periodically checked until call setup is attempted or a timeout (usually 30 minutes) occurs. Both the customer and the called party may originate and receive calls without affecting the AR feature status. A customer may have multiple AR feature activations in effect concurrently, and multiple AR activations to the same telephone number from different calling stations are allowed. As part of the completion attempt, the calling station is given a special ringback (two short rings and one long ring in six seconds) and, when the customer (calling party) answers, the call is set up and the called station is given regular ringing.

For information on call processing for CLASS features, refer to the respective CLASS feature generic requirements documents listed in the References section.

---

## 14.4 Service Enabling Technologies — Simplifying the User Interface

A common complaint of the 1990's has been that many of the new telecommunications technologies and/or services are too complex and difficult to use. In some cases, the services are used infrequently and the user forgets the instructions for the service or device. Telephone services have not been exempt from this criticism. The number of telephone services being deployed has exploded in recent years, and many services have not only their own service activation codes, but their own particular service characteristics as well.

The user interface to the telephone network, on the other hand, has not kept pace with these developments until recently. This interface has not significantly changed since Dual-Tone Multifrequency (DTMF) Touch-Tone signaling was introduced into the network in the 1950's. Telephone users have had a limited and non-intuitive interface to navigate, consisting of ten numbers, two abstract symbols, and an unforgiving momentary signal called the "flash hook." For services that require a "flash hook," such as Call Waiting and Three-Way Calling, the user must depress the "flash hook" for between 300 and 1100 milliseconds (ms). Some people find this a difficult task and refrain from using the service.

Two technical advancements in network interface technology have emerged that are making new telephone and information services not just easier to use, but actually more useful to the subscriber. One interface uses a visual screen-based approach, while the other interface uses the recognition of human speech as its basis. These new network interface technologies are the Analog Display Services Interface (ADSI) and Voice Activated Dialing/Voice Activated Network Control (VAD/VANC).

ADSI builds on the network interface developed for the Caller Identity Delivery (CID) services: Calling Name Delivery (CNAM), Calling Number Delivery (CND), and Calling Identity Delivery on Call Waiting (CIDCW). ADSI allows specialized Customer Premises Equipment (CPE), with a screen display and soft-key capabilities, to interact with the subscriber's network service software to provide visual menus and options that the user can select with the touch of a button.

VAD/VANC takes a different, audible approach. VAD/VANC does not require new or specialized CPE but uses the emerging voice recognition technologies to act on the user's wishes. This could make dialing and using complex services as easy to use as saying "Call Forward to Mom's."

### 14.4.1 Analog Display Services Interface (ADSI)

Visual access to voice services via display-based CPE can improve the usability of current and future services by providing customers visual choices or options for services at appropriate times during a call or service transaction. To provide this capability generically to users served on the local analog loop, Bellcore defined the ADSI protocol in 1993. It describes a signaling interface between network voice services (also information services such as electronic directories) and advanced CPE (i.e., telephones with visual displays and

---

---

soft keys). ADSI allows the service provider to offer context-sensitive, screen-based management of telephone and information services.

LECs started deploying ADSI services in late 1994. Today, there are over 1 million ADSI telephones in U.S. and Canadian households. Call Waiting Deluxe (discussed below) is the first LEC service to use ADSI. ADSI is also used to provide screen telephones with a visual menu of available CLASS features and Custom Calling service options. Future ADSI services will include Visual Directory Assistance, Visual Voice Mail, E-mail, and short-messaging and alerting services.

#### 14.4.1.1 Definition

The ADSI protocol builds upon the protocol developed for CIDCW. It expands that protocol by identifying two types of network-to-CPE communications: Server Display Control and Feature Download. This section briefly describes both. For full descriptions of both types of communications and the details of the ADSI protocol, see TR-NWT-001273, *Generic Requirements for an SPCS to Customer Premises Equipment Data Interface for Analog Display Services*, and SR-INS-002461, *Customer Premises Equipment Compatibility Considerations for the Analog Display Services Interface*. The full set of ADSI documentation is introduced in SR-2727, *The Analog Display Services Interface (ADSI) Guide*.

The ADSI protocol and interface take advantage of existing network hardware and residential analog loop technology for rapid deployment. It uses an abstract CPE concept, which is a collection of logical components that physical CPE may implement. The abstract CPE is the network's generic view of what the ADSI CPE looks like. It allows communication with any type of ADSI CPE that is compatible with the ADSI abstract CPE functionality. Mapping rules developed for each CPE define how abstract CPE functionality is implemented in that ADSI CPE (e.g., screen size, number of soft keys). The data to be displayed on the screen and the soft keys to be displayed can be downloaded interactively (Server Display Control) or all at once (Feature Download).

#### 14.4.1.2 Server Display Control

Server Display Control provides interactive, transaction-based communications. The network (i.e., the ADSI server) sends messages that populate the CPE display screen, providing instructions to the CPE on how to display information and provide user interface controls such as soft keys. That screen display remains until the user responds or issues some command that causes the network to send more messages (or screens), or until the user terminates the transaction by going on-hook.

The Server Display Control portion of the ADSI protocol is well-suited to providing screen-based access to Interactive Voice Response (IVR) features, such as the CLASS Screening

---

List Editing (SLE) features. Where SLE currently provides instructions via voice announcements and audible access to the current lists, an ADSI-based visual SLE could display the instructions and current lists on the screen and allow users to modify their feature profile on the screen. Screen-based access to features such as voice mail and Directory Assistance can also be provided via ADSI Server Display Control.

Since the messages that are used for these communications are sent over network facilities in the voice band, a remote host, such as one owned by an Information Service Provider (ISP), could also use the ADSI protocol to provide screen-based access to its interactive services. ADSI interactive services available today by various information providers include the following:

- Home banking
- Food order and delivery services
- Ordering of tickets or reservations at restaurants, movies, or sporting events
- Lottery information
- Weather.

#### 14.4.1.3 Feature Download

Feature Download provides semi-permanent downloading of an ADSI script into the ADSI CPE. The network or remote host transmits Feature Download messages to the CPE, which are loaded into memory resident in the CPE. The messages contain the service script and related information. The service script provides the functional logic of the service, as well as instructions on how to display information and provide user interface controls such as soft keys. The service script stays in the CPE and is used to create screen displays in response to network signals (for example, busy, audible ringback) until such time as it is overwritten by a new Feature Download script.

Downloading of service scripts using the Feature Download portion of the ADSI protocol is well-suited to providing screen-based management of many current telephony features. The response time requirements for many advanced call management telephony functions require CPE memory-resident programs, since new screens triggered by network state changes must appear quickly to the user. The requirement for the semi-permanent downloading of the ADSI script, in place of hard-coded programs permanently in the CPE, stems from the fact that different customers subscribe to different services, have different serving switches, different generics of the same switch type, and different local service options on switches of the same type and generic. This means that the scripts in each CPE must be matched to the specific customer and switch, and be up-datable when customers subscribe to new services, the switch software is updated by the LEC, or the switch is changed.

---

ADSI Feature Download, therefore, allows the LEC to customize ADSI screen displays to their particular customer's service needs. Screens can also be customized for their particular operating areas, and they can be provided in different languages to better meet the needs of linguistically diverse customers.

These ADSI service scripts provide context-sensitive menus to the user that show the features available at certain times during a call. For example, a Three-Way Calling customer would be reminded during a stable call that a third party could be added.

As with Server Display Control, the messages that are used for these communications are sent over network facilities in the voiceband, and a remote host owned by an ISP could also use the ADSI protocol to download other scripts into their customer's ADSI CPE to support an interactive feature offered by the ISP. Each ADSI has a limited number of script slots, and scripts are stored in the CPE on a first-come, first-served basis.

#### 14.4.1.4 Illustrative Example

This section describes an example that illustrates the visual, context-sensitive nature of ADSI.

Figure 14-5 shows what the telephone screen might display before or immediately after the customer lifts the receiver. The customer may dial a number to call someone, or press a button next to one of the available options. The buttons are usually referred to as soft keys because their functionality is not fixed - it is controlled and defined by the ADSI script in the CPE or by an ADSI server.

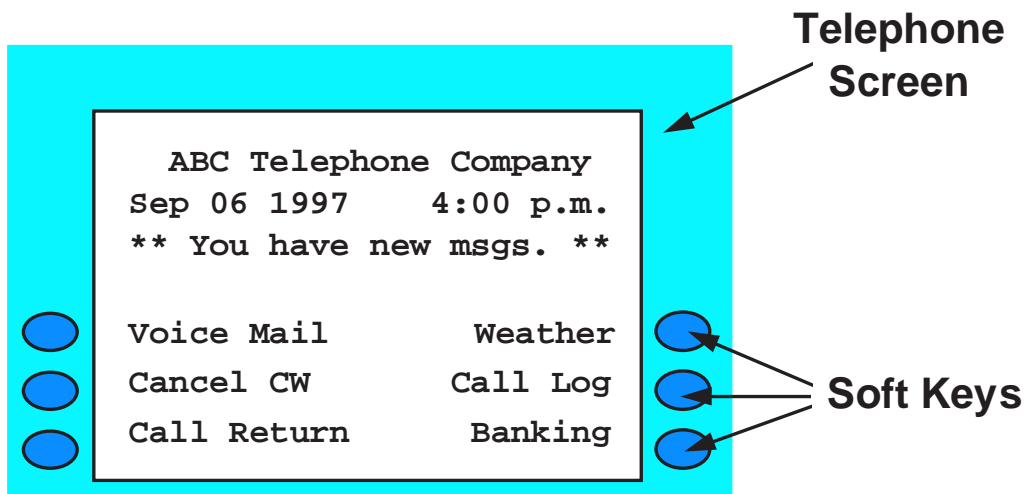
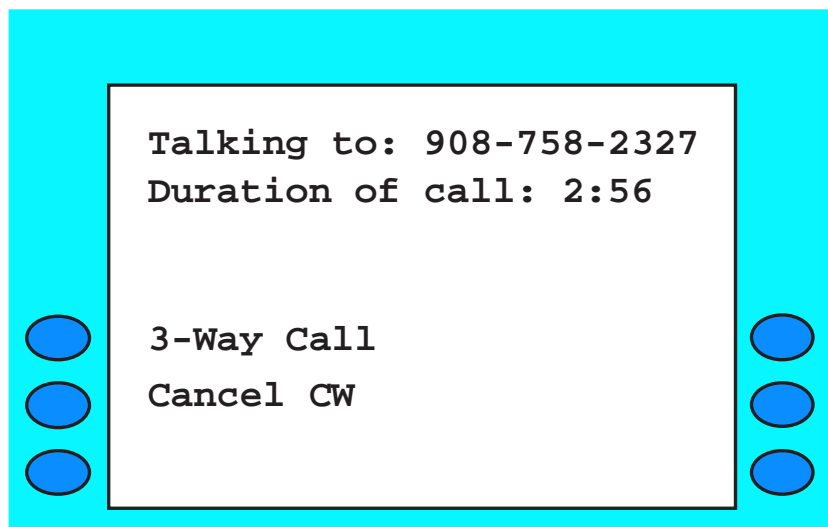


Figure 14-5. Sample Initialization Screen

Figure 14-6 shows that the customer has called someone and has been connected to the called party. The previous options, which are no longer available during a two-party call, are no longer displayed. Since Cancel Call Waiting is still available, it is still displayed. Also, 3-Way Call is now displayed as an option, whereas before it was not displayed because it was not an available option. The call timer is local CPE functionality and not directly related to ADSI.



**Figure 14-6.** Sample Connection Screen

Figure 14-7 depicts the Call Waiting Deluxe service. The customer is talking on the phone with a party whose telephone number is 908-758-2327, and they receive visual notification that Fred Smith is trying to call them. (They also hear the Call Waiting tone.) Call Waiting Deluxe provides the customer with the following options:

- FORWARD the call to another number or voice mail
- Play a BUSY announcement indicating that the call will be returned later
- DROP the current party you are talking to, and connect the waiting party
- ANSWER the waiting party and put the current party on hold
- Put the waiting party on HOLD, and play announcement that you will be with them shortly
- JOIN the current party and the waiting party.

If the Call Waiting Deluxe customer does nothing, then the caller will either be forwarded to voice mail (or another number), or continue to hear ringing, depending on the Call Forwarding/Don't Answer line treatment.

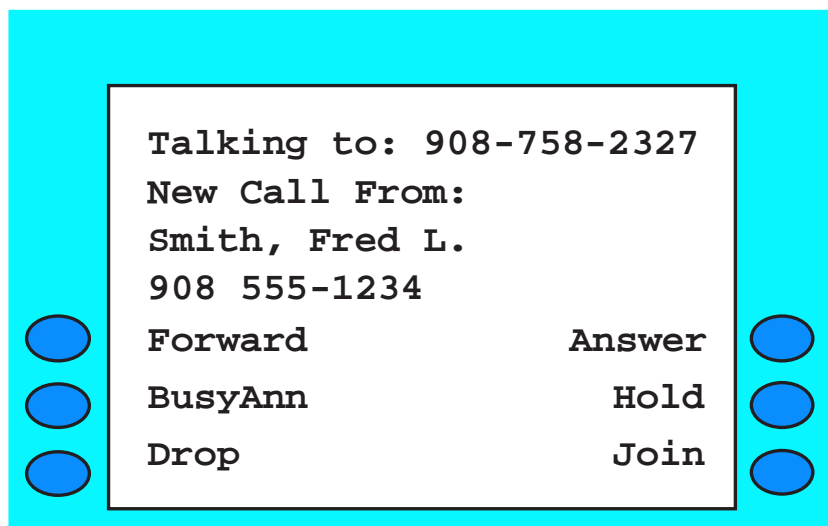


Figure 14-7. Sample Call Waiting Deluxe Screen

#### 14.4.1.5 Network Capabilities

The ADSI protocol uses existing hardware developed for CLASS and CIDCW, and residential loop technology (e.g., the hardware used to generate and detect the CPE Alerting Signal (CAS) tone). Switch-based Server Display Control features, such as the visual SLE feature described above, will require new switching software. A Feature Download server (which could be in a switch or an operations system) for creating, maintaining, and downloading service scripts for management of advanced call-management features is also needed in the network.

#### 14.4.2 Voice Activated Services

Voice Activated Services are network-based services that use Automatic Speech Recognition (ASR) capabilities. ASR is an enabling technology that allows a machine to recognize spoken words. There are two main classes of ASR technology:

- *Speaker Independent ASR* — Recognizes spoken words without requiring any previous training by the speaker.
- *Speaker Dependent ASR* — Recognizes spoken words that each speaker trains into the system in advance.

Voice Activated Services use both Speaker Independent and Speaker Dependent ASR technology to provide a more natural interface to new and current network-based services.



---

A number of voice input technology based services are becoming available in the network. The following list provides a sample of service concepts. Voice dialing services are currently available in the network. These services are supported with a variety of supplier platforms.

- Voice Activated Dialing (VAD) allows customers to pick up the telephone and speak the name, or the digits in the telephone number, of the person they wish to call. The VAD system will recognize the spoken input and dial the appropriate telephone number. Using VAD, customers will need to train their own personal directory of names and numbers into the system. VAD provides a more convenient way to dial a number, and it eliminates the need for customers to remember or look up a person's telephone number every time they wish to make a call.
- Voice Activated Network Control (VANC) is very similar to VAD; however, instead of using voice to dial a telephone number, customers use voice to control network services such as Custom Calling, CLASS, and Centrex services. For example, a customer wishing to activate the CLASS Automatic Callback feature would speak a command (for example, "Redial") rather than dial a Vertical Service Code (VSC) (\*XX). VANC can be combined with VAD to offer new or improved services to customers. For example, a service may combine a phone number in a customer's personal directory with a VANC service. Customers might say "Forward calls to Jane" where Jane is a name in the customer's VAD personal directory. VANC provides a new and more natural interface to existing services.
- Voice Activated Premier Dialing allows telephone users to place calls to national or local businesses by speaking a voice command (for example, "Call IBM Sales"). The customers for this service are the companies that would like to have their names in this voice directory that all telephone customers can access. This service uses Speaker Independent ASR so users do not have to train the system in advance.
- Voice Activated Voice Messaging allows voice messaging subscribers to interact with their voice messaging system using voice commands rather than DTMF digits.
- Calling Card Authentication uses a voice verification technology to authenticate calling card customers before they are allowed to complete calling card calls.
- Vote-By-Phone allows customers to vote via their telephone in public and corporate elections using voice commands to authenticate themselves and cast their ballot.



---

## 14.5 Line Information Database Services

Another set of services based on Common Channel Signaling (CCS) are those provided by Line Information Databases (LIDBs). One of these is Alternate Billing Service (ABS), a set of billing options for non sent-paid calls (calls that are billed to a number other than the calling number) that require operator system handling for call completion. These billing options include collect, calling card, and bill-to-third-number. ABS is supported by a network of LIDBs, which contain information about valid calling card and other billing numbers.

LIDB also contains non-billing information about individual line numbers. The LIDB Administration System (AS/LIDB) maintains the data in LIDB for all LIDB services. The AS/LIDB also maintains data screening information, which allows a LIDB owner to restrict the data that will be returned to various query originators.

Requests for LEC non sent-paid billing options, which are typically dialed with a "0" prefix, are handled by specially equipped tandem switching offices known as Operator Services Systems (OSSs). OSSs interface with LIDBs using the Common Channel Signaling/Signaling System 7 (CCS/SS7) network. LIDB provides a basic level of protection against toll fraud by validating calling card and billing number information.

ABS currently has two components: Exchange ABS (EABS) and LIDB validation service. EABS is the provision of ABS billing options to end users on Local Exchange Carrier (LEC) intraLATA calls. LIDB validation service is a tariffed offering to Interexchange Carriers (ICs) and Operator Service Providers (OSPs) that enables LEC billing and calling card numbers to be used to bill calls on IC networks.

Beginning in 1981, ABS service was provided using AT&T's Common Channel Interoffice Signaling (CCIS) and Billing Validation Application (BVA). Under the terms of the Bell System Plan of Reorganization (POR), the Bell Operating Companies (BOCs) were able to lease CCIS and BVA capacity from AT&T to continue to provide intraLATA ABS after divestiture. The introduction of LEC-owned LIDBs enabled the LECs to validate billing numbers using their own network elements. Because of the initial use of a common database (BVA) to validate and bill calls, AT&T and the LECs issued the same calling card number for any particular customer. This arrangement impacted the scope of EABS when the Modification of Final Judgment (MFJ) Court ruled in 1988 on the BOC's equal access obligations with regard to calling card acceptance. The POR agreement to share BVA expired on December 31, 1991.

Another LIDB service is Originating Line Number Screening (OLNS). OLNS is a means of providing an OSS with information about the line originating a telephone call. Originating line information may be used to determine things such as billing and service restrictions, the Originating InterLATA Carrier (OIC), IntraLATA Presubscription (ILP) information, and Service Provider associated with the originating line. OLNS functionality moves the provision of originating line information from OSS internal tables to centralized databases, the LIDBs. OSSs access originating line information by launching OLNS

---

queries over the CCS network using the SS7 protocol to the LIDB containing the originating line.

OLNS deployment schedules vary by company. It was first implemented in 1996, and various companies have plans to deploy the capability in their OSSs and LIDBs during 1997 and beyond. Companies not deploying OLNS continue to provide ABS and other operator services using originating line information stored internally in OSSs. Companies with OLNS capability may choose to launch OLNS queries to LIDBs on every call received by the OSS, or on a subset of calls based on ANI Information Digits (ANI II) and/or incoming trunk group.

Another LIDB service is GetData. GetData is a LIDB feature that provides flexible query and data element definition capabilities that allow LIDB owners to rapidly develop and store new data elements on a per-line basis.

The GetData query is a service-independent LIDB query (and associated responses) that can be used to request specific data elements from a record in LIDB. To support the GetData query, Query Originators (QOs) access the LIDB associated with a service key (e.g., the line number provided by a calling customer) to obtain data element information stored with the given line number. The data that is available from LIDB via a GetData query includes many of the parameters that are returned in the OLNS, ABS, and Calling Name services, as well as any custom elements defined by a LIDB owner. Included as part of the LIDB GetData service is a mechanism that allows LIDB owners to define customized LIDB data elements over the AS/LIDB-to-LIDB interface.

Calling Name (CNAM) is another service supported by LIDB (see Section 14.3). The LIDB can be accessed with a calling number in order to return the name associated with that number. CNAM queries (known as Generic Name queries) are routed to LIDB for the CNAM service in a manner similar to the routing of queries to LIDB for ABS. Some companies use LIDB for their CNAM services, while others have deployed other implementations that do not use LIDB data.

## **14.5.1 LIDB Services Overview**

### **14.5.1.1 ABS**

ABS is an umbrella term for several services that use the CCS/SS7 network and intelligent network capability of LIDB. These services include EABS, LIDB validation service, and Exchange Access ABS (EAABS).

#### **A. Exchange ABS**

EABS is the performance of traditional operator functions on an intraLATA basis. These functions include processing and validating the following non sent-paid billing options: LEC calling card, IC calling card, collect, and bill-to-third-number. The latter

---

---

two options are increasingly being provided by the LECs on a completely automated basis. This service, which relies on voice recognition technology, is called Automated ABS (AABS). The LECs provide EABS to their end users and, in some cases, to the end users of independent LECs.

#### B. LIDB Validation Service

LIDB validation service is a tariffed offering that enables LECs, ICs, and other industry participants to have access to LEC billing and calling card information contained in LIDB. The technical interface specification for this service is found in GR-954-CORE, *Common Channel Signaling (CCS) Network Interface Specification (CCSNIS) Supporting Line Information Database (LIDB) Services*. GR-954-CORE requires that the calling and called number associated with an ABS call be included in the LIDB query. Inclusion of these mandatory parameters improves toll fraud detection processes and enables ABS features that rely on this information.

#### C. Exchange Access ABS

EAABS is a potential service with which the LEC would determine, via a query to LIDB, the preferred carrier of the billed party on 0+ interLATA ABS calls. In addition to the carrier identification component of EAABS, an optional component called EAABS service processing would enable the LEC to perform traditional operator service processing (for example, securing acceptance of a collect call) on behalf of an IC. Currently, there are no plans to implement this functionality.

### 14.5.1.2 Originating Line Number Screening (OLNS)

Before the implementation of OLNS, when a 0-, 0+, or Directory Assistance (DA) call was received at the OSS, the OSS determined whether or not originating line number screening was necessary based on the ANI II Digits received. If the OSS determined screening was needed, limited originating line information needed by the OSS was derived from local screening tables maintained and administered at each OSS. These internal OSS screening tables stored a limited number of screen codes. The screen codes representing originating line information was limited in its granularity of billing and service restriction information. The OSS performed a 10-digit match of the originating line number in its screening table to determine the screening for that originating line.

For 0+, 0-, and 00- calls that are routed to an IC operator system, the IC operator system examines internal screen tables to determine subsequent screening restrictions for the originating line number. Since screening codes are not standard, each IC must coordinate proper screening information associated with each LEC to properly identify the specific screening information associated with each calling line. Therefore, an IC may need to maintain multiple screening tables. The IC screening process is even further complicated in cases where the screening codes are not consistent among the OSSs within a single LEC.

---

In addition, IC operator systems contain screening information only about its own customers, and therefore cannot screen calls received from non-subscribers.

The updating of the internal tables at each LEC OSS and IC operator system is time- and labor-intensive. Information in the OSS is not current until the update (which may be manual) is performed, and does not occur immediately.

OLNS eliminates the need for the use of internal OSS screening tables. With OLNS, LEC OSSs and potentially IC operator systems access the LIDB containing the originating line via the CCS network using SS7 protocol. The LIDB then returns the information associated with the originating line, in the form of multiple parameters rather than one screen code, to the querying OSS. The OSS then continues call processing based on the information received in the OLNS response message. This processing is transparent to the caller.

Line-based data is stored at centralized LIDBs as multiple, independent parameters. Data passed from the LIDB in the OLNS response is greatly expanded from the internal OSS screening code information. When one new screening condition occurs in a pre-OLNS environment, every existing condition that can interact with the new one will need an additional, new screening code assigned to account for the multiplier effect of the new condition with each existing applicable condition. OLNS eliminates this effect by allowing each line number to have each of its associated parameters independently set; the complete set of parameter values then defines the line's conditions.

The LEC OSS can be provisioned with criteria for launching or not launching OLNS based on ANI II/incoming trunk group. This enables the OSS owner to choose for which calls OLNS queries should be launched if launching OLNS queries on all calls is not desired. Default parameter values are stored in OSSs to continue call processing for cases where an OLNS query is launched but a screened response is received or an error is encountered.

0+ interLATA and 00- calls would continue to be routed by the EO to the IC, and 0- calls initially routed to the LEC OSS that require IC handling are routed from the LEC OSS to the IC in many LECs. If an IC chooses to access LEC LIDBs for OLNS, no screening tables would be needed at IC operator systems since they could launch OLNS queries for all line numbers, including non-subscribers, reducing fraud potential for non-subscribers.

The AS/LIDB offers centralized data administration and maintenance of OLNS data via an on-line, real-time AS/LIDB-LIDB interface, thereby eliminating maintenance and provision of distributed switch data (table updates).

#### 14.5.1.3 GetData

GetData allows QOs to request certain information from LIDB that is associated with a given line number that is served by the LIDB. A QO, e.g., an AIN SCP, may need customer information from the LIDB to process a call. This information could be standard data that is associated with every line, such as OLNS line screening information, or may be customized data that the LEC has created for a small number of customers, e.g., custom

---

---

data might be quantification of the dollar value of account sizes for business customers. Such custom data may be used by the QO to determine the appropriate account representative to which a business office call should be routed.

The QO formulates a GetData query consisting of the following three parts:

1. An identifier, which indicates that it is a GetData query
2. A service key, which contains an indication of the LIDB line record for which information is requested
3. A set of LIDB data elements (each identified by unique TCAP Data Element Identifiers) about which the QO wishes to receive information.

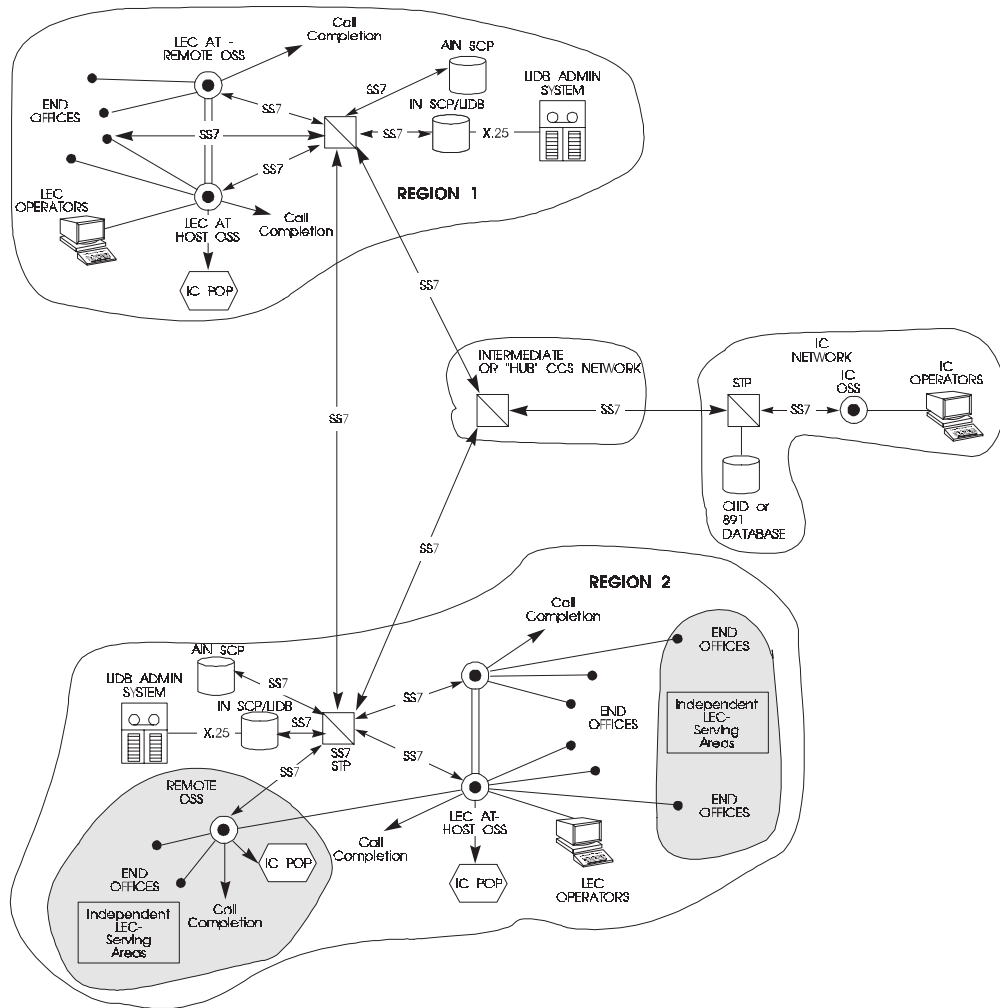
Based on the information provided in the GetData query, the LIDB then returns a response containing information associated with the requested data elements to the QO. This data may be restricted based on data screening settings where the LIDB owner has chosen to restrict the data available to a given query originator.

#### 14.5.1.4 Calling Name (CNAM)

The CNAM service is supported by LIDB by associating a name with a line number in LIDB. When the CLASS CNAM service is implemented such that LIDB is the source for the name, an end office accesses the LIDB containing the calling number via a Generic Name query. The LIDB then returns the name associated with that number to the querying end office. Note that not all CNAM implementations obtain the name from the LIDB; in some companies, a different database is accessed. See Section 14.3 for details on CNAM service.

### 14.5.2 Network Architecture

Figure 14-5 shows the network architecture for ABS, OLNS, GetData, and CNAM services. The underlying architecture is the same as the network architecture for CCS described in Section 14.2. It consists of end offices and OSS switches equipped with LIDB interface capabilities, mated Signaling Transfer Point (STP) pairs, Service Control Points (SCPs) equipped with LIDB application software and hardware, and SCPs equipped with AIN application software and hardware. Signaling links connect the OSSs and end offices with STPs and SCPs. For additional availability, the LIDB can be deployed in a mated configuration.



**Legend:**

- |                                  |                                |
|----------------------------------|--------------------------------|
| AT = Access Tandem               | OSS = Operator Services System |
| CIID = Card Issuer Identifier    | POP = Point of Presence        |
| IC = Interexchange Carrier       | SCP = Service Control Point    |
| LEC = Local Exchange Carrier     | STP = Signaling Transfer Point |
| LIDB = Line Information Database |                                |

**Figure 14-5.** LIDB Architecture

---

#### 14.5.2.1 Line Information Database

The LIDB is a real-time transaction processing system containing all the valid line and billing numbers for a specific group of LECs. The LIDB application resides in an IN-SCP that provides the network interface for LIDB to the CCS/SS7 network. LIDBs are accessible to OSSs in other CCS/SS7 networks. Since each LIDB contains unique line number and billing number data specific to a given set of end users, LIDB data is not replicated in more than one LIDB (other than its mated pair). LIDB supports the following query types:

1. *Calling Card Validation* — This transaction is used to validate that the calling card number can be used to bill a particular call. The calling card number consists of a 10-digit billing number and a 4-digit Personal Identification Number (PIN).
2. *Billed Number Screening (BNS)* — This transaction is used to determine if a collect or bill-to-third-number request is allowed for the particular billing number.
3. *Originating Line Number Screening (OLNS)* — This transaction is used to obtain information about the line originating the call, including billing restrictions and the line's service provider.
4. *GetData* — This transaction is used to request specific data element information associated with a query for information in LIDB associated with a given line number.
5. *Generic Name*— This transaction is used to obtain the customer name associated with the line number originating a call. This data is used in the CLASS feature, Calling Name (CNAM).

#### 14.5.2.2 Signaling Transfer Point

The STP provides the routing and screening functions for SS7 message packets on the CCS network. STP translations, which use the first six digits (see Section 14.5.4) of the calling card or line number, enable LIDB transactions to be routed to the proper CCS/SS7 network. The distributed nature of ABS requires that all CCS/SS7 networks be interconnected to provide access to all billing numbers. LECs use intermediate CCS networks as LIDB "hubs" for efficient transport of LIDB queries to "foreign" LIDBs (that is, to validate billing numbers contained in LIDBs not in the same Region as where the call is being made from).

#### 14.5.2.3 Operator Services System

The LEC OSS is a tandem switch equipped with OSS software and hardware that enables it to process 0-, 0+, and certain types of 1+ calls from its subtending end offices. An OSS is equipped with SS7 and LIDB interface software and hardware to enable it to suspend call

---



processing on ABS calls and on calls on which OLNS processing is needed, formulate the OLNS and/or ABS query that is routed over the CCS/SS7 networks to the proper LIDB(s), process the responses from the LIDB, and dispose of the call based on information contained in the response messages.

#### 14.5.2.4 LIDB Administrative System

The LIDB Administrative System (AS/LIDB), while not directly involved in call processing, plays a critical role in provisioning line number data in LIDB accessed for various services (OLNS, ABS, GetData, and CNAM). The AS/LIDB processes customer updates passed to it from the LEC's service order system. These updates include disconnects and requests for new service, such as a calling card. The AS/LIDB translates this information into a customer record update that is passed to the SCP that houses the LIDB application. The AS/LIDB also provides initial loads of LIDB, immediate as well as routine updates, customer queries, special studies, and other administrative functions. Generic requirements for the AS/LIDB-to-LIDB interface are described in GR-446-CORE, *Generic Requirements for the Administrative System/LIDB-LIDB Interface*.

#### 14.5.3 LIDB Modification of Final Judgment Waiver

To ensure that all LECs could participate in EABS, the BOCs and the United States Telephone Association (USTA) filed a joint request with the MFJ Court for a waiver of the interLATA restriction. The remedy sought by the waiver request was to permit the BOCs to carry LIDB queries that originate in independent LEC service areas across LATA boundaries. On February 10, 1992 the Court granted the LIDB waiver.

#### 14.5.4 Call Processing

This section describes the call processing for an EABS calling card call as an example; all LIDB queries are routed in basically the same way. Call processing for all OSS services is defined in GR-1173-CORE, *OSSGR: Common Functions*, and the appropriate OSSGR Feature Specification Documents (FSDs).

The end user goes off-hook and dials 0 followed by an intraLATA destination. The serving end office recognizes that special assistance is required and the call is trunked to an OSS. If the OSS determines to launch an OLNS query for this call, it formulates a LIDB OLNS query, which the CCS network routes to the LIDB containing the calling number. When the LIDB receives an OLNS query (LIDB is notified by receipt of an N-Unitdata indication from its SCCP layer), and if the search for a line number with the calling number as primary key is successful, the LIDB returns a Response message to the OSS with a ReturnResult

---



---

component (issuing an N-Unitdata request to its SCCP layer), including the mandatory OLNS response parameters and available optional parameters.

The OSS prompts the caller to enter a billing number in the manner prescribed in the OLNS response. After the number is input, the OSS determines whether the requested billing option (in this example, calling card) is permitted from the particular calling line, based on the OLNS data. If it is permitted, the OSS formulates a LIDB calling card validation query, addresses it to the mated pair of STPs that have the translation capability to route the query to its destination CCS network, and transmits it onto its signaling links.

If the NPA-NXX is portable (see Section 3 for information on Local Number Portability), then the query is sent to a network element that performs a Message Relay Function (MRF). The MRF may be located in an SCP or associated with an STP. The MRF uses the 10-digit billing number to determine the location of the appropriate LIDB. There are two methods in use for routing the query to the appropriate STP before additional STP routing to the correct LIDB is done. One method requires that a second STP perform additional translations; the second method uses revised address information and a new translation type to route the query to the correct LIDB.

If the NPA-NXX is not portable, the STP that receives the query translates the first six digits of the billing number into a destination CCS network address. The query is modified with the new address information and is transmitted toward the destination network by the STP. After possibly traversing an intermediate CCS network, the LIDB validation query reaches the destination CCS network. In that network, a final translation is done at the destination network's STP on the first six digits of the calling card number to select the network address of the SCP and the application on the SCP (that is, LIDB). After the LIDB receives the query, it first examines the 6-digit database to determine if the calling card's NPA-NXX code is active or vacant. If the code is active, the LIDB examines its 10-digit database for the billing number. Once the billing number is found, the LIDB determines if the calling card PIN matches. If it matches, the appropriate response is returned to the originating OSS. Like the query, the response message may need to traverse an intermediate CCS network before returning to the OSS. If there are no service restrictions, the OSS will complete the intraLATA call.

For CNAM call processing, see Section 14.3.

The following documents contain generic requirements concerning LIDB, its interfaces, and OSS call processing:

- GR-1149-CORE, *OSSGR Section 10: System Interfaces*
- GR-1158-CORE, *OSSGR Section 22.3: Line Information Database*
- GR-1173-CORE, *OSSGR Common Functions*
- GR-1177-CORE, *OSSGR Special Billing Features*
- GR-954-CORE, *Common Channel Signaling (CCS) Network Interface Specification (CCNIS) Supporting Line Information Database (LIDB) Services*

- GR-2838-CORE, *Generic Requirements for GetData*.

#### 14.5.5 Calling Card Formats

LEC calling card numbers that reside in LIDB consist of a 10-digit billing number, plus a 4-digit PIN. When the billing number is the directory number to which the call is billed, the calling card number is of the form:

NPA-NXX-XXXX-NYYY

where (NYYY) is a PIN number from 2000 to 9999. Alternatively, a calling card number can take a special form:

RAO-(0/1)XX-XXXX-NYYY

where RAO is the LEC Revenue Accounting Office assigned to this billing number. The fourth digit (0/1) distinguishes the special calling card numbers from the directory number calling cards.

Calling card PINs can be designated by the customer to be “restricted,” “domestic,” or “unrestricted.” An unrestricted PIN is valid for calls to all destinations. In addition, if the called number is the same as the billing number, the user only needs to enter the 4-digit PIN. A domestic calling card can only be used to alternately bill calls to domestic destinations. (The definition of “domestic” is, in some degree, determined by the LIDB owner.) A restricted PIN can only be used to bill calls placed to the directory number that is the same as the billing number.

Because in the past, the LECs and AT&T shared AT&T’s validation database and network, at one time both used the same numbering structure for calling cards. Until alternate numbering structures were made available, a LEC calling card and an AT&T calling card issued to the same customer had the same 14 digits. In the MFJ Court’s 1988 Calling Card Order, the LECs were required to file plans on how they would afford to ICs’ calling cards the same acceptance as had been given to AT&T’s card for intraLATA calls. The LECs offered two options to the Court and to the industry. The first is for ICs to issue calling cards in the ANSI-standard format (as described in ANSI T1.212, *Enhanced Telecommunications Credit Card Physical Characteristics and Numbering Structure*), or more commonly, the “891” format. The numbering structure of the 891 card is as follows:

891-III-AAAAAAAAAAAA-L-YYYY

where 89 is the major industry identifier for telecommunications, 1 is the country code (World Zone 1), III is a 3-digit issuer identifier, A is an account number with a maximum of 12 digits, L is a Luhn check digit, and YYYY is an optional 4-digit PIN. The LECs have the technical capability to honor 891 cards for intraLATA calls and to route validation

---

queries to a technically compatible card issuer's database (see description in GR-1149-CORE, *OSSGR Section 10: System Interfaces*).

The second plan, known as Card Issuer Identifier (CIID), is a 14-digit format that has the same numbering structure as the LEC's RAO card and is described in SR-BDS-001511, *Administration Guidelines for Card Issuer Identifier*. The format is as follows:

NXX-(0/1)XX-XXXX-NYYY

where NXX-(0/1)XX is the 6-digit CIID assigned by Bellcore, XXXX is a 4-digit account number assigned by the card issuer, and NYYY is a 4-digit PIN assigned by the card issuer. When an IC's CIID card is presented to the LEC operator services system as a billing option on 0+ intraLATA calls, the LEC OSS is able to recognize the card issuer and route the CIID validation query to a GR-1149-CORE compatible validation database. On May 8, 1990 the MFJ Court endorsed the CIID plan.

#### 14.5.6 Deployment Status

EABS services, using LIDB and the CCS/SS7 network, were first provided on an intraLEC basis in 1988. By 1991 the deployment and interconnection of all LEC LIDBs enabled EABS to be provided on an intraLEC and interLEC basis. The deployment of the network components that enabled nationwide EABS services to be delivered (LEC OSSs, SCPs, LIDBs, and interconnected CCS/SS7 networks) was completed in 1992. Shared use of the AT&T-owned BVA tapered off in 1992 as LIDB connectivity increased, and by the end of 1992, the BVA was decommissioned by AT&T.

OLNS, GetData, and CNAM are optional LIDB capabilities that may be implemented in certain LIDBs but not in others. The first company implemented OLNS in 1996, and a number of other companies have plans for deployment in 1997 and 1998. GetData was first implemented in 1995 and additional companies have scheduled deployment in 1997.

#### 14.5.7 Regulatory Developments

Before 1989 the BOCs routed all interLATA ABS traffic from their payphones to AT&T. In the MFJ Court's October 1988 Order, the BOCs were required to establish, by April 1989, a system of equal access whereby the owners of the premises where the BOC payphone is located would presubscribe the phone to their IC of choice. The implementation of this Order meant that the IC carrying 0+interLATA payphone traffic at BOC payphones was selected by the premises owner and not the caller.

On April 13, 1989 Bell Atlantic filed a petition for rulemaking with the FCC proposing a new equal access plan for BOC payphones. This plan, known as "Billed Party Preference" or BPP, proposes to change the routing of 0+interLATA payphone calls so that the caller's preferred IC would be used for the call instead of the presubscribed IC selected by the

premises owner. BPP is another term for the carrier identification component of the EAABS service defined earlier.

On May 8, 1992 the FCC released a Notice of Proposed Rulemaking (NPRM) in regard to BPP (CC Docket No. 92-77). In it, the FCC tentatively concluded that a nationwide BPP system of equal access was in the public interest and sought information on the costs and benefits of BPP. The industry responded to the NPRM in 1992 and the industry now awaits the FCC's analysis of this and other input it has received on BPP.

---

## 14.6 Toll-Free Database Service

Toll-Free Database Service, like Alternate Billing Services (ABS) and other LIDB services, uses Common Channel Signaling/Signaling System 7 (CCS/SS7) as an integral part of its architecture. This database access arrangement enables number portability for Toll-Free Database subscribers. Customers are able to change their Toll-Free Service Provider and/or Transport Carrier without changing their toll-free telephone number because carrier identification will be performed using the entire 10-digit toll-free number.

### 14.6.1 Background

Originally, Toll-Free Service was introduced in 1967 to provide toll-free service to the caller. From 1967 to 1981, Toll-Free Service calls were handled by designated originating and terminating switching offices that employed a special 800 NXX routing and screening methodology. The methodology verified that the call originated from a subscribed service area and used all 10 digits for screening and routing Toll-Free Service calls.

Beginning in 1981, Toll-Free Service was provided by using the Common Channel Interoffice Signaling (CCIS) system and a database containing Toll-Free Service information. Each Toll-Free Service call was routed to and held at an Originating Screening Office (OSO) while the Toll-Free number and 3-digit Numbering Plan Area (NPA) or area code of the originating call were provided to the Toll-Free Service database through the CCIS system. The database ensured that the call originated from an area from which the subscriber paid and also translated the toll-free number into a 10-digit Plain Old Telephone Service (POTS) number that was returned to the OSO for routing over the network.

At divestiture (1984), the Plan of Reorganization (POR) allowed the Regional Bell Operating Companies (RBOCs) to lease CCIS and database capacity from AT&T to continue to provide the intraLATA (Local Access and Transport Area) portion of Toll-Free Service. No provision was made, however, to allow these facilities to be used for providing exchange access to other Interexchange Carriers (ICs). The Department of Justice sought modification of the POR so that AT&T's facilities could be used to provide carrier access for Toll-Free Service. The Court denied this motion, and a modified version of the pre-1981 serving arrangement was implemented until the RBOCs could deploy their own Toll-Free Database Service. All of the RBOCs filed tariffs to offer this interim service commonly referred to as the *Interim 800 NXX Plan*. Under this plan, the carrier who handled each Toll-Free Service call was determined based on the NXX (the three digits that immediately follow the 800 prefix). This method required unique NXXs to be assigned to particular carriers. Consequently, Toll-Free Service subscribers could not change their toll-free carrier without changing their toll-free number. In addition, subscribers who wanted a particular toll-free number were required to obtain their Toll-Free Service from the carrier to which the NXX digits in that number were assigned. The major limitation of that arrangement was that subscribers who wanted more than one IC or wanted to change their IC had to have multiple numbers or change their 800 number.

---

In 1991, the Federal Communications Commission (FCC) mandated 800 Number Portability by March 1993. Number Portability discontinued assignment of 800-NXXs to individual Service Providers, allowed new Toll-Free subscribers to purchase service from any Toll-Free Service Provider, and provided the ability to select any available toll-free number from the portability pool. In February of 1993, the FCC extended the deadline for portability to May 1, 1993.

During the period from 1989 to 1993, the RBOCs, along with many independent Local Exchange Carriers (LECs), upgraded their networks with Common Channel Signaling (CCS) capabilities based on the Signaling System 7 (SS7) protocol. Within their CCS networks, they deployed databases containing Toll-Free Service information, commonly referred to as the 800 Data Base Plan, which replaced the Interim 800 NXX Plan. Under the Database Plan, information on the screening and routing of each toll-free number in service is downloaded from the Service Management System (SMS/800) to databases resident in Service Control Points (SCPs) across the country. LECs obtain routing instructions for each toll-free call by accessing these databases through the CCS networks. Because these databases provide routing instructions based on full 10-digit screening of the toll-free number (the 800 or 888 prefix, plus the 7-digit number), there is number portability. This means that Toll-Free Database Service subscribers are able to change carriers without changing their toll-free number.

Toll-Free Database Service is principally designed to facilitate efficient provisioning of Toll-Free exchange and exchange-access service. Descriptions of the Toll-Free Database Service network architecture (Subsection 14.6.2), service characteristics (Subsection 14.6.3), call processing (Subsection 14.6.4), regulatory developments (Subsection 14.6.5), and deployment status (Subsection 14.6.6) are provided in the subsections that follow.

## **14.6.2 Network Architecture**

The Toll-Free Database Service architecture consists of a set of network capabilities that are directly involved in identifying the carrier and in transporting Toll-Free Database Service calls, and a set of operations systems capabilities that support all other aspects of the service offering. The components are described below and depicted in Figure 14-6.

### **14.6.2.1 Local Network**

All Toll-Free Database Service calls must be processed by a Service Switching Point (SSP). Therefore the network is arranged so that all originating Toll-Free Database Service calls reach an SSP.

Terminating calls reenter the LEC networks, via switched access, from the IC networks as ordinary POTS calls. These calls complete to either a line or an announcement in the normal way and are billed accordingly for network access. Individual LECs arrange for

---

Toll-Free Database Service call completion within their networks on various types of terminations.

#### 14.6.2.2 SSP

SSP functionality is added to the capabilities of equal-access switching systems to provide Toll-Free Database Service. The primary function of the SSP is to process calls that require remote database translation. The role of the SSP in a Toll-Free Database Service call is to recognize the 800 or 888 Service Access Code (SAC), suspend normal call processing, form a CCS message, send this CCS message via the Signaling Transfer Point (STP) to a Service Control Point (SCP), and act on commands received from the SCP. Functions that the SSP can be instructed to perform include delivering the call to a carrier Point of Presence (POP), delivering the call to an intraLATA destination, sending call termination information to the SCP, writing a billing record for the call containing data supplied by the SCP, terminating the call to an announcement, and/or instituting network-management controls per instructions from the SCP.

#### 14.6.2.3 CCS Network

CCS networks that use the SS7 protocol are an integral part of the Toll-Free Database Service architecture. The CCS networks provide the highly reliable signaling connections that are required to access the appropriate database. The CCS networks consist of both a hierarchy of STPs, which act as packet switches that provide CCS message routing and transport, and digital signaling links that operate at 56 kbps and interconnect the STPs and extend from the STPs to the SSPs and SCPs.

Although the CCS networks differ from one another in architecture (for example, STP hierarchy, STP hardware, etc.), they all use the SS7 protocol and its transaction capability as the SSP/SCP communications language. Also, they all support mated database operation so that the required level of service availability is achieved, and provide global title translation (that is, route a Toll Free database inquiry to the appropriate pair of SCPs based upon translation of the dialed toll-free NXX). For a representation of basic system architecture, see Figure 14-6.

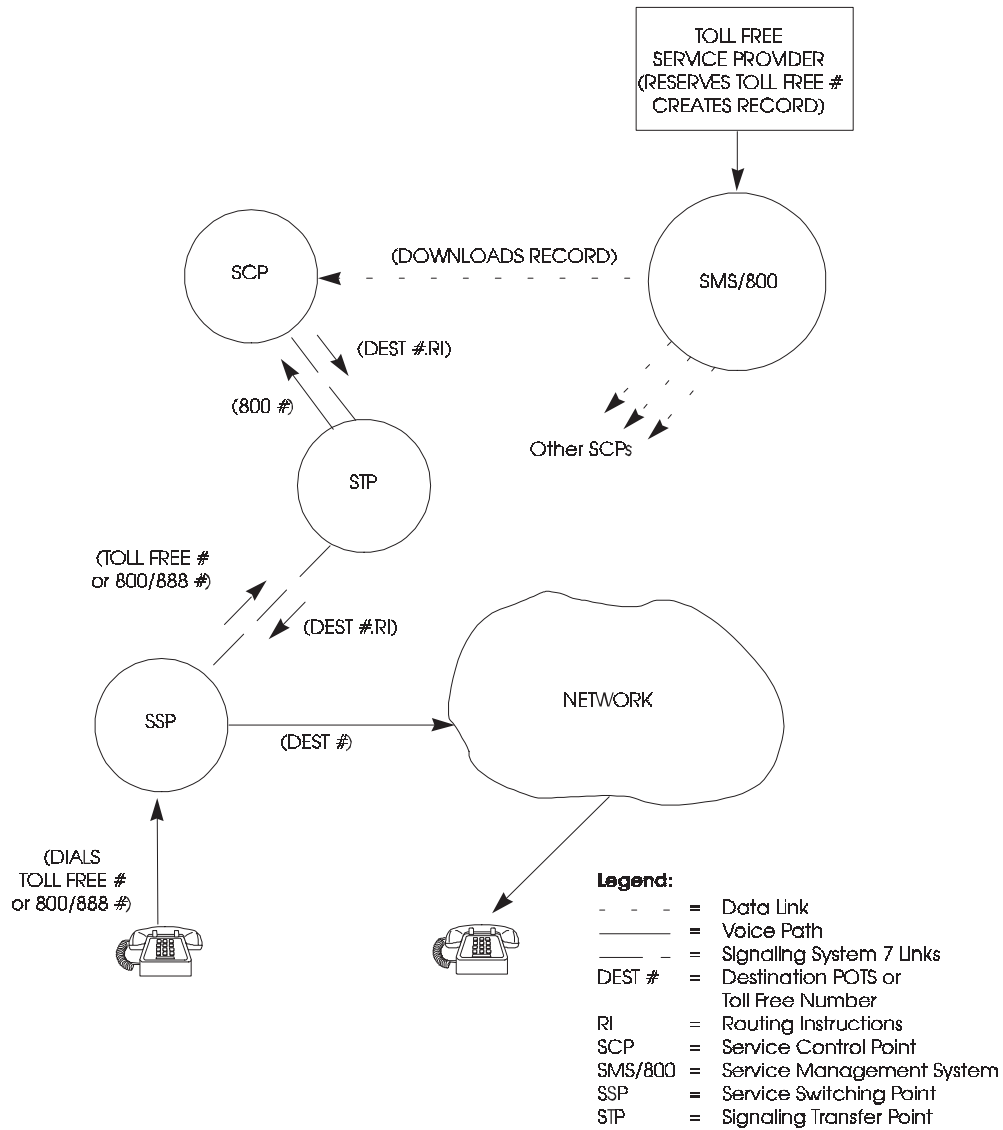


Figure 14-6. Toll-Free Database Service — Basic System Architecture



---

#### 14.6.2.4 SCP

The SCP is a transaction processor-based system designed to provide various network database services including Toll-Free Database Service. The SCP contains service-defining logic that determines what actions are performed on each Toll-Free Database Service call for which it has a customer record. The destination of the initial inquiry message is an SCP that has a copy of the customer record associated with the dialed toll-free number. This record is used to determine how the call should be handled. The SCP determines the carrier and/or POTS translation based on the time of day, the day of the week, the originating NPA, and other algorithms. The SCP instructs the SSP to send the call to a POTS destination within the originating LATA via LEC facilities, or to a specified IC along with specific call-completion information (such as calling number and either dialed toll-free or destination POTS number). The SCP also instructs the SSP to create a billing record for the call, including such information as call-connect, disconnect, and duration times; the dialed number, calling number, destination number; and the carrier to which the call was delivered.

The Toll-Free Database Service application at the SCP also supports additional functions:

- *Network Management* to monitor call traffic and direct the application of call-gapping controls at the SSP
- *Customer Sample Collection* to allow the specification of call-sampling parameters (for example, Automatic Number Identification [ANI], time of day, call duration, sample size) and the initiation, if authorized, of the collection of customer-requested call samples
- *Service Maintenance* to report exception conditions encountered by the SSP or SCP in executing Call-Processing Record (CPR) logic
- *Application Sample Collection* to collect sample data on all Toll-Free Database Service calls for engineering performance studies
- *CPR Data Maintenance* to allow the Service Management System (SMS/800) to add, replace, delete, or audit CPRs.

#### 14.6.2.5 SMS/800

Although the SMS/800 is not directly involved in the real-time processing of Toll-Free Database Service calls, it plays a key role in the provisioning of Toll-Free Database Service. The SMS/800 interacts with either the customer or a representative from the LEC or IC or other Toll-Free Service provider in the service-provisioning process. It translates a customer's service request into a CPR and delivers the CPR to the appropriate SCPs. The SMS/800 also receives service data from the SCP. The SMS/800 production system is located at the St. Louis Data Center, with backup processors in the Dallas Data Center.

---

Before and during Toll-Free Database implementation, Bellcore operated the 800 Number Administration and Service Center (NASC) and was responsible for the administration of the SMS/800 including, for example, system security, on-line SMS/800 user support, and user training. The LECs transitioned NASC responsibilities to the SMS/800 Help Desk currently operated by Sykes, an independent vendor, on December 1, 1993.

In February 1993, the FCC ruled that access to SMS/800 would be offered under a tariff. As a result of that Order, the LECs provided access to any interested Responsible Organizations (RESPORGs) via the *800 Service Management System (SMS/800) Functions* tariff. A RESPORG is any company that accesses the SMS/800 in order to provide 800 Service. Further definitions of these responsibilities can be found in the Carrier Liaison Committee (CLC) document *Industry Guidelines for 800 Number Administration*.

### 14.6.3 Service Characteristics

The Toll-Free Database Service is an originating exchange and exchange-access service. The service is designed to support carrier identification and, as an option, 800 or 888-to-POTS number translation for interLATA Toll-Free Database Service traffic, as well as to allow LECs to offer a sophisticated intraLATA Toll-Free Database Service. The service supports Toll-Free Access Service, Basic Toll-Free Database Service, Optional Toll-Free Database Service Capabilities, and Vertical Features. Descriptions of these offerings are contained in the sections that follow.

#### 14.6.3.1 Toll-Free Access Service

Toll-Free access consists of originating switched access. Originating access offers carrier identification, connects the calling party to the appropriate carrier, and provides optional number translation. Carriers purchase originating access in all LATAs from which they will accept Toll-Free Database Service calls using the switched facilities. The components of Toll-Free access service are as follows.

- *Carrier Identification/Connection* — The subscriber must select carriers to provide both intraLATA and interLATA toll-free transport. The intraLATA carrier may be the same as the interLATA carrier where intraLATA competition is permitted. The carrier is determined by the Toll-Free database using all ten digits of the dialed toll-free number. This database also identifies the call as intraLATA or interLATA. Once the carrier is identified, the call is delivered to the carrier's network for completion.
  - *Number Translation* — The database has the ability to translate the dialed toll-free number into a POTS number. The carrier has the option to receive either the translated number or the dialed toll-free number. Carriers electing to receive the toll-free number are responsible for translating the toll-free number into the destination POTS number.
-

- 
- *Network-Management Controls* — LECs will administer their networks to ensure that acceptable service levels are provided to all subscribers. The application of network-management controls (including, for example, call gapping) selectively cancels the completion of traffic carried over the network. Such protective measures will be taken in response only to network failures, overload of facilities, natural disasters, mass-calling situations, or national security demands.

#### 14.6.3.2 Basic Toll-Free Database Service

Representatives of each of the LECs (and some independent LECs) have agreed, in principle, to support provision of a set of Basic Toll-Free Database Service features to ensure a viable service offering. The Basic Toll-Free Database Service offerings available to individual subscribers consist of the following service capabilities.

- *Toll-Free Number Assignment* — Toll-Free Number Assignment allows, but does not require, subscribers to use a single, portable, nationwide toll-free number. A single toll-free number can be used for Toll-Free Database Service that is provided by multiple carriers and in multiple jurisdictions, thus allowing the use of one toll-free number nationwide.
- *Switched-Access Termination* — A termination that connects a subscriber-specified location to the LEC's switched facilities.
- *Access to an IC for InterLATA Transport* — Carrier selection for access to a single IC for interLATA transport.
- *Access to a Carrier for IntraLATA Transport* — Carrier selection for access to a single LEC or carrier for intraLATA transport.
- *Customer-Defined Area of Service* — Subscribers are able to select the areas of the country from which originating Toll-Free Database Service access may occur. The database will screen the toll-free call to determine if the calling party's location is within the area of service specified for that toll-free number.

#### 14.6.3.3 Optional Toll-Free Database Service Capabilities

In addition to the previously described capabilities, additional service capabilities are available and considered optional since the LECs have not committed to offer them.

Optional service capabilities include the following:

- *IntraLATA Toll-Free Database Transport* — This capability allows calls from within the LATA to be completed via the LEC's intraLATA facilities to the subscriber's destination number.

- 
- *Alternative Terminations* — Four different types of terminations are possible with Toll-Free Database Service and vary with the regional service offering.
    1. *Toll-Free (or Wide Area Telecommunications Service [WATS]) Access Lines* are dedicated for terminating Toll-Free Database Service calls.
    2. *Bidirectional WATS Access Lines (WALs)* permit the termination of Toll-Free Database Service calls and the origination of outward WATS calls on the same switched-access line.
    3. *Common Access Lines* are POTS lines for terminating Toll-Free Database Service calls as well as originating and terminating POTS calls.
    4. *Special-Access Lines* allow carriers to terminate Toll-Free Database Service calls directly (that is, without using LEC switched access).

Bidirectional WALs, Common Access Lines, and Special Access Lines are separately offered LEC services that can be used in conjunction with Toll-Free Database Service to the extent they are permitted by regulators.

- *Terminating Recording Capabilities* — WALs and Bidirectional WALs allow the LECs to provide terminating recording capabilities for 800 Database Service using the recording facilities of the terminating offices to record incoming call information.

#### 14.6.3.4 Vertical Features

Vertical features were developed to increase the flexibility and marketability of this service offering. They provide additional capabilities, and allow carriers and Toll-Free Database Service subscribers control over several nonessential but desirable features. The decision to offer these additional features is made by each LEC independently. Because each LEC may choose to limit the availability of vertical features, subscribers may not have access to or have use of certain vertical features for calls originating in those areas where the features are not made available. The vertical features can be grouped into two categories: those used to define call handling and destination of a subscriber's Toll-Free Database Service, and those that give the Toll-Free Service Provider and/or the subscriber a large degree of service control and management.

1. *Call Handling and Destination Features* give subscribers additional flexibility and options with respect to routing and carrier selection.
  - *Alternative Carrier and Destination Features* — These features offer subscribers options and additional flexibility to terminate their Toll-Free Database Service calls at multiple terminating locations in multiple LECs using multiple carriers, using a single toll-free number. Routing can be based upon *where* the call originates (that is, originating NPA, originating state, originating LATA, originating NPA-NXX, calling number), *when* the call originates (that is, time of

---

day, day of week, specific date), and *percent allocation* (for example, 75 percent to destination A and 25 percent to destination B).

- *Creation of Inactive Subtrees* — This feature allows the subscriber to pre-store and activate quickly, the logic that was established to modify the routing of Toll-Free Database Service calls if conditions requiring changes are anticipated.

2. *Service Control and Management Features* give subscribers a more rapid, flexible, and direct control of their service.

- *Call Data* — This feature allows subscribers to obtain information on a sample of the Toll-Free Database Service calls they receive. For each sample, the subscriber selects the sample rate, data items, and sampling interval.
- *Customer Reports* — The subscriber is able to request information relative to the service description, audit trail, and call-sampling reports.
- *Emergency Updates* — This feature allows the subscriber to provide for alternate destination/carrier selection within 15 minutes after the request is initiated.
- *Service Updates via Terminal* — Updates to vertical feature parameters that do not alter the fundamental aspects of the service can be made directly by the Toll-Free Service Provider or subscriber. This feature allows the subscriber to change the CPR containing the vertical feature parameters without initiating a service order. Through a terminal interaction, the subscriber can control the following: destination/carrier selection parameters, call data requests, requests for SMS/800 reports, normal updates and emergency updates. The subscriber is limited in making these changes by the existing customer-defined area of service, destination numbers requested, and carriers requested. Changes to these three fields can be made using service orders only.

#### 14.6.4 Call Processing

The dialing plan background and Toll-Free access is discussed in this section.

##### 14.6.4.1 Dialing Plan Background

A toll-free number is a *dialable* toll-free number in the format 1-800- (or 888-) NXX-XXXX. Subsequently, toll-free numbers will be in the form 8XX, beginning with 877 scheduled in April 1998. The Toll-Free Database Service subscribers uniquely define the eligible terminations and control destination/carrier selection associated with their particular toll-free numbers.

The 10XXX prefix cannot be used in conjunction with a Toll-Free SAC, nor does presubscription to an IC apply. With Toll-Free Database Service, the 10-digit number

---

(800 or 888 NXX-XXXX) is analyzed by a LEC database to determine the proper carrier and optionally to provide a 10-digit translated address. The carrier may perform its own translation as an alternative. In this case, the LEC database determines the IC and provides the dialed toll-free number. (This is commonly referred to as Toll-Free turnaround.)

#### 14.6.4.2 Toll-Free Access with Calling Station NPA

The LEC networks can be arranged to route Toll-Free Database Service calls to an SSP when the end office is not equipped as an SSP. All Toll-Free Database Service calls generated in subtending offices must be routed to the serving tandem office. If the serving tandem is not equipped as an SSP, the call is routed to the LATA tandem that is equipped as an SSP.

When a conforming office is equipped as an SSP, Toll-Free Database Service calls are processed at the end office in the same way that Toll-Free Database Service calls from collocated stations are processed at the Access Tandem/Service Switching Point (AT/SSP). Calls not passed on direct trunk groups to the carriers are passed to the carriers via the access tandem using equal-access signaling.

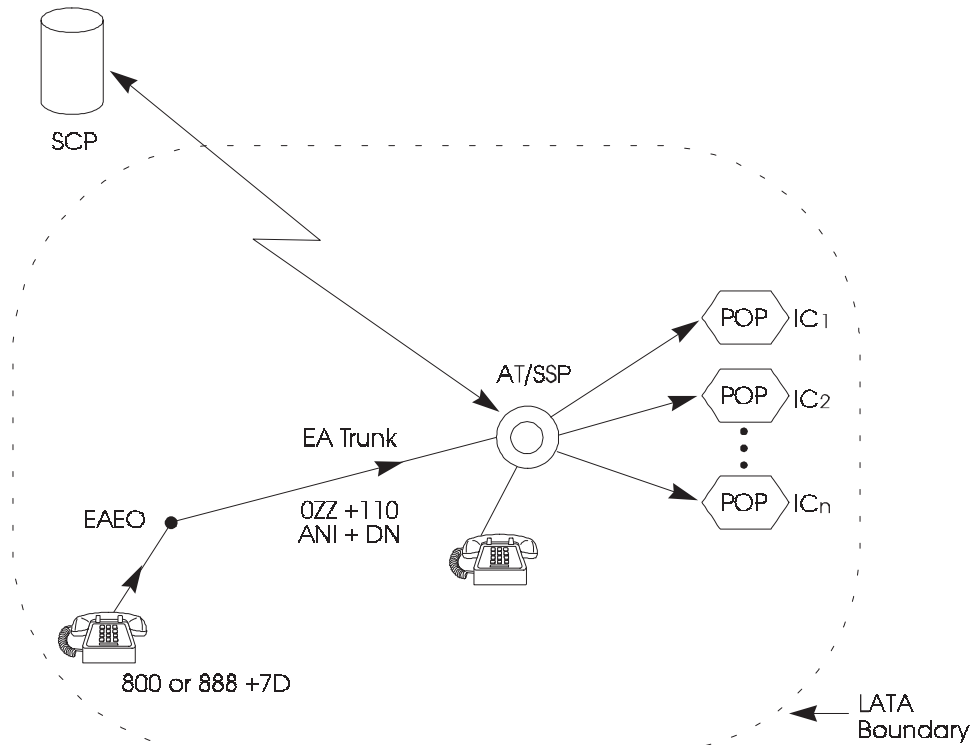
#### 14.6.4.3 Toll-Free Access with Automatic Number Identification

The following information describes how the LEC networks are arranged to route all Toll-Free Database Service calls to an SSP *with* calling station ANI. It is a business decision made independently by each LEC whether or not a LATA is equipped for toll-free access with 10-digit ANI.

- *End Offices Equipped for Equal Access* — Equal-Access End Offices (EAEOs) handle Toll-Free Database Service calls in one of two ways.
  1. If the office is equipped with the SSP capability, Toll-Free Database Service calls will be handled directly by the EAEO at their source; ANI will be passed to the SCP in the inquiry message. The EAEO will then route the call to the designated carrier using standard equal-access methods (either via direct trunks or via the access tandem).
  2. If the EAEO is not equipped with the SSP capability, the EAEO will route all Toll-Free Database Service calls to an SSP (either an AT/SSP or an EAEO/SSP) using equal-access signaling.

Figure 14-7 illustrates Toll-Free access with ANI where the access tandem is used as the SSP. The EAEO can be programmed to assign a special Carrier Identification Code (CIC) (which is really a Toll Free Database Service call indicator for the access tandem) to all Toll-Free Database Service calls. The EAEO would then forward the call to the access tandem in the normal way using the equal-access signaling protocol.

(Presubscription does not apply to these calls, and if the 10XXX prefix is dialed, the call is blocked.) When the Toll-Free Database Service call is received at the AT/SSP, the special CIC alerts the access tandem that it is receiving a call that requires special handling. The AT/SSP does not try to “hand the call off” to a carrier at that point. Instead, it obtains calling station ANI, if available, and the dialed number from the EAEO and then queries the SCP.



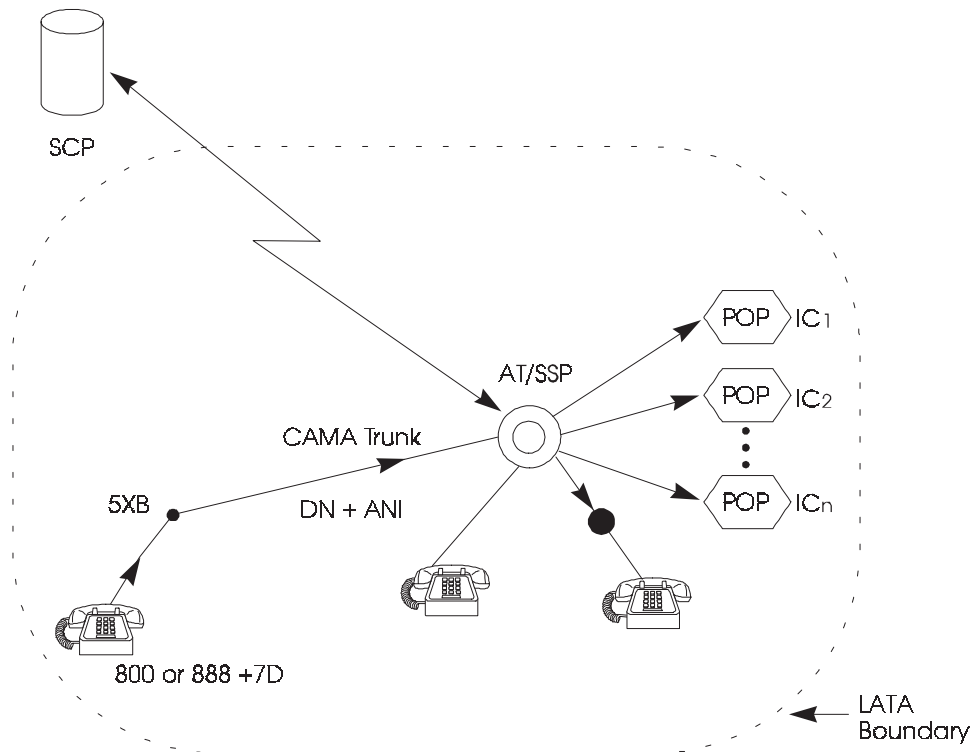
**Legend:**

ANI	=	Automatic Number Identification
AT	=	Access Tandem
DN	=	Dialed Number
EA	=	Equal Access
EAEO	=	Equal-Access End Office
LATA	=	Local Access and Transport Area
0ZZ	=	Office Code Assigned to Exchange Access
POP	=	Point of Presence
SSP	=	Service Switching Point
110	=	Carrier Identification Code
SCP	=	Service Control Point

**Figure 14-7.** Toll-Free Access with ANI

- *End Offices Not Equipped for Equal Access* — Nonconforming offices with three-digit translation capability will translate on the 800 or 888 SAC and route these calls to an SSP (for example, AT/SSP).

An end office routes Toll-Free Database Service calls to an SSP in its LATA. This arrangement requires that Toll-Free Database Service calls be returned by the AT/SSP to either an IC POP or to a LEC switch in the LATA from which the call originated. (See Figure 14-8.)



**Legend:**

ANI	=	Automatic Number Identification
AT	=	Access Tandem
CAMA	=	Centralized Automatic Message Accounting
DN	=	Dialed Number
LATA	=	Local Access and Transport Area
POP	=	Point of Presence
SSP	=	Service Switching Point
SCP	=	Service Control Point

**Figure 14-8.** Toll-Free Access from End Offices not Equipped for Equal Access



---

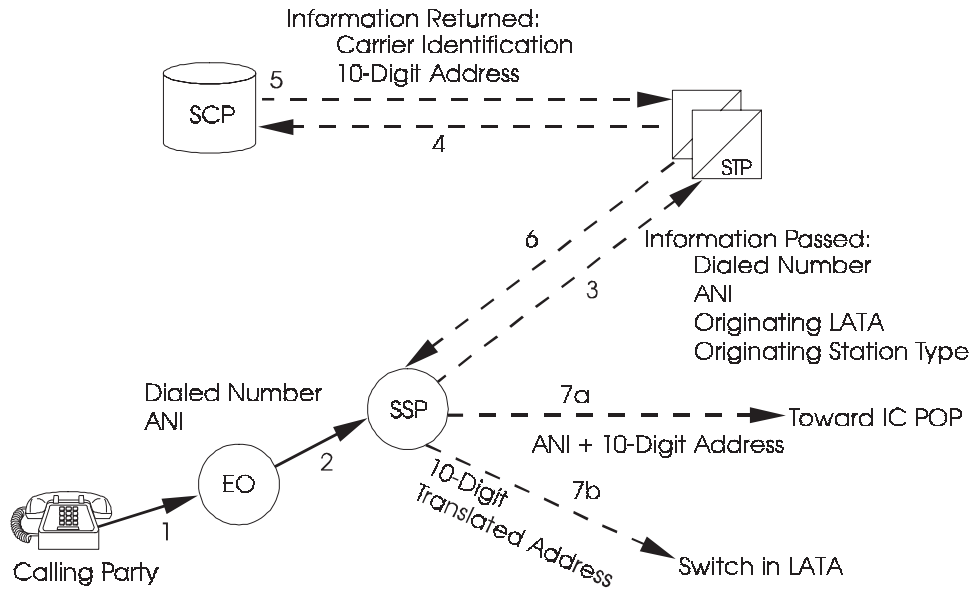
Nonconforming offices that lack three-digit translation capability route all calls dialed on a 1+ basis. Toll-Free Database Service calls will be dialed on a 1+ basis at these end offices and routed to an AT/SSP.

If the end office is not equipped to forward ANI, the SSP can generate a LATA indicator and a representative originating NPA-NXX based upon the incoming trunk group.

#### 14.6.4.4 SSP Functionality

SSP functionality is added to the capabilities of the equal-access switching systems (access tandems and EAEOs) to provide Toll-Free Database Service. There are two ways that this functionality is incorporated into the access tandems and EAEO switching systems.

1. *Combined AT/SSP Functionality* — Information describing the operation of a switching system equipped with combined access tandem and SSP capabilities (the AT/SSP) follows (see Figure 14-9). An EAEO/SSP is equipped with the same set of SSP capabilities and, therefore, is also capable of functioning as an 800 tandem.
  - *Network Access/Digit Analysis*: Toll-Free Database Service calls arrive at the AT/SSP from subtending offices via equal-access trunks utilizing multifrequency (MF) or CCS signaling, or non conforming (for example, Centralized Automatic Message Accounting [CAMA]) trunk groups.
  - *AT/SSP - SCP Interaction*: Following the Network Access/Digit Analysis phase of call processing, the AT/SSP continues to process the call using the SSP capabilities described previously. An SCP query that includes the call address, the calling-station location (ANI or NPA), the calling station's LATA, and the identity of the AT/SSP is launched. The AT/SSP uses the full 10-digit call address as the routing address of the initial inquiry message that is sent to the SCP. The CCS network translates the routing address to determine the destination of the initial inquiry message.



**Legend:**

- ANI = Automatic Number Identification
- EO = End Office
- IC = Interexchange Carrier
- LATA = Local Access and Transport Area
- POP = Point of Presence
- SCP = Service Control Point
- SSP = Service Switching Point
- STP = Signaling Transfer Point

**Figure 14-9.** Current Toll-Free Network Configuration

- *AT/SSP Routing of 800 Calls:* The AT/SSP receives routing instructions from the SCP in the form of a carrier ID and a 10-digit call address (either the original dialed toll-free number or the POTs translated number). If the carrier specified is an IC, the call is forwarded over existing trunks using the equal-access protocol. With this equal-access protocol, calling-station ANI initially received by the AT/SSP can be forwarded to the carrier along with the 10-digit address supplied by the SCP. The ANI information digits (II digits in MF and/or Originating Line Information Parameters [OLIP] in SS7) will be used to indicate that the call originated as a toll-free call if a POTs number translation has been made.

The carrier designated to complete the Toll-Free Database Service call can also be the LEC. When this is the case, the special CIC assigned to the LEC is returned in the routing instructions, and the AT/SSP uses the translated 10-digit address to complete the call within the LATA.

2. *Combined SSP/EAEO Functionality* — Due to the requirements of the deployment of Toll-Free Database Service many EAEOs have been equipped with the SSP capability. The EAEO/SSP capability required to process Toll-Free Database Service calls that originate at this office is similar to that portion of the AT/SSP capability required to handle Toll-Free Database Service calls that originate on subtending lines. One exception is the additional requirement that the EAEO/SSP be able to pass Toll-Free Database Service calls to an IC via the access tandem.

In addition to having an EAEO/SSP handle Toll-Free Database Service calls that originate from its subtending lines, it is also possible to use the EAEO/SSP as a Toll Free tandem for Toll-Free Database Service calls that originate in other nearby end offices. In this case, the EAEO/SSP will use all the Toll-Free Database Service call-processing features that are built into the AT/SSP. If the architecture is modified to include an access tandem between the EAEO/SSP and the IC POP, the impacts associated with the inability to forward ANI must be addressed.

### 14.6.5 Regulatory Developments

On March 30, 1989, the FCC discussed the Provision of Access for 800 Service (Common Carrier [CC] Docket No. 86-10). On April 21, 1989, the FCC released a Report and Order announcing that it would allow LECs to implement the database system of 800 access provided that the LECs retain the current "NXX" system of 800 access until portability was achieved. The FCC recommended that these two systems coexist until the level of access delay under the database plan was substantially reduced. The FCC indicated that it would permit LECs to discontinue NXX access when CCS/SS7 was deployed to access tandems and, on a nationwide average basis, to end offices accounting for 80 percent of originating 800 traffic. Because each of the LECs had its own unique CCS deployment plans and schedules, many of the LECs addressed the end office deployment requirement and the nationwide average in their Petitions for Reconsideration (PFR) to the FCC.

In response to the PFRs, the FCC, in its Memorandum and Order on Reconsideration released September 4, 1991, ordered the LECs and GTE to implement number portability by March 4, 1993 (this date was later delayed until May 1, 1993), such that 97 percent of their originating 800 traffic was subject to a call setup time of 5 seconds or less. This memorandum superseded the April 1989 order and altered the basis for achieving portability from percentage of trunks converted to CCS/SS7 to achieving call setup time requirements. Additionally, by March 4, 1995, 100 percent of the originating 800 traffic must have a call setup time of 5 seconds or less with a mean time of 2.5 seconds or less. Many of the LECs applied for waivers to the 1993 call setup time criteria, offering alternative percentages, on the basis of their current CCS deployment plans. On July 28, 1992 the Commission granted all requests for 1993 access time waivers.

A Report and Order was issued on January 29, 1993 in response to a Supplemental Notice of Proposed Rule Making (NPRM) addressing Toll-Free Database pricing and rate structure for the optional vertical features. In a separate order the FCC reaffirmed that independent telephone companies are required to convert from 800 NXX to 800 Database, however, they did not need to meet the access time standards for 1993. Effective 1995, all 800 Database participants must meet all access time standards.

#### **14.6.6 Deployment Status**

On May 1, 1993, portability was achieved in accordance with the guidelines set forth for 800 Database Service. Since 1989, the LECs have actively engaged in the activities (for example, network deployment, tariff filings, billing system modifications) to offer intraLATA Toll-Free Database Service. By the end of 1990, tariffed intrastate shared-service offerings were available in several companies. InterLATA 800 Database Service became available in all LECs in 1993 as a result of FCC orders mandating 800 Number Portability. Canada offered Number Portability jointly with the United States, effective January 1994.

After 800 Number Portability was implemented in 1993, 800 service started to grow rapidly in terms of the number of allocated numbers. The industry and the FCC realized that the 800 code had begun to approach exhaust by the last quarter of 1994. Members of the industry fora selected "888" as the first toll-free code to provide relief for 800 exhaust and agreed that subsequent codes would be in the form of 8XX, with "888" to be followed by "877, 866, ..."

Initially, the LECs indicated they would not be able to make the necessary modifications to their networks until April 1996. By June 1995, the weekly assignment rate of 800 numbers had tripled and without regulatory intervention 800 numbers would have exhausted within a month. The FCC at the request of the industry developed a plan that would

1. Conserve the remaining 800 numbers by establishing limits;
2. Advance the April 1996 date to March 1, 1996; and

---

### 3. Reclaim unused 800 numbers.

In October 1995, the FCC initiated a rulemaking on Toll-Free Service Access Codes (CC Docket No. 95-155) that would ensure the continued fair and equitable distribution of toll free numbers. The "800" number conservation plan was ended by the FCC in May 1996 and the "888" number conservation plan was modified. Efficient use of toll free numbers was further addressed in the Second Report and Order and Further Notice of Proposed Rulemaking released on April 11, 1997 (CC Docket No. 97-123).

Currently, over 12 million toll-free numbers are "in-service" and the rate of consumption of 800/8XX numbers has been steadily increasing. The FCC and the industry are addressing this to determine what steps may be necessary to preserve the remaining numbers until "877" is implemented in April 1998.

In 1997, approximately 200 to 250 million calls per day were routed using the 800 Database with the CCS/SS7 network. Traffic on the network continue to grow at a rate of approximately 15-20 percent annually with revenue growth projections somewhat lower due to price competition.

An Intelligent Network (IN) infrastructure has been put in place for Toll-Free Service that supports the introduction of new features, more flexible networking arrangements, and greater customer control. With the advent of Advanced Intelligent Networks (AINs), Toll-Free Database will capitalize on AIN's abilities to deliver additional features to benefit the users of 800 Service.

## 14.7 Advanced Intelligent Network

### 14.7.1 Introduction

The Advanced Intelligent Network (AIN) is an evolving network and service control architecture which the Local Exchange Carriers (LECs) are deploying. AIN is an outgrowth of the architectures that were deployed for the intelligent network 800 Database Service and Alternate Billing Service (ABS). The basic concept of AIN is to migrate some service control functions from the switch to a LEC-programmable system so new services can be created rapidly and independently of the traditional switch vendor generic release cycles. AIN relies on the Common Channel Signaling/Signaling System 7 (CCS/SS7) protocol and provides a set of service-independent capabilities to allow the LECs and their customers to program new services.

In 1991, LECs began technology and service trials using a version of AIN known as AIN 0.0. These trials were followed by tariffed offerings of AIN 0.0-based services. Area Wide Centrex Extension Dialing Service which permits Centrex customers to make inter-switch calls between Centrex extensions by dialing only the extension numbers, is an example of such a service. AIN 0.1 extended the concepts of AIN 0.0 in a manner that is aligned with longer term AIN plans and objectives which call for a substantial expansion of AIN capabilities. In addition, AIN 0.1 provided a starting point for alignment with the International Telecommunication Union—Telecommunication Standardization Sector (ITU-T)<sup>1</sup> Recommendations for the Intelligent Network (IN). In this regard, the scope of functionality supported by AIN 0.1 is generally a subset of the functionality of IN Capability Set 1 (CS1), the first set of IN capabilities to be standardized by ITU-T.

AIN is continuing to evolve beyond AIN 0.1.<sup>2</sup> A new network component and additional call-processing capabilities augment AIN 0.1 to enable services such as voice dialing, speech recognition, and more sophisticated PCS offerings. The following sections focus on the AIN platform capabilities. Section 14.7.2 presents an overview of the AIN architecture. Section 14.7.3 describes the AIN service characteristics, Section 14.7.4 describes the AIN Call Model, and Section 14.7.5 describes the AIN call processing capabilities.

### 14.7.2 Architecture

Figure 14-10 shows the AIN physical architecture.

The AIN Service Switching Point (SSP) functionality allows a switching system to identify calls associated with AIN services. When the SSP detects that conditions for AIN service

---

1. Formerly the International Telegraph and Telephone Consultative Committee (CCITT).

2. The numbering scheme, 0.1, 0.2, etc. is no longer used when identifying AIN capabilities.

---

---

are met, it initiates a dialogue with the AIN Service Control Point (SCP) in which service information for the requested service resides.<sup>1</sup>

AIN SSPs contain additional capabilities required to allow caller interaction with a range of new devices. One such device is an ISDN connected device called the Intelligent Peripheral (IP). The IP is used to provide information to a network user and/or to collect information from a network user via a circuit-switched bearer connection. Some of the IP functions include voice announcements and speech recognition. An IP terminates on a set of ISDN BRI or PRI ports to an SSP<sup>2</sup> and also may exchange data with an SCP.<sup>3</sup>

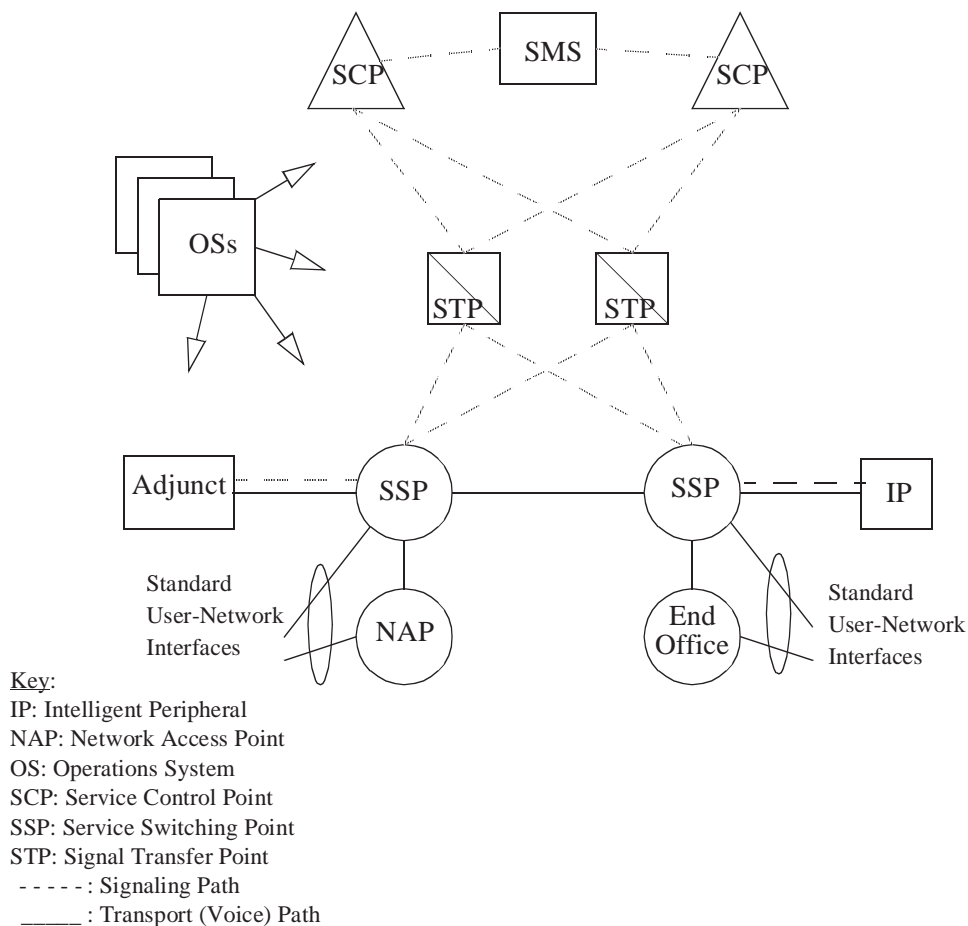
Limited AIN capabilities can be provided by switches that do not have SSP functionality. A switching system having the Network Access Point (NAP) functionality can recognize when a call requires AIN involvement and route the call to an SSP. In this case, based on the information received in trunk signaling, the SSP can recognize that AIN service logic is needed and initiate a dialogue with an SCP. Limited AIN capabilities can also be provided by switches without SSP or NAP functionality. In this case, normal switching system translations or class of service information can be set up such that the non-SSP, non-NAP switch routes certain calls to an SSP for AIN processing. However, only those users directly connected to a switching system equipped with the AIN SSP functionality or a Remote Switching Module (RSM) served by an AIN SSP host can access the full complement of AIN services.

When an AIN SSP detects that AIN service control is needed, it sends a CCS/SS7 message containing information, such as calling/called party identity and other call processing information, to the appropriate SCP. The SCP uses service control logic and subscription information to return a message to the SSP requesting it to perform some further processing of a call or customer service request.

AIN SCPs and Adjuncts contain AIN service logic or service-related applications. The Adjunct uses the same application layer protocol as the SCP, but does not use the CCS network for routing to and from AIN switching systems. The Adjunct is not currently deployed.

The Service Management System (SMS) is one of several Operations Systems (OSs) that may be used in the AIN architecture. These OSs, together with capabilities provided by SSPs and SCPs, support functions necessary to provision, maintain, and administer AIN services. The SMS is specifically designed to facilitate the provisioning and administration of service and subscription data required by the SCP.

- 
1. An SSP can communicate with one or more SCPs by means of Signaling Transfer Points (STPs) within the CCS network. Likewise, a single SCP can communicate with multiple SSPs. STPs are treated as part of the existing CCS network. AIN does not impose any new procedural requirements on STPs.
  2. For a detailed description of the Switch-Intelligent Peripheral Interface (IPI), refer to GR-1129-CORE, Issue 2.
  3. For a detailed description of the Switch-SCP/Adjunct Interface, refer to GR-1299-CORE, Issue 3.
-



**Figure 14-10.** Advanced Intelligent Network Architecture

### 14.7.3 Services

The following are a few services that may be offered using AIN.

- *Hot Line* — Automatically completes a call to a pre-designated telephone number when the calling party's terminal equipment is "off-hook."
- *Inter-Dialing* — Enables the station users of private-line service subscribers to dial other selected station users with a 1- or 2-digit code instead of 7+ digits.
- *Toll Usage Control* — Allows a subscriber to control toll usage by implementing toll restrictions that are tailored to specific user needs. The subscriber would have the



---

ability to restrict calls per user based on NXX, NPA, Time-Of-Day, Day-Of-Week, and Day-Of-Year.

- *Computer Access Restriction (CAR)* — Improves security for phone lines, especially those allowing access to computer systems. CAR allows its subscribers to have a list of phone numbers and Personal Identification Numbers (PINs) to identify authorized callers. Unauthorized callers can be forwarded to another directory number or to a network announcement.
- *Personal Communications Services (PCS)* — A family of telecommunications services which can be provided to individuals to support personal and/or terminal mobility. With PCS, a user can have a Universal Personal Telecommunications (UPT) number that is used for both wireless and wireline access to the network. PCS routes calls to the user wherever he or she is located.
- *Voice Activated Dialing (VAD)* — Allows a subscriber to give spoken dialing directions to the network through the use of voice recognition.

#### 14.7.4 The AIN Call Model

An AIN switching system is viewed as having two functionally separate sets of call processing logic that coordinate call processing activities to create and maintain a basic two-party call. The AIN Call Model describes the processing done by an SSP to establish a two-party call. The Call Model identifies various Points In Call (PICs), which are stages of call processing, beginning with off-hook by the calling party through on-hook by either party. The model consists of originating and terminating half-call models: the Originating Basic Call Model (OBCM) and the Terminating Basic Call Model (TBCM).

##### 14.7.4.1 The Originating Basic Call Model

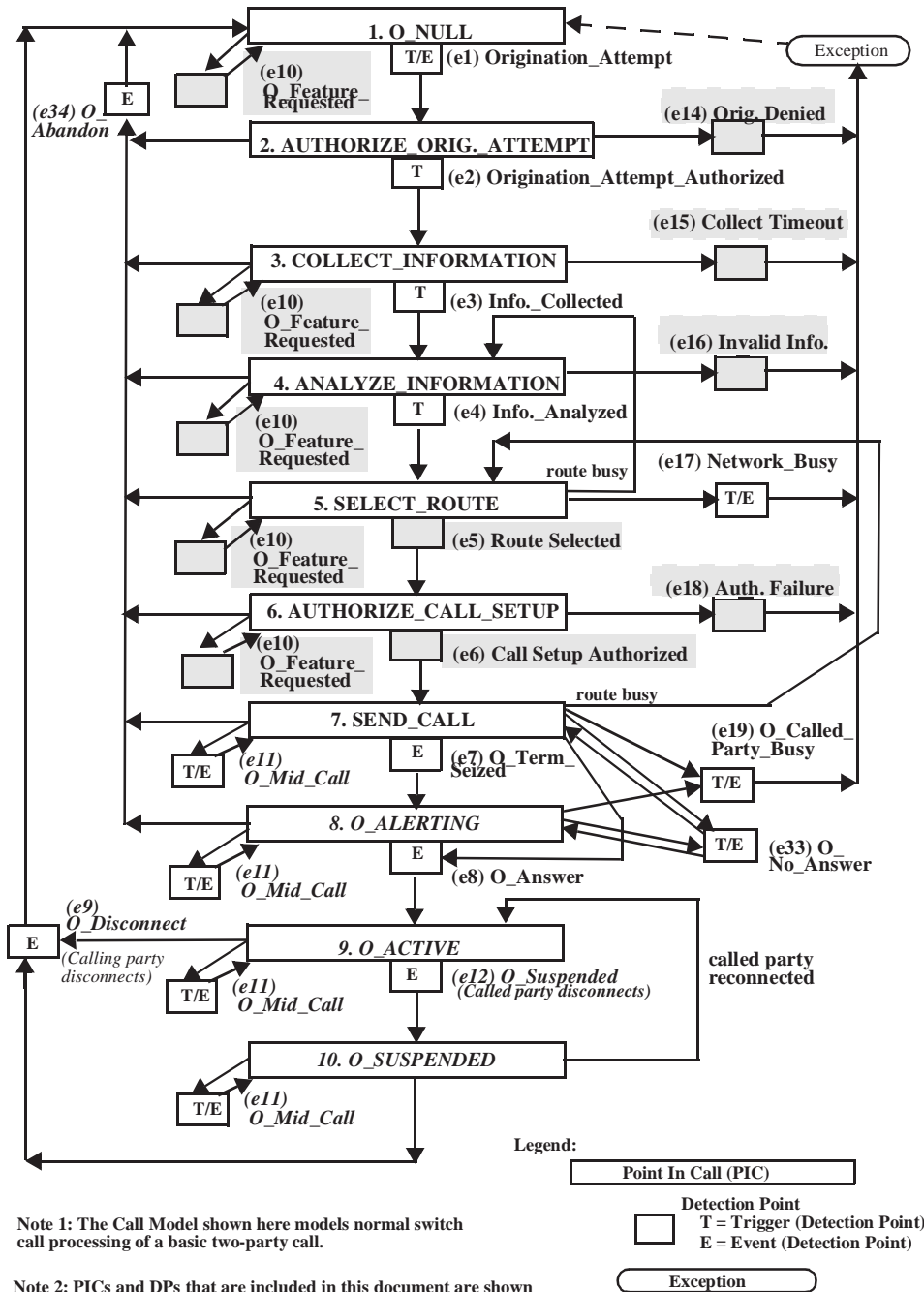
Switching functions modeled by the Originating Basic Call Model (OBCM) (shown in Figure 14-11) rely on information about the calling party's line or the incoming trunk for call setup. OBCM functions are meant to provide connectivity toward the originator, and to provide the selection of an outgoing route. Examples of OBCM functions include providing dial tone and performing routing translations.

The first ten PICs of the call model describe three different stages of OBCM call processing: call setup, stable call, and call clearing. OBCM call setup occurs during the first six PICs, stable call during the seventh through ninth PICs, and call clearing at the tenth PIC.<sup>1</sup>

---

1. For a detailed description of the OBCM, refer to GR-1298-CORE, Issue 3.





Note 1: The Call Model shown here models normal switch call processing of a basic two-party call.

Note 2: PICs and DPs that are included in this document are shown in unshaded boxes; PICs and DPs that have been added since GR-1298-CORE, Issue 1 are shown in italics; and DPs that are defined in AIN Release 1 but are not yet included here are shown in shaded boxes.

Figure 14-11. Originating BCM

#### 14.7.4.2 The Terminating Basic Call Model

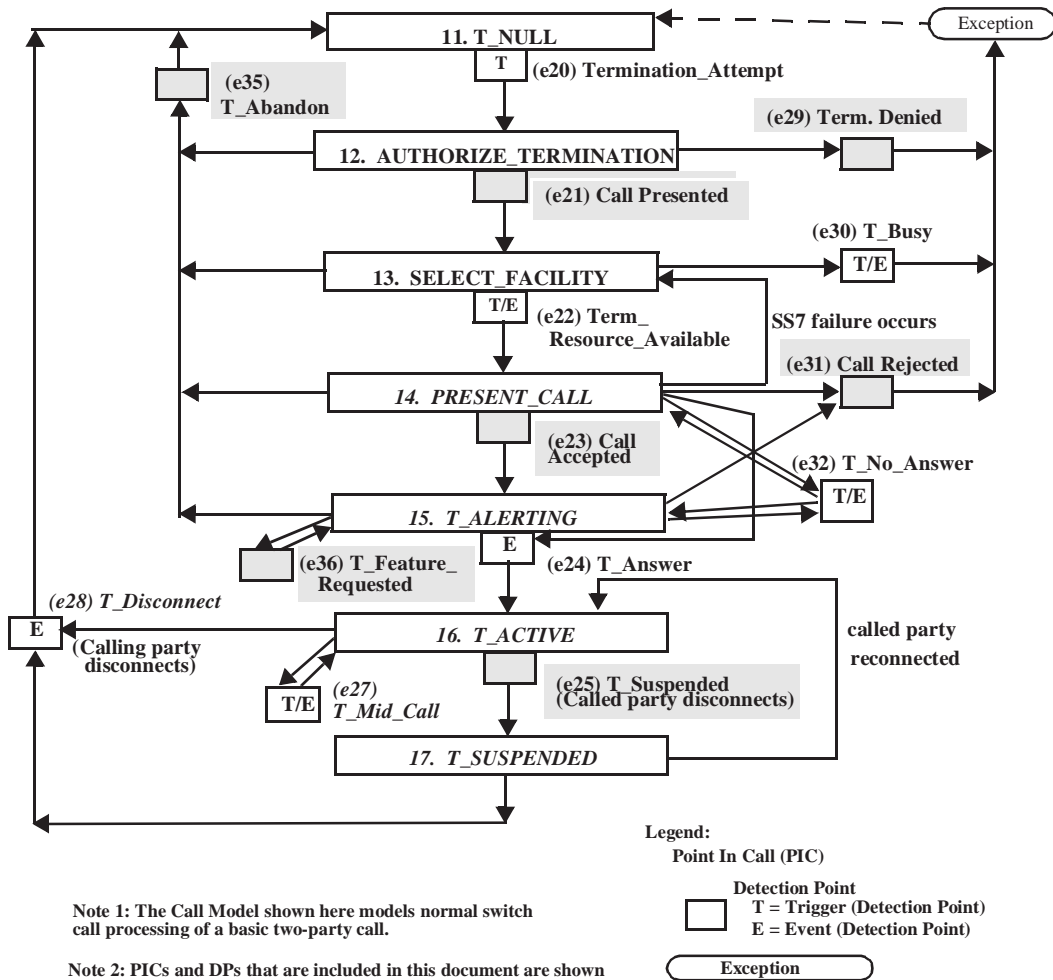
The functions of the Terminating Basic Call Model (TBCM) (shown in figure 14-12) begin once the outgoing route is selected. The TBCM describes switch operation during terminating line or trunk service. TBCM functions operate in parallel with the post-route selection portion of the OBCM. Examples of TBCM functions include delivering the Initial Address Message (IAM) over the outgoing trunk, or providing power ringing on the terminating line.

TBCM call setup occurs during the eleventh through fifteenth PICs, stable call at the sixteenth PIC, and call clearing at the seventeenth PIC.<sup>1</sup>

---

1. For a more detailed description of the TBCM, refer to GR-1298-CORE, Issue 3.

---



Note 1: The Call Model shown here models normal switch call processing of a basic two-party call.

Note 2: PICs and DPs that are included in this document are shown in unshaded boxes; PICs and DPs that have been added since GR-1298-CORE, Issue 1 are shown in italics; and DPs that are defined in AIN Release 1 but are not yet included here are shown in shaded boxes.

Figure 14-12. Terminating BCM

---

## 14.7.5 Call Processing

There are two types of AIN events that cause the SSP to communicate with an SCP during a call: triggers and requested events. These AIN events may occur at certain points in call, called Detection Points (DPs). During the AIN call, the SSP can encounter triggers at Trigger Detection Points (TDPs) and events at Event Detection Points (EDPs). Some DPs may be both TDPs and EDPs.

### 14.7.5.1 Trigger Detection Points

The need for AIN service control can be detected by an SSP at the Trigger Detection Points (TDPs). A trigger specifies a condition under which an AIN SSP should suspend call processing and invoke AIN service logic. Triggers are placed at TDPs, which are associated with PICs, as Figures 14-11 and 14-12 show. As a trigger is encountered, the SSP queries service logic residing in an SCP to produce instructions for influencing subsequent call processing.

To activate TDPs, an AIN trigger must first be provisioned at the TDP. Some triggers are provisionable on a subscriber (line) basis, others are provisionable per groups of lines, while others are provisionable on an office-wide basis. The TDPs supported for an AIN 0.1 SSP are as follows:

- *Origination\_Attempt* — This TDP is encountered after the SSP has received a call setup request.  
For example, an “off-hook immediate” trigger can be placed at this TDP to support AIN 0.1 services such as Hot Line.
- *Origination\_Attempt\_Authorized* — The SSP verifies the authority of a user to place a call with the properties given at this TDP.
- *Information\_Collected* — This TDP is encountered after the SSP has received enough information to process the call.  
For example, an “off-hook delay (end of dialing)” trigger can be placed at this TDP to support AIN 0.1 services such as Toll Usage Control.
- *Information\_Analyzed* — This TDP is encountered after the SSP has analyzed information received.  
For example, a “3-/6-/10-digit office dialing plan” trigger can be placed at this TDP to support services such as PCS.
- *Network\_Busy* — This TDP is encountered when all routes associated with an Automatic Flexible Routing (AFR) table are unavailable.

---

The SSP can detect an “AFR trigger” placed at this TDP and query the SCP for further routing information. For example, the SCP may respond to the SSP to re-route, disconnect, or play a terminating announcement to the caller.

- *Termination\_Attempt* — When the switch recognizes that a call is to terminate to a Directory Number (DN) on the switch.

For example, a “Termination Attempt” DN trigger can be placed at this TDP to support services such as CAR and PCS. In response to the above triggers, AIN service logic in an SCP can request an AIN 0.1 SSP to perform actions such as rerouting the call or playing a terminating or interactive announcement to the caller.

Evolving AIN SSP capabilities support four new call processing triggers: O\_Called\_Party\_Busy, O\_No\_Answer, T\_Busy, and T\_No\_Answer. These triggers allow AIN SSPs to detect a busy condition from the originating or terminating end of a call, and to detect when the called party does not answer from the originating or terminating end of a call. These new triggers provide AIN with the capability to redirect calls on busy/no answer. Other TDPs defined subsequent to AIN 0.1 include: O\_Term\_Seized, O\_Answer, and Term\_Resource\_Available, as shown in Figures 14-11 and 14-12.<sup>1</sup> The Off\_Hook\_Delay trigger has been extended to apply to ISDN PRI interfaces. The 3/6/10-digit trigger has been extended to trigger on any number of three to ten digits and has been renamed “Specific\_Digit\_String” trigger to reflect this extension.

In addition, AIN provides the non-call related functions such as:

- *Monitor* — Allows an SSP to notify an SCP when a designated facility, such as a line, changes status.
- *Update* — Allows an SCP to change the status of triggers in an SSP, for example, from inactive to active.
- *Non-Call Associated Signalling* — Allows the exchange of data between an IP and an SCP.

#### 14.7.5.2 Event Detection Points (EDPs)

Events are detected as a result of processing a call. AIN enables an SCP to send a *list* of subsequent events that may occur during a call handled by an AIN SSP such that when one of the events on the list occurs, the SSP may be required to suspend call processing and launch a query to the SCP. This list of events is known as a Next Event List (NEL). The NEL allows an SCP to request information regarding the status of a call (e.g., network busy conditions, called party busy conditions). When a NEL request is made, the TCAP transaction remains open between the SCP and SSP, and the SCP awaits notification of the event from the SSP.

---

1. For more detailed descriptions of trigger detection points and associated triggers, refer to GR-1298-CORE, Issue 3.

Like TDPs, Event Detection Points (EDPs) are associated with PICs. However, requested events are not administered at the SSP. The SCP activates EDPs dynamically (during an already open transaction) in the form of a returned NEL. The SCP activates EDPs (during an already open transaction) by sending the SSP a NEL. The SSP detects the need for additional AIN control when an event included in the NEL is encountered at an EDP. There are two types of requested events: EDP-Requests and EDP-Notifications. When the SSP recognizes an event as an EDP-Request, the SSP stops call processing, sends an EDP-Request message to the SCP, and awaits instruction from the SCP for further call processing. When the SSP recognizes an event as an EDP-Notification, the SSP does not stop call processing, but sends an EDP-Notification message to the SCP. Upon receiving an EDP-Notification message, the SCP does not respond to the SSP, but may record the occurrence of the event for subsequent processing.

Some EDPs supported by AIN include the following:

A. EDP-R

- *Origination\_Attempt* — tells the calling party's service that an off-hook indication or SETUP message is received by the SSP.
- *Network\_Busy* — tells the calling party's service that the network beyond the AIN switch cannot complete the call due to no available routes.
- *O\_Called\_Party\_Busy* — tells the calling party's service that the called party is busy.
- *O\_No\_Answer* — tells the calling party's service that the called party has not answered the call before a timer expired.
- *O\_Suspended* — tells the calling party's service that the called party has released the call.
- *O\_Disconnect* — tells the calling party's service that the called party has released the call and disconnect timing has completed.
- *O\_Mid\_Call* — tells the calling party's service that a switch-hook flash (analog) or a feature activator indication (ISDN) has been received.
- *T\_Busy* — tells the called party's service that the subscriber's line is not idle or is unable to receive calls.
- *T\_Mid\_Call* — tells the called party's service that a switch-hook flash (analog) or a feature activator indication (ISDN) has been received.
- *T\_No\_Answer* — tells the called party's service that the subscriber's line has not answered the call before a timer expired.
- *T\_Disconnect* — tells the called party's service that the called party has released the call and disconnect timing has completed.

B. EDP-N

---



- 
- *Origination\_Attempt*— tells the calling party's service that an off-hook indication or setup is received by the SSP.
  - *O\_Term\_Seized*— tells the calling party's service that the called party's access has been successfully seized.
  - *O\_Answer*— tells the calling party's service that the called party has answered the call.
  - *Term\_Resource\_Available*— tells the called party's service that the subscriber's line is idle or able to receive calls.
  - *T\_Answer*— tells the called party's service that the subscriber's line has answered the call.

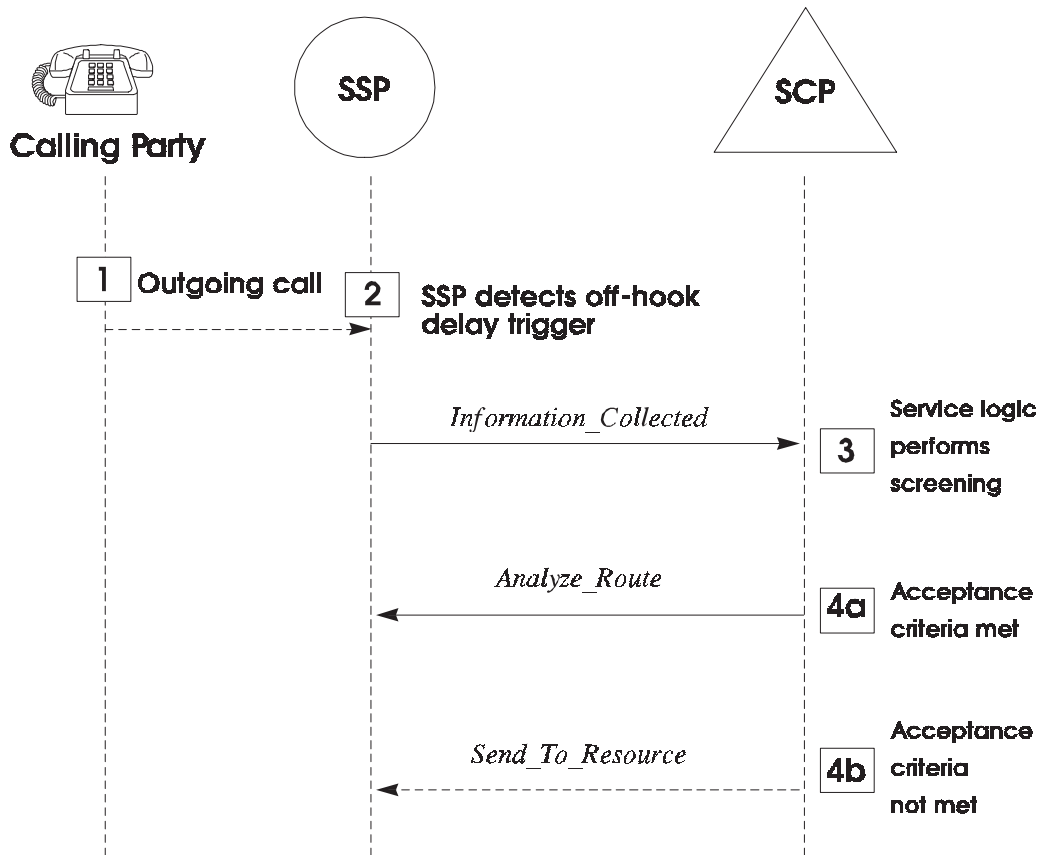
#### 14.7.6 Service Illustration

This section illustrates the AIN call processing capabilities such as triggers and describes the exchange of messages between an SSP and SCP by walking through the call flow procedures of the *Toll Usage Control* service.

The Toll Usage Control service allows subscribers to control toll usage by specifying call acceptance criteria that are tailored to their needs (based on NXX, NPA, Time-Of-Day, Day-Of-Week, etc.). Figure 14-13 illustrates the call-flow scenario for this service.

The individual steps of the call flow are described as follows:

1. — The calling party places an outgoing call to an NPA-NXX-XXXX number.
2. — The SSP serving the calling party detects an off-hook delay trigger at the *Information Collected* TDP and sends an *Information\_Collected* message containing the collected digits and calling party identification to the SCP.
3. — The service logic in the SCP performs the screening based on the subscriber pre-specified criteria (for example, Time-Of-Day).
- 4a. — If the screening acceptance criteria are met, the SCP responds with an *Analyze\_Route* message requesting the SSP to route the call to the called number.
- 4b. — If the screening acceptance criteria are not met, the SCP responds with a *Send\_To\_Resource* message requesting the SSP to play a terminating announcement indicating that the call is not authorized at this time.



**Legend:**  
 SSP = Service Switching Point  
 SCP = Service Control Point

**Figure 14-13.** Toll Usage Control Service Example

---

## 14.8 Integrated Service Control Point

Since the early 1980's, the capabilities of the network have been greatly expanded through the deployment of the Intelligent Network, or IN - systems designed to provide enhanced routing and screening functions, voice and messaging services, and greater customization of enhanced services to individual subscribers.

The basic Intelligent Network includes network elements and operations systems in support of Toll Free or 800 Number services, as well as a Line Information Data Base (LIDB) for support of CLASS, Calling Name (CNAM), Originating Line Number Screening (OLNS), and various other enhanced services.

The IN introduced specialized switching software, and a new network element known as a Service Control Point (SCP). The SCP is a highly available, highly reliable computing platform, capable of processing hundreds or thousands of queries a second from switches, and returning routing instructions to those switches in order to effect call completion. The SCP platform was deployed to support a Toll Free application, in which calls to 800 numbers were routed to specific destinations based on time of day or area of service from which the call originated. Coupled with the deployments of IN SCPs by each LEC or IXC was the development of a national Service Management System (SMS/800) to support the administration of toll free numbers nationwide.

The SCP was also deployed to support a LIDB application, which in turn provided support for Alternate Billing Services, Calling Name, Originating Line Number Screening and other line-related services. In almost all cases, the deployment of IN is predicated on the deployment of a Common Channel Signaling/Signaling System 7 (CCS/SS7) network.

While the deployment of IN opened up new opportunities in the local exchange network, it was also somewhat limited - new enhanced services and applications required significant development time before they could be introduced in to the network. From the IN efforts evolved the Advanced Intelligent Network (AIN), which provides telecommunications carriers with a more flexible structure for developing services. Through the use of Service Independent Building Blocks (SIBBs), a carrier can assemble and deploy new services in their network in significantly less time than ever before. The AIN architecture extended the types of network elements to be deployed to include the following:

- AIN Service Switching Points (SSPs), which contain specific trigger and event handling routines that instruct the switch to interact with an AIN SCP for routing instructions
- AIN SCPs, which execute a number of different AIN services on a single platform
- AIN Service Creation Environment (SCE) and Service Management Systems (SMSs), which together provide a development and provisioning environment for new services
- Intelligent Peripherals (IPs), which provide specialized resource related functions such as announcement invocation, voice recognition, and digit collection to voice and fax messaging

- 
- Service Nodes (SNs), which typically combine the functions of an AIN SCP and IP into a single system, often coupling these functions with a programmable switching platform in order to offer enhanced services such as pre-paid calling cards or unified messaging platforms

AIN plays a significant role in the opening of local exchange markets, as the AIN architecture forms the basis for the deployment of Local Number Portability (LNP) solutions. Through the use of AIN triggers and specialized applications residing in AIN SCPs or Signal Transfer Points (STPs), it is now possible to ensure the proper termination of calls so as to allow subscribers to switch from one Local Service Provider (LSP) to another without having to change their phone number. The deployment of LNP is a basic requirement of the opening of the local exchange market, and has an impact on IN and AIN deployments of all LEC, CAP, Wireless and IXC carriers.

The AIN is quickly being extended to offer similar capabilities for rapid service creation and deployment of enhanced services to the wireless network under the auspices of the Wireless Intelligent Network (WIN), and efforts are underway to define a Broadband Intelligent Network.

Many LECs have deployed IN and AIN systems developed by Bellcore's Intelligent Network Solutions (INS) organization.

#### **14.8.1 Toll Free Service**

Initially, the LECs supported 800 service on a switch basis whereby 800 calls were directly routed to the IC associated with the dialed 800-NXX. This scheme did not allow 800 subscribers to change service providers without also changing their 800 number. This deterred 800 subscribers from changing providers, particularly for those subscribers that relied on vanity numbers, thereby impeding competition. However, on May 1, 1993, full number portability for 800 service was mandated to be available whereby subscribers could change 800 providers without changing their 800 number. Full 800 number portability resulted in a need to access a LEC regional database to determine subsequent routing information based on the full 10-digit 800 number, instead of relying on switch translations of the dialed 800-NXX. In addition, the availability of full number portability for 800 service allowed for increased competition in the 800 service arena. In such a competitive environment, it became critical that 800 service remain a reliable, high quality service offering, while supporting enhancements to the 800 service offering to remain competitive.

As the 800 service offering expanded, the rate of 800 number assignments significantly increased, greatly exceeding the original expectations. The industry was faced with the imminent exhaust of 800 numbers. To alleviate the exhaust problem, the Industry Numbering Committee (INC) determined that additional numbering resources would be needed to meet the future demand for toll free services. On January 25, 1995, the INC designated "888" as the new toll free code and reserved future toll free codes 877, 866, 855, 844, 833, and 822 for use after exhaust of 888 codes. Therefore, the 800 service solution

---

---

needed to be expanded to support 888, 877, etc., as new toll free codes were assigned. The LECs considered the following two different approaches for supporting the introduction of new toll free codes in their networks: 1) expand existing IN 800 service arrangements to accommodate additional toll free codes, and 2) use AIN functionality to provide for new toll free codes.

As most LECs are strongly focused on AIN functionality and are deploying AIN functionality throughout their networks, there is a strong need to consolidate operations environment to align with the new equipment introduced for AIN. In addition, as toll free service expands, the query capacity needs are increasing significantly. Both of these trends point strongly towards the continued evolution of Toll Free services towards an AIN infrastructure.

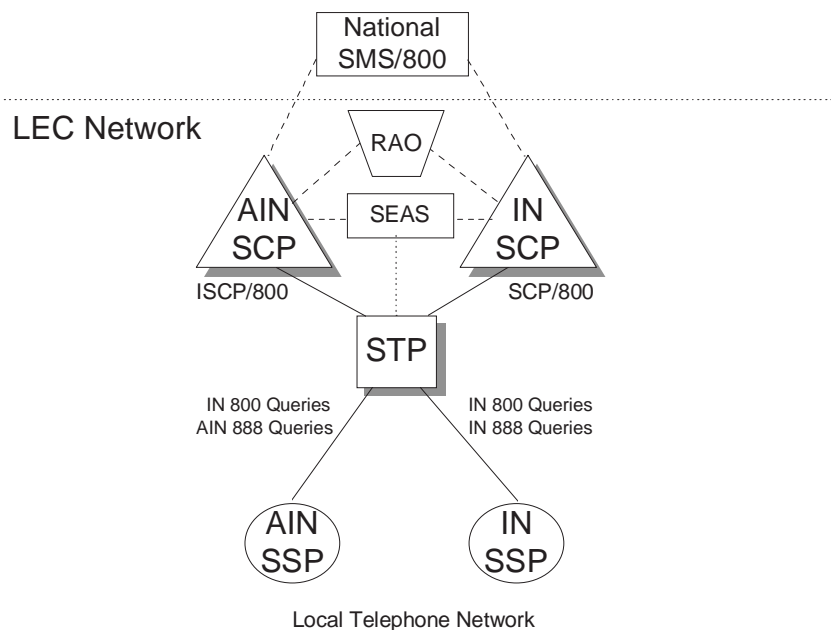
#### 14.8.1.1 Bellcore INS Solution

The initial 800 service offering were the SCP/800 and SMS/800 products:

- The SCP/800 product supports translation of the dialed 10-digit 800 number to the appropriate routing information for the given call. Additional feature functionality was also supported by the SCP/800 to support vertical features such as time-of-day and percent routing.
- The SMS/800 product supports national administration of the information associated with each 800 number. The SMS/800 system is a national system that is responsible for data administration of all of the toll free number routing information and for loading this information into the network databases.

With the introduction of 888 codes, and future toll free codes, some of our clients were interested in expansion of the IN SCP/800 solution, while other customers were interested in the use of AIN functionality to support the new toll free codes. The INS solution which addressed the ability to support either the IN or AIN solution for the new toll free codes were enhancement of the SCP/800 platform and the introduction of an AIN-based ISCP/800 platform. These products were defined to continue to interwork with the SMS/800 product to support the national 800 data administration solution.

Figure 14-14 shows support for Toll Free services with both an IN SCP (SCP/800) and an AIN SCP (ISCP/800).



**Figure 14-14.** IN/AIN Network Configuration for Toll Free Service

Major IN and AIN components include the following:

- Common Channel Signaling (CCS) Network - A Signaling System 7 (SS7) packet-switched network that routes query and response messages between the Service Switching Points (SSPs) and the SCPs/ISCPs in the IN/AIN.
- Local Telephone Networks - In the IN/AIN environment, local networks include electromechanical and electronic switches operating as end offices and access tandems.
- Revenue Accounting Office (RAO) - Provides billing functions based on information gathered from SCPs and SSPs. In the case of Toll Free services, the IN and AIN SCPs typically generate aggregate “peg count” billing information, tracking the number of query originated by SSP, and provide this to the RAO via AMATPS (SCP/800) or AMADNS (ISCP/800) mechanisms.
- Signaling Transfer Points (STPs) - Perform translation functions and control the routing of CCS messages through the network.
- Service Switching Points (SSPs) - Electronic stored-program controlled switching systems located within the local telephone networks.
- SEAS System - Provides administration for STPs, which perform routing and translation of CCS Network messages.

- 
- Service Management System (SMS) - Provides an interactive OSS for the Toll Free service on a national basis.
  - Service Control Points (SCPs) - An on-line, fault-tolerant, transaction processing database system that provides the execution environment for the IN or AIN Toll Free service application. INS provides both the SCP/800 and ISCP/800 systems.

The major functions of the SCP/800 and ISCP/800 systems include the following:

- Call Processing - Translates 800 number queries forwarded by the CCS Network into destination numbers or turnaround records to ICs. The SCP returned these numbers for routing back to the CCS Network.
- Network Management - Protects the SCP Node and the telephone network from overloads by limiting the number of calls being handled.
- Call Sampling - The collection of data about a percentage of certain types of calls that the Toll Free service application handles. Types of samples collected by the Toll Free service application are application samples and customer samples.
- Performance and Traffic Measurements - The Toll Free service application keeps counts of the messages it processes and what it does with them. Periodically, the SMS polls the SCP for these measurements. The Toll Free service measurements are also used by a local system administrator to track performance statistics via a Maintenance and Operations Console (MOC)
- Special Studies - The SMS can direct the Toll Free service application to collect samples of calls that meet certain criteria (such as dialed or destination number).
- SMS Reports - The Toll Free service application sends the SMS unscheduled and scheduled reports contain information about exceptions, control lists and special studies.
- Database and Table Updates - The Toll Free service application accepts real-time database updates from the SMS and reflects those changes in the database.
- Access Billing Measurements - The Toll Free service application provides the means for LECs to bill for the Toll Free number database translation service.

#### 14.8.1.2 Toll Free Service Interfaces

The Toll Free service SCPs contain external interfaces to the CCS Network and operations systems such as the SMS. The SCP/800 and ISCP/800 systems use the SS7 protocol class 0, basic connectionless service, to communicate with the SS7 network. This communication consists of an exchange of messages with SSPs, via the STP Pair (and CCS Network) connected to the SCPs and SSPs. Interfaces to the SMS systems will use a point-to-point X.25 links, running at a transmission speed of 9.6 kbps.

The SCP/800 provides billing information to the RAO in Bellcore Accounting Format (BAF), via an AMATPS transmission mechanism. The ISCP/800 system provides the same information, but uses an AMADNS transmission mechanism.

## 14.8.2 LIDB Services

The term “Line Information Database (LIDB) Services” is a collective term that is used in reference to the following line number services: Alternate Billing Service (ABS), Calling Name Deliver (CNAM), GetData, and Originating Line Number Screening (OLNS). The solution defined for each of these services must be examined for each of these services individually since: 1) each service was introduced to address a different business need, and 2) each of these services is supported by a different customer base because of individual LEC business needs and regulatory environment.

The current INS solutions for the various LIDB services involve support of IN services using the SCP/LIDB platform and supporting operations systems. As AIN functionality is introduced into the networks, the LIDB functions have expanded to support interaction with the AIN network (e.g., through support of GetData for AIN services or AIN CNAM service).

### 14.8.2.1 Alternate Billing Service (ABS)

The SCP/LIDB was initially developed to support validation of alternately billed calls (which include Calling Card, Collect, and Third Number Billing calls). That is, the deployment of LIDBs supported the ability for the LECs to validate alternately billed calls without relying on AT&T’s facilities. Since each LEC is responsible for only the line number information within their own region, national access to each SCP/LIDB was needed. National access to the SCP/LIDBs allows for:

- Centralization of data administration on a regional basis,
- Validation of intraLATA ABS calls through access by the LEC themselves, other RBOCs and Independent LECs,
- Validation of interLATA and international ABS calls through access by the ICs.

LIDBs are responsible for determining if the requested alternate billing number is valid for the given call and performing basic fraud monitoring.

As the “basic” ABS validation process supported by LIDBs matured, the LECs ABS needs evolved. Calling Cards became a highly competitive product for the LEC and the responsibility for the fraud incurred on ABS calls, which resulted in billions of dollars a year, became a big issue. Therefore, the LECs needed attractive Calling Card (CC) feature offerings and enhanced fraud monitoring and detection mechanisms. As a result, the ABS/LIDB solution expanded to include development of features to support the following:

---

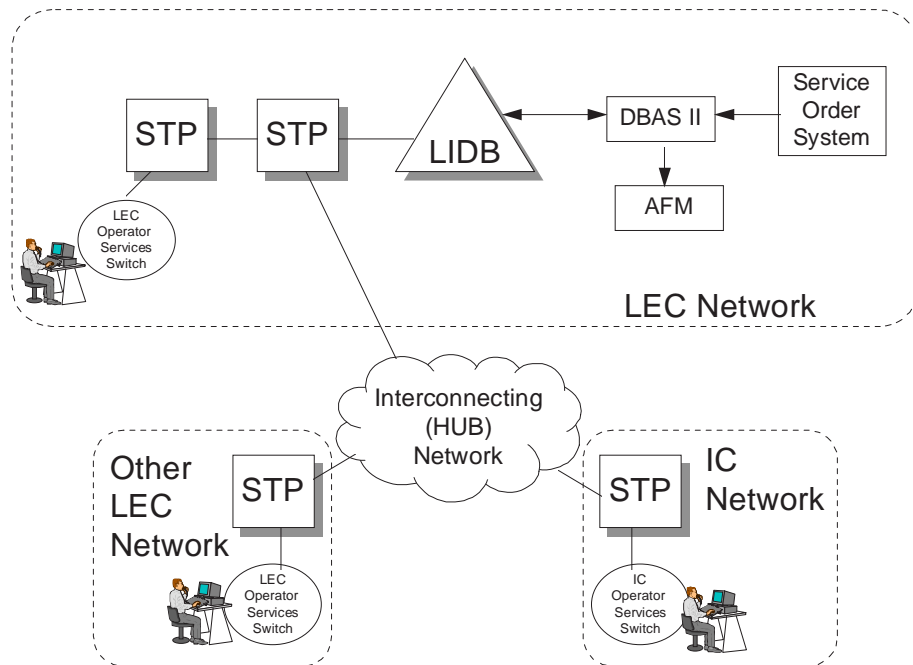


enhanced fraud detection; new Calling Card features such as the N-Number Calling Card, Domestic Calling Card, and Carrier Specific Deactivation; and additional ABS features applicable to Calling Card, Collect, and Third Number such as Selective Call Blocking.

The INS solution to support validation of ABS calls was the development and national interconnection of the SCP/LIDB product. The LIDB was initially administered by the DBAS product which played a critical role in the provisioning of LIDB services. Specifically, DBAS processed customer updates from the Service Order System, provided the initial load of LIDB data, and provided ongoing updates of customer information, special studies, and other administrative functions. The initial DBAS system was replaced with the current DBAS II system to meet the growing needs of the LECs, including the introduction of enhanced ABS features and increased data administration capacity.

Since the LIDBs were responsible for validation of ABS numbers for interLATA and international calls, in addition to intraLATA calls, the responsibility of fraud incurred on these calls became a big issue for the LECs. The INS solution offers an external fraud monitoring system, the Advanced Fraud Module (AFM), which works in conjunction with DBAS II to provide fraud monitoring and investigation features for ABS calls.

Figure 14-15 shows how a LEC LIDB database can be interconnected to various other networks in support of ABS and other LIDB services.



**Figure 14-15.** Interconnection of LEC/IXC Networks in Support of LIDB Alternate Billing Services

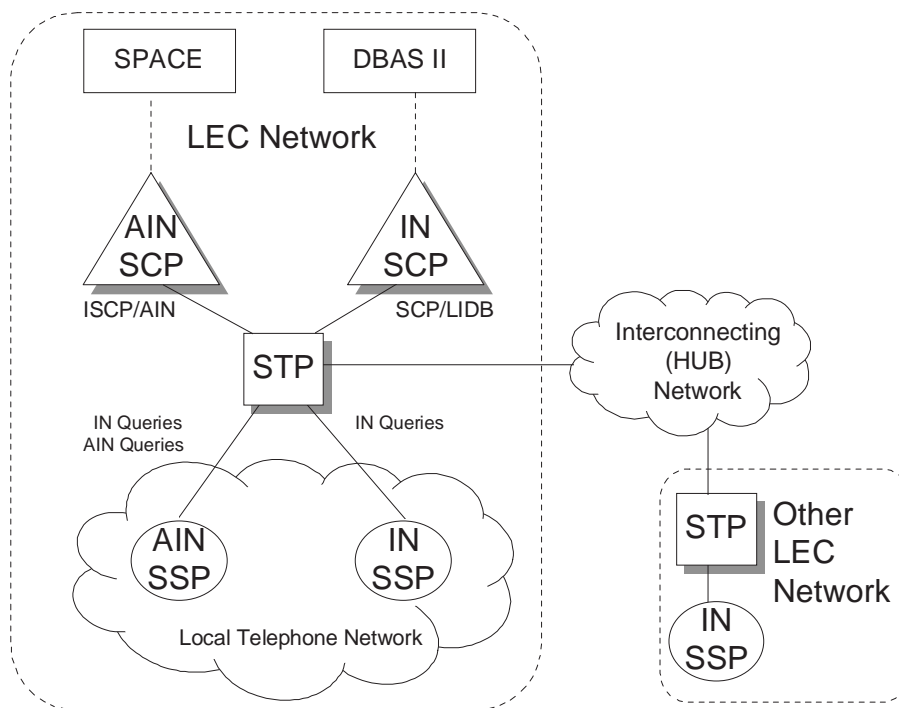
#### 14.8.2.2 Calling Name

Many LECs have deployed a CLASSSM service, referred to as Caller ID, whereby the calling number is displayed to the called party. LECs wanted to enhance this feature offering by also displaying the name associated with the calling number. Display of the name (referred to as Calling Name Delivery [CNAM] service) and number would greatly improve end user satisfaction with the feature and increase the penetration rate for subscription of the CLASS features. The feature initially needed to be supported on an intra-network basis, since the calling number was not initially passed across LATA boundaries. However, the FCC mandated that the calling number be passed across LATA boundaries effective December, 1995. This enabled the LECs to expand the CNAM offering on a national basis, which would improve end user satisfaction since display of the name and number could now be supported for both intraLATA and interLATA calls. Therefore, access to the name information associated with the originating number on a national basis was needed.

The LECs needed the ability to access subscriber name information to support CNAM for their customers (retail), along with the ability to sell CNAM database access to other LECs to enable them to offer CNAM on an interLATA basis (wholesale).

The INS solution to support retrieval of the name information associated with the originating line number included enhancement of the SCP/LIDB and DBAS II products to include the name information. LIDBs are a natural place to address the LECs need since national access to the LIDBs, centralized line number data administration, and storage of all working line numbers within a region were already supported. The INS solution allows companies to utilize their LIDB and DBAS II products to support a high-revenue service with an existing system, rather than deployment of new network systems.

As the introduction of AIN functionality become a reality, LECs' needs are evolving in the AIN direction. Therefore, INS has expanded its CNAM solution to support both IN and AIN CNAM service. The complete INS solution for CNAM consists of either the SCP/LIDB and DBAS II products for IN CNAM, or a combination of the ISCP and SPACE system, along with the DBAS II product for AIN CNAM. [Figure 14-16](#) describes both an IN and AIN CNAM service solution.



**Figure 14-16.** CNAM Solutions Supporting Both IN and AIN Network Protocols

#### 14.8.2.3 Originating Line Number Screening (OLNS)

Operator services calls include ABS, Directory Assistance (DA), coin, and hotel/motel calls. When an operator services call is attempted, the operator services system needs to know billing and service restrictions associated with the line in order to perform proper call handling (e.g., prison lines are not allowed to make calling card calls). The originating line information was initially maintained and administered at each originating operator services system. This information was distributed among the various operator services systems and limited in scope (it included such things as basic billing and service restrictions and basic originating station types).

The continued support of originating line screening at the individual operator services systems was insufficient to meet ongoing LEC needs. This initial environment needed to be modified to support the following:

- Centralization of the line data administration,
- Mechanization of the data administration interface,
- Support of near-real time administration of the data,

- Expansion of the line number information, e.g., to support recent state mandates associated with intraLATA toll presubscription, and
- National access to the originating line information, particularly for ICs and CLECs.

The Originating Line Number Screening (OLNS) service was defined to remove the information from the operator services systems, and to centralize the information in a database that could be accessed in real-time. The OLSN information includes billing and service restrictions, preferred interLATA carrier, intraLATA toll carrier, international carrier, treatment indicator, DA restrictions, and service or equipment indicator associated with a line number. This OLSN information has subsequently been expanded to include things such as the originating service provider (particularly important in an unbundled environment to support proper branding of, and to remedy intercompany settlements issues associated with operator services calls), a foreign language indicator, and additional information to attract operator service business as competition increases.

The INS solution to support OLSN was to enhance the SCP/LIDB and DBAS II products to support the necessary information. These products met the needs outlined above since national access to the LIDBs, centralized line number data administration, and storage of all working line numbers within a region were already supported. The INS solution allowed LECs to utilize their LIDB and DBAS II products to support this service, again with existing systems rather than new deployments.

#### 14.8.2.4 GetData Services

In the increasingly competitive telecommunications environment it is essential for companies to rapidly develop and deploy new revenue generating services to meet the necessary market windows. LECs have been deploying AIN functionality throughout their network to meet these market challenges. In order to support many of the AIN features, they need a database that could support the line number information necessary for their various AIN services. Characteristics of the database needed to include the following:

- Exhibit high performance and reliability characteristics,
- Support centralized data administration for the customer,
- Allow access from all necessary query originators (in or out of region),
- Support secure access to the data via advanced data screening functionality, particularly for access from query originators out of region, and
- Generate appropriate billing measurements for access to the information.

Furthermore, the database and its administrative system needed to be flexible to support the necessary information for the newly defined AIN service rapidly (i.e., the new information needed to be incorporated into the database and administrative system without requiring software development).

---

---

The INS GetData solution complements the rapid deployment functionality available with AIN by allowing the ISCP (or any AIN SCP) to access the LIDB for the desired elements, as well as support the definition of those new desired LIDB elements via DBAS II. GetData consists of a service-independent LIDB query that is used to request specific data elements from a line record in LIDB. AIN SCPs access the LIDB associated with the queried number to obtain the requested data element. Also included with GetData is a mechanism that allows LIDB owners to define customized LIDB data elements via the LIDB Administration System (i.e. DBAS II).

This INS solution allows LECs to deploy the desired (possibly proprietary) AIN services requiring line number information rapidly, based on their market windows and time schedules. Specifically, the INS solution defined to meet the business needs outlined above includes support of GetData functionality in the ISCP, SCP/LIDB, and DBAS II products as follows:

- ISCP and the SPACE service creation environment are used to support the desired AIN service as defined by the customer
- DBAS II is used to define new elements and perform updates to the newly defined fields for the line records
- LIDB performs the job of the data store, responding to GetData queries originated by the ISCP (or any AIN SCP)

This solution allows for access of information currently being administered for IN services (e.g., name information), as well as supports the flexibility for defining new data fields associated with line numbers needed for new AIN features. Example AIN features which are currently supported by several LECs using the INS solution include Single Number Service (SNS) and Customer Contact service.

### 14.8.3 AIN Services

As mentioned in the introduction to this section, the Advanced Intelligent Network is being deployed by LECs in an effort to bring more control over service design and deployment into their own hands. Through the AIN network architecture, SSPs provide a set of generic triggers and events during call processing, which can be set to invoke service logic in an AIN SCP. The definition and creation of this service logic is accomplished through the interactions with an Service Creation Environment (SCE).

Since many enhanced services often require specialized resources, such as text-to-speech or voice recognition software and hardware, AIN networks often include Intelligent Peripheral (IP) or Service Node (SN) components, typically operating under control of an AIN SCP. Through this combination of SCPs, IPs and SNs, carriers are able to offer a wide variety of complex or enhanced services to their subscribers. And by using the rapid service development and deployment functions inherent in the AIN SCE and AIN Service Management Systems (SMSs), new service can be introduced in the matter of weeks or

---

months, rather than years. To date, LECs have introduced over 75 new services using AIN technologies.

AIN SCPs usually contain a variety of interfaces, including SS7 network interfaces to support interactions with AIN switches as well as with LIDB databases, provisioning interfaces to AIN SMSs, billing interfaces, and a variety of vendor specific interfaces to Intelligent Peripherals, remote databases or operations systems, network management systems, etc.

Bellcore's Intelligent Network Solutions (INS) Advanced Intelligent Network (AIN) solution is composed of the following system components:

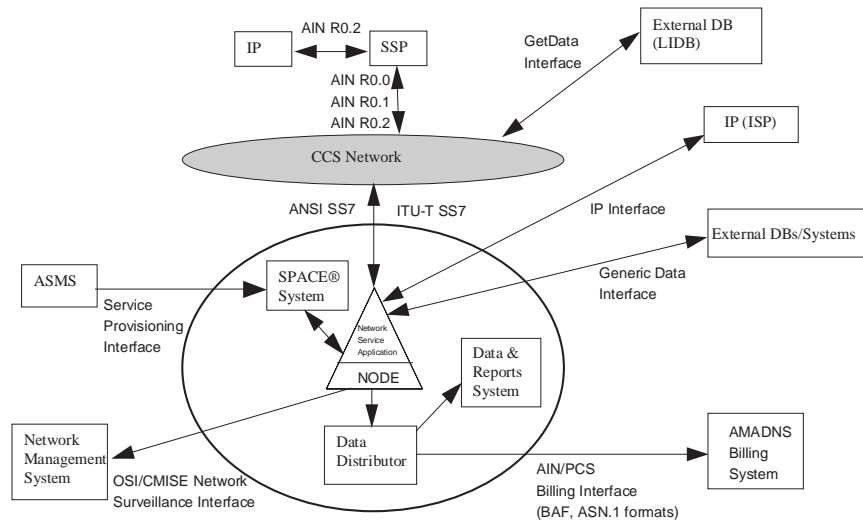
- The Advanced Service Management System (ASMS), which provides AIN SMS functionality
- The ISCP family of systems, including
  - The SPACE System, providing both an AIN service creation environment as well as network element management functions for a mated pair of ISCP Nodes
  - The ISCP Node Service Control Point, providing the execution environment for AIN services created using the SPACE system
  - The Data Distributor (DD) System, providing for the collection and storage of billing and measurements information produced by the ISCP Node during service execution
  - The Data and Reports System (DRS), providing the carriers with the ability to produce both pre-defined and ad-hoc reports of measurements information generated by the ISCP Node and Data Distributor systems
- The Intelligent Services Peripheral (ISP) system, an AIN Intelligent Peripheral providing a variety of resources including text-to-speech, fax, and voicemail functions
- The TELEGATE Internet Gateway (TIG), which operates with ASMS to allow subscribers internet/intranet based access to service information and features, and a collection of AIN services for a variety of enhanced offerings

Figure 14-17 describes the components of the INS AIN solution, and identifies external interfaces.

#### 14.8.3.1 The ASMS System

The ASMS system provides a network-grade, user-programmable service management system designed to enable automation of service management tasks for a variety of enhanced services. ASMS is designed to allow LECs to specify and develop their own Service Management Programs (SMPs), corresponding to the set of enhanced services that they develop using other INS products such as the ISCP system and ISP. The ASMS system

---



**Figure 14-17.** Elements of AIN

can be used with a variety of element management systems for SSPs and STPs, as well as with traditional Operations Systems for service provisioning to provide end-to-end automated service provisioning and management, reducing overall operations costs for the client and enabling mass market deployment of enhanced services. When combined with the TIG system, ASMS can provide service management functions to other carriers in a wholesale or unbundled network, or directly to end-user subscribers. Bellcore also provides a number of pre-packaged Service Management Programs supporting Local Number Portability and other enhanced services.

#### 14.8.3.2 The ISCP Family of Systems

The ISCP family of systems together provide clients with a high performance, highly customizable platform for designing and deploying advanced service solutions. The SPACE system is an integrated service creation and testing environment, coupled with service administration functionality to manage Service Logic Programs (SLPs) and subscriber service data deployed on the ISCP Service Control Points. As with ASMS, the SPACE system can be used with the TIG system to provide end-user subscribers with direct control over their service information. And the SPACE system can be deployed with the ASMS system to enable automated service provisioning and management of enhanced services.

The ISCP Service Control Point provides a highly available, network grade platform for the execution of enhanced AIN services in the network. The ISCP Service Control Point can be interfaced with a variety of external Intelligent Peripherals (including the ISP system), as well as other network and corporate databases. The ISCP Service Control Point feeds



billing information and customer measurements to the Data Distributor system, which provides a real-time store-and-forward platform for this bulk information. Carriers can then offload billing or measurement data directly from the Data Distributor, or pass measurement data further downstream to the Data and Reports System (DRS).

The DRS software provides carriers the ability to define report formats and automatically generate reports on data consolidated from a number of ISCP Service Control Points. These reports can be used for a variety of purposes, including service refinement and additional revenue opportunities through data mining activities.

The ISCP and ASMS systems share a common underlying hardware and software platform, based on the IBM RISC System/6000 family of processors. All INS systems provide a graphical Maintenance and Operations Console (MOC) for ease of use.

#### 14.8.3.3 The Intelligent Services Peripheral (ISP)

The Intelligent Services Peripheral (ISP) is Bellcore's Intelligent Peripheral product, providing LECs the ability to extend their enhanced services offerings with voicemail, facsimile, and voice recognition/voice response capabilities. While the ISP system can be used as a standalone service node application platform through the development of specific enhanced service applications, it is most flexible when deployed with an ISCP Service Control Point. The advanced services executing on the ISCP platform can then direct the actions of the ISP system, allowing carriers to provide enhanced services for call centers, single-number services, as well as subscriber control over their own service data. The ISP system is available on the DEC platform. The ISP system also provides the underlying platform for Bellcore's AIRBOSS family of wireless solutions.

#### 14.8.3.4 The TELEGATE Internet Gateway (TIG) System

The TELEGATE Internet Gateway (TIG) system provides end-user subscriber control over service data through the provision of World Wide Web (WWW) interfaces to Bellcore INS systems such as the ASMS system. Through the development of JAVA and HTML screens, carriers can offer their subscribers easier access and management of their service data through a graphical Internet/intranet interface, increasing subscriber satisfaction and lowering the learning curve for new services. The TIG system can also be used with other INS systems such as DBAS II (for provisioning of LIDB information) and SMS/800 to provide access to system functions in a wholesale or unbundled environment.

### 14.8.4 Local Number Portability

As a precursor to the opening of local exchange markets to service provider competition, the need for number portability solutions has become critical. Based in part on the efforts

---



---

of the Illinois Commerce Commission (ICC) and Federal Communications Commission (FCC) in 1996, the industry at large has been mandated to provide number portability in a fair and non-discriminatory manner. By and large, the industry has settled on a number portability solution that involves the following components:

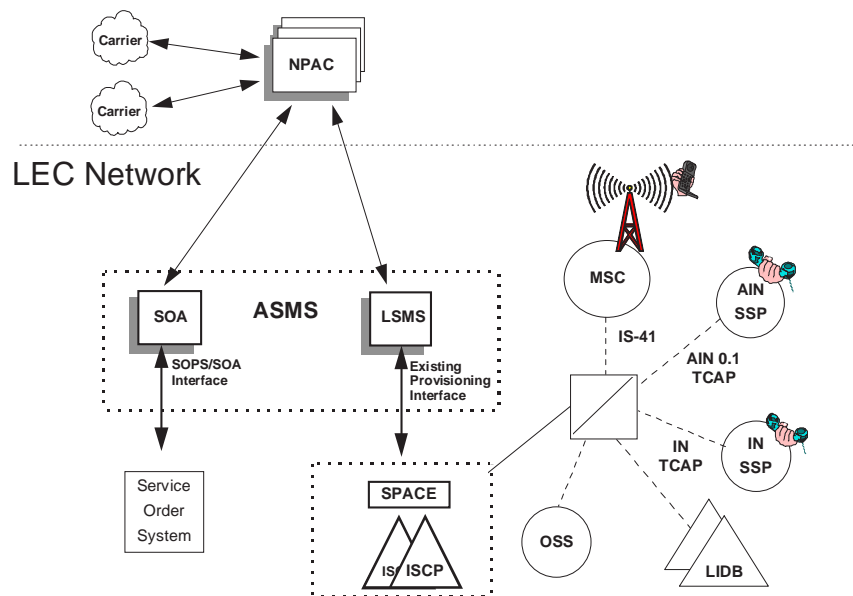
- A regional level Number Portability Administration Center (NPAC), which oversees the coordination of porting requests between carriers. The FCC has ruled on the deployment of seven regional NPACs (corresponding to the original boundaries of the seven RBOCs as established at divestiture), and efforts are underway in 1997 to put these systems into place.
- A Local Service Management System (LSMS), one instance of which is maintained by each carrier competing within a given NPAC region. The LSMS is responsible for coordinating updates between the NPAC and the Number Portability database (i.e. SCP) to effect the proper network routing of calls and LIDB queries.
- A Service Order Activation (SOA) system, which provides the link between a carriers operations systems and the NPAC to initiate or resolve a porting request with another competing carrier.
- A Number Portability database, typically an SCP, which provides support for a Location Routing Number (LRN) services as well as Message Relay Service (MRS) functions.

The Location Routing Number (LRN) service has been adopted by the industry as a defacto standard for ensuring proper routing of requests in the network. LRN services can support both through IN and AIN protocols, although most carriers are deploying an AIN infrastructure to support number portability. The execution of the LRN service is based on a switch recognizing that a particular call has been placed to a destination number that lies within an area open for portability, in which case the switch will query an LNP SCP for routing instructions. Based on the information contained in the LNP SCP (which was loaded through interactions between the NPAC and LSMS), the LNP SCP will instruct the querying switch to either route the call as normal (meaning that the destination number was not ported itself), or it will provide a new destination switch upon which the ported subscriber now obtains service.

The MRS service works in a similar way, but is primarily used to support queries to LIDB databases from SSPs or SCPs for CNAM, CLASS and GetData services, in addition to InterSwitch Voice Messaging (ISVM) services.

Bellcore has an integrated solution through the combined deployment of our ASMS and ISCP systems.

Figure 14-18 describes Bellcore's LNP solution, highlighting the SOA, LSMS, and LSCP functionality. The Advanced Service Management System (ASMS) provides a platform for both the SOA and LSMS functions, while the ISCP and SPACE systems together provide the LSCP functionality supporting both LRN and GTT functions.



**Figure 14-18.** Bellcore INS Solution for Number Portability

The systems form the network infrastructure providing the service control element within the network and the software operational support systems to manage the network system. This ISCP infrastructure and its associated service management system can be extended to support additional AIN revenue producing features and services.

The two key functions required of the LNP function which are supported by the ISCP are:

- Supporting the Location Routing Number (LRN) model for LNP queries - the ISCP/LNP supports the LRN model for providing the necessary information back to the switch for routing calls to ported numbers. The ISCP/LNP supports both the AIN and IN query formats for access to LRN routing information.
- Providing the Message Relay Service (MRS) - the ISCP/LNP also supports the MRS that allows the ISCP to receive service messages, perform a 10-digit translation on the relevant address if the number has been ported, and relay those messages to the recipient switch or network data base. This functionality is necessary to ensure the proper routing of LIDB, Calling Name Delivery Service, CLASS and Interswitch Voice Messaging (ISVM) queries in an LNP environment.

Bellcore's LNP SMS product, part of the ASMS family of products, provides both the Service Order Administration (SOA) and Local Service Management System (LSMS) functions based on the NPAC SMS Interoperable Interface Specifications (IIS).

The LNP SMS can interface with Operations Systems flows for LNP, with the Number Portability Administration Center (NPAC), and with the ISCP/LNP network database solution.

## 14.9 Integrated Services Digital Network

Integrated Services Digital Network (ISDN) is a digital, public telecommunication network that integrates both voice and data. It has signaling, switching, and transport capabilities.

ISDN is the principal component of the evolving *Intelligent Network* (IN). As such, it will provide the capability to offer a wide variety of services that can take full advantage of a worldwide digital network.

ISDN technical standards and requirements have developed, and ISDN-based services are being deployed in the Network. An important component of service development is interworking between ISDN and existing services. Functionality with non-ISDN services is key to the successful deployment of ISDN.

Development of ISDN is driven by a combination of cost and operational savings considerations, and by demand for new services. Before ISDN can be fully deployed, however, network products must be developed to appropriate standards for the achievement of a nationally and internationally compatible environment. At this time many of these ISDN standards have been developed in recommendations of the International Telecommunication Union—Telecommunication Standardization Sector (ITU-T)<sup>1</sup> and the American National Standards Institute (ANSI).

### 14.9.1 Types of Service

There are two types of ISDN service, narrowband ISDN and broadband ISDN. This section will focus on narrowband ISDN. (See Section 14.12 for a description of Asynchronous Transfer Mode [ATM] based Broadband ISDN [BISDN].) The network architecture of ISDN will be compatible with other network architectures and must be consistent across vendor equipment.

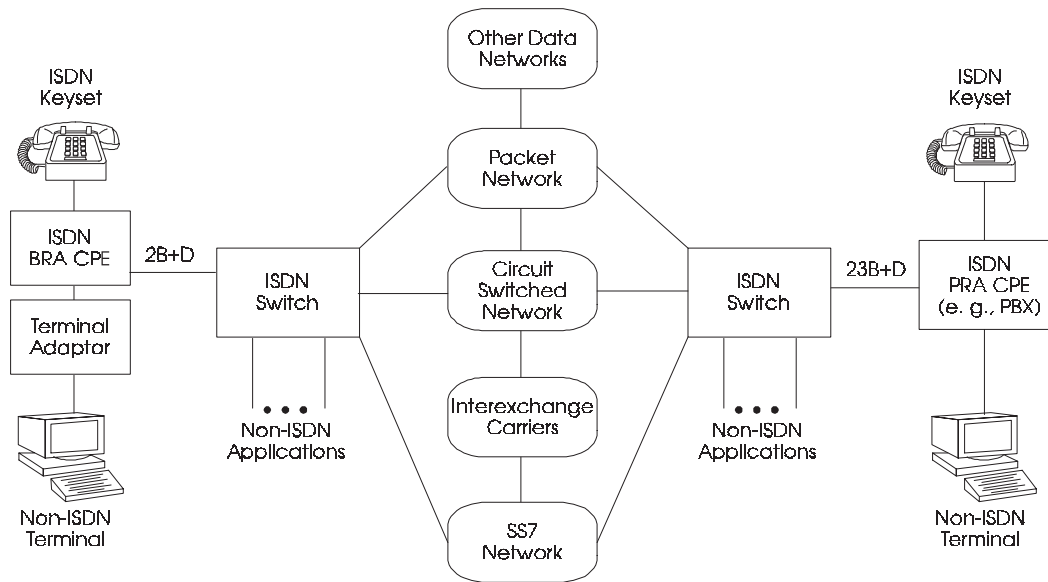
Figure 14-19 illustrates the network architecture of compatible ISDNs. The drawing shows both voice and data applications for Basic Rate Access (BRA) and Primary Rate Access (PRA) ISDN. As illustrated, ISDN provides the customer with access to the circuit-switched network, the packet network, and signaling access over the Common Channel Signaling (CCS) network (Signaling System 7 [SS7]).

A circuit-switched connection gives the subscriber exclusive use of the channel. Packet-switched data is transmitted one packet at a time as channel capacity becomes available. This allows users to send voice and data information simultaneously.

---

1. Formerly the International Telegraph and Telephone Consultative Committee (CCITT).

---

**Legend:**

- BRA = Basic Rate Access
- CPE = Customer Premises Equipment
- PBX = Private Branch Exchange
- PRA = Primary Rate Access
- SS7 = Signaling System 7
- 2B+D = Two 64 kbps B (bearer) channel and one 16 kbps D (delta) channel
- 23B+D = 23 B channels and 1 D channel

**Figure 14-19.** ISDN Network Architecture**14.9.2 The Local Loop**

The BRA ISDN line provides full-duplex transport of ISDN basic access over a 2-wire, nonloaded copper loop up to 18 kft, regardless of bridged-tap. The standard ISDN 2 Binary to 1 Quaternary (2B1Q) line code product will provide this range capability. Subscribers beyond 18 kft must be served from either a remote switching device or a Digital Loop-Carrier (DLC) system. The PRA ISDN line is a T1-carrier system that uses 4-wire transmission.

**14.9.3 Central Office Equipment**

ISDN service is provided from a digital switch, a digital Remote Switching Unit (RSU), or a DLC system. Line demand, growth rate, and current and future customer requirements

must be analyzed in the design of the serving arrangement. An ISDN line consumes more power than a Plain Old Telephone Service (POTS) line.

A BRA ISDN line can replace as many as three existing frame terminations with a single line, thus reducing the number of cross-connects required. The ISDN PRA line will be cross-connected the same as a Digital Signal level 1 (DS1).

#### **14.9.4 SS7**

Clear-Channel Capability (CCC) of 64 kbps is required on ISDN interoffice facilities. Without CCC, only 56 kbps of the DS0 signal is usable by the customer because of signaling and maintenance requirements. CCC allows all 64 kbps to be used by the customer because signaling is passed out-of-band on a channel separate from customer information. This network is commonly referred to as CCS and SS7 protocol. Other than island applications, CCS is a prerequisite for compatible ISDN. SS7 establishes and releases interoffice circuit connections for calls that either originate from or terminate at an ISDN interface.

#### **14.9.5 Service Characteristics**

There are two types of narrowband ISDN access, BRA and PRA.

##### **14.9.5.1 BRA ISDN**

BRA ISDN provides the user with two 64 kbps B (Bearer) channels and one 16 kbps D (Delta) channel, also known as 2B+D. Additionally, a 4 kbps M channel is available for service provider use to manage the line. Information is transmitted over the BRA ISDN line at 144 kbps.

The B channel delivers either digitized voice, data, or image. It can carry a variety of services such as pulse-code modulated voice or data.

The D channel is multifunctional. It delivers signaling information and multiplexed packet data.

##### **14.9.5.2 PRA ISDN**

The North American PRA ISDN offers 23 B channels and 1 D channel, also known as 23B + D. Information is delivered over a single T1-carrier system at a rate of 1.544 Mbps, which includes 8 kbps for overhead. PRA ISDN is full duplex and can serve large-business applications and Private Branch Exchanges (PBXs).

---

### 14.9.5.3 Call-Processing Numbering Plan

ISDN will be integrated into the 10-digit format of the North American Numbering Plan (NANP). Numbers will be assigned to ISDN lines within existing geographic central-office codes, in the same format that POTS numbers are assigned (NPA-NXX-XXXX). ISDN numbering is defined in the CCITT Recommendation E.164 numbering plan.

## 14.9.6 National ISDN

The goal of the various ISDN deployment plans is to ensure that all users will be able to utilize a broad spectrum of integrated voice and data services, locally, nationally, and internationally in a convenient and consistent manner. This includes interoperability with existing networks and services.

To achieve this goal, the LECs, as well as other telecommunications service providers, network and customer equipment suppliers, and end users have adopted National ISDN.

National ISDN is an evolving ISDN architecture with a wide array of capabilities and features serving a variety of applications and users. The foundation of National ISDN is a platform of basic building blocks upon which additional services, driven by user needs, are developed and provided in a standard format.

### 14.9.6.1 National ISDN-1

The initial step toward achieving the long term goal of National ISDN was National ISDN-1 (NI-1), which was introduced into the LEC networks during the fourth quarter of 1992 (see SR-NWT-001937, *National ISDN-1*, for description). NI-1 users are able to communicate with vendor proprietary ISDN, non-ISDN and PRA users, and vice versa, regardless of location and equipment. This requires the ability to interconnect with Interexchange Carriers (IC) and independent LEC networks.

NI-1 provides the following network capabilities briefly described below.

#### **Access, Call Control, and Signaling**

If switching systems are to communicate with other equipment (network and user), it is critical that protocols be established to permit these communications to take place. NI-1 defined uniform protocols for BRA call control and services.

---

---

## Standard Network/Customer Premises Equipment Interface

NI-1 provided protocol portability, that is, Customer Premises Equipment (CPE) must be able to work on any network switch and be able to access the services provided by that switch.

In addition, NI-1 provided backward compatibility with some prestandard services provided to existing large business Centrex customers. The ISDN terminal on a standard network/CPE interface is able to access all analog POTS and Centrex features. Analog customers on the network did not lose functionality when NI-1 was introduced.

## Service Configurations

There are two service configurations supported by the switch for NI-1.

1. *Single User with Multiple Applications* (up to three — speech, circuit-switched data, and packet on the D channel) on a single 2B + D interface. The user has access to both B channels in order to use the applications simultaneously. This may be supported by a single integrated terminal.
2. *Sharing of an Interface Between Two Users* where each user may have multiple applications (up to three — speech, circuit switched data, and packet on the D channel). It is possible to restrict each user to a single B channel and to configure the interface for a single user with access to a single B channel. Each user may be supported by a single integrated terminal.

## Basic Rate Access Services

The following ISDN voice and circuit-switched data services and subfeatures are available on the BRA interface for NI-1:

- Call Forwarding
  - Call Forwarding Variable
  - Call Forwarding Interface Busy
  - Reminder Notification
  - Redirecting Number
  - Redirecting Reason
  - Courtesy Call.
- Automatic Callback
  - Automatic Callback Intraswitch.
- Call Hold

- Hold and Retrieve.
  - Additional Call Offering
    - Additional Call Offering, Unrestricted
    - Notification Busy Line.
  - Flexible Calling
    - Consultation Hold
    - Add On
    - Implicit and/or Explicit Transfer
    - Three-Way Conference Calling
    - Six-Party Conference Calling
    - Conference Hold and Retrieve
    - Drop Last Call on Conference
    - Add Previously Held Call to Conference.
  - Calling Number Identification Services
    - Calling Party Number Privacy
    - Network Provided Number Delivery
    - Redirecting Number
    - Redirecting Reason.
  - Message Service
    - Message Waiting Indicator.
  - Display Service
    - Protocol and Procedures.
  - Electronic Key Telephone System (EKTS)
    - Multiple Directory Numbers per Terminal
    - Multiple Directory Number Appearances
    - Hold/Retrieve
    - Bridging/Directory Number (DN) Bridging
    - Intercom Calling
    - Membership in a Multiline Hunt Group (MLHG)
-



- 
- Abbreviated and Delayed Ringing
  - Automatic Bridged Call Exclusion
  - Call Appearance Call Handling.
  - Station Message Detail Recording (SMDR)
  - MLHGs
    - Linear Hunting
    - Circular Hunting
    - Uniform Hunting
    - Stop Hunt
    - Make Busy
    - Analog Members in Hunt Group.
  - Basic Business Group (BBG)
    - Simulated Facility Groups for In and Out Calls.
  - Business Group Dial Access Features
    - Business Group Dialing Plan
    - Intercom Dialing
    - Abbreviated Dialing
    - Dial Access to Private Facilities
    - Dial Access to ARS
    - Customer Access Treatment Code Restrictions
    - Code Restriction and Diversion
    - Direct Outward Dialing (DOD)
    - Direct Inward Dialing (DID).
  - Call Pickup.

The following ISDN packet-mode services are available on the BRA interface for NI-1:

- ISDN Call Control
    - D channel packet on Basic Rate Interface (BRI) (single and multiple terminal)
    - Provisioned B channel packet on BRI
    - User access to both B channel and D channel packet
-

- 
- Subscription on a per-terminal basis is sufficient, using the model of one DN per terminal.
  - Public Packet Switched Network (PPSN) Call Control and X.25 Features:
    - CUG, CUG/OS, CUG/IA
    - Reverse Charging, Reverse Charging acceptance
    - Recognized Private Operating Agency (RPOA) selection
    - IC preselection
    - ITU-T Data Terminal Equipment (DTE) facilities.
  - PPSN Call Control, and X.75 and X.75 Utility Support:
    - All X.75 utilities in minimal subset, including RPOA selection
    - Selective support of X.75 utilities:
      - a. X.75 utilities on X.75
      - b. Access characteristics
      - c. X.75 interface identifier
      - d. IC preselection indication.
    - Full Automatic Message Accounting (AMA) support for packet, with the exception of aggregate records for virtual circuit services.
  - Numbering and Routing
    - All PMD routing and digit analysis requirements
    - Numbering plan interworking.
  - User-to-User with Call Control
    - Fast Select, Fast Select Acceptance
    - 16 octets of data in call request.
  - ISDN X.25 Supplementation Services
    - 1-way logical channel outgoing/incoming
    - Incoming/outgoing calls barred
    - Parameter negotiation
    - Throughput class negotiation
    - Transit delay
    - User testing.
-

- 
- BBG
    - Inclusion of packet in BBG.
  - Business Group Dialing Plan
    - Inclusion of packet in Business Group Dialing Plan.
  - MLHG
    - Linear and/or circular hunting for packet
    - Assignment of non-hunt DNs to hunt terminals.
  - ISDN Calling Number ID
    - Inband calling number for packet.
  - ISDN AMA
    - Full AMA support for packet, with the exception of aggregate records for virtual circuit services.

### **Primary Rate Interface Capabilities**

NI-1 provides a basic set of supplier-specific Primary Rate Interface (PRI) capabilities.

### **Operations Support and Billing Capabilities**

NI-1 defines the capabilities necessary for network providers to maintain and bill the services offered. Some of the capabilities are testing, surveillance, memory administration, data collection, and traffic management. SR-NWT-001937 provides the list of NI-1 operations and billing capabilities.

#### **14.9.6.2 National ISDN-2**

National ISDN-2 builds on the work begun in NI-1 (see description in SR-NWT-002120, *National ISDN-2*). It offers an expansion of the uniform user-to-network interface configurations for BRA. NI-2 began in 1993-1994.

### **Uniform Interface Configurations for BRA**

NI-2 removes the interface restrictions placed on the user due to the technical limitations of NI-1 by providing the following capabilities:

1. Support of more than two B-channel terminals on a BRA
2. Support of DN sharing over multiple call types on an integrated terminal.

## Uniformity of BRA Services

With NI-1, a switching system is not required to support uniform operation of the services. Thus, an end user may notice differences in the manner in which a feature operates among the various switching systems. With NI-2, selected ISDN features are provided with uniform feature operation. A list of features and subfeatures provided with uniform operation follows:

- Electronic Key Telephone Service (EKTS)
  - Multiple DNs per Terminal
  - Analog Member in an EKTS Group
  - Multiple DN Appearances/Call Appearance Call Handling
  - Hold/Retrieve
  - Bridging/DN Bridging
  - Intercom Calling
  - Membership in an MLHG
  - Abbreviated Ringing and Delayed Ringing
  - Automatic and/or Manual Bridged Call Exclusion.
- ISDN Call Forwarding
  - Call Forwarding Variable
  - Call Forwarding Interface Busy
  - Call Forwarding Don't Answer
- ISDN Call Hold
  - Hold and Retrieve
  - B-Channel Reservation (excluding release).
- Additional Call Offering (ACO)
  - ACO — Unrestricted
  - Notification Busy Limit.

**Note:** NI-2 requires a switching system to provide ACO for circuit-mode calls (that is, speech and circuit-switched data call types). ACO for packet-mode is not part of NI-2.

- Flexible Calling
    - Conference Calling (3-port and 6-port)
    - Consultation Hold
-

- 
- Implicit Call Transfer
  - Explicit Call Transfer
  - Drop Last Call on Conference.
  - Calling Number Identification Services for BRI
    - Delivery of network-provided Calling Number
    - Privacy of Calling Number
    - Delivery of Redirecting Number
    - Privacy of Redirecting Number
    - Delivery of Redirecting Reason
    - Ability to segregate Number Delivery on InterBBG/IntraBBG basis.
  - ISDN Display Service
    - Uniform Text (for NI-2 Uniform Services).

### **Primary Rate Interface Capabilities**

NI-2 began to define uniform PRA call control and the following additional PRI capabilities:

- The following subfeatures of Call-by-Call Service Selection are provided in a uniform manner in NI-2:
    - Access to and termination from non-ISDN Foreign Exchange (FX) facilities
    - Access to and termination from non-ISDN tie trunks
    - Inward Wide Area Telecommunication Service (INWATS)
    - Outward Wide Area Telecommunication Service (OUTWATS)
    - Access to electronic tandem networks on a call-by-call basis (provided on a supplier-specific basis).
  - Calling Number Identification Services for PRA
    - Delivery of network-provided Calling Number
    - Privacy of Calling Number
    - Delivery of Redirecting Number
    - Privacy of Redirecting Number
    - Delivery of Redirecting Reason
    - Screening Functions.
-

- Switched DS1/Switched Fractional DS1 (SWF-DS1) service capability [described in TR-NWT-001203, *Generic Requirements for the Switched DS1/Switched Fractional DS1 Service Capability from an ISDN Interface (SWF-DS1/ISDN)*] allows the user to establish and clear calls to and from a PRI at N times 64 kbps rates, where N is a value ranging from 2 through 24. The 384 kbps rate (that is, where N equals 6) is referred to as an H0 channel and the 1536 kbps rate (that is, where N equals 24) is referred to as an H11 channel.
- Interworking with Private Networks allows a PRI to be used within a private network as a tie trunk. A tie trunk can connect two PBXs, two BBGs, or a PBX and a BBG. A tie trunk is leased by a user for exclusive utilization by that user. Access to a tie trunk can be via dial-access codes or a private network routing feature. Supplier-specific implementations of this capability are provided in NI-2.

### Improved Data Capabilities

NI-2 provided the following improved data capabilities:

- User-originated, on demand B-Channel packet on BRI
- PPSN capabilities including
  - Clearing subnetwork identification for X.75
  - Transit subnetwork count for X.75
  - Multilink procedures on X.75/X.75 (supplier-specific alternative acceptable in NI-2)
  - Support of X.75 end office connections.
- ISDN X.25 local charging prevention.

### Operations Support Capabilities

- *Parameter Downloading* (described in TR-NWT-001281, *ISDN Parameter Downloading Generic Requirements*) is a capability where the switch will send certain service parameters (for example, DNs, feature activators/indicators) to the terminal. It is intended to minimize the need for end users to manually enter these parameters into their terminals.
  - *The NI-2 focus for network operations* was to provide the capabilities to adequately support NI-1 and NI-2 services to maximize service quality and minimize operations costs. The regional companies identified the 15 most critical operations items needed for NI-2. The switch suppliers may offer partially compliant implementations at the onset of NI-2. Refer to SR-NWT-002120 for a list of NI-2 operations capabilities.
-

---

These 15 items are a subset of the complete set of operations capabilities identified by the LECs for full support of National ISDN. A complete list is found in Appendix D of SR-NWT-002120.

### **Billing Capabilities**

The features defined for NI-2 require uniform and compliant AMA to allow the LECs to meet the end users' need to have accurate, usage-sensitive billing. In addition, uniform measurements for these features will allow LECs flexibility in tailoring their product offerings to the requirements of individual end users.

Detailed information on AMA requirements for NI-2 are found in Section 3.7 of SR-NWT-002120.

#### **14.9.6.3 National ISDN-3 and National ISDN 1995, 1996, 1997, and 1998**

The first step of the National ISDN evolution was the initial deployment of National ISDN-1 (described in SR-NWT-001937, National ISDN-1[2]) in the fourth quarter of 1992. The second step, National ISDN-2 (described in SR-NWT-002120, National ISDN-2[3]), was introduced beginning in late 1993. National ISDN-3 (described in SR-NWT-002457, National ISDN-3[4]) along with other services developed through the National ISDN Enhancements Process was introduced starting in 1995.

As National ISDN-3 was introduced, it was recognized that tracking the substantial number of features available in each of the National ISDN product issues was becoming more complex. To simplify this process, SR-3476, National ISDN 1995 and 1996[5] was released in June 1995 to describe the National ISDN features and capabilities that would be supported by the National ISDN switch suppliers by the end of the first quarter of 1996. SR-3476 includes a cumulative view of the services that are generally available as of the end of the first quarter of 1995 and the additional services that became generally available in the first quarter of 1996.

Similarly, SR-3875, National ISDN 1995, 1996, and 1997 was released in June 1996 to describe the National ISDN features and capabilities that were to be supported by the National ISDN switch suppliers by the end of the first quarter of 1997. SR-3875 includes a cumulative view of the services that are generally available as of the end of the first quarter of 1996 and the additional services that are generally available in the first quarter of 1997.

Issue 2 of SR-3875, summarizes the National ISDN features and capabilities that will be supported by the National ISDN switch suppliers by the end of the first quarter of 1998. This includes a cumulative view of the services that are generally available as of the end of the first quarter of 1995, those services available by the first quarter of 1996, those services available by the first quarter of 1997 and the additional services that are planned to be generally available in the first quarter of 1998.

---

Tables 14-1 through 14-8 summarize the complete set of National ISDN capabilities available in 1995, 1996, 1997, and 1998. To be included on the matrix, the National ISDN capability must be generally available by at least two of the three major National ISDN switch suppliers by the first quarter of the given year

The reference column provides SR and/or TR/GR documentation references for the feature.

In the case of SR references, an additional letter or number is included in parentheses. The numbers (1), (2), and (3) indicate that the SR cited defines National ISDN - 1, - 2, or - 3, respectively. The letters (E), (G), or (N) indicate that the SR defines the NI Enhancements, the 1996 or 1997 CPE Guidelines, or the previous NI-95/96/97 feature set document, respectively.

A dash (-) in the NI-95, NI-96, or NI-97 column indicates that the associated capability is either not supported by any suppliers or supported by only one supplier. An asterisk (\*) in the NI-95, NI-96, NI-97, or NI-98 columns indicates that the capability is supported by two suppliers. A "Yes" indication in the NI-95, NI-96, NI-97, or NI-98 columns denotes that the capability is supported by three suppliers.

**Table 14-1. BRI Access, Call Control, and Signaling**

Feature or Capability	References	NI-95	NI-96	NI-97	NI-98
ISDN BRI Layer 1	SR1937 (1)	Yes	Yes	Yes	Yes
4:1 TDM Method for ISDN Basic Access	SR2457 (3)	*	Yes	Yes	Yes
ISDN BRI Layer 2	SR1937 (1)	Yes	Yes	Yes	Yes
BRI Circuit-Mode Call Control	SR1937 (1)	Yes	Yes	Yes	Yes
Basic Call Control	SR1937 (1)	Yes	Yes	Yes	Yes
BRI Terminal Initialization	SR1937 (1)	Yes	Yes	Yes	Yes
Service Profile Identifier	SR2120 (2)	Yes	Yes	Yes	Yes
Parameter Downloading	SR2120 (2)	*	*	*	Yes
Parameter Downloading - Version 2 (Extensions for Virtual Key Service)	SR3681 (E)	-	-	-	*
Automatic SPID	SR3681 (E)	-	-	-	*
Default Services for Terminals	SR2457 (3)	-	*	*	Yes
BRI Interworking with SS7	SR1937 (1)	Yes	Yes	Yes	Yes
ISDN BRI Packet-Mode Call Control	SR1937 (1)	Yes	Yes	Yes	Yes
User Originated, On-Demand B- Channel Packet	SR2120 (2)	*	*	*	*
Conditional Notification	SR3476 (N)	*	*	*	*



**Table 14-2.** Uniform Interface Configurations for BRI

Feature or Capability	References	NI-95	NI-96	NI-97	NI-98
Uniform Interface Configurations for BRIs					
Single User with Multiple Applications	SR1937 (1)	Yes	Yes	Yes	Yes
Two Users Sharing a BRI	SR1937 (1)	Yes	Yes	Yes	Yes
More than 2 B-Channel Terminals on a BRI (Passive Bus)	SR2120 (2)	*	*	*	*
Associated Group Indicator	SR3476 (N)	*	*	*	Yes
DN Sharing over Multiple Call Types on an Integrated Terminal	SR2120 (2)	*	*	*	Yes
Non-Initializing Terminals	SR2457 (3)	-	*	*	Yes
Assignment of Feature Keys to Default TSP (NITs)	SR2457 (3)	-	-	-	*
Feature Available to NITs	SR2457 (3)				
Message Service	SR2457 (3)	-	-	-	*
Flexible Calling	SR2457 (3)	-	-	-	*
Automatic Callback	SR2457 (3)	-	-	-	*
Support of 2 Simultaneous Voice Calls on Different B-Channels from a Single TEI	SR3681 (E)	-	-	-	Yes

**Table 14-3.** BRI Features (Sheet 1 of 8)

Feature or Capability	References	NI-95	NI-96	NI-97	NI-98
EKTS					
Multiple DNs per Terminal	SR2120 (2)	Yes	Yes	Yes	Yes
Analog Member in an EKTS Group	SR2120 (2)	Yes	Yes	Yes	Yes
Multiple DN Appearances/CACH	SR2120 (2)	*	*	*	Yes
Hold/Retrieve	SR2120 (2)	Yes	Yes	Yes	Yes
Bridging/DN-Bridging	SR2120 (2)	Yes	Yes	Yes	Yes
Intercom Calling	SR2120 (2)	Yes	Yes	Yes	Yes
Membership in a Multiline Hunt Group	SR2120 (2)	Yes	Yes	Yes	Yes
Abbreviated and Delayed Ringing	SR2120 (2)	Yes	Yes	Yes	Yes
Automatic Bridged Call Exclusion	SR2120 (2)	Yes	Yes	Yes	Yes
Manual Bridged Call Exclusion	SR2120 (2)	Yes	Yes	Yes	Yes

**Table 14-3. BRI Features (Sheet 2 of 8)**

<b>Feature or Capability</b>	<b>References</b>	<b>NI-95</b>	<b>NI-96</b>	<b>NI-97</b>	<b>NI-98</b>
Allow EKTS DNs and Call Appearances to be Restricted to Originating or Terminating Only	SR3681 (E), TR205	-	-	-	*
Allow EKTS DNs and Call Appearances to be Restricted to Originating and Priority Incoming Only	SR3681 (E), TR205	-	-	-	*
Call Forwarding					
Call Forwarding Variable	SR2120 (2)	*	*	*	Yes
Courtesy Call	SR2120 (2)	*	*	*	Yes
Reminder Notification	SR2120 (2)	*	*	*	Yes
Call Forwarding Interface Busy	SR2120 (2)	*	*	*	Yes
Call Forwarding Don't Answer	SR2120 (2)	*	*	*	Yes
Call Forwarding Variable Customer Group	SR1937 (1)	Yes	Yes	Yes	Yes
Redirecting Number	SR2120 (2)	-	*	*	*
Redirecting Reason	SR2120 (2)	-	*	*	*
Call Forwarding Intragroup Only	SR1937 (1)	Yes	Yes	Yes	Yes
Call Forwarding Incoming Only	SR3339 (G)	-	-	-	*
Call Forwarding Interface Busy Incoming Only	SR1937 (1)	Yes	Yes	Yes	Yes
Call Forwarding Don't Answer Incoming Only	SR1937 (1)	Yes	Yes	Yes	Yes

Table 14-3. BRI Features (Sheet 3 of 8)

Feature or Capability	References	NI-95	NI-96	NI-97	NI-98
Call Forwarding Over Private Facilities					
Voice	SR3476 (N)	*	Yes	Yes	Yes
Circuit-Mode Data	SR3476 (N)	*	*	*	*
ISDN Call Hold	SR2120 (2)	Yes	Yes	Yes	Yes
Hold and Retrieve	SR2120 (2)	Yes	Yes	Yes	Yes
Flexible Calling					
Three-Way and Six-Way Conference Calling	SR2120 (2)	Yes	Yes	Yes	Yes
Simultaneously Assign 3-Way and 6-Way Conference to Controller	SR3476 (N)	*	*	*	Yes
Consultation Hold	SR2120 (2)	Yes	Yes	Yes	Yes
Conference Hold and Retrieve	SR2120 (2)	Yes	Yes	Yes	Yes
Drop Last Call on Conference	SR2120 (2)	Yes	Yes	Yes	Yes
Implicit Call Transfer	SR2120 (2)	Yes	Yes	Yes	Yes
Explicit Call Transfer	SR2120 (2), TR858	-	-	-	*
Additional Call Offering - Unrestricted	Yes	Yes	Yes	Yes	
Notification and Call Reference Busy Limits	SR2120 (2)	Yes	Yes	Yes	Yes
Calling Number Identification Services for BRI					
Delivery of NP CPN	SR2120 (2)	*	*	*	*
Privacy of CPN	SR2120 (2)	*	*	*	Yes
Delivery of Redirecting Number	SR2120 (2)	*	*	*	*
Privacy of Redirecting Number	SR2120 (2)	*	*	*	*
Delivery of Redirecting Reason	SR2120 (2)	*	*	*	*
Privacy Change Allowed	SR3681 (E)	-	-	-	*
Calling Party Number Subaddress	SR3339 (G)	Yes	Yes	Yes	Yes
Screening	SR3339 (G)	*	*	*	*
Ability to Segregate Number Delivery on Intra-BBG/Inter-BBG Basis	SR2120 (2)	*	Yes	Yes	Yes
Allow number privacy change to be generally available to all users w/o subscription	SR2120 (2)	*	*	*	Yes

**Table 14-3. BRI Features (Sheet 4 of 8)**

<b>Feature or Capability</b>	<b>References</b>	<b>NI-95</b>	<b>NI-96</b>	<b>NI-97</b>	<b>NI-98</b>
ISDN Display Service					
Protocol and Procedures	SR1937 (1)	Yes	Yes	Yes	Yes
Uniform Text (for NI-2 Uniform Services)	SR2120 (2)	*	*	*	*
Automatic Callback Intraswitch	SR1937 (1)	Yes	Yes	Yes	Yes
Any Designated Call	SR1937 (1), TR855	*	*	*	Yes
Message Service					
Message Waiting Indicator	SR1937 (1)	Yes	Yes	Yes	Yes
Audible Message Waiting Indicator	SR3339 (G)	*	*	*	*
Message Waiting Indicator Deactivation	SR3339 (G)	*	*	*	*
Multiline Hunt Group					
Analog Members in Hunt Group	SR1937 (1)	Yes	Yes	Yes	Yes
Linear Hunting	SR1937 (1)	Yes	Yes	Yes	Yes
Circular Hunting	SR1937 (1)	Yes	Yes	Yes	Yes
Uniform Hunting	SR1937 (1)	Yes	Yes	Yes	Yes
Stop Hunt	SR1937 (1)	Yes	Yes	Yes	Yes
Queuing and Delay Announcement	SR3339 (G)	*	*	*	*
Calls Waiting Lamps	SR3339 (G)	*	*	*	*
Make Busy	SR1937 (1)	Yes	Yes	Yes	Yes
Basic Business Group					
Inclusion of Non-ISDN Circuit-Mode Lines	SR1937 (1)	Yes	Yes	Yes	Yes
Inclusion of Non-ISDN Circuit-Mode Private Facilities	SR1937 (1)	Yes	Yes	Yes	Yes
Semi-Restricted Originating Access	SR1937 (1)	Yes	Yes	Yes	Yes
Semi-Restricted Terminating Access	SR1937 (1)	Yes	Yes	Yes	Yes
Semi-Restricted Line	SR1937 (1)	Yes	Yes	Yes	Yes
Fully-Restricted Originating Access	SR1937 (1)	Yes	Yes	Yes	Yes
Fully-Restricted Terminating Access	SR1937 (1)	Yes	Yes	Yes	Yes
Fully-Restricted Line	SR1937 (1)	Yes	Yes	Yes	Yes
Denied Originating	SR1937 (1)	Yes	Yes	Yes	Yes
Special Intercept Announcement	SR3339 (G)	*	*	*	*
Denied Terminating	SR1937 (1)	Yes	Yes	Yes	Yes

**Table 14-3. BRI Features (Sheet 5 of 8)**

Feature or Capability	References	NI-95	NI-96	NI-97	NI-98
Simulated Facility Groups for In and Out Calls	SR1937 (1)	Yes	Yes	Yes	Yes
Distinctive Alerting Indication	SR3476 (N)	Yes	Yes	Yes	Yes
Business Group Dial Access Features					
Business Group Dialing Plan	SR1937 (1)	Yes	Yes	Yes	Yes
Manual/Direct Connect	SR3339 (G)	-	-	-	*
Expensive Route Warning Tone	SR3339 (G)	Yes	Yes	Yes	Yes
Abbreviated Dialing for Circuit-Mode Calls	SR1937 (1)	Yes	Yes	Yes	Yes
Intercom Dialing	SR1937 (1)	Yes	Yes	Yes	Yes
Single-Digit Dialing	SR1937 (1)	Yes	Yes	Yes	Yes
Attendant Access	SR1937 (1)	Yes	Yes	Yes	Yes
Speed Dialing Access	SR1937 (1)	Yes	Yes	Yes	Yes
Dial Access to Private Facilities	SR1937 (1)	Yes	Yes	Yes	Yes
Dial Access to Automatic Flexible Routing	SR1937 (1)	Yes	Yes	Yes	Yes
Customer Access Treatment Code Restrictions	SR1937 (1)	Yes	Yes	Yes	Yes
Code Restriction and Diversion	SR1937 (1)	Yes	Yes	Yes	Yes
Direct Outward Dialing	SR1937 (1)	Yes	Yes	Yes	Yes
Direct Inward Dialing	SR1937 (1)	Yes	Yes	Yes	Yes
ISDN Call Pickup	Yes	Yes	Yes	Yes	
ISDN Directed Call Pickup					
Barge-In	SR3476 (N)	*	*	*	*
Nonbarge-In	SR3476 (N)	*	*	*	*
Attendant Access	SR1937 (1)	Yes	Yes	Yes	Yes
Station Message Detail Recording	SR1937 (1)	Yes	Yes	Yes	Yes
Access to Analog					
Multiline Variety Package	SR1937 (1)	Yes	Yes	Yes	Yes
Free Terminating Service	SR1937 (1)	Yes	Yes	Yes	Yes
Speed Calling	SR1937 (1)	Yes	Yes	Yes	Yes
Customer-Changeable Speed Calling	SR1937 (1)	Yes	Yes	Yes	Yes
Remote Call Forwarding	SR1937 (1)	Yes	Yes	Yes	Yes
Trunk Answer Any Station	SR1937 (1)	Yes	Yes	Yes	Yes

**Table 14-3. BRI Features (Sheet 6 of 8)**

Feature or Capability	References	NI-95	NI-96	NI-97	NI-98
Foreign Exchange Facilities	SR1937 (1)	Yes	Yes	Yes	Yes
800 Service (INWATS)	SR1937 (1)	Yes	Yes	Yes	Yes
800 Service - Simulated Facility Group (SFG)	SR1937 (1)	Yes	Yes	Yes	Yes
Regulatory - Two-Way WATS	SR1937 (1)	*	*	Yes	Yes
Outward Wide Area Telecommunications (OUTWATS)	SR1937 (1)	Yes	Yes	Yes	Yes
OUTWATS Simulated Facility Group	SR1937 (1)	Yes	Yes	Yes	Yes
Tie Facility Access	SR1937 (1)	Yes	Yes	Yes	Yes
Electronic Tandem Switching (ETS) Access	SR1937 (1)	Yes	Yes	Yes	Yes
Enhanced Private Switched Communication Service (EPSCS) Access	SR1937 (1)	Yes	Yes	Yes	Yes
Dial Access to Private Facilities	SR1937 (1)	Yes	Yes	Yes	Yes
Tandem Tie Facility Dialing	SR1937 (1)	Yes	Yes	Yes	Yes
Radio Paging Access	SR1937 (1)	Yes	Yes	Yes	Yes
Code Calling	SR1937 (1)	Yes	Yes	Yes	Yes
Loudspeaker Paging	SR1937 (1)	Yes	Yes	Yes	Yes
Selective Control of Facilities	SR1937 (1)	Yes	Yes	Yes	Yes
Deluxe Queuing	SR1937 (1)	Yes	Yes	Yes	Yes
Off-Hook Queuing	SR1937 (1)	Yes	Yes	Yes	Yes
On-Hook Queuing	SR1937 (1)	Yes	Yes	Yes	Yes
Post-Queue Routing	SR1937 (1)	Yes	Yes	Yes	Yes
Priority Queuing	SR1937 (1)	Yes	Yes	Yes	Yes
Service Protection	SR1937 (1)	*	*	*	Yes
Automatic Route Selection (ARS)	SR1937 (1)	Yes	Yes	Yes	Yes
Deluxe Automatic Route Selection	SR1937 (1)	Yes	Yes	Yes	Yes
Automatic Alternate Routing	SR1937 (1)	Yes	Yes	Yes	Yes
Uniform Numbering	SR1937 (1)	Yes	Yes	Yes	Yes
Off-Network-to-On-Network Conversion	SR1937 (1)	Yes	Yes	Yes	Yes
On-Network-to-Off-Network Conversion	SR1937 (1)	Yes	Yes	Yes	Yes
Facility Restriction Level	SR1937 (1)	Yes	Yes	Yes	Yes

**Table 14-3. BRI Features (Sheet 7 of 8)**

Feature or Capability	References	NI-95	NI-96	NI-97	NI-98
Alternate Facility Restriction Level	SR1937 (1)	Yes	Yes	Yes	Yes
Expensive Route Warning Tone	SR1937 (1)	Yes	Yes	Yes	Yes
Manual/Time-of-Day Routing Control	SR1937 (1)	Yes	Yes	Yes	Yes
Authorization Codes for AFR	SR1937 (1)	Yes	Yes	Yes	Yes
Account Codes for AFR	SR1937 (1)	Yes	Yes	Yes	Yes
Customer Dialed Account Recording (CDAR)	SR1937 (1)	Yes	Yes	Yes	Yes
Attendant Access to Code Calling	SR1937 (1)	Yes	Yes	Yes	Yes
Attendant Conference	SR1937 (1)	Yes	Yes	Yes	Yes
Night Service - Attendant	SR1937 (1)	Yes	Yes	Yes	Yes
Power Failure Transfer - Attendant	SR1937 (1)	Yes	Yes	Yes	Yes
Dial Through Attendant	SR1937 (1)	Yes	Yes	Yes	Yes
Attendant Tie Trunk Busy Verification	SR1937 (1)	Yes	Yes	Yes	Yes
Basic Emergency Service (911)	SR1937 (1)	Yes	Yes	Yes	Yes
Tracing of Terminating Calls	SR1937 (1)	Yes	Yes	Yes	Yes
Tandem Call Tracing	SR1937 (1)	Yes	Yes	Yes	Yes
Trace of a Call in Progress	SR1937 (1)	Yes	Yes	Yes	Yes
Series Completion	SR1937 (1)	Yes	Yes	Yes	Yes
Automatic Callback (Interswitch)	SR1937 (1)	Yes	Yes	Yes	Yes
Automatic Recall	SR1937 (1)	Yes	Yes	Yes	Yes
Bulk Calling Line Identification	SR1937 (1)	*	*	*	*
Customer Originated Trace	SR1937 (1)	Yes	Yes	Yes	Yes
Screening List Editing	SR1937 (1)	Yes	Yes	Yes	Yes
Selective Call Acceptance	SR1937 (1)	Yes	Yes	Yes	Yes
Selective Call Forwarding	SR1937 (1)	Yes	Yes	Yes	Yes
Selective Call Rejection	SR1937 (1)	Yes	Yes	Yes	Yes
ISDN Calling Name Identification Services					
Calling Name Delivery	SR2457 (3)	-	-	*	Yes
Calling Name Delivery Blocking (Privacy)	SR2457 (3)	-	-	*	*
Calling Identity Delivery and Suppression	SR2457 (3)	-	-	*	Yes
ISDN Delivery Feature Deactivation/Reactivation	SR2457 (3)	-	-	*	Yes

**Table 14-3. BRI Features (Sheet 8 of 8)**

Feature or Capability	References	NI-95	NI-96	NI-97	NI-98
911 Limitations and Restrictions					
Hold Not Allowed for a 911 Call	SR3681 (E), TR858	*	*	*	*
Add a 911 Call to a Conference	SR3681 (E), TR858	*	*	*	*
Music On Hold	SR2457 (3)	-	-	-	Yes
Remote Access to ISDN Call Forwarding	SR3476 (N)	*	*	*	*

**Table 14-4. PRI Access, Call Control and Signaling**

Feature or Capability	References	NI-95	NI-96	NI-97	NI-98
PRI Layer 1	SR2120 (2)	*	*	*	Yes
PRI Layer 2 (Circuit)	SR2120 (2)	*	*	*	Yes
PRI Call Control and Signaling					
Basic Call Control for Circuit-Mode Calls	SR2120 (2)	*	*	*	Yes
Multiple DS1 Facilities Controlled by a Single D-Channel	SR2120 (2)	*	*	*	Yes
D-Channel Backup	SR2120 (2), TR1268	-	-	*	Yes
Access to Selected Primary Rate Services on a Per-Call Basis	SR2120 (2)	*	*	*	Yes
PRI Interworking with SS7	SR2120 (2)	*	*	*	Yes
PRI Packet-Mode Call Control	SR2120 (2)	*	*	*	*



**Table 14-5. PRI Features**

<b>Feature or Capability</b>	<b>References</b>	<b>NI-95</b>	<b>NI-96</b>	<b>NI-97</b>	<b>NI-98</b>
Calling Number Identification Services					
Delivery of Network-Provided Calling Number	SR2120 (2)	*	*	*	Yes
Privacy of Calling Number	SR2120 (2)	*	*	*	Yes
Delivery of Redirecting Number	SR2120 (2),TR1187	-	*	*	Yes
Privacy of Redirecting Number	SR2120 (2),TR1187	-	*	*	Yes
Delivery of Redirecting Reason	SR2120 (2),TR1187	-	*	*	Yes
Screening Functions	SR2120 (2)	*	*	*	Yes
Number Privacy Generally Available	SR3338 (G)	*	*	*	*
Billing Number Selection (Subset)	SR2120 (2), TR1187	-	-	-	*
Call-by-Call Service Selection					
FX	SR2120 (2)	*	*	*	Yes
Non-ISDN Tie	SR2120 (2)	*	*	*	Yes
INWATS	SR2120 (2)	*	*	*	Yes
OUTWATS	SR2120 (2)	*	*	*	Yes
Non-ISDN ETN	SR2120 (2)	*	*	*	*
Hotel/Motel Selective Class of Call Screening	SR2457 (3), TR1397	-	-	-	*
ISDN Calling Name Identification Services for PRI					
Calling Name Delivery	SR2457 (3), GR1367	-	-	-	*
Control of Presentation of Calling Name (Privacy)	SR2457 (3), GR1367	-	-	-	*

**Table 14-6. Packet Data Features and Capabilities (Sheet 1 of 2)**

<b>Feature or Capability</b>	<b>References</b>	<b>NI-95</b>	<b>NI-96</b>	<b>NI-97</b>	<b>NI-98</b>
PPSN Call Control and Features - X.25 Features					
CUG, CUG/OA, CUG/IA	SR1937 (1)	Yes	Yes	Yes	Yes
Reverse Charging, Reverse Charging Acceptance	SR1937 (1)	Yes	Yes	Yes	Yes
RPOA Selection	SR1937 (1)	Yes	Yes	Yes	Yes
IC Preselection	SR1937 (1)	Yes	Yes	Yes	Yes
CCITT DTE Facilities	SR1937 (1)	Yes	Yes	Yes	Yes
PPSN Call Control and Features - X.75 and X.75' Utility Support					
All X.75 Utilities in Minimal Subset	SR1937 (1)	Yes	Yes	Yes	Yes
Multilink Procedures on X.75/X.75'	SR2120 (2)	Yes	Yes	Yes	Yes
Support of X.75 End Office Connections	SR2120 (2)	Yes	Yes	Yes	Yes
Selective Support of X.75' Utilities:					
- X.75 Utilities on X.75'	SR1937 (1)	Yes	Yes	Yes	Yes
- Access Characteristics	SR1937 (1)	Yes	Yes	Yes	Yes
- X.75 Interface Identifier	SR1937 (1)	Yes	Yes	Yes	Yes
- IC Preselection Indication	SR1937 (1)	Yes	Yes	Yes	Yes
- Clearing Subnetwork Identification	SR2120 (2)	-	Yes	Yes	Yes
- Transit Subnetwork Count	SR2120 (2)	*	Yes	Yes	Yes
Packet Numbering and Routing					
PMD Routing & Digit Analysis Requirements	SR1937 (1)	Yes	Yes	Yes	Yes
Numbering Plan Interworking per TR-448 and GR-301	SR1937 (1)	Yes	Yes	Yes	Yes
User-to-User with Call Control (Packet)					
Fast Select, Fast Select Acceptance	SR1937 (1)	Yes	Yes	Yes	Yes
16 Octets of data in call request	SR1937 (1)	Yes	Yes	Yes	Yes
ISDN X.25 Supplementary Services					
ISDN Local Charging Prevention	SR2120 (2)	Yes	Yes	Yes	Yes
One-Way Logical Channel Outgoing/Incoming	SR1937 (1)	Yes	Yes	Yes	Yes
Incoming/Outgoing Calls Barred	SR1937 (1)	Yes	Yes	Yes	Yes
Default Throughput Class Assignment	SR1937 (1)	Yes	Yes	Yes	Yes
Nonstandard Default Packet Sizes	SR1937 (1)	Yes	Yes	Yes	Yes

**Table 14-6.** Packet Data Features and Capabilities (Sheet 2 of 2)

Feature or Capability	References	NI-95	NI-96	NI-97	NI-98
Nonstandard Default Window Sizes	SR1937 (1)	Yes	Yes	Yes	Yes
Flow Control Parameter Negotiation	SR1937 (1)	Yes	Yes	Yes	Yes
Throughput Class Negotiation	SR1937 (1)	Yes	Yes	Yes	Yes
Transit Delay	SR1937 (1)	Yes	Yes	Yes	Yes
User Testing	SR1937 (1)	Yes	Yes	Yes	Yes
Multiline Hunt Group					
Linear and/or Circular Hunting	SR1937 (1)	Yes	Yes	Yes	Yes
Assignment of Non-Hunt DNs to Hunt Terminals	SR1937 (1)	Yes	Yes	Yes	Yes
ISDN Calling Number Identification Services, Packet					
Inband Calling Number ID for Packet	SR1937 (1)	Yes	Yes	Yes	Yes
Basic Business Group					
Inclusion of Packet in BBG	SR1937 (1)	Yes	Yes	Yes	Yes
Inclusion of Packet in Business Group Dialing Plan	SR1937 (1)	Yes	Yes	Yes	Yes

**Table 14-7.** Operations Capabilities

Feature or Capability	References	NI-95	NI-96	NI-97	NI-98
Switch Loopback	SR1937 (1)	Yes	Yes	Yes	Yes
BRI point-to-point eoc	SR1937 (1)	Yes	Yes	Yes	Yes
ISDN Inspect					
Feature Key	SR2457 (3), GR2800	-	-	*	*

**Table 14-8. Cross-Platform Capabilities**

Feature or Capability	References	NI-95	NI-96	NI-97	NI-98
ISDN-PCS Interworking					
Registration	SR2457 (3)	-	*	*	*
PCS Calling	SR2457 (3)	-	*	*	*
Automatic Link Transfer	SR2457 (3)	-	*	*	*
Supplementary Services					
PCS Call Waiting	SR2457 (3)	-	*	*	*
PCS Three-Way Calling	SR2457 (3)	-	*	*	*
PCS Calling Line Identification Services	SR2457 (3)	-	*	*	*
PCS Call Forwarding	SR2457 (3)	-	*	*	*
Profile Management	SR2457 (3)	-	*	*	*
PCS Call Screening	SR2457 (3)	-	*	*	*
PCS-BRI Multiplexing	SR2457 (3)	-	*	*	*

Table 14-9 summarizes the National ISDN operations capabilities available in 1995, 1996, and 1997. To be included in the table, the National ISDN capability must be generally available by at least one of the three major National ISDN switch suppliers by the first quarter of the given year. A dash (-) in the NI-95 or NI-96 column indicates that the associated capability is not supported by any suppliers. The (†) symbol indicates that the capability is supported by one supplier. Capabilities supported by only two suppliers in a given year are marked by an asterisk (\*). A “Yes” indication denotes that the capability is supported by three suppliers.

The reference column provides SR and/or TR/GR documentation references for the feature. In the case of SR references, an additional letter or number is included in parentheses. The numbers (1), (2), and (3) indicate that the SR cited defines National ISDN - 1, - 2, or - 3, respectively. The letters (E), (G), or (N) indicate that the SR cited defines the NI Enhancements, the 1996 CPE Guidelines, or the previous NI-95/96 feature set document, respectively.

**Table 14-9.** Operations Capabilities - Availability Matrix (Sheet 1 of 2)

Feature or Capability	References	NI-95	NI-96	NI-97	NI-98
BRI Layer 1 Surveillance	SR3476 (N)				
- Basic Line Monitoring		Yes	Yes	Yes	Yes
- Computations/Performance-Parameters		Yes	Yes	Yes	Yes
- Data Storage/Retrieval		*	*	*	*
- Alarm/Status Information		*	*	*	*
PRI Surveillance Layer 1 (Near End)	SR3476 (N)	†	†	†	†
BRI/PRI Layer 2 & 3 Surveillance					
- Layer 2 Performance Monitoring	SR3476 (N)	-	-	-	-
- Layer 2 & 3 Service Disruption/High Abnormality Counters	SR3476 (N)	-	-	-	-
- PAL Information Fields	SR3476 (N)	†	†	†	†
- On-Demand Protocol Capture	SR3476 (N)	†	†	†	†
Logging and Processing TEI Abnormalities	SR3476 (N)	†	†	†	*
TSC/RTU	SR3476 (N)	Yes	Yes	Yes	Yes
Metallic Testing	SR3476 (N)				
- Metallic Test Access and Test Access Configurations		Yes	Yes	Yes	Yes
-Metallic Access - LILO		*	*	*	*
-Multimeter Measurements		Yes	Yes	Yes	Yes
-Noise Measurements		Yes	Yes	Yes	Yes
-Sealing Current Measurements		*	*	*	*
Digital Test Access Unit	SR3476 (N)				
-Monitor Access Function		*	*	Yes	Yes
-Split Access Function		†	†	*	Yes
-Release Access Function		*	*	Yes	Yes
BRI Test Control	SR3476 (N)	Yes	Yes	Yes	Yes
Loopback Testing	SR3476 (N)	*	*	Yes	Yes
Cold Start Verification	SR3476 (N)	*	*	*	*
Loop Performance Verification	SR3476 (N)	*	*	*	*
Protocol Monitoring	SR3476 (N)	*	*	Yes	Yes
BRI Multipoint eoc	SR3476 (N)	-	-	-	†

**Table 14-9.** Operations Capabilities - Availability Matrix (Sheet 2 of 2)

Feature or Capability	References	NI-95	NI-96	NI-97	NI-98
PRI D-channel Backup Maintenance	SR3476 (N)	*	*	Yes	Yes
Trouble Detection Requirements	SR3476 (N)	Yes	Yes	Yes	Yes
Call Trace	SR3476 (N)	†	†	†	†
Automatic Internal Administration	SR3476 (N)	†	†	†	†
Network Traffic Management	SR3476 (N)	*	*	*	*
Network Data Collection	SR3476 (N)	*	*	*	*
TL1 Messages	SR3476 (N)				
- TL1 Memory Administration Messages		†	†	†	†
- TL1 OS-TSC/RTU Interface Messages		†	†	†	†
Memory Administration Parameters	SR3476 (N)	*	*	*	*
Basic Rate Interface Verification	SR3476 (N)	†	*	*	*
Packet Handler Loopback Test Line	SR1937 (1)	†	†	†	†
PRI B-Channel Availability Signaling Procedures	SR3681 (E), GR892	-	-	-	*
Logging of Clearing Subnetwork Identification (CSI)	SR2457 (3)	-	†	†	†

### 14.9.7 Customer Premises Equipment

ISDN CPE includes station sets, data terminals, terminal adaptors, network terminations, and integrated voice/data terminals. The ISDN CPE will be provided by the customer.

#### 14.9.7.1 BRA ISDN Configuration

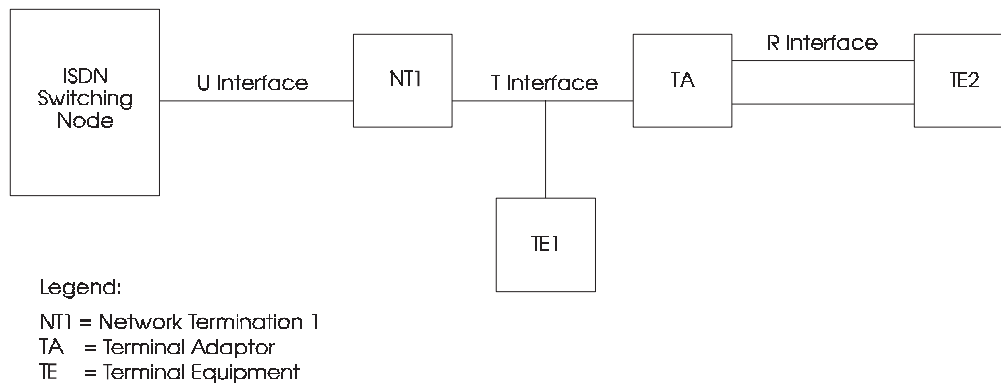
Figure 14-20 illustrates a BRA ISDN configuration from the switch to the customer, showing the four interfaces.

1. The *Network Termination 1 (NT1)* connects the ISDN 2-wire pair from the telephone network to the T interface. The NT1 transmits information to the ISDN switch. A basic-access NT1 can handle up to eight terminals simultaneously. The number of terminals supported by an NT1 is determined by the distance from the NT1 to the terminal. The NT1 performs layer-1 processing.
2. *Terminal Equipment (TE)* connects directly to an NT1 or NT2. Digital telephones are an example of terminal equipment.
3. *TE2* is non-ISDN equipment and requires a terminal adaptor to connect to an ISDN system.

4. *Terminal Adaptor (TA)* interfaces a non-ISDN terminal to an NT1 or NT2. When using a terminal adaptor, an NT2 works as an NT1. The terminal adaptor allows the customer to connect existing terminals and analog telephones directly to an ISDN line.

#### 14.9.7.2 Reference Points for BRA ISDN

Reference points (or interfaces) are used to identify a particular point or location on the ISDN system (Figure 14-20).



**Figure 14-20.** ISDN BRA Configuration

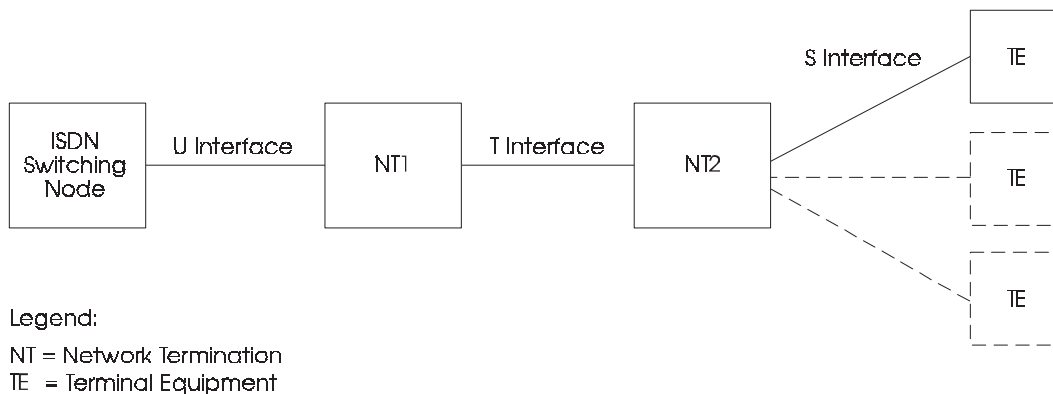
- The *basic-access U interface* identifies a point between the NT1 and the ISDN switching node.
- The *T interface* identifies the point between the NT1 and NT2, or the NT1 and the terminal adaptor. The point between the NT2 and the TE1 (or terminal adaptor) is called the S interface.
- The *R interface* identifies the point between non-ISDN terminal equipment (TE2) and a terminal adaptor

#### 14.9.7.3 PRA ISDN Configuration

Figure 14-21 illustrates a PRA ISDN configuration. All PRA components are the same as the BRA except for the NT2. NT2 and PRA NT1 perform as follows.

- The *Network Termination 2 (NT2)* serves as the interface between the network and various pieces of terminal equipment. Some vendors will combine NT1 and NT2 functions into one network termination, thus eliminating the need for two network terminations with PRA. An example of an NT2 is a PBX.

- The *PRA NT1* terminates the ISDN 4-wire loop from the telephone network. The T interface exists from the NT1 towards the terminal equipment. One pair in the 4-wire loop operates as the transmit pair and the other pair operates as the receive pair.



**Figure 14-21.** ISDN PRA Configuration

#### 14.9.7.4 Reference Points for PRA

See reference points in Figure 14-21.

- The *U interface* identifies the 4-wire connection between the ISDN switching node and the NT1.
- The *T reference point* identifies the 4-wire interface between the NT1 and NT2.

The *S reference point* identifies the interface between an NT2 and TE1 (or terminal adaptor).



---

## 14.10 Public Switched Digital Service

Public Switched Digital Service (PSDS) is the generic name for a Local Exchange Carrier (LEC) circuit-switched digital service that provides customers with the capability of sending data at 56 kbps using the existing digital interoffice facilities within the Public Switched Network (PSN). LEC circuit-switched digital service offerings, as of the date of this publication, are currently based on three access technologies:

- *Type I* technology is offered on digital switches using a 4-wire customer loop that transmits full-duplex 56-kbps data. Several suppliers provide Customer Premises Equipment (CPE) and loop transmission equipment, and this access technology is supported on many switch types using a trunk interface. Type I technology can also be offered on 1A ESS switches using special line and trunk equipment. Detailed examples of different architectures and the various hardware configurations are outside the scope of this document. The interface for CPE accessing this service is described in TIA/EIA-596-1993, *Network Channel Terminating Equipment for Public Switched Digital Service*.
- *Type II* technology is offered using the Circuit-Switched Digital Capability (CSDC) feature of the 1A ESS space-division switch. CSDC is based upon plug-in module additions to the line side and trunk side of existing 1A ESS end-office switches, and it provides 56-kbps full-duplex data capability over the existing 2-wire loops to the customer. CSDC performs off-hook, on-hook, and address signaling in the voice mode. Once the end-to-end connection is established, the customer must switch the local loop into the digital mode. More information can be found in TR-880-22135-84-01, *Circuit Switched Digital Capability Network Access Interface Specifications*. The interface for CPE accessing this service is described in TIA/EIA-596-1993.
- *Type III* technology is offered using the DATAPATH feature of the DMS-100 time-division switch. DATAPATH is based upon the DMS-100 family switches and their associated peripherals as described in TR-EOP-000277, *DATAPATH™ Network Access Interface Specification*. It provides the digital equivalent of Plain Old Telephone Service (POTS) at 56 kbps over the existing 2-wire loops to the customer. The DATAPATH service performs off-hook, on-hook data, and address signaling only in the digital mode with an 8-kbps signaling channel. There is always an end-to-end digital connection with 64-kbps data capability even when the customer's line is idle. The interface for CPE accessing this service is described in TIA/EIA-596-1993.

PSDS service functions are available with customer access and Local Access and Transport Area (LATA) access. Type I technology customer access is based on a full-duplex 56-kbps baseband bipolar bit stream over 4-wire local metallic loops to the serving central office. Type II and III technology is based on Time Compression Multiplexing (TCM) to support at least a full-duplex 56 kbps over 2-wire metallic loops to the serving central office. Customers requiring access beyond the serving range of the PSDS technology, can be supported by a digital loop carrier or channel bank equipment and Digital Signal level 1 (DS1) facilities. LATA access is based on routing calls using only digital trunks and digital

---

switches. With conventional signaling, LECs need to ensure that PSDS calls use only digital facilities; this is often accomplished by using dedicated trunk for PSDS. With Common Channel Signaling (CCS), dedicated trunks are not needed because each call includes bearer service information in the call setup messages.

PSDS supports many different customer applications including remote terminal access, electronic mail, bulk data transfer, Group 4 facsimile, computer graphics, encrypted voice or data, video teleconferencing, channel aggregation for bandwidth higher than 56 kbps, and backup for Digital Data Services (DDSs).

### **14.10.1 Network Architecture**

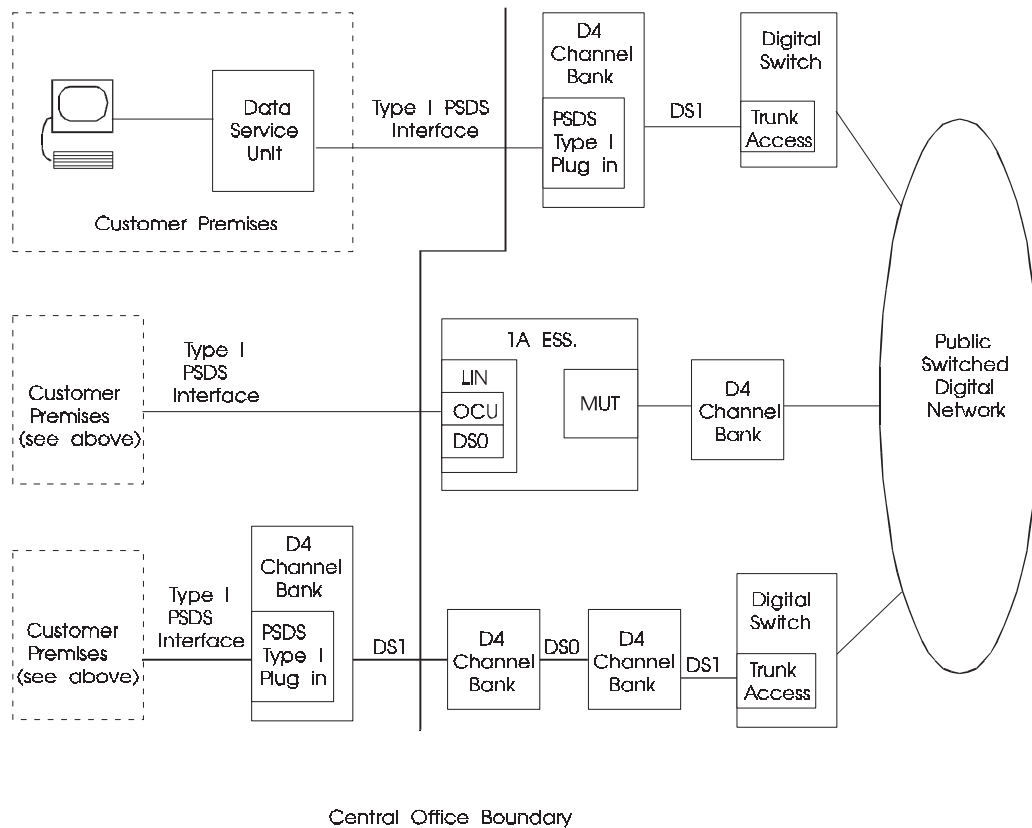
Three types of network architecture are discussed in this section.

#### **14.10.1.1 Type I Architecture**

On digital switches, Type I network architecture uses 4-wire baseband 56-kbps access to a digital trunk. The 4-wire loops are connected to a D4 channel bank equipped with the appropriate plug-ins. The D4 channel bank in turn is connected to the trunk side of the digital switch. The digital switch must have software and translations to support customer access on such trunks.

On the 1A ESS, Type I technology is deployed using 4-wire baseband 56-kbps access connected to a Loop Interface (LIN) shelf. The LIN shelf is equipped with the standard power plug-in plus an Office Channel Unit (OCU) and a DS0 channel unit. On the trunk side, interoffice facilities are provided using a Miniaturized Universal Trunk (MUT) which is connected to a D4 channel bank for interoffice transmission.

Several suppliers provide equipment to support this type of access. Figure 14-22 shows some typical configurations to support this type of service. Other configurations are possible. More detail on how to engineer equipment and outside plant is outside the scope of this document and should be obtained from the manufacturers.

**Legend:**

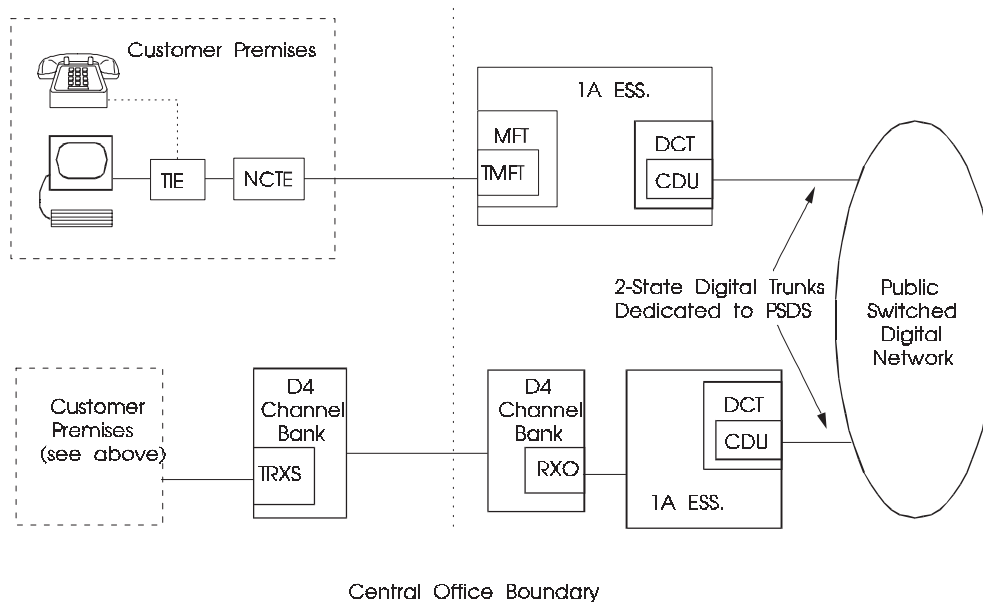
- DS0 = Digital Signal level 0
- LIN = Loop Interface Shelf
- MUT = Miniaturized Universal Trunk
- OCU = Office Channel Unit

**Figure 14-22.** Type I Technology Architecture

## 14.10.1.2 Type II Architecture

Type II architecture uses the CSDC feature of the 1A ESS switch as shown in Figure 14-23. The serving 1A ESS switch is equipped with the Digital Carrier Trunk (DCT) and CSDC Data Unit (CDU) plug-in modules. Calls are established using standard line signaling. Once a connection is established, the CDU signals the line to switch to digital mode by transmitting a specific tone to the CSDC local line. Once the CSDC line switches to digital mode, a digital connection is made, provided that the far end has also switched to

digital mode. The data mode is digital in the loops, requires no analog-to-digital conversion, and provides direct customer access to the digital stream in the network via full-duplex 56-kbps digital transmission. The CDU module allows only digital data calls (nonvoice) to be established, and the DS0 interface to a DS1 interoffice facility uses standard MTS trunk 2-state signaling.

**Legend:**

- CDU = CSDC Digital Unit Plug-in
- CSDC = Circuit-Switched Digital Capability
- DCT = Digital Carrier Trunk
- MFT = Metallic Facility Terminal
- NCTE = Network Channel Terminating Equipment
- RXO = Remote Exchange Office Plug-in
- TCM = Time Compression Multiplexing
- TIE = Terminal Interface Equipment
- TMFT = TCM Metallic Facility Terminal Plug-in
- TRXS = TCM Remote Exchange Subscriber Plug-in

**Figure 14-23.** Type II Technology Architecture

The CDU plug-in module can be replaced with a CSDC Alternate Voice Data (CAVD) plug-in module which allows a customer to complete a call and to alternate between the voice communication mode and the 56-kbps digital data mode. The voice-mode transmission is analog in the customer loops and digitized voice in the network. This plug-

---

in module requires the use of Common Channel Interoffice Signaling (CCIS) or 4-state signaling for compatibility through tandem switches. Generally, the ability to alternate between voice and data is not supported on interLATA connections and may not be supported on intraLATA connections.

Customer access is provided via 2-wire nonloaded metallic loops terminating at the Metallic Facility Terminal (MFT) of the CSDC-equipped 1A~ESS switch. A TCM Metallic Facility Terminal (TMFT) plug-in is used in the MFT to provide TCM transmission capability on the 2-wire subscriber line to the customer location. The TMFT plug-in also provides the adaptive echo-cancellation transmission capability to establish a full-duplex digital transmission path across the switch to the CDU trunk plug-in.

Customers at a distance from a CSDC-equipped central office can access a CSDC-equipped wire center by remote access arrangements using plug-in units for the SLC-96 or D4 channel banks. A remote extension via a T1 facility connects a Remote Exchange Office (RXO) plug-in housed in the D4/SLC bay with a TCM Remote Exchange Subscriber (TRXS) plug-in housed in the remote wire center D4/SLC bay. The required CPE includes the Network Channel Terminating Equipment (NCTE) to terminate the loop and the Terminal Interface Equipment (TIE) to interface CSDC with the customer's Data Terminal Equipment (DTE) and voice telephone set.

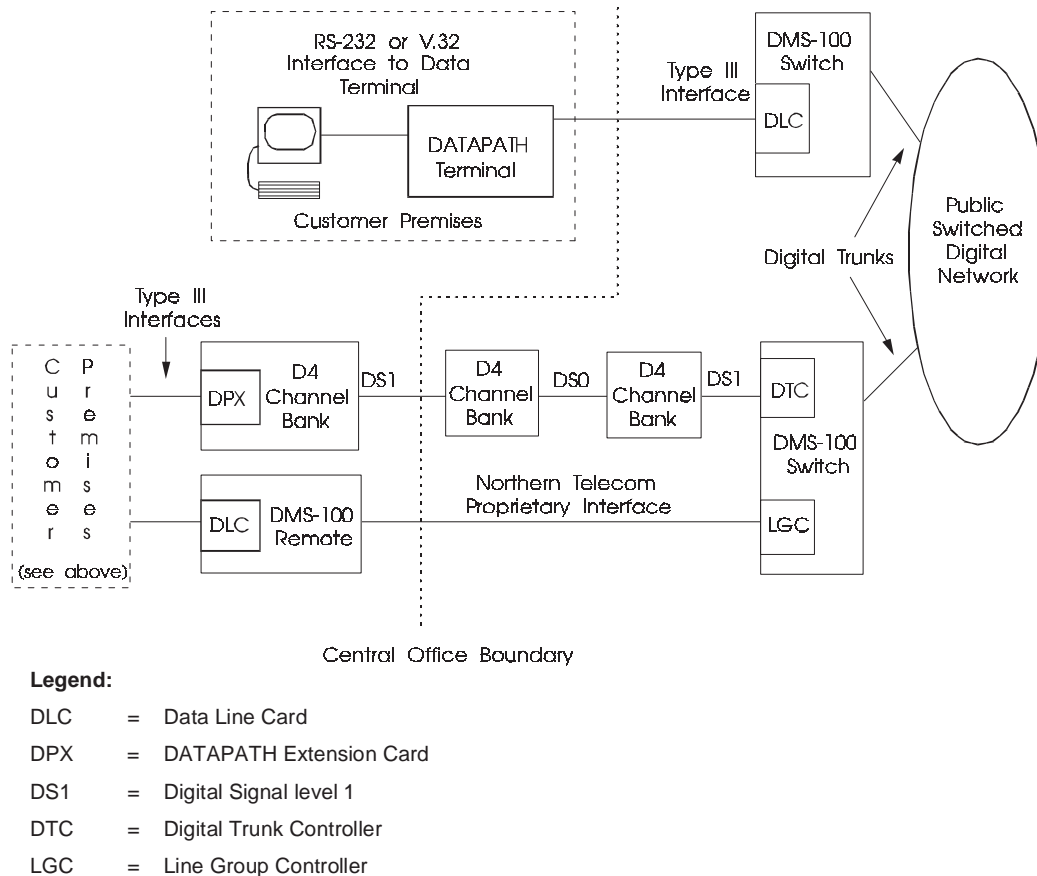
#### 14.10.1.3 Type III Architecture

Type III architecture uses the DATAPATH feature of the DMS-100 family of switches shown in Figure 14-24. The serving DMS-100 switch, equipped with Data Line Cards (DLCs) which reside in its Line Control Modules (LCMs), provides TCM transmission capability on a 2-wire subscriber line to the customer location. The DLC controls the transmission over the subscriber loop and provides two duplex transmission channels: a 64-kbps data channel and an 8-kbps signaling channel. The DLC and data unit communicate over the signaling channel.

Customer access is provided via 2-wire, nonloaded, metallic loops terminating on the DLC of the DMS-100 switch equipped with the DATAPATH feature. The DLC plug-in module provides the interface between the data unit and the DMS-100 switch.

Customers not close to the central office equipped with the DATAPATH feature can access the service through remote peripheral modules which include:

- Remote Line-Concentrating Modules (RLCMs)
- Remote Switching Centers (RSCs)
- Outside Plant Modules (OPMs).



**Figure 14-24.** Type III Technology Architecture

These peripheral modules are configured in the usual way and connected to the host DMS-100 through a Line Group Controller (LGC) peripheral module. The remote peripheral modules use the DLC plug-in module to provide the interface between the data unit and the DMS-100 switch.

Remote customer access can also be provided using either D4 or DE4-E channel banks. The D4 or DE4-E channel bank, containing a DATAPATH Extension (DPX) card (the equivalent of a DLC), is connected to a Digital Trunk Controller (DTC) in the DMS-100. These remote access configurations can be used to support all DATAPATH features on an extended-loop basis.

The required CPE includes the data unit to connect the DATAPATH service directly with the customer's data terminal. The connection can be a RS-232 connector or a computer for low-speed applications (up to 19.2 kbps) or a V.35 electrical interface for high-speed applications (up to 64 kbps). The data unit supports full-duplex operation at speeds up to 64 kbps.

## 14.10.2 Service Characteristics

Transmission, signaling, and routing are discussed in the following subsections.

### 14.10.2.1 Transmission Characteristics

Type I technology employs 4-wire baseband 56-kbps full-duplex transmission.

Type II and Type III technologies implement TCM transmission technology to provide virtual full-duplex, digital channels on the 2-wire subscriber line. In TCM, a burst of high-speed digital information is sent in one direction. After a short period of time to allow for propagation delay and attenuation for echoes to die out, a burst of high-speed digital information is sent in the opposite direction. This *ping-pong* transaction occurs so quickly and the half-duplex transmissions alternate so fast that full duplex is realized as not being practicable. The TCM technique used is different for each implementation. Type II data bursts are transmitted at 144 kbps to give the customer a continuous data stream at 56 kbps. Type III data bursts are transmitted at 160 kbps to give the customer a capability of 64 kbps of clear-channel transmission with 8 kbps of signaling channel within the same serving central office switch.

### 14.10.2.2 Signaling Characteristics

The three access technologies use different signaling techniques between the switch and the CPE:

- Type I technology uses codes that contain Bipolar Violations (BPVs) for signaling on the network interface. One code represents an on-hook state and another code represents an off-hook state. The CPE uses these codes to provide dial-pulse signaling. Other BPV codes are used to convey other information for maintenance and testing functions.
- Type II technology uses POTS inband signaling to establish calls. After calls are established, the 1A ESS signals the CPE to switch to data mode by transmitting a "switch to data" tone. The CPE signals the 1A ESS whether it is in voice mode or data mode by providing either a voice termination or a data termination. The CPE signals that it is on-hook by providing no termination.
- Type III technology uses its 8-kHz channel to provide out-of-band signaling.

All three types of technology can use standard 2-state A- and B-bit trunk signaling and provide transparency over tandem switches.

---

---

### 14.10.2.3 Routing Characteristics

With conventional inband trunk signaling, dedicated trunks may be required to identify PSDS traffic and to assure digital routing. If a network contains all digital switches and trunks, then dedicated intranetwork trunks are not required since all calls will be routed over compatible facilities. For internetwork connections, dedicated trunks may be required so that the intermediate network knows to route the calls using only digital facilities.

CCS provides the capability of associating a bearer capability with a call so that the routing requirements are delivered to each intermediate switch. Bellcore's SR-NWT-002598, *Clarification of the Requirements for Public Switched Digital Service (PSDS)*, describes how PSDS services interact with CCS trunks. When PSDS calls are routed over SS7 trunks, the bearer capability of 64-kbps rate adapted from 56 kbps is assigned to the call. CCS removes the need to dedicate trunks for PSDS routing.

### 14.10.3 Call Processing

PSDS calls must be carried on DS0 channels on digital facilities rather than analog facilities. Customers may use special dialing procedures to indicate that a PSDS call is being originated or may have special line translations to indicate that calls must be routed over digital facilities. PSDS should employ the following numbering plan, as shown in TR-TSY-000534, *Data Services Public Switched Digital Service, FSD 32-10-1000*:

$$\#56 +10XXX +1 + 7/10 \text{ digits} +\#$$

where #56 is the PSDS transmission indicator and may be omitted if only PSDS calls are permitted on the line.

10XXX determines the chosen IC and may be omitted if the customer is presubscribed.

1 is optional depending upon local dialing procedure in the caller's service area.

7/10 is a directory number for the called customer.

Trailing # is optional, and indicates to the switching system that dialing is complete, thus avoiding any timing delay if ambiguous digit strings or dialing errors are present.

#### 14.10.3.1 Type I Call Establishment

To establish a Type I call, the customer goes off-hook and dials a data phone number via a Channel Service Unit/Data Service Unit (CSU/DSU) at the customer premises. The CSU/DSU sends a stream of Mark Hold sequences to the digital switch to signal the off-hook state. After receiving dial tone, the calling party uses pulse dialing by sending the sequences

---



---

Mark Hold or Control Mode Idle (a BPV) for the off-hook and on-hook states, respectively. The digital switch processes the pulse dialing information and routes the call. To terminate the call, either party goes on-hook.

#### 14.10.3.2 Type II Call Establishment

To establish a CSDC call, the customer goes off-hook using a standard analog telephone. Normal calls are set up in the voice mode using Dual-Tone Multifrequency (DTMF) dialing to the 1A~ESS switch. Once a connection is established the 1A~ESS transmits a "switch to data" tone over the voice connection. Both the calling and called parties should then change the termination on the CSDC line from voice to data. Once both ends are in the data mode, a full-duplex 56-kbps data connection is established. The connection is taken down at either end by going on-hook.

#### 14.10.3.3 Type III Call Establishment

To establish a DATAPATH call, the customer uses a data unit to dial another data unit just like an ordinary telephone call. The customer pushes the directory number key on the data unit to access the digital facilities, and dial tone is returned. The host DMS-100 switch establishes the end-to-end connection through the network between the two data units. The switch sends call progress tones to the originating data unit as the connection is set up. If the called data unit is busy, a busy signal is returned to the calling data unit. If the called data unit is idle and ready, the call is answered either automatically or by a customer at the called end. If the call is answered, an end-to-end connection is established through inband signaling. Connection is taken down at either end by pressing the release key on the data unit or returning the data terminal's ready lead off.

#### 14.10.4 Interoperability Issues

The two main issues of interoperability are compatibility requirements and PSDS/Integrated Services Digital Network (ISDN) internetworking.

Customers must be able to establish calls and transfer data among different types of CPE. To achieve end-to-end call compatibility, PSDS compatibility requirements are as follows:

- Two-state *LSSGR*-compatible inband signaling for PSDS trunk interfaces.
- PSDS CPE should send the most significant bit to the user first (telecommunications convention).
- If the PSDS CPE employs an inband handshaking protocol, it must be able to recognize the completion of the first phase (synchronization) of the handshake within 2 seconds after the end-to-end connection. If the CPE fails to detect the synchronization phase of

the handshake or the subsequent completion, it should default to the 56-kbps mode (bit 8 in each byte set to 1).

- When CPE uses an inband handshaking protocol, a protocol identification will be initiated by the CPE to establish whether a compatible protocol is available at the other CPE. If a compatible protocol exists, an inband parameter exchange takes place in which each CPE sends a series of parameters to the other indicating the preferred mode of operation. These parameters indicate the data rate to be used, and whether the data to be sent is synchronous or asynchronous. If both CPE send compatible parameters, the call proceeds. Incompatible parameters may result in a conflict and meaningful data exchange may not occur.
- Using different suppliers for the Type I interface for the DSU and the D4 channel bank plug-ins may result in interoperability issues. It is expected that DSUs and D4 plug-ins that are built to TIA/EIA-596-1993 standards will be able to interoperate and provide basic service. Enhanced capabilities or supplier specific capabilities may not work correctly if the DSU and D4 plug-ins are from different suppliers or from different vintages of the same supplier.

The second interoperability issue is PSDS/ISDN internetworking. PSDS is compatible with the 64-kbps rate adapted from 56-kbps bearer service. Bellcore's SR-NWT-002598 covers issues that arise from interoperating PSDS and ISDN. Calls from ISDN to PSDS will not be made transparently since the calling party will get a message saying that the called party is not ISDN. PSDS originated calls will be assigned a bearer capability of 64-kbps rate adapted from 56 kbps when the calls use trunks with CCS.

## 14.11 Public Packet Switched Service

Public Packet Switched Service (PPSS) is the generic term for a data communications offering, based on the packet service specified by the International Telecommunication Union—Telecommunication Standardization Sector (ITU-T)<sup>1</sup> X.25 access protocol provided in GR-301-CORE, *Public Packet Switched Network Generic Requirements (PPSNGR)*. This section describes aspects of this service and associated network equipment that are generally common among the Local Exchange Carriers (LECs). However, service names and feature details vary among the LECs. Detailed service information must be obtained from the respective LEC.

### 14.11.1 Service Description

PPSS is a connection-oriented, packet-switched communication service designed to provide economical data transport. As described in subsequent subsections, customer access to PPSS is based on internationally standardized packet protocols. The service is packet switched in that the customer's data is transported as a sequence of data blocks (packets) that do not exceed a specified size. This packetization permits data from many data conversations to share a given transmission facility economically through statistical multiplexing. Such data conversations are known as *virtual circuits*, which are full duplex and connection-oriented. Data can flow simultaneously in both directions, and packets associated with a given virtual circuit are all routed through the network over a single path that is established in advance. The service also guarantees sequential delivery of packets and detects/corrects transmission bit errors.

PPSS provides public service within Local Access and Transport Areas (LATAs) and LATA access to other packet networks, including packet Interexchange Carriers (ICs). When combined with facilities owned or leased by a customer, PPSS can also provide private intraLATA and interLATA packet transport for that customer via Private Subscriber Network (PSN) capability. PPSS is designed to support switched and nonswitched, point-to-point data communication applications with throughput requirements up to 56 kbps.

A LATA network providing PPSS is generically called a Public Packet Switched Network (PPSN). The *PPSNGR* provides a detailed description of this network and generic requirements for the equipment used to provide PPSS.

---

1. Formerly the International Telegraph and Telephone Consultative Committee (CCITT). Note that there are some references in this section to *CCITT* Recommendations. In these cases, the PPSS is based on versions of the Recommendations published before CCITT was renamed to ITU-T.

---

### 14.11.2 Network Elements

A PPSN consists of three primary types of network elements.

- The *packet switch* is the primary switching element of the network allowing efficient connectivity to many customers. The packet handler function used in an Integrated Services Digital Network (ISDN) is a special packet switch, because it provides digital access to PPSS on the same pair of wires, which can also provide simultaneous access to other services (for example, voice and circuit-mode data).
- The *access concentrator* concentrates traffic from lower-speed access lines for more efficient packet-switch port usage and performs any necessary protocol conversion via the Packet Assembler/Disassembler (PAD) function.
- The *administrative processor system* provides capabilities to operate and administer the network.

These network elements are connected to one another, to other packet networks, and to end customers with transmission facilities. Additional details on these network elements and the types of connections supported by these devices are provided in later subsections.

### 14.11.3 Service Applications

With current transmission and switching technology, PPSS can support individual data connections with throughputs up to 56 kbps. It is particularly well-suited for applications characterized by short *bursty* transmissions. Such applications take full advantage of packet switching's ability to share transmission facilities efficiently among multiple conversations, even when the throughput demands of each conversation vary widely over time. Typical applications with short, bursty traffic characteristics are database queries, credit authorization transactions, certain health care transactions, Automated Teller Machine (ATM) transactions, and reservation/shopping transactions. Because access to PPSS by customers and other networks is via internationally standardized protocols, the service is also well-suited for any application that requires data communication among diverse or widely separated organizations.

### 14.11.4 Network Architecture

Figure 14-25 illustrates the architecture of a PPSN. This architecture includes the topology of network elements, connections to customers and other networks, and the protocols supported on these connections.

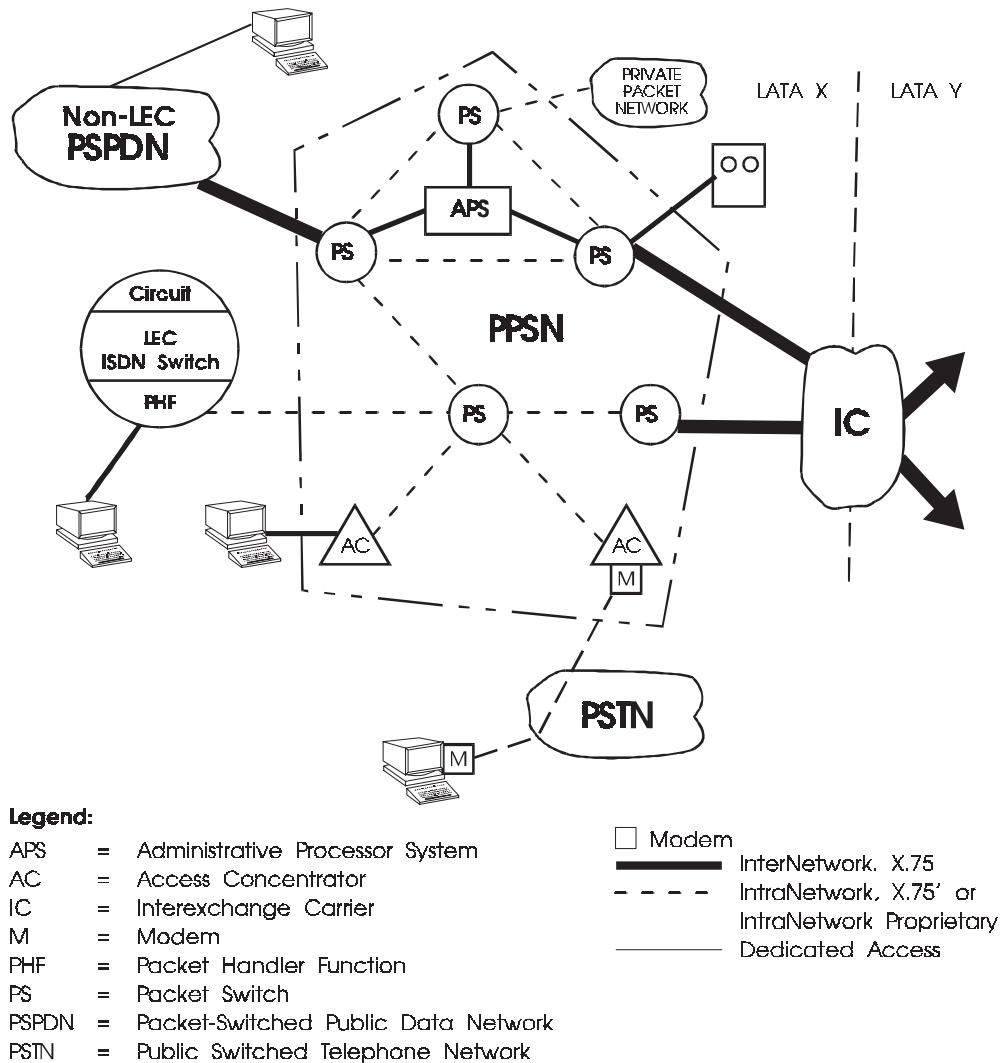


Figure 14-25. PPSN Architecture

### 14.11.5 PPSN Topology

The PPSN backbone consists of one or more packet switches, connected by single- or multiple-transmission facilities. These transmission facilities typically operate at 56 or 9.6 kbps. The packet switches are the primary switching and call-processing nodes of the network. Packet switches also terminate connections to other networks and high-speed customer equipment. Customers with lower-speed devices or who require protocol conversion services usually access the network through an access concentrator.

The access concentrator concentrates traffic from multiple customers so that it can be more efficiently delivered to the high-capacity ports of a packet switch. If the customer's equipment does not directly support the native packet protocol of PPSN, the access concentrator can also provide the PAD function necessary to packetize the customer's data stream and/or convert it to the PPSN packet protocol. The Administrative Processor System (APS) provides the functions necessary to operate and administer the PPSN. Typical APS functions include monitoring network maintenance status, reporting of alarms, and terminating connections to external operations systems. Although illustrated as a separate device, the APS function can be part of one or more packet switches/access concentrators.

The next three subsections address network interfaces in greater detail. Figure 14-25 illustrates intranetwork and internetwork interfaces. Figure 14-26 details the same for access (customer-to-network) interfaces.

#### 14.11.6 Physical-Access Interfaces

Both dial-up (circuit-switched) and dedicated interface alternatives are available for PPS access (Figure 14-26). Dial-access physical connections are appropriate for customers with low/moderate volume and occasional communications needs. Dedicated access is appropriate for customers with higher traffic volumes or the need for access during a large percentage of the day.

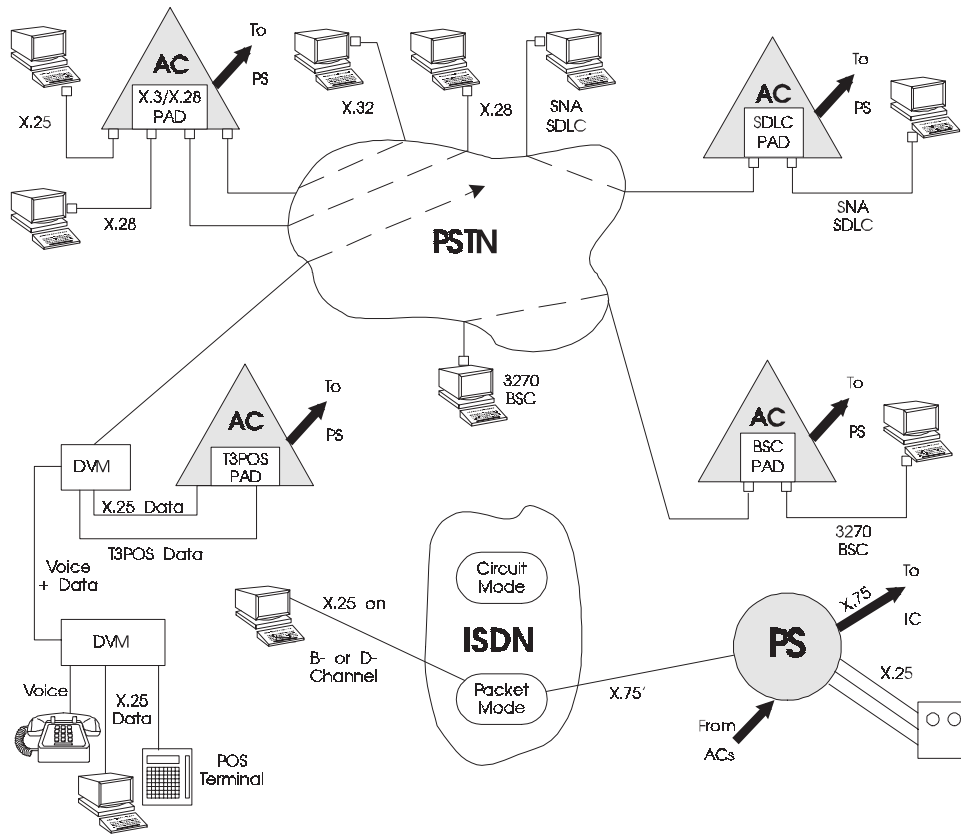
#### 14.11.7 Dial Access

Dial (circuit-switched) access provides low- to moderate-volume PPSN access through the voice telephone network. With dial-in access, a customer terminal and modem are attached to a Public Switched Telephone Network (PSTN) loop. The customer dials a North America Numbering Plan (NANP) address and the PSTN routes the call to a PPSN dial-up port. The PPSN answers the call with a modem supporting all (or a subset) of the following five modem protocols:

- 103A (PUB 41101, *Data Set 103A Interface Specification*)
- 212A (CCITT Recommendation V.22)
- CCITT V.22 bis (CCITT Recommendation V.32)
- CCITT V.32 (TR-TSY-000918, *Generic Requirements for Modem Interface Support on PPSNs* and CCITT Recommendation V.25)
- CCITT V.32 bis (CCITT Recommendation V.32 bis).

These modems support speeds ranging from 300 bps to 14.4 kbps and may be used for dedicated as well as dial access.

---



**Legend:**

- AC = Access Concentrator
- BSC = Binary Synchronous Communication
- DVM = Data/Voice Multiplexer
- IC = Interexchange Carrier
- PAD = Packet Assembler/Disassembler
- POS = Point of Sale
- PS = Packet Switch
- PSN = Public Switched Telephone Network
- SDLC = Synchronous Data Link Control
- SNA = Systems Network Architecture

- Modem
- InterNetwork. X.75
- Dedicated Access
- - - Circuit-Switched Access
- PPSN NEs

Figure 14-26. PPSN Access Interfaces

With dial-out access, a call is routed to a PPSN interface supporting dial-out service. At this interface, the access concentrator obtains the NANP address and uses the CCITT V.25 bis calling procedures to instruct the PPSN modem to establish a physical connection with a customer via the PSTN. Dial-out modems support speeds ranging from 1.2 to 14.4 kbps.

PPSN modems on asynchronous dial-access interfaces may support Link Access Procedures for Modems (LAPM) error detection/correction and flow control specified in CCITT Recommendation V.42. With support of CCITT V.42 and V.42 bis data compression, higher speeds (up to 112 kbps) may be provided to asynchronous dial-access customers. Once the dial-up physical connection from customer to PPSN is established, virtual call setup is similar to dedicated access.

#### **14.11.8 Dedicated Access**

Dedicated (nonswitched) access provides the customer with continuously available interfaces to the PPSN, supporting speeds that range from 1.2 to 56 kbps. High-volume access interfaces are generally digital facilities, such as those of the digital data system. For Data/Voice Multiplexer (DVM) dedicated access, also known as Virtual Private Line (VPL) access, loop electronics are used to multiplex data and voice over a single wire pair, with data split off from the voice at the central office and routed to the access concentrator.

The physical connection for interfaces operating at up to 20 kbps is based on EIA-232-D (CCITT Recommendation V.35). Interfaces operating above 20 kbps are based on CCITT Recommendation V.35, as described in *Information Processing Systems — Open Systems Interconnections — Basic Reference Model*. Some access concentrators support DS0B interfaces for subpart multiplexing of 20, 2.4-kbps access lines onto a 64-kbps transmission facility (described in TA-TSY-000077). However, the physical connection to other networks is the same as the high-volume, direct-access connections.

#### **14.11.9 Access Protocols**

Access protocols are used on different types of access interfaces. The following subsections discuss the protocols used for dedicated packet, dial-up packet, asynchronous, and proprietary interface access.

##### **14.11.9.1 Dedicated Packet**

The native access protocol of PPSS and the associated communication services are specified by an international standard, CCITT Recommendation X.25 (1988), as extended by the *PPSNGR*. This standard specifies the interface used to connect Data Terminal Equipment (DTE) to Data Circuit-terminating Equipment (DCE) for native packet-mode terminals accessing the network by dedicated circuit. DTE is the ITU-T term for terminal

---



---

equipment owned by the customer (in other words, Customer Premises Equipment [CPE]). DCE is the term for the access interface termination on the network end. CCITT Recommendation X.25 specifies procedures and a protocol corresponding to the lowest three layers of the Open Systems Interconnection (OSI) Reference Model: physical, data link, and network.

The *physical layer* is concerned with details such as physical connection, voltage levels, and the representation of bits on the transmission medium. The *data link layer* is responsible for flow control and the error-free transmission of data between adjacent nodes. The *network layer* is responsible for routing of data through the network from calling to called party. The protocol unit at the network layer is the packet. Various types of packets are defined to carry out the following functions of the network layer: establishing calls, clearing calls, and transferring data over an established connection. For example, the call-request packet is used to establish a connection, negotiate relevant service parameters, and assign a unique connection identifier that is then used during data transfer. Data packets carry this unique connection identifier and the actual user data after call establishment.

#### 14.11.9.2 Dial-Up Packets

X.32 dial-access service is based on the dial-access procedures specified in CCITT Recommendation X.32, which supports dial-in and dial-out service, providing customers with X.25 dial access to or from a PPSN via the PSTN. Three levels of dial-access service may be available when X.32 is supported: nonidentified, identified, and customized service. Each of these is defined below.

- *Nonidentified service* provides the customer with a uniform basic level of service. With nonidentified dial-in service, a customer whose identity has not been verified by the network is allowed to establish a virtual call, but only with limited access to network services.
- *Identified dial-in service* provides a customer establishing a virtual call with a less restrictive access to network services since the customer has been identified and can be billed.
- *Customized dial-in service* provides an identified customer with a data communications service that is tailored for that user.

The presence or absence of a customer identity, the method by which that identity was obtained, and the configuration of the customer interface determine the level of service provided to a customer. (See TR-TSY-000926, *Public Packet Switched Network X.32 Interface Requirements*.)

Dial-out service is initiated when a virtual call is routed to an interface on an access concentrator that supports either nonidentified, identified, or customized dial-out service. With nonidentified dial-out service, the called party *has not* registered its NANP address with the PPSN. The access concentrator obtains the called party's NANP address from the

---

call setup information transmitted by the calling party and uses this E.164 number to dial-out to the called party. With identified and customized dial-out service, the called party *has* registered with the network. The access concentrator uses the E.164 address that is associated with the registered, called PPSN address for dial out.

#### 14.11.9.3 Asynchronous and Proprietary Protocols

PPSN asynchronous interfaces may support two principle protocols: traditional X.28 and T3POS. The traditional X.28 asynchronous interface consists of three essential components that adhere to CCITT Recommendations X.3, X.28, and X.29. User data is sent to and from the PPSN in American Standard Code for Information Interchange (ASCII) format. Likewise, network service signals (call progress, termination, and trouble signals) are sent to the terminal as ASCII messages. The Packet Assembler/Disassembler (PAD) function of the access concentrator packetizes the user data for transmission through the PPSN and depacketizes data received from the PPSN. Both dial-access, dedicated-access, and VPL options are available. (See TR-NWT-001036, *PPSN Asynchronous Interface Generic Requirements*.)

PPSN PAD protocol conversion capabilities have also been specified in support of other widely used terminal equipment interfaces. Specifically, PAD requirements have been specified for support of character-oriented IBM 3270 bisynchronous (BSC) devices (or equivalent)<sup>2</sup> and more recent bit-oriented IBM Systems Network Architecture/Synchronous Data Link Control (SNA/SDLC) devices (or equivalent). Information pertaining to this can be found in TR-TSY-000885, *PPSN Support of SNA/SDLC Interfaces*.

PPSN support of 3270 BSC devices is based on the 3270 Display System Protocol (3270 DSP), which defines a method of transmitting BSC information via a packet network. Support of SNA/SDLC devices is based on the Qualified Logical Link Control (QLLC) protocol. While BSC information can be found in *3270 Display System Protocol*, information about QLLC is provided in two separate articles published by IBM. These articles are *The X.25 1984 Interface for Attaching SNA Nodes to Packet-Switched Data Networks General Information Manual*, and *The X.25 1984 Interface for Attaching SNA Nodes to Packet-Switched Data Networks Architecture Reference*.

#### 14.11.10 Internetwork and Intranetwork Interfaces

Connections between a PPSN and other public packet networks, or Packet Switched Public Data Networks (PSPDNs) in ITU-T are the packet equivalent of trunks in the PSTN. These connections use the protocol specified in CCITT Recommendation X.75 (1988), as extended by the *PPSNGR*. Each end of an X.75 interface is called a Signaling Terminal

---

2. See GR-301-CORE, *PPSNGR*.

---

Equipment (STE) in ITU-T terminology. PPSN X.75 interfaces typically operate at 56 or 9.6 kbps. The Multilink Procedure (MLP) defined within the X.75 protocol allows multiple interfaces between a pair of networks to operate on a coordinated basis, effectively increasing throughput capacity and connection availability.

As illustrated in Figure 14-26, X.75 interfaces terminate on packet switches within a PPSN and are used to connect the PPSN to packet-mode ICs and other PSPDNs with Points of Presence (POPs) within the LATA. Although not explicitly shown in the figure, X.75 facilities owned or leased by a PPSN customer can also be used to connect PPSNs in different LATAs for carrying that customer's traffic, as part of a Private Subscriber Network (PSN). However, PPSN connections to private packet networks (those not offering communications services to the general public) are typically based on X.25 interfaces.

The *PPSNGR* defines an X.75' (X.75 Prime) protocol for connections between LEC packet-switching network elements within a LATA. To connect a PPSN subnetwork with another subnetwork of equipment provided by a different manufacturer (illustrated through shading of network elements in Figure 14-26), X.75' interfaces are used. A subnetwork is a contiguous collection of equipment (one or more network elements) using compatible intranetwork protocols (typically provided by the same manufacturer). Within a subnetwork, connections among network elements may utilize proprietary protocols, as long as the access interfaces/services and internetwork interfaces comply with the X.25, X.75 and X.75' specifications.

The X.75' protocol is a Bellcore-developed extension of X.75, which provides a common method for connecting LEC packet network equipment of multiple manufacturers. X.75' connections can be used both between two packet switches and between an access concentrator and a packet switch. Since a LEC may connect its packet-mode ISDN customers to its PPSN to provide X.25 packet service within a LATA, X.75' is also used on intraLATA connections between a packet switch and the Packet Handler Function (PHF) of an ISDN switch and between different PHFs.

#### 14.11.11 Service Characteristics

CCITT Recommendation X.25 specifies both an access interface and protocol, and associated packet services and call-processing procedures. This section provides an overview of packet services provided by PPSS. The following section addresses call processing.

---

#### 14.11.11.1 Standard Packet Facilities

Packet services specified in X.25 are defined in terms of *network user facilities*, which should not be confused with physical-layer transmission facilities. There are two categories of the X.25-type facility: subscription and per-call.

*Subscription facilities* are those that are specified at the time the X.25 interface is configured, and apply until changed by customer request. Such subscription facilities are typically implemented through interface configuration options, which are set and changed through the service order process.

*Per-call facilities* differ in that they are requested by the customer during the call establishment process and apply only for the duration of the call. In many cases, the use of one or more per-call facilities is contingent on, or is restricted by, an associated subscription facility.

Many X.25 facilities are also specified in CCITT Recommendations X.28 or X.29, in support of asynchronous terminal access to packet networks. Illustrative subscription facilities defined for both packet-mode (X.25) and asynchronous (X.28/X.29) access are as follows.

- *Reverse charging acceptance* allows the interface to accept the reversed charges on calls it receives from others.
- *Closed user groups* restrict communications (originating on/destined for the interface) to be only among members of a specified user group.
- *Network User Identification (NUI) Subscription* permits the NUI Selection facility to be signaled across that interface.

In some cases, X.25 and X.28/X.29 interfaces do *not* have the same subscription facilities.

- *Outgoing/incoming calls barred* allows the interface to only receive or originate calls — specified *only* for X.25
- *Call redirection* allows calls received at the interface to be redirected (forwarded) automatically to another specified destination — specified *only* for X.25. However, a packet-mode terminal communicating with an X.28 terminal can be configured with the X.29 Called DTE Reselection facility, which permits it to request that the remote end PAD clear the existing virtual circuit and establish a new connection to a specified alternate destination.

Per-call facilities defined in both X.25 and X.28 include the following.

- *Reverse charging* requests that the call be charged to the called (destination) party.
  - *NUI selection* specifies a verifiable user identification value (such as a LEC calling card number and personal identification number) to be used in billing the call when the calling address is not adequate (for example, when the user dials into the PPSN through the telephone network).
-

- 
- *Recognized Operating Agency (ROA) Selection* specifies a network (for example, a specific IC) that the originating network should use in completing the call.
  - *Called-line address-modified notification (CLAMN)* tells the calling party that the originally called address has been changed (because of call redirection or hunt group operation).

#### 14.11.11.2 PPSS-Specific Facilities

In addition to facilities specified by the ITU-T, the *PPSNGR* specifies facilities to meet additional service needs of PPSS customers. These PPSS-specific facilities are primarily the subscription type that do not require CPE to adopt signaling capabilities beyond those specified in the international standard. The following illustrates the PPSS-specific facilities that have been defined.

- *IC Preselection* designates a default IC to be used in completing an interLATA call if an ROA Selection is not explicitly signaled (this supports equal-access requirements).
- *ROA Selection Barred* prevents the calling party from signaling an ROA Selection on a per-call basis.
- *1980 X.25 DTE Interface* designates an interface as supporting a DTE that implements the 1980 version of X.25, so that features introduced after 1980 (and thus not implemented by the DTE) are not used. A similar *1984 X.25 DTE Interface* capability exists so that features introduced after 1984 are not provided on an interface.

The *PPSNGR* also specifies additional asynchronous interface subscription options to meet specific customer needs. Two PPSS-specific facilities have been defined for asynchronous interfaces.

- *Automatic Call* allows, upon establishment of the physical connection, the access concentrator to automatically initiate a call to a predefined destination.
- *Abbreviated Addressing* reduces the called address to ASCII characters that are more easily remembered.

#### 14.11.11.3 Protocol Conversion

Although the X.25 protocol is an international standard, there is a large embedded base of terminal equipment that communicates using other protocols. Thus, protocol conversion may be needed to allow owners of this equipment the benefits of PPSS offerings. It is useful to understand three different protocol conversion concepts within the context of PPSS.

- *Local protocol conversion* occurs between the internal-packet protocol of the PPSS and the protocol used on a local access interface. PPSN PAD support of traditional asynchronous (X.3/X.28/X.29), T3POS, 3270 BSC, and SNA/SDLC devices provides

---

such local protocol conversion. This conversion is needed to permit the PPSN to carry data from a device other than a native X.25 packet terminal.

- *End-to-end protocol compatibility* is the net difference in protocol between the originating and destination DTE interfaces (independent of the network on which each DTE resides). This is key in determining whether the two DTEs can successfully communicate. Across PPSS packet connections, and assuming the necessary PAD functions, asynchronous terminals can successfully communicate with X.25 devices and other asynchronous terminals; 3270 BSC devices can communicate with other such devices; and SNA/SDLC devices can communicate with like devices and devices supporting QLLC over an X.25 interface. However, in the absence of additional protocol conversion services, a 3270 BSC terminal cannot communicate successfully across a packet network with a SNA/SDLC device or a simple X.25 terminal, even if 3270 DSP and SDLC PADs are used. This is because the local protocol conversions provided are not adequate to provide end-to-end compatibility in such device pairings. A PAD may allow a packet network to carry a BSC terminal's character-oriented data stream as a sequence of packets, but the X.25 device at the remote end will normally be incapable of handling the BSC protocol encapsulated in the packets it receives.
- *Net protocol conversion across network* distinguishes between the net difference in protocol between the originating/incoming and destination/outgoing interfaces at the edge of the LEC network, and the actual (local interface) protocol conversions made along the way. Thus, when two asynchronous devices communicate across a PPSN, there is no net protocol conversion, even though protocol conversion between X.28 and the internal-packet protocol of the network is performed by PADs at either end of the connection. This distinction is important.

Although it is not formally protocol conversion, PPSS supports interworking with ISDN. This was discussed previously (see Section 14.11.10).

### 14.11.12 Call Processing

In addition to interface and protocol specifications, the CCITT X.25 and X.75 Recommendations detail procedures for establishing and clearing connections. The *PPSNGR* also specifies the numbering scheme used to identify PPSS calling and called parties and routing procedures to ensure that equal-access requirements are met.

Two basic categories of service, Switched Virtual Circuit (SVC) and Permanent Virtual Circuit (PVC), are provided by X.25 and PPSS. SVC service, also known as Virtual Call, allows connections to be established dynamically for a period of time and then cleared when no longer needed. There are distinct call setup, data transfer, and call-clearing phases for this service. Subscription facilities specify service defaults and define the ability to alter service characteristics dynamically, using per-call facilities.



PVCs are the packet equivalent of private-line service. The virtual-circuit connection is established by service order, which also specifies all service parameters that will apply. The PVC remains active with these specified service characteristics until they are modified or deleted by a subsequent service order. A PVC only has a data-transfer phase, and X.25 packets applying to the call setup or clearing phases are not used.

Addresses of calling and called DTEs carried by the X.25 and X.75 protocols conform to CCITT Recommendation X.121 (1992). This numbering plan is designed to provide for internationally unique addresses. The internationally unique form of an X.121 address is called an International Data Number (IDN). The IDN consists of at least five digits, but no more than 14 digits. When, as in the U.S., different public networks administer separate numbering schemes, the first four digits of the IDN is the Data Network Identification Code (DNIC). The remainder of the address (one to ten digits) is the Network Terminal Number (NTN), which uniquely identifies a DTE/DCE interface for the network associated with the DNIC.

In the U.S., each LEC, as well as the United States Telephone Association (USTA), has been assigned a separate DNIC. Under the current DNIC assignment policy, the LEC administers the addresses associated with its assigned DNIC and shares this address space with other PSPDNs in its geographic service area that request such sharing. The USTA DNIC code is available for sharing by independent LEC data networks. Since DNICs are also used for network identification in the ROA Selection facility, U.S. networks that serve as packet ICs are assigned their own DNIC from among those available for use in the U.S.

The NTN for all PPSN DTE/DCE interfaces (and all networks sharing a DNIC assigned to a LEC) are ten digits in length and have the following format.

NXX (DNPA)	NXX (DCO)	XXXX (EPN)
---------------	--------------	---------------

where: DNPA = Data Numbering Plan Area (3 digits)

DCO = Data Central Office (3 digits)

EPN = End-Point Number (4 digits)

N is a digit in the range 2-9

X is a digit in the range 0-9

A DNPA, at least initially, designates a geographic area that corresponds to a telephony NPA. A DCO, in conjunction with a DNPA, identifies an undivided geographic area, network, or subnetwork capable of interconnection with other networks at a single interconnection point. The EPN uniquely identifies a DTE/DCE interface or hunt group within the DNPA/DCO.

PPSS routes interLATA calls in compliance with equal-access requirements. In routing such calls, the PPSS makes use of the ROA Selection and IC Preselection facilities described earlier. If ROA Selection is signaled for a call, the call is always routed through the designated IC (if one exists). If no ROA Selection is signaled, the call is routed within

---

the LEC's LATA network or to a directly connected network on the basis of the called address. If the called address does not correspond to a DTE served by the LEC's LATA network or a directly connected network, the network designated by the IC Preselection is used. If none of the above apply or succeed, the call is cleared.

### 14.11.13 Interoperability Issues

PPSS interoperates with several other LEC network services. Compatibility with other PSPDNs and the provision of nationally consistent packet services are also important interoperability issues.

Figure 14-25 illustrates PPSS interworking with two other LEC network services: the PSTN and ISDN. PPSS access through the PSTN provides dial-in/dial-out access arrangements when dedicated connections to the PPSN are not justified by the anticipated traffic. Dial-access arrangements were previously described.

The ISDN packet-mode bearer capability, using the ISDN PHF permits ISDN customers to directly communicate with other ISDN customers and with customers on PSPDNs in the packet-mode using the X.25 protocol. As illustrated in Figures 14-25 and 14-26, ISDN packet mode customers can access PPSN customers and packet-mode customers on other packet networks via X.75' interfaces between ISDN PHFs and PPSN packet switch within the same LATA. Public InterLATA connections would require X.75 interfaces to an IC, either via a PPSN packet switch or directly supported by an ISDN PHF. Since PPSN and other PSPDN customers have addresses conforming to the CCITT Recommendation X.121, while ISDN addresses conform to CCITT Recommendation E.164, address interworking rules have been established. The native address assumed over any X.75/X.75' interface is X.121, unless both ends of the interface are ISDN PHFs, in which case E.164 is assumed.

Currently, escape codes (initial digits that cannot be initial digits of valid native addresses — 0 or 9) are used to indicate that the non-native address type is being requested. However, a more flexible long-term approach to address interworking, called the Type of Address/Numbering Plan Identifier (TOA/NPI) mechanism, was developed by the ITU-T and is expected to be available for use in the future.

Because numerous PPSNs in different LATAs, packet ICs, and other PSPDNs must work together to provide national and international service, interoperability among PSPDNs is critical. Two degrees of this interoperability can be distinguished. For all packet-mode networks participating in a connection, there must be basic compatibility of user access and internetwork interface protocols. Beyond this basic interface compatibility, the LECs have developed agreements on a minimal subset of protocol and service options to be supported to provide for a nationally available common core of compatible packet services.

Interoperability among PPSNs and all other PSPDNs is based on implementation of a single set of internationally standardized protocols for customer/network access (CCITT



X.25, X.32, T3POS, and X.28/X.29) and internetwork (CCITT X.75) interfaces. Compatible implementation of a single set of protocols ensures that networks can effectively interconnect, and DTEs can connect to any conforming network. It also ensures that there is a common set of (nonoptional) services provided across multiple networks. Because of differing interpretation of the standards of the ITU-T, and to reduce the potential for incompatibility between PPSN and other network implementations, detailed specifications for common elements of PPSN X.25 and X.75 interfaces have been published.

#### 14.11.13.1 National PPSN Compatibility

The minimal subset<sup>3</sup> of generic PPSS capabilities identifies Bellcore's view of features required for efficient cross-network compatibility. This minimal set of capabilities is necessary if commonly used service features and common procedures for activating those features are to be available nationwide on PPSN customer interfaces. Support of such a minimal subset is also necessary if commonly used service features are to be supported in a uniform manner across network-access interfaces.

---

3. See GR-301-CORE, *PPSNGR*. Section 2, for the most recent minimal subset list.

---

---

## 14.12 Asynchronous Transfer Mode (ATM)-Based Broadband Integrated Services Digital Network (B-ISDN)

A number of forces have been driving toward broadband networks. Technologies that allow more information to be delivered to the user and provide higher speed backbones, new computer communications techniques, the doubling of processor power approximately every 18 months, and new switching technologies inevitably drive out old technologies. Customer needs for higher bandwidth applications in the business environment and residential services such as Internet access and entertainment, which have widely different traffic and cost characteristics, are another concern. Competition and regulatory changes require more flexible and scalable solutions. These factors led to the realization and conception of a Broadband Integrated Services Digital Network (B-ISDN).

### 14.12.1 B-ISDN Principles

The emerging technologies of high-speed multiplexing, switching, and optical transmission systems foreshadow the realization of Integrated Services Digital Networks (ISDN) with broadband capabilities. The appropriate application of these technologies can provide users and service providers with enormous information transfer capacity that can be flexibly drawn upon to meet existing and future service needs. Since switching and transmission requirements of emerging applications cannot be known precisely, it is crucial that the capabilities of a B-ISDN be all-purpose and flexible.

To understand B-ISDN, one must go back to the original ISDN standards. In 1984, the CCITT<sup>1</sup> adopted a series of recommendations dealing with integrated services over digital networks. The CCITT stated that “an ISDN network ... provides end-to-end digital connectivity to support a wide range of services, including voice and non-voice services, to which users have access by a limited set of standard multipurpose user-network interfaces.” The digitized telephony network is characterized by its two interfaces. One is the Basic Rate Interface (BRI) access consisting of two 64-kbps channels (frequently referred to as B channels) and a 16-kbps signaling D-channel. The D-channel could also be used to send data but to date no such implementations exist. The other interface is the Primary Rate Interface (PRI). PRI provides a channelized interface rate of 1.544 Mbps (generally structured as 23B + D@64 kbps) for “T1” transmission hierarchy or 2.048 Mbps (generally structured as 30B + D@64 kbps) for the “E1” transmission hierarchy. Other structures are possible consisting of certain multiples of 64-kbps channels. The important concept ISDN introduced was the ability to support multiple connections and different media over the same facilities at the same time. The channelized approach was applied and extended for B-ISDN with the addition of Virtual Channels, Virtual Paths, and logical connections.

---

1. The CCITT is now known as the ITU.

With the need to support interconnection of Local Area Networks (LANs), the transmission of video and image with good resolution, circuit switching, connection oriented packet and connectionless packet communication needs, new transmission and multiplexing techniques being developed, it was apparent that ISDN was too limiting.

Considering the ongoing costs associated with the deployment and maintenance of parallel service-specific networks typically requiring technology-specific/optimized equipment implementations, operation, maintenance, provisioning, etc., the total cost of ownership of dedicated overlay networks when aggregated together represents a significant cost to public carriers/service providers.

Dedicated networks require several distinct and separate subscriber access lines/interfaces increasing costs to users and service providers. These factors drove the global telecommunications industry toward a single solution. After much technical debate, the Asynchronous Transfer Mode (ATM) technique was selected. It was concluded that a number of the signaling, service control, network management protocols, and standards that were developed for ISDN were extensible. Subsequently, ATM broadband standards and industry implementation agreements that have been developed leverage existing standards. This is particularly important from the perspective of easing the transition from existing networks and applications, and it minimizes interworking functions between the existing equipment and ATM broadband network implementations.

#### 14.12.1.1 What is B-ISDN?

B-ISDN is both a protocol model and architecture. The objective was to extend the original ISDN concept of a single network. A key element of service integration on a single network is the provision of a wide variety of services to a broad spectrum of users utilizing a limited set of connection types and multipurpose user-network interfaces. Some of the factors taken into consideration include the following:

- The need to provide flexibility to handle emerging demand for broadband services (candidate services contained in I.211 for both the user and operator)
- Considering the availability of high-speed transmission, switching, and signal processing technologies
- Improved data and image processing capabilities to users and service providers
- Applying software advances in computer and telecommunications
- The need to integrate interactive and distribution services, and circuit and packet transfer modes into a universal broadband network.

The goal was to define a protocol reference model that would be flexible in its ability to support divergent application requirements.

---

#### 14.12.1.2 B-ISDN Protocol Reference Model

The B-ISDN Protocol Reference Model (PRM) was developed as a common framework to facilitate the development of B-ISDN protocols and readily identify critical protocol architecture issues. It models the interconnection and exchange of information in a B-ISDN environment. The model was developed using a layered communication architecture similar to the one developed by the International Standard Organization (ISO).

##### **Protocol Layer Specification**

Before delving into the complete B-ISDN PRN, a list of the basic items that need to be described for a complete protocol specification is given. In general, the specifications of a protocol layer should include the following items:

- A general description of the purpose of the layer and the services it provides
- An exact specification of the services that the layer provides to the upper layer and the services that it expects to receive from the lower layer
- The structure of the layer in terms of entities and their relation
- The description of the interactions between the entities which includes the informal operation of the entities, and the types and formats of messages exchanged between these entities.

##### **Description of the B-ISDN PRM**

The PRM has several layers in the model. First is the physical layer, which describes the physical media and the transmission of information through the network. The next layer is the ATM layer. This layer defines the cell structure (explained in more detail in the next section) and how the ATM cells flow through the logical connections in an ATM-based network. The next layer consists of the ATM Adaptation Layer (AAL). The AAL is responsible for chopping up the user information (voice, data, graphics, video) and multiplexing the different types of information that are to be sent over the ATM network. The final layer is the user layer where the various service specific functions are available to the end user applications. This is illustrated in the two dimensional protocol stack in Figure 14-27.

The full B-ISDN PRM is based on the framework defined in ITU-T Recommendations I.121 and I.321. While it uses similar layering concepts, the model had to be extended to meet the needs of B-ISDN to support functions such as signaling. This led to the concept of separated planes for the segregation of User, Control, and Management functions.

Figure 14-27 shows the B-ISDN PRM. This model contains the three structural elements named: User Plane, Control Plane, and Management Plane.

---

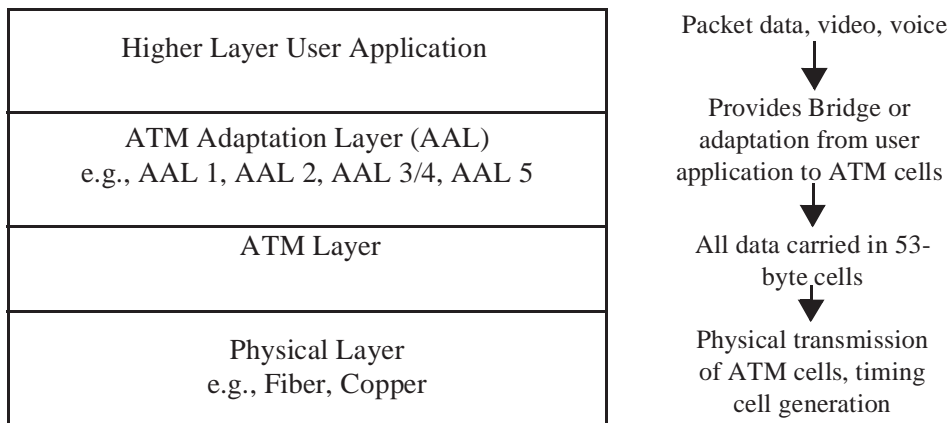


Figure 14-27. Simple Protocol Stack

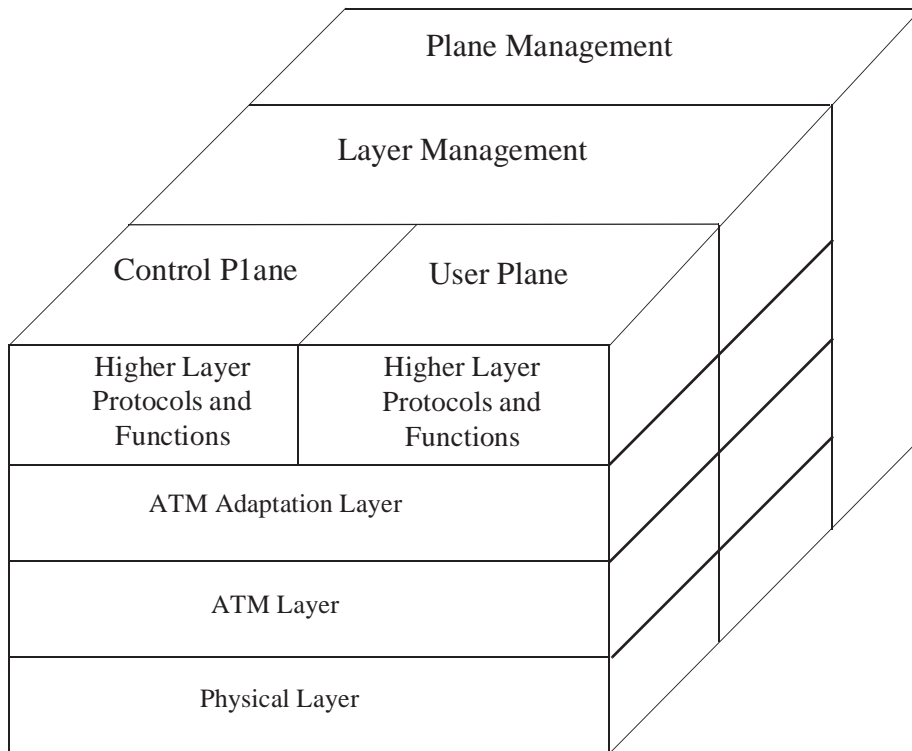


Figure 14-28. B-ISDN Protocol Reference Model

---

The User Plane, with its layered structure provides transfers user application information. The Control Plane, also with a layered structure, handles the call and connection control functions, including the signaling necessary to establish and release calls and connections, negotiation and allocation of network resources, etc.

The Management Plane manages application functions, and has a mechanism for information interchange between the User Plane and Control Plane processes. Functions related to the management aspects include coordinating local operations across layers in establishing network connections, monitoring established connections for failures, and responding to status queries to support network supervision all reside in the Management Plane. The Management Plane has two sections: Layer Management and Plane Management. The Layer Management performs the management functions specific to a layer, such as layer-specific Operation, Administration, and Maintenance (OAM) tests/ functions, and interacts with the layer entities and the Plane Management entities. The Plane Management section performs the management functions related to the system as a whole, the coordination between all the planes and the various Layer Management Entities (LMEs). The Plane Management is not layered.

The ATM and Physical Layers are common to both the User Plane and the Control Plane. The functions of the Physical Layer are grouped into two sublayers: the Physical Medium Dependent (PMD) Sublayer, and the Transmission Convergence (TC) Sublayer. The PMD deals with the bit transmission over the physical medium of choice. While B-ISDN concepts initially assumed that the PMD would be based on SONET/Synchronous Digital Hierarchy (SDH), the ATM principles apply to nearly any physical medium. Since the initial standards were developed, the ATM Forum<sup>2</sup> has adapted ATM to more than 20 physical interfaces, providing users a choice of physical media that best meets their needs, while others adapt ATM to the different transmission hierarchies around the world.

The TC Sublayer deals with the transmission framing and OAM functions, as well as blocking and deblocking of physical data units. The ATM Layer provides the transparent and sequential transfer of fixed size data units between a source and the associated destination(s) with an agreed Quality of Service (QoS). The Physical and ATM layers are service-independent, that is only functions that apply to all services are supported.

The AAL performs the necessary functions to adapt the services provided by the ATM Layer to the services required by the different service users. Therefore, the AAL functions are service-dependent, and several AALs with different protocol characteristics have been standardized. Some of the functions of the AAL entities are targeted to support services that require Constant Bit Rates (CBR) and timing relationships such as circuit emulation. Other functions support Variable Bit Rate (VBR) bursty data traffic such as Internet Protocol (IP) and Switched Multimegabit Data Service (SMDS) based connectionless data services or connection oriented data services like Frame Relay as well as the signaling control channel. Due to the extreme variability of the requested services to be supported, five different AAL

---

2. The ATM Forum is a research consortium formed in 1991 to speed the development and deployment of interoperable ATM products and services.

---

protocols have been developed. The use of an AAL is optional. A user can operate without an AAL. This is referred to as the “null AAL,” native ATM, or Cell Relay (CR) service. Additional details are provided in the next section.

### 14.12.2 ATM Concepts

ATM is a switching and multiplexing technique that uses fixed size data units or “cells” in the transfer of information from the source to the destination. The ATM Layer defines the cell structure and how ATM cells flow through the logical connections in a network. A cell consists of an information field (cell payload) that is transported transparently and a header. A label field inside each cell header is used to define and recognize individual communications. In this respect, ATM resembles conventional packet transfer protocols. In addition, similar to packet switching techniques, ATM can provide communication with a bit rate that is individually tailored to the actual need of the user application, including time-variant bit rates. The term asynchronous refers to the fact that cells allocated to the same connection may exhibit an irregular recurrence pattern as they are filled before transmission according to the actual user application characteristic.

Leveraging these fundamental characteristics, ATM is designed to be a general purpose service-independent, connection-oriented transfer mode that can be used for a wide range of services, and applied to LAN, public, and private network technologies. ATM handles connection-oriented traffic either directly over ATM (Cell Relay or native ATM) or through adaptation layers for service-specific support. It handles connectionless traffic using an adaptation layer. ATM connections may operate at either a CBR or VBR. The label field of each ATM cell header sent into the network contains address information that is used to establish a Virtual Connection (VC). All cells associated with a connection are transferred in sequence. ATM provides either Permanent Virtual Connections (PVCs) or Switched Virtual Connections (SVCs). The transfer capacity of each ATM connection may be assigned on demand (through signaling) depending on resource availability.

The ATM Layer provides ATM connection switching (cell relaying), multiplexing and demultiplexing, in-band layer management, generic flow control, and some basic traffic control. It supports multiple grades of service based on loss and/or delay priorities. Cell sequence integrity on an ATM Layer connection is preserved by the ATM Layer.

#### 14.12.2.1 ATM Cell

The ATM cell consists of a 5-octet header and a 48-octet payload. Two different encoding schemes for the cell header are adopted according to the type of interface being considered, i.e. the User Network Interface (UNI), or the Network Node Interface (NNI). The payload, however, is unchanged. The UNI is the interface between the user customer equipment and the network switch. The NNI is the interface between switches or between networks. The cell header is used to identify the destination, cell type, and priority.

---

Figure 14-29 illustrates the format of the 53-octet ATM cell for both the UNI and NNI.

5-Byte Cell Header	48-Byte Information Field
--------------------	---------------------------

**Figure 14-29a. ATM Cell**

GFC (4 bits)	VPI (4 bits)	
VPI (4 bits)	VCI (4 bits)	
VCI (8 bits)		
VPI (4 bits)	VPI (4 bits)	CLP (1 bit)
HEC (8 bits)		
User Information		

**Figure 14-29b. ATM Cell Format (UNI)**

VPI (4 bits)	VPI (4 bits)	
VPI (4 bits)	VCI (4 bits)	
VCI (8 bits)		
VCI (4 bits)	PTI (4 bits)	CLP (1 bit)
HEC (8 bits)		
User Information		

**Figure 14-29c. ATM Cell Format (UNI)**

**Figure 14-29. ATM Cell Formats**



---

The cell header contains the following fields:

**Generic Flow Control (GFC):** The GFC is a 4-bit field intended to provide a generic flow control mechanism to assist in controlling the flow of traffic at each UNI. The function is similar to IEEE 802.6 Distributed Queue Dual Bus (DQDB) standard with a shared access medium but was never defined as part of the standard. Currently, it is being considered as a means of controlling contention for shared trunk resources.

**Connection Identifier (VPI/VCI):** The Virtual Path Identifier (VPI) and Virtual Channel Identifier (VCI) is a label field used to identify the destination of a connection. The VPI/VCI have local significance applying to that interface connection and do not extend through the switch or network on an end-to-end basis. Use of VPIs/VCIs is described in the next section.

UNI VPI/VCI field consists of 24 bits divided into the 2 subfields: 8 bits for VPI, and 16 bits for VCI.

NNI VPI/VCI field consists of 28 bits: 12 bits for VPI, and 16 bits for VCI. For the NNI, the GFC function is not provided and the additional bits are allocated for VPI use.

**Payload Type (PT):** The 3-bit PT field is used to indicate whether a cell contains upper layer or user information or a cell carrying Layer Management information in the payload. A later section describes the details of the PT field coding.

**Cell Loss Priority (CLP):** This 1-bit field is used to indicate the cell loss priority to assist the cell discarding process in the event of network congestion and to minimize the degradation in grade of service that may be perceived if the network has to discard cells. If the CLP is set (CLP value is 1), the cell is subject to discard, depending on network conditions. If the CLP is not set (CLP value is 0), the cell has a higher priority.

**Header Error Control (HEC):** The 8-bit HEC field applies to the 5-octet ATM cell header. The HEC code is used by the Physical Layer to provide error control and cell delineation functions performed at the physical layer. The HEC code is able to provide single-bit error correction and detection of multiple-bit errors over the cell header. Since the cell header VPI/VCI field is used to route and switch cells to the proper destination, it is important that errors are detected before delivery of information to the incorrect user occurs or an incorrect action is taken in the ATM layer. The TC sublayer generates the HEC on cell transmissions and uses the HEC to determine if the received cell header has any errors.

#### 14.12.2.2 Virtual Path and Virtual Channel Concept

The ATM cell structure and the ATM layer define how information carried in cells flows through the logical connections in ATM-based network equipment. The logical connections in the ATM layer are based on the concept of Virtual Paths (VP) and Virtual

Channels (VC). A VP is a bundle or collection of VC connections made through an ATM network. See Figure 14-30.

Each VP and VC can be individually established in one of two ways — either permanently established, or set up dynamically for the duration of time necessary to transmit the user information. VC connections and VP connections that are set up permanently are referred to as PVCs and PVPs, respectively. VC and VP connections that are dynamically established use the access signaling and control protocol to communicate the characteristics of the connection desired from the user to the network, depending on the version of the signaling protocol<sup>3</sup> may be able to negotiate the characteristics if the traffic and QoS parameters originally requested are not available, and communicate when to set up and take down the connection. VC and VP dynamically set-up connections are switched through the network based on the ATM cell header connection identifier field or VPI and VCI, and are referred to as SVCs and SVPs.

- Virtual Channels (VCs) carried in Virtual Paths (VPs)



- Thousands of VCs can be carried in a Virtual Path
- Hundreds/ thousands of VPs can be carried in a Physical Link
- Virtual Channel Identifier (VCI) contained in ATM cell header
- Virtual Path Identifier (VPI) contained in ATM cell header
- VCI, VPI read at network elements (e.g., ATM switches) and customer equipment which process ATM layer
- Bandwidth can be flexibly assigned on per VC basis
- End to end VC Connection (VCC) is concatenation of VCs between customer and network equipment elements

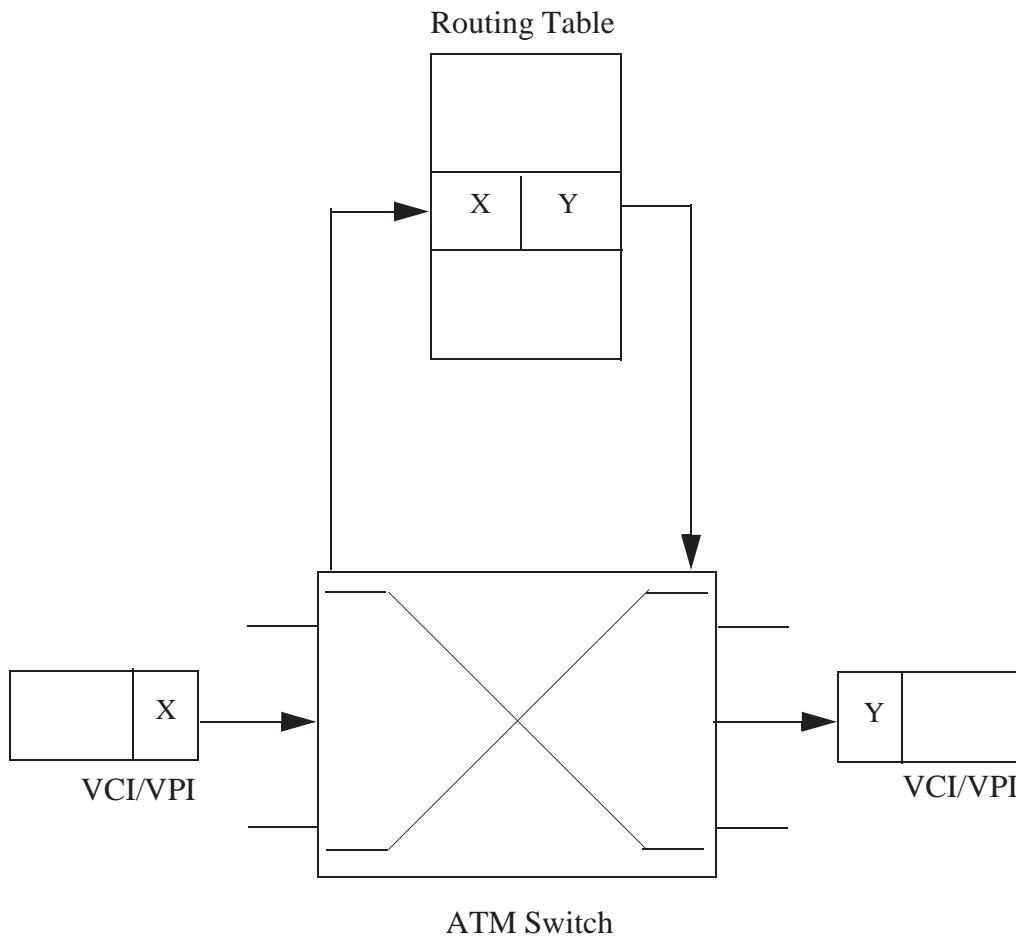
**Figure 14-30.** Virtual Path and Virtual Channels

### 14.12.2.3 ATM Layer Processing

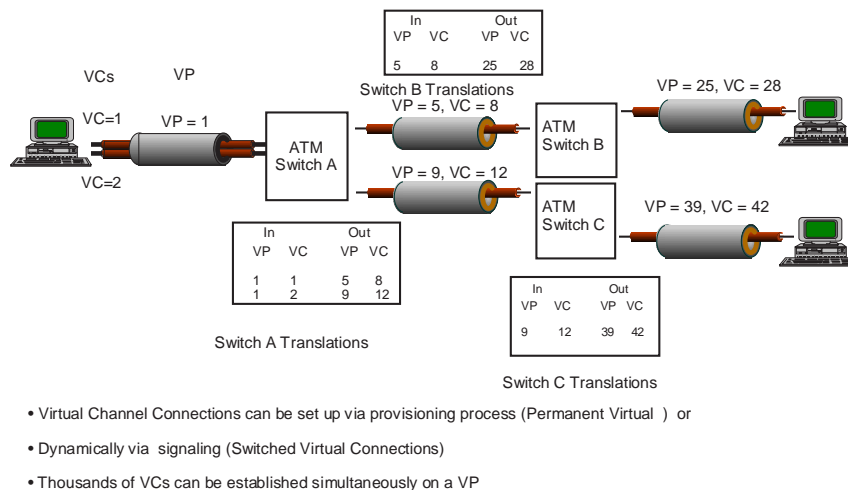
The high-performance processing of ATM cells is enabled by the small, fixed-size cell format. The ATM cell header is only five bytes long and requires minimal processing as cells arrive and flow through equipment. In fact, the ATM principles are simple. To fully use the capabilities ATM provides requires additional functions to build on top of the ATM Layer.

3. GR-1111-CORE, *Broadband Access Signaling Generic Requirements*, and ATM Forum, *UNI Signaling version 4.0*, define procedures for dynamic negotiation but ITU-T Recommendation Q.2931 has not yet been developed to support negotiation capability.

As each ATM cell arrives, the ATM layer is first checked for errors by processing the header checksum field. If no errors are present, the cell header is checked to determine if the cell is for network use only (i.e., signaling message, network management, or maintenance check), or if user information. If user information, then the VCI and VPI are looked up in the routing table of the switching equipment to determine to which outgoing facility the cell should be switched and routed. Since the outgoing connection involves a different channel, the switch replaces the VPI/VCI value with new VPI/VCI values prior to sending them through the ATM switching fabric. See Figures 14-31 and 14-32.



**Figure 14-31.** ATM Layer Processing



**Figure 14-32. Switching Virtual Channels**

To further simplify processing and increase performance, multiple VC connections can be bundled into one VP. The VP can be switched and routed in whole, without having to examine each individual VC connection. The expectation was to bundle traffic going to the same next point or destination. Traffic management and policing functions are performed only on the aggregated VP level. Consequently, the QoS characteristics of the bundled VC connections would be that of the most stringent VC carried within that bundled path since only the VPI part of the cell header may need to be processed. In addition, CBR connection types would not be mixed with VBR connection types, nor would VBR “best effort” connections be mixed/bundled with VBR connections with QoS guarantees.

The ATM switch can add/change certain QoS information in the ATM cell (i.e., cell loss priority bit), and provide current congestion information in special resource management cells, before transmission out of the switch. Contrasted with TCP/IP-based Internet and Intranet technology, the packet sizes vary considerably, and packet headers contain much more information that must be processed at each link/hop by router processors through the network. This requires more computing power and buffer space within every route server in the network than does ATM.

#### 14.12.2.4 Connection Setup

To establish a connection, one of two methods can be used. ATM connections can be set up permanently through a manual service order provisioning process. These connections are referred to as Permanent Virtual Connections (PVCs). With PVCs, while simple to establish and manage, resources are dedicated on a continuous basis, 7 days a week, 24 hours a day, whether used or not. Alternatively, connections can be set up dynamically or on demand only when a connection is desired or needed. In these cases, users are billed only

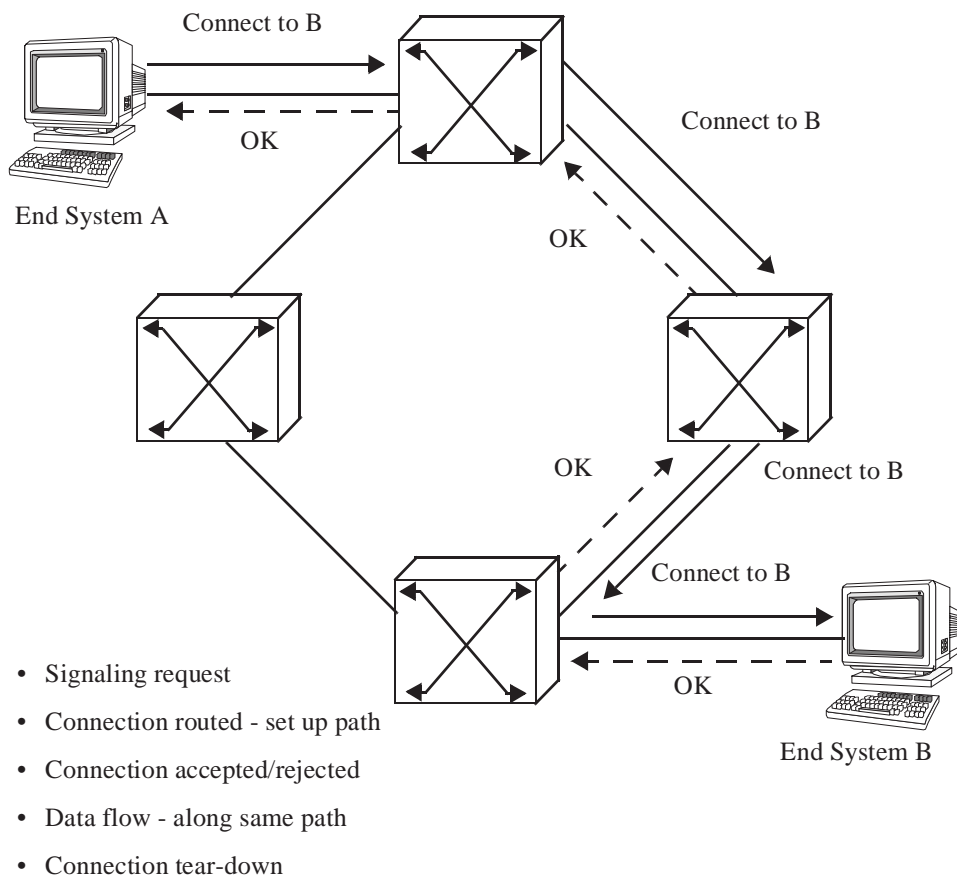
---

for the resources used during the connection. These connections are referred to as Switched Virtual Connections (SVCs). The mechanism used to communicate from the user to the network the type of connection needed and the characteristics of that connection is called signaling. The ATM Layer predefines a VC for the use of signaling message. The signaling from the user into the network is referred to as access signaling, and is carried across the User Network Interface (UNI). The signaling between network elements within a network (e.g., switches, signaling transfer points, databases), and between different carriers/service providers is referred to as network signaling. Network signaling is carried over a Network Node Interface (NNI).

To establish a connection, the user communicates to the network, via signaling messages, the characteristics of the connection desired and the user destination address. The characteristics are then communicated from the originating network switch through the network to the destination. This allows network resources to be checked for availability and allocated to handle the requested connection type, bandwidth and QoS, and VPI/VCI values initialized and assigned from the attached device and all intermediate ATM devices. Once this is done and the terminating device signals it is ready to receive information, a connection established message is communicated to the source that connectivity exists and information can flow. Therefore, this makes ATM a connection oriented network technique. See Figure 14-33.

When the connection setup is complete, cells can flow. As cells arrive at a switch node, the only processing that is required is of the VPI and VCI values that determine the output link to forward the cell. Throughout connection setup and while user information is flowing, tests are performed to ensure reliable service. These tests include verifying continuity utilizing the ATM OA&M cell capability, verifying resource availability, traffic monitoring traffic and QoS in a manner that does not exist with other technologies or is much more difficult to perform. These additional ATM mechanisms and capabilities contribute to more reliable and easier to maintain and operate networks.

Contrasting the above again with the IP/Internet techniques, the tradeoff of taking a little more time to signal and establish a connection versus the IP approach of simply sending a packet of information that must be self-contained with source and destination address information, and each router having to lookup and process every packet before a route can be determined. Further, if reliable information exchange is important, the user must layer on higher protocol functions and procedures to ensure the information gets to the proper destination. Identifying troubles and isolating faults with the IP/Internet protocols are more difficult, and greater delays can be incurred before corrective action can be taken.



**Figure 14-33.** Connection Setup

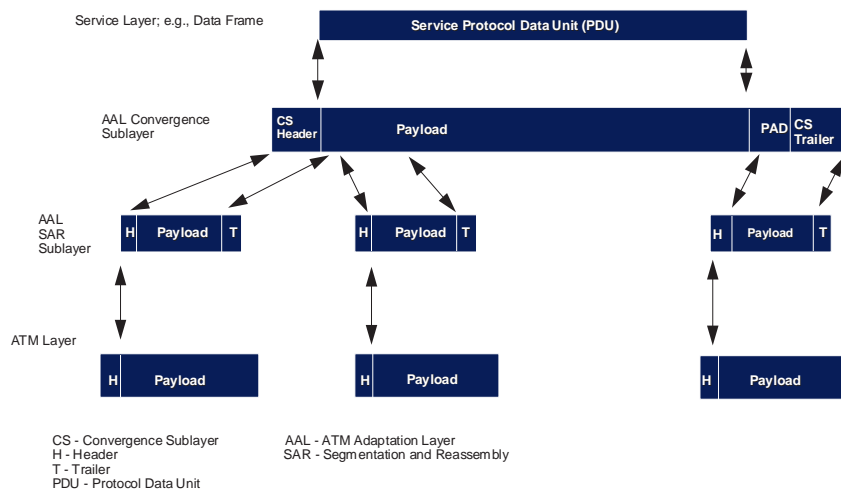
### 14.12.3 ATM Adaptation Layers (AAL)

The ATM Adaptation Layers (AALs) provide functions needed to match or “adapt” the services provided by the ATM Layer to the services required by the higher layers, generally the service carried/offered to the user. Therefore, the AAL provides the interface between the user applications and the ATM layer. The AAL is divided into two sublayers, the Segmentation and Reassembly (SAR) sublayer, and the Convergence Sublayer (CS).

The SAR is responsible for dividing or segmenting the user information into a 48-octet payload field of the ATM cell for transport, and reassembly of user information on the receive side.

The CS is service-dependent and is further divided into Service Specific (SS) and Common Part (CP) components. The SSCS sublayer may not be required and can be null. The CPCS

must always be implemented along with the SAR. Figure 14-34 illustrates how user data may be mapped into ATM cells.



**Figure 14-34.** Mapping User Data Into ATM Cells

Services are broadly characterized by the way information flows, CBR or VBR. With CBR, the user communicates with a continuous stream of information for an application where end-to-end synchronization or timing is critical. In VBR applications, the source sending information in a bursty fashion typically used for packet data communication techniques. VBR connections can support both connection oriented as well as connectionless-oriented packet modes.

To minimize the number of AAL protocols that may be needed, a service classification was developed. The classification categories are made based on the timing relationship between source and destination, bit rate, and connections mode. The four service classes identified to date are labeled A through D. Figure 14-35 depicts the service classes and the corresponding AAL protocols.

- Class A - CBR service with end-to-end timing, connection-oriented. Applications include voice, circuit emulation (for example, transport of T1/E1 transmission rate of 1.544 Mbit/s/2.048 Mbit/s or T3/E3 rates), and video.
- Class B - VBR service with end-to-end timing, connection-oriented. Expected applications may be packet video, audio/voice.
- Class C - VBR service with no timing required, connection-oriented. Example applications are user signaling, Frame Relay, and X.25.
- Class D - VBR service with no timing needed, connectionless mode. Applications include IP and SMDS.

	Service Classes			
Attribute	Class A	Class B	Class C	Class D
Timing relationship (source/destination)	Synchronous (Clocking Required)		Asynchronous (No Clocking)	
Bit Rate	Constant	Variable		
Connection Mode	Connection-oriented			Connection-less
ATM Adaptation Layers (AALs)	AAL 1 or AAL 5*	AAL 2	AAL 3/4 or AAL 5	AAL 3/4 or AAL 5

\* Note: AAL 5 has recently been specified for Voice, and for Audio/visual Multimedia Service (AMS) ATM Forum specifications. ITU-T Voice Recommendations require AAL 1 and use of AAL 5 as option.

**Figure 14-35.** ATM Service Classes and Corresponding AAL Protocols

The AAL can be used, depending on the service, by the end users only or can be terminated in the network, again depending on the service offered/requested. Currently four AAL types have been specified in standards:

*AAL Type 1* - used for carrying CBR applications (e.g., voice), transparent transport of a synchronous DS1 through the ATM asynchronous network, service capability known as Circuit Emulation Service (CES), and real-time dependent video. In these applications, at the receiving end where the AAL is terminated and the CBR stream is reconstructed, the source clock is recovered, the jitter accumulation through the transit network is eliminated, and cell sequence is verified.

*AAL Type 2* - used to handle VBR traffic where a strong timing relationship needs to exist between the source and the destination, but the bit rate may vary. AAL 2 was approved as a standard by ITU-T in September 1997. The driver for AAL 2 development is for composite cells where multiple voice samples may be carried in one ATM cell. The PBX, enterprise network, and long distance trunking applications were the drivers while it is expected that future Wireless ATM systems will also use AAL2 for voice.

*AAL 3/4* - used for transmitting VBR information where the network cell delay and its variation have no deleterious real-time effects, and cell loss is less critical because of the



---

recuperative effects of the higher layer application protocols applied by the user. AAL 3/4 is used in connectionless SMDS applications.

*AAL 5* - used originally to carry VBR connections between computers, with a simple encapsulation of the packets generated by the source. Applications using AAL 5 include IP protocol over ATM, Frame Relay (FR) Service, and user and network signaling messages. However, AAL 5 can also support CBR connections. The ATM Forum developed specifications for Audiovisual Multimedia Service (AMS) supporting MPEG 2 video for video-on-demand distribution services, future video conferencing, and the Voice and Telephony Over ATM (VTOA) to Desktop using AAL 5 in CBR connections.

In addition, there are applications where the user and/or service provider may not need or want any AAL functions provided. This case is referred to as null AAL, which provides basic functions of ATM switching and transport, and is called Cell Relay Service (CRS). This provides users flexibility in providing their own proprietary AALs for special applications. In these cases, the AAL involves only the CPE at both ends of the connections and is transparent to the network.

#### 14.12.4 Benefits of ATM

ATM provides a number of advantages that will enable ATM networks to become the underlying infrastructure allowing users to take advantage of new computing and communications power. The key benefits of ATM include the following:

- **Efficient use of network resources** - ATM allocates bandwidth dynamically (bandwidth-on-demand) according to user needs and resources available within the network. ATM mechanisms reserve network resources for user applications based on bandwidth and QoS requirements. This enables real-time dependent applications to be guaranteed resources when needed to adhere to performance requirements, and at the same time allows unused resources to be shared by those applications that require only “best effort” service.

Certain applications demand a deterministic level of service such as audio and real-time video. ATM’s Virtual Connection (VC) oriented methodology and ability to negotiate QoS parameters ensure that multimedia application requirements of low latency and low cell delay variation can be met. The VC capability ensures that the one user’s traffic doesn’t degrade the services of another VC user on the same facilities.

- **Flexibility and Scalability** - ATM is not restricted to certain speeds and distance limitations. While ATM was initially developed for optical fiber physical media and high-speed carrier networks, ATM essentially applies to any physical media from wireless, copper twisted pair, coax, and various types of fiber (single mode and multimode, glass, and plastic fiber) operating over a wide range of speeds. ATM has been adapted to the transmission hierarchies around the world, and to media used for LANs.

---

Scalability refers to its ability to grow in terms of physical size (local and wide areas), speed, and in the number of users it can support without having one user's traffic/application interfere with that of another user. This achieved in part because of ATM's standardized cell format, and its use of switching elements. ATM's universal cell format is being used in by communications equipment in the local and wide area environments. This allows a uniform method of transport independent of the physical media and speed on an end-to-end basis over a diverse range of systems.

- **Integrated Services - Accommodation of Mixed Media** - ATM was designed to carry voice, data, image, and video simultaneously. Bandwidth management VC oriented cell based operation enables the deployment of a single, multiservice network where all traffic types can be transported. This eliminates the need for parallel and technology-specific overlay networks, thereby reducing costs, operations and maintenance, and ultimately complexity.
- **Transparency to Existing Applications** - ATM has the unique ability to emulate nearly any protocol. This is important since there is a tremendous base of embedded equipment and applications on the part of users and service providers. These applications will be around for a long time, and nobody is going to throw out their existing equipment and re-write application software so that they can use ATM.
- **Internetworking with Existing LANs and WANs** - ATM will serve as the underlying technology unifying existing LAN and Wide Area Network (WAN) services offerings. In the local area, LAN Emulation (LANE) of Ethernet and Token Ring technologies, and CES for T1/T3 and E1/E3 circuits have been developed. In the wide area, Frame Relay, Narrowband ISDN (N-ISDN), and SMDS interworking specifications are available, enabling a smooth migration and seamless integration with existing network applications, and allowing the introduction of ATM when and where needed without wholesale replacement.

#### 14.12.5 Broadband Services

An important goal of B-ISDN is to provide a common ATM platform in support of a variety of services. These services are what users see; they define the communications network. Generally, services fall into one of two categories — permanent and switched connections.

##### 14.12.5.1 Permanent Virtual Connections (PVCs)

The first broadband services to be introduced were PVC-based to support applications such as PVC CRS, PVC Frame Relay Service (FRS), SMDS, and Classical IP over ATM. Private Line DS1/DS3 services can also be supported using CES. These PVC services do not require functions related to terminating call control signaling, performing real-time call

---

---

management, traffic management, and policing functions. The following briefly summarizes PVC services commonly available:

- *PVC-based ATM Cell Relay Service (CRS)* — Cell Relay is the native fast-packet service of ATM-based B-ISDN. It is a connection-oriented, cell-based information transfer service providing wide-area, high-speed information transfer among distributed locations. It is designed to support a mix of applications, including data, video, image transfer, and multimedia. CRS can support connections with peak rates up to the maximum wire speeds of User Network Interfaces (UNIs). Currently the highest rate UNI defined is 622 Mbps.
- *PVC-based Frame Relay Service (FRS)* — Frame Relay is a 64-kbps to 1.5-Mbps connection-oriented data service designed to support LAN interconnection and terminal-host applications. Additional details on FRS are in the Section 14.13.
- *Switched Multi-megabit Data Service (SMDS)* — SMDS is a Public Packet Switched Data (PPSD) service that provides for the transfer of variable-length data units at high speed (initially up to DS3 without ATM and up to maximum rate of UNIs) without the need for call establishment procedures. It supports applications such as LAN interconnect, data transfer, and image transfer.
- *Classical IP Over ATM* — The Classical IP Over ATM RFC 1577 standard was developed by the Internet Engineering Task Force (IETF) to enable existing IP applications to run transparently over ATM with no modifications. It allows ATM hosts to transparently communicate to existing IP hosts (e.g., Ethernet). Classical IP Over ATM is supported on any rate UNI. However, early implementations have revealed that TCP flow control limits before maximum UNI wire speeds can be achieved. This will change as vendors optimize their TCP implementations.
- *Private Line or Circuit Emulation Service* — This service will support the interoperability between the ATM-based B-ISDN and the existing embedded base of equipment developed to operate using DS1 or DS3 connections between locations. CES defines how the DS1 and DS3 signalings are encapsulated and carried over ATM transparently.

#### 14.12.5.2 Switched Virtual Connections (SVCs)

While PVC services were introduced into the network first, the ultimate objective is to offer SVC services. SVC services offer potential for lower costs since users are charged only when connections exist. The introduction of the signaling mechanisms allow applications to gain access to more of the capabilities that ATM offers, and allows added value network services to be provided.

The introduction of SVC services provides many more opportunities and applies to many environments. To ease discussion of these service capabilities, their requirements, and specifications that apply, the services are divided into the following categories:

- Integrating Voice and Video
- ATM Local Area Internetworking Services
- Campus/Enterprise Internetworking
- Wide Area Networking.

#### 14.12.5.2.1 Integrating Voice and Video

Standards and industry implementation agreements to support voice and video were only recently completed. After the original 13 ITU-T ATM concept Recommendations were approved, priority was placed on adapting data applications to ATM because of greater need and opportunity. The ITU standards to take voice coding and adapt it to ATM were completed in 1996. The ATM Forum built on these international standards and developed the Voice and Telephony Over ATM (VTOA) to the Desktop, and VTOA ATM Trunking Using AAL1 for Narrowband Services.

VTOA Desktop defines the use of AAL 5 operated in the CBR mode to carry voice and timing information. The use of AAL 1 is optional. However, within international standards, the situation is reversed. AAL 1 is preferred and use of AAL 5 is optional. Interworking between AAL 1 and AAL 5 is also addressed in the VTOA Desktop specification. Additional aspects in conjunction with UNI Signaling version 4.0, ITU-T Q.2931 Access Signaling protocol, address interworking between B-ISDN and N-ISDN, and how tones and announcement are provided/handled, and a few supplementary services. However, the vast majority of added value/supplementary services defined and developed for narrowband networks have not been extended or adapted to ATM users. This is an area of future work that is just beginning in the industry. New work is also underway on VBR/packet voice over ATM.

The VTOA Trunking specification defines in more detail interworking between ATM B-ISDN and N-ISDN. The specification defines several reference configurations for Interwork Function (IWF) unit, and specifies how information from the User, Signaling, and Control planes, and OAM functions are handled and interworked.

Video On Demand (VOD) initial capabilities are specified in the ATM Forum's Audio-visual Multimedia Services (AMS) specification. The specification addresses carrying audio, video, and data over ATM in support of AMS. However, currently only the Phase 1 specification is available. Phase 1 specifically addresses the service requirements for VOD using CBR Packet Rate (CPR) MPEG-2 program transport stream support. The areas specified are the AAL 5 requirements for CBR mode of operation, the encapsulation of MPEG-2 Transport Streams into AAL 5 PDUs, signaling and connection control requirements, traffic characteristics, and QoS characteristics and requirements. Phase 2 of AMS will address VBR Video/AMS services.

---

---

Currently, work is not complete regarding ATM-based access distribution arrangements for residential broadband applications. Work is underway in the ATM Forum developing technology-independent access distribution requirements on which other organizations are basing their technology-specific approaches. For example, there are efforts in the Asymmetric Digital Subscriber Loop (ADSL) Forum on ADSL/ATM Mode implementation agreements for twisted wire pair loops, and IEEE 802.14 for cable modems for Hybrid Fiber Coax network distribution.

#### 14.12.5.2.2 ATM Local Area Internetworking Services

There is a large installed base of Local Area Network (LAN) solutions. Integrating ATM into an existing local environment to leverage current investment, experience, and a large number of applications requires that ATM technology support features in legacy LANs and end-systems in a transparent manner. However, there are several technical differences between traditional LAN technologies and ATM. These include the following:

- LAN technologies such as Ethernet and Token Ring are connectionless packet oriented while ATM is connection-oriented.
- The packet sizes of LANs vary up to 1500 octets for Ethernet and even higher in with other LAN standards. ATM has fixed size cells or packets of 53 octets.
- LANs operate as best-effort mode. No guarantees are provided. If information delivery is important, users implement higher layer protocol processing to ensure delivery. ATM has developed equivalent traffic management mode of operations offering Available Bit Rate (ABR) service and Unspecified Bit Rate (UBR) service.
- LANs use broadcast and group Media Access Control (MAC) addresses. ATM equivalent functionality has been developed using point-to-point connections between servers.

There are two common approaches to ATM and LAN internetworking with the existing LAN protocols. The IETF developed Classical IP Over ATM, and the ATM Forum has developed LAN Emulation (LANE). Both approaches achieve the objective of existing applications operating transparently. However, the two approaches achieve this at different layers in the protocol stack, and consequently offer somewhat different capabilities. Both are briefly discussed.

Classical IP Over ATM operates at the network layer (i.e., the IP layer) in a TCP/IP system implementation. Users need to load new IP applications over ATM drivers and traditional IP applications will operate transparently over ATM. It does not support other protocols such as Internet Packet Exchange (IPX), DECnet, NetBIOS, Appletalk, System Network Architecture (SNA), or the newer generation APPN. Classical IP Over ATM also does not support broadcasting or multicasting. Classical IP over ATM registers its own address with an address server located in the ATM network. The ATM adapter with IP Over ATM protocol uses the server to learn the ATM addresses of other Classical IP Over ATM

---

---

devices within the network. This differs from traditional IP where devices use Address Resolution Protocol (ARP) broadcasts to learn remote addresses. Since Classical IP over ATM doesn't support broadcast, an IP over ATM device must rely on ATM address resolution services explicitly, and not the traditional LAN broadcast/response mechanisms.

LANE was developed to enable existing LAN technologies (e.g., Ethernet, Token Ring) to run over ATM to take advantage of the higher speeds. LANE uses ATM as a backbone to interconnect and extend the reach of existing legacy LANs. LANE specifies how end stations communicate with each other across an ATM network, and how ATM attached devices/servers communicate with devices on an Ethernet or Token Ring segment. LANE is a layer 2 bridging protocol (operating at the MAC sub-layer of the protocol stack) that causes the ATM connection-oriented network to appear to the higher protocol layers and applications as a connectionless Ethernet or Token Ring LAN segment. By operating at this layer of the protocol, LANE provides several capabilities not possible with Classical IP Over ATM. The LANE approach solves the problem of a device discovering the MAC address of the destination station by clients registering their MAC address with the LAN Emulation Server (LES). LANE also provides broadcast functions, offers Virtual LAN (VLAN) capabilities, and with the LANE version 2.0 specification, supports redundant and replicated services. This also eases the network manager's job of upgrading and/or doing maintenance on servers and routers without interrupting user activities.

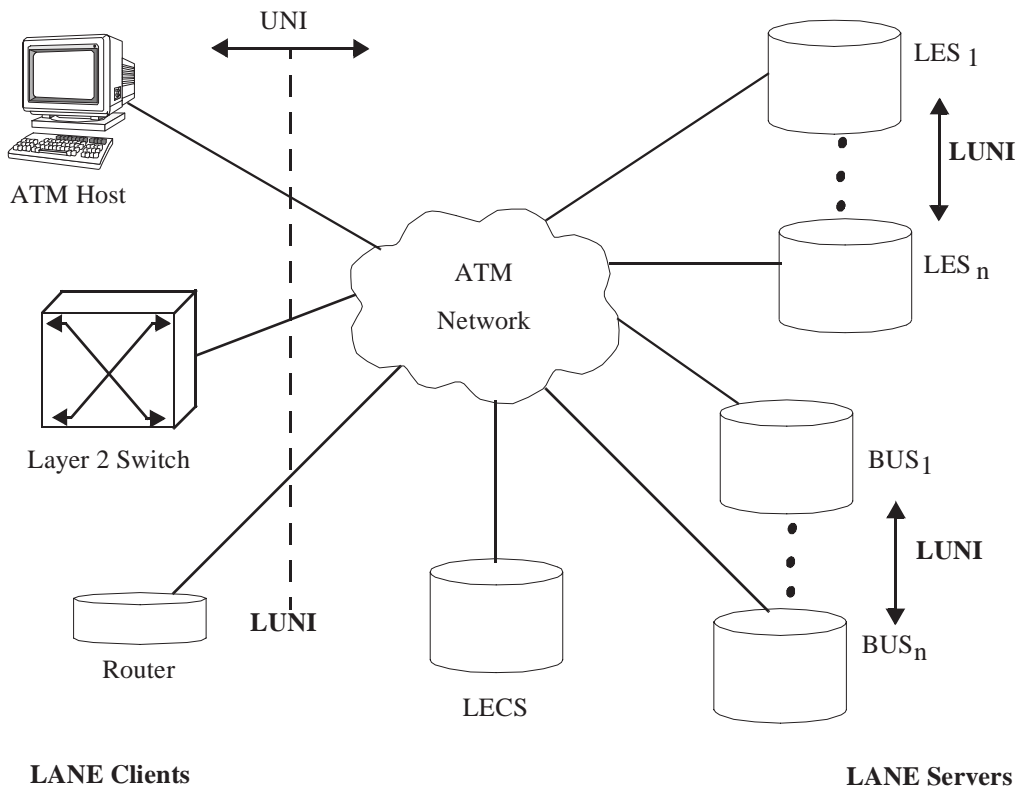
LANE 2.0 can work with and support Multiprotocols Over ATM (MPOA) for higher performance campus and wide area networking beyond what traditional LAN networking can achieve. LAN can accommodate multiple protocols. It is not limited just to IP. LANE can support routable protocols such as IPX and DECnet, as well as non-routable protocols such as NetBIOS, SNA, and APPN.

LANE operates by emulating a single LAN segment by providing the connectionless broadcast service needed by the IP network layer protocol. It performs the necessary data conversion between LAN packets and ATM Cells, and resolves MAC addresses to ATM addresses. LANE does not, however, emulate the Carrier Sense Multiple Access with Collision Detection (CSMA/CD) for Ethernet or token passing for Token Rings.

Figure 14-36 illustrates the various components making up a LANE configuration. The LANE model is based on client/server approach where multiple LANE Clients (LECs) connect to LANE servers. LANE defines three types of servers: LANE Server (LES), Broadcast and Unknown Server (BUS), and the LANE Configuration Server (LECS). While these servers are shown as separate servers for illustration purposes, they represent software components. Since the LANE specification was developed with the requirement of easy migration, most implementations functionally combine these software server functions typically in the ATM switch rather than as separate host computers. The LES is responsible for resolving MAC addresses to ATM addresses. The BUS handles flooding multicast and unicast packets with unknown destination ATM addresses among LECs on an emulated LAN. The LECS provides the functions necessary for configuring LECs with the addresses of the LES used by the attached emulated LAN.

---





**Figure 14-36.** LANE Components

Each station on an Ethernet or Token Ring has an associated LEC that is used to handle ATM transfers. Assume that a sending device on a traditional LAN segment wants to send data to another device on another segment over an ATM backbone network. The device uses its LEC to transfer/receive data over the ATM part of the path. The LEC sends the LES a MAC ATM address resolution query containing the destination device's MAC address. The LES responds with the ATM address of the LEC associated with the target device. The originating LEC then sets up an ATM switched virtual connection, converts the MAC frames into ATM cells, and transmits the cells over the network. At the receiving destination LEC, the ATM cells are re-assembled back into MAC frames and forwarded to the receiving device.

---

#### 14.12.5.2.3 Campus/Enterprise Internetworking Services

The campus and extended campus environments essentially address the need of escalating (and sometimes uncontrolled) LAN bandwidth growth. These environments provide bandwidth on demand (primarily for data) via ATM for burgeoning backbones in either the campus or in the extended campus (or short-haul WAN environments). Enterprises are focusing on their core business competencies. They want to drive down the costs not associated with the core areas of their business. Campus and enterprise environments also have needs to support a variety of different networks. All have voice networks (PBXs), many with leased or private lines. Many enterprises have an SNA network and most have a router-based LAN network. For wide area access, most connect to the Internet, and use services such as private lines, Frame Relay, SMDS, or Cell Relay to interconnect campus and enterprise networks. ATM can be a cost-effective method for satisfying the need for escalating bandwidth requirement while providing new capabilities not possible with other technologies.

VTOA Desktop and Trunking allow voice to be migrated onto the ATM platform. VTOA Trunking, combined with UNI Signaling, UNI Traffic Management, and Integrated Local Management Interface (ILMI) provide the key foundation specifications to interconnect a PBX to a public carrier/service provider.

For the Campus and Enterprise data needs, two ATM Forum specification are essential. They are the *LAN Emulation (LANE) v2.0 LANE User Network Interface (LUNI)* combined with *Multiprotocol Over ATM (MPOA)*. These specifications build on the UNI 4.0 related specifications (Signaling, Traffic Management, and ILMI) and are important to begin exploiting the power of ATM in the Campus.

First, consider what LANE 2.0 provides. LANE 2.0 represents the next incremental step in the migration of LANs toward a Campus environment. It consists of two parts: the LUNI 2.0 (LANE UNI), a backward compatible upgrade to a LANE 1.0 client's interface to the LES; and the LNNI 2.0, which defines the interfaces between components that go into the LES. New features in LUNI 2.0 allow the following:

- a. LANE clients to multiplex multiple Emulated LANs (ELANs) over the same VCC, useful for VCC constrained edge devices when there are a lot of ELANs.
- b. Improved support for QoS and mapping of IEEE 802.1p traffic classes to ATM QoS, and with support of additional ATM VCCs each having differing service categories and traffic parameters being used as Data Direct VCCs between two LANE clients. In LANE 1.0, only one UBR Data Direct VCC was recommended.
- c. Support for separating multicast traffic by providing the ability of a LANE Client to register for those multicast MAC addresses it wishes to receive, and thereby allow the LANE service not to send it frames addressed to other multicast MAC addresses, and generalize the Configuration Server so that it can apply to more than just LANE. In particular, this aspect is being coordinated with the IETF's work on Next Hop



---

Resolution Protocol (NHRP). Most of these features are being optimized in such a manner in which LANE fits as one of the individual components of MPOA.

- d. The ability to associate additional control information with the MAC address when registering the MAC address or responding to an LE ARP. This is used by MPOA Clients/Servers to indicate that they are MPOA capable (i.e., MPOAs auto configuration/auto learning is piggy backed on top of LANE).

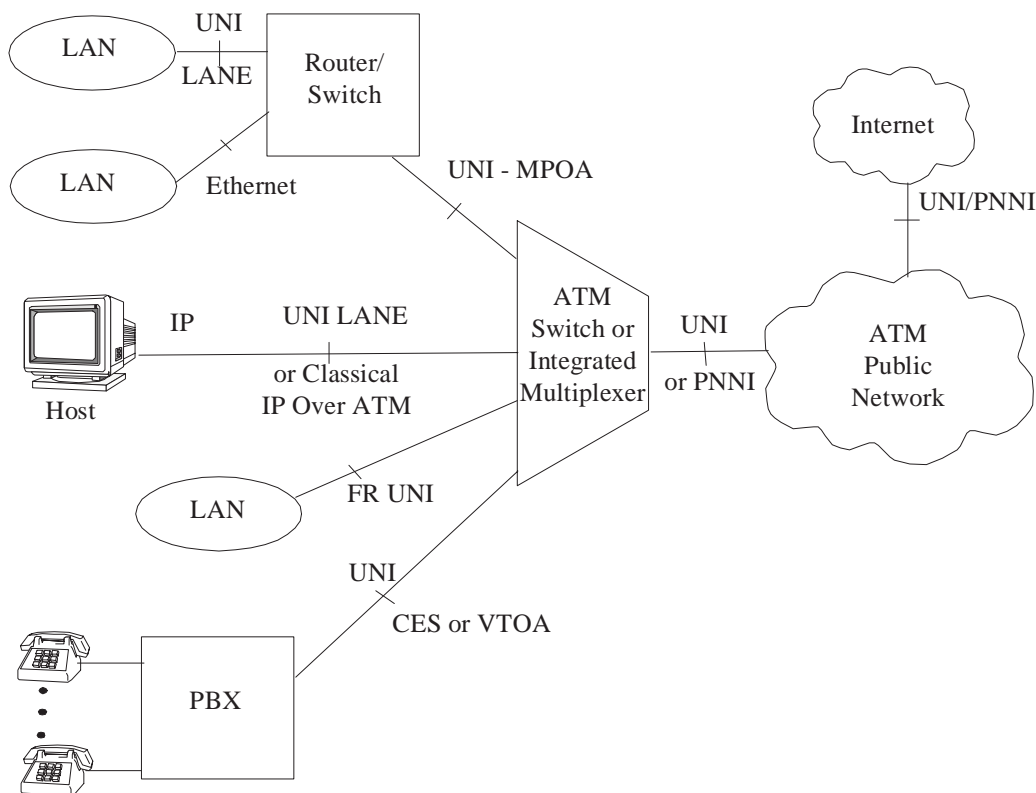
The LNNI is a new part of the specification, LANE 2.0, and is still under development. While LANE 1.0 did not preclude distributed implementations of the LANE Service components, neither did it describe how it might work. Thereby suppliers had no choice but to go with proprietary implementations. The LNNI 2.0 not only describes how the sub components can be distributed, but also defines the interfaces and protocols by which they exchange control and data. The LNNI's design goals are that a single ELAN can consist of 2000 LANE Clients, and 20 LES/BUS Servers. Therefore, LANE 2.0, by enabling multiple distributed components, will provide a more reliable and robust local area/campus network.

MPOA is the next piece needed for efficient, high-performance campus, extended campus, and enterprise network applications. MPOA is essentially a native mode (i.e., ATM-based) internetworking protocol that provides a framework for effectively synthesizing bridging and routing with ATM in an environment of diverse protocols, network technologies and Virtual LANs (VLANs). It enables application programs to gain access to the QoS properties of ATM, and it supports multiple protocols. IP however, is the most critical of these protocols. It provides a unified means for overlaying layer 3 protocols (IP and others) and the recently approved PNNI routing specification.

MPOA operates on an end to end basis rather than hop by hop. This provides a multilayer switching means to route and bridge multiple protocols over switched ATM backbones involving a maximum of three routers in the worst case. It significantly reduces the need for traditional routers to handle inter-subnet traffic where the current Internet congestion problems occur. This congestion problem also motivated the many flavors of IP switching (a hybrid of IP software and ATM switching hardware) proposals getting a great deal of attention. Although IP switching may provide some immediate congestion relief, many await MPOA implementations to solve the ultimate problem.

The MPOA version 1.0 specification was approved in April 1997 and initial implementations are now available. The IETF has a related effort underway called Multi Layer Protocol Switching, which will be completed during 1998. Its goals are similar in that it attempts to address the router processing bottleneck for the generic Internet. However, it does not provide the multiprotocol support and the Traffic Management or QoS provided by ATM-based solutions. Figure 14-37 illustrates a simplified Campus/Enterprise environment.

---



**Figure 14-37.** Campus/Enterprise Environment

The MPOA framework consists of a number of protocols being developed or completed in the ATM Forum, IETF, and IEEE. MPOA is adopting and integrating NHRP from the IETF, the ATM Forum's LANE 1.0 and coordinating requirements for LANE 2.0, and IEEE 802.1 for VLANs. In some areas, these protocols are being extended in either the originating group or by the MPOA group to better operate in the MPOA framework.

MPOA provides solutions that are only now beginning to be addressed by any other body. Most notable is the separation of switching from routing into a multilayer approach. There are several benefits of doing this. It will enable application programs to gain access to Traffic Management and the QoS properties of ATM and it allows integration of intelligent VLANs.

The ability to logically group related users and their traffic on one or more campus/enterprise switches by VLANs benefits users. In addition to simplifying the add/move/change process, it also offers a greater degree of security, reliability, and traffic reduction. Perhaps most important, it facilitates direct connectivity and improved performance between attached devices (also known as "shortcuts" in the form of IP/ATM switching

---

without incurring multiple router table calculations), enables more cost-effective edge devices, and provides a migration path for LANE.

For the extended Enterprise network, the Private Network Node Interface (PNNI) specification and its precursor specification Interim Inter-Switch Signaling Protocol were developed. The PNNI objective is to enable switch to switch, full function private/enterprise networks supporting services already defined or adapted to ATM while facilitating new applications for corporate or enterprise networking.

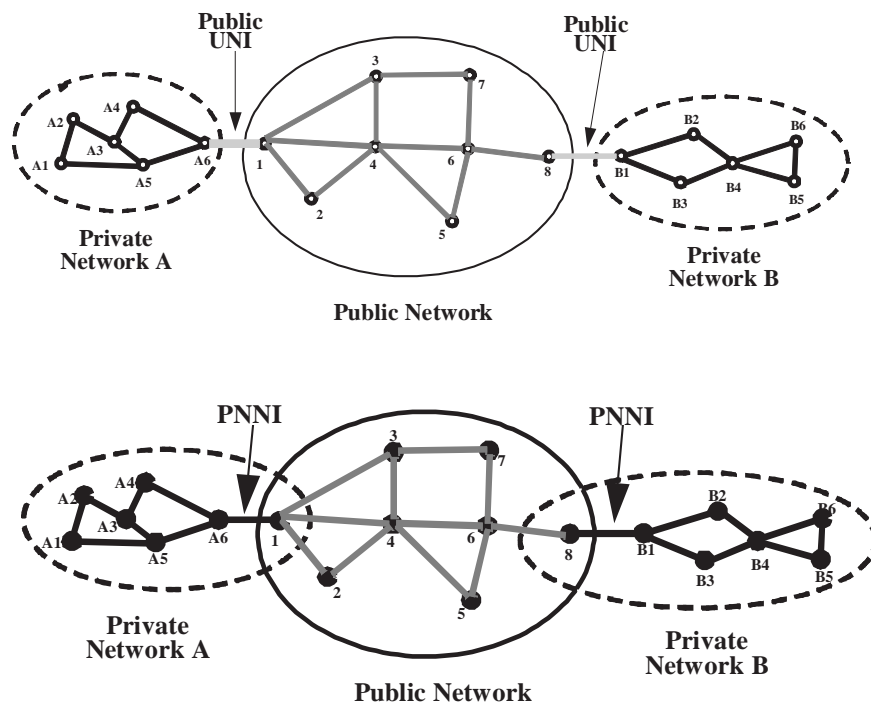
The PNNI and associate specifications (e.g. VTOA, LANE, AMS) also provide real network consolidation benefits by providing a single “wire” solution capable of, for the first time, meeting all the communication needs for any business on one platform rather than parallel, overlay, and technology-specific deployments. The savings in associated operational and maintenance costs can be significant in addition to the greater performance, scalability, and flexibility in meeting the constantly changing multi-service business environment possible with PNNI.

The PNNI builds on the ATM User to Network Interface (UNI) specifications. Rather than using the Broadband-Inter Carrier Interface (B-ICI) specification, which was developed as the interface between carriers/service providers and the use of Networking Signaling Protocol, the industry decision made in the ATM Forum was to base its work on extending the UNI for PNNI applications.

The two major technical areas addressed include extending UNI access signaling protocol for symmetrical switch-to-switch control, and developing a dynamic hierarchical state-of-the-art routing protocol. The PNNI routing protocol is able to maintain link availability information on the facilities between switches in the PNNI network and select the optimum route. The route calculation takes into account the type of ATM connection, bandwidth availability, and other QoS parameters.

Based on the PNNI specification, a much larger private/enterprise can be built with up to 2000 ATM switches within a network. Figure 14-38 illustrates two possible views on network interconnection architectures. Finally, PNNI implementations are interoperable with the Interim Inter switched Signaling Protocol (ISSP) previously developed for small, static routed private ATM network implementations.

Future enhancements of PNNI capabilities include support of some supplementary services, extending PNNI for use in place of B-ICI as carrier/service provider interconnect, and additional capabilities in support of IP that further leverage strengths of ATM. Possible extended IP features provided by PNNI may include PNNI Augmented Routing (PAR) which would develop a method of simplifying configuration and ongoing operation of Internet level routing protocols (such as OSPF) when operated over PNNI/ATM. A possible second activity, called Integrated PNNI (I PNNI), is to develop a single protocol for routing of both IP and ATM in combined IP/ATM environments.



**Figure 14-38.** Private/Public ATM Interconnection Architectures

Using PAR, routers with an ATM interface in the existing Internet are able to locate other routers on the ATM network and directly participate in the operation of PNNI and participating in the routing of the network (Internet or Intranet) where the router resides. With this method, the routers that have a direct ATM interface understand the “full topology,” which includes the routers (as advertised in one protocol such as OSPF and NHRP in the future) and the ATM network (as advertised in another protocol such as PNNI).

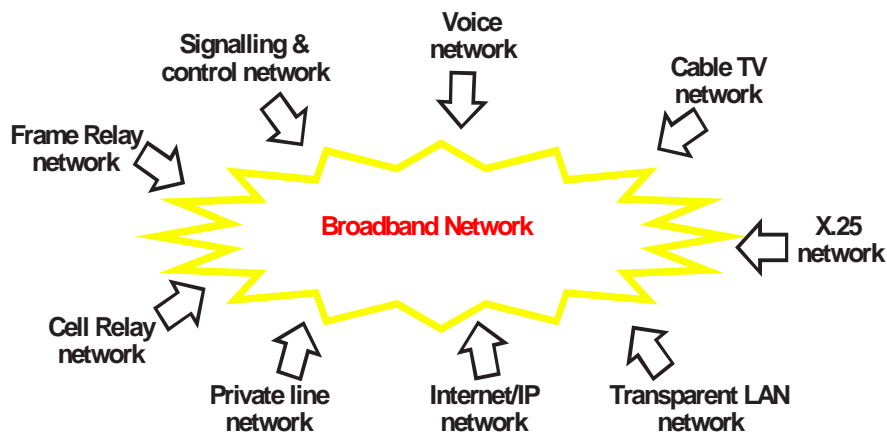
The I PNNI initiative, if developed, would extend PNNI routing to support IP routing in addition to the current signaling-based PNNI routing mechanism. PNNI has a number of capabilities that may be highly desirable and applicable to IP, including powerful QoS routing, ease of configuration, topological flexibility, and scalability through use of a multi-level hierarchy.

The PNNI routing protocol was developed to be extensible. It is therefore easy to support IP in a manner that is compatible with ATM switches conforming to PNNI without requiring ATM switches to have any knowledge of IP. I PNNI could provide a routing protocol that can be simultaneously used to support routing of IP packets and ATM SVCs in a combined router and ATM network. The approach taken does not require any change to hosts on either ATM networks or on any other physical network. The assumption is that

any large ATM and multi-protocol environment will have a large number of hosts from multiple suppliers supporting multiple protocols. It's simply not practical to require all the hosts to change. IPNNI simplifies and optimizes the co existence and interoperability of IP and ATM.

#### 14.12.5.2.4 Wide Area Networking Services

The target ATM-based BISN will provide an integrated platform for supporting multiple information services over shared interfaces. However, while many different interface and network element generic requirements and industry specifications have been developed, they are not all complete and network evolution and migration will continue as new capabilities become standard. Further, many carriers/service providers adopt an incremental investment strategy. Consequently, these carriers/service providers are offering a variety of services on parallel, service-specific networks (e.g., Frame Relay, X.25, Hybrid Fiber-Coax), each built and managed separately. See Figure 14-39. Users also have embedded investments that they want to continue to use independent of the technology-base of carrier service provider networks. This places additional requirements on ATM-based B-ISDN network elements to provide access to user and network equipment with service specific non-ATM interfaces, for example Frame Relay interfaces using High-level Data Link Control (HDLC) protocols on DS1 facilities, SMDS Subscriber Network Interface (SNI) using the IEEE 802.6 protocol standard, emulated DS1, DS3 interfaces, and interworking functions to connect B-ISDN to narrowband ISDN.



**Figure 14-39.** Multiple Service-specific Networks Evolve Toward a Broadband Network

ATM provides the network planner not only with bandwidth on demand, but allows for an intelligent mix of multiple types of applications or types of wide area services (both data and voice-based) on the same ATM network. This capability is provided by ATM's QoS features. QoS guarantees allow for multiple applications or service types to gracefully coexist - each receiving their optimized use of network resources. Furthermore, ATM's multi-service capability allows new ATM-enabled applications and wide-area services to be integrated with existing non-ATM based applications and wide-area services in the same network while under the control of ATM-based network management. In contrast with IP-based QoS RSVP technology, which allows QoS requests to be made but the companion RFCs defining supporting functions required in equipment don't exist, ATM offers the network mechanisms to satisfy those requests. In addition, ATM enables cost-reduction in network moves, adds, changes, and ongoing operations via satisfying the need for multi-service capability.

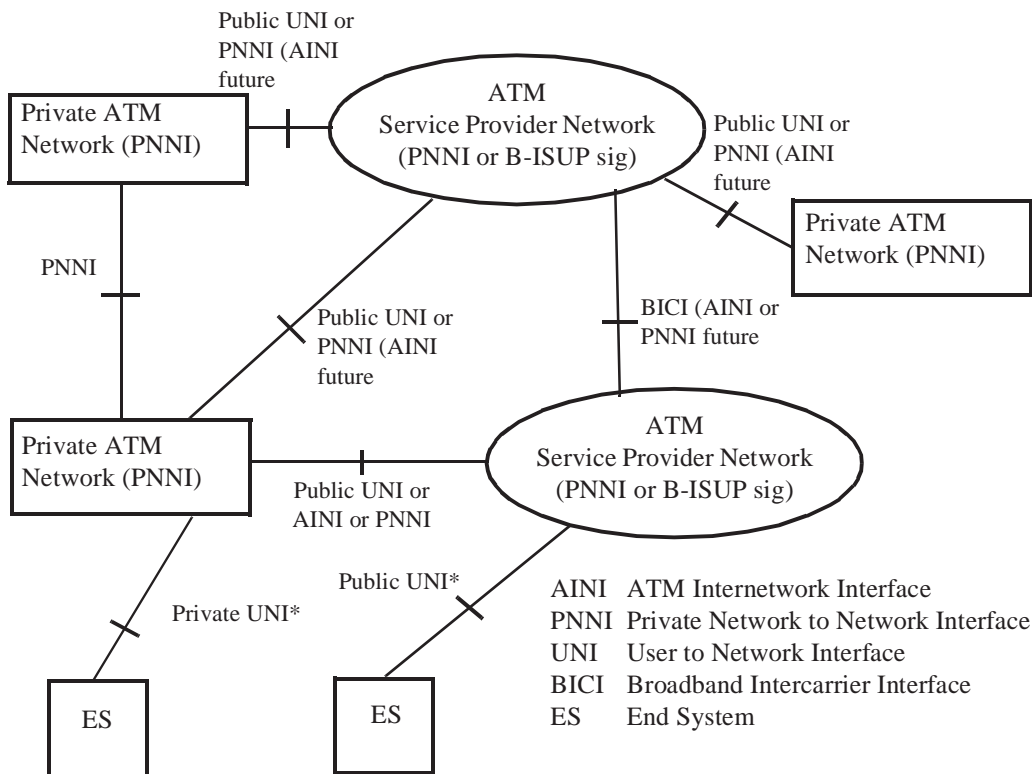
#### 14.12.5.2.5 Interworking Among ATM Networks

The objective is to have end-to-end connectivity between the end users, with no regard to the type of network those end users are connected. The interface specification for interworking between private ATM networks is based on PNNI using an extended UNI Access signaling protocol. The interface specification for interworking between public networks is based on B-ICI using Common Channel Signaling (CCS) extended protocol. A number of factors are influencing the fundamental technical approach to interworking among ATM based networks which has led to the initiation and development of a still emerging new interface specification call ATM Inter Network Interface (AINI).

A number of factors led to this decision. These include but are not limited to the following. First, there are new addressing/numbering techniques beyond the International E.164 numbering standard which provides the means of supporting IP applications over ATM and specific private networking needs. These are specified in UNI v3.1 and v4.0 in conjunction with PNNI. The development of dynamic routing capabilities by PNNI which leverage ATM's Traffic Management and QoS capabilities based upon an extended UNI user-network access signaling protocol for switch-to-switch signaling and control protocol. This eases network management of statically configured networks. These equivalent capabilities and functions are not currently specified or provided by existing network signaling and control protocols. The opening up of networks for competition, and with switching systems from vendors who were not previously suppliers to carriers/service providers, many do not have CCS protocol expertise, nor do they want to. These vendors and service providers are considering the use of PNNI access signaling as an alternative in place of CCS network signaling protocols. Consequently, this has led to industry activities to develop implementation agreements.

---

While industry activities are currently underway on the AINI, Figure 14-40 illustrates the possible combinations of interconnect interfaces. There is also a clear industry trend where the distinction and capabilities between Private/Enterprise networks and public service provider networks is going away. Increasingly, the same scalable equipment is used in both types of networks.

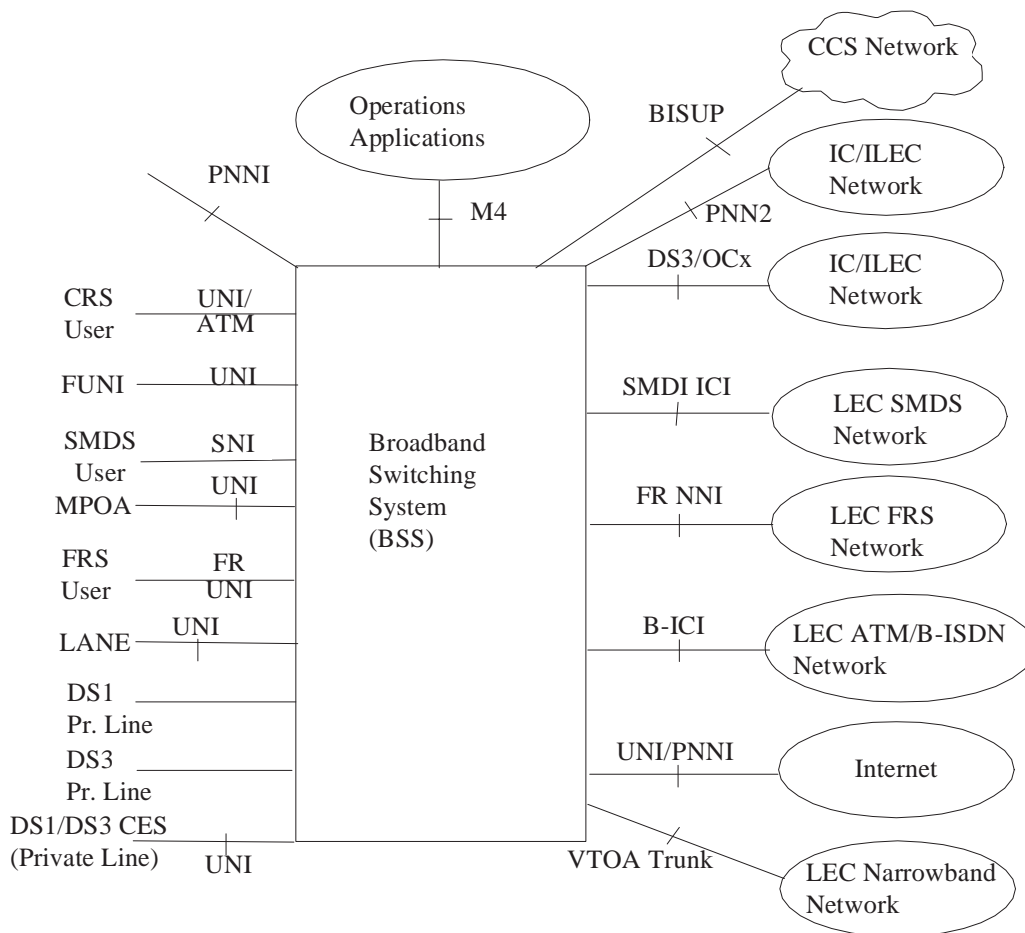


\* The interface between end user and private ATM network, and the interface between end user and Service Provider ATM network are physically the same ATM equipment. Differences are essentially in the service capabilities and features supported.

Figure 14-40. Interworking among ATM Networks

### 14.12.6 ATM-based BISDN Architecture

Figure 14-41 is a schematic of the possible types of interfaces an ATM-based ATM Broadband Switching System (BSS) may have to support. For illustrative purposes, nearly all potential types of interfaces a large BSS are shown for both Private and Public ATM switches. In practice, with careful and cost effective evolution plan, only a subset of these will actually be required on any BSS. Interworking functions will need to be incorporated into these BSSs so that legacy systems/network elements are supported transparently.



**Legend**

- |   |  |
|---|--|
| ATM = Asynchronous Transfer Mode            | ILEC = Independent LEC   |
| B-ICI = Broadband Inter-Carrier Interface   | LANE = LAN Emulation   |
| B-ISDN = Broadband ISDN                     | LEC = Local Exchange Carrier   |
| BISUP = Broadband ISDN User Part            | M4 = Series of specs. making up the network mngt operations system interface to ATM broadband network elements, e.g., switch, interfaces |
| CES = Circuit Emulation Service             | MPOA = Multiprotocols Over ATM   |
| CRS = Cell Relay Service                    | PNNI = Private Network Node Interface  |
| FR NNI = Frame Relay Network Node Interface | SMDS = Switched Multimegabit Data Service  |
| FRS = Frame Relay Service                   | SNI = Subscriber Network Interface   |
| FUNI = Frame-based ATM UNI                  | VTOA = Voice and Telephony Over ATM Trunk interface for interworking   |
| IC = Interexchange Carrier                  | UNI = User-Network Interface   |

**Figure 14-41.** Schematic of ATM-based Broadband Switching System Interfaces



The BSS interfaces are classified into three categories, User Access Interfaces, LEC Intra-Network Interface, and Inter-Carrier Interfaces.

#### 14.12.6.1 User Access Interfaces

Table 14-10 contains the possible interfaces a BSS may have to support. It includes a mix of service specific and ATM-based interfaces. One interface to note since it has not been discussed previously, is the Frame based User Network Interface (FUNI). The FUNI takes an approach similar to Frame Relay. However, in the case of FUNI, frame based protocols are mapped and supported directly over ATM rather than requiring frame protocols adapted to FR which in turn is carried over ATM. The FUNI interface represents a more efficient UNI.

#### 14.12.6.2 LEC Intra-Network Interfaces

Trunk interfaces to carry intra-network connections or connectionless messages to other local or transit BSSs within the LEC network will be based on multi-service ATM SONET facilities at 155 and 622 Mbps rates initially, followed by 2.4- and 10-Gigabit interfaces. DS3 facilities will be used where SONET is not deployed. This will enable the full connectivity within the LEC network of users of all services regardless of the type of switch serving each user. Table 14-11 shows the interfaces planned for the BSS to permit its interconnection with other BSSs and service specific switches within the LEC.

**Table 14-10.** User-Network BSS Interfaces

Item	Interface			Type
	Supported Service(s)	Higher Layers	Physical Transport	
1	SMDS (SNI)	802.6	DS1	SS
2	SMDS (SNI)	802.6	DS3	SS
3	FRS (UNI)	HDLC	DS1	SS
4	FRS (UNI)	HDLC	DS1 (Channelized)	SS
5	DS1 Private Line	None	DS1	SS
6	DS3 Private Line	None	DS3	SS
7	CRS (UNI)	ATM	DS1	SS
8	CRS (UNI)	ATM	DS3	SS
9	CRS (UNI)	ATM	STS-1	SS
10	CRS,SMDS (UNI)	ATM	STS-3c	MS
11	CRS,SMDS (UNI)	ATM	STS-12c	MS
12	UNI	ATM	UTP3, 25.6 Mbps	MS
13	UNI	ATM	UTP3, 51Mbps	MS
14	UNI	ATM	UTP5, 155Mbps	MS
15	LANE/UNI	ATM+UNI 3.1/ 4.0 suite+LANE	Any UNI PHY	SS
16	MPOA/UNI	ATM+UNI 4.0 suite+LANE+ MPOA	Any UNI PHY	MS
17	P-NNI/UNI	ATM+UNI 4.0 suite+P-NNI	STS-3c, STS12c	MS
18	FUNI	ATM+UNI+ FUNI	Any UNI PHY	MS
19	CES	ATM+CES	DS1 or DS3	SS

CRS	Cell Relay Service	MPOA	Multiprotocol Over ATM
FRS	Frame Relay Service	PNNI	Private Network Node Interface
MS	Multi-Service Interface	LANE	LAN Emulation
SNI	Subscriber Network Interface	CES	Circuit Emulation Service
SS	Service Specific Interface		
UTP3	Unshielded Twisted Pair Category 3		
UTP5	Unshielded Twisted Pair Category 5		
FUNI	Frame based UNI		

**Table 14-11.** LEC Intra-Network Interfaces

Interface				Type
Item	Supported Service(s)	Higher Layers	Physical Transport	
20	SMDS, FR, CRS (B-ISSI)	ATM	DS3	SS
21	SMDS, FR, CRS (B-ISSI)	ATM	STS-3c	MS
22	SMDS, FR, CRS (B-ISSI)	ATM	STS-12c	MS
23	FR (NNI)	HDLC	DS1	SS
24	PNNI	ATM+PNNI	Any PNNI PHY	MS
25	UNI MPOA	ATM+LANE+MPOA	Any UNI rate	MS

B-ISSI Broadband Inter-Switching System Interface

NNI Network Node Interface

#### 14.12.6.3 Inter-Carrier Interfaces

This set of interfaces provides for the interconnection of the services between a LEC and another carrier/service provider. The Inter-Carrier Interfaces (ICI) are trunks which will be multi-service ATM-SONET based facilities at 155 and 622 Mbps initially and 2.4 and 10 Gbps when available. Service specific interfaces, for example to interconnect SMDS switches will be provided through DS3 transport using the IEEE 802.6 protocol, and for Frame Relay, DS1 facilities. Table 14-12 shows types of ICIs.

**Table 14-12.** Inter-Carrier Interfaces

Interface				Type
Item	Supported Service(s)	Higher Layers	Physical Transport	
26	SMDS ICI	802.6	DS3	SS
27	CRS B-ICI	ATM	DS3	SS
28	SMDS†, FR, CRS B-ICI	ATM	STS-3c	MS
29	SMDS†, FR, CRS B-ICI	ATM	STS-12c	MS
30	PNNI	ATM +	DS3, any STS rate	MS

† — Interface could be applied to carry exclusively SMDS traffic

ICI Inter-Carrier Interface

B-ICI BISDN Inter-Carrier Interface

### 14.12.7 Multiservice ATM-based BISDN Architecture

ATM enables a multiservice BISDN network. This enable many of the benefits discussed in the previous sections. Furthermore, ATM provides capabilities not possible with other technologies and will play an important role stimulating development of “native” ATM services, and facilitate the convergence of IP/Internet and ATM based networking. ATM can easily be adapted to support other higher layer protocols and/or emulate those protocols. This unique flexibility is important and assists in the migration from embedded or legacy systems towards an ATM platform.

The previous sections focused on various sub-networks for the sake of clarity. The multiservice ATM-based BISDN architecture pieces these sub-network segments together (as Figure 14-42 illustrates), and comprises an interconnected set of ATM and non-ATM based switches. The degree of connectivity among switches in the network will depend on traffic patterns, economics of switching and transmission, and carrier/service provider business strategies. It is the objective of this ATM network to provide a single multi-service platform to optimize life-cycle costs through the efficiency of sharing a common infrastructure and consolidating network management and operations.

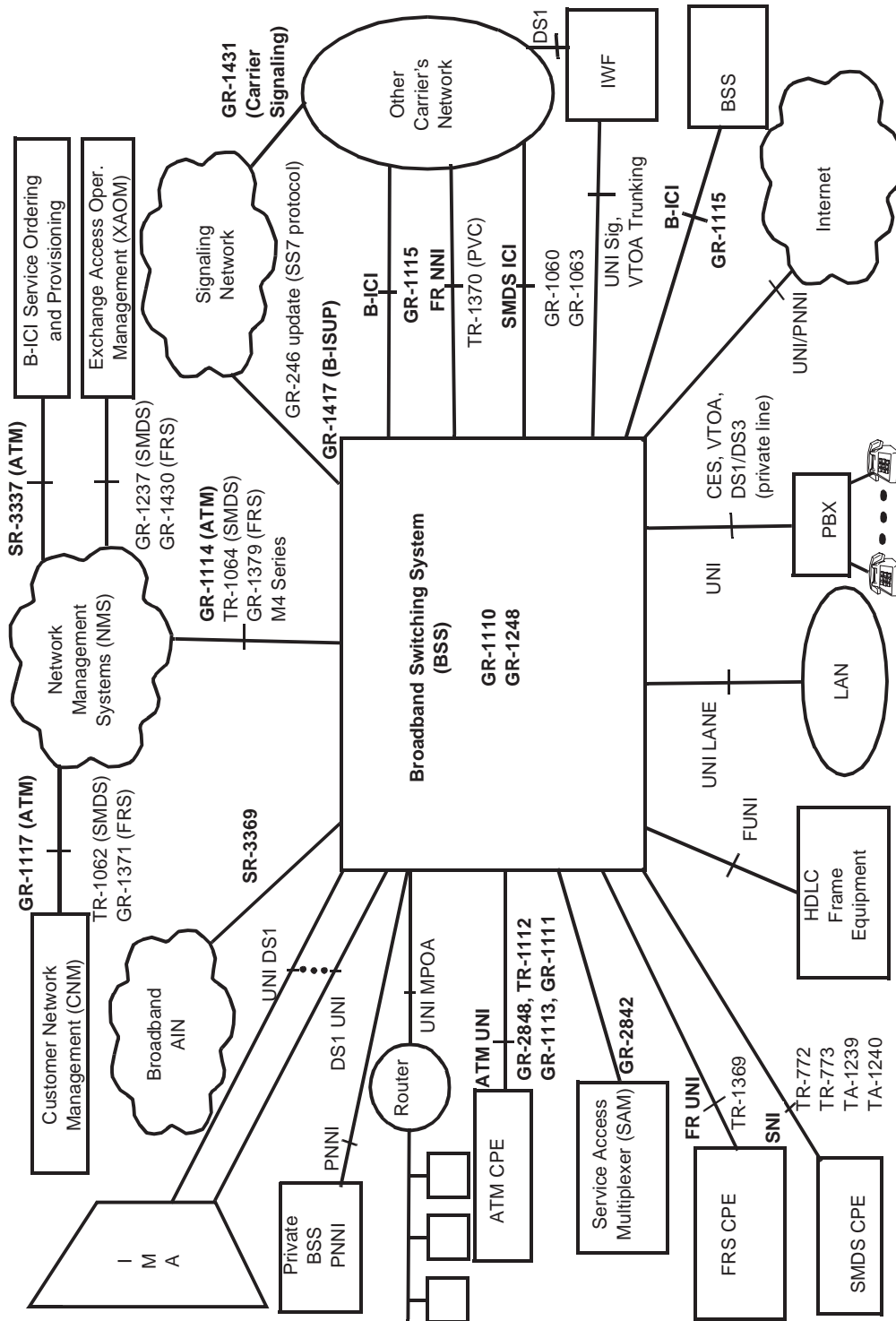


Figure 14-42. Structure of a Broadband Network

---

## 14.13 Frame Relay

### 14.13.1 Overview

Frame Relay is a connection-oriented data service that allows the transfer of variable length frames (packets of customer data) across large geographical areas to provide LATA-wide, interLATA, interstate and international connectivity. Frames are relayed from the source to the desired destination by means of virtual connections. (**Note:** bandwidth and switch capacity within the network are only allocated to a virtual connection when frames are transported.) Virtual connections can be established and deleted either through administrative procedures (referred to as Permanent Virtual Connections [PVCs]) or via network signaling (referred to as Switched Virtual Connections [SVCs]). Frame Relay operates using only the physical layer and a portion of the data link layer in the International Standards Organization's (ISO's) seven-layer model for Open Systems Interconnection (OSI). Compared to X.25, Frame Relay adds a routing function to the data link layer, but eliminates others.<sup>1</sup> For example, no error correction occurs in Frame Relay nodes; errored frames are simply discarded. The elimination of this function takes advantage of the availability of higher-layer error and loss recovery capabilities and the widespread availability of low bit-error rate digital transmission facilities.

The following summarizes the key (end-user) customer benefits of Frame Relay:

- Since multiple virtual connections can be established over a single physical access line, Frame Relay can reduce the number of CPE (for example, router) ports and digital access circuits (for example, T1 lines) necessary for Wide Area Network (WAN) communications relative to dedicated private lines.
- As a "simple" data link layer protocol, Frame Relay is well suited to handle multiprotocol communications. Network layer protocols (for example, TCP/IP, SNA, XNS, and IPX) can be encapsulated, with their attendant data, and relayed across the network.
- Due to its streamlined protocol, Frame Relay can provide high throughput and low transit delay. It is especially well-suited to support the bursty data requirements of LAN-to-LAN traffic. Customer applications suited for Frame Relay include image/graphics transmission, real-time file/record updates and transfers, distributed processing (remote applications), remote database access, facsimile transmission, electronic mail transmission, and document sharing.
- Although Frame Relay was designed to support bursty data applications, CPE has been designed to permit users to take advantage of the remaining bandwidth capacity on their frame relay interfaces for the transport of packetized voice. Voice encoding algorithms are used to achieve voice quality that is adequate for many applications, at

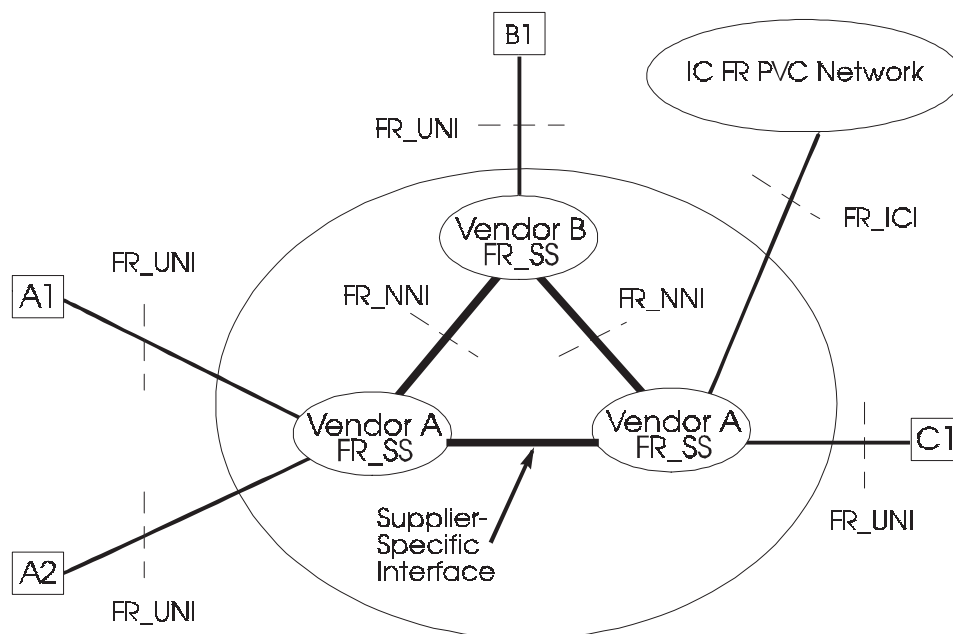
---

1. For more information on X.25, see Section 14.11.10.

reduced bit rates. Because of growing interest in Voice over Frame Relay (VoFR), the Frame Relay Forum has recently developed an Implementation Agreement to facilitate interoperability among vendors supporting VoFR in their equipment.<sup>2</sup>

- Because it is a variant of the widely implemented High-Level Data Link Control (HDLC) family of link layer protocols, Frame Relay protects existing investments in CPE. In many instances, only a minor software upgrade is required to support Frame Relay.

Figure 14-43 illustrates a high-level model of an example Local Exchange Carrier (LEC) intraLATA network supporting FR PVC service.



**Legend:**

- FR = Frame Relay
- FR\_SS = Frame Relay Switching System
- FR\_UNI = Frame Relay User-Network Interface
- FR\_NNI = Frame Relay Network-to-Network Interface
- FR\_ICI = Frame Relay Inter-Carrier Interface
- IC = Interexchange Carrier

**Figure 14-43.** Example LEC IntraLATA Network Supporting FR PVC Service

2. Frame Relay Forum, *Voice over Frame Relay Implementation Agreement*, FRF.11, May 1997.

---

To support FR PVC service, Frame Relay Switching Systems (FR\_SSs) have been introduced into LEC networks. As shown in Figure 14-43, FR\_SSs are typically interconnected by supplier-specific interoffice trunks. However, a standardized Network-to-Network Interface (NNI) can also be used, and is indeed required when interconnecting FR\_SSs of different vendors. Four customer locations are represented in Figure 14-43 by the labeled boxes (A1, A2, B1, and C1). Each box represents the CPE that provides a customer with access to the LEC network. The interface between a customer's CPE and the LEC network, called a Frame Relay User-Network Interface (UNI), is shown as a line labeled "FR\_UNI."

Frame Relay PVC Exchange service refers to communication between customers in the same LATA. In Figure 14-43, communication between all four customers is supported by intraLATA FR PVC service. When customer sites within the same LATA are served by different LECs, Frame Relay LEC-LEC serving arrangements are used to support intraLATA, intercompany communications.

Exchange Access FR PVC service is provided by a LEC to an Interexchange Carrier (IC) in support of an IC's interLATA FR PVC offering, where at least one customer is directly served by the LEC's network. The interface between the two networks is shown as a line labeled "FR\_ICI" identifying it as a Frame Relay Inter-Carrier Interface (FR\_ICI). Such inter-carrier interfaces are typically standardized FR\_NNIs, as are those used within a carrier network between FR\_SSs of different vendors. The same FR\_UNI is used to support both intraLATA and interLATA communications.

The following are key Bellcore documents that specify requirements for Frame Relay PVC service:

- TR-TSY-001369, *Generic Requirements for Frame Relay PVC Exchange Service*, May 1993
- TR-TSV-001370, *Generic Requirements for Exchange Access Frame Relay PVC Service*, May 1993
- GR-1327-CORE, *Frame Relay Network Element Operations*, March 1994
- GR-1371-CORE, *Phase 1 Frame Relay PVC CNM Service*, March 1994.

There are numerous standards and industry implementation agreements that address Frame Relay service, its interfaces, and various service aspects and extensions. The following table lists selected international standards and industry specifications.



Aspect of Frame Relay	CCITT/ITU-T Recommendation	Frame Relay Forum Implementation Agreement(s)
Overall frame relay service	I.223 <sup>a</sup>	
Basic frame relay protocol	Q.922 Annex A <sup>b</sup>	
SVC Signaling	Q.933 <sup>c</sup>	FRF.4, <sup>d</sup> FRF.10 <sup>e</sup>
UNI	X.36 <sup>f</sup>	FRF.1.1 <sup>g</sup>
NNI	X.76 <sup>h</sup>	FRF.2.1, <sup>i</sup> FRF.10 <sup>e</sup>
Multiprotocol encapsulation		FRF.3.1 <sup>j</sup>
Frame relay/ATM interworking	I.555 <sup>k</sup>	FRF.5, <sup>l</sup> FRF.8 <sup>m</sup>
Customer Network Management		FRF.6 <sup>n</sup>
Multicast service		FRF.7 <sup>o</sup>
Voice over Frame Relay		FRF.11 <sup>p</sup>

- a. *Frame Relay Bearer Services*, Recommendation I.233, CCITT (ITU-T), 1992.
- b. *ISDN data link layer specification for frame mode bearer services*, Recommendation Q.922, Annex A, CCITT (ITU-T), February 1992.
- c. *Signaling specifications for frame mode switched and permanent virtual connection control and status monitoring*, Recommendation Q.933, ITU-T, October 1995.
- d. *User-to-Network SVC Implementation Agreement*, Frame Relay Forum, FRF.4, 1994.
- e. *Frame Relay Network-to-Network SVC Implementation Agreement*, Frame Relay Forum, FRF.10, September 1996.
- f. *Interface between Data Terminal Equipment (DTE) and Data Circuit-terminating Equipment (DCE) for public data networks providing frame relay data transmission service by dedicated circuit*, Recommendation X.36, ITU-T, April 1995. *Switched Virtual Circuit (SVC) signaling and refinements of Permanent Virtual Circuit (PVC) signaling*, X.36 Amendment 1, October 1996.
- g. *User-to-Network Implementation Agreement (UNI)*, Frame Relay Forum, FRF.1.1, January 1996.
- h. *Network-to-network interface between public data networks providing the frame relay data transmission service*, Recommendation X.76, ITU-T, April 1995.
- i. *Frame Relay Network-to-Network Implementation Agreement (NNI)*, Frame Relay Forum, FRF.2.1, July 1995.
- j. *Multiprotocol Encapsulation Implementation Agreement*, Frame Relay Forum, FRF.3.1, June 1995.
- k. *Frame Relay Bearer Service Interworking*, Recommendation I.555, ITU-T, November 1993.
- l. *Frame Relay/ATM PVC Network Interworking Implementation Agreement*, Frame Relay Forum, FRF.5, December 1994.
- m. *Frame Relay/ATM PVC Service Interworking Implementation Agreement*, Frame Relay Forum, FRF.8, April 1995.
- n. *Frame Relay Service Customer Network Management Implementation Agreement (MIB)*, Frame Relay Forum, FRF.6, March 1994.
- o. *Frame Relay PVC Multicast Service and Protocol Description Implementation Agreement*, Frame Relay Forum, FRF.7, October 1994.
- p. *Voice over Frame Relay Implementation Agreement*, Frame Relay Forum, FRF.11, May 1997.

### 14.13.2 LEC Frame Relay Service Deployment

All LECs and most independents are offering Frame Relay PVC service. All major ICs also offer Frame Relay service. Frame Relay is available in most major metropolitan areas, and is currently the most ubiquitous of the Fast Packet Services (Frame Relay, Switched Multi-megabit Data Service [SMDS], and Asynchronous Transfer Mode [ATM]). The remainder of this section describes features typically included in LEC service offerings, and identifies features that are likely to be available in the future. The lists provided are not exhaustive. Refer to a specific LEC's tariff for exact details.

#### 14.13.2.1 Common LEC Frame Relay Service Features

The following is a list of Frame Relay service features that are commonly available:

- Frame Relay PVC service
- FR\_UNI access rates of 56/64 kbps and 1.536 Mbps.
- Support of ANSI T1.617 (Annex D), Frame Relay Forum Layer Management Interface (LMI), and the ITU-T Q.933 Annex A protocols for FR\_UNI PVC management.
- Forward and backward explicit congestion notification (FECN and BECN) generation according to LEC-defined congestion states. Once set, these indicators will not be cleared by the LEC network.
- The Discard Eligibility (DE) bit, if set, will not be cleared (i.e., set to "0") by the LEC network.
- Information field can range in size from 1 octet to 1600 octets or more (up to a maximum of 4096 octets).

#### 14.13.2.2 Emerging Features

The following features are now becoming available or are expected to be available on at least a selective basis in the near future:

- Frame Relay SVC service
  - Switched (POTS dial-up and BRI) access to frame relay
  - Frame Relay to ATM PVC interworking
  - Standardized NNI for support of inter-carrier connections
  - SNMP-based access to configuration and performance information via Customer Network Management service.
-

### 14.13.2.3 Recently Completed and Ongoing Standardization Work

Areas of work that have been recently standardized or are expected to be standardized soon include the following:

- Support of packetized Voice over Frame Relay
- Service level definitions
- Frame Relay to ATM SVC interworking
- Multilink Frame Relay.

---

## 14.14 Switched Multi-megabit Data Service

Switched Multi-megabit Data Service (SMDS) is a high-performance, packet switched service that various service providers (including LECs, interexchange carriers, and international carriers) are offering. SMDS is able to interconnect computers and Local Area Networks (LANs), including very high-speed LANs such as Fiber Distributed Data Interface (FDDI) networks, over wide geographic areas. This packet-switched data service serves existing and emerging high-speed, wide-area data communications needs.

User needs and applications are fueling the market for high-speed, data-networking products and services. Firmly established in the local premises environment, demand is now developing for wide-area multi-megabit communications. Leased-line and dark fiber<sup>1</sup> network solutions are the currently available predominant alternatives as demand begins to emerge. However, technologies are becoming available that can significantly expand the possibilities for switched wide-area, high-speed data-network solutions. With a rapidly growing base of bandwidth, carriers can use the available technology and respond to emerging customer needs with alternative public switched services.

As the market for high-speed data is developing, initial demand is most likely to emerge from those customers with relatively sophisticated data communications needs, and thus from the ranks of large- and medium-size businesses. SMDS may be critical to future carrier success in cultivating these important accounts. The following sections provide a detailed description of SMDS and the service architecture.

### 14.14.1 Service Description

SMDS is a packet-switched data service that provides multi-megabit per second throughput and very low delay characteristics between subscriber sites. Access to the service ranges from a Digital Signal level 3 (DS3 [44.736 Mbps]) or DS1 (1.544 Mbps) path to as low as a 56-kbps path into the network, and is designed for easy integration with Customer Premises Equipment (CPE). SMDS provides for *datagram* packet transfer; that is, each unit of information is handled and switched as a separate operation that does not require prior establishment of a network connection. This mode of operation and other features of SMDS, such as group addressing, have been designed to be analogous to the features currently found in high-speed data networks such as LANs and the Internet. Thus, applications (TCP/IP, NetWare, AppleTalk, SNA) that currently use LANs can be easily extended to use SMDS, or to include SMDS as part of an *internetwork* (for example, a set of individual networks interconnected to form a single communications system) to communicate over a wide area. SMDS includes the following characteristics:

---

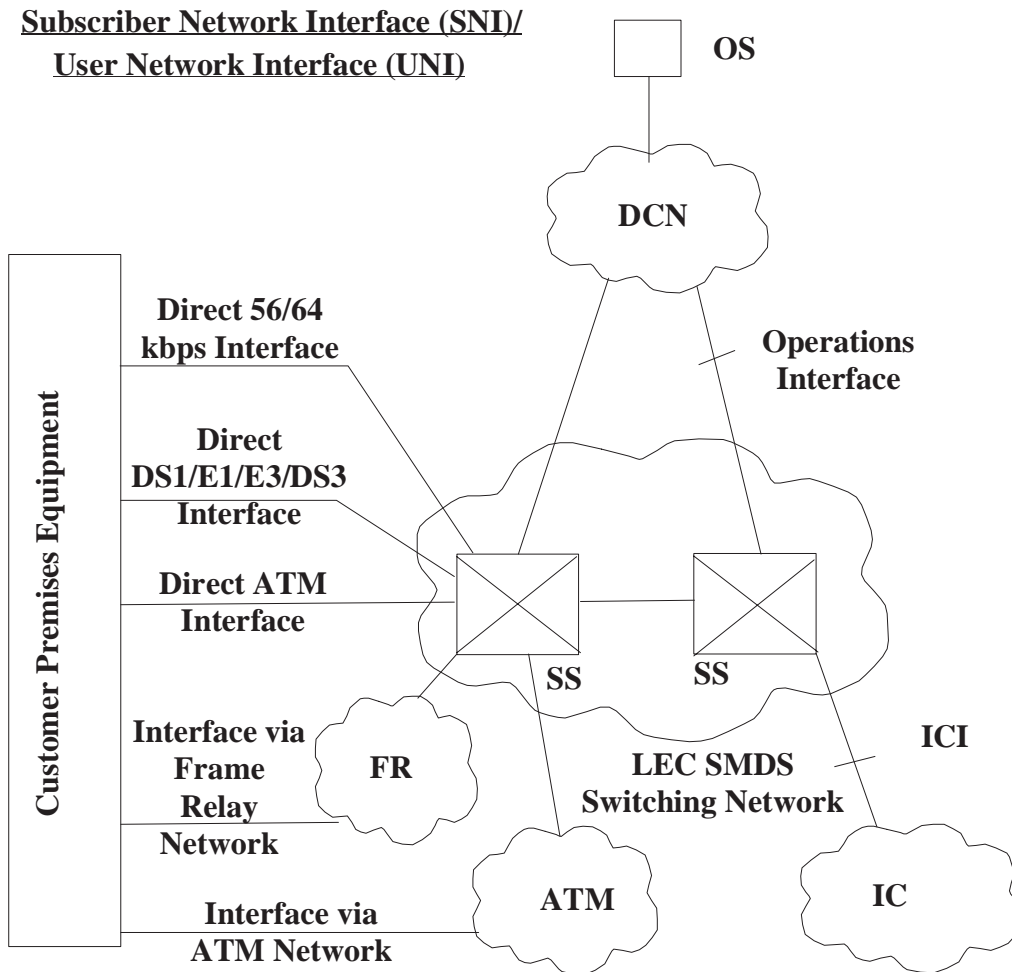
1. Dark fiber facilities are fiber-optic facilities between customer locations that consist of nonrepeated fiber pairs without electro-optical terminals supplied by a telephone company.

- 
- Interconnects individual host computers and high-speed devices, as well as customer routers or bridges that provide for interconnection of LANs
  - Transfers information on an individual packet-by-packet (*datagram*) basis; there is no need to establish a connection or virtual call before sending or receiving data
  - Supports private logical data networks, as well as public interconnection, by means of source and destination screening lists
  - Provides access at rates ranging from 56 kbps to 44.736 Mbps; these rates include non-American rates such as E1 and E3 in Europe
  - Provides multiple *access classes* allowing customers to choose service characteristics such as the average data rate; customers can thus subscribe to the access class that best fits their expected traffic needs
  - Supports multi-cast, a key capability to efficiently support internetworking architectures such as TCP/IP, NetWare, and AppleTalk
  - Supports a variety of customer scenarios, including routing, bridging, multiplexing, and virtual private networking
  - Supports E.164 addressing compatible with the current telephony numbering plan, ISDN, and future broadband networks
  - SMDS is a *service* and as such it can be offered over a variety of networks with different access protocols, including HDLC-frame based access, DQDB, Frame Relay based access, and ATM
  - Supports Customer Network Management, allowing customers access to alarms, traffic and error statistics, and subscription profiles
  - Provides cost efficiencies and scalability through a) a single interface with the service provider (no mesh of leased lines is needed), and b) its *datagram* capability - no (mesh of) virtual circuits are needed.

#### 14.14.2 Service Architecture

Networks supporting SMDS may employ different modes of access, ranging from 56/64 kbps lines to fiber-optic transmission systems and from direct dedicated access to shared access over ATM or Frame Relay networks. [Figure 14-31](#) shows the generic architecture in support of SMDS. Minor network interconnection differences may apply for non-LEC carriers (e.g., in Europe - see definitions specified by the European SMDS Interest Group). The only criteria for the architecture/technology used are that it meets the functional and performance requirements of SMDS and the specifications for the interfaces shown. SMDS required some new operations functions in several areas such as customer service and network administration. However, since existing transmission standards were used, much functionality was already available to support transmission operations.

---



**Figure 14-31.** Example of Networks in Support of SMDS

TR-TSV-000772, *Generic System Requirements in Support of Switched Multi-Megabit Data Service*, specifies criteria for networks supporting SMDS. This document proposes requirements for external interfaces that should be met for equipment compatibility and interoperability within a network, while imposing minimum constraints on the technologies to be used by different vendors providing SMDS switching systems. Description, use, and applications of SMDS are detailed in *SMDS - Wide Area Data Networking with Switched Multi-megabit Data Service* (by R.W.Klessig, K.Tesink - Prentice Hall 1995).

Since SMDS has been defined in such a way that its features are independent of the network architecture and technology used to provide it, SMDS can also be offered as a service of multiple-service broadband networks, e.g., using ATM.

---

### 14.14.3 Supporting Requirements for SMDS

This section describes the generic requirements documents that support SMDS. Ordering information for Bellcore documents is in the References section.

#### 14.14.3.1 Access

- TR-TSV-000773, *Local Access System Generic Requirements, Objectives, and Interfaces in Support of Switched Multi-megabit Data Service*
  - Presents generic system requirements for access systems to SMDS, and the physical layer of the SMDS Interface Protocol (SIP).
- TR-TSV-001239, *Generic Requirements for Low Speed SMDS Access*
  - Presents Bellcore's preliminary view of proposed generic criteria for Low Speed SMDS Access which provides frame-based access to SMDS, initially at an access rate of DS0, using the Data Exchange Interface (DXI) protocol.
- TA-TSV-001240, *Generic Requirements for Frame Relay Access to SMDS*
  - Presents Bellcore's preliminary view of proposed generic criteria for Frame Relay Access to SMDS. It defines specifications for a Frame Relay Permanent Virtual Circuit (PVC) access path to the network supporting SMDS using the SIP Relay Interface (SRI). It also defines requirements for a near term LEC network implementation in support of this access method.
- *Protocol Interface Specification for Implementation of SMDS over an ATM-based Public UNI*, SMDS Interest Group SIG-TWG-008/1996.
  - Defines the protocol for providing SMDS over ATM using Adaptation Layer AAL3/4 and 5.

#### 14.14.3.2 Interconnection

- GR-1060-CORE, *Switched Multi-Megabit Data Service Generic Requirements for Exchange Access and Intercompany Serving Arrangements*
    - Finalized Exchange Access SMDS (XA-SMDS) service definition and related LEC switching system generic requirements. Also includes requirements for LEC to independent LEC interconnection.
  - TA-TSV-001238, *Generic Requirements for SMDS on the 155.520 Mbps Multi-Services Broadband ISDN Inter-Carrier Interface (B-ICI)*
    - Presents Bellcore's preliminary view of proposed generic requirements for SMDS offered over an ATM/SONET/BISDN platform.
-

#### 14.14.3.3 Customer Network Management

- TR-TSV-001062, *Generic Requirements for Phase 1 SMDS Customer Network Management Service*
  - Presents Bellcore's preliminary view of proposed generic requirements for CNM for SMDS. It identifies a network-management information model to be provided as part of CNM for SMDS, management capabilities that can be provided using this information, and the procedural means for providing access to (and modification of) SMDS CNM information.

#### 14.14.3.4 Operations Interconnection

- GR-1237-CORE, *SMDS Generic Requirements for Initial Operations Management Capabilities in Support of Exchange Access and Intercompany Serving Arrangements*
  - Presents Bellcore's preliminary view of proposed generic requirements for SMDS Exchange Access Operations Management (XA-OM) service.

#### 14.14.3.5 Usage Measurements

- TR-TSV-000775, *Usage Measurement Generic Requirements in Support of Billing for Switched Multi-megabit Data Service*
  - Presents Bellcore's preliminary view of proposed usage measurement requirements to support billing and other uses (e.g., cost allocation and trend analysis).

#### 14.14.3.6 Operations (Using OSI)

Generic system requirements for usage measurements in support of billing for Phase 1 SMDS are contained in the following documents:

- TR-TSV-000774, *SMDS Operations Technology Network Element Generic Requirements*
  - Functional operations generic requirements for LEC switching systems providing Phase 1 SMDS.
- TR-TSV-001064, *SMDS Generic Criteria on Operations Interfaces - SMDS Information Model and Usage*



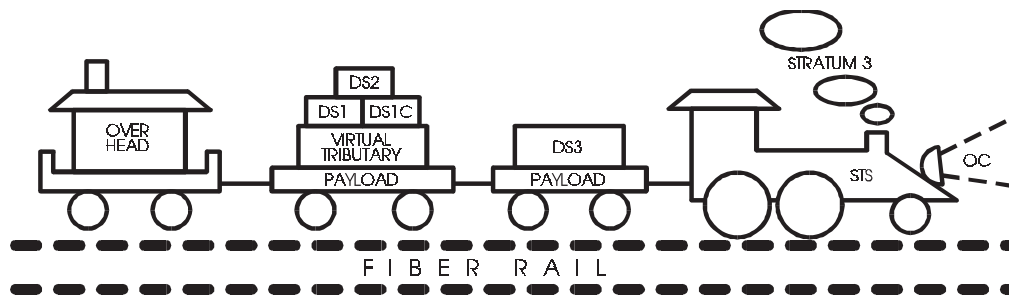
- 
- Phase 1 SMDS Operations System/Network Element (OS/NE) interface information model, including support for initial Customer Network Management (CNM) features.
  - GR-1063-CORE, *Generic Operations Criteria in Support of Intercarrier SMDS*
    - Functional operations generic requirements for LEC switching systems providing XA-SMDS and LEC to independent LEC interconnections.
  - TR-TSV-001235, *SMDS Generic Criteria on Operations Interfaces - Information Model Supporting Intercarrier SMDS*
    - Presents Bellcore's preliminary view of proposed generic requirements for Intercarrier SMDS OS/NE Information Model.

## 14.15 Synchronous Optical Network

Synchronous Optical Network (SONET) is a standard format for transporting a wide range of digital telecommunications services over optical fiber through the public networks. SONET is characterized by standard line rates, optical interfaces, and signal formats.

SONET's main attribute is its ability to transport many different (asynchronous or synchronous) digital signals using a basic building block called the STS-1 (Synchronous Transport Signal level 1) which operates at 51.840 Mbps. The optical counterpart of this signal at the same basic rate (an electrical-to-optical mapping) is the OC-1 (Optical Carrier level 1). All higher rate signals (STS-N) are multiples (N) of the basic STS-1 signal rate, which creates an associated byte-interleaved multiplex structure. The value of N currently can be 1, 3, 9, 12, 18, 24, 36, 48, or 192. The optical counterpart of the STS-N is the OC-N. These line rates are described in more detail in Section 14.15.2.1.

The basic signal is divided into a portion assigned to overhead and a portion that carries the payload (see Figure 14-32). The mapping of tributary signals (DS1, DS1C, DS2, and DS3) into an STS is accomplished through the use of Virtual Tributaries (VTs) and payload pointers. The pointers allow for flexible alignment of payload within the transport signal by indicating where the asynchronous or synchronous payload begins (for more detail see Section 14.15.2.1).



### Legend:

- DS1, 1C, 2, 3 = Digital Signal level 1, 1C, 2, 3
- OC = Optical Carrier
- STS = Synchronous Transport Signal

**Figure 14-32.** A SONET Analogy

### 14.15.1 Motivation for SONET

Optical transmission facilities are being deployed in every segment of the telecommunications network. The fiber transmission medium offers high quality service at a low cost. In the 1980s and 1990s there has been a widespread deployment of fiber optic

equipment. In 1989, 41 percent of all interoffice circuits were on fiber, and by 1999, 99 percent of all interoffice circuits will be on fiber optics. Fiber is not as extensively deployed in the local loop. However, this indicates that there is ample opportunity for placing fiber in the loop. The extensive deployment of fiber optic facilities was one motivation for creating a set of standardized optical interfaces for use in transport networks. However, the motivation for deploying SONET goes beyond widespread fiber optic deployment. SONET will continue the downward trend in transport costs while providing a network transport infrastructure that will help simplify the network. There are also many network applications and capabilities that network providers will obtain from SONET deployment. Several of these applications may be offered to customers as services or service features. SONET may also serve as a platform for supporting or providing services to customers.

The SONET transport network provides an infrastructure that is backward compatible with existing products and services and compatible with future products and services.

#### 14.15.1.1 Standardized Optical Transmission

The initial motivation for SONET was to standardize the optical network. Up until SONET deployment, the existing embedded optical network consisted of supplier-proprietary systems operating at a set of non-standard rates. With supplier-proprietary systems, two suppliers' optical systems cannot be interconnected. Standardized optical transmission enables network providers to provide a mid-span meet of optical equipment from different suppliers without converting the optical signal into a standard electrical signal. The mid-span meet may be extended to allow carrier-to-carrier interconnection at the optical level as well as Customer Premises Equipment (CPE) to Local Exchange Carrier (LEC).

#### 14.15.1.2 Single-Ended Operations and Network Management

The SONET standard is designed to contain overhead that will provide many Operations, Administration, Maintenance, and Provisioning (OAM&P) capabilities in a multi-supplier environment. The SONET overhead specifies an Embedded Operations Channel (EOC) which provides Network Element-Network Element (NE-NE) communications within the SONET overhead structure. Single-ended operations allows management systems to communicate with remote Network Elements (NEs) through the SONET EOC.

Several network management capabilities that SONET will help provide via its overhead are:

- Rapid Provisioning
- Remote Network Configuration
- Software Management.

#### 14.15.1.3 Cost Reduction

The network capabilities listed above will lead to cost reduction in the transport networks. First, standardized optical transmission will enable multi-supplier interconnection. Second, the synchronization implicit in SONET enables Add-Drop Multiplexers (ADM)s to economically replace back-to-back asynchronous multiplexers and to provide Self-Healing Ring (SHR) applications. Third, additional capital cost savings may come from optical terminations integrated into NEs (for example, Digital Cross-connect Systems [DCSs]), resulting in reduced costs from sharing of common equipment and elimination of mediation circuitry.

In addition, the SONET standard includes many maintenance features in the SONET overhead toward the purpose of providing automated maintenance capabilities.

#### 14.15.1.4 Survivability and Availability

Considerable work is being done to provide self-healing networks using SONET. Survivability and availability are important services or features to provide customers, since lost service results in lost revenue for both network providers and their customers.

#### 14.15.1.5 Customer Network Management

SONET can be used to provide Customer Network Management (CNM) capabilities. Rapid provisioning, performance monitoring, remote configuration, and bandwidth management can all be offered to the customer as network management services.

Bandwidth management allows higher, lower, or redirected bandwidth when needed. Rapid provisioning and remote network configuration form the basis of bandwidth management. Bandwidth management may be viewed as a service provided by network providers to their customers. For example, bandwidth management will allow a customer to rearrange or reallocate lower rate bandwidth, such as STS-1s within an OC-3.

Bandwidth management would allow the network provider to reconfigure the network according to the time of the day, possibly allocating extra STS-1s in the morning and fewer STS-1s in the evening, depending on traffic patterns.

#### 14.15.1.6 High Speed Services

With the variety of rates specified by the SONET standard, SONET transport could be used for access to high speed circuit switching services at many different rates. SONET can also serve as the platform for providing Asynchronous Transfer Mode (ATM) Broadband Networking, which can support a wide range of services including Switched Multi-megabit

---

---

Data Service (SMDS), Frame Relay Service, and Cell Relay Service. In addition, SONET may be used to offer private line services.

### 14.15.2 Rates and Format

This section defines the rates and formats for SONET signals. A primary goal in defining these signals was to articulate a synchronous hierarchy that has sufficient flexibility to carry many different capacity signals. This is realized by defining a basic signal of 51.840 Mbps and a byte interleaved multiplex scheme that results in a family of rates and formats defined at a rate of  $N$  times 51.840 Mbps, where  $N$  is an integer.

The basic signal is divided into a portion assigned to overhead and a portion that carries the payload. In addition to SONET and other payload mappings, this payload can transport Digital Signal level 3 (DS3) signals or a variety of sub-DS3 signals. Because some signals requiring transport have a rate greater than the basic rate, a technique of linking several basic signals together to build a higher rate transport signal is accomplished through concatenation of basic rate signals. To maintain a consistent payload structure while providing for the transport of a variety of lower rate services (such as DS1, DS1C, or DS2 signals), a structure called the Virtual Tributary (VT) was defined. All services below the DS3 rate are transported within a VT structure.

Overhead functions include maintenance, protection switching, frequency justification, orderwire, identification, and user channels. Growth channels are identified to allow for future uses not defined at this time. Overhead bandwidth is allocated in layers based on the function addressed by that particular layer.

#### 14.15.2.1 Synchronous Hierarchical Rates

The Synchronous Transport Signal level 1 (STS-1) is the basic modular signal. Its rate is 51.840 Mbps. The optical counterpart of the STS-1 is the Optical Carrier level 1 (OC-1), which is the result of a direct optical conversion of the STS-1 after frame synchronous scrambling.

The definitions of the first levels (STS-1 and OC-1) define the entire hierarchy of synchronous optical signals because the higher level signals are obtained by synchronously multiplexing lower level signals. The higher level signals are denoted by STS- $N$  and OC- $N$ , where  $N$  is an integer. There is an integer multiple relationship between the rates of the basic module OC-1 and the multiplexed signal OC- $N$  (that is, the rate of OC- $N$  is equal to  $N$  times the rate of OC-1).

SONET optical transmission systems support only certain values of  $N$ . Currently, these are 1, 3, 12, 24, 36, 48, and 192. Table 14-13 lists standard optical carrier rates from 51.840

Mbps up through 9953.28 Mbps. STS-N electrical signals are currently defined for N equal to 1 or 3.

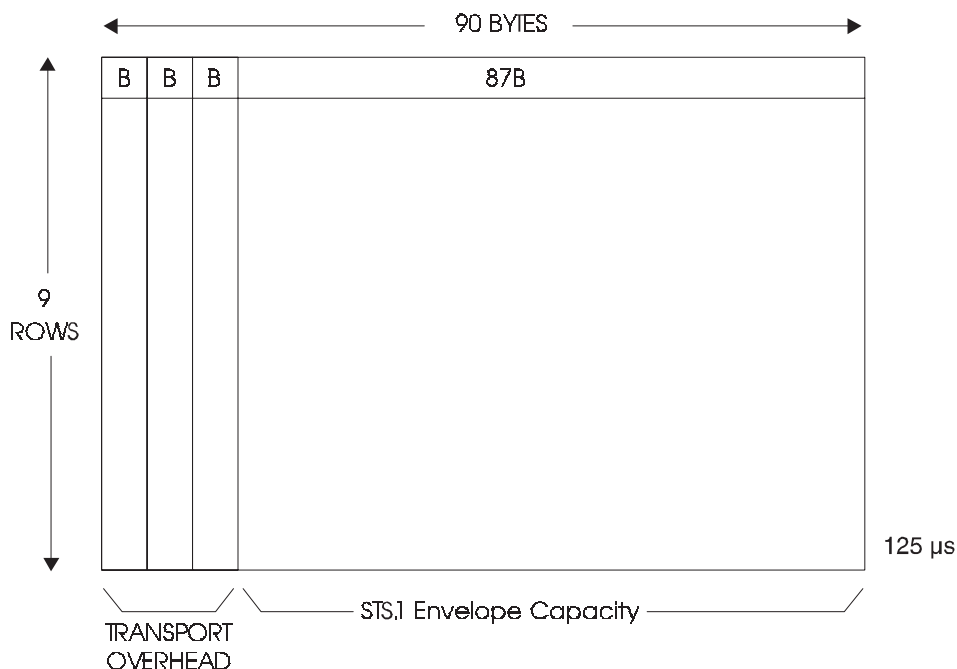
**Table 14-13.** Line Rates for the Allowable OC-N Signals

OC-N Level	STS-N Electrical Level	Line Rate (Mbps)
OC-1	STS-1	51.840
OC-3	STS-3	155.520
OC-12	-	622.080
OC-24	-	1244.160
OC-48	-	2488.320
OC-192	-	9953.28

### Frame Structure of the STS-1

The STS-1 frame, which Figure 14-33 depicts, consists of 90 columns and 9 rows of 8-bit bytes, for a total of 810 bytes (6480 bits). With a frame length of 125  $\mu$ s (that is, 8000 frames per second), the STS-1 has a bit rate of 51.840 Mbps. The order of transmission of bytes is row-by-row, from left to right. In each byte, the most-significant bit is transmitted first.

The first three columns are the Transport Overhead, which contains overhead bytes of Section and Line layers. Twenty-seven bytes have been assigned, with nine bytes for Section Overhead and eighteen bytes for Line Overhead. The remaining 87 columns constitute the STS-1 Envelope Capacity.

**Legend:**

B = Byte

**Figure 14-33. STS-1 Frame****STS-1 Synchronous Payload Envelope (SPE)**

Figure 14-34 depicts the STS-1 SPE. It consists of 87 columns and 9 rows of bytes, for a total of 783 bytes. Column 1 contains nine bytes, designated as STS Path Overhead (POH). The remaining 774 bytes are available for payload.

The STS-1 SPE may begin anywhere in the STS Envelope Capacity. Typically, it begins in one frame and ends in the next (although it may be wholly contained in one frame). The STS-1 Payload Pointer contained in the Transport Overhead designates the location of the byte where the STS-1 SPE begins.

STS POH is associated with each payload and is used to communicate functions from the point where a service is mapped into the STS SPE, to where it is delivered.

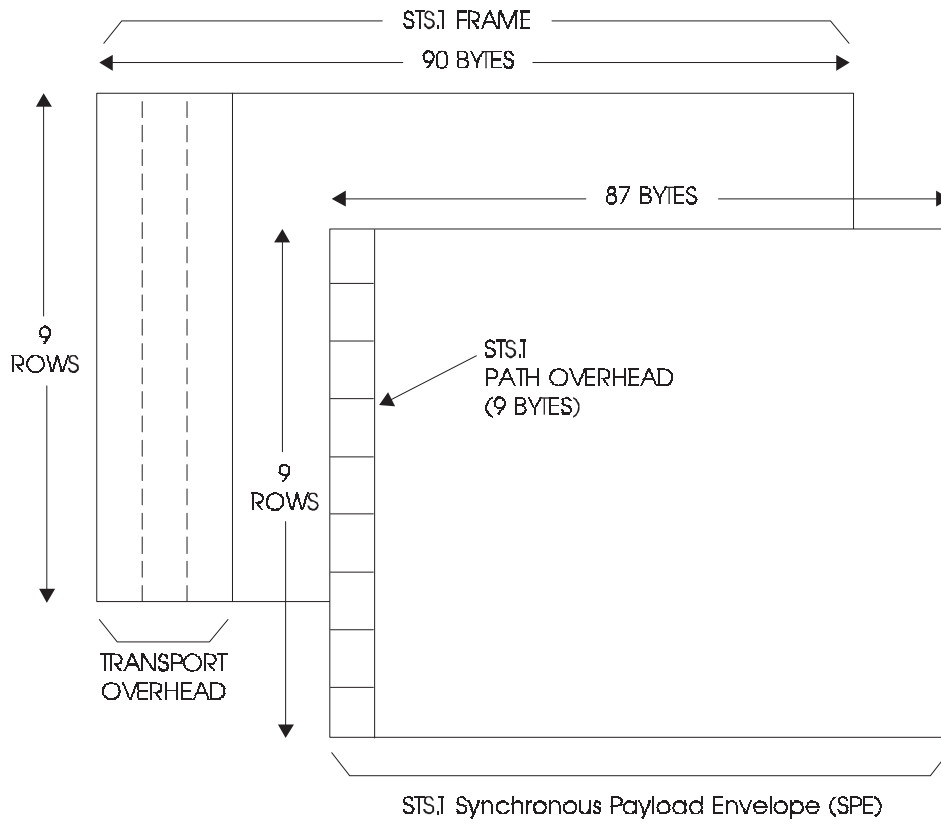
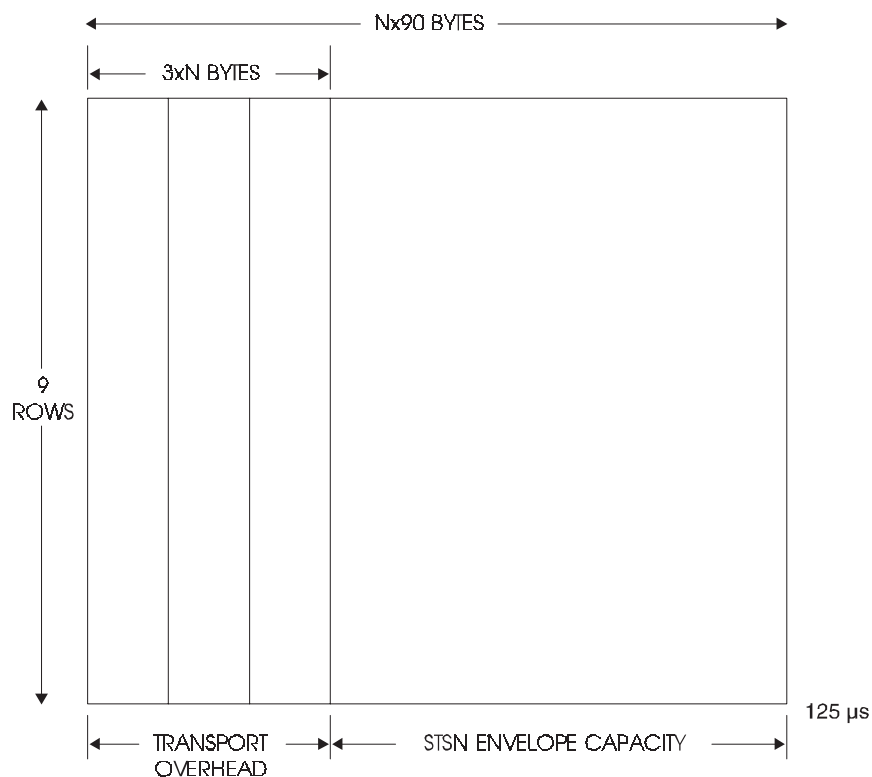


Figure 14-34. Synchronous Payload Envelope



## Frame Structure of the STS-N

The STS-N signal, shown in Figure 14-35, is formed by byte interleaving N STS-1 signals. Higher rate SONET signals are formed by byte interleaving the N lower level constituents. Byte interleaving and frame alignment are referenced at the STS-3 level (155.52 Mbps) which is acceptable to the International Telecommunication Union—Telecommunication Standardization Sector (ITU-T).<sup>1</sup> Levels higher than STS-3 (OC-3) are obtained through byte interleaving the lower level constituents yet maintaining a multiple STS-3 arrangement.



**Legend:**

B = Byte

**Figure 14-35. STS-1 Frame**

The Transport Overhead bytes of the individual STS-1 signals are frame aligned before interleaving. The associated STS SPEs are not required to be aligned because each STS-1 has a unique Payload Pointer to indicate the location of the SPE.

1. Formerly the International Telegraph and Telephone Consultative Committee (CCITT).

## STS Concatenation

Super Rate services, such as the Asynchronous Transfer Mode-based Broadband Integrated Services Digital Network (ATM-based BISDN) service, require contiguous multiples of the STS-1 rate. These multiples are mapped into an STS-Nc SPE and transported as a concatenated STS-Nc. The STS-Nc can be carried by an STS-N or OC-N (or higher level) line signal.

The STS-Nc is multiplexed, switched, and transported through the network as a single entity. A concatenation indicator is used to show that the STS-1s of an STS-Nc are linked together, and is contained in the STS-1 Payload Pointer.

## Sub-DS3 Payload Mapping (DS1, DS1C, DS2)

To transport payloads requiring less than an STS-1 payload capacity, the STS-1 SPE is divided into payload structures called Virtual Tributaries (VTs). VTs are correspondingly packaged into virtual tributary groups (VT groups).

The VT payload pointer provides a method of allowing flexible and dynamic alignment of the VT SPE within the VT Superframe (and therefore within the STS SPE), independent of the actual content of the VT SPE. (see Figure 14-36)

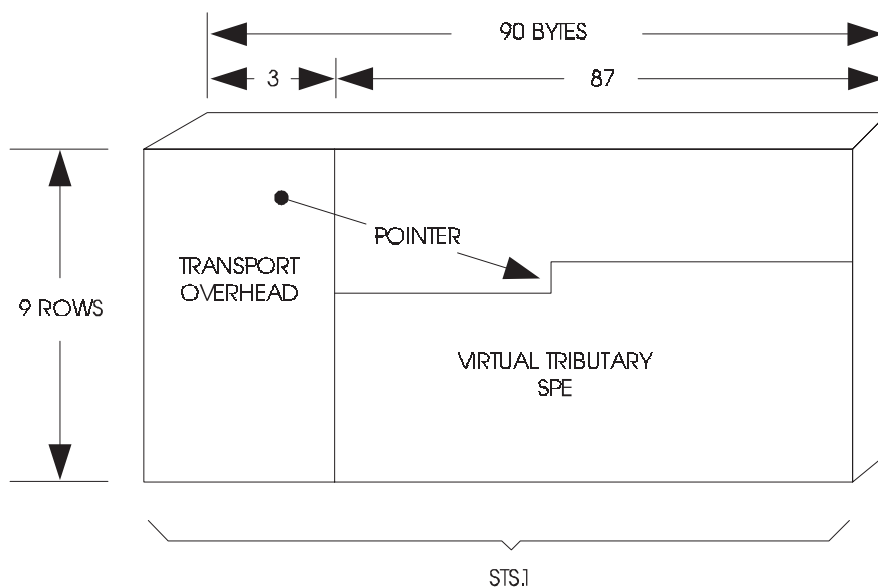


Figure 14-36. Sub-DS3 Payloads

## Virtual Tributary Structure

The VT structure is designed for transport and switching of sub-STS-1 (sub-DS3) payloads. There are four sizes of VTs as shown in Table 14-14.

**Table 14-14.** VT Sizes

<b>Tributary</b>	<b>Carried Signal</b>	<b>Overhead</b>	<b>Carrying Capacity</b>
VT1.5	= 1.544 Mbps	+ Overhead = 27 bytes	= 1.728 Mbps
VT2	= 2.048 Mbps	+ Overhead = 36 bytes	= 2.304 Mbps
VT3	= 3.152 Mbps	+ Overhead = 54 bytes	= 3.456 Mbps
VT6	= 6.312 Mbps	+ Overhead = 108 bytes	= 6.912 Mbps

VTs are packaged into VT groups; a VT group is always 9 rows by 12 columns or 108 bytes total.

Figure 14-37 illustrates the VTs. In the 9-row structure of the STS-1 SPE, these VTs occupy 3 columns, 4 columns, 6 columns, and 12 columns, respectively.

### 14.15.2.2 Layered Overhead and Transport Functions

The overhead and transport functions are broken into layers that increase in complexity from the viewpoints of hardware and the optical interface frame format. The layers are Physical, Section, Line, and Path (see Figures 14-38 and 14-39). The layers have a hierarchical relationship and are considered from the top down. The top-down approach provides a general introduction to the individual layers and their functionalities.

#### Physical Layer

The Physical layer deals with the transport of bits as optical or electrical pulses across the physical medium. No overhead is associated with the Physical layer.

The main function of this layer is conversion between STS signals and optical or electrical SONET signals. Issues dealt with at this layer include pulse shape, power levels, and line code. For example, electro-optical units communicate at this level.

The Section layer deals with the transport of an STS-N frame across the physical medium. The layer uses the Physical layer for transport.

Functions of this layer include framing, scrambling, section error monitoring, and communicating Section level overhead. The overhead defined for this layer is interpreted and modified or created by Section Terminating Equipment (STE).

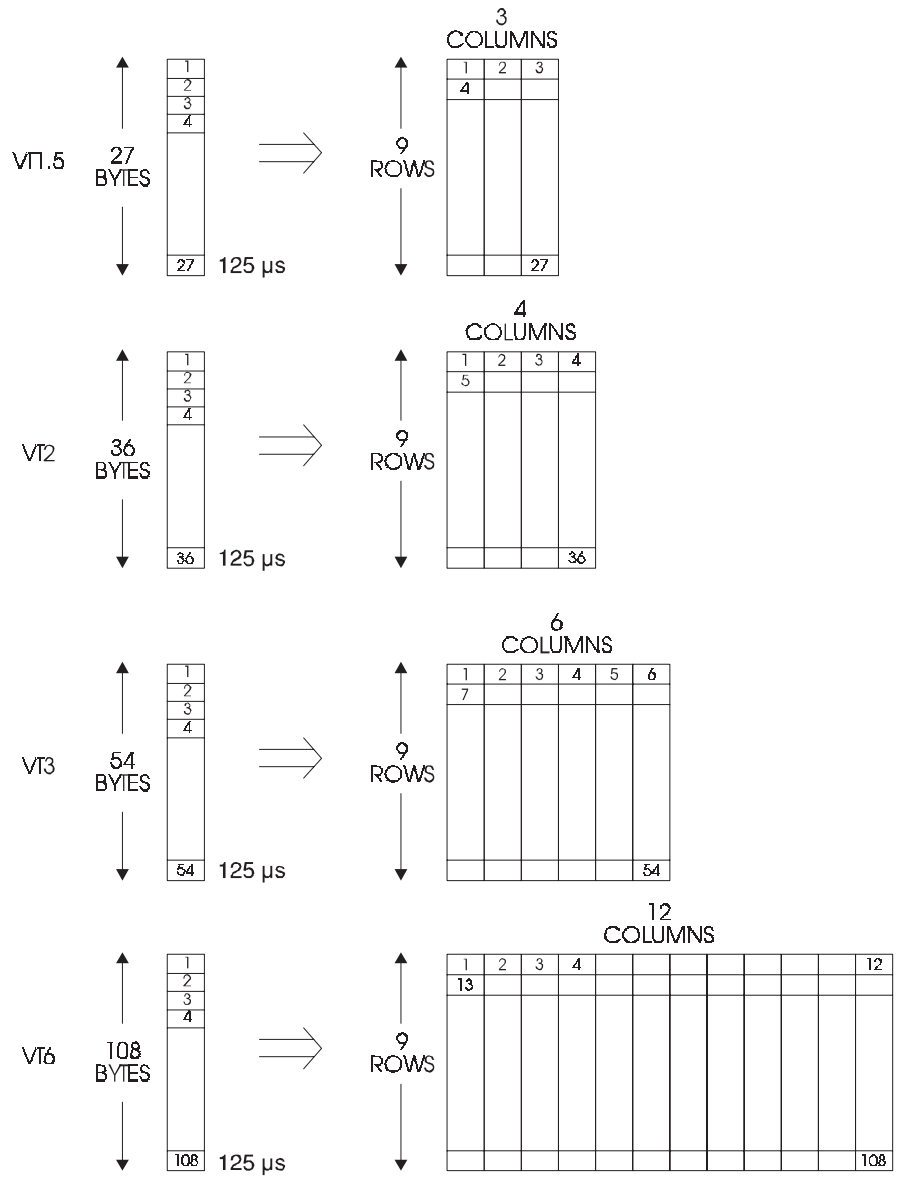
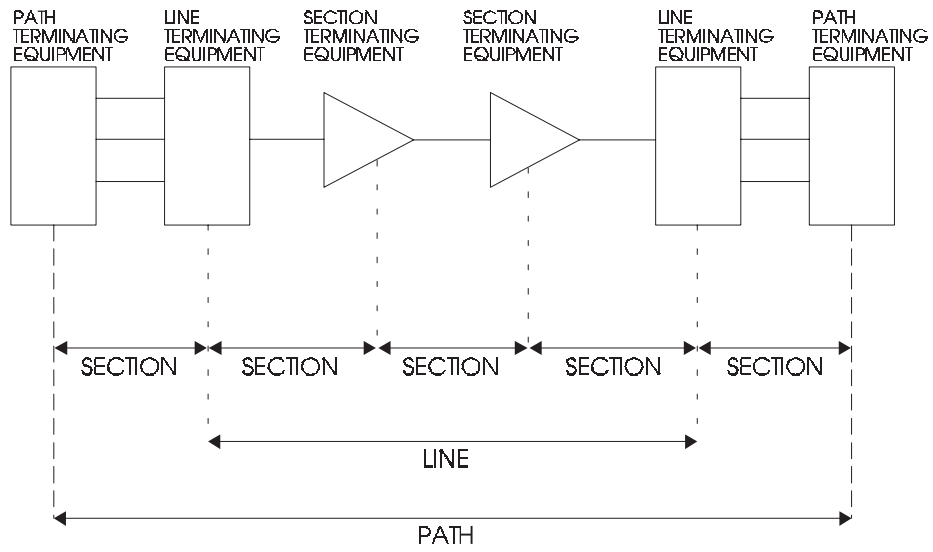


Figure 14-37. VT Sizes



**Figure 14-38.** Simplified Diagram Depicting SONET Section, Line, and Path Definitions

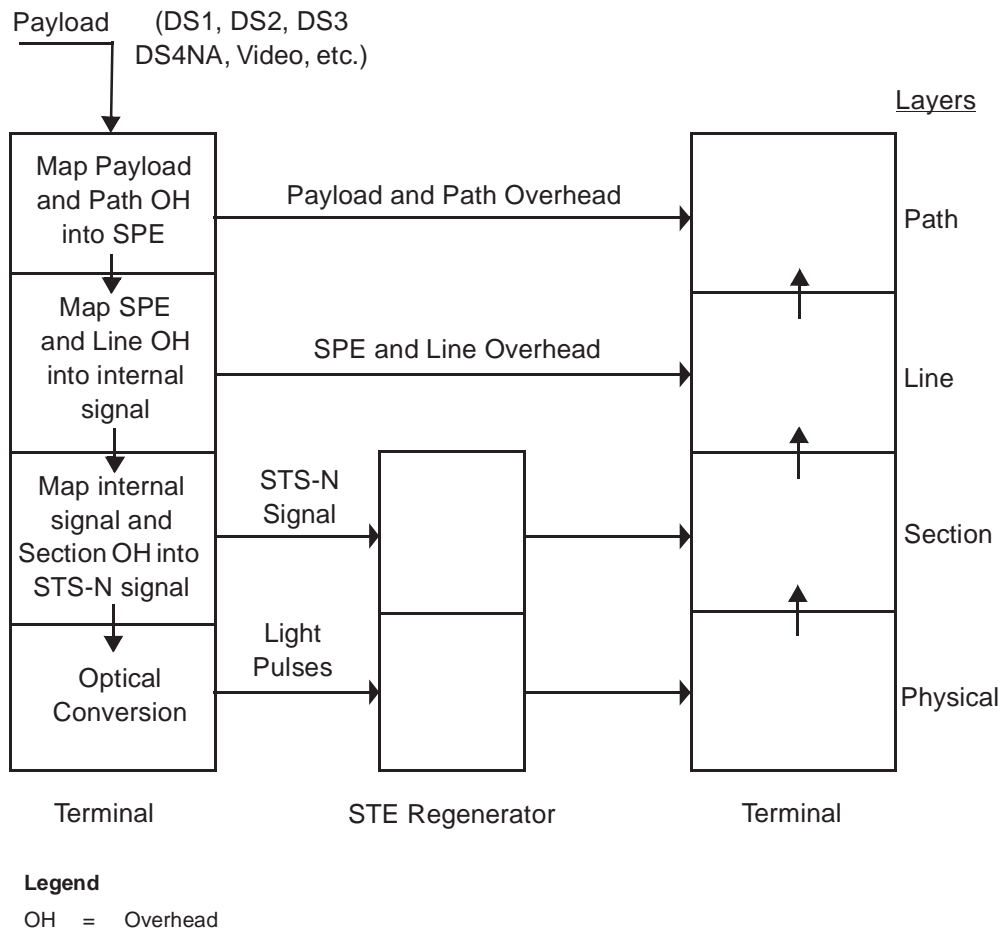


Figure 14-39. Optical Interface Layers

---

## Section Layer

The Section and Physical layers can be used in some equipment (for example, the STE regenerator) without involving the higher layers.

## Line Layer

The Line layer deals with the transport of STS SPE Path layer payload and its overhead across the physical medium. All lower layers exist to provide transport for this layer.

This layer provides synchronization and multiplexing functions for the Path layer. The overhead associated with these functions includes overhead for maintenance and protection purposes and is inserted into the Line overhead channels. The Line overhead for this layer is interpreted and modified by Line Terminating Equipment (LTE). Because the LTE contains Section layer functions, it is also an STE.

An example of system equipment that communicates at this level is an OC-N to OC-M multiplex (see Section 14.15.3.1).

## Path Layer

The Path layer deals with the transport of network services between SONET terminal multiplexing equipment. Examples of such services are DS1, DS3, and DS4NAs.

The Path layer maps the services into the format required by the Line layer. In addition, this layer communicates end-to-end via the POH. The overhead defined for this layer is interpreted and modified or created by Path Terminating Equipment (PTE). Because the PTE contains Line and Section layer functions, it is also considered an LTE and STE.

An example of system equipment that communicates at this level is DS3 to STS-1 mapping circuits.

## Interaction of the Layers

Figure 14-39 depicts the interaction of the optical interface layer. Each layer

- Communicates horizontally to peer equipment in that layer
- Processes certain information and passes it vertically to the adjacent layers.

The interactions are described in terms of each level's horizontal and vertical transactions.

Figure 14-39 also shows network services as inputs to the Path layer. This layer transmits horizontally to its peer entities the services and the POH. The Path layer maps the services and POH into SPEs that it passes vertically to the Line layer.

### 14.15.2.3 Operations Capabilities of the Signal Format

To accommodate the new flexibility of fiber optic networks that SONET allows, the SONET signal format contains numerous operations-related capabilities. Many of the overhead bytes in a SONET STS-1 frame are utilized by NEs for network maintenance operations including trouble detection, service restoration, trouble notification, trouble sectionalization and isolation, and trouble/repair verification. The overall philosophy governing maintenance of the SONET network and NEs is that these operations should be automated in the network to the greatest extent possible. Thus the SONET frame structure contains overhead to facilitate these maintenance steps. The SONET frame format also provides the capability for pro-active maintenance via performance monitoring. In addition, overhead functions also support single-ended maintenance operations.

SONET NEs are capable of detecting a variety of troubles, including internal equipment faults and troubles on the incoming signal. Troubles on the outgoing signal can also be detected, because the far end returns information about the troubles via the SONET overhead.

### 14.15.2.4 Performance Monitoring

Performance monitoring in SONET can be a critical part of a network provider's overall maintenance plan. SONET networks will support a variety of services such as voice, digital data, and video. Each of these services has its own distinct operational characteristics and sensitivity to various digital network impairments. These impairments may not always be simple, "hard" failures, but rather "soft" (gradual or intermittent) degradations in performance. Performance monitoring is important to capture these effects and provide a basis for effective network maintenance. In addition, performance monitoring also enables network providers the ability to address the increasing concerns of performance conscious end customers who often are capable of accumulating performance data of their own from CPE and who may desire detailed performance reports from the network supporting their services.

By using the SONET overhead bytes, the NEs in a SONET network can work together to accumulate performance data on sections, lines and paths, restore services and notify each other of the detection of troubles. The operation of the maintenance signals in SONET are defined such that NEs automatically provide notification of a trouble if maintenance action is required, and multiple notifications (in the form of alarms to management systems) so the same trouble can be suppressed. Alarms and performance alerts are defined in such a way that problems are automatically sectionalized to a regenerator section, or to a line when no regenerators are present.



---

#### 14.15.2.5 Embedded Operations Channel

Bytes are also allocated in the SONET frame structure to provide channels for message-oriented communications of operations data between SONET NEs. Bytes allocated in the section overhead provide a 192-kbps *section* Data Communications Channel (DCC). Bytes allocated in the line overhead provide a 576-kbps *line* DCC. The section DCC is currently used for NE-NE and Operations System-Network Element (OS-NE) communications. The line DCC is currently unassigned.

The SONET section DCC, a message-oriented Embedded Operations Channel (EOC), with its protocols and language, allows SONET signals to be used for networking operations information. SONET NEs can use the DCC to report troubles to a remote management system, for example, an Operations System (OS). Management systems can use the DCC to perform a software download to a remote SONET NE, or to query data or request other functions from the remote SONET NE. This embedded communications capability eliminates the need for a physically separate network for operations data communications within the SONET network.

Standards bodies (both the American National Standards Institute [ANSI] T1 and the ITU-T) have reached consensus on the 7-layer protocol stack to be used on both the section and the line DCCs. This 7-layer stack consists of protocols selected from the Open Systems Interconnection (OSI) model. Use of OSI protocols and management principles for communicating operations messages on the DCC allows systems (for example, OSs and NEs) from different suppliers to communicate with each other in a standardized fashion.

#### 14.15.2.6 Simplified Multiplexing

Synchronization allows the retrieval of lower rate signals from higher rate signals without completely demultiplexing the higher rate signal. Synchronization has facilitated the development of the Add-Drop Multiplexer (ADM), an NE that allows lower rate signals to be added and dropped from a higher rate signal without complete demultiplexing. The higher rate signal passes through the ADM while the signals are being added or dropped. A signal not being added or dropped at the location of the ADM, will pass through the ADM. The ADM eliminates the need for back-to-back multiplexing used in the asynchronous network.

#### 14.15.2.7 Integrated Optical Terminations

An advantage of SONET is that NEs will have standard integrated optical terminations. The most important use of integrated optical terminations will be with Digital Cross-connect Systems (DCSs). In the existing asynchronous network, Optical Line Terminating Multiplexers (OLTM) are needed to convert optical signals to electrical before entering

---

the DCS. SONET DCSs with integrated optical terminations will have OLTM functionality built into the DCS. This should reduce the overall cost of the equipment.

#### 14.15.2.8 Mappings

SONET has the capability to provide mappings from non-SONET formats into the SONET structure. SONET is, therefore, backward compatible with the existing data rates and formats, and remains flexible for mappings into future data rates and formats. Table 14-15 gives the data rates that have mappings from non-SONET rates into SONET.

**Table 14-15.** Mappings into SONET

<b>Non-SONET Signal and Mapping</b>	<b>SONET Rate</b>
Asynchronous Mapping for DS1 (1.544 Mbps)	VT1.5
Byte-synchronous Mapping for DS1 (1.544 Mbps)	VT1.5
European CEPT1 Mapping (2 Mbps)	VT2
Asynchronous for DS1C (3.2 Mbps)	VT3
Asynchronous Mapping for DS2 (6.3 Mbps)	VT6
Asynchronous Mapping for DS3	STS-1
Asynchronous Mapping for DS4NA (139.264 Mbps)	STS-3c
Asynchronous Mapping for Fiber Distributed Data Interface (FDDI: Token Ring)	STS-3c
Distributed Queue Dual Bus Mapping (DQDB: IEEE 802.6 standard)	STS-3c
Asynchronous Transfer Mode (ATM) Mapping for BISDN Applications	STS-3c STS-12c STS-48c STS-192c

#### 14.15.2.9 Protection Switching

The SONET standard offers Automatic Protection Switching (APS) to enhance the survivability of the network. The protection switching feature allows the switching of working lines to protection lines in the event of a failure on the working lines. The protection switching concept was originally used in asynchronous point-to-point systems. With SONET APS, a single protection line can be used with up to 14 working lines.

Linear APS is defined to provide protection at the line layer. Therefore, all of the STS SPEs carried in an OC-N signal are protected together (i.e., if a switch occurs, all of the STS SPEs are switched simultaneously). Two linear APS architectures are defined - these are the 1+1 architecture and the 1:n architecture. The most common use of the 1:n architecture being 1:1.

---

The 1+1 architecture is defined as being an architecture in which the head-end signal is continuously bridged (at the electrical level) to working and protection equipment so that the same payloads are transmitted identically to the tail-end working and protection equipment. At the tail-end, the working and protection OC-N signals are monitored independently and identically for failures. The receiving equipment chooses either the working or the protection signal as the one from which to select traffic, based on some switch initiation criteria.

A 1:n architecture may have any of n working channels bridged to a single protection line. Permissible values of n are from 1 to 14. Head-end to tail-end signaling is accomplished by using the APS channel. Because the head end is switchable, the protection line can be used to carry an extra traffic channel.

Linear protection switching can be used in point-to-point, tree, hubbing, and mesh architectures. Self healing ring architectures (Unidirection Path Switched Rings - UPSR and Bidirectional Line Switched Rings - BLSR) use protection switching protocols that are based on linear protection switching.

#### 14.15.2.10 Network Synchronization

The existing network provider synchronization networks are expected to evolve to an OC-N based network for the transport of timing references between locations. The reliability and overall accuracy of transported timing references will be enhanced by the use of OC-N based synchronization networks. Conversely, planning the interofficesynchronization network and avoiding timing loops is much more challenging with the deployment of SONET.

Where BITS (Building Integrated Timing Supply) timing is available, SONET NEs are externally timed from the BITS clock. Where no BITS timing is available, SONET NEs are timed from a received high speed OC-N (or low speed OC-M) signal. External timing references to a SONET NE are from a BITS clock of stratum 3 or better quality. Timing signals delivered to the synchronization network from a SONET NE are derived directly from a terminating high speed OC-N (or low speed OC-M).

#### 14.15.3 Network Architecture

This section will provide a look at specific SONET architectures.<sup>2</sup> One or more of these specific SONET architectures will be deployed within a network. Since the number of available SONET architectures and features increases with time (as NEs and OS support

---

2. The term "architecture" is used instead of "topology" because there may be different implementations of the same topology. For example, there are several variations on the ring topology: unidirectional and bidirectional.

---

becomes available), the long-term SONET deployments may have a different mix of architectures than near-term SONET deployments.

#### 14.15.3.1 Point-to-Point

In a point-to-point architecture, shown in Figure 14-40, SONET ADMs in the terminal mode or Terminal Multiplexers (TMs)<sup>3</sup> provide transport between two distinct locations. At the two locations in the network, the ADM multiplexes/demultiplexes DS<sub>n</sub> or STS-M electrical signals into an OC-N optical signal (where  $M < N$ ). SONET point-to-point architectures are already being deployed in the loop and interoffice. The majority of the equipment being deployed in point-to-point architectures are TMs. TMs and ADMs in terminal mode are currently available for a wide range of rates: OC-3, OC-12, OC-24, and OC-48.

Point-to-Point architectures can provide survivability features as previously mentioned.

Advantages of the point-to-point architecture are:

- The architecture is economical for routes with large demand, that is, close to the capacity of the optical system.
- Operationally, the SONET point-to-point architecture is very similar to the asynchronous point-to-point architecture.

Disadvantages of the point-to-point architecture are:

- Point-to-point architectures cannot provide any protection against node failures.
- Since traffic can travel only between the two terminating ADMs, the point-to-point architecture is not very flexible.

#### 14.15.3.2 Linear and Tree

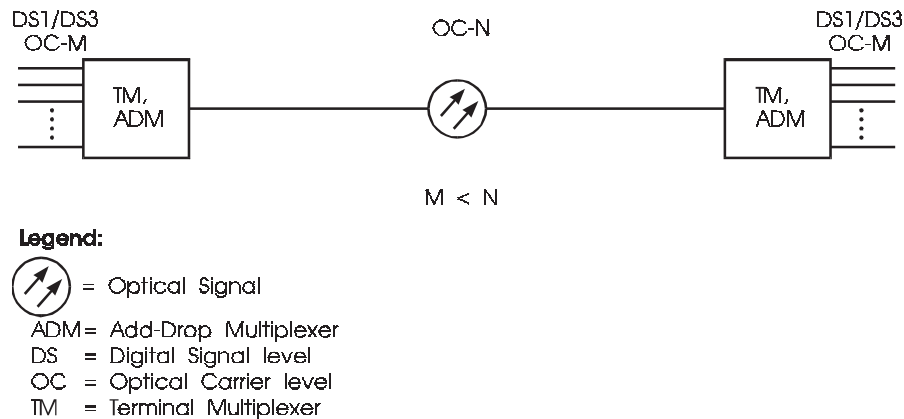
A linear configuration, shown in Figure 14-41, consists of a string of identical ADMs in the add/drop mode transversing multiple locations (central office or loop). Each ADM transports an OC-N signal and add/drops DS1, DS3s, or optical OC-M signals (where  $M < N$ ). A tree configuration, shown in Figure 14-42, uses ADMs in the add/drop and terminal mode. For example, a tree architecture uses ADMs in the terminal mode to multiplex lower rate signals, such as DS1s and/or DS3s, into a higher rate signal at an OC-M rate. ADMs in the add/drop mode carry the OC-M between locations.

Advantages of the linear and tree architectures are:

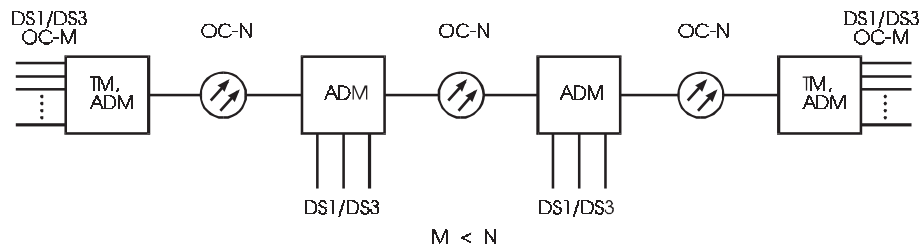
---

3. The difference between the TM and an ADM in the terminal mode is that the TM is not upgradable to an ADM in the add-drop mode.

---



**Figure 14-40.** Point-to-Point Architecture



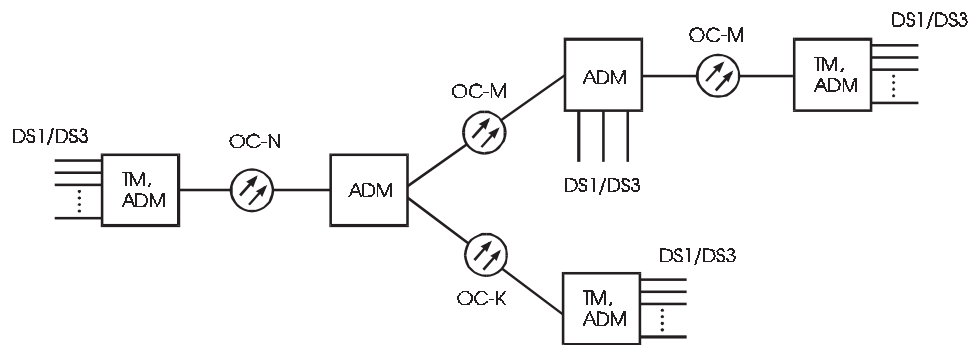
**Figure 14-41.** Linear Architecture

- Both linear and tree architectures are well suited for loop networks, in particular, for providing OC-3 and DS1 interfaces with Digital Loop Carrier (DLC) products.
- Linear architectures are more economical than back-to-back asynchronous terminals.
- Linear architectures operate similarly to existing architectures.

Disadvantages of the linear and tree architectures are the same as the point-to-point architecture, such as limited flexibility and upgradability for reconfiguration. Also, linear architectures are frequently less economical than rings for centralized demand patterns.

#### 14.15.3.3 Ring: UPSR

In a Unidirection Path Switched Ring (UPSR), the two directions of a duplex channel travel over different routes. Figure 14-43 shows the UPSR architecture. A UPSR consists of two fibers: one is designated the working fiber, the other the protection fiber. The sending node transmits simultaneously on both the working and the protection fibers. During normal operation, only the working signal is used, although both are monitored for alarms and maintenance signals. The same signal travels on both fibers in opposite directions;

**Legend:**

 = Optical Signal

ADM = Add-Drop Multiplexer

DS = Digital Signal level

OC = Optical Carrier level

TM = Terminal Multiplexer

$$M + K \leq N$$

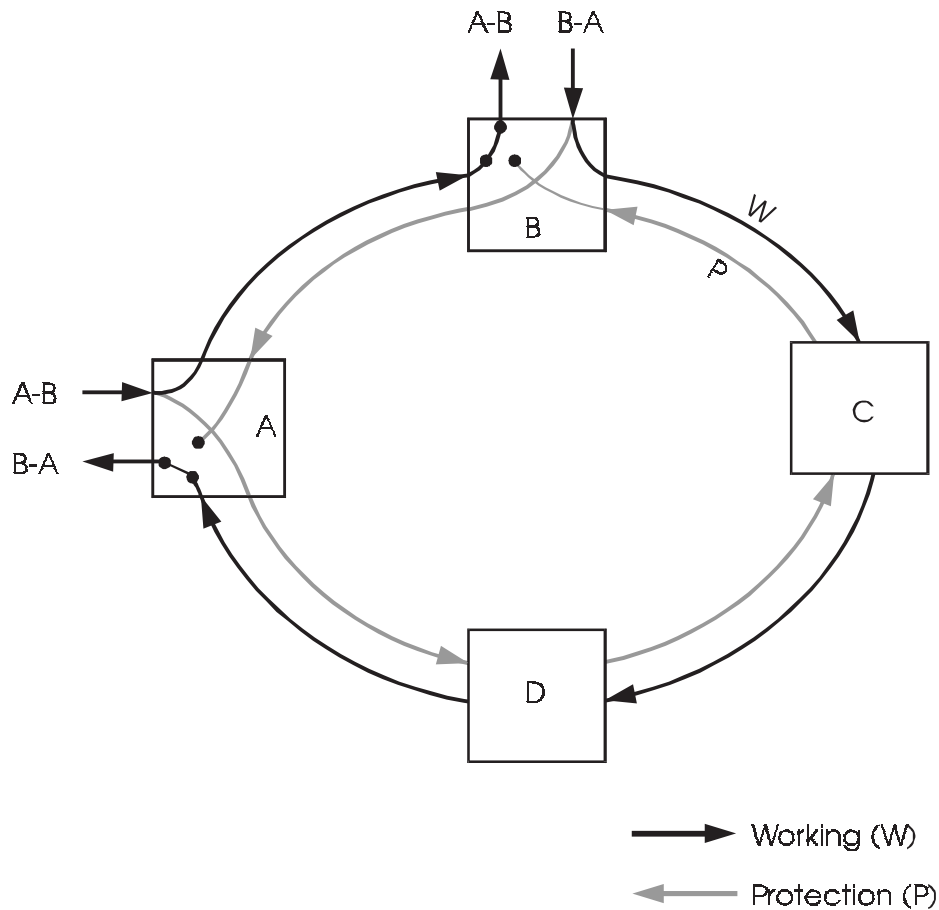
**Figure 14-42.** Tree Architecture

therefore, the protection ring cannot be used for other services. The UPSR uses Path Alarm Indications Signals (Path AISs) and Path Bit Interleaved Parity (Path BIP) when a failure is detected. If the ring is broken due to a failure (a fiber cut or hardware failure, for example), it is possible to resume service by selecting the signal that has not encountered a failure.

Advantages of the UPSR architecture are:

- Ring architectures provide increased survivability in the interoffice network over point-to-point, linear, and hubbing (described later in this section) architectures.
- A UPSR can survive multiple failures on the working fiber or a complete fiber cut. With a node failure or multiple failures in both fibers, some traffic will be disrupted, but not all.
- The UPSR is economical, compared with other ring architectures, for centralized traffic patterns (that is, networks where most of the traffic terminates or originates at one node). An example of a centralized traffic pattern is the loop which carries traffic to and from a central office.
- During a single link failure or maintenance activity, the UPSR provides full service.
- The UPSR potentially provides a broadcast structure, that is, the drop and continue feature could be used to broadcast information to multiple central offices on the ring.

Disadvantages of the UPSR architecture are:



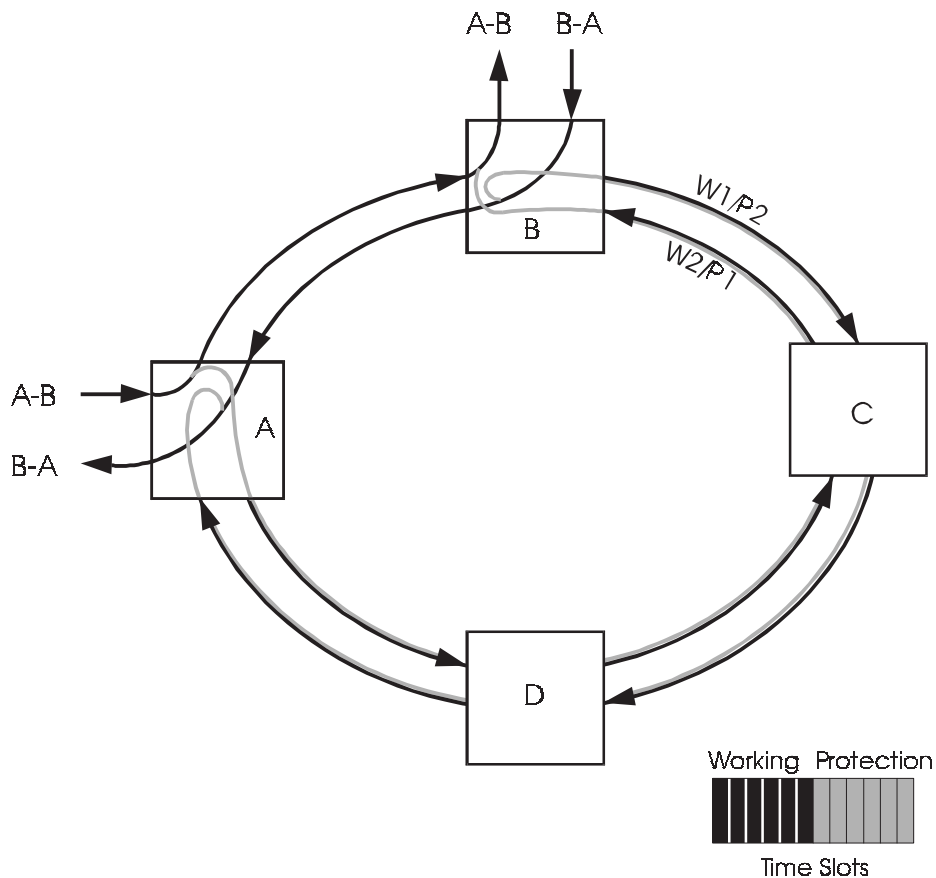
**Figure 14-43.** Unidirectional Self-Healing Ring Architecture

- The UPSR may have less capacity than a Bidirectional Line Switched Ring (BLSR), in distributed traffic patterns.
- The UPSR has less flexibility compared to a BLSR for traffic assignment.
- The UPSR may not be economical for demand patterns that are not centralized, such as interoffice applications.

#### 14.15.3.4 Ring: 2-Fiber BLSR

With a 2-fiber BLSR, shown in Figure 14-44, the two directions of a duplex channel travel over the same route. With a 2-fiber BLSR architecture, the working and protection systems use the same fibers. Half of the bandwidth of each fiber is reserved for protection. SONET line protection switching is used with a restricted form of Time-Slot Interchange (TSI) in the event of an alarm or failure. In the event of a failure, working traffic from one fiber is

automatically switched into vacant time slots of the other fiber, traveling in the opposite direction, to avoid the failure.



**Figure 14-44.** 2-Fiber Bidirectional Line Switched Ring Architecture

One characteristic of a 2-fiber BLSR architecture that will impact network planning is that the available capacity of the ring depends on the traffic patterns within the ring. The best case capacity is for a demand pattern where traffic tends to be between adjacent nodes, and capacity utilization becomes equal to the number of nodes on the ring multiplied by half the capacity of the ring. The worst case capacity of a 2-fiber BLSR is with a centralized demand pattern, for example, the traffic goes to a single node, and is equal to the ring transmission rate.

Advantages of the 2-fiber BLSR architecture:

- This type of ring may be economical, compared with the USHR/P, for the interoffice network with a decentralized demand.
- The 2-fiber BLSR may be upgradable to a 4-fiber BLSR ring.



- 
- The 2-fiber BLSR operation is similar to the existing asynchronous point-to-point network.

Disadvantages of the 2-fiber BLSR architecture:

- Traffic over a 2-fiber BLSR must be load balanced, adding planning and engineering complexity.
- The limited TSI functionality in a 2-fiber BLSR must be managed.
- The 2-fiber BLSR is only capable of surviving a single failure, such as a node failure, a fiber cut, or a link failure compared to the 4-fiber BLSR.

#### 14.15.3.5 4-Fiber BLSR

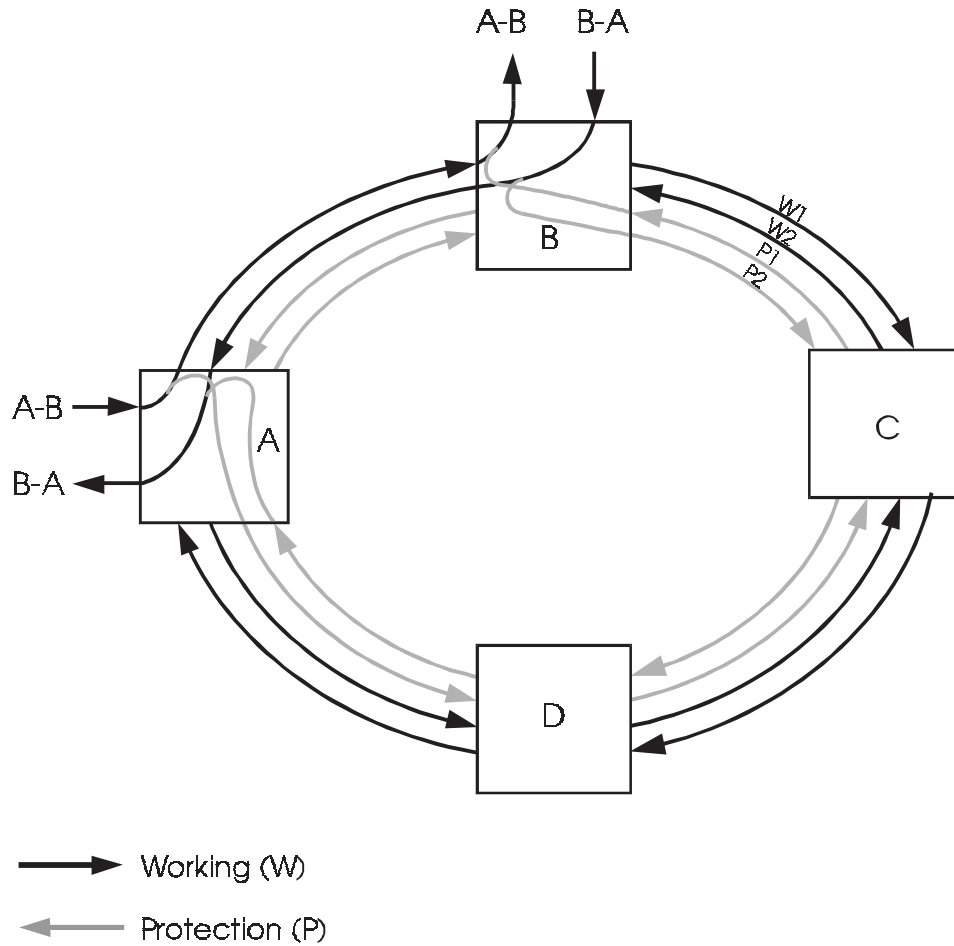
With a 4-fiber BLSR architecture, shown in Figure 14-45, the two directions of a duplex channel travel on separate fibers over the same route. Two fibers serve as a back-up; therefore, there are four fibers. The 4-fiber BLSR architecture has evolved from existing point-to-point and linear protection systems.

Advantages of the 4-fiber BLSR architecture:

- Like the 2-fiber BLSR, this ring may be economical, compared with the USHR/P, for interoffice traffic because demand patterns in the interoffice are generally not centralized.
- The SONET DCC has a physical protection option through the alternative fiber pair.
- With loopback and span protection, the 4-fiber BLSR can survive multiple link failures or a node failure.
- Since a separate fiber pair is provided for protection, the self-healing function remains available during maintenance activity.
- 4-fiber BLSR operation is similar to the existing asynchronous point-to-point network.

Disadvantages of the 4-fiber BLSR architecture:

- The 4-fiber BLSR may not be economical for centralized demand patterns.
  - Traffic over a 4-fiber BLSR must be load balanced, adding planning and engineering complexity.
  - With only high-speed loopback, the 4-fiber BLSR can only sustain one failure or maintenance activity which requires a working line to be out of service.
-



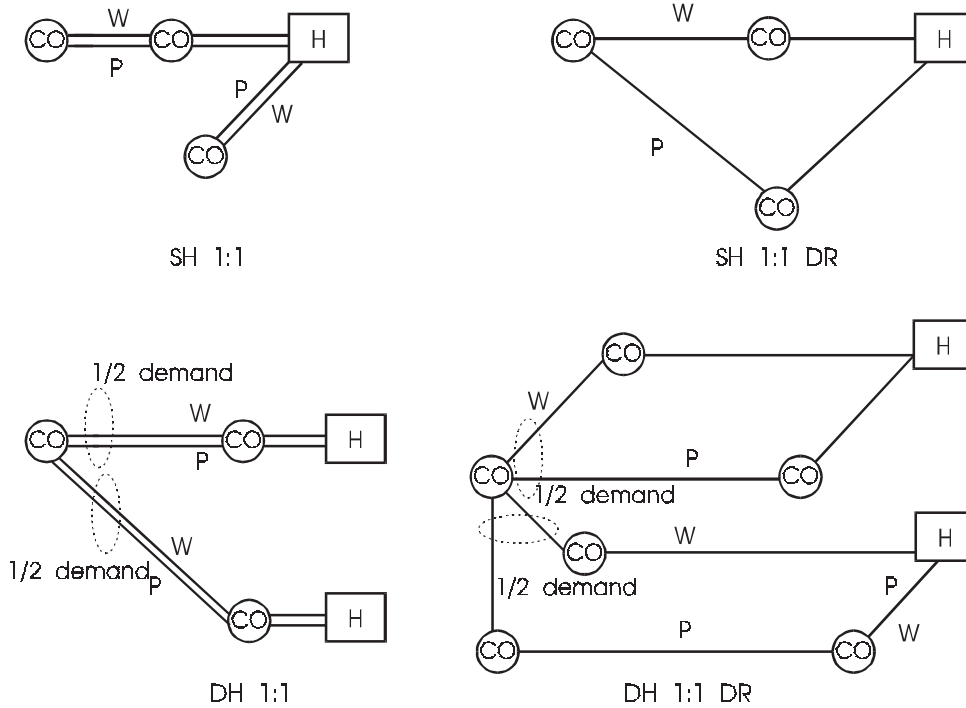
**Figure 14-45.** 4-Fiber Bidirectional Line Switched Ring Architecture

#### 14.15.3.6 Hubbing

With a facility hubbing architecture, traffic from multiple locations is aggregated and sent to a hub central office for cross-connection. The traffic is distributed to other destinations attached to the hub central office. Hubbing is used in asynchronous fiber networks because it is economical to aggregate traffic to a central location rather than use point-to-point copper or fiber networks.

Hubbing architectures, in general, use a DCS at the hub central office to provide cross-connection. A typical SONET hubbing network could have SONET ADMs in the subtending central offices sending interoffice traffic to the hub central office.

One way to categorize hubbing architectures is by their robustness in the face of different types of network failures. Four point-to-point approaches are shown in Figure 14-46:



- Legend:**
- CO = Central Office
  - DH = Dual Homing
  - DR = Diverse Routing
  - H = Hub
  - P = Protection
  - SH = Single Homing
  - W = Working

**Figure 14-46.** Hubbing Architectures

- SH 1:1 (Single Homing, one-to-one protection): all traffic terminates at the nearest hub central office, each fiber is 1:1 protected, and both the working and the protection fibers follow the same route. This architecture does not protect against a hub failure, or a complete cable cut.
- SH 1:1 DR (Single Homing, one-to-one protection, Diverse Routing): all traffic terminates at the nearest hub central office, each fiber is 1:1 protected, and the working and the protection fibers follow different routes. This architecture gives protection against a complete cable cut, but not against a hub failure.

- 
- DH 1:1 (Dual Homing, one-to-one protection): half of the traffic terminates at the nearest hub central office, half terminates on a foreign hub central office, each fiber is 1:1 protected, and both the working and the protection fibers follow the same route. This architecture protects half of the traffic against hub failures, but does not protect against a complete cable cut.
  - DH 1:1 DR (Dual Homing, one-to-one protection, Diverse Routing): half of the traffic terminates at the nearest hub central office, half terminates on a foreign hub central office, each fiber is 1:1 protected, and the working and the protection fibers follow different routes. This architecture protects half the traffic against hub central office failures and all of the traffic against complete cable cuts.

Advantages of the hubbing architecture are:

- Hubbing networks, are more economical than rings for spans with large circuit demand, such as downtown areas.
- Hubbing architectures with APS will meet the 50 ms protection switching objective.
- Hubbing architectures with DCSs provide flexibility for rapid provisioning and bandwidth management.
- Dual homing architectures protect against node failures.

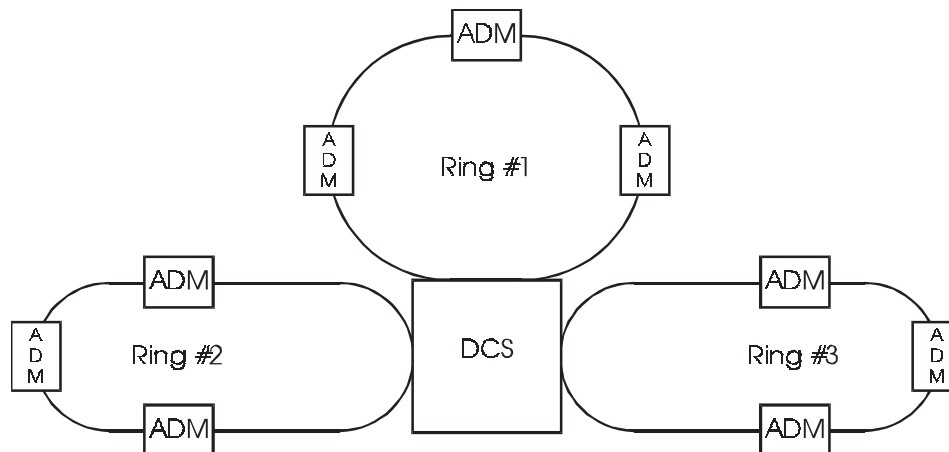
Disadvantages of the hubbing architecture are:

- If the hub central office goes down in a single homing architecture, the results could be catastrophic.
- Single homing networks do not provide the same level of survivability as rings.
- Dual homing architectures can be more expensive than ring architectures.

Hubbing architectures are not limited to the four point-to-point based homing arrangements described above. Hubbing architectures may be combined with a linear, tree, or ring architecture.

#### 14.15.3.7 DCS Ring and DCS Mesh

Ring transport and interconnection can be provided using a SONET DCS with integrated optical terminations. In a DCS ring architecture, the DCS would not necessarily replace ADMs in every central office. For example, as shown in Figure 14-47, a single ring may contain ADMs in all central offices except for large central offices where a DCS provides ring transport and interconnection between multiple rings.

**Legend:**

- DCS = Digital Cross-connect System  
ADM = Add-Drop Multiplexer

**Figure 14-47.** DCS Ring Architecture (Single Homing)

Mesh networks are defined as networks that have connections among many nodes. When fiber was deployed in the 1980s, hubbing networks became more economical than mesh networks. However, concern arose regarding hubbing networks because a hubbing network will lose a considerable amount of traffic if the hub central office fails. Although mesh networks are not as widely deployed as ring networks, algorithms for mesh networks have been developed that minimize the number of links needed in the network and the spare capacity needed for protection.

**14.15.4 Higher Bandwidth Evolution**

The evolving SONET network must be able to incorporate future transport technologies so that network providers can deploy a ubiquitous transport infrastructure that provides their customers a competitive edge with a path forward. Higher speed optical architectures continue to push the envelope of transport technology, and are being deployed today. Two approaches to achieve higher bandwidth (i.e., 10 Gbps, and beyond) are Time Division Multiplexing (TDM) and Wavelength Division Multiplexing (WDM).

To date, network elements using TDM techniques to increase the bit rate of a channel have been less costly than WDM technology. The deployment history of SONET clearly demonstrates this point. Initially, SONET OC-3 NEs were introduced. This was followed very closely by OC-12 NEs. Several years later, OC-48s were introduced. Historically, deploying one OC-N system was more cost effective than four OC-N/4 systems. Until very

recently, OC-48 was the highest rate SONET system. When the OC-48 capacity exhausted, increased bandwidth demand was satisfied by installing an additional OC-48 system operating in parallel. This approach of deploying more systems to satisfy the demand is referred to as SDM, space division multiplexing, referring to the use of more fibers. Today, advances in TDM technology have resulted in the availability of OC-192 systems. These two evolving high bandwidth solutions are not necessarily competitive solutions, rather they offer two options, and the selection of a WDM system or OC-192 system to meet particular applications may be dictated by price and business drivers.

#### 14.15.4.1 SONET OC-192 Systems

Initially, OC-192 technology is likely to be used in metropolitan and long haul areas, potentially in both ring and point-to-point architectures. One likely near-term application is due to the increasing deployment of SONET rings and the potential high aggregate capacities associated with those rings. OC-192 technology provides additional capacity and flexibility and may provide an economic alternative to, for instance, the deployment of multiple OC-48 rings. In addition, the availability of OC-192 systems may reduce operations and planning complexity associated with ring capacity exhaust. Depending on the demand and traffic patterns, an OC-48 ring may exhaust with only a few nodes on the ring, and, because high traffic demand limits the number of nodes on a ring, the result may be a proliferation of smaller rings. To maximize the benefits of SONET ring architectures and to allow for expected growth, it may be desirable to connect a larger number of nodes (e.g., 5 or more) to a ring. An OC-192 system operating at 10 Gb/s allows more nodes to be placed on the ring and provides the capability to process more added and dropped traffic at each node than currently available (lower bit-rate) SONET systems. In addition, the higher bit-rate could allow consolidation of existing smaller rings, simplifying the overall network architecture. Therefore, a network that utilizes higher capacity rings may require less interconnection between rings.

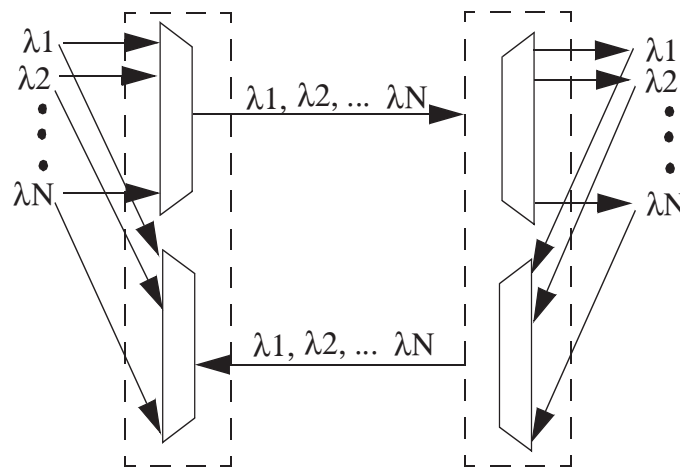
As seen in the earlier discussions on SONET rates and formats, etc., standards and requirements for OC-192 systems have made substantial progress, and equipment is available and deployed. Bellcore generic requirements for OC-192 systems are in GR-1377-CORE, *SONET OC-192 Transport Systems Generic Criteria*. Those criteria rely heavily on the SONET generic criteria in GR-253-CORE for SONET rates, formats, overhead definition, NE architectural features, and operations criteria. The criteria in GR-1377-CORE supplement the GR-253-CORE criteria and, where necessary, supersede or add additional criteria for the 10-Gb/s systems. In particular, the physical layer criteria are specific to the special high-speed fiber optic needs of OC-192 systems.

#### 14.15.4.2 WDM Systems

Wavelength Division Multiplexing (WDM) is a technique that significantly improves the bandwidth utilization within a fiber by allowing light from two or more optical sources operating at different wavelengths to propagate through the same optical fiber. It is therefore no surprise that a near term need to address cable (fiber) exhaust triggers interest in WDM technology. While WDM devices have been available for over a decade, the ever increasing demand for more and more bandwidth has renewed interest in WDM research.

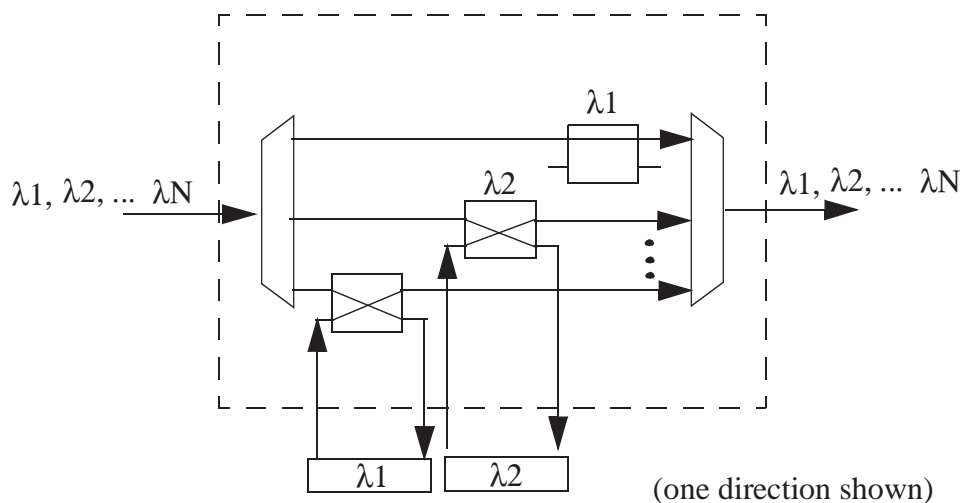
WDM research promises technology that could be the foundation for a new transport layer in the telecommunications network, viz., an all-optical, high throughput network. The ability to transport large amounts of traffic in a single fiber can lead to the creation of an all optical transport layer with new, all-optical network elements. The optical network would concentrate, route, and rearrange wavelengths originated in today's transport layer, which uses single channel (or wavelength) optical systems, like SONET. Because of the concentration, the optical layer would most likely have comparatively fewer nodes than the SONET transport layer.

Figure 14-48 illustrates a WDM system which is composed of two WDM Terminal Multiplexers (TM) and the fiber pair between them. The simple point-to-point WDM system provides fiber relief in today's network. As a concentrator, it has a role in most network applications: the access network (distribution, feeder, or loop portions), the metropolitan network, and the backbone network. One approach for using WDM TM is to assign a wavelength to a service to create overlay networks using a single fiber.



**Figure 14-48.** N-wavelength Point-to-Point WDM System

The WDM-based add/drop multiplexer (ADM-ADM) provides a function analogous to the SONET ADM, but it operates on wavelengths rather than timeslots. The WDM-ADM would have interfaces to two multiwavelength fiber pairs plus multiple, single wavelength fibers. Optical signals arriving on the multiwavelength fiber are demultiplexed and either passed through for transmission on the other multiwavelength fiber, or dropped to one of the single wavelength interfaces as shown in Figure 14-49. The WDM-ADM is the first real step toward a wavelength rearrangeable network. Early versions of WDM-ADM are just now starting to come to market.



**Figure 14-49.** Example of WDM-ADM Function

While more advanced WDM NEs (i.e., full capability WDM-ADM, WDM cross connects) are not yet commercially available, research and development and standards work are quite active. Thus initial WDM NE deployment has been limited to point-to-point and tree networks; more sophisticated WDM network architectures (i.e., ring, mesh, interconnected ring, hubbing, etc.) will require the advanced optical network capability of WDM-ADMs and WDM crossconnects that are not yet commercially available.

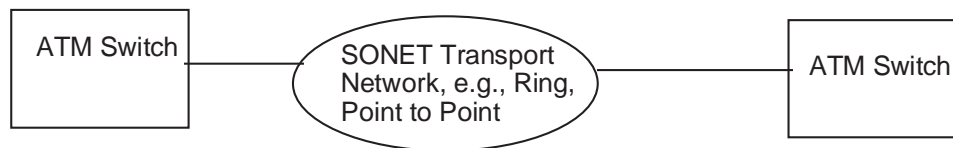
### 14.15.5 SONET and ATM Network Integration

Network providers have made a substantial investment in their transport networks by deploying SONET equipment and associated management systems. While the SONET transport layer can accommodate ATM traffic, STM traffic will continue to dominate in the near future. However, as more ATM equipment gets deployed in support of business services, it will impact the transport network and network planners will want to protect their large SONET transport network and management systems investments. The use of ATM



transport NEs can be a way to protect existing transport network investments while leveraging this same network to efficiently transport ATM services.

Figure 14-50 shows an example network using conventional SONET and ATM NEs. SONET rings, ADMs and DCSs can be used for transport and ATM edge and hub switches can be used for ATM cell switching. ATM cells are mapped to SONET payloads (e.g., into an STS-Nc Synchronous Payload Envelope) but the SONET transport NEs only process at the SONET layer; they do not process at the ATM layer. The SONET transport network provides transport of ATM from the customer ATM CPE to the ATM switch and back to the customer ATM CPE.



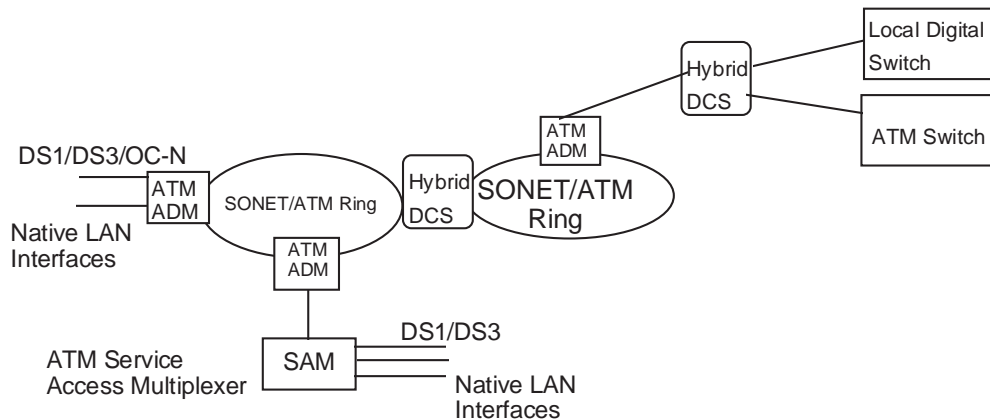
**Figure 14-50.** Conventional SONET and ATM Network

The term *hybrid SONET/ATM* has been used to refer both to equipment and to traffic. Hybrid SONET/ATM equipment is SONET transport equipment with ATM cell processing capability.

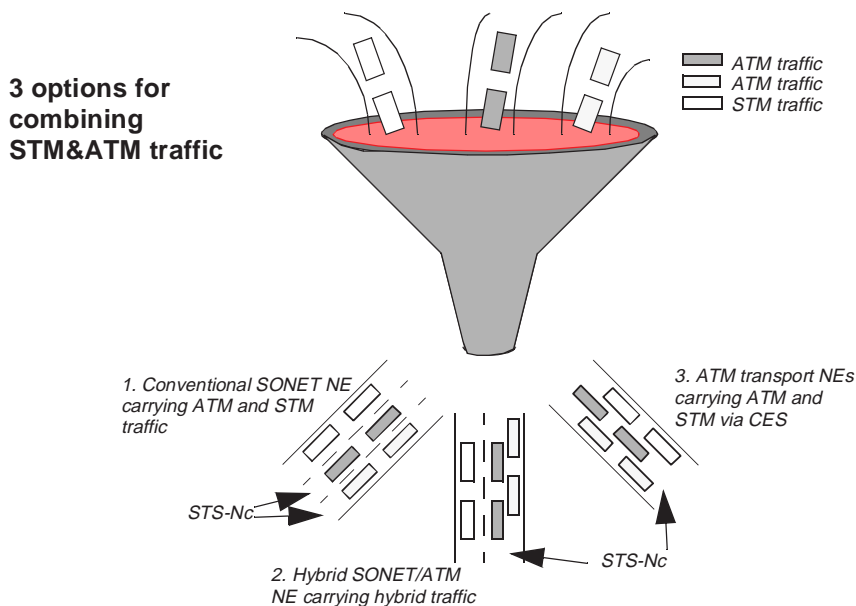
To help minimize the transport inefficiencies associated with conventional SONET and ATM transport networks, hybrid NEs may be used to aggregate ATM traffic to achieve better fill of the SONET “pipe”. Figure 14-51 shows an example network using hybrid SONET/ATM NEs. An ATM Service Access Multiplexer (SAM) is used at the edge of the public ATM network to provide ATM interfaces and adaptation for customer services. The hybrid ATM ADM ring is a SONET based ring (either UPSR or BLSR) in which the ADMs have ATM cell processing capabilities. This allows sharing of a SONET payload among several ring nodes. The hybrid DCS provides ATM cell cross-connection, grooming and management based on virtual paths.

Hybrid STM/ATM traffic refers to the transport of both STM and ATM services<sup>4</sup> on the same network, where ATM traffic is carried in ATM cells and STM traffic is carried in STM format (e.g., DS1, or DS3 mapped to a SONET payload). Figure 14-52 shows three different techniques for combining STM and ATM traffic over a single transport network.

4. ATM traffic refers to services adapted to ATM format at CPE. STM traffic is plesiochronous bit streams such as private line DS1s, DS3, or voice traffic.



**Figure 14-51.** Hybrid SONE/ATM NEs in an Example Network



**Figure 14-52.** Three Ways of Combining STM and ATM Traffic

The first technique uses a conventional SONE transport and ATM switching network as depicted in Figure 14-50 to combine the STM and ATM traffic onto the same SONE “pipe” but over different STS-Ncs. Note that each ATM stream from the customer requires its own STS-Nc with this method. The second technique for combining SONE and ATM traffic also combines the STM and ATM traffic onto the same SONE “pipe” over different STS-Ncs. However, by using hybrid SONE/ATM NEs, the ATM traffic can be

---

aggregated and carried in a single STS-Nc, allowing for more efficient transport. The traffic carried in the SONET “pipe” in the second method has been called hybrid traffic since the same physical medium is used to carry two different types of traffic in their native format – STM and ATM. The third technique for combining STM and ATM traffic on the same SONET “pipe” is by converting the STM traffic (via ATM Circuit Emulation Service [CES]) into ATM cells and carrying all STM and ATM traffic as ATM cells in a single STS-Nc. This last technique would not result in hybrid traffic, but is considered pure ATM transport. While this last technique may provide the more efficient bandwidth utilization, it requires CES for the STM traffic, which is costly today.

#### 14.15.6 SONET Operations Communications Network

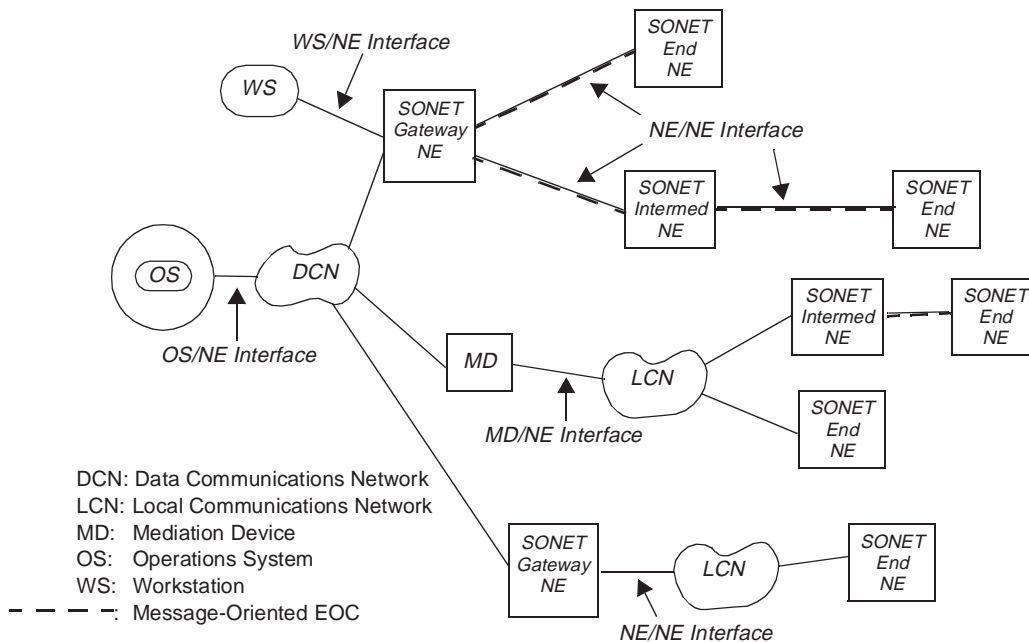
Network operations consists of a wide range of functions, including configuration management, fault management, and performance management. To perform such functions for managing services and equipment in a telecommunications network, management systems (for example, OSs) must be able to communicate with and control remote NEs as part of a Telecommunications Management Network (TMN) architecture. NEs must also communicate among each other to manage their resources.

SONET NE operations communications criteria are consistent with the Telecommunications Management Network (TMN) concept in ANSI T1.210–1993, *Operations, Administration, Maintenance and Provisioning (OAM&P) – Principles of Functions, Architectures and Protocols for Telecommunications Management Network (TMN) Interfaces*. A TMN is a support network that provides operations communications paths for SONET Operations System/Network Element (OS/NE), Mediation Device (MD)/NE, NE/NE, and Work Station (WS)/NE communications. This section briefly describes the role of SONET NEs in a TMN, and focuses on the implementation of the communications network functions and mediation functions by using SONET NEs and SONET overhead channels, specifically SONET Data Communications Channels (DCCs). The use of other technologies including Local Area Networks (LANs) and Mediation Devices (MDs) for mediation functions is also briefly discussed.

Operations communications criteria for SONET NEs depend on the location of the NE in the TMN architecture. More specifically, operations communications criteria depend on whether the NE serves as a Gateway NE, Intermediate NE, or End NE, as Figure 14-53 shows.

##### 14.15.6.1 Operations Communications Architecture Overview

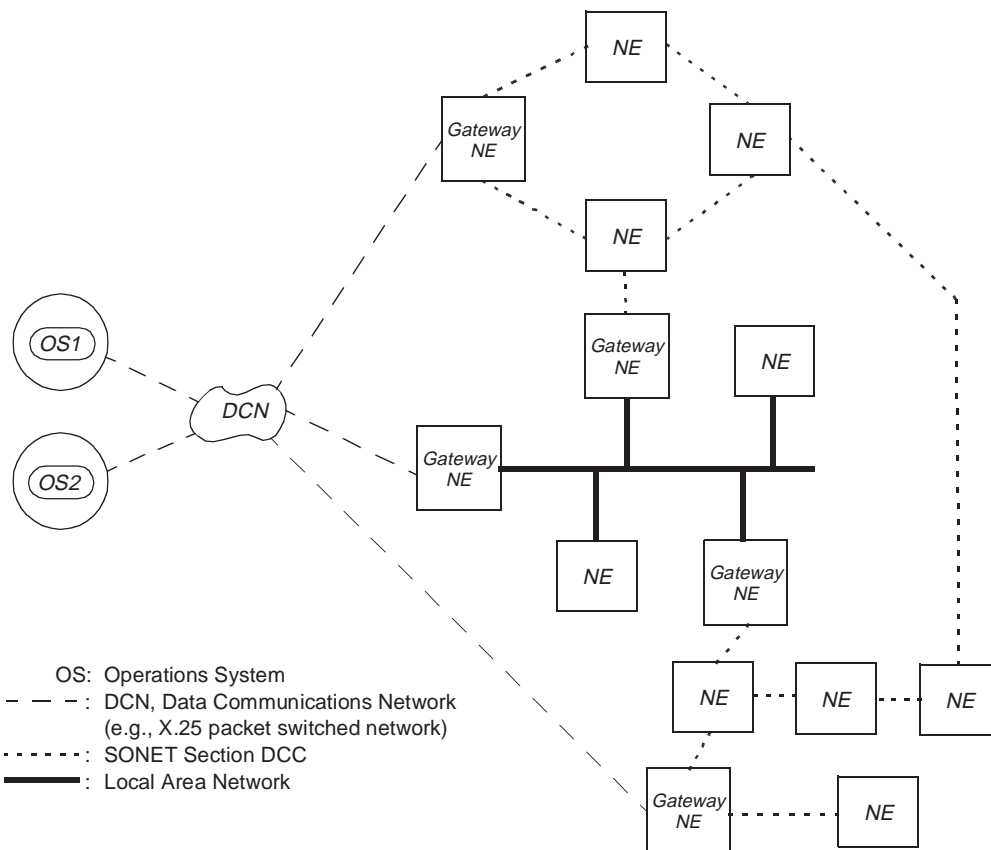
SONET operations communications architectures will vary depending on configuration (e.g., communications within a site or between sites) and application (e.g., OS-NE or NE-



**Figure 14-53.** SONET Operations Communication: Example NE and Interface Types

NE, IEC-LEC, survivable rings). This section will look at some operations communications architectures that may be used by network providers. Within a site, typically drop-side SONET interfaces will be used between connected SONET NEs; thus, no DCC will be supported. In this case, a Local Area Network (IEEE 802.3 LAN) can provide an alternate means for intra-site operations communications. However, there may be cases where a line-side interface (i.e., with the DCC) is required by a network provider for an intra-site transport connection. One such example may be for transport connections between exchange carriers where operations communications security is a concern. Another example of where a DCC may be used for intra-site communications is a Controlled Environment Vault (CEV) where only a few SONET NEs may reside. Therefore, for certain applications, security, reliability, or cost may make the use of the DCC, rather than an intra-site LAN, a better choice for intra-site operations communications.

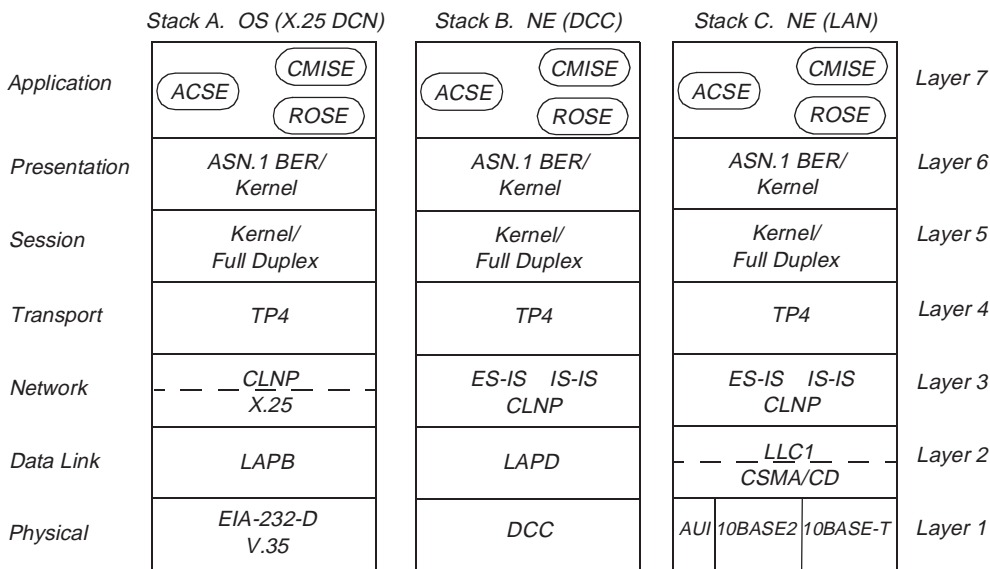
Figure 14-54 shows a generalized view of a SONET operations communications architecture that includes an X.25 wide area Data Communications Network (DCN), an intra-site LAN, and DCC tree and ring connections. This example can be viewed as three operations communications subnetworks. Each operations communications subnetwork is connected to OSs via the X.25 DCN. Communications between the subnetworks (such as for NE-NE communications)<sup>5</sup> can be done using the DCC links. Figure 14-55 shows the protocol stacks for the X.25 DCN, the DCC, and the intra-site LAN. In all three cases, the Connectionless Network layer Protocol (CLNP ISO 8473) resides at layer 3. Thus, interworking the three protocol stacks is done by standard routing and relaying functions.



**Figure 14-54.** Example SONET Operations Communications Architecture

Network providers' initial deployments will likely be much more limited than the example in Figure 14-54, with simpler operations communications networks as shown in Figures 14-56 and 14-57. Figure 14-56 shows two OSs (such as a memory administration OS and a surveillance OS) communicating with a SONET network via the X.25 DCN. Most of the SONET NEs are in the Central Office (CO) on a LAN with one far-end SONET NE in a

5. There are currently no messages defined *strictly* for NE-NE communications. However, in the future, NE-NE messages may be defined for applications such as auto-provisioning of ring map data for SONET bidirectional self-healing rings.



ACSE: Association Control Service Element  
 CMISE: Common Management Information Service Element  
 ROSE: Remote Operations Service Element  
 ASN.1: Abstract Syntax Notation 1  
 BER: Basic Encoding Rules  
 TP4: Transport Class 4  
 CLNP: Connectionless Network Protocol  
 LAPD: Link Access Procedure - D Channel  
 IS-IS: Intermediate System to Intermediate System  
 DCC: Data Communications Channel  
 LAPB: Link Access Procedure - B Channel  
 LLC1: Logical Link Control  
 CSMA/CD: Carrier Sense Multiple Access with Collision Detection  
 AUI: Attachment Unit Interface  
 10BASE2: 10 Mb/s Baseband Coax Cable  
 10BASE-T: 10 Mb/s Baseband over Twisted Pair  
 ES-IS: End System to Intermediate System

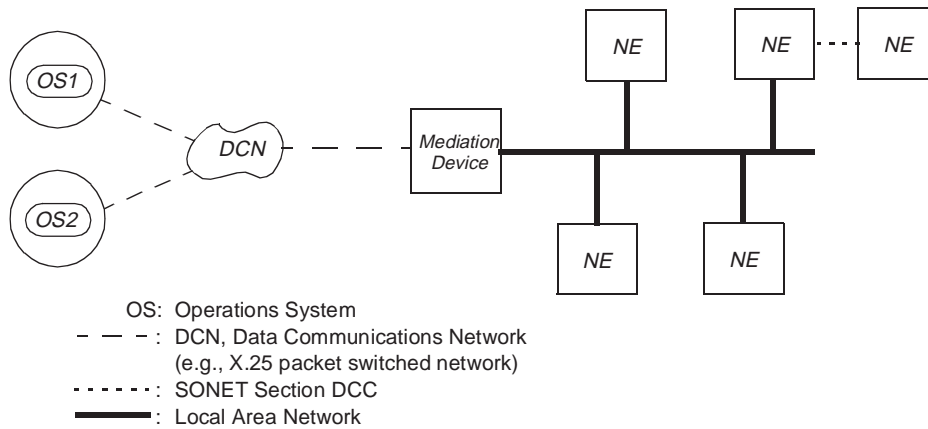
**Figure 14-55.** Interactive Protocol Stacks for SONET Operations Communications

point-to-point DCC configuration. This example also illustrates how a mediation device might be used to provide gateway functions such as interworking the X.25 network with the LAN.

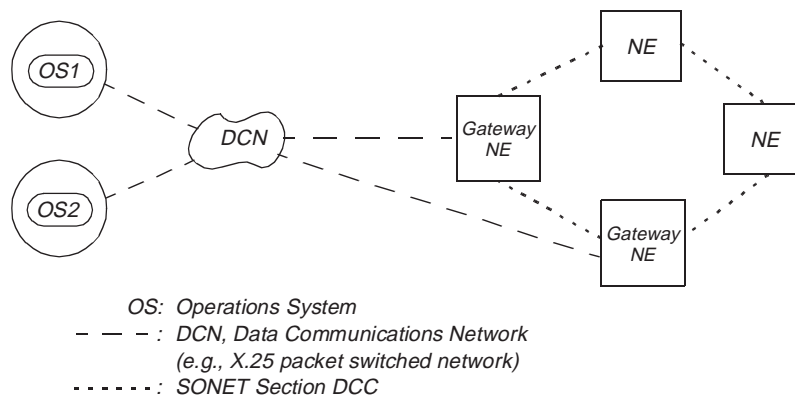
Figure 14-57 shows an example of how the SONET DCC may be used in a survivable ring application. In this example, two of the NEs on the ring support gateway functions for added OS-NE operations communications reliability (one gateway is primary and the other provides a backup).

Depending on an NE's placement and application within a network, it may be a Gateway NE (GNE), Intermediate NE (INE), or End NE (ENE). Figure 14-58 shows the same operations communications architecture as in Figure 14-54, but the nodes (NEs) have been labeled by the operations communications role they perform. Note that the OSs are not explicitly labeled with the type of role they may play.

The role that a given SONET NE supports (i.e., GNE, INE, or ENE) is determined by the operations communications network architecture. Thus, network providers should work

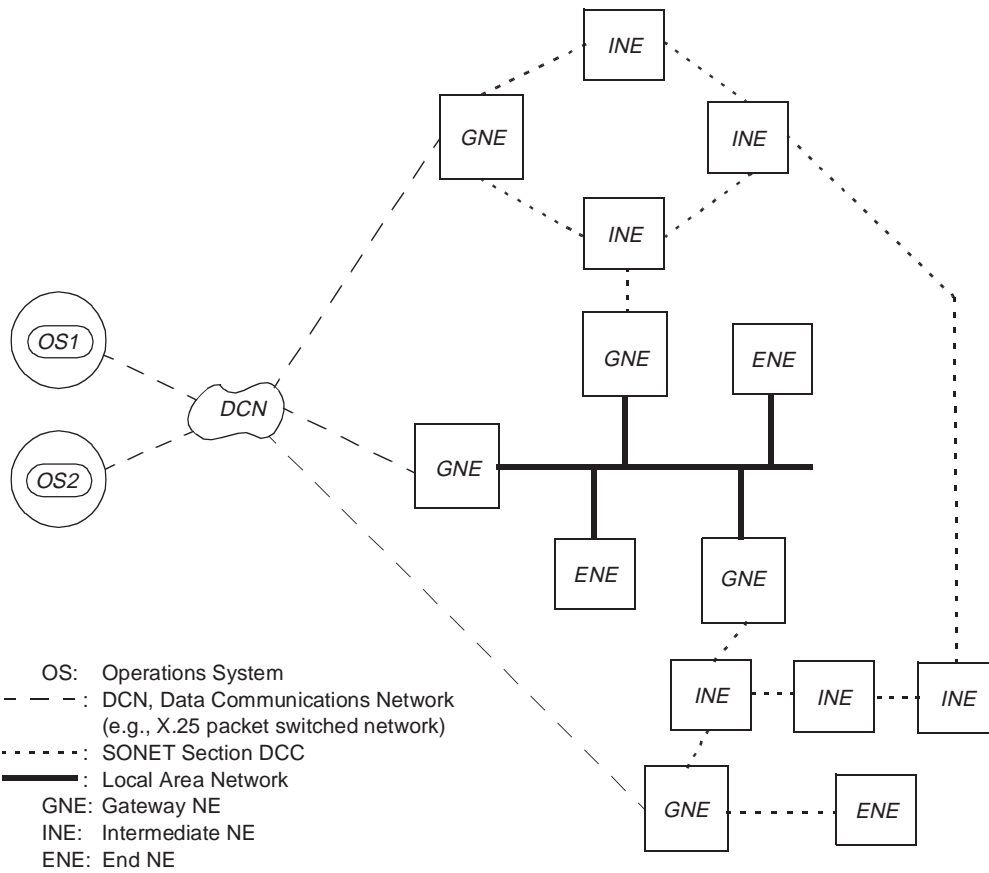


**Figure 14-56.** Example Intra-site LAN and Point-to-Point DCC



**Figure 14-57.** Example Operations Communications Network for a Survivable Ring

closely with equipment suppliers to ensure that the operations communications functions provided by SONET NEs meet the needs of individual architectures. (This may include possible migration strategies to more complex operations communications network architectures.)



**Figure 14-58.** Operations Communications Functions



---

## Section 15

### Exchange Access

### Contents

15. Exchange Access.....	15-1
15.1 Points of Presence .....	15-1
15.2 Expanded Interconnection.....	15-1
15.3 Switched-Access Service .....	15-2
15.3.1 Service Description .....	15-3
15.3.2 Types of Switched Access Available.....	15-3
15.3.2.1 Lineside Basic Servicing Arrangements.....	15-6
15.3.2.2 Trunkside Basic Servicing Arrangements .....	15-6
15.3.2.3 Database Access Service .....	15-8
15.3.2.4 500 Access Service .....	15-9
15.3.3 Dialing Plan for Switched Exchange Access .....	15-9
15.4 Special-Access Service .....	15-12
15.4.1 Service Description .....	15-12
15.4.2 Types of Special-Access Services.....	15-12
15.4.2.1 Metallic Service .....	15-12
15.4.2.2 Telegraph-Grade Service .....	15-12
15.4.2.3 Voice-Grade Service.....	15-13
15.4.2.4 Video Service.....	15-13
15.4.2.5 Wideband Data/Analog Service .....	15-13
15.4.2.6 Digital Data Service.....	15-14
15.4.2.7 Program Audio Service.....	15-14
15.4.2.8 High-Capacity Service.....	15-14
15.5 Other Network Services .....	15-15
15.5.1 800 Data Base Service .....	15-15
15.5.2 900 Access Service .....	15-15
15.5.3 Common Channel Signaling/Signaling System Number 7.....	15-16
15.6 Interconnecting Entities .....	15-17
15.6.1 Interexchange Carriers .....	15-17
15.6.2 Information Service Providers .....	15-17
15.6.3 Operator Service Providers .....	15-17
15.6.4 Competitive Access Providers .....	15-17
15.6.5 Other Access Customers .....	15-17
15.6.6 Incumbent Local Exchange Carrier .....	15-17
15.6.7 Telecommunications Carriers .....	15-18
15.7 Transmission .....	15-18
15.8 Signaling .....	15-18
15.9 Automatic Message Accounting Measurement Requirements .....	15-19

---

## List of Tables

Table 15-1. Feature Group Comparison ..... 15-11

---

## 15. Exchange Access

The geographic areas served by the Local Exchange Companies (LECs) are divided into Local Access and Transport Areas (LATAs). LATAs define those areas within which a LEC may offer telecommunications services. Many independent LECs are associated with Bell Operating Companies (BOCs), that is Ameritech, Bell Atlantic, BellSouth, SBC, and U S WEST, and provide exchange access individually or jointly with a BOC.

The LEC-provided access arrangements permit the Interexchange Carriers (ICs) and other customers to originate and terminate telecommunications between and, in some cases, within LATAs. This section covers LEC exchange access (both switched and special) offered to ICs and customers under state and Federal Communications Commission (FCC) access service tariffs, and other customer-specific services.

### 15.1 Points of Presence

A Point of Presence (POP) is a location within a LATA that has been designated by an access customer for the connection of its facilities with those of a LEC. Typically, a POP is at a location that houses an access customer's switching system or facility node. The location is at an interconnecting party's facility or, given recent regulatory initiatives, it may be at a LEC central office (see Section 15.2). An access customer may have more than one POP within a LATA. In the case of LECs not under the provisions of the Modification of Final Judgment (MFJ), or a similar decree, these locations are determined by mutual agreement between the LEC and the access customer.

At each POP, the access customer is required to designate a physical Point of Termination (POT) consistent with technical and operational characteristics specified by the LEC. The POT provides a clear demarcation between the LEC's exchange-access functions and the access customer's interexchange functions. The POT generally is a distributing frame or other item of equipment at which the LEC's access facilities terminate and where cross-connection, testing, and service verification can occur.

### 15.2 Expanded Interconnection

In the Virtual Collocation Order, the Commission adopted virtual collocation as the basic architecture for providing expanded interconnection services. However, in the Telecommunications Act of 1996, Congress states that each incumbent LEC has the duty to provide collocation to all telecommunications providers. The Act states that "the duty to provide, on rates, terms, and conditions that are just, reasonable, and nondiscriminatory, for physical collocation of equipment necessary for interconnection or access to unbundled network elements at the premises of the local exchange carrier, except that the carrier may provide for virtual collocation if the local exchange carrier demonstrates to the State

---

commission that physical collocation is not practical for technical reasons or because of space limitations.”

Physical collocation is an offering that enables an interconnector to locate its own transmission equipment in a portion of the central office space, and the interconnector may enter the central office to install, maintain, and repair the equipment. Expanded interconnection through virtual collocation enables an interconnector to terminate its circuits in central office transmission equipment owned by the LEC and under the physical control of the LEC. The interconnector has the right to designate its choice of central office equipment, which is dedicated to the exclusive use of the interconnector, and installed, maintained, and repaired by the LEC. Both virtual and physical collocation enables the interconnector-designated equipment to interconnect with local telephone facilities.

Interconnectors will not be permitted to “ratchet,” that is, to interconnect with switched traffic using special access interconnection facilities. Virtual collocation is an option if the LEC and its customer agree to use this form of interconnection. Microwave and fiber were authorized by the FCC.

The FCC authorized switched collocation for Tier 1 carriers beginning August 1993. Tariffs for switched collocation became effective February 1994. Interconnectors, however, are not permitted to collocate switches, enhanced services, and Customer Premises Equipment (CPE) in LEC central offices.

### **15.3 Switched-Access Service**

Switched-Access Service is provided in two unbundled Basic Serving Arrangements (BSAs). The provision of each BSA requires local transport facilities and the appropriate local switching functions. In addition, WATS Access Line Service may be provided for use with the Lineside BSA and the Trunkside BSA. There are three packages for Trunkside BSA that correlate closely with Feature Groups B, C, and D. They are Trunkside BSA- 950 Package, Trunkside BSA- Message Telecommunications Service/ Wide Area Telecommunications Service (MTS/WATS) Package, and Trunkside BSA - 10XXX Package.

There are also various local transport and local switching optional features and Basic Service Elements (BSEs) available with a BSA. Unless specifically stated otherwise, these BSEs and features are available at all LEC end office switches.

There are three specific transmission specifications (i.e., Types A, B, and C) that have been identified for the provision of BSAs. The specifications provided depend on the interface group and the routing of the service (i.e., whether the service is routed directly to the end office or via an access tandem).

BSAs are arranged for either originating, terminating, or two-way calling, based on the customer end office switching capacity ordered. Originating calling permits the delivery of calls from telephone exchange service locations to the customer’s premises. Terminating

---

---

calling permits the delivery of calls from the customer's premises to telephone exchange service locations. Two-way calling permits the delivery of calls in both directions, but not simultaneously. The LEC determines the type of calling to be provided unless the customer requests that a different type of directional calling is to be provided. In such cases, the LEC works cooperatively with the customer to determine the directionality.

The following sections describe the available BSAs. Each BSA is described in terms of its specific physical characteristics and calling patterns, the transmission specifications with which it is provided, the optional features and BSEs available for use with it, and the standard testing capabilities.

The name of the BSA offered and the name of the service as provided are Lineside BSA (identified in Bell Operating Companies ONA Special Report #5 as Circuit Switched Lineside BSA) and Trunkside BSA (identified in Bell Operating Companies ONA Special Report #5 as Circuit Switched Trunkside BSA).

### 15.3.1 Service Description

Switched access provides a two-point communications path between the access customer terminal location and telephone exchange service location. Each path is capable of the transmission of voice with inband signaling and associated telephone signals within the frequency bandwidth of approximately 300 to 3000 Hz. Switched access includes all access arrangements that use an end office switching system to establish public switched connections between the access customer's POP and its end user customers. It is typically used for origination and termination of MTS/WATS, Signaling System Number 7 (SS7), the switched end of foreign exchange, and the switched end of Off-Network Access Lines (ONALs) from private switched networks.

### 15.3.2 Types of Switched Access Available

The LECs offer the access customers a choice of several switched-access arrangements. The access customers select from the available access arrangements and use the one that meets their technical and business needs. Four separate switched-access arrangements, called *feature groups*, and two BSAs are available. These feature groups are distinguished by their standard operational capabilities. Supplemental features are also offered that allow an access customer to customize, within limits, the standard arrangements. Brief descriptions of the feature groups, their various standard arrangements, and their supplemental features follow.

In the matter of CC Docket No. 89-79, "Amendment of the Commission's Rules Relating to the Creation of Access Charge Subelements for Open Network Architecture," and CC Docket No. 92-91, "Commission Requirements for Cost Support Material to be Filed with Open Network Architecture Access Tariffs," the FCC amended its Part 69 rules to require

---

---

the LECs to replace the present feature groups with BSAs. In its order, the Commission indicated there will be one trunkside and one lineside BSA. Furthermore, the LECs were ordered to file tariffs offering BSAs and BSEs. Today, LECs have the option of continuing to offer both feature groups and BSAs to their customers. Also available as part of Access Service is 900 Access Service, 500 Access Service, and 800 Access Service.

- Feature Group A

Feature Group A (FGA) is normally a 2-wire, lineside connection between the access customer and the end office. These lines can be accessed by subscribers to originate/terminate interLATA calls via an access customer. Subscribers typically dial a 7-digit directory number to reach an access customer; receive a second dial tone from the access customer; often satisfy accounting requirements by entering a password; and dial a second number that is the called-party's directory number. FGA typically uses Dual-Tone Multifrequency (DTMF) signaling in accordance with access customer specifications.

The standard features offered by FGA access arrangements are dial tone (originating service), dial-pulse address signaling, and lineside terminating service.

Other features offered by FGA access arrangements are DTMF address signaling, multiline hunting, Uniform Call Distribution (UCD), call restriction (toll restriction), and dial-code (3- or 6-digit) screening.

For more information on FGA access arrangements, see GR-334-CORE, *Switched Access Service: Transmission Parameter Limits and Interface Combinations*.

- Feature Group B

Feature Group B (FGB) is a trunkside connection to an end office or access tandem switch. FGB has a universal 7-digit access code associated with the participating interconnecting entity for the purpose of originating or terminating calls to or from subscribers served by an end office or by the end offices subtending an access tandem.

The FGB Carrier Identification Codes (CICs) are in a 4-digit format (XXXX) within the Carrier Access Code (CAC) 950-XXXX. The generic requirements for FGB are contained in TR-TSY-000698, *Feature Group B, FSD 20-24-0300*, June 1989, Revision 1, July 1990.

The standard features offered with FGB access arrangements include multifrequency trunk signaling, trunk protocols, trunk transmission, and trunk testing. The FGB arrangements also provide connect-and-disconnect supervision. FGB includes 2- and 4-wire trunk terminating equipment and both 2-way and directionalized terminating equipment. The principal supplemental features offered by FGB access arrangements are 7-digit only Automatic Number Identification (ANI) and rotary-dial station access. These features are only available on direct connections from appropriately equipped end offices.

---

For further information on the FGB technical interface, see TR-NPL-000175, *Compatibility Information for Feature Group B Switched Access Service*.

- Feature Group C

Feature Group C (FGC) represents the generalized access offered to AT&T at divestiture. FGC provides a trunkside connection and is provided through all LEC end offices. In most cases, it offers an access area that includes all station lines terminated directly at the end office where the trunk terminations are made. FGC is available to AT&T only; when an end office converts to equal access capabilities, FGC trunks are converted to Feature Group D. "FGC-like" signaling is sometimes used for other forms of access services (for example, 900 service).

Because FGC offers trunk interconnection as a standard feature, it provides trunk signaling, trunk protocol, trunk transmission, trunk testing, and connect-and-disconnect supervision. It may also include, at LEC discretion, 2- and 4-wire trunk terminating equipment and/or both 2-way and directionalized trunk equipment.

A number of supplemental features are available with FGC. These include WATS screening, international dialing option, ANI, and several features used in connection with operator services.

- Feature Group D

Feature Group D (FGD) provides access through a trunkside connection. FGD arrangements are provided through appropriately equipped, Stored Program Control (SPC) or electromechanical end offices either on a direct-trunked basis or through access tandem offices. FGD allows any telephone served by an appropriately equipped end office to place an interLATA call through an access customer by dialing a uniform 5-digit access code (10XXX), followed by prefix digits 0 or 1 when necessary, and then by the standard 7- or 10-digit directory number. Access-code dialing is not required for interLATA calls to an access customer over FGD service, if the customer is accessing their Primary Interexchange Carrier (PIC) from a line presubscribed to that same IC. To gain CIC capacity, plans are proceeding to replace the 10XXX format with a 101XXXX format.

The standard FGD offering includes signaling, protocol, transmission, and testing associated with trunkside interconnection. It also includes connect-and-disconnect supervision and, at the LEC's discretion, 2- and 4-wire, trunk-terminating equipment, and/or both 2-way and directionalized trunk equipment.

Several supplemental features are associated with FGD, such as WATS screening, international dialing options, 10-digit ANI, ANI Information Digit Pairs (ANI II), and features used in connection with operator services.

For further information on the FGD technical interface, see TR-NPL-000258, *Compatibility Information for Feature Group D Switched Access Service*.

---

### 15.3.2.1 Lineside Basic Servicing Arrangements

Lineside BSA is provided in connection with the LEC electronic and electromechanical end offices. At the option of the customer, Lineside BSA is provided on a single or multiple line group basis and is arranged for originating calling only, terminating calling only, or two way calling. Lineside BSA, which is available to all customers, provides line side access to LEC end office switches with an associated 7-digit local telephone number for the customer's use in originating communications from and terminating communications to an Interexchange Carrier's interstate service or a customer provided interstate communications capability. The customer must specify the IC to which the Lineside BSA service is connected or, in the alternative, specify the means by which the Lineside BSA access communication is transported to another state.

Lineside BSA provides for a line side termination at the first point of switching, which shall be selected by the LEC within the requested LATA, unless the customer requests a different location where LEC facilities and measurement capabilities are available to accommodate such a request.

The LEC assigns a 7-digit telephone number associated with the selected end office to provide access to Lineside BSA in the originating direction. The assigned number will be in the form NXX XXXX. If the customer requests a specific number that is currently unassigned, the requested number will be assigned to the customer if the LEC can comply with that request with reasonable effort.

### 15.3.2.2 Trunkside Basic Servicing Arrangements

Trunkside BSA is provided in switched access packages. These are differentiated by their technical characteristics, e.g., the manner in which an end user accesses them in originating calls. Three packages are offered as Trunkside BSA 950 Package, Trunkside BSA MTS/WATS Package, and Trunkside BSA 10XXX Package.

Trunkside BSAs provide trunkside access to LEC end office switches, either directly or through a LEC-designated Switched-Access Service tandem switch. The LEC establishes a trunk group (or groups) between the customer premises and end office or access tandem switches, based on the technical limitations imposed by the type, directionality, and quantity of traffic specified by the customer. Different Switched-Access Service arrangements may be combined in a single trunk group at the option of the LEC.

#### 15.3.2.2.1 Trunkside BSA 950 Package Basic Servicing Arrangements

Trunkside BSA 950 Package, which is available to all customers, provides trunkside access to LEC end office switches with an associated uniform 950 XXXX access code for non-800 and non-900 Access Service for the customer use in originating communications from and

---



---

terminating communications to an IC's interstate service or a customer-provided interstate communications capability. The customer must specify the IC to which the Trunkside BSA 950 Package is connected, or specify the means by which the access communication is transported to another state.

Trunkside BSA 950 Package may be directly routed only to appropriately equipped electronic end office switches. Trunkside BSA 950 Package may be provided via LEC designated electronic access tandem switches to other LEC electronic and electromechanical end office switches.

Trunkside BSA 950 Package switch trunk equipment is provided with wink start start pulsing signaling, and answer and disconnect supervisory signaling.

Trunkside BSA 950 Package is provided with multifrequency address signaling. With the exception of Trunkside BSA 950 Package provided with the Automatic Number Identification (ANI) or rotary dial station signaling local switching optional features, any other address signaling required by the customer in the originating direction must be provided by the customer's end user using inband tone signaling techniques.

#### 15.3.2.2.2 Trunkside BSA MTS\WATS Package

Trunkside BSA MTS\WATS Package is available only to a customer furnishing interstate MTS/WATS, i.e., AT&T. It is available in all LEC end offices that are not equipped to provide Switched-Access Service arrangements.

No access code is required for Trunkside BSA MTS\WATS Package switching. The telephone number dialed by the customer's end user shall be a 7- or 10-digit number for calls in the North American Numbering Plan (NANP). For international calls outside the NANP, a 7- or 12-digit number may be dialed. The form of the numbers dialed by the customer's end user is NXX XXXX, 0 or 1 + NXX XXXX, NPA + NXX XXXX, 0 or 1 + NPA + NXX XXXX. When the end office is equipped for International Direct Distance Dialing (IDDD) the form is 01 + CC + NN or 011 + CC + NN.

Trunkside BSA MTS\WATS Package switch trunk equipment is provided with answer and disconnect supervisory signaling. Wink start start pulse signaling is provided in all offices where available. In those offices where wink start start pulse signaling is not available, delay dial start pulse signaling is provided, unless immediate dial pulse signaling is provided, in which case no start pulsing signaling is provided.

Trunkside BSA MTS\WATS Package is provided with multifrequency address signaling except in certain electromechanical end office switches where such signaling is not available. In these switches, the address signaling will be dial pulse, revertive pulse, immediate dial pulse, or panel call indicator signaling, whichever is available. Up to 12 digits of the called party number dialed by the customer's end user using DTMF or dial pulse address signaling is provided by the LEC equipment to the customer premises where

---

the Switched-Access Service terminates. Called party number signals are subject to the ordinary transmission capabilities of the local transport provided.

#### 15.3.2.2.3 Trunkside BSA 10XXX or 101XXXX Package

Trunkside BSA 10XXX or 101XXXX Package is available to all customers at LEC designated electronic end office switches, whether routed directly or via LEC designated electronic access tandem switches. Trunkside BSA 10XXX Package provides trunkside access to end office switches with an associated uniform 10XXX or 101XXXX access code for use in originating and terminating communications.

No access code is required for calls to a customer over a Trunkside BSA 10XXX Package if the Switched-Access Service customer's end user has presubscribed its telephone exchange service to that customer.

When no access code is required, the telephone number dialed by the customer's end user shall be a 7- or 10-digit number for calls in the NANP. When the end office is equipped for IDDD, the form is 01 + CC + NN or 011 + CC + NN.

Trunkside BSA 10XXX Package switch trunk equipment is provided with the following:

- Wink start start pulsing signaling
- Answer and disconnect supervisory signaling.

Trunkside BSA 10XXX Package is provided with multifrequency address signaling. Up to 12 digits of the called party number dialed by the customer's end user using DTMF or dial pulse address signaling is provided by the LEC equipment to the customer premises where the Switched-Access Service terminates. Called party number signals are subject to the ordinary transmission capabilities of the local transport provided.

#### 15.3.2.3 Database Access Service

Database Access Services are provided using components of the LEC Common Channel Signaling (CCS) network. Database Services can use application software in processing a CCS call. Database Services includes 800 services. 800 Service is a generic term for access services associated with toll-free numbers.

800 Access Service is available to all customers of Switched-Access Service trunk side arrangements and provides an identification function on 1+800 or 888+NXX XXXX calls originated by end users to determine the Switched-Access Service customer location to which the call is to be routed. Calls originating from an end office to which the customer has not ordered 800 Access Service are blocked.

Unless prohibited by technical limitations, e.g., different dialing plans, a customer may elect to have 800 Access Service traffic combined in the same trunk group arrangement

---

---

with non 800 Access Service traffic. When required by technical limitations, or at the request of the customer, a separate trunk group will be established for 800 Access Service.

When 800 Access Service is provided from an end office equipped to provide equal access, the 800 Access Service will be provided in accordance with the technical characteristics available with FGD or Trunkside BSA 10XXX Package, e.g., premises interfaces, design blocking criteria, address signaling. In an office not equipped for equal access, such service is provided in accordance with the technical characteristics available with FGC, FGD, Trunkside BSA MTS\WATS Package, or Trunkside BSA 10XXX Package.

For purposes of applying Switched-Access Service usage charges, 800 Access Service usage shall be measured as follows:

- In end offices not equipped with equal access capabilities, access minutes are measured in the same manner as FG C or Trunkside BSA MTS\WATS Package access minutes.
- In end offices equipped with equal access capabilities, access minutes are be measured in the same manner as FGD or Trunkside BSA 10XXX Package access minutes.

The FCC has concluded that hoarding, defined as the acquisition of more toll-free numbers than one intends to use for the provision of toll-free service, as well as the sale of a toll-free number by a private entity for a fee, is contrary to the public interest in the conservation of the scarce toll-free number resource, and contrary to the FCC's responsibility to promote the orderly use and allocation of toll-free numbers.

#### 15.3.2.4 500 Access Service

500 Access Service is an originating offering using trunkside Switched Access Service. This provides a customer identification function for numbers using the 500 service access code (i.e., 1+500+NXX-XXXX). Some companies have expanded 500 Access Service to include 0+500+NXX-XXXX dialing capability with the 0+Option.

When a 1+500 +NXX-XXXX or NXX-XXXX call is originated by an end user, the LEC uses the 500 NXX dialed digits to determine the customer identification and the customer location where the call is to be routed. If the call originates from an end office not equipped to provide the customer identification function, the call is routed to an office where the function is available. Once customer identification has been established, the call is routed to the customer.

### 15.3.3 Dialing Plan for Switched Exchange Access

The access arrangement provided determines the required end-user dialing procedure. There are current and planned dialing procedures for each of the four feature groups used to reach access customers.

---

A brief discussion of each end-user dialing procedure follows.

- FGA and Lineside BSA — With FGA and Lineside BSA, a caller typically reaches an access customer's facility by dialing a locally assigned 7-digit number. A talking path is established to the access customer's POP. Any subsequent dialing procedures are specified by the access customer and usually employ tone dialing.
- FGB — An FGB caller currently gains access to an access customer's facilities by dialing a 7-digit number in the form of 950-XXXX. The 950 number was designed to identify FGB service. The "XXXX" currently identifies the desired access customer in this number form, and is also known as the CIC. As with FGA, any subsequent dialing procedures are as specified by the access customer and usually employ tone dialing.
- FGC — FGC was intended for interim AT&T-only access service from an end office until FGD was made available. A caller gains FGC access by dialing the traditional (0/1) + 7/10 digits.
- FGD — This feature group allows the end user to select an access customer via presubscription or on a per-call basis. With presubscription, the dialing procedure is the traditional (0/1) + 7/10 digits. The current (pre-expansion) dialing procedure to specify an access customer on a per-call basis is 10XXX + 0/1 + 7/10 digits. The post-expansion dialing procedure to specify an access customer on a per-call basis is 10XXXX + 1/0 + 7/10 digits.

An access customer must have an assigned CIC to use either FGB or FGD service. Only certain end office and tandem switching systems are capable of providing FGD carrier interconnection.

Customer dialing procedures are discussed in detail in Section 3. Table 15-1 is a comparison of the feature groups.

**Table 15-1. Feature Group Comparison**

Access Arrangement	FGA	FGB	FGC	FGD*
Access code	7-digit (NXX-XXXX)	Current: 7-digit (950-XXXX)	None	Current: 10XXX Planned**: 101XXXX
Dialing procedure	NXX-XXXX	Current: (950-XXXX) (0/1) + 7/10 digits	Current: (0/1) + 7/10 digits	Current: (10XXX) + (0/1) + 7/10 digits  Planned: 101XXXX + (0/1) + 7/10 digits
Type of termination	Line	Trunk	Trunk	Trunk
Typical service use	FX, ONAL, MTS/WATS-like (switched-end)	MTS/WATS-like (switched-end)	MTS/WATS	MTS/WATS MTS/WATS-like (switched-end)
Exchange area accessible	All lines	NXX codes designated to be received by access customer	All lines	NXX codes designated to be received by access customer
Typical standard features	Dial tone, dial- pulse address signaling	Answer supervision multifrequency signal	Answer supervision multifrequency signal	Answer supervision multifrequency signaling, SS7, presubscription
Typical supplemental features	DTMF service address signaling, dial- code screening	7-digit ANI, rotary dial, direct inward dialing	10-digit ANI, international direct distance dialing	10-digit ANI, ANI II, international direct distance dialing
Availability	Access customers	Access customers	AT&T only	Access customers

\* 101XXXX or 10XXX need not be dialed from presubscribed lines.

\*\* Due to the popularity of these access arrangements, the supply of CICs is projected to be exhausted in the 1990s. In 1988, the industry reached consensus on a plan that increases the digits in a CIC from 3 to 4, using the sequences shown, to make additional CICs available. Beginning January 1, 1998, the new CICs will become effective and the 10XXX codes will no longer be accepted.

## 15.4 Special-Access Service

This section describes the special-access network configurations.

### 15.4.1 Service Description

Special-Access Service is a transmission path used to connect customer premises (e.g., end user, IC, Competitive Access Providers [CAPs]), either directly or through a LEC hub where bridging or multiplexing functions are performed. Special-Access Service is not intended to include switching at the LEC end office. However, Special-Access Services may be used to provision switched services (e.g., dedicated transport) and may be ratcheted in providing Special- and Switched-Access Services.

### 15.4.2 Types of Special-Access Services

#### 15.4.2.1 Metallic Service

A *metallic channel* is an unconditioned, nonswitched, 2-wire channel capable of transmitting low-speed varying signals at rates of up to 30 baud. This channel is provided by metallic or equivalent facilities. Metallic channels are provided between a customer's designated premises, or between a customer's premises and a LEC hub where bridging functions are performed. Interoffice metallic facilities are limited to a total length of 5 miles per channel.

Metallic service is used for applications that include alarm control, metering facilities, and control of bridging equipment. This service was initially provided to Western Union for low-speed teletype service.

TR-NPL-000336, *Metallic and Telegraph Grade Special Access Services — Transmission Parameter Limits and Interface Combinations*, provides further technical information on this type of special-access service.

#### 15.4.2.2 Telegraph-Grade Service

A *telegraph-grade channel* is an unconditioned, nonswitched channel capable of transmitting binary signals at rates of 0-75 baud or 0-150 baud. This channel is furnished for half-duplex (2-wire) or full-duplex (4-wire) operation. Telegraph-grade channels are provided between customer-designated premises and a LEC hub.

---

---

Telegraph-grade channels are used for applications including telegraph, teletypewriter, control, and metering facilities. This service was originally provided to Western Union for Telex and TWX-type services.

TR-NPL-000336 provides further technical information on this type of special-access service.

#### 15.4.2.3 Voice-Grade Service

A *voice-grade channel* is a channel that provides voice-frequency transmission capability in the nominal frequency range of 300 to 3000 Hz and may be terminated on a 2- or 4-wire basis. Voice-grade channels are provided between customer-designated premises, or between customer-designated premises and a LEC hub.

Voice-grade service applications include WATS access lines; analog data services; voiceband services; voice/data applications; and telephoto, protective relaying, and alarm services. Voice-grade service is further discussed in TR-NWT-000335, *Voice Grade Special Access and IntraLATA Private Line Services — Transmission Parameter Limits and Interface Combinations*.

#### 15.4.2.4 Video Service

A *video channel* is a channel with 1-way transmission capability for a standard 525-line/60-field monochrome, or National Television System Committee (NTSC) color, video signal, and one or two associated 5- or 15-kHz audio signals. The associated audio signals may be either duplexed or provided as one or two separate channels. The bandwidth for a video channel is either 30 Hz to 4.5 MHz, or 30 Hz to 6.6 MHz. The associated audio signal bandwidth depends on the channel interface selected by the customer. Video channels are provided between customer-designated premises, or between a customer-designated premises and a LEC hub, and may be offered on either a part-time or full-time (i.e., 1 month) basis.

Video service is generally used for television broadcasting and is discussed in GR-338-CORE, *Television Special Access and Local Channel Services — Transmission Parameter Limits and Interface Combinations*.

#### 15.4.2.5 Wideband Data/Analog Service

A *wideband data/analog channel* is an analog channel for the transmission of synchronous serial or asynchronous data at the rate of 19.2, 50.0, or 230.4 kbps. Optional arrangements are available for transmission of synchronous data at 18.75 or 40.8 kbps. The actual bit rate is a function of the channel interface selected by the customer. The 303 data station is

---

required for this service, and provides coupling between the customer's equipment and the wideband data transmission medium. A voiceband coordinating channel is also provided. Wideband data channels are provided between customer-designated premises.

Wideband data service is provided on an individual-case basis to transmit bulk information and is presented in further detail in TR-NPL-000340, *Wideband Data Special Access Service — Transmission Parameter Limits and Interface Combinations*. Wideband analog is also sometimes used for the transmission of a wideband signal and is the topic of TR-NPL-000339, *Wideband Analog Special Access Service — Transmission Parameter Limits and Interface Combinations*.

#### 15.4.2.6 Digital Data Service

A *digital data channel* is used for duplex 4-wire transmission of synchronous serial data at the rate of 2.4, 4.8, 9.6, 19.2, or 56.0 kbps with or without a secondary channel. The actual bit rate is a function of the channel interface selected by the customer. The channel provides synchronous service with timing provided through the LEC's facilities to the customer in the received bit stream. Digital data channels are available from LEC-designated serving offices and, in some cases, on the customer premises. This service is provided between customer-designated premises, or between a customer premises and a LEC serving location.

Digital Data Service (DDS) allows for the direct transmission of data from a customer's location to an IC digital data network and is described in TR-NWT-000341, *Digital Data Special Access Service — Transmission Parameter Limits and Interface Combinations*.

#### 15.4.2.7 Program Audio Service

A *program audio channel* is a channel measured in Hz (cycles per second) for the transmission of a complex signal voltage. The actual bandwidth is a function of the channel interface selected by the customer. Only 1-way transmission is provided. Program audio channels are provided between customer premises, or between a customer premises and a LEC hub, and may be offered on either a part-time or full-time (i.e., monthly) basis.

Program audio service is generally used for radio broadcasting and is discussed in GR-337-CORE, *Program Audio Special Access and Local Channel Services*.

#### 15.4.2.8 High-Capacity Service

A *high-capacity channel* is a channel for the transmission of nominal 1.544, 3.152, 6.312, 44.736, or 274.176 Mbps, synchronous serial data. The actual bit rate and framing format is a function of the channel interface selected by the customer. High-capacity service is

---



---

available between customer-designated premises, between a customer-designated premises and access customer POP, or between a customer-designated premises and a LEC hub.

High-capacity service provides an effective method of transporting large volumes of data, voice, and WATS transmission on a single facility. Features offered with high-capacity service include battery backup, transfer arrangement, automatic loop transfer, central office multiplexing, and clear channel capability. GR-54-CORE, *DS1 High-Capacity Digital Service End User Metallic Interface Specifications*, defines electrical and physical parameters at the LEC POT with an end user. Services at 44.736 Mbps and higher may be obtained with either an electrical or optical interface. Optional payment plans are available for most of these high-capacity services.

## 15.5 Other Network Services

Other network services include 800 Data Base Service, 900 Access Service, and CCS/ SS7.

### 15.5.1 800 Data Base Service

Dialed digits determine the routing of the call to a specific entity, using 800 Data Base Service. This service offers increased flexibility in routing via new databases that use all ten (800 + 7-digits) dialed digits in call routing.

When an 800-NXX-XXXX call is dialed, the database is queried before the call leaves the LATA of origin for call routing instructions. A single 800-NXX-XXXX number can be used for optional call routing services. Numbers within a specific 800 NXX are no longer restricted to a single carrier because the database is able to use the entire 10-digit 800 number dialed to determine which carrier will route the call. The database translates the 800-NXX-XXXX dialed number into a Plain Old Telephone Service (POTS) number, and routes the call to that number, or it determines the carrier and forwards the call to that carrier with either the translated number or the 800 number for the carrier to do number translation. The 10XXX CAC dialing procedures cannot be used with 800 Data Base Service.

Section 14.6 contains additional information on 800 Data Base Service.

### 15.5.2 900 Access Service

900 Access Service is a LATA-wide offering using originating trunkside Switched-Access Service. The service provides for the forwarding of end-user dialed 900 NXX XXXX calls to a LEC switch capable of performing a customer identification function. Based on the NXX, the call is forwarded to the appropriate customer.

No access code is required for 900 Access Service. When a 1+900+NXX XXXX call is originated by an end user, the LEC performs the customer identification function based on

---

the dialed digits to determine the customer location where the call is to be routed. The customer identification function is available at suitably equipped end office or access tandem switches. If the call originates from an end office switch not equipped to provide the customer identification function, the call is routed to the access tandem at which the function is available. Once customer identification has been established, the call is routed to the customer.

The manner in which 900 Access Service is provisioned depends on the status of the end office from which the service is provided (i.e., equipped with equal access capabilities or not equipped with equal access capabilities) and/or the status of the customer (i.e., MTS/WATS provider or MTS/WATS type provider). When 900 Access Service is provided from an end office equipped with equal access capabilities, all such service is provisioned as FGD or Trunkside BSA 10XXX Package. When 900 Access Service is provided from an end office not equipped with equal access capabilities, such service is provisioned in the same manner in which the customer's non 900 Switched Access Service from such end office is provisioned.

Unless prohibited by network considerations, the customer's 900 Access Service traffic may, at the option of the customer, be combined in the same trunk group arrangement with the customer's other Access Service traffic of the same Trunkside BSA Package, or be combined in the same trunk group arrangement with the customer's 800 Access Service traffic of the same Feature Group or BSA.

Calls to a 900 number originating from LEC provided coin telephones, Hotel/Motel Service with no on premises billing system, calls dialed as 0+, calling card, and third number billed calls are usually blocked.

### **15.5.3 Common Channel Signaling/Signaling System Number 7**

CCS/SS7 architecture is part of the access structure. CCS, a critical component of the emerging, and still evolving, intelligent network architecture, is currently being deployed in most LEC networks. The CCS network is a separate overlay network used to transport signaling messages between network nodes using specialized signaling links. SS7 is the network protocol that defines how the information that governs call control and services based on CCS will be communicated across the network. SS7 has been designed to meet the needs of the digital telecommunications environment by providing high-speed, high-volume, low-delay transport of control information. Further information can be found in Section 6.25, Section 14.2, and in FR-905, *Common Channel Signaling Network Interface Specifications (CCSNIS) Family of Requirements*.

---

---

## 15.6 Interconnecting Entities

This section provides a brief overview of entities that interconnect to the LEC network.

### 15.6.1 Interexchange Carriers

An IC is a carrier of telecommunications services registered with the FCC and is authorized to carry customer transmissions between and within LATAs. Interexchange access is not limited to such carriers, however, as other entities can qualify.

### 15.6.2 Information Service Providers

An Information Service Provider (ISP) is an entity that offers information services to the public over telecommunications facilities, for example, stock market quotations, library information, and transportation schedules.

### 15.6.3 Operator Service Providers

An Operator Service Provider (OSP) offers call-processing assistance to end-user customers including, but not limited to, directory assistance, call-completion assistance, and specialized call processing, such as person-to-person calls.

### 15.6.4 Competitive Access Providers

CAPs are entities that provide local access services and facilities that may, in total or in part, bypass the LEC network. CAPs may provide these services via their own equipment/facilities or by collocating at a LEC central office and interconnecting with LEC services.

### 15.6.5 Other Access Customers

In general, any entity purchasing services from the access tariff is considered an access customer, including the entities mentioned above.

### 15.6.6 Incumbent Local Exchange Carrier

As stated in the Telecommunications Act of 1996, section 251, the term “incumbent local exchange carrier” means, with respect to an area, the LEC that--

(A) on the date of enactment of the Telecommunications Act of 1996, provided telephone exchange service in such area; and

(B) (i) on such date of enactment, was deemed to be a member of the National Exchange Carrier Association pursuant to section 69.601(b) of the Commission's regulations (47 C.F.R. 69.601(b)); or

(ii) is a person or entity that, on or after such date of enactment, became a successor or assign of a member described in clause (I).

The Commission may, by rule, provide for the treatment of a LEC (or class or category thereof) as an incumbent LEC for purposes of this section if--

- A. Such carrier occupies a position in the market for telephone exchange service within an area that is comparable to the position occupied by a carrier described in paragraph (1);
- B. Such carrier has substantially replaced an incumbent local exchange carrier described in paragraph (1); and
- C. Such treatment is consistent with the public interest, convenience, and necessity and the purposes of this section.

### **15.6.7 Telecommunications Carriers**

Telecommunications carriers are not incumbent LECs. Each telecommunications carrier has the duty--

- To interconnect directly or indirectly with the facilities and equipment of other telecommunications carriers; and
- Not to install network features, functions, or capabilities that do not comply with the guidelines and standards established pursuant to section 255 or 256.

### **15.7 Transmission**

Section 7 covers transmission for all feature groups and the transmission considerations that impact end-to-end connections.

### **15.8 Signaling**

The access customer can specify the type of supervisory signaling interface to be used at the POT between the LEC access facilities and the access customer facilities at the access customer's location. Multifrequency signaling is handled inband, but CCS/SS7 signaling, by definition, is out-of-band.

---

## **15.9 Automatic Message Accounting Measurement Requirements**

Automatic Message Accounting (AMA) systems measure switched exchange access for charging purposes. AMA systems provide an accurate, accountable method of accumulating exchange-access usage. Section 5 provides information regarding AMA measurements for all feature groups.



---

## Section 16

### Mobile Services Interconnection

### Contents

16. Mobile Services Interconnection .....	16-1
16.1 Wireless Services Providers .....	16-1
16.1.1 Brief History .....	16-1
16.1.2 Significant FCC Rulings .....	16-2
16.1.3 Equal-Access Service by WSPs .....	16-2
16.2 Interconnection Types .....	16-3
16.2.1 Type 1 Interconnection .....	16-3
16.2.1.1 Incoming Calls .....	16-4
16.2.1.2 Outgoing Calls .....	16-4
16.2.1.3 Variation .....	16-4
16.2.2 Type 2A Interconnection .....	16-8
16.2.2.1 Incoming Calls .....	16-8
16.2.2.2 Outgoing Calls .....	16-9
16.2.2.3 Variation .....	16-9
16.2.3 Type 2B Interconnection .....	16-10
16.2.3.1 Incoming Calls .....	16-10
16.2.3.2 Outgoing Calls .....	16-10
16.2.3.3 Variation .....	16-10
16.2.4 Type 2C Interconnection .....	16-14
16.2.5 Type 2D Interconnection .....	16-16
16.2.6 Type S Interconnection .....	16-18
16.2.7 WSC-Cell Site Private Lines .....	16-22
16.2.8 Assignment of NXX Codes .....	16-26
16.2.9 Location of NXX Codes .....	16-26
16.2.10 Mobile-to-Land Calls .....	16-26
16.2.11 Land-to-Mobile Calls .....	16-27
16.2.12 Automatic Message Accounting Recordings for Usage .....	16-27
16.2.12.1 Recording Mobile-to-Land with Type 1 Connections .....	16-27
16.2.12.2 Recording Mobile-to-Land with Type 2A Connections .....	16-27
16.2.12.3 Recording Mobile-to-Land with a Type 2B Connection .....	16-28
16.2.13 Recording Land-to-Mobile Calls .....	16-28
16.2.14 911 Traffic from Wireless Services Subscribers .....	16-28
16.2.15 Operator Services .....	16-29
16.2.16 Transmission and Signaling Requirements .....	16-29
16.2.16.1 Digital Interfaces .....	16-29

---

---

16.2.16.2	Analog Interfaces.....	16-30
16.2.16.3	Summary of Transmission Requirements.....	16-31
16.2.16.4	Synchronization.....	16-31
16.2.17	Glare Resolution.....	16-32
16.2.18	Call Progress Tones and Recorded Announcements.....	16-32
16.3	Optional Features.....	16-33
16.4	Conventional 2-Way Mobile Service.....	16-33
16.4.1	Brief History.....	16-33
16.4.2	Operating Areas.....	16-34
16.4.3	Wireline versus Nonwireline.....	16-34
16.4.4	Connection Types.....	16-34
16.4.5	DID Connections.....	16-35
16.4.6	Dial-Line Connections.....	16-36
16.4.7	Private-Line Connections.....	16-36
16.4.8	NXX Codes for 2-Way Mobile Service.....	16-36
16.4.9	Location of NXX Codes.....	16-36
16.4.10	Mobile-to-Land Calls.....	16-37
16.5	Land-to-Mobile Calls.....	16-37
16.5.1	Automatic Message Accounting Recordings for Usage.....	16-37
16.5.2	911 Traffic from a 2-Way Mobile Subscriber.....	16-37
16.6	Transmission and Signaling Requirements.....	16-37
16.6.1	Summary of Transmission Requirements.....	16-38
16.6.2	Glare Resolution.....	16-39
16.6.3	Call Progress Tones and Recorded Announcements.....	16-39
16.6.4	Optional Features.....	16-40
16.7	Common-Carrier Paging Systems.....	16-40
16.7.1	Brief History.....	16-40
16.7.2	Operating Areas.....	16-40
16.7.3	Wireline versus Nonwireline.....	16-41
16.7.4	Connection Types.....	16-41
16.7.5	NXX Codes for Paging Service.....	16-41
16.7.6	Location of NXX Codes.....	16-41
16.7.7	Pager-to-Land Calls.....	16-42
16.7.8	One-Way Paging.....	16-42
16.7.9	Automatic Message Accounting Recordings for Usage.....	16-42
16.7.10	Transmission and Signaling Requirements.....	16-42
16.7.11	POIs.....	16-43
16.7.12	Synchronization.....	16-43
16.7.13	Summary of Transmission Requirements.....	16-43
16.7.14	Glare Resolution.....	16-43
16.7.15	Call Progress Tones and Recorded Announcements.....	16-43
16.7.16	Optional Features.....	16-43
16.8	FCC Part 90 Private Carriers.....	16-44
16.8.1	Enhanced Specialized Mobile Radio Systems.....	16-44

---



---

16.9 CT2 Concept .....	16-45
16.10 Personal Communications Services .....	16-45
16.10.1 Regulation .....	16-45
16.10.2 Service Concepts.....	16-46
16.10.3 Signaling System 7.....	16-48

## List of Figures

Figure 16-1. WSP to LEC Switched Interconnection Configuration for Type 1, 2A, and 2B Interfaces .....	16-5
Figure 16-2. WSP to LEC Switched Interconnection for the Type 1 Variation ISDN Compatibility.....	16-7
Figure 16-3. WSP to LEC Switched Interconnection for the Type 2A or Type 2B with SS7 Interfaces.....	16-12
Figure 16-4. WSP to LEC Switched Interconnection Alternate Configuration for the Type 2A or Type 2B with SS7 Interfaces.....	16-13
Figure 16-5. WSP to LEC Switched Interconnection Configurations for Type 2C Interface .....	16-15
Figure 16-6. WSP to LEC Switched Interconnection Configuration for Type 2D Interface .....	16-17
Figure 16-7. WSP to LEC Switched Interconnection Configuration for Type S Interface.....	16-19
Figure 16-8. WSP to LEC Switched Interconnection Configuration for Type S Interface — Alternate.....	16-20
Figure 16-9. Typical 2-Way Mobile Configuration .....	16-35
Figure 16-10. Typical Dial-Paging System .....	16-41

## List of Tables

Table 16-1. Summary of Interconnection Types .....	16-23
Table 16-2. Summary of Transmission Requirements.....	16-30
Table 16-3. Summary of Transmission Requirements for Private-Line Circuits.....	16-32
Table 16-4. Summary of Transmission Requirements for Dial-Line, DID, and Private-Line Circuits.....	16-39

---



---

## 16. Mobile Services Interconnection

Consumers use a number of mobile services for their communications needs, many of which require interconnection with the intraLATA (Local Access and Transport Area) networks of the Local Exchange Carrier (LEC). This section addresses the interconnections required by Wireless Services Providers (WSPs) to exchange traffic between their mobile networks and the landline network.

Since the WSPs use radio as their transmission medium, they must obtain a radio license from the Federal Communications Commission (FCC). The WSPs described in this section are governed by the rules in either Part 22 or Part 90 of the FCC rules, as contained in Title 47 of the Code of Federal Regulations.

Part 22 of the FCC rules applies to those services defined as common carrier operations. The majority of Part 22 carriers provide 2-way mobile, cellular, or paging services. This section will focus on the interconnection requirements of these Part 22 common carriers and will describe how this traffic is interchanged with the LEC's network.

Other mobile services requiring interconnection are covered by Part 90 of the FCC rules. These are private carriers, although their customer base and interconnections may be similar to Part 22 carriers. A brief summary of interconnection for these private carriers also will be addressed in this section.

Mobile (wireless carrier) interconnection has shown signs of rapid change. An example of the dynamic environment of interconnection is the industry effort to provide input in the Bellcore updating of GR-145-CORE, *Interconnection of WSP/LEC Network*. The industry envisions GR-145-CORE as playing a key role in future interconnection between the wireless carriers (cellular, Personal Communications Services [PCS], paging, mobile data carriers, etc.) and the LEC.

### 16.1 Wireless Services Providers

#### 16.1.1 Brief History

The concept of cellular service began in response to growing congestion within the existing 2-way mobile services, which began in the 1940s. As envisioned by the designers of the service, cellular service was supposed to alleviate this congestion by using low-power transceivers in small geographic areas called cell sites. Through the use of a computer, these cell sites could be linked together to provide the desired mobility while at the same time permitting the reuse of frequencies to increase the number of mobile customers that could be served. Cellular service became possible in the 1960s when electronic switching machines were introduced. Because of regulatory actions, however, it was 1983 before the first commercial cellular service began in the United States.

### 16.1.2 Significant FCC Rulings

To promote competition, the FCC issues two cellular licenses for each defined geographic area. One of these licenses belongs to a subsidiary of a company that provides landline telephone service in the given geographic area and is known as the “wireline” licensee, or “B” band. The other belongs to a company that has no association with the landline exchange carriers in that area and is called the “nonwireline” licensee, or “A” band. Recently, this distinction has become somewhat blurred. Due to mergers and acquisition of licenses, wireline companies sometimes operate as nonwireline carriers outside of the franchised area of their landline exchange carriers.

The FCC initially proposed that the geographic areas to be served would be defined by the Wireless Services Providers (WSPs)<sup>1</sup> themselves. These areas would be known as Cellular Geographic Service Areas (CGSAs). Later, when the rules were established, the CGSAs would be restricted to the 305 Metropolitan Statistical Areas (MSAs) as defined in the 1980 United States Census.

The original plan was to select the licensees based on the technical merits of their proposals. However, because of the huge number of applicants, particularly for the nonwireline license, Congress passed a law that allowed the FCC to select the licensees using a lottery system.

Although the MSAs covered most of the major cities in the United States, a sizable amount of geography still remained. To serve these areas, the FCC created 428 Rural Service Areas (RSAs), which are counties not contained in the MSA definitions, and again awarded licenses using a lottery system. Because these RSAs are based on county boundaries, they often overlap LATAs. Moreover, even though the FCC grants only two licensees per RSA, they will allow the WSPs to share service within an RSA for the same license. Thus, unlike the MSAs, there are often more than two WSPs for each license, and each may define its own CGSA within that RSA.

In a policy statement issued in 1986 and a declaratory ruling issued in 1987, the FCC said that the WSPs are co-carriers, not end users, who are entitled to the interconnection arrangement of their choice. Further, the WSPs are not generally subject to access tariffs, and there must be a reasonable accommodation of their numbering requirements. Moreover, these policies apply to all Part 22 carriers, not just cellular carriers.

### 16.1.3 Equal-Access Service by WSPs

Equal-access service via a mobile telephone is possible with cellular service. However, many WSPs have chosen not to provide equal-access service because of the administrative burden involved, and some have chosen to offer similar services.

---

1. Formerly referred to as Cellular Mobile Carriers (CMCs).

---

---

## 16.2 Interconnection Types

There are various switched interconnection alternatives available for the interconnection of a wireless system with a LEC network. This subsection focuses on six specific interconnection arrangements which include the following:

1. *Type 1* — Direct Wireless Services Provider (WSP) connection through a LEC end office with a variation for Integrated Services Digital Network (ISDN) interconnection
2. *Type 2A* — Direct WSP connection with a LEC tandem office using multifrequency or Signaling System 7 (SS7) signaling
3. *Type 2B* — Direct WSP connection with a specific LEC end office using multifrequency or SS7 signaling
4. *Type 2C* — Direct WSP connection with a LEC tandem office arranged for 911 emergency calls
5. *Type 2D* — Direct WSP connection with a LEC tandem arranged for LEC operator assisted calls or directory service using multifrequency or SS7 signaling
6. *Type S* — Direct WSP connection with a LEC Common Channel Signaling (CCS) system's Signaling Transfer Point (STP).

For interconnection Types 1 and 2A, WSP interconnection to the LEC local network and other carriers (for example, another WSP, other LEC, or Interexchange Carriers [ICs]) can be provided through the LEC interface switch. The Type 2B interconnection is utilized only for interconnection with Directory Numbers (DNs) served by a specific end office.

Generally, it would be used in conjunction with the Type 2A tandem interconnection for access to the Public Switched Network (PSN). The Type 2C interconnection is used for connection to a LEC tandem arranged for 911 emergency calls. Type 2C calls would be routed to a Public Safety Answering Point (PSAP) and may transfer cell site, sector information, and/or subscriber Automatic Number Identification (ANI) provided by the WSP. The Type 2D interconnection is used with a LEC operator services tandem to complete LEC operator assisted, directory, and directory assistance call completion calls. The Type S interconnection is used with a LEC STP for access to the CCS network. The network configurations for the six interconnection types are illustrated in Figures 16-1 to 16-8. A summary of the interconnection types is shown in Table 16-1.

### 16.2.1 Type 1 Interconnection

The Type 1 interface is at the Point of Interface (POI) of a trunk between a WSP and a LEC end office switching system. The WSP establishes connections to the DNs served by this LEC end office and other carriers through this interconnection arrangement.

---

### 16.2.1.1 Incoming Calls

Incoming calls are handled through the Type 1 interconnection using multifrequency trunk signaling protocols. However, with special software, generally referred to as Trunk with Line Treatment (TWLT), the LEC switch is able to process and record the calls as if they were from an ordinary line-side connection. With Type 1 interconnection, the WSP Wireless Switching Center (WSC) can establish connections through the LEC network to valid office codes (NXXs) within the LEC local network, LEC directory assistance, LEC operator assistance, or services provided by ICs, International Carriers (INCs), and other WSPs or LECs. In addition, via Feature Group D (FGD) switched access services, an IC can be selected on each interexchange call by transmitting the proper IC identification code (for example, 10XXX). If desired, presubscription to a specific IC can be made by the WSP on each trunk group. Then, the LEC end office will route interexchange calls from the WSP to the presubscribed IC, unless a different IC identification code is transmitted prior to the called customer address digits. More details on the interconnection protocols for these types of incoming calls are contained in Section 3 of GR-145-CORE. In the Type 1 interconnection, DNs are contained in the LEC end office. Further information is available from the LEC.

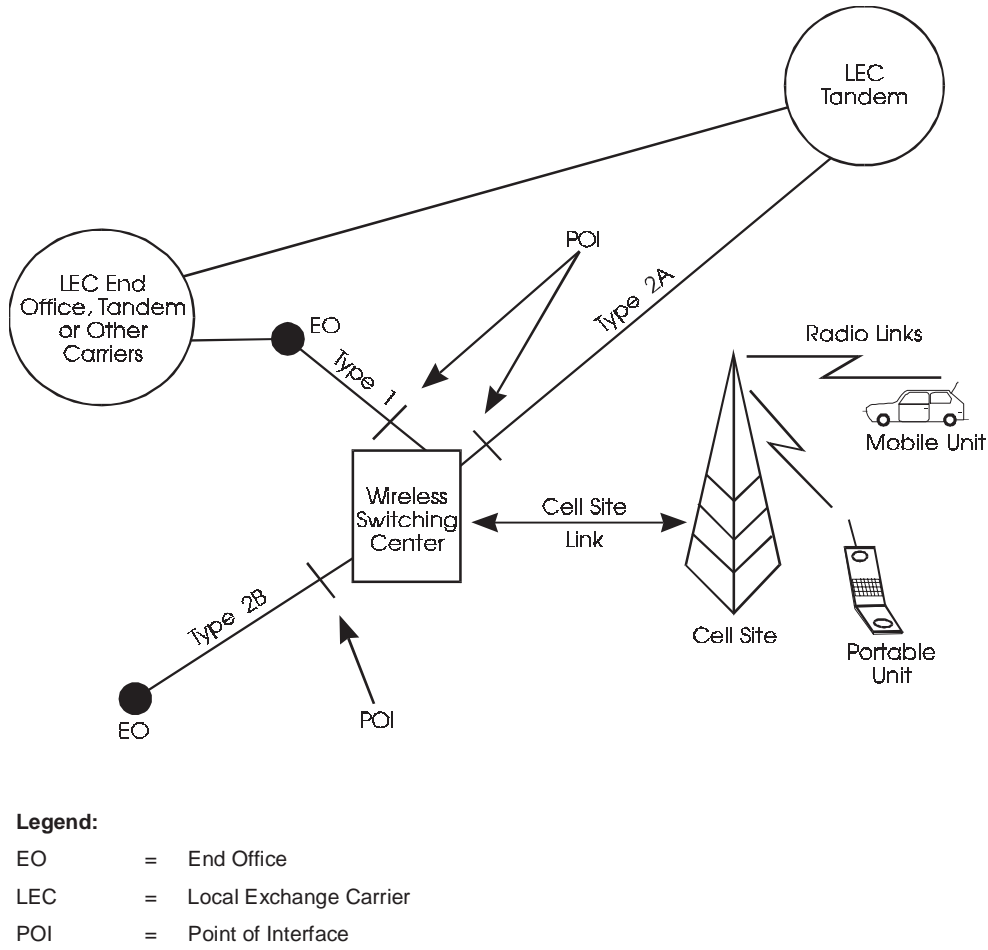
### 16.2.1.2 Outgoing Calls

Outgoing calls from the LEC switched network to the WSP are handled through the Type 1 interconnection using multifrequency trunk signaling to identify the called wireless customer station number without manual or operator assistance. When utilizing the Type 1 interconnection, the WSP is responsible for handling calls to the NXX, or blocks of numbers assigned to the WSP.

### 16.2.1.3 Variation

The Type 1 Variation interface is based on a National ISDN arrangement. The National ISDN arrangement is based on either a Primary Rate Interface (PRI) or Basic Rate Interface (BRI). National ISDN-1 (NI-1), as defined in SR-NWT-001937, *National ISDN-1*, constitutes the initial step toward National ISDN with a major focus on some of the more fundamental building blocks, for example, providing protocol uniformity and a minimum set of supplementary services on BRI (see SR-NWT-001937). National ISDN-2 (NI-2), as defined in SR-NWT-002120, *National ISDN-2*, builds on the work begun in NI-1, with the intent of furthering ISDN toward the goals of National ISDN, for example, providing uniform protocol on PRI and a set of services on BRI and PRI in a uniform manner (see SR-NWT-002120).

---



**Figure 16-1.** WSP to LEC Switched Interconnection Configuration for Type 1, 2A, and 2B Interfaces

---

The ISDN concept uses digital technology to provide advanced digital services to sophisticated digital terminals over an end-to-end digital network. The basic ISDN concept is described below in terms of service capabilities offered to the user and the architectural components in the network and on the user's premises.

For the purposes of this section, the WSC is shown in the interconnection between the WSP and the LEC for ISDN arrangements (Figure 16-2). For Type 1 Variation ISDN interconnection compatibility, the WSC should be compatible with ISDN arrangements described in this section and need not be more sophisticated than required to meet these arrangements.

The capabilities that can be offered using Type 1 Variation are: 1) speech, 2) 3.1-kHz audio, 3) high-speed digital channels and end-to-end digital channels, basically 64 kbps but with multiples available, for example, 384 kbps, and 4) packet-mode transmission. These capabilities may be provided as permanent, reserved, or switched-on-demand. The use of out-of-band signaling between switching systems is covered in Section 16.2.6 of this document and in Section 3.8 of GR-145-CORE. Out-of-band signaling between the LEC local switching office and the WSC makes it possible to provide network-wide versions of call management features.

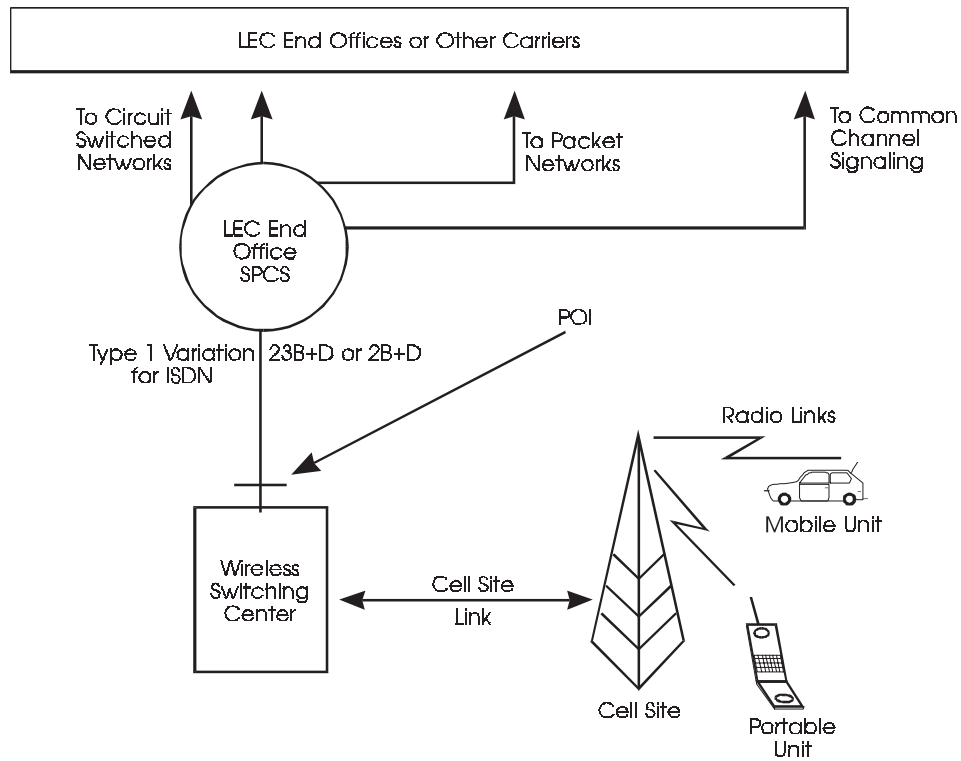
The Type 1 Variation for ISDN will consist of one of two physical interface arrangements. They are known as PRI and BRI. The Type 1 Variation interface is based on TR-NWT-001268, *ISDN Primary Rate Interface Call Control Switching and Signaling Generic Requirements for Class II Equipment*, for PRI, and TR-TSY-000268, *ISDN Access Call Control Switching and Signaling Requirements* for BRI.

The Type 1 Variation, based on an ISDN PRI, consists of one or more Digital Signal level 1 (DS1) time division multiplexed signals provided on 4-wire copper circuits (using standard regenerators as necessary). Each DS1 facility allows 24 bi-directional, symmetric digital channels to the user's premises. The PRI includes a D-channel that supports 64 kbps of signaling and user information flows in each direction. The D-channel has a message-oriented protocol that supports call control signaling. The remaining channels on the PRI are referred to as B-channels. Each B-channel supports 64-kbps information flow in each direction. Thus, a typical Type 1 Variation ISDN PRI consists of a single DS1 configured as a "23B+D" interface: 23 B-channels and 1 D-channel providing for 1.536 Mbps of user information in each direction.

The number of B-channels associated with a PRI may vary from the typical 23. In particular, twenty DS1 facilities may be controlled using a single D-channel, thereby increasing the number of B-channels to 479 (or 478 if a 64 kbps slot is reserved for D-channel backup). A WSP may also subscribe to less than full DS1 PRI (for example, a D-channel with fewer than 23 B-channels). Additional details on the PRI which supports the Type 1 Variation are in Section 2 of SR-NWT-002343, *ISDN Primary Rate Interface Generic Guidelines for Customer Premises Equipment*, for an NI-2 interface.

---



**Legend:**

- ISDN = Integrated Services Digital Network
- LEC = Local Exchange Carrier
- POI = Point of Interface
- SPCS = Stored Program Control System

**Figure 16-2.** WSP to LEC Switched Interconnection for the Type 1 Variation ISDN Compatibility

The Type 1 Variation based on an ISDN BRI consists of 2 B-channels (64 kbps each) and 1 D-channel (16 kbps). The 16-kbps D-channel is used for call control signaling across the user-network interface. It may also be used to support packet-mode calls. The two 64-kbps B-channels are used for circuit-mode or packet-mode information flow. Additional details on the BRI which supports the Type 1 Variation are in Section 2 of SR-NWT-001953, *Generic Guidelines for ISDN Terminal Equipment on Basic Access Interfaces*, for an NI-1 interface, and Section 2 of SR-NWT-002361, *Generic Guidelines for ISDN Terminal Equipment on National ISDN-2 Basic Rate Interfaces*, for an NI-2 interface.

The Type 1 Variation interface is an ISDN line-side connection. As such, existing ISDN line Automatic Message Accounting (AMA) recording requirements are based on TR-NWT-000862, *ISDN Automatic Message Accounting Generic Requirements*. For a Type 1 Variation interface, the existing AMA recording capabilities are a subset of TR-NWT-000862, as covered in SR-NWT-001937 for NI-1, and SR-NWT-002120 for NI-2. Additional AMA recording requires development of new ISDN requirements. See Section 3.3.5.10 of GR-145-CORE for details regarding the use of the Calling Party Number (CPN) and CPN delivery. The Type 1 Variation interface will support recording of a limited set of DN's assigned to the WSP based on the type of interface support (BRI or PRI). For additional details on calling number identification services over ISDN Type 1 Variation interface see Section 3.3.5 of GR-145-CORE. Additional recording capability is under study.

## 16.2.2 Type 2A Interconnection

The Type 2A interface is at the POI of a trunk between a WSP and a LEC tandem switching system. Through this interconnection arrangement, the WSP can establish connections to the LEC end office and to other carriers accessible through the tandem.

### 16.2.2.1 Incoming Calls

Incoming calls are handled through the Type 2A interconnection using inband multifrequency trunk signaling and trunk address signaling protocols. With the Type 2A interconnection, the WSP can establish connections via the LEC network to valid local network area office codes (NXXs) accessible through the tandem or services provided by ICs, INCs, and other WSPs or LECs associated with the local network area. In contrast to the Type 1 interconnection, there is no "line treatment" with Type 2A, and the address signaling sequence for incoming WSP calls through the LEC network to FGD carriers is a sequence used for FGD switched access signaling. Services such as LEC directory assistance and LEC operator assistance (0- and 0+) are available through a Type 1 interface, as well as the Type 2D interface.

The LEC tandem equipped with FGD can function as an access tandem (AT) for interexchange calls, and ICs equipped for FGD switched access signaling can be selected

---

---

by transmitting the proper 0ZZ-XXX code. 0ZZ tells the access tandem that translation of the XXX is necessary to identify the IC and the trunk group used to connect to the IC. The XXX is the Carrier Identification Code (CIC) and is the same XXX as in the 10XXX in the IC Carrier Access Code (CAC) used with the Type 1 interconnection. Development of a 4-digit (XXXX) code arrangement is underway. A future issue of GR-145-CORE will reflect the impact of the 4-digit CIC on WSP/LEC interconnections.

#### 16.2.2.2 Outgoing Calls

Outgoing calls from the LEC switched network to the WSP are handled through the Type 2A interconnection using trunk address signaling protocols and multifrequency signaling for identification of the called WSP station. Calls are routed to the POI based on the NPA and NXX, or 1000s block, if required and available. The WSP is responsible for handling calls to any numbers assigned to the WSC. Additional information on numbering planning and network routing is available in Section 3.

#### 16.2.2.3 Variation

A Type 2A interface may be arranged using SS7-supported trunks. This variation of the Type 2A interface will be called the Type 2A with SS7 interface. SS7 ISDN User Part (ISDNUP) messages are used to set up and release SS7-supported trunks in the Type 2A with SS7 interface. The Type 2A with SS7 interface supports the trunk circuit connection between a LEC tandem and a WSC. The Type S interface, described in Section 16.2.6, supports the SS7 signaling link connection between a LEC and a WSP. When the Type 2A with SS7 interface is used, the Type S interface must also be used to allow for the transport of SS7 ISDNUP messages between a LEC and a WSP.

Coupled with the Type S interface, the Type 2A with SS7 interface will allow for additional capabilities beyond those able to be supported with the Type 2A (without SS7) interface with trunks setup and released using inband signaling. For example, the CPN may be included in the call setup signaling on the Type S interface when the Type 2A with SS7 interface is used for establishing trunk connections. Operator services may be supported over a Type 2A with SS7 interface as well as over a Type 2D with SS7 interface. The difference between the two interfaces is that the Type 2D with SS7 interface is dedicated solely for operator services, whereas the Type 2A with SS7 interface may be used for many services such as basic call setup, 800 call setup, and operator services.

### 16.2.3 Type 2B Interconnection

The Type 2B interface is at the POI of a trunk between a WSP and LEC end office switching system. The Type 2B interconnection may only provide connections between the WSP and DNs served by the one end office to which it is interconnected. A Type 2B interconnection may be used in conjunction with the Type 2A interconnection on a high-usage alternate routing basis to serve high-volume traffic between the WSC and the LEC end office.

The Type 2B interface is also used to provide interconnection directly to a LEC end office when there is no local LEC tandem. In this case, Type 2B is a direct final trunk interface.

#### 16.2.3.1 Incoming Calls

Incoming calls are handled through the LEC Type 2B interconnection using trunk address signaling protocols and multifrequency signaling to identify the called station number. With this interconnection, the WSP can establish connections with customers or carriers (for example, FGA IC or a WSP using a Type 1 interconnection) served by DNs in the LEC end office to which it is interconnected. In contrast to the Type 1 interconnection, Type 2B should not be used to route WSP calls to FGB, FGC, or FGD ICs or to INCs.

#### 16.2.3.2 Outgoing Calls

Outgoing calls from the LEC end office to the WSP are handled through the Type 2B interconnection using trunk address signaling protocols and multifrequency signaling for identification of the called WSP station. Calls are routed to the POI based on the NPA and NXX, or 1000s block, if required.

#### 16.2.3.3 Variation

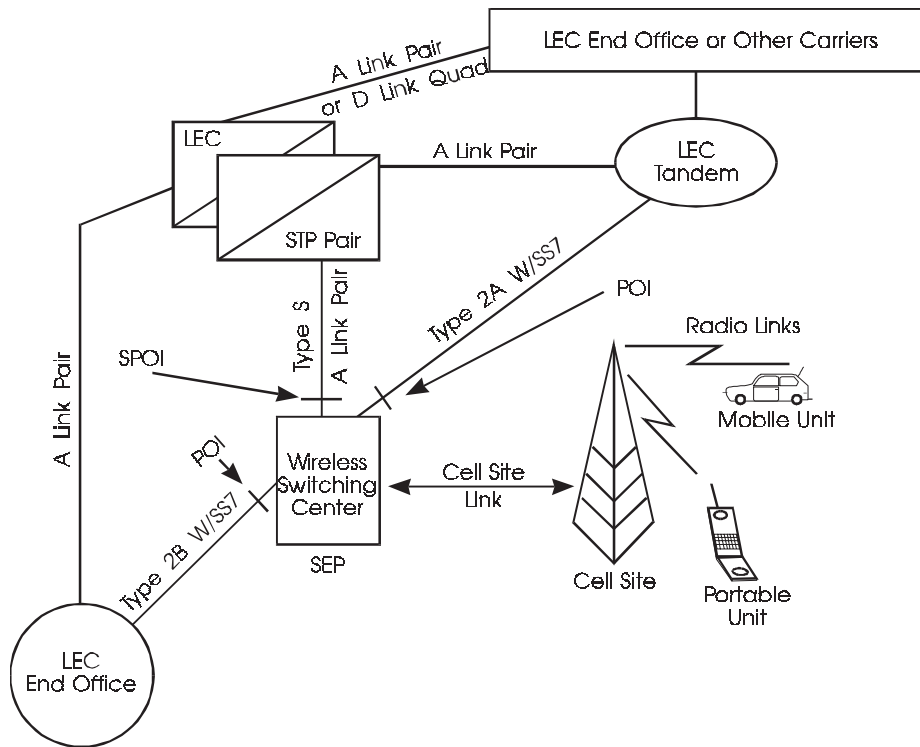
A Type 2B interface may be arranged using SS7-supported trunks. This variation of the Type 2B interface will be called the Type 2B with SS7 interface. SS7 ISDNUP messages are used to set up and release SS7-supported trunks in the Type 2B with SS7 interface. The Type 2B with SS7 interface supports the trunk circuit connection between a particular LEC end office and a WSC. The Type S interface, described in Section 16.2.6, supports the SS7 signaling link connection between a LEC STP and a WSP. When the Type 2B with SS7 interface is used, the Type S interface is used to allow for the transport of SS7 ISDNUP messages between a LEC and a WSP. Coupled with the Type S interface, the Type 2B with SS7 interface will allow for additional capabilities beyond those supported with the Type 2B (without SS7) interface with trunks setup and released using inband signaling. For example, the CPN may be included in the call setup signaling on the Type S interface when

---

---

the Type 2B with SS7 interface is used for establishing trunk connections to a particular LEC end office.

The applications that can be used over the Type 2B with SS7 interface are more limited than those that can be used over the Type 2A with SS7 interface. For example, applications that require calls to be tandemed (such as operator services with 800 call setup) may be used over a Type 2A with SS7 interface but not over a Type 2B with SS7 interface. The WSP should consult the LEC for more information on the availability of these arrangements.

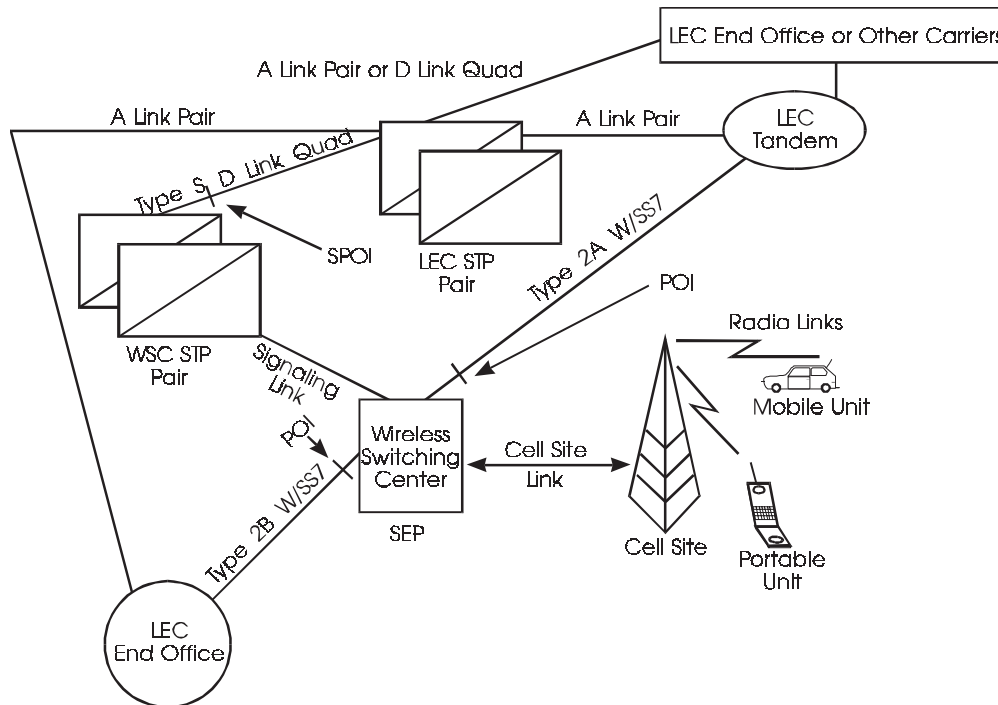


**Legend:**

- LEC = Local Exchange Carrier
- POI = Point of Interface
- SEP = Signaling End Point
- SPOI = Signaling Point of Interface
- STP = Signaling Transfer Point
- WSC = Wireless Switching Center

**Note:** The Type 2A or Type 2B with SS7 is a call carrying trunk that requires the Type S out-of-band signaling link to function.

**Figure 16-3.** WSP to LEC Switched Interconnection for the Type 2A or Type 2B with SS7 Interfaces



**Legend:**

- LEC = Local Exchange Carrier
- POI = Point of Interface
- SEP = Signaling End Point
- SPOI = Signaling Point of Interface
- STP = Signaling Transfer Point
- WSC = Wireless Switching Center

**Note:** The Type 2A or Type 2B with SS7 is a call carrying trunk that requires the Type S out-of-band signaling link to function.

**Figure 16-4.** WSP to LEC Switched Interconnection Alternate Configuration for the Type 2A or Type 2B with SS7 Interfaces

#### 16.2.4 Type 2C Interconnection

Four models for interconnection of WSP wireless subscriber originated 911 calls through a LEC network to emergency services provider(s) are described in Section 3.6 of GR-145-CORE. Each LEC may have specifications or requirements different from the models described. Therefore, WSPs should communicate directly with the appropriate LEC to determine that company's specifications and requirements before developing an emergency services call (911) completion plan. See the introduction of TR-TSY-000350, *E911 Public Safety Answering Point: Interface Between a I/IA ESS™ Switch and Customer Premises Equipment*, for an example of LEC emergency 911 connection to a PSAP.

The emergency services interconnection models described in GR-145-CORE may or may not be appropriate for specific locations. The models are offered as a starting point for negotiations between the WSPs and LECs in order to provide a method of providing WSP emergency services interconnection appropriate for a given area. Factors to consider when using them include the following:

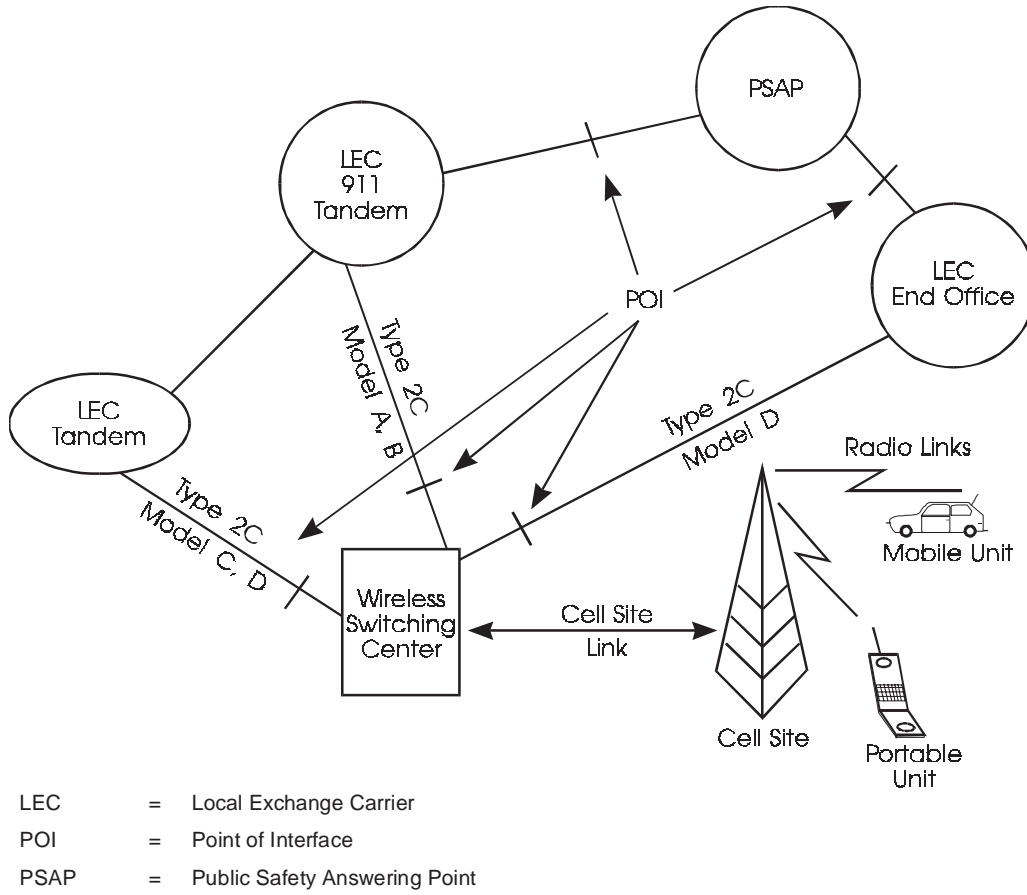
- Technical constraints of equipment employed by all parties
- Directions from governing bodies
- Hand-off agreements between emergency service providers
- Individual company policies.

The subscriber mobility characteristics of wireless communications networks preclude these calls from being readily adaptable to the existing emergency services networks. Thus, emergency service calls (911) between the WSPs and the emergency services providers that interconnect through the LEC require unique arrangements. The WSP, the LEC, and the emergency services provider(s) for the area from which the wireless subscriber can call, must mutually agree to the interconnection arrangement(s). The WSP is primarily responsible for initiating and coordinating the planning and implementation of the 911 call completion arrangement(s) for wireless subscribers.

The Basic 911 (B911) and Enhanced 911 (E911) systems have been designed to provide emergency service call completion for LEC landline subscribers. Both systems provide expeditious and efficient routing for response to 911 calls from landline subscribers. Enhanced 911, for example, can provide the emergency service provider(s) with the phone number, address, and name of the landline subscriber based on the calling number. These capabilities are possible because the landline subscriber services provided by the LEC are at fixed locations. Emergency service provider PSAPs, the emergency services contact points, have said that the calling party's telephone number is the single most important piece of information that can be furnished.

---





**Figure 16-5.** WSP to LEC Switched Interconnection Configurations for Type 2C Interface

Current WSP technology may not provide the ability to identify, with absolute certainty, the specific geographic area where the wireless subscriber's call (911) originates. It is possible for the WSP to determine the general area from which the 911 call originates. Even when a wireless subscriber's exact location can be determined, the information may be of limited value because the caller may be some distance from the site of the emergency by the time the call is completed. Because the boundaries of the WSP call service areas and the emergency services provider(s) may not be the same, an initial choice must be made on a single way to route 911 calls from wireless subscribers. This choice must be made together by the WSP, the emergency services provider(s), and the LEC.

The factors mentioned in the previous paragraph illustrate the difficulties in proper 911 call routing from wireless subscribers to the appropriate emergency services provider(s). The emergency nature of 911 calls, and the need for expediency, complicate the process. Thus, the WSP must use interconnection methods based on the unique characteristics of the existing emergency services network architecture, the area being served by the WSP, and the emergency services provider(s)' agreements for handling calls. It must be clearly understood that an interconnection of a WSP through a LEC to emergency services provider(s) does not have the capability of either the total Basic 911 or Enhanced 911 service and should not be described as such.

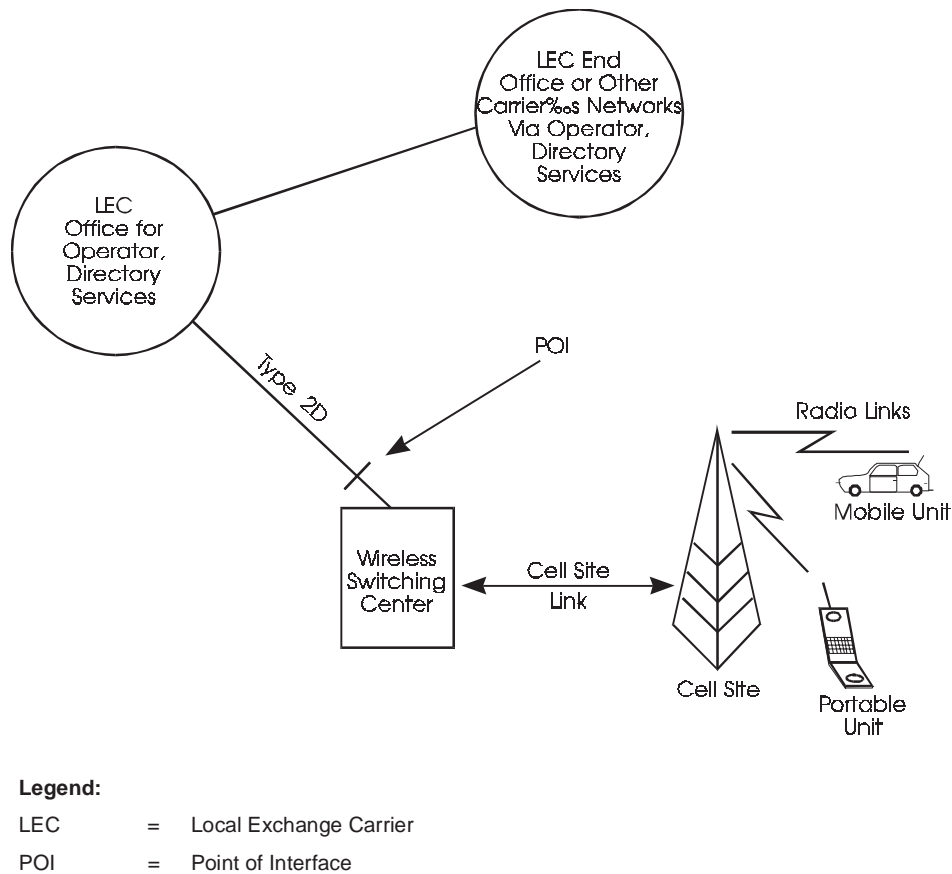
#### **16.2.5 Type 2D Interconnection**

A Type 2D interface provides a direct voice-grade transmission path to a LEC Operator Services System (OSS) switch. A LEC OSS switch is a tandem switch with operator services call processing capabilities. LEC OSSs provide Alternate Billing Service (ABS) (for example, calling card processing), directory assistance services (including directory assistance call completion), and general assistance services.

The nature and range of services accessed by a Type 2D interface are determined by mutual agreement between the interconnecting companies. The Type 2D connection described is the physical interface and does not include the services accessed by that connection.

Three signaling protocols support calls carried over a Type 2D interface. Two of these protocols are inband, multifrequency protocols that travel over the Type 2D interface with the calls themselves. The third protocol is carried out-of-band over a Type S interface. If the third protocol is used, no call control signaling travels over the Type 2D interface. A Type 2D interface with SS7 which carries the call, but not the signaling protocol, is used with the Type S interface. These three protocols are not compatible. That is, one trunk cannot be dedicated to the use of more than one of these signaling options. All signaling options are not available in all locations. The WSP should contact the LEC of interest for more information on available arrangements. SS7 for the Type 2D interface has been documented in Section 3.7.2.3 of GR-145-CORE. A comparison of Type 2A with SS7 and Type 2D with SS7 for operator services traffic is found in Section 16.2.2.3.

---



**Figure 16-6.** WSP to LEC Switched Interconnection Configuration for Type 2D Interface

When a LEC OSS provides services which involve completing the call to another destination (for example, alternately-billed calls, directory assistance call completion calls), the LEC OSS generates a billing record. Therefore, the LEC OSS must receive sufficient information to identify the calling party, or the party to be billed for the call.

The Type 2D LEC/WSC interface does not transmit sufficient information for the WSP to generate a complete billing record on calls completed by an OSS. The interface does not transmit (to the WSP) the called number, the billing option associated with the call, the number of calls attempted, or the number of calls completed. Answer indications, under these circumstances, are meaningless to the WSC. Answer indications are not provided.

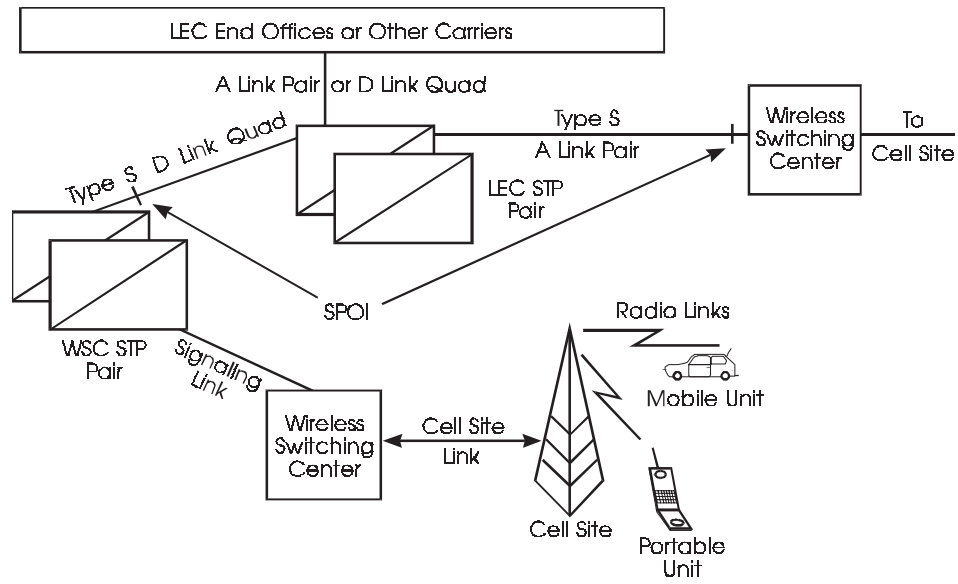
### 16.2.6 Type S Interconnection

The Type S (Signaling) interface is a physical SS7 signaling link connection between a LEC network and WSP network. The “S” in Type S indicates that signaling information is passed via this interface. The Type S interface is used between a LEC and a WSP to exchange SS7 ISDNUP and SS7 Transaction Capabilities Application Part (TCAP) messages to support the applications to be provided between the two networks. The physical interface specifications for the Type S interface are described in Section 6 of GR-905-CORE, *Common Channel Signaling Network Interface Specification (CCSNIS) Supporting Network Interconnection, Message Transfer Part (MTP), and Integrated Services Digital Network User Part (ISDNUP)*.

The Type S interface is a physical interconnection and does not by itself include any applications. The word “applications” in this subsection refers to SS7-specific functions or services that are provided by a LEC for a WSP or by a WSP for a LEC. Not all LECs support the same set of applications, and a given LEC may support an application in some geographic areas and not in others. Exactly which applications are to be supported on a Type S interface between a WSP and a LEC should be the subject of arrangements between the WSP and the LEC. For more information the WSP should contact the LEC.

Some examples of ISDNUP and TCAP applications that may be supported between a WSP and LEC follow:

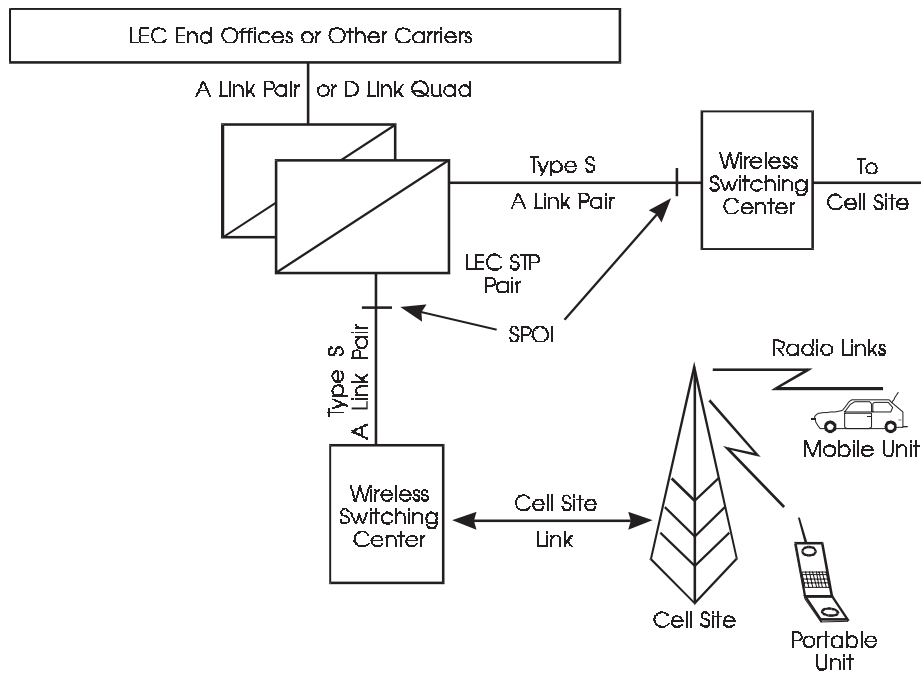
- Basic non-ISDN call setup and release using ISDNUP in conjunction with a Type 2A with SS7 or Type 2B with SS7 interface
  - Passage in both directions (that is, mobile-to-land and land-to-mobile) of ISDNUP parameters related to call forwarding service
  - Passage in both directions of TCAP messages to support the transport of Interim Standard 41 (IS-41) Revision A and/or IS-41 Revision B messages from a WSP to another interconnecting CCS network (**Note:** IS-41 Revision C is under development)
  - Passage in both directions of TCAP messages to support Automatic Callback (AC), Automatic Recall (AR), and Screening List Editing (SLE) services provided by a WSP or a LEC
  - Passage of the ISDNUP CPN parameter in the Initial Address Message (IAM), in both directions, to support Calling Number Delivery (CND), Selective Call Acceptance (SCA), Selective Call Rejection (SCR), Selective Call Forwarding (SCF), Automatic Recall (AR), Calling Name Delivery (CNAM), Customer-Originated Trace (COT), and other services
  - TCAP messages exchanged between a WSP and a LEC to support Calling Name Delivery (CNAM)
-



**Legend:**

- LEC = Local Exchange Carrier
- SPOI = Signaling Point of Interface
- STP = Signaling Transfer Point
- WSC = Wireless Switching Center

**Figure 16-7.** WSP to LEC Switched Interconnection Configuration for Type S Interface



- Legend:**
- LEC = Local Exchange Carrier
  - SPOI = Signaling Point of Interface
  - STP = Signaling Transfer Point

**Figure 16-8.** WSP to LEC Switched Interconnection Configuration for Type S Interface — Alternate

- 
- Support for ISDNUP call setup between a WSP and a LEC 800 Service Switching Point (SSP) to provide 800 service
  - Support for TCAP messages sent between a WSP and a LEC 800 Service Control Point (SCP) to support 800 service
  - Support for TCAP messages sent between a WSP and a LEC to support turning on/off a message waiting indicator to provide message service.
  - Support for ISDNUP procedures to provide operator services on a Type 2A with SS7 interface (**Note:** This capability is not currently available, but is planned for the future)

See Section 3.8 of GR-145-CORE and GR-1434-CORE, *Common Channel Signaling (CCS) Network Interface Specification Supporting Wireless Services Providers (WSPs)*, for more information regarding applications that can be supported with a Type S interface.

No trunk connections are included in, or with, the Type S interface. The Type S interface can support the transport of circuit-associated signaling messages (ISDNUP) as well as non-circuit-associated signaling messages (TCAP).

With regard to the setup and release of a trunk connection for a call, the Type S interface must be used in conjunction with the Type 2A with SS7 interface (see Section 16.2.2.3) or the Type 2B with SS7 interface (see Section 16.2.3.3). In this case, the Type S interface is used for the transport of ISDNUP messages, and the Type 2A with SS7 interface or the Type 2B with SS7 interface provides the SS7-supported trunk connection.

With regard to non-circuit-associated applications (for example, cellular registration), the Type S interface can support the transport of TCAP signaling messages. TCAP messages originating in a WSP network may be sent across the Type S interface to the LEC network (and these messages may terminate in the LEC network or may be transported to other networks). TCAP messages originating in a LEC network (these include both messages initially formulated at LEC network nodes and messages received by the LEC from other networks to be transported to the WSP) may be sent across the Type S interface to the WSP network. Determination of exactly which non-circuit-associated applications may be used on the Type S interface requires discussion between a LEC and a WSP.

This interface description does not fully address support for services (for example, roaming services, CLASS<sup>SM</sup> services) that use ISDNUP signaling or TCAP signaling. Further work is required to describe interface specifications to support services. Such service-specific interface material may be included in a future issue of GR-145-CORE.

GR-1434-CORE contains more detailed information regarding the SS7 interface between LECs and WSPs. This detailed information includes message flows and coding details for SS7-specific applications to be supported between LECs and WSPs. Detailed message contents are provided to explain the parameters that are included in messages sent from a LEC network to a WSP network and what values are populated within those parameters (for

---

CLASS is a service mark of Bellcore.

example, a 10-digit North American Numbering Plan [NANP] number will be included in the CPN parameter). LEC expectations for the content of parameters in messages, received from a WSP across the Type S interface network are also provided in GR-1434-CORE.

For more information on SS7 and relevant American National Standards Institute (ANSI) standards documents see Section 6.25 of this document.

### **16.2.7 WSC-Cell Site Private Lines**

Links between the Wireless Switching Center (WSC) and the cell sites are used to carry both voice traffic and signaling data. Since cellular systems use a separate signaling channel for call setup, handoff, and disconnect, typically there are only a few signaling channels in comparison to the quantity of channels required for voice traffic. The number of voice channels is dependent upon the traffic volume in a particular cell site.

The WSP often provides its own WSC-cell site links using microwave facilities. However, landline facilities can also be used, and these are either digital DS1 channels or individual voice channels delivered on an analog basis.

When digital DS1 channels are used, they are generally ordered from the LEC's private-line tariff and provide a 1.544 Mbps facility that can be used as required by the WSP. The use of bit-compression devices is usually allowed by the LEC on these links.

Although not as common as digital links, the WSP can obtain analog private-line facilities from the LEC. If a signaling capability is needed, these links are essentially a 4-wire lossless tie-trunk interface that permits the WSP to specify the transmission levels in both directions.



**Table 16-1.** Summary of Interconnection Types

Interconnection Type	Service Description	Call Direction	Signaling Method	Information Transferred	Connecting LEC Network Node(s)
Dial line (no type assigned)	End office line-side connection, loop or ground start	M→L	DP DTMF BRI	Called number	End office
Dial line (no type assigned)	End office line-side connection, loop start	L→M	Ringing	Alerting upon seizure	End office
Dial line (no type assigned)	End office line-side connection, ground start	L→M	Ringing and tip ground	Alerting upon seizure	End office
Type 1	End office trunk with line treatment	M→L	(DP/DTMF) MF BRI PRI	Called number	End office
Type 1	End office trunk with line treatment	L→M	(DP/DTMF) MF BRI PRI	Called number	End office
Type 1	End office DID trunk	L→M	(DP/DTMF) MF BRI PRI	Called number	End office
Type 2A	Tandem trunk access	M→L	MF	CIC/routing to IC/INC (except intraLATA primary carrier) Called number ANI-II digit pair (62,63 standard) (61 for call point of origin resolution) ANI (MDN [w/62,63] or BBN [w/61])	Access tandem -or- Local tandem
Type 2A	Tandem trunk access	L→M	MF	Called number	Access tandem -or- Local tandem

**Table 16-1. Summary of Interconnection Types (Continued)**

Interconnection Type	Service Description	Call Direction	Signaling Method	Information Transferred	Connecting LEC Network Node(s)
Type 2A	Tandem trunk access	M→L	ISDNUP via Type S	CIC for routing to IC/INC (except intraLATA primary carrier) Called number Charge number (ANI) Originating Line Information Parameter (OLIP) ANI II digits Other optional parameters* (e.g., calling party number, jurisdiction information, original called number, redirecting number, charge number [ANI].)	Access tandem -or- Local tandem
Type 2A	Tandem trunk access	L→M	ISDNUP via Type S	Called number Other optional parameters* (e.g., calling party number, jurisdiction information, original called number, redirecting number, charge number [ANI].)	Access tandem -or- Local tandem
Type 2B	End office direct trunk access	M→L	MF	Called number	End office
Type 2B	End office direct trunk access	L→M	MF	Called number	End office
Type 2B	End office direct trunk access	M→L	ISDNUP via Type S	Called number Other optional parameters* (e.g., calling party number, jurisdiction information, original called number, redirecting number, charge number [ANI].)	End office
Type 2B	End office direct trunk access	L→M	ISDNUP via Type S	Called number Other optional parameters* (e.g., calling party number, jurisdiction information, original called number, redirecting number, charge number [ANI].)	End office
Type 2C	Public safety emergency services	M→L	MF	Wireless cell identity as 7/10d ANI -or- User ANI (MDN) (10d) -or- Wireless system identity as 7/10d ANI**	E911 tandem -or- Local Tandem
Type 2D	Operator Services System (OSS)	M→L	MF	CIC/routing to IC/INC (except intraLATA primary carrier) Called number ANI-II digit pair (62 standard) (61 for call point of origin resolution) ANI (MDN [w/62] or BBN [w/61])	Access tandem w/operator services -or- Operator services tandem -or- DA switching machine

**Table 16-1. Summary of Interconnection Types (Continued)**

Interconnection Type	Service Description	Call Direction	Signaling Method	Information Transferred	Connecting LEC Network Node(s)
Type 2D	Operator Services System (OSS)	M→L	ISDNUP via Type S	CIC for routing to IC/INC (except intraLATA primary carrier) Called number Charge number (ANI) Originating Line Information Parameter (OLIP) ANI II digits Other optional parameters* (e.g., calling party number, jurisdiction information, original called number, redirecting number)	Access tandem w/operator services -or- Operator services tandem -or- DA switching machine
Type S	SS7 link	M→L	SS7 protocols	†	Signaling Point (SP)
Type S	SS7 link	L→M	SS7 protocols	†	Signaling Point (SP)

\* The WSP should contact the LEC to discuss optional parameters arrangements.

\*\* The WSP should contact the LEC to discuss local 911 system arrangements.

† See Section 3.8 of TR-NPL-000145.

### 16.2.8 Assignment of NXX Codes

Every mobile station served by a WSP has a unique address that is consistent with the North American Numbering Plan (NANP). Blocks of numbers (meaning that the NXX code is shared with other users) may be obtained by the WSP from the LEC, or an entire NXX code may be assigned. The numbering requirements of the WSP and the type of connection used determine whether a shared NXX arrangement or a dedicated code is used. Type 1 connections may use numbers from either a shared or a dedicated NXX code; Type 2 connections must use a dedicated NXX code.

### 16.2.9 Location of NXX Codes

While dedicated NXX codes are often used with a Type 1 connection, the code itself resides in the LEC end office location. Thus, the Vertical and Horizontal (V&H) coordinates for codes associated with a Type 1 connection, as well as the CLLI™ code, are the same as those established for the LEC end office. The V&H coordinates define a unique geographic location and are used for billing purposes. The CLLI code provides a name that is used by a number of operational systems, including those used for billing and routing.

With a Type 2 connection, a dedicated code must be used. The V&H coordinates and a CLLI code are associated with the WSP's location instead of the LEC end office. Usually, but not always, this location is the WSC. The WSPs do not have a WSC in every CGSA because it is not cost effective. They do have cell sites in these smaller CGSAs that pick up cellular traffic, which is then hauled back to the WSC. The Point of Interface (POI) for interconnection with the LEC is located at one of these cell sites, which becomes the official location of the NXX code. To use the WSC location in these instances would be very misleading for call routing and billing since the WSC may well be located physically in another Numbering Plan Area (NPA) and state. The V&H coordinates and CLLI codes for a location other than the WSC may be used when a dedicated NXX is assigned for a Type 2 arrangement.

### 16.2.10 Mobile-to-Land Calls

When a mobile subscriber wants to place a call, the subscriber is connected to the nearest cell site by a radio link and then to the WSC by a WSC-cell site link. The mobile subscriber dials seven to ten digits, depending on the policies of the particular WSP, and presses the "send" button on the mobile set. The digits are transmitted to the WSC over the signaling channel. The WSC seizes a trunk (Type 1, Type 2A, or Type 2B), depending on the call type and connection used, and outputs the required number of digits to the LEC office.

---

COMMON LANGUAGE is a registered trademark, and CLEI, CLLI, CLFI, and CLCI are trademarks of Bellcore.

---

---

When the call is answered, the WSC connects the mobile set to the voice channel so conversation can begin.

### **16.2.11 Land-to-Mobile Calls**

To reach a mobile subscriber in a cellular system, the landline customer dials the 7- to 10-digit number, depending on the local dialing plan. The call is directed to either the end office providing a Type 1 or Type 2B connection, or the tandem office, if a Type 2A connection is employed. In either case, the 7-digit number of the mobile subscriber is outpulsed by the LEC office to the WSC or POI. The location of the mobile set is determined by broadcasting a paging code to all cell sites via a separate paging channel. This paging code includes the mobile subscribing telephone number and the ringing signal. The cell site with the strongest signal strength from the responding sites is selected and a voice channel is assigned by the WSC. The digits and a ringing signal are outpulsed over the signaling channel. When the mobile subscriber answers, the voice channel is connected so conversation can begin.

### **16.2.12 Automatic Message Accounting Recordings for Usage**

Most of the contracts or tariffs covering cellular interconnection contain provisions for usage charges. Generally, these charges pertain to mobile-land traffic, although some jurisdictions also have land-mobile charges. To collect these charges, call details must be recorded so that usage can be accumulated and accurate bills rendered.

#### **16.2.12.1 Recording Mobile-to-Land with Type 1 Connections**

Call details for mobile-to-land calls from a Type 1 connection are made in the end office using the Trunk with Line Treatment (TWLT) feature or its equivalent. Using the TWLT feature, along with a Billing Telephone Number (BTN), which is a valid NXX within that office used for billing purposes, information regarding the called number, the duration, and time of the call is obtained. Currently, only the 1A ESS, 5ESS, DMS-100, and DMS-100/200 switches are capable of recording call details for mobile-to-land calls.

#### **16.2.12.2 Recording Mobile-to-Land with Type 2A Connections**

Whether recordings can be made for mobile-to-land calls from a Type 2A connection depends on the type of LEC tandem switch and whether the WSP provides equal-access service. With the proper generics, the DMS-200 and the 4ESS machines can record all call types via the Type 2A connection, including those with equal access. By translating the

---

DMS-100, 1A ESS, or the 5ESS switches as a Type 1 connection, recordings can be made of all traffic types except those using equal-access signaling.

Specific feature packages that enable recordings to be made for all call types from the Type 2A connections are available in AT&T generic 4E13 and higher for the 4ESS switch and in BCS-28 and higher for the DMS-200 switch. With the proper generic and feature package, along with a BTN from a valid NXX code used for billing, the called number, the duration of the call, the time of the call, and a unique cellular call-type code is obtained.

When equal-access service is not provided or when the tandem is used for local traffic only, the DMS-100, 1A ESS, and 5ESS switches can record call details if the machine is translated as a Type 1 connection. If equal-access traffic is forwarded by the WSP to this trunk group, it will not be recorded.

#### 16.2.12.3 Recording Mobile-to-Land with a Type 2B Connection

Because the calling scope of a Type 2B connection is limited to the NXX codes within the office that provides the Type 2B connection, the manner in which call details are recorded is the same as that used for a Type 1 connection.

#### 16.2.13 Recording Land-to-Mobile Calls

In cases where usage charges are applied to land-to-mobile calls, recordings should be made at the end office for each call destined for the WSP. The usage for each call is measured and then aggregated at the end of the month to bill the WSP for the total usage. This technique is similar to the technique used for FGB-originating traffic for ICs.

#### 16.2.14 911 Traffic from Wireless Services Subscribers

In most cases, the WSP must make arrangements with the local public safety agency responsible for handling 911 emergency calls before it begins forwarding such traffic to the LEC. As noted in Sections 16.2 through 16.2.3, 911 traffic can be routed over Type 1, but not Type 2A or Type 2B connections.

When a 911 call is forwarded by a WSP over a Type 1 connection, the ANI that is forwarded to the 911 Public Safety Answering Point (PSAP) is the BTN used for billing the Type 1 connection, and the street address used is that of the associated WSC or POI. There are ways to identify the originating cell site to the PSAP operator, but there is no way to do it automatically. Essentially, this is why the agreement of the local public safety agency is needed before these calls are forwarded to the LEC network.

---

### 16.2.15 Operator Services

Access to a LEC operator (0-) or the ability to place a call on either the LEC network or via an IC using a calling card 0+ is currently restricted to a Type 1 connection. Calls to a LEC directory assistance position reached by dialing the 411 access code are currently permitted only with a Type 1 connection. Calls to a LEC directory assistance position reached by dialing 555-1212 or NPA-555-1212 are permissible with a Type 1 connection, and in some cases, a Type 2A connection.

IC operators may be accessed through either a Type 1 or a Type 2A connection. Using the Type 1 connection, the IC operator of the presubscribed carrier is reached by dialing 00, or 10XXX+0 for all other ICs. IC operator access via the Type 2A connection is limited to 10XXX+0.

### 16.2.16 Transmission and Signaling Requirements

When cellular service was initially established in the United States, a primary goal of WSPs was to provide the mobile subscriber with a grade of service that was comparable to that achieved on the LEC network. To accomplish this objective, a transmission plan was developed jointly by representatives from the cellular industry, Bellcore, and LECs. More complete information concerning the transmission requirements is contained in TR-EOP-000352, *Cellular Mobile Carrier Interconnection Transmission Plans*.

Table 16-2, Summary of Transmission Requirements, provides information regarding the transmission parameters for the more common interfaces, digital or 4-wire analog, that are used for the interconnection.

As explained in previous paragraphs, both Type 1 and Type 2 connections use E&M supervision and multifrequency address pulsing.

#### 16.2.16.1 Digital Interfaces

Virtually all cellular switches are digital, and the majority of the facilities serving the WSP's location are digital. Regardless of the type of interconnection used, digital interfaces are usually cheaper and more reliable than analog facilities.

Because information about signal power is contained in the digital signal itself, the use of Transmission Level Points (TLPs) at each end of a trunk to describe its Inserted Connection Loss (ICL) is inappropriate because digital trunks have no ICL value.

**Table 16-2.** Summary of Transmission Requirements

	<b>4-Wire Analog Interface</b>	<b>Digital Interface</b>
Loss		
Type 1	0 dB maximum (3 dB nominal)	DRS
Type 2A	3 dB	DRS
Type 2B	3 dB	DRS
Attenuation Distortion (404 Hz to 2804 Hz)		
All types	-1.5 to +3.5 dB	-1.5 to +3.5 dB
C-Message Noise		
This parameter is facility-dependent, regardless of the interface that is chosen.		
Balance		
Echo Return Loss (ERL) and Singing Return Loss (SRL)		
All types	20/16 dB	20/16 dB
Note: This assumes a 2-wire interface at the LEC switch. If the LEC switch is digital, there is no balance requirement		

Instead, digital trunks are designed to be transparent, and their loss is a function of the decode level selected by the digital switch. This decode level refers to a 1004-Hz signal known as a Digital Reference Signal (DRS). Generally, the DRS produces a level that is equivalent to a -6 dB TLP.

Particularly with Type 1 connections, the POI at the WSP's location is digital, but the LEC switch is often analog. However, as the LECs replace existing analog electronic switches with digital switches, the entire connection becomes digital end-to-end. This is already the case with many Type 2A connections, because many of the LEC tandem switches are already digital machines.

#### 16.2.16.2 Analog Interfaces

Analog interfaces are available and are usually used when the number of trunks required is very small or when the WSP has a POI location in a remote area where digital facilities are not readily available. Because the transmission levels at the interface are usually +7 TLP



---

(Transmit) and -16 TLP (Receive), some type of channel-terminating equipment needs to be placed by the LEC at the POI location.

### 16.2.16.3 Summary of Transmission Requirements

Although a number of interface possibilities exist for Type 1, Type 2A, and Type 2B connections (each is more fully explained in TR-EOP-000352), the 4-wire analog and the digital interfaces are by far the most common.

When the 4-wire analog interface is used, the WSP can select the receive levels at the LEC end office and at the POI location for the Type 1 connection. This enables the WSP to design this link for any loss up to 0 dB, although it is usually designed for an ICL of 3 dB.

Like a normal interoffice trunk in the LEC network, Type 2A connections that use a 4-wire analog interface are designed between an end office and a tandem office for an ICL of 3 dB.

When digital interfaces are used, the loss is determined by the decode levels of the equipment, or DRS.

Other transmission parameters that must be considered are attenuation distortion, C-Message Noise, and, in some cases, balance. TR-EOP-000352 contains more specific information for Type 1, Type 2A, and Type 2B connections, while Table 16-2 shows a summary of the significant parameters for 4-wire analog and digital interfaces.

Transmission specifications for the private-line circuits that connect the cell sites to the WSC were formerly contained in TA-76. Current specifications are included in TR-NWT-000965, *IntraLATA Voice Grade Private Line Service — Transmission Parameter Limits and Interface Combinations*, or an equivalent LEC document, and are briefly summarized in Table 16-3.

### 16.2.16.4 Synchronization

When digital switches and/or digital facilities are interconnected, some means of synchronizing the clock rates must be used to avoid errors. The method of synchronization must be agreed upon by both the LEC and the WSP. Generally, the following conventions are used.

- If the WSP has a digital switch, the facility is digital; if the LEC has an analog switch, the WSP derives timing from its own source, and the channel banks at the end office are loop timed.
- If both the WSP and the LEC have a digital switch, and particularly if the LEC has implemented the Building-Integrated Timing Supply (BITS) plan or if a Type 2A connection is employed, the LEC will provide the primary source of timing.

Further information regarding digital synchronization can be found in Section 11.

**Table 16-3.** Summary of Transmission Requirements for Private-Line Circuits

	<b>4-Wire Analog Interface</b>	<b>Digital Interface</b>
<b>Loss</b>		
Cell Site/WSC PL	0-16 dB	DRS
<b>Attenuation Distortion (404 Hz to 2804 Hz)</b>		
Cell Site/WSC PL	-2 to +6 dB	-2 to +6 dB
<b>C-Message Noise</b>		
This parameter is dependent on the facilities used regardless of the interface chosen.		
<b>Balance (ERL &amp; SRL)</b>		
Cell Site/WSC PL	18/12 dB	18/12 dB
<b>Note:</b> This assumes a 2-wire interface at either or both ends of the circuit, and some portion of the circuit contains 4-wire facilities. If the circuit is entirely 4-wire, there is no balance requirement. If the circuit is entirely 2-wire, the requirement is 6/3 dB.		

### 16.2.17 Glare Resolution

Glare is a condition that occurs when both the LEC and the WSP switching machines simultaneously seize a trunk. This happens because of the unguarded interval between the seizure of a trunk at one end and the consequent making busy of the trunk at the other end. To resolve this condition, both the LEC and the WSP switches have a “glare bit” that identifies which entity retains control of the trunk and which one backs out in this situation.

An agreement must be reached by the WSP and the LEC regarding glare resolution, but traditionally the lower-ranked office in the network backs off first. For example, end offices back off from tandems, and tandems generally back off from IC switches. Following this tradition, the WSP would back off first with both Type 1 and Type 2A connections, while the Type 2B glare resolution would be determined by the lower alpha character of the CLLI code since both offices would be of equal rank.

### 16.2.18 Call Progress Tones and Recorded Announcements

Call progress tones are used to inform the originating caller of the status of the call during the time an attempt to establish a connection is made. Examples of call progress tones are audible ringing, line busy, or reorder. For calls terminating on the LEC network, these tones are usually provided by the LEC. Likewise, the WSP supplies these tones for calls terminating on the WSP's network.

---

Recorded announcements are used to inform the caller of special conditions of call setup. An example of a common recorded announcement is a vacant number announcement. Where the called number (either from a shared NXX or a dedicated NXX) is used by the WSP, the WSP is responsible for providing the necessary recorded announcement (for example, vacant code, no circuit, etc.).

Special information tones consisting of a series of three tones are used to precede some recorded announcements. The responsibility for providing these tones is the same as for the recorded announcements themselves.

Further information concerning call progress tones, recorded announcements, and Special Information Tones (SITs) can be found in Section 6 of this document and GR-145-CORE.

### **16.3 Optional Features**

Two options that WSPs often order from the LECs are not a fundamental requirement for Type 1, Type 2A, or Type 2B connections. These options provide a valuable service by reducing, but not totally preventing, fraud for the WSPs. While they may have other names, they are generally referred to as Toll Billing Exception (TBE) and Selective Class-of-Call Screening (SCCS).

TBE is designed to eliminate third-number billing to a telephone number assigned to a mobile carrier. When the WSP requests the TBE feature, the telephone numbers assigned to the WSP are entered into a database that can be accessed by LEC operators as well as some ICs. The Billing Validation Application (BVA) database, owned by AT&T, once performed this function. Now, however, each LEC has its own Line Information Database (LIDB) which has superseded the BVA. When a caller attempts to place a call and requests that the charges be applied to a telephone number assigned to the WSP, the database alerts the operator that billing against that number is not allowed.

SCCS is a feature in a 1A ESS machine that can be used with Type 1 connections to restrict operator-assisted (0-, 0+), mobile-originated calls to collect calls, calling card, or third-number billing calls only. It is not yet available in the other switching machines capable of providing Type 1 connections, specifically the DMS-100 or the 5ESS switches.

### **16.4 Conventional 2-Way Mobile Service**

#### **16.4.1 Brief History**

The first fully commercial public mobile service began after World War II in St. Louis, MO, when a mobile system was interconnected with the landline network. A number of LECs also offered mobile service by means of dial signaling from mobile units connected through unattended central offices. These systems made it possible for the LEC to offer

---

mobile service in areas where the use of mobile operators was not economical. These early systems were manually operated and required push-to-talk operation at the mobile stations. In many cases, multiple channels were provided to increase the number of stations being served. To use such access, the mobile user would switch from channel to channel and listen for one that was idle.

Improvements were made over the years, culminating in an automatic-dial system provided by the LECs, known as Improved Mobile Telephone Service (IMTS). With IMTS, a trunked arrangement is used whereby each receiver can be automatically directed to a vacant radio channel instead of being restricted to a specific dedicated channel. This improvement, combined with reduced radio spectrum needed per channel, increased the capacity of the system. However, because IMTS is limited to a maximum of 12 channels per system, congestion continued to be a problem. This is why the cellular concept was developed. However, 44 channels are now available.

#### **16.4.2 Operating Areas**

Two-way conventional mobile systems, like IMTS, employ a large transmitter to cover a geographic area of about 40 to 80 miles. To minimize interference, transmitters for systems using the same frequencies must be separated by about 80 miles. Due in part to this limitation, not all areas are effectively served by 2-way mobile service.

#### **16.4.3 Wireline versus Nonwireline**

Although the terms wireline and nonwireline were popularized with the introduction of cellular service, traditional 2-way mobile service is actually one of the first areas where competition was authorized to the LEC's services. In 1949, the FCC authorized nontelephone companies to provide mobile service. These entities, now known as Radio Common Carriers (RCCs), today provide 2-way mobile services much like IMTS and, in fact, have the largest share of the 2-way mobile market. Moreover, unlike cellular, the number of licensees in a given area is limited by radio spectrum constraints rather than an arbitrary regulatory constraint.

#### **16.4.4 Connection Types**

Per a 1987 declaratory ruling by the FCC, RCCs providing 2-way mobile service may also obtain the same interconnections used by the WSPs, that is, Type 1, Type 2A, and Type 2B connections. As a practical matter, though, most modern conventional 2-way mobile systems are designed to operate using a Direct Inward Dial (DID) trunk (also called an outpulsing-of-digits circuit) for land-to-mobile calls and a line-side connection (that is, dial-line circuits like a Private Branch Exchange [PBX] trunk) for mobile-to-land calls.

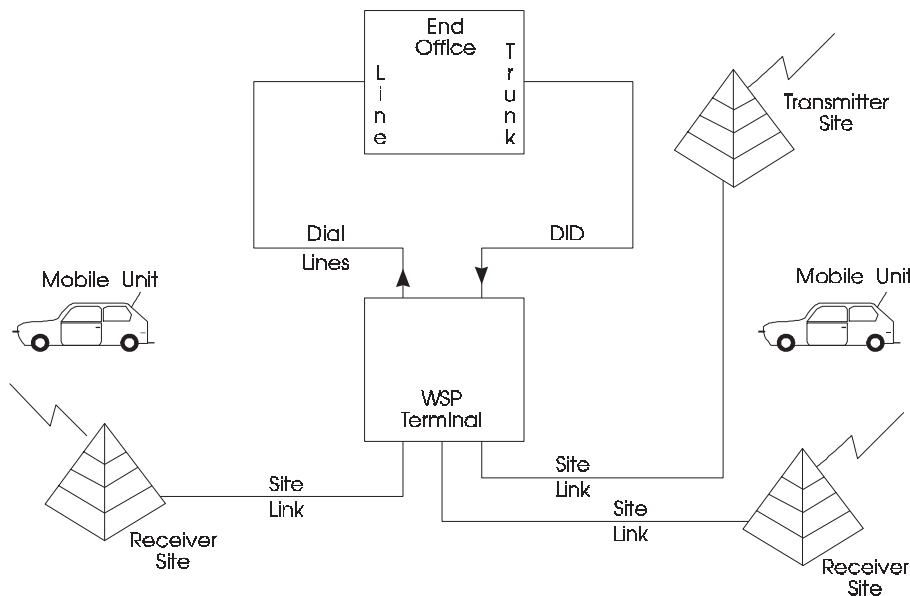
---

Private-line circuits, also known as radio-transmitter circuits, are also used by the WSPs to connect terminals to the transmitter or receiver sites. These private lines are voice-grade circuits that have no specific signaling capability provided by the LEC. Although not generally used, the WSPs may also obtain Digital Signal level 1 or 3 (DS1 or DS3) facilities.

Further information concerning the DID trunks (or outpulsing-of-digits circuits) and the dial-line circuits can be found in TA-NPL-000912, *Compatibility Information for Telephone Exchange Service*.

Private-line, radio-transmitter circuits are described in TR-NWT-000965 or its equivalent LEC publication.

Figure 16-9 is a schematic view of a typical interconnection arrangement for a WSP that provides 2-way mobile service.



**Figure 16-9.** Typical 2-Way Mobile Configuration

#### 16.4.5 DID Connections

DID circuits (or outpulsing-of-digits circuits) offer a 2-wire, trunk-side, 1-way connection to an end office. They are available from most types of end offices, including older electromechanical switches.

DID circuits use reverse-battery supervision and dial-pulse address pulsing. Wink start is the usual method of controlling outpulsing, although some LECs permit the use of delay-dial and immediate-dial operation as well. In addition to dial-pulse address pulsing, some

LECs also offer Dual-Tone Multifrequency (DTMF) or multifrequency address pulsing options with DID trunks.

With the DID trunk, the WSP can receive calls from other end offices within the LATA as well as traffic from ICs and INCs.

#### **16.4.6 Dial-Line Connections**

Dial-line circuits are 2-wire line-side connections from an end office that may be used on a 1-way basis (WSP to LEC or LEC to WSP) or 2-way basis. These lines are available from all types of switching machines. Dial lines use loop supervision and can use ground-start or loop-start control. Outgoing calls (WSP to LEC) may use dial-pulse or DTMF address pulsing. A 20-Hz ringing signal is used to alert the user on incoming (LEC to WSP) calls.

With the dial-line circuit, the WSP can establish connections to valid NXX codes within the LATA, directory assistance, operator services (0-, 0+), N11 codes (411, 911, etc.), SACs (800, 900), and access to ICs and INCs.

Dial-line circuits must be presubscribed to an IC chosen by the WSP. Other ICs may be accessed by using the 10XXX code.

#### **16.4.7 Private-Line Connections**

A LEC may provide circuits between the WSP's terminal equipment and its transmitter or receiver sites. Typically, these circuits are 2-wire or 4-wire voiceband analog circuits that have no signaling capability.

#### **16.4.8 NXX Codes for 2-Way Mobile Service**

Each mobile station served by a WSP has a unique address that is consistent with the NANP. Usually, the WSP obtains blocks of numbers from the LEC (meaning the NXX code is shared with other users), but the use of a dedicated NXX code is also possible. The numbering requirements of the WSP, and in some cases the type of interconnection, will determine whether a shared NXX arrangement or a dedicated code is used.

#### **16.4.9 Location of NXX Codes**

Similar to the discussion of cellular service in Section 16.2.9, the location of the NXX code is either the end office or the POI at the WSP's location. Unless a Type 2 connection is used, the V&H coordinates of the end office will be used.

---

---

### 16.4.10 Mobile-to-Land Calls

To place a call, the mobile subscriber receives a dial tone from the WSP's terminal and dials the desired called number. The terminal receives the digits via the radio-transmitter circuits connecting the receiver site to the terminal, then seizes a dial-line circuit, and outpulses the digits to the end office. The end office processes the call just like a call from any other line-side connection in the office and routes the call to its appropriate destination.

## 16.5 Land-to-Mobile Calls

For calls to the WSP, the end office that received the call seizes the DID trunks and outpulses four to seven digits to the WSP's terminal. The WSP interprets the digits and alerts the mobile unit via the radio-transmitter circuit that connects the terminal and the transmitter.

### 16.5.1 Automatic Message Accounting Recordings for Usage

Some contracts or tariffs covering mobile service interconnection contain provisions for usage charges. Generally, these charges pertain to mobile-land traffic, although some also have land-mobile charges. To collect these charges, call details must be recorded so that usage can be accumulated and accurate bills rendered.

The techniques for recording mobile-land calls with Type 1, Type 2A, and Type 2B connections are the same if the WSP uses these same connections.

If a usage charge is applied to mobile-land calls and a dial-line connection is used, the switch is translated to record the call at the end office providing the dial-line connection. If the dial line is served from an office incapable of recording call details, this function is handled by the tandem office using the Centralized Automatic Message Accounting (CAMA) technique.

### 16.5.2 911 Traffic from a 2-Way Mobile Subscriber

As with the WSPs, the 2-way mobile service WSPs usually must obtain the concurrence of the local public safety agency responsible for 911 emergency calls before it begins forwarding 911 traffic to the LECs.

## 16.6 Transmission and Signaling Requirements

WSPs providing 2-way mobile service have historically used DID and dial-line connections whose transmission objectives were established to provide an acceptable grade

---

of service within the landline telephone network. This is not surprising, since even the improved versions of dial-mobile systems (such as IMTS) were introduced over a quarter of a century ago. Also, unlike cellular service, 2-way mobile service was not specifically designed to achieve a grade of service comparable to the landline network. Nonetheless, satisfactory transmission performance is possible with these connections.

As further explained in TA-NPL-000912, dial-line circuits use loop supervision, while DID trunks employ reverse-battery supervision. According to TR-NWT-000965, the nominal 1-kHz loss for each is 5 dB.

Any signaling required for the private-line circuits is supplied by the WSP using an inband signaling technique. Per TR-NWT-000965, the 1-kHz loss for a 2-wire private-line circuit is typically 10 dB, while the 4-wire circuits have a 16-dB loss.

### **POIs**

Two-wire analog interfaces are by far the most common form of interface obtained by the WSP offering 2-way mobile service. Digital interfaces are a possibility, but because most of the 2-way mobile terminal equipment is designed to accept an analog signal and the trunk quantities are usually quite small, analog remains the preference.

### **Synchronization**

If a digital interface is used, the clock rates must be synchronized between the two systems in the manner described in Section 16.2.16.4.

## **16.6.1 Summary of Transmission Requirements**

TR-NWT-000965, or its LEC equivalent, contains the transmission requirements for the circuit types used by the WSPs providing 2-way mobile service. Table 16-4 shows a brief summary of the requirements for the more common parameters.

Should the WSP employ Type 1, Type 2A, or Type 2B connections, the requirements in TR-EOP-000352 and Table 16-2 would be applicable.



**Table 16-4.** Summary of Transmission Requirements for Dial-Line, DID, and Private-Line Circuits

	<b>4-Wire Analog Interface</b>	<b>Digital Interface</b>
<b>Loss</b>		
Dial Line	0-10 dB	DRS
DID Trunks	0-5 dB	DRS
Private Line	0-16 dB	DRS
<b>Attenuation Distortion (404 Hz to 2804 Hz)</b>		
Dial Line	-2 to +11.5 dB	-2 to +11.5 dB
DID Trunks	-2 to +6 dB	-2 to +6 dB
Private Line	-2 to +11.5 dB	-2 to +11.5 dB
<b>C-Message Noise</b>		
This parameter is facility-dependent regardless of the interface that is chosen.		
<b>Balance (ERL &amp; SRL)</b>		
Private Line	18/12 dB	18/12 dB
<b>Note:</b> This assumes a 2-wire interface at either or both ends of the circuit. Some portion of the circuit contains 4-wire facilities. If the circuit is entirely 4-wire there is no balance requirement. If the circuit is entirely 2-wire, the requirement is 6/3 dB.		

### 16.6.2 Glare Resolution

Because the signaling sequences for line-side connections (like a dial line) differ from trunk-side connections (like Type 2 arrangements), glare resolution is not necessary when dial-line connections are employed. For trunk-side DID connections, glare resolution is also not necessary because the circuit is 1-way operation only, so a glare condition cannot exist.

### 16.6.3 Call Progress Tones and Recorded Announcements

WSPs providing 2-way mobile service have the same responsibilities for call progress tones, recorded announcements, and SITs, which are described in Section 16.2.18. Further information concerning call progress tones, recorded announcements, and SITs can be found in Section 6 of this document, in GR-145-CORE, and in TA-NPL-000912.

#### **16.6.4 Optional Features**

Like the WSPs, 2-way mobile service WSPs often find the SCCS and TBE features useful in reducing fraud.

### **16.7 Common-Carrier Paging Systems**

#### **16.7.1 Brief History**

Because many people really need only 1-way communications and the available radio spectrum is limited, the paging industry began in the 1950s as a means of reducing the demand for 2-way spectrum. By using the individual channel for 1-way paging service, more people were able to use the service for the same amount of spectrum than if it were used for 2-way communications.

Competition was authorized by the FCC allowing entities other than telephone companies to provide these services. These non-telephone company entities, now known as Radio Common Carriers (RCCs), provide the vast majority of paging services in the United States.

Early paging service used a manual system whereby a call was made to an attendant who then paged the paging subscriber from the paging terminal. These systems have been almost entirely replaced by automatic terminals that page the paging subscriber based on a unique 7-digit telephone number that is dialed, or by dialing a 7-digit telephone number for the paging system and then, using a phone with DTMF signaling, dialing a unique access code for the pager.

Paging services currently available to subscribers include tone only, voice and tone, and digital display operation. Each represents an evolution in technology, and each still has an appeal to certain segments of the paging market.

#### **16.7.2 Operating Areas**

As with 2-way mobile service, the number of entities providing paging service within a given geographic area is limited by spectrum availability rather than regulatory constraints. A geographic area labeled a Reliable Service Area (RSA) is established. RSA is based on signal-strength contours, meaning the average reliability is expected to be greater than 90 percent within these contours. Note that the acronym "RSA" is used in defining cellular rural service areas, but the criteria are completely different.

---

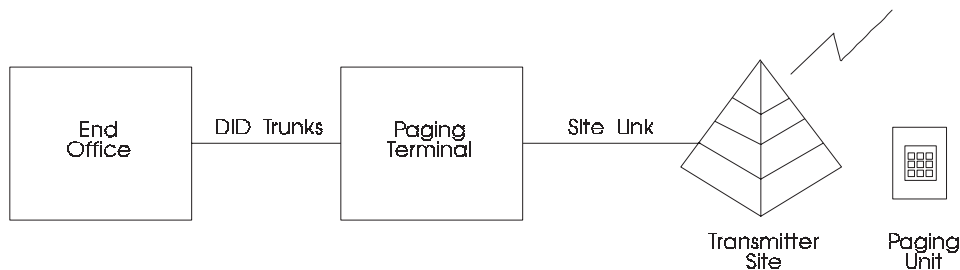
### 16.7.3 Wireline versus Nonwireline

While these terms were popularized with cellular service, they are applicable to paging service as well, because paging can be provided by either LECs or RCCs.

### 16.7.4 Connection Types

Under a 1987 declaratory ruling of the FCC, RCCs providing paging service may obtain the same interconnections used by the WSPs (for example, Type 1, Type 2A, or Type 2B). As a practical matter, most paging systems are designed to operate using DID trunks for the land-to-mobile calls and may use private-line circuits to connect the paging terminal to the transmitter.

Figure 16-10 shows a typical paging system.



**Figure 16-10.** Typical Dial-Paging System

### 16.7.5 NXX Codes for Paging Service

In a dial-paging system, each paging unit is generally identified by a unique address that conforms to the NANP. The WSP may obtain blocks of numbers from the LECs (meaning the NXX code is shared with other users), but the use of a dedicated code is also possible. The numbering requirements of the WSP and, in some cases, the form of interconnection determine whether a shared NXX arrangement or a dedicated code is assigned.

### 16.7.6 Location of NXX Codes

Similar to the discussion of cellular service in Section 16.2.9, the location of the NXX code is either the end office or the POI at the WSP's location. Unless a Type 2 connection is used, the V&H coordinates of the end office will be used.

### **16.7.7 Pager-to-Land Calls**

By definition, paging is a 1-way service, so there are no pager-to-land calls.

### **16.7.8 One-Way Paging**

The routing of a land-to-pager call within the LEC network depends on the type of connection the WSP has elected to use. For Type 1, Type 2B, or DID connections, the call is routed to the LEC end office that provides that connection, whereas calls for a Type 2A connection are routed to the appropriate tandem office. From that point on, the operation is identical. The LEC office will outpulse four to ten digits, depending on the dialing plan and the connection type, to the WSP's terminal equipment. The terminal equipment interprets the digits, sends the code to the transmitter via the private-line circuit or its own facilities, and the transmitter in turn transmits the paging code to alert the paging subscriber.

### **16.7.9 Automatic Message Accounting Recordings for Usage**

Some contracts or tariffs covering mobile service interconnection contain provisions for usage charges. Generally, these charges pertain to mobile-to-land traffic, although some have land-to-mobile charges, too. To collect these charges, call details must be recorded so that usage can be accumulated and accurate bills rendered.

Since paging is a 1-way service involving land-to-pager calls, recording techniques for mobile-to-land calls are irrelevant. However, if land-to-pager usage charges are applicable, the same technique outlined in Section 16.2.13 would apply.

### **16.7.10 Transmission and Signaling Requirements**

Typically, paging systems use DID trunks and private-line circuits for their interconnection requirements, so there are no unique transmission objectives for paging services when these circuits are employed.

As further explained in TA-NPL-000912, DID trunks employ reverse battery supervision and, according to TR-NWT-000965, have a nominal 1-kHz loss that is typically 5 dB.

Any signaling required for the private-line circuits is supplied by the WSP using an inband signaling technique. Per TR-NWT-000965, the 1-kHz loss for a 2-wire private-line circuit is typically 10 dB, while 4-wire circuits have a 16-dB loss.

### **16.7.11 POIs**

Two-wire analog interfaces are by far the most common obtained by the WSPs offering 1-way paging service. While digital interfaces remain a possibility, most of the 1-way paging terminal equipment is designed to accept an analog signal, and the trunk quantities are usually quite small, making analog the preference.

### **16.7.12 Synchronization**

If a digital interface is used, the clock rates must be synchronized between the two systems in the manner described in Section 16.2.16.4.

### **16.7.13 Summary of Transmission Requirements**

TR-NWT-000965, or its LEC equivalent, contains the transmission requirements for the circuit types used by the WSPs providing 1-way paging service.

Table 16-4 shows a brief summary of the requirements for the more common parameters.

### **16.7.14 Glare Resolution**

Because paging systems are by definition a 1-way service, glare resolution is not necessary because a glare condition cannot exist.

### **16.7.15 Call Progress Tones and Recorded Announcements**

WSPs providing 1-way paging service have the same responsibilities for call progress tones, recorded announcements, and SITs as those described in Section 16.2.18.

Further information concerning call progress tones, recorded announcements, and SITs can be found in Section 6 of this document and TA-NPL-000912.

### **16.7.16 Optional Features**

Even though paging service is 1-way, the TBE feature described in Section 16.3 is useful in reducing fraud.

---

## 16.8 FCC Part 90 Private Carriers

Under Part 90 of the FCC rules, radio spectrum is reserved for private carriers. Some of these private carriers are authorized to provide communications services to others on a commercial basis and are generally referred to as Specialized Mobile Radio (SMR) and Private Carrier Paging (PCP) operators. The services they provide are similar to those provided by common carriers who are licensed under Part 22 of the FCC's rules. The distinctions between these Part 90 private carrier operators and Part 22 common carriers are primarily due to regulatory classifications instead of technical requirements. Some of these differences are listed below.

- The Part 90 end user must meet certain FCC rules for eligibility and must be licensed to use the system. However, recent FCC rulings have liberalized these eligibility requirements so that almost anyone can now be licensed as a Part 90 end user.
- Because these Part 90 operators are private carriers instead of common carriers, they are not obligated to provide service to anyone who requests it.
- Part 90 operators must meet certain FCC loading criteria on their systems.
- As Part 90 carriers, they generally are not subject to state or federal regulation to the same extent as common carriers.

From an interconnection perspective, the Part 90 carriers have needs that are very similar to the Part 22 carriers. SMRs provide 2-way mobile service, while PCPs offer paging service. Each has a need for its customers to communicate with landline subscribers.

Some state jurisdictions have determined that the services offered by both the Part 22 and Part 90 carriers are quite similar and, therefore, have ordered that the interconnection policies be the same for both Part 22 and Part 90 carriers.

Currently, the interconnection requirements of the SMRs and PCPs are identical to the 2-way mobile service and 1-way paging WSPs, which were previously described. These operators use equipment designed to interface with dial-line circuits and DID trunks. In addition, some private-line connections may be needed to connect the terminal sites to the transmitters or transceivers.

Also similar to their Part 22 counterparts, the Part 90 carriers generally use analog interfaces because of their analog-based terminal equipment design and the relatively small quantities of circuit needed.

### 16.8.1 Enhanced Specialized Mobile Radio Systems

NEXTEL is a Part 90 carrier authorized to provide SMR service. On February 13, 1991, the FCC authorized NEXTEL to construct and operate 800 MHz Enhanced Specialized Mobile Radio (ESMR) systems. The ESMR systems will offer wide-area dispatch systems as well as mobile data communications. This concept will include, because of system design,

---

---

automatic hand-off of calls as mobile units travel throughout the mobile area. NEXTEL plans to convert its existing analog system to digital transmission systems. All channels will be combined in each market into a multi-site, low-power base station configuration employing frequency reuse throughout the system. The individual low-power base stations will be operated through a centralized switching facility, providing seamless hand-off of communications on mobile units moving throughout the service area.

## 16.9 CT2 Concept

Cordless Telephone-Second Generation-type (CT2-type) technologies and services in the United States are presently being explored by the FCC in its Notice of Inquiry in Docket 90-314.

## 16.10 Personal Communications Services

In Docket 90-314, the FCC is also examining the Personal Communications Network (PCN) concept for application in the United States, including possible spectrum allocations or reallocations.

### 16.10.1 Regulation

In 1989, the FCC initiated a proceeding to establish new Personal Communications Services (PCS). This proceeding was initiated after the Commission received petitions for rulemaking from Cellular 21, Inc. and PCN America, Inc. They requested that the FCC allocate spectrum for the implementation of new personal communications services.

On June 14, 1990, the FCC adopted a Notice of Inquiry to solicit comments on a broad array of issues concerning the availability of PCS. Most commenters supported the Commission's decision to initiate a rulemaking on PCS.

On October 24, 1991, the FCC adopted a Policy Statement and Order. This action provided the preliminary guidance for the further development of PCS, as well as serving as a basis for an "en banc" hearing on PCS. On December 5, 1991, an "en banc" hearing was conducted. It confirmed, among other things, that there is a high level of interest in PCS, and strong support for the allocation of substantial spectrum for them.

On July 16, 1992, in combined Notices of Proposed Rulemaking (General Docket No. 90-314 and ET Docket 92-100) the Commission's proposal included spectrum allocation and regulatory and licensing schemes for PCS. It also sought comprehensive comments on how to make PCS available as soon as possible.

The Commission asked for comments on whether PCS should be regulated as a common carrier or private service. It has proposed that PCS licensees be given a federally protected

---

---

right to interconnect with the Public Switched Telephone Network (PSTN). The FCC is also asking interested parties to address the extent to which preemption is necessary for different types of interconnection arrangements. (For example, to what extent would the FCC's federal authority over cellular interconnection apply to PCS?)

With regard to interoperability and roaming, the FCC is proposing to not require intersystem operability among different licensees at this time as it may impede the development of PCS.

Also included in Appendix A of the Notice is a proposed definition of PCS. In the Proposed Rules, Part 99 of the FCC's Code of Federal Regulations (CFR). PCS is defined as:

“A very broadly defined and flexible radio service that encompasses a wide array of mobile and ancillary fixed communications on frequencies in the 901-902 MHz, 930-931 MHz, 940-941 MHz, 1850-1895 MHz, and 1930-1975 MHz bands. This includes all types of voice or data services to be provided to all segments of the U.S. economy.”

The FCC further stated that the primary focus of PCS will be to meet the communications requirements of people on the move. In addition, the FCC has proposed that spectrum allocated for PCS not be used for broadcasting service.

Under the proposed rules pertaining to permissible communications, PCS licensees may provide any mobile communications service on their assigned spectrum. Fixed services may be provided only on an ancillary basis to mobile operations.

With regard to the issuance of pioneer preference licenses, the FCC, under Rule Making 90-314, has tentatively awarded preference status to American Personal Communications (APC), Cox Enterprises Inc., and Omnipoint Communications Inc.

According to the FCC, PCS will include advanced forms of cellular telephone service, advanced digital cordless telephone service, portable facsimile services, wireless PBX/Centrex services, wireless data, and wireless Local Area Network (LAN) services. These services could use the existing PSTN or alternative local networks such as cable television systems.

### **16.10.2 Service Concepts**

One common industry view of PCS is that they represent a family of telecommunications services supporting personal, terminal, and service mobility. Bellcore defines personal mobility as the ability of an end user to access his/her telecommunications services on any terminal, in any location, and the ability of the network to locate and identify the end user as he/she moves. Terminal mobility refers to the ability of a terminal to access telecommunications services from any location, while in motion, and the capability of the network to locate and identify this terminal as it moves. Service mobility refers to the ability to associate services with an end user rather than with the particular equipment.

---



---

These services, associated with an end user, can follow the end user as he/she moves with respect to the network.

In order to provide these end user services, a provider of PCS offers a particular set of functionality and features to particular market segments. This integrated PCS will allow the end user, via a personal number, to use a wireless communications device (such as a portable handset) to do the following:

- Make and receive calls while in a wireless PCS serving area
- Register his/her personal number on a wireless handset to be able to receive calls
- Access wireline features using his/her wireless communications device
- Be provided with the quality and security comparable to the wireline network.

PCS are provided to the end user by the PCS Services Provider (PSP). The PSP may choose to complement the functionality of its network with that of an infrastructure provider (for example, a LEC) to provide services. The degree to which a PSP requires access service capabilities depends upon the sophistication of its own network. PCS access services can be defined by a set of functions and the interfaces over which these functions are supported. PCS access service functions include the following:

- Registration
- Authentication
- Service validation
- Call delivery
- Call origination
- Vertical services support
- Automatic link transfer
- Channel encipherment
- Radio port control
- Accounting management
- Operations management (for example, profile manipulation).

A particular access service is a package of these capabilities; the specific package will be chosen by the PSP to complement its network functionality. Thus, access services are designed to be tailored to meet different PSP's needs.

Bellcore envisions three types of PSPs, each with a different level of functionality to provide access services:

- *PSP-N* — a PCS provider with full network capabilities, that is, with switching capability and radio management capabilities, as well as radio ports.
-

- *PSP-C* — a PCS provider with radio port control (Controller) capabilities and radio ports.
- *PSP-P* — a PCS provider with only radio ports.

As PCS evolve they shall require storage, access, and updates of data related to the PCS user. These database capabilities may be provided as part of the aforementioned PCS access services envisioned by Bellcore or they may be provided by a third party, a PSP-D. Access to these third-party database capabilities adds the following additional category of PSP:

- *PSP-D* — a PCS provider with databases that allow lookup and update functions that may support the access services and operation management functions.

Network control for PCS can encompass the LEC network functions that manage PCS calls and the associated mobility of PCS users. Examples are shown in GR-1411-CORE, *PCS Access Services Interface Specification in Support of PCS Routing Service, PCS Home Database Service, and PCS IS-41 Message Transport Service*, and SR-3285, *PCS Access Service for Radio Controllers (PASC) Interface Specifications*. The level of control exercised by the LEC network for a PSP is a function of the access service being offered. In general, the level of network control decreases as functionality provided by the PSP increases. The PCS access services may use the network control functions of SS7, Advanced Intelligent Network (AIN), and ISDN.

### 16.10.3 Signaling System 7

Until recently, many WSPs had been deploying SS7 within their networks and interconnecting that capability with the landline networks, largely for the support of TCAP and IS-41 message transport. IS-41 is an Intersystem Operations Interim Standard (IS) developed by the Telecommunications Industry Association (TIA), and provides for transport of mobile intersystem hand-off and user verification messages. Over the last year or two, however, many of the larger cellular carriers have arranged for additional SS7 capabilities within their networks, and have interconnected with landline carriers for ISDUP (call set up) as well. Paging service providers have just begun the deployment of SS7 capabilities and interconnection with the landline networks.

---

## Section 17

### Open Network Architecture

#### Contents

17. Open Network Architecture .....	17-1
17.1 Common ONA Model.....	17-1
17.1.1 Basic Serving Arrangements.....	17-1
17.1.2 Basic Service Elements.....	17-2
17.1.3 Complementary Network Services .....	17-2
17.2 Basic Serving Arrangement Categories .....	17-3
17.2.1 Category 1 — Circuit Switched BSA .....	17-3
17.2.1.1 Category 1, Type A — Circuit Switched Line BSA .....	17-3
17.2.1.2 Category 1, Type B — Circuit Switched Trunk BSA .....	17-5
17.2.2 Category 2 — Packet Switched BSA.....	17-6
17.2.2.1 Category 2, Type A — X.25 Packet Switched BSA .....	17-6
17.2.2.2 Category 2, Type B — X.75 Packet Switched BSA.....	17-8
17.2.3 Category 3 — Dedicated BSA .....	17-9
17.2.3.1 Category 3, Type A — Dedicated Metallic BSA .....	17-10
17.2.3.2 Category 3, Type B — Dedicated Telegraph BSA.....	17-11
17.2.3.3 Category 3, Type C — Dedicated Voice Grade BSA.....	17-12
17.2.3.4 Category 3, Type D — Dedicated Program Audio BSA.....	17-13
17.2.3.5 Category 3, Type E — Dedicated Video BSA .....	17-14
17.2.3.6 Category 3, Type F — Dedicated Digital (< 64 kbps) BSA .....	17-15
17.2.3.7 Category 3, Type G — Dedicated High Capacity Digital (1.544 Mbps) BSA.....	17-16
17.2.3.8 Category 3, Type H — Dedicated High Capacity Digital (>1.544 Mbps) BSA .....	17-17
17.2.3.9 Category 3, Type I — Dedicated Alert Transport BSA.....	17-17
17.2.3.10 Category 3, Type J — Dedicated Derived Channel BSA.....	17-18
17.2.3.11 Category 3, Type K — Dedicated Digital (64 Kbps) BSA .....	17-19
17.2.4 Category 4 — Dedicated Network Access Link BSA .....	17-20
17.3 Regulatory Background .....	17-21
17.3.1 The Telecommunications Act of 1996.....	17-25

---

---

## List of Figures

Figure 17-1. ONA Model .....	17-2
Figure 17-2. Digital Grade — Line Circuit Switched BSA .....	17-4
Figure 17-3. Voice Grade — Circuit Switched Trunk BSA .....	17-5
Figure 17-4. Packet Switching BSA.....	17-7
Figure 17-5. Dedicated Private Line BSA.....	17-10
Figure 17-6. Dedicated Network Access Link (DNAL) BSA.....	17-21

---

## 17. Open Network Architecture

Open Network Architecture (ONA) is a regulatory concept created by the Federal Communications Commission (FCC) to further the FCC's goals of bringing the full benefits of the "Information Age" to the American public. The FCC requires the Bell Operating Companies (BOCs) to offer unbundled Basic Serving Arrangements (BSAs) and Basic Service Elements (BSEs) under tariff so Enhanced Service Providers (ESPs) can access them to provide enhanced services.<sup>1</sup>

### 17.1 Common ONA Model

The Common ONA Model (Figure 17-1), approved by the FCC in an Order released December 22, 1988 (CC Docket No. 88-2, Phase I), consists of three integral parts:

- Basic Serving Arrangements (BSAs)
- Basic Service Elements (BSEs)
- Complementary Network Services (CNSs).

It has been structured so that it is technology independent and therefore can accommodate a variety of existing and future architectures. Its purpose is to provide a uniform and common basis for discussion of ONA in all BOCs.

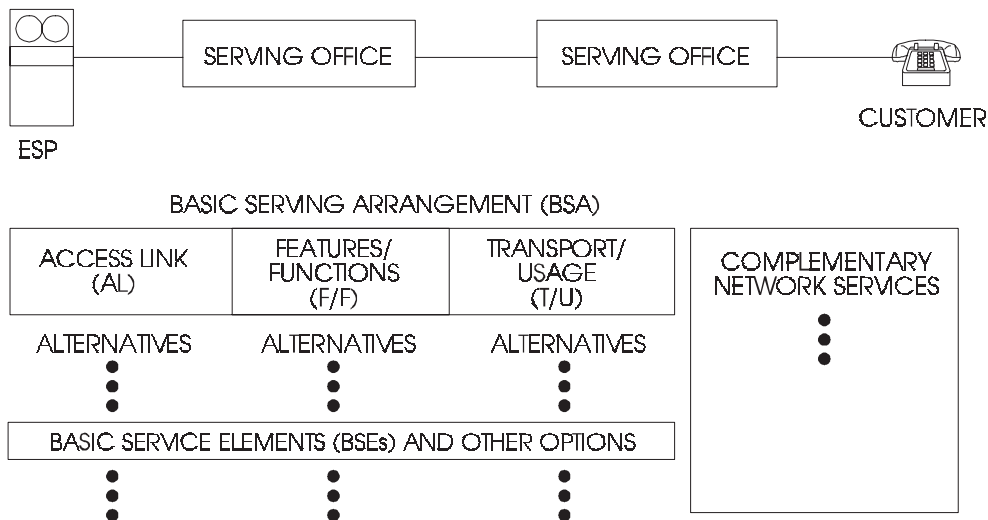
#### 17.1.1 Basic Serving Arrangements

A BSA is the underlying connection of an ESP to and through the BOC networks, and should be considered the fundamental ONA connection to those networks. It is comprised of an ESP access link, the features/functions associated with that access link at the ESP's serving office and/or other offices, and the transport (dedicated or switched) within the network that completes the connection from the ESP to its customers' serving offices or to capabilities associated with a customer's CNSs. Each one of these may have a number of alternatives.

- ESP Access Link - The ESP access link portion of the ONA Model consists of the facilities used to connect the ESP to its serving office. The ESP has a choice of alternatives.

---

1. As defined by the FCC in Computer Inquiry II (CI-II), enhanced services are services offered over common carrier transmission facilities which employ computer processing applications that act on the format, content, code, protocol, or similar aspects of the subscriber's transmitted information; provide the subscriber additional, different, or restructured information; or involve subscriber interaction with stored information.



**Figure 17-1.** ONA Model

- **Features/Functions** - The features/functions portion of the ONA Model consists of capabilities located at the ESP's serving office and/or a distant office and could include, but not be limited to, those features/functions associated with circuit or packet switching arrangements. There may be several alternatives available to ESPs.
- **Transport/Usage** - The transport/usage portion of the ONA Model completes the connection from the ESP's serving office to its customers' serving offices or to capabilities associated with the customer's CNSs. It may be switched or dedicated, and there may be several alternatives available.

In the ONA Model, an alternative is an item that must be selected for the BSA to be technically meaningful.

### 17.1.2 Basic Service Elements

A BSE is an optional network capability associated with a BSA. An option is a technically defined capability that may or may not be selected in conjunction with a particular alternative.

### 17.1.3 Complementary Network Services

CNS is the term used to describe the means for a customer to connect to the network. CNSs may be used to access an ESP in an ONA environment. Many existing services would fall

---

into this category. A CNS would usually consist of the customer's local service (for example, business or residence line) and could have several service options associated with it.

## 17.2 Basic Serving Arrangement Categories

ONA services classified as BSAs include those described in the following paragraphs. The descriptions included here are based on the July 1997, *ONA Services User Guide*. **Note:** Not all services are offered by each regional company.

More details about these BSAs, and descriptions of CNSs and associated BSEs can be found in the *ONA Services User Guide*, available upon request from any regional company or the Network Interconnection/Interoperability Forum (NIIF) secretary.

### 17.2.1 Category 1 — Circuit Switched BSA

A circuit switched BSA provides an ESP with a connection to the circuit switched network. This BSA is capable of supporting analog signals of approximately 300 to 3000-Hz or a circuit-switched digital interface with a call type of digital encoded voice, 3.1~kHz or 7 kHz audio, 56 kbps or 64 kbps data transmission. This BSA may also transmit voice-grade analog data. The transmission interface may be 2-wire or 4-wire, or derived from a variety of multiplexing alternatives (for example, Digital Signal level 0 [DS0] from DS1, or DS1 from DS3).

This BSA may support one-way or two-way directionality. Calls are set up and taken down on a call-by-call basis. The transport/usage element could be intraoffice or interoffice.

Route diversity may be available with this serving arrangement.

#### 17.2.1.1 Category 1, Type A — Circuit Switched Line BSA

##### Service Description

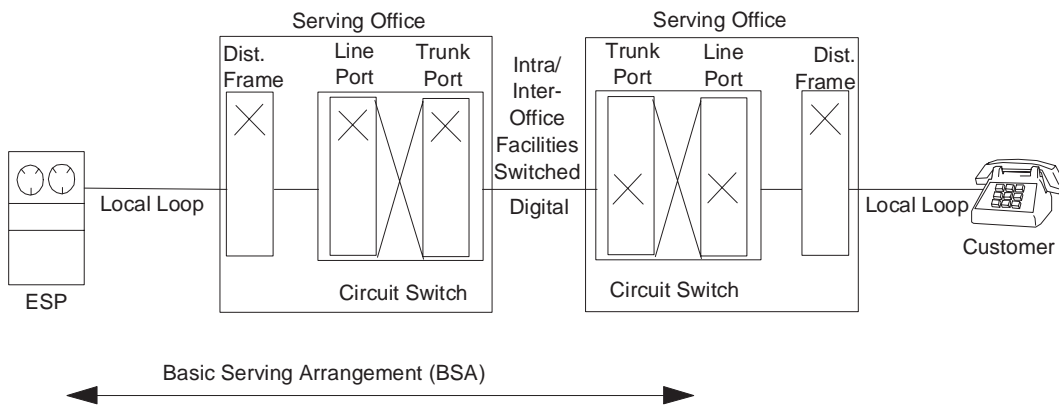
A circuit switched line BSA provides an ESP with a line-side connection to the circuit switched network. See Figure 17-2 for an example.

This line-side connection could include alternative types of network connection, address and supervisory inband or out-of-band signaling. Examples of network connections are standard telephone line or a line-side type connection (such as PBX service). This BSA may support one-way or two-way directionality on a 2-wire or 4-wire transmission interface.

Calls are set up and taken down on a call-by-call basis. The calling scope may include, for example, an entire Local Access and Transport Area (LATA), a market area, or be limited

---

to all or part of a metropolitan area. Directory numbers are assigned from the North American Numbering Plan (NANP) without any special routing or other use of the number.



**Figure 17-2.** Digital Grade — Line Circuit Switched BSA

## Alternatives

An alternative is an item that must be selected for the BSA to be technically meaningful. Alternative items may be available from some or all of the Local Exchange Carriers (LECs). Refer to the individual LEC tariff reference diskette for the reference information where LEC-defined alternatives may be found. Examples of potential alternatives may be: Service Code Denial and Uniform Call Distribution (UCD).

## Signaling

Signaling arrangements extend line circuit or signaling circuit alerting information on metallic or fiber facilities from one customer premises location to another customer premises location. The signaling arrangement can be terminated on trunk-like or line-side interfaces of the LEC switch. Examples of address signaling on an analog interface are dial pulse or Dual-Tone Multifrequency (DTMF) with supervisory signaling of loop start or ground start. A digital interface will offer address and supervisory signaling via an out-of-band standardized protocol.

## Transmission

The subject of transmission covers a broad range of performance considerations related to the physical facilities that compose network architecture. Transmission parameters are designed to provide objective transmission performance characteristics, as perceived by the end user and LEC, between the points of termination. Transmission parameters are defined for each Network Interface (see below) supporting this BSA. These parameters are defined



in the reference documentation section of the full BSA description in the *ONA Services User Guide*.

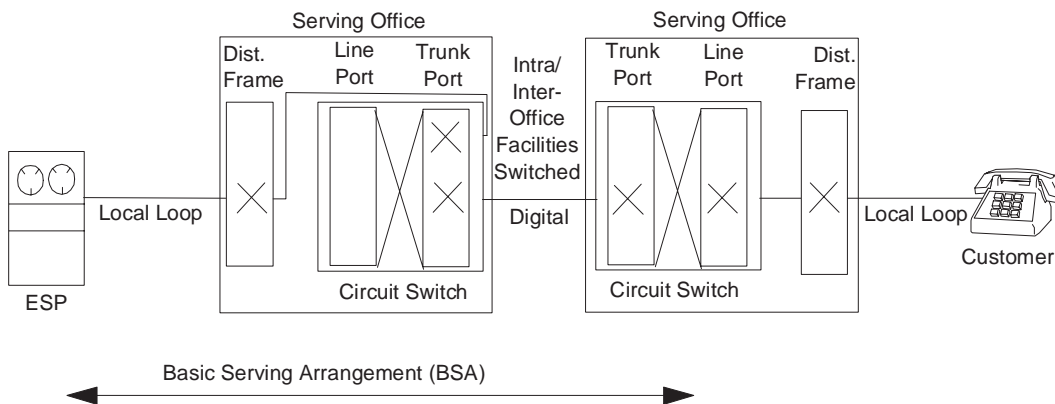
## Network Interfaces

The electrical and physical interface with the LEC is described by a Network Channel Interface (NCI) code for each end user termination and each service provider termination. NCI codes are provided to aid the user in understanding the relationship of the network interface to the electrical or optical characteristics of the interface. NCI codes have four basic components: (1) number of conductors (wire or fibers), (2) protocol code, (3) nominal reference impedance code, and (4) any applicable protocol options.

### 17.2.1.2 Category 1, Type B — Circuit Switched Trunk BSA

#### Service Description

A circuit switched trunk BSA provides an ESP with a trunk-side connection to the circuit switched network. See Figure 17-3 for an example.



**Figure 17-3.** Voice Grade — Circuit Switched Trunk BSA

Various types of network connections, address signaling and supervisory signaling are available. An example of network connections to the serving office may be direct trunk or a tandem connection. Calls are set up and taken down on a call-by-call basis. Different access arrangements, based on the NANP, are available from the LECs. This BSA may support one-way or two-way directionality.

## Alternatives

An alternative is an item that must be selected for the BSA to be technically meaningful. Alternative items may be available from some or all of the LECs. Refer to the individual LEC tariff reference diskette for the reference information where LEC-defined alternatives may be found. Examples of potential alternatives may be: Service Class Routing, Dial Pulse Address Signaling, and Cut Through.

## Signaling

Signaling arrangements extend trunk circuit or signaling circuit alerting information on metallic or fiber facilities from one customer premises location to another customer premises location. These signals are the means by which the end user initiates a request for service, holds a connection or releases a connection. The signaling arrangements can be terminated on line-like or trunk-side interfaces of the LEC switch. Examples of point-of-termination supervisory signaling arrangements that may be ordered are Multifrequency (inband), Signaling System 7 (SS7) (out-of-band), reverse battery, and E&M.

## Transmission

See Section 17.2.1.1 for information on transmission parameters.

## Network Interfaces

See Section 17.2.1.1 for information on network interfaces.

### 17.2.2 Category 2 — Packet Switched BSA

A packet switched BSA provides an ESP with a connection to the packet switched network via virtual and permanent virtual circuit connections. This BSA is capable of supporting analog or digital signals of various transmission rates. The transmission interface may be 2-wire or 4-wire, or derived from a variety of multiplexing alternatives (for example, DS0 from DS1, or DS1 from DS3).

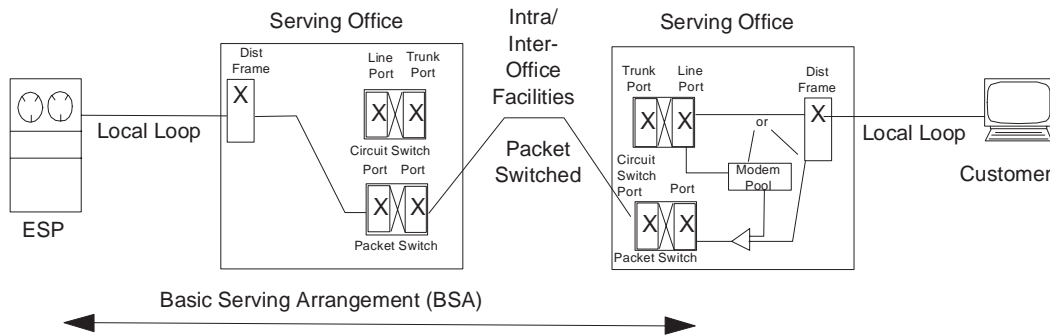
#### 17.2.2.1 Category 2, Type A — X.25 Packet Switched BSA

### Service Description

The Type A Packet Switched BSA provides an ESP with X.25 or X.31 access to the LEC packet switching network via virtual and permanent virtual circuit connections. This

---

interface conforms to Recommendations X.25 and X.31 of the International Telecommunication Union — Telecommunication Standardization Sector (ITU-T).<sup>2</sup> See Figure 17-4 for an example of a Packet Switched BSA.



**Figure 17-4.** Packet Switching BSA

X.25 includes physical, link, and packet level procedures. At the physical level, data signaling rates of 1.2, 2.4, 4.8, 9.6 and 56 kbps are supported. The link level protocol supported at the interface is Link Access Protocol Balanced (LAPB). The main functions of the link level protocol are to ensure that the packets cross the Data Terminal Equipment/Data Communications Equipment (DTE/DCE) interface essentially error free and reach their destination in a correctly transmitted sequence. The network level access protocol provides the procedures required to set up, maintain, and clear virtual calls. X.31 defines the recommended procedures for using Q.931 protocol to establish digital Customer Premises Equipment (CPE) calls to a packet network in accordance with defined bearer services.

## Alternatives

An alternative is an item that must be selected for the BSA to be technically meaningful. Alternative items may be available from some or all of the LECs. Refer to the individual LEC tariff reference diskette for the reference information where LEC-defined alternatives may be found. Examples of potential alternatives may be: Logical Channel, Flow Control Parameters, and Multiple Network Addresses.

## Signaling

Signaling arrangements extend alerting information on metallic or fiber facilities from one customer premises location to another customer premises location. Dial (circuit-switched) access provides low- to moderate-throughput Public Packet Switched Network (PPSN)

2. Formerly the International Telegraph and Telephone Consultative Committee (CCITT).

access through the voice telephone network. With dial-in access, a customer terminal and modem are attached to the Public Switched Telephone Network (PSTN) loop. The customer dials an NANP address and the PSTN routes the call to a PPSN dial-up port. The PPSN answers the call with a modem supporting one of several modem protocols.

With dial-out access, a call is routed to a PPSN interface supporting dial-out service. At this interface, the access concentrator obtains the NANP address and uses the ITU-T V.25 calling procedures to instruct the PPSN modem to establish a physical connection with the customer via the PSTN.

Dedicated (nonswitched) access provides the customer with continuously available interfaces to the PPSN.

### **Transmission**

See Section 17.2.1.1 for information on transmission parameters.

### **Network Interfaces**

See Section 17.2.1.1 for information on network interfaces.

#### **17.2.2.2 Category 2, Type B — X.75 Packet Switched BSA**

### **Service Description**

The Type B Packet Switched BSA provides an ESP with X.75 access to the LEC packet switching network. The X.75 interface conforms to Recommendation X.75 of the ITU-T (formerly the CCITT). See Figure 17-4 for example of a Packet Switched BSA.

X.75 includes physical, link, and packet level procedures. At the physical level, data signaling rates of 9.6 kbps are supported over analog or digital facilities. Speeds of 56 kbps are supported over digital facilities only. The link level protocol supported at the interface is LAPB. The main functions of the link level protocol are to ensure that the packets cross the network interface essentially error free and reach their destination in a correctly transmitted sequence. The network level access protocol provides the procedures required to set up, maintain, and clear virtual calls.

### **Alternatives**

An alternative is an item that must be selected for the BSA to be technically meaningful. Alternative items may be available from some or all of the LECs. Refer to the individual LEC tariff reference diskette for the reference information where LEC-defined alternatives

---

may be found. Examples of potential alternatives may be: Logical Channel, Flow Control Parameters, and Multiple Network Addresses.

## Signaling

Signaling arrangements extend alerting information on metallic or fiber facilities from one customer premises location to another customer premises location. Dial (circuit-switched) access provides low- to moderate-throughput PPSN access through the voice telephone network. With dial-in access, a customer terminal and modem are attached to the PSTN loop. The customer dials an NANP address and the PSTN routes the call to a PPSN dial-up port. The PPSN answers the call with a modem supporting one of several modem protocols.

With dial-out access, a call is routed to a PPSN interface supporting dial-out service. At this interface, the access concentrator obtains the NANP address and uses the ITU-T V.25 calling procedures to instruct the PPSN modem to establish a physical connection with the customer via the PSTN.

Dedicated (nonswitched) access provides the customer with continuously available interfaces to the PPSN.

## Transmission

See Section 17.2.1.1 for information on transmission parameters.

## Network Interfaces

See Section 17.2.1.1 for information on network interfaces.

### 17.2.3 Category 3 — Dedicated BSA

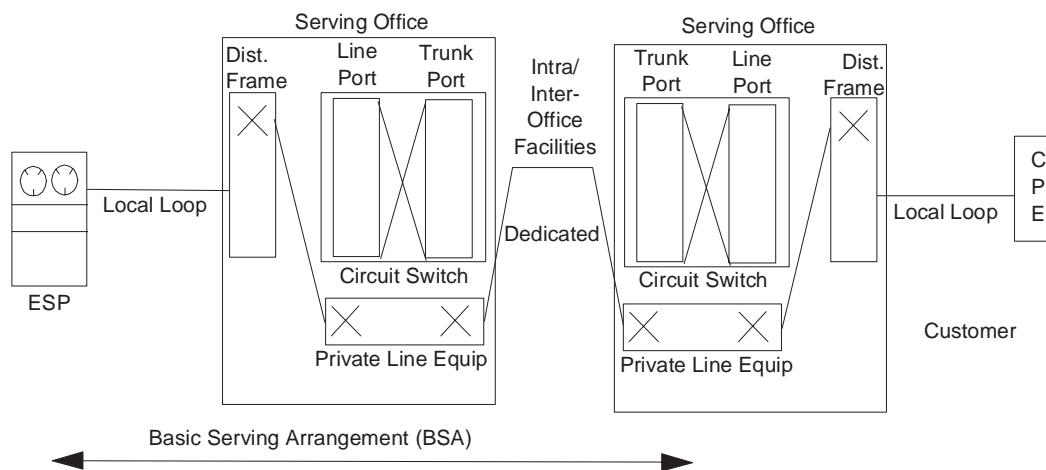
A dedicated BSA provides an ESP with a dedicated point-to-point connection through the network. This category of serving arrangements is available full-time so that individual calls are not set up and taken down. This BSA is capable of supporting analog or digital signals at various transmission rates. The transmission interface may be 2-wire or 4-wire, or derived from a variety of multiplexing alternatives (for example, DS0 from DS1, or DS1 from DS3). It is also capable of providing supervisory signaling in some configurations.

Route diversity may be available with this serving arrangement.

## 17.2.3.1 Category 3, Type A — Dedicated Metallic BSA

**Service Description**

The Dedicated Metallic BSA provides a nonswitched channel between the ESP and the ESP's client for the transmission of low speed varying signals at rates up to 30 baud. This service can only be provided where metallic facilities are available. See Figure 17-5 for example of a dedicated private line BSA.



**Figure 17-5.** Dedicated Private Line BSA

Metallic dedicated services are nonswitched services used for applications such as alarm, pilot wire protective relaying, and direct current tripping protective relaying. Interoffice metallic facilities will be limited in length to a total of five miles per channel. Metallic dedicated service (called MT1 in TR-NPL-000336, *Metallic and Telegraph Grade Special Access Service Transmission Parameter Limits and Interface Combinations*) provides a metallic or equivalent pair between an end user and the service provider's point of termination.

Metallic dedicated service MT1 may have a second end user point of termination bridged to the first.

**Alternatives**

An alternative is an item that must be selected for the BSA to be technically meaningful. Alternative items may be available from some or all of the LECs. Refer to the individual LEC tariff reference diskette for the reference information where LEC-defined alternatives may be found. Examples of potential alternatives may be provision of services between

---

customer designated premises through serving wire centers or between a customer designated premises and a LEC hub.

### Signaling

Metallic dedicated serving arrangements are available full-time and therefore signaling arrangements are not applicable.

### Transmission

See Section 17.2.1.1 for information on transmission parameters.

### Network Interfaces

See Section 17.2.1.1 for information on network interfaces.

#### 17.2.3.2 Category 3, Type B — Dedicated Telegraph BSA

The Dedicated Telegraph BSA provides a nonswitched channel between the ESP and the ESP's client for the transmission of binary signals at rates of 0 to 75 baud or 0 to 150~baud. See Figure 17-5 for an example.

Telegraph dedicated services are nonswitched services used for applications such as teletypewriter, telegraph grade control/remote metering, telegraph grade channel, telegraph grade extension, and telegraph grade entrance facilities. Certain applications must be provided using metallic facilities, and may only be offered where appropriate metallic facilities are available.

Telegraph Special Access services TG1 and TG2 may be available, described as follows:

- TG1 service provides transmission of asynchronous transitions between two current levels at rates up to 75 baud between an end user and the ESP's point of termination. This service may be furnished for half-duplex or duplex operation in a two-point or multipoint configuration. Neither direct current (DC) continuity of this service nor the capability to continuously transport varying alternating current (AC) is assured.
- TG2 service provides transmission of asynchronous transitions between two current levels at rates up to 150 baud between an end user and the ESP's point of termination. This service may be furnished for half-duplex or duplex operation in a two-point or multipoint configuration. Neither DC continuity of this service nor the capability to continuously transport varying AC is assured.

Telegraph services TG1 and TG2 may have active or passive multipoint-bridging, the maximum number of bridges to be determined by service application design limitations.

---

## Alternatives

An alternative is an item that must be selected for the BSA to be technically meaningful. Alternative items may be available from some or all of the LECs. Refer to the individual LEC tariff reference diskette for the reference information where LEC-defined alternatives may be found. Examples of potential alternatives may be: half-duplex or full-duplex operation in a two-point or multipoint configuration.

## Signaling

Telegraph dedicated serving arrangements are available full-time and therefore signaling arrangements are not applicable.

## Transmission

See Section 17.2.1.1 for information on transmission parameters.

## Network Interfaces

The electrical interface with the LEC for metallic services is described by a Network Channel Interface (NCI) code for each end user termination and each service provider termination. The NCI codes for the desired service must be specified by the customer when ordering telegraph grade services. NCI codes are provided to aid the user in understanding the relationship of the network interface to the electrical or optical characteristics of the interface. NCI codes have four basic components: (1) number of conductors (wire or fibers), (2) protocol code, (3) nominal reference impedance code, and (4) any applicable protocol options.

### 17.2.3.3 Category 3, Type C — Dedicated Voice Grade BSA

#### Service Description

The dedicated voice grade BSA provides an ESP with a dedicated connection through the network to the ESP's client. This BSA is capable of supporting the transmission of analog signals within an approximate bandwidth of 300 - 3000 Hz. The transmission interface may be 2-wire or 4-wire. Voice grade services are provided between service provider designated premises through serving wire centers or between a service provider designated premises and a LEC hub. It is capable of providing various supervisory signaling alternatives. See Figure 17-5 for an example.

---



## Alternatives

An alternative is an item that must be selected for the BSA to be technically meaningful. Alternative items may be available from some or all of the LECs. Refer to the individual LEC tariff reference diskette for the reference information where LEC-defined alternatives may be found. Examples of potential alternatives may be: transfer arrangement, improved termination, data capability, telephoto capability, and signaling capabilities.

## Signaling

Signaling capability provides for the process by which one customer premises alerts another customer premises on the same service with which it wishes to communicate. These signals are the means by which the end user initiates a request for service, holds a connection, or releases a connection. Examples of signaling arrangements are loop-start, ground-start, E&M, and reverse-battery.

## Transmission

See Section 17.2.1.1 for information on transmission parameters.

## Network Interfaces

See Section 17.2.1.1 for information on network interfaces.

### 17.2.3.4 Category 3, Type D — Dedicated Program Audio BSA

## Service Description

The dedicated program audio BSA provides an ESP with a one-way nonswitched channel to the ESP's client that can pass an analog signal up to 15000 Hz. This serving arrangement is usually provided for transmission of music, but it is capable of voice and data within the band pass limits. Nominal frequency bandwidths for this serving arrangement are 50 to 15000 Hz, 200 to 3500 Hz, 100 to 5000 Hz, 300 to 2500 Hz, or 50 to 8000 Hz. See Figure 17-5 for an example.

## Alternatives

An alternative is an item that must be selected for the BSA to be technically meaningful. Alternative items may be available from some or all of the LECs. Refer to the individual LEC tariff reference diskette for the reference information where LEC-defined alternatives may be found. Examples of potential alternatives may be: stereo and gain conditioning.

---

## Signaling

Program Audio services are available full-time and therefore signaling arrangements are not applicable.

## Transmission

See Section 17.2.1.1 for information on transmission parameters.

## Network Interfaces

See Section 17.2.1.1 for information on network interfaces.

### 17.2.3.5 Category 3, Type E — Dedicated Video BSA

## Service Description

The dedicated video BSA provides an ESP with a dedicated, broadband communications channel to the ESP's client. See Figure 17-5 for an example. Applications may include, but are not limited to, full-time and part-time commercial broadcast quality television, noncommercial broadcast quality television, video teleconferencing, distance-learning applications, surveillance, and closed-circuit television. The channel is capable of transmitting a standard 525 line/60 field monochrome or National Television Systems Committee (NTSC) color video signal and associated audio signals. The associated audio signal(s) may be either duplexed or provided as separate channels. Video services are provided between customer designated premises through Serving Wire Center(s) or between a customer designated premises and a LEC hub.

## Alternative

An alternative is an item that must be selected for the BSA to be technically meaningful. Alternative items may be available from some or all of the LECs. Refer to the individual LEC tariff reference diskette for the reference information where LEC-defined alternatives may be found. Examples of potential alternatives may be: 5 or 15 Hz audio channels, duplexed or separate channel audio signals, and video/audio delay difference.

## Signaling

Video services are available full-time and therefore signaling arrangements are not applicable.

---

## Transmission

See Section 17.2.1.1 for information on transmission parameters.

## Network Interfaces

The electrical and physical interface with the LEC is described by a Network Channel Interface (NCI) code for each end user termination and each service provider termination. NCI codes define the bandwidth and the provision of the audio signal(s) associated with a broadcast video channel. NCI codes are: (1) Total Conductors, (2) Protocol, (3) Impedance, (4) Protocol Options, and (5) Transmission Level Point (ignored for Television Special Access).

### 17.2.3.6 Category 3, Type F — Dedicated Digital (< 64 kbps) BSA

## Service Description

The dedicated digital (< 64 kbps) BSA provides an ESP with a 4-wire digital channel to the ESP's client. This serving arrangement provides for digital transmission of synchronous serial data at primary rates of 2.4, 4.8, 9.6, 19.2, or 56 kbps, plus associated secondary channel rates of 2.4, 4.8, 9.6, 19.2, or 56 kbps. Error Detection/Correction is an inherent part of this BSA. See Figure 17-5 for an example.

Digital Data special access services are nonswitched channels that provide the capability to transmit digital data between two end user points of termination or an end user point of termination and a service provider point of termination.

## Alternative

An alternative is an item that must be selected for the BSA to be technically meaningful. Alternative items may be available from some or all of the LECs. Refer to the individual LEC tariff reference diskette for the reference information where LEC-defined alternatives may be found. Examples of potential alternatives may be: Transfer Arrangement.

## Signaling Arrangements

These services are available full-time and therefore supervisory signaling arrangements are not applicable. The signaling service is synchronous with timing provided through the LEC's facilities to the end user on the received bit stream. Individual calls are not set up and taken down.

---

## Transmission

See Section 17.2.1.1 for information on transmission parameters.

## Network Interfaces

See Section 17.2.1.1 for information on network interfaces.

### 17.2.3.7 Category 3, Type G — Dedicated High Capacity Digital (1.544 Mbps) BSA

## Service Description

The dedicated high capacity digital (1.544 Mbps) BSA provides an ESP with a dedicated channel. See Figure 17-5 for an example. High Capacity Digital service is defined as a service that provides two-point, private-line, full duplex transmission at 1.544 Mbps isochronous serial data with a payload of 1.536 Mbps between an end user and an end user or between an end user and a LEC central office.

In some cases, this BSA can be provisioned for dedicated transport of Extended Superframe Format (ESF) data channel capability.

## Alternatives

An alternative is an item that must be selected for the BSA to be technically meaningful. Alternative items may be available from some or all of the LECs. Refer to the individual LEC tariff reference diskette for the reference information where LEC-defined alternatives may be found. An example of a potential alternative may be: transfer arrangement.

## Signaling

The signaling service is isochronous with timing provided through the LEC's facilities to the end user on the received bit stream. Individual calls are not set up and taken down.

## Transmission

See Section 17.2.1.1 for information on transmission parameters.

## Network Interfaces

See Section 17.2.1.1 for information on network interfaces.

---

---

### 17.2.3.8 Category 3, Type H — Dedicated High Capacity Digital (>1.544 Mbps) BSA

#### **Service Description**

The dedicated high capacity digital (>1.544 Mbps) BSA provides an ESP with a dedicated channel to the ESP's client via a digital facility. See Figure 17-5 for an example. High Capacity Digital service is defined as a service that provides two-point, private-line transmission at speeds above 1.544 Mbps between an end user and an end user or between an end user and a LEC central office. Individual calls are not set up and taken down. The ESP must specify the desired transmission speed as an alternative with this BSA.

#### **Alternatives**

An alternative is an item that must be selected for the BSA to be technically meaningful. Alternative items may be available from some or all of the LECs. Refer to the individual LEC tariff reference diskette for the reference information where LEC-defined alternatives may be found. Examples of potential alternatives may be: transmission speed and transfer arrangement.

#### **Signaling**

The signaling service is isochronous with timing provided through the LEC's facilities to the end user on the received bit stream. Individual calls are not set up and taken down.

#### **Transmission**

See Section 17.2.1.1 for information on transmission parameters.

#### **Network Interfaces**

See Section 17.2.1.1 for information on network interfaces.

### 17.2.3.9 Category 3, Type I — Dedicated Alert Transport BSA

#### **Service Description**

The dedicated alert transport BSA using derived local channel technology and a LEC-provided scanner offers ESPs a 24-hour supervised monitoring capability using compatible local loop access lines. See Figure 17-5 for an example.

---

The scanner continuously monitors the status of all clients. A host processor monitors all scanners and, in response to a change in status, will identify the subscriber from which the alert condition originates and notify the appropriate ESP.

This serving arrangement utilizes derived channels which comply with Underwriter's Laboratories (UL) AA and National Fire Protection Association (NFPA) requirements.

### **Alternatives**

An alternative is an item that must be selected for the BSA to be technically meaningful. Alternative items may be available from some or all of the LECs. Refer to the individual LEC tariff reference diskette for the reference information where LEC-defined alternatives may be found.

### **Signaling**

Dedicated serving arrangements are available full-time and therefore supervisory signaling arrangements are not applicable.

### **Transmission**

See Section 17.2.1.1 for information on transmission parameters.

### **Network Interfaces**

The NCI codes for the desired service must be specified by the customer when ordering metallic services. See Section 17.2.1.1 for more information on network interfaces.

#### **17.2.3.10 Category 3, Type J — Dedicated Derived Channel BSA**

### **Service Description**

The dedicated derived channel BSA provides one or more low-speed dedicated data channels (for example, 9.6 kbps) derived on a dial tone line in addition to the voice channel. See Figure 17-5 for an example. The customer is provided with a multiplexed interface requiring the use of a Data/Voice Multiplexer (DVM) on the customer's premises. A matching DVM in the central office splits off the data channel(s) from the voice path before the voice path enters the circuit switch.

Several options may be available for extending the derived data channel to the ESP, including a low-speed private line, a multiplexing arrangement whereby several derived

---

---

channels are transmitted on a higher speed private line, or a DVM similar to the equipment employed on the end user's access link resulting in "back-to-back" derived channels.

### **Alternatives**

An alternative is an item that must be selected for the BSA to be technically meaningful. Alternative items may be available from some or all of the LECs. Refer to the individual LEC tariff reference diskette of the *ONA Services User Guide* for the reference information where LEC-defined alternatives may be found.

### **Signaling**

Dedicated serving arrangements are available full-time and therefore signaling arrangements are not applicable.

### **Transmission**

See Section 17.2.1.1 for information on transmission parameters.

### **Network Interfaces**

The NCI codes for the desired service must be specified by the customer when ordering metallic services. See Section 17.2.1.1 for more information on network interfaces.

#### **17.2.3.11 Category 3, Type K — Dedicated Digital (64 Kbps) BSA**

### **Service Description**

Dedicated Digital (64 kbps) Service will provide a channel for duplex 4-wire transmission of synchronous serial data at 64 kbps. The channel provides a synchronous service with timing provided by the LEC. The 64 kbps channel will be provided between two customer-designated premises or between a customer-designated premise and a telephone company serving wire center. See Figure 17-5 for an example.

### **Alternative**

An alternative is an item that must be selected for the BSA to be technically meaningful. Alternative items may be available from some or all of the LECs. Refer to the individual LEC tariff reference diskette for the reference information where LEC-defined alternatives may be found. An example of potential alternatives may be: Transfer Arrangement.

---

## Signaling Arrangements

These services are available full-time and therefore supervisory signaling arrangements are not applicable. The signaling service is synchronous with timing provided through the LEC's facilities to the end user on the received bit stream. Individual calls are not set up and taken down.

## Transmission

See Section 17.2.1.1 for information on transmission parameters.

## Network Interfaces

The NCI codes for the service desired must be specified by the customer when ordering. Only certain code combinations are compatible, as listed in TR-NWT-000341, *Digital Data Special Access Service — Transmission Parameter Limits and Interface Combinations*. See Section 17.2.1.1 for more information on network interfaces.

### 17.2.4 Category 4 — Dedicated Network Access Link BSA

#### Service Description

The Dedicated Network Access Link (DNAL) BSA provides a dedicated data channel between the ESP's termination and a designated central office which contains the specific features required by the ESP. The DNAL is used to transmit network information or network control information from the ESP to the network (for example, activating a message waiting indicator), or to deliver network information or network control information from the network to the ESP (for example, calling number identification over a message desk interface). The type of DNAL BSA used will determine the bandwidth alternatives and capabilities available to the ESP.

The DNAL BSA can support one-way or two-way transmission depending on the alternatives used.

Route diversity may be available with this serving arrangement.

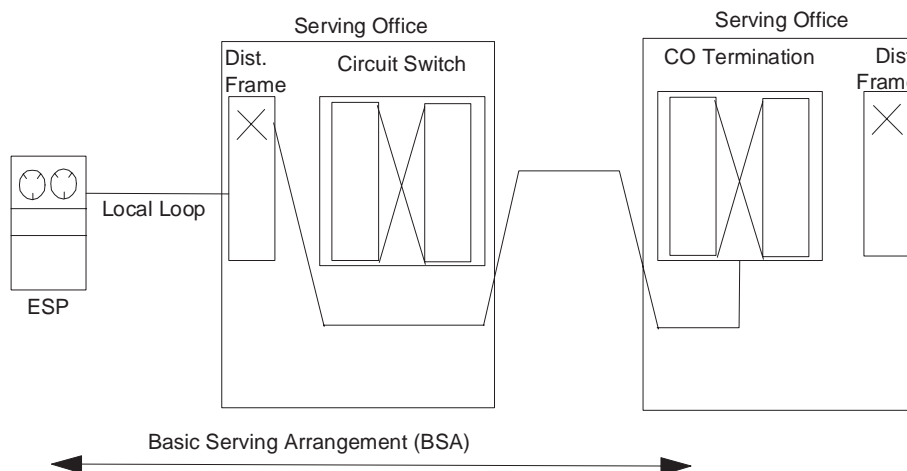
See Figure 17-6 for example of the DNAL BSA.

#### Alternatives

An alternative is an item that must be selected for the BSA to be technically meaningful. Alternative items may be available from some or all of the LECs. Refer to the individual

---





**Figure 17-6.** Dedicated Network Access Link (DNAL) BSA

LEC tariff reference diskette for the reference information where LEC-defined alternatives may be found.

### Signaling

Signaling capability provides for the process by which one customer premises alerts another customer premises on the same service with which it wishes to communicate. These signals are the means by which the end user initiates a request for service, holds a connection or releases a connection.

### Transmission

See Section 17.2.1.1 for information on transmission parameters.

### Network Interfaces

See Section 17.2.1.1 for information on network interfaces.

## 17.3 Regulatory Background

ONA is part of the FCC's Computer Inquiry III (CI-III). Due to significant advances in computer technology, many believed by the mid-1980's that the CI-II rules were outdated. On August 16, 1985, the FCC opened its third Computer Inquiry. The Commission's Report and Order of June 1986 required the BOCs and AT&T to file ONA plans on

---

February 1, 1988, stating the set of basic services that each would offer under tariff to be used by ESPs, including the BOCs' enhanced operations, to provide enhanced service offerings. The FCC required that a set of unbundled "basic serving arrangements (BSAs), or basic service elements (BSEs)" be offered under tariff. The FCC stated that "such unbundling is essential to give competing service providers an opportunity to design offerings that utilize network services in a flexible and economical manner."

Until ONA plan approval was received, BOCs would be permitted to offer enhanced services without structural separation on an interim basis for specific services with approved Comparably Efficient Interconnection (CEI) plans. The CEI plans listed all the basic services that would be used by the BOC to provide the enhanced service, and provided "comparable interconnection" to unaffiliated ESPs. Upon FCC approval of the ONA plans, a BOC would be permitted to offer enhanced services that made use of tariffed basic ONA services, without filing for approval of enhanced services on a case-by-case basis. Other nonstructural safeguards required, in addition to interim CEI plans and long term ONA plans, included

- Accounting plans
- Network disclosure
- Customer Proprietary Network Information (CPNI)
- Non-discrimination.

The initial set of ONA services filed in the 2/1/88 ONA plans were to be implementable by one year after the FCC's approval of a BOC's ONA plan, and ESP input was to be sought so that the ONA services would be responsive to ESPs' needs. The FCC directed each BOC to make available, under tariff, the initial set of BSEs according to the following unbundling criteria:

- Technical and costing feasibility
- Utility as perceived by the ESP
- Market demand.

ONA Forums, hosted by the BOCs, were held in October 1986 and April 1987, with a Network Capabilities Overview tutorial held in January 1987. These ONA Forums, several additional forums hosted by individual BOCs and by ESP industry segments, plus filings made by interested parties, resulted in a list of 118 technically-oriented ESP requests. These were documented in *BOC ONA Special Reports #1 & #3* (dated August 21, 1987 and October 26, 1987).

In October 1987, the Exchange Carriers Standards Association (ECSA)<sup>3</sup> chartered the Information Industry Liaison Committee (IILC) to deal with issues associated with the provision of ONA services. The stated mission of the IILC was "to serve as an interindustry

---

3. Now called the Alliance for Telecommunications Industry Solutions (ATIS).

---

---

mechanism for the discussion and voluntary resolution of industry-wide concerns about the provision of Open Network Architecture (ONA) services and related matters.”

Participation was open to any party with an interest in ONA and related IILC activities, including exchange carriers, Interexchange Carriers (ICs), ESPs, end users, equipment manufacturers, trade associations, and government agencies. Issues were brought to the IILC on a voluntary basis, and resolution was reached by consensus. The FCC recognized the IILC as the forum to deal with information services/enhanced services industry issues, and has directed the BOCs to work through the IILC on various ONA issues since 1988. Effective January 1, 1997, the Network Interconnection/Interoperability Forum (NIIF) is responsible for dealing with ONA related issues formerly addressed by the IILC.

To assist ESPs in understanding the BOCs' generic requirements process used to develop technology that equipment suppliers were requested to provide, *BOC ONA Special Report #2* was contributed to the ESP industry on 10/9/87, with an update (Issue 2) provided on 3/27/89. To facilitate a common description of information to be included in the 2/1/88 ONA plans, the BOCs contributed *BOC ONA Special Report #4, Common ONA Model*, to the ESP industry on 11/11/87. (See Section 17.1 for description of ONA model.)

In December 1988, the FCC released an Order on the 2/1/88 ONA plans, approving them in part, and directing the BOCs to examine each other's plans to see if each company could identify additional ONA services. The FCC also requested that the BOCs work towards greater uniformity with respect to nomenclature and technical description of services, and work on several issues through the IILC. Amendments to the ONA plans were required to be filed by the BOCs on 5/19/89.

The BOCs contributed an *ONA Plan Reference Document* to the industry in April and June 1988, that included each company's response to the ESP requests received in the list of 118 requests (April contribution). Information was also provided about responses to ESP requests received individually by particular regional companies (June contribution). *BOC ONA Special Report #5* was contributed to the industry 5/24/89, following the filing of the ONA plan amendments. *BOC ONA Special Report #5* listed the ONA services offered by each company, using common nomenclature and service descriptions, and stating each regional company's name for the services they offered. The service descriptions included in *BOC ONA Special Report #5* ultimately evolved into the service descriptions section of the *ONA Services User Guide*, which was developed as a result of an issue brought to the IILC by ESPs (IILC Issue #006 - *ONA Services User Guide*).<sup>4</sup>

The *ONA Services User Guide* consists of three parts: service descriptions, tariff reference information, and wire center deployment data. All three parts are available on diskettes, and can be used in IBM or IBM-compatible personal computers. Upon request, the information will be provided in paper form. Each section available on diskette has a software utility program that enables the user to generate a set of simple output reports. The wire center deployment diskettes and tariff reference diskettes are produced individually by each BOC, following a uniform format employing American Standard Code for Information Interexchange (ASCII) flat files used by the appropriate software utility programs. This uniform format enables any interested party to develop their own software that will work

---

---

for any BOC's data files. The *ONA Services User Guide* has been updated twice a year for the past several years in the January and July time frames.

The FCC approved the amended ONA plans on 5/8/90. The FCC's preemption of state regulation of enhanced services and its lifting of structural separation resulted in litigation. The U.S. Ninth Circuit Court of Appeals issued a ruling on 6/6/90 which determined that the FCC's substitution of non-structural safeguards for the federal structural separation requirements applying to the BOCs was unlawfully arbitrary and capricious. In addition, the FCC had failed to carry its burden of showing that its preemption orders were necessary to avoid frustrating its regulatory goals. The Court vacated certain CI-III orders, and remanded them to the FCC for further proceedings.

As a result of the ruling, the FCC shortly thereafter granted interim CI-II waivers for previously approved BOC CEI plans, required that pending CEI plans be withdrawn and no new CEI plans filed, and permitted no further "integrated planning and development" by a BOC for new enhanced services. The FCC initiated the "CI-III Remand Proceedings" (Notice of Proposed Rulemaking [NPRM], CC Docket No. 90-368) on 8/6/90, and after reviewing stakeholder comments, reinstated ONA obligations on the BOCs in a Report and Order released 12/17/90 (CC Docket No. 90-368).

Meanwhile, a second proceeding was initiated by the FCC and released 12/17/90 (NPRM and Order, CC Docket No. 90-623) which dealt with the FCC's re-examination of the lifting of structural separation and preemption of states. On 12/20/91, the FCC released its "BOC Safeguards Order" (Report and Order, CC Docket No. 90-623) which determined that BOCs should be allowed to offer enhanced services and basic communications service on an integrated basis, subject to a comprehensive set of safeguards that would prevent cross-subsidization and discrimination. The Commission authorized LECs to provide enhanced services pursuant to the safeguards described in the Order once all conditions for lifting structural separation have been met. CEI plans and CEI waivers were again permitted to be filed with the Commission in the interim. The conditions for lifting structural separation requirements were that the LEC files notice with the FCC stating

1. It is technically prepared to offer each of its initial ONA services;
2. Federal tariffs for each of its initial interstate ONA services are in effect; and
3. State tariffs have been filed for each of its initial intrastate ONA services (although it is not necessary to have state tariffs effective at time of LEC filing requesting structural separation relief).

The BOCs were required to file federal ONA tariffs by November 1, 1991, which were approved by the Commission on February 2, 1992, subject to further investigation. BOCs were also permitted, on January 1, 1992, to engage in integrated planning and development of their companies' new enhanced services, once any necessary changes to their cost allocation manuals had been made. On an ongoing basis, BOCs are required to file ONA Plan Amendments updates every April 15.

---

---

In orders released in June 1992, Ameritech, Bell Atlantic, and U S WEST received relief from structural separation requirements. In an order released in November 1992, Southwestern Bell received relief from structural separation requirements. NYNEX received relief in an order released in December 1992, Pacific Bell received relief in an order released May 1993, and BellSouth received relief in an order released July 1993.<sup>4</sup>

In 1994, the Ninth Circuit Court held that the Commission had not sufficiently explained its conclusion that totally removing structural separation requirements was in the public interest given that ONA requirements no longer called for fundamental unbundling. The Court then vacated parts of CI-III and remanded the proceeding back to the Commission. The specific issue remanded is whether the Commission should totally lift structural separation requirements, as applied to BOC provision of enhanced services, given the current state of unbundling under ONA.

As a result of the Court's action, the Commission required the BOCs to return to service-specific CEI plans for enhanced services offerings. In addition, the Commission initiated a Notice of Proposed Rulemaking in 1995 to address the issues remanded by the Court (CI-III, Further Remand Proceedings, CC Docket No. 95-20).

The Commission concluded in the 1996 Interconnection Order (CC Docket No. 96-98), that enhanced service providers that do not also provide domestic or international telecommunications, are thus not telecommunications carriers within the meaning of the 1996 Telecommunications Act, may not interconnect under Section 151. The Commission further concluded in the Implementation of the Non-Accounting Safeguards of Sections 271 and 272 Proceeding (CC Docket No. 96-149), that the pending CI-III, Further Remand Proceedings, are the appropriate forum in which to examine the necessity of retaining any or all of the individual CI-III and ONA requirements.

### **17.3.1 The Telecommunications Act of 1996**

The Telecommunications Act of 1996 was passed by the 104th Congress and was signed into law by President Clinton on February 8, 1996. Among its many provisions, the Act opened the local exchange market to competition by requiring Incumbent Local Exchange Carriers (ILECs) to interconnect with other carriers.

The Interconnection Order addressed three types of entry into the local telephone market: facilities-based entry, purchasing of unbundled network elements from the ILEC, and resale of the incumbent's retail services.

---

4. Memorandum Opinion and Orders, CC Docket No. 90-623 and CC Docket No. 88-2, Phase I: released June 8, 1992 (Bell Atlantic); June 9, 1992 (U S WEST); June 15, 1992 (Ameritech); November 2, 1992 (Southwestern Bell Telephone Company); December 16, 1992 (NYNEX); May 21, 1993 (Pacific Bell); and July 14, 1993 (BellSouth).

The FCC prescribed minimum points of interconnection with the ILEC's network, including interconnection at out-of-band signaling transfer points necessary to exchange traffic and access call related databases:

- The line side of a local switch (e.g., at the main distributing frame),
- The trunk side of a local switch,
- The trunk interconnection points for a tandem switch, and
- Central office cross-connect points in general.

The FCC specified a minimum set of unbundled network elements, as follows:

- Local loops,
- Local and tandem switches,
- Interoffice transmission facilities,
- Network interface devices,
- Signalling and call-related databases,
- Operations support system functions, and
- Operator and directory assistance facilities.

The FCC specified a methodology for states to use in establishing rates for interconnection and the purchase of unbundled elements. Actual prices were to be set by the states. The FCC concluded that a cost-based pricing methodology based on forward-looking economic costs would be consistent with the goals of the 1996 Act. For those states that elect not to apply this methodology in time to complete arbitration process specified under Section 252, the FCC established default proxies for State PUCs to use to resolve arbitrations prior to a required study.

The FCC's Interconnection Order was subsequently appealed and was assigned to the Eighth Circuit Court of Appeals, which stayed certain provisions having to do with negotiated agreements and pricing.

---

---

## Section 18

### Industry Forums and Standards Committees

#### Contents

18. Industry Forums and Standards Committees .....	18-1
18.1 Overview .....	18-1
18.2 Asynchronous Transfer Mode (ATM) Forum.....	18-1
18.3 Internet Engineering Task Force (IETF).....	18-2
18.4 Intelligent Network Forum (IN Forum) .....	18-2
18.5 Digital Audio-Visual Council (DAVIC).....	18-3
18.6 International Telecommunications Union - Telecommunications (ITU-T).....	18-3
18.7 International Telecommunications Advisory Committee - Telecommunications (ITAC-T) .....	18-6
18.8 Telecommunications Industry Association (TIA).....	18-7
18.9 Alliance for Telecommunications Industry Solutions.....	18-9
18.9.1 Accredited Standards Committee: T1 — Telecommunications .....	18-13
18.9.1.1 Technical Subcommittee T1A1 — Performance and Signal Processing.....	18-15
18.9.1.2 Technical Subcommittee T1E1 — Interfaces, Power, and Protection for Networks.....	18-16
18.9.1.3 Technical Subcommittee T1M1 — Internetwork Operations, Administration, Maintenance, and Provisioning.....	18-17
18.9.1.4 Technical Subcommittee T1P1 — Wireless/Mobile Services and Systems.....	18-18
18.9.1.5 Technical Subcommittee T1S1 — Services, Architectures, and Signaling.....	18-19
18.9.1.6 Technical Subcommittee T1X1 — Digital Hierarchy and Synchronization .....	18-19
18.9.2 Carrier Liaison Committee.....	18-20
18.9.2.1 Network Interconnection/Interoperability Forum (NIIF) .....	18-20
18.9.2.2 Ordering and Billing Forum (OBF).....	18-22
18.9.2.3 Industry Numbering Committee (INC) .....	18-24
18.9.2.4 Toll Fraud Prevention Committee (TFPC).....	18-25
18.9.3 Telecommunications Industry Forum .....	18-25
18.9.4 Network Reliability Steering Committee.....	18-27
18.9.5 Electronic Communications Service Provider Committee .....	18-27
18.9.6 Protection Engineers Group .....	18-28

---

18.9.7 Standards Committee 05 - Wood Poles ..... 18-28  
18.9.8 SONENT Interoperability Forum ..... 18-29  
18.9.9 Internetwork Interoperability Test Coordination (IITC)  
Committee ..... 18-31

### List of Figures

Figure 18-1. ATIS Sponsored Committees ..... 18-11



---

## 18. Industry Forums and Standards Committees

### 18.1 Overview

There are many industry forums, standards bodies, and associations that operate in the United States and internationally that address various issues related to interconnection, technical standards, reliability, and operations in the telecommunications industry. These bodies may be either accredited or non-accredited. An accredited organization is an entity composed of industry members accredited by an institution vested with the responsibility for accreditation by the industry. In the United States, the American National Standards Institute (ANSI) has been vested with the responsibility for standards accreditation. Standards development organizations are generally characterized by open, voluntary and consensus-based standards that are developed under due process.

Industry forums are non-accredited, and operate under processes developed and approved by their membership. They may or may not be open and consensus-based, but are viewed by the industry as the most efficient and least contentious vehicles to resolve interconnection and interoperability related industry issues.

Numerous bodies have been formed or have evolved to address a wide range of telecommunications issues, many of which are discussed in Bellcore's SR-3776, *Telecommunications Industry catalog of Forums, Standards Bodies and Associations*, issued February 1997. A sampling of the more prominent bodies are listed below, and specific functions and responsibilities of the Alliance for Telecommunications Industry Solutions (ATIS) are detailed in Section 18.9.

### 18.2 Asynchronous Transfer Mode (ATM) Forum

The ATM Forum was established to promote and expedite the use of ATM products and services through rapid convergence of interoperability specifications, and to encourage industry cooperation and awareness. The ATM Forum works to promote ATM internationally with the industry and end-user community, and works closely with standards bodies like ANSI and the ITU.

Additional information for the ATM Forum may be obtained from

ATM Forum  
2570 W. El Camino Real, Suite 304  
Mountain View, CA 94040-1313  
(415) 949-6700; fax (415) 949-6705  
Homepage <http://www/atmforum.com>

### 18.3 Internet Engineering Task Force (IETF)

The IETF is an industry forum that was formed to

- Identify and propose solutions to pressing operational and technical problems in the Internet
- Specify the development or usage of protocols and the near-term architecture to solve technical problems for the Internet
- Facilitate technology transfer from the Internet Research Task Force (IRTF) to the wider Internet community
- Provide a forum for the exchange of relevant information within the Internet community between vendors, users, researchers, agency contractors, and network managers.

Internal operational management of the IETF is the responsibility of the Internet Engineering Steering Group (IESG). The Internet Architecture Board (IAB) is responsible for overall architectural considerations in the Internet, and also serves to adjudicate disputes in the Internet standards process. Additional information for the IETF may be obtained from

IETF Secretariat  
c/o Corporation for National Research Initiatives  
1895 Preston White Drive, Suite 100  
Reston VA 22091  
  
(703) 620-8990; fax: (703) 758-5913  
email: [ietf-secretariat@cnri.reston.va.us](mailto:ietf-secretariat@cnri.reston.va.us)

### 18.4 Intelligent Network Forum (IN Forum)

The IN Forum was formed to promote the continued growth and acceptance of Intelligent Networks (IN) by providing an international forum to address issues related to the implementation of IN technology and applications.

The IN Forum is an open industry forum that addresses interoperability and management issues related to INs. It comprises service providers, equipment vendors, software developers, systems integrators, research and engineering organizations, user, and other interested parties who promote the acceptance and implementation of IN technology and standards based on national and international standards. Two standing working committees of the INF have been established: the Technical Committee and the Marketing Awareness and Education Committee.

---

Additional information for the IN Forum may be obtained from

INF Executive Director Cathy Horn (903) 769-3717

Chairperson Kamal Sethia (AGCS) (602) 582-7079

Homepage <http://www.inf.org>

## **18.5 Digital Audio-Visual Council (DAVIC)**

DAVIC is an international standards body that was formed to aid in the success of emerging digital audio-visual applications and services, by the timely availability of internationally agreed-upon specifications. These include open interfaces and protocols that maximize interoperability across countries, applications, and services.

Membership in DAVIC is open to any corporation or individual firm, partnership, governmental body, or international organization. Members of DAVIC intend to make results of its activities available to all interested parties on reasonable terms, and intends to contribute results to appropriate formal standards bodies. Additional information for DAVIC may be obtained from

Nicola Bellina  
DAVIC Secretariat  
via Servais 125  
I-10146  
Torino, ITALY

fax: 39-11-725-679; email: [nicola.bellina@davic.it](mailto:nicola.bellina@davic.it)

## **18.6 International Telecommunications Union - Telecommunications (ITU-T)**

The ITU-T is the principle international standards body for telecommunications issues. It is responsible for studies of international concern to the telecommunications industry. In essence, the ITU's mission covers the following domains:

- A technical domain to promote the development and efficient operation of telecommunications facilities
- A development to promote and offer technical assistance to developing countries in the field of telecommunications
- A policy domain to promote, at the international level, the adoption of a broader approach to the issues of telecommunications in the global information economy and society.

The ITU-T is composed of 14 Study Groups as follows:

---

- Study Group 2 - Network and Service Operations

Responsible for studies relating to general aspects of service definition related to telecommunication services; PSTN based, ISDN(s), mobile, and UPT services; principles of their interworking and relevant user quality of service (QoS); network operations including routing, numbering, network management, and service quality of networks (traffic engineering, operational performance, and service measurements); human factors; and service and operational aspects of fraud prevention.

- Study Group 3 - Tariff and Accounting Principles Including Related Telecommunication Economic and Policy Issues

Responsible for studies relating to tariff and accounting principles for international telecommunication services and study of related telecommunication economic and policy issues, as well as policy issues related to carriage and content.

- Study Group 4 - TMN and Network Maintenance

Responsible for Telecommunication Management Network (TMN) studies. Additionally responsible for studies relating to maintenance of networks, including their constituent parts; identifying needed maintenance mechanisms; and for applications of specific maintenance mechanisms provided by other Study Groups.

Study Group 4 is the Lead Study Group on TMN.

- Study Group 5 - Protection Against Electromagnetic Environmental Effects

Responsible for studies relating to Electromagnetic Compatibility (EMC) of telecommunication systems including precautions to avoid hazard to human beings

- Study Group 6 - Outside Plant

Responsible for studies relating to outside plant such as the construction, installation, joining, terminating, protection from corrosion, and other forms of damage from environmental impact, except electromagnetic process, of all types of cable for public telecommunications and associated structures.

- Study Group 7 - Data Networks and Open System Communications

Responsible for studies relating to data communication networks, and for studies relating to the development of open systems communications and to the application of open systems communications including networking, message handling, directory, security, and open distributed processing.

Study Group 7 is the Lead Study Group on Open Distributed Processing (ODP), Frame Relay, and for Communication System Security.

- Study Group 8 - Characteristics of Telematic Services

Responsible for studies of telematic terminal characteristics and related service aspects.

Study Group 8 is the Lead Study Group on facsimile.

---

---

- Study Group 9 - Television and Sound Transmission

Responsible for studies of the specifications to be satisfied by telecommunication systems used for contribution, primary and secondary distribution of video, audio and the associated data signals related to television, sound-program and associated services, including interactive ones.

- Study Group 10 - Languages for Telecommunications Operations

Responsible for studies relating to technical languages and methods for telecommunication applications.

- Study Group 11 - Signaling Requirements and Protocols

Responsible for studies relating to signaling requirements and protocols for telephone, N-ISDN, B-ISDN, UPT, mobile and multimedia communications.

Study Group 11 is the Lead Study Group on Intelligent Network and FPLMTS

- Study Group 12 - End-to-End Transmission Performance of Networks and Terminals

Responsible for studies concerning the end-to-end transmission performance of networks and terminals in relation with the perceived quality and the acceptance of text, speech, and image signals by users and for related transmission implications.

- Study Group 13 - General Network Aspects

Responsible for studies relating to general network aspects and the initial studies for the impact of new system concepts and innovative technologies on telecommunication networks with far-reaching consequences, including broadband ISDN and global information infrastructure studies, taking into account the functional responsibilities of other Study Groups.

Study Group 13 is the Lead Study Group on general network aspects, Global Information Infrastructures (GII) and broadband ISDN.

- Study Group 15 - Transport Networks, Systems and Equipment

Responsible for studies concerning transmission networks, switching and transmission systems, and equipment including the relevant signal processing aspects.

Study Group 15 is the Lead Study Group on Access Network Transport

- Study Group 16 - Multimedia Services and Systems.

Responsible for studies relating to multimedia service definition and multimedia systems, including the associated terminals, modems, protocols, and signal processing.

Study Group 16 is the Lead Study Group on multimedia services and systems.

---

Additional information for ITU-T may be obtained from

International Telecommunications Union (ITU)  
Place des Nations  
CH-1211 Geneva 20  
Switzerland

Telephone +41 22 730 51 11  
Homepage <http://www.itu.ch>

### **18.7 International Telecommunications Advisory Committee - Telecommunications (ITAC-T)**

The ITAC-T is responsible for the preparation for activities of the ITU-T's Telecommunications Standardization Advisory Group's (TSAG) International meetings. ITAC-T has four primary functions.

- To promote the best interests of the US in ITU-T TSAG activities
- To provide advice on matters of policy and positions in preparation for ITU- TSAG Plenary Assemblies and Study Groups
- To provide advice on the disposition of proposed contributions to the ITU-T TSAG
- To assist in the resolution of administrative/procedural problems pertaining to the national committee.

ITAC-T consists of a number of study groups that advise on particular areas. The role of the study groups is as advisory to the Department of State, which is the designated US Government entity representing US membership in the ITU. The work of the T-Sector study groups is aimed at the development of non-binding international technical recommendations whose purpose is to advance international interconnection and interoperability. Companies make recommendations to study groups, which in return are responsible for recommending US contributions to the ITU-T TSAG in Geneva.

ITAC-T has three study groups, each with responsibilities for specific ITU-T study groups, as follows:

- Study Group A - ITU Study Groups 2, 3 and 12
  - Study Group B - ITU Study Groups 4, 6, 10, 11, 13, 15
  - Study Group D - ITU Study Groups 5, 7, 8, 9, 16.
-

---

Additional information for ITAC-T and Study Groups A, B, and D may be obtained from

Earl Barbely, Director of Technical Standards  
U. S. Department of State  
(EB/CIP/SIO)  
Room 2529  
2201 C Street NW  
Washington, DC 20520

(202) 647-0197; fax: (202) 647-7407

Secretary: Charlene Mecklenburg  
(202) 647-2593

## 18.8 Telecommunications Industry Association (TIA)

The TIA is a full service trade organization that promotes the industry, sponsors trade shows, and develops industry standards through its five product oriented divisions. TIA members include companies that provide communications materials, products, systems, distribution services, and professional services to the US and other countries. Additional information for TIA may be obtained from

Matthew J. Flanigan, President  
Telecommunications Industry Association  
2500 Wilson Boulevard  
Suite 300  
Arlington, VA 22201

(703) 907-7700; fax: (703) 907-7727; TELEX: 595236 USTSACGO

Homepage <http://www.industry.net/tia>

The Product Divisions of TIA and their functions include

- User Premises Equipment Division

The activities of this Division center around regulatory changes at the FCC that are related to the safety and performance standards of customer premises equipment. The Division also negotiates Mutual Recognition Agreements of testing results with foreign countries, and represents the industry's position on the implementation of the North American Free Trade Agreement (NAFTA).

The Division also includes a number of Engineering Committees developing standards:

- TR-29 Facsimile Systems and Equipment - protocol standards for facsimile equipment
- TR-30 Data Transmission Systems and Equipment - protocol standards for data transmission

- 
- TR-32 Personal Radio Equipment - consumer oriented product standards such as Citizens Band Radios and cordless telephones
  - TR-41 User Premises Telephone Equipment Requirements
    - a. TR-41.6 Wireless User Premises Equipment - a forum to discuss wireless user premises equipment
    - b. TR-41.8 Commercial and Residential Building Distribution Systems - standards related to building distribution systems for grounding and bonding.

- Network Equipment Division

The Network Equipment Division encompasses three sections: policy and technical issues related to intelligent networks, point-to-point microwave, and broadcast transmission. The Engineering Committees are currently working to upgrade standards for communications towers and interference criteria for microwave systems. Technical standards for emerging technologies such as NII, Personal Communications Services (PCS), and HDTV are anticipated. TR-14 - Point-to-Point Communications Systems maintains standards and recommends practices relating to fixed terrestrial point-to-point radio communications equipment.

- Mobile and Personal Communications Division (MPCD)

Supports the needs and interests of manufacturers of portable and vehicular two-way radio equipment.

- Public 800 Section - policy and technical issues related to cellular telephone systems
- Private Radio Section - commercial two-way radio systems used by the industrial, transportation, and government sectors
- 1800 Section - development of PCS
- Intelligent Transportation Systems Section - telecommunications needs of the emerging Intelligent Vehicular Highway System (IVHS) industry.

Four Engineering Committees fall within the realm of MPCD:

- TR-8 Mobile and Personal Private Radio Standards - develops standards related to traditional land mobile radio products and systems including voice and data applications
  - TR-45 Mobile and Personal Communications Public 800 Standards - develops performance, compatibility, interoperability and service standards for cellular telephone systems in the 800 MHz spectrum
  - TR-46 Mobile and Personal Communications 1800 - develops performance, compatibility, interoperability, and service standards for PCS in the 2000 MHz band.
-



- Fiber Optics Division

The Fiber Optics Division supports two standing Engineering Committees:

- FO-2 Optical Communications Systems - fiber optic system standards for telecommunications and multi vendor compatibilities
- FO-6 Fiber Optics - standardization of fiber optic system components such as cables and connectors

- Satellite Communications Division

The Satellite Communications Division was established to meet the need for maintaining communications, interoperability, and proper utilization of the spectrum and orbits. The Division has established two Sections:

- Communications and Interoperability Section (CIS)
- Spectrum and Orbit Utilization Section (SOUS).

## 18.9 Alliance for Telecommunications Industry Solutions

The Alliance for Telecommunications Industry Solutions (ATIS) (formerly the Exchange Carriers Standards Association [ECSA]) is a major standards body self-described as “problem solvers to the telecommunications industry.” ATIS has as its mission the resolution of national and international telecommunications issues involving technical interconnection standards, as well as the development of operational guidelines.

ATIS was created in 1983 as part of the breakup of the Bell System, which had generally established de facto technical interconnection standards for the U.S. Its initial charter was to help establish a new environment for the development of technical network interconnection and interoperability standards.

From that narrowly focused beginning, the organization has grown to encompass a wide range of open industry forums that resolve a broad spectrum of national interconnection and interoperability issues, including technical standards, billing, installation, testing and maintenance, provisioning, reliability, and numbering. Other issues under consideration by the ATIS-sponsored committees involve number portability, bar coding of telecommunications products, court-authorized electronic surveillance by law enforcement agencies, toll fraud practices, standards for telephone poles, and recommendations for electrical protection in telephone plant.

In June 1993, ATIS members voted to expand membership and the board of directors to include all domestic providers of telecommunications services and manufacturers of telecommunications equipment. ATIS now includes long distance companies, cellular service providers, Competitive Local Exchange Carriers (CLECs), cable operators, Personal Communications Services Providers (PSPs), and resellers, among others.

ATIS is located in Washington, D.C., but does not lobby policy issues in either regulatory or legislative arenas. It is the only telecommunications industry group dedicated solely to problem solving based on consensus agreements.

More than 2000 experts in technical and operational aspects of telephony, representing more than 300 companies, meet in a variety of open forums. These forums reach consensus through voluntary resolutions or develop technical standards through due process procedures sanctioned by the American National Standards Institute (ANSI).

Because ATIS's forum participants represent a cross-section of the telecommunications industry, the Federal Communications Commission acknowledges the expertise that resides in the forums and frequently refers issues to ATIS for discussion and proposed resolution.

ATIS sponsors nine committees or forums; each sponsored group in turn may have many working subcommittees (see Figure 18-1).

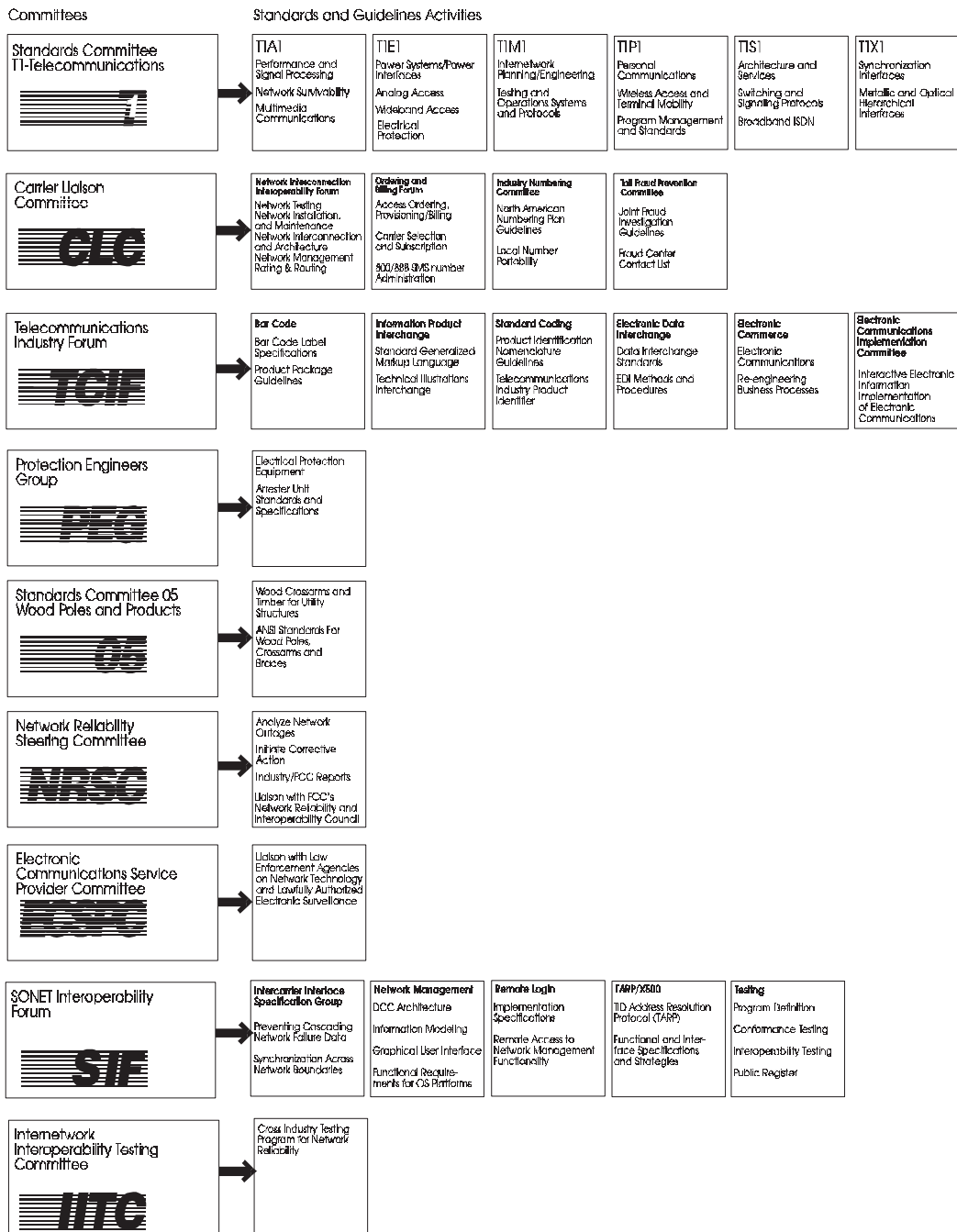


Figure 18-1. ATIS Sponsored Committees

The sponsored committees are as follows:

- *Accredited Standards Committee T1—Telecommunications (T1)*, which is accredited by ANSI to develop interconnection standards for U.S. networks.
- *Carrier Liaison Committee (CLC)*, whose subtending units resolve nation-wide problems involving the provision of exchange access and telecommunications network interconnections
  - *Network Interconnection/Interoperability Forum (NIIF)*
  - *Ordering and Billing Forum (OBF)*
  - *Industry Numbering Committee (INC)*
  - *Toll Fraud Prevention Committee (TFPC)*.
- *Telecommunications Industry Forum (TCIF)*, which addresses issues on industry standards supporting the electronic exchange of data between trading partners. This includes the establishment of standard codes and nomenclature, bar coding, Electronic Data Interchange (EDI), electronic transfer of complex documents, and other aspects of electronic commerce.
- *Network Reliability Steering Committee (NRSC)*, which is responsible for on-going tracking and analysis of nation-wide telecommunications network outages.
- *Electronic Communications Service Provider Committee (ECSPC)*, which discusses technical issues relating to lawfully authorized electronic surveillance.
- *Protection Engineers Group (PEG)*, whose specialists work on electrical protection of telecommunications facilities.
- *Accredited Standards Committee 05 (05)*, which is accredited by ANSI to develop standards for wood poles and wood products in the telecommunications industry.
- *SONET Interoperability Forum (SIF)*, which discusses and resolves interoperability issues to allow widespread deployment of SONET.
- *Interconnection Interoperability Testing Committee (IITC)*, which provides industry funding and mechanisms for test coordination and a test coordination program.

ATIS also represents service provider interests directly through a standing committee of its Board of Directors. Telecommunications Industry Group Committee (TIGC) ensures that ATIS has qualified individuals representing member company interests in a wide variety of standards bodies not directly related to telecommunications. Through the TIGC, telecommunications services providers are represented in other ANSI-accredited organizations that develop standards for electrical, vehicular, and eyeglass safety, for example.

The following subsections contain a more detailed examination of each of the sponsored committees of ATIS.

---

---

### 18.9.1 Accredited Standards Committee: T1 — Telecommunications

Committee T1 develops U.S. standards and technical reports for telecommunications network interconnection and interoperability. T1 also is a leading advocate of globalizing telecommunications standards.

Since its formation in February 1984, Committee T1 has created hundreds of standards and technical reports. Before divestiture, de facto network interconnection standards were set by the Bell System. Under the sponsorship of ATIS, Committee T1 was accredited by ANSI to develop network interconnection standards for the U.S. ATIS also became the Secretariat for Committee T1. Currently, about 1500 technical experts from more than 125 voting and observer member companies in the U.S. and Canada participate in T1.

Committee T1 is also actively involved in standards development globally. T1 annually prepares industry contributions for the International Telecommunication Union (ITU) as U.S. positions via the U.S. Department of State. T1 also directly makes contributions to other international standards bodies such as the International Standards Organization (ISO). T1 also has initiated regional and international standards cooperation forums such as the Global Standards Collaboration group and the Americas Telecommunications Standards Symposium. Each continuing activity is aimed at accelerating the pace of standards development, enhancing regional and international trade, and promoting globalization of standards.

Committee T1's work in the development of domestic standards, technical reports, and U.S. industry contributions to international standards organizations is accomplished through six technical subcommittees. The technical subcommittees and their areas of expertise are as follows:

- T1A1 — Performance and Signal Processing
- T1E1 — Interfaces, Power, and Protection of Networks
- T1M1 — Internetwork Operations, Administration, Maintenance, and Provisioning
- T1P1 — Wireless/Mobile Services and Systems
- T1S1 — Services, Architecture, and Signaling
- T1X1 — Digital Hierarchy and Synchronization.

The six technical subcommittees are advised and managed by the T1 Advisory Group (T1AG) made up of elected representatives from the industry. Standards development efforts are prioritized through membership surveys and overall work is directed by a 5-year strategic plan, reviewed and revised biannually. Recommendations for standards development can come from any source. However, each technical subcommittee develops standards and technical reports in its particular area of expertise.

Membership in Committee T1 is open to all parties with a direct and material interest in standards development and standards related activities.

---

There are four interest categories:

- Exchange Carriers
- Interexchange Carriers (ICs)
- Manufacturers
- Users and General Interest.

No single interest category may dominate the membership and thus unduly influence the standards formulation process; ANSI due process procedures further ensure fairness in standards development. These procedures include announcing meetings in advance, distributing the agenda in advance, following written procedures governing the methods used to develop standards, and giving public notice and opportunity for comment on proposed standards. The ANSI Board of Standards Review verifies that requirements are met for due process consensus and other criteria for standards approval.

Organizations may participate as voting members or observers. Dues for voting member status in Committee T1 are \$5000 a year. Voting membership entitles the organization to be either a voting member or observer in any or all of the six technical subcommittees. Dues for observer member status in Committee T1 are \$3000 a year and permit non-voting observer membership in any or all technical subcommittees.

Organizations also may participate only at the technical subcommittee level. Dues for voting member status in a technical subcommittee are \$850 a year with a maximum fee of \$5000 for membership on three or more subcommittees. Dues for observer status in a technical subcommittee are \$600 with a maximum fee of \$3000 for observer status on all six technical subcommittees.

In the international arena, Committee T1 maintains active liaisons with the International Telecommunication Union—Telecommunication Standardization Sector (ITU-T),<sup>1</sup> the International Telecommunication Union—Radiocommunication Sector (ITU-R),<sup>2</sup> the European Telecommunications Standards Institute (ETSI), the Telecommunications Technology Committee (TTC) of Japan, the Telecommunications Technology Association of Korea, and CITELE, the telecommunications arm of the Organization of American States.

The six technical subcommittees are described in the following subsections.

---

1. Formerly the International Telegraph and Telephone Consultative Committee (CCITT).  
2. Formerly the International Radio Consultative Committee (CCIR).

---

---

### 18.9.1.1 Technical Subcommittee T1A1 — Performance and Signal Processing

#### **Mission**

The Performance and Signal Processing Technical Subcommittee develops and recommends standards and technical reports related to the description of performance and the processing of speech, audio, data, image, video signals, and their multimedia integration within U.S. telecommunications networks. The technical subcommittee also develops and recommends positions on, and fosters consistency with, standards and related subjects under consideration in other North American and international standards bodies.

#### **Scope**

T1A1 focuses on two main areas.

1. Performance of networks and services at and between carrier-to-carrier and carrier-to-customer interfaces, with due consideration of end-to-end performance and the performance of customer systems.
2. Signal processing for the transport and integration of voice, audio, data, image, and video signals, with due consideration of
  - Interaction with telecommunications networks
  - Integration of inputs and outputs between information processing and multimedia systems and telecommunication networks
  - Techniques for assessing the performance and impact of such signal processing on telecommunication networks.

T1A1 is in the process of developing standards, technical reports, and contributions that

- Identify and define performance parameters (including survivability parameters) and levels for the speed, accuracy, dependability, and availability of connection establishment, information transfer, and connection disengagement, taking into account the characteristics of signal processing and multimedia systems
  - Define measurement techniques for these performance parameters
  - Define methods for characterizing network and signal processing performance for customer applications
  - Identify and develop signal processing algorithms and interface requirements, for example, coding and compression, interpolation, rate adaptation, echo cancellation, and packetization techniques
  - Take into account interworking of telecommunications networks with customer systems, international networks, other signal processing systems, and new network
-

technologies and services such as Asynchronous Transfer Mode (ATM), personal communications, and multimedia communications.

Subcommittees of T1A1 include the following:

- T1A1.2 - Network Survivability Performance
- T1A1.3 - Performance of Digital Networks and Services
- T1A1.5 - Multimedia Communications Coding and Performance
- T1A1.7 - Signal Processing and Network Performance for Voiceband Services.

#### 18.9.1.2 Technical Subcommittee T1E1 — Interfaces, Power, and Protection for Networks

##### **Mission**

The Interfaces, Power, and Protection for Networks Technical Subcommittee develops and recommends standards and technical reports related to power systems, electrical and physical protection for the exchange carrier and IC networks, and interfaces associated with user access to telecommunications networks.

##### **Scope**

The scope of the T1E1 Technical Subcommittee includes, but is not limited to, work on developing standards and technical reports covering the following areas:

- *Network Interfaces* — Covers subjects of interfaces and interface functionality involving access to the telecommunications networks (including data communications and integrated digital services) of exchange carriers and ICs, end-users, and Enhanced Service Providers (ESPs). This work will include the electromagnetic, optical, and mechanical characteristics of the interfaces and may include aspects of the physical layer transmission and signaling protocols.
  - *Power* — Covers subjects involving power systems and their user and power interfaces with dc-powered telecommunications equipment.
  - *Electrical Protection* — Covers subjects involving electrical protection for the exchange carrier and IC networks. It includes grounding systems, electrostatic discharge (ESD) susceptibility, electromagnetic interference (EMI), and electromagnetic pulse (EMP) susceptibility.
  - *Physical Protection* — Covers areas involving electrical physical protection of the exchange carrier and IC networks. These subjects include, but are not limited to, temperature, humidity, fire resistance, earthquake resistance, and contamination prevention.
-



---

There is a close and coordinated working liaison with other T1 technical subcommittees, as well as with external standards setting bodies. The work also includes the development of proposed U.S. contributions to related work of international standards bodies, such as ITU-T.

Subcommittees of T1E1 include the following:

- T1E1.1 - Analog Access
- T1E1.2 - Wideband Access
- T1E1.4 - DSL Access
- T1E1.5 - Power Systems - Power Interfaces
- T1E1.6 - Power Systems - Human and Machine Interfaces
- T1E1.7 - Electrical Protection
- T1E1.8 - Physical Protection.

#### 18.9.1.3 Technical Subcommittee T1M1 — Internetwork Operations, Administration, Maintenance, and Provisioning

##### **Mission**

The mission of the T1M1 Technical Subcommittee is to develop internetwork operations, administration, maintenance, and provisioning standards and technical reports related to interfaces for U.S. telecommunications networks, some of which are associated with other North American telecommunications networks. These standards may apply to planning, engineering, and provisioning of network resources; to operations, maintenance, or administration process; or to requirements and recommendations for support systems and equipment that may be used for these functions. This subcommittee also develops positions on related subjects under consideration in other domestic and international standards bodies.

##### **Scope**

The scope of T1M1 covers standards and reports for internetwork planning and engineering functions such as traffic routing plans; measurements and forecasts; trunk group planning; circuit and facility ordering; network tones and announcements; location, circuit, equipment identification, and other codes; and numbering plans. The technical subcommittee will also consider standards and reports for all aspects of internetwork operations such as network management; circuit and facility installation, line-up, restoration, routine maintenance, fault location and repair; contact points for internetwork operations; and service evaluation. The work of the technical subcommittee includes standards and reports regarding test equipment and Operations Support Systems (OSSs)

---

together with the required network access and operator interfaces. In addition, the technical subcommittee is concerned with administrative support functions such as methods for charging, accounting, and billing data. Of necessity, the scope of this work requires a close and coordinated working liaison with other T1 technical subcommittees as well as global standards-setting bodies.

Subcommittees of T1M1 include the following:

- T1M1.3 - Testing and Operations Support Systems and Equipment
- T1M1.5 - OAM&P Architecture, Interfaces, and Protocols.

#### 18.9.1.4 Technical Subcommittee T1P1 — Wireless/Mobile Services and Systems

##### **Mission**

The mission of T1P1 is to develop and recommend standards and technical reports related to wireless and/or mobile services and systems, including service descriptions and wireless technologies. This technical subcommittee develops and recommends positions on related subjects under construction in other North American, regional, and international standards bodies.

##### **Scope**

The Wireless/Mobile Services and Systems technical subcommittee coordinates and develops standards and technical reports primarily relevant to wireless/mobile telecommunications networks in the U.S., and reviews and prepares contributions on such matters for submission to the appropriate U.S. preparatory body for consideration as ITU contributions or for submission to other domestic and regional standards organizations. The technical subcommittee maintains liaison with other technical subcommittees as well as external forums as appropriate. The technical subcommittee coordinates closely with other standards developing organizations (for example, TIA, IEEE, ETSI) on wireless issues to ensure the work programs are complementary.

Subcommittees of T1P1 include the following:

- T1P1.1 - Program Management and NII/GII
  - T1P1.2 - Personal Communications Service Descriptions and Network Architecture
  - T1P1.3 - Personal Advanced Communications Systems (PACS)
  - T1P1.5 - PCS 1900
  - T1P1.6 - CDMA/TDMA
  - T1P1.7 - Wideband-CDMA.
-

#### 18.9.1.5 Technical Subcommittee T1S1 — Services, Architectures, and Signaling

##### **Mission**

This technical subcommittee develops and recommends standards and technical reports related to services, architectures, and signaling. It also develops and recommends positions on related subjects under consideration in other North American and international standards bodies.

##### **Scope**

The T1S1 technical subcommittee coordinates and develops standards and technical reports relevant to telecommunications networks in the U.S.; reviews and prepares contributions on such matters for submission to U.S. ITU-T/ITU-R Study Groups or other standards organizations; and reviews for acceptability or per contra the positions of other countries in the related standards development, and takes or recommends appropriate actions. Because the development of standards for services, architectures, and signaling may be evolved or influenced by several of the technical subcommittees, this technical subcommittee maintains liaison with the appropriate technical subcommittees, as well as with standards-setting bodies external to T1.

#### 18.9.1.6 Technical Subcommittee T1X1 — Digital Hierarchy and Synchronization

##### **Mission**

The Digital Hierarchy and Synchronization technical subcommittee develops and recommends standards and prepares technical reports on telecommunications network technology pertaining to network synchronization interfaces and hierarchical structures for U.S. telecommunications networks, some of which are associated with other telecommunications networks. The technical subcommittee focuses on those functions and characteristics necessary to define and establish the interconnection of signals in network transport. This includes aspects of asynchronous and synchronous networks. The technical subcommittee also makes recommendations on related subject matter under consideration in various North American and international standards organizations.

##### **Scope**

The scope of the work undertaken by the T1X1 technical subcommittee includes the conception, definition, analysis, and documentation of matters pertaining to the interconnection of network transport signals. All theoretical and analytical work necessary to support the documented results is generated or coordinated by the technical

---

subcommittee. This requires close liaison with other Committee T1 technical subcommittees as well as standards organizations external to Committee T1.

### **18.9.2 Carrier Liaison Committee**

The CLC is an inter-industry organization that provides for the identification, discussion, and voluntary resolution of nation-wide concerns regarding exchange access and telecommunications network interconnections. Proposed by ATIS in 1984, and endorsed by the FCC in 1985, the CLC was established in response to an industry need for national coordination on issues related to the provision of exchange access. The CLC generally meets three times each year, with all meetings open to interested parties. When issues are received at the CLC level, they are referred to the appropriate forums or subtending units, such as the NIIF, OBF, INC, or TFPC. The subtending units whose work the CLC monitors are described below.

#### **18.9.2.1 Network Interconnection/Interoperability Forum (NIIF)**

The NIIF provides an open forum under the auspices of the CLC to encourage the discussion and resolution, on a voluntary basis, of industry-wide issues associated with telecommunications network interconnection and interoperability that involve network architecture, network management, testing and operations, and facilitates the exchange of information concerning these topics.

The NIIF is a new forum organized based on the previous functional responsibilities of the consolidated Information Industry Liaison Committee (IILC) and the CLC's Network Operations Forum (NOF) and Industry Carriers Compatibility Forum (ICCF). These functional areas include network installation and maintenance, network management, network testing, network interconnection/architecture, and network rating and routing. Five subcommittees of the NIIF have been formed:

- Network Installation and Maintenance (NIM) Committee

The NIM Committee was formed from previous subcommittees of the NOF. The NIM Committee provides an open forum to address and resolve industry-wide issues related to the installation, maintenance, and testing guidelines for exchange access, interconnected telecommunications, and signaling networks to promote industry progress and network integrity/reliability, and facilitates the exchange of information concerning these topics.

Functional areas of the NIM Committee include

- Trouble management
  - Installation guidelines
-

- 
- Installation and maintenance testing guidelines
  - Maintenance guidelines
  - Facility guidelines
  - Maintenance windows
  - Notification (maintenance and trouble)
  - Signaling operational issues (for example, SS7).

- Network Interconnection/Architecture (NIA) Committee

The NIA Committee was formed from the functions of the IILC and portions of the ICCF. The NIA Committee provides an open forum to address and resolve industry-wide issues associated with telecommunications network architecture and technical interconnection, including Open Network Architecture (ONA) and/or network interaction, and facilitates the exchange of information concerning these topics.

Functional areas of the NIA Committee are

- Interconnection/interworking
- Network functionalities to support enhanced services
- IN/AIN
- Signaling/switching
- Mediation
- Call triggers
- ISDN
- Unbundled elements
- Unbundled services
- Requests for ONA service elements
- OSS access
- Notifications (network enhancements)
- Protocol.

- Network Management (NM) Committee

The NM Committee was formed from a previous subcommittee of the NOF. The NM Committee provides an open forum to address and resolve industry-wide issues related to the network management activities associated with interconnected telecommunications and signaling networks to promote industry progress and network reliability, and facilitates the exchange of information concerning these topics. The functional areas of the NM Committee include

---

- 
- Traffic management
  - Notifications (traffic affecting network outages and changes)
  - Mass calling
  - Emergency communications
  - Security
  - Test line coordination.

- Network Testing (NT) Committee

The NT Committee was formed from the Internetwork Interoperability Test Plan (IITP) Committee of the NOF. The NT Committee provides the opportunity for participating service providers and vendors/manufacturers of telecommunications equipment to develop test scenarios and scripts, as well as perform tests in a controlled environment. The committee facilitates the exchange of information regarding the interoperability of the equipment (hardware/software) and specific applications towards maintaining the highest standards of network reliability and integrity. Functional areas of the NT Committee include

- Internetwork interoperability testing for network nodes and services
- Test scenarios
- Test scripts.

- Network Rating and Routing Information (NRRI) Committee

The NRRI Committee was formed from Data Integrity Group (DIG) functions of the ICCF. The NRRI Committee provides an open forum to address and resolve issues associated with local exchange rating and routing mechanisms, including associated databases, and related topics, to facilitate the exchange of information concerning these topics to support maintaining the highest standards of network rating and routing information and integrity. Functional areas of the NRRI Committee include the following:

- Local exchange rating and routing mechanisms (for example, informational sources, databases)
- Line information databases.

#### 18.9.2.2 Ordering and Billing Forum (OBF)

The OBF provides an open industry forum dedicated to resolving issues that are national in scope and involve ordering, provisioning, billing, exchange of information between carriers, and subscription processes surrounding access services. Issues are identified by individual companies or through regulatory changes. Resolutions are developed in working

---

---

committees and are accepted by forum consensus. Meetings of the OBF are held four times a year, are open to all interested parties, and on average, attract about 350 participants representing about 100 companies.

The OBF

- Produces resolutions to ordering and billing issues for access services
- Resolves issues involving the Customer Account Record Exchange (CARE) information between access customers and access providers
- Provides input to the ongoing maintenance of the Exchange Message Interface (EMI) to improve and implement billing service offerings
- Performs some of the functions of the former Ad Hoc 800 Database Committee, which has closed.

Subcommittees include

- Telecommunications Service Ordering Request (TOR)  
Maintains manual and mechanized access ordering documentation and guidelines through resolution of national issues.
  - Billing Committee  
Addresses access billing-related issues within the confines of the OBF mission.  
Maintains the following documents:
    - Multiple Exchange Carrier Access Billing (MECAB)
    - Small Exchange Carrier Access Billing (SECAB)
    - CABS Auxiliary Report Specifications (CARS)
  - Message Processing Committee  
Facilitates the communication, review, and resolution of issues relative to message processing between Exchange Carriers and other telecommunications participants.
  - Ordering and Provisioning  
Addresses and resolves issues focused on the ordering and/or provisioning of access services.  
Develops and maintains ordering and provisioning processes.  
Maintains the documentation to support these processes.
  - Subscription Committee  
Is a forum for Access Providers and Access Customers to develop common definitions and recommendations for resolution of national subscription issues.
-

Develops and maintains the Customer Account Record Exchange/Industry Support Interface (CARE/ISI) document and addresses issues relative to the exchange in accordance with this document.

- SMS/800 Number Administration Committee (SNAC)

Identifies, develops and implements the resolution of issues focused on the support of the 800 Service Management System (SMS) under OBF auspices.

Significant issues:

- ASR
- Phrase code review
- Implication of year 2000 on various mechanized systems
- 888 and associated toll-free codes
- Standards for EC
- 800 Number Assignment Rate - conservation measures.

A new role - LEC to LEC issues.

### 18.9.2.3 Industry Numbering Committee (INC)

The INC provides an open forum to address and resolve industry-wide issues associated with the planning, administration, allocation, assignment, and use of resources and related dialing considerations for public telecommunications within the North American Numbering Plan (NANP) area.

Currently active INC workshops include the following:

- Carrier Identification Code (CIC) Workshop: addresses issues related to the assignment and administration of carrier identification codes.
  - CO Code Workshop: addresses issues related to the assignment and administration of Central Office Codes (NXXs).
  - Public Data Services Numbering and Addressing Workshop: develops numbering/addressing plans for public data services.
  - NPA Workshop: addresses issues relating to the allocation, use, and reclamation of area codes.
  - NANP Expansion Workshop: seeks to develop an industry-agreed upon recommendation for expanding the capacity of the NANP.
  - 500/900 Workshop: examines numbering impacts of making 500 and 900 numbers assigned to LECs portable.
-



- LNP Workshop: addresses local number portability numbering issues.
- Document Management/Maintenance Workshop: modifies/changes/upgrades existing INC documentation.

#### 18.9.2.4 Toll Fraud Prevention Committee (TFPC)

The Toll Fraud Prevention Committee (TFPC) develops resolutions for voluntary implementation by the industry to deter domestic and international fraud affecting the industry. The group periodically issues detailed white papers on particular types of fraud and reviews industry efforts aimed at deterrence. Resolutions reached by this committee help protect the industry from unscrupulous activities ranging from coin station fraud to international long distance fraud. Although meetings are open to the industry, the committee operates under the terms of non-disclosure agreements so participants can share cases of fraud or vulnerability without fear of further exploitation.

### 18.9.3 Telecommunications Industry Forum

TCIF was created in 1986 in response to the increasing need for guidelines and standards associated with automating the business operations of companies in the telecommunications industry. TCIF has more than 300 participants representing more than 80 companies within the industry. Their mission is to develop and achieve common benefits related to the business processes associated with procurement, provision, distribution, and use of telecommunications equipment, products, and services. Central to this mission is the promotion and understanding of existing standards and guidelines. Where appropriate or necessary standards do not exist, TCIF acts as a catalyst to ensure that guidelines are produced and that appropriate standards-setting organizations address the need for such standards.

TCIF carries out its mission principally through the following six committees:

- TCIF Executive Board
- Bar Code and Standard Coding (BCSC)
- Electronic Commerce Committee
- Electronic Data Interchange (EDI)
- Information Product Interchange (IPI) Committee
- Electronic Communications Implementation Committee (ECIC).

The TCIF Executive Board provides general supervision of the business and affairs of the Forum between its meetings. The Board makes recommendations to the Forum and

---

performs such other duties as specified by the Forum. The Executive Board is subject to the authority of the Forum and none of its acts shall conflict with action taken by the Forum.

The BCSC is responsible for the determination of guidelines for bar code symbology, data identifiers, and format of various labels for products, product packaging, and shipping containers used for receiving, shipping, transporting, and tracing of telecommunications products.

The Electronic Commerce Committee is responsible for identifying standards and protocols that will facilitate the integration and use of electronic technologies to improve communications between trading partners. The electronic technologies include, but are not limited to, bar coding, EDI, electronic document transfer, facsimile, e-mail, and bulletin boards. The output of this committee enables member companies to re-engineer business processes to take advantage of technology to reduce operating costs.

The EDI Committee is responsible for establishing guidelines that assist telecommunications industry companies to avoid the costs and delays associated with paper-based business transactions. The committee uses ANSI Accredited Standards Committee X12 (ASCX12) standards and United Nations/EDI for Administration Commerce and Transport (UN/EDIFACT) messages, and interprets how they can be used within the industry. Where no transaction set is available, the committee will develop a new transaction set for ANSI ASCX12 approval.

The IPI Committee establishes guidelines to facilitate the electronic interchange of information products in the telecommunications industry. The Committee examines, interprets, evaluates, and recommends existing and emerging electronic interchange standards and guidelines for voluntary industry acceptance and use. The standards and guidelines recommended by the IPI Committee are a means to ensure that text, graphics, voice annotated, and animated forms of information created by one organization can be delivered to, stored, retrieved, and used by others in the telecommunications industry. The IPI Committee's goal is to define common standards that software and hardware tool vendors will support, but the committee is not attempting to recommend a specific product, system, or tool set for industry-wide compliance.

The ECIC was established to foster the implementation of electronic communications to improve customer service. Its mission is to identify and resolve technical and operational issues for the implementation of electronic information exchange.

The ECIC

- Focuses on the implementation of application-to-application communications for Operations, Administration, Maintenance, and Provisioning (OAM&P) functions
  - Identifies additional functionalities for standardization and champions the development with appropriate standards groups
  - Identifies and resolves common issues that may fall outside the existing standards documents.
-

---

The ECIC is currently involved with

- Implementing trouble administration between telecommunications customers and suppliers
- Implementing the PIC/CARE process between telecommunications customers and suppliers
- Preparing recommendations on connectivity, security, testing, data reconciliation, and change management to support the electronic bonding implementations.

#### **18.9.4 Network Reliability Steering Committee**

The NRSC, created in 1993 by the FCC Network Reliability Council (NRC) and sponsored by ATIS, is part of the industry's effort to track and analyze network outages. Key to its mission is enlisting industry cooperation to ensure the highest degree of network reliability. The steering committee reviews analysis of all network service outages reported to the FCC (see *FCC Report and Order*, CC Docket No. 91-273) and matches them to the technical areas covered by NRC reliability reports: fire prevention, signaling network systems, switching systems, fiber optic systems, Digital Cross-connect Systems (DCSs), power systems, and Enhanced 911 emergency reporting systems. NRSC's purpose is to analyze the industry's reporting of network outages to identify trends, distribute the results of its findings to industry, and, where applicable, refer matters to appropriate industry forums for further resolution.

The steering committee (currently 24 members) is made up of representatives from LECs, ICs, manufacturers, major users, Communications Workers of America (CWA), National Association of Regulatory Utility Commissioners (NARUC), consumers, cellular carriers, and alternative access providers.

#### **18.9.5 Electronic Communications Service Provider Committee**

Established in March 1993, the ECSPC's purpose is to discuss technical issues relating to lawfully authorized electronic surveillance and to develop resolutions for voluntary implementation by the industry. At the request of an ad hoc group of telecommunications representatives and law enforcement agencies, principally the FBI, ATIS agreed to sponsor this committee as a permanent forum for continued discussions on the lawful surveillance of electronic communications services. The primary focus of ECSPC in 1995 centered on its role as part of a consultative process described in the Communications Assistance for Law Enforcement Act (CALEA).

The committee includes electronic communications service providers, law enforcement agencies, and manufacturers. Due to the sensitive nature of the committee's work, participants are required to sign a confidentiality agreement.

### 18.9.6 Protection Engineers Group

PEG is an organization of specialists who share a common interest in the electrical protection of telecommunications service provider facilities. Its primary goals are to

- Encourage the free flow of ideas among electrical protection specialists
- Develop draft contributions for introduction to ANSI-accredited standards forums by ATIS representatives
- Provide guidance to ATIS representatives on accredited standards organizations.

The principal working group within PEG, the Equipment Performance Task Group (EPTG), develops draft technical specifications for electrical protection apparatus such as surge arrester modules and station protectors. These draft specifications provide a valuable reference to exchange carrier companies which may adopt all or part of these documents in the purchase specifications for such electrical apparatus. Protection issues will now include new broadband services, architectures, and cellular systems.

As of 3Q97, PEG has completed the following specifications:

- Gas Tube Surge Arresters on Wire Line Telephone Circuits (*published as ANSI C62.61-1993*)
- Specification for Telephone Station Protectors (*June 1990*)
- Specification for Telecommunications Main Distribution Frame Connectors/Protectors and Associated Arrester Modules (*January 1992*)
- Specification for Telecommunications Carbon Arrester Units (*January 1992*)
- Specification for Telecommunications Building Entrance Terminals and Associated Arrester Modules (*Draft 1993*)
- Specification for Network Interface Devices One- and Two-Line (*Withdrawn in July 1993*)
- Specification for Solid-State Voltage Arresters on Metallic Line Telecommunications Circuits (*Draft 1993*)
- Electrical Protection for Headset-User Equipment Positions (*forwarded to Committee T1 and published as ANSI T1.321-1995*).

### 18.9.7 Standards Committee 05 - Wood Poles

Committee 05 is the second ANSI-accredited committee sponsored by ATIS (Committee T1, described earlier, is the other). Organized in 1924, Committee 05 develops standards for use by the telecommunications industry in technical areas dealing with wood poles and other wood products. ATIS assumed sponsorship of the committee in 1985. Committee 05

---

has 30 representatives from organizations that have a direct and material interest in wood products.

This Committee creates standards for wood poles, crossarms and braces, and glue laminated timber for utility structures. Wood poles continue to be the least expensive method to provide telecommunications service (telephone and cable) to rural areas of the U.S. There are approximately 100 million wood poles in use nation-wide; 45 percent are owned by the telecommunications industry. The scope of this Committee includes the following:

- Standardization of dimensional classifications
- Defect descriptions and limitations
- Manufacturing practices
- Fiber stresses
- Quality assurance procedures for wood poles and other wood products used in the construction of electric supply and communication lines.

#### **18.9.8 SONET Interoperability Forum**

The SIF is an industry group that was established to define and resolve Synchronous Optical Network (SONET) implementation issues. The mission of the SIF is to provide an open industry forum for the discussion and resolution of SONET interoperability issues leading to the development of functional and interface specifications and strategies, and to liaise with the appropriate standards forums as required by the specific issue.

First established by Southwestern Bell Telephone Company and Southwestern Bell Technology Resources as the Southwestern Bell Standard for SONET Interoperability Team (SSSI), the team grew to include other Bell operating companies and Bellcore to cooperatively and jointly resolve SONET interoperability issues. The successes the SSSI demonstrated became well known in the industry and other service providers and vendors of SONET equipment began to participate. As a result, the SIF was established as an open industry forum to resolve SONET network interoperability issues.

SIF membership is open to any interested party. SIF members establish working groups to identify SONET network and equipment interoperability issues and define solutions. Work of the SIF groups often continues between SIF meetings via e-mail discussions. Once a SIF document is approved by the SIF, it becomes publicly available.

SIF work groups include the following:

- Common Applications

The Common Applications work group is responsible for the definition of requirements for management functions. The Common Applications work group relies on service provider contributions to establish need, scope, and priority of its efforts.

- Distributed Network Management Environment (DNME)

The DNME work group is responsible for defining OS platform requirements for a distributed SONET management environment.

- Information Model

The Information Model work group was formed in October 1995 to focus on application needs that service providers had specified. The group decided it was important to concentrate on a network layer Information Model.

- Intercarrier Interface Specification (ICI)

The ICI work group is responsible for defining the network interface between network providers and between network providers and end users that will preclude the cascading of network failure data and allow OAM&P data.

- Network Architecture

The Network Architecture work group has a dual mission. First, it is the SIF group that investigates and resolves newly discovered SONET interoperability problems. The Network Architecture work group's second mission is the ongoing investigation of SONET TMN architectures, applications, traffic, and their interrelationships with a general goal of ensuring that all SONET TMN components operate together in a well functioning, cohesive, and problem-free manner.

- Remote Login (NE-NMS and NE-NE)

The Remote Login work group was established in 1994 with a charter to provide a remote login capability that includes a Graphical User Interface (GUI) capability.

---

- Testing

The Testing work group is responsible for identifying and defining methods and procedures, based on SIF-approved documents, to verify the interoperation of SONET products.

### **18.9.9 Internetwork Interoperability Test Coordination (IITC) Committee**

The IITC Committee was formed at the request of the FCC's Network Reliability and Interoperability Council (NRIC, formerly known as the Network Reliability Council or NRC). The NRIC has recommended and is strongly urging the industry — service providers as well as manufacturers — to initiate broad-based programs to prevent service outages.

The first official meeting of the IITC Committee was held in Reston, Virginia on September 19, 1997, following the NRIC's industry readout of their recommendations. An IITC Steering Committee has been formed to lay the foundation for which the IITC Committee can begin their work.

The IITC will be responsible for coordinating internetwork interoperability stress testing of services and architectures resulting from the introduction of increased network interconnections and new technologies that have the potential to adversely impact the nation's network if their reliability and interoperability is not first tested in a coordinated, industry-wide, off-line manner.





---

## Section 19

### Interexchange Access/ Local Exchange Services Ordering

#### Contents

19.	Interexchange Access/Local Exchange Services Ordering.....	19-1
19.1	Access Service Ordering .....	19-1
19.2	Local Exchange Access Ordering .....	19-2
19.3	Access Service Ordering Guidelines (ASOG) .....	19-3
19.3.1	Access Service Request (ASR) Form .....	19-3
19.3.2	Feature Group A (FGA) Form .....	19-3
19.3.3	Feature Groups B, C, D (FGB-C-D) Form .....	19-3
19.3.4	WATS Access Line (WAL) Form .....	19-3
19.3.5	Special Access (SA) Form .....	19-4
19.3.6	Multipoint Service Legs (MSL) Form .....	19-4
19.3.7	Additional Circuit information (ACI) Form .....	19-4
19.3.8	Testing Service Request (TSR) Form .....	19-4
19.3.9	Open Billing (OBF) Form.....	19-4
19.3.10	ICSC Confirmation Notice (CN) Form.....	19-5
19.3.11	End User Special Access (EUSA) Form.....	19-5
19.3.12	End Office Detail (EOD) Form.....	19-5
19.3.13	800 Data Base Basic Service Number (BSF) Form.....	19-5
19.3.14	Call Handling and Destination (CHD) Form .....	19-5
19.3.15	Multi-EC (MEC) Form .....	19-6
19.3.16	Translation Questionnaire (TQ) Form .....	19-6
19.3.17	Ring (RNG) Form .....	19-6
19.3.18	Additional Ring information (ARI) Form.....	19-6
19.3.19	Database Services Interconnection (DBSI) Form .....	19-7
19.3.20	Enhanced Customer Interface (ECI) Form .....	19-7
19.3.21	Virtual Connection (VCF) Form.....	19-7
19.4	Local Service Ordering Guidelines (LSOG).....	19-7
19.4.1	Local Service Request (LSR) Form .....	19-7
19.4.2	End User information (EUI) Form.....	19-8
19.4.3	Loop Service (LS) Form .....	19-8
19.4.4	Local Service Request Confirmation (LSC) Form .....	19-8
19.4.5	Loop Service with Number Portability (LSNP) Form .....	19-9
19.4.6	Number Portability (NP) Form .....	19-9
19.4.7	Port Service (PS) Form .....	19-9
19.4.8	Resale Service (RS) Form.....	19-9
19.4.9	Resale Frame Relay (RFR) Form.....	19-9
19.4.10	Resale Private Line (RPL) Form.....	19-10
19.4.11	Directory Listing (DL) Form .....	19-10

---

19.4.12 Directory Service Request Completion Notice (DSCN)  
Form ..... 19-10

19.4.13 Directory Service Request (DSR) Form ..... 19-10

19.4.14 Directory Service Request Error Detail (DSRED) Form..... 19-11

19.4.15 Directory Service Caption Request (DSCR) Form ..... 19-11

---

## 19. Interexchange Access/Local Exchange Services Ordering

### 19.1 Access Service Ordering

The 1984 break-up of AT&T brought about numerous changes that required the creation of new processes for ordering telecommunications service. Among these was the need to create a method for ordering interconnection between an Interexchange Carrier (IXC) and a Local Exchange Company (LEC).

Shortly after divestiture, the Ordering & Billing Forum (OBF) was formed to address the needs of the telecommunications industry in a post divestiture environment. The OBF soon became an industry recognized telecommunications forum that was sanctioned by the Federal Communications Commission (FCC), with an open invitation to virtually any LEC or IXC wishing to participate.

The forum declared its mission as follows:

*The OBF provides a forum for customers and providers in the telecommunications industry to identify, discuss, and resolve national issues which affect ordering, billing, provisioning, and exchange of information about access services, other connectivity, and related matters.*

There are currently six standing committees that function under the auspices of the OBF each specializing in a particular aspect of access service as follows:

- **Billing (BLG)** - Addresses access billing related issues and maintains the Multiple Exchange Carrier Access Billing (MECAB) document, Small Exchange Carrier Access Billing (SECAB) document, and the CABS Auxiliary Report Specifications (CARS) document.
- **Message Processing (MSG)** - Addresses non-access issues relative to message processing.
- **Ordering & Provisioning (O&P)** - Addresses issues focused on the ordering and/or provisioning of access services and their related documentation.
- **SMS/800 Numbering Administration (SNAC)** - Addresses issues related to the Service Management System/800 (SMS/800) and toll free (800/888) number administration.
- **Subscription (SUB)** - Provides a forum for customers and providers to develop common definitions and recommendations for resolution of national subscription issues.
- **Telecommunications Service Ordering Request (TOR)** - Maintains the manual and mechanized ordering documents and guidelines.

The agreements of the forum are achieved through consensus, and voting is not permitted. While the decisions reached by the forum are non-binding, an overwhelming majority of the industry abides by the forum's agreements and guidelines.

Among its many roles, the OBF is responsible for creating and maintaining the Access Service Ordering Guidelines (ASOG). The ASOG consists of 19 service-specific sections that provide the instructions for completing the forms used to order any one of a number of services. A description of each of these documents follows.

## **19.2 Local Exchange Access Ordering**

The enactment of the Telecommunications Act of 1996 ushered in a new era for the telecom industry. The Act changed the rules for competition and regulation in virtually all sectors of the communications industry. This includes local and long distance telephone services, cable television, broadcasting, and equipment manufacturing.

Coincident with the Act, the OBF agreed to accept Local Exchange Ordering issues, and to address the concerns of Competitive Local Exchange Carriers (CLECS), for discussion and resolution at the Forum.

Faced with the need to address competition in the local loop, the OBF created a separate ordering document to be used for ordering Local Exchange Services. The Local Service Ordering Guidelines (LSOG) were modeled after the ASOG and contain the necessary instructions for ordering the various elements of Local Exchange Access.

A description of the LSOG follows below.

The ASOG and LSOG documents can be obtained by contacting Alliance for Telecommunications Industry Solutions (ATIS):

Alliance for Telecommunications Industry Solutions  
1200 G Street, NW, Suite 500  
Washington, DC 20005  
202 628-6380 (phone)  
202393-5453 (fax)

or

at their Internet site: [www.atis.org](http://www.atis.org)

---

## 19.3 Access Service Ordering Guidelines (ASOG)

### 19.3.1 Access Service Request (ASR) Form

The ASR Form contains administrative and bill detail information necessary for the provisioning of a request for service. An ASR Form must accompany each service-specific form associated with a request for service.

All information required for administrative, billing and contact details is provided for in the various fields contained within the ASR Form. The Administrative Section contains Information pertaining to the service being ordered such as: quantity, requisition type, desired due date, etc. The Bill Section provides billing name and address information and the Contact Section contains initiator information, design contact name, address and telephone number, and implementation contact name and telephone number.

**The following service specific forms are used to order and/or supply information needed to order various types of access service.**

### 19.3.2 Feature Group A (FGA) Form

The FGA Form contains all data elements necessary all Information required for ordering a FGA Access Line. The Form is divided into three sections; a Circuit Detail Section; a Location Section; and an End User Section.

### 19.3.3 Feature Groups B, C, D (FGB-C-D) Form

This Form is used to order FGB-C-D Access Trunks or Common Channel Signaling (CCS) Links. The Circuit Detail Section provides entries for the specification of ordering options, transmission levels, special routing, and service class routing. The location section of this Form provides entries to identify a secondary location and serving area for tandem, end office, or signaling point.

### 19.3.4 WATS Access Line (WAL) Form

This Form is used to order a WATS Access Line. The Circuit Detail section provides entries for the specification of ordering options, transmission levels, hunting requirements, General Exchange Tariff options and for registration requirements. The Location Section provides entries for describing the termination of the WAL at an end user location and entries that may be necessary for gaining access for installation purposes.

---

### **19.3.5 Special Access (SA) Form**

This Form contains the fields to identify the necessary data elements for ordering two point special access circuits. The Circuit Detail Section of the Form provides entries for the specification of ordering options, transmission levels, General Exchange Tariff options, and for registration requirements. The Location Section provides entries for describing the termination of the Special Access circuit at an end user location and the entries that may be necessary for gaining access for installation purposes.

### **19.3.6 Multipoint Service Legs (MSL) Form**

This Form is used by the access customer to order a circuit configuration that branches off an access providers bridge configuration. This can be either a leg to an end user location branching off a bridge, or another bridge that branches off a bridge.

### **19.3.7 Additional Circuit information (ACI) Form**

The ACI Form is used by either an access customer or an access provider to stipulate circuit specific information that is not readily provided on a service specific Form. For example, the ACI Form can be used by the access customer to identify the disconnect of a non-sequential range of circuit numbers.

### **19.3.8 Testing Service Request (TSR) Form**

This Form is used by the access customer to order any testing services offered by an access provider in its access tariff. These are additional tests that are requested above and beyond any tests done as part of the normal installation and maintenance of a circuit. The TSR Form may also be used to request additional Cooperative tests, normal acceptance testing, repair verification testing, future requests for non-scheduled testing, and scheduled automatic/manual testing.

### **19.3.9 Open Billing (OBF) Form**

This Form is used by the Access Providers (APs) to pass billing related information on WATS Access Lines to the Access Customers (ACs) and must always be associated with the Confirmation Notice (CNN) Form. The information is required so that the ACs may then interact with the AP to create a Customer Records information System (CRIS) billing order.

---

---

### **19.3.10 ICSC Confirmation Notice (CN) Form**

The CN Form is prepared by the access provider and is forwarded to an access customer to confirm a request for service. This Form provides the access customer with information such as critical dates, circuit identification, trunk quantities, and order numbers, which are necessary for the control and tracking of the applicable request for the provisioning of the requested access service.

### **19.3.11 End User Special Access (EUSA) Form**

The EUSA Form is used to order special access service where neither end of the circuit is an Access Customer Terminal Location (ACTL). The Form provides entries for the specifications of ordering options, transmission levels, General Exchange Tariff Options and for registration requirements. The location section of the Form provides entries for describing the termination of the circuit at an end user location and/or an access customer off location.

### **19.3.12 End Office Detail (EOD) Form**

The EOD Form can be used for any of the following functions:

- Forecasting telecommunications traffic being routed from end offices subtending a tandem
- Identification of end offices for initial SAC Code activities
- Identification of subtending end offices for originating traffic requests
- Providing an estimate of telecommunications traffic distribution requirements when traffic is switched through an access tandem.

### **19.3.13 800 Data Base Basic Service Number (BSF) Form**

The 800 Form may be used to reserve an 800 number and/or the implementation of an 800 Data Base Basic Service Number.

### **19.3.14 Call Handling and Destination (CHD) Form**

The CHD Form must accompany the ASR and 800 Data Base Basic Service Number Form when ordering initial service with call handling and destination options. The CHD Form provides a worksheet or input sheet for establishing the call processing portion of the customer record used to define the call routing treatment for the 800 number. The CHD

---

Form is used to facilitate entering and modifying data on the customer record in the Service Management System (SMS).

### **19.3.15 Multi-EC (MEC) Form**

This Form must be used whenever an Access Service passes through more than one APs territory. This Form identifies the additional administrative and billing information for each AP. The Access Service Coordination Exchange Company (ASC-EC) details must always be populated.

### **19.3.16 Translation Questionnaire (TQ) Form**

This Form is used by the AC when Feature Group B, Feature Group D, or Service Access Codes (SAC NXX) require translation/routing for New, Change or Disconnects and for activation or deactivation of Carrier Identification Codes (CICs). The TQ should be submitted when FGB or FGD translations/routing are required for the following activities:

- New
- Change
- Disconnects
- Activation or deactivation of CICs or SAC NXX codes.

### **19.3.17 Ring (RNG) Form**

This Form provides all information required for ordering ring services and must always be associated with an ASR Form. The circuit detail section provides entries for the specification of ordering options. The location section provides entries for describing the termination of the ring services.

### **19.3.18 Additional Ring information (ARI) Form**

This Form provides additional information that may be necessary when ordering Ring services. The ARI Form must always be associated with an ASR Form and a RING Form containing circuit and location information. The field entries contained within the ARI Form are provided by the AC. The circuit detail section provides entries for the specification of ordering options. The location section provides entries for describing the termination of the ARI.

---



---

### **19.3.19 Database Services Interconnection (DBSI) Form**

This Form provides information required for ordering data base services interconnecting with Common Channel Signaling (CCS) Links and must always be associated with an ASR Form. The Administrative Section provides entries for the interconnection to the CCS Links. The Service Detail Section provides entries for transporting the queries from and to customer signaling point codes.

### **19.3.20 Enhanced Customer Interface (ECI) Form**

The ECI is a process that enables ACs and APs to communicate data elements that are either not national in scope or that require a turn around time sooner than the ASR process allows. The ECI must always be associated with at least the ASR Form and may be associated with other service specific Forms.

### **19.3.21 Virtual Connection (VCF) Form**

This Form contains all the information required for ordering Virtual Connection services. It must be associated with an ASR Form and an SA or EUSA Form. The virtual circuit detail section provides entries for the specification of ordering options. The related circuit detail section provides entries for describing the information related to establishing the physical connection associated with the VC order.

## **19.4 Local Service Ordering Guidelines (LSOG)**

### **19.4.1 Local Service Request (LSR) Form**

The LSR is used to provide all information required for administrative, billing and contact details necessary when ordering Local Exchange services. The LSR Form must always be associated with an End User information (EU) Form and a service specific Form containing loop and location detail necessary for the provisioning of this request. The Administrative Section contains information pertaining to the service being ordered such as: purchase order number, requisition type, desired due date, etc. Account telephone number (ATN) and account number (AN) are also included in the administrative section. The Bill Section provides billing name and address information and the Contact Section contains initiator information, design contact name, address and telephone number as well as implementation contact name and telephone number. The associated End User information Form contains the existing account telephone number (EATN) and existing account number (EAN) fields.

---

**The following service specific Forms are used to order and/or supply information needed to order various types of local service.**

#### **19.4.2 End User information (EUI) Form**

This form provides all location and access information required for ordering local service and must always be associated with the LSR and service specific Forms. The End User Form is necessary to provide the following information

- Identifies the end user location and access information
- Provides entries for specification of ordering options such as inside wire and disconnect.
- Provides the details necessary for gaining access to the customer premises for installations

#### **19.4.3 Loop Service (LS) Form**

This Form provides all information required for ordering Loop Service and must always be associated with the LSR and EUI Forms. The Service Details section provides entries for the specifications of ordering options.

#### **19.4.4 Local Service Request Confirmation (LSC) Form**

The Local Service Request Confirmation (LSC) is prepared by the provider and is forwarded to the customer. This Form provides the customer with Information regarding:

- Critical Dates
- Circuit ID
- Disconnect Telephone Number(s)
- Order Numbers
- Tie Down Information

When an LSC is issued in response to a FIRM ORDER LSR, its issuance signifies the provider's good faith effort to provide the local service as ordered by the customer on the matching version of the referenced LSR Form.

---

---

#### **19.4.5 Loop Service with Number Portability (LSNP) Form**

The LSNP Form must always be associated with LSR and EU Forms which contain administrative, bill detail and location Information necessary for the provisioning of this request. The field entries contained within the LSNP Form are to be provided by the customer.

#### **19.4.6 Number Portability (NP) Form**

The Number Portability Form is divided into three sections, the Administrative Section, the Service Details section and the Remarks section. The NP Form must always be associated with the LSR and EUI Forms. The service details section provides Information such as the providers circuit ID, what route index applies, does Toll Billing Exception apply etc.

#### **19.4.7 Port Service (PS) Form**

The Port Service Form is divided into three sections, the Administrative Section, the Hunting Section and the Service Details section and must always be associated with the LSR and EUI Forms. The Hunting and Service Details sections provide information about hunting arrangements and circuit details.

#### **19.4.8 Resale Service (RS) Form**

The RS Form contains hunting and service details necessary for the ordering of Resale services and must always be associated with the LSR and EUI Forms.

#### **19.4.9 Resale Frame Relay (RFR) Form**

The RFR Form must always be associated with an LSR Form and an EUI Form. The RFR Form contains five sections, Administrative, UNI Circuit Detail, Virtual Circuit Detail, Related Circuit Detail and Remarks. The Administrative Section relates the RFR Form to the LSR. The Virtual Circuit Detail Section carries the information specific to the primary end point. The Related Circuit Detail Section contains information specific to the secondary end point. The Remarks Section is used for additional narrative information. The field entries contained within the RFR Form are provided by the customer.

#### **19.4.10 Resale Private Line (RPL) Form**

The RPL Form is designed for the ordering of (point-to-point) non-switched, dedicated private line service. The RPL Form must always be associated with an LSR Form. The location sections provide entries specific to the primary and terminating (secondary) end of the service being provided. The RPL Form also contains entries that provide service details for the requested service.

#### **19.4.11 Directory Listing (DL) Form**

The DL Form provides specific directory listing information related to the Directory Service Request (DSR). The DL Form will always be accompanied by a DSR Form. The Listing Control Section provides entries for the type of activity and listing involved, the type of account for which the listing is being requested, etc. The Listing Instruction Section provides specific listing details. Caption listings also require DSCR Form for additional details.

#### **19.4.12 Directory Service Request Completion Notice (DSCN) Form**

The DSCN is prepared by the provider and is forwarded to the customer. This Form provides the customer with administrative and listing appearance information associated with the customer's request. When a DSCN is issued in response to a Directory Service Request (DSR), its issuance signifies the provider's good faith effort to provide the listing(s) as ordered by the customer on the matching version of the referenced DSR Form.

#### **19.4.13 Directory Service Request (DSR) Form**

The DSR Form will always be associated with the applicable directory specific Form(s), e.g., Directory Listing Form, Directory Service Caption Request Form, etc. The DSR Form may be associated with an LSR, EUI, and a service specific Form containing loop and location detail necessary for the provisioning of the request or it may be transmitted as a stand alone request. All information required for administrative, billing and contact details is provided for in the various fields contained within page 1 of the DSR Form. The Administrative Section contains information pertaining to the directory listings and/or directory assistance listings being requested such as: purchase order number, version number, expected due date, requisition type, class of service, etc. The Bill Section provides billing name and address information. The Contact Section contains initiator information and the Advertising Section contains advertising contact information.

The second page of this Form is identified as Directory Service and Delivery/information.

---

---

#### **19.4.14 Directory Service Request Error Detail (DSRED) Form**

The DSRED Form provides the customer with the error information necessary for control, tracking and correction of errors from the applicable request(s) for directory services. DSRED is prepared by the provider and is forwarded to the customer. It is returned as a result of a DSR Form requesting listing(s). The DSRED will be returned if the requester specifies that the confirmation should contain error detail, or may be initiated at any time by the provider when errors are encountered in processing a directory listing request.

#### **19.4.15 Directory Service Caption Request (DSCR) Form**

The DSCR Form will always be associated with the DSR and DL Forms. All information required for captions and degree of indent level detail is provided for in the various fields contained within the DSCR Form. The Administrative Section contains information pertaining to the service being ordered such as: purchase order number, version number, account telephone number, etc. The Degree of Indent Sections provide the sequence merge, override, name, address, telephone number and associated degree of indent level information.



## Glossary Contents

Glossary .....	Glossary-1
Abbreviations .....	Glossary-1
Acronyms .....	Glossary-3
Definitions.....	Glossary-34
Symbols.....	Glossary-61





---

## Glossary

### Abbreviations

$\Omega$	ohm
$\mu\text{A}$	microampere
$\mu\text{F}$	microfarad
$\mu\text{s}$	microsecond
$\mu$	mu
A	ampere
ac	alternating current
AM	amplitude modulation
Bd	baud
bps	bits per second
C	Celsius or coulomb
cm	centimeter
dB	decibel
dBA	“A-weighted” SPL
dBm	decibel relative to one milliwatt
dBm0	the decibels relative to 1 milliwatt, referenced to a 0 TLP
dBrnC or dBrnc	the decibels relative to reference noise with C-message weighting
dBrnC0 or dBrnc0	the dBrnC value referenced to a 0 TLP
dBrnf	decibel referenced noise 3 kHz flat frequency weighting
dc	direct current
FM	frequency modulation
ft	foot
Hz	hertz
IPM	interruptions per minute
kBd	kilobaud
kbit	kilobit
kbps	kilobits per second

---

kft	kilofoot
kHz	kilohertz
km	kilometer
k $\Omega$	kilohm
kW	kilowatt
lb	pound
MHz	megahertz
MW	megawatt
mA	milliamperere
Mbps	megabits per second
mi	mile
ms	millisecond
mW	milliwatt
pps	pulses per second
rms	root mean square
V	volt
VU	volume unit
W	watt
wps	words per second

---

## Acronyms

<b>AABS</b>	Automated Alternate Billing Service
<b>AAL</b>	Asynchronous Transfer Mode (ATM) Adaptation Layer
<b>AAP</b>	Alternate Access Provider
<b>ABD</b>	Average Business Day
<b>ABL</b>	Area Business Listing
<b>ABR</b>	Available Bit Rate
<b>ABS</b>	Alternate Billing Service
<b>AC</b>	Access Concentrator or Automatic Callback
<b>ACC</b>	Automatic Congestion Control
<b>ACD</b>	Automatic Call Distributor
<b>ACM</b>	Address Complete Message
<b>ACNA</b>	Automated Customer Name and Address
<b>ACO</b>	Additional Call Offering
<b>ACR</b>	Automatic Call Rejection
<b>ACTS</b>	Automated Coin Toll Service
<b>ADM</b>	Add-Drop Multiplexer
<b>ADPCM</b>	Adaptive Differential Pulse-Code Modulation
<b>ADSI</b>	Analog Display Services Interface
<b>ADSL</b>	Asymmetrical Digital Subscriber Line
<b>AFR</b>	Automatic Flexible Routing
<b>AIC</b>	Automatic Intercept Center
<b>AIN</b>	Advanced Intelligent Network
<b>AINI</b>	ATM Inter Network Interface
<b>AIOD</b>	Automatic Identified Outward Dialing
<b>AIS</b>	Alarm Indication Signal or Automatic Intercept System
<b>ALC</b>	Analog Loop Carrier
<b>A-Link</b>	Access Link
<b>AMA</b>	Automatic Message Accounting
<b>AMADNS</b>	AMA Data Networking System
<b>AMAT</b>	AMA Transmitter

---

<b>AMATPS</b>	AMA Teleprocessing System
<b>AMI</b>	Alternate Mark Inversion
<b>AML</b>	Actual Measured Loss
<b>AMPS</b>	Advanced Mobile Phone Service
<b>AMS</b>	Audiovisual Multimedia Service
<b>ANI</b>	Automatic Number Identification
<b>ANM</b>	Answer Message
<b>ANSI</b>	American National Standards Institute
<b>AOCR</b>	Automatic Out-Of-Chain Reroute
<b>AOX</b>	Automated Optical Cross-connect
<b>APC</b>	Automatic Power Control
<b>APP</b>	Application date
<b>APS</b>	Administrative Processor System or Automatic Protection Switching
<b>APT</b>	Automatic Progression Trunk
<b>AR</b>	Automatic Recall
<b>ARP</b>	Address Resolution Protocol
<b>ARS</b>	Automatic Route Selection
<b>ARSB</b>	Automatic Repair Service Bureau
<b>ASCII</b>	American Standard Code for Information Interexchange
<b>ASCX12</b>	Accredited Standards Committee X12 (ANSI)
<b>ASN.1</b>	Abstract Syntax Notation One
<b>ASR</b>	Access Service Request or Automatic Speech Recognition
<b>ASU</b>	Automatic Service Unit
<b>AT</b>	Access Tandem
<b>ATA</b>	Automatic Trouble Analysis
<b>ATIS</b>	Alliance for Telecommunications Industry Solutions (formerly ECSA)
<b>ATM</b>	Asynchronous Transfer Mode or Automated Teller Machine
<b>ATRS</b>	Automatic Trouble Reporting System
<b>ATT</b>	Automatic Trunk Testing
<b>AVD</b>	Alternate Voice/Data
<b>B8ZS</b>	Bipolar with 8-Zero Substitution

---

---

<b>BnZS</b>	Bipolar with n-Zero Substitution
<b>BAF</b>	Bellcore AMA Format
<b>BBG</b>	Basic Business Group
<b>BCLID</b>	Bulk Calling Line Identification
<b>BCSC</b>	Bar Code and Standard Coding
<b>B-DCS</b>	Broadband Digital Cross-connect System
<b>BEF</b>	Band-Elimination Filter
<b>BER</b>	Bit Error Rate or Bit Error Ratio
<b>BERT</b>	Bit Error Ratio Testing
<b>BETRS</b>	Basic Exchange Telecommunications Radio Service
<b>BEXR</b>	Basic Exchange Radio
<b>BFSK</b>	Binary Frequency-Shift-Keying
<b>B-ICI</b>	Broadband Inter-Carrier Interface
<b>BIP</b>	Bit Interleaved Parity
<b>BIS</b>	Business Information System
<b>B-ISDN</b>	Broadband Integrated Services Digital Network
<b>B-ISSI</b>	Broadband Inter-Switching System Interface
<b>BISUP</b>	Broadband ISDN User Part
<b>BITS</b>	Building-Integrated Timing Supply
<b>BK</b>	Break
<b>BLER</b>	Block Error Ratio
<b>BLG</b>	Billing (Committee)
<b>B-Link</b>	Bridge Link
<b>BLSR</b>	Bidirectional Line Switched Ring
<b>BNS</b>	Billed-Number Screening
<b>BO</b>	Business Office
<b>BOC</b>	Bell Operating Company
<b>BUS</b>	Broadcast and Unknown Server
<b>BPP</b>	Billed Party Preference
<b>BPV</b>	Bipolar Violation
<b>BRA</b>	Basic Rate Access
<b>BRI</b>	Basic Rate Interface
<b>BSA</b>	Basic Serving Arrangement

---

---

<b>BSC</b>	Binary Synchronous Communication
<b>BSE</b>	Basic Service Element
<b>BSS</b>	Broadband Switching System
<b>BTN</b>	Billing Telephone Number
<b>BVA</b>	Billing Validation Application
<b>CABS</b>	Carrier Access Billing System
<b>CAC</b>	Carrier Access Code or Circuit Administration Center
<b>CAD/CAM</b>	Computer-Aided Design/Computer-Aided Manufacture
<b>CALEA</b>	Communications Assistance for Law Enforcement Act
<b>CAMA</b>	Centralized Automatic Message Accounting
<b>CANF</b>	Cancel From
<b>CANT</b>	Cancel To
<b>CAP</b>	Competitive Access Provider or Computer Access Restriction
<b>CARE</b>	Customer Account Record Exchange
<b>CAROT</b>	Centralized Automatic Reporting On Trunks
<b>CARS</b>	Communications Analysis Reporting System or CABS Auxiliary Report Specifications
<b>CAS</b>	CPE Alerting Signal
<b>CATLAS</b>	Centralized Automatic Trouble Locating and Analysis System
<b>CATV</b>	Cable Television
<b>CAVD</b>	CSDC Alternate Voice Data
<b>CBR</b>	Constant Bit Rate
<b>CC</b>	Composite Clock or Country Code
<b>CCC</b>	Calling Card Call or Clear-Channel Capability
<b>CCIS</b>	Common Channel Interoffice Signaling
<b>CCITT</b>	International Telegraph and Telephone Consultative Committee (now the ITU-T)
<b>CCS</b>	Carrier Conversion Signaling or Common Channel Signaling or One Hundred Call-Seconds
<b>CCSA</b>	Common-Control Switching Arrangement

---

---

<b>CCSN</b>	Common Channel Signaling Network
<b>CCSS</b>	Common Channel Signaling System
<b>CCSSO</b>	Common Channel Signaling Switching Office
<b>CD</b>	Call Distribution
<b>CDA</b>	Call Disposition Analyzer
<b>CDC</b>	Coin Detection Circuit
<b>CDM</b>	Code Division Multiplex
<b>CDO</b>	Community Dial Office
<b>CDU</b>	CSDC Data Unit
<b>CEF</b>	Cable-Entrance Facility
<b>CEI</b>	Comparably Efficient Interconnection or Comparably Efficient Interface
<b>CEMF</b>	Counter Electromotive Force
<b>CEPT</b>	European Conference of Post and Telecommunication
<b>CES</b>	Circuit Emulation Service
<b>CEV</b>	Controlled Environmental Vault
<b>CFA</b>	Carrier Failure Alarm
<b>CGA</b>	Carrier Group Alarm
<b>CGSA</b>	Cellular Geographic Service Area
<b>CI</b>	Customer Installation
<b>CI-I</b>	Computer Inquiry I
<b>CI-II</b>	Computer Inquiry II
<b>CI-III</b>	Computer Inquiry III
<b>CIC</b>	Carrier Identification Code or Circuit Identification Code
<b>CID</b>	Caller Identity Delivery
<b>CIDB</b>	Calling Identity Delivery Blocking
<b>CIDCW</b>	Calling Identity Delivery on Call Waiting
<b>CIDS</b>	Caller Identity Delivery and Suppression
<b>CIID</b>	Card Issuer Identifier
<b>CIMAP</b>	Circuit Installation and Maintenance Assistance Package
<b>CIMAP/CC</b>	Circuit Installation and Maintenance Assistance Package for Control Centers
<b>CIR</b>	Committed Information Rate

---

---

<b>CKL</b>	Circuit Location
<b>C-Link</b>	Cross Link
<b>CLC</b>	Carrier Liaison Committee
<b>CLEC</b>	Competitive Local Exchange Company
<b>CLP</b>	Cell Loss Priority
<b>CLS</b>	Combined Link Set
<b>CMDF</b>	Combined Main Distributing Frame
<b>CMIP</b>	Common Management Information Protocol
<b>CMIS</b>	Common-Management Information Services
<b>CMRS</b>	Cellular Mobile Radio Telecommunications Service
<b>CMS</b>	Circuit Maintenance System
<b>CMSA</b>	Consolidated Metropolitan Statistical Area
<b>CMSDB</b>	Call Management System Database
<b>CNAB</b>	Calling Name Delivery Blocking
<b>CNAM</b>	Calling Name Delivery
<b>CND</b>	Calling Number Delivery
<b>CNDB</b>	Calling Number Delivery Blocking
<b>CNM</b>	Customer Network Management
<b>CNS</b>	Complementary Network Service
<b>CO</b>	Central Office
<b>COCOT</b>	Customer-Owned Coin-Operated Telephone
<b>COG</b>	Centralized Operations Group
<b>CO-LAN</b>	Central Office-based Local Area Network
<b>COT</b>	Central Office Terminal or Continuity Check Message or Customer-Originated Trace
<b>COTC</b>	Circuit Order Test and Completion
<b>CP</b>	Common Point
<b>CPCS</b>	Customer-Provided Communication System
<b>CPE</b>	Customer Premises Equipment
<b>CPGS</b>	Cost of Pair-Gain Systems
<b>CPN</b>	Calling Party Number
<b>CPNI</b>	Customer Proprietary Network Information

---



---

<b>CPR</b>	Call Processing Record or Constant Bit Rate Packet Rate
<b>CPT</b>	Coinless Public Telephone
<b>CPU</b>	Central Processing Unit
<b>CR</b>	Cell Rate
<b>CRAS</b>	Cable Repair Administration System
<b>CRC</b>	Cyclic Redundancy Check
<b>CREG</b>	Concentrated Range Extender with Gain
<b>CRIS</b>	Customer Record Information System or Customer Records Inventory System
<b>CRS</b>	Cell Relay Service or Centralized Results System
<b>CRSAB</b>	Centralized Repair Service Attendant Bureau
<b>CRT</b>	Cathode Ray Tube
<b>CS</b>	Convergence Sublayer
<b>CS1</b>	Capability Set 1
<b>CSA</b>	Carrier Serving Area
<b>CSC</b>	Common Signaling Channel
<b>CSCANS</b>	Customer Services Computer Access Network Standards
<b>C-SCANS</b>	Customer Service Computer Access Network (Northern Telecom)
<b>CSCN</b>	Canadian Steering Committee on Numbering
<b>CSDC</b>	Circuit-Switched Digital Capability
<b>CSMA/CD</b>	Carrier Sense Multiple Access with Collision Detection
<b>CSU</b>	Channel Service Unit
<b>CT2</b>	Cordless Telephone-2nd Generation
<b>CTMS</b>	Carrier Transmission Maintenance System
<b>CTT</b>	Cable Trouble Ticket
<b>C</b>	Central Trunk Test Unit
<b>CU</b>	Channel Unit
<b>CWA</b>	Communications Workers of America
<b>CWD</b>	Call Waiting Deluxe
<b>CWL</b>	Circuit Work Location
<b>CX</b>	Composite Signaling
<b>CXR</b>	Carrier

---

---

<b>CZ</b>	Carrier Zone
<b>D&amp;R</b>	Data and Reporting (Subsystem)
<b>DAA</b>	Data Access Arrangement
<b>DACS</b>	Digital-Access and Cross-connect System
<b>DAL</b>	Dedicated Access Line
<b>DAS</b>	Digital Access Survey
<b>DBM</b>	Database Manager
<b>DCC</b>	Data Communications Channel
<b>DCE</b>	Data Circuit-terminating Equipment
<b>DCN</b>	Data Communications Network
<b>DCO</b>	Data Central Office
<b>DCOS</b>	Data Collection Operations System
<b>DCS</b>	Digital Cross-connect System
<b>DCT</b>	Digital Carrier Terminal or Digital Carrier Trunk
<b>DDD</b>	Direct Distance Dialing
<b>DDS</b>	Digital Data Service or Digital Dataphone Service
<b>DE</b>	Discard Eligibility (bit)
<b>DF</b>	Distributing Frame
<b>DFMS</b>	Digital Facilities Management System
<b>DFT</b>	Digital Facility Terminal
<b>DH</b>	Dual Homing
<b>DIC</b>	Direct InterLATA Connecting (trunk)
<b>DID</b>	Direct Inward Dialing
<b>DIG</b>	Data Integrity Group
<b>DIS</b>	Digital Interface System
<b>DIU</b>	Digital Interface Unit
<b>DLC</b>	Digital Loop Carrier or Data Line Card
<b>D-Link</b>	Diagonal Link
<b>DLP</b>	Decode Level Point
<b>DLSE</b>	Dial-Line Service Evaluation
<b>DMSI</b>	Database Service Management Incorporated

---

---

<b>DMV</b>	Data/Voice Multiplexed
<b>DMW</b>	Digital Milliwatt
<b>DN</b>	Directory Number
<b>DNAL</b>	Dedicated Network Access Link
<b>DNHG</b>	Directory Number Hunt Group
<b>DNIC</b>	Data Network Identification Code
<b>DNME</b>	Distributed Network Management Environment
<b>DNPA</b>	Data Numbering Plan Area
<b>DOC</b>	Dynamic Overload Control
<b>DOCS</b>	Documentation
<b>DOD</b>	Direct Outward Dialing
<b>DOJ</b>	Department of Justice
<b>DP</b>	Dial Pulse or Dial Pulsing
<b>DPA</b>	Different Premises Address
<b>DPC</b>	Destination Point Code
<b>DPO</b>	Dial Pulse Originating
<b>DPT</b>	Dial Pulse Terminating
<b>DPX</b>	DATAPATH Extension
<b>DQDB</b>	Distributed Queue Dual Bus
<b>DRAM</b>	Digital Recorded Announcement Machine
<b>DRCW</b>	Distinctive Ringing/Call Waiting
<b>DRE</b>	Directional Reservation of Equipment
<b>DRS</b>	Data and Reports System or Digital Reference Signal
<b>DRT</b>	Dynamic Routing Technique
<b>DS0</b>	Digital Signal (level 0)
<b>DS0 CCC</b>	DS0 Clear-Channel Capability
<b>DS1</b>	Digital Signal (level 1)
<b>DS1 CCC</b>	DS1 Clear-Channel Capability
<b>DS3</b>	Digital Signal (level 3)
<b>DSE</b>	Data Switching Exchange
<b>DSL</b>	Digital Subscriber Line
<b>DSP</b>	Display System Protocol

---

---

<b>DSU</b>	Data Service Unit
<b>DSX</b>	Digital Signal Cross-connect or Digital System Cross-connect
<b>DSX-1</b>	Digital Signal Cross-connect (DS1 Rate)
<b>DTA</b>	Digitally Terminated Analog (trunk)
<b>DTC</b>	Digital Trunk Controller
<b>DTE</b>	Data Terminal Equipment
<b>DTF</b>	Dial-Tone First
<b>DTMF</b>	Dual-Tone Multifrequency
<b>DU</b>	Data Unit
<b>DVM</b>	Data/Voice Multiplexer
<b>DX</b>	Duplex (signaling)
<b>DXI</b>	Data Exchange Interface
<b>E911-DMS</b>	Expanded (formerly Enhanced) 911 - Data Management System [Use EDMS]
<b>EAABS</b>	Exchange Access Alternate Billing Service
<b>EABS</b>	Exchange Alternate Billing Service
<b>EAEO</b>	Equal Access End Office
<b>EAS</b>	Extended-Area Service
<b>EAT</b>	Equal Access Tandem
<b>EB&amp;F</b>	Equipment Blockage and Failure
<b>ECSS</b>	Economic Hundred Call Seconds
<b>ECH</b>	Echo Cancelers with Hybrid
<b>ECIC</b>	Electronic Communications Implementation Committee
<b>ECM</b>	Expanded Call Model
<b>ECSA</b>	Exchange Carriers Standards Association (now ATIS)
<b>ECSPC</b>	Electronic Communications Service Provider Committee
<b>EDD</b>	Envelope Delay Distortion
<b>EDI</b>	Electronic Data Interchange
<b>EDMS</b>	Expanded 911-Data Management System
<b>EDSX</b>	Electronic Digital Signal Cross-connect
<b>EFS</b>	Error-Free Second
<b>EIS</b>	Expanded Inband Signaling
<b>EKTS</b>	Electronic Key Telephone System

---

---

<b>ELAN</b>	Emulated LAN
<b>E-Link</b>	Extended Link
<b>ELP</b>	Encode Level Point
<b>EMI</b>	Electromagnetic Interference Exchange Message Interface
<b>EML</b>	Expected Measured Loss
<b>EMP</b>	Electromagnetic Pulse
<b>EO</b>	End Office
<b>EOC</b>	Embedded Operations Channel
<b>EPN</b>	End-Point Number
<b>EPTG</b>	Equipment Performance Task Group
<b>ERC</b>	Easily Recognizable Code
<b>ERL</b>	Echo Return Loss
<b>ES</b>	Errored Seconds
<b>ESAC</b>	Electronic Systems Assistance Center
<b>ESD</b>	Electrostatic Discharge
<b>ESF</b>	Extended Superframe Format
<b>ESN</b>	Electronic Serial Number or Emergency Service Number
<b>ESP</b>	Enhanced Service Provider
<b>EST</b>	Echo Suppressor Terminal
<b>ETS</b>	Electronic Translation System
<b>ETSI</b>	European Telecommunications Standards Institute
<b>EUT</b>	Equipment Under Test
<b>EXM</b>	Exit Message
<b>FCC</b>	Federal Communications Commission
<b>FCG</b>	False Cross Ground
<b>FDDI</b>	Fiber Distributed Data Interface
<b>fdf</b>	Fiber Distributing Frame
<b>FDI</b>	Feeder Distribution Interface
<b>FDM</b>	Frequency Division Multiplex
<b>FDMA</b>	Frequency-Division Multiple Access
<b>FEBE</b>	Far End Block Error
<b>FERF</b>	Far End Receive Error

---

---

<b>FGA</b>	Feature Group A
<b>FGB</b>	Feature Group B
<b>FGC</b>	Feature Group C
<b>FGD</b>	Feature Group D
<b>FITL</b>	Fiber in the Loop
<b>F-Link</b>	Fully Associated Link
<b>FMAC</b>	Facility Maintenance and Administration Center
<b>FNPA</b>	Foreign Numbering Plan Area
<b>FPOS</b>	First Point of Switching
<b>FPS</b>	Framing Pattern Sequence
<b>FR_ICI</b>	Frame Relay Inter-Carrier Interface
<b>FR_NNI</b>	Frame Relay Network-Network Interface
<b>FRS</b>	Frame Relay Service
<b>FR_SS</b>	Frame Relay Switching System
<b>FR_UNI</b>	Frame Relay User-Network Interface
<b>FSK</b>	Frequency Shift Keying
<b>FTA</b>	Facility Test Acknowledgment
<b>FTL</b>	Facility Test Loopback
<b>FTR</b>	Facility Test Results
<b>FTTC</b>	Fiber-To-The-Curb
<b>FTU</b>	Facility Test Underway
<b>FX</b>	Foreign Exchange
<b>FXO</b>	Foreign Exchange Office
<b>FXS</b>	Foreign Exchange Station
<b>GCS</b>	Global Counter Subsystem
<b>GDX</b>	Gated Diode Crosspoint
<b>GFC</b>	Generic Flow Control
<b>GOS</b>	Grade of Service
<b>GPS</b>	Global Positioning System
<b>GSTN</b>	General-Switched Telephone Network
<b>GTP</b>	General Trade Product
<b>GUI</b>	Graphical User Interface
<b>HCC</b>	High-Capacity Circuit

---

---

<b>HD-FDF</b>	High-Density Fiber Distributing Frame
<b>HDLC</b>	High-Level Data Link Control
<b>HDSL</b>	High bit-rate Digital Subscriber Line
<b>HDT</b>	Host Digital Terminal
<b>HEC</b>	Header Error Control
<b>HLSC</b>	High-Level Service Circuit
<b>HLR</b>	Home Location Register
<b>HNPA</b>	Home Numbering Plan Area
<b>HRC</b>	Hypothetical Reference Connection
<b>HTR</b>	Hard-To-Reach
<b>HTU</b>	High bit-rate Transmission Unit
<b>IAL</b>	Immediate-Action Limit
<b>IAM</b>	Initial Address Message
<b>IC</b>	Intercept or Interexchange Carrier
<b>ICCF</b>	Industry Carriers Compatibility Forum
<b>ICH</b>	Interprocessor Communication Handler
<b>ICI</b>	Inter-Carrier Interface
<b>ICL</b>	Inserted Connection Loss
<b>ICSC</b>	Interexchange Carrier Service Center
<b>ICT</b>	Incoming Trunk
<b>ICUP</b>	Individual Circuit Usage and PEG
<b>IDDD</b>	International Direct Distance Dialing
<b>IDF</b>	Intermediate Distributing Frame
<b>IDLC</b>	Integrated Digital Loop Carrier
<b>IDN</b>	International Data Number
<b>IDOC</b>	Internal Dynamic Overload Control
<b>IDT</b>	Integrated Digital Terminal
<b>IEEE</b>	Institute of Electrical and Electronics Engineers
<b>IETF</b>	Internet Engineering Task Force
<b>IF</b>	Identification Failure
<b>IILC</b>	Information Industry Liaison Committee
<b>IITC</b>	Internetwork Interoperability Test Committee
<b>IITP</b>	Internetwork Interoperability Test Plan

---

---

<b>IL</b>	Information Letter
<b>ILMI</b>	Integrated Local Management Interface
<b>ILU</b>	Intermediate Line Unit
<b>IMA</b>	Ineffective Machine Attempts
<b>IMP</b>	Impulses Per Minute
<b>IMTS</b>	Improved Mobile Telephone Service
<b>IN</b>	Intelligent Network
<b>INC</b>	Industry Numbering Committee or International Carrier
<b>IO</b>	Ineffective Other
<b>IOT</b>	Interend Office Trunk or Interoffice Terminator
<b>IPNNI</b>	Integrated Private Network Node Interface
<b>IP</b>	Information Provider [900 Service] or Intelligent Peripheral
<b>IPI</b>	Information Product Interchange
<b>IPM</b>	Interruptions Per Minute
<b>IPX</b>	Internet Packet Exchange
<b>IRC</b>	International Record Carrier
<b>IRR</b>	Immediate Reroute
<b>IRRS</b>	Immediate Reroute Spray
<b>IS</b>	Inband Signaling
<b>ISC</b>	International Switching Center
<b>ISCP</b>	Integrated Service Control Point
<b>ISDN</b>	Integrated Services Digital Network
<b>ISDNUP</b>	Integrated Services Digital Network User Part
<b>IS-41</b>	Interim Standard - 41
<b>ISI</b>	Industry Support Interface
<b>ISNI</b>	Intermediate Signaling Network Identification
<b>ISO</b>	International Standards Organization
<b>ISP</b>	Information Service Provider
<b>ISSI</b>	Inter-Switching System Interface
<b>ISUP</b>	Integrated Services Digital Network (ISDN) User Part
<b>ITS</b>	Integrated Test System

---



---

<b>ITSE</b>	Incoming-Trunk Service Evaluation
<b>ITT</b>	Intertandem Trunk or International Telephone and Telegraph
<b>ITU</b>	International Telecommunication Union
<b>ITU-R</b>	International Telecommunication Union — Radiocommunication Sector (formerly the CCIR)
<b>ITU-T</b>	International Telecommunication Union — Telecommunication Standardization Sector (formerly the CCITT)
<b>IVR</b>	Interactive Voice Response
<b>IWF</b>	Interwork Function
<b>IX</b>	Interexchange
<b>KCDC</b>	Kansas City Data Center
<b>KP</b>	Keypulse signal
<b>KTS</b>	Key Telephone System
<b>LADC</b>	Local-Area Data Channel
<b>LAMA</b>	Local Automatic Message Accounting
<b>LAN</b>	Local Area Network
<b>LANE</b>	Local Area Network Emulation
<b>LAN/MAN</b>	Local Area Network/Metropolitan Area Network
<b>LAPB</b>	Link Access Protocol Balanced
<b>LAPD</b>	Link Access Procedure on the D-channel
<b>LAPM</b>	Line Access Procedures for Modems
<b>LAS</b>	LIDB Administrative System
<b>LASS</b>	Local Alarm Scanning System
<b>LATA</b>	Local Access and Transport Area
<b>LCAMOS</b>	Loop Cable Maintenance Operations System
<b>LCM</b>	Line Control Module
<b>LCN</b>	Local Communications Network
<b>LDS</b>	Local Digital Switching
<b>LEA</b>	Link Equipment Available
<b>LEC</b>	Local Exchange Carrier or LANE Client
<b>LECS</b>	LANE Configuration Server
<b>LEF</b>	Link Equipment Failure

---

---

<b>LERG</b>	Local Exchange Routing Guide
<b>LES</b>	Local Area Network Emulation Server
<b>LEU</b>	Link Equipment Unavailable
<b>LFS</b>	Link Fault Sectionalization
<b>LGC</b>	Line Group Controller
<b>LIDB</b>	Line Information Database
<b>LIE</b>	Lightguide Interconnection Equipment
<b>LIN</b>	Loop Interface Shelf
<b>LIT</b>	Lightguide Interconnection Terminal
<b>LLP</b>	Line Link Pulsing
<b>LME</b>	Layer Management Entity
<b>LMI</b>	Layer Management Interface
<b>LMOS</b>	Loop Maintenance Operations System
<b>LNP</b>	Local Number Portability
<b>LOF</b>	Loss of Frame
<b>LOP</b>	Loss of Pointer
<b>LORAN</b>	Long Range Navigation
<b>LOS</b>	Loss of Signal
<b>LOST</b>	Local Originating Station Treatment
<b>LP</b>	Local Portability
<b>LPCDF</b>	Low-Profile Conventional Distribution Frame
<b>LRD</b>	Long-Route Design
<b>LS</b>	Loop Start
<b>LSDB</b>	Listing Services Database
<b>LSSGR</b>	LATA Switching Systems Generic Requirements
<b>LSSU</b>	Link Status Signal Unit
<b>LSTP</b>	Local Signaling Transfer Point
<b>LT</b>	LATA Tandem or Line Termination or Loop Termination
<b>LTE</b>	Line Terminating Equipment
<b>LTF</b>	Loop Testing Frame
<b>LTS</b>	Loop Testing System
<b>LUNI</b>	LANE User Network Interface

---

---

<b>MAC</b>	Media Access Control
<b>MAN</b>	Metropolitan Area Network
<b>MAP</b>	Maintenance Access Panel
<b>MAR</b>	Multialternate Route
<b>MDF</b>	Main Distributing Frame
<b>MDII</b>	Machine-Detected Interoffice Irregularity
<b>MDMF</b>	Multiple Data Message Format
<b>MDR</b>	Message Detail Recording
<b>ME</b>	Miscellaneous Equipment
<b>MECAB</b>	Multiple Exchange Carrier Access Billing
<b>MECCA</b>	Mechanized Evaluation of Call Completion Anomalies
<b>MF</b>	Multifrequency (signaling)
<b>MFJ</b>	Modification of Final Judgment
<b>MFO</b>	Multifrequency Signaling Originating
<b>MFT</b>	Metallic Facility Terminal
<b>MLHG</b>	Multiline Hunt Group
<b>MLI</b>	Multilink Irregularity
<b>MLP</b>	Multilink Procedure
<b>MLRD</b>	Modified Long-Route Design
<b>MLT</b>	Mechanized Loop Testing
<b>MMOC</b>	Minicomputer Maintenance and Operations Center
<b>MOC</b>	Maintenance and Operations Console
<b>MOP</b>	Method of Procedure
<b>MOS</b>	Maintenance and Operations Subsystem
<b>MPC</b>	Message Processing Committee
<b>MPOA</b>	Multiprotocols Over ATM
<b>MRVA</b>	MTP Routing Verification Acknowledgment
<b>MRVR</b>	MTP Routing Verification Result
<b>MRVT</b>	MTP Routing Verification Test
<b>MSA</b>	Metropolitan Statistical Area
<b>MSAP</b>	Multi-Services Application Platform
<b>MSC</b>	Maintenance of Service Charge or Mobile Switching Center
<b>MSS</b>	MAN Switching System

---

---

<b>MLT</b>	Mechanical Loop Testing
<b>MTM</b>	Maintenance Trunk Module
<b>MTP</b>	Message Transfer Part or Message Transfer Point
<b>MTS</b>	Message Telecommunications Service
<b>MTU</b>	Maintenance Terminating Unit
<b>MUT</b>	Miniaturized Universal Trunk
<b>MUX</b>	Multiplexer
<b>NA</b>	Node Administration
<b>NANP</b>	North American Numbering Plan
<b>NANPA</b>	North American Numbering Plan Administration
<b>NAP</b>	Network Access Point
<b>NARUC</b>	National Association of Regulatory Utility Commissioners
<b>NASC</b>	(800) Number Administration and Service Center
<b>NAS/CARS</b>	Network Analysis System/Call Analysis Reporting System
<b>NBOC</b>	Network Build-Out Capacitor
<b>NBOR</b>	Network Build-Out Resistor
<b>NC</b>	No Circuit
<b>NCA</b>	No-Circuit Announcement
<b>NCI</b>	Network Channel Interface
<b>NCTE</b>	Network Channel Terminating Equipment
<b>NDCOS</b>	Network Data Collection Operations System
<b>N-DCS</b>	Narrowband Digital Cross-connect System
<b>NDF</b>	New Data Flag
<b>NE</b>	Network Element
<b>NEBS</b>	Network Equipment-Building System
<b>NFPA</b>	National Fire Protection Association
<b>NHRP</b>	Next Hop Resolution Protocol
<b>NI-1</b>	National ISDN-1
<b>NI-2</b>	National ISDN-2
<b>NIA</b>	Network Interconnection/Architecture
<b>NIIF</b>	Network Interconnection/Interoperability Forum
<b>NIM</b>	Network Installation and Maintenance
<b>N-ISDN</b>	Narrowband Integrated Services Digital Network

---

---

<b>NIT</b>	Network Interoffice Transmission
<b>NM</b>	Node Manager or Network Management
<b>NMC</b>	Network Management Center
<b>NMPR</b>	Network Management Printer
<b>NMS</b>	Noise Measuring Set
<b>NN</b>	Nation Number
<b>NNI</b>	Network Node Interface or Network-Network Interface
<b>NNX</b>	End Office Code
<b>NOC</b>	Network Operations Center
<b>NOF</b>	Network Operations Forum
<b>NOTE</b>	Network Office Terminating Equipment
<b>NOTIS</b>	Network Operations Trouble Information System
<b>NPA</b>	Numbering Plan Area (area codes)
<b>NPI</b>	Numbering Plan Identification
<b>NPRM</b>	Notice of Proposed Rulemaking
<b>NRC</b>	Network Reliability Council
<b>NRIC</b>	Network Reliability and Interoperability Council
<b>NRRI</b>	Network Rating and Routing Information
<b>NRSC</b>	Network Reliability Steering Committee
<b>NSC</b>	Network Service Center
<b>NSCS</b>	Network Service Center System
<b>NS/EP</b>	National Security Emergency Preparedness
<b>NSP</b>	Not Sent Paid
<b>NSPMP</b>	Network Switching Performance Measurement Plan
<b>NT</b>	Network Termination or Network Testing
<b>NT1</b>	Network Termination 1
<b>NT2</b>	Network Termination 2
<b>NTCA</b>	National Telephone Cooperative Association
<b>NTE</b>	Network Terminating Equipment
<b>NTEC</b>	Network Technical Engineering Center
<b>NTF</b>	No Trouble Found

---

---

<b>NTM</b>	Network Traffic Management
<b>NTMOS</b>	Network Traffic Management Operations System
<b>NTN</b>	Network Terminal Number
<b>NTSC</b>	National Television System Committee
<b>NTTMP</b>	Network Trunk-Transmission Measurement Plan
<b>NUI</b>	Network User Identification
<b>NXX</b>	End Office Code
<b>O&amp;P</b>	Ordering and Provisioning
<b>OA&amp;M</b>	Operations, Administration, and Maintenance
<b>OAM&amp;P</b>	Operations, Administration, Maintenance, and Provisioning
<b>OBF</b>	Ordering and Billing Forum
<b>OC-N</b>	Optical Carrier level N
<b>OCU</b>	Office Channel Unit
<b>ODSX</b>	Optical Digital Signal Cross-connect
<b>OFDI</b>	Optical Feeder Distribution Interface
<b>OGT</b>	Outgoing Trunk
<b>OIM</b>	Operations Interface Module
<b>OIS</b>	Optical Interface System
<b>OKTR</b>	Operator-Keyed Trouble Report
<b>OLIP</b>	Originating Line Information Parameters
<b>OLNS</b>	Originating Line Number Screening
<b>OLTM</b>	Optical Line Terminating Multiplexer
<b>OMAP</b>	Operations, Maintenance, and Administration Part
<b>ONA</b>	Open Network Architecture
<b>ONAL</b>	Off-Network Access Line
<b>ONI</b>	Operator Number Identification
<b>ONU</b>	Optical Network Unit
<b>OOF</b>	Out of Frame
<b>OPASTCO</b>	Organization for the Protection and Advancement of Small Telephone Companies
<b>OOPC</b>	Originating Point Code
<b>OPDU</b>	Operation Protocol Data Unit
<b>OPM</b>	Outside Plant Module
<b>ORB</b>	Office Repeater Bay

---

---

<b>ORDB</b>	Operator Reference Database
<b>OS</b>	Operations System or Operator Service
<b>OSC</b>	Operator Services Center
<b>OSHA</b>	Occupational Safety and Health Administration
<b>OSI</b>	Open Systems Interconnection or Open Switching Interval
<b>OSO</b>	Originating Screening Office
<b>OSP</b>	Operator Service Provider
<b>OSPS</b>	Operator Services Position System
<b>OSS</b>	Operator Service Signaling or Operator Services System or Operations Support System
<b>OSSGR</b>	Operator Services Systems Generic Requirements
<b>OST</b>	Originating-Station Treatment
<b>OTGR</b>	Operations Technology Generic Requirements
<b>OTR</b>	Operator Trouble Reports
<b>PAD</b>	Packet Assembler/Disassembler
<b>PAM</b>	Pulse-Amplitude Modulation
<b>PAR</b>	PNNJI Augmented Routing
<b>P/AR</b>	Peak-to-Average Ratio
<b>PBX</b>	Private Branch Exchange
<b>PCA/DAA</b>	Protective Connecting Arrangement/Data Access Arrangement
<b>PCM</b>	Pulse-Code Modulation
<b>PCN</b>	Personal Communications Network
<b>PCP</b>	Private Carrier Paging
<b>PCS</b>	Personal Communications Service
<b>PDMA</b>	Provisioning-Driven Memory Administration
<b>PDN</b>	Passive Distribution Network or Public Data Network
<b>PDU</b>	Protocol Data Unit
<b>PDV</b>	Pulse Density Violation
<b>PEG</b>	Protection Engineers Group
<b>% GOB</b>	Percent Good-or-Better
<b>% POW</b>	Percent Poor-or-Worse

---

---

<b>PFR</b>	Petitions for Reconsideration
<b>PGTC</b>	Pair-Gain Test Controller
<b>PHF</b>	Packet Handler Function
<b>PIC</b>	Pre-designated Interexchange Carrier or Primary Interexchange Carrier
<b>PIN</b>	Personal Identification Number
<b>PL</b>	Private Line
<b>PM</b>	Performance Monitoring
<b>PMD</b>	Physical Medium Dependent
<b>PNNI</b>	Private Network Node Interface
<b>POH</b>	Path Overhead
<b>POI</b>	Point of Interface
<b>POP</b>	Point of Presence
<b>POR</b>	Plan of Reorganization
<b>POT</b>	Point of Termination
<b>POTS</b>	Plain Old Telephone Service
<b>PPLN</b>	Preplanned Number control
<b>PPS</b>	Permanent Presentation Status
<b>PPSD</b>	Public Packet Switched Data
<b>PPSN</b>	Public Packet Switched Network (formerly Local Area Data Transport [formerly CSCC])
<b>PPSNGR</b>	Public Packet Switched Network Generic Requirements
<b>PPSS</b>	Public Packet Switched Service
<b>PRA</b>	Primary Rate Access
<b>PRE</b>	Protectional Reservation of Equipment
<b>PRI</b>	Primary Rate Interface
<b>PRM</b>	Protocol Reference Model
<b>PRS</b>	Primary Reference Source
<b>PS</b>	Packet Switch
<b>PSAP</b>	Public Safety Answering Point
<b>PSDS</b>	Public Switched Digital Service
<b>PSL</b>	Pre-Service Limit
<b>PSN</b>	Private Subscriber Network or Public Switched Network

---



---

<b>PSP</b>	Personal Communications Services (PCS) Services Provider
<b>PSPDN</b>	Packet Switched Public Data Network
<b>PSTN</b>	Public Switched Telephone Network
<b>PT</b>	Payload Type
<b>PTC</b>	Positive Temperature Coefficient
<b>PTE</b>	Path Terminating Equipment
<b>PTN</b>	Public Telephone Network
<b>PTS</b>	Public Telephone Service
<b>PVC</b>	Permanent Virtual Circuit or Permanent Virtual Connection
<b>PVN</b>	Private Virtual Network
<b>PVP</b>	Permanent Virtual Path
<b>PX</b>	Power Cross
<b>QLLC</b>	Qualified Logical Link Control
<b>QoS</b>	Quality of Service
<b>QRS</b>	Quasi-Random Signal
<b>RAO</b>	Revenue Accounting Office
<b>RBS</b>	Radio Base Station
<b>RCC</b>	Radio Common Carrier
<b>RCLM</b>	Remote Line Concentrating Module
<b>RCM</b>	Release Complete Message
<b>RD</b>	Resistance Design
<b>RDAT</b>	Data Reception
<b>RDBS</b>	Routing Database System
<b>RDI</b>	Remote Defect Indication
<b>RDSN</b>	Region Digital Switched Network
<b>RDT</b>	Remote Digital Terminal
<b>REA</b>	Rural Electrification Administration
<b>RED</b>	Relative Envelope Delay
<b>REL</b>	Release Message
<b>RESPORG</b>	Responsible Organization
<b>RF</b>	Radio Frequency
<b>RFI</b>	Remote Failure Indication
<b>RLC</b>	Release Complete Message

---

---

<b>RLCM</b>	Remote Line Concentrating Module
<b>RLMS</b>	Return Loss Measuring Set
<b>RLR</b>	receive loudness rating
<b>RO</b>	Reorder
<b>ROH</b>	Receiver Off Hook
<b>ROLR</b>	Receiving Objective Loudness Rating
<b>ROM</b>	Read-Only Memory
<b>ROS</b>	Remote Operations Service or Remote Operator System
<b>ROTL</b>	Remote Office Test Line
<b>RPOA</b>	Recognized Private Operating Agency
<b>RRD</b>	Revised Resistance Design
<b>RRS</b>	Regular Reroute Spray
<b>RSA</b>	Reliable Service Area or Rural Service Area or Repair Service Attendant
<b>RSC</b>	Remote Switching Center
<b>RSM</b>	Remote Switching Module
<b>RSS</b>	Remote Switching System
<b>RSTP</b>	Regional Signaling Transfer Point
<b>RSU</b>	Remote Switching Unit
<b>RT</b>	Remote Terminal
<b>RTA</b>	Remote Trunking Arrangement
<b>RTRS</b>	Real Time Rating System
<b>RTTU</b>	Remote Trunk Test Unit
<b>RTU</b>	Remote Test Unit
<b>RXO</b>	Remote Exchange Office
<b>RZ</b>	Resistance Zone
<b>SAC</b>	Service Access Code or Serving Area Concept
<b>SAR</b>	Segmentation and Reassembly
<b>SARTS</b>	Switched Access Remote Test System
<b>SADR</b>	Sender Attachment Delay Recorder
<b>SB</b>	Signal Battery

---

---

<b>SB-ADPCM</b>	SubBand-Adaptive Differential Pulse-Code Modulation
<b>SCA</b>	Selective Call Acceptance
<b>SCANS</b>	Software Change Administration and Notification System (AT&T)
<b>SCC</b>	Switching Control Center
<b>SCCP</b>	Signaling Connection Control Part
<b>SCCS</b>	Selective Class-of-Call Screening or Switching Control Center System
<b>SCOTS</b>	Surveillance and Control of Transmission System
<b>SCF</b>	Selective Call Forwarding
<b>SCP</b>	Service Control Point
<b>SCR</b>	Selective Call Rejection
<b>SCSA</b>	Standard Consolidated Statistical Area
<b>SD</b>	Signal Distributor
<b>SDH</b>	Synchronous Digital Hierarchy
<b>SDLC</b>	Synchronous Data Link Control
<b>SDM</b>	Service Definition Module
<b>SDMF</b>	Single Data Message Format
<b>SDOC</b>	Selective Dynamic Overload Control
<b>SDPO</b>	Sleeve ground Dial-Pulse Originating
<b>SEC</b>	Service Evaluation Center
<b>SECAB</b>	Small Exchange Carrier Access Billing
<b>SEF</b>	Severely Errored Frame
<b>SEP</b>	Signaling End Point
<b>SES</b>	Severely Errored Second or Service Evaluation System
<b>SF</b>	Single Frequency or Superframe Format
<b>SG</b>	Signal Ground
<b>SIBB</b>	Service Independent Building Block
<b>SIESCAN</b>	Siemens Customer Access Network (Siemens Stromberg-Carlson)
<b>SIF</b>	SONET Interforum
<b>SILC</b>	Selective Incoming Load Control
<b>SIO</b>	Signaling Information Octet
<b>SIP</b>	SMDS Interface Protocol

---

---

<b>SIT</b>	Special Information Tone
<b>SJ</b>	Smart Jack
<b>SK</b>	Skip
<b>SLC</b>	Signaling Link Code or Subscriber Loop Carrier
<b>SLE</b>	Screening List Editing
<b>SLR</b>	send loudness rating
<b>SLS</b>	Signaling Link Selection
<b>SMAS</b>	Switched Maintenance Access System
<b>SMC</b>	SONET Minimum Clock
<b>SMDF</b>	Subscriber Main Distributing Frame
<b>SMDR</b>	Station Message Detail Recording
<b>SMDS</b>	Switched Multi-megabit Data Service
<b>SMR</b>	Specialized Mobile Radio
<b>SMS</b>	Service Management System
<b>SMSA</b>	Standard Metropolitan Statistical Area
<b>SNA</b>	Systems Network Architecture
<b>SNAC</b>	SMS/800 Number Administration Committee
<b>SNI</b>	Service Network Interface or Subscriber Network Interface
<b>SONET</b>	Synchronous Optical Network
<b>SP</b>	Signal Present or Signal Processor or Signaling Point
<b>SPC</b>	Stored Program Control
<b>SPCS</b>	Stored Program Control Switch or Stored Program Control System
<b>SPE</b>	Synchronous Payload Envelope
<b>SPL</b>	Sound Pressure Level
<b>SPOI</b>	Signaling Point of Interface
<b>SPP</b>	Service Provider Portability
<b>SRI</b>	SIP Relay Interface
<b>SRL</b>	Singing Return Loss
<b>SRS</b>	Subscriber Recording System
<b>SRVA</b>	SCCP Routing Verification Acknowledgment

---

---

<b>SRVR</b>	SCCP Routing Verification Result
<b>SRVT</b>	SCCP Routing Verification Test
<b>SS</b>	Service Specific
<b>SS7</b>	Signaling System 7
<b>SSC</b>	Special Services Center
<b>SSI</b>	Support System Interface
<b>SSN</b>	Subsystem Number
<b>SSP</b>	Service Switching Point
<b>SSSI</b>	Southwestern Bell Standard for SONET Interoperability Team
<b>SST</b>	Short Sender Timing
<b>ST</b>	Start signal
<b>STE</b>	Section Terminating Equipment
<b>STE</b>	Signaling Terminal Equipment
<b>STN</b>	Screening Telephone Number
<b>STP</b>	Signaling Transfer Point
<b>STR</b>	Selective Trunk Reservation
<b>STS</b>	Shared Tenant Services or Synchronous Transport Signal
<b>STS-N</b>	Synchronous Transport Signal level N
<b>SUB</b>	Subscription (Committee)
<b>SVC</b>	Switched Virtual Circuit or Switched Virtual Connection
<b>SVP</b>	Switched Virtual Path
<b>SW</b>	Switch
<b>SWAL</b>	Switched Access Line
<b>SWF-DS1</b>	Switched Fractional DS1
<b>SX</b>	Simplex signaling
<b>SXS</b>	Step-by-Step
<b>SYNTRAN</b>	Synchronous Transmission
<b>T1AG</b>	T1 Advisory Group
<b>TA</b>	Terminal Adaptor or Test Access
<b>TASC</b>	Telecommunications Alarm Surveillance and Control
<b>TASI</b>	Time Assignment Speech Interpolation

---

---

<b>TBE</b>	Toll Billing Exception
<b>TC</b>	Transmission Convergence
<b>TCA</b>	Threshold Crossing Alert
<b>TCAP</b>	Transaction Capabilities Application Part
<b>TCAS</b>	T-Carrier Administration System
<b>TCIF</b>	Telecommunications Industry Forum
<b>TCM</b>	Time-Compression Multiplexing
<b>TCP/IP</b>	Transmission Control Protocol/Internet Protocol
<b>TCT</b>	Tandem Connecting Trunk
<b>TDC</b>	Terrestrial Digital Circuit
<b>TDM</b>	Tandem or Time-Division Multiplexing
<b>TDMA</b>	Time-Division Multiple Access
<b>TDP</b>	Trigger Detection Point
<b>TE</b>	Terminal Equipment
<b>TFPC</b>	Toll Fraud Prevention Committee
<b>TG</b>	Trunk Group
<b>TIA</b>	Telecommunications Industry Association
<b>TIC</b>	Tandem InterLATA Connecting
<b>TIE</b>	Terminal Interface Equipment
<b>TIGC</b>	Telecommunications Industry Group Committee
<b>TLC</b>	Trunk Logic Circuit
<b>TLP</b>	Transmission Level Point
<b>TLU</b>	Terminating Line Unit
<b>TM</b>	Terminal Multiplexer
<b>TMC</b>	Time Slot Management Channel
<b>TMDF</b>	Trunk Main Distributing Frame
<b>TMFT</b>	TCM Metallic Facility Terminal
<b>TMN</b>	Telecommunications Management Network
<b>TNN</b>	Trunk Network Number
<b>TOA/NPI</b>	Type of Address/Numbering Plan Identifier
<b>TOLR</b>	Transmitting Objective Loudness Rating
<b>TOR</b>	Telecommunications Service Ordering Request
<b>TOSC</b>	Trunk Operations Support Center

---

---

<b>TP0</b>	0-dB Test Pad
<b>TP2</b>	2-dB Test Pad
<b>TPDF</b>	Tie-Pair Distributing Frame
<b>TRCC</b>	T-Carrier Restoration Control Center
<b>TREAT</b>	Trouble Report Evaluation and Analysis Tool
<b>TRS</b>	Telecommunications Relay Service
<b>TRXS</b>	TCM Remote Exchange Subscriber
<b>TSG</b>	Timing Signal Generator
<b>TSGR</b>	Transport Systems Generic Requirements
<b>TSI</b>	Time-Slot Interchange
<b>TSPS</b>	Traffic Service Position System
<b>TTC</b>	Telecommunications Technology Committee (of Japan)
<b>TWLT</b>	Trunk With Line Treatment
<b>2B1Q</b>	2 Binary to 1 Quaternary
<b>2SCCS</b>	No. 2 Switching Control Center System
<b>TWS</b>	Trunk Work Station
<b>UAS</b>	Unavailable Seconds
<b>UBR</b>	Unspecified Bit Rate
<b>UCD</b>	Uniform Call Distribution
<b>UDC</b>	Universal Digital Channel
<b>UDLC</b>	Universal Digital Loop Carrier
<b>UG</b>	Unigauge design
<b>UI</b>	Unit Interval
<b>UL</b>	Underwriter's Laboratories
<b>UNI</b>	User-Network Interface
<b>UPS</b>	Uninterruptible Power System
<b>UPT</b>	Universal Personal Telecommunications
<b>USHR/P</b>	Unidirectional Self-Healing Ring with Path Protection Switching
<b>USOC</b>	Universal Service Order Code
<b>USTA</b>	United States Telephone Association
<b>UTR</b>	Universal Tone Receiver
<b>V&amp;H</b>	Vertical and Horizontal
<b>VAD</b>	Voice Activated Dialing

---

---

<b>VANC</b>	Voice Activated Network Control
<b>VBR</b>	Variable Bit Rate
<b>VC</b>	Vacant Code or Virtual Channel
<b>VCC</b>	Virtual Circuit Connection
<b>VCI</b>	Virtual Channel Indicator or Virtual Circuit Identifier
<b>VF</b>	Voice Frequency
<b>VHD-FDF</b>	Very-High-Density Fiber Distributing Frame
<b>VLAN</b>	Virtual Local Area Network
<b>VLC</b>	Voice Line Card
<b>VLR</b>	Visitor Location Register
<b>VLSI</b>	Very Large-Scale Integrated
<b>VMWI</b>	Visual Message Waiting Indicator
<b>VNL</b>	Via Net Loss
<b>VOD</b>	Video On Demand
<b>VoFR</b>	Voice over Frame Relay
<b>VP</b>	Virtual Path
<b>VPI</b>	Virtual Path Identifier
<b>VPL</b>	Virtual Private Line
<b>VSC</b>	Vertical Service Code
<b>VSLE</b>	Visual Screening List Editing
<b>VT</b>	Virtual Tributary
<b>VTOA</b>	Voice and Telephone Over ATM
<b>VU</b>	Volume Unit
<b>WAL</b>	WATS Access Line
<b>WAN</b>	Wide Area Network
<b>WATS</b>	Wide Area Telecommunications Service
<b>WATS CO</b>	WATS Central Office
<b>WDM</b>	Wavelength Division Multiplexing
<b>WEPL</b>	Weighted Echo Path Loss
<b>WSC</b>	Wireless Switching Center
<b>WSP</b>	Wireless Services Provider
<b>WT</b>	Wireless Telephone

---



---

<b>XA-OM</b>	Exchange Access - Operations Management
<b>XA-SMDS</b>	Exchange Access - Switched Multi-megabit Data Service
<b>XB</b>	Crossbar
<b>XBR</b>	Crossbar
<b>XDAT</b>	Transmit Data
<b>XE</b>	X Enable
<b>ZBTSI</b>	Zero-Byte Time-Slot Interchange

---

## Definitions

**2-way trunk.** A trunk that can be seized at either end.

**4-wire circuit.** A circuit using two 1-way transmission paths, one for each direction of transmission. It may be two pairs (four wires) of metallic conductors or equivalent 4-wire as in a carrier system.

**A-Link/Access Link.** A CCS/SS7 signaling link used to connect a Signaling End Point (SEP) and its home pair of STPs.

**Access charge.** A charge imposed by applicable access tariffs that compensates the BOC for the provision of connections between end users and interexchange carrier or other access customers via LEC-provided facilities.

**Access tandem.** A LEC switching system that provides traffic concentration and distribution functions for interLATA traffic originating/terminating within a LATA. The access tandem provides the interexchange carrier with access to more than one end office within the LATA. More than one access tandem may be required to provide access to all end offices within a LATA.

**Address Complete Message (ACM).** A CCS/SS7 signaling message that contains call-status information. This message is sent prior to the called customer's going off-hook.

**Address signals.** Address signals provide information to the system concerning the desired destination of the call. This is usually the dialed digits of the called telephone number or access codes. Typical types of address signals are DP, DTMF, and MF.

**Adjacent signaling points.** Two CCS/SS7 signaling points that are directly interconnected by signaling links.

**Alarm Indication Signal (AIS).** A signal that replaces the normal traffic signal when a maintenance alarm indication has been activated.

**Alerting signals.** Alerting signals (for example, ringing, receiver off-hook) are transmitted over the loop to notify the customer of some activity on the line.

**Alternate route.** A second or subsequent choice path between two points, usually consisting of two or more trunk groups in tandem. This term (or alternate routing) is also used as a verb to define the act of selecting an alternate route.

**Alternate route network.** A network that includes both high-usage trunk groups and final trunk groups.

**Alternate routing.** The feature of a switching system by which a call, after encountering an "all trunks busy" (which is usually referred to as a "no circuit" or NC condition), in the first choice route, is offered to another route to or toward its destination.

---

**Alternate Voice/Data (AVD).** A feature of CSDC that allows a user to alternately transmit 56 kbps digital data or analog voice over the same subscriber line (but not simultaneously). AVD is currently a feature intended only for intraLATA service.

**Analog signal.** A signal that varies in a continuous manner, such as voice or music. An analog signal may be contrasted with a digital signal which can assume only discrete values. Signals generated by a data set can be analog or digital.

**Anonymous Telephone Number.** A telephone number that should not be displayed or voiced back to the called party. Such a designation is stored in switch memory and is included in signaling information sent to the terminating switch for interSPCS calls.

**Answer Message (ANM).** A CCS/SS7 signaling message that informs the signaling points involved in a telephone call that the call has been answered and that call charging should start.

**Automatic identification on outward dialing.** The ability of some central office equipment devices to provide an itemized breakdown of charges (including individual charges for toll calls) for calls made by each CPE telephone extension.

**Automatic Intercept Center (AIC).** The centrally located set of equipment that is part of an Automatic Intercept System (AIS) that automatically advises the calling customer, by means of either recorded or electronically assembled announcements, of the prevailing situation that prevents completion of connection to the called number.

**Automatic Message Accounting (AMA).** The automatic collection, recording, and processing of information relating to calls for billing purposes. (See CAMA also.)

**Automatic Number Identification (ANI).** The automatic identification of the calling station.

**Auxiliary service trunk groups.** A category of trunk groups that provides selected services for customers or operators and terminates at announcement systems, switchboards, or desks. Typical applications commonly employ the following types of trunk groups:

- Directory Assistance
- Intercept
- Public Announcement
- Repair Service
- Time
- Weather.

**Available state.** An available circuit state occurs when all of the following are true:

1. The Bit Error Ratio (BER) is better than 1 in 10 to the  $n$ th power for a specific number of consecutive observation periods of fixed duration.

- 
2. Block Error Ratio (BLER) is better than 1 in 10 to the  $n$ th power under the same conditions.
  3. There are a specific number of consecutive observation periods of fixed duration without a severely errored unit of time.

**B-Link/Bridge Link.** A CCS/SS7 signaling link used to connect STP pairs that perform work at the same functional level. These links are arranged in sets of four (called quads).

**Band Elimination Filter (BEF).** A filter that has a single continuous attenuation band, with neither the upper nor lower cut-off frequencies being zero or infinite.

**Billing Telephone Number (BTN).** Sometimes known as a screening telephone number, the BTN is a telephone number used by the AMA process as the calling-party number for recording purposes.

**Bipolar signal.** A line code that uses a ternary signal to convey binary digits in which successive binary ones are represented by signal elements that are normally of alternating positive and negative polarity, but equal in amplitude. Binary zeros are represented by signal elements that have zero amplitude.

**Bipolar violation.** A non-zero signal element in an AMI that has the same polarity as the previous non-zero element. A bipolar violation occurs whenever two consecutive non-zero elements of the same polarity occur in an AMI signal.

**Bit error.** A bit is said to be in error when it is transferred from the source to the destination within the assigned time slot, but the delivered bit is of a different value than that sent from the source.

**Bit Error Ratio (BER).** The ratio of the number of bit errors to the total number of bits transmitted in a given time interval. BER may be measured directly by detecting errors in a known signal or approximated from code violations or framing bit errors. Numerical values of error ratio are expressed in the form  $(N \times 10^{-P})$  where P is an integer greater than zero.

**Bits per second (bps).** Digital information rate expressed as the number of binary information units transmitted per second. Typically, a digital channel is described as having a stated bit rate and a stated expected error rate.

**Bit rate.** The speed at which bits are transmitted. Usually expressed in bps.

**Block error.** A block is said to be in error when at least one bit error occurs in that block when it is transferred from the source to the destination within the time slot assigned.

**Block Error Ratio (BLER).** The ratio of the blocks in error received in a specified time period to the total number of blocks received in the same period.

**BnZS code.** A bipolar line code with n zero substitution.

---

**Building-Integrated Timing Supply (BITS).** A clock, or a clock with an adjunct, in a building that supplies DS1 and/or composite clock timing reference to all other clocks in that building.

**Busy.** The condition of a line resulting in the inability to complete a call because it is in use or in trouble.

**Busy hour.** A consecutive 60-minute interval with the highest levels of measurement or derived load used in traffic engineering. A busy hour may also be identified by the period of the day, the class of service of the traffic, etc., for example, morning busy hour, coin busy hour, etc.

**Busy season.** An annual recurring and reasonably predictable period of maximum busy hour requirements for networks that are engineered to traffic characteristics and levels. A busy season may be regular and well defined or may be less regular, occurring at different intervals of a generally longer busy period. It may be a period of one or more consecutive months. For the purpose of engineering network facilities, a busy season may occur within a predefined 12-month interval, not necessarily a calendar year.

**Busy tone.** An audible signal indicating a call cannot be completed because the called line is busy. The tone is applied 60 times per minute.

**C-Link/Cross Link.** A CCS/SS7 signaling link used to connect mated pairs of STPs.

**Call.** An attempt for which the complete destination code is provided.

**Caller Identity Delivery (CID) Feature.** A service such as Calling Number Delivery (CND) or Calling Name Delivery (CNAM) that delivers information about a calling party to a called customer.

**Caller Identity Delivery (CID) Data.** The information delivered to the customer on an incoming call (new or waited).

**Call gapping.** A control application that limits the rate of flow to a specific destination code or station address.

**Carrier Access Code (CAC).** The sequence an end user dials to obtain access to the switched services of a carrier. CACs for Feature Group D are composed of five digits, in the form 10XXX, where XXX is the CIC. (See Section 3 for information on expansion.)

**Carrier Group Alarm (CGA).** A system used to minimize the effects of carrier failures on switching systems and on service. The system busies out the failed circuit, releases customers from the failed circuits, stops charging, and prevents false charging, and prevents the failed circuits from seizing the central office equipment.

**Carrier Identification Code (CIC).** The 3-digit number that uniquely identifies a carrier. The CIC is indicated by XXX in the Carrier Access Code (CAC). (See Section 3 for information on expansion.) The same code applies to an individual carrier throughout the area served by the NANP.

**Carrier Serving Area (CSA).** A geographical area that is or may be served by a digital-loop carrier from a single remote terminal site capable of providing, without any conditioning or design, voice-grade message; digital data service (64 kbps and less); and some 2-wire locally switched voice-grade special services.

**Carrier system.** A system for transmitting one or more channels of information by processing and converting to a form suitable for the transmission medium used by the system. Many information channels can be carrier by one broadband carrier system. Common types of carrier systems are frequency division, in which each information channel occupies an assigned portion of the frequency spectrum; and time division, in which each information channel uses the transmission medium for periodic assigned time intervals.

**Cell site.** A transmitter/receiver location, operated by the WSP, through which radio links are established between the wireless system and wireless units. The area served by a cell site is referred to as a "cell."

**Cellular Geographic Service Area (CGSA).** The geographic area served by the wireless (cellular) system within which a WSP is authorized to provide service.

**Cellular system.** A high-capacity, land-wireless radio system in which an assigned frequency spectrum is divided into discrete channels that are assigned in groups to cells covering the CGSA. The discrete cells can be reused in different cells within the same service area. Calls are handed off automatically from a channel in one cell to a different channel in an adjacent cell as the wireless unit moves across cell boundaries within the CGSA and between CGSAs.

**Central office.** This term is usually used to refer to a local switching system that connects lines and trunks. Sometimes it is used to refer to a telephone company building in which switching system and telephone equipment are installed.

**Central office code.** A 3-digit identification under which up to 10,000 station numbers are subgrouped. Exchange area boundaries are associated with the central office code that generally have billing significance. Note that multiple central office codes may be served by a central office. Also called NXX code or end office code.

**Centralized Automatic Message Accounting (CAMA).** An arrangement that provides for the recording of detailed billing information at a centralized location other than an end office, usually a tandem. CAMA equipment also may be associated with operator systems, etc.

**Centralized Automatic Reporting On Trunks (CAROT).** Mechanized system for testing trunks to ensure that trunks are accessible to traffic, function properly during call setup and termination, and to provide a proper transmission path during a call.

**Centrex.** A service for customers with many stations that permits station-to-station dialing. The switching functions are performed in a central office.

---

---

**Channel.** A transmission path between two points. The term channel may refer to a 1-way path or, when paths in the two directions of transmission are always associated, a 2-way path. It is usually the smallest subdivision of a transmission system by means of which a single type of communication service is provided, for example, a voice channel, or data channel.

**Channel bank.** Terminal equipment used to combine (multiplex) channels on a frequency-division or time-division basis.

**Circuit.** A circuit is

1. A communication path between two or more points.
2. A network of circuit elements, such as resistors, inductors, capacitors, semiconductors, etc., that performs a specific function.
3. A closed path through which current can flow.

**Circuit Identification Code (CIC).** The part of a CCS/SS7 signaling message used to identify the circuit that is being established between two signaling points (14 bits in the ISDNUP).

**Circuit-Switched Digital Capability (CSDC).** A network capability that provides a high-speed, digital path over portions of the public switched network.

**Clock.** A source of timing reference for digital equipment. A clock may also provide timing reference for other clocks, and usually contains a frequency generator and associated synchronization equipment. A BITS-controlled node.

**Code of Federal Regulations (CFR).** CFR is a codification of the general and permanent rules published in the Federal Register. It is divided into 50 titles that represent broad areas subject to federal regulation. Title 47 of the CFR pertains to telecommunications and contains the rules covering Part 22 Common Carriers and Part 90 Private Carriers.

**Code violation.** Violation of a coding rule; for example, the AMI coding rule is corrupted by a bipolar violation.

**Codec.** A combination of a coder and decoder operating in different directions of transmission in the same equipment.

**Combined signaling link set.** A pair of CCS/CCS signaling link sets from a signaling point sharing a common routing priority towards a specific destination.

**Common Channel Interoffice Signaling (CCIS).** A signaling system, developed for use between switching systems with stored-program control, in which all of the signaling information for one or more groups of trunks is transmitted over a dedicated high-speed data link, rather than on a per-trunk basis.

**Common Channel Signaling (CCS).** A signaling method in which a single channel conveys, by means of labeled messages, signaling information relating to many circuits or calls and other information, such as that used for network management.

---

**Common control.** An automatic arrangement in which items of control equipment in a switching system are shared; they are associated with a given call only during the periods required to accomplish the control functions. All crossbar and electronic switching systems have common control.

**Composite signaling.** A dc signaling system for address and supervisory signaling. Two pairs (a quad) provide talking paths and full-duplex signaling for three channels.

**Connection-oriented.** A type of packet-switched service in which all packets associated with an established connection are routed via a fixed network path.

**Connection-oriented network service.** A network service that transfers information between end users by establishing a logical connection or virtual circuit.

**Connectionless network service.** A network that transfers information between end users without establishing a logical connection or virtual circuit.

**Consolidated Carrier.** Carriers that provide connections both as interexchange carriers as well as international carriers. (See Interexchange Carrier, International Carrier.)

**Continuity check.** A check made to a circuit or circuits in a connection to verify that an acceptable path (for transmission of data, speech, etc.) exists for a CCS/SS7 message.

**Control signals.** Control signals are used for auxiliary functions in both customer loop signaling and interoffice trunk signaling. Control signals used in the customer loop for Coin Collect and Coin Return and Party Identification. Control signals used in interoffice trunk signaling include Start Dial (Wink or Delay Dial) signals, Keypulse (KP) signals or Start Pulse (ST) signals.

**Country code.** One to three digits that precede the national number in an international call. This code is assigned in and taken from Recommendation E.163 (Numbering Plan for International Service) adopted by the ITU-T. A list of the country codes can be found in Section 1.8 of the *Local Exchange Routing Guide (LERG)*.

**Crossbar tandem.** A 2-wire common-control switching system with a space-division network used as local tandem, toll tandem, and CAMA switching. While originally designed to switch trunks, some systems have been locally modified to accept loop-start or ground-start lines.

**Customer Premises Equipment (CPE).** All telecommunication terminal equipment located on the customer's premises, except coin-operated telephones.

**Cyclic Redundancy Check (CRC).** A cyclic redundancy check code is defined for some digital transmission formats. The CRC is the result of a calculation carried out on a set of transmitted bits by the transmitter. The CRC is encoded into the transmitted signal with the data. At the receiver, the calculation creating the CRC will be repeated and compared to that encoded into the signal. CRC is usually stated with the number of bits used for calculation, that is, CRC-6.

---



**Cyclic Redundancy Check (CRC) violation.** If the transmitted and received CRC codes are not identical, a CRC violation is reported. This means that one or more errors has occurred in the transmission. CRC violations may be used to calculate other parameters, such as errored seconds, or to approximate BER.

**D-Link/Diagonal Link.** A CCS/SS7 signaling link used to connect STP pairs that perform work at different functional levels. These links are arranged in sets of four (called quads).

**Data communications.** End-to-end transmission of any kind of information other than sound (including voice) or video. Data sources may be either digital, such as a computer; or analog, such as an electrocardiogram transmitter. Data transmission should not be confused with digital transmission. Data transmission refers to transmission of information from a data source, whereas digital transmission refers to a particular kind of transmission facility implementation.

**Dark fiber.** Dark fiber facilities are fiber-optic facilities between customer locations that consist of nonrepeated fiber pairs without electro-optical terminals supplied by a telephone company.

**DC signaling.** Refers to a variety of techniques for transmitting signaling information using direct current over metallic circuits, for example, loop-reverse-battery, loop-start, or duplex signaling. DC signaling is a subset of out-of-band signaling.

**Decibel (dB).** The logarithmic unit of signal ratio expressed as a dimensionless quantity. In the expression

$$D = 10 \log_{10} (p_1/p_2)$$

D represents the relative magnitude, in decibels, of power quantities  $p_1$  and  $p_2$  (as long as the quantities are expressed in the same units of power, such as watts, milliwatts, etc.). Other associated expressions are

- dBm - A power ratio expressed in dB referred to 1 mW; employed in communication work as a measure of absolute power values. 0 dBm = 1 mW.
- dBm0 - Signal power expressed in dB referred to or measured at zero transmission level point (0TLP). The 0TLP is also called a point of zero relative transmission level (0dBr0).
- dBrn - Decibels above reference noise. Weighted noise power in dB referred to 1 picowatt, thus 0dBrn = -90dBm.
- dBrnC - Weighted noise power in dBrn measured by a noise measuring set with C-message weighting.

**Degraded minute.** A degraded minute is 60 seconds of available time that has a BER worse than  $10^{-6}$  and better than  $10^{-3}$ . Degraded minutes are expressed as an integer.

**Delay - absolute.** The time elapsed between transmission of a signal and reception of the same signal.

---

**Demarcation point.** The point of demarcation and/or interconnection between telephone company communications facilities and terminal equipment, protective apparatus, or wiring at a subscriber's premises. Carrier-installed facilities at or constituting the demarcation point consist of a wire or a jack conforming to Subpart F of Part 68 of the FCC Rules.

**Destination Point Code (DPC).** The part of a routing label that identifies where the CCS/SS7 signaling message should be sent.

**Dial Pulse (DP).** A change in direct current of a signaling system that provides address information.

**Dial tone.** An audible tone sent from an automatic switching system to a customer to indicate the equipment is ready to receive dial signals.

**Digital Carrier Trunk (DCT).** An internal interface that combines certain T-carrier transmission functions and electronic switching system control functions.

**Digital data system.** A private-line synchronous data communications network formed by interconnecting digital transmission facilities and providing special maintenance and testing capabilities.

**Digital milliwatt.** The repetitive transmission of a sequence of codes in a given channel that will be decoded at the receiving terminal as a 0-dBm0 1000-Hz signal.

**Digital network.** A network consisting of transmission and switching equipment capable of interconnecting digital circuits and requiring timing reference to avoid slip impairment.

**Digital rate.** The number of bits transmitted per unit of time.

**Digital Reference Signal (DRS).** A digital reference signal is a sequence of bits that represents a 1004-Hz to 1020-Hz signal with the same power as the digital mW.

**Digital signal.** A signal that has a limited number of discrete states. This may be contrasted with an analog signal that varies in a continuous manner and can be said to have an infinite number of states.

**Digital Signal Cross-Connect (DSX).** A facility for circuit rearrangements, patching and testing purposes. The DSX is designated DSX-N, where N indicates the hierarchy of the digital network interconnected at that point.

**Digital signal level.** One of several transmission rates in the time-division multiplex hierarchy.

**Digital Signal level 0 (DS0).** The 64 kbps zero-level signal in the digital transmission hierarchy.

**Digital Signal level 1 (DS1).** The 1.544 Mbps first-level signal in the digital transmission hierarchy. In the time-division multiplexing hierarchy of the telephone network, DS1 is the initial level of multiplexing. Traditionally, twenty-four 64-kbps DS0 channels have been

---

multiplexed up to the 1.544 Mbps DS1 rate, with each DS0 channel carrying the digital representation of an analog voice channel.

**Digital transmission.** A mode of transmission in which all information to be transmitted as a stream of pulses. Any analog signal—voice, data, television—can be converted to digital form.

**Direct connection.** Connection of terminal equipment to the telephone network by means other than acoustic and/or inductive coupling.

**Disconnect.** The means by which the calling end of a telecommunication notifies the called end that the connection is no longer needed and should be released, usually with an on-hook signal that is transmitted toward the called end.

**Distributing frame.** An MDF is a connection system that interfaces between loop cable pairs and switching equipment. Other distributing frames are often used to interconnect other equipment within an office.

**Dual-Tone Multifrequency (DTMF).** A tone-signaling method of transmitting address and other information in which a set of dual-tone pulses is used to represent a corresponding set of characters. Each DTMF pulse consists of two components; one component from a group of four low-frequency tones (697, 770, 852, and 941 Hz), and another component from a group of four high-frequency tones (1209, 1336, 1477, and 1633 Hz). There are 16 combinations of tones, of which 12 have been assigned.

**Dual-Tone Multifrequency (DTMF) signaling.** A means of address signaling that uses a simultaneous combination of one of a lower group of frequencies and one of a higher group of frequencies to represent each digit or character. It is the signaling method used by modern touch-tone telephone sets.

**Duplex signaling.** A facility signaling system and range extension technique that used bridge-type detection of small dc changes. Duplex signaling is typically used on long metallic trunks.

**Dynamic Overload Control (DOC).** A control application that is automatically activated by switching systems to speed up call processing and limit attempts from connected offices.

**Dynamic Routing Technique.** A traffic routing method in which one or more central controllers determine near real-time routes for a switched network, based on the state of network congestion, measured as trunk group busy/idle status and switch congestion.

**E&M lead signaling.** A specific form of interface between a switching system and a trunk in which the signaling information is transferred across the interface via 2-state voltage conditions on two leads, each with ground return, separate from the leads used for message information. The message and signaling information are combined (and separated) by a signaling system appropriate for application to the transmission facility.

**Echo.** A signal derived from a primary signal by reflection at one or more impedance discontinuities and delayed relative to the primary signal.

---

**Echo canceler.** A device that reduces echo on a 4-wire path by cancellation of the returned (echo) signal using digital processing techniques.

**Echo, listener.** An echo of a talker's voice signal that is heard by the listener after the original talker signal was received.

**Echo suppressor.** A device that detects speech signals transmitted in either direction on a 4-wire circuit and introduces loss in the opposite direction of speech transmission for suppressing echoes.

**Echo, talker.** An echo of a talker's voice that is returned to the talker. When there is delay between the original signal and the echo, the effect is disturbing unless the echo is attenuated to a tolerable level.

**E-Link/Extended Link.** A CCS/SS7 signaling link used to connect a Signaling End Point (SEP) to an STP pair not considered its home STP pair.

**End Office (EO).** A LEC switching system within a LATA or market area where customer station loops are terminated for purposes of interconnection to each other and to trunks.

**Equal Access End Office (EAEO).** An end office that provides Feature Group D.

**Error-free second.** A 1-second time interval of digital signal transmission during which no error occurs.

**Error - logical.** An error in the binary content of a digital signal, for example, bit error.

**Error rate.** A measure of the performance of a digital transmission system. It can be specified as a bit error rate (the probability of error per bit transmitted), as a block error rate (the probability of one or more errors in a specified-length block of bits), or in other forms such as percent error-free seconds.

**Errored second.** An errored second is a 1-second time interval during which one or more errors are received.

**Exchange carrier.** A company that provides telecommunication within a franchised territory.

**Extended Superframe Format (ESF).** A transmission structure consisting of 24 DS1 frames. The frame overhead bit positions are shared between an extended superframe frame alignment signal, a CRC, and a data link.

**F-Link/Fully Associated Link.** A link used to connect two CCS/SS7 signaling points when there is a high community of interest between them and it is economical to link them. Also called associated signaling.

**Facility.** Any one of the elements of physical telephone plant that is needed to provide service. Switching systems, cables, and microwave radio transmission systems are examples of facilities. Facility is sometimes used in a more restricted sense to mean transmission facility.

---

---

**Federal Communications Commission (FCC).** The Federal agency empowered by law to regulate all interstate and foreign radio and wire communications services originating in the United States, including radio, television, facsimile, telegraph, and telephone systems. The agency was established under the Communications Act of 1934.

**Feeder cable.** A large pair-size loop cable emanating from a central office and usually placed in an underground conduit system with access available at periodically placed manholes.

**Final trunk group.** A last-choice trunk group that receives overflow traffic and which may receive first-route traffic for which there is no alternate route.

**Foreign Numbering Plan Area (FNPA).** Any other NPA outside the geographic NPA where the customer's number is located. (See Home NPA.)

**Frame alignment.** The state in which the frame of the receiving terminal is synchronized with respect to that of the received signal.

**Frame alignment signal.** The distinctive signal inserted in every frame or once in  $n$  frames that always occupies the same relative position within the frame and is used to establish and maintain frame alignment.

**Frame - DS1.** The DS1 frame comprises 193 bit positions. The first bit is the frame overhead bit, while the remaining 192 bits are available for data (payload) and are divided into 24 blocks (channels) of 8 bits each.

**Framing.** The process of establishing a reference so that time slots of elements within the frame can be identified.

**Frequency division.** A method of serving a number of simultaneous calls by means of a common transmission path with a different frequency for the transmission of each call.

**Full-duplex transmission.** A method of operating a communications circuit so that each end can simultaneously transmit and receive.

**Generic program.** A set of instructions for an electronic switching system or operations system that is the same for all offices using that exact type of system. Detailed differences for each individual office are usually listed in a separate parameter table.

**Global title.** An address such as customer-dialed digits that does not explicitly contain information that would allow routing in the CCS/SS7 signaling network, that is, the SCCP translation function is required.

**Ground start.** A supervisory signal given at certain coin telephones and other terminal types of equipment by connecting one side of the line to ground.

**Half-duplex transmission.** A method of operating a communication circuit so that each end can transmit or receive, but not simultaneously. Thus, normal operation is alternate, one-way-at-a-time, transmission.

---

**High-usage trunk group.** A trunk group that is designed to overflow a portion of its offered traffic to an alternate route.

**Hundred Call Seconds (CCS).** A unit of measurement. CCS is a unit of time equivalent to 100 seconds. There are 36 CCSs in an hour's time.

**Idle channel code.** A repetitive pattern (code) that identifies an idle channel.

**Inband signaling.** Signaling that uses the same path as a message and in which the signaling frequencies are in the same band used for the message.

**Incoming calls barred.** An interface configuration option that blocks call delivery attempts to the customer using the interface (only outgoing calls are allowed).

**Information signals.** Information signals inform the customer or operator about the progress of the call. They are generally in the form of universally understood audible tone (for example, dial tone, busy, ringing) or recorded announcements (for example, intercept, all circuits busy).

**Initial Address Message (IAM).** A CCS/SS7 signaling message that contains the address and routing information required to establish a point-to-point telephone connection.

**Integrated digital network.** A network in which connections established by digital switching are used for the transmission of digital signals.

**Integrated Services Digital Network (ISDN).** An integrated digital network in which the same digital switches and digital paths are used to establish connections for different services, for example, telephony, data.

**Integrated Services Digital Network User Part (ISDNUP or ISUP).** The part of a CCS/SS7 signaling node that is used to develop and format signaling messages.

**Interchangeable NPA code.** Code in the NXX format used as a central office code (NNX format), but that can also be used as an NPA code. Interchangeable NPA codes are scheduled to be introduced on or after January 1, 1995.

**Interexchange Carrier (IC).** A common carrier that provides services to the public between local exchanges on an intra or interLATA basis in compliance with local or Federal regulatory requirements and that is not an end user of the services provided.

**Interface.** The point of interconnection between terminal equipment and telephone company communication facilities.

**InterLATA.** A term used to describe services, revenues, functions, etc., that relate to telecommunications originating in one LATA and terminating in another LATA or outside of the originating LATA.

**Intermediate high-usage trunk group.** A high-usage trunk group that receives route-advanced overflow traffic and may receive first-route traffic and/or switched-overflow traffic.

---

**International carrier.** A carrier that generally provides connections between a customer located in World Zone 1 and a customer located outside of World Zone 1, but with the option of providing service to World Zone 1 points in North American Numbering Plan area codes outside the U.S.

**International Direct Distance Dialing (IDDD).** The direct calling by the originating customer to the distant (international) called customer via automatic switching. IDDD is synonymous with the phrases international direct dialing and international subscriber dialing.

**International prefix.** The combination of customer-dialed digits prior to dialing of the country code required to access the automatic outgoing international equipment in the originating country.

**International Switching Carrier (ISC).** An exchange whose function is to switch telecommunications traffic between national network and the networks of other countries. Also known as an international gateway office.

**International Telecommunication Union (ITU).** An agency of the United Nations established to maintain and extend international cooperation for the improvement and rational use of all types of telecommunication.

**International Telecommunication Union — Radiocommunication Sector (ITU-R) (formerly the International Radio Consultative Committee [CCIR]).** The technical study branch of the International Telecommunication Union responsible for the study of technical and operating questions relating specifically to radio communications.

**International Telecommunication Union — Telecommunication Standardization Sector (ITU-T) (formerly the International Telegraph and Telephone Consultative Committee [CCITT]).** One of two committees that supports the ITU by conducting studies on technical and operating questions and recommending standards; the other is the ITU-R.

**Intertandem trunk groups.** A category of trunk groups that interconnects tandems.

**IntraLATA.** A term used to describe services, revenues, functions, etc., that relate to telecommunications that originate and terminate with the same single LATA.

**Intraoffice call.** A call involving only one switching system.

**Land-line.** Any individual, partnership, association, joint stock company, trust, corporation, government entity, or any entity that subscribes to the exchange services offered by a LEC.

**Line.** Line has the following definitions:

1. A circuit carrying direct current between a central office and a customer's terminal. A line is the most common type of loop.



- 
2. In carrier systems, the portion of a transmission system that extends between two terminal locations. The line includes the transmission media and associated line repeaters.
  3. Also used to indicate the side of a piece of central office equipment that connects to or toward the outside plant; the other side of the equipment is called the drop side.
  4. A family of equipment or apparatus designed to provide a variety of styles, a range of sizes, or a choice of service features.

**Line equipment.** Equipment located in a central office and associated with a particular line. This includes a line scan point or equivalent that is activated when the customer's telephone is off-hook.

**Line load control.** A control application that limits the number of customers that can obtain dial tone.

**Link set.** A group of signaling links that connect the same two CCS/SS7 signaling points. There are a maximum of 16 signaling links located within one link set.

**Link Status Signal Unit (LSSU).** A packet sent between MTPs to provide CCS/SS7 information about the sending node and its links. This information is sent during the initial alignment of the links, when there is an associated processor outage, or when link congestion is detected.

**Local Access and Transport Area (LATA).** LATA has been adopted to identify the decree-prescribed "exchange areas" per the plan of reorganization.

**Local Exchange Carrier (LEC).** A company that provides intraLATA telecommunication within a franchised territory.

**Local tandem.** A LEC switching system that provides a traffic concentration and distribution function for local traffic. Intraexchange calls to and from a WSP using a Type 2A interconnection could be routed through a LEC local tandem office.

**Loop.** Loop has the following definitions:

- A channel between a customer' terminal and a central office. The most common form of loop, a pair of wires, is also called a line.
- Also used to mean a 2-wire ungrounded connection between pieces of equipment (as distinguished from a 1-wire and ground connection).

**Loop reverse-battery.** A method of signaling over interoffice trunks in which dc changes, including directional changes associated with battery reversal, are used for supervisory states. This technique provides 2-way signaling on 2-wire trunks; however, a trunk can be seized at only one end—it cannot be seized at the office at which battery is applied. It is also called reverse-battery signaling.

**Loop signaling.** A method of signaling over dc circuit paths that uses the metallic loop formed by the line or trunk conductors and terminating circuits.



---

**Loop-start.** A supervisory signal given by customer-provided equipment in response to completing the loop current path.

**Main Distributing Frame (MDF).** A distributing frame used to interconnect cable pairs and line and trunk equipment terminals on a switching system.

**Maintenance Terminating Unit (MTU).** Equipment located at the demarcation point to isolate the terminal from the network for testing.

**Make-busy.** Conditioning a circuit, terminal, or termination to be unavailable for service. When unavailable, it is generally necessary that these appear busy to circuits that seek to connect to them.

**Media.** In transmission systems, the structure or path along which the signal is propagated, such as wire pair, coaxial cable, waveguide, optical fiber, or radio path.

**Message.** Message has the following definitions:

- In telephone communications, a successful call attempt, that is, one answered by the called party and followed by some minimum period of connection.
- In data communications, a set of information, typically digital and in a specific code such as ASCII, to be carried from a source to a destination. A header, with address and other information regarding handling, may be considered part of or separate from the message.

**Message Telecommunications Service (MTS).** Non-private-line intrastate and interstate long-distance telephone service that uses in whole or in part the public telephone network.

**Message Transfer Part (MTP).** The part of CCS/SS7 signaling node that is used to place formatted signaling messages into packets, strip formatted signaling messages from packets, and send or receive packets.

**Metropolitan Statistical Area (MSA).** Sometimes known as SMSA, MSAs are areas based on counties as defined by the U.S. Census Bureau that contain cities of 50,000 or more population and the surrounding counties. Using data from the 1980 census, the FCC allocated two cellular licenses in each of the 305 MSAs in the United States.

**Modem.** A contraction of the words modulator and demodulator, signifying an equipment unit that performs both of these functions.

**Modification of Final Judgment (MFJ).** The agreement reached between the Department of Justice and AT&T on January 8, 1982, and approved by the courts on August 24, 1982. The MFJ replaces the 1956 Consent Decree and settles the 1974 antitrust case of the United States versus AT&T.

**Multialternate routing.** Alternate routing with provision for advancing a call to more than one alternate route, each of which is tested in sequence in the process of seeking an idle path.

---

**Multifrequency.** A type of address signaling in which ten decimal digits and five auxiliary signals are each represented by selecting a pair of frequencies out of the following group: 700, 900, 1100, 1300, 1500, and 1700 hertz (Hz). Traditionally, multifrequency signaling has not been available on circuits that extend to customer premises. Recently, however, multifrequency has been available with special access lines under certain circumstances.

**Multifrequency (MF) pulsing.** An inband interoffice address signaling method in which ten decimal digits and five auxiliary signals are each represented by selecting two frequencies of the following group: 700, 900, 1100, 1300, 1500, and 1700 Hz.

**Multilink procedure.** A procedure (defined in ITU-T Recommendations X.25 and X.75) that permits multiple links connecting a single pair of nodes to provide service to the network layer on a shared basis. Such sharing provides greater effective throughput capacity and availability than a single link.

**Multiplex.** The process or equipment for combining a number of individual channels into a common spectrum or into a common bit stream for transmission.

**National (significant) number.** All the digits dialed after the country code. It can also be the number that is dialed when making a call that originates and terminates within the same country. International agreement limits the total quantity of digits, including country code and national number, that may be dialed on an international call to 12 digits. However, ITU-R Recommendation E.164 increases this number to 15 digits at Time "T" which has been designated as December 31, 1996 at 11:59 p.m., Coordinated Universal Time (UTC).

**Network.** Network has the following definitions:

- The facilities network is the aggregate of transmission systems, switching systems, and station equipment; it supports a large number of traffic networks.
- A traffic network is an arrangement of channels, such as loops and trunks, associated switching arrangements, and station equipment designed to handle a specific body of traffic. A traffic network is a subset of the facilities network.
- An electrical/electronic circuit, usually packaged as a single piece of apparatus or on a printed circuit pack. Examples are a transformer network and an equalization network.
- The switching stages and associated interconnections of a switching system are collectively called the switching network.
- A private-line network is one constructed under a special arrangement between the service provider and the user (usually large business or government). These networks are outside the PTN, but usually have access to the PTN.

**Network address.** The CCS/SS7 signaling point code that contains (for U.S. national networks) the network identification, network cluster, and network cluster member fields. It is 24 bits.

**Network Channel Terminating Equipment (NCTE).** Equipment located at the end user's premises on the carrier's side of the POT. This equipment performs certain functions that

---

are inherent in the provision and maintenance of specific network channel services in order to meet network service requirements at the POT. These functions may include, but are not limited to, multiplexing, maintaining, and terminating tariffed network channel services.

**Node.** A geographic location at which there are one or more interconnected synchronous digital equipments controlled by one BITS clock.

**Nonconforming end office.** Office that is not yet equipped or incapable of being equipped, for provision of originating and terminating Feature Group D LATA access service.

**Nonwireline.** See Radio Common Carrier (RCC) definition.

**North American Dial Network.** World Zone 1, as defined by the ITU-T, includes the United States, Canada, Puerto Rico, the Virgin Islands of the United States, Bermuda, and other Caribbean Islands.

**North American Numbering Plan (NANP).** The numbering plan used in the U.S. that also serves Canada, Bermuda, Puerto Rico, and certain Caribbean Islands. The NANP format is a 10-digit number that consists of a 3-digit NPA code (commonly called the area code), followed by a 3-digit central office code and 4-digit line number.

**NPA code.** A unique 3-digit code in the N 0/1 X series that identifies a Numbering Plan Area (NPA). An NPA code is the first three digits of the 10-digit destination number for all inter-NPA calls within the North American Numbering Plan Area. After July 1, 1995, new NPA codes will be in the NXX format.

**Numbering Plan Area (NPA).** A specific geographical area identified by a unique NPA code. The boundaries of an NPA code are normally within a state, province, or subdivision of another country within the North American Numbering Plan.

**NXX code.** A code normally used as a central office code. It may also be used as an NPA code or special NPA code.

**Off-hook.** The station switch-hook contacts are closed, resulting in line current or whatever supervision condition indicates the in-use or request-for-service state.

**Offered load.** The total load, including any load that results from retrials, submitted to a group of servers.

**Offered traffic.** The total attempts to seize a group of servers.

**On-hook.** The station switch-hook contacts are open or whatever supervision condition indicates the equipment-idle state.

**Only-route trunk group.** A trunk group that is the one and only route for particular traffic items. It receives only first-route traffic, does not receive overflow traffic, and has no alternate route.

**Open Switching Interval (OSI).** A period of equipment reconfiguration characteristic of most common-control local switching systems, during which service circuits are connected to or disconnected from the line, or when customer calling features are invoked by

---

---

terminals. An OSI appears to a terminal as an open-loop condition (no dc voltage between tip and ring) during the off-hook state of the terminal.

**Operator Services System (OSS).** A software, switching, and trunking arrangement specifically designed to handle live or recorded operator services such as operator assistance, alternate billing (for example, third party or person to person calls), and directory assistance.

**Originating Point Code (OPC).** The part of a routing label that identifies which CCS/SS7 signaling point sent a signaling message.

**Out-of-band signaling.** A method of signaling that uses the same path as voice-frequency transmission, but in which the signaling band is outside the band used for voice frequencies.

**Outgoing calls barred.** An interface configuration option that blocks call origination attempts from the network customer using the interface (only incoming calls are allowed).

**Outside plant.** The part of the telephone system that is physically located outside of telephone company buildings. This includes cables, supporting structures, and certain equipment items such as load coils. Microwave towers, antennas, and cable-system repeaters are not considered outside plant.

**Overflow load.** The part of an offered load that is not carried. Overflow load equals offered load minus carried load.

**Overflow traffic.** That part of the offered traffic that is not carried, for example, overflow traffic equals offered traffic minus carried traffic.

**Overhead bits.** Overhead bits are bits assigned at the source. They are transmitted with the information payload and are used for functions associated with transporting that payload.

**Packet.** A network layer protocol unit that includes control information and may include a block of user data. End user messages are broken into such blocks for efficient transmission across packet networks.

**Packet handler function.** The packet switching function within an ISDN switch, for the packet mode bearer service.

**Packet switching.** A data transmission and switching technique based on the division of messages into blocks of data, which are placed in packets for routing through the network. Packets associated with various data conversations are statistically multiplexed to efficiently share transmission facilities.

**Pair gain.** The number of customers served by a communication system less the number of wire pairs used by that system. Pair gain can be achieved by multiplexing and by concentration.

**Peaked load.** The load that results from peaked traffic. Peakedness cannot be determined from a statement of load.

**Peaked traffic.** Random traffic that has a variance-to-mean ratio greater than one.

---

---

**Peakedness.** The ratio of variance to mean of traffic.

**Per-Call Calling Identity Delivery Blocking (CIDB) Feature.** Allows a caller to toggle or override the value of a calling identity item's Permanent Presentation Status (PPS) for a particular call.

**Permanent Calling Identity Delivery Blocking (CIDB) Feature.** Allows assignment of a value of "anonymous" to the Permanent Presentation Status (PPS) of a calling identity item.

**Permanent Presentation Status (PPS).** A PPS has a value of "public" or "anonymous" and is used as the presentation status of a call if no per-call CIDB feature is active. A PPS should exist for each calling identity item.

**Plesiochronous.** Two signals are plesiochronous if their corresponding significant instants occur at nominally the same rate, any variation in rate being constrained within specific limits.

**Point of Interface (POI).** A POI is a demarcation point between a LEC and a Wireless Services Provider (WSP). This point establishes the technical interface, the test point(s), and the point(s) for operational division of responsibility.

**Point of Presence (POP).** A physical location within a LATA at which an access customer establishes itself for the purpose of obtaining LATA access and to which the LEC provide access services.

**Point of Termination (POT).** The point of demarcation within a customer-designated premises at which the telephone company's responsibility for the provision of access service ends.

**Power systems.** A system that provides a conversion of a primary alternating current power source to direct current voltages required by the network equipment, and generates emergency power when the primary alternating current source is interrupted.

**Prefix.** Any dialed digit or digits input prior to the destination address. Prefixes are used to place an address in proper context, to indicate service options, or both. Examples: prefix 1, to indicate a 10-digit call; prefix 0, to request the services of an operator; 011 for an IDDD call.

**Presentation Status.** For a particular call, an item that indicates if a calling identity item may be presented to the called party. If the presentation status is "public," presentation is allowed. If it is "anonymous," presentation is restricted.

**Presubscription.** The process by which customers indicate to a LEC their choice of preferred interexchange carrier. Customers' interLATA calls will then be routed to their presubscribed interexchange carrier, unless the customer designates otherwise, on a per-call basis, by use of a CAC.

**Primary high-usage trunk group.** A high-usage trunk group that is offered first-route traffic only.

---

---

**Private carrier.** An entity licensed in the private services and authorized to provide communications service to other private services on a commercial basis.

**Private subscriber network.** A virtual private network service supported by Public Packet Switched Service (PPSS) and incorporating interLATA transmission facilities owned or leased by the customer for private traffic.

**Protocol.** An agreed-to set of procedures between a sender and a receiver, so that communication between the two will be intelligible in both directions of communication (transmit and receive). Protocols include procedures for establishing and maintaining the communication path; error detection and correction; and retransmission, if required.

**Pseudo-random test signal.** A pseudo-random test signal is a signal consisting of a bit sequence that approximates a random signal.

**Public Packet Switched Network (PPSN).** A PPSS network serving a LATA.

**Public Packet Switched Service (PPSS).** A BOC connection-oriented, packet-switched data communication service that permits customers to economically communicate with data terminals of other customers and on other packet networks, at throughputs of up to 56 kbps.

**Public Safety Answering Point (PSAP).** The 911 emergency services coordinator that is a public agency (for example, police or sheriff dispatcher) providing the emergency service upon completion of the 911 emergency call.

**Public Switched Digital Service (PSDS).** A generic name for BOCs service offerings that provide customers with the capability of transporting information at 56 kbps over the public circuit-switched network.

**Pulse-Amplitude Modulation (PAM).** A modulation technique in which the amplitude of each pulse is related to the amplitude of an analog signal. It is used, for example, in time-division multiplex arrangements in which successive pulses represent samples from the individual voiceband channels; PAM is also used in time-division switching systems of small and moderate size.

**Pulse-Code Modulation (PCM).** Conversion of an analog signal, such as voice, to a digital format, ordinarily in terms of binary-coded pulses representing the quantized amplitude samples of the analog signal.

**Pulse density violation.** A pulse density violation occurs if a signal contains more than a specified number of zeros, or the percentage of ones in the signal is less than specified.

**Pulsing.** That part of signaling that forwards the destination code required to route a call.

**Quasi-Random Signal (QRS).** A pseudo random test signal that has artificial constraints to limit the maximum number of zeros in the bit sequence.



---

**Radio Common Carrier (RCC).** A common carrier engaged in the provision of Public Mobile Service, which is also not in the business of providing land-line local exchange telephone service. These carriers were formerly called Miscellaneous Common Carriers.

**Range extender.** A device that permits a central office to serve a line that has resistance that exceeds the normal limit for signaling. A range extender does not extend transmission range.

**Range Extender with Gain (REG).** A unit that provides range extension in a loop for both signaling and transmission.

**Receiver Off-Hook Tone (ROH).** Receiver off-hook tone is a loud tone applied to a line to alert that customer that the telephone receiver is off-hook. In some situations, it is used as a ringing signal when the receiver is off-hook.

**Recognized Private Operation Agency (RPOA).** The ITU-T term for a packet interexchange carrier.

**Regeneration.** The process of receiving and reconstructing a digital signal so that the amplitudes, waveforms, and timing of its signal elements are constrained within specified limits.

**Registered terminal equipment.** Terminal equipment that is registered in accordance with Part 68 of the FCC's Rules and Regulations.

**Reliable Service Area (RSA).** The area specified by the field strength contour within which the reliability of communication service is 90 percent for a mobile unit.

**Remote Switching Unit (RSU).** An electrical switching system that is remote from its host or control office. All or most of the central control equipment for the RSU is located in the host switching system.

**Reorder.** The announcement, or 120 interruptions per minute tone, returned to the call originator when a call is blocked in the network.

**Reorder tone.** A tone applied 120 times per minute that indicates all switching paths are busy, all toll trunks are busy, equipment blockages, unassigned code dialed, or incomplete registration of digits at a switching point. Also call Channel Busy or Fast Busy Tone.

**Rerouting.** A short-term change in the routing of selected traffic items. Rerouting may be planned and recurring or a reaction to a nonrecurring situation. It is generally associated with network management activity.

**Retrial.** Any subsequent attempt by a customer, operator, or a switching system to complete a call within a measured period.

**Ring.** The process of alerting the called party by the application of an intermittent 20-Hz signal to the appropriate line; this produces a sound at the call terminal equipment. When the ringing signal is applied to the called line, an intermittent signal called audible ringing is sent to the calling telephone to indicate that ringing is taking place.

---

**Robbed-bit signaling.** A signaling scheme in which the signaling bits for each channel are assigned to the least-significant bit (bit 8) of frames 6 and 12 of the superframe format or frames 6, 12, 18, and 24 of the ESF.

**Route.** The particular trunk group or interconnected trunk groups between two reference points used to establish a path for a call. This term is also used as a verb to define the act of selecting a route or routes.

**Route advance.** Within a switching system, the routing to an alternative route trunk group (or trunk subgroup) when all trunks in a prior trunk group (or trunk subgroup) are busy.

**Rural Service Area (RSA).** An area not included in either an MSA or a New England County Metropolitan Area for which a common carrier may have a license to provide cellular service.

**Service Access Code (SAC).** SACs are 3-digit codes in the NPA (N00) format that are used as the first three digits of a 10-digit address, and that are assigned for special network uses. Whereas NPA codes are normally used for identifying specific geographical areas, certain SACs have been allocated in the NANP to identify generic services or provide access capability. Currently only four SACs have been assigned and are in use: 600, 700, 800, and 900.

**Service code.** A 3-digit code in general use by customers to reach telephone company service, for example, 411 (Directory Assistance), 611 (Repair Service), 811 (Business Office). In addition, Emergency Service is addressed with the 911 code.

**Service objective.** A statement of the quality of service that is to be provided to the customer; for example, no more than 1.5 percent of customers should have to wait more than 3 seconds for dial tone during the average busy hour or, the busy-hour blocking on a last-choice trunk group should not exceed 1 percent.

**Severely Errored Second (SES).** A second during which the bit error ratio is greater than a specified limit. During a severely errored second, transmission performance is significantly degraded.

**Signal.** A state that is applied to operate and control the component groups of a telecommunications circuit to cause it to perform its intended function. Generally speaking, there are five basic categories of "signals" commonly used in the telecommunications network. Included are supervisory signals, information signals, address signals, control signals, and alerting signals (which see).

**Signaling Connection Control Part (SCCP).** The part of a CCS/SS7 signaling node that is used when the SCCP method of end-to-end signaling is invoked.

**Signaling link.** The facility used to convey signaling messages to the various signaling points in a CCS/SS7 network.

**Signaling Link Selection (SLS) code.** The part of a routing label that identifies the CCS/SS7 signaling link on which the message should be sent.



---

**Signaling Point (SP).** A node in a CCS/SS7 signaling network that either originates and receives signaling messages, or transfers signaling messages from one signaling link to another, or both.

**Signaling point code.** A binary code uniquely identifying a CCS/SS7 signaling point in a signaling network. This code is used, according to its position in the label, either as destination point code or as originating point code.

**Signaling Point Interface (SPOI).** The demarcation point on the SS7 signaling link between a LEC network and a Wireless Services Provider (WSP) network. The point establishes the technical interface and can designate the test point and operational division of responsibility for the signaling.

**Signaling System 7 (SS7).** An internationally standardized, general-purpose CCS protocol.

**Signaling Transfer Point (STP).** A signaling point with the function of transferring signaling messages from one signaling link to another and considered exclusively from the viewpoint of the transfer.

**Slip-controlled.** The occurrence at the receiving terminal of a replication or deletion of the information bits in a frame.

**Slip-uncontrolled.** The loss or gain of a digit position of a set of consecutive digit positions in a digital signal resulting from an aberration of the timing processes associated with the transmission or switching of the digital signal. The magnitude or the instant of the loss or gain is not controlled.

**Source/sink device.** A source/sink device is byte-synchronous with a byte orientation. Source devices originate; sink devices terminate.

**Special routing code.** A 3-digit code in the form 0XX and 1XX available for use within a network used to modify routing or call-handling logic. End users are prevented from using system codes by the arrangement of the switching equipment to block all customer-dialed calls with a 0 or a 1 in the fourth digit of a 10-digit call, as well as 7-digit calls with a 0 or 1 in the first digit.

**Statistical multiplexing.** A multiplexing technique that differs from simple multiplexing in that the share of the available transmission bandwidth allocated to a given user varies dynamically.

**Stored Program Control System (SPCS).** An automatic switching system in which system operations are controlled by a stored program executed by one or more processors. Operation of the system can be altered significantly by changing programs.

**Superframe format.** The superframe transmission structure consists of 12 DS1 frames (2316 bits). The DS1 frame comprises 193 bit positions, the first of which is the frame overhead-bit position. Frame overhead bit positions are used for frame and signaling phase alignment only.

---

---

**Supervisory signals.** Supervisory signals are the means by which a customer initiates a request for service; or holds or releases a connection; or flashes to recall an operator or to initiate additional local features (for example, 3-way calling). Supervisory signals are also used to initiate and terminate charging on a call.

**Switching point.** Same as end office and intermediate office.

**Tip, ring, ground.** The conductive paths between a central office and a station. The tip and ring leads constitute the circuit that carries a balanced speech or data signal. The ground path in combination with the conductor is used occasionally for signaling.

**Toggle.** If a Permanent Presentation Status (PPS) is "public," use of a toggle indicates that the presentation status should be "anonymous." If a PPS is "anonymous," use of a toggle indicates that the presentation status should be "public."

**Toll traffic.** Traffic that is classified as toll in the tariff on file with the appropriate regulatory body. This term generally includes all traffic for destinations beyond the local service area and extended service area.

**Traffic.** A flow of attempts, calls, and messages.

**Transaction capabilities.** Function that control non-circuit-related information transfer between two or more nodes via a CCS/SS7 signaling network.

**Translation.** The interpretation by a switching system of all or part of a destination code to determine the routing of a call.

**Transmission.** Transmission has the following definitions:

- Designates a field of work, such as equipment development, system design, planning, or engineering, in which electrical communication technology is used to create systems to carry information over a distance.
- Refers to the process of sending information from one point to another.
- Used with a modifier to describe the quality of a telephone connection: good, fair, or poor transmission.
- Refers to the transfer characteristic of a channel or network in general or, more specifically, to the amplitude transfer characteristic. You may sometimes hear the phrase, "transmission as a function of frequency."

**Transmission facility.** An element of physical telephone plant that performs the function of transmission, for example, a multipair cable, a coaxial cable system, or a microwave radio system.

**Transmission Level Point (TLP).** A point in a transmission system evaluated by the ratio (in decibels) of the power of the test signal at that point to the power of the test signal at a reference point. A 0 TLP is an arbitrarily established point in a communications circuit to which all relative levels at other points in the circuit are referred.

---

**Transmission objectives.** Electrical performance characteristics for communication circuits, systems, and equipment based on both economics and technical considerations of telephone facilities and on reasonable estimates of the performance desired. Characteristics for which objectives are stated include loss, noise, echo, crosstalk, frequency shift, attenuation distortion, envelope delay distortion, etc.

**Transmission payload.** The interface bit rate minus the overhead bits.

**Trunk.** In a network, a communication path connecting two switching systems used in the establishment of an end-to-end connection. In selected applications, it may have both of its terminations in the same switching system.

**Trunk group.** A set of trunks, traffic engineered as a unit, for the establishment of connections within or between switching systems in which all of the paths are interchangeable except where subgrouped.

**Trunk group alternate route.** The alternate route for a high-usage trunk group. A trunk group alternate route consists of all the trunk groups in tandem that lead to the distant terminal of the high-usage trunk group. Where multiple traffic items are offered to the alternate route, specific traffic items may have alternate routes in which the second subsequent leg is different from the second leg of the trunk group alternate route.

**Trunk occupancy.** The percentage of time (normally an hour) that trunks are in use. Trunk occupancy may also be expressed as the carried CCS per trunk.

**Trunks-in-service.** The number of trunks in a group in use or available to carry calls. Trunks-in-service equals total trunks minus the trunks made busy for any reason.

**Twisted pair.** A pair of wires used in transmission circuits and twisted about one another to minimize electrical coupling with other circuits. Twisted paired cable is made up of a few to several thousand twisted pairs.

**Usage.** A measurement of the load carried by a server or group of servers, usually expressed in CCS. Usage may also be expressed in erlangs.

**Vacant Code.** An unassigned NPA or central office code. A call dialed using a vacant code is normally directed to a vacant code announcement.

**Vertical and Horizontal (V&H) Coordinates.** For purposes of determining airline mileage between locations, vertical and horizontal coordinates have been established across the United States. These V&H coordinates are derived from the geographic latitude and longitude coordinates.

**Via Net Loss (VNL).** A loss objective for trunks, the value of which has been selected to obtain a satisfactory balance between loss and talker echo performance.

**Virtual call service.** A packet switching capability that allows a customer to establish a virtual circuit between two data terminals for the duration of the call.

**Virtual circuit.** A logical association of sequential links in packet networks, forming a path between two data terminals that wish to communicate. Packets associated with the virtual circuit are routed over this logical path. However, an individual link in the path is not dedicated to this connection and is available to carry packets associated with other virtual circuits with which it is simultaneously associated.

**Wire center.** The location of one or more local switching systems. A point at which customers' loops converge.

**Wireless Services Provider (WSP).** A carrier authorized to provide wireless communications exchange services (for example, cellular carriers and paging services carriers).

**Wireless Switching Center (WSC).** A switching system used to terminate wireless stations for purposes of interconnection to each other and to trunks interfacing with the Public Switched Telephone Network (PSTN) and other networks.


















**World Zone 1.** The area of the World Numbering Plan which is identified with the single-digit country code "1" and includes the territories of the United States and Canada, and the following Caribbean countries:

Antigua	Jamaica
Bahamas	Montserrat
Barbados	Puerto Rico
Bermuda	St. Kitts
British Virgin Islands	St. Lucia
Cayman Islands	St. Vincent
Dominican Republic	Virgin Islands
Grenada	

**Zero Byte Time Slot Interchange (ZBTSI).** A method of coding in which a variable address code is exchanged for any zero octet. The address information describes where, in the serial bit stream, zero octets originally occurred. It is a five-step process where data enters a buffer, zero octets are identified and removed, the nonzero bytes move to fill in the gaps, the first gap is identified, and a transparent flag bit is set in front of the message to indicate that one or more bytes originally contained zeros.

---

## Symbols

	(Equal Access) Conforming End Office
	Non-Conforming End Office (NCEO)
	Remote Switching Unit (RSU)
Or	
 	RSU Host/End Office
	Sector Tandem (ST)
	Access Tandem (AT) FGD
	Access Tandem (AT) FGC
	Access Tandem (AT) FGB
	Principal Tandem (PT)
	Point of Presence (POP)
	Point of Termination (POT)
	Combined ST and AT
	Signaling Transfer Point (STP)
	Optical Signal
	Transformer
	Resistor

---



---

## References Contents

References .....	References-1
Bellcore Documents .....	References-1
Pre-Divestiture Documents .....	References-13
ANSI Documents .....	References-14
ATIS Documents.....	References-16
ICCF Documents.....	References-16
NIIF Documents.....	References-16
INC Documents.....	References-16
Carrier Liaison Committee Documents .....	References-17
ATM Forum .....	References-18
IEEE Documents.....	References-20
ISO Documents.....	References-22
ITU (CCITT) Documents.....	References-23
EIA Documents.....	References-26
Frame Relay Forum Documents .....	References-27
Miscellaneous Documents .....	References-28





---

## References

### Bellcore Documents

- **TR-TSY-000008**, *Digital Interface Between the SLC<sup>®</sup>-96 Digital Loop Carrier System and a Local Digital Switch*, Issue 2 (Bellcore, August 1987); plus Revision 1, September 1993 and Bulletin 1, October 1994.
- **TR-TSY-000009**, *Asynchronous Digital Multiplexes, Requirements and Objectives*, Issue 1 (Bellcore, May 1986).
- **TR-NWT-000029**, *Service Control Point Node Generic Requirements for IN1*, Issue 2 (Bellcore, September 1990).
- **GR-30-CORE**, *Voiceband Data Transmission Interface*, Issue 1 (Bellcore, December 1994). (A module of *LSSGR*, FR-64 and *ADSI*, FR-12.)
- **TR-NWT-000031**, *CLASS<sup>SM</sup> Feature: Calling Number Delivery*, FSD 01-02-1051, Issue 4 (Bellcore, December 1992). (A module of *LSSGR*, FR-64 and *ADSI*, FR-12.)
- **TR-NWT-000032**, *CLASS<sup>SM</sup> Feature: Bulk Calling Line Identification*, FSD 02-02-1280, Issue 2 (Bellcore, September 1991); plus Revision 1, December 1991. (A module of *LSSGR*, FR-64.)
- **ST-TSY-000041**, *Characterization of Subscriber Loops for Voice and ISDN Services*, Issue 1 (Bellcore, June 1997).
- **ST-TEC-000051**, *Telecommunications Transmission Engineering Textbook, Volume 1: Principles*, Third Edition, Issue 1 (Bellcore, August 1987).
- **ST-TEC-000052**, *Telecommunications Transmission Engineering Textbook, Volume 2: Facilities*, Third Edition, Issue 1 (Bellcore, May 1989).
- **GR-54-CORE**, *DS1 High-Capacity Digital Service End User Metallic Interface Specifications*, Issue 1 (Bellcore, December 1995).
- **TR-NWT-000057**, *Functional Criteria for Digital Loop Carrier Systems*, Issue 2 (Bellcore, January 1993). (A module of *TSGR*, FR-440.)
- **GR-63-CORE**, *Network Equipment-Building System (NEBS) Requirements: Physical Protection*, Issue 1 (Bellcore, October 1995). (A module of *LSSGR*, FR-64; *TSGR*, FR-440, and *NEBS FR*, FR-2063.)
- **FR-64**, *LATA Switching Systems Generic Requirements (LSSGR)* (Bellcore, 1997 Edition).
- **GR-82-CORE**, *Signaling Transfer Point (STP) Generic Requirements*, Issue 1 (Bellcore, December 1996).

- **TR-EOP-000085** through **TR-EOP-000092**, or TR-EOP-000315, *Local Exchange Routing Guide (LERG)* (Bellcore).

Issued quarterly:

TR-EOP-000085	Vol. 1	NYNEX, 100-Series LATAs
TR-EOP-000086	Vol. 2	Bell Atlantic, 200-Series LATAs
TR-EOP-000087	Vol. 3	Ameritech, 300-Series LATAs
TR-EOP-000088	Vol. 4	BellSouth, 400-Series LATAs
TR-EOP-000089	Vol. 5	Southwestern Bell, 500-Series LATAs
TR-EOP-000090	Vol. 6	U S WEST, 600-Series LATAs
TR-EOP-000091	Vol. 7	Pacific Telesis, 700-Series LATAs
TR-EOP-000092	Vol. 8	Offshore and International 800-Series LATAs & Independents, 900-Series LATAs
TR-EOP-000315		All eight volumes.

Issued monthly:

TR-EOP-000315 T1 (6250 bpi)	<i>LERG</i> Data Tape
TR-EOP-000315 T2 (1600 bpi)	<i>LERG</i> Data Tapes (2)
TR-EOP-000315	<i>LERG</i> Microfiche.

- **GR-145-CORE**, *Interconnection of WSP/LEC Network*, Issue 1 (Bellcore, March 1996).
- **TR-NPL-000175**, *Compatibility Information for Feature Group B Switched Access Service*, Issue 1 (Bellcore, July 1985).
- **TR-TSY-000181**, *Dual-Tone Multifrequency Receiver Generic Requirements for End-to-End Signaling Over Tandem-Switched Voice Links*, Issue 1 (Bellcore, March 1987).
- **SR-TAP-000191**, *Trunk Traffic Engineering Concepts and Applications*, Issue 2 (Bellcore, December 1989).
- **TR-NWT-000215**, *CLASS<sup>SM</sup> Feature: Automatic Callback, FSD 01-02-1250*, Issue 3 (Bellcore, June 1993). (A module of *LSSGR*, FR-64.)
- **TR-TSY-000216**, *CLASS<sup>SM</sup> Feature: Customer Originated Trace, FSD 01-02-1052*, Issue 2 (Bellcore, June 1988); plus Bulletin No. 1, February 1992, and Revision 1, May 1992. (A module of *LSSGR*, FR-64.)
- **TR-TSY-000217**, *CLASS<sup>SM</sup> Feature: Selective Call Forwarding, FSD 01-02-1410*, Issue 2 (Bellcore, November 1988); plus Bulletins and Revision 1, May 1992. (A module of *LSSGR*, FR-64.)

- 
- **TR-TSY-000218**, *CLASS<sup>SM</sup> Feature: Selective Call Rejection, FSD 01-02-0760*, Issue 2 (Bellcore, November 1988); plus Bulletins and Revision 1, May 1992. (A module of *LSSGR*, FR-64.)
  - **TR-TSY-000219**, *CLASS<sup>SM</sup> Feature: Distinctive Ringing/Call Waiting, FSD 01-01-1110*, Issue 2 (Bellcore, November 1988); plus Bulletins and Revision 1, May 1992. (A module of *LSSGR*, FR-64.)
  - **TR-NWT-000220**, *CLASS<sup>SM</sup> Feature: Screening List Editing, FSD 30-28-0000*, Issue 3 (Bellcore, December 1993). (A module of *LSSGR*, FR-64.)
  - **TR-TSY-000222**, *InterLATA Dial Pulsing Requirements*, Issue 1 (Bellcore, January 1986).
  - **TR-NWT-000227**, *CLASS<sup>SM</sup> Feature: Automatic Recall, FSD 01-02-1260*, Issue 3 (Bellcore, June 1993). (A module of *LSSGR*, FR-64.)
  - **TR-NWT-000233**, *Wideband and Broadband Digital Cross-connect Systems Generic Criteria*, Issue 3 (Bellcore, November 1993). (A module of *TSGR*, FR-440.)
  - **GR-246-CORE**, *Bell Communications Research Specification of Signaling System Number 7*, Issue 1 (Bellcore, December 1994); plus revisions.
  - **GR-253-CORE**, *Synchronous Optical Network (SONET): Common Generic Criteria*, Issue 2 (Bellcore, December 1995). (A module of *TSGR*, FR-440.)
  - **TR-NPL-000258**, *Compatibility Information for Feature Group D Switched Access Service*, Issue 1 (Bellcore, October 1985).
  - **TR-TSY-000268**, *ISDN Access Call Control Switching and Signaling Requirements*, Issue 3 (Bellcore, May 1989); plus Supplement 1, June 1990, Bulletin No. 2, August 1991, and revisions.
  - **FR-271**, *OSSGR Operator Services Systems Generic Requirements* (Bellcore, 1997 Edition).
  - **TR-EOP-000277**, *DATAPATH<sup>TM</sup> Network Access Interface Specification*, Issue 1 (Bellcore, September 1985).
  - **TR-NWT-000295**, *Isolated Ground Planes: Definition and Application to Telephone Central Offices*, Issue 2 (Bellcore, July 1992).
  - **GR-301-CORE**, *Public Packet Switched Network Generic Requirements (PPSNGR)*, Issue 1 (Bellcore, December 1988).
  - **GR-303-CORE**, *Integrated Digital Loop Carrier System Generic Requirements, Objectives, and Interface*, Issue 1 (Bellcore, September 1995). (A module of *TSGR*, FR-440.)
  - **GR-314-CORE**, *Generic Requirements for Telephone Headsets at Operator Consoles*, Issue 1 (Bellcore, October 1994).
-

- 
- **GR-317-CORE**, *Switching System Generic Requirements for Call Control Using the Integrated Services Digital Network User Part (ISDNUP)*, Issue 1 (Bellcore, February 1994).
  - **GR-334-CORE**, *Switched Access Service: Transmission Parameter Limits And Interface Combinations*, Issue 1 (Bellcore, June 1994).
  - **TR-NWT-000335**, *Voice Grade Special Access Service — Transmission Parameter Limits and Interface Combinations*, Issue 3 (Bellcore, May 1993).
  - **TR-NPL-000336**, *Metallic and Telegraph Grade Special Access Services — Transmission Parameter Limits and Interface Combinations*, Issue 1 (Bellcore, October 1987).
  - **GR-337-CORE**, *Program Audio Special Access and Local Channel Services*, Issue 1 (Bellcore, December 1995).
  - **GR-338-CORE**, *Television Special Access and Local Channel Services — Transmission Parameter Limits and Interface Combinations*, Issue 1 (Bellcore, December 1995).
  - **TR-NPL-000339**, *Wideband Analog Special Access Service — Transmission Parameter Limits and Interface Combinations*, Issue 1 (Bellcore, October 1987).
  - **TR-NPL-000340**, *Wideband Data Special Access Service — Transmission Parameter Limits and Interface Combinations*, Issue 1 (Bellcore, October 1987).
  - **TR-NWT-000341**, *Digital Data Special Access Service — Transmission Parameter Limits and Interface Combinations*, Issue 2 (Bellcore, February 1993).
  - **GR-342-CORE**, *High-Capacity Digital Special Access Service — Transmission Parameter Limits and Interface Combinations*, Issue 1 (Bellcore, December 1995).
  - **TA-EOP-000345**, *Equipment Framework Generic Requirements*, Issue 1 (Bellcore, May 1986).
  - **TR-TSY-000350**, *E911 Public Safety Answering Point: Interface Between a 1/1A ESS<sup>TM</sup> Switch and Customer Premises Equipment*, Issue 1 (Bellcore, November 1987).
  - **TR-EOP-000352**, *Cellular Mobile Carrier Interconnection Transmission Plans*, Issue 1 (Bellcore, May 1986).
  - **TR-TSY-000385**, *Automatic Message Accounting Teleprocessing System (AMATPS) Generic Requirements*, Issue 1 (Bellcore, September 1986); plus Revision 1, February 1990. (A module of RQGR, FR-796.)
  - **TR-NWT-000391**, *CLASS<sup>SM</sup> Feature: Calling Identity Delivery Blocking Features, FSD 01-02-1053*, Issue 3 (Bellcore, September 1992). (A module of LSSGR, FR-64.)
  - **TR-NWT-000393**, *Generic Requirements for ISDN Basic Access Digital Subscriber Lines*, Issue 2 (Bellcore, January 1991). (A module of TSGR, FR-440.)
-

- 
- **GR-394-CORE**, *Switching System Generic Requirements for Interexchange Carrier Interconnection Using the Integrated Services Digital Network User Part (ISDNUP)*, Issue 1 (Bellcore, February 1994)
  - **TR-NWT-000397**, *ISDN Basic Access Transport System Requirements*, Issue 3 (Bellcore, December 1993). (A module of *TSGR*, FR-440.)
  - **TR-TSY-000398**, *Universal Digital Channel (UDC) Generic Requirements and Objectives*, Issue 1 (Bellcore, March 1990); plus Revision 1, August 1992. (A module of *TSGR*, FR-440.)
  - **TA-NWT-000406**, *DC Bulk Power System for Confined Locations*, Issue 2 (Bellcore, August 1993).
  - **GR-416-CORE**, *Call Waiting Deluxe Feature, FSD 01-02-1215*, Issue 1 (Bellcore, April 1995). (A module of *LSSGR*, FR-64.)
  - **TR-NWT-000418**, *Generic Reliability Assurance Requirements for Fiber Optic Transport Systems*, Issue 2 (Bellcore, December 1992). (A module of *RQGR*, FR-796.)
  - **TR-NWT-000444**, *Switching System Generic Requirements Supporting ISDN Access Using the ISDN User Part*, Issue 3 (Bellcore, May 1993).
  - **GR-446-CORE**, *Generic Requirements for the Administrative System (AS)/Line Information Database (LIDB) -LIDB Interface*, Issue 4 (Bellcore, March 1997)
  - **TR-TSY-000456**, *Public Terminals Generic Requirements*, Issue 1 (Bellcore, November 1989) plus Bulletin 1, December 1991. **GR-436-CORE**, *Digital Network Synchronization Plan*, Issue 1 (Bellcore, June 1994).
  - **TA-NPL-000464**, *Generic Requirements and Design Considerations for Optical Digital Signal Cross-connect Systems*, Issue 1 (Bellcore, September 1987).
  - **TR-TSY-000465**, *Interface Between Loop Carrier Systems and Loop Testing Systems*, Issue 2 (Bellcore, April 1987).
  - **FR-472**, *OTGR Section 2: Network Element (NE) Memory Administration* (Bellcore, 1997 Edition). (A module of *OTGR*, FR-439.)
  - **TR-NWT-000474**, *OTGR Section 4: Network Maintenance: Alarm and Control — Network Element*, Issue 4 (Bellcore, December 1993). (A module of *OTGR*, FR-439.)
  - **FR-476**, *OTGR Section 6: Network Maintenance: Access and Testing* (Bellcore, 1997 Edition). (A module of *OTGR*, FR-439.)
  - **TR-NWT-000496**, *SONET Add-Drop Multiplex Equipment (SONET ADM) Generic Criteria*, Issue 3 (Bellcore, May 1992). (A module of *TSGR*, FR-NWT-000440.)
  - **GR-499-CORE**, *Transport Systems Generic Requirements (TSGR): Common Requirements*, Issue 1 (Bellcore, December 1995). (A module of *TSGR*, FR-440.)
-

- 
- **SR-504**, *SPCS Capabilities and Features, Section 4*, Issue 2 (Bellcore, March 1996). (A module of *LSSGR*, FR-64.)
  - **GR-505-CORE**, *Call Processing, Section 5*, Issue 1 (Bellcore, December 1997). (A module of *LSSGR*, FR-64.)
  - **GR-506-CORE**, *LSSGR: Signaling for Analog Interfaces*, Issue 1 (Bellcore, June 1996). (A module of *LSSGR*, FR-64.)
  - **TR-NWT-000507**, *Transmission, Section 7*, Issue 5 (Bellcore, December 1993). (A module of *LSSGR*, FR-64.)
  - **TR-TSY-000510**, *System Interfaces, Section 10*, Issue 2 (Bellcore, July 1987) plus revisions. (A module of *LSSGR*, FR-64.)
  - **GR-512-CORE**, *LSSGR: Reliability, Section 12*, Issue 1 (Bellcore, January 1995). (A module of *LSSGR*, FR-64.)
  - **GR-528-CORE**, *LSSGR: Public Telecommunications Service, FSD 10-01-0000*, Issue 1 (Bellcore, December 1994). (A module of *LSSGR*, FR-64.)
  - **TR-NWT-000533**, *Service Switching Points, FSD 31-01-0000*, Issue 3 (Bellcore, January 1994). (A module of *LSSGR*, FR-64.)
  - **TR-TSY-000534**, *Public Switched Digital Service, FSD 32-10-1000*, Issue 2 (Bellcore, July 1987); plus Revision 1, April 1991. (A module of *LSSGR*, FR-64.)
  - **TR-NWT-000567**, *CLASS<sup>SM</sup> Feature: Anonymous Call Rejection, FSD 01-02-1060*, Issue 1 (Bellcore, December 1991). (A module of *LSSGR*, FR-64.)
  - **TR-NWT-000575**, *CLASS<sup>SM</sup> Feature: Calling Identity Delivery on Call Waiting, FSD 01-02-1090*, Issue 1 (Bellcore, October 1992). (A module of *LSSGR*, FR-64.)
  - **GR-610-CORE**, *Message Detail Recording (MDR), FSD 02-02-1110*, Issue 1 (Bellcore, October 1993). (A module of *LSSGR*, FR-64.)
  - **GR-690-CORE**, *Exchange Access Interconnection, FSD 20-24-0000*, Issue 2 (Bellcore, November 1996). (A module of *LSSGR*, FR-64.)
  - **TR-TSY-000697**, *Feature Group A, FSD 20-24-0200*, Issue 1 (Bellcore September 1989). (A module of *LSSGR*, FR-64.)
  - **TR-TSY-000698**, *Feature Group B, FSD 20-24-0300*, Issue 1 (Bellcore, June 1989); plus Revision 1, July 1990. (A module of *LSSGR*, FR-64.)
  - **TR-TSY-000742**, *No. 2 Service Evaluation System Interface, FSD 45-13-0200*, Issue 1 (Bellcore, March 1990). (A module of *LSSGR*, FR-64.)
  - **TR-TSY-000754**, *ISDN Primary Rate Access Transport System Requirements*, Issue 1 (Bellcore, July 1990). (A module of *TSGR*, FR-440.)
  - **TR-TSY-000762**, *Impulse Noise Tape No. 201*, Issue 1 (Bellcore, July 1987).
-



- 
- **TR-TSY-000763**, *Digit Simulation Test Tape*, Issue 1 (Bellcore, July 1987).
  - **TR-TSV-000772**, *Generic System Requirements in Support of Switched Multi-Megabit Data Service*, Issue 1 (Bellcore, May 1991).
  - **TR-TSV-000773**, *Local Access System Generic Requirements, Objectives, and Interfaces in Support of Switched Multi-megabit Data Service*, Issue 1 (Bellcore, June 1991); plus Revision 1, January 1993.
  - **TR-TSV-000774**, *SMDS Operations Technology Network Element Generic Requirements*, Issue 1 (Bellcore, March 1992); plus Supplement 1, March 1993.
  - **TR-TSV-000775**, *Usage Measurement Generic Requirements in Support of Billing for Switched Multi-megabit Data Service*, Issue 1 (Bellcore, June 1991).
  - **GR-820-CORE**, *OTGR Section 5.1: Generic Transmission Surveillance*, Issue 1 (Bellcore, November 1994). (A module of OTGR, FR-439.)
  - **TR-NWT-000862**, *ISDN Automatic Message Accounting Generic Requirements*, Issue 3 (Bellcore, May 1993), plus revisions plus supplements.
  - **TR-TSY-000885**, *PPSN Support of SNA/SDLC Interfaces*, Issue 1 (Bellcore, December 1989).
  - **FR-905**, *Common Channel Signaling Network Interface Specifications (CCSNIS) Family of Requirements* (Bellcore, 1997 Edition).
  - **GR-905-CORE**, *Common Channel Signaling (CCS) Network Interface Specification (CCSNIS) Supporting Network Interconnection, Message Transfer Part (MTP), and Integrated Services Digital Network User Part (ISDNUP)*, Issue 2 (Bellcore, December 1996).
  - **TA-NWT-000909**, *Generic Requirements and Objectives for Fiber in the Loop Systems*, Issue 2 (Bellcore, December 1993).
  - **TR-NWT-000911**, *Generic Criteria for Basic Exchange Radio Systems*, Issue 1 (Bellcore, September 1990). (A module of TSGR, FR-440.)
  - **TA-NPL-000912**, *Compatibility Information for Telephone Exchange Service*, Issue 1 (Bellcore, February 1989).
  - **TR-TSY-000918**, *Generic Requirements for Modem Interface Support on PPSNs*, Issue 1 (Bellcore, January 1990).
  - **TR-TSY-000926**, *Public Packet Switched Network X.32 Interface Requirements*, Issue 1 (Bellcore, September 1989).
  - **GR-954-CORE**, *Common Channel Signaling (CCS) Network Interface Specification (CCSNIS) Supporting Line Information Database (LIDB) Services*, Issue 2 (Bellcore, March 1997).
-

- 
- **TR-NWT-000965**, *IntraLATA Voice Grade Private Line Services — Transmission Parameter Limits and Interface Combinations*, Issue 1 (Bellcore, December 1991).
  - **TA-TSY-001034**, *CLASS<sup>SM</sup> Feature: Selective Call Acceptance*, Issue 1 (Bellcore April 1990). (A module of *LSSGR*, FR-64.)
  - **TR-NWT-001036**, *PPSN Asynchronous Interface Generic Requirements*, Issue 1 (Bellcore, December 1991).
  - **TR-NWT-001050**, *Expansion of Carrier Identification Code (CIC) Capacity for Feature Group D (FGD)*, Issue 1 (Bellcore, April 1991).
  - **TA-TSV-001059**, *Generic Requirements for SMDS Networking*, Issue 2 (Bellcore, August 1992).
  - **GR-1060-CORE**, *Switched Multi-Megabit Data Service (SMDS) Generic Requirements for Exchange Access and Intercompany Serving Arrangements*, Issue 1 (Bellcore, March 1994).
  - **TR-TSV-001062**, *Generic Requirements for Phase 1 SMDS Customer Network Management Service*, Issue 1 (Bellcore, March 1993).
  - **GR-1063-CORE**, *Generic Operations Criteria in Support of Inter-carrier SMDS*, Issue 1 (Bellcore, April 1994).
  - **TR-TSV-001064**, *SMDS Generic Criteria on Operations Interfaces - SMDS Information Model and Usage*, Issue 1 (Bellcore, December 1992).
  - **GR-1100-CORE**, *Bellcore Automatic Message Accounting Format (BAF) Requirements*, Issue 1 (Bellcore, January 1995); plus revisions.
  - **GR-1110-CORE**, *Broadband Switching System (BSS) Generic Requirements*, Issue 1 (Bellcore, September 1994).
  - **GR-1111-CORE**, *Broadband Access Signaling Generic Requirements*, Issue 2 (Bellcore, October 1996).
  - **TR-NWT-001112**, *BISDN User to Network Interface and Network Node Interface Physical Layer Generic Criteria*, Issue 1 (Bellcore, June 1993).
  - **GR-1113-CORE**, *Asynchronous Transfer Mode and ATM Adaptation Layer (AAL) Protocols Generic Requirements*, Issue 1 (Bellcore, July 1994).
  - **GR-1114-CORE**, *Generic Operations Interface Requirements: ATM Information Model*, Issue 3 (Bellcore, September 1996).
  - **GR-1115-CORE**, *BISDN Inter-Carrier Interface (B-ICI) Generic Requirements*, Issue 2 (Bellcore, October 1994).
  - **GR-1117-CORE**, *Generic Requirements for Exchange PVC Cell Relay Customer Network Management (CNM) Service*, Issue 1 (Bellcore, June 1994).
-



- 
- **GR-1129-CORE**, *AINGR: Switch — Intelligent Peripheral Interface (IPI)*, Issue 2 (Bellcore, July 1996). (A module of *AINGR*, FR-15.)
  - **GR-1149-CORE**, *OSSGR Section 10: System Interfaces*, Issue 2 (Bellcore, March 1997). (A Module of *OSSGR*, FR-271.)
  - **GR-1158-CORE**, *OSSGR Section 22.3: Line Information Database (LIDB)*, Issue 3 (Bellcore, March 1997). (A Module of *OSSGR*, FR-271.)
  - **GR-1173-CORE**, *OSSGR Common Functions (FSD 65-01-0100)*, Issue 2 (Bellcore, March 1997). (A module of *OSSGR*, FR-271.)
  - **GR-1177-CORE**, *OSSGR special Billing Features*, Issue 1 (Bellcore, June 1997). (A module of *OSSGR*, FR-271.)
  - **TR-NWT-001188**, *CLASS<sup>SM</sup> Feature: Calling Name Delivery Generic Requirements, FSD 01-02-1070*, Issue 1 (Bellcore, December 1991); plus Bulletin No. 1, April 1992, and Revision 1, December 1993. (A module of *LSSGR*, FR-64.)
  - **TR-NWT-001203**, *Generic Requirements for the Switched DSI/Switched Fractional DSI Service Capability from an ISDN Interface (SWF-DSI/ISDN)*, Issue 2 (Bellcore, December 1992); plus Revisions.
  - **TR-TSV-001235**, *SMDS Generic Criteria on Operations Interfaces - Information Model Supporting Intercarrier SMDS*, Issue 1 (Bellcore, November 1993).
  - **GR-1237-CORE**, *SMDS Generic Requirements for Initial Operations Management Capabilities in Support of Exchange Access and Intercompany Serving Arrangements*, Issue 1 (Bellcore, June 1994).
  - **TA-TSV-001238**, *Generic Requirements for SMDS on the 155.520 Mbps Multi-Services Broadband ISDN Inter-Carrier Interface (B-ICI)*, Issue 1 (Bellcore, December 1992).
  - **TR-TSV-001239**, *Generic Requirements for Low Speed SMDS Access*, Issue 1 (Bellcore, December 1993).
  - **TA-TSV-001240**, *Generic Requirements for Frame Relay Access to SMDS*, Issue 1 (Bellcore, June 1993).
  - **GR-1241-CORE**, *Supplemental Service Control Point (SCP) Generic Requirements*, Issue 1 (Bellcore, June 1996).
  - **TR-NWT-001244**, *Clocks for the Synchronized Network: Common Generic Criteria*, Issue 1 (Bellcore, May 1995).
  - **GR-1248-CORE**, *Generic Requirements for Operations of ATM Network Elements*, Issue 3 (Bellcore, August 1994).
  - **GR-1250-CORE**, *Generic Requirements for Synchronous Optical Network (SONET) File Transfer*, Issue 1 (Bellcore, June 1995)
-

- 
- **TR-NWT-001251**, *CLASS<sup>SM</sup> Feature: Numbering Plan Area Split Management, FSD 30-29-0000*, Issue 1 (Bellcore, December 1992). (A module of *LSSGR*, FR-64.)
  - **TR-NWT-001268**, *ISDN Primary Rate Interface Call Control Switching and Signaling Generic Requirements for Class II Equipment*, Issue 1 (Bellcore, December 1991) plus revisions.
  - **TR-NWT-001273**, *Generic Requirements for an SPCS to Customer Premises Equipment Data Interface for Analog Display Services*, Issue 1 (Bellcore, December 1992); plus Revisions and Bulletins. (A module of *ADSI*, FR-12.)
  - **TR-NWT-001281**, *ISDN Parameter Downloading Generic Requirements*, Issue 1 (Bellcore, October 1992); plus Revisions.
  - **GR-1298-CORE**, *AINGR: Switching Systems*, Issue 3 (Bellcore, November 1996). (A module of *AINGR*, FR-15.)
  - **GR-1299-CORE**, *AINGR: Switch — Service Control Point (SCP)/Adjunct Interface*, Issue 3 (Bellcore, July 1996). (A module of *AINGR*, FR-15.)
  - **GR-1327-CORE**, *Frame Relay Network Element Operations*, Issue 1 (Bellcore, July 1993).
  - **GR-1343-CORE**, *Generic Requirements for the Automatic Message Accounting Data Networking System (AMADNS)*, Issue 2 (Bellcore, September 1996).
  - **TR-TSV-001369**, *Generic Requirements for Frame Relay PVC Exchange Service*, Issue 1 (Bellcore, May 1993).
  - **TR-TSV-001370**, *Generic Requirements for Exchange Access Frame Relay PVC Service*, Issue 1 (Bellcore, May 1993).
  - **GR-1371-CORE**, *Phase 1 Frame Relay PVC CNM Service*, Issue 1 (Bellcore, September 1993).
  - **GR-1379-CORE**, *Generic Requirements for Frame Relay PVC Operations Interface*, Issue 1 (Bellcore, April 1994).
  - **TR-NWT-001401**, *Visual Message Waiting Indicator Generic Requirements*, Issue 1 (Bellcore, September 1993). (A module of *LSSGR*, FR-64; and *ADSI*, FR-12.)
  - **TA-TSV-001408**, *Generic Requirements for Exchange PVC Cell Relay Service*, Issue 1 (Bellcore, August 1993).
  - **GR-1411-CORE**, *PCS Access Services Interface Specification in Support of PCS Routing Service, PCS Home Database Service, and PCS IS-41 Message Transport Service*, Issue 1 (Bellcore, March 1994).
  - **GR-1417-CORE**, *Broadband Switching System SS7 Generic Requirements*, Issue 3 (Bellcore, October 1996).
-

- 
- **GR-1430-CORE**, *Generic Requirements for Frame Relay PVC Exchange Access Operations Management*, Issue 1 (Bellcore, September 1994).
  - **GR-1431-CORE**, *CCS Network Signaling Specification Supporting B-ISDN Generic Requirements*, Issue 3 (Bellcore, November 1996).
  - **GR-1434-CORE**, *Common Channel Signaling (CCS) Network Interface Specification Supporting Wireless Services Providers (WSPs)*, Issue 1 (Bellcore, April 1994).
  - **TR-NWT-001436**, *CLASS<sup>SM</sup> Feature: Visual Screening List Editing, FSD 30-28-0100*, Issue 1 (Bellcore, December 1993). (A module of LSSGR, FR-64.)
  - **TA-NWT-001501**, *Generic Requirements for Exchange SVC Cell Relay Service*, Issue 1 (Bellcore, December 1993).
  - **SR-BDS-001511**, *Administration Guidelines for Card Issuer Identifier*, Issue 2 (Bellcore, July 1993).
  - **SR-OPT-001843**, *Service Access Codes (N00) NXX Assignments*, Issue 4, Volume 5 (Bellcore, December 1995).
  - **SR-NWT-001937**, *National ISDN-1*, Issue 1 (Bellcore, February 1991); plus Supplement 1, February 1993.
  - **SR-NWT-001953**, *Generic Guidelines for ISDN Terminal Equipment on Basic Access Interfaces*, Issue 1 (Bellcore, June 1991); plus Revision 1, December 1991.
  - **SR-NWT-002026**, *X.25-Based Packet Network Packet Assembler/Disassembler Support of T3POS*, Issue 1 (Bellcore, September 1991).
  - **SR-NWT-002120**, *National ISDN-2*, Issue 1 (Bellcore, May 1992); plus Revision 1, June 1993.
  - **SR-NWT-002343**, *ISDN Primary Rate Interface Generic Guidelines for Customer Premises Equipment*, Issue 1 (Bellcore, June 1993), plus Bulletin 1, January 1994.
  - **SR-NWT-002361**, *Generic Guidelines for ISDN Terminal Equipment on National ISDN-2 Basic Rate Interfaces*, Issue 1 (Bellcore December 1992); plus Revision 1, November 1993.
  - **SR-INS-002461**, *Customer Premises Equipment Compatibility Considerations for the Analog Display Services Interface*, Issue 1 (Bellcore, December 1992) plus Bulletins. (A module of ADSI, FR-12.)
  - **SR-TSV-002476**, *Customer Premises Equipment Compatibility Considerations for the Voiceband Data Transmission Interface*, Issue 1 (Bellcore, December 1992); plus Bulletin No. 1, September 1993. (A module of ADSI, FR-12.)
  - **SR-NWT-002598**, *Clarification of the Requirements for Public Switched Digital Service (PSDS)*, Issue 1 (Bellcore, February 1993).
-

- 
- **SR-2727**, *Analog Display Services Interface (ADSI) Guide*, Issue 4 (Bellcore, March 1996). (A module of *ADSI*, FR-12.)
  - **GR-2838-CORE**, *Generic Requirements for GetData*, Issue 1 (Bellcore, August 1994).
  - **GR-2842-CORE**, *ATM Service Access Multiplexer (SAM) Generic Requirements*, Issue 2 (Bellcore, November 1996).
  - **GR-2848-CORE**, *Broadband Multi-service User Network Interface Generic Requirements*, Issue 1 (Bellcore, June 1994).
  - **GR-2875-CORE**, *Generic Requirements for Digital Interface Systems*, Issue 1 (Bellcore, May 1996).
  - **GR-2891-CORE**, *SONET Digital Cross-connect Systems with ATM Functionality Generic Criteria*, Issue 2 (Bellcore, June 1996). (A module of *TSGR*, FR-440.)
  - **GR-2898-CORE**, *Generic Requirements for Fiber Demarcation Boxes*, Issue 1 (Bellcore, December 1995).
  - **GR-2932-CORE**, *Database Functionalities*, Issue 1 (Bellcore, May 1997). (A module of *LSSGR*, FR-64.)
  - **GR-2936-CORE**, *Local Number Portability Capability Specification*, Issue 2 (Bellcore, December 1996).
  - **SR-3285**, *PCS Access Service for Radio Controllers (PASC) Interface Specifications*, Issue 1 (Bellcore, October 1994).
  - **SR-3337**, *Guidelines for Ordering and Provisioning Multiservice B-ICIs*, Issue 3 (Bellcore, October 1996).
  - **SR-3369**, *Broadband Switching Systems (BSS) Requirements to Support ATM Based Services*, Issue 1 (Bellcore, December 1994).
  - **SR-3776**, *Telecommunications Industry Catalog of Forums, Standards Bodies & Associations*, Issue 3 (Bellcore, February 1997).
  - **IL-94-01-002**, *Opening of 710 NPA Code*, Issue 1 (Bellcore, January 1994).
  - **IL-96-03-001**, *Reissuance of Notification of Assignment of 880 and 881 NPAs for Inbound Foreign Billed Calls to Toll-Free Numbers*, Issue 1 (Bellcore, March 1996).

---

### Pre-Divestiture Documents

- **AL-86-07-006**, *900 NXX Code Assignment Guidelines*, Issue 1 (Bellcore, July 1986).
- **CB 154**, *Specifications for Special Information Tones (SIT) for Encoding Recorded Announcements*, Issue 3 (Bellcore, June 1983).
- **MDP-326-125**, *Description of the Analog Voiceband Interface between the Bell System Local Exchange Lines and Terminal Equipment* (Bellcore, January 1983) (also known as **PUB 61100**).
- **MDP-326-140**, *Digital Channel Bank Requirements and Objectives* (Bellcore, November 1982) (also known as **PUB 43801**).
- **TR-880-22135-84-01**, *Circuit Switched Digital Capability Network Access Interface Specifications*, Issue 1 (Bellcore, July 1984).

### NOTE:

All Bellcore documents are subject to change, and their citation in this document reflects the most current information available at the time of this printing. Readers are advised to check current status and availability of all documents.

To obtain Bellcore documents, contact:

Bellcore Customer Service  
8 Corporate Place, Room 3A-184  
Piscataway, New Jersey 08854-4156  
1-800-521-CORE (2673) (US & Canada)  
(732) 699-5800 (all others)  
(732) 336-2559 (FAX)

[www.bellcore.com/marketplace.html](http://www.bellcore.com/marketplace.html)

BCC personnel should contact their company document coordinator, and Bellcore personnel should call (732) 699-5802 to obtain documents.

---

## ANSI Documents

- ANSI T1.111-1996, *American National Standard for Telecommunications - Signaling System Number 7 (SS7) - Message Transfer Part (MTP)* (American National Standards Institute, 1996).
- ANSI T1.401-1988, *Interface Between Carriers and Customer Installations — Analog Voicegrade Switched Access Lines Using Loop-Start and Ground-Start Signaling* (American National Standards Institute, 1988).
- ANSI T1.405-1989, *Interface Between Carriers and Customer Installations — Analog Voicegrade Switched Access Using Loop Reverse—Battery Signaling* (American National Standards Institute, 1989).
- ANSI T1.409-1991, *American National Standard for Telecommunications — Interface Between Carriers and Customer Installation — Analog Voicegrade Special Access Lines Using E&M Signaling* (American National Standards Institute, 1991).
- ANSI X3.4-1986, *Coded Character Set — 7-bit American National Code for Information Exchange*, Issue 1 (American National Standards Institute, 1986).
- ANSI T1.110, 111, 112, 113 and 114, *American National Standards for Telecommunications — Signaling System No. 7*, American National Standards Institute.
- *American National Standard for Telecommunications — Interface Between Carriers and Customer Installation — Analog Voicegrade Special Access Lines Using E&M Signaling*, ANSI T1.409-1991. American National Standards Institute, 1991.
- ANSI/EIA 470-A-1987, *Telephone Instruments with Loop Signaling*.
- ANSI/IEEE STD 661-1979, *Methods of Determining Objective Loudness Ratings of Telephone Connections*.
- ANSI/IEEE STD 743-1984, *Methods and Equipment for Measuring the Transmission Characteristics of Analog Voice Frequency Circuits*.
- ANSI TIA/EIA-596-1993, *Network Channel Terminating Equipment for Public Switched Digital Service*.
- ANSI T1.501-1988, *Network Performance — Tandem Encoding Limits for 32 kbit/s Adaptive Differential Pulse-Code Modulation* (American National Standards Institute, 1988).
- ANSI T1.508-1992, *Network Performance — Loss Plan for Evolving Digital Networks* (American National Standards Institute, 1993).
- ANSI EIA/TIA 579-1991, *Acoustic-To-Digital and Digital-To-Acoustic Transmission Requirements for ISDN Terminals*.

- 
- ANSI EIA/TIA-464-A-1989, *Private Branch Exchange (PBX) Switching Equipment for Voiceband Application*.
  - ANSI T.206-1988, *Digital Exchanges and PBXs — Digital Circuit Loopback Test Line* (American National Standards Institute, 1988).
  - ANSI T1.101-1987, *Synchronization Interface Standards for Digital Networks*, 1987.
  - ANSI T1.403-1994, *Carrier-to-Customer Installation - DS1 Metallic Interface* (American National Standards Institute, 1994).
  - ANSI T1.410-1992, *Carrier-to-Customer Metallic Interface - Digital Data at 64 Kbs and Subrates* (American National Standards Institute, 1992).
  - ANSI T1.212, *Enhanced Telecommunications Credit Card Physical Characteristics and Numbering Structure* (American National Standards Institute, 1990).
  - ANSI T1.601-1992, *Telecommunications ISDN Basic Rate Access Interface for use on Metallic Loops for Application on the Network Side of the NT Layer 1 Specification* (American National Standards Institute, 1992).
  - ANSI T1.408-1990, *ISDN Primary Rate Customer Installation Interface Layer 1 Specification* (American National Standards Institute, 1990).
  - ANSI/TIA/EIA 596-92, *Network Channel Terminating Equipment for Public Switched Digital Service* (American National Standards Institute/Telecommunications Industry Association/Electronic Industries Association, 1992)
  - ANSI T1.231-1993, *In-Service Digital Transmission Performance Monitoring* (American National Standards Institute/Telecommunications Industry Association/Electronic Industries Association, 1993)
  - ANSI T1.409-1996, *American National Standard for Telecommunications — Network-to-Customer Installation Interfaces— Analog Voicegrade Special Access Lines Using E&M Signaling*
  - ANSI T1.401-1993, *American National Standard for Telecommunications — Interface Between Carriers and Customer Installations — Analog Voicegrade Switched Access Lines Using Loop-Start and Ground-Start Signaling*.

To obtain ANSI documents, call (212) 642-4900 or visit ANSI at [www.ansi.org](http://www.ansi.org).



## ATIS Documents

- *Alliance for Telecommunications Industry Solutions Annual Report 1996*. ATIS, 1996

## ICCF Documents

- ICCF 92-0726-002, *CIC Administrative Guidelines*.
- ICCF 92-1127-005, *Vertical Service Codes Assignment Guidelines*.
- ICCF 93-0729-008, *TRS — Technical Needs*.
- ICCF 93-0729-010, *Central Office Code (NNX/NXX) Assignment Guidelines*.
- ICCF 96-0411-014, *555 Technical Service Interconnection Arrangements*

## NIIF Documents

- *ONA Services User Guide* (NIIF or regional companies, January 31, 1994).
- *Final Consensus Resolution of IILC Issue #006* (IILC, June 13, 1991).

## INC Documents

- INC 94-0429-002, *555 NXX Assignment Guidelines*.
  - INC-94-0826-003, *International Inbound NPA (INT/NPA/NXX) Assignment Guidelines*.
  - INC 95-0407-008, *Central Office Code (NXX) Assignment Guidelines*.
  - INC-95-0407-009, *Personal Communications Services N00 NXX Code Assignment Guidelines*.
  - INC 95-0127-006, *CIC Administrative Guidelines*.
  - INC 96-0308-011, *NPA Allocation Plan and Assignment Guidelines*.
  - INC 96-0802-015, *Vertical Service Code Assignment Guidelines*.
  - INC 97-0131-017, *Industry Numbering Committee Uniform Dialing Plan*.
  - INC 97-0404-012, *900 NXX Code Assignment Guidelines*.
  - INC 97-0404-016, *NPA Code Relief Planning and Notification Guidelines*.
-



### **Carrier Liaison Committee Documents**

- *Industry Guidelines for 800 Number Administration*, Issue 3.0.

ATIS documents can be obtained through the

Alliance for Telecommunications Industry Solutions (ATIS)  
1200 G Street NW, Suite 500  
Washington, DC 20005

ATIS phone: (202) 628-6380

Homepage <http://www.ATIS.org>

---

## ATM Forum

- af-saa-0049.000, Audio/Visual Multimedia Services: Video on Demand Specification, version 1.0 (ATM Forum, December 1995).
- af-vtoa-0083.000, Voice and Telephony Over ATM to the Desktop specification, version 1.0 (ATM Forum, May 1997).
- af-saa-0032.000, Circuit Emulation version 1.0, (ATM Forum, September 1995)
- af-vtoa-0078.000, Circuit Emulation Service version 2.0 (ATM Forum, January 1997)
- af-sig-0061.000, UNI Signaling version 4.0, with af-sig-0076.000 Signaling ABR Addendum (ATM Forum, June 1996)
- af-vtoa-0083.00, Voice and Telephony Over ATM to the Desktop Specification, version 1.0 (ATM Forum, March 1997)
- af-vtoa-0089.000, Voice and Telephony Over ATM Trunking using AAL 1 for Narrowband Services, version 1.0 (ATM Forum, April 1997)
- af-saa-0049.001, Audio-visual Multimedia Services: Video on Demand Specification, version 1.1 (ATM Forum, December 1996)
- af-lane-0021.000, LAN Emulation Over ATM, version 1.0 (ATM Forum, January 1995)
- af-lane-0038.000, LANE Emulation Client Management Specification, version 1.0 (May 1995)
- af-lane-0084-000, LAN Emulation Over ATM Version 2.0 - LUNI Specification, (ATM Forum, April 1997)
- af-mpoa-0087-000, Multi-Protocol Over ATM, version 1.0 (ATM Forum, April 1997)
- af-tm-0056.000, UNI Traffic Management, version 4.0 (ATM Forum, April 1996), with Addendum to Traffic Management V4.0 for ABR Parameter Negotiation, (ATM Forum, January 1997)
- af-ilmi-0065.000, Integrated Local Management Interface, version 4.0 (ATM Forum, September 1996)
- af-pnni-0055.000, Private-Network Node Interface (P-NNI), version 1.0 (ATM Forum, March 1996)
- af-pnni-0026.000, Interim Inter-Switch Signaling Protocol, version 1.0 (ATM Forum, December 1994)
- af-bici-0013.003, Broadband Inter-Carrier Interface, version 2.0 (ATM Forum, November 1995)
- af-bici-0068.000, B-ICI 2.0 Addendum, version 2.1 (ATM Forum, November 1996)

- af-saa-0031.000, Frame-UNI, version 1.0 (ATM Forum, July 1995).
- af-saa-0089.000, Frame Based User-to-Network Interface (FUNI), version 2.0 (ATM Forum, April 1997).

Contact the ATM Forum Worldwide Headquarters at

2570 West El Camino Real, Suite 304  
Mountain View, CA 94040-1313  
+1.650.949.6700 or +1.415.949.6700 Phone  
+1.650.949.6705 or +1.415.949.6705 Fax

or online at <http://www.atmforum.com>

---

## IEEE Documents

- IEEE STD 753-1983, *Standard Functional Methods and Equipment for Measuring the Performance of Dial-Pulse (DP) Address Signaling Systems* (Institute of Electrical and Electronics Engineers, Inc., 1983).
- IEEE STD 752-1986, *IEEE Standard for Functional Requirements for Methods and Equipment for Measuring the Performance of Tone Address Signaling Systems* (Institute of Electrical and Electronics Engineers, Inc., 1986).
- IEEE 455-1985, *Measuring Longitudinal Balance of Telephone Equipment Operating in the Voice Band, Test Procedures for* (Institute of Electrical and Electronics Engineers, Inc., 1985).
- IEEE STD 152-1991, *IEEE Standard for Audio Program Level Measurement* (Institute of Electrical and Electronics Engineers, Inc., 1991).
- Kovac, E. J. and Mitchell, W. J., *The DCS as a Universal Digital Cross-Connect System*, IEEE Journal on Selected Areas in Communications, v.SAC-5, n. 1 (January 1987), pp. 53-38.
- S. H. Lin and R. S. Wolff, *Basic Exchange Radio - From Concept to Reality*, IEEE International Conference on Communications, April 16-19, 1990, Conference Record, pp. 206.2.1-206-2.7.
- *Distributed Queue Dual Bus (DQDB) Subnetwork of Metropolitan Area Networks*, IEEE Standard 802.6 (The Institute of Electrical and Electronics Engineers, Inc., December 1990).
- C.G. Rudolph, "Business Continuation Planning/Disaster Recovery: A Marketing Perspective," *IEEE Communications Magazine*, Vol. 28, No. 6 (Institute of Electrical and Electronics Engineers, Inc., June 1990).
- M. Kerner, H.L. Lemberg, D.M. Simmons, "An Analysis of Alternative Architectures for the Interoffice Network," *IEEE Journal on Selected Areas in Communications*, vol. SAC-4, no. 9 (Institute of Electrical and Electronics Engineers, Inc., December 1986).
- W. Grover, "A Fast Distributed Restoration Technique for Networks Using Digital Cross-connect Machines," *IEEE Globecom* (Institute of Electrical and Electronics Engineers, Inc., 1987).
- A. Bellary, K. Mizushima, "Intelligent Transport Network Survivability: Study of Distributed and Centralized Control Techniques Using DCS and ADM," *IEEE Globecom* (Institute of Electrical and Electronics Engineers, Inc., December 1990).
- P.W. Shumate, Jr., "Cost Projections for Fiber in the Loop," *IEEE LCS Magazine* (Institute of Electrical and Electronics Engineers, Inc., February 1990).

- 
- P.W. Shumate, R.K. Snelling, "Evolution of Fiber in the Residential Loop Plant," *IEEE Communications Magazine* (Institute of Electrical and Electronics Engineers, Inc., March 1991).
  - Tsong-Ho Wu, Maurice E. Burrowes, "Feasibility Study of High-Speed SONET Self-Healing Ring Architecture in Future Interoffice Networks," *IEEE Communications Magazine* (Institute of Electrical and Electronics Engineers, Inc., November 1990).
  - P1007, *Methods and Equipment Standard for Measuring the Transmission Characteristics of PCM Telecommunications Circuits and Systems* (Institute of Electrical and Electronics Engineers, 1989).
  - IEEE STD 752-1986, *IEEE Standard for Functional Requirements for Methods and Equipment for Measuring the Performance of Tone Address Signaling Systems*.

To obtain IEEE documents, call 1-800-678-4333, or visit IEEE at [www.ieee.org](http://www.ieee.org).

## ISO Documents

- ISO/IEC 8877, *Information Technology Telecommunications and Information Exchange Between Systems, Interface Connectors and Contact Assignments for ISDN Basic Rate Access Interface Located at Reference Points S and T* (International Standards Organization/International Electrotechnical Commission, 1992).
- ISO 7498-1984 (E), *Information Processing Systems - Open System Interconnection - Basic Reference Model*, American National Standards Association, Inc., N.Y.
- ISO/IEC IS 13818-6/ITU-T Recommendation H.262, *Information Technology - Generic Coding of Moving Pictures and Associated Audio - Part 2: Video* (ISO/IEC and ITU-T, 1996).
- ISO/IEC IS 13818-3, *Information Technology - Generic Coding of Moving Pictures and Associated Audio - Part 3: Audio* (ISO/IEC, 1996).

ISO documents can be obtained by contacting

International Organization for Standardization)  
1 Rue de Varembe  
CH-1211 Geneva 20  
Switzerland

Telephone + 41 22 749 01 11

Homepage <http://www.iso.ch>

---

## ITU (CCITT) Documents

- CCITT *Yellow Book*, International Telecommunication Union, Vol. VI, fascicle VI.6 (1980).
- CCITT *Red Book*, International Telecommunication Union, Vol. VI, fascicles VI.7, VI.8 (1985).
- CCITT *Blue Book*, International Telecommunication Union, Vol. VI, fascicles VI.7, VI.8 and VI.9 (1988).
- “Reference Model of Open Systems Interconnection for CCITT Applications (X.200),” CCITT *Blue Book*, International Telecommunication Union, Vol. VIII, fascicle VIII.4 (1988).
- CCITT: COM XVIII-228-E, Geneva, Switzerland, 1984.
- “Data Communication Networks: OSI — Protocol Specifications,” CCITT *Blue Book*, International Telecommunication Union, Vol. VIII, fascicle VIII.5 (1988).
- ITU-T Recommendation I.150, *B-ISDN Asynchronous Transfer Node Functional Characteristics*, 1991.
- ITU-T Recommendation I.121, *Broadband Aspects of ISDN*, Revision 1, 1991.
- ITU-T Recommendation I.211, *Broadband Service Aspects*, Revision 1, 1991.
- CCITT Recommendation I.233, *Frame Relay Bearer Services*, 1992.
- ITU-T Recommendation I.321, *B-ISDN Protocol Reference Model and Its Applications*, 1991.
- ITU-T Recommendation I.361, *B-ISDN ATM Layer Specification*, 1991.
- ITU-T I.363.1, *B-ISDN ATM Adaptation Layer (AAL) Specification Types 1 and 2*, 1996
- ITU-T I.363.5, *B-ISDN ATM Adaptation Layer (AAL) Specification Type 5*, 1996
- ITU-T Recommendation I.363, *B-ISDN ATM Adaptation Layer (AAL) Specification*, 1993.
- ITU-T Recommendation I.364, *Support of Connectionless Data Service on a B-ISDN*, 1992.
- ITU-T Recommendation I.365.1, *Frame Relaying Bearer Service Specific Convergence Sublayer (FR-SSCS)*, 1993
- ITU-T Recommendation I.555, *Frame Relay Bearer Service Interworking*, 1993.
- CCITT Recommendation Q.931 (I.451) of the VIIth Plenary Assembly, *ISDN User-Network Interface Layer 3 Specification*, Fascicle VI.9, October 1984; as modified by

- 
- Revision 2 of Recommendation Q.931, Chapters 3 and 4, Committee XI-52-E, February 1986.
- Recommendation Q.922, Annex A, *ISDN data link layer specification for frame mode bearer services*, February 1992.
  - CCIR XVIIth Plenary Assembly, Düsseldorf, 1990, *Radio Systems Operating in Bands 8 and 9 for Provision of Subscriber Telephone Connections in Rural Areas*, CCIR Report 380-2 (MOD F), 1966-1982-1986 (Geneva: International Telecommunication Union).
  - CCIR XVIIth Plenary Assembly, Düsseldorf, 1990, *Point-to-Multipoint Systems Utilizing Time Division Multiple Access Techniques*, CCIR Report 1057 (MOD F) (Geneva: International Telecommunication Union).
  - CCITT Handbook prepared by the Special Autonomous Group 7 (GAS 7) of CCITT, *Rural Telecommunications*, ISBN 92-61-01921-8, 1985 (Geneva: International Telecommunication Union).
  - Recommendation X.36, *Interface between Data Terminal Equipment (DTE) and Data Circuit-terminating Equipment (DCE) for public data networks providing frame relay data transmission service by dedicated circuit*, April 1995. *Switched Virtual Circuit (SVC) signaling and refinements of Permanent Virtual Circuit (PVC) signaling*, Amendment 1, October 1996.
  - Recommendation X.76, *Network-to-network interface between public data networks providing the frame relay data transmission service*, April 1995.
  - *2400 Bits Per Second Duplex Modem Using the Frequency Division Technique Standardized for Use on the General Switched Telephone Network and on Point-to-Point 2-wire Leased Telephone-type Circuits*, CCITT Recommendation V.22 bis, International Telecommunication Union, 1988.
  - *A Family of 2-wire, Duplex Modems Operating at Data Signaling Rates of up to 9600 bit/s for Use on the General Switched Telephone Network and on Leased Telephone-type Circuits*, CCITT Recommendation V.32, International Telecommunication Union, 1988.
  - *Automatic Calling and/or Answering Equipment on the General Switched Telephone Network (GSTN) Using the 100-Series Interchange Circuits*, CCITT Recommendation V.25 bis, International Telecommunication Union, 1988.
  - CCITT Recommendation V.32 bis, International Telecommunication Union.
  - *Error-Correcting Procedures for DCEs Using Asynchronous-to-Synchronous Conversion*, CCITT Recommendation V.42, International Telecommunication Union, 1988.
  - *Data Compression Procedures for DCEs Using Error-Correcting Procedures*, CCITT Recommendation V.42 bis, International Telecommunication Union, 1989.
-



- 
- *Data Transmission at 48 Kilobits Per Second Using 60-108 kHz Group Band Circuits*, CCITT Recommendation V.35, International Telecommunication Union, Geneva, Switzerland, 1984.
  - *Information Processing Systems — Open Systems Interconnection — Basic Reference Model*, International Organization for Standardization, 1984.
  - TA-TSY-000077, *Digital Channel Banks Requirements for Dataport Channel Unit Functions*, Issue 3 (Bellcore, April 1986).
  - *Interface Between Data Terminal Equipment (DTE) and Data Circuit-Terminating Equipment (DCE) for Terminals Operating in the Packet Mode and Accessing a Packet Switched Public Data Network Through a Public Switched Telephone Network or an Integrated Services Digital Network or a Circuit Switched Public Data Network*, CCITT Recommendation X.32, International Telecommunication Union, 1988.
  - *Packet Assembly Disassembly (PAD) Facility in a Public Data Network*, CCITT Recommendation X.3, International Telecommunication Union, 1988.
  - *DTE/DCE Interface for a Start-Stop Mode Data Terminal Equipment Accessing the Packet Assembly/Disassembly (PAD) Facility in a Public Data Network Situated in the Same Country*, CCITT Recommendation X.28, International Telecommunication Union, Geneva, Switzerland, 1988.
  - *Procedures for the Exchange of Control Information and User Data Between a Packet Assembly/Disassembly (PAD) Facility and a Packet Mode DTE or Another PAD*, CCITT Recommendation X.29, International Telecommunication Union, Geneva, Switzerland, 1988.
  - *Terminal and Transit Call Control Procedures and Data Transfer System on International Circuits Between Packet Switched Data Networks*, CCITT Recommendation X.75, International Telecommunication Union, 1984.
  - *International Numbering Plan for Public Data Networks*, CCITT Recommendation X.121, International Telecommunication Union, 1992.

ITU documents can be obtained by contacting

International Telecommunications Union (ITU)  
Place des Nations  
CH-1211 Geneva 20  
Switzerland

Telephone + 41 22 730 51 11

Homepage <http://www.itu.ch>

## EIA Documents

- EIA/TIA 464-A-1989, *Private Branch Exchange (PBX) Switching Equipment for Voiceband Application*, Issue 1 (Electronic Industries Association, 1989).
- EIA 470-A-1987, *Telephone Instruments with Loop Signaling*, Issue 1 (Electronic Industries Association, 1987).
- TIA/EIA-596-1993, *Network Channel Terminating Equipment for Public Switched Digital Service* (TIA/EIA, February 17, 1993).
- EIA/TIA 464-B-1996, *Private Branch Exchange (PBX) Switching Equipment for Voiceband Application*.
- EIA/TIA 464-B-1996, *Private Branch Exchange (PBX) Switching Equipment for Voiceband Application*;
- EIA 470-A-1987, *Telephone Instruments with Loop Signaling*;

To obtain EIA/TIA documents, call (202) 457-4966.

---

## Frame Relay Forum Documents

- FRF.1.1, *User-to-Network Implementation Agreement (UNI)*, January 1996.
- FRF.2.1, *Frame Relay Network-to-Network Implementation Agreement (NNI)*, July 1995.
- FRF.3.1, *Multiprotocol Encapsulation Implementation Agreement*, June 1995.
- FRF.4, *User-to-Network SVC Implementation Agreement*, Frame Relay Forum, 1994
- FRF.5, *Frame Relay/ATM PVC Network Interworking Implementation Agreement*, December 1994.
- FRF.6, *Frame Relay Service Customer Network Management Implementation Agreement (MIB)*, March 1994.
- FRF.7, *Frame Relay PVC Multicast Service and Protocol Description Implementation Agreement*, October 1994.
- FRF.8, *Frame Relay/ATM PVC Service Interworking Implementation Agreement*, April 1995.
- FRF.10, *Frame Relay Network-to-Network SVC Implementation Agreement*, September 1996.
- FRF.11, *Voice over Frame Relay Implementation Agreement*, May 1997.
- FRF.11, *Voice over Frame Relay Implementation Agreement*, May 1997.

To order Frame Relay Forum documents, contact

Frame Relay Forum  
39355 California St., Suite 307  
Fremont, CA 94538  
Phone (510) 608-5920  
<http://www.frforum.com>

---

## Miscellaneous Documents

- C. Breen and C. A. Dahlbom, "Signaling Systems for Control of Telephone Switching," *Bell System Technical Journal*, Vol. 39 (November 1960) pp. 1381-1444.
- Huntley, H. R., "Transmission Design of Intertoll Trunks," *Bell System Technical Journal*, Vol. 32, Sept. 1953, pp. 1019-1036.
- FCC CC Docket No. 92-297; RM-7872; RM-7722; Second Notice of Proposed Rulemaking released February 11, 1994.
- *Code of Federal Regulations (Telecommunications) 47*, Part 68 (Office of the Federal Register National Archives and Records Administration, October 1, 1991).
- *The National Electric Code* (National Fire Protection Association, 1996 Edition).
- PUB 41101, *Data Set 103A Interface Specification* (AT&T Pre-divestiture Historical Document, February 1967).
- *Compatibility Criteria for Data Set 212A*, Compatibility Bulletin 109, Issue 3 (AT&T, September 1977). Also available as TA 20 from the United States Telephone Association (USTA).
- *3270 Display System Protocol*, 2nd Edition, Issued jointly by TransCanada Telephone System (GTE Telenet and Tymnet, June 1983).
- GA27-3761-0, *The X.25 1984 Interface for Attaching SNA Nodes to Packet-Switched Data Networks General Information Manual* (IBM, November 1986).
- SC30-3409-0, *The X.25 1984 Interface for Attaching SNA Nodes to Packet-Switched Data Networks Architecture Reference* (IBM, December 1987).
- L.K. Vanston, R.C. Lenz, "Technological Substitution in Transmission Facilities for Local Telecommunications," *Technology Futures* (Technology Futures, Inc., 1989).
- *FCC Report and Order*, CC Docket No. 91-273.
- CS-03 Part III, *Methods of Connection for Single-Line and Multiple-Line Terminal Equipment*, Issue 7
- C. Sunshine, "Formal Method for Communication Protocol Specification and Verification, A Rand Note," November 1979, ARPA Order No. 3460/3681.
- D. Minoli and G. H. Dobrowski, "Principles of Signaling for Cell Relay and Frame Relay," Artech House, Norwood, MA, 1995.
- J. Heinanen. "IETF RFC 1483, Multiprotocol Encapsulation over ATM Adaptation Layer 5," July 1993.
- M. Laubach, "IETF RFC 1577 - Classical IP and ARP over ATM," January 1994.