

**OPERATIONS
MANUAL**

Z80 Starter System

LIMITED WARRANTY

This unit is warranted for a period of ninety (90) days from the date of purchase to be free from material or workmanship defects. Should the product fail to perform satisfactorily return it prepaid to SD Systems and it will, at our option, be repaired or replaced free of charge, provided the unit is received during the warranty period. This warranty is invalid if product has been misused or modified. Warranty is limited to replacement of defective parts and no responsibility is assumed for damage to other equipment.

This warranty is made in lieu of all other warranties expressed or implied.

Z80 STARTER KITTM

OPERATIONS MANUAL

S.D. Systems and Micro Design Concepts reserves the right to make changes to this publication at any time and without notice. The information furnished herein is believed to be accurate and reliable. However, no responsibility is assumed by S.D. Systems or Micro Design Concepts for its use; nor for any infringements of patents or other rights of third parties resulting from its use.

Copyright © 1978 by Micro Design Concepts

All Rights Reserved

August 1978

TABLE OF CONTENTS

| SECTION | DESCRIPTION | PAGE |
|---------|--|------|
| 1 | INTRODUCTION | 1-1 |
| 1-1 | GENERAL | 1-1 |
| 1-2 | USES FOR THE Z80 STARTER KIT | 1-2 |
| 1-3 | Z80 OVERVIEW | 1-4 |
| 1-4 | ADDITIONAL INFORMATION | 1-7 |
| 2 | CONSTRUCTION | 2-1 |
| 2-1 | INTRODUCTION | 2-1 |
| 2-2 | ASSEMBLY PROCEDURE | 2-1 |
| 2-3 | VOLTAGE CHECK | 2-6 |
| 3 | ZBUG MONITOR DESCRIPTION | 3-1 |
| 3-1 | INTRODUCTION | 3-1 |
| 3-2 | RESET PUSH BUTTON | 3-2 |
| 3-3 | MONITOR | 3-2 |
| 3-4 | MEMORY EXAMINE | 3-3 |
| 3-5 | PORT EXAMINE | 3-4 |
| 3-6 | REGISTER EXAMINE | 3-5 |
| 3-7 | ALTERNATE REGISTER EXAMINE | 3-6 |
| 3-8 | BREAKPOINTS | 3-6 |
| 3-9 | SINGLE STEP | 3-8 |
| 3-10 | EXECUTE | 3-9 |
| 3-11 | CASSETTE DUMP | 3-10 |
| 3-12 | CASSETTE LOAD | 3-14 |
| 3-13 | EPROM PROGRAMMER | 3-15 |
| 3-14 | NEXT KEY | 3-17 |
| 3-15 | RELATIVE OFFSET CALCULATION | 3-17 |
| 3-16 | RST INSTRUCTIONS | 3-18 |
| 3-17 | CTC CHANNEL ZERO INTERRUPTS | 3-20 |
| 3-18 | MEMORY MAP - RAM USAGE | 3-20 |
| 3-19 | ZBUG COMMAND SUMMARY | 3-22 |
| 3-20 | SUBROUTINES CALLABLE IN ZBUG | 3-24 |
| 4 | HARDWARE DESCRIPTION | 4-1 |
| 4-1 | GENERAL | 4-1 |
| 4-2 | CLOCK CIRCUITRY | 4-1 |
| 4-3 | Z80-CPU | 4-1 |
| 4-4 | Z80-PIO | 4-2 |
| 4-5 | Z80-CTC | 4-2 |
| 4-6 | KEYBOARD AND DISPLAY | 4-3 |
| 4-7 | AUDIO CASSETTE INTERFACE | 4-3 |
| 4-8 | EPROM PROGRAMMER | 4-5 |
| 4-9 | MEMORY DECODING | 4-7 |
| 4-10 | PORT DECODING | 4-8 |
| 4-11 | SYSTEM RAM | 4-9 |

TABLE OF CONTENTS

| SECTION | DESCRIPTION | PAGE |
|--------------|---|------|
| 4-12 | SINGLE STEP LOGIC | 4-10 |
| 4-13 | PROM1 RESTART | 4-10 |
| 4-14 | INTERRUPT DAISY CHAIN | 4-11 |
| 4-15 | S-100 BUS INTERFACE | 4-11 |
| 4-16 | WIRE WRAP AREA | 4-12 |
| 5 | EXAMPLE PROGRAMS | 5-1 |
| 5-1 | USING ZBUG COMMANDS | 5-1 |
| 5-2 | CALCULATING RELATIVE ADDRESS | 5-4 |
| 5-3 | WRITING TO THE DISPLAY | 5-7 |
| 5-4 | INTERRUPT DRIVEN DELAY | 5-7 |
| 5-5 | GENERATE AN INTERRUPT FROM THE PIO | 5-10 |
| 5-6 | USING THE Z80 STARTER KIT AS AN EPROM PROGRAMMER | 5-11 |
| APPENDIX I | SCHEMATIC DIAGRAM, ASSEMBLY DRAWING, PARTS LIST | |
| APPENDIX II | ZBUG MONITOR LISTING | |
| APPENDIX III | SOLDERING AND ASSEMBLY TECHNIQUES | |

SECTION 1
INTRODUCTION

1-1 GENERAL

Congratulations on your choice of the Z80 STARTER KIT! This kit has been designed to be the best value on the market for the hobbyist/experimenter/student who wants to learn about and work with microcomputers. Its expansion capabilities are limited only by your imagination with the on-board wire 'wrap area and the two optional S-100 bus connectors. Compatibility with S-100 provides you with a varied selection of modules from several manufacturers to accomplish your task whether it be learning, running Basic, or industrial control. Use of this expansion capability is entirely optional, as the Z80 STARTER KIT enclosed is a fully functional microcomputer with debug Monitor (ZBUG) by the addition of a 5 volt power supply.

The choice of the Z80 Microprocessor as the "brains" of this kit was no accident. The Z80 is the most powerful 8-bit machine available on the market, as its instruction set capability and throughput exceeds that of any other 8-bit machine available. Its vast instruction set of 158 instruction types and clear, easy-to-learn mnemonics make it an ideal processor on which to learn assembly language programming. The 8080A instruction set is a subset of the Z80's, so that programs written for the 8080A will run on the Z80 allowing you access to many programs written for the 8080A and documented in the trade and personal computing magazines. The straightforward

hardware architecture (no multiplexing) of the Z80 make it ideal for the experimenter who wants to connect other peripherals or custom circuitry onto the bus. The Z80's indexing capability, 16-bit Op Codes, and 16-bit Arithmetic operations provide features normally found only in a 16-bit minicomputer.

Two forms of permanent storage for your programs have been provided in the Z80 STARTER KIT. The first is a Kansas City Standard audio cassette interface that can be used with inexpensive home audio recorders. Programs can be transferred from RAM to cassette tape using this feature, providing an inexpensive method of saving and reloading your programs. Second, on-line Non-Volatile memory has been provided in the form of two EPROM sockets on the Z80-CPU bus and an EPROM Programmer for 2758/2716 5 volt only EPROMs. With this facility, user programs can be placed in EPROM and on the bus for immediate access by the Z80-CPU.

1-2 USES FOR THE Z80 STARTER KIT

The Z80 STARTER KIT was designed with five major types of user in mind. These are the computer hobbyist, electronics experimenter, amateur radio operator, instructor/student, and industrial OEM evaluation/control.

The computer hobbyist may have experience with other microcomputers or minicomputers, but needs a low-cost method to get "hands on" experience with the Z80. The diagnostic capability of the Z80 STARTER KIT and its mass storage facilities provide the user with the capability to meet this goal.

The expansion capabilities make it possible to add memory and a CRT Interface in order to turn the KIT into a BASIC terminal for high level language experience.

The electronics experimenter is probably familiar with TTL integrated circuits and is looking for a low-cost method to "get into microcomputing". The wire wrap area with the Z80-CPU signals brought to wire wrap pins is intended for those who want to connect additional circuitry onto the Z80 bus for experimentation. With the on-board keyboard and display, no computer peripherals such as Teletypes are required to communicate with and to control the Z80-CPU. The experimenter can easily learn how to substitute Z80 instructions for gates, flip-flops, adders, and shift registers.

The amateur radio operator may be looking for methods to integrate computers into his "shack" in order to more fully automate his station. Areas the power of the Z80 could be used is in automatic keying - the key could be connected to the Z80-PIO and the Z80 Microcomputer programmed to make precise "dits" and "dahs". A Morse code to ASCII conversion program could be written for the Z80 STARTER KIT to allow the operator to type on an ASCII keyboard and view a CRT Display while communicating in Morse code.

An instructor of, or a student in a course in microcomputers, can use the Z80 STARTER KIT to provide a low-cost method to provide lab experience with a microcomputer. Each student could have his own cassette of the program being developed and would load it into the Z80 STARTER KIT(s) during

the lab session in order to debug it. Timeshare could be used as a supplement to provide experience in Assembly Language Programming, but "hands on" experience at the hardware level is needed to gain a working knowledge of microcomputers. The timeshare charges from one class would be sufficient to equip an entire lab with Z80 STARTER KITS!

The engineer in industry can use the Z80 STARTER KIT as an evaluation tool in order to determine if microcomputers, or the Z80 in particular, can solve the problem. Short programs or benchmarks can be written and debugged using the diagnostic features of the ZBUG Monitor (Single Step, Breakpoints, etc.). The Restart to EPROM feature of the KIT would allow its use as a dedicated computer in a test fixture or process control system. Whenever power was applied, the KIT would begin to run the Control Program in EPROM. The integral Keyboard/Display and the ZBUG Monitor would also be available should debugging be required in the final installation.

1-3 Z80 OVERVIEW

The Z80 component set is a third generation design based on the Intel 8080A. The Z80 has at its base the entire 8080A instruction set with an additional 80 instruction types added (158 total). The Z80-CPU hardware configuration with no multiplexed signals and a simple to generate TTL compatible single phase clock is straightforward and easy to understand. Enhanced features such as Relative Addressing, two 16-bit Index Registers, bit addressing, full Rotates and Shifts, 22 CPU

Registers, 16-bit Arithmetic capability, Block operations, dynamic memory refresh, and 16-bit Op Codes make the Z80 a more flexible and more powerful Microcomputer than any other 8-bit machine available including: 8080A/8085, 6502, or the 6800/6802. It is this computing power that has made the Z80 STARTER KIT possible.

Included in the Z80 STARTER KIT is the MOSTEK Z80 Micro-Reference Manual. This is a summary of the Z80 Instruction Set and will be used in the following discussion. Further information on the Z80 can be found in Section 1-4. The cover shows the Z80-CPU registers as viewed by the programmer. The main register set is exactly the same as those in an 8080A/8085 and are used by the 8080A compatible instructions. The alternate register set is an exact duplicate of the main set and is a unique feature to the Z80. These registers can be used to handle additional variables/flags, or can be used to preserve the status of the Z80-CPU during an interrupt or subroutine. The Special Purpose Registers contain the two 16-bit Index Registers, the I register used to provide the fast Z80 Mode 2 interrupts, the R register used in dynamic memory refresh, the Stack Pointer, and the Program Counter.

Page 1 is a summary of the Z80 Flag (F) Register and how instruction types affect it. Pages 2 and 3 are a summary of the 8-bit load operations. Those blocks shaded are the instruction Op Codes compatible with the 8080A. Unshaded blocks are the new Z80 instructions. The new instructions deal with Indexed loads, as the 8080A has a rather complete 8-bit load

group. Page 3 details each instruction--additional information is provided in the Z80 Programming Manual. The 16-bit loads on pages 4 and 5 show the addition of the load and store of the two Index Registers. BC and DE have additional pointer capability, as they can be loaded directly from memory without having to go through HL. The Exchange group shows the Z80 Block Operations which are complete subroutines implemented in a single Z80 instruction. The Exchange instructions allow the programmer access to the Alternate Registers. Pages 8 and 9 contain the 8-bit arithmetic instructions, most of which are compatible with the 8080A. The indexed operations show up here as new instructions. Pages 10 and 11 contain some miscellaneous instructions. New instructions include the 2's complement (negate) and interrupt mode selection. Mode zero emulates an 8080A, while Mode 2 is used by Z80 Peripherals such as the Z80-PIO and Z80-CTC included in this kit.

The 16-bit arithmetic instructions allow additions with the index registers for pointer address modifications. Two new instructions (ADC and SBC) use the HL register pair as a 16-bit accumulator providing 16-bit arithmetic capability normally found only in minicomputers. Pages 14 and 15 detail all of the new Rotates and Shifts added to the 8080A subset. Note that these instructions can also operate on memory with the HL, IX, and IY registers as pointers much like the 6800. The RLD and RRD instructions allow the packing and unpacking of BCD digits from memory to the accumulator. The Bit Manipulation Group allows the programmer to address any one bit in

memory or the CPU registers. Individual bits can be tested, reset, and set. On pages 18 and 19 the Relative Jump additions, which allow two byte jumps rather than the 8080A three byte jumps are described. The hexadecimal arithmetic capability of the ZBUG Monitor make Relative Jump offsets easy to calculate. The Call and Return group is the same with the addition of two new Return instructions (RETI and RETN). RETI is decoded by the Z80 Peripherals to signal the end of an Interrupt Service Routine and RETN is used to exit Non-Maskable Interrupts. Several new instructions have been added to the Input and Output group on pages 22 and 23. These new instructions allow the use of the C register as a pointer to the port, and data can be transferred from all 8-bit CPU registers to the I/O Port. The Block I/O instructions also use C as the port pointer with HL used as the memory buffer pointer. Page 24 is a summary of the Z80-CPU Interrupt Structure which will be useful when programming an interrupt driven system. Pages 25 and 26 are programming summaries for the Z80-PIO and CTC.

1-4 ADDITIONAL INFORMATION

Additional information on the Z80 hardware and software is available from your local dealer or S.D. Sales. References are given below in two categories:

General information on Microcomputers

- 1) An Introduction to Microcomputers, Volume 0-The Beginner's Book, Osborne and Associates.

If you know nothing about computers, then this is the book for you. It introduces computer logic and terminology in language a beginner can understand. Computer software, hardware, and component parts are described, and simple explanations are given for how they work. The text is supplemented with creative illustrations and numerous photographs. Volume 0 prepares the novice for Volume 1. (300 pages)

- 2) An Introduction to Microcomputers, Volume 1-
Basic Concepts, Osborne and Associates.

This best selling text describes hardware and programming concepts common to all microprocessors. These concepts are explained clearly and thoroughly, beginning at an elementary level.
(350 pages)

More information on the Z80

- 1) Z80-CPU Technical Manual, MOSTEK/Zilog.
- 2) Z80-CTC Technical Manual, MOSTEK/Zilog.
- 3) Z80-PIO Technical Manual, MOSTEK/Zilog.

These manuals completely describe the three Z80 chips that form the heart of the Z80 STARTER KIT.

4) Z80 Programming Manual, MOSTEK/Zilog.

A complete description of how every Z80 instruction operates--the absolute reference when programming the Z80.

5) Z80 Programming for Logic Design, Osborne and Associates.

Describes programming/logic design tradeoffs. Detailed examples to illustrate effective usage of microprocessors in traditional digital applications.

SECTION 2
CONSTRUCTION

2-1 INTRODUCTION

The Z80 STARTER KIT is intended for those people who have had some prior experience with kit building and digital electronics. If you do not fall into this category, it is highly recommended that you find an experienced person to help you in assembly and check out of the board. Appendix I shows the parts list for the Z80 STARTER KIT.

2-2 ASSEMBLY PROCEDURE - Check () when done.

- () 1. Install the nylon legs and metal screws in the holes spread around the board. Use Figure 2-1 to locate holes for the nylon legs. Do not overtighten the screws (finger tight is OK) or be concerned if the metal screws touch a PC etch run - this is normal.

- () 2. Install the IC sockets in their proper locations as follows: (Pin 1 alignment is shown with a ".")
 - () a. Three 8-pin sockets at U4, U5, and U6.
 - () b. Twelve 14-pin sockets at U7, U14, U36, U37, U39, U40, U41, U42, U43, U44, U45, and U46.
 - () c. Eleven 16-pin sockets at U15, U24, U25, U26, U27, U28, U29, U30, U31, U35, and U47.
 - () d. Four 20-pin sockets at U11, U12, U13, and U48.

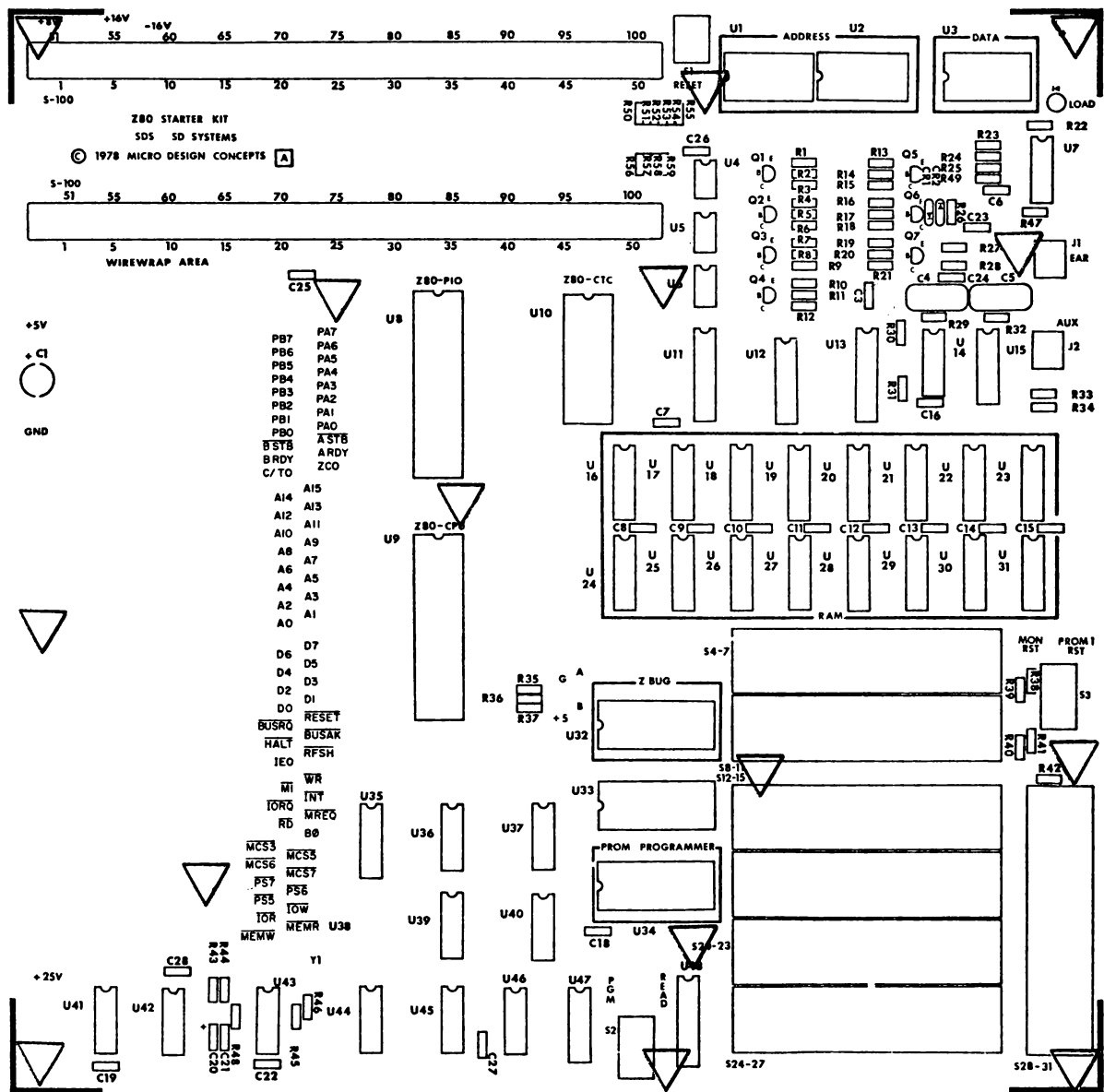

▽ = NYLON LEG LOCATION

FIGURE 2-1 NYLON LEG MOUNTING DIAGRAM

- () e. Three 24-pin sockets at U32, U33, and U34.
 - () f. One 28-pin socket at U10.
 - () g. Two 40-pin sockets at U8 and U9.
 - () h. Three 18-pin sockets at U1, U2, and U3.
- () 3. Install the resistors as follows:
- () a. R3, R6, R9, R12, R15, R18, R21 - 68 Ohm, $\frac{1}{4}$ W, 5%
(Blue, Grey, Black)
 - () b. R22, R46 - 330 Ohm, $\frac{1}{4}$ W, 5% (Orange, Orange,
Brown)
 - () c. R23, R27, R28, R33, R43, R45, R48 - 1K Ohm, $\frac{1}{4}$ W,
5% (Brown, Black, Red)
 - () d. R2, R5, R8, R11, R14, R17, R20 - 4.7K Ohm, $\frac{1}{4}$ W,
5% (Yellow, Violet, Red)
 - () e. R1, R4, R7, R10, R13, R16, R19, R25, R30, R34,
R35, R36, R37, R38, R39, R40, R41, R42, R47, R50,
R51, R52, R53, R54, R55, R56, R57, R58, R59 -
10K Ohm, $\frac{1}{4}$ W, 5% (Brown, Black, Orange)
 - () f. R26, R31, R49 - 100K Ohm, $\frac{1}{4}$ W, 5% (Brown, Black,
Yellow)
 - () g. R24 - 220K Ohm, $\frac{1}{4}$ W, 5% (Red, Red, Yellow)
 - () h. R29, R32 - 470K Ohm, $\frac{1}{4}$ W, 5% (Yellow, Violet,
Yellow)
 - () i. R44 - 47K Ohm, $\frac{1}{4}$ W, 5% (Yellow, Violet, Orange)

- () 4. Install diodes CR1 and CR2 with the banded ends as shown on the PC board.
- () 5. Install the capacitors as follows:
- () a. C1 - 10uF Tantalum (note polarity)
 - () b. C21 - 10pF Mica 2%
 - () c. C4, C5 - 620pF Mica 2%
 - () d. C16 - .0047uF Ceramic 20%
 - () e. C22 - .01uF Ceramic 20%
 - () f. C23 - .047uF Ceramic 20%
 - () g. C2, C3, C6, C7, C8, C9, C10, C11, C12, C13, C14, C15, C18, C19, C24, C25, C26, C27, C28 - .1 Ceramic 20%
 - () h. C20 - 1uF Tantalum 20% (note polarity)
- () 6. Install the three display modules at U1, U2, and U3. Make sure that the decimal point on the display is oriented away from the edge of the PC board.

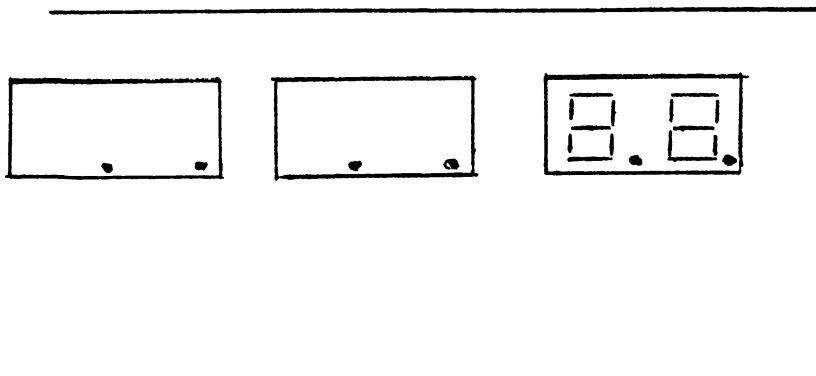

- () 7. Install the LED at DS1 observing the cathode orientation (the flat portion of the LED housing is the cathode).
- () 8. Install transistors Q1, Q2, Q3, Q4, Q5, Q5, and Q7 observing the proper orientation marked on the pc board.

BOARD HOLE PATTERN

E ○
B ○
C ○

TYPE #1

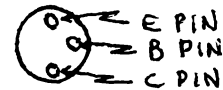

TYPE #2

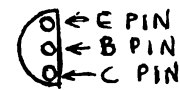

- () 9. Install the Crystal at location Y1.
- () 10. Install the two audio jacks J1 and J2 in $\frac{1}{4}$ in. holes. On J2 connect the TIP to the pad with "A" next to it. Connect the SLV terminal to the "G" pad as shown. On J1 connect the TIP to the pad with "E" next to it and the SLV terminal to the "G" pad.

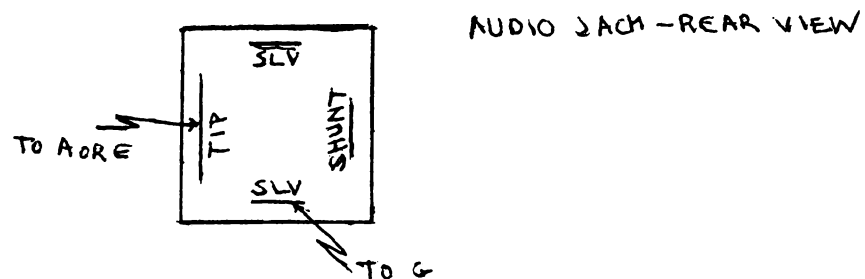

- () 11. Install the Push Button Switch at S1.

- () 12. Install the two Toggle Switches at S2 and S3.
- () 13. Install a switch bank at locations S4-S27 and lock down with the plastic nuts provided. Make sure that the switch bank is securely mounted against the pc board before soldering it in. Make sure that the switch leads are coming straight out of the switch body for easier assembly.
- () 14. Mount the keytops using the layout given in the following sketch:

| | | | | |
|------|------|------|-------|----------------|
| PROM | CASS | CASS | BREAK | |
| PROG | LOAD | DUMP | POINT | |
| MEM | PORT | REG | REG' | |
| EXAM | EXAM | EXAM | EXAM | |
| 7 | 8 | 9 | A | NEXT |
| 4 | 5 | 6 | B | MON |
| 1 | 2 | 3 | C | SINGLE STEP |
| 0 | F | E | D | EXEC |

2-3 VOLTAGE CHECK

- () 1. Connect a +5v^{±5%} power supply capable of supplying at least 1 Ampere to the designated points on the left hand side of the board.
- () 2. Measure the power at socket U35--pin 16 should be +5v with pin 8 being ground. Do not proceed past this point until this voltage reading is correct. Remove the power from the board.
- () 3. Install the IC's in their sockets observing pin 1 designation (small solder spot on PC board).
- | | | |
|--------|---|--------------------|
| () a. | U4, U5, U6 | 75452 |
| () b. | U7 | 339 |
| () c. | U9 | MK3880 Z80-CPU |
| () d. | U10 | MK3882 Z80-CTC |
| () e. | U8 | MK3881 Z80-PIO |
| () f. | U11, U12 | 74LS273 |
| () g. | U13, U48 | 74LS244 |
| () h. | U14 | 14013 |
| () i. | U15 | 14538 |
| () j. | U24, U25, U26, U27, U28, U29, U30, U31 | 21L02 |
| () k. | U32 | 8316/2316 ZBUG ROM |
| () l. | U35, U47 | 74LS138 |
| () m. | U36 | 74LS08 |
| () n. | U37, U44 | 74LS04 |

| | | |
|--------|---------------|--------|
| () o. | U39, U40, U46 | 74LS32 |
| () p. | U41, U42 | 74LS74 |
| () q. | U45 | 74LS02 |
| () r. | U43 | 7404 |

- () 4. Double check all IC's for proper orientation and location.
- () 5. Make sure S3 is in the MONITOR RST position. Apply power to the board ($5v \pm 5\%$) and depress the Reset switch (S1). A "-" should appear on the display indicating the kit is alive and well. If this is the case, read Section 3 concerning the ZBUG Monitor commands.
- () 6. If the prompt "-" does not come up, remove the power and carefully inspect the underside of the board for cold solder joints, unsoldered joints, and solder shorts. Experience has found these problems to be the most likely cause of kit malfunction.
- () 7. If the kit still fails to operate and you do not have the equipment available to diagnose the problem contact your dealer or S.D. Systems for further instructions.

SECTION 3

ZBUG MONITOR DESCRIPTION

3-1 INTRODUCTION

The ZBUG Monitor program is a 2048 byte program written for the Z80 which allows the user to enter and debug machine level Z80 programs. This program is supplied in a mask programmed Read Only Memory (ROM) in the Z80 STARTER KIT. The ZBUG Monitor uses a Hexadecimal keyboard for data entry and a six digit Hexadecimal display for data readout. Also included in ZBUG are Load and Dump programs which allow inexpensive audio cassette recorders to be used for storage of programs. An EPROM Programmer for 2716/2758 EPROMs is included so that user's programs can be placed in these non-volatile memory devices for on-line use at any time. Advanced diagnostic capability such as multiple Breakpoints, Instruction Single Step, and Z80-CPU Register display/modification provides the user with diagnostic capability normally found only in expensive development equipment. The ZBUG Monitor provides the user with a Hexadecimal arithmetic capability which makes the Z80's relative addressing mode easy to use. In summary, the ZBUG Monitor provides the user of the Z80 STARTER KIT with complete control over the execution and debug of the program being developed and provides for non-volatile data or program storage in either EPROM or cassette tape. The use of ZBUG is described in the following paragraphs.

3-2 RESET PUSH BUTTON

The RESET push button near the top center of the Z80 STARTER KIT forces the Z80-CPU to reset and begin program execution at address 0000H. The ZBUG Monitor is located in the lower 2K bytes of the address space so that a RESET of the Z80-CPU will restart to the ZBUG Monitor. The ZBUG Monitor initializes the user's Stack Pointer to 23C0H, initializes RAM variables, and if switch S3 is set to the MONITOR RESTART position the ZBUG Monitor places the prompt symbol "-" on the left hand display and begins scanning the keyboard for an entry. If switch S3 is in the PROM1 RESTART position, the ZBUG Monitor automatically vectors the program execution after reset to PROM1 at address 0800H, providing a means to do a power-up restart to a user's program in PROM1. This feature can be useful if the Z80 STARTER KIT is being used in a dedicated control application and it is desired to always restart to the control program in PROM1. Interrupts are disabled in the Z80-CPU and a Mode 0 interrupt is selected upon reset. Active interrupts in Mode 2 will normally be selected by instructions in a user's program.

3-3 MONITOR

The purpose of the MONitor key is to suspend program execution and to return control to that portion of ZBUG that scans the keys for a new input or command. While RESET will also return control to ZBUG, the MON key preserves the status of the Z80-CPU registers and ZBUG RAM variables. The MON

key is used in one of two basic ways: first it is used to cancel or terminate a previous command or data entry. Depressing of the MON key will terminate a partial or complete data entry or will allow one to exit a command mode such as Port Examine or Memory Examine. Second, the MON key has been designed to produce a Non-Maskable Interrupt to the Z80-CPU whenever it is depressed while the Z80-CPU is executing a user's program. This feature is very useful in trouble shooting; e.g. if the processor has executed a Halt instruction or has gone "out into the weeds" due to a faulty program, the MON key allows the user to return to ZBUG while saving the Z80-CPU registers so that it can be determined where the Z80-CPU was executing at the time the MON key was depressed. Whenever the MON key is depressed the Prompt symbol "-" will be displayed on the left hand display. Make sure this prompt symbol is displayed before a new mode of operation is attempted.

3-4 MEMORY EXAMINE

The MEM EXAM key is used to examine and change memory locations. The first step in using the MEM EXAM key is to enter four Hex digits (0 through F) representing the memory address desired. Enter the address high digit first and it will be registered on the address displays as it is entered. When all four address digits have been entered, press the MEM EXAM key and the data in that memory location will appear on the data displays. If the MEM EXAM key is depressed before

four hex digits have been entered, no data will be displayed and ZBUG will wait for the remaining address digit(s). Depressing the NEXT key will cause the memory address to increment by one and the data display will update corresponding to the new address. At any time there are six digits showing (four address, two data) new data can be entered into that memory address by simply entering two more hex digits. The data display will not update until both digits have been entered because ZBUG first writes data into the memory, then reads it back to the data display. This is done in order to display to the user the actual data taken by memory so that attempts to change ROM or non-existent memory will be noticed by the user. Continual depressing of the MEM EXAM key will re-read and re-display the contents of the address displayed.

3-5 PORT EXAMINE

The PORT EXAM key is used to examine and change port locations. The first step in using the PORT EXAM key is to enter two hex digits (there are 256 port addresses in the Z80 architecture) representing the port address desired. Enter the address high digit first and it will be registered on the address displays as it is entered. When both address digits have been entered, press the PORT EXAM key and the data at that port location will appear on the data displays. If the PORT EXAM key is depressed before two address digits have been entered, no data will be displayed and ZBUG will wait for the remaining address digit. Depressing the NEXT key will cause

the port address to increment by one and the data display will update corresponding to the new address. Any time there are four digits showing (two address, two data), new data can be entered into that port address by simply entering two more hex digits. Depressing the NEXT key will cause the port address to increment by one and the data display will update corresponding to the new address. Continual depressing of the PORT EXAM key will re-read and re-display the contents of the port address displayed. This can be useful with the Z80-CTC because the down counter can be observed counting by using this technique. The Port Examine mode can be aborted at any time by depressing the MON key.

3-6 REGISTER EXAMINE

The following registers can be examined and changed by use of the REG EXAM key: A, B, C, D, E, F, H, L, I, IFF, PC, IX, and IY. The Stack Pointer can be examined with this key but it cannot be changed. Depress the data key corresponding to the register desired followed by the REG EXAM key. The display will show the register selected and its value. The values displayed come from the "User's Register Map" area of RAM and are unloaded from the Z80-CPU whenever a breakpoint is encountered, a single step is commanded, or the MON key is depressed. To change the value shown for a register simply enter two digits of new data (four digits for IX, IY, and PC). IFF is the state of the Interrupt Flip Flop inside the Z80-CPU (a value of 00 means that interrupts are disabled and a

value of 04 means that interrupts are enabled). This mode of operation can be aborted at any time by depressing the MON key. Whenever an execution or a single step is commanded, the Z80-CPU registers will be initialized with the values from the "User's Register Map", allowing the user to modify registers before execution begins.

3-7 ALTERNATE REGISTER EXAMINE

The following registers can be examined and changed by the use of the ALT REG EXAM key: A', B', C', D', E', F', H', and L'. The prime mark is another designation for the alternate register set. Depress the data key corresponding to the register desired followed by the REG EXAM' key. The display will show the register selected and its value. The values displayed come from the "User's Register Map" area of RAM and are unloaded from the Z80-CPU whenever a breakpoint is encountered, a single step is commanded, or the MON key is depressed. to change the value shown for a register simply enter two digits of new data. This mode of operation can be aborted at any time by depressing the MON key. Whenever an execution or a single step is commanded, the Z80-CPU registers will be initialized with the values from the "User's Register Map" allowing the user to modify registers before execution begins.

3-8 BREAKPOINTS

The ZBUG Monitor has the capability to set up to five breakpoints in any user's program that is executing out of

RAM. The method of breakpointing is to exchange the user's Op Code with a RST8 (CFH) and to preserve the user's Op Code in a table of breakpoint addresses and Op Codes (BPTAB). Whenever a breakpoint is set it is entered into the table and then a RST8 inserted into the user's code just before execution of the user's code. Upon encountering a breakpoint, control is returned to ZBUG through the RST8 and all Z80-CPU registers are preserved in the "User's Register Map". All RST8 instructions are removed and replaced by the user's Op Codes which have been saved in BPTAB. This is done so that whenever control is transferred to ZBUG, all user code is intact and can be examined and modified by the MEM EXAM command. Breakpoints are set by entering the four digit address of the Op Code at which the breakpoint is desired, followed by the BREAKPOINT key. When setting a breakpoint at a two byte Op Code, the address of the first byte of the Op Code must be used as the breakpoint address. The display will show the address entered after the BREAKPOINT key is released to indicate that the breakpoint has been accepted. To enter another breakpoint press the MON key to get the prompt sign, followed by a new four digit address and then the BREAKPOINT key. Should an attempt be made to enter more than five breakpoints, ZBUG will notify the user by not displaying the address after the BREAKPOINT key is released and instead will display the prompt sign. The five breakpoints already entered are left intact.

Breakpoints can be canceled at any time in one of three ways: First, if the breakpoint key is depressed before four

address digits have been entered, all breakpoints will be canceled or removed. Thus, when the prompt sign is being displayed, depressing the BREAKPOINT key will clear all previous entries. Second, use of the SINGLE STEP key will cancel or remove all existing breakpoints. Third, depressing the RESET push button will cancel or remove all breakpoints. Use of the MON key has no effect on breakpoints with the following exception: The only way the ZBUG Monitor will restore the user's Op Codes is if it is entered through the RST8 instruction. Should the MON key be used to abort execution of the user's code (because the user's code has a HALT instruction, it is hung in a loop, or just "out in the weeds") the RST8 breakpoint instructions will be left imbedded in the user's code. The addresses of the breakpoints can be determined by examining the BPTAB table (23E4H) - the format of this table is first breakpoint address high byte, first address low byte, first Op Code, second address high byte, etc. The number of breakpoints currently active is contained in BFLG (23F4H).

3-9 SINGLE STEP

The SINGLE STEP command key provides the user with the capability to execute the program under development one instruction at a time - returning to the ZBUG Monitor after each instruction for examination of registers, memory, ports, etc. Single step can be used on programs in RAM, ROM, or EPROM because no modification of user's code is required. One channel of the Z80-CTC is used to produce a pulse on the Non-Maskable

interrupt input to the Z80-CPU at the beginning of the first instruction, thereby returning the Z80-CPU to the ZBUG Monitor, As with breakpoints, all Z80-CPU registers are preserved in the "User's Register Map" after the one instruction has been executed.

The instruction that will be executed is the one pointed to by the PC in the "User's Register Map" and can be examined or changed by using the Register Examine Mode. Depressing the SINGLE STEP key will re-load all Z80-CPU registers from the "User's Register Map" and execute one instruction. The Z80-CPU will return to the ZBUG Monitor through 66H (NMI address) and ZBUG will save all Z80-CPU registers in the "User's Register Map" portion of memory. The address of the next instruction to be executed is displayed in the Address displays and the current state of the Accumulator is displayed in the Data displays. By repeatedly depressing the SINGLE STEP key, the user can step through the program under development, viewing the address of the next instruction to be executed (very useful for conditional Jumps and Calls) and the current contents of the Accumulator. Other registers can be examined or changed by depressing the MON key, followed by the appropriate Register Examine keys. Use of the SINGLE STEP key will cancel or remove any breakpoints inserted to date.

3-10 EXECUTE

The EXECute key allows the user to command the Z80-CPU to begin execution of a user's program in either RAM, ROM,

or EPROM. Two modes of operation are provided: Proceed from the current address, or Execute from the address entered and shown on the display. The Proceed mode uses the Program Counter saved in the "User's Register Map" as the beginning point of execution. To use this mode simply depress the EXEC key and execution will begin at the address displayed by the PC key in the Register Examine mode. This mode is very useful to resume execution (Proceed) after hitting a Breakpoint or after using the Single Step mode. To execute from the beginning of a program, enter the four digits of the desired starting address followed by the EXEC key. Once execution has been started, control will remain in the user's program until a breakpoint is hit or until the MON abort key is used.

3-11 CASSETTE DUMP

This mode of operation is used to save volatile programs or information in the RAM on inexpensive cassette tape using the Kansas City Standard recording technique. Experience has shown that this mode can be used with most recorders and audio cassette tape on the market. Should you be buying an audio recorder to use with this mode, a Panasonic Model No. RQ-309DS is recommended. Radio Shack Realistic C-30 cassettes (Cat. No. 44-601A) can be used for inexpensive cassette tapes. Connect the recorder to the Z80 STARTER KIT using an audio patch cord (also available at Radio Shack) connecting the "AUX" connector on the Z80 STARTER KIT to the "AUXILIARY" or "MIC" input of the tape recorder. Once the data to be saved is in RAM, set

up memory locations 23C0H-23C3H with the starting and ending address of the memory locations to be saved using the following procedure:

- 1) Place tape to be recorded into tape recorder and rewind fully.
- 2) Using the Memory Examine mode, enter the starting address of the memory locations to be saved into 23C0H and 23C1H (high byte into 23C0H and low byte into 23C1H).
- 3) Using the Memory Examine mode, enter the address of the last RAM location to be saved into 23C2H and 23C3H (high byte to 23C2H and low byte to 23C3H).
- 4) Make sure the prompt symbol is being displayed and depress the CASS DUMP key, followed by turning the recorder on in the record mode. The prompt will disappear.
- 5) No volume adjustments are required as this is handled by the AGC of the recorder. When the Dump is completed, the prompt sign will reappear, indicating that the Dump is complete and that the recorder can be shut off. At least 30 seconds will be required for a Dump - see the following for more details on the recording format.

The format used to record data on the cassette tape adheres to two standards: the Kansas City Standard for recording "1's" and "0's" and the Intel Hex Format for recording

blocks of data - both of these standards will be explained in the following paragraphs.

The Kansas City Standard was formulated on November 7 and 8 of 1975 at a symposium held in Kansas City, Mo. by BYTE Magazine. The purpose of this symposium was to standardize audio cassette recording techniques among the manufacturers of equipment being sold into the hobby market. The following list is a summary of the Kansas City Standard (to which the Z80 STARTER KIT adheres):

- 1) A mark (logical one) bit consists of eight cycles at a frequency of 2400Hz.
- 2) A space (logical zero) bit consists of four cycles at a frequency of 1200Hz.
- 3) A recorded character consists of a space as a start bit, seven or eight data bits, and two or more as stop bits. (The Z80 STARTER KIT uses a seven bit ASCII data character and one stop bit.)
- 4) The seven ASCII data bits are organized least significant bit first, most significant bit last.
- 5) There will be at least a 30 second leader and a 5 second trailer on all data blocks.
- 6) Data rate is 300 baud (3.33 mSec bit width).
- 7) The contents of a data block are not specified.

*LOW - STARTER KIT - SPACE
HIGH - STOP - KIT*

Because the Kansas City Standard does not specify the contents of the data blocks recorded, another standard - the Intel Hex Format - has been selected to define the organization

of the data blocks. The following is a summary of the Intel Hex Format:

1) Each record within a block of data starts with a colon(:) and ends with a carriage return and line feed.

2) All information is in ASCII (seven bits no parity).

3) Data Record Format

| | |
|------------------|--|
| Byte 1 | Colon(:) delimiter |
| 2-3 | Number of binary bytes in this record. The maximum is 16 binary bytes (32 ASCII bytes). |
| 4-5 | Most significant byte of the start address of the data. |
| 6-7 | Least significant byte of the start address of the data. |
| 8-9 | ASCII zeros |
| 10- | Data bytes in ASCII |
| Last two bytes - | Checksum of all bytes except the delimiter, carriage return, and line feed. The checksum is the negative of the binary sum of all bytes in the record. |

Carriage return, Line feed

4) End-of-file Record

| | |
|--------|--------------------|
| Byte 1 | Colon(:) delimiter |
| 2-3 | ASCII zeros |
| 4-5 | ASCII zeros |

- 6-7 ASCII zeros
- 8-9 Record type 01 (ASCII 0, ASCII 1)
- 10-11 Checksum

3-12 CASSETTE LOAD

This mode of operation is used to load programs or information from cassette tape to RAM using the Kansas City Standard as the recording technique on the tape. To load a tape simply follow these steps:

- 1) Connect the recorder to the Z80 STARTER KIT using an audio patch cord to connect "MONITOR OUT" or "EARPHONE" to the connector marked "EAR" on the Z80 STARTER KIT.
- 2) Turn the recorder's tone control to maximum treble and minimum bass. Rewind the tape.
- 3) Turn the recorder's volume control to minimum volume.
- 4) Make sure the prompt is showing and depress the CASS LOAD key - the prompt will disappear.
- 5) Increase the volume until the LOAD LED just lights and then increase the volume control about 20% more. The LED should stay lit during the load.
- 6) If the load is successful (i.e. all checksums have been verified) ZBUG will respond with the prompt symbol and the recorder can be shut off.
- 7) If a checksum error is detected during loading, the address of the next block of data will be shown on the display. All data up to the previous block of

data had been loaded successfully. Try to load the tape again and verify the volume and tone control settings.

- 8) The LOAD LED can be used to index into several records on the same cassette, as it will light when data is present on the tape and go off during inter-record gaps. This feature will allow the user to put several programs on the same cassette tape.

3-13 EPROM PROGRAMMER

The EPROM Programmer moves data from RAM at address 2000H to a 2716/2758 five volt only EPROM in socket PROM2 (address 1000H). To program an EPROM requires an auxiliary power supply of +25±1 volts capable of supplying at least 30mA of current. This power supply should be connected to the Z80 STARTER KIT at the designated spot on the left hand edge of the board. The EPROM to be programmed should be erased and then placed in socket PROM2 with the power turned off. Turn on both the +5v and +25v supplies and then load the desired data into RAM using the Memory Examine mode or the Cassette Load mode. Make sure a prompt character is being displayed. If it is not, depress the MON key. Enter a four digit hex number (high digit first) representing the number of bytes to be transferred from RAM to PROM1. Place switch S2 in the PGM position and depress the PROM PROG key, which will cause the display to go dark. After programming, ZBUG will respond with one of two indications. The first and most likely indication

is the return of the prompt character which indicates that the EPROM has been programmed and verified to be exactly like RAM. The second indication possible is a four digit address of the first location in EPROM that doesn't agree with RAM and the data in EPROM at that address. By pressing the NEXT key, ZBUG will continue checking the EPROM against RAM and will display the next EPROM address where the data doesn't match. This error indication is caused by an attempt to program an un-erased EPROM or an attempt to program a faulty EPROM. Return switch S2 to the READ position after programming is completed.

The EPROM programmer inserts Wait states of 52.5 mSec in duration (timing pulses generated by the Z80-CTC) and will suspend the Z80-CPU's refresh of dynamic memories during EPROM programming. This has no effect on the Z80 STARTER KIT but is mentioned should the user be experimenting with dynamic memories.

The top 110 bytes of RAM are used for system RAM (see Memory Map discussion - Section 3-18) and cannot be used to hold data to be transferred to the EPROM Programmer. Should an advanced user desire to remove this restriction, a new EPROM Programmer routine could be written based on ZBUG routine CCS12 (see listing in Appendix) and placed into EPROM in the PROM1 socket. By this means an advanced user of the Z80 STARTER KIT could modify the EPROM Programmer to move data from anywhere in RAM to EPROM in the PROM2 socket. The availability of an EPROM Programmer and inexpensive five volt only EPROMs

allows an advanced user the capability to easily expand and enhance ZBUG to suit a particular need. (See example 5-6.)

3-14 NEXT KEY

The NEXT key is used in conjunction with three modes of operation: Memory Examine, Port Examine, and next EPROM Programmer error. In the Memory and Port Examine modes the NEXT key selects the next sequential memory or port location and automatically displays its contents. If there should be errors during the programming of an EPROM, the NEXT key can be used to step through the errors. (An error is where the contents of EPROM are different from the RAM locations providing the data - 2000H and above.) Errors during EPROM Programming are caused by an attempt to program an EPROM which hasn't been erased or by an attempt to program a defective EPROM.

3-15 RELATIVE OFFSET CALCULATION

One of the enhanced features of the Z80 Microprocessor is the Relative Addressing Mode. In this mode the next address is determined by the addition of a two's complement offset to the current address. The Relative Jumps (JR) use this addressing mode with a one byte Op Code followed by the two's complement offset. When programming at the machine level (no Assembler is used), the calculation of this offset requires the user to do addition and subtraction in hexadecimal, which can be error prone. In order to make the Relative Addressing Mode easy to use (as it should be), an automatic

offset calculation routine has been included in the ZBUG Monitor. This routine will automatically calculate the correct offset for Relative Addressing and place it in the proper location in RAM.

DE

To use this feature of ZBUG proceed as follows: First, using the Register Examine mode, initialize HL to the address of the Op Code at the destination of the Relative Jump (high byte to H). Second; set DE to the address of the Relative Op Code (high byte to D). Third, execute the Relative Offset routine at address 00C0H using the ZBUG's Execute command. Note the similarity between this address and the initial value of the Stack Pointer (23C0H); this was done to make both addresses easier to remember. This display will contain the offset that was calculated and placed into RAM in the low byte of the Address display and either 00 or FF in the high byte of the Address display. Should any other value appear in the high byte of the Address display, it is an indication that the Relative Offset was outside the Z80's legal range and therefore invalid.

3-16 RST INSTRUCTIONS

The Z80 instruction set has eight restart instruction addresses and an NMI vector address. The hardware reset address (0000H) is used as the entry point into ZBUG so that on power-up the Z80 automatically starts executing ZBUG. The NMI vector address (0066H) is used by the MON key's Abort function and provides a method to always gain control of the Z80

from the keyboard. One restart address (0008H) is used to provide the breakpoint capability and as such cannot be used. The other six restart instruction addresses (RST16, RST24, RST32, RST40, RST48, and RST56) are available for use. These one byte instructions, when executed, save the program counter on the stack and then vector to one of the following addresses: 0010H, 0018H, 0020H, 0028H, 0030H, 0038H - same order as above. Since these address locations are in the ZBUG Monitor ROM, jumps have been placed in ZBUG to jump to specific locations in RAM where the user can place another Jump to anywhere desired. The following table is a summary of the mapping to RAM of the free Restart instructions:

| Instruction | Op Code | ZBUG ROM Address | RAM address |
|-------------|---------|------------------|-------------|
| RST 0 | C7H | 0000H | --- |
| RST 8 | CFH | 0008H | --- |
| RST 16 | D7H | 0010H | 23C4H |
| RST 24 | DFH | 0018H | 23C7H |
| RST 32 | E7H | 0020H | 23CAH |
| RST 40 | EFH | 0028H | 23CDH |
| RST 48 | F7H | 0030H | 23DOH |
| RST 56 | FFH | 0038H | 23D3H |

For example, if an RST 32 (E7H) instruction is used in a program, the Z80-CPU will first save the Program Counter and then go to address 0020H. This address is in the ZBUG Monitor ROM and contains a Jump instruction to RAM location 23CAH. The

user may place any one to three byte instruction desired at this location, however, a three byte Jump would probably be used in most cases.

3-17 CTC CHANNEL ZERO INTERRUPTS

Within a user program both the Z80-PIO and Z80-CTC interrupt vectors can be set up as desired. However, should it be desired to use Channel zero of the CTC while the ZBUG Monitor is using the other three channels (Channel 1 is used for Cassette Dump timing, Channel 2 is used for EPROM Programmer timing, and Channel 3 is used for Cassette Load timing) the following provisions have been made. Since the four CTC Channel vectors are related (see Z80-CTC Technical Manual for further details) a provision has been made in ZBUG to map the Channel 0 interrupt into RAM where a Jump to the actual service routine can be placed. When setup by ZBUG, the CTC's Channel 0 will first go to a look up table at address 07F8H where 23D6H has been placed. 23D6H would be the address of the first instruction to be executed after Channel 0 interrupts and is in RAM so that the user can place a jump at this address to the interrupt service routine.

3-18 MEMORY MAP - RAM USAGE

The ZBUG Monitor resides in the bottom 2K of memory (addresses 0000-07FFH) and uses the top 110 bytes of RAM. The memory map of the Z80 STARTER KIT is shipped is defined by the following:

| | |
|---------|-----------------------|
| 2800H ↑ | UNUSED |
| <hr/> | |
| 27FFH | OPTIONAL RAM |
| 2400H | 1K BYTES U16-U23 |
| <hr/> | |
| →23FFH | ZBUG SCRATCH RAM |
| <hr/> | |
| AND | |
| 23C1H | BREAKPOINT TABLES |
| <hr/> | |
| 23C0H | USER'S REGISTER MAP |
| 23A9H | |
| <hr/> | |
| 23A8H | ZBUG STACK |
| 2390H | WORKING AREA |
| <hr/> | |
| 238FH | RAM AVAILABLE TO USER |
| 2000H | |
| <hr/> | |
| 1FFFH | UNUSED |
| 1800H | |
| <hr/> | |
| 17FFH | PROM PROGRAMMER |
| 1000H | PROM2 SOCKET (U34) |
| <hr/> | |
| 0FFFH | PROM1 SOCKET (U33) |
| 0800H | |
| <hr/> | |
| 07FFH | ZBUG MONITOR |
| 0000H | |
| <hr/> | |

The two EPROM sockets reside just above the ZBUG ROM at 0800H and 1000H. In addition, the EPROM socket at address 1000H has the capability of programming EPROMs. The standard RAM memory begins at 2000H and is available to the user up to 2390H. RAM above this value is used by the ZBUG Monitor. From address 2390H to 23A8H is the ZBUG stack working area

where return addresses of subroutine calls and interrupts are saved as ZBUG is executed by the Z80-CPU. The User's Register Map resides from address 23A8H to 23C0H. Whenever control is switched to the ZBUG Monitor, the state of the Z80-CPU is saved in this area. The registers can be examined and changed by using the REG EXAM and REG EXAM' keys. Whenever execution is transferred from ZBUG to a user's program, register values from this map are loaded into the CPU. From 23C0H to 23FFH are scratch RAM Variables and a breakpoint table containing the addresses and Op Codes of active breakpoints.

3-19 ZBUG COMMAND SUMMARY

DUMP - Punch to audio cassette in Kansas City Standard Format. Memory block starting address at 23C0H and 23C1H, ending address at 23C2H and 23C3H.

LOAD - Load Kansas City Standard formatted audio cassette tape to memory.

REGISTER DISPLAY - Press key for desired register and then either REG EXAM or REG EXAM' for display of that register on the hex display. Change the register by entering new data.

MEMORY EXAMINE - Press keys for desired memory address (four digits required) and then the MEM EXAM key. The memory data will be displayed in the right hand two digits of the display. By entering two new digits, the memory location may be changed.

PORT EXAMINE - Enter a two digit port number followed by the

PORT EXAM key to display the port data in the right hand two digits of the display. By entering two new digits, the data at that port address will be changed.

BREAKPOINT - Enter a four digit address where the breakpoint is desired, followed by the BREAKPOINT key. Up to five breakpoints are allowed; if the address remains on the display after the BREAKPOINT key is pressed, then the breakpoint was installed. If the breakpoint was not installed, the display address will clear after the BREAKPOINT key is pressed. Clear all breakpoints by pressing BREAKPOINT key with no digit entry or by using single step.

SINGLE STEP - Initialize the Program Counter with a four digit address and press the SINGLE STEP key. The instruction at that address will be executed (after the CPU registers are restored for the register map) and the program counter plus the accumulator will be returned in the display. If no address is entered before the SINGLE STEP key is pressed, the instruction pointed to by the program counter in the register map will be executed. Repeated pressing of the SINGLE STEP key will single step down a user's program.

MONITOR - Pressing this key will force a restart of the ZBUG Monitor through an NMI interrupt and save all CPU registers. This is useful for getting the processor "out of the weeds".

EXECUTE - Entering a four digit address followed by the EXEC

key will cause the registers in the register map to be loaded into the CPU. The CPU will start executing the user's program at the entered address. If no address is entered, the CPU will start execution at the address pointed to be the program counter in the register map.

PROGRAM - Enter a four digit hex number to indicate the number of bytes of memory to be moved from RAM (starting at address 2000H) to EPROM (starting at address 1000H). Pressing the PROM PROG key will initiate the transfer. 2716 or 2758 type EPROMs can be programmed.

NEXT - Opens next memory or port location for examination or change.

HEX ARITHMETIC - A hexadecimal arithmetic routine allows easy calculation of the relative offset required for relative jump instructions. Load HL with the address of the Op Code at the destination of the relative jump. Load DE with the address of the relative Op Code. Execute hex arithmetic routine at 00C0H and the hex result will appear in the display.

3-20 SUBROUTINES CALLABLE IN ZBUG

Several general purpose subroutines were written to be used by the different functions of ZBUG. These programs are in the UTILITY section of the ZBUG listing in the Appendix. Several of these subroutines are listed below; an advanced user of the Z80 STARTER KIT can use these subroutines to simplify his programming task. For the inexperienced user, these

subroutines provide programming examples which can be analyzed to learn Z80 programming.

- 1) U1X3 - Calling address is 0634H. This program adds three to the Index Register (IX) and decrements the B register. Registers affected are IX, B, and F.
- 2) UFOR1 - Calling address is 063CH. IX points at two locations in memory and A contains two Hex digits to be written into memory (high nibble to (IX), low nibble to (IX+1)). Registers affected are A, B, and F.
- 3) D20MS - Calling address is 064FH. This subroutine delays 20 mSec before returning to the caller. Registers affected are H, L, and F.
- 4) UABIN - Calling address is 06B3H. Converts one ASCII character to its equivalent binary value. Registers used: A and F. ASCII character is in A upon calling and binary equivalent is also in A upon return.
- 5) UBASC - Calling address is 06BBH. Converts one binary character in Accumulator to its equivalent ASCII character in the Accumulator. Registers used are A and F.

SECTION 4

HARDWARE DESCRIPTION

4-1 GENERAL

Figure 4-1 is a block diagram of the Z80 STARTER KIT. Refer to this diagram and the schematic diagram in Appendix I during the following discussion.

4-2 CLOCK CIRCUITRY

The clock circuitry is set to run the Z80-CPU at slightly below 2 MHz for a 500 nSec T State. This was done to insure maximum compatibility with 8080A peripherals and to allow the use of inexpensive memories. The clock source is a crystal oscillator based on a 74LS04 (U43) running at 3.9936 MHz. This frequency was chosen because it is a multiple of both 1200/2400 Hz and the 300 Baud frequencies required for the Kansas City Standard audio cassette interface. This frequency is divided by two by U41 to form the 1.9968 MHz CPU clock. A 74LS04 gate with a 330 ohm pull-up resistor is used to drive the $\bar{\Phi}$ inputs of all three Z80 devices.

4-3 Z80-CPU

The Z80-CPU is the "brains" behind the Z80 STARTER KIT and provides the major control signals to scan the display and keyboard as well as reading and writing memory. The Z80-CPU generates a 16-bit address bus, an 8-bit bi-directional data bus, and 8 control signals. These signals are all routed

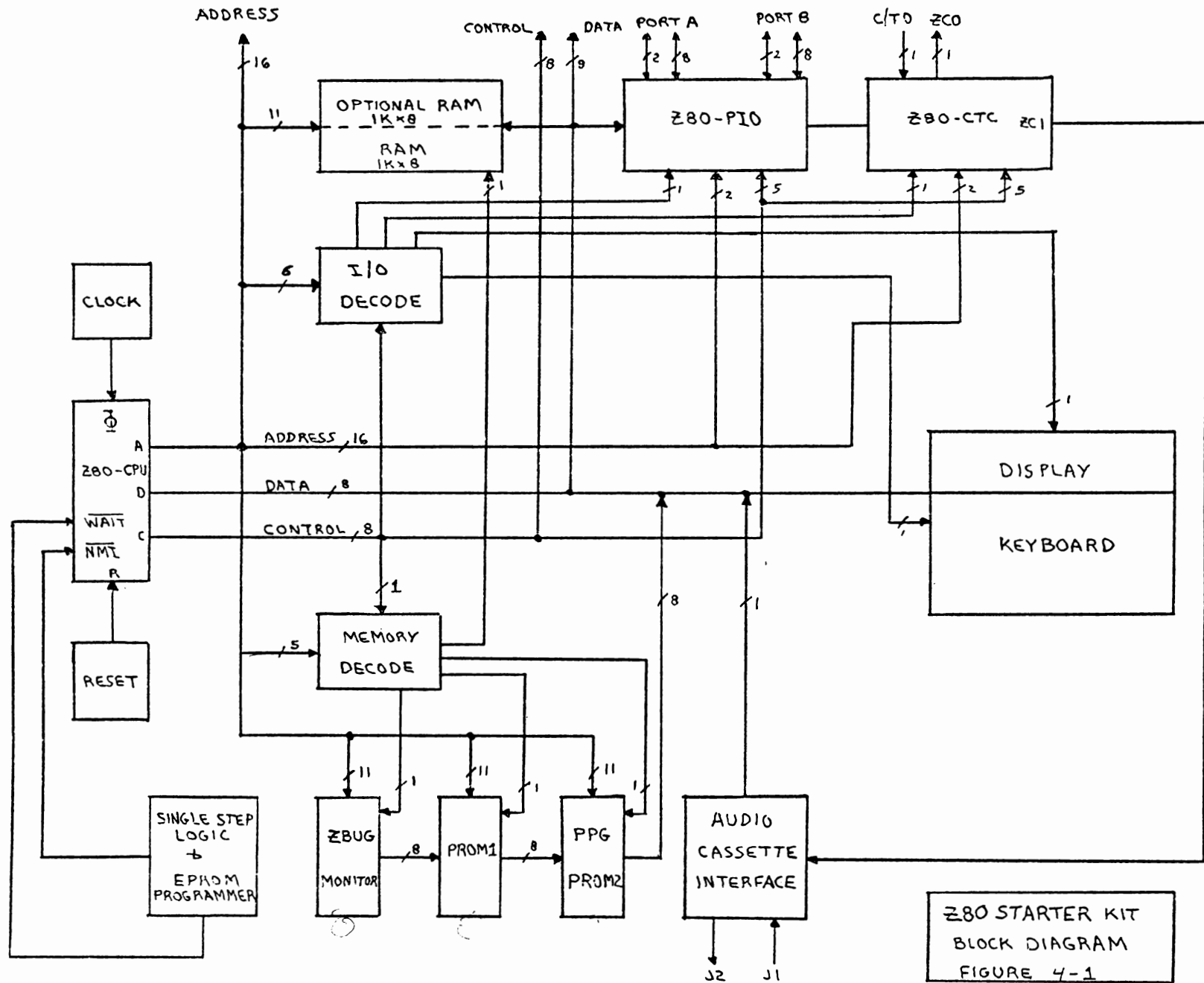

4-1A

Z80 STARTER KIT
BLOCK DIAGRAM
FIGURE 4-1

to the wire wrap area and marked so that it will be easy for experimenters to add circuitry to the CPU bus. More information on this device can be found in the MOSTEK or Zilog Z80-CPU Technical Manual.

4-4 Z80-PIO

The Z80-PIO is a generalized parallel interface for the Z80 family. It supports fully interrupt driven software with two sets of handshake lines and an integral interrupt controller. Two 8-bit ports plus handshake lines are available on the PIO for interfacing parallel devices. These lines are brought to the wire wrap area for connection to custom circuitry. More information on the PIO can be found in the MOSTEK or Zilog Z80-PIO Technical Manual.

4-5 Z80-CTC

The Z80-CTC is a device which contains four independent 16-bit counters which may be used to divide down the Φ clock, or as an event counter. The ZBUG Monitor heavily uses the CTC to implement Z80 STARTER KIT functions. CTC Ch. 0 is unused by ZBUG and is always available to the user. During ZBUG routines other CTC channels are used as follows:

CTC Ch. 1 Audio Cassette during Dump

CTC Ch. 2 Single Step and EPROM Programmer

CTC Ch. 3 Audio Cassette during Load

See Section 3-17 for a description of how to use CTC Ch. 0 while ZBUG is using the other channels. Whenever one of the

Channel counters counts through zero, a pulse is produced on the Zero Count Output line (ZCO). An input to each channel is the Clock/Trigger (C/T0) which can be used to initiate timing or as an external clock. Both of these signals for Channel 0 are brought to the wire wrap area. More information on the CTC can be found in the MOSTEK or Zilog Z80-CTC Technical Manual.

4-6 KEYBOARD AND DISPLAY

The Hexidecimal display is scanned by the Z80-CPU under control of ZBUG. Data for the display is written to U12 (port address 88H), while the active display is selected by U11 (port address 8CH). Each display is left on for about 1 mSec and then new data is supplied to U12 and the next digit selected by U11. Q1-Q7 provide high current drive capability while U4, U5, and U6 provide high current sinking capability for digit selection. While U11 is scanning the display, it also scans the keyboard. U13 (port address 90H) is the keyboard input to the Z80-CPU data bus. As U11 scans the keyboard, data is input from U13 to determine if a key is closed. S3 (MONITOR/PROM1 RESTART) is sampled by U13 during the Monitor Reset sequence to determine if program execution should be directed to PROM1 or ZBUG.

4-7 AUDIO CASSETTE INTERFACE

The Z80 STARTER KIT has a Kansas City Standard audio cassette interface. The data rate is 300 Baud and a "1" is

represented by a 2400Hz tone while a "0" is represented by a 1200Hz tone. There is a 30 second leader and a 5 second trailer of "1"'s on all records.

During a Load from an audio cassette tape player, the data from the player's Earphone jack is connected to J1. U7 is a combination limiting and squaring circuit to provide a non-distorted square wave to U15. Data amplitude from the player must be about 2 volts peak to peak and part of U7 is an LED driver to indicate when correct amplitude data is being received by U15. One-half of U15 and U14 form a frequency detector to discriminate between 1200Hz ("0") and 2400Hz ("1"). Pin 12 of U14 contains the demodulated data stream (similar to Asynchronous data used in data communications) and is gated onto the Z80-CPU bus by U13. The Z80-CPU and Z80-CTC under control of ZBUG become a software UART to receive this serial Asynchronous data and form parallel words which are then written to memory.

During a Dump of data from RAM to the audio cassette recorder, the CTC Channel 1 is set to generate either a 4800Hz pulse train ("1") on CTC-ZC1 or a 2400Hz pulse train ("0"). These two pulse trains are divided in half to form the proper square wave frequencies by one-half of U14. R31 and C16 filter out the high frequency components of this square wave to prevent distortion of the data by the tape recorder. J2 is normally connected to the C16 side of R34 and then to the Auxillary Input of the recorder. The crystal frequency of the system clock oscillator has been selected to be a multiple of

1200Hz (and 2400Hz) so that the CTC can generate these frequencies by simply dividing down the system clock (Φ).

4-8 EPROM PROGRAMMER

In order to program 2758/2716 5 volt only EPROMs, correct address and data is applied to the EPROM, the Vpp pin is placed at +25 VDC, $\overline{CS} = 1$, and PD/PGM is pulsed high for 50-55 mSec. This is repeated for any address that is to be programmed. (Note: Texas Instruments has a three voltage 2Kx8 EPROM, also called the 2716, which will not work with this kit - the EPROMs must be 5 volt only.)

The technique used in the Z80 STARTER KIT to provide the necessary programming signals is described in the following: A Z80-CPU block move instruction (LDI) is used to move the data from locations in RAM to the EPROM Programming Socket (1000-17FFH). The Z80-CTC Channel 2 is set up to time out every 26 mSec. U42 and one-half of U41 form a synchronous counter clocked by the ZC2 output to time two outputs or 52 mSec. One-fourth of U45 decodes states of this counter to produce the 52 mSec positive pulse required by the EPROMs. This output is also inverted and applied to the \overline{WAIT} input of the Z80-CPU to force the CPU to hold valid data and addresses during this 52 mSec pulse. The sequence of events to program one location is the following:

- 1) Synchronous counter enabled by PGM PULSE ENABLE being set to a "1".
- 2) CTC Channel 2 is set to time out after 26 mSec delay.

- 3) LDI instruction starts to write into address space decoded by PROM2 (1000-17FFH) causing $\overline{\text{PROM2 SEL}}$ to go low. Address and data are now valid on the PROM2 socket.
- 4) $\overline{\text{PROM2 SEL}}$ going low clocks one-half of U42 which makes PROM2 $\overline{\text{CS}}$ go high, PD/PGM goes high and Z80-CPU $\overline{\text{WAIT}}$ goes low.
- 5) Z80-CPU stays suspended in wait state until ZC2 times out twice (52 mSec), causing the timing chain to advance setting PD/PGM low and $\overline{\text{WAIT}}$ high, thereby releasing the Z80-CPU from the wait state. PGM PULSE ENABLE is set low, resetting the timing chain.

Note that when using the EPROM Programmer the Z80-CPU suspends memory refresh during this 52 mSec period, which may affect any dynamic memory circuitry being used with the KIT. The 21L02 memory used on the KIT is static, so this method of implementing the EPROM Programmer does not cause a problem.

Both 2758 and 2716 EPROMs can be programmed without any hardware modifications subject to the restrictions discussed in 3-13. This is because the 2758s available at the writing of this manual specify that A10 should be low (i.e. they were the lower half of a 2716 2Kx8 EPROM). Should 2758s be available with A10 specified as a "1", a jumper provision has been provided to allow strapping the A10 pin of sockets PROM2 (U34) and PROM1 (U33) either high, low, or to A10 of the Z80-CPU. (See schematic.) As shipped, the KIT has the CPU's A10 wired

to U33 and U34 so that 2716s will work. 2758s will also work in this configuration if they require A10 tied low.

4-9 MEMORY DECODING

Memory decoding is done by U35, which is a 74LS138 1 of 8 decoder. The lower 16K bytes (0000H-3FFFH) of the Z80's address space is fully decoded into 2K byte blocks. The following tables specify this memory decoding.

| <u>Chip Select</u> | <u>Memory Address Space</u> | <u>Connected to</u> |
|--------------------|-----------------------------|---------------------|
| $\overline{CS0}$ | 0000H-07FFH | ZBUG MONITOR |
| $\overline{CS1}$ | 0800H-0FFFH | PROM1 |
| $\overline{CS2}$ | 1000H-17FFH | PPG-PROM2 |
| $\overline{CS3}$ | 1800H-1FFFH | UNUSED |
| $\overline{CS4}$ | 2000H-27FFH | RAM |
| $\overline{CS5}$ | 2800H-2FFFH | UNUSED |
| $\overline{CS6}$ | 3000H-37FFH | UNUSED |
| $\overline{CS7}$ | 3800H-3FFFH | UNUSED |

All outputs of the decoder are connected through a 16-pin hole pattern (U38) compatible with a 16-pin socket and header allowing the user to easily modify addressing. Connections to U38 are as follows:

| | | |
|------------------|------------------------------------|-------------------------------------|
| $\overline{CS0}$ | $\underline{9}$ ○ $\underline{8}$ | $\overline{MON SEL}$ (ZBUG MONITOR) |
| $\overline{CS1}$ | $\underline{10}$ ○ $\underline{7}$ | $\overline{PROM1 SEL}$ (PROM1-U33) |
| $\overline{CS2}$ | $\underline{11}$ ○ $\underline{6}$ | $\overline{PROM2 SEL}$ (PROM2-U34) |

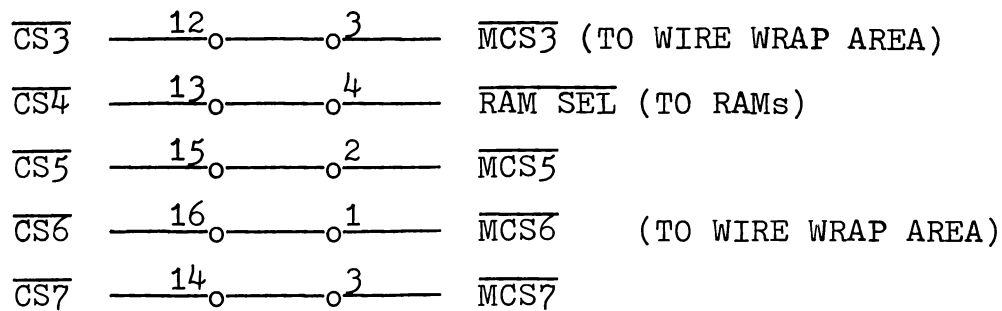

16-pin hole pattern-jumpers in pc etch

By cutting the etch on the pc board and installing a 16-pin socket and header at U38, memory addressing can be modified; however, if changes to $\overline{MON SEL}$, $\overline{PROM2 SEL}$, or $\overline{RAM SEL}$ are made, then the ZBUG Monitor will not function correctly. $\overline{MCS3}$, $\overline{MCS5}$, $\overline{MCS6}$, and $\overline{MCS7}$ are all brought out to the wire wrap area so that they can be used to select custom circuitry built in the wire wrap area.

4-10 PORT DECODING

I/O Ports are completely decoded into blocks of four by the 1 of 8 decoder at U47. The Z80-PIO and the Z80-CTC further decode the four address blocks into unique addresses. The following table shows this Port address decoding:

| Port Select | Port Address Space | Connected to |
|------------------|--------------------|--------------------------|
| $\overline{PS0}$ | 80H-83H | Z80-PIO |
| $\overline{PS1}$ | 84H-87H | Z80-CTC |
| $\overline{PS2}$ | 88H-8BH | $\overline{SEG LATCH}$ |
| $\overline{PS3}$ | 8CH-8FH | $\overline{DIGIT LATCH}$ |

| | | |
|------------|---------|---------------|
| <u>PS4</u> | 90H-93H | <u>KB SEL</u> |
| <u>PS5</u> | 94H-97H | UNUSED |
| <u>PS6</u> | 98H-9BH | UNUSED |
| <u>PS7</u> | 9CH-9FH | UNUSED |

PS5, PS6, and PS7 are routed to the wire wrap area to be used as I/O decodes for custom circuitry. The following table is a further breakout of the addresses assigned to registers with the PIO and the CTC.

| <u>PORT ADDRESS</u> | <u>USED BY</u> | |
|---------------------|--------------------|-------|
| 80H | A Data Register | } PIO |
| 81H | B Data Register | |
| 82H | A Control Register | |
| 83H | B Data Register | |
| 84H | Channel 0 | } CTC |
| 85H | Channel 1 | |
| 86H | Channel 2 | |
| 87H | Channel 3 | |

4-11 SYSTEM RAM

1024 bytes of 21L02-1 RAM located at U24-31 are standard with the KIT. Provision has been made to add an additional 1K bytes of RAM in locations U16-U23 with eight additional 21L02-1 (500 nSec). The use of part of the standard RAM for ZBUG scratch and stack is detailed in Section 3-18. Data

from the RAM is gated onto the Z80-CPU bus using a 74LS244 Hex buffer (U48).

4-12 SINGLE STEP LOGIC

The Z80 STARTER KIT has a "hardware single step" which means that the Single Step command operates on programs located either in RAM or EPROM/ROM. Channel 2 of the CTC is used to produce a pulse at the beginning of the first user's instruction after Single Step is commanded. This pulse (ZC2) is routed through gates U44 and U45 to the Non-Maskable Interrupt ($\overline{\text{NMI}}$) input of Z80-CPU. The $\overline{\text{NMI}}$ input is always recognized at the end of the current instruction, and vectors the CPU to address 66H, which is in the ZBUG Monitor. ZBUG preserves all CPU registers and displays the current program counter location and Accumulator contents on the display.

4-13 PROM1 RESTART

When a RESET is applied to the Z80-CPU, the ZBUG Monitor checks the position of S3. If S3 is set to MONITOR RESTART, then ZBUG will place the prompt symbol on the display and scan the keyboard for a command. If S3 is in the PROM1 RESTART position, then the ZBUG Monitor automatically vectors the program execution after Reset to PROM1 at address 0800H. This feature provides a means to Restart to a user's program without having to enter commands through the keyboard.

4-14 INTERRUPT DAISY CHAIN

All Z80 family peripheral devices have built-in interrupt control circuitry, so that no dedicated interrupt controller is required. Priority of interrupts is determined by a daisy chain running between Z80 peripheral devices (IEI-input, IEO-output). On the Z80 STARTER KIT the CTC has been given highest priority, with the PIO next in line. The output of the daisy chain is brought to the wire wrap area (marked IEO) and can be used to continue the daisy chain should additional Z80 peripherals be added. Refer to Z80 Technical Manuals for additional information on the daisy chain interrupt structure.

4-15 S-100 BUS INTERFACE

Provision has been made on the KIT to add two 100 pin connectors, which have been pre-wired to a S-100 configuration. This interface is compatible with general static memory or I/O expansion cards. Specifically this interface is directly compatible with the S.D. Systems' 4K byte Static RAM cards, but not with the EXPANDORAM modules. Interface with modules that require specific 8080A signals such as SYNC, INTA, DBIN, POC, PWR, and PRD may require addition of some logic to the wire wrap area and/or the wiring of additional signals to the S-100 connectors. Refer to the KIT schematic for the exact connections to these S-100 connectors. Power (+8v, \pm 18v) can be connected to the S-100 connectors via the appropriate pads at the top of the KIT.

4-16 WIRE WRAP AREA

The wire wrap area has room for about 25-30 additional IC's for experimentation, memory expansion, video interface, etc. Power and ground are alternated on the bottom side so that each IC is close to a low impedance power source and ground, thereby reducing noise problems in user's circuitry. Z80-CPU, PIO, and decoded system signals have been placed near the wire wrap area so that by installing wire wrap pins in the holes provided, it will be easy to connect user's circuitry to the Z80 bus signals.

SECTION 5

EXAMPLE PROGRAMS

5-1 USING ZBUG COMMANDS

In the examples that follow, all user's key entries are underlined, while ZBUG responses are not underlined. ZBUG Commands will be used to execute the following program:

```

                ORG 2000H
2000  3E AA  LD  A,0AAH  ;load A with AA
2002  06 BB  LD  B,0BBH  ;load B with BB
2004  76      HALT      ;Z80-CPU HALT

```

Display/KeyboardExplanation

-

Turn on Z80 STARTER KIT, press
RESET - S1

²²⁰⁰
2000 MEM EXAM

Open location 2000 with MEM

2000 XX

EXAM key - location has
random value XX.

2000 XX 3E NEXT

Enter program using NEXT key

2001 XX AA NEXT

to advance to next memory

2002 XX 06 NEXT

location.

2003 XX BB NEXT

2004 XX 76 NEXT MON

| | | | | |
|------|-------------|--------------------|---------------------------------|----------------------------------|
| - | <u>A</u> | <u>REG EXAM</u> | Examine register A's contents | |
| A | XX | <u>MON</u> | which are undefined. | |
| | | | | |
| - | <u>B</u> | <u>REG EXAM</u> | Examine register B's contents | |
| b | XX | <u>MON</u> | which are undefined. | |
| | | | | |
| - | <u>2002</u> | <u>BREAKPOINT</u> | <u>MON</u> | Set Breakpoint at location 2002. |
| | | | | |
| - | <u>2000</u> | <u>EXEC</u> | Execute program starting at | |
| | | | address 2000. | |
| | | | | |
| 2002 | AA | | ZBUG responds with address of | |
| | | | next instruction and value | |
| | | | of Accumulator - Note ef- | |
| | | | fect of first instruction. | |
| | | | | |
| 2002 | AA | <u>SINGLE STEP</u> | Command execution of one in- | |
| | | | struction at 2002. | |
| | | | | |
| 2004 | AA | <u>MON</u> | Next instruction is at 2004, | |
| | | | cancel Single Step Mode | |
| | | | with MON. | |
| | | | | |
| - | <u>B</u> | <u>REG EXAM</u> | | |
| | | | | |
| b | bb | <u>MON</u> | Examine B register, it now con- | |
| | | | tains bb due to execution | |
| | | | of second instruction. | |

Cancel Register Examine

Mode with MON.

- PC REG EXAM Examine current Program Counter value.

- 1 ~~20~~ 04 MON PC is at 2004 which is the HALT instruction. Cancel mode with MON.

- 2000 EXEC Start from beginning of program and execute.

- Display dark MON Program runs down to HALT instruction - Z80-CPU is not in ZBUG Monitor, so display is dark. The one breakpoint was removed by the Single Step operation. Press MON key to abort user's program and regain control.

- 1 REG EXAM Look at PC, it is now pointing
- 1 2005 MON to the instruction after the HALT which is outside the program. Cancel mode.

5-2 CALCULATING RELATIVE ADDRESS

The following program requires the calculation of a Relative Address (2's complement Hexadecimal subtraction).

```

                ORG  2000H
2000  3E 00      LD  A,00H
2002  06 05      LD  B,05H
2004  3C      LOOP: INC  A
2005  10  _      DJNZ LOOP-$
2007  76          HALT

```

- 2000 MEM EXAM Enter the program.

2000 XX 3E NEXT

2001 XX 00 NEXT

2002 XX 06 NEXT

2003 XX 05 NEXT

2004 XX 3C NEXT

2005 XX 10 NEXT

2006 XX NEXT

Do not enter 2006 as this is
the Relative Offset to
be calculated.

2007 XX 76 MON

- H REG EXAM

7 XX 20 MON

Destination Op Code is at
2004 which is loaded
into HL.

- L REG EXAM

8 XX 04 MON

| | | | |
|------|--------------------|--------------------|---|
| - | <u>D</u> | <u>REG EXAM</u> | Relative Op Code (DJNZ) is |
| d | XX | <u>20 MON</u> | at 2005 which is loaded into DE. |
| | | | |
| E | XX | <u>05 MON</u> | |
| | | | |
| - | <u>00C0</u> | <u>EXEC</u> | Execute Relative address calculation program at 00COH. |
| | | | |
| FF | Fd | <u>MON</u> | FF indicates a valid offset and Fd is the offset value. |
| | | | |
| - | <u>2006</u> | <u>MEM EXAM</u> | Examine 2006 to see if offset got placed into memory - it did! Cancel with MON. |
| 2006 | Fd | <u>MON</u> | |
| | | | |
| - | <u>1</u> | <u>REG EXAM</u> | Set Program Counter to begin- ning of program. |
| 1 | XXXX | <u>2000 MON</u> | |
| | | | |
| - | <u>SINGLE STEP</u> | | Single Step down program. |
| | | | |
| 2002 | 00 | <u>SINGLE STEP</u> | |
| 2004 | 00 | <u>SINGLE STEP</u> | |
| 2005 | 01 | <u>SINGLE STEP</u> | First INC A |
| 2004 | 01 | <u>SINGLE STEP</u> | Loop back |

| | | | |
|------|--------------------|------------------------|---|
| 2005 | 02 | <u>SINGLE STEP</u> | Second INC A |
| 2004 | 02 | <u>SINGLE STEP</u> | Loop back |
| 2005 | 03 | <u>SINGLE STEP</u> | Third INC A |
| 2004 | 03 | <u>SINGLE STEP</u> | Loop back |
| 2005 | 04 | <u>SINGLE STEP</u> | Fourth INC A |
| 2004 | 04 | <u>SINGLE STEP</u> | Loop back |
| 2005 | 05 | <u>SINGLE STEP MON</u> | Fifth INC A |
| - | <u>B</u> | <u>REG EXAM</u> | |
| b | 01 | <u>MON</u> | B has been decremented down to 1. |
| - | <u>SINGLE STEP</u> | | Decrement B and Jump if not zero - B is now zero so we fell through to next instruction at 2007. |
| 2007 | 05 | <u>MON</u> | |
| - | | | ZBUG waits for new command. |

$$\begin{array}{r} \emptyset \\ 5 \overline{) 6} \\ \underline{4} \\ 4 \\ \underline{3} \\ \end{array}$$

$$\begin{array}{r} 0010 \overline{) 111} \\ \underline{2} \\ \end{array}$$

5-3 WRITING TO THE DISPLAY

The following program causes the character "8" to move from right to left across the display.

```

      D
      ↓
A → 2250 2000 3E 00          LD    A,00H
      2002 D3 88          OUT   (88H),A    ;ACTIVATE ALL SEGMENTS
      2004 3E 01 ←       LD    A,01H
      → 2006 D3 8C      LOOP: OUT   (8CH),A    ;SELECT FIRST DIGIT
      2008 CD 4F 06     CALL   D20MS
      200B CD 4F 06     CALL   D20MS
      200E CD 4F 06     CALL   D20MS ←
      2011 CD 4F 06     CALL   D20MS
      2014 CD 4F 06     CALL   D20MS    ;DELAY APPROX 100MS
      2217 2017 07     ← 2217 2017 07     ← RLCA    ;ROTATE TO NEXT DIGIT
      2018 18 EC          JR     LOOP-$    ;LOOP BACK
  
```

Enter the program and Execute address 2000. Use MON key to return to ZBUG. This is not a good program to Single Step through, as the Single Step routines use the display which destroys the "8" character loaded in the first two instructions.

5-4 INTERRUPT DRIVEN DELAY

The following program uses Channel zero of the Z80-CTC to interrupt after a fixed delay, rather than the software timing loop (D20MS) used in the previous example. This program uses the Z80 Mode 2 interrupts in which the interrupting device sends in a vector during the Interrupt Acknowledge

cycle. The vector is used with the CPU's I register to form a pointer to a table which contains the address of the interrupt service routine. Refer to the Z80-CPU and the Z80-CTC Technical Manuals for a complete description of Z80 interrupts.

Load the program and double check that it is entered correctly. Follow these steps to test the program:

- 1) Load PC with 2000 and Single Step Down the program. Stop when you get to address 2200 (the interrupt service routine).
- 2) Single Step a few more times and notice that the Accumulator is rotated left every time address 2201 is executed (remember the address display is the NEXT instruction to be executed).
- 3) Stop Single Stepping with address 2201 showing. Hit the MON key and look at the Stack Pointer. (SP followed by REG EXAM.) It is at 22FE decremented two from the initial value of 2300. Check the contents of 22FE and 22FF, where you will find 18 and 20, which is the return address.
- 4) Hit MON and then Single Step until 2018 shows on the display. Now look at the Stack Pointer again - it is now 2300, as we have executed the RET1 instruction and recovered the return address address from the stack.
- 5) Set a BREAKPOINT at 2200 and Execute from 2000. Continually hit the EXEC key and note that the

Accumulator is rotated left once each time the break-
point is encountered. Reset using S1 to clear CTC.

;INTERRUPT DRIVEN DELAY

```
                                ORG 2000H
2000 3E 21                      LD  A,21H
2002 ED 47                      LD  I,A      ;INITIALIZE I=21
2004 31 00 23                   LD  SP,2300H ;INITIALIZE STACK POINTER
/ 2007 3E 00                    LD  A,00H
2009 D3 84                      LD  (84H),A ;CTC VECTOR
200B 3E A5                      LD  A,#A5H
200D D3 84                      OUT (84H),A ;CONFIGURE CTC-SEE PAGE 26
                                ;OF MICRO REFERENCE MANUAL
200F 3E FF                      LD  A,#FFH
2011 D3 84                      OUT (84H),A
2013 3E 01                      LD  A,01H
2015 ED 5E                      IM  2
2017 FB      LOOP: EI
2018 76                        HALT
2019 C3 17 20                   JP  LOOP
```

;TABLE OF INTERRUPT SERVICE ROUTINES

2100 00 22

;INTERRUPT SERVICE ROUTINE

```
2200 FB      EI                ;ENABLE INTERRUPTS
2201 07      RLCA              ;ROTATE ACCUMULATOR
2202 ED 4D   RETI              ;RETURN FROM INTERRUPT CLEAR
                                ;CTC
```

5-5 GENERATE AN INTERRUPT FROM THE PIO

Place a 10K ohm pull-up resistor from $\overline{\text{ASTRB}}$ (marked near wire wrap area) to +5 volts. Enter the following program that initializes the PIO to accept an interrupt on the A Port. Set a BREAKPOINT at 2200 and Execute from 2000. The display will go dark as the Z80-CPU has executed the HALT instruction. Take a clip lead and momentarily touch $\overline{\text{ASTRB}}$ to GND, which will cause a PIO interrupt and the breakpoint should be displayed. For more details on the Z80-PIO operation, see the MOSTEK or Zilog PIO Technical Manual.

;PIO INTERRUPT TEST

```
2000 3E 21 LD A,21H
2002 ED 47 LD I,A ;INITIALIZE I UPPER 8 Bits
2004 3E 00 LD A,00
2006 D3 82 OUT (82H),A ;VECTOR LOWER 8 Bits
2008 3E 4F LD A,4FH ;SET UP PIO FOR INPUT
200A D3 82 OUT (82H),A ;MODE - SEE PAGE 25 OF MI-
200C 3E 87 LD A,87H ;CRO REF MANUAL MODE TWO
200E D3 82 OUT (82H),A ;INTERRUPTS
2010 ED 5E IM 2
2012 FB EI
2013 76 HALT
```

;INTERRUPT SERVICE ROUTINE TABLE

```
2100 00 22
```

```
;INTERRUPT SERVICE ROUTINE
2200 FB      EI
2201 ED 4D   RETI                ;RETURN AND CLEAR PIO
```

5-6 USING THE Z80 STARTER KIT AS AN EPROM PROGRAMMER

Due to limitations in the memory allotted for the ZBUG Monitor, (it had to fit in a 2K byte ROM) some restrictions were placed on the operation of the EPROM programmer. These restrictions are fully documented in Section 3-13 and should not hinder the average user of the Z80 STARTER KIT.

Should a user desire to program the entire contents of a 2758 (1024 bytes) or a 2716 (2048 bytes) EPROM, the above mentioned restrictions need to be removed. The following two example programs give the user the capability of copying any block of memory to any other block of memory, plus allowing any RAM location to be the source of data for the EPROM programmer. These programs can be put on cassette tape to be loaded into RAM when needed, or they can be put into EPROM in the PROM1 socket for on-line use.

The first program is a copy utility based on the Z80 block move instruction. It can be used to copy a block of data from any memory location (source data) to any new memory location (destination data). It can also be used to copy the data from an EPROM in either socket PROM1 or PROM2 into RAM for minor modification before re-programming. To use the following program initialize the Z80 registers using the REG EXAM key as follows:

HL = Address of source data - high byte in H
DE = Address of destination data - high byte in D
BC = Number of bytes to be transferred from source to
destination - high byte in B

Execute the following program to move the data:

```
                ;COPY UTILITY  
2050 ED B0      LDIR          ;BLOCK MOVE  
2052 C3 AE 00   JP    RESTR1 ;RETURN TO ZBUG
```

The second program modifies the ZBUG PROM Programmer to allow source data to come from any memory location. This feature allows the user to use the standard RAM, add-on RAM, or another EPROM as the source of data for the EPROM being programmed. (This last transfer would be used for copying EPROMs.) To use this program press Reset (S1) first, then initialize 23C0H, 23C1H, 23C2H, 23C3H, and HL as follows:

23C0H - High byte of the address of source data to be programmed.

23C1H - Low byte of the address of the source data to be programmed.

23C2H - High byte of the address of the first byte in PROM to be programmed.

23C3H - Low byte of the address of the first byte in PROM to be programmed.

HL - Number of bytes to be programmed in hex (high byte in H). Use REG EXAM mode to initialize HL.

Because the 2758/2716 EPROMs can be programmed a block or section at a time, the capability is provided by the initialization of 23C2H and 23C3H to start the programming at any address in the EPROM. This feature can be used to program a full 2K byte EPROM with less than 1K of RAM in the standard kit by programming the EPROM a section at a time.

```

;PROGRAM TO MOVE ANY RAM BLOCK TO ANY
;STARTING ADDRESS IN EPROM

2000 3E 01    C12:  LD  A,01H
2002 32 DA 23      LD  (PRFLG),A ;SET PROM PROG FLG
2005 E5          PUSH HL      ;BYTE COUNT IN HL
2006 C1          POP  BC       ;SAVE IT
2007 E5          PUSH HL
2008 3A C0 23     LD  A,(23C0H) ;SOURCE DATA
200B 67          LD  H,A
200C 3A C1 23     LD  A,(23C1H)
200F 6F          LD  L,A
2010 3A C2 23     LD  A,(23C2H) ;DESTINATION DATA
2013 57          LD  D,A
2014 3A C3 23     LD  A,(23C3H)
2017 5F          LD  E,A
2018 3E 25    C12A; LD  A,25H      ;CTC FOR 26 MS
201A D3 86          OUT (86H),A   ;ZC/TO, NO INTR
201C 3E CB          LD  A,203D
201E D3 86          OUT (86H),A   ;TIME CONST
201F26 3E 80      LD  A,80H      ;CLEAR DISPLAY, SET

```

```

2022 D3 8C      OUT  (DIGLH),A ;PROM PROG EN = 1
2024 ED A0      LDI                    ;WAIT STATE INSERTED
2026 3E 00      LD   A,00H      ;UNTIL CTC TIMES TWICE
2028 D3 8C      OUT  (DIGLH),A ;CLEAR PROM PROG EN
202A 3E 03      LD   A,03H      ;RESET CTC2
202C D3 86      OUT  (86),A
202E EA 18 20   JP   PE,C12A    ;LOOP BACK IF BC-1 NE 0
2031 C1         POP  BC          ;RESTORE BYTE COUNT
2032 3A C0 23   LD   A,(23C0H)
2035 67         LD   H,A
2036 3A C1 23   LD   A,(23C1H) ;SOURCE DATA
2039 6F         LD   L,A
203A 3A C2 23   LD   A,(23C2H)
203D 57         LD   D,A
203E 3A C3 23   LD   A,(23C3H) ;DEST DATA
2041 5F         LD   E,A
2042 C3 04 06   JP   CCS12B    ;USE ROM CODE

```

APPENDIX I

Schematic

Assembly Drawing

Parts List

7H
8C
04H
10L
12L
13L
14H
15L

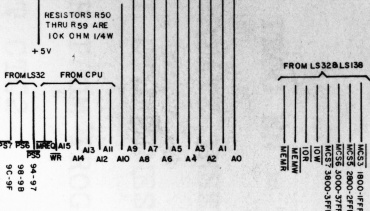
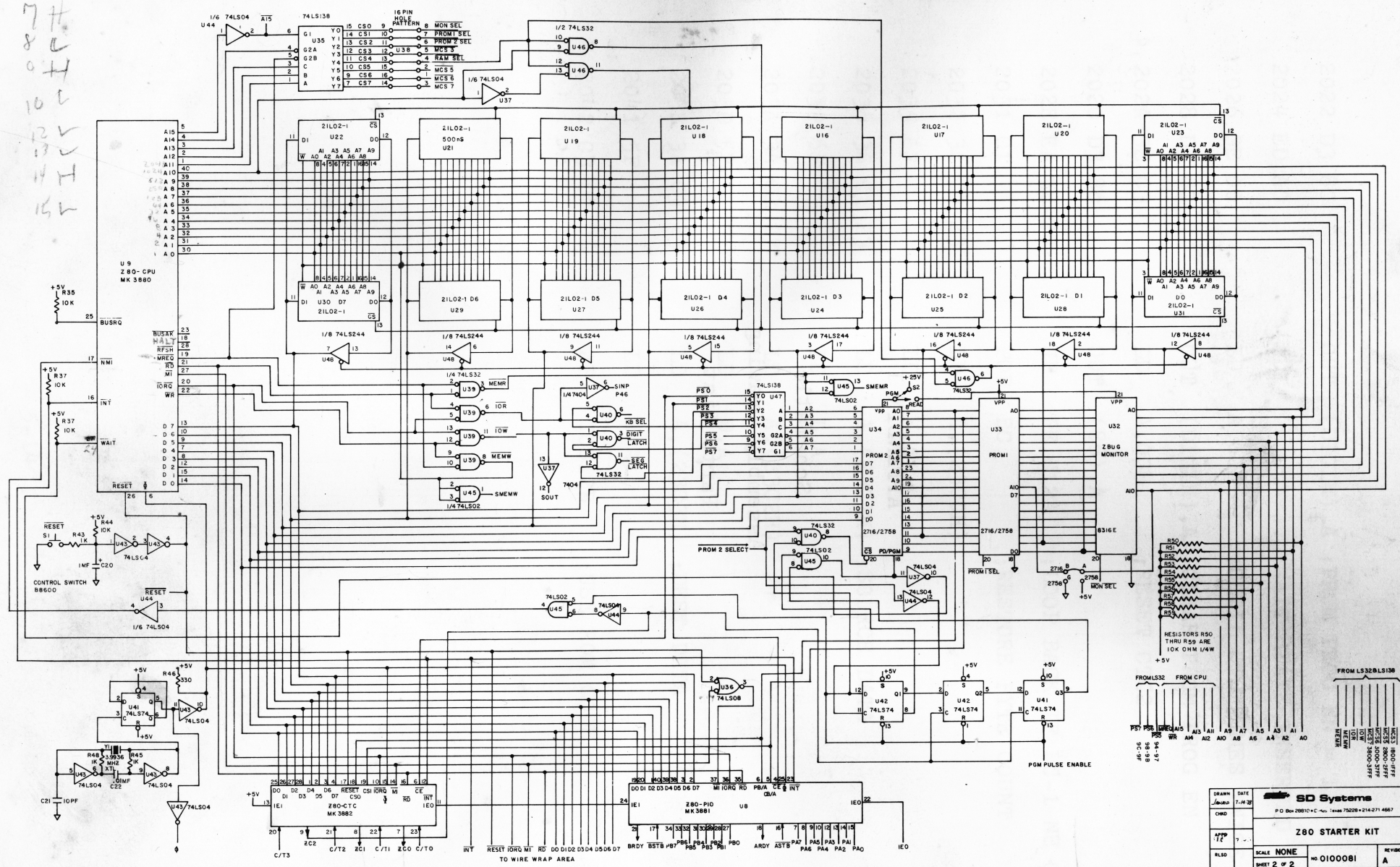

| | | |
|------------------------|------------|--|
| DRAWN | DATE | SD Systems |
| CHKD | 7-14-78 | |
| APP'D | | P.O. Box 20810 • San Jose, CA 95128 • 415-271-4667 |
| Z80 STARTER KIT | | |
| REVISED | SCALE NONE | REVISION |
| SHEET 2 OF 2 | NO 0100081 | A |

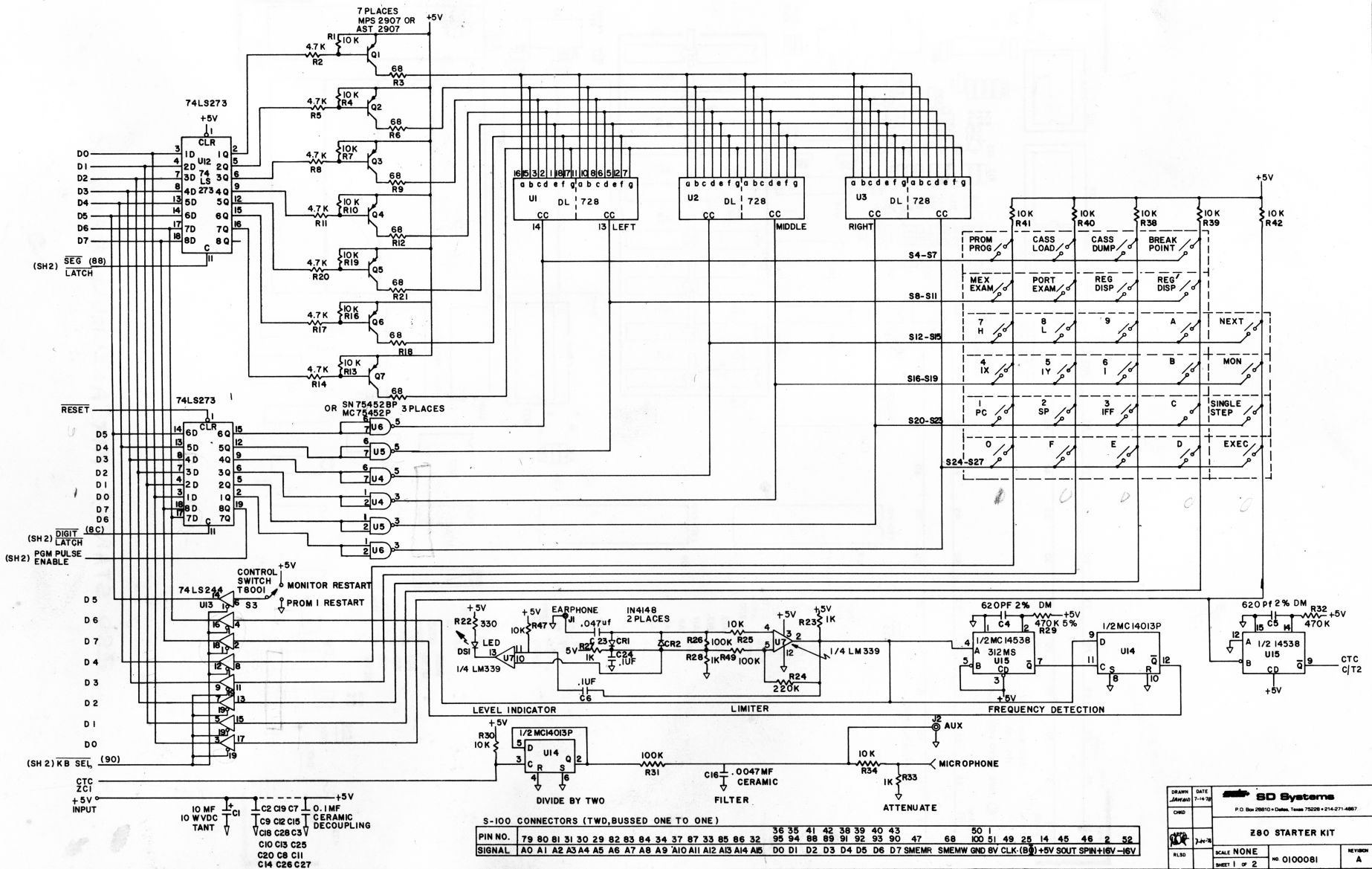

S-100 CONNECTORS (TWD, BUSSED ONE TO ONE)

| | | | | | | | | | | | | | | | | | | | | | | | | | | | | | | | | | | |
|---------|----|----|----|----|----|----|----|----|----|----|-----|-----|-----|-----|-----|-----|----|----|----|----|----|----|----|----|-------|-------|-----|----|----------|-----|------|------|------|------|
| PIN NO. | 79 | 80 | 81 | 31 | 30 | 29 | 82 | 83 | 84 | 34 | 37 | 87 | 33 | 85 | 86 | 32 | 36 | 35 | 41 | 42 | 38 | 39 | 40 | 43 | 50 | 1 | | | | | | | | |
| SIGNAL | A0 | A1 | A2 | A3 | A4 | A5 | A6 | A7 | A8 | A9 | A10 | A11 | A12 | A13 | A14 | A15 | DO | D1 | D2 | D3 | D4 | D5 | D6 | D7 | SMEMR | SMEWM | GND | BV | CLR (B0) | +5V | SOUT | SPIN | +16V | -16V |

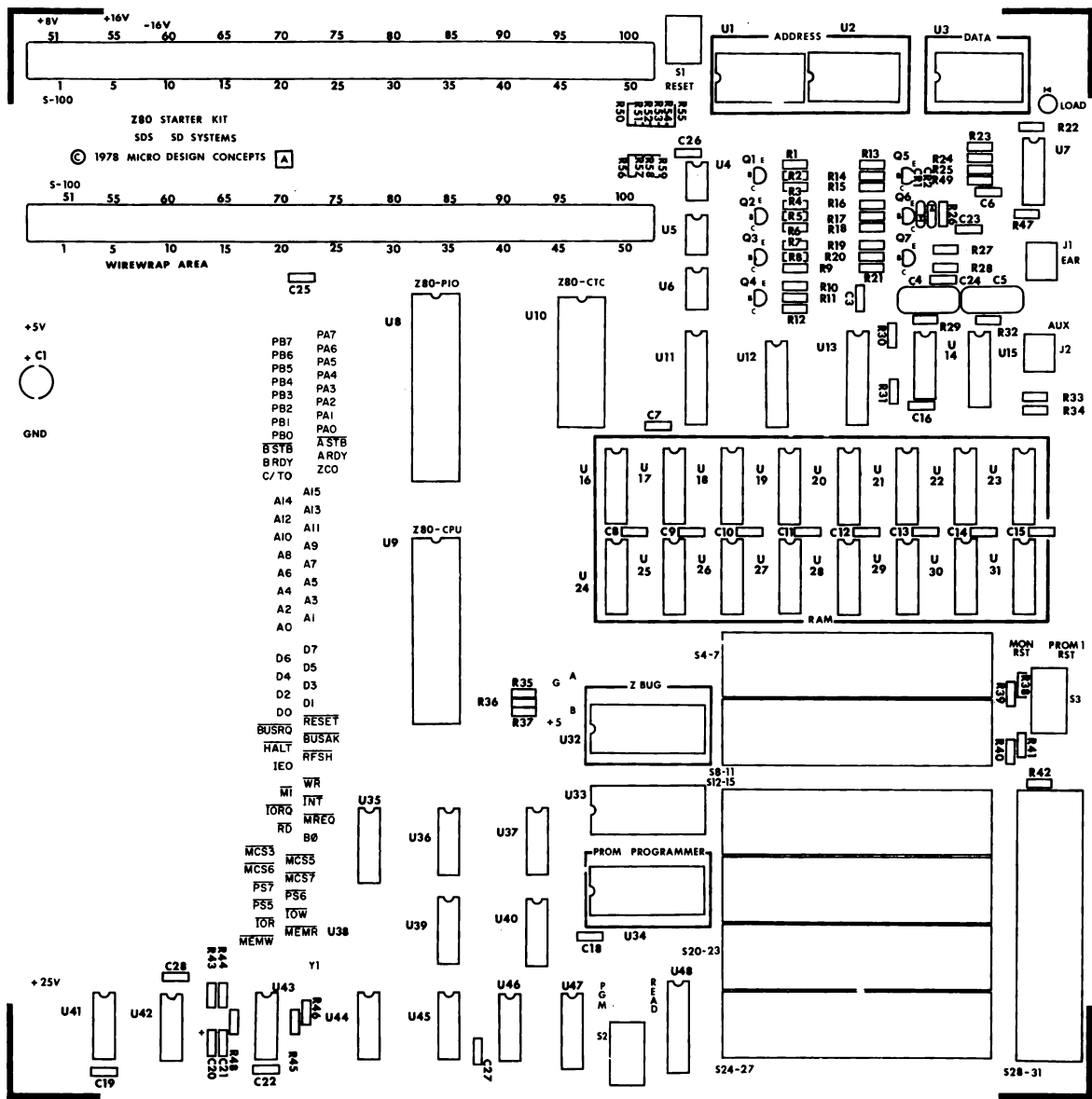

Z80 STARTER KIT ASSEMBLY DRAWING

BILL OF MATERIALS

| | | |
|----------------------------------|--------------------------|------------------|
| Title: Z80 STARTER KIT | PL No. 0100080 | Rev. A |
|----------------------------------|--------------------------|------------------|

| | | |
|--|------------------|----------------------------|
| Date Released: July 14, 1978 | Approved: | Sheet 1 Of 3 |
|--|------------------|----------------------------|

| Item no | Qty | SD-P/N | Description | Unit Cost | Extension |
|---------|-----|---------|--|-----------|-----------|
| 1 | 1 | 7010318 | MK3880 Z80-CPU | | |
| 2 | 1 | 7010319 | MK3881 Z80-PIO | | |
| 3 | 1 | 7010320 | MK3882 Z80-CTC | | |
| 4 | 8 | 7010340 | 21L02-1 500 NSEC RAM | | |
| 5 | 1 | 7010350 | 8316 E ROM-ZBUG | | |
| 6 | 2 | 7010219 | 74LS138 DECODER | | |
| 7 | 3 | 7010181 | 74LS32 QUAD OR GATE | | |
| 8 | 2 | 7010164 | 74LS04 QUAD BUFFER | | |
| 9 | 1 | 7010166 | 74LS08 QUAD AND GATE | | |
| 10 | 2 | 7010264 | 74LS244 OCTAL BUFFER | | |
| 11 | 2 | 7010276 | 74LS273 OCTAL LATCH | | |
| 12 | 2 | 7010195 | 74LS74 DUAL LATCH | | |
| 13 | 1 | 7010162 | 74LS02 QUAD NOR GATE | | |
| 14 | 3 | 7010342 | 75452P PERIPHERAL DRIVER | | |
| 15 | 1 | 7010351 | MC14538BCP CMOS MONOSTABLE | | |
| 16 | 1 | 7010352 | MC14013BCP CMOS LATCH | | |
| 17 | 1 | 7160004 | LM339 QUAD COMPARITOR (MLM339P) | | |
| 18 | 3 | 7180001 | DL728 DUAL DISPLAY | | |
| 19 | 7 | 7040009 | AST2907 PNP TRANSISTOR (MPS2907) | | |
| 20 | 1 | 7080004 | 3.9936 MHZ PARALLEL RESONANT CRYSTAL | | |
| 21 | 1 | 7180002 | LED | | |
| 22 | 7 | 7020089 | 4.7K OHM CARBON COMP RESISTOR $\frac{1}{4}W \pm 5\%$ | | |
| 23 | 29 | 7020097 | 10K OHM CARBON COMP RESISTOR $\frac{1}{4}W \pm 5\%$ | | |
| 24 | 7 | 7020045 | 68 OHM CARBON COMP RESISTOR $\frac{1}{4}W \pm 5\%$ | | |

BILL OF MATERIALS

| | | |
|--|--------------------------|----------------------------|
| Title: Z80 STARTER KIT | PL No. 0100080 | Rev. A |
| Date Released: July 14, 1978 | Approved: | Sheet 2 Of 3 |

| Item no | Qty | SD-P/N | Description | Unit Cost | Extension |
|---------|-----|---------|---|-----------|-----------|
| 25 | 7 | 7020073 | 1K OHM CARBON COMP RESISTOR $\frac{1}{4}$ W $\pm 5\%$ | | |
| 26 | 2 | 7020137 | 470K OHM CARBON COMP RESISTOR $\frac{1}{4}$ W $\pm 5\%$ | | |
| 27 | 1 | 7020129 | 220K OHM CARBON COMP RESISTOR $\frac{1}{4}$ W $\pm 5\%$ | | |
| 28 | 3 | 7020121 | 100K OHM CARBON COMP RESISTOR $\frac{1}{4}$ W $\pm 5\%$ | | |
| 29 | 2 | 7020061 | 330 OHM CARBON COMP RESISTOR $\frac{1}{4}$ W $\pm 5\%$ | | |
| 30 | 1 | 7020113 | 47K OHM CARBON COMP RESISTOR $\frac{1}{4}$ W $\pm 5\%$ | | |
| 31 | 19 | 7030007 | .1 UF CERAMIC CAPACITOR $\pm 20\%$ | | |
| 32 | 1 | 7030019 | 1 UF 10V TANTALUM CAPACITOR $\pm 20\%$ | | |
| 33 | 1 | 7030009 | 10 UF 10V TANTALUM CAPACITOR $\pm 20\%$ | | |
| 34 | 1 | 7030012 | .0047 UF CERAMIC CAPACITOR $\pm 20\%$ | | |
| 35 | 1 | 7030021 | 10 PF DIPPED MICA CAPACITOR $\pm 2\%$ | | |
| 36 | 1 | 7030008 | .01 UF CERAMIC CAPACITOR $\pm 20\%$ | | |
| 37 | 2 | 7030013 | 620 PF DIPPED MICA CAPACITOR $\pm 2\%$ | | |
| 38 | 1 | 7030014 | .047 UF CERAMIC CAPACITOR $\pm 20\%$ | | |
| 39 | 1 | 7050004 | PUSH BUTTON-CONTROL SWITCH B8600 | | |
| 40 | 2 | 7050005 | TOGGLE SWITCH-CONTROL SWITCH T8201 | | |
| 41 | 28 | 7050006 | KEYSWITCH STACKPOLE LO-PRO5 or CONTROL DEVELOPMENT | | |
| 42 | 28 | 7050007 | KEYTOPS - DURALITH LEGENDS | | |
| 43 | 1 | 7000004 | 12" x 12" PWB | | |
| 44 | 1 | 7140020 | OPERATIONS MANUAL | | |
| 45 | 1 | 7140019 | MOSTEK Z80 MICRO-REF MANUAL MK78516 | | |
| 46 | 2 | 7090001 | AUDIO JACKS SWITCHCRAFT 142A | | |
| 47 | 15 | 7130011 | NYLON SPACER-H H SMITH 4059 (3/4" MIN) | | |
| 48 | 15 | 7130010 | 4-40 x $\frac{1}{4}$ " STEEL SCREW | | |

BILL OF MATERIALS

| | | | | | |
|-----------------|-----------|--------|---------|------|------|
| Z80 STARTER KIT | | PL No. | 0100080 | Rev. | A |
| Released: | Approved: | | Sheet | 3 | Of 3 |
| July 14, 1978 | | | | | |

| Qty | SD-P/N | Description | Unit Cost | Extension |
|-----|---------|----------------------------------|-----------|-----------|
| 1 | 7180003 | RED PLASTIC LENS (3 1/2" x 7/8") | | |
| 14 | 7130012 | 2-56 NYLON NUT | | |
| 3 | 7060001 | 8 PIN SOCKET | | |
| 12 | 7060002 | 14 PIN SOCKET | | |
| 11 | 7060003 | 16 PIN SOCKET | | |
| 4 | 7060005 | 20 PIN SOCKET | | |
| 3 | 7060007 | 24 PIN SOCKET | | |
| 1 | 7060008 | 28 PIN SOCKET | | |
| 2 | 7060009 | 40 PIN SOCKET | | |
| 3 | 7060004 | 18 PIN SOCKET (600 MIL SPACING) | | |
| 2 | 7040001 | IN4148 DIODE | | |
| 1 | 7010005 | 7404 QUAD BUFFER | | |

APPENDIX II

ZBUG Monitor Version 1.0

Copyright © 1978 by

Micro Design Concepts

LOAD MAP

| | | | |
|---------------------|-----|---------------|---------------|
| DK1: RESTR . OBJ[1] | REL | BEG ADDR 0000 | END ADDR 00F3 |
| DK1: DISUP . OBJ[1] | REL | BEG ADDR 00F4 | END ADDR 0122 |
| DK1: DECKY . OBJ[1] | REL | BEG ADDR 0123 | END ADDR 0633 |
| DK1: UTIL . OBJ[1] | REL | BEG ADDR 0634 | END ADDR 07F4 |
| DK1: UTILR . OBJ[1] | ABS | BEG ADDR 07F8 | END ADDR 07FF |

GLOBAL CROSS REFERENCE TABLE

| SYMBOL | ADDR | REFERENCES |
|--------|------|--|
| ARFLG | 23E0 | 06A4 03C5 02F0 |
| BFLG | 23F4 | 0681 04BF 04BB 049E 0275 00A9 |
| BPTAB | 23E4 | 067E 0250 |
| CTC1P | 07FA | 04D5 |
| CTC3L | 07FE | 0759 |
| DZOMS | 064F | 0172 0135 |
| DECKY | 0123 | 0121 |
| DIG2 | 23F5 | 068F 036C 01A6 |
| DIG4 | 23F6 | 0692 0498 0396 0235 01AC |
| DISMEM | 23F7 | 06AA 0687 065B 0617 05BB 0470 0443 03B6 02F4 00F5 00E4 |
| + | | 00B4 0080 |
| DISUP | 00F4 | 062E 05CB 04C8 04B3 03B2 0393 0369 02EB 02D6 01BC 01A3 |
| + | | 014D 0132 00F2 00D0 009D |
| DSMEM1 | 23F8 | 017F 00B9 |
| DSMEM2 | 23F9 | 061F 05C3 0420 0378 0340 0334 00EB 00BC |
| DSMEM3 | 23FA | 037B 0187 00C3 |
| DSMEM4 | 23FB | 0627 03E2 03A4 0385 0357 034A 0327 0315 0301 02E5 00C6 |
| DSMEM5 | 23FC | 043A 00C9 |
| DSMEM6 | 23FD | 0363 |
| DSMEM7 | 23FE | 0434 0360 0192 |
| FLG24 | 23D9 | 0737 072D 0724 0714 0707 04D0 |
| INCHR | 0758 | 0591 |
| INCHR4 | 079D | 07FE |
| KEYPTR | 23DB | 068A 03AF 0390 0366 0351 032B 01B9 01B5 01A0 019C 0195 |
| + | | 018A 017A |
| KYTB | 07B9 | 0160 |
| MFLG | 23E1 | 069E 03CC 039C 02A5 |
| NMIS | 01CB | 0067 |
| OTCHR | 06F4 | |
| OTCHR1 | 06F7 | 050C |
| OTCHR6 | 0732 | 07FA |
| PFLG | 23DE | 069B 03B9 0373 02AC |
| PRFLG | 23DA | 0698 05D6 02B3 |
| PUNHEH | 23C2 | 04EE |
| PUNHEL | 23C3 | 04F2 |
| PUNHSH | 23C0 | 0552 0529 04E6 |
| PUNHSL | 23C1 | 0556 0530 04EA |
| REGTB | 07D5 | 047A |
| REGTBP | 07E5 | 045D |
| REMBP2 | 007E | 0208 |
| RESTAR | 009F | |
| RESTR1 | 00AE | 060A 05D1 057F 04B0 0482 0465 043F 03D0 02B8 02A2 |
| RFLG | 23DF | 06A1 03BF 030B |
| RST16 | 23C4 | 0011 |
| RST24 | 23C7 | 0019 |
| RST32 | 23CA | 0021 |
| RST40 | 23CD | 0029 |
| RST48 | 23D0 | 0031 |
| RST56 | 23D3 | 0039 |
| SEGPT | 07A6 | 0102 |

```

SSFLG  23F3  0695 027A 0202 01F9
STKPT  23E2  0485 0468 0346 023F 01F6 01E6 01CD 00A1 0083 004B 0043
+
STKPT1 23E3  033C
UABIN  06B3
UBASC  06BB
UFGCR  0686  00AF
WFOR1  063C  082B 082Z 082B 05CZ 03B4 04E8 03E5 03B7 036B 026B 094B 00E7 009A 0

UFOR2  0659  05D9 04A3 03E9 03D3 039F 037E 02D9 02BE 023B
UFOR3  067C  04A6 0248 0205 0062
UFOR4  06A7  04CB
UIF    23DD  0437 035A 0295 01F2 00AC 005F
UIX3   0634  04B6 0260 007A
ULACC  06DB  05B3 05AC 05A5 05A1 059D 0599
UPACC  06C4
UPACCS 06D5  056B 0566 055F 054E 0549 0544 053C 0538 0534 052D 0526

```

GLOBAL SYMBOL TABLE

| | | | | | | | |
|--------|------|--------|------|--------|------|--------|------|
| ARFLG | 23E0 | BFLG | 23F4 | BPTAB | 23E4 | CTC1P | 07FA |
| CTC3L | 07FE | DZOMS | 064F | DECKY | 0123 | DIG2 | 23F5 |
| DIG4 | 23F6 | DISMEM | 23F7 | DISUP | 00F4 | DSMEM1 | 23F8 |
| DSMEM2 | 23F9 | DSMEM3 | 23FA | DSMEM4 | 23FB | DSMEM5 | 23FC |
| DSMEM6 | 23FD | DSMEM7 | 23FE | FLG24 | 23D9 | INCHR | 0758 |
| INCHR4 | 079D | KEYPTR | 23DB | KYTB1 | 07B9 | MFLG | 23E1 |
| NMIS | 01CB | OTCHR | 06F4 | OTCHR1 | 06F7 | OTCHR6 | 0732 |
| PFLG | 23DE | PRFLG | 23DA | PUNHEH | 23C2 | PUNHEL | 23C3 |
| PUNHSH | 23C0 | PUNHSL | 23C1 | REGTB | 07D5 | REGTBP | 07E5 |
| REMBP2 | 007E | RESTAR | 009F | RESTR1 | 00AE | RFLG | 23DF |
| RST16 | 23C4 | RST24 | 23C7 | RST32 | 23CA | RST40 | 23CD |
| RST48 | 23D0 | RST56 | 23D3 | SEGPT | 07A6 | SSFLG | 23F3 |
| STKPT | 23E2 | STKPT1 | 23E3 | UABIN | 06B3 | UBASC | 06BB |
| UFGCR | 0686 | UFOR1 | 063C | UFOR2 | 0659 | UFOR3 | 067C |
| UFOR4 | 06A7 | UIF | 23DD | UIX3 | 0634 | ULACC | 06DB |
| UPACC | 06C4 | UPACCS | 06D5 | | | | |

```

0002          NAME      RESTR
0003 ;RST,NMI AND BP ROUTINES
0004 ;VERSION 1.7 5/18/78
0005          PSECT    REL
0006          GLOBAL  DSMEM4
0007          GLOBAL  DSMEM1
0008          GLOBAL  DISUP
0009          GLOBAL  UIF
0010          GLOBAL  UIX3
0011          GLOBAL  STKPT
0012          GLOBAL  RST16
0013          GLOBAL  RST24
0014          GLOBAL  RST32
0015          GLOBAL  RST40
0016          GLOBAL  RST48
0017          GLOBAL  RST56
0018          GLOBAL  DSMEM5
0019          GLOBAL  DSMEM2
0020          GLOBAL  DISMEM
0021          GLOBAL  DSMEM3
0022          GLOBAL  UFGCR
0023          GLOBAL  UFOR1
0024          GLOBAL  NMIS
0025          GLOBAL  UFOR3
0026          GLOBAL  RESTAR
0027          GLOBAL  REMBP2
0028          GLOBAL  RESTR1
0029          GLOBAL  RFLG
>0000          0030          ORG      0000H
0031 ;****RESTART INSTRUCTION HANDLER****
0032 ;****RESET ENTRY POINT - RST0 ****
0033 ;****RST0 IS RESERVED FOR RESET AND RST8 IS RESERVED
0034 ;   FOR BREAKPOINTS.  ALL OTHER RST'S ARE MAPPED
0035 ;   TO LOCATIONS IN RAM WHERE THE USER CAN INSERT
0036 ;   A JUMP TO THE SERVICE ROUTINE IN RAM FOR
0037 ;   RST 8, 16, 24, 32, 48, AND 56.  THE USER'S REGISTERS
0038 ;   ARE STACKED UPON BREAKPOINT ENTRY AND ALL
0039 ;   BREAKPOINTS ARE REMOVED FROM THE USER'S PROGRAM.
0040 ;****RESET PUSHBUTTON ENTRY POINT - RST0
^0000 31C023 0041          LD      SP,23C0H
^0003 C39F00' 0042          JP      RESTAR ;FINISH INITIALIZATION
0043 ;****BREAKPOINT ENTRY - RST8
>0008          0044          ORG      0008H ;START RESTART TABLE
^0008 ED73FEFF 0045 BPENT: LD      (STKPT),SP ;SAVE USER'S SP
^000C F5          0046          PUSH   AF ;STACK USER REGISTERS
^000D C5          0047          PUSH   BC
^000E 1803       0048          JR      BPENT2-#
          0049 ;****USER ENTRY - RST16
^0010 C3FFFF     0050          JP      RST16 ;MAP INTO RAM
^0013 ED57       0051 BPENT2: LD      A,I ;I INTO A, IFF INTO F
^0015 F3          0052          DI
^0016 1803       0053          JR      BPENT3-#
          0054 ;****USER ENTRY - RST24
^0018 C3FFFF     0055          JP      RST24
^001B D5          0056 BPENT3: PUSH   DE
^001C E5          0057          PUSH   HL
^001D F5          0058          PUSH   AF ;SAVE I AND IFF
^001E 1803       0059          JR      BPENT4-#

```

```

      C A 2 3
^0020 C3FFFF 0060 ;****USER ENTRY - RST32
      08      0061      JP      RST32
^0023 08      0062 BPENT4: EX      AF,AF' ;GET ALT REGS
^0024 D9      0063      EXX
^0025 F5      0064      PUSH     AF
^0026 1803   0065      JR      BPENT5-$
      C 0 2 3
^0028 C3FFFF 0066 ;USER ENTRY - RST40
      C5      0067      JP      RST40
^002B C5      0068 BPENT5: PUSH     BC
^002C D5      0069      PUSH     DE
^002D E5      0070      PUSH     HL
^002E 1803   0071      JR      BPENT6-$
      D 0 2 3
^0030 C3FFFF 0072 ;****USER ENTRY - RST48
      DDE5   0073      JP      RST48
^0033 DDE5   0074 BPENT6: PUSH     IX
^0035 00      0075      NOP
^0036 1803   0076      JR      BPENT7--$
      0 3 2 3
^0038 C3FFFF 0077 ;****USER ENTRY - RST56
      FDE5   0078      JP      RST56
^003B FDE5   0079 BPENT7: PUSH     IX
^003D 3E03   0080      LD      A,03H
^003F D386   0081      OUT     (CIC2),A ;DISABLE KYBD INTR
^0041 DD2A0A00' 0082      LD      IX,(STKPT) ;GET USERS SP
^0045 DD23   0083      INC     IX
^0047 DD23   0084      INC     IX
^0049 DD224300' 0085      LD      (STKPT),IX
^004D DD7EFE 0086      LD      A,(IX-2) ;TEST PC LOW BYTE
^0050 B7      0087      OR      A ;SET STATUS
^0051 2003   0088      JR      NZ,BPENT8--$
^0053 DD35FF 0089      DEC     (IX-1) ;DEC HIGH BYTE
^0056 DD35FE 0090 BPENT8: DEC     (IX-2) ;DEC LOW BYTE
^0059 DD7EF4 0091      LD      A,(IX-12) ;IFF ON STACK
^005C E604   0092      AND     4 ;MASK OUT IFF
^005E 32FFFF 0093      LD      (UIF),A ;SAVE FOR LATER
^0061 CDFFFF 0094      CALL   UF0R3 ;GET TAB ADDR AND BPFLG
^0064 1803   0095      JR      BPNT8A-$
^0066 C3FFFF 0096      JP      NMIS
^0069 2813   0097 BPNT8A: JR      Z,REMBP2-$ ;NO BKPTS FO DISPLAY REGS
      0098 ;*****BREAKPOINT REMOVAL*****
      0099 ;REMOVE BREAKPOINTS WHILE IN ZBUG. THEY WILL BE RESTORED ON
^006B DD7E02 0101 REMBP: LD      A,(IX+2) ;GET OP CODE TO RESTORE
      0102 ;CHECK FOR MULTI-DEFINED BREAKPOINTS
^006E FECE   0103      CP      0CFH
^0070 2807   0104      JR      Z,REMBP1-$ ;BRANCH IF MULTI-DEFINED
^0072 DD6E01 0105 REMBP0: LD      L,(IX+1)
^0075 DD6600 0106      LD      H,(IX+0) ;GET ADDR OF BP
^0078 77      0107      LD      (HL),A ;RESTORE OP CODE
^0079 CDFFFF 0108 REMBP1: CALL   UIX3 ;GET NEXT POSITION AND DEC B
^007C 20ED   0109      JR      NZ,REMBP-$ ;GO AGAIN
      0110 ;DISPLAY PC AND A
^007E DD21FFFF 0111 REMBP2: LD      IX,DISMEM ;POINT TO DISMEM
^0082 ZA4B00' 0112      LD      HL,(STKPT) ;POINT TO STACK
^0085 2B      0113      DEC     HL
^0086 7E      0114      LD      A,(HL) ;GET PCH
^0087 CDFFFF 0115      CALL   UF0R1 ;WRITE TO DISMEM
^008A DD23   0116      INC     IX
^008C DD23   0117      INC     IX

```

```

008E 2B 0118 DEC HL
008F 7E 0119 LD A,(HL) ;GET PCL
0090 CD8800 0120 CALL UFOR1 ;WRITE TO DISMEM
0093 DD23 0121 INC IX
0095 DD23 0122 INC IX
0097 2B 0123 DEC HL
0098 7E 0124 LD A,(HL) ;GET A
0099 CD9100 0125 CALL UFOR1 ;WRITE TO DISMEM
009C C3FFFF 0126 JP DISUP ;GO DISPLAY
0127 ;*****FINISH RESTART ROUTINE*****
009F ED738300 0128 RESTAR: LD (STKPT),SP ;INIT SP
00A3 31A823 0129 LD SP,23A8H ;INIT SP (ZBUGS)
00A6 3E00 0130 LD A,00H
00A8 32FFFF 0131 LD (BFLG),A ;CLEAR BFLG
00AB 325F00 0132 LD (UIF),A ;CLEAR INTR BIT
00AE C0FFFF 0133 RESTR1: CALL UFGCK ;CLR FLAGS
00B1 3E11 0134 LD A,11H ;PROMPT CHARACTER
00B3 328000 0135 LD (DISMEM),A
00B6 3E10 0136 LD A,10H ;B CHARACTER
00B8 32FFFF 0137 LD (DSMEM1),A
00BB 32FFFF 0138 LD (DSMEM2),A
00BE 1802 0139 JR RESTR2-$
00C0 1813 0140 JR RESTR3-$ ;RELATIVE OFFSET CALCULATI
00C2 32FFFF 0141 RESTR2: LD (DSMEM3),A
00C5 32FFFF 0142 LD (DSMEM4),A
00C8 32FFFF 0143 LD (DSMEM5),A
00CB DB90 0144 IN A,(KBSEL) ;SENSE SWITCH
00CD CB6F 0145 BIT 5,A ;BIT TEST
00CF C29D00 0146 JP NZ,DISUP ;GO TO ZBUG
00D2 C30008 0147 JP 0800H ;RESTART TO PROM
0148 ;RELATIVE OFFSET CALCULATION ROUTINE-AUTOMATICALLY CALCULA
0149 ;RELATIVE OFFSET AND PLACES IT IN MEMORY AND ON THE DISPLA
0150 ;HL = ADDRESS OF OPCODE AT DESTINATION OF RELATIVE JUMP
0151 ;DE = ADDRESS OF THE INSTRUCTION WHICH HAS THE OFFSET
00D5 13 0152 RESTR3: INC DE ;POINT TO OFFSET
00D6 D5 0153 PUSH DE
00D7 DDE1 0154 POP IX ;SAVE DISPLACEMENT ADDRESS
00D9 13 0155 INC DE ;POINT TO NEXT OPCODE
00DA 7D 0156 LD A,L ;GET LOW BYTE
00DB 93 0157 SUB E ;SUBTRACT
00DC 6F 0158 LD L,A ;SAVE OFFSET
00DD DD7700 0159 LD (IX+0),A ;CHANGE MEMORY
00E0 7C 0160 LD A,H ;GET HIGH BYTE
00E1 9A 0161 SBC A,D ;SUBTRACT
00E2 DD21B400 0162 LD IX,DISMEM
00E6 CD9A00 0163 CALL UFOR1 ;WRITE OVERRANGE TO DISPLAY
00E9 DD21BC00 0164 LD IX,DSMEM2
00ED 7D 0165 LD A,L
00EE CDE700 0166 CALL UFOR1 ;WRITE OFFSET TO DISPLAY
00F1 C30000 0167 JP DISUP ;GO DISPLAY
0086 F400 0168 CTC2: EQU 86H ;SS/PROM PGM
0090 0169 KBSEL: EQU 90H ;MONITOR/PROM1 SENSING
0170 END
  
```

ERRORS=0000

```

0002          NAME      DISUP
0003 ; DISPLAY UPDATE ROUTINE
0004 ; VERSION 0.3 3/13/78
0005          PSECT    REL
0006          GLOBAL  DISMEM
0007          GLOBAL  SEGPT
0008          GLOBAL  DECKY
0009          GLOBAL  DISUP
0010          GLOBAL  DISUP
>00F4 0011          ORG      00F4H
0012 ; *****DISPLAY UPDATE ROUTINE*****
0013 ; **FUNCTION: MOVES DATA FROM DISMEM TO DISPLAYS.
0014 ; **ENTRY: DATA TO BE DISPLAYED IN SIX MEMORY LOCATIONS
0015 ;          STARTING AT LOCATION DISMEM.
0016 ; **EXIT: ALL SIX DIGITS REFRESHED - REGISTERS DESTROYED AR
0017 ;          IX, A, B, D, E, H, L
0018 ; **REGISTER USAGE: HL IS POINTER TO CURRENT LOC IN DISMEM
0019 ;          IX IS POINTER TO SEG PATTERN TABLE
0020 ;          B IS CURRENT DIGIT POINTER
0021 ;          E HOLDS DIGIT DATA TO BE DISPLAYED
0022 ;          A AND D ARE SCRATCH REGISTERS
^00F4 21FFFF 0023 DISUP: LD      HL,DISMEM      ; POINT TO START OF BUFFER
^00F7 0620   0024          LD      B,020H      ; POINT TO LEFT DIGIT
^00F9 5E     0025 DISUP1: LD      E,(HL)      ; GET FIRST BYTE
^00FA 1600   0026          LD      D,0        ; CLR D
^00FC 3E00   0027          LD      A,0
^00FE D38C   0028          OUT     (DIGLH),A      ; TURN OFF DISPLAY
^0100 DD21FFFF 0029          LD      IX,SEGPT      ; INDEX INTO TABLE
^0104 DD19    0030          ADD     IX,DE          ; FOR SEGMENT PATTERN
^0106 DD7E00  0031          LD      A,(IX+0)      ; GET PATTERN
^0109 D388   0032          OUT     (SEGLH),A      ; OUT TO SEG LATCH
^010B 78     0033          LD      A,B
^010C D38C   0034          OUT     (DIGLH),A      ; OUT TO DIGIT LATCH
^010E 1E2D   0035          LD      E,45H      ; SET DELAY FOR 1 MS
^0110 1D     0036 DISUP2: DEC     E
^0111 3E00   0037          LD      A,0        ; DELAY LOOP
^0113 EB     0038          CP      E
^0114 20FA   0039          JR      NZ,DISUP2-$
^0116 3E01   0040          LD      A,01H
^0118 B8     0041          CP      B          ; B=1?
^0119 2805   0042          JR      Z,DISUP3-$      ; YES, RE-INIT & EXIT
^011B 23     0043          INC     HL          ; NO, POINT TO NEXT DIGIT
^011C CB38   0044          SRL     B          ; SHIFT TO NEXT DIGIT
^011E 18D9   0045          JR      DISUP1-$
^0120 C3FFFF  0046 DISUP3: JP      DECKY      ; GO DECODE KEYS
>008C          0047 DIGLH: EQU     8CH      ; WRITE ONLY - DIGIT SELECT
>0088          0048 SEGLH: EQU     88H      ; WRITE ONLY - SEG PATTERN
          0049          END

```

ERRORS=0000

```

>0123      0002      ORG      0123H
0003 ; KEY DECODE AND EXECUTION
0004 ; VERSION 2.1 5/17/78
0005      PSECT    REL
0006      NAME     DECKY
0007      GLOBAL   UF0R4
0008      GLOBAL   UF0R1
0009      GLOBAL   UF0R2
0010      GLOBAL   UF0R3
0011      GLOBAL   REMBP2
0012      GLOBAL   D20MS
0013      GLOBAL   KEYPTR
0014      GLOBAL   STKPT
0015      GLOBAL   STKPT1
0016      GLOBAL   SSFLG
0017      GLOBAL   UPACCS
0018      GLOBAL   OTCHR1
0019      GLOBAL   OTHCR6
0020      GLOBAL   UF0R1
0021      GLOBAL   BPTAB
0022      GLOBAL   DIG4
0023      GLOBAL   DIG2
0024      GLOBAL   DIG8
0025      GLOBAL   MFLG
0026      GLOBAL   BFLG
0027      GLOBAL   RFLG
0028      GLOBAL   ARFLG
0029      GLOBAL   PFLG
0030      GLOBAL   PRFLG
0031      GLOBAL   INCHR
0032      GLOBAL   PUNHSH
0033      GLOBAL   PUNHSL
0034      GLOBAL   PUNHEH
0035      GLOBAL   PUNHEL
0036      GLOBAL   REGTB
0037      GLOBAL   RESTAR
0038      GLOBAL   RESTR1
0039      GLOBAL   DISUP
0040      GLOBAL   REGTBP
0041      GLOBAL   DISMEM
0042      GLOBAL   RFLG
0043      GLOBAL   UIF
0044      GLOBAL   DSMEM1
0045      GLOBAL   DSMEM2
0046      GLOBAL   DSMEM3
0047      GLOBAL   DSMEM4
0048      GLOBAL   DSMEM5
0049      GLOBAL   DSMEM6
0050      GLOBAL   DSMEM7
0051      GLOBAL   ULACC
0052      GLOBAL   FLG24
0053      GLOBAL   UIX3
0054      GLOBAL   KYTBL
0055      GLOBAL   CTC1P
0056      GLOBAL   NMIS
0057      GLOBAL   DECKY
0058 ; FUNCTION: BLANKS DISPLAY, SCANS ENTIRE MATRIX FOR CLOSURE.
0059 ;           IF CLOSURE IS FOUND A 20 MS DELAY IS INVOKED
  
```

```

0060 ; TO DEBOUNCE KEYS. KEY MATRIX IS SCANNED ONE
0061 ; ROW AT A TIME, CHECKING ALL COLUMNS. KEY VALUE
0062 ; IS FOUND AND IF IT IS A HEX DIGIT IT IS PLACED
0063 ; IN THE NEXT EMPTY LOCATION OF DISMEM (POINTER=
0064 ; KEYPTR). FLAGS ARE SET WHEN 2 DIGITS (DIG2)
0065 ; AND 4 DIGITS HAVE BEEN ENTERED (DIG4). WHEN
0066 ; 8 DIGITS HAVE BEEN ENTERED A MEMORY CHANGE IS
0067 ; CALLED. IF A COMMAND KEY IS DECODED THE CORRECT
0068 ; SERVICE ROUTINE IS FOUND IN A JUMP TABLE (JPTAB)
0069 ; COMMAND KEY EXECUTION ROUTINES ARE ALSO INCLUDED
0070 ; IN THIS MODULE.
0071 ; ENTRY: NONE REQUIRED, DONE AFTER DISP UPDATE (DISUP)
0072 ; EXIT: IF CMND KEY, CMND HAS BEEN EXECUTED. IF HEX
0073 ; KEY, DATA HAS BEEN ENTERED INTO DISMEM.
0074 ; REGISTERS USED:
0075 ; A-SCRATCH-KEYSL VALUE
0076 ; B-DIGLH VALUE
0077 ; C-SCRATCH-UNIQUE WORD FROM ROW AND CLMN DATA
0078 ; HL-POINTER INTO KYTBL
0079 ; HL-POINTER INTO DISMEM (KYPTR)
0080 ; BC-SCRATCH-USED TO COMPUTE OFFSET INTO DISMEM
0081 ; EXX-USED BY PROM PROGRAMMER TO HOLD POINTERS
0082 ; DURING ERROR CHECKING AND DISP USING NEXT KEY.
^0123 3E7F 0083 DECKY: LD A,7FH
^0125 D388 0084 OUT (SEGLH),A ;TURN OFF DISPLAY
^0127 3E3F 0085 LD A,3FH
^0129 D38C 0086 OUT (DIGLH),A ;OUTPUT ALL ROWS LOW
^012B DB90 0087 IN A,(KBSEL) ;INPUT COLUMN DATA
^012D E61F 0088 AND 1FH ;MASK OUT OTHER INPUTS
^012F FE1F 0089 CP 1FH ;ANY KEY DOWN?
^0131 CAFFFF 0090 JP Z,DISUP ;NO, RETRUN TO DISPLAY
^0134 CDFFFF 0091 CALL DZ0MS ;YES, WAIT FOR DEBOUNCE
^0137 0E8C 0092 LD C,DIGLH
^0139 0601 0093 LD B,01H
^013B FD41 0094 KEYDN1: OUT (C),B ;PLACE SELECTED ROW LOW
^013D DB90 0095 IN A,(KBSEL) ;INPUT COLUMN DATA
^013F E61F 0096 AND 1FH ;MASK OUT D5,D6,D7
^0141 FE1F 0097 CP 1FH ;KEY DOWN?
^0143 200A 0098 JR NZ,KEYDN2-$ ;YES,DECODE KEY
^0145 CB20 0099 SLA B ;NO,SELECT NEXT ROW
^0147 3E40 0100 LD A,40H
^0149 B8 0101 CP B ;ALL DONE?
^014A 20EF 0102 JR NZ,KEYDN1-$ ;NO LOOP BACK
^014C C33201' 0103 JP DISUP ;YES EXIT
0104 ;**ENTRY CONDITIONS TO KEYDECODE ARE ROW IN B AND
0105 ; COLUMN (MASKED BY 1F) IN A.
^014F 0E00 0106 KEYDN2: LD C,00H
^0151 0D 0107 KEYDN3: DEC C
^0152 CB38 0108 SRL B
^0154 20FB 0109 JR NZ,KEYDN3-$ ;FALL THROUGH WHEN B=0
^0156 CB21 0110 SLA C
^0158 CB21 0111 SLA C
^015A CB21 0112 SLA C
^015C CB21 0113 SLA C ;GET VALUE TO HIGH NIBBLE
^015E 81,907 0114 ADD A,C ;COMBINE WITH A
^015F 21FFFF 0115 LD HL,KYTBL ;SETUP POINTER TO NEXT DIG
^0162 BE 0116 KEYDN4: CP (HL) ;A=TABLE FOUND
^0163 2804 0117 JR Z,KEYDN5-$ ;YES,FOUND IT

```

```

^0165 23          0118      INC      HL
^0166 04          0119      INC      B          ;ADJ POINTERS
^0167 18F9        0120      JR       KEYDN4-$      ;LOOP BACK
^0169 DB90        0121 KEYDN5: 1N      A, (KBSEL)          ;CK FOR KEY RELEASE
^016B E61F        0122      AND     01FH          ;MASK OTHER INPUTS
^016D FE1F        0123      CP      01FH
^016F 20F8        0124      JR       NZ,KEYDN5-$    ;LOOP BACK TILL KEY UP
^0171 C03501^    0125      CALL   DZOMS          ;DEBOUNCE
^0174 784F06      0126      LD      A,B          ;GET KEY VALUE
^0175 FE10        0127      CP      10H
^0177 3045        0128      JR       NC,KEYDN6-$    ;COMMAND KEY GO DECODE
^0179 2AFF^      0129      LD      HL,(KEYPTR)    ;HEX KEY, SAVE IN DISMEM
^017C 700b20      0130      LD      (HL),B
^017D B7          0131      OR      A
^017E 01FFFF^    0132      LD      BC,DSMEM1
^0181 ED42        0133      SBC    HL,BC          ;ENTERED DIGIT 2?
^0183 2820        0134      JR       Z,KEYDNA-$
^0185 B7          0135      OR      A          ;CLEAR CARRY
^0186 01FFFF^    0136      LD      BC,DSMEM3      ;CLEAR CARRY
^0189 2A7A01^    0137      LD      HL,(KEYPTR)
^018C ED42        0138      SBC    HL,BC          ;ENTERED DIGIT 4?
^018E 281B        0139      JR       Z,KEYLN8-$    ;YES, INC FLAG
^0190 B7          0140      OR      A
^0191 01FFFF^    0141      LD      BC,DSMEM7
^0194 2A8A01^    0142      LD      HL,(KEYPTR)    ;HEX KEY, SAVE IN DISMEM
^0197 ED42        0143      SBC    HL,BC          ;8 DIGITS IN?
^0199 2816        0144      JR       Z,KEYDN9-$    ;YES, INC FLAG
^019B 2A9501^    0145 KEYDN7: LD      HL,(KEYPTR)    ;GET KEY POINTER
^019E 23          0146      INC     HL          ;INCREMENT IT
^019F 229C01^    0147      LD      (KEYPTR),HL    ;SAVE HL
-^01A2 C34D01^    0148      JP     DISUP          ;EXIT
^01A5 21FFFF^    0149 KEYDNA: LD      HL,DIG2
^01A8 34          0150      INC     (HL)
^01A9 18F0        0151      JR       KEYDN7-$
^01AB 21FFFF^    0152 KEYLN8: LD      HL,DIG4
^01AE 34          0153      INC     (HL)
^01AF 18EA        0154      JR       KEYDN7-$
^01B1 CDB403^    0155 KEYDN9: CALL   ALTER          ;ENTER DATA TO MEM,PORT OR REG
^01B4 2AA001^    0156      LD      HL,(KEYPTR)
^01B7 2B          0157      DEC     HL          ;BACKUP POINTER TO 6 DIGITS IN
^01B8 22B501^    0158      LD      (KEYPTR),HL    ;SAVE HL
^01BB C3A301^    0159      JP     DISUP
^01BE D610        0160 ;FIND ADDRESS OF COMMAND KEY HANDLER-KEYVALUE IN A
^01C0 4F          0161 KEYDN6: SUB     10H          ;KEY 16=0 KEY 17=3
^01C1 81          0162      LD      C,A
^01C2 81          0163      ADD     A,C          ;DOUBLE OFFSET
^01C3 4F          0164      ADD     A,C          ;TRIPLE OFFSET
^01C4 0600        0165      LD      C,A
^01C6 210C02^    0166      LD      B,00H
^01C9 09          0167      LD      HL,JPTAB      ;GET TABLE ADDR
^01CA E9          0168      ADD     HL,BC          ;ADD OFFSET
^01CB ED73FFFF^    0169      JP     (HL)
^01CB ED73FFFF^    0170 ;SERVICE ROUTINE FOR NMI INTERRUPTS, SINGLE STEP OR ABORT
^01CF F5          0171 NMIS:  LD      (STKPT),SP    ;PRESERVE USER'S SP
^01D0 3E03        0172      PUSH   AF
^01D2 D386        0173      LD      A,03H
^01D4 ED57        0174      OUT    (CTC2),A      ;SHUT DOWN CTC
^01D4 ED57        0175      LD      A,I          ;GET 1 INTO A, IFF INTO F

```

| | | | | | | |
|-------|-----------|------|---------|------|--------------|---|
| '01D6 | C5 | 0176 | | PUSH | BC | |
| '01D7 | D5 | 0177 | | PUSH | DE | ; SAVE REGISTERS |
| '01D8 | E5 | 0178 | | PUSH | HL | |
| '01D9 | F5 | 0179 | | PUSH | AF | |
| '01DA | 08 | 0180 | | EX | AF, AF' | |
| '01DB | D9 | 0181 | | EXX | | |
| '01DC | F5 | 0182 | | PUSH | AF | |
| '01DD | C5 | 0183 | | PUSH | BC | |
| '01DE | D5 | 0184 | | PUSH | DE | |
| '01DF | E5 | 0185 | | PUSH | HL | |
| '01E0 | DD05 | 0186 | | PUSH | IX | |
| '01E2 | FD05 | 0187 | | PUSH | IY | |
| '01E4 | DD2ACD01' | 0188 | | LD | IX, (STKPT) | ; GET USER'S SP |
| '01E8 | DD23 | 0189 | | INC | IX | |
| '01EA | DD23 | 0190 | | INC | IX | ; ADJUST TO USER'S REAL SP |
| '01EC | DD7EF4 | 0191 | | LD | A, (IX-12) | ; IFF ON STACK |
| '01EF | E604 | 0192 | | AND | 4 | ; MASK 1FF |
| '01F1 | 32FFFF | 0193 | | LD | (UIF), A | ; SAVE |
| '01F4 | DD22E601' | 0194 | | LD | (STKPT), IX | ; SAVE USER'S SP |
| '01F8 | 3AFFFF | 0195 | NMIS1: | LD | A, (SSFLG) | ; IN SS MODE? |
| '01FB | B7 | 0196 | | OR | A | ; SET STATUS |
| '01FC | CA2301' | 0197 | | JP | Z, DECKY | ; NO, ITS A KB INTR |
| '01FF | 3E00 | 0198 | NMIS2: | LD | A, 00H | |
| '0201 | 32F901' | 0199 | | LD | (SSFLG), A | ; CLEAR FLAG |
| '0204 | 0DFFFF | 0200 | | CALL | UF0R3 | ; GET BP DATA |
| '0207 | CAFFFF | 0201 | | JP | Z, REMBP2 | ; NO BP, DISP PC AND A |
| '020A | 1842 | 0202 | | JR | CCS1C-\$ | ; INSTALL BP, ACTIVATE KB AND RET |
| | | 0203 | | | | ; JUMP TABLE FOR COMMAND KEYS |
| '020C | C33002' | 0204 | JPTAB: | JP | CCS1 | ; EXEC |
| '020F | C37202' | 0205 | | JP | CCS2 | ; SS |
| '0212 | C3A102' | 0206 | | JP | CCS3 | ; MON |
| '0215 | C3A402' | 0207 | | JP | CCS4 | ; NEXT |
| '0218 | C3ED02' | 0208 | | JP | CCS5 | ; REG' DISP |
| '021B | C30803' | 0209 | | JP | CCS6 | ; REG DISP |
| '021E | C36B03' | 0210 | | JP | CCS7 | ; PORT EXAM |
| '0221 | C39503' | 0211 | | JP | CCS8 | ; MEM EXAM |
| '0224 | C39704' | 0212 | | JP | CCS9 | ; BP |
| '0227 | C3CA04' | 0213 | | JP | CCS10 | ; PUNCH TAPE |
| '022A | C38105' | 0214 | | JP | CCS11 | ; LOAD TAPE |
| '022U | C3D305' | 0215 | | JP | CCS12 | ; PROG PROM |
| | | 0216 | | | | ; EXEC KEY HANDLER |
| '0230 | 3E00 | 0217 | CCS1: | LD | A, 00H | |
| '0232 | D38C | 0218 | | OUT | (DIGLH), A | ; CLEAR DISPLAY |
| '0234 | 3AAC01' | 0219 | | LD | A, (DIG4) | |
| '0237 | B7 | 0220 | | OR | A | ; SET STATUS |
| '0238 | 280D | 0221 | | JR | Z, CCS1A-\$ | ; 4 DIGITS NOT IN PROCEED |
| '023A | 0DFFFF | 0222 | | CALL | UF0R2 | ; GET STARTING ADDR IN HL |
| '023D | DD2AF601' | 0223 | | LD | IX, (STKPT) | ; SET POINTER TO USER'S SP |
| '0241 | DD75FE | 0224 | | LD | (IX-2), L | |
| '0244 | DD74FF | 0225 | | LD | (IX-1), H | ; CHANGE PC TO NEW ONE |
| | | 0226 | | | | ; PROCEED NONE |
| '0247 | 0D0502' | 0227 | CCS1A: | CALL | UF0R3 | ; CHECK IF BP'S ACTIVE |
| '024A | 202B | 0228 | | JR | NZ, CCS2A-\$ | ; YES SS ONCE |
| '024C | 1816 | 0229 | | JR | CCS1D-\$ | ; NO, ENABLE KB AND RET |
| | | 0230 | | | | ; INSTALL BREAKPOINTS AND SAVE USERS OP CODES |
| '024E | DD21FFFF | 0231 | CCS1C: | LD | IX, BP1AB | ; POINTER TO BP TAB |
| '0252 | DD6600 | 0232 | CCS1CA: | LD | H, (IX+0) | |
| '0255 | DD6E01 | 0233 | | LD | L, (IX+1) | ; GET ADDR OF OP CODE |

6.F
5.F

```

^0258 7E      0234      LD      A,(HL) ;GET OP CODE
^0259 0ECF    0235      LD      C,0CFH ;INSTALL RST7 OP CODE
^025B 71      0236      LD      (HL),C ;AS A BP
^025C DD7702  0237      LD      (IX+2),A ;SAVE USERS OP CODE
^025F C0FFFF    0238      CALL   UIX3 ;POINT TO NEXT LOCATION
^0262 20EE     0239      JR      NZ,CCS1CA-$ ;LOOP BACK FOR MORE
                0240 ;ENABLE KEYBOARD FOR ABORT
^0264 3E04    0241 CCS1D: LD      A,04H
^0266 D38C    0242      OUT    (DI1GH),A ;ENABLE NMI INTERRUPT
^0268 3E45    0243      LD      A,45H
^026A D386    0244      OUT    (CTC2),A ;CTC TO MAKE A ZC/TO
^026C 3E01    0245      LD      A,01H
^026E D386    0246      OUT    (CTC2),A ;ON ONE NEG PULSE IN
^0270 1812    0247      JR      CCS2B-$ ;RESTORE USER'S REGISTERS
                0248 ;SINGLE STEP KEY HANDLER
^0272 3E00    0249 CCS2: LD      A,00H
^0274 32FFFF F4230250 LD      (BFLG),A ;CLEAR OUT ANY BP
^0277 3E01    0251 CCS2A: LD      A,01H
^0279 320202' 0252      LD      (SSFLG),A ;SET SS FLG
^027C 3E07    0253      LD      A,07H
^027E D386    0254      OUT    (CTC2),A ;NO INTR RESET CTC2
^0280 3E0B    0255      LD      A,11D ;INIT CTC FOR 176 COUNTS
^0282 D386    0256      OUT    (CTC2),A ;UNTIL NMI INTR
                0257 ;RESTORE REGISTERS
^0284 FDE1    0258 CCS2B: POP    IY
^0286 DDE1    0259      POP    IX
^0288 E1      0260      POP    HL
^0289 D1      0261      POP    DE
^028A C1      0262      POP    BC ;ALTERNATE REGISTERS
^028B F1      0263      POP    AF
^028C 08      0264      EX     AF,AF'
^028D D9      0265      EXX
^028E F1      0266      POP    AF ;I AND IFF
^028F ED47    0267      LD      I,A ;RESTORE I
^0291 E1      0268      POP    HL
^0292 D1      0269      POP    DE
^0293 C1      0270      POP    BC
^0294 3AF201' 0271      LD      A,(UIF) ;GET IFF
^0297 B7      0272      OR     A ;SET STATUS
^0298 C29E02' 0273      JP     NZ,CCS2C ;GO ENABLE INTR
^029B F1      0274      POP    AF
^029C F3      0275      DI ;DISABLE INTERRUPTS
^029D C9      0276      RET ;TO USER'S PROGRAM
^029E F1      0277 CCS2C: POP    AF
^029F FB      0278      EI ;ENABLE INTERRUPTS
^02A0 C9      0279      RET ;RETURN TO USER PROGRAM
                0280 ;MON KEY HANDLER - FORCES RESTART OF MONITOR
                0281 ;AND SAVES USER'S REGISTERS
^02A1 C3FFFF    0282 CCS3: JP     RESTR1 ;CLEAR FLAGS, DISP HDR
                0283 ;NEXT KEY HANDLER
                0284 ;USED TO SELECT NEXT MEMORY, NEXT PORT OR NEXT ERROR
                0285 ;IN FROM PROGRAMMING ROUTINE
^02A4 3AFFFF    0286 CCS4: LD      A,(MFLG)
^02A7 FE01    0287      CP     01H ;MEMORY EXAM MODE ACTIVE
^02A9 2812    0288      JR     Z,CCS4B-$
^02AB 3AFFFF    0289      LD      A,(PFLG)
^02AE FE01    0290      CP     01H ;PORT EXAM MODE ACTIVE?
^02B0 2826    0291      JR     Z,CCS4C-$

```

```

^02B2 3AFFFF 0292 LD A,(PRFLG)
^02B5 FE01 0293 CP 01H ;PROM PROG MODE ACTIVE?
^02B7 C2A202' 0294 CCS4A: JP NZ,RESTR1 ;KEY HAD NO MEANING
^02BA C33006' 0295 JP CCS12D ;YES, PROM PROG MODE ACTIVE
0296 ; GO DISPLAY NEXT ERROR
^02BD CD3B02' 0297 CCS4B: CALL UF0R2 ;FORMAT TO FOUR BYTES IN HL
^02C0 23 0298 INC HL ;SELECT NEXT MEMORY ADDR
^02C1 7C 0299 LD A,H
^02C2 C0FFFF 0300 CALL UF0R1 ;UPDATE FIRST TWO DIGITS
^02C5 DD23 0301 INC IX ;IX IS ALREADY PTING TO DISMEM
^02C7 DD23 0302 INC IX
^02C9 7D 0303 LD A,L
^02CA CDC302' 0304 CALL UF0R1 ;UPDATE SECOND TWO DIGITS
^02CD DD23 0305 INC IX
^02CF DD23 0306 INC IX
^02D1 7E 0307 LD A,(HL) ;READ NEW MEMORY
^02D2 CDCB02' 0308 CALL UF0R1 ;UPDATE THIRD TWO DIGITS
^02D5 C3BC01' 0309 JP DISUP ;GO DISPLAY
^02D8 CDBE02' 0310 CCS4C: CALL UF0R2 ;FORMAT TO FOUR BYTES IN HL
^02DB 4C 0311 LD C,H ;;ONLY H HAS MEANING
^02DC 0C 0312 INC C ;SELECT NEXT PORT
^02DD ED78 0313 IN A,(C) ;READ PORT
^02DF 79 0314 LD A,C ;IX ALREADY POINTING TO DISMEM
^02E0 CDD302' 0315 CALL UF0R1
^02E3 DD21FFFF 0316 LD IX,DSMEM4 ;POINT TO LAST TWO DIGITS
^02E7 CDE102' 0317 CALL UF0R1 ;WRITE INTO DISMEM
^02EA C3D602' 0318 JP DISUP ;GO DISPLAY
0319 ;ALTERNATE REGISTER DISPLAY
^02ED 3E01 0320 CCS5: LD A,01
^02EF 32FFFF 0321 LD (ARFLG),A ;SET ARFLG
^02F2 DD21FFFF 0322 LD IX,DISMEM ;POINT TO REG
^02F6 3E12 0323 LD A,12H ;PRIME CHAR
^02F8 DD7701 0324 LD (IX+1),A ;WRITE TO DISPLAY
^02FB CD5504' 0325 CALL ALTER5
^02FE 7E 0326 LD A,(HL) ;GET INTO A
^02FF DD21E502' 0327 LD IX,DSMEM4 ;PT TO LAST 2 DIGITS
^0303 CDE802' 0328 CALL UF0R1 ;WRITE A TO DISMEM
^0306 185A 0329 JR CCS6C-$
0330 ;MAIN REGISTER DISPLAY
^0308 3E01 0331 CCS6: LD A,01H
^030A 32FFFF 0332 LD (RFLG),A ;SET RFLG
^030D CD6E04' 0333 CALL ALTER6
^0310 380A 0334 JR C,CCS6A-$ ;SPEC REG LT 6?
^0312 7E 0335 LD A,(HL) ;GET INTO A
^0313 DD210103' 0336 LD IX,DSMEM4 ;PT TO LAST 2 DIGITS
^0317 CD0403' 0337 CALL UF0R1 ;WRITE A TO DSMEM4,5
^031A 1846 0338 JR CCS6C-$
0339 ;HANDLE PC, SP, IX, IY
^031C FE03 0340 CCS6A: CP 3 ;IS IT KEY 3
^031E 2835 0341 JR Z,CCS6B-$ ;YES, IFF
^0320 FE02 0342 CP 2 ;KEY 2?
^0322 2817 0343 JR Z,CCS6A1-$ ;YES, STACK POINTER
^0324 7E 0344 LD A,(HL) ;LOW BYTE INTO A
^0325 DD211503' 0345 LD IX,DSMEM4
^0329 DD22B901' 0346 LD (KEYPTR),IX ;PREPARE FOR FOUR DIGITS I
^032D CD1803' 0347 CALL UF0R1 ;FIRST BYTE TO DSMEM2,3
^0330 23 0348 INC HL
^0331 7E 0349 LD A,(HL) ;HIGH BYTE TO A

```

```

^0332 DD21FFFF 0350          LD      IX,DSMEM2          ;POINT TO FIRST TWO
^0336 CD2E03^ 0351          CALL   UFOR1          ;SECOND BYTE TO DSMEM4,5
^0339 182D    0352          JR     CCS6D-$        ;GO DISPLAY
^033B 3AFFFF 0353 CCS6A1: LD      A,(STKPT1)
^033E DD213403^ 0354          LD      IX,DSMEM2
^0342 CD3703^ 0355          CALL   UFOR1          ;FIRST BYTE TO DISMEM
^0345 3A3F02^ 0356          LD      A,(STKP1)
^0348 DD212703^ 0357          LD      IX,DSMEM4
^034C CD4303^ 0358          CALL   UFOR1          ;SECOND BYTE TO DISMEM
^034F DD222B03^ 0359          LD      (KEYPTR),IX    ;PREPARE FOR 4 DIGITS IN
^0353 1813    0360          JR     CCS6D-$
                0361 ;HANDLE IFF
^0355 DD214A03^ 0362 CCS6B: LD      IX,DSMEM4
^0359 3A9502^ 0363          LD      A,(UIF) ;GET VALUE 4 OR 0
^035C CD4D03^ 0364          CALL   UFOR1          ;WRITE TO DISMEM
^035F 219201^ 0365          LD      HL,DSMEM7
^0362 21FFFF 0366 CCS6C: LD      HL,DSMEM6          ;SETUP FOR REG CHG
^0365 225103^ 0367          LD      (KEYPTR),HL
^0368 C3EB02^ 0368 CCS6D: JP     DISUP
                0369 ;EXAMINE PORTS
^036B 3AA601^ 0370 CCS7:  LD      A,(DIG2)
^036E FE01    0371          CP     1
^0370 2020    0372          JR     NZ,CCS7A-$    ;VERIFY TWO DIGITS IN
^0372 32AC02^ 0373          LD      (PFLG),A      ;SET PFLG
^0375 3E10    0374          LD      A,10H
^0377 324003^ 0375          LD      (DSMEM2),A
^037A 328701^ 0376          LD      (DSMEM3),A    ;BLANK DIGITS 2 AND 3
^037D CDD902^ 0377          CALL   UFOR2          ;GET PORT ADDR INTO HL
^0380 4C      0378          LD      C,H          ;MOVE FIRST TWO DIGITS TO C
^0381 ED78    0379          IN     A,(C)        ;READ THE PORT
^0383 DD215703^ 0380          LD      IX,DSMEM4    ;PT TO DATA DIGITS
^0387 CD5D03^ 0381          CALL   UFOR1          ;WRITE INTO DISMEM
^038A DD23    0382          INC    IX
^038C DD23    0383          INC    IX          ;SETUP TO CHANGE PORTS
^038E DD226603^ 0384          LD      (KEYPTR),IX  ;SETUP TO CHG PORT
^0392 C36903^ 0385 CCS7A: JP     DISUP          ;GO DISPLAY
                0386 ;EXAMINE MEMORY
^0395 3A3502^ 0387 CCS8:  LD      A,(DIG4)
^0398 B7      0388          OR     A          ;VERIFY FOUR DIGITS IN
^0399 2816    0389          JR     Z,CCS8A-$
^039B 32A502^ 0390          LD      (MFLG),A      ;SET MFLG
^039E CD7E03^ 0391          CALL   UFOR2          ;GET FOUR BYTE ADDR IN HL
^03A1 7E      0392          LD      A,(HL)      ;GET MEMORY DATA
^03A2 DD218503^ 0393          LD      IX,DSMEM4    ;POINT TO CORRECT DIGITS
^03A6 CD8803^ 0394          CALL   UFOR1          ;WRITE INTO DISMEM
^03A9 DD23    0395          INC    IX
^03AB DD23    0396          INC    IX
^03AD DD229003^ 0397          LD      (KEYPTR),IX  ;SETUP FOR DATA CHG
^03B1 C39303^ 0398 CCS8A: JP     DISUP
^03B4 DD21F402^ 0399 ALTER: LD      IX,DISMEM
^03B8 3A7303^ 0400          LD      A,(PFLG)
^03BB B7      0401          OR     A
^03BC 202A    0402          JR     NZ,ALTER2-$   ;PORT CHNG
^03BE 3A0B03^ 0403          LD      A,(RFLG)
^03C1 B7      0404          OR     A
^03C2 2035    0405          JR     NZ,ALTER3-$   ;REG CHANGE
^03C4 3AF002^ 0406          LD      A,(ARFLG)
^03C7 B7      0407          OR     A

```

```

'03C8 C24104' 0408 JP NZ,ALTR4 ;ALT REG CHANGE
'03CB 3A9C03' 0409 LD A,(MFLG)
'03CE B7 0410 OR A
'03CF CAB802' 0411 JP Z,RESTR1 ;FALSE ALARM RESTART
'03D2 CD9F03' 0412 CALL UFOR2 ;GET ADDR INTO HL
'03D5 DD7E06 0413 LD A,(IX+6) ;GET HIGH NIBBLE
'03D8 CD8E04' 0414 CALL ALTER7
'03DB DDB607 0415 OR (IX+7) ;OR WITH LOW NIB
'03DE 77 0416 LD (HL),A ;WRITE TO MEMORY
'03DF 7E 0417 LD A,(HL) ;READ IT BACK
'03E0 DD21A403' 0418 ALTER1: LD IX,DSMEM4
'03E4 CDA703' 0419 CALL UFOR1 ;WRITE NEW DATA INTO DISMEM
'03E7 C9 0420 RET
'03E8 CDD303' 0421 ALTER2: CALL UFOR2 ;GET ADDRESS INTO HL
'03EB DD7E06 0422 LD A,(IX+6) ;GET ONE NIB
'03EE CD8E04' 0423 CALL ALTER7
'03F1 DDB607 0424 OR (IX+7) ;OR WITH LOW NIB
'03F4 4C 0425 LD C,H
'03F5 ED79 0426 OUT (C),A ;WRITE TO PORT
'03F7 18E7 0427 JR ALTER1-$
0428 ;MAIN REGISTER CHANGE
'03F9 CD6E04' 0429 ALTR3: CALL ALTER6
'03FC 380D 0430 JR C,ALTR3A-$ ;SPEC REG LT 6?
'03FE DD7E06 0431 LD A,(IX+6) ;GET HIGH NIBBLE
'0401 CD8E04' 0432 CALL ALTER7
'0404 DDB607 0433 OR (IX+7) ;OR WITH HIGH NIBBLE
'0407 77 0434 LD (HL),A ;MODIFY REGS ON STACK
'0408 C3E003' 0435 JP ALTER1
'040B FE03 0436 ALTR3A: CP 3 ;IS IT KEY 3?
'040D 2824 0437 JR Z,ALTR3B-$ ;YES, IFF
'040F FE02 0438 CP 2 ;IS IT KEY 2?
'0411 282A 0439 JR Z,ALTR3C-$ ;YES, SP
'0413 DD7E04 0440 LD A,(IX+4) ;GET HIGH NIBBLE
'0416 CD8E04' 0441 CALL ALTER7
'0419 DDB605 0442 OR (IX+5) ;OR WITH LOW NIBBLE
'041C 23 0443 INC HL
'041D 77 0444 LD (HL),A ;MODIFY HIGH BYTE
'041E DD217803' 0445 LD IX,DSMEM2
'0422 CDE503' 0446 CALL UFOR1 ;WRITE DATA TO DISPLAY
'0425 DD7E04 0447 LD A,(IX+4) ;GET HIGH NIBBLE
'0428 CD8E04' 0448 CALL ALTER7
'042B DDB605 0449 OR (IX+5) ;OR WITH LOW NIBBLE
'042E 2B 0450 DEC HL
'042F 77 0451 LD (HL),A ;MODIFY HIGH BYTE
'0430 C3E003' 0452 JP ALTER1
'0433 3A6003' 0453 ALTR3B: LD A,(DSMEM7) ;GET NEW VALUE
'0436 325A03' 0454 LD (UIF),A ;MODIFY UIF
'0439 32FFFF 0455 LD (DSMEM5),A ;WRITE TO DISPLAY
'043C C9 0456 RET
0457 ;SP CHANGE IS ILLEGAL
'043D E1 0458 ALTR3C: POP HL ;DUMMY TO SIM RET
'043E C3D003' 0459 JP RESTR1
0460 ;ALTERNATE REGISTER CHANGE
'0441 DD21B603' 0461 ALTR4: LD IX,DISMEM ;POINT TO REG
'0445 CD5504' 0462 CALL ALTER5
'0448 DD7E06 0463 LD A,(IX+6) ;GET HIGH NIBBLE
'044B CD8E04' 0464 CALL ALTER7
'044E DDB607 0465 OR (IX+7) ;OR WITH LOW NIBBLE

```



```

^0451 77          0466          LD      (HL),A ;MODIFY REG ON STK
^0452 C3E003^    0467          JP      ALTER1 ;GO DISPLAY
^0455 DD5E00    0468 ALTER5: LD      E,(IX+0) ;GET REGISTER
^0458 0600      0469          LD      B,00H
^045A 1600      0470          LD      D,00H
^045C 21FFFF    0471          LD      HL,REGTBP ;POINT TO ALT TABLE
^045F 19        0472          ADD     HL,DE ;ADD KEYVALUE OFFSET
^0460 4E        0473          LD      C,(HL) ;GET VALUE
^0461 79        0474          LD      A,C
^0462 FE19     0475          CP      25D ;ILLEGAL VALUE?
^0464 CA3F04^   0476          JP      Z,RESTR1 ;YES, RESTART MONITOR
^0467 2A4603^   0477          LD      HL,(STKPT) ;POINT TO USER'S STACK
^046A B7        0478          OR      A ;CLEAR CARRY
^046B ED42     0479          SBC    HL,BC ;SUB OFFSET FROM SP
^046D C9        0480          RET
^046E DD214304^ 0481 ALTER6: LD      IX,DISMEM ;POINT TO REGISTER
^0472 DD5E00    0482          LD      E,(IX) ;GET REGISTER
^0475 0600      0483          LD      B,00H
^0477 1600      0484          LD      D,00H
^0479 21FFFH    0485          LD      HL,REGTB ;POINT TO MAIN TABLE
^047C 19        0486          ADD     HL,DE ;ADD KEYVALUE OFFSET
^047D 4E        0487          LD      C,(HL) ;GET VALUE
^047E 79        0488          LD      A,C
^047F FE19     0489          CP      25D ;ILLEGAL VALUE?
^0481 CA6504^   0490          JP      Z,RESTR1 ;IF SO RESTART
^0484 2A6804^   0491          LD      HL,(STKPT) ;POINT TO USER'S STACK
^0487 7B        0492          LD      A,E ;GET KEYVALUE AGAIN
^0488 B7        0493          OR      A ;CLEAR CARRY
^0489 ED42     0494          SBC    HL,BC ;SUB OFFSET FROM SP
^048B FE06     0495          CP      6 ;SPEC REG?
^048D C9        0496          RET
^048E CB27     0497 ALTER7: SLA    A
^0490 CB27     0498          SLA    A
^0492 CB27     0499          SLA    A
^0494 CB27     0500          SLA    A
^0496 C9        0501          RET
0502 ;BREAKPOINT INSTALLATION
0503 ;MAKES AN ENTRY INTO BREAKPOINT TABLE IF ENOUGH SPACE
0504 ;EXISTS. THE ACTUAL BREAKPOINTS ARE PUT INTO RAM
0505 ;ON THE EXECUTE COMMAND.
^0497 3A9603^   0506 CCS9: LD      A,(DIG4) ;GET FLAG
^049A B7        0507          OR      A ;SET STATUS
^049B 2005      0508          JR      NZ,CCS90-$ ;FOUR DIGITS IN?
^049D 327502^   0509          LD      (BFLG),A ;NO CLEAR ALL BP'S
^04A0 1810      0510          JR      CCS91-$
^04A2 CDE903^   0511 CCS90: CALL   UF0R2 ;GET BP ADDR INTO HL
^04A5 CD4802^   0512          CALL   UF0R3 ;GET BP STATUS
^04A8 2810      0513          JR      Z,CCS9B-$ ;NO BP, INSTALL ONE
^04AA 78        0514          LD      A,B
^04AB FE05     0515          CP      05 ;TABLE FULL?
^04AD 2006      0516          JR      NZ,CCS9A-$ ;NO GO ON
^04AF C38204^   0517          JP      RESTR1 ;YES, CLEAR DISPLAY
^04B2 C3B203^   0518 CCS91: JP      DISUP
0519 ;FIND FIRST FREE SPACE IN TABLE
^04B5 CD6002^   0520 CCS9A: CALL   UIX3 ;IX+3 AND B-1
^04B8 20FB     0521          JR      NZ,CCS9A-$ ;LOOP TIL FREE SPC
0522 ;INSERT NEW BREAKPOINTS IN TABLE
^04BA 3A9E04^   0523 CCS9B: LD      A,(BFLG)

```

TR
K19857463

```

04BD 3C          0524          INC      A
04BE 32BB04     0525          LD       (BFLG),A      ; INCREMENT FLAG
04C1 DD7400     0526          LD       (IX),H      ; WRITE TO TABLE
04C4 DD7501     0527          LD       (IX+1),L
04C7 C3B304     0528          JP       DISUP
0529 ; PUNCH DATA TO CASSETTE INTERFACE IN KC FORMAT
0530 ; STARTING ADDRESS IN DE, ENDING ADDRESS IN HL.
0531 ; INTERRUPTS ARE LIVE DURING THIS ROUTINE.
04CA C0FFFF     0532 CCS10: CALL  UF0R4      ; CLEAR DISPLAY
04CD 3E01       0533          LD       A,1
04CF 32FFFF     0534          LD       (FLG24),A    ; SET FLG24 FOR MARKS
04D2 ED5E     0535          IM      2
04D4 01FFFF     0536          LD       BC,CTC1P
04D7 78        0537          LD       A,B
04D8 ED47     0538          LD       I,A
04DA 79        0539          LD       A,C
04DB D384     0540          OUT      (CTC0),A    ; INTERRUPT VECTOR
04DD 3E85     0541          LD       A,85H
04DF D385     0542          OUT      (CTC1),A    ; CTC1 TO INTR
04E1 3E1A     0543          LD       A,26D
04E3 D385     0544          OUT      (CTC1),A    ; WITH THIS TIME CONST
04E5 3AFFFE     0545          LD       A,(PUNHSH)
04E8 57        0546          LD       D,A
04E9 3AFFFE     0547          LD       A,(PUNHSL)  ; GET STARTING ADDR
04EC 5F        0548          LD       E,A
04ED 3AFFFE     0549          LD       A,(PUNHEH)
04F0 67        0550          LD       H,A
04F1 3AFFFE     0551          LD       A,(PUNHEL)  ; GET ENDING ADDE
04F4 6F        0552          LD       L,A
04F5 AF        0553          XOR      A      ; CLEAR CARRY
04F6 E152     0554          SBC     HL,DE    ; CALCULATE BLOCK SIZE
04F8 23        0555          INC     HL
04F9 E5        0556          PUSH   HL      ; SAVE IT
04FA 210000    0557          LD     HL,0000H
04FD 0603     0558          LD     B,3D     ; SETUP FOR 40 SEC DELAY
04FF FB        0559          EI
0500 76        0560 CCS10A HALT      ; WAIT FOR CTC1 INTR
0561 ; *****

0501 2D        0562          DEC     L
0502 20FC     0563          JR     NZ,CCS10A-$
0504 25        0564          DEC     H
0505 20F9     0565          JR     NZ,CCS10A-$    ; DELAY LOOP
0507 10F7     0566          DJNZ   CCS10A-$      ; 40 SEC FOR LEADER
0509 3E3A     0567 CCS10B: LD     A,3AH    ; START WITH A COLON
050B C0FFFF     0568          CALL  OTCHR1    ; OUTPUT COLON
050E AF        0569          XOR     A      ; CLEAR CARRY,INTRPTS DISABLED
050F 011000    0570          LD     BC,10H
0512 E1        0571          POP    HL
0513 ED42     0572          SBC     HL,BC    ; COMPARE HL WITH 10
0515 3009     0573          JR     NC,CCS10C-$  ; NC=>HL>10H
0517 09        0574          ADD    HL,BC    ; RESTORE BLOCK SIZE<10H
0518 85        0575          ADJ    A,L      ; SET STATUS IF L=0
0519 47        0576          LD     B,A
051A 2E00     0577          LD     L,0
051C 283C     0578          JR     Z,CCS10F-$
051E 1801     0579          JR     CCS10D-$
0520 41        0580 CCS10C: LD     B,C    ; B=BLOCK SIZE
0521 E5        0581 CCS10D: PUSH   HL      ; SAVE
  
```

```

0522 0E00 0582 LD C,0 ; CLEAR CHECKSUM
0524 78 0583 LD A,B ; PUNCH RECORD LENGTH
0525 CDFFFF 0584 CALL UPACCS
0528 3A1804 0585 LD A,(PUNHSH)
052B 67 0586 LD H,A
052C CD2605 0587 CALL UPACCS
052F 3AEA04 0588 LD A,(PUNHSL) ; PUNCH HIGH BYTE FIRST
0532 6F 0589 LD L,A
0533 CD2105 0590 CALL UPACCS
0536 AF 0591 XOR A ; ACC=0, PUNCH RECORD TYPE
0537 CD3405 0592 CALL UPACCS
053A 7E 0593 CCS10E: LD A,(HL) ; PUNCH DATA
053B CD3805 0594 CALL UPACCS
053E 23 0595 INC HL
053F 10F9 0596 DJNZ CCS10E-$
0541 97 0597 SUB A
0542 91 0598 SUB C
0543 CD3C05 0599 CALL UPACCS ; PUNCH CHECKSUM
0546 3E0D 0600 LD A,ODH ; CR
0548 CD4405 0601 CALL UPACCS
054B 3E0A 0602 LD A,0AH ; LF
054D CD4905 0603 CALL UPACCS
0550 7C 0604 LD A,H
0551 322905 0605 LD (PUNHSH),A ; SAVE HIGH BYTE
0554 7D 0606 LD A,L
0555 323005 0607 LD (PUNHSL),A ; SAVE LOW BYTE
0558 18AF 0608 JR CCS10B-$ ; PUNCH SOME MORE
055A 0603 0609 CCS10F: LD B,3
055C AF 0610 CCS10G: XOR A
055D 4F 0611 LD C,A
055E CD4E05 0612 CALL UPACCS ; PUNCH EOF
0561 10F9 0613 DJNZ CCS10G-$
0563 3E01 0614 LD A,1
0565 CD5F05 0615 CALL UPACCS
0568 97 0616 SUB A
0569 91 0617 SUB C
056A CD6605 0618 CALL UPACCS ; CHECKSUM FOR EOF
056D 21FFFF 0619 CCS10H: LD HL,OFFFH ; SETUP 5 SEC TRAILER
0570 FB 0620 EI ; ENABLE INTERRUPTS
0571 76 0621 HALT
0622 ;*****
0572 2D 0623 CCS10J: DEC L
0573 20FD 0624 JR NZ,CCS10J-$
0575 25 0625 DEC H
0576 20FA 0626 JR NZ,CCS10J-$
0578 F3 0627 DI
0579 3E03 0628 LD A,03H
057B D385 0629 OUT (CTC1),A ; DISABLE CTC KILL TONE
057D F3 0630 DI ; DISABLE INTERRUPTS
057E C3B004 0631 JP RESTR1 ; RESTART MONITOR
0632 ; LOAD DATA FROM CASSETTE TAPE TO MEMORY (KC FORMAT)
0581 ED5E 0633 CCS11: IM 2 ; SELECT MODE TWO INTERRUPTS
0583 21FF0F 0634 LD HL,OFFFH ; START 15 SEC DELAY
0586 0620 0635 LD B,20H
0588 2D 0636 CCS11A: DEC L
0589 20FD 0637 JR NZ,CCS11A-$
058B 25 0638 DEC H
058C 20FA 0639 JR NZ,CCS11A-$
  
```

```

00 058E 10F8      0640      DJNZ   CCS11A-$
                0641 ;NOW INTO LEADER - START MAIN LOOP
05 0590 C0FFFF      0642 CCS11G: CALL   INCHR   ;GET FIRST CHARS
0593 D163A      0643      SUB#   3AH   ;CHECK FOR COLON
0595 20F9      0644      JR     NZ,CCS11G-$   ;LOOP BACK
0597 4F         0645      LD     C,A<=      ;ZERO CHECKSUM
0598 C0FFFF      0646      CALL  ULACC   ;GET RECORL LENGTH AND CKSUM
059B 47         0647      LD     B,A
059C CD9905'    0648      CALL  ULACC   ;GET HIGH BYTE OF ADDR
059F 57         0649      LD     D,A
05A0 CD9105'    0650      CALL  ULACC   ;GET LOW BYTE OF ADDR
05A3 5F         0651      LD     E,A
05A4 CDA105'    0652      CALL  ULACC<=   ;GET RECORD TYPE
05A7 3D         0653      DEC   A       ;RECORD TYPE=EOF?
05A8 F5         0654      PUSH  AF
05A9 2807      0655      JR     Z,CCS11J-$   ;JP IF YES
05AB CDA505'    0656 CCS11H: CALL  ULACC   ;GET DATA
05AE 12         0657      LD     (DE),A   ;STORE IT
05AF 13         0658      INC   DE
05B0 10F9      0659      DJNZ  CCS11H-$   ;LOOP FOR MORE
05B2 CDAC05'    0660 CCS11J: CALL  ULACC   ;GET CHECKSUM
05B5 AF         0661      XOR   A       ;CLEAR ACC
05B6 81         0662      ADD   A,C
05B7 2814      0663      JR     Z,CCS11K-$   ;CKSUM OK
                0664 ;ERROR REPORTING
05B9 DD217004'  0665      LD     IX,DISMEM ;POINT TO BUFFER
05BD 7A         0666      LD     A,D
05BE CD2304'    0667      CALL  UFOR1   ;DISPLAY HIGH BYTE
05C1 DD212004'  0668      LD     IX,DSMEM2
05C5 7B         0669      LD     A,E
05C6 CDBF05'    0670      CALL  UFOR1   ;DISPLAY LOW BYTE
05C9 F1         0671      POP   AF      ;RESTORE SP_
05CA C3C804'    0672      JP    DISUP   ;GO DISPLAY
05CD F1         0673 CCS11K: POP   AF      ;EST FOR EOF
05CE 20C0      0674      JR     NZ,CCS11G-$   ;GO LOOK OF NEXT RECORD
05D0 C37F05'    0675      JP    RESTR1  ;RESTART MONITOR
                0676 ;FROM PROGRAMMER FOR 2758 AND 2716 PROMS
                0677 ;MOVES DATA FOR RAM STARTING AT 2000H TO PROM
                0678 ;STARTING AND 1000H. NUMBER OF BYTES TO BE
                0679 ;TRANSFERED (EXPRESSED IN FOUR HEX DIGITS) IS
                0680 ;IN DISPLAY BUFFER (DISMEM).
05D3 3E01      0681 CCS12: LD     A,01H
05D5 32B302'    0682      LD     (PRFLG),A ;SET PROM PR0G FLG
05D8 CDA304'    0683      CALL  UFOR2   ;GET BYTE COUNT
05DB E5         0684      PUSH  HL     ;SAVE IT
05DC C1         0685      POP   BC
05DD E5         0686      PUSH  HL
05DE 210020    0687      LD     HL,2000H ;RAM SOURCE DATA
05E1 110010    0688      LD     DE,1000H ;PROM DEST ADDR
05E4 3E25      0689 CCS12A: LD     A,25H ;CTC FOR 26MS ZC/TO2
05E6 D386      0690      OUT   (CTC2),A ;NO INTR
05E8 3ECB      0691      LD     A,203D
05EA D386      0692      OUT   (CTC2),A ;TIME CONST
05EC 3E80      0693      LD     A,80H   ;CLEAR DISPLAY SET
05EE D38C      0694      OUT   (DIGLH),A ;PROM PR0G EN=1
05F0 EDA0      0695      LDI                    ;WAIT STATE INSERTED UNTIL
05F2 3E00      0696      LD     A,00H  ;CTC2 TIMES OUT TWICE
05F4 D38C      0697      OUT   (DIGLH),A ;CLEAR PROM PR0G EN

```

```

'05F6 3E03      0698      LD      A,03H      ; RESET CTC2
'05F8 D386      0699      OUT     (CTC2),A
'05FA EAE405'    0700      JP      FE,CCS12A      ; LOOPBACK IF BC-1 NE ●
                0701 ; VERIFY FROM IS LIKE RAM
'05FD C1        0702      POP     BC          ; RESTORE BYTE COUNT
'05FE 210020   0703      LD      HL,2000H     ; HL PTS TO RAM
'0601 110010   0704      LD      DE,1000H     ; DE PTS TO PROM
'0604 1A       0705 CCS12B: LD      A,(DE)      ; GET FROM DATA
'0605 EDA1      0706      CP1     ; COMPARE WITH RAM
'0607 2006      0707      JR      NZ,CCS12C-$  ; ERROR REPORT IT
'0609 EZD105'  0708      JP      PO,RESTRI    ; NO ERRORS - RETURN
'060C 13       0709      INC     DE          ; UPDATE DE
'060D 18F5      0710      JR      CCS12B-$     ; CHECK NEXT BYTE
                0711 ; ERROR HANDLER
'060F F5       0712 CCS12C: PUSH   AF      ; PRESERVE ERROR DATA
'0610 C5       0713      PUSH   BC          ; PRESERVE BYTE COUNT
'0611 D5       0714      PUSH   DE          ; PRESERVE ERROR ADDR
'0612 D9       0715      EXX    ; PRESERVE MAIN REGISTERS
'0613 D1       0716      POP    DE          ; DE=ERROR ADDR IN PROM
'0614 C1       0717      POP    BC          ; BC=BYTE COUNT
'0615 DD21B05' 0718      LD      IX,DISMEM
'0619 7A       0719      LD      A,D
'061A CDC705'  0720      CALL   UFOR1      ; HIGH BYTE TO DISMEM
'061D DD21C305' 0721      LD      IX,DSMEM2
'0621 7B       0722      LD      A,E
'0622 CD1B06'  0723      CALL   UFOR1      ; LOW BYTE TO DISMEM
'0625 DD21E203' 0724      LD      IX,DSMEM4
'0629 F1       0725      POP    AF          ; RETRIEVE ERROR DATA
'062A CD2306'  0726      CALL   UFOR1      ; ERROR DATA TO DISMEM
'062D C3CB05'  0727      JP      DISUP     ; DISPLAY IT
                0728 ; NEXT KEY INPUT DURING ERROR DISPLAY
'0630 D9       0729 CCS12D: EXX    ; GET BACK POINTERS
'0631 13       0730      INC     DE          ; SETUP FOR NEXT ERROR
'0632 18D0     0731      JR      CCS12B-$     ; LOOP FOR MORE ERRS
                0732 ; *****EQUATES
>008C      0733 DIGLH EQU     8CH      ; WRITE ONLY DIGIT SEL
>0090      0734 KBSEL EQU     90H     ; READ ONLY KB SEL
>0084      0735 CTC0: EQU     84H     ; INTRPT VECTOR
>0085      0736 CTC1: EQU     85H     ; CASSETTE INTERFACE-PUNCH
>0086      0737 CTC2: EQU     86H     ; SS/PROM PROGRAMMER
>0087      0738 CTC3: EQU     87H     ; CASSETTE INTERFACE-LOAD
>0088      0739 SEGLH: EQU     88H     ; WRITE ONLY SEGMENT LATCH
                0740      END

```

ERRORS=0000



```

0002          NAME      UTIL
0003 ;UTILITY PACKAGE
0004 ;VERSION 1.5 5/13/78
>0634 0005          ORG      0634H
0006          PSECT     REL
0007          GLOBAL   DIG2
0008          GLOBAL   DIG4
0009          GLOBAL   DIG8
0010          GLOBAL   UIX3
0011          GLOBAL   UFOR1
0012          GLOBAL   DZOMS
0013          GLOBAL   UFOR2
0014          GLOBAL   UFOR3
0015          GLOBAL   UFOR4
0016          GLOBAL   BPTAB
0017          GLOBAL   SSFLG
0018          GLOBAL   UABIN
0019          GLOBAL   UBASC
0020          GLOBAL   UPACC
0021          GLOBAL   UPACCS
0022          GLOBAL   ULACC
0023          GLOBAL   OTCHR
0024          GLOBAL   KYTBL
0025          GLOBAL   REGTB
0026          GLOBAL   REGTBP
0027          GLOBAL   DISMEM
0028          GLOBAL   STKPT
0029          GLOBAL   SEGPT
0030          GLOBAL   KEYPTR
0031          GLOBAL   OTCHR
0032          GLOBAL   OTCHR1
0033          GLOBAL   INCHR
0034          GLOBAL   FLG24
0035          GLOBAL   RFLG
0036          GLOBAL   ARFLG
0037          GLOBAL   BFLG
0038          GLOBAL   PFLG
0039          GLOBAL   CTC1P
0040          GLOBAL   MFLG
0041          GLOBAL   PRFLG
0042          GLOBAL   CTC3L
0043          GLOBAL   CTC1P
0044          GLOBAL   UFGCR
0045          GLOBAL   OTCHR6
0046          GLOBAL   INCHR4
0047 ;ADDS THREE TO IX AND DECREMENTS B
0048 ;USED IN MANIPULATING THE TABLE HOLDING
0049 ;BREAKPOINT ADDRESSES AND USER OP CODES
^0634 DD23 0050 UIX3:  INC      IX
^0636 DD23 0051          INC      IX
^0638 DD23 0052          INC      IX
^063A 05   0053          DEC      B
^063B C9   0054          RET              ;USER TO CHECK FOR BP OVRFLW
0055 ;IX POINTS TO NEXT TWO LOCATIONS IN DISMEM TO BE
0056 ;WRITTEN INTO. A CONTAINS THE DATA AND UFOR1 DOES
0057 ;THE WRITING.
^063C 47   0058 UFOR1:  LD      B,A      ;SAVE A IN TEMP REG
^063D E60F 0059          AND     00FH   ;MASK OUT HIGH NIBBLE

```

```

^063F DD7701 0060 LD (IX+1),A ;PUT IN LOW NIBBLE
^0642 78 0061 LD A,B ;GET FULL BYTE
^0643 CB3F 0062 SRL A
^0645 CB3F 0063 SRL A
^0647 CB3F 0064 SRL A
^0649 CB3F 0065 SRL A ;HIGH NIBBLE TO LOW
^064B DD7700 0066 LD (IX+0),A ;PUT HIGH NIBBLE IN DISMEM
^064E C9 0067 RET
0068 ;DELAY 20 MILLISECONDS AND RETURN
^064F 21FF08 0069 DZOMS: LD HL,08FFH
^0652 2D 0070 DZOMS1: DEC L
^0653 20FD 0071 JR NZ,DZOMS1-$
^0655 25 0072 DEC H
^0656 20FA 0073 JR NZ,DZOMS1-$
^0658 C9 0074 RET
0075 ;FORMATS FIRST FOUR DIGITS IN DISMEM INTO AN ADDRESS IN
0076 ;HL, USED BY MEMORY AND PORT UPDATE COMMANDS.
^0659 DU21FFFF 0077 UFOR2: LD IX,DISMEM ;POINTER TO FIRST DIGIT
^065D DD7E00 0078 LD A,(IX) ;GET FIRST DIGIT
^0660 CB27 0079 SLA A
^0662 CB27 0080 SLA A
^0664 CB27 0081 SLA A
^0666 CB27 0082 SLA A ;MOVE TO HIGH NIBBLE IN A
^0668 DDB601 0083 OR (IX+1) ;BRING IN LOW NIBBLE
^066B 67 0084 LD H,A ;SAVE
^066C DD7E02 0085 LD A,(IX+2) ;SECOND BYTE HIGH NIBBLE
^066F CB27 0086 SLA A
^0671 CB27 0087 SLA A
^0673 CB27 0088 SLA A
^0675 CB27 0089 SLA A
^0677 DDB603 0090 OR (IX+3) ;BRING IN LOW NIBBLE
^067A 6F 0091 LD L,A ;COMPLETE POINTER
^067B C9 0092 RET
0093 ;GETS TABLE ADDRESS INTO IX AND BFLG INTO B
^067C DU21FFFF 0094 UFOR3: LD IX,BPTAB ;POINT IX TO START OF TABL
^0680 3AFFFF 0095 LD A,(BFLG) ;NO. OF BP ACTIVE
^0683 B7 0096 OR A ;SET STATUS
^0684 47 0097 LD B,A
^0685 C9 0098 RET ;USER TESTS STATUS
0099 ;FLAG INITIALIZATION ROUTINE
^0686 215B06 0100 UFGCR: LD HL,DISMEM
^0689 22FFFF 0101 LD (KEYPTR),HL ;POINT INTO DISMEM
^068C 3E00 0102 LD A,00H
^068E 32FFFF 0103 LD (DIG2),A ;ZERO FLAGS
^0691 32FFFF 0104 LD (DIG4),A
^0694 32FFFF 0105 LD (SSFLG),A
^0697 32FFFF 0106 LD (PRFLG),A
^069A 32FFFF 0107 LD (PFLG),A
^069D 32FFFF 0108 LD (MFLG),A
^06A0 32FFFF 0109 LD (RFLG),A
^06A3 32FFFF 0110 LD (ARFLG),A
^06A6 C9 0111 RET
0112 ;PUTS BLANKS INTO DISPLAY MEMORY - DISMEM
^06A7 0608 0113 UFOR4: LD B,8
^06A9 218706 0114 LD HL,DISMEM
^06AC 3E10 0115 LD A,10H ;BLANK CODE
^06AE 77 0116 UFOR4A: LD (HL),A
^06AF 23 0117 INC HL

```

```

^06B0 10FC      0118      DJNZ      UFOR4A-#      ; LOOP TILL DONE
^06B2 C9        0119      RET
                0120 ; CONVERTS ONE ASCII DIGIT IN ACC TO BINARY
^06B3 D630     0121 UABIN:  SUB      030H
^06B5 FE0A     0122      CP        10
^06B7 F8       0123      RET      M
^06B8 D607     0124      SUB      7
^06BA C9       0125      RET
                0126 ; CONVERTS ONE DIGIT OF BINARY IN ACC TO ASCII
^06BB E60F     0127 UBASC:  AND      0FH      ; MASK OUT HIGH DIGIT
^06BD C690     0128      ADD      A, 90H
^06BF 27       0129      DAA
^06C0 CE40     0130      ADC      A, 40H
^06C2 27       0131      DAA
^06C3 C9       0132      RET
                0133 ; PUNCHES TWO CHARACTERS IN ACCUMULATOR-HIGH NIBBLE FIRST
^06C4 D9       0134 UPACC:  EXX      ; USE ALT REGS IS OTCHR
^06C5 F5       0135      PUSH     AF      ; SAVE ACC
^06C6 0F       0136      RRCA
^06C7 0F       0137      RRCA
^06C8 0F       0138      RRCA
^06C9 0F       0139      RRCA      ; GET UPPER DIGIT
^06CA CDF406^  0140      CALL     OTCHR
^06CD F1       0141      POP     AF
^06CE E60F     0142      AND      0FH      ; MASK OUT HIGH NIBBLE
^06D0 CDF406^  0143      CALL     OTCHR
^06D3 D9       0144      EXX      ; RESTORE REGISTERS
^06D4 C9       0145      RET
                0146 ; PUNCHES TWO CHARACTERS IN ACCUMULATOR AND ADDS CHECKSUM
^06D5 F5       0147 UPACC:  PUSH     AF      ; SAVE ACC
^06D6 81       0148      ADD      A, C      ; SUM CHECKSUM
^06D7 4F       0149      LD      C, A      ; SAVE IN C
^06D8 F1       0150      POP     AF
^06D9 18E9     0151      JR      UPACC-# ; PUNCH ACC
                0152 ; READS TWO CHARACTERS FROM TAPE AND CONVERTS TO BINARY
                0153 ; DATA RETURNED IN ACC AND CHECKSUM KEPT IN C
^06DB C5       0154 ULACC  PUSH     BC      ; SAVE C REG (CHECKSUM)
^06DC CD5807^  0155      CALL     INCHR   ; READ CHAR FIRST DIGIT
^06DF CDB306^  0156      CALL     UABIN   ; CONVERT TO BINARY
^06E2 07       0157      RLCA
^06E3 07       0158      RLCA
^06E4 07       0159      RLCA
^06E5 07       0160      RLCA      ; SHIFT TO HIGH NIBBLE
^06E6 4F       0161      LD      C, A      ; SAVE FIRST DIGIT
^06E7 CD5807^  0162      CALL     INCHR   ; GET SECOND DIGIT
^06EA CDB306^  0163      CALL     UABIN   ; CONVERT
^06ED B1       0164      OR      C      ; MERGE NIBBLES
^06EE C1       0165      POP     BC      ; RESTORE CHECKSUMS
^06EF F5       0166      PUSH     AF      ; SAVE ACC SAVE D-7#
^06F0 81       0167      ADD      A, C <  ADD TWO DIGITS TO CKSUM
^06F1 4F       0168      LD      C, A      ; SAVE IN C
^06F2 F1       0169      POP     AF      ; RESTORE ACC
^06F3 C9       0170      RET
                0171 ; ROUTINE USES CTC CHANNEL 1 AS BASIC TIME BASE (4800HZ
                0172 ; OR 2400HZ). ENTRY IS WITH ONE BINARY CHARACTER IN THE
                0173 ; LOW NIBBLE OF A. THIS ROUTINE WILL CONVERT TO ASCII AND
                0174 ; THE SHIFT THE CHARACTER OUT WITH ONE START AND TWO STOP
                0175 ; BITS. OUTPUTS ARE PULSES (ZC/TO) FROM CTC1 AT TWICE THE

```



```

0176 ;KANSAS CITY STANDARD RATES (1=4800HZ, 0=2400HZ).
^06F4 CDBB06^ 0177 OTCHR: CALL UBASC ; CONVERT TO ASCII
^06F7 FB 0178 OTCHR1: EI
00^06F8 57 0179 LD D,A ; A TO D
01^06F9 3E10 0180 LD A,10H ; INIT A FOR CTC INTR
03^06FB 2E0A 0181 LD L,0AH ; BIT COUNT OF WORD
05^06FD CB12 0182 RL D ; CARRY TO DO
07^06FF FE01 0183 OTCHR2: CP 01D ; A=1? WAIT UNTIL
09^0701 20FC 0184 JR NZ,OTCHR2-$ ; CTC ON NEXT TO LAST CNT
0B^0703 47 0185 LD B,A ; SAVE A
0C^0704 3E00 0186 LD A,0
0E^0706 32FFFF 0187 LD (FLG24),A ; CLEAR FLG24-START BIT
15^0709 78 0188 LD A,B
11^070A 76 0189 OTCHR3: HALT
0190 ;*****
^070B 37 0191 SCF ; SET CARRY
^070C CB1A 0192 RR D ; SHIFT D ONE RIGHT
^070E 2D 0193 DEC L
^070F 2007 0194 JR NZ,OTCHR4-$
^0711 3E01 0195 LD A,1
^0713 320707^ 0196 LD (FLG24),A ; WORD OUT-MARK LINE
^0716 F3 0197 DI ; EXIT WITH INTERRUPTS DISABLED
^0717 C9 0198 RET
^0718 FE01 0199 OTCHR4: CP 1 ; NEXT TO LAST COUNT
^071A 20FC 0200 JR NZ,OTCHR4-$ ; NO WAIT
^071C CB42 0201 BIT 0,D ; TEST NEXT BIT
^071E 2009 0202 JR NZ,OTCHR5-$ ; NEXT BIT IS A ONE
^0720 47 0203 LD B,A
^0721 3E00 0204 LD A,0 ; NEXT BIT IS A ZERO
^0723 321407^ 0205 LD (FLG24),A ; CLEAR FLG24
^0726 78 0206 LD A,B
^0727 18E1 0207 JR OTCHR3-$
^0729 47 0208 OTCHR5: LD B,A
^072A 3E01 0209 LD A,1
^072C 322407^ 0210 LD (FLG24),A ; SET FLG24
^072F 78 0211 LD A,B ; RESTORE A
^0730 18D8 0212 JR OTCHR3-$ ; WAIT FOR END OF CHAR
0213 ; CTC1 INTERRUPT SERVICE ROUTINE DURING PUNCH
^0732 3D 0214 OTCHR6: DEC A ; A IS CYCLE COUNTER
^0733 2020 0215 JR NZ,OTCHR8-$ ; NOT LDAT COUNT, RETURN
^0735 DD212D07^ 0216 LD IX,FLG24
^0739 DDCB0046 0217 BIT 0,(IX+0) ; TEST FLG24
^073D 200C 0218 JR NZ,OTCHR7-$
^073F 3E85 0219 LD A,85H ; FLG24 IS CLR=ZERO
^0741 D385 0220 OUT (CTC1),A ; NEW CONTROL WORD
^0743 3E34 0221 LD A,52D ; INTERRUPTS LIVE
^0745 D385 0222 OUT (CTC1),A ; TIME CONST FOR 1200HZ
^0747 3E08 0223 LD A,8 ; COUNT 8 CYCLES
^0749 180A 0224 JR OTCHR8-$ ; RETURN
^074B 3E85 0225 OTCHR7: LD A,85H
^074D D385 0226 OUT (CTC1),A ; NEW CONTROL WORD
^074F 3E1A 0227 LD A,26D
^0751 D385 0228 OUT (CTC1),A ; TIME CONST FOR 2400HZ
^0753 3E10 0229 LD A,16D ; SETUP FOR 16 COUNTS
^0755 FB 0230 OTCHR8: EI
^0756 ED4D 0231 RETI
0232 ; INPUT BIT RATE HAS BEEN AVERAGED AND IS IN (BITRT)
0233 ; ON EXIT CHARACTER IS IN A

```

```

0234 ; REGISTERS USED ARE A, B, H
0235 ; INTERRUPTS ARE ENABLED AND CTC1 INTERRUPTS AT THE BIT RATE
^0758 21FFFF 0236 INCHR: LD HL, CTC3L
^075B 7C 0237 LD A, H
^075C ED47 0238 LD I, A ; SETUP I REGISTER
^075E 7D 0239 LD A, L
^075F D384 0240 OUT (CTC0), A ; CTC INTERRUPT VECTOR
^0761 0608 0241 INCHR1: LD B, 8D ; BIT COUNT FOR A WORD
^0763 FB 0242 EI
^0764 3E00 0243 LD A, 0
^0766 2600 0244 LD H, 0 ; CLEAR WORDS
^0768 DB90 0245 INCH1A: IN A, (KBSEL) ; GET INPUT DATA
^076A CB7F 0246 BIT 7, A
^076C 20FA 0247 JR NZ, INCH1A-$ ; LOOP BACK FOR START BIT
^076E 3EA5 0248 LD A, 0A5H ; INTR-256 PRESCALER
^0770 D387 0249 OUT (CTC3), A ; CTC3 CONTROL WORD
^0772 3E00 0250 LD A, 0DH ; DIVIDE BY 2 FOR MID OF BIT
^0774 D387 0251 OUT (CTC3), A ; CTC3 TIME CONSTANT
^0776 3EA5 0252 LD A, 0A5H
^0778 D387 0253 OUT (CTC3), A
^077A 3E1A 0254 LD A, 01AH
^077C D387 0255 OUT (CTC3), A ; NEXT ONE FULL BIT WIDTH
^077E 76 0256 HALT
0257 ; *****
^077F CB7F 0258 BIT 7, A
^0781 2014 0259 JR NZ, INCHR3-$ ; START BIT GONE-FALSE ST
^0783 76 0260 INCHR2: HALT ; WAIT FOR FIRST BIT
0261 ; *****
^0784 E680 0262 AND 80H ; MASK OUT OTHER INPUTS
^0786 B4 0263 OR H
^0787 67 0264 LD H, A ; SAVE
^0788 1018 0265 DJNZ INCHR5-$
^078A CB7F 0266 BIT 7, A
^078C 2809 0267 JR Z, INCHR3-$ ; FRAMING ERROR, RESTART
^078E F3 0268 DI
^078F 3E03 0269 LD A, 03H
^0791 D387 0270 OUT (CTC3), A ; RESET CTC RTN WITH DATA
^0793 7C 0271 LD A, H
^0794 E67F 0272 AND 7FH ; MASK OUT START BIT
^0796 C9 0273 RET
^0797 3E03 0274 INCHR3: LD A, 03H
^0799 D387 0275 OUT (CTC3), A ; RESET CTC3, FRAMING ERROR
^079B 18C4 0276 JR INCHR1-$ ; GO LOOK FOR ANOTHER CHAR
0277 ; CTC INTERRUPT SERVICE ROUTINE DURING LOAD
^079D DB90 0278 INCHR4: IN A, (KBSEL) ; GET DATA
^079F FB 0279 EI
^07A0 ED4D 0280 RETI
^07A2 CB0C 0281 INCHR5: RRC H
^07A4 18DD 0282 JR INCHR2-$ ; WAIT FOR NEXT BIT
0283 ; *****EQUATES AND TABLES*****
0284 ; CTC READ ACCESSES DOWN COUNTER, WRITE SETS UP COUNTER
>0084 0285 CTC0: EQU 84H ; RESERVED FOR USER
>0085 0286 CTC1: EQU 85H ; AUDIO CASSETTE-PUNCH
>0086 0287 CTC2: EQU 86H ; SINGLE STEP AND PROM PROGRAMMER
>0087 0288 CTC3: EQU 87H ; AUDIO CASSETTE-LOAD
>0090 0289 KBSEL: EQU 90H ; CASSETTE DATA
0290 ; **SEVEN SEGMENT DISPLAY PATTERNS
^07A6 40 0291 SEGPT: DEFB 40H ; 0

```

```

^07A7 79      0292      DEFB      79H      ; 1
^07A8 24      0293      DEFB      24H      ; 2
^07A9 30      0294      DEFB      30H      ; 3
^07AA 19      0295      DEFB      19H      ; 4
^07AB 12      0296      DEFB      12H      ; 5
^07AC 02      0297      DEFB      02H      ; 6
^07AD 78      0298      DEFB      78H      ; 7
^07AE 00      0299      DEFB      00H      ; 8
^07AF 18      0300      DEFB      18H      ; 9
^07B0 08      0301      DEFB      08H      ; A
^07B1 03      0302      DEFB      03H      ; B LOWER CASE
^07B2 46      0303      DEFB      46H      ; C
^07B3 21      0304      DEFB      21H      ; D LOWER CASE
^07B4 06      0305      DEFB      06H      ; E
^07B5 0E      0306      DEFB      0EH      ; F
^07B6 7F      0307      DEFB      7FH      ; BLANK
^07B7 3F      0308      DEFB      3FH      ; PROMPT
^07B8 7D      0309      DEFB      7DH      ; PRIME MARK
                0310 ;***KEY VALUE LOOKUP TABLE
^07B9 FF      0311 KYTBL: DEFB      OFFH     ; 0 B=01, A=0F
^07BA EF      0312      DEFB      0EFH     ; 1 B=02, A=0F
^07BB F7      0313      DEFB      0F7H     ; 2 B=02, A=17
^07BC FB      0314      DEFB      0FBH     ; 3 B=02, A=1B
^07BD DF      0315      DEFB      0DFH     ; 4 B=04, A=0F
^07BE E7      0316      DEFB      0E7H     ; 5 B=04, A=17
^07BF EB      0317      DEFB      0EBH     ; 6 B=04, A=1B
^07C0 CF      0318      DEFB      0CFH     ; 7 B=08, A=0F
^07C1 D7      0319      DEFB      0D7H     ; 8 B=08, A=17
^07C2 DB      0320      DEFB      0DBH     ; 9 B=08, A=1B
^07C3 DD      0321      DEFB      0DDH     ; A B=08, A=1D
^07C4 ED      0322      DEFB      0EDH     ; B B=04, A=1D
^07C5 FD      0323      DEFB      0FDH     ; C B=02, A=1D
^07C6 0D      0324      DEFB      0DDH     ; D B=01, A=1D
^07C7 0B      0325      DEFB      00BH     ; E B=01, A=1B
^07C8 07      0326      DEFB      07H      ; F B=01, A=17
^07C9 0E      0327      DEFB      0EH      ; EXEC B=01, A=1E
^07CA FE      0328      DEFB      0FEH     ; SS B=02, A=1E
^07CB EE      0329      DEFB      0EEH     ; MON B=04, A=1E
^07CC DE      0330      DEFB      0DEH     ; NEXT B=08, A=1E
^07CD CD      0331      DEFB      0CDH     ; REG DISP B=10, A=1D
^07CE CB      0332      DEFB      0CBH     ; REG DISP B=10, A=1B
^07CF C7      0333      DEFB      0C7H     ; PORT EXAM B=10, A=17
^07D0 BF      0334      DEFB      0BFH     ; MEM EXAM B=10, A=0F
^07D1 BD      0335      DEFB      0BDH     ; BP B=20, A=1D
^07D2 BB      0336      DEFB      0BBH     ; PUNCH B=20, A=1B
^07D3 B7      0337      DEFB      0B7H     ; LOAD B=20H, A=17
^07D4 AF      0338      DEFB      0AFH     ; PROG B=20, A=0F
                0339 ;***REGTAB-RELATES KEYVALUE TO POSITION OF REGISTER ON STK
^07D5 19      0340 REGTB: DEFB      25D     ; KEY 0 NU NO DISPLAY
^07D6 02      0341      DEFB      02D     ; KEY 1=PC
^07D7 02      0342      DEFB      2D      ; KEY 2=SP
^07D8 0C      0343      DEFB      12D     ; KEY 3=1FF DISPLAY UIF
^07D9 16      0344      DEFB      22D     ; KEY 4=IX
^07DA 18      0345      DEFB      24D     ; KEY 5=IY
^07DB 0B      0346      DEFB      11D     ; KEY 6=I
^07DC 09      0347      DEFB      9D      ; KEY 7=H
^07DD 0A      0348      DEFB      10D     ; KEY 8=L
^07DE 19      0349      DEFB      25D     ; KEY 9=NU NO DISP

```

0 = 23
1 = 2F

U

```
07DF 03 0350 DEFB 3D ;KEY A=A
07E0 05 0351 DEFB 5D ;KEY B=B
07E1 06 0352 DEFB 6D ;KEY C=C
07E2 07 0353 DEFB 7D ;KEY D=D
07E3 08 0354 DEFB 8D ;KEY E=E
07E4 04 0355 DEFB 4D ;KEY F=F
0356 ;***ALTERNATE REGISTER SET
07E5 19 0357 REGTBP: DEFB 25D ;KEY 0 NU NO DISPLAY
07E6 19 0358 DEFB 25D ;KEY 1 NU NO DISPLAY
07E7 19 0359 DEFB 25D ;KEY 2 NU NO DISPLAY
07E8 19 0360 DEFB 25D ;KEY 3 NU NO DISPLAY
07E9 19 0361 DEFB 25D ;KEY 4 NU NO DISPLAY
07EA 19 0362 DEFB 25D ;KEY 5 NU NO DISPLAY
07EB 19 0363 DEFB 25D ;KEY 6 NU NO DISPLAY
07EC 13 0364 DEFB 19D ;KEY 7=H
07ED 14 0365 DEFB 20D ;KEY 8=L
07EE 19 0366 DEFB 25D ;KEY 9=NU NO DISPLAY
07EF 0D 0367 DEFB 13D ;KEY A=A
07F0 0F 0368 DEFB 15D ;KEY B=B
07F1 10 0369 DEFB 16D ;KEY C=C
07F2 11 0370 DEFB 17D ;KEY D=D
07F3 12 0371 DEFB 18D ;KEY E=E
07F4 0E 0372 DEFB 14D ;KEY F=F
0373 END
```

ERRORS=0000

9d 01

```

0002          NAME      UTILR
0003 ; UTILITY RAM AND CONSTANTS
0004 ; VERSION 1.2 5/13/78
>07F8 0005          ORG      07F8H
0006          PSECT ABS
0007          GLOBAL  CTC3L
0008          GLOBAL  CTC1P
0009          GLOBAL  OTCHR6
0010          GLOBAL  INCHR4
0011 ; CTC INTERRUPT VECTOR TABLE
07F8 D623 0012 CTC0:  DEFW  CTC0V  ; MAP TO RAM
07FA FEEF 0013 CTC1P: DEFW  OTCHR6 ; PUNCH VECTOR FA
>07FC 0014 CTC2:  DEFS  2      ; NOT USED FOR INTR
07FE FFFF 0015 CTC3L: DEFW  INCHR4 ; LOAD VECTOR FE
>23C0 0016          ORG      23C0H
0017          GLOBAL  DIG2
0018          GLOBAL  DIG4
0019          GLOBAL  DIG8
0020          GLOBAL  BPTAB
0021          GLOBAL  SSFLG
0022          GLOBAL  UIF
0023          GLOBAL  DISMEM
0024          GLOBAL  DSMEM1
0025          GLOBAL  DSMEM2
0026          GLOBAL  DSMEM3
0027          GLOBAL  DSMEM4
0028          GLOBAL  DSMEM5
0029          GLOBAL  DSMEM6
0030          GLOBAL  DSMEM7
0031          GLOBAL  STKPT
0032          GLOBAL  STKPT1
0033          GLOBAL  RST16
0034          GLOBAL  RST24
0035          GLOBAL  RST32
0036          GLOBAL  RST40
0037          GLOBAL  RST48
0038          GLOBAL  RST56
0039          GLOBAL  KEYPTR
0040          GLOBAL  FLG24
0041          GLOBAL  RFLG
0042          GLOBAL  ARFLG
0043          GLOBAL  BFLG
0044          GLOBAL  PFLG
0045          GLOBAL  MFLG
0046          GLOBAL  PRFLG
0047          GLOBAL  PUNHSH
0048          GLOBAL  PUNHSL
0049          GLOBAL  PUNHEH
0050          GLOBAL  PUNHEL
0051 ; ***RAM VARIABLES
>23C0 0052 PUNHSH: DEFS  1      ; DUMP STARTING ADDR-HIGH BYTE
>23C1 0053 PUNHSL: DEFS  1      ; DUMP STARTING ADDR-LOW BYTE
>23C2 0054 PUNHEH: DEFS  1      ; DUMP ENDING ADDR-LOW BYTE
>23C3 0055 PUNHEL: DEFS  1      ; DUMP ENDING ADDR-LOW BYTE
>23C4 0056 RST16: DEFS  3      ; USER INSERTS JUMPS TO
>23C7 0057 RST24: DEFS  3      ; HANDLE RESTART 16-56
>23CA 0058 RST32: DEFS  3
>23CD 0059 RST40: DEFS  3

```

```

>23D0      0060 RST48:  DEFS    3
>23D3      0061 RST56:  DEFS    3
           0062 ;**USER INSERTED JUMP FOR CTC0 INTERRUPT
>23D6      0063 CTC0V:  DEFS    3           ; CTC0 INTR WILL BE VECTORED HERE
           0064 ;**USER INSERTED JUMP FOR CTC3 INTERRUPT
>23D9      0065 FLG24:  DEFS    1           ; FLAG FOR MARK (1) OUT (PUNCH)
>23DA      0066 PRFLG:  DEFS    1           ; PROM PROGRAMMER FLAG
>23DB      0067 KEYPTR: DEFS    2           ; PTR FOR NEXT WRITE INTO DISMEM
>23DD      0068 UIF     DEFS    1           ; USERS IFF2
>23DE      0069 PFLG   DEFS    1           ; PORT EXAMINE FLAG
>23DF      0070 RFLG   DEFS    1           ; REGISTER EXAMINE FLAG
>23E0      0071 ARFLG  DEFS    1           ; REGISTER EXAMINE FLAG (ALT)
>23E1      0072 MFLG:  DEFS    1           ; MEMORY EXAMINE FLAG
>23E2      0073 STKPT: DEFS    1           ; USERS STACK POINTER-HIGH BYTE
>23E3      0074 STKPT1:DEFS    1           ; USERS STACK POINTER-LOW BYTE
           0075 ;**BREAKPOINT TABLE ORGANIZED AS TWO BYTES OF ADDR (H,L)
           0076 ;**WHERE BREAKPOINT IS INSTALLED FOLLOWED BY THE ONE BYTE
           0077 ;**OF THE OP CODE REPLACED BY THE RST 8 INSTRUCTION
>23E4      0078 BPTAB:  DEFS   15           ; BP ADDR AND OP CODE REMOVED
>23F3      0079 SSFLG  DEFS    1           ; SINGLE STEP MODE FLAG
>23F4      0080 BFLG   DEFS    1           ; NO OF BREAKPOINTS INSTALLED
>23F5      0081 DIG2   DEFS    1           ; 2 DIGITS ENTERED FLAG
>23F6      0082 DIG4   DEFS    1           ; 4 DIGITS ENTERED FLAG
>23F7      0083 DISMEM DEFS    1           ; DISPLAY MEMORY BUFFER
>23F8      0084 DSMEM1 DEFS    1
>23F9      0085 DSMEM2 DEFS    1
>23FA      0086 DSMEM3 DEFS    1
>23FB      0087 DSMEM4 DEFS    1
>23FC      0088 DSMEM5 DEFS    1
>23FD      0089 DSMEM6 DEFS    1
>23FE      0090 DSMEM7 DEFS    1
           0091      END
  
```

ERRORS=0000

APPENDIX III

Soldering
and
Assembly Techniques

SOLDERING TECHNIQUE

THE NEED

The assembly of electronic components is essentially the exercise of the art of soldering. If the many connections are soldered properly, the resulting assembly will normally operate properly right from the first application of power. A hasty job here can mean endless hours trying to locate short circuits or intermittent connections.

THE SOLDER

Use a #20 gauge resin or rosin core solder with a ratio of 63% tin and 37% lead. A 60/40 ratio is acceptable. "Kester" and "Ersin" are two dependable brands of solder. Acid core solders or acid flux must not be used as they will corrode electronic joints and will damage printed circuit boards.

THE SOLDERING IRON

Use a small, 30 watt maximum iron with a small, chisel shaped tip. Too much heat will damage both components and boards. Soldering guns are too hot and should not be used. Heat the iron, wipe its tip quickly on the damp sponge, and apply a tiny amount of solder to the tip - just enough to make it silver in color but not so much that it will drip off. This cleaning procedure should be repeated whenever the solder of the tip of the soldering iron begins to thicken or take of a brownish color.

REMOVAL OF MULTI-PIN SOLDERED-IN PARTS

CAUTION

If for any reason, it becomes necessary to remove a soldered-in part having more than just two leads, do not try to remove the part intact. It can be done but only with great risk of damaging the printed circuit board in the process.

Hold the printed circuit board in well padded jaws of a bench vice to avoid damage.

REMOVAL OF SOLDERED-IN IC SOCKETS

Crush the plastic body with a pair of pliers to pull the pins from the body. Gently remove the pins from the top of the board with needle nosed pliers while touching the joint on the other side of the board with the tip of the iron. Do not use force. The pin will come out quite easily once the solder melts.

Clear the holes of any excess solder by rapidly inserting and removing a piece of wire while very briefly holding the soldering iron to the hole at the back of the board.

REMOVAL OF SOLDER-IN INTEGRATED CIRCUIT CHIPS

Cut each pin with a pair of diagonal cutters at a point between the chip and the printed circuit board which is as close to the chip as possible so that there is enough of the pin showing above the board to be grasped by needle nosed pliers while removing as described above.

THE PROCEDURE

The entire soldering operation should take little more than two seconds per joint. The sequence is as follows:

Touch the tip of the soldering iron to the joint, as shown below, so that both the conductors to be joined are simultaneously heated sufficiently to melt the solder.

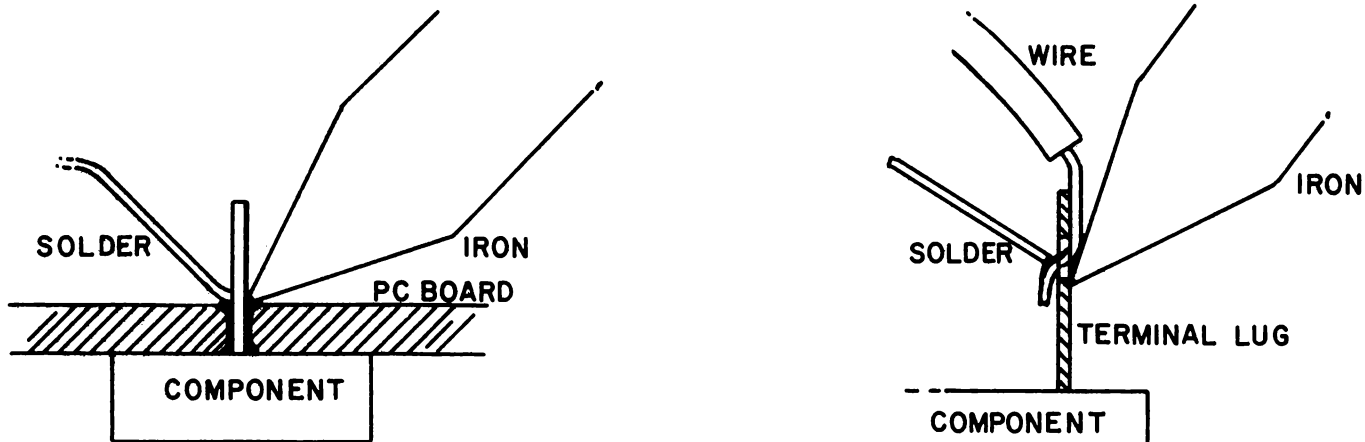

Touch the end of the solder roll to the joint, as shown above, just long enough to let no more than a 1/8" length melt into the joint. Too much solder will short circuit the bottom of the board or flow through the holes and short circuit the top of the board. The melted solder will appear wet and shiny. It will quickly flow completely around the wire and over the surface to which the wire is attached.

Remove the soldering iron as soon as both surfaces have been completely wetted. Remember, the total time from application to removal of the soldering iron should be only two or three seconds. Removal of the soldering iron too soon will result in an incomplete bond between the metals, but leaving the soldering iron at the joint too long will cause heat damage to both components and board.

ORIENTATION OF INTEGRATED CIRCUIT CHIPS

Extreme care must be taken to insure that each integrated circuit chip is so oriented, prior to insertion in its socket, that pin #1 is at the location so designated on the printed circuit board or in the individual assembly instructions for the kit.

Pin #1 is, unfortunately, designated in a variety of ways depending upon the integrated circuit manufacturer. Several methods are indicated in the chart below. With the leads of the chip pointing away from the viewer, Pin #1 is in the position indicated with respect to the various end notches or tiny circular markings or depressions in one corner.

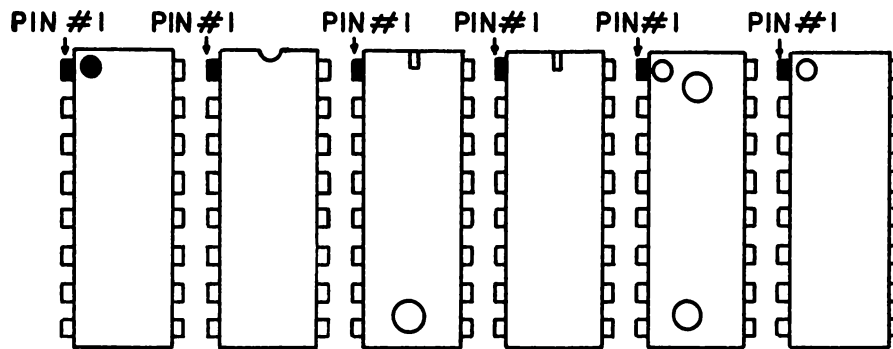

INSERTION OF INTEGRATED CIRCUIT CHIPS

Be sure all leads are straight and parallel. If not, gently straighten and align the bent pins with needle nosed pliers.

Integrated circuit chips usually come from the manufacturer with their rows of leads spread wider than the distance between rows of holes in the socket into which they are to be inserted. To slightly close the rows of pins in a uniform manner so they are aligned with the socket holes, place the chip on its side on a flat surface so that one row of pins is flat against the surface as shown on the following page.

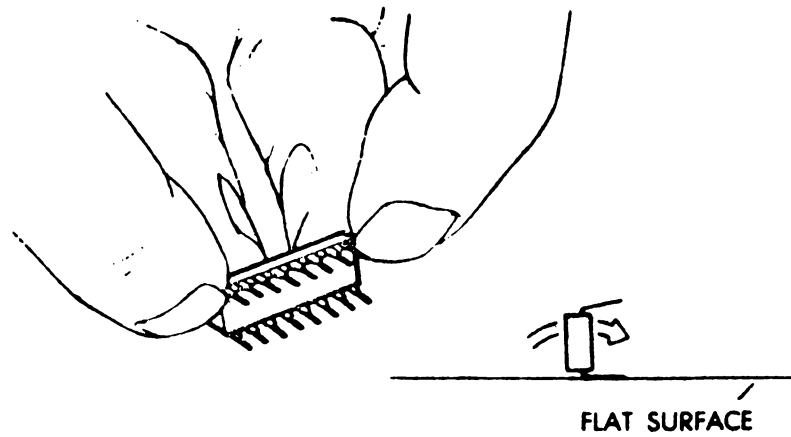

HOLDING THE SIDE OF THE CHIP FIRMLY AGAINST THE FLAT SURFACE WITH BOTH HANDS, ROTATE IT A SHORT DISTANCE TOWARD ITS PINS UNTIL IT IS IN A FULL VERTICAL POSITION. THIS WILL PUT ITS BODY AT A RIGHT ANGLE TO THAT ROW OF PINS. PLACE THE OTHER ROW OF PINS ON THE FLAT SURFACE AND REPEAT THE PROCESS AS ABOVE.

PARTIALLY INSERT ALL ICs WITH THE PIN #1 ORIENTED AS SHOWN ON THE ASSEMBLY LAYOUT WHICH IS SILK SCREENED ON THE FRONT OF THE BOARD. THE LAYOUT SYMBOL FOR IC PIN #1 IS DESIGNATED BY A WHITE DOT ADJACENT TO THE UPPER LEFT HAND CORNER OF EACH RECTANGULAR IC CHIP LOCATION SYMBOL. RECHECK TO INSURE THAT EACH PIN IS IN ITS HOLE AND HAS NOT BEEN FOLDED UNDER THE CHIP OR BENT OUTSIDE THE SOCKET. COMPLETE INSERTION EVENLY AND FIRMLY.

UNPLUGGING INTEGRATED CIRCUIT CHIPS

UNPLUGGING AND INTEGRATED CIRCUIT CHIP MUST BE DONE EVENLY FROM BOTH ENDS SIMULTANEOUSLY SO THAT THE PINS WILL NOT BE BENT DURING REMOVAL. GENTLY PRYING WITH A SCREWDRIVER A LITTLE BIT AT A TIME FIRST AT ONE END, THEN AT THE OTHER IS RECOMMENDED. IF ACCESS IS POSSIBLE ONLY FROM ONE END, BE SURE THE SCREWDRIVER IS PUSHED AS FAR IN AS POSSIBLE SO AS TO GIVE A UNIFORM LIFTING ACTION OVER THE FULL LENGTH OF THE CHIP.

POWER ON

PLUG THE BOARD INTO YOUR COMPUTER AND CHECK IT OUT IN ACCORDANCE WITH THE USERS MANUAL PRECEDING THESE ASSEMBLY INSTRUCTION.