



STEVE

"Selectric" Typewriter

Adjustment Parts Manual

Revised November, 1980

S241-5939-3

- IBM "Selectric" Typewriter (7XX)
- IBM "Selectric" II Typewriter (8XX)
- IBM "Selectric" III Typewriter (670X)
- IBM 96 "Selectric" Typewriter (9XX)

SAFETY PRECAUTIONS

The drawings and specifications contained herein shall not be reproduced in whole or in part without written permission.

IBM has prepared this maintenance manual for the use of IBM Customer Engineers in the installation, maintenance and repair of the specific machines indicated. IBM makes no representations that it is suitable for any other purpose.

Information contained in this manual is subject to change from time to time. Any such change will be reported in subsequent revisions or distributed through Customer Engineering Memorandums (CEMs) to all subscribers.

Requests for copies of IBM publications should be made to your IBM representative or to the IBM Branch Office servicing your locality.

Comments about the publications may be addressed to (IBM Corporation, 740 New Circle Road N.W., Information Development, Dept. A58, Lexington, Ky. 40511). IBM may use or distribute any of the information you supply in any way it believes appropriate without incurring any obligation whatever. You may, of course, continue to use the information you supply.

"It is possible that this material may contain reference to, or information about, IBM products (machines and programs, programming, or services that are not announced in your country. Such references or information must not be construed to mean that IBM intends to announce such IBM products, programming, or services in your country."

"IBM," "Executive," "IBM EXECUTARY," and "Selectric" are registered trademarks of the IBM Corporation.

© Copyright International Business Machines Corporation 1964, 1966, 1967, 1968, 1969, 1971, 1973, 1975, 1976, 1979, 1980

All IBM Customer Engineers are expected to take every safety precaution possible and observe the following safety practices when servicing IBM equipment.

Mechanical Safety:

- 1. Safety glasses must be worn.*
- 2. All safety devices, such as guards, shields, signs, ground wires, etc., must be restored after maintenance. When a guard or shield is removed to observe or make an adjustment, that shield must be replaced when work in the area is completed.*
- 3. Watches, rings, necklaces, ID bracelets, etc., must be removed when servicing the machine.*
- 4. Care must be used when working near moving parts. Keep hair away from moving parts. Avoid wearing loose clothing that might be caught in the machine. Shirt sleeves must be kept buttoned or rolled above the elbows. Ties must be tucked in the shirt or have a tie clasp approximately three inches from the end. Tie chains are not recommended.*

Electrical Safety:

- 1. The equipment referenced in this manual may use high voltages. Check voltage labels!*
- 2. Safety glasses must be worn when checking energized circuits.*
- 3. If a circuit is disconnected for servicing or parts replacement, it must be reconnected and tested before allowing the use of the machine.*
- 4. Power should be removed from the machine for servicing whenever possible. Remember, when checking voltages, avoid contacting ground potential, such as metal floor strips, machine frame, etc.*
- 5. Meter continuity checks should be used instead of voltage checks whenever possible.*
- 6. Do not apply power to any part, component, or subassembly when it is not physically mounted in the machine, or its approved service position.*

General Safety:

- 1. Each Customer Engineer is responsible to be certain no action on his/her part makes the product unsafe or exposes customer personnel to hazards.*
- 2. Store the removed machine covers in a safe, out of the way place where no one can trip over them.*
- 3. If you must leave the machine in a down condition, always install the covers and disconnect the power before leaving the customer's office.*
- 4. Always place CE tool kit away from walk areas where no one can trip over it.*
- 5. Maintain safe conditions in the area of the machine while performing and after completing maintenance.*
- 6. Before starting the equipment, make sure fellow CEs and customer personnel are not in a hazardous position.*
- 7. All the machine covers must be in place before the machine is returned to the customer.*

Note: Refer to the Safety CEMs relating to this product(s) for further safety precautions.

INTRODUCTION

This manual is written for both U.S. and World Trade usage. It contains an adjustment section, a parts manual section, and a diagnostics section for the following products:

| Product Name | Model | Machine Type |
|--|-------|--------------|
| IBM "Selectric" Typewriter | 7XX | 6121 |
| IBM "Selectric" II Typewriter And IBM Correcting "Selectric" II Typewriter | 8XX | 6126 |
| IBM "Selectric" III Typewriter And IBM Correcting "Selectric" III Typewriter | 670X | 6701-05 |
| IBM 96-Character "Selectric" Typewriter | 9XX | |

World Trade Note: The IBM 96-Character "Selectric" Typewriter applies only to some World Trade countries.

ADJUSTMENT SECTION

Purpose

This section provides a reference for the most commonly used adjustments. Refer to other product service publications if additional information is needed.

Adjustment Identification

The headline of each page shows the product name identification code, product code, and the name of the mechanism covered on that page. Each adjustment is indicated by a black frame number in the top left corner, followed by the adjustment

name and mechanism code/reference number. If one frame covers adjustments for more than one product or product level, they are indicated by the identification code and/or the level number. The machine mode, the view of the drawing, and safety precautions are also noted when required.

Adjustment Sequence

The frame numbers indicate the sequence of adjustments. One adjustment could affect a following adjustment. Therefore, check all the following adjustments in that mechanism. A solid red bar indicates the end of the mechanism.

Red numbers on the bottom left corner of the frame indicate adjustments out of sequence that could be affected and should be checked.

Adjustment Procedure

The part to be adjusted is colored red, and a red arrow shows the direction of movement. Tolerances and/or additional information on how to perform the adjustment are shown when required.

Always use the adjustment tolerance shown in the publication with the latest date.

Call Reporting

Use the mechanism codes/reference numbers shown after the frame number and frame name for call reporting. The reference number is not always the number of the part that is colored red.

PARTS MANUAL SECTION

Introduction

This section contains parts drawings of mechanisms, reference numbers and other special information. It must be used with a separate part number/price list manual which contains reference numbers, part numbers, part descriptions and prices.

Mechanism Identification

The headline of each page shows the product name, identification code and product code covered on that page. The headline of each frame (two frames per page) shows the mechanism name and the mechanism code covered in that frame. Some frames will show a model identification code after the mechanism name. Some mechanisms require more than one frame. However, each mechanism consists of a group of parts that work together to perform a function.

Part Identification

Red numbers indicate the reference number of a part, a bill of material (B/M) or an assembly.

Red blocks within a frame indicate either one, or a combination of more than one, of the following:

- Differences between the models (7XX, 8XX, 670X, or 9XX)
- Different modes within the same model [for example: rotary backspace (RB/S) and non-rotary backspace (NRB/S)]
- Different machine sizes (7X1, 7X3, or 7X5 "Selectric" Typewriter)
- Different levels within the same model, mode, or size (level 1, level 2, etc.). (8X3 and 8X5 apply to the "Selectric" Typewriter.) (XX3 and XX5 apply to the "Selectric" Typewriter and "Selectric" II Typewriter.)
- Field replacement parts
- Bill of material (B/M) or assemblies (shown with a description - parts shown in the drawing)
- World Trade applications or differences

If different levels exist, which can be used for all models, modes or sizes, only the newest level is shown in the drawing. However, the part number/price list manual will show all level parts.

(Continued On Page 4)

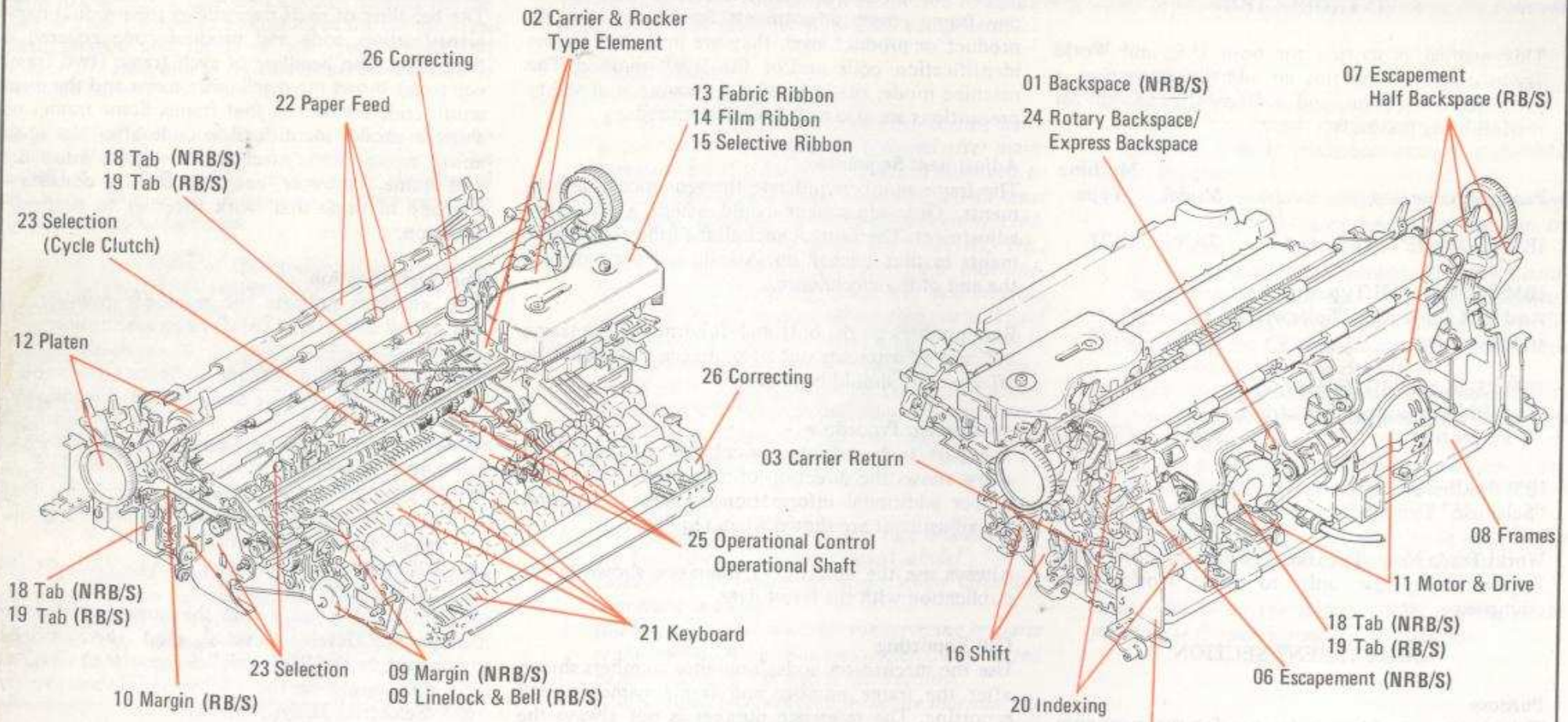

Covers & Mountings 04/05

Sound Reduction 30

Special Features . . . 39 Thru 51

Packing Parts & Inst. 65

04 Covers &
05 Mountings

**IBM "SELECTRIC" TYPEWRITER
CONTENTS
(Alphabetical)**

| PARTS | | ADJUSTMENTS | |
|---------------------------------|------|---|------------|
| Mech Code | Page | Mechanism | Frame Page |
| INTRODUCTION 1 | | | |
| <i>Backspace</i> | | | |
| 24 . . . 91 . . . | | Express Backspace | 200 . 30 |
| 07 . . . 70 . . . | | Half Backspace | 195 . 29 |
| 01 . . . 63 . . . | | Non-Rotary Backspace (NRB/S) | 179 . 28 |
| 24 . . . 91 . . . | | Rotary Backspace (RB/S) | 183 . 28 |
| | | 64 . . . Cardholder Chart | |
| 02 . . . 63 . . . | | Carrier | |
| 03 . . . 66 . . . | | Carrier Return | 167 . 25 |
| 23 . . . 90 . . . | | Character Selection | 55 . 11 |
| | | Character Selection (Rotate Tool) | 78 . 14 |
| | | Character Selection (Typehead) | 67 . 13 |
| 26 . . . 93 . . . | | Correcting | 327 . 46 |
| 04 . . . 67 . . . | | Covers & Mountings (7XX) | 375 . 52 |
| 05 . . . 68 . . . | | Covers & Mountings (8XX, 9XX) | 375 . 52 |
| 05 . . . 69 . . . | | Covers (670X) | 375 . 52 |
| 06 . . . 70 . . . | | Escapement (NRB/S) | 101 . 17 |
| 07 . . . 70 . . . | | Escapement (RB/S) | 101 . 17 |
| | | Fine Alignment | 43 . 10 |
| 08 . . . 71 . . . | | Frames | |
| 20 . . . 84 . . . | | Indexing | 262 . 39 |
| 20 . . . 85 . . . | | Indexing (Double) | 385 . 54 |
| 20 . . . 85 . . . | | Indexing (W.T.) | 262 . 39 |
| 21 . . . 86 . . . | | Keyboard | 12 . 6 |
| 21 . . . 87 . . . | | Keyboard (Dual Impression) | 11 . 6 |
| 09 . . . 72 . . . | | Linelock & Bell | 356 . 50 |
| 09 . . . 71 . . . | | Margins (NRB/S) | 356 . 50 |
| 10 . . . 73 . . . | | Margins (RB/S) | 356 . 50 |
| 11 . . . 77 . . . | | Motor & Drive (Canadian) | 1 . 5 |
| 11 . . . 75 . . . | | Motor & Drive (Netherlands) | 1 . 5 |
| 11 . . . 73 . . . | | Motor & Drive (U.S.) | 1 . 5 |
| 25 . . . 92 . . . | | Operational Control | 134 . 22 |
| 25 . . . 92 . . . | | Operational Shaft Assembly | |
| 22 . . . 88 . . . | | Paper Feed ("A-Frame") | 250 . 37 |
| 22 . . . 88 . . . | | Paper Feed (Tie-Rod) | 250 . 37 |
| 12 . . . 78 . . . | | Platen | |
| | | Print | 229 . 34 |
| 13 . . . 78 . . . | | Ribbon, Fabric | 294 . 43 |
| 14 . . . 79 . . . | | Ribbon, Film | 278 . 40 |
| 15 . . . 80 . . . | | Ribbon, Selective | 307 . 44 |

| PARTS | | ADJUSTMENTS | |
|-------------------|------|---|------------|
| Mech Code | Page | Mechanism | Frame Page |
| 02 . . . 65 . . . | | Rocker (Gear Type Tilt) | |
| 02 . . . 65 . . . | | Rocker (Gearless Type Tilt) | |
| 23 . . . 90 . . . | | Selection | |
| 16 . . . 80 . . . | | Shift | 32 . 9 |
| 17 . . . 81 . . . | | Spacebar | 152 . 24 |
| 18 . . . 82 . . . | | Tab (NRB/S) | 206 . 31 |
| 19 . . . 83 . . . | | Tab (RB/S) | 206 . 31 |
| 02 . . . 65 . . . | | Type Elements | |
| FEATURES | | | |
| 39 . . . 95 . . . | | Cardholding Platen | |
| 40 . . . 95 . . . | | Dead Key (U.S.) | 379 . 53 |
| 40 . . . 96 . . . | | Dead Key (W.T.) Thailand | |
| 40 . . . 95 . . . | | Dead Key Disconnect | 382 . 53 |
| 13 . . . 78 . . . | | External Ribbon Control | 392 . 54 |
| 45 . . . 97 . . . | | Handicapped Attachments | |
| 21 . . . 86 . . . | | Manual Velocity Control | 394 . 55 |
| 49 . . . 99 . . . | | Overhead Pin Feed Platen (W.T.) | |
| 49 . . . 98 . . . | | Pin Feed Platen | 397 . 55 |
| 41 . . . 96 . . . | | Shift Sensing (Dual Impression) | 402 . 56 |
| 30 . . . 94 . . . | | Sound Reduction | |
| 51 . . . 99 . . . | | Stroke Counter | |

| PARTS | | ADJUSTMENTS | |
|---|------|--|--------------------|
| Mech Code | Page | Mechanism | Frame Page |
| GENERAL INFORMATION | | | |
| | | Broken Tapes Check | 57 |
| | | Common Abbreviations | 4 |
| | | Correcting Diagnostics | 59 |
| | | Electrical Safety Check | 57 |
| | | Functional Check | 57 |
| | | Identification Codes | Inside Rear Cover |
| | | Lubrication Guide | 56 |
| | | Ribbon Applications | 58 |
| | | Safety Precautions | Inside Front Cover |
| | | Service Call Procedure | 56 |
| | | Type Element Arrangement | 58 |
| | | Voltage Checks "Selectric" III | |
| | | Dual-Pitch Typewriter | 60 |
| | | Wiring Diagrams | 62 |
| BOLT DOWN PARTS AND INSTRUCTIONS | | | |
| | | 101 . . . Bolt Down Instructions | |
| 04 . . . 67 . . . | | Bolt Down Parts (7XX) | |
| 05 . . . 69 . . . | | Bolt Down Parts (8XX, 9XX, 670X) | |
| PACKING PARTS AND INSTRUCTIONS | | | |
| 65 . . . 102 . . . | | Packing (U.S.) | |
| 65 . . . 100 . . . | | Packing (W.T.) | |
| CHARTS | | | |
| | | Cardholder Chart | 64 |
| 04 | | *Painted Cover Parts (7XX) | |
| 05 | | *Painted Covers Parts (8XX, 9XX, 670X) | |
| 12 | | *Platen Indexing | |
| *These charts are printed in the Part Number/Price List (P/N 241-5103). | | | |

(Introduction Continued From Page 1)

Some parts are shown for assembly purposes only and do not show a reference number. Replace these parts by ordering either the assembly or a later level part.

Parts Ordering

Locate the mechanism in which the part functions by using the contents page. Note the mechanism code, find the part in the drawing, and note the reference number. Use this mechanism code/reference number to locate the part number and price in the part number/price list manual.

World Trade should use the country's procedures to find the prices.

Features and devices (MESs) or specification changes (SERs) desired by the customer must be ordered through CE management and Branch Office sales.

Replacement parts for features, devices and SERs not shown in the parts manual must also be ordered through CE management and Branch Office sales.

COMMON ABBREVIATIONS

The following list is provided as a reference for some of the common abbreviations used in this manual. It should be noted that some of these are new since the last revision.

| | |
|----------------|---------------------------------------|
| APM | Adjustment Parts Manual |
| ASM | Assembly |
| AVC | Automatic Velocity Control |
| B/M | Bill Of Material |
| CC | Cycle Clutch |
| CR | Carrier Return |
| CSI | Combined Service Information |
| DI | Dual Impression |
| DP | Dual Pitch |
| ECC OT | Eccentric Index Overthrow Stop |
| FI | Field Installable |
| FTB | Floating Torque Bar |
| g | Grams |
| mm | Millimeters |
| N | Newtons |
| NRB/S | Non-Rotary Backspace |
| PN/PL | Part Number/Price List |
| Pre-DI | Pre-Dual Impression |
| Pre-FTB | Pre-Floating Torque Bar |
| RB/S | Rotary Backspace |
| SB | Spacebar |
| SER | Special Engineering Request |
| SHP | Shop Manual 241-6670 |
| SP | Single Pitch |
| TII | Technical Information Index |
| TYP | Type Catalog 241-5687 |
| UBS | Upper Ball Socket |
| U.S. | United States |
| W.T. | World Trade |

1 Cycle Shaft End Play (23-421)

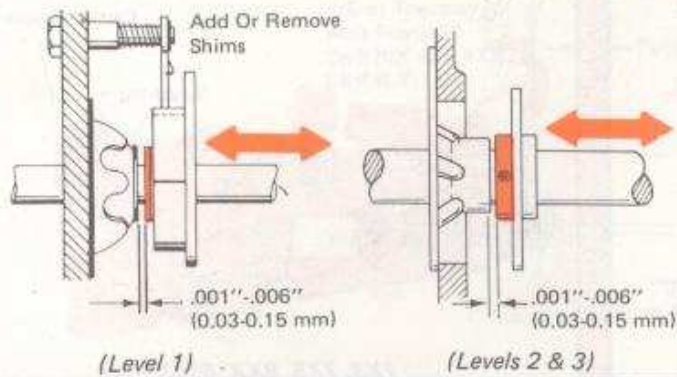

2 Gear Train Backlash (23-461)

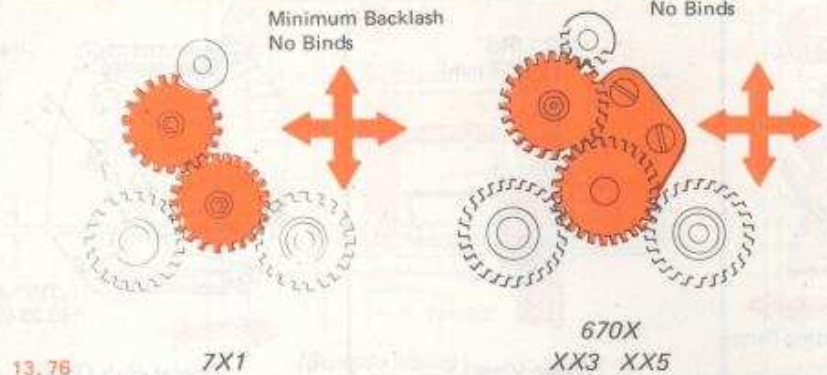

3 Cycle Clutch Latch Bracket (21-532)

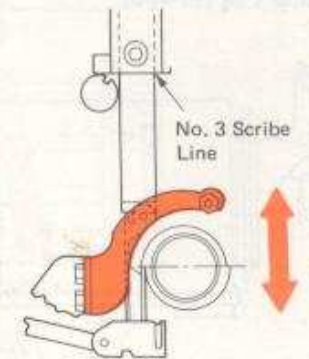

4 Cycle Clutch Spring (23-404)

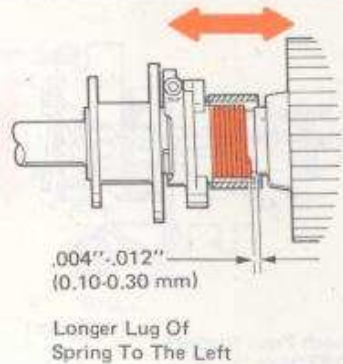

5 Cycle Clutch Sleeve End Play (23-409)

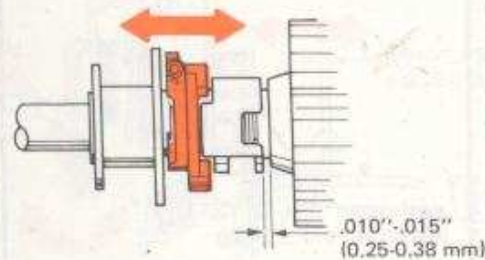

6 Cycle Clutch Drive (23-404)

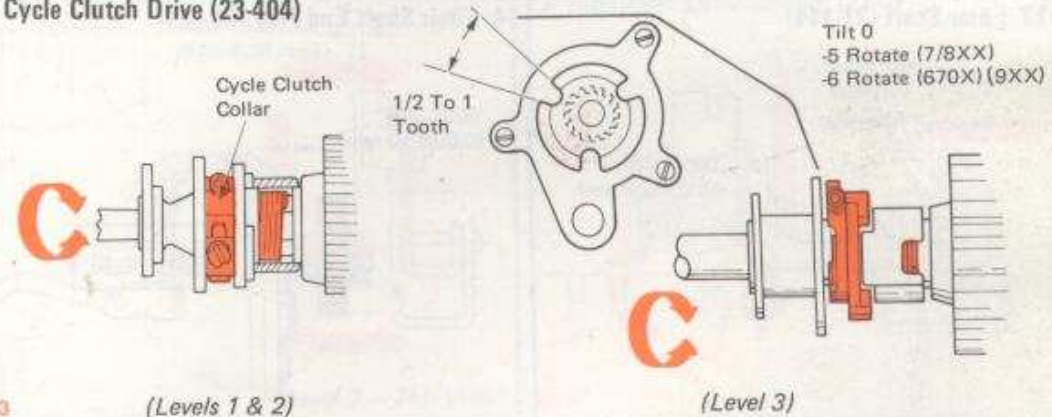

7 Cycle Clutch Overthrow (23-412)

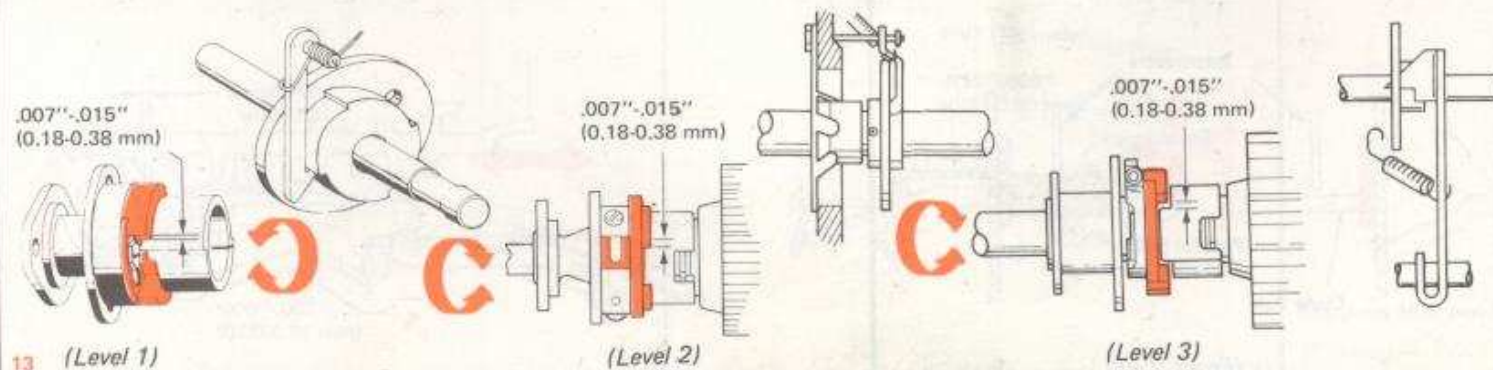

8 Drive Belt (11-68)

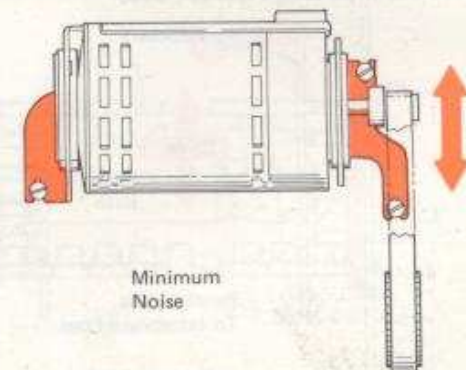

9 Motor Fan (11-400)

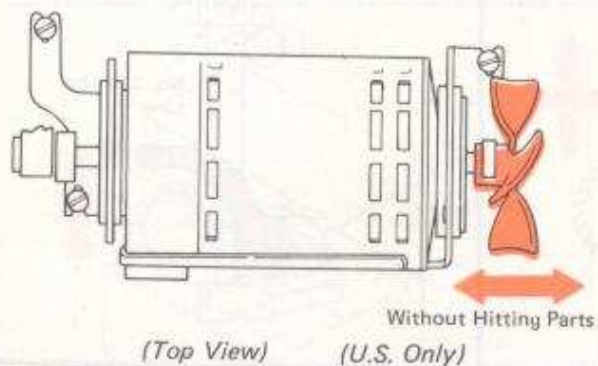

10 Motor Pulley (11-48)

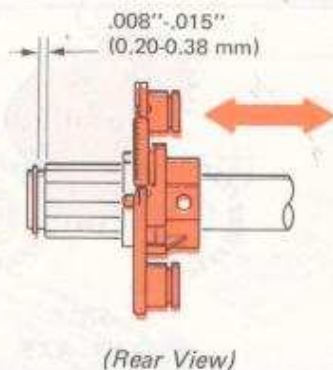

11 Motor Clutch Pawl Stops (11-43)

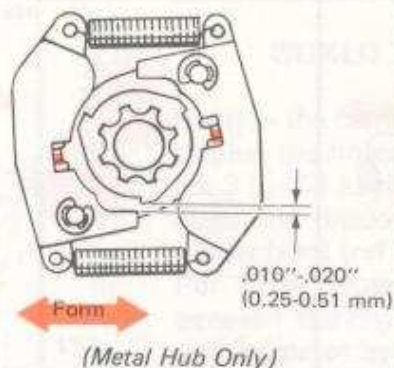

12 Keyboard Position (21-100)

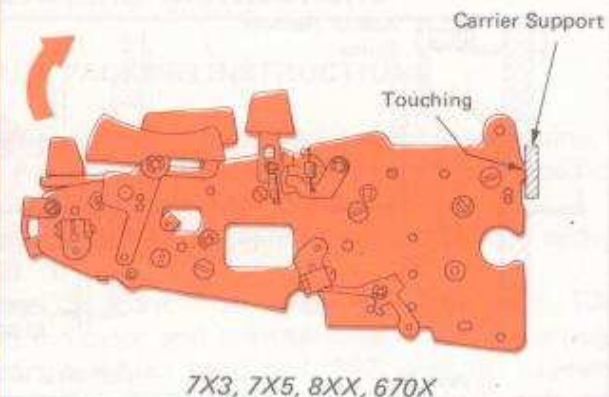

13 Filter Shaft (21-114)

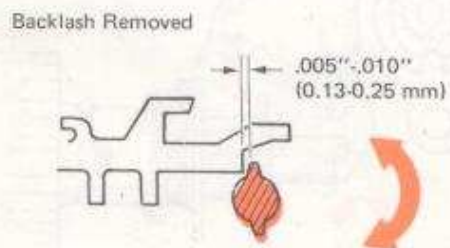

14 Filter Shaft End Play (21-121)

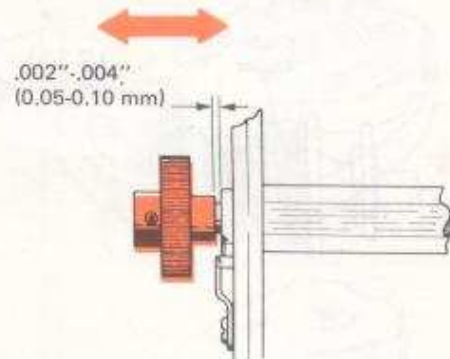

15 Rear Bearing Support (21-06)

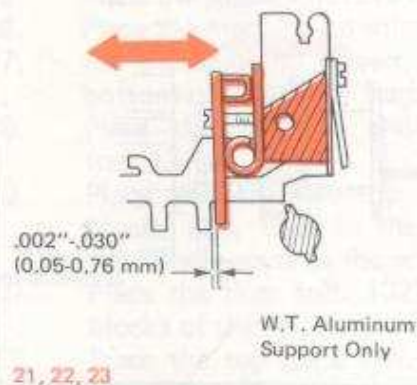

16 Rear Interposer Guide Comb (21-29)

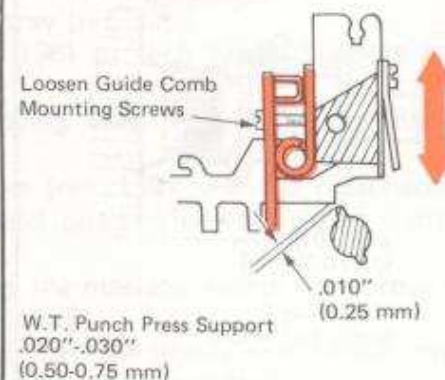

17 Bail Mounting Plate (21-303)

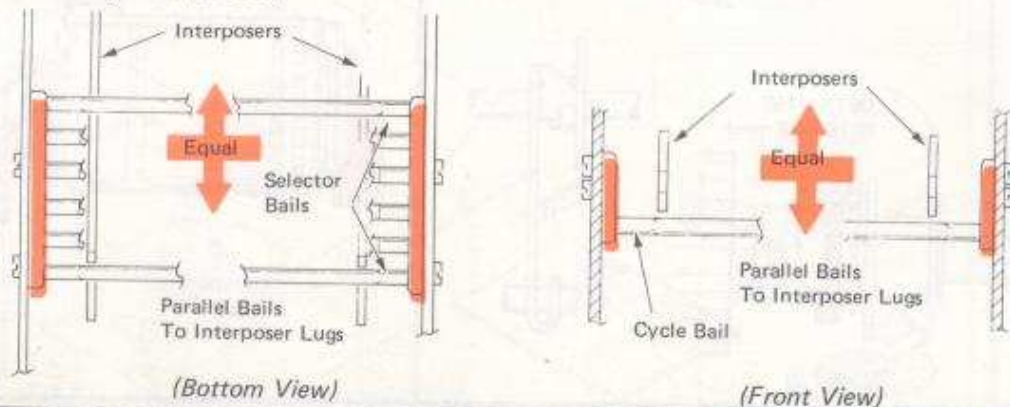

18 Keeper Bracket (21-204)

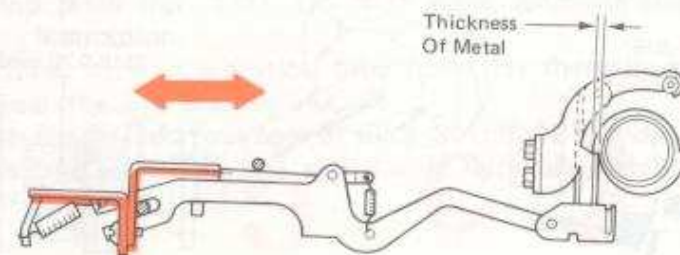

19 Cycle Bail Damper Spring (21-240)

Adjust Together
With Frame 18
On 670X And 8XX,
9XX W.T.

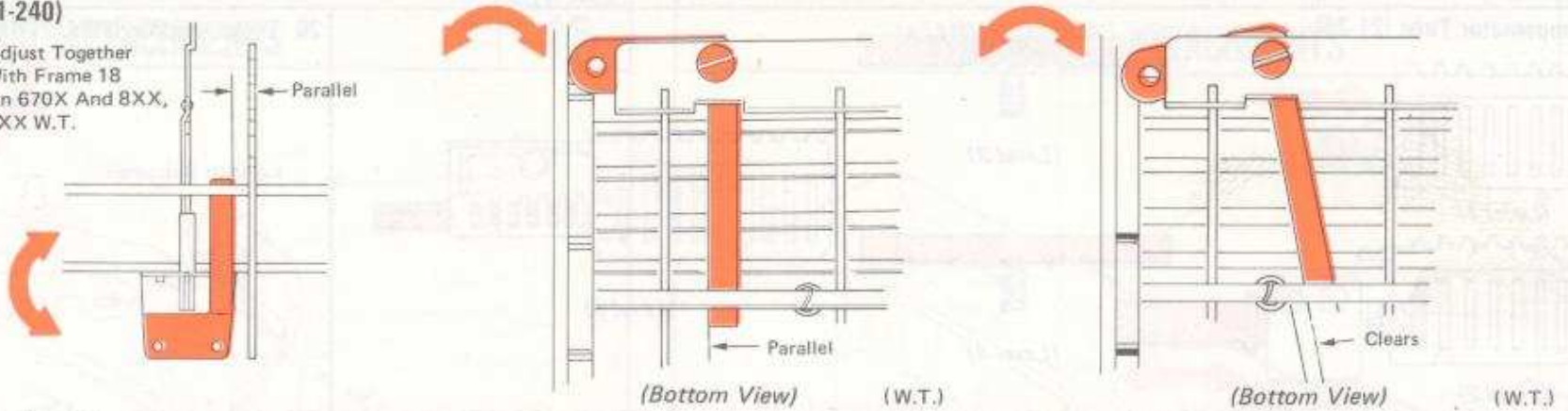

20 Cycle Clutch Latch Restoring (21-206)

.030"-.045"
(0.76-1.14 mm)

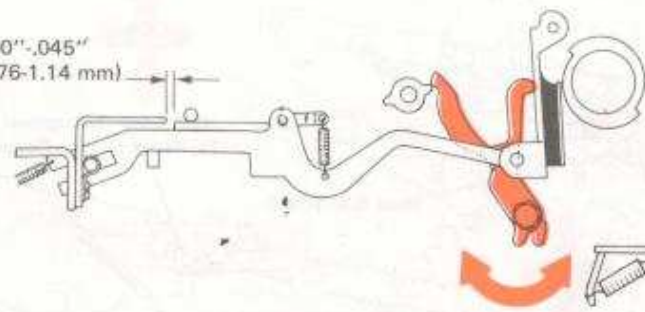

(Level 1)

.010"-.035"
(0.25-0.89 mm)



(Level 2)

.000"-.015"
(0.00-0.38 mm)

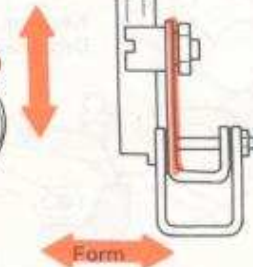

(Level 2 - Top View)

21 Interposer Latch Springs (21-4)

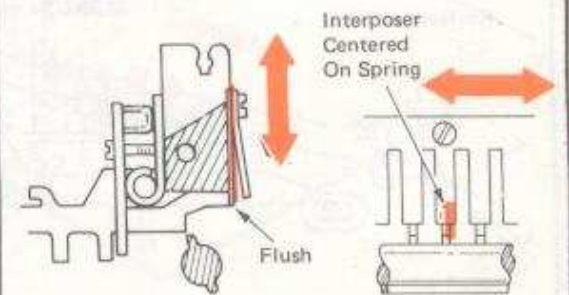

26, 27

22 Cycle Clutch Keeper (21-205)

.000"-.002"
(0.00-0.05 mm)

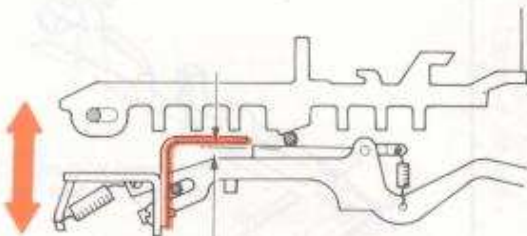

23 Cycle Bail Upstop (21-208)

Half Thickness
.030"-.035"
(0.76-0.89 mm)

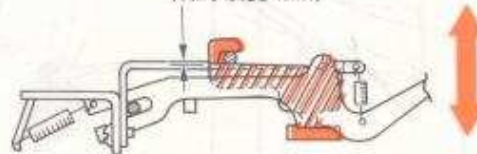

24 Front Keylever Guide Comb (21-132)

Interposer Must Not Bottom In Rear Guide Comb
.016"-.024"
(0.41-0.61 mm)

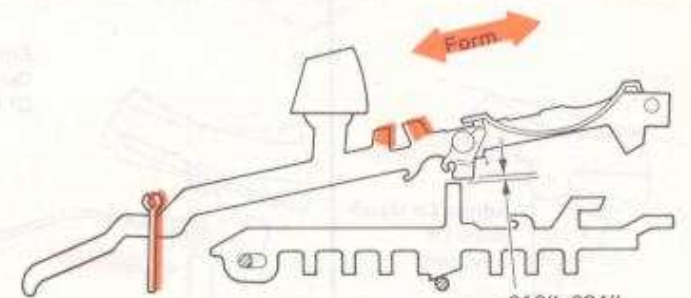

37, 143, 144, 202, 212

25 Compensator Tube (21-28)

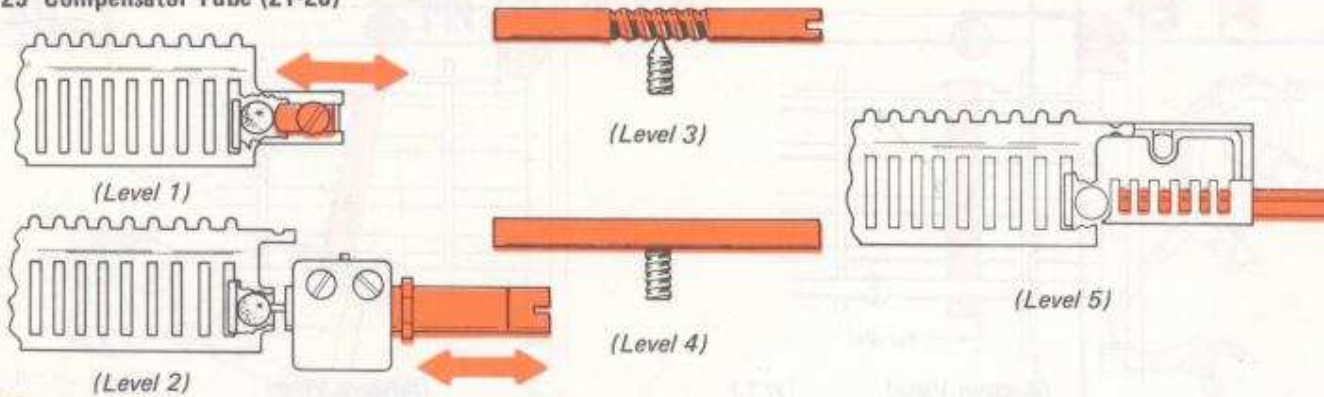

26 Typamatic Keylever (21-109)

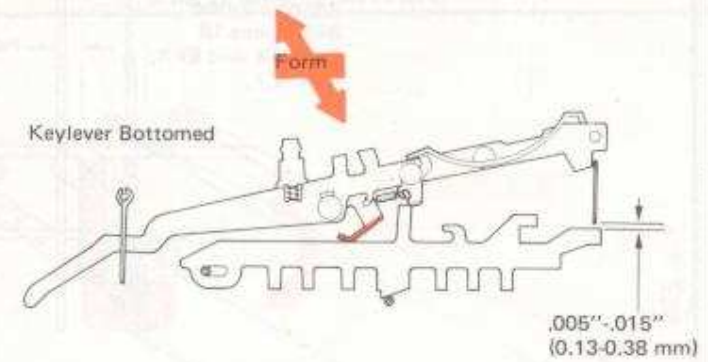

27 Repeat Keylever (21-106)

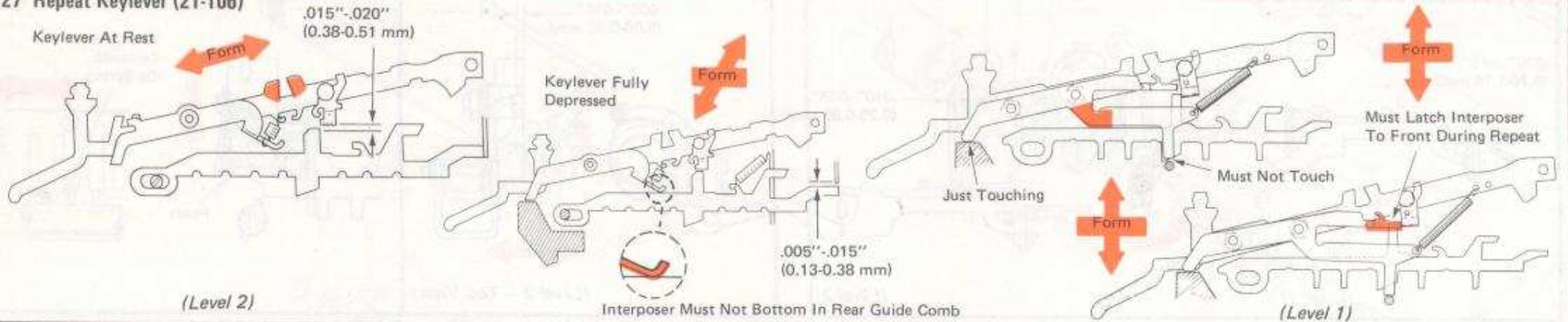

28 Switch Link (21-709)

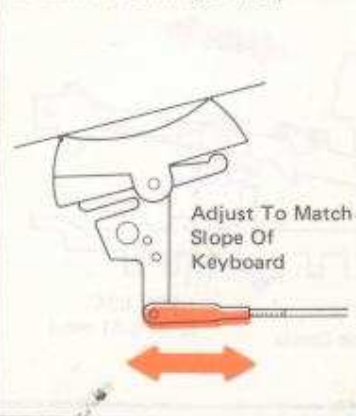

29 Lockout Bail Link (21-546)

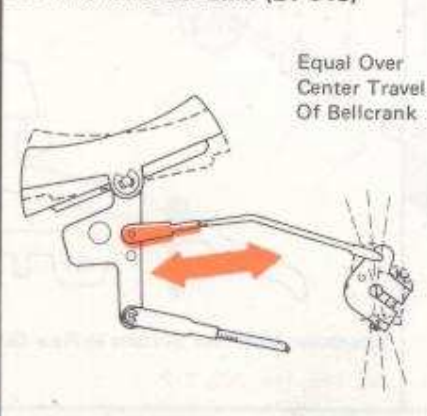

30 Lockout Bail Bellcrank (21-553)

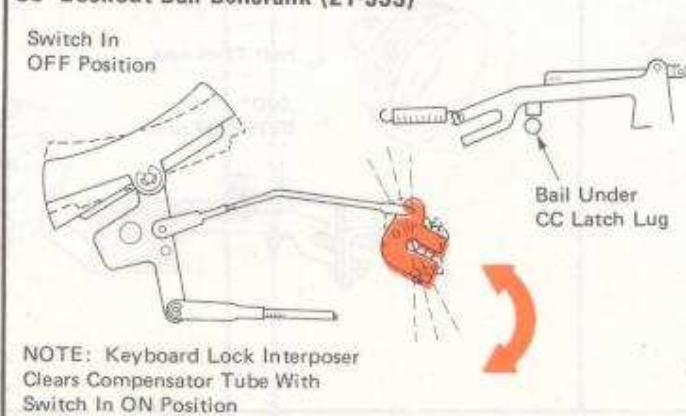

31 Keyboard Lock Bellcrank Link (21-305)

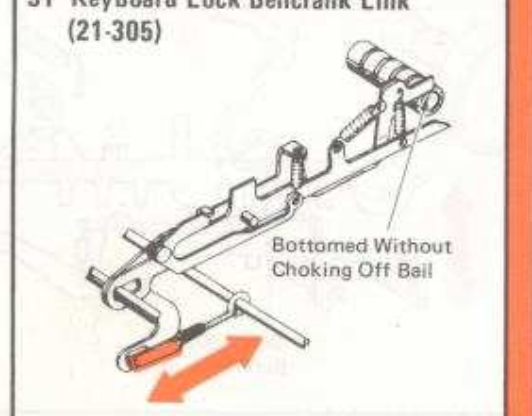

32 Shift Cam Backup Roller (16-46)

.001"-.004"
(0.03-0.10 mm)

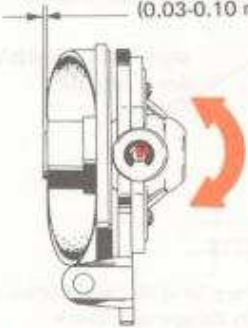

70 (Level 1 - Rear View)

33 Shift Cam Bearing (16-112)

Without Washer

.000"-.003"
(0.00-0.07 mm)

With Washer

.000"-.001"
(0.00-0.03 mm)

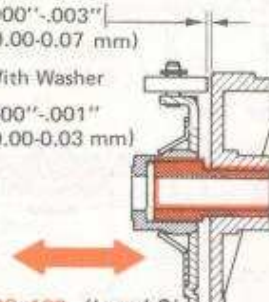

136, 137 (Level 2)

34 Shift Spring Clutch Retaining Plate (16-55)

Plastic And Steel Sintered Cams
Upper Case - 1-1/2 To 2 Teeth
Rotation Of Ratchet When
Released



Early Level Metal Cam
Lower Case - 1 Tooth
Rotation Of Ratchet
When Released

35 Shift Overthrow Stop (16-203)

.010"-.030"
(0.25-0.76 mm)

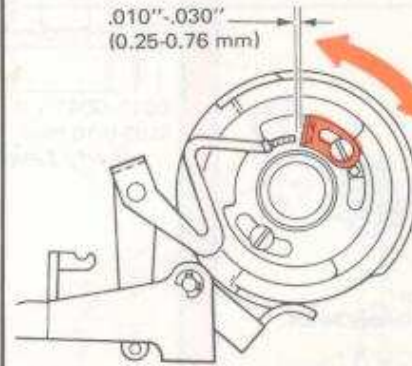

36 Shift Bracket (16-208)

.045"-.065"
(1.14-1.65 mm)

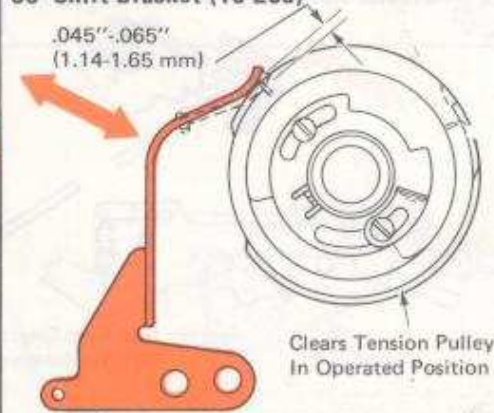

Clears Tension Pulley
In Operated Position

37 Shift Release (16-19)

Equal Over Center Travel

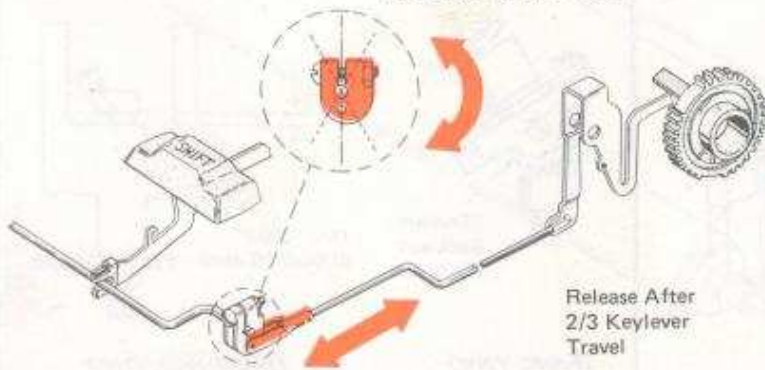

Release After
2/3 Keylever
Travel

38 Shift Lock (16-37)

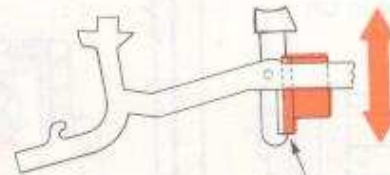

Adjust To Lock
Just As Shift
Clutch Operates

39 Shift Interlock (16-73)

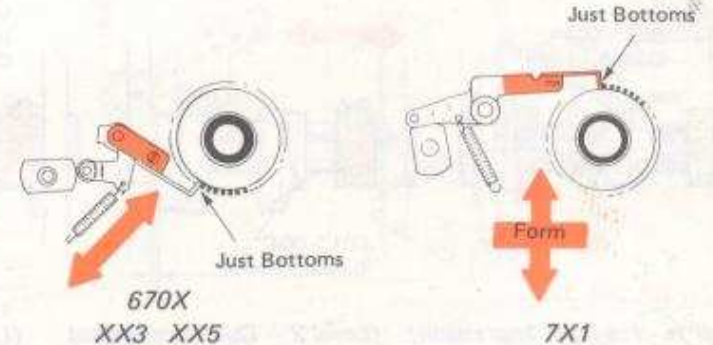

670X
XX3 XX5

7X1

40 Shift Interlock Cam (16-14)

.040"-.060"
(1.01-1.52 mm)

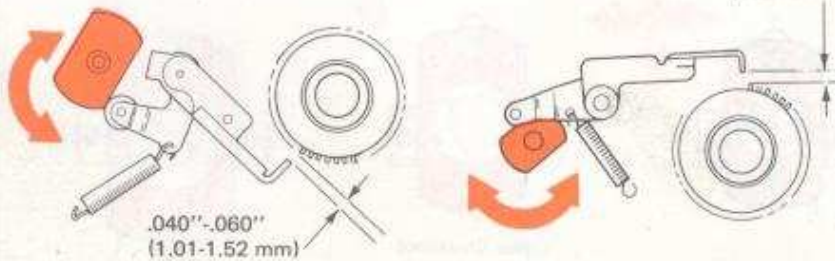

.040"-.060"
(1.01-1.52 mm)

670X
XX3 XX5

7X1

41 Character Interrupter (21-285)

Cycle Clutch
Latch Link
Released
Forward



Minimum
Clearance

42 Character Interrupter Bracket (21-287)



43 Carrier Shoe (02-107)

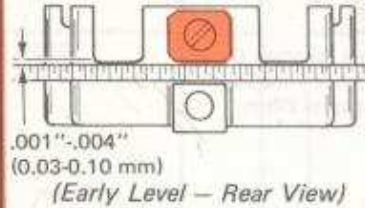

(02-119)

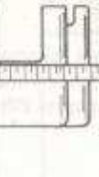

(02-112)

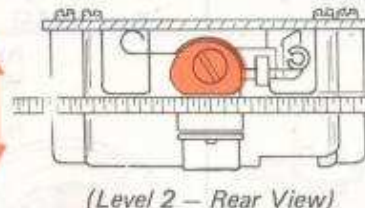

(02-96)

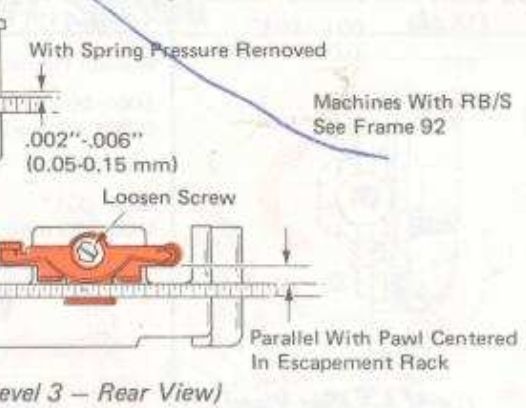

44 Print Sleeve End Play (02-152)

(26-56)

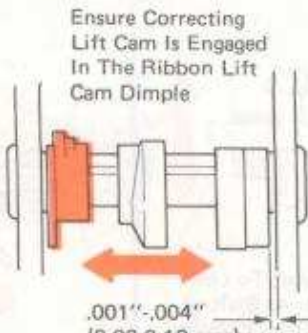
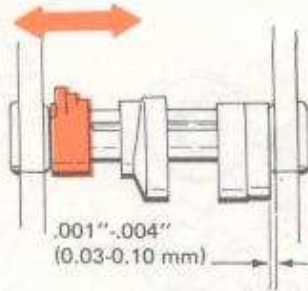

45 Rocker End Play (02-530)

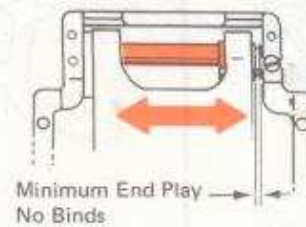

46 Tilt Tube End Play (02-305)

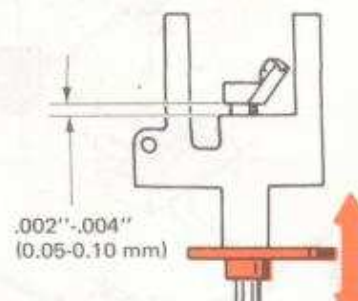

47 Rotate Shaft End Play (02-415)

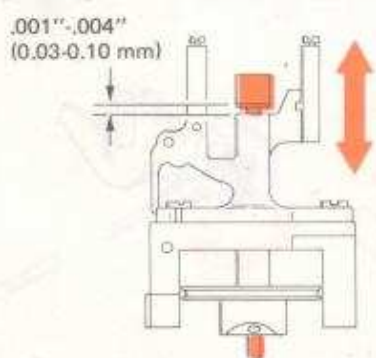
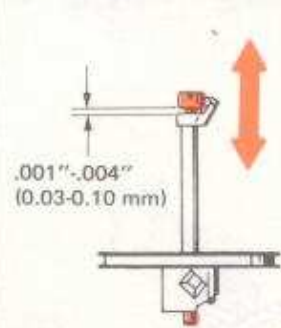

48 Upper Ball Socket (02-400)

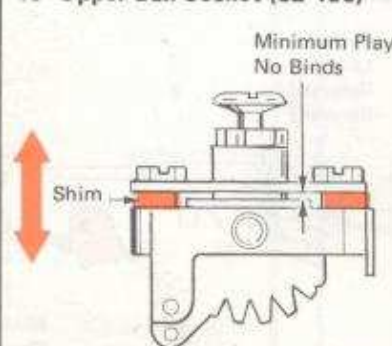

49 Tilt Ring Spacer (02-402)

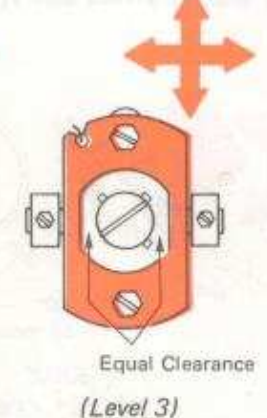
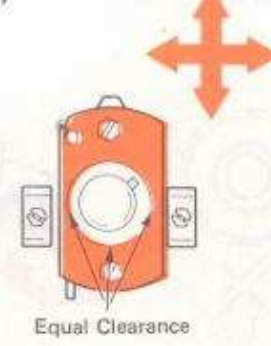
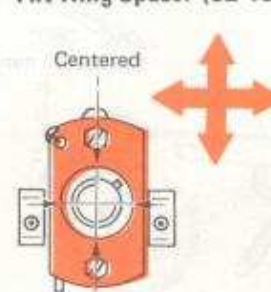

50 Rotate Detent (02-406)

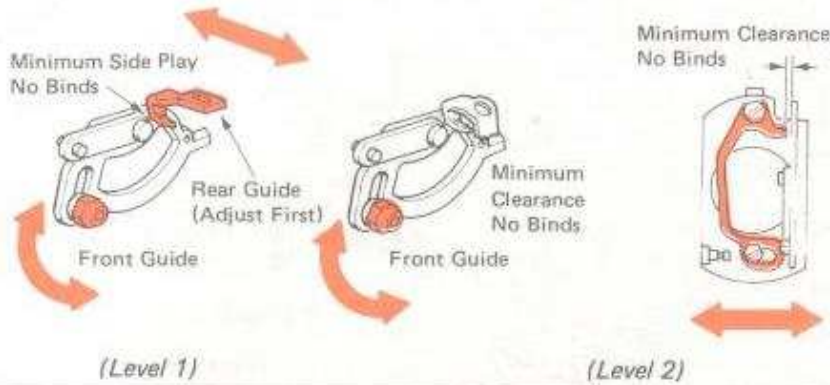

51 Tilt Detent (02-311)

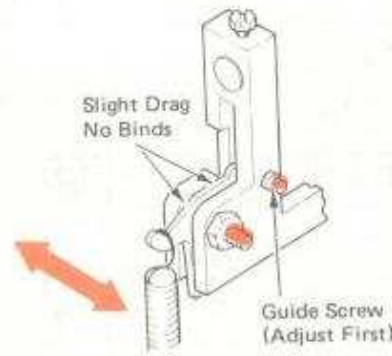

52 Tilt Ring Pivot Pins (02-300)

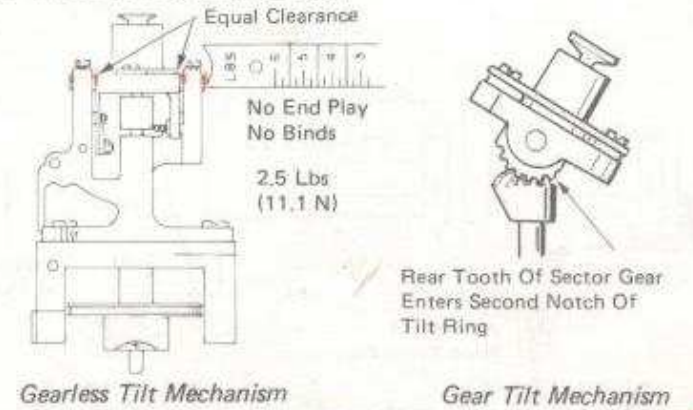

53 Detent Cam Follower Bracket (02-501)

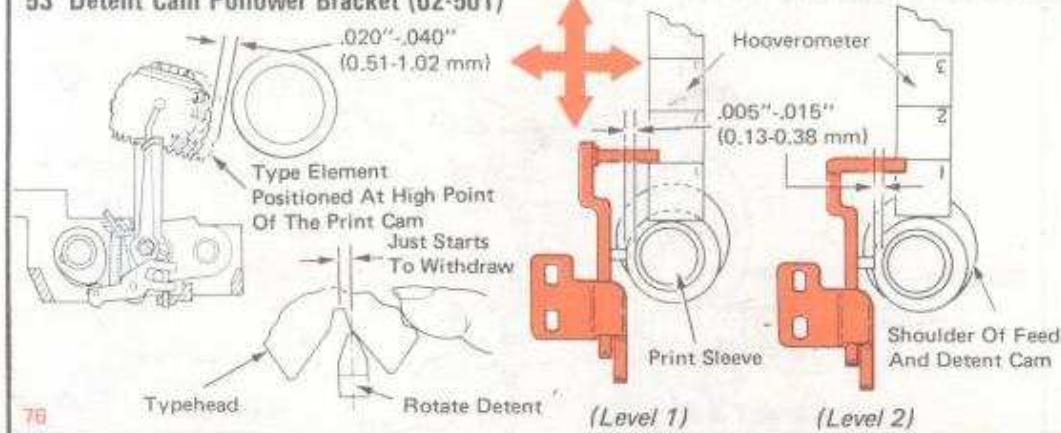

54 Skirt Clearance (02-505)

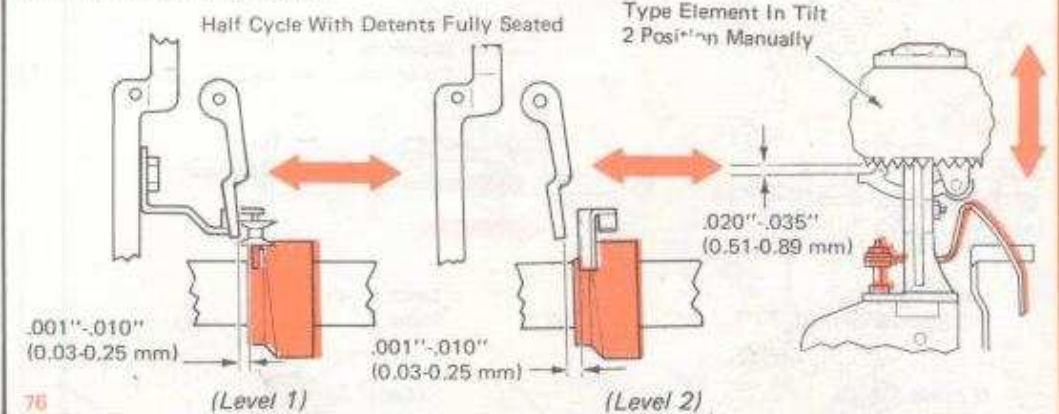

55 Print Shaft Timing (Preliminary) (02-30)

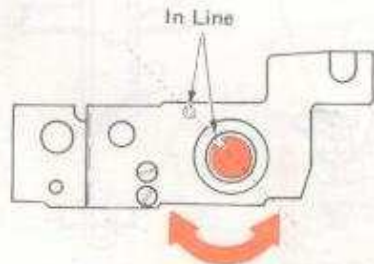

56 Latch Bail Shaft (23-115)

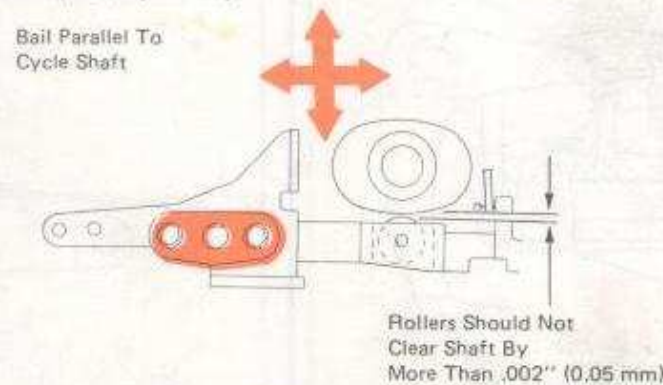

57 Differential Guides (23-207) (23-34)

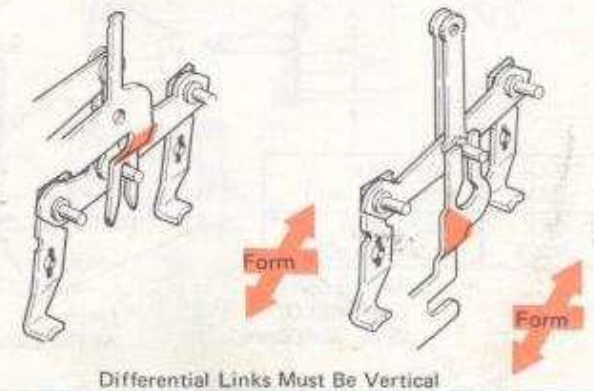

58 Positive Latch Bail Guide (23-107)

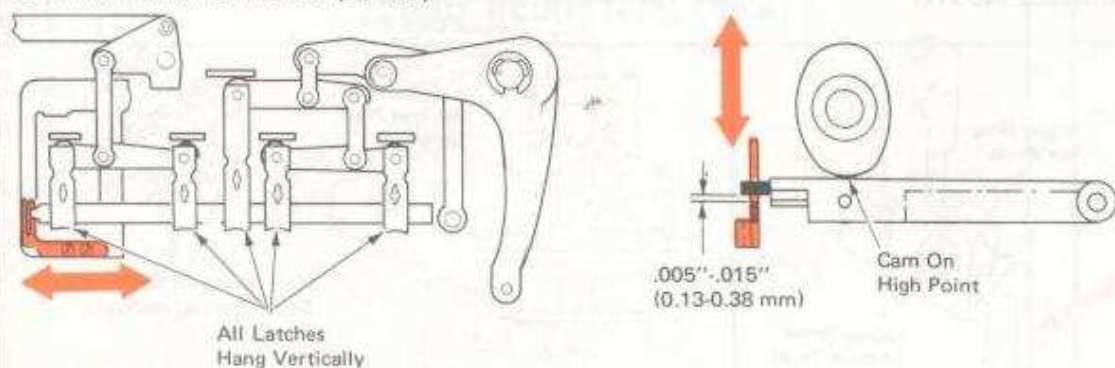

59 Interposer Stop Lugs (21-310) (21-325)

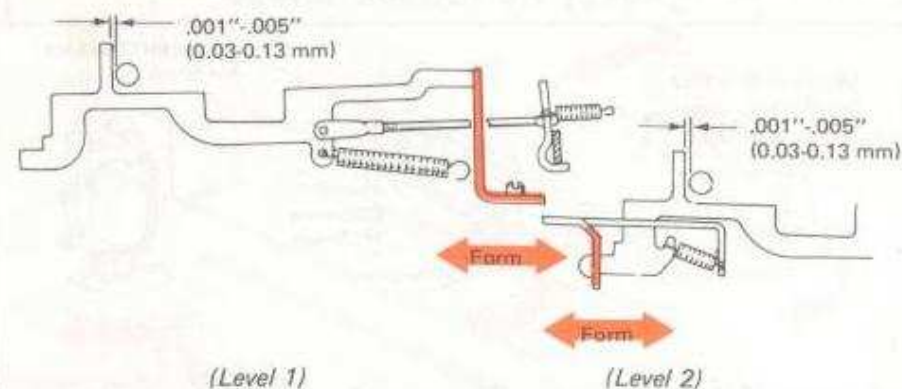

60 Selector Latch Links (21-316)

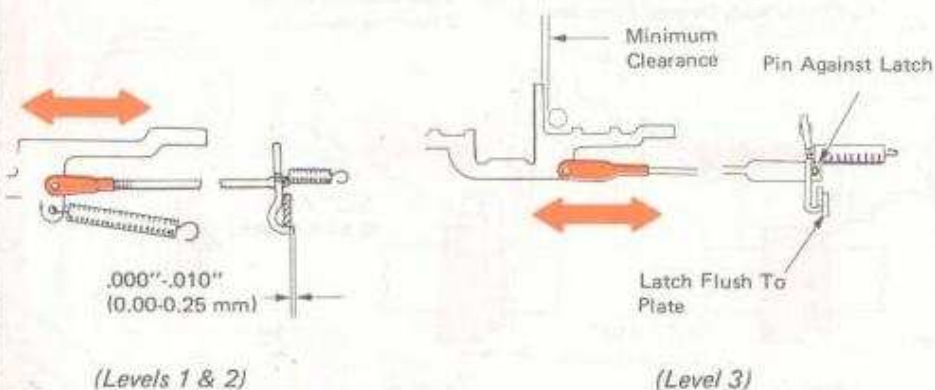

61 Negative 5 Or 6 Latch Link (21-317)

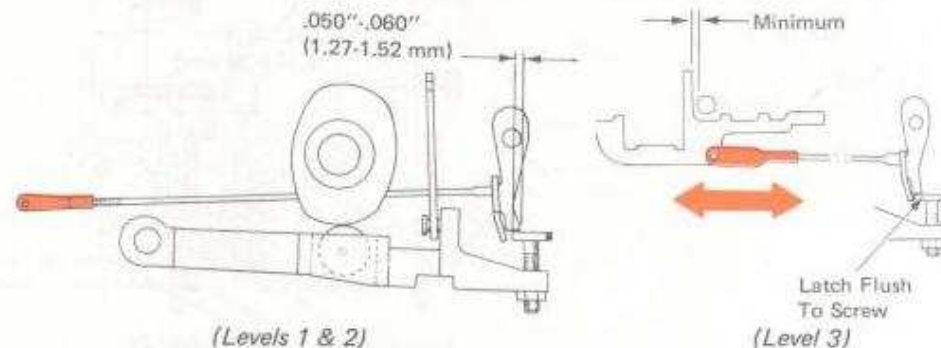

62 (Latch Stop Pads (23-486)

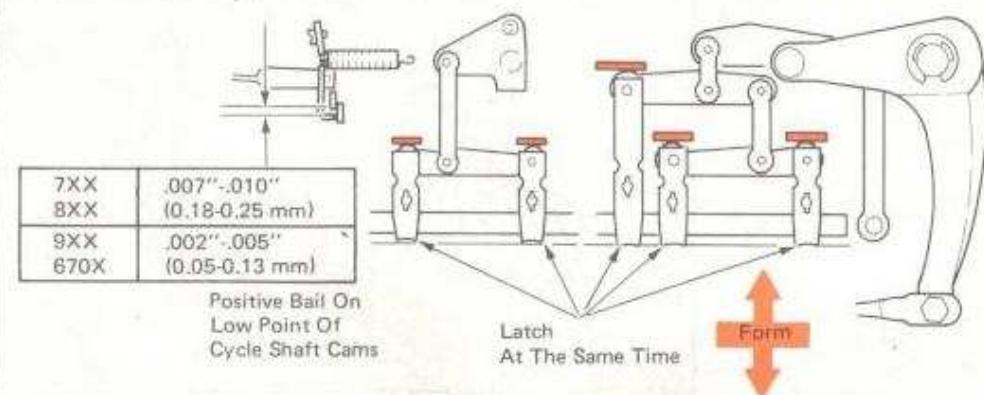

63 Negative Bail Stop Screw (Preliminary) (23-216)

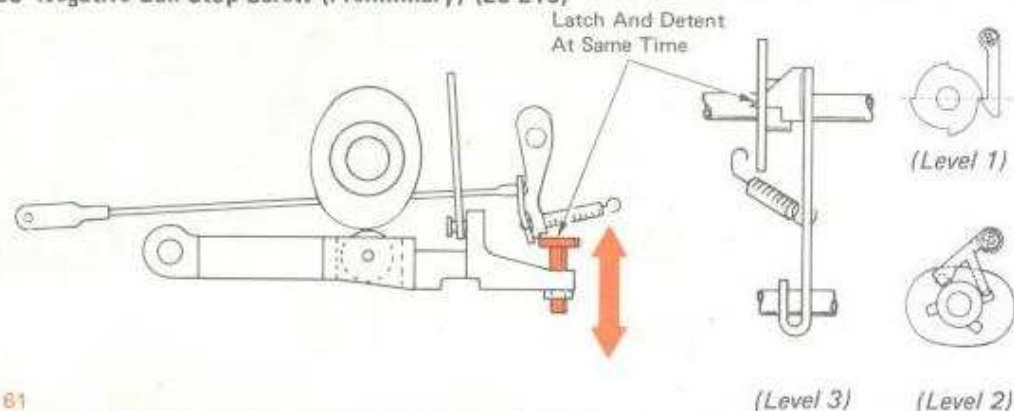

64 Tilt Arm Motion (23-28)

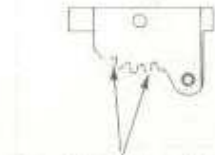
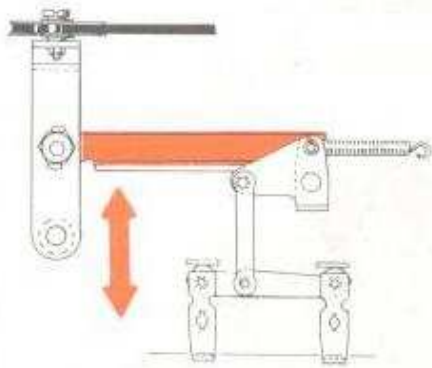

Equal Detenting Check

| | |
|-------------|-------------|
| Tilt Zero | Tilt 3 |
| Rotate zero | Rotate Zero |
| Z = J | 7XX - 8XX |
|) = P | 670X |

65 Tilt Homing (23-007)

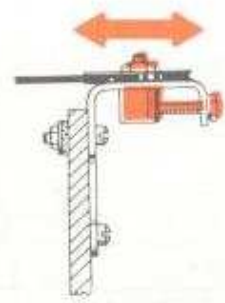

Play Removed
Negative
Will Raise
Approximately
.010" (0.25 mm)

Play
Removed
Positive

66 Rotate Spring Tension (02-424)

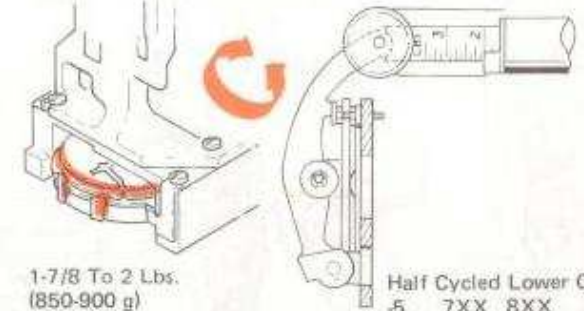

1-7/8 To 2 Lbs.
(850-900 g)
Take Reading Just
Before Arm Contacts
Lower Case Stop

Half Cycled Lower Case
-5 7XX 8XX
-6 670X
Typehead Removed

67 Compensator Arm (23-363)

Compensator
Arm Must Be
Disabled.
See Service
Manual

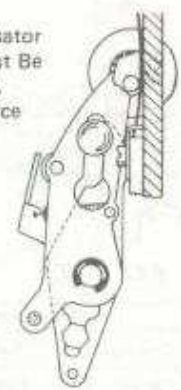

68 Balance Arm Preliminary (23-200)



69 Rotate Arm Vertical (Preliminary) (23-367)

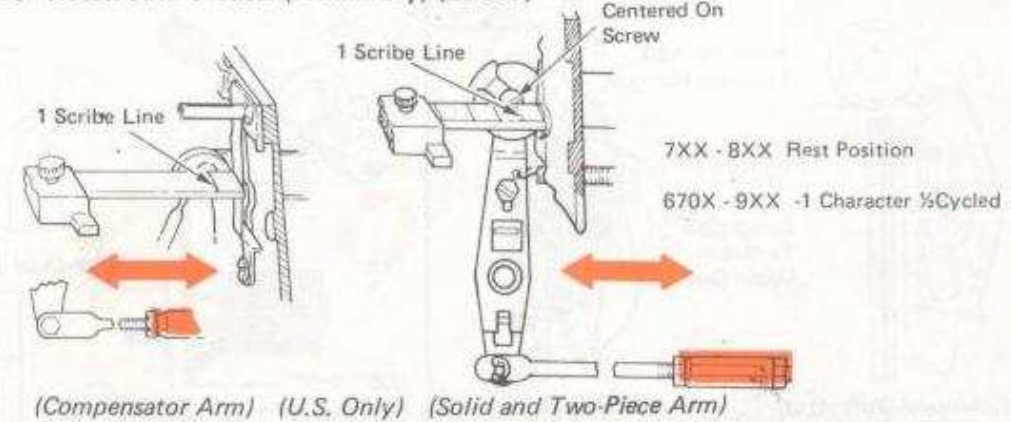

70 Typehead Homing (Preliminary) (02-420)

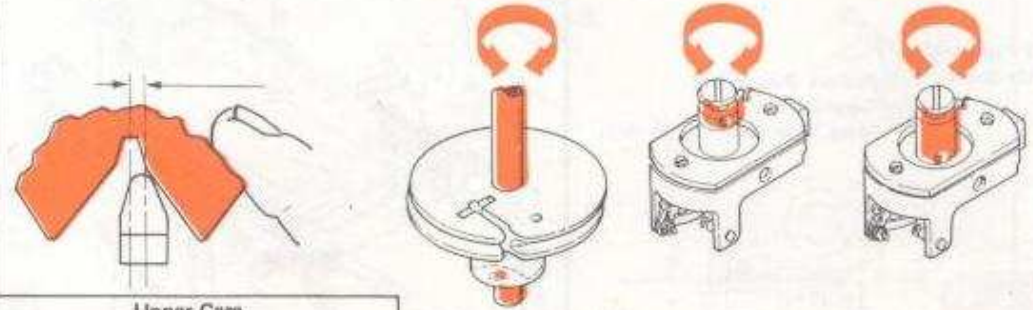

| | |
|--------------------|-------------|
| Upper Case | |
| "Degree" - 7XX 8XX | Tilt 2 |
| "R" - 670X | Rotate Zero |

7XX 8XX 670X
9XX W.T. 8XX W.T.

71 Negative 6 Upstop (23-241)

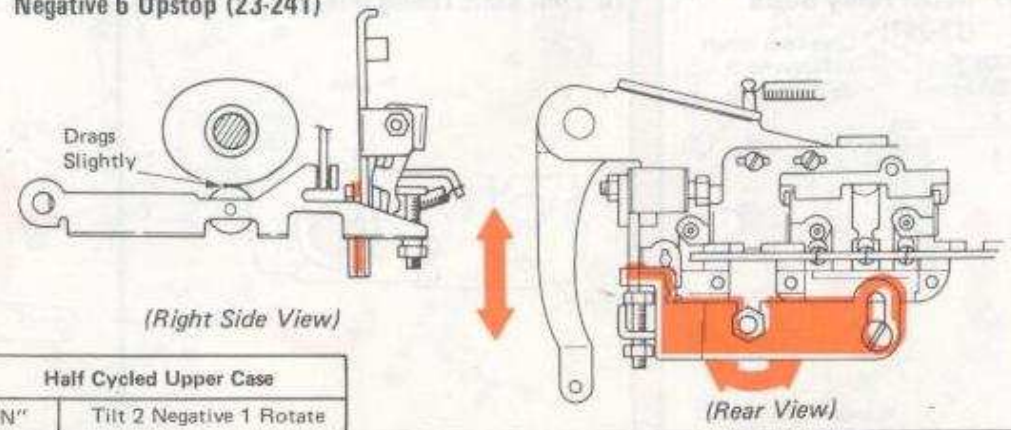

| | |
|------------------------|--------------------------|
| Half Cycled Upper Case | |
| "N" | Tilt 2 Negative 1 Rotate |

72 Rotate Arm Motion (23-369)

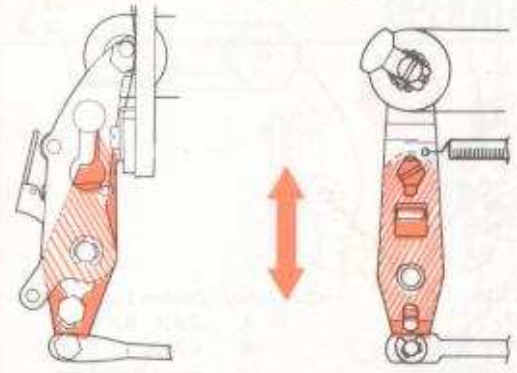

(Compensator Arm) (Solid And Two Piece Arm)

| Upper Case | | 7XX | 8XX |
|----------------|-----------------------------------|------|-----|
| "Degree" = "W" | Tilt 2 Zero Rotate = +5 Rotate | 7XX | 8XX |
| "R" = "V" | | 670X | |

73 Balance (Final) (23-216)



| Upper Case | | | |
|-----------------------------------|-----|-----------------------------------|-----|
| 7XX | 8XX | 7XX | 8XX |
| "degree" = "m" | | 670X | |
| Tilt 2 Zero Rotate = -5 Rotate | | Tilt 2 Zero Rotate = -6 Rotate | |

74 Typehead Homing (Final) (02-420) (02-441)

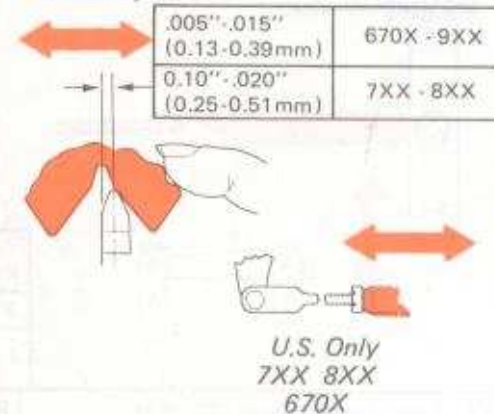

| | |
|------------------------------|------------|
| .005"-.015" (0.13-0.39mm) | 670X - 9XX |
| 0.10"-.020" (0.25-0.51mm) | 7XX - 8XX |

U.S. Only
7XX 8XX
670X

75 Shift Motion (16-101)

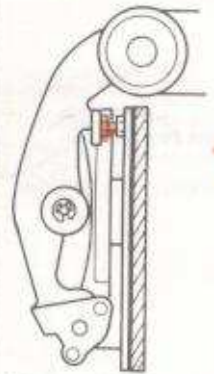

(Stamped Shift Arm)

(16-41)

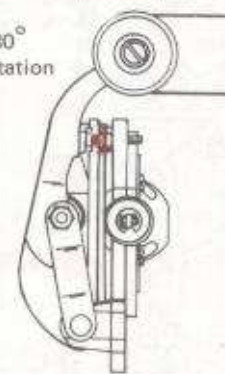

(Die Cast Shift Arm)

Adjust For 180°
Typehead Rotation

Lower Case
To Match
Upper Case

76 Fine Timing (02-30)

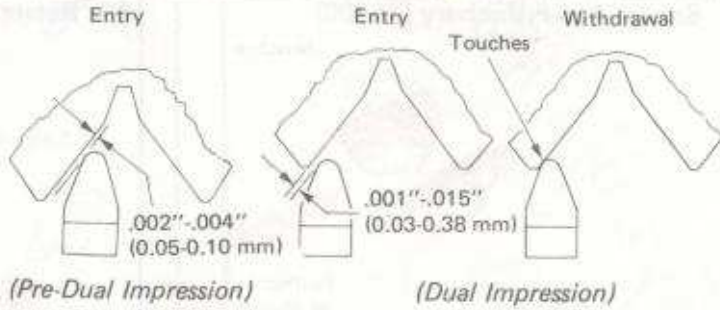
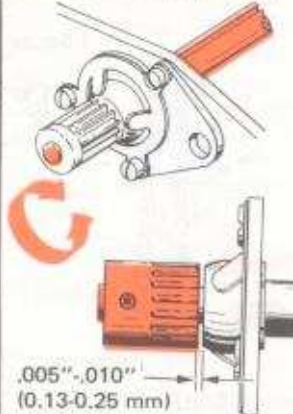

| | Hand Cycle Upper Case M | Tilt 2 -5 Rotate | 7XX | 8XX |
|------------------------------|-------------------------|---------------------|------|----------|
| Hand Cycle Upper Case Degree | | Tilt 2 -6 Rotate | 670X | 9XX W.T. |



9XX W.T.



8XX W.T.

| Upper Case | | |
|------------|-----------------------|-----|
| "degree" | 7XX | 8XX |
| "R" | 670 | X |
| | Tilt 2 Zero Rotate | |

77 Rotate Pulley Guard (23-351)

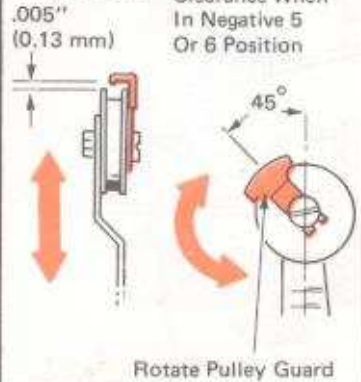

Rotate Pulley Guard

78 Print Shaft Timing (Preliminary) (02-30)

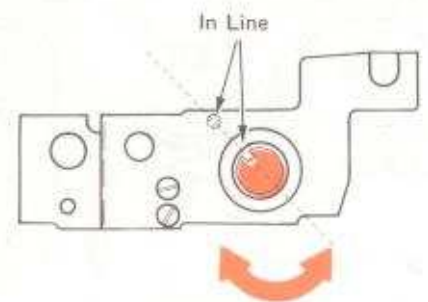

79 Latch Bail Shaft (23-115)

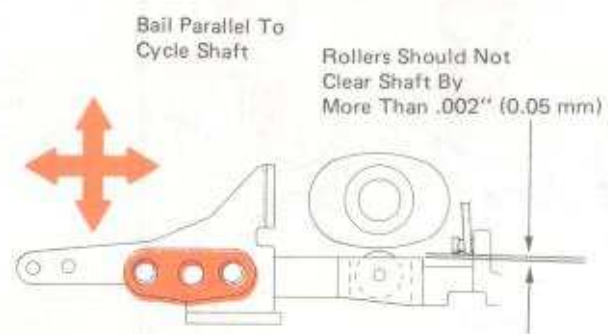

80 Differential Guides (23-207) (23-34)

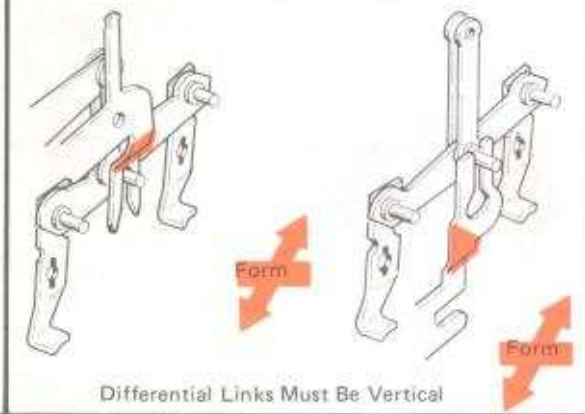

Differential Links Must Be Vertical

81 Positive Latch Bail Guide (23-107)

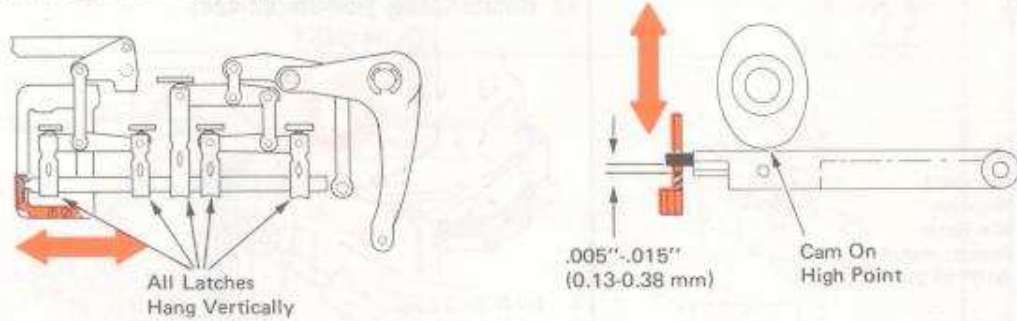

All Latches Hang Vertically

.005"-.015"
(0.13-0.38 mm)

Cam On High Point

82 Interposer Stop Lugs (21-310) (21-325)

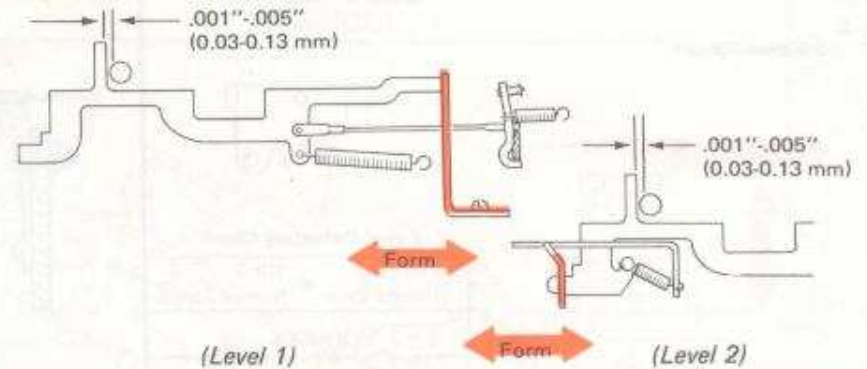

(Level 1)

Form

(Level 2)

83 Selector Latch Links (21-316)

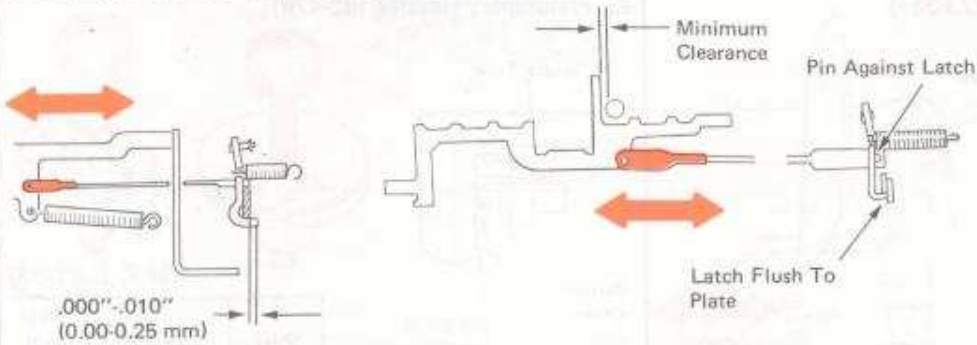

.000"-.010"
(0.00-0.25 mm)

(Levels 1 & 2)

Minimum Clearance

Pin Against Latch

Latch Flush To Plate

(Level 3)

84 Negative 5 Or 6 Latch Link (21-317)

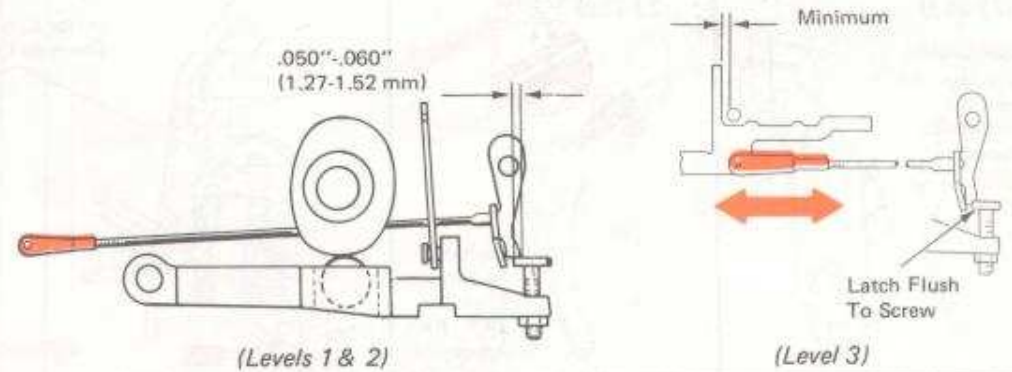

(Levels 1 & 2)

Minimum

Latch Flush To Screw

(Level 3)

85 Latch Stop Pads (23-486)

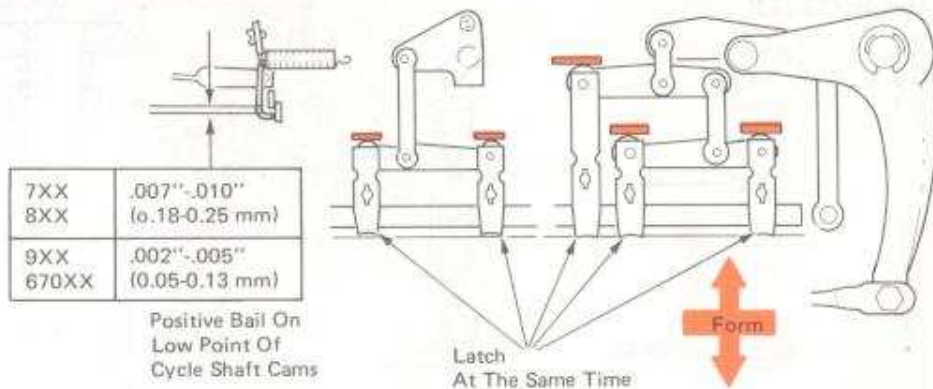

Positive Bail On Low Point Of Cycle Shaft Cams

Latch At The Same Time

Form

86 Negative Bail Stop Screw (Preliminary) (23-216)

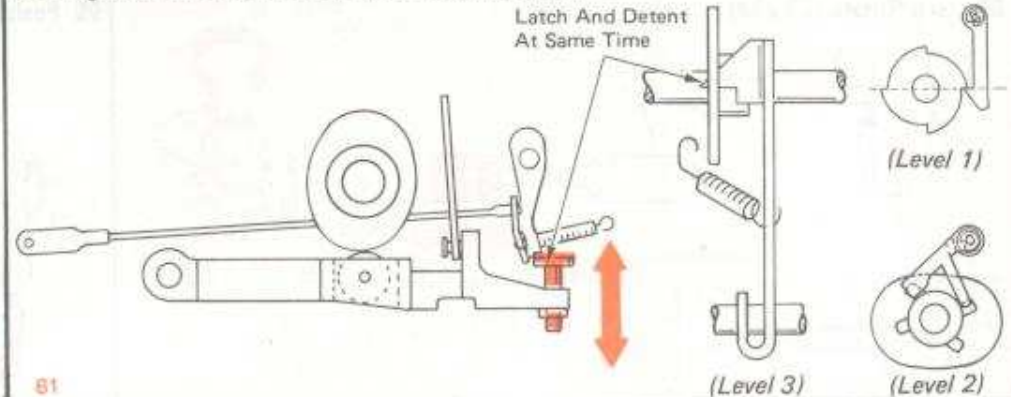

Latch And Detent At Same Time

(Level 1)

(Level 3)

(Level 2)

87 Tilt Arm Motion (23-28)

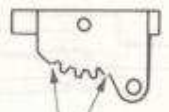
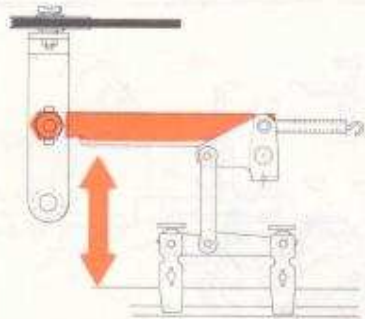

Equal Detenting Check

| | |
|-----------------|-------------|
| Tilt Zero | Tilt 3 |
| Rotate Zero | Rotate Zero |
| Z = J 7XX - 8XX | |
|) = P 670X | |

88 Tilt Homing (23-007)

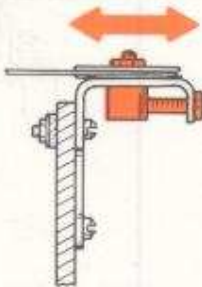

Play Removed
Negative Will Raise
Approximately .010" (0.25 mm)

Play Removed
Positive

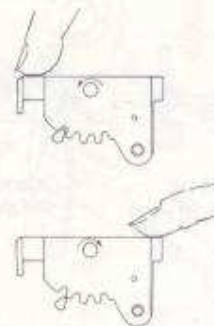

89 Rotate Spring Tension (02-424)

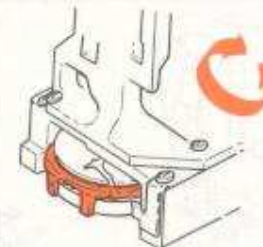

1-7/8 To 2 Lbs.
(850-900 g)
Take Reading Just Before Arm Contacts Lower Case Stop

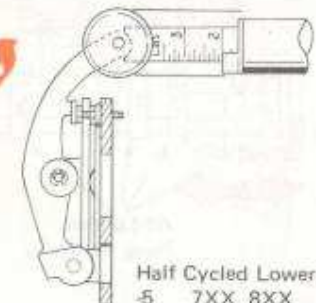

Half Cycled Lower Case
-5 7XX 8XX
-6 670X
Typehead Removed

90 Compensator Arm (23-363)

Compensator Arm Must Be Disabled. See Service Manual

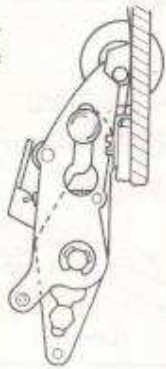

91 Balance Arm Preliminary (23-200)



Position As Shown Then Use 7XX 8XX Adjustment

(Adjustable Balance Arm)

92 Rotate Arm Vertical (Preliminary) (23-367)

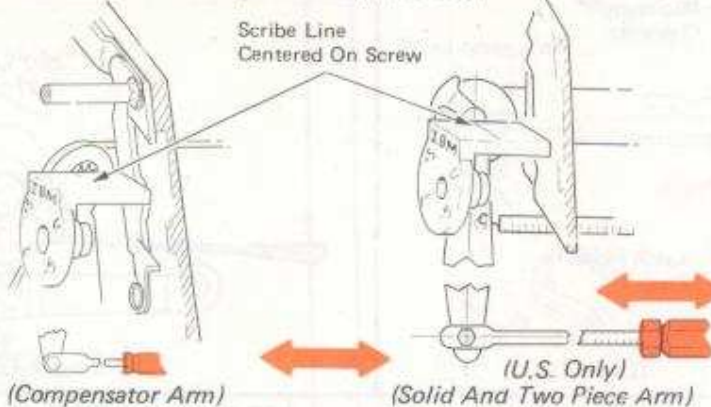

Scribe Line Centered On Screw

(U.S. Only)
(Solid And Two Piece Arm)

(Compensator Arm)

93 Preliminary Homing (02-420)

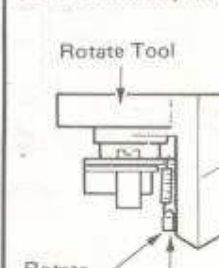

Rotate Tool
Rotate Detent Just Touches

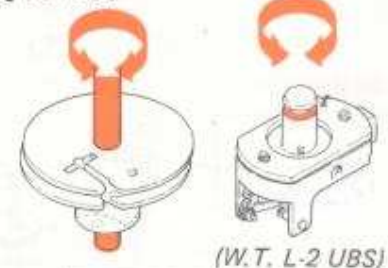

(W.T. L-2 UBS)

No Binds
No Clearance

| Shift | Character | Tool Slot |
|-------|--------------------------|-----------|
| UC | 1 Tilt 2 +3 Rotate | U |

94 Zero Rotate (23-228)

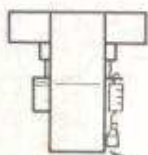

No Binds
No Clearance

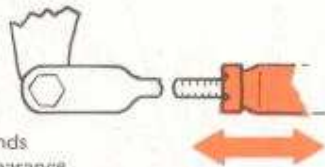

Leave Turnbuckle Loose (U.S. Only)

(W.T. L-2 UBS)

| Shift | Character | Tool Slot |
|-------|------------------------------|-----------|
| UC | 1/4 Tilt 2 Zero Rotate | U |

95 Positive 5 Motion (23-369)

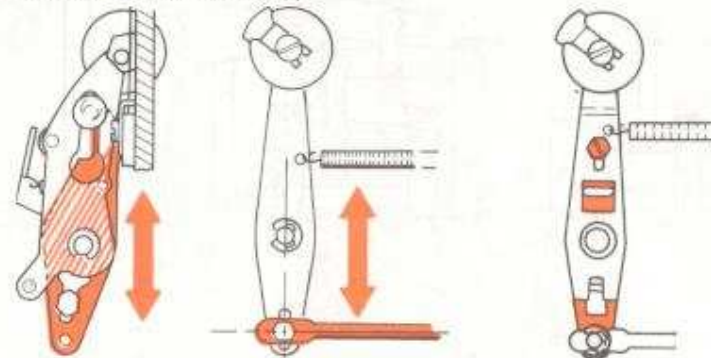

(Compensator Arm)

(Solid Arm)

(Two Piece Arm)

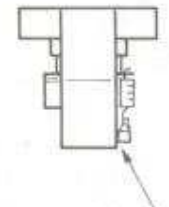

No Clearance
No Binds

| Shift | Character | Tool Slot |
|-------|--------------------------|-----------|
| UC | W Tilt 2 +5 Rotate | +5 |

96 Negative 5 Motion (23-369)

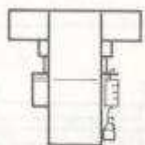

No Clearance
No Binds

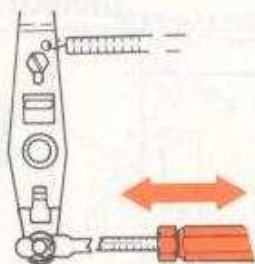

(U.S. Only)



(W.T. L-2 UBS)

| Shift | Character | Tool Slot |
|-------|--------------------------|-----------|
| UC | M Tilt 2 -5 Rotate | -5 |

97 Balance (Final) (23-216)

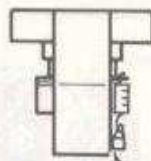

No Clearance
No Binds

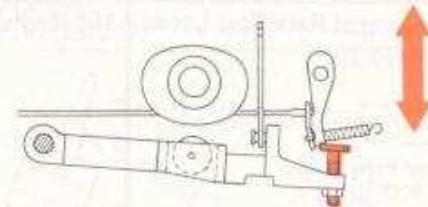

Adjustable Balance Arm
Check Frame 91 First

| Shift | Character | Tool Slot |
|-------|------------------------------|-----------|
| UC | 1/4 Tilt 2 Zero Rotate | U |

98 Shift Motion (16-101) (16-41)

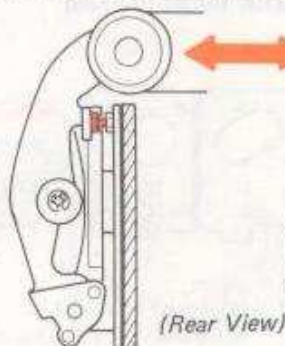

(Stamped Arm)

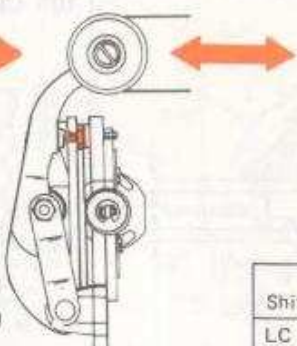

(Die Cast Arm)

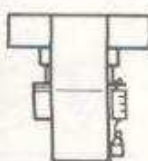

No Clearance
No Binds

| Shift | Character | Tool Slot |
|-------|------------------------------|-----------|
| LC | 1/2 Tilt 2 Zero Rotate | L |

99 Fine Timing (02-30)

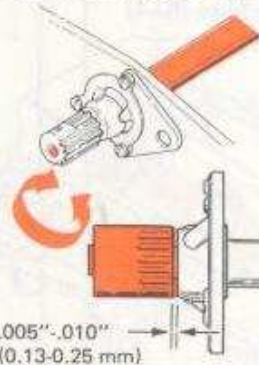

.005"-.010"
(0.13-0.25 mm)

Entry

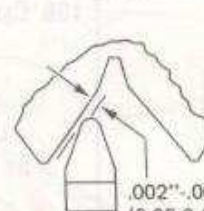

(Pre-Dual Impression)

Entry



(Dual Impression)

Withdrawal

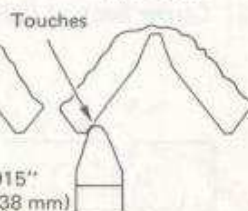

Touches

| Hand Cycle Upper Case M | Tilt 2 -5 Rotate | 7XX 8XX |
|------------------------------|---------------------|---------------|
| Hand Cycle Upper Case Degree | Tilt 2 -6 Rotate | 670X 9XX W.T. |

100 Rotate Pulley Guard (23-351)

.005"
(0.13 mm)

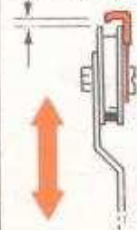

Rotate Pulley Guard

101 Escapement Rack Or Rail (07-11)

Hoovermeter On Number One Scribe Line

Just Spans The Distance

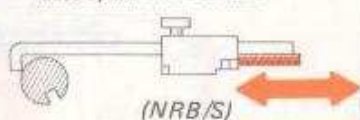

(NRB/S)

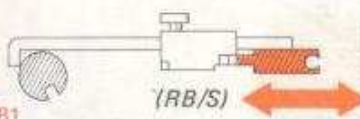

(RB/S)

181
Check At Left, Center, And Right

102 Escapement Rack Guide (07-20)

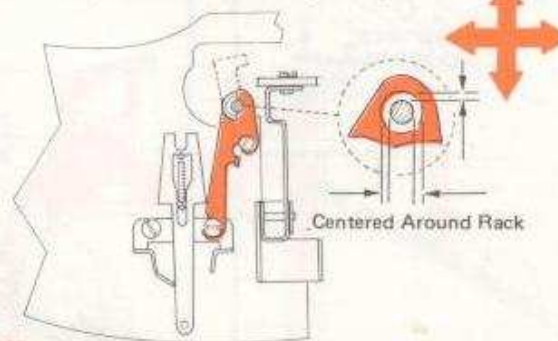

Centered Around Rack

105
(Dual Pitch Only) (Left Side View)

103 Escapement Rack Teeth Vertical (07-23)

10 Pitch

Levels 2 & 3
Gear Flush
Against 1/2 B/S Cam

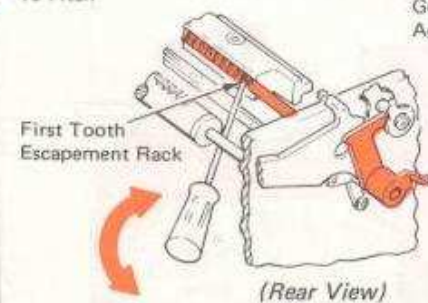

First Tooth
Escapement Rack

Level 1
.005"-.010"
(0.13-0.25 mm)
End Play
Of Switch
Pitch Gear

(Rear View)
(Dual Pitch Only)

104 Escapement Rack Gear Lower Stop (07-20)

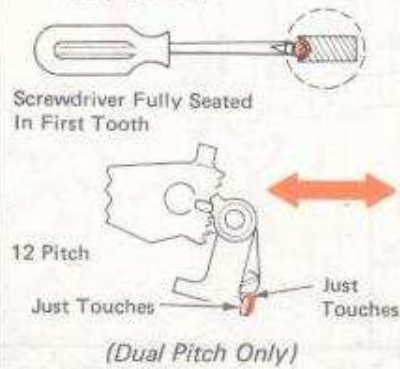

105 Switch Pitch Sector Gear (07-31)

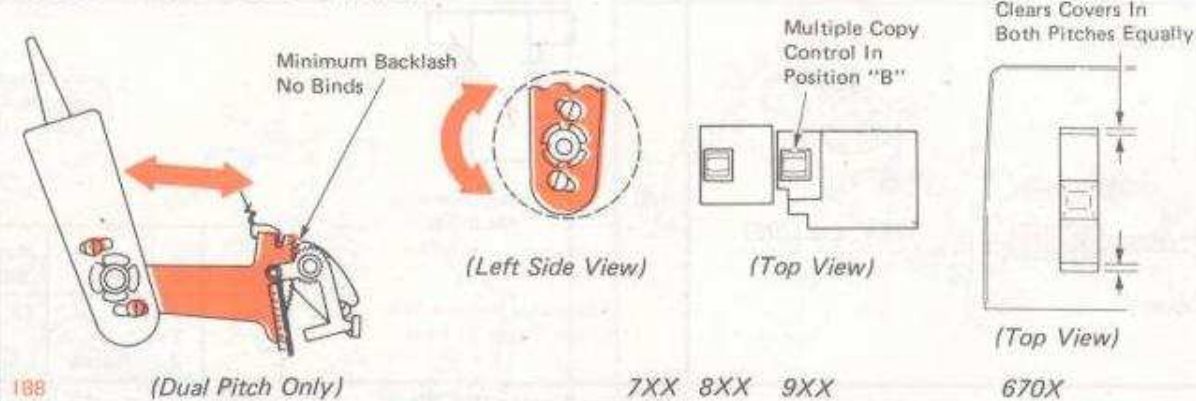

106 Escapement Pawl Guide Lug (07-4)

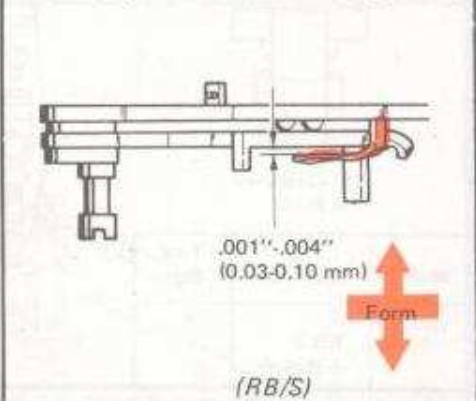

107 Carrier Support (02-8)

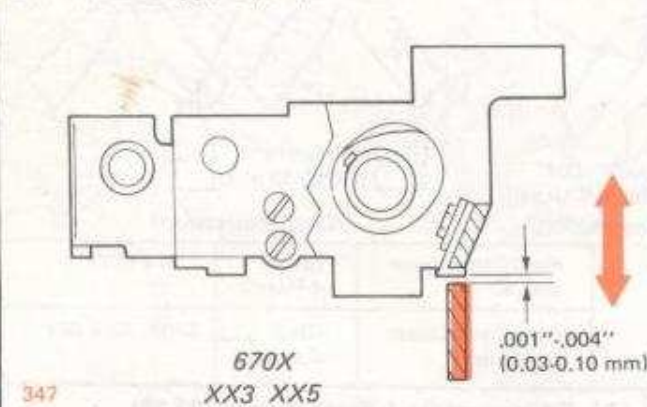

108 Carrier Shoe (07-4)

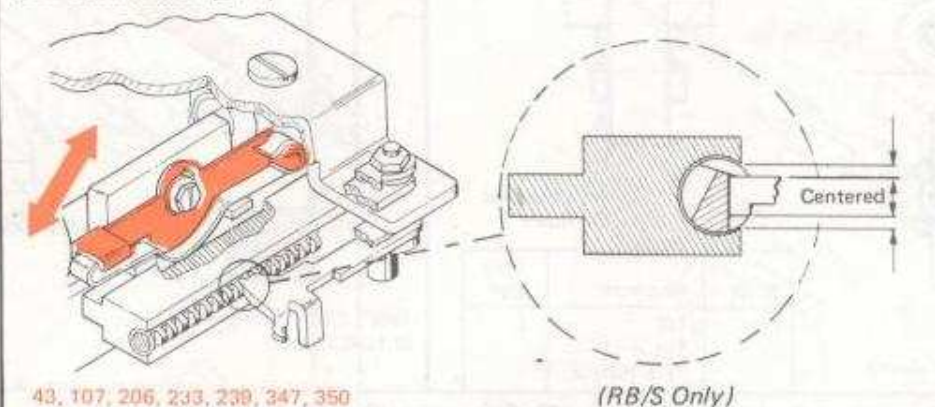

109 Carrier Buffer (02-130)

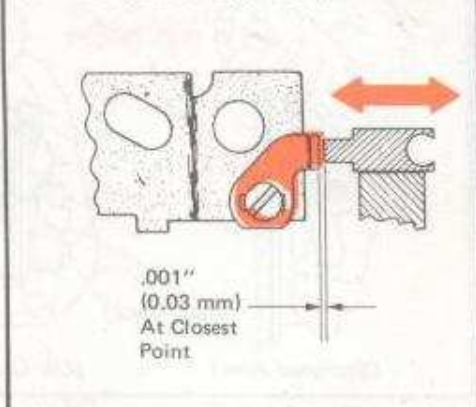

110 Escapement Bracket (06-23)

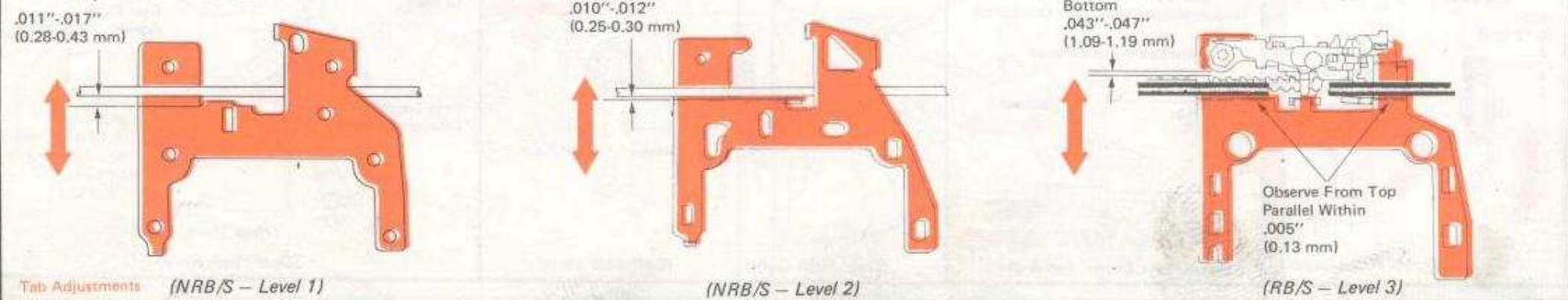

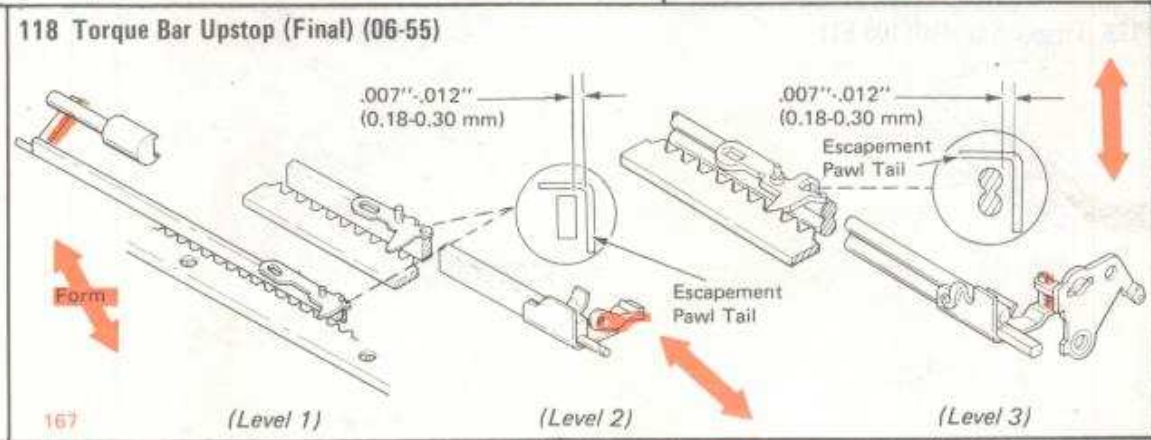
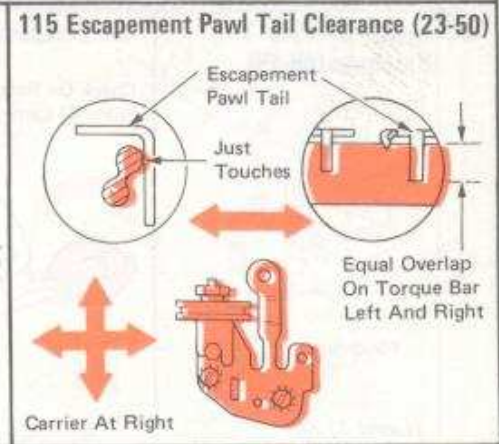
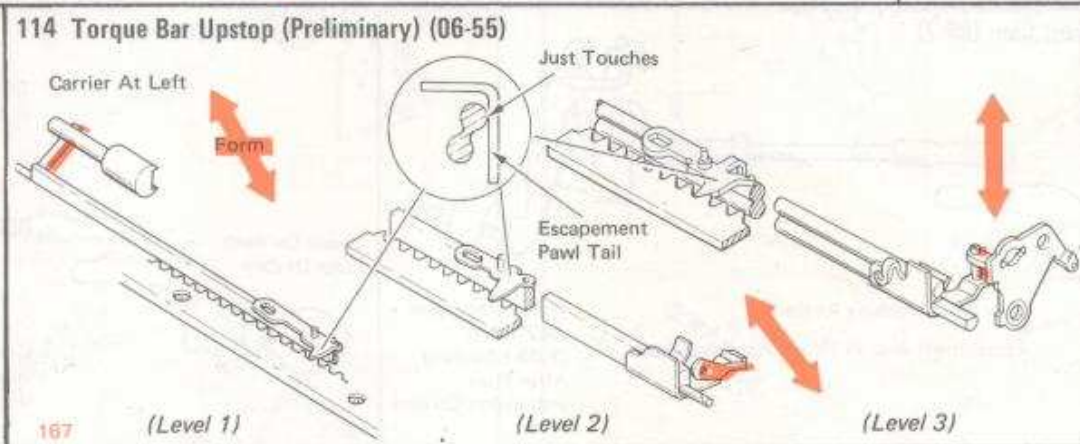
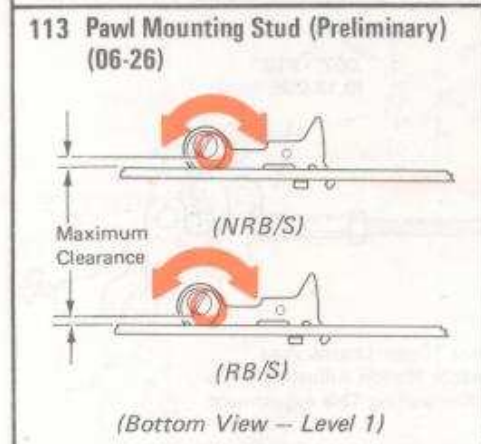
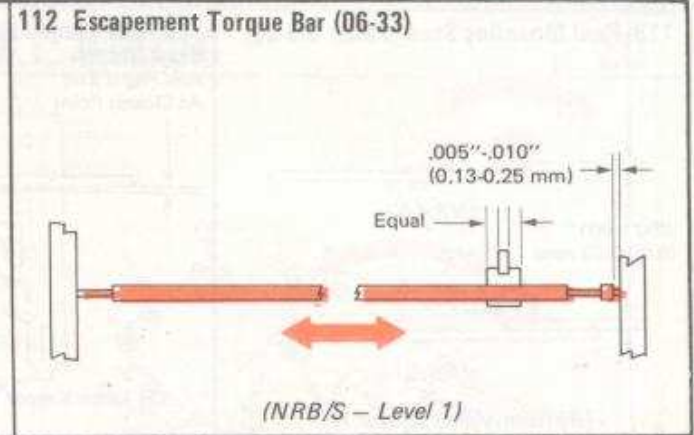
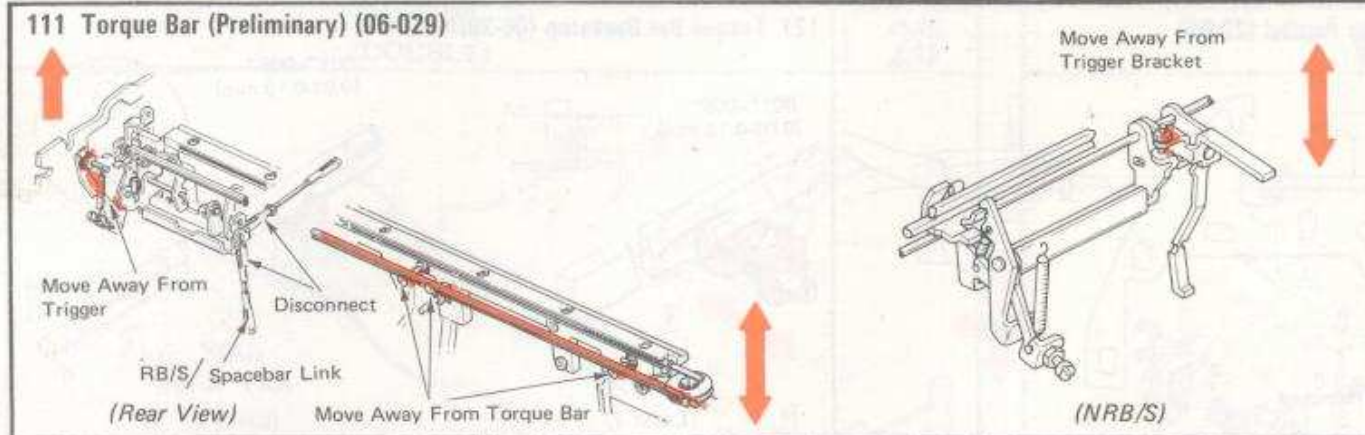

119 Pawl Mounting Stud (Final) (06-26)

(NRB/S)
(RB/S)

(Bottom View) (Level 1)

120 Tab Torque Bar Parallel (23-50)

Equal On Left
And Right End
At Closest Point

CR Latch Keeper Removed

Form

121 Torque Bar Backstop (06-39)

Form

7X3 7X5
(Level 1)

670X
XX3 XX5
(Level 2)

122 Knock-Off Pivot Pin Eccentric (06-19)

Touches

(Level 1)

123 Escapement Cam (06-7)

Check On Both
Sides Of Cam

Touches

Low Point Machine At Rest
Escapement Should Occur Just After Print

W.T. Escapement
.042\"-.060\"
(1.00-1.50 mm)
After Print
Impression Control
At 5

124 Trip Link (06-10)

Check On Both
Sides Of Cam

Ensure Trigger Upstop And
Spacebar Motion Adjustment Are
Not Controlling This Adjustment

333

125 Trigger Knockoff (06-51)

(Level 1)

(06-19)

(Level 2)

(06-14)

(Level 3)

.010\"-.015\"
(0.25-0.38 mm)

126 Trigger Upstop (Final) (06-36)

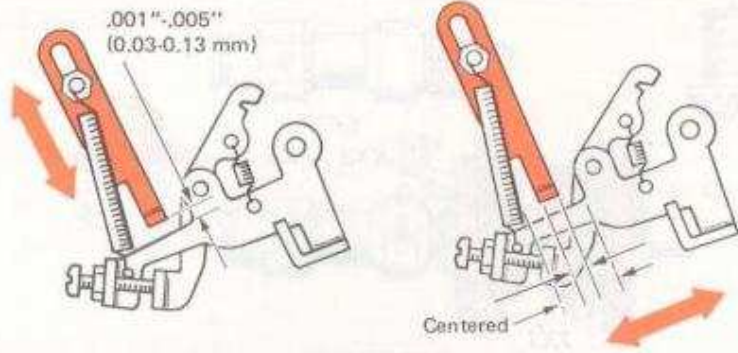

127 Spacebar Link (17-306)

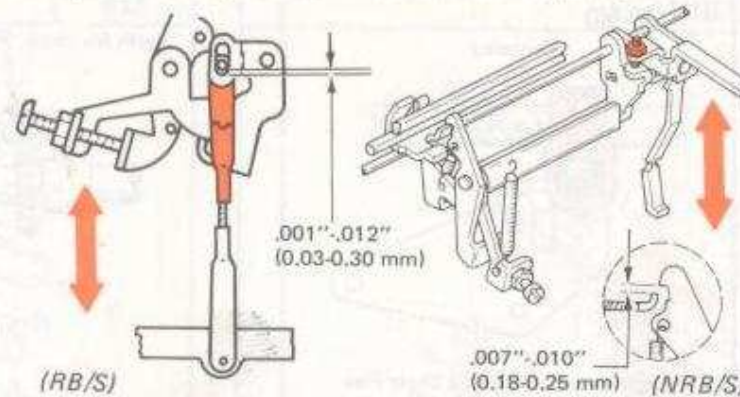

(07-40)

128 Mainspring Hub (19-13)

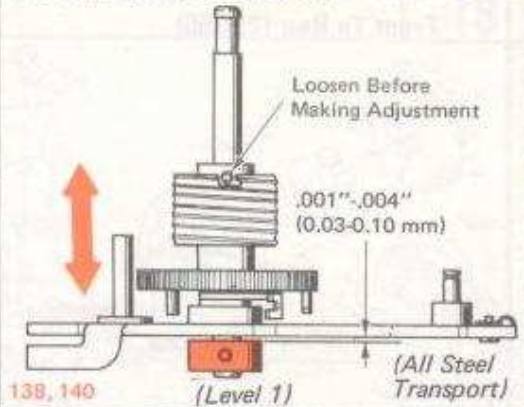

129 Escapement Shaft Collar (03-363)

(24-8)

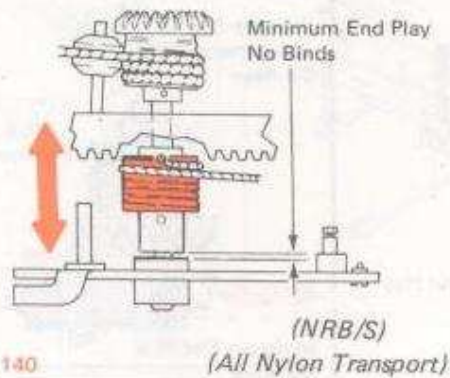

138, 140

(NRB/S)
(All Nylon Transport)

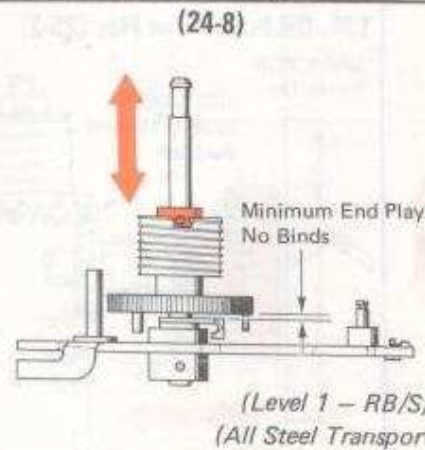

(Level 1 - RB/S)
(All Steel Transport)

(24-6)

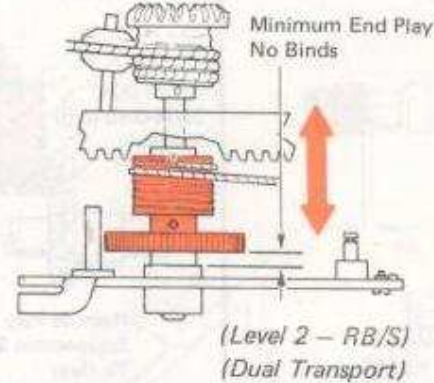

(Level 2 - RB/S)
(Dual Transport)

130 Mainspring (18-95)

(19-12)

This Spring
Requires 5 Turns
At The RH Margin

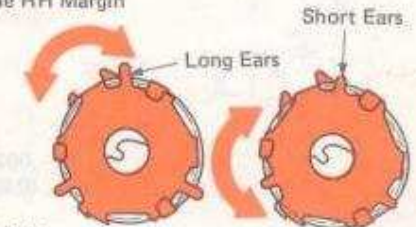

1/2-3/4 Lbs.
(226.8-340.2 g)
Tension As Carrier
Escapes Through
Extreme RH Margin

This Spring
Requires 7 Turns
At The RH Margin

131 Idler Pulley Eccentric (18-124) (19-16)

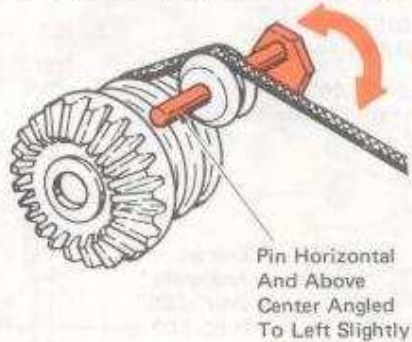

Pin Horizontal
And Above
Center Angled
To Left Slightly

132 Cord Tension (03-363) (24-6)

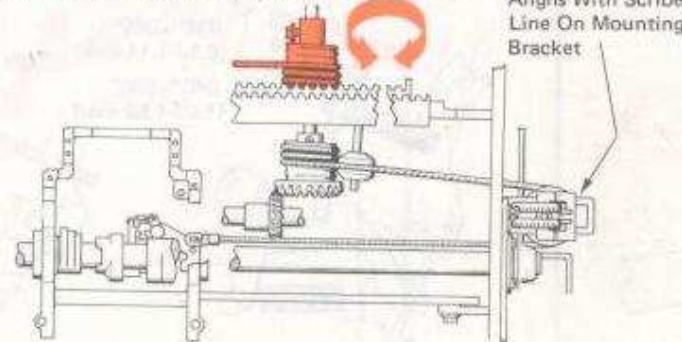

Aligns With Scribe
Line On Mounting
Bracket

129

(NRB/S And Level 2 RB/S)

133 Cable Tension (19-23)

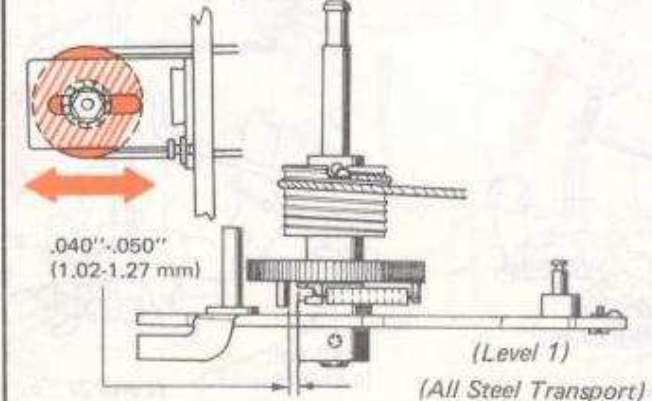

(Level 1)
(All Steel Transport)

134 Operational Shaft Support Bracket, Front To Rear (25-350)

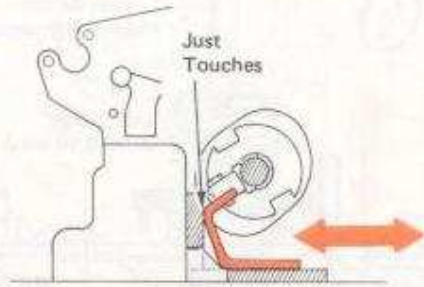

135 Operational Shaft Support (25-56)

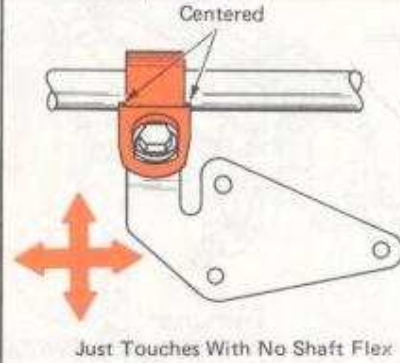

136 Operational Shaft Position (25-24)

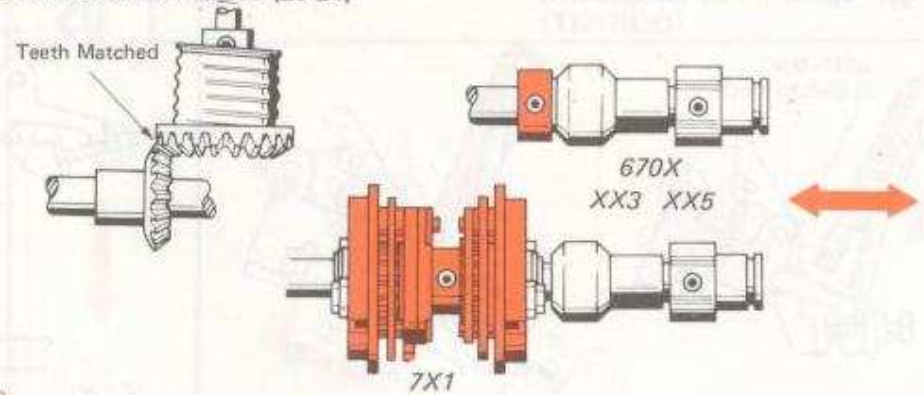

137 Operational Shaft End Play (25-23)

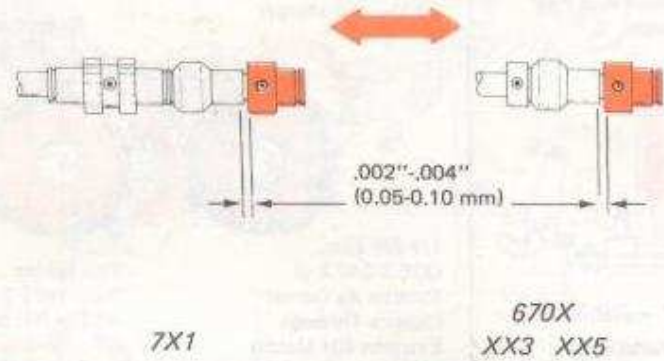

138 CR Pinion Backlash (18-103)

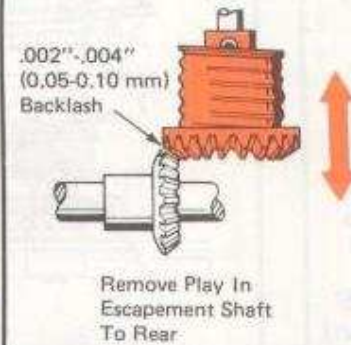

139 CR Pinion End Play (25-3)

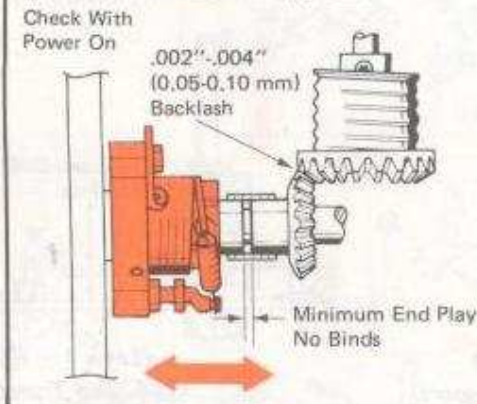

140 Tab Pinion Backlash (25-20)

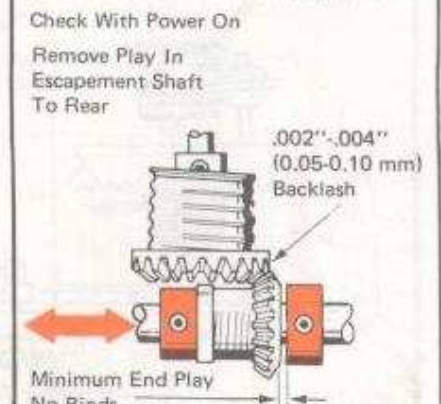

141 Index Keylever Pawl Clearance (25-224)

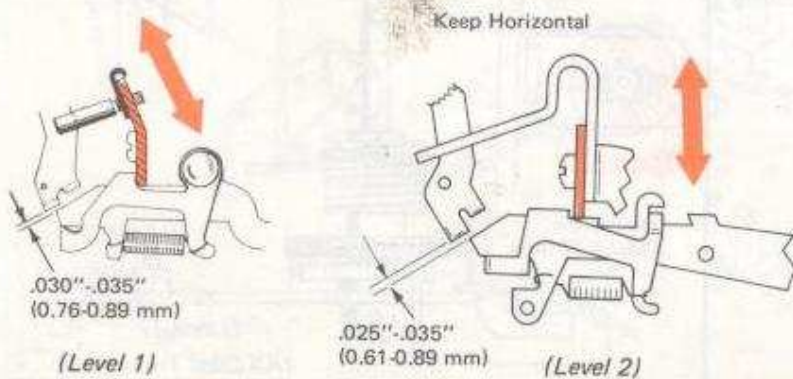

142 Keylever Pawl Overlap (25-302) (25-238)

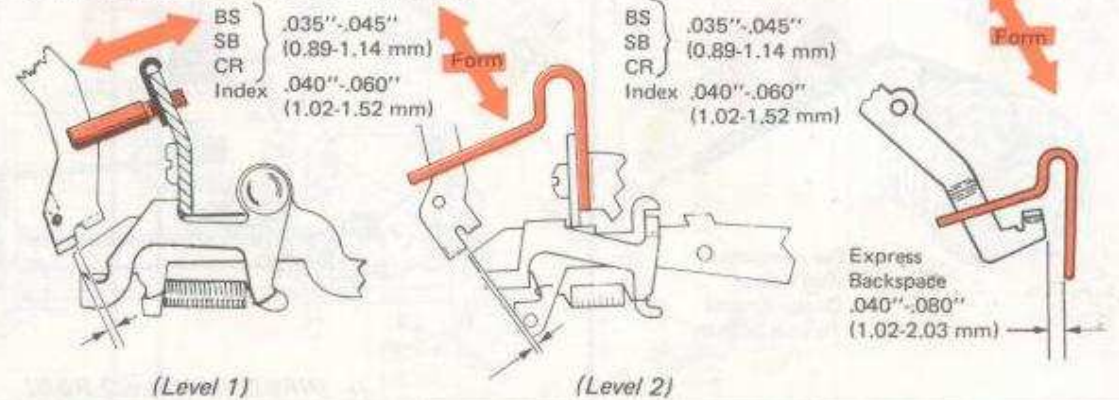

143 Spacebar Keylever Pawl Clearance (17-110) (17-150)

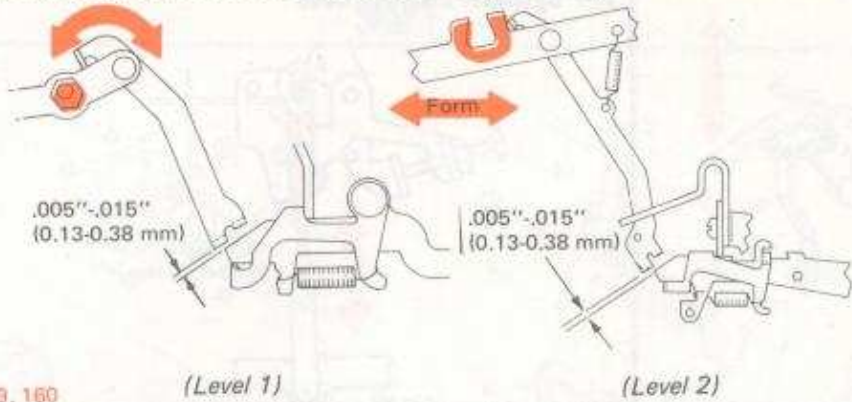

144 CR And BS Keylever Pawl Clearance (03-101)

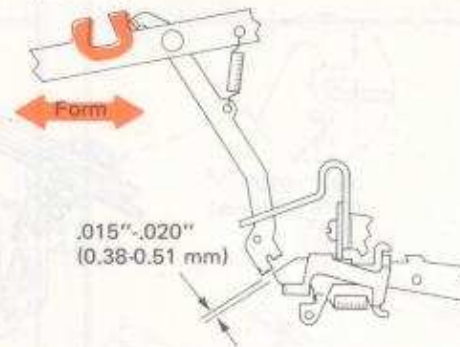

145 Check Ring (25-29)

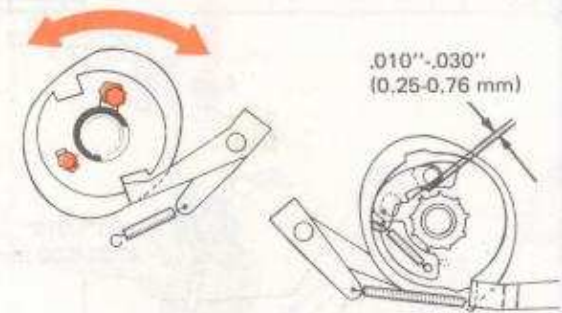

146 Operational Cam Position (25-101)

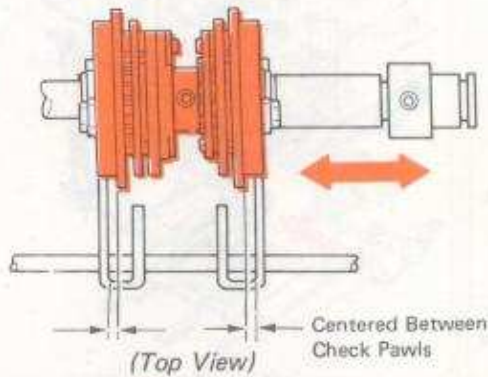

147 Release Arm Overlap (25-205)

Maximum Overlap Without Touching Cam

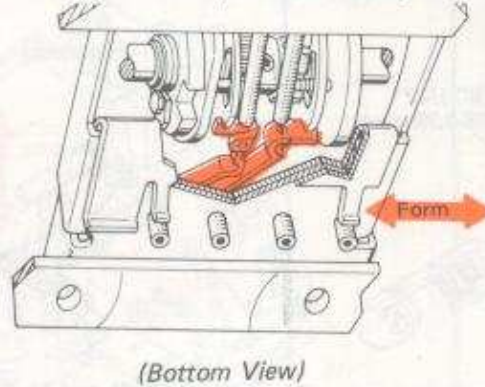

148 Clutch Release Arm Overlap (25-205)

NOTE: Interposer Latched
Operational Cam Released Manually



149 Clutch Release Arm (25-205)

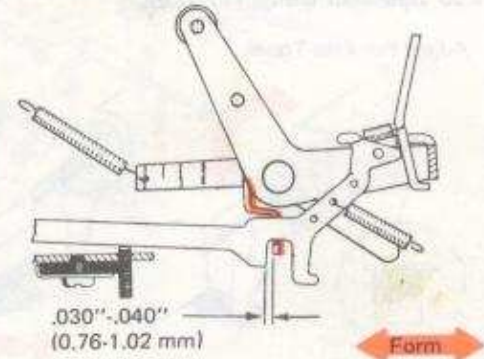

150 Interposer Restoring Bail (25-216)

Cam On High Point

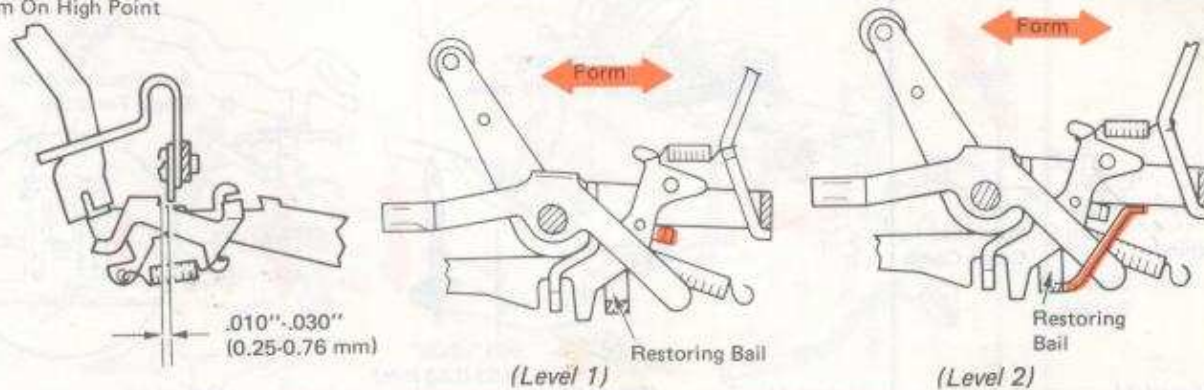

151 Interposer Adjusting Screw (25-222)

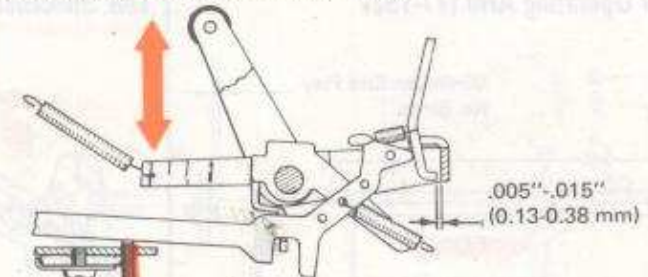

| Adjust | Adjustment |
|-----------------------|------------------------------|
| 1. B/S And CR | .005\"-.015\" (0.13-0.38 mm) |
| 2. SB (RB/S Machines) | To Match B/S And CR |
| 3. Index | To Match All Others |

152 Latch Height (17-300)

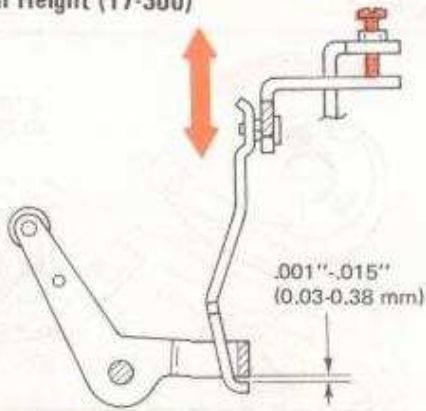

151

153 Latch Lever Screw (07-40)

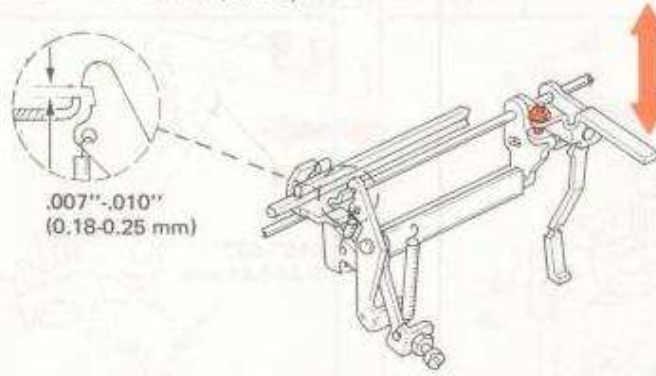

124

154 Spacebar Link (17-306)

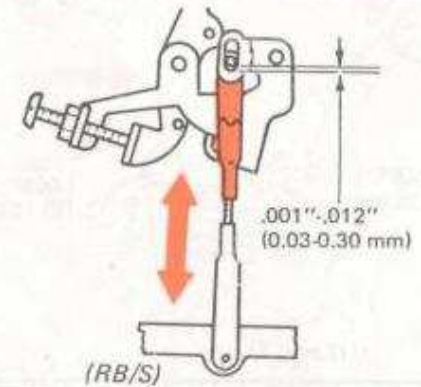

124

155 Spacebar Guide (17-129)

Adjust For Free Travel

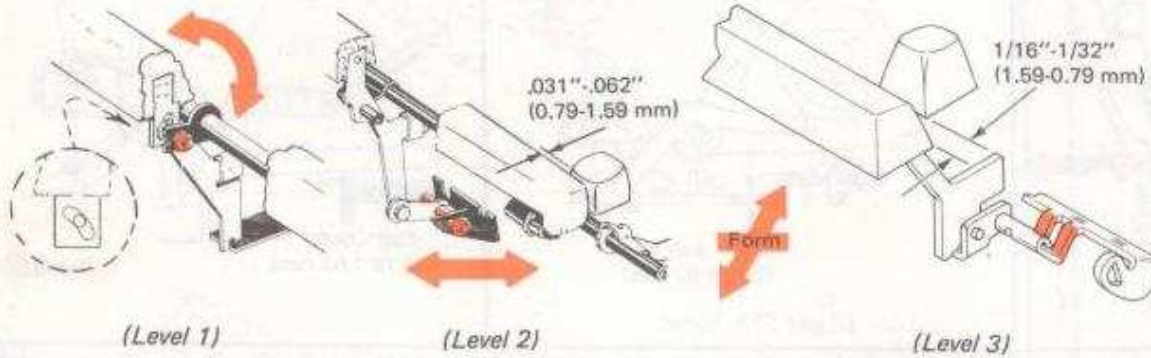

156 Spacebar Return (17-124) (17-146)

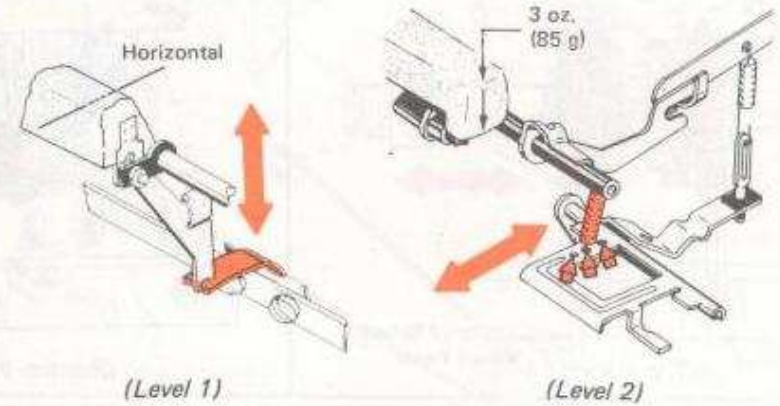

157 Spacebar Operating Arm (17-152)

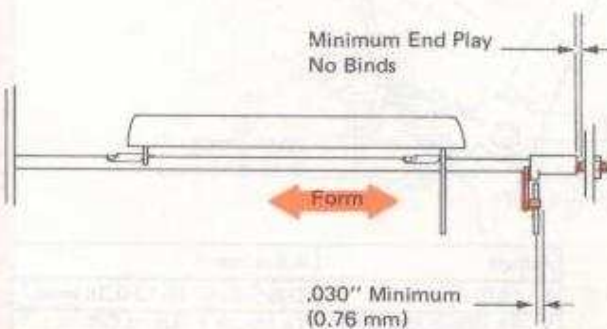

158 Spacebar Operating Cam (17-132)

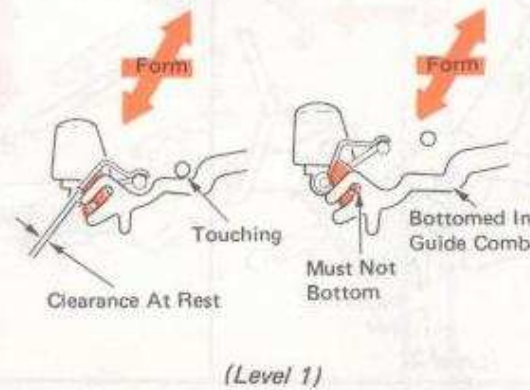

159 Repeat Stop (17-106) (17-148)

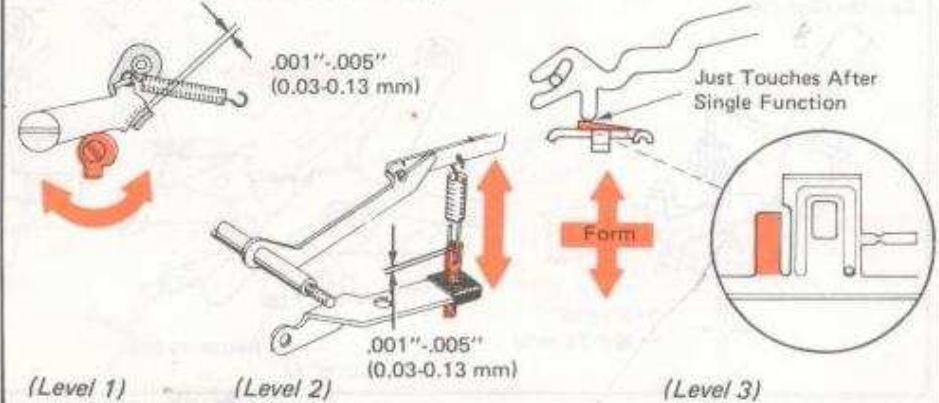

160 Spacebar Final Stop (17-119) (21-143)

.005"-.010"
(0.13-0.25 mm)

.005"-.010"
(0.13-0.25 mm)

Form

161 Interlock Cam (17-353)

.050"-.060"
(1.27-1.52 mm)
Lateral Motion

Adjust For High Point - Machine At Rest

(Level 1) NOTE: 96-Character Machine. Use Frame 107. (Level 2)

162 Spacebar Lockout (17-353)

.015"-.025"
(0.38-0.64 mm)

(Level 1)

163 Interposer Guide (25-238)

.015"-.025"
(0.38-0.64 mm)

(Level 1)

164 Spacebar Interlock Bracket (25-226)

Machine At Rest
Interposer Released
.040"-.050"
(1.02-1.27 mm)

(Level 2)

165 Interlock Stop (25-232)

Machine Half Cycle
Interposer Latched

Interlock Stop

.020"-.025"
(0.51-0.64 mm)

(Level 2)

166 Space-To-Print Interlock (17-404)

.001"-.010"
(0.03-0.25 mm)

Form

167 CR Latch Actuating Arm (03-203)

.001"-.005"
(0.03-0.13 mm)

Form

(Level 4 Only)

168 Pawl Clearance (03-420) (03-612) (03-203)

.002"-.006"
(0.05-0.15 mm)
At Closest Point

.002"-.006"
(0.05-0.15 mm)
At Closest Point

Form

(Level 1) (Levels 2 & 3) (Level 4)

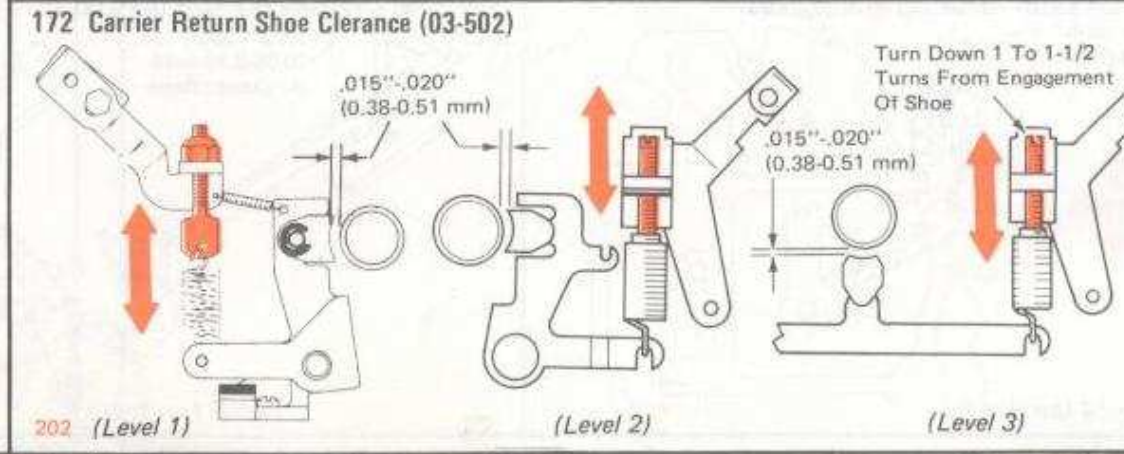
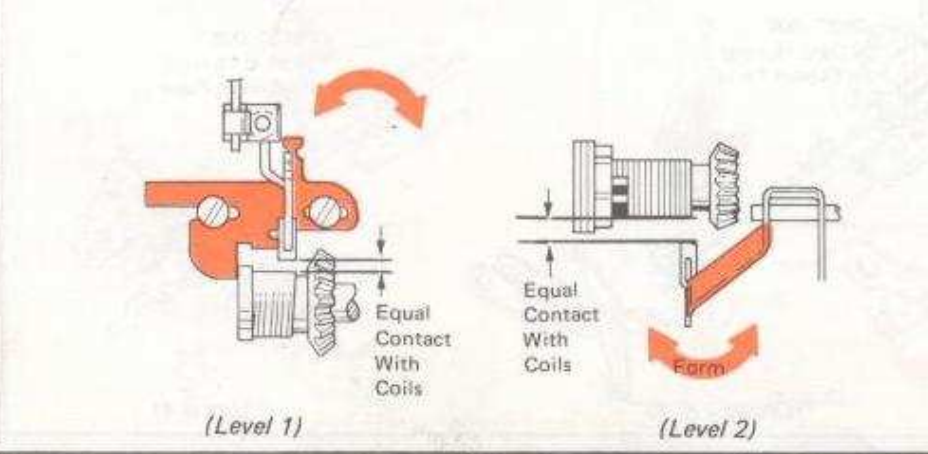
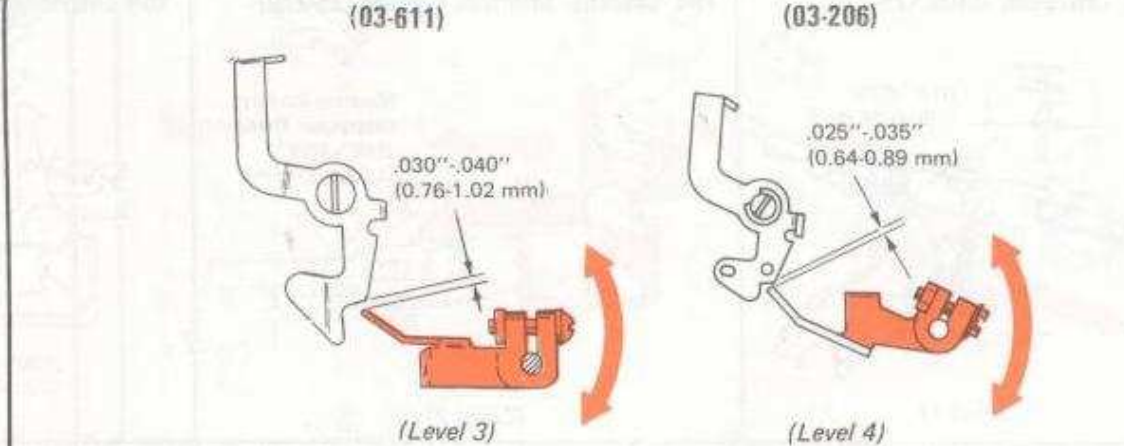
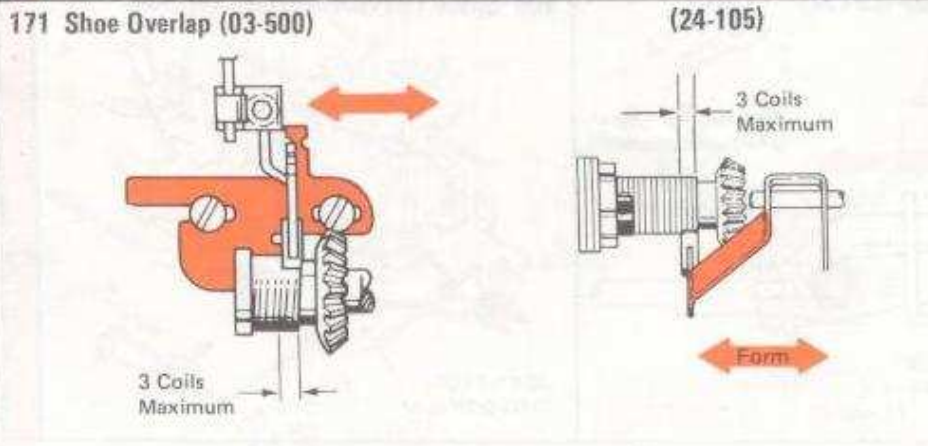
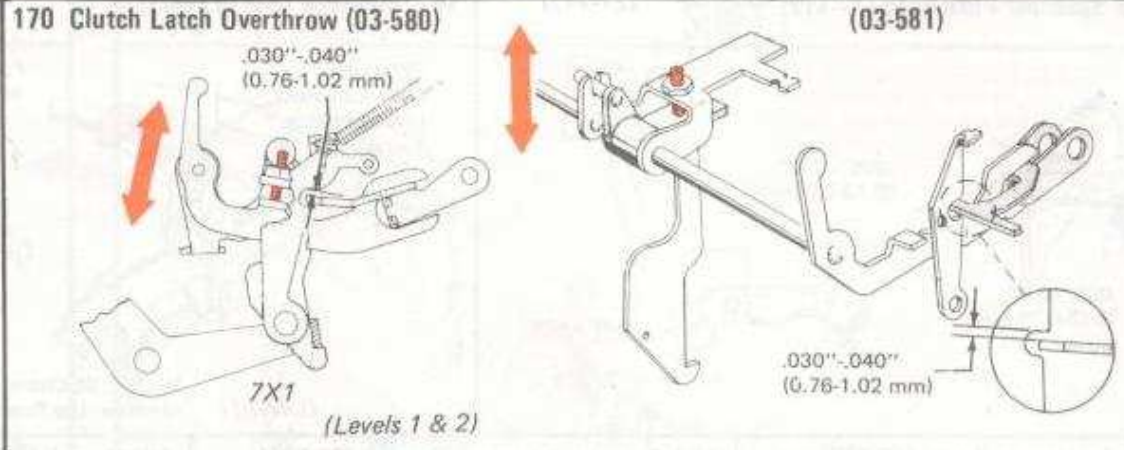
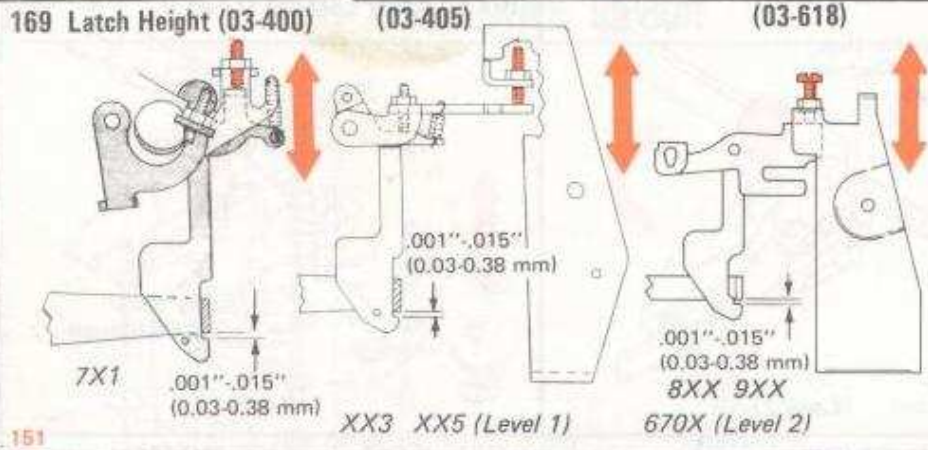

151

202

173 Overbank (09-6)

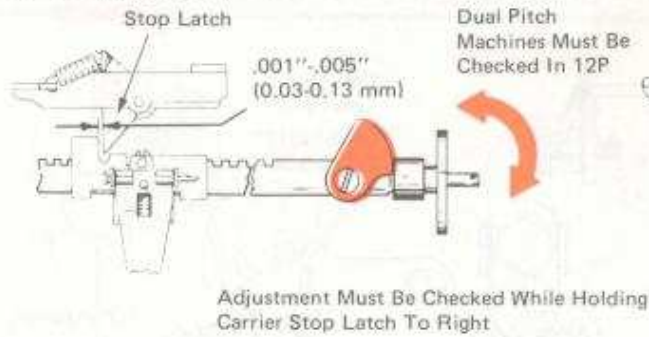

360 (Level 1)

(09-59) (10-10)

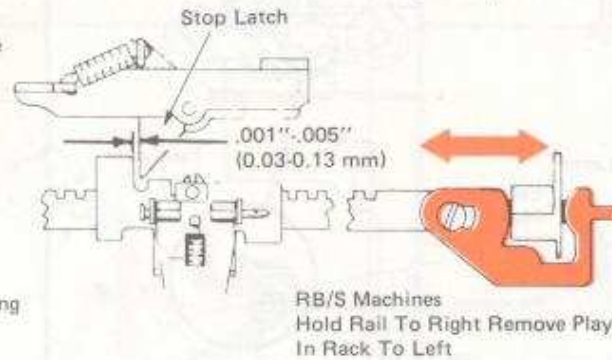

(Level 2)

174 Overbank Motion (09-21)

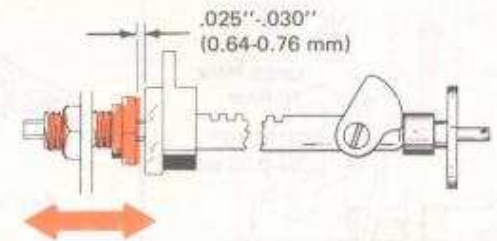

(Level 1)

175 Clutch Unlatching (03-557)

Margin Rack Held
To Left

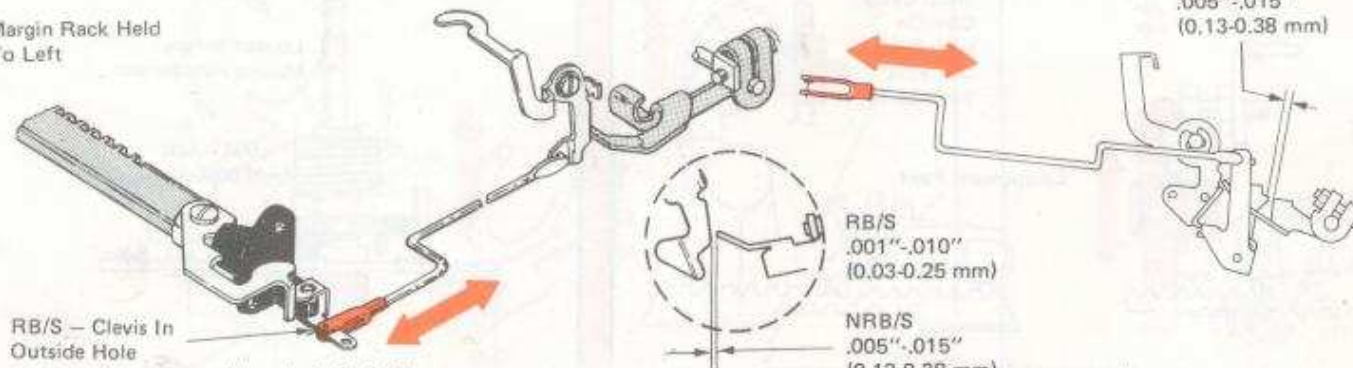

221 (Levels 1, 2, & 3)

(03-202)

(Level 4)

176 Torque Bar Latch (03-207)

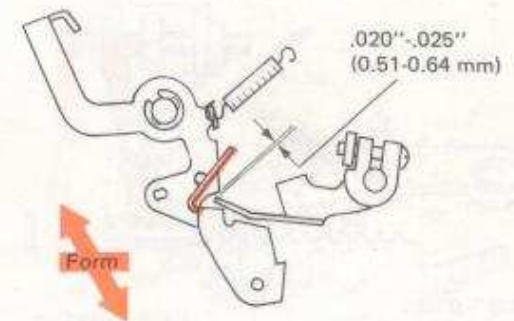

(Level 4 Only)

177 Torque Limiter (25-5)

1-2 Lbs.
(0.45-0.90 KG)
Pull

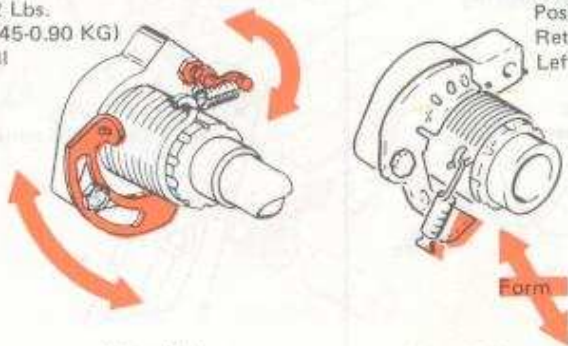

(Level 1)

(Level 2)

178 CR Printer Interlock (03-625)

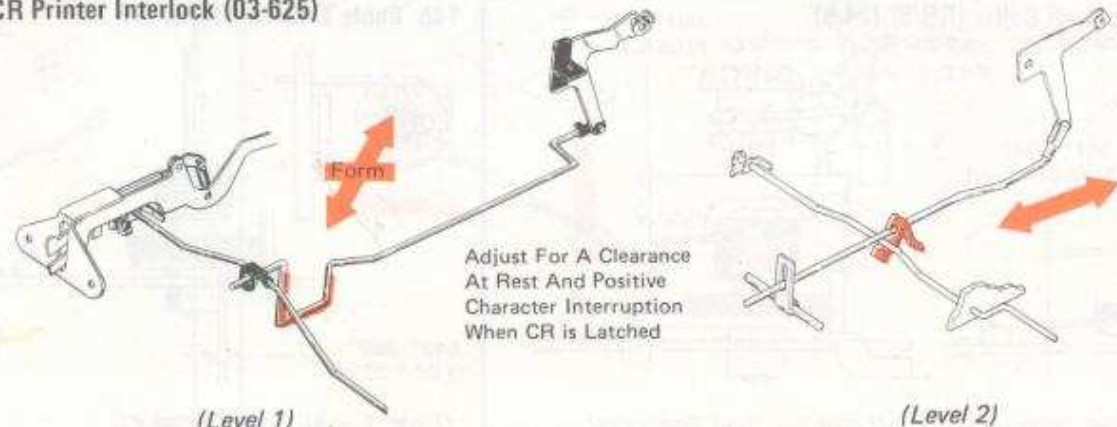

(Level 1)

(Level 2)

179 Backspace Latch Height (NRB/S)

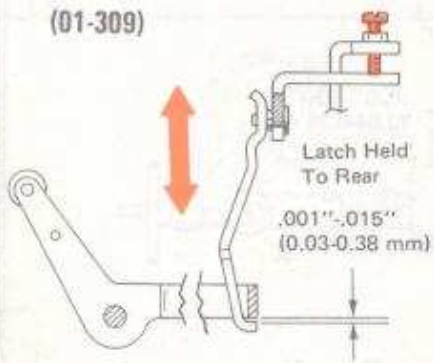

180 Tab Lever Stop (NRB/S) (01-314)

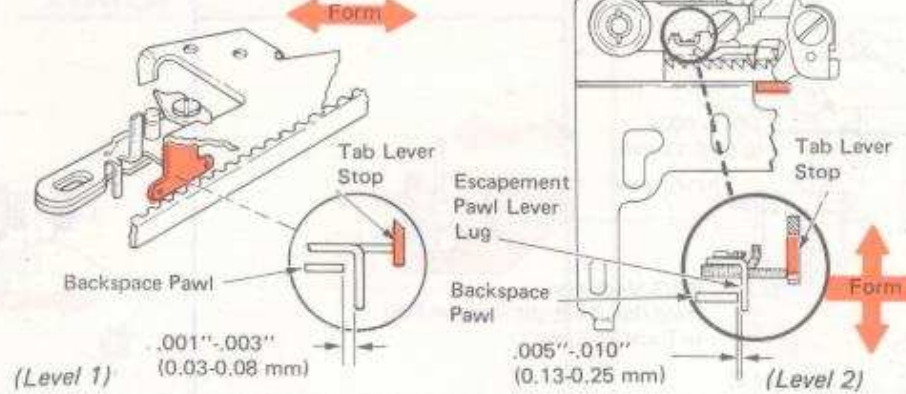

181 Backspace Rack (NRB/S) (01-307)

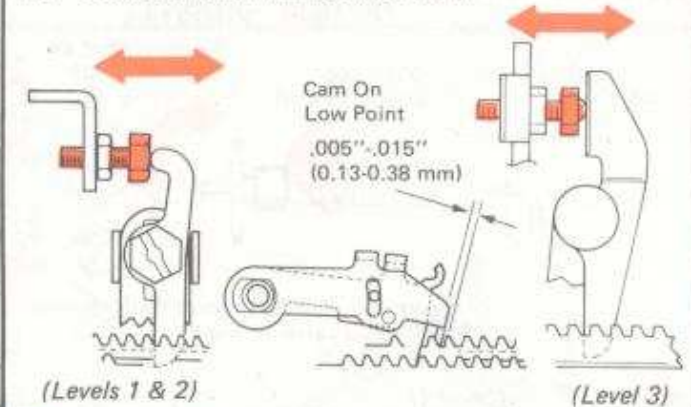

182 Backspace Rack Motion (NRB/S) (01-329)

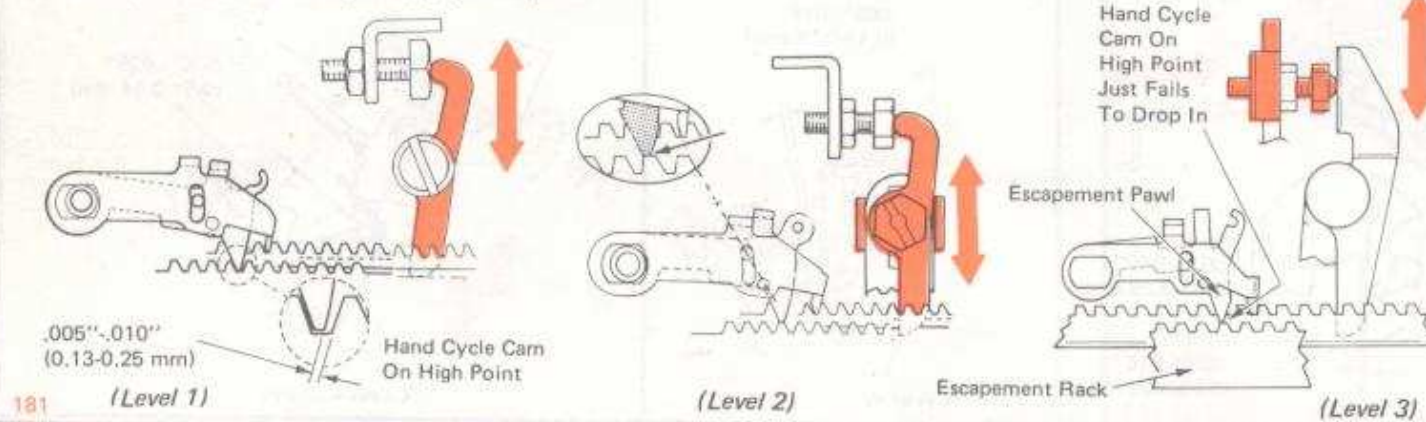

183 Mainspring Hub (RB/S) (19-13)

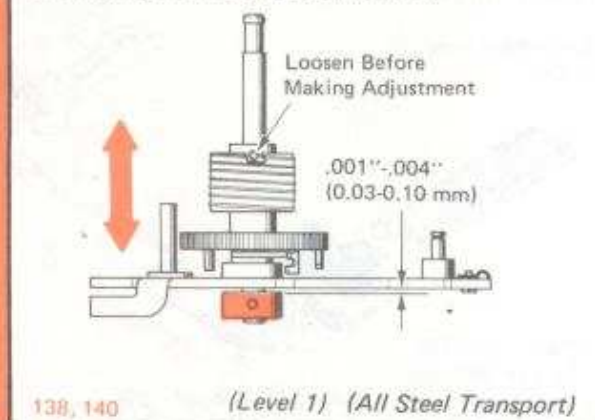

184 Escapement Shaft Collar (RB/S) (24-8)

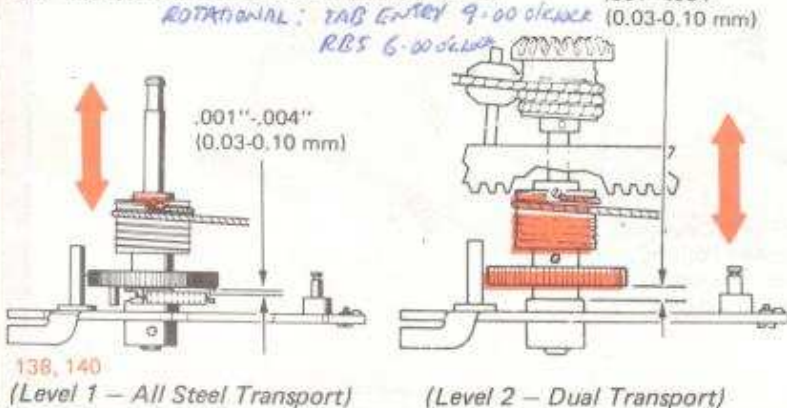

185 Cable Tension (RB/S) (19-23)

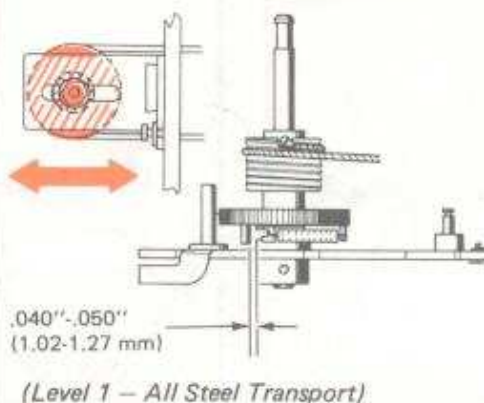

186 Rotary Backspace (25-210) Interposer Spring



187 Pitch Cam Cable Cover (24-37)

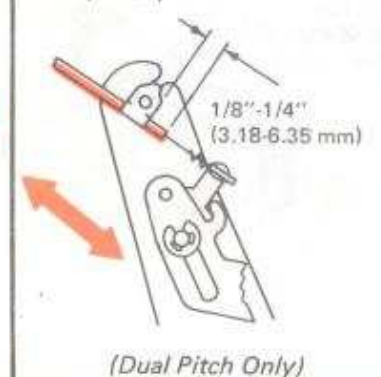

188 Pitch Cam (24-37)

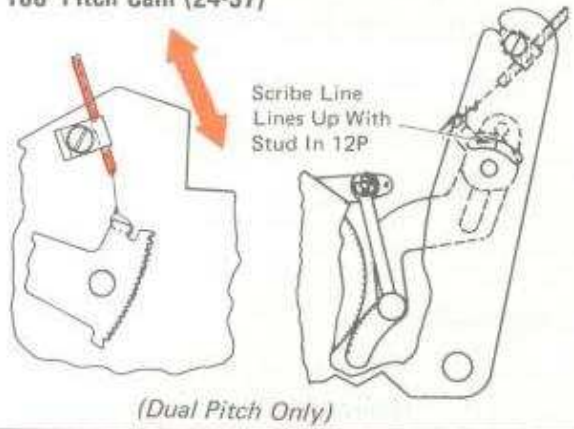

189 Backspace Motion (24-26)

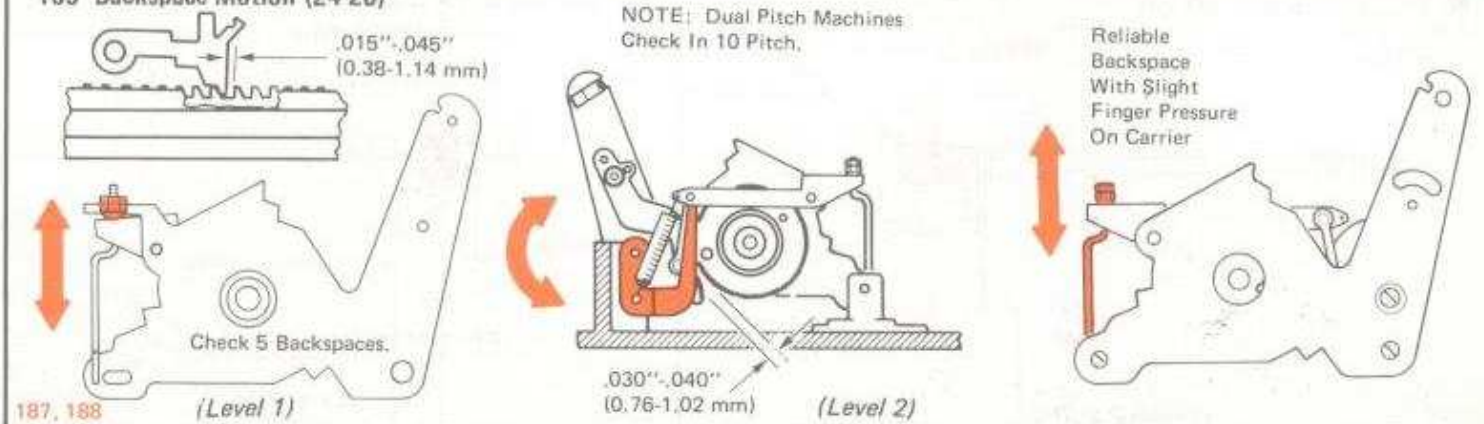

190 Backspace Latch Height (24-15)

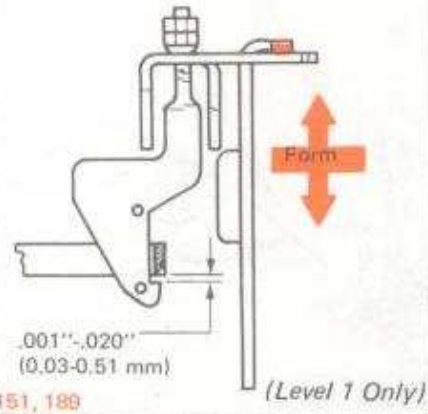

191 Index Interlock Link (24-16)

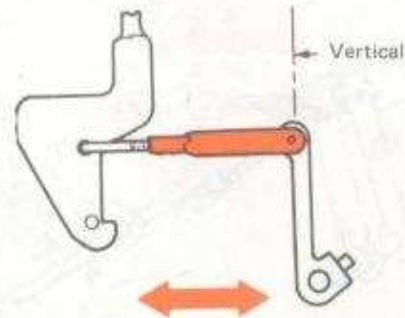

192 Index Interlock Shaft (24-20)

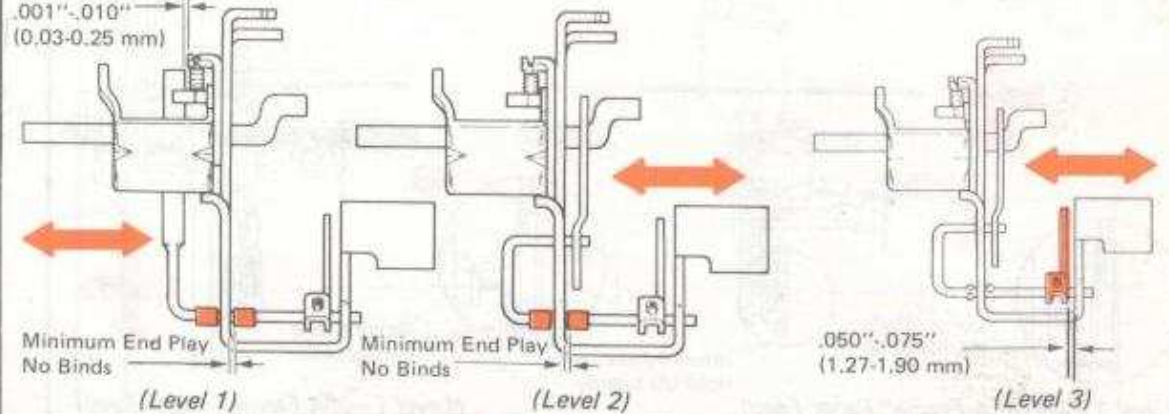

193 Index Interlock Paddle (24-20)

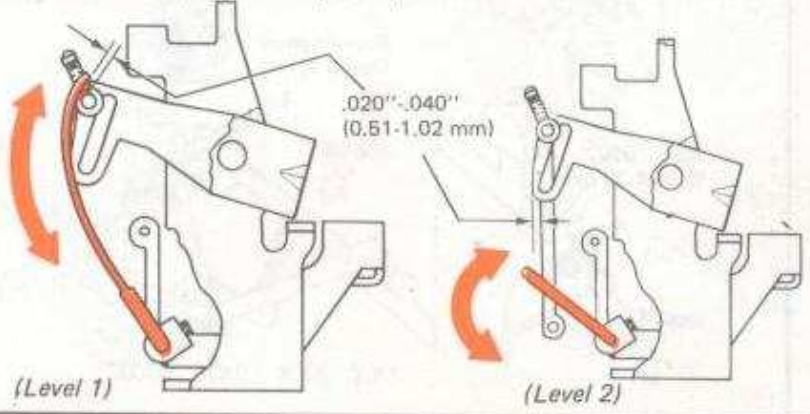

194 Index Transfer Bellcrank Stop Lug (24-9)

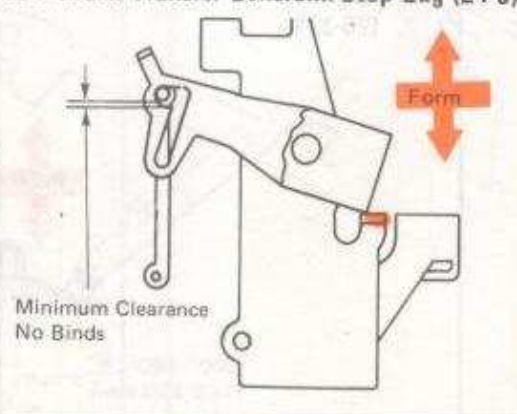

195 Lower Half Backspace Link (07-7)

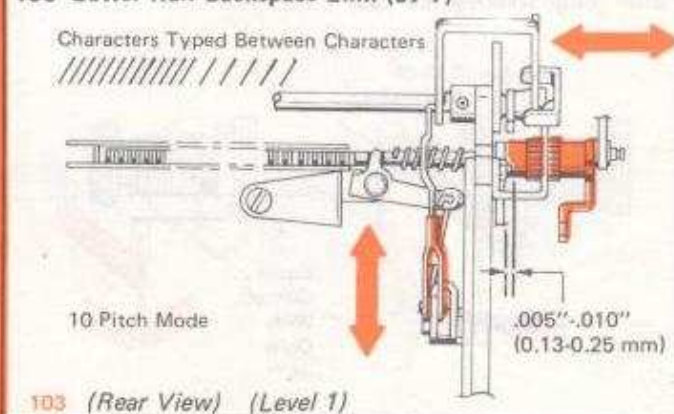

196 Switch Pitch Gear (07-23)

12 Pitch Mode

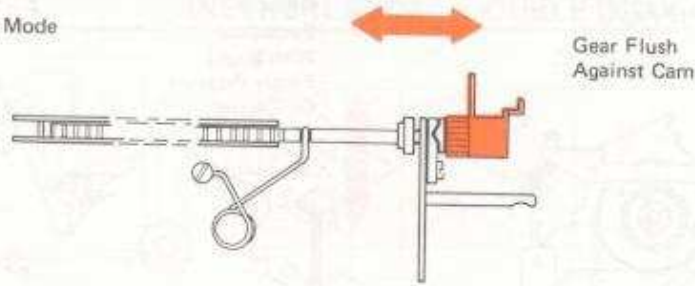

(Levels 2 & 3)

197 Half Backspace Collar (07-105)

Characters Typed Between Characters

.045" (1.14 mm)

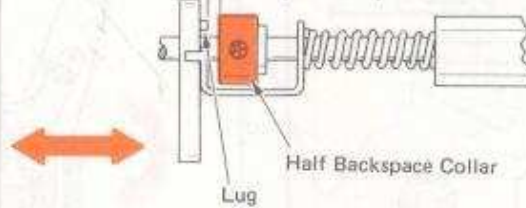

12 Pitch Mode

(Level 2)

12 Pitch Mode

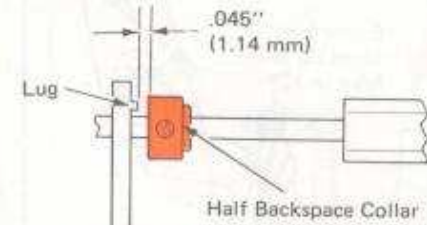

Half Backspace Collar

(Level 3)

198 Half Backspace Rest Position (07-37)

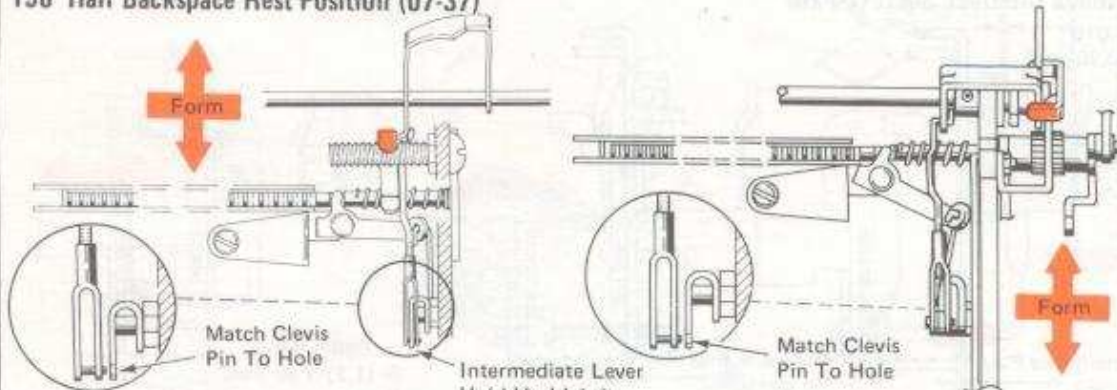

(Level 1 - Pre- "A-Frame" Paper Feed)

(Level 1 - "A-Frame" Paper Feed)

199 Half Backspace Lever (07-32)

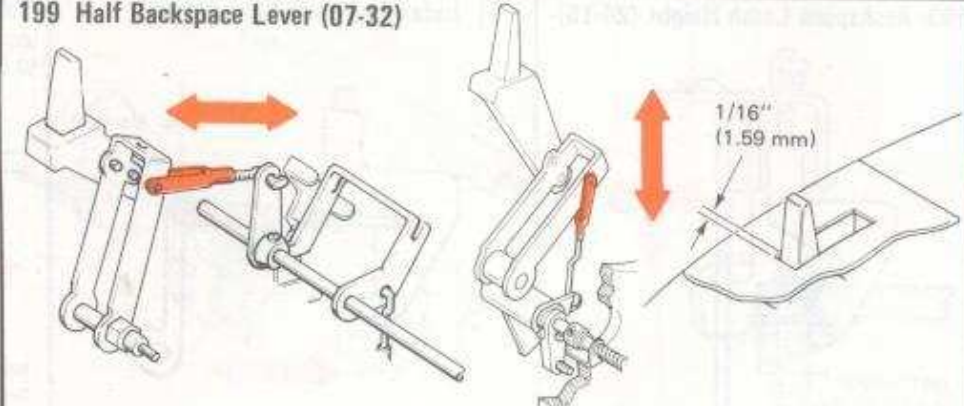

(Level 1)

(Levels 2 & 3)

200 Shoe Overlap (24-105)

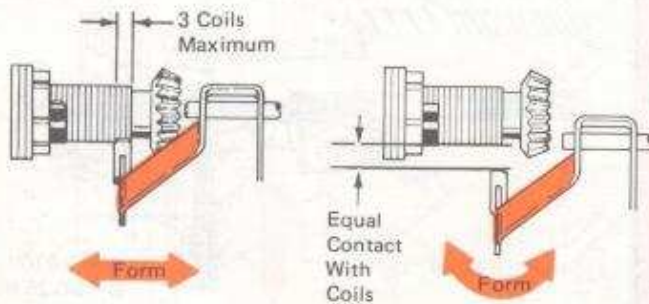

201 Keylever Pawl Guide (25-238)

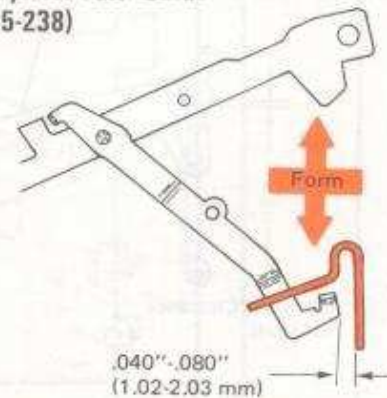

202 Shoe Clearance (24-111)

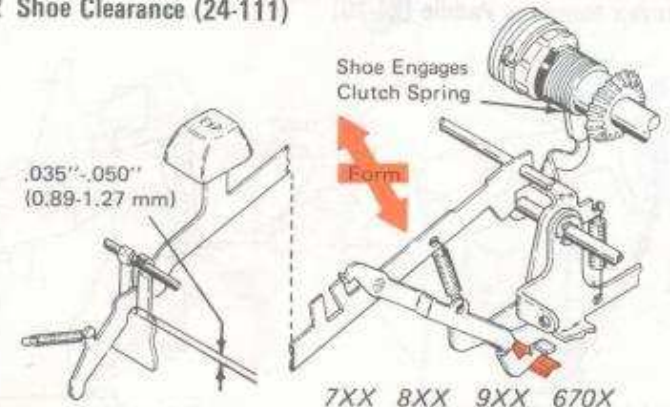

7XX 8XX 9XX 670X

203 Keylever Pawl (24-102)

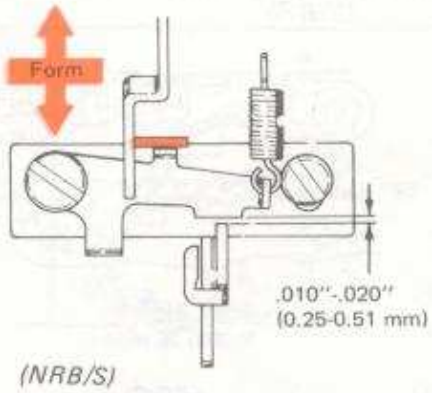

204 Keylever Pawl (24-205)

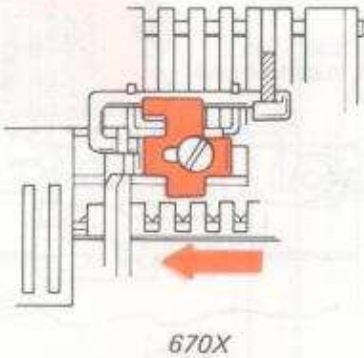

205 Express Backspace Latch (24-102)

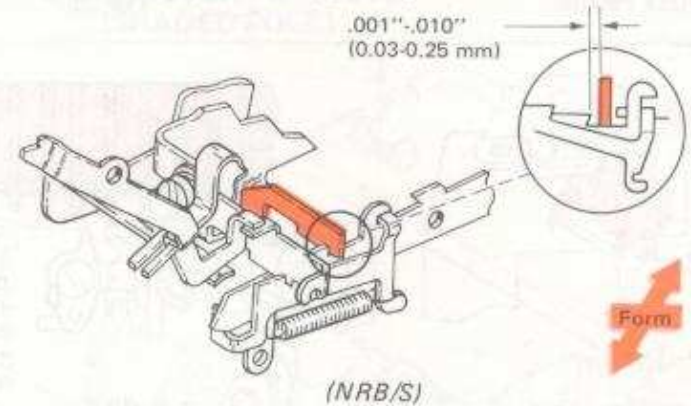

206 Tab Rack Radially (18-35) (19-31)

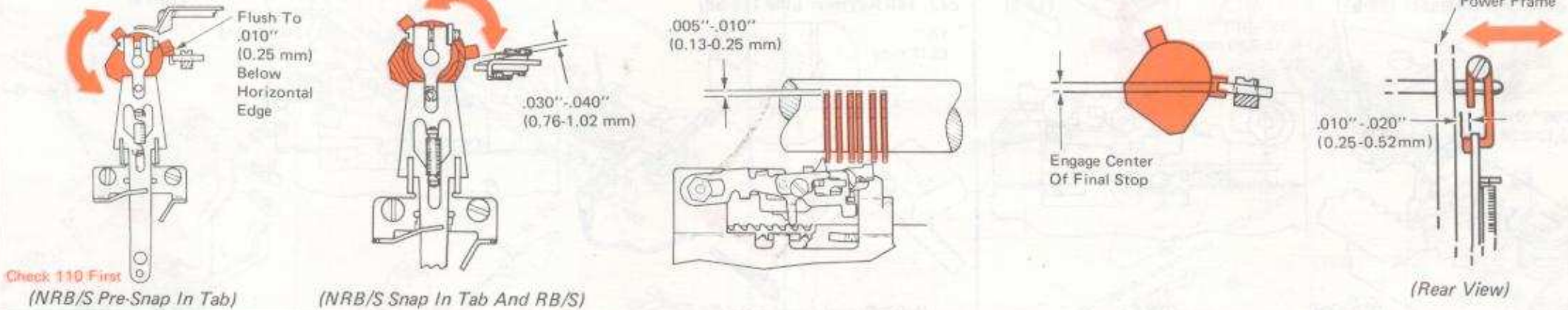

207 Tab Lever Stop (18-153)

(19-69)

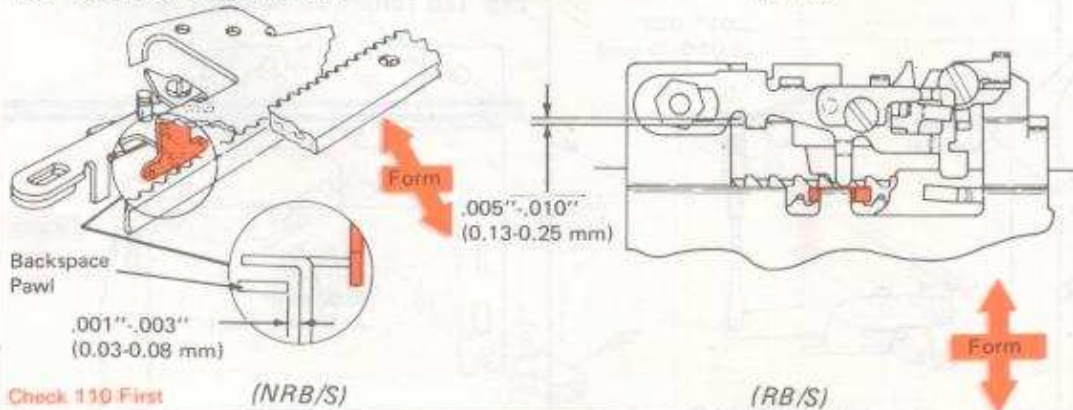

208 Tab Lever Pawl (18-152)

(19-68)

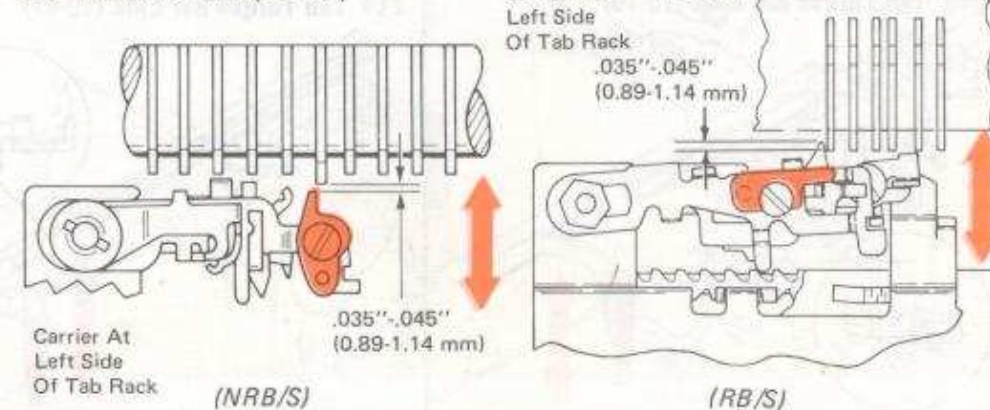

209 Tab Rack Parallel

(18-39)

(19-29)

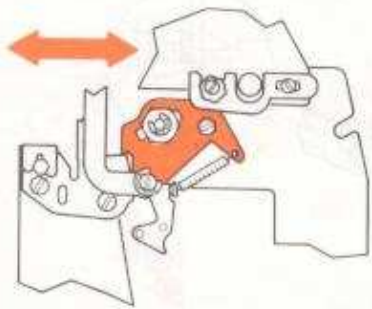

(Right Side View)

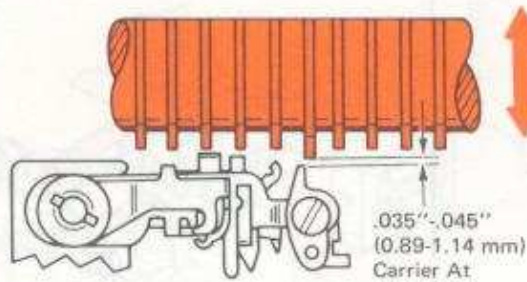

(NRB/S)

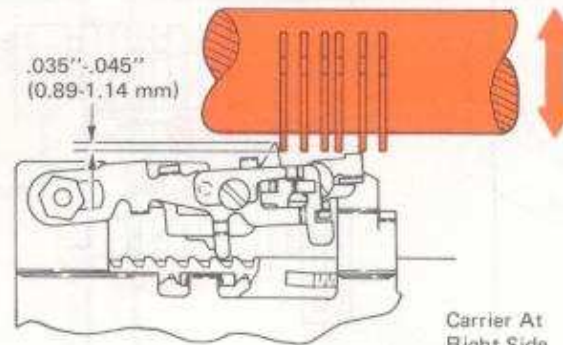

Carrier At Right Side Of Tab Rack

(RB/S)

210 Tab Latch Bite (07-002)

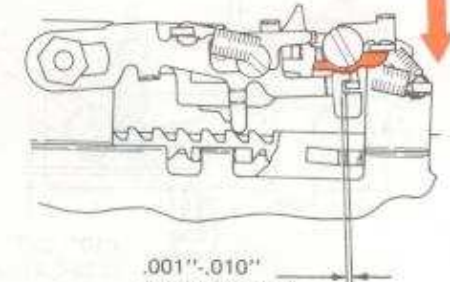

.001\" (0.08-0.25 mm)

(RB/S)

211 Pawl Clearance (18-81)

(19-9)

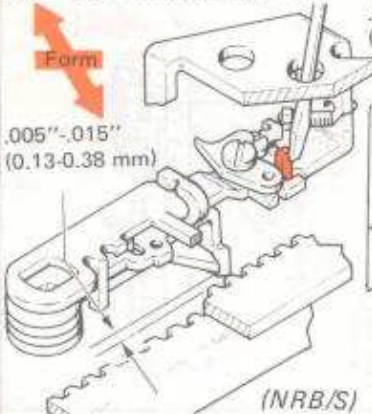

.005\"-.015\" (0.13-0.38 mm)

(NRB/S)

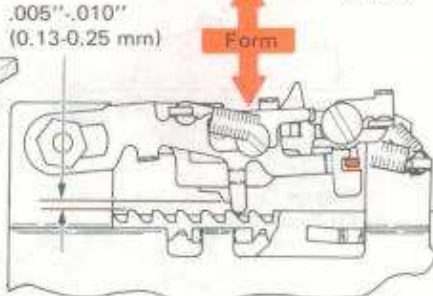

.005\"-.010\" (0.13-0.25 mm)

(RB/S)

212 Tab Keylever Link (18-58)

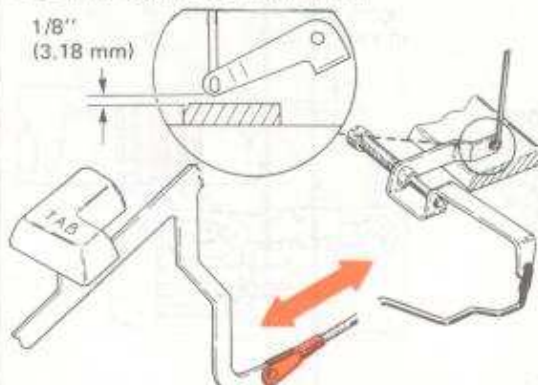

1/8\" (3.18 mm)

(NRB/S And Level 1 RB/S)

212 Tab Keylever Link (19-78)

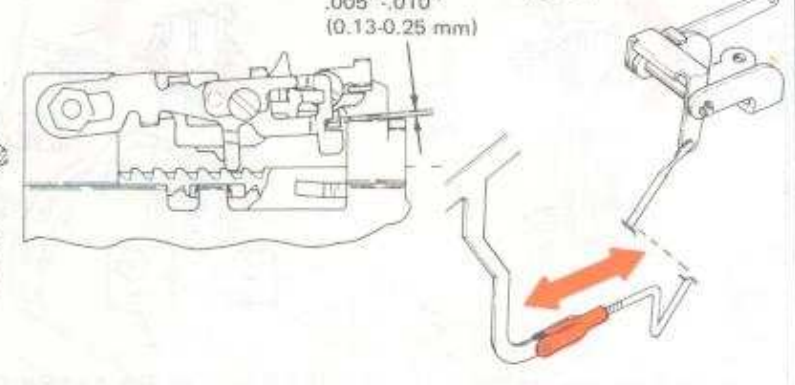

.005\"-.010\" (0.13-0.25 mm)

(Level 2 - RB/S)

213 Tab Torque Bar Link (18-19)

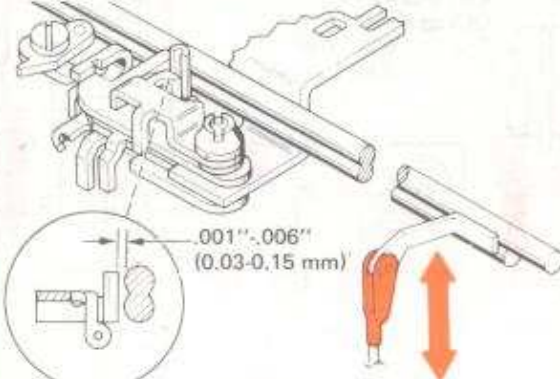

.001\"-.006\" (0.03-0.15 mm)

(NRB/S)

214 Tab Torque Bar Link (19-47)

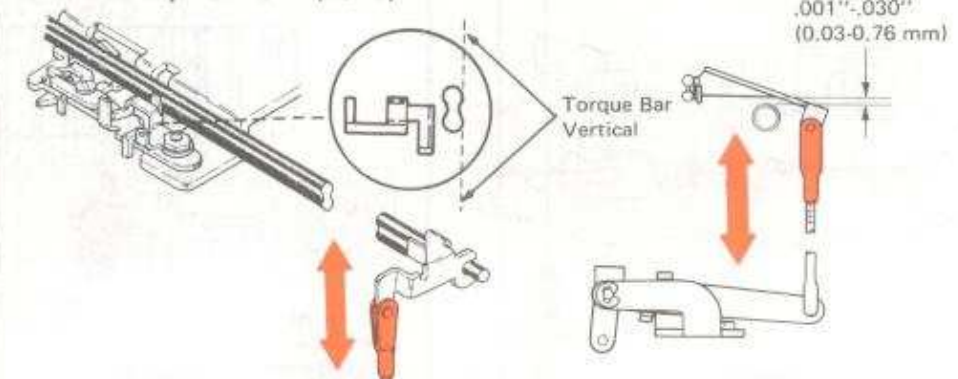

.001\"-.030\" (0.03-0.76 mm)

Torque Bar Vertical

(Level 1)

(RB/S)

(Level 2)

(Right Side View)

215 Tab Torque Bar Backup Lug (07-001)

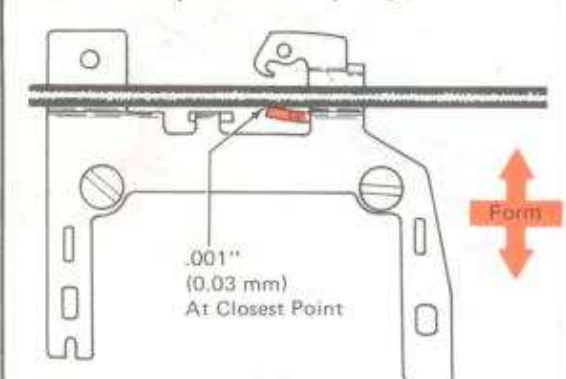

.001\" (0.03 mm) At Closest Point

212

(RB/S)

| | | | |
|--|--|--|---|
| <p>216 Tab Trigger (19-71)</p> <p>.001"-.005" (0.03-0.13 mm)</p> <p>Form</p> <p>(RB/S)</p> | <p>217 Overthrow Stop (18-91)</p> <p>.005"-.015" (0.13-0.38 mm)</p> <p>(NRB/S) (Level 1)</p> | <p>218 Tab Lever Overthrow (19-41)</p> <p>.005"-.010" (0.12-0.25 mm)</p> <p>(Level 1)</p> <p>(RB/S)</p> | <p>(19-39)</p> <p>.005"-.010" (0.12-0.25 mm)</p> <p>(Level 2)</p> |
| <p>219 Tab Rack Left To Right (18-07)</p> <p>.005"-.020" (0.13-0.51 mm)</p> <p>Set Tab Stop</p> <p>First Escapement Rack Tooth</p> <p>(NRB/S)</p> <p>(19-27)</p> <p>.000"-.002" (0.00-0.05 mm)</p> <p>Dual Pitch Check In 10-Pitch Mode</p> <p>First Tab Stop</p> <p>(RB/S)</p> | <p>220 Tab Interlock (18-81) (19-9)</p> <p>.005"-.025" (0.13-0.64 mm)</p> <p>Form</p> | | |
| <p>221 Carrier Return Tab Interlock (03-575)</p> <p>.002"-.020" (0.05-0.51 mm)</p> <p>Form</p> <p>(Level 1)</p> <p>(Level 2)</p> <p>175</p> | <p>222 Tab Rack Vertical (18-30) (19-29)</p> <p>.010"-.020" (0.25-0.51 mm)</p> <p>.005"-.015" (0.13-0.38 mm)</p> <p>Equal Clearance With Carrier At Each End Of Tab Rack</p> <p>(Right Side View)</p> <p>209, 219</p> | | |

223 Tab Set And Clear Bracket (19-2)

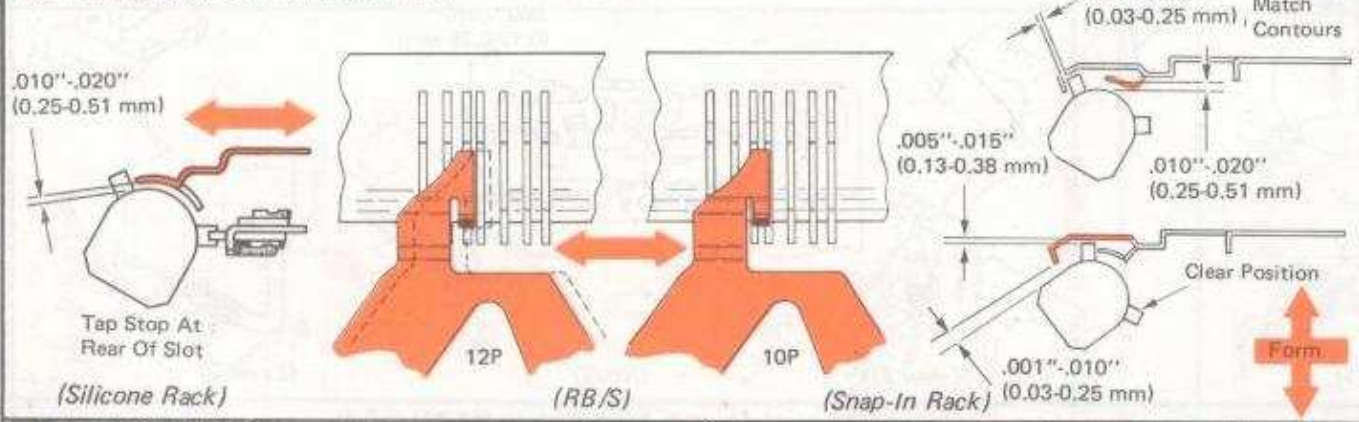

224 Tab Set (18-16) (19-55)

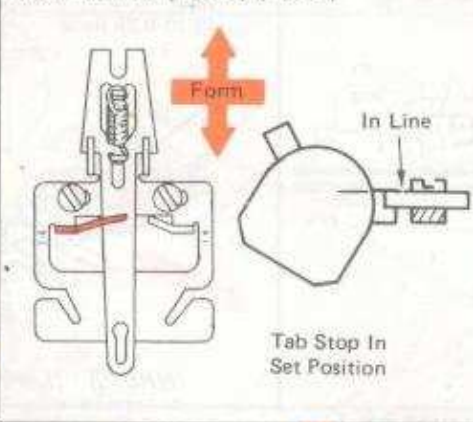

225 Tab Clear Bracket (18-132)

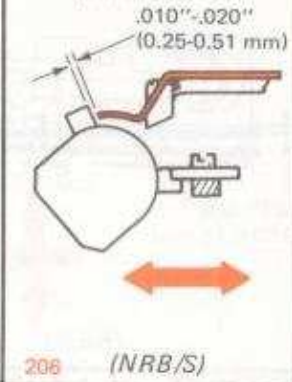

226 Tab Clear (18-16)

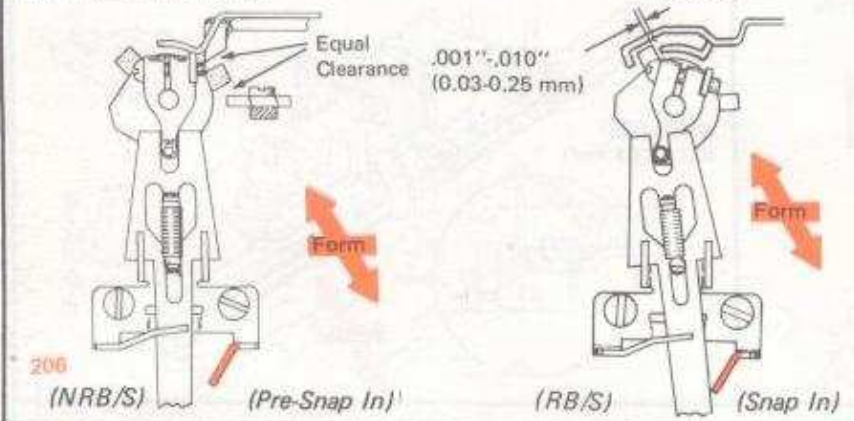

227 Tab Set And Clear Link (19-54) (18-20)



228 Tab Pinion Backlash (25-20)

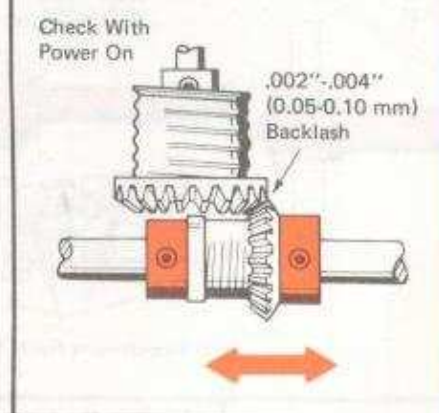

229 Copy Control Lever (22-254)

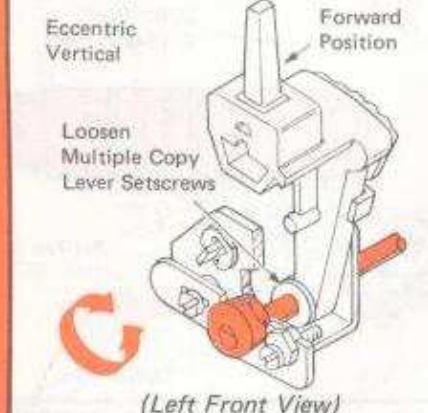

230 Platen Adjusting Plates (22-252)

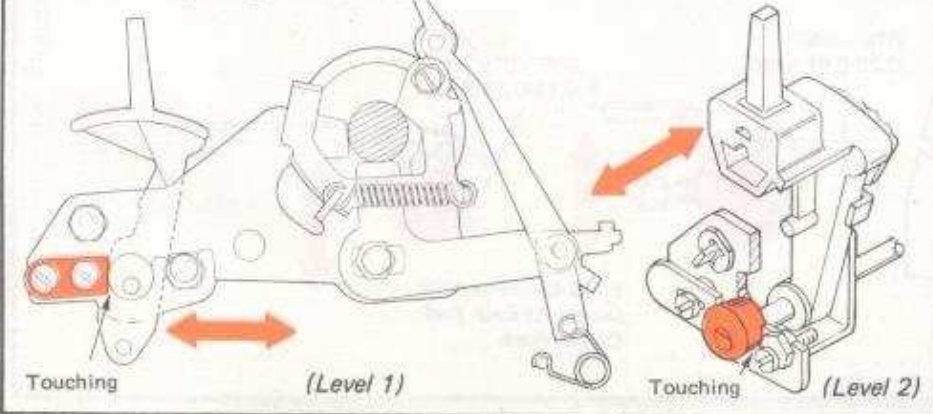

231 Carrier Shoe (02-119)

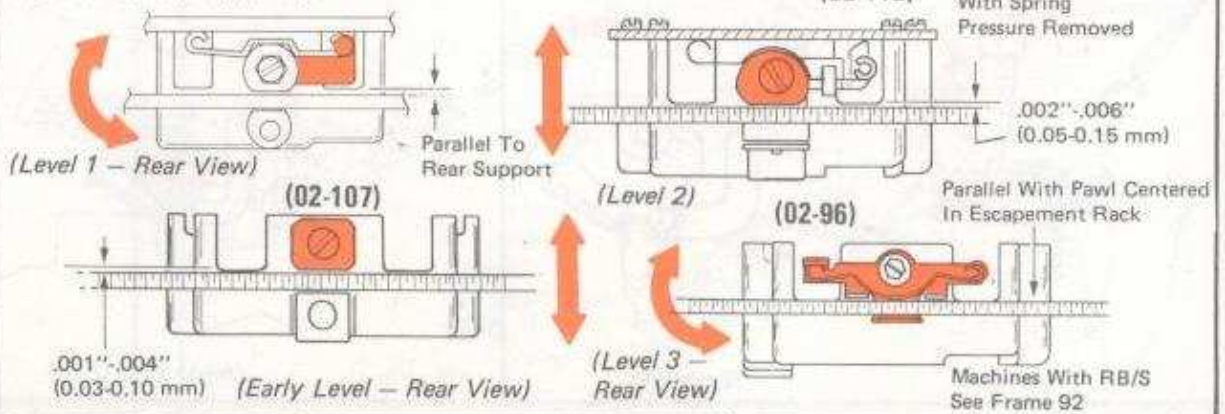

232 Carrier Support (02-8)

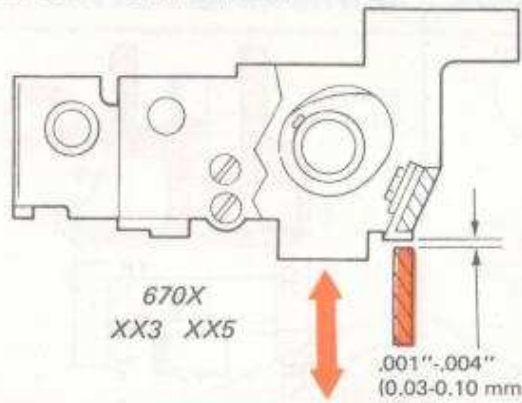

233 Anvil (02-008)

Should Not Print { Period Or Point - Copy Lever -5
 Light Print { Period Or Point - Copy Lever -4

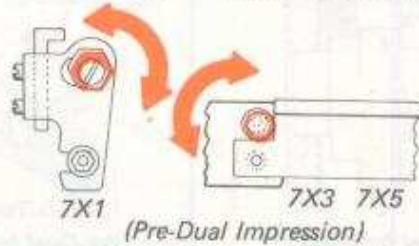

234 Buffers (02-101)

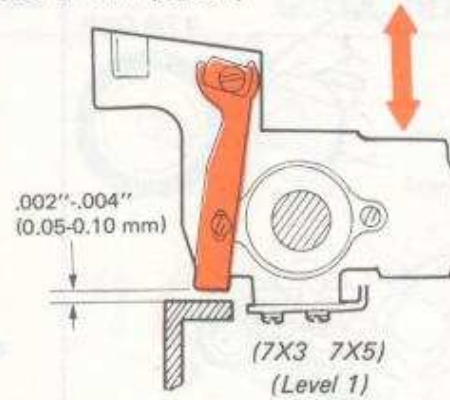

(02-105)

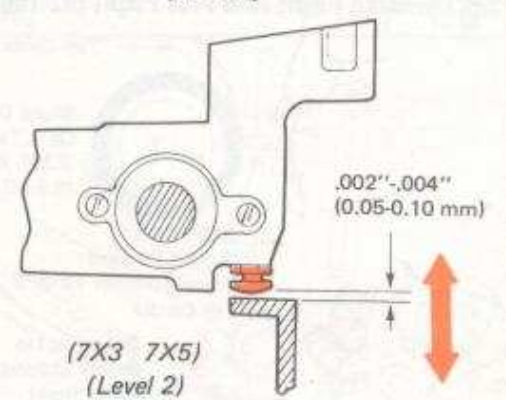

235 Platen Latches (22-293)

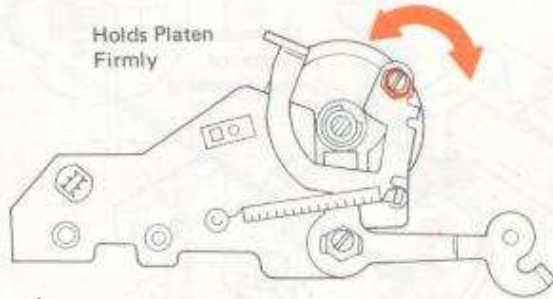

236 Platen Front To Rear (22-253)

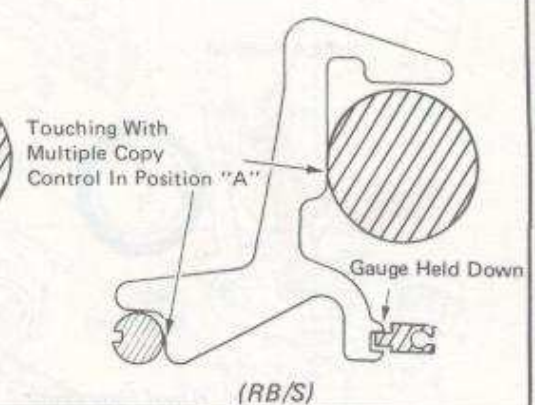
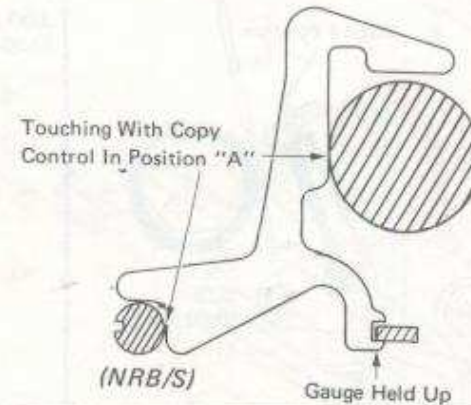
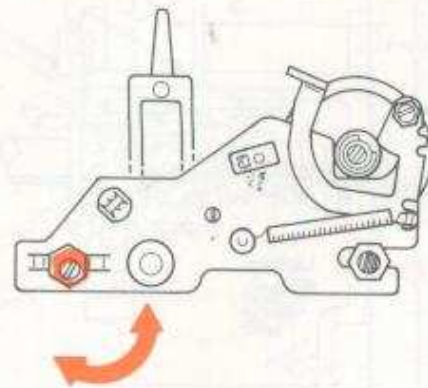

237 Platen Height (22-291)

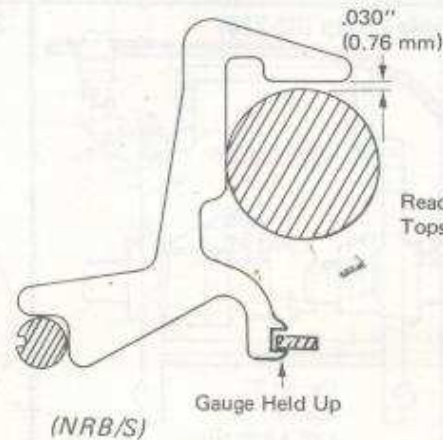
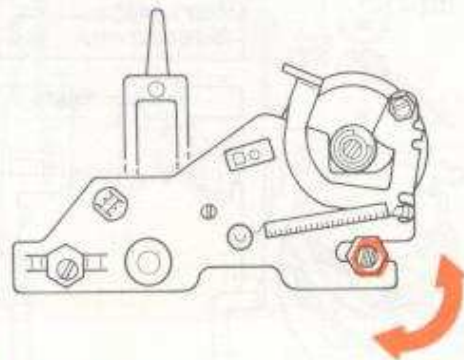

Readjust For Even Tops And Bottoms

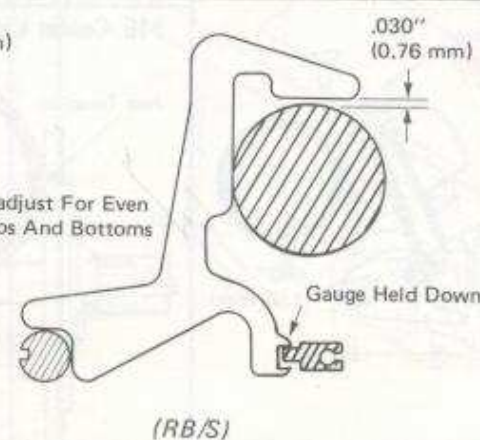

238 Print Cam Follower Stop Screw (02-205)

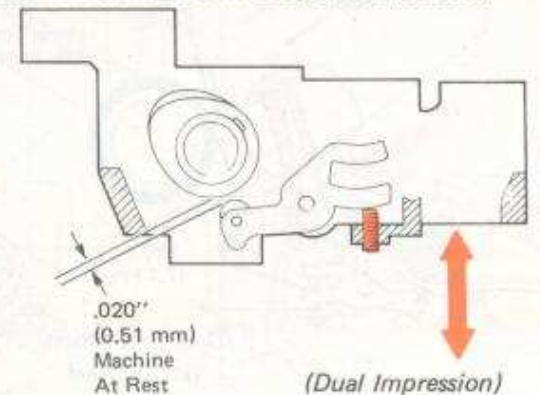

233 Check Paper Feed And Index

239 Powered Flight And Free Flight (02-160)

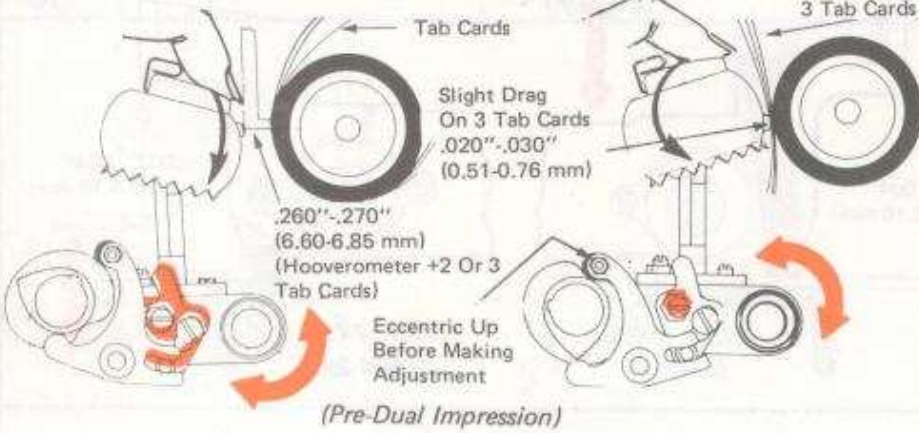

240 Print Cam Follower (02-165)

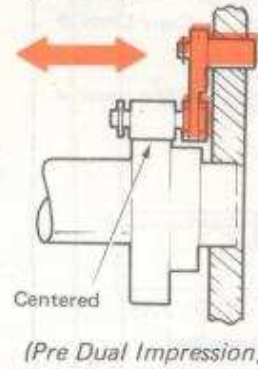

241 Cam Follower Restoring (02-165)

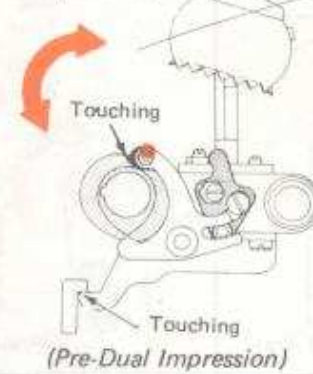

242 Yoke (02-520)

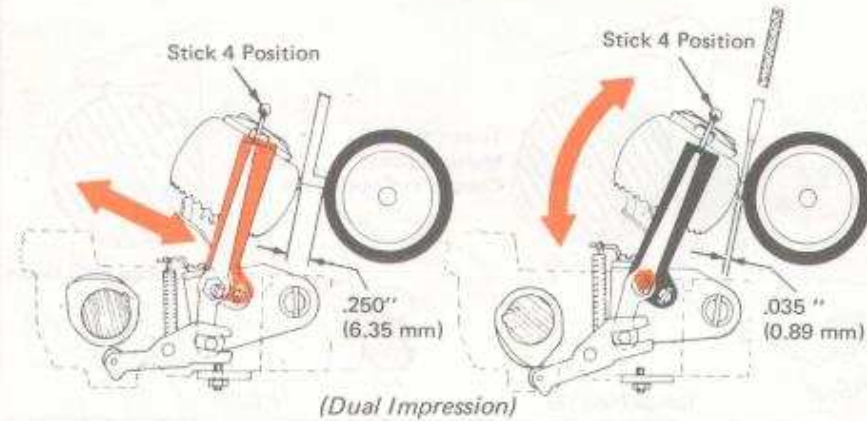

243 Velocity Control Cable Clamp (02-216)

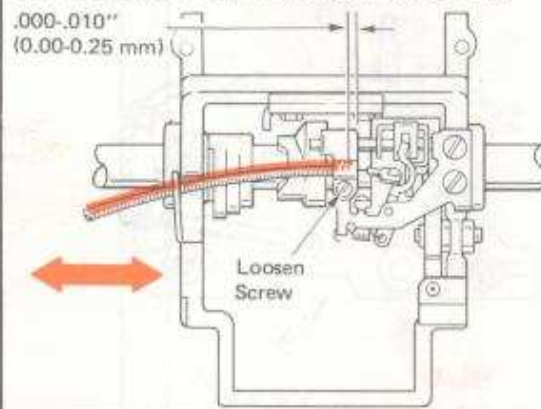

244 Carrier Cable Deflector (19-74)

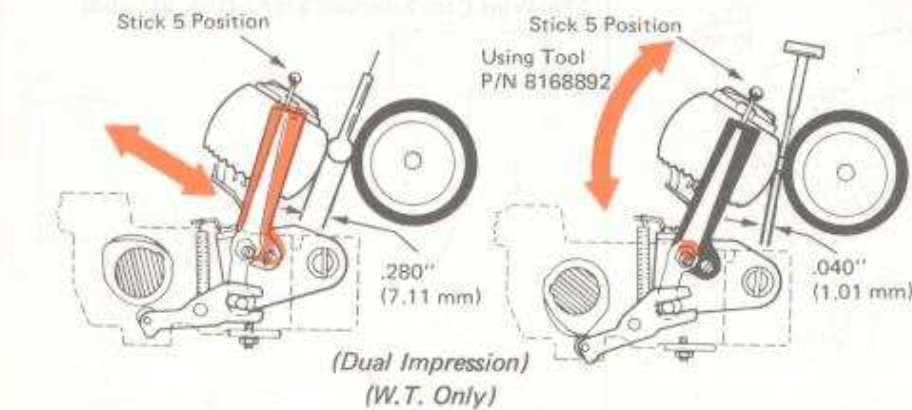
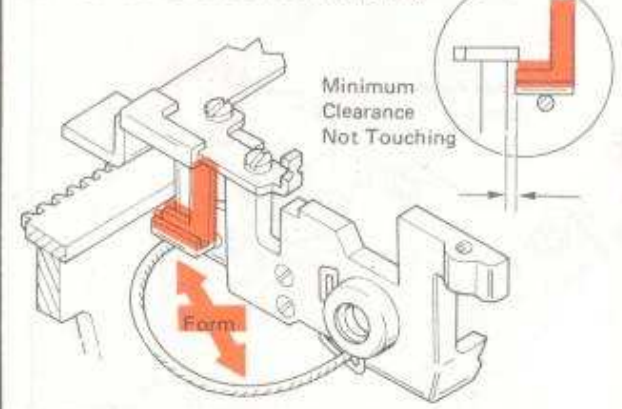

245 Center Cable Clamp (02-216)

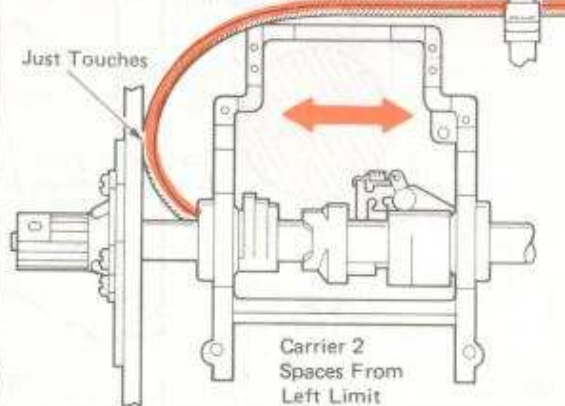

246 Velocity Control Keyboard Cable Clamp (02-216)

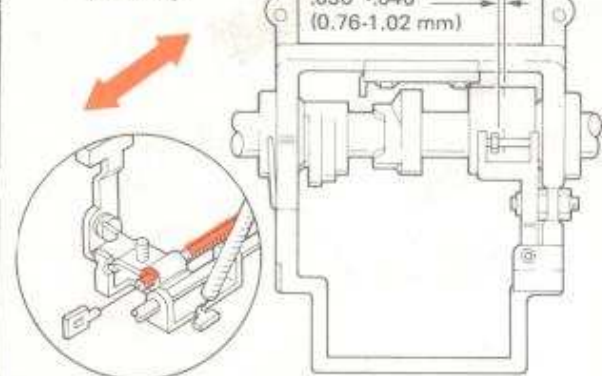

247 Low Velocity Latch Link (21-411)

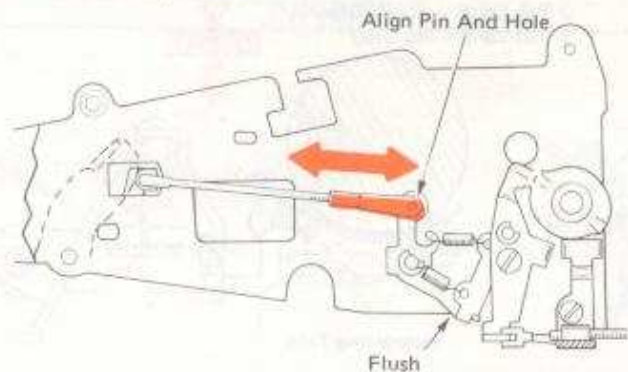

248 Low Velocity Cam (21-426)

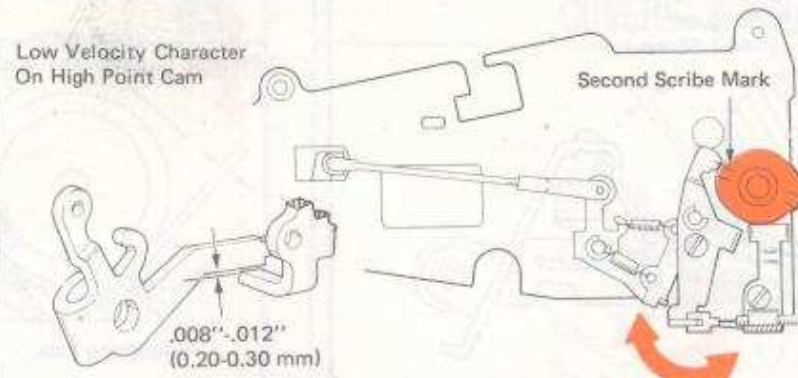

249 Low Velocity Cam Follower Stop (21-415)

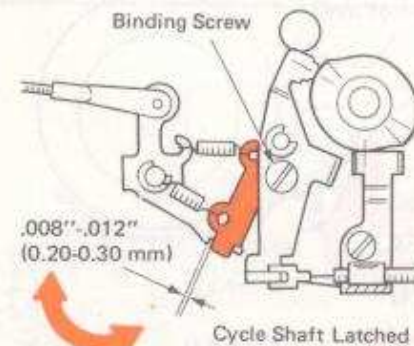

250 Paper Feed Support (22-208)

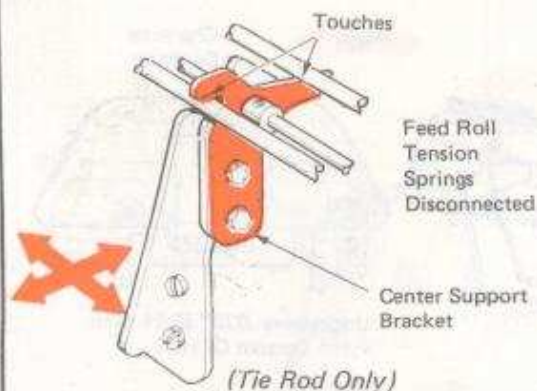

251 Platen Latches (22-293)



252 Feed Roll Tension (22-286)

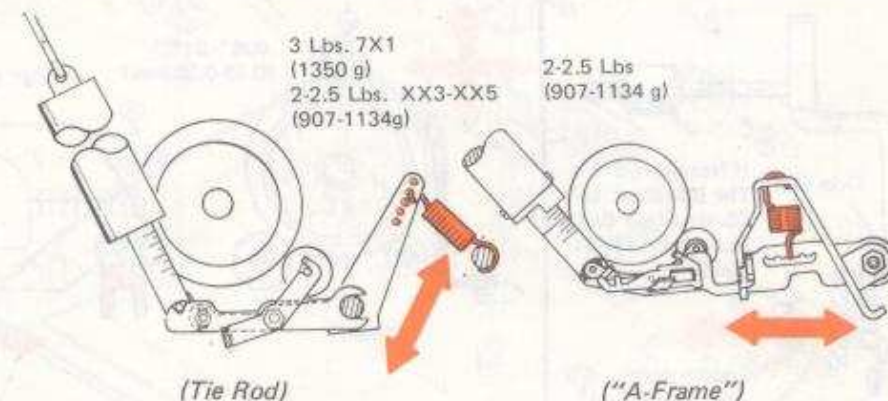

253 Feed Roll End Play (22-96)

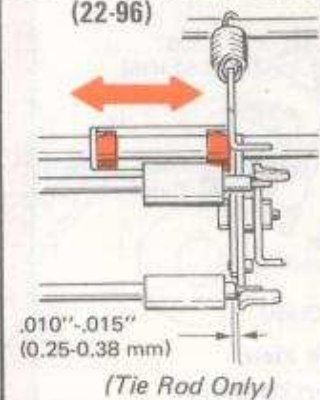

254 Feed Rolls (22-286)

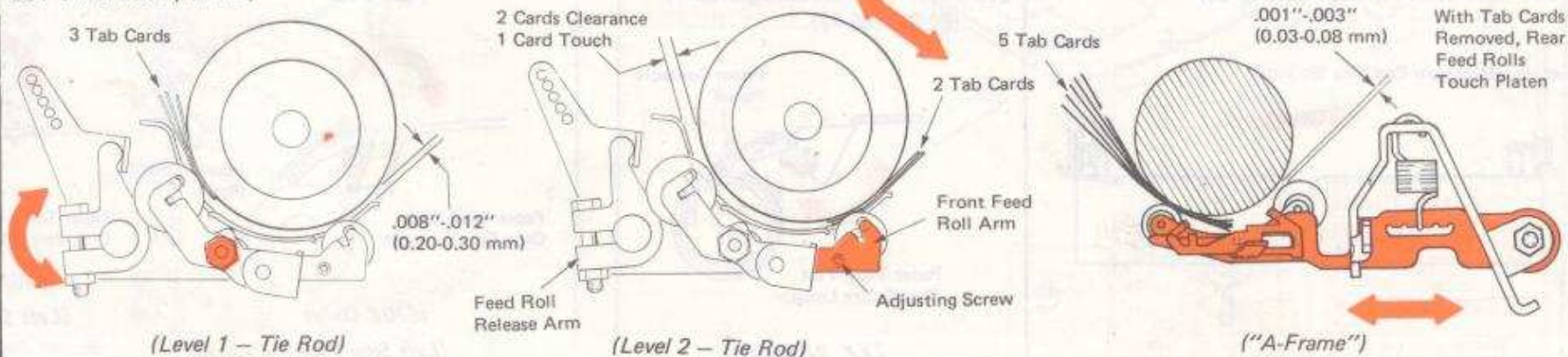

255 Paper Release (22-93)

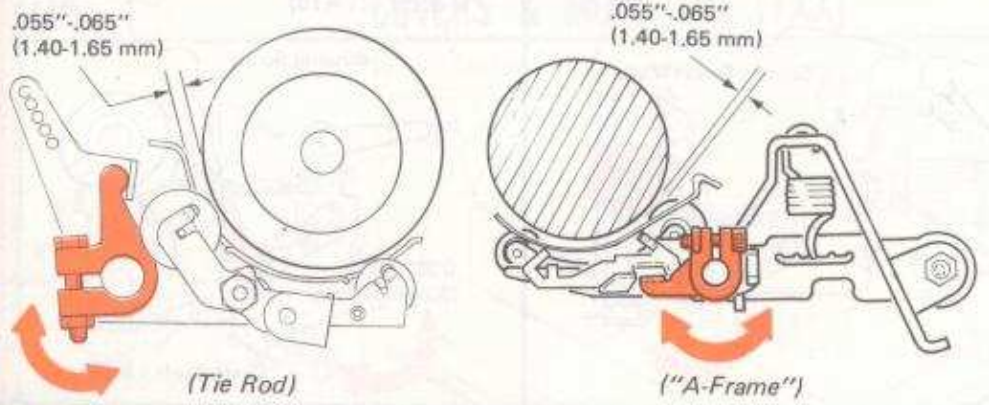

256 Deflector (22-134)

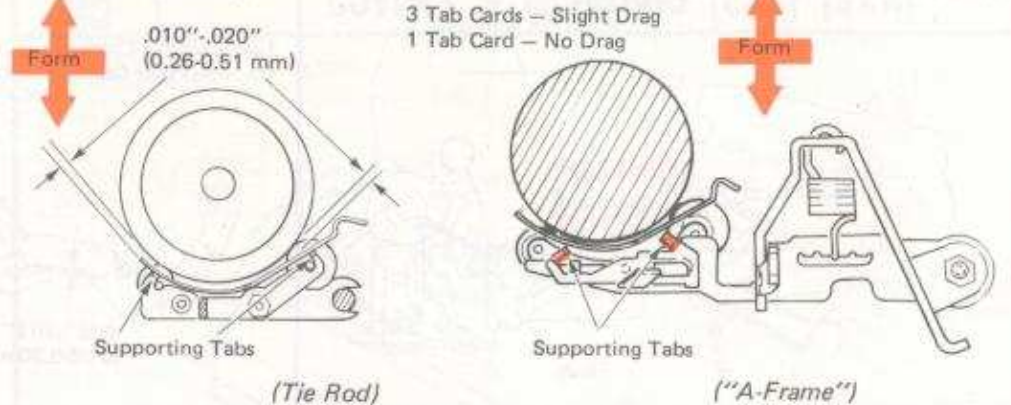

257 Paper Bail (22-1)

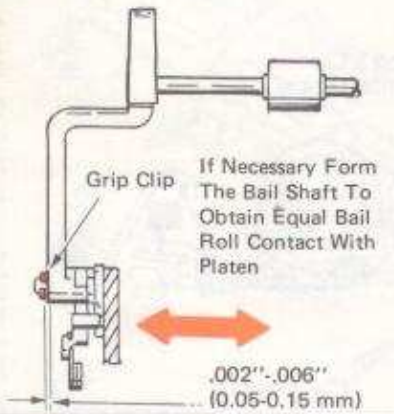

258 Cardholder (22-216)

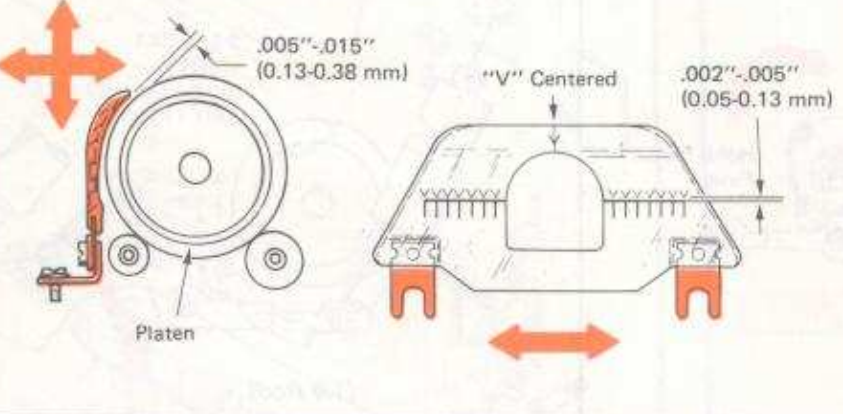

259 Removable Print Shield (22-226)

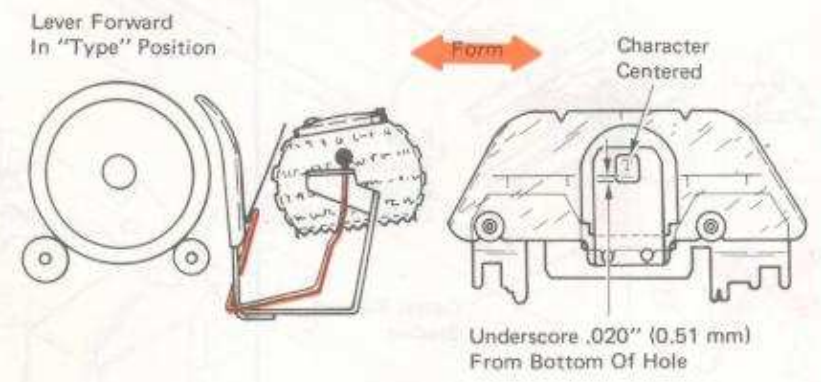

260 Paper Table Arm (04-90) (05-56)

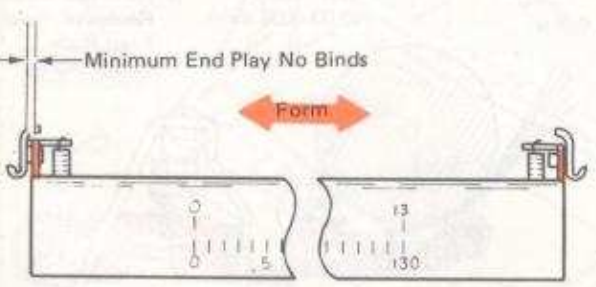

261 Paper Table Mounting Bracket (04-92) (05-47)

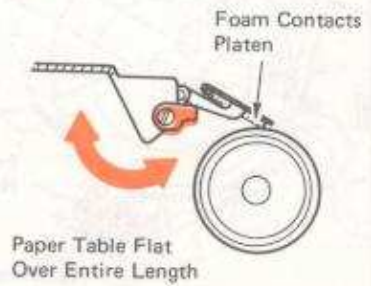

7XX 8XX 9XX

(05-141)

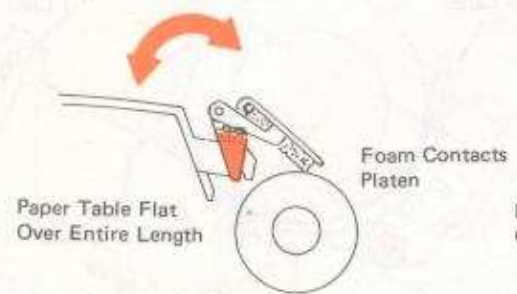

(670X Only) (Left Side View)

(30-141, 166)



(670X Only) (Left Side View) (Sound Reduction Only)

262 Switch Bracket (24-9)

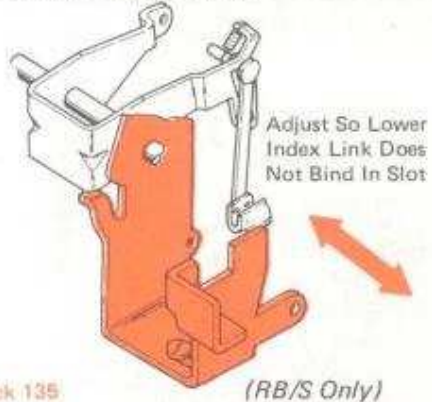

Check 135 (RB/S Only)

263 Multiplying Lever Stop (20-412)

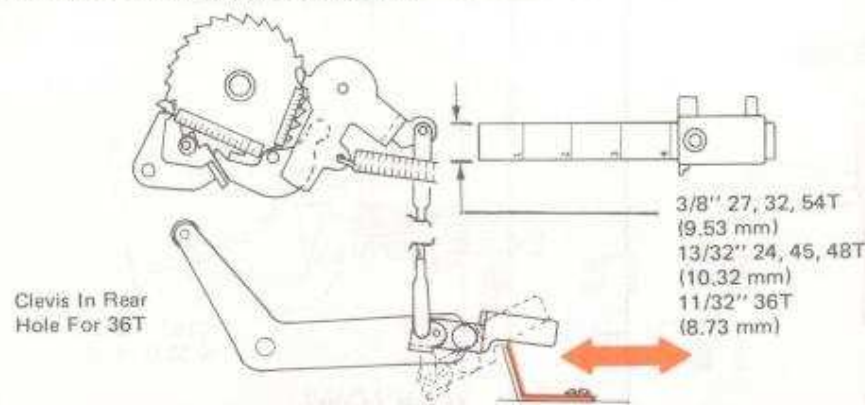

264 Index Transfer Bellcrank Stop Lug (24-9)

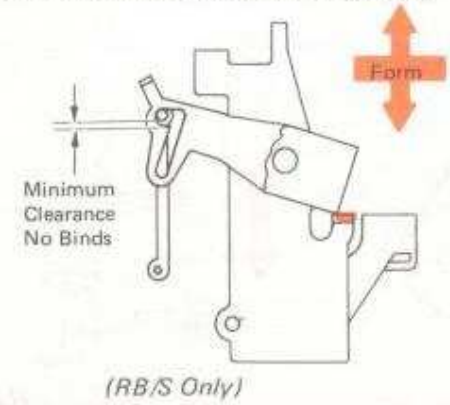

265 Ratchet Alignment (12-20)

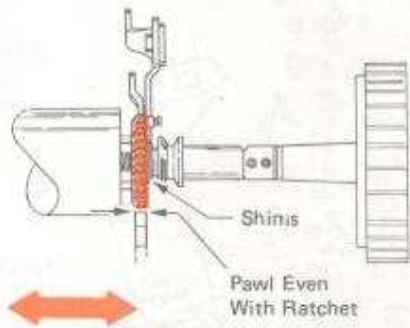

266 Index Selector Cam (20-318)

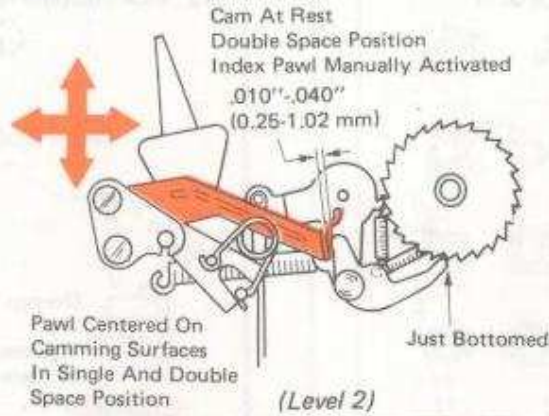

267 Index Selector Cam 54T (20-322)

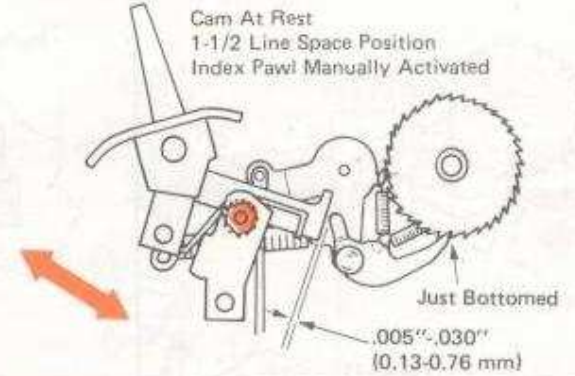

268 Index Link (20-403)

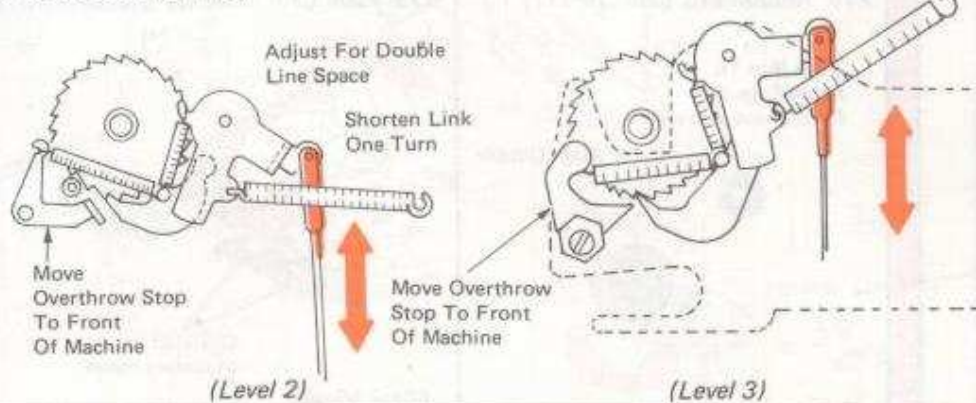

269 Overthrow Stop (20-452)



280 Ribbon Plate (14-44)

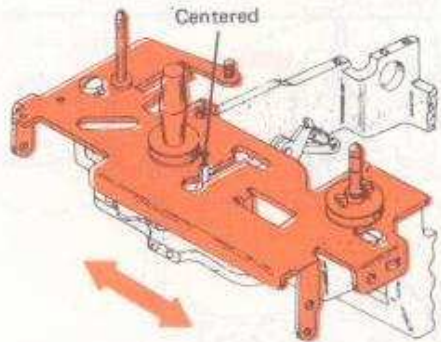

281 Ribbon Feed Cam Follower Stud (14-136)



(Level 1 - Top View)

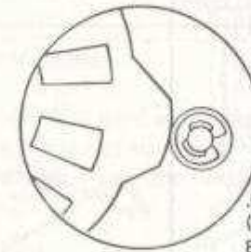

.005"-.015"
(0.13-0.38 mm)
Beyond Detent Position
Cam On High Point

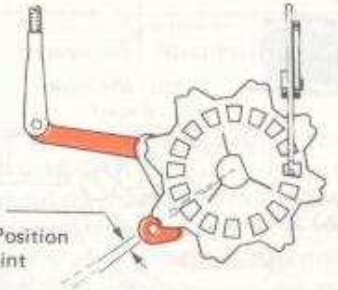

(Level 2 - Top View)

282 Feed And Lift Wheel Detent Spring (14-48)

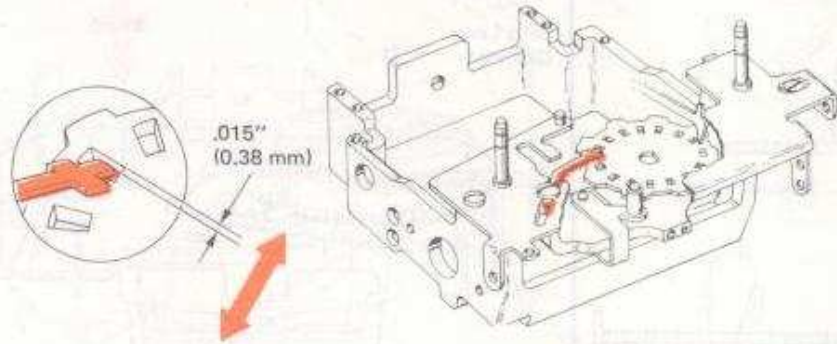

(Level 1 Only)

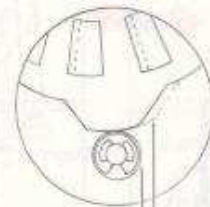

.015"
(0.38 mm)

283 Brake Actuating Lever (14-30)

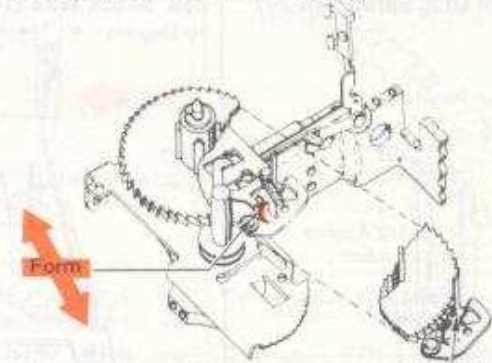

(Level 1 Only)

284 Ribbon Lift Guide Plate (14-207)

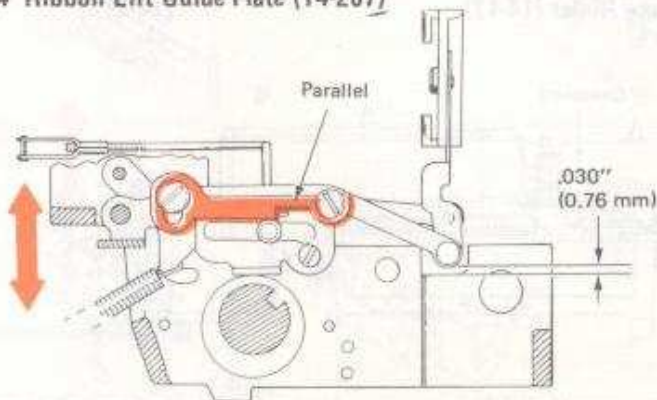

LIFT GUIDE
PLATE PARALLEL
TO SLOT IN CAM
FOLLOWER



LIFT GUIDE
PLATE OUT OF
PARALLEL TOO
HIGH AT THE
REAR



LIFT GUIDE
PLATE OUT OF
PARALLEL TOO
HIGH AT THE
FRONT



LIFT GUIDE
PLATE PARALLEL
TO SLOT IN CAM
FOLLOWER

Approximately .030"
(0.76 mm)

NO CHARACTER OVERLAP

LIFT GUIDE
PLATE PARALLEL
TO SLOT IN CAM
FOLLOWER

Approximately .050"
(1.27 mm)

285 Ribbon Lift Control Link (14-128)

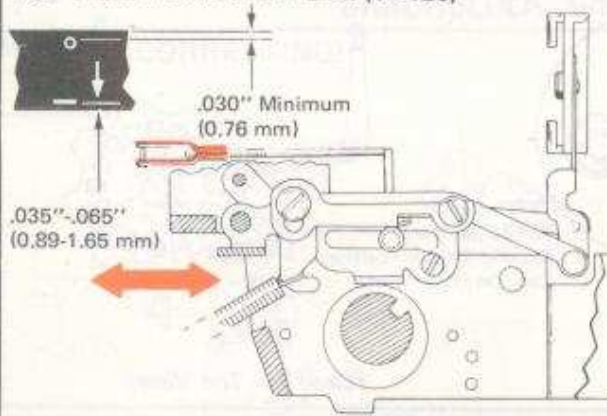

286 Load Lever Link (14-147)

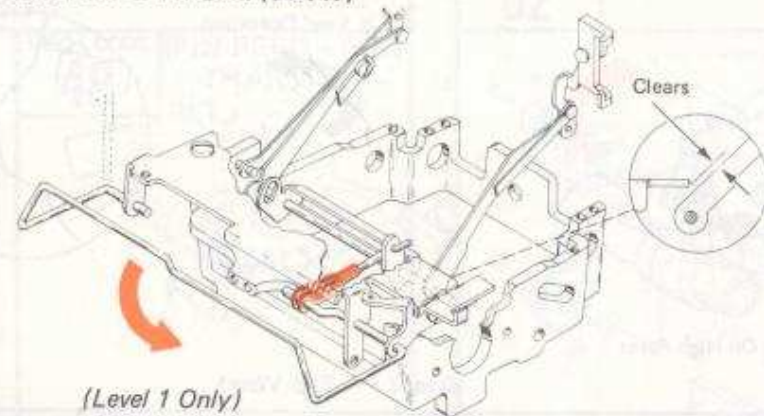

(Level 1 Only)

287 Pressure Roller Release Arm (14-116)

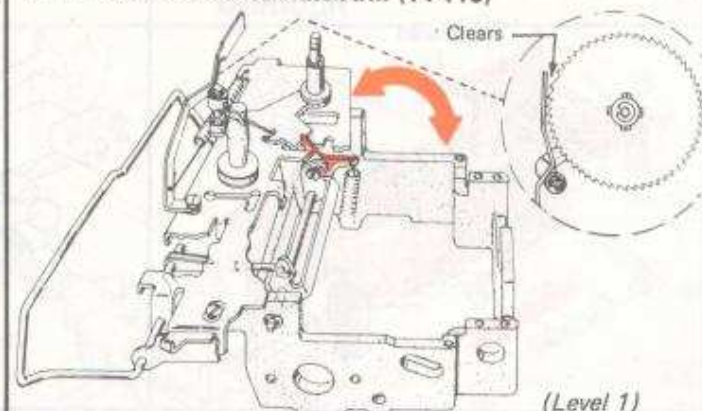

(Level 1)

288 Supply Spool Drag Spring (14-30)

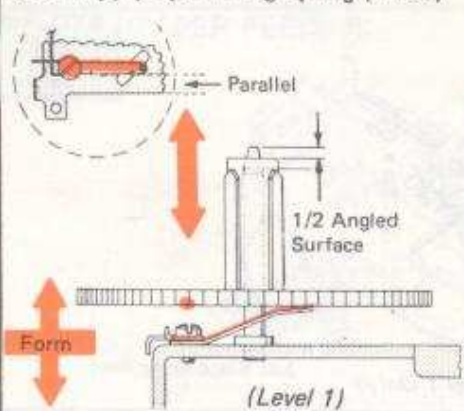

(Level 1)

289 Shock Wire (14-26)

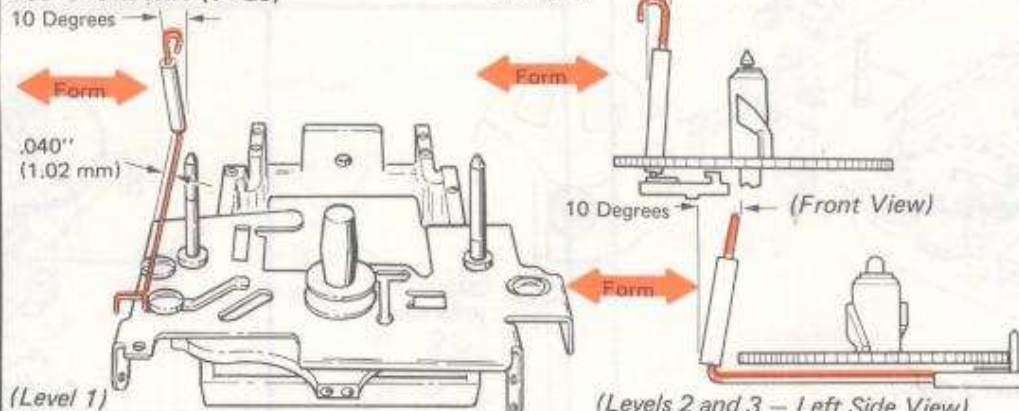

(Level 1)

(Levels 2 and 3 - Left Side View)

290 Drag Lever (14-80)

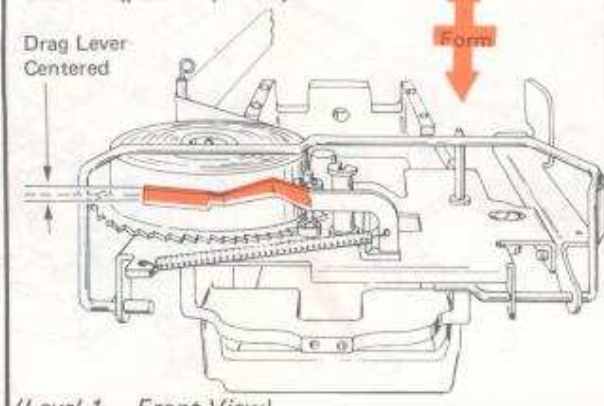

(Level 1 - Front View)

291 Tracking Post Vertical (14-82)

Center Tracking Post Vertical

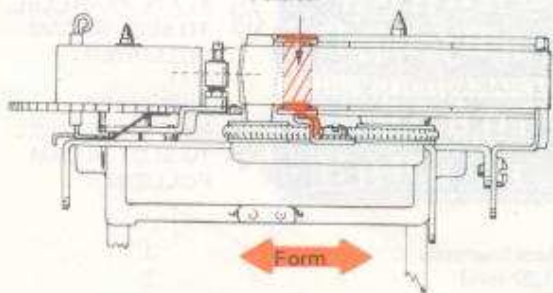

(Level 1 - Front View)

292 Tracking Post (14-82)

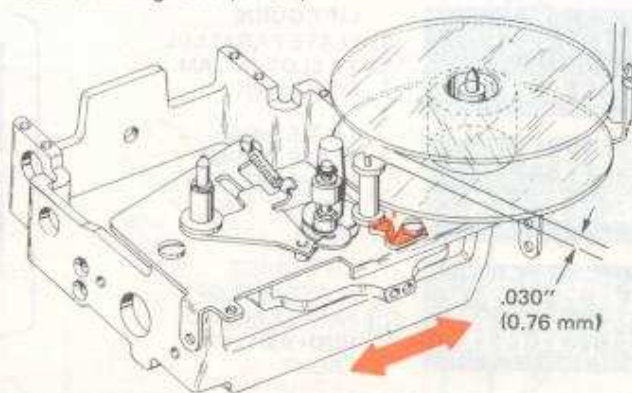

293 Pressure Roller (14-12)

(14-217)

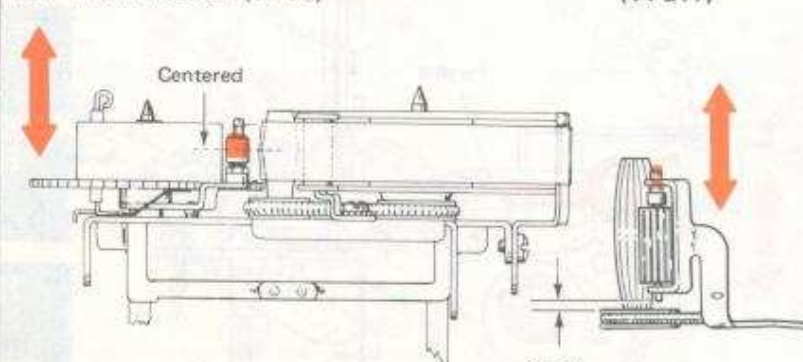

(Level 1)

(Levels 2 and 3)

294 Ribbon Lift Cam (13-58)

Align Dimple

Align Slot To Front Edge Of Print Sleeve Keyway
44, 54

295 Centering Spring (13-38)

.003"-.005"
(0.08-0.13 mm)

.003"-.005"
(0.08-0.13 mm)

(Level 1 Only - Top View)

296 Ribbon Feed Plate (13-38)

.005"-.010"
(0.13-0.25 mm)

(Level 1 Only - Top View)

297 Cartridge Guide Lugs (13-38)

.005"-.010"
(0.13-0.25 mm)

Cartridge Spools Centered Over Ratchets

(Front View)

298 Cartridge Retaining Springs (13-76)

Flush

Centered

(Level 2)

299 Ribbon Lift Lever (13-78)

Centered

(Level 2 Only)

300 Ribbon Lift Lever Rear Lug (13-78)

Detented

Low Lift Position

.010"-.040"
(0.25-1.02 mm)

(Level 2)

301 Ribbon Lift Lever Front Lug (13-78)

Low Lift Position

Detented

Must Move Freely Into Stencil Position
.010"-.040"
(0.25-1.02 mm)

(Level 2)

302 Ratchet Detent Lugs (13-74)

Feed Cam On High Point

.025"-.050"
(0.64-1.27 mm)

303 Ratchet Detent Lug (13-74)

Ribbon Feed Pawl Engage By 1/2 The Depth Of The Tooth

304 Ribbon Lift Guide Plate (13-37)

Cam On Low Point

Parallel

305 Ribbon Lift Control Link (13-62)

.016"-.045"
(0.41-1.14 mm)

High Lift Position

306 Stencil Lockout (13-65)

.010"
(0.25 mm)

Form

(Level 1)

307 Feed Cam Follower Bracket (15-12)

Feed Pawl
Centered
In Window

(Rear View)

308 Lift Arm (15-6)

.005"-.010"
(0.13-0.25 mm)

309 Spiked Driver Post (15-61)

Spiked Driver Post
Parallel Within .005"
(0.13 mm)

Hooverometer

(Right Side View) (Front View)

310 Ribbon Lift Cam (15-17)

Align Slot To Front
Edge Of Print Sleeve
Keyway

44, 54

311 Feed Cam Follower Eccentric (15-8)

.005"-.010"
(0.13-0.25 mm)

312 Lift Control Lever (15-76)

.020"-.030"
(0.51-0.76 mm)

Form

313 Spread Adjusting Plate (15-22)

Bias

.380"-.410"
(9.65-10.41 mm)

314 Lift Height (15-30)

.030"-.040"
(0.76-1.02 mm)

313

315 Lift Arm Lower Stop (15-2)

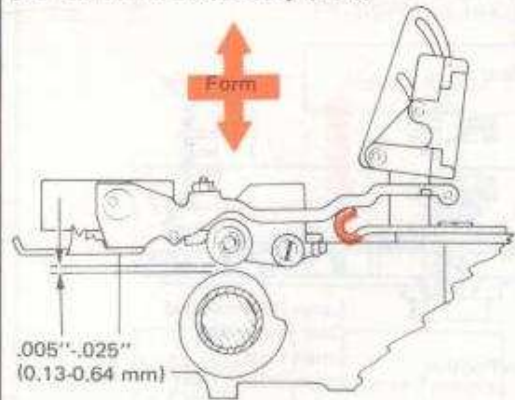

316 Shock Wire (15-83)

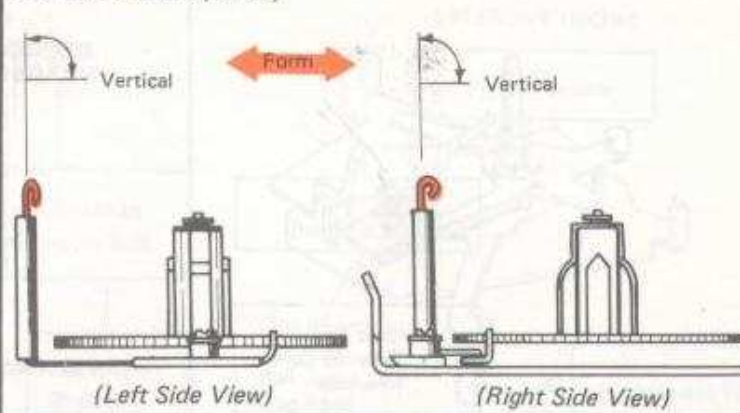

317 Stencil Adjustment (15-76)

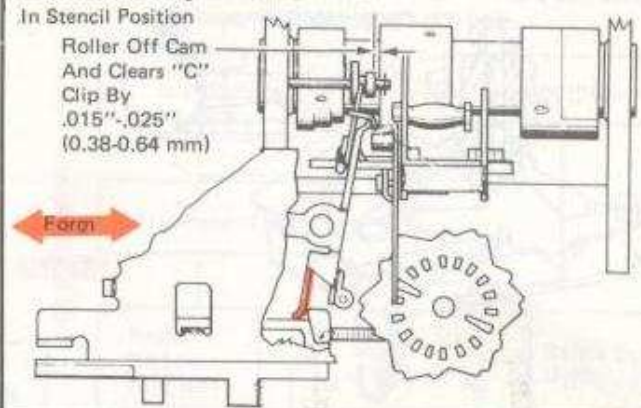

318 Swing Arm Lug (15-62)

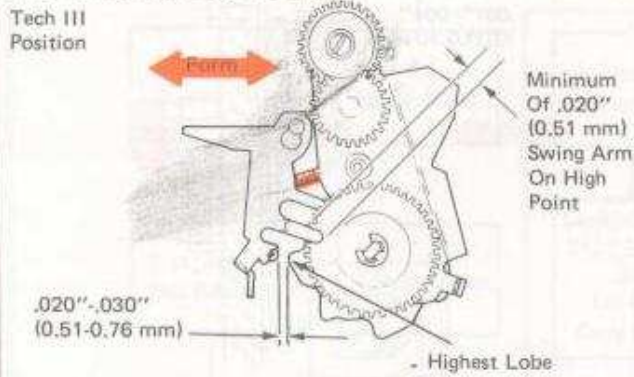

319 Shock Wire Disengage Lever (15-87)

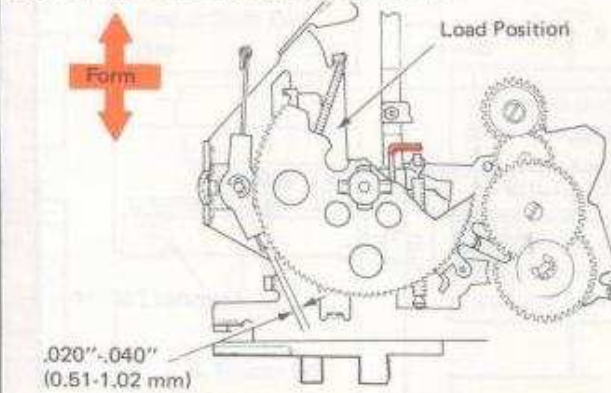

320 Shock Wire Disengage Lever (15-87)

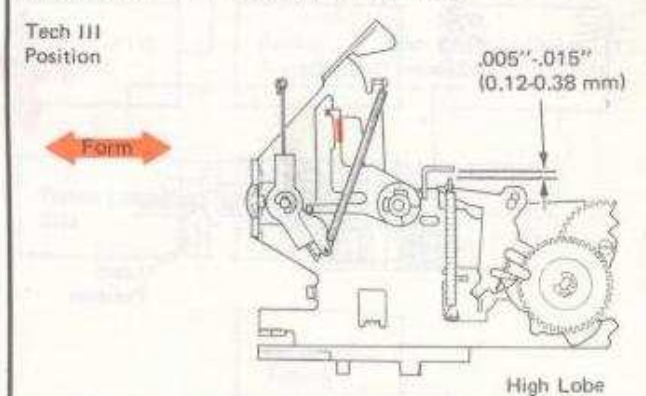

321 Cartridge Guides (15-86)

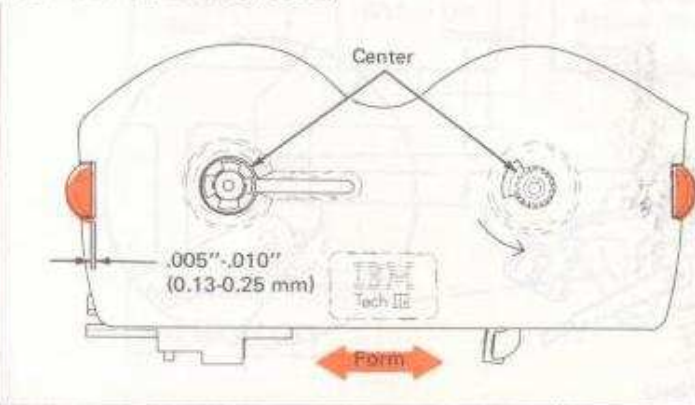

322 Cartridge Retaining Springs (15-59)

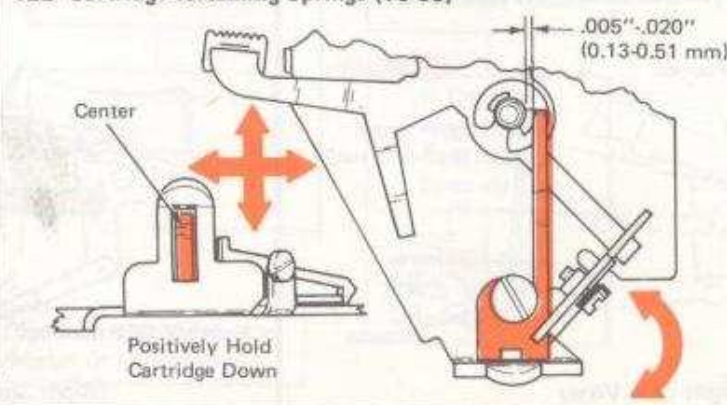

323 Take-Up Core Interlock (15-59)

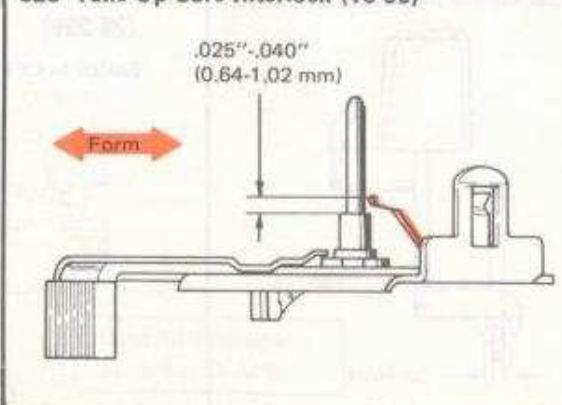

324 Load Lever (15-64)

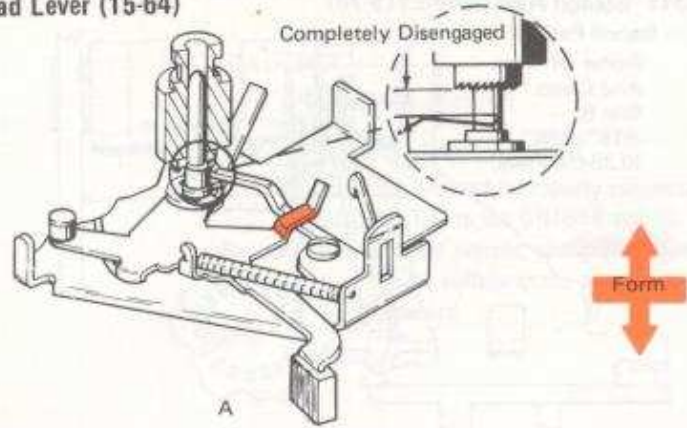

325 Mode Button Grip Clip Position (15-93)

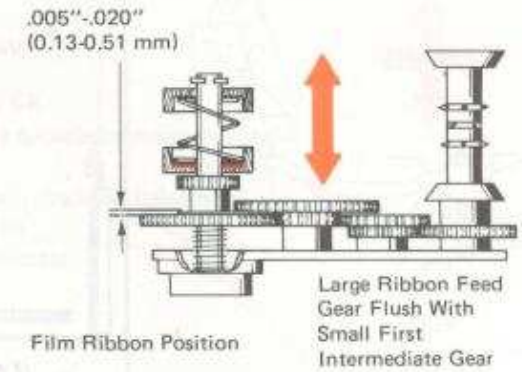

326 Load Lever Spring (15-85)

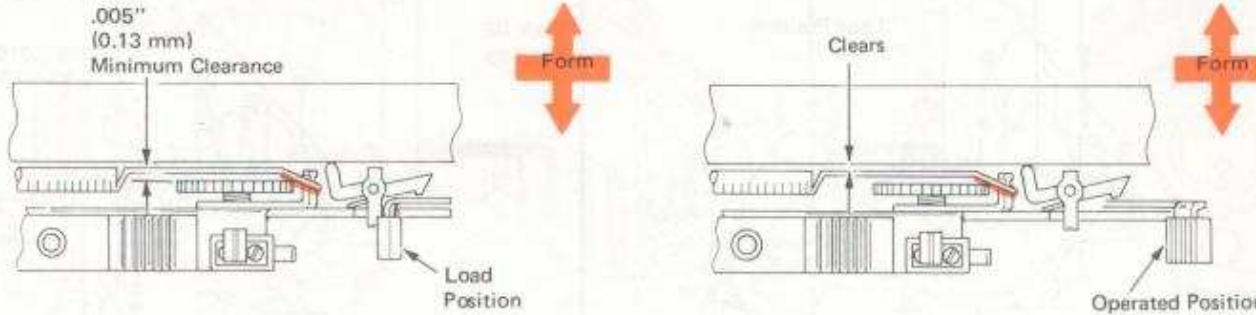

327 Correcting Keylever Side Play (26-95)

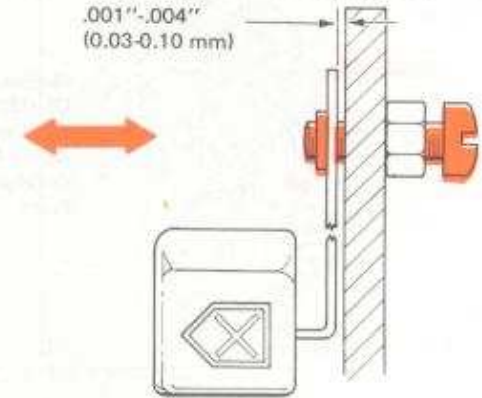

328 Backspace Keylever (01-101)

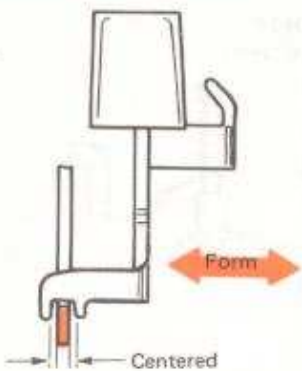

329 Correcting Keybutton Interlock Front To Rear (26-259)

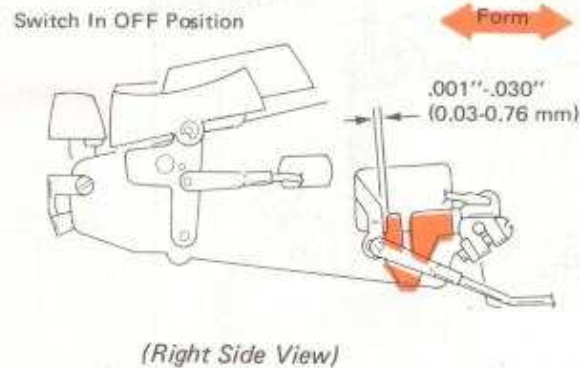

330 Lockout Bail Link (21-546)

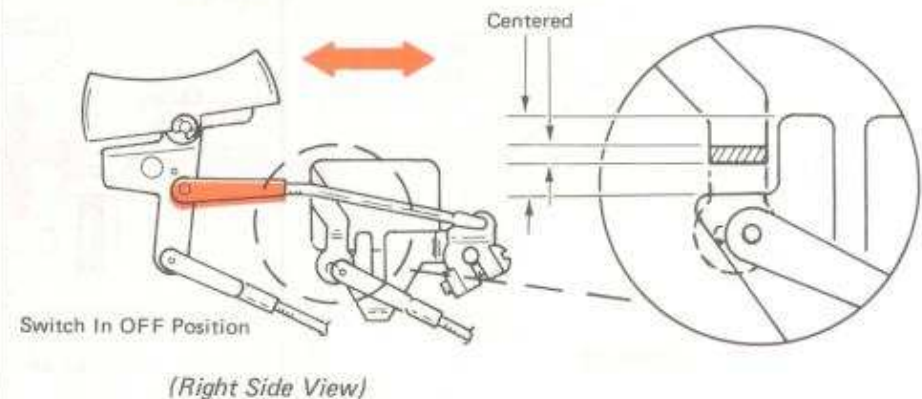

331 Correcting Keybutton Interlock And Lockout Bail (26-259)



332 Correcting Keylever Link (26-90)

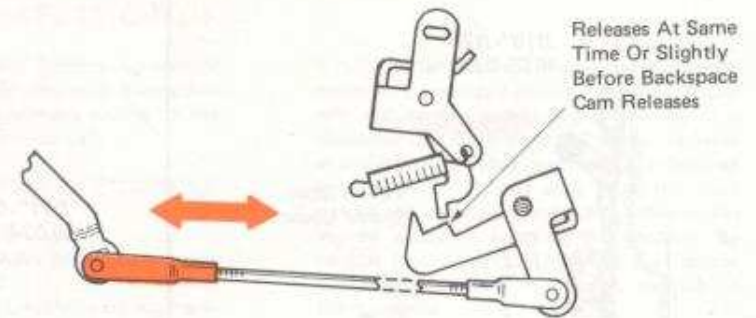

333 Mode Actuating Bellcrank (26-80)

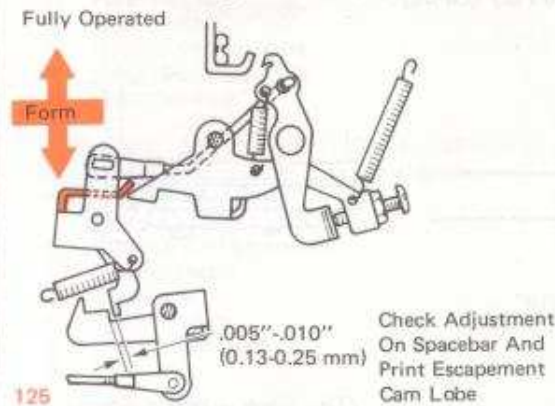

334 Trigger Link (26-76)

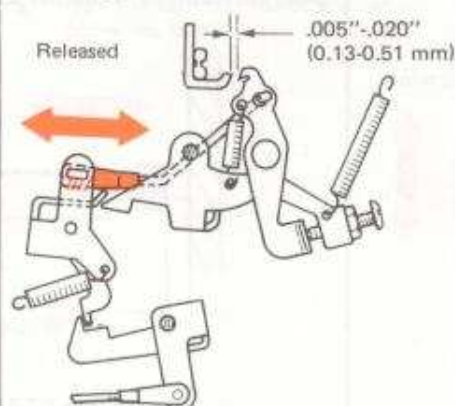

335 Cable Guide Bracket (26-59)

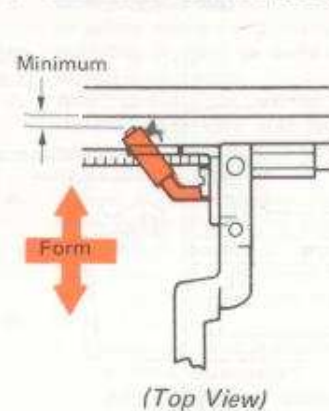

336 Cable Guide Lug (26-71)

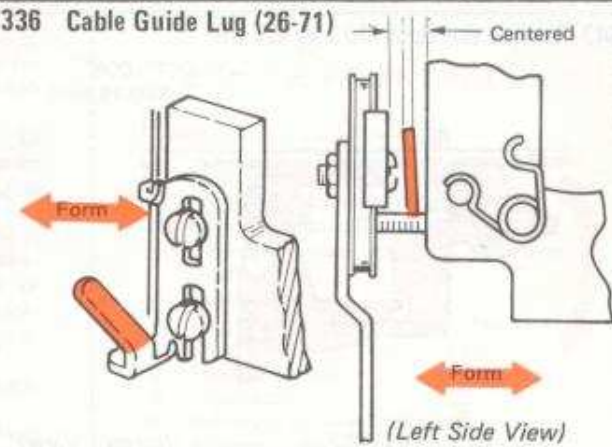

337 Cardholder (26-41)

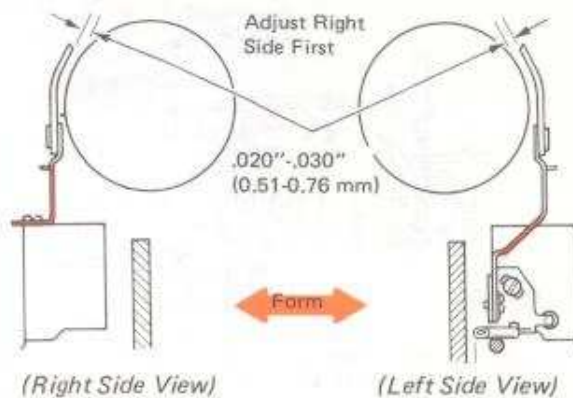

338 Cardholder (26-41)

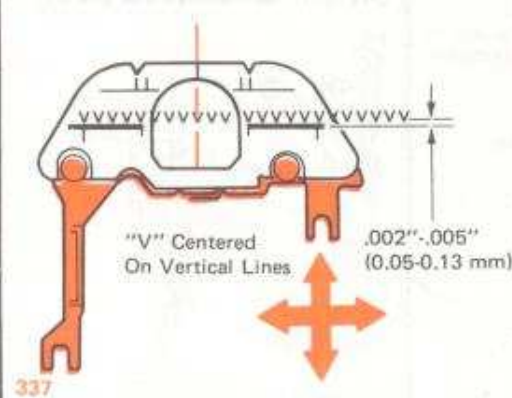

339 Left-Hand Ribbon Lift Guide (26-72)

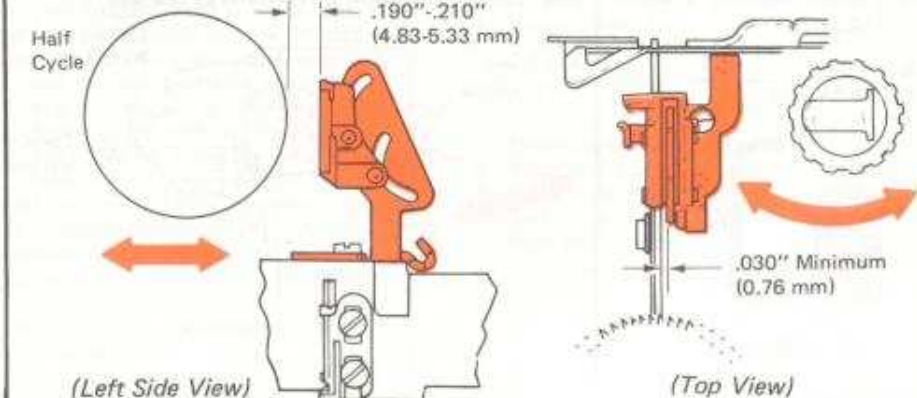

340 Tape Lift Assembly Front To Rear (26-71)

$.010''-.020''$
(0.25-0.51 mm)

Tape Supply Cradle Loose

W. T.
.020''-.030''
(0.51-0.76 mm)

341 Tape Lift Assembly Vertical (26-71)

Underscore Half Cycled

$.001''-.005''$
(0.03-0.13 mm)

340

342 Tape Supply Cradle Fork (26-34)

Centered

343 Torque Bar Back-Up Lug (26-55)

$.001''-.006''$
(0.03-0.15 mm)

(Pre-FTB) (Bottom View)

(26-132)

$.065''-.070''$
(1.65-1.78 mm)

(FTB)

344 Correcting Torque Bar End Play (26-98)

$.010''-.025''$
(0.25-0.64 mm)

$.003''-.010''$
(0.08-0.25 mm)

(Pre-FTB) (Top View - World Trade)

345 Torque Bar Stop Bracket (26-89)

$.010''-.015''$
(0.25-0.38 mm)

(Pre-FTB)

346 Torque Bar Link (Preliminary) (26-86)

Correction Mechanism At Rest; Latched Condition

Just Spans The Distance

Torque Bar Vertical

347 Lift Actuating Arm (26-62)

Full Travel Front To Rear

$.001''-.005''$
(0.03-0.13 mm)

$.001''-.005''$
(0.03-0.13 mm)

$.002''$ (0.05 mm)

(Pre-FTB) (FTB)

348 Lift Arm Latch (26-66)

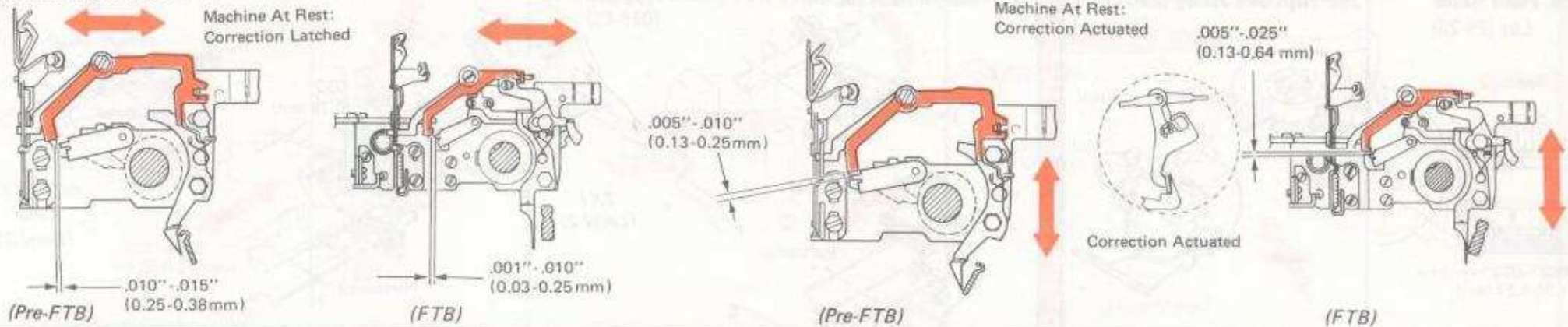

349 Torque Bar Link (Final) (26-86)

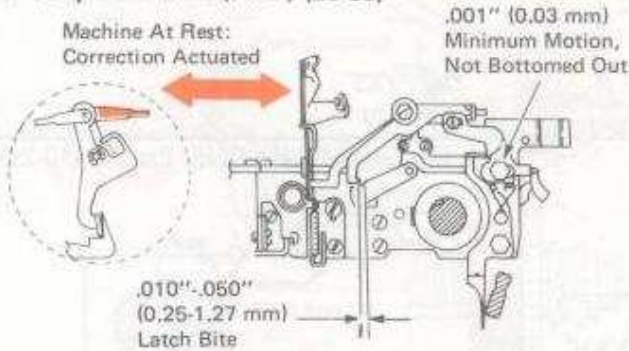

350 Tape Feed Cam Follower Front Lug (26-53)

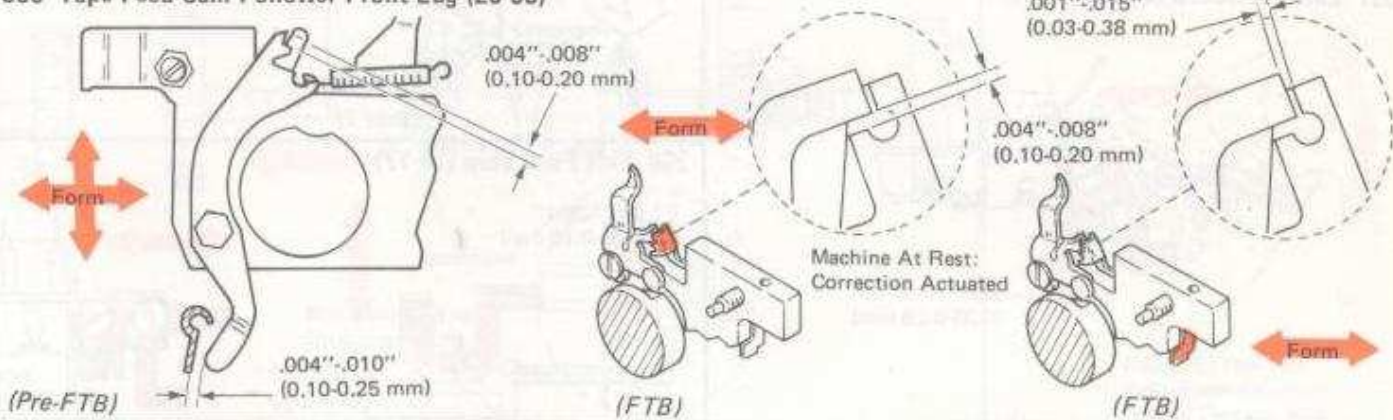

351 Tape Feed Cam Follower Rear Lug (26-45)

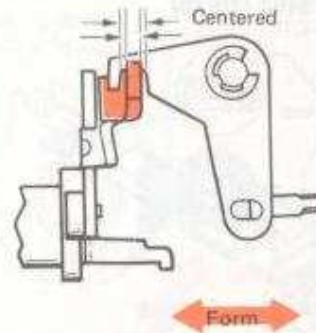

352 Guide (26-13)

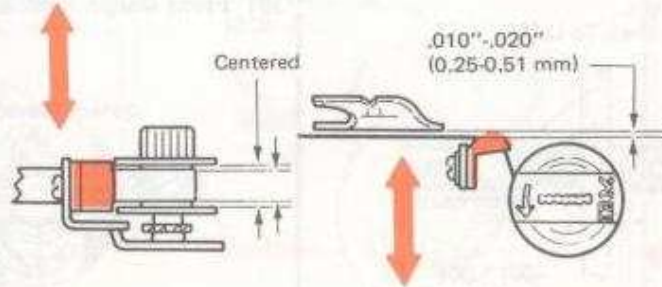

353 Separator Wire (26-9)

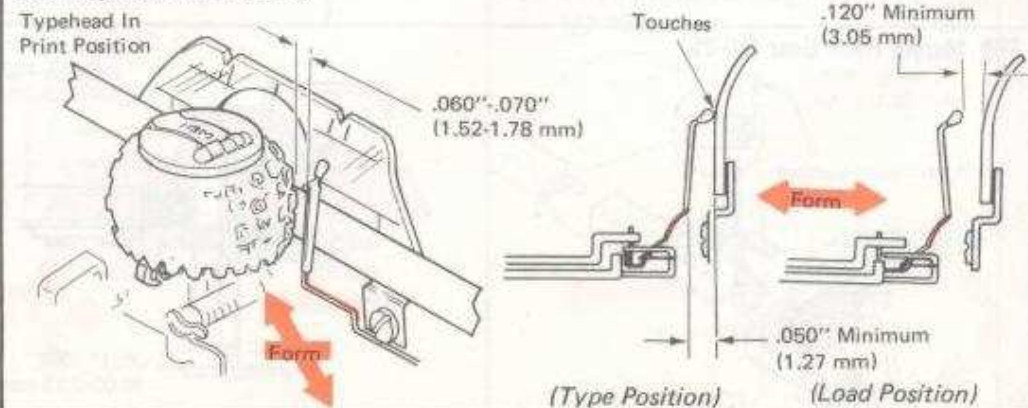

354 Paper Guide Lug (26-20)

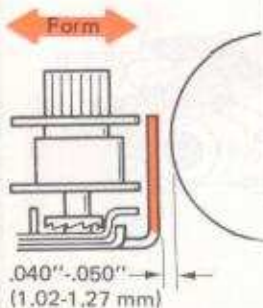

355 High Bias Spring (26-34)

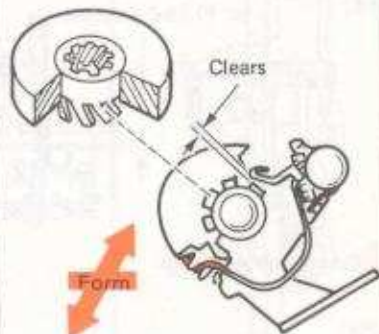

356 Margin Rack (09-19)

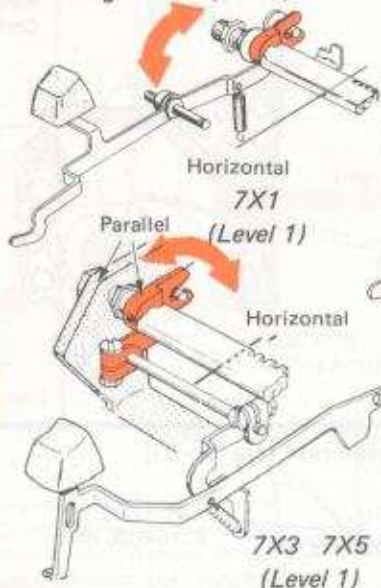

(09-61)

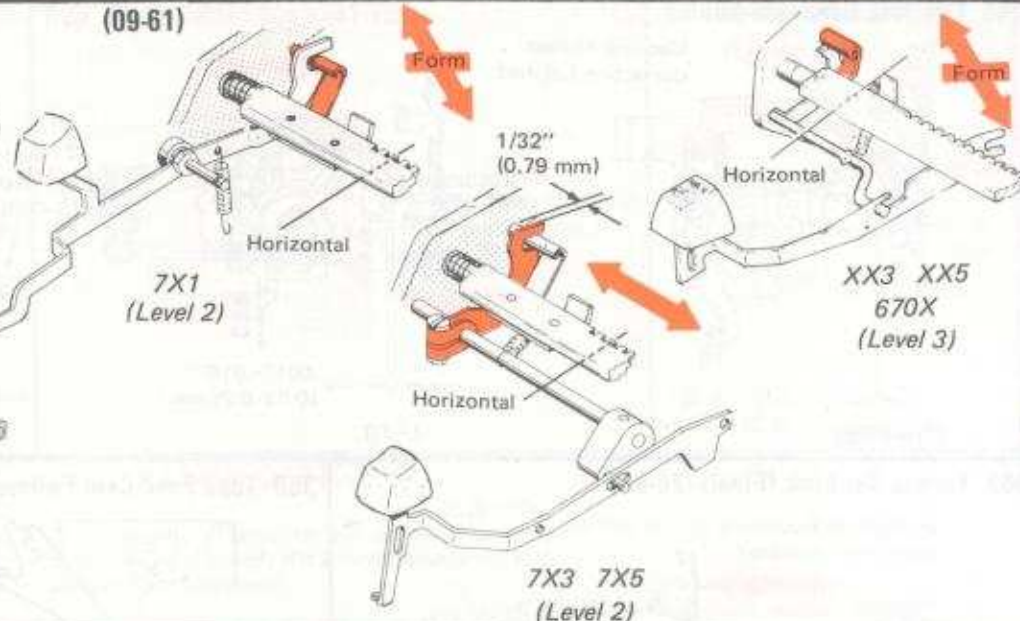

357 Left Final Stop (09-61)

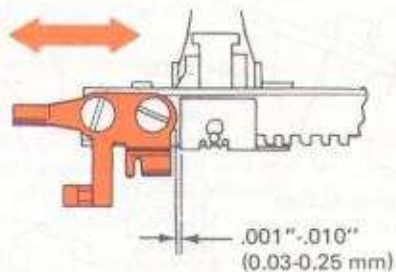

(NRB/S)

358 Left Final Stop (10-17)

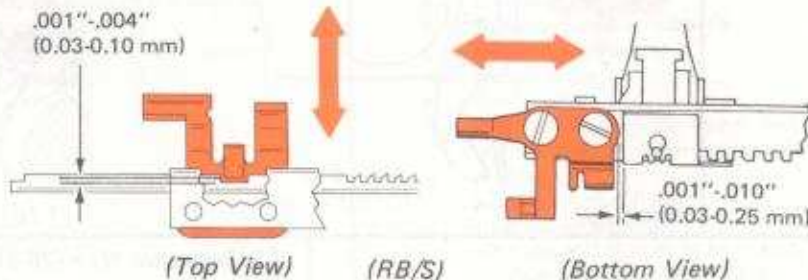

(Top View)

(RB/S)

(Bottom View)

359 Margin Pitch Link Guide Bracket (10-25)

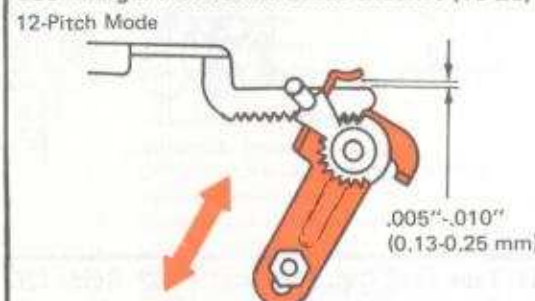

360 Margin Rack Gear (10-29)

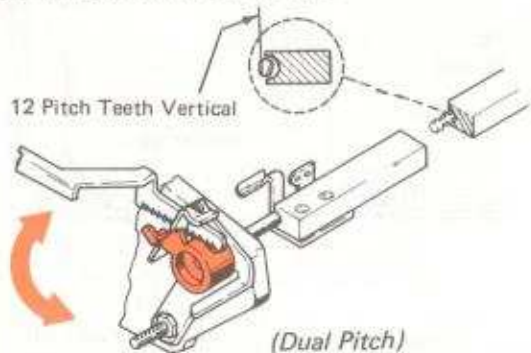

(Dual Pitch)

Hold Rail To Right.
Remove Play In Rack To Left.

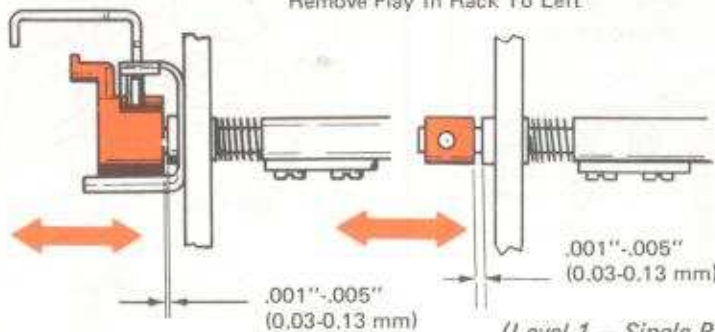

(Level 1 - Single Pitch)

361 Front Margin Rack Gear Stop (10-25)

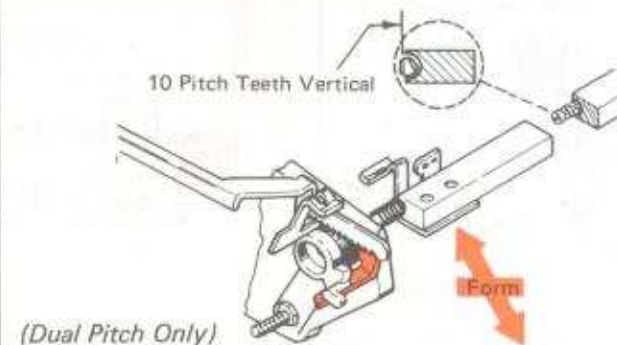

(Dual Pitch Only)

362 Lighted Margin Switch (10-112)

Machine In 12 Pitch

$.030''-.060''$ Overthrow
(0.76-1.52 mm)

(Right Side View) (Dual-Pitch 670X Only)

363 Lamp Shield (10-117)

Lamps Align With Inside Of Shield

365

(Front View) (Dual-Pitch 670X Only)

364 Lamp Mounting Bracket (10-117)

$.015''-.035''$
(0.38-0.76 mm)

(Right Side View) (Dual-Pitch 670X Only)

365 Lamp Bracket (10-117)

$.020''-.040''$
(0.51-1.02 mm)

Even Light Across Scale

(A) (B) (C)

363

(Rear View) (Dual-Pitch 670X Only)

366 Linelock Bracket (09-5)

Carrier At Left

$.050''-.060''$
(1.27-1.52 mm)

(Right Side View)

367 Margin Rack (09-71)

366

367 Margin Rack (09-71)

Carrier At Right

$.050''-.060''$
(1.27-1.52 mm)

Front-To-Rear Clearance Same As Left Side

368 Bellringer Bail Extension (09-80)

Form

369 Bellclapper Bellcrank (09-76)

$.015''-.025''$
(0.38-0.64 mm)

370 Margin Set Lever Pointer (10-101)

Align

(Dual-Pitch 670X Only)

371 Margin Set Lever Pointer (10-100)



(Dual-Pitch 670X Only)

372 Carrier Pointer Left To Right (10-40)

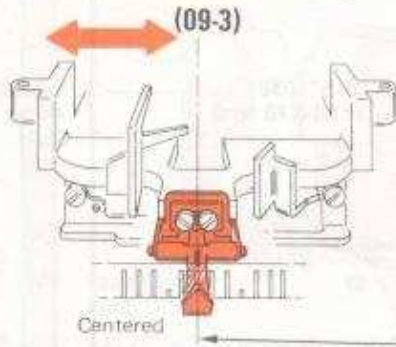

(Level 1)

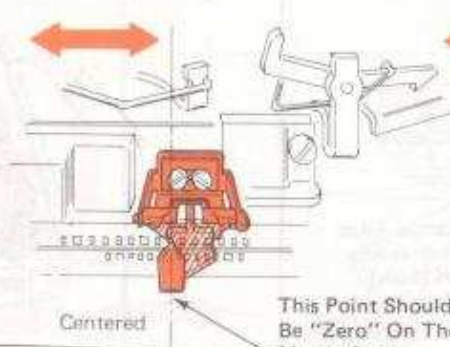

(Level 2)

This Point Should Be "Zero" On The Margin Scale.

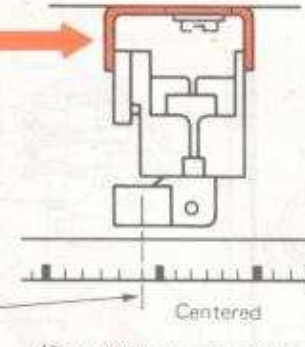

(Sound Reduction 8XX)
(Single-Pitch 670X)

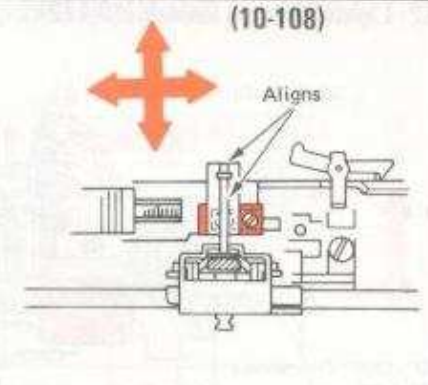

(Dual-Pitch 670X)

373 Carrier Pointer Parallel (10-108)

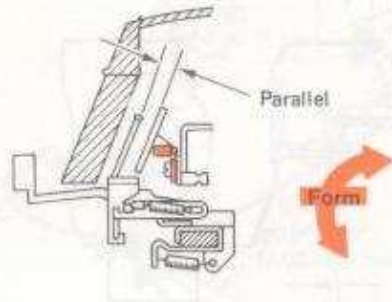

374 (Dual-Pitch 670X Only)

374 Carrier Pointer Front To Rear (10-37)

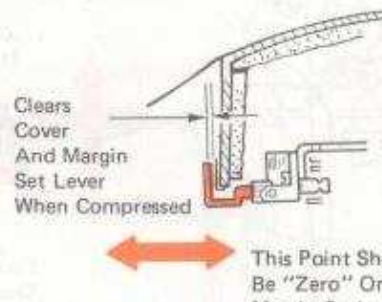

(Level 2)

This Point Should Be "Zero" On The Margin Scale.

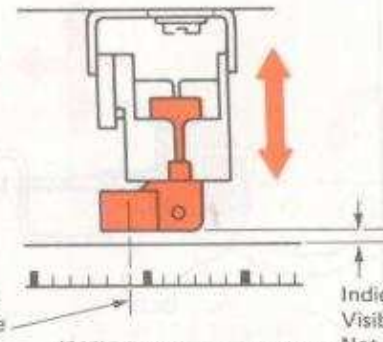

(8XX Sound Reduction)
(Single-Pitch 670X)

(10-107)



(Dual-Pitch 670X Only)

375 Top Cover Hinge (04-04) (05-04)

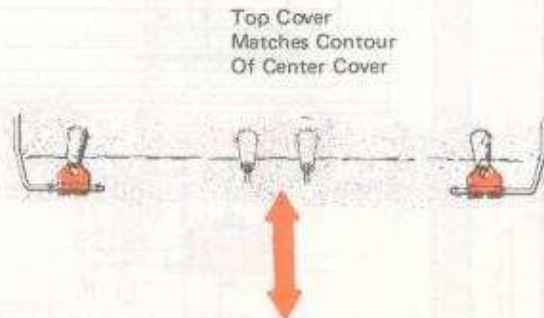

376 Top Cover Latches (04-83)

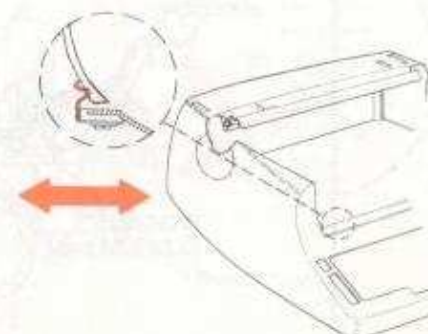

(Level 1)

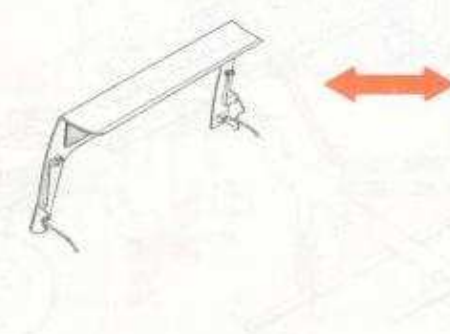

(Level 2)

377 Cover Mounts (04-251) (04-230)

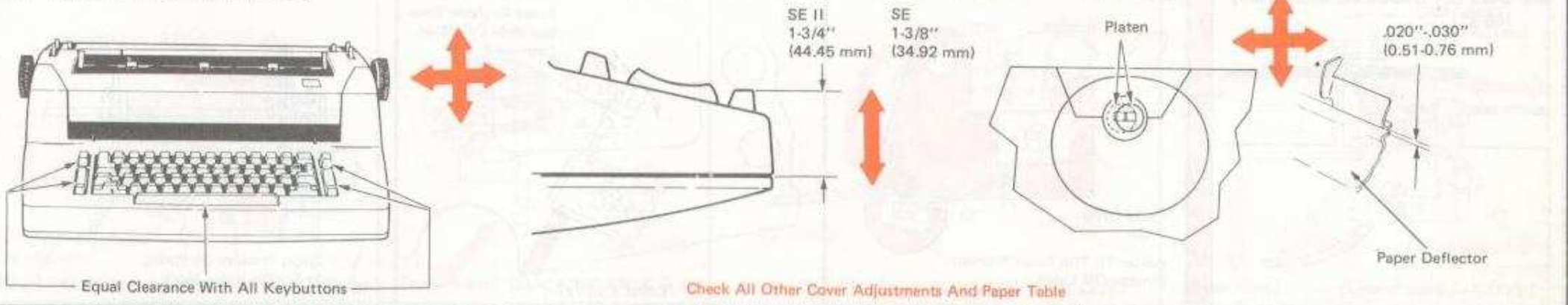

378 Acoustical Filter Hood (30-126)

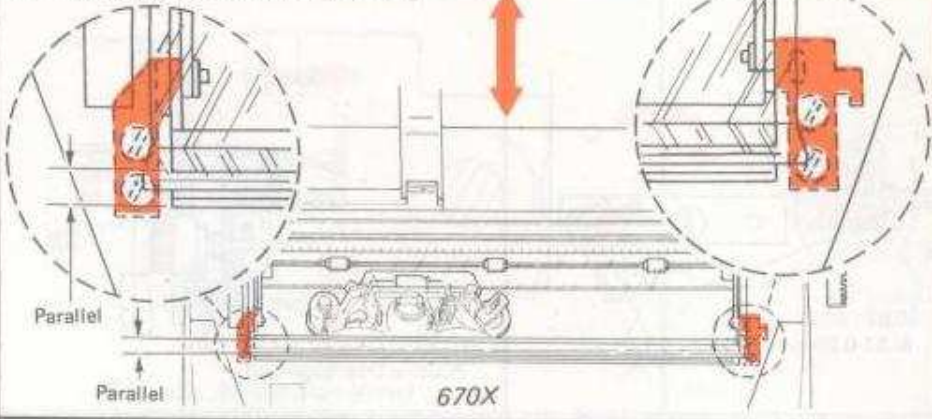

379 Trigger Link (Dead Key Only) (26-76)

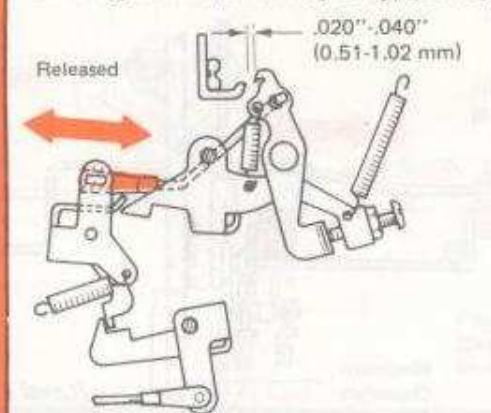

380 Dead Key Rear Cable Clamp (40-11)

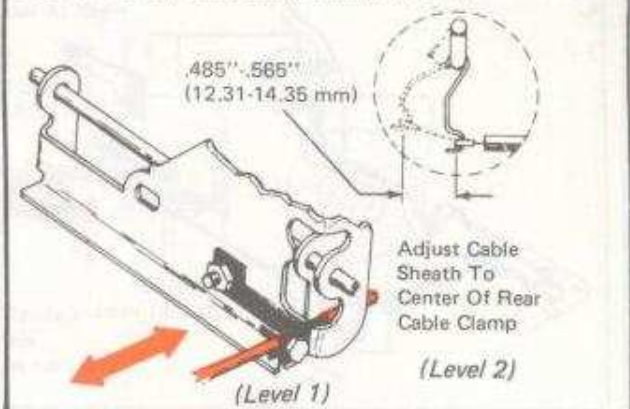

381 Dead Key Front Cable Clamp (40-11)

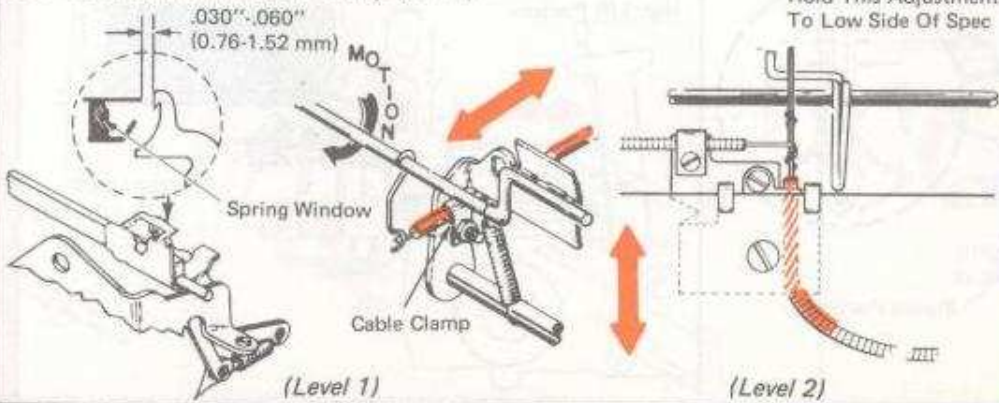

382 Dead Key Disconnect Indicator (40-29)

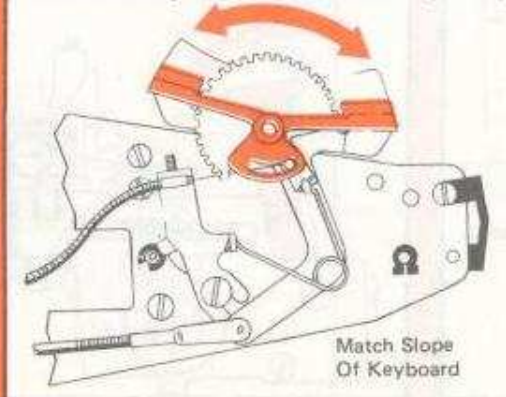

383 Cable Sheath (40-41)

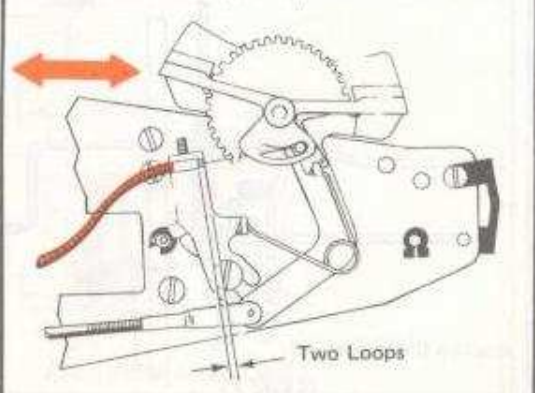

384 Dead Key Disconnect Cable Clamp (40-41)

385 Double Index Bellcrank

Cable Cover Flush
Adjust To Trip Index Without Binding Off Latch
(Level 1 Only)

386 Side Frame Clamp

Index Keylever Does Not Bind Off When Depressed
(Level 1 Only)

387 Trip Shaft Clip (20-33)

Slight Pressure On Spring In Double Index Mode

388 Carrier Return Interlock Link (20-35)

.001\"-.020\"
(0.03-0.51 mm)

389 Tripper (20-39)

Minimum Clearance
(Level 2)

.020\"-.035\"
(0.51-0.89 mm)

390 Locator (20-45)

Positive Disengagement
(Level 2)

391 Locator (20-44)

Positive Disengagement
(Level 2)

392 External Ribbon Control Bracket (13-91)

Centered
Stencil Position

393 Ribbon Lift Control Link (13-63)

High Lift Position
.030\"-.045\"
(0.76-1.14 mm)

394 Manual Velocity Control Indicator (21-543)

Slopes Parallel

.002"-.010"
(0.05-0.25 mm)

ON

OFF

395 Manual Velocity Low Velocity Link (21-550)

Adjust
.020"-.025"
(0.51-0.64 mm)

396 Manual Velocity Control Link (21-546)

Velocity Control Link

.015"-.020"
(0.38-0.51 mm)

(Top View)

397 Platen Core Lateral Position (49-07)

Core Centered

Locknuts

Minimum End Play
No Binds

(Level 1)

(49-109)

Core Centered

Setscrews

Minimum End Play
No Binds

(Level 2)

398 Pinwheel (49-08)

Adjust So Pins Are Fully Extended After Passing Through Slot

399 Pinwheel Paper Guide (49-105)

Pins Centered In Guide

.001"-.030"
(0.03-0.76 mm)

.050"-.060"
(1.27-1.53 mm)

.010" Minimum
(0.25 mm)

Form

(Large Rollers)

(Small Rollers)

400 Cardholder (49-21)

.002"-.005"
(0.05-0.12 mm)

Center On Vertical Marks

401 Cardholder Mounting Bracket (22-164) (22-167)

.005"-.015"
(0.13-0.38 mm)

.035" Maximum
(0.89 mm)

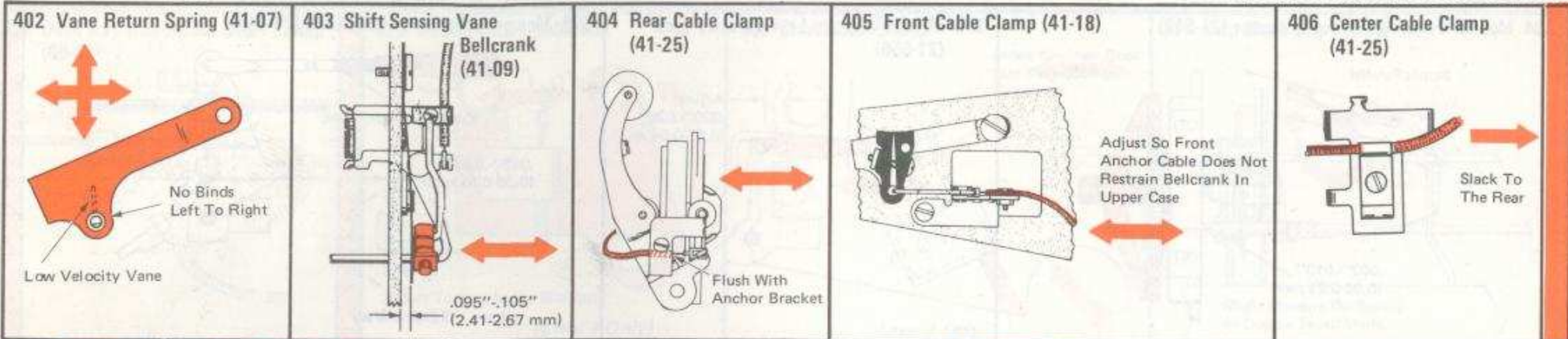

SERVICE CALL PROCEDURE

Preventive Maintenance MUST BE PERFORMED On Each Service Call.

Each Service Call Must Include:

- A. Note operator comments.
- B. Identify and correct operator complaint.
- C. Initial functional check - Look for parts wear, marginal adjustments, and proper lubrication.

With Special Attention To:

1. Character Selection
 2. Keyboard
 3. Carrier And Rocker
 4. Cycle Shaft/Gear Train
 5. Operational Area (Carrier Return, Backspace, Tab, Spacebar, Index)
 6. Shift
- D. Repair, replace parts, and lubricate as necessary.
 - E. *Perform electrical safety check.
 - F. When necessary, remove covers and clean.
 - G. All areas visible to the operator (e.g., rubber parts, cardholder, element/type, and covers) must be clean and in good repair.
 - H. Perform final functional check.
 - I. Work performed should be discussed with the operator and must be recorded on the history card.

*A visual or physical inspection must be made of the primary wiring on the machine during each service call. Defects in any electrical component must be replaced immediately! Do not wait until the next service call. Always exercise care when working on electrical areas of the machine. Be certain that no action on your part makes the product unsafe or exposes the customer to hazards.

LUBRICATION

The "Selectric" Typewriter will not operate dependably and reliably if it is not thoroughly and properly lubricated.

Use IBM No. 10 oil on the following:

- a. Print shaft wipers
- b. Selector cam shaft bearing
- c. Margin rack bearing
- d. Margin stops
- e. Carrier shoe
- f. Rotate detent guide, upper and lower ball sockets, tilt detent pivots
- g. Motor
- h. Selection ball rollers
- i. Index pawl assembly
- j. All links and clevises at both ends
- k. Ribbon feed and reverse plate
- l. Backspace intermediate lever
- m. Differential assemblies
- n. All functional parts and pivots in operational box assembly
- o. Tilt arm pivot and rotate link stud
- p. Rotate arm pivot and rotate link pivot studs
- q. Carbon ribbon drive spring and bearing
- r. Power frame center bearing
- s. Platen bushings
- t. Tilt latch mounting stud and bellcrank
- u. All other rotating or pivoting members at the bearing area which are not excepted in the following lists:

Use IBM No. 23 grease on the following:

- a. Operational ratchets
- b. Keylever return springs
- c. Interposer latch springs
- d. Ribbon lift control lever
- e. Linelock bracket
- f. Filter shaft flutes
- g. Operational keylever pawl guide studs
- h. Tape guide
- i. All cams on print sleeve
- j. Ball joint
- k. Cycle clutch and shift clutch springs
- l. Feed roll bearing
- m. Cycle clutch restoring cam
- n. Low velocity latch contacts
- o. All sliding parts not excepted
- p. All selective ribbon takeup gears
- q. Selective ribbon lift guide sliding members
- r. Correcting tape feed bellcrank latching surface
- s. Torque limiter spring
- *t. Element (or silicone grease)

DO NOT LUBRICATE:

- a. Shift brake (braking surface)
- b. Gear train
- c. Carrier return and tab pinions

FUNCTIONAL CHECK**MISCELLANEOUS**

1. Visual Inspection
2. ON/OFF Switch, Keyboard Lock
3. Margin Set
4. Margin Release
5. Linelock And Bell
6. Scales And Carrier Indicator
7. Switch Pitch Lever (Dual Pitch)
8. Index
9. Shift Lock
10. Margin Lights

PAPER HANDLING

1. Paper Insertion
2. Paper Release
3. Multiple Copy Control
4. Detent Release
5. Platen Variable

CARRIER MOVEMENT (Check all items in both pitches on dual-pitch machines.)

1. Spacebar And Escapement
2. Half Backspace
3. Backspace
4. Carrier Return
5. Express Backspace
6. Tab

RIBBON OPERATION

1. Ribbon Feed
2. Ribbon Lift Pattern
3. Ribbon Path And Tracking
4. Stencil Position
5. Ribbon Reverse (Fabric Ribbon)

PRINT

1. Strike Up — Check For:
 - a. Impression
 - b. Selection
 - c. Alignment
 - d. Keyboard Touch
 - e. Shift
2. Repeat Character
3. Impression Control

CORRECTING MECHANISM

1. Type several characters.
2. Depress correcting key.
 - a. Carrier should backspace once.
3. Restrike last character.
 - a. Character removed (lift-off tape) or character covered (cover-up tape)
 - b. No escapement
4. Type new character.
 - a. Same position as original character.
 - b. Normal escapement and print should resume.
5. Repeat steps 1 through 4.
 - a. No overlap of characters on correcting tape.

ELECTRICAL SAFETY CHECK

For both Per Call and Service Agreement machines, a visual or physical inspection must be made of the primary wiring on the machine during each service call.

VISUAL CHECK FOR ELECTRICAL HAZARDS

1. Linecords that have become damaged must be replaced.
2. Wires that are cut, rubbing on mechanical parts, or loose in the machine, must be replaced or relocated. Use cable tie or something similar to hold loose wires.
3. Whenever a switch cover, wire retainer, or safety shield has been removed for servicing, it must be reinstalled when service is completed.
4. Wire connections should only be replaced with wire nuts for crimp-on connectors. Neither tape nor insulating splice should be used.
5. Inspect all linecords that pass through holes in metal desks for cuts or markings. When necessary, grommets or tape should be placed over these edges that come in contact with the linecord.
6. Check to ensure:
 - a. that all double-insulation components are installed
 - b. that insulating paper isolates capacitors from a machine frame on two-wire products
 - c. that no parts, such as paper clips, staples, etc., have become jammed between electrical components and the machine frame, grounding that component to the machine frame. Check the particular product CEMs for a description of the required components.
7. Modifications made by customers to their machines, which expose Customer Engineers to electrical hazards, must be reported to your management.

CAUTION: Unplug the machine before working on electrical area.

A quick visual check of the electrical components in equipment during each service call will reduce the possibility of exposing a customer or CE to electrical shock. **Defects in any electrical component must be replaced immediately!** Do not wait until the next service call. Always exercise care when working on electrical areas of the machine. Be certain that no action on your part makes the product unsafe or exposes hazards to the customer.

BROKEN TAPES CHECK**Rotate Tape**

1. Rotate detent clearance (skirt)
2. Print shaft timing
3. Shift interlock adjustments
4. Defective rotate arm and shift arm pulleys
5. Tape guide
6. Negative latch clearance insufficient
7. Latch links: too long/too short
8. Popping latches
9. Latch angle
10. Broken or sticking rotate spring
11. Binding on non-greased type element
12. Shift arm pulley
13. Chips or defects in rotate pulleys
14. Rotate pulley key
15. Loose screw in differential bracket

Tilt Tape

1. Detent to tilt ring clearance
2. Burrs on tilt pulleys
3. Binds in tilt ring
4. Sector gear
5. Print shaft timing
6. Tilt pulley spring (off or broken)
7. Loose detent follower
8. Tilt tape/carrier shoe eccentric stud

STANDARD U.S. TYPE ELEMENTS 7XX 8XX

| Tilt Latches Used | Rotate | | | | | | | | | | Type Element Positions | |
|-------------------|--------|-----------|-----------|------------------|-------------------|------------------|-----|-----|------------|-------------|------------------------|---------------------------|
| | R-5 | R-4 | R-3 | R-2 | R-1 | H O M E | R+1 | R+2 | R+3 | R+4 | | R+5 |
| T-0 | | # | & | * | \$ | Z | @ | % | ¢ | | | Tilt T-0 |
| T-1 | X | U | D | C | L | T | N | E | K | H | B | T-1 |
| T-2 | M | V | R | A | O | . | "/ | ! | S | W | | T-2 |
| T-1, T-2 | G | F | : | ? | J | + | P | Q | Y | - | | T-3 |
| | -5 | -5 R-1 | -5 R-2 | -5 R-1 R-2 | -5 R-2 R-2A | H O M E | R-1 | R-2 | R-1 R-2 | R-2 R-2A | R-1 R-2A | Rotate Latches Used |

STANDARD U.S. 96 TYPE ELEMENTS

| Tilt Latches Used | Rotate | | | | | | | | | | Type Element Positions | | |
|-------------------|--------|-----------|-----------|------------------|-------------------|------------------|------------------|-----|------------|-------------|------------------------|---------------------------|-------------|
| | R-6 | R-5 | R-4 | R-3 | R-2 | R-1 | H O M E | R+1 | R+2 | R+3 | | R+4 | R+5 |
| T-0 | 7 | = | 3 | 9 | 8 | 4 | 6 | 0 | 2 | 5 | 7 | Z | Tilt T-0 |
| T-1 | + | S | U | K | B | C | E | T | S | ! | . | . | T-1 |
| T-2 | . | 1/2 | H | X | A | N | R | O | D | W | M | V | T-2 |
| T-1, T-2 | . | | G | L | F | Y | P | Q | J | ! | - | | T-3 |
| | -6 | -6 R-1 | -6 R-2 | -6 R-1 R-2 | -6 R-2 R-2A | H O M E | R-1 | R-2 | R-1 R-2 | R-2 R-2A | R-1 R-2A | Rotate Latches Used | |

FILL IN FOR OTHER TYPE ELEMENTS 7XX 8XX

| Tilt Latches Used | Rotate | | | | | | | | | | Type Element Positions | |
|-------------------|--------|-----------|-----------|------------------|-------------------|------------------|-----|-----|------------|-------------|------------------------|---------------------------|
| | R-5 | R-4 | R-3 | R-2 | R-1 | H O M E | R+1 | R+2 | R+3 | R+4 | | R+5 |
| T-0 | / | / | / | / | / | / | / | / | / | / | / | Tilt T-0 |
| T-1 | / | / | / | / | / | / | / | / | / | / | / | T-1 |
| T-2 | / | / | / | / | / | / | / | / | / | / | / | T-2 |
| T-1, T-2 | / | / | / | / | / | / | / | / | / | / | / | T-3 |
| | -5 | -5 R-1 | -5 R-2 | -5 R-1 R-2 | -5 R-2 R-2A | H O M E | R-1 | R-2 | R-1 R-2 | R-2 R-2A | R-1 R-2A | Rotate Latches Used |

FILL IN FOR OTHER TYPE ELEMENTS

| Tilt Latches Used | Rotate | | | | | | | | | | Type Element Positions | | |
|-------------------|--------|-----------|-----------|------------------|-------------------|------------------|------------------|-----|------------|-------------|------------------------|---------------------------|-------------|
| | R-6 | R-5 | R-4 | R-3 | R-2 | R-1 | H O M E | R+1 | R+2 | R+3 | | R+4 | R+5 |
| T-0 | / | / | / | / | / | / | / | / | / | / | / | / | Tilt T-0 |
| T-1 | / | / | / | / | / | / | / | / | / | / | / | / | T-1 |
| T-2 | / | / | / | / | / | / | / | / | / | / | / | / | T-2 |
| T-1, T-2 | / | / | / | / | / | / | / | / | / | / | / | / | T-3 |
| | -6 | -6 R-1 | -6 R-2 | -6 R-1 R-2 | -6 R-2 R-2A | H O M E | R-1 | R-2 | R-1 R-2 | R-2 R-2A | R-1 R-2A | Rotate Latches Used | |

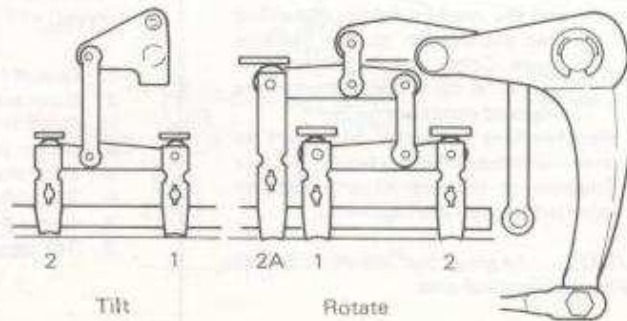

APPLICATIONS RECOMMENDATIONS FOR IBM RIBBONS

TYPING APPLICATIONS

| | IBM General Purpose Fabric Ribbons | Film Carbon Ribbons (All) | OCR Film Carbon Ribbon | "Special" Film Carbon Ribbon (5122) | IBM Tech III Ribbon | IBM Correctable Film Ribbon |
|--|------------------------------------|---------------------------|------------------------|-------------------------------------|---------------------|-----------------------------|
| Correspondence | | x | | | x | x |
| Statistical Correspondence | | x | x | | x | x |
| Specification Writing | | x | x | | x | x |
| Medical Reports | | x | x | | x | x |
| Executive Correspondence | | | x | | x | x |
| Routine Correspondence | | x | x | | x | x |
| Typing on Hard-to-Image Originals Ex.: Engineering Drawings | | x | | x | x | x |
| Optical Character Recognition | | x | x | | x | |
| Manifolding | | | | | | x |
| ** Speech Writing | | x | x | | x | |
| Negotiable Instruments (checks, stocks, etc.) | | x | x | | x | x |
| * Erasable Bond Papers | | x | | x | x | x |

REPRODUCTION APPLICATIONS

| | IBM General Purpose Fabric Ribbons | Film Carbon Ribbons (All) | OCR Film Carbon Ribbon | "Special" Film Carbon Ribbon (5122) | IBM Tech III Ribbon | IBM Correctable Film Ribbon |
|--|------------------------------------|---------------------------|------------------------|-------------------------------------|---------------------|-----------------------------|
| Heat Transfer Copying | | x | x | x | x | x |
| Transfer Electrostatic Reproduction | | x | x | x | x | x |
| Direct Electrostatic Reproduction | | x | x | x | x | x |
| Offset Masters (Direct to Plate) | | x | x | | x | x |
| Offset Masters (Copier Process) | | x | x | x | x | x |
| Offset Masters (Photo Process) | | x | x | | x | x |
| Stencil Writing (Mimeograph) | | | | | | x |
| Diazo Process (Ozalid or Bruning) | | | | | | |
| Spirit Duplication (Hechtographic or Ditto) | | | | | | |

* The receptivity of the surface of these materials vary widely and care must be used in the selection of a specific material, typestyle and ribbon to produce the best result. When in doubt, let the customer try it first.

** Best results with Orator element are obtained by using IBM Tech III Ribbon.

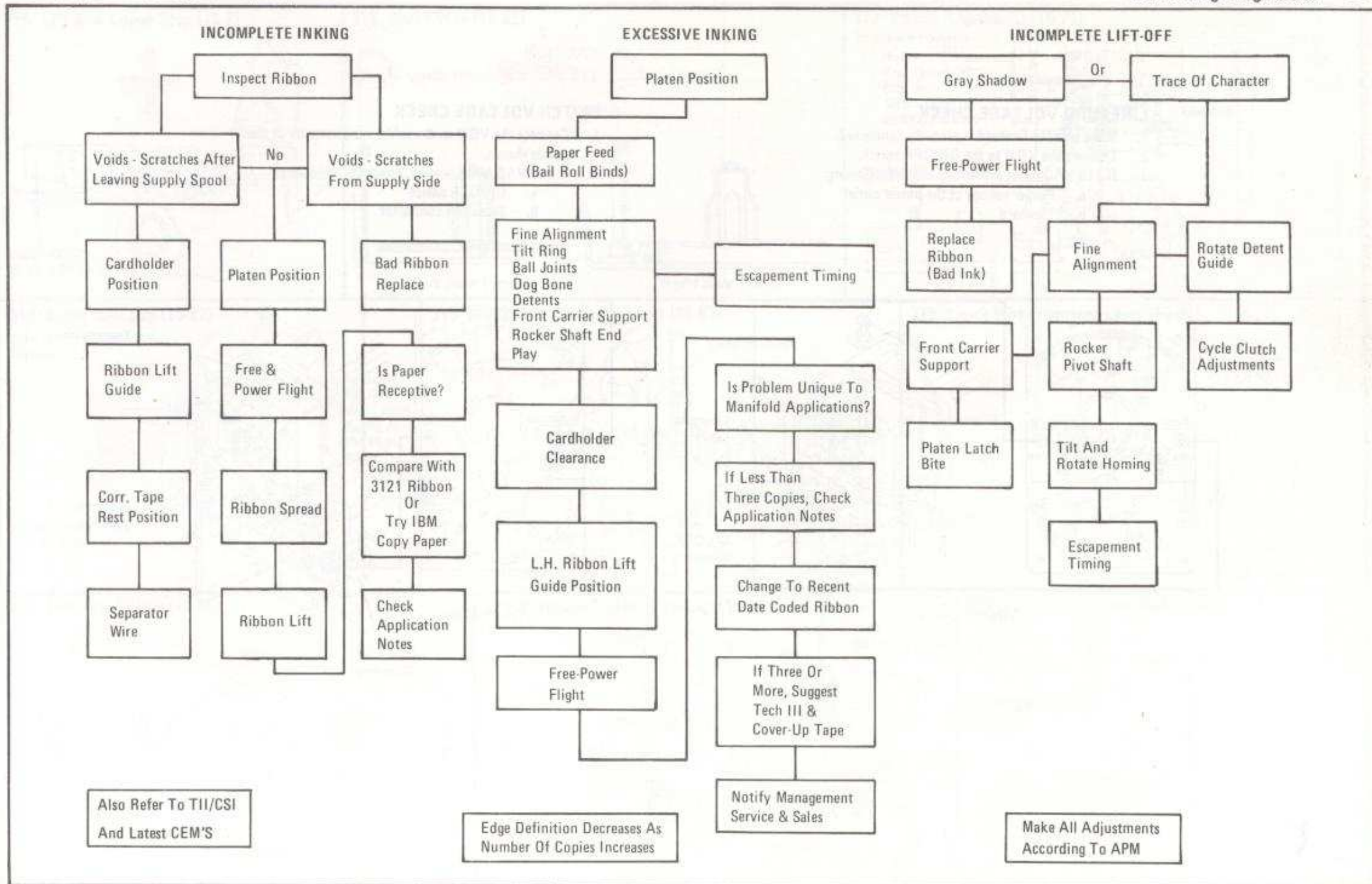

CAUTION
115 VAC may be present.

LINECORD VOLTAGE CHECK

1. Make sure the linecord is properly connected.
2. Connect the VOM to the ON/OFF switch.
3. If 115 VAC is not present, check the following:
 - a. Proper voltage at the power outlet
 - b. Linecord

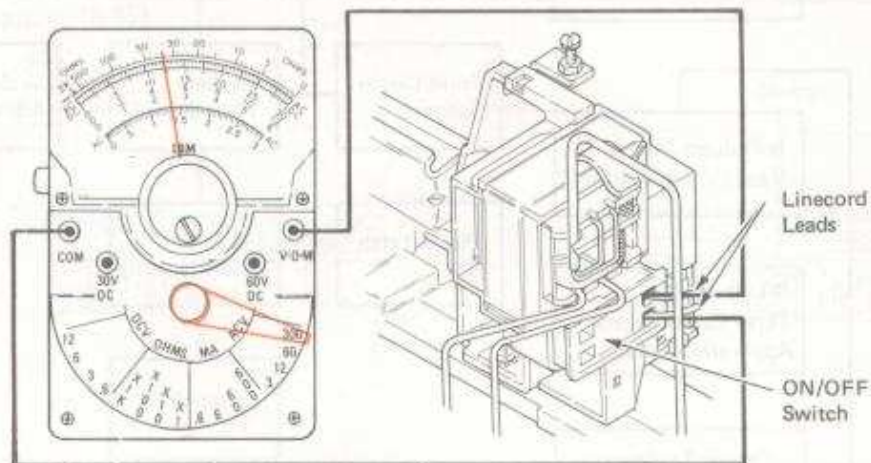

(Rear View)

CAUTION
115 VAC may be present.

SWITCH VOLTAGE CHECK

1. Connect the VOM to the solderless connector at the points shown.
2. If 115 VAC is not present, check the following:
 - a. ON/OFF switch
 - b. Solderless connector

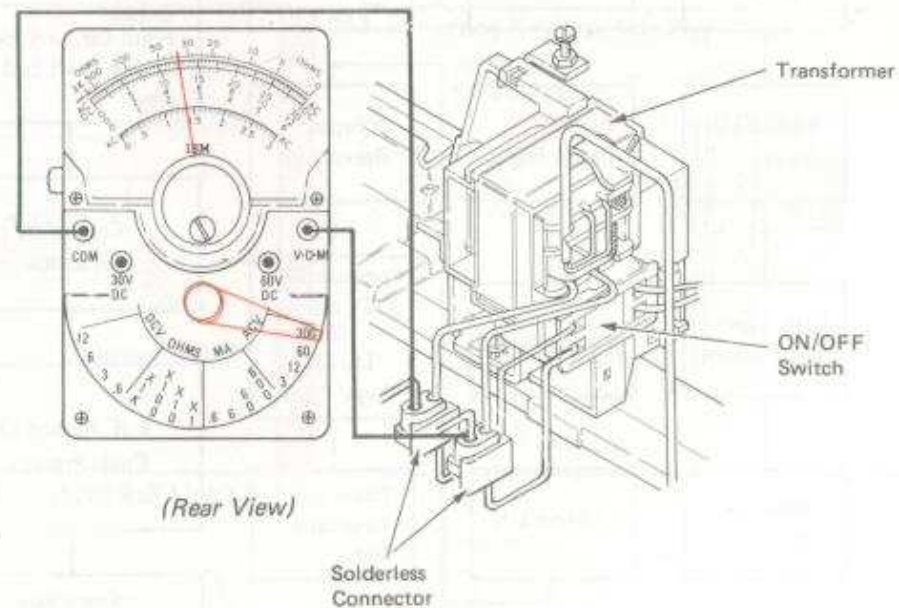

(Rear View)

TRANSFORMER VOLTAGE CHECK

1. Connect a VOM to the anchor point and the O/P of the lamp selector switch.
2. If 2.3 to 3.0 VAC is not present, check the following:
 - a. Solderless connector
 - b. Transformer

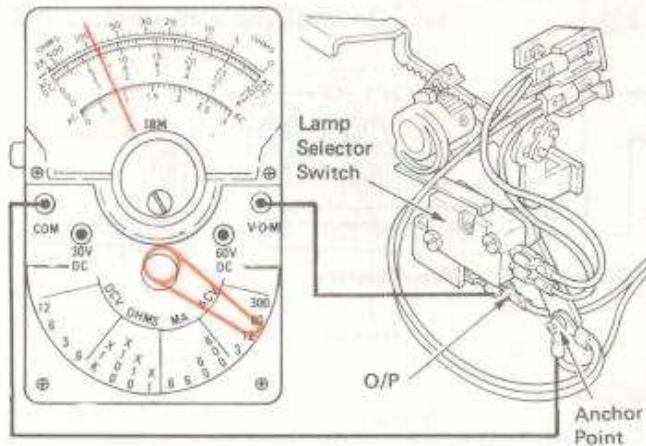

(Left Side View)

12 PITCH VOLTAGE CHECK

1. Connect a VOM to the anchor point and to the N/O connector.
2. If 2.3 to 3.0 VAC is not present, check the following:
 - a. Lamp selector switch
 - b. 12-pitch lamp
 - c. 12-pitch lamp wires

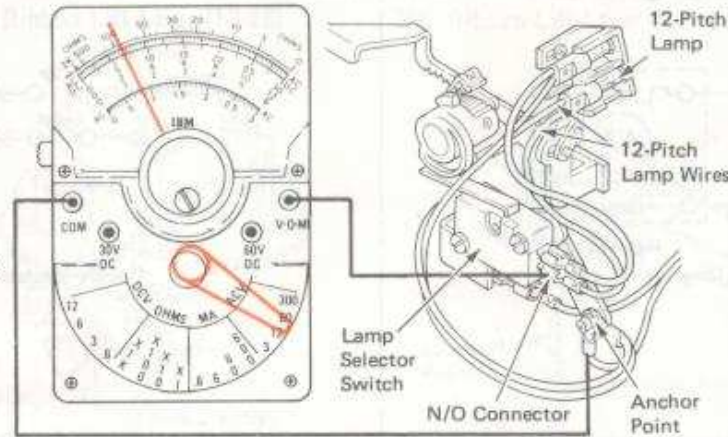

(Left Side View)

10 PITCH VOLTAGE CHECK

1. Connect a VOM to the anchor point and to the N/C connector.
2. If 2.3 to 3.0 VAC is not present, check the following:
 - a. Lamp selector switch
 - b. 10-pitch lamp wires
 - c. 10-pitch lamp

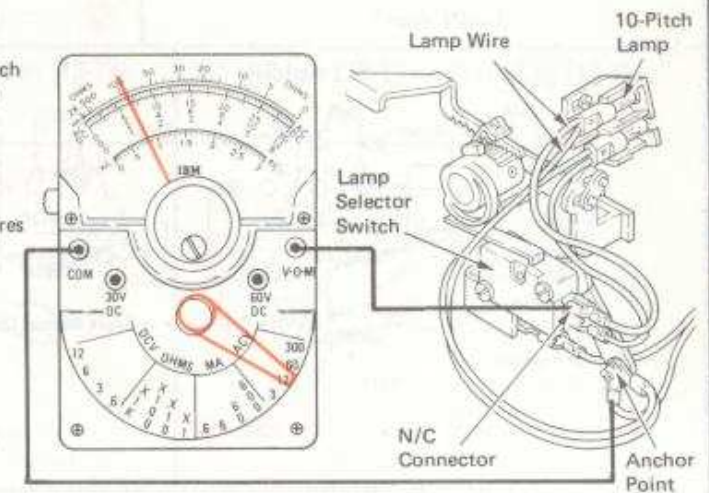

(Left Side View)

MOTOR WIRING DIAGRAMS

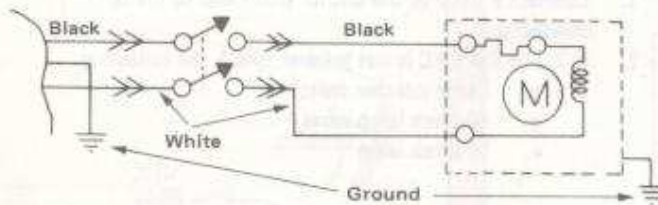

3-Wire Shaded Pole Motor Diagram

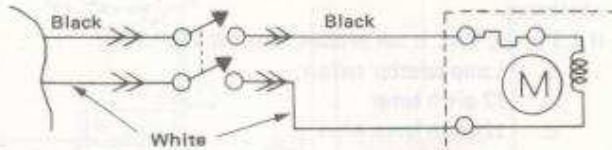

Double-Insulated Shaded Pole Motor Diagram

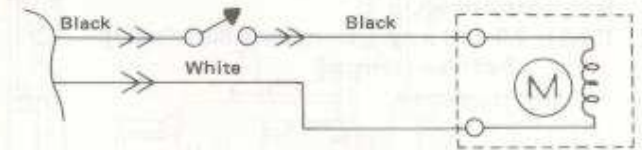

**2-Wire Double-Insulated Shaded Pole Motor Diagram
(Single Pole Switch)**

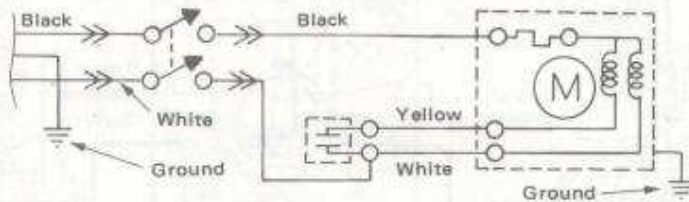

3-Wire Capacitor - Start Motor Diagram

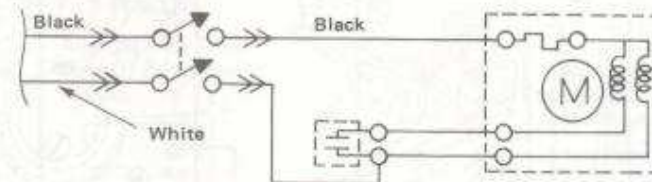

Double-Insulated Capacitor - Start Motor Diagram

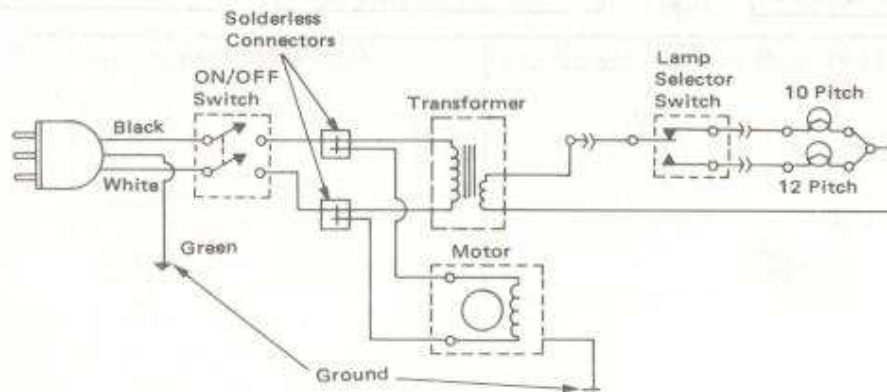

**Dual-Pitch 3-Wire Double Insulated Shaded Pole Motor
"Selectric" III**

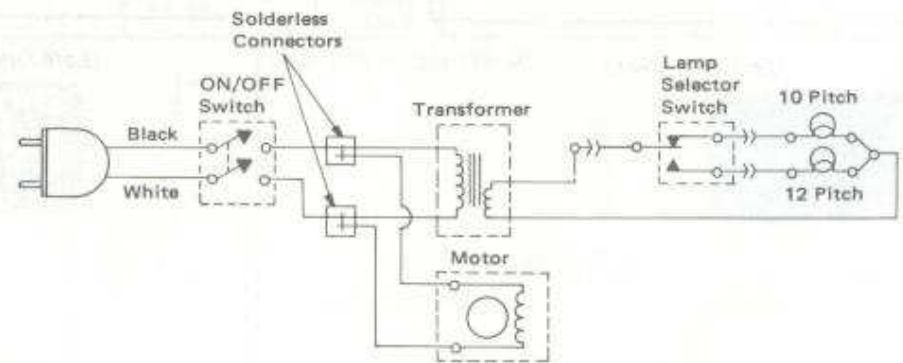

**Dual-Pitch 2-Wire Double Insulated Shaded Pole Motor
"Selectric" III**

BACKSPACE (NR B/S)

MECH. CODE
01

FOR ROTARY BACKSPACE
PARTS SEE MECH 24

LEVEL 3

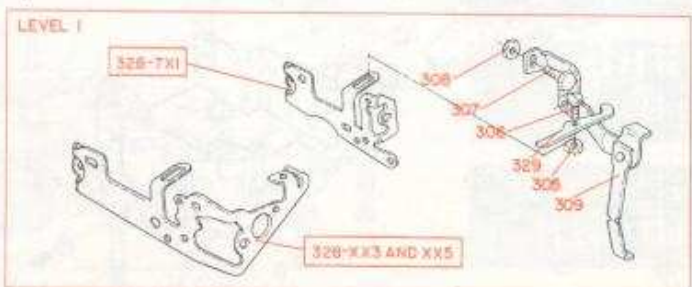
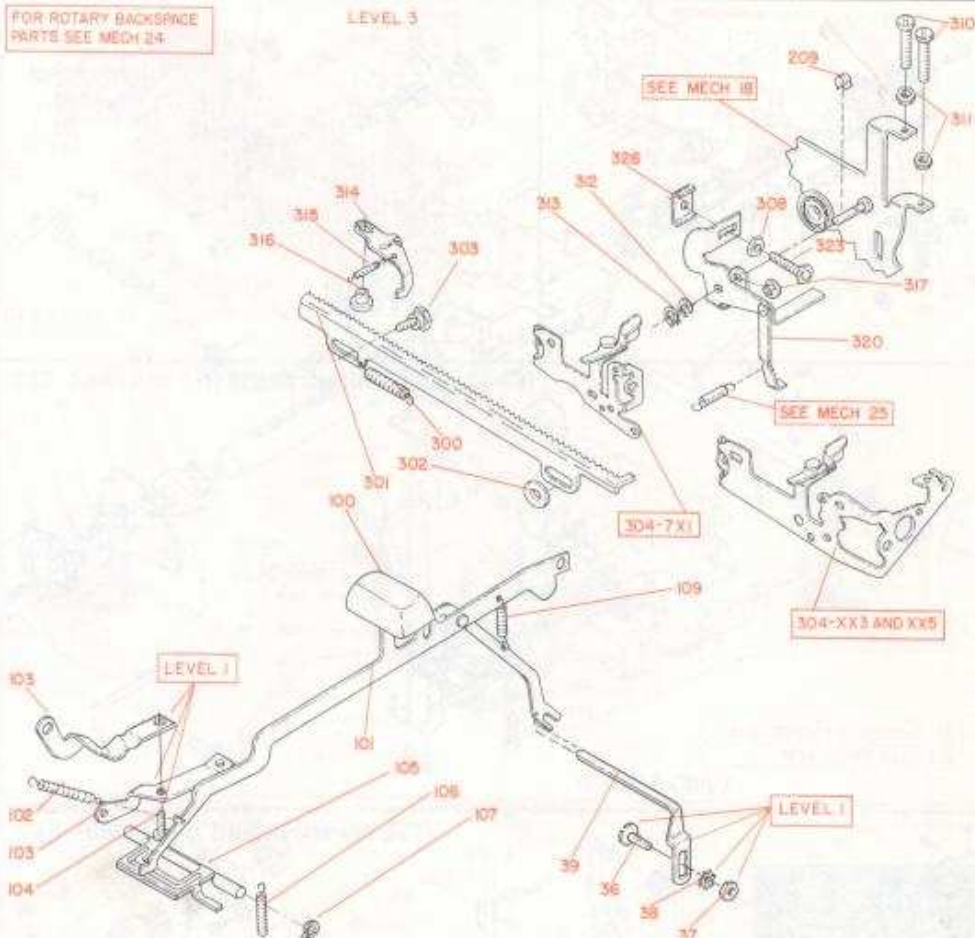

CARRIER

MECH. CODE
02

Predual Impression Machines

This stud, P/N 1124176, is used as a replacement part on all machines not equipped with dual impression which have the original "non-faced" carriers.

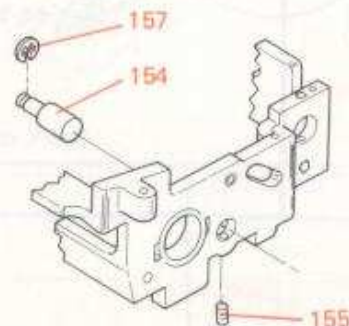

Predual Impression Machines With New Carrier

This stud P/N 1164865 and nut, P/N 6503, must be used with a carrier change on all machines not equipped with dual impression. This is necessary because all field replacement carriers are "faced" and do not have a setscrew hole for mounting the original stud.

| Part No. | Description |
|----------|-----------------|
| 1164865 | Stud, Fol. Mtg. |
| 6503 | Nut |

Early Dual Impression Machines

This stud, P/N 1175054, must be used on the early dual impression machines. The follower, P/N 1141619, must also be replaced to ensure compatibility. This procedure is necessary because the early DI carriers were "non-faced." Note: Use washer, P/N 1164290, to reduce side play.

| Part No. | Description |
|----------|-----------------|
| 1175054 | Stud, Fol. Mtg. |
| Shorter | Shorter |

Current Level Machines

This stud, P/N 1164878 and nut, P/N 6503, can be used on all dual impression carriers that are "faced." It must be used with the new print cam follower, P/N 1141619.

| Part No. | Description |
|----------|-----------------|
| 1164878 | Stud, Fol. Mtg. |
| Shorter | Shorter |

ROCKER (GEARLESS TYPE TILT)

MECH. CODE
02

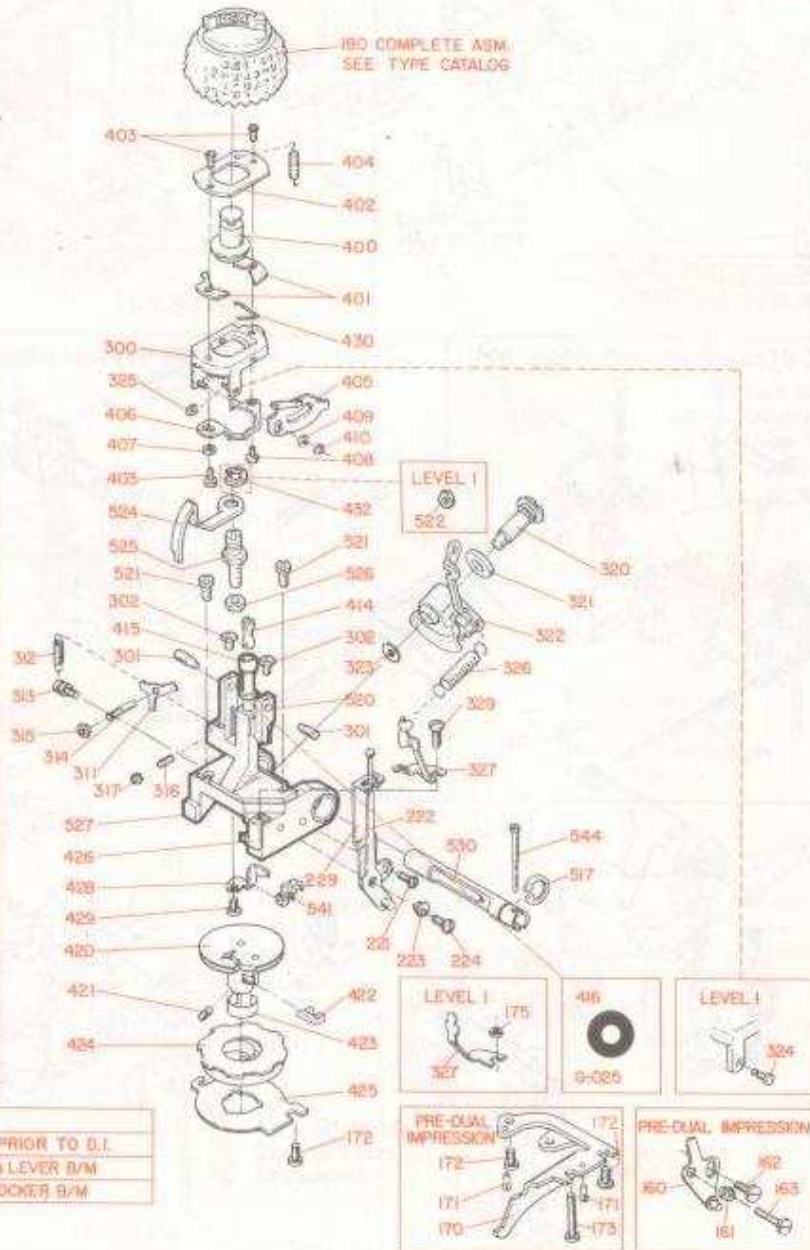

ROCKER (GEAR TYPE TILT)

MECH. CODE
02

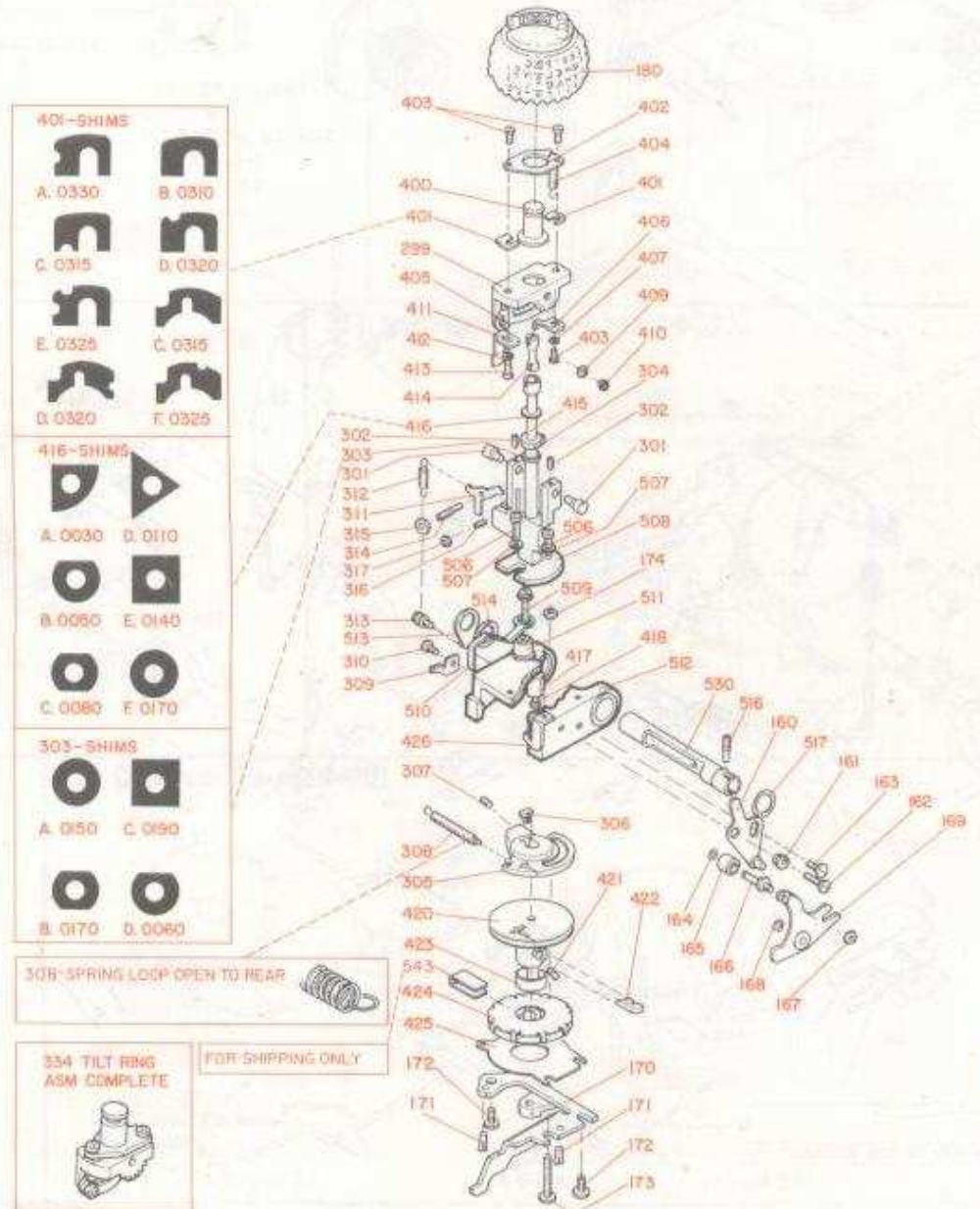

MECH. CODE

03

CARRIER RETURN
(R B/S)

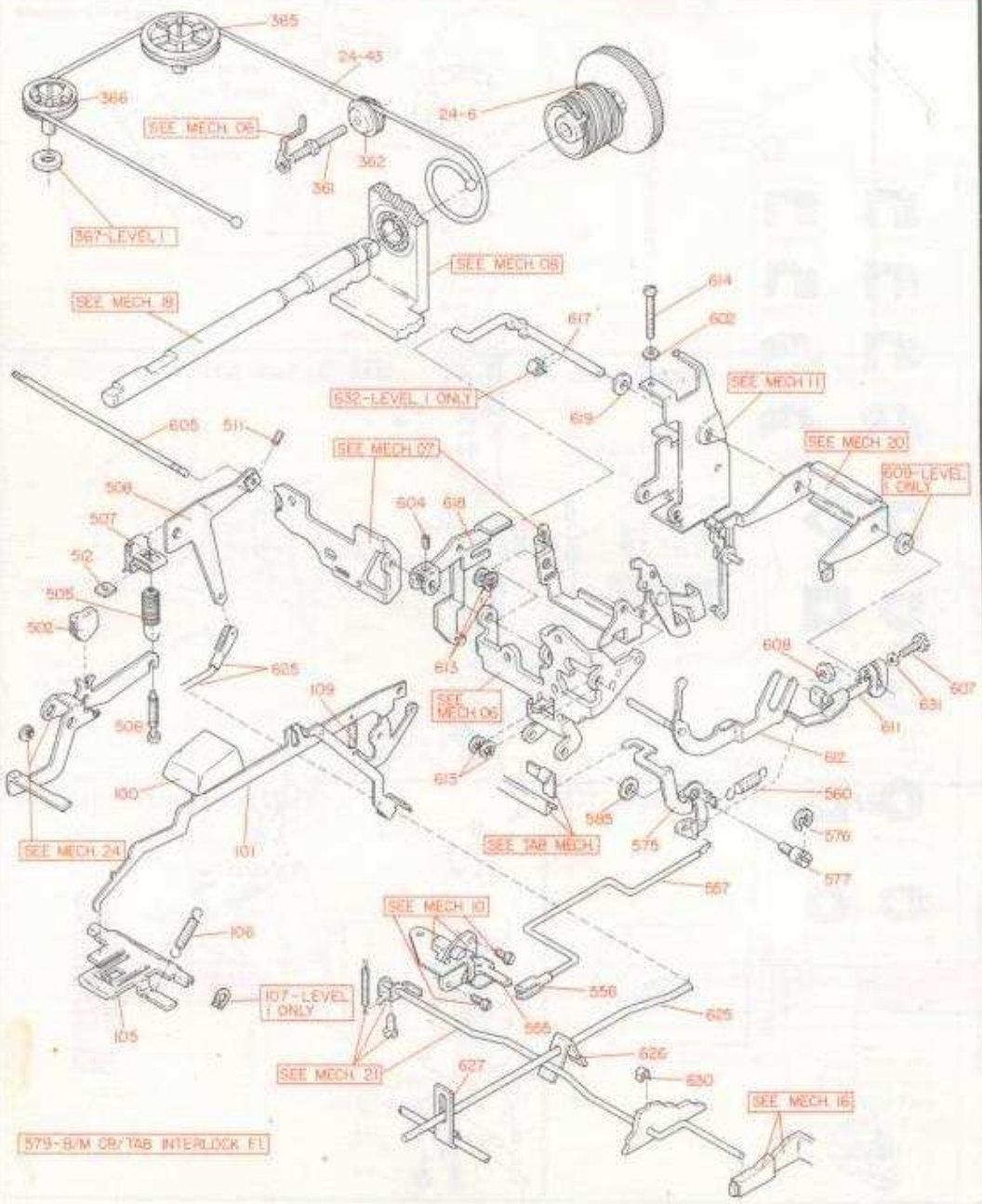

MECH. CODE

03

CARRIER RETURN
(NR B/S)

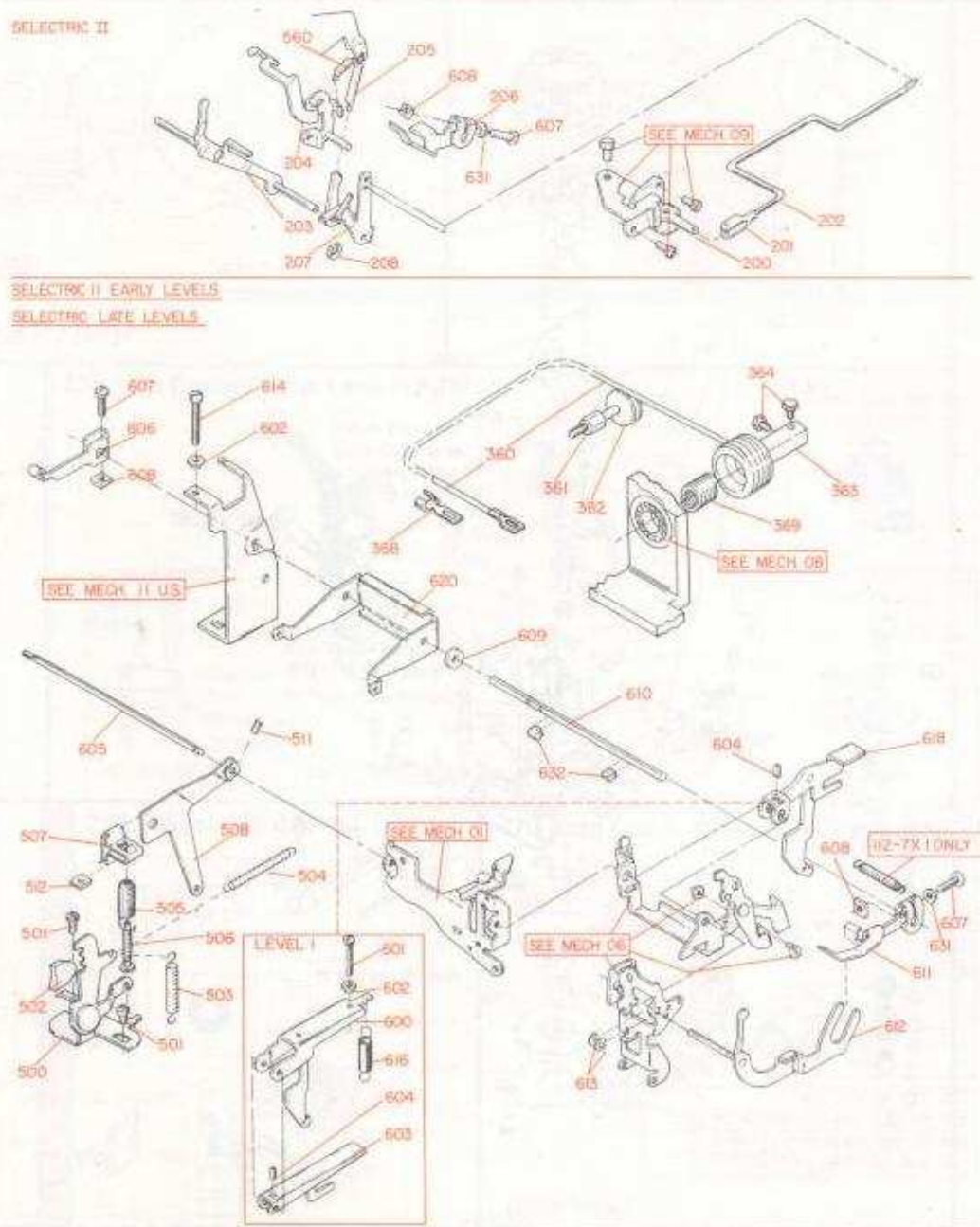

CARRIER RETURN (NR B/S)

MECH. CODE
03

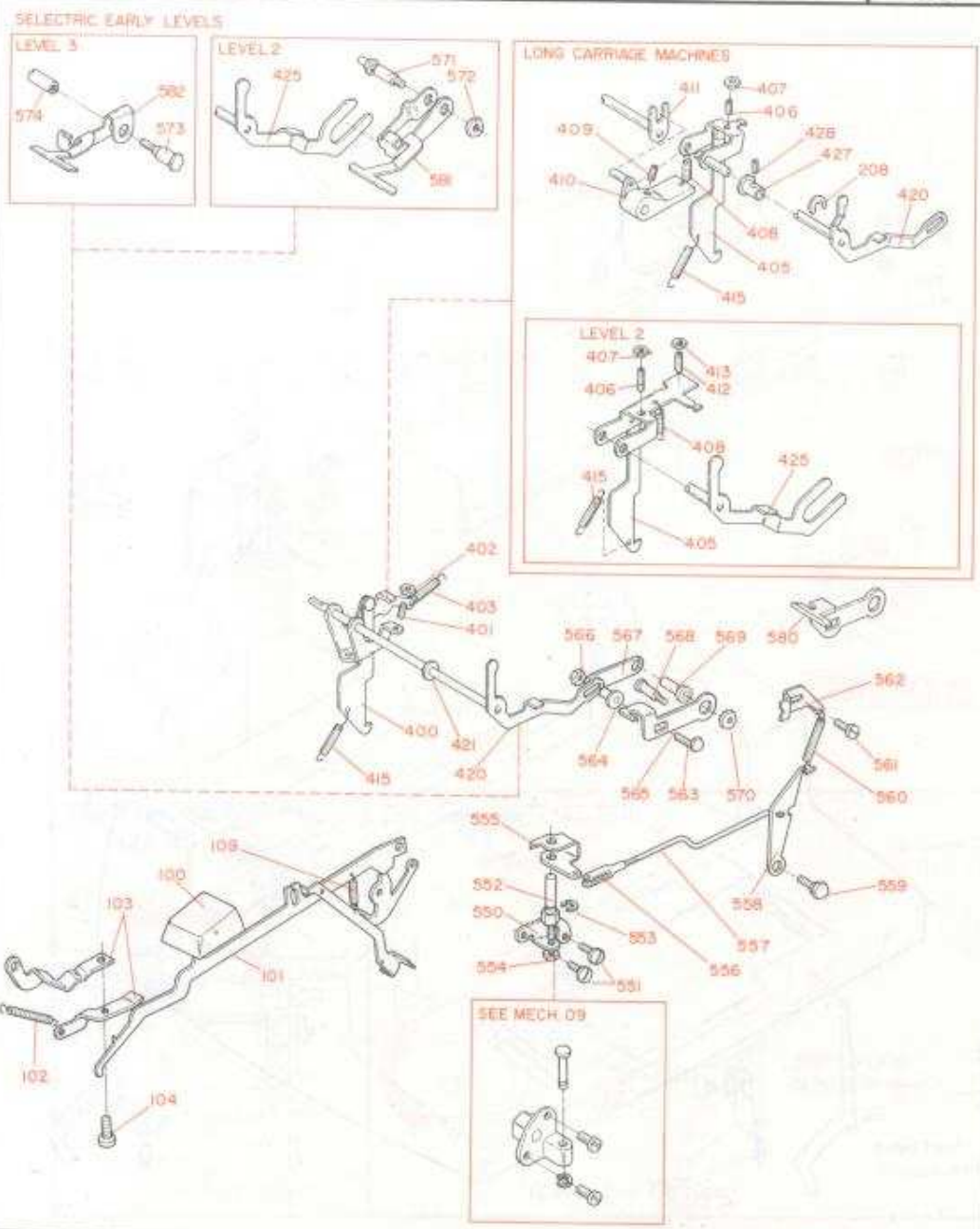

COVERS & MOUNTING (7XX)

MECH. CODE
04

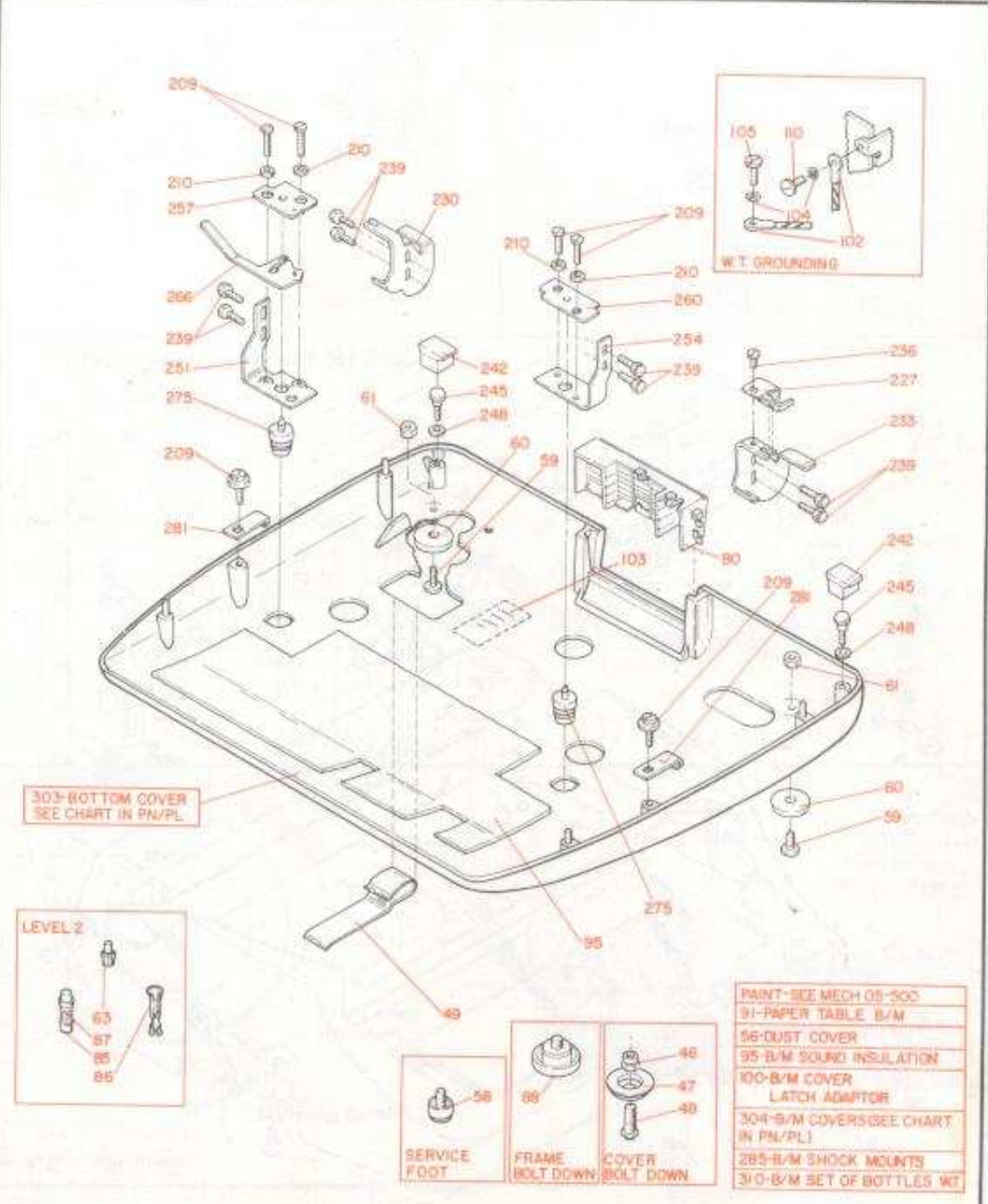

MECH. CODE
04

COVERS & MOUNTING (7XX)

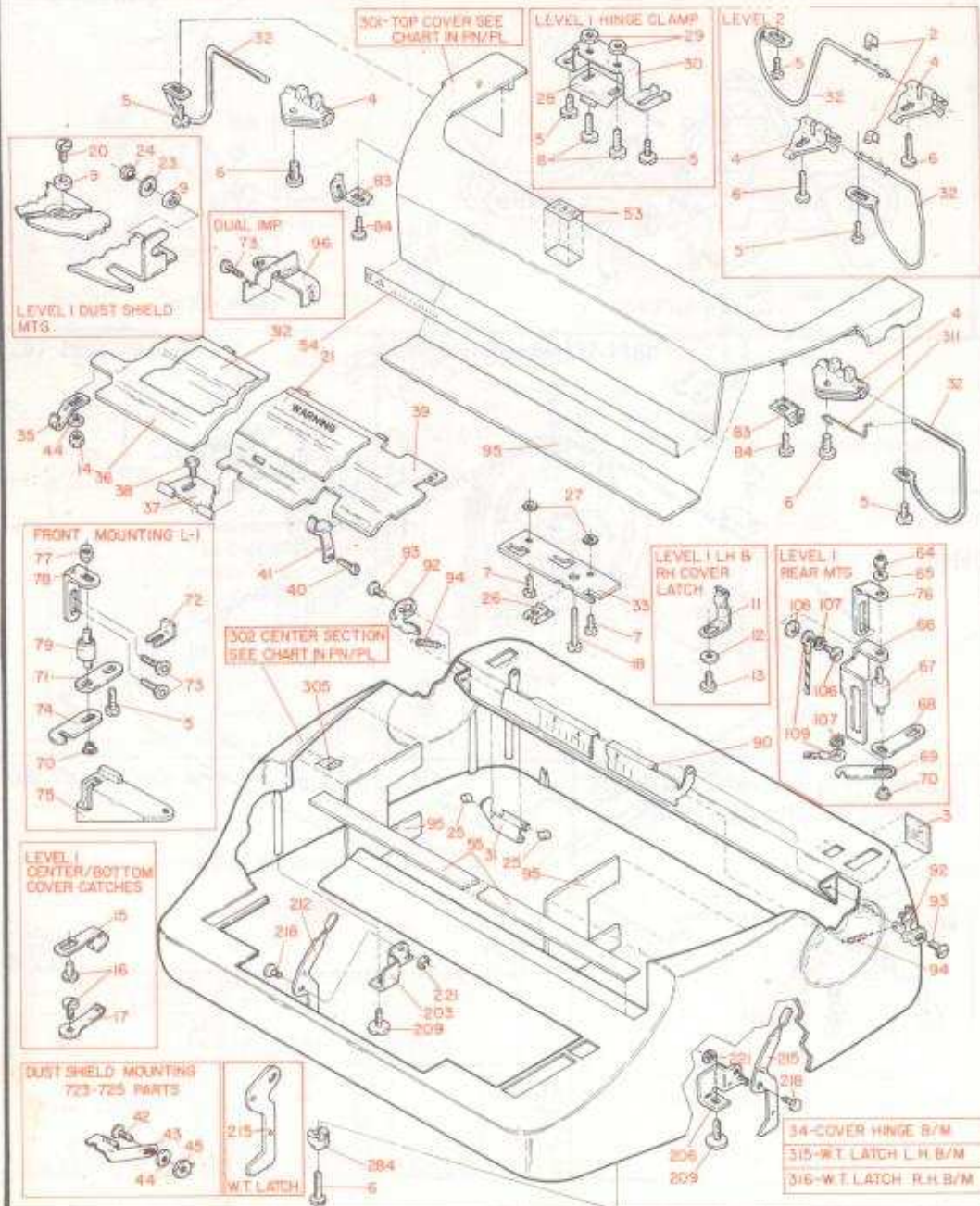

MECH. CODE
05

COVERS & MOUNTING (8XX) (9XX)

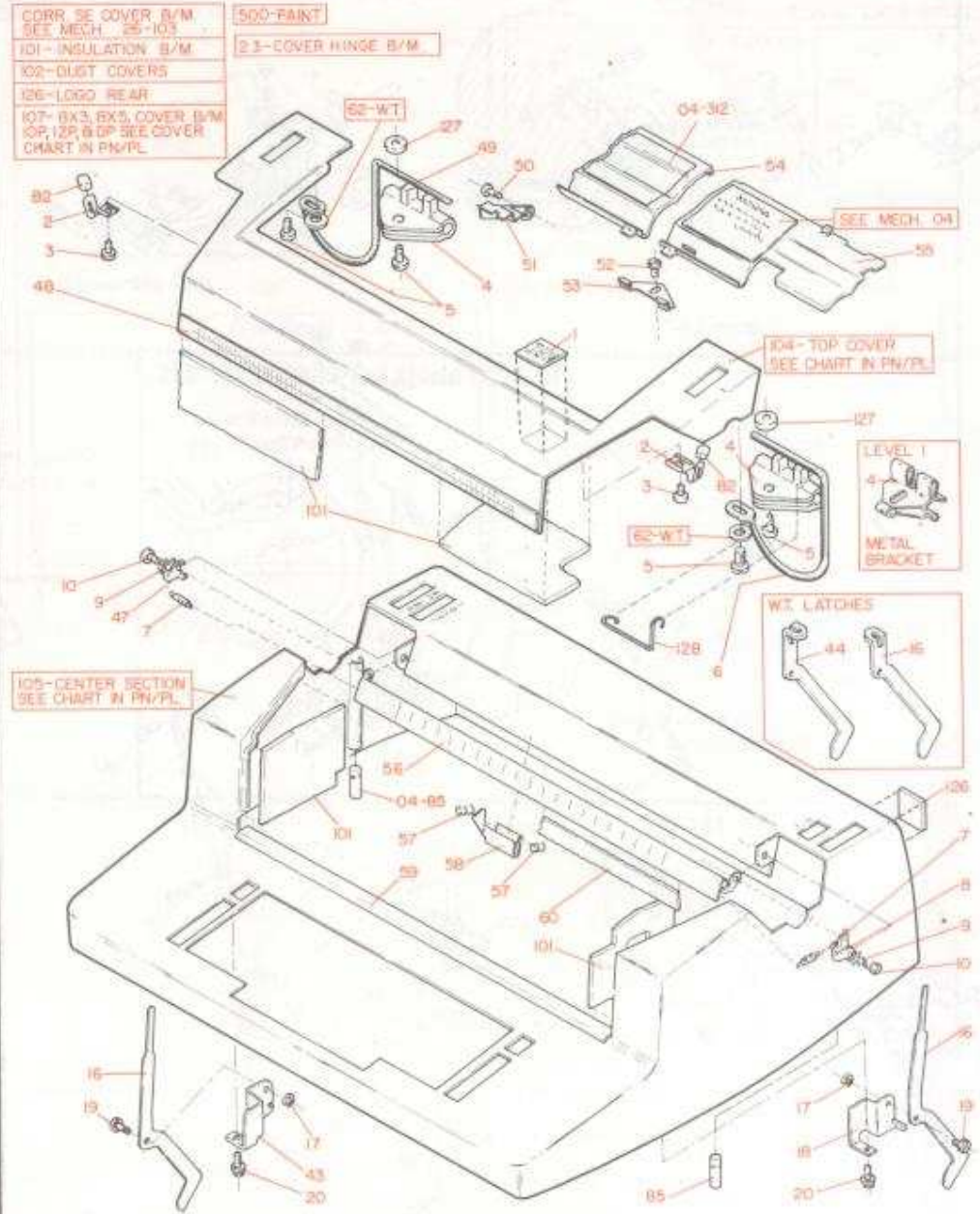

COVERS & MOUNTING (8XX) (9XX) (670X)

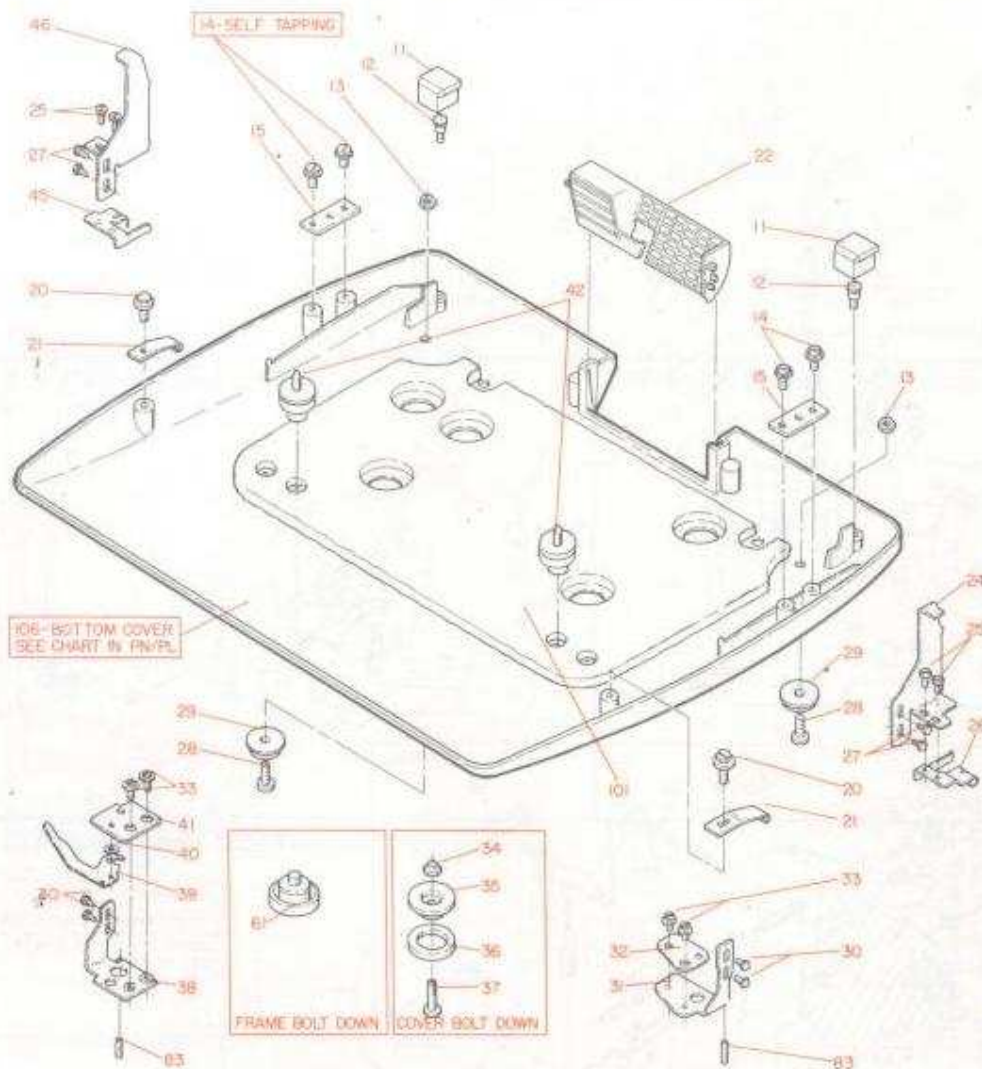
MECH. CODE
05

COVER (670X)

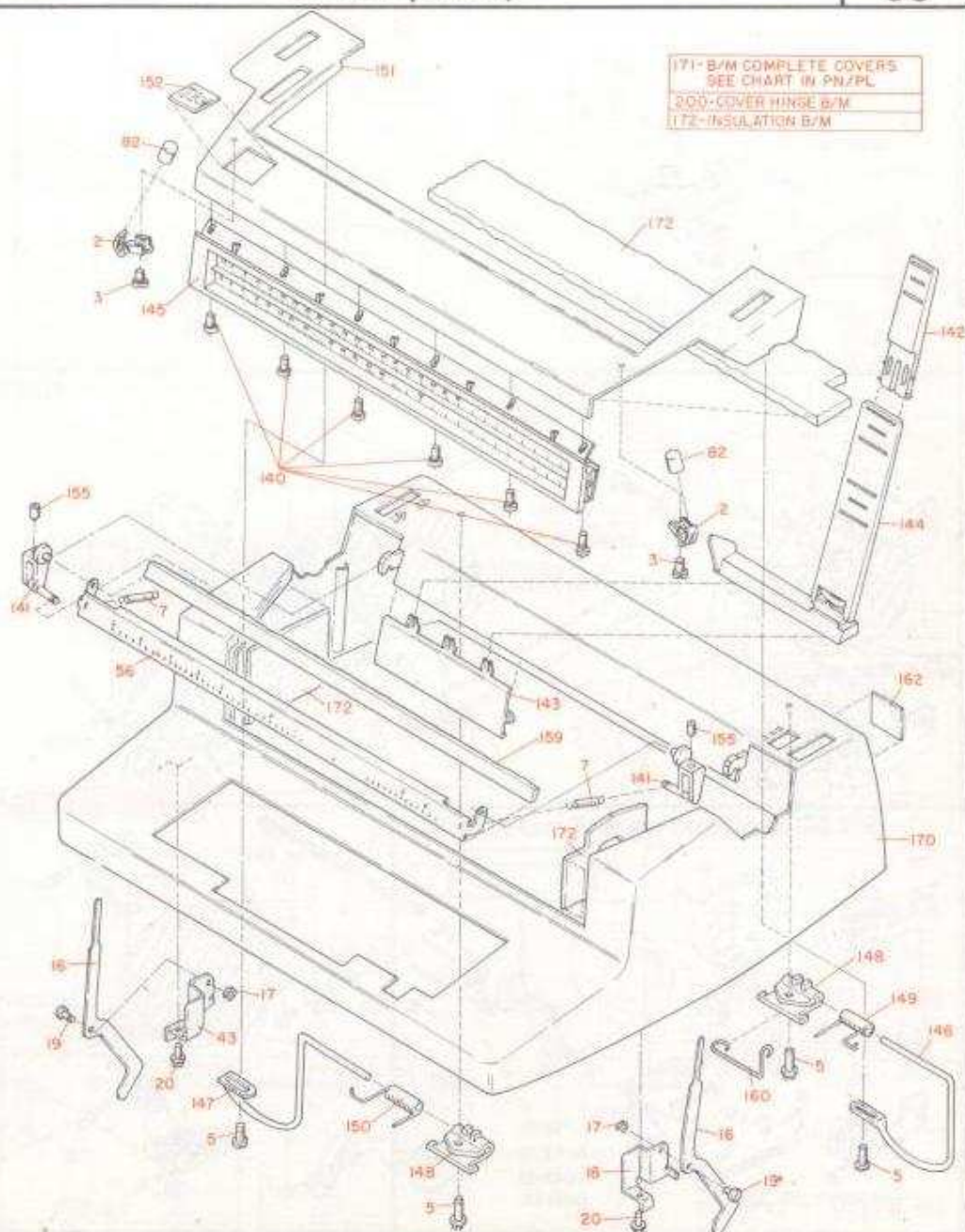
MECH. CODE
05

MECH. CODE
06

ESCAPEMENT (NRB/S)

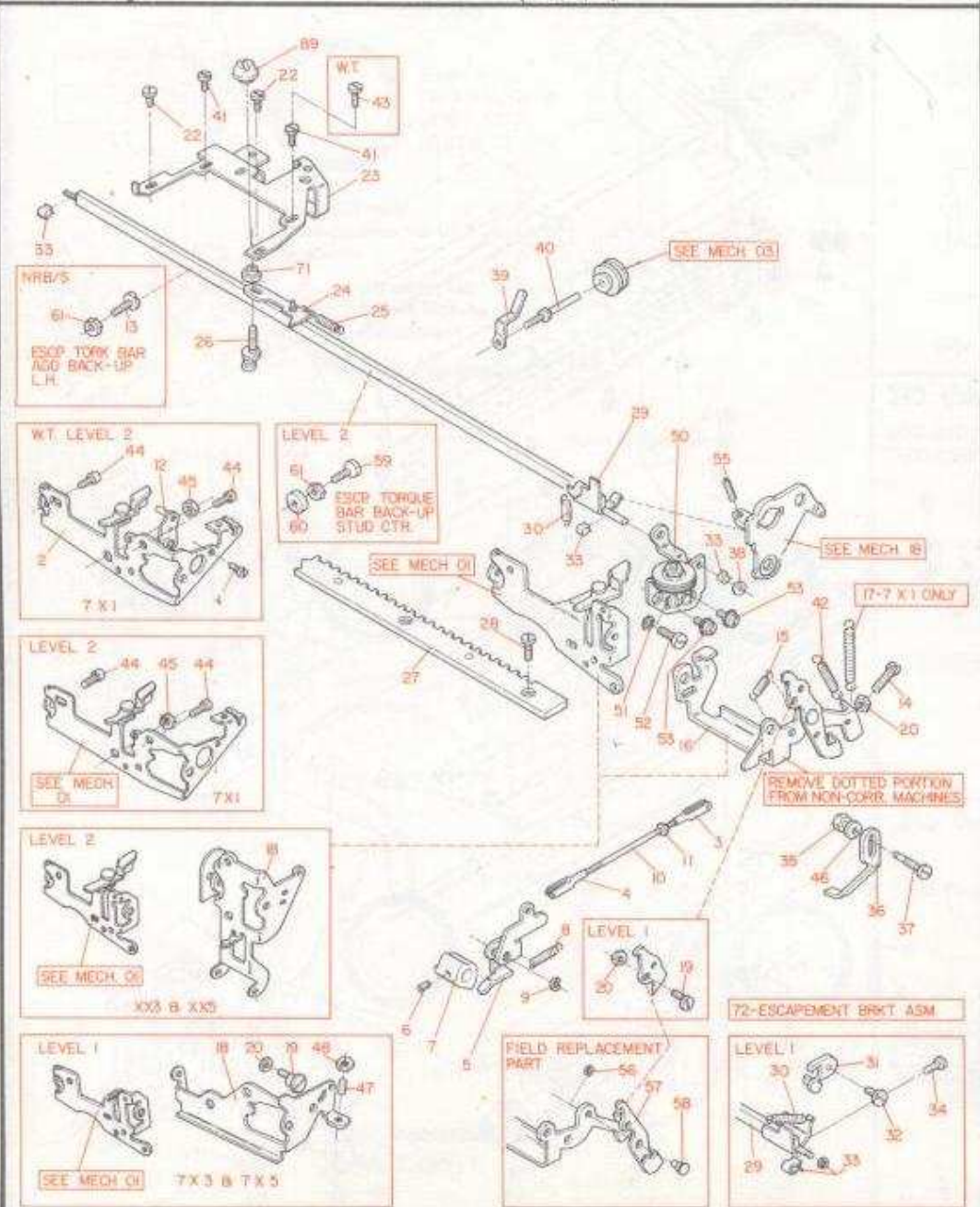

MECH. CODE
07

ESCAPEMENT HALF/BACKSPACE (RB/S)

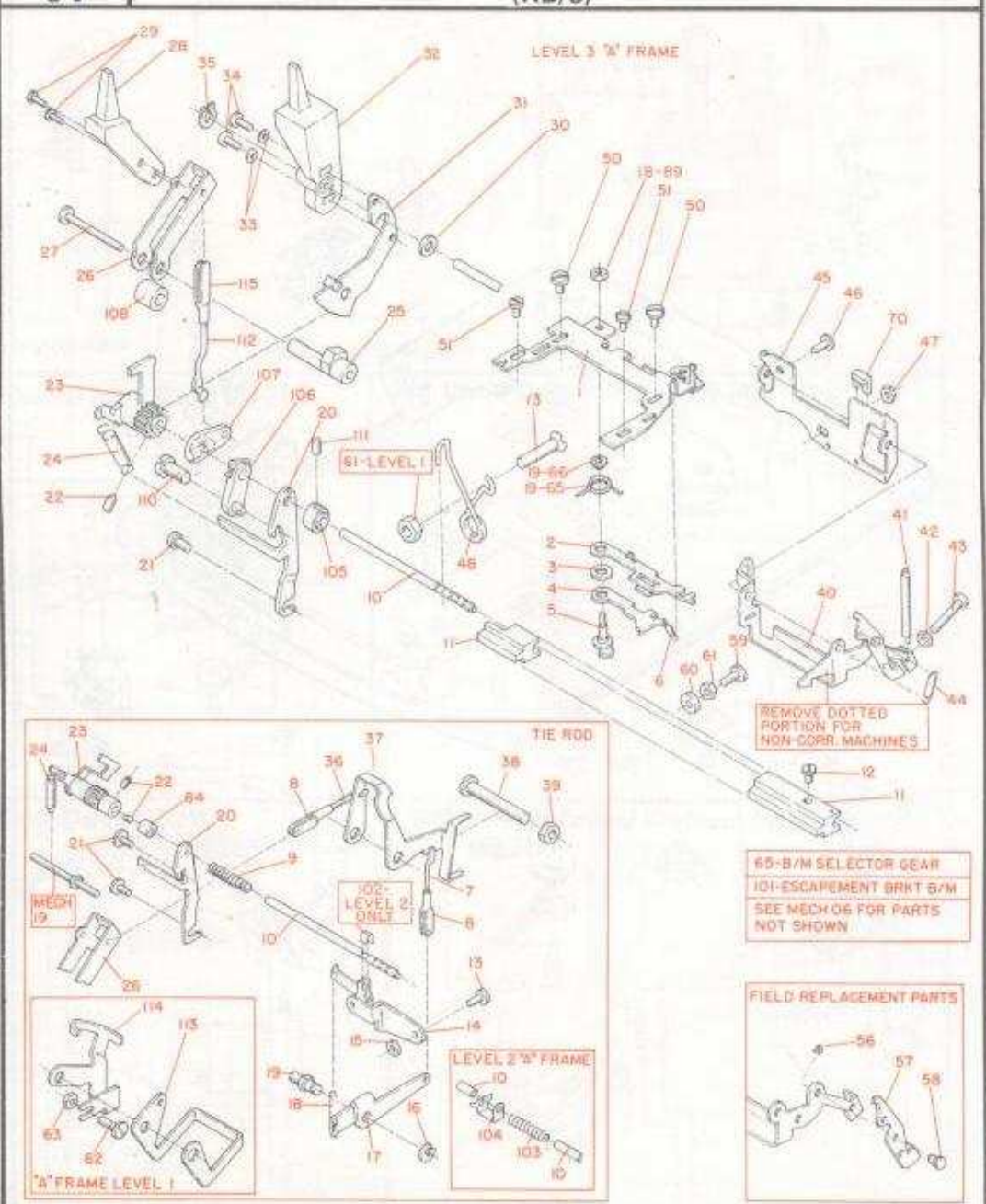

FRAMES

MECH. CODE
08

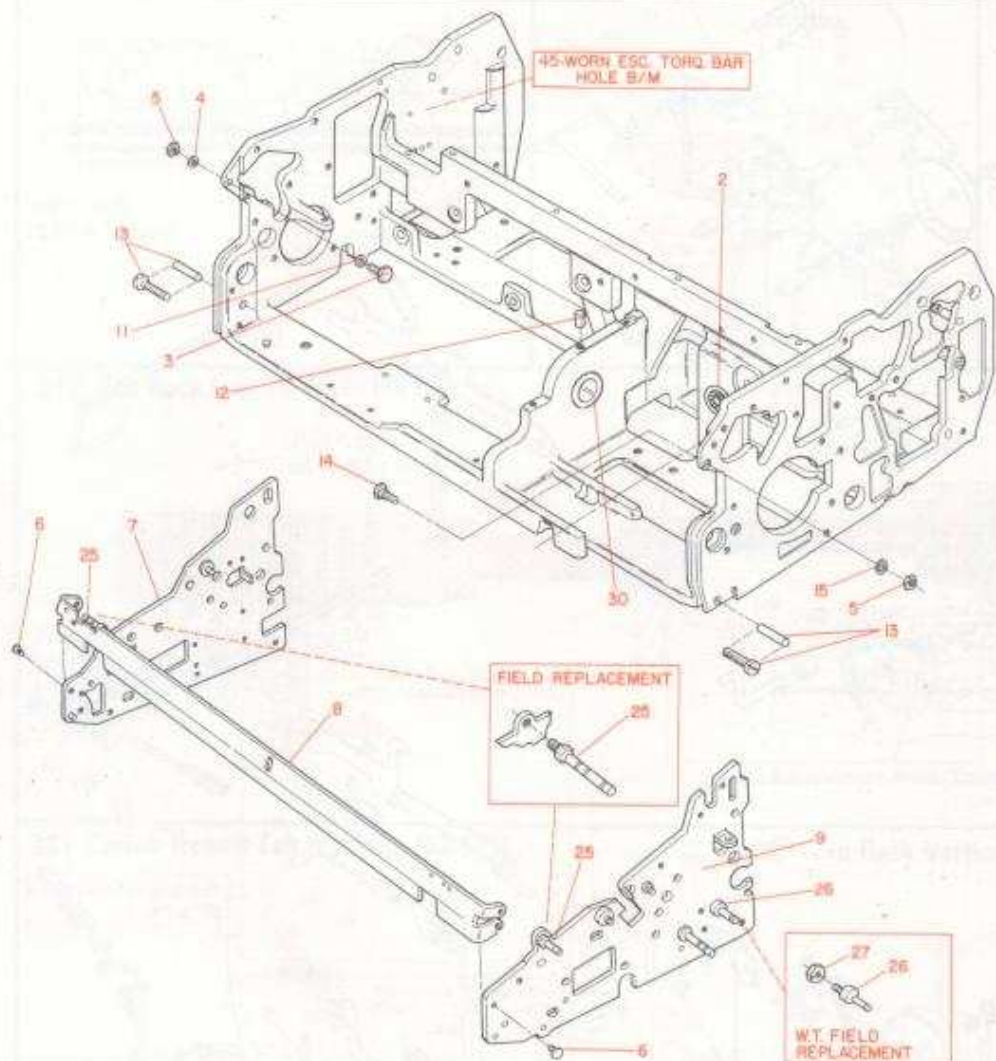

MARGINS (NR B/S)

MECH. CODE
09

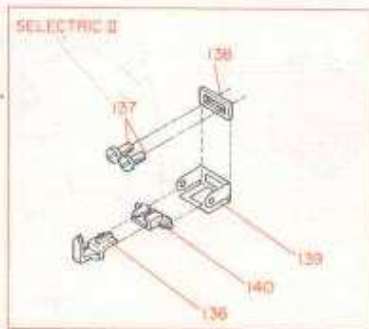
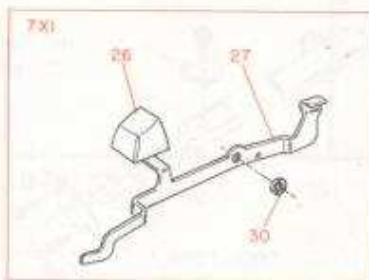
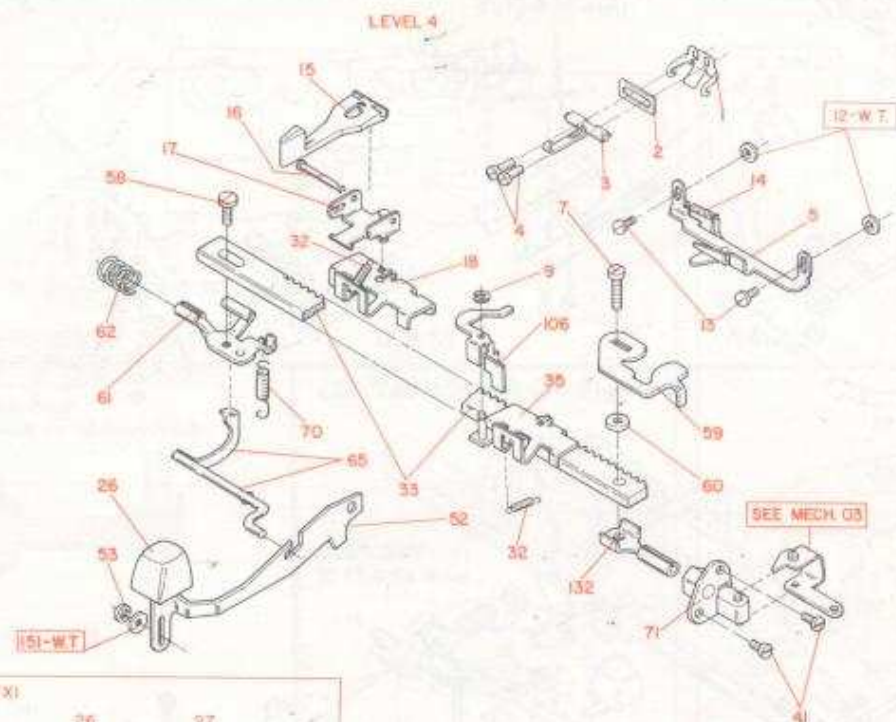

MECH. CODE

09

MARGINS (NR B/S)

LEVEL 3

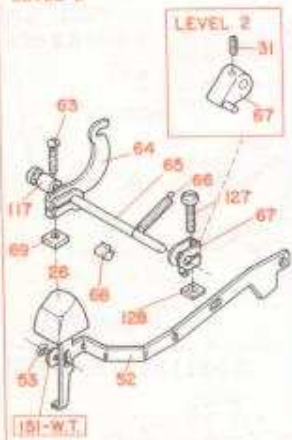

LEVEL 2

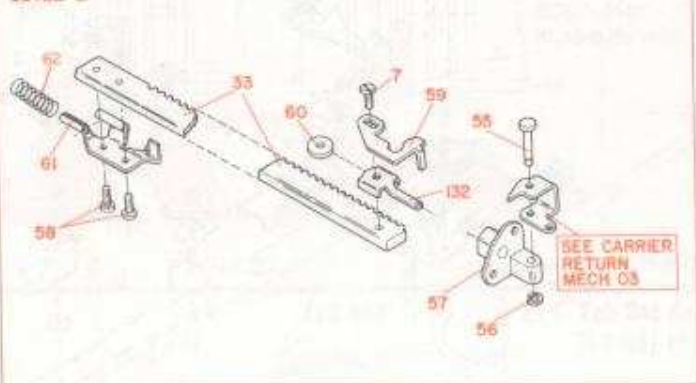

LEVEL 1 LONG CARRIAGE



LEVEL 1

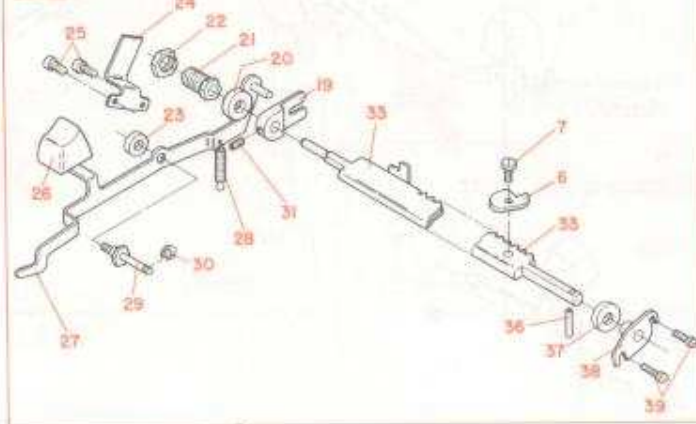

- 105 - B/M CARRIER POINTER 7XX
- 125 - MARGIN LEVER ASM
- 126 - B/M MARGIN RACK
- 133 - B/M MARGIN PIVOT
- 150 - MARGIN RACK ASM. INCL. REF. 125

MECH. CODE

09

LINELOCK & BELL

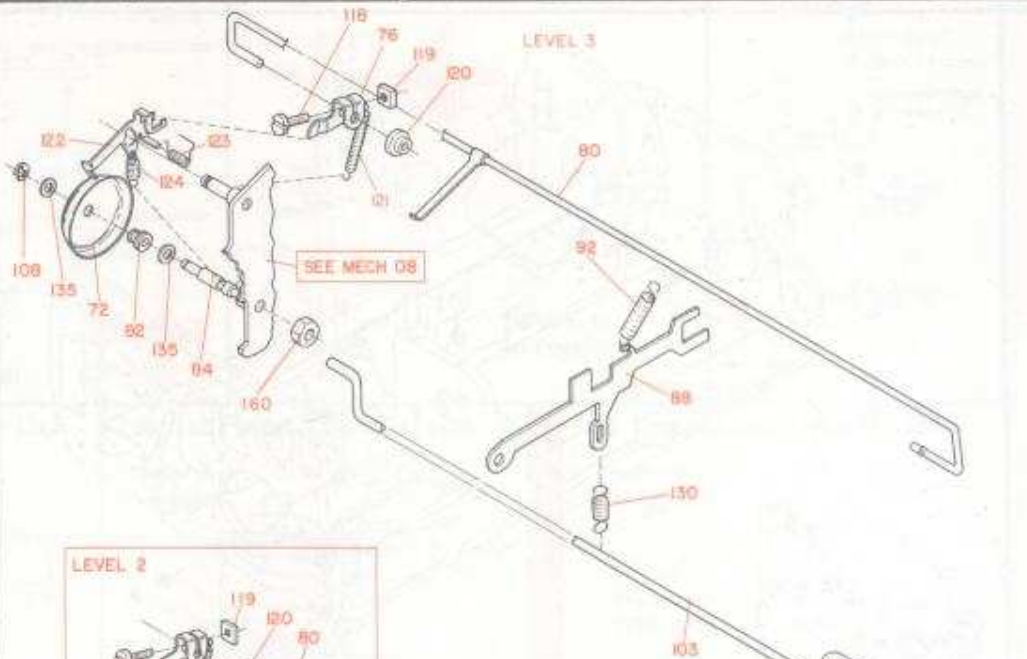

LEVEL 2

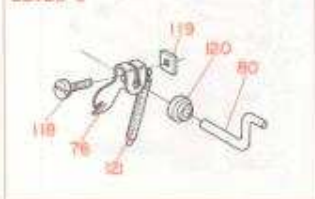

LEVEL 1

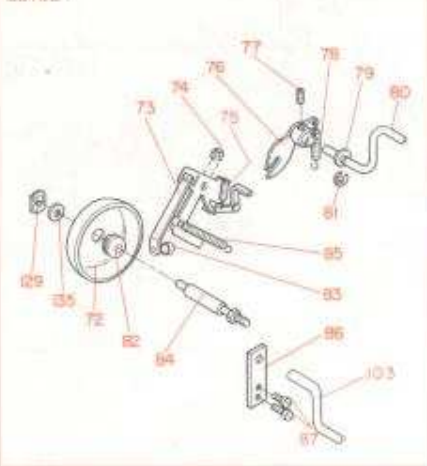

LEVEL 2 KEYBOARD LOCK

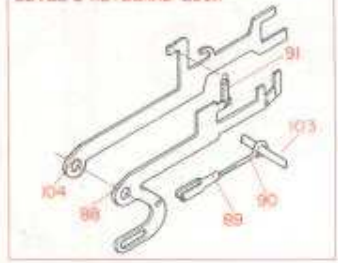

EARLY LEVEL KEYBOARD LOCK / OBSOLETE PARTS NOT REFERENCED

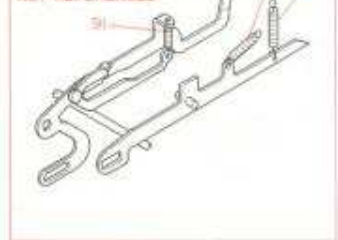

MARGINS
(RB/S)

MECH. CODE
10

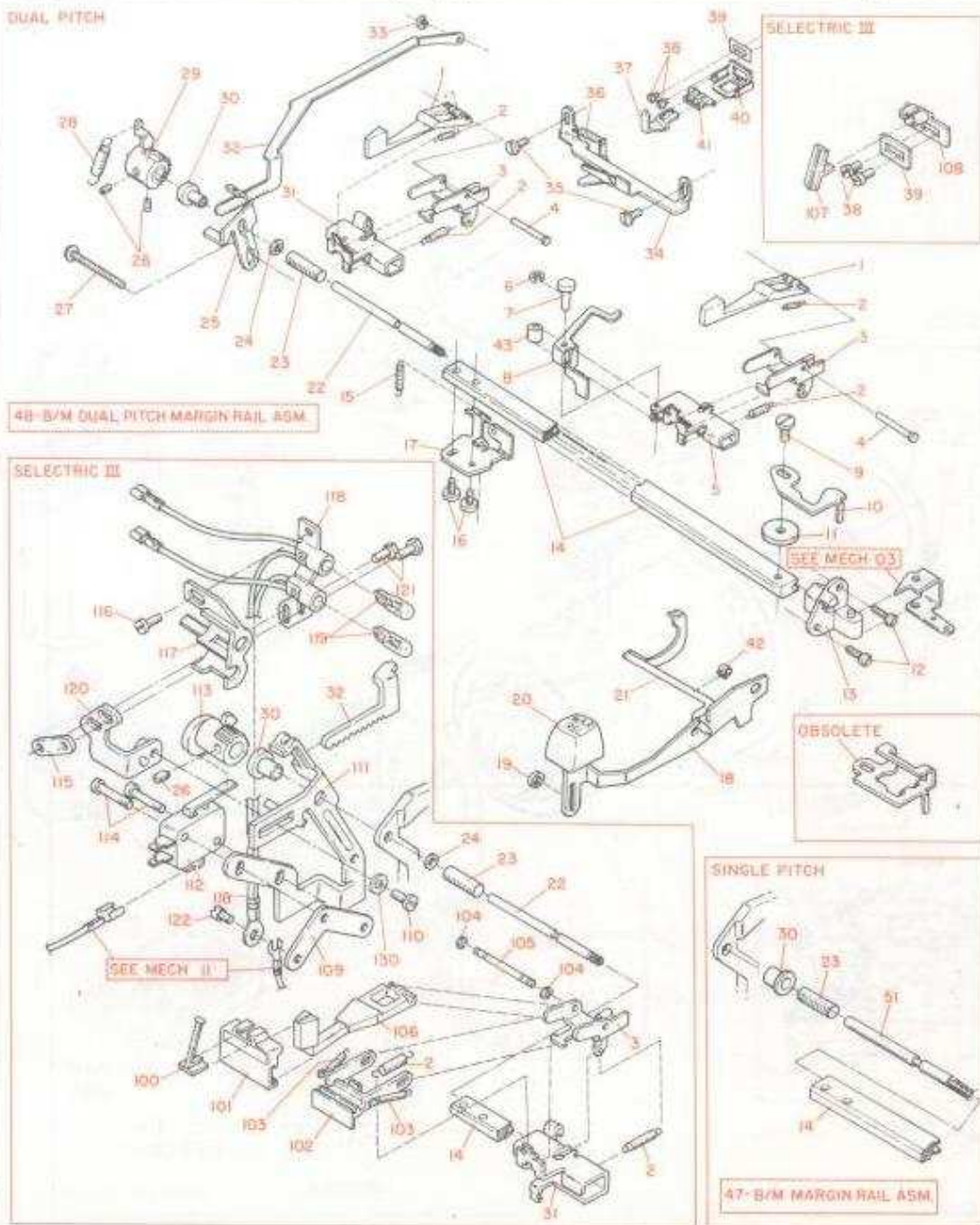

U.S. MOTOR & DRIVE
(SHADED POLE)

MECH. CODE
11

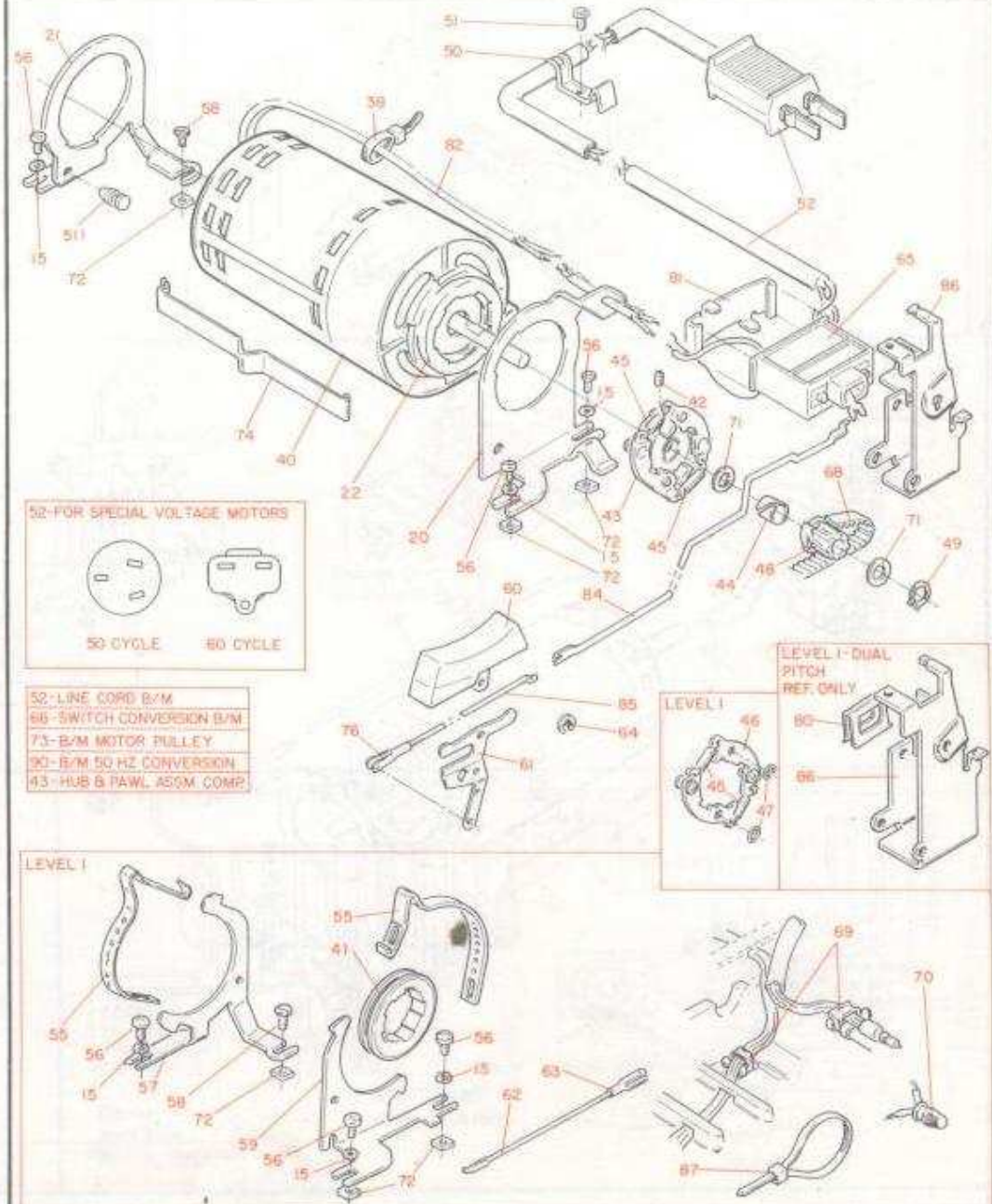

MECH. CODE
11

W.T. MOTOR & DRIVE (NETHERLANDS - DOUBLE INSULATION)

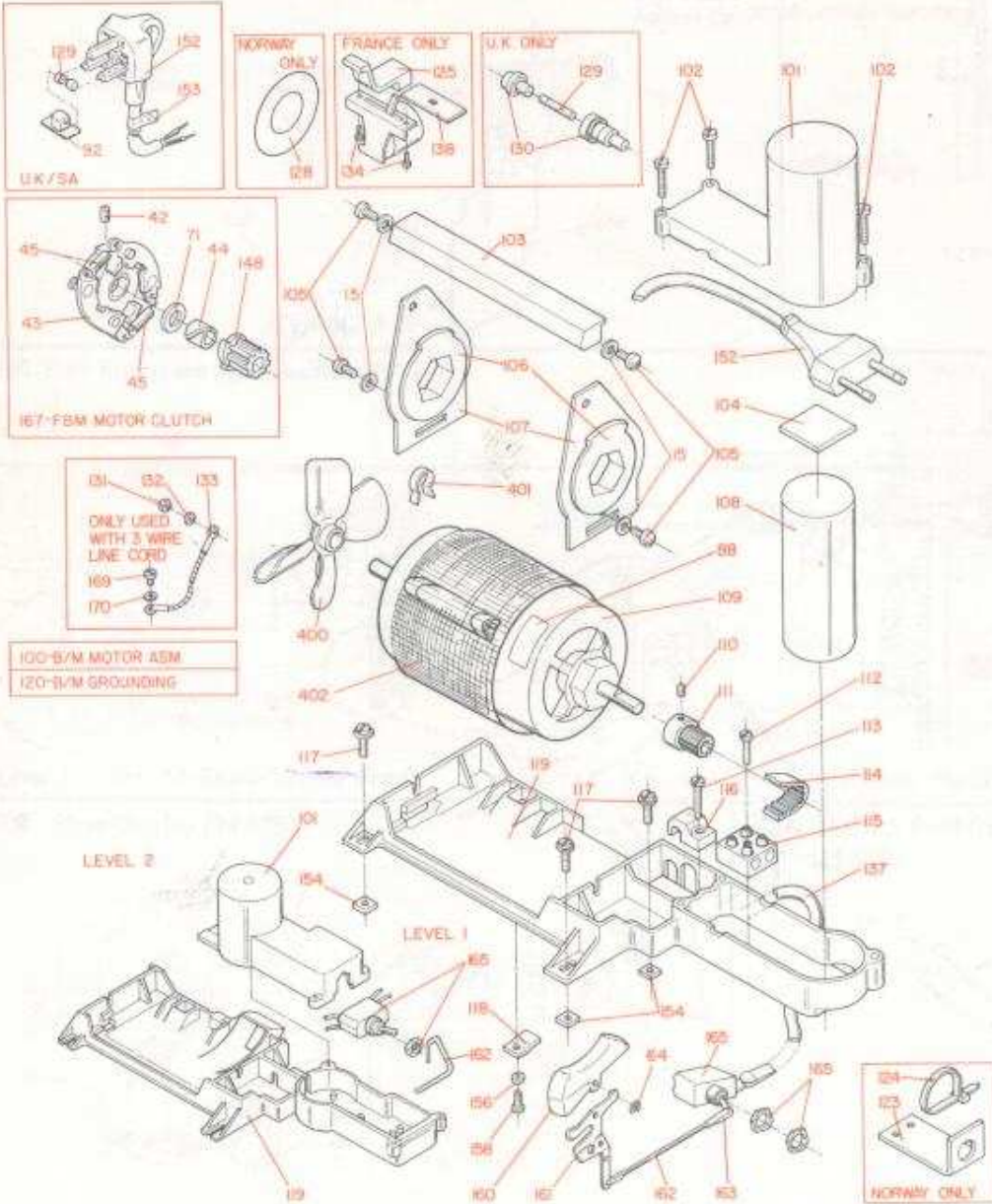

MECH. CODE
11

W.T. MOTOR & DRIVE

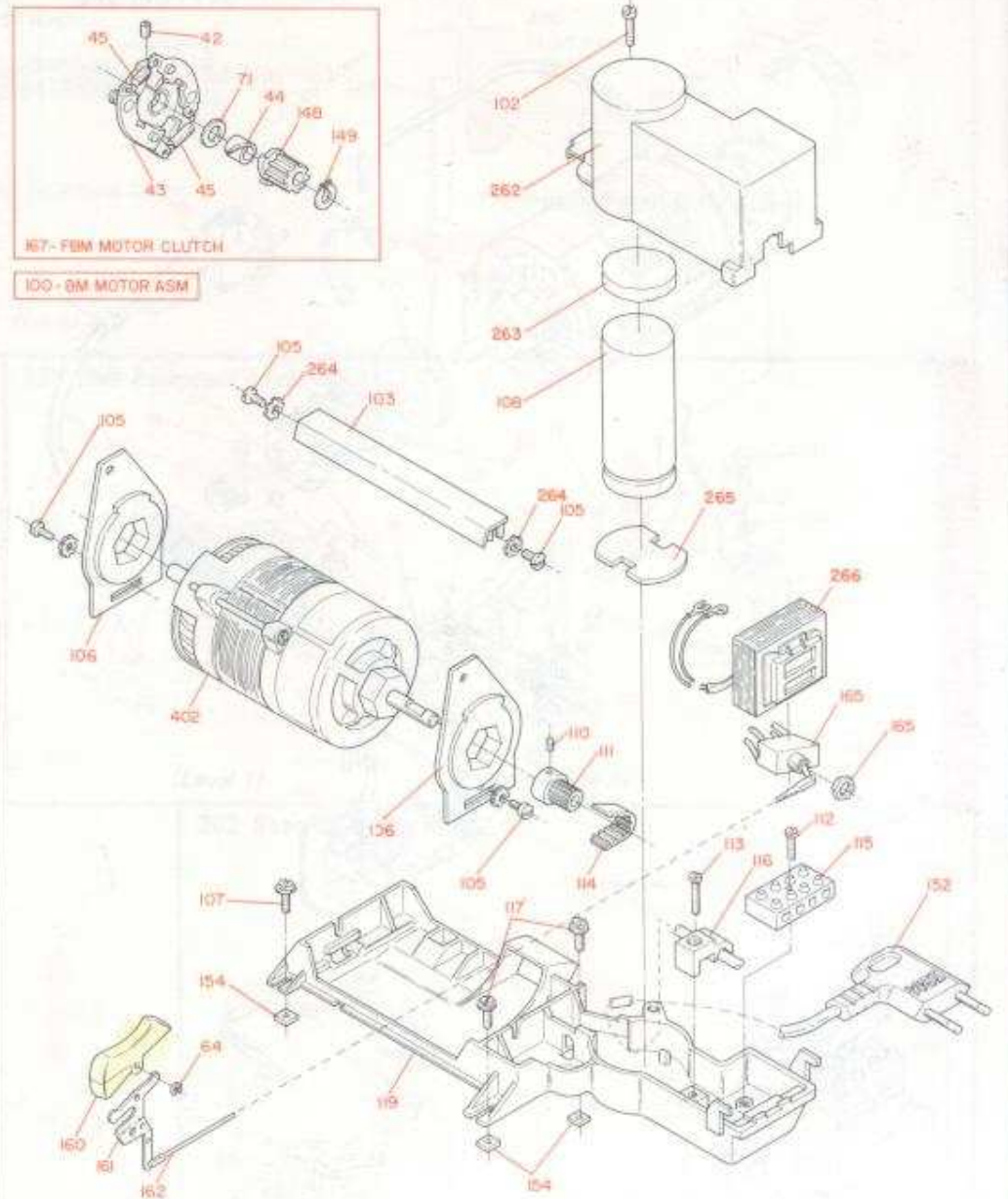

W.T. MOTOR & DRIVE
(CANADIAN - SHADED POLE)

MECH. CODE
11

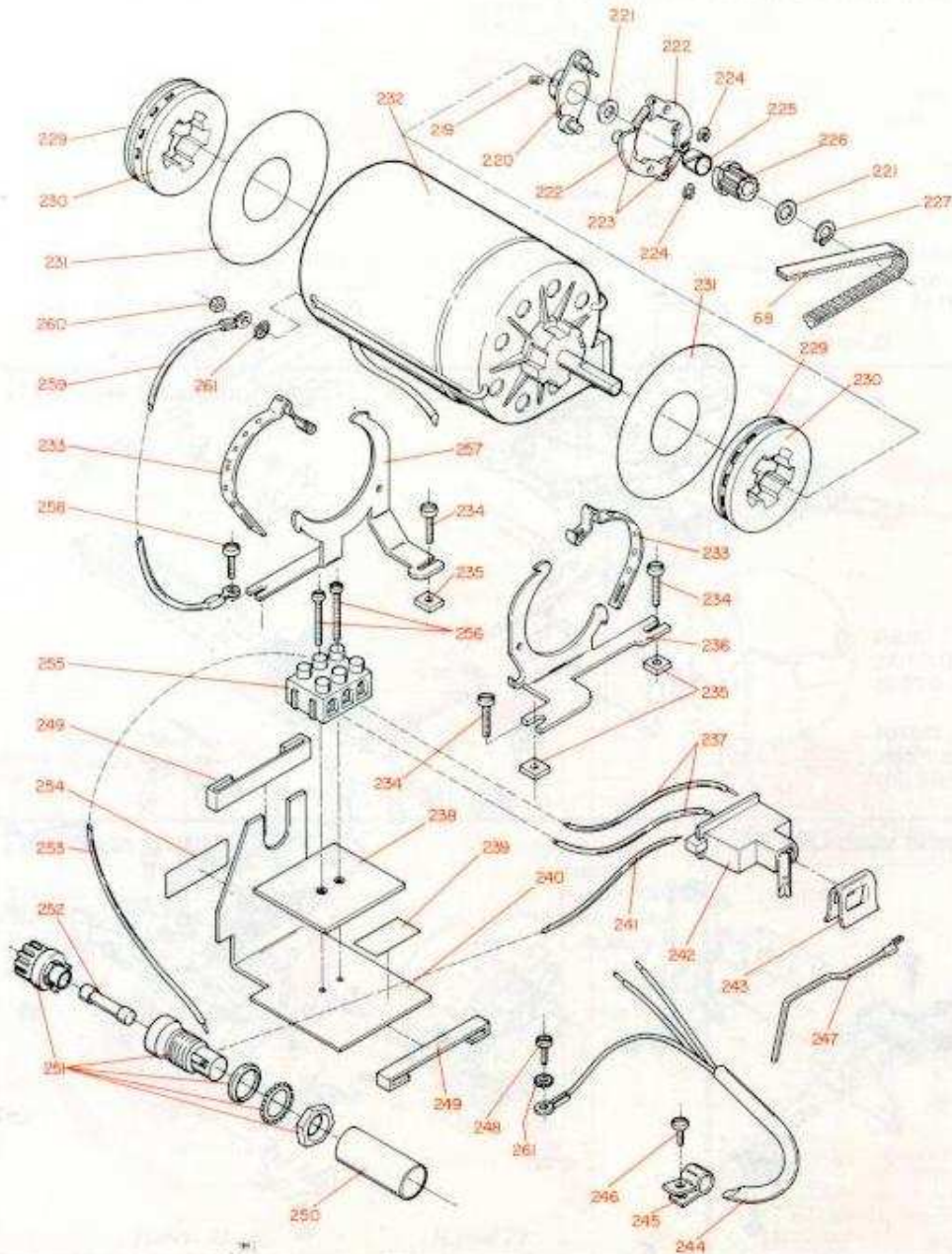

W.T. MOTOR & DRIVE
(CANADIAN - DOUBLE INSULATION)

MECH. CODE
11

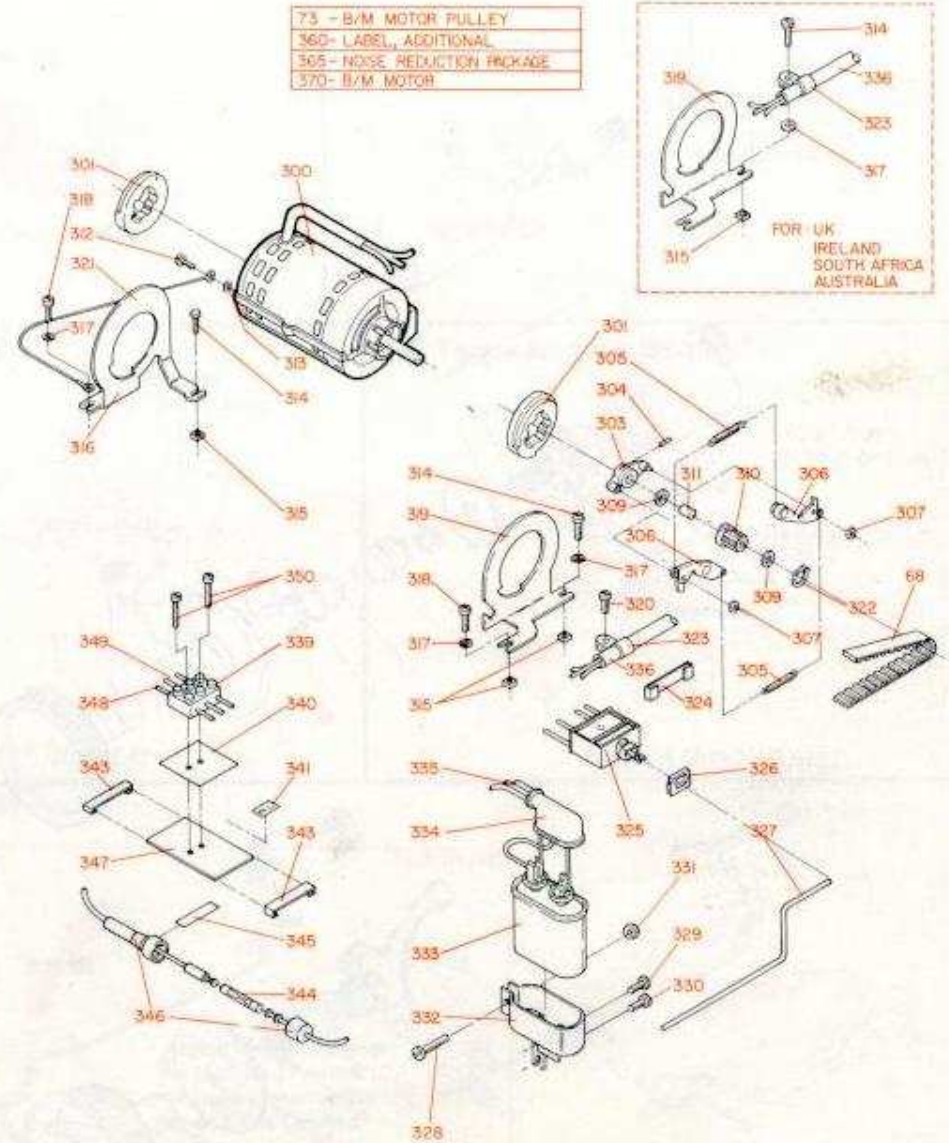

FILM RIBBON

MECH. CODE
14

FILM RIBBON

MECH. CODE
14

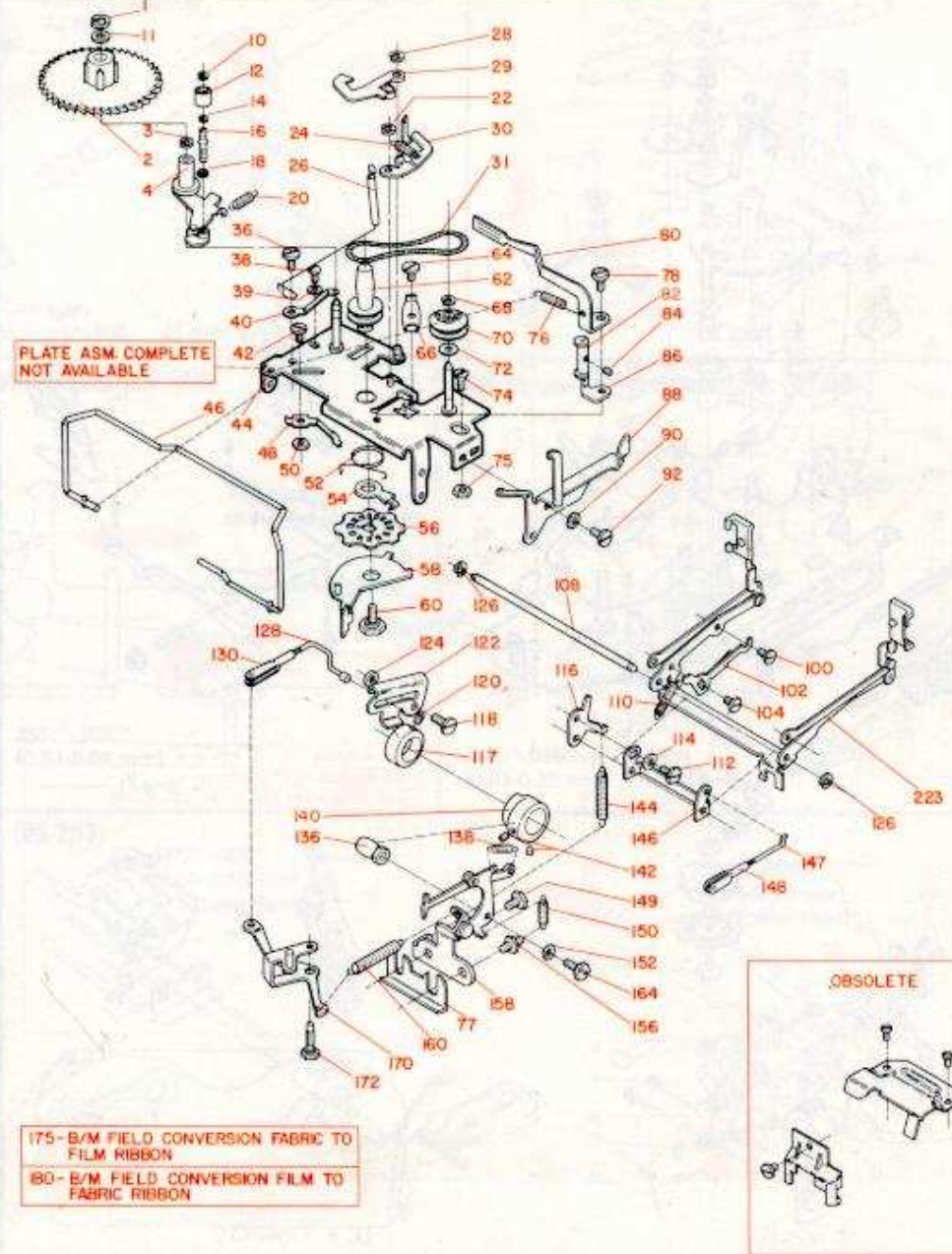
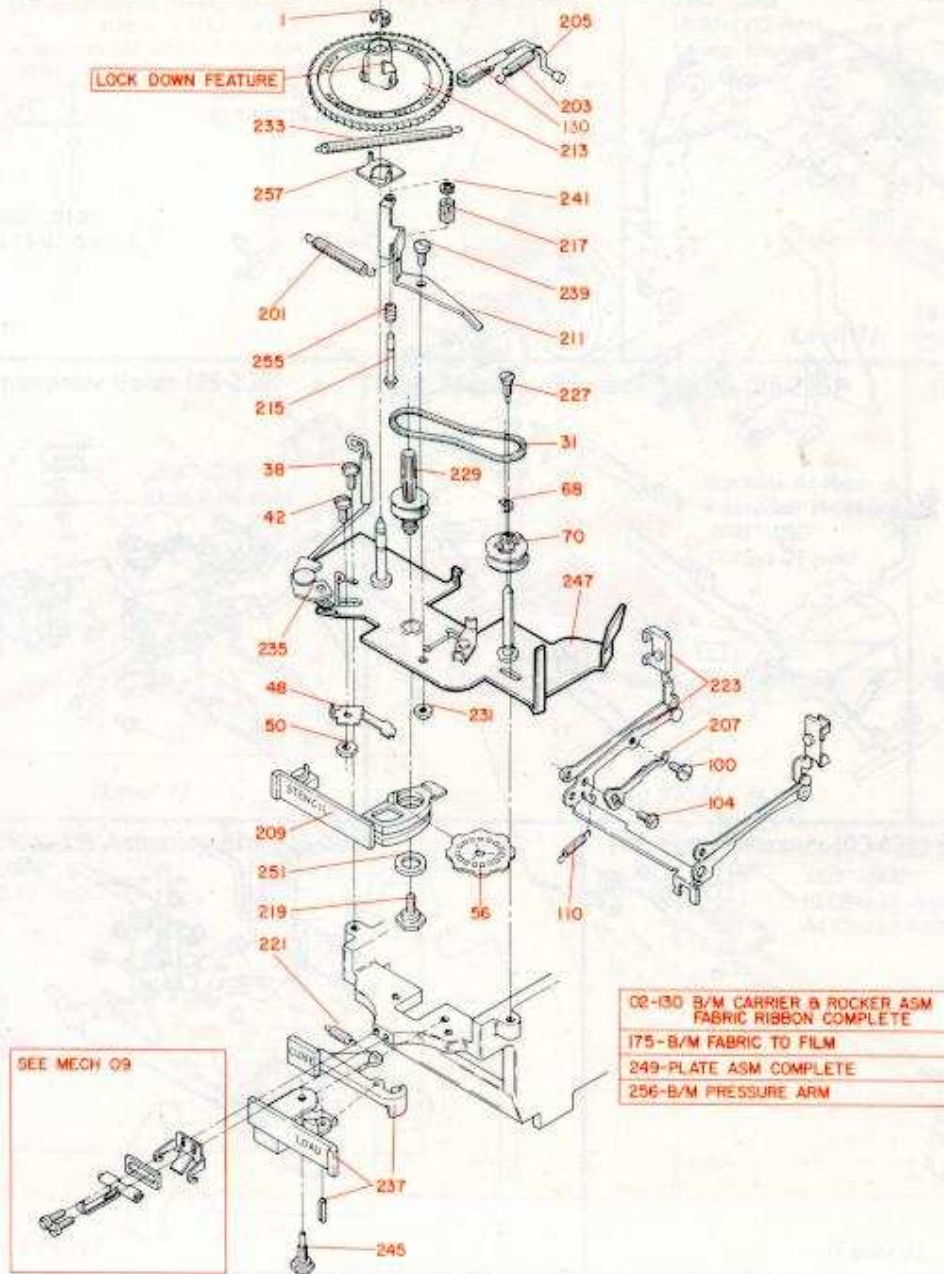

MECH. CODE

15

SELECTIVE RIBBON

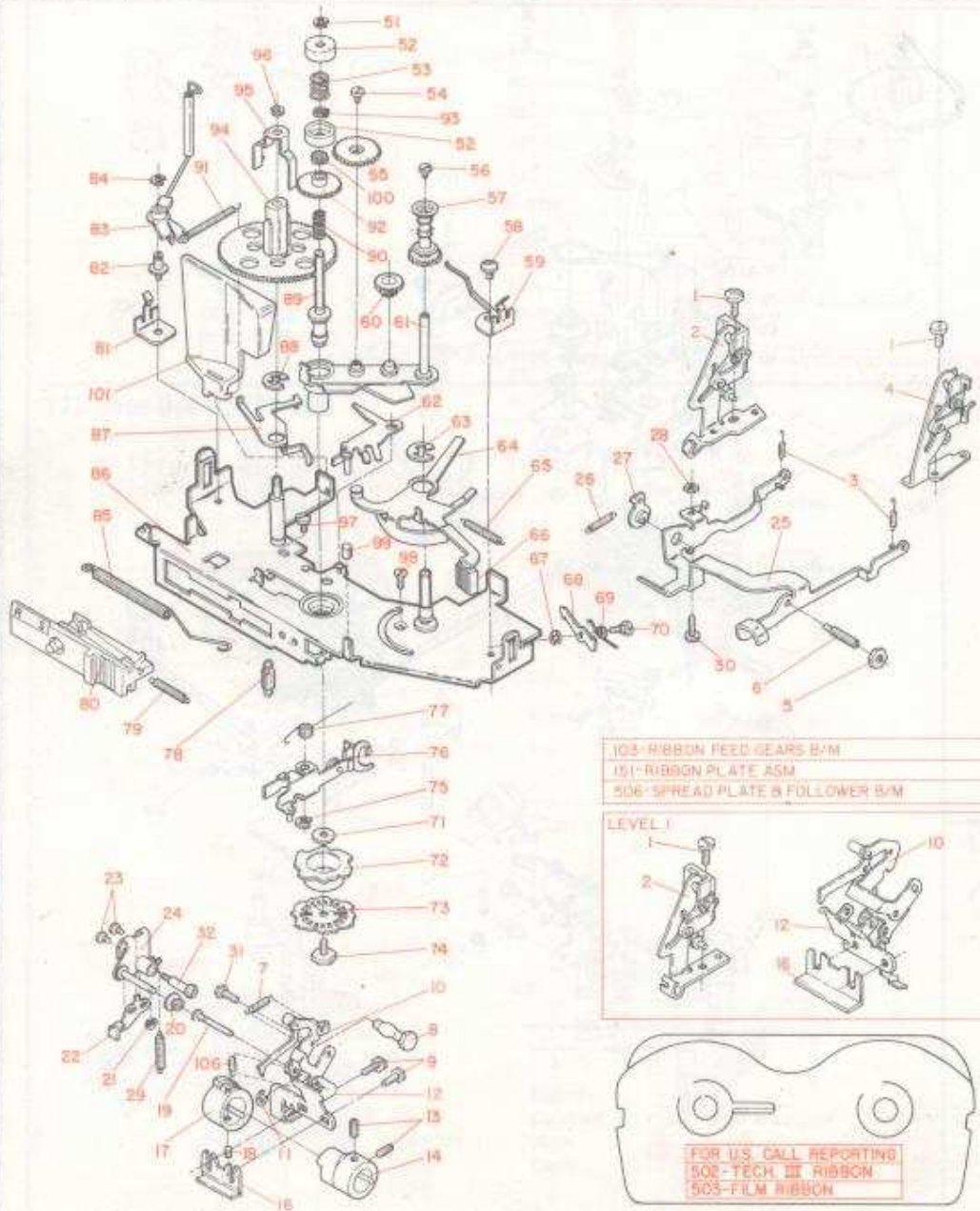

MECH. CODE

16

SHIFT

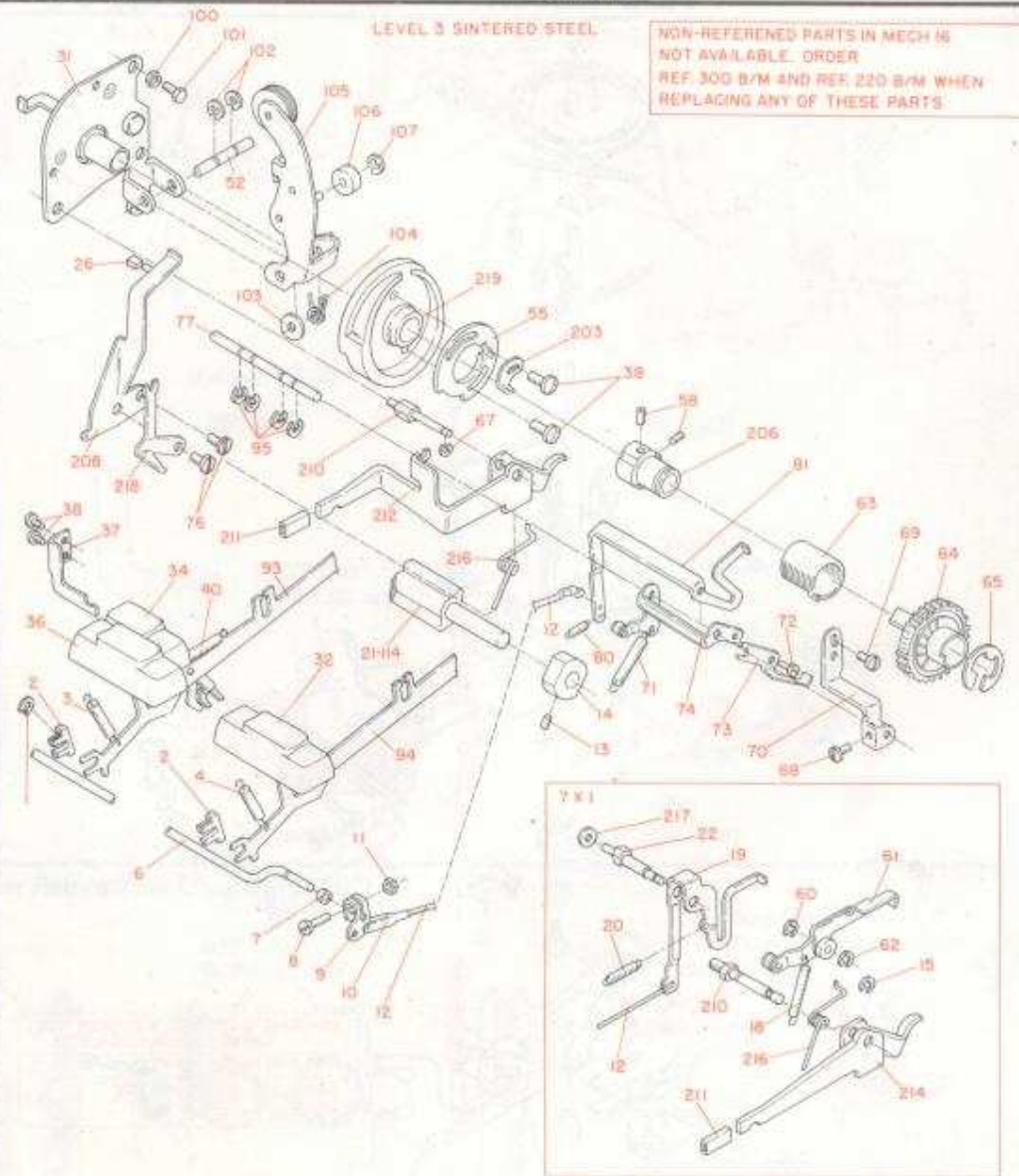

FOR U.S. CALL REPORTING
502-TECH III RIBBON
503-FILM RIBBON

SHIFT

MECH. CODE
16

LEVEL 2 7X1 PLASTIC CAM

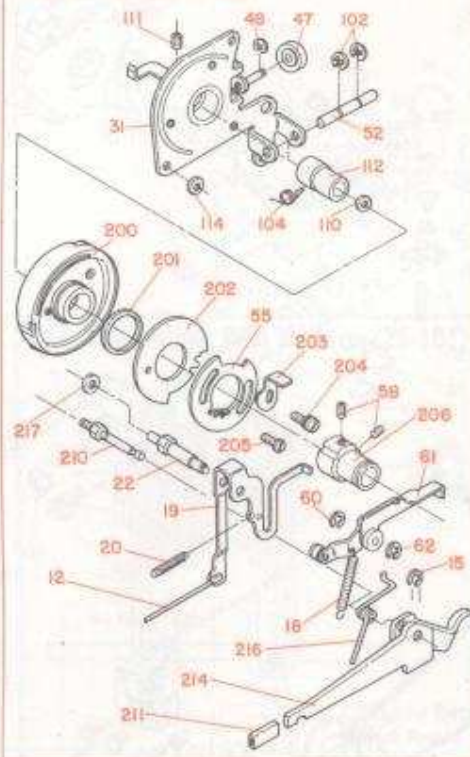

LEVEL 2 XX3 AND XX5 PLASTIC CAM

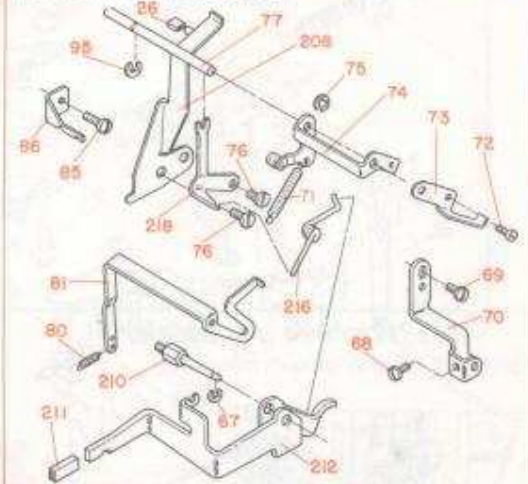

LEVEL 1 7X1 STEEL CAM

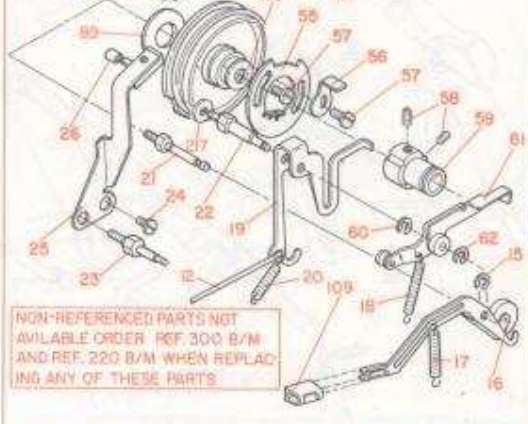
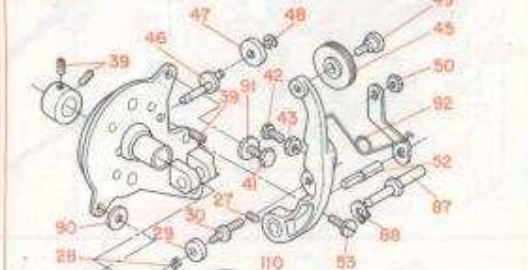

NON-REFERENCED PARTS NOT AVAILABLE ORDER REF. 300 B/M AND REF. 220 B/M WHEN REPLACING ANY OF THESE PARTS

SPACEBAR

MECH. CODE
17

LEVEL 3

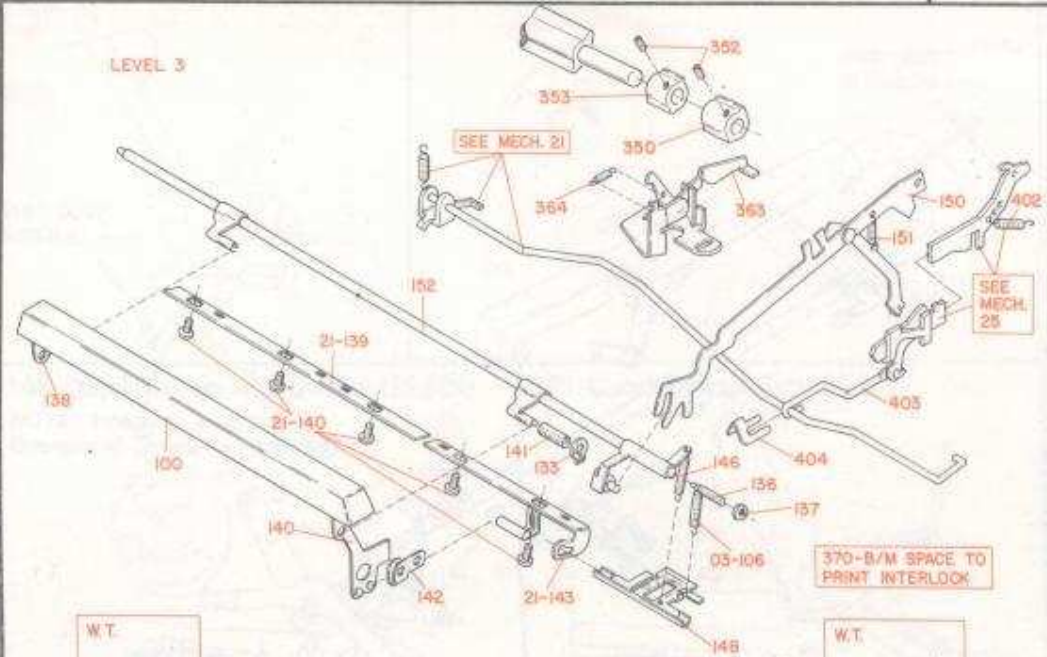

370-B/M SPACE TO PRINT INTERLOCK

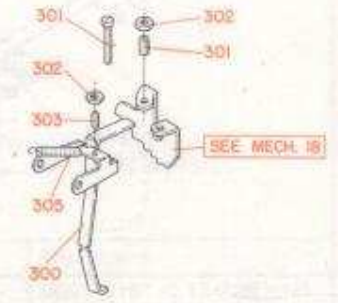
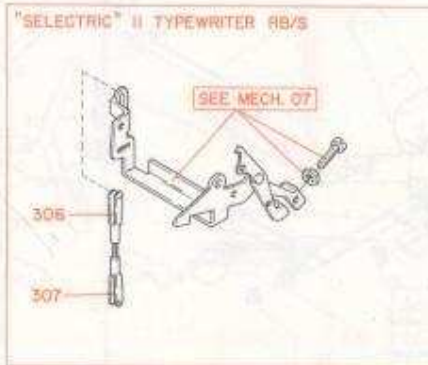
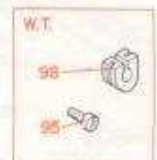

**TAB
(NR B/S)**

MECH. CODE
18

LEVEL 2 TAB LEVER

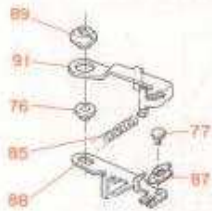

LEVEL 1 TAB LEVER

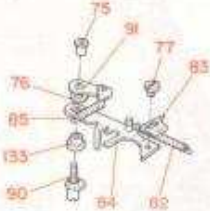

TAB PULLEY AND BRACKET

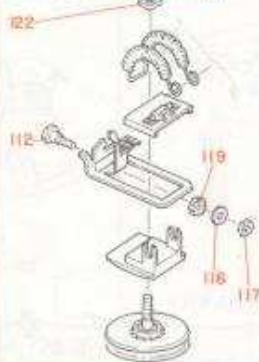

FOR PARTS NOT REFERENCED ORDER
B/M (30-R/M TRANSPORT PULLEY &
BRKT ASM. COMPLETE

200-B/M TAB KEYLEVER LINE LOCK



7X3-7X5 TAB BELLCRANK LEVEL 1

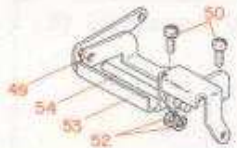

OBsolete PARTS - SEE REC 24

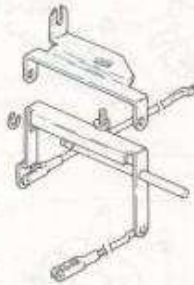

7 X 1



LEVEL 1

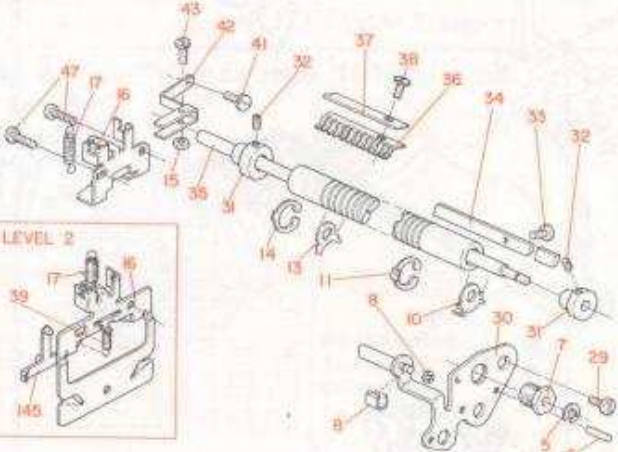

LEVEL 2

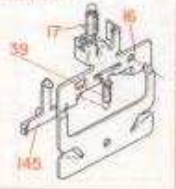

LEVEL 1 ESCAPEMENT SHAFT



**TAB
(RB/S)**

MECH. CODE
19

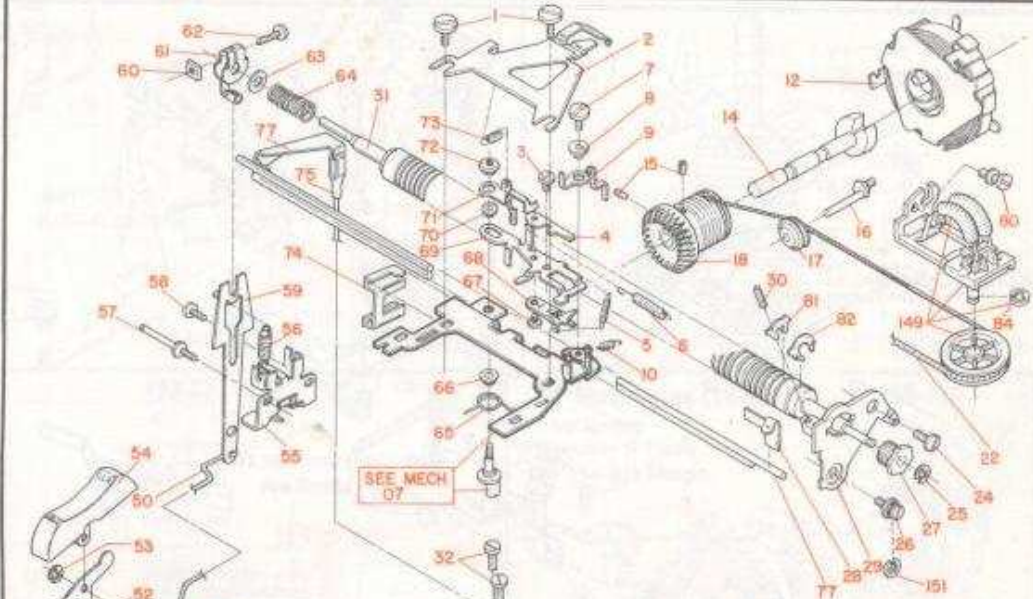

SEE MECH 07

152-B/M CONVERSION FROM ALL
STEEL TO DUAL TRANSPORT



150-B/M TAB LINKAGE AND TORQUE
BAR 8X3-6X5 LEVEL 2
152-B/M CONVERSION FROM ALL
STEEL TO DUAL TRANSPORT

**LEVEL 1 TAB TORQUE BAR &
LINKAGE**

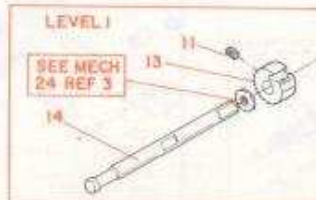
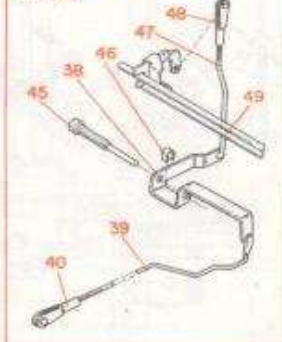

LEVEL 1
SEE MECH
24 REF 3

**INDEXING
(DOUBLE)**

MECH. CODE
20

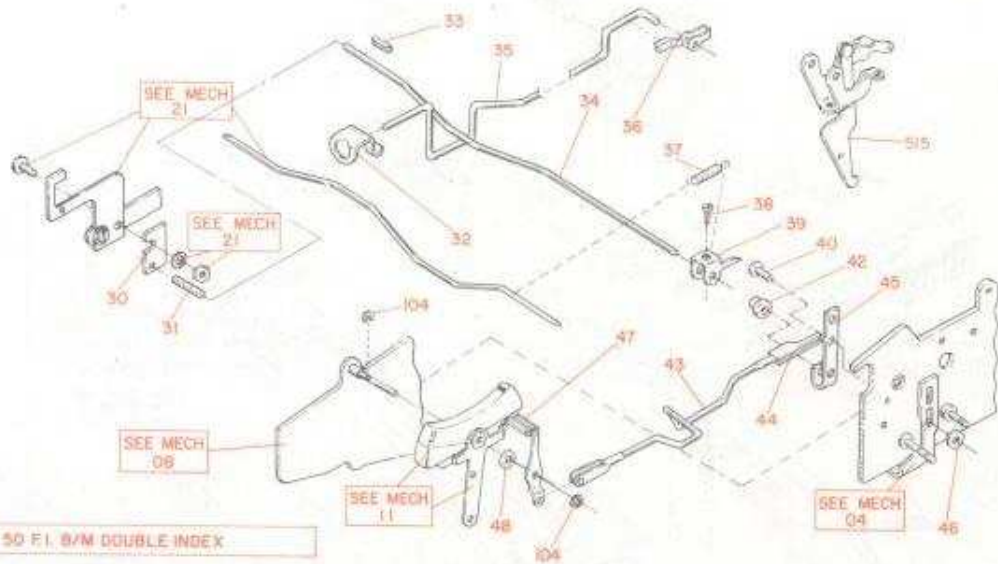

50 F.I. B/M DOUBLE INDEX

LEVEL 3

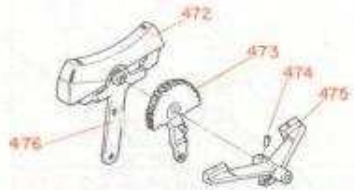

LEVEL 1 - 2, 2 1/4, 3 LINES

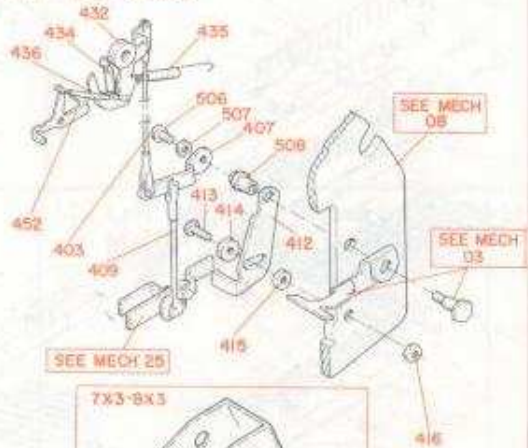

7X3-8X3



50S-B/M INDEX 2, 2 1/4, 3 LINES

W.T. INDEXING

MECH. CODE
20

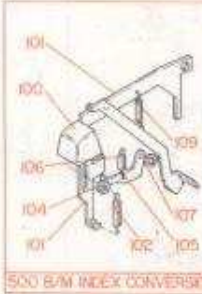
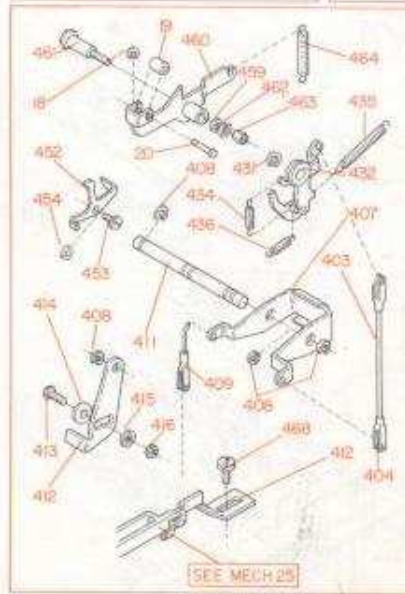
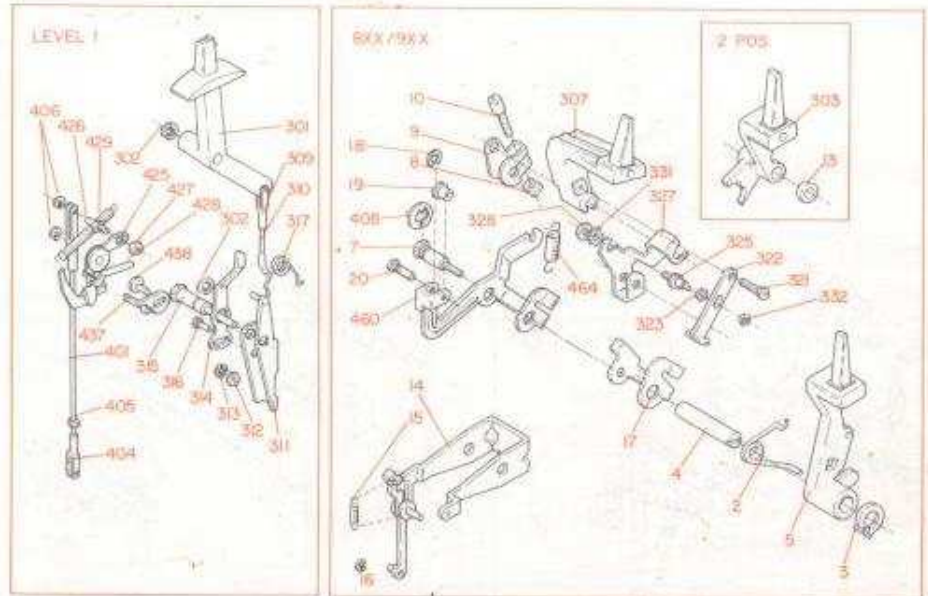

500 B/M INDEX CONVERSION

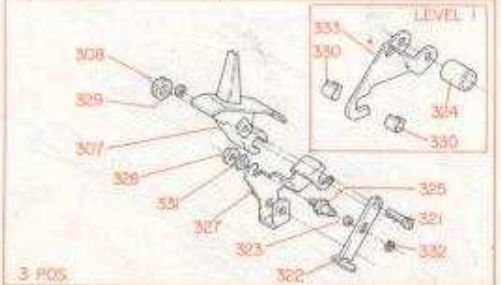
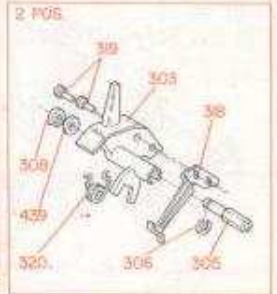

3 POS

MECH. CODE **21** **KEYBOARD**

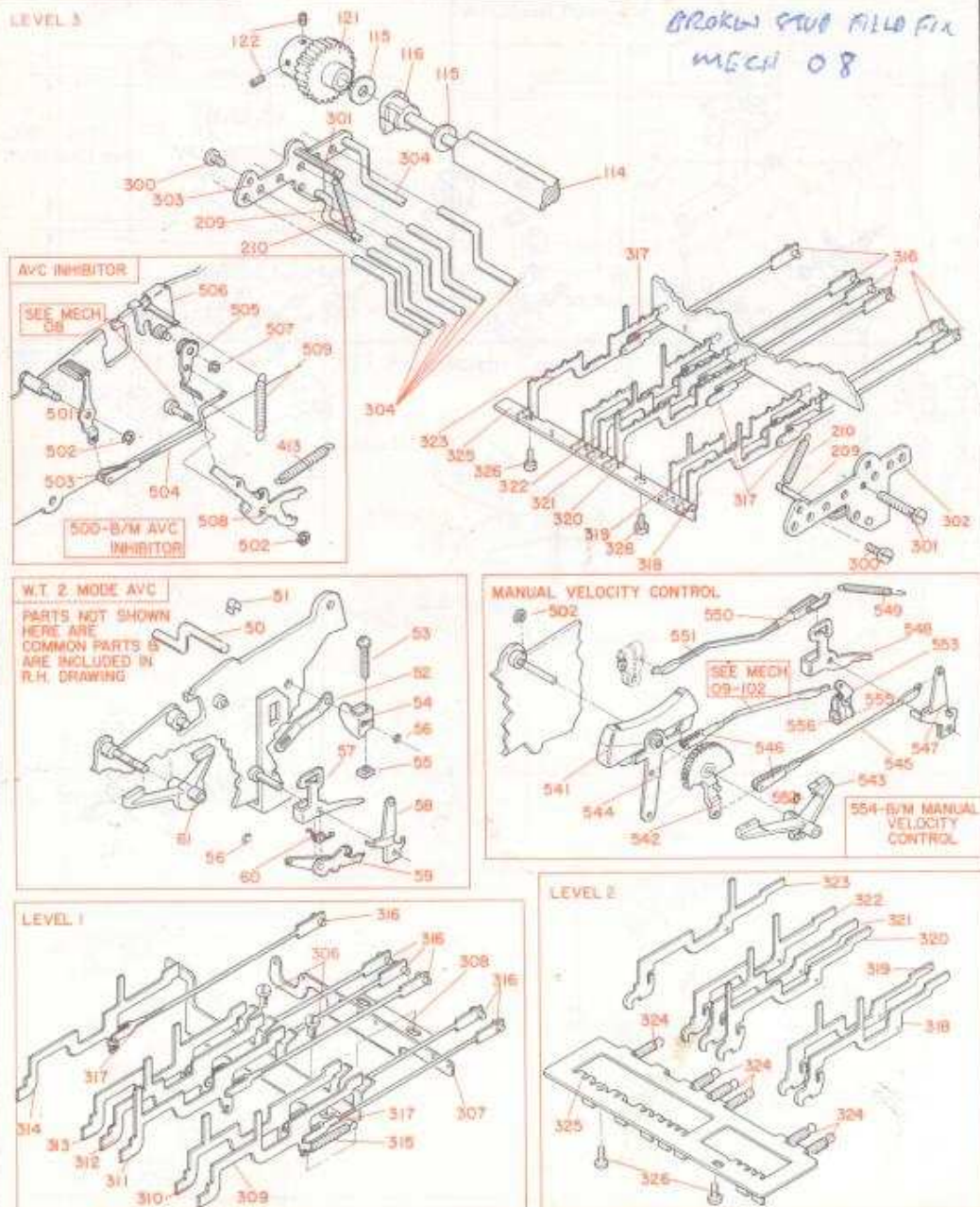

MECH. CODE **21** **KEYBOARD**

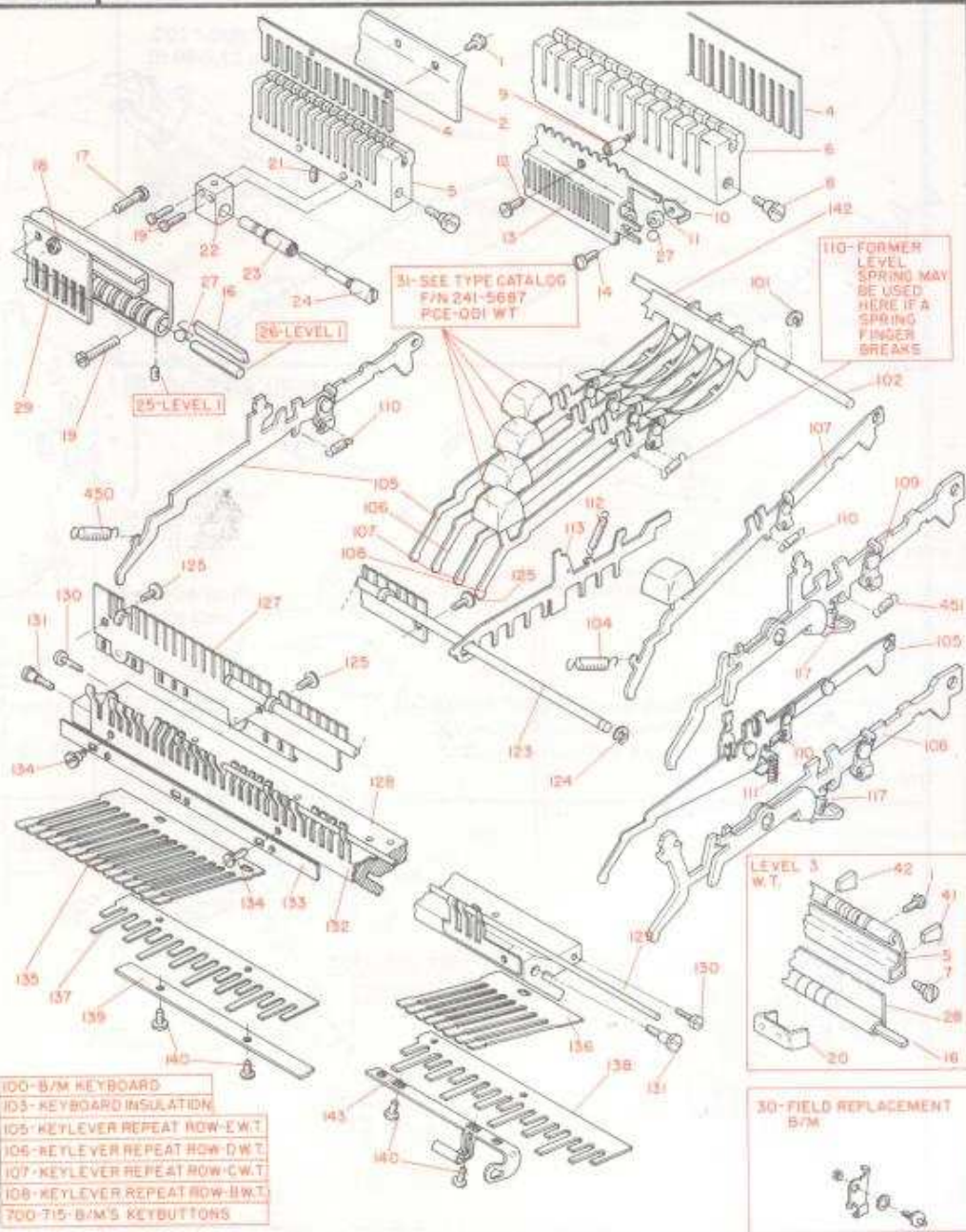

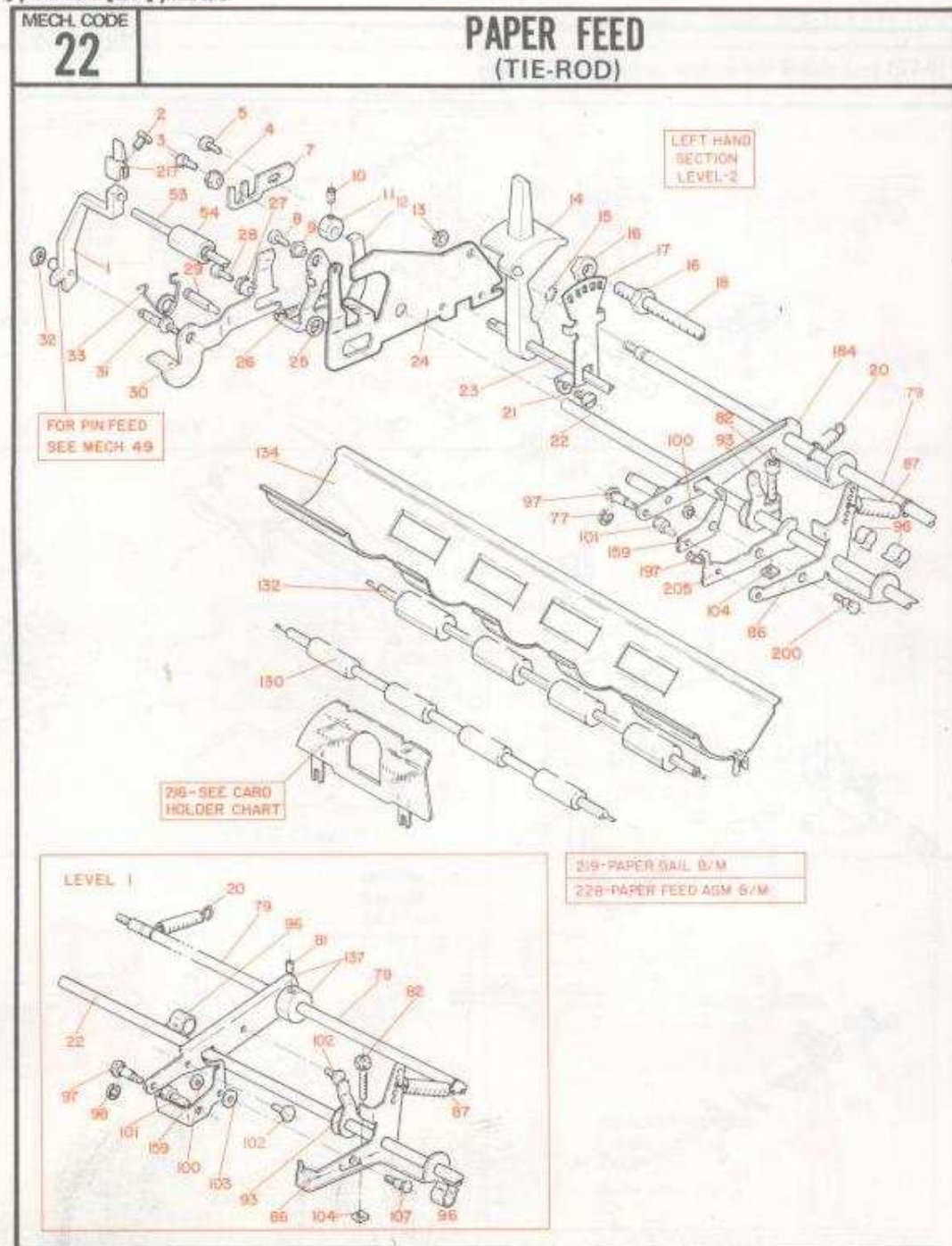
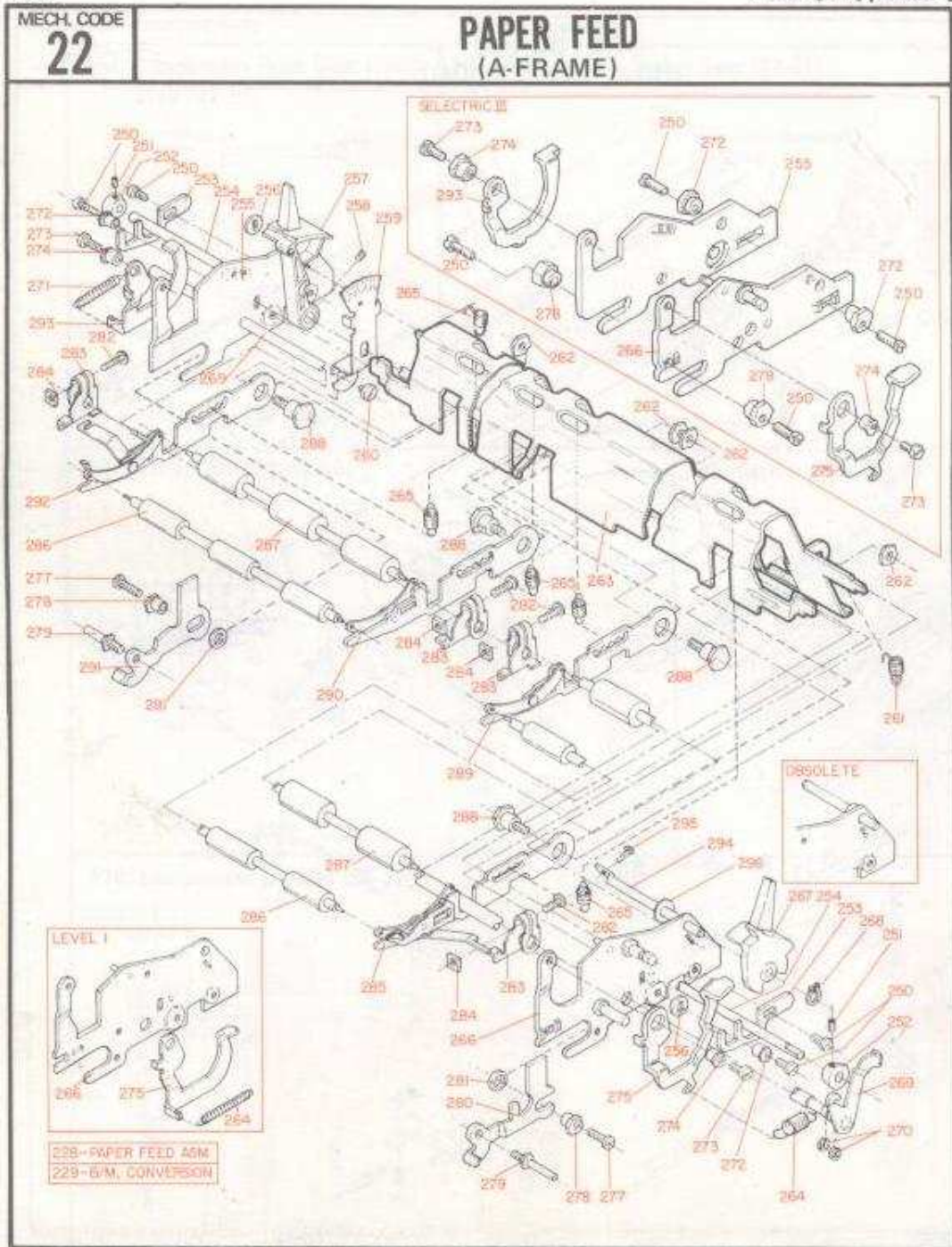

**PAPER FEED
(TIE-ROD)**

MECH. CODE
22

CENTER SECTION
LEVEL 2

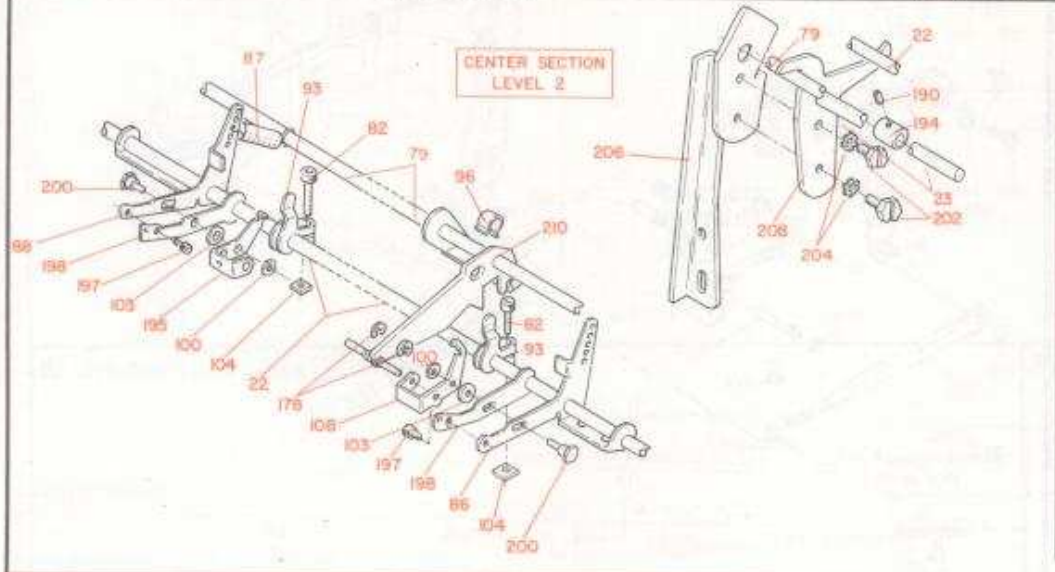

LEVEL 1

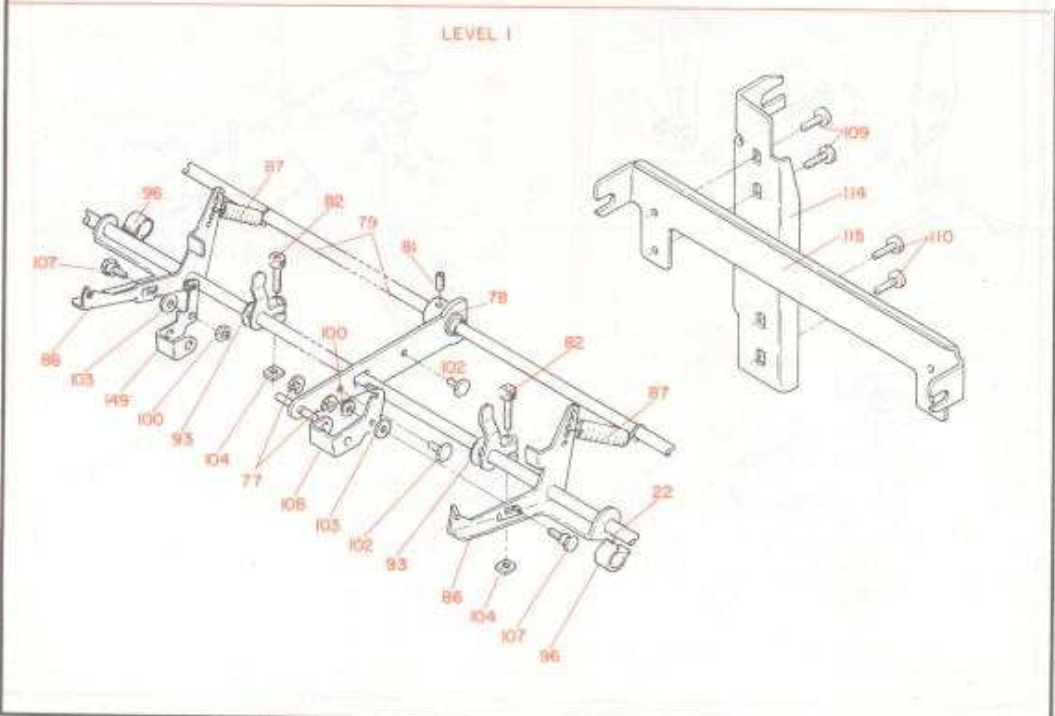

**PAPER FEED
(TIE-ROD)**

MECH. CODE
22

RIGHT HAND
SECTION
LEVEL-2

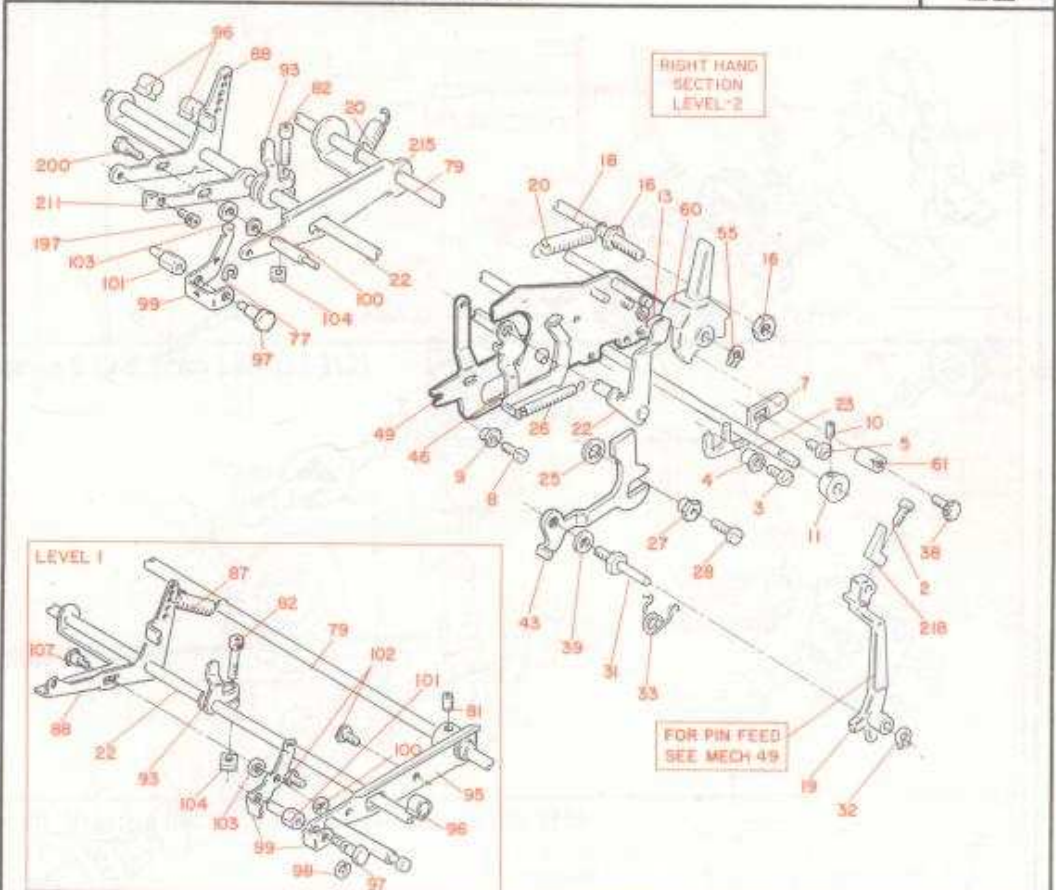

FOR PIN FEED
SEE MECH 49

LEVEL 1

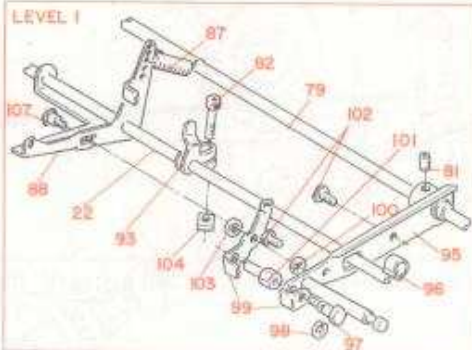

LEVEL 1



LEVEL 1
LONG CARRIAGE



LEVEL 1

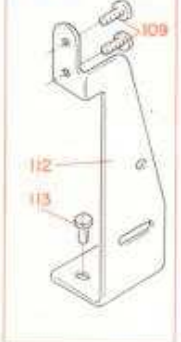

LEVEL 2

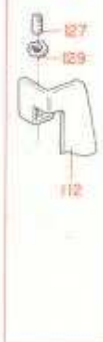

LEVEL 3



MECH. CODE

23

SELECTION

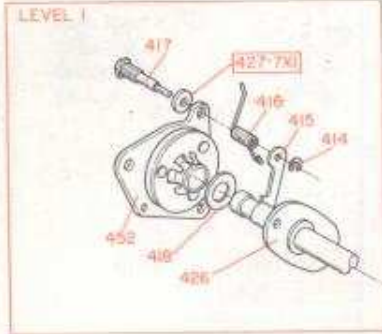
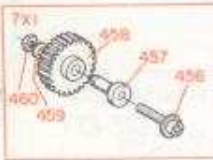
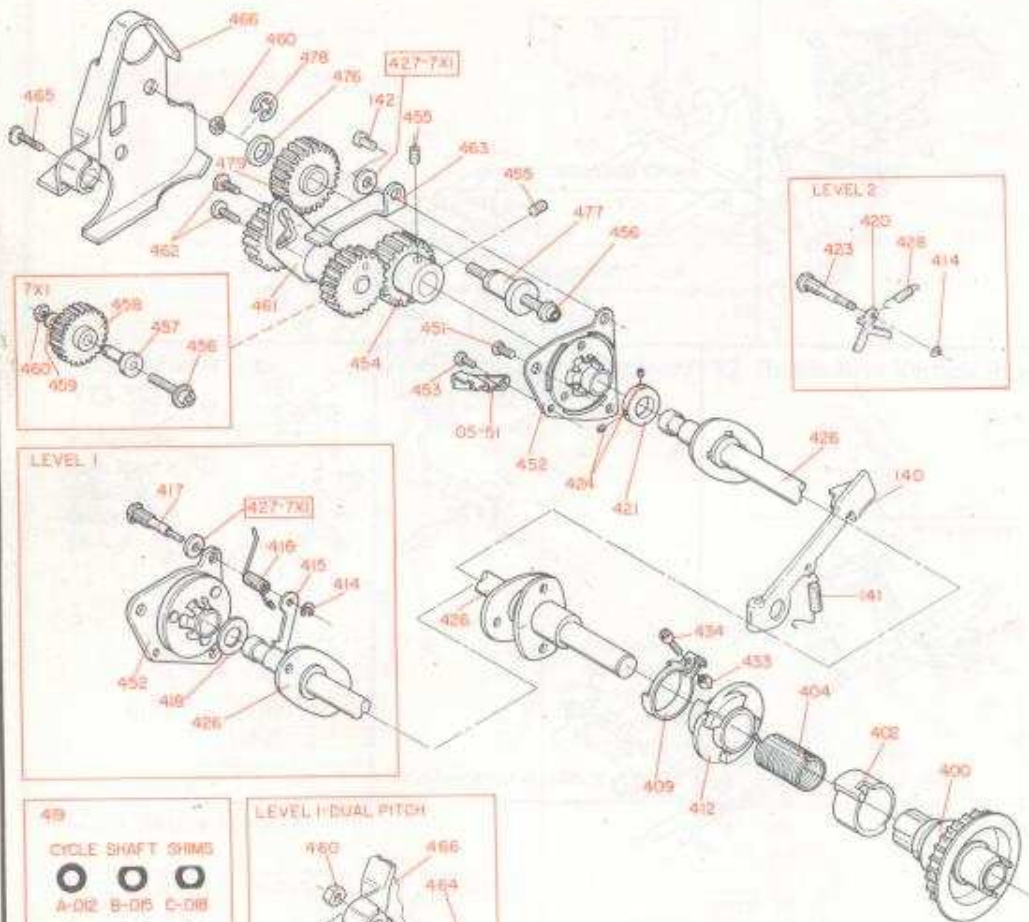

| |
|-----------------------------|
| 435-B/M CYCLE CLUTCH |
| 437-B/M CYCLE SHAFT |
| 470-B/M GEAR TRAIN |
| 500-B/M CYCLE SHAFT L-2 WT. |

MECH. CODE

23

SELECTION

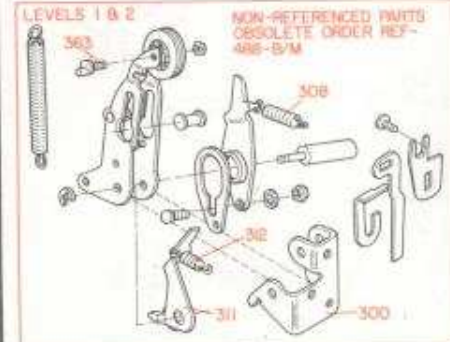
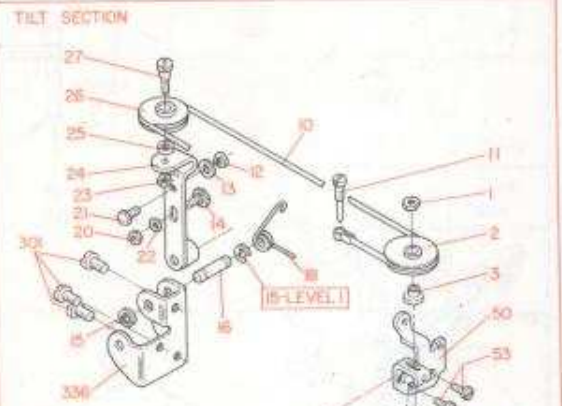
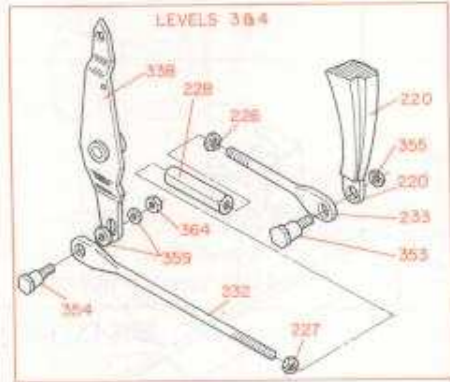
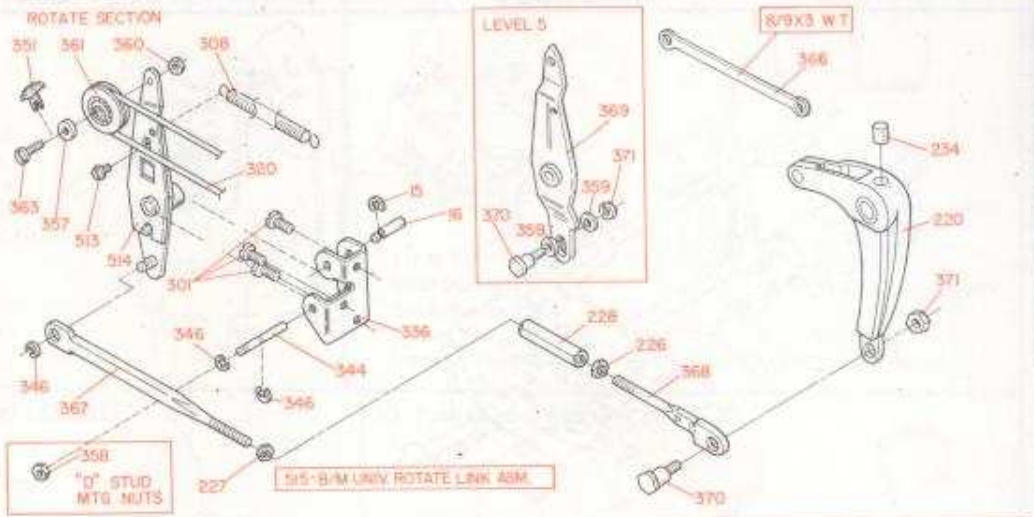

MECH. CODE
25

OPERATIONAL CONTROL

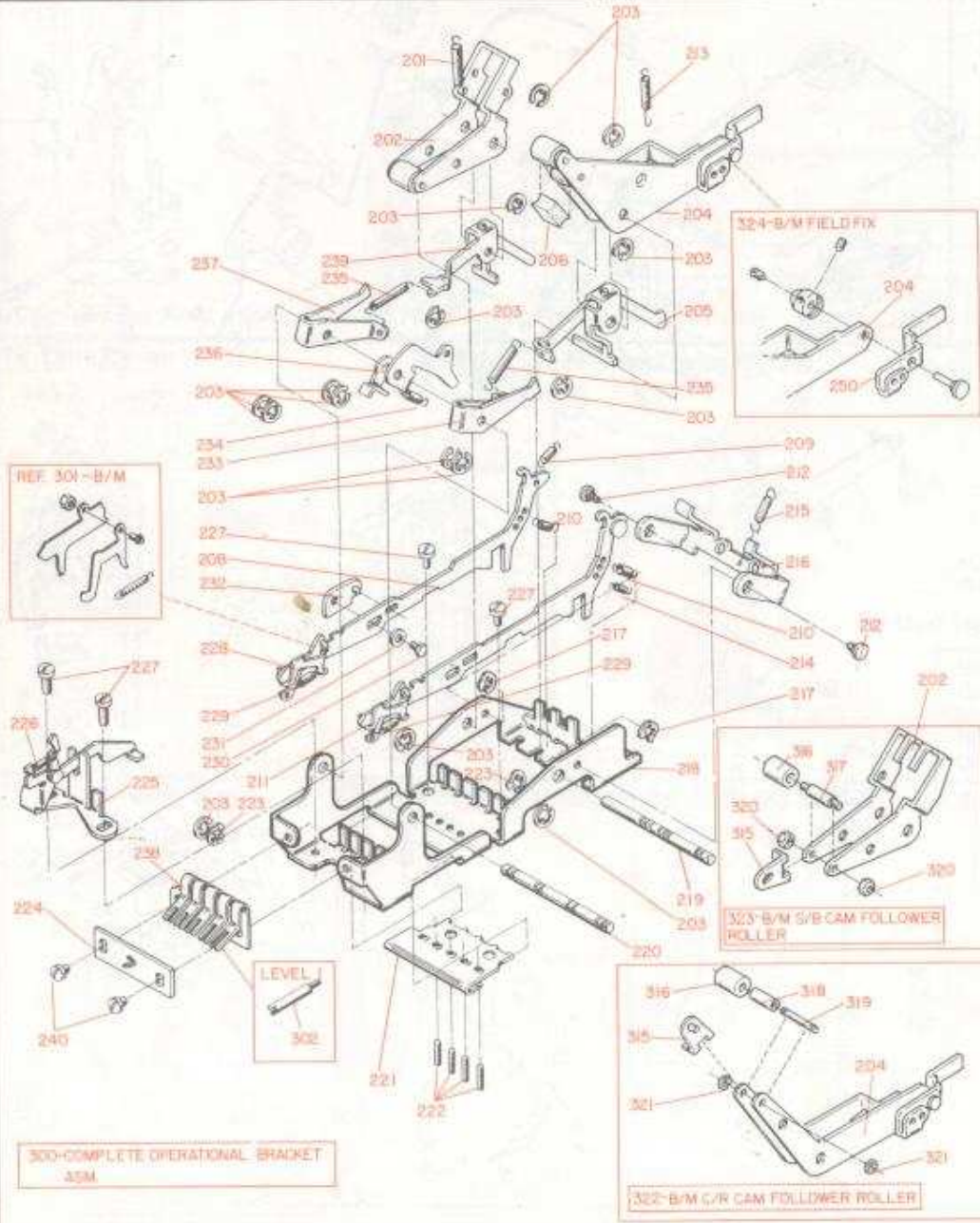

MECH. CODE
25

OPERATIONAL SHAFT ASSEMBLY

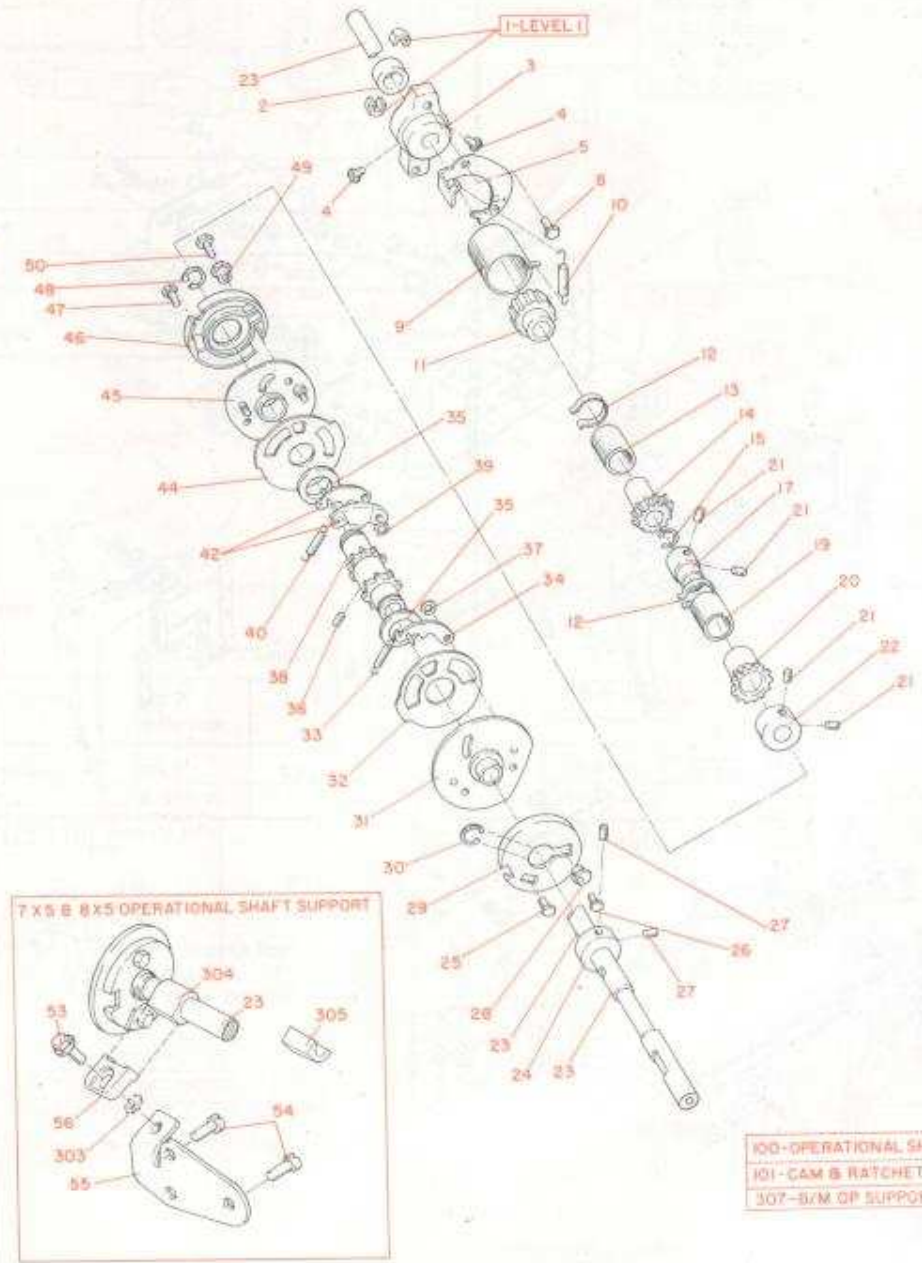

CORRECTING

MECH. CODE
26

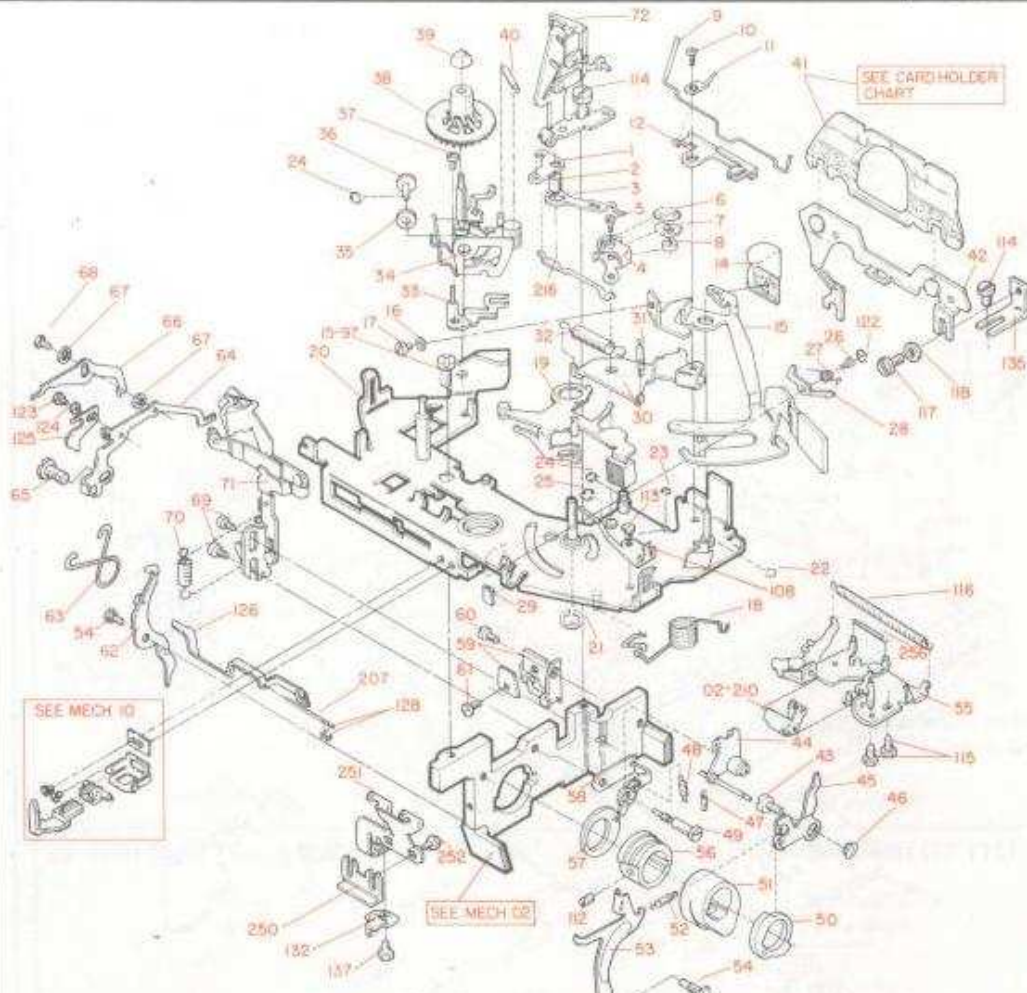

SEE MECH 10

SEE MECH 02

- 34-CRADLE ASM B/M
- 102-CARRIER & ROCKER ASM
- 106-RIBBON PLATE ASM
- 13-TAPE FEED B/M

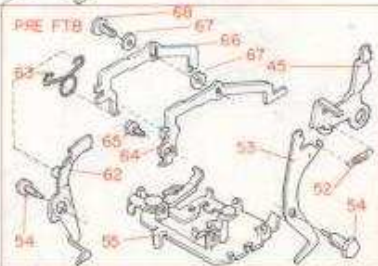

CORRECTING

MECH. CODE
26

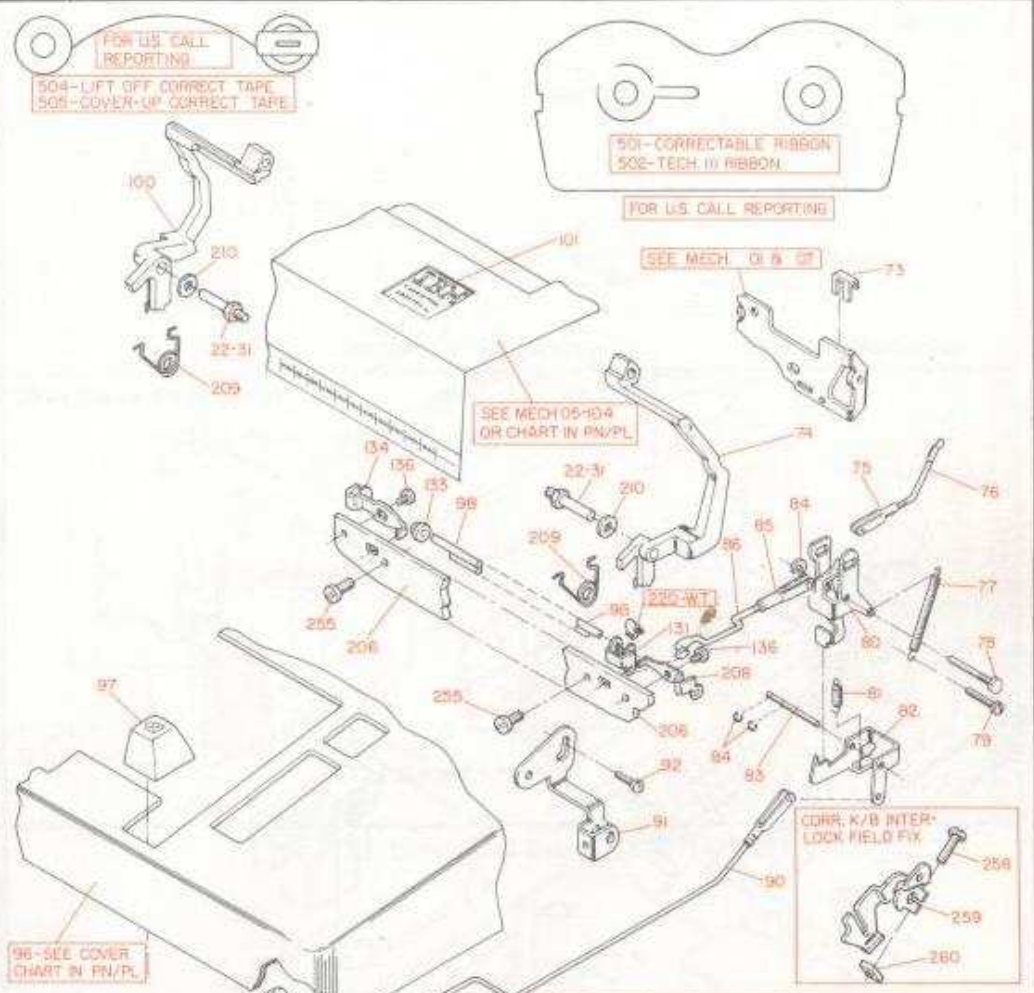

FOR U.S. CALL REPORTING

504-LIFT OFF CORRECT TAPE
505-COVER-UP CORRECT TAPE

501-CORRECTABLE RIBBON
502-TECH. II RIBBON

FOR U.S. CALL REPORTING

SEE MECH. 01 & 07

SEE MECH 05-10-4
OR CHART IN PN/PL

220-WT

CORR. K/B INTER-
LOCK FIELD FIX

96-SEE COVER
CHART IN PN/PL

LEVEL I-NON FTB

- 103-B/M COVER (VENT GRILL NOT INCL.) SEE CHART IN PN/PL
- 104-B/M PAPER BAIL
- 107-REAR LOGO
- 130-B/M FRONT CARRIER SUPPORT & TORQUE BAR



MECH. CODE
30

SOUND REDUCTION (8XX)

- 30-INSULATION B/M
- 31-FIELD INSTALL SOUND PACKAGE
B/M BX2-BX5
- 32-COMPLETE COVER B/M
SOUND PACK (SEE CHART IN PN/PL)
- 50-B/M HOOD SOUND REDUCTION W/T
- 100-B/M COVER W/T

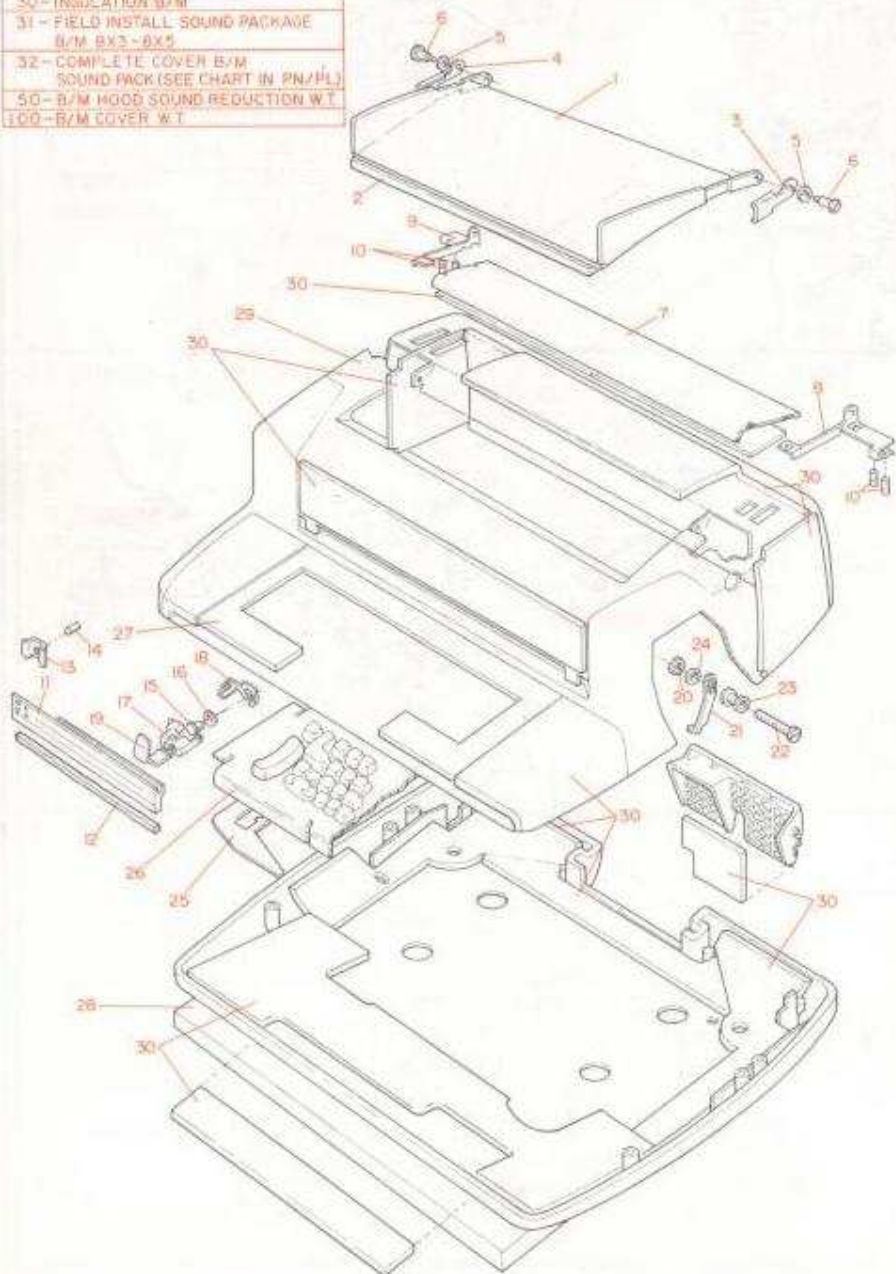

MECH. CODE
30

SOUND REDUCTION (670X)

- 140-INSULATION B/M
- 165-FIELD INSTALLED
B/M SOUND PACKAGE
- 163-COMPLETE COVER B/M
SOUND PACK. SEE
CHART IN PN/PL

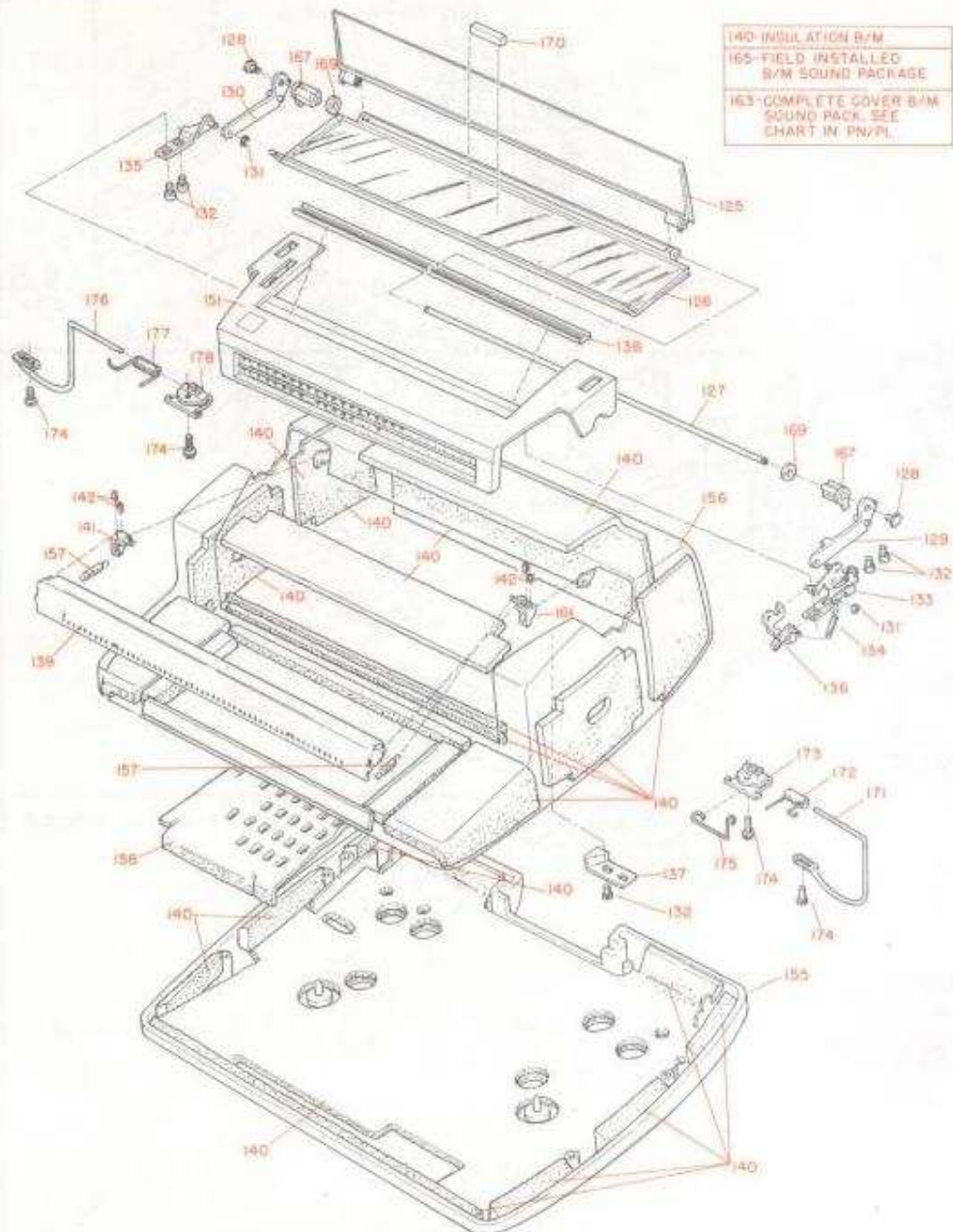

CARD HOLDING PLATEN

MECH. CODE
39

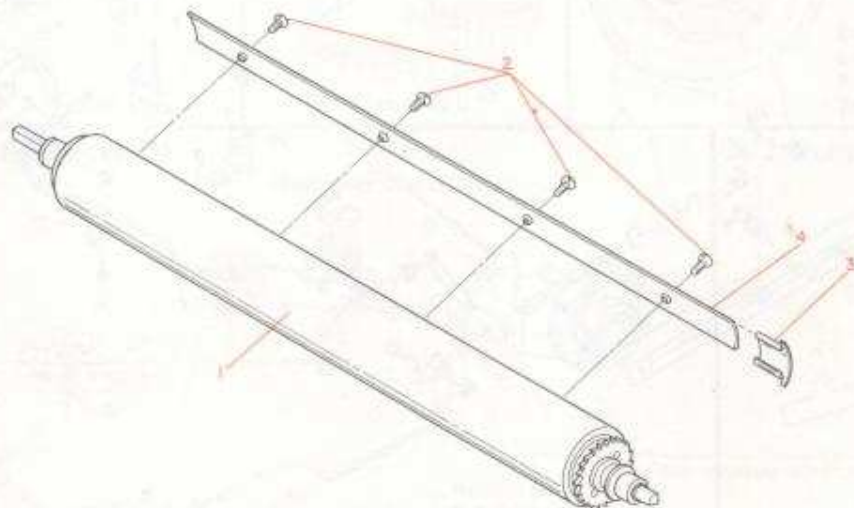

NOTE: REFER TO STD PLATEN FOR PARTS NOT REFERENCED

DEAD KEY

MECH. CODE
40

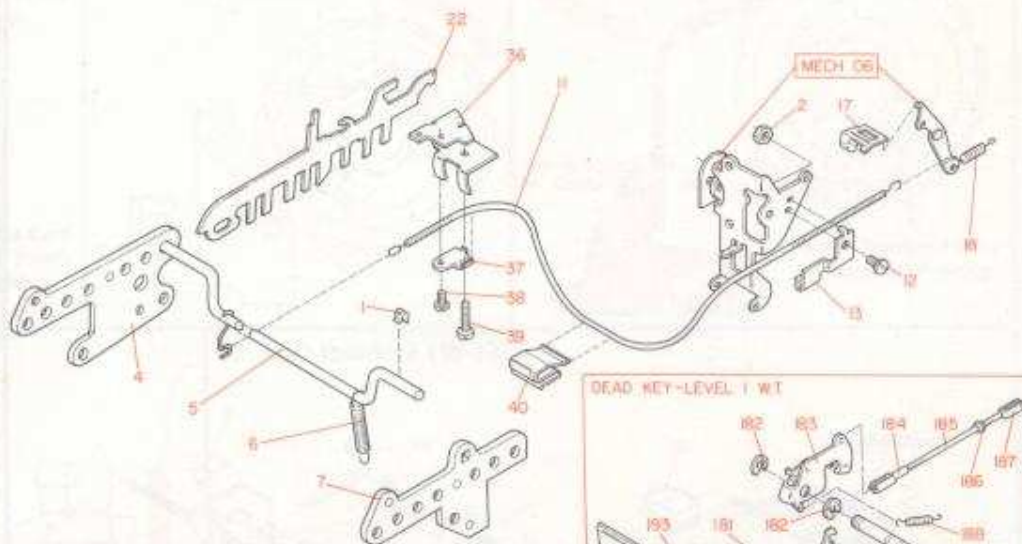

50-DEAD KEY DISCONNECT 2/M
FIELD INSTALLED ONLY ON
MACHINES WITH US SN
BEGINNING WITH 5 OR 9
OR ANY SELECTRIC II

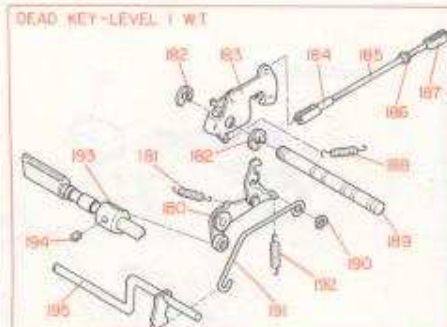

DEAD KEY DISCONNECT

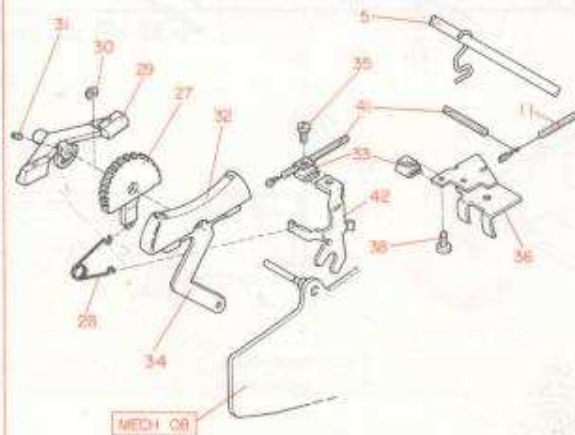

723 & 725

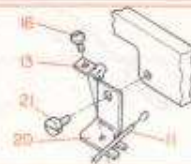

LEVEL I

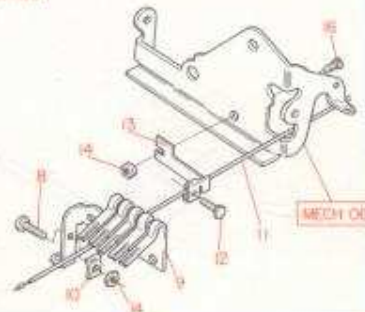

MECH. CODE
40

W.T. DEAD KEY (THAILAND)

PARTS NOT SHOWN HERE ARE COMMON PARTS
AND ARE INCLUDED IN DEAD KEY DRAWING MECH. 40

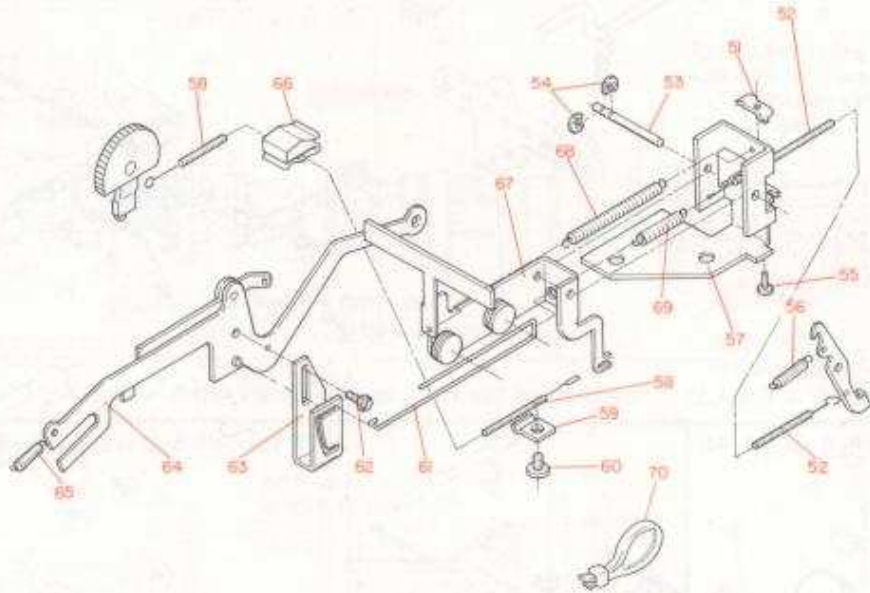

MECH. CODE
41

SHIFT SENSING

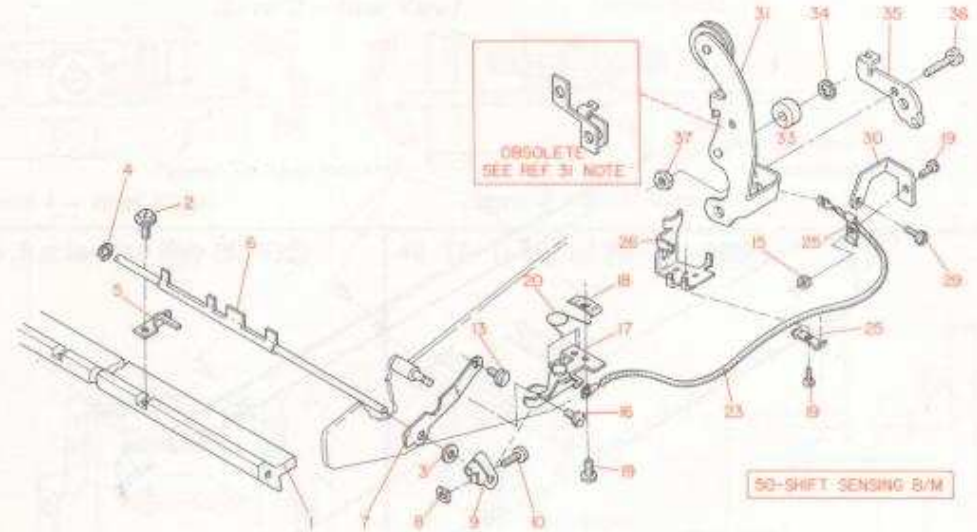

OBSOLETE
SEE REF 31 NOTE

50-SHIFT SENSING S/M

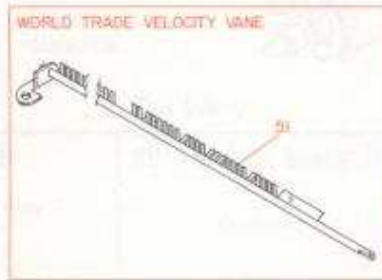

WORLD TRADE VELOCITY WANE

HANDICAPPED ATTACHMENTS

MECH. CODE
45

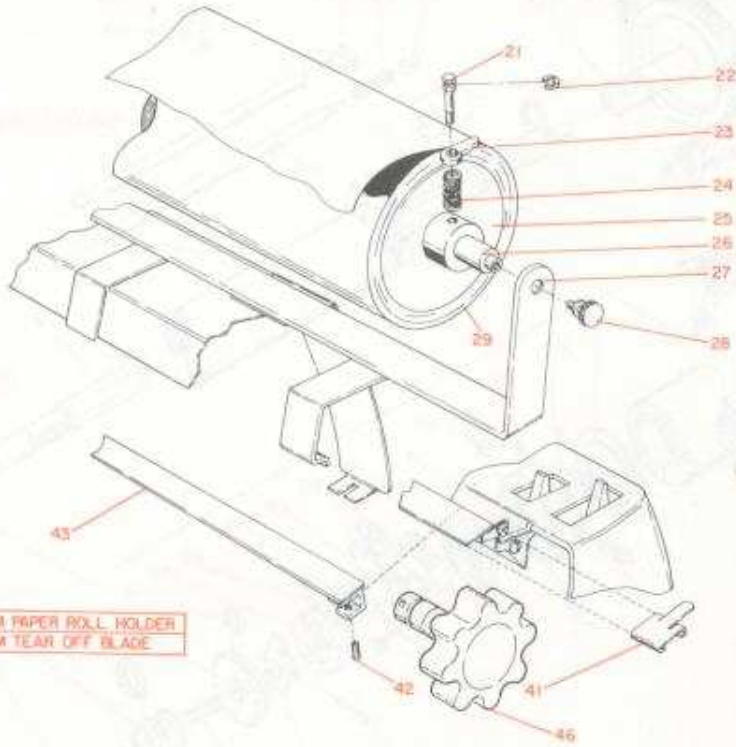

30-B/M PAPER ROLL HOLDER
44-B/M TEAR OFF BLADE

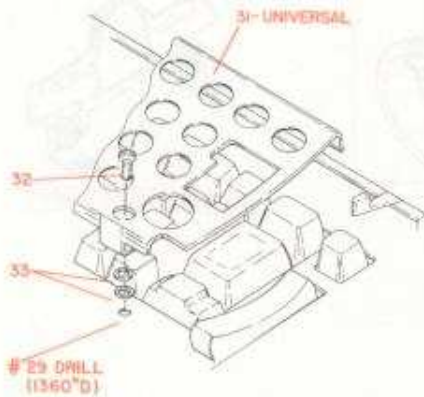

34-B/M KEYBOARD REST

#29 DRILL
(1360°D)

HANDICAPPED ATTACHMENTS

MECH. CODE
45

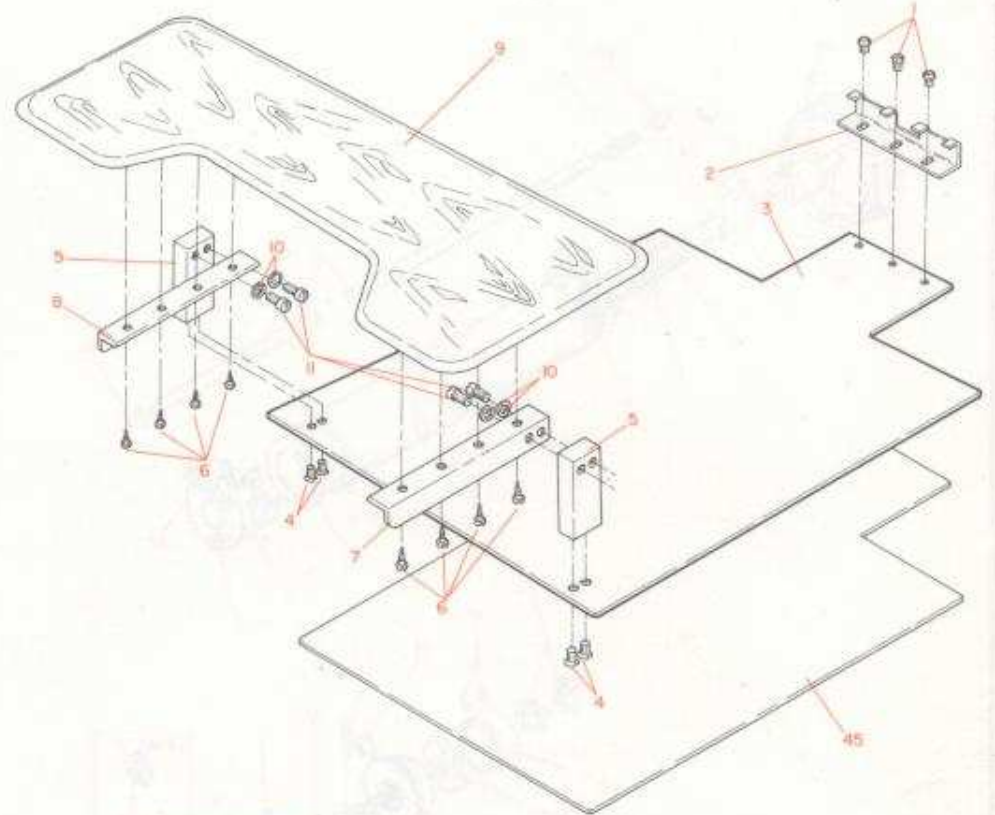

42-B/M ARM REST

MECH. CODE
49

PIN FEED PLATEN

LEVEL 1

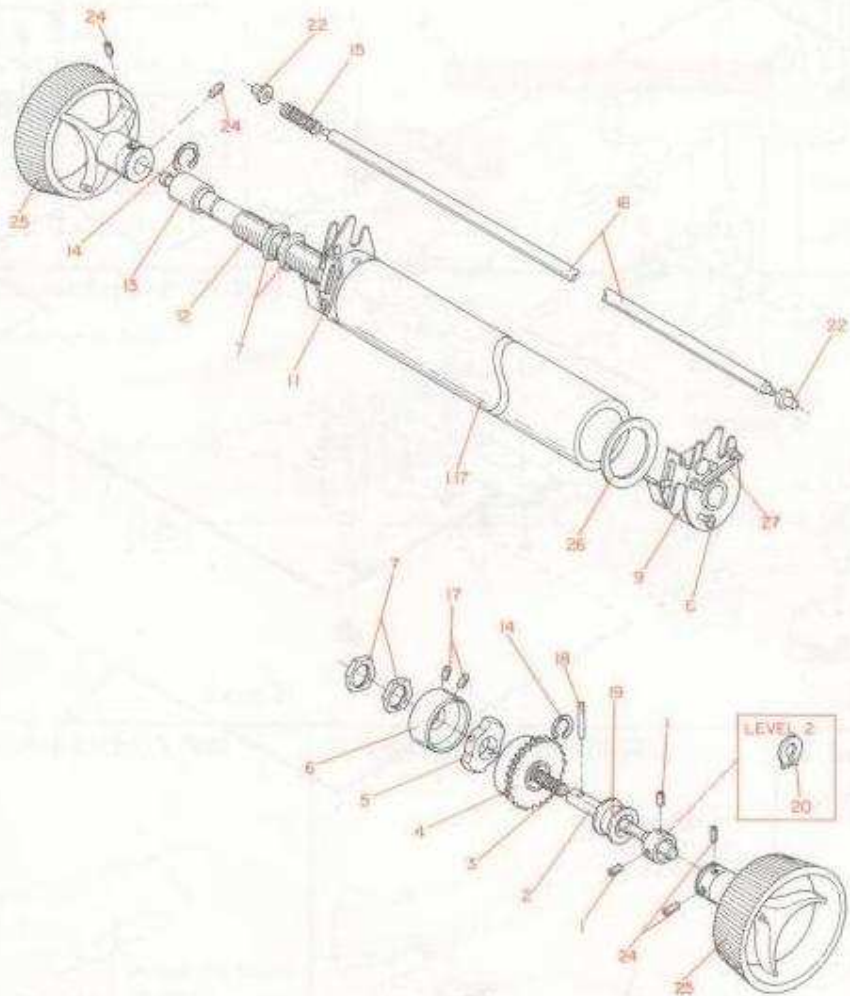

MECH. CODE
49

PIN FEED PLATEN

LEVEL 2

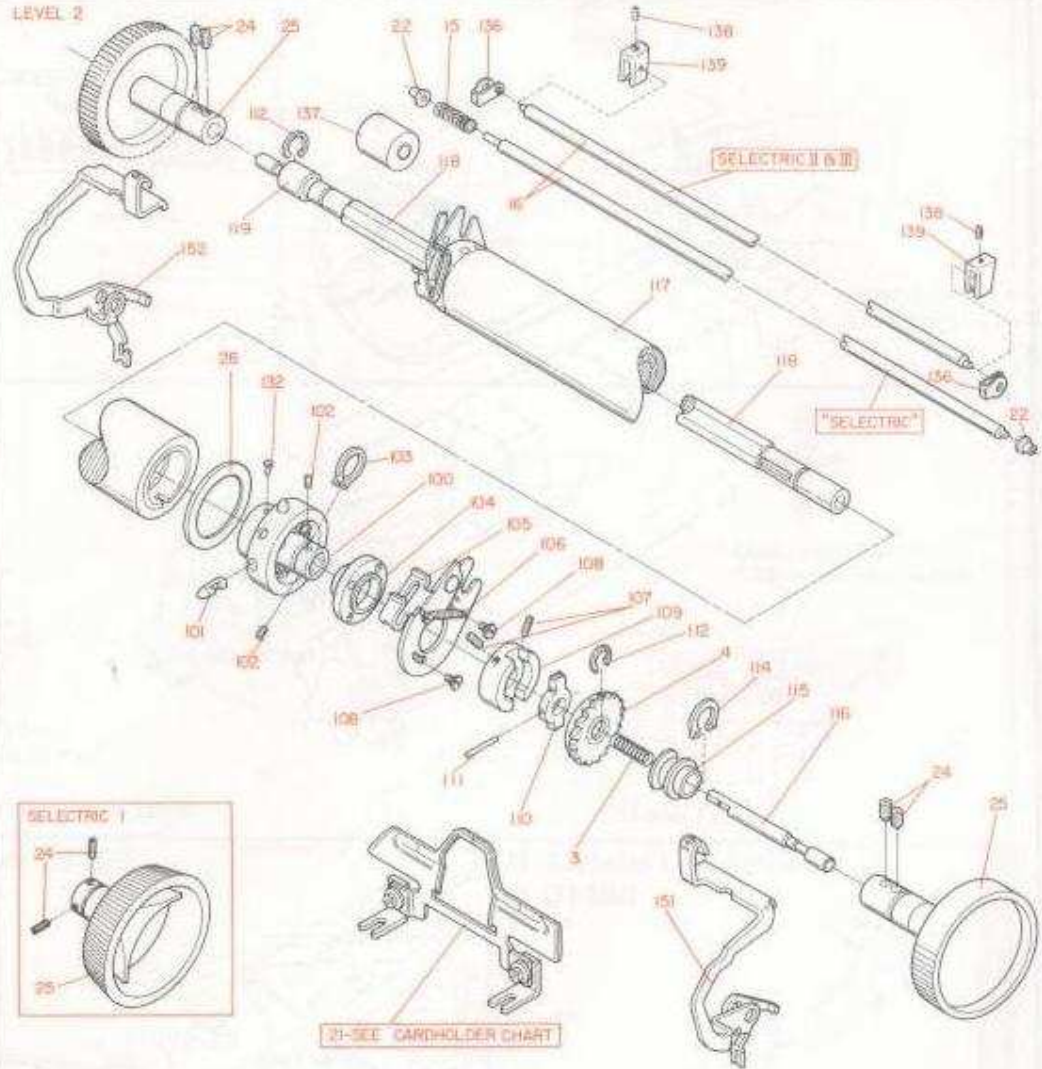

W. T. OVERHEAD PIN FEED PLATEN

MECH. CODE
49

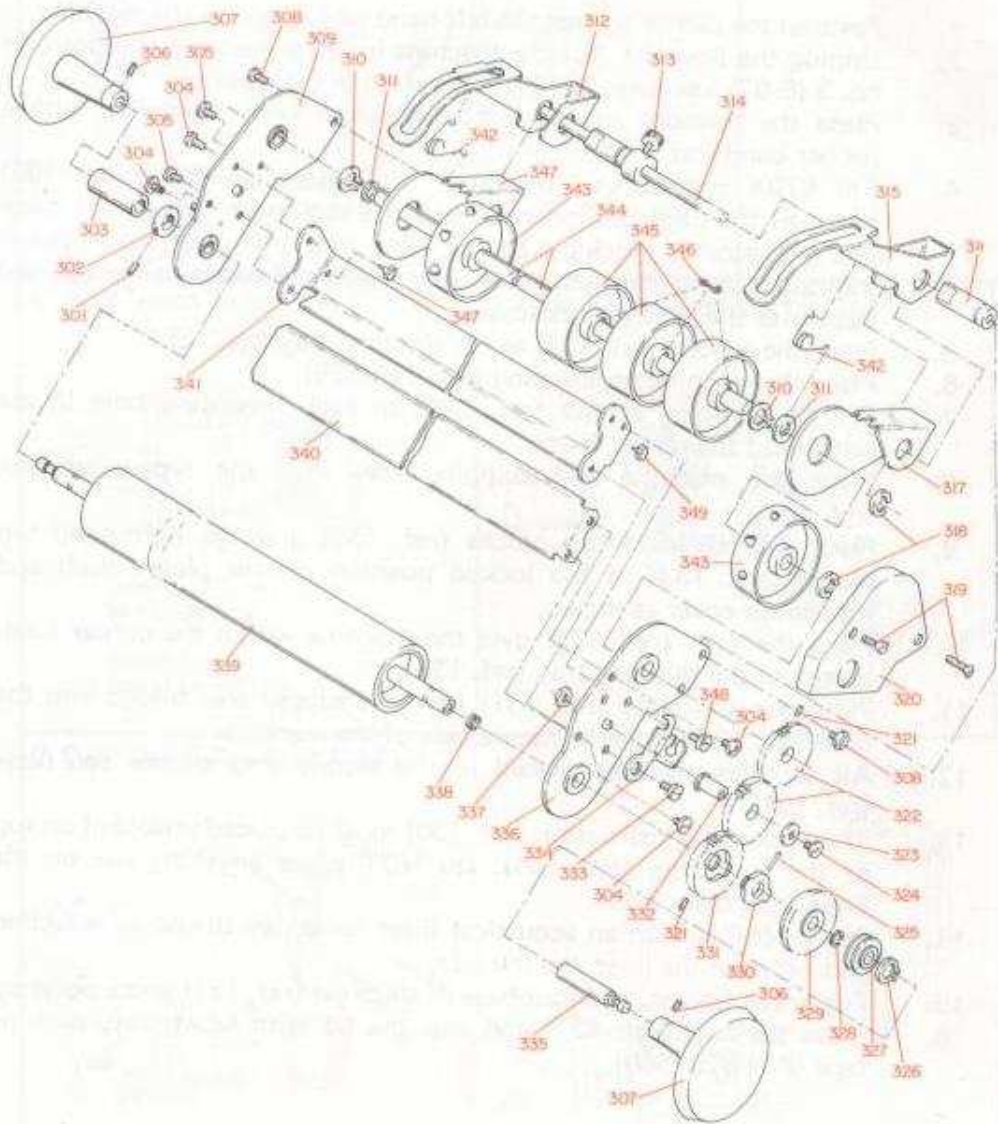

STROKE COUNTER

MECH. CODE
51

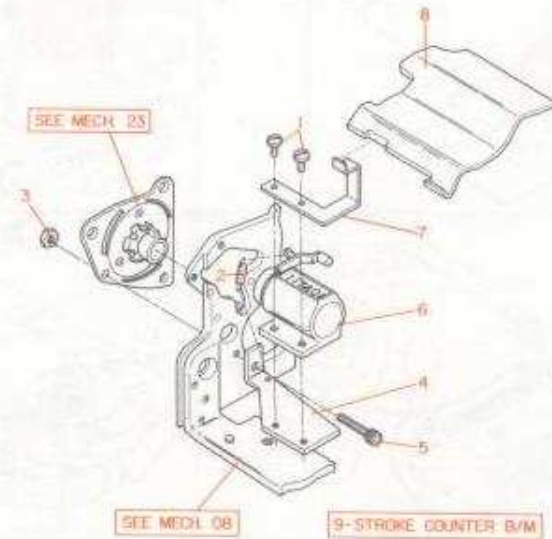

MECH. CODE

65

W.T. PACKING PARTS

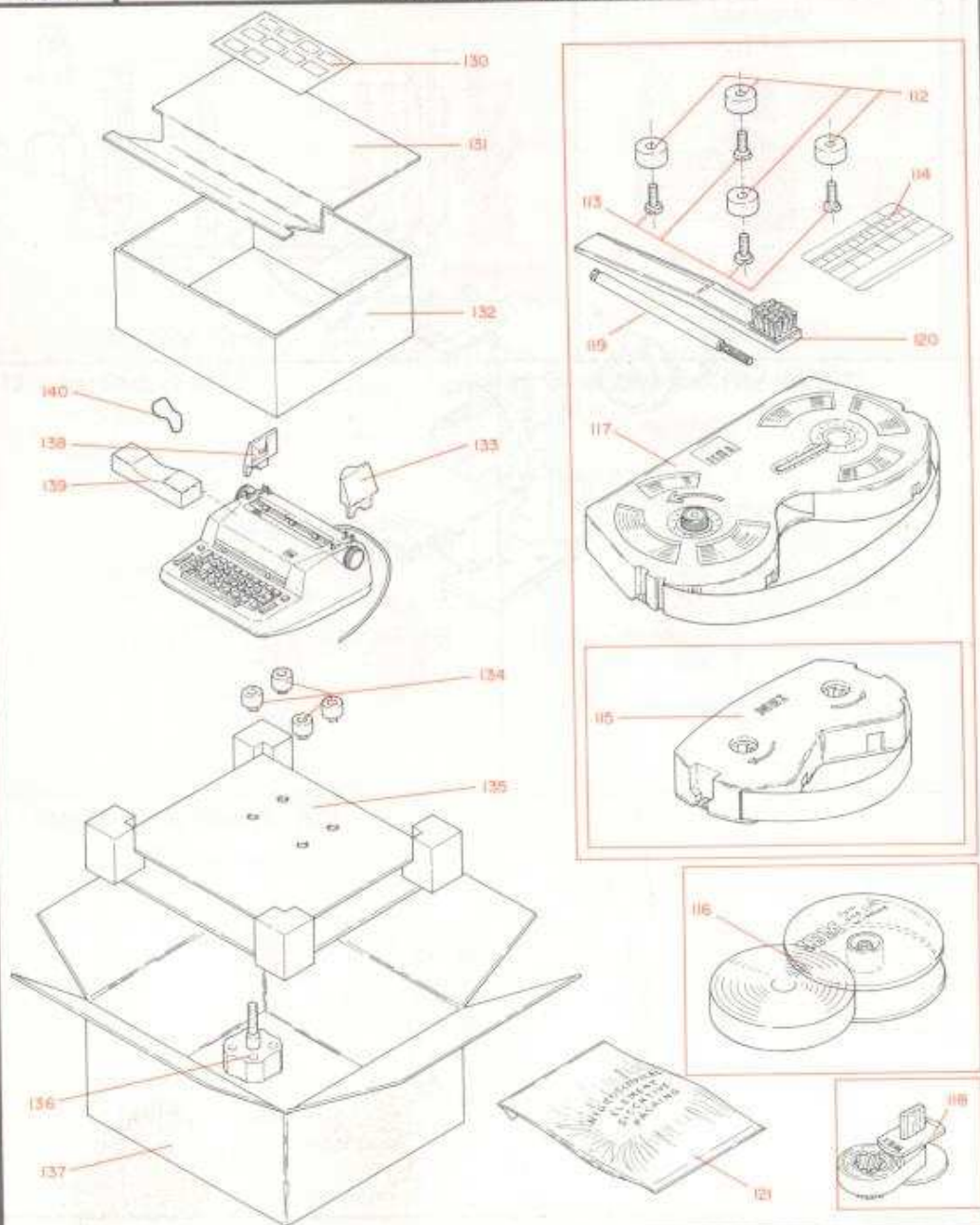

W.T. PACKING INSTRUCTIONS

WORLD TRADE PACKING INSTRUCTIONS

1. Position the carrier against the left-hand side frame of the machine.
2. Unplug the linecord. Put the machine in lower case and trip position no. 3 (E-02) keylever. Put On/Off switch in off position.
3. Place the linecord around left-hand platen knob. Secure it with a rubber band (ref. 140).
4. For 670X typewriter ("Selectric" III), place the foam (ref. 139) between the page-end indicator and the top cover. Secure the page-end indicator by placing a rubber band (ref. 140) over the page-end indicator, under the acoustical filter hood and paper bail shaft, and back over the page-end indicator.
5. Place the spacers (ref. 134) in the shipping tray (ref. 135).
6. Place the machine on shipping tray (ref. 135).
7. Fit the shipping screws (ref. 136) in each mounting hole in the bottom of the power frame.
8. Place the machine and shipping tray into the typewriter box (ref. 137).
9. Place the left-hand top blocks (ref. 138) and the right-hand top blocks (ref. 133) in the locked position on the platen shaft and top/center cover as shown.
10. Place the liner (ref. 132) over the machine within the corner foam blocks of the shipping tray (ref. 135).
11. Place the top plate (ref. 131) with the supply area folded into the liner (ref. 132) at the keyboard side of the machine.
12. All supplies must be placed in the supply area of the top plate (ref. 131).
13. The unpacking instruction (ref. 130) must be placed unfolded on top of the top plate (ref. 131). Do NOT place anything else on the unpacking instruction.
14. For machines with an acoustical filter hood, lay the noise reduction pad between the liner and the box.
15. For ocean freight, add four bags of silica gel (ref. 121) and a polybag.
16. Close the box (ref. 137) and seal the lid with heavy-duty packing tape (P/N 8199660).

BOLT DOWN INSTRUCTIONS

BOLT DOWN INSTRUCTIONS – DROP CENTER DESKS

1. Install four mounting feet – P/N 1128485 for "Selectric" Typewriters or P/N 1205981 for "Selectric" II and III Typewriters or Correcting "Selectric" II and III Typewriters – to power frame.
2. Place a small amount of grease on the feet just around the outside of the threaded holes.
3. Set typewriter down in the correct position on the desk. Lift typewriter off the desk. The position of the holes to be made can now easily be seen.
4. Use a drill to make four holes and bolt machine to desk. See C-D Catalog, Code 204, Ref. 67 for mounting bolts.
5. **Warning:** The two front bolts must have some clearance between the bolt heads and the desk bottom. They must not pull down on the feet or the power frame may twist. The two rear feet may be tightened.

COVER BOLT DOWN

1. Remove machine from covers.
2. Place bottom cover in correct position on desk.
3. With a cover adapter in each of the two center holes of the bottom cover, mark where to drill the hole. On the "Selectric" II Typewriter, use spacer between adapter and bottom cover.
4. Use proper length of bolt and fasten the bottom cover to the desk. To find out which bolt to use, add 1/2" (12.70 mm) to the thickness of the desk.

CAUTION

Bolting a machine down by other than these procedures can cause an electrical safety hazard or machine failure. An excessively long bolt could interfere with the motor windings or other inner mechanisms of the machine.

MECH. CODE

65

U.S. PACKING PARTS

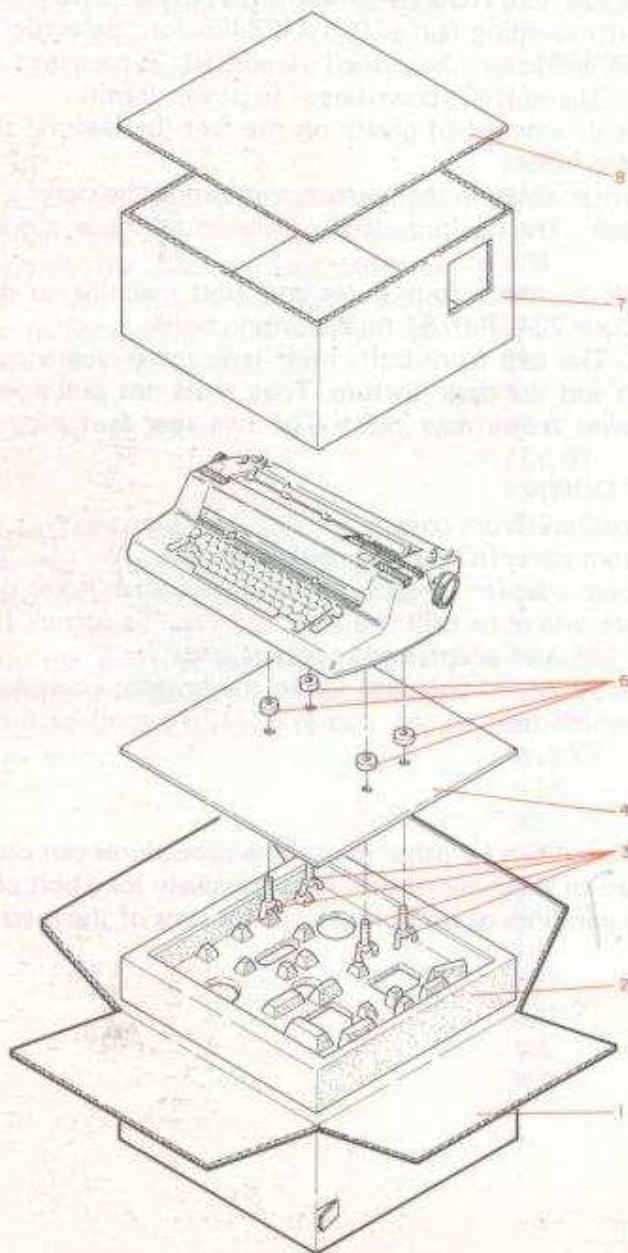

U.S. PACKING INSTRUCTIONS

PACKING INSTRUCTIONS

1. Position the carrier all the way to the right, latch out tab and attach Minnesota Mining Y-9035 or similar tape as shown in Mech. 765.
2. Place Minnesota Mining Y-9035 or similar tape on top cover as shown.
3. Place four rubber grommets under the bottom of the typewriter case as shown.
4. Use wing nut screws to mount the pallet to the machine.
5. Place hair pad in bottom of the box and insert machine.
6. Place liner around the machine and place cord to the back of the liner with Minnesota Mining Y-9035 or similar tape.
7. Insert chipboard tray as shown and seal the carton with tape.

Warning: Do not excessively tighten the front right-hand wing nut screw.

UNPACKING INSTRUCTIONS

1. Open carton by pulling tear tape completely around four sides. Remove top part of the box. Remove top cardboard chipboard tray. Lift out liner by moving the sides away from the platen knobs and lift machine out of the tray.
2. Tilt machine and pallet so the machine rests on the back cover.
3. Remove the four thumb screws. These can normally be turned by hand, but, if necessary, use a pencil as an additional lever.
4. Remove pallet board and plastic spacers.
5. Remove rubber grommets from the five mounting holes in the machine bottom cover (seven on the 7X5 and 8X5).
6. Install the four nylon spacers found in the plastic accessory bag into four of the mounting holes from which the thumb screws were removed.
7. Set the machine down and remove the tape, holding the top cover and the type carrier.
8. The machine is now ready for preinstallation checkout.

APPROXIMATE MACHINE AND CARTON WEIGHT AND SIZE

7X1 — Size 14" (355.6 mm) Deep, 15" (381.0 mm) Wide

7X5, 8X5 — Size 14" (355.6 mm) Deep, 20" (508.0 mm) Wide

| | | |
|------------------------|---------|-----------|
| Model 7X1 | 32 lbs. | (14.5 kg) |
| Models 7X3, 8X3 | 35 lbs. | (16.5 kg) |
| Models 7X5, 8X5 | 37 lbs. | (17.5 kg) |
| Carton 7X1 | 10 lbs. | (4.5 kg) |
| Cartons 7X5, 8X5, 670X | 14 lbs. | (6.35 kg) |

RIBBON CASSETTE

MECH. CODE

27

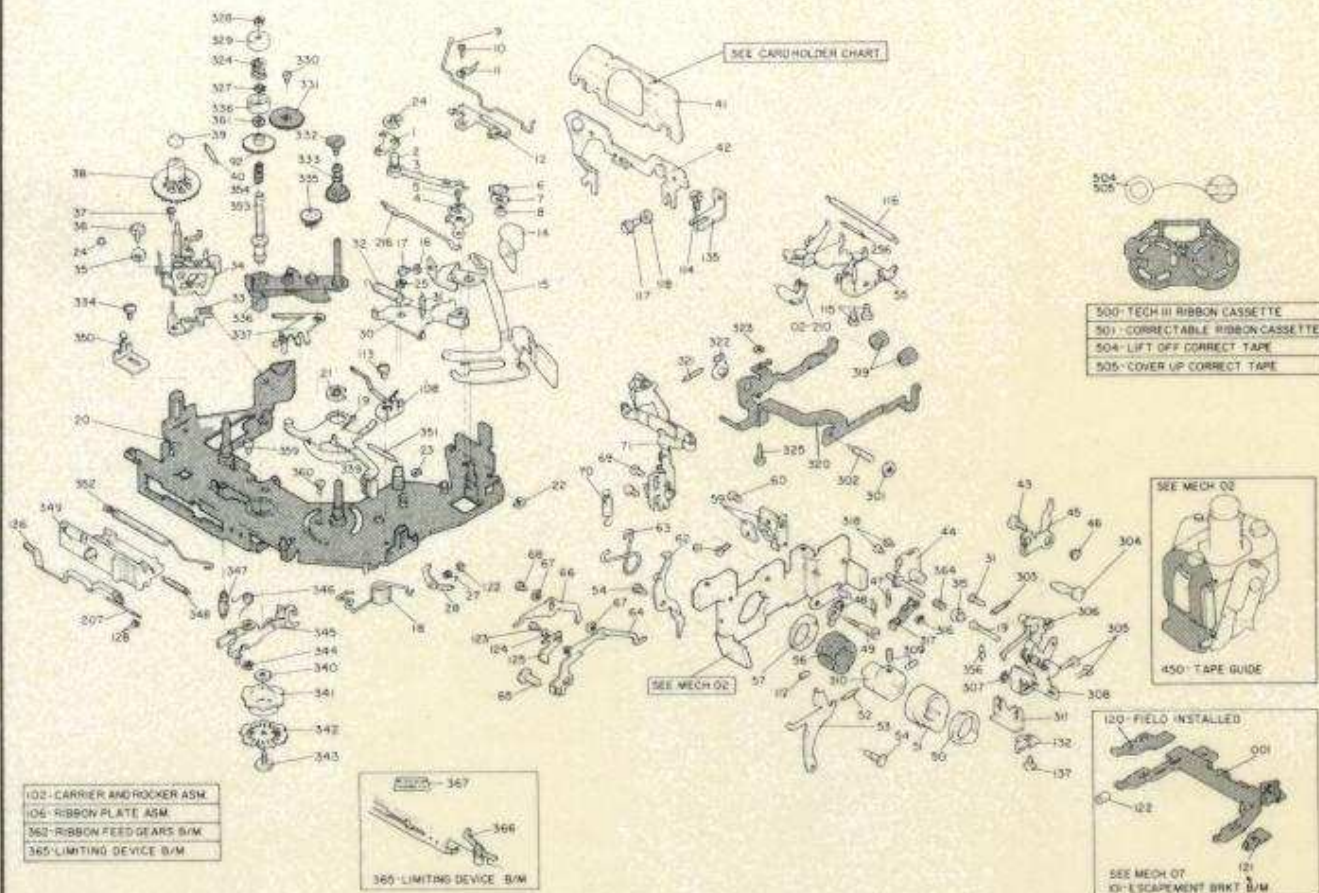

- 102 CARRIER AND ROCKER ASM
- 106 RIBBON PLATE ASM
- 362 RIBBON FEED GEARS B/M
- 365 LIMITING DEVICE B/M

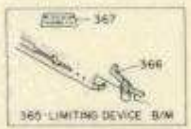

1. Attach this insert on last page of APM S241-5939-3.
2. Shaded parts are unique to Ribbon Cassette Mechanism

Frame 314-Lift Height

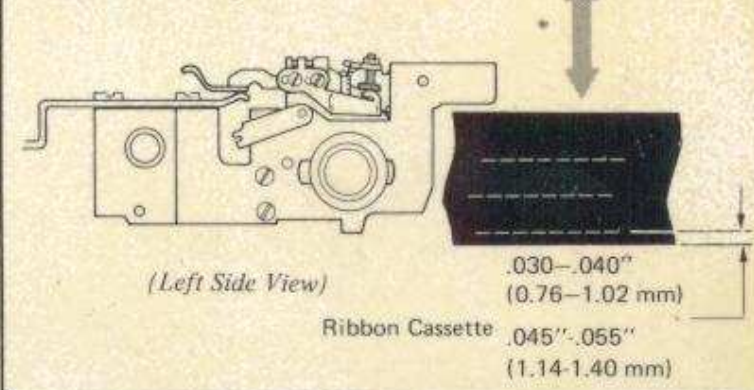

Frame 315 - Lift Arm Stop (Ribbon Cassette)
"For RC Only - Form Stop On Escapement Bracket"

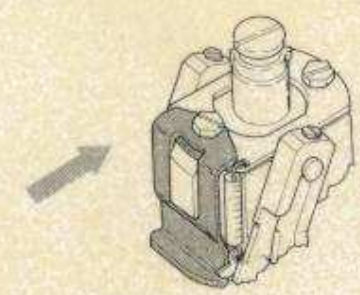
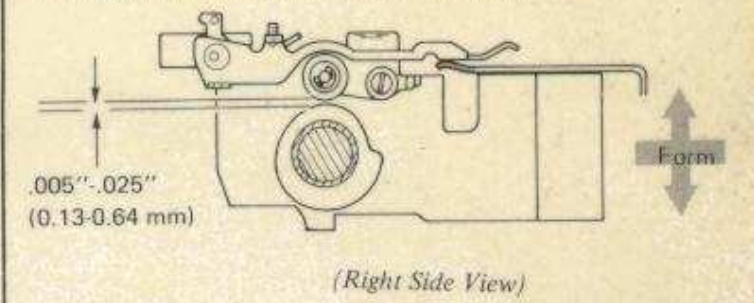

Tape Deflector - Adjust the deflector against the tilt ring

MACHINE IDENTIFICATION CODES

"SELECTRIC" TYPEWRITER – MACHINE TYPE 6121

1st Digit – 7

2nd Digit – 1 – Film Ribbon
 2 – Fabric Ribbon

3rd Digit – 1 – 8-1/2" writing line
 3 – 11" writing line
 5 – 13" writing line

"SELECTRIC" II AND CORRECTING "SELECTRIC" II TYPEWRITERS – MACHINE TYPE 6126

1st Digit – 8

2nd Digit – 3 – Single-Pitch Selective Ribbon
 4 – Single-Pitch Fabric Ribbon
 5 – Single-Pitch Correcting "Selectric" Typewriter
 7 – Dual-Pitch Selective Ribbon
 8 – Dual-Pitch Fabric Ribbon
 9 – Dual-Pitch Correcting "Selectric" Typewriter

3rd Digit – 3 – 11" writing line
 5 – 13" writing line

WRITING LINE PAPER WIDTH CAPACITY

8-1/2" = 11"
 11" = 13-1/2"
 13" = 15-1/2"

"SELECTRIC" III AND CORRECTING "SELECTRIC" III TYPEWRITERS – PRODUCT CODE 27

| MACHINE DESCRIPTION | MACHINE TYPE |
|--|--------------|
| 13" Writing Line Single-Pitch Fabric | .6701 |
| 13" Writing Line Single-Pitch Non-Correcting | .6702 |
| 15" Writing Line Single-Pitch Correcting | .6703 |
| 13" Writing Line Dual-Pitch Correcting | .6704 |
| 15" Writing Line Dual-Pitch Correcting | .6705 |

96-CHARACTER "SELECTRIC" TYPEWRITER

1st Digit – 9

2nd Digit – 6 – Single-Pitch Selective Ribbon
 4 – Single-Pitch Fabric Ribbon
 5 – Single-Pitch Correcting "Selectric" Typewriter
 1 – Dual-Pitch Selective Ribbon
 2 – Dual-Pitch Fabric Ribbon
 9 – Dual-Pitch Correcting "Selectric" Typewriter

3rd Digit – 3 – 11" writing line
 5 – 13" writing line