

 Data General

DESKTOP GENERATION[®]
Systems

Installation Guide

Warning

Model 10 and 10/SP

Model 10 and 10/SP systems have undergone rigorous testing and have been found to comply with FCC Rules for computing devices as described in the following paragraphs.

The statement below applies to systems configured with a maximum of the following components, or less: system computer unit (including 15-megabyte Winchester disk, dual floppy diskettes, cartridge tape subsystem, CPU logic, memory and I/O cards); Model 10 and 10/SP system console (including a keyboard and either one monochrome or one color monitor); a model 4434 multifunction dot matrix printer; and a model 4435 color graphics plotter.

This equipment generates and uses radio frequency energy and if not installed and used properly, that is, in strict accordance with the manufacturer's instructions, may cause interference to radio and television reception. It has been type tested and found to comply with the limits for a Class B computing device in accordance with the specifications in Subpart J of Part 15 of FCC Rules, which are designed to provide reasonable protection against such interference in a residential installation. However, there is no guarantee that interference will not occur in a particular installation. If this equipment does cause interference to radio or television reception, which can be determined by turning the equipment off and on, the user is encouraged to try to correct the interference by one or more of the following measures:

- reorient the receiving antenna
- relocate the computer with respect to the receiver
- move the computer away from the receiver
- plug the computer into a different outlet so that the computer and receiver are on different branch circuits.

If necessary, the user should consult the dealer or an experienced radio/television technician for additional suggestions. The user may find the following booklet prepared by the Federal Communications Commission helpful: "How to Identify and Resolve Radio-TV Interference Problems."

This booklet is available from the US Government Printing Office, Washington, DC 20402, Stock No. 004-000-000345-4.

If you expand the above-described system configuration to include other peripherals, such as the second Winchester disk unit or additional terminals, the statement below applies.

All Other Models

This equipment generates, uses, and can radiate radio frequency energy and if not installed and used in accordance with the instruction manual, may cause interference to radio communications. It has been tested and found to comply with the limits for Class A computing devices pursuant to Subpart J of Part 15 of FCC Rules, which are designed to provide reasonable protection against such interference when operated in a commercial environment. Operation of this equipment in a residential area is likely to cause interference, in which case the user, at his own expense, will be required to take whatever measures may be required to correct the interference.

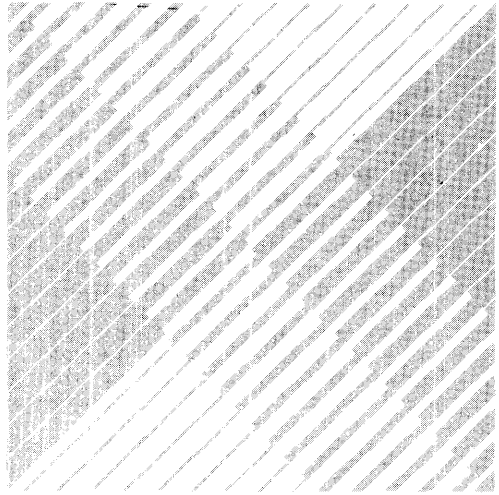

Notice

Data General Corporation (DGC) has prepared this document for use by DGC personnel, customers, and prospective customers. The information contained herein shall not be reproduced in whole or in part without DGC's prior written approval.

DGC reserves the right to make changes in specifications and other information contained in this document without prior notice, and the reader should in all cases consult DGC to determine whether any such changes have been made.

The terms and conditions governing the sale of DGC hardware products and the licensing of DGC software consist solely of those set forth in the written contracts between DGC and its customers. No representation or other affirmation of fact contained in this document including but not limited to statements regarding capacity, response-time performance, suitability for use or performance of products described herein shall be deemed to be a warranty by DGC for any purpose, or give rise to any liability of DGC whatsoever.

In no event shall DGC be liable for any incidental, indirect, special or consequential damages whatsoever (including but not limited to lost profits) arising out of or related to this document or the information contained in it, even if DGC has been advised, knew or should have known of the possibility of such damages.

CEO, DASHER, DATAPREP, DESKTOP GENERATION, ECLIPSE, ECLIPSE MV/4000, ECLIPSE MV/6000, ECLIPSE MV/8000, INFOS, MANAP, microNOVA, NOVA, PRESENT, PROXI, SWAT and TRENDVIEW are U.S. registered trademarks of Data General Corporation, and AEC/STAGE, AI/STAGE, AOSMAGIC, AOS/VIS MAGIC, ArrayPlus, AWE/4000, AWE/8000, AWE/10000, BusiGEN, BusiPEN, BusiTEXT, COMPUCALC, CEO Connection, CEO Drawing Board, CEO Wordview, CEOwrite, CSMAGIC, DASHER/One, DATA GENERAL/One, DESKTOP/UX, DG/GATE, DG/L, DG/STAGE, DG/UX, DG/XAP, DGConnect, DXA, ECLIPSE MV/2000, ECLIPSE MV/10000, ECLIPSE MV/20000, Electronics/STAGE, FORMA-TEXT, GATEKEEPER, GDC/1000, GDC/2400, GENAP, GW/4000, GW/8000, GW/10000, Mechanical/STAGE, microECLIPSE, MV/UX, PC Liaison, RASS, REV-UP, Software Engineering/STAGE, SPARE MAIL, TEO, UNITE, and XODIAC are trademarks of Data General Corporation.

DESKTOP GENERATION® Systems
Installation Guide
014-001118-03

Revision History

Original Release - April 1985

First Revision - August 1985

Second Revision - November 1985

Third Revision - September 1986

A vertical bar in the margin of a page indicates substantive change from the previous revision.

Ordering No. 014-001118

© Copyright Data General Corporation 1985, 1986

All Rights Reserved

Printed in the United States of America

Contents

About This Manual

1 Unpacking and Installation Guidelines

Getting Started	1-2
Checking Your Shipment	1-2
Unpacking and Installing Procedure	1-3

2 Site Planning

Environmental Conditions	2-2
Temperature and Humidity	2-2
Static Electricity	2-3
Mechanical Specifications	2-4
Electrical Specifications	2-6
Radio Frequency Interference	2-9

3 Adding or Replacing Modules

Removing Modules	3-2
Unpacking Modules	3-4
Installing Modules	3-5

4 Adding or Replacing Cards

Unpacking Cards	4-2
DC Power Requirements	4-5
Calculating DC Requirements	4-7
Removing and Installing Cards	4-12
Slot Assignments	4-12
Priority Switches	4-15
Removing Cards	4-16
Installing Cards	4-22
Installing a Color Controller Card	4-28

5 Configuring Cards

Configuring Cards	5-0
Switches	5-3
Jumpers	5-3
Jumper Posts	5-3
Configuring Model 10 and 10/SP Cards	5-4
SPU Card Set	5-4
SPU1 Jumpers	5-5
SPU2 Jumpers	5-6
Color Controller Card	5-7
Memory Expansion Cards	5-8
Configuring Model 20 and 30 Cards	5-12
SPU Card	5-12
Hardware Floating-Point Card	5-14
Memory Cards	5-14
4207 Asynchronous Interface Card	5-20
Configuring Model 45 Cards	5-22
SPU Card	5-22
ATP Card	5-25
Memory Cards	5-27

USAM Cards	5-32
SW1 Switches	5-32
SW2 Through SW6 Switches	5-34
SW7 Switches	5-35
Related Documentation	5-36
Telephone Assistance	5-38

Index

Foldout Configuration Sheets

Configuring Model 10 and 10/SP Systems

Configuring Model 20 and 30 Systems

Configuring a Model 45 System

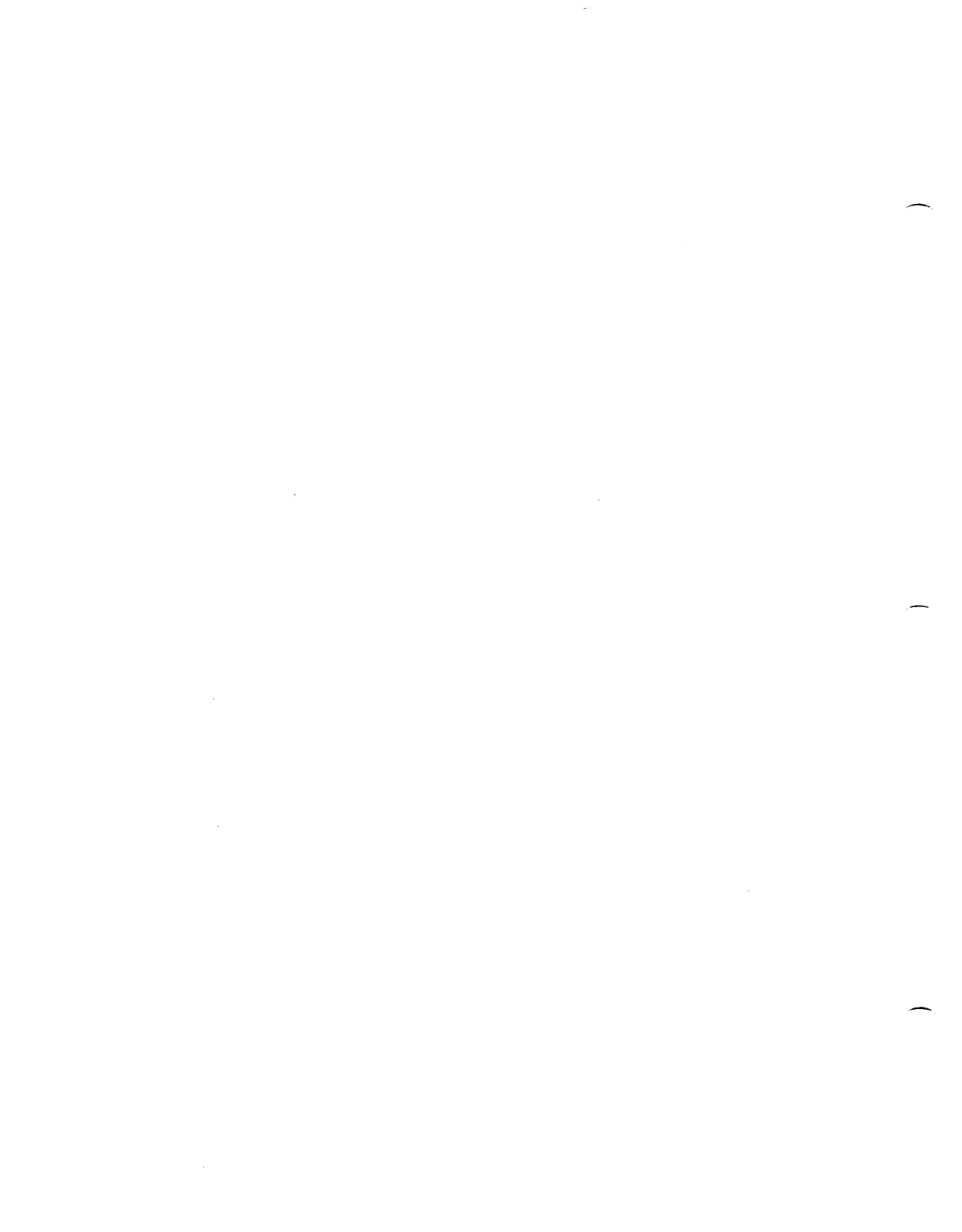



About This Manual

This manual is intended for both new and experienced users of DESKTOP GENERATION® systems. You can use this manual to plan a new system installation or add to an existing one.

Refer to the first chapter for guidelines on unpacking and installing your system. Read the second chapter on site planning if you are not familiar with the requirements of DESKTOP GENERATION systems. After you install your system with the help of the sheets, *How to Install a DESKTOP GENERATION Computer*, you can replace or add modules or cards with the help of chapters three, four, and five.

Use a configuration chart in the back of this manual to record the components of your system.

To install peripherals to a new or existing system, refer to the installation sheet, *How to Connect Peripherals to a DESKTOP GENERATION Computer*.

To order additional documentation, refer to Related Documentation at the end of the book.

If you are unable to solve a problem with the information in this manual, contact one of the Data General Service Operations Centers listed in the back of the book.



1

Unpacking and Installation Guidelines

This chapter gives you guidelines for unpacking and installing your system in an organized manner. Any questions about the site requirements of your system can be answered in the next chapter, "Site Planning." If you are familiar with the material in both of these chapters, unpack and install your system using the installation sheets, *How to Install a DESKTOP GENERATION Computer*. You can use a configuration chart in the back of this book to record the components of your system.

For information on service and support plans, check the DESKTOP GENERATION service package.

Getting Started

To unpack and install your system, you need the following:

- Scissors or knife
- 5mm nutdriver
- #1 Phillips screwdriver
- 1/8" or 3/16" flathead screwdriver

To begin, organize your installation, operator's, and operating system manuals in their binders. Set aside the diagnostic diskette set from the Installation Library and the operating system diskette set from the System User's Library. You will use these diskette sets after you install and power up your system.

Checking Your Shipment

Your computer unit has been shipped to you as components in individual cartons. Each is marked with a label and, usually, a graphic design to help you identify its contents. Attached to the side of one of the cartons is a plastic envelope containing your shipping information and the Final Inspection Checklist. This checklist includes Data General part number(s) for the main components and the cables in your shipment.

Unpacking and Installing Procedure

Below is recommended procedure for unpacking and installing your system. As you unpack and install your system you can compare the components to the front and rear view drawings of the system on Sheet A of *How to Install a DESKTOP GENERATION Computer*.

1. Inventory your shipment by checking it against the Final Inspection Checklist as you unpack the following modules:

Power supply

CPU logic

Logic expansion (optional)

Winchester disk (optional on some systems)

Diskette

Cartridge tape (optional)

2. Examine the components, especially the connector pins

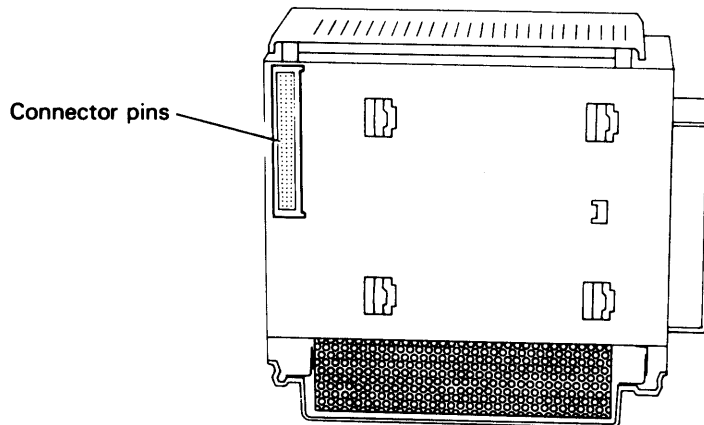
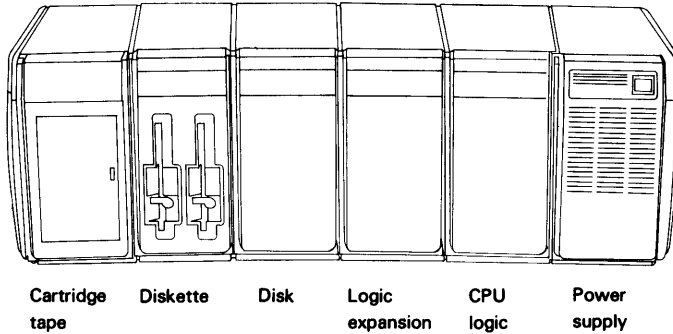

Figure 1-1

- 3.** Install the modules, following the steps on Sheets A and B of *How to Install a DESKTOP GENERATION Computer*.



DG-27140

- 4.** Unpack, inventory, and install the disk expansion unit (optional), using Sheet C of *How to Install a DESKTOP GENERATION Computer*.

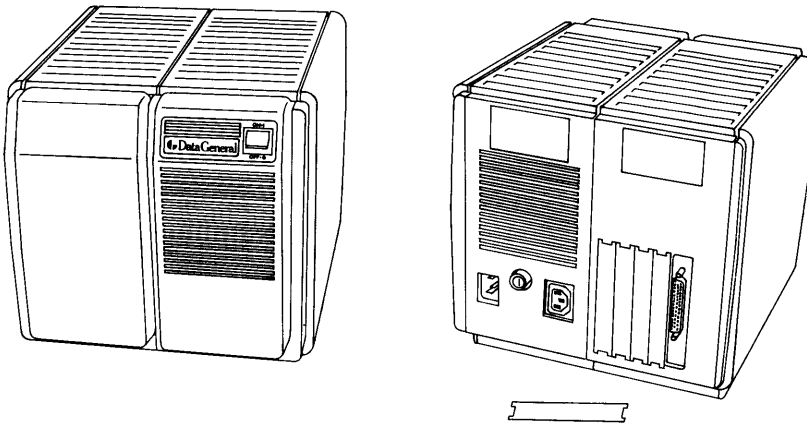

DG-26133

5. Unpack, inventory, and install your system console, referring to the sheet, *How to connect Peripherals to a DESKTOP GENERATION Computer*, for general information and to the *DESKTOP GENERATION Peripherals Installation Guide* for information specific to your system console.

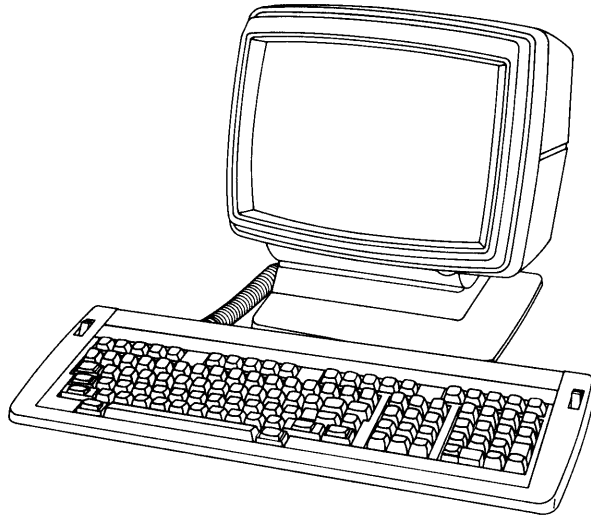

DG-25876

6. Unpack, inventory, and connect any peripheral equipment using the sheet, *How to Connect Peripherals to a DESKTOP GENERATION Computer*, for general information and to the *DESKTOP GENERATION Peripherals Installation Guide* for information specific to the device.

7. Store the installation sheets in front of the Installation Library binders.

8. Record your system on a system configuration chart in the back of this book.

9. If you want to install equipment not described on the installation sheets or *DESKTOP GENERATION Peripherals Installation Guide*, refer to the documentation shipped with that equipment.

If you need to review site requirements, turn to the next chapter. If not, install your system using the sheets, *How To Install a DESKTOP GENERATION Computer*.

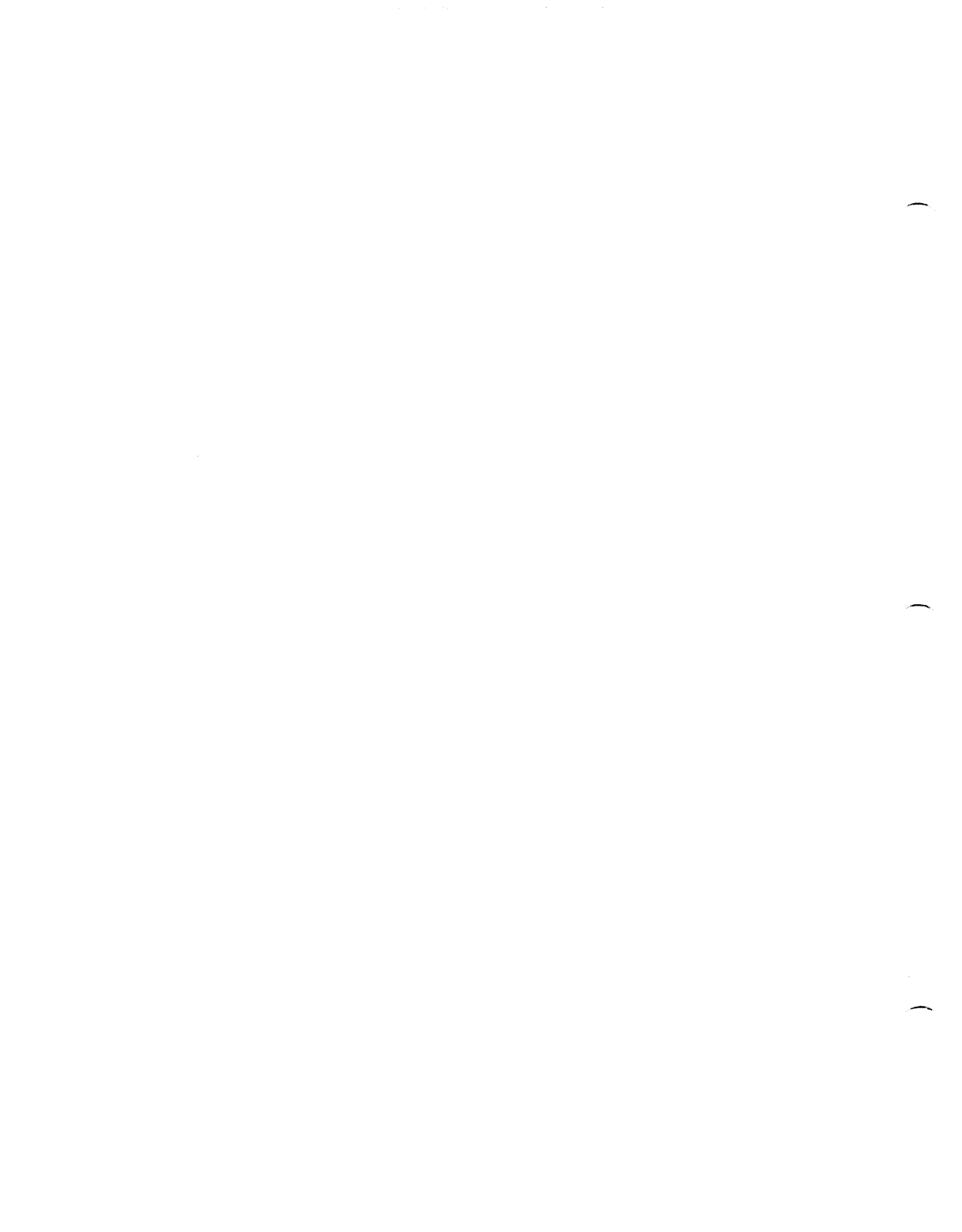



Site Planning

When selecting a site for your DESKTOP GENERATION computer, you need to consider environmental conditions, electrical and mechanical specifications, and radio frequency interference. This chapter discusses each of these factors and helps you select a proper site.

If you are planning an office or industrial site, you may refer to Data General's Site Planning guide (DGC no. 015-000912) for general requirements of a computer facility.

Environmental Conditions

Several environmental conditions affect the proper operation of your equipment. These include temperature and humidity, static electricity, magnetism, contamination, and vibration.

Temperature and Humidity

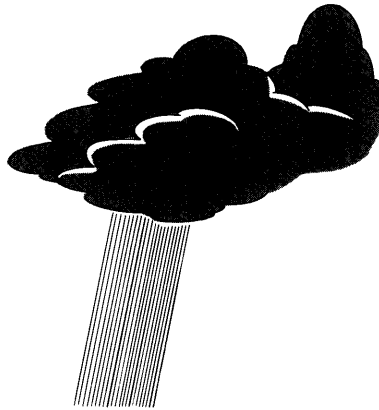
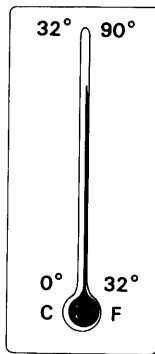

DG-25985

Your system works best when operating within the following ranges:

Temperature 50 to 100 degrees F
 (10 to 38 degrees C)

Relative humidity: 20 to 80 percent (noncondensing)

If you are storing your computer system, make sure storage conditions conform to the following ranges:

Temperature -29 to 122 degrees F
 (-20 to 50 degrees C)

Relative humidity: 10 to 90 percent (noncondensing)

Static Electricity

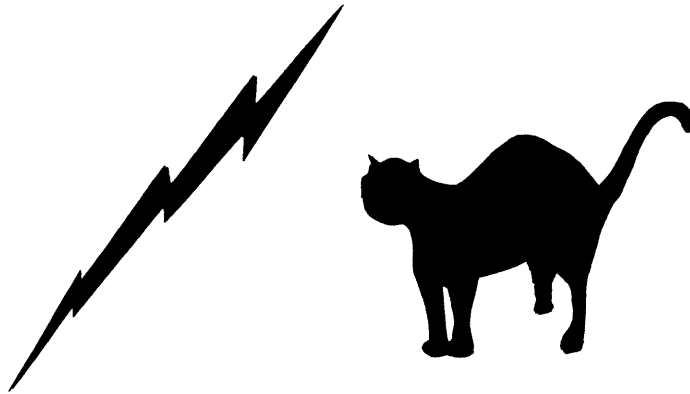

DG-25986

Static electricity can cause the following:

- Data in memory is lost
- Incorrect data is sent from terminals to the computer
- Monitor screens lose displays
- Printers overprint or print garbled data
- Fuses blow and cards fail.

If you find you have a static electricity problem, place a static-proof mat or piece of carpeting at the entrance to the room you have selected as the site for your computer system; place a second static-proof mat or carpet in front of the computer system. This should permanently eliminate any static electricity problem.

Mechanical Specifications

The following tables list mechanical specifications for your equipment:

3-Module Computer Unit-with covers (1 power supply, 1 or 2 diskette drives)

Weight (maximum)	38.5 lbs (17.3 kg) with 1 diskette drive 41.8 lbs (18.8 kg) with 2 diskette drives
Height	10.7 in (27.2 cm)
Depth	13.0 in (33.0 cm)
Width	15.7 in (39.9 cm)

4-Module Computer Unit-with covers (2 power supplies, 1 or 2 diskette drives, 1 disk drive)

Weight (maximum)	54.0 lbs (24.5 kg)
Height	10.7 in (27.2 cm)
Depth	13.0 in (33.0 cm)
Width	20.5 in (52.0 cm)

Logic Expansion Module-empty, without covers

Weight	6.5 lbs (3.0 kg)
Height	10.7 in (27.2 cm)
Depth	13.0 in (33.0 cm)
Width	4.8 in (12.2 cm)

Disk Module-without covers

Weight	14.5 lbs (6.6 kg)
Height	10.7 in (27.2 cm)
Depth	13.0 in (33.0 cm)
Width	4.8 in (12.8 cm)

Cartridge Tape Module-without covers

Weight	15.5 lbs (7.0 kg)
Height	10.7 in (27.2 cm)
Depth	13.5 in (34.3 cm)
Width	4.8 in (12.2 cm)

Expansion Disk Unit-without covers

Weight	28.5 lbs (12.9 kg)
Height	10.7 in (27.2 cm)
Depth	12.8 in (32.5 cm)
Width	10.9 in (27.7 cm)

Mechanical specifications for the system console, terminals, printers, plotter, data tablet, and mouse are listed in the *DESKTOP GENERATION Peripherals Installation Guide* or the documentation shipped with the peripheral.

Electrical Specifications

Your computer system requires that electrical specifications such as voltage, current, and line frequency be within a certain range for correct operation and reliability. Your main concern will be to supply the proper voltage and current required by your system. You have little or no control over the line frequency unless you install special equipment.

To prevent damage to your system or injury to yourself, use only three-pronged ac outlets and be sure that your electrical system is wired in accordance with the National Electrical Code. If you find that operating your system causes blow fuses or tripped circuit breakers, try unplugging other electrical equipment on the same line that may be causing the problem. Heavy electrical loads such as air conditioners, office copying machines, or elevators should not be connected to the same fuse box, even though they may be on separate lines. Also try using different ac outlets protected by a different fuse or circuit breaker.

At power on, all electrical equipment draws a momentary surge of current called *inrush* current. In general, the sum of all inrush currents on *one line* should never exceed 10 times the amp rating on your fuse or circuit breaker. Any more will overload the circuit. For example, if all electrical equipment on one line has a total inrush current of 140 amps and your fuse or circuit breaker is rated 15 amps, your electrical system should be able to draw 150 amps or inrush current with no problem.

WARNING *Never replace blown fuses or circuit breakers with others that have a higher amp rating. This will cause extremely hazardous conditions.*

If you have any doubts about the wiring at your site, a licensed electrician can answer your questions.

The tables ahead list the electrical specifications of components that require an ac power source; each of these components needs access to on one ac power outlet. electrical specifications for the system console, terminals, printers, plotter, data tablet, and mouse are listed in the *DESKTOP GENERATION Peripherals Installation Guide* or the documentation shipped with each peripheral.

Power type	100 V	120 V	220/240 V
Voltage range	85-115 V	102-132 V	187-264 V
Line frequency	47-63 hz	47-63 hz	47-63 hz
Current ² (maximum, per supply)	3 A/3.5A	3 A/3.5A	1.5 A/1.75A
Power consumed ² (maximum, per supply)	225 W/240 W	225 W/240 W	225 W/240 W
Inrush current (maximum, per supply)	30 A 1/2 cycle	30 A 1/2 cycle	30 A 1/2 cycle
Equivalent ² Heat output (per supply)	770/820 BTU/hr	770/820 BTU/hr	770/820 BTU/hr
Power cord length	8.2 ft (2.5 m)	8.2 ft (2.5 m)	8.2 ft (2.5 m)

¹The power supply module in a three-module unit contains one power supply. The power supply module in a system with either a disk or logic expansion module contains two power supplies.

²The first figure is for 135-watt supplies; the second figure is for 150-watt supplies.

Power type	100 V	120 V	220/240 V
Voltage range	90-110 V	102-132 V	187-264 V
Line frequency	47-63 Hz	47-63 Hz	47-63 Hz
Current (maximum)	1.2 A	1.2 A	1.2 A
Power consumed (maximum)	54 W	54 W	54 W
Inrush current (maximum)	1.5 A	1.5 A	1.5 A
Power cord length	8.2 ft 2.5 m)	8.2 ft (2.5 m)	8.2 ft (2.5 m)

Expansion	Desk Unit		
Power type	100 V	120 V	220/240 V
Voltage range	85-115 V	102-132 V	187-264 V
Line frequency	47-63 hz	47-63 hz	47-63 hz
Current (maximum)	1.5 A	1.5 A	0.75 A
Power consumed (maximum)	70 W	70 W	70 W
Inrush current (maximum)	30 A 1/2 cycle	30 A 1/2 cycle	30 A 1/2 cycle
Power cord length	8.2 ft (2.5 m)	8.2 ft (2.5 m)	8.2 ft (2.5 m)

Radio Frequency Interference

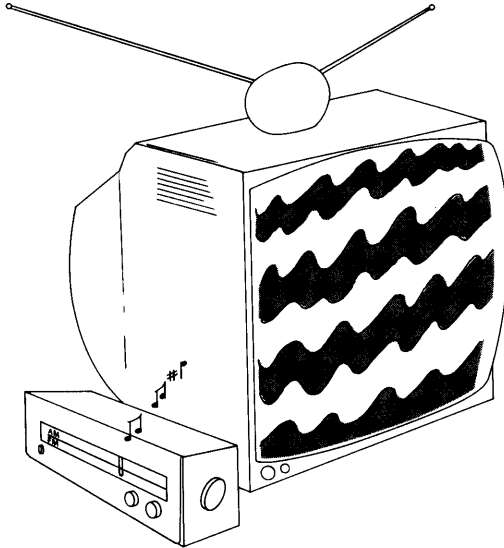

DG-25989

Because your computer system generates and uses radio frequencies, it may interfere with or be affected by other devices which generate radio frequencies — radios, microwave ovens and the like. You can avoid this problem by installing the computer properly, according to the procedures outlined in this manual.

Choose a site for the computer free of radios, televisions, and other devices generating or using radio frequencies. Make sure that this site has no ac outlets that share a line with such devices.

If you properly install your computer unit, connect its optional equipment, and find that you have an interference problem such as distortion of your display screen, radio sound, or television picture, contact your nearest Service Operations Center.

After choosing a site for your new computer system with the help of this chapter, you are ready to unpack and install it. Refer to your sheets, *How to Install a DESKTOP GENERATION Computer*.

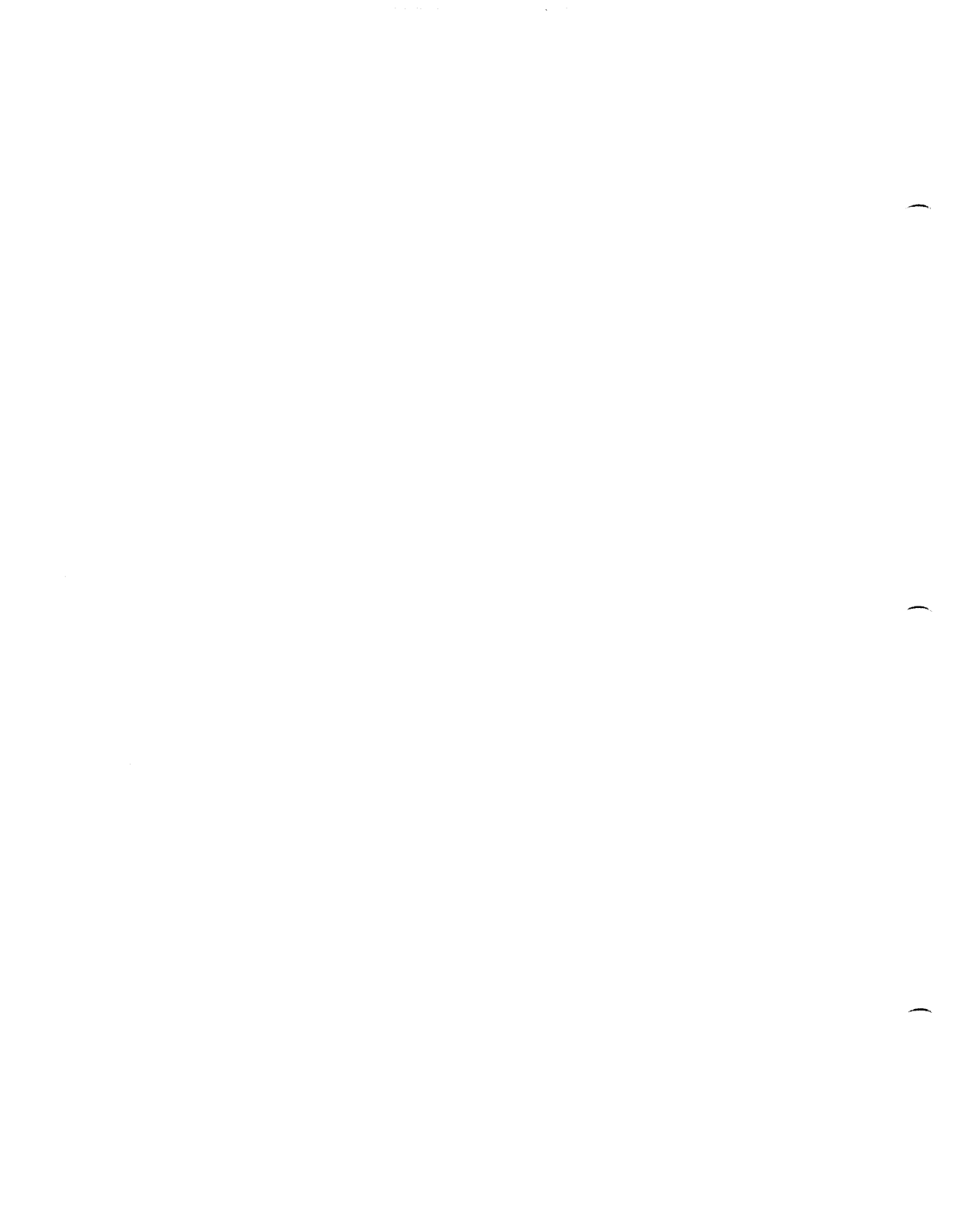



Adding or Replacing Modules

This chapter gives you guidelines for removing a module to return it for service or for adding a new module to a system previously installed.

Removing Modules

When removing a module, always turn off the main power switches of the computer unit and cartridge tape module, if present. Unplug the power cords from their ac outlets and disconnect any devices (printers, plotter, terminals, data tablet, or mouse) cabled to the module you are disconnecting.

When disconnecting two modules, *never* force them apart from the top.

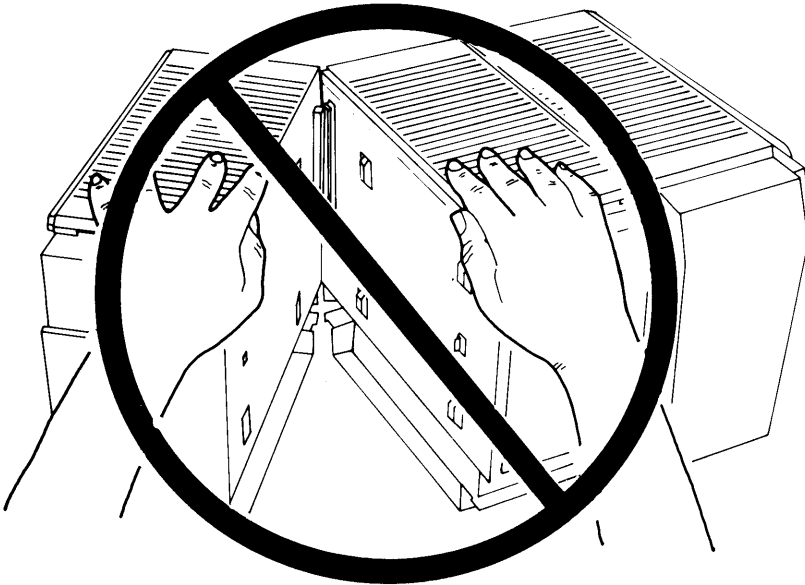

Instead, insert a screwdriver or similar tool between the backs of the two modules and gently pry them apart. Always disconnect and remove the modules while keeping them parallel to avoid bending the pins.

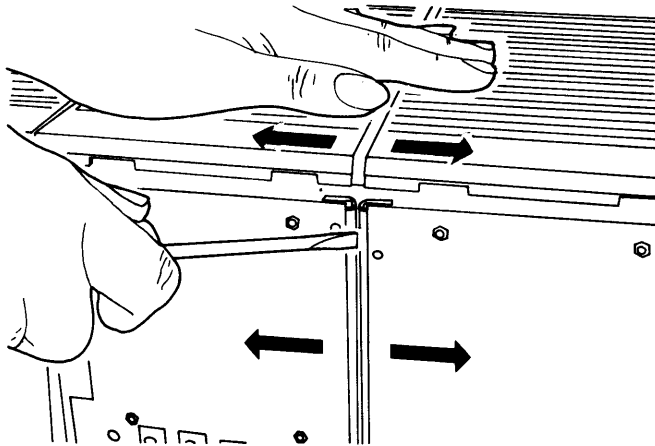

DG-25653

To disconnect one or more modules in your system, simply reverse the instructions on the sheets, *How To Install a DESKTOP GENERATION Computer*. To uncable peripherals, reverse the instructions on the installation sheet, *How to Connect Peripherals To a DESKTOP GENERATION Computer*.

Unpacking Modules

Unpack your new module using the following procedures:

- Unpack the module, checking your shipment against the Final Inspection Checklist
- Examine the components, especially the connector pins

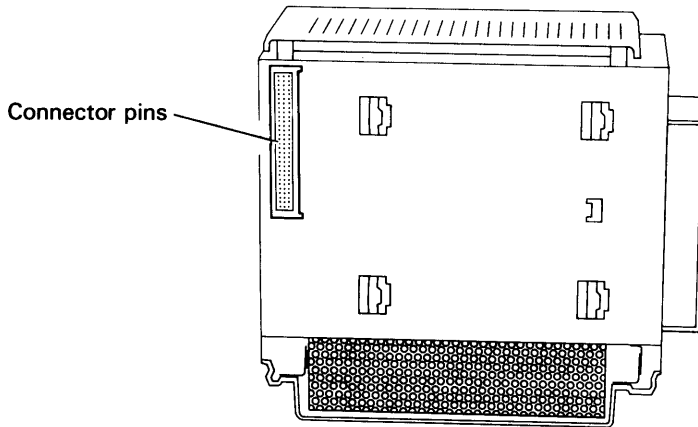

DG-25637

- Record your module on a system configuration chart in the back of this book.

Installing Modules

Depending on your order, install the new modules, using sheets, *How to Install a DESKTOP GENERATION Computer*. Use the table below to select the correct sheet.

CPU logic, power supply, and diskette modules	Sheet A
Winchester disk (optional in some systems)	Sheet A
Cartridge tape module	Sheet B
Logic expansion module (optional)	Sheet A
Second power supply (optional)	Sheet A
Expansion disk unit (optional)	Sheet C

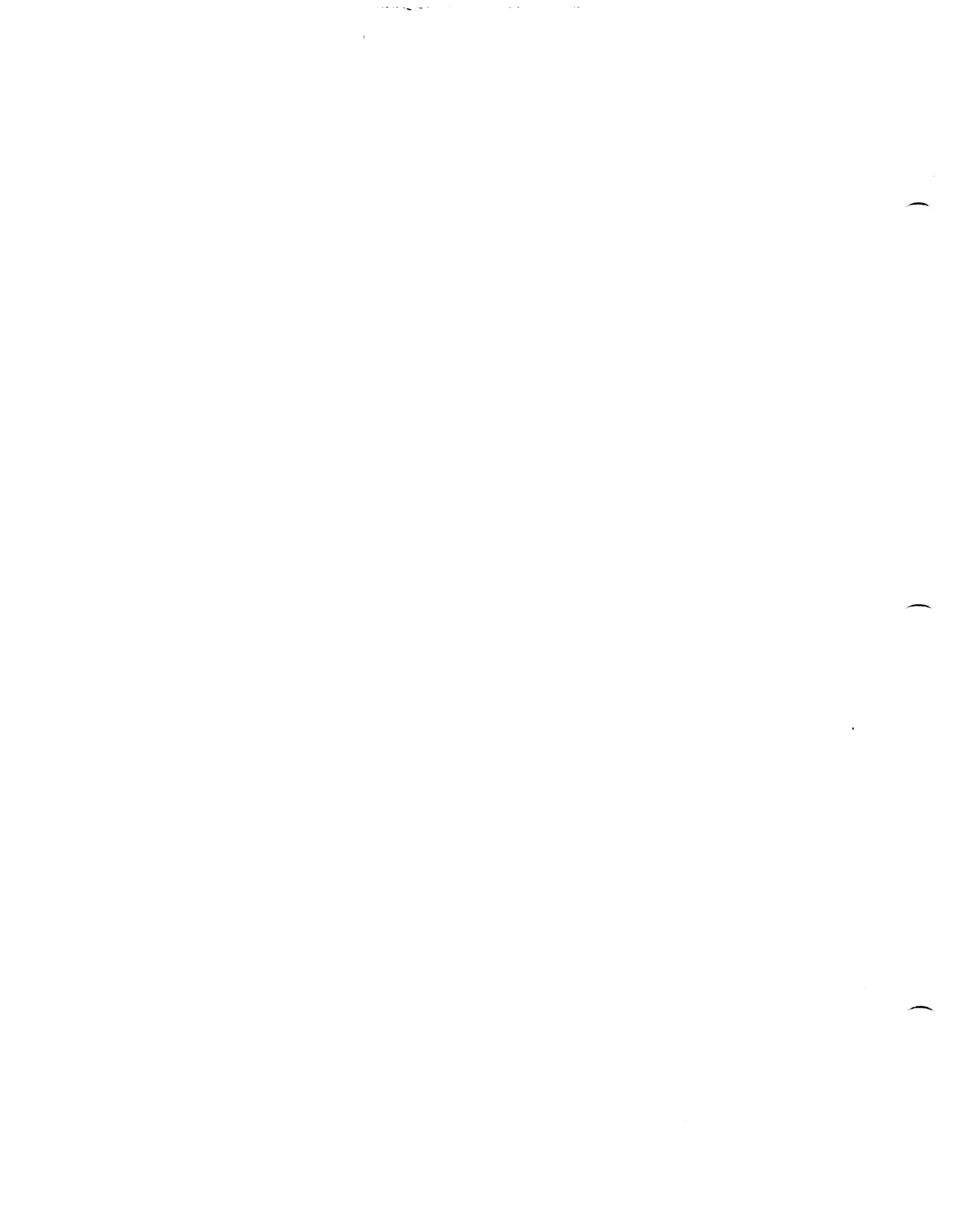



4

Adding or Replacing Cards

This chapter explains how to add or replace printed circuit cards in your DESKTOP GENERATION computer system. It also explains how to calculate the dc power requirements when you add cards to your system and configure the cards for Model 10 and 10/SP, Model 20 and 30, and Model 45.

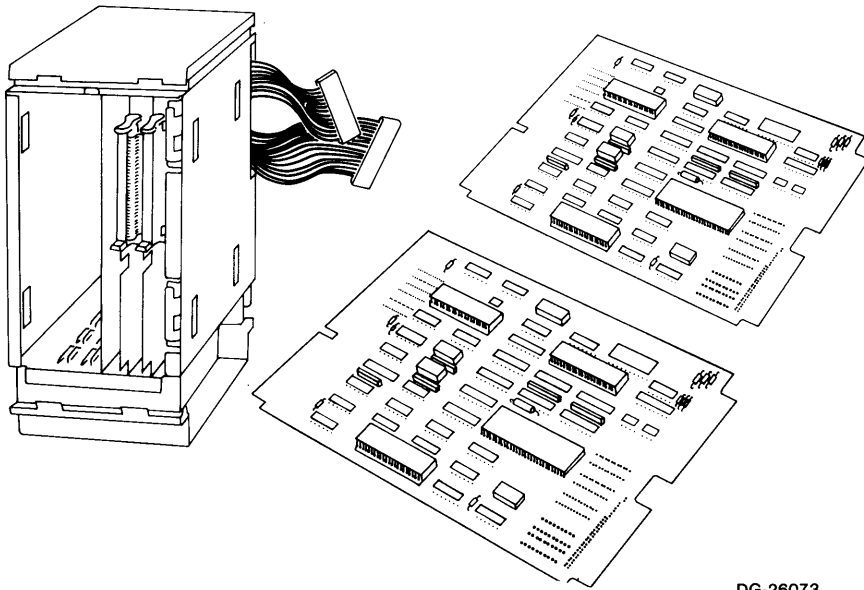

DG-26073

Unpacking Cards

Printed circuit cards are extremely sensitive to environmental conditions such as static electricity and humidity. Take the following precautions before unpacking and handling any card:

- Touch a grounded object such as a doorknob to eliminate static electricity
- Unpack your card only at the site of your computer
- Avoid carpeted floors when handling cards out of their packing bags, especially when the humidity is low.

Take the following steps to unpack a card:

1. Open the shipping carton and remove the card and any other items.
2. Gently remove all packing materials.

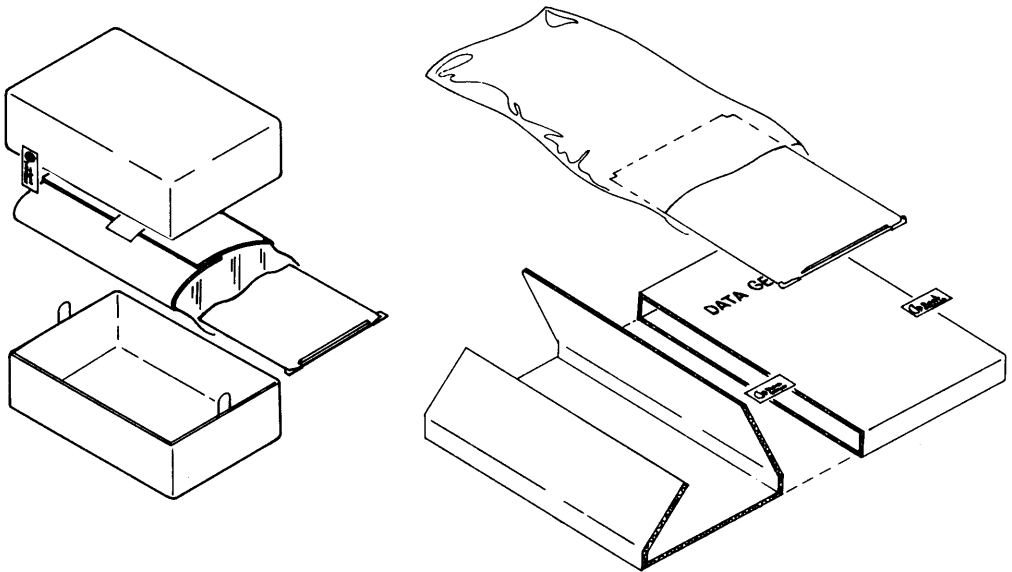

DG-26205

NOTE *Your card comes with a small label (about 1 1/4 by 1/2 inch) which identifies the card. Save this label to attach to the configuration label on the back cover of the logic module when you install the card.*

3. Check the 005 number on the card and its cable (if there is one) against the 005 number listed below. If the numbers do not match or you believe you have been sent the wrong card, call your nearest Service Operations Center immediately.
4. Save the cartons and packing materials to use if you must return the card.
5. Carefully inspect the card and cable (if there is one) for any visible damage. If a card or cable appears damaged, call the Service Operations Center and report the problem. If you need to return a card, repack it as shown in the packing diagram.

Model 10 and 10/SP systems

Card	Part Number	Cable
SPU1 without FIS	005-020621	005-021148
SPU1 with FIS	005-020626	005-021148
SPU2 with 128 Kbytes	005-020622	N/A
SPU2 with 256 Kbytes	005-020623	N/A
Memory with 256 Kbytes	005-020375	N/A
Memory with 512 Kbytes	005-020349	N/A
4-line USAM	005-021071	005-021041
1-line USAM	005-020619	005-020688
Color controller	005-019594	005-019922

Model 20 and 30 systems

Card	Part Number	Cable
SPU with FIS	005-017609	005-021148
SPU with CIS	005-020324	005-021148
Memory with 256 Kbytes	005-019538	N/A
Memory with 512 Kbytes	005-019537	N/A
Memory with 1 Mbyte	005-23820	N/A
Memory with 2 Mbytes	005-23668	N/A
4-line USAM	005-021071	005-021041
1-line USAM	005-020619	005-020688
4207	005-013951	005-021148

Model 45 system

Card	Part Number	Cable
SPU	005-022144	005-021148
ATP	005-021749	N/A
Memory with 1 Mbyte	005-022143	N/A
Memory with 2 Mbytes	005-022198	N/A
Memory with 512 Kbytes	005-019537	N/A
4-line USAM	005-021071	005-021041
1-line USAM	005-020619	005-020688

DC Power Requirements

Each printed circuit card and some other components of your system — the diskette module, for instance — draw dc current from the power supplies in the power supply module.

Power supply 1 provides dc power to the CPU logic module and the diskette module. Power supply 2 provides dc power to the logic expansion and disk modules. The current draw on the power supplies depends on the particular components in your system.

Below are tables for Model 10 and 10/SP, Model 20 and 30, and Model 45 systems listing the running current requirements for all standard components that receive power from the power supply module, except for optional Microproducts I/O cards. Current requirements for Microproducts I/O cards are listed on the installation data sheets for each card.

Model 10 and 10/SP systems dc current draw

Component	+5V	+12V	+24V	-12V
SPU card set	6.15A	0.02 A	0.40 A	0.02 A
Color controller card	4.6	None	None	None
Keyboard	2.25	None	None	None
Each memory card	2.2 A	None	None	None
1-line USAM card	2.3 A	0.04 A	0.11 A	0.06 A
4-line USAM card	2.3 A	0.10 A	0.23 A	0.06 A
Each diskette drive	1 A	None	1 A	None
Disk module (In computer unit) ¹				
15 MB	5.0 A	.05 A	1.6 A	None
38.6 MB	4.0 A	.05 A	3.1 A	None

¹The expansion (remote) disk unit and the cartridge tape unit have their own power supplies.

Model 20 and 30 systems dc current draw

Component	+5V	-5V	+12V	-12V
SPU card set	5.0 A	0.022 A	0.11 A	0.026 A
FPU card	3.8 A	None	None	None
Each memory card	2.4 A	None	None	None
1-line USAM card	2.3 A	0.04 A	0.11 A	0.06 A
4-line USAM card	2.3 A	0.10 A	0.23 A	0.06 A
4207 card	1.1 A	0.017 A	0.25 A	0.022 A
First diskette drive	2.5 A	0.025 A	1.025 A	None
Second diskette drive	1 A	None	1 A	None
Disk module (in computer unit) ¹				
15 MB	5.0 A	.05 A	1.6 A	None
38.6 MB	4.0 A	.05 A	3.1 A	None
71 MB	2.0 A	None	2.5 A	None

¹The expansion (remote) disk unit and the cartridge tape unit have their own power supplies.

Model 45 systems dc current draw

Component	+5V	-5V	+12V	-12V
SPU card set	4.0 A	0.022 A	0.2 A	0.026 A
ATP card	3.8 A	None	None	None
Each memory card	2.5 A	None	None	None
1-line USAM card	2.3 A	0.04 A	0.11 A	0.06 A
4-line USAM card	2.3 A	0.10 A	0.23 A	0.06 A
First diskette drive	2.5 A	0.025 A	1.025 A	None
Second diskette drive	1 A	None	1 A	None
Disk module (in computer unit) ¹				
15 MB	5.0 A	.05 A	1.6 A	None
38.6 MB	4.0 A	.05 A	3.1 A	None
71 MB	2.0 A	None	2.5 A	None

¹The expansion (remote) disk unit and the cartridge tape unit have their own power supplies.

Calculating DC Requirements

Make sure the power supply module provides enough dc current by taking the following steps.

- 1.** Using your previous table on dc current draw, and, if necessary, the Microproducts installation data sheets, fill in the forms ahead for your system with the current drawn by each component. Be sure to include any new card(s) you are installing. If you are using custom components, you will need to supply the dc current requirements.

CAUTION *The total current drawn on each dc voltage must never exceed the maximum current available for that voltage from the power supply. It is therefore essential that you figure the dc power draw of your system when adding a printed circuit card to it.*

- 2.** On each form, add up the current draw for each dc voltage and enter the sum next to the "Total current draw."
- 3.** On each form, compare total current draw for each voltage with maximum current available. If the current draw is less than the current available, your system has enough dc power for the additional card(s). If the current draw exceeds the current available, *do not install the card(s)*: your system does not have enough power for them. Instead, contact your nearest Service Operations Center.

Model 10 and 10/SP systems

DC Current Draw on Power Supply 1				
Component	+5V	-5V	+12V	-12V
CPU logic module				
SPU card	6.4 A	0.009 A	0.41 A	0.020 A
Color controller card	—	—	—	—
Memory card(s)	—	—	—	—
1-line USAM card	—	—	—	—
4-line USAM card	—	—	—	—
Other I/O cards:				
_____	—	—	—	—
_____	—	—	—	—
_____	—	—	—	—
Diskette module				
Diskette drive(s)	—	—	—	—
Total current draw	—	—	—	—
Maximum current available				
135-watt supply	18.5A	0.5A	2.6A	0.8A
150-watt supply	20.0A	0.5A	3.1A	0.8A

DC Current Draw on Power Supply 2				
Component	+5V	-5V	+12V	-12V
Logic expansion module				
1-line USAM card	—	—	—	—
4-line USAM card	—	—	—	—
Other I/O cards:				
_____	—	—	—	—
_____	—	—	—	—
_____	—	—	—	—
Disk module				
(in computer unit)	—	—	—	—
Total current draw	—	—	—	—
Maximum current available				
135-watt supply	16.5 A	0.5 A	3.1/5.0 A ¹	0.8 A
150-watt supply	15.3 A	0.5 A	5.1/6.1 A ¹	0.8 A

¹First value is running current; second value is start-up current.

Model 20 and 30 systems

	5.0 A	0.022 A	0.11 A	0.026 A
CPU logic module				
SPU card	5.0 A	0.022 A	0.11 A	0.026 A
FPU card	_____	_____	_____	_____
Memory card(s)	_____	_____	_____	_____
1-line USAM card	_____	_____	_____	_____
4-line USAM card	_____	_____	_____	_____
4207 card	_____	_____	_____	_____
Other I/O cards:	_____	_____	_____	_____
_____	_____	_____	_____	_____
_____	_____	_____	_____	_____
_____	_____	_____	_____	_____
Diskette module				
First diskette drive	_____	_____	_____	_____
Second diskette drive	_____	_____	_____	_____
Total current draw	_____	_____	_____	_____
Maximum current available				
135-watt supply	18.5A	0.5A	2.6A	0.8A
150-watt supply	20.0A	0.5A	3.1A	0.8A

Model 20 and 30 systems (continued)

Logic expansion module				
1-line USAM card	_____	_____	_____	_____
4-line USAM card	_____	_____	_____	_____
4207 card	_____	_____	_____	_____
Other I/O cards:				
_____	_____	_____	_____	_____
_____	_____	_____	_____	_____
_____	_____	_____	_____	_____
Disk module (in computer unit)	_____	_____	_____	_____
Total current draw	_____	_____	_____	_____
Maximum current available				
135-watt supply	16.5A	0.5A	3.1/5.0A ¹	0.8A
150-watt supply	15.3A	0.5A	5.1/6.1A ¹	0.8A

¹First value is running current; second value is start-up current.

Model 45 system

CPU logic module				
SPU card	4.0A	0.022A	0.2A	0.026A
ATP	3.8A	0	0	0
Memory card(s)	_____	_____	_____	_____
1-line USAM card	_____	_____	_____	_____
4-line USAM card	_____	_____	_____	_____
Other I/O cards:				
_____	_____	_____	_____	_____
_____	_____	_____	_____	_____
_____	_____	_____	_____	_____
Diskette module				
First diskette drive	_____	_____	_____	_____
Second diskette drive	_____	_____	_____	_____
Total current draw	_____	_____	_____	_____
Maximum current available				
150-watt supply	20.0A	0.5A	3.1A	0.8A

Model 45 system (continued)

DC Current Draw on Power Supply 2				
Component	+5V	-5V	+12V	-12V
Logic expansion module				
1-line USAM card	_____	_____	_____	_____
4-line USAM card	_____	_____	_____	_____
Other I/O cards:	_____	_____	_____	_____
_____	_____	_____	_____	_____
_____	_____	_____	_____	_____
_____	_____	_____	_____	_____
_____	_____	_____	_____	_____
Disk module(in computer unit)	_____	_____	_____	_____
Total current draw	_____	_____	_____	_____
Maximum current available				
150 watt-supply	15.3A	0.5A	5.1 / 6	0.8A

Removing and Installing Cards

This section contains important information about removing and installing cards from your system. Before you remove or install a card, you must determine which slot it does or will occupy. Next you must check the position of certain switches, called priority switches, inside the module that will contain the card. And last, you remove or install the card.

Slot Assignments

The cards in your system must occupy certain slots in the CPU logic module and logic expansion module. The next figure shows which type of cards can occupy which slots.

WARNING *Slot 1 of the logic expansion module must always contain a card, even if you have to leave an empty slot in the CPU logic module.*

Model 10 and 10/SP

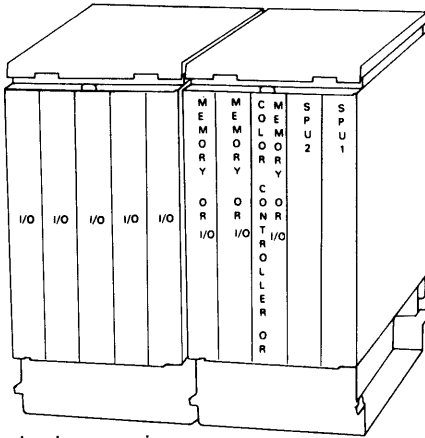

Logic expansion module

CPU logic module

Model 20 and 30

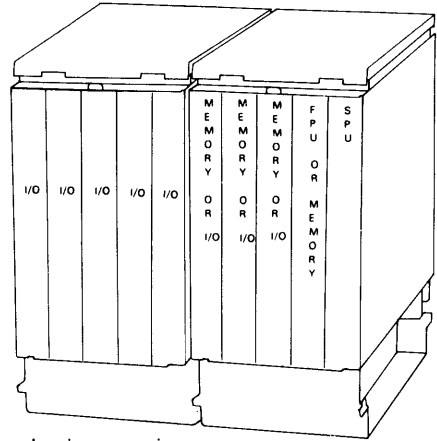

Logic expansion module

CPU logic module

Model 45

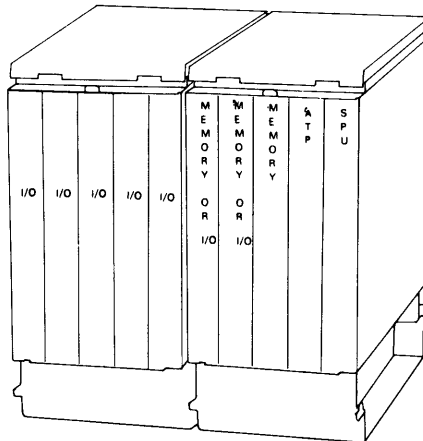

Logic expansion module

CPU logic module

When you add a card to an already installed system, attach the small label which identifies the card to the configuration label on the back cover of the logic module.

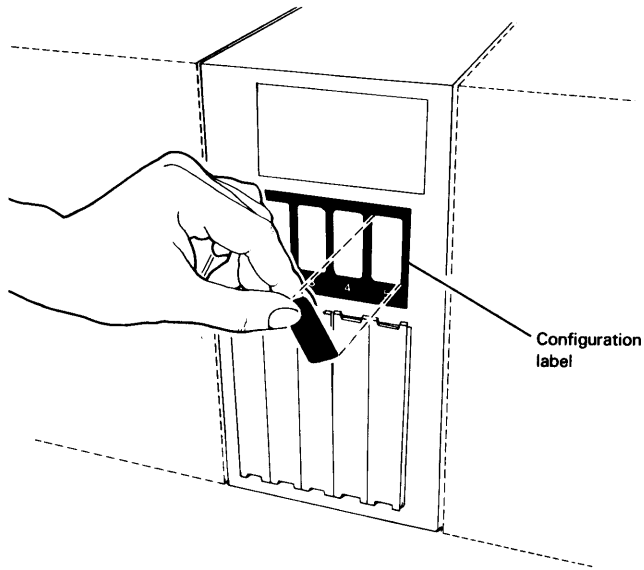

DG-26286

If you remove a card or move it to another slot, always remember to note the change on the configuration label. This way the configuration label always correctly identifies the card in each slot.

Priority Switches

The cards in your system pass important control signals back and forth between certain equipment and the SPU cards. If a slot in a logic module is unoccupied, some control signals are not passed and your system will not function as it should.

To allow these signals to pass across unoccupied slots, each logic module has a switch set containing four switches. These are the priority switches. They are located inside the module at the back and are accessible through the front of the module.

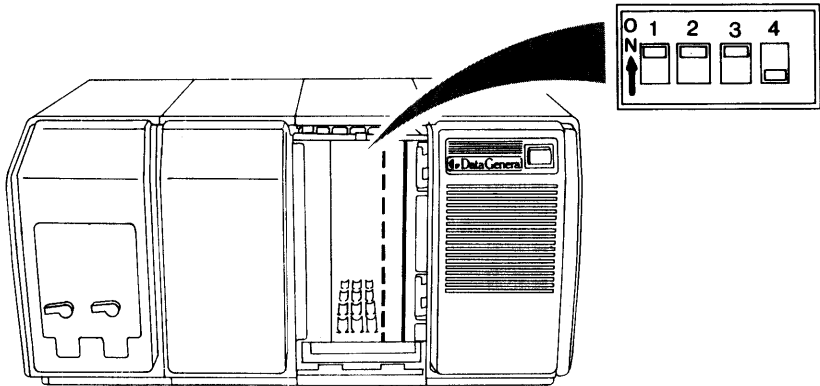

DG-26212

Slot 1 of the CPU logic module always contains a card, so it does not need a switch. Switch 1 is for slot 5, switch 2 is for slot 4, and so on. When a switch is in the UP(on) position, it allows control signals to cross its slot even though the slot is unoccupied. If the slot is occupied, its priority switch must be DOWN(closed).

Your system's priority switches are set at the factory according to the cards installed in your original system. You should not need to change the settings of these switches unless you remove or install a card.

If you remove a card and leave its slot empty, place the priority switch for the slot in the UP(on) position. If you install a new card in a slot previously unoccupied, place the switch for the slot in the DOWN (closed) position.

Removing Cards

If you are removing any card except the color controller card, take the following steps. (To remove or install the color controller card, see the section, "Installing a Color Controller Card." If you are installing any other card, turn to the next section, "Installing Cards.")

1. Turn off the computer unit.
2. Turn off any equipment connected to the card you are removing.
3. Remove the plastic front cover of the module containing the card by pressing up on the bottom of the cover and pulling it away from the module.

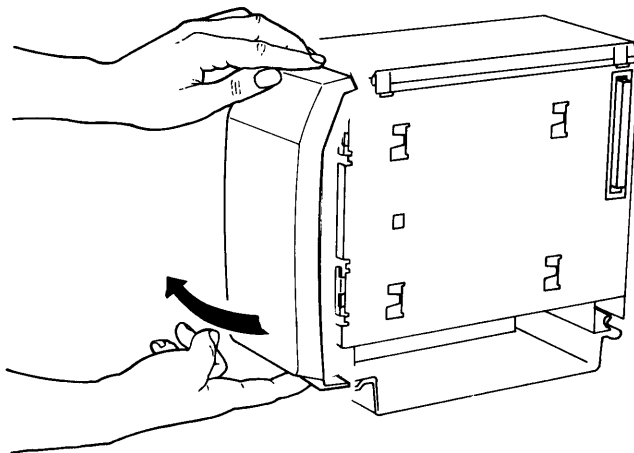

4. Remove the card puller from the metal shield on the front of the module.

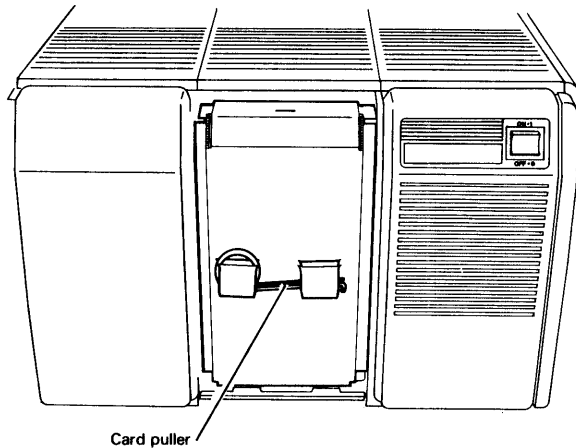

DG-26089

5. Remove the metal shield by pressing down firmly on the top of the shield until it pops free of the module. Pull it away from the module.

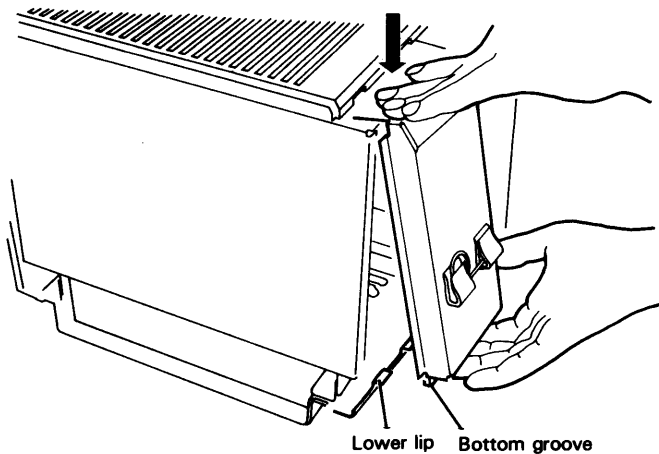

DG-26230

6. If you are removing the FPU card or the SPU card from a Model 30 system, grasp the short cable connecting the two cards between your thumb and forefinger; pull the cable off of the cards' connectors. Then plug the short cable back onto the SPU card remaining in the chassis.

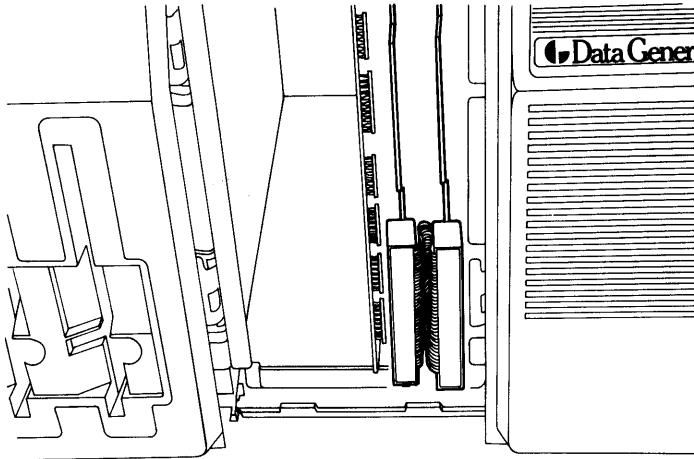

DG-26093

7. In Model 10 and 10/SP systems, pull the diskette's ribbon cable off of the SPU1 card.

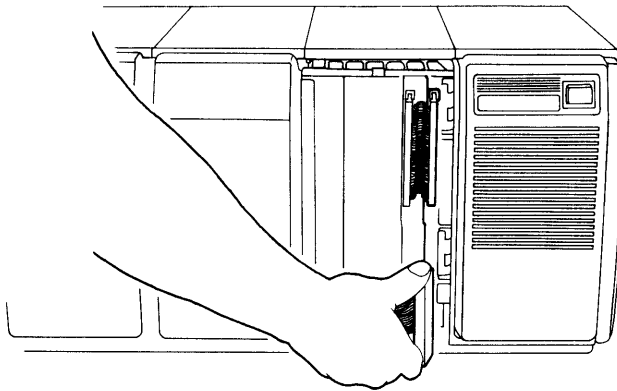

DG-26094

8. If removing a Model 10 and 10/SP SPU card, grasp the short cable connecting the two SPU cards between your thumb and forefinger; pull the cable off of the cards' connectors.

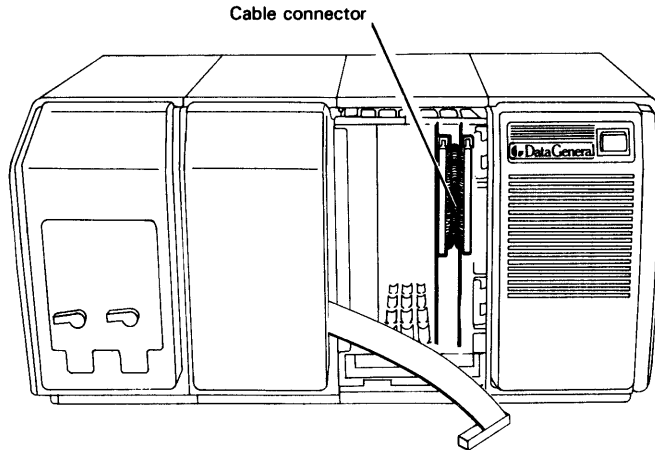

DG-26095

9. Insert the card puller into the small hole in the top of the card; pull the card towards you until it is part-way out of the module. Pull it the rest of the way out with your hands.

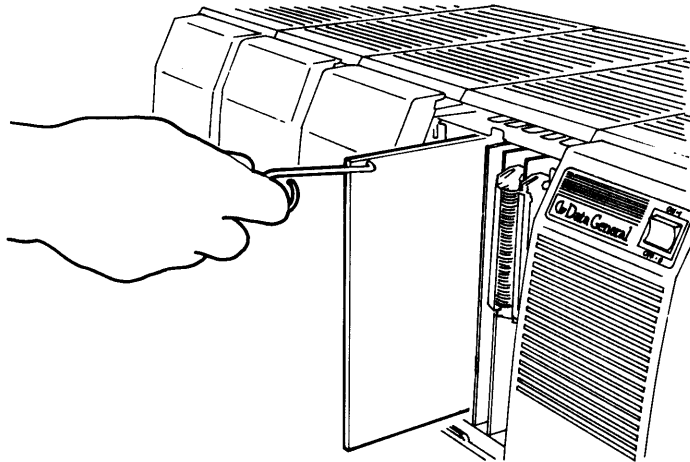

DG-26222

NOTE *If you do not replace the card you removed with a new one, reinsert the fiberglass strip into the empty slot on the bottom of the module.*

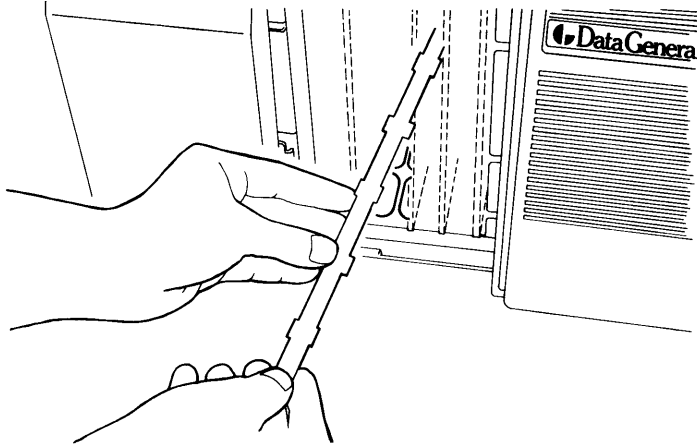

DG-26090

10. If your Model 10 and 10/SP system has a color system console and you are removing the SPU2 card, unplug the cable for the color controller from the bottom connector on the back of the SPU2 card.

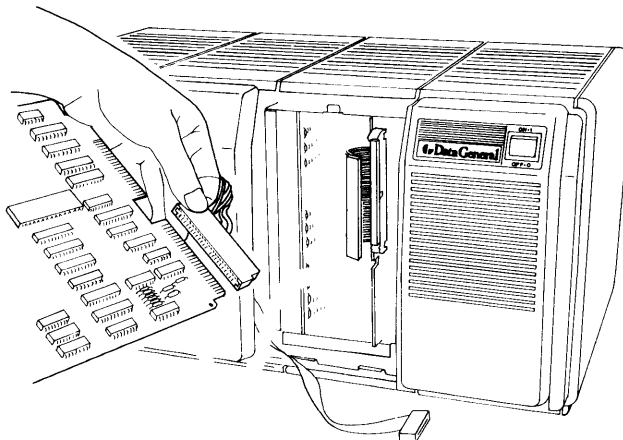

DG-27142

11. If you are not installing a card at this time, replace the metal shield on the module by fitting the groove at the bottom of the shield onto the module's bottom lip. Press the shield towards the module until it snaps into place. (If you are installing a card, go to the next section.)

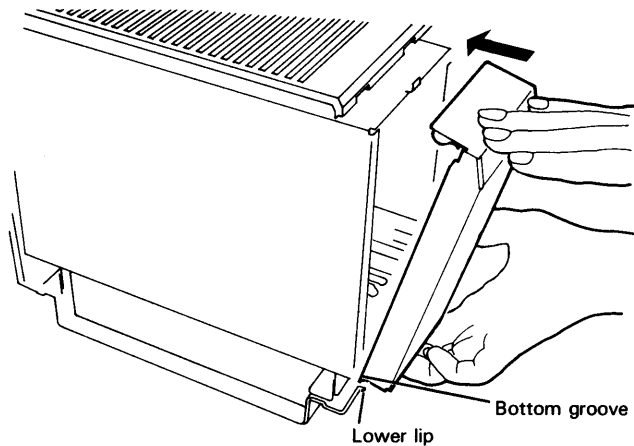

DG-25965

12. Replace the card puller on the front of the metal shield.

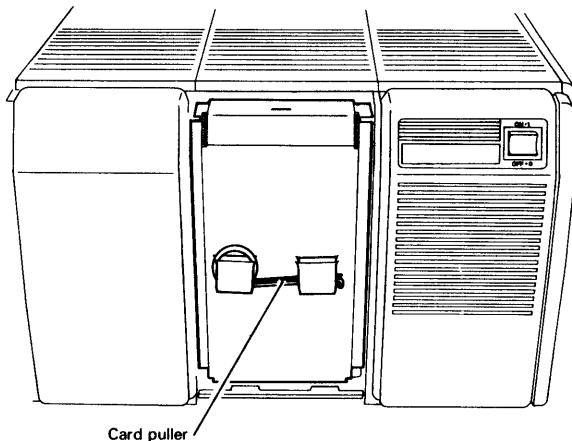

DG-26089

13. Replace the module's front cover by inserting its two tabs under the module's plastic top. Push up on the bottom of the cover while moving it towards the module. The cover will snap into place.

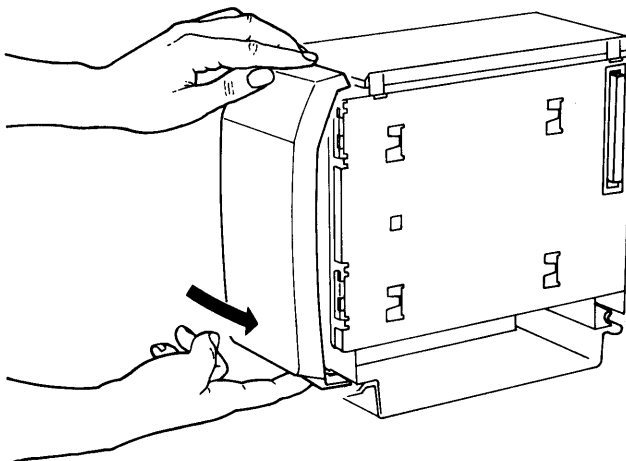

DG-26216

Installing Cards

Take the following steps to install any card except the color controller card in your system. To install a color controller card, go to the next section.

1. Turn off the computer unit.
2. Remove the front plastic cover of the logic module where the card is to be installed; press up on the bottom of the cover and pull it away from the module.
3. Remove the metal shield from the front of the module by pressing down firmly on the top of the shield and pulling it away from the module.

4. In the Model 10 and 10/SP system, remove the diskette cable from the bottom of the SPU card in slot 1.

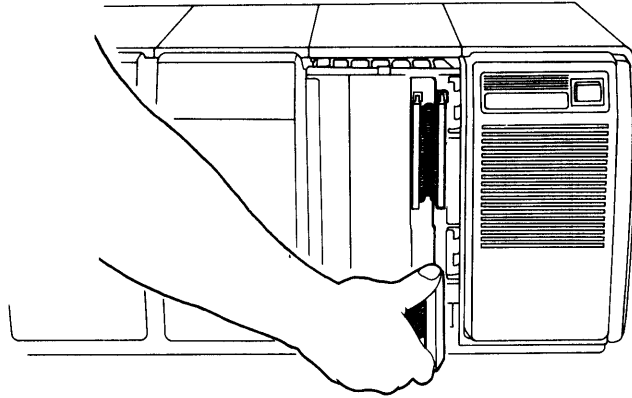

DG-26094

5. Locate the slot the card will occupy. If there is a fiberglass strip covering the bottom of the slot, remove the strip and save it.

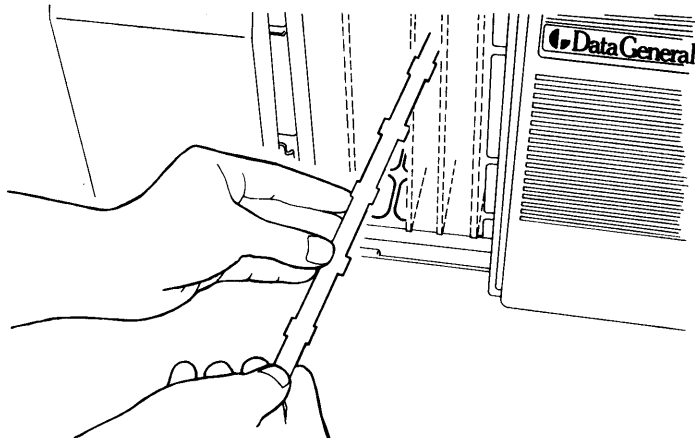

DG-26090

6. Locate the priority switch for the slot and make sure it is in the DOWN (closed) position.

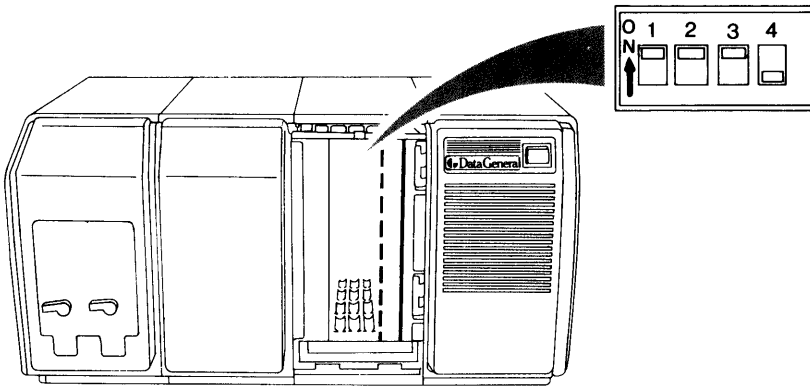

DG-26212

7. Check the jumper and switch settings of the new card. (If you are replacing a card, you can copy the settings on the old card.)

8. Holding the card by its edges, place the bottom edge of the card into its slot. Make sure the printed component side is on the right and the 60-pin connector on top. Fit the top edge of the card into the corresponding top slot and, gently but firmly, push the card into the module until it clicks into place.

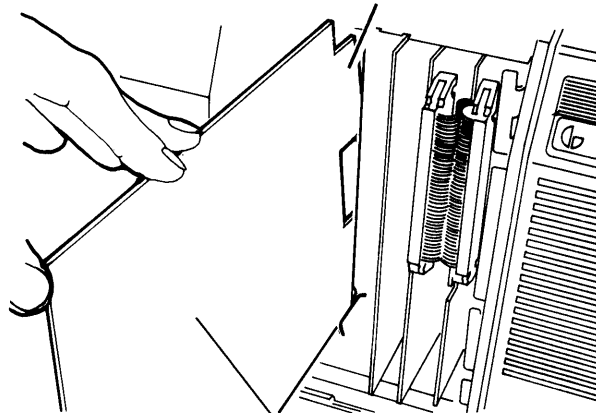

Component side

DG-27141

9. If the card is the SPU or FPU card in a Model 30 system, plug the short cable (which interconnects the two cards) onto the top edge connector of the card.

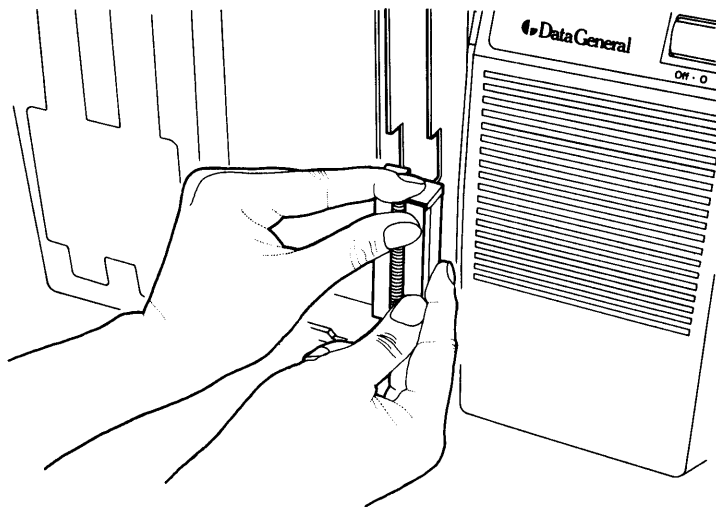

10. If the card is an SPU card in a Model 10 and 10/SP system, plug the short cable (which interconnects the two SPU cards) onto the top edge connector of the card.

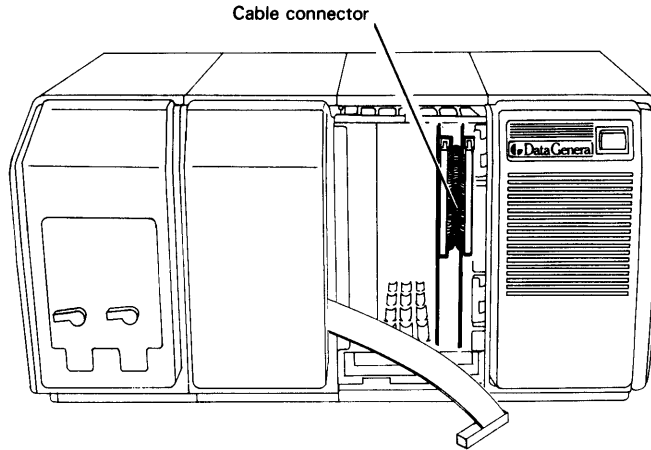

DG-26095

11. In the Model 10 and 10/SP system, plug the diskette cable back onto the bottom connector of the SPU card in slot 1.

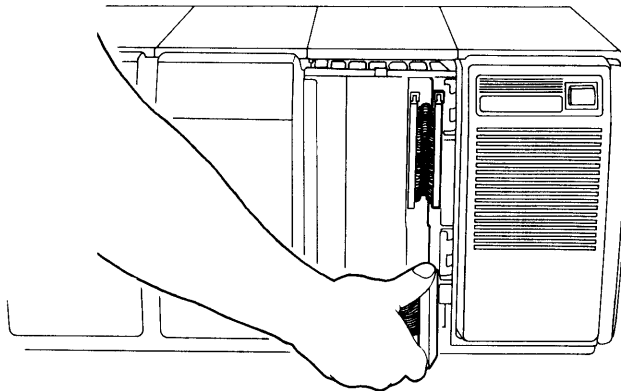

DG-26094

12. Replace the metal shield on the module by fitting the groove at the bottom of the shield onto the module's bottom lip. Press the shield towards the module until it snaps into place.
13. Replace the module's front cover by inserting its two tabs under the module's plastic top. Push up on the bottom of the cover while moving it towards the module. The cover will snap into place.
14. If the card controls peripheral equipment, such as a data tablet or printer, remove the plastic and metal slot inserts covering the opening for the slot behind the module.

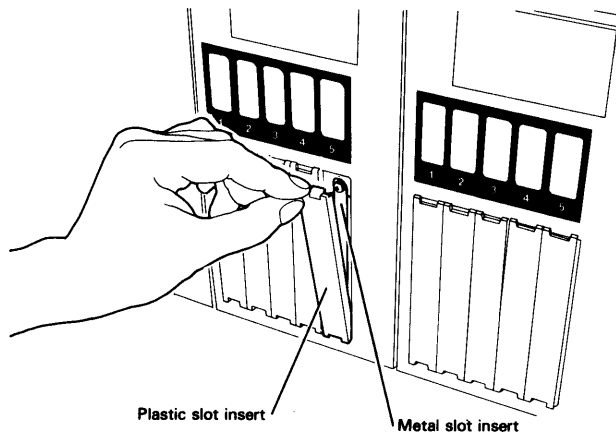

15. If the card is the SPU, USAM, or 4207 card, plug the adapter cable onto the card through the opening for the slot behind the module. Make sure the arrow and word "TOP" on the cable's connector are in the up position. Tighten the two screws that hold the cable in place. (The figure below shows the connection of the adapter cable for a 4-line USAM card in slot 5.)

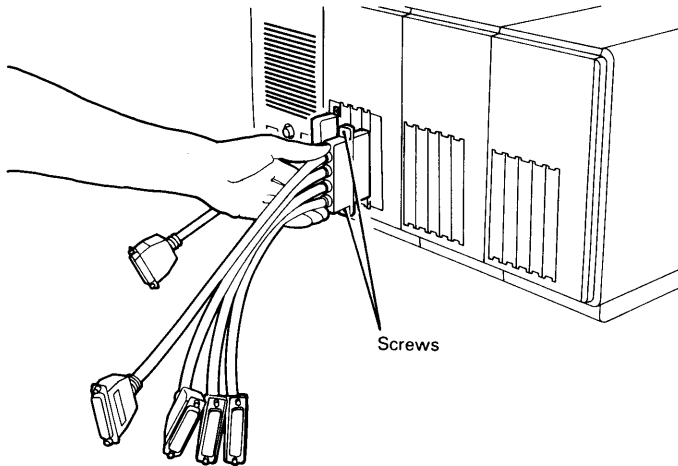

DG-26085

If you are installing a Model 10 and 10/SP color controller card, read the next section.

Installing a Color Controller Card

Take the following steps to install a color controller card in Model 10 and 10/SP systems. Follow these steps in reverse to remove the card from your system.

- 1.** Turn off the computer unit.

- 2.** Remove the front plastic cover of the CPU logic module by pressing up on the bottom of the cover and pulling it away from the module.

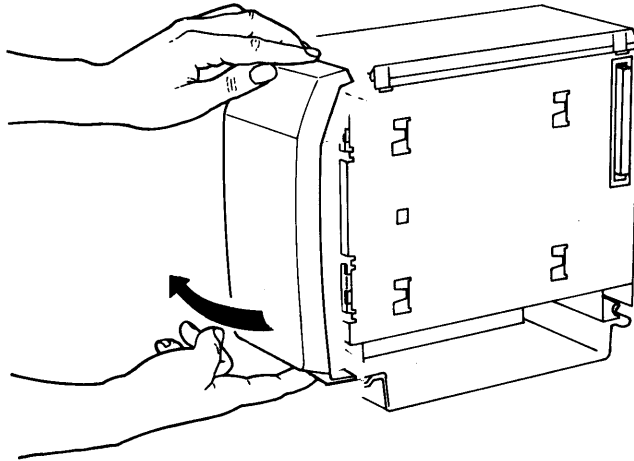

DG-25639

- 3.** Remove the metal shield from the front of the module by pressing down firmly on the top of the shield and pulling it away from the module.

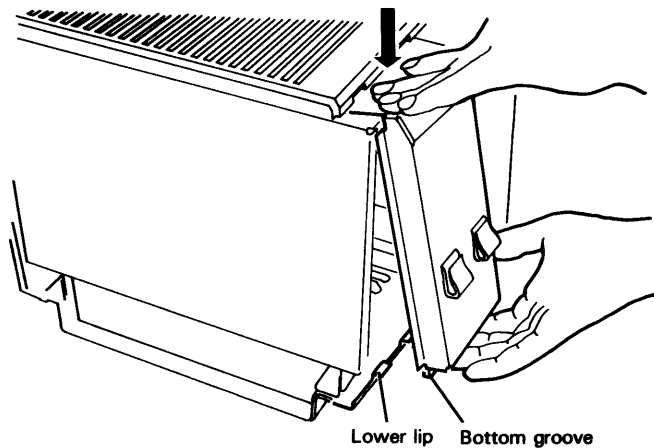

DG-25963

4. Remove the diskette's ribbon cable from the bottom connector of the SPU1 card.

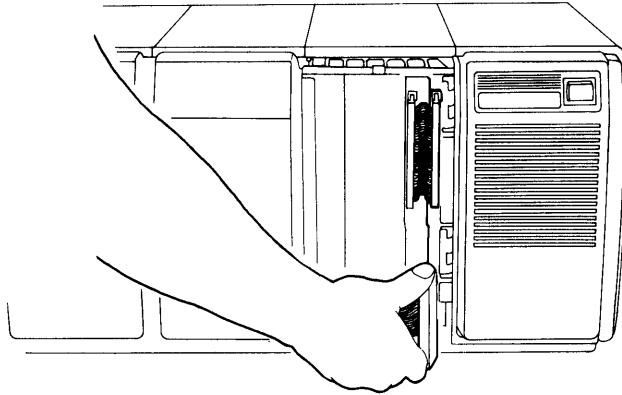

DG-26094

5. If a card occupies slot 3 of the CPU logic module, move it to another suitable slot as described previously in "Installing Cards" and "Removing Cards." Make sure you set the priority switch in the new slot to the DOWN (off) position before you install the card.
6. Grasp the cable connecting the two SPU cards between your thumb and forefinger; pull the cable off of the cards' connectors.

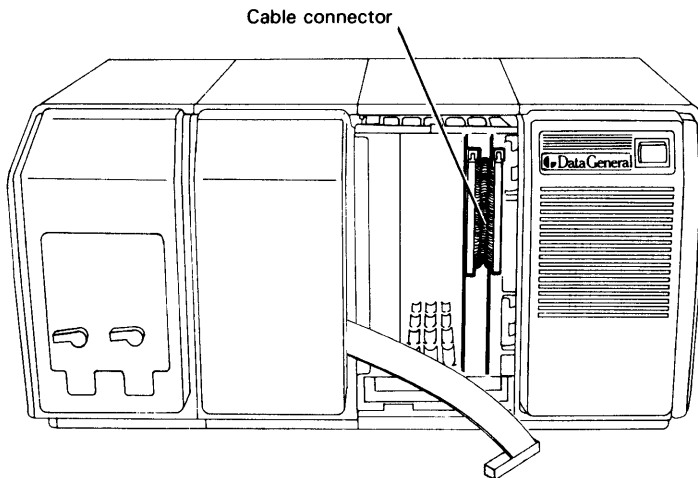

DG-26095

- 7.** Remove the SPU2 card from the module and plug the large connector on the end of the controller cable to the bottom connector on the back of the SPU2 card.

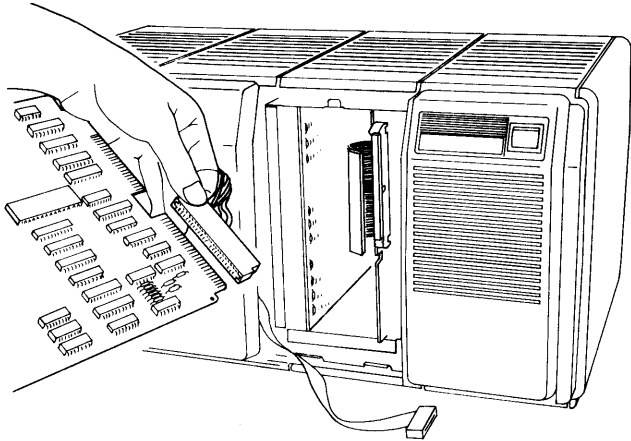

DG-26097

- 8.** Holding the cable against the SPU2 card, reinstall the card in slot 2.

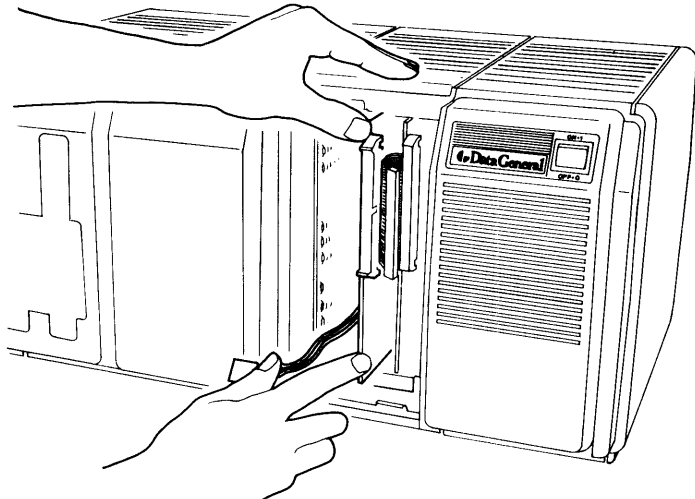

DG-26098

9. Plug the short cable that you removed from the SPU cards back into their top connectors.

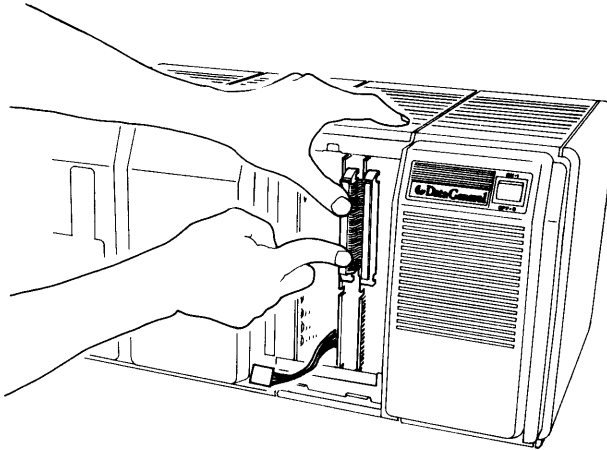

DG-26099

10. Insert the color controller card into slot 3 and push it, gently but firmly, into the module until it clicks into place.

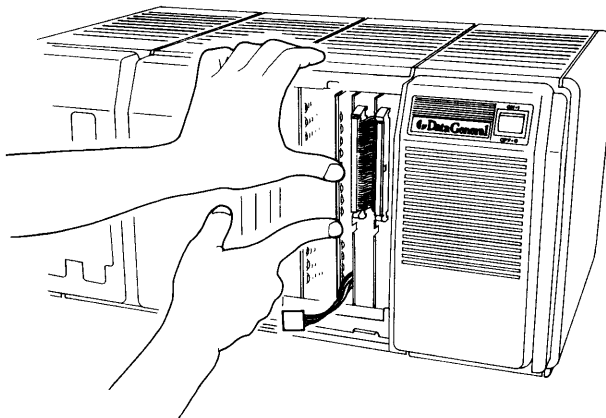

DG-26100

11. Plug the loose connector of the controller cable into the 6-pin connector on the end of the color controller card.

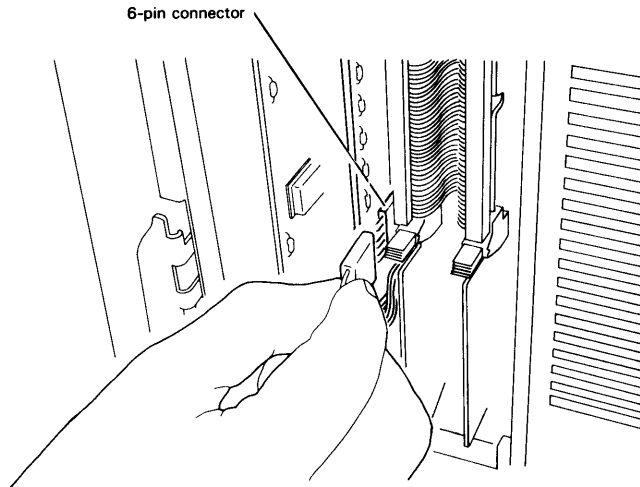

DG-26101

12. Plug the diskette's ribbon cable into the bottom connector of the SPU1 card.

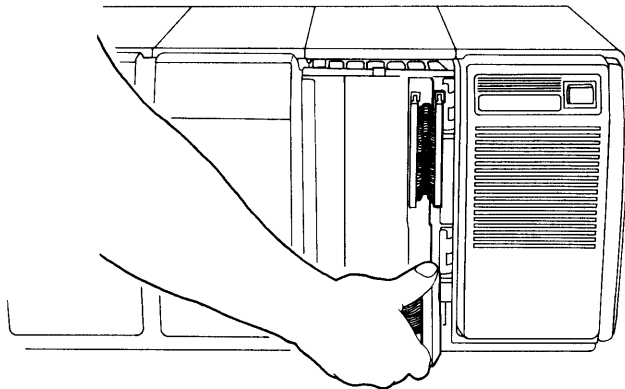

DG-26094

- 13.** Replace the metal shield on the module by fitting the groove at the bottom of the shield onto the module's bottom lip. Press the shield towards the module until it snaps into place.

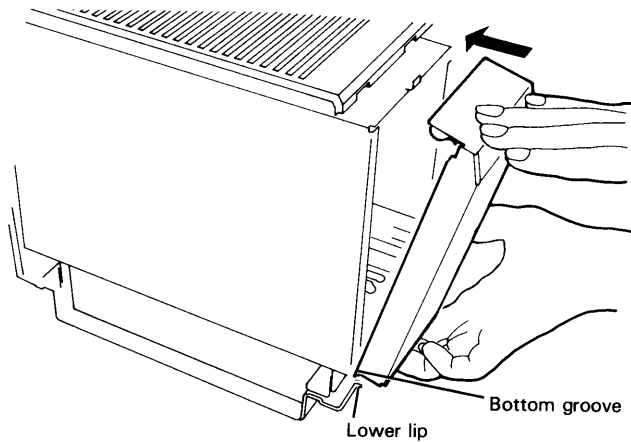

DG-25965

- 14.** Replace the module's front cover by inserting its two tabs under the module's plastic top. Push up on the bottom of the cover while moving it towards the module. The cover will snap into place.

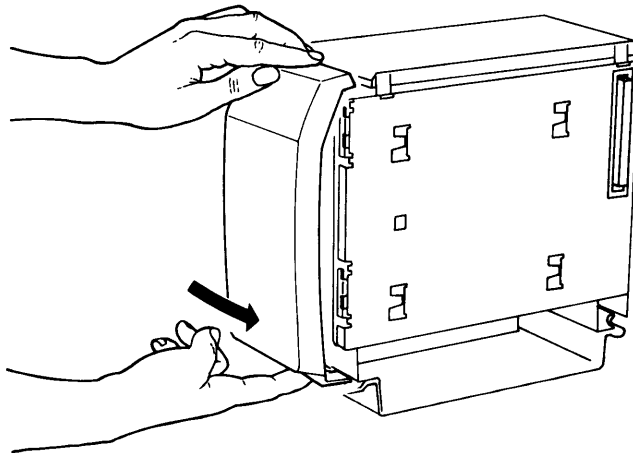

DG-26216

15. Plug the cable (DGC no. 005-19913) into the back of the color controller card at slot 3. Connect the other end of the cable to the color monitor.

If you installed a card that controls peripheral equipment such as a printer, connect this component to the card with the help of the installation sheet, *How to Connect Peripherals to a DESKTOP GENERATION Computer*. Then refer to *DESKTOP GENERATION Peripherals Installation Guide* for information specific to installing standard peripherals.

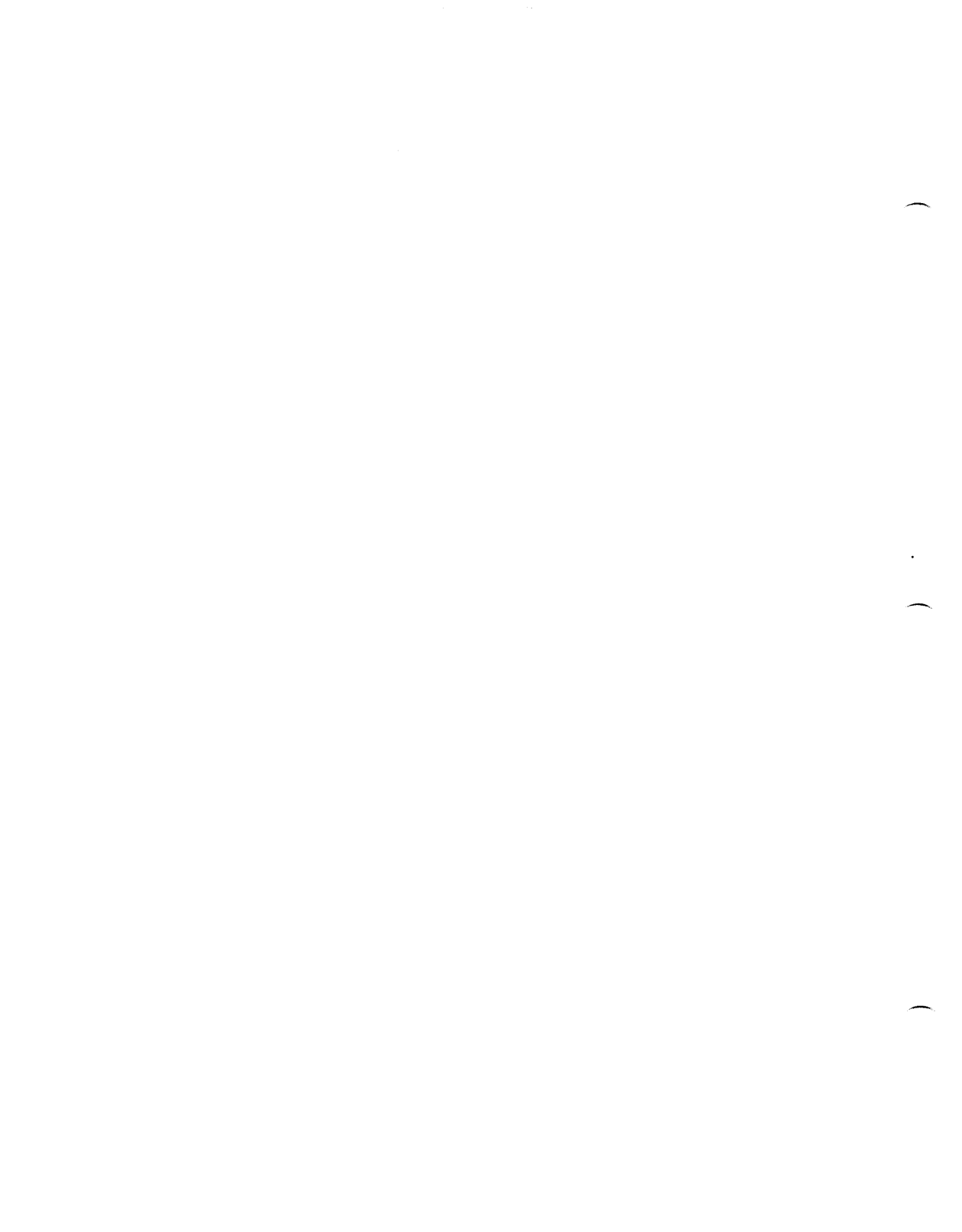



5

Configuring Cards

The characteristics of the cards already installed in your system were set at the factory; ordinarily, you will not be concerned with them. If you have to replace a failing card with a new one, you need to make sure that any switches or jumpers on the new card are set to match those on the old one. Also, when you add a new card to a previously installed system, you may need to change the characteristics to those used in a standard DESKTOP GENERATION system.

This section provides switch and jumper information and tells you how to configure the cards for use in your system. The information is organized as follows:

Model 10 and 10/SP cards: SPU set, color controller, memory expansion

Model 20 and 30 cards: SPU, FPU, memory, 4207 interface

Model 45 cards: SPU, ATP, memory

USAM cards.

Information for configuring Microproducts I/O cards can be found in the installation data sheets shipped with the card.

When installing a card in a computer whose operating system is not supported by Data General, or to change the characteristics of a card, refer to the maintenance service guide for your computer system.

To remove or install a card, turn back to the section, "Removing and Installing Cards," in the previous chapter.

Switches

Some cards include one or more sets of switches. Each switch set is a block of small rocker or slide switches that can be placed in one of two positions ON or OFF (or open or closed, depending on the particular switch).

Jumpers

Some cards include a set of jumpers. Jumpers are wires, either plain or push-pin, that can be inserted into or removed from jumper locations on a card.

A jumper location contains a pair of jumper sockets about a half inch apart. Jumper locations are usually labeled W1, W2 or P1, P2, and so on. A jumper that is inserted in a location is said to be "in"; a jumper that is removed, or not inserted, is said to be "out."

Plain jumpers are thin gold wires about 1 inch long. Before you can insert a plain jumper, you must bend it into a U shape the width of the distance between the jumper sockets, using either your fingers or needle-nose pliers.

Push-pin jumpers are already bent and have a plastic handle-type part to help you insert them.

Insert a jumper by pushing the ends into the jumper sockets until you hear a click indicating that the jumper has snapped into place. If the jumper extends much beyond the level of the other components on the card, remove it, trim it using a wire cutter, and reinsert it.

Jumper Posts

Some cards contain 2 gold-wire jumper posts instead of jumper sockets. Jumper posts, usually labeled P1, P2, and so on, have plastic connector plugs which are inserted over posts. Unused or unconnected plugs should be stored by sliding the plug down over only one post. Do not discard connector plug.

Configuring Model 10 and 10/SP Cards

This section provides switch and jumper information for the Model 10 and 10/SP SPU, color controller, and memory expansion cards. For information on USAM cards, turn to the section, "USAM Cards," later in this chapter.

SPU Card Set

The SPU 1 card is available in two different versions, one with circuitry for the optional firmware floating-point instruction set (FIS), and the other without it. The SPU2 card is also available in two versions, one containing 128 Kbytes of memory and the other, 256 Kbytes. The SPU1 card with FIS always comes with the SPU2 card with 256 Kbytes of memory.

The two SPU cards are connected by an internal cable (DGC part no. 005-019373) which is part of the SPU card set. The SPU1 card has a printer port adapter cable (DGC part no. 005-021148).

Each card is labeled with a part number. The following table lists the part numbers for the different types of SPU1 and SPU2 cards.

Card	Part Number
SPU1 without FIS	005-20621
SPU1 with FIS	005-20626
SPU2 with 128 Kbytes memory ¹	005-20622
SPU2 with 256 Kbytes	005-20623

¹You can only use the SPU2 card with 128 Kbytes of memory (DGC part no. 005-020622) with the SPU1 card that has no FIS (DGC part no. 005-020621). The SPU2 card with 256 Kbytes of memory (DGC part no. 005-020623) can be used with either SPU1 card.

SPU2 Jumpers

The SPU2 card has three push-pin jumpers, labeled P1 through P3. Insert all of these jumpers, unless you have the line frequency generator option. Do not insert P2 if you have this option.

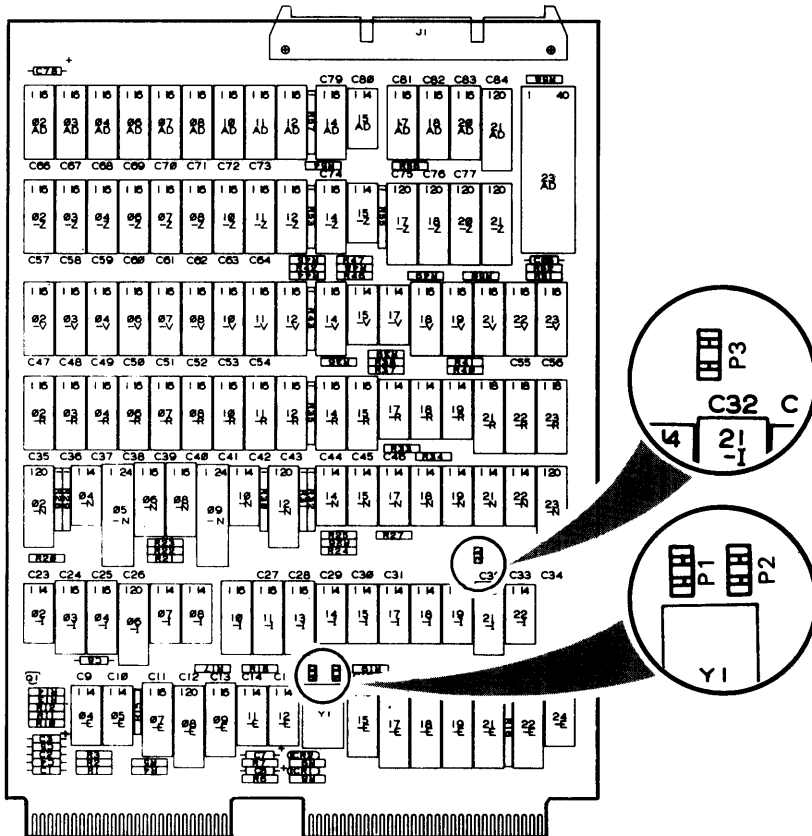

Model 10 and 10/SP SPU2 card

Memory Expansion Cards

Memory expansion cards are available in two different versions, one with 256 Kbytes of memory and the other with 512 Kbytes. Each card is labeled with the following part numbers.

Memory Card	Part Number
256-Kbyte	005-020375
512-Kbyte	005-020349

SW1 and SW2 Switches

Both cards have two sets of switches, labeled SW1 and SW2, that select the range of the addresses which the card contains. An address identifies the location where a word (two bytes) of information is stored on the card. Your system must have a continuous range of addresses.

If you have an SPU2 card with 128 Kbytes of memory, it contains the locations for the first 64 Kwords - address range 0 to 64 Kwords; locations for additional words will be on the memory expansion card(s), if you have any.

Likewise, an SPU2 card with 256 Kbytes of memory contains the locations for the first 128 Kwords - address range 0 to 128 Kwords. For this reason, switch positions vary with the type of SPU2 card your system has.

P1 and P2 Jumpers

The P1 jumper is always in if a system has only one expansion memory card. If your system includes more than one expansion memory card, install the P1 jumper on the memory card farthest from the SPU card.

The P2 jumper is always out.

Your system can have up to three memory expansion cards as long as the total memory does not exceed 1792 Kbytes.

If your system has a 128 Kbyte SPU2 card, set the switches listed below to the ON position, and set all other switches to the OFF position.

Card	1	2	3	4
Memory	256	512	512	512
Switches on				
SW1	8	7,8	7,8	7,8
SW2	7	6,7	6,7	6,7
Address Range	64KW-192KW	64KW-320KW	64KW-320KW	64KW-320KW
Card	1	2	3	4
Memory	256	256	512	512
Switches on				
SW1	7	6	5,6	5,6
SW2	6	5	4,5	4,5
Address Range	192KW-320KW	320KW-448KW	320KW-576KW	320KW-576KW
Card	1	2	3	4
Memory	256	256	256	512
Switches on				
SW1	6	5	4	3,4
SW2	5	4	3	2,3
Address Range	320KW-448KW	448KW-576KW	576KW-704KW	576KW-832KW

If your system has a 256 Kbyte SPU2 card, set the switches listed below to the ON position, and set all other switches to the OFF position.

Card	1	1	1	1
Kbytes	256	512	512	512
Switches on				
SW1	7	6,7	6,7	6,7
SW2	7	6,7	6,7	6,7
Address range	128KW-256 KW	128KW-384KW	128KW-384KW	128KW-384KW
Card	2	2	2	2
Kbytes	256	256	512	512
Switches on				
SW1	6	5	4,5	4,5
SW2	6	5	4,5	4,5
Address range	256KW-384KW	384KW-512KW	384KW-640KW	384KW-640KW
Card	3	3	3	3
Kbytes	256	256	256	512
Switches on				
SW1	5	4	3	2,3
SW2	5	4	3	2,3
Address range	384KW-512KW	521KW-640KW	640KW-768KW	640KW-896KW

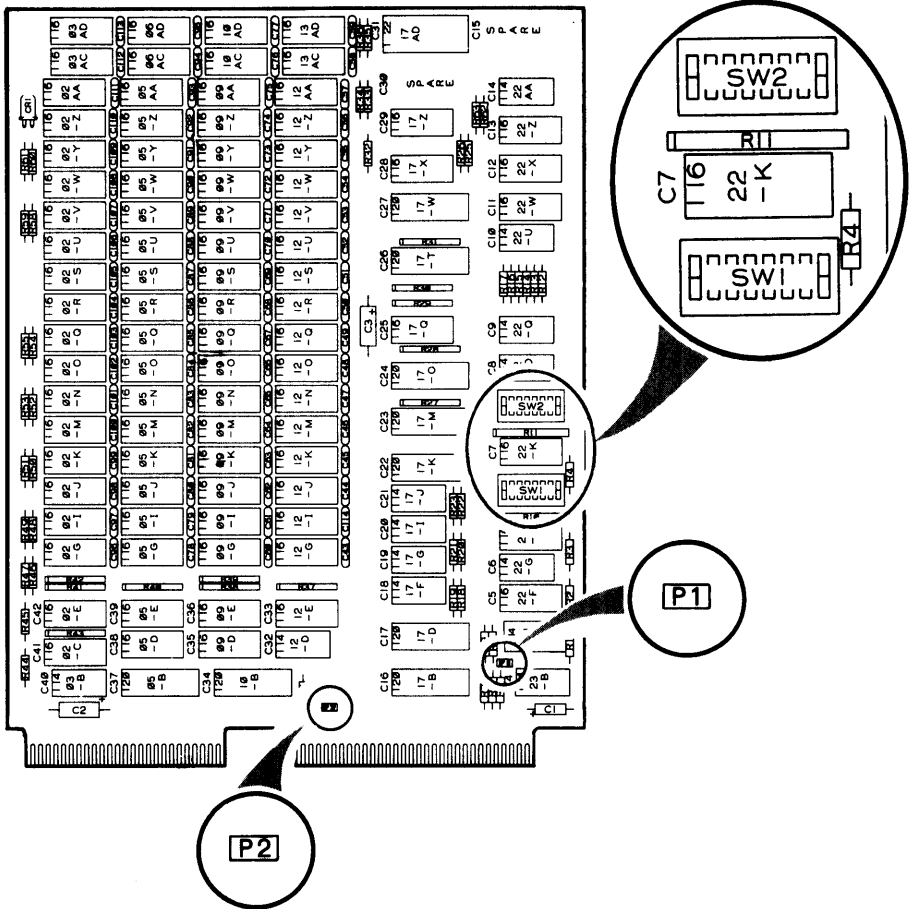

Model 10 and 10/SP memory expansion card

DG-27146

NOTE For information on USAM cards, refer to the subsection "USAM Cards," later in this chapter.

Configuring Model 20 and 30 Cards

This section provides switch and jumper information for the Model 20 and 30 SPU, FPU, 4207, and memory cards. For information on USAM cards, turn to the section, "USAM Cards," later in this chapter.

SPU Card

The SPU card is available in two different versions, one with circuitry for the firmware floating-point instruction set (FIS) and one with circuitry for the commercial instruction set (CIS). The SPU card with CIS must be used with the hardware floating-point card.

Each card is labeled with a part number. The table below lists the part numbers for the different cards.

Card	Part Number
SPU with FIS	005-017609
SPU with CIS	005-020324

The SPU card has eight plain jumpers, labeled W1 through W9, and two switch sets, SW1 and SW2. Position these jumpers and switches on either SPU card as shown in the following table.

Jumpers	Position	SW1 Switches	Position	SW2 Switches	Position
W1	Out	1	Off	1	On
W2	Out	2	Off	2	On
W3	In	3	Off	3	On
W4	In	4	Off	4	Off
W5	In	5	Off	5	Off
W6	In	6	Off	6	On
W7	In	7	Off	7	On
W8	In	8	Off	8	Off
W9	Out				

The following table shows the characteristics selected by these jumpers and switches.

Interface type	EIA
Clear to Send	Enabled
Baud rate	9600
PIT rate	10 KHz
Halt dispatch	Enabled
Break enable	Enabled

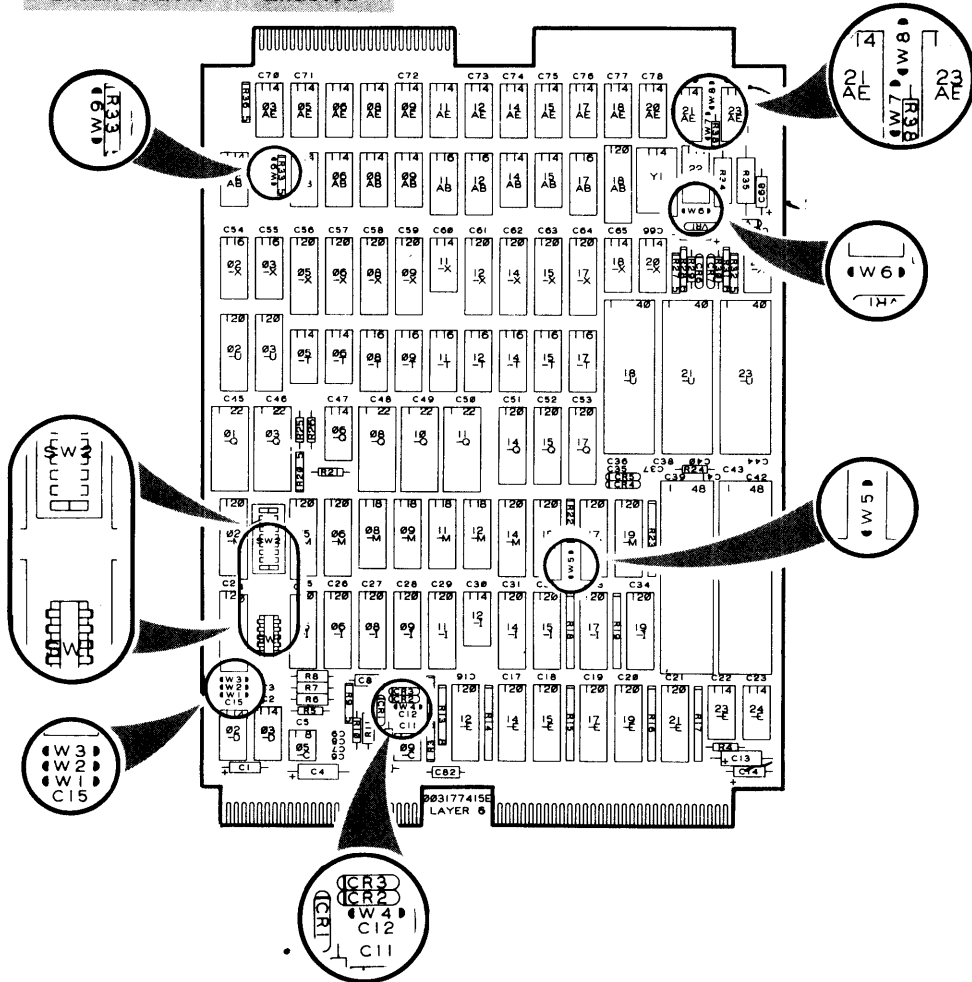

Model 20 and 30 SPU card

Hardware Floating-Point Card

The hardware floating-point card is labeled with DGC part no. 005-020323. It must be used only with the SPU card with CIS (DGC part no. 005-020324). It comes with an internal cable (DGC part no. 005-009663), which connects it to the SPU card. The hardware floating-point card has no jumpers or switches.

Memory Cards

Memory cards are available in four different versions: 256 Kbytes, 512 Kbytes, 1 Mbyte, or 2 Mbytes of memory. Part numbers for each card are listed below.

Card	Part Number
256-Kbyte memory card	005-019538
512-Kbyte memory card	005-019537
1-Mbyte memory card	005-23820
2-Mbyte memory card	005-23668

Your system can hold a maximum of three memory cards if it includes a hardware floating-point card, and four memory cards if it does not. Note that the USAM card must reside in the logic expansion module if all memory slots are used.

You can use the memory cards as follows, providing the total system memory does not exceed 2 Mbytes:

- 512-Kbyte cards, 256-Kbyte cards, 1-Mbyte cards, or a combination of the three cards
- 256-Kbyte cards and 512-Kbyte cards combined
- 256-Kbyte cards and 1-Mbyte card combined
- 512-Kbyte cards and 1-Mbyte card combined
- Two 1-Mbyte cards
- One 2-Mbyte card.

If the card combination includes 512-Kbyte cards, they should reside in the slots closest to the SPU card. Memory card 1 resides in slot 2 if there is no hardware floating-point card, and in slot 3 if there is. Memory card 2 resides in slot 3 or 4, and so on.

512-and 256-Kbyte Memory Cards

The 512-and 256-Kbyte memory cards have six jumpers, labeled W1 through W4, and W5 and W7. (There is no W6.) Insert all the jumpers listed below for the memory card(s) you are installing. The W5 jumper is always out. Make sure jumper W7 is inserted on the memory card farthest away from the SPU card. Remove all other jumpers from the memory card(s) you are installing. The next figure shows the jumper locations.

Card Number	512-Kbyte Cards Only	256-Kbyte Cards Only
1	W1, W2	W1, W2, W3
2	W1	W1, W2
3	W2	W1, W3
4	None	W1

Card Number	512-Kbyte and 256-Kbyte Cards Combined		
1	512 Kb W1, W2	512 Kb W1, W2	512 Kb W1, W2
2	512 Kb W1	512 Kb W1	256 Kb W1, W3
3	512 Kb W2	256 Kb W2, W3	256 Kb W1
4	256 Kb W3	256 Kb W2	256 Kb W2, W3

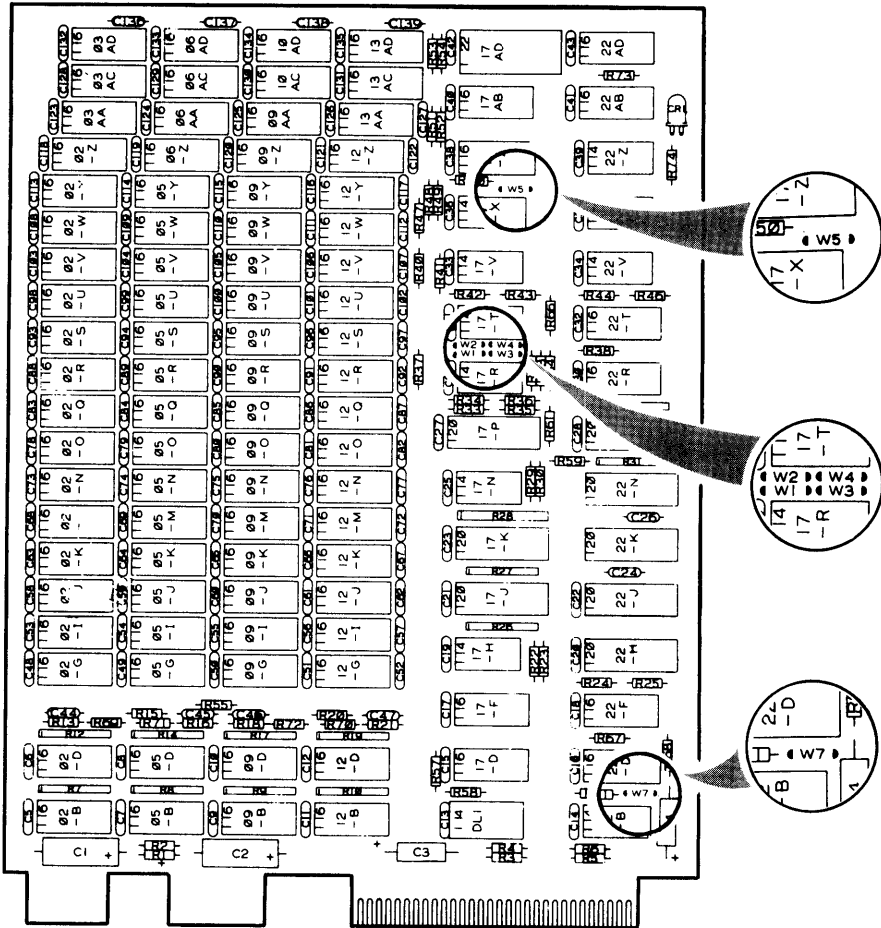

Model 20 and 30 512-Kbyte memory card

System Configurations

The P1 jumper, a terminator connector, is always installed in a system configuration that has only one memory board. In multiple memory board configurations, P1 should be installed in the memory card farthest away from the CPU. P2 is used as a test jumper and should never be installed. P1 and P2 are depicted in the next figure.

Light Emitting Diode

The memory circuit contains a light emitting diode (LED), which indicates that the board is being accessed.

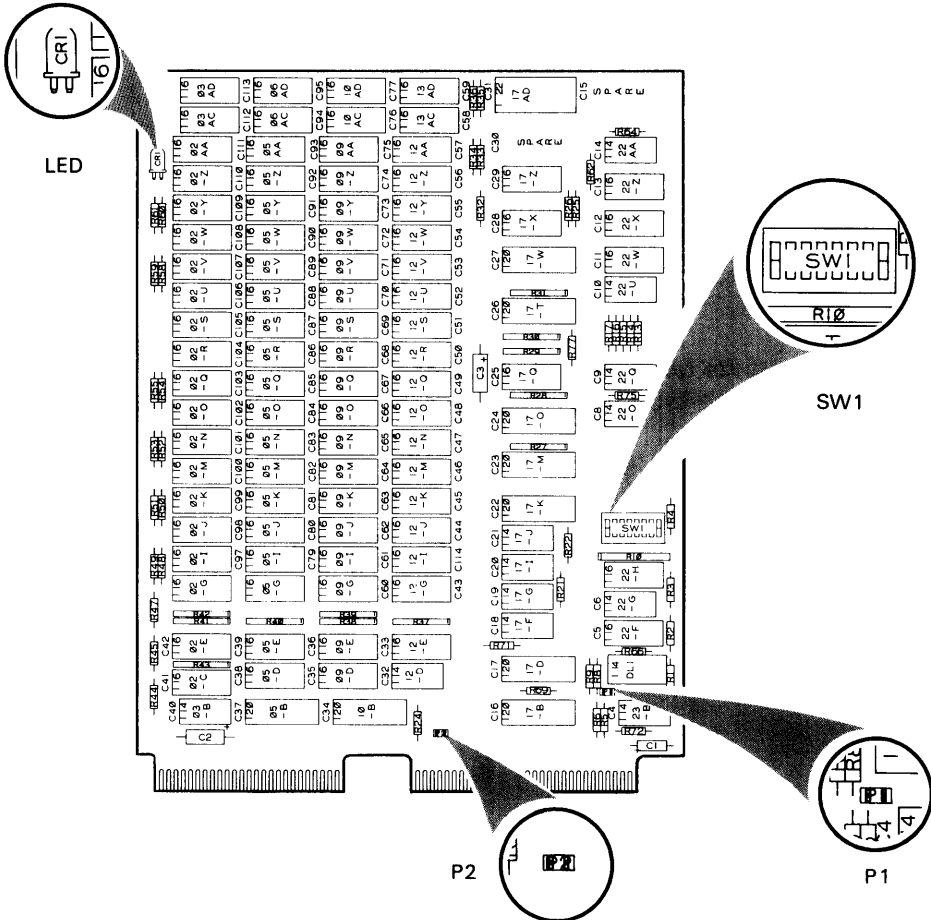

2-Mbyte memory card

1-Mbyte Cards, 512- and 256-Kbyte Cards

You can combine 512-Kbyte, 256-Kbyte, and 1-Mbyte cards in your system. Install your memory cards by inserting the 512- or 256-Kbyte card jumpers and setting the 1-Mbyte card SW1 switches as shown below.

NOTE *If the card combination includes the 512-Kbyte card(s), install the card(s) closest to the SPU. Install the P1 jumper in the 1-Mbyte card farthest from the SPU.*

If you need more information on the jumpers on the 512- or 256-Kbyte cards or the SW1 switch and P1 jumper on the 1-Mbyte cards, refer back to the sections on these cards.

256-Kbyte and 1-Mbyte cards combined

Card 1	256 Kb	256 Kb	256 Kb
Jumpers IN	W1,W2,W3	W1,W2,W3	W1,W2,W3
Card 2	256 Kb	256 Kb	1 Mb _____
Jumpers IN	W1, W2	W1, W2	4,5,6,7
SW1 switch ON	_____	_____	
Card 3	256 Kb	1 Mb	
Jumpers IN	W1, W3	_____	
SW1 switch ON	_____	3,4,5,6	
Card 4	1 Mb		
SW1 switch ON	2,3,4,5		

512-Kbyte and 1-Mbyte cards combined

Card 1	512 Kb	512 Kb
Jumpers IN	W1,W2	W1,W2
Card 2	512 Kb	1 Mb
Jumpers IN	W1	_____
SW1 switch ON	_____	3,4,5,6
Card 3	1 Mb	
SW1 switch ON	1,2,3,4	

512-Kbyte 256-Kbyte, and 1-Mbyte cards combined

Card 1	512 Kb	512 Kb
Jumpers IN	W1,W2	W1,W2
Card 2	256 Kb	256 Kb
Jumpers IN	W1, W3	W1, W3
Card 3	1 Mb	256 Mb
Jumpers IN	_____	W1
SW1 switch ON	2,3,4,5	_____
Card 4	_____	1 Mb
SW1 switch ON	_____	1,2,3,4

4207 Asynchronous Interface Card

The 4207 asynchronous interface card can be included in Model 20 and 30 systems. It is labeled with DGC part number 005-13951, and its adapter cable is labeled with DGC part number 005-021148. It has 29 jumpers labeled W1 through W29. Position all the jumpers according to the following table. The figure on the next page shows the jumper locations.

Jumper	Position	Jumper	Position
W1	In	W16	In
W2	Out	W17	Out
W3	In	W18	Out
W4	Out	W19	Out
W5	Out	W20	Out
W6	In	W21	In
W7	Out	W22	Out
W8	In	W23	Out
W9	Out	W24	In
W10	Out	W25	Out
W11	In	W26	Out
W12	In	W27	In
W13	In	W28	Out
W14	Out	W29	Out
W15	Out		

These jumpers select the following characteristics:

Interface type	RS232C
Data bits	8
Parity	None
Stop bit	1
Baud rate	9600
Clear to send	Disabled
Device code	50/51

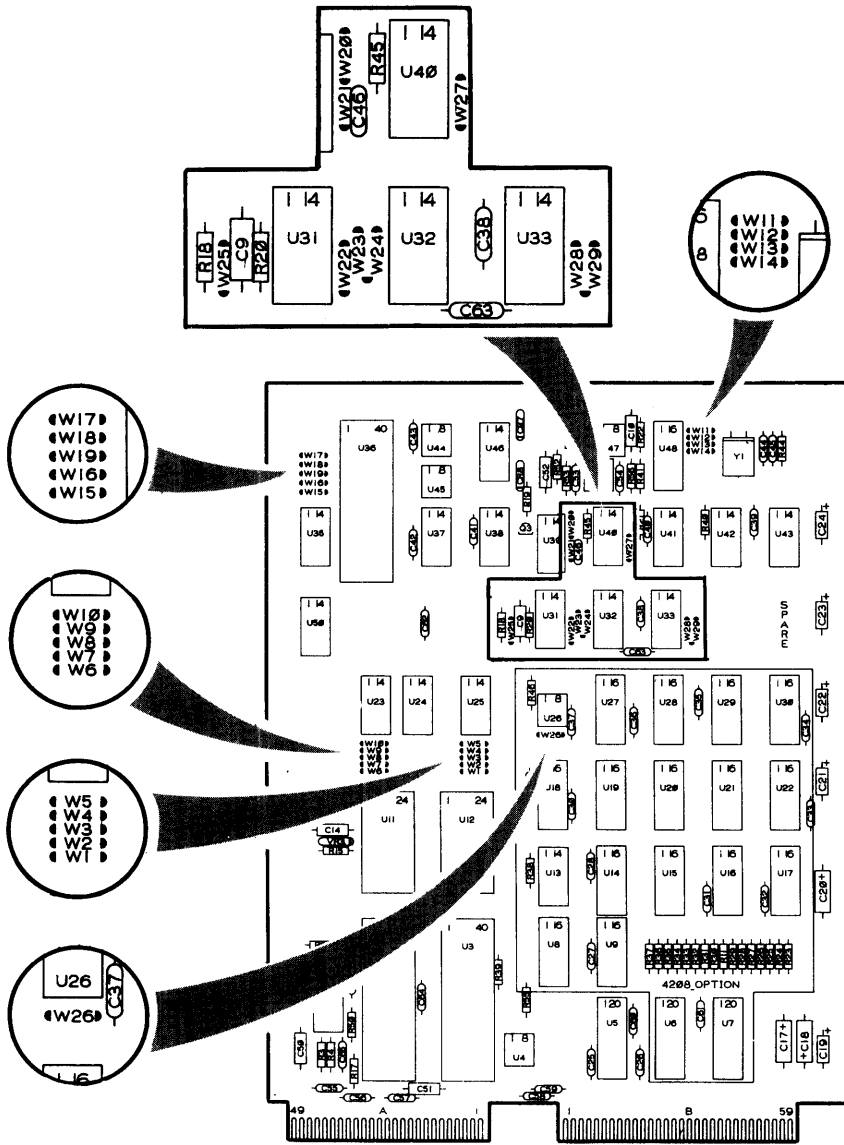

4207 Asynchronous interface card

DG-26219

NOTE For information on USAM cards, refer to the section, "USAM Cards," later in this chapter.

Configuring Model 45 Cards

This section provides switch and jumper information for the Model 45 SPU, ATP, and memory cards. For information on USAM cards, turn to the section, "USAM Cards," later in this chapter.

SPU Card

The SPU card, DGC part no. 005-022144, is always inserted in slot 1 and includes character manipulation instructions.

Three switches are contained in the SPU card. SW1 is a teletype asynchronous port; SW2 is the power-up switch for system I/O; SW3 is the auto program load switch. Switch settings are OFF when set to open and ON when set to closed. The table below presents standard switch positions.

SW1	Position	SW2	Position	SW3	Position
1	On	1	On	1	Off
2	Off	2	On	2	On
3	Off	3	On	3	Off
4	On	4	Off	4	Off
5	Off	5	Off	5	Off
6	Off	6	On	6	Off
7	On	7	On	7	Off
		8	Off	8	Off

The following table shows the characteristics selected by these jumpers and switches.

Interface type	EIA
Clear to send	Enabled
Baud rate	9600
PIT rate	10KHz
Automatic program load	Disabled
Break enable	Enabled
Halt dispatch	Enabled

To automatically load software from the diskette for disk when you power-up the system, set the SW3 switches as shown below.

SW3	For Diskette	For Disk
1	On	On
2	On	On
3	Off	Off
4	On	On
5	Off	Off
6	Off	On
7	Off	On
8	Off	Off

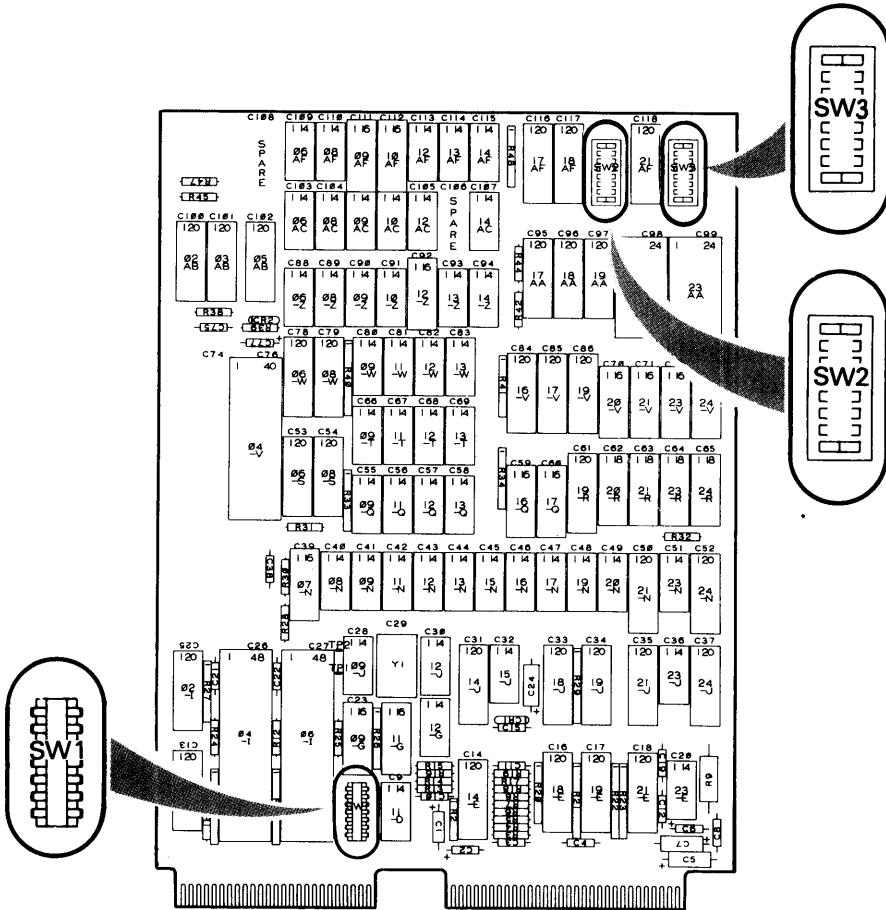

Model 45 SPU card

ATP Card

The ATP card, DGC Part no. 005-21749, contains 2 sets of gold-wire jumper posts. Jumper posts, labeled P1 and P4, have plastic connector plugs which are inserted over posts.

Unused or unconnected plugs should be stored by sliding the plug down over only one post. Do not discard connector plug.

P1, the two-posted jumper, is located at the right of the board. The board will respond to device code 7 when the jumper is "in" (standard board configuration). Device code 47 will be implemented when the jumper is "out"

P4, the three-posted jumper, is located at the left of the board. Its location is said to be "in" when the connector plug is inserted over the two leftmost posts (the two posts farthest away from the 68000 pin-grid array). P4 is "out" when the connector plug is inserted over the two rightmost posts (the two posts closest to the 68000 pin-grid array).

Jumper P4's standard configuration has the jumper "out." If a user wants to implement the 68000 Test and Set Instruction (TAS), P4 should be "in."

Standard jumper positions are indicated below.

Jumper Position	
P1	In
P4	Out

The following table shows the characteristics selected by jumpers.

TAS instruction (indivisible cycle)	Disabled
Device code	7

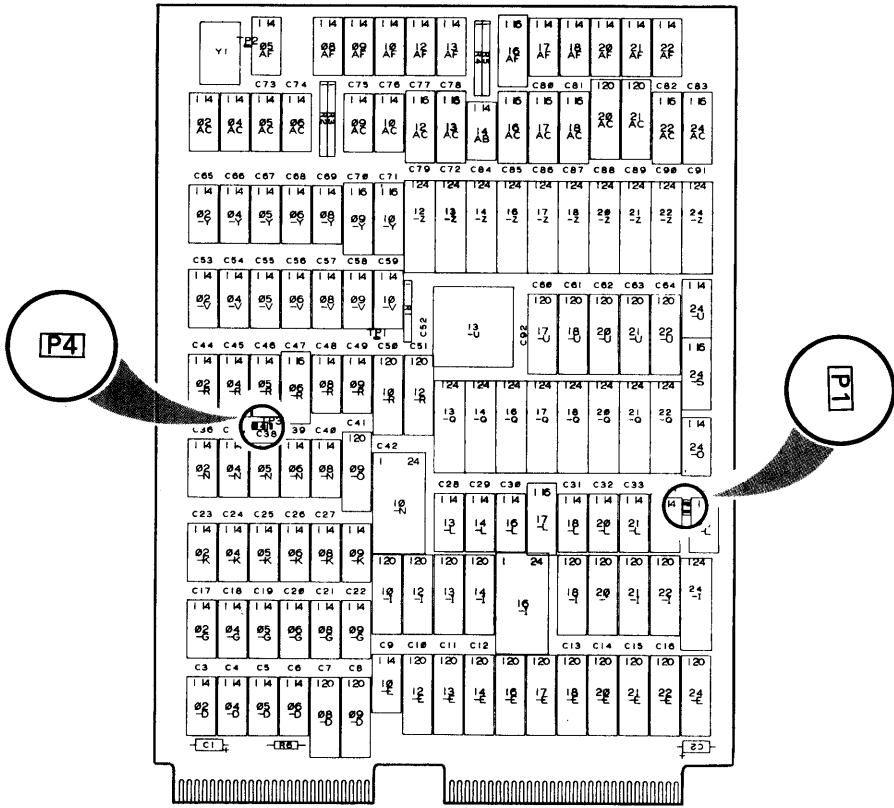

Model 45 ATP card

Memory Cards

Memory cards are available in three different versions -- 1Mbyte, 2Mbytes, and 512Kbytes. Each card is labeled with a part number. The table below lists the part numbers for each card.

Card	Part Number
1-Mbyte memory card	005-22143
2-Mbyte memory card	005-22198
512-Kbyte memory card	005-019537

Your system can hold a maximum of three memory cards. 512-Kbyte cards may be configured together; and 1- and 2-Mbyte cards may be combined. The 512-Kbyte cards should reside in the slots closest to the SPU card. In the Model 45, memory cards reside in slots 3, 4, or 5 of the CPU logic module.

512-Kbyte Memory Cards

These memory cards have six jumpers, labeled W1 through W4, and W5 and W7. There is no W6. Insert all the jumpers listed below for the memory card(s) you are installing. Make sure jumper W7 is inserted on the memory card farthest away from the SPU card. Remove all other jumpers from the memory card(s) you are installing. The figure on the next page shows the jumper locations.

512-Kbyte Memory Cards	Number of Cards	Slot	Jumpers		
			W1	W2	W7
512-Kbyte	1	3	In	In	In
1-Mbyte	2	3	In	In	Out
		4	In	Out	In
1.5-Mbyte	3	3	In	In	Out
		4	In	Out	Out
		5	Out	In	In

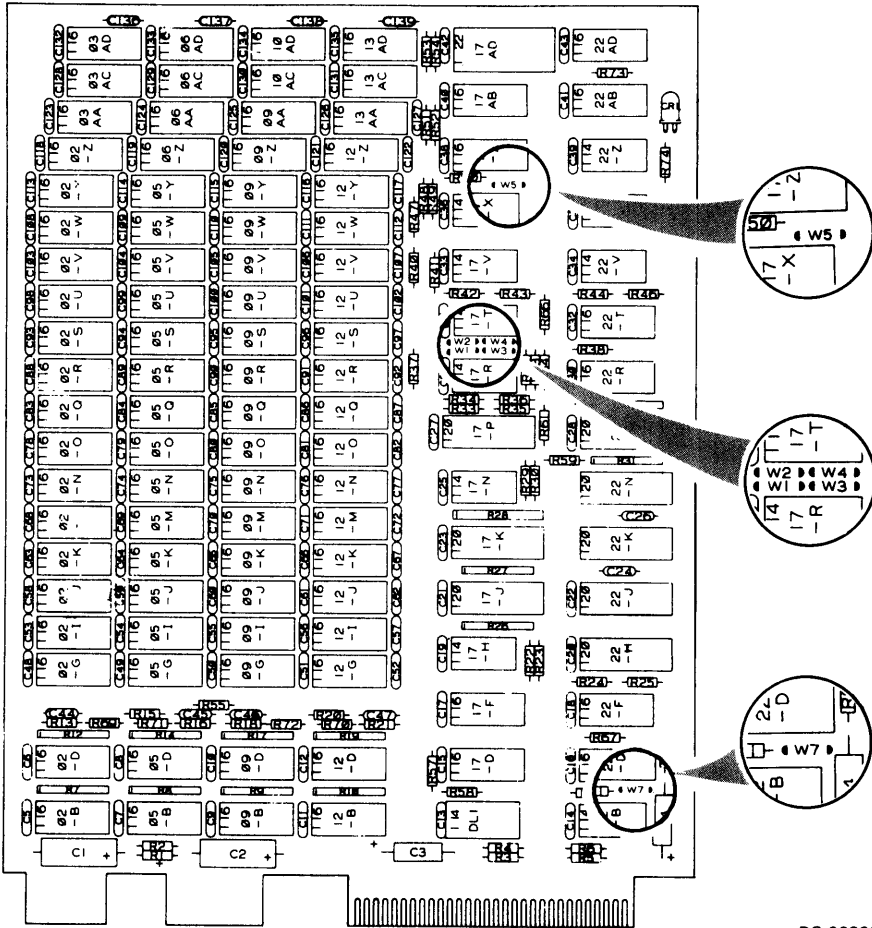

Model 45 memory card

DG-26903

1- and 2-Mbyte Memory Cards

Using 1- and 2-Mbyte memory cards, switch 1 is used to select the system memory range of each memory card. This eight-position switch is OFF when depressed on the open side; and ON when it is not depressed on open side. Listed below are the memory configurations for switch 1, (SW1) that may be developed with Model 45.

1-Mbyte table

		Switch Numbers							
Card Number	System Memory Range	1	2	3	4	5	6	7	8
1	0 — 1-Mbyte	OFF	OFF	OFF	OFF	OFF	OFF	ON	ON

2-Mbyte table

		Switch Numbers							
Card Number	System Memory Range	1	2	3	4	5	6	7	8
1	0 — 2-Mbyte	OFF	OFF	OFF	OFF	ON	ON	ON	ON

2-Mbyte table using 1-Mbyte cards

		Switch Numbers							
Card Number	System Memory Range	1	2	3	4	5	6	7	8
1	0 — 1-Mbyte	OFF	OFF	OFF	OFF	OFF	OFF	ON	ON
2	1 — 2-Mbyte	OFF	OFF	OFF	OFF	ON	ON	OFF	OFF

3-Mbyte table using one 2-Mbyte and one 1-Mbyte card

		Switch Numbers							
Card Number	System Memory Range	1	2	3	4	5	6	7	8
1	0 — 2-Mbyte	OFF	OFF	OFF	OFF	ON	ON	ON	ON
2	2 — 3-Mbyte	OFF	OFF	ON	ON	OFF	OFF	OFF	OFF

3-Mbyte table using three 1-Mbyte cards

		Switch Numbers							
Card Number	System Memory Range	1	2	3	4	5	6	7	8
1	0 — 1-Mbyte	OFF	OFF	OFF	OFF	OFF	OFF	ON	ON
2	1 — 2-Mbyte	OFF	OFF	OFF	OFF	ON	ON	OFF	OFF
3	2 — 3-Mbyte	OFF	OFF	ON	ON	OFF	OFF	OFF	OFF

4-Mbyte table using two 2-Mbyte cards

		Switch Numbers							
Card Number	System Memory Range	1	2	3	4	5	6	7	8
1	0 — 2-Mbyte	OFF	OFF	OFF	OFF	ON	ON	ON	ON
2	2 — 4-Mbyte	ON	ON	ON	ON	OFF	OFF	OFF	OFF

4-Mbyte table using one 2-Mbyte and two 1-Mbyte cards

		Switch Numbers							
Card Number	System Memory Range	1	2	3	4	5	6	7	8
1	0 — 2-Mbyte	OFF	OFF	OFF	OFF	ON	ON	ON	ON
2	2 — 3-Mbyte	OFF	OFF	ON	ON	OFF	OFF	OFF	OFF
3	3 — 4-Mbyte	ON	ON	OFF	OFF	OFF	OFF	OFF	OFF

System Configurations

The P1 jumper, a terminator connector, is always installed in a system configuration that has only one memory board. In multiple memory board configurations, P1 should be installed farthest away from the CPU. P2 is used as a test jumper and should never be installed. P1 and P2 are depicted on the following page.

Light Emitting Diode

The memory circuit contains a light emitting diode (LED) which indicates that the board is being accessed. The LED is shown on the page that follows.

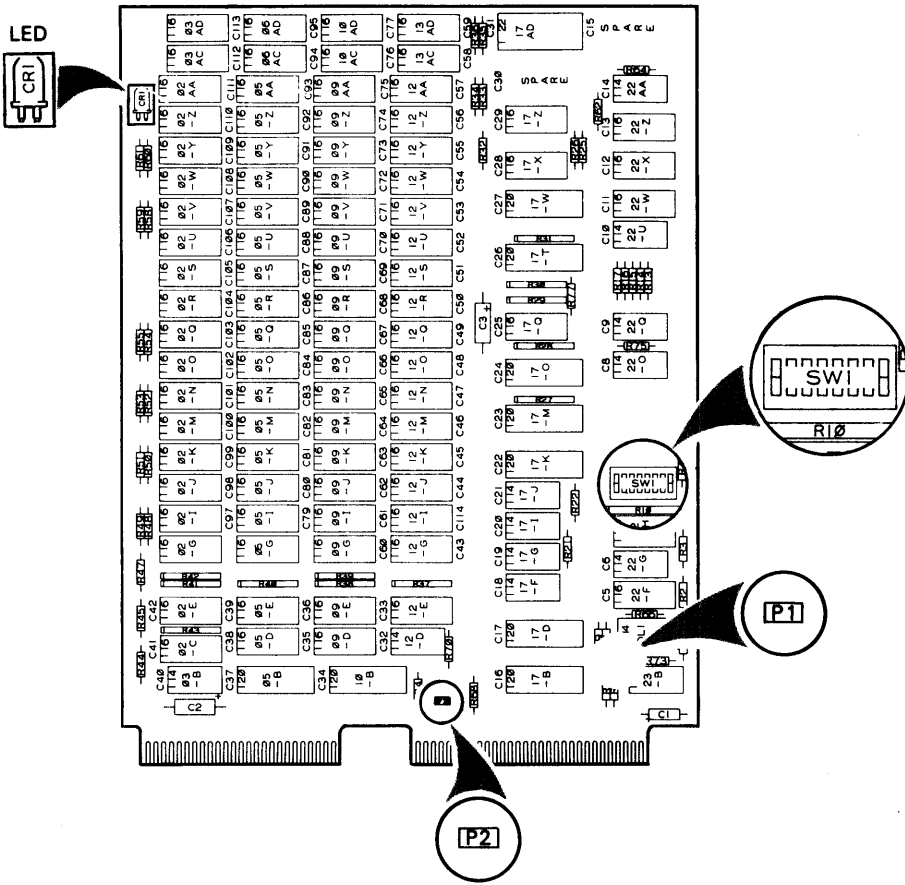

Model 45 1- or 2-Mbyte memory card

USAM Cards

The USAM card is available in two different versions, one with 4 lines and one with 1 line. Your Model 10, 10/SP, 20, or 30 system may contain up to four USAM cards; the Model 45 system contains 1 or 2 USAM-4 cards . A short adapter comes with each card.

The cards and cables are labeled with a part number. The table below lists the part numbers for the two cards and their cables.

Card	Card Number	Cable Number
4-line USAM	005-021071	005-021041
1-line USAM	005-020619	005-020688

The 4-line card has seven switch sets, labeled SW1 through SW7. The 1-line card has the same switch sets except for sets SW2 and SW3. The next figure shows the switch locations.

SW1 Switches

Set SW1 has four switches, one for each line; switch 1 is for line 1, switch 2 for line 2, and so on. These switches are never used unless the line is connected to a modem. A switch determines how the line responds to a modem signal called Ring Indicator, which the modem sends when a telephone rings on a line connected to it.

If you will be connecting a modem to the line, set the line's switch to the on position so the USAM card will notify the computer when it receives the Ring Indicator signal. Set the switch to the off position to inhibit the card from notifying the computer. Set the switch for any unused line to the off position.

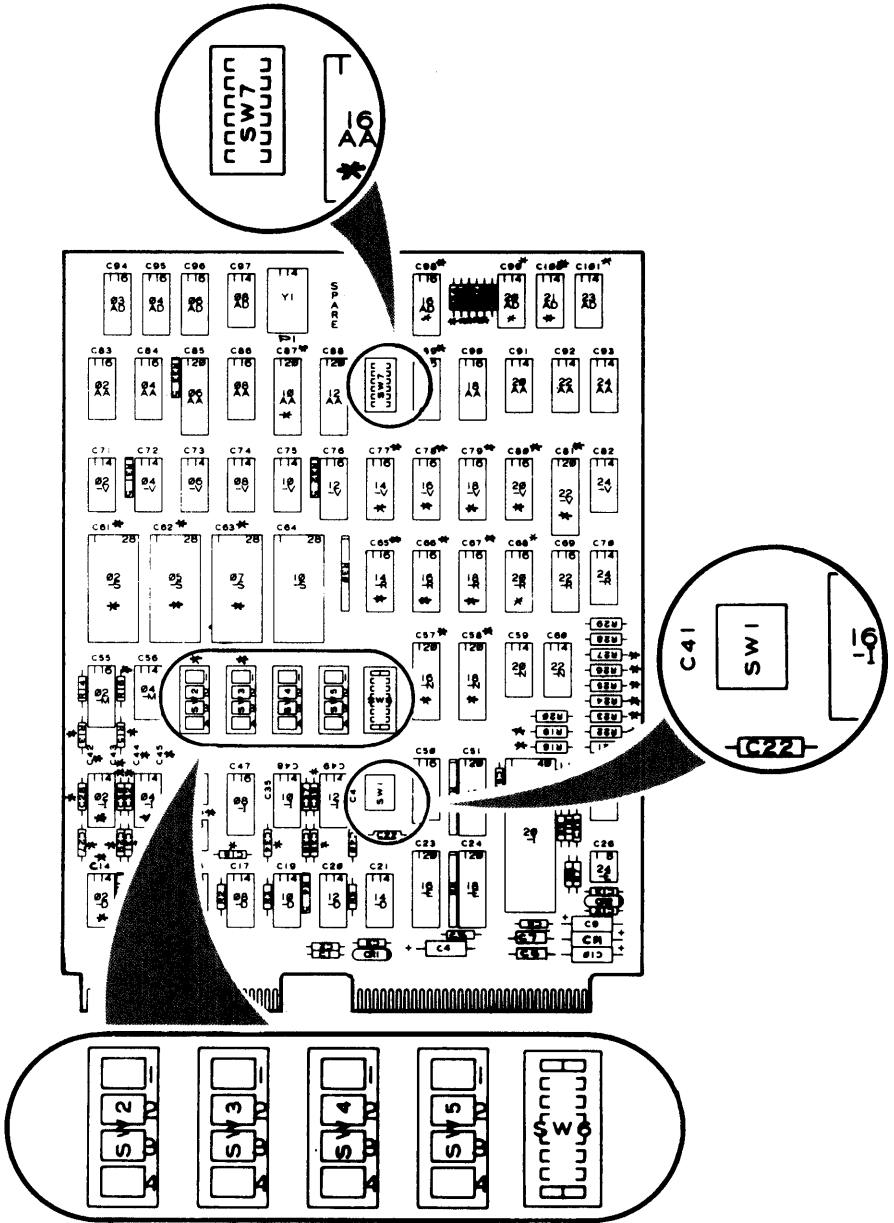

USAM card

SW2 Through SW6 Switches

These switch sets select a line's interface type. A line can have either an EIA RS-232-C, EIA RS-422-A, or 20 mA current loop interface; however, a line's interface must be the same type as that of the peripheral equipment connected to it.

A DASHER D211, D220, D410, D460, or D470C terminal can have any one of the three types of interfaces. The terminal's interface is selected by its device cable. Thus, if you use an EIA RS-422-A device cable, the terminal has an EIA RS-422-A interface.

The DASHER D210, plotter, data tablet, mouse, and some printers have only an EIA RS-232-C interface. Some printers, such as the Model 4433 printer may have a current loop, although they are preset at the factory for an EIA RS-232-C interface.

Using the following table, set the switches in each set to the interface type for your USAM lines.

Line	SW	Positions	Interface Type		
			RS-232-C	RS-422-A	Current Loop
1	SW4	1, 2	Off	Off	On
	SW5	1, 2	Off	On	Off
	SW6	1	On	Off	Off
2		2	On	Off	On
	SW4	3,4	Off	Off	On
	SW5	3,4	Off	On	Off
	SW6	3	On	Off	Off
3		4	On	Off	On
	SW2	1, 2	Off	On	Off
	SW3	1, 2	Off	Off	On
	SW6	5	On	Off	Off
4		6	On	Off	On
	SW2	3,4	Off	On	Off
	SW3	3,4	Off	Off	On
	SW6	7	On	Off	Off
		8	On	Off	On

SW7 Switches

This switch set selects a number, called the device code, which the USAM sends to the computer to identify itself. Each USAM card must have a different number. The standard device codes for the USAM cards are (octal) 34, 74, 55, and 56. Select a unique number for each USAM card and set the SW7 switches as listed below.

Select the device codes in order: your first USAM is 34; the second is 74; the third is 55; the fourth is 56.

	Position for Device Code				
	Switch	34	74	55	56
1	Off	On	On	On	On
2	On	On	Off	Off	Off
3	On	On	On	On	On
4	On	On	On	On	On
5	Off	Off	Off	Off	On
6	Off	Off	On	Off	Off

Related Documentation

A comprehensive documentation set supports all the hardware and software products available for the DESKTOP GENERATION computer system. The documentation listed below is meant to be read in sequence by anyone who owns a DESKTOP GENERATION system.

DESKTOP GENERATION System Operator's Guide

Tells operators how to use system, perform routine cleaning and maintenance, load Customer Diagnostics, and perform simple troubleshooting tasks. DGC ordering no. 014-001117.

DESKTOP GENERATION Peripherals Operator's Guide

Provides operator with information on care and usage of DESKTOP GENERATION supported terminals, printers, plotters, data tablet, and mouse. DGC ordering no. 014-001133.

How to Install a DESKTOP GENERATION Computer

Is a multi-sheet, intallation guide summary, containing an illustrated description of the steps needed to install the basic DESKTOP GENERATION computer modules, the cartridge tape module, and the expansion disk module. DGC ordering no. 014-001132.

How to Connect Peripherals to a DESKTOP GENERATION Computer

Is a single-sheet, illustrated summary of the steps needed to connect peripherals to the system. It includes information on connector and adapter cables. DGC ordering no. 014-001131.

DESKTOP GENERATION Peripherals Installation Guide

Contains information on the installation of DESKTOP GENERATION supported terminals, printers, plotters, data tablet, and mouse. DGC ordering no. 014-001130.

Using DG/RDOS on DESKTOP GENERATION Systems

Follows the installation and operating guides with instructions for loading and using the DG/RDOS operating system and other software. Exercises and examples get you started with DG/RDOS. DGC ordering no. 069-000056.

Using AOS on DESKTOP GENERATION Systems

Follows the installation and operating guides with instructions for loading and using the AOS operating system and other software. Exercises and examples lay the groundwork for working with AOS and with several programming languages. DGC ordering no. 069-000058.

/UX Family Operator Guide

Follows the installation and operating guides with instructions for loading and using the DESKTOP/UX operating system on DESKTOP GENERATION Model 45 systems. DGC ordering no. 093-701015.

Your source for other DESKTOP GENERATION and Data General publications is TIPS: the Technical Information and Publications Service. To order the TIPS catalog of publication, obtain order forms or information, write or call:

Data General Corporation
Attn: TIPS Administrator F019
4400 Computer Drive
Westboro, MA 01580
Tel. (617) 366-2900

Telephone Assistance

If you are unable to solve a problem with your system with the information in this manual, call the Data General Customer Support Center (CSC) at the following number: 1-800-DGHELP (1-800-344-3577). The CSC will put you in touch with one of Data General's telephone assistance staff to answer such questions as, "If one of my terminals isn't working, can I try connecting it to another USAM line?"

Free telephone assistance is available with your warranty and with most Data General service options. Lines are open from 8:30 a.m. to 8:30 p.m., Eastern Standard Time, Monday through Friday.

A call to Data General's general information hot-line, 1-800-DATAGEN, can also help you solve problems with your order and give you additional telephone assistance.

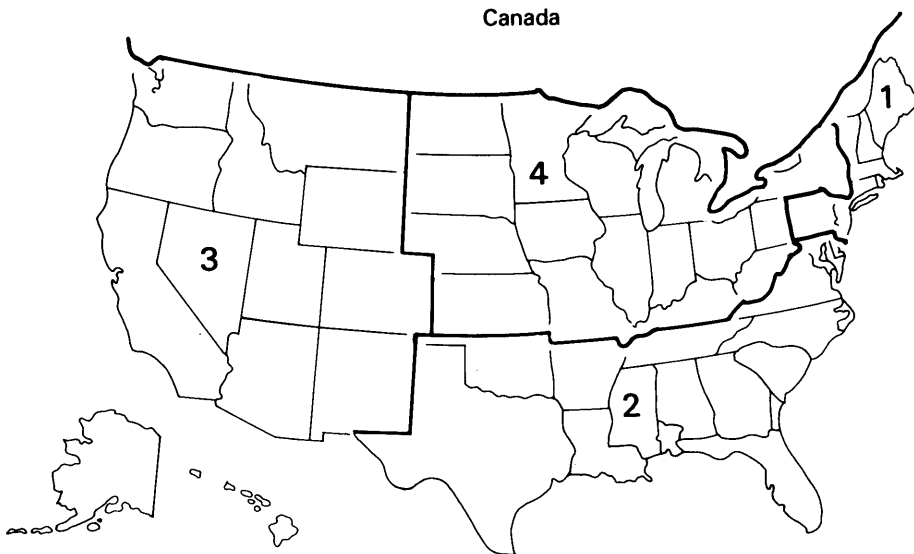

DG-25956

Figure 5-1

For telephone assistance in areas outside the continental United States, ask your Data General salesperson for the nearest phone number.

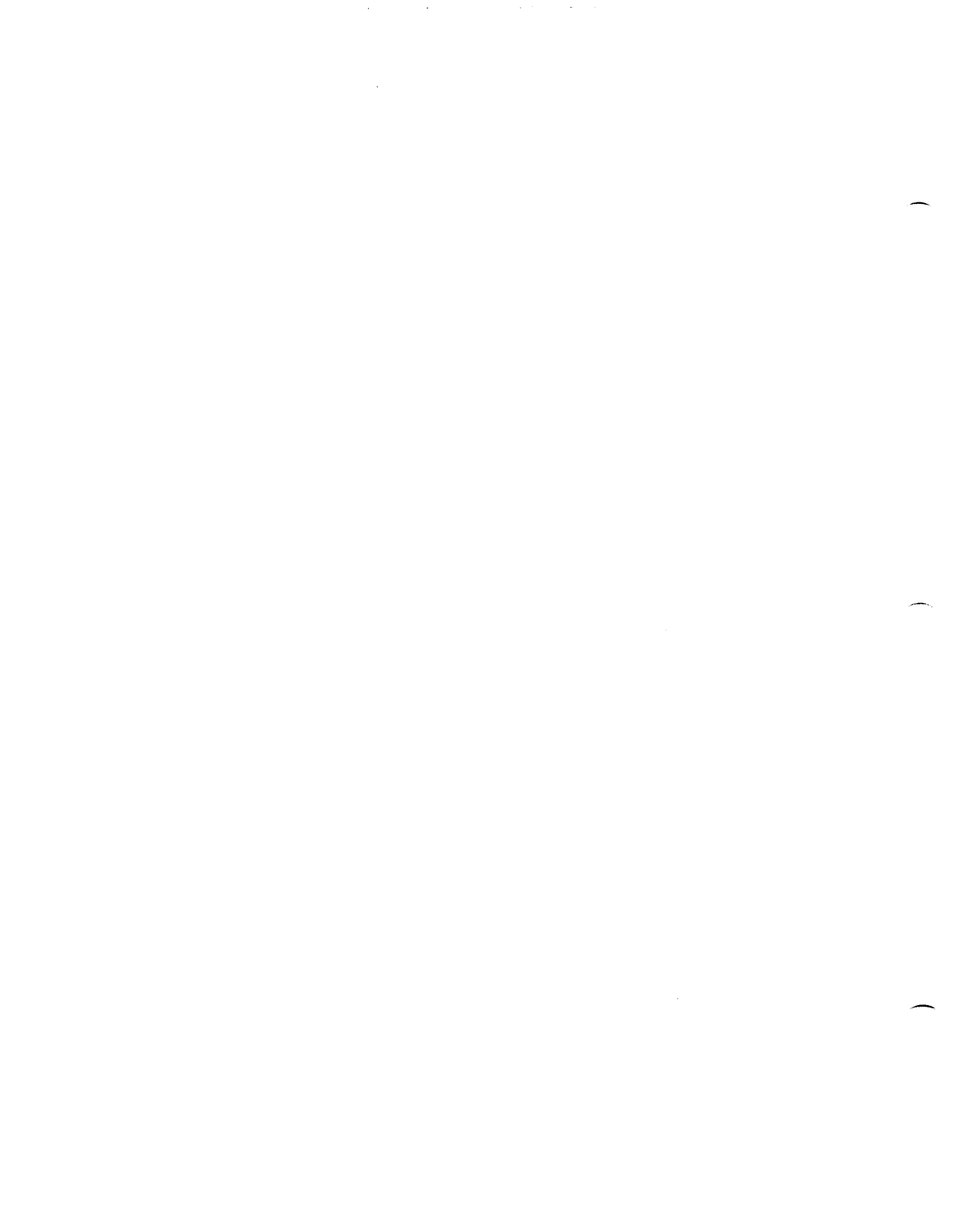

Index

Within the index, the letter “f” following a page entry indicates that the index item continues onto the next page. The letters “ff” following a page entry indicate that the index item continues on for the next several pages.

4207 card 4-4ff, 4-12f, 4-28, 4-35, 4-50f

A

Adding modules 3-1ff

Adding cards 4-1ff

ATP card 4-4, 4-6, 4-11, 4-12f, 4-35, 4-52, 4-55f

C

Checklist, final inspection 1-2

Cables

Model 10, 10/SP

color controller/SPU2, connecting 4-31, 4-33

color controller/SPU2, removing 4-20

diskette ribbon, connecting 4-26, 4-33

diskette ribbon, removing 4-18, 4-23, 4-33

part numbers 4-4

SPU set, connecting 4-26

SPU set, removing 4-19, 4-30

Model 20, 30

part numbers 4-4

SPU/FPU, removing 4-18

SPU/FPU, connecting 4-25

Model 45 part numbers 4-4

Cards *See also* individual cards

adding 4-1ff

cables for, part numbers 4-4

characteristics 4-35 *See also*

Characteristics, cards

configuring 5-1ff

dc power requirements 4-5ff

calculating 4-7ff

Model 10, 10/SP 4-8

Model 20, 30 4-9f

Model 45 4-11f

installing 4-12ff

labels 4-3, 4-14

light emitting diode (LED) 5-18, 5-30f

Model 10 and 10/SP 4-4

Model 20 and 30 4-4

Model 45 4-4

part numbers 4-4

priority switches, slots 4-15, 4-24

removing 4-12ff

- slots 4-12f
- unpacking 4-2f
- Characteristics, cards 4-35
 - 4207 asynchronous interface 5-20
 - Model 20, 30 SPU 5-13
 - Model 45 ATP 5-25
 - Model 45 SPU 5-22f
- Color controller card 4-4ff, 4-12f, 4-20, 4-28ff, 4-35, 4-40
- Configuration charts 1-5, 3-4, back of book
- Configuring cards 5-1ff
 - jumpers 4-24, 5-2 *See also* Jumpers
 - Microproduct I/O 4-35
 - Model 10, 10/SP
 - color controller 5-7
 - memory expansion 5-8 f
 - SPU card set 5-4f
 - SPU 1 jumpers 5-5
 - SPU 2 jumpers 5-6
 - Model 20, 30
 - hardware floating point 5-14
 - memory, 256 Kbyte 5-14f, 5-19
 - memory, 512 Kbyte 5-14f, 5-19
 - memory, 1/2 Mbyte 5-17f, 5-19
 - SPU 5-12f
 - 4207 asynchronous interface 5-20
 - Model 45
 - ATP 5-25
 - memory, 512 Kbyte 5-27f
 - memory, 1/2 Mbyte 5-29f
 - SPU 5-22f
 - USAM 5-32f
 - SW1 switches 5-32
 - SW 2-6 switches 5-34
 - SW 7 5-35

D

- Device codes, USAM card 5-35
- Documentation, storing 1-2, 1-5

E

- Electrical specifications 2-6ff

- cartridge tape module 2-8
- expansion disk unit 2-8
- power supply module 2-7

H

- Hardware floating point card 4-4ff, 4-12f, 4-18, 4-25, 4-35, 4-47
- Humidity, environmental 2-2f

I

- Installing cards 4-22ff
 - configuring *See* Configuring, cards
 - fiberglass strip 4-23
 - inserting 4-25
 - Model 10, 10/SP
 - color controller 4-28ff
 - diskette ribbon cable, installing 4-26
 - diskette ribbon cable, removing 4-23
 - SPU 4-26
 - Model 30
 - FPU 4-25
 - SPU 4-25
 - peripherals, controlling 4-35
 - priority switch setting 4-24
 - procedure 4-22ff
- Installing procedure 1-3ff

J

- Jumpers
 - description 5-2
 - Model 10, 10/SP
 - color controller 5-7f
 - memory expansion 5-8f
 - SPU card set 5-4f
 - SPU 1 jumpers 5-5
 - SPU 2 jumpers 5-6
 - Model 20, 30
 - memory 5-14f
 - memory, 256 5-14f, 5-19
 - memory, 512 5-14f, 5-19
 - memory, 1/2 Mbyte 5-17f, 5-19

- SPU 5-12f
- 4207 asynchronous interface 5-20
- Model 45
 - ATP 5-25
 - memory, 512 Kbyte 5-27f
 - memory, 1/2 Mbyte 5-29
- P1, P2, 1 and 2 Mbyte memory card 5-18, 5-30f
- posts 5-3
 - setting, in general 4-24 *See also*
- Configuring, Jumpers, Switches

M

- Mechanical specifications 2-4f
 - 3-module unit 2-4
 - 4-module unit 2-4
 - cartridge tape module 2-5
 - disk module 2-5
 - expansion disk unit 2-5
 - logic expansion module 2-4
 - peripherals 2-5
 - system console 2-5
- Memory card(s)
 - dc power requirements 4-5f
 - light emitting diode 5-30f
- Model 10, 10/SP 5-8f
- Model 20, 30 5-14f
- Model 45 5-27f
 - part numbers 4-4
 - P1 and P2 jumpers 5-30f
 - slot assignment 4-12f

P

- Part numbers
 - cables, for cards 4-4
 - cards 4-4
- Priority switches, card slots 4-15, 4-24

R

- Radio frequency interference 2-9

- Removing cards 4-1ff
 - Model 10, 10/SP
 - color controller 4-20
 - SPU 4-19
 - Model 30
 - FPU 4-18
 - SPU 4-18
 - procedure 4-16ff
- Removing modules, procedure 3-2f
- Removing peripherals 3-3
- Replacing modules 3-1ff

S

- Sheets, installation
 - using 3-5
- Site planning 2-1ff
 - electrical specifications 2-6ff
 - environmental conditions 2-2f
 - humidity 2-2
 - mechanical specifications 2-4f
 - radio frequency interference 2-9
 - static electricity 2-3
 - temperature 2-2
- SPU cards
 - Model 10, 10/SP 4-4f, 4-12f, 4-18f, 4-23, 4-26, 4-31, 4-35, 4-37ff, 5-4f
 - Model 20, 30 4-4f, 4-12f, 4-18, 4-25, 4-35, 5-12 f
 - Model 45 4-4f, 4-12f, 4-35, 5-22f
 - part numbers 4-4, 4-37
 - power requirements 4-5f
 - slot assignment 4-12f
- Static electricity 2-3
- Switches, cards 4-24, 5-3
 - automatic program load, Model 45 5-23
- Model 10, 10/SP memory 5-8f
- Model 20, 30
 - SPU 5-12f
 - memory, 1/2 Mbyte 5-17
- Model 45
 - SPU 5-22f
 - memory, 1/2 Mbyte 5-29f
- USAM 5-32f

T

Temperature, environmental 2-2f

Tools needed 1-2

U

Unpacking

cards 4-2

checklist, final inspection 1-2

modules, procedure 3-4

peripherals 1-5

procedure 1-3ff

system console 1-5

tools needed 1-2

USAM card 4-4ff, 4-12f, 4-28, 4-35, 5-32f

Configuring Model 10 and 10/SP Systems

If you have a Model 10 or 10/SP system, use this foldout to record information about your system's components and its functional characteristics.

The foldout includes a diagram showing where components are located in your system; a configuration chart containing a component checklist with space for your comments; and, on the back, there are supplementary worktables allowing you to describe the devices and lines in your system.

As you unpack and install your system, use this configuration chart to record your system components. This information will be useful to you when you expand your system or when you call a Data General Service Operations Center with any questions or problems.

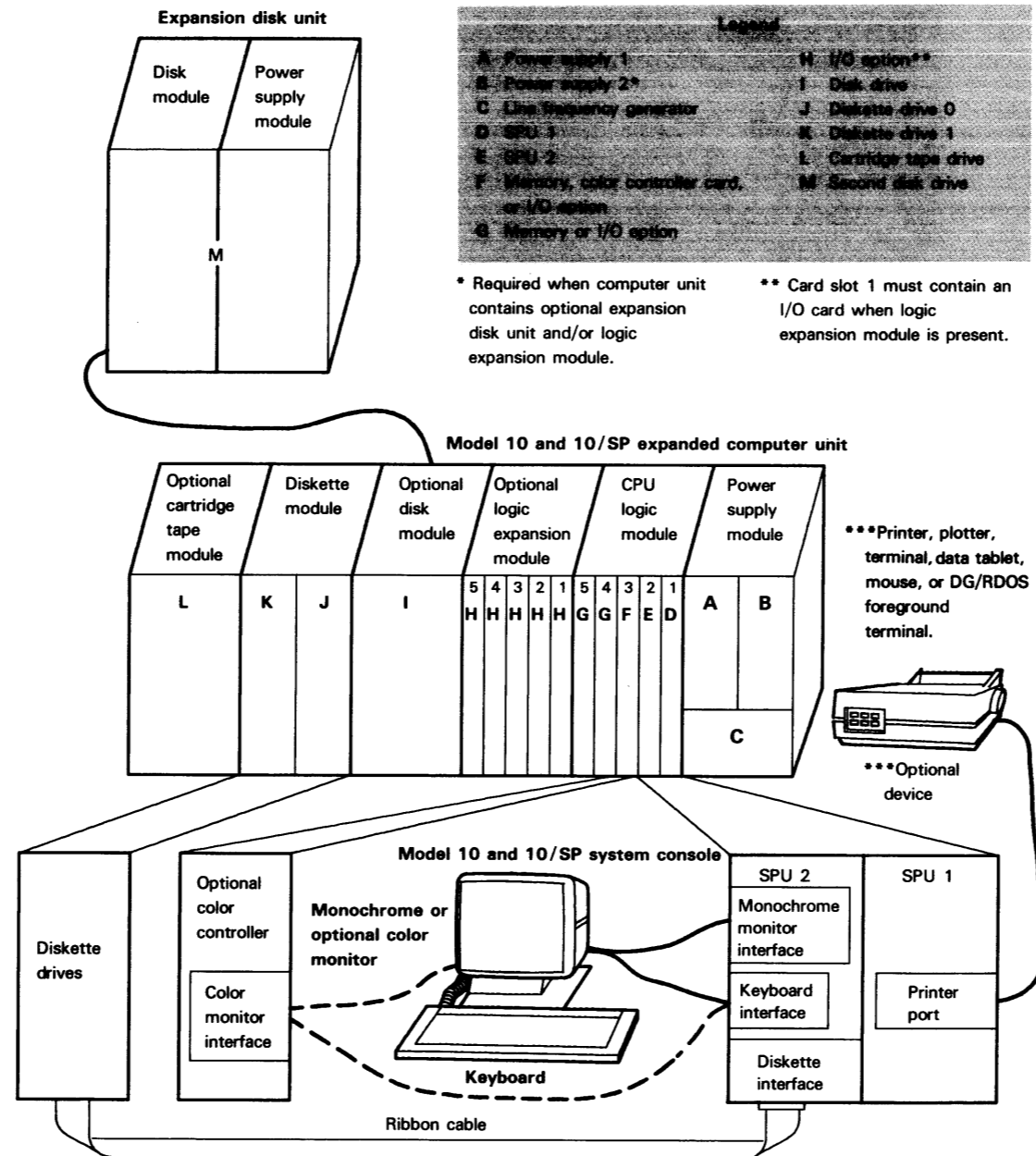

Configuring Model 10 and 10/SP Systems

System Configuration Chart

Power supply module	A	Power supply 1	✓		
	B	Power supply 2			
	C	Line frequency generator			
CPU logic module	D slot 1	SPU1	✓	FIS?	
	E slot 2	SPU2	✓	128K or 256K memory?	
	F slot 3	Color controller		Memory size:	Address range:
		Memory		Card name:	Devices connected:
		I/O option ¹		Memory size:	Address range:
G slot 4	Memory		Card name:	Devices connected:	
G slot 5	Memory		Memory size:	Address range:	
Logic expansion module ²	H slot 1	I/O option ¹		Card name:	Devices connected:
		I/O option ¹		Card name:	Devices connected:
	H slot 3	I/O option ¹		Card name:	Devices connected:
		I/O option ¹		Card name:	Devices connected:
		I/O option ¹		Card name:	Devices connected:
Disk module	I	Winchester disk subsystem		Capacity:	
	J	Diskette drive 0	✓		
Diskette module	K	Diskette drive 1			
	L	Cartridge tape subsystem			
Cartridge tape module	L	Cartridge tape subsystem			
	M	Second disk and power supply		Capacity:	
Expansion disk unit ³	M	Second disk and power supply		Capacity:	
		Keyboard	✓		
System console		Monitor ⁴	✓	Monochrome or color?	

¹ Complete appropriate I/O configuration table.
² Slot 1 must contain an I/O option card when this module is present.
³ A disk module is a prerequisite for this unit. The capacity of this unit is the same as the capacity of the disk module.
⁴ The color monitor requires a color controller card.

Configuring Model 20 and 30 Systems

If you have a Model 20 or 30 system, use this foldout to record information about your system's components and its functional characteristics.

The foldout includes a diagram showing where components are located in your system; a configuration chart containing a component checklist with space for your comments; and, on the back, there are supplementary worktables allowing you to describe the devices and lines in your system.

As you unpack and install your system, use this configuration chart to record your system components. This information will be useful to you when you expand your system or when you call a Data General Service Operations Center with any questions or problems.

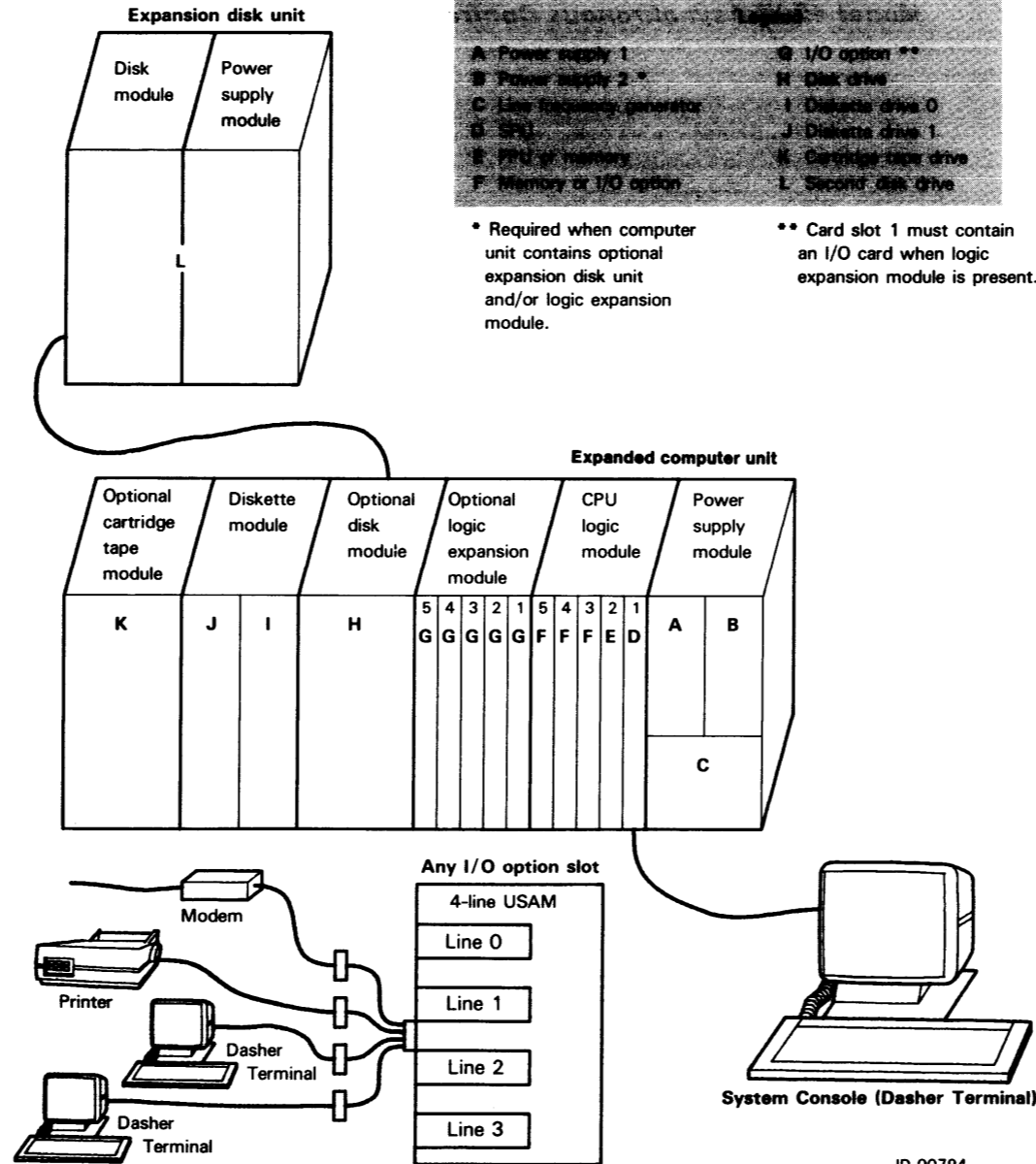

Legend	
A Power supply 1	Q I/O option **
B Power supply 2 *	H Disk drive
C Line frequency generator	I Diskette drive 0
D SPU	J Diskette drive 1
E MPU or memory	K Cartridge tape drive
F Memory or I/O option	L Second disk drive

* Required when computer unit contains optional expansion disk unit and/or logic expansion module.

** Card slot 1 must contain an I/O card when logic expansion module is present.

System Configuration Chart

Component	Location	Description	Checked	Comments
Power supply module	A	Power supply 1	✓	
	B	Power supply 2		
	C	Line frequency generator		
CPU logic module	D slot 1	SPU	✓	Model 20 or 30 FIS?
	E slot 2	Floating point card ¹		
	F slot 3	Memory ²		Memory size: Address range:
	F slot 4	I/O option ³		Card name: Devices connected:
	F slot 5	Memory		Memory size: Address range:
Logic expansion module ⁴	G slot 1	I/O option ³		Card name: Device connected:
	G slot 2	I/O option ³		Card name: Device connected:
	G slot 3	I/O option ³		Card name: Device connected:
	G slot 4	I/O option ³		Card name: Device connected:
	G slot 5	I/O option ³		Card name: Device connected:
Disk module	H	Winchester disk subsystem		Capacity:
Diskette module	I	Diskette drive 0	✓	
	J	Diskette drive 1		
Cartridge tape module	K	Cartridge tape subsystem		
Disk expansion unit ⁵	L	Second disk and power supply		Capacity:
System console		DASHER terminal ⁶	✓	Model no.

¹ Required with Model 30 SPU.

² At least one memory card required in system.

³ Complete the appropriate I/O configuration table.

⁴ Slot 1 must contain an I/O option card when this module is present.

⁵ The capacity of this unit is the same as the capacity of the disk module.

A disk module is a prerequisite for this unit.

⁶ See the configuration chart for SPU I/O facilities for asynchronous line characteristics.

Configuring a Model 45 System

If you have a Model 45 system, use this fold out to record information about your system's components and its functional characteristics.

The foldout includes a diagram showing where components are located in your system; a configuration chart containing a component checklist with space for your comments; and, on the back, there are supplementary worktables allowing you to describe the devices and lines in your system.

As you unpack and install your system, use this configuration chart to record your system components. This information will be useful to you when you expand your system or when you call a Data General Service Operations Center with any questions or problems.

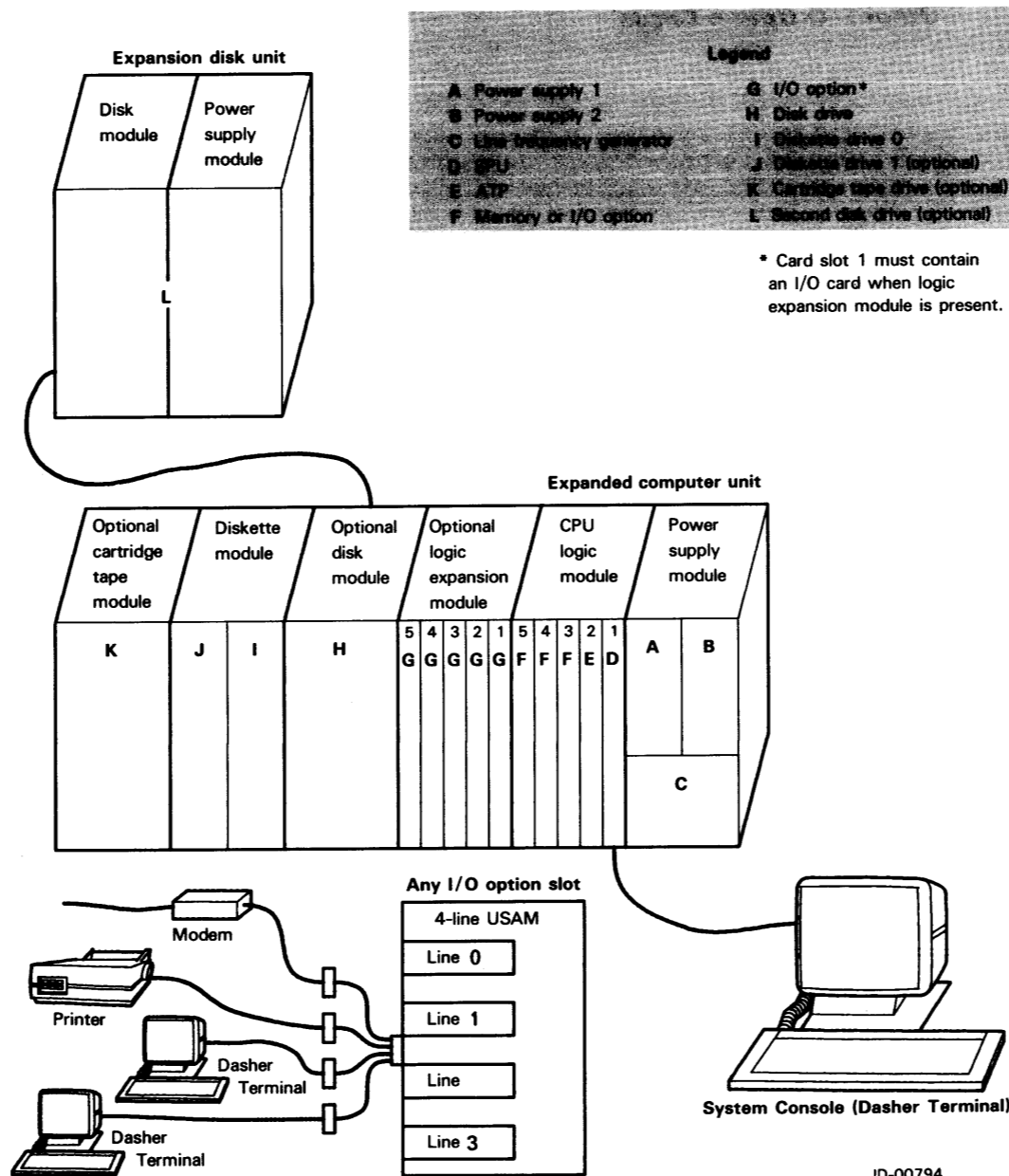

Legend	
A Power supply 1	G I/O option*
B Power supply 2	H Disk drive
C Line frequency generator	I Diskette drive 0
D SPU	J Diskette drive 1 (optional)
E ATP	K Cartridge tape drive (optional)
F Memory or I/O option	L Second disk drive (optional)

* Card slot 1 must contain an I/O card when logic expansion module is present.

System Configuration Chart

Location (see wiring diagram)	Component	Check	Characteristics/Comments
Power supply module	A Power supply 1	✓	
	B Power supply 2	✓	
	C Line frequency generator	✓	
CPU logic module	D slot 1 SPU	✓	
	E slot 2 ATP	✓	
	F slot 3 Memory ¹	✓	Memory size: Address range:
	F slot 4 I/O option ²	✓	Memory size: Address range: Card name: Device connected:
	F slot 5 Memory I/O option ²		Memory size: Address range: Card name: Device connected:
Logic expansion module ⁴	G slot 1 I/O option ^{2,3}		Card name: Device connected:
	G slot 2 I/O option ²		Card name: Device connected:
	G slot 3 I/O option ²		Card name: Device connected:
	G slot 4 I/O option ²		Card name: Device connected:
	G slot 5 I/O option ²		Card name: Device connected:
Disk module	H Winchester disk subsystem	✓	Capacity:
Diskette module	I Diskette drive 0	✓	
	J Diskette drive 1		
Cartridge tape module	K Cartridge tape subsystem		
Disk expansion unit ³	L Second disk and power supply		Capacity:
System console	DASHER terminal ⁵	✓	Model no.

- At least one memory card required in system.
- Complete the appropriate I/O configuration table.
- Slot 1 must contain an I/O option card when this module is present.
- The capacity of this unit is the same as the capacity of the disk module.

A disk module is a prerequisite for this unit.

5 See the configuration chart for SPU I/O facilities for asynchronous line characteristics.



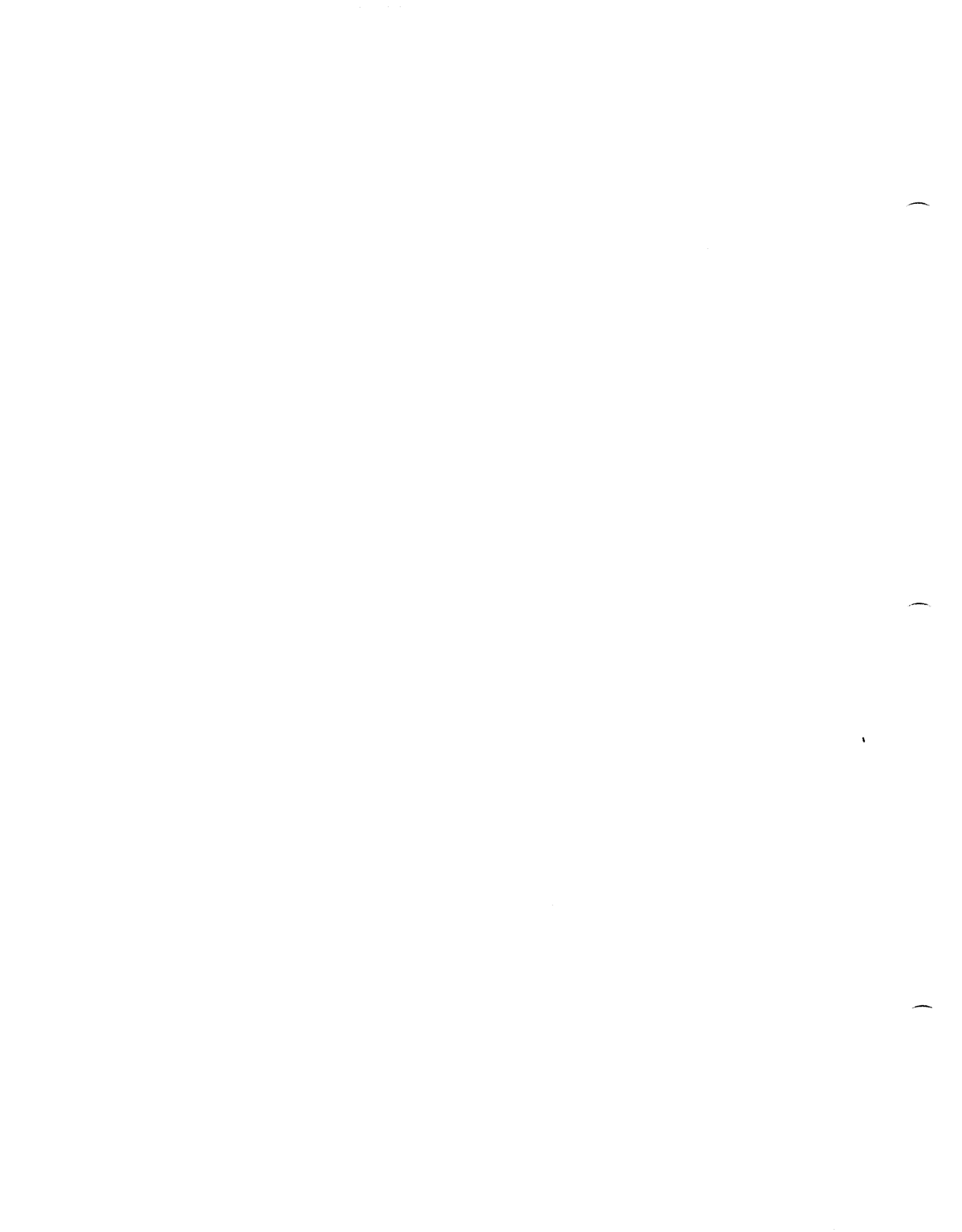

CUSTOMER DOCUMENTATION COMMENT FORM

Your Name _____ Your Title _____

Company _____

Street _____

City _____ State _____ Zip _____

We wrote this book for you, and we made certain assumptions about who you are and how you would use it. Your comments will help us correct our assumptions and improve the manual. Please take a few minutes to respond. Thank you.

Manual Title _____ Manual No. _____

Who are you? EDP/MIS Manager Analyst/Programmer Other _____
 Senior Systems Analyst Operator
 Engineer End User

How do you use this manual? (List in order: 1 = Primary Use)

___ Introduction to the product ___ Tutorial Text ___ Other _____
 ___ Reference ___ Operating Guide

fold

About the manual:		Yes	No
Is it easy to read?		<input type="checkbox"/>	<input type="checkbox"/>
Is it easy to understand?		<input type="checkbox"/>	<input type="checkbox"/>
Are the topics logically organized?		<input type="checkbox"/>	<input type="checkbox"/>
Is the technical information accurate?		<input type="checkbox"/>	<input type="checkbox"/>
Can you easily find what you want?		<input type="checkbox"/>	<input type="checkbox"/>
Does it tell you everything you need to know?		<input type="checkbox"/>	<input type="checkbox"/>
Do the illustrations help you?		<input type="checkbox"/>	<input type="checkbox"/>

If you wish to order manuals, contact your sales representative or dealer.

Comments:



Customer Documentation
MS E-219
4400 Computer Drive
Westboro, MA 01581-9973



Postage will be paid by addressee

FIRST CLASS PERMIT NO. 26 SOUTHBORO, MA 01772

BUSINESS REPLY MAIL

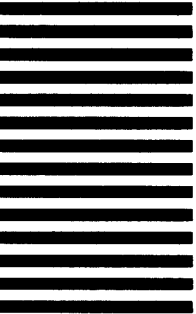

NO POSTAGE
NECESSARY
IF MAILED
IN THE
UNITED STATES

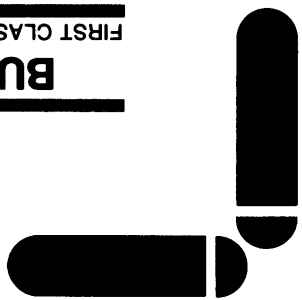



 **Data General**

Data General Corporation, Westboro, Massachusetts 01580



014-001118-03