

SONY

**EXTERNAL COMPUTER INTERFACE MANUAL**

LDP-1000A Videodisc Player  
SFA-1000 Still-Frame Audio Adaptor

## ご注意

このマニュアルに記載されている事柄の著作権は当社にあり、説明内容は機器購入者の使用を目的としています。

従って、当社の許可なしに無断で複写したり、説明内容(操作、保守等)と異なる目的で本マニュアルを使用することを禁止します。

## CONFIDENTIAL

The material contained in this manual consists of information that is the property of Sony Corporation and is intended solely for use by the purchasers of the equipment described in this manual.

Sony Corporation expressly prohibits the duplication of any portion of this manual or the use thereof for any purpose other than the operation or maintenance of the equipment described in this manual without the express written permission of Sony Corporation.

## CONFIDENTIEL

Le matériel contenu dans ce manuel consiste en informations qui sont la propriété de Sony Corporation et sont destinées exclusivement à l'usage des acquéreurs de l'équipement décrit dans ce manuel.

Sony Corporation interdit formellement la copie de quelque partie que ce soit de ce manuel ou son emploi pour tout autre but que des opérations ou entretiens de l'équipement à moins d'une permission écrite de Sony Corporation.

## VERTRAULICH

Das in dieser Anleitung enthaltene Material besteht aus Informationen, die Eigentum der Sony Corporation sind, und ausschließlich zum Gebrauch durch den Käufer der in dieser Anleitung beschriebenen Ausrüstung bestimmt sind.

Die Sony Corporation untersagt ausdrücklich die Vervielfältigung jeglicher Teile dieser Anleitung oder den Gebrauch derselben für irgendeinen anderen Zweck als die Bedienung oder Wartung der in dieser Anleitung beschriebenen Ausrüstung ohne ausdrückliche schriftliche Erlaubnis der Sony Corporation.

## TABLE OF CONTENTS

I.	Introduction .....	1-1
II.	Communications Link	
	A. Connector, Pin Assignment and Signals....	2-1
	B. RS232-C Driver/Receiver Signal Levels....	2-2
	C. Standard and "Null Modem" Cables	
	i. Standard Cable.....	2-4
	ii. "Null Modem" Cable.....	2-5
	D. Intel 8251A and Factory Pre-Settings ....	2-6
	E. How to Change Factory Pre-Settings	
	i. Baud Rates.....	2-6
	ii. Stop Bits.....	2-7
	F. How to Connect the SFA-1000 .....	2-8
	G. Power On Procedure and Trouble Shooting	
	i. Power On Procedure.....	2-10
	ii. Trouble Shooting.....	2-11
III.	An Example of an External Computer Interface, The Sony SMC-70 Microcomputer.....	3-1
	A. Preparation for Communication	
	i. Signal direction selector setting.	3-1
	ii. Baud rate setting.....	3-2
	iii. Selection of the CD or DSR input..	3-2
	B. Ports Used	
	i. Transmitted/received data.....	3-3
	ii. Mode setting, control instruction, status data.....	3-3
	iii. Interrupt control.....	3-3
	C. Making the Communication Line Available..	3-4
	i. Mode Setting.....	3-4
	ii. Command Writing.....	3-6
	iii. Initialization Steps.....	3-8
	D. Transmitting and Receiving Data.....	3-9
	i. Transmitter/Receiver Status.....	3-9
	ii. Transmitting/Receiving Procedure..	3-12
	iii. Data transmitting program example.	3-12
	iv. Data receiving program example....	3-13
IV.	LDP-1000A Commands	
	A. Command Structure .....	4-1
	B. Layout of Video Frames.....	4-2
	C. Return Codes	
	i. HEX(01) COMPLETION.....	4-2
	ii. HEX(02) ERROR.....	4-2
	iii. HEX(04) PGM END.....	4-2
	iv. HEX(05) NOT TARGET.....	4-4
	v. HEX(06) NO FRAME.....	4-4
	vi. HEX(0A) ACK.....	4-5
	vii. HEX(0B) NAK.....	4-5

#### IV. LDP-1000A Commands (Continued)

D.	Clear Operations	
	i. HEX(41) C.E. ....	4-6
	ii. HEX(56) C.L. ....	4-6
E.	Numeric Keys .....	4-7
F.	SEARCH and REPEAT Operations	
	i. HEX(43) SEARCH.....	4-8
	ii. HEX(44) REPEAT .....	4-10
G.	Audio Switching Operations	
	i. HEX(64) CH-1,HEX(65) CH-2.....	4-14
	ii. HEX(46) CH-1 ON, HEX(47) CH-1 OFF..	4-14
	HEX(48) CH-2 ON, HEX(49) CH-2 OFF..	4-14
H.	Playback Operations	
	i. HEX(3A) F-PLAY, HEX(4A) R-PLAY.....	4-15
	ii. HEX(3B) F-FAST, HEX(4B) R-FAST.....	4-15
	iii. HEX(3C) F-SLOW, HEX(4C) R-SLOW.....	4-15
	iv. HEX(3D) F-STEP, HEX(4D) R-STEP.....	4-15
	v. HEX(3E) F-SCAN, HEX(4E) R-SCAN.....	4-15
I.	STILL, STOP, CONTINUE Operations	
	i. HEX(3F) STOP.....	4-16
	ii. HEX(4F) STILL.....	4-16
	iii. HEX(61) CONTINUE.....	4-16
J.	Query Operations	
	i. HEX(60) ADDR INQ.....	4-16
	ii. HEX(67) STATUS INQ.....	4-16
	iii. HEX(68) DISC ID INQ.....	4-21
K.	MOTOR ON/OFF Operations	
	i. HEX(63) MOTOR OFF.....	4-23
	ii. HEX(62) MOTOR ON.....	4-23
L.	Index Display	
	i. HEX(66) INDEX.....	4-24
	ii. HEX(50) INDEX ON,HEX(51) INDEX OFF.	4-24
M.	Segment Playback Operation.....	4-25
	i. Segment Definition.....	4-26
	ii. Execution.....	4-27
	iii. Commands during SEGMENT playback..	4-34

V. PROM Revision Levels..... 5-1

VI. SFA-1000 Commands..... 6-1

#### VII. Appendix

A.	Place to Write for Specifications	
	i. EIA RS232-C.....	7-1
	ii. Application Notes for RS232-C.....	7-1
	iii. Intel 8251A.....	7-1
B.	RS232-C COMMAND CHART.....	7-2
C.	Time to return ACK/NAK for each command..	7-3

## I. Introduction

This manual is intended to aid systems integrators with connections of the LDP-1000A Videodisc Player to an external computer. A working knowledge of computers is assumed and no efforts are made to teach the fundamentals of computer hardware and software.

This reference manual is the primary documentation concerning the characteristics of the LDP-1000A Videodisc Player and SFA-1000 Still-Frame Audio Adaptor when used under external computer control. Explanations of the operation of the LDP-1000A and SFA-1000 in the stand-alone mode will be made only as required to describe the external-computer interface.

There are several PROM revisions for both the LDP-1000A and the LDP-1000. This manual describes the most recent PROM version. Deviations from this PROM revision are explained in section V.

Unless otherwise specified, all references to EXT CPU should be translated to mean external computer.

Unless otherwise specified, all references to LDP-1000 is a reference to LDP-1000A and vice versa.

## II. Communications Link

### A. Connector, Pin Assignment and Signals on LDP-1000A

The connector used for the RS232-C port on the Sony Videodisc Player is the standard D-sub 25 pin socket. A matching male connector must be used. Most electronics suppliers will recognize this and should be able to supply you with a suitable connector.

RS232-C

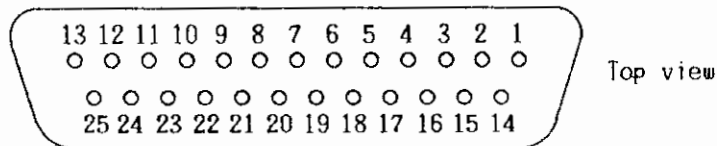

<u>Pin No.</u>	<u>Signal</u>	<u>Description</u>	<u>Signal Direction</u>
1	--	unused	-
2	T x D	Transmitted Data	LDP --->
3	R x D	Received Data	LDP <---
4	$\overline{\text{RTS}}$	Request to Send Data	LDP --->
5	$\overline{\text{CTS}}$	Clear to Send Data	LDP <---
6	$\overline{\text{DSR}}$	Data Set Ready	LDP <---
7	GND	Signal Ground	-
8-19		Unused	
20	$\overline{\text{DTR}}$	Data Terminal Ready	LDP --->
21-25		Unused	-

LDP ---> outgoing signal from videodisc player

LDP <--- incoming signal to videodisc player

\* This pin is needed only for long cables - 12 feet is the usual definition of a long cable. It should be attached to a metal shield that encloses all the other wires in the cable and grounded to a neutral ground (not a signal ground) at both ends of the cable. The purpose of the shield is to prevent stray magnetic fields from inducing false data in the other wires. Although this pin is rarely needed, it is defined as distinct from the signal ground attached to pin 7. The LDP-1000A treats these two signals separately.

## B. RS232-C Driver/Receiver Signal Levels

TYPE SN75188

QUADRUPLE LINE DRIVER

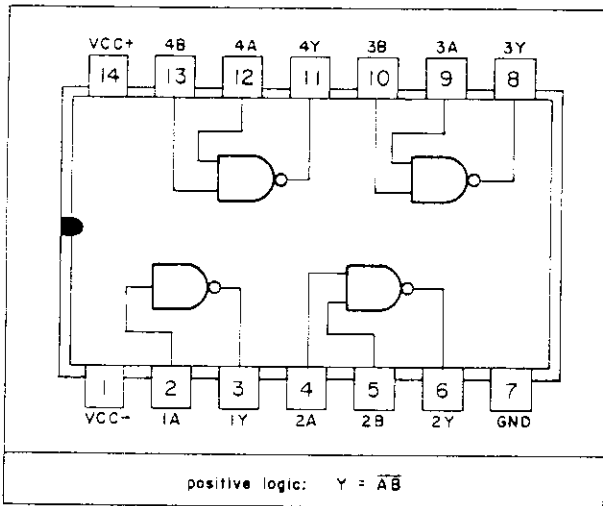

Schematic (each driver)

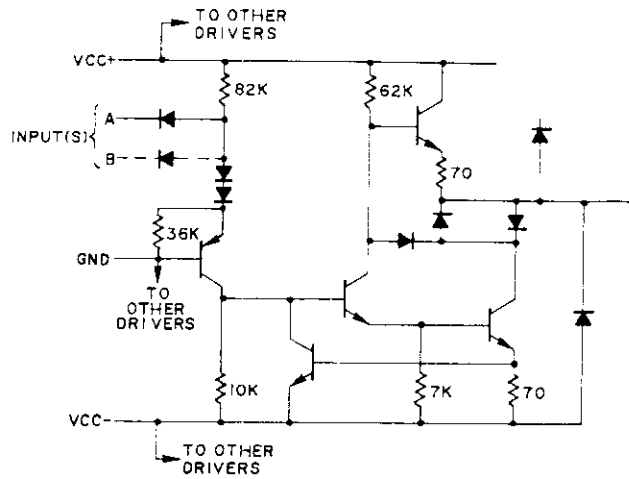

TYPES SN75189, SN75189A

QUADRUPLE LINE RECEIVERS

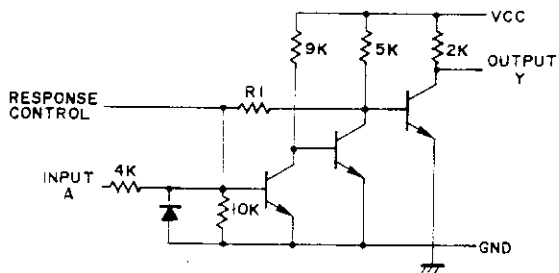

R1	SN75189	SN75189A
	10K	2K

Resistor values shown are nominal and in ohms.

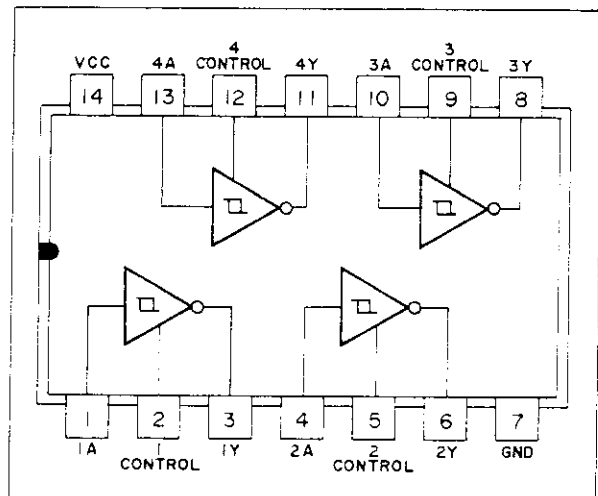





### C. Standard and "Null Modem" Cable

The LDP-1000A has been setup to appear as a terminal to the EXT CPU's serial interface. The cable requirements are determined by whether the external computer can choose to be connected to a modem (DCE=Data Communications Equipment) or (DTE=Data Terminal Equipment), as is the case with the SMC-70. (Please refer to page 3-1, "Signal direction selector setting".)

In RS232-C connections for communications, pins 2,3, and 7 are absolutely required.

Pins 4 and 20 are both used to show that the terminal is ready. Because of this redundancy, some manufacturers use either 20 or 4 (but not both). In the case of the LDP-1000A, pin 20 is used. This line is high at all times when the player is powered-on and the EXT CPU switch is set to ON.

Pins 5, 6, and 8 are all used to show the terminal (videodisc player) that the connected device is ready to communicate. Some manufacturers use one or two, but not all signals to flag this state. The LDP-1000A uses pin 6.

#### i. Standard Cable

Below are standard cables, which assume that the EXT CPU is in terminal mode. (For SMC-70 users, a standard RS232-C cable is provided as an optional accessory: SMK-0031.) The "universal" serial cable will work for devices using any one of the handshake lines in either set (described below.)

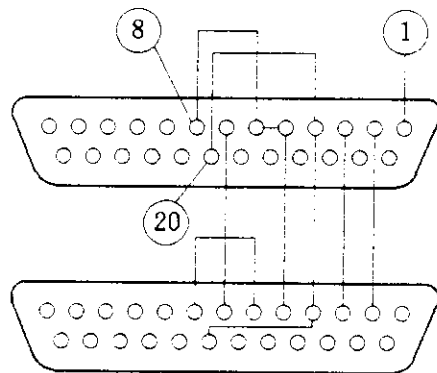

"Universal" Cable

The minimum configuration standard cable is as follows.

<u>External CPU</u>			<u>LDP-1000A</u>		
FG	1	—————	1	1	frame ground
RxD	2	<—————	2	2	transmitted data
TxD	3	—————>	3	3	received data
CTS	4	<—┐	4	4	request to send
RTS	5	└—>	5	5	clear to send
DTR	6	—————>	6	6	data set ready
DSR	20	<—————	20	20	data terminal ready
GND	7	—————	7	7	GND

**ii. "Null Modem" Cable**

If the external computer assumes it is communicating with a modem, then a "null modem" cable is required. It is so called because there is no modem in the link. This cable is different from the standard cable in that certain lines are wired to cross the needed pins. The practical result is that the videodisc player appears as a terminal to the EXT CPU. A "null modem" modification of the "universal" data cable is shown below.

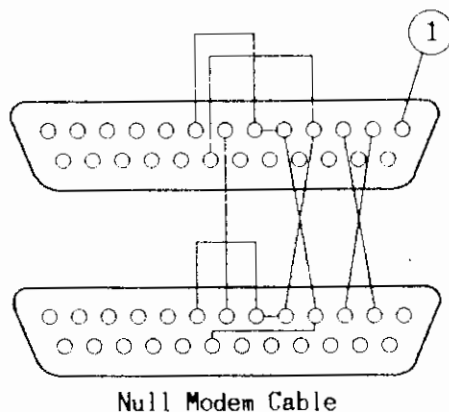

The minimum configuration "null modem" cable is as follows.

<u>External CPU</u>			<u>LDP-1000A</u>		
FG	1	—————	1	1	frame ground
TxD	2	—————>	2	3	transmitted data
RxD	3	<—————	3	2	received data
RTS	4	<—┐	4	4	request to send
CTS	5	└—>	5	5	clear to send
DSR	6	—————>	6	20	data set ready
DTR	20	<—————	20	6	data terminal ready
GND	7	—————	7	7	GND

**D. Intel 8251A and Factory Pre-Settings**

The LDP-1000A uses as its serial interface the Intel 8251A chip, the industry standard Universal Synchronous/Asynchronous Receiver Transmitter (USART). The USART accepts data characters in parallel format from the Z80A CPU in the videodisc player and then converts them into a continuous serial data stream for transmission to an external computer. Simultaneously, it can receive serial data streams from the external computer and convert them into parallel data characters for the videodisc player. The USART will signal the videodisc player whenever it can accept a new character for transmission or whenever it has received a character from the external computer.

The 8251A chip on the LDP-1000A is preset at the factory as listed below.

Mode: Asynchronous  
 Word Length: 8 bits  
 Baud Rate: 1200 bits/second  
 Baud Rate Factor: 16 times  
 Parity Check: None  
 Stop Bit: 1

**E. How to Change Factory Pre-Settings**

The mode, word length, baud rate factor and parity check are fixed and can not be changed.

**i. Baud Rate**

The baud rate on the videodisc player is hardware selectable. The possible baud rate settings are: 300, 600, 1200, 2400, 4800, and 9600. The factory-set baud rate may be changed by rearranging jumper wires in S1 on the MP-11 board. In order not to void your warranty, refer this modification to your Sony authorized dealer or Sony Factory Service Center.

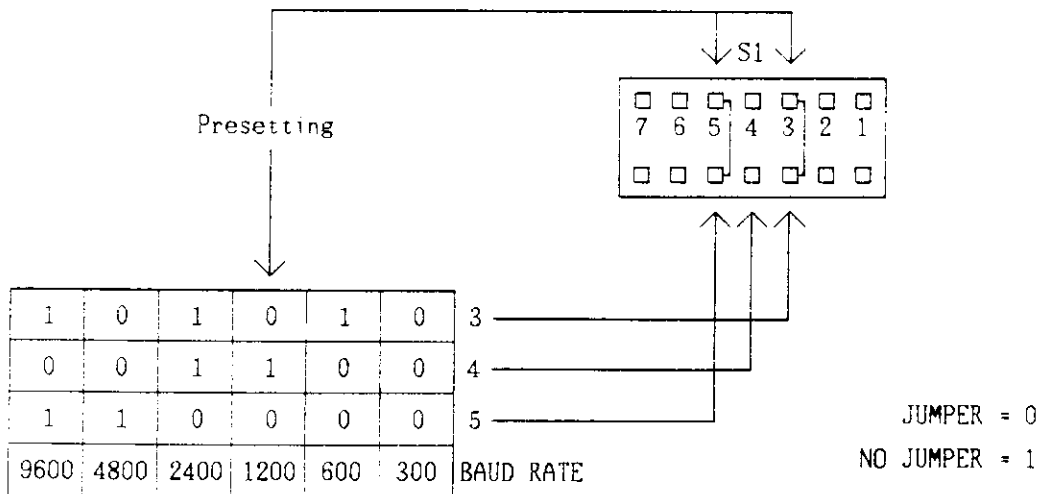

**ii. Stop Bits**

The number of stop bits on the videodisc player is hardware selectable. The possible number of stop bits is: 1, 1½, or 2. The factory-set stop bit may be changed by rearranging jumper wires in S1 on the MP-11 board. In order not to void your warranty, refer this modification to your Sony authorized dealer or Sony Factory Service Center.

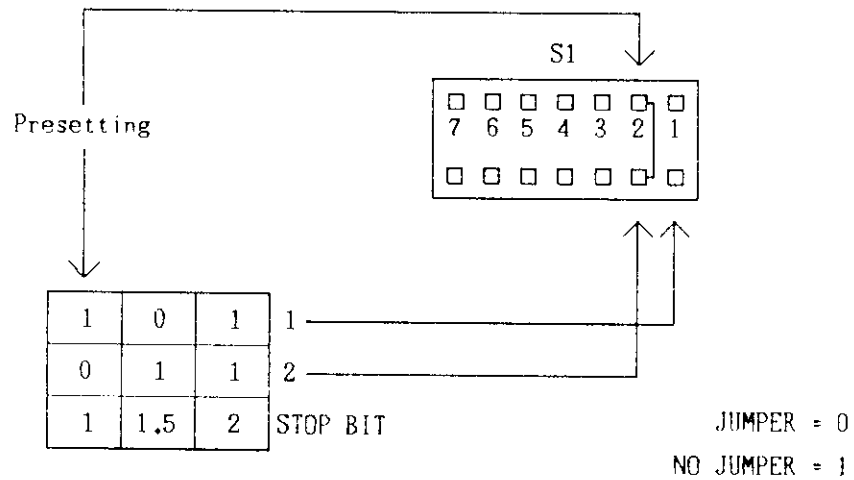

**F. How to Connect the SFA-1000**

1. Cable connection.

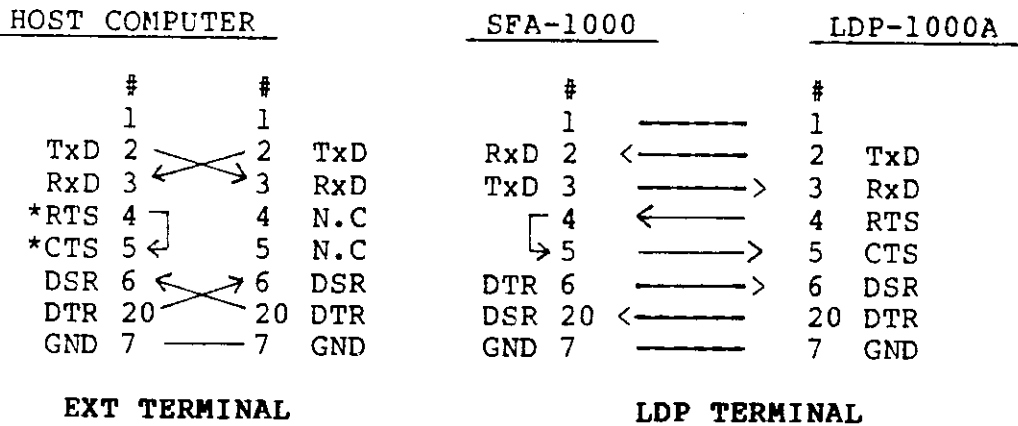

**EXT TERMINAL**

**LDP TERMINAL**

\*NOTE: Connect host computer pins 4 and 5 to each other when the host computer puts out a signal on them.

2. When the SFA-1000 is connected to the LDP-1000A with the RS-232C cable, the EXT CPU/REMOTE switch operates as follows:
  - i. When using the RM-1002 and with the switch set at REMOTE, the LDP-1000A can be operated by the command sensor through the REMOTE terminal.
  - ii. When the switch is set at EXT CPU, and with an RS232-C cable connected to the EXT CPU terminal, the LDP-1000A and the SFA-1000 can be operated by the external CPU.

The switch will initiate the mode in which it is set.

**CAUTION:** When the SFA-1000 is connected to the LDP-1000A with the RS232-C cable, and the LDP-1000A is used in the EXT CPU ON mode, avoid stopping the header (the first frame) of the SFA data. Otherwise, the CPU within the SFA will stop and control of the LDP-1000A will be lost.

### 3,4. SFA-1000 Stop bit, baud rate setting

MP-20 Board

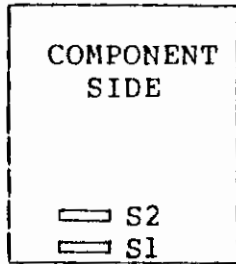

S1: Preset switch for external CPU  
 S2: Preset switch for the LDP-1000A

(S 1) PRE-SETTING SW FOR EXTERNAL CPU

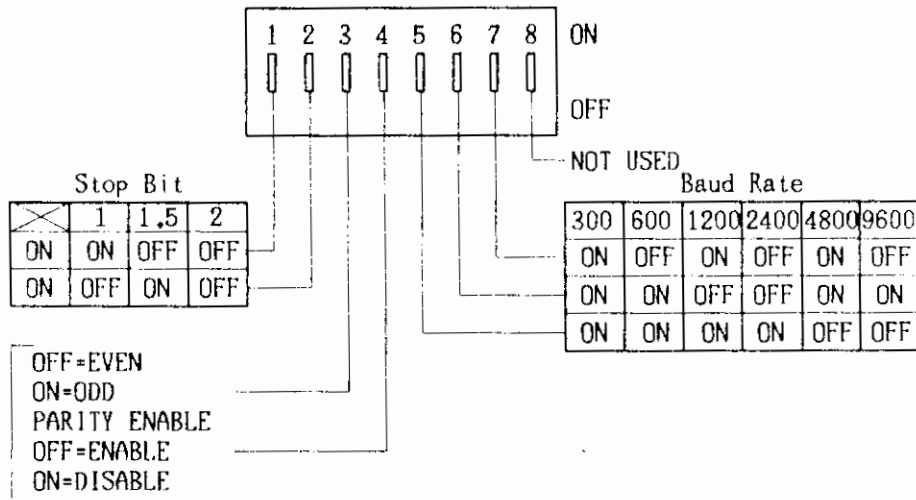

(S 2) PRE-SETTING SW FOR LDP

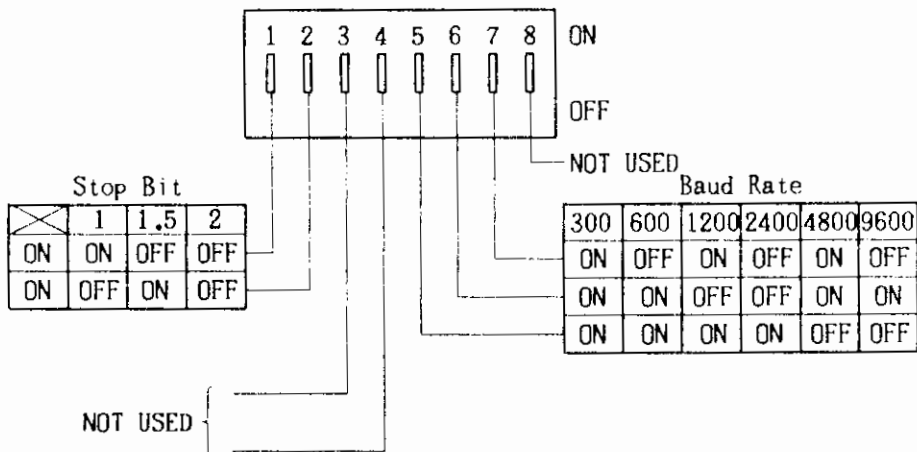

## G. Power On Procedures and Trouble Shooting

### i. Power On Procedures

- (a) Initialize the external computer RS232-C. The external computer must set DSR to high ("1").
- (b) Set the EXT CPU switch on the back panel of the LDP-1000A to the ON position.
- (c) Power up the LDP-1000A, press the COVER OPEN switch on the front panel, and insert the videodisc. The cover on the videodisc player will not open unless EXT CPU switch is set to ON and Data Set Ready (DSR) is set high ("1").
- (d) Once the disc is inserted, the player will come up to speed within 15 seconds approximately. If the disc contains audio control data, then the player will download the program from the disc to the internal microprocessor RAM and begin to execute it. If there is no audio control data, then the player will simply display frame number 1 in STILL mode. The player is now ready to receive commands from the external computer.
- (e) If the audio control program is to be ignored, then initially send a C.L. command HEX(56) before sending other commands.

In order to switch between EXT CPU ON/OFF without powering down (OFF) the player, the following is the recommended procedure.

#### EXT CPU OFF to EXT CPU ON

- 1) Set the EXT CPU switch to ON
- 2) Press the C.L. key on the commander.
- 3) RS232-C communications should be possible.

#### EXT CPU ON to EXT CPU OFF

- 1) Set the EXT CPU switch to OFF.
- 2) Send a C.L. command HEX(56) from the external computer to the player.
- 3) Operations from the remote commander keypad should be possible.

## ii. Trouble Shooting

### 1. Tester for the RS232-C Communications Line:

Tektronix Model 834, 834R

This is an extremely powerful and low-cost Programmable Data Communications Tester. It can be purchased for approximately \$6,000.

### 2. When the above tester is not available:

- i. Confirm that the baud rate, stop bit, character length and baud rate factor are set correctly.
- ii. Check the voltage of the TxD and RxD line. It should be less than -8V.
- iii. Check the voltage of the DTR, DSR, CTS and RTS lines. It should be greater than +8V.
- iv. Transmit data from the computer, check the voltage of the TxD and RxD lines. It should be greater than +8V.

### 3. Check the status of the LDP-1000A or the host computer when it is idle.

Check the voltage of the DTR, DSR, CTS and RTS lines. It should be greater than +8V.

When a pulsating voltage is present at the RTS and CTS lines of the LDP-1000A, the LDP-1000A is waiting for the DSR line to become +8V.

Versions 1.7, 2.1, 3.1 and higher of the LDP-1000A initialize the 8251A regardless of the DTR line.



### III. An Example of an External Computer Interface The Sony SMC-70 Microcomputer

The SMC-70 has a built-in serial interface conforming to EIA RS232-C specifications. The interface consists of an Intel 8251A and is set for asynchronous communications.

Although not all LDP-1000A Videodisc Player-based systems will be tied to an SMC-70, this section should be of value as a reference to all systems integrators. Program examples written in Z80A Assembly Language have been provided. For a complete treatment on the hardware and software specifications of the 8251A, please refer to Intel's data sheets. (Place to write on page 6-1.) For information on the interface for a particular EXT CPU please refer to the manufacturer-supplied information.

Unlike the rest of this manual, this section assumes the perspective of the EXT CPU looking out to connected devices. Care must be taken to avoid confusing references to the 8251A chip on the SMC-70 and the 8251A chip on the LDP-1000A. This section takes a look at the 8251A chip on the SMC-70; the remaining sections refer to the 8251A chip on the LDP-1000A.

#### A. Preparation for Communication

##### i. Signal direction selector setting

Signal flow must be reversed when the SMC-70 is connected to a modem or acoustic coupler or when it is connected to a terminal device such as a printer, character display or videodisc player. The internal switch should be set according to the attached device. The LDP-1000A is a terminal device.

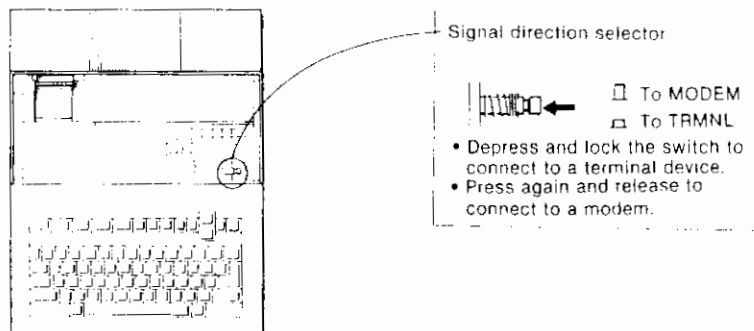

**ii. Baud rate setting**

The baud rate must be the same between the transmitter and the receiver. The baud rate of the SMC-70 is selectable from 75, 110, 300, 1200, 2400, 4800, 9600, 19200 baud (bits/ second) and is factory-preset to 300 baud. Set the DIP switch to match the baud rate of the connected device. Set only one of switches 1 through 7 to ON at any one time. The LDP-1000A is factory preset to 1200 baud.

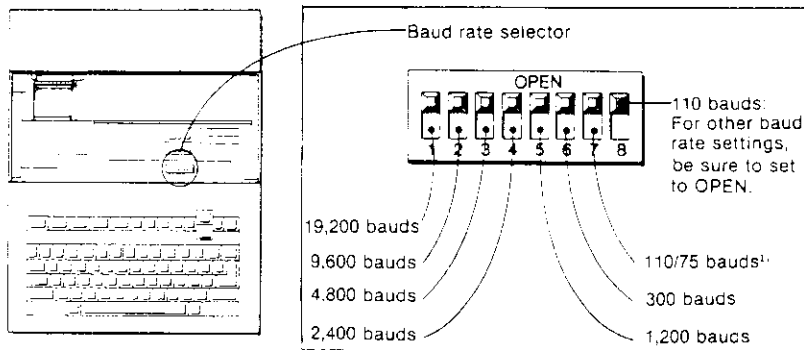

**iii. Selection of the CD or DSR input**

Either the CD (carrier detect) signal or DSR (Data Set Ready) signal can be used to check the status of the connected equipment. Set the internal connector (CN-202) as follows to select which signal is to be used. This connector is set at the factory for the CD signal. The LDP-1000A requires a Data Set Ready signal.

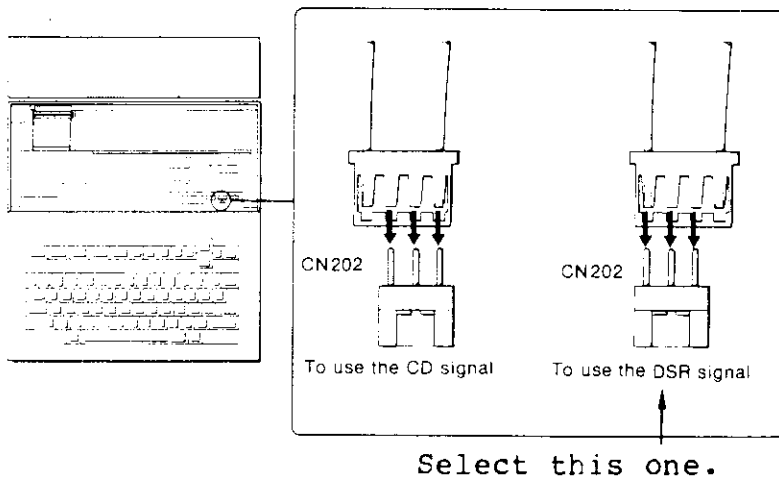

**B. Ports Used**

The built-in RS232-C interface is controlled through the following ports:

i. **Transmitted/received data: Port 26H**

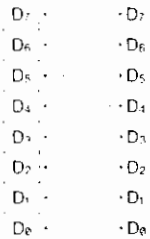

ii. **Mode setting, control instruction, status data: Port 27H**

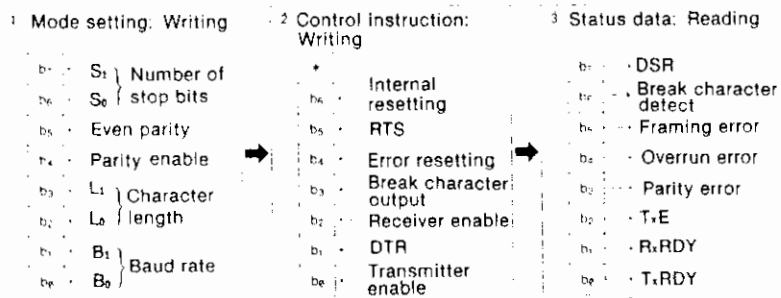

iii. **Interrupt control: Port 1EH or 1FH (either port may be used)**

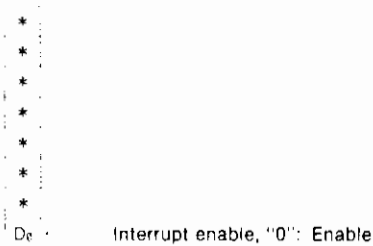

**C. Making the Communication Line Available**

The RS232-C interface is made available for communication by determining general operation specifications and making the interface ready for transmitting and receiving data. This operation is known as initialization and is accomplished by the following procedure:



In the system Monitor, the Z command processing routine performs initialization by specifying the operation of parity check, stop bit length, and character length. If initialization by your own program is required, proceed as follows just after resetting the SMC-70.

**i. Mode Setting**

The mode setting data must be output to port 27H according to the following bit assignment:

Bit No.	MSB				LSB			
	7	6	5	4	3	2	1	0
Port 27H	S <sub>1</sub>	S <sub>0</sub>	EP	PEN	L <sub>1</sub>	L <sub>0</sub>	B <sub>1</sub>	B <sub>0</sub>
	Number of stop bits				Baud rate/operation mode			
	Even parity				Character length			
					Parity enable			

**Baud rate/operation mode (Bit 1 and 0)**

Two bits of bit 0 and bit 1 are used for operation mode switching between synchronous and asynchronous, and for selection of the basic clock frequency for the baud rate. The relationship between the data values and mode setting is as follows:

Data value B <sub>1</sub> B <sub>0</sub>	Operation mode/baud rate
0 0	Synchronous mode (inoperable)
0 1	Asynchronous mode/no frequency division
1 0	Asynchronous mode/frequency division by 16
1 1	Asynchronous mode/frequency division by 64

The built-in interface cannot operate in the synchronous mode. In general, set this data to "10" since this interface is designed for operation based on basic clock frequency divided by 16. The actual baud rate is selected by operating an internal DIP switch. (See "Baud rate setting" on page 3-2 for details.) "10" are the required data for use with the LDP-1000A.

**Character length (Bit 2 and 3)**

Two bits of bit 2 and bit 3 are used to indicate the number of bits for representing each character. The LDP-1000A transmits and receives 8 bit characters.

Data value		Character length
L <sub>1</sub>	L <sub>0</sub>	
0	0	5 bits
0	1	6 bits
1	0	7 bits
1	1	8 bits ←

**Parity enable (Bit 4)**

Bit 4 is used to determine whether parity check should be performed as follows:

- 0: Parity check disable
- 1: Parity check enable

The LDP-1000A has no parity check.

**Even parity (Bit 5)**

Bit 5 is used to determine whether parity check should be performed based on even or odd parity in the parity check enable state (when bit 4 is set to "1") as follows:

- 0: Odd parity
- 1: Even parity

The SMC-70 generates parity bits to follow data bits when sending data according to the specification of this bit. When receiving data the SMC-70 checks whether the error has occurred according to the specification of this bit. This bit is ignored when bit 4 is set to 0. This bit is irrelevant for the LDP-1000A since the parity check is disabled.

### Number of stop bits

Two bits of bit 6 and bit 7 are used to determine the length of a stop bit as shown in the following table:

Data value S <sub>1</sub> S <sub>0</sub>	Number of stop bits
0 0	(inoperable)
0 1	1 bit
1 0	1½ bits
1 1	2 bits

The LDP-1000A utilizes 1 stop bit.

### ii. Command Writing

After mode setting, command data must be written to make the system ready for transmitting and receiving data. The bit assignment for command data is as follows. Any data written to port 27H after mode setting is regarded as command data.

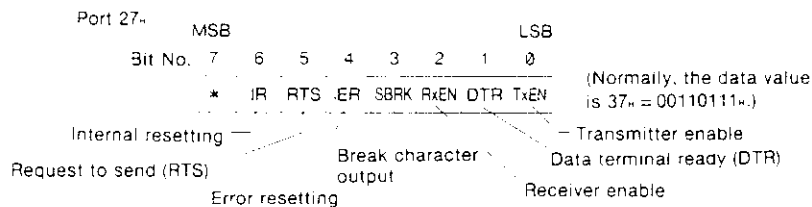

### Transmitter enable (Bit 0)

This bit is a flag that makes the SMC-70 ready for sending data. The bit values are defined as follows:

- 0: Transmitter disable
- 1: Transmitter enable

**Data terminal ready (Bit 1)**

This bit is used for control of the DTR output of the 8251A chip. This bit notifies the unit connected to the SMC-70 whether the SMC-70 is ready for sending and receiving data. This bit sets the DTR or CD(or DSR) output on or off according to the signal direction selector setting.

Data value	Signal direction selector setting	
	"TO MODEM"	"TO TRMNL"
0	DTR OFF	CD/DSR OFF
1	DTR ON	CD/DSR ON

**Receiver enable (Bit 2)**

This bit is a flag that makes the SMC-70 ready for receiving data. The bit values are defined as follows:

- 0: Receiver disable
- 1: Receiver enable

**Break character output (Bit 3)**

This bit is a flag to set all the transmitted data to "0".

- 0: Normal sending
- 1: All the transmitted data bits are set to "0"s.

When this bit is set to "1", the break character which is always "0" is output even if the data to be transmitted is written.

**Error resetting (Bit 4)**

This bit is used for resetting the error flags of the status signals (data read from port 27H).

- 0: Error resetting not performed.
- 1: All the error flags are reset.

**Request to send (Bit 5)**

This bit controls the RTS output signal of the 8251A chip. This bit notifies the connected unit that the SMC-70 is to start transmitting data. This bit sets the RTS or CTS output on or off according to the signal direction selector setting.

Data value	Signal direction selector setting	
	"TO MODEM"	"TO TRMNL"
0	RTS OFF	CTS OFF
1	RTS ON	CTS ON

**Internal resetting (Bit 6)**

This bit resets the internal circuit of the interface element 8251A. Once the internal circuit is reset, the previous mode setting is cleared and the interface is ready for receiving new mode setting data.

**iii. Initialization Steps**

Three dummy data 00H are written to ensure that the 8251A treats the data 40H, an internal reset, as a command. For example, if the 8251A is ready to receive the mode setting data, the first data 00H is received as the mode setting data (synchronous mode), the sequential two 00H's are received as the sync characters and the data 40H is received as a command.



## Initialization program example

Set-up values:  
 Character length...8 bit  
 Parity check..... None  
 Stop bit..... 1 bit

Mnemonic representation		
LD E,03H	Internal reset for 8251 <sup>1</sup>	
LD A,00H		
RST: OUT (27H),A		
DEC E		
JF NZ,RST		
LD A,40H		
OUT (27H),A		
LD A,040H		Output mode setting data 01001110 <sup>1</sup>
OUT (27H),A		
LD A,37H		Enable sending and receiving
OUT (27H),A		

### D. Transmitting and Receiving Data

Data is sent and received through port 26H. During data transfer, check the interface circuit status and confirm the completion of processing each time a character is sent or received.

#### i. Transmitter/Receiver Status

##### Status data bit assignment

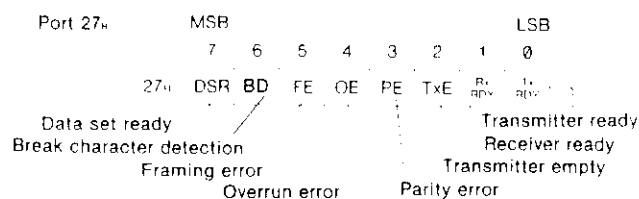

### Transmitter ready (Bit 0)

This flag indicates whether data exists in the data bus buffer of interface element 8251A. This flag is used to determine whether it is possible to write data for sending from the CPU.

0: Data bus buffer full (not ready for writing)

1: Data bus buffer empty (ready for writing)

This flag is reset when a data is written into 8251A.

### Receiver ready (Bit 1)

This flag indicates whether the received data has been stored in the receiver buffer of the interface element.

0: Data reception is not yet completed (not ready for reading)

1: Data has been stored in the receiver buffer (ready for reading)

### Transmitter empty (Bit 2)

This bit indicates the status of the transmitter buffer\*, and is used as a flag for confirmation of sending completion.

0: Transmitter buffer full

1: Transmitter buffer empty (sending completed)

---

### \* Difference between the TxE and TxRDY

Data flow in transmitting is as follows:

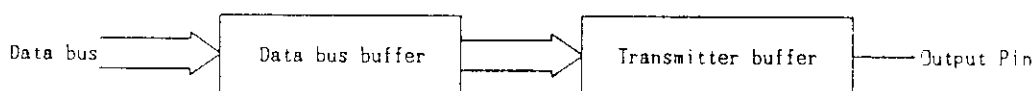

The TxE bit indicates the state of the transmitter buffer and the TxRDY bit indicates the state of the data buffer. You can transfer data correctly if you check only the TxRDY flag in the transmission program. The 8251A stops and starts the transmission automatically according to the CTS input. The transmission of data starts when the CTS input becomes low level to indicate that the connected device is ready for receiving data.

**Error flags (Bit 3,4 and 5)**

The status data includes 3 bits which are set to 1's to indicate received data errors. The three bits of bit 3,4 and bit 5 indicate a parity error, an overrun error, and framing error respectively. A parity error is an error detected during parity check. An overrun error indicates that data was received before the data in the receiver buffer was read by the CPU, thereby destroying the previous data. A framing error indicates that no stop bit was detected. The sending and receiving operations continue without regard to the status of these flags. All these flags are reset to 0's by setting bit 4 of output data to port 27H to "1".

**Break character detection (Bit 6)**

This bit is set to "1" when a break character is received indicating that the transmission is suspended. This flag is reset after the break character reception is completed.

**Data set ready (Bit 7)**

This bit shows whether the connected unit (such as a modem or acoustic coupler) is ready for sending and receiving data. The status of either the CD (or DSR) or DTR input can be checked with this bit depending on the internal signal direction selector status.

Data value	Signal direction selector setting	
	"TO MODEM"	"TO TRMNL"
0	CD/DSR OFF	DTR OFF
1	CD/DSR ON	DTR ON

## ii. Transmitting/Receiving Procedure

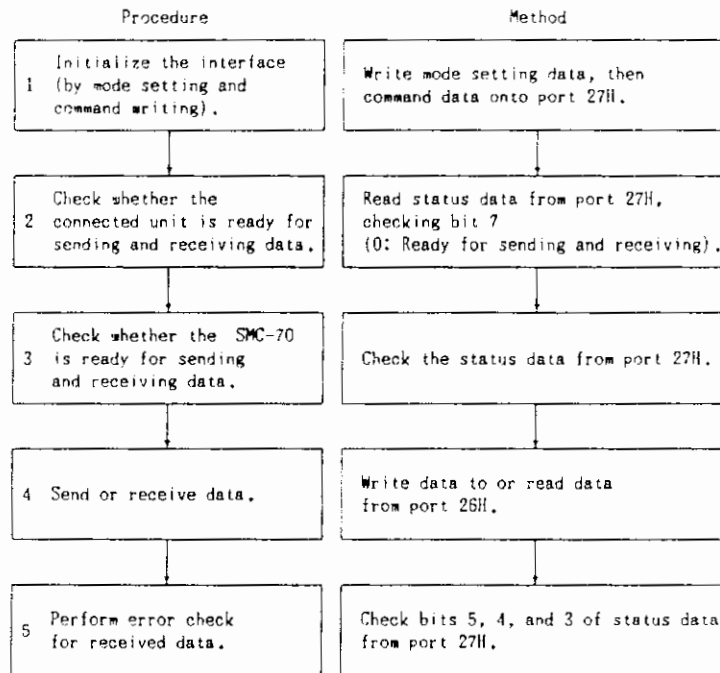

Here is an example of how to transmit data from the SMC-70 to the LDP-1000A.

LDP.READY:

```
IN      A, (27H)
BIT     0, A
jp     Z, LDP.READY
```

```
OUT     (26H), A
```

;at this point, the LDP command is in the A-reg

## iii. Data transmitting program example

Mnemonic representation	ANN representation
LD HL,1000H	0100 h1=1000
LD B,80H	0103 b=80
WAIT: IN A,(27H)	0105 a=0127
AND 81H	0107 a=8081
XOR 81H	0109 a=8081
JR NZ,WAIT	010B ->0105,70
LD C,26H	010D c=26
OUTI	010F p/c= h1+1
JR NZ,WAIT	0111 - 0105,70
	Specify the number of data bytes to be sent.
	Check the TxRDY and DSR flags.
	Send data
	Prepare for sending the next data.

#### iv. Data receiving program example

Mnemonic representation		ANN representation
	LD HL,1000H	Specify the number of data bytes 0100 a=1000
WAIT:	IN A,(27H)	Conduct error check 0103 a=0127 0105 c=a 0106 a=0138 0108 =>0150,10
	LD C,A	
	AND 3BH	
	JF NZ,ERR	
	LD A,C	Check the RxDY flag 010E a=c 010C a.1F 010E -->0103,0
	BIT 1,A	
	JF Z,WAIT	
	IN A,(26H)	Input data 0110 a=0126
	LD HL,A	Transfer data to memory 0112 h1+=a
	INC HL	Prepare for reading the next data 0113 h1+ 0114 -->0103
	JR WAIT	
ERR:	LD A,37H	0150 a=37
	OUT (27H),A	0152 P(27)=a
	JR WAIT	0154 =>0103

Here is an example of how to receive data (such as return codes) from the LDP-1000A, into the SMC-70.

BUF.EMPTY:

```

IN      A, (27H)
BIT     1, A
jp     Z, BUF.EMPTY

```

```

IN      A, (26H)

```

; at this point, the return code from the LDP is in the A-reg

**B. Layout of Video Frames**

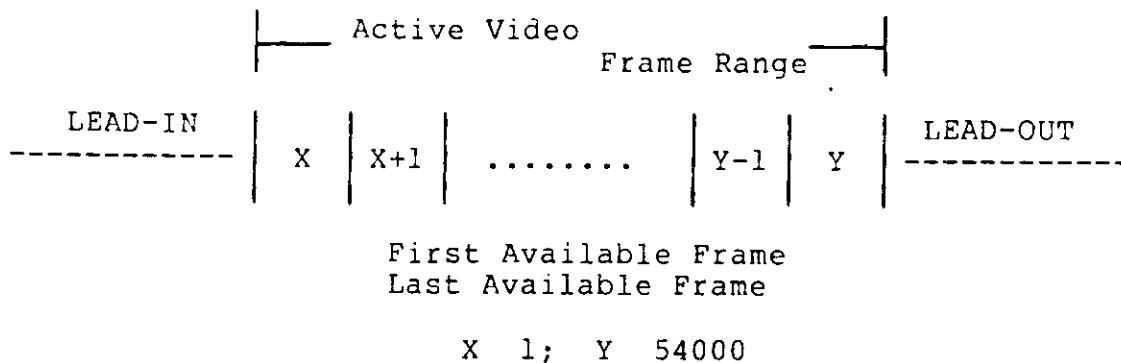

X is the first available video frame. Anything before X is denominated as lead-in and is not accessible by the external computer. Y is the last available video frame. Anything after Y is denominated as lead-out and is not accessible by the external computer. Thus the active video frame range falls between X and Y, inclusive.

**C. Return Codes**

HEX(00) to HEX(0F) have been reserved as codes returned by either the LDP-1000A or SFA-1000.

**i. HEX(01) COMPLETION**

This return code is sent by the videodisc player to notify the external computer of either

- a) the successful completion of a SEARCH (i.e. the correct frame is displayed in STILL mode after a SEARCH operation.)
- b) the completion of a REPEAT operation and the display of the correct target video frame in STILL mode.

Refer to the explanations on NOT TARGET for the complementary return code.

**ii. HEX(02) ERROR**

(Described on the following page)

**iii. HEX(04) PGM END**

This code is output when the internal program is finished.

## ERROR HEX (02)

There are commands which can be accepted and executed and those which cannot be accepted, depending on the status of the LDP-1000A. The error code HEX (02) is sent in place of ACK HEX (0A) when the LDP-1000A cannot accept the command. When an error occurs, CE HEX (41) or CL HEX (56) is sent and the error state must be cleared. The error HEX (02) is returned for all commands other than CE and CL.

The following commands can be input in the various modes of the LDP-1000A as indicated.

1. NATIVE MODE  
F/R (SCAN, FAST, SLOW, STEP, PLAY) MEMORY, M-SEARCH, PGM, SEG, REPEAT, SEARCH, CH-1, CH-2, INDEX, STOP, CE, CL, MENU.
2. SEARCH INPUT MODE  
0 - 9, ENTER, CE, CL, MENU, MODE
3. REPEAT INPUT MODE  
0 - 9, ENTER, CE, CL, MENU, MODE,  
F (SLOW, STEP, FAST, PLAY).
4. PGM INPUT MODE  
0 - 9, ENTER, CE, CL, MENU, MODE, CH-1, CH-2, INDEX  
F - (FAST, SLOW, STEP, PLAY), STOP,  
J - (SEG), +1 (MEMORY), =(INT), GO TO (RUN)  
-1, (M-SEARCH), INPUT (SKIP)
5. PGM Display  
PGM
6. PGM EXECUTE MODE  
MEMORY, M-SEARCH, INT, END, REVIEW, STOP,  
F/R - (SCAN, FAST, SLOW, STEP, PLAY),  
CH-1, CH-2, INDEX, MENU  
  
(NOTE) 1 - 9 (only when in the NUMBER INPUT MODE)  
(NOTE) CE, RUN, MODE, and ENTER do not cause an ERROR, but no action occurs.

7. SEGMENT input mode  
0 - 9 ENTER, CE, CL,

Commands which are input in modes other than those shown above, constitute an ERROR. However, the following RS232-C commands can be input regardless of the mode of the LDP-1000A.

CH-1 ON, CH-1 OFF, CH-2 ON, CH-2 OFF, DUMP IN, DUMP OUT,  
SEG MODE, FRAME # MODE, ADDR INQ, CONTINUE, STILL, MOTOR ON,  
MOTOR OFF, STATUS, DISC ID INQ, CHAPTER # MODE.

**iv. HEX(05) NOT TARGET**

This return code is sent by the videodisc player to the external computer when a COMPLETION code can not be sent. Specifically, it is sent to notify the EXT CPU of either

a) the inability of the player to display the correct frame in STILL mode after a SEARCH to a target within the active video frame range.

b) the inability of the player to display the correct target video frame in STILL mode at the conclusion of a REPEAT operation. The target frame number must be within the active video frame range.

The inability to access frames within the active video frame range may be due to several problems. A persistent inability to search correctly should be checked out. The videodisc itself may be the cause because of faulty mastering or replication. In this case, the frame number may be missing or inaccessible. The videodisc player can also be the culprit. The optics could have too much dust or the focusing and tracking mechanisms may be out of alignment.

**v. HEX(06) NO FRAME**

This return code is sent by the player when a SEARCH is made to a frame number not in the active video frame range. Attempts to access the lead-in or lead-out portions of the disc will force the player to display a frame in STILL mode. For SEARCH to the lead-in, a frame "close" to X, the first active frame, will be displayed. There is no guarantee as to what that frame will be. If an NO FRAME return code is received, check the actual position by executing an ADDR INQ command. Likewise, for a SEARCH to the lead-out, a frame "close" to Y, the last active video frame, will be displayed.

NO FRAME is not returned for REPEAT operations.

The LDP-1000(not LDP-1000A) videodisc player does not support this feature. NOT TARGET HEX (05) is sent.



**vi. HEX(OA) ACK**

An ACK is sent by the player to notify the EXT CPU of either of two conditions:

- a) Acknowledge the fact that a valid command has been received by the player. Valid commands fall in the range of HEX(30) to HEX(69), inclusive. The above statement is not an absolute rule and is dependent on the state in which the player is in.
- b) Notify the EXT CPU that the videodisc player is no longer in the STANDBY state. During this STANDBY state, the player is unable to communicate. The player goes into this STANDBY state (STANDBY indicator lights up) when (1) it is first powered ON, the spindle motor comes up to speed and the initialization routine is performed and (2) it receives a MOTOR ON command and the spindle motor comes up to speed. An ACK is sent once the player is ready to receive and execute commands.

An ACK is not necessarily sent to flag an absence of a condition (or the existence of a negative condition) described in the NAK explanation below.

**vii. HEX(OB) NAK**

NAKs are sent by the player to notify the EXT CPU of the inability to execute several operations. A NAK is not necessarily sent to flag an absence of a condition (or the existence of a negative condition) described in the ACK explanation above.

- a) When a command not in the valid range is received, a NAK is returned. The valid command range is HEX(30) to HEX(69), inclusive. A NAK is not sent by the player for an incorrect "string"ing of commands, even though the command may be in the valid command range. Refer to explanations on SEARCH, REPEAT and ERROR.
- b) When a DISC ID INQ command is sent to the player and the videodisc has no DISC ID (incorporated at the time of mastering), then a NAK is returned.
- c) When the player has been powered down using the MOTOR OFF command, a NAK will be sent for each command other than a MOTOR ON. There are two exceptions to this rule, both are queries to the player. During the powered-down state, the STATUS INQ and DISC ID INQ commands are operational and will not result in NAKs. (Refer to the section V on differences between different PROM versions regarding this feature.)

**D. CE and CL OPERATIONS**

**i. HEX (41) CE (Clear Entry)**

1. Used for correction of numerical input in SEARCH, REPEAT, SEGMENT and PROGRAM commands.

For example: SEARCH 10010  
CE SEARCH 01001

2. Used to clear errors. The equipment returns to the state it was in prior to the error.
3. When CE is sent in cases other than those mentioned above, ACK returns, but no operation is initiated.

**ii. HEX (56) CL (Clear All)**

All commands currently being executed are cancelled and the equipment returns to the initial state. This command takes top priority.

## E. NUMERIC KEYS

Numeric keys have the following applications.

- i. SEARCH: Frame # input  
Chapter # input (for the LDP-1000A only)  
Segment # input
- ii. REPEAT: Frame # input  
Chapter # input  
Segment # input (for the LDP-1000A only)  
# of repetitions input
- iii. SEGMENT: Start/End frame # input
- iv. PROGRAM: Program address input  
Segment # input  
Frame # input  
Register # input  
Register value input
- v. AUTO STEP: Auto step times input

## F. SEARCH AND REPEAT OPERATION

### i. HEX (43) SEARCH

The SEARCH procedure is as follows:

```
SEARCH  ----->
        <----- ACK
M1      ----->           M1 to M5 = Frame #
        <----- ACK
M2      ----->
        <----- ACK
M3      ----->
        <----- ACK
M4      ----->
        <----- ACK
M5      ----->
ENTER   ----->
        <----- ACK

        SEARCH EXECUTE

        <----- COMPLETION  HEX(01)
```

There are three possible results of a search, as follows:

1. The target frame is found. COMPLETION HEX (01) is returned.
2. The approximate location of the frame is found, but the target frame is not found in the allotted time.  
NOT TARGET HEX (05) is returned
3. \* A LEAD IN or LEAD OUT signal is detected while the frame is being searched, and the target frame is not found in the allotted time.

NO FRAME HEX (06) is returned

\* For the LDP-1000A only

The following actions take place when searching for the starting point of a chapter or segment.

1. CHAPTER #

```

CHAPTER MODE ----->
HEX (69)    <----- ACK  set chapter mode
  M1        ----->          M1 M2 = CHAPTER #
           <----- ACK          01 - 79
  M2        ----->
           <----- ACK
ENTER (40H) ----->
           <----- ACK

                $ EXECUTE SEARCH OPERATION

           <----- COMPLETION HEX (01)
                END OF SEARCH OPERATION

```

2. SEGMENT #

(for details on segment use, see section M.)

```

SEGMENT # MODE ----->
           <----- ACK  set segment # mode
  M1        ----->          M1 M2 = SEGMENT #
           <----- ACK          01 - 63

  M2        ----->
           <----- ACK

ENTER (40H) ----->
           <----- ACK

           <----- EXECUTE SEARCH OPERATION

           <----- COMPLETION HEX (01)
                END OF SEARCH OPERATION

```

Once the search mode has been set, the LDP-1000A will remain in that mode. Therefore, CL HEX (56) and MENU HEX (42) initiate the frame # mode.

When lead in or lead out is detected during playback, the frame # mode is initiated.

ii. **HEX (44) REPEAT**

The REPEAT command is used to replay a certain part of the disc for a designated number of times. The starting frame is defined as the frame at which the REPEAT command is input, and the end frame is the target frame which is input next. Usually, SEARCH is used to establish the starting frame.

For use of REPEAT with segments, see section M.

The FWD mode is initiated when the end frame no. is greater than or equal to the start frame no., and the REV mode is initiated when the end frame no. is less than the start frame no.

REPEAT PROCEDURE

```
REPEAT  -----> The start frame no. is stored
        <-----  ACK

M1      ----->
        <-----  ACK      M1 to M5 = Frame #
                               The playback mode can be
M2      ----->                               designated during this
        <-----  ACK      time. If it is not, the
                               player will be set in the
M3      ----->                               X1 play mode.
        <-----  ACK

M4      ----->
        <-----  ACK

M5      ----->
        <-----  ACK

F FAST  -----> This sets the Fast Mode.
        <-----  ACK The direction (FWD or
                               REV) is determined by the
                               start frame and end frame
                               numbers.

ENTER   ----->
        <-----  ACK
```

## RETURN CODES

A return code is sent when the designated number of repetitions is finished.

1. Completion HEX (01) is sent when repetitions are completed at the correct end frame.
2. Not target HEX (05) is sent when repetitions are completed after passing the end frame.
3. "Lead Out" is detected without detection of the end frame.

At present, the player locks up.  
Therefore, be careful not to input a target frame number that is larger than the end frame of the disc used.

## OPERATION OF THE REPEAT COMMAND

1. Frame # Mode

RM1	----->	RM1 and RM2 = # of repeat times.
	<----- ACK	If the number of repetitions is not input, it will be set at "1".
RM2	----->	A maximum of "15" repetitions can be designated. When "0" is set, the number of repetitions is unlimited.
	<----- ACK	
ENTER	----->	
	<----- ACK	
SM1	----->	SM1, SM2 and SM3 = step factor.
	<----- ACK	If STEP is selected when in the playback mode, a step factor input is requested. The step factor must be input at 1/SM. Therefore, when SM = 1, the player operates the same as during normal playback. An SM of 1 through 255 can be input.
SM2	----->	
	<----- ACK	
SM3	----->	
	<----- ACK	
ENTER	----->	
	<----- ACK	

REPEAT PLAY  
EXECUTE

<----- Completion  
HEX (01)



- a. The player enters the still mode and awaits the target frame # input.
- b. Input the target frame #. The FAST, PLAY, SLOW and STEP modes can be set by mean of the ( ) key. Send ENTER.
- c. Input the number of repetitions. Send ENTER. The player will repeat from 1 through 15 times. If 0 is input, it will repeat indefinitely.

The repeat operation is executed at this point when in the FAST, PLAY and SLOW modes. If the STEP mode has been selected, the following additional input is needed.

- d. Input the STEP FACTOR (1 through 255). Send ENTER.

"1" mean 1 times the actual speed; "255" means 1/255 times the actual speed of 1 frame every 8.5 seconds.

The auto step operation will be executed.



## 2. CHAPTER # MODE

The repeat operation for the chapter # mode is different from the frame # and segment # modes.

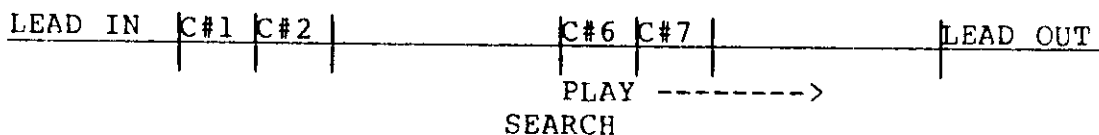

### a. REPEAT

The player enters the still mode and waits for the chapter # input.

- b. Input the chapter # (for example, C#6). The mode can then be set just as in the frame # mode. Send ENTER.
- c. Input the number of repetitions and send ENTER. The repeat operation will be executed at this point for the FAST, SLOW and PLAY modes.
- d. Input the step factor when needed and send ENTER, just as in the Frame # mode.

In the above diagram, the beginning of C#6 is found and then C#6 is repeated.

## 3. SEGMENT # MODEL

For details on segment use, see section M.

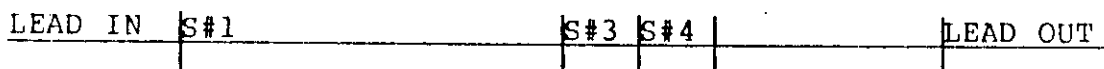

### a. REPEAT

The player enters the still mode and waits for the segment # input.

- b. Input the segment # just as in the frame # mode and send ENTER.
- c. Input the number of repetitions and send ENTER as in the frame # mode.
- d. Input the step factor input if needed, and send ENTER, as in the frame # mode.

When the lead in or lead out is detected during the repeat operation, the player will lock up. Therefore, when generating a control, be careful not to set the target frame # beyond the lead out.

## G. AUDIO SWITCHING COMMANDS

### i. Toggled Commands

1. **HEX (64)** CH-1
2. **HEX (65)** CH-2

These commands can be input when the player is in the normal mode (when FWD/REV PLAY can be done) such as when repeating, and when in the PGM input and play modes.

For example, when CH-1 is ON:

```
CH-1 HEX (64)  ----->
                <-----  ACK CH-1 OFF
CH-1 HEX (64)  ----->
                <-----  ACK CH-1 ON
```

### ii. Absolute Commands

1. **HEX (46)** CH-1 ON, **HEX (47)** CH-1 OFF
2. **HEX (48)** CH-2 ON, **HEX (49)** CH-2 OFF

These are ON-OFF commands for the RS232-C.

For example, when CH-1 is ON:

```
CH-1 ON HEX (46)  ----->
                  <-----  ACK CH-1 ON (no action)
CH-1 OFF HEX (47) ----->
                  <-----  ACK CH-1 OFF
```

These are direct commands which are executed regardless of the mode the player is in.

**CAUTION:** If these commands are sent to the player while SEARCH, REPEAT, SEGMENT or PGM is being executed, the audio muting of the player will be affected and noise will occur. Therefore, do not use these commands when in the above modes.

**H. PLAYBACK OPERATIONS**

- i. **HEX (3A) F-PLAY, HEX (4A) R-PLAY**
  - ii. **HEX (3B) F-FAST, HEX (4B) R-FAST**
  - iii. **HEX (3C) F-SLOW, HEX (4C) R-SLOW**
  - iv. **HEX (3D) F-STEP, HEX (4D) R-STEP**
  - v. **HEX (3E) F-SCAN, HEX (4E) R-SCAN**
- a. PLAY initiates the X1 mode; FAST, the X3 mode, and SLOW, the X 1/5 mode.
  - b. STEP initiates the auto step function in the X 1/7 mode. When a single frame step is desire, the STILL command HEX (4F) is sent within 33-200ms after the STEP command is designated.
  - c. When a different step rate is desired, the step rate (1-255) and ENTER HEX (40) will be sent after the STEP command is designated.

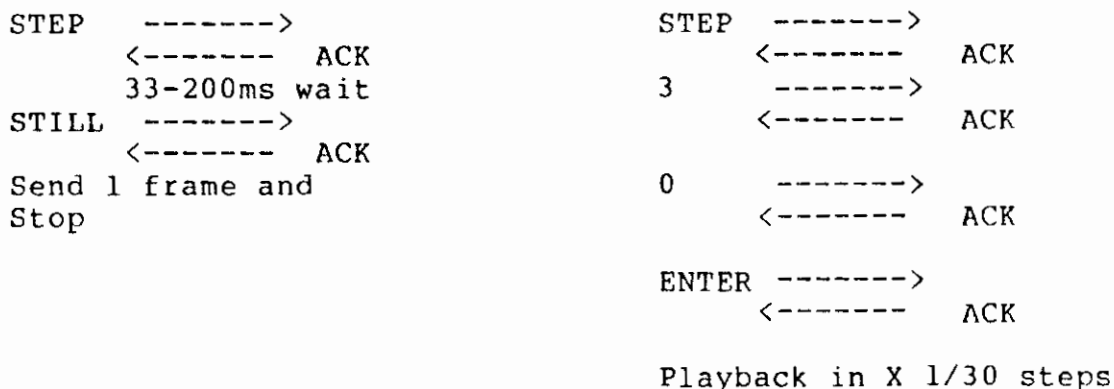

The setting of parameters for the repeat operation is described in the section on repeat commands.

If lead in or lead out is detected during the normal playback operation, frame #1 is searched and ACK is returned.

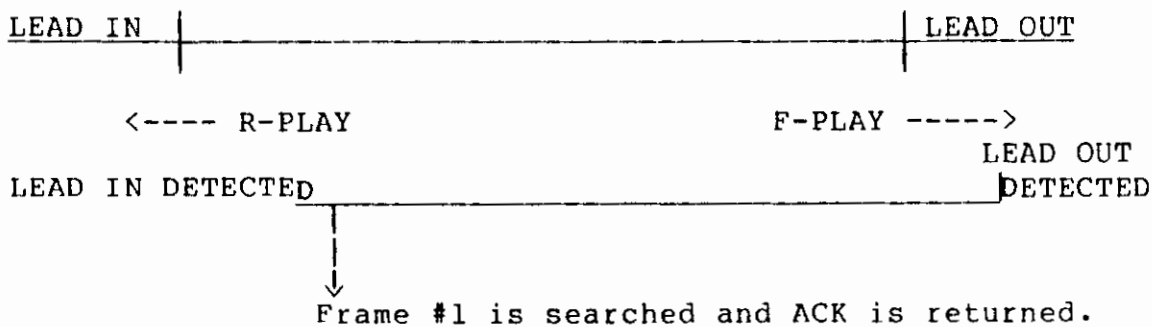

If lead in or lead out is detected, the equipment returns to the initialize routine and searches for frame #1. Therefore, communication cannot be accomplished until ACK is sent out. Be careful to avoid this situation when making commands.

## I. STILL, STOP, CONTINUE OPERATIONS

- i. **HEX (3F) STOP**
  - ii. **HEX (4F) STILL**
  - iii. **HEX (61) CONTINUE**
- a. STOP initiates the still mode in which the video and audio are muted.
  - b. In the STILL operation, only the audio is muted. The video continues to operate. STILL is also related to the STEP commands. (This is described in the section on playback operation).
  - c. The CONTINUE command returns the player to the mode it was in before the STILL command was given. If the CONTINUE command is sent without first sending the STILL command, misoperation may result. Therefore, this command must be used with care.

## J. QUERY OPERATIONS

- i. **HEX (60) ADDR INQ**  
The current frame no. of the player is requested.

```
ADDR INQ  ----->
HEX (60)  <----- M1      M1 - M5 are 5 bytes in ASCII
           <----- M2
           <----- M3
           <----- M4
           <----- M5
```

For example, when the player is at frame # 01500: 30 (n1), 31 (n2), 35 (n3), 30 (n4) and 30 (n5) are sent.

This command can be sent whenever the player is ready (except when the motor is off) to obtain the frame number.

The five bytes are set when the 24-bit frame number (in the vertical interval) can be read accurately. If the frame number cannot be read accurately (due to dropout etc), the previously read frame is retained in the five bytes.

- ii. **HEX (67) STATUS INQ**  
This command can be used to determine the current status of the player. The status is composed of 5 bytes. The procedure is:

```
STATUS INQ  ----->
HEX (67)    <----- 1st
             <----- 2nd
             <----- 3rd
             <----- 4th
             <----- 5th
```

This inquiry can be made any time that communication is possible. The contents of each byte are as follows:

A. 1st byte

D7: = 0  
D6: SEARCH/REPEAT mode  
D5: MOTOR OFF mode (RS232-C CMD)  
D4: INIT FLAG  
D3: LID OPEN  
D2: X  
D1: X  
D0: ERROR

B. 2nd byte (Program status byte)

D7: X  
D6: MEMORY SEARCH mode  
D5: STOP KEY ON  
D4: DECIMAL mode  
D3: PGM INITIAL mode  
D2: PGM DISPLAY mode  
D1: PGM EXECUTE mode  
D0: PGM INPUT mode

C. 3rd byte (Key Mask Status)

D7: PGM mode  
D6: NATIVE Mode: F/R PLAY, FAST, SCAN, etc.  
D5: = 0 can be input in this mode.  
D4: = 0 When the SEARCH/REPEAT Key  
D3: = 0 is depressed, D6 and D7  
D2: = 0 become 0.  
D1: = 0  
D0: = 0

D. 4th byte (Key Mode Status)

D7: STEP NUMBER IN  
D6: NUMBER INPUT mode for PGM EXECUTE  
D5: X  
D4: SEGMENT NUMBER IN  
D3: CMD OUT FOR PICTURE STOP CODE  
D2: REPEAT mode  
D1: SEARCH mode  
D0: NUMBER INPUT - also becomes 1 when STEP  
NUMBER is input.

E. 5th byte (CMD Status)

D7: 0 = FWD 1 = REV  
D6: STOP  
D5: X  
D4: SCAN  
D3: STEP  
D2: SLOW  
D1: FAST  
D0: PLAY

Note: D2 and D3 become 1 when in the SLOW mode.

X: This flag is not used.

Below are explanations of the functions of each of the flags.

a. 1st Byte

1. SEARCH/REPEAT mode

This flag is set when the program is executing SEARCH or REPEAT.

2. MOTOR OFF mode

This flag is set when MOTOR OFF HEX(63) is received, the player has executed it and the RS232-C handler is active.

3. INIT

This is set when the player is in its initial state. If power is turned on with the lid open, or if the MOTOR ON command is sent, this flag is set.

4. LID OPEN

This flag is set whenever the lid is opened.

5. ERROR

This flag is set whenever an error occurs due to an incorrect being receive.

As can be understood from the above explanation, the spindle motor is rotating only when MOTOR OFF = 0 and INIT = 0. In other words, the LDP is active.

b. 2nd Byte (program status byte)

1. MEMORY SEARCH

This flag is set when in MEMORY SEARCH HEX(58) is received. It is reset when the target location has been reached, and playback starts under a previously received MEMORY command.

2. STOP KEY

This flag is set when the STOP command is received during program mode.

3. Decimal mode

This mode is set when the program input or display is shown with a 3 digit decimal. The decimal mode is initiated by: PGM - Program start ADDR-INT-ENTER.

4. Program Initial mode

This mode is set when PGM HEX(57) is received. The player waits for input of the program start ADDR.

5. Program Display mode

This mode is set when ADDR is input (after item 4) and PGM HEX(57) is received. The player is then in the display mode.

6. Program Execute mode

This mode is set when ADDR is input (after item 4) and RUN HEX(58) is received. The player is then in the program execute mode.

7. Program input mode

This mode is set when ADDR is input (after item 4) and ENTER HEX(40) is received. The player is then in the PROGRAM INPUT mode.

c. 3rd Byte (Key Mask Status)

1. PGM mode

This mode is set when in the program mode (INPUT, DISPLAY, EXECUTE).

2. NATIVE mode

This mode is set when the player is in such a state (other than the program mode) where FWD/REV, PLAY can be directly input.

Both flags are reset when in the SEARCH/REPEAT mode (input/execut).

D. 4th Byte (Key Mode Status)

1. Step number in

This flag is set when the FWD/REV STEP command is received. It is reset by entering other commands or numerals.

2. Number in for PGM execute

This flag is set when the branching command (NUMBER INPUT) is executed while running the program.

3. Segment number in

This flag is set when the SEG HEX(45) command is received.

4. CMD out for picture stop code

This flag is set when the player is automatically stopped by the PICTURE STOP CODE.

5. REPEAT

This flag is set when REPEAT HEX(44) is received and remains set until the command is executed.

6. SEARCH

This flag is set when SEARCH HEX(43) is received and remains set until the desired frame is found.

7. NUMBER INPUT

This flag is set when waiting for numerical input in the SEARCH, REPEAT and PGRM modes.



### iii. Disc ID INQ HEX (68)

This command requests the ID of the disc currently being used in the LDP-1000A. The disc ID is a part of the data contained in the audio code.

ASCII code is used for all characters, with ";" indicating the end.

There is a maximum of 40 characters, including colons, commas and semicolons.

Semicolons must not be used midway in the ID code.

SEG # 59 - 63 should be reserved for the disc ID.

One example of a possible disc ID is as below;

"SONY-DISC-ID:EJ"003:300:37500;"

#### 1. Program material ID

For example, "SONY-DISC-ID"

#### 2. Audio channel language code

For example, "EJ" means Audio Channel 1 - English, Audio Channel 2 - Japanese.

#### 3. Release number

For example: 003

This means that the program material ID is the third version of the disc called "SONY-DISC-ID"

#### 4. First frame containing video information

For example: 300

#### 5. Last frame containing video information

For example: 37500

The frame numbers which contain a valid video signal can be determined by means of (4) and (5).

Communication takes place in the following manner:

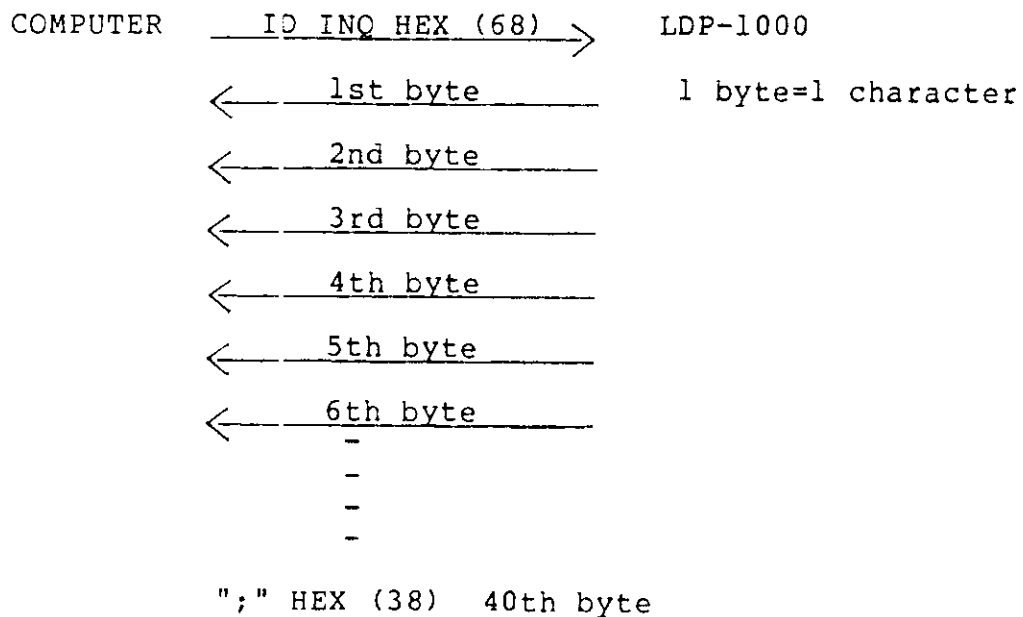

**TERMINATE**

Communication is terminated when a semicolon is sent from the LDP-1000A to the HOST.

When there is no disc II, the first byte becomes NAK HEX (0B). Therefore, it is necessary to program the host computer to check the first byte and terminate communication if it is NAK. If this is not done, the host computer could lock up.

## K. MOTOR ON/OFF OPERATION

### i. HEX (63) Motor Off

This command is generated by the RS232-C and stops the rotation of the disc. When the Motor Off command is received, the LDP-1000A returns the sled to the home position and stops the spindle motor. This occurs with the lid remaining closed.

```
MOTOR OFF  ----->
           :      The sled is returned to the home
           :      position and the spindle motor is
           :      stopped.
           :      *During this period(about 5 sec.)
           :      no communication is possible.
           :
<----- ACK
```

The lid can now be opened. Only STATUS INQ or MOTOR ON can be performed. NAK (0B) will be returned for all other commands. (Version 2.1 and higher). Version 1.7 will send ACK (0A) and no action will occur.

### ii. HEX (62) Motor On

This command will re-activate the motor after it has been stopped by HEX (63).

```
MOTOR ON  ----->
           <----- ACK
           :
           :      (Initialize)
           :      The motor is activated, a check is
           :      performed for an audio code, and if
           :      there is no code, the STILL mode is
           :      initiated at frame #1.
           :      *During this period(12 to 15 sec.)
           :      no communication is possible.
           :
<----- ACK
           Communication Standby
```

The MOTOR ON command can only be executed when the motor is off (for Versions 2.1 and higher).

Version 1.7 player will receive and execute this command when in any state, thus causing a lockup. Therefore, when using the Motor On/Off commands with the Version 1.7 player, it is necessary to first check bit 4 of the first status byte.

## L. INDEX DISPLAY OPERATION

### i. Toggled Commands

#### 1. HEX (66) INDEX

- a. This command turns the display on and off. For example, when the index is in the off status:

```
INDEX ----->
(66H) <----- ACK INDEX ON

INDEX ----->
      <----- ACK INDEX OFF
```

- b. It is used to control INDEX ON/OFF when a program is input. For example, when FUNCTION is displayed in the program input mode:

```
INDEX ----->
(66)  <----- ACK

N      ----->
      <----- ACK Index control set
```

N = 0: INDEX OFF  
N = 1: INDEX ON  
N = 2: TOGGLED

### ii. Absolute Commands

#### 1. HEX (50) INDEX ON

This command turns on the index. No action occurs if the index is already on.

```
INDEX ON ----->
(50H)  <----- ACK
```

HEX (50) can be accepted in any mode of the LDP-1000A (except motor off).

#### 2. HEX (51) INDEX OFF

This command turns the index off. No action takes place if the index is already off.

```
INDEX OFF ----->
(51H)  <----- ACK
```

HEX (51) can be accepted in any mode of the LDP-1000A (except motor off).

## M. SEGMENT Playback Operations

- i. SEGMENT Definition **HEX (45)**
- ii. Execution
  - a) Modes
    - 1) SEGMENT MODE **HEX (54)**
    - 2) FRAME # MODE **HEX (55)**
    - 3) CHAPTER MODE **HEX (69)**
  - b) Speeds
    - 1) PLAY (normal) **HEX (3A)**
    - 2) FAST **HEX (3B)**
    - 3) SLOW **HEX (3C)**
    - 4) STEP **HEX (3D)**
  - c) Caution on use of start/end points
- iii. Commands during SEGMENT playback
  - a) STILL **HEX (4F)**
  - b) CONTINUE **HEX (61)**

These functions can be thought of as using the LDP-1000A's internal CPU and RAM to execute a certain type of subroutine, namely video segments.

This saves interface communication time when, for example, a particular portion of a video program will be played repeatedly. If a portion is to be played more than about 3 times, use of segments will be somewhat quicker due to fewer instructions.

The functions are exactly the same as found on the RM-1002 programmable remote control unit. Input sequencing via RS232-C is done in the same way as for the RM-1002.

Within your application program, the general usage pattern is:

- 1) Define your segments, early on.
  - segment number
  - start/end points, as videodisc frame numbers
- 2) Execute these segments, as called for by your application program. On each execution you must:
  - first select SEGMENT MODE
  - send SEARCH and specify the segment number
  - when the player reaches the segment start point, send REPEAT and indicate a speed
  - indicate the number of repetitions
- 3) During playback, you can interrupt execution by using STILL. (Of course, you can also send C.L. and a new command sequence.)
- 4) Upon finishing the segment, the LDP-1000A will stop on the segment's end point and send COMPLETION HEX (01).

The segment's audio will play back with whatever audio channels you set up prior to sending SEGMENT MODE HEX (54).

i. SEGMENT Definition

HEX (45)

A 'segment' is any portion of the video material on a videodisc, between a start point and an end point. The points are indicated by videodisc frame numbers, which are five-digit numbers between 00001 and 54000. Segments can be as short as one frame (start and end points are the same number) or as long as the whole side.

Up to 63 segments (including the number 00) can be defined. Numbering does not have to start at 00, and can be non-continuous (i.e. random).

Segment definitions can be rewritten at any time. Previous definitions of the same segment number will be lost upon rewrite.

A segment can be played in reverse by defining the start point to be higher than the end point. (Example: if start = frame 02000, end = 01000, the playback will go from frame 02000 to frame 01000.)

Segments are useable only with CAV discs.

The sequence for inputting a SEGMENT definition is:

<u>Ext. CPU</u>		<u>LDP-1000A</u>
SEG	----->	
	<-----	ACK
SEG # 1st digit		(*)
HEX (30) to (36)	----->	
	<-----	ACK
SEG # 2nd digit		
HEX (30) to (39)	----->	
	<-----	ACK
ENTER	----->	
	<-----	ACK
IN POINT 1st digit		
HEX (30) to (35)	----->	(**)
	<-----	ACK
IN POINT 2st digit		
HEX (30) to (39)	----->	
	<-----	ACK
IN POINT 3rd digit		
HEX (30) to (39)	----->	
	<-----	ACK
IN POINT 4th digit		
HEX (30) to (39)	----->	
	<-----	ACK
IN POINT 5th digit		
HEX (30) to (39)	----->	
	<-----	ACK
ENTER	----->	
	<-----	ACK

(continued to next page)

(continued from previous page)

```
OUT POINT 1st digit
      HEX (30) to (35)  ----->
                        <-----   ACK
OUT POINT 2st digit
      HEX (30) to (39)  ----->
                        <-----   ACK
OUT POINT 3rd digit
      HEX (30) to (39)  ----->
                        <-----   ACK
OUT POINT 4th digit
      HEX (30) to (39)  ----->
                        <-----   ACK
OUT POINT 5th digit
      HEX (30) to (39)  ----->
                        <-----   ACK
ENTER
      ----->
      <-----   ACK
C.L.
      ----->
      <-----   ACK
```

If you want to keep putting in segment data in segment numbers which are continuous (i.e. 10, 11, 12, or 45, 46, 47 etc), leave off the C.L. command. The segment number will increment automatically. From the point at (\*) above, do as follows:

```
ENTER
      ----->
      <-----   ACK
      (player automatically
      enters both digits of
      segment number)
IN POINT 1st digit....
```

From the IN POINT 1st digit, continue as from (\*\*) above.

Put the C.L. after the last segment data you wish to enter. Failure to put this will cause an ERROR.

For the segment start and end points, please note the comments at the end of part (ii), 'Execution'.

## ii. Execution

You execute the segments defined in (i) above, as called for by your application program. On each execution you must:

- first select SEGMENT MODE
- send SEARCH and specify the segment number
- when the player reaches the segment start point, send REPEAT and indicate a speed
- indicate the number of repetitions

Let's first discuss modes and speeds.

### a) Modes

The LDP-1000A has three different ways to handle indications of video portions of a videodisc:

1) SEGMENT MODE            HEX (54)

This is the mode described in (i) above.

2) FRAME # MODE            HEX (55)

This uses frame numbers to directly indicate portions to be played back. It is most frequently used with SEARCH/REPEAT operations, STOP operation, etc.

3) CHAPTER MODE            HEX (69)

This uses a chapter number encoded on the videodisc (separately from the frame numbers), to access specified portions of video. It is commonly used with CLV discs on manually-controlled players.

The LDP-1000A automatically switches into FRAME # MODE in any of these conditions:

- at power on
- when C.L. HEX (56) is sent
- when the player goes into the lead-in or lead-out areas on a disc (usually inadvertently)

To get into another mode, one of the above commands must specifically be sent. The LDP-1000A will stay in that mode until another mode command is sent, or one of the above conditions occurs. You will probably use C.L. frequently, and it is sometimes hard to determine whether the player has gone into lead-in or lead-out areas. So you should be prudent and send SEGMENT MODE frequently.

If a SEARCH/REPEAT operation, STOP etc using frame numbers is to be done after a SEGMENT operation, be sure to send FRAME # MODE HEX (55) before the operation itself. Otherwise an ERROR will occur.

### b) Speeds

Any of the following speeds may be used:

- 1) PLAY (normal)            HEX (3A)
- 2) FAST                      HEX (3B)
- 3) SLOW                      HEX (3C)
- 4) STEP                      HEX (3D)

Reverse-direction speed commands are not possible with SEGMENT usage. To get reverse play of a segment, define its start point as higher than its end point as mentioned in (i) above, then specify one of the speed commands just above.



The general sequence for executing a segment is as follows. We will assume a simple example first, namely PLAY forward. A segment has been defined as in (i) above.

<u>Ext. CPU</u>		<u>LDP-1000A</u>	
SEG MODE	----->		
	<-----	ACK	
SEARCH	----->		
	<-----	ACK	
SEG # 1st digit			
HEX (30) to (36)	----->		
	<-----	ACK	
SEG # 2nd digit			
HEX (30) to (39)	----->		
	<-----	ACK	
ENTER	----->		
	<-----	ACK	
	(Player searches to start point; upon reaching it:)		
SEG MODE	----->	COMPLETION	(*)
	<-----	ACK	
REPEAT	----->		
	<-----	ACK	
SEG # 1st digit			
HEX (30) to (36)	----->		
	<-----	ACK	
SEG # 2nd digit			
HEX (30) to (39)	----->		
	<-----	ACK	
PLAY	----->		(**)
	<-----	ACK	
ENTER	----->		
	<-----	ACK	
REPETITIONS 1st digit			(***)
HEX (30) TO (31)	----->		
	<-----	ACK	
REPETITIONS 2nd digit			(***)
HEX (30) TO (39)	----->		
	<-----	ACK	
ENTER	----->		
	<-----	ACK	
	(Segment is played back; upon reaching end point:)		
	<-----	COMPLETION	

To use FAST or SLOW in the above, substitute HEX (3B) or HEX (3C) in place of the HEX (3A) used for PLAY.

The SEGMENT MODE instruction at (\*) can be deleted if you are sure the player has not gone into a lead-in or lead-out area while searching to the start point.

The portion marked (\*\*) above can be skipped if your speed is PLAY (i.e. default = PLAY).

The portions marked (\*\*\*) above can be skipped if you want to go through the segment only once this time (i.e. default repetitions = 1.) Maximum repetitions is 15. However, if you specify 00, the segment will be repeated endlessly, until a further command is sent.

To terminate the repetitions before all are done, send C.L. HEX (56). You can then send the sequence you want to do next. You use C.L. to terminate a segment playback even when the "repetition" is 1 (i.e. default value).

Now let's assume you want to step through a segment, in the forward direction.

The frame advance rates can be set anywhere from 1/1 to 1/255 of normal speed. The denominator of the desired rate is entered as data. Fractions of normal speed translate into the following seconds of display per frame:

1/1	=	.033 sec		1/120	=	4.0 sec
1/2		.066		1/150		5.0
1/3		.1		1/180		6.0
1/10		.33		1/210		7.0
1/30		1.0		1/240		8.0
1/60		2.0		1/255		8.5
1/90		3.0				

<u>Ext. CPU</u>		<u>LDP-1000A</u>
SEG MODE	----->	
	<-----	ACK
SEARCH	----->	
	<-----	ACK
SEG # 1st digit		
HEX (30) to (36)	----->	
	<-----	ACK
SEG # 2nd digit		
HEX (30) to (39)	----->	
	<-----	ACK
ENTER	----->	
	<-----	ACK
	(Player searches to start point; upon reaching it:)	
	<-----	COMPLETION
SEG MODE	----->	(*)
	<-----	ACK
REPEAT	----->	
	<-----	ACK
SEG # 1st digit		
HEX (30) to (36)	----->	
	<-----	ACK
SEG # 2nd digit		
HEX (30) to (39)	----->	
	<-----	ACK
STEP	----->	
	<-----	ACK
ENTER	----->	
	<-----	ACK
REPETITIONS 1st digit		(**)
HEX (30) TO (31)	----->	
	<-----	ACK
REPETITIONS 2nd digit		(**)
HEX (30) TO (39)	----->	
	<-----	ACK
ENTER	----->	
	<-----	ACK
RATE 1st digit		
HEX (30) to (32)	----->	
	<-----	ACK
RATE 2st digit		
HEX (30) to (39)	----->	
	<-----	ACK
RATE 3rd digit		
HEX (30) to (39)	----->	
	<-----	ACK
ENTER	----->	
	<-----	ACK
	(Segment is stepped through; upon reaching end point:)	
	<-----	COMPLETION

The SEGMENT MODE instruction at (\*) can be deleted if you are sure the player has not gone into a lead-in or lead-out area while searching to the start point.

The portions marked (\*\*) above can be skipped if you want to go through the segment only once this time.

### c) Caution on use of start/end points

Please note the following when defining your segments' start and end points:

--For both the start and end points, the player actually sends COMPLETION upon entering the specified frame (around horizontal line 20, to be precise). The player will usually go through one or two rotations (i.e. the frame is displayed for 1/30 sec or 2/30 sec--too short to be noticed) before your external computer can respond with the next commands. What happens next depends on what command you send: the net result with PLAY/FAST/SLOW varies slightly from STEP.

--Let's assume that you want to show frames 00095 through 00100 inclusive (i.e. you want to show those two frames, as well as all in between). In Case A, you use PLAY. In Case B, you use STEP. The two cases are illustrated below. Carefully note the different start points needed, and the display of frames.

Case A -- using PLAY

<u>frame no.</u>	<u>specified</u>	<u>interval shown</u>
00093		not shown
00094		not shown
00095	start	shown 1/30 or 2/30 sec
00096		shown 1/30 sec
00097		shown 1/30 sec
00098		shown 1/30 sec
00099		shown 1/30 sec
00100	end	interval depends on command's timing
00101		not shown
00102		not shown

Case B -- using STEP

<u>frame no.</u>	<u>specified</u>	<u>interval shown</u>
00093		not shown
00094	start	shown 1/30 or 2/30 sec (not noticeable)
00095		shown at STEP interval
00096		shown at STEP interval
00097		shown at STEP interval
00098		shown at STEP interval
00099		shown at STEP interval
00100	end	interval depends on command's timing
00101		not shown
00102		not shown

--Start points:

In both cases, the player reaches the start point of the segment specified in your SEARCH command, and sends COMPLETION as it starts playing back this frame. When your next commands are received, the player will begin execution of those commands from the next frame after the specified start point.

If your next command is a PLAY sequence, the player continues forward at normal speed. The one or two rotations while the player waited for your commands, appear to be part of the PLAY action.

If your next command is a STEP sequence, the player starts the stepping interval with the next frame after the specified start point.

--End points:

In both cases, the player reaches the end point of the segment specified in your REPEAT command, and sends COMPLETION as it starts playing back this frame. How long this frame is shown, depends on when your next commands are received.

If the completed segment was done in PLAY, you could send your next commands as soon as you wanted. Even with your fastest command dispatch, the player will have played this last frame 1 or 2 times before your commands arrive. This would fit in with the segment's PLAY timing.

If the completed segment was done in STEP, you will probably want to show this last frame for the same interval as the others in the segment. So you should wait that interval before sending your next command.

### iii. Commands during SEGMENT playback

If you send STILL HEX (4F) at any time during a segment's playback, the LDP-1000A will go into still frame on the video frame the player was on at the time the STILL command was received. The player will stay in still on that frame, until you send another command.

At this point, you have three choices of action:

- a) send CONTINUE HEX (61). The player will resume execution of the segment, with nothing changed (same speed, etc).
- b) send a different speed. The end point will remain the same. For example, let's assume you were in normal PLAY before, and want to go to SLOW:

<u>Ext. CPU</u>		<u>LDP-1000A</u>
SLOW	----->	
	<-----	ACK
	(Player resumes in SLOW; upon reaching end point:)	
	<-----	COMPLETION

Note that ENTER is not needed.

STEP can also be used, as follows:

<u>Ext. CPU</u>		<u>LDP-1000A</u>
STEP	----->	
	<-----	ACK
RATE 1st digit		
HEX (30) to (32)	----->	
	<-----	ACK
RATE 2st digit		
HEX (30) to (39)	----->	
	<-----	ACK
RATE 3rd digit		
HEX (30) to (39)	----->	
	<-----	ACK
	(Player resumes in STEP; upon reaching end point:)	
	<-----	COMPLETION

Note that ENTER is not needed.

The player's handling of the end point is the same as explained in part (ii.c) above, "Caution...".

- c) terminate the segment playback entirely, and send an entirely new sequence of commands. This is done by sending C.L. HEX (56). You need not take any action on the STILL command that had been sent.

V. PROM REVISION LEVELS

SUMMARY OF ROM Versions

NO.		1.5	1.6	1.7	1.8	2.1	3.1	3.2
1	"ACK" and "NAK" added to ensure correct transmission of data through the RS232-C.	X	0	0	0	0	0	0
2	Commands added to enable programming of "INDEX ON/OFF", "AUDIO CH-1/2 ON/OFF" in the EXT-CPU mode.	x	0	0	0	0	0	0
3	When SEARCH, REPEAT, etc. is sent from the external CPU, the display appears automatically and is very poor. Modification was done to prevent automatic display when in the EXT-CPU mode.	X	0	0	0	0	0	0
4	The spindle motor and laser can be turned ON and OFF by the external CPU. Commands added.	X	0	0	0	0	0	0
5	There was no response when "PGM" or "RUN" was sent from an external CPU. "ACK" was added.	X	0	0	0	0	0	0
6	When "not target" resulted from a frame number search, the correct frame number was not reported. Modification was done to prevent stopping at a point where the frame number cannot be read.	X	0	0	0	0	0	0
7	When "PGM-AAA-RUN" is sent from the external CPU, only line no. AAA is executed.	X	0	0	0	0	0	0





NO.		1.5	1.6	1.7	1.8	2.1	3.1	3.2
17	Random numbers are sent when in standby mode.							
18	RS232-C cannot communicate when in the standby mode.							
19	The RAM area of the audio code is dumped in and out.	0	0	0	0	X	X	0
20	Modifications done to prevent 1 - 2 frame overrun in the repeat fast mode.	X	X	X	X	X	X	0 DEC
21	5 dump memory.	X	X	X	X	X	0	0
22	Chapter function. V 3.1 cannot search beyond 20 chapters.	X	X	X	X	X	0	0

## LDP-1000A ROM VERSIONS

1. Summary of differences vs LDP-1000
  - 1.1 Frame number reading capability improved
  - 1.2 Chapter capabilities expanded:  
CAV/CLV chapter search, repeat
  - 1.3 CLV disc time code search, repeat capability added
  - 1.4 Audio control code:  
Memory area expanded from 1 Kbyte to 5 Kbytes  
(however, dumps in multiple locations are not possible)  
New commands:  
    --input wait  
    --extended dump
  - 1.5 RS232-C interface

## 2. RS232-C improvements

The following LDP-1000 improvements were made in version 3.1.

- 2.1 When SEARCH to present frame number, ACK was returned (not COMPLETION), and the ext. computer locked up.

example: assume present frame is 01000

```
if LDP-1000:
SEARCH 01000 ENTER  ----->
                   <-----  ACK
                   no completion
```

```
if LDP-1000A:
SEARCH 01000 ENTER  ----->
                   <-----  ACK
                   <-----  COMPLETION
```

- 2.2 For REPEAT, same situation as (2.1).
- 2.3 With no disc, and upon closing the lid, ACK is not output continuously.
- 2.4 When the RS232-C cable is disconnected, the lid can still not be opened.

3. Added RS232-C command and return code

3.1 Command

--set chapter mode: HEX (69)

This puts the SEARCH and REPEAT into chapter mode.

3.2 Return code

--no frame: HEX (06)

During search, a lead-out condition is checked, and when the search is terminated this code is returned. The LDP-1000 sent HEX (05) (NOT TARGET) in this situation.

## VI. SFA-1000 Control Commands

### i. RS232-C commands

H	0	1	2	3	4	5	6	7
0		RESET		4	ENTER	INDEX ON	ADDR INQ	
1	COMPLETION	REPLAY		1	C.E	INDEX OFF	CONTINUE	
2	ERROR	STATUS SET		2	MENU	DUMP IN LDP-CPU	MOTOR ON	
3		STATUS INQ		3	SEARCH	DUMP OUT LDP-CPU	MOTOR OFF	
4	PGM END	SPLIT PLAY BACK		4	REPEAT	SEG MODE	CH-1	
5	NOT TARGET NO FRAME #	Additional commands for SFA		5	SEGMENT	FRAME # MODE	CH-2	
6				6	CH-1 ON	C L	INDEX	
7			Reserved	7	CH-1 OFF	PGM	STATUS INQ	
8				8	CH-2 ON	RUN	DISCID INQ	
9				9	CH-2 OFF	END	CHAPTER # MODE	
A	ACK			F-PLAY	R-PLAY	MEMORY		
B	NAK			F-FAST	R-FAST	M-SEARCH		
C				F-SLOW	R-SLOW	SKIP		
D	PLAY BACK START			F-STEP	R-STEP	INT		
E	NORMAL END	Additional return code for SFA		F-SCAN	R SCAN	REVIEW		
F	ERROR END			STOP	STILL	MODE		

### ii. Additional commands for SFA control

- a) RESET HEX (10): Stops the playback.
- b) REPLAY HEX (11): Functions the same as the REVIEW switch of the SFA-1000.
- c) STATUS SET HEX (12): Sets the following statuses. BY transmitting the following data(1 byte) after this command, the status will be Written in the status register.
  - D7 0 not used
  - D6 0 not used
  - D5 RETURN CODE OUTPUT ON
    - 1: At the end of audio playback, NORMAL END HEX (0E) or ERROR END HEX (0F) will be output.
    - 0: NO output  
When the power is turned on, the bit is reset to 0.
  - D4 STILL CMD OUTPUT ON
    - 1: The still command is output to LDP-1000A when reading the SFA audio data from the video signal.
    - 0: No output  
When the power is turned on, the bit is reset to 0.

- D3 CH-2 ON
  - 1: The SFA audio signal is output to channel 2.
  - 0: No output
  - When the power is turned on, the bit is reset to 1.
- D2 CH-1 ON
  - 1: The SFA audio signal is output to channel 1.
  - 0: No output
  - When the power is turned on, the bit is reset to 1.
- D1 VIDEO MUTE ON
  - 1: Mutes the video signal and output a sync signal only.
  - 0: Muting not performed.
  - When the power is turned on, the bit is reset to 0.
- D0 AUDIO MUTE ON
  - 1: Mutes the audio signal.
  - 0: Muting not performed.
  - When the power is turned on, the bit is reset to 0.

d) STATUS INQ HEX(13): When the SFA-1000 receives this command, it will send the following status data.

- D7-D3 0 not used
- D2 STANDBY
  - indicates that the unit is preparing to read SFA data when the bit is set to 1.
- D1 AUDIO PB ON
  - indicates that the SFA signal is now being output when the bit is set to 1.
- D0 ERROR END
  - indicates that an incorrectable error has occurred while SFA data is being decoded when the bit is set to 1.

e) SPLIT PB HEX(14): Outputs the SFA data at the start time you set for a length you set. Input command, start time, and length in this order. Start time and length are set in 0.2 second step by a hexadecimal number.

### iii. Additional return code for SFA

When RETURN CODE OUTPUT ON flag is set to the status register, the following return codes are output from the SFA-1000 to the external computer.

- 1) PB START HEX(0D): When a SFA datum is to be output.
- 2) NORMAL END HEX(0E): When a SFA datum is decoded normally.
- 3) ERROR END HEX(0F): When decoding of the SFA data is stopped because of an error.

iV. Commands sequesce

1) Single command

<u>CPU</u>		<u>SFA-1000</u>
RESET	----->	
	<-----	ACK
		Operation ends.
REPLAY	----->	
	<-----	ACK
		Operation ends.
PB START	----->	
	<-----	NORMAL END
		When RETURN CODE
		OUTPUT ON flag is
		set to 1.

2) Commands followed by data

<u>CPU</u>		<u>SFA-1000</u>
STATUS	----->	
	<-----	ACK
status byte	----->	
	<-----	ACK
		Operation ends.
STATUS INQ	----->	
	<-----	ACK
status byte	<-----	Operation ends.
SPLIT PB	----->	
	<-----	ACK
start time	----->	
	<-----	ACK
length	----->	
	<-----	ACK
REPLAY	----->	
	<-----	ACK
		Operation ends.

**VII. APPENDIX**

**A. Places to Write for Specifications**

i. EIA RS232-C

2001 Eye Street, N.W.  
Washington, D.C. 20006  
Telephone: (202) 457-4966

ii. Application Notes for RS232-C

Same as above.

iii. Intel 8251A Programmable Communication Interface

Intel Corporation  
Literature Department  
3065 Bowers Avenue  
Santa Clara, CA 95051

B. RS232-C Commands

L \ H	φ	1	2	3	4	5	6	7
φ				φ	ENTER	INDEX ON	ADDR INQ	
1	COMPLETION			1	C.E	INDEX OFF	CONTINUE	
2	ERROR			2	MENU		MOTOR ON	
3				3	SEARCH		MOTOR OFF	
4	PGM END			4	REPEAT	SEG MODE	CH-1	
5	NOT TARGET			5	SEGMENT	FRAME# MODE	CH-2	
6	NO FRAME			6	CH-1 ON	C.L.	INDEX	
7				7	CH-1 OFF	PGM	STATUS INQ	
8				8	CH-2 ON	RUN	DISC ID INQ	
9				9	CH-2 OFF	END	CHAPTER# MODE	
A	ACK			F-PLAY	R-PLAY	MEMORY		
B	NAK			F-FAST	R-FAST	M-SEARCH		
C				F-SLOW	R-SLOW	SKIP		
D				F-STEP	R-STEP	INT		
E				F-SCAN	R-SCAN	REVIEW		
F				STOP	STILL	MODE		

- \* How to read this chart:
1. Read the column number first, then the row number.  
EX: 40 = ENTER  
01 = COMPLETION
  2. Commands relevant to control of the LDP-1000A, are from 30 to 69.
  3. The 0x column shows the return codes from the LDP-1000A.
  4. a): A small black triangle in a box, indicates that command is only useable via RS232-C.  
b): Commands without the triangle are equivalent to those possible with the RM-1002 keys, and may also be used via RS232-C.



LDP-1000A Command execution time

Time to return ACK/NACK for each command, as measured at player RS232-C port

COMMANDS	EXEC TIME	COMMANDS	EXEC TIME
0 ~ 9	1.2mS (4.3mS)	INT	2.5mS (6.0mS)
PLAY	2.0mS (5.5mS)	REVIEW	1.5mS (9.6mS)
FAST		MODE	1.7mS (3.7mS)
SLOW		CH-1	0.47mS (0.53mS)
STEP		CH-2	
STOP		INDEX	0.58mS (0.53mS)
C. E From ERROR		2.0mS (8.0mS)	MOTOR ON
ENTER	2.6mS (1.3mS)	MOTOR OFF	
MENU	20.0mS (11.5mS)		
SEARCH	2.6mS (9.0mS)		
REPEAT	2.6mS (8.0mS)		
SEG	2.5mS (10.0mS)		
CH-1 ON/OFF	0.43mS (0.4mS)		
CH-2 ON/OFF			
INDEX ON/OFF			
MODE ( SEG )			
MODE ( FRAME )			
STILL			
C. L.	4.3mS (5.5mS)		
PGM	2.2mS (7.9mS)		
RUN	7.9mS (7.0mS)		
END From PGM	5.6mS (10.5mS)		
MEMORY	0.76mS (0.76mS)		
M-SEARCH	1.0mS (11.1mS)		
SKIP	2.5mS (5.8mS)		

( ) : Used for LDP-1000.

LDP-1000A/SFA-1000  
9-966-756-61

**Sony Corporation**  
© 1984

Printed in Japan  
1984. 12 11