

28 TELETYPEWRITER KEYBOARD AND BASE
DESCRIPTION AND PRINCIPLES OF OPERATION

CONTENTS	PAGE	CONTENTS	PAGE
1. GENERAL	1	REPEAT-ON-SPACE MECHANISM . .	16
2. DESCRIPTION	1	RADIO FREQUENCY NOISE AND ARC SUPPRESSION	16
KEYBOARD	1	ANSWER-BACK MECHANISM	17
A. General	1	A. Called Station	17
B. Base Assembly	2	B. Originating Station	19
C. Keyboard Mechanism	4	SYNCHRONOUS PULSED TRANSMISSION	20
D. Signal Generator Mechanism	4		
E. Wall Mounted Keyboard	4	1. GENERAL	
F. Variable Features	5	1.01 The 28 keyboard provides mounting and transmission facilities for the 28 Key- board Send-Receive (KSR) Teletypewriter Set. The 28 receive-only base provides mounting facilities for the 28 Receive-Only (RO) Tele- typewriter Set.	
RECEIVE-ONLY BASE	6	2. DESCRIPTION	
3. PRINCIPLES OF OPERATION	6	KEYBOARD (Figs. 1, 2 and 3)	
KEYBOARD	6	A. General	
A. Depression of Keys	6	2.01 The 28 keyboard is a device for convert- ing the mechanical action resulting from the manual depression of a key into electrical pulses that are transmitted over a signal line. In addition, the keyboard provides mounting fa- cilities for the typing and motor units of a Key- board Send-Receive (KSR) Teletypewriter Set, as well as for a variety of accessories.	
B. Positioning of Code Bars	8	2.02 The keyboard is installed on a cradle assembly in the floor and table model enclosures, on a base plate assembly in the wall and rack mounted enclosures, and on slide-type mountings in the multiple KSR and RO cabinet. The front of the keyboard protrudes beyond the enclosure and is fitted with a rubber pad that seals the edges of the aperture from dust and for a silencing effect.	
C. Resetting of the Code Bars	9		
FUNCTION KEYS	10		
A. Local Carriage Return Mechanism	10		
B. Local Line Feed Mechanism	10		
C. Signal Line Break Mechanism	10		
D. Keyboard Lock Mechanism	13		
E. Keyboard Unlock Mechanism	13		
F. Margin Indicator Mechanism	13		
4. RECEIVE-ONLY BASE	13		
5. VARIABLE FEATURES	13		
MOTOR START FOR PAGE FEED OUT	13		
TIME DELAY MECHANISM	14		
LOCAL REVERSE LINE FEED	16		
LOCAL BACK SPACE	16		
REPETITION OF CHARACTERS	16		

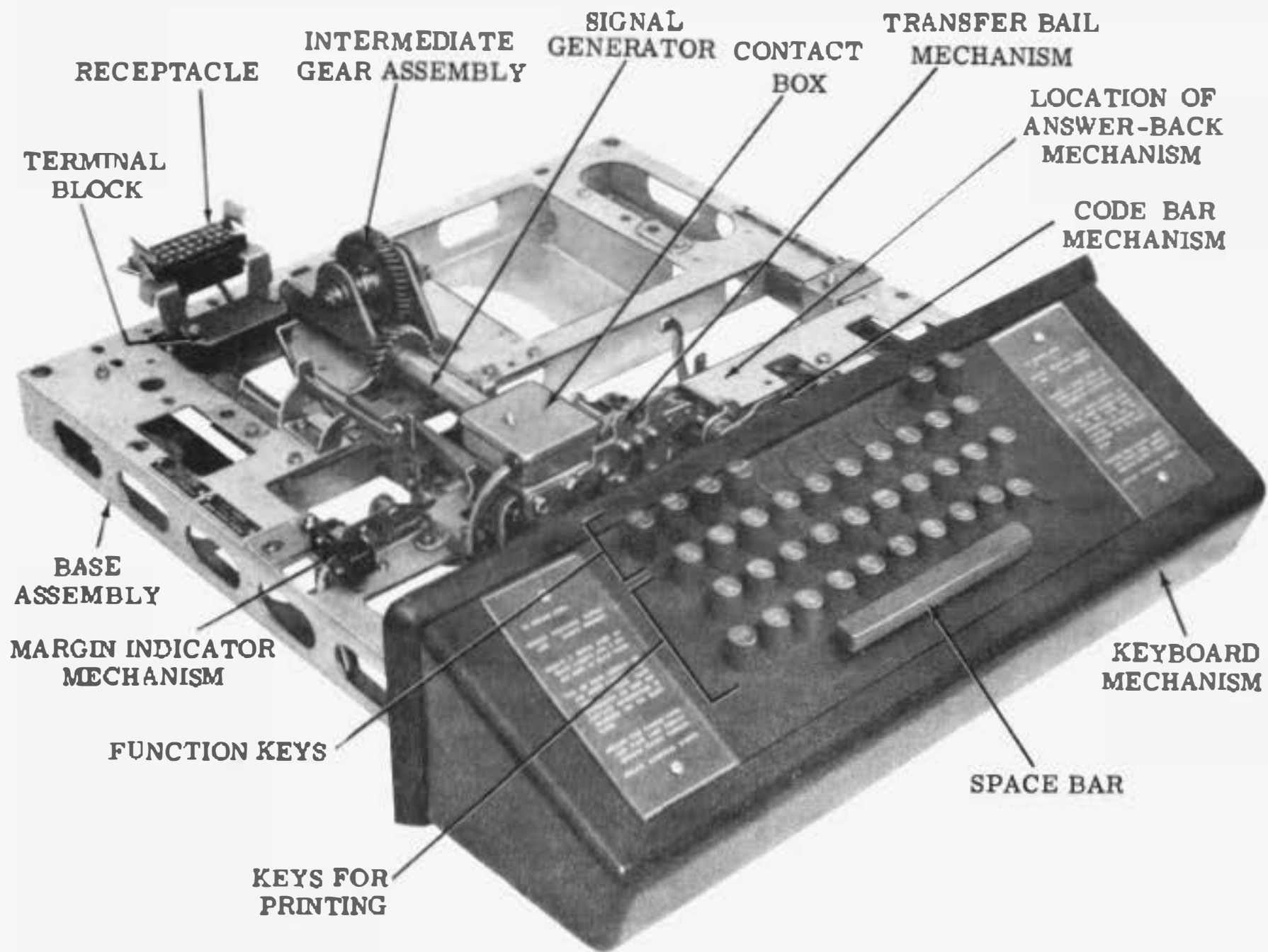

Figure 1 - 28 Teletypewriter Keyboard

2.03 Motive force for activating the keyboard is derived from the motor unit by way of the typing unit. The electrical wiring to and from the keyboard is terminated in a connector mounted at the left rear of the unit. Fuses for the power circuits are located in the electrical service unit.

2.04 The keyboard is operable on line at the following speeds; 60, 75 and 100 words-per-minute; or 366, 460, and 600 operations-per-minute. Operating speeds are varied by interchanging sets of gears that are supplied as optional components. The signal generator contact box may be adapted to provide either polar or neutral signals.

2.05 The major sections of the keyboard are the base assembly, keyboard mechanism, and the signal generator mechanism.

B. Base Assembly

2.06 The base assembly provides mounting facilities for the keyboard and signal generator mechanisms, the intermediate gear assembly, cable and switch assembly, margin indicator switch, power terminal block, and optional accessories, such as the time delay and paper feed-out mechanisms.

2.07 The intermediate gear assembly consists of two helical gears, a shaft, and a mounting bracket. The assembly transfers motive

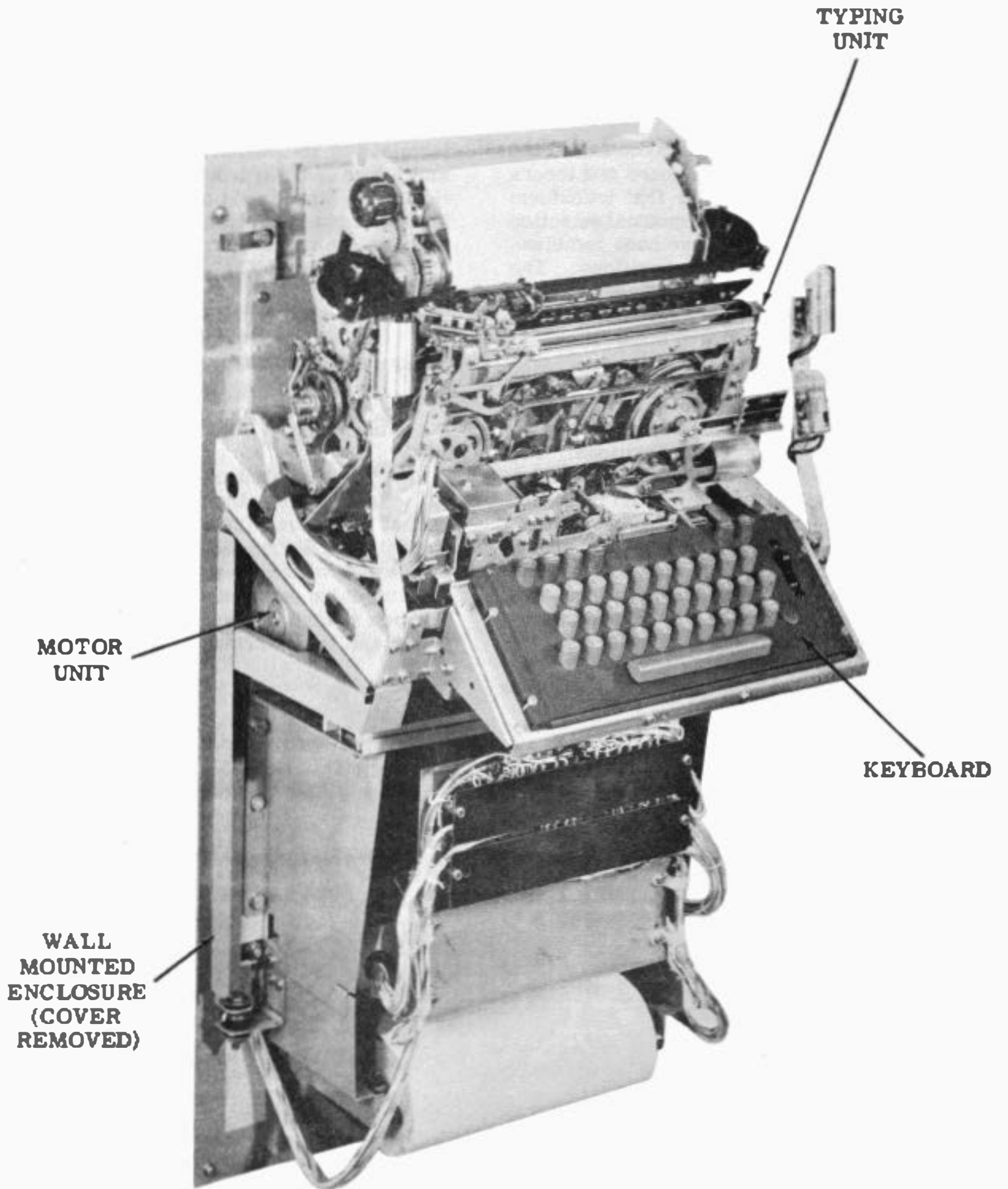

Figure 2 - 28 Teletypewriter Keyboard in Wall Mounted Set (Cover Removed)

power from the motor to the associated typing unit. Changes in operating speed are made by changing the motor pinion and the intermediate gear assembly driving gear.

C. Keyboard Mechanism

2.08 The keyboard mechanism contains the keytops, keylevers, code bars and levers and other code selecting parts that transform the intelligence contained in the manual selection of a keytop into a teletypewriter code combination, represented by code bar positions. The code combination for the selected character is transferred from the code bars through transfer levers to the signal generator mechanism.

2.09 The keytops are positioned in the conventional three-bank arrangement, with numerals, punctuation marks, and special symbols available in upper case positions. The space bar is located centrally below these keys. Keytops for local carriage return and local line feed are provided above the standard keytops for facility of operation. This row has provisions for 9 additional keys for optional, special operations. A wedge lock assembly prevents the simultaneous depression of more than one keytop.

D. Signal Generator Mechanism

2.10 The signal generator mechanism generates the start-stop teletypewriter signal. It consists of, basically, an enclosed contact box containing a set of fulcrum-type transmitting contacts, a transfer ball that controls the opening and closing of the contacts, selector levers that engage the transfer ball in a sequence determined by the position of the code bars, and a multi-lobe cam which determines the pulse duration of the signal code elements. A shaft, which mounts a gear and clutch, receives motive power to drive the mechanism from a gear on the associated typing unit.

2.11 The contact box will generate either neutral or polar signals, and may be equipped with an rf or arc suppression network.

E. Wall Mounted Keyboard (Fig. 2)

2.12 The keyboard used in wall mounted KSR sets differs from the standard keyboard in that its intermediate gear assembly contains one helical gear and one pulley. The motor unit mounts below the keyboard, on the left rear side, and its pinion engages with and drives the belt. The belt in turn engages with and drives the belt pulley and the attached intermediate shaft as-

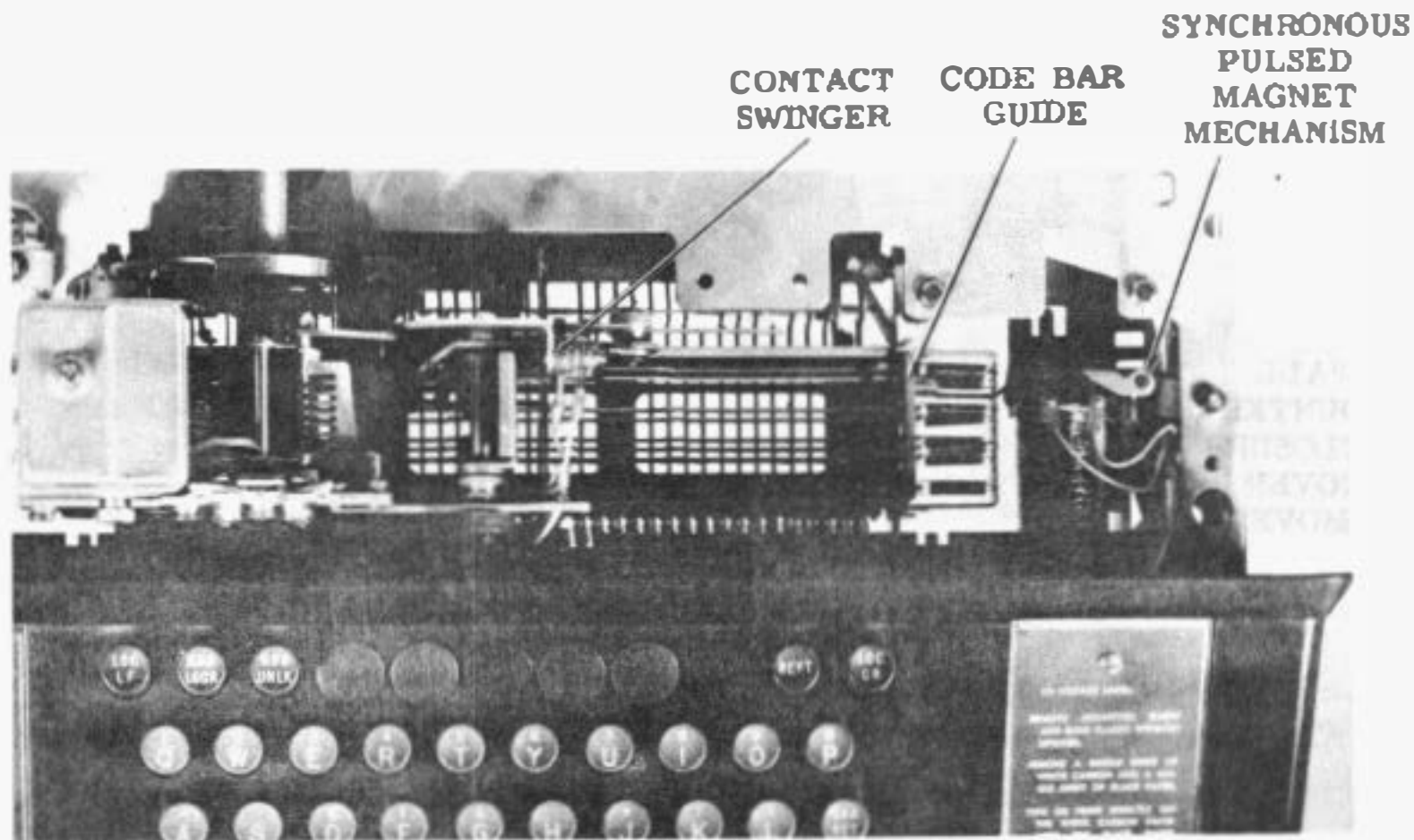

Figure 3 - 28 Teletypewriter Keyboard (Top View)

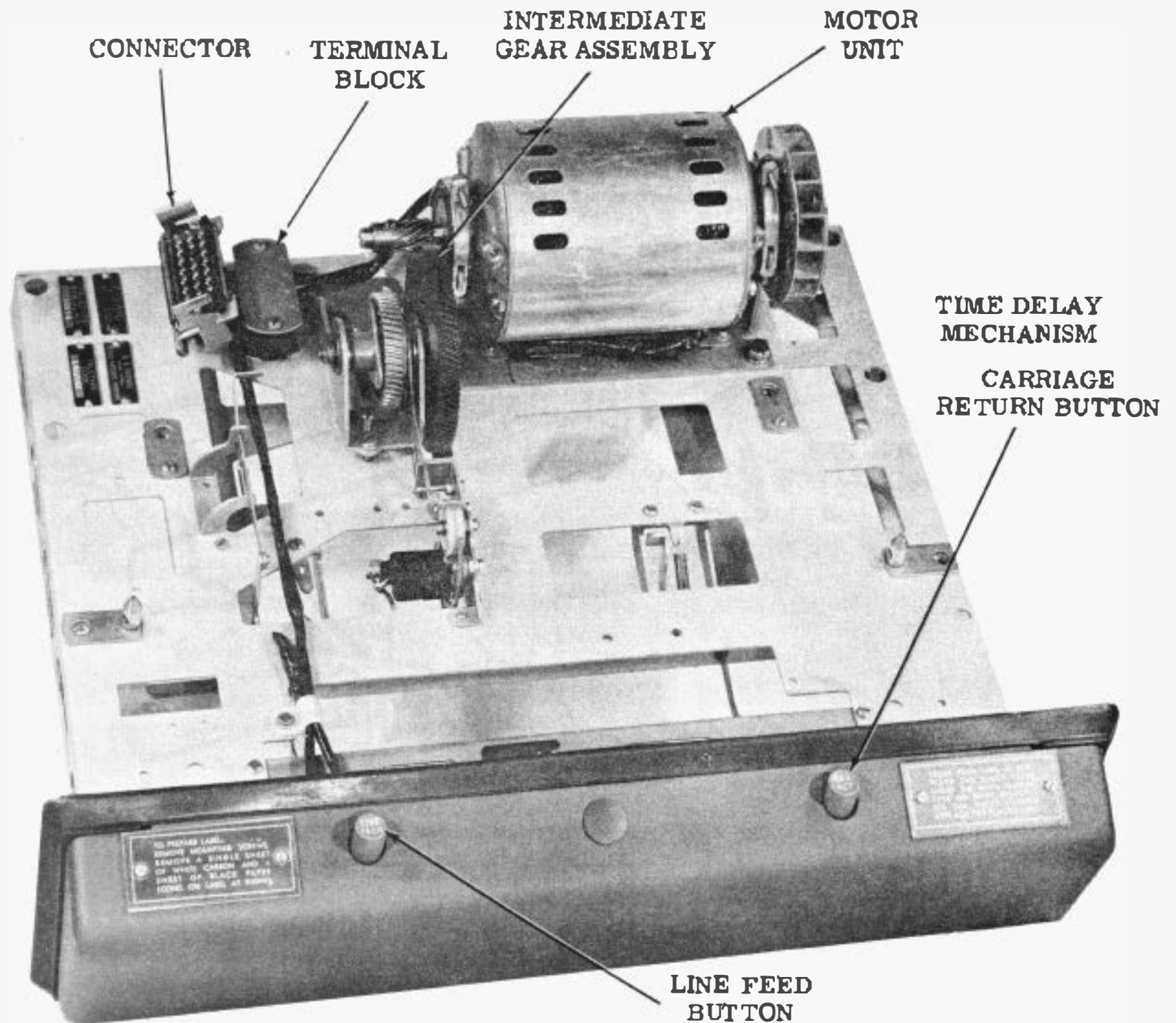

Figure 4 - 28 Teletypewriter Receive-Only Base with Motor Unit

sembly. A gear on the intermediate shaft assembly transfers the motive power to the typing unit.

F. Variable Features

2.13 The keyboard has provisions for accommodating a variety of accessories, including the following:

- (a) Motor start for page feed out.
- (b) Time delay motor stop.
- (c) Local reverse line feed.
- (d) Local back space.
- (e) Signal line break.
- (f) Keyboard lock and unlock.
- (g) Repetition of characters.
- (h) Repeat on space.
- (i) RF and arc suppression.
- (j) Answer-back (automatic station identification).
- (k) Synchronous pulsed transmission.

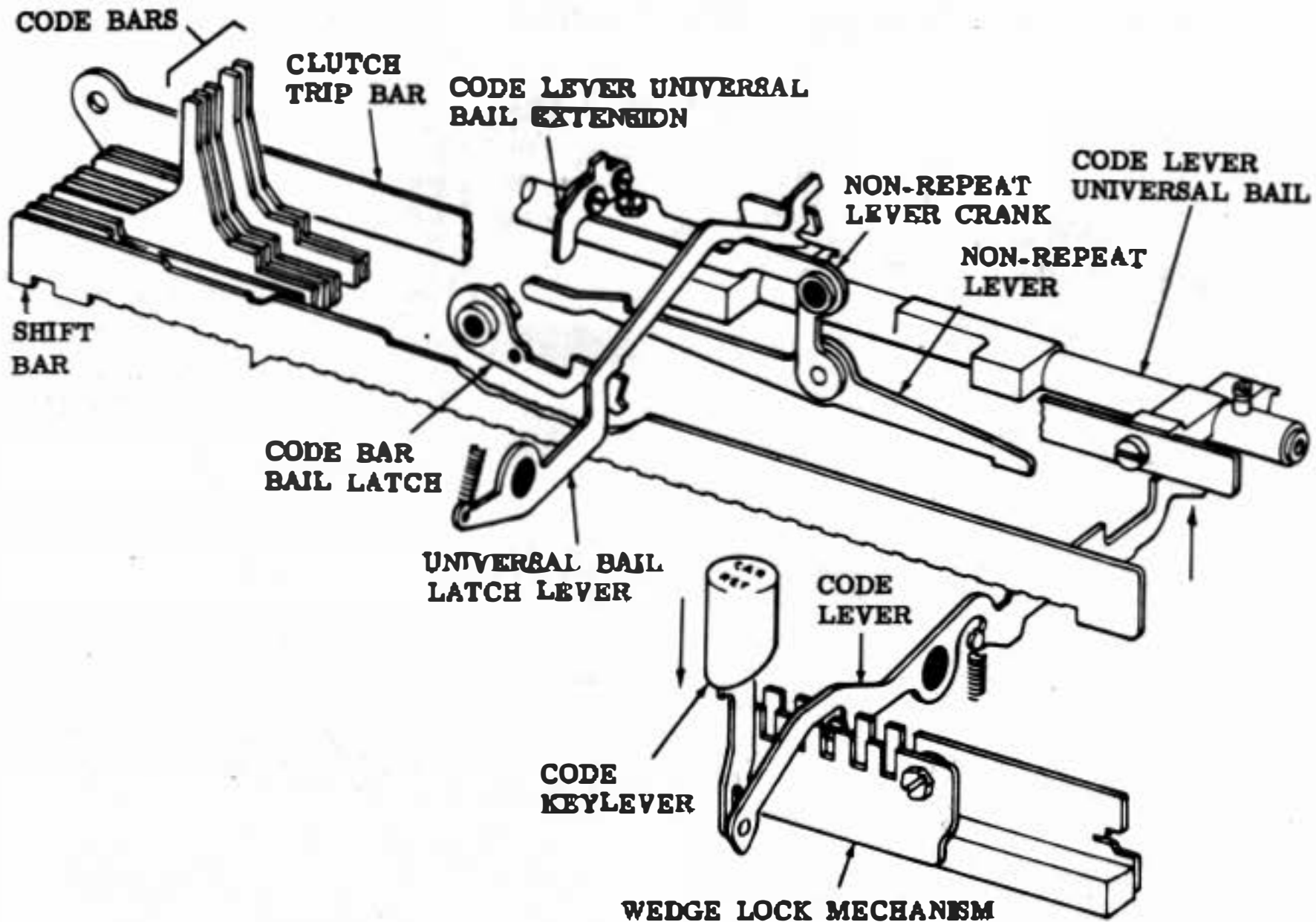

Figure 5 - Code Bar and Code Lever Universal Bail Mechanism

RECEIVE-ONLY BASE (Fig. 4)

2.14 The receive-only base is an aluminum, sheet metal structure used in place of the send-receive keyboard when receiving facilities only are required. It supports the motor unit and the typing unit and provides for carriage return and line feed operation of the local typing unit. It does not incorporate code selecting and signal generating mechanisms. The receive-only base may include the following accessories:

- (a) Signal line break.
- (b) Motor start for page feed out.
- (c) Time delay motor stop.
- (d) Margin indicator lamp contact.
- (e) Print/non-print switch.

- (f) Local transmitter control.

2.15 The wall mounted receive-only base used in wall mounted RO sets differs from the standard base in that its intermediate gear assembly contains only one helical gear, and a belt drive system is used.

3. PRINCIPLES OF OPERATION

KEYBOARD

A. Depression of Keys (Figs. 5 through 9)

3.01 As a code selecting keytop is depressed, the corresponding code lever rotates about its pivot point. The rear end of the code lever comes up and rotates the universal bail. The extension arm on the top of the universal bail moves out of engagement with the step at the rear end of the universal bail latch. This

occurs when the key and corresponding code lever are about two-thirds of the way toward full stroke. The universal ball latch then moves downward under spring force developed by the universal ball latch spring. As this latch comes down, it strikes the code bar reset ball latch lever and carries it downward. When the corner of the reset ball latch descends beyond the center line of the needle bearing (mounted on the reset bail), the various spring forces acting on the reset bail cause it to swing to the right. This in turn allows the various code bars to move to the right (in the direction of the spring forces acting on each code bar). During this time, the code lever is moved up to its full position. Therefore, the code lever may stop some of the code bars from moving to their extreme right hand position. The code bars have vertical extensions that engage a curved part of the signal generator transfer levers. Those code bars that are permitted to move to the extreme right also move the corresponding transfer lever to the right. However, those code bars that are stopped, because their teeth engage the actuated code lever, do not quite touch or move their corresponding transfer levers. Therefore, these

transfer levers remain in their normal left hand position (Fig. 8).

3.02 A locking wedge is mounted on the projection of the lower position of all code levers and function levers. When the lever is operated, its locking wedge moves downward between the lock balls in the lock ball channel preventing the simultaneous operation of more than one key lever (Fig. 6).

3.03 Simultaneously with the trip-off of the reset bail and the movement of the code bars to the right, the clutch trip bar (located in the rear slots of the code bar guides) moves to the right. This clutch trip bar engages the clutch stop lever and moves it out of latch with the clutch stop lug. Up to this point, all of the action has been caused by manual operation of the keytop and its associated code lever (Fig. 5).

3.04 The motor unit (mounted on the rear right corner of the keyboard base) supplies the mechanical power to drive the associated typing unit and the signal generator shaft that is geared to the typing unit main shaft. Re-

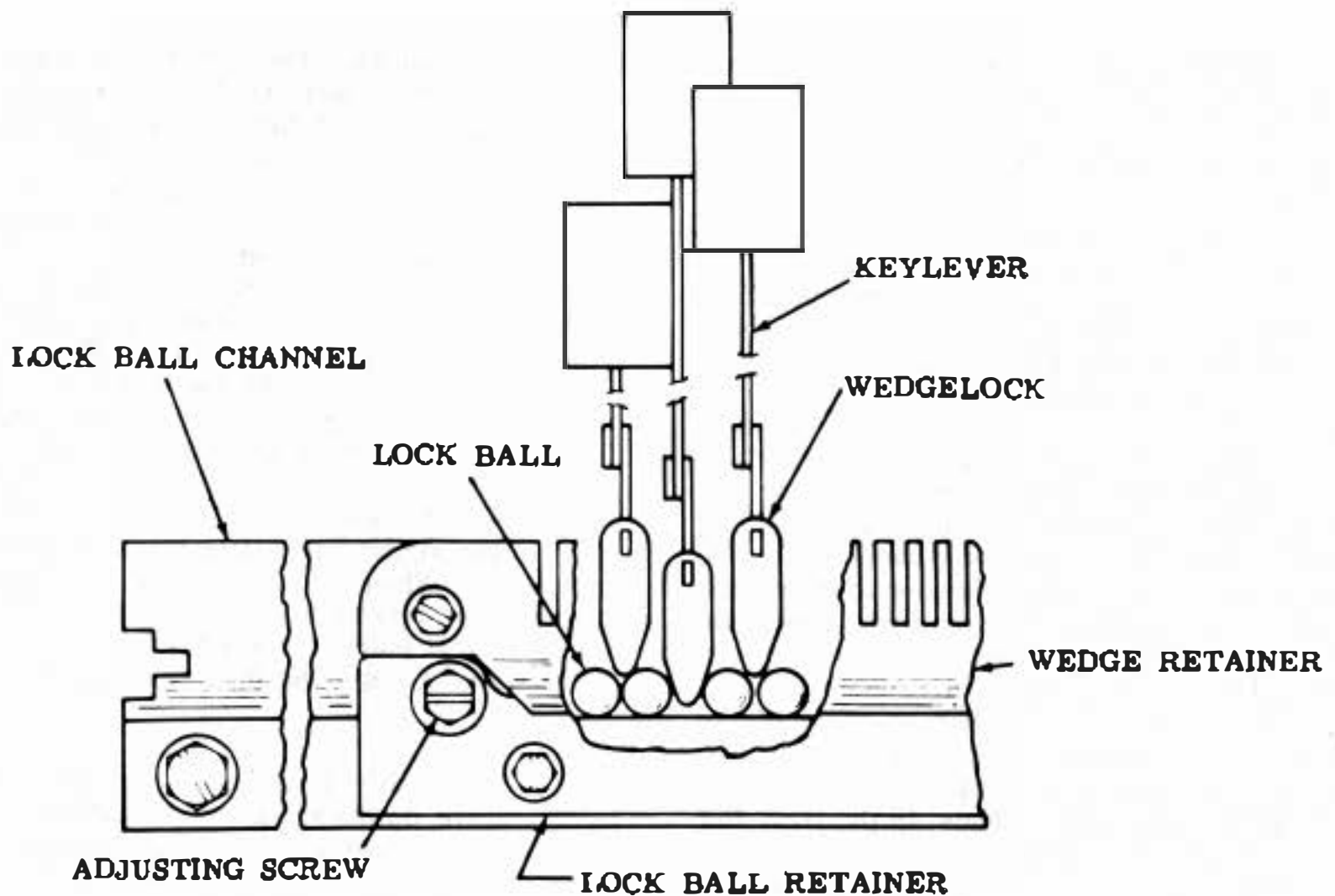

Figure 6 - Wedgelock Mechanism

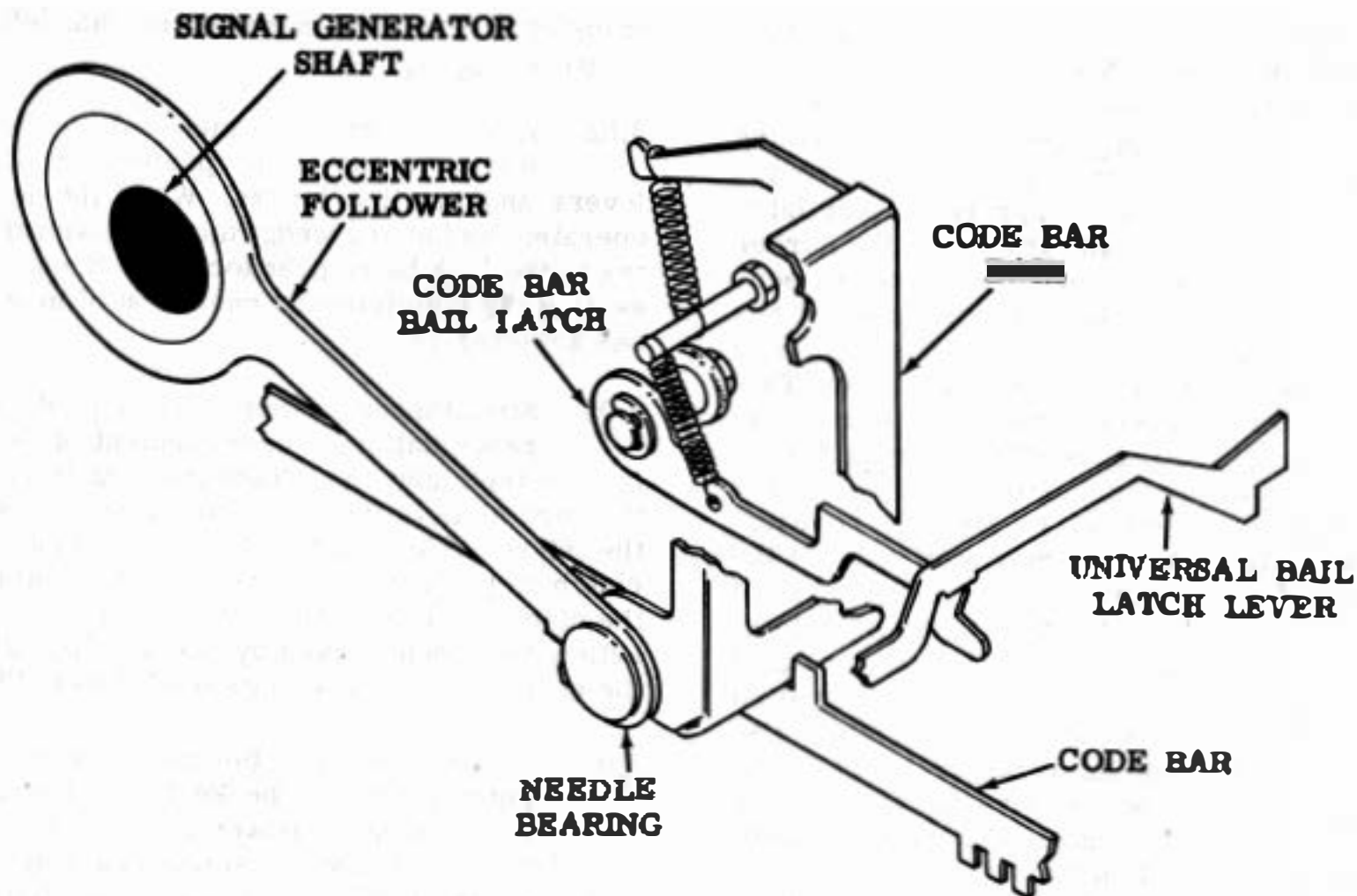

Figure 7 - Code Bar Mechanism

fer to the appropriate section for description and principles of operation for the motor unit.

B. Positioning of Code Bars (Figs. 5, 7 and 8)

3.05 Once the clutch is stripped, it rotates continuously as long as the keyboard is turned on. Since the clutch shoes are mounted on a plate that is part of the cam assembly, the cam begins to rotate (clockwise when viewed from the front of the keyboard).

3.06 The arrangement of the cam assembly is such that the third cam from the rear begins to push downward on its corresponding transfer lever. At almost the same time, the eighth cam from the rear begins to move the transfer lever locking ball upward. The blade portion of this locking ball goes up beside a downward projection on each transfer lever. The locking projection is left or right of the locking ball, depending upon the position of the transfer lever (as set up by the permutation action of the code bars). Thus, in the first few degrees of cam rotation, the permuted position of the transfer levers is located into position and the code bars are free to be reset in their normal latched position.

3.07 The cams and their corresponding transfer levers are numbered from rear to front. The number 3 cam engages its transfer lever first; and moves it down. Since the start pulse is always spacing, no code bar is required to engage this lever and it is always held to the left by its spring. Therefore, as the third cam moves the lever down, the hook at the upper right side of the transfer lever engages the right side of the transfer (rocker) ball. This tips the transfer ball to the right and pulls the contact drive link to the right. The resulting action of the contact toggle is such that the left set of contacts acts as a pivot and the right hand contacts begin to open. The right hand contacts control the signal current in single contact type operation. When these contacts are open, the result is no current in the signal circuit. Therefore, the first pulse, the start pulse of any character code is a spacing (no current) pulse.

3.08 The number 1 cam and the transfer lever move downward next. In turn, the upper left hook of the associated transfer lever pulls down on the rocker ball (holding it to the right or tilting it back to the left). This pushes the drive link to the left (or right) resulting in clos-

ing the right (or left) contacts and allowing a marking (or spacing) pulse to be transmitted.

3.09 Similarly, the remaining transfer levers 2, 4, 5 and 6 are pulled downward by their respective cams. The resulting pulse is marking if the transfer lever is to the right or spacing if it is to the left. The number 7 transfer lever is held to the right by a stop pin. Therefore, the last pulse (the stop pulse) is always marking (current on).

3.10 The locking bail is actuated by the number 8 cam lobe. This cam begins to move the locking bail up into its locking position almost as soon as the cam starts to rotate (Fig. 9). Full lock position occurs approximately at the half-way point of the start pulse (48-1/2 degrees of rotation). The dwell on the eighth cam from the front holds the lock ball in its lock position until after the beginning of the number 5 pulse. Then the cam pulls the bail down out of lock, and all transfer levers are free to return to their initial positions at a point about half-way through the stop pulse.

C. Resetting of the Code Bars (Fig. 7)

3.11 Reset of the code bars is accomplished by means of an eccentric on the front of the cam assembly, which drives an eccentric follower arm (Fig. 7). This arm engages a stud on the side of the reset ball and pulls the reset bail to the left as the cam rotates. At the peak position of the reset eccentric, the code bar reset bail latch is clear of the needle bearing stud. This permits the latch spring to pull the latch up into locking position and the code bar reset ball is latched as the eccentric drives the follower arm back to its initial position. As the code bar reset ball is moved to the left (into reset), it engages projections on the permutation code bars, clutch trip bar, and a step on the non-repeat lever. Thus, all of these elements are moved to the left into latched reset position.

3.12 The reset eccentric is positioned in angular relationship to the remainder of the cam so that pick-up of the code bars and non-repeat lever begins. Just after the number 2 pulse begins, near the end of the start pulse, the

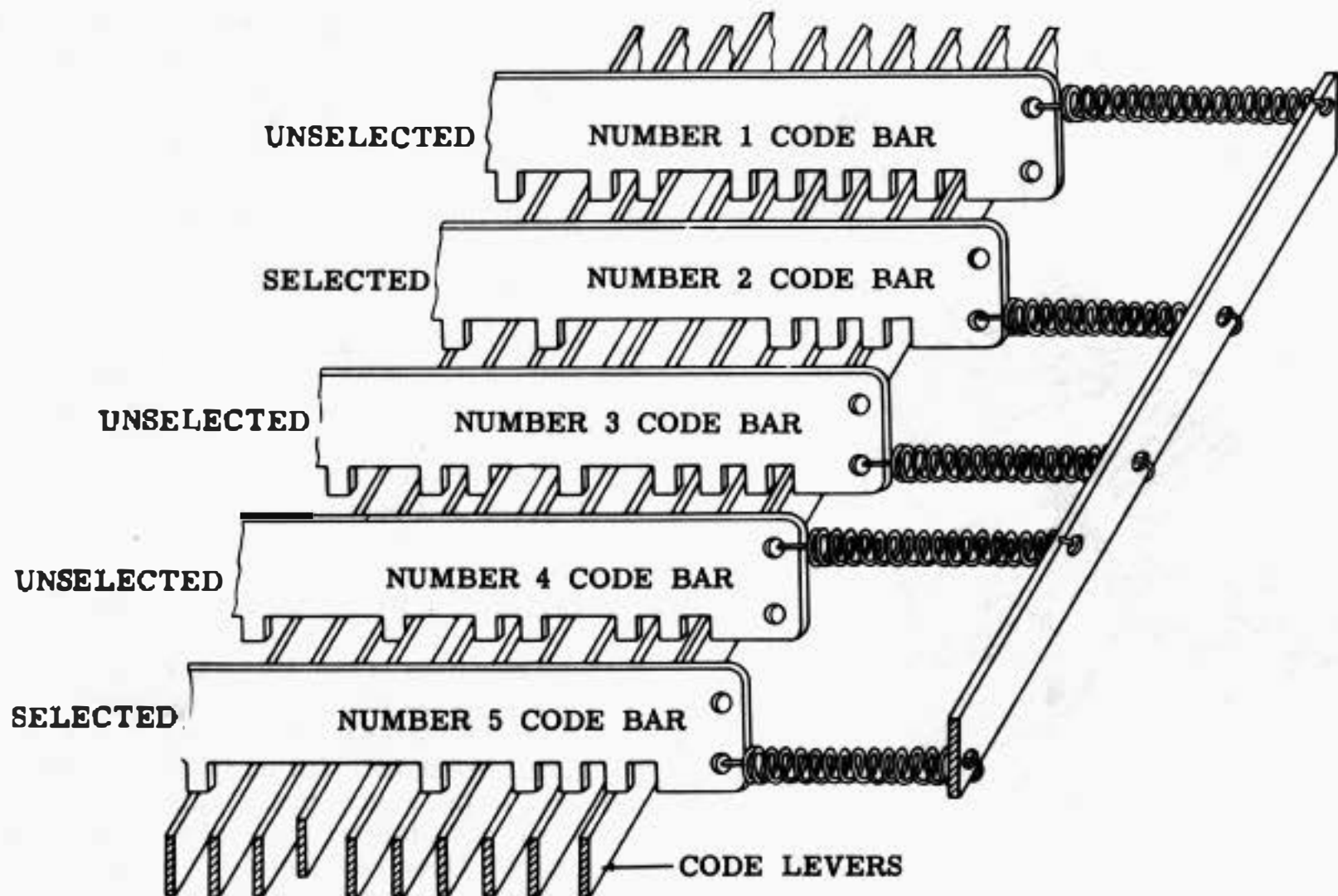

Figure 8 - Code Bar Selection

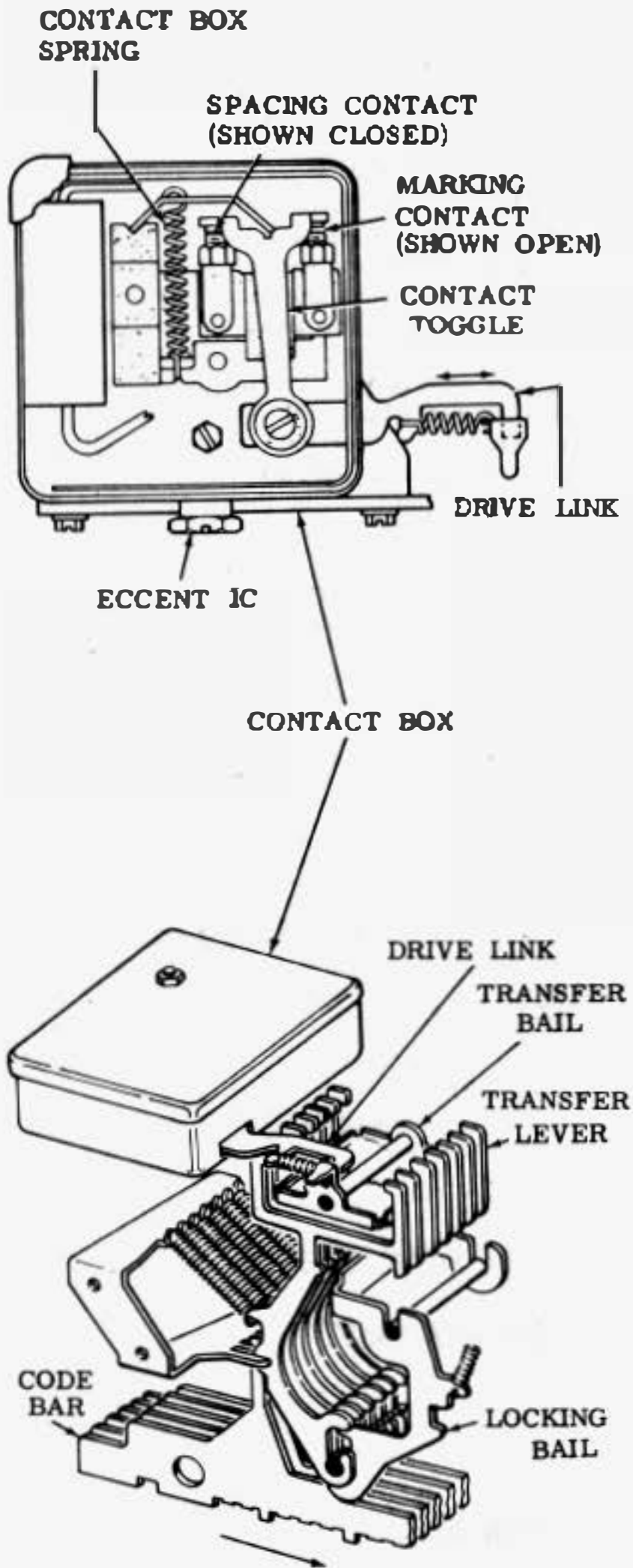

Figure 9 - Transfer Lever Mechanism and Contact Box Mechanism

code bars have been moved to the left a sufficient distance to permit the code lever (that determined the permutation) to drop down out of the universal ball. This permits the universal bail to rotate forward and move the non-repeat lever down and off the reset ball. At the same time, the extension of the universal bail moves in under its latch lever and holds this latch lever up almost in the same position that the pawl on the non-repeat lever had held it in the early reset movement. With the universal bail latch held up, the reset bail continues to move to the left. Full rest occurs at approximately 180 degrees of cam rotation $1/4$ through the number 3 pulse). As soon as the universal ball is permitted to move forward, a second keytop can be depressed. However, from that point on, full time of cam rotation must expire before a third and successive keytops can be operated.

FUNCTION KEYS

A. Local Carriage Return Mechanism (Fig. 10)

3.13 Operation of the local carriage return keylever causes its function lever to raise the forward end of the local carriage return bail (Figure 10). The bail rotates about its pivot point until the upper end engages the carriage return lever on the typing unit. Thus, the carriage return mechanism on the local typing unit is made to operate without disturbing the other typing units on the same line circuit.

B. Local Line Feed Mechanism (Fig. 12)

3.14 Operation of the local line feed keylever causes its function lever to raise the forward end of the local line feed bail (Fig. 12). The bail rotates about its pivot point and the upper end pushes the trip link until the link engages the line feed clutch trip lever on the typing unit. The actuated line feed mechanism on the local typing unit operates without disturbing the other typing units on the same line circuit.

C. Signal Line Break Mechanism (Fig. 11)

3.15 Operation of the BREAK keylever opens the signal line circuit until the keylever is released. Depression of the keylever engages the signal break bail, lifting it upward. The upper area of the signal break bail moves downward and actuates the normally closed signal line switch. Upon release of the keylever, a return spring exerts a force that moves the upper end of the signal break bail upward, closing the signal line circuit.

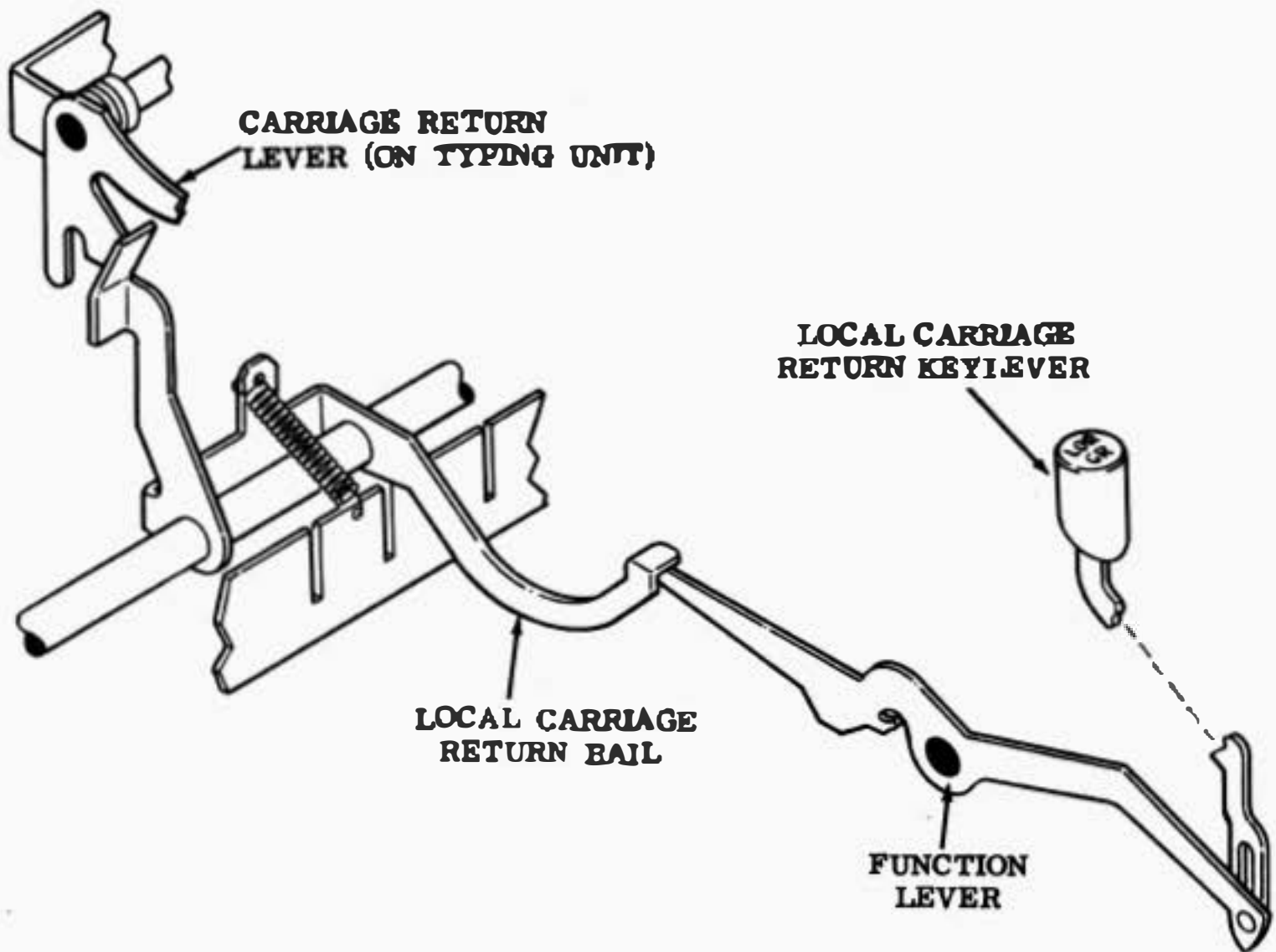

Figure 10 - Local Carriage Return Mechanism

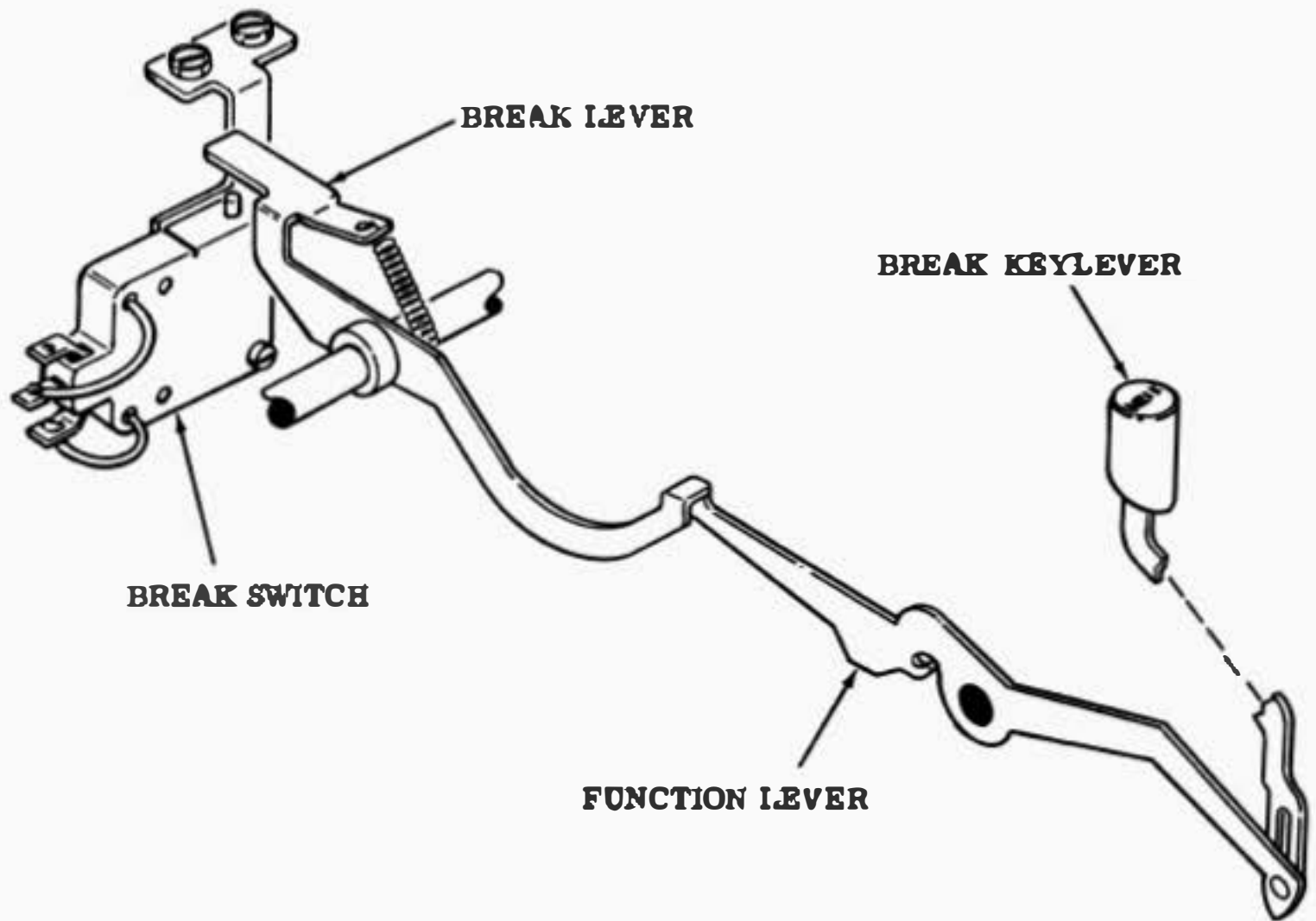

Figure 11 - Signal Line Break Mechanism

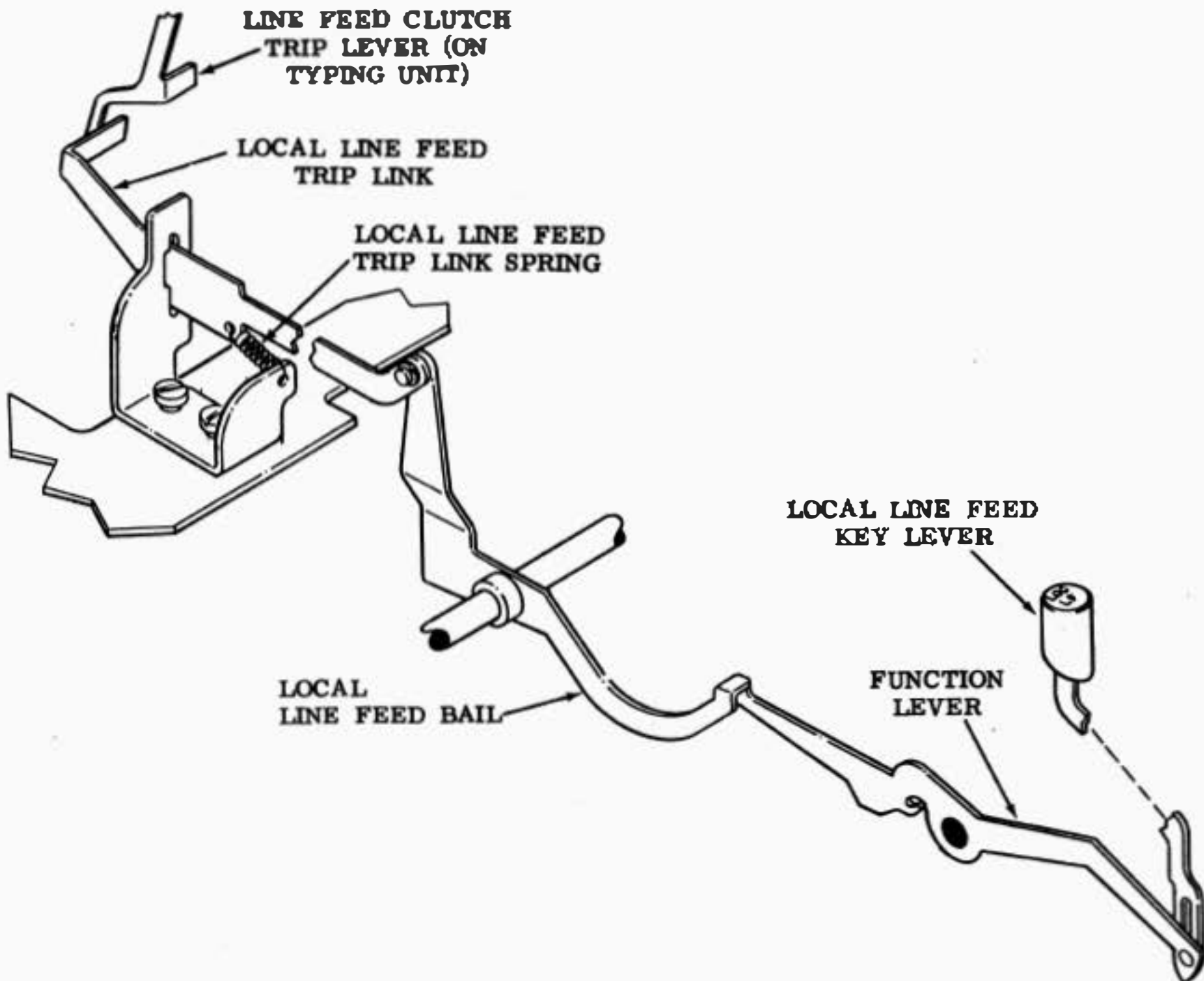

Figure 12 - Local Line Feed Mechanism

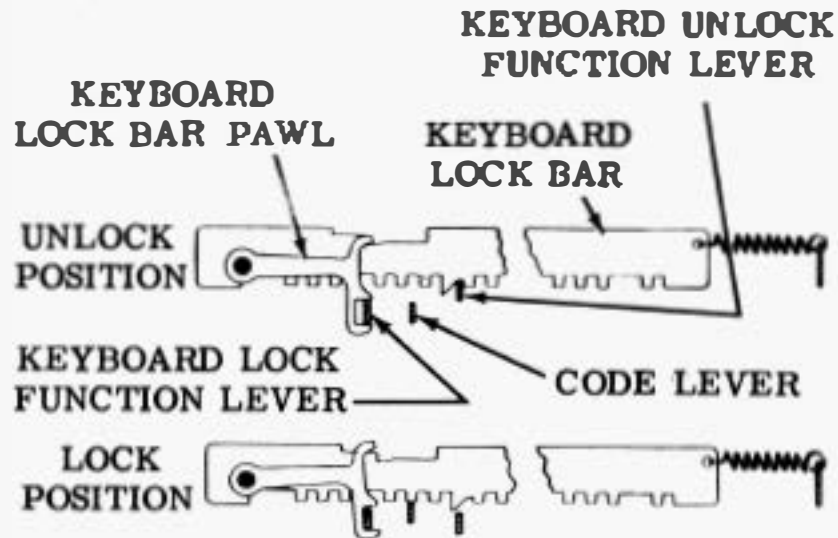

Figure 13 - Keyboard Lock Mechanism

D. Keyboard Lock Mechanism (Fig. 13)

3.16 The keyboard may be locked manually (local) or electrically (remote). Local locking of the keyboard is achieved by operation of the keyboard lock (KBD LOCK) keylever, which causes its function lever to raise the lock bar pawl. Spring tension on the lock bar moves it to the extreme right position. In this position, the square teeth on the lower part of the lock bar are positioned over each code keylever. This restricts the movement of any selected keylever, preventing trip off of latches and the generation of a signal.

3.17 Remote keyboard locking occurs when two consecutive blank code signals are received by the associated typing unit. Reception of this code results in the keyboard lock lever to move downward. The lock lever engages the keyboard lock plunger and moves it downward. As the plunger operates, it exerts a pressure on a yield spring, which engages the keyboard lock ball. The lock ball rotates about its pivot point, engages the keyboard lock function lever, and raises it. This operation trips off the lock bar pawl. With the tripping of the lock bar pawl, the locking action that results is identical to that described above.

E. Keyboard Unlock Mechanism (Fig. 14)

3.18 Operation of the keyboard unlock keylever (KBD UNLK) causes its function lever to move the lock bar to the left to a position where the lock bar pawl falls into a notch in the top of the lock bar. In this position, the lock bar teeth are between code selection levers and do not restrict their operation.

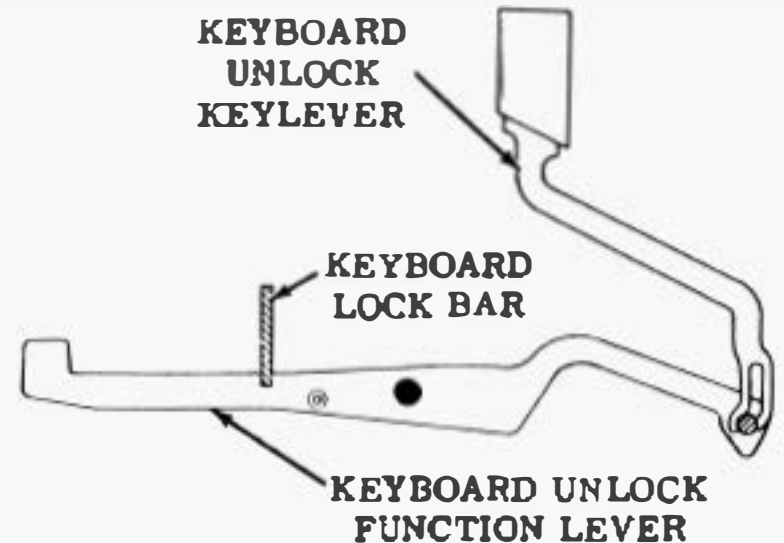

Figure 14 - Keyboard Unlock Mechanism

F. Margin Indicator Mechanism (Fig. 15)

3.19 The margin indicator cam disc on the typing unit spring drum rotates with the drum as printing or spacing occurs. As the end of each line is approached, the cam surface of the disc makes contact with the margin indicator contact lever and rotates it clockwise about its pivot point (Fig. 15). When the contact lever leaves the switch plunger, the margin indicator switch closes the circuit to a margin indicator lamp, mounted in the set's enclosure. A carriage return cycle returns the cam disc to its starting position and opens the switch.

4. RECEIVE-ONLY BASE

4.01 The receive-only base is a structure which supports an intermediate gear assembly and provides mounting facilities for a typing unit and a motor unit. Two keylevers, CR (carriage return) and LF (line feed) are mounted on the front of the unit, and provide off-line operation only. All electrical wiring is brought into the base through a receptacle mounted at the left rear of the base (Fig. 4).

5. VARIABLE FEATURES

5.01 The operation of some of the mechanisms and components available as accessories to the keyboard or base (as indicated) is covered in the following paragraphs.

MOTOR START FOR PAGE FEED OUT

5.02 This accessory device installs on the keyboard or base and provides motor-driven feed out of copy paper when the IOC LF

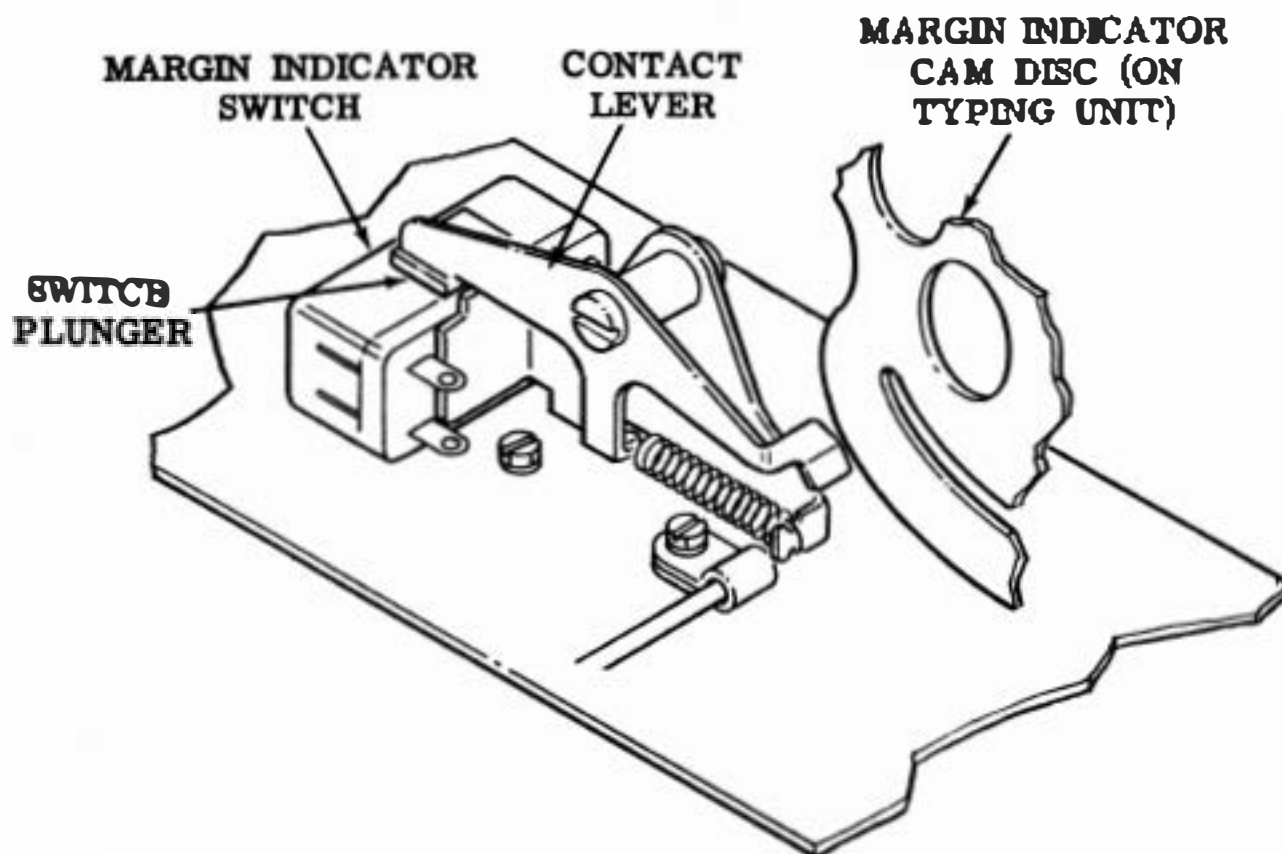

Figure 15 - Margin Indicator Mechanism

(local line feed) key is depressed. This operation may be performed independent of the position of the main power switch.

TIME DELAY MECHANISM (Fig. 16)

5.03 The time delay mechanism operates in conjunction with the motor control mechanism in the electrical service unit to provide automatic motor unit stop after a predetermined interval of idle signal line time has elapsed. The mechanism contains two ratchet wheels - one with 27 teeth, and one with 28 teeth. A reciprocating eccentric follower pawl, powered by the keyboard intermediate shaft, drives the ratchet wheels, one tooth at a time. The latch pawl rides the inside flanges of the ratchet wheels and controls the contact pawl latching lever, which holds the contact pawl away from the flanges. Each ratchet wheel has an indentation in its inside flange. After a maximum of 756 revolutions of the intermediate shaft, these indentations are adjacent for almost one revolution. When the adjacent indentations pass over the latch pawl, it drops into them, briefly, and then disengages the contact pawl latching lever from the contact pawl. This permits the contact pawl to ride the flanges of the ratchet wheels until either one of two events occur.

5.04 If a line signal is received before 756 revolutions of the intermediate shaft, the typing unit mainball drive extension engages the upper end of the contact pawl and causes it to again be latched by the contact pawl latching lever. This begins a new cycle of time measurement.

5.05 If a line signal is not received before 756 revolutions of the intermediate shaft, the indentations in the flanges of the ratchet wheels again become adjacent and permit the contact pawl to drop. This action results in a pulse transmission to the motor control mechanism, which responds by switching off the motor unit.

5.06 The time elapsed between the reception of the last line signal and the stopping of the motor unit varies with the operating speed. For 60 wpm, the range is 86 to 172 seconds; 75 wpm, 80 to 120 seconds; and 100 wpm, 53 to 106 seconds.

5.07 The mechanism may be disabled by adjusting an eccentric that moves the eccentric follower pawl out of engagement with the ratchet wheels. Motor unit operation may be restored by opening the signal line circuit (eg, depressing the BREAK keylever).

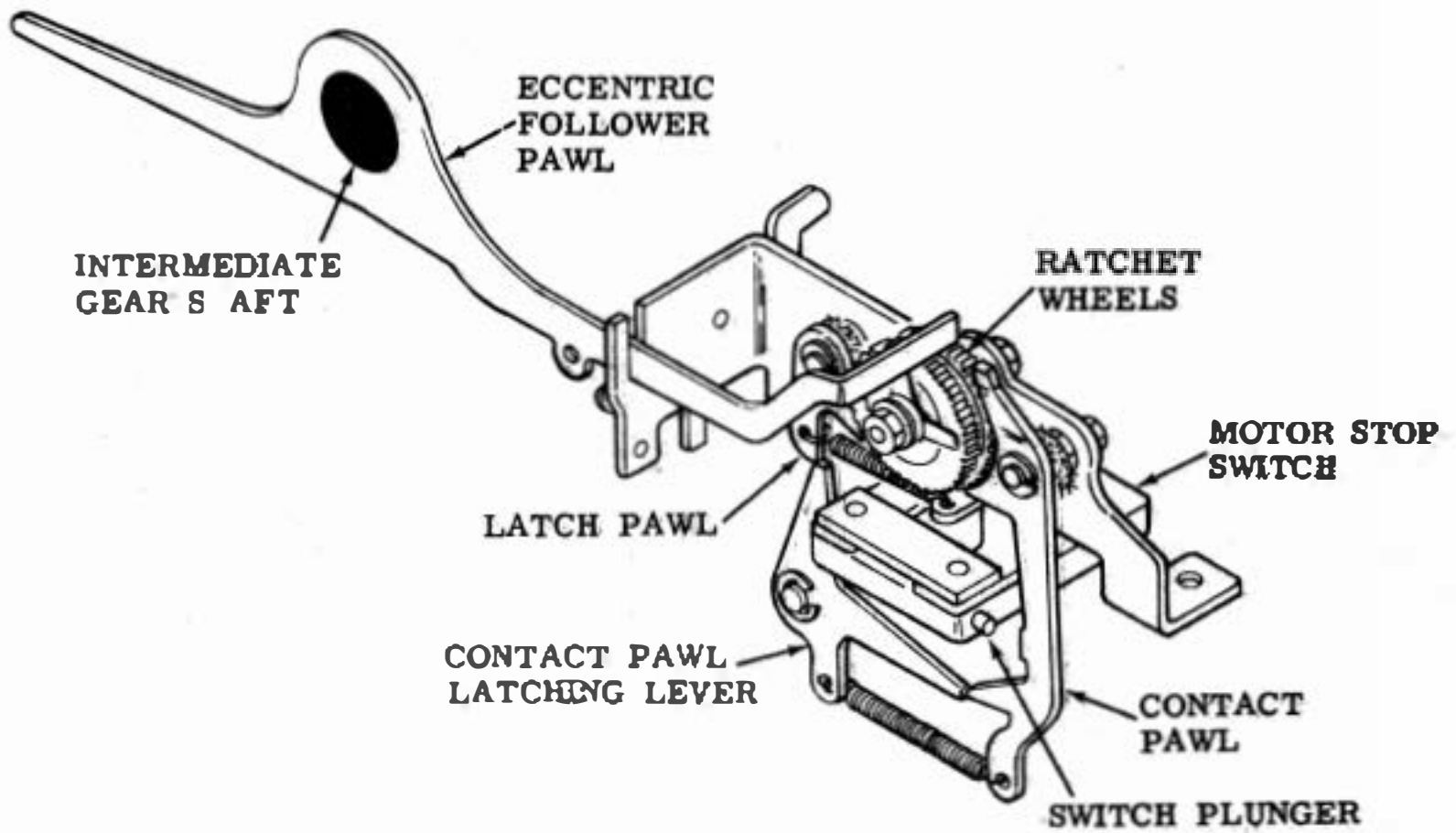

Figure 16 - Time Delay Mechanism

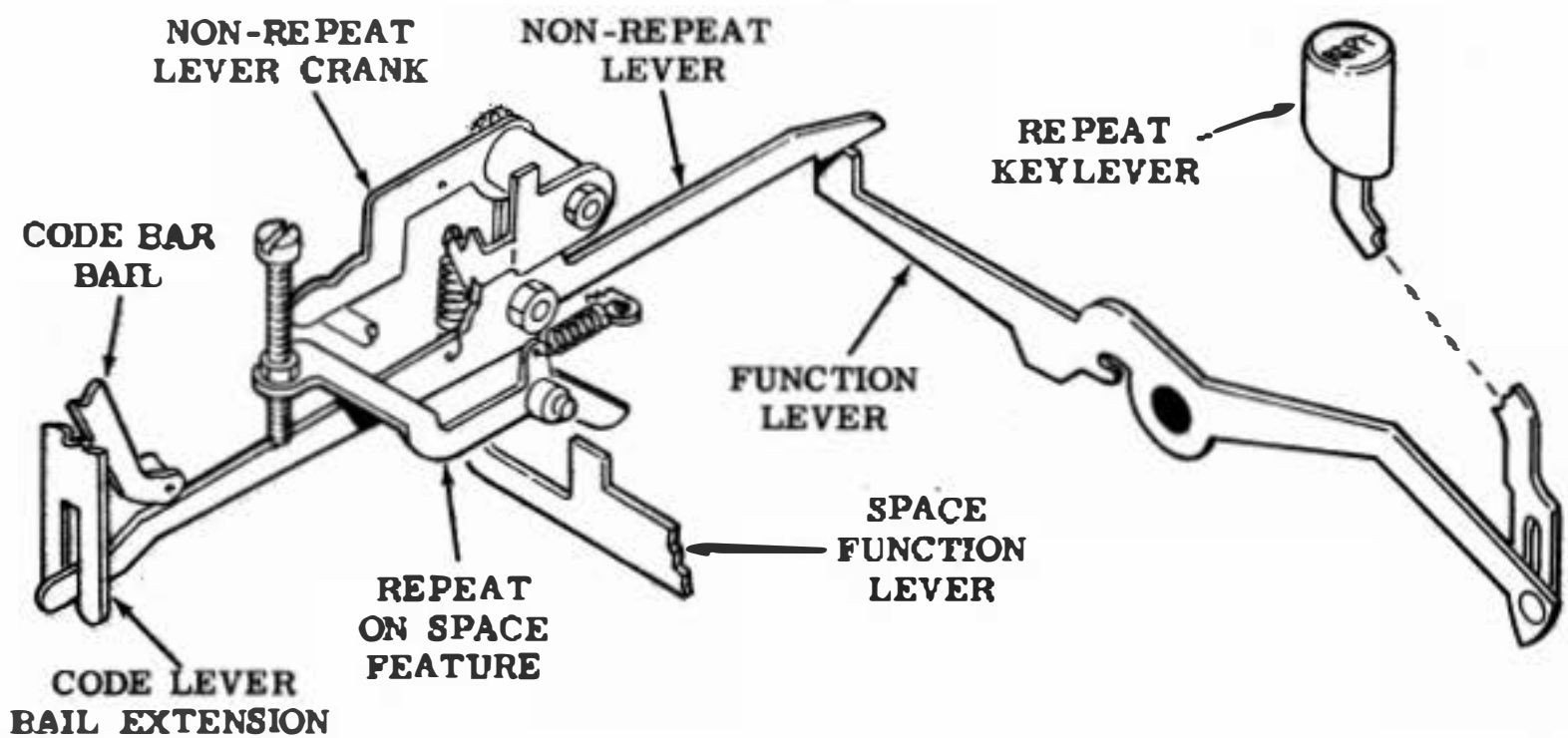

Figure 17 - Repeat Mechanism

LOCAL REVERSE LINE FEED

5.08 This mechanism is installed on a keyboard to enable off-line feeding of the copy paper in the downward (reverse) direction. The LOC R LF (local reverse line feed) keylever initiates the operation.

LOCAL BACK SPACE

5.09 This mechanism permits the insertion of a back space at the local typing unit when the LOC B&P (local back space) keylever is operated. It is installed on the keyboard only. Refer to the sectionalized literature for the 28 typing unit for description of operation.

REPETITION OF CHARACTERS (Fig. 17)

5.10 To repeat a character, the REPT (repeat) keylever is operated simultaneously with one of the keylevers in the three-row bank, or the spacebar. Levers associated with the REPT keylever engage the non-repeat lever, preventing the reset bail from engaging the step. Therefore, the universal bail latch lever remains in the down position, preventing the code bar reset bail from moving up into the full latch position. This permits the reset bail to

follow the eccentric arm movement. As a result, the code bars and their transfer levers are in the permutation position at the start of each repetitive cycle, and the same pulse pattern is transmitted to the signal line.

REPEAT-ON-SPACE MECHANISM (Fig. 17)

5.11 A keyboard equipped with a repeat-on-space mechanism will automatically transmit the space function for as long as the space bar is operated. When the space bar is depressed, the rear portion of the space code lever engages and lifts the lower end of the space repeat lever. As the space repeat lever moves clockwise (viewed from the front), it engages the code bar bail latch lever. The code bar bail latch lever drops downward and is held in this position until the space bar is released.

RADIO FREQUENCY NOISE AND ARC SUPPRESSION

5.12 The keyboard may be equipped with rf noise and arcing suppression circuitry. Installed in the signal generator contact box, the suppression circuit may be for rf or arcing only, or a combination circuit for both types of interference.

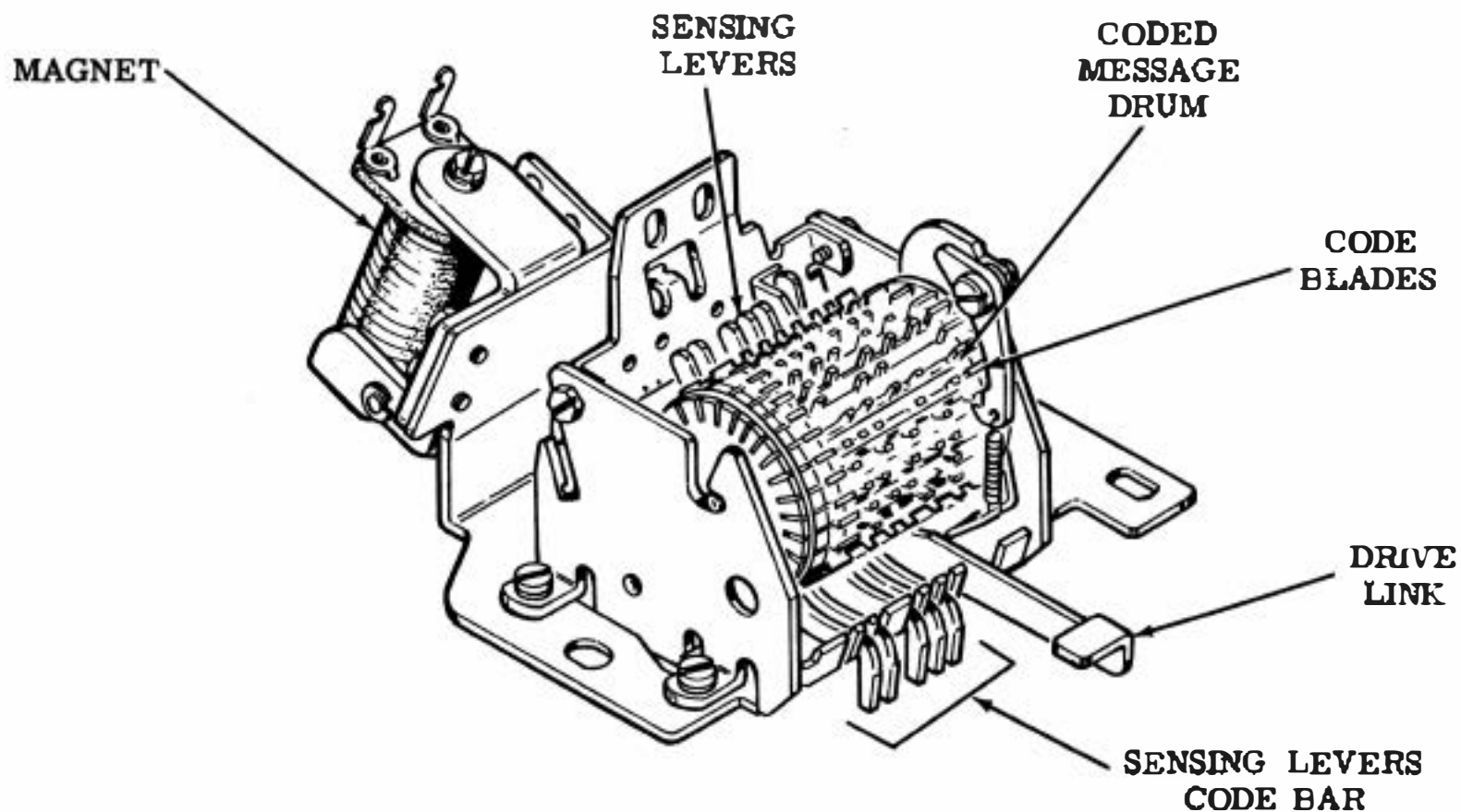

Figure 18 - Answer-Back Mechanism

ANSWER-BACK MECHANISM (Figs. 18 and 19)

5.13 The answer-back mechanism is an electro-mechanical device which permits the identity of a called station to be transmitted automatically to the originating station, in response to a coded, sequential message from the signal line. The **HERE IS** keytop is provided for manual operation. Transmissions are generated in the normal manner by the keyboard, which, through its code bar mechanism, reads the code combination contained in a message drum.

5.14 The mechanism is comprised basically, of a coded message drum, control relay, and keyboard contacts. The drum is coded for the desired combination by removing code lines from the 21 code blades provided, as required (Fig. 18). The first character transmitted is always a **LTRS** combination to place the called station in the unshift position; the other 20 may be any characters desired. However, the first transmission is usually followed by **CR** and **LF**. This sequence is also typically used to end a coded sequence, to insure that the answer-back message will appear at the beginning of a line at the distant station and that over-printing of the message will not occur. Typically, 16 characters are available for the answer-back identification.

5.15 The following explanation of operation uses the combination **FIGS - D** as an example. The combination used may vary with the application.

A. Called Station

5.16 The answer-back message is initiated at the called station by depressing the **FIGS**, uppercase **D** combination at the originating station. The operation of the **FIGS** function box contact at the called station will de-energize the answer-back (non-contention) control relay if this relay is in an energized condition prior to the reception of the **FIGS** combination. The closing of the **D** function box contact then completes a circuit to the answer-back trip magnet via normally closed control relay contacts; the **D** contact also locks the keyboard through a lever extension to the blank-blank sequence locking mechanism, if the set is so equipped.

5.17 The closure of this circuit energizes the answer-back trip magnet and results in the counter-clockwise rotation of the armature and associated stop-lever latch, thereby unblocking and releasing the stop lever. Under the bias of a spring attached to the code bar bail

latch operating lever, the stop lever rotates counter-clockwise until it comes to rest against the mechanism base plate. Before coming to rest the stop lever moves the blocking lever counter-clockwise, thereby unblocking the drive plate and releasing it to its spring action. The drive plate rotates counter-clockwise to a stop where the attached drive link is in a position to accept the feeding motion from the keyboard code bar bail. As the stop lever continues its counter-clockwise rotation, the code bar bail latch operating lever rotates clockwise, striking the code bar ball latch. The latch rotates clockwise and releases the code bar bail. The code bar bail releases the keyboard code bars and the clutch trip bar, which move to the right under spring action. The clutch trip bar thereby trips the signal generator clutch and initiates an operating cycle.

5.18 While the code combination transmitted during the first cycle must be a letters combination, the code combinations of the succeeding 20 cycles may be any arbitrary character determined by the detachable code blades fastened to the code drum. The code combination on each blade is read by five sensing levers which transfer the code selections to a vertical projection on each of the 5 code bars. Each code combination is thus transmitted in the normal manner by the keyboard signal generator mechanism. A spacing condition occurs whenever a code bar is prevented from moving to the right by its associated sensing lever; unrestricted movement of a code bar results in a marking condition. Since the sensing levers must be held away from the code bars, in order to prevent their interference during normal keyboard operation, a stop code blade having a letters combination is used. This results in a letters combination for the first character.

5.19 Once during each rotation of the signal generator cam assembly, the code bar ball is pulled to the left by a cam eccentric, causing it to rotate clockwise. The ball thereby resets the keyboard code bars and, with the character generator drive link now in its released position, rotates the drive plate clockwise. This action causes the stepping pawl to step the code drum one position clockwise.

5.20 With the stop lever in its released position, the code bar ball latch operating lever also maintains the code bar ball latch in a released position. The signal generator mechanism will cycle continuously until it rotates the code drum one full revolution or 21 characters. The first code blade, which is the

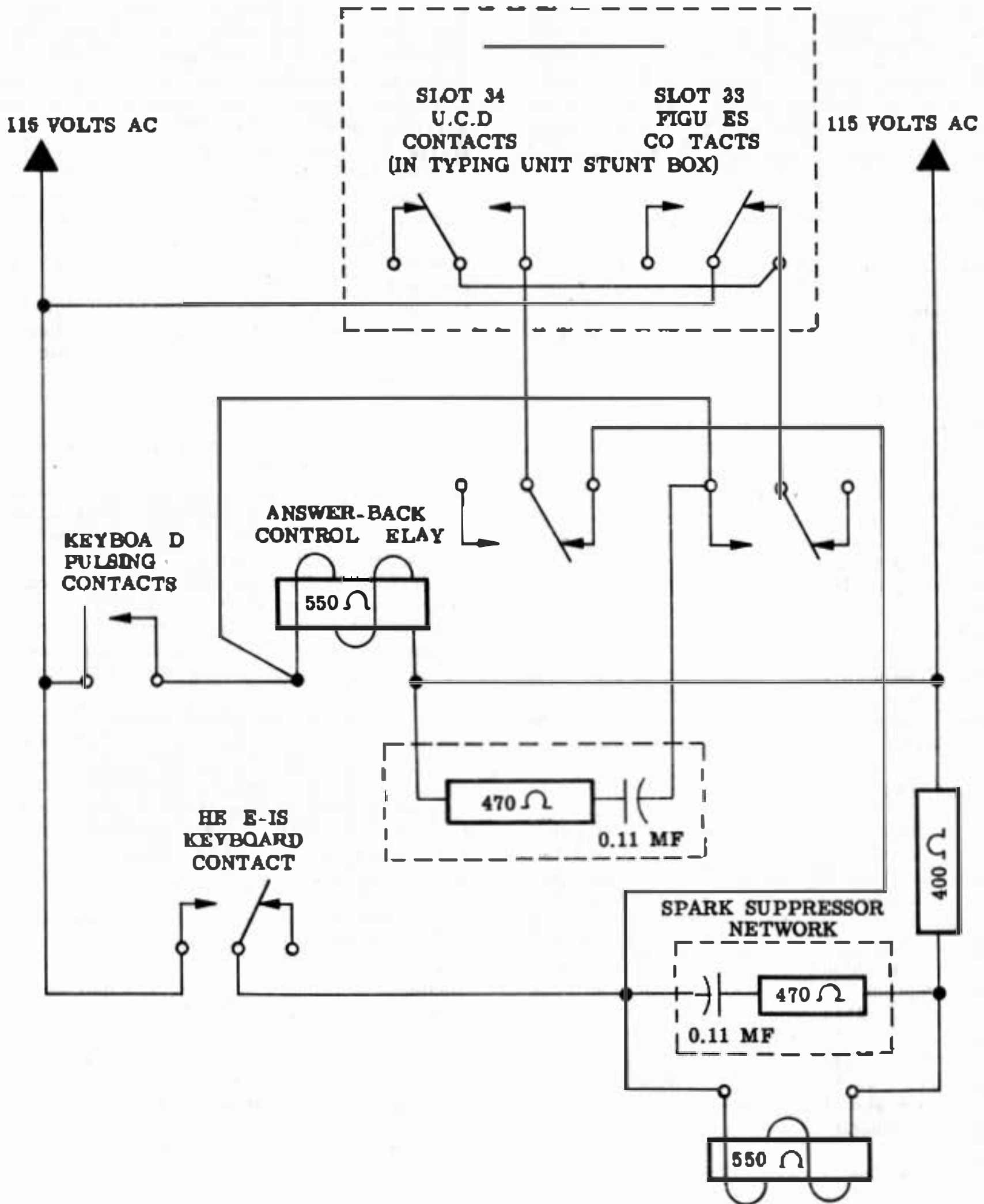

Figure 19 - Typical Answer-Back Circuit

stop code blade having a letters combination, has an additional projection. When it is being rotated into the sensing position, the projection contacts the stop lever, rotating it clockwise. The left extension of the stop lever rotates the code bar bail latch operating lever counterclockwise, which in turn releases the code bar bail latch to the action of its attached spring. Continued rotation of the stop lever brings it in a position where if released to the action of the spring attached to the code bar bail latch operating lever, it will reverse rotation and become latched on the stop lever attached to the trip magnet armature. Such a position is reached when the stop code blade passes its area of contact with the stop lever which is just prior to the complete movement of the stop code blade into the sensing position.

5.21 When the code bar bail latch is released to its spring action, it rotates counterclockwise in contact with the code bar bail latch roller until it latches the code bar bail. At this point the blocking lever is also released to its spring action and it rotates counterclockwise until it rests against a projection on the stop lever. In this position the blocking lever holds the drive plate in its extreme clockwise position and the attached drive link is once more unable to follow the feeding motion from the code bar bail. Further operation of the signal generator and character generator is thus pre-

vented. At this point the operator must manually unlock the keyboard to restore it to its normal operating condition if the set is equipped with the blank-blank sequence locking mechanism.

B. Originating Station

5.22 The keyboard pulsing (or blinding) contact, mounted on the signal generator assembly, is operated every keyboard cycle by a cam which is mounted on the signal generator shaft. The pulsing contact is timed to close before the beginning of the start pulse and remain closed until after the end of the 5th pulse.

5.23 Each time it operates, the keyboard pulsing contact will energize the answer-back control relay; the control relay will remain energized via its own contacts, and the FIGS stunt box contact.

5.24 The FIGS stunt box function pawl in the typing unit is specially designed to engage the FIGS function bar at all times. The pawl is never stripped by the stripper bail. This means that the function pawl holds the function lever away from the FIGS contact. When the FIGS function bar is selected, it will permit the pawl and lever to move forward and operate the FIGS contact (the normal stunt box

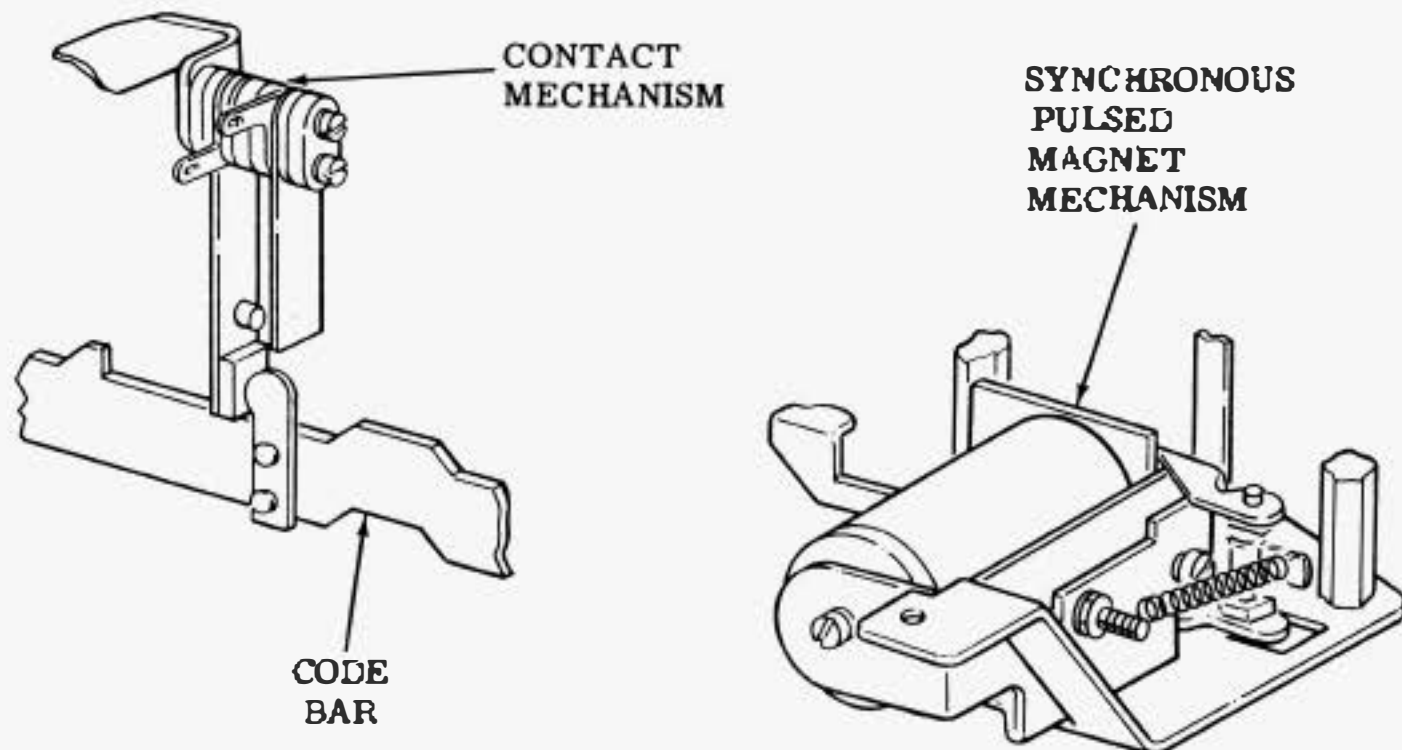

Figure 20 - Synchronous Pulsed Transmission Mechanism

operation is such that the contact does not operate until the selected function bar has first moved forward and then rearward).

5.25 This arrangement converts a normally-open, momentary-operate FIGS contact to a normally-closed, momentary-operate FIGS contact and advances the timing of the FIGS contact operation to insure that either the FIGS contact or the keyboard pulsing contact will keep the control relay energized during every signal generator cycle.

5.26 The local operator depresses the FIGS - D combination to call the remote station. The FIGS contact may or may not de-energize the control relay depending upon how long afterwards the operator depresses the D combination. In any event, the D combination will again energize the control relay, if necessary. The local answer-back will, therefore, be disabled due to the opening of the normally closed control relay contacts, which are in series with answer-back trip magnet.

SYNCHRONOUS PULSED TRANSMISSION (Fig. 3 and 20)

5.27 Upon operation in the appropriate key-lever, the reset bail in the keyboard is moved to the right and releases the selected code bars. The universal code bar (a modified clutch trip bar) is released and moved to the right also, at which time it closes the clutch magnet conditioning contact. This action enables the clutch trip magnet to respond to an externally supplied synchronous pulse (50 or 100 milliamperes of 20 millisecond duration). When energized by the synchronous pulse, the clutch trip magnet releases and moves the clutch trip bar to the right. This movement causes the clutch trip bail extension to trip the signal generator clutch. The signal generator cam shaft then rotates and transmits the selected signal.

5.28 During the single rotation of the signal generator cam shaft, the reset bail is rotated clockwise and latched. The universal code bar, clutch trip bar, and the five code bars are moved and held to the left by the reset ball.