

DMAF1 Important Notes

After completing assembly of the DMAF1 disk controller board, there is one modification which must be made to insure proper operation of the system. Use the light gauge wire supplied with the kit to make the following changes:

- () Connect IC22 pin 29 to IC19 pin 12
- () Connect IC19 pin 13 to IC19 pin 14
- () Connect IC19 pin 11 to pin number 8 of the ribbon cable connector. The location of pin 8 is shown in the figure below.

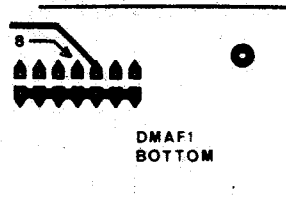

Jot down the above changes on the bottom of page 3 of the instruction set for possible future reference.

Also, change the value of capacitor C1 on the FD-M motor control board to a 0.047 @250 V capacitor. This new value should be written in on page 11 of the instruction set.

Before installing the drives in the chassis check the programming of the JPR1-JPR4 option on both drives. On drive 1 the only thing that should be installed on any of these pins is the two-wire cable that goes back to the motor control board as described in the instructions. On drive 0 no programming jumper should be installed on any position of JPR1, JPR2, JPR3 or JPR4. If one is installed, remove it.

The hardware and software documentation for this kit are being shipped separately. Therefore, if you have received one but not the other, be patient. The rest of the kit should arrive shortly.

There is an addition to the list of modifications to the MP-A (not MP-A2) for compatibility with the DMAF1. It should be noted on page 23 of your instruction set under the **Modifying the MP-A Processor Board** heading.

✓ Carefully cut and lift away pin 6 of integrated circuit IC12 on the MP-A board from the top side of the board. Cut the pin as near the top surface of the board as you can. Now using a short piece of light gauge wire, connect together pins 12 and 13 of IC12 on the MP-A board by soldering the wire to the bottom side of the board.

Assembly Instructions – DMAF1 Floppy Disk System

Introduction

The Southwest Technical Products Corporation DMAF1 is a dual drive, single density, double sided 8" floppy disk system. The hardware consists of a SS-50 bus (SWTPC 6800) compatible DMA (direct memory access) controller capable of handling up to four drives, two CalComp 143M double density rated disk drives, 5 3/8" H x 17 1/8" W x 20 1/2" D aluminum chassis, regulated power supply, drive motor control board, cooling fan, diskette and interfacing cables.

The DMA controller board for the disk system is a 5 1/2" x 9" circuit board that plugs onto one of the unused 50-pin connector rows on the SWTPC 6800 computer system. The board contains all of the circuitry required to interface up to four disk drives. Connections between the controller and the drives are made thru a daisy chained 50 conductor flat ribbon cable with the terminating connector along the top edge of the controller board. The controller board contains a 1771 disk controller chip, 6844 DMA controller, programmable address decoding, full address/data line buffering and on board regulation. The board utilizes low power Schottky technology and has a current consumption of approximately 600 ma.

Although the board features selectable address decoding in 1K byte blocks from 32K thru 40K and 48K thru 56K, the supplied software assumes positioning at 36K (9000 hex). The SWTPC MP-B Mother Board requires a minor patch to allow this. The newer MP-B2 Mother Board requires no modifications. The controller board requires this memory allocation since the disk controller chip, DMA controller chip and drive select latch are addressed and accessed just like computer memory and, hence, require memory addresses.

The DOS (disk operating system) and BASIC Interpreter require a minimum of 20K of RAM memory on the computer system. The first 16K bytes must be located in the lower 12K bytes of addressable memory. The remaining 8K bytes must be located at 40K thru 48K (A000 thru BFFF hex). Since this is the address range allocated to the scratchpad RAM on the SWTPC MP-A and MP-A2 processor boards, the scratchpad must be switch disabled on the MP-A2 board and patch disabled on the earlier MP-A processor board for proper operation. The DOS itself and most utility programs either reside or are loaded into this 8K segment. This frees the entire 0 thru 32K byte address range for user programs, interpreters, and compilers. That small area of memory assigned for scratchpad RAM (A000 thru A07F) is not over written by the DOS, therefore, the ROM monitor is not affected.

The DMAF1 disk system is being made available in kit and assembled form. Although this instruction set has been written for the kit version, it is being supplied with both the kit and assembled versions of the system. The assembled system owner should skip over those sections of the manual that involve system assembly.

When assembling the DMAF1 disk system, work on only one assembly at a time. Start with the large disk controller board, followed by the drive configuration, small motor control board, power supply, and then system checkout. This instruction set has been written in this order.

The MOS integrated circuits supplied with this kit are susceptible to static electricity damage and for this reason have been packed with their leads impressed onto a special conductive foam or possibly wrapped in a conductive foil. In either case, **do not** remove the protective material until told to do so later in the instructions.

DMAF1 Controller PC Board Assembly

NOTE: Since all of the holes on the PC board have been plated thru, it is only necessary to solder the components from the bottom side of the board. The plating provides the electrical connection from the "BOTTOM" to the "TOP" foil of each hole. Unless otherwise noted, it is important that none of the connections be soldered until all of the components of each group have been installed on the board. This makes it much easier to interchange components if a mistake is made during assembly. Be sure to use a low wattage iron (not a gun) with a small tip. Do not use acid core solder or any type of paste flux. We will not guarantee or repair any kit on which either product has been used. Use only the solder supplied with the kit or a 60/40 alloy resin core equivalent. Remember all of the connections are soldered on the bottom side of the board only. The plated-thru holes provide the electrical connection to the top foil.

- () Before installing any parts on the circuit board, check both sides of the board over carefully for incomplete etching and foil "bridges" or "breaks". It is unlikely that you will find any, but should there be, especially on the "TOP" side of the board, it will be very hard to locate and correct after all of the components have been installed on the board.
- () Attach all of the resistors to the board. As with all other components unless noted, use the parts list and component layout drawing to locate each part and install from the "TOP" side of the board bending the leads along the "BOTTOM" side of the board and trimming so that 1/16" to 1/8" of wire remains. Solder.
- () Install all of the capacitors on the board. Be sure to install the electrolytic capacitor oriented exactly as shown on the component layout drawing. Solder.
- () Install the transistors and diodes on the board. The diodes must be turned so the banded end corresponds with that shown on the component layout drawing, and the transistors must be turned to match the outline on the component layout drawing as well. Solder.
- () Starting from one end of the circuit board install each of the five , 10-pin Molex female edge connectors along the lower edge of the board. These connectors must be inserted from the "TOP" side of the board and must be pressed down firmly against the board. Make sure the body of the connector seats firmly against the board and that each pin extends completely into the holes on the circuit board. Not being careful here will cause the board to either wobble and/or be crooked when plugged onto the mother board. It is suggested that you solder only the two end pins of each of the five connectors until all have been installed; at which time, if everything looks straight and rigid you should solder the as yet unsoldered pins.
- () Insert the small nylon indexing plug into the lower edge connector pin indicated by the small triangle on the "BOTTOM" side of the circuit board. This prevents the board from being accidentally plugged on incorrectly.
- () Install the three programming headers on the board. There is one sixteen pin and two three pin headers. These must be installed from the "TOP" side of the board with the shorter pin side going into the board. Using the component layout drawing, install one three-pin header in the NOR/MR position, the other three-pin in the 32K/48K position and the sixteen-pin header in the 01234567 position. The three small shorting blocks are used for programming the board and will be detailed later in this instruction set. Until then, temporarily plug one shorting block between the center pin and NOR terminal on the NOR/MR header. Plug another between the center pin and the 32K terminal on the 32K/48K header. Plug the remaining shorting block between the 4 and the pin immediately below it on the 01234567 header.
- () The 50-pin ribbon cable connector should now be attached to the board. Install the connector from the "TOP" side of the board and orient the connector such that the pins face the top edge of the board. Solder. The connector supplied may have locking ears either attached to or detached from the connector. The locking ears may be inserted and/or removed from the connector even after it is soldered in place. If you will be operating the 6800 Computer System with the cover off you should install the locking ears. If you will be operating the 6800 Computer System with the cover on you will have to remove the locking ears because the cover will not go on with the ears in place. The locking ears lock the flat ribbon cable connector in place when installed and when folded back, eject the mating connector for easy removal. If you are not using the locking ears, you will have to use a small bladed screwdriver to unplug the mating connector whenever removal is necessary. Do not attempt to remove the mating connector by pulling on the flat ribbon cable.
- () The crystal should now be installed on the board. Bend the crystal's leads at a 90° angle approximately 1/8" from its body and mount from the top side of the board. After soldering, fasten the crystal to the board using a short piece of stripped wire by passing the wire through the two holes next to the crystal.
- () Install all integrated circuits, except IC6, IC9, IC22, IC26 and IC29. As each one is installed, make sure it is down firmly against the board and solder only two of the leads to hold the pack in place while the other IC's are being inserted. Do not bend the leads on the back side of the board. Doing so makes it very difficult to remove the integrated circuits should replacement

ever be necessary. The semicircle notch, dot or bar on the end of the package is used for orientation purposes and must match with the outlines shown on the component layout drawing for each of the IC's. After inserting all of the integrated circuits, go back and solder each of the as yet unsoldered pins.

- () Install the integrated circuit sockets for IC 6 and IC22. The sockets have a pin 1 index mark on them, so orient them so they match with the component layout drawing. Solder.
- () Install integrated circuit IC29 and its heatsink on the circuit board. This component must be oriented so its metal face is facing the circuit board and is secured to the circuit board with a #4-40 x 1/4" screw and nut. The three leads of the integrated circuit must be bent down into each of their respective holes. The hole on the heatsink should be positioned to allow maximum contact area between the regulator and the heatsink. Solder.
- () **NOTE: READ THE FOLLOWING BEFORE REMOVING MOS INTEGRATED CIRCUITS FROM CONDUCTIVE FOAM:**

MOS devices are susceptible to damage by relatively low DC voltages applied across the leads of the device. It is easy to acquire a potential difference of many hundreds of volts between your body and ground by walking on dry carpet in tennis shoes. The same sort of potential differences may be present on your workbench.

Although it is not necessary to ground yourself, your tools, and the components to an Earth ground, it is necessary to bring yourself, your tools and the components to the same potential before handling and installing the MOS devices. Your skin is a conductor and can be used to equalize potentials between everything involved.

Remove and install integrated circuits IC9 and IC26 **ONE AT A TIME**. Handle the foam with both hands as you remove the IC. Hold the IC between thumb and forefinger touching all the pins. With the other hand, touch the printed circuit foil pattern where the IC is to be installed. Press the IC into place, simultaneously making a double check of correct position and orientation. The semicircular notch or dot on the end of the IC package must match with the outlines printed on the circuit board. Never cut or bend leads of the IC packages. While still holding the component in the board, handle your solder and soldering iron with the other hand. Several seconds of handling is long enough in humid climates. Handle the parts and tools longer if you work in a dry climate. Even with the devices in the circuit, it is still possible to damage them with stray voltage. Avoid touching the conductors or devices in the circuit any more than necessary. Use this procedure for installing each MOS device. Press the IC's firmly onto the board before soldering. Most soldering irons with 3 wire line cords have grounded tips. If you do not use a soldering iron with a grounded tip, you should assure yourself that the iron you use does not carry an AC or DC voltage on the tip. When you feel confident that you have done everything possible to avoid damaging the integrated circuit with stray high voltage, solder all connections and repeat the procedure for each of the MOS devices.

- () Install MOS integrated circuits IC6 and IC22 into the sockets provided following the precautions given in the preceding step. Be sure to orient them as shown in the component layout drawing. Make sure that none of the IC pins fold under the IC instead of going into the socket pins.
- () Working from the "TOP" side of the circuit board, fill in all of the feed-thru's with molten solder. The feed-thru's are those unused holes on the board whose internal plating connects the "TOP" and "BOTTOM" circuit connections. Filling these feed-thru's with molten solder guarantees the integrity of the connections and increases the current handling capability.
- () Now that all of the components have been installed on the board, double check to make sure all have been installed correctly in their proper location.
- () Check very carefully to make sure that all connections have been soldered. It is very easy to miss some connections when soldering which can really cause some hard to find problems later during checkout. Also look for solder "bridges" and "cold" solder joints which are another common problem. ✕

This completes the DMAF1 Controller Board assembly. Since the circuit board now contains MOS devices, it is susceptible to damage from severe static electrical sources. One should avoid handling the board any more than necessary and when you must, avoid touching or allowing anything to come into contact with any of the conductors on the board.

CONNECT IC22 PIN 29 TO IC19 PIN 12 ()
" IC19 PIN 13 " IC19 PIN 13 ()
" IC19 PIN 14 " IC19 PIN 14 ()

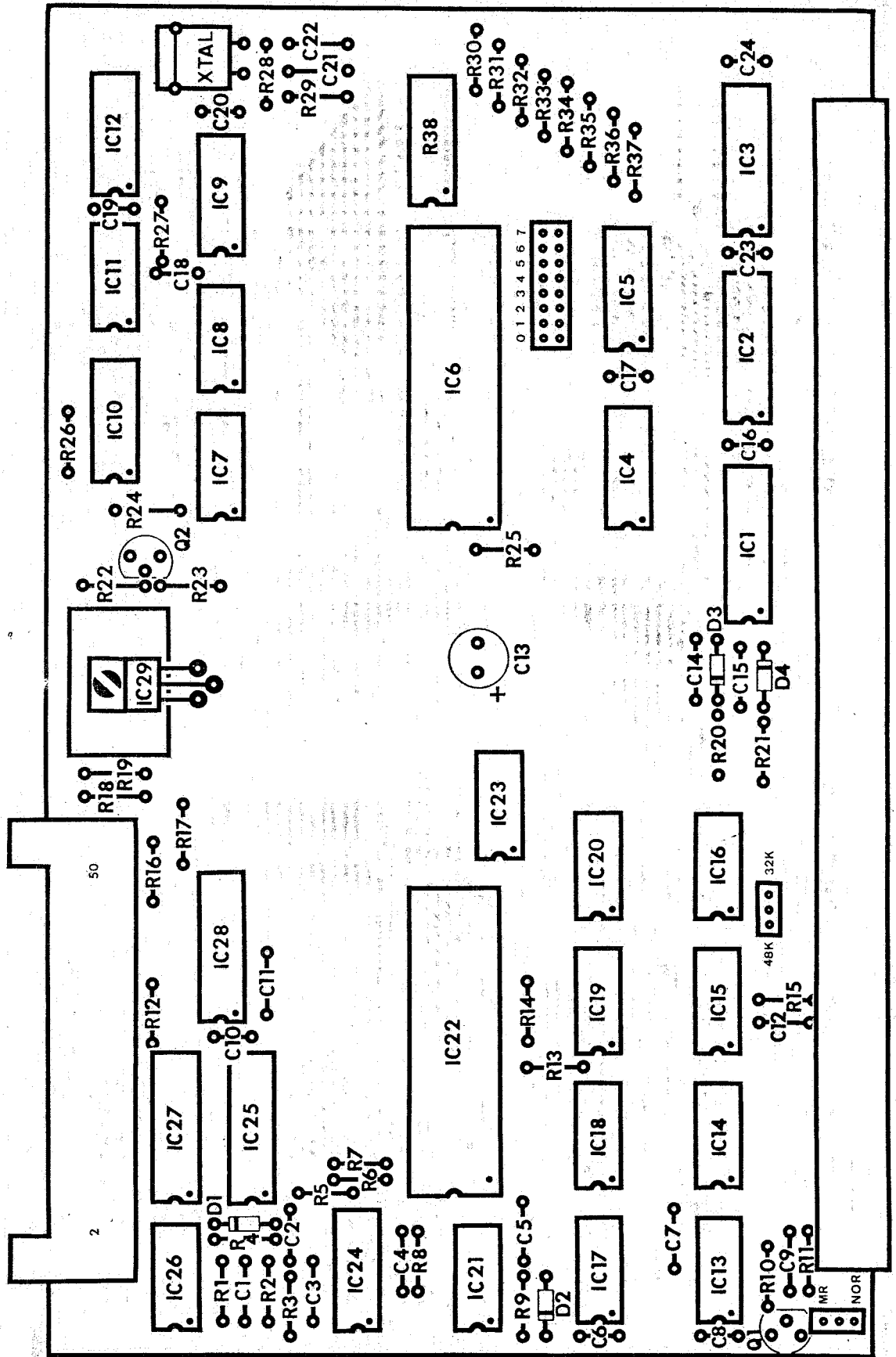

Parts List — DMAF1 Disk Controller

Resistors

—	R1	47K	ohm	¼ watt resistor		—	R20	100 ohm	¼ watt resistor
—	R2	100K	ohm	" " "		—	R21	680 ohm	" " "
—	R3	470K	ohm	" " "		—	R22	10K ohm	" " "
—	R4	10K	ohm	" " "		—	R23	10K ohm	" " "
—	R5	10K	ohm	" " "		—	R24	150 ohm	" " "
—	R6	10K	ohm	" " "		—	R25	10K ohm	" " "
—	R7	10K	ohm	" " "		—	R26	10K ohm	" " "
—	R8	7.5K	ohm	" " "		—	R27	10K ohm	" " "
—	R9	10K	ohm	" " "		—	R28	10M ohm	" " "
—	R10	22K	ohm	" " "		—	R29	1K ohm	" " "
—	R11	4.7K	ohm	" " "		—	R30	10K ohm	" " "
—	R12	150	ohm	" " "		—	R31	10K ohm	" " "
—	R13	10K	ohm	" " "		—	R32	10K ohm	" " "
—	R14	10K	ohm	" " "		—	R33	10K ohm	" " "
—	R15	470	ohm	" " "		—	R34	10K ohm	" " "
—	R16	150	ohm	" " "		—	R35	10K ohm	" " "
—	R17	150	ohm	" " "		—	R36	10K ohm	" " "
—	R18	330	ohm	" " "		—	R37	10K ohm	" " "
—	R19	150	ohm	" " "		—	R38	10K ohm	integrated resistor optionally used in place of R30-R37

Capacitors

—	C1	.022	mfd	capacitor		—	*C13	220 mfd @ 10 VDC	electrolytic cap.
—	C2	470	pf	"		—	C14	0.1 mfd	film capacitor
—	C3	0.22	mfd	"		—	C15	0.1 mfd	film capacitor
—	C4	100	pf	"		—	C16	0.1 mfd	capacitor
—	C5	470	pf	"		—	C17	0.1 mfd	"
—	C6	0.1	mfd	"		—	C18	470 pf	"
—	C7	100	pf	"		—	C19	0.1 mfd	"
—	C8	0.1	mfd	"		—	C20	0.1 mfd	"
—	C9	20	pf	"		—	C21	60 pf	"
—	C10	0.1	mfd	"		—	C22	20 pf	"
—	C11	100	pf	"		—	C23	0.1 mfd	"
—	C12	470	pf	"		—	C24	0.1 mfd	"

Transistors and Diodes

—	* D1	1N4148	silicon diode
—	* D2	1N4148	" "
—	* D3	1N4742	12.0 volt 1W zener diode
—	* D4	1N4733	5.1 volt 1W zener diode
—	* Q1	2N5210	NPN transistor
—	* Q2	2N5210	NPN transistor

Integrated Circuits

—	*IC1	74LS245 octal non-inverting bi-directional transceiver
—	*IC2	74LS244 octal non-inverting buffer
—	*IC3	74LS245 octal non-inverting bi-directional transceiver
—	*IC4	74LS139 dual 1 of 4 decoder
—	*IC5	74LS138 1 of 8 decoder
—	*IC6	6844 DMA controller (MOS)
—	*IC7	74LS00 quad NAND gate
—	*IC8	74LS74 dual D flip-flop
—	*IC9	4049B or 14049B hex inverter (MOS)
—	*IC10	74LS175 quad D flip-flop
—	*IC11	74LS08 quad AND gate
—	*IC12	74LS163 4-bit counter
—	*IC13	74121 one shot
—	*IC14	74125 quad tri-state buffer
—	*IC15	74LS00 quad NAND gate
—	*IC16	74LS32 quad OR gate
—	*IC17	74LS00 quad NAND gate
—	*IC18	74LS04 hex inverter
—	*IC19	74LS86 quad exclusive OR gate
—	*IC20	74LS00 quad NAND gate
—	*IC21	74LS32 quad OR gate
—	*IC22	1771 disk controller (MOS)
—	*IC23	74LS74 dual D flip-flop
—	*IC24	74LS123 dual one shot
—	*IC25	74LS273 octal D flip-flop
—	*IC26	14541 or 40541 timer (MOS)
—	*IC27	74LS240 octal inverting buffer
—	*IC28	74LS240 octal inverting buffer
—	*IC29	7805 5 volt regulator

Miscellaneous

— XTAL 4.0000 MHz crystal

* Note: All components flagged with a * must be oriented as shown on the component layout drawing.

Drive Programming

In order to use the supplied disk drives they must first be programmed to enable the functions required by the system. The following description should be used in conjunction with the DRIVE PROGRAMMING PICTORIAL to program the CalComp 143M disk drives.

- () Carefully remove one of the drives from the chassis. It is attached to the bottom of the chassis with #6 screws. Be careful not to pick up the drive by its door or front panel. Remove the two plastic bags taped to the back containing the power connectors.
- () Turn the drive upside down so that the door is toward you and so that you are looking at the component side of the circuit board. Jumper selections are made on these drives by small shorting blocks which look like connectors without any wires attached. Notice that at each jumper location has a "center" pin which is unmarked. The shorting block always goes between this center pin and an adjacent labeled pin. In most cases, the desired jumpers will be in the correct position as supplied.
- () Install the JPR-7 jumper. This jumper will cause the LED on the front panel to activate when the drive is selected. Use the attached pictorial for reference.
- () Install the JPR-11 jumper. This jumper selects this drive as drive #0.
- () The JPR-14, JPR-15 and JPR-16 jumper is for selecting a hard sectored drive and is not used in this system. If any jumper is installed at these locations, it should be removed.
- () Install the JPR-13 jumper. This will cause the heads to load when the drive is selected.
- () Switch S1 should now be programmed by flipping the switch to the desired OPEN (off) or CLOSED (on) positions. The OPEN or CLOSED position will be noted on the switch. The switch section A, B, C or D is marked along side the switch on the circuit board. The next four steps describe how to program this switch.
- () Flip switch section A to the CLOSED (on) position.
- () Flip switch section B to the OPEN (off) position.
- () Flip switch section C to the OPEN (off) position.
- () Flip switch section D to the CLOSED (on) position.

This drive is now programmed as drive #0. Using a pencil or felt pen, write 0 on the back of the drive for future reference.

- () The above procedure should now be followed for the second drive except that the JPR-9 jumper should be installed instead of the JPR-11 jumper. This jumper selects this drive as drive #1. Using a pencil or felt pen, write 1 on the back of the drive for future reference.
- () Included with the kit is what appears to be a 14-pin integrated circuit, but it is separate and probably blue. This is not an IC but is a network of resistors. This resistor network should be installed in the "resistor block socket" on drive #1. Be sure to install the block so that pin 1 as marked agrees with the DRIVE PROGRAMMING PICTORIAL.

This completes the disk drive programming. Set the drives aside until they are called for later during assembly.

TO MOTOR CONTROL BOARD
(FOR DRIVE 1 ONLY) POINT S
POINT T

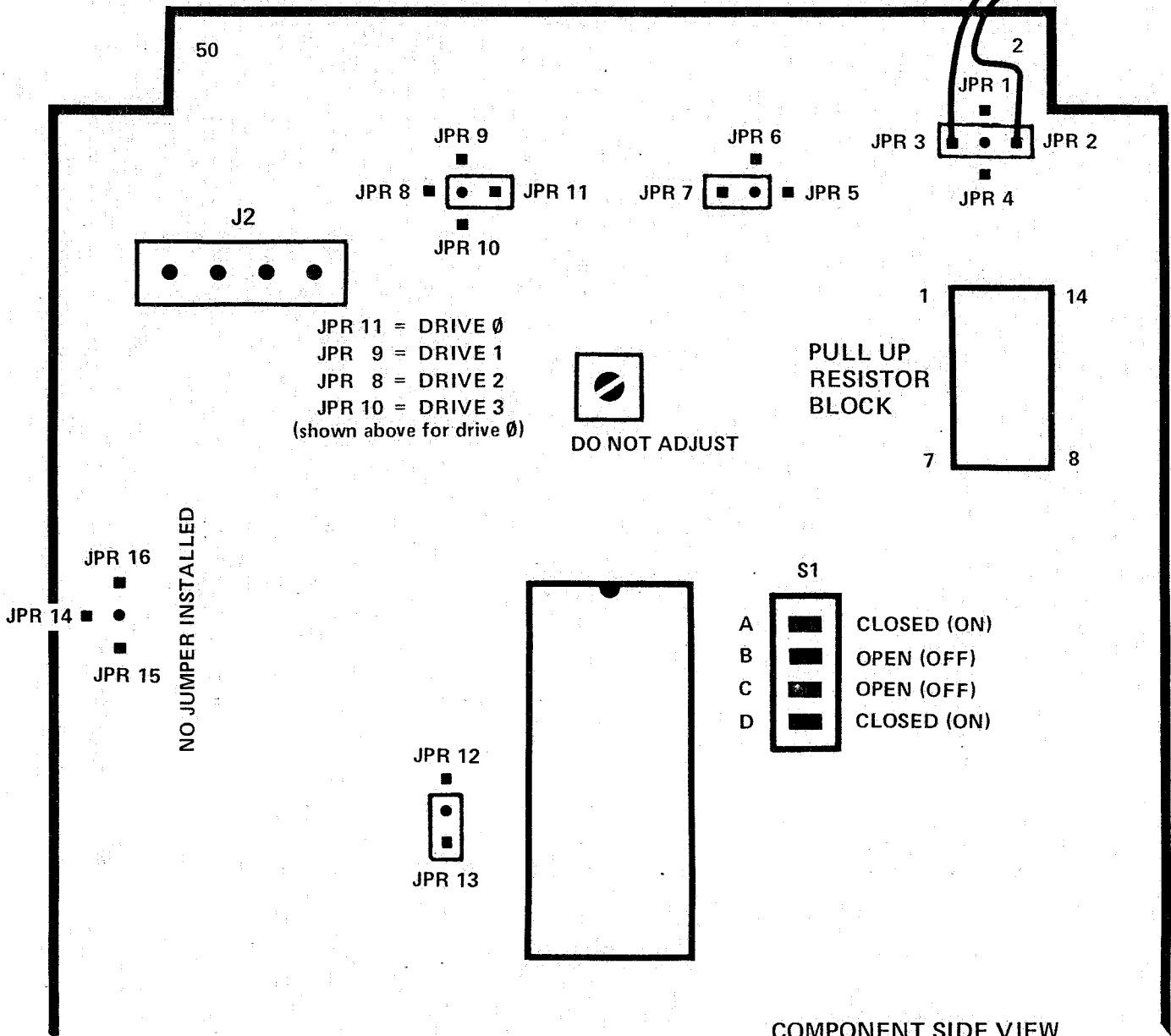

COMPONENT SIDE VIEW
CORRECT JUMPERS SHOWN FOR DRIVE 0

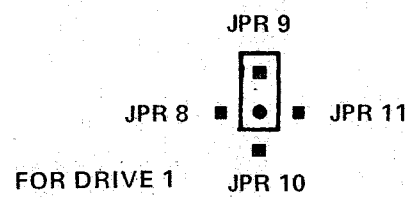

DRIVE PROGRAMMING PICTORIAL

Assembly Instructions – FD-M Motor Control Board

The FD-M motor control board is used to turn the AC disk drive motors off when disk data is not being continually accessed. This technique reduces noise and minimizes drive and diskette wear. The actual ON/OFF and timing circuitry is on the DMAF controller board. The FD-M board contains the optical isolation and noise suppression circuitry required to isolate the system's logic circuitry from the AC power line.

The board itself is a 3 5/8" x 2" single sided circuit board and, once assembled, is installed in the right rear corner of the disk system chassis. Anytime the disk system is plugged into the AC line various points on the FD-M board carry AC line voltage regardless of whether or not the unit is turned on or running. So be careful! Never touch any components on the FD-M circuit board while the disk system's AC plug is attached to an AC power receptacle.

PC Board Assembly

- () Clean the copper side of the circuit board with a piece of Scotchbrite® to remove all oxidation.
- () Attach all of the resistors to the board. As with all other components unless noted, use the parts list and component layout drawing to locate each part and install from the "TOP" side of the board bending the leads along the "BOTTOM" side of the board and trimming so that 1/16" to 1/8" of wire remains. Solder.
- () Install all of the capacitors on the board. Solder.
- () Install integrated circuit, IC1. As it is installed, make sure it is down firmly against the board. Do not bend the leads on the back side of the board. Doing so makes it very difficult to remove the integrated circuit should replacement ever be necessary. The semicircular notch, dot or bar on the end of the package is used for orientation purpose and must match with the outline shown on the component layout drawing. Solder.
- () Install triac Q1 and its heatsink on the circuit board. This component must be oriented so its metal face is facing the circuit board and is secured to the circuit board with a #4-40 x 1/4" screw, lockwasher and nut. The three leads of the triac must be bent down into each of their respective holes. The hole on the heatsink should be positioned to allow maximum contact area between the regulator and heatsink. Solder.
- () Twist together two 16" lengths of the heavy gauge wire supplied with the kit to form a twisted pair. Attach and solder one end of the pair, with one wire to point Y and the other to point Z on the FD-M board.
- () Attach and solder the female pins supplied with the three-pin connector shell packed with one of the disk drives, to the as yet unattached ends of these wires.
- () Snap one of the pins (with wire attached) into pin 1 of the shell. Snap the other into pin 3. Polarity is not important. Nothing is connected to pin 2.
- () Twist together two 9½" lengths of the heavy gauge wire supplied with the kit to form a second twisted pair. Attach and solder one end of the pair, with one wire to point Y and the other to point Z on the FD-M board.
- () Attach and solder the male pins supplied with the three-pin connector shell packed with the remaining disk drive to the as yet unattached ends of these wires.
- () Snap one of the pins (with wire attached) into pin 1 of the shell. Snap the other into pin 3. Polarity is not important. Nothing is connected to pin 2.
- () Twist together two 9" different colored lengths of the light gauge supplied with the kit to form a third twisted pair. Attach and solder one end of the pair with one wire to point S and the other to point T.
- () Attach and solder the small connector pins supplied with the miniature three-pin connector shell to the as yet unattached ends of these wires.

- () Carefully snap one of the connector pins with a wire attached into one of the outer positions on the miniature connector shell. Bend the ears of the connector pin tight against the wire if necessary. Insert the pin completely into the shell until it snaps into place.
- () Carefully snap the remaining connector pin with a wire attached into the remaining outer position on the miniature connector shell. Follow the procedure given in the previous step. Nothing is installed in the center pin position.
- () Attach and solder a 8¼" piece of the heavy gauge wire supplied with the kit to point B.
- () Attach and solder a separate 7½" piece of the heavy gauge wire to point W.
- () Now that all of the components have been installed on the board, double check to make sure all have been installed correctly in their proper location.
- () Check very carefully to make sure that all connections have been soldered. It is very easy to miss some connections when soldering which can really cause some hard to find problems later during checkout. Also look for solder "bridges" and "cold" solder joints which are another common problem.

This completes the FD-M motor control board assembly.

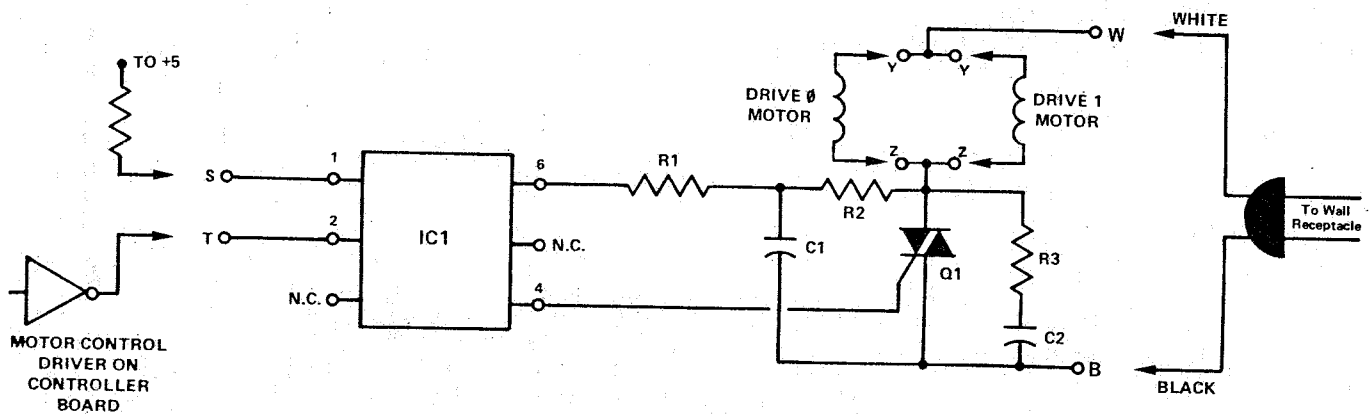

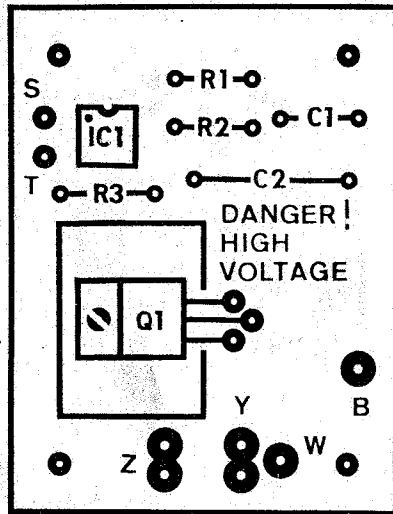

Parts List FD-M Motor Control Board

Resistors

- R1 180 ohm ½ watt resistor
- R2 220 ohm " " "
- R3 4.7 K ohm ½ watt resistor

Capacitors

- C1 0.01 mfd @ 400 V capacitor
- C2 0.1 mfd @ 400 V capacitor

Semiconductors

- Q1 TIC206D or TIC216D 400 V triac
- IC1 MOC3011 optically coupled driver

Note: All voltage specifications are minimums.

P-200 DF Power Supply

The P-200 Power Supply is a fixed voltage power supply designed to be used with several SWTPC kits. The P-200 DF version is supplied with those parts required to power the DMAF1 Dual Floppy Disk System. The P-200 DF provides the following outputs:

+24 VDC \pm 5% @ 1.5 amps.

+ 5 VDC \pm 5% @ 3.0 amps

The power supply consists of the 3 1/8" W x 3 3/8" L x 3 3/4" H power transformer, two large diameter filter capacitors, 3 1/4" W x 4" L circuit board and two regulator transistors. The design utilizes integrated regulators for adjustment free outputs and built-in overload protection. The power supply itself may be operated from 120 or 240 VAC, 50 to 60 Hz power systems; however, the disk drives themselves are manufactured to operate at only one voltage and line frequency.

PC Board Construction

- () Clean the copper foil side of the circuit board with a piece of Scotchbrite® (available at most hardware stores) to remove any oxidation. Scotchbrite® is a registered trademark of 3M Corp.
- () Attach all of the resistors to the circuit board. Use the parts list and the component layout drawing to locate the proper position for each part. As with all components unless otherwise noted, mount each flush with the top of the board, bend the leads parallel to the board on the foil side and trim so that 1/16" to 1/8" of wire remains. Solder.
- () Attach all of the diodes to the circuit board. Be sure the banded end of each diode matches with the outline shown in the component layout drawing. Solder.
- () Using some #18 gauge bus wire, install a jumper in the location indicated with the number "24". Solder. Make sure NO jumper is installed in the "12" positions. Use the component layout drawing. Solder.
- () Attach the twelve pin Wafercon connector to the circuit board. Be **sure** to orient the connector as shown in the component layout drawing. Solder.
- () Complete the first half of steps 1 thru 10 of the wiring table. Cut each wire to the specified length and attach and solder it to the specified point on the circuit board from the top side. Do not connect the other ends of the wires to their destination terminations yet.
- () This completes the circuit board assembly. Check to make sure that all connections have been soldered and that there are no cold solder joints. Also make sure that all components have been installed correctly as called for in the instructions. Take note that there are many power supply components not used in the P-200 DF version of the kit. Install only those components listed in the parts list.

Attaching the Connector to the Power Transformer

Leave all of the power transformer **secondary** leads full length and trim the ends of the wires so that only 1/8" protrudes beyond the insulation. Attach and solder the specified connector pins to each of the leads using the table below for reference. Use the connector reference sheet contained within this instruction set if you have any problem distinguishing between the connector pins. Do **NOT** insert the connector pins into the connector shell until told to do so later in the instructions.

Transformer Secondary Wire	Connector pin Gender	Connector Pin #
yellow	female	1
green-white	female	2
green-yellow	male	3
green	female	4
blue-white	male	7
brown	female	9
blue	female	10
blue	female	11
brown	male	12

- () Take note that the backside of the male connector shell is numbered. Using the previous table, carefully insert each of the specified connector pins into the correct numerical position of the connector shell. Insert the pins from the back or numbered side of the connector and be careful not to make a mistake. The pins cannot be removed without destroying them once they have been pressed into place. This completes the transformer connector assembly.

Power Supply onto Chassis Assembly

- () Attach the rear panel of the chassis to the base plate using three #6-32 x 3/8" screws, lockwashers, and nuts. Slip a ground lug under the mounting screw indicated in the chassis pictorial.
- () Attach the four stick on rubber feet to the bottom of chassis base plate. Inset each about 1 1/2" from each corner.
- () Attach the clamps for electrolytic capacitors C3 and C4 to the chassis using #6-32 x 3/8" screws, lockwashers and nuts. Orient the clamps as shown in the chassis pictorial. Leave the mounting screws loose until the capacitors have been installed as called for later in the instructions. Attach a ground lug under the C4 capacitor clamp screw nearest the front of the chassis.
- () Place the fan guard on the outside of the chassis and attach the cooling fan to the chassis using four #8-32 screws, flatwashers and nuts. Orient the fan as shown in the chassis pictorial.
- () Attach fuseholder F1 to the chassis. Sandwich the rubber washer if supplied between the fuseholder and the outside of the chassis. Orient the fuseholder as shown in the chassis pictorial.
- () Snap power switch S1 into the chassis oriented so its contacts are oriented as shown in the chassis pictorial.
- () Strip off about 4 1/2" of outer insulation from the end of the line cord.
- () Using a pair of pliers, crimp the strain relief onto the line cord at a point about 5 1/2" from the end of the line cord and insert the compressed strain relief and line cord assembly into the 5/8" hole provided on the rear of the chassis from the outside of the chassis, then release.
- () Loosely install the #6-32 x 1/2" capacitor hold down screws in the C3 and C4 capacitor clamps. Secure with #6 lockwashers and nuts.
- () Now insert electrolytic capacitors C3 and C4 into their clamps. Use the parts list and chassis pictorial to determine position and orientation. Install them exactly as shown in the pictorial. These capacitors are polarized so the + terminal must be positioned as shown in the drawings. Secure the capacitors with the #6-32 x 1/2" screws, lockwashers and nuts.
- () Tighten all of the capacitor clamp mounting screws.
- () Using #10-32 x 1/4" screws attach two terminal lugs to the (+) terminal and five terminal lugs to the (-) terminal of capacitor C4. Use the chassis pictorial to show proper orientation.
- () Put a loop in each of capacitor C3's terminals so that connecting wires can easily be attached and soldered.
- () Orient the power transformer so the nine wire secondary side is nearer the left side of the chassis and secure with four #8-32 x 3/8" screws, flatwashers and nuts.
- () Remove the precoated insulators from their packages and place over the pins on the bottom of regulator transistors Q3 and Q4.
- () Install transistors Q3 and Q4 onto the chassis in the appropriate set of holes from the outside of the chassis. Be sure you have put the right transistor in the right set of holes. Secure each transistor with #6-32 x 3/8" screws, insulated shoulder washers, ground lugs and nuts. **NOTE:** The case of each power transistor is electrically a transistor junction and hence must be electrically isolated from all other electrical junctions including the chassis. The mounting screws are electrically connected to each transistor case and you must be sure the screws do not contact the chassis as they pass through. Keep in mind also that the wire leads of each power transistor

must be centered in the large holes through which they pass. The mounting screws must be tightened evenly and with enough pressure to slightly compress the transistor insulators. The entire bottom of the transistor case must be in solid contact with the insulator for good heat transfer.

- () Orient the P-200 power supply printed circuit board as shown in the chassis pictorial and secure it to the chassis using four #6-32 x 5/8" screws, 1/4" spacers, lockwashers and nuts.
- () Orient the FD-M motor control board as shown in the chassis pictorial and secure it to the chassis using four #4-40 x 5/8" screws, 1/4" spacers, lockwashers and nuts.
- () For American standard 120 VAC line operation complete steps 11 thru 14 of the wiring table. For European standard 240 VAC operation complete steps 15 thru 17 of the wiring table.

NOTE: Although it is a simple matter to change the power supply for 120/240 VAC, 50/60 Hz operation, it is not so easy with the disk drives themselves. Since their AC motor uses the AC line voltage, the drive motor and/or pulley must be changed in some instances. Those systems supplied directly by SWTPC and its U.S. dealers will probably be configured for 120 VAC 60Hz operation. Those systems supplied by SWTPC overseas dealers will vary depending upon the locality. If you are not sure of the disk drive's AC electrical requirements, remove the cover plate on the top of the drive near the back. The motor's specifications will be stamped on the motor housing. Changing from 120 to 240 VAC or vice versa requires a new motor. Changing from 60 Hz to 50 Hz or vice versa requires a new pulley. Be sure to reinstall the cover plate.

- () Now go back and complete the second half of wiring steps 1 thru 10. When attaching the wires to the regulator transistors Q3 and Q4, slip a 1" piece of heat shrinkable tubing over each of the wires to be attached first. Solder the wire directly to the transistor pin, slip the heat shrinkable tubing over the exposed connection and shrink the tubing with the heat from your soldering iron. The female pins specified in steps 9 and 10 are those for the four pin connectors J2-0 and J2-1 which attach to the disk drives. These connectors and their pins are individually packed in small plastic bags. Use a 1" piece of heat shrinkable tubing over all of the terminals on power switch S1. This means that you must run each wire thru the tubing and after all wires have been attached and soldered, the tubing is slipped over the terminal and shrunk with the heat from the tip of your soldering iron. This is done later during assembly.
- () Complete wiring steps 18 thru 35 of the wiring table. Use a 1" piece of heat shrinkable tubing over all of the terminals on power switch S1. This means that you must run each wire thru the tubing and after all wires have been attached and soldered, slip the tubing over the terminal and shrink with the heat from the tip of your soldering iron. Connector J2 is the four-pin connector supplied with the disk drives. The 0 or 1 suffix specifies the drive number.
- () Go back and double check all wiring steps and solder connections for correctness and completion. Even a simple mistake can cause costly damage to your power supply and or disk drives.
- () Plug the twelve-pin male connector attached to the power transformer's secondary leads onto the twelve-pin receptacle on the power supply printed circuit board. Be sure to orient the connector correctly. It will fit only one way.
- () Install fuse F1 into the fuseholder.
- () Without having anything plugged onto power connectors J0-0, J0-1, J2-0 or J2-1 and after making sure these connectors are not inadvertently touching anything they shouldn't, plug the line cord into a wall outlet and turn the power switch ON. When ON the fan should run.
- () Using one of the (-) terminals on capacitor C3 or C4 as a ground reference, measure the following voltages on the two DC power connectors J2-0 and J2-1 listed below. If you find that any of the voltages do not measure as specified, immediately remove power and recheck all wiring and solder connections.

Connectors J2-0 and J2-1		
Pin #	Voltage	Tolerance
1	+24 VDC	±5%
2	0 VDC	±5%
3	+5 VDC	±5%
4	0 VDC	±5%

- () DO NOT make any voltage checks on connectors J0-0 or J0-1 on the FD-M motor control board.
 - () If everything checks out as called for then remove power and unplug the unit. Once you are convinced that the power supply is working as it should be, use the wire ties supplied with the kit to bundle the wires where necessary. If the power supply voltages do not measure as specified, unplug the unit and recheck all previous assembly steps.
 - () Double check to make sure the unit is unplugged.
- This completes the power supply assembly.

Parts List P-200 MF Power Supply

Resistors		Diodes			
—	R1	243 ohm 1% resistor	—	D1*	1N5402 high current diode
—	R2	4320 ohm 1% resistor	—	D2*	" " " "
			—	D3*	" " " "
			—	D4*	" " " "
			—	D5*	1N4003 diode
			—	D7*	1N5402 high current diode
			—	D8*	" " " "
			—	D9*	" " " "
			—	D10*	" " " "
			—	D11*	1N4003 diode

Capacitors

—	C3*	4,000 mfd @ 50 VDC electrolytic capacitor
—	C4*	29,000 mfd @ 15 VDC " "

Regulators

—	Q3*	LM323 +5 VDC regulator
—	Q4*	LM317 adjustable regulator

Miscellaneous

—	T1*	Power transformer 50-60 Hz Primary: 120/240 VAC Secondaries: 12 VAC @ 1.5 amp 12 VAC @ 1.5 amp 7 VAC @ 3 amp 24 VAC @ 200 ma
—	F1	2 ½ amp slo-blo fuse

All components flagged with a (*) must be oriented as shown in the component layout drawing and pictorials.

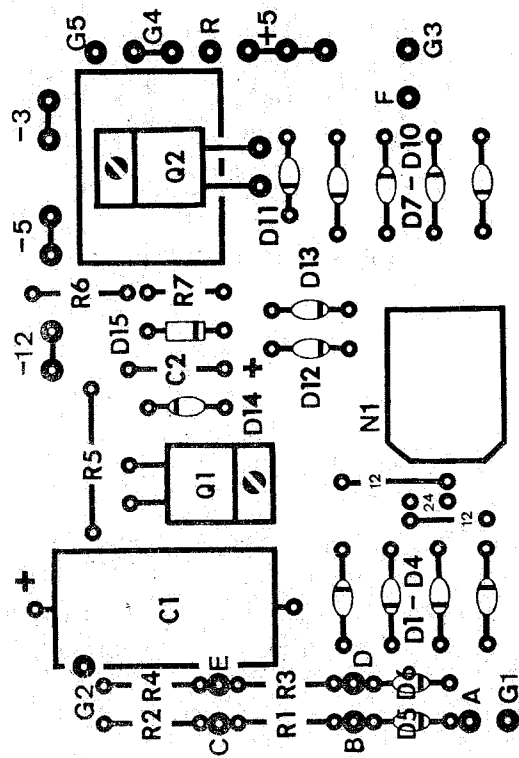

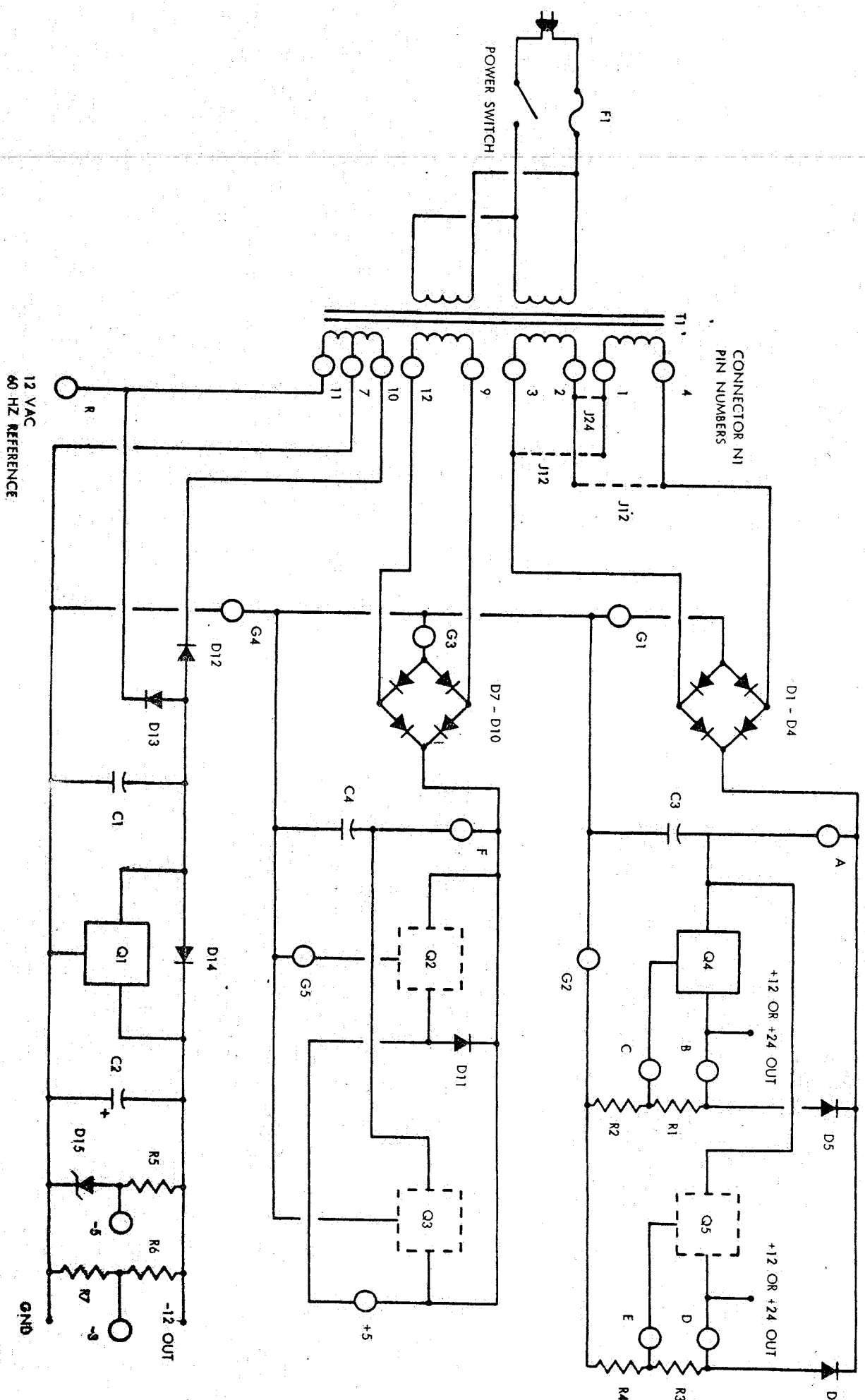

SCHEMATIC P - 200 POWER SUPPLY

WIRE			FROM			TO		
STEP	LENGTH	GAUGE	PART	TERMINAL	SOLDER	PART	TERMINAL	SOLDER
1	6¼"	#18	PC board	A	yes	C3 lug	(+)	no
2	8 "	#18	PC board	B	yes	Q4	B3	yes
3	7½"	#18	PC board	C	yes	Q4	B1	yes
4	15½"	#18	PC board	F	yes	C4 lug	(+)	yes
5	6¼"	#18	PC board	G1	yes	C3 lug	(-)	no
6	6½"	#18	PC board	G2	yes	C3 lug	(-)	no
7	14"	#18	PC board	G3	yes	C4 lug	(-)	yes
8	9 "	#18	PC board	+5	yes	Q3	A2	yes
9	9½"	#18	PC board	+5	yes	female pin	J2-0 pin 3	yes
10	17"	#18	PC board	+5	yes	female pin	J2-1 pin 3	yes

120 VAC OPERATION

11	full	----	T1	black	----	S1	A	no
12	full	----	T1	white	----	S1	A	no
13	5"	----	T1	blk-wht	----	F1	A	no
14	5"	----	T1	blk-red	----	F1	A	no

240 VAC OPERATION

15	----	----	T1	black	----	S1	A	no
16	----	----	T1	white	----	T1	blk-red	yes
17	----	----	T1	blk-wht	----	F1	A	no
18	----	----	line cord	black	----	S1	B	yes
19	----	----	line cord	white	----	F1	B	yes
20	----	----	line cord	green	----	gnd lug	----	yes
21	full	----	fan	A	----	S1	A	no
22	full	----	fan	B	----	F1	A	no
23	8¼"	----	FD-M	B	----	S1	A	yes
24	7½"	----	FD-M	W	----	F1	A	yes
25	8½"	#18	C3 lug	(-)	yes	gnd lug	----	no
26	9"	#18	C4 lug	(-)	yes	gnd lug	----	yes
27	9½"	#18	C4 lug	(-)	yes	Q3	A3	yes
28	10½"	#18	C4 lug	(+)	yes	Q3	A1	yes
29	12"	#18	C3 lug	(+)	yes	Q4	B2	yes
30	22½"	#18	C4 lug	(-)	yes	female pin	J2-0 pin 4	yes
31	28½"	#18	C4 lug	(-)	yes	female pin	J2-1 pin 4	yes

Configuring the DMAF1 Disk for the SWTPC 6800 Computer System and Vice-Versa.

When using the DMAF1 Disk Controller Board with the SWTPC 6800 Computer System, program the DMAF1 Controller Board as follows:

- ✓ 1.) Plug one shorting block between the center pin and NOR terminal on the NOR/MR header.
- ✓ 2.) Plug another shorting block between the center pin and 32K terminal on the 32K/48K header.
- ✓ 3.) Plug the remaining shorting block between the 4 and the pin immediately below it on the 01234567 header.

If you are using the DMAF1 Disk Controller Board with a SWTPC 6800 Computer System with a MP-B2 mother board and MP-A2 processor board, no modifications to the computer system other than with one of the memory board(s) are necessary. Check to see which boards are being used in your computer. The nomenclature for each board is printed on the "TOP" side of the board.

Modifying the MP-B Mother Board

If your computer system has a MP-B (not MP-B2) mother board, power down the system, unplug the connector going to the power supply board and remove the board. Make the following modifications.

- ✓ 1.) Cut the foil conductor connecting pin 10 to pin 12 of IC4, the 7400 NAND gate, on the "BOTTOM" side of the mother board.
- ✓ 2.) Attach and solder an insulated jumper between pin 11 of IC4 (7400 NAND gate) to pin 6 of IC6 (74S138 decoder) on the "BOTTOM" side of the board.
- ✓ 3.) Attach and solder a separate insulated jumper between pin 12 of IC4 (7400 NAND gate) and address line A12 on the "BOTTOM" side of the board.
- ✓ 4.) Tape the two jumper wires to the "BOTTOM" side of the board so they do not break off or get pinched.
- ✓ 5.) Reinstall the mother board and reconnect the connector going to the MP-P power supply board.

Modifying the MP-A Processor Board

If your computer system has a MP-A (not MP-A2) processor board, power down the system, carefully remove the MP-A processor board and make the following modifications:

- ✓ 1.) First, check to see that integrated circuit IC15 (second IC from the left on the bottom row as viewed from the "TOP" side) is a DM8098 or 74368. If it has a DM8096 or 74366 substituted the IC will have to be replaced with a DM8098 or 74368.
- ✓ 2.) Carefully cut pin 15 of IC15 from the "TOP" side of the board very close to the surface of the board. Bend the IC pin 15 up and away from the foil trace.
- ✓ 3.) Attach and solder an insulated jumper from now unconnected pin 15 to pin 8 of IC15 on the "TOP" side of the board. This effectively grounds pin 15.
- ✓ 4.) Now cut the foil trace connecting pin 10 to pin 13 on IC16 from the "TOP" side of the board. IC16 is the third IC from the left on the bottom row as viewed from the "TOP" side. It is a 7420.
- ✓ 5.) Attach and solder an insulated jumper from the now unconnected pin 13 on IC16 to pin 3 of IC7 on the "BOTTOM" side of the board. IC7 is the third IC from the right on the bottom row as viewed from the "TOP" side. IC7 is a DM8097 or 74367.
- ✓ 6.) Cut the foil trace connecting to pin 13 of IC3 on the "BOTTOM" side of the board. IC3 is the 6810 RAM memory on the board. Now run a jumper from pin 13 of IC3 to pin 12 of IC3. This effectively grounds pin 13 of IC3.

✓ (See also 2-11-1980 SWTPC 6800 Computer System and Vice-Versa)

- 7.) Reinstall the modified MP-A processor board on the computer system. NOTE: The previous modifications have disabled the 6810 scratchpad RAM memory on the processor board. This was necessary so that an external 8K byte contiguous block of memory from A000 thru BFFF (40K thru 48K) may be installed in the computer system for the DOS. The processor board **will not** now function at all without this extra memory installed. The ROM monitor will not work without RAM memory at memory locations A000 thru A07F. The DOS is loaded into locations A080 thru BFFF.

Memory Board Modification

Regardless of which processor or mother board your system uses, one of the MP-8M 8K or two of the MP-M 4K memory boards will have to be modified for operation from A000 thru BFFF (40K thru 48K) where the scratchpad and disk operating system (DOS) reside. The MP-A processor board should have already been modified for external memory from A000 thru BFFF. If you are using the MP-A2 processor board, it will be necessary to switch OFF the RAM dip switch on the processor board once the modified memory boards are plugged onto the computer system.

Modifying the 4K MP-M Memory Board

To modify the MP-M memory board for operation above 32K break the conductor foil between pin 6 of integrated circuit IC22 and pin 1 of IC24 as well as the conductor foil between pin 4 of IC22 and connector pin A15. Break the conductors near IC22 using a small screwdriver or knife to scribe a small line across the trace deep enough to break the conductive path. Using a piece of light gauge hookup wire connect pin 6 of IC22 to connector pin A15. Using a separate piece of hookup wire connect pin 4 of IC22 to pin 2 of IC24. Check your modifications and wiring for accuracy. This completes the modification. Use the table below to determine the proper position for the address select programming jumper which must be installed on the memory board. One 4K board must be modified and jumper programmed for #2. Another 4K board must be modified and programmed for #3. This will provide RAM memory from A000 thru BFFF.

TABLE 1
MP-M Memory Address Assignment Table (Hex above 32K)

Programming Jumper #	Memory Quadrant (K of memory)	Starting Address	Ending Address
2	1	A000	A3FF
	2	A400	A7FF
	3	A800	ABFF
	4	AC00	AFFF
3	1	B000	B3FF
	2	B400	B7FF
	3	B800	BBFF
	4	BC00	BFFF

MP-M/MP-MX Memory IC Assignment Map

	Bit 7	Bit 6	Bit 5	Bit 4	Bit 3	Bit 2	Bit 1	Bit 0
Quadrant 1 (1K)	IC15	IC13	IC11	IC9	IC7	IC5	IC3	IC1
Quadrant 2 (2K)	IC16	IC14	IC12	IC10	IC8	IC6	IC4	IC2
Quadrant 3 (3K)	IC40	IC38	IC36	IC34	IC32	IC30	IC28	IC26
Quadrant 4 (4K)	IC25	IC39	IC37	IC35	IC33	IC31	IC29	IC27

00 hex = 0000 0000 binary
 01 hex = 0000 0001 binary
 02 hex = 0000 0010 binary
 04 hex = 0000 0100 binary

08 hex = 0000 1000 binary
 10 hex = 0001 0000 binary
 20 hex = 0010 0000 binary
 40 hex = 0100 0000 binary
 80 hex = 1000 0000 binary

Modifying the 8K MP-8M Memory Board

To modify the MP-8M memory board for operation above 32K first flip all of the address select slide switches on the memory board to their OFF position. For operation from 40K to 48K (8000 to 9FFF) solder a piece of light gauge hookup wire from pin 1 of IC22 to pin 10 of IC18. Check your wiring for accuracy. This completes the modification. Table II gives the new memory assignments for each of the memory integrated circuits. All of the switches must be left "OFF". The board is now configured for operation for A000 thru BFFF.

TABLE II
MP-8M Memory Address Assignment Table (Hex) above 32K

Half of Memory	Starting Address	Ending Address
lower	A000	AFFF
upper	B000	BFFF

MP-8M Memory IC Assignment Table

	Bit 7	Bit 6	Bit 5	Bit 4	Bit 3	Bit 2	Bit 1	Bit 0
Lower 4K	IC7	IC6	IC5	IC4	IC3	IC2	IC1	IC0
Upper 4K	IC15	IC14	IC13	IC12	IC11	IC10	IC9	IC8

Hex to Binary Conversion

00 hex = 0000 0000 binary	08 hex = 0000 1000 binary
01 hex = 0000 0001 binary	10 hex = 0001 0000 binary
02 hex = 0000 0010 binary	20 hex = 0010 0000 binary
04 hex = 0000 0100 binary	40 hex = 0100 0000 binary
	80 hex = 1000 0000 binary

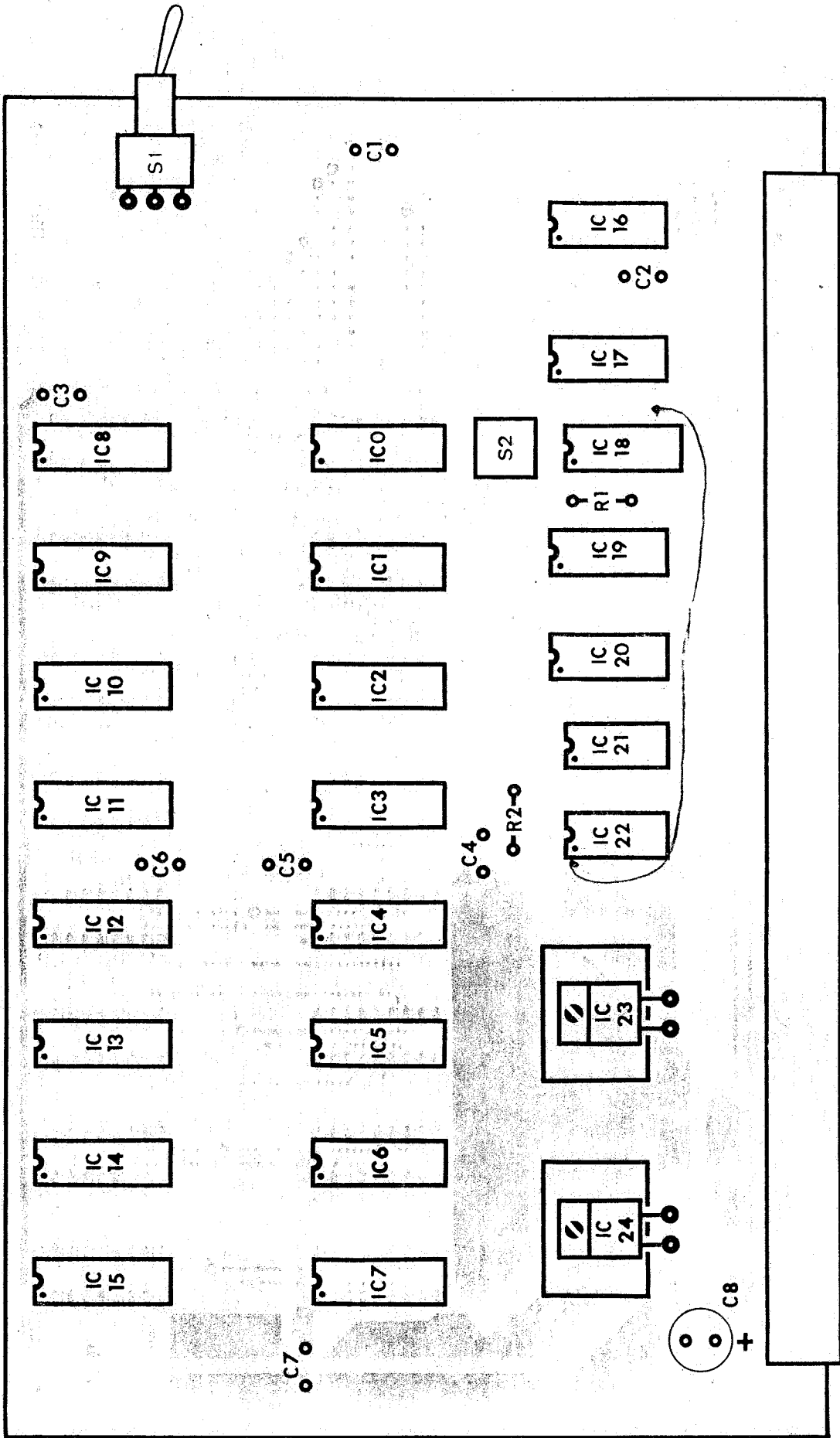

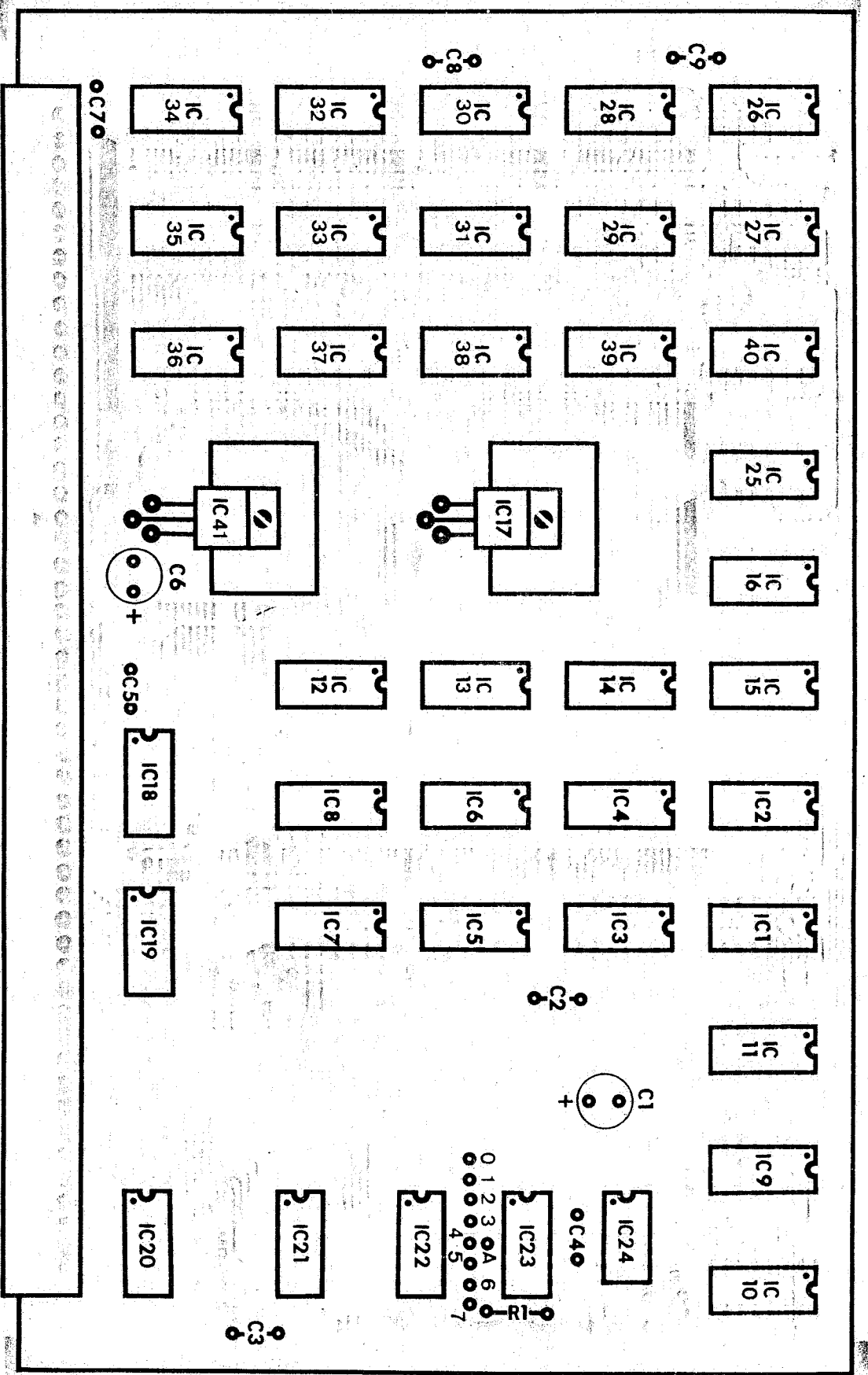

Getting It All Together

Before attempting to check out the DMAF1 Disk System, let's go thru the hardware just to make sure everything required is plugged in and configured properly. First of all the computer system must have a minimum of 20K of RAM memory installed (24K recommended) with 8K positioned from A000 thru BFFF (40K thru 48K). The remaining 12K thru 32K of RAM must be the contiguous memory starting at memory location 0000.

If your system has a MP-B (not MP-B2) mother board, it must be modified as per the instructions in the preceding section of this manual. If your system has a MP-B2 mother board, no mother board modifications are necessary.

✓ If your system has a MP-A (not MP-A2) processor board, it must also be modified as per the instructions in the preceding section of this manual. If your system has a MP-A2 processor board, it will be necessary to switch the DIP switch marked RAM on the MP-A2 board to the OFF position.

✓ Before attaching the disk and its controller board to the system, it is suggested that you run memory diagnostics on all areas of RAM memory in the system. If there are any signs of problems especially on more than one of the memory boards, make sure you are not drawing too much power from the computer system's power supply. It is suggested that your memory boards not draw a total of more than 7.5 amps from the power supply. Each MP-M 4K and MP-8M 8K memory board consumes approximately 1.5 amps. The advantage of the 8K board is, of course, that you may have twice as much memory for the same amount of power. The 16K/32K dynamic memory boards now available consume approximately 1.5 amps.

Most of the SWTPC memory diagnostics are loaded into the scratchpad RAM memory from A000 thru A07F so when you run the memory diagnostics on the 40K thru 48K memory board(s) start the diagnostic at A080 rather than A000 otherwise the diagnostic will destroy itself.

At the time of this writing three monitor ROMs are available for the SWTPC 6800 Computer System.

The newest monitor and the one suggested for those DMAF1 owners with an MP-A2 processor board is DISKBUG[®]. DISKBUG[®] is presently the only monitor containing a boot for the DMAF1 disk system. The SWTBUG[®] and MIKBUG[®] monitors require that this bootstrap program be entered by hand. The bootstrap, for those confused, is a short program that configures the disk controller and initiates the loading of the disk operating system (DOS) into computer memory. DISKBUG[®] may be installed only on a MP-A2 processor board. It is a preprogrammed 2716 PROM and is installed in one of the PROM sockets. It sells for \$60.00 ppd. in the continental U.S. #DISKBUG-2716.

✓ Although the SWTBUG[®] ROM contains a disk boot, it is for the SWTPC MF-68 Mini-Floppy Disk System and is not compatible with the DMAF1 disk system.

Unlike SWTBUG[®] and MIKBUG[®], DISKBUG[®] has been written to operate with a MP-S serial interface only and will not work with a MP-C control interface.

For those who do not have the DISKBUG monitor, the eighty-byte program may be entered by hand using the monitor's memory examine and change function. Once entered it may be saved to cassette tape (if available) or blown in a 2716 EPROM by the user with a MP-A2 and MP-R EPROM programmer, for future convenience. The code for the boot is listed in the appendix of the DOS User's Guide.

Once you are sure that the computer system's memory is good, remove power. Check over the DMAF1 controller board once more for proper soldering and correct installation of the shorting blocks as detailed earlier in this manual. Carefully install the controller board onto one of the unused 50-pin board positions on the computer mainframe. Make sure the board is seated properly. With nothing plugged onto the connector along the top edge of the controller board, apply power to the computer system. The terminal should respond with the monitor's prompt. Use the monitor's memory examine/change function to write a 55 into hex location 9000. Using the same function, go back and read hex 9000. It should still contain a 55. If it does not, then data is not being written to and/or read from the DMA chip on the disk controller board. Now try writing a 55 into hex location 9022. Using the memory examine and change function, go back and read hex 9022. It

should still contain a 55. If it does not, then data is either not being written to and/or read from the disk controller chip on the disk controller board.

If you have a voltmeter handy, measure the DC voltage of the rightmost lead of the voltage regulator, IC using the center lead as a ground. It should measure +5 VDC $\pm 5\%$. Do not continue assembly if you have difficulty with any of these three tests. Instead, remove power, remove the controller board and recheck component installation and orientation. Check carefully for missed solder connections, solder and foil bridges or breaks. If you cannot find the problem, carefully pack up just the controller board and return it to SWTPC attn: "Repair Dept." with a description of the problem.

If the board successfully performs the previous tests, continue with assembly. Power down the computer system. Set the disk chassis base plate within four feet of the computer system mainframe. Set each of the two disk drives vertically onto the base plate so the circuit boards attached to the drives face to the right. Place the drive programmed for 0 on the left and the one programmed for 1 on the right. This is important. Do not get them reversed. Make absolutely sure the line cord for the disk system is not attached to an AC receptacle. Attach the three-pin AC power connectors J0-0 and J0-1 to the rear of each of the disk drives. The three-pinned connectors are interchangeable and their length should dictate which cable connects to which drive. Attach the four-pinned DC power connectors J2-0 and J2-1 to the rear of each of the disk drives. The four-pinned connectors are interchangeable and their length should dictate which cable connects to which drive.

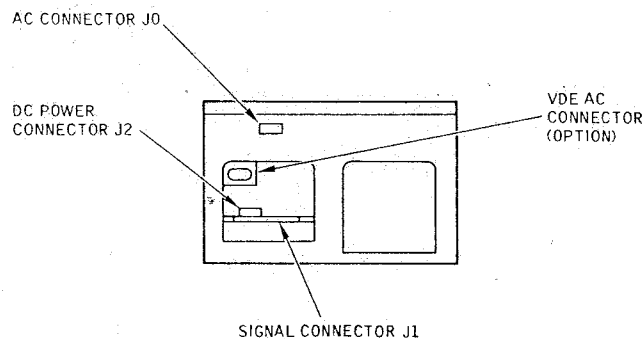

Connector Locations

Run the three-pinned miniature connector from the FD-M motor control board thru the $\frac{1}{2}$ " x 4" opening on the rear to the right hand drive (1) from the outside. This connector must be oriented as shown in the drive programming pictorial earlier in this manual and plugged onto the JPR 3 and JPR 2 posts. It is important that the JPR 3 terminal connect to point S and the JPR 2 terminal connect to point T on the FD-M motor control board. Getting these reversed will not damage anything but will prevent the drive motors from functioning, so be careful.

Now attach the terminating PC connector of the flat ribbon cable to the drive 1 (the rightmost drive). The connector may be keyed and if so will go on only one way. If not, orient the connector so the tracer on the flat ribbon cable is nearer the side of the PC connector with the cutout. Attach the adjacent PC connector of the flat ribbon cable to drive 0 (the leftmost drive) using the same orientation procedures. Now plug the remaining flat ribbon connector onto the controller board connector along the top edge of the board. The connector may be keyed and thus will plug on only one way. If not, orient the connector so the tracer on the flat ribbon cable is nearer the left edge of the controller board as viewed from the front of the computer system. Double check all wiring for accuracy.

The following information should be read to familiarize you with diskettes and their use in the system. Read it carefully before proceeding with the diagnostics.

Final Checkout Using the Disk System

The DMAF1 Floppy Disk System is designed to be as straightforward and easy to use as possible. There are certain things that the user must be aware of, however, for correct operation.

All RAM memory in the system must be operational for the disk to operate properly. If any doubt exists, run the memory diagnostics to verify correct operation.

Loading Flexible Disks

To load a flexible disk, simply depress the pushbutton located on the center of the loading handle. The loading handle is spring loaded and will then expose the load aperture.

Insert the flexible disk in the load aperture with the label toward the operator and facing the loading handle (see figure). Ensure that the flexible disk is inserted fully within the drive.

Grasp the bar on the loading handle and close it firmly; it will lock shut.

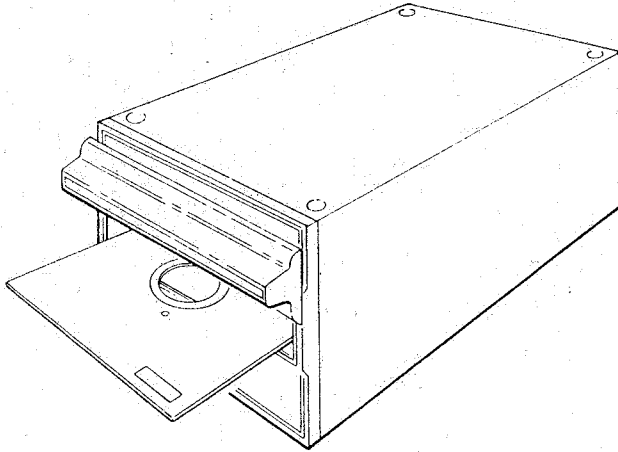

A. FLOPPY DISK IN LOAD POSITION

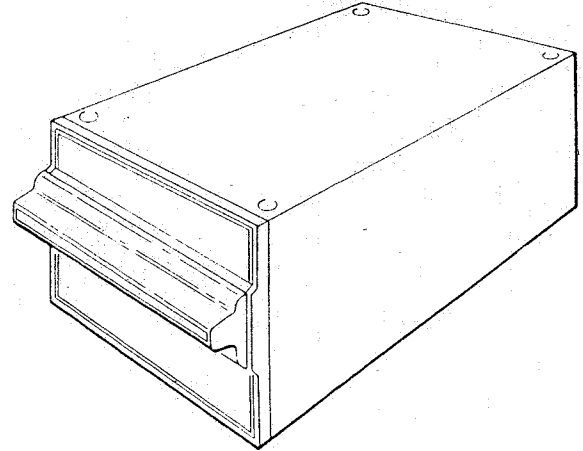

B. FLOPPY DISK LOADED

Flexible Disk Loading

Having the write protect notch on a diskette closed with a piece of tape will allow the diskette to be written on. Leaving the notch open will disable write privileges.

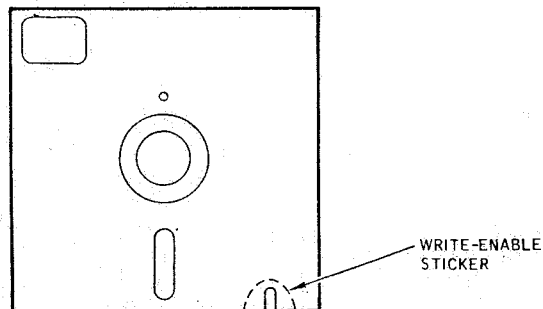

Write-Protect Option

The LED's on the drives are drive select/head load lights and are activated only when the head for a particular drive is loaded on a diskette. They are not power indicators.

The disk controller has been designed to load the head and turn on the drive motors only when necessary. When the computer requests data from the disk both motors will activate and the correct head will load. After the information has been retrieved the head will unload, and after approximately 60 seconds, both motors will turn off.

Just like cassette tapes, diskettes are made of magnetic materials and can be erased by stray magnetic fields. Also, it is an excellent idea to back-up all important disks on a spare diskette. The following precautions should be followed concerning diskettes.

1. Return the diskette to its storage envelope whenever it is removed from a drive.
2. Keep diskettes away from magnetic fields and from ferromagnetic materials which might become magnetized. Strong magnetic fields can distort recorded data on the disk.
3. Replace storage envelopes when they become worn, cracked or distorted. Envelopes are designed to protect the disk.

4. Do not write on the plastic jacket with a lead pencil or ball-point pen. Use a felt tip pen.
5. Heat and contamination from a carelessly dropped ash can damage the diskette.
6. Do not expose diskettes to heat or sunlight.
7. Do not touch or attempt to clean the disk surface. Abrasions may cause loss of stored data.
8. Flexible disks must be in the same temperature and humidity environment as the disk drive for a minimum of 5 minutes before installing the diskette in the disk drive. These environmental requirements are as follows:

Temperature	50°F (10°C) to 125°F (51.6°C); maximum gradient of 20°F (11.1°C) per hour
Relative Humidity	8% to 80%, maximum wet bulb 85°F (29.4°C)

Diagnostics

It is recommended that you try running the two following diagnostics before attempting to boot the disk system. Power up the computer system and the DMAF1 disk system. The disk system is on when the cooling fan runs. If you do run into a problem, try to pin it down to the DMAF1 controller board, motor control board, power supply or one of the disk drives. If you appear to be having a problem with a particular drive, reprogram them both so that drive 0 is drive 1 and vice versa. If it is a drive problem, this should confirm it. If you do run into some kind of problem(s) check the following:

- 1.) Make sure you have at least 12K of contiguous RAM memory from 0000 thru 2FFF (0-12K).
- 2.) Check to see that you also have 8K of contiguous RAM memory from A080 thru BFFF (40K-48K).
- 3.) Run the memory diagnostics and verify this memory to be good.
- 4.) Make sure the DMAF1 disk controller board is properly programmed with the shorting blocks.
- 5.) Make sure there are no cold solder joints or foil bridges on the controller board. Also make sure all components are installed and oriented correctly.
- 6.) Make sure the DMAF1 disk controller board is plugged onto the computer system and is properly seated.
- 7.) Make sure the flat ribbon cable is plugged on the disk controller board and is oriented correctly.
- 8.) Make sure the flat ribbon cable is plugged onto both disk drives and is oriented correctly. Check the orientation very carefully.
- 9.) Make sure the J2-0, J2-1, J0-0 and J0-1 power connectors are plugged into their mates on the back of both drives.
- 10.) Make sure the miniature connector going to the FD-M motor control board is oriented properly and plugged onto disk drive connector pins specified in the instruction set.
- 11.) Confirm that the cooling fan on the disk system is running. It should run whenever the disk system is turned on.
- 12.) Make sure you have modified your computer's MP-A processor and MP-B mother boards if applicable and have flipped the RAM switch OFF on the MP-A2 processor board if applicable.
- 13.) Run the REGTEST diagnostic (details follow).
- 14.) Run the STEPTEST diagnostic (details follow).
- 15.) Try booting the system (details follow) if the diagnostics run correctly.

REGTEST

The REGTEST diagnostic can be used to verify that the various registers on a DMAF1 disk controller board are being accessed properly. REGTEST assumes that the disk drives are connected to the controller and power is applied as described in the checkout instructions.

To use the REGTEST diagnostic, the code must be entered into the computer instruction by instruction using the memory examine and change function of the computer's monitor. Program execution should then be started at hex location 0100 by either setting A048 and A049 to 0100 and typing G or by typing J 0100 depending on your monitor. REGTEST will then check each register and will alternately select drive 0 and then drive 1. Correct drive selection is indicated if the LED on the front of drive 0 lights briefly and if the LED on drive 1 lights briefly when the one on drive 0 goes out. Both LEDs should never be on at the same time. Both drive motors should be running. If any register errors are seen an X will be displayed. If no errors are seen a + will be displayed. The diagnostic should be allowed to run until 256 +'s have been displayed.

REGTEST may be exited by depressing the RESET switch on the computer. A diskette need not be installed in the drive.

	NAM	REGTEST	
0100 CE 90 00	START	LDX	##9000
0103 F6 01 61		LDA B	BYTE
0106 E7 00		STA B	0, X
0108 E7 01		STA B	1, X
010A E7 02		STA B	2, X
010C E7 03		STA B	3, X
010E E7 21		STA B	\$21, X
0110 E7 22		STA B	\$22, X
0112 E7 23		STA B	\$23, X
0114 E6 00		LDA B	0, X
0116 8D 37		BSR	TEST
0118 E6 01		LDA B	1, X
011A 8D 33		BSR	TEST
011C E6 02		LDA B	2, X
011E 8D 2F		BSR	TEST
0120 E6 03		LDA B	3, X
0122 8D 2E		BSR	TEST
0124 E6 21		LDA B	\$21, X
0126 8D 27		BSR	TEST
0128 E6 22		LDA B	\$22, X
012A 8D 23		BSR	TEST
012C E6 23		LDA B	\$23, X
012E 8D 1F		BSR	TEST
0130 7C 01 61		INC	BYTE
0133 26 CB		BNE	START
0135 86 FE		LDA A	##FE
0137 E7 90 24		STA A	DRVREG
013A 8D 1E		BSR	DELAY
013C 86 FD		LDA A	##FD
013E E7 90 24		STA A	DRVREG
0141 8D 17		BSR	DELAY
0143 86 2B		LDA A	#+
0145 BD E1 D1		JSR	OUTEEE

-Continued on next page-

0148 86 FF		LDA A	##FF	
014A E7 90 24		STA A	DRVREG	
014B 20 E1		BRA	START	STORE NEW DATA
014F F1 01 61	TEST	CMF B	BYTE	
0152 27 05		BED	OK	
0154 86 58		LDA A	#X	ERROR FOUND
0156 ED E1 01		JSR	OUTEEE	
0159 39	OK	RTS		
015A CE FF FF	DELAY	LDX	##FFFF	
015D 09	DEC	DEX		
015E 26 FD		BNE	DEC	
0160 39		RTS		
0161 00	BYTE	FCB	00	

STEPTEST

The STEPTEST diagnostic can be used to verify that the track selection circuitry of the system drive and the controller is working properly. If desired, a blank diskette may be used in place of the supplied system diskette.

To use the STEPTEST diagnostic, it should first be entered into the computer instruction by instruction using the memory examine and change function of the computer's monitor. A diskette (preferably blank or at least write protected) should then be installed in drive 0 and the door closed. Program execution should then be started at hex location 0100 by setting A048 and A049 to 0100 and typing G or by typing J0100 depending on the computer's monitor. STEPTEST will then select drive #0 and check to see if the index hole sensing and motor control circuitry is working properly. If so, the disk drive heads will be moved back and forth between track 00 and track 76. STEPTEST outputs no information to the user—if the heads move back and forth across the diskette proper operation is assumed.

0100 CE 90 20	START	NAM	STEPTEST	
0103 C6 FE		LDX	#COMREG	
0105 E7 04		LDA B	##FE	SELECT DRIVE 0
0107 E6 00		STA B	4, X	
0109 05 80		LDA B	0, X	WAIT UNTIL READY
010B 26 F3		BIT B	##80	
010D C6 08		BNE	START	
010F E7 00	LOOP	LDA B	#08	RESTORE
0111 8D 12		STA B	0, X	
0113 C6 4C		BSR	WAIT	WAIT UNTIL THRU
0115 E7 03		LDA B	#76	TRACK 76
0117 8D 13		STA B	3, X	
0119 C6 18		BSR	DEL28	DELAY
011B E7 00		LDA B	##18	SEEK
011D 8D 06		STA B	0, X	
011F 20 EC		BSR	WAIT	
0121 E7 00	EXEC	BRA	LOOP	
0123 8D 07		STA B	0, X	
0125 E6 00	WAIT	BSR	DEL28	
0127 05 01		LDA B	0, X	
0129 26 FA		BIT B	#1	LOOP UNTIL 1771 THRU
012B 39		BNE	WAIT	
012C 8D 00	DEL28	RTS		
012E 8D 00	DEL14	BSR	DEL14	
0130 39	DEL	BSR	DEL	
		RTS		

Booting the System

If you do not have an MP-A2 processor board with the DISKBUG[®] monitor installed, it will be necessary to enter the code for the bootstrap program by hand using the memory examine and change function of the monitor. The instructions and listing for the bootstrap program are contained in the DOS User's Manual. The boot will load the disk operating system from a system diskette installed in drive 0 (the left drive) only. Make sure the door on the disk drive is closed after inserting the diskette.

How It Works

The DMAF1 disk system can be broken down into four major parts: disk controller board, motor control board, power supply and the disk drives.

Disk Controller Board

The purpose of the disk controller board is to interface the disk drives to the computer system. Most of the control logic for the drives is handled by IC22, the 1771 disk controller chip. Since the data exchange rate between the computer system and the disk controller chip is a little too fast for a byte by byte transfer, a 6844 direct memory access (DMA) chip IC6 is used for disk data transfers between the 6800 Computer System and the 1771 disk controller chip. Much of the logic on the disk controller board is provided for interfacing these two chips together and to the rest of the system. Eight bit latch IC25 is used for drive and side select. It is a write only register and may be accessed at hex 9024. Timer IC24 is responsible for feeding the motor control board which turns the disk drive motors off if they have not been accessed for sixty seconds or so. This reduces drive and media wear and cuts down noise. Integrated circuits IC7, IC8, IC9, IC10, IC11 and IC12 are part of the clocked data separator that is external to the 1771 controller chip. The advantage here is that there are no adjustments to be made as with some data separators. The data separator internal to the 1771 is not reliable at the 2.0 MHz clock rate. Address decoding for the board is provided by integrated circuits IC4 and IC5. The board uses a 1K block of memory addresses anywhere from 32K thru 40K or 48K thru 54K jumper programmable. Bidirectional transceiver IC1 and buffer IC2 buffer the address lines to and from the board. Voltage regulator IC29 supplies +5 VDC power for the board while zener diodes D3 and D4 provide the +12 and -5 voltages required by the 1771 disk controller chip.

FD-M Motor Control Board

The motor control board turns AC power to the disk drives motors on and off as determined by the timer on the controller board. Integrated circuit IC1 on the board is an optically coupled triac which in turn drives Q1, a larger triac. The optical coupling is required to isolate the disk system's ground from the AC power line. NOTE: The motor control signal from the disk controller board is fed to two unused pins on both of the disk drives thru the flat ribbon cable. The miniature three-pin connector on the motor control board must be plugged onto these unused pins on one of the two drives otherwise the drive motors will not turn on. The orientation of the connector is important. Check the instruction set for complete details. Some of the components on this motor control board are connected to one side of the AC power line whenever the disk system's line cord is plugged into an AC receptacle regardless of whether or not it is turned on or running. Therefore, exercise extreme caution and never put your hands or tools near the board while the disk system is plugged into an AC receptacle.

P-200DF Power Supply

The power supply on the disk system is just about as simple as you can make it. The secondaries of the transformer are wired to provide 7 VAC and 24VAC outputs. These in turn are rectified by separate full wave bridge rectifier circuits providing +9 VDC and +30 VDC outputs. These outputs are then run thru separate integrated regulators Q3 and Q4 to yield the +5 VDC and +24 VDC outputs required by the disk drives. Power for the disk controller board is supplied by the 6800 Computer System.

Final Assembly

If everything seems to be working properly, you may now fasten down the disk drives and install the cover. Turn the power off and unplug the line cord on the disk system. Carefully turn each of the disk drives so they set flat on the chassis baseplate with the LED indicators nearer the bottom of the chassis. Let the plastic front panel of the disk drives overhang the front of the chassis. Make sure that none of the inter-connecting cables are twisted or sandwiched between the disk drives and chassis base plate. Carefully lift up the front of the chassis and secure the disk drives with #6-32 x 1/2" screws. Six are used to hold each drive in place. Install all of the screws finger tight until all twelve have been installed then tighten the screws being careful not to overtighten. The disk drive castings are aluminum and strip easily.

Before installing the cover, snap the two tinnerman nuts into the 3/16" holes on the sides of the chassis back panel. Carefully check once more to make sure that all of the interconnection cables are routed properly and that none are crimped. Route the flat ribbon cable so it lies neatly in the slot provided in the back panel. Carefully install the cover so that the center mounting hole on each side aligns with the one in the disk drive. Secure the cover using six black 3/8" screws. Here again be careful not to overtighten the screws.

IN CASE OF PROBLEMS

If your DMAF1 Disk System fails to operate properly we suggest that you first go back and double check all component installation and orientation. Be sure that they are turned as shown on the drawings and that each is the correct part number. The majority of problems turn out to be incorrect assembly. Using the printed pattern as a guide look over the board for solder bridges. Accidental solder bridges are the second most common problem in kits that are returned for repair. Be sure that all programming jumpers called for are in place and that all connections have been soldered.

If you suspect that one of the CalComp 143M disk drive units is not working properly, you may reprogram the drives and interchange the two. If your suspicions are correct remove the drive and return it to us for testing. **Do not** attempt to adjust, or repair the drive unit. Special equipment and tools are required and considerable damage can be done by attempting to work on these units without proper training.

If you have difficulty getting the disk system to work, repair services are available, however, it is advisable to try to determine which element of the system is not working and return only that portion rather than the entire assembly. The power supply circuitry is very straightforward and may be checked with a DC voltmeter. If it has a problem and you cannot repair it yourself, remove the power transformer and disk drives and return the entire chassis base plate. Do not return just the power supply board itself. If the disk drive motors do not turn on it is more than likely a problem with the disk controller board rather than the motor control board. If you have to return any part of your system, it would be a good idea to include your supplied system diskette containing the FDOS. Repairs are performed for a flat labor charge per item plus parts and postage.

Item	Labor Charge
Controller board and cable	\$35.00
Power supply	\$15.00
Disk drives	depends on individual drive

If we find that the controller board, drive or power supply is functional as received and does not require service, the Checkout Charge is \$15.00

A confirmation sheet will be sent upon receipt of the kit. Please do not ask for a detailed report on exactly what was done in repairing your unit as we cannot provide this service.

It is not necessary to enclose any funds with the kit, you will be billed for authorized repairs.

SHIPPING INSTRUCTIONS

Pack in a large carton with at least 3 inches of padding on all sides. We will not service a kit if there is any postal damage until the claim is settled.

Include all relevant correspondence and a brief description of the difficulty.

Ship prepaid by UPS or insured Parcel Post. We cannot pick up repairs sent by bus.

Ship to:

Southwest Technical Products Corp.
Repair Department - Digital Group
219 W. Rhapsody
San Antonio, Texas 78216