

## Assembly Instructions AC-30 Audio Cassette Interface

### Introduction

Cassette tape is one of the most flexible and least expensive means of mass data storage for computer systems. When compared to paper tape readers and punches, you'll find that although the paper tape readers can be made rather inexpensively, the punches cannot. Paper tape systems are typically slower and the punched tapes cannot of course be repunched and used over and over again, as you can with cassettes. Disk systems on the other hand offer significant advantages over cassettes but are still too expensive for many applications, and for most hobbyists. Even those lucky enough to have a disk system still need a more universal medium for exchanging programs.

Although there are several commercial digital cassette tape decks on the market today, recording techniques vary and they are of course much more expensive than the average audio cassette unit. As could be expected most hobbyist computer system mass data storage designs have been based on the audio cassette recorder.

The use of inconsistent recording techniques among the various manufacturers makes it impossible for example to record a program, or data tape on a SWTPC 6800 Computer System and play it back on a MITS 680 Computer System. In order to coordinate manufacturer design efforts, and exploit the most effective recording technique, BYTE Magazine of Peterborough, New Hampshire, 03458 held a symposium in the Fall of 1975 in Kansas City in an attempt to establish a recording standard for the storage of digital data on audio cassette recorders. The standard which was adopted has been tested and fully supported by Southwest Technical Products Corporation. It appears to be the best compromise between economy and reliability. Although complete details are contained in the Feb., 1976 issue of BYTE Magazine, the recording philosophy is to record data serially using the standard UART format at 300 baud (30 characters/second). Marks or logic ones are represented by recording a 2400 Hz sine wave on the tape while spaces or logic zeroes are represented by recording a 1200 Hz sine wave. With the proper circuitry this recorded data can then be read off the tape and transposed into a self clocking UART based tare system which will tolerate audio recorder speed variations of approximately +30%. This figure is far better than that of most other modulation techniques and is a real advantage when you consider the degree of worst case speed variation between inexpensive audio recorders. In addition we have speed variations due to line voltage, battery voltage, wow and flutter, mechanism wear, etc. Thus evolved the "Kansas City" standard. It should be noted that the standard does not specify how the data is to be organized on the tape, so there can, and probably will be some incompatibility among various manufacturer's units. This is however more of a software problem than a hardware problem and thus a little easier to resolve.

Although the SWTPC AC-30 Audio Cassette Interface has been used extensively with the SWTPC 6800 Computer System and CT-1024 (TV Typewriter II) Terminal System, it has been designed to be as universal and flexible a system as possible. If your computer's control terminal is interfaced to the computer thru 300 baud, RS-232 compatible serial interfaces with accessible UART type 16 X baud rate clocks on both computer and terminal, the SWTPC AC-30 Cassette Interface Unit is simply plugged between the computer and terminal interfaces. This is the ideal mode of

operation since the cassette unit can take full advantage of computer resident tape load and dump routines and requires no additional interfaces. Switching the cassette unit to the LOCAL mode directly interconnects the terminal and cassette unit for terminal "only" cassette tape operation just like the LOCAL mode of operation on teletypewriters. While operating in the REMOTE mode the computer communicates with both the terminal and cassette unit, here again just like the REMOTE mode of operation on teletypewriters. Those customers using the CT-1024 (TV Typewriter II) Terminal System or any terminal system with accessible control character decoders may even pick Reader ON (Control Q), Reader OFF (Control S), Record On (Control R), and Record OFF (Control T) control commands right off the control character decoder circuitry on their terminal system giving the computer system program control over cassette recorder data flow and even motor operation. Those not having access to decoded control commands may still have cassette control by driving the cassette interface with control lines from a separate parallel interface option located on the attached computer system.

Those users not operating their control terminal RS-232 serial at 300 baud or not having access to their terminal's 16 X UART clock may still use the cassette interface, but must attach it to the computer system thru a separate RS-232 serial 300 baud interface with accessible 16 X clocks located on the computer system. This however eliminates the ability to use the computer resident control terminal tape load and dump routines as well as the LOCAL/REMOTE feature described previously.

The cassette interface circuitry is constructed on a 7 3/4" X 7 1/2" double sided, plated thru hole fiberglass circuit board with all electrical connections made to the board thru one of the five edge connectors. The three connectors along the back edge of the circuit board are for connections to the computer, control decoder and terminal while the two along the front edge are for connections to the cassette interface's control panel. The PC board in turn is mounted inside a 12 3/4" wide X 3" high X 11" deep aluminum chassis with dress panel and perforated cover.

#### PC Board Assembly

NOTE: Since all of the holes on the PC board have been plated thru, it is only necessary to solder the components from the bottom side of the board. The plating provides the electrical connection from the "BOTTOM" to the "TOP" foil of each hole. Unless otherwise noted it is important that none of the connections be soldered until all of the components of each group have been installed on the board. This makes it much easier to interchange components if a mistake is made during assembly. Be sure to use a low wattage iron (not a gun) with a small tip. Do not use acid core solder or any type of paste flux. We will not guarantee or repair any kit on which either product has been used. Use only the solder supplied with the kit or a 60/40 alloy resin core equivalent. Remember all of the connections are soldered on the bottom side of the board only. The plated-thru holes provide the electrical connection to the top foil.

- ( ) Before installing any parts on the circuit board, check both sides of the board over carefully for incomplete etching and foil "bridges" or "breaks". It is unlikely that you will find any but should there be one especially on the "TOP" side of the board it will be very hard to locate and correct after all of the components have been installed on the board.
- ( ) Attach all of the resistors to the board. As with all other components unless noted, use the parts list and component layout drawing to locate each part and install from the "TOP" side of the board bending the leads along the "BOTTOM" side of the board and trimming so that 1/16" to 1/8" of wire remains. Solder. You may find that there are no pads on the "BOTTOM" side of the board for resistor R42. If not be sure its two leads are soldered from the "TOP" side of the board.
- ( ) Install all of the capacitors on the board. Be sure to orient the electrolytic capacitors correctly. The polarity is indicated on the component layout drawing. The body of electrolytic capacitor C21 should be insulated so as not to "short" to foil conductors under it. If the body of the capacitor is not insulated attach the capacitor so it is up off the board about 1/8". Solder.
- ( ) Starting from one end of the circuit board install each of the five Molex female edge connectors along the edges of the board. These connectors must be inserted from the "TOP" side of the board and must be pressed down firmly against the board. Make sure the body of the connector seats firmly against the circuit board and that each pin extends completely into the holes on the circuit board.
- ( ) Insert the small nylon indexing plugs into the edge connector pins indicated by the small triangular arrows on the "BOTTOM" side of the circuit board. This prevents mating plugs from being accidentally plugged onto the board incorrectly.
- ( ) Install the transistors on the board. The transistors must be turned to match the outlines on the component layout drawing. Solder.
- ( ) Install all of the diodes on the board excluding diodes D18 thru D22. The diodes must be turned to match the outlines on the component layout drawing. Solder.
- ( ) Install LED diode D18 on the circuit board. Be sure the flat on the side of the LED matches that shown on the component layout drawing. Attach the diode so the bottom of its case is 1/8" to 1/4" above the top of the board. Solder.
- ( ) Install reed relays RLY1 and RLY2 on the circuit board. These relays are not polarized so they need not be oriented in any particular position other than matching the end with three leads and the one with just one to the respective holes on the circuit board. Solder.
- ( ) Install integrated circuit IC16 on the circuit board. This component must be oriented so its metal face is facing the circuit board. The IC is secured to the circuit board with a #4-40 X 1/4" screw, lockwasher and nut. The three leads of the integrated circuit must be bent down into each of their respective holes and trimmed. Solder.

NOTE: Most of the integrated circuits used in this kit are CMOS and are susceptible to damage by static electricity. Although some degree of protection is provided internally within the integrated circuits, their sensitivity demands the utmost in care. Before opening and/or installing any CMOS integrated circuits you should ground your body and all metallic tools coming into contact with the leads, thru a 1 M ohm 1/4 watt resistor (supplied with the kit). The ground must be an "earth" ground such as a water pipe, and not the circuit board ground. As for the

connection to your body, attach a clip lead to your watch or metal ID bracelet. Make absolutely sure you have the 1 Meg ohm resistor connected between you and the "earth" ground, otherwise you will be creating a dangerous shock hazard. Avoid touching the leads of the integrated circuits any more than necessary when installing them, even if you are grounded. On those MOS IC's being soldered in place; the tip of the soldering iron should be grounded as well (separately from your body ground) either with or without a 1 Meg ohm resistor. Most soldering irons having a three prong line cord plug already have a grounded tip. Static electricity should be an important consideration in cold, dry environments. It is less of a problem when it is warm and humid.

- ( ) Install integrated circuits ICI thru IC15 following the precautions given in the preceding section. As each is installed, make sure it is down firmly against the board before soldering all of its leads. Be very careful to install each in its correct position. Do not bend the leads on the back side of the board. Doing so makes it very difficult to remove the integrated circuits should replacement ever be necessary. The "dot" on the end of the package is used for orientation purposes and must match with that shown on the component layout drawing for each of the IC's.
- ( ) Working from the "TOP" side of the circuit board, fill in all of the feed-thru's with molten solder. The feed-thru's are those unused holes on the board whose internal plating connects the "TOP" and "BOTTOM" circuit connections. Filling these feed-thru's with molten solder guarantees the integrity of the connections and increases the current handling capability.
- ( ) Now that most of the components have been installed on the board, double check to make sure all have been installed correctly in their proper location.
- ( ) Check very carefully to make sure that all connections have been soldered. It is very easy to miss some connections when soldering which can really cause some hard to find problems later during check out. Also look for solder "bridges" and "cold" solder joints which are another common problem.

Since the circuit board now contains CMOS devices it is susceptible to damage from severe static electrical sources. One should avoid handling the board any more than necessary and when you must, avoid touching or allowing anything to come into contact with any of the conductors on the board.

Parts List AC-30 Audio Cassette Interface

Resistors

R1	33K ohm 1/4 watt resistor
R2, R3, R9, R11, R12, R15	10K ohm 1/4 watt resistor
R19-R22, R27 R29, R32-R34,	10K ohm 1/4 watt resistor
R36, R40-R42, R44-R47	10K ohm 1/4 watt resistor
R4, R48, R49	330 ohm 1/4 watt resistor
R5	2.2K ohm 1/4 watt resistor
R6	4.7K ohm 1/4 watt resistor
R7, R30, R31, R35, R37, R43	470 ohm 1/4 watt resistor
R8, R17, R18, R23-R26	100K ohm 1/4 watt resistor
R10	330K ohm 1/4 watt resistor
R13, R14	22K ohm 1/4 watt resistor
R16	20K ohm trimmer resistor
R38	47K ohm 1/4 watt resistor
R39	200K ohm trimmer resistor

Capacitors

C1, C6, C12-C15	1000 pfd capacitor
C2	2000 pfd capacitor
C3, C8	0.022 mfd capacitor
C4	1 mfd @15 VDC electrolytic capacitor
C5, C18	0.01 mfd capacitor
C7, C9	0.047 mfd capacitor
C10	2700 pfd capacitor
C11, C19, C20	470 pfd capacitor
C16, C22	100 mfd @16 VDC electrolytic capacitor
C17	10 mfd @10 VDC tantalum, capacitor
C21	1000 mfd @25 VDC electrolytic capacitor
C23-C25	0.1 mfd disc capacitor

Semiconductors

IC1, IC5, IC8	4013 dual D flip-flop
IC2, IC11	4001 quad NOR gate
IC3, IC13	4070 quad EX-OR gate
IC4	4558 dual op amp
IC6, IC14	4053 triple multiplexer
IC7	4049 hex buffer
IC9	4023 triple 3-input NAND gate
IC10	555 timer
IC12	1489 quad RS-232 receiver
IC15	1488 quad RS-232 transmitter
IC16	7805 5 VDC regulator
D1, D2, D4, D5-D11	1N4148 silicon diode
D3	4.7 volt zener diode 1N4732 or 1N5230
D12, D13	7.5 volt zener diode 1N4737 or 1N5236
D14-D17	1N4003 silicon rectifier
D18-D22	light emitting diode
Q1, Q2, Q4-Q8	2N5210 NPN transistor
Q3, Q9-Q11	2N5087 PNP transistor

RLY1, RLY2  
S1-S3  
S4, SS  
S6, S7  
T1  
  
F1

Misc.

6 VDC reed relay  
DPDT miniature toggle switch  
SPDT center off miniature toggle switch  
SPDT miniature toggle switch  
18 VAC @300 Ma. secondary 120/240 VAC  
50-60 Hz primary power transformer  
1 amp standard fuse

### Chassis Assembly

- ( ) Sandwich the dress panel between the chassis and mounting hardware and attach switches S1-S7 to the chassis using the wiring pictorial to show proper location and orientation. Secure each switch using a finishing washer and nut.
- ( ) Insert each of the four LED plastic mounting clips into the front panel holes provided for LED diodes D19 thru D22. Insert each of the LED diodes into the clips so that the flat on the side of each diode matches with that shown in the wiring pictorial. Just for reference the side with the flat is the same as the side with the shorter lead. Secure each LED diode with the plastic retaining ring. This ring must be pressed on tightly to prevent the LED from being loose.
- ( ) Attach RCA jacks J6 thru J9 to the chassis. Jack J6 should have a ground lug put under it. Secure each jack with a 1/4" nut.
- ( ) RCA jacks J10 and J11 must be electrically insulated from the chassis. In order to do this, first slip a shoulder washer over each RCA jack with the shoulder against the inside of the chassis, place the jack against the outside of the chassis, put another shoulder washer on the back side of the jack with the shoulder against the inside of the chassis, follow this with the ground lug and finally secure with a 1/4" nut.
- ( ) Attach the power transformer to the chassis using #6-32 X 1/4" screws, lockwashers and nuts. Orient the transformer so the end with the three wires coming out of it is toward the front of the chassis.
- ( ) Attach the fuseholder to the chassis using a #6-32 X 3/8" screw, lockwasher and nut.
- ( ) Snap the four nylon PC board supports into the holes provided for them in the chassis.
- ( ) Snap the 1 1/2" bushing into the large hole provided on the back of the chassis. The bushing should be installed from the outside of the chassis.
- ( ) Turn the chassis upside down and attach each of the four press on rubber feet about 1" in from each of the corners.
- ( ) Using a pair of pliers, crimp the strain relief onto the line cord at a point 12" from the end of the cord. While compressing the strain relief insert the 12" length of the line cord and the strain relief into the 7/16" hole provided on the back of the chassis, from the outside of the chassis.
- ( ) Press the specified color of switch cap onto the handle of each toggle switch as specified below:
  - S1 - white
  - S2 - green
  - S3 - green
  - S4 - yellow
  - S5 - yellow
  - S6 - red
  - S7 - white
- ( ) Snap the ten tinnerman clips onto the holes provided on the front and back lips of the chassis.

### Chassis Wiring

- ( ) All connections made between the components on the chassis and the printed circuit board are made thru connectors J1 and J2. This allows one to easily remove the PC board for service or access to the bottom side of the PC board. When soldering the wires to the main plugs for connectors J1 and J2, the plugs must not be plugged into the PC board. If they are the female connectors may melt and be ruined. Follow the wiring steps outlined on the next two pages.
- ( ) Note for 220 VAC Operation - To wire the unit for 220 VAC operation, omit wiring steps 1 thru 4 and instead solder together and insulate T1's BlackWhite and Black leads. Then connect T1's White wire to F1 terminal A and solder. Also connect T1's Red-Black wire to S6 terminal A and solder.
- ( ) Plug connectors J1 and J2 to the appropriate jacks on the PC board. Be sure to orient the jacks correctly.
- ( ) Bundle any loose wires with the wire ties supplied with the kit.
- ( ) Snap the PC board into place.



STEP	WIRE		PART	FROM			TO		
	LENGTH	GAUGE		TERMINAL	SOLDER	PART	TERMINAL	SOLDER	
1	-	-	T1	White	-	F1	A	No	
2	-	-	T1	Black	-	F1	A	Yes	
3	-	-	T1	Blk-White	-	S6	A	No	
4	-	-	T1	Red-Blk	-	S6	A	Yes	
5	-	-	line cord	-	-	F1	B	Yes	
6	-	-	line cord	-	-	S6	B	Yes	
7	9"	#24	S1	B	No	S5	B	No	
8	2"	#24	S1	E	No	J6	B	Yes	
9	12"	#24	S1	E	No	S7	B	Yes	
10	4"	#24	S2	F	Yes	J6	A	Yes	
11	3"	#24	S2	D	Yes	J7	A	Yes	
12	2"	#24	S2	A	Yes	S3	D	No	
13	2"	#24	S2	C	Yes	S3	F	No	
14	2 1/2"	#24	S3	A	Yes	J9	A	Yes	
15	3 1/2"	#24	S3	C	Yes	J8	A	Yes	
16	2"	#24	S3	B	Yes	S5	B	Yes	
17	2"	#24	S4	B	No	D20	A	No	
18	1 1/2"	#24	S5	A	No	D19	A	Yes	
19	3"	#24	D20	A	Yes	D22	A	No	
20	1 1/2"	#24	D22	A	Yes	D21	A	Yes	
21	5"	#24	MOTOR 1A		Yes	J10	B	Yes	
22	5 1/2"	#24	+5		Yes	S1	B	Yes	
23	9 1/2"	#24	READ DATA		Yes	D22	B	Yes	
24	5"	#24	GROUND		Yes	S1	E	Yes	
25	6 1/2"	#24	RELAY 1		Yes	S3	F	Yes	
26	11"	#24	RECORD DATA		Yes	D21	B	Yes	
27	4 1/2"	#24	MOTOR 1B		Yes	J10	A	Yes	
28	11"	#24	LOCAL/REMOTE		Yes	S7	C	Yes	
29	9"	#24	READER OFF		Yes	S5	C	Yes	
30	8"	#24	RECORD RLY DRIVER		Yes	S2	B	Yes	
31	6 1/2"	#24	MANUAL MOTOR CNTRL		Yes	S1	C	Yes	
32	7"	#24	READ RELAY-DRIVER		Yes	S3	E	Yes	
33	6 1/2"	#24	RELAY 2		Yes	S3	D	Yes	
34	3"	#24	MOTOR 2A		Yes	J11	B	Yes	
35	7"	#24	MOTOR 2B		Yes	J11	A	Yes	
36	5 1/2"	#24	READER ON		Yes	S5	A	Yes	
37	7"	#24	RECORD ON		Yes	S4	A	Yes	
38	7"	#24	RECORD OFF		Yes	S4	C	Yes	
39	4"	#24	READ READY		Yes	D20	B	Yes	
40	6"	#24	RECORD READY		Yes	D19	B	Yes	
41	5 1/2"	#24	AUDIO OUTPUT		Yes	S2	E	Yes	
42	4"	#24	AUDIO INPUT		Yes	S3	B	Yes	
43	10"	#24	CARRIER DELAY EN.		Yes	S1	F	Yes	
44	5"	-	GROUND		Yes	T1	Grn.-Yel	-	
45	5"	-	18 VAC A		Yes	T1	Green #1	-	
46	5"	-	18 VAC B		Yes	T1	Green #2	-	

## Switches, Indicators & Jacks

The complement of front panel switches, indicators and jacks includes the following:

MIC, EAR and REMOTE jacks for recorder A: These jacks should be connected thru patch cords to the cassette recorder's respective jacks. It is often times necessary to patch the MIC output of the cassette interface to the AUX input rather than the MIC input of the recorder to be used. Some experimentation may be necessary here. Be sure the cassette recorder(s) you select have a REMOTE jack on them. This is necessary in order to have cassette recorder motor control.

MIC, EAR and REMOTE jacks for recorder B: These jacks may be used for feeding a second cassette recorder often required when using Editor/Assembler software packages. Their functional description is identical to that provided for recorder A.

RECORD SELECT A/B: When this two position switch is in the A position, the cassette interface will output all record data to cassette recorder A. When in the B position it will output all record data to cassette recorder B.

READ SELECT A/B: When this two position switch is in the A position, the cassette interface will input all read data from cassette recorder A. When in the B position it will input all read data from cassette recorder B.

RECORD STATUS ON/OFF: This three position switch is normally left in the center position allowing computer program generated control commands to set the state of the record latch. Momentarily flipping the switch to the ON or OFF position will manually update the status of the record latch. Leaving the switch in either the ON or OFF position will override computer program control entirely. A convenient LED status indicator just to the left of this switch always shows the state of the record latch. The operation of the cassette interface as a function of the state of the record latch is dependent upon the setting of the motor control switch which is described in detail later.

READ STATUS ON/OFF: This three position switch is normally left in the center position allowing computer program generated control commands to set the state of the read latch. Momentarily flipping the switch to the ON or OFF position will manually update the status of the read latch. Leaving the switch in either the ON or OFF position will override computer program control entirely. A convenient LED status indicator just to the left of the switch always shows the state of the read latch. The operation of the cassette interface as a function of the state of the read latch is dependent upon the setting of the motor control switch which is described in detail later.

RECORD DATA INDICATOR: This LED indicator shows the transmission of valid record data out of the cassette interface. It lights only when the record latch is on and logic zeros or spaces are being transmitted. This allows the operator to confirm that a tape dump is in progress when lit since the null data marking output does not light the indicator.

READ DATA INDICATOR: This LED indicator shows the receipt of valid read data into the cassette interface. It lights only when the read latch is on, valid FSK data is detected on the tape and logic zeros or spaces are being received. This allows the operator to confirm that a tape load is in progress when lit since the null data marking input or a loss of audio tones does not light the indicator.

MOTOR CONTROL - MANUAL/AUTO: The position of the motor control switch actually determines the function of the record and read status latches. In the MANUAL position both the record and read cassette recorder motors are always activated thru their respective REMOTE jacks. If the record latch is off, the interface's selected recorder MIC jack will output a constant marking carrier, even if there is data flowing back and forth between the computer and terminal. As soon as the record latch is turned on either by the computer or manual control, all data transmitted from the computer to the terminal is simultaneously transmitted out thru this same MIC jack. Data flow out of the MIC jack ceases as soon as the record latch is again reset by either manual or computer control.

If the read latch is off the interface will ignore all data incoming thru its selected EAR jack and yet pass data back and forth between the terminal and computer. If the read latch is turned ON either by manual or computer control and valid audio tones are sensed from the selected EAR jack, read data is stored from the cassette unit to the computer. This same data is simultaneously displayed on the attached terminal system only if the computer is programmed to echo the incoming cassette data. Data flow from the cassette to the computer system ceases either upon resetting the read latch or loss of audio tones on the tape.

Operation in the AUTO position is quite different. If both the record and read latches are reset, cassette recorder motor operation is inhibited thru the respective REMOTE jacks on both the record and read recorders. The interface's selected record MIC jack will output no audio data, even if there is data flowing back and forth between the computer and terminal. As soon as the record latch is turned ON, the recording recorder's motor is turned on thru the respective REMOTE jack and a variable delay timer is fired which delays the output of audio marking data to allow this same cassette recorder's tape to come up to normal tape speed. This hardware delay circuit must be supplemented with a software delay loop written into your programs to guarantee that you don't start outputting record data until after this hardware delay timer on the cassette interface has already timed out. When the record latch is again turned off, the interface will cease to output audio data and the selected recorder's motor is turned off. Here again it is wise to include a software delay loop in your programs to give the recorder time to come to a complete stop. This guarantees a sufficient gap between multiple recorded segments to allow one to do either incremental (start-stop) or continuous reads from the same tape.

When the read latch is turned on the read recorder's motor is started. The interface inhibits all read recorder data until valid audio tones are detected, at which time all incoming cassette data is stored to the computer and simultaneously displayed on the terminal only if the computer's echo is enabled. Reads may be either continuous or incremental (start-stop). Since incremental tapes have blank gaps between recorded segments, the cassette interface's audio tone sensing circuitry has been designed to ignore all but the valid data segments stored on the tape.

LOCAL/REMOTE switch: The LOCAL/REMOTE switch on this cassette interface is analogous to that on standard teletypewriters. In the LOCAL mode there is a direct data link between the terminal and cassette recorder(s). The computer is electrically eliminated from the system. In the REMOTE or normal mode of operation, the computer, terminal and cassette recorder(s) are all linked together.

POWER ON/OFF: This switch controls AC power to the cassette interface unit. It must be powered up consistently with the interconnected computer and terminal systems even if cassette operation is not desired.

### Attaching the Interface to the Recorders

If you will be using the interface just for loading and storing programs and data files to and from tape you will probably need just one cassette recorder. If however, you will be doing tape file editing or using assembler packages you will probably have to use two cassette recorders. The same single interface will handle both configurations. Electrical connections between the cassette interface and recorders are best made by cutting several 3' to 4' audio patch cords with the molded RCA connectors on both ends, in half and fitting the newly cut ends with the appropriate recorder jack mating connectors. Some cassette recorders such as the ones used with the prototype have both high level AUX and low level MIC inputs. In our case it was necessary to use the AUX input since the cassette recorder circuitry would not permit the reading of a tape with a plug simultaneously installed in the MIC jack. Be sure to use a cassette recorder featuring an AGC (automatic gain control) circuit. Most all late model cassette recorders have this feature. Since cassette motor control is available you will want a recorder with a REMOTE jack that stops the recorder's motor. Here again recorder circuitry varies. Some units disable just the motor while others disable everything. It is best in this instance to just disable the motor, the idea being to minimize the recorded transients between blocks of data when using the interface in the incremental (start-stop) mode of recording. The recorders used with the prototype were Superscope models C-101A. Although they were reliable, close examination of the quality of recorded data with an oscilloscope left a lot to be desired. The optimum volume control setting was around 7 on a scale of 0 to 10.

The quality of the cassette tape used with your recorder(s) will also affect the reliability of your system. Here the best rule of thumb is to assume you get what you pay for. The most expensive tapes will generally give you better reliability. Remember too that you are recording audio frequency data not saturated pulses, so don't use digital computer grade cassette tapes. Always erase previously recorded tapes with a bulk tape eraser such as a Radio Shack #44-210 (\$9.95) before rerecording them. This is especially important when using the system in the incremental (start-stop) mode of operation. Bulk tape erasers generally do a better job of erasing than your recorder's internal circuitry and guarantee that you don't pick up segments of previously recorded programs or data.

Superscope is a registered trademark of Superscope Inc.

The interface's read circuitry must be calibrated for use in the read mode before using the interface. This is best done by using your computer or terminal to generate a calibration tape with continuous ASCII 5's recorded on it and then reading back the tape to the computer in the REMOTE mode or terminal in the LOCAL mode while adjusting trimmer resistor R16 for a center setting between errored reads. ASCII fives have an alternating bit sequence ideal for calibration. It is a good idea to periodically recheck this setting using your previously generated calibration tape.

Before using your cassette interface unit in the incremental (start-stop) mode of recording it will be necessary to set the time delay on the carrier enable one shot, trimmer resistor R39, so as to allow the recorder's motors to come up to speed before outputting a marking audio tone. This is best done by visually measuring your recorder's motor start time and then multiplying by two just for a safety factor. The interface's delay is then set by adjusting trimmer resistor R39 for this same time delay between the time the RECORD "READY" indicator lights and the CARRIER ENABLED indicator (LED diode D18) comes on. The latter is mounted right on the interface's PC board adjacent trimmer resistor R39.

Whenever you are writing to tape in the incremental (start-stop) mode you must provide a software delay loop in your program that is at least as long as the adjustable hardware timer delay plus 0.5 seconds. The additional half second is required to guarantee a carrier detect signal before data flow when the tape is being read. It is also a good idea to put a header character or characters at the beginning of each incremental record. Upon reading these records, your program should be written such that it ignores all data between these recorded segments until this header data is read. The cassette interface is more vulnerable to error reads between incrementally recorded data than at any other time. The end of each data block may easily be detected by recording some non-displayed control character at the end of each data block. If you are using the cassette interface with the SWTPC 6800 Computer system and CT-1024 (TV Typewriter II) terminal system, the decoded RECORD OFF ASCII Control T command (14<sub>16</sub>) not only turns the recorder off but is written at the end of the data record as well, for an end-of-record character.

Incrementally recorded records may be read either continuously or incrementally. In either case you must provide a software delay in your program at least one character time (33 milliseconds) between the time the end-of-record character is read and the time data is output from the interface. The reason being that there is a slight delay between the loss of carrier on the tape and action of the CARRIER DETECT circuitry which in turn creates a gap in the 16 X UART clock. This gap causes no problems so long as you are not outputting data during the clock gap thus the reason for the delay.

Fortunately all of the formentioned considerations are only necessary when using the interface in the incremental (start-stop) mode. Operating the system in the continuous (motor control disabled) mode isn't much different from paper tape operation. You will of course have to manually start and stop the recorders but no special recording considerations are necessary which usually allows use of unmodified computer resident tape load and dump routines for program storing and loading.

## Interfacing to a SWTPC 6800 and CT-1024 Terminal System

As mentioned earlier the ideal configuration for using the AC-30 Audio Cassette Interface is with the SWTPC 6800 Computer System and CT-1024 Terminal System. The Terminal system must be outfitted with the CT-S Serial Interface along with the CT-SO optional baud rate kit. For those not already having the baud option, we now offer the optional baud rate kit for \$14.75 Ppd, in the U.S. The terminal and computer must be operated at 300 baud. The terminal system must also be outfitted with the CT-CA Computer Controlled Cursor Option. This board is necessary to generate the decoded control commands which are fed to the AC-30 Cassette Interface.

Electrically the AC-30 Cassette Interface is plugged in series between the 6800 and the CT-1024. You simply remove the plug connecting the CT-1024 Terminal System to the computer's control interface and plug it into the AC-30 instead. A separate connector then connects the AC-30 Cassette Interface to the MP-C Control Interface on the Computer System. The computer's MP-C Control Interface must be jumpered for 300 baud operation. In this configuration all data passing between the computer and terminal may if selected be written to tape or supplemented with data from tape. Connections from the CT-1024 Terminal System's CT-S Serial Interface 16X baud rate clock and CT-CA Computer Controlled Cursor decoded control command logic are made to the AC-30 Cassette Interface thru the center connector on the back of the AC-30 circuit board.

The SWTPC 6800/CT-1024 Interconnection Drawing shows all connections that need be made for this configuration. The AC-30 Cassette Interface must always be powered up when using the system even if you are not using a cassette tape since all computer/terminal data flow is thru the cassette interface. After attaching the supplied connector to the CT-1024 Terminal System you should note that the 16X clock for the CT-S Serial Interface was broken when installing the cassette connector. This brake prevents the CT-1024 Terminal System from operating if it is not attached to the AC-30 Cassette Interface. For this reason the connections for a dummy plug have been shown which must be plugged onto the CT-1024 Terminal System's connector for stand-alone operation. so don't forget to install the dummy plug on the terminal's connector when using the terminal system without the AC-30 Cassette Interface.

After actually interconnecting the AC-30 with your system flip the LOCAL/REMOTE switch to the REMOTE position and you should find that you have normal communication with the computer system. If you flip the same switch to the LOCAL position you should find that everything typed on the terminal's keyboard is echoed to the terminal's screen, even though the ECHO ON/OFF switch on the keyboard is in the OFF position. Before you actually try to load or store a program on tape, the unit must be calibrated using the FIVPNT-1 Interface Calibration Program. A copy of this program is contained within a separate section of this instruction set. It might also be wise to run the other diagnostic programs which are also contained within this instruction set. When you are running the diagnostic programs you may find that the terminal will occasionally omit a character when reading a tape back in the LOCAL mode. This as we found is a problem in the terminal and not in the AC-30 Cassette Interface. If you wish to correct the problem carefully separate pin 1 of IC31 on the CT-1024 Terminal System from its connection to the circuit board. Attach and solder a wire from this now isolated pin to IC26 pin 13. It is a good idea to increase the value of C4 on the CT-CA board on the CT-1024 Terminal System from a 100 pfd capacitor to a 1000 pfd capacitor. You may also find when you are reading back tapes recorded in the incremental mode that question marks occasionally show up between incrementally recorded records. This is where the AC-30 is most vulnerable to errored reads and is best solved by your putting a header character s) at the beginning of each incrementally recorded record as the

Editor/Assembler programs do. Header characters have not been used in the diagnostics so that the user may see all non-control character data written to tape.

Some experimentation with volume control settings will probably be necessary. Run the diagnostics at various volume control settings and choose the one that gives you the most reliable results.

Let's assume now we have a SWTPC 6800 Computer and CT-1024 Terminal System interfaced together with 300 baud RS-232 serial interfaces. As mentioned earlier for this configuration, the cassette interface is connected in series between the two taking full advantage of the computer's firmware resident tape dump and load routines. Let's assume we have a program we wish to dump to tape which is already stored in the computer's memory with the computer's program counter, storage addresses (A048 and A049), set to the starting location of the program. Now use the memory change function to set the starting and ending addresses of the memory segment to be dumped in locations A002 thru A005.

The cassette interface's switches should be set for manual motor control with the RECORD/READ status switches in the center position and the LOCAL/REMOTE switch in the REMOTE position. Load a blank or previously erased tape into the selected cassette recorder and depress the REWIND button to get to the beginning of the tape. Then depress the PLAY button to advance several seconds beyond the leader on the tape. Stop the recorder and this time depress the cassette recorder RECORD button. Then enter a P for punch on the terminal's keyboard. The record STATUS light will come on and the record DATA light will flicker as program data is stored to the cassette tape. When the dump is completed both the STATUS and DATA lights will go out. Do not stop the recorder, instead set memory locations A002 thru A005 to dump the data stored in the program counter storage addresses as well. Since the record STATUS light is not lit, none of this data passing back and forth between the terminal and computer is written to the still operating recorder. Again enter a P for punch. The STATUS and DATA lights will again come on, but only for a fraction of a second since only two memory locations are written to the tape. Now while the cassette recorder is still recording flip the LOCAL/REMOTE switch to the LOCAL position, use the manual RECORD status switch to set the record STATUS latch and type in on the terminal's keyboard S9. Reset the RECORD status latch to the off position and stop the recorder. Don't forget to flip the LOCAL/REMOTE switch back to the normal REMOTE position.

Before trying to load this same program you might want to momentarily turn the computer off just to make sure the memory resident program is destroyed before loading. Reapplying power will force an auto-reset and bring up the resident MIKBUG firmware on the SWTPC 6800. Rewind the tape to the beginning, make sure the cassette recorder's volume is set to a reliable setting and depress the play button. Then type in a L for load on the terminal's keyboard. The read STATUS light will immediately come on since the firmware outputs a READ ON control command. The DATA light however will remain off until program data is detected on the tape at which time it will begin to flicker. When it stops flickering it means that the program data has been loaded to the computer's memory but don't forget that the program counter data was also written to the tape so the next flicker is that of the program counter being loaded. A S9 was also written to the tape which is an end of tape marker. Upon reading this the computer will output a READ OFF control command forcing the read STATUS light to go out hence ignoring all subsequent data stored on the tape should the recorder be left to run. The program as well as the program counter have been loaded. Simply typing in the character "G" for go should initiate the program.

MIKBUG is a registered trademark of Motorola Inc.

## Interfacing to a SWTPC 6800 and non-CT-1024 300 Baud Terminal System

The terminal used must be a 300 baud RS-232 terminal as is the CT-1024 Terminal System. It is desirable that the terminal have an accessible 16X baud rate clock. If not, it is still usable but you will not be guaranteed of reliable tape reads when reading tapes in the LOCAL mode. You will also not be able to record tapes directly from the terminal in the LOCAL mode since the AC-30 logic requires the terminal's 16X baud rate clock for recording. If your terminal does not have control character decode circuitry you may still load programs but without software control. The Editor/Assembler software package requires motor control and for this reason has motor control logic fed out of unused lines on the MP-C Control Interface board. This means that you can derive the cassette logic control for the AC-30 Cassette Interface from a connector installed on the MP-C Control Interface board. This cassette control logic is only functional when the Editor/Assembler software is resident and will not operate with the MIKBUG firmware or other software packages unless the appropriate driving software has been written into them. Since MIKBUGR is tolerant of non-program data encountered when loading tapes we may fortunately still load and store programs without cassette logic control. If by chance your terminal does have control character decode circuitry, it is unlikely its timing and phasing are the same as that of the CT-CA board on the CT-1024 Terminal System. The Reader ON, Reader OFF, Record ON and Record OFF control lines should be TTL compatible pulses between 1 and 1000 microseconds duration. The logic is set up for negative going pulses, however, grounding the CONTROL INVERT line on the AC-30 board programs the AC-30 for positive going pulses.

If you are forced to use the cassette control logic put out on the SWTPC 6800's MP-C Control Interface board by the Editor/Assembler software, make the following connections from the indicated pins of IC1 on the MP-C Control Interface board to the specified pins of a twelve pin male connector shell. Be sure to make the wires long enough to reach your AC-30 Cassette Interface where the connector will be plugged. If you do have access to your terminal's 16X baud rate clock, the terminal's clock buss should be broken and the 16X clock OUT and 16X clock IN lines brought out to the same connector:

FROM	TO
MP-C IC1 pin 7	12 pin male shell female pin #1
MP-C IC1 pin 4	12 pin male shell female pin #2
MP-C IC1 pin 6	12 pin male shell female pin #3
MP-C IC1 pin 5	12 pin male shell female pin #4
Terminal's 16X clock OUT	12 pin male shell female pin #5
Terminal's 16X clock IN	12 pin male shell female pin #6
MP-C ground	12 pin male shell female pin #12

The mating connector on the AC-30 Cassette Interface as well as other interconnections to the unit should be installed just as it is shown in the interconnection drawing for the SWTPC 6800 and CT-1024 Terminal System.

Let's assume now that we have a SWTPC 6800 Computer System, AC-30 Cassette Interface and 300 baud terminal system and are taking cassette control commands off the MP-C Control Interface on the SWTPC 6800 Computer System. Although the AC-30 Cassette Interface is in series between the computer and terminal systems we have no means of getting the cassette control commands to the cassette interface since the MIKBUG R firmware does not generate cassette control commands on the MP-C Control Interface board. Once the Editor/Assembler program has been loaded the input/output routines within the package provide the necessary cassette control commands required for the software motor control mode of operation of the package.



You do not have to have cassette control logic to simply load and store programs with the AC-30 Cassette Interface although it is easier to use if you do.

Let's assume now we have a program we wish to dump to tape which is already stored in the computer's memory with the computer's program counter, storage addresses (A048 and A049), set to the starting location of the program. Now use the memory change function to set the starting and ending addresses of the memory segment to be dumped in locations A002 thru A005. The cassette interface's switches should be set for manual motor control with the RECORD/READ status switches in the center position with the status lights nut and the LOCAL/REMOTE switch in the REMOTE position. Load a blank or previously erased tape into the selected cassette recorder and depress the REWIND button to get to the beginning of the tape. Then depress the PLAY button to advance several seconds beyond the leader on the tape. Stop the recorder and this time depress the cassette recorder RECORD button. Flip the RECORD status switch to set the RECORD status light ON. Then enter a P for punch on the terminal's keyboard

The record DATA light will flicker as program data is stored to the cassette tape. When the dump is completed the DATA light will go out. Do not stop the recorder, instead set memory locations A002 thru A005 to dump the data stored in the program counter storage addresses as well. Since the record STATUS light is lit this data passing back and forth between the terminal and computer is written to the still operating recorder but is however ignored when loading the program. Again enter a P for punch. The DATA light will again come on, but only for a fraction of a second since only two memory locations are written to the tape. Now while the cassette recorder is still recording flip the LOCAL/REMOTE switch to the LOCAL position and type in on the terminal's keyboard, S9. You can only type the S9 if you have the 16X baud rate clock fed from your terminal to the AC-30 Cassette Interface otherwise omit this step. Now you may stop the recorder. Don't forget to flip the LOCAL/REMOTE switch back to the normal REMOTE position and reset the record STATUS light OFF.

Before trying to load this same program you might want to momentarily turn the computer off just to make sure the memory resident program is destroyed before loading. Reapplying power will force an auto-reset and bring up the resident MIKBUG R firmware on the SWTPC 6800. Rewind the tape to the beginning. Make sure the cassette recorder's volume is set to a reliable setting and depress the play button. Then type in a L for load on the terminal's keyboard set the read STATUS light ON. The DATA light will remain off until program data is detected on the tape at which time it will begin to flicker. When it stops flickering it means that the program data has been loaded to the computer's memory but don't forget that the program counter data was also written to the tape so the next flicker is that of the program counter being loaded. If an S9 was written to tape which is an end of tape marker, a \* will be printed on the screen upon termination of loading. The read STATUS light must be immediately manually reset OUT. If an S9 was not written to tape, a \* will not be printed and the read STATUS light will have to be manually reset OFF immediately upon loading the second string of data. The S9 is then manually typed in from the terminal's keyboard and the computer responds with a \*.

The program, as well as the program counter, have now been loaded. Simply typing in the character G for go should initiate the program.

## Interfacing to a SWTPC 6800 and non-300 Baud Terminal System

Since the AC-30 Audio Cassette Interface must be operated RS-232 serial at 300 baud, it cannot be implemented serially between the computer's control interface and the terminal system on non-300 baud or non-RS-232 terminal systems. The only option the user has in these cases is to operate the AC-30 Cassette Interface thru an optional serial type interface connected to one of the unused I/O slots on the computer system. The big disadvantage here is that the MIKBUG resident tape load and dump routines are only functional on the I/O slot #1, the MP-C Control Interface position. Locating the AC-30 Cassette Interface at any other I/O position means that all tape load and dump routines will have to be keyed in manually by the user before the AC-30 Audio Cassette Interface can actually be used to load programs. The other problem is that we no longer have any way of deriving motor control for the cassette unit since motor control commands sent out thru the MP-C Control Interface on I/O card slot #1 are of no use to us. On top of that the standard MP-S serial interface option does not have enough control lines available to provide READER ON, READER OFF, RECORD ON and RECORD OFF logic control for the attached AC-30 Cassette Interface. For these reasons it is our recommendation that the AC-30 be interfaced to the computer system thru a separate MP-C Control Interface configured for 300 baud located at some unused I/O card position on the interface buss. This means there will be a larger overhead in software for the user but the extra unused parallel lines on the parallel PIA integrated circuit may be used for AC-30 READER ON, READER OFF, RECORD ON, and RECORD OFF control functions. Our cassette version of the Editor/Assembler software already has I/O routines contained within to drive an MP-C Control Interface located at any I/O card position on the SWTPC 6\$00 Computer System. READER ON, READER OFF, RECORD ON and RECORD OFF control commands may be taken off unused pins on the PIA parallel interface chip. The lines have been assigned on the control interface when using the Editor/Assembler software package. It is suggested that you use the same assignments to maintain consistency.

To actually use these logic/control lines within your own programming you will have to write routines within your own cassette I/O software package to put a TTL compatible 1 to 1000 microsecond negative going strobe pulse on the respective PIA pin to generate the desired command. A connector is attached from these MP-C PIA pins to the control lines on the AC-30 Cassette Interface and is installed as follows.

Make the connections from the indicated pins of ICI on the MP-C Control Interface board to the specified pins of a twelve pin male connector shell, Be sure to make the wires long enough to reach your AC-30 Cassette Interface where the connector will be plugged:

FROM	TO
MP-C IC1 pin 7	12 pin male shell female pin #1
MP-C IC1 pin 4	12 pin male shell female pin #2
MP-C IC1 pin 6	12 pin male shell female pin #3
MP-C IC1 pin 5	12 pin male shell female pin #4
Terminal's 16X clock OUT	12 pin male shell female pin #5
Terminal's 16X clock IN	12 pin male shell female pin #6
MP-C ground	12 pin male shell female pin #12

The mating connector on the AC-30 Cassette Interface should be installed just as is shown in the interconnection drawing for the SWTPC 6800 and CT=1024 Terminal System. Other connections are made as shown in the appropriate block diagram. All data connections made to the AC-30 should be thru the connector provided for the computer. Since there will be no terminal connected directly to the AC-30 there is of course no LOCAL mode of operation for the cassette system.

You will have to write your own cassette tape I/O routines in order to be able to load and dump programs to and from the AC-30 Cassette Interface which is now interfaced to an MP-C Control Interface somewhere other than I/O Card position #1. You should be able to use the MIKBUG R source listings of the tape load and punch routines to aid you in writing your own for the cassette interface. If the routines are kept short enough you might be able to load them into unused areas of the MIKBUG RAM which would give your programs complete use of 0-32K user memory. The tape load and dump programs will however have to be typed in manually from the terminal before using them.

#### How It Works

For simplicity the cassette interface's circuitry has been broken up into three separate systems: The modulator/demodulator circuitry, the switching circuitry and the power supply.

The modulator works by feeding a 4800 Hz (16 X 300 baud) clock into divide by two IC5B. This insures a 50% duty cycle required by the modulator. The CARRIER ENABLE input provides a means of suppressing audio output from the modulator. IC5A functions as a divide by two if the DATA IN line is high and a divide by one if the DATA IN line is low. This gives a 1200 Hz tone for a low and a 2400 Hz tone for a high. This resulting output is then fed into two pole active filter IC4A where it is converted to more of a sinusoidal audio waveform which is more easily handled by audio recorders.

Incoming audio data is first fed into a high pass filter consisting of R5 and C5 and then onto comparator IC4B. The comparator's 0.5 volt hysteresis reduces the possibility of false triggering. The +7.5 volt zener regulated power busses feeding IC4 are necessary to stabilize this hysteresis value. Zener diode clamp D3 limits comparator IC4B's output to CMOS compatible voltage levels. Each time the comparator changes states IC3C and IC3D generate a 5 microsecond negative pulse at IC3 pin 11. This pulse is repetitive when data is being received and pulls capacitor C7 down to ground thru diode D4. Capacitor C7's output is in turn inverted and buffered thru IC3A to form the CARRIER DETECT output signal. This same negative going pulse is inverted by IC2A where it feeds four separate circuits. The first is a missing pulse detector composed of transistor Q2 and inverter IC2B. This forces the buffered CARRIER DETECT signal low whenever several cycles of audio carrier are missed. The second circuit is also an adjustable missing pulse detector but this one times out whenever 1200 Hz or space data is being fed into the demodulator. Trimmer resistor R16 sets the period for this timer. The third circuit driven by this pulse is flip flop IC1A which outputs the demodulated data. This DATA OUT line is high when 1200 Hz audio is being demodulated and low when 2400 Hz audio is being demodulated. The fourth circuit fed by the pulse is IC2D which with the addition of the output of IC3B synthesizes the 16 X CLOCK OUT data. Take note that although this 16 X clock is accurate, it, by design, jitters.

Within the switching portion of the circuit, integrated circuit halves IC8A and IC8B form RS status latches for the record and read circuitry. Either latch may be independently set or reset thru manual toggle switches on the interface's front panel or thru control pulses buffered and selectively inverted by IC13. Convenient front panel LED indicators always show the current status of these latches.

The multitude of data and clock switching is performed by six data selectors within IC6 and IC14. NAND gates IC9A and IC9B inhibit data and clock flow out to the cassette recorders unless the read latch is set and valid recorder carrier data is detected. Timer IC10 provides the adjustable CARRIER ENABLE delay needed when using the system for recording in the incremental (start-stop) mode. All 300 baud data communication with the cassette interface is done thru integrated EIA RS-232 receiver and transmitter integrated circuits IC12 and IC15 respectively. Motor control for each recorder is provided by reed relays RLY1 and RLY2.

# INTERCONNECTION BLOCK DIAGRAMS

## SWTPC 6800 Computer System /AC-30 /CT-1024 Terminal System

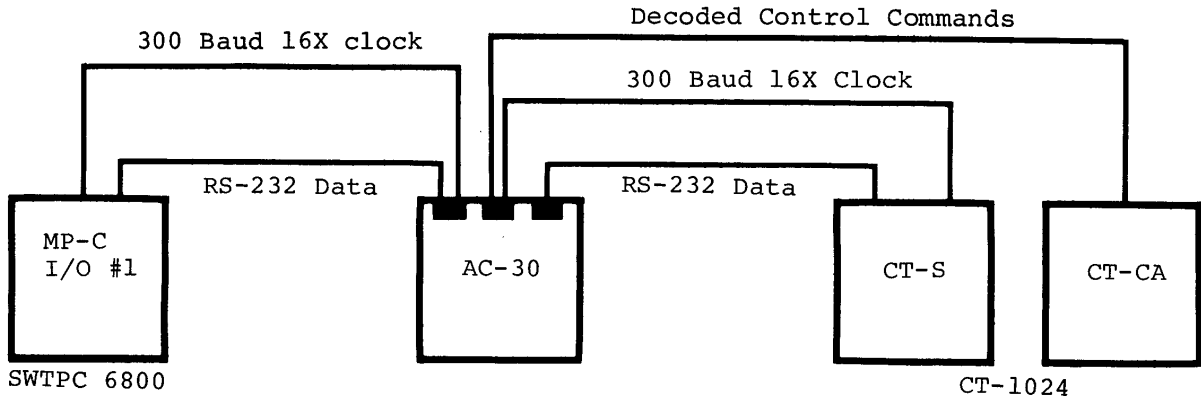

## SWTPC 6800 Computer System /AC-30 /NON-CT-1024 300 Baud Terminal System

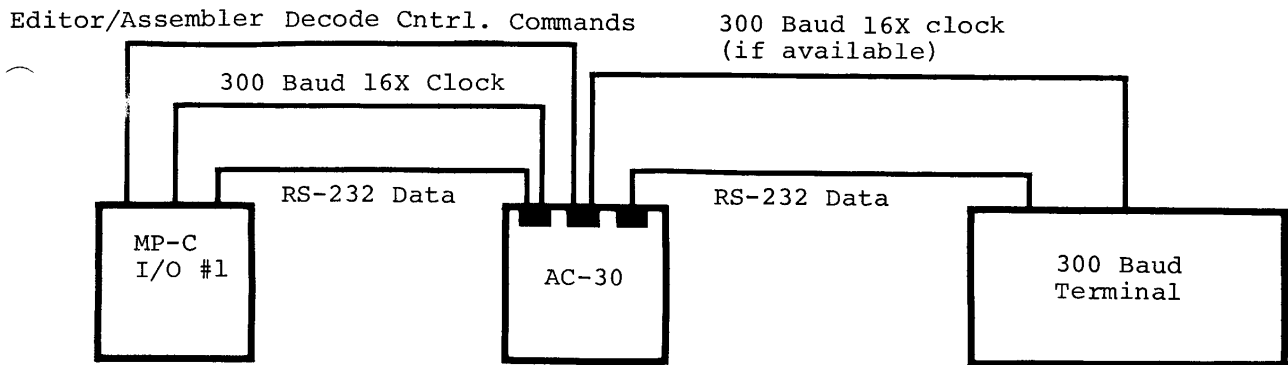

## SWTPC 6800 Computer System /AC-30 /NON-300 Baud Terminal System

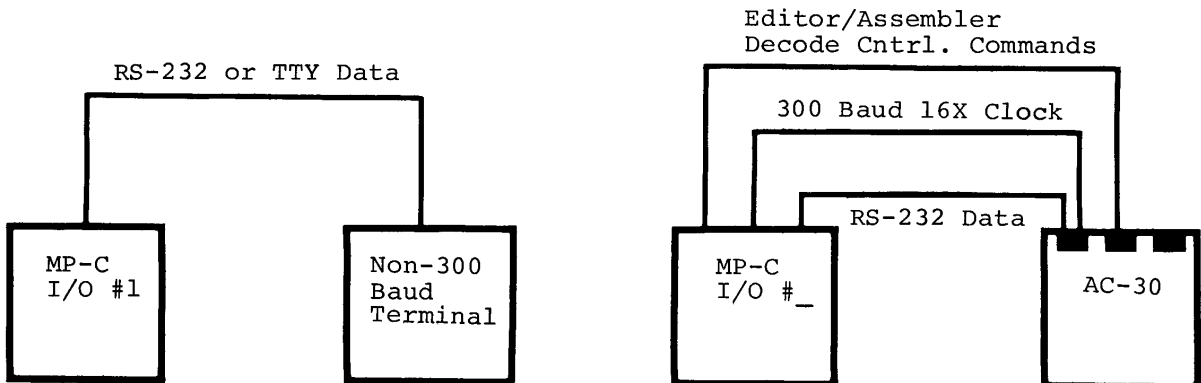

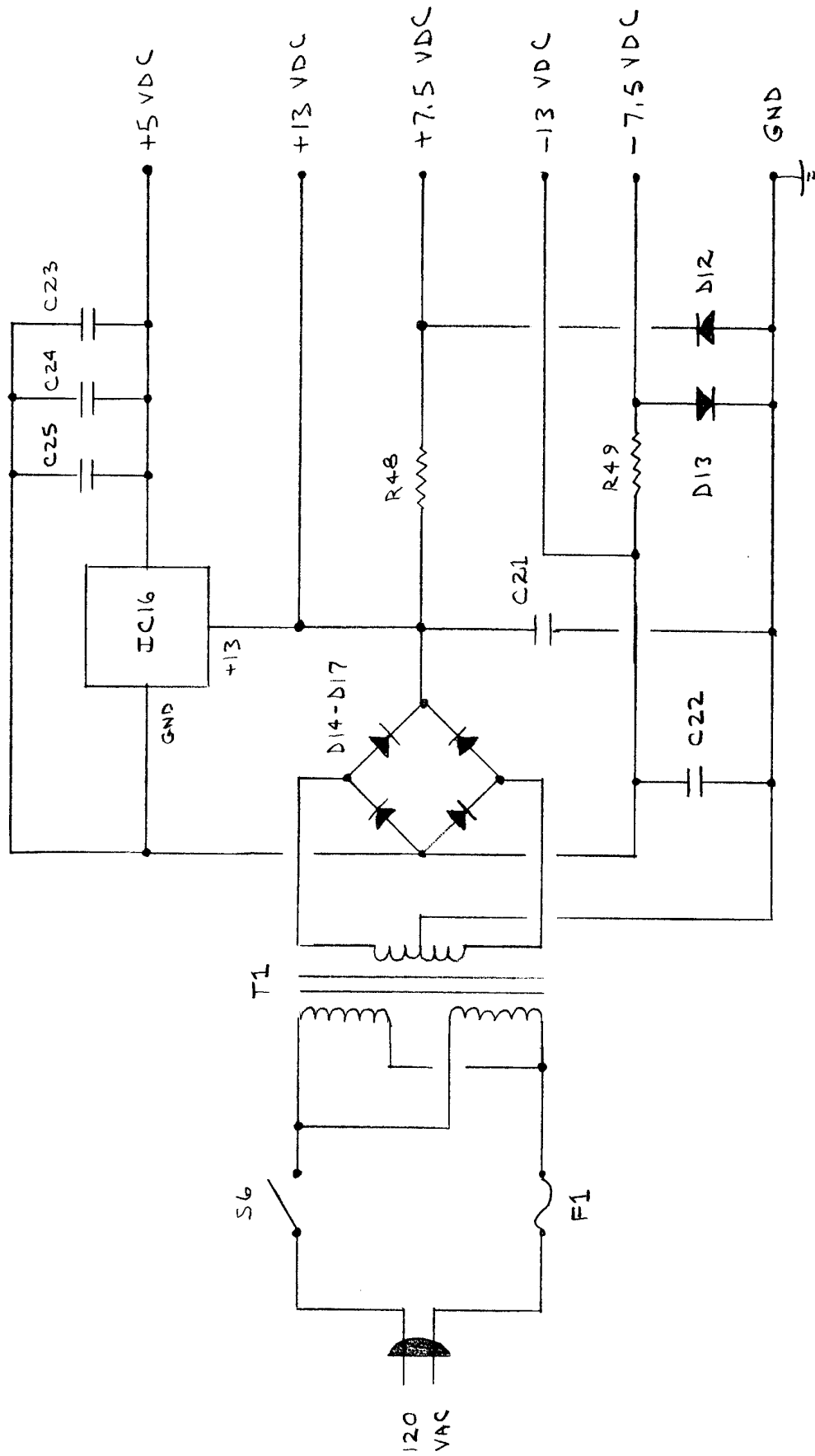

SWTPC AC-30 AUDIO CASSETTE POWER SUPPLY SCHEMATIC

