

# The Evil, Infamous, Unreliable, Flaming... Electrohome

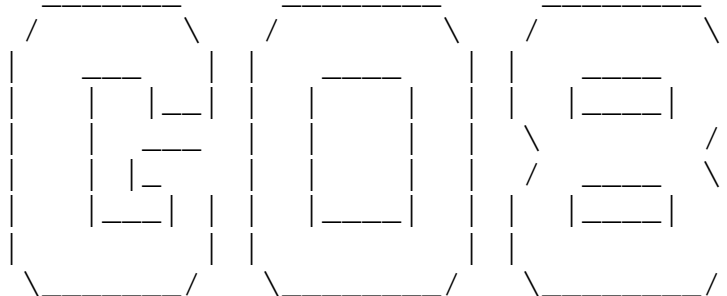

FAQ version 1.1  
Oct 7th, 2002

## Table of Contents

INTRODUCTION .....	2
MONITOR HISTORY .....	3
PART DESCRIPTIONS .....	5
HOW IT ALL WORKS .....	14
REPAIR PREPARATION.....	15
DEBUGGING THE MONITOR .....	19
INSTALLING A CAP KIT .....	26
MAKING THE MONITOR MORE RELIABLE.....	31
TUBE REPLACEMENT .....	33
USING A G08-003 WITH COSMIC CHASM .....	34
Appendix A: Common Ground Connections.....	36
Appendix B: Testing Transistors .....	37
Appendix C: Parts Lists .....	39
REFERENCES .....	41
DOCUMENT HISTORY .....	41

**CAUTION: The Electrohome G08 monitor is extremely flammable. Do not operate around combustible liquids or materials. This document should not be used to put out any flames caused by the monitor.**

---

## INTRODUCTION

---

Ok, enough making fun of the G08 :-). It is actually a pretty strong monitor considering the work that it does, and when it is working it is a fairly impressive color vector monitor. There are horror stories about this monitor, and most of them **are** true (and the list is long), but on the other hand, there are others have had theirs for 15 years without it breaking down once. Before working on your G08 monitor, read through this entire document, and be certain you have schematics for additional review.

### Acknowledgements

The following people have contributed to the development of this document: Mark Jenison; David Shuman; Michael Kelley; Al Kossow; Roger Boots; Zonn Moore and David Fish.

### DISCLAIMER

**CAUTION!!! LETHAL VOLTAGES ARE PRESENT IN ARCADE MONITORS. SUITABLE PRECAUTIONS SHOULD BE TAKEN BEFORE ATTEMPTING TO SERVICE YOUR MONITOR. REMEMBER, NO WARRANTIES, EXPRESS OR IMPLIED, ARE GIVEN. USE THIS INFORMATION AT YOUR OWN RISK. I AM NOT RESPONSIBLE FOR ANY DAMAGES THAT MAY OCCUR TO YOUR PERSON OR PROPERTY.**

The Electrohome G08 is the monitor that was used in the Sega/Gremlin color vector games Space Fury, Eliminator, Zektor, Tac/Scan, and Star Trek and in the Cinematronics game Cosmic Chasm. The Electrohome G08 monitors, like other vector monitors, were notorious for their failure rate. There were a few different versions of the G08 monitor in an attempt to evolve towards a more reliable design.

The first model of the Electrohome G08 monitor was the G08-001. Since Space Fury was Sega/Gremlins first color vector release, one might find this monitor in an early production Space Fury. The monitor, however, must have been very prone to failure, as in the initial manual there already was a “future” version already being worked on. The G08-001 monitor used MJ15003 and MJ15004 deflection transistors and had direct connections from the deflection transistors to the deflection board. Sega determined that the problems encountered with the G08-001 were centered around the deflection amplifiers. Underrated power transistors combined with an extended "on" time during the power-up routine resulted in damage to the amplifier circuit.

The second model was the G08-003 (there does not seem to be a G08-002). The most notable change in the G08-003 was the addition of two “current limiting” boards that are plugged in between the deflection board and the heatsink mounted deflection transistors. These boards provide current limiting and short circuit protection for the deflection transistors. All four deflection transistors were upgraded to 2N6259 transistors, and a HV regulator board was added to the HV unit.

However, Electrohome confused the issue of the G08-003 by releasing several different deflection board revisions under the same model number. These different “issues” are covered in the deflection board section of this document.

The third model of the monitor was the Electrohome G08-004. The preliminary manual, though it includes the G08-004 in the title, does not mention the G08-004, nor does it provide schematics. It is thought that the G08-004 is the monitor model used in the cocktail versions of the Sega XY games, meaning it is nothing more than a G08-003 mounted on a different frame. Whether or not the G08-004 is another version of the deflection board or just a monitor frame change is still a mystery.

According to the manual, Cinematronics’ Cosmic Chasm uses still *another* version of the monitor called the G08-105. There has been some speculation that Electrohome made this version of the monitor specifically for Cinematronics. The G08-105 was manufactured in October of 1982, and it uses SDT 1064’s for deflection transistors. A special transformer(s) used for this game outputs 49VAC from the center tap. On this version, the current limiting boards are removed, and their circuitry has been integrated into the deflection board. Also, the monitor expects inputs in the 1VDC to 4VDC range, whereas the other versions of the G08 expect inputs in the 0VDC (off) to 4VDC range (full brightness). The G08-105 also uses a Rauland medium resolution tube, 19VNJP22, and a different deflection yoke than the standard G08. Unfortunately, there is very little information known about this monitor.

This document mostly covers the Electrohome G08-003 model, since it is the most common of the monitor versions, and experience with the other versions of the monitor is limited. This document will discuss the parts of the Electrohome G08-003 monitor and the symptoms and testing procedures of the entire set up. Hopefully this document will assist in the repair and debugging of this monitor. But first, a little background into the history of the Electrohome G08 monitor.

---

## MONITOR HISTORY

---

The following information is a compilation of conversations, e-mails, and chats between Michael Kelley and Don Mahler, a Sega/Gremlin designer who worked on many of the vector games that used the Electrohome G08.

Don started at Sega/Gremlin in May 1981, while he was on recess from Cal Poly for the summer. He was hired initially to help design the Vector control and timing boards that are in the G-80 boardsets.

“At the time I came to work at Sega, the G80 setup was already there. I think Astro Blaster was one of the first to use the configuration. For the time it was pretty impressive. The modular design got some things done that would have been very difficult to do on a single board. The main CPU was not being taxed with sound/speech operations, so the speech was excellent for that time, and the sounds were nice, too.

They had already begun working on a game that they wanted to be vector, and decided they wanted it to be color as well. Initially, it reminded me of a vector version of Gorf, with the player being taunted by a weird alien during the game. None of the color routine was set up yet, (I think we were running a G05), and the game didn't look very much like the final product at all. This game ended up being Space Fury.

I was brought in after I spoke with an Electrohome representative who was lecturing at Cal [Poly]. He told me that they were working on a color Vector monitor, and since I was (and always have been) interested in games, he suggested that I apply to Sega/Gremlin on a co-op for summer work. I ended up working there for almost 3 years.”

“My job was to take the rough breadboard they had as a AVG and design something that would fit into the G-80 setup (this was a must, they were really in love with it) and eliminate the massive board they were using in the lab. I was initially going to try to do this on one board. But, after about 3 weeks into it, I decided that it would be impossible to do one board that would fit into the G80 cage. So, I came up with the idea of both the vector timing and control boards, and it ended up working out.”

“When I heard of the problems that plagued the monitor, I felt terrible. We at Sega (and Electrohome) really wanted a spot killer, but at the time, Atari sued whomever they wanted, and always won. The G05 design (Asteroids, Asteroids Deluxe, Battlezone, Red Baron, Bally's Omega Race, etc.) was actually developed by Atari. Atari's production was not geared to making monitors, so they commissioned Electrohome to produce the monitor (Atari actually received a cut for Bally using the G05 in Omega Race). So, using a spot killer was definitely out, and Electrohome had to come up with something else. Many aspects of the monitor and x/y timing and control boards were developed so that we wouldn't get crushed by Atari's legal dept...”

“I remember Mark Shayton (Sega/Gremlin head of engineering) having a fit over the G08's problems. Initially, they pointed the finger at me (I was the dumb intern, I made the x/y timing/control boards), but things got pretty hot (no pun intended) between Sega and Electrohome when it was proven that the monitor was the problem...”

## PART DESCRIPTIONS

The following sections describe the different major assemblies of the Electrohome G08-003 vector monitor. Before we delve into the different parts of the G08 monitor, it is important to discuss the different schematics that exist. The best schematics to reference are included in the Tac/Scan, Zektor or Star Trek manuals. These contain the schematics with the HV Regulator PCB, the Input Clamp board and the Current Limiting boards. From review, it appears Electrohome made updates to the G08 monitor, but Sega neglected to change this information in their manuals.

Below is a brief summary of the different manuals and their attributes. I have given some descriptions an “a”, “b”, or “c” designation. The “a” signifies the inclusion of the HV Regulator board only, while the “b” suffix includes both the HV Regulator board and the Input Clamp board. The “c” denotes the most complete information on the G08-003 monitor.

<u>Manual</u>	<u>Schematics</u>	<u>Parts List</u>	<u>Sega Drawing Number</u>
Eliminator	none	none	200-0025
Space Fury Preliminary	none	none	none
Star Trek	G08-003c	G08-003b	200-0025
Tac/Scan	G08-003c	G08-003b	200-0025
Zektor	G08-003c	G08-003b	200-0025
G08 Service Manual	G08-001; G08-003a	G08-001	none
G08-003/004 Preliminary Service Manual	G08-003b	G08-003c	none

### Input Clamp Board

This small 1 ½ x 3” board is usually mounted on a thin metal support across the back chassis of the monitor. This board prevents invalid inputs from overdriving the monitor. Without this board, the monitor picture will be too large, so the board does some “trimming down” of the signal inputs.

The input clamp board is the first interface into the monitor, and plugs into the main deflection board. Since it is screwed to a thin piece of metal, usually you will find non-conductive tape on the back of this board to prevent the header pins from grounding to the metal. A detailed parts list of the Input Clamp board is provided in Appendix A.

The Input Clamp board has a pinout as follows:

<b>Pin #</b>	<b>Description</b>	<b>Specification</b>
1	Horizontal Input	+/- 4V maximum
2	Vertical Input	+/- 3V maximum
3	Common	Ground
4	Red Input	+4V @ full brightness
5	Green Input	+4V @ full brightness
6	Blue Input	+4V @ full brightness

---

### **Deflection Board**

---

The deflection board is the large PCB mounted to the bottom of the chassis (7" x 10"). The G08-003 version will also have two vertically mounted PCBs (2" x 2") connected to the deflection board which mount on the header pins on the right side of the board. These are the "current limiting" boards. According to the schematics, the G08-001 does not have the "current limiting" boards, nor the header pins on the deflection board. Therefore, the deflection transistors would plug in directly to the G08-001 deflection board.

The horizontal and vertical "current limiting" boards were an attempt to add short circuit and current limiting protection for the output transistors. These boards would typically fail catastrophically in the event that something went wrong with the deflection circuitry.

The deflection board creates a low voltage power supply for the HV board, and controls the "X" and "Y" video amplifiers. Looking at the board with the potentiometers (controls) towards you, the upper right side of the board is "Y" deflection circuitry, the lower right/middle is the "X" deflection circuitry, and the left side of the board is the low voltage power supply.

There are several different versions of the deflection board that were made for the G08-003. They are easily distinguished from one another by looking at the top of the deflection board under the large 3-ohm 20W ceramic resistors (or 2 1.5-ohm 20W resistors, depending on your deflection board version) and looking for text stating "Issue X Component Layout", where "X" is the issue number.

Issue 1, 2, and 3 deflection boards have the same or similar component layouts as found in the "Sega/Gremlin" Color X-Y monitor manual. Issue 1, 2 and 3 deflection boards have resistors R636, R637, R736, and R737 typically on the bottom of the deflection board, or hacked into the current limiting boards.

Issue 4 deflection boards may or may not exist. It is currently unknown if any G08 Issue 4 deflection boards were produced.

Issue 5 deflection boards have places for resistors R636, R637, R736, R737 screened on top of the board. Issue 5 deflection boards may be found with or without diodes D601, D602, D701, and D702 populated. If your deflection board has these diodes, just leave them installed. They do not appear to make a functional difference.

There are even different issue numbers for the foil patterns screened on the bottom of the deflection boards. These issue numbers on the bottom of the deflection boards do not necessarily match the issue number on the top of the board. For example, you might find an issue 2 screen on a issue 3 deflection board, or issue 4 screen on an issue 5 deflection board.

All these different variations make it very difficult to write a document for a very specific deflection board. While one deflection PCB may look much different than another physically, most of the time one will find the components mounted or soldered somewhere else which makes the two boards functionally equivalent.

The schematics found in the Tac/Scan and Star Trek manuals matches the schematics found in the "Preliminary service data for the G08-003/004 X-Y color monitor (up to date as of Feb 1982)". Neither the schematics nor the parts list show diodes D601, D602, D701, or D702. For the most part, it appears that all issues of the G08-003 deflection board are attempts to hack (and probably should be hacked) to support the G08-003/004 schematics in general.

I would not recommend modifying any G08 deflection board from issue to issue, but to simply verify that the current hacks on the board match the schematics in the Tac/Scan or Star Trek manuals. If they do not, modify the deflection board accordingly.

The input amplifier, IC600, and surrounding circuitry on the deflection board serve two purposes: First, it compensates for a type of distortion known as the pincushion effect. This occurs because the electron-beam must travel a greater distance when striking the edges of the CRT than when it hits the center. If we cause the beam to trace along the edges of the CRT, the beam would draw a box with its left and right sides bowed inward. To compensate for the effect, this circuit offsets the point where the beam would normally strike the CRT surface.

Secondly, this circuit contains two error amplifiers, one for the horizontal and one for the vertical inputs. Each error amp has two inputs; one is set to zero volts, the other accepts the analog signal from the G-80 system, sensing current movement in the deflection coil. The analog signal is allowed to pass through the error amps and drive the deflection (power) amps. The outputs of the "X" and "Y" power amps pass current through their respective deflection coils. The output leads of the two coils are connected back to the analog inputs of the respective error amps, as mentioned above. This acts as an error, or feedback, signal and ensures that the current through the deflection coil remains proportional to the voltage on the error amp inputs. If this signal were not provided, there would be a slight deflection error when an analog input signal was present.

IC600 is a custom chip, Electrohome part number 14-002156-01 (and Sega part number 315-0117). This IC can be destroyed in certain failure modes, and since it is custom, the only way to repair a deflection board that has a bad or missing chip is to find another deflection board.

The circuit of D409, R410, and R411, in combination with IC900 on the HV board, is a spot-killer that prevents the electron-beams from burning a hole in the phosphor surface of the CRT when the monitor is turned off.

The outputs of the “X” and “Y” deflection amps can swing between +60V and -60V. This voltage is high enough to provide up to 8 amps, peak-to-peak, of current through the deflection coils. The power input of the deflection board is an isolated +45V Center Tap.

Pin #	Connection
1	45 VAC
2	Center Tap
3	45 VAC

One of the most important things to watch on these monitors is the input power. Input voltage is 91 VAC nominal. You are better off running lower than higher. If the input voltage is too high, the rectified voltages for everything also increases, and overvoltage may cause problems for some parts, especially the deflection transistors.

The low voltage power supply section creates the following voltages:

- +/-63 VDC (goes to X-Y power amplifiers)
- +55 VDC to RGB video drivers and spot killer
- +/-9.1 VDC to the IC's
- +126 VDC to the EHT oscillator

When you look at your deflection board and your schematics, you may notice some discrepancies and ask "Where is part x?"

- R636, R637, R736, and R737: On issues 1, 2 and 3 deflection boards, these resistors should be found on the bottom of the deflection PCB, or possibly the current limiting boards.
- C726: The capacitor C726 is typically found in parallel across R726 (either over the resistor itself, or soldered to the bottom of the board). C626 is attached in the same manner.
- Diode near R726: Sometimes there is no diode near R726. The diode is a 1N914. If you want to insert the diode, simply place the board in a position where the current limiting boards are on your left. Lift the right leg of the resistor, and attach the banded end of the diode away from the resistor, and place the end of the diode in the hole the resistor leg was in.
- D701, D702, D601, D602: These diodes are a bit of a mystery. They originally appeared in the G08-001 and G08-003 schematics in the “Sega/Gremlin Color X-Y Monitor” manual, but then dropped out of the “Preliminary Service Data G08-003/004 X-Y Color Monitor” manual’s parts list and schematics. If they are missing, don’t bother installing them.



- R635 and R735: Some G08 deflection boards have a ‘teepee’ of large ceramic resistors in these locations. As noted in the schematics, there should be a single 3-Ohm 20W resistor in each location. Some have been replaced with two 1.5-Ohm resistors in series. It is unclear why this modification was done to some G08-003 deflection boards (possibly cooling reasons?).
- Two resistors hacked onto the back of the current limiting boards: These resistors appear on Issue 2 and Issue 3 deflection boards for the most part. On both of the current limiting boards, the trace for pin 1 is cut near the top connector and a 0.2-Ohm 5W resistor is inserted (i.e., the traces are cut and hooked back together via the resistor). The trace for pin 2 of the connector is also cut near the top, and a 100-Ohm resistor goes from pin 2 to the BOTTOM CONNECTOR “pin 1” (connecting with the other end of the 0.2-Ohm resistor). Pin 2 (top) is then jumpered down to the collector of Q704. These resistors are in the transistor #1 circuit. On issues 5 deflection boards, you will find these resistors missing, but there will be 100-ohm resistors on the deflection board transistor harness across the terminals of transistor #1.

This resistor ‘hack’ is detailed from an Issue 2 deflection board with an issue 2 screen on the bottom, and no cut traces on the bottom of the PCB as usually seen on most deflection boards. I think when this hack is used, the bottom of the PCBs did not have to be cut.

---

### Deflection Transistors And Heat Sink

---

When looking at the back of the monitor, the deflection transistors and associated heatsink is on the right, mounted to the metal frame. This metal box is a heat sink that holds two pairs of deflection transistors mounted on opposite sides. A cooling fan is mounted such that it blows air into the heat sink. The function of this part is to provide cooling of the deflection transistors.

The deflection transistors for the G08-001 are listed in the schematics as MJ15003 and MJ15004. These transistors were replaced with the more heavy-duty 2N6529 transistors in the G08-003 model. Unfortunately, the 2N6529 transistors have been discontinued, making these beasts difficult to find.

If you are working on a G08-001 monitor, be VERY careful. The original G08-001 design used the MJ15003/MJ15004 in a push-pull combination - one NPN and one PNP. The later models of the G08 used the 2N6259 design where BOTH outputs were NPN. The driver circuit is quite different between the two models. Be certain you know which monitor you are working on!

Rodger Boots had the following to say about the 2N6259 transistors:

“There is nothing wrong with the 2N6259 and you are going to be hard pressed to find a better part. Just because the NTE388 LOOKS to be a better part doesn’t tell the whole story. There is not much out there that has better secondary breakdown characteristics than a 2N6259, but you will never tell

that by looking at just numbers, you need to see a breakdown chart. This will show you where secondary breakdown is.

For example, looking at the 2N3716 data sheet you will see that at full voltage (80 volts) the part will withstand 0.2 amps. That is only 16 watts allowed for what is supposed to be a 150-watt part! Compare that with a 2N6259 that can take 200 watts of dissipation with 90 volts across the part!

It is about a 200-watt part and you can dissipate ALL OF IT with 90 volts across the part!!! A normal transistor would go into secondary breakdown (definition: localized melting of the junction due to current hogging - very destructive) at 20 to 40 volts. There are VERY few transistors that even come close to what this thing can do.

What kills the 2N6259 is over voltage, plain and simple. The part is rated for (I think) 125 volts, maybe as high as 150. However, the G08 uses +/-63 volts IDEALLY. So when the amplifier swings to the rail during a fast vector draw you have close to 125 volts.

Remember I said IDEALLY? That is with the game plugged in to a 110-volt line, since that is what the Gremlin/Sega power transformer was designed for. Are there any of you with only 110 volts coming out of the wall? More like 120 to 130, isn't it? THAT is why I keep saying the game needs to be re-strapped to match the power line. Either buck out the extra voltage with some filament transformers or whatever, but DO reduce the voltage. And what happens when the occasional power line spike comes along? The monitor blows up, that's what.

In my Showbiz Pizza days we used to use NTE388's in an Eliminator at about \$10 per part. They still blew up until one of the techs (not me) ran the power into the 110 and 240 taps of the game power transformer. The result was a 130 volt winding. The transistors quit blowing. It was just that simple."

There might be a 100-Ohm resistor placed across the terminals of the deflection transistors. I have no idea what to say about this other than "some do, some don't". This resistor(s) do not show up in the schematics, and I have no idea what effect these resistors have on the circuit.

---

### **HV Unit**

---

The High Voltage (HV) unit creates the high voltage for the tube as well as the AC voltage for the CRT heater. The HV unit consists of a PCB mounted in a metal box. The PCB has a HV transformer mounted on it. A small PCB (1" x 2") is mounted to the outside of the box; this PCB is the HV Regulator PCB. The HV is mounted in a metal frame and has a 10-pin header at the top. The deflection board plugs in here.

The pinouts for the HV 10-pin header are as follows:

<b>Pin #</b>	<b>Description</b>
1	Y
2	X
3	-9.1 VDC
4	+9.1 VDC
5	GND
6	GND (heater)
7	+6.3 VAC (heater)
8	+126 VDC
9	NC
10	VG2 (variable gain; part of brightness circuitry)

The HV PCB has three controls on it: R917 (frequency control), R918, and R933 (sensing voltage). Frequency control regulates the voltage the transformer puts out. Sensing voltage controls the level at which the HV supply will shut itself off to prevent a dangerous, X-ray producing overvoltage condition. R918 provides a sensitivity setting for shutting down the HV when the beam is not changing. Some manuals incorrectly reference R933 as R920. R920 was the G08-001 name for this control.

The large control on the HV unit (R922) is the focus control.

The small PCB affixed to the outside of the metal cage is a voltage regulator, which regulates the input between +100VDC and +126VDC.

IC900 on the HV unit is a high-voltage oscillator. This is Electrohome part number 14-002155-01 (EHT Control Circuit), and is another custom Sega part (Sega Part number 315-0118). This IC operates the high-voltage transformer, T901. This transformer is technically a flyback type, but it is not used to deflect the beam. IC900 serves two other functions; it senses the presence of the 10.3KV through R921 and R932 and compares it against the 9.1 supply voltage to ensure a regulated output, and also senses the varying current in either deflection coil. If no change is detected, the IC shuts down the high-voltage oscillator to prevent the beam from "burning" the face of the CRT.

The HV transformer (T901) is otherwise unavailable for replacement. These HV transformers are **extremely** reliable compared to all other vector monitors out there, but if yours does go bad, you will have to find another G08 HV cage for a replacement.

---

## **CRT Neck Board**

---

The CRT neck board is a 4" x 4" PCB with a large tube socket mounted directly in the middle of it. It connects to the end of the monitor tube. The board controls the color guns of the tube.

The neck board has a few controls on it. One side contains a single "blue gain" control, while the opposite side has "red cutoff", "red gain", "green gain", "green cutoff".

The color drive circuits accept a 4-volt maximum signal on the RGB inputs. The outputs drive the three electron-beams in the CRT. Three neon glow-bulbs, NE-100, 101, and 102 act as spark arrestors for the color-drive outputs to the CRT.

Most of the neck PCBs will have different Issues numbers screen into the top of the board and the bottom of the board. It is unknown if there are any different revisions of the neck board. However, this may be the one portion of the G08 monitor that was correctly designed, and you should have little or no problems with the neck PCB.

---

## **Tube**

---

This is large glass funnel shaped... it's a monitor tube for crying out loud! The tube is nothing special. It is a 19VLUP22, which is also found in the Wells Gardner 6100 color XY monitors. However, these monitors often came with a "tinted gel" covering or shield over the front of the monitor to make the vectors look better.

A degaussing circuit is provided through D404, D405, and R400. The CRT is automatically degaussed when R400 is cooled sufficiently to conduct current through the degaussing coil.

**Part Number Summary**

---

This following list summarizes all the Electrohome part numbers for the G08 monitors. These numbers do not reflect the issue numbers between the deflection board revisions.

	<b><u>Monitor</u></b>	<b><u>Electrohome Part Number</u></b>
<b><u>G08-001 Manual</u></b>		
EHT Supply Assembly	G08-001	02-170003-01
Deflection Amp PCB Assembly	G08-001	02-170005-01
CRT Socket PCB Assembly	G08-001	02-170006-01
Heat Sink Assembly	G08-001	02-170004-01
<b><u>G08-003 Preliminary Manual</u></b>		
EHT Supply Assembly	G08-003	02-170002-02
EHT Regulator Assembly	G08-003	02-170016-01
Input Clamp Assembly	G08-003	03-170021-01
Deflection Amp Assembly	G08-003	02-170005-02
Horizontal Current Limiter	G08-003	03-170020-01
Vertical Current Limiter	G08-003	03-170020-02
CRT Socket PCB Assembly	G08-003	02-170006-01
Heat Sink Assembly	G08-003	03-170025-01

---

## **HOW IT ALL WORKS**

---

Inputs come in from the game boards (most commonly the Sega G-80 system XY timing and control boards) and are fed into the input protection board. The input signals then go to the deflection board, and the deflection board does its stuff. The deflection board sends an “OK, these signals are cool” signal to the HV unit, which turns on and provides the HV to the picture tube and the AC to the heater. The deflection board then feeds the color signals to the neck board, and controls their position with the deflection yoke.

The G-08 monitor has a unique spot killer system, in that if the monitor receives no valid inputs from the game board, the monitor will shut down the high voltage. This method of self-preservation differs from that built into the Wells-Gardner 6100 color XY monitor, which, in a zero-deflection mode, shuts down the Z amplifier, which is like turning the brightness level to zero. The G08 has no Z amplifier, and must protect itself by more drastic measures.

---

## REPAIR PREPARATION

---

So you have a G08, and you have no idea of its condition. Well, let's do a few basic things before we fire it up ("fire it up" might be a poor choice of words here ;-)).

1) Start by dismantling the monitor.

First, discharge the monitor tube. There is high voltage under the monitor's anode cup if the monitor has been powered up recently. It may not be necessary to discharge a monitor tube that has been sitting for a while, but it is best to be on the safe side, so get in the practice of always discharging a monitor tube before you begin work on a monitor.

There are many ways to discharge a tube. The recommended way is via a High Voltage probe. Connect the ground of the HV probe to the monitor chassis, and insert the probe end underneath the anode cup and watch the voltage go to 0 (do not touch the chassis during this procedure). However, as some people may not have access to a HV probe, a cheaper (but less safe) alternative is provided below.

Place the monitor on a non-conductive surface. Do not touch the monitor with your hands while doing this procedure, as we will be discharging the monitor to the monitor chassis. Locate the anode cup; it is the suction cup thingy attached to the tube that has a red wire coming out of it. A few inches from it, there is a metal shield that surrounds the back of the tube. We will be discharging the tube to this shield.

Insert a long screwdriver with a plastic handle under the anode cup, and tilt the screwdriver such that it also makes contact with the metal shield. There should be a few quick snaps. Hold the screwdriver there for a second, and then you are done.

Next, remove the neck board, as bumping it may cause you to break the tube's neck. Getting the neck board out of the way will keep you from accidentally bumping it when trying to reach other parts. Next, unsolder the wire that goes from the back of the focus knob to the neck board. This is required in order to separate the HV unit from the deflection board. Everything else is connectorized and screwed together, so it should be easy enough to take the monitor apart.

Make sure you have removed the neck board from the tube before removing the 10-pin connector on the HV unit! Trust me, you are less likely to break the tube's neck this way.

2) Check the deflection transistors.

Visually inspect the transistors and make sure they are even the correct transistor type. I have seen operators attempt to substitute other types of transistors for the 2N6259s or MJ15003 / MJ15004, so make sure they are correct to start out with.

Test the deflection transistors through the connectors. Please read the procedure in “Appendix B” before continuing.

Unlike the Wells Gardner 6100 color XY monitor, which uses 2N3716 and 2N3972 transistors in a push-pull configuration, all the transistors in the G08 should be identical (unless you have an original G08-001 which used the MJ15003 for one set, and MJ15004 for the other set).

#### Deflection Transistor Harness Connector

<b>Pin</b>	<b>Description</b>
1	emitter #1
2	base #1
3	NC
4	collector #1
5	emitter #2
6	base #2
7	collector #2

Get out your multimeter and do a resistance test between the following pins, using the red and black probes (indicating + and common/ground, respectively). Example: 1Red means you are touching pin 1 with the red probe. These tests are performed with the power turned OFF.

Typically, there is a 100-ohm resistor across the transistor #1. If so, you will get these readings:

#### Deflection Transistor Resistance

1Red - 2Black: 20 ohms
1Red - 4Black: 0 ohms
2Red - 1Black: 100 ohms
2Red - 4Black: 0 ohms
4Red - 1Black: 50 ohms
4Red - 2Black: 0 ohms
5Red - 6Black: 0 ohms
5Red - 7Black: 0 ohms
6Red - 5Black: 20 ohms
6Red - 7Black: 20 ohms
7Red - 5Black: 0 ohms
7Red - 6Black: 0 ohms

If yours does not have the 100-ohm resistor, you will get both transistors reading like the bottom half of the table above.



Most shorts will occur between the collector and either the base or emitter. If your test through the connector reveals a short, pull the transistor and test it separately. If it is good out of circuit, you may have accidentally shorted either the base or emitter against the heat sink, or the transistor socket may have been bent. If the transistor tests bad detached from the heat sink, it is ready for the garbage.

If you have to replace transistors, replace them all with the same type. I would use 2N6259s, but these may be very difficult to find. Recently, I had someone try using the MJ15003 transistors that were original used in the design, and they had no luck with them (however, 2N6259s that I sent them worked just fine). My new recommendation for a replacement transistor is the MJ15024. I have used these as replacements myself and they appear to run cooler than the original 2N6259s. I tested 4 of them in a G08 for 18 hours non-stop and they worked fine.

Again, if you have a G08-001 (which is doubtful; I think all were returned to Electrohome), you must use the MJ15003 and MJ15004 combination.

### 3) Resolder pins, joints, etc.

There are a few key points that generally need resoldered on these monitors.

Resolder all header pins. These are the pins that accept connectors. Check all the header pin joints on the bottom of the deflection board, the current limiting boards (if present), the input protection board, and the HV unit. Do not just reflow the solder; add a little fresh solder to each pin (do not overflow onto adjacent pins, though). Double-check your work with an ohmmeter when you are done.

Another common place where solder joints go bad is the HV regulator PCB. Sometimes the regulators on this board get bumped and they break. Unscrew the HV regulator PCB from the side of HV unit and resolder the pins to the HV regulators.

Be very careful when resoldering devices, as the screen has traces that lift very easily.

### 4) Do a visual inspection of the boards.

If you look at the bottom of the HV PCB or the bottom (or even top) of the deflection board, you may see cut traces with jumper wires here and there, some resistors, transistors and diodes soldered to the bottom. Do not let this frighten you. Assume that these are “factory modifications” and leave them alone.

Look for burnt resistors, loose capacitors, broken solder joints, and broken transistor legs. Resolder anything that looks suspect. If the deflection board has the current limiting boards, carefully inspect them as they commonly have destroyed components. Reflow and increase the quantity of solder on the joints for the large capacitors and the HV transformer. I have seen broken solder joints cause monitor failures in both cases. Make sure the heat sinks on the small

transistors on the deflection board do NOT TOUCH ANYTHING except the transistor it is trying to cool. Replace burnt resistors and loose capacitors. If you can, it is a good idea to replace all the electrolytic capacitors on the deflection board (except the LARGE ones), since these components tend to dry out and fail as they age.

### 5) Do an ohmmeter inspection of the boards.

Test the diodes on the HV and deflection boards. Put the negative test lead on one end of the diode, and the positive test lead on the other end of the diode. Then reverse. You should get a “definite” reading only in one direction (due to testing in circuit, you may see a negligible reading in the other direction).

Test the transistors on the HV and deflection boards. This is a little hard to do in-circuit, but you should get a definite reading in at least two of the combinations, and none of the combinations should look like a short.

Test the fuses. A visual inspection may not catch a blown fuse. Use the ohmmeter across the fuse holder, not just the fuse itself.

### 6) Reassemble.

Reconnect and screw things into place. Reconnect the focus knob lead. Double-check your work. This is about all you can do to prepare for launch. Let the count down begin....

Connect the monitor to a known good game boardset. Here is the catch-22: if you picked up a non-working game, you won't know if the monitor is bad, or the game boardset is bad, or both. You have two unknowns, which could make monitor debugging a real pain. My advice, therefore, is to NOT test with an unknown game boardset.

Do what you can to borrow someone's working set to test the monitor. The unknown monitor has virtually NO chance of hurting a working set of boards (unless the monitor decides to torch the whole cabinet. ;-)). The following debugging section assumes you have a working game boardset.

If you don't have a working game boardset to test with, contact Mark Jenison (Jenison@enteract.com) and he should be able to help you out in most cases.

---

## DEBUGGING THE MONITOR

---

Ok, to debug the monitor, you will need a known working game boardset and power supply. Hook up the power and video inputs to the monitor.

Now, unplug the connector that goes to the monitor yoke. This removes the load off of the deflection board so nothing will burn up if some there is a problem, and allows you to take direct reading of the inputs to the yoke. You need either a scope or a digital auto-ranging multimeter because the voltage at the yoke inputs is going to be swinging from +62V to -62V very quickly. On an auto-ranging multimeter, you will see a bunch of random numbers between +62V and -62V. This will indicate the deflection circuit is working. During this time, there will be no deflection of the beam, so the beam will shoot straight to the center of the monitor. Do not test like this for a long period of time because it may damage the phosphors. However, this is normally not a problem because it should take less than 30 seconds to determine the output of the deflection circuit.

Since getting to the pins of the yoke input are difficult to get to, you will want to make a connector with wires similar to that of the yoke itself. Plug in your "fake yoke" connector and attach meter probes to it instead. Pins 1 and 2 are the Y output, and Pins 3 and 4 are the X output.

Ok, we are ready to begin. Connect black and red multimeter probes to pins 2 and 1 respectively and power on the game. Note the values for a few seconds. Power the game off. Connect the black and red probes to pins 3 and 4 respectively and power on the game. Notes the values for a few seconds. Power the game off. Random changing values, either negative or positive, are good; static numbers near 0, +62V or -62V are bad and there is something wrong with the deflection circuit or the custom chip.

It is difficult to determine if it is the custom chip that is causing a problem. Here is a listing of the pins of the custom chip on the deflection board:

Pin 1	wiper of height pot. Other inputs to pot are Y analog signal and Y yoke output
Pin 2	Output that drives X deflection circuit
Pin 3	wiper of horizontal center. Other inputs to pot are -9.1VDC and +9.1VDC
Pin 4	GND
Pin 5	Connected to width pot. Wiper is connected to X yoke output, and other input is NC
Pin 6	+9.1VDC
Pin 7	hooked to pin 10 via 12pf capacitor. According to manual, output should be 7.5VDC
Pin 8	NC
Pin 9	hooked to GND via 1K resistor
Pin 10	Y analog input
Pin 11	Y analog input
Pin 12	-9.1VDC
Pin 13	connected to pin 14 via 22k resistor
Pin 14	X analog input
Pin 15	connected to pin 14 via 22k resistor (same as pin 13)
Pin 16	Y input; hooked to pin 10 via 22pf capacitor and 30k resistor in parallel
Pin 17	wiper for vertical center; Other inputs to pot are -9.1VDC and +9.1VDC
Pin 18	output that drives Y circuit

If you are getting bad readings at the yoke output, check pins 2 and 18; they should also be varying in values. If one or the other is stuck, check to see that the X and Y inputs to the monitor are reaching the chip (pins 14 and 10). If the X and Y analog inputs look good but the outputs of the chip still look bad, most likely this chip is bad, and the only solution to date is finding another good one. If the outputs look good, then you can narrow it down to devices in the deflection circuit.

If there is something wrong, determine which circuit and thus which parts are in question. Check voltages on the deflection board and look at the schematics. If the output to the yoke is +62V, then a transistor that controls the +62V is probably in question. So forth for the -62V.

If everything looks good, power down the monitor, hook up the yoke, and power up the monitor.

**WARNING: Working with monitors of unknown operating condition can be EXTREMELY dangerous. The Electrohome G08 is no exception. In fact, there are probably more horror stories about this monitor than any other. Proceed with extreme caution.**

---

**Symptom: No picture; No fuses blow; No heater glow; All is quiet**

Make sure everything is hooked up, and that the game boardset is operating correctly. If all that checks out, you have most likely have problems in the deflection circuitry.

---

**Symptom: No picture, but you can hear deflection chatter**

If the heater is glowing, that means you have HV, and you should be able to get a picture. Adjust the screen brightness to see if any lines are being drawn on the screen. Adjust the intensity and gain knobs on the neckboard accordingly. If at this point you have a dot in the middle, or a line across the screen, you have a problem in your deflection circuitry.

If the heater is not glowing, most likely you have no HV. Check for the presence of HV by inserting an HV probe under the anode cup. You should read about 19.5 KV. If there is HV, something is wrong with the heater connection or the tube itself (possibly a bad tube).

If there is no HV, check the voltages on the 10-pin connector on the HV unit. Be careful not to short the pins together! The voltages are listed below:

Pin	Description
Pin 1	Approx +2.8VDC
Pin 2	Approx +3.5VDC
Pin 3	-9.1VDC
Pin 4	+9.1VDC
Pin 5	GND
Pin 6	GND (heater)
Pin 7	+6.3VAC (heater)
Pin 8	+126VDC
Pin 9	NC
Pin 10	Approx 400 VDC

Wiggle, press or flex the 10-pin connector on the HV unit. Intermittent connections can cause the HV to drop out. If this restores HV, reflow and resolder the HV header pins until the intermittent connection is repaired. You may want to try replacing the connector pins as well.

If the voltages on the 10-pin connector look good, and there is still no HV, there is something wrong with your HV unit. At this point, it probably wouldn't hurt to try adjusting pots R933 and

R918 on the HV unit. The HV unit may be shutting down because of the input signal sensitivity settings.

---

**Symptom: Fuse 600/700 blows**

Fuse 700: Check transistors Q703; Q704; Q705; Q706.

Fuse 600: Check transistors Q603; Q604; Q605; Q606.

These fuses almost NEVER blow, so something must be REALLY screwed up. The schematics state that these are 3 amp fuses. The silkscreen on the boards say 4 amp 125V SB (Buss. fuse MDL). I'd go with the 4 amp.

---

**Symptom: Picture has retrace lines between points, and a bright dot is in the center of the picture**

If the dot is one particular color, adjust the color pots on the neck board. These control the drive of the color guns. If there is still a dot, try turning down the brightness control on the deflection board. Sometimes the solder joints for this pot, and the nearby resistor, break and can cause the brightness to shoot up too high. If the dot is still present, try adjusting R933 on the HV unit.

---

**Symptom: The neon bulbs on the neck board are glowing**

These are not supposed to light. These are spark gap bulbs, meaning that if they light, your guns are sparking internally. Most likely there is a problem with the tube.

When debugging the monitor, you may need to swap the deflection board in and out quite often, and it gets to be a pain to hook up the focus each time. If you want, you can actually leave this lead disconnected while debugging. Tie a piece of electrically tape around the end so it does not accidentally touch anything. When you finally get a picture, remember that the picture will be extremely out of focus. You will, however, be able to tell that there is a picture. Also, double check that all the connectors are connected each time you swap out the deflection board.

**Symptom: Picture, But Only Partial Deflection, or Just A Vertical or Horizontal Line**

Part of your deflection is failing. Check the appropriate section of the deflection board, which deals with that range of deflection. The components in the 700's are for the "X" deflection, and the 600's are the "Y" directions.

	Input Voltage	Related Voltage	Beam Movement
Y-AMP (Vertical; 6XX parts)	Positive	+63VDC	Up
	Negative	-63VDC	Down
X-AMP (Horizontal; 7XX parts)	Positive	+63VDC	Right
	Negative	-63VDC	Left

Usually caused by bad deflection transistors, bad connections/cracked solder joints. A single vertical or horizontal line can also be caused by failure to receive the input, so make sure the input clamp board is making good connection.

If there is a problem with the deflection circuitry, and you're getting things like burning resistors and transistors are being destroyed, this can be annoying and expensive to repair. If you have a board like this, I would recommend NOT hooking up the deflection coil any more until you verify the voltages being fed into the coil. To do such, instead of the coil, take a multimeter and measure the voltage across the X coil or Y coil (whichever you are having trouble with). When powered, normal readings will fall within +/- 20V (this voltage is an approximation; normally the deflection coil is getting voltages ranging from +60 to -60 volts at very high speeds; typical multimeters aren't that fast so it reports an approximation, which in theory should be around 0). If you are getting a constant +60V or -60V or 0, that says either there is a problem with devices on the +60V rail, -60V rail, or voltages aren't even reaching this part of the circuit.

**Symptom: Occasional Extraneous Vectors On Right Side Of Screen**

Assuming you are using your G08 monitor with the Sega G-80 vector game boards, you will need to add the following two capacitors to the X-Y Timing board on the G-80 game boardset. Install two 100pF, 50V ceramic capacitors in locations C32 and C33. Install C32 between pin 2 and pin 6 of U2. Install C33 between pin 2 and pin 6 of U3.

**Symptom: Blowing Main Fuses**

If a monitor is blowing main fuses, check the deflection amp power transistors Q605, Q606, Q705 and Q706, WITH THE POWER OFF. Shorted transistors or diodes in the deflection amplifiers will also blow main line AC fuses.

**Symptom: One Or More Colors Is Missing**

Check the transistors and diodes on the Input Clamp board for shorts or opens when one or more colors is missing from the display, and the G-80 boards are known to be good. Check the connections from the Input Clamp board to the deflection board.

---

**Symptom: Picture Flickers In and Out**

This is a difficult problem to solve, as this symptom can be caused by many things:

- Fluctuating voltages from power supply to the game boardset
- Bad connections of XY pair with card cage in G-80 game boardset
- Bad connections of ribbon cables between XY pair in G-80 game boardset
- Bad connections to HV unit from the deflection board
- Bad connections at the Input Clamp board (cracked solder joints)
- Bad connections at the deflection board (cracked solder joints)

I would start by reseating connections in this order: connections to the power supply, to the game boardset, the XY pair, and the ribbon cable between them. Also, re-solder the pins on the Input Clamp board and deflection PCB. If that does not fix it, you will need a scope to see where the signal is getting dropped.



**Voltages**

The following G08-003 voltages are measured during running of the monitor (taken from the Zektor manual):

*All Readings are DC Level Voltages*

**B=BASE E=EMITTER C=COLLECTOR AN=ANODE CA=CATHODE**

D401 CA 63.0	D403 CA 63.0	D400 AN -63.0	D402 AN -63.0
ZD400 59.0	ZD401 9.0	ZD402 -9.1	
Q400 B 59.0 E 58.8 C 63.5		Q401 B 9.7 E 9.1 C 17.0	
Q600 C 34.5	Q700 C 35.9	Q601 C 0.8	Q701 C 0.5
Q602 C -0.5	Q603 C 63.5	Q604 C -63.9	
Q605 C 63.9 B 0.1 E 0.1		Q606 C -63.9 B -0.1 E -0.1	
Q702 C -0.8	Q703 C 63.5	Q704 C -63.5	
Q705 C 63.9 B 0.1 E 0.1		Q706 C -63.9 B -0.1 E -0.1	
Q901 E 8.0 B 7.5 C 0.3	Q902 E 0.0 B 0.3 C 0.5	Q903 E 0.0 B 0.5 C 3.0	
IC 600		IC 900	
Pin 1 0.0	Pin 10 0.0	Pin 1 0.4	Pin 10 1.7
Pin 2 4.2	Pin 11 0.0	Pin 2 0.0	Pin 11 8.7
Pin 3 0.0	Pin 12 -9.1	Pin 3 0.1	Pin 12 8.7
Pin 4 0.0	Pin 13 0.0	Pin 4 -9.1	Pin 13 2.3
Pin 5 0.0	Pin 14 0.0	Pin 5 9.0	Pin 14 9.0
Pin 6 9.1	Pin 15 0.0	Pin 6 0.7	Pin 15 0.5
Pin 7 7.5	Pin 16 0.0	Pin 7 1.7	Pin 16 0.1
Pin 8 0.0	Pin 17 0.0	Pin 8 7.5	Pin 17 8.7
Pin 9 0.0	Pin 18 4.2	Pin 9 0.1	Pin 18 0.0

---

## INSTALLING A CAP KIT

---

Zanen Electronics  
5023 52nd Street  
Lubbock TX 79414  
806-793-6337  
Fax: 806-793-9136  
Zanen Kit #110

Bob Roberts also sells cap kits. Bob provides a kit for the G08 Vector Monitor.

bob147@bellsouth.net  
<http://www.therealbobroberts.com>

Key:

- Q = Transistor
- R = Resistor
- C = Capacitor (all polarized electrolytic)
- F = Fuse
- D = Diode
- ZD = Zener Diode

Note that the capacitors come in two "types":

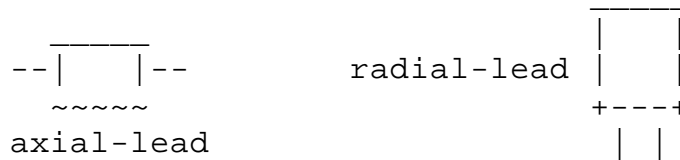

Note, if you cannot find an exact replacement for one of the capacitors, you may keep this in mind. A capacitor with a difference that is less than 5% of the original value should work just fine. Back in the days of the G08, electrolytic capacitors had tolerances that were typically over 20%. So a modern capacitor will probably be a lot closer to the ideal value than the original cap that was in the chassis when it was new.

**CAP KIT SUMMARY:**

There are some known problems with Zanen and Bob Roberts cap kits. Below is a recommended list of parts. Almost all of the suggested replacement capacitors are upgraded in terms of voltage rating and should make your G08 monitor last longer and run cooler. If you would like to make a cap kit of your own, here are the suggested parts that you will need:

<b>G08-003 Cap Kit Parts List</b>				
<u>PCB</u>	<u>Location</u>	<u>Part Description</u>	<u>Upgrade</u>	<u>Notes</u>
Deflection	C401	1000uf 160V Radial Capacitor	Yes	Original was 80V
Deflection	C405	10uf 50V Radial Capacitor	Yes	Original was 25V
Deflection	C406	10uf 50V Radial Capacitor	Yes	Original was 25V
Deflection	C411	22uf 350V Radial Capacitor	Yes	Original was 250V
Deflection	C601	47uf 35V Radial Capacitor	Yes	Original was 16V
Deflection	C701	47uf 35V Radial Capacitor	Yes	Original was 16V
Input	C800	10uf 50V Radial Capacitor	Yes	Original was 16V
Input	C801	10uf 50V Radial Capacitor	Yes	Original was 16V
Input	C802	10uf 50V Radial Capacitor	Yes	Original was 16V
Input	C803	10uf 50V Radial Capacitor	Yes	Original was 16V
HV	C900	4.7uf 35V Radial Capacitor	Yes	Original was 16V
HV	C901	4.7uf 35V Radial Capacitor	Yes	Original was 16V
HV	C904	22uf 35V Radial Capacitor	Yes	Original was 16V
HV	C905	22uf 35V Radial Capacitor	Yes	Original was 16V
HV	C911	100uf 35V Radial Capacitor		
HV	C916	47uf 200V Radial Capacitor	Yes	Original was 160V

Note: some of the capacitor locations will differ slightly from the descriptions above, depending on the deflection board revision you have. Generally speaking, you will be replacing all electrolytic capacitors on the deflection and HV boards. If the list above states C405, it could be C407 on your board. Make notes on what capacitors you remove, and replace those locations.

Capacitors C601 and C701 on the deflection board appear only on the schematics and are not listed on the parts list of any manual. C601 and C701 are connected to pins 12 and 6 of IC600 respectively.

---

## CHASSIS TRANSISTORS

All the monitor chassis transistors are mounted in a socket with two machine screws. No soldering is necessary; just unscrew the old one and replace. You cannot put these chassis transistors in backwards; the leads are offset so they will only fit into the chassis and screw down in one direction. If you put the transistors in backwards, the screw holes will not line up.

Make sure you install a new clear plastic Mica insulator between the transistor and the metal monitor chassis. New ones are not included in the Zanen kit! If you have some white heat sink grease, put a light coating on both sides of the Mica insulator.

NOTE: The transistors shipped with the Zanen and Bob Roberts kits are 2N3716s. These transistors are not sufficient to work with the G08 monitor. Replace them with 2N6259s (if you can find them) or MJ15024s. Keep the 2N3716s for your other vector monitors!

Deflection Transistors		
<u>Location</u>	<u>Part Number</u>	<u>Notes</u>
Q605	2N6259	Substitute is MJ15024
Q606	2N6259	Substitute is MJ15024
Q705	2N6259	Substitute is MJ15024
Q706	2N6259	Substitute is MJ15024

**Important:** after replacing the above transistors, before plugging them back into the deflection board, use your DMM set to Ohms and check the continuity between the metal monitor chassis and the metal case of the above transistors. There should be NO continuity! Unscrew the transistor and check the mica insulator or pins to make sure they are not touching the heatsink. If there is continuity, you will usually burn out R636, R637; R736, R737, and others in the pre-amplification stage. You will probably also take out the deflection transistor involved as well.

You will most likely find bad solder joints at many of the connector pins, which should always be reflowed.

If you have a G08-001, the MJ15003 transistors should be hooked up to pins 1-4 on the P600 connector (Y amp) and pins 5-7 on the P700 connector (X amp). MJ15004 transistors should be hooked up to pins 5-7 on the P600 connector (Y amp) and pins 1-4 on the P700 connector (X amp). Check your G08-001 schematics for reference.

## G08-003 DEFLECTION BOARD

Not all of these parts are necessary for a monitor rebuild, but are good to have on hand. For capacitors, see “Cap Kit Summary” section above.

<u>NON-Zanen Deflection PCB Parts</u>			
<u>Location</u>	<u>Part Description</u>	<u>Upgrade</u>	<u>Notes</u>
F400	5 amp 125V Slo-Blo Fuse		Replacing these is a good idea
F401	5 amp 125V Slo-Blo Fuse		Replacing these is a good idea
F600	4 amp 125V Slo-Blo Fuse		Schematics shows 3 amp
F700	4 amp 125V Slo-Blo Fuse		Schematics shows 3 amp
ZD400	1N5263B 9.1V, 1/2W 5% Zener Diode		
ZD401	1N5239B 9.1V, 1/2W 5% Zener Diode		
ZD402	1N4739 9.1V, 1W 5% Zener Diode	Yes	Replace with a Motorola part
Q201; Q251	2N3904		Current Limiting Board
Q202; Q252	2N3906		Current Limiting Board
Q602; Q603	MPSU10		Cross is 2N6558 or NTE171
Q702; Q703	MPSU10		Cross is 2N6558 or NTE171
Q601; Q604	MPSU60		Cross is NTE240
Q701; Q704	MPSU60		Cross is NTE240
D400; D401	MR502 200V, 1A or 1N5402		G08-801 is a MR752 (200V, 6amp)
D402; D403	MR502 200V, 1A or 1N5402		G08-801 is a MR752 (200V, 6amp)
D404; D405	1N4003 ER, 1A 200V or 1N5059		G08-801 is a 1N4001 (200V, 1amp)
R636; R637	100-Ohm ¼ W Resistor		G08-801 shows 1K resistors
R736; R737	100-Ohm ¼ W Resistor		G08-801 shows 1K resistors

---

## G08-003 HIGH VOLTAGE UNIT

Not all of these parts are necessary for a monitor rebuild, but are good to have on hand. For capacitors, see “Cap Kit Summary” section above.

<u>NON-Zanen HV PCB Parts</u>			
<u>Location</u>	<u>Part Description</u>	<u>Upgrade</u>	<u>Notes</u>
ZD903	1N751 Zener Diode		
ZD904	1N751 Zener Diode		
Q900	Power transistor, 5A 1400V		Hitachi 14-601-36
Q901	2N3906		
Q902	MPSU07		
Q903	2N3904		Found on back of PCB
L900	12 uH Horiz. Delay Choke		8 uH on G08-001
D901	Rectifier, 1A 1400V		GI1-1400 (NTE506 cross)

---

## G08-003 NECK BOARD

I have never had to replace a part on a neck board yet (seems it was the only board Electrohome got right the first time). So, I have no recommendations for replacement parts.

## MAKING THE MONITOR MORE RELIABLE

Ok, so now you have a working G08 monitor (hopefully). Here are just a few things you can do to the monitor to prolong its life just a bit longer.

### Input Clamp Board Modification

Replace the tape on the back of the input protection board with a strip of electrical tape or other non-conductive material to prevent it from shorting to the metal bar it is typically mounted on.

### Deflection Board Modification

For capacitors, see “Installing A Cap Kit” section of this document.

### Deflection Transistors Modification

From Zonn Moore:

The biggest problem with the Sega G08 is the underrated Deflection Transistors (the second biggest is all the proprietary Ics). To fix the transistor problem you can do just what Rick suggests. Parallel two power transistors for each one currently being fan cooled.

The thing to do is to get two of each transistor, connect the bases and collectors together. Then connect a resistor from each emitter to the place the old emitter used to go...

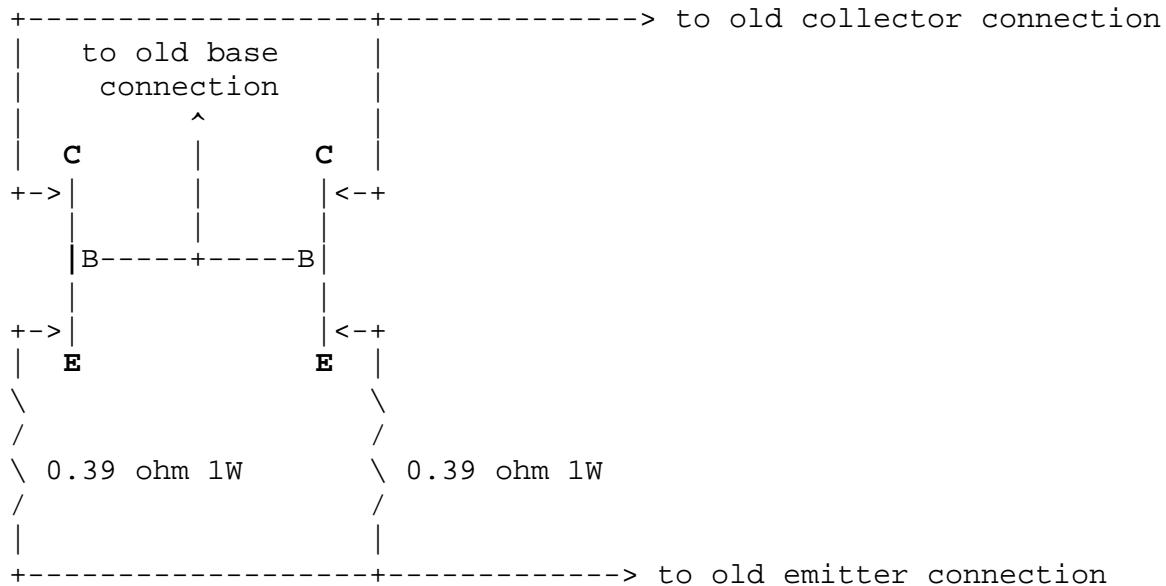

(Pretty bad drawing huh?)

The 0.39-ohm resistor allows the transistors to be hooked in parallel without one transistor going into thermal runaway and trying to drive the whole load itself. (A good place to find out more about hooking transistors in parallel is a Voltage Regulator handbook of some kind)

---

### Heat Sink Modification

From anonymous:

“The deflection transistors mounted on the heat sink can be more efficiently cooled (and therefore will last longer) if you place them on the *inside* of the heatsink instead of on the outside. To do this:

- 1) Remove the heat sink assembly from the monitor chassis by removing the screws on the side of the chassis and disconnecting the fan and deflection transistor harnesses from the deflection board.
- 2) Remove two upper or lower screws from the fan so that the heat sink assembly can be split in two.
- 3) Unscrew the deflection transistors from the heat sinks.
- 4) Place the transistor sockets on the outside of the heatsink, and then mount the transistors on the inside of the heat sink. Make sure to reinstall the mica insulators with a thin layer of silicon grease on both sides of the mica insulator.
- 5) Reassemble and remount the heatsink. Before hooking up the harness to the transistors again, do a transistor test through the connectors (as mentioned previously in this document) to make sure that they are mounted correctly, and that there are no shorts.
- 6) Reconnect the fan and deflection transistor harnesses to the deflection board and retest the monitor.

The deflection transistors should now run much cooler.”

One of the main problems with the fan-cooling setup is that the airflow through the closed cabinet is pretty miserable. You may want to consider running your Sega XY cabinet with the back access door removed.

---

### HV Unit Modification

For capacitors, see “Installing a Cap Kit” section of this document.

---

### Neck Board Modification

None available as of this version of the document.

---



---

## TUBE REPLACEMENT

---

If you are unfortunate enough to come across a G08 with a bad tube, there is still something you can do about it.

You can replace the tube. As mentioned before, the tube is the same as the one used in the Wells-Gardner 6100 series color XY monitors. You can also buy a brand new color vector tube (19VLUP22) from Richardson Electronics (1-800-222-2787) for around \$165. It will not come with the tinted gel, nor a deflection yoke or convergence rings, so you will have to transfer those from the broken tube and reconverge the monitor colors.

From Mark Jenison:

“I tried doing a tube swap with a 19VJTP22 tube from a Wells-Gardner 4600. I did not have any luck. I could not adjust out the green band down the middle of the picture. Apparently this is due to the fact that the deflection coil could not be positioned far enough down the neck tube (because the degree of the neck tubes are different). The deflection coil is not angled to work well with a 90-degree tube.”

---

## USING A G08-003 WITH COSMIC CHASM

---

Cosmic Chasm uses the G08-105 monitor, which takes slightly different inputs and is basically a better version monitor than the G08-003. It is, however, hard as hell to find the G08-105 monitor. If you have a Cosmic Chasm game or boardset and it is missing this monitor, there is hope.

The G08-003 can be substituted in place of the G08-105 (as can the WG6400 monitor, but that is an equally difficult monitor to find). To use the G08-003 with Cosmic Chasm, read the following from David Fish:

“As per the request of several V-List members here is the instructions for reworking a Cinematronics Cosmic Chasm boardset to work with a standard G08-003 monitor. While the procedure will correct the color intensity problems it does nothing to help the [relatively] crappy slew rate of the G08-003, you’re on your own there.

This modification is used to adjust the color signal (R, G & B) levels of a Cosmic Chasm board so that they are compatible with a standard Electrohome G08-003. When a Cosmic Chasm boardset is run using a G08-003 there will be visible 'black level' or 'return-to-origin' lines on the screen. The origin points will also be visible and will burn several small holes in the phosphor relatively quickly. The problem occurs because the Cosmic Chasm RGB outputs are designed to be compatible with a Wells-Gardner 19K6401 or Electrohome G08-105 which are 1V (BLACK level) to 3.6V-4.0V (full ON). The color levels of the more common Wells-Gardner 19K6101 are similar. Why Electrohome chose 0-4V is anyone's guess.

To correct this, the gain and offset of the RGB signals must be modified. The mod is fairly simple and reversible in case you ever get your hands on the correct monitor. It requires 6 resistors, three potentiometers and some soldering skill.

Components required:

- QTY 3 15.4K 1% metal film resistor
- QTY 3 90.1K 1% metal film resistor
- QTY 3 25K potentiometer, Bourns P/N 3266W-1-253 (Digi-Key P/N 3266W-253-ND)

Modification Instructions:

- 1) Carefully remove the three 9.1K resistors R1, R9 and R17 from the Cosmic Chasm Game Processor PCB. I suggest the following method: cut one leg of the resistor right at the body and bend both the resistor and the cut lead vertical. Heat the solder fillet on the trace side and pull the resistor/lead out the component side. Use a solder sucker to remove the leftover solder.
- 2) Install the 15.4K resistors in the R1, R9 and R17 locations.
- 3) Using a non-permanent adhesive (rubber cement or similar) attach a 25K potentiometer to the top of IC U29, U14 and U15. Orient the pots so that the pot's #1 lead is right above and close as possible to the IC's pin #7 (+15V) and the adjustment screw is on the side with pins 1 thru 4. Let the glue set.
- 4) For each pot bend the #1 lead down and solder to the IC's pin #7.

- 5) Using a short piece of wire-wrap wire connect the each pot's #3 lead to the IC's #4 pin (-15V).
- 6) Connect a 90.1K resistor between pin #2 of the IC and #2 lead of the pot for each.

Power up the boardset. Connect a scope to the RED color output on connector P2 pin 6. Note: all ODD numbered pins are GND. Adjust the pot attached to U29 so that the signal level swings between 0 volts and 4 volts. Repeat the adjustment for GREEN (U14) and BLUE (U15).

\* Modification complete \*

CAVEAT! - I have done this modification to two boardsets so far and got the expected results. However, since electronics is three parts Black Magic, two parts blood sacrifice and one part skill, I cannot take responsibility for what occurs to your board should you make this modification. All I can say is 'It worked for me'."

---

## Appendix A: Common Ground Connections

---

From: John Robertson <jrr@flippers.com>  
Newsgroups: rec.games.video.arcade.collecting  
Subject: TechTIP: How to make VECTOR MONITORS very RELIABLE!  
Date: 22 Oct 2001

It's been a little while since my last Tech Tip, but this is something that's been on my mind for a while now, and a posting in the Vector mail-list got the following response from me...:

Vector monitors blow up because the ground reference for the monitor drifts relative to the logic boards (MPU and video) when the power supply connections overheat. This will then bias the input signals offset enough to overdrive the outputs. Hence my argument for chucking the original power supply and putting in a switching supply. I started doing that about ten years ago and have not lost a single Electrohome/Sega monitor since. I assume this also kills Tempest/Star Wars/Major Havoc/... monitors etc. Those pesky grounds get a few ohms resistance and all sorts of nasty things happen.

I first discovered this on Gottlieb pinballs over ten years ago-the ground for the regulator would overheat the pin/wiper contact which would become a small resistor and thus the ground of the MPU would drift up relative to the cabinet ground, which also happened to be the ground path for the driver transistors. When the MPU ground would change to about 0.5 to 0.7VDC above cabinet ground the base of the transistors would then start to conduct as the MPU would be trying to turn off the transistors, but the Emitters are tied to the cabinet ground. Hence the transistors would start to conduct... You will recall that transistors generate far more heat when they are used at the beginning of their working range rather when they are switched completely on and off as in regular vector monitors (or solenoid drivers, etc.). So in a little while, it croaks. No obvious cause...replace the transistors and everything works. For now...

So get VERY GOOD GROUND (COMMON) CONNECTIONS BETWEEN THE MONITOR, MPU AND POWER SUPPLY for reliability!!!!!!!!!!!!!!!!!!!!!! Solder fat conductors with nasty heavy gauge connectors between each component in the system. Put in healthy SWITCHING SUPPLIES!

Happy vectors will result.

John :-#)#

---

## Appendix B: Testing Transistors

---

Most of the failures in the Electrohome G08 monitor (as is the case with most electronic devices) are semiconductor failures, specifically, the transistors. All transistors discussed in this document can be tested in the same way; it does not matter if they are the large chassis-mounted transistors or the tiny PCB-mounted transistors. With the transistors out of circuit, set your multi-meter on Rx1K scale and use the following procedures.

**NOTE: ANALOG AND DIGITAL MULTI-METERS REQUIRE DIFFERENT TESTING PROCEDURES FOR TRANSISTORS!** Digital meters always show infinite resistance for all 6 combinations (if you accidentally get your skin involved it will show something around 2M Ohms). The best way to test transistors with a DMM is to make use of the "diode test" function, which will be described after the analog test. For both methods, if you read a short circuit (0 Ohms or voltage drop of 0) or the transistor fails any of the readings, it is bad and must be replaced.

Why do Digital Voltmeters read open circuits on diodes and transistors?

Because of the ability to use amplifiers, DVM can use much smaller voltages to check resistance. For the most part this is a good thing. It allows you to check resistors in circuit, without turning on things, like transistors.

Diode junctions (which there are two of in a transistor) do not “turn on” until they reach somewhere around 0.4 ~ 0.7 volts, depending upon what they are made of, and a lot of other stuff. In a way, diode junctions are similar to neon light bulbs, they act like open circuits until the right voltage is reached, and then they act like shorts, until the voltage drops below the critical threshold. Without proper current limiting, the diode junctions explode. The thing about diodes is that they only do this in one direction, if you switch the test leads, they do not conduct at all. (Well, until the voltage gets **much** higher, and then it is a bad thing. ;^)

Sometimes you want to be able to “turn on” the diode junctions (to test them), so DVMs have a “Diode” test mode. This places enough voltage on the test leads to turn on the diode junction. The number you read on most meters is the actual turn on voltage threshold across the diode.

---

### TESTING TRANSISTORS WITH AN ANALOG OHMMETER

For type NPN transistors, lead "A" is black and lead "B" is red; for type PNP transistors, lead "A" is red and lead "B" is black (**NOTE:** this is the standard polarity for resistance but many multi-meters have the colors reversed; if the readings do not jive this way, switch the leads and try it again). Start with lead "A" of your multi-meter on the base and lead "B" on the emitter. You should get a reading of 2.5K Ohms. Now move lead "B" to the collector. You should get the same reading. Now try the other 4 combinations and you should get a reading of infinite Ohms (open circuit). If any of these resistances is wrong, replace the transistor. Only 2 of the 6 possible combinations should show a resistance and that value should be 2.5K Ohms; none of the resistances should be 0 Ohms (shorted).

## TESTING TRANSISTORS WITH A DIGITAL MULTI-METER

Set your meter to the diode test. Connect the red meter lead to the base of the transistor. Connect the black meter lead to the emitter. A good NPN transistor will read a JUNCTION DROP voltage of between 0.45v and 0.9v. A good PNP transistor will read OPEN. Leave the red meter lead on the base and move the black lead to the collector. The reading should be the same as the previous test. Reverse the meter leads in your hands and repeat the test. This time, connect the black meter lead to the base of the transistor. Connect the red meter lead to the emitter. A good PNP transistor will read a JUNCTION DROP voltage of between 0.45v and 0.9v. A good NPN transistor will read OPEN. Leave the black meter lead on the base and move the red lead to the collector. The reading should be the same as the previous test. Place one meter lead on the collector, the other on the emitter. The meter should read OPEN. Reverse your meter leads. The meter should read OPEN. This is the same for both NPN and PNP transistors. Thanks to Randy Fromm <randy@randyfromm.com> for this excellent summary of the diode test method.

---

## Appendix C: Parts Lists

---

The Input Clamp Board is only discussed in the Preliminary G08-003/004 Service Manual. Included below is the parts list. Not all of these parts are necessary for a monitor rebuild, but are good to have on hand.

<b>Input Clamp Assembly Parts List</b>			
<b><u>Location</u></b>	<b><u>Part Description</u></b>	<b><u>Upgrade</u></b>	<b><u>Notes</u></b>
D800	1N914		
D801	1N914		
D802	1N914		
D803	1N914		
D804	1N914		
D805	1N914		
D806	1N914		
D808	1N914		
Q800	2N3904		
Q801	2N3906		
Q802	2N3904		
Q803	2N3906		
R800	10K 1/4W Resistor		
R801	4.7K 1/4W Resistor		
R802	4.7K 1/4W Resistor		
R803	10K 1/4W Resistor		
R804	10K 1/4W Resistor		
R805	4.7K 1/4W Resistor		
R806	4.7K 1/4W Resistor		
R807	10K 1/4W Resistor		
R809	1K 1/4W Resistor		
C800	10 uF 16V Radial Capacitor		
C801	10 uF 16V Radial Capacitor		
C802	10 uF 16V Radial Capacitor		
C803	10 uF 16V Radial Capacitor		

The Current Limiter boards are attached to the deflection board and are only discussed in the Preliminary G08-003/004 Service Manual. Included below is the parts list. Not all of these parts are necessary for a monitor rebuild, but are good to have on hand.

<b>Horizontal Current Limiter</b>		<b>Vertical Current Limiter</b>	
<u>Location</u>	<u>Description</u>	<u>Location</u>	<u>Description</u>
D200	1N914	D250	1N914
D201	1N914	D251	1N914
D202	1N4935	D252	1N4935
D203	1N4935	D253	1N4935
Q201	2N3904	Q251	2N3904
Q202	2N3904	Q252	2N3904
R200	100-Ohm 0.25W Resistor	R250	100-Ohm 0.25W Resistor
R201	100-Ohm 0.25W Resistor	R251	100-Ohm 0.25W Resistor
R202	0.15-Ohm 2W Resistor	R252	0.15-Ohm 2W Resistor
R203	0.15-Ohm 2W Resistor	R253	0.15-Ohm 2W Resistor
C201	0.1mF 200V capacitor	C251	0.1mF 200V capacitor



---

## **REFERENCES**

---

1. The 'Wiretap' Arcade Game Collector's Archive - <http://www.spies.com/arcade/>  
Contains information about G-08 system games, as well as schematics for the monitor and game boards.
2. Star Trek Manual  
This manual contains the most up-to-date information on the Electrohome G08-003 model monitor.
3. Sega-to-Atari color XY circuit  
If you have given up on the G08, this is an alternative solution.
4. Sega/Gremlin Color X-Y manual – [www.arcademonitors.com](http://www.arcademonitors.com)  
Contains schematics for G08-001, future G08-003
5. Preliminary Service Data G08-003/004 X-Y Color monitor – [www.arcademonitors.com](http://www.arcademonitors.com)

---

## **DOCUMENT HISTORY**

---

- Version 0.1: Looking for contributors
- Version 0.2: David Shuman's additions
- Version 0.3: Michael Kelley's additions
- Version 0.4: Updated cocktail and Cosmic Chasm Information
- Version 0.5: Additional tips added
- Version 0.6: Added more info about neck tube swap
- Version 0.7: Major revision. Added more info about G08-105
- Version 0.8: Major revision. Reformatting and additional info on cap kit, parts, power supply
- Version 0.9: Minor Fixes
- Version 1.0: Fixed deflection transistor harness table; added additional debugging comments.
- Version 1.1: Updating debugging procedure, recommend MJ15024 instead of MJ15003

---

**END**

---

NOTES  
 UNLESS OTHERWISE SPECIFIED RESISTANCE (R)K-K, M-M, Ω-Ω  
 1/4(W) CARBON RESISTOR  
 FOR SAFETY PURPOSES (AND CONTINUING RELIABILITY) Δ REPLACE ALL COMPONENTS MARKED WITH SAFETY SYMBOL WITH IDENTICAL TYPE

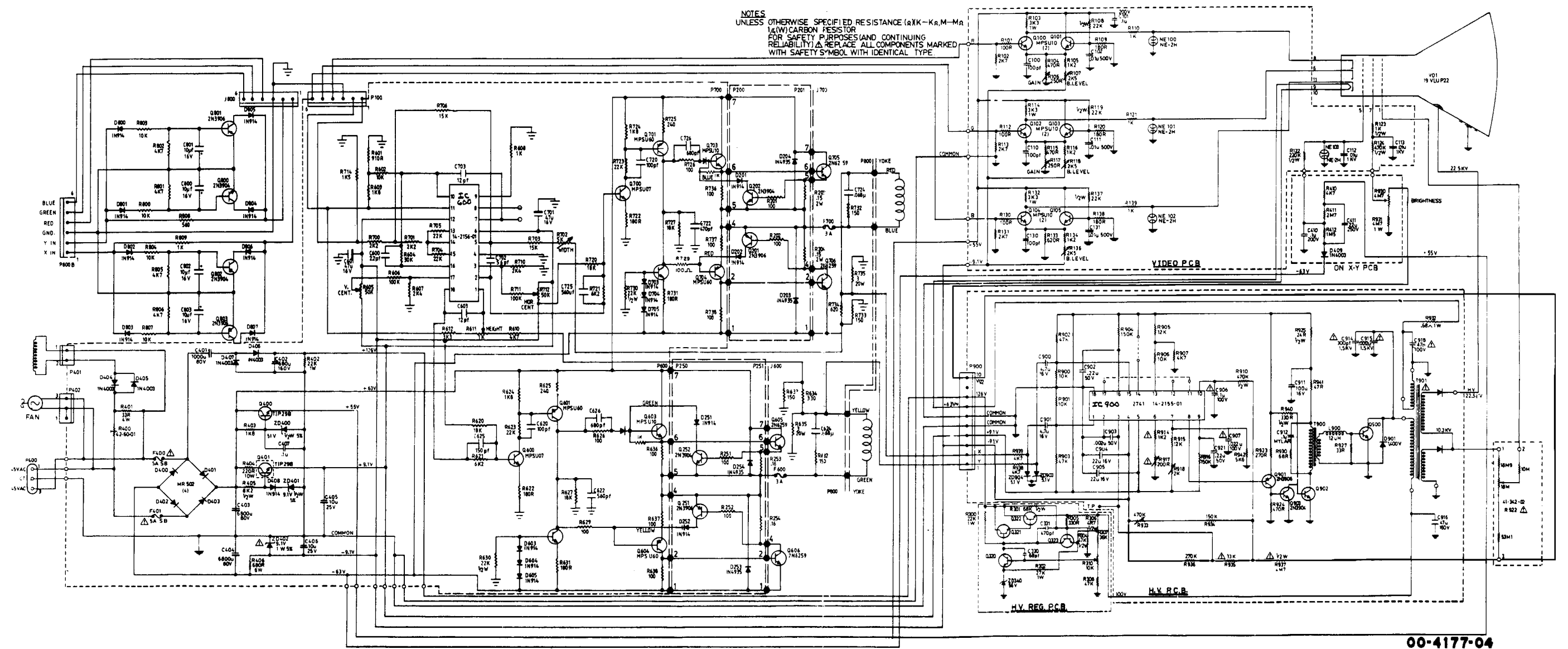

00-4177-04

# Model Number GO8-003

19" X-Y Color Monitor  
 200-0025