

# Sheet 2, Side B

## ASTEROIDS DELUXE™

### Switch Inputs, Coin Counter, LED and Audio Outputs



NOTICE TO ALL PERSONS RECEIVING THIS DRAWING  
 CONFIDENTIAL: Reproduction forbidden without the  
 specific written permission of Atari, Inc., Sunnyvale, CA.  
 This drawing is only conditionally issued, and neither  
 receipt nor possession thereof confers or transfers any  
 right in, or license to use, the subject matter of the draw-  
 ing or any design or technical information shown thereon,  
 nor any right to reproduce this drawing or any part  
 thereof. Except for manufacture by vendors of Atari, Inc.,  
 and for manufacture under the corporation's written  
 license, no right to reproduce this drawing is granted or  
 the subject matter thereof unless by written agreement  
 with or written permission from the corporation.

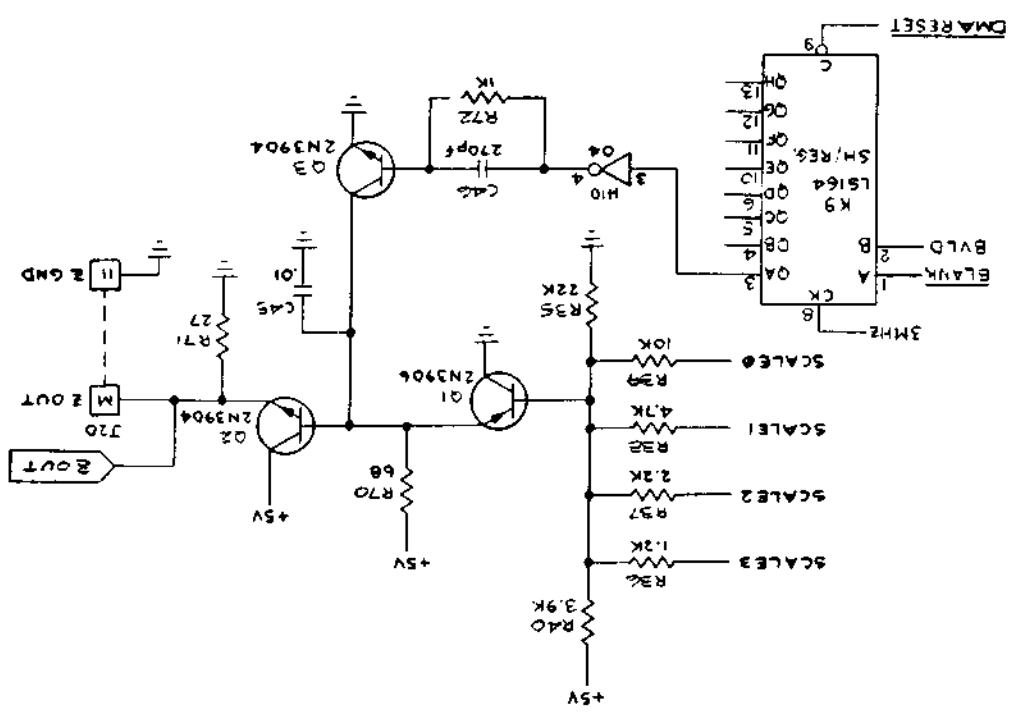
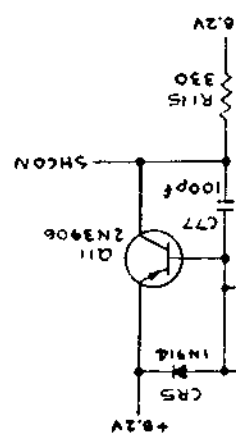

The scale inputs at the base of transistor Q1 determine Q1's emitter voltage, during the  
 line draw period. The SCALE0 thru SCALE3 resistors R36 thru R39, resistor R35, and  
 resistor R40 result in a range of about +1.0 VDC when all are low and +4.0 VDC when all  
 are high. The emitter of Q1 follows at about +1.7 to 4.7 VDC, while the emitter of tran-  
 sistor Q2 follows at about +1.0 to 4.0 VDC. This output is applied to the Z input of the  
 monitor. Since there are brightness and contrast controls in the monitor, there are no ad-  
 justments in this circuit.

signal is grounded at the base of transistor Q2.  
 When BLANK goes low, a low is clocked through K9, transistor Q3 turns on, and the  
 turns transistor Q3 off. This allows the scale inputs to be passed through transistor Q2.

SHPNSD

ANT  
C21

EXPLOSD

Denotes a test point  
denotes change by indicated revision

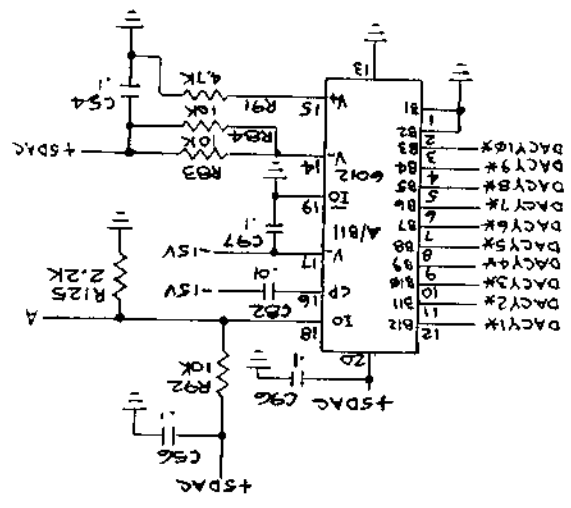
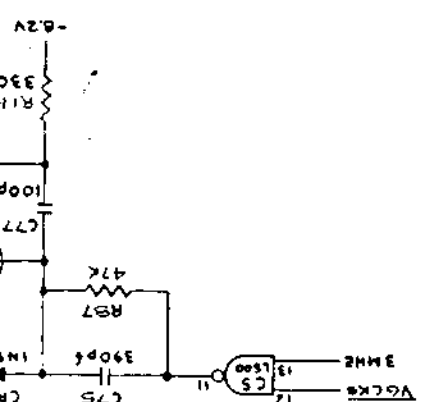
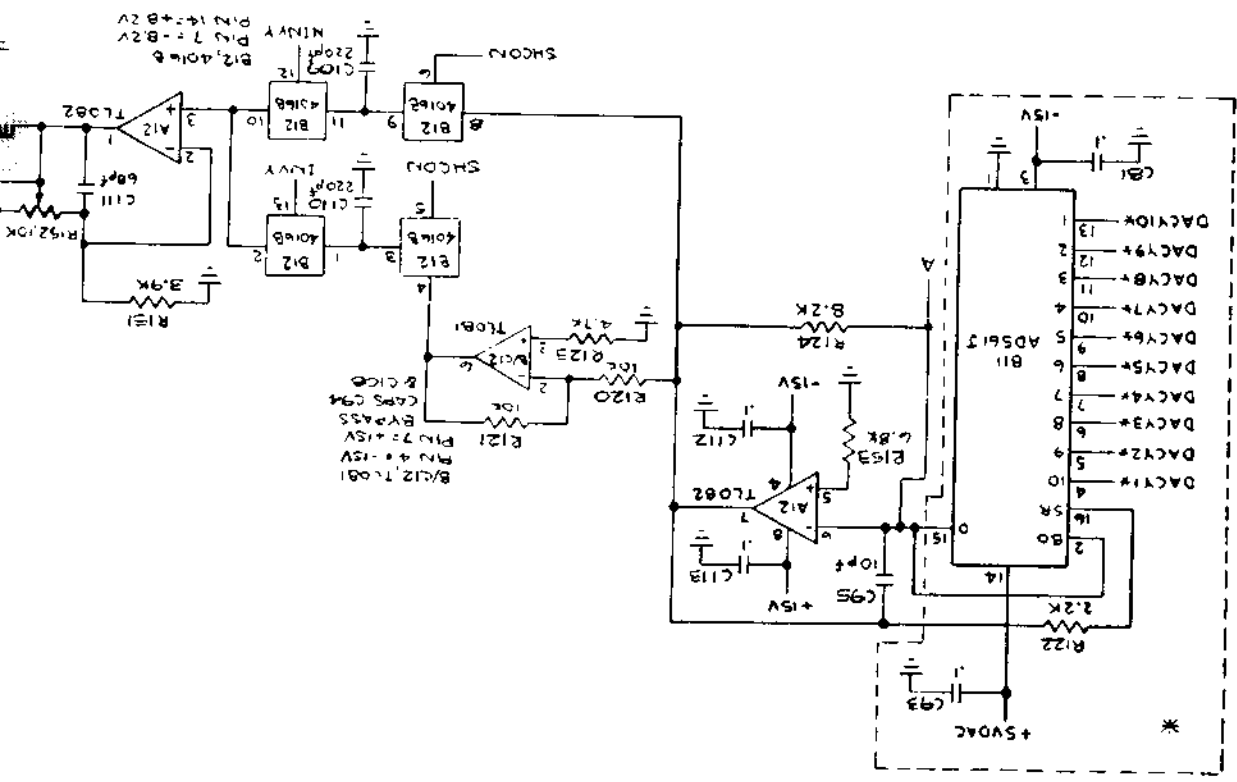

\* The circuitry within the dotted lines is optional circuitry for DAC 6012 at positions B11 and D11.

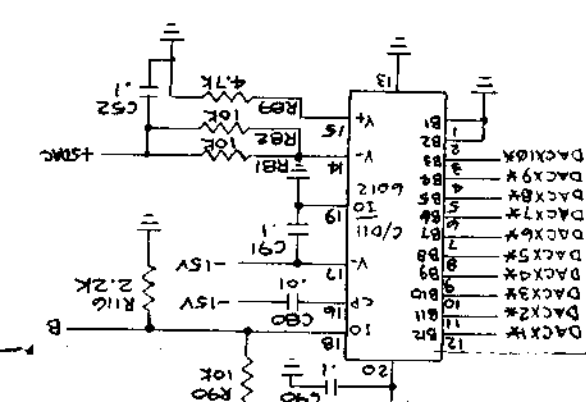

generate random noise. This noise is heard when the ship is

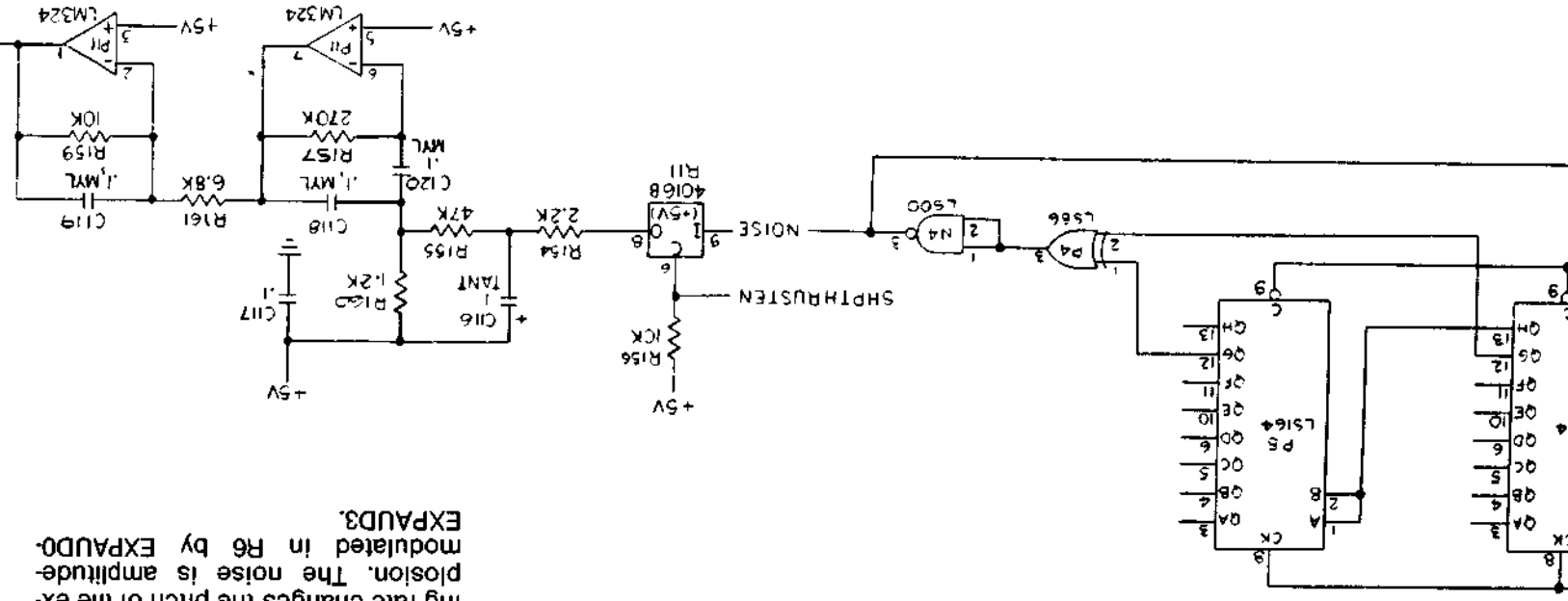

The EXPLODE sound is heard when any object explodes. Noise is sampled at a frequency determined by P7, and control bits EXPITCH0 and EXPITCH1. Changing the sampling rate changes the pitch of the explosion. The noise is amplitude-modulated in R6 by EXPAUD0, EXPAUD1, EXPAUD2, and EXPAUD3.

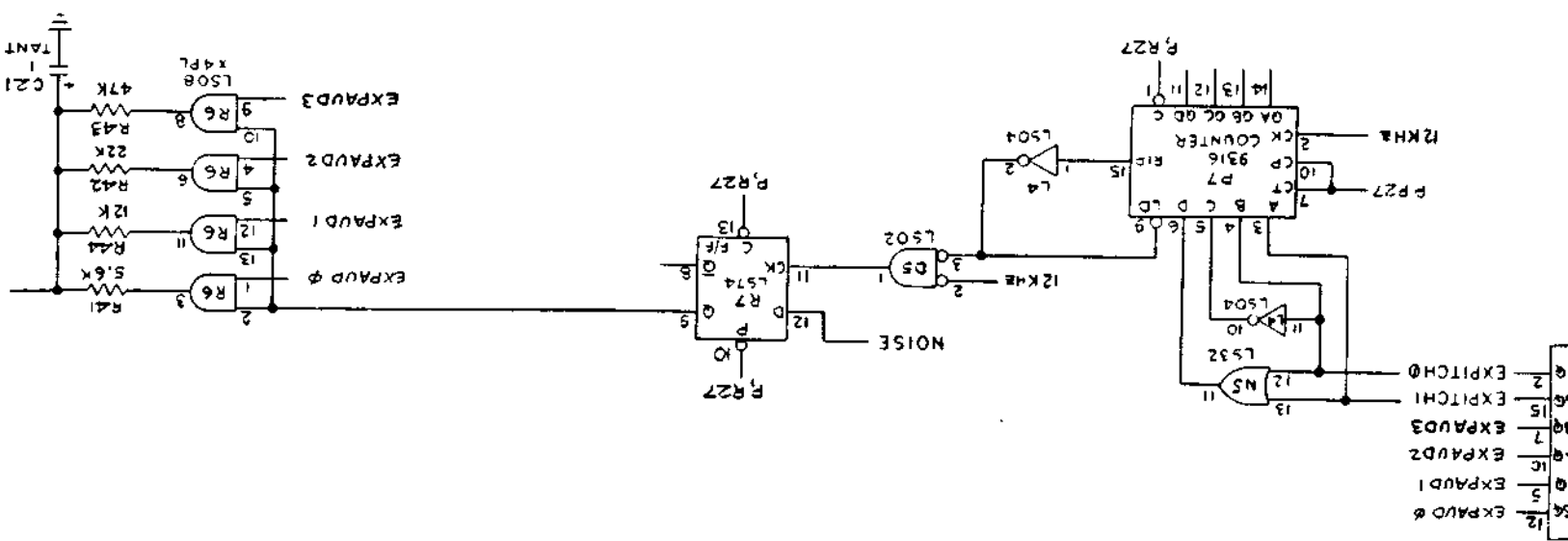

- 12 EXPAUD0
- 11 EXPITCH0
- 10 EXPITCH1
- 9 EXPAUD3
- 8 EXPAUD2
- 7 EXPAUD1
- 6 EXPAUD0
- 5 EXPITCH0
- 4 EXPITCH1
- 3 EXPAUD3
- 2 EXPITCH0

### VIDEO INVERTER

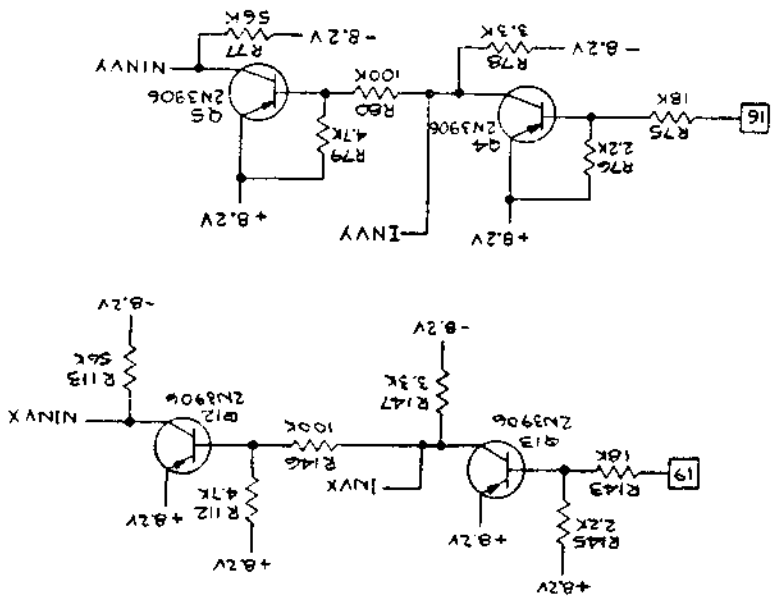

The x- and y-video inverter circuits are identical; therefore, only the x-video inverter circuit is explained. For inverted video operation, pin 19 is grounded which turns on transistor Q13 and turns off transistor Q12. In this state INV is +8.2 VDC and NONINV is -8.2 VDC. For a noninverted video output, pin 19 is unconnected and floats. In cocktail games, pins 19 and 7 are shorted and have a potential of +5 VDC. This causes transistor Q13 to be cut off and transistor Q12 to be turned on. INV is then -8.2 VDC and NONINV is approximately +8.2 VDC. In upright games, only the x-video inverter is used. In cocktail games both x- and y-video inverters are used, and in cabaret games video inversion is not necessary, so neither is used.

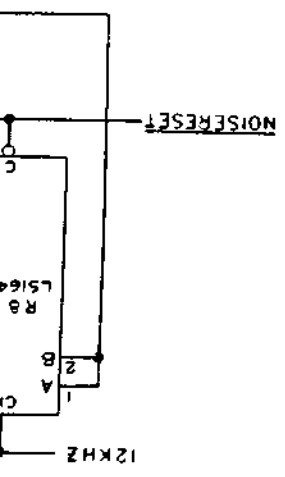
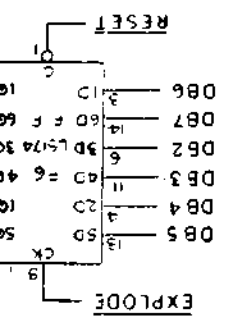

R8 and R9 g  
 noise is filtere  
 rumble sound  
 thrusting.

# INPUTS

## PLAYER INPUT CIRCUITRY

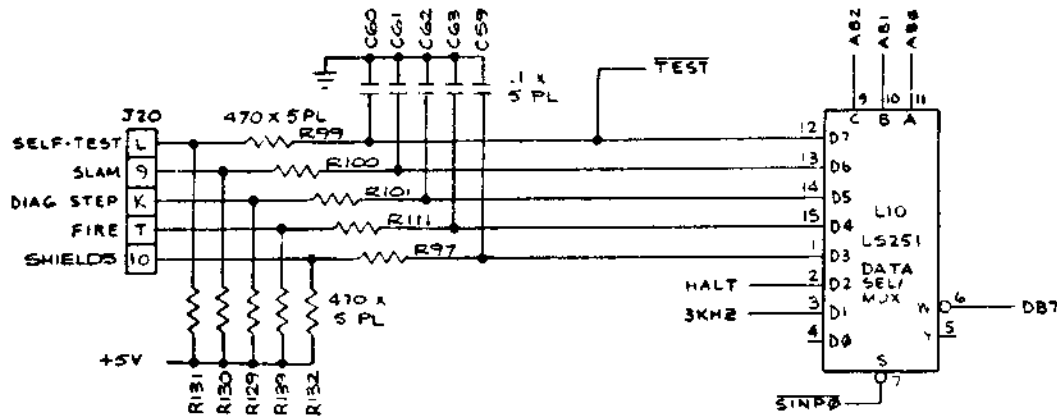

DIAG STEP (diagnostic step), 3 KHz, SELF-TEST SLAM, HALT, FIRE, and SHIELDS inputs are read by the MPU when SINP0 (switch input zero enable) is low. Switches to be read are selected by AB0 thru AB2 from the MPU. All inputs are read on DB7. Switch inputs are active when pulled to ground. DIAG STEP, 3 KHz, and SELF-TEST are signals read by the MPU to initiate and control the game's self-test procedure. SLAM is a signal read by the MPU to indicate the status of the anti-slam switch mounted on the coin door. The MPU reads HALT to determine the state of the vector generator.

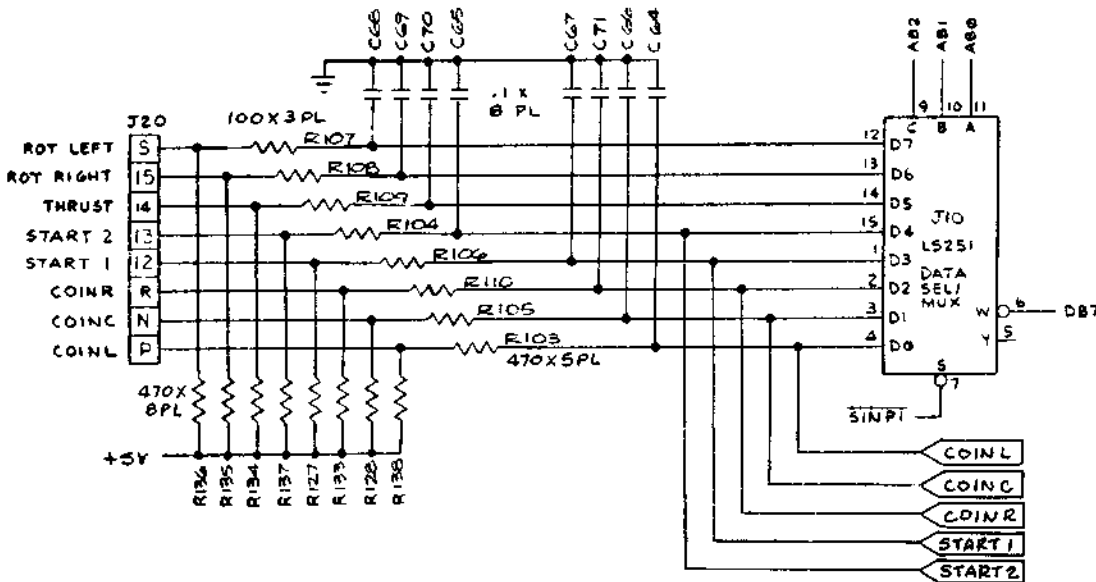

The coin door and some control panel switches are read by the MPU when SINP1 (switch input one enable) is low. Switches to be read are selected by AB0 thru AB2 from the MPU. All inputs are read on data line DB7. Switch inputs are "on" when pulled to ground.

◀ Denotes a test point

## OPTIONS INPUT CIRCUITRY

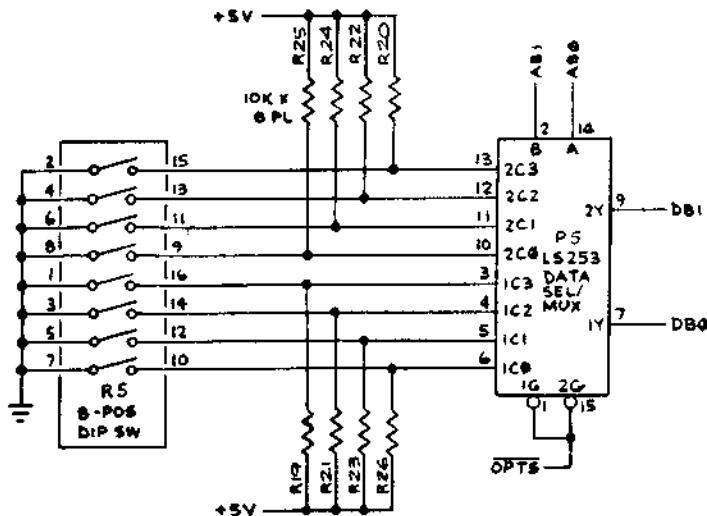

The game option switches are read by the MPU when OPTS (option switch enable) is low. Switch toggles to be read are selected by AB0 and AB1 from the MPU. Switch toggles 1, 3, 5 and 7 are read on data line DB0 and toggles 2, 4, 6 and 8 are read on DB1. Toggle inputs are "on" when pulled to ground.

# OUTPUTS

The Custom Audio chip M7/8 generates most of the sounds for Asteroids Deluxe™.

$\overline{R/\overline{W}}$  determines the direction of data flow (DB0-DB7) as addressed by AB0-AB3. When  $\overline{R/\overline{W}}$  is high, the MPU reads the input data from DIP switch L8. When  $\overline{R/\overline{W}}$  is low, the MPU writes the audio I/O instruction for an output.

The  $\phi 2$  input from the MPU is the operating frequency for the audio I/O chip and sets the timing for data bus lines DB0-DB7.

When PKYDCD, AB10, and AB11 are high and AB6 is low, a chip select pulse is gated to the audio I/O chip. This pulse prepares the audio I/O for operation.

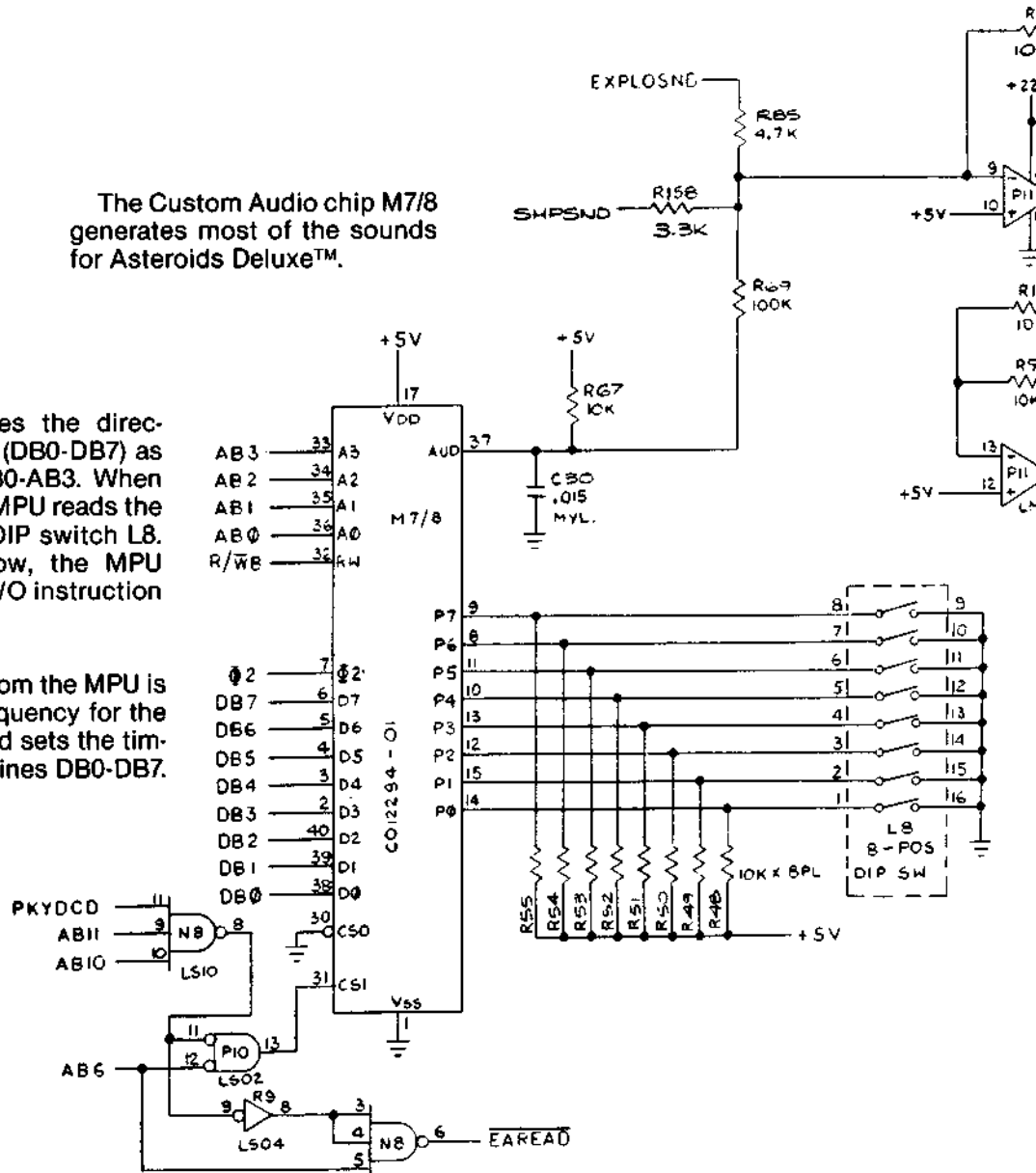

Denotes a

# LAMP, LED, AND COIN COUNTER OUTPUT

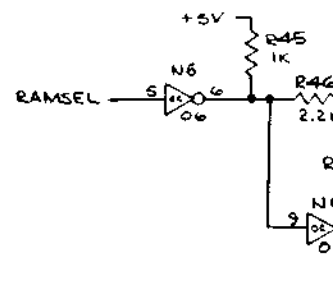
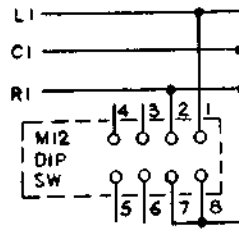
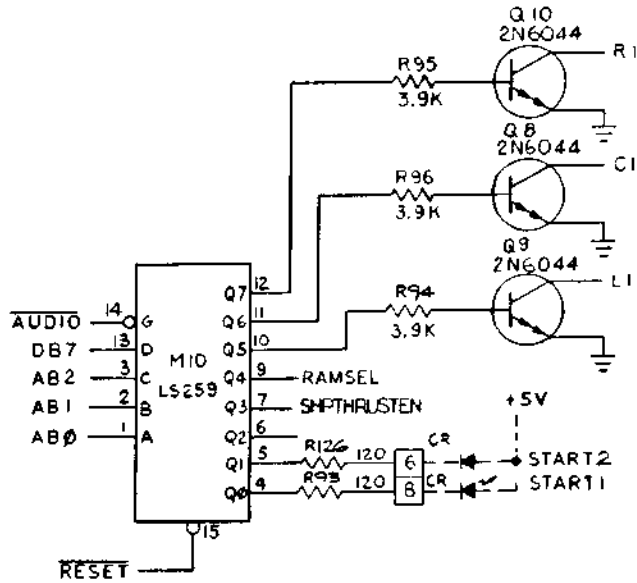
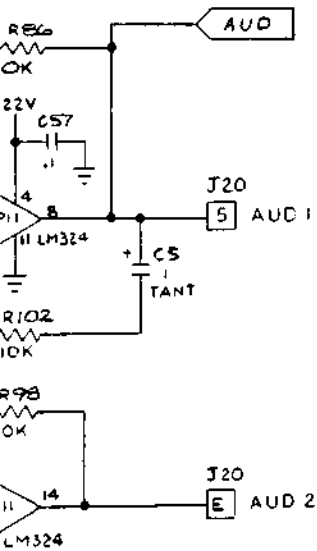

# VIDEO OUTPUTS

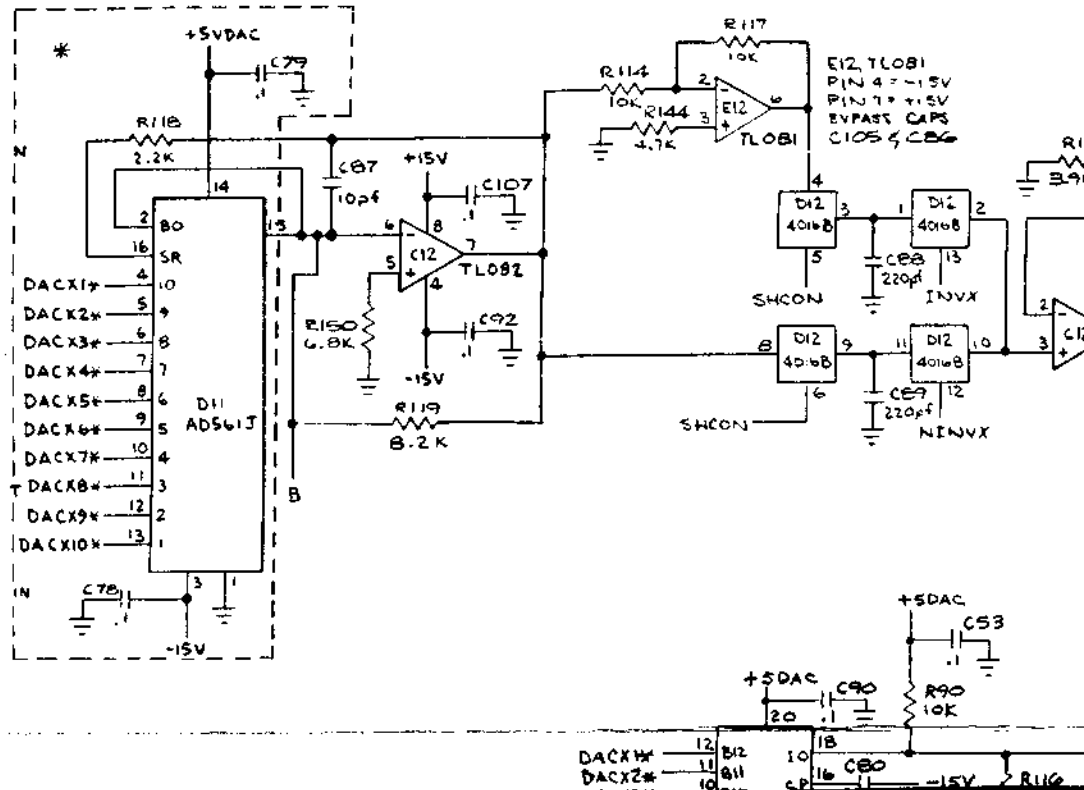

is a test point

This circuit consists of coin counter drivers Q8, Q9, Q10 and data latch M10, clocked by the micro-computer's address decoder. When the input to a driver is clocked high, its collector goes low, grounding the return of the coin counter in the coin door. When START1 or START2 is clocked low, it grounds the START LEDs in the control panel.

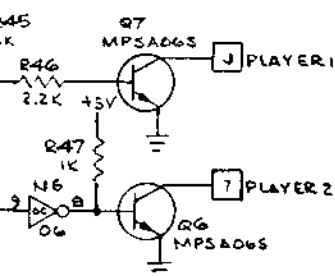
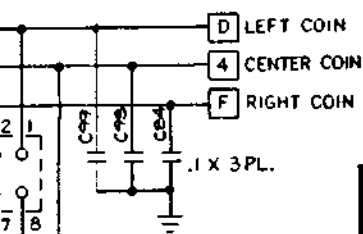

The video-output circuit consists of three individual circuits: X-axis, Y-axis, and Z-axis. The X-axis and Y-axis video-output circuits each consist of a digital-to-analog converter (DAC), current-to-voltage converter, two sample and holds, and amplifier. The Z-axis video-output circuit consists of a shift register and a summer.

### X and Y Outputs

The DACs (D11 and B11) each receive binary numbers from the vector generator's position counter outputs. These numbers represent the location of the beam on the monitor. For the non-inverted X axis, the numbers range from 0 to 1023, where 0 is at the far left of the monitor screen, 512 is at the center, and 1023 is at the far right. For the non-inverted Y axis, the numbers range from 128 to 996, where 128 is at the bottom of the monitor screen, 512 is at the center, and 996 is at the top. When the X axis and Y axis are inverted, the monitor picture is turned upside down. This is used for a two-player cocktail game.

The DACs convert these binary number inputs to current outputs. The DACs' current outputs are applied to the pin-6 inputs of current-to-voltage converters C12 and A12.

From the current-to-voltage converters, the signal is fed to two sample-and-hold circuits: One is non-inverted and the other is inverted. The non-inverted sample and hold consists of one stage of analog switch D12 and capacitor C89 for the X axis, and B12 and C109 for the Y axis. The inverting sample and hold consists of inverter E12, one stage of analog switch D12, and capacitor C88 for the X axis and B/C12, B12 and C110 for the Y axis.

The sample-and-hold circuits are controlled by SHCON (sample and hold control). SHCON is derived by gating 3 MHz from the microcomputer clock circuitry and VGCK\* from the vector generator's state generator. The result of these inputs insures that the non-inverted and inverted analog signals that are applied to the analog switches have sufficiently stabilized before being applied to the sample-and-hold capacitors.

The output swing of SHCON is -8 to +8 VDC. When SHCON is high, the voltage charges or discharges the sample-and-hold capacitors to the X and Y analog voltage value. The voltages are then applied to the inputs of the second analog switch. These switches select either the non-inverted or inverted X-axis and Y-axis outputs. The outputs are then amplified by the second stages of C12 and A12 for an impedance-matched output to the X and Y inputs to the monitor. Since the monitor doesn't have field-adjustable X and Y gains, the gains are adjustable by variable resistors R120 and R126.

### Z Output

The Z-axis video output receives six inputs. BVLD (beam valid), from the output of the vector generator's position counters, tells the Z axis to draw the line. BLANK (vector line blank), from the vector generator's state machine, tells the Z axis to stop drawing a line. SCALE0 thru SCALE3 (grey-level shading scale), from the output of the vector generator's data latch, tells the Z axis the grey-level shading of the line that is being drawn on the monitor.

When BVLD and BLANK are both high, a high is clocked through shift register K9 that turns transistor Q3 off. This allows the scale inputs to be passed through transistor Q2. When BLANK goes low, a low is clocked through K9, transistor Q3 turns on, and the signal is grounded at the base of transistor Q2.

