

**THANK YOU FOR DOWNLOADING THIS MANUAL. I HOPE IT HELPS YOU RESOLVE ANY ISSUES YOU HAVE HAD WITH YOUR GAME.**

**THIS MANUAL WAS PURCHASED, AND SCANNED BY BASEMENT ARCADE ASSOCIATES, [WWW.BASEMENTARCADE.COM](http://WWW.BASEMENTARCADE.COM) AND IS OFFERED FOR FREE DOWNLOAD AT OUR SITE.**

**THIS PDF IS NOT TO BE DISTRIBUTED ON ANY COLLECTION CD / DVD, NOR IS TO BE LINKED TO VIA ANY OTHER INTERNET SITE WITHOUT PERMISSION FROM US. LIKEWISE IT IS NOT TO BE DISTRIBUTED FROM ANY OTHER SITE WITHOUT OUR PERMISSION.**

**ABIDING BY THESE REQUESTS, WILL INSURE THE CONTINUING SUPPORT OF NEW MANUALS ADDED TO OUR SITE.**

**ALL ORIGINAL COPYRIGHTS HELD BY THEIR ORIGINAL OWNERS, THIS PDF COPYRIGHTED BASEMENT ARCADE ASSOCIATES.**

**==MARK==**

# Operation, Maintenance and Service Manual

Complete with Illustrated Parts Lists

# ASTEROIDS DELUXE™



[www.basementarcade.com](http://www.basementarcade.com)

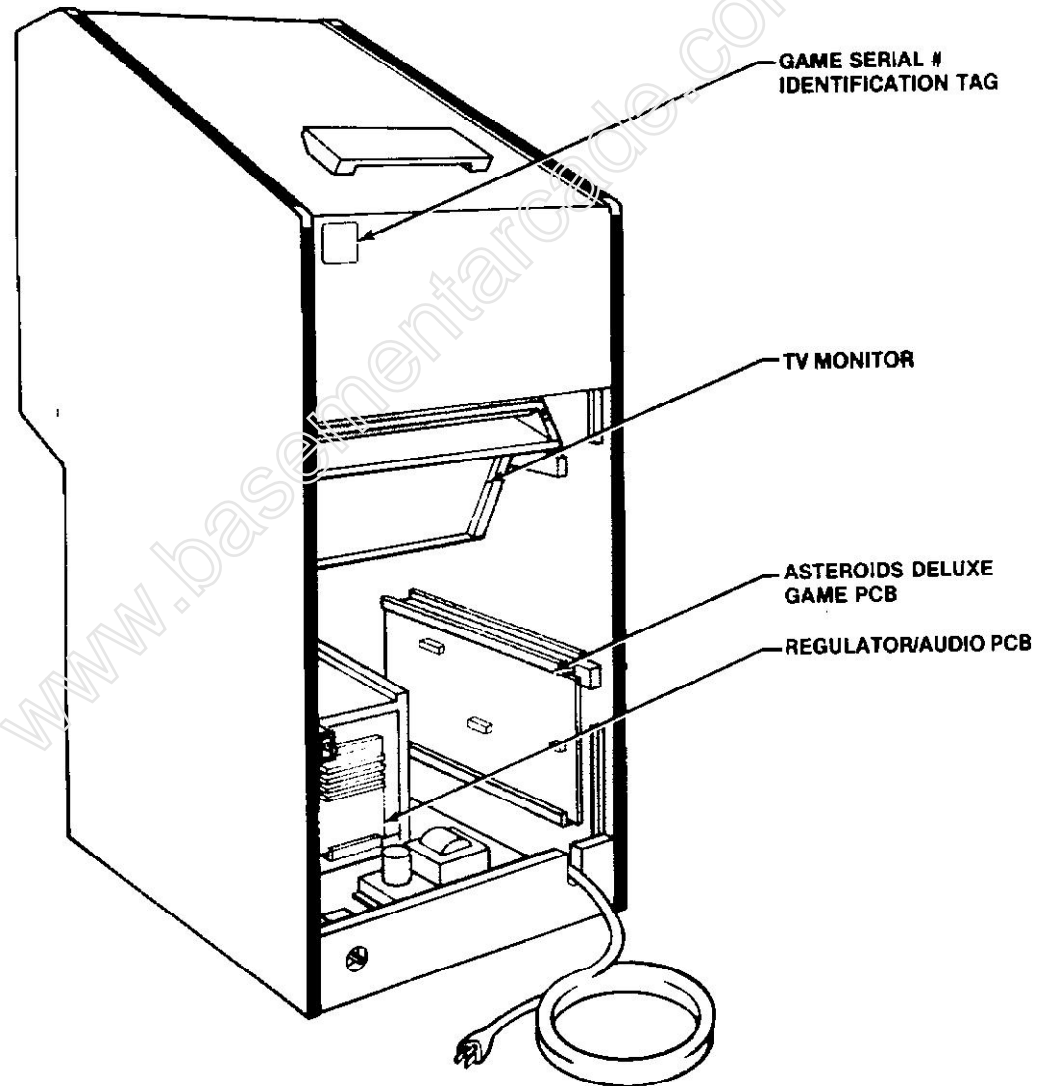

### GAME SERIAL NUMBER LOCATION

Your game's serial number is stamped on a plate on the outside of the game. The same number is also stamped on the chassis of the TV monitor, Regulator/Audio PCB, and the Asteroids Deluxe™ Game PCB. Please mention this number whenever calling your distributor for service.



# ASTEROIDS DELUXE

## Operation, Maintenance and Service Manual

Complete with Illustrated Parts Lists

Published by:  
**ATARI INC.**  
1265 Borregas Avenue  
P. O. Box 427  
Sunnyvale, California 94086

Copyright © 1981 by Atari, Inc. All rights reserved.

No part of this publication may be reproduced by any mechanical, photographic, or electronic process, or in the form of a phonographic recording, nor may it be stored in a retrieval system, transmitted, or otherwise copied for public or private use, without permission from the publisher.

Lithographed in the U.S.A. 2K



**ATARI**®

 A Warner Communications Company

# Table of Contents

<b>1</b>	<b>Location Setup</b>	
A.	New Parts	1
B.	Game Inspection	3
C.	Game Installation	3
	1. Line Voltage Selection	3
	2. Interlock and Power On/Off Switches	4
D.	Self-Test Procedure	7
E.	Option Switch Settings	9
	1. Bonus Play Feature	9
	2. Coin Mechanism Multipliers	10
	3. Examples of Option Switch Settings	10
F.	Game Play	13
	1. Attract Mode	13
	2. Ready-to-Play Mode	14
	3. Play Mode	14
	4. High Score Initial Mode	14
<b>2</b>	<b>Maintenance and Repair</b>	
A.	Cleaning	16
B.	Fuse Replacement	16
C.	Opening the Control Panel	16
	1. LED Start-Switch Replacement	17
	2. Leaf-Switch Replacement	17
D.	Monitor Removal	17
E.	Fluorescent Tube Replacement	18
F.	Printed-Circuit Board Replacement	19
	1. Game PCB Removal	19
	2. Regulator/Audio I PCB Removal	19
G.	Game Operation	20
<b>3</b>	<b>Illustrated Parts Lists</b>	
	Illustrations and parts lists begin on page	23

# List of Illustrations

Figure 1	Overview of Game	2
Figure 2	Installation Requirements	3
Figure 3	International Line Voltage Selection	4
Figure 4	Interlock and Power On/Off Switches	5
Figure 5	Location of Self-Test Switch, Volume Control and Option Switches	6
Figure 6	Self-Test Procedure	7
Figure 7	Game Option Settings	9
Figure 8	Game Price Settings	11
Figure 9	Coin Counter Option Settings	13
Figure 10	Opening the Control Panel and Replacing Switches	16
Figure 11	Monitor Removal	17
Figure 12	Fluorescent Tube Replacement	18
Figure 13	Printed-Circuit Board Replacement	19
Figure 14	Power Distribution	21
Figure 15	Signal Distribution	22
<i>Illustrated Parts Lists:</i>		
Figure 16	Cabinet-Mounted Assemblies	24
Figure 17	Control Panel Assembly	26
Figure 18	Fluorescent Light and Speaker Assembly	27
Figure 19	Regulator/Audio I PCB Assembly	28
Figure 20	Asteroids Deluxe™ Game PCB Assembly	30
Figure 21	Power Supply Assemblies for X-Y Games	34
Figure 22	American-Made Coin Door	36
Figure 23	British-Made Coin Door	40

## NOTE

If reading through this manual does not lead to solving a certain maintenance problem, call Tele-Help™ at the Atari Customer Service office in your geographical area, as shown in one of the two maps below. Order all parts from the California office.

### WEST and CENTRAL U.S.A.

Parts for all Atari Customers. Sales and Service

Atari Coin-Op Customer Service  
1105 N. Fair Oaks Avenue  
P. O. Box 427, Sunnyvale, CA 94086  
Telex 17-1103

(Monday - Friday, 7:30 - 4:00 pm Pacific Time)

 From California, Alaska or Hawaii  
(408) 745-2900

 From anywhere else in this area  
toll-free (800) 538-1611

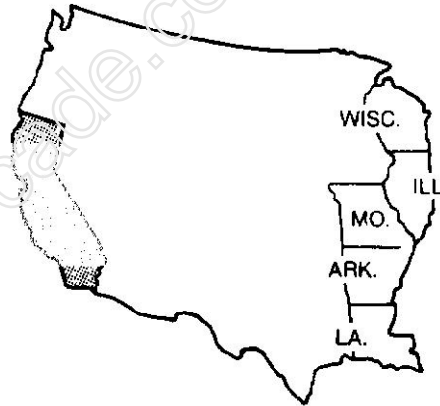



### EAST U.S.A.

Sales and Service Only

Atari Inc.  
New Jersey Customer Service Office  
Cottontail Lane, Somerset, NJ 08873  
Telex 37-9347

(Monday - Friday, 7:30 - 4:00 pm Eastern time)

 From New Jersey  
(201) 469-5993

 From anywhere else in this area  
toll-free (800) 526-3849



# Notice Regarding Non-Atari Parts



Atari, Inc.'s warranty (printed on the inside back cover of this manual) may be voided, if you do any of the following:

- 1.) you substitute non-Atari parts in your coin-operated game, or
- 2.) you modify or alter any circuits in your Atari game by using kits or parts **not** supplied by Atari.

Not only may the use of any non-Atari parts void your warranty, but any such alteration may also adversely affect the safety of your game, and may cause injury to you and your players.



# Location Setup

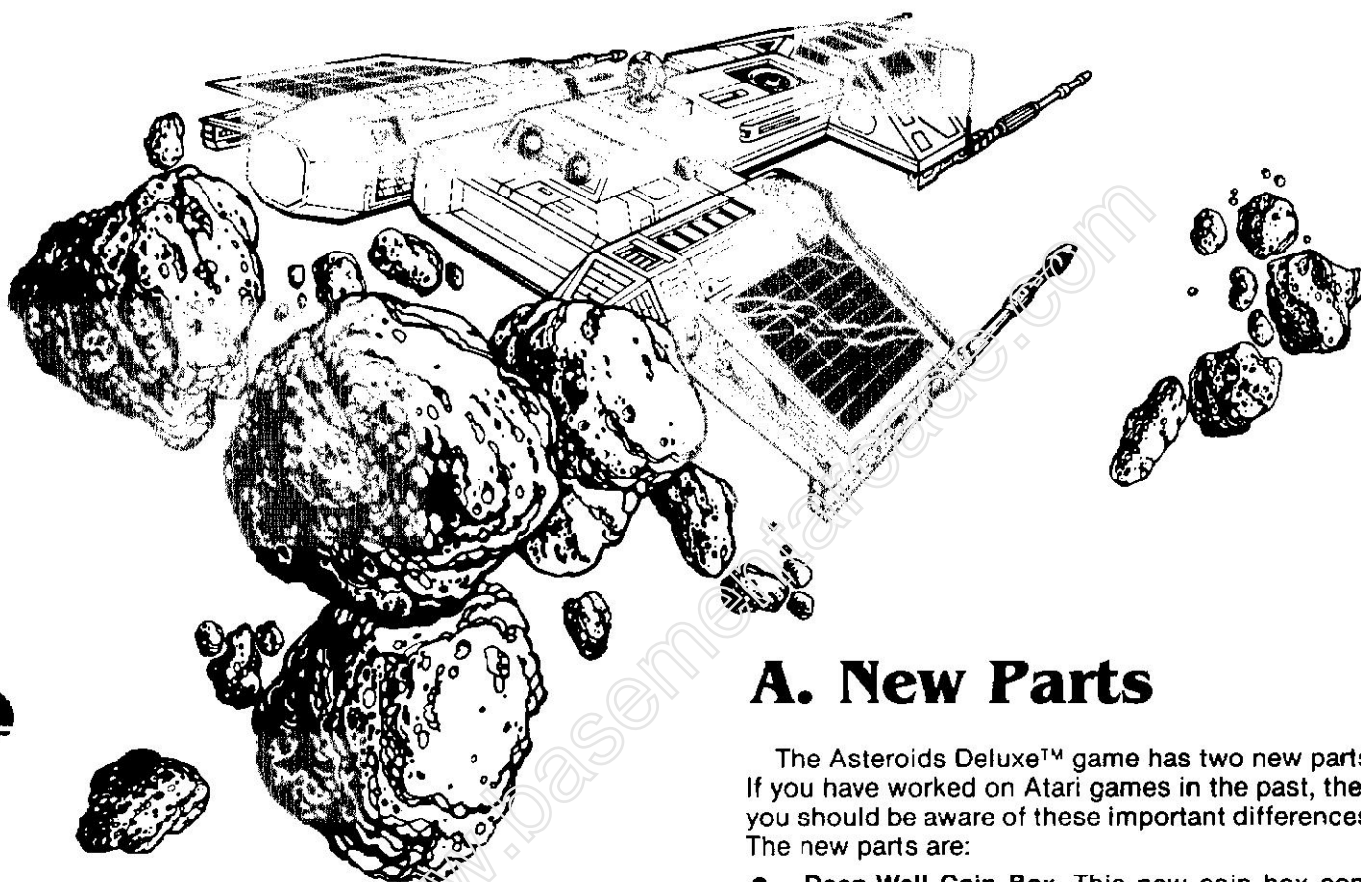

## A. New Parts

The Asteroids Deluxe™ game has two new parts. If you have worked on Atari games in the past, then you should be aware of these important differences. The new parts are:

- **Deep-Well Coin Box.** This new coin box conservatively holds \$600 in U.S. quarters. Please note that \$500 in quarters weighs over 11 kg (25 lbs.), and \$600 in quarters weighs 12¾ to 13½ kg (28-30 lbs.).
- **Game PCB Circuitry.** Most video games to date have used the raster-scan method of display. This game uses vector-generation with X and Y

### ⚠ WARNING — SHOCK HAZARD ⚠

Connect this game only to a grounded 3-wire outlet. If you have only a 2-wire outlet, we recommend you hire a licensed electrician to install a grounded outlet. **Players may receive an electric shock** if this game is not properly grounded!

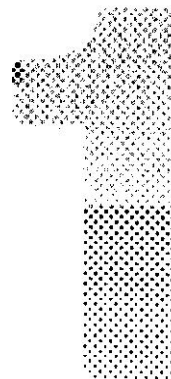

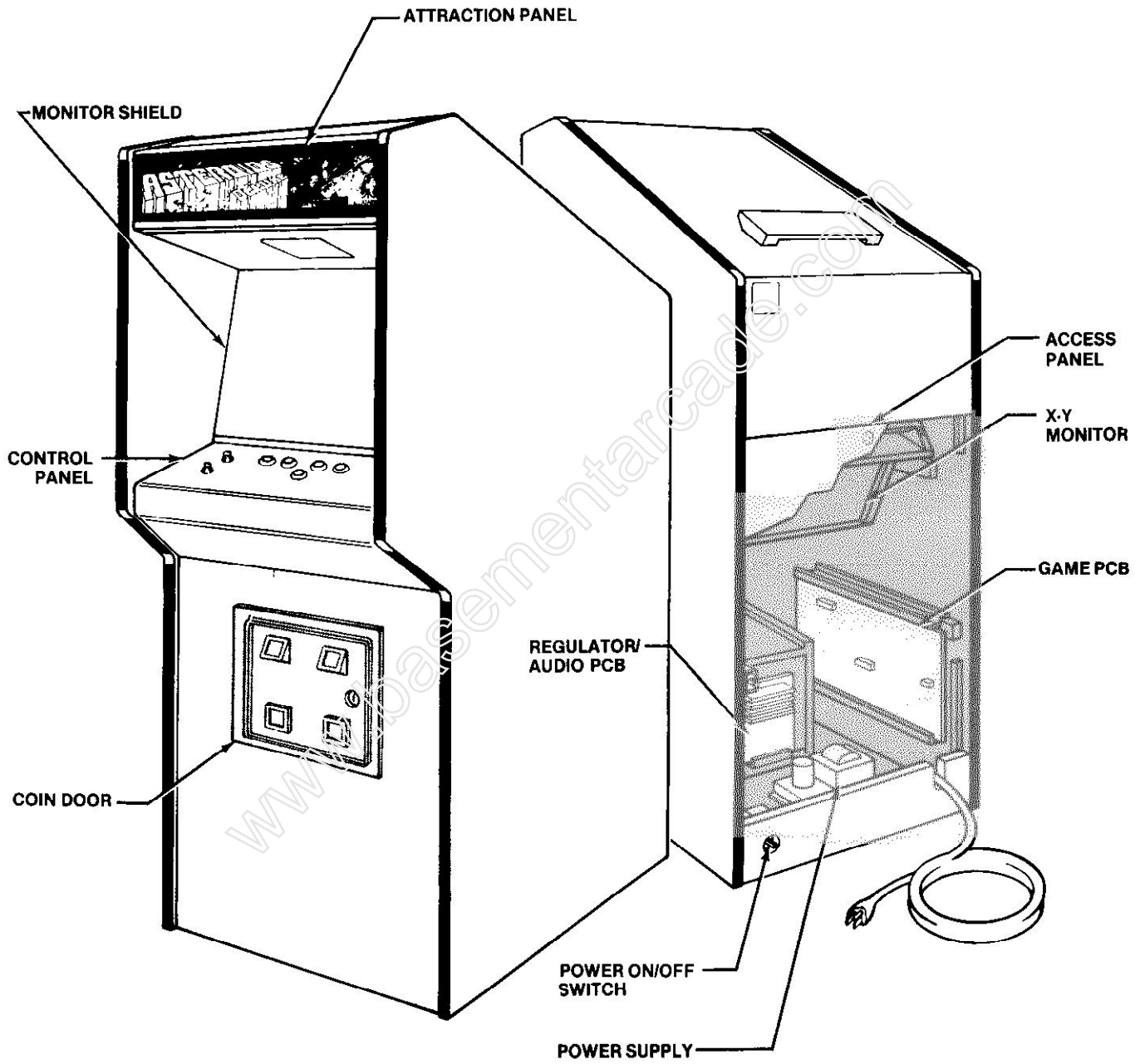

Figure 1 Overview of Game

axes which allows better contrast and a greater number of moving objects, and draws lines at any angle.

In addition, Asteroids Deluxe™ is one of the first Atari games to have non-volatile memory for part of the high score table. This means that even if power is removed from the game, the three highest scores will permanently stay in memory. You may erase these scores by following the instructions in Figure 6, Self-Test Procedure.

These new parts, as well as all other major parts in the game, are illustrated in Figure 1. Throughout this manual, wherever one of these new parts is mentioned, you will see this symbol:



## B. Game Inspection

This new game is ready to play upon removal from the shipping carton. However, your careful inspection is needed to supply the final touch of quality control. Please follow these steps to help us insure that your new game was delivered to you in good condition.

### NOTE

Do not plug the game in yet!

1. Examine the exterior of the game cabinet for dents, chips, or broken parts.
2. Unlock and open the access panel of the cabinet and inspect the interior of the game as follows:
  - Check that all plug-in connectors (on the game harness) are firmly seated. Replug any connectors found unplugged. **DON'T FORCE CONNECTORS TOGETHER.** The connectors are keyed so they only go on in the proper orientation. **A reversed edge connector will damage a PCB** and will void your warranty.
  - Check that all plug-in integrated circuits on the game PCB are firmly seated in their sockets.

### WARNING

To avoid possible unpleasant electrical shock, do not touch internal parts of the monitor with your hands or metal objects held in your hands!

- Note the location of the game's serial number—it is printed on the special label on the outside of the game cabinet. Verify that the serial numbers also stamped on the Asteroids Deluxe™ Game-PCB, Regulator/Audio PCB and monitor are all identical. A drawing of the serial number locations is on the inside front cover of this manual. Please mention this number whenever you call your distributor for service.
- Check all major subassemblies such as the power supply, control panel and monitor for secure mounting.

## C. Game Installation

### Figure 2 Installation Requirements

Power	175 watts
Temperature	0° to 38°C (32° to 100°F)
Humidity	Not over 95% relative
Space Required	64 × 81¼ cm (25¼ × 32 in.)
Game Height	182¼ cm (71¾ in.)

### 1. Line Voltage Selection

This game has two possible power supplies: the U.S. or international power supply. The U.S. power supply operates on one line voltage range: 105 to 135 VAC. The international power supply has four colored voltage selection plugs and operates on the line voltage of almost any country in the world.

Before plugging in your game, check your power supply. If the supply *doesn't* have voltage selection plugs and a connector at J3 (see Figure 3), then the game operates on any voltage from 105 to 135 VAC. If the supply *has* the colored voltage selection plugs, make sure that the voltage selection plug is correct for your location's line voltage. Check the wire color on the plug and see if it is correct per the list below.

Line Voltage Range	Voltage Selection Plug Color
90-110 VAC (100)	Violet
105-135 VAC (120)	Yellow
200-240 VAC (220)	Blue
220-260 VAC (240)	Brown

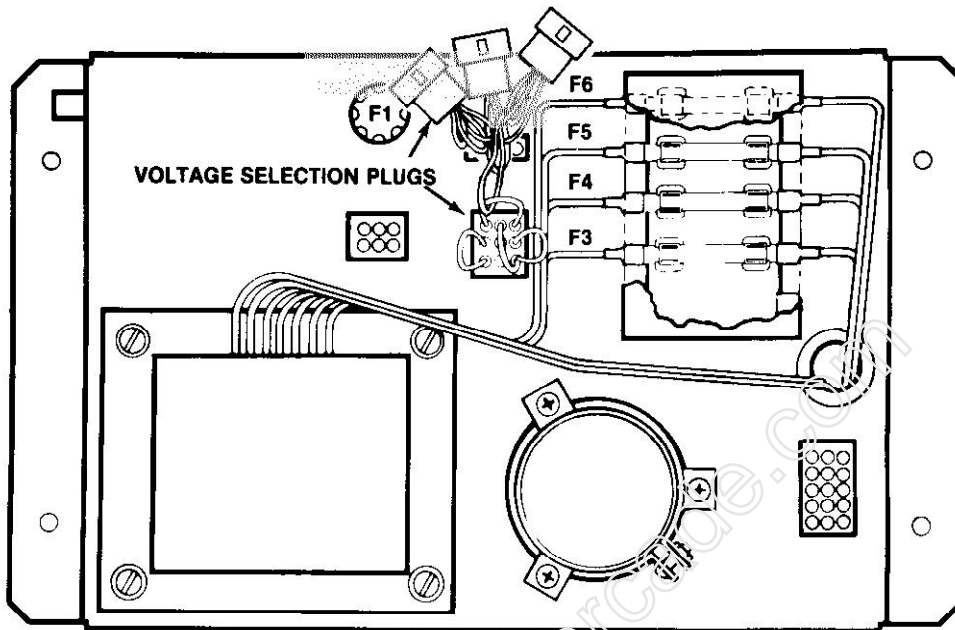

**Figure 3 International Line Voltage Selection**

## 2. Interlock and Power On/Off Switches

To minimize the hazard of electrical shock while working on the inside of the game cabinet, two interlock switches have been installed (see Figure 4). One is located behind the access panel and one is behind the coin door. These switches remove all AC line power from the game circuitry when a door is opened.

Check for proper operation of the interlock switches by performing the following steps:

- Plug the AC line power cord into an AC outlet.
- Close the access panel and coin door.
- Set the power on/off switch to the **on** position. Within 30 seconds the TV monitor should display a picture.
- Slowly open the access panel. The TV monitor picture should disappear when the panel is opened approximately 2.5 cm (1 inch). Close and lock the access panel and repeat this step with the coin door.
- If the results of the preceding step are satisfactory, the interlock switches are operating properly. If the TV monitor doesn't go off as described, check to see if the corresponding interlock switch is broken from its mounting or stuck in the **on** position.

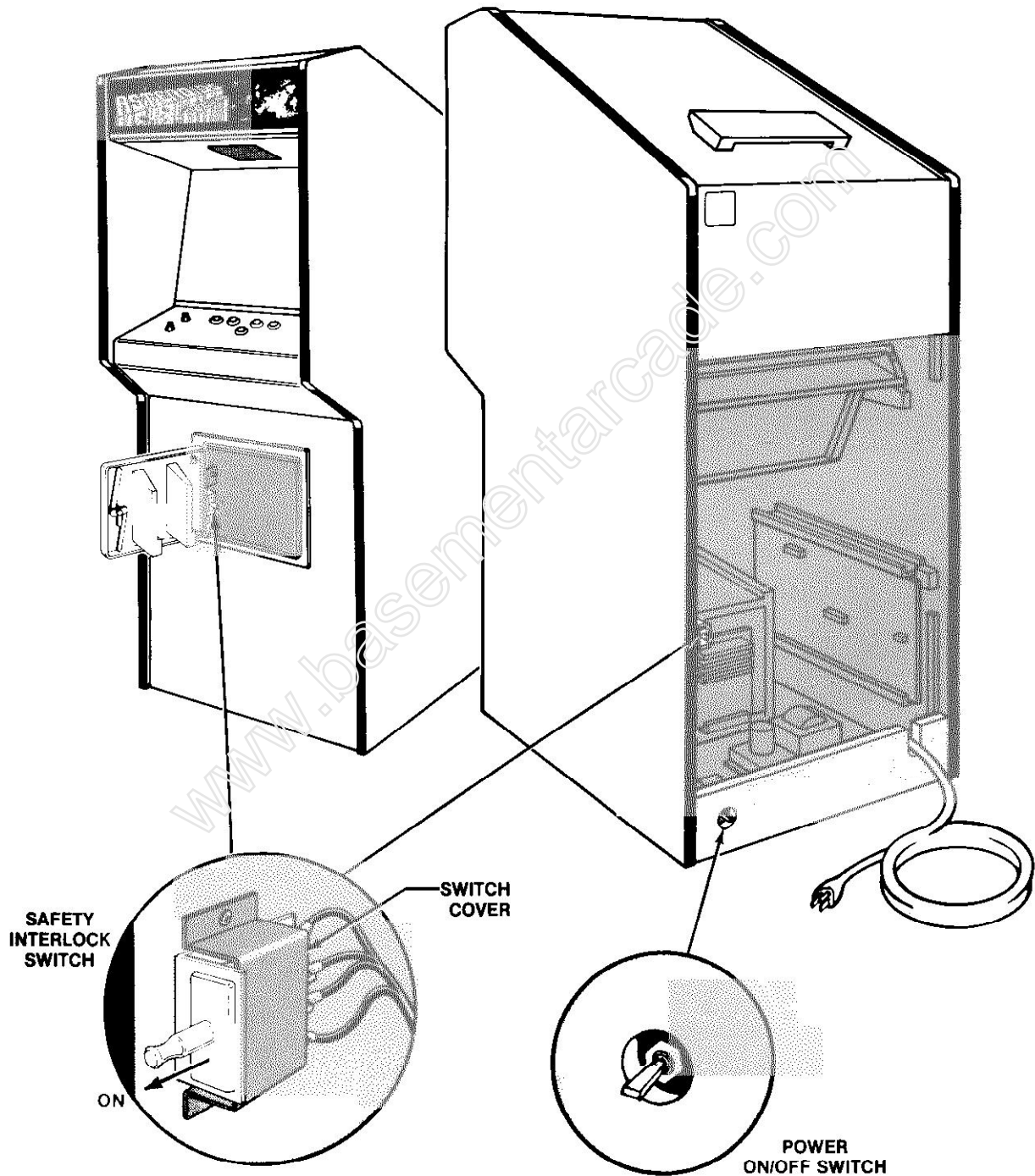
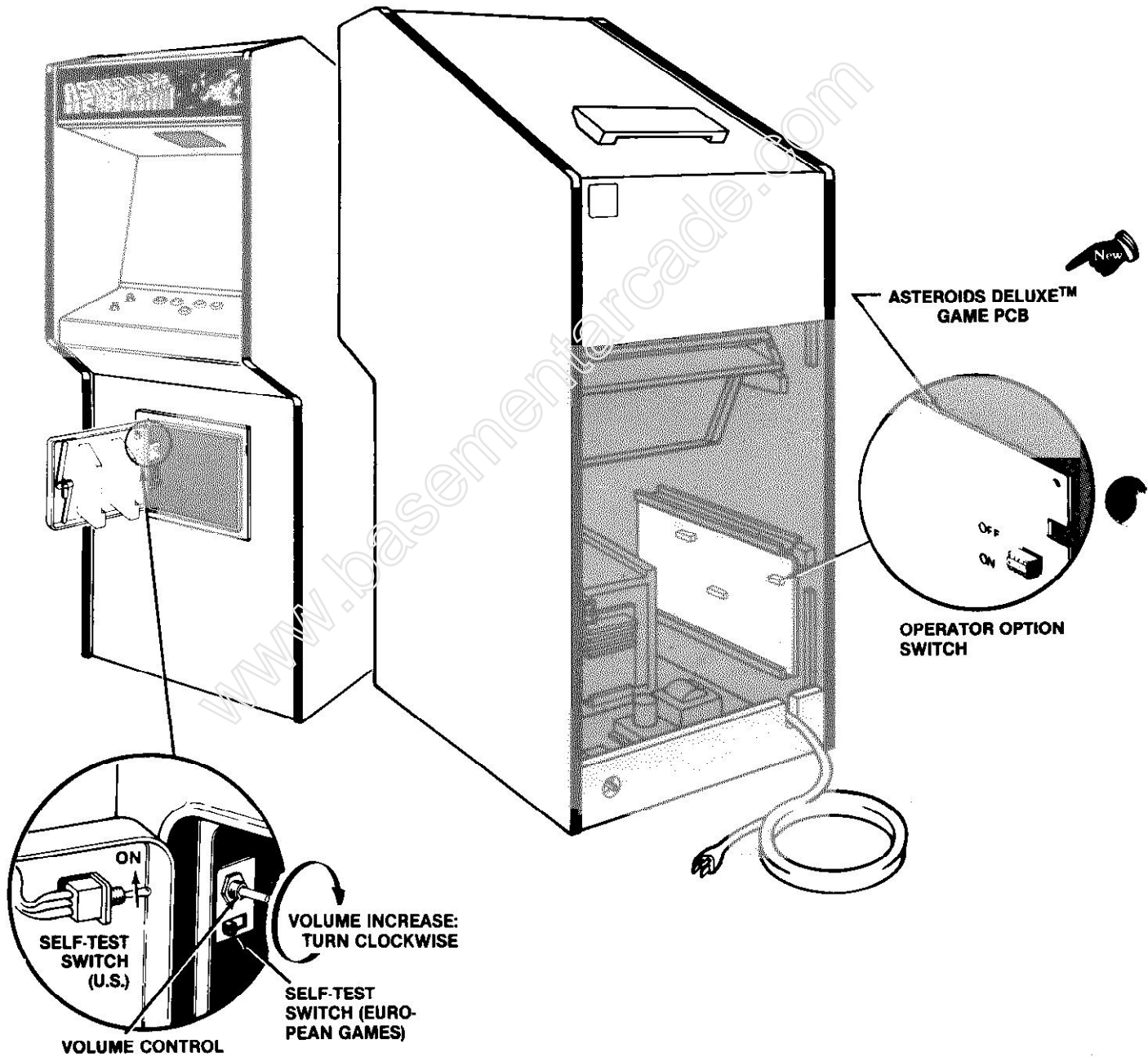

Figure 4 Interlock and Power On/Off Switches



**Figure 5 Location of Self-Test Switch,  
Volume Control and Option Switches**

## D. Self-Test Procedure

This game will test itself and provide data to demonstrate that the game's circuitry and controls are operating properly. The data is provided on the monitor and the game speaker; no additional equipment is necessary.

Part of the self-test procedure includes a display of the operator-selectable game options. Therefore, we suggest you run the self-test procedure in Figure 6 anytime you need to change the game's options.

**Figure 6 Self-Test Procedure**

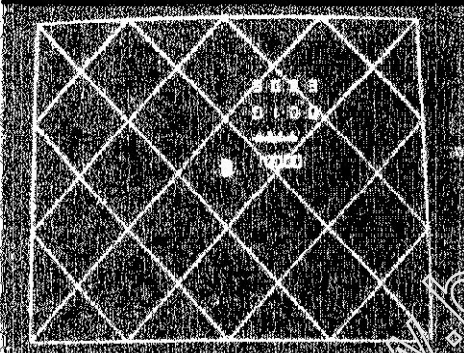
Instruction	Results if Test Passes	Results if Test Fails																				
1. Set self-test switch to <b>on</b> position (see Figure 5).	The monitor displays the picture below. The game produces only a very short beep sound.	<b>RAM FAILURE</b> is indicated by a sequence of low and high beeps. Note the sequence of beeps and determine which RAM(s) may be bad. To restart the sequence, press the reset pushbutton on the game PCB, or set the self-test switch to <i>off</i> , then again to the <i>on</i> position.																				
		<table border="1"> <thead> <tr> <th data-bbox="716 743 906 764">Sequence of Beeps</th> <th data-bbox="1138 722 1349 764">Possible Bad RAM Chip Location(s)</th> </tr> </thead> <tbody> <tr> <td data-bbox="781 768 841 789">1 low</td> <td data-bbox="1203 768 1230 789">L1</td> </tr> <tr> <td data-bbox="781 793 841 814">2 lows</td> <td data-bbox="1182 793 1252 814">L1, M1</td> </tr> <tr> <td data-bbox="748 819 873 840">1 high, 1 low</td> <td data-bbox="1203 819 1230 840">M1</td> </tr> <tr> <td data-bbox="737 844 885 865">2 highs, 1 low</td> <td data-bbox="1203 844 1230 865">M3</td> </tr> <tr> <td data-bbox="737 869 885 890">2 highs, 2 lows</td> <td data-bbox="1182 869 1252 890">M3, R3</td> </tr> <tr> <td data-bbox="737 894 885 915">3 highs, 1 low</td> <td data-bbox="1203 894 1230 915">R3</td> </tr> <tr> <td data-bbox="737 919 885 940">4 highs, 1 low</td> <td data-bbox="1203 919 1230 940">N3</td> </tr> <tr> <td data-bbox="737 945 885 966">4 highs, 2 lows</td> <td data-bbox="1182 945 1252 966">N3, P3</td> </tr> <tr> <td data-bbox="737 970 885 991">5 highs, 1 low</td> <td data-bbox="1203 970 1230 991">P3</td> </tr> </tbody> </table>	Sequence of Beeps	Possible Bad RAM Chip Location(s)	1 low	L1	2 lows	L1, M1	1 high, 1 low	M1	2 highs, 1 low	M3	2 highs, 2 lows	M3, R3	3 highs, 1 low	R3	4 highs, 1 low	N3	4 highs, 2 lows	N3, P3	5 highs, 1 low	P3
		Sequence of Beeps	Possible Bad RAM Chip Location(s)																			
1 low	L1																					
2 lows	L1, M1																					
1 high, 1 low	M1																					
2 highs, 1 low	M3																					
2 highs, 2 lows	M3, R3																					
3 highs, 1 low	R3																					
4 highs, 1 low	N3																					
4 highs, 2 lows	N3, P3																					
5 highs, 1 low	P3																					
<p>Example only—detail on next page explains these four rows of symbols.</p>		<p>Any bad RAMs must be replaced before the self-test can continue.</p> <p><b>SGM/PROM FAILURE</b> is indicated by the display of the actual PROM or ROM chip location(s) on the center left side of the monitor screen. Both a PROM or its equivalent ROM are inserted into the same socket. Therefore, the displays are correct regardless of whether your game PCB has PROMs or ROMs or a combination of both.</p> <p>If the screen is blank or displays "garbage," the chips at locations N2 and/or J1 are probably bad.</p> <p><b>INVERTING CIRCUITRY FAILURE</b> is indicated by the <i>BANK ERROR</i> message in the lower center part of monitor screen. This circuitry is necessary for the cocktail-table version to function properly, that is, the picture turns 180° with every other ship in 2-player cocktail games.</p> <p><b>AUDIO CHIP FAILURE</b> is indicated by the <i>ERROR</i> message at center bottom of the screen. The large audio chip is at location M7/B on the game PCB.</p>																				
2. Activate all 7 control-panel switches, the slam switch, and coin door switches.	As you activate and deactivate each switch, you'll hear a short low beep. Both start switch LEDs will be constantly lit.	You will not hear a short low beep for the defective switch, or dark LED.																				
<p><b>3. Erasing the High Score Table (optional)</b></p> <p>The current three highest scores are held in permanent memory, even if the game is unplugged. These three are marked with spaceship symbols in the high score table. If you want to erase these scores, simultaneously press the rotate left, rotate right, thrust, and fire buttons. The <i>ERASING</i> message near the center of the screen will then be displayed for several seconds, until the entire table is erased.</p>																						
4. When satisfied with test, set self-test switch to <i>off</i> position.																						

[Self-test continued on next page]

Figure 6 Self-Test Procedure, continued

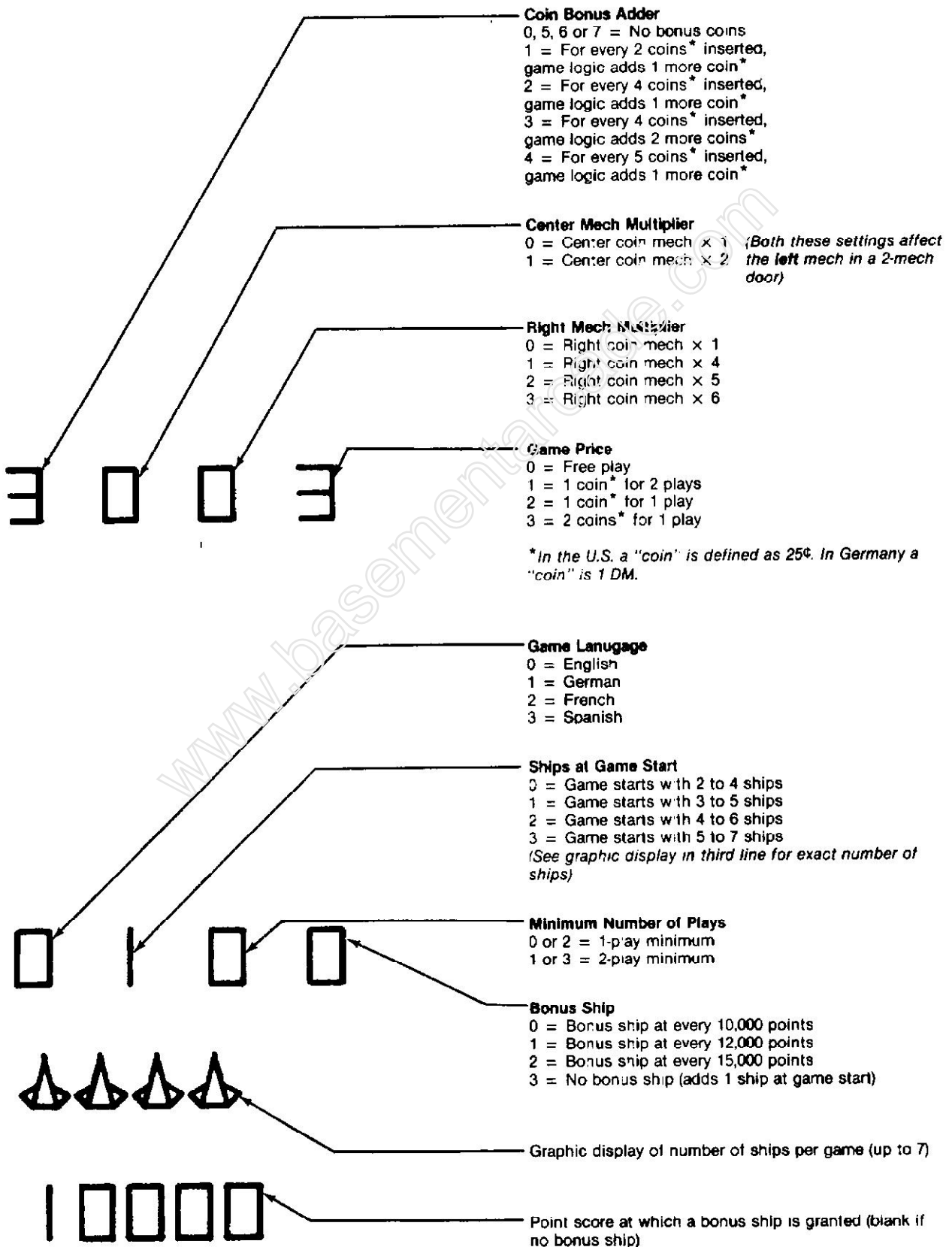



## E. Option Switch Settings

### 1. Bonus Play Feature

Asteroids Deluxe™ offers a bonus play for certain combinations of coins inserted. This bonus feature is operator-selectable, meaning you may choose to offer it or not.

For example, with your game set at 50¢ per play, players who deposit four successive quarters or a \$1.00 coin, then press the start button, can receive a bonus play. Therefore, players can receive 3 plays for \$1.00.

This bonus feature encourages players to insert more money than just the minimum 50¢ required for one game. Various other bonuses are also available (see Figure 8).

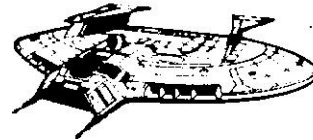

**Figure 7 Game Option Settings**

To change toggle positions on the switch assemblies, you need not remove the game PCB. The switches, usually colored blue, are easily accessible when the Asteroids Deluxe™ Game PCB is mounted in place.

When changing the options, verify proper results on the monitor display by performing the self-test. Note that changing an option on any of the following eight toggles will cause an immediate change on the monitor screen during the self-test.

**Toggle Settings of 8-Toggle Switch on Asteroids Deluxe PCB**  
(at R5—LEFT switch when PCB is in game)

8	7	6	5	4	3	2	1	Option
						On	On	English language \$
						On	Off	German language
						Off	On	French language
						Off	Off	Spanish language
		Not Used		On	On	Depending on settings of certain other switches...		
				On	Off	Game starts with 2 to 4 ships		
				Off	On	Game starts with 3 to 5 ships \$		
				Off	Off	Game starts with 4 to 6 ships		
			On					Game starts with 5 to 7 ships
			Off					1-play minimum \$
								2-play minimum
On	On							Bonus ship at every 10,000 points \$
On	Off							Bonus ship at every 12,000 points
Off	On							Bonus ship at every 15,000 points
Off	Off							No bonus ship

\$ Manufacturer's suggested settings

## 2. Coin Mechanism Multipliers

Available since early 1980, Atari's coin door has either two or three mechanisms. All recent Atari game PCBs identify the different mechanisms in a certain pattern.

The right coin mechs are all the same to the game's logic, regardless of whether you have two or three mechs in your door. In addition, the logic sees the left mech in a 2-mech door and the center mech in a 3-mech door as the same. Refer to the diagram below.

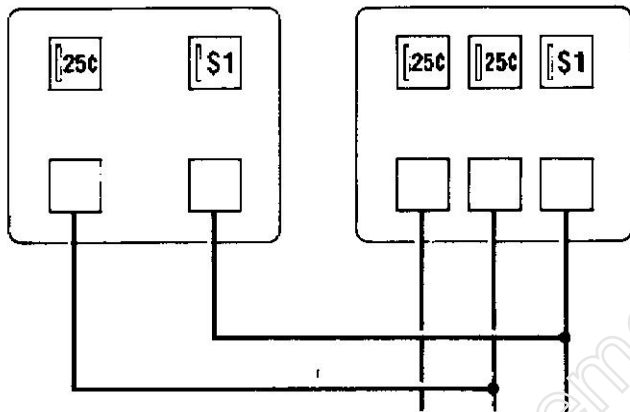

This pattern is important for you to know, so you can correctly set the "multipliers" for each mech. The multipliers determine how much each mechanism will be worth to the game's logic.

The basic unit of measurement is 25¢, which equals a multiplier of  $\times 1$ . Therefore, if you have a 25¢/25¢/\$1 coin door, you will probably want to set the center and right option-switch multipliers at  $\times 1/\times 4$ . (The left mech in a 3-mech door always has a value of  $\times 1$ —you cannot change its value.)

You can set these multipliers with toggles 3 thru 5 on the Asteroids Deluxe™ Game PCB switch assembly at location L8. For exact settings of these toggles, refer to Figure 5.

## 3. Examples of Option Switch Settings

Figure 8 explains the options, giving twelve examples of the most common U.S. situations. The toggles mentioned are all in the switch at location L8; they **only** relate to game price, coin mechanism multipliers, and bonus play. You should set the toggles relating to other functions as you see fit, although Figure 7 provides "\$" symbols indicating Atari's recommendations.

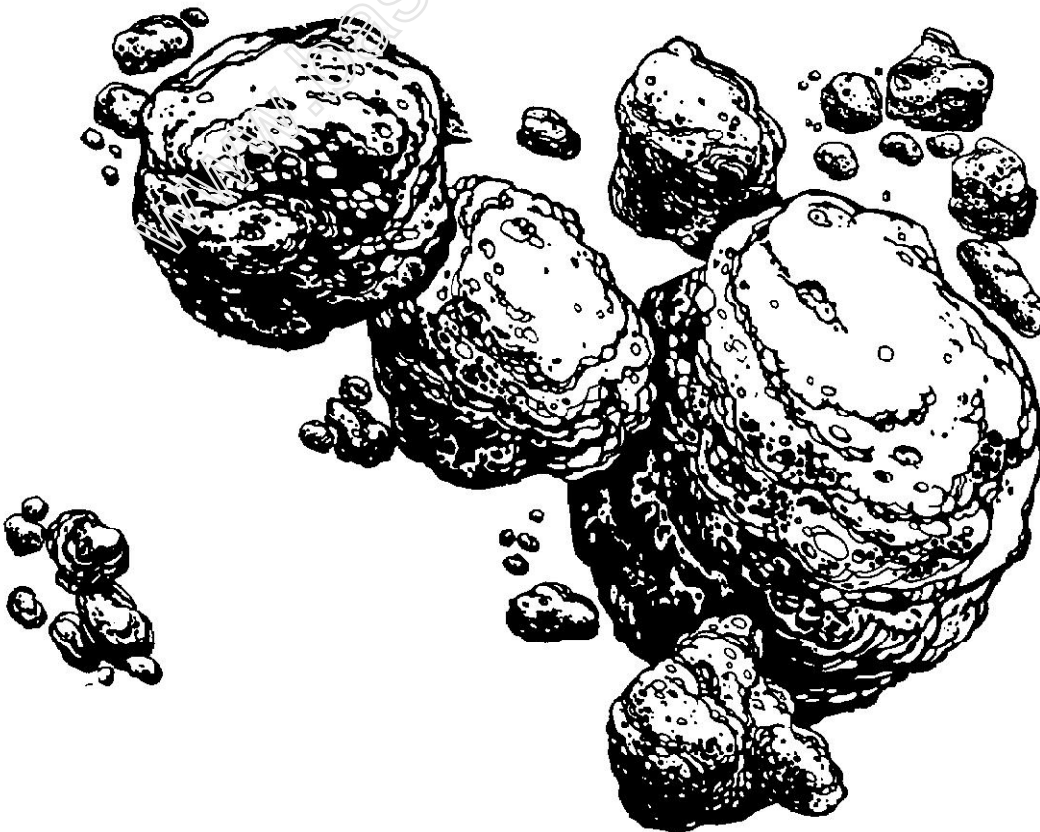

### Figure 8 Game Price Settings

The white block below contains Atari's suggested settings. All numbers 1 thru 8 are toggle settings on the 8-toggle switch at location L8, on the Asteroids Deluxe™ game PCB (the CENTER switch assembly).

#### 50¢ PER PLAY:

	No bonus				Bonus \$1.00 = 3 plays				Bonus \$.50 = 1 play \$.75 = 2 plays \$1.00 = 3 plays			
Straight 25¢ Door	8	7	6	5	8	7	6	5	8	7	6	5
	On	On	On	On	On	Off	Off	On	On	On	Off	On
25¢/\$1.00 Door or 25¢/25¢/\$1.00 Door	8	7	6	5	8	7	6	5	8	7	6	5
	On	On	On	On	On	Off	Off	On	On	On	Off	On

#### 25¢ PER PLAY:

	No bonus				Bonus \$.50 = 3 plays				Bonus \$1.00 = 5 plays			
Straight 25¢ Door	8	7	6	5	8	7	6	5	8	7	6	5
	On	On	On	On	On	On	Off	On	On	Off	On	On
25¢/\$1.00 Door or 25¢/25¢/\$1.00 Door	8	7	6	5	8	7	6	5	8	7	6	5
	On	On	On	On	On	On	Off	On	On	Off	On	On

Circled numbers refer to coin-door labels you should use with each situation (labels are illustrated on the following page).

Use the label no. 6 (indicated above with ⑥) only if you set toggle 5 at PCB switch assembly R5 to off.

## Figure 8 Game Price Settings, continued

For your information, we have defined below the switch settings for those options relating to game price, coin mechanism multipliers, and bonus play. This information is useful in case you need to temporarily set the Asteroids Deluxe™ game on free play, or if you have German coin mechanisms in your door.

The label no. 6 shown below should be used only if you set toggle 5 at PCB switch assembly R5 to off.

Toggle Settings of 8-Toggle Switch on Asteroids Deluxe PCB (at L8—CENTER switch when PCB is in game)							Option	
8	7	6	5	4	3	2	1	
						On	On	Free play
						On	Off	1 coin* for 2 plays
						Off	On	1 coin* for 1 play
						Off	Off	2 coins* for 1 play \$
				On	On			Right coin mech x 1 \$
				On	Off			Right coin mech x 4
				Off	On			Right coin mech x 5
				Off	Off			Right coin mech x 6
			On					Center coin mech x 1 \$
			Off					Center coin mech x 2 \$ (Both these settings affect the left mech in a 2-mech door)
On	On	On						No bonus coins
On	On	Off						For every 2 coins* inserted, game logic adds 1 more coin*
On	Off	On						For every 4 coins* inserted, game logic adds 1 more coin*
On	Off	Off						For every 4 coins* inserted, game logic adds 2 more coins* \$
Off	On	On						For every 5 coins* inserted, game logic adds 1 more coin*

\*In the U.S., a "coin" is defined as 25¢. In Germany a "coin" is 1 DM.

\$ Manufacturer's suggested settings

To achieve bonus plays, all coins must be inserted before pressing start button.

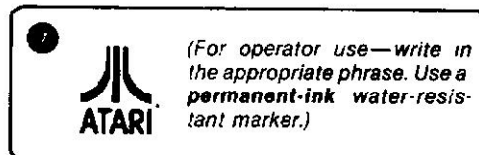
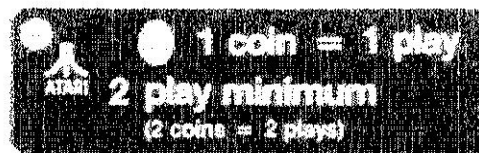
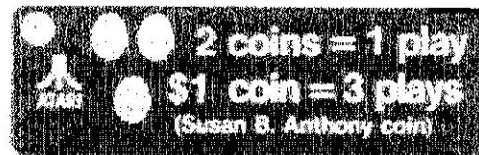
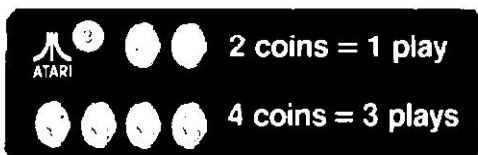

## Figure 9 Coin Counter Option Settings

[These toggles determine which coin mechanisms activate which counters]

Toggle Settings of 4-Toggle Switch on Game PCB (at M12)				For Games Having These Coin Doors:	Option
4	3	2	1		
	On	On		Thai 1 Baht/1 Baht, German 1 DM/1 DM, U.S. 25¢/25¢, Belgian or French 5 Fr/5 Fr, Swiss or French 1 Fr/1 Fr, U.S. 25¢/25¢/25¢, Japanese ¥100/¥100, Swedish 1 Kr/1 Kr, U.K. 10 P/10 P, Australian 20¢/20¢, or Italian 100 L/100 L.	All 3 coin mechanisms are same denomination; all register on <b>one</b> coin counter. \$
	Off	On		German 2 DM/1 DM, German 1 DM/5 DM, U.S. 25¢/25¢/\$1, or U.S. 25¢/\$1.	Left and center mechanisms are same denomination; right mech is another denomination. Requires <b>two</b> coin counters.
	On	Off		<i>No coin door is currently designed for this configuration.</i>	Left mech is one denomination; center and right mech are another denomination. Requires <b>two</b> coin counters.
	Off	Off		German 1 DM/2 DM/5 DM.	Left, center and right mechs are 3 different denominations. Requires <b>three</b> coin counters.

\$ *Manufacturer's suggested settings*

## F. Game Play

Atari's Asteroids Deluxe™ is a one- or two-player game with an X-Y or vector-generator monitor. The game depicts a third-person view of a player's spaceship battling to destroy asteroids, flying saucers and enemy ships or "death stars" (shaped like clusters of triangles). When hit, the asteroids and death stars will break into progressively smaller pieces.

Players can put up an octagon-shaped "shield" to temporarily protect their spaceship. However, this shield wears out with use.

The game has five possible modes of operation: Attract, Ready-to-Play, Play, High Score Initial, and Self-Test. Self-test is a special mode for checking the game switches and computer functions. You may enter this mode at any time. When entered, all game credits are cancelled.

### 1. Attract Mode

The attract mode begins when power is applied to the game, after a play or high score initial mode, or after self-test. This mode is continuous and is only interrupted when a game is paid for and accepted or when you enter self-test.

In this mode, the monitor displays two possible pictures. One picture is of randomly tumbling asteroids, large and small saucers, and death stars—all in a simulated game. The other picture shows the ten currently highest scores.

If you erase the special "permanent" memory (see Figure 6, Self-Test Procedure), then the second picture with the high-score table will not appear on the screen. The table is redeveloped from scores of subsequent games.

## 2. Ready-to-Play Mode

This mode begins when sufficient coins have been accepted for a one- or two-player game. It ends when the 1 PLAYER START or 2 PLAYER START pushbutton is pressed.

Operators may choose one- or two-play minimums by selecting one of the option switch settings on the game PCB (see Figure 7, Game Option Settings). If you have selected the two-play minimum and a player has inserted enough money for only one play, the message 2 GAME MINIMUM and CREDITS ½ will stay on the screen until the second coin has been inserted.

When this mode begins, the message PRESS START flashes immediately below the center score at the top of the screen. The displayed pictures are otherwise the same as those shown in the attract mode.

## 3. Play Mode

The play mode begins when either start pushbutton is pressed. The mode ends when the player's last ship of the game is lost.

Six large asteroids appear and drift in from the outer edges of the display. By pressing the ROTATE LEFT and ROTATE RIGHT pushbuttons on the control panel, the player may aim a spaceship toward any of the asteroids. The player uses the FIRE pushbutton to shoot at the asteroids and other objects.

When shot, each large asteroid divides into two medium-sized asteroids, and the game adds 20 points to the player's score. Medium-sized asteroids, when shot, divide into two small-sized asteroids, and the game awards 50 points to the player. When shot, the smallest asteroid disappears and the game adds 100 points to the player's score.

In addition to asteroids, the players can score points for shooting the various enemy ships. When hit, the large ships ("death stars" shaped like hexagons) score 50 points and break into three diamond shapes. The medium-sized enemy or diamond, when hit, grants the player 100 points and breaks into two small triangular pieces. These small pieces disappear when the player hits them, and the score increases by 200 points.

At any time during game play, a flying saucer may appear from either side of the display. The game awards players 200 points for shooting a large saucer and 1000 points for a small saucer. (The latter is a smaller target for players, though not any faster moving than the large one. It also shoots more accurately.)

The player's objective in the game is to shoot and destroy as many asteroids, saucers, and enemy ships as possible before all his or her spaceships are destroyed. A ship is destroyed if an asteroid, saucer or enemy ship smashes into it, or if a flying saucer shoots it. To prevent losing a ship, the player may press the THRUST pushbutton to move out of the path of an oncoming object.

As an emergency maneuver, a player can press the SHIELDS pushbutton. An octagon will then appear around the player's ship as protection from all enemies. For challenge the shield power lasts only about 10 seconds, but the power is renewed with each ship. The amount of shielding power available is shown by the brightness of the octagon (dim means almost exhausted power).

An operator option allows you to award an extra ship each time a player's score reaches multiples of 10,000, 12,000 or 15,000 points. As an alternative, you may not offer any bonus ships at all to players. Refer to Figure 7, Game Option Settings, for how to set your game for this option.

When the last ship of the game is destroyed, the message GAME OVER appears below the high score. This message remains for three seconds before the high score initial mode begins.

## 4. High Score Initial Mode

At the beginning of the high score initial mode, the player instructions appear at the top of the screen, and A \_ \_ appears at the lower center of the display. Players enter initials one character at a time.

By pressing the ROTATE LEFT pushbutton, the displayed character steps through the alphabet from A to Z. By pressing the ROTATE RIGHT pushbutton, the character shown will step backwards through the alphabet from A to a blank space, then from Z to A. Once the game displays the desired letter, players should press the SHIELDS pushbutton to record the letter; then an A appears in the next space.

If players need only two letters for their initials, they should use the blank between Z and A in one of the three locations. Pressing the SHIELDS pushbutton a third time will cause the initials and game score to be transferred to the high score table. This table contains a maximum of 10 scores and appears during the attract mode.

# Maintenance and Repair

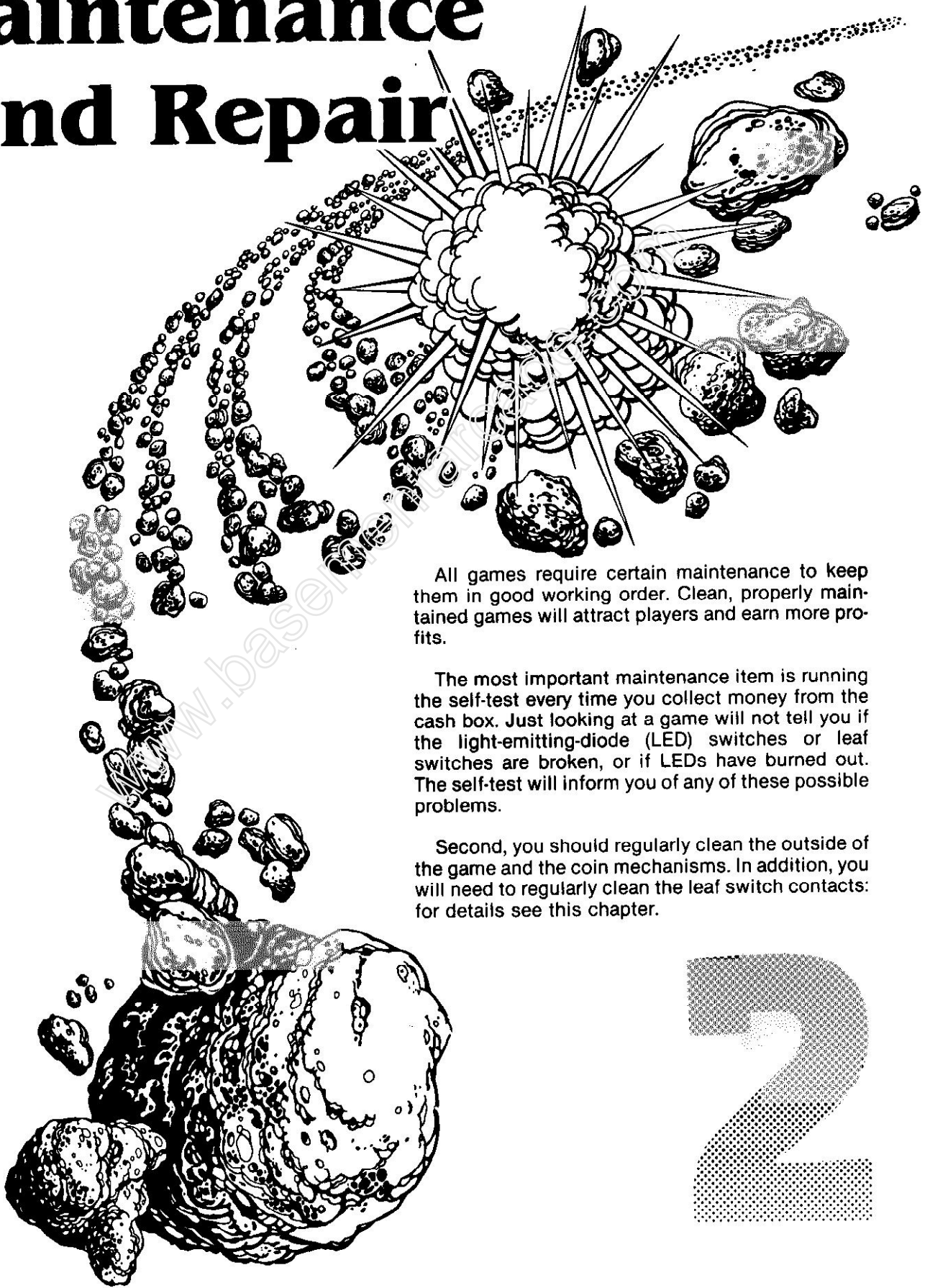

All games require certain maintenance to keep them in good working order. Clean, properly maintained games will attract players and earn more profits.

The most important maintenance item is running the self-test every time you collect money from the cash box. Just looking at a game will not tell you if the light-emitting-diode (LED) switches or leaf switches are broken, or if LEDs have burned out. The self-test will inform you of any of these possible problems.

Second, you should regularly clean the outside of the game and the coin mechanisms. In addition, you will need to regularly clean the leaf switch contacts: for details see this chapter.

# 2

## A. Cleaning

The exterior of the game cabinet and the metal and acrylic surfaces may be cleaned with any non-abrasive household cleaner. If desired, special coin machine cleaners that leave no residue can be obtained from your distributor. **Do not dry-wipe** any of the acrylic panels, because any dust can scratch the surface and result in fogging the plastic.

## B. Fuse Replacement

This game contains five fuses—all on the power supply assembly (not including the monitor fuses). Replace fuses only with the same type as listed in Figure 21 of this manual. See the *Quadrascan™* monitor manual for the monitor fuse data.

## C. Opening the Control Panel

Prior to repairing or replacing any switch on the control panel or prior to removing the monitor, unplug the game. Then open the coin door.

Reach up through the opening and remove both sets of carriage bolts, wing nuts, split lock washers, and large flat washers, located on the underside of the control panel (see Figure 10).

Lift up on the control panel and tilt it towards you. **Be sure that the acrylic monitor shield does not fall on you.** The top edge of the control panel acts as a retainer strip for the shield: once the control panel is opened, the shield is free and could slide out under its own power.

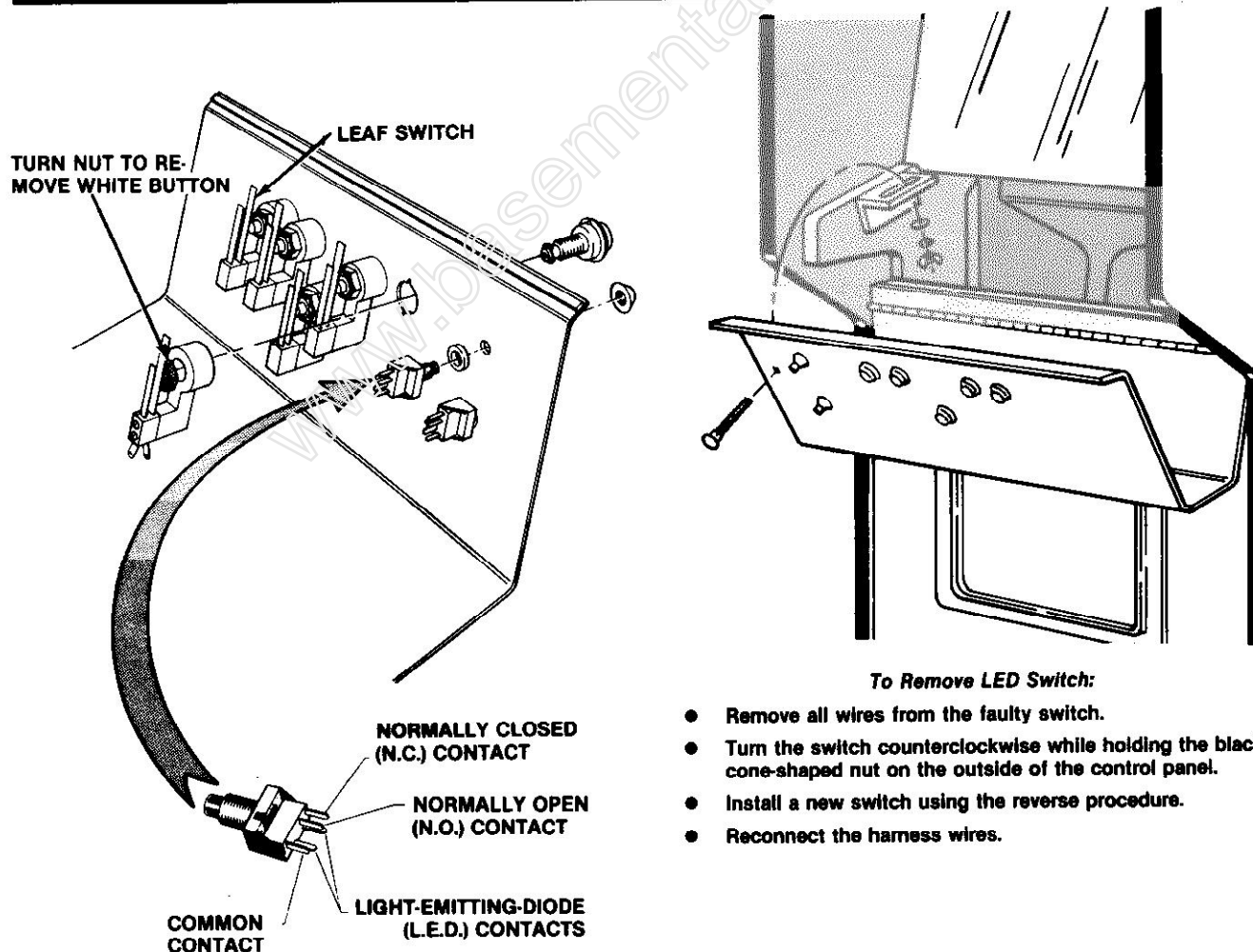

**Figure 10** Opening the Control Panel and Replacing Switches

- To Remove LED Switch:**
- Remove all wires from the faulty switch.
  - Turn the switch counterclockwise while holding the black cone-shaped nut on the outside of the control panel.
  - Install a new switch using the reverse procedure.
  - Reconnect the harness wires.



## 1. LED Switch Replacement

The light-emitting diode (LED) switches on the control panel have a very low failure rate. In case a switch should ever be suspect, first test it per the description that follows. To replace the switch, refer to Figure 10.

- Remove the wires from the suspected switch.
- Set multimeter to ohms scale. Set ohms scale to  $R \times 1$ , then zero the meter.
- Connect multimeter leads to appropriate LED switch contacts (see Figure 10 for designation of switch contacts and meter lead placement).
- Check contacts (push and release the switch button) for closed and open continuity.
- If the contacts do not operate sharply or always remain closed or open, then replace the LED switch as outlined in the figure.

## 2. Leaf-Switch Replacement

### NOTE

Adjust switches for a narrow gap. When a switch button is depressed, the resulting wiping action of the contacts provides a self-cleaning feature.

All five of these leaf switches operate on 5 volts at a very low current. Therefore, pitting of these switches would be extremely rare. Probably the only reason that pitting would occur is in very high-humidity locations.

**Don't burnish the switches.** Burnishing them removes their plating, thus increasing the corrosion of the contacts. **The best method of cleaning the switch contacts is to wipe them with a non-abrasive surface.** A business card works very well.

To replace any of the five leaf switches, remove both of its screws with a Phillips-head screwdriver—see Figure 10.

If the white button itself needs to be replaced, turn the stamped nut with a wrench in a counter-clockwise direction, as seen from the inside of the control panel. The white ring on the outside of the control panel should not spin, due to its design.

## D. Monitor Removal

### WARNING

High voltages may exist in any television monitor, even with power disconnected. Use extreme caution and do not touch electrical parts of the yoke area with your hands or with metal objects in your hands! If you drop the monitor and it breaks, **it will implode!** Shattered glass and the yoke can fly 5 feet or more from the implosion. Use care when replacing any monitor.

If you should need to remove the Quadrascan X-Y monitor, follow steps 1 thru 4 as listed on this page. Refer to Figure 11.

1. **Unplug the game from its wall outlet.** Open the coin door. Reach in the opening and unplug the 12-pin harness connector underneath the monitor.
2. Open the rear access panel. Unplug the harness connector located at the center left side of the access panel opening.
3. Locate the two brass-colored "L" brackets that fasten down the wood monitor shelf. Remove the two sets of carriage bolts, flat and split lock washers, and hex nuts that secure the monitor assembly to these brackets.
4. Carefully bend the bottom rear flap of the large background bezel completely inward. (If the flap has tape on each end, cut thru the tape first.) Slide the monitor chassis out the rear of the game.

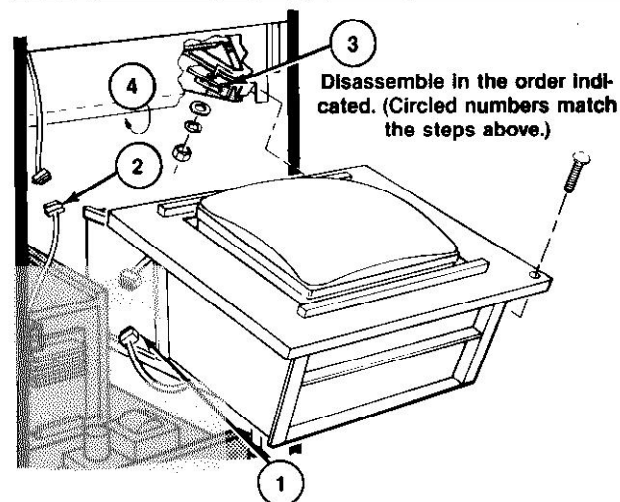

Figure 11 Monitor Removal

## E. Fluorescent Tube Replacement

### ⚠ WARNING ⚠

If you drop a fluorescent tube and it breaks, it will implode! Shattered glass can fly 6 feet or more from the implosion. Use care when replacing any fluorescent tube. Avoid looking at the blacklight when it is on. It may damage your eyes.

To replace the fluorescent white- or blacklight tube behind the front graphics attraction panel, follow this procedure (see Figure 12):

1. Remove the three Allen-head screws and lock washers at the top of the game (they secure the black metal retainer for the attraction panel). Lift the attraction panel up and out of its lower retainer.
2. If you need to replace the **blacklight** tube, remove the two Phillips screws that secure the light board to the cabinet, and slide out the whole assembly. The harness has plenty of length, so you can pull the assembly about two feet out of the game.
3. Remove the two Y-shaped connectors from the ends of the fluorescent tube; you may find it helpful to use a flat-head screwdriver. Now carefully remove the tube from its clamps by pulling it towards you.
4. Replace with a new tube. Do not snap the tube in vigorously—you may break it, causing an **implosion!**
5. Reconnect the Y-shaped connectors. Reinstall the fluorescent light assembly with the two screws (if you removed it). Replace the attraction panel on the front of the game. When tightening the Allen screws, be sure the top retainer strip is pushed tightly back against the attraction panel.

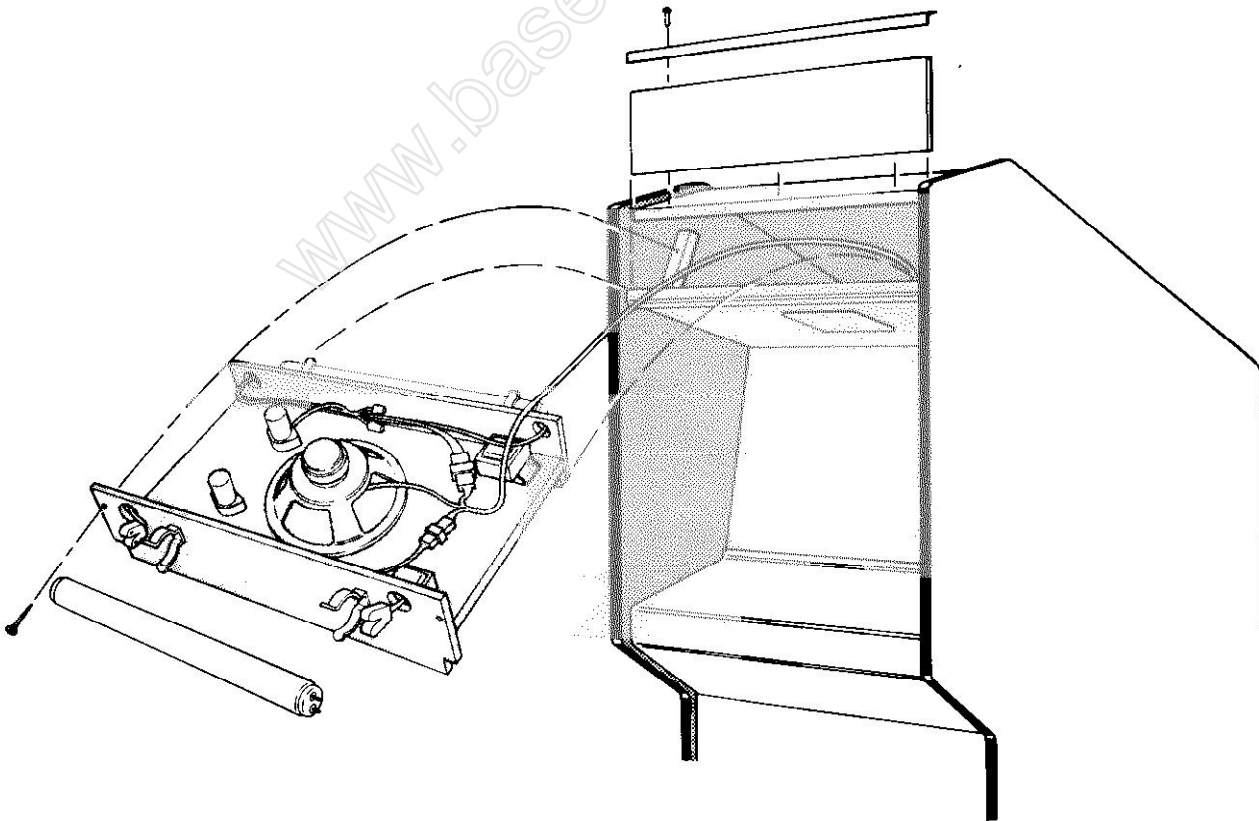

Figure 12 Fluorescent Tube Replacement

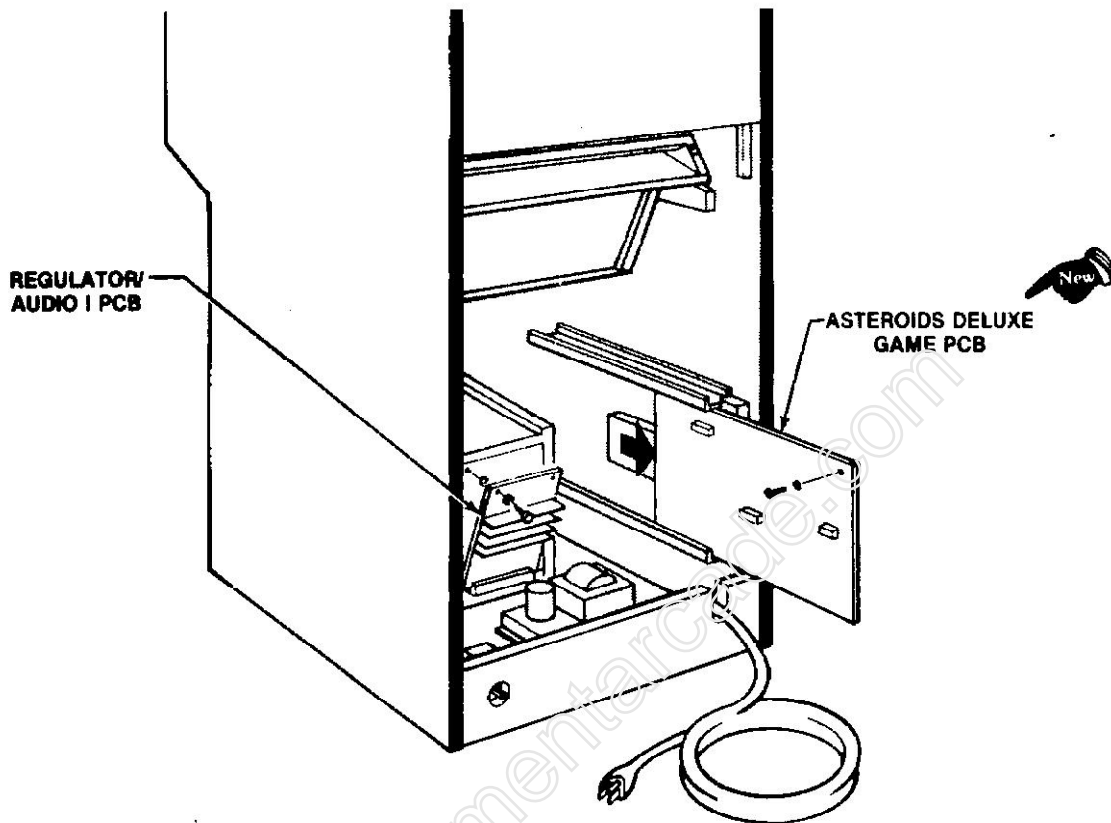

Figure 13 Printed-Circuit Board Replacement

## F. Printed-Circuit Board Replacement

You may wish to remove the Asteroids Deluxe™ game PCB or the Regulator/Audio I PCB for service or inspection. To do this, refer to Figure 13 and proceed as follows:

### 1. Game PCB Removal

- Unlock and open the access panel.
- Remove the two beaded nylon tie wraps from the PCB's edge connector. Remove the 44-pin edge connector from the right side of the PCB.
- Locate the Phillips-head screw that extends through the PCB and into the wood block (at the right side of the board). Remove and save this screw as well as the fiber washer.
- Remove the PCB from the cabinet by carefully pulling it out of the plastic PCB retainer.

- After servicing it, reinstall the PCB, making sure that the 44-pin edge connector is properly plugged in. Note that the connector is keyed to fit on only one way, so if it doesn't slip on easily, don't force it! **A reversed connector will probably damage your game and will void the warranty.**
- Check that the operation of the game is correct by **performing the self-test**. This is especially important with any game when you replace a PCB.

### 2. Regulator/Audio I PCB Removal

- Unlock and open the access panel.
- Remove the five plug-in connectors on the Regulator/Audio I PCB. Note that all of these connectors are keyed for proper orientation.
- Locate the two Phillips-head screws that extend through the PCB and into the wood behind the PCB. Remove and save these two screws and the two fiber washers.
- Remove the PCB from the interior wall of the cabinet.

## G. Game Operation

With this manual you received two large sheets that contain the wiring and schematic diagrams for the Asteroids Deluxe™ game. Sheet 1, Side A, includes information that shows the arrangement of these diagrams. These diagrams include information that explains the functions of the circuits and defines inputs and outputs.

Atari's Asteroids Deluxe is a microprocessor-controlled game. The microprocessor is contained on the game PCB. The game PCB receives switch inputs from the control panel and coin door. These inputs are processed by the game PCB and output to the monitor, Regulator/Audio I PCB, and control panel.

The monitor is an X-Y monitor. Therefore, the monitor receives signals for the X, Y and Z axes. Since the location of the beam in the monitor is totally controlled by the X- and Y-axis outputs of the game PCB, the game PCB does not contain a standard sync circuit. The X- and Y-axis inputs to the monitor step in increments of 1024 steps for the X (horizontal) axis, and 768 steps for the Y (vertical)

axis. The Z axis merely controls the intensity of the beam.

The Regulator/Audio I PCB performs two functions: 1) it regulates the + 10.3 VDC from the power supply to + 5 VDC, and 2) it amplifies the audio output from the game PCB. The + 5 VDC from the Regulator/Audio I PCB provides most logic power to the game PCB. The audio output from the Regulator/Audio I PCB directly drives the game speaker and is controlled by the volume control, mounted inside the coin door.

The Power Supply is the source of all voltages in the game. These voltages are protected by four fuses in the fuse block on the power supply chassis. The primary winding of the power supply transformer is protected by the cartridge-type fuse in the power supply chassis.

Figure 14 illustrates the distribution of power in this game. Figure 15 illustrates the distribution of signals.

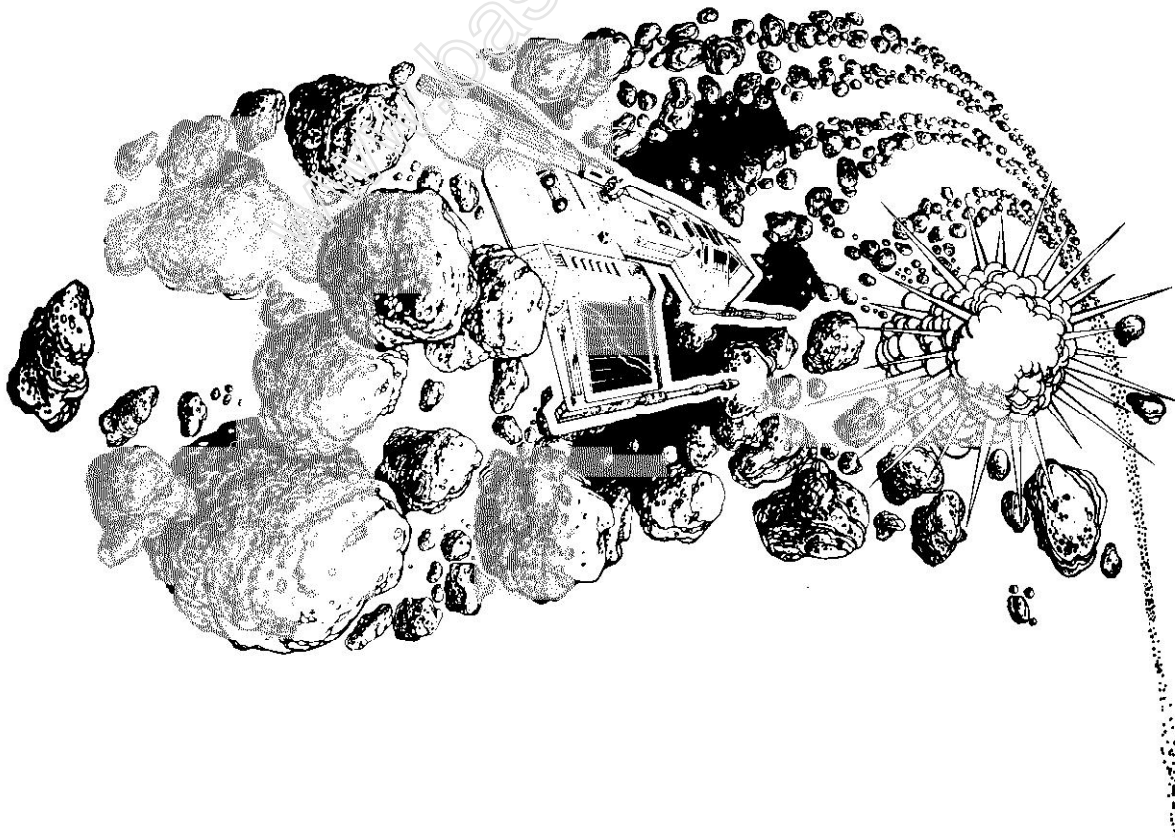

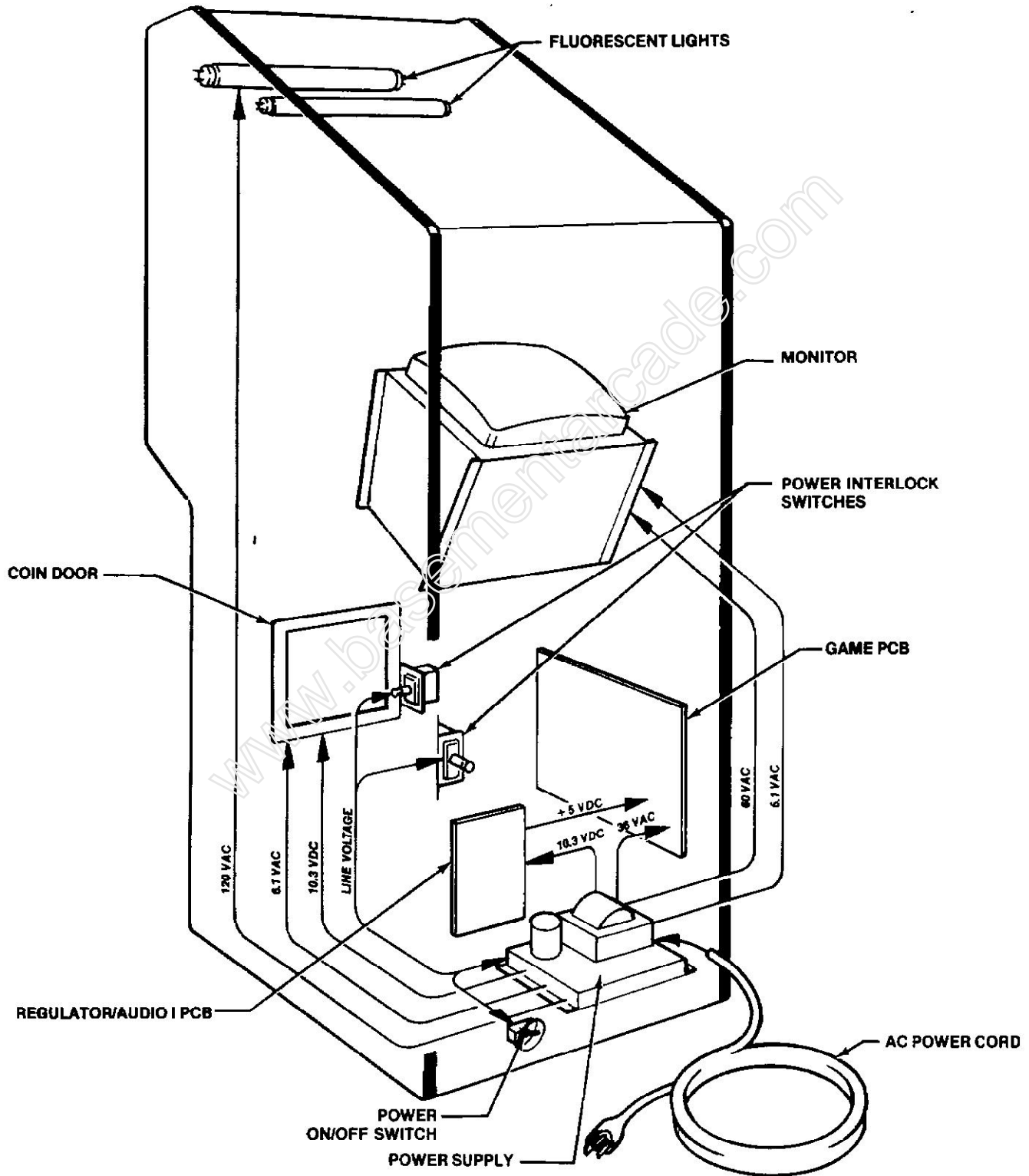

Figure 14 Power Distribution

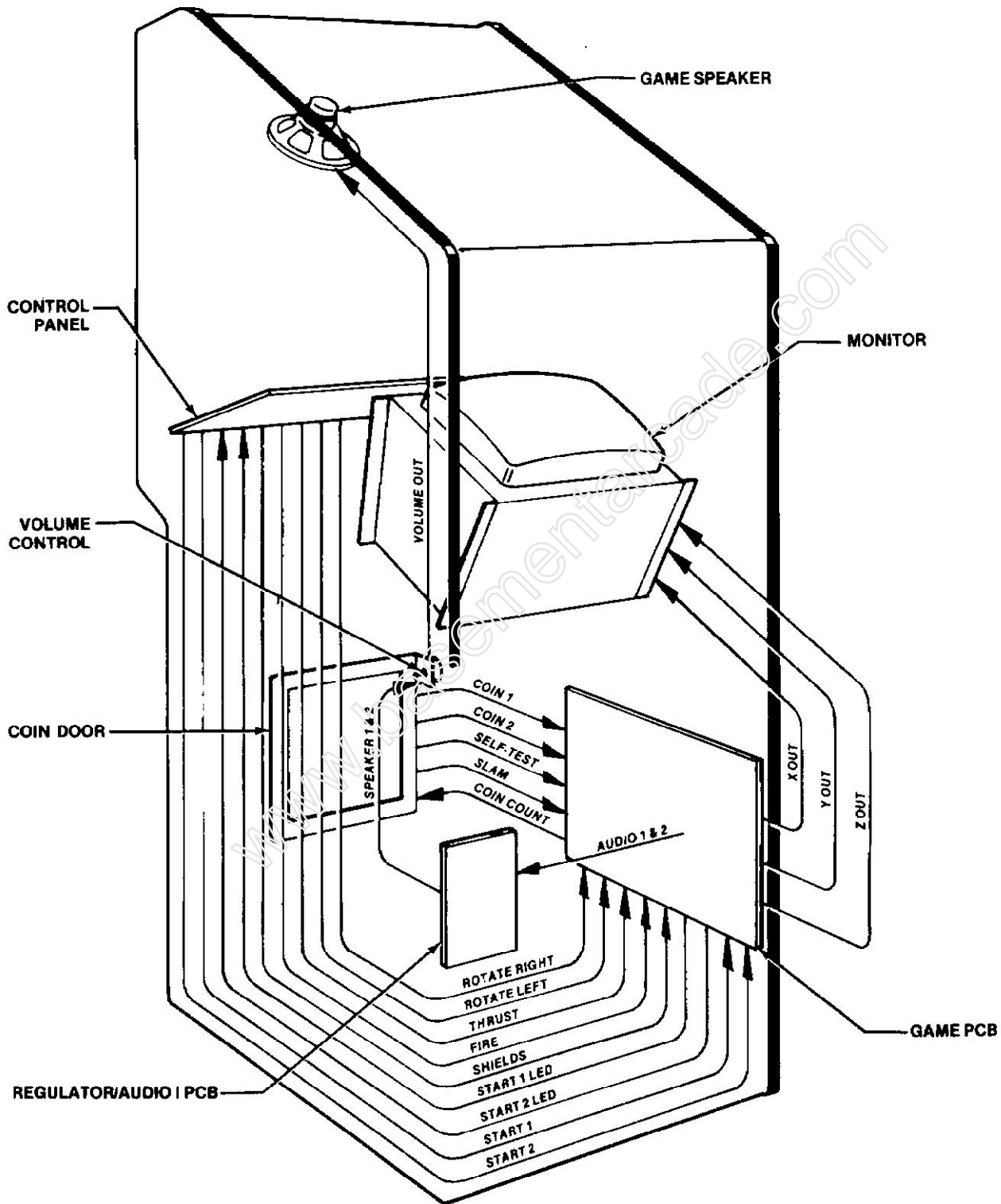
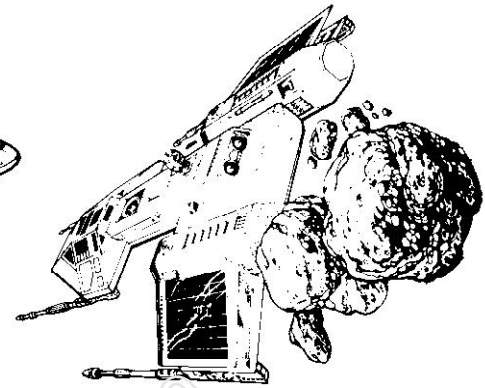
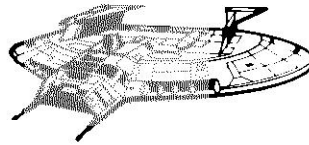
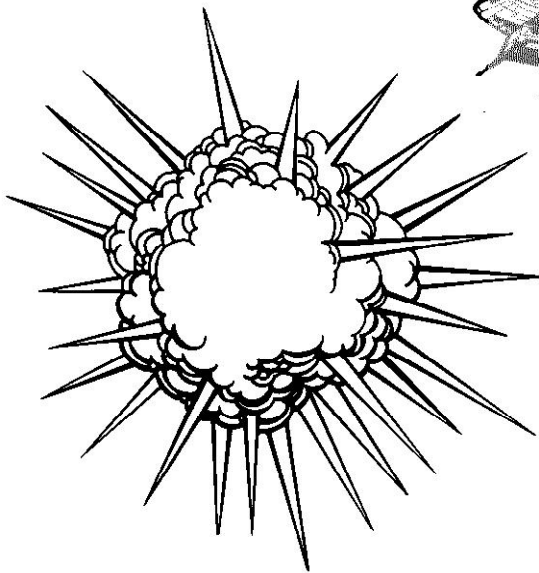

Figure 15 Signal Distribution



# Illustrated Parts Lists

This chapter provides you with the necessary information for ordering replacement parts for your Asteroids Deluxe™ game. Please note that, for simplicity, **common hardware has been deleted** from most of these parts lists. This includes screws, nuts, washers, bolts, etc.

The parts lists are arranged in alphanumeric order. For example, all "A-" prefix numbers come first. Following this are numbers in sequence evaluated up to the hyphen, namely 00- thru 99-, then 000598- thru approximately 190000-.

When ordering parts from your distributor, give the part number, part name, applicable figure number of this manual, and serial number of your game. This will help to avoid confusion and mistakes in your order. We hope the results will be less downtime and more profit from your game.

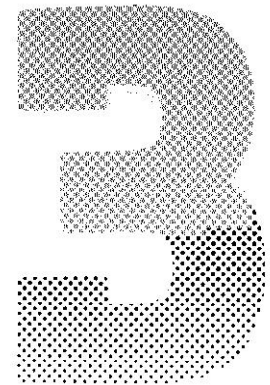
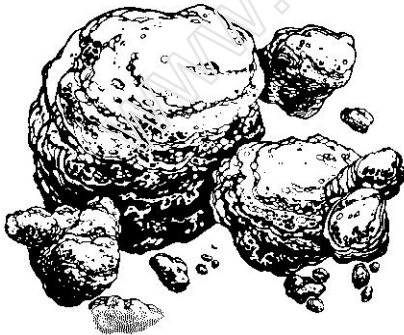

NOTICE TO ALL PERSONS RECEIVING THIS DRAWING  
 CONFIDENTIAL: Reproduction forbidden without the  
 specific written permission of Atari, Inc., Sunnyvale, CA.  
 This drawing is only conditionally issued, and neither  
 receipt nor possession thereof confers or transfers any  
 right in, or license to use, the subject matter of the drawing  
 or any design or technical information shown thereon,  
 nor any right to reproduce this drawing or any part  
 thereof. Except for manufacture by vendors of Atari, Inc.,  
 and for manufacture under the corporation's written  
 license, no right to reproduce this drawing is granted or  
 the subject matter thereof unless by written agreement  
 with or written permission from the corporation.

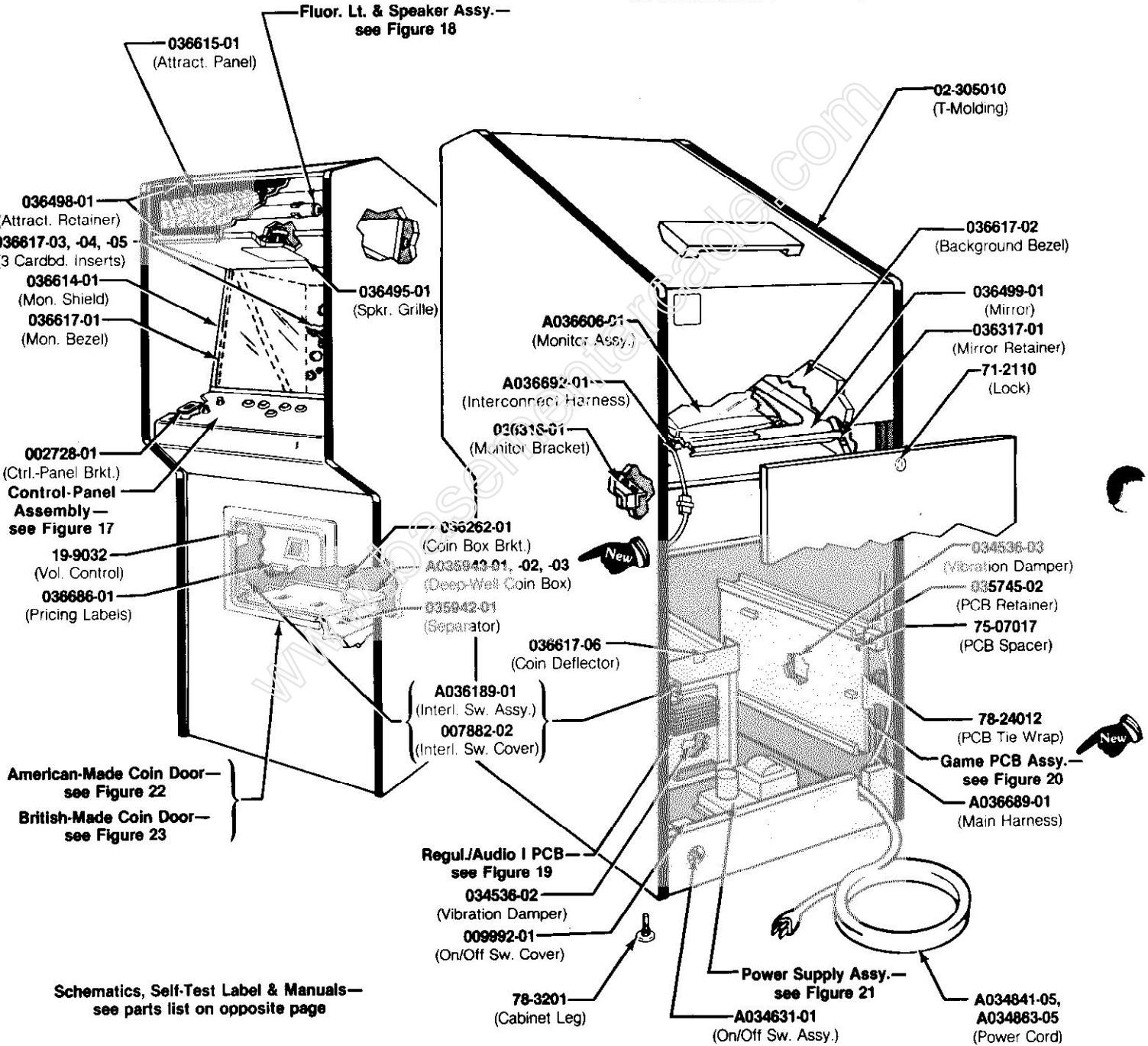

**Figure 16 Cabinet-Mounted Assemblies**  
**A036500-xx B**



## Figure 16 Cabinet-Mounted Assemblies Parts List

Part No.	Description
A034631-01	On/Off Switch Assembly
A034841-05	Strain Relief Power Cord (U.S.)
A034863-05	Strain Relief Power Cord (German)
A035943-01	Deep-Well Coin Box Assembly (for all the same coins)
A035943-02	Deep-Well Coin Box Assembly (for two different coin denominations—has one separator)
A035943-03	Deep-Well Coin Box Assembly (for three different coin denominations—has two separators)
A036189-01	Interlock Switch Assembly (modified for safety)
A036606-01	Monitor Assembly (monitor itself is part no. 92-047 for Electrohome or 92-050 for Wells-Gardner; wood monitor shelf is part no. 036489-01)
A036689-01	Main Harness Assembly (also includes on/off switch, 2 interlock switches and their brackets, and volume control and its bracket)
A036692-01	Interconnect Harness Assembly (in upper rear part of game)
<i>The following six items are the technical information supplements to this manual:</i>	
DP-165-01	Asteroids Deluxe™ Schematic Drawings (Sheet 1)
DP-165-02	Asteroids Deluxe Schematic Drawings (Sheet 2)
ST-165	Label with Self-Test Procedure and Option Switch Settings
TM-151	Instruction and Service Manual for Electrohome G05-802/805 Quadrascan™ X-Y Monitor, OR
TM-164	Service Manual for Wells-Gardner Quadrascan X-Y Monitor
TM-165	Asteroids Deluxe Operation, Maintenance and Service Manual
02-305010	3/4-Inch Plastic T-Molding
19-9032	Volume Control
71-2110	Panel Cartridge Lock Mechanism (for access panel)
75-07017	Spacer for Mounting Printed Circuit Boards
78-3201	Cabinet-Leveling Leg
78-24012	5-Inch Beaded Nylon Tie Wrap (for PCB Edge Connector)
002728-01	Control-Panel Mounting Bracket
007882-02	Interlock Switch Cover
009992-01	On/Off Switch Cover
034536-02	Foam Vibration Damper (for Regulator/Audio I PCB)
034536-03	Foam Vibration Damper (for Game PCB)
035745-02	18-Inch Plastic PCB Retainer
035942-01	Deep-Well Coin Box Separator
036262-01	Coin Box Bracket
036316-01	Monitor Mounting "L" Bracket
036317-01	Mirror Retainer
036495-01	Speaker Grille
036498-01	Attraction-Panel Retainer
036499-01	Half-Silvered Mirror
036614-01	Monitor Shield with Graphics
036615-01	Attraction Panel with Graphics
036617-01	Cardboard Monitor Bezel with Blue Acetate Window
036617-02	Cardboard Background Bezel
036617-03	Cardboard Starship Insert
036617-04	Cardboard Asteroids Insert for Center (five asteroids)
036617-05	Cardboard Asteroids Insert for Side (four asteroids)
036617-06	Cardboard Coin Deflector
036686-01	Card of Coin-Door Pricing Labels

**NOTICE TO ALL PERSONS RECEIVING THIS DRAWING**  
**CONFIDENTIAL:** Reproduction forbidden without the specific written permission of Atari, Inc., Sunnyvale, CA. This drawing is only conditionally issued, and neither receipt nor possession thereof confers or transfers any right in, or license to use, the subject matter of the drawing or any design or technical information shown thereon, nor any right to reproduce this drawing or any part thereof. Except for manufacture by vendors of Atari, Inc., and for manufacture under the corporation's written license, no right to reproduce this drawing is granted or the subject matter thereof unless by written agreement with or written permission from the corporation.

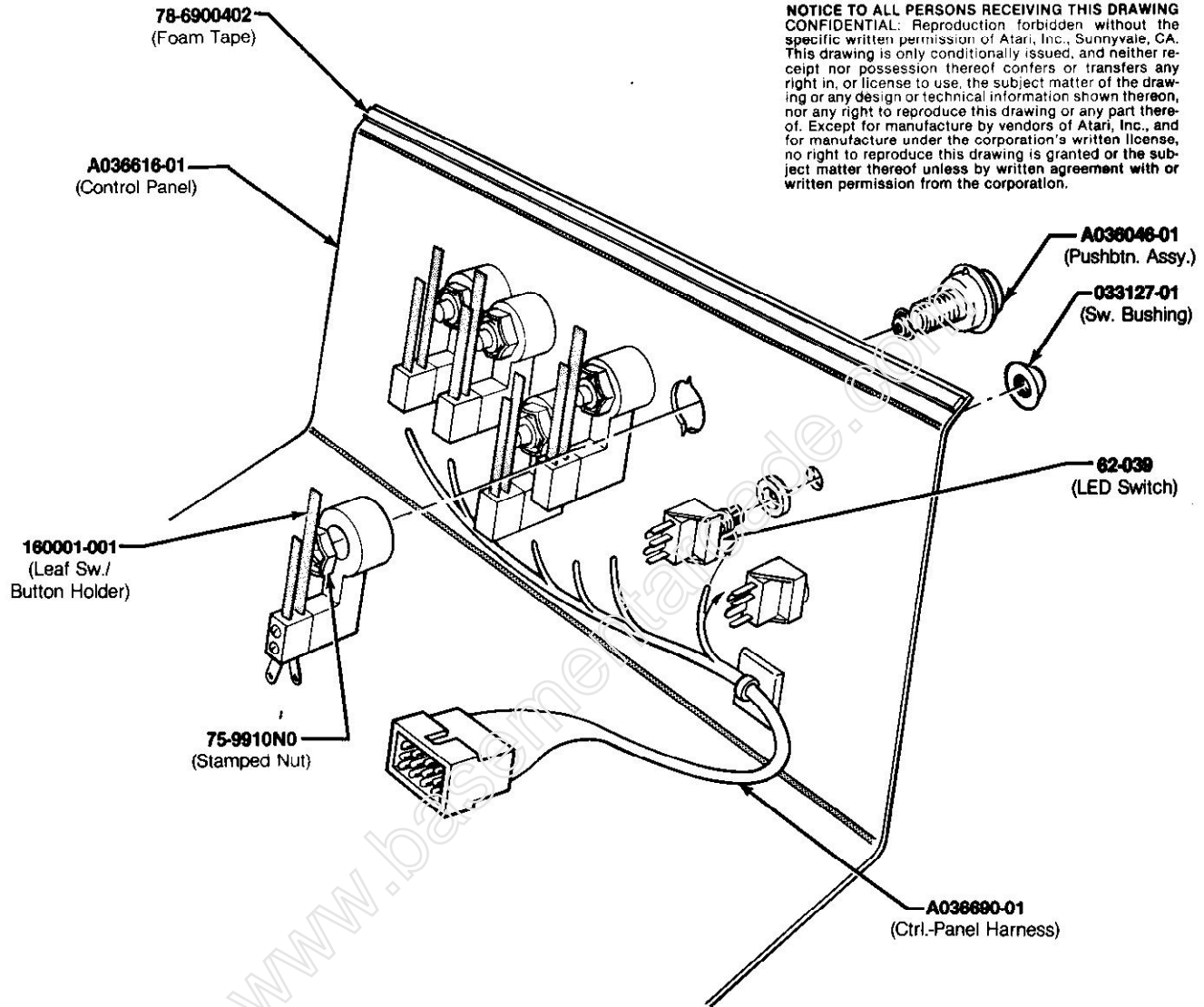

**Figure 17 Control Panel Assembly**  
**A036611-01 A**

**Parts List**

<i>Part No.</i>	<i>Description</i>
A036046-01	Pushbutton Assembly
A036690-01	Control Panel Harness Assembly
62-039	Momentary-Contact SPDT Light-Emitting Diode Switch
75-9910N0	5/8"-11 Steel Stamped Nut
78-6900402	Vinyl Foam Single-Coated-Adhesive Tape, 1/8-Inch thick × 1/4-Inch wide
033127-01	Black Molded Switch Bushing
A036616-01	Control Panel with Graphics
160001-001	Leaf Switch and Button Holder <i>(Leaf Switch only is part no. 160004-001)</i>

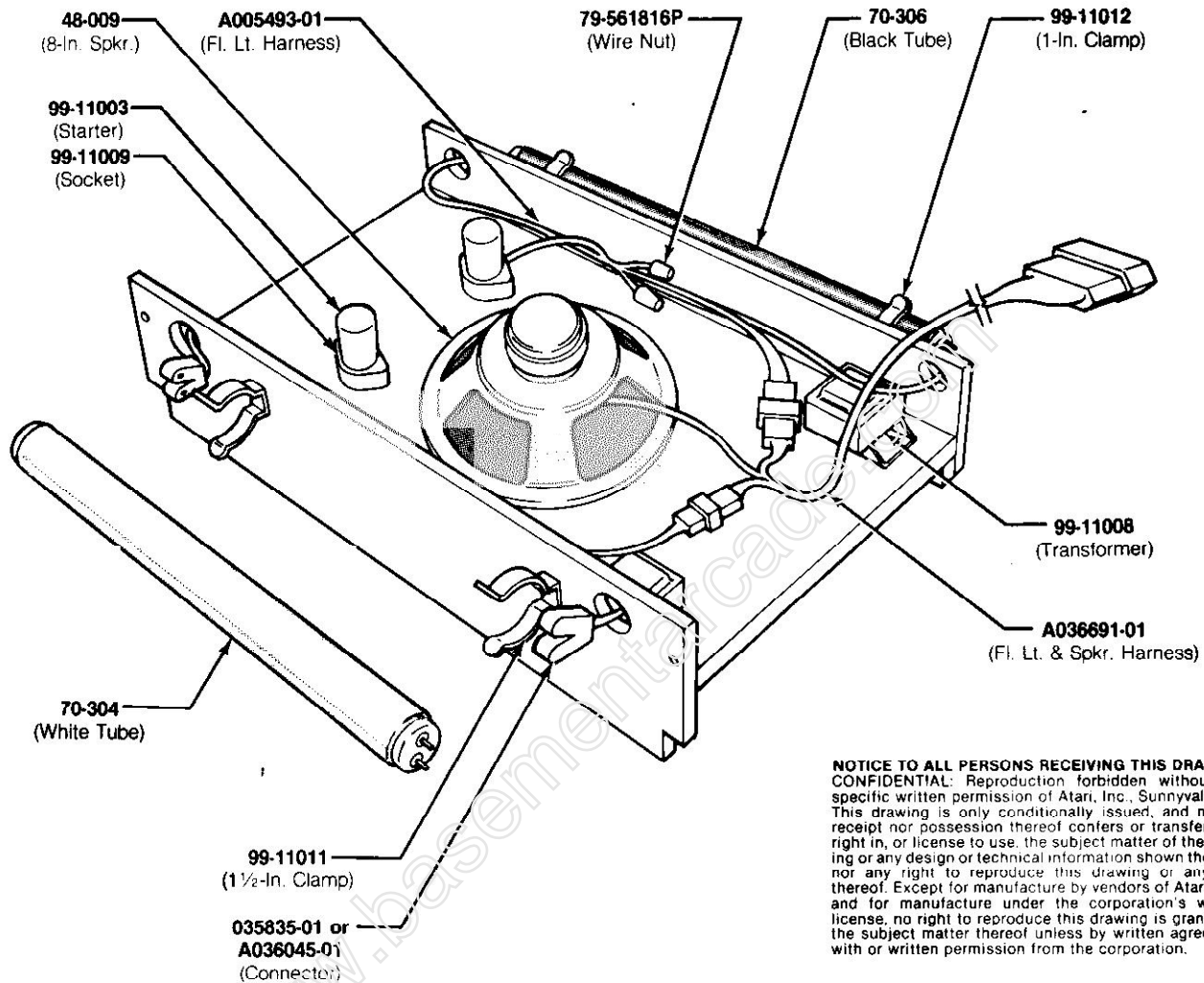

**Figure 18 Fluorescent Light and Speaker Assembly**  
**A036610-01 A**

### Parts List

Part No.	Description
A005493-01	Fluorescent Light Harness
A036691-01	Fluorescent Light and Speaker Harness
48-009	8-Inch High-Fidelity Speaker
70-304	18-Inch 15-Watt Cool White Fluorescent Tube
70-306	18-Inch 15-Watt Blacklight Fluorescent Tube
79-561816P	Spring Connector Wire Nut for 16- to 18-Gauge Wires
99-11003	Fluorescent Lamp Starter
99-11008	Ballast Transformer
99-11009	Starter Socket
99-11011	1 1/2-Inch Clamp (for white tube)
99-11012	1-Inch Clamp (for blacklight tube)
035835-01	Y-Lead Connector (part no. A036045-01 is an acceptable substitute)

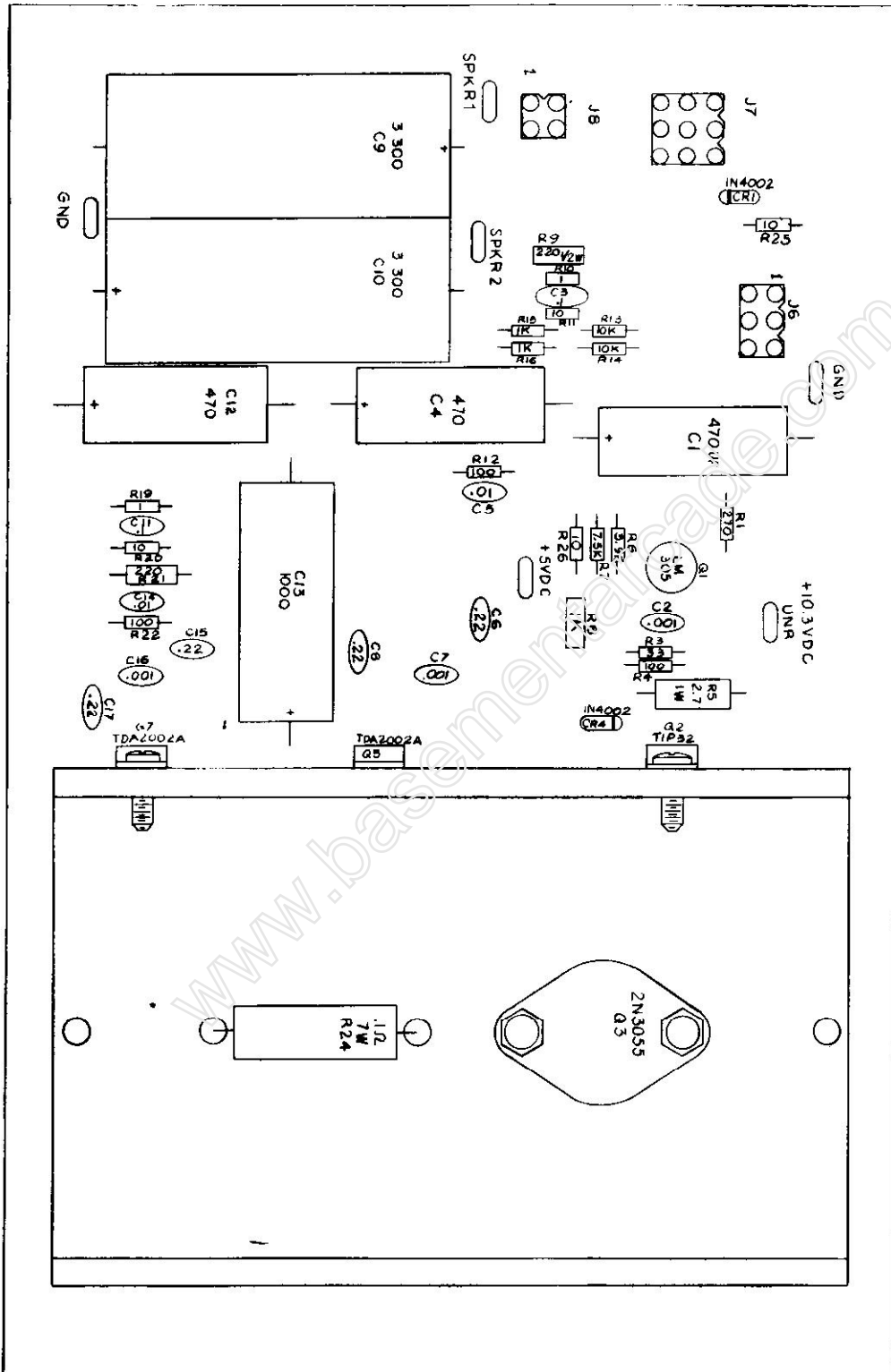

**NOTICE TO ALL PERSONS RECEIVING THIS DRAWING**  
**CONFIDENTIAL:** Reproduction forbidden without the specific written permission of Atari, Inc., Sunnyvale, CA. This drawing is only conditionally issued, and neither receipt nor possession thereof confers or transfers any right in, or license to use, the subject matter of the drawing or any design or technical information shown thereon, nor any right to reproduce this drawing or any part thereof. Except for manufacture by vendors of Atari, Inc., and for manufacture under the corporation's written license, no right to reproduce this drawing is granted or the subject matter thereof unless by written agreement with or written permission from the corporation.

**Figure 19 Regulator/Audio I PCB Assembly**  
**A034485-03 A**

## Figure 19 Regulator/Audio I PCB Assembly Parts List

Part No.	Description (Reference Designations and Locations in Bold)
12-52P7	2.7 Ohm, $\pm$ 5%, 1W Resistor (R5)
19-100P1015	.1 Ohm, $\pm$ 3%, 7W Wirewound Resistor (R24)
19-315102	1K Ohm Vertical PCB-Mounting Cermet Trimpot (R8)
24-250108	1000 uf Aluminum Electrolytic Fixed Axial-Lead 25V Capacitor (C13)
24-250477	470 uf Aluminum Electrolytic Fixed Axial-Lead 25V Capacitor (C1, 4, 12)
24-350338	3300 uf Aluminum Electrolytic Fixed Axial-Lead 35V Capacitor (C9, 10)
29-088	.1 uf Ceramic-Disc 25V Radial-Lead Capacitor (C3, C11)
31-1N4002	100V 1-Amp. Silicon Rectifier 1N4002 Diode (CR1, 4)
33-TIP32	PNP Power Transistor, Type TIP32 (Q2)
34-2N3055	NPN Silicon Transistor, Type 2N3055 (Q3)
37-LM305	5V Linear Voltage Regulator (Q1)
75-F60405	#6-32 x 1/4 Inch Binder-Head Nylon Screw
78-16008	Thermally Conductive Compound for the 2N3055
78-16014	Thermally Conductive Compound for the TIP32
79-58306	6-Position Connector Receptacle (J6)
79-58308	9-Position Connector Receptacle (J7)
79-58354	4-Position Square Connector Receptacle (J8)
020670-01	Test Point
034531-01	Heat Sink
100015-103	.01 uf Ceramic-Disc 25V Radial-Lead Capacitor (C5, 14)
110000-010	1 Ohm, $\pm$ 5%, 1/4W Resistor (R10, 19)
110000-100	10 Ohm, $\pm$ 5%, 1/4W Resistor (R11, 20, 25, 26)
110000-101	100 Ohm, $\pm$ 5%, 1/4W Resistor (R4, 12, 22)
110000-102	1K Ohm, $\pm$ 5%, 1/4W Resistor (R15, 16)
110000-103	10K Ohm, $\pm$ 5%, 1/4W Resistor (R13, 14)
110000-271	270 Ohm, $\pm$ 5%, 1/4W Resistor (R1)
110000-330	33 Ohm, $\pm$ 5%, 1/4W Resistor (R3)
110000-392	3.9K Ohm, $\pm$ 5%, 1/4W Resistor (R6)
110000-752	7.5K Ohm, $\pm$ 5%, 1/4W Resistor (R7)
110001-221	220 Ohm, $\pm$ 5%, 1/2W Resistor (R9, 21)
122002-102	.001 uf Ceramic-Disc 25V Radial-Lead Capacitor (C2, 7, 16)
122004-224	.22 uf Ceramic-Disc 25V Radial-Lead Capacitor (C6, 8, 15, 17)
137151-002	8W Linear Audio Amplifier Integrated Circuit (Q5, 7)

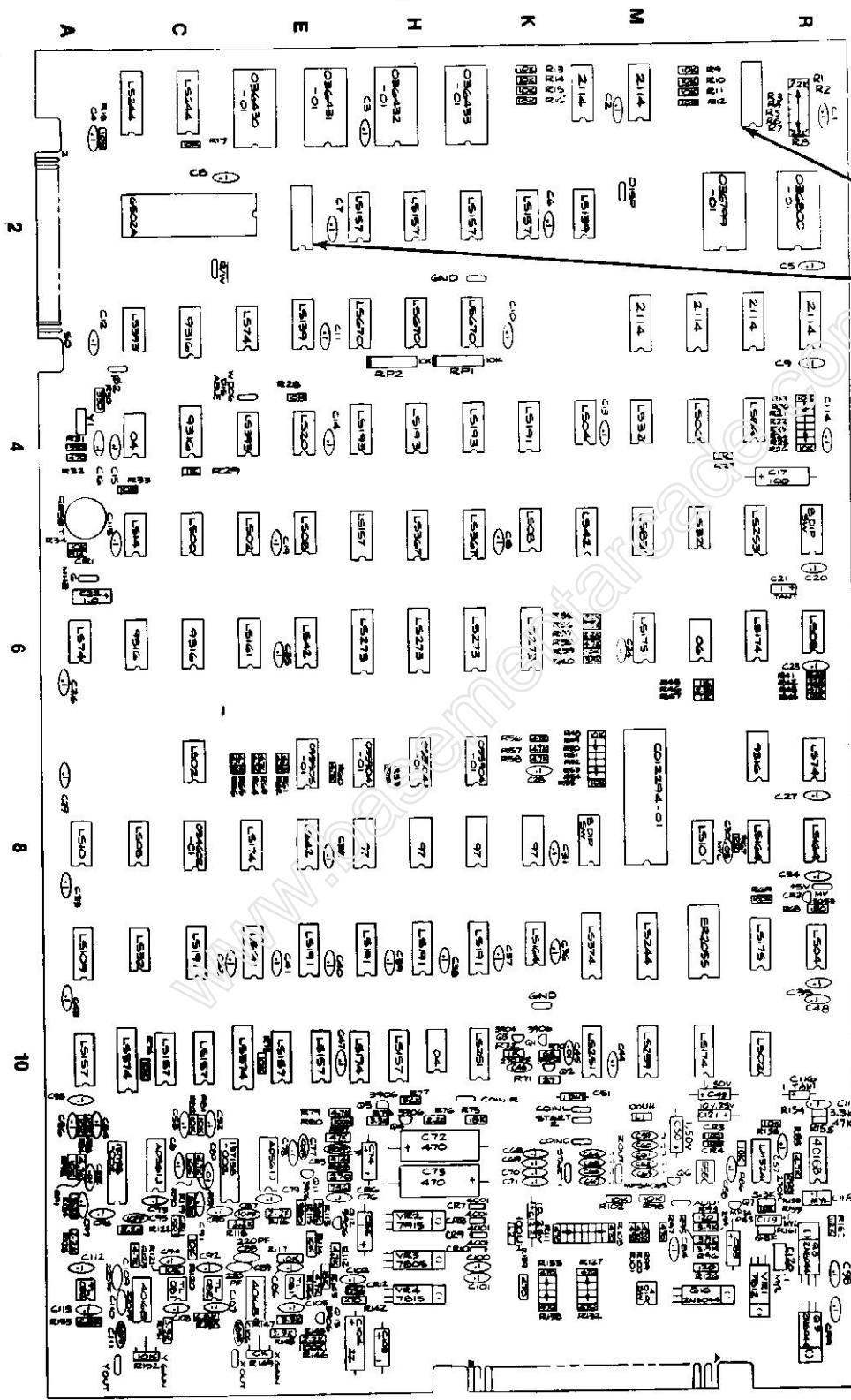

Detail of PCB at Locations E2 and P1:  
Use IC pads enclosed with dotted lines  
when inserting 74LS245.  
Use other pads when inserting an 8304B.

NOTICE TO ALL PERSONS RECEIVING THIS DRAWING  
CONFIDENTIAL. Reproduction forbidden without the  
specific written permission of Atari, Inc., Sunnyvale, CA.  
This drawing is only conditionally issued and neither  
receipt nor possession thereof confers or transfers any  
right in, or license to use, the subject matter of the draw-  
ing or any design or technical information shown thereon,  
nor any right to reproduce this drawing or any part  
thereof. Except for manufacture under the corporation's written  
license, no right to reproduce this drawing is granted or  
with or written permission from the corporation.

Figure 20 Asteroids Deluxe™ Game PCB Assembly  
A036471-01 and -02 A



## Figure 20 Asteroids Deluxe™ Game PCB Assembly Parts List

Part No.	Description (Reference Designations and Locations in Bold)
C012294-01 19-007	Audio I/O N-Channel MOS/LSI Custom Chip <b>(M7/B)</b> 10K Ohm, $\pm 20\%$ , 1/4W 8-Pin Dual-Inline-Package Resistor Network <b>(RP1, RP2—use only if board has 74LS170s or 74LS670s at locations F3, H3, J3)</b>
19-315103 21-101104	10K Ohm Vertical PCB-Mounting Cermet Trimpot <b>(R149, 152)</b> .1 uf, $\pm 10\%$ , Radial-Lead Epoxy-Dipped 100V Mylar Capacitor <b>(C116-120)</b>
21-101153 24-250106 24-250107 24-250226	.015 uf, $\pm 10\%$ , Radial-Lead Epoxy-Dipped 100V Mylar Capacitor <b>(C30)</b> 10 uf Aluminum Electrolytic Fixed Axial-Lead 25V Capacitor <b>(C121, 122)</b> 100 uf Aluminum Electrolytic Fixed Axial-Lead 25V Capacitor <b>(C17)</b> 22 uf Aluminum Electrolytic Fixed Axial-Lead 25V Capacitor <b>(C104)</b>
24-250477 24-500105 28-101100 28-101101	470 uf Aluminum Electrolytic Fixed Axial-Lead 25V Capacitor <b>(C72, 73)</b> 1 uf Aluminum Electrolytic Fixed Axial-Lead 50V Capacitor <b>(C22, 49, 50, 74, 83, 85, 103)</b> 10 pf Epoxy-Dipped 100V Radial-Lead Mica Capacitor <b>(C87, 95)</b> 100 pf Epoxy-Dipped 100V Radial-Lead Mica Capacitor <b>(C77)</b>
28-101100 28-101271 28-101391 28-101680	220 pf Epoxy-Dipped 100V Radial-Lead Mica Capacitor <b>(C88, 89, 109, 110)</b> 270 pf Epoxy-Dipped 100V Radial-Lead Mica Capacitor <b>(C46)</b> 390 pf Epoxy-Dipped 100V Radial-Lead Mica Capacitor <b>(C75)</b> 68 pf Epoxy-Dipped 100V Radial-Lead Mica Capacitor <b>(C106, 111)</b>
29-006 29-088	1 uf, $\pm 10\%$ , 35V Tantalum Capacitor <b>(C21, 51, 116)</b> .1 uf Ceramic-Disc 25V Radial-Lead Capacitor <b>(C1-16, 18-20, 23-29, 31-44, 47, 48, 52-71, 76, 78, 79, 81, 84, 86, 90-94, 96-102, 105, 107, 108, 112-115, 117)</b>
31-1N100 31-1N914	100V Type 1N100 Germanium Switching Diode <b>(CR3, 4, 11)</b> 75V Type 1N914 Silicon Switching Diode <b>(CR1, 5)</b>
31-1N4001 32-1N756A 33-2N3906 34-2N3904	50V Type 1N4001 Silicon Rectifier Diode <b>(CR7-10)</b> 8.2V, $\pm 5\%$ , Type 1N756A Zener Diode <b>(CR6, 12)</b> Type 2N3906 PNP Switching and Amplifying Transistor <b>(Q1, 4, 5, 11-13)</b> Type 2N3904 NPN 60V 1-Watt Transistor <b>(Q2, 3)</b>
34-2N6044 34-MPSA06S 37-LM324 37-TL082CP	Type 2N6044 NPN Darlington Transistor <b>(Q8-10)</b> Type MPSA06S NPN 80V 500ma Transistor <b>(Q6, 7)</b> Type LM324 Integrated Circuit <b>(P11)</b> Type TL082CP Integrated Circuit <b>(A12, C12)</b>
37-4016B 37-555 37-74LS00 37-74LS02	Type 4016B Integrated Circuit <b>(R11, B12, D12)</b> Type 555 Timer Integrated Circuit <b>(N11)</b> Type 74LS00 Integrated Circuit <b>(C5, N4)</b> Type 74LS02 Integrated Circuit <b>(D5, P10. Also, for -02 PCB assy. only: C7)</b>
37-74LS04 37-74LS08 37-74LS10 37-74LS14	Type 74LS04 Integrated Circuit <b>(L4, R9)</b> Type 74LS08 Integrated Circuit <b>(E5, K5, R6, B8)</b> Type 74LS10 Integrated Circuit <b>(A8, N8)</b> Type 74LS14 Integrated Circuit <b>(B5)</b>
37-74LS20 37-74LS32 37-74LS42 37-74LS74	Type 74LS20 Integrated Circuit <b>(E4)</b> Type 74LS32 Integrated Circuit <b>(M4, N5, B9)</b> Type 74LS42 Integrated Circuit <b>(L5, E6, E8)</b> Type 74LS74 Integrated Circuit <b>(D3, A6, R7)</b>
37-74LS83 37-74LS86 37-74LS109 37-74LS139	Type 74LS83 Integrated Circuit <b>(M5)</b> Type 74LS86 Integrated Circuit <b>(P4)</b> Type 74LS109 Integrated Circuit <b>(A9)</b> Type 74LS139 Integrated Circuit <b>(L2, E3)</b>

[Continued on next page]

## Figure 20 Asteroids Deluxe™ Game PCB Assembly, continued Parts List

Part No.	Description (Reference Designations and Locations in Bold)
37-74LS157	Type 74LS157 Integrated Circuit (F2, H2, J2, K2, F5, A10, B/C10, C10, D/E10, E10, F/H10)
37-74LS161	Type 74LS161 Integrated Circuit (D6)
37-74LS164	Type 74LS164 Integrated Circuit (P8, R8, K9)
37-74LS174	Type 74LS174 Integrated Circuit (P6, D8, F10, N10)
37-74LS175	Type 74LS175 Integrated Circuit (M6, P9)
37-74LS191	Type 74LS191 Integrated Circuit (K4, C9, D9, E9, F9, H9, J9)
37-74LS193	Type 74LS193 Integrated Circuit (F4, H4, J4)
37-74LS244	Type 74LS244 Integrated Circuit (B1, C1, M9)
37-74LS245	Type 74LS245 Integrated Circuit (P1, E2) <i>Acceptable substitute is part no. 37-8304B</i>
37-74LS251	Type 74LS251 Integrated Circuit (J10, L10)
37-74LS253	Type 74LS253 Integrated Circuit (P5)
37-74LS259	Type 74LS259 Integrated Circuit (M10)
37-74LS273	Type 74LS273 Integrated Circuit (F6, H6, J6, K6)
37-74LS367	Type 74LS367 Integrated Circuit (H5, J5)
37-74LS393	Type 74LS393 Integrated Circuit (B3, D4)
37-74LS374	Type 74LS374 Integrated Circuit (L9, B10, D10) <i>Acceptable substitute is part no. 37-74LS273</i>
37-74LS670	Type 74LS670 Integrated Circuit (F3, H3, J3) <i>Acceptable substitute is part no. 37-74LS170</i>
37-7404	Type 7404 Integrated Circuit (B4, H10)
37-7406	Type 7406 Integrated Circuit (N6)
37-7497	Type 7497 Integrated Circuit (For -01 PCB assy. only: F8, H8, J8, K8)
37-7805	+ 5V Voltage Regulator (VR3)
37-7812	+ 12V Voltage Regulator (VR1)
37-7815	+ 15V Voltage Regulator (VR4)
37-7915	- 15V Voltage Regulator (VR2)
37-9316	Type 9316 Integrated Circuit (C3, C4, B6, C6, P7)
38-MV5053	Type MV5053 Light-Emitting Diode (CR2)
41-3004	100 $\mu$ H, $\pm$ 10%, Hot-Molded Plastic Fixed R.F. Choke (L1, 2)
62-001	SPST Momentary Pushbutton Switch (A5)
66-114P1T	4-Station Single-Throw, Dual-Inline-Package Bit Switch (M12)
66-118P1T	8-Station Single-Throw, Dual-Inline-Package Bit Switch (R5, L8)
79-42C24	24-Contact Medium-Insertion-Force Integrated Circuit Socket (D1, E/F1, H1, J1, N/P2, R2)
79-42C40	40-Contact Medium-Insertion-Force Integrated Circuit Socket (C2, M7/8)
81-4302	Nylon Snap-In Fastener (VR1-4, Q8-10)
90-102	12.096 MHz, + .005%, Crystal (Y1)
90-6013	Microprocessor (C2)
90-7033	Random-Access Memory (L1, M1, M3, N3, P3, R3)
020670-01	Test Point
034602-01	Programmable Read-Only Memory (C8)
035904-01	Type 82S131 Integrated Circuit (For -02 PCB assy. only: F7, H7, J7)
035905-01	Type 82S131 Integrated Circuit (For -02 PCB assy. only: E7)
036430-01	Read-Only Memory (D1)
036431-01	Read-Only Memory (E/F1)
036432-01	Read-Only Memory (H1)
036433-01	Read-Only Memory (J1)



## Figure 20 Asteroids Deluxe™ Game PCB Assembly, continued Parts List

Part No.	Description (Reference Designations and Locations in Bold)
036799-01	Read-Only Memory (N/P2)
036800-01	Read-Only Memory (R2)
100015-103	.1 uf Ceramic-Disc 25V Radial-Lead Capacitor (C45, 80, 82)
110000-102	1K Ohm, ±5%, ¼W Resistor (R27, 29, 45, 47, 72)
110000-103	10K Ohm, ±5%, ¼W Resistor (R9-26, 28, 33, 34, 39, 48-55, 67, 73, 74, 81-84, 86, 90, 92, 98, 102, 114, 117, 120, 121, 156, 159)
110000-104	100K Ohm, ±5%, ¼W Resistor (R69, 80, 146)
110000-121	120 Ohm, ±5%, ¼W Resistor (R93, 126)
110000-122	1.2K Ohm, ±5%, ¼W Resistor (R36, 160)
110000-123	12K Ohm, ±5%, ¼W Resistor (R44)
110000-151	150 Ohm, ±5%, ¼W Resistor (R68)
110000-183	18K Ohm, ±5%, ¼W Resistor (R75, 143)
110000-222	2.2K Ohm, ±5%, ¼W Resistor (R37, 46, 75, 116, 118, 122, 125, 145, 154)
110000-223	22K Ohm, ±5%, ¼W Resistor (R1-8, 35, 42)
110000-270	27 Ohm, ±5%, ¼W Resistor (R71)
110000-271	270 Ohm, ±5%, ¼W Resistor (R48, 142)
110000-274	270K Ohm, ±5%, ¼W Resistor (R157)
110000-331	330 Ohm, ±5%, ¼W Resistor (R30, 31, 115)
110000-332	3.3K Ohm, ±5%, ¼W Resistor (R78, 147, 158)
110000-392	3.9K Ohm, ±5%, ¼W Resistor (R40, 94-96, 148, 151)
110000-471	470 Ohm, ±5%, ¼W Resistor (R32, 97, 99-101, 103-111, 127-139)
110000-472	4.7K Ohm, ±5%, ¼W Resistor (R38, 79, 85, 89, 91, 112, 123, 144. Also, for -02 PCB assy. only: R56-66)
110000-473	47K Ohm, ±5%, ¼W Resistor (R43, 87, 155)
110000-562	5.6K Ohm, ±5%, ¼W Resistor (R41)
110000-563	56K Ohm, ±5%, ¼W Resistor (R77, 113)
110000-680	68 Ohm, ±5%, ¼W Resistor (R70)
110000-682	6.8K Ohm, ±5%, ¼W Resistor (R150, 153, 161)
110000-822	8.2K Ohm, ±5%, ¼W Resistor (R119, 124)
137108-001	Operational Amplifier Integrated Circuit (B/C12, E12)
137158-002	Type AM6012ADC Digital-to-Analog Converter (A/B11, C/D11) Acceptable substitute is part no. 37-AD561J (B11, D11)
137161-001	Electrically Alterable Read-Only Memory (N9)

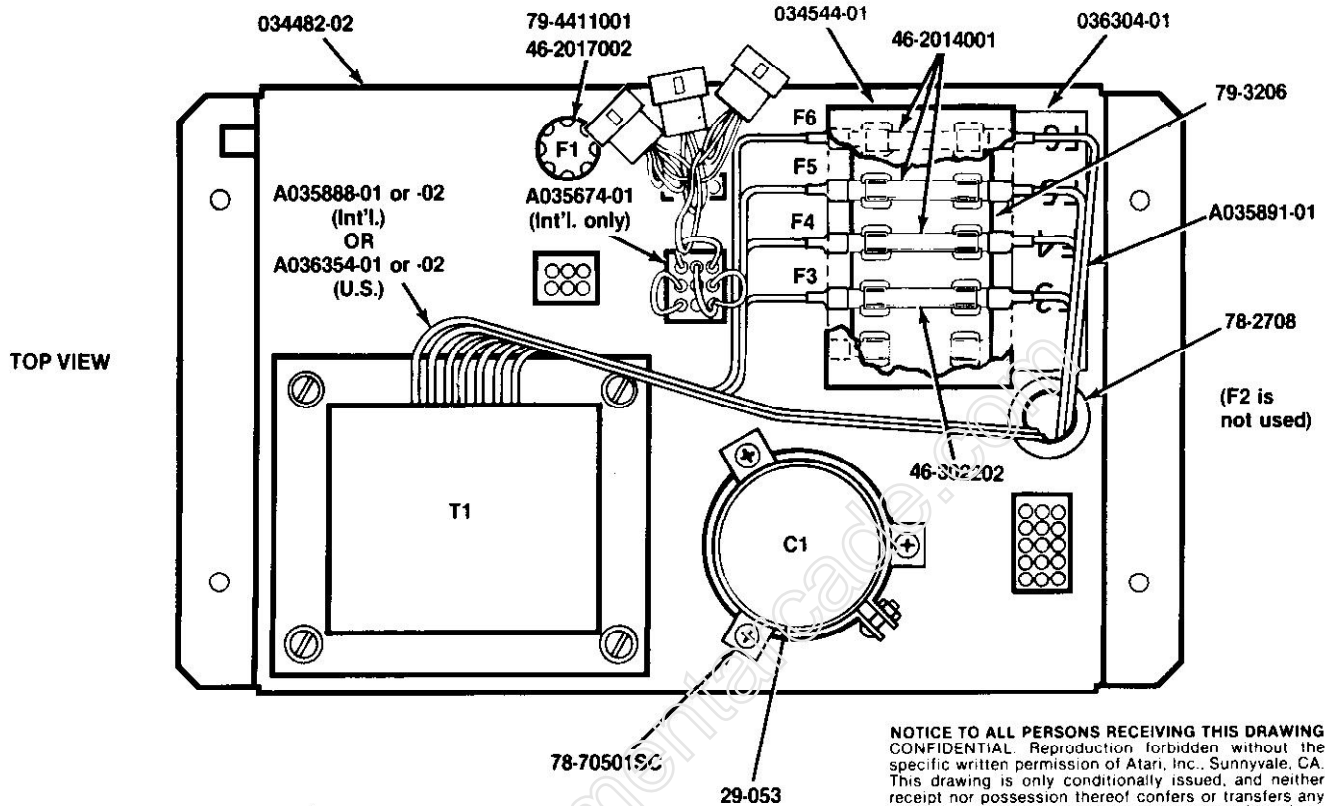

**NOTICE TO ALL PERSONS RECEIVING THIS DRAWING**  
 CONFIDENTIAL. Reproduction forbidden without the specific written permission of Atari, Inc., Sunnyvale, CA. This drawing is only conditionally issued, and neither receipt nor possession thereof confers or transfers any right in, or license to use, the subject matter of the drawing or any design or technical information shown thereon, nor any right to reproduce this drawing or any part thereof. Except for manufacture by vendors of Atari, Inc., and for manufacture under the corporation's written license, no right to reproduce this drawing is granted or the subject matter thereof unless by written agreement with or written permission from the corporation.

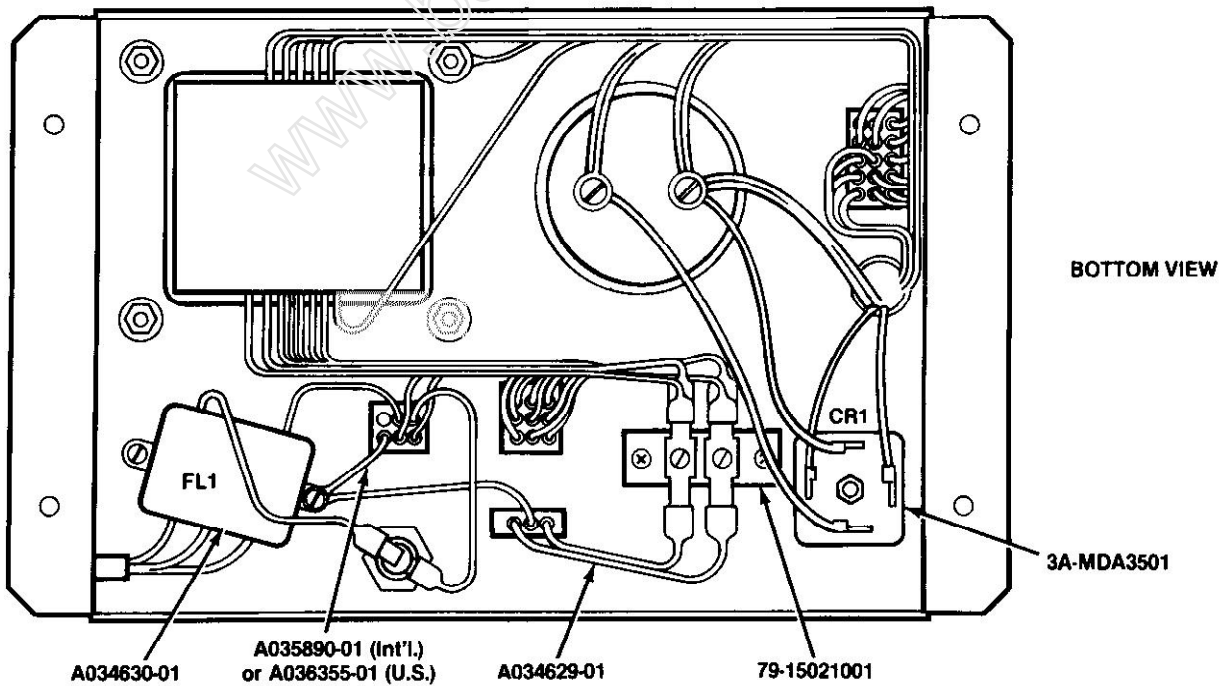
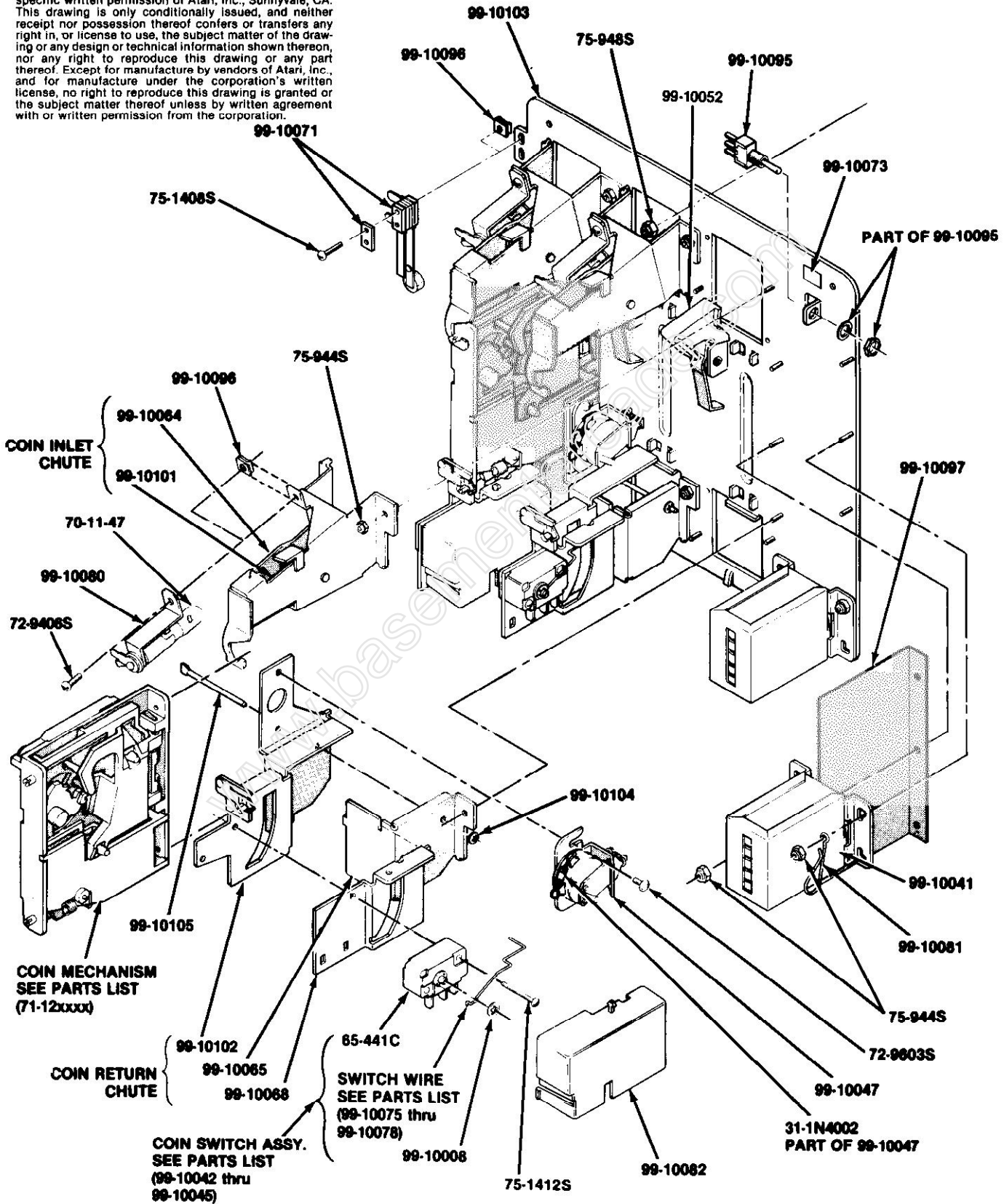

**Figure 21 Power Supply Assemblies for X-Y Games  
 A035892-01 (International) A / A036353-01 (U.S.) A**

## Figure 21 Power Supply Assemblies for X-Y Games Parts List

Part No.	Description (Reference Designations in Bold)
A034629-01	A.C. Harness Assembly
A034630-01	RFI Filter Assembly <b>(FL1)</b>
A035674-01	Voltage Plug Assembly (set of four plugs—for international power supply only)
A035888-01 or -02	Transformer Assembly—international only <b>(T1)</b>
A035890-01	Power Harness Assembly (international only)
A035891-01	Fuse Harness Assembly
A036354-01 or -02	Transformer Assembly—U.S. only <b>(T1)</b>
A036355-01	Power Harness Assembly (U.S. only)
29-053	26,000 uf 15 VDC Electrolytic Capacitor <b>(C1)</b>
3A-MDA3501	Bridge Rectifier, Type MDA 3501 <b>(CR1)</b>
46-2014001	4-Amp. 125 V 3AG Slow-Blow Glass Cartridge-Type Fuse <b>(F4, F5, F6)</b>
46-2017002	7-Amp. 250 V 3AG Slow-Blow Glass Cartridge-Type Fuse <b>(F1)</b>
46-302202	20-Amp. 250 V 3AB Slow-Blow Ceramic Cartridge-Type Fuse <b>(F3)</b>
78-2708	Nylon Type 6/6 Hole Bushing with 5/8-Inch Inside Diameter x 55/64-Inch Outside Diameter x 1/4-Inch Thick
78-70501SC	2-Inch Diameter Capacitor Mounting Bracket
79-15021001	2-Circuit Single-Row Terminal Block
79-3206	5-Position 3AG Fuse Block with 1/4-Inch Quick-Disconnect Terminals
79-4411001	Panel-Mounting Non-Indicating 3AG Cartridge-Type Fuse Post
034482-02	Power Supply Chassis
034544-01	Fuse Block Cover
036304-01	Label for Fuse Values

**NOTICE TO ALL PERSONS RECEIVING THIS DRAWING**  
**CONFIDENTIAL:** Reproduction forbidden without the specific written permission of Atari, Inc., Sunnyvale, CA. This drawing is only conditionally issued, and neither receipt nor possession thereof confers or transfers any right in, or license to use, the subject matter of the drawing or any design or technical information shown thereon, nor any right to reproduce this drawing or any part thereof. Except for manufacture by vendors of Atari, Inc., and for manufacture under the corporation's written license, no right to reproduce this drawing is granted or the subject matter thereof unless by written agreement with or written permission from the corporation.



**Figure 22 American-Made Coin Door  
 71-10xxxx D**

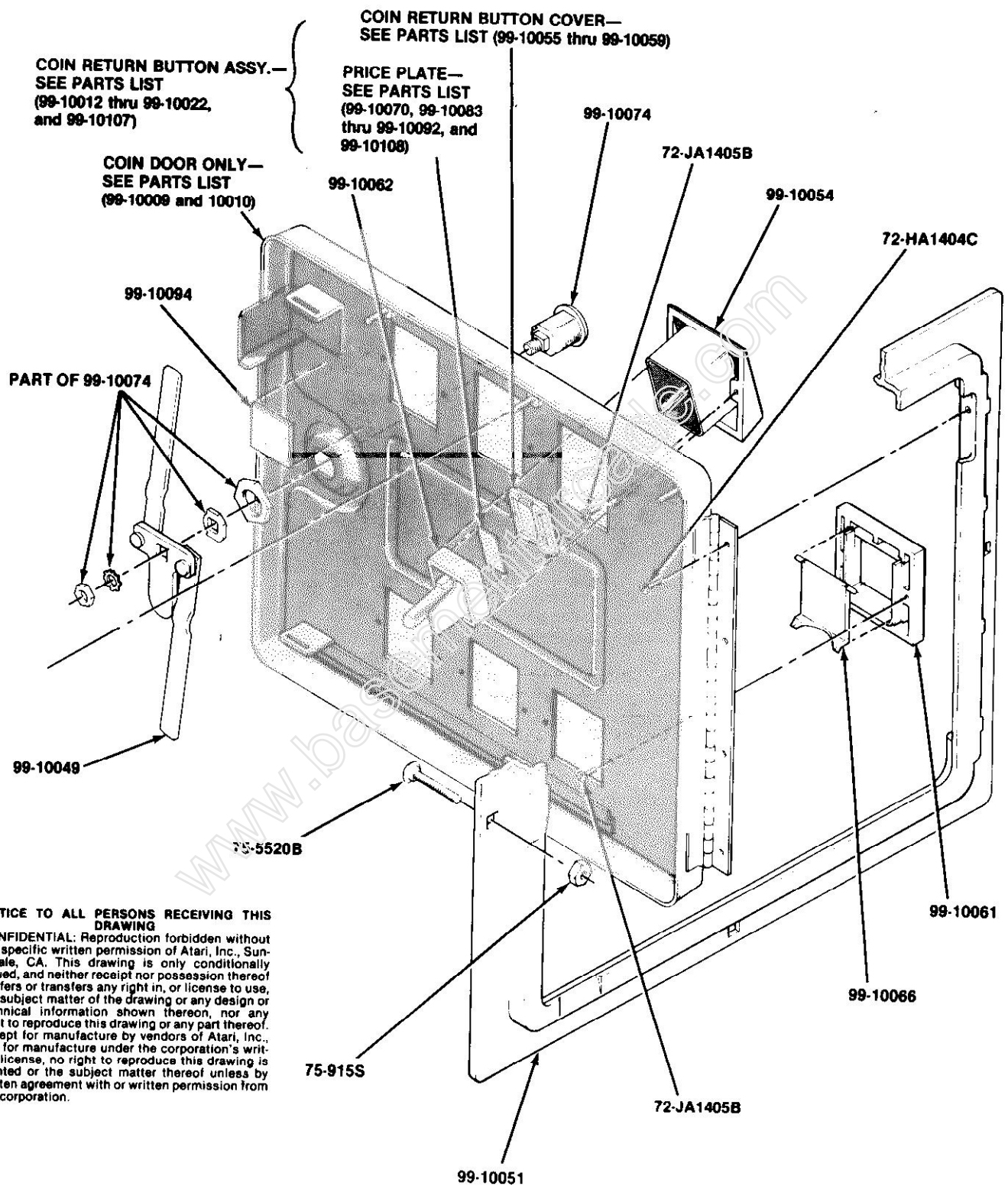

**NOTICE TO ALL PERSONS RECEIVING THIS DRAWING**  
**CONFIDENTIAL:** Reproduction forbidden without the specific written permission of Atari, Inc., Sunnyvale, CA. This drawing is only conditionally issued, and neither receipt nor possession thereof confers or transfers any right in, or license to use, the subject matter of the drawing or any design or technical information shown thereon, nor any right to reproduce this drawing or any part thereof. Except for manufacture by vendors of Atari, Inc., and for manufacture under the corporation's written license, no right to reproduce this drawing is granted or the subject matter thereof unless by written agreement with or written permission from the corporation.

- 71-102201 — U.S. 25¢/25¢ Coin Door
- 71-103202 — U.S. 25¢/25¢/25¢ Coin Door
- 71-103203 — U.S. 25¢/25¢/\$1 Coin Door
- 71-102204 — German 2 DM/1 DM Coin Door
- 71-103205 — German 1/2/5 DM Coin Door

- 71-102206 — German 1 DM/5 DM Coin Door
- 71-102207 — Belgian 5 Fr/5 Fr Coin Door
- 71-102208 — Swiss 1 Fr/1 Fr Coin Door
- 71-102209 — Japanese 100Y/100Y Coin Door
- 71-102210 — British 10 P/10 P Coin Door

- 71-102211 — Australian 20¢/20¢ Coin Door
- 71-102212 — Italian 100 L/100 L Coin Door
- 71-102213 — U.S. 50¢/50¢ (2 x 25¢) Coin Door
- 71-103214 — U.S. 50¢/50¢/50¢ Coin Door
- 71-103215 — U.S. 50¢/50¢/\$1 Coin Door

**Figure 22 American-Made Coin Door**  
**71-10xxxx D**

## Figure 22 American-Made Coin Door, continued Parts List

Part No.	Description
31-1N4002	100V Silicon Rectifier 1N4002 Diode
65-441C	General-Usage Low-Force Miniature Switch
70-11-47	Miniature Bayonet-Base Incandescent Lamp, Type #47
71-1201ADU	U.S. \$1.00 Coin Mechanism
71-1201FCH	Swiss 1 Fr Coin Mechanism
71-1201MG	German 1 DM Coin Mechanism
71-1202MG	German 2 DM Coin Mechanism
71-1205FB	Belgian 5 Fr Coin Mechanism
71-1205MG	German 5 DM Coin Mechanism
71-1210PE	U.K. 10 P Coin Mechanism
71-1220CA	Australian 20¢ Coin Mechanism
71-1225CU	U.S. 25¢ Coin Mechanism
71-12100LI	Italian 100 Lire Coin Mechanism
71-12100YJ	Japanese Y100 Coin Mechanism
72-HA1404C	#4 x 1/4-Inch Slotted Pan-Head Thread-Rolling Tri-Fluted "Taptite" Cadmium-Plated Screw
72-JA1405B	#4 x 5/16-Inch Slotted Pan-Head Thread-Rolling Tri-Fluted "Plastite" Black Screw
72-9406S	#4-40 x 3/8-Inch Slotted Truss-Head Steel Machine Screw
72-9603S	#6-32 x 3/16-Inch Slotted Truss-Head Steel Machine Screw
75-915S	#1/4-20 Standard-Pattern Cadmium-Plated Steel Hex Nut
75-918S	#8-32 Standard-Pattern Cadmium-Plated Steel Hex Nut
75-944S	#4-40 Polymer Self-Locking Steel Hex Nut
75-948S	#8-32 Polymer Self-Locking Steel Hex Nut
75-1408S	#4-40 x 1/2-Inch Slotted Pan-Head Steel Machine Screw
75-1412S	#4-40 x 3/4-Inch Slotted Pan-Head Steel Machine Screw
75-5520B	#1/4-20 x 1 1/4-Inch Round-Head Square-Neck Steel Bolt with Black Finish
99-10008	Switch Wire Retainer
99-10009	2-Mech Coin Door Only
99-10010	3-Mech Coin Door Only
99-10011	Inner Panel
99-10012	U.S. 25¢ Coin Return Button Assembly
99-10013	U.S. \$1.00 Coin Return Button Assembly
99-10014	German 1 DM Coin Return Button Assembly
99-10015	German 2 DM Coin Return Button Assembly
99-10016	German 5 DM Coin Return Button Assembly
99-10017	Belgian 5 Fr Coin Return Button Assembly
99-10018	Swiss 1 Fr Coin Return Button Assembly
99-10019	Japanese Y100 Coin Return Button Assembly
99-10020	U.K. 10 P Coin Return Button Assembly
99-10021	Australian 20¢ Coin Return Button Assembly
99-10022	Italian 100 Lire Coin Return Button Assembly
99-10040	Coin Inlet Chute Assembly
99-10041	Coin Counter Assembly
99-10042	Coin Switch Assembly for U.S. 25¢ and Belgian 5 Fr Coins <i>(silver wire)</i>
99-10043	Coin Switch Assembly for German 1 DM, Swiss 1 Fr, and Japanese Y100 Coins <i>(black wire)</i>
99-10044	Coin Switch Assembly for U.S. \$1.00, German 2 DM, and Italian 100 Lire Coins <i>(gold wire)</i>

## Figure 22 American-Made Coin Door, continued Parts List

Part No.	Description
99-10045	Coin Switch Assembly for German 5 DM, U.K. 10 P, and Australian 20¢ Coins <i>(green wire)</i>
99-10047	Lockout Coil Assembly
99-10048	Coin Door Harness Assembly
99-10049	Locking Arm Assembly
99-10051	Coin Door Frame
99-10052	Coin Return Lever
99-10054	Coin Button Housing
99-10055	Coin Return Button Cover for Japanese 100Y Coin
99-10056	Coin Return Button Cover for German 1 DM and Swiss 1 Fr Coins
99-10057	Coin Return Button Cover for U.S. 25¢ and Belgian 5 Fr Coins
99-10058	Coin Return Button Cover for U.S. \$1.00, German 2 DM, and Italian 100 Lire Coins
99-10059	Coin Return Button Cover for German 5 DM, U.K. 10 P, and Australian 20¢ Coins
99-10061	Coin Return Bezel
99-10062	Coin Return Button
99-10063	Right Half of Coin Inlet Chute
99-10064	Left Half of Coin Inlet Chute
99-10065	Coin Return Box
99-10066	Coin Return Cover
99-10070	U.S. 25¢ Price Plate
99-10071	Slam Switch Assembly
99-10073	Test Switch Decal
99-10074	Lock Assembly
99-10075	Black Switch Wire for German 1 DM, Swiss 1 Fr and Japanese 100Y Coins
99-10076	Silver Switch Wire for U.S. 25¢ and Belgian 5 Fr Coins
99-10077	Gold Switch Wire for U.S. \$1.00, German 2 DM and Italian 100 Lire Coins
99-10078	Green Switch Wire for German 5 DM, U.K. 10 P and Australian 20¢ Coins
99-10080	Miniature Bayonet-Base Lamp Socket
99-10081	Wire Key Holder
99-10082	Switch Cover
99-10083	U.S. \$1.00 Price Plate
99-10084	German 1 DM Price Plate
99-10085	German 2 DM Price Plate
99-10086	German 5 DM Price Plate
99-10087	Belgian 5 Fr Price Plate
99-10088	Swiss 1 Fr Price Plate
99-10089	Japanese Y100 Price Plate
99-10090	U.K. 10 P Price Plate
99-10091	Australian 20¢ Price Plate
99-10092	Italian 100 Lire Price Plate
99-10094	Fish Paper Insulation
99-10095	Toggle Switch
99-10096	"U"-Type Fastener
99-10097	Fish Paper Insulation
99-10101	Coin Inlet Chute Sub-Assembly
99-10102	Switch and Lockout Coil Bracket Sub-Assembly
99-10103	Inner Panel with Levers Sub-Assembly
99-10104	Anti-Penny-Flip Bar Retainer
99-10105	Anti-Penny-Flip Bar
99-10107	U.S. 50¢ Coin Return Button Assembly <i>(for two quarters)</i>
99-10108	U.S. 50¢ Price Plate <i>(for two quarters)</i>

**NOTICE TO ALL PERSONS RECEIVING THIS DRAWING**  
**CONFIDENTIAL:** Reproduction forbidden without the specific written permission of Atari, Inc., Sunnyvale, CA. This drawing is only conditionally issued, and neither receipt nor possession thereof confers or transfers any right in, or license to use, the subject matter of the drawing or any design or technical information shown thereon, nor any right to reproduce this drawing or any part thereof. Except for manufacture by vendors of Atari, Inc., and for manufacture under the corporation's written license, no right to reproduce this drawing is granted or the subject matter thereof unless by written agreement with or written permission from the corporation.

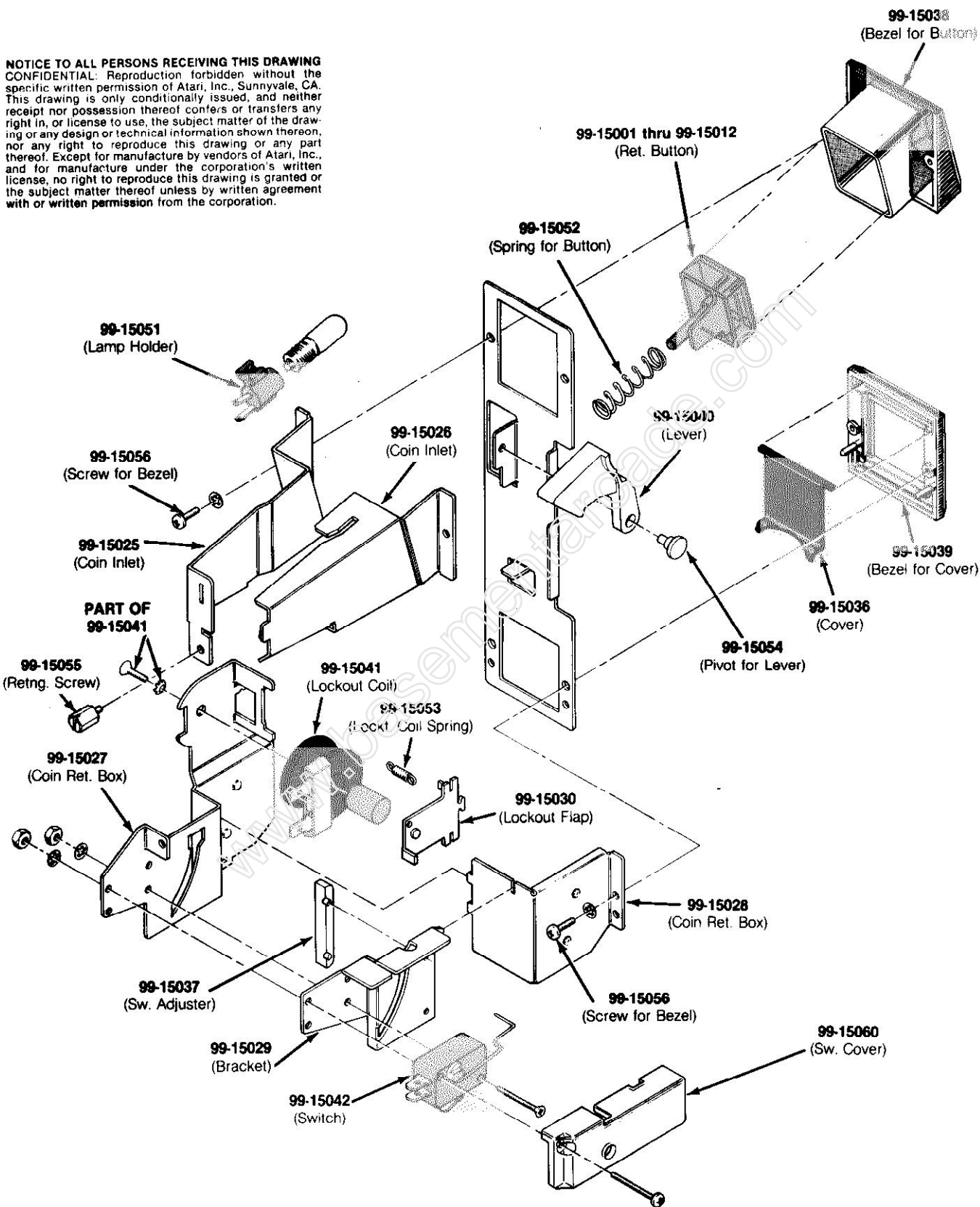

**Figure 23 British-Made Coin Door**  
**171000-xxx A**



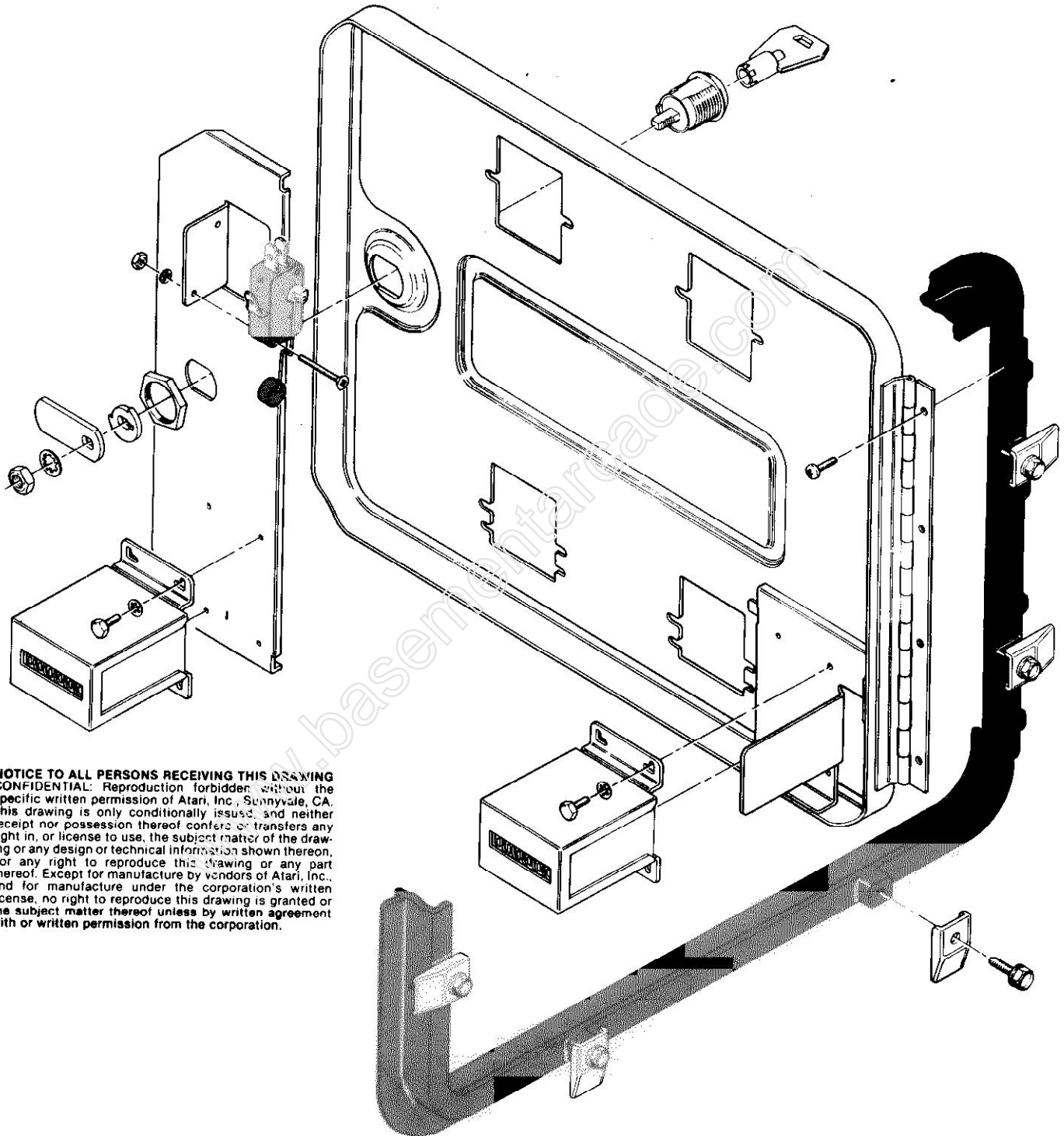

**NOTICE TO ALL PERSONS RECEIVING THIS DRAWING**  
**CONFIDENTIAL:** Reproduction forbidden without the specific written permission of Atari, Inc., Sunnyvale, CA. This drawing is only conditionally issued, and neither receipt nor possession thereof confers or transfers any right in, or license to use, the subject matter of the drawing or any design or technical information shown thereon, nor any right to reproduce this drawing or any part thereof. Except for manufacture by vendors of Atari, Inc., and for manufacture under the corporation's written license, no right to reproduce this drawing is granted or the subject matter thereof unless by written agreement with or written permission from the corporation.

171001-001 — British 10 P/10 P Coin Door  
 171000-002 — British 10 P/50 P Coin Door  
 171000-003 — British 20 P/50 P Coin Door  
 171000-004 — German 1 DM/1 DM Coin Door  
 171000-005 — German 2 DM/1 DM Coin Door

171000-006 — German 2 DM/5 DM Coin Door  
 171000-007 — Belgian 5 Fr/5 Fr Coin Door  
 171000-008 — French 1 Fr/1 Fr Coin Door  
 171000-009 — French 2 Fr/1 Fr Coin Door  
 171000-010 — Swedish 1 Kr/1 Kr Coin Door

171000-011 — Hong Kong \$1/\$1 Coin Door  
 171000-012 — Canadian 25¢/25¢ Coin Door  
 171000-013 — U.S. 25¢/25¢ Coin Door  
 171000-014 — Spanish 25 Pts/25 Pts Coin Door  
 171000-015 — Swiss 1 Fr/1 Fr Coin Door

**Figure 23 British-Made Coin Door**  
**171000-xxx A**

## Figure 23 British-Made Coin Door, continued Parts List

<i>Part No.</i>	<i>Description</i>
99-15001	Coin Return Button with U.S. 25¢ Price Plate
99-15002	Coin Return Button with U.S. \$1 Price Plate
99-15003	Coin Return Button with German 1 DM Price Plate
99-15004	Coin Return Button with German 2 DM Price Plate
99-15005	Coin Return Button with German 5 DM Price Plate
99-15006	Coin Return Button with Belgian 5 Fr Price Plate
99-15007	Coin Return Button with French 1 Fr Price Plate
99-15008	Coin Return Button with Japanese 100 Yen Price Plate
99-15009	Coin Return Button with British 10 Pence Price Plate
99-15010	Coin Return Button with Australian 20¢ Price Plate
99-15011	Coin Return Button with Italian 100 Lire Price Plate
99-15012	Coin Return Button with U.S. 50¢ (2 × 25¢) Price Plate
99-15025	Left Half of Coin Inlet
99-15026	Right Half of Coin Inlet
99-15027	Side Plate of Coin Return Box
99-15028	Base Plate of Coin Return Box
99-15029	Switch Bracket
99-15030	Flap for Lockout Coil (U.S. 25¢)
99-15036	Coin Return Cover
99-15037	Switch Adjuster
99-15038	Bezel for Coin Return Button
99-15039	Bezel for Coin Return Cover
99-15040	Coin Return Lever
99-15041	Lockout Coil
99-15042	Coin Switch for U.S. 25¢
99-15051	Lamp Holder
99-15052	Spring for Coin Return Button
99-15053	Spring for Lockout Coil
99-15054	Pivot for Coin Return Lever
99-15055	Retaining Screw
99-15056	Screw for Both Bezels
99-15060	Switch Cover

## YOUR COMMENTS, PLEASE!

Your comments will assist Atari in improving the usefulness of our publications. They are an important part of preparing for revisions of manuals and parts catalogs. No postage stamp is necessary if mailed in the U.S.A.

If you have any technical questions about certain Atari or Kee Games products, or are requesting additional publications, we will immediately forward your note to the appropriate person.

Page: \_\_\_\_\_ Comments: \_\_\_\_\_

www.basementarcade.com

Fill in if you wish a reply:

Name \_\_\_\_\_

Firm \_\_\_\_\_

Address \_\_\_\_\_

City \_\_\_\_\_ State \_\_\_\_\_ Zip \_\_\_\_\_

Area Code \_\_\_\_\_ Phone \_\_\_\_\_

Distributor

Operator

Other \_\_\_\_\_



ATARI INC  
1265 BORREGAS AVENUE  
P.O. BOX 427  
SUNNYVALE, CALIFORNIA 94086  
408/745-2000 • TELEX 35-7488

 A Warner Communications Company

[www.basementarcade.com](http://www.basementarcade.com)

