

TYPES SN5440, SN54H40, SN54LS40, SN54S40, SN7440, SN74H40, SN74LS40, SN74S40 DUAL 4-INPUT POSITIVE-NAND BUFFERS

REVISED APRIL 1985

- Package Options Include Both Plastic and Ceramic Chip Carriers in Addition to Plastic and Ceramic DIPs
- Dependable Texas Instruments Quality and Reliability

description

These devices contain two independent 4-input NAND buffer gates.

The SN5440, SN54H40, SN54LS40, and SN54S40 are characterized for operation over the full military temperature range of -55°C to 125°C . The SN7440, SN74H40, SN74LS40, and SN74S40 are characterized for operation from 0°C to 70°C .

FUNCTION TABLE (each gate)

INPUTS				OUTPUT
A	B	C	D	Y
H	H	H	H	L
L	X	X	X	H
X	L	X	X	H
X	X	L	X	H
X	X	X	L	H

logic diagram (each gate)

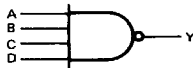

positive logic

$$Y = \overline{A \cdot B \cdot C \cdot D} \text{ or } Y = \overline{A + B + C + D}$$

SN5440, SN54H40 ... J PACKAGE
SN54LS40, SN54S40 ... J OR W PACKAGE
SN7440, SN74H40 ... J OR N PACKAGE
SN74LS40, SN74S40 ... D, J OR N PACKAGE

(TOP VIEW)

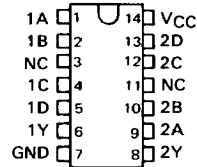

SN5440, SN54H40 ... W PACKAGE

(TOP VIEW)

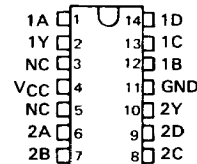

SN54LS40, SN54S40 ... FK PACKAGE
SN74LS40, SN74S40 ... FN PACKAGE

(TOP VIEW)

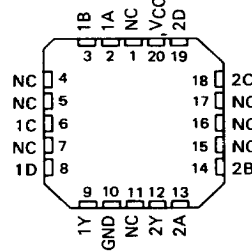

NC - No internal connection



TTL DEVICES

PRODUCTION DATA
This document contains information current as of publication date. Products conform to specifications per the terms of Texas Instruments standard warranty. Production processing does not necessarily include testing of all parameters.



POST OFFICE BOX 276017 DALLAS, TEXAS 75265

3-175

TYPES SN5440, SN54H40, SN54LS40, SN54S40, SN7440, SN74H40, SN74LS40, SN74S40 DUAL 4-INPUT POSITIVE-NAND BUFFERS

schematics (each gate)

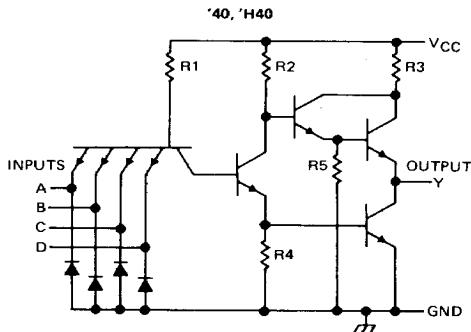

CIRCUIT	R1	R2	R3	R4	R5
'40	4 k Ω	600 Ω	100 Ω	400 Ω	4 k Ω
'H40	1.4 k Ω	390 Ω	45 Ω	250 Ω	2 k Ω

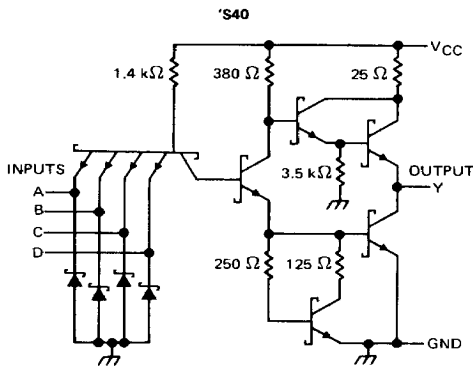
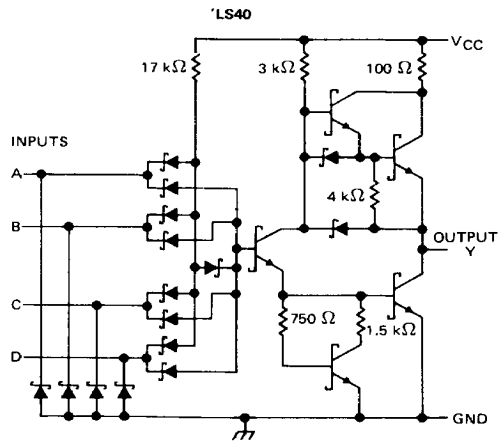

Resistor values shown are nominal.

absolute maximum ratings over operating free-air temperature range (unless otherwise noted)

Supply voltage, V_{CC} (see Note 1)	7 V
Input voltage: '40, 'H40, 'S40	5.5 V
'LS40	7 V
Operating free-air temperature: SN54'	-55°C to 125°C
SN74'	0°C to 70°C
Storage temperature range	-65°C to 150°C

NOTE 1: Voltage values are with respect to network ground terminal.

TYPES SN5440, SN7440 DUAL 4-INPUT POSITIVE-NAND BUFFERS

recommended operating conditions

	SN5440			SN7440			UNIT
	MIN	NOM	MAX	MIN	NOM	MAX	
V_{CC} Supply voltage	4.5	5	5.5	4.75	5	5.25	V
V_{IH} High-level input voltage	2			2			V
V_{IL} Low-level input voltage	0.8			0.8			V
I_{OH} High-level output current	-1.2			-1.2			mA
I_{OL} Low-level output current	48			48			mA
T_A Operating free-air temperature	-55			0			70 °C

electrical characteristics over recommended operating free-air temperature range (unless otherwise noted)

PARAMETER	TEST CONDITIONS †	SN5440			SN7440			UNIT
		MIN	TYP ‡	MAX	MIN	TYP ‡	MAX	
V_{IK}	$V_{CC} = \text{MIN}, I_I = -12 \text{ mA}$	-1.5			-1.5			V
V_{OH}	$V_{CC} = \text{MIN}, V_{IL} = 0.8 \text{ V}, I_{OH} = -1.2 \text{ mA}$	2.4	3.3		2.4	3.3		V
V_{OL}	$V_{CC} = \text{MIN}, V_{IH} = 2 \text{ V}, I_{OL} = 48 \text{ mA}$	0.2			0.2			V
I_I	$V_{CC} = \text{MAX}, V_I = 5.5 \text{ V}$	1			1			mA
I_{IH}	$V_{CC} = \text{MAX}, V_I = 2.4 \text{ V}$	40			40			µA
I_{IL}	$V_{CC} = \text{MAX}, V_I = 0.4 \text{ V}$	-1.6			-1.6			mA
$I_{OS} §$	$V_{CC} = \text{MAX}$	-20	-70		-18	-70		mA
I_{CCH}	$V_{CC} = \text{MAX}, V_I = 0 \text{ V}$	4			4			8 mA
I_{CCL}	$V_{CC} = \text{MAX}, V_I = 4.5 \text{ V}$	17			17			27 mA

† For conditions shown as MIN or MAX, use the appropriate value specified under recommended operating conditions.

‡ All typical values are at $V_{CC} = 5 \text{ V}, T_A = 25^\circ\text{C}$.

§ Not more than one output should be shorted at a time, and the duration of the short circuit should not exceed 100 milliseconds.

switching characteristics, $V_{CC} = 5 \text{ V}, T_A = 25^\circ\text{C}$ (see note 2)

PARAMETER	FROM (INPUT)	TO (OUTPUT)	TEST CONDITIONS	MIN	TYP	MAX	UNIT
t_{PLH}	Any	Y	$R_L = 133 \Omega, C_L = 15 \text{ pF}$	13		22	ns
t_{PHL}				8		15	ns

NOTE 2: See General Information Section for load circuits and voltage waveforms.

3

TTL DEVICES

TYPES SN54H40, SN74H40

DUAL 4-INPUT POSITIVE-NAND BUFFERS

recommended operating conditions

	SN54H40			SN74H40			UNIT
	MIN	NOM	MAX	MIN	NOM	MAX	
V _{CC} Supply voltage	4.5	5	5.5	4.75	5	5.25	V
V _{IH} High-level input voltage	2			2			V
V _{IL} Low-level input voltage	0.8			0.8			V
I _{OH} High-level output current	-1.5			-1.5			mA
I _{OL} Low-level output current	60			60			mA
T _A Operating free-air temperature	-55			0			70 °C

electrical characteristics over recommended operating free-air temperature range (unless otherwise noted)

PARAMETER	TEST CONDITIONS †	SN54H40			SN74H40			UNIT
		MIN	TYP ‡	MAX	MIN	TYP ‡	MAX	
V _{IK}	V _{CC} = MIN, I _I = -8 mA	-1.5			-1.5			V
V _{OH}	V _{CC} = MIN, V _{IL} = 0.8 V, I _{OH} = -1.5 mA	2.4	3.4		2.4	3.4	V	
V _{OL}	V _{CC} = MIN, V _{IH} = 2 V, I _{OL} = 60 mA	0.2	0.4		0.2	0.4	V	
I _I	V _{CC} = MAX, V _I = 5.5 V	0.1			0.1			mA
I _{IH}	V _{CC} = MAX, V _I = 2.4 V	0.1			0.1			mA
I _{IL}	V _{CC} = MAX, V _I = 0.4 V	-4			-4			mA
I _{OS} §	V _{CC} = MAX	-40	-125		-40	-125	mA	
I _{CCH}	V _{CC} = MAX, V _I = 0 V	10.4			10.4			16 mA
I _{CCL}	V _{CC} = MAX, V _I = 4.5 V	25			25			40 mA

† For conditions shown as MIN or MAX, use the appropriate value specified under recommended operating conditions.

‡ All typical values are at V_{CC} = 5 V, T_A = 25°C.

§ Not more than one output should be shorted at a time, and the duration of the short-circuit should not exceed one second.

switching characteristics, V_{CC} = 5 V, T_A = 25°C (see note 2)

PARAMETER	FROM (INPUT)	TO (OUTPUT)	TEST CONDITIONS	MIN	TYP	MAX	UNIT
t _{PLH}	Any	Y	R _L = 93 Ω, C _L = 25 pF	8.5		12	ns
t _{PHL}				6.5		12	ns

NOTE 2: See General Information Section for load circuits and voltage waveforms.

3

TTL DEVICES

TYPES SN54LS40, SN74LS40 DUAL 4-INPUT POSITIVE-NAND BUFFERS

recommended operating conditions

		SN54LS40			SN74LS40			UNIT
		MIN	NOM	MAX	MIN	NOM	MAX	
V_{CC}	Supply voltage	4.5	5	5.5	4.75	5	5.25	V
V_{IH}	High-level input voltage	2			2			V
V_{IL}	Low-level input voltage			0.7			0.8	V
I_{OH}	High-level output current			-1.2			-1.2	mA
I_{OL}	Low-level output current			12			24	mA
T_A	Operating free-air temperature	-55		125	0		70	°C

electrical characteristics over recommended operating free-air temperature range (unless otherwise noted)

PARAMETER	TEST CONDITIONS †	SN54LS40			SN74LS40			UNIT
		MIN	TYP ‡	MAX	MIN	TYP ‡	MAX	
V_{IK}	$V_{CC} = \text{MIN}, I_I = -18 \text{ mA}$			-1.5			-1.5	V
V_{OH}	$V_{CC} = \text{MIN}, V_{IL} = \text{MAX}, I_{OH} = -1.2 \text{ mA}$	2.5	3.4		2.7	3.4		V
V_{OL}	$V_{CC} = \text{MIN}, V_{IH} = 2 \text{ V}, I_{OL} = 12 \text{ mA}$		0.25	0.4		0.25	0.4	V
	$V_{CC} = \text{MIN}, V_{IH} = 2 \text{ V}, I_{OL} = 24 \text{ mA}$					0.35	0.5	
I_I	$V_{CC} = \text{MAX}, V_I = 7 \text{ V}$			0.1			0.1	mA
I_{IH}	$V_{CC} = \text{MAX}, V_I = 2.7 \text{ V}$			20			20	µA
I_{IL}	$V_{CC} = \text{MAX}, V_I = 0.4 \text{ V}$			-0.4			-0.4	mA
$I_{OS} §$	$V_{CC} = \text{MAX}$	-30		-130	-30		-130	mA
I_{CCH}	$V_{CC} = \text{MAX}, V_I = 0 \text{ V}$		0.45	1		0.45	1	mA
I_{CCL}	$V_{CC} = \text{MAX}, V_I = 4.5 \text{ V}$		3	6		3	6	mA

† For conditions shown as MIN or MAX, use the appropriate value specified under recommended operating conditions.

‡ All typical values are at $V_{CC} = 5 \text{ V}, T_A = 25^\circ \text{C}$.

§ Not more than one output should be shorted at a time, and the duration of the short circuit should not exceed one second.

switching characteristics, $V_{CC} = 5 \text{ V}, T_A = 25^\circ \text{C}$ (see note 2)

PARAMETER	FROM (INPUT)	TO (OUTPUT)	TEST CONDITIONS		MIN	TYP	MAX	UNIT
			$R_L = 667 \Omega,$	$C_L = 45 \text{ pF}$				
t_{PLH}	Any	Y	$R_L = 667 \Omega,$	$C_L = 45 \text{ pF}$		12	24	ns
t_{PHL}						12	24	ns

NOTE 2: See General Information Section for load circuits and voltage waveforms.

3

TTL DEVICES

TEXAS
INSTRUMENTS

POST OFFICE BOX 225012 • DALLAS, TEXAS 75265

3-179

TYPES SN54S40, SN74S40

DUAL 4-INPUT POSITIVE-NAND BUFFERS

recommended operating conditions

	SN54S40			SN74S40			UNIT
	MIN	NOM	MAX	MIN	NOM	MAX	
V _{CC} Supply voltage	4.5	5	5.5	4.75	5	5.25	V
V _{IH} High-level input voltage	2			2			V
V _{IL} Low-level input voltage			0.8			0.8	V
I _{OH} High-level output current			-3			-3	mA
I _{OL} Low-level output current			60			60	mA
T _A Operating free-air temperature	-55		125	0		70	°C

electrical characteristics over recommended operating free-air temperature range (unless otherwise noted)

PARAMETER	TEST CONDITIONS †	SN54S40			SN74S40			UNIT	
		MIN	TYP ‡	MAX	MIN	TYP ‡	MAX		
V _{IJK}	V _{CC} = MIN, I _I = -18 mA			-1.2			-1.2	V	
V _{OH}	V _{CC} = MIN, V _{IL} = 0.8 V, I _{OH} = -3 mA	2.5	3.4		2.7	3.4		V	
V _{OL}	V _{CC} = MIN, V _{IH} = 2 V, I _{OL} = 60 mA			0.5			0.5	V	
I _I	V _{CC} = MAX, V _I = 5.5 V			1			1	mA	
I _{IH}	V _{CC} = MAX, V _I = 2.7 V			0.1			0.1	mA	
I _{IL}	V _{CC} = MAX, V _I = 0.5 V			-4			-4	mA	
I _{OS} §	V _{CC} = MAX	-50		-225	-50		-225	mA	
I _{CCH}	V _{CC} = MAX, V _I = 0 V			10	18		10	18	mA
I _{CCL}	V _{CC} = MAX, V _I = 4.5 V			25	44		25	44	mA

† For conditions shown as MIN or MAX, use the appropriate value specified under recommended operating conditions.

‡ All typical values are at V_{CC} = 5 V, T_A = 25°C.

§ Not more than one output should be shorted at a time, and the duration of the short-circuit should not exceed 100 milliseconds.

switching characteristics, V_{CC} = 5 V, T_A = 25°C (see note 2)

PARAMETER	FROM (INPUT)	TO (OUTPUT)	TEST CONDITIONS		MIN	TYP	MAX	UNIT
t _{PLH}	Any	Y	R _L = 93 Ω,	C _L = 50 pF	4		6.5	ns
t _{PHL}					4		6.5	ns
t _{PLH}			R _L = 93 Ω,	C _L = 150 pF	6			ns
t _{PHL}					6			ns

NOTE 2: See General Information Section for load circuits and voltage waveforms.

3 TTL DEVICES