

2101A/8101A-4*

256 X 4 BIT STATIC RAM

2101A-2	250 ns Max.
2101A	350 ns Max.
2101A-4	450 ns Max.

RAM

- **256 x 4 Organization to Meet Needs for Small System Memories**
- **Single +5V Supply Voltage**
- **Directly TTL Compatible: All Inputs and Output**
- **Static MOS: No Clocks or Refreshing Required**
- **Simple Memory Expansion: Chip Enable Input**
- **Inputs Protected: All Inputs Have Protection Against Static Charge**
- **Low Cost Packaging: 22 Pin Plastic Dual In-Line Configuration**
- **Low Power: Typically 150 mW**
- **Three-State Output: OR-Tie Capability**
- **Output Disable Provided for Ease of Use in Common Data Bus Systems**

The Intel® 2101A is a 256 word by 4-bit static random access memory element using N-channel MOS devices integrated on a monolithic array. It uses fully DC stable (static) circuitry and therefore requires no clocks or refreshing to operate. The data is read out nondestructively and has the same polarity as the input data.

The 2101A is designed for memory applications where high performance, low cost, large bit storage, and simple interfacing are important design objectives.

It is directly TTL compatible in all respects: inputs, outputs, and a single +5V supply. Two chip-enables allow easy selection of an individual package when outputs are OR-tied. An output disable is provided so that data inputs and outputs can be tied for common I/O systems. The output disable function eliminates the need for bi-directional logic in a common I/O system.

The Intel® 2101A is fabricated with N-channel silicon gate technology. This technology allows the design and production of high performance, easy-to-use MOS circuits and provides a higher functional density on a monolithic chip than either conventional MOS technology or P-channel silicon gate technology.

Intel's silicon gate technology also provides excellent protection against contamination. This permits the use of low cost plastic packaging.

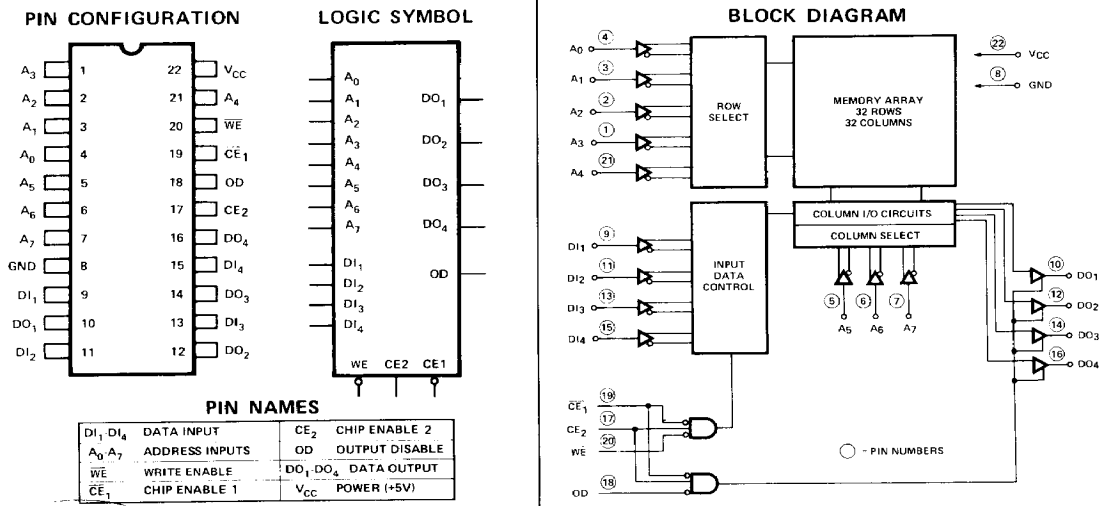

*All 8101A-4 specs are identical to the 2101A-4 specs.

ABSOLUTE MAXIMUM RATINGS*

Ambient Temperature Under Bias -10°C to 80°C
 Storage Temperature -65°C to +150°C
 Voltage On Any Pin
 With Respect to Ground -0.5V to +7V
 Power Dissipation 1 Watt

**COMMENT:*

Stresses above those listed under "Absolute Maximum Rating" may cause permanent damage to the device. This is a stress rating only and functional operation of the device at these or at any other condition above those indicated in the operational sections of this specification is not implied. Exposure to absolute maximum rating conditions for extended periods may affect device reliability.

RAM

D.C. AND OPERATING CHARACTERISTICS

T_A = 0°C to 70°C, V_{CC} = 5V ±5% unless otherwise specified.

Symbol	Parameter	Min.	Typ. ^[1]	Max.	Unit	Test Conditions
I _{LI}	Input Current		1	10	μA	V _{IN} = 0 to 5.25V
I _{LOH}	Data Output Leakage Current		1	10	μA	Output Disabled, V _{OUT} =4.0V
I _{LOL}	Data Output Leakage Current		-1	-10	μA	Output Disabled, V _{OUT} =0.45V
I _{CC1}	Power Supply Current	2101A, 2101A-4	35	55	mA	V _{IN} = 5.25V, I _O = 0mA T _A = 25°C
		2101A-2	45	65		
I _{CC2}	Power Supply Current	2101A, 2101A-4		60	mA	V _{IN} = 5.25V, I _O = 0mA T _A = 0°C
		2101A-2		70		
V _{IL}	Input "Low" Voltage	-0.5		+0.8	V	
V _{IH}	Input "High" Voltage	2.0		V _{CC}	V	
V _{OL}	Output "Low" Voltage			+0.45	V	I _{OL} = 2.0mA
V _{OH}	Output "High" Voltage	2101A, 2101A-2	2.4		V	I _{OH} = -200μA
		2101A-4	2.4		V	I _{OH} = -150μA

TYPICAL D.C. CHARACTERISTICS

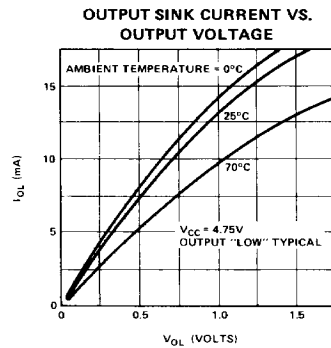
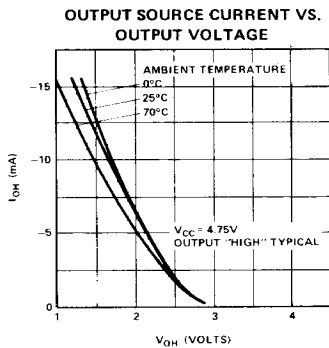

NOTES: 1. Typical values are for T_A = 25°C and nominal supply voltage.

A.C. CHARACTERISTICS FOR 2101A-2 (250 ns ACCESS TIME)

READ CYCLE $T_A = 0^\circ\text{C}$ to 70°C , $V_{CC} = 5V \pm 5\%$, unless otherwise specified.

Symbol	Parameter	Min.	Typ. ^[1]	Max.	Unit	Test Conditions
t_{RC}	Read Cycle	250			ns	$t_r, t_f = 20\text{ns}$ Input Levels = 0.8V or 2.0V Timing Reference = 1.5V Load = 1 TTL Gate and $C_L = 100\text{pF}$.
t_A	Access Time			250	ns	
t_{CO}	Chip Enable To Output			180	ns	
t_{OD}	Output Disable To Output			130	ns	
$t_{DF}^{[3]}$	Data Output to High Z State	0		180	ns	
t_{OH}	Previous Read Data Valid after change of Address	40			ns	

WRITE CYCLE

Symbol	Parameter	Min.	Typ. ^[1]	Max.	Unit	Test Conditions
t_{WC}	Write Cycle	170			ns	$t_r, t_f = 20\text{ns}$ Input Levels = 0.8V or 2.0V Timing Reference = 1.5V Load = 1 TTL Gate and $C_L = 100\text{pF}$.
t_{AW}	Write Delay	20			ns	
t_{CW}	Chip Enable To Write	150			ns	
t_{DW}	Data Setup	150			ns	
t_{DH}	Data Hold	0			ns	
t_{WP}	Write Pulse	150			ns	
t_{WR}	Write Recovery	0			ns	
t_{DS}	Output Disable Setup	20			ns	

CAPACITANCE ^[2] $T_A = 25^\circ\text{C}$, $f = 1\text{MHz}$

Symbol	Test	Limits (pF)	
		Typ. ^[1]	Max.
C_{IN}	Input Capacitance (All Input Pins) $V_{IN} = 0V$	4	8
C_{OUT}	Output Capacitance $V_{OUT} = 0V$	8	12

WAVEFORMS

READ CYCLE

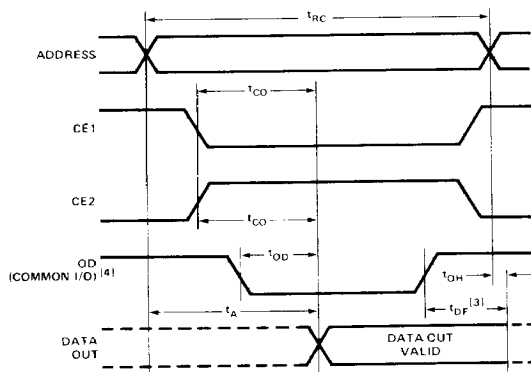

WRITE CYCLE

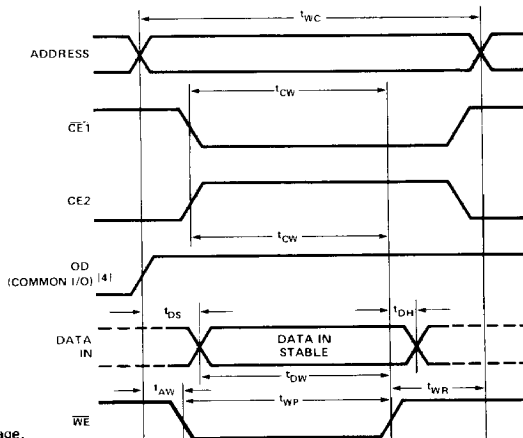

- NOTES:
1. Typical values are for $T_A = 25^\circ\text{C}$ and nominal supply voltage.
 2. This parameter is periodically sampled and is not 100% tested.
 3. t_{DF} is with respect to the trailing edge of CE_1 , CE_2 , or OD , whichever occurs first.

4. OD should be tied low for separate I/O operation.

2101A (350 ns ACCESS TIME)**A.C. CHARACTERISTICS**

READ CYCLE $T_A = 0^\circ\text{C}$ to 70°C , $V_{CC} = 5\text{V} \pm 5\%$, unless otherwise specified.

Symbol	Parameter	Min.	Typ. ^[1]	Max.	Unit	Test Conditions
t_{RC}	Read Cycle	350			ns	$t_r, t_f = 20\text{ns}$ Input Levels = 0.8V or 2.0V Timing Reference = 1.5V Load = 1 TTL Gate and $C_L = 100\text{pF}$.
t_A	Access Time			350	ns	
t_{CO}	Chip Enable To Output			240	ns	
t_{OD}	Output Disable To Output			180	ns	
$t_{DF}^{[2]}$	Data Output to High Z State	0		150	ns	
t_{OH}	Previous Read Data Valid after change of Address	40			ns	

WRITE CYCLE

Symbol	Parameter	Min.	Typ. ^[1]	Max.	Unit	Test Conditions
t_{WC}	Write Cycle	220			ns	$t_r, t_f = 20\text{ns}$ Input Levels = 0.8V or 2.0V Timing Reference = 1.5V Load = 1 TTL Gate and $C_L = 100\text{pF}$.
t_{AW}	Write Delay	20			ns	
t_{CW}	Chip Enable To Write	200			ns	
t_{DW}	Data Setup	200			ns	
t_{DH}	Data Hold	0			ns	
t_{WP}	Write Pulse	200			ns	
t_{WR}	Write Recovery	0			ns	
t_{DS}	Output Disable Setup	20			ns	

2101A-4 (450 ns ACCESS TIME)**A.C. CHARACTERISTICS**

READ CYCLE $T_A = 0^\circ\text{C}$ to 70°C , $V_{CC} = 5\text{V} \pm 5\%$, unless otherwise specified.

Symbol	Parameter	Min.	Typ. ^[1]	Max.	Unit	Test Conditions
t_{RC}	Read Cycle	450			ns	$t_r, t_f = 20\text{ns}$ Input Levels = 0.8V or 2.0V Timing Reference = 1.5V Load = 1 TTL Gate and $C_L = 100\text{pF}$.
t_A	Access Time			450	ns	
t_{CO}	Chip Enable To Output			310	ns	
t_{OD}	Output Disable To Output			250	ns	
$t_{DF}^{[2]}$	Data Output to High Z State	0		200	ns	
t_{OH}	Previous Read Data Valid after change of Address	40			ns	

WRITE CYCLE

Symbol	Parameter	Min.	Typ. ^[1]	Max.	Unit	Test Conditions
t_{WC}	Write Cycle	270			ns	$t_r, t_f = 20\text{ns}$ Input Levels = 0.8V or 2.0V Timing Reference = 1.5V Load = 1 TTL Gate and $C_L = 100\text{pF}$.
t_{AW}	Write Delay	20			ns	
t_{CW}	Chip Enable To Write	250			ns	
t_{DW}	Data Setup	250			ns	
t_{DH}	Data Hold	0			ns	
t_{WP}	Write Pulse	250			ns	
t_{WR}	Write Recovery	0			ns	
t_{DS}	Output Disable Setup	20			ns	

NOTES: 1. Typical values are for $T_A = 25^\circ\text{C}$ and nominal supply voltage.

2. t_{DF} is with respect to the trailing edge of CE_1 , CE_2 , or OD , whichever occurs first.