

ADM-3A **interactive display terminal**

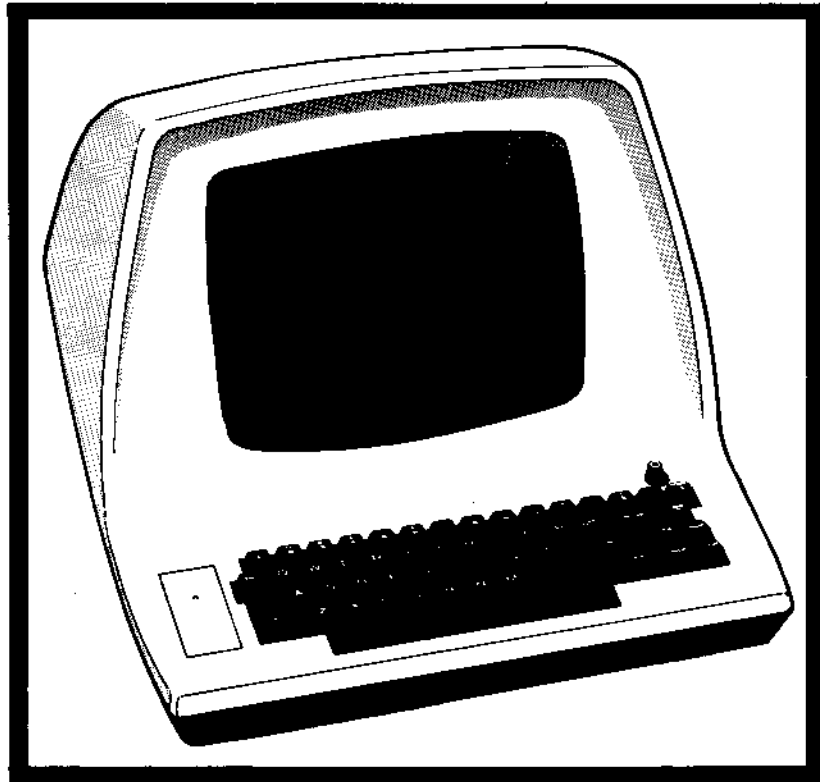

OPERATORS MANUAL

ADM-3A OPERATORS MANUAL

 **LEAR SIEGLER INC.**
DATA PRODUCTS DIVISION
714 NORTH BROOKHURST STREET, ANAHEIM, CALIFORNIA 92803

TABLE OF CONTENTS

SECTION		PAGE
1	GENERAL DESCRIPTION	
1.1	INTRODUCTION.....	1-1
1.2	PURPOSE AND USE.....	1-1
1.3	OPERATIONAL DESCRIPTION.....	1-2
1.3.1	Keyboard.....	1-2
1.3.2	Input/Output (I/O) Channel.....	1-2
1.3.3	ADM-3A Control Logic.....	1-2
1.3.4	Display Memory.....	1-2
1.3.5	CRT Display Monitor.....	1-4
1.4	PHYSICAL DESCRIPTION.....	1-4
1.5	SPECIFICATIONS.....	1-4
1.5.1	Send/Receive Modes.....	1-4
1.5.2	Character Format.....	1-7
1.5.3	Word Structure.....	1-7
1.5.4	Data Entry and Overflow.....	1-7
1.5.5	Configuration Control.....	1-9
1.6	OPTIONAL FEATURES.....	1-12
1.7	RELATED DOCUMENT.....	1-13
2	INSTALLATION	
2.1	INTRODUCTION.....	2-1
2.2	SAFETY REQUIREMENTS.....	2-1
2.3	SITE REQUIREMENTS.....	2-1
2.4	UNPACKING AND INITIAL INSPECTION.....	2-2
2.5	INITIAL PREPARATION.....	2-2
2.5.1	Line Voltage Selection.....	2-2
2.5.2	Configuration Control Switch Settings.....	2-3
2.6	INTERFACE INFORMATION.....	2-6
2.6.1	RS-232C MODEM Port Interface.....	2-6
2.6.2	RS-232C EXTENSION Port Interface..	2-6
2.7	INSTALLING THE ADM-3A.....	2-6
2.8	TURN-ON and TURN-OFF PROCEDURES.....	2-10
2.8.1	Turn-On Procedures.....	2-10
2.9	CARE OF THE ADM-3A TERMINAL DISPLAY.....	2-12
2.9.1	Cleaning.....	2-12
2.9.2	Inspection.....	2-12

TABLE OF CONTENTS (cont'd)

SECTION		PAGE
3	OPERATING INSTRUCTIONS	
3.1	INTRODUCTION.....	3-1
3.2	KEYBOARD OPERATIONS.....	3-1
	3.2.1 Displayable Character Keys.....	3-1
	3.2.2 Special Function Keys.....	3-3
3.3	INTERFACE CONTROL OPERATIONS.....	3-8
	3.3.1 Code Turnaround Operation.....	3-9
	3.3.2 Reverse-Channel Turnaround Operation.....	3-9
3.4	PROGRAMMING CONSIDERATIONS.....	3-10
	3.4.1 Remote CTRL Operation.....	3-10
	3.4.2 Remote Load-Cursor Operation.....	3-10

LIST OF FIGURES

FIGURE		PAGE
1-1	ADM-3A Interactive Display Terminal.....	vi
1-2	ADM-3A Data Flow Block Diagram.....	1-4
1-3	ADM-3A Graphic Character Set and CTRL Codes.....	1-9
1-4	Word Format Codes with Front Panel Switch Configurations.....	1-10
1-5	Front Panel Switch Locations.....	1-11
2-1	ADM-3A Configuration Control Switch Locations.....	2-3
2-2	Typical ADM-3A Interfaces.....	2-7
2-3	ADM-3A Interface Logic.....	2-8
2-4	ADM-3A Rear Panel Controls.....	2-11
3-1	ADM-3A Standard Keyboard.....	3-2
3-2	Chart of Absolute Cursor Positioning Codes.....	3-4

LIST OF TABLES

TABLE		PAGE
1-1	ADM-3A Specifications.....	1-5
2-1	Configuration Control Switch Functions.....	2-4
2-2	Data Interface Connector Pin/Signal List.....	2-9
3-1	ADM-3A Control Codes.....	3-5

PREFACE

This Operator's Manual describes the function and operation of the ADM-3A Data Display Terminal. The instructions and information are presented to aid operational personnel in the installation, operation, and care of the ADM-3A. All operator controls are described in detail, and remote programming considerations are presented in sufficient detail to enable an experienced operator to use the equipment efficiently when confronted with non-standard applications.

The major topics described in the manual include:

- Section 1 General Description
- Section 2 Installation
- Section 3 Operation

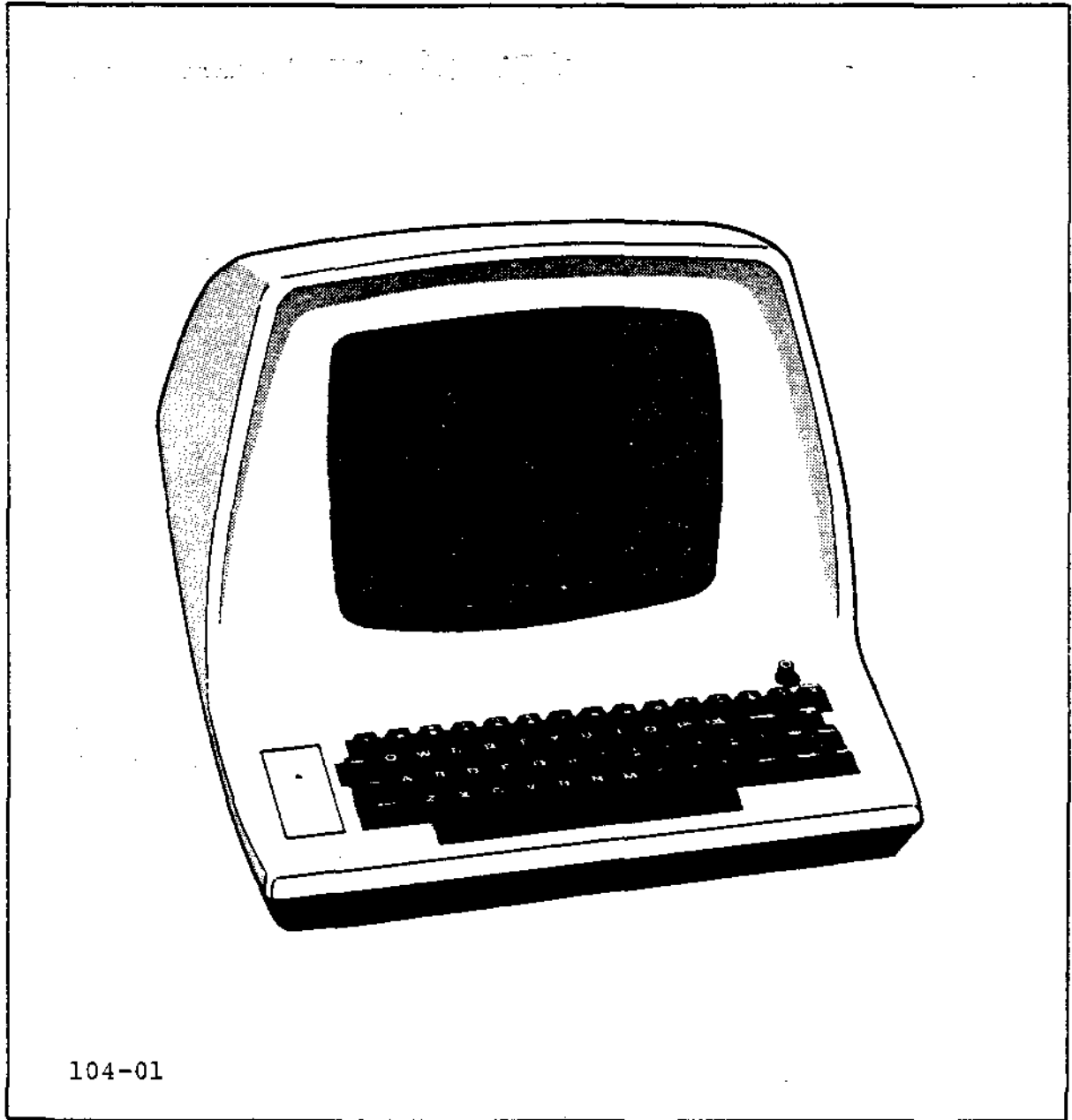

Figure 1-1. ADM-3A Interactive Display Terminal

SECTION 1

GENERAL DESCRIPTION

1.1 INTRODUCTION

This section contains a description of the primary functions of the Lear Siegler ADM-3A Interactive Display Terminal (see figure 1-1), along with physical dimensions, specifications, ranges, and operating features.

1.2 PURPOSE AND USE

There are numerous applications of the ADM-3A, all involving the transfer of asynchronous data. Data transfer in some applications, may be exclusively unidirectional; either from the ADM-3A to the computer, or from the computer. A more frequent application of the ADM-3A, however, is one in which an operator communicates with a computer, and the computer responds in accordance with its stored program.

The ADM-3A has the following general capabilities:

- Full 128 ASCII character set with 80 x 12 (optional 80 x 24) character non glare display
- 11 communication rates in full duplex and half duplex send/receive modes
- Selectable downline scrolling or bottom line entry
- Local and remote absolute cursor positioning
- Variable 10- or 11-bit word structures
- Selectable AUTO New Line operation
- Selectable standard RS-232C or 20mA current loop interface, with RS-232C extended interface for auxiliary devices

1.3 OPERATIONAL DESCRIPTION

The ADM-3A is an interactive device which is used to enter, display, and send information to a host computer, and to receive and display information from the computer. Using a keyboard similar to that of a teletypewriter an operator may enter information which is immediately transmitted to the computer (and may be simultaneously displayed on a CRT). Data from the computer is received and displayed at a rate as great as 1920 characters per second. Figure 1-2 illustrates the functional areas of the ADM-3A and the overall flow of data through them.

1.3.1 Keyboard

Data to be processed by the terminal originates either at the keyboard or with the host computer. Keyboard entry is made using one of the 59 keys on the keyboard. Each key-stroke is encoded into a parallel ASCII character which is immediately transmitted to the host computer. The character is also echoed back to the CRT display: directly, via the I/O Channel, in Half Duplex operation; via the host computer and the I/O Channel, in Full Duplex operation.

1.3.2 Input/Output (I/O) Channel

The I/O Channel is the link, or interface, which handles the flow of data in both directions between the ADM-3A and the computer. In Half Duplex operation, the I/O Channel also routes each character entered and transmitted back to the Control Logic and Display Memory for CRT display. The I/O Channel includes the baud rate selection logic and the RS-232C extension circuitry.

1.3.3 ADM-3A Control Logic

The ADM-3A Control Logic interprets all the control codes which originate either at the keyboard or host computer, and directs the activities of the ADM-3A accordingly. These activities include: basic timing; data, handling and formatting; video and status control; and I/O interfacing control.

1.3.4 Display Memory

The Display Memory contains the random access memory (RAM), video logic, and character generation circuits appropriate for controlling the CRT display. The memory is capable of holding 960 (optionally 1920) characters, which are stored in sequentially scanned locations. The scanned data is sent to the CRT for display. Input to the Display Memory consists of the data character codes from the I/O Channel, under the control of Control Logic signals.

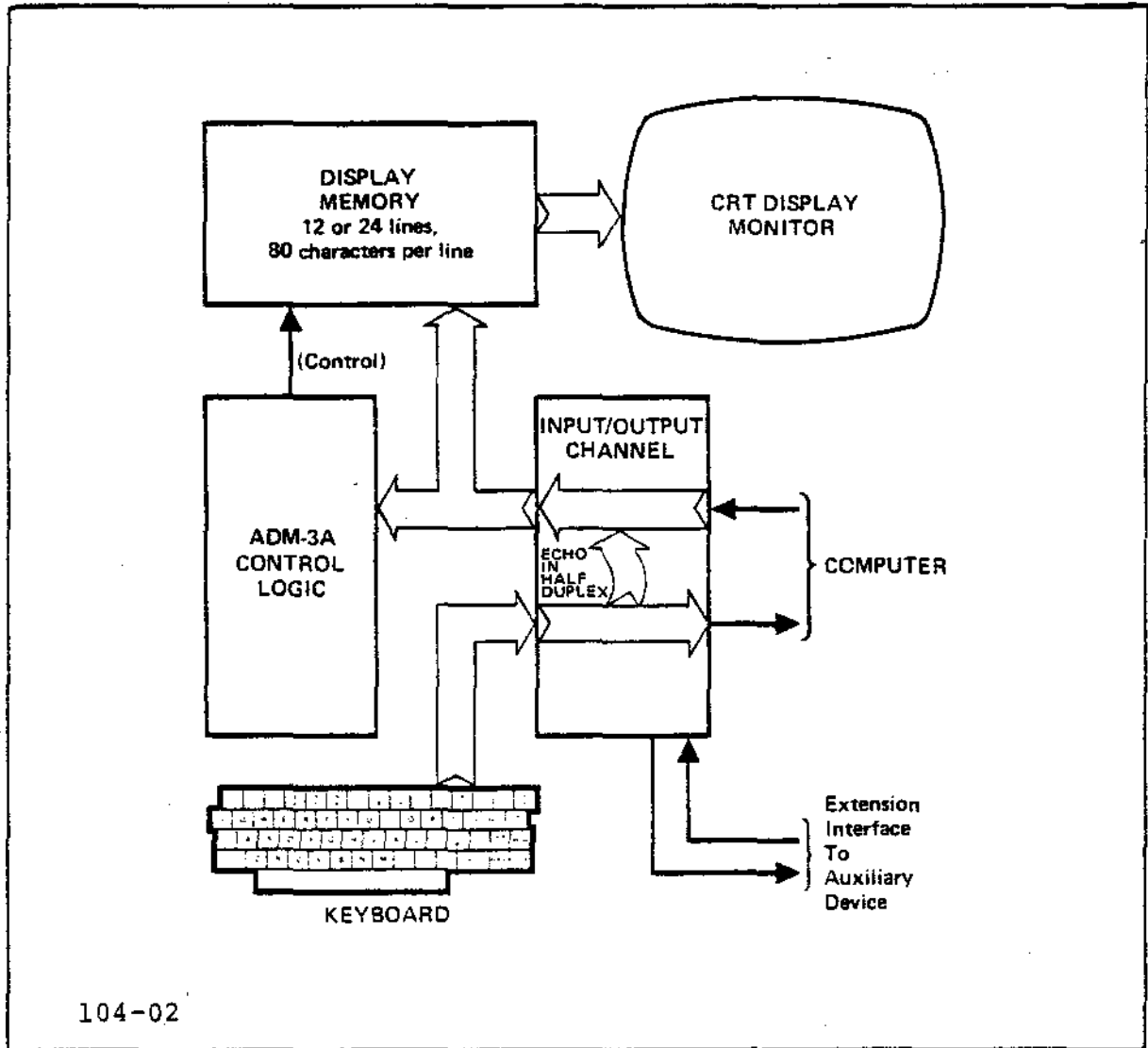

Figure 1-2. ADM-3A Data Flow Block Diagram

1.3.5 CRT Display Monitor

The CRT Display Monitor consists of a 12-inch (diagonal) screen containing 12 lines (optionally 24) of 80 characters each. The 80-character lines are displayed in large, clear letters, numbers and symbols at a refresh rate determined by the line frequency.

1.4 PHYSICAL DESCRIPTION

The ADM-3A is a complete self-contained unit consisting of three principal assemblies: base and cover assembly, main printed circuit board assembly (PCBA), and CRT monitor. The base portion of the base and cover assembly contains the power switch, power transformer, beeper speaker, and intercomponent cabling. Supports and guide pins are provided in the base for installing the main PCBA.

The cover part of the base and cover assembly contains the CRT monitor and other monitor subassemblies. The cover is hinged at the rear so that it can be swung open to expose all the components of the ADM-3A.

The main PCBA contains all the operating elements of the ADM-3A not contained in the CRT monitor and the base assembly, including the keyboard. The keyboard consists of integrated key rows and is built directly on the main PCBA. The PCBA rests on supports within the base and is held in place by guide pins. Two connectors at the rear edge of the PCBA provide the RS-232C/ current loop interface and the RS-232C extended interface.

The CRT monitor is a fully transistorized unit featuring three-subassembly construction: the CRT itself, a printed circuit board assembly containing most video circuitry, and a flyback assembly. The monitor display screen is a 12-inch diagonal CRT similar to that of a black-and-white television receiver.

1.5 SPECIFICATIONS

Table 1-1 lists the leading specifications for the ADM-3A. In addition, several operational features, such as send/receive modes, character format, word structure, data entry and overflow, and configuration control are discussed in the paragraphs that follow.

1.5.1 Send/Receive Modes

Two switch-selectable send/receive modes are available in the ADM-3A: Half Duplex (HDX switch position), and Full Duplex (FDX switch position).

Table 1-1. ADM-3A Specifications

SPECIFICATION	DESCRIPTION
Input Power:	
Standard	115 volts $\pm 1\%$, 50/60 Hz; Single Phase; 3-wire
Optional	230 volts $\pm 10\%$, 50/60 Hz; Single Phase; 3-wire
Power Dissipation	60 watts, nominal (rated: 0.67A at 120 volts)
Operating Temperature	Between 41 ^o F (5 ^o C) and 122 ^o F (50 ^o C)
Relative Humidity	From 5% to 95% non-condensing
Altitude	Up to 10,000 feet (3048M)
Physical Dimensions	13.5 in. (34.3 cm) High X 15.6 in. (39.6 cm) Wide X 19.0 in. (48.3 cm) Deep
Weight	32 pounds (14.54 Kg)
CRT Screen Size	12 inches (30.5 cm) diagonally
Display Format	80 characters per line x 12 lines (optional 24 lines)
Character Set, Generated	128 ASCII characters (with 32 control characters)
Character Set, Displayed	Standard: 64 ASCII characters Optional: 95 ASCII characters
Character Generation	5 x 7 dot matrix, 0.18 in. (0.46 cm) high x 0.075 in. (0.19 cm) wide
Refresh Rate	50/60 Hertz (depending upon line frequency)
Cursor:	
Format Control ON	Reverse video rectangle (7 x 9 dot matrix) homing to upper left of screen

Table 1-1. ADM-3A Specifications (cont'd)

SPECIFICATION	DESCRIPTION						
Format, Control OFF	Double underline, 5 dots wide, homing to first position of bottom line						
Control	CTRL/H (←); CTRL/J (↓); CTRL/K (↑); CTRL/L (→); CTRL/HOME; CTRL/M (RETURN); absolute positioning						
Keyboard:							
Construction	Solid state logic; similar to teletypewriter layout						
Key Assignment	<table border="0"> <tr> <td>Alphanumeric</td> <td>47</td> </tr> <tr> <td>Special Function</td> <td>7</td> </tr> <tr> <td>Terminal Control</td> <td>5</td> </tr> </table>	Alphanumeric	47	Special Function	7	Terminal Control	5
Alphanumeric	47						
Special Function	7						
Terminal Control	5						
Communications:							
Standard Interface	RS-232-C; 20mA current loop; extended RS-232C						
Optional Interface	Extended RS-232C current loop						
Data Transmission Rates	75, 110, 150, 300, 600, 1200, 1800, 2400, 4800, 9600, 19200 baud						
Transmission Modes	Half Duplex; Full Duplex						
Code for Transmission	Asynchronous ASCII						
10-Bit Word Format	<table border="0"> <tr> <td>(1)</td> <td>7 data bits; odd/even parity; START bit,</td> </tr> <tr> <td>(2)</td> <td>8 data bits; START bit; 1 STOP bit</td> </tr> </table>	(1)	7 data bits; odd/even parity; START bit,	(2)	8 data bits; START bit; 1 STOP bit		
(1)	7 data bits; odd/even parity; START bit,						
(2)	8 data bits; START bit; 1 STOP bit						
11-Bit Word Format	<table border="0"> <tr> <td>(1)</td> <td>7 data bits; START bit; odd/even parity; 2 STOP bits</td> </tr> <tr> <td>(2)</td> <td>8 data bits; START bit; odd/even parity; 1 STOP bit</td> </tr> </table>	(1)	7 data bits; START bit; odd/even parity; 2 STOP bits	(2)	8 data bits; START bit; odd/even parity; 1 STOP bit		
(1)	7 data bits; START bit; odd/even parity; 2 STOP bits						
(2)	8 data bits; START bit; odd/even parity; 1 STOP bit						

Half Duplex. In this mode, the ADM-3A can send and receive information to and from the computer. As each character is entered at the keyboard it is transmitted to the computer and simultaneously echoed back from the I/O Channel for CRT display.

Full Duplex. The ADM-3A can transmit and receive information in both directions simultaneously in full-duplex operation. Characters are transmitted as they are entered at the keyboard, but are displayed only on reception. In order for transmitted characters to be displayed, they must be echoed back from the host computer.

1.5.2 Character Format (See Figure 1-3.)

The standard ADM-3A character set contains 96 ASCII characters, 32 of which are control characters that require special two-key sequences from the keyboard. Control characters are not displayed when they are generated. The displayable 64 characters consist of upper case letters, numerics and punctuation. When a non-displayable lower case character is typed (lower case option not installed), a lower case code is transmitted, but the character displayed is upper case. The lower case option permits the display of 95 ASCII characters, consisting of upper and lower case letters, numerics and punctuation.

1.5.3 Word Structure

The ADM-3A can transmit and receive data characters in any one of the asynchronous character formats shown in figure 1-4. These word format codes are selected by means of toggle switches located beneath the front panel access plate.

1.5.4 Data Entry and Overflow

New data enters on progressive lines, top to bottom (cursor control ON) or on bottom line of the screen (cursor control OFF). Line Feed causes upward scrolling of the entire display page. With top-of-page overflow, if the cursor is at the end of the bottom line.

1.5.5 Configuration Control

Twenty front panel toggle switches and 13 toggle switches located on the main PCBA are provided for the purpose of establishing certain default conditions for the ADM-3A. The 13 PCBA switches are factory set and may be checked and reset at the time of terminal installation. Refer to Section 2. The 20 front panel toggle switches (see figure 1-5), located beneath the nameplate

BITS 4321 ↓	BITS 765 →	CONTROL		GRAPHIC CHARACTER SET					
		0	1	2	3	4	5	6	7
		000	001	010	011	100	101	110	111
0000		NUL	DLE	SP	Ø	@	P	'	p
0001		SOH	DC1	!	1	A	Q	a	q
0010		STX	DC2	"	2	B	R	b	r
0011		ETX	DC3	#	3	C	S	c	s
0100		EOT	DC4	\$	4	D	T	d	t
0101		ENQ	NAK	%	5	E	U	e	u
0110		ACK	SYN	&	6	F	V	f	v
0111		BEEP	ETB	'	7	G	W	g	w
1000		BS	CAN	(8	H	X	h	x
1001		HT	EM)	9	I	Y	i	y
1010		LF	SUB	*	:	J	Z	j	z
1011		VT	ESC	+	:	K	[k	{
1100		FF	FS	.	<	L	\	l	!
1101		CR	GS	-	=	M		m	}
1110		SO	RS	.	>	N	^	n	~
1111		SI	US	/	?	O	-	o	DEL

104-03

Control Codes

(Generated by holding CTRL key while typing the corresponding key shown in columns 4 and 5.)

Displayable in standard ADM-3A

Displayable with ADM-3A Upper/Lower Case Display feature.

Figure 1-3. ADM-3A Graphic Character Set and CTRL Codes

WORD FORMAT	FRONT PANEL SWITCHES					10-OR 11-BIT WORD STRUCTURE										
	PAR	DATA	STOP	PAR- ITY	BIT 8	BITS										
	POSITIONS					0	1	2	3	4	5	6	7	8	9	10
	SW2	SW3	SW4	SW5	SW6											
Eleven-Bit Word with EVEN Parity and 2 STOP Bits	EVEN	7	2	PAR- ITY	X	START	ACTIVE BITS = 1 OR 0							EVN PAR	STOP	STOP
Eleven-Bit Word with ODD Parity and 2 STOP Bits	ODD	7	2	PAR- ITY	X	START	ACTIVE BITS = 1 OR 0							ODD PAR	STOP	STOP
Ten-Bit Word with EVEN Parity and 1 STOP Bit	EVEN	7	1	PAR- ITY	X	START	ACTIVE BITS = 1 OR 0							EVN PAR	STOP	X
Ten-Bit Word with ODD Parity and 1 STOP Bit	ODD	7	1	PAR- ITY	X	START	ACTIVE BITS = 1 OR 0							ODD	STOP	X
Eleven-Bit Word with No Parity and 2 STOP Bits	X	8	2	INH	0	START	ACTIVE BITS = 1 OR 0							AL- WAYS 0	STOP	STOP
Ten-Bit Word with No Parity and 1 STOP Bit	X	8	1	INH	0	START	ACTIVE BITS = 1 OR 0							AL- WAYS 0	STOP	X
Eleven-Bit Word with EVEN Parity and 1 STOP Bit	EVEN	8	1	PAR- ITY	0	START	ACTIVE BITS = 1 OR 0							AL- WAYS 0	EVN PAR	STOP
Eleven-Bit Word with ODD Parity and 1 STOP Bit	ODD	8	1	PAR- ITY	0	START	ACTIVE BITS = 1 OR 0							AL- WAYS 0	ODD PAR	STOP

104-04

Figure 1-4. Word Format Codes with Front Panel
Switch Configurations

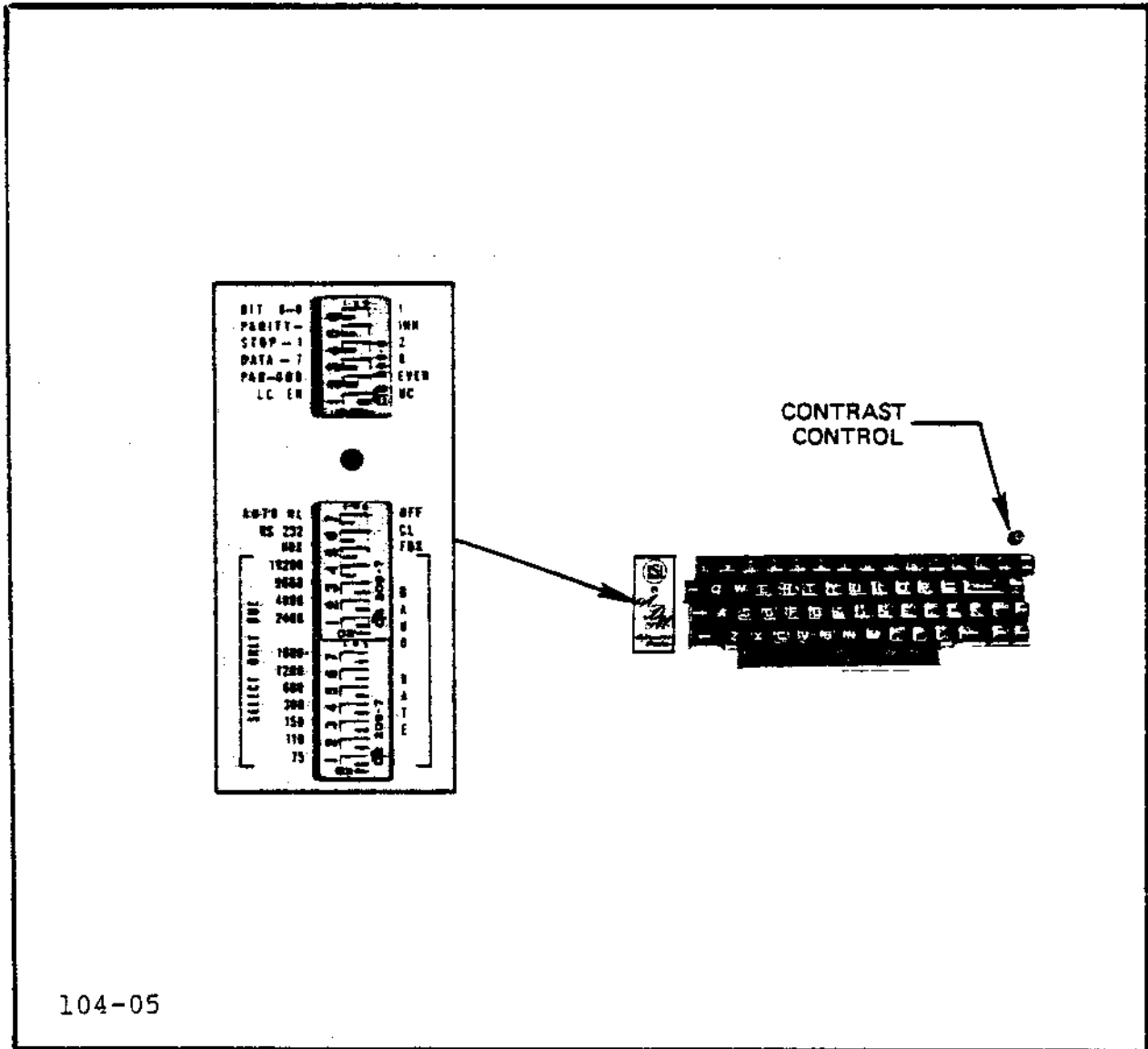

Figure 1-5. Front Panel Switch Locations

1.6 . OPTIONAL FEATURES

The following options are available for use on the ADM-3A:

Option A - 24 Lines

This option provides the capability of displaying 24 lines of 80 characters each. The option must be installed before Options 1 thru 5 can be installed.

Option No. 1 - Lower Case Characters

This option provides the capability of displaying, as well as generating and transmitting, lower case characters.

Option No. 2 - Answer Back

This option is activated by the HERE IS key which, when activated, transmits an identification message (stored in a special ADM-3A memory) to identify the terminal and alert the host computer that a message is to follow. The HERE IS key has no function if the option is not installed.

Option No. 3 - Numeric Key Pad

This option provides 14 keys on a movable pad for operator convenience. The pad contains the following upper and lower case characters which parallel those on the main keyboard: numerics (0 - 9); punctuation (- . ,); and ENTER (equivalent to RETURN).

Option No. 4 - Display Test

This option provides a toggle switch mounted on the main PCBA which may be used to test the CRT display.

Option No. 5 - Extension Port Current Loop

This option extends the RS-232C 20mA current loop capability to the device connected to the ADM-3A through the EXTENSION port interface.

Option No. 6 - Split Baud Rate

This option involves the addition of a 12-position rotary switch adjacent to the present BAUD RATE switches, to permit the ADM-3A to transmit at one baud rate (using current switches) and receive at another baud rate (using new switch).

Option No. 7 - BEEP Defeat

For this option a switch is added to provide the switch-selectable capability of defeating or not defeating the BEEP signal.

Option No. 11 - 230V AC, European

For this option, a 230-volt transformer and appropriate power cord are provided to make the ADM-3A suitable for operation in Europe.

Option No. 12 - 230V AC, Australian

For this option, a 230-volt transformer and appropriate power cord are provided to make the ADM-3A suitable for operation in Australia.

1.7 RELATED DOCUMENT

ADM-3A Maintenance Manual DP305.

SECTION 2
INSTALLATION

2.1 INTRODUCTION

Installation procedures involving unpacking, initial set-up, and operational checkout of the ADM-3A Data Display Terminal are described in this section of the manual. In addition, the several interface modes of installation are described in detail.

2.2 SAFETY REQUIREMENTS

No special safety precautions are required for ADM-3A installation.

2.3 SITE REQUIREMENTS

The ADM-3A Data Display Terminal may conveniently be used in a normal office environment, as no special mounting provisions are required. However, it is recommended that a weather protected environment with an ambient temperature range of 41° F to 122° F (5° C to 50° C), relative humidity not greater than 95% be maintained for equipment use.

Whenever the ADM-3A is physically moved from a cold location to a warmer environment, be sure to allow sufficient time for the equipment temperature to equalize with the warmer location before activating the terminal. Condensation developed by the temperature differential could possibly impair ADM-3A operation.

CAUTION

Allow warm up of unit when changing locations from one room to another, because condensation may develop in the unit, which may effect the operation of the device.

The physical dimensions of the ADM-3A are given in Section 1, along with installation power and environmental parameters. The basic requirements for installation are the following:

- Table or desk for mounting
- Standard three-pronged 115-volt (230 volt) power outlet
- Data signal interface connection to the computer, modem, serial printer, or other auxiliary device. If connection to a remote computer is desired, a modem or data set is required.

2.4 UNPACKING AND INITIAL INSPECTION

Each ADM-3A unit is packed using standard practices for the shipping of electronic equipment. Every precaution is taken to ensure that each unit is complete and ready for installation at the customer site. However, it is recommended that each unit be inspected upon receipt for transit damage. Inspect for exterior evidence of damage. Contact the carrier and LSI immediately if damage is evident, specifying the nature and extent of the damage (if known).

If there is no apparent shipping damage, open the shipping carton and remove the items, checking them against the shipping list to verify the contents of the carton. Contact LSI immediately in the event of a packing shortage. Check to verify that the serial number of the unit corresponds to that shown on the invoice. Visually inspect the exterior of the enclosure for evidence of physical damage which may have occurred in shipment.

Check the hardware to determine if any assemblies or screws have been loosened during shipment. Tighten as required. Inspect for dust or foreign material which may impair electrical contact when cable connections are made. Vacuum to remove any loose dirt. Remove the bubble packing from the interior of the terminal.

2.5 INITIAL PREPARATION

2.5.1 Line Voltage Selection

The ADM-3A is shipped connected for either 115-volt or 230 volt operation, as specified in the purchase order. Any change in line voltage requires circuit changes in the ADM-3A which can be accomplished only by authorized LSI maintenance personnel.

2.5.2 Configuration Control Switch Settings

Thirteen toggle switches located on the main PCBA are provided for establishing the default state of selected system operating characteristics. These switches are set at the factory in accordance with customer requirements, as expressed on the Terminal Ordering Form. Any changes in switch settings should be made before attempting to operate the terminal. Figure 2-1 shows the location and identity of the 13 switches. Table 2-1 describes the function and factory setting of each switch.

WARNING

Dangerous voltages exist within the ADM-3A. Always disconnect the ac power cord before opening the ADM-3A case to access any internal component.

The main PCBA toggle switches can be reached by opening the ADM-3A cover, as follows:

1. Disconnect the ac power cord from the source receptacle.
2. Remove the two slot-head screws located under the front corners of the base and lift the cover upwards and rearwards until it rests on the table or desk.

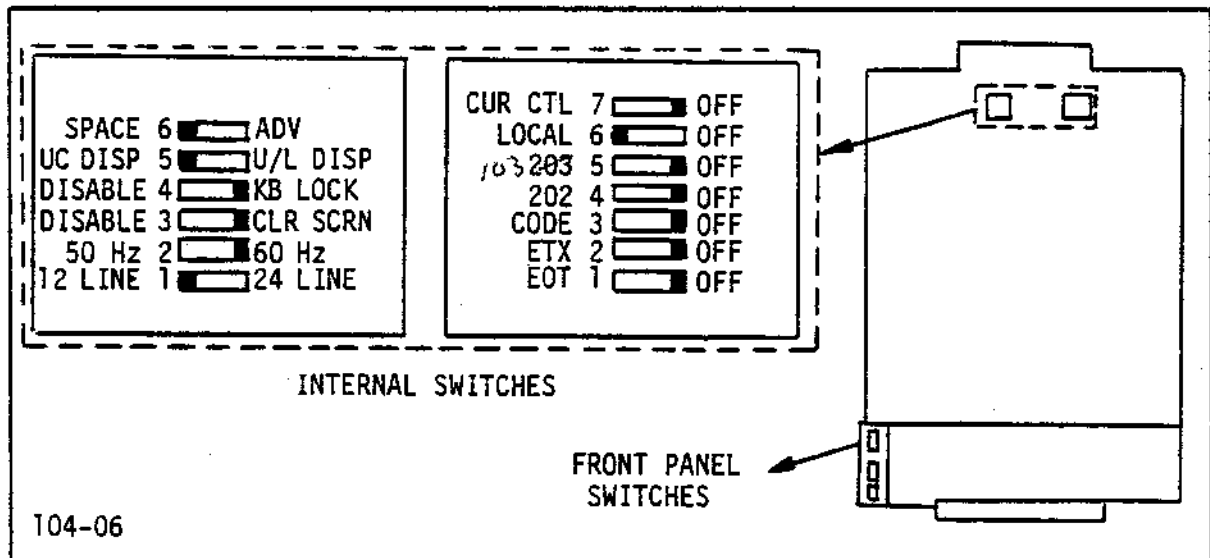

Figure 2-1. ADM-3A Configuration Control Switch Locations

Table 2-1. Configuration Control Switch Functions

SWITCH		FACTORY SETTING	FUNCTION
NO.	NAME		
1	12 LINE - 24 LINE	12 LINE*	If 24-line option is installed, switch may be used to select 12 or 24-line display.
2	50 Hz - 60 Hz	60 Hz*	Selects 50 Hz or 60 Hz refresh rate to correspond with power line frequency.
3	DISABLE - CLR SCRN	CLR SCRN	DISABLE: prevents clearing of screen except by executing successive LINE FEEDS. CLR SCRN: permits CTRL/Z control code to clear screen.
4	DISABLE - KB LOCK	KB LOCK	DISABLE: prevents locking of keyboard. KB LOCK: permits keyboard to be locked (disabled) by remote control codes.
5	UC DISP - U/L DISP	UC DISP*	UC DISP: allows display of upper case characters only. Lower case codes are transmitted but not displayed. U/L DISP: used only if lower case option is installed. Allows display of upper and lower case characters.
6	SPACE - ADV	ADV	SPACE: selects destructive cursor; that is, space code always overwrites the display memory location under cursor and advances cursor. ADV: selects non-destructive cursor between RETURN and subsequent LINE FEED. Cursor may be advanced but space code does not overwrite display memory location; however, cursor is destructive between LINE FEED and next RETURN.

*For standard operation; setting may differ if appropriate option is installed.

Tabel 2-1. Configuration Control Switch Functions (cont'd)

SWITCH		FACTORY SETTING	FUNCTION
NO.	NAME		
1 2	EOT - OFF ETX - OFF	See Function	Switches active only in conjunction with 202-type modem operation to select the primary channel turnaround code. 202 switch must be ON; then: <ul style="list-style-type: none"> • If CODE selected - one switch ON, the other OFF. • If SEC CHAN selected - both switches must be OFF (also if 202 is OFF).
3	CODE - SEC CHAN	See Function	Active only when 202 is ON; used to select method of line turnaround for half-duplex operation as follows: <p>CODE: enables line turnaround using primary channel. Turnaround code may be either ETX or EOT.</p> <p>SEC CHAN: enables line turnaround using secondary channel; ETX and EOT must be OFF.</p>
4 5 6	202 - OFF 103 - OFF LOCAL - OFF	See Function	Only one switch may be active at any time. Used to select one of the following methods of communicating with host computer. <p>LOCAL: enables direct computer connection without modems. Request to Send (CA) line rises and falls with each character transmitted.</p> <p>103: enables connection to 103-type modem. CA line is held high.</p> <p>202: enables connection to 202-type modem. Secondary channel or line turnaround code changes direction of data in primary channel.</p>

Table 2-1. Configuration Control Switch Functions (cont'd)

SWITCH		FACTORY SETTING*	FUNCTION
No.	NAME		
7	CUR CTL - OFF	OFF	ALL OFF: CA line is held low (transmission inhibited). CUR CTL: selects moveable re- verse block cursor which acces- ses any screen position. OFF: selects standard double underlined cursor; data entered from bottom of screen.

2.6 INTERFACE INFORMATION

The ADM-3A may be cabled directly to a local computer, or it may be connected via telephone data lines to a remote computer located anywhere in the world. Remote computer connections require the use of a modem or data set. Figure 2-2 shows several typical ADM-3A interfaces, while figure 2-3 shows the ADM-3A interface logic associated with the interfaces.

2.6.1 RS-232C MODEM Port Interface

The MODEM port interface is used to connect the terminal directly to a computer, modem or data set, or to a computer or device in a current-loop application. Table 2-2 lists the connector pin vs. signal functions for this interface.

2.6.2 RS-232C EXTENSION Port Interface

The EXTENSION port interface enhances the standard RS-232C capabilities of the ADM-3A to permit daisy chaining of several terminals or other auxiliary devices. Table 2-2 provides interface data associated with this port.

2.7 INSTALLING THE ADM-3A

CAUTION

Be sure the bubble packing has been removed from the interior of the unit. Damage to the equipment may result if packing is not removed.

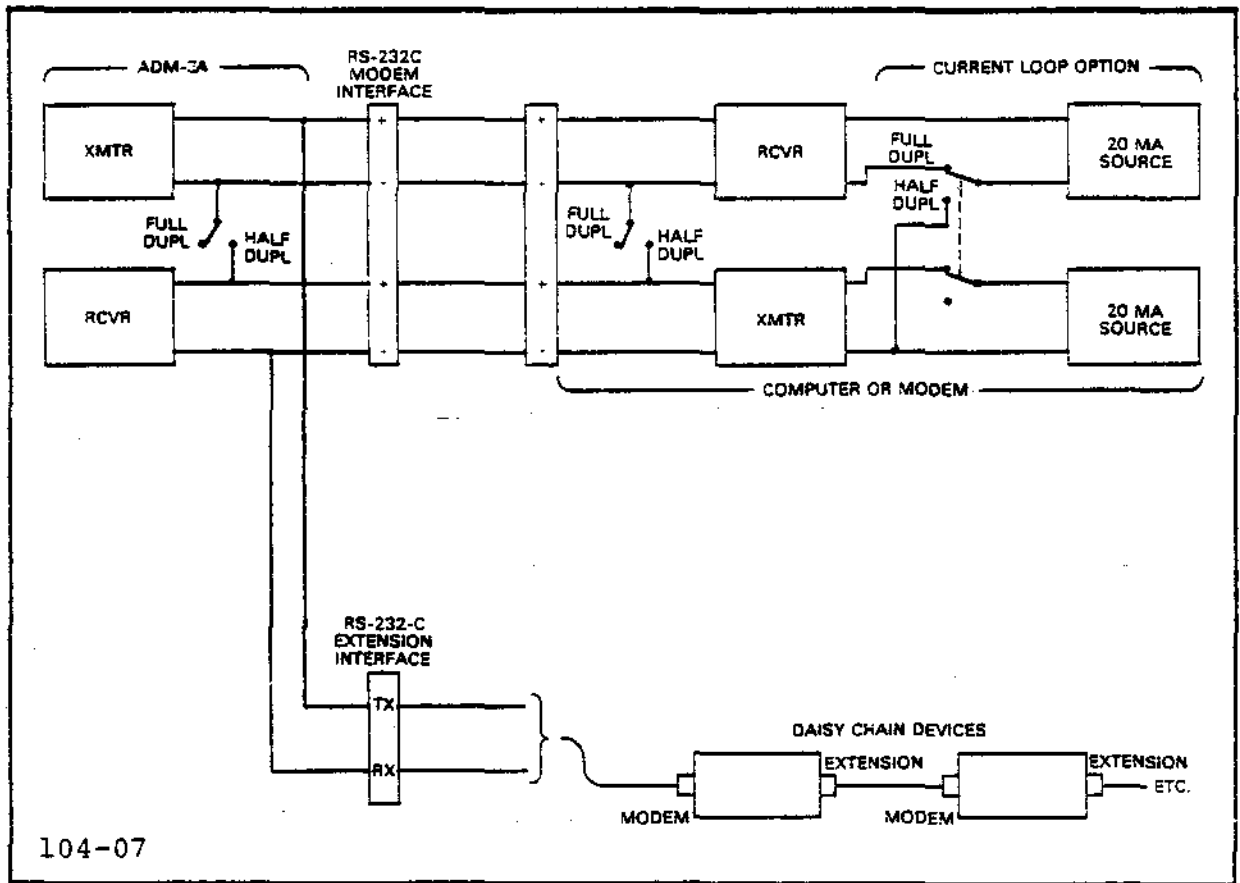

Figure 2-2. Typical ADM-3A Interfaces

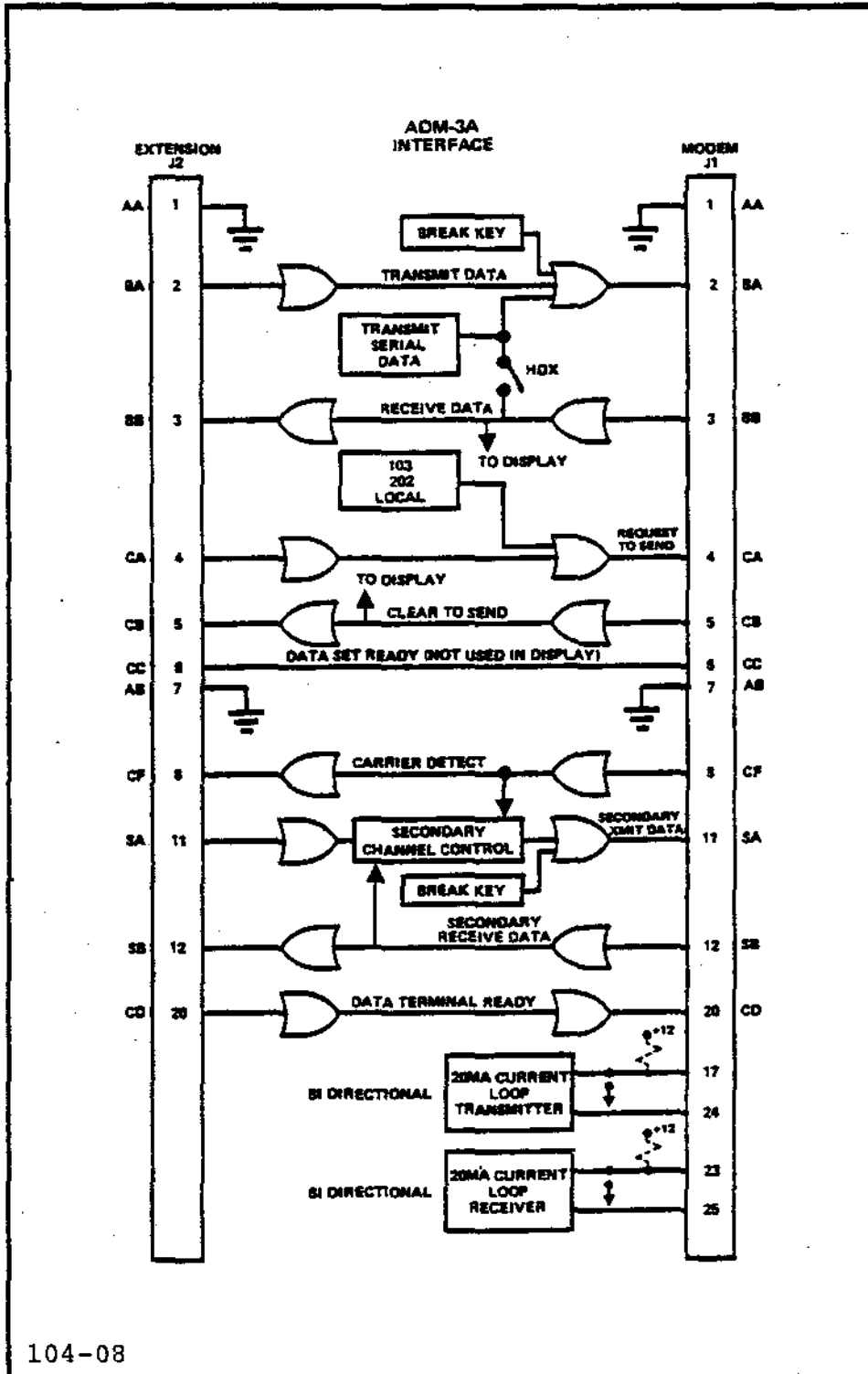

Figure 2-3. ADM-3A Interface Logic

Table 2.2. Data Interface Connector Pin/Signal List

CONNECTOR	PIN NO.	SIGNAL FUNCTION	TTY CODE
MODEM J1	1	Equipment Ground (GND)	AA
	2	Transmit Data (XMIT)	BA
	3	Receive Data (RCVR)	BB
	4	Request to Send (RTS)	CA
	5	Clear to Send (CTS)	CB
	6	Data Set Ready (DSR)	CC
	7	Signal Ground (GND)	AB
	8	Carrier Detect (DCD)	CF
	11	Secondary Transmit Data	SA
	12	Secondary Carrier Detect (SCF)	SCF
	17,24	Current Loop Transmitter (Bipolar)	
20	Data Terminal Ready (DTR)	CD	
23,25	Current Loop Receiver (Bipolar)		
EXTENSION J2	1	Equipment Ground (GND)	AA
	2	Transmit Data (XMIT)	BA
	3	Receive Data (RCVR)	BB
	4	Request to Send (RTS)	CA
	5	Clear to Send (CTS)	CB
	6	Data Set Ready (DSR)	CC
	7	Signal Ground (GND)	AB
	8	Carrier Detect (DCD)	CF
	11	Secondary Transmit Data	SA
12	Secondary Receive Data	SB	
20	Data Terminal Ready (DTR)	CD	

To install the ADM-3A, proceed as follows:

1. Check the ON/OFF switch to ensure it is in the OFF position.
2. Connect the data interface cable(s) from the computer, modem and auxiliary device, as required, to the terminal using the appropriate information from table 2-2.
3. Set the configuration control switches to the positions desired to control the terminal characters summarized in table 2-1.
4. Set the appropriate BAUD RATE switch to the desired baud rate.
5. Plug the terminal into a grounded AC outlet of the proper voltage.
6. Proceed to turn on the terminal.

2.8 TURN-ON and TURN-OFF PROCEDURES

2.8.1 Turn-On Procedures

Proceed as follows:

1. Set the ON/OFF switch (figure 2-4) to the ON position.
2. Wait approximately 20 seconds for the unit to warm up.
 - If the CUR CTL-OFF switch is set to CUR CTL (table 2-1), a reverse block cursor should appear in the upper left corner of the screen.
 - If the CUR CTL-OFF switch is set to OFF (table 2-1), a double underline cursor should appear in the bottom left corner of the screen.
 - If the cursor does not appear, momentarily press CTRL/HOME keys. If this fails to produce the cursor, adjust the CONTRAST control on the front panel until the background is barely visible. The cursor should be present.

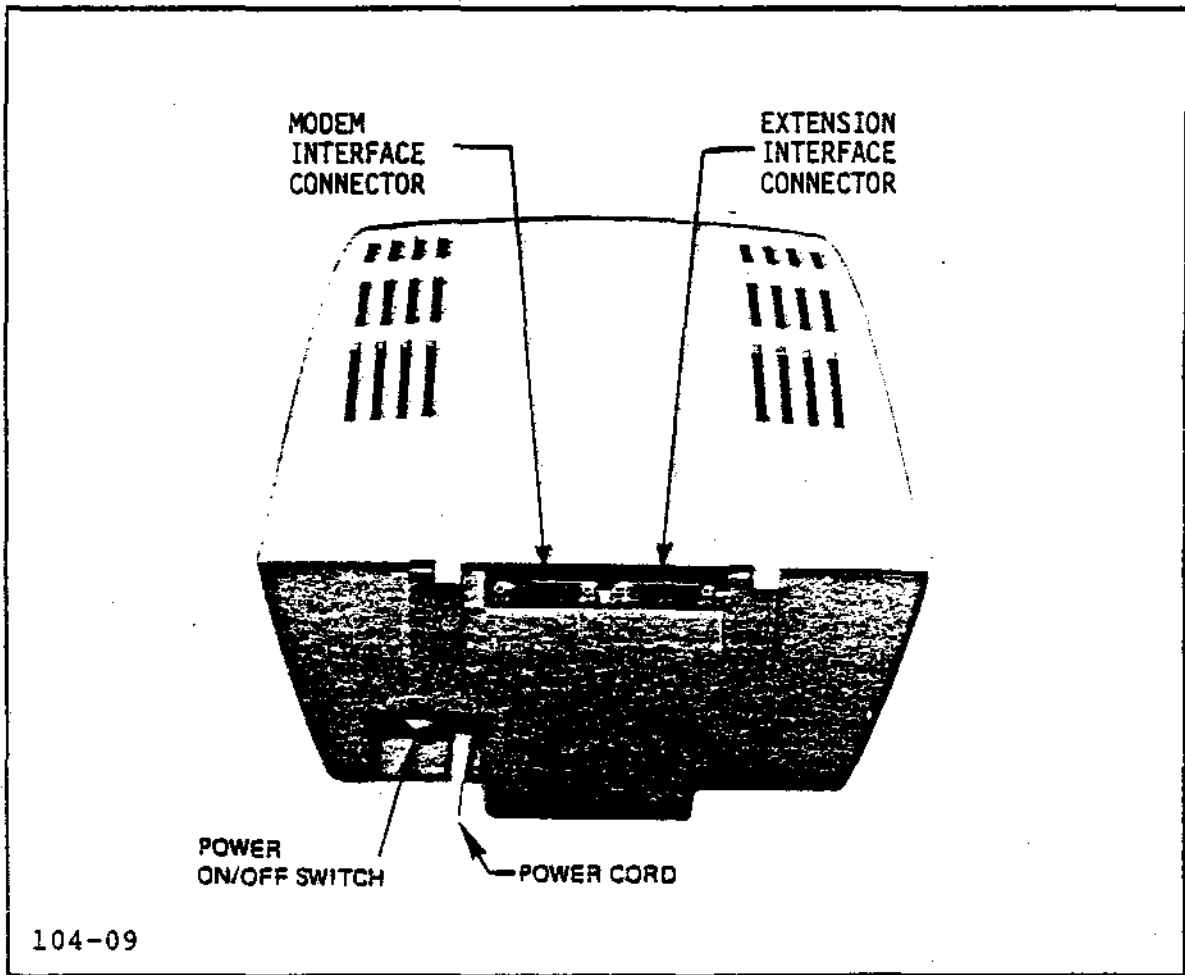

Figure 2-4. ADM-3A Rear Panel Controls

Note

If the Full-Duplex mode is selected, typing at the keyboard will not display characters unless echo-back from the host computer or modem is provided. If Half-Duplex mode is selected, data will be displayed only if CLEAR TO SEND is present or interface cable is disconnected.

2.9 CARE OF THE ADM-3A TERMINAL DISPLAY

This portion of the manual provides the required operator instructions pertaining to routine maintenance for the ADM-3A Data Terminal Display. Preventive maintenance procedures are limited primarily to cleaning and inspection steps.

2.9.1 Cleaning

At periodic intervals, clean the exterior housing and lightly dust the unit using a soft brush or damp lint-free cloth. However, paper towels may be substituted if desired. Remove smudges from the CRT exterior screen and the housing with conventional spray cleaners or alcohol. Do not use petroleum base cleaners, such as lighter fluid, as this could be harmful to the painted surface. Be careful not to scratch the CRT screen, and do not use freon cleaners.

2.9.2 Inspection

Periodically, inspect switches and keyboard assembly for freedom of movement. Determine that the intensity of character trace on the CRT screen has not diminished. Any required mechanical and electrical adjustment shall only be performed by an authorized Lear Siegler Service representative.

SECTION 3

OPERATING INSTRUCTIONS

3.1 INTRODUCTION

The purpose of this section is to describe how to use the ADM-3A Interactive Display Terminal. The terminal is used to enter, display, and send information to a remote computer or modem, printer, terminal or other auxiliary device, and to receive and display information from the computer or modem.

3.2 KEYBOARD OPERATIONS

The operator uses a keyboard that resembles the keyboard of a conventional typewriter to enter data. Information typed by the operator may be displayed on a cathode ray tube (CRT) immediately, as during full duplex operation, or as an echo from the remote computer, as during full-duplex operation. Figure 3-1 shows a layout of a standard ADM-3A terminal. Functionally, the keyboard consists of displayable character keys and special function keys. In addition, using some special function keys in conjunction with certain displayable character keys causes the character keys to command specific control operations, which are discussed under Programming Considerations.

3.2.1 Displayable Character Keys

In the standard ADM-3A, 64 characters (upper case alphabet, numbers, punctuation, and most symbols) are displayed. When a non-displayable lower case character is typed (LC EN - UC switch set to UC0), the proper lower case code is transmitted but the character is displayed as upper case.

If the terminal is equipped with the lower case option (LC EN - UC switch set to LC EN), 95 characters will be displayed (upper and lower case alphabet, numbers, punctuation and all symbols).

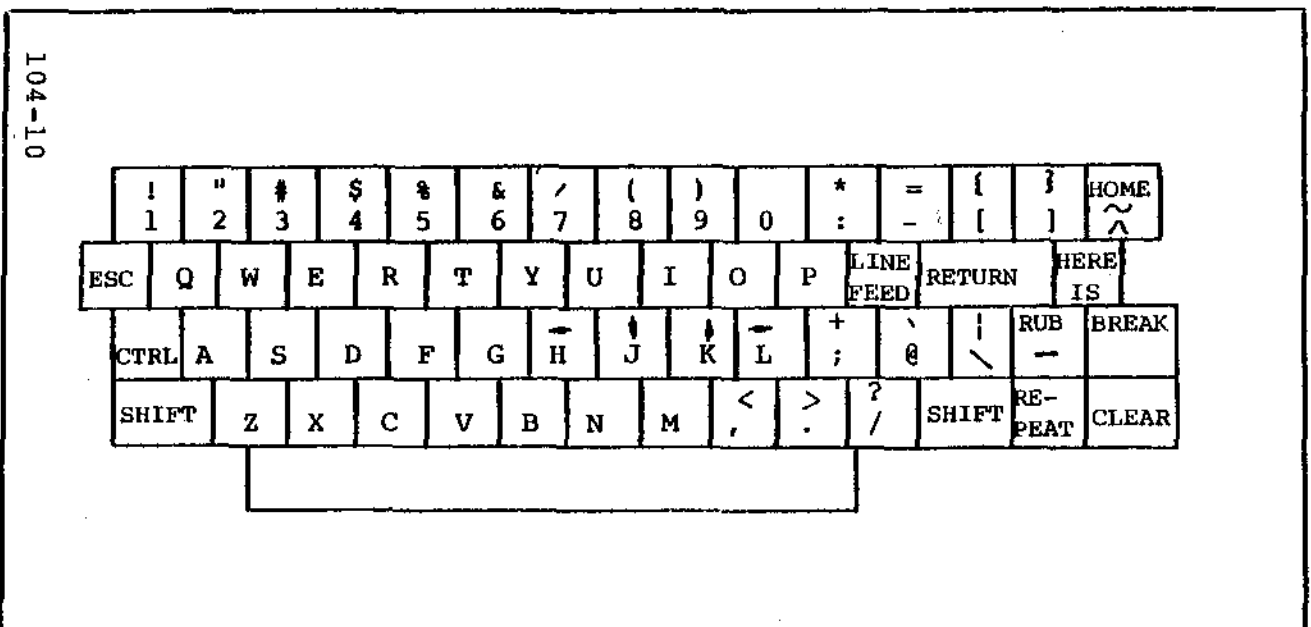

Figure 3-1. ADM-3A Standard Keyboard

Note

Typing at the keyboard always generates codes which are transmitted; however, in order for characters to be displayed and for control codes to affect the ADM-3A display, the characters must be echoed back from either the ADM-3A I/O Channel (in HDX mode) or the host computer (in FSX mode). All display actions described below assume that the generated codes are properly echoed.

3.2.2 Special Function Keys

In addition to the displayable character keys, the ADM-3A keyboard contains a number of other keys which are used for various terminal and system control operations, as follows:

1. ESC. The ESC key is used in conjunction with other character keys to produce a load-cursor operation, when in the Cursor Control Mode (CUR CTL-OFF switch set to CUR CTL). The load-cursor operation is used to position the cursor to a specific (absolute) screen position and to identify that position for the host computer. This operation may also be initiated by the host computer using the same escape sequences (refer to Programming Considerations).

Four characters are required to complete the operation. The first two characters are always ESC =; they enable the load-cursor operation. The next two characters establish the Y-X (column-row) coordinates of the desired screen position. Figure 3-2 is a chart showing the ASCII characters (and their HEX codes) which must be typed to establish the desired column (Y) and row (X) screen location for the cursor.

2. CTRL. The CTRL Key does not produce an ASCII character. When held down while typing another key, CTRL modifies the ASCII code generated by the typed key, producing a non-displayable control code. The ADM-3A can produce 32 ASCII control codes. As shown in table 3-1, only 14 control codes are applicable to ADM-3A operation. These codes may also be initiated by the host computer (refer to Programming Considerations).

X or Y	ASCII CODE	HEX CODE	X or Y	ASCII CODE	HEX CODE	X or Y	ASCII CODE	HEX CODE
1	SPACE	20	28	,	3B	55	V	56
2	!	21	29	<	3C	56	W	57
3	"	22	30	=	3D	57	X	58
4	#	23	31	>	3E	58	Y	59
5	\$	24	32	?	3F	59	Z	5A
6	%	25	33	@	40	60	[5B
7	&	26	34	A	41	61	\	5C
8	'	27	35	B	42	62]	5D
9	(28	36	C	43	63	>	5E
10)	29	37	D	44	64	^	5F
11	*	2A	38	E	45	65	_	60
12	+	2B	39	F	46	66	a	61
13	,	2C	40	G	47	67	b	62
14	-	2D	41	H	48	68	c	63
15	.	2E	42	I	49	69	d	64
16	/	2F	43	J	4A	70	e	65
17	0	30	44	K	4B	71	f	66
18	1	31	45	L	4C	72	g	67
19	2	32	46	M	4D	73	h	68
20	3	33	47	N	4E	74	i	69
21	4	34	48	O	4F	75	j	6A
22	5	35	49	P	50	76	k	6B
23	6	36	50	Q	51	77	l	6C
24	7	37	51	R	52	78	m	6D
25	8	38	52	S	53	79	n	6E
26	9	39	53	T	54	80	o	6F
27	:	3A	54	U	55			

104-11

Figure 3-2. Chart of Absolute Cursor Positioning Codes

Table 3-1. ADM-3A Control Codes

CODE	ASCII MNEMONIC	FUNCTION ADM-3A
CTRL/@	NUL	
CTRL/A	SOH	
CTRL/B	STX	
CTRL/C	ETX	Available as secondary channel line turnaround code for 202 modem operation
CTRL/D	EOT	Available as secondary channel line turnaround code for 202 modem operation
*CTRL/E	ENQ	Initiates ID message in terminals with automatic "Answer Back" option
CTRL/F	ACK	
CTRL/G	BEL	Sounds audible beep in ADM-3A
CTRL/H	BS	Backspace
CTRL/I	HT	
CTRL/J	LF	Line Feed
CTRL/K	VT	Upline
CTRL/L	FF	Forward Space
CTRL/M	CR	Return
*CTRL/N	SO	Unlock Keyboard
*CTRL/O	SI	Lock Keyboard
CTRL/P	DLE	
CTRL/Q	DC1	
CTRL/R	DC2	
CTRL/S	DC3	
CTRL/T	DC4	
CTRL/U	NAK	
CTRL/V	SYN	
CTRL/W	ETB	
CTRL/X	CAN	
CTRL/Y	EM	
CTRL/Z	SUB	Clear Screen
CTRL/[ESC	Initiate Load Cursor
CTRL/^	FS	
CTRL/]	GS	
CTRL/_	RS	Home Cursor

*Executable only from computer.

When CTRL is used in conjunction with another character key and the REPEAT key, the resulting control operation will be repeated at the same rate as for the character typed.

3. SHIFT. Either of two identical SHIFT keys may be held down while typing another key to produce an upper case alphabet character or the character shown in the upper portion of the typed key.

Note

Setting the LC EN - UC switch, located under the front panel nameplate, to UC causes upper case alphabet characters to be produced without operating the SHIFT key. The SHIFT key remains operational for all non-alphabet keys.

4. Space Bar (SP). The Space Bar is considered a displayable character key. When typed, SP causes the ASCII space code to be transmitted and stored in display memory; a space appears on the screen. (For the only exceptions, refer to RETURN key.)
5. Backspace (←). Backspace is executed by typing the H key while holding down the CTRL key. CTRL/H causes the cursor to move non-destructively one character position to the left, and "BS" to be transmitted to the host computer.
6. Downline (↓). Downline is executed by typing the J key while holding down the CTRL key. CTRL/J duplicates the action of the LINE FEED key.
7. Upline (↑). Upline is executed by typing the K key while holding down the CTRL key, with the ADM-3A in Cursor Control Mode. CTRL/K causes the cursor to move non-destructively to the same character position in the line immediately above the current line, and "VT" to be transmitted to the host computer. When the top line is reached, no further action takes place.
8. Forespace (→). Forespace is executed by typing the L key while holding down the CTRL key, with the ADM-3A in the Cursor Control Mode. CTRL/L causes the cursor to advance non-destructively to the next character position on the current line, or from the 80th position on the current line to the first character position on the next line, unless the current line is the bottom line of the display. In that circumstance, the display scrolls

upward one line, and the cursor moves to the first character position in the new line. "FF" is transmitted to the computer as the L key is typed.

9. LINE FEED. When the CUR CTL - OFF switch is set to CUR CTL, the code generated by LINE FEED causes the cursor to move non-destructively to the same character position in the line immediately below the current line, and "LF" is transmitted to the computer. When LINE FEED is executed with the cursor on the bottom line, the entire display scrolls upward one line and the cursor remains stationary.

When the CUR CTL - OFF switch is set to OFF, all data entry is on the bottom line, LINE FEED causes the entire display to scroll upward one line, leaving the cursor positioned on the new bottom line.

10. RETURN. Typing this key causes the cursor to move to the first character position of the present line, and "CR" is transmitted to the computer. If the SPACE-ADV switch is set at ADV, space codes (SP) entered after typing RETURN are non-destructive until a LINE FEED code is generated. Thus, after a RETURN, the operator or computer can space over data on the line without overwriting each character with a space, until LINE FEED is executed.
11. RUB. When the RUB (rubout) key is typed while holding down the SHIFT key, a non-displayable rubout code (ASCII DEL) is transmitted to the computer. The cursor is not advanced and the character code stored in display memory is not overwritten. RUB is normally used to tell the computer that a previous character should be deleted.
12. REPEAT. When REPEAT is held down while holding a character key, the character (or control function) is repeated at the rate of 12.5 per second. (If the terminal is operating at a baud rate that will not permit 12.5 cps transmission, the repeat rate is reduced to the transmission rate.)
13. HOME. Typing HOME while holding down the CTRL key causes the cursor to "home" and the "RS" code to be transmitted to the computer. In the Cursor Control Mode (CUR CTL - OFF switch set to CUR CTL), "home" is the first character position in the top line of the display. If not in Cursor Control Mode (CUR CTL - OFF switch at OFF), "home" is the first character position in the bottom line.

14. HERE IS. If the Answer Back option is installed, typing this key transmits an identification message (stored in a special ADM-3A memory) that identifies the terminal and alerts the host computer that a message is to follow. If no Answer Back option is installed, the key has no function.
15. BREAK. This key activates the standard teletypewriter BREAK function, normally used to interrupt an incoming message.

Note

The BREAK function is sustained as long as the BREAK key is held. Holding the key for an extended period of time may cause the computer to disconnect the terminal.

16. CLEAR. Typing the CLEAR key while holding down the SHIFT key clears the entire screen to spaces. (This function may be disabled by setting the DISABLE - CLR SCRN switch to DISABLE.)

3.3 INTERFACE CONTROL OPERATIONS

Communication between the ADM-3A and the host computer or modem is accomplished using two transmission channels: a primary channel offering high-speed data communication, and a secondary channel for low-speed control signals. Transmission may be in one direction at a time, as in Half-Duplex operation; or in both directions simultaneously, as in Full-Duplex operation.

All data communications take place over the primary channel. The secondary channel, when used, is only for control of the direction of data over the primary channel. The ADM-3A may receive data at any time over the RCVE line (BB). Data transmission is controlled by Request to Send (RTS) over line CA, Clear to Send (CTS) over line CB, and Carrier Detect (DCD) over line CF.

Request to Send (RTS) is set (high) to inform the host that the ADM-3A wishes to transmit; when RTS is reset (low) no transmission can take place. RTS may be controlled in one of five ways, as follows:

1. RTS may originate at an EXTENSION port.
2. RTS remains low (XMIT disable) if LOCAL-OFF, 103-OFF, and 202-OFF switches are all set to OFF (open).

3. LOCAL-OFF switch set to LOCAL: RTS rises to transmit each character, and falls when character has been transmitted.
4. 103-OFF switch set to 103(ON): RTS remains high all the time.
5. 202-OFF switch set to 202(ON): RTS is controlled through the ADM-3A interface in either code turnaround or reverse-channel turnaround operation. Transmission may be in only one direction at a time (Half-Duplex).

3.3.1 Code Turnaround Operation

Code turnaround operation is enabled by setting 202-OFF switch to 202(ON) and CODE - SEC CHAN switch to CODE. Additionally, either ETX-OFF or EOT-OFF switch must be set to ON. RTS over line CA is set (high) when DCD (Carrier Detect) over line CF falls as the result of decoding the ETX (EOT) code from the host, indicating that (character) transmission is complete. Data transmission from the ADM-3A may take place when CTS (Clear to Send) from the host over line CB is set (high).

When ETX (EOT), terminating each character, is again decoded, RTS (and CTS from the host) are reset to the marking state. ADM-3A transmission is inhibited, and the terminal will not recognize any further commands or codes for approximately 250 milliseconds, to allow time for the host to propagate its signals.

3.3.2 Reverse-Channel Turnaround Operation

Reverse-channel turnaround operation is enabled by setting 202-OFF switch to 202(ON) and CODE - SEC CHAN switch to SEC CHAN. Both ETX-OFF and EOT-OFF switches must be set to OFF. In this operation, RTS is controlled by secondary channel signals, instead of turnaround codes on the primary channel.

ADM-3A transmission takes place when the host raises SEC RCVE (Secondary Receive Data) over line SB, and DCD (Carrier Detect) on line CF falls to indicate that the host has completed (character) transmission. RTS (Request to Send) over line CA goes high; the CTS (Clear to Send) over line CB from the host initiates ADM-3A transmission.

When SEC RCVE (Secondary Receive Data) over line SB goes low while DCD over line CF is high, RTS is unconditionally reset, thus inhibiting ADM-3A transmission. SEC XMIT (Secondary Transmit Data) over line SA rises, allowing the host to transmit. Each time RTS transits between high and low, the ADM-3A ignores any further commands or codes for approximately 250 milliseconds, to allow time for the host to propagate signals.

3.4 PROGRAMMING CONSIDERATIONS

3.4.1 Remote CTRL Operation

The host computer has full control over the ADM-3A. All control operations which are possible from the keyboard, plus a few additional operations, can also be executed from the computer by transmitting the appropriate CTRL codes. (Refer to table 3-1.) Displayable characters will be displayed, and valid control codes will be recognized and acted upon, in the same manner as that described for keyboard operations.

3.4.2 Remote Load-Cursor Operation

The computer may command the ADM-3A cursor to an absolute screen position (in Cursor Control Mode), using the same four-character escape sequence (ESC = Y X) required for keyboard operations (paragraph 3.2.2). For the remote operation, the required ASCII codes are initiated by the host computer, instead of the ADM-3A keyboard. The codes are non-displayable.

CAUTION

<p>In cold climates, care should be exercised to allow the temperature of the terminal to equalize with room temperature before removing the unit from the shipping carton; this will prevent moisture from condensing on a cold terminal exposed to warm air.</p>	<p>Avoid operating the unit on a soft surface, such as carpeting, which would obstruct the flow of cooling air up through the bottom of the chassis. This could result in overheating and damage to the unit.</p>
--	---

ADM-3A DISPLAY TERMINAL

"THIS IS THE WAY YOUR TERMINAL IS SET. IF YOU NEED TO MAKE CHANGES, PLEASE REFER TO THE OPERATOR'S HANDBOOK."

KEYBOARD

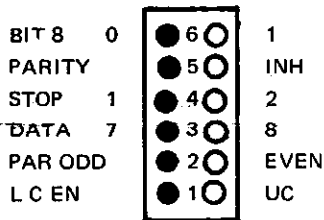

@ A6

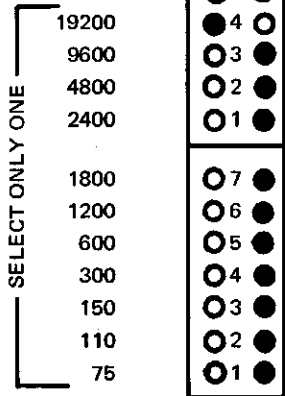
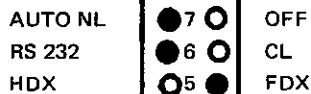
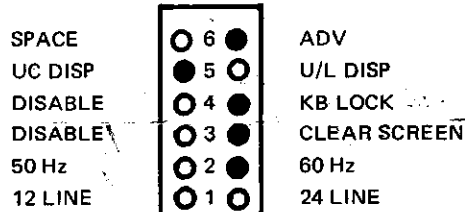

@ A10

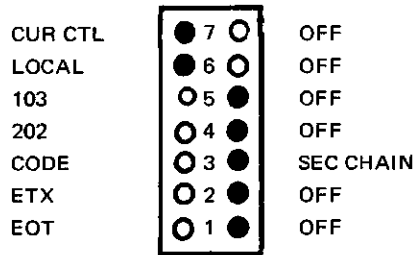

● STANDARD
○ OPTIONAL

Note: To operate in the off-line or Local Mode, the HDX/FDX Switch should be in the HDX position.



LEAR SIEGLER, INC.
DATA PRODUCTS DIVISION

714 NORTH BROOKHURST STREET, ANAHEIM, CALIFORNIA 92803
PHONE: (714) 774-1010 TELEX: 65-5444 TWX 910-591-1157