

# MINI BEE COMPUTER TERMINAL



BEEHIVE MEDICAL ELECTRONICS, INC.  
870 WEST 2600 SOUTH  
SALT LAKE CITY, UTAH 84119

# MINI BEE COMPUTER TERMINAL

## SERVICE MANUAL

MARCH 1974

This Document has been prepared by Beehive Medical Electronics and is furnished on the condition that it will be used by the customer solely for the purpose of supporting the operation, service and maintenance of Beehive Terminals. The rights of the customer with respect to this Document will be governed by mutually acceptable provisions of the contract with Beehive Medical Electronics. This Document shall not be duplicated by the customer, nor be released, disclosed nor used, in whole or in part, for any purpose other than stated herein without the express written permission of said Beehive Medical Electronics.

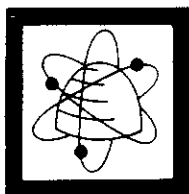

*Beehive Medical  
Electronics, Inc.*

870 West 2600 South  
P.O. Box 19244  
Salt Lake City, Utah  
Phone: (801) 487-0741, TWX 910-925-5271

## TABLE OF CONTENTS

### SECTION I

#### GENERAL INFORMATION

1-1.	Introduction	1-1
1-3.	Identification	1-1
1-5.	Description	1-1
1-8.	Specification	1-1
1-10.	Equipment Supplied	1-1

### SECTION II

#### OPERATION

2-1.	Introduction	2-1
2-3.	Operator Controls and Indicators	2-1
2-5.	Initial Turn On Procedure	2-6
2-7.	Operator Checkout Procedure	2-6
2-9.	Operating Modes	2-6
2-11.	Memory and Display Organization	2-6
2-14.	Receiving and Transmitting Data	2-6
2-17.	Timing Considerations	2-8

### SECTION III

#### INSTALLATION

3-1.	Introduction	3-1
3-3.	Unpacking	3-1
3-5.	Inspection for In-Shipment Damage	3-1
3-7.	Placement for Operation	3-1
3-9.	Data Interface Connection	3-1
3-11.	Special Precautions	3-2
3-12.	Preparation for Use	3-2
3-13.	Rear Panel Switch Selections	3-2
3-15.	Mini Bee Logic Card Strap Selection Location	3-2

**SECTION IV  
THEORY OF OPERATION**

4-1.	Introduction	4-1
4-3.	General Discussion	4-1
4-5.	Basic Power Supply	4-1
4-7.	Basic Monitor	4-1
4-9.	Basic Keyboard	4-1
4-11.	Basic Mini Bee Logic Card	4-1
4-13.	Detailed Discussion	4-1
4-15.	Power Supply	4-1
4-17.	Transformer	4-1
4-19.	Rectifier	4-7
4-21.	+5VDC, +15VDC Regulation Circuits	4-7
4-23.	Monitor	4-7
4-25.	Vertical Synchronization	4-7
4-27.	Horizontal Synchronization	4-7
4-29.	Video Information	4-7
4-31.	Keyboard	4-7
4-33.	Key-Switch Matrix	4-8
4-35.	½ (One Half) Word Encoders	4-8
4-37.	Output Network	4-8
4-39.	Strobe Level Generator	4-8
4-41.	On Line/Local Switch	4-8
4-43.	Indicators	4-8
4-46.	Mini Bee Logic Card	4-8
4-48.	Display Organization	4-8
4-50.	Oscillator	4-8
4-52.	Dot Counter	4-8
4-54.	Character Counter	4-10
4-56.	Scan Counter	4-10
4-58.	Line Counter	4-10
4-60.	Scan 0 Character 0 to 79 (S0C0-79)	4-10
4-62.	Fast/Slow Clock Cleaner	4-10
4-64.	Horizontal and Vertical Drive	4-10
4-67.	Memory Reference Counter	4-10

4-69.	Marker Reference Counter	4-10
4-71.	Cursor Location Counter	4-10
4-73.	UART (Receiver)	4-11
4-74.	Page Memory	4-11
4-76.	Line Memory	4-11
4-78.	Character Generator	4-11
4-80.	Video Shift Register	4-11
4-81	Video Shift Register	4-11
4-82.	Control Decoder	4-11
4-84.	Parity Error	4-12
4-86.	UART (Transmit)	4-12

## **SECTION V MAINTENANCE**

5-1.	Introduction	5-1
5-3.	Preventive Maintenance	5-1
5-8.	Troubleshooting Aids	5-1
5-10.	Troubleshooting Equipment	5-1
5-12	Full Duplex Echoplex Test	5-2
5-14.	Corrective Maintenance	5-2
5-16.	Troubleshooting Preliminary Considerations	5-2
5-18.	How to Use Table 5-1	5-2
5-20.	Power Supply Adjustments	5-26
5-25.	Monitor Adjustments	5-26
5-36.	Keyboard	5-31
5-38.	Mini Bee Logic Card	5-31
5-40	Removal and Replacement Procedures for the Mini Bee Terminal	5-31
5-42.	Removal of the Outer Cover	5-31
5-44.	Removal of the Power Supply	5-31

5-46.	Removal of the Keyboard P.C. Card	5-32
5-48.	Removal of the Monitor	5-32
5-50.	Removal of the Fan	5-32
5-52.	Removal of the Mini Bee Logic Board	5-32

**SECTION VI  
DIAGRAMS**

**SECTION VII  
GLOSSARY OF TERMS**

## FIGURES

1-1.	Identification	1-2
1-2.	Mini Bee Terminal	1-2
2-1.	Keyboard	2-1
2-2.	Rear Control Panel	2-2
2-3.	ASCII Code Chart	2-5
2-4.	Input/Output Word Structure	2-7
3-1.	Mini Bee Logic Card Strap Selections	3-4
4-1.	Basic Block Diagram	4-2
4-2.	Basic Functional Flow Diagram	4-3/4-4
4-3.	Detailed Block Diagram	4-5/4-6
4-4.	Character Dot Matrix	4-9
5-1.	Echoplex Connector	5-3
5-2.	Elexon Power Supply Adjustments	5-27
5-3.	Powerbee Power Supply PC board	5-28
5-4.	Monitor P.C. Card Adjustments	5-29
5-5.	Monitor Yolk Adjustment	5-30

## TABLES

1-1.	Mini Bee Specifications	1-3
2-1.	Keyboard Controls and Indicators	2-2
2-2.	Rear Panels Controls	2-4
3-1.	Connector J2 Pin Assignments	3-2
3-2.	Filler Codes	3-3
5-1.	Troubleshooting Flow Diagram Index	5-4

# SECTION I

## GENERAL INFORMATION

### 1-1. INTRODUCTION

1-2. This manual is furnished to provide detailed instructions concerning the MINI BEE Computer Terminal. It contains illustrations and information pertaining to the unit itself, as well as interfacing requirements for the unit when operating in conjunction with other equipment. This section contains a general description, discussion and basic information regarding the purpose, function specifications, and performance characteristics of the MINI BEE Terminal.

### 1-3. IDENTIFICATION

1-4. Identification of the computer terminal can be made by reviewing the identification plate located on the bottom area of the terminal. (Refer to Figure 1-1.). This plate provides model number, serial number, weight, voltage, current, frequency and power classification. To receive best service and warranty coverage, do not remove this identification plate.

### 1-5. DESCRIPTION

1-6. The MINI BEE Computer Terminal is a self-contained, operator/computer-accessible, remote display terminal with a detachable keyboard designed for use in serially transmitting information to, and receiving information from, an interconnected data source (See Figure 1-2.). The terminal will

operate to exchange data at any of several pre-selected transmission rates to a maximum of 9600 baud.

1-7. The MINI BEE employs a 12-inch (measured diagonally) rectangular television-type monitor which is formatted to display 12 lines with 80 characters on each line, or 25 lines with 80 characters on each line. The terminal has a total page memory of 960/2000 characters. Each character is generated from 5 x 7 dot matrix with two dot spacing between adjoining characters.

### 1-8. SPECIFICATION

1-9. MINI BEE Computer Terminal specifications are contained in Table 1-1.

### 1-10. EQUIPMENT SUPPLIED

1-11. The following items are supplied with the MINI BEE Computer Terminal:

- a. Display terminal
- b. Detachable keyboard with cable
- c. Power cord
- d. MINI BEE Operators Manual



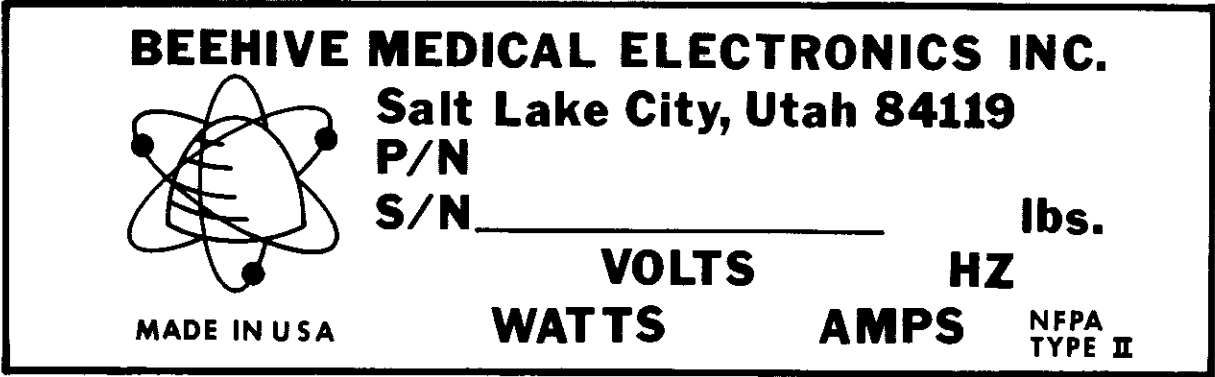

Figure 1-1. Identification Plate

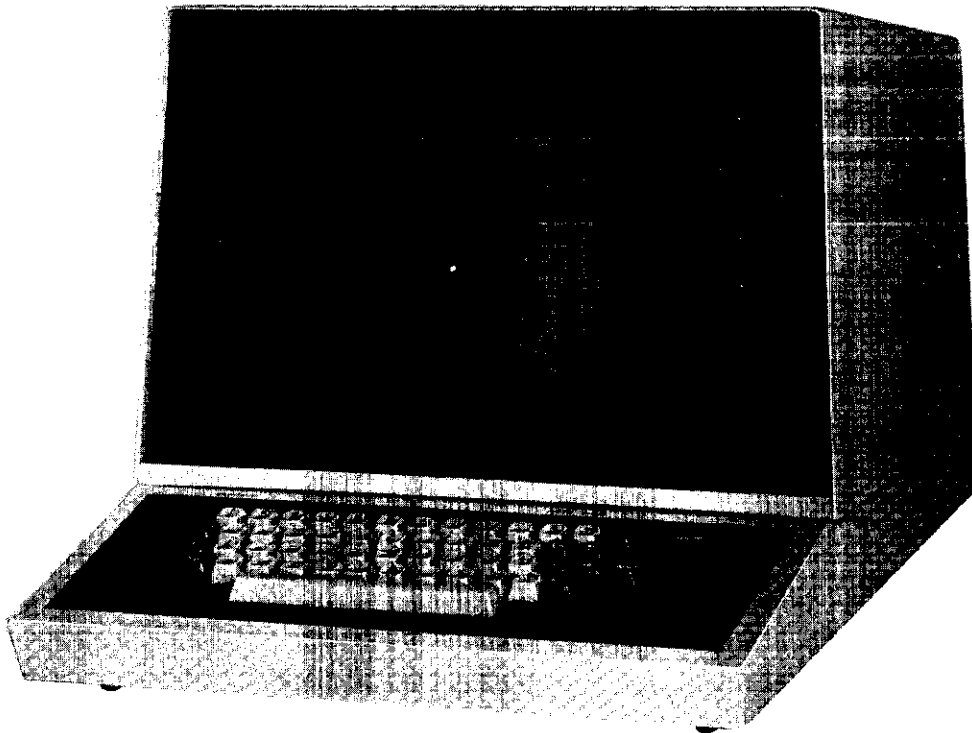

Figure 1-2 Mini Bee Terminal

**Table 1-1. MINI BEE Specifications**

**PHYSICAL SPECIFICATIONS**

**Dimensions:**

Width	16.55 inches (419.1 mm)
Height	13.88 inches (372.43 mm)
Depth w/keyboard	21.38 inches (542.9 mm)
Depth less keyboard	15.00 inches (381 mm)
Depth of keyboard only	9.75 inches (247.65 mm)

**Weight:**

Monitor	45 lbs (20.43 kg) approx.
Keyboard	8 lbs (3.6 kg) approx.

**POWER REQUIREMENTS**

Input Voltage Options:	115 V/230 V $\pm$ 10% 60 Hz 115 V/230 V $\pm$ 10% 50 Hz (optional)
Power Consumption:	100 watts (max.)

**ENVIRONMENTAL SPECIFICATIONS**

Altitude:	Sea Level to 10,000 ft. (operational)
Temperature:	
Non-operating temperature	-20°C to +60°C (-4°F to +140°F)
Operating temperature	+5°C to +40°C (50°F to +104°F)
BTU:	30 BTU/hr.
Humidity:	5% to 90% non-condensing
Vibration:	
Shock in shipping container	Drop tested from 18 inches
Vibration	10 Hz to 55 Hz; .01 inch peak-to-peak

**GENERAL SPECIFICATIONS**

Display Size:	
Standard	12" (304.8 mm) rectangular
Active Display Size:	
Standard	6½" x 7½" (165.1 mm x 190 mm) Approx.
Display Format:	
Standard	25 lines of 80 characters
Optional	12 lines of 80 characters

**Table 1-1. MINI BEE Specifications (continued)**

Character Type: Standard	5 x 7 dot matrix (7 x 10 scan) Approximately .08 x .18 inch
Character Set:	64 upper case ASCII set
Cursor Type:	Non-destructive blinking double underscore
Erase Functions:	Clear memory Erase line Erase to end of screen
Operation Modes:	ON-LINE OFF-LINE
Transmission Modes:	HDX/FDX 10/11 bit asynchronous
Strapping Option:	External I/O clock (Times eight clock) Parity odd/even Parity check on/off 10/11 bit word
Communications Interface:	Per EIA Standard RS232C
Signal Characteristics:	
Transmit	
Mark	-10 volts nominal
Space	+12 volts nominal
Receive	
Mark	-3 to -25 volts
Space	+3 to +25 volts
Transmission Rates:	
X 110 switch setting	110, 220, 440, 880, 1760, 3520, and 7040 baud
X 150 switch setting	150, 300, 600, 1200, 2400, 4800 and 9600 baud
Transmission Code:	
Start bit	1 bit
Data bits	7 bits USASCII
Parity bit	1 bit
Stop bit	1/2 bits
Baud Selection:	Switch selectable

**Table 1-1. MINI BEE Specifications (continued)**

Refresh Rate:	60 Hz
Display Memory:	MOS shift registers
Character Generation:	MOS ROM

## SECTION II OPERATION

### 2-1. INTRODUCTION

2-2. This section provides basic operating instructions for the MINI BEE Computer Terminal. To operate this terminal efficiently, the operator should be familiar with the instructions contained in this section and the computer program with which he will converse. The MINI BEE terminal should be properly installed in accordance with the procedures outlined in Section III of this manual.

### 2-3. OPERATOR CONTROLS AND INDICATORS

2-4. The keyboard is illustrated in Figure 2-1. Rear panel controls are shown in Figure 2-2. Table 2-1 describes the functions of the keyboard controls and indicators and Table 2-2 describes the functions of the rear panel controls. Operation of any key on the keyboard causes either character codes, control codes, or function codes to be generated. The keycaps are engraved as alphanumeric keys, control keys, and escape keys. All escape sequence keys are indicated by the red legend on the key. The sequence of operation is to depress the escape key followed by the desired legend key to perform the desired escape sequence (Refer to Table 2-1.).

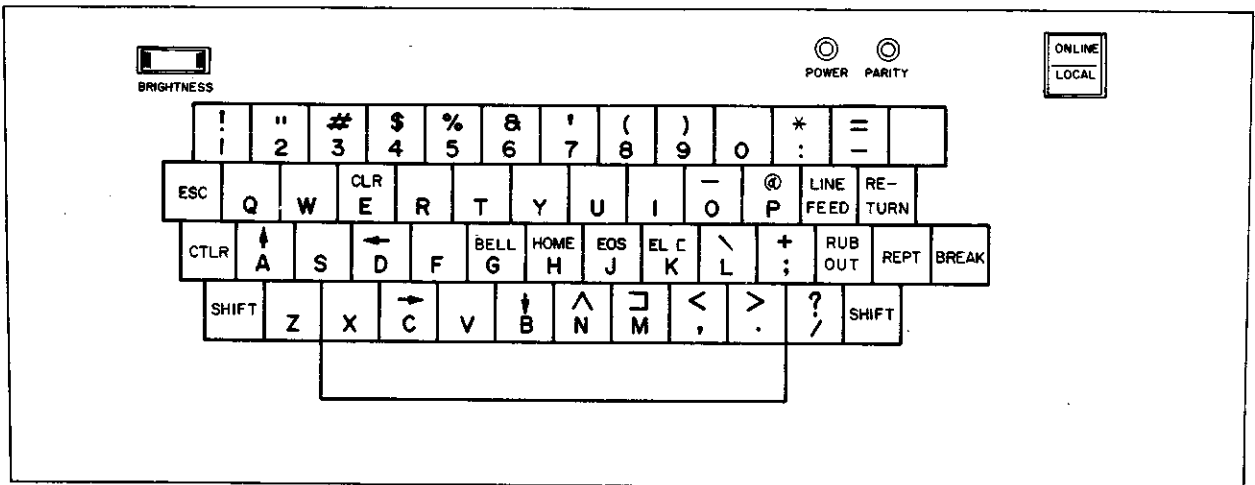

Figure 2-1. Keyboard

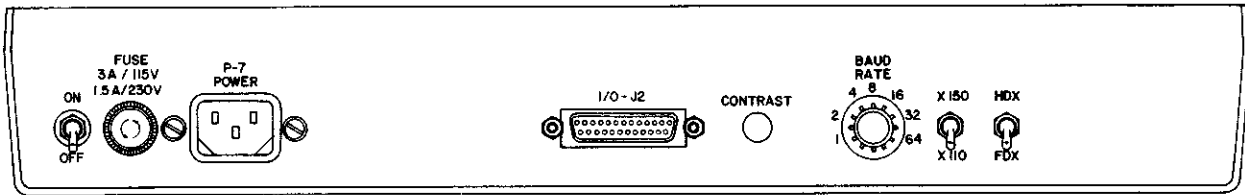

Figure 2-2. Rear Control Panel

Table 2-1. MINI BEE Computer Terminal Keyboard, Controls and Indicators

FUNCTION	DESCRIPTION
Alphabetical and numerical keys, SHIFT, and space bar.	Generate character codes corresponding to letter, number, or symbol engraved on key. The keyboard layout is similar to a standard Model 33 TTY.
ESC (Escape) key	Generates the initial code in an escape code sequence.
↑ (Cursor Up) Escape/A	Repositions the cursor up one line in same column as previously located. If the cursor is on the first line, it will wrap around to the bottom line.
↓ (Cursor Down) Escape/B	Repositions the cursor down one line in same column as previously located. If the cursor is on the last line, it will wrap around to the top line.
→ (Cursor Right) Escape/C	Repositions the cursor one character location to the right. If the cursor is located in the last character position of a line, it will reposition to the first character position of the next line. If the cursor is located in the last character location of the display, it will reposition to its home position.

Table 2-1 (continued)

FUNCTION	DESCRIPTION
← (Cursor Left) Escape/D	Repositions the cursor one character location to the left. If the cursor is located in the first character position of a line, it will reposition to the last character position of the preceding line. If the cursor is located in the home position, it will reposition to the last display character location.
CLR (Clear) Escape/E	Fills all memory locations with space codes and cursor moves to the home position.
HOME Escape/H	Repositions the cursor to first character location of the memory. Contents of the memory are not altered.
EOS (Erase to End of Screen) Escape/J	Fills all memory locations on the line where the cursor is located to the end of the screen, with space codes.
EL (Erase Line) Escape/K	Fills all memory locations of the line where the cursor is located with space codes.
CTRL (Control) key	When used in conjunction with any alpha key, the code structure of the alpha key is changed by forcing the seventh bit to "0". This allows operation of the control codes assigned to Column One and Two of the ASCII Code Chart shown in Figure 2-3.
Bell Control/G	Causes the audio alarm to sound.
Back Space Control/H	Repositions the cursor one character position to the left. If the cursor is located in the first character position of a line, it will reposition to the last character position of the preceding line. If the cursor is located in the home position, it will reposition to the last display character location.
LINE FEED Control/J	Repositions the cursor one line down in the same column. If the cursor is located on the bottom line, the cursor will remain stationary and the entire display will scroll up one line leaving the bottom line blank. The top line is lost.
RETURN Control/M	Repositions the cursor to first character location of the current line.
BRIGHTNESS control	Adjusts the brightness level of the video display. Reference 2-6b.
ON LINE/LOCAL	Selects either ON LINE or LOCAL operating mode. Refer to para 2-10.

Table 2-1 (continued)

FUNCTION	DESCRIPTION
POWER indicator	Lit when power is applied to unit.  Lit by a parity error and reset to off by depressing any key on the keyboard, with the exception of the break key.
Parity Error indicator	

Table 2-2. MINI BEE Computer-Terminal Rear Panel, Controls

CONTROL OR CONNECTOR	DEFINITION
HDX/FDX switch	Selects half-duplex (HDX) or full-duplex (FDX) operation. During FDX operation, data characters generated by the keyboard are routed to the I/O but not stored in memory or displayed. During HDX operation, the data characters are stored in memory, displayed, and routed to the I/O.
X150/X110 switch	Multiplies baud rate selected by BAUD RATE switch by either 150 or 110.
BAUD RATE switch	Selects basic baud rate to be multiplied by 110 or 150.
CONTRAST control	Adjusts the contrast level of the video display
I/O J2 connector	Provides data source interface with the terminal.
P7 POWER connector	Provides AC power input to the terminal.
FUSE	Protects terminal from power overloads.
ON/OFF switch	Applies AC power to the terminal.



BIT 4321	CONTROL CHARACTERS		DISPLAYABLE CHARACTER						ESCAPE SEQUENCE					
	000	001	010	011	100	101	110	111	010	011	100	101	110	111
0000	NUL ☐	DLE P ☐	SP	0	@	P								
0001	SOH A ☐	DC1 ENTER ☐	!	1	A	Q				↑ A				
0010	STX B ☐	DC2 ☐	"	2	B	R				↓ B				
0011	ETX C ☐	DC3 ☐	#	3	C	S				→ C				
0100	EOT D ☐	DC4 ☐	\$	4	D	T				← D				
0101	ENQ E ☐	NAK ☐	%	5	E	U				CLR E				
0110	ACK OFF LINE ☐	SYN ☐	&	6	F	V								
0111	BEL G ☐	ETB (XMIT) ☐	/	7	G	W								
1000	BS H ☐	CAN X ☐	(	8	H	X				HOME H				
1001	HT I ☐	EM Y ☐	)	9	I	Y								
1010	LF J ☐	SUB Z ☐	*	:	J	Z				EOS J				
1011	VT K ☐	ESC ☐	+	:	K	[				EL K				
1100	FF L ☐	FS ☐	.	<	L	\								
1101	CR M ☐	GS ☐	-	=	M	]								
1110	SO N ☐	RS ☐	.	>	N	^								
1111	SI O ☐	US NEW LINE ☐	/	?	O	-								

- Note: 1. Lower case code will display upper case characters on Mini Bee.  
2. Mini Bee will initiate all control codes, But act on only those specified in Table 2-1

Figure 2-3. ASCII Code Chart

## **2-5. INITIAL TURN ON PROCEDURE**

2-6. The proper turn-on procedure for the terminal is as follows:

a. Set the rear panel ON/OFF power switch to ON. Ensure that the power on light illuminates and allow a warm-up period of approximately five minutes.

b. Turn BRIGHTNESS control (located on keyboard) clockwise until a raster is faintly visible on the screen. Turn contrast adjustment (located through access hole, rear panel) until a blinking cursor appears in the home position. Write several different characters on the screen and turn the brightness control counter-clockwise until the raster scan lines disappear from the screen. Then adjust the contrast adjustment until the displayed characters are sharp and provide the operator with maximum eye comfort and then clear the screen. The contrast adjustment should be performed by technical personnel.

## **2-7. OPERATOR CHECKOUT PROCEDURE**

2-8. To test the functional capabilities of the terminal, actuate the keys and ensure that the observed display agrees with the functions listed in Table 2-1 in the local mode.

## **2-9. OPERATING MODES**

2-10. The MINI BEE terminal operates in one of two modes, Local and On-Line. During LOCAL operation, characters entered from the keyboard are stored in the terminal memory and displayed, but are not communicated to the I/O port. Characters received at the I/O port are ignored. During ON-LINE operation, characters entered from the keyboard are transmitted from the I/O port as they are entered. If operated in half duplex (HDX), the characters are stored in the memory and displayed as they are transmitted. When operated in full duplex (FDX), the characters are transmitted to the I/O port only, and are stored in the memory and displayed if a remotely connected data source echoes each transmitted code. This technique provides the operator with a character-by-character check to ensure that the terminal transmission was correctly received by the data source.

## **2-11. MEMORY AND DISPLAY ORGANIZATION**

2-12. The memory has 960/2000 displayable character locations and is a line oriented organization where characters are stored in the memory on a line basis. The line always has 80 characters. The lines in the memory are organized on a page basis where 12/25 lines make up one page. The memory location where characters are stored is marked by the cursor. Character codes already entered can be replaced by a space or any other code. A memory overwrite condition occurs when any attempt is made to write beyond the end of the display.

2-13. The display is organized on a page basis where the page contains 12/25 lines with 80 character positions in each line. Any of the 64 ASCII codes can be displayed on the monitor in a line-page organization. If the line in the memory has less than 80 characters, the displayed line has spaces written to the eightieth character.

## **2-14. RECEIVING AND TRANSMITTING DATA**

2-15. Two conditions are required for the MINI BEE to receive and react to incoming data. The terminal must be ON LINE and, if a modem or other device is interfaced which utilizes the RS232 circuit, CF (Received Line Signal Detector) must be in an "ON" condition. A parity error light is provided to indicate an error for the received data if the terminal is strapped for parity check. A check will be made according to the even/odd parity strap. The parity error light is reset when a key on the keyboard is depressed with the exception of the break key.

2-16. When the terminal in On Line and a key is depressed on the keyboard, the I/O will place circuit CA (Request-to-Send) in an "ON" condition. If a modem or other device interfaced to MINI BEE utilizes circuit CB (Clear-to-Send), transmission of the keyed character will be ineffective until this line is in an "ON" condition. If Clear-to-Send is not used the data will be transmitted immediately. The parity bit position will be transmitted according to the even/odd parity strap. The MINI BEE terminal affords serial asynchronous transmission and reception of data. Asynchronous word structure consists of a start bit, seven data bits, a parity bit and one or two stop bits depending on the configuration of the stop bit option strap (See Figure 2-4.).

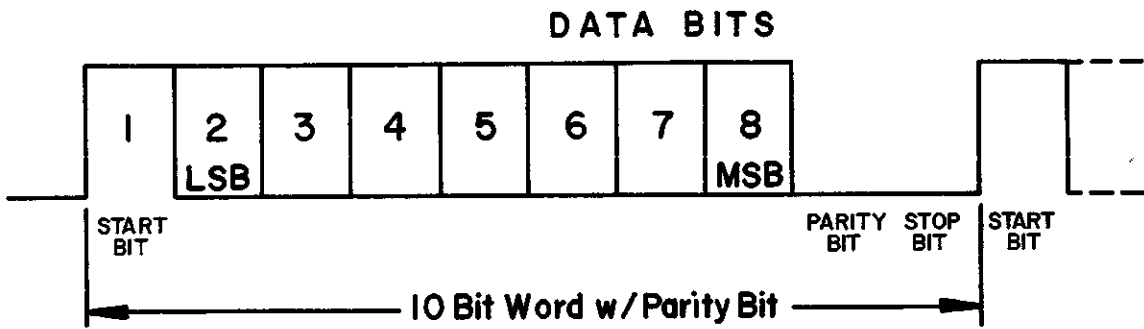
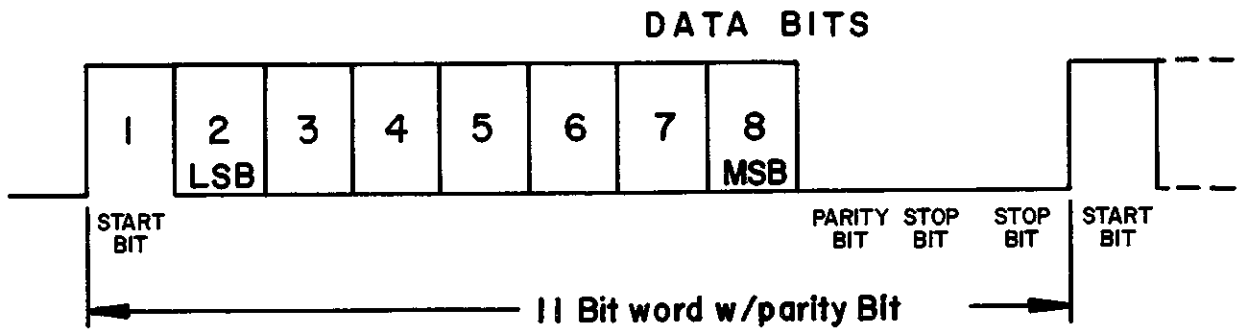

Figure 2-4. Input/Output Word Structure

## SECTION III INSTALLATION

### 3-1. INTRODUCTION

3-2. This section contains information for unpacking, initial inspection, connection of the communications interface, physical placement of the terminal, and preliminary selection of functional control settings for the specific requirements of a given user.

### 3-3. UNPACKING

3-4. The MINI BEE is ready for operation after removal from its shipping container. There are no tiedowns or packing materials inside the unit which need to be removed. Store the carton for future use during relocation or reshipment.

### 3-5. INSPECTION FOR IN-SHIPMENT DAMAGE

3-6. BMEI's MINI BEE is carefully inspected and tested prior to shipment from the factory. Upon receipt, carefully remove all components from the shipping container and check each item against the packing slip to ensure completeness of your order. Visually inspect all items for any possible shipping damage. All shipping containers have been custom engineered to protect their contents and special care has been taken to prevent damage under normal shipping conditions. Damage to the contents should not occur unless the package has been mishandled. Mishandling should be evident upon inspection of the shipping container and, if damage is found after visual inspection, care should be taken not to destroy the evidence. Take pictures of the damaged container and contact the transport carrier as soon as possible.

### 3-7. PLACEMENT FOR OPERATION

**CAUTION:** The terminal relies on air flow for cooling through its perforated bottom panel and slots in the rear of the terminal case. Therefore it is important that the terminal never be placed in a position where free air circulation is restricted. To maintain efficient air circulation, maintain at least two inches of clearance at the rear and on the sides of the terminal. Avoid placing the terminal on plush carpet or on soft or spongy material where the bottom plate might come in contact with the mounting surface and shut off or restrict air circulation.

3-8. The MINI BEE is fully self-contained and can be moved and relocated to alternate operating positions without removing or altering any hard wiring. Select a convenient level surface and place the terminal where the power cable and data I/O cables will not be in the way of the operator. Route the cables in such a manner that they will not be inadvertently pulled, or disturbed by nearby personnel. Rotate the terminal until it is conveniently oriented for operator viewing. The cable which attaches the keyboard to the terminal is flexible which allows the keyboard to be placed in almost any position within a 30-inch distance of the viewed terminal.

### 3-9. DATA INTERFACE CONNECTION

3-10. All data source interconnections are made through the rear panel RS232C type I/O connector J2. The I/O connector mates with ITT Cannon solder pin connector, Part No. DM-25P or Amphe-nol Part No. 17-20250-1. Table 3-1 contains a list of pin assignments for I/O connector J2.

**Table 3-1. Connector J2 Pin Assignments**

Pin No.	Signal Description	RS232 Circuit	Signal	
			in	out
1	Frame Ground	AA		
2	Transmitted Data	BA		→
3	Received Data	BB	←	
4	Request to Send	CA		→
5	Clear to Send	CB	←	
7	Signal Ground	AB		
8	Received Line Signal Det.	CF	←	
16	X8 Terminal Data Clock (TTL Level) (Strap Selectable)	*		→
20	Data Terminal Ready	CD		→

\* Not RS232 (Optional)

The terminal interface complies with the electrical requirements of RS232. All voltages are measured at the connector with respect to AB. The output line delivers between -12v and +15v into a resistance of 3000 ohm. The input circuit will respond to voltages between 3v and 25v.

**Frame Ground (AA)**

This conductor, where used, is electrically bonded to the machine frame.

**Transmitted Data (BA)**

This circuit transfers data from the terminal to the data set for transmission to the external device. The terminal holds circuit BA in the mark condition during any time interval between characters or words, or when no signals are to be transmitted.

**Received Data (BB)**

This circuit transfers data from the data set to the terminal. Signals on this circuit are generated by the data set in response to data signals received from the external device. The data set holds this line in the mark condition when the line is idle or the carrier is not detected.

**Request To Send (CA)**

Signals on this circuit are generated by the terminal to condition the local data set to transmit. The "on" condition is maintained whenever the terminal has information ready for transmission or being transmitted. The terminal transmits data on circuit BA (Transmitted Data) only when the "on" condition is maintained on circuits CA, CB and CD. In half-duplex service, the "off" condition holds data set in the Receive Data condition, and the "on" condition holds the data set in the Transmit Data condition.

**Clear To send (CB)**

Signals on this circuit are generated by the data set to indicate that it is prepared to transmit data. The "on" condition on circuit CA (Request to Send) is delayed as long as may be required to establish a connection to a external device. When circuit CA is turned off, circuit CB is also turned off.

**Signal Ground (AB)**

This conductor established the common ground reference for all interface lines.

**Terminal Ready (CD)**

Terminal Ready is high whenever power is on.

**Received Line Signal Detector (CF)**

The signal on this line indicates that the data set has established the carrier and the data set is about to input data to the terminal.

### Transmitter Signal Element Timing (DB)

Signals on this circuit are used to provide the data terminal with signal transmit element timing information.

### Receiver Signal Element Timing (DD)

Signals on this circuit are used to provide the data terminal with received signal element timing information.

### 3.5.4 Printer Interface Connections

Printer interface connections are listed in Table 3-2.

## 3-11. SPECIAL PRECAUTIONS

**CAUTION:** If the terminal is to be operated in conjunction with a data phone or data modem, special care should be taken to ensure that the interfaces are per EIA Specification RS232C. The logic levels required by this specification may cause serious damage to communication interfaces designed strictly for standard DTL or TTL integrated circuit logic levels. The same precaution should be made when connecting hard wire to any communications I/O.

**WARNING:** To protect operating personnel, this unit is equipped with a detachable, three-conductor, shielded power cable that grounds the unit. The unit should be operated only with this or a similar type grounded power cable.

## 3-12. PREPARATION FOR USE

## 3-13. REAR PANEL SWITCH SELECTIONS (Refer to Figure 2-2.)

## 3-14. Set rear panel switches as follows:

a. Set the HDX/FDX toggle switch to the desired mode of operation.

b. Set the BAUD RATE toggle switch and rotary switch in accordance with Table 2-2. The MINI BEE will operate under any condition at 2400 baud or less with no timing considerations.

Certain functions require longer than one character time at high transmission rates. For example, when the memory scrolls as a result of a LF (line feed) code and the cursor is positioned on the bottom line, code fillers are required as follows: (Refer to Table 3-2.)

Table 3-2. Filler Codes

Function	Baud Rate	Number of Fillers	
		102-0455	BOARD
LF	4800	1	0
LF	9600	2	1
EL	9600	0	1
	9600	0	1

## 3-15. MINI BEE LOGIC CARD STRAP SELECTION LOCATION

3-16. Refer to Figure 3-1 for location and strap selections. Note: When no PARITY test is selected, the terminal output will be either even or odd as per the Even/Odd strap. The X8 clock strap applies a TTL signal to pin 16 of the RS 232C interface connector. This signal is eight times the baud rate frequency.

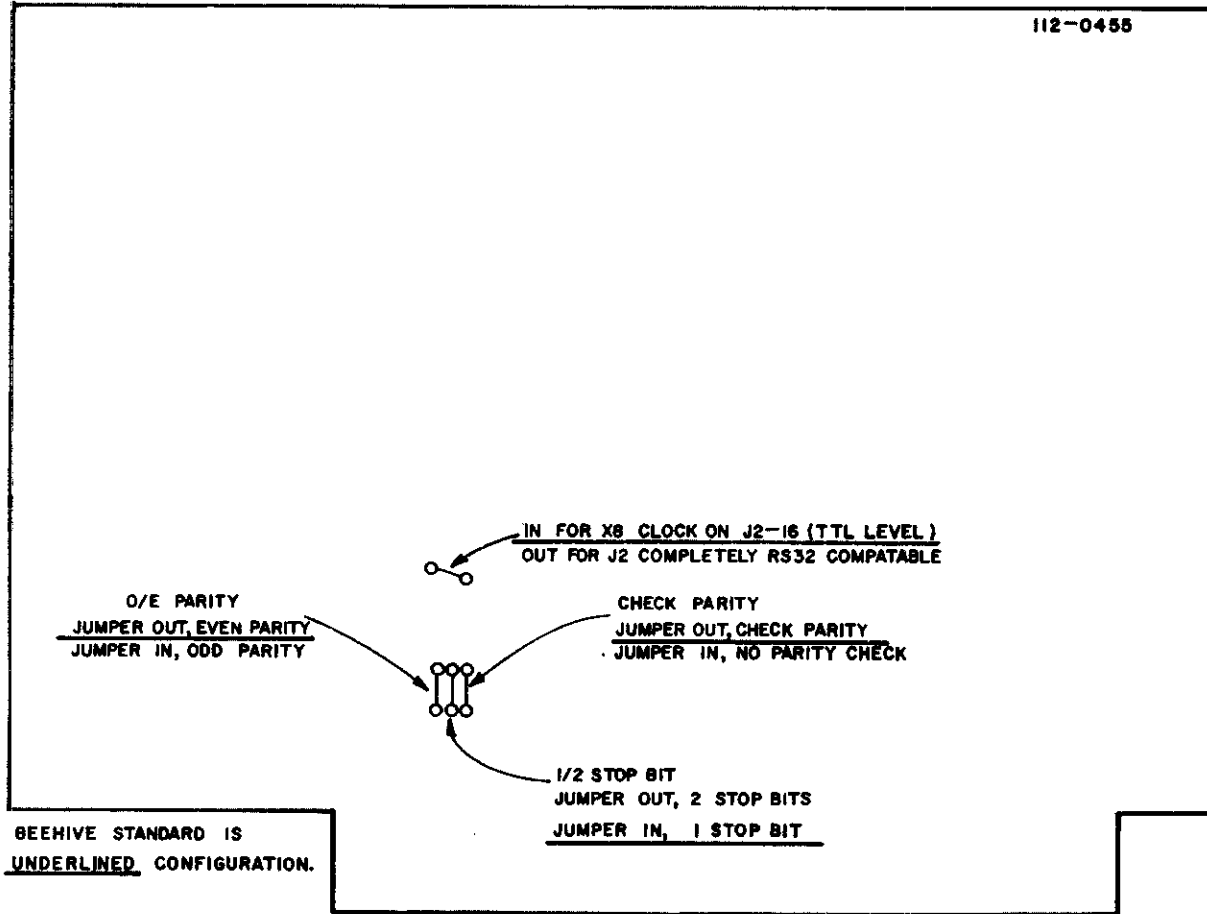

TERMINAL BLOCK IS LOCATED ON BOTTOM OF CHASSIS

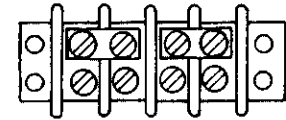

115 VOLTS

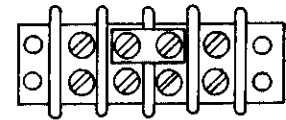

230 VOLTS

Figure 3-1. Mini Bee Logic Card Strap Selections

## SECTION IV

# THEORY OF OPERATION

### 4-1. INTRODUCTION

4-2 This section contains the theory of operation for the MINI BEE computer terminal.

### 4-3. GENERAL DISCUSSION

4-4. The MINI BEE is a stand-alone CRT terminal composed of the four basic blocks shown in Figure 4-1. The interaction of these blocks provide the capabilities of the terminal. Individual operation of these blocks is discussed in paragraphs 4-5 through 4-12. Figure 4-2 is a basic functional flow diagram of the MINI BEE and shows the relationship of the major operations performed by the terminal.

### 4-5. BASIC POWER SUPPLY

4-6. The power supply block contains the necessary transforming, rectifying and solid state controlling circuitry to provide the other major assemblies, through the MINI BEE LOGIC CARD, with the proper D.C. potentials for their operation. The power may be either the Elexon or Scintilloncs power supply.

### 4-7. BASIC MONITOR

4-8. The monitor block contains a 12" T.V. type CRT screen and its supporting solid state circuitry. The monitor is controlled by the vertical and horizontal synchronization signals developed on the MINI BEE LOGIC CARD and the video output signal to produce a full screen of information consisting of either 25 lines, or 12 lines of 80 characters each.

### 4-9. BASIC KEYBOARD

4-10. The keyboard block contains the key switches and supporting solid state logic circuitry to generate the appropriate control signals and ASCII characters utilized in the MINI BEE. It also contains indicators and receives signals for the indicators and logic circuitry from the MINI BEE LOGIC CARD.

### 4-11. BASIC MINI BEE LOGIC CARD

4-12. The main logic block consists of the major functioning and controlling circuits in the MINI BEE. It receives the various output voltage from the POWER SUPPLY and distributes the proper voltages to their respective destinations in the other main assemblies and within itself. As a product of the timing and synchronization considerations, control signals are impressed upon the MONITOR to present an organized pictorial of the data under consideration. The MINI BEE LOGIC CARD also receives 7 bit encoded data words and several control signals from the KEYBOARD, which it scrutinizes and then reacts accordingly. It also supplies the KEYBOARD with signals to control the operator monitored indicators. In addition, it controls the reception and transmission of data between the MINI BEE and any external equipment.

### 4-13. DETAILED DISCUSSION

4-14. A detailed discussion of the MINI BEE terminal operation is contained in paragraphs 4-13 through 4-87. A detailed block diagram of the terminal is shown in Figure 4-3. Schematic diagrams of the MINI BEE terminal are contained in the Diagrams section of this manual (Section VI).

### 4-15. POWER SUPPLY

4-16. The POWER SUPPLY has the capability of being connected to either 117 VAC or 230 VAC  $\pm 10\%$  at 50/60 Hz with proper strapping of the terminal block (Refer to Figure 3-1.)

NOTE: 50 Hz operation requires additional magnetic flux shielding.

### 4-17. TRANSFORMER

4-18. Once power is applied to the POWER SUPPLY the voltage is stepped down by two parallel connected transformers which comprise the transformer block (refer to Figure 3-1.)



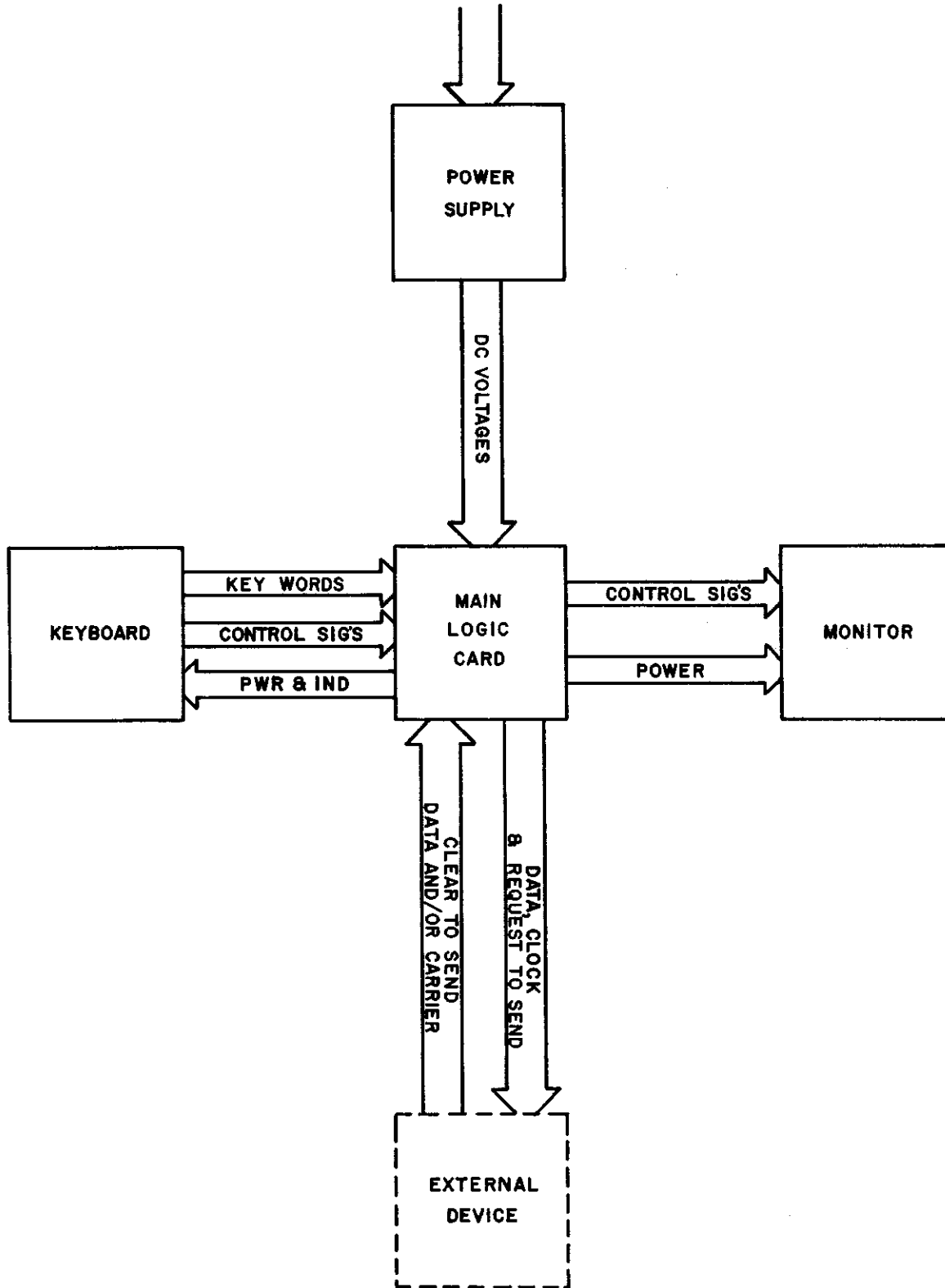

**MINI BEE BASIC BLOCK DIAGRAM**

Figure 4-1. Basic Block Diagram

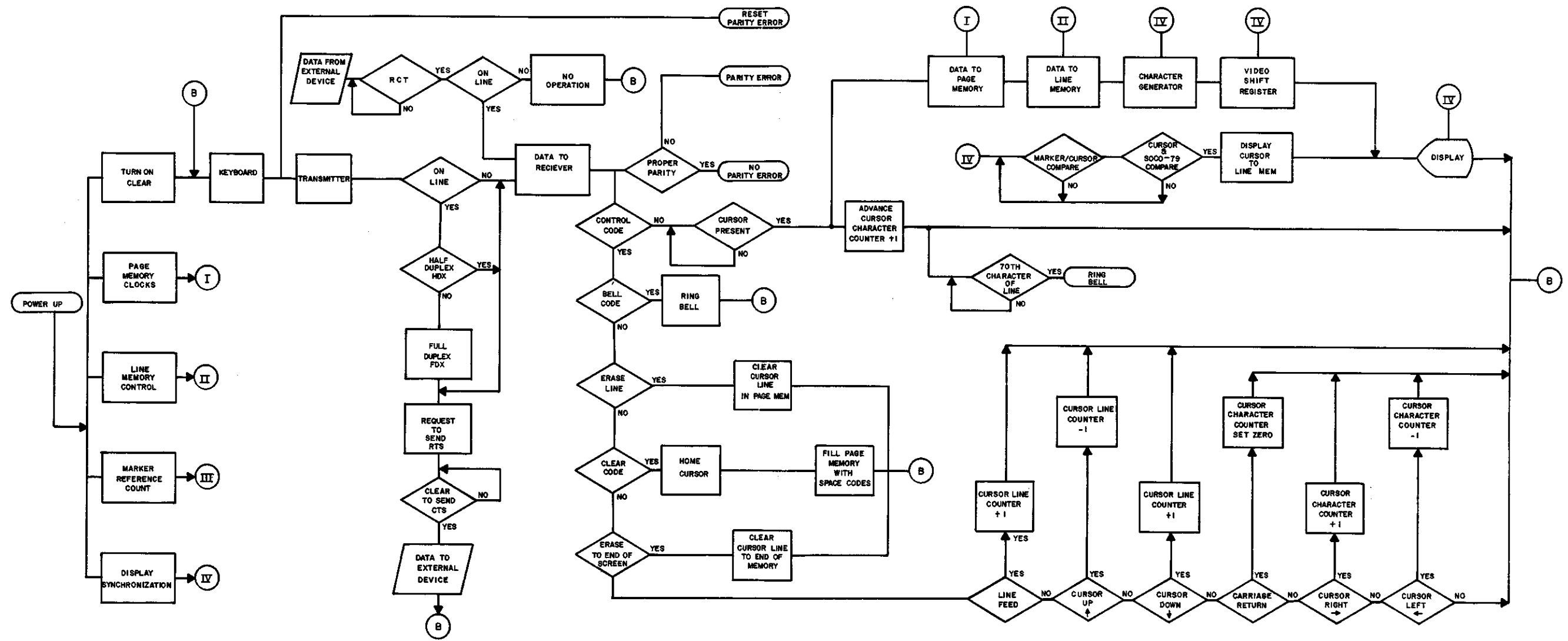
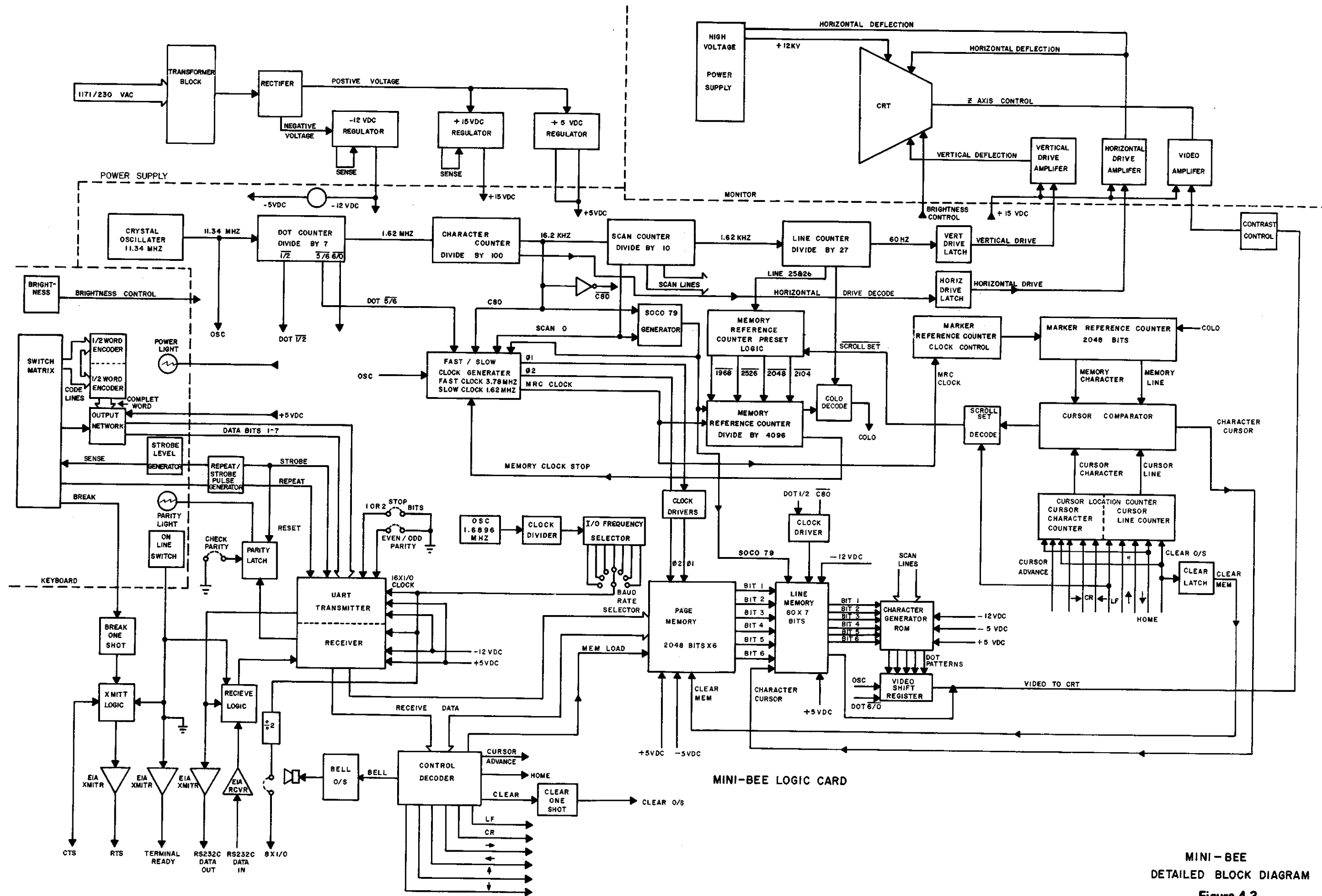

Figure 4-2. Basic Functional Flow Diagram



MINI-BEE  
 DETAILED BLOCK DIAGRAM  
 Figure 4-3.  
 4-5/4-6

#### 4-19. RECTIFIER

4-20 The Transformer voltages are rectified in the rectifier block. The output from the rectifier and filter supplies provide power to the +5VDC, +15VDC, and -12VDC regulator circuits.

#### 4-21. +5VDC, +15VDC, -12VDC REGULATION CIRCUITS

4-22. The Voltage received from the rectifier and filter circuit is applied to an IC regulating Chip, a pre-regulator transistor, and a series pass transistor to provide regulated voltages. In addition voltages are applied to the current sense and over voltage protect circuit for short circuit and over voltage protection.

#### 4-23. MONITOR

4-24. The function of the monitor is to display data on the face of the CRT in an organized manner determined by the design of the logic driving the monitor and requires three separate signals to cause proper operation. These signals are:

1. Vertical synchronization.
2. Horizontal synchronization.
3. Video information.

Positive 15 VDC is applied through the MINI BEE LOGIC CARD from the POWER SUPPLY to the various amplifying circuits for their low voltage operating potential.

NOTE: A low voltage power supply is shown in the Ball Monitor Manual. This supply is not used or provided in the monitor assembly that is currently used in the MINI BEE terminal.

#### 4-25. VERTICAL SYNCHRONIZATION

4-26. Vertical synchronization is applied to the vertical oscillator and triggers it at the vertical refresh rate as determined by the driving logic. The vertical frequency is stabilized by the vertical frequency control, which determines the point of oscillation. The output pulse of the vertical oscillator is applied to the driver amplifier which shapes

the pulse and is controlled by the vertical linearity control. The output of the driver amplifier is applied to the vertical driver, by way of the height control. The vertical drivers output pulse is applied to the yoke of the CRT and causes vertical deflection.

#### 4-27. HORIZONTAL SYNCHRONIZATION

4-28. The horizontal synchronization pulses are applied to the horizontal amplifier where they are amplified and applied to the horizontal driver. The output of the horizontal drive is applied through the width coil to the yoke, where it causes the horizontal deflection. The horizontal deflection signal is also applied to the flyback transformer. The horizontal deflection signal is stepped-up to approximately +12KV where it is then rectified, filtered, and applied to the anode cap of the CRT to provide the high voltage required.

#### 4-29. VIDEO INFORMATION

4-30. The video information is applied to the video amplifier by way of the contrast control, external to the monitor. From the video amplifier, the signal is applied to the cathode of the CRT gun to cause an on/off condition corresponding to light patterns on the screen.

The brightness control is external to the monitor and varies the voltage on the acceleration grid of the CRT gun. The focus control varies the voltage on the focusing grid of the CRT gun.

#### 4-31. KEYBOARD

4-32. The keyboard enables the operator to manually input information to the terminal and is comprised of the following assemblies:

1. Key-switch matrix
2. Two ½ word (4 bit) encoders
3. Output Network
4. Strobe Level Generator
5. On Line/Local Switch
6. Indicators

#### **4-33. KEY-SWITCH MATRIX**

4-34. The KEY-SWITCH MATRIX is sensed by the STROBE LEVEL GENERATOR for the operation of any key. Depressing a key raises the level of the proper output code lines which are fed to the ½ (one half) word encoders.

#### **4-35. ½ (ONE HALF) WORD ENCODERS**

4-36. The code lines are processed by the two ½ WORD ENCODERS which are 4 bits wide each and are assembled into the proper ASCII code for the key that was exercised and sends it to the OUTPUT NETWORK.

#### **4-37. OUTPUT NETWORK**

4-38. Once in the OUTPUT NETWORK the assembled data word is scrutinized and assigned the desired parity. The OUTPUT NETWORK is also responsive to a control code line from the KEY-SWITCH MATRIX to identify control codes. The completed data word is then sent to the MINI BEE LOGIC CARD with the appropriate strobe level.

NOTE: The eight bit (parity) is provided by the OUTPUT NETWORK, but not used in the MINI BEE.

#### **4-39. STROBE LEVEL GENERATOR**

4-40. The STROBE LEVEL GENERATOR senses the execution of any key. As a product of sensing key operation, the proper strobe level is then generated and is sent to the MINI BEE LOGIC CARD with one exception; when a two key roll-over condition exists, i.e. two keys depressed at one time, the strobe level reverts to its idle state and only the first key struck will be processed.

#### **4-41. ON LINE/LOCAL SWITCH**

4-42. The output of the ON LINE/LOCAL SWITCH is directly coupled to the MINI BEE LOGIC CARD where it is applied to the appropriate logic to execute one of the two major modes of the MINI BEE terminal.

#### **4-43. INDICATORS**

4-44. The POWER ON INDICATOR tells the

operator that the MINI BEE terminal has power applied and is in an operational state.

4-45. The PARITY INDICATOR makes the operator cognizant of the reception of a character from an external device having improper parity assignment. The ON condition can be reset by operating any key on the KEYBOARD with the exception of the break key.

#### **4-46. MINI BEE LOGIC CARD**

4-47. The MINI BEE LOGIC CARD is the logical and operational heart of the MINI BEE terminal. It controls and initiates all of the major functions as well as distributes operating potentials. The following paragraphs explain the major functions carried on within the MINI BEE LOGIC CARD.

#### **4-48. DISPLAY ORGANIZATION**

4-49. The main timing chain (Oscillator, Dot Counter, Character Counter, Scan Counter, and Line Counter) defines the configuration of the display on the CRT. There are 27 lines, two of which are used for vertical retrace and 25 of which are used to display characters. The 27 lines are composed of ten scans each, each scan being composed of 100 characters, 80 for display and 20 for horizontal retrace, each character being composed of a 5 x 7 character dot matrix (refer to Figure 4-4).

#### **4-50. OSCILLATOR**

4-51. The Oscillator is a standard crystal oscillator with a frequency of 11.34 MHZ. Two 7404's are connected in series by a .002 microfarad capacitor. Each 7404 is biased with a 1Kohm resistor connected from their input to their output. A 11.34 MHz crystal is connected from the input of the first 7404 to the output of the second 7404. The output of the oscillator is inverted and feed to the dot counter.

#### **4-52. DOT COUNTER**

4-53. The Dot Counter defines each of the seven dots required to compose one character. The Dot Counter is a shift register that operates as a ring counter. The Dot Counter has available on any output a low which is two dots wide. The outputs are labeled 6 and 0, 0 and 1, 1 and 2, etc. The divide-

# DOT MATRIX

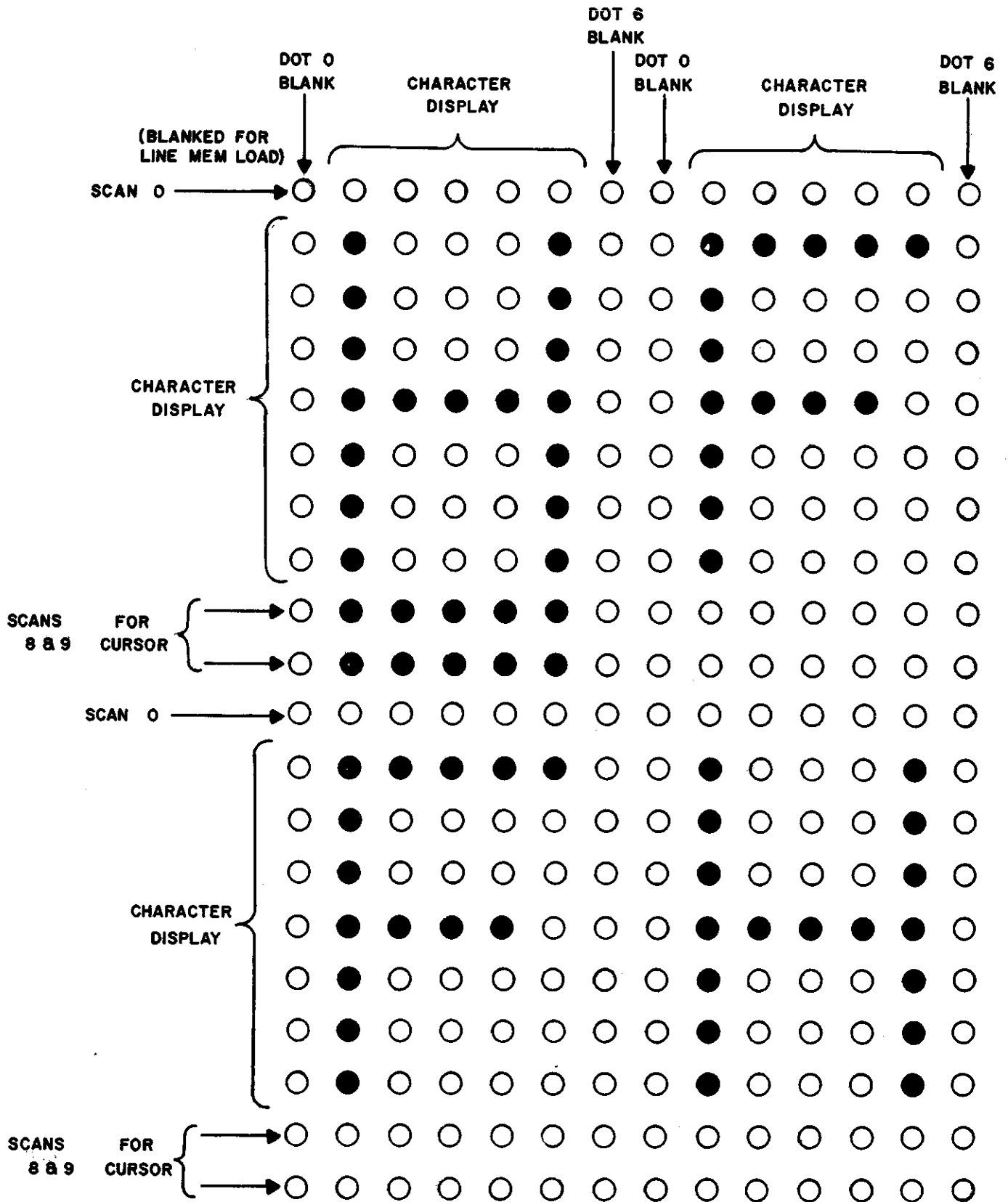

Figure 4-4. Character Dot Matrix

by-seven Dot Counter's output is applied to the Character Counter.

#### **4-54. CHARACTER COUNTER**

4-55. The Character Counter is composed of two decade counters that define 100 character times, each being seven dots wide. The output of the Character Counter is applied to the Scan Counter.

#### **4-56. SCAN COUNTER**

4-57. The Scan Counter is a standard decade counter that defines 10 scans of 100 characters each, with each character being seven dots wide. The output of the Scan Counter is applied to the Line Counter.

#### **4-58. LINE COUNTER**

4-59. The Line Counter (a combination of A72, a 4-bit decode counter and A60, a flip-flop) is a standard 5-bit binary counter preset to the count of five and overflows at the count of 32, which is a modulus of 27.

#### **4-60. SCAN 0 CHARACTER 0 TO 79 (SOCO-79)**

4-61. Signal SOCO-79 represents the first eighty characters of SCAN 0 and this signal is used to generate slow clocks to transfer the Page Memory information to the Line Memory. This is generated by way of a latch and gating which comes off the Scan Counter and indicates the receipt of the first eighty characters of the Scan Counter.

#### **4-62. FAST/SLOW CLOCK GENERATOR**

4-63. The page memory makes in excess of one revolution per line. Slow clocks are applied during SOCO-79 and fast clocks are applied during the remaining scans until the memory has made a revolution, at which time the memory stops and waits for Scan 0. The 11.34 MHz signal from the Oscillator is also applied to a circuit which divides down to the clocking signals required for the fast clock and the slow clock. This is broken down into Phase 1 and Phase 2 clocks and applied to the Memory Clock Drivers to provide the clocking signals needed to drive the clock at the appropriate MOS interfacing.

#### **4-64. HORIZONTAL AND VERTICAL DRIVE**

4-65. The Horizontal drive latch is set by a count of 84 from the Character Counter. The Character Counter counts from 84 to 99 and overflows to 0 and continues to count. At the count of 20 the Horizontal Drive latch is reset. This generates a high level Horizontal Drive pulse which causes horizontal retrace in the monitor.

4-66. The Vertical Drive is derived by the count of 24/30 from the Line Counter (depending on 12/25 line configuration). This causes Vertical Drive which is reset by the Line Counter going to zero.

#### **4-67. MEMORY REFERENCE COUNTER**

4-68. The Memory Reference Counter counts from a preset value determined by the line counter and the scroll latch to 4096 and identifies each location in memory. This counter overflow indicates that the memory has completed a revolution and denotes the time which the memory should stop to wait for the housekeeping to be finished on the display so that the memory and the display are again in synchronization. The reset of the main timing chain is gated with the Memory Reference Counter overflow and is designated COLO which signifies CHARACTER 0 LINE 0 or that one page has been written on the screen. The same signal that clocks the Memory Reference Counter also clocks the Marker Reference Counter.

#### **4-69. MARKER REFERENCE COUNTER**

4-70. The Marker Reference Counter is broken up to indicate the character and the line that the memory is now on. The Counter will count to 2048 in increments of 80 counts (to define one line) for 25 lines with 48 undefined locations. It has the capability of identifying each of the 2000 locations on the screen.

#### **4-71. CURSOR LOCATION COUNTER**

4-72. The Cursor Location Counter identifies the location of the cursor. This is a count made up of the location of the Cursor Line Number and the Cursor Character Number. The Cursor

Location Counter is compared with the Marker Reference Counter and, when the compare is true, the output signal is designated the Character Cursor signal. Also associated with the Cursor Location Counter is the appropriate circuitry to move the cursor up, down, right, left, home, etc. The capability of doing a line feed or a carriage return also exists as a function of altering this counter.

#### **4-73. UART (RECEIVER)**

4-74. Data can be received by the MINI BEE from one of two modes; from the EIA RS232C interface into the UART or from the Keyboard through the transmit side of the UART to the receive side of the UART. The interface has a clock which has the capability of transfer rates between 110 baud and 9600 baud. This is composed of an oscillator running at 1.6896 MHz into a counter which has a 110/150 switch. This goes into a counter which act as dividers to provide 16 times the I/O rate. This clock is applied to the receive side of the UART and the UART has the circuitry to take the 16 times and baud rate and break it down to the baud rate. The EIA line receiver can receive data at EIA levels and gate them into the UART when the MINI BEE is On-Line. Through the same gating, data is brought in from the transmit side of the UART. Also monitored through an EIA line receiver is the carrier detect from the modem. The data is brought into the UART and the UART converts it to parallel data on a data buss (seven bits). The UART also does VRC parity checks. The data from the data buss is applied to two points. It is applied to a series of decoders which decode the data to check if it is a control code or a printable character. It is applied first to the input of the Page Memory. If the data is a printable character, the associated circuitry generates the signal Mem Load. As the character is decoded, a Mem Load is generated as well as a Cursor Advance which makes the cursor move one character to the right.

#### **4-75. PAGE MEMORY**

4-76. The Page Memory holds all 2000 characters possible to display onto the screen. These are transferred 80 at a time to the Line Memory for display. In order to write data into the

Page Memory, the Character Cursor comes up and, if this is a displayable character, the signal Mem Load is generated. Upon generating Mem Load, the UART is reset and is now capable of receiving the next character. The new character to be loaded into the Page Memory is applied to the Memory Input Multiplexer. The signal Mem Load switches the multiplexer, inhibits the recirculate path for the Page Memory, and enables the new character to be loaded into the next clock. This corresponds to the proper location in the Cursor Location Counter. The character that is applied to the Page Memory is then loaded into the Page Memory and is recirculated. The Page Memory is organized as a 2048 x 6 bit recirculating shift register. Every SOCO-79 the Page Memory has slow clocks applied to it and is now running at the same rate as the Line Memory for data transfer.

#### **4-77. LINE MEMORY**

4-78. The Line Memory holds eighty characters and recirculates them nine times while applying them to the Character Generator. The Line Memory's recirculate path is disabled by SOCO-79, and 80 characters of new information are loaded into the Line Memory. At the end of SOCO-79, the Line Memory's internal recirculate path is enabled, fast clocks are again applied to the Page Memory, and it resumes its fast clock rate. The information now in the Line Memory is recirculated nine more scans and, during these nine scans, is applied to the Character Generator.

#### **4-79. CHARACTER GENERATOR**

4-80. The Character Generator is a read-only-memory (ROM) that is addressed by the character (in ASCII) and the scan configuration. The binary scan codes indicates the present scan configuration and the character indicates the pattern desired on that scan. At this point, five-bit dot patterns are generated which are representative of a portion of a character. The output of the Character Generator is applied to the Video Shift Register.

#### **4-81. VIDEO SHIFT REGISTER**

4-82. The video shift register is loaded with data by dot 6/0 and is clocked by the oscillator.



The dots are shifted out, mixed with cursor information, and blanking signals and applied to the MONITOR through the contrast control as video information.

#### **4-83. CONTROL DECODER**

4-84. If a defined control code is decoded, it is executed. The Control Decoder can decode Cursor Up, Cursor Down, Cursor Right, Cursor Left, Home, Clear, Bell, Line Feed, Carriage Return, Erase Line, Erase-to-End-of-Screen, and Back Space. In the event that a bell is decoded, a one-shot is set which enables Scan 4 (a tone of approximately 2 kiloHertz) to be applied to a speaker. The other side of the speaker is wired to +5 volts. The bell is enabled on the 70th character of each line or on receipt at a Control G.

#### **4-85. PARITY ERROR**

4-86. Parity is based on the use of an additional bit to the ASCII code, known as a "Parity Bit," or "Parity-Check Bit," in each code group or data word. The parity bit associated with each code group in an even-parity-bit checking system has such a value that the total number of 1's or true bits, in each code group plus the parity bit is always even. An odd-parity-bit checking system has a parity bit such that the sum of the 1's or true bits, in each code group plus the parity bit is always an odd number.

In the event the MINI BEE is strapped to check parity and the terminal receives a code having an erroneous total of high bits, the parity error light located on the keyboard is illuminated and the code is acted upon by the terminal. The parity error light may be reset by depress-

ing any key (with the exception of the break key).

#### **4-87. UART (TRANSMIT)**

4-88. The Keyboard data lines bit 1-7 are applied to the transmit side of UART. Also coming from the Keyboard is Keyboard Strobe and Keyboard Repeat which, together, enable the repeat oscillator which retriggers the UART and retransmits the character being generated. As the UART receives the character from the Keyboard, it performs the appropriate parity generation, considers one or two stop bits for a 10- or 11-bit word, and, by having a 16 times the baud rate clock applied to it, breaks down the clock and transmits the character. The character is applied through an EIA RS232C interface to the computer. Also coming from the UART is output data at a TTL level which is applied to the receive side of the UART through the previously mentioned logic. Also generated to the EIA output interface is a Terminal Ready signal which indicates the status of the MINI BEE to the computer and a Request to Send signal which indicates a desire to transmit data to the computer. The Clear to Send line coming from the computer is monitored at the EIA RS232 interface levels. It is received by a line receiver which converts it to TTL levels and applies it to the UART as a consideration for enabling transmission. The 16x baud rate clock is also applied to the computer interface and, if required, a clock which is at 8 times the baud rate (TLL levels). The BREAK key on the keyboard fires a one shot which holds the RS232 interface to a mark position for a predetermined period of time.

## SECTION V

# MAINTENANCE

### 5-1. INTRODUCTION

5-2. This section contains information to aid in the maintenance of the MINI BEE CRT Terminal. Preventive and corrective maintenance procedures are specified as well as troubleshooting aids and techniques.

### 5-3. PREVENTIVE MAINTENANCE

5-4. There is no scheduled periodic maintenance; however, there are several things that could be done should the need arise.

5-5. Care should be exercised to see that there is proper air circulation for the fan. The unit should not be set on a shag carpet or other soft surface that could impede the air entrance to the fan. Also, the degree of dust density in the air should be considered because there is a possibility of foreign matter clogging up the fan filter. In the event that this should occur, the filter must be vacuumed out. The dust can be sucked out of the filter while still in the unit. In more severe instances, the fan filter can be replaced. This is done by first taking off the main cover of the unit, removing four screws, taking out the fan and filter guard, then the filter itself.

5-6. The absite coating makes the plexi-glass highly scratch resistant. It may be wiped with a soft cloth.

5-7. The interior of the unit may be wiped free of dust. Accumulation of dirt causes overheating and component breakdown. Dirt acts as an insulating blanket and prevents efficient heat dissipation. A small brush is very useful for dislodging dirt; a cotton-tipped applicator is good for narrow or hard to get places.

### 5-8. TROUBLESHOOTING AIDS

5-9. The following is a list of the troubleshooting aids that are provided in this manual to assist in the troubleshooting of functional failures.

- Circuit Schematics
- Basic Block Diagram
- Detail Block Diagram
- Functional Flow Diagram
- Interconnect Diagram
- Timing Diagrams
- Glossary of Terms
- Troubleshooting Flow Diagrams
- Disassembly/Assembly Procedures
- Adjustment Procedures
- ASCII Code Sheet
- Configuration/Strapping Information
- Character Dot Matrix
- Pictures of Wave Shapes

### 5-10. TROUBLESHOOTING EQUIPMENT

5-11. The following is a list of tools and standard equipment required to repair a MINI BEE terminal:

- V/O Multimeter
- Oscilloscope
- Assorted Electronic Hand Tools

## 5-12 FULL DUPLEX ECHOPLEX TEST

5-13. A specially wired connector may be assembled which mates with J2 (See Figure 5-1). This connector tester allows the terminal to be operated and tested independent of an external data device. The basic set-up for the test is as follows:

- FDX (Full Duplex Mode)
- On-line
- Baud Rate - Any Setting

Enter data from the keyboard as you would if you were on-line to a computer. If data is displayed on the screen properly, then the MINI BEE is transmitting and receiving data properly.

The test connector is wired as follows: (Refer to Figure 5-1.)

- Connects Transmitted Data Line out of the terminal to received data line into the terminal. Pin 2 to Pin 3 of J2.
- Connects Request to Send control line out of the terminal to Clear-to-send line into the terminal Pin 4 to Pin 5 of J2
- Connects Receive Line Signal Detector line into Data Terminal Ready. Pin 8 to Pin 20 of J2

## 5-14. CORRECTIVE MAINTENANCE

5-15. This section provides corrective maintenance information to aid in servicing the MINI BEE terminal. It is suggested that the configuration sheet and the turn-on procedure be consulted before performing the corrective maintenance described here.

## 5-16. TROUBLESHOOTING PRELIMINARY CONSIDERATIONS

5-17. The most common problems occurring in MINI BEE are switch, control, and operation-related. A simple procedure may be followed to help determine if the problem is control and/or operation-related or internal circuitry related by checking the following:

- Illegal Operation (Refer Section II)
- Improper Baud Rate Setting
- Wrong Transmit or Receive Mode (HDX/FDX)
- Loose Interconnect Cable

NOTE: Because the POWER SUPPLY output voltages may affect the terminal in various ways, manifesting itself differently each time, it is suggested that the output voltages be verified good in accordance with the POWER SUPPLY adjustment procedures.

## 5-18. HOW TO USE TABLE 5-1

5-19 A list of trouble shooting flow diagrams is given in Table 5-1. This index lists apparent failure and refers the user to the proper flow diagram. To derive the maximum benefit from Table 5-1, the following procedure is recommended:

1. Find the apparent trouble in the Troubleshooting Flow Diagram Index.
2. Proceed to the specified troubleshooting flow diagram in the diagram section and begin the troubleshooting procedure.
3. If an adjustment procedure is referenced in the troubleshooting flow diagram, perform the adjustment and return to the flow diagram to complete the troubleshooting process.
4. Reference is made to Timing Diagrams and Wave Shapes which are contained in the Diagrams Section (Section VI) of this manual.

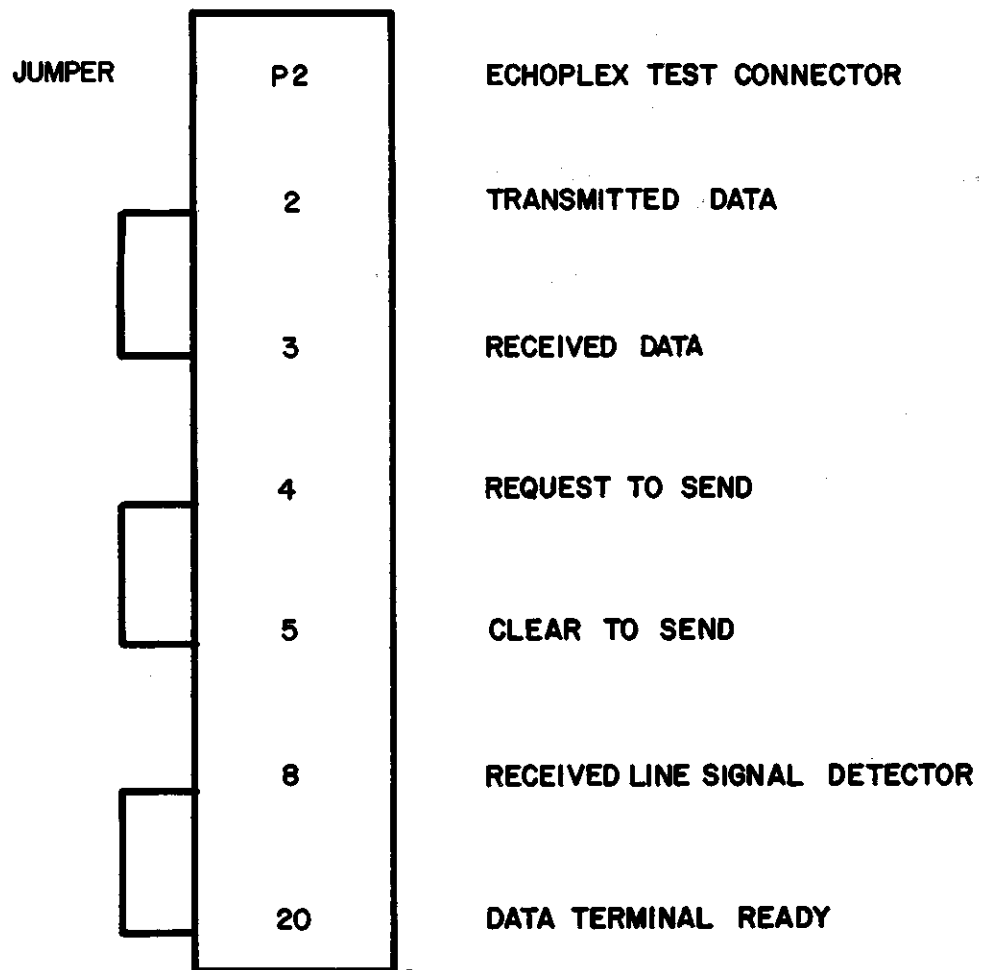

Figure 5-1. Echoplex Connector

Table 5-1. Troubleshooting Flow Diagram Index

Apparent Failure	Troubleshooting Flow Diagram
<b>GENERAL</b>	
1. Power indicator off, but raster present on CRT screen	5-1A
2. No raster present, but power indicator on	5-1B
3. No raster present and power indicator off	5-1C
<b>OFF LINE</b>	
1. Cursor either absent, multiple cursors, cursor not in home position or screen filled with video blocks	5-2A
2. No character displayed when written non cursor advance	5-2B
3. Wrong character displayed	5-2C
4. No escape functions	5-2D
5. No control functions	5-2E
<b>ON LINE</b>	
1. No data being transmitted	5-3A
2. Transmits invalid data	5-3B
3. No reception	5-3C
4. Receives invalid data and/or improper parity	5-3D
5. No break function	5-3E
6. No parity error light reset	5-3F
<b>DISPLAY</b>	
1. All displayed characters out of focus	5-4A
2. Rolling display	5-4B
3. Display too tall/short for screen size	5-4C
4. Height of displayed characters uneven	5-4D

Table 5-1 (continued)

Apparent Failure	Troubleshooting Flow Diagram
5. Display too wide/narrow for screen size	5-4E
6. Display not centered	5-4F
7. Tilted display	5-4G
8. Others <ul style="list-style-type: none"> <li>A. Single vertical line</li> <li>B. Physical damage</li> <li>C. Dot in center of screen</li> <li>D. Uneven intensity/focus</li> <li>E. Burned phosphor</li> <li>F. Uneven display dimensions</li> <li>G. Excessive H.V. Arching</li> </ul>	5-4H

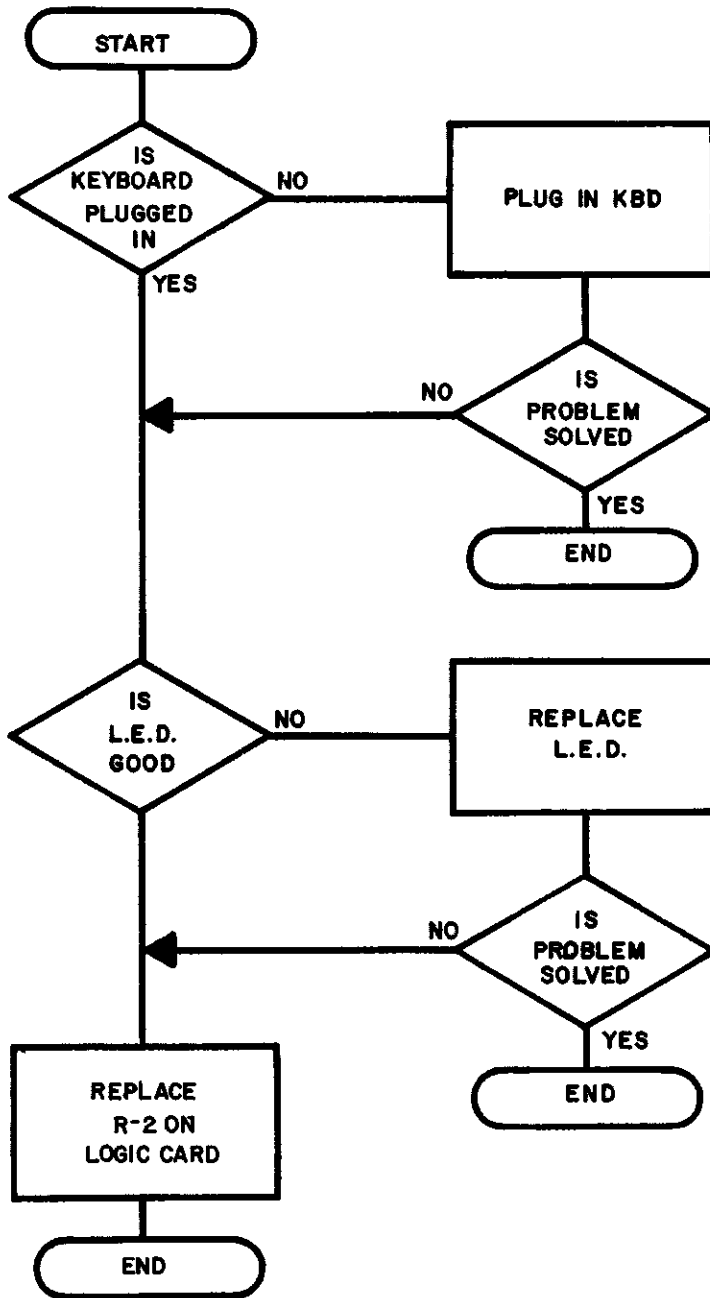

5-1B

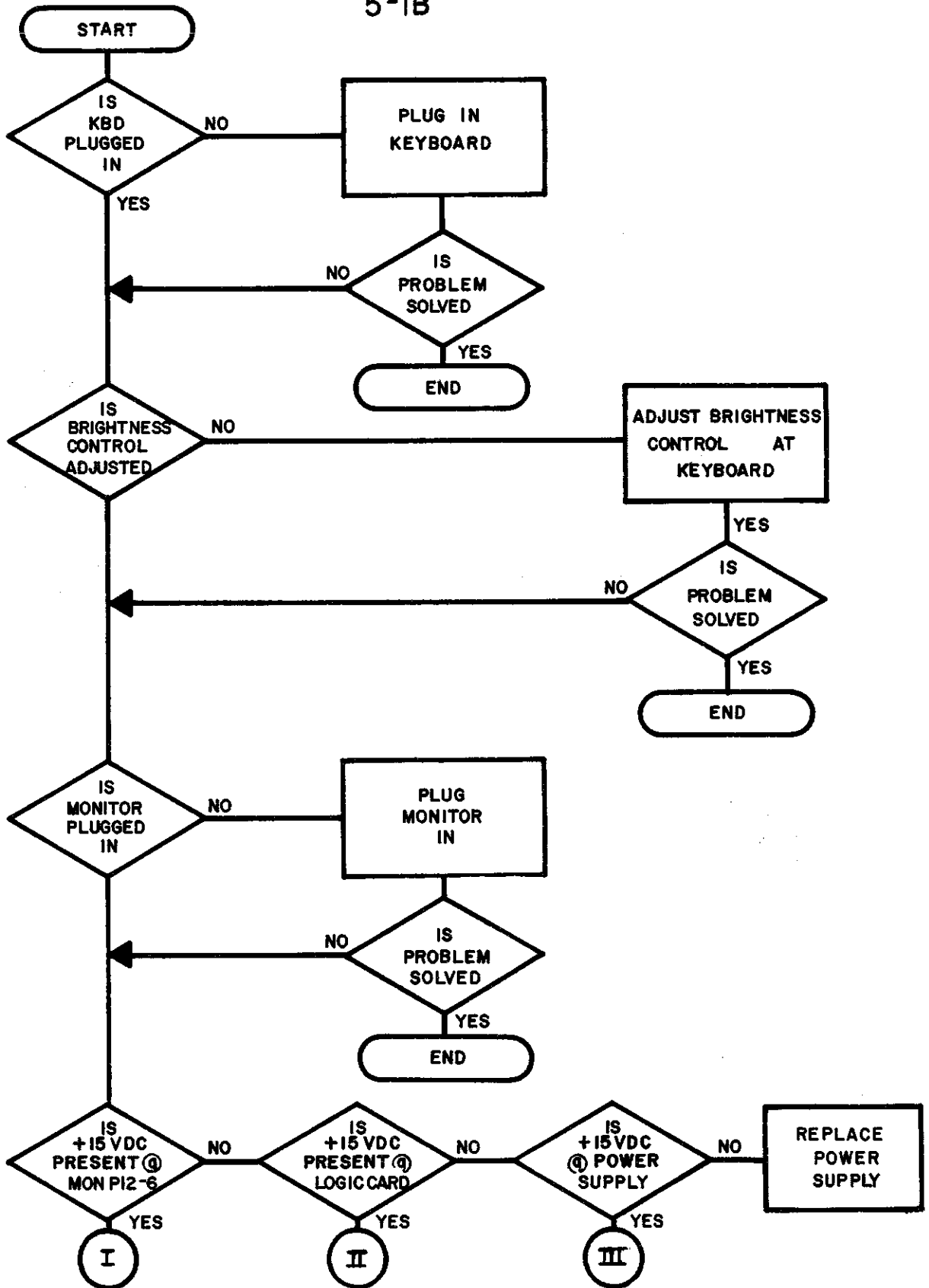



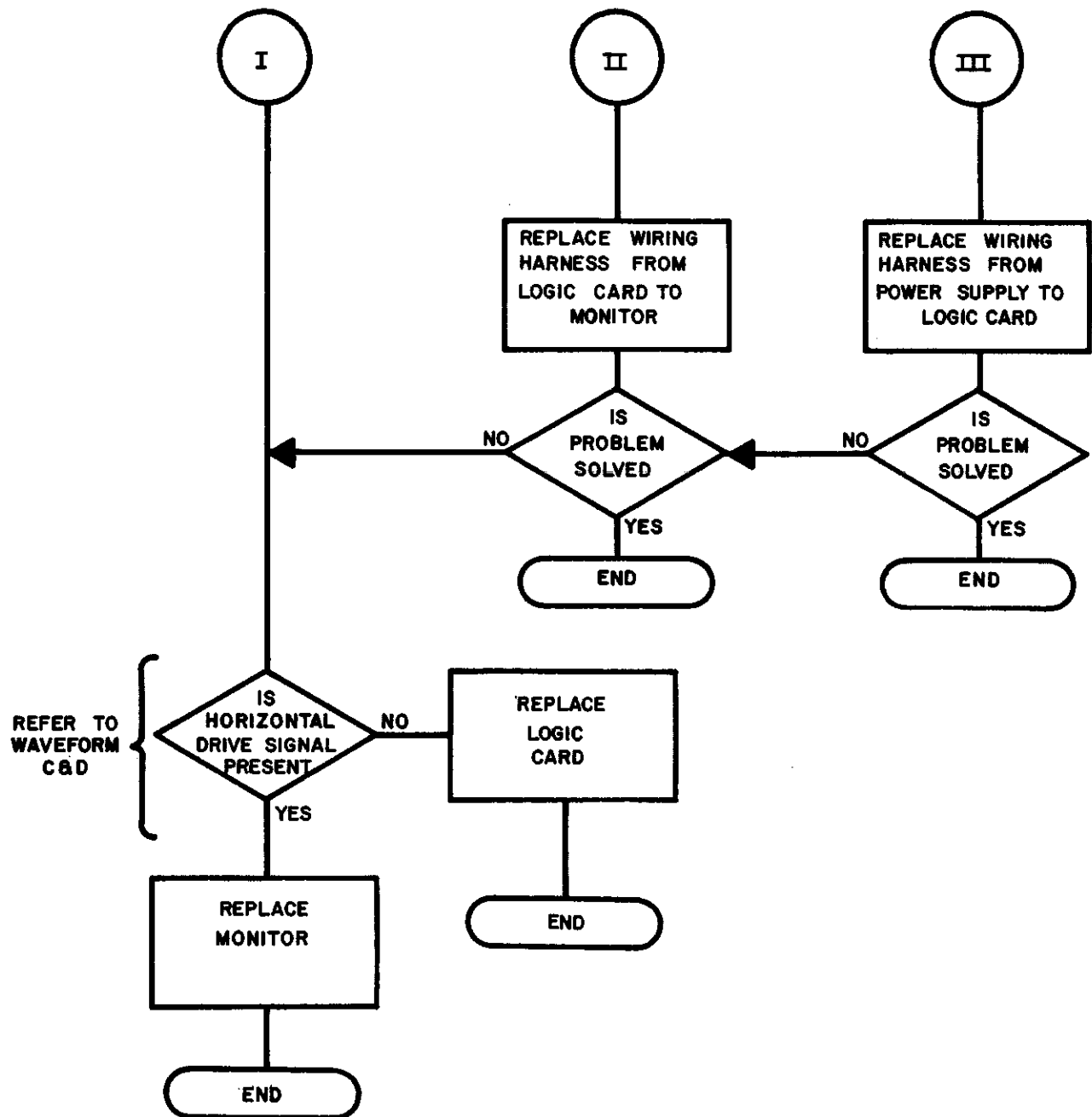

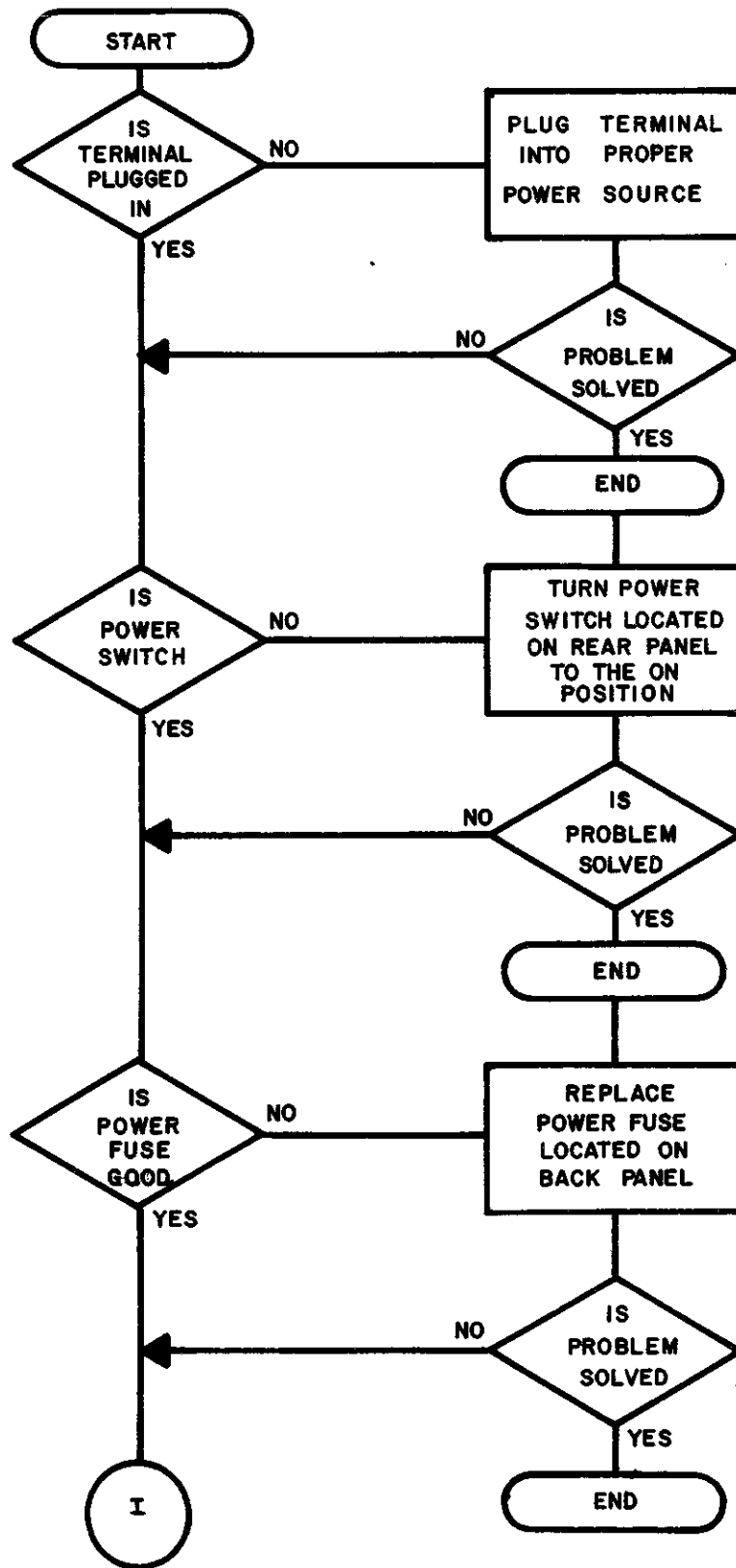

REFER TO POWER DIST. BLOCK DIAGRAM FIG. 3-1

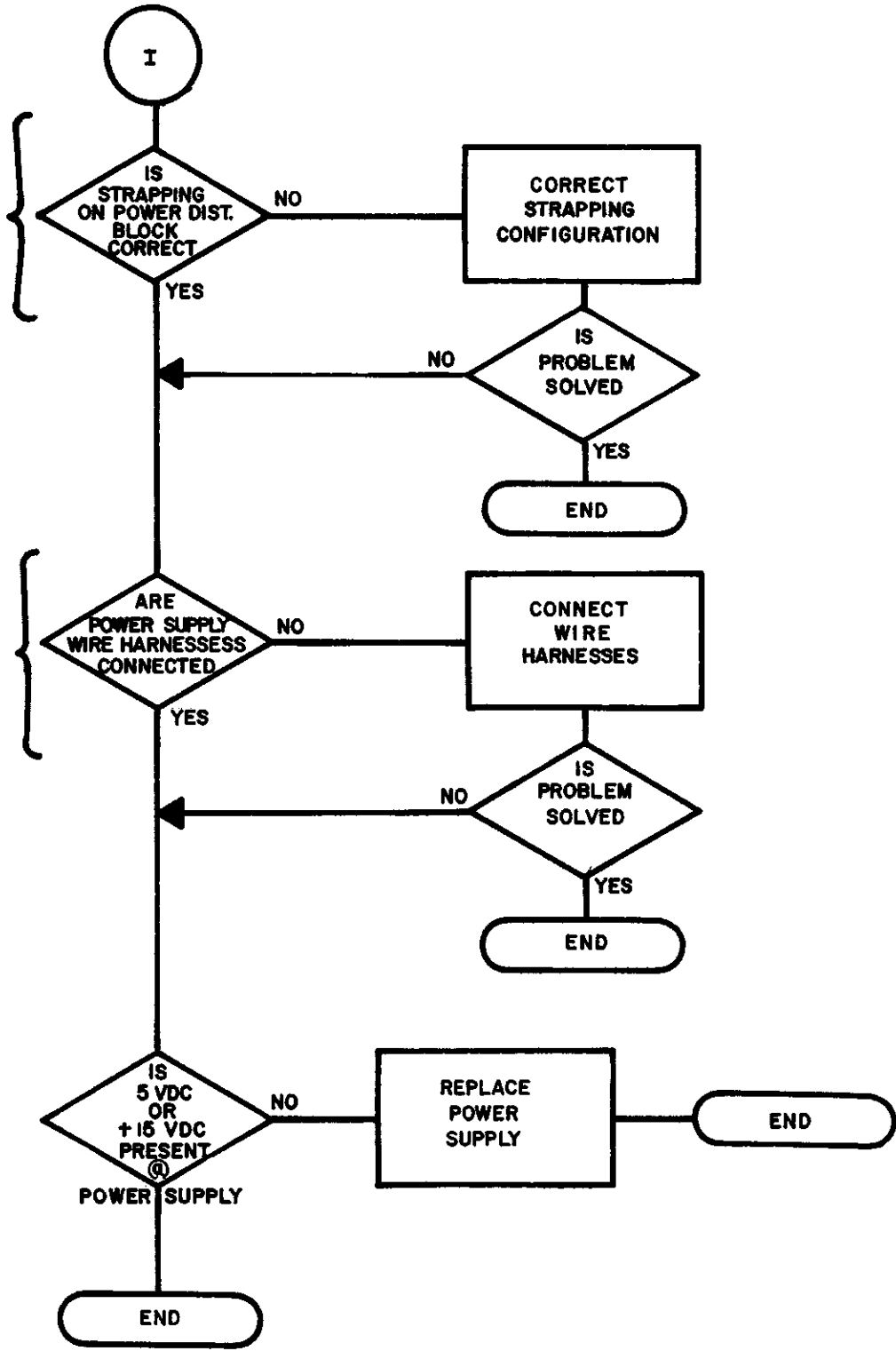

REFER TO POWER DIST. BLOCK DIAGRAM FIG. 3-1

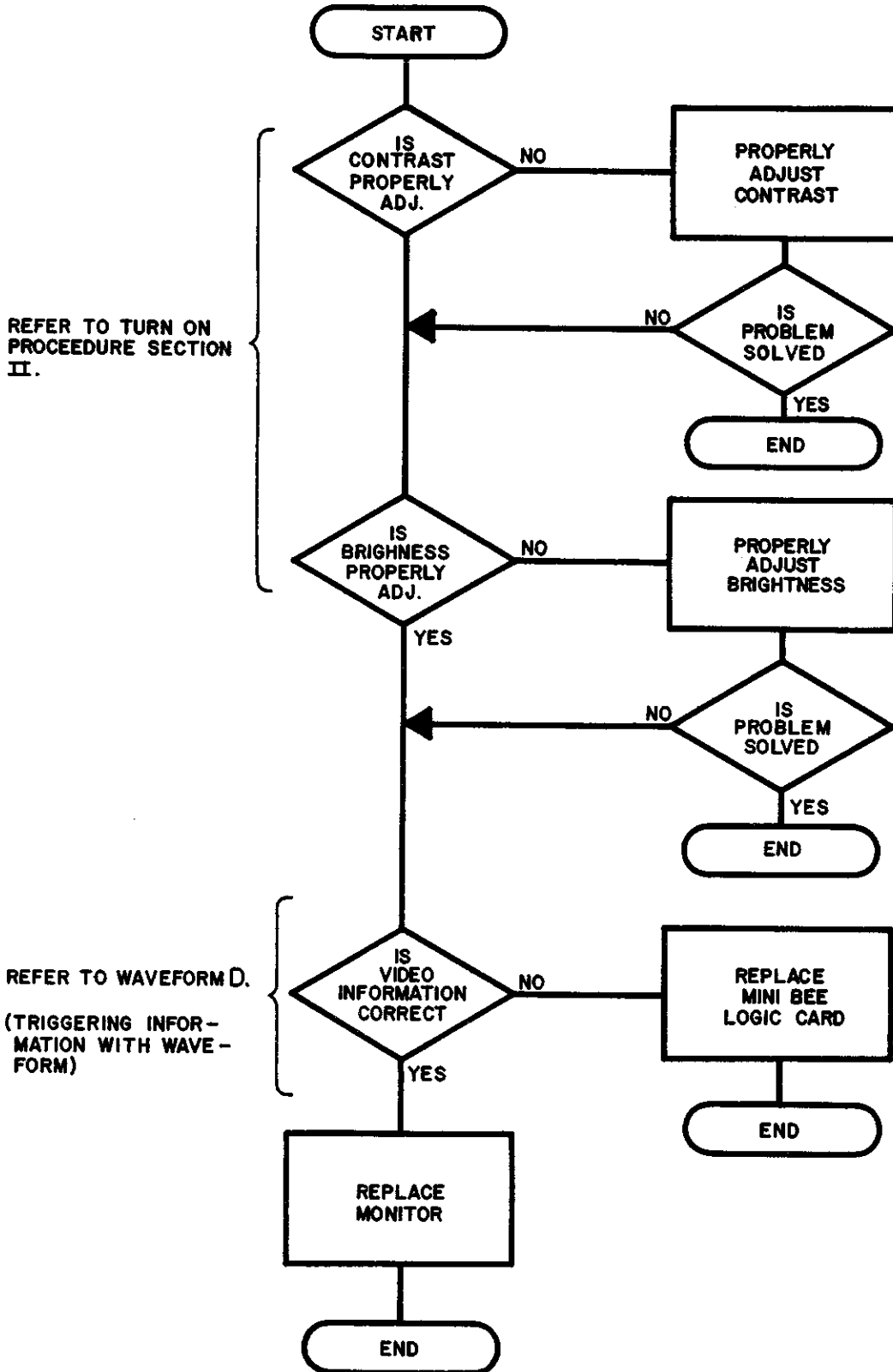

5-2B

REFER TO TIMING DIAGRAM E.

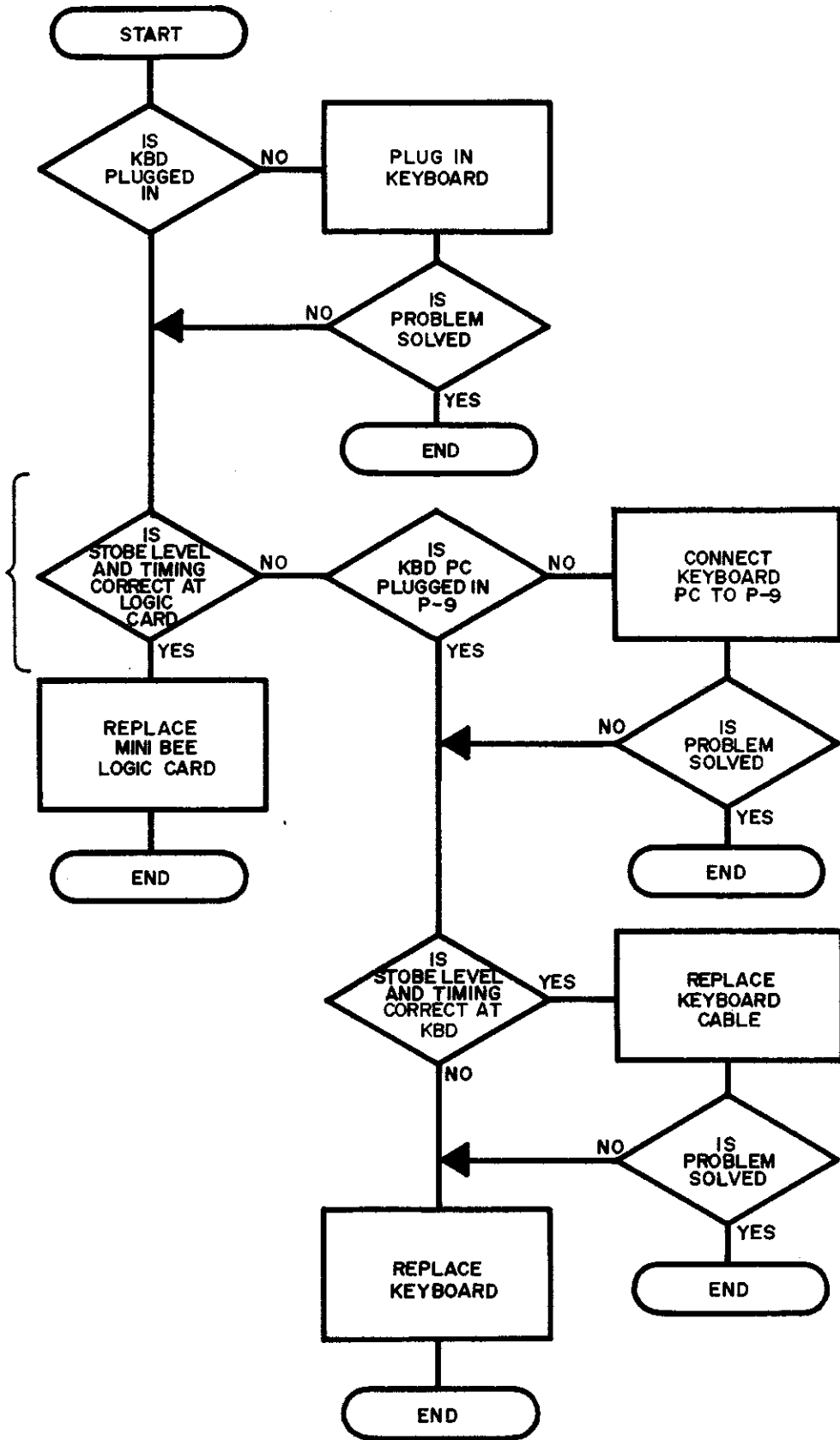

# 5-2C, 5-2D & 5-2E

PREREQUISITE FOR 5-2D & 5-2E: VERIFY PROPER DISPLAY OF ALFA-NUMERIC CHARACTERS.

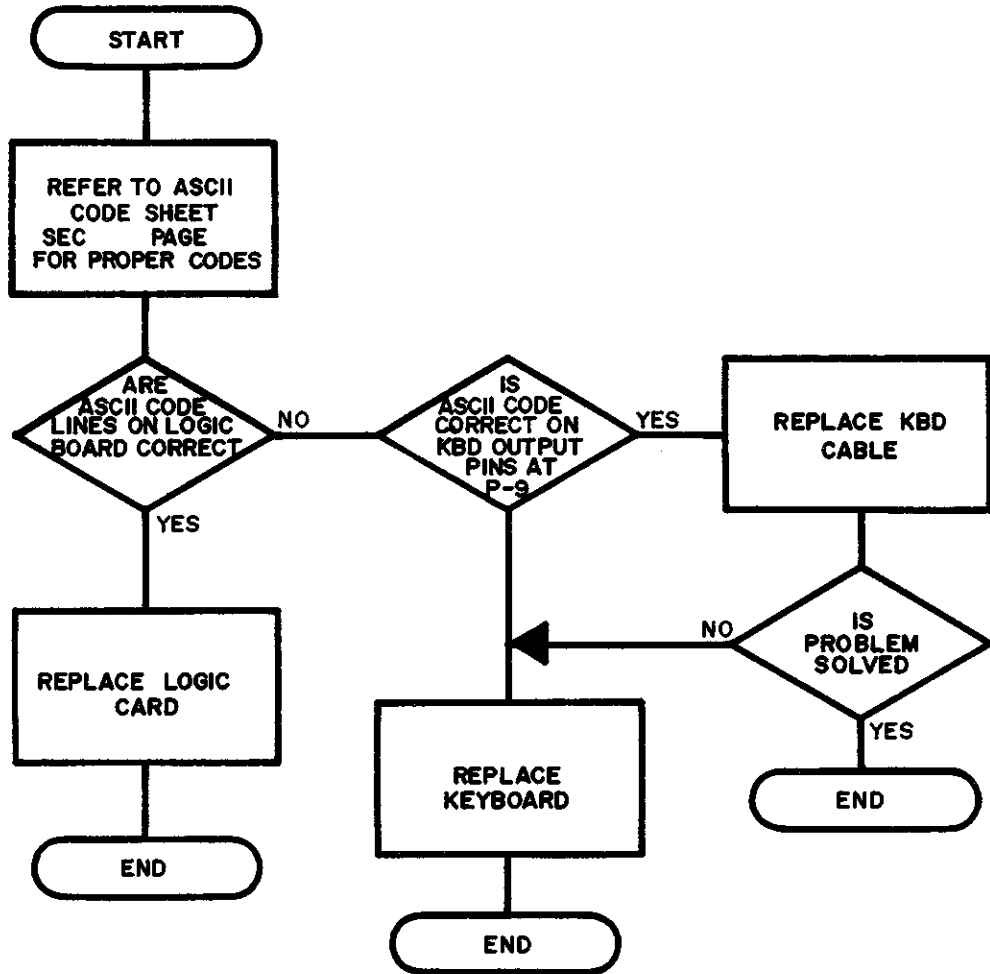

5-3A

PREREQUISITE: VERIFY PROPER OPERATION OF TERMINAL IN LOCAL MODE. REFER TO SECTION II OF THIS MANUAL.

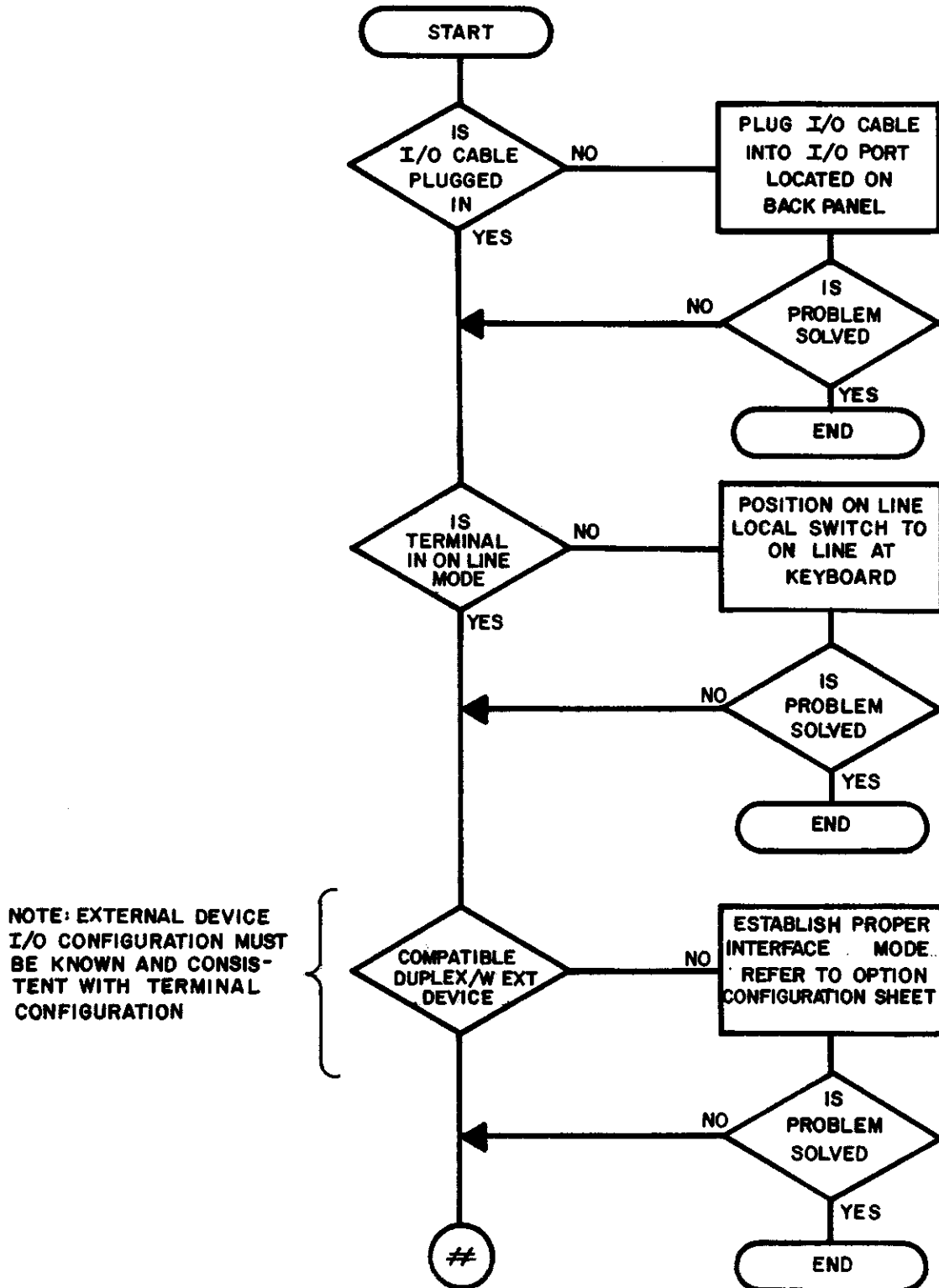

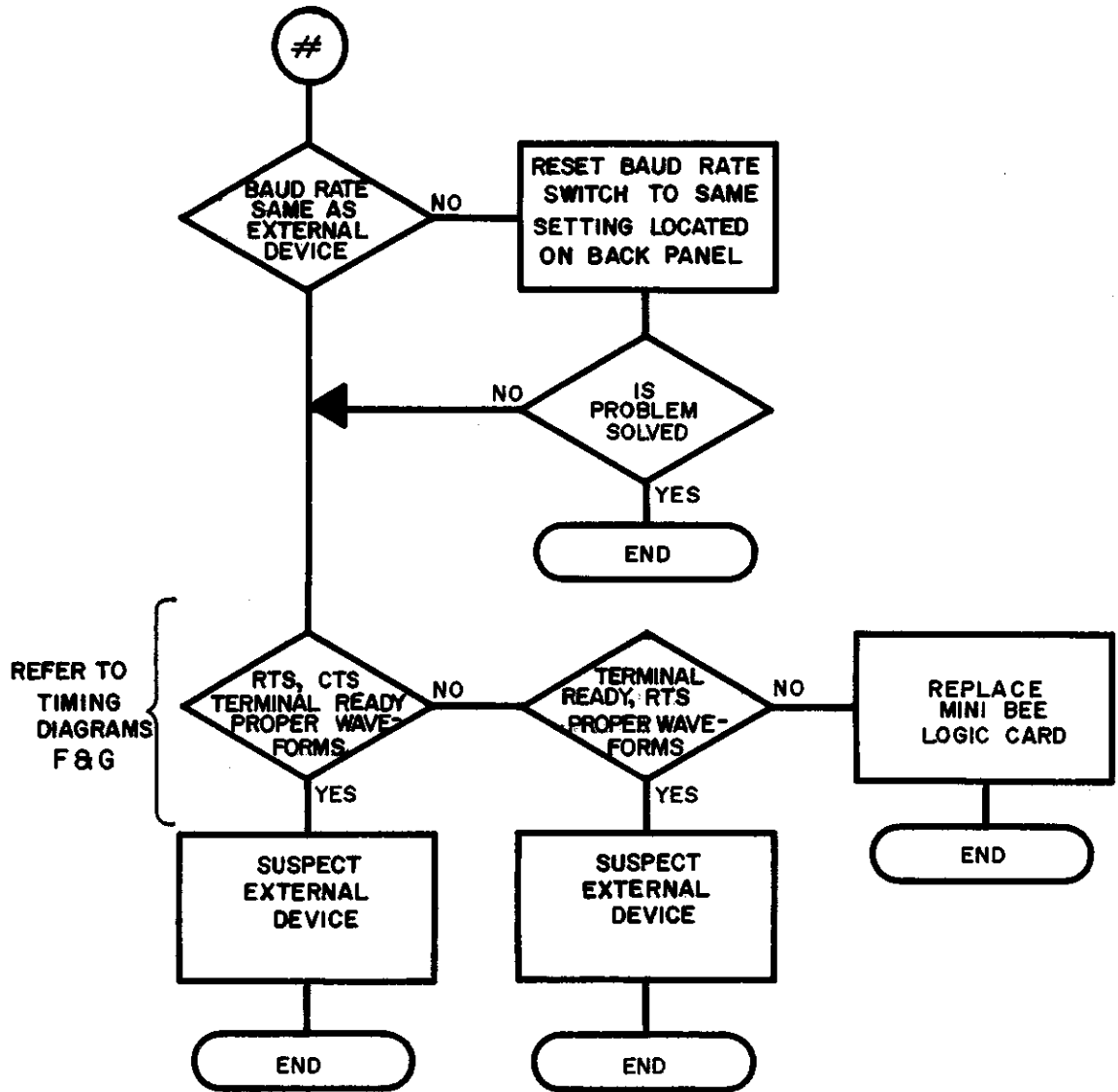



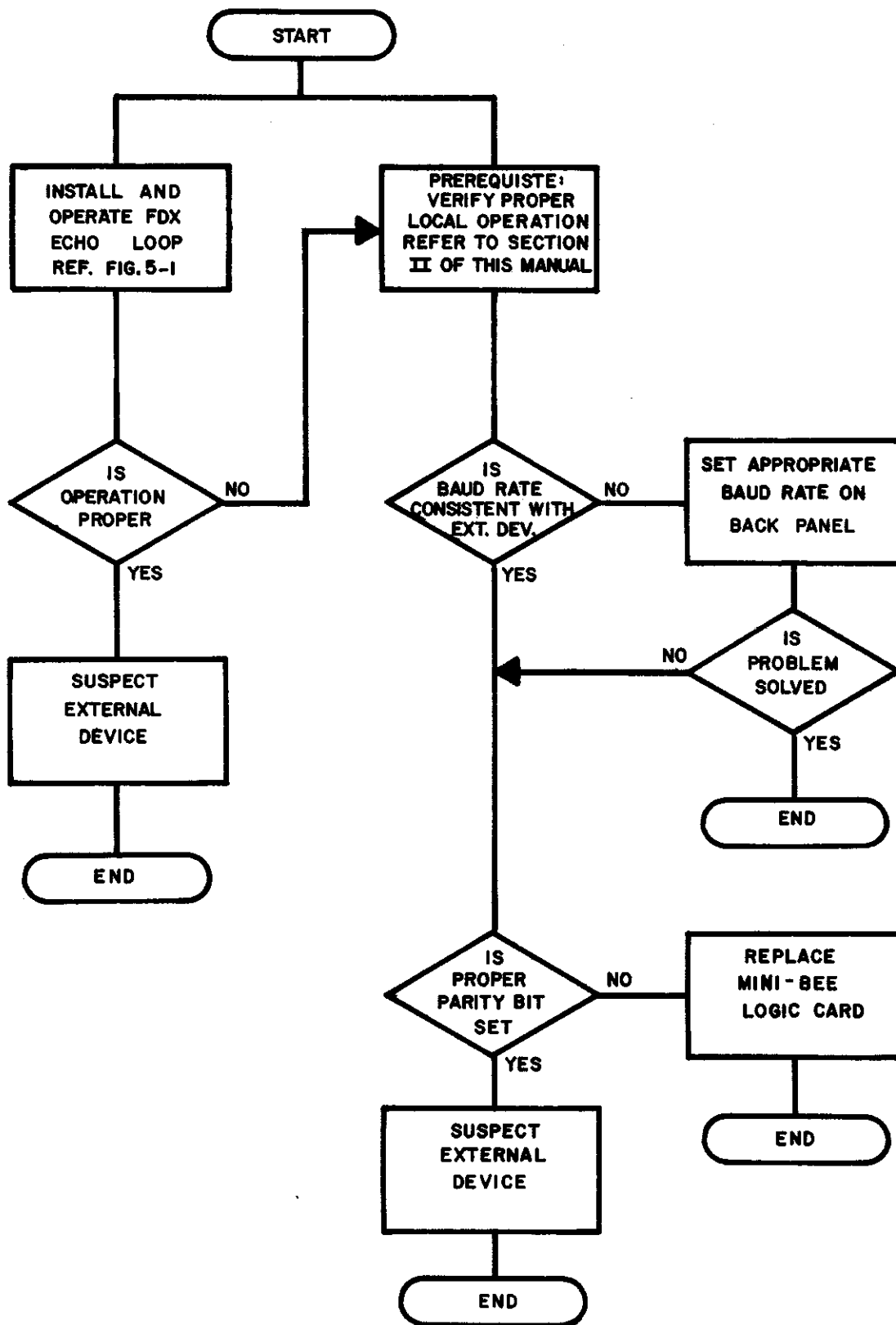

5-3C

PREREQUISITE: VERIFY PROPER OPERATION IN TERMINAL IN LOCAL MODE. REFER TO SECTION II OF THIS MANUAL.

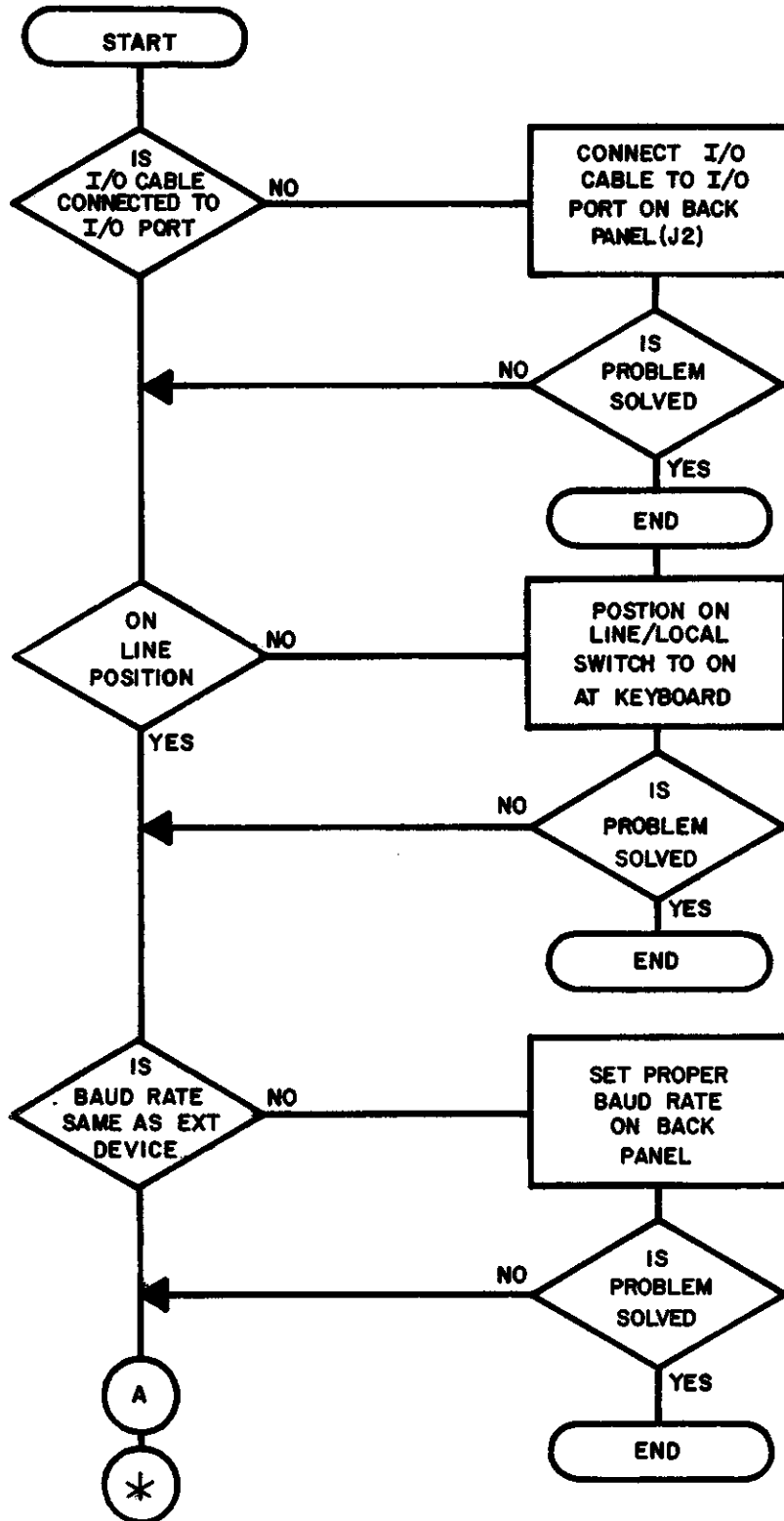

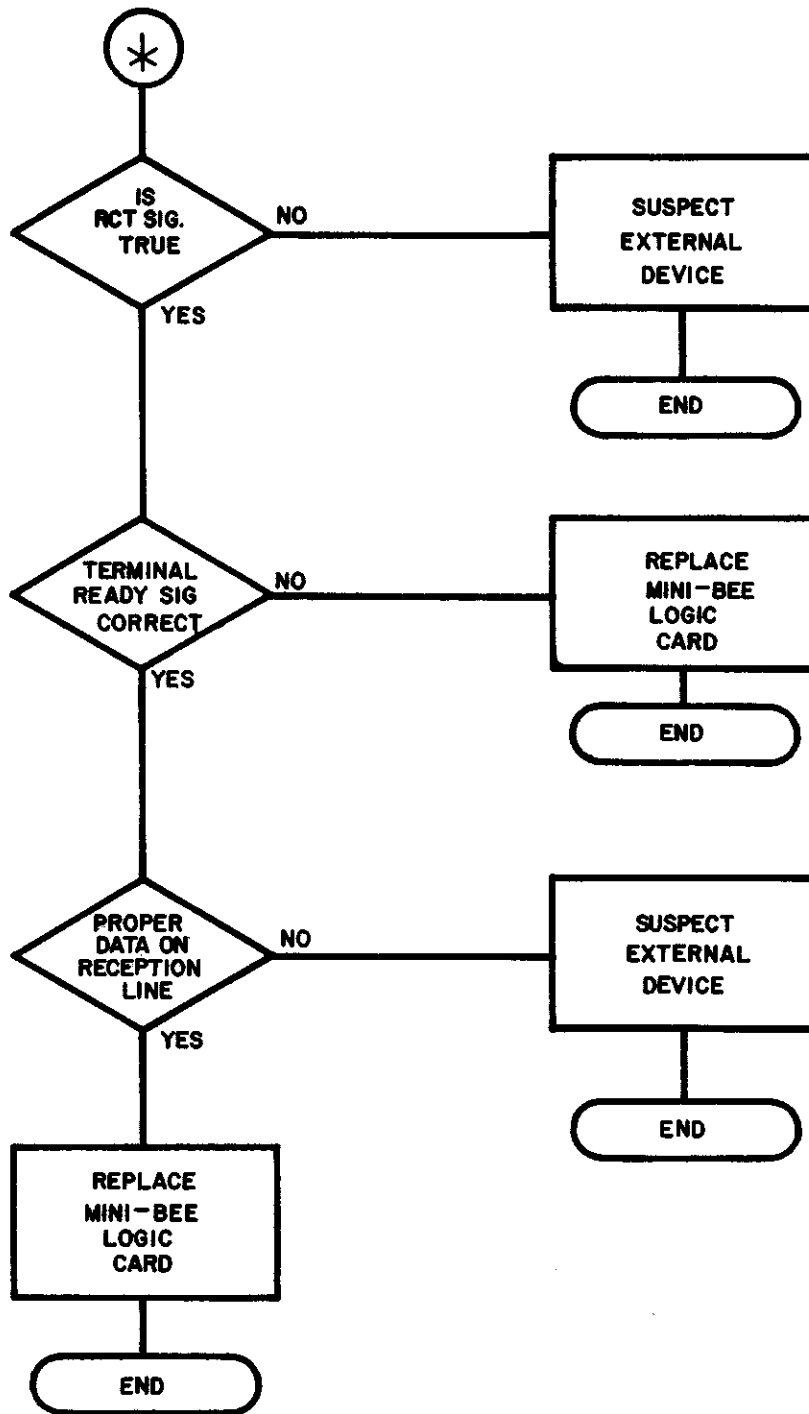

**A** — IF MINI-BEE CLOCK IS NECESSARY FOR EXTERNAL DRIVING CLOCK, CHECK CLOCK, REFER TO TIMING DIAGRAM F.

REFER SECTION II OF THIS MANUAL

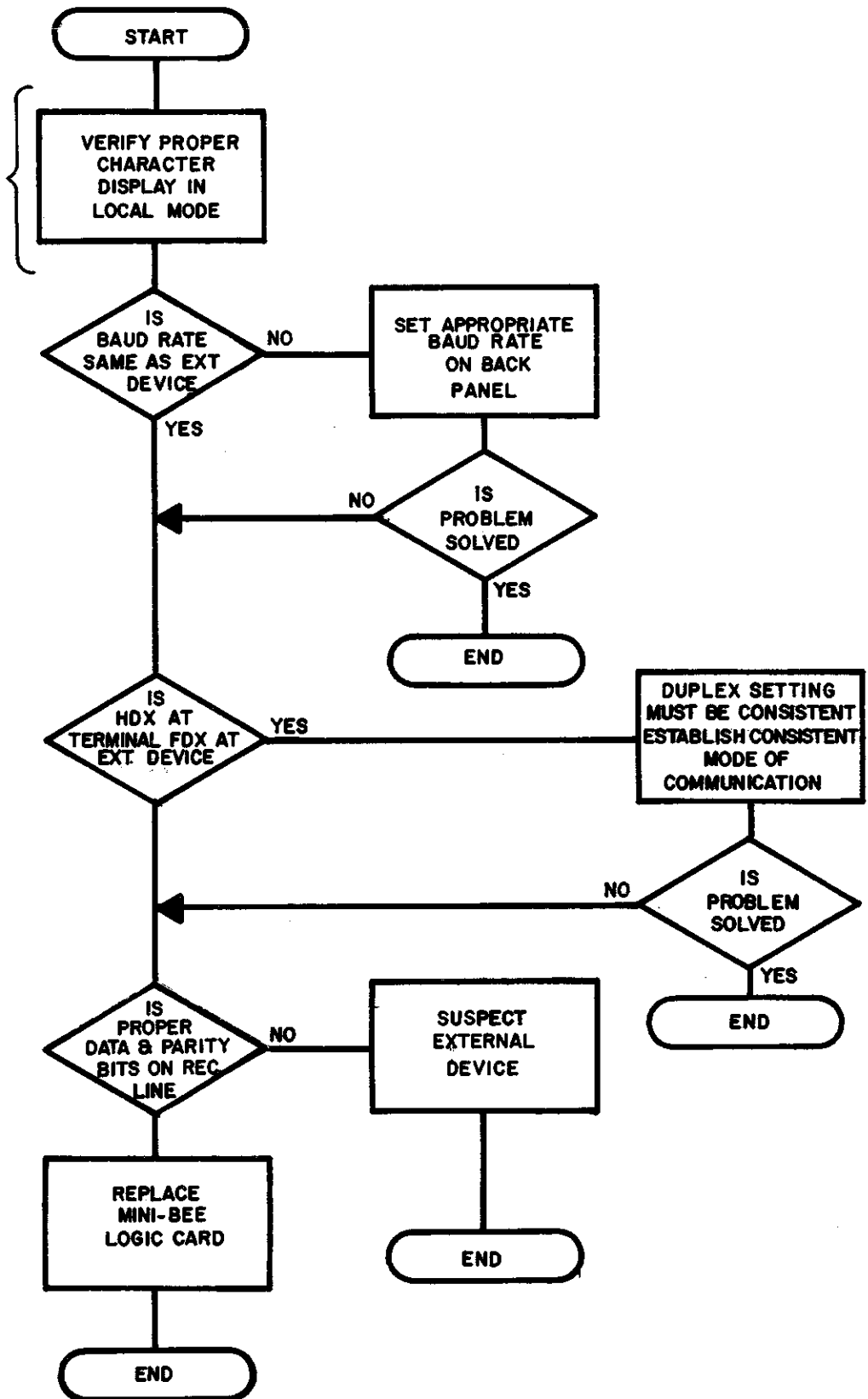

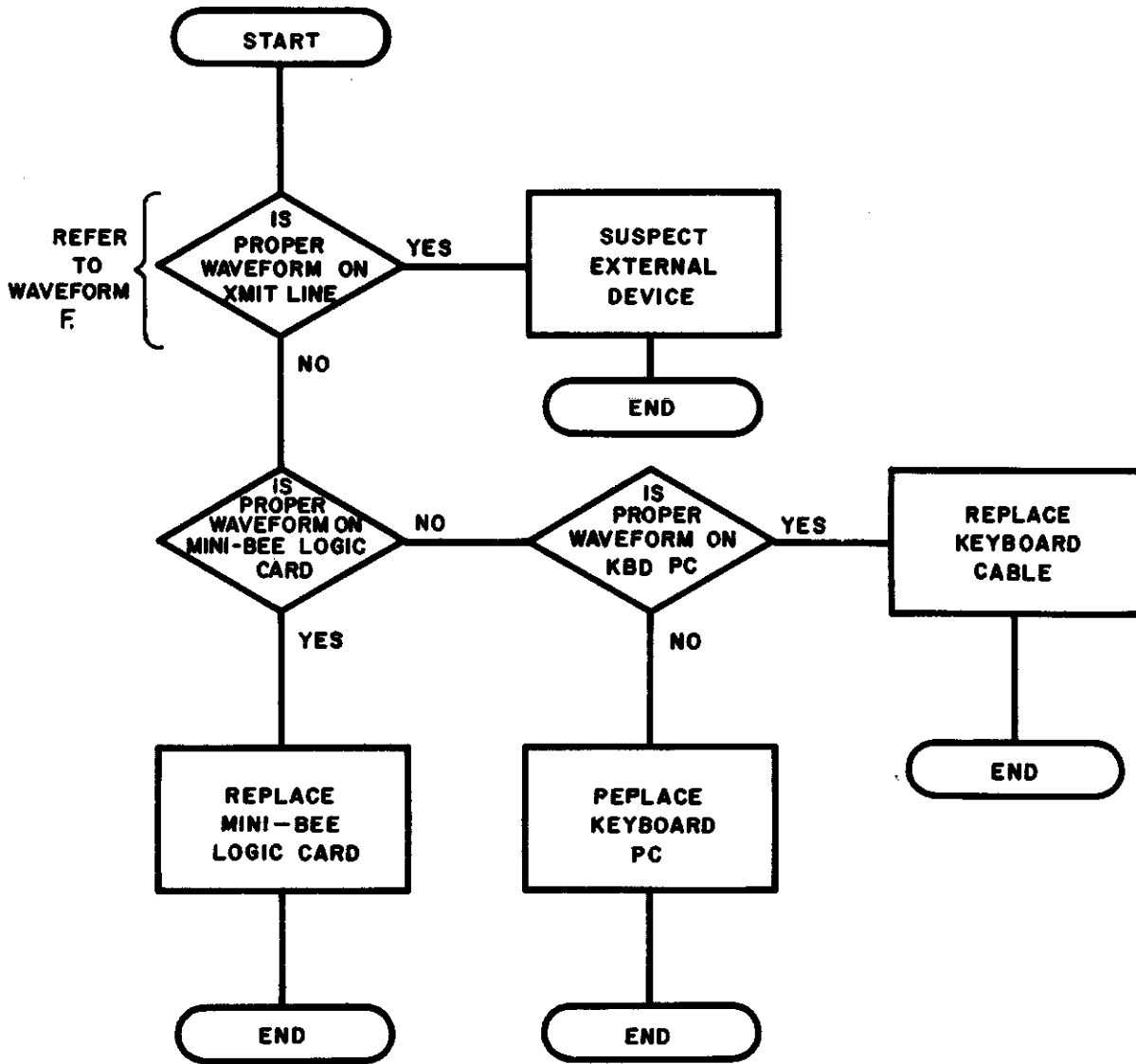

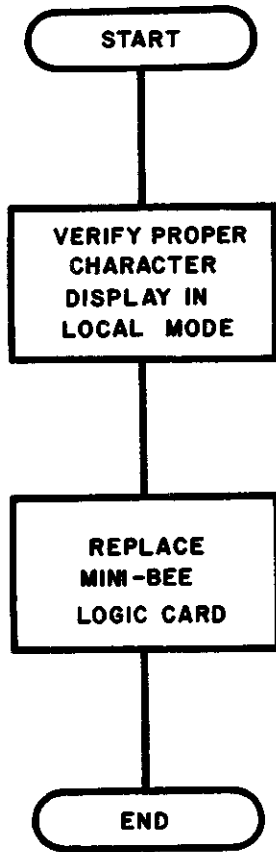

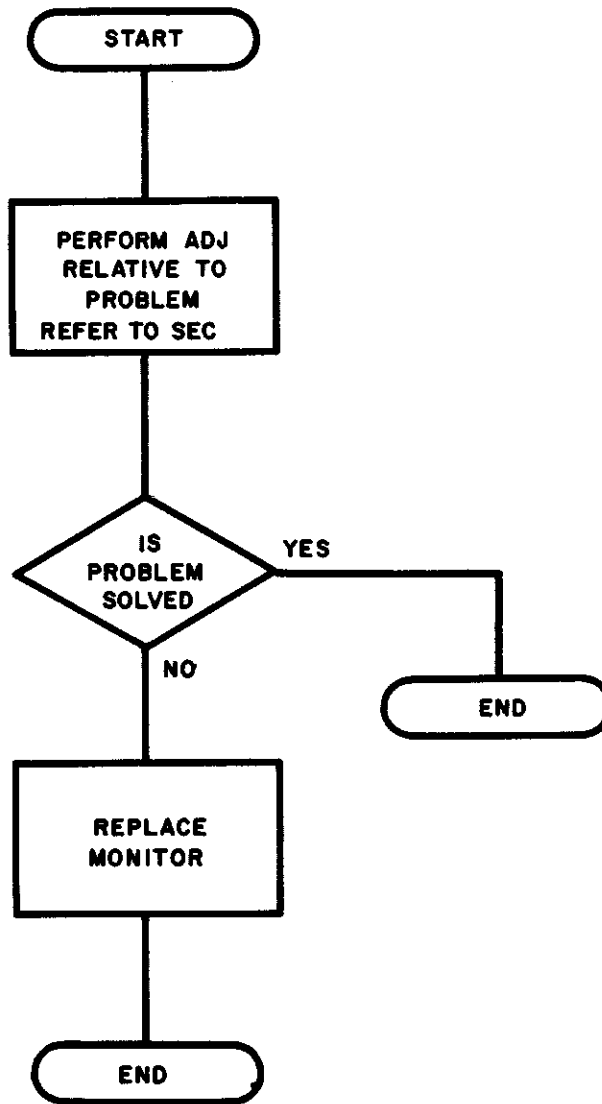

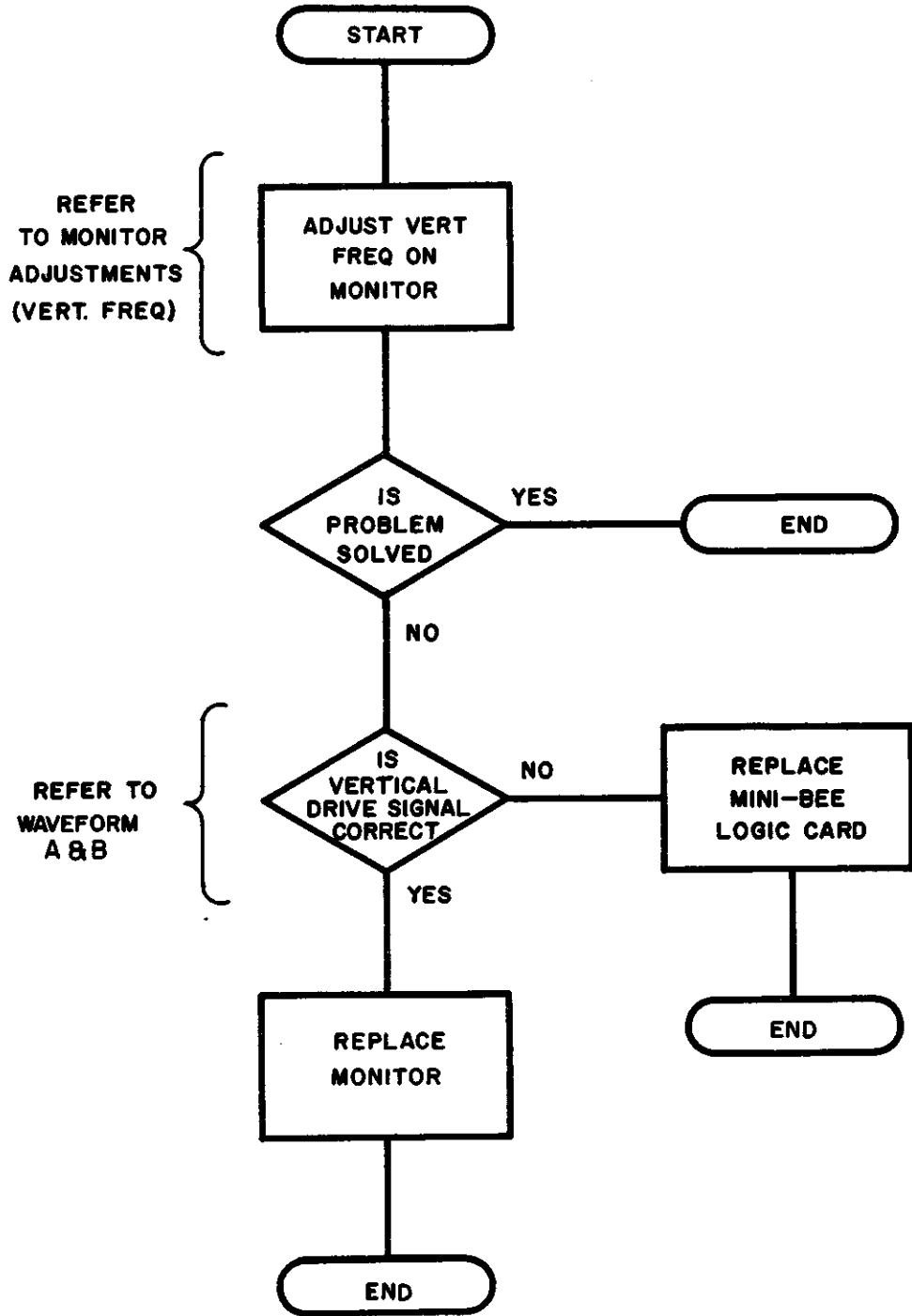



5-4C, 5-4D, 5-4E, 5-4F, 5-4G

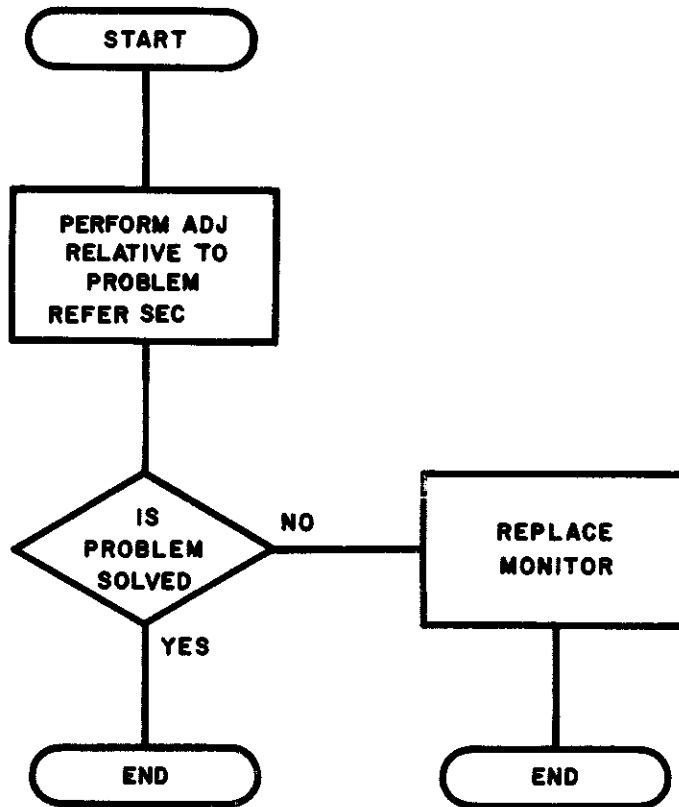

5-4H

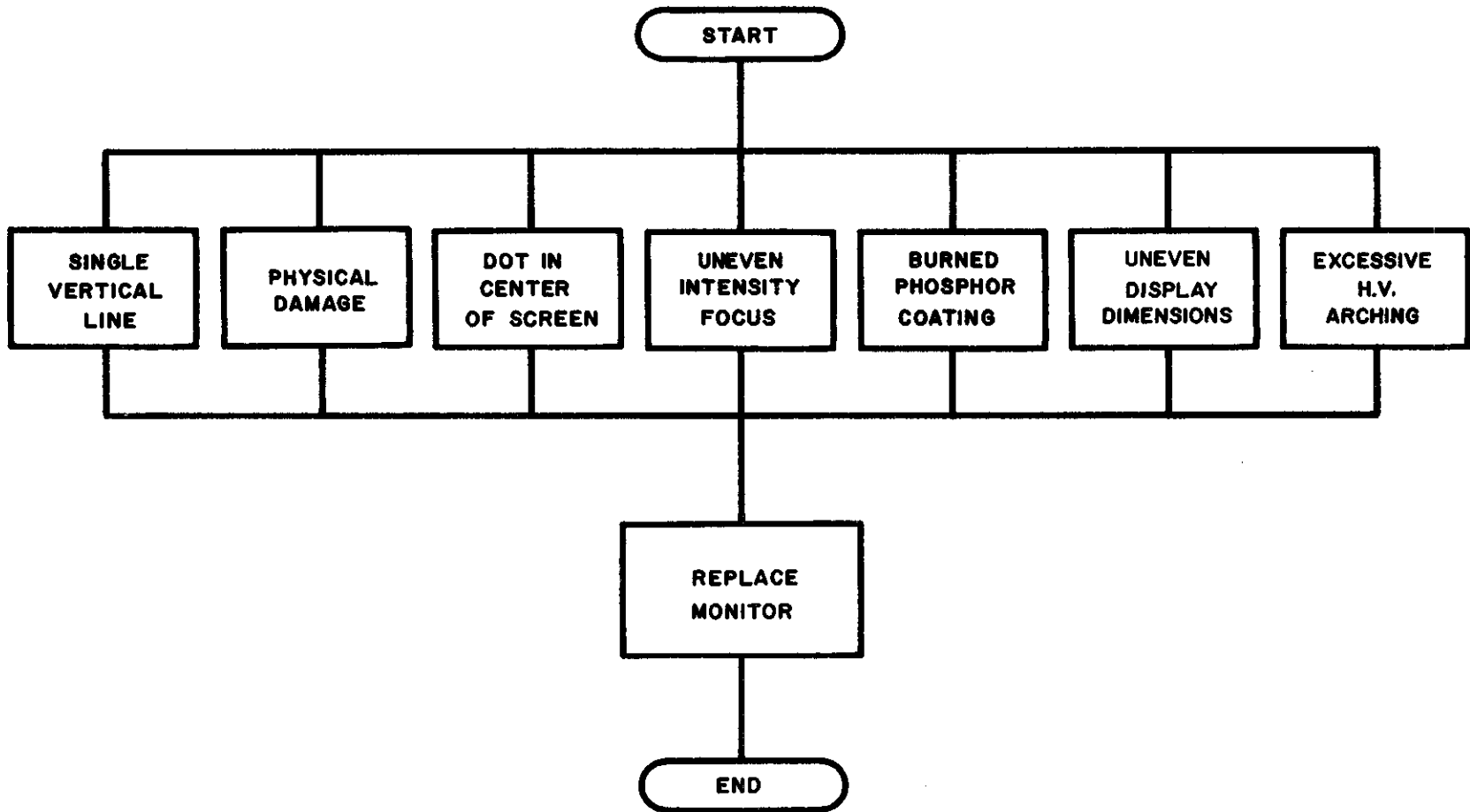

5-25

## 5-20. POWER SUPPLY ADJUSTMENTS

5-21 The MINI BEE is produced using powers supplies manufactured by three companies. All are the same in form, fit and function. Any difference in the assemblies is discribed in the following paragraph.

### 5-22 ELEXON POWER SUPPLY

To adjust the +5 VDC voltage level, the meter should be connected between point A, (Figure 5-2) and a good chassis ground. The voltage at this point should be +5 VDC  $\pm$  .2v. If it is not, rotating the adjustment lug on R7 (point B) should bring the voltage within specified limits.

To adjust the +15 VDC voltage level, connect the meter between point C and a good chassis ground. The voltage at this point should be +15 VDC  $\pm$  .2v. If it is not, rotating the adjustment lug on R17 (point D) should bring the voltage within specified limits.

To adjust the -12 VDC voltage level, connect the meter between point E and a good chassis ground. The voltage at this point should be -12 VDC  $\pm$  .2v. If it is not, rotating the adjustment lug on R27 (point F) should bring the voltage within specified limits.

The overload protection adjustment is aligned and clamped at the factory and should not be changed. However, adjustment can be made by connecting the meter between point G and a good chassis ground and should read approximately 3 VDC. The desired setting should be obtainable by rotating the lug on R33, point H.

### 5-23 SCINTILLONICS POWER SUPPLY

The Powerbee PC board is shown in figure 5-3 and the schematic included in Section VI.

The +5V output is adjustable from approximately 4.7V to a maximum of 6.5V or until OVP threshold is reached through turning the potentiometer, R2, clockwise (CW). A meter should be connected between a good ground and P-12-12 to adjust the +5V output.

To adjust the +15V output, the meter should be connected between a good ground and P2-5. The +15V output can range from 11.0V to 16.0V and adjusted by turning potentiometer R22.

The -12V output adjustment, meter connected from -ground to P2-4, by turning R42 CW. The -12V output may range from -9.0V to 14.0V.

Determination of the overvoltage protection circuit trigger level is accomplished simply through adjusting the applicable potentiometer until the SCR triggers.

To check the +5volt output, adjust R2 CCW for an output voltage of approximately 13.0V. A 2.2K ohm resistor is thereafter paralleled with R28. The voltage will increase to approximately 16.5V. R22 can then be adjusted until SCR 21 triggers and the threshold voltage measured.

To check the -12volt output, adjust R42 CCW for an output voltage of approximately -10.0V. A 2.2K ohm resistor is thereafter paralleled with R48. The voltage will then be adjusted CW until SCR 41 triggers and the threshold voltage measured.

## 5-25. MONITOR ADJUSTMENTS

5-26. The following adjustments should be made while the monitor is in the MINI BEE terminal. The adjustments described here are in reference to Figures 5-4, and 5-5 and consist of the following sections:

- BRIGHTNESS
- CONTRAST
- VERTICAL ADJUSTMENTS
- HORIZONTAL ADJUSTMENTS
- FOCUS
- CENTERING

Figure 5-4 shows the physical location of the specific adjustments on the MONITOR PC board, while Figure 5-5 shows the CRT mounted adjustments.

**WARNING:** The MONITOR employs high voltages. Care should be used in making any adjustments as power will be applied to the MONITOR.

5-27. The BRIGHTNESS control (located on the MINI BEE KEYBOARD assy.) should be positioned to a point where the white raster on the CRT is extinguished.

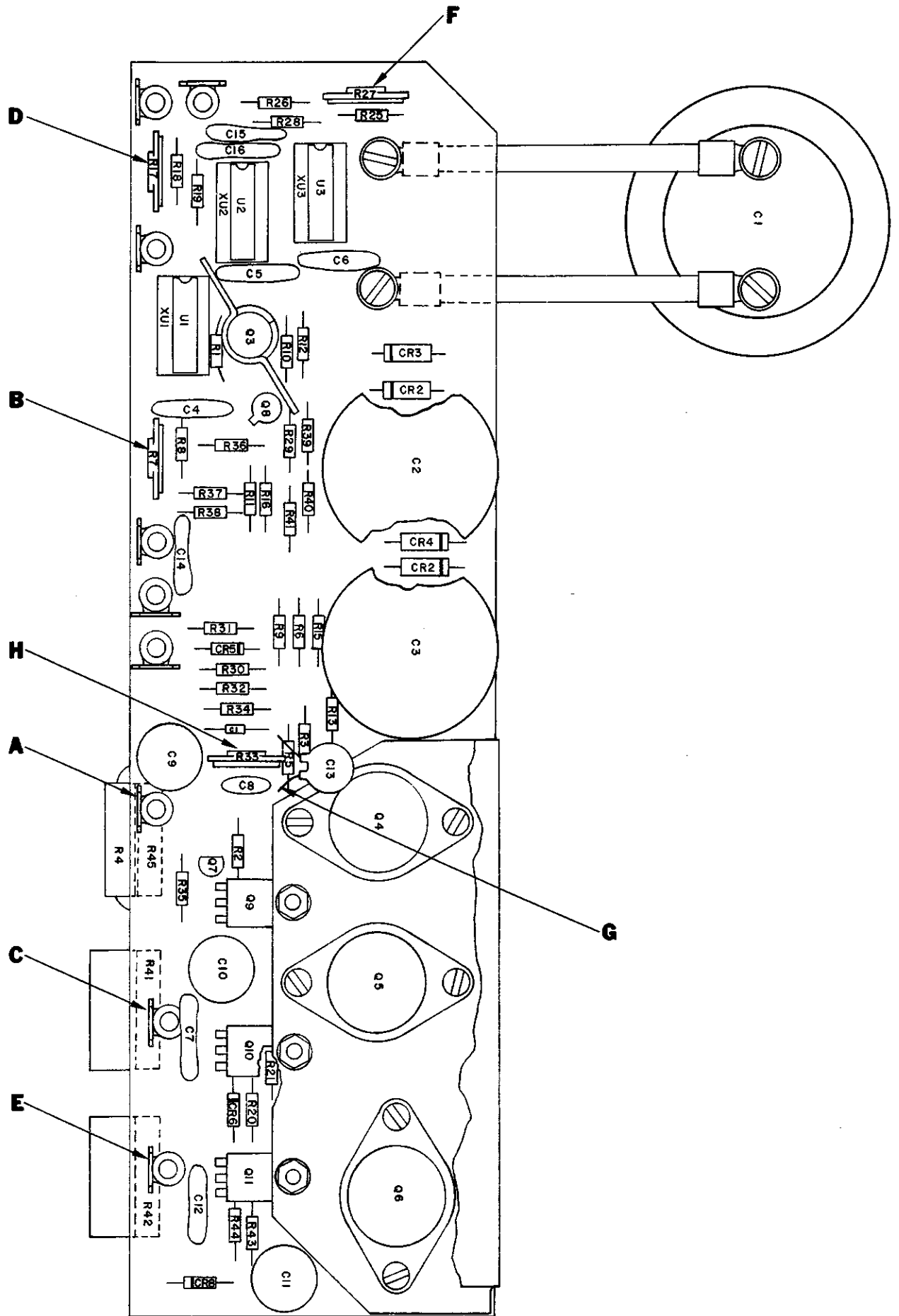

Figure 5-2. Power Supply Adjustments

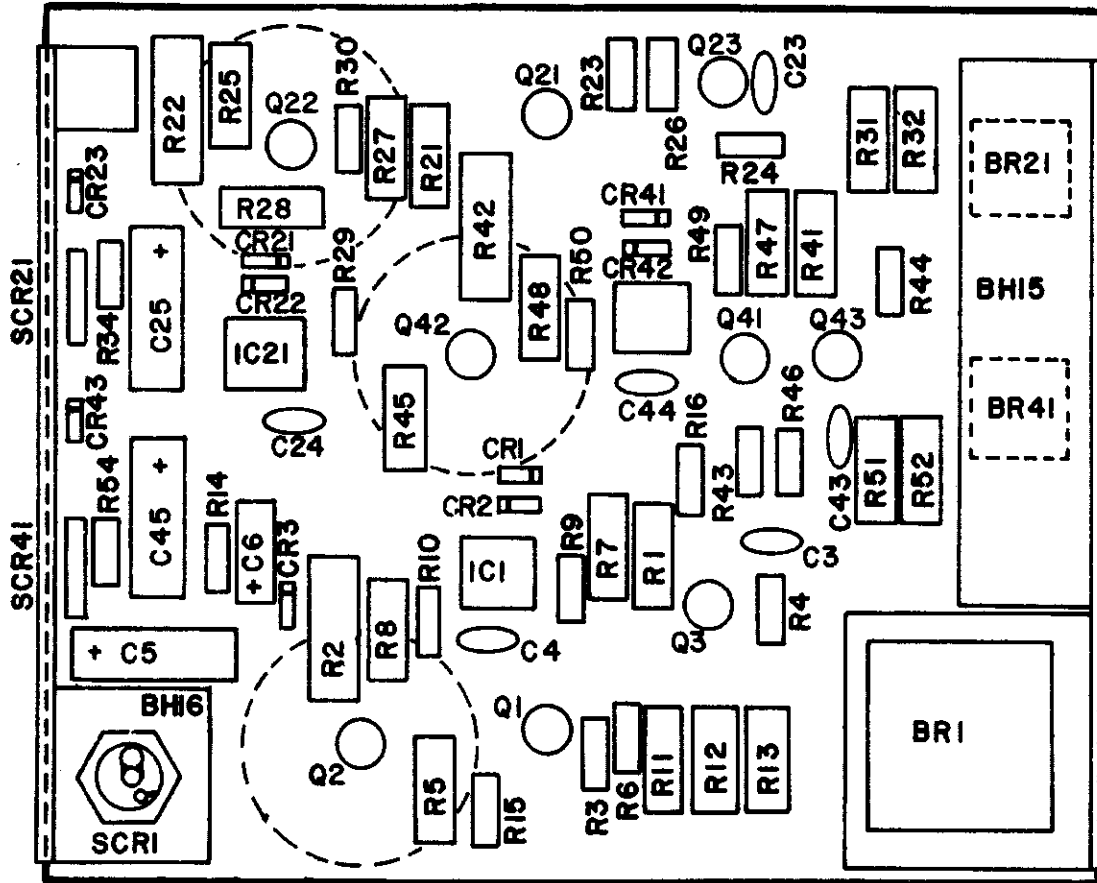

Figure 5-3 Powerbee P.C. Board Assembly

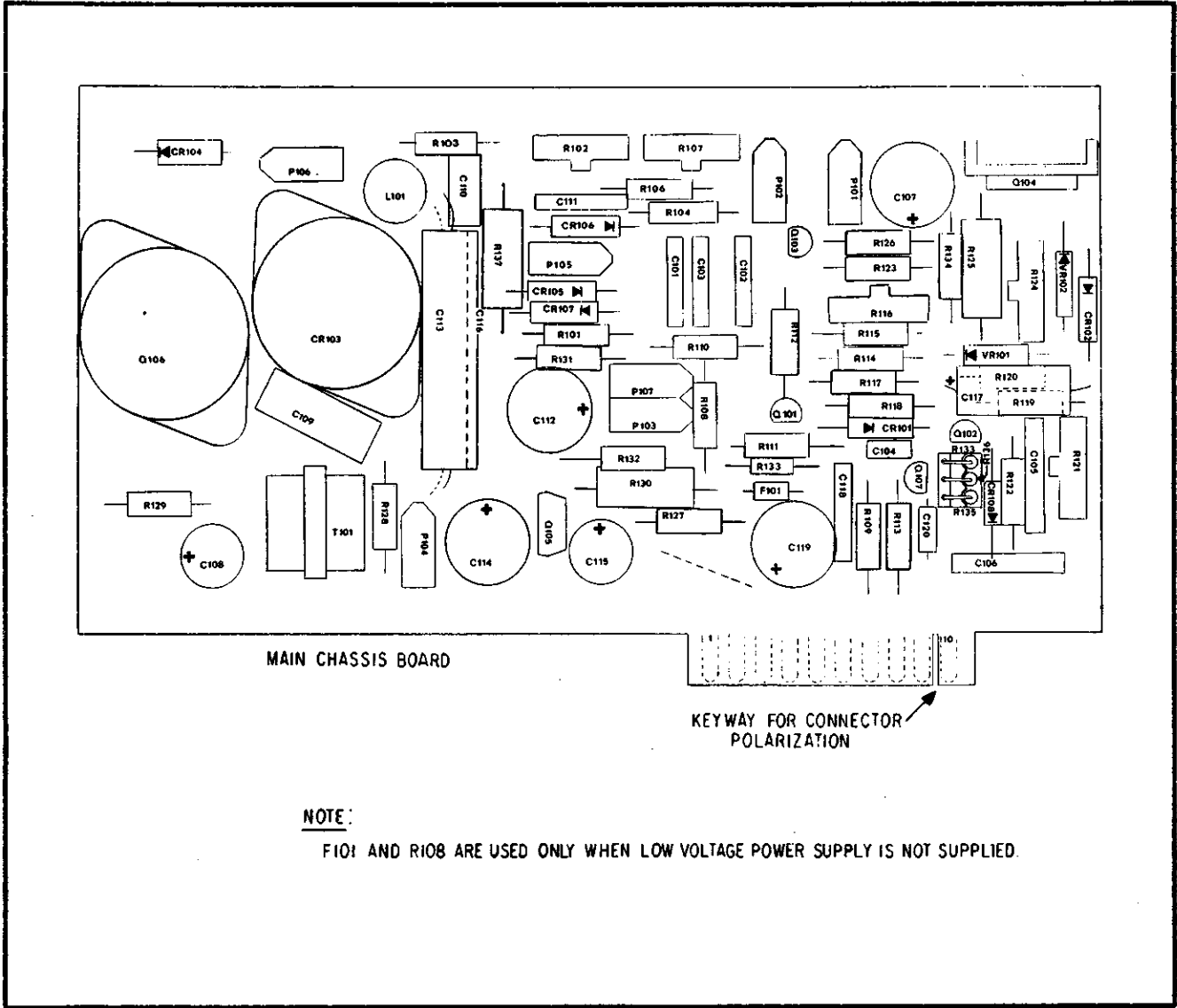

Figure 5-4. Monitor P.C. Card Adjustments

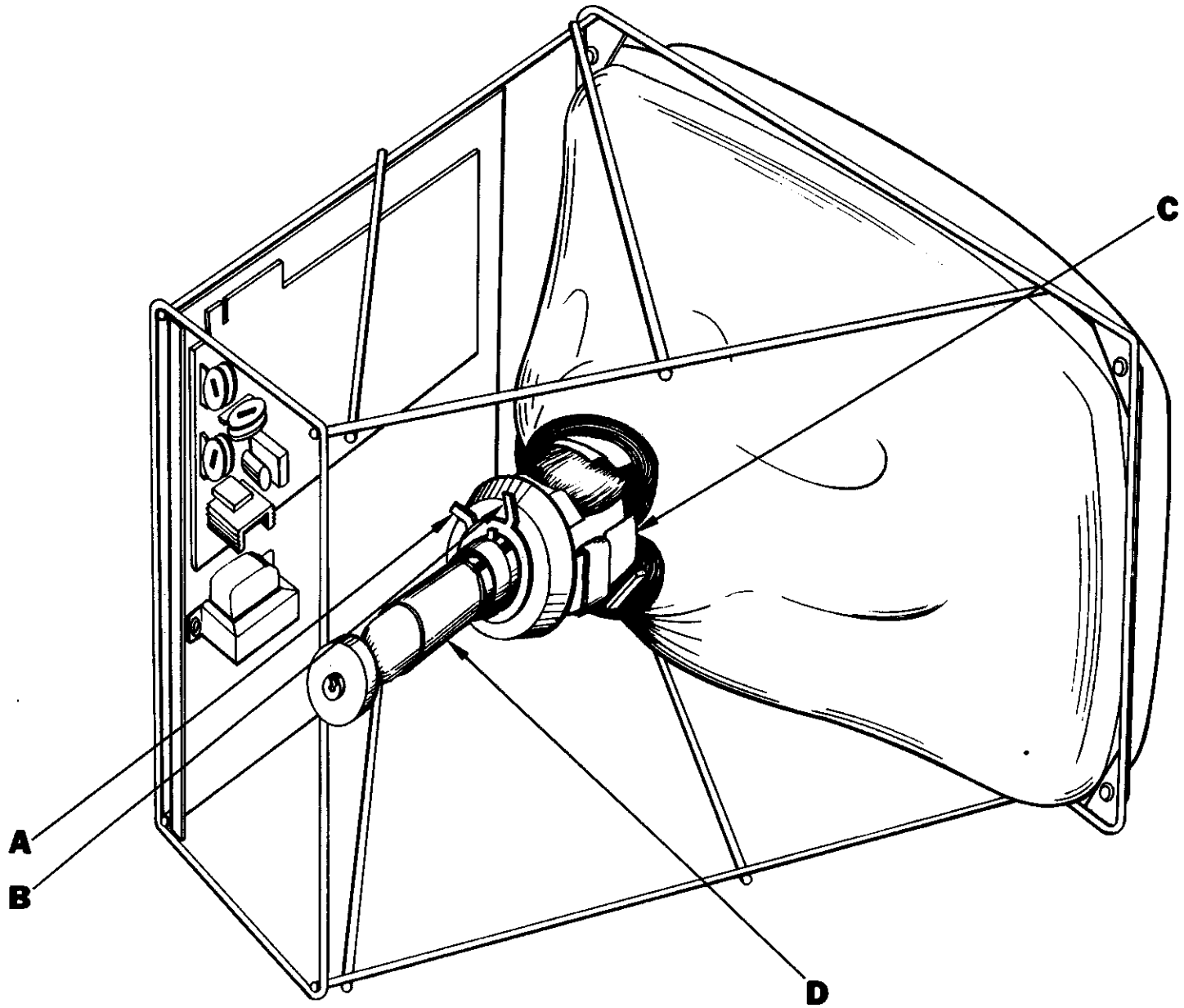

Figure 5-5. Monitor Yoke Adjustments

5-28. Fill the screen of the CRT with characters from the KEYBOARD (i.e., all E's) and adjust the contrast control for the sharpest display of the characters in the upper left hand side of the screen.

5-29. The vertical frequency control R 116 Fig. 5-4 is set to approximately its mechanical mid-point initially. This adjustment will correct for a rolling display and should be adjusted to correct that symptom alone. No discrete measurement is necessary, except for a visual observation as to the steadiness of the display.

5-30. Fill the screen once again with characters, if none exist. The vertical height control R 124 Fig. 5-3 should be adjusted for 6½ inches from the top of the characters on the first row to the bottom of the characters on the last row in the center of the display.

5-31. The vertical linearity control Fig. 5-4 should be adjusted so the characters on the first row are equally as tall as the characters on the last row. Their height should be approximately .18 inches.

5-32. If the screen is blank, fill it with a character and adjust the horizontal width coil L 101 Fig. 5-4 for 7½ inches from the left margin to the right margin of the displayed characters.

5-33. The horizontal linearity is adjusted to correct for the compression of the display on the left-hand side of the screen. To correct this, loosen the clamp securing the yoke and slide the cardboard sleeve (horizontal linearity sleeve), refer Figure 5-5 (point D) in or out to give uniform width to the characters on the right and left-hand borders of the display.

5-34. Adjust the FOCUS control R 107 Fig. 5-4 for the best over-all display focus. It may be necessary to readjust the contrast control and repeat this step.

5-35. Centering of the display is accomplished by rotating the tabbed ring magnets on the CRT behind the deflection yoke, refer to Figure 5-4 points A and B. If the display as a whole is tilted, correction may be accomplished by rotating the entire yoke, point C.

## 5-36. KEYBOARD

5-37. The keyboard requires no adjustment. If there is an apparent failure, refer to the maintenance section of this manual.

## 5-38. MINI BEE LOGIC CARD

5-39. The only adjustable components on the MINI BEE LOGIC CARD are associated with the specific operation to be performed by the MINI BEE terminal, i.e., baud rate, contrast, etc. If there is an apparent failure, refer to the maintenance section of this manual.

## 5-40. REMOVAL AND REPLACEMENT PROCEDURES FOR THE MINI BEE TERMINAL

5-41. The procedures presented here are disassembly steps. To assemble the MINI BEE these procedures should be executed in the reverse order.

**WARNING:** These procedures should not be attempted with any electrical power connected, or terminal circuits energized.

## 5-42. REMOVAL OF THE OUTER COVER

5-43. The outer cover, or skin has six flat head no. 6 bolts holding it to the lower base assembly; three on the right and three on the left,

- a. Remove the six screws to free the outer covering.
- b. Lift the upper shell up and off the terminal.

## 5-44. REMOVAL OF THE POWER SUPPLY

5-45. The removal procedure for the three power supply designs is the same.

- a. Remove the J4 connector on the upper left hand corner of the MINI BEE LOGIC CARD. This is accomplished by placing the tip of a standard screw driver in the gap between the logic card and the connector and prying the connector off. (Use caution not to break the connector.)
- b. Disconnect the connector (P10) that connects to the AC power outlet and is located in the rear, bottom left-hand corner of the terminal near the power supply.



- c. Tip the terminal on its side so the power supply is at the bottom.
- d. Remove the front bottom foot.
- e. Remove the three large (No. 10) bolts located on the bottom that secure the POWER SUPPLY to the terminal base.
- f. Lift the terminal away from the power supply.

**WARNING:** The power supply is very heavy and care must be taken not to allow it to fall away from the terminal.

#### 5-46. REMOVAL OF THE KEYBOARD P.C. CARD

5-47 Care must be used in removing the P.C. card to prevent damage to the components.

- a. Unplug the keyboard from the terminal.
- b. Tip the keyboard upside down on a protected surface (i.e. mat, carpet, etc.). You will find three large holes on the bottom front edge of the keyboard.
- c. Remove the nuts located in the holes and lift the front of the keyboard housing up. The keyboard insert assembly should fall away from the housing. If not, push it through by pushing it with a small screw driver from the center hole on the bottom side.
- d. Turn the keyboard right side up and completely remove the keyboard insert assembly, if it has not fallen completely off.
- e. Remove the connector in the left hand corner of the keyboard P.C. assembly.
- f. Remove the four nuts and washers securing the P.C. card to the keyboard insert assembly located on either side of the P.C. assembly.
- g. Remove the P.C. assembly using care not to snag any of the wires or components.

Note: Care must be used not to lose spacers between P.C. assembly and insert.

#### 5-48. REMOVAL OF THE MONITOR

5-49 Use extreme caution in handling the MONITOR to prevent damage to the CRT tube.

- a. Remove the edge (J12) connector from the MONITOR P.C. card located on the top of the MONITOR assembly by removing the two holding clamps at each end of the connector and pull the connector away. Look inside the edge (J12)

connector and ensure the polarity key is intact and in position.

- b. Turn terminal so the face is toward you.
- c. Remove the window assembly from the MINI BEE by pulling it directly out from the terminal.
- d. Remove the four bolts which connect the bezel frame to the MONITOR, remove the frame and spacers. Bolts should be retightened to secure the CRT to frame.
- e. With the front of the terminal to your right, locate and remove two bolts in bottom edge of the MONITOR frame . These bolts attach the MONITOR to the MONITOR mount.
- f. Lift the MONITOR directly away from the terminal.

#### 5-50. REMOVAL OF THE FAN

5-51 Removal of the fan is required in whole or in part, to remove the Logic Card.

- a. Position the terminal so the terminal is facing your right. (Terminal front to your right).
- b. Remove the four bolts holding the fan deflection cover to the fan housing.
- c. Disconnect fan cable from terminal block.
- d. Turn Terminal on its side, and locate and remove four bolts attaching fan to base.
- e. Turn Terminal right side up and remove fan housing, finger guard and screen.

#### 5-52. REMOVAL OF THE MINI BEE LOGIC BOARD

5-53 When removing the LOGIC CARD, care must be used to protect the components on the board.

- a. Turn the terminal so the back is facing you. Note: The fan inhibits the removal of the logic board.
- b. If fan has not been removed entirely, remove the two outer bolts and the rear inner bolt that secures the fan to the terminal base leaving the remaining bolt to hold the fan to the terminal.
- c. Rotate the fan counter-clockwise.
- d. Disconnect the P5 connector from the upper left-hand corner by replacing the tip of a standard screwdriver in the gap between the logic card and the connector and prying the connector off. (This should require only moderate force, and should not damage the logic card.)

- e. Remove the P4 connector located adjacent to the P5 connector in the same manner.
- f. Remove the black rotary baud switch knob with a 1/16th inch Allen wrench.
- g. Remove the three nuts holding the HDX/FDX switch, the 110/150 selector switch, and the rotary selector baud rate switch with a 5/16th inch wrench.
- h. Remove the two bolts on both sides of the I/O connector (J2) with a 3/16th inch wrench or nut driver.
- i. Tip the MINI BEE so it rests on the side of the terminal on a protected surface.
- j. Remove the four bolts at the right rear and left rear of the terminal base that hold the upright supports for the MINI BEE LOGIC CARD to the chassis. Care should be taken to support the logic card so no damage will occur when it is freed in the terminal.)
- k. Return the terminal to its upright position with the back of the terminal facing you.
- l. Tilt the top of the LOGIC CARD toward you.
- m. Remove the two bolts connecting the keyboard (PI) extension cable connector to the logic card and disconnect their coupling.
- n. Carefully lift the MINI BEE LOGIC CARD, with the upright supports attached, out of the terminal.
- o. Remove the four bolts securing the upright support brackets to the Logic Card and remove the brackets.

**SECTION VI  
DIAGRAMS**

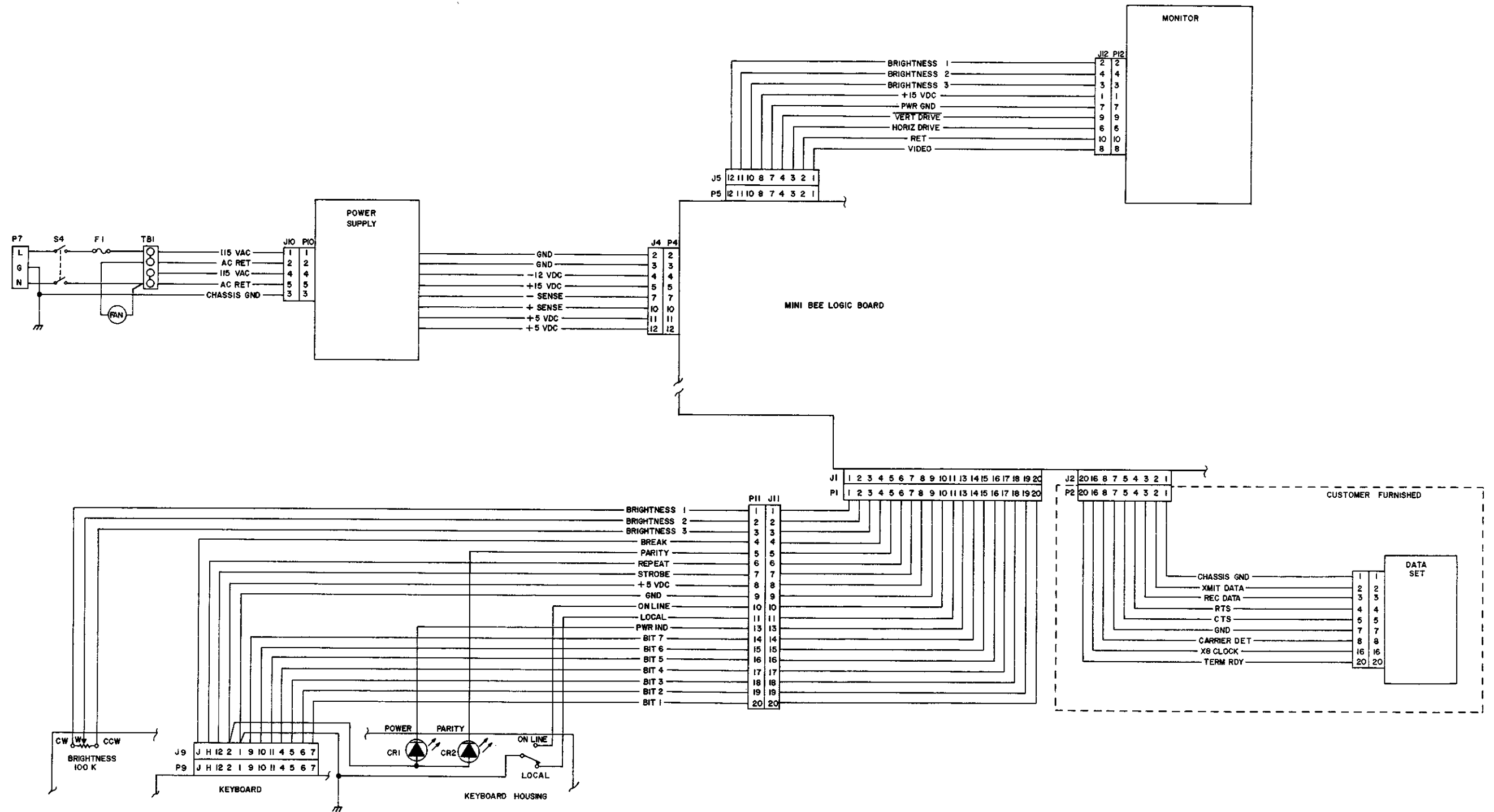

**MINI BEE  
INTERCONNECTION DIAGRAM**

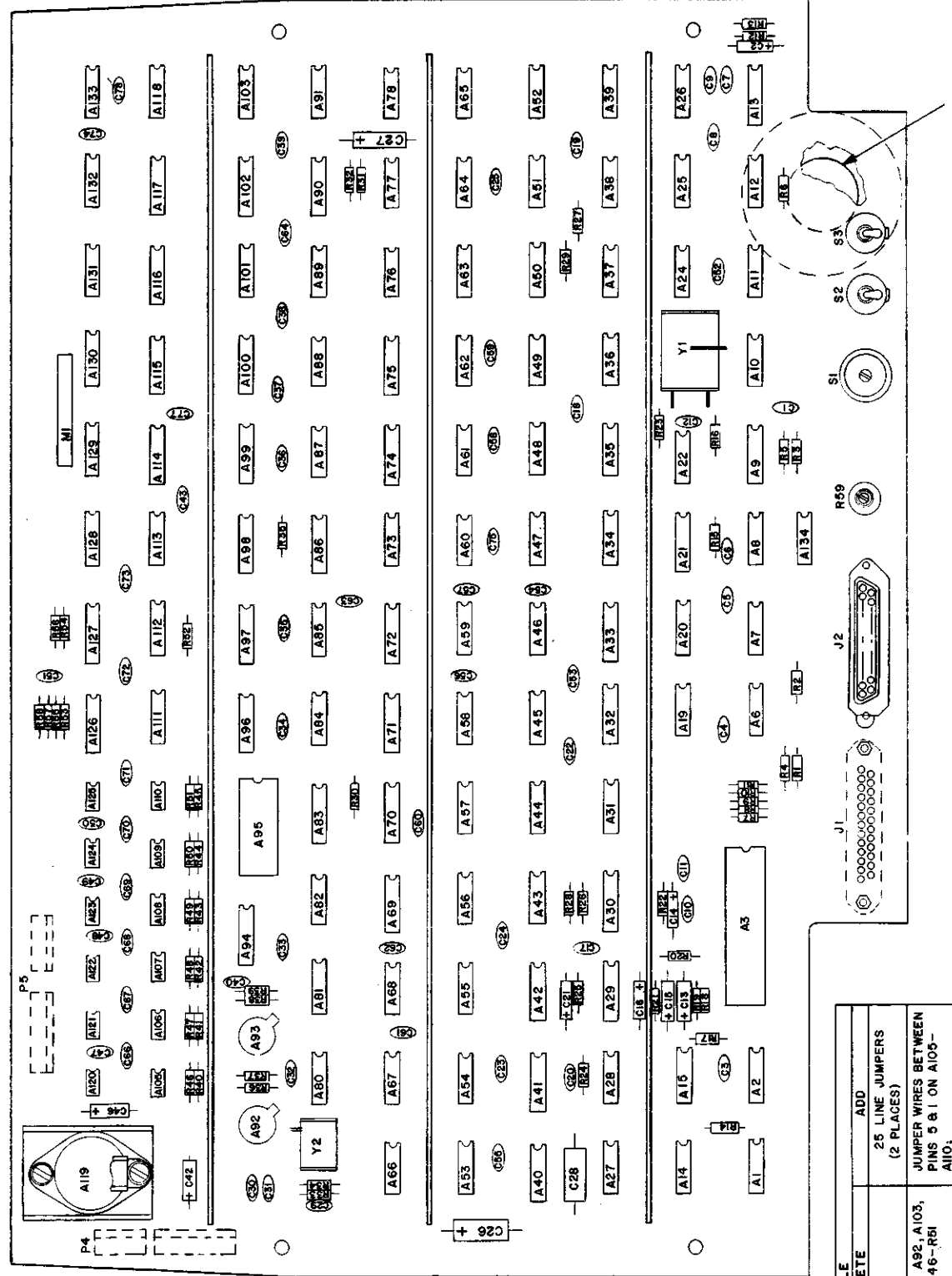

PART NO. & OPTION	DELETE	ADD
112-0455-0001 (25 LINE OPTION)	A91	25 LINE JUMPERS (2 PLACES)
112-0455-0002 (12 LINE OPTION)	A106-A110, A92, A103, R36, R37, R46-R61	JUMPER WIRES BETWEEN PINS 5 & 1 ON A105- A110, 12 LINE JUMPERS (2 PLACES)
112-0455-0003 (25 LINE OPTION WITH TO MARKING STATE)	COMPONENT SIDE-CUT CONDUCTOR BETWEEN A3 PIN 35 & A3 PIN 36	DIP SIDE - ADD A JUMPER BETWEEN A3 PIN 35 & A3 PIN 36 JUMPERS
112-0455-0004 (25 LINE OPTION WITH METER)		M1 & 25 LINE JUMPERS

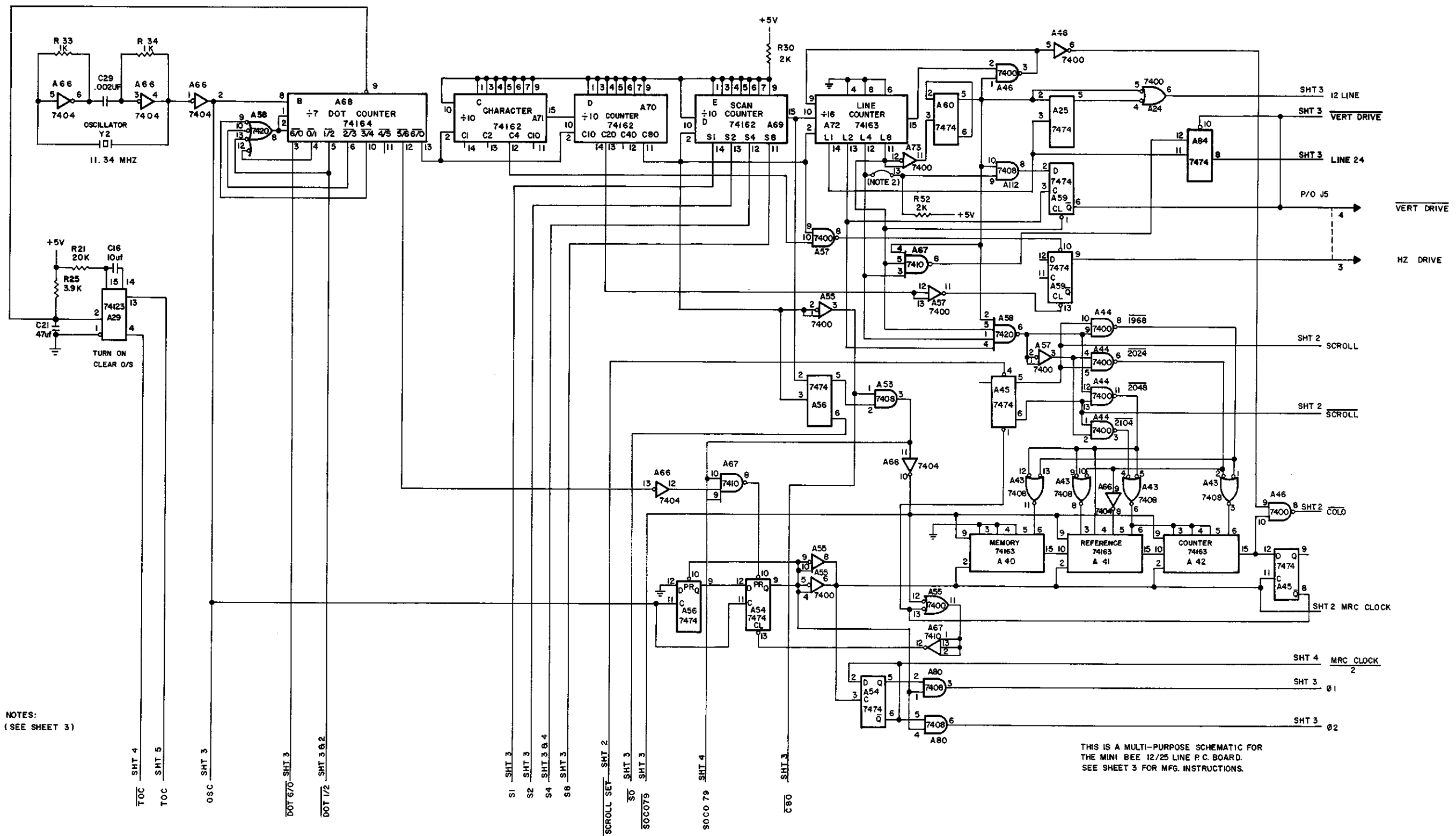

NOTES:  
(SEE SHEET 3)

THIS IS A MULTI-PURPOSE SCHEMATIC FOR THE MINI BEE 12/25 LINE P.C. BOARD. SEE SHEET 3 FOR MFG. INSTRUCTIONS.

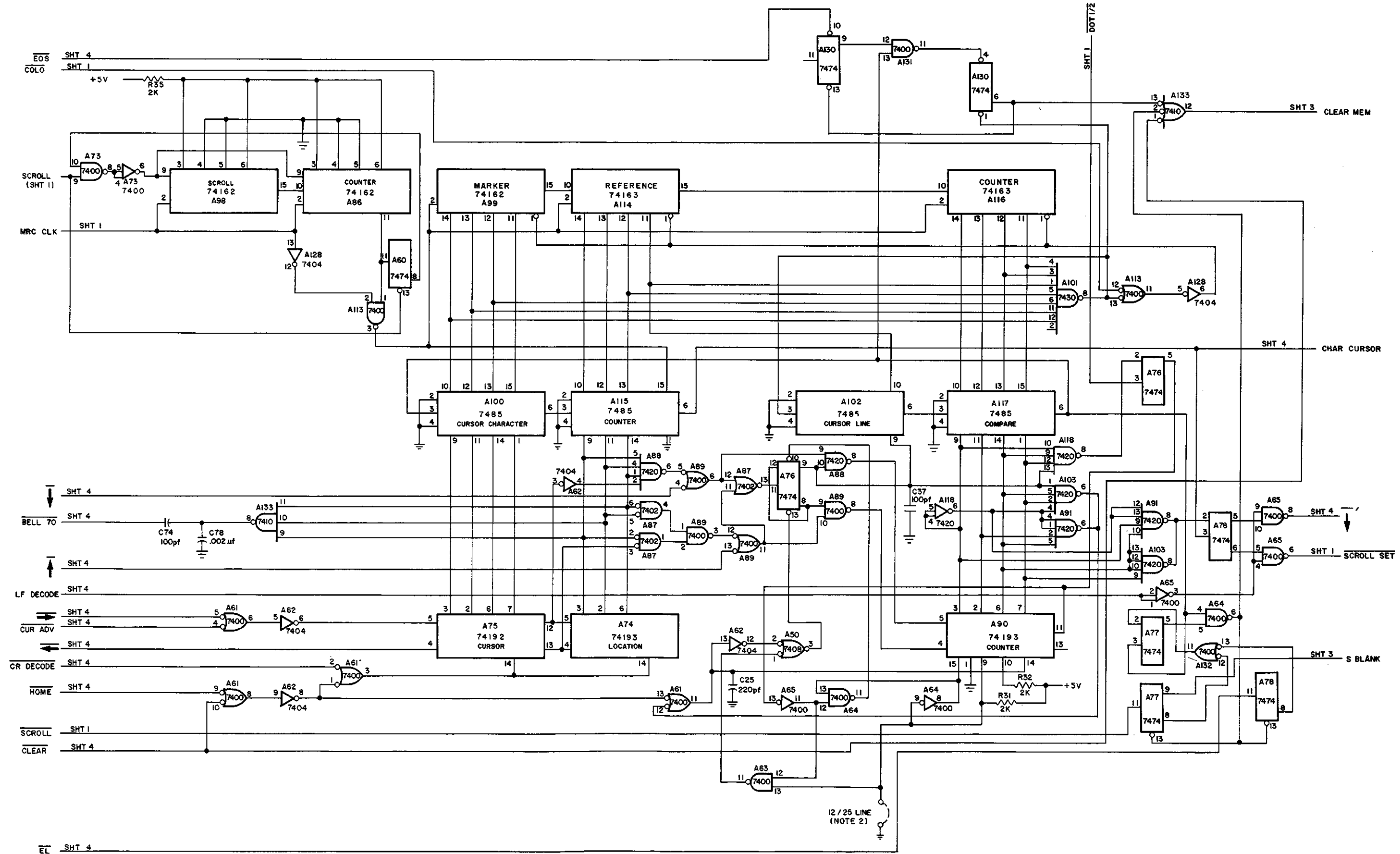

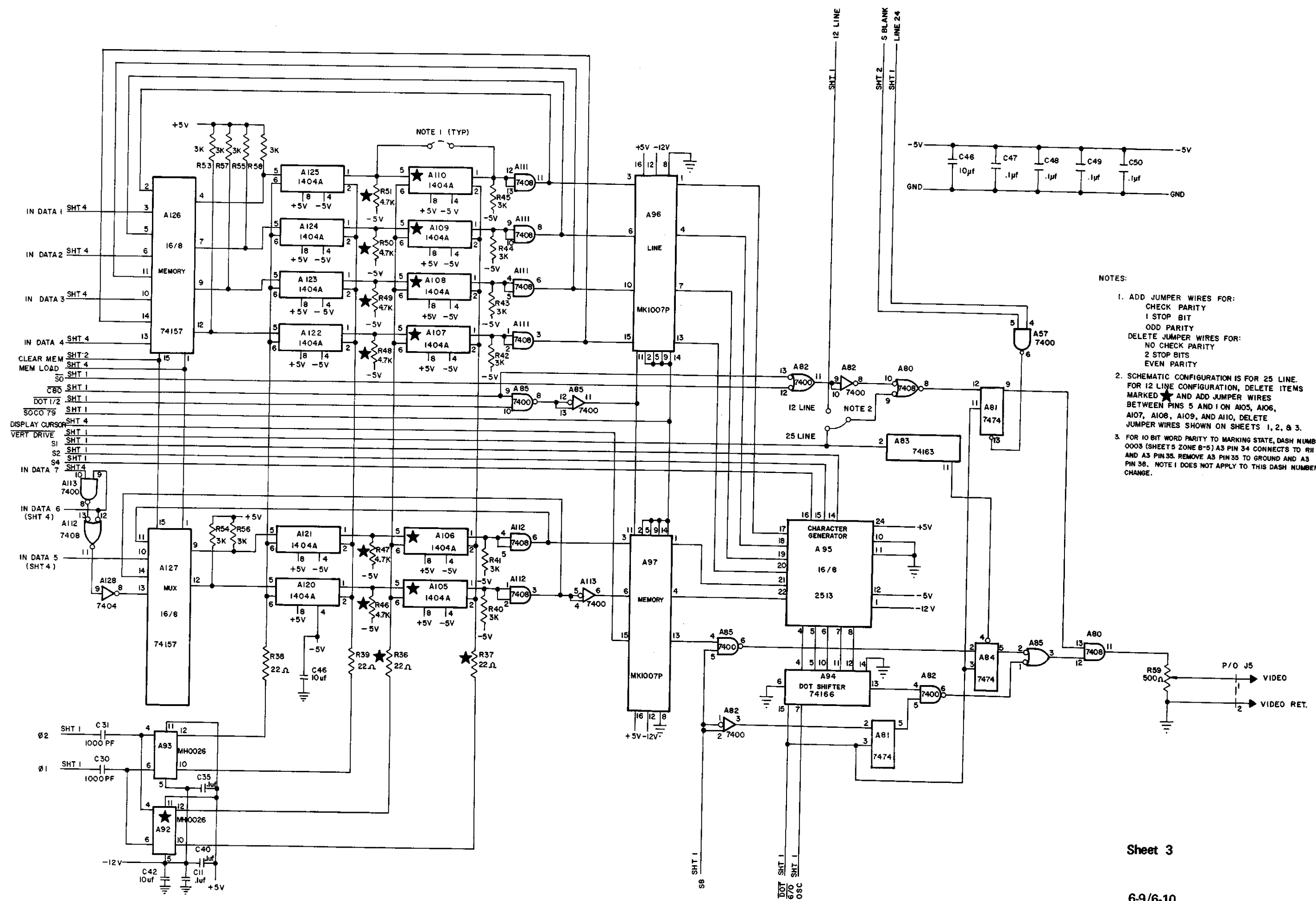

- NOTES:
- ADD JUMPER WIRES FOR:  
 CHECK PARITY  
 1 STOP BIT  
 ODD PARITY  
 DELETE JUMPER WIRES FOR:  
 NO CHECK PARITY  
 2 STOP BITS  
 EVEN PARITY
  - SCHEMATIC CONFIGURATION IS FOR 25 LINE.  
 FOR 12 LINE CONFIGURATION, DELETE ITEMS  
 MARKED ★ AND ADD JUMPER WIRES  
 BETWEEN PINS 5 AND 1 ON A105, A106,  
 A107, A108, A109, AND A110, DELETE  
 JUMPER WIRES SHOWN ON SHEETS 1, 2, & 3.
  - FOR 10 BIT WORD PARITY TO MARKING STATE, DASH NUMBER  
 0005 (SHEET 5 ZONE B-5) A3 PIN 34 CONNECTS TO R11  
 AND A3 PIN 35. REMOVE A3 PIN 35 TO GROUND AND A3  
 PIN 38. NOTE 1 DOES NOT APPLY TO THIS DASH NUMBER  
 CHANGE.



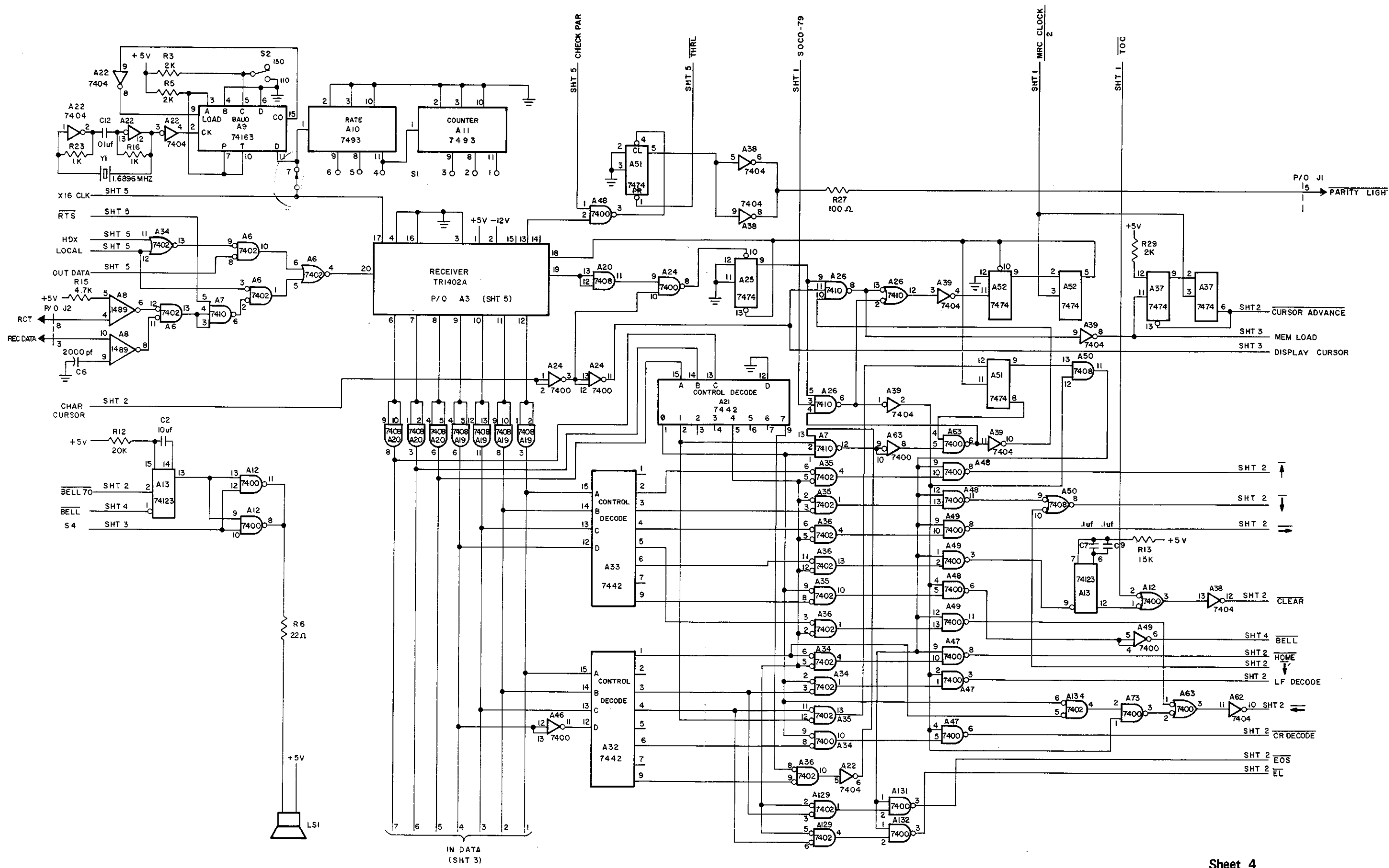

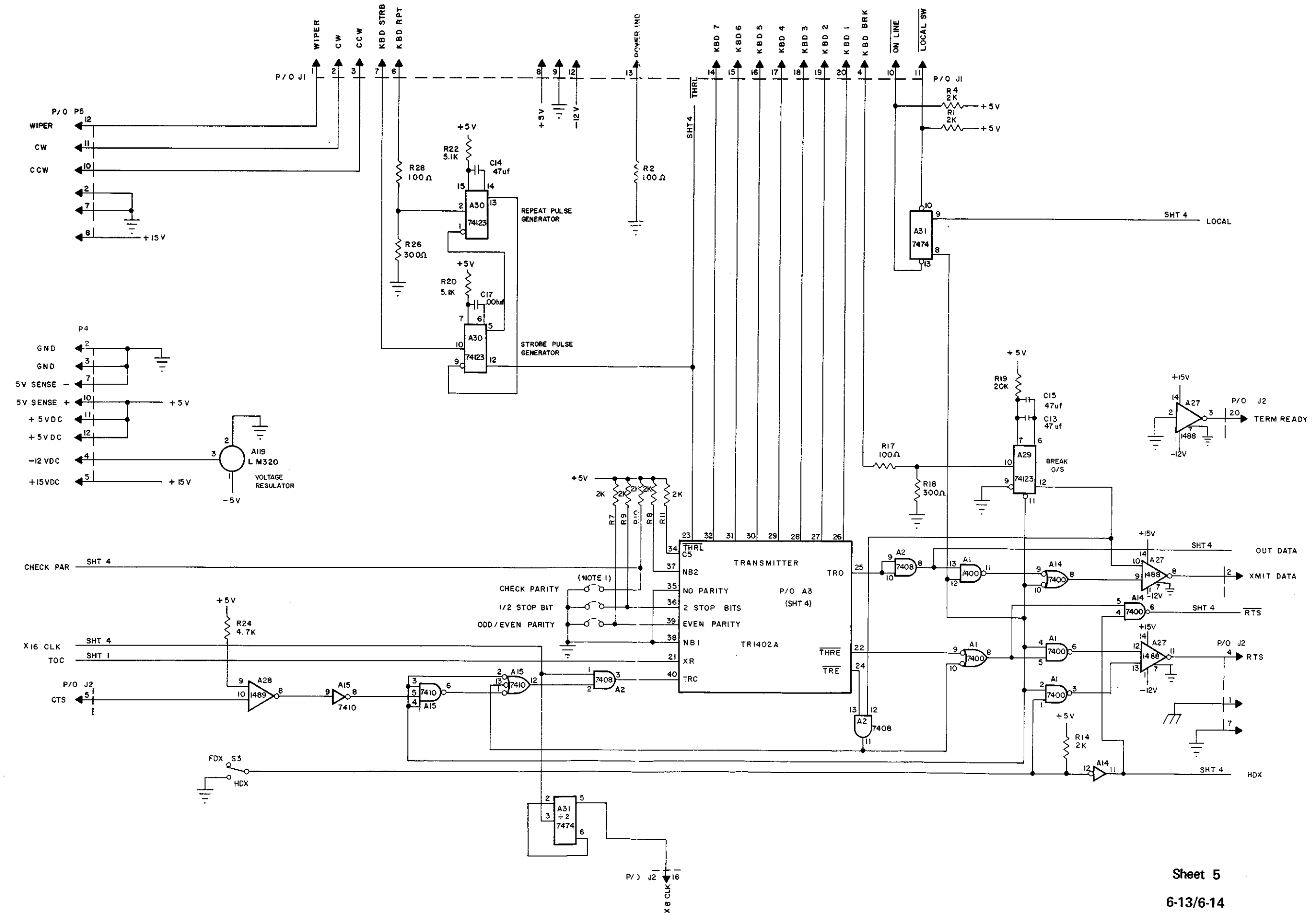

6-15/6-16

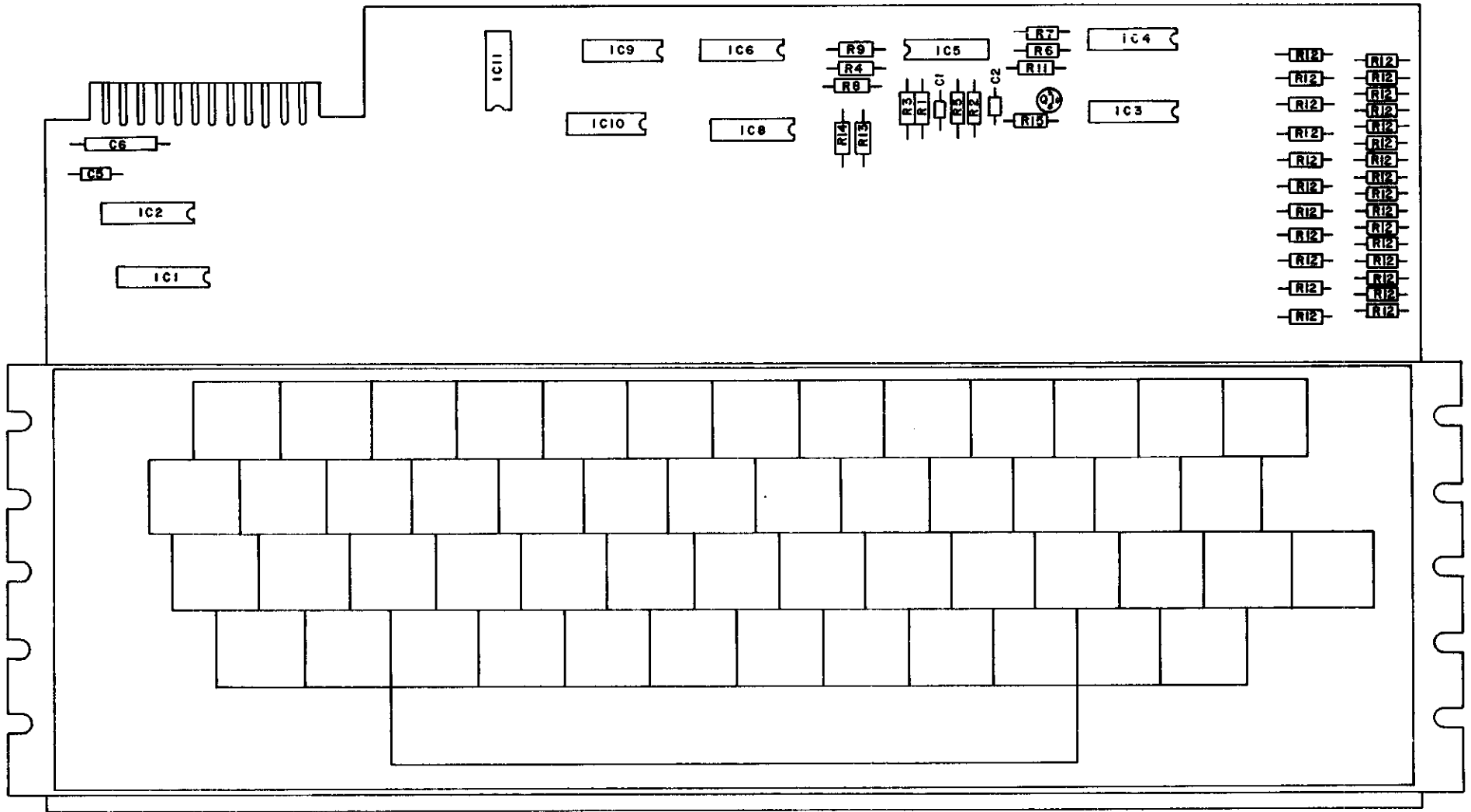

Circuit Board (SW10259) Keyboard Assembly

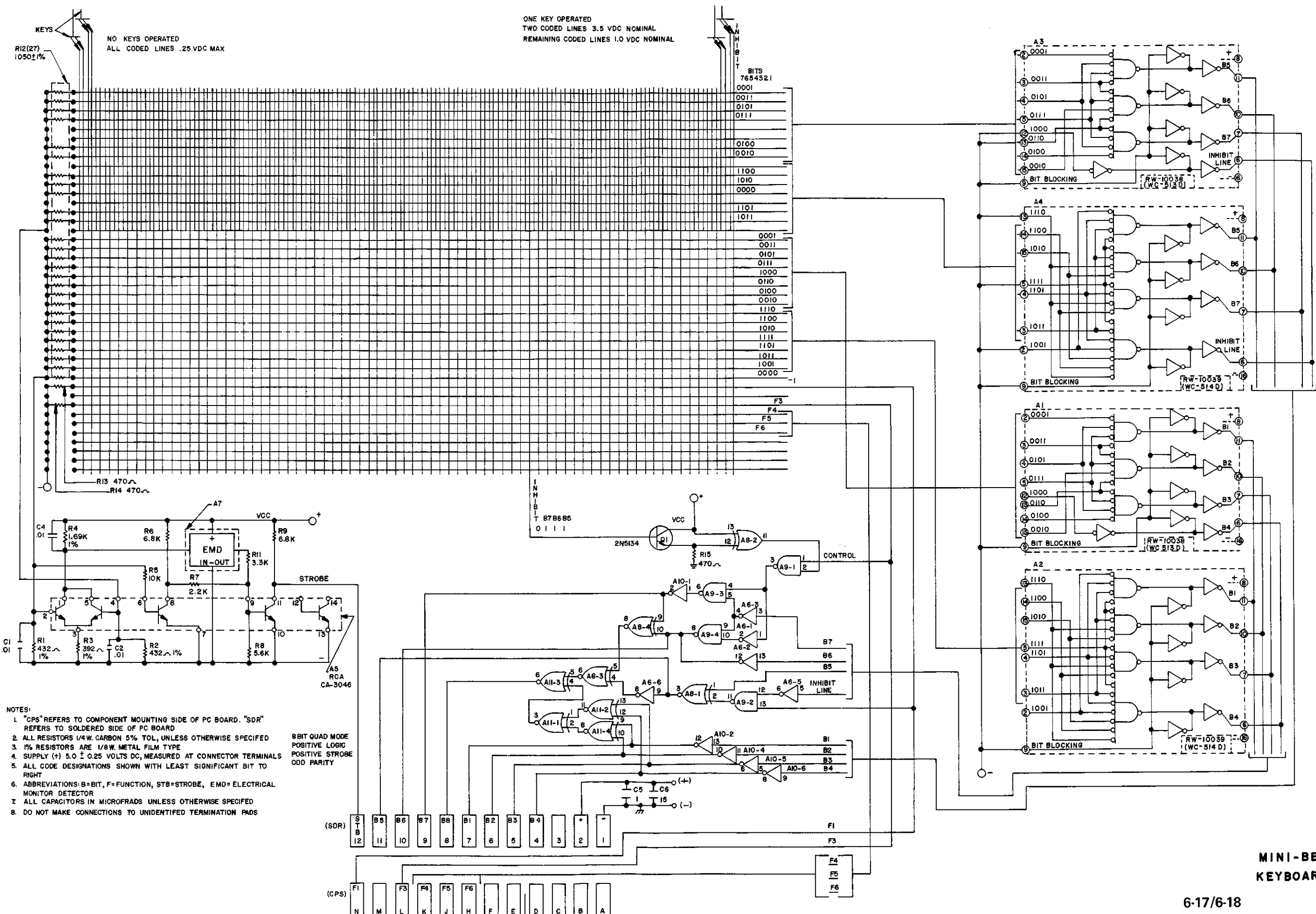

- NOTES:
- "CPS" REFERS TO COMPONENT MOUNTING SIDE OF PC BOARD. "SDR" REFERS TO SOLDERED SIDE OF PC BOARD
  - ALL RESISTORS 1/4W. CARBON 5% TOL, UNLESS OTHERWISE SPECIFIED
  - 1% RESISTORS ARE 1/8W. METAL FILM TYPE
  - SUPPLY (+) 5.0 ± 0.25 VOLTS DC, MEASURED AT CONNECTOR TERMINALS
  - ALL CODE DESIGNATIONS SHOWN WITH LEAST SIGNIFICANT BIT TO RIGHT
  - ABBREVIATIONS: B=BIT, F=FUNCTION, STB=STROBE, EMD=ELECTRICAL MONITOR DETECTOR
  - ALL CAPACITORS IN MICROFRADS UNLESS OTHERWISE SPECIFIED
  - DO NOT MAKE CONNECTIONS TO UNIDENTIFIED TERMINATION PADS

8BIT QUAD MODE  
POSITIVE LOGIC  
POSITIVE STROBE  
ODD PARITY

MINI-BEE  
KEYBOARD

6-17/6-18

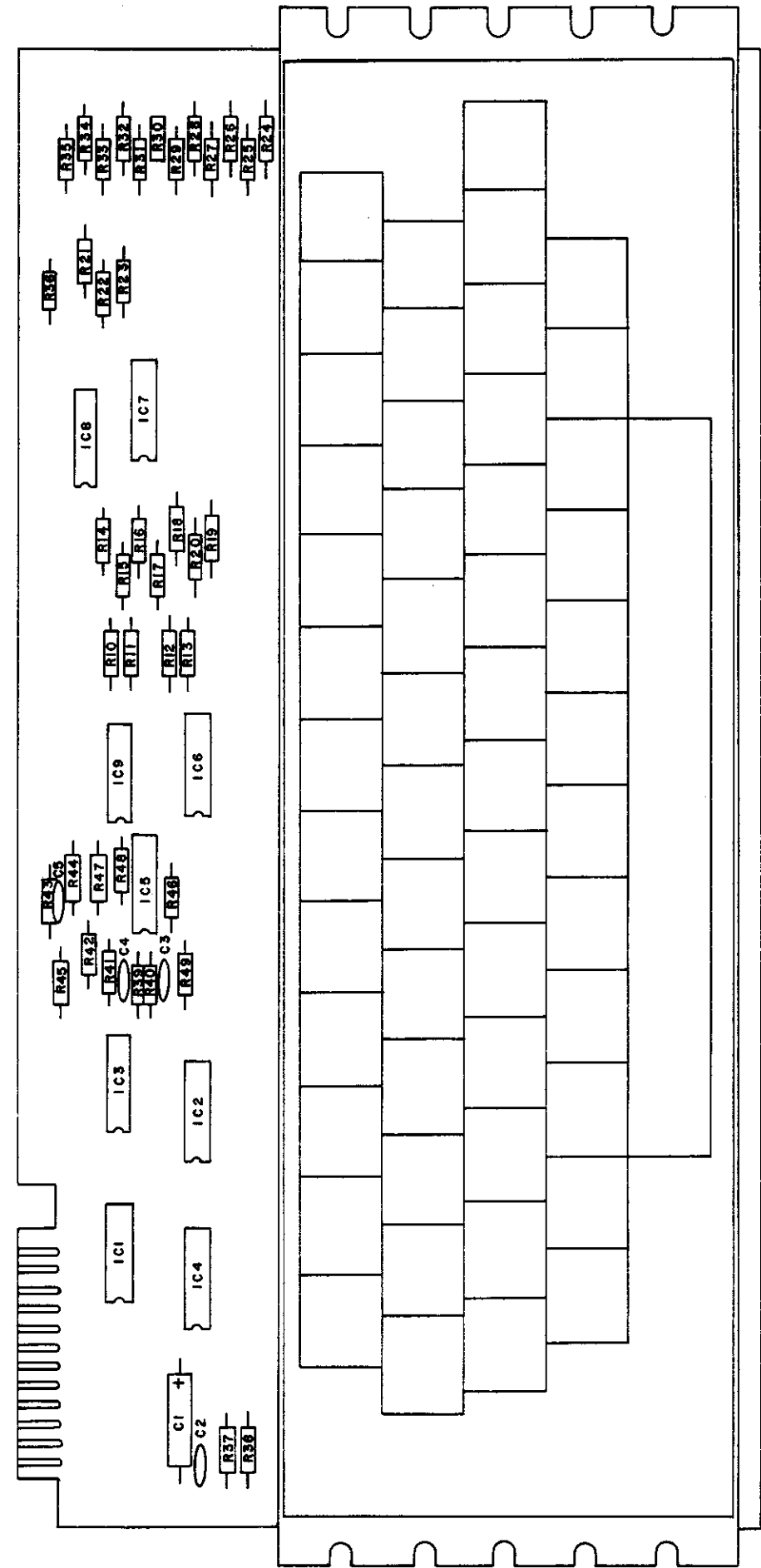

6-19/6-20

Circuit Board (SW1339) Keyboard Assembly

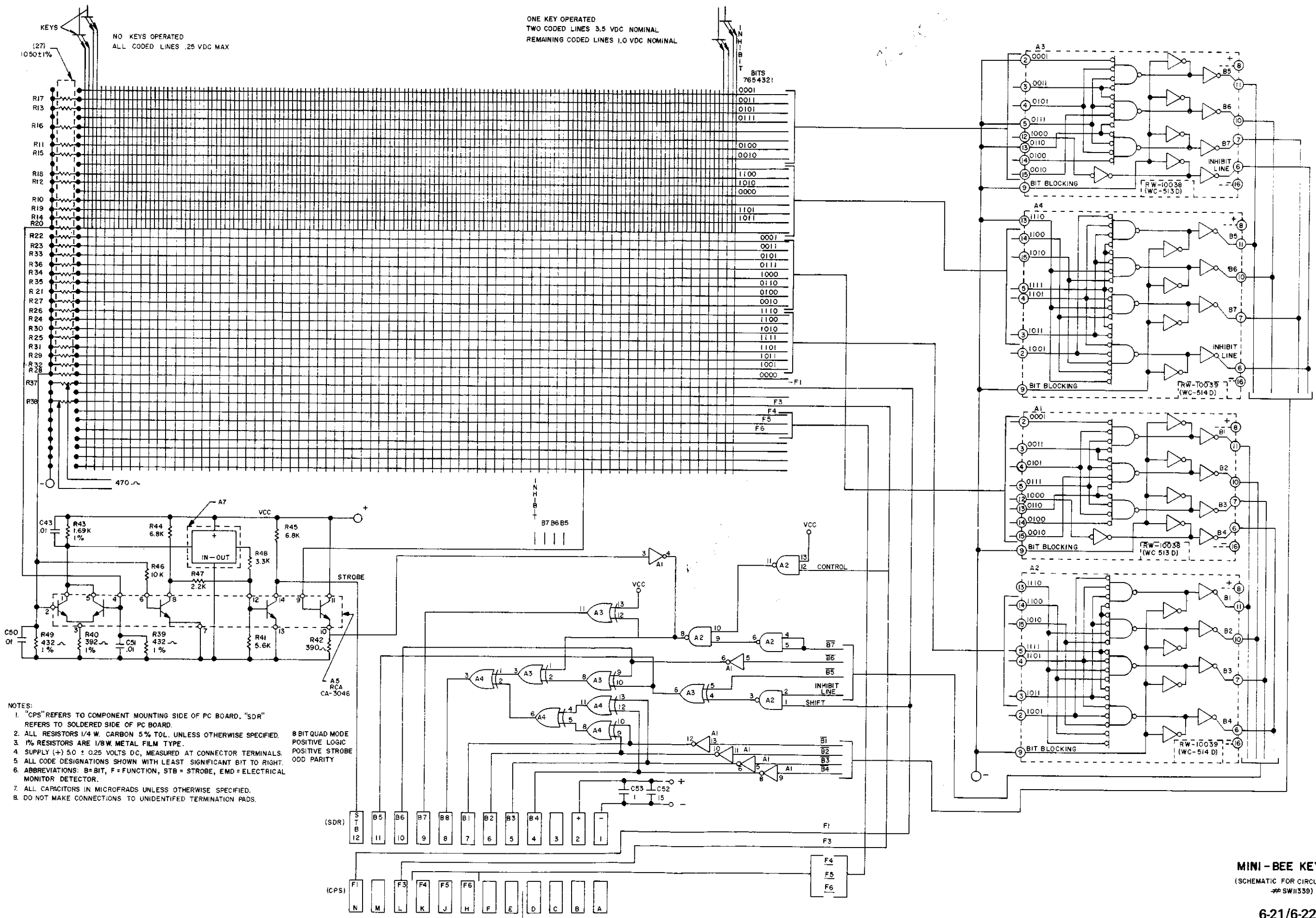

ONE KEY OPERATED  
 TWO CODED LINES 3.5 VDC NOMINAL  
 REMAINING CODED LINES 1.0 VDC NOMINAL

KEYS  
 (27) 1050±1%  
 NO KEYS OPERATED  
 ALL CODED LINES .25 VDC MAX

- NOTES:
1. "CPS" REFERS TO COMPONENT MOUNTING SIDE OF PC BOARD. "SDR" REFERS TO SOLDERED SIDE OF PC BOARD.
  2. ALL RESISTORS 1/4 W. CARBON 5% TOL. UNLESS OTHERWISE SPECIFIED.
  3. 1% RESISTORS ARE 1/8W. METAL FILM TYPE.
  4. SUPPLY (+) 5.0 ± 0.25 VOLTS DC, MEASURED AT CONNECTOR TERMINALS.
  5. ALL CODE DESIGNATIONS SHOWN WITH LEAST SIGNIFICANT BIT TO RIGHT.
  6. ABBREVIATIONS: B=BIT, F=FUNCTION, STB=STROBE, EMD=ELECTRICAL MONITOR DETECTOR.
  7. ALL CAPACITORS IN MICROFRADS UNLESS OTHERWISE SPECIFIED.
  8. DO NOT MAKE CONNECTIONS TO UNIDENTIFIED TERMINATION PADS.
- 8 BIT QUAD MODE  
 POSITIVE LOGIC  
 POSITIVE STROBE  
 ODD PARITY

MINI-BEE KEYBOARD  
 (SCHEMATIC FOR CIRCUIT BOARD  
 #SW11339)

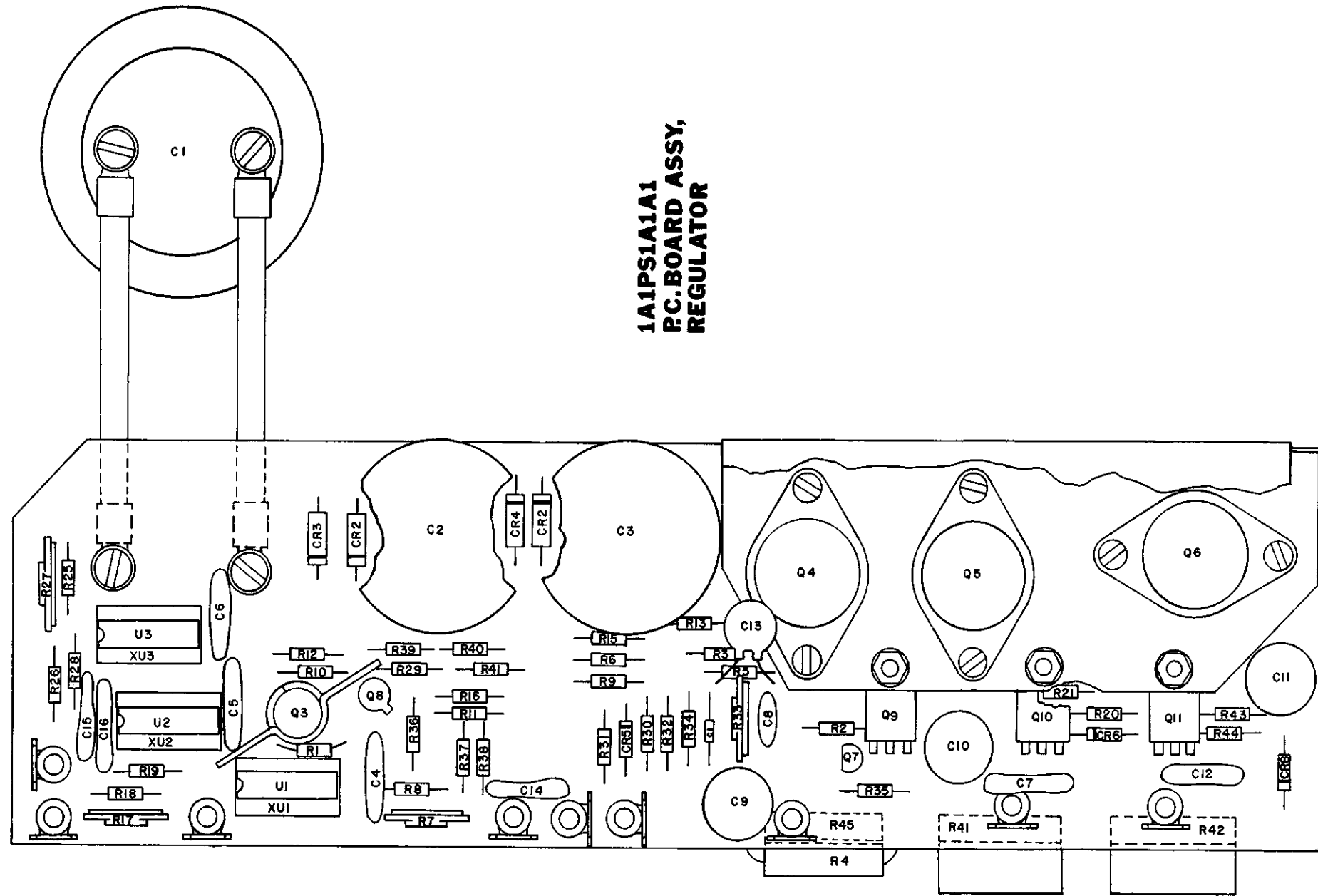

**1A1PS1A1A1  
P.C. BOARD ASSY,  
REGULATOR**

**1A1PS1A1  
REGULATOR,  
3 OUTPUT**

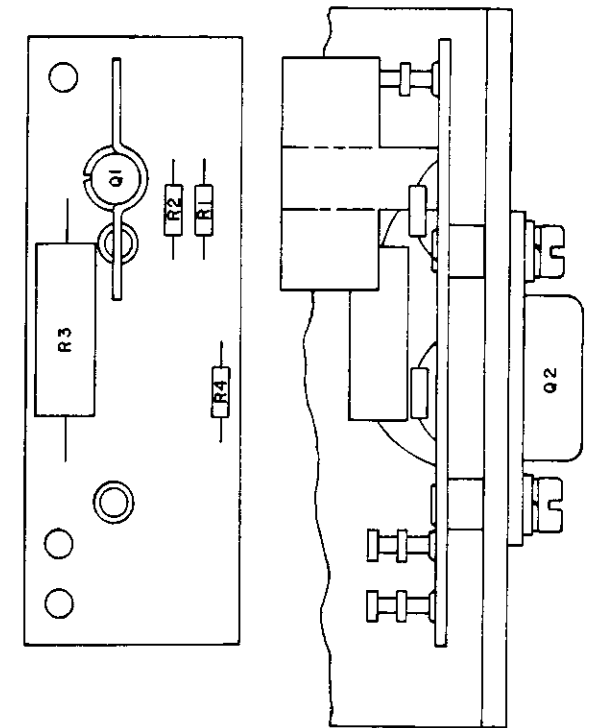

**3 Output Regulator and Regulator P.C. Board Assembly**

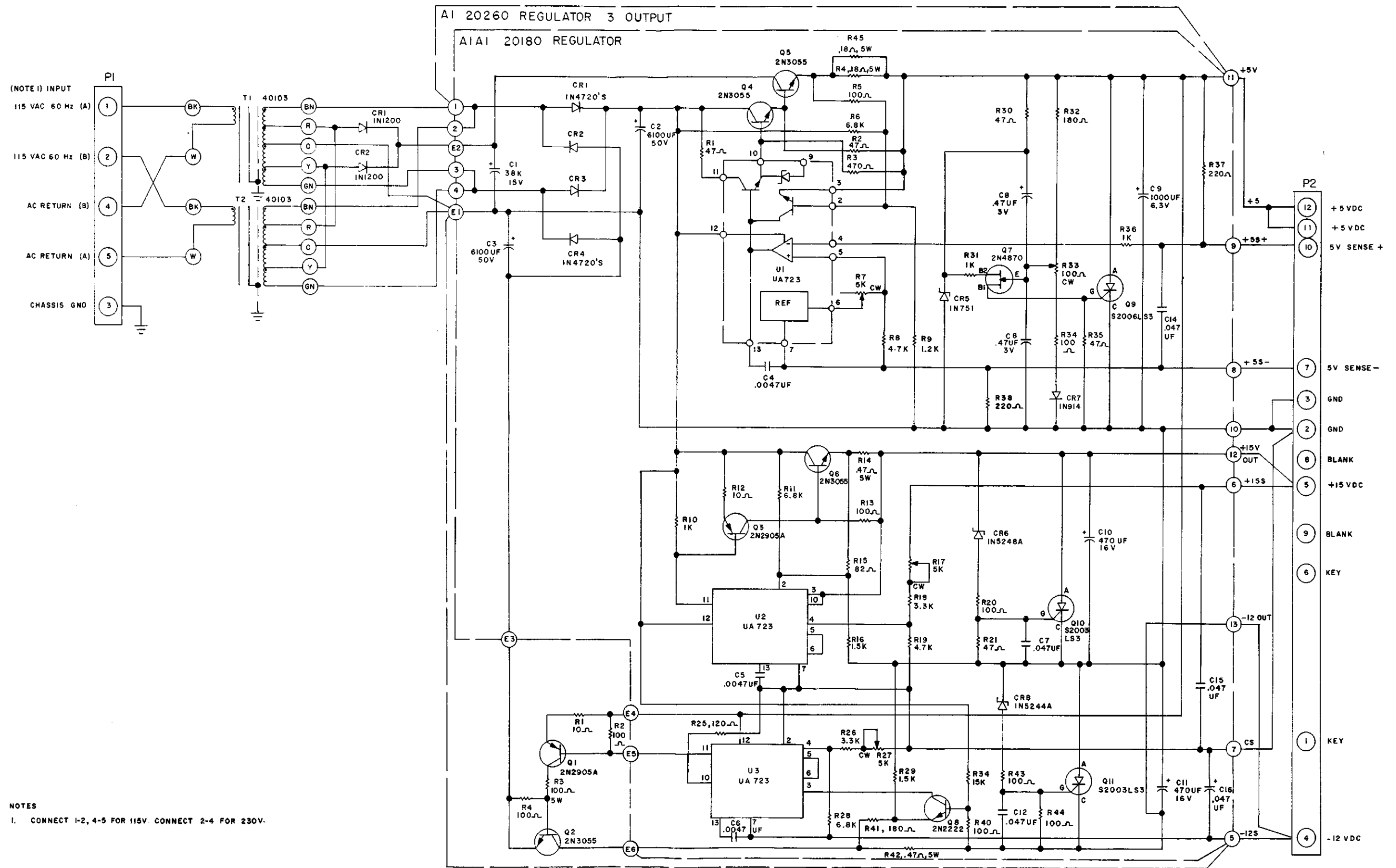



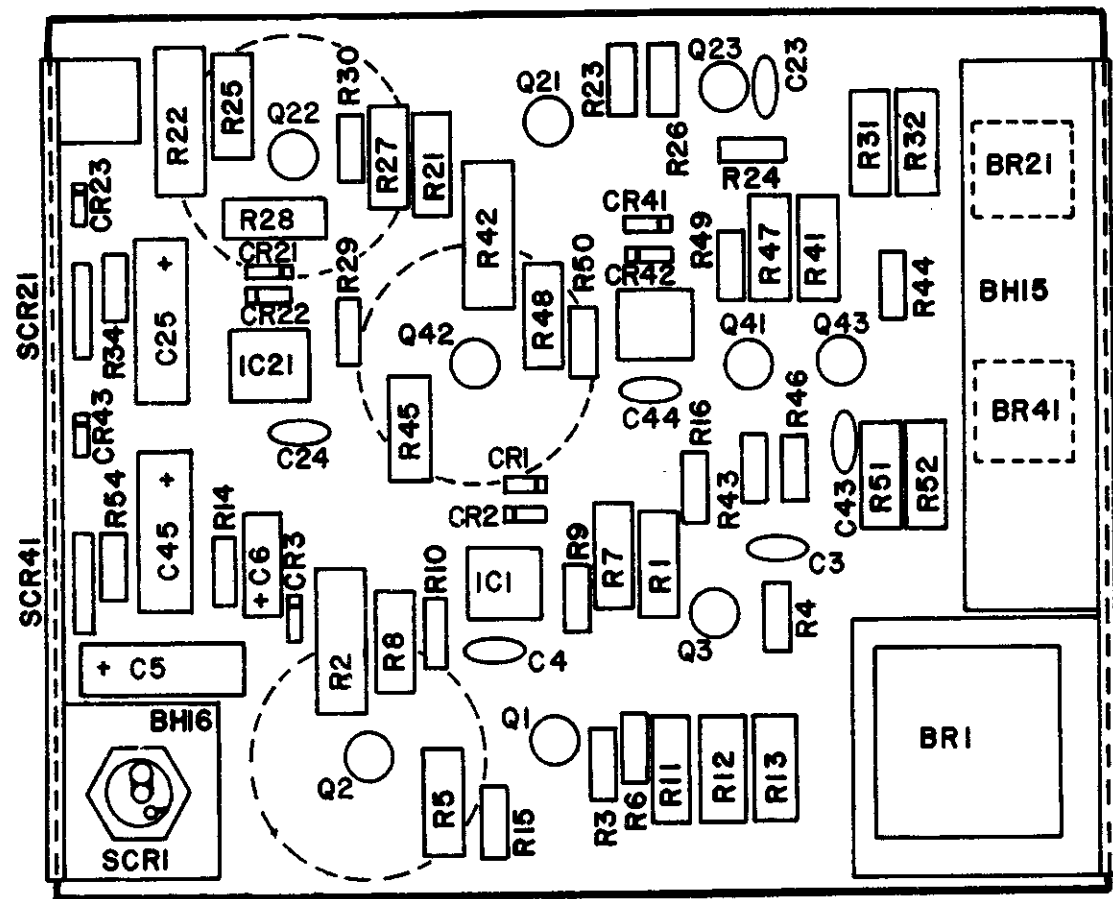

Powerbee P.C. Board Assembly

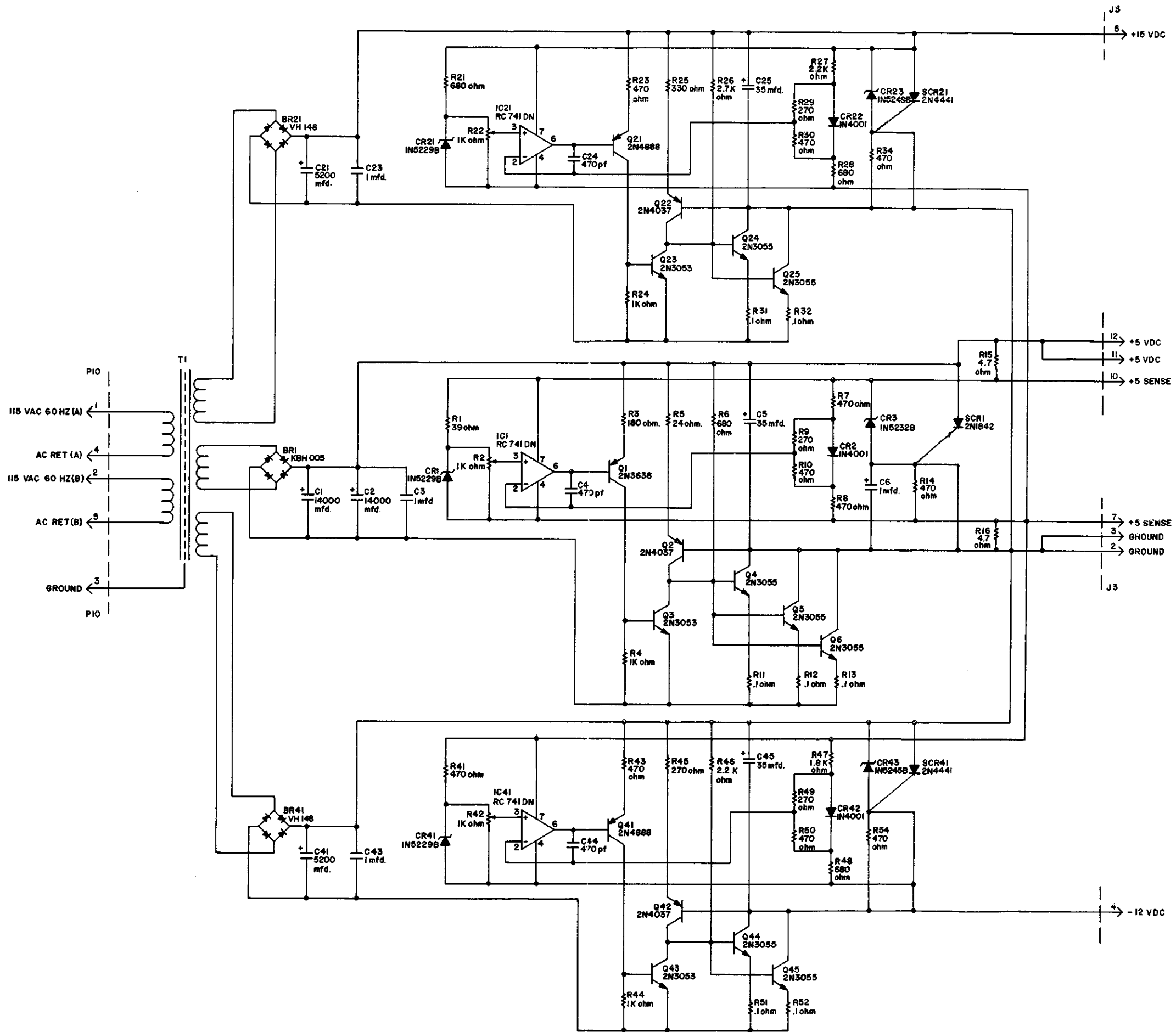

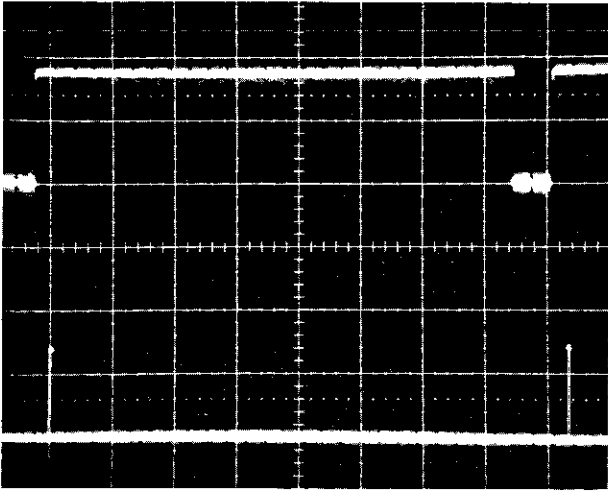

Vert. Drive/Cursor Home  
 1 M Sec/Div Clear Screen  
**WAVEFORM A**

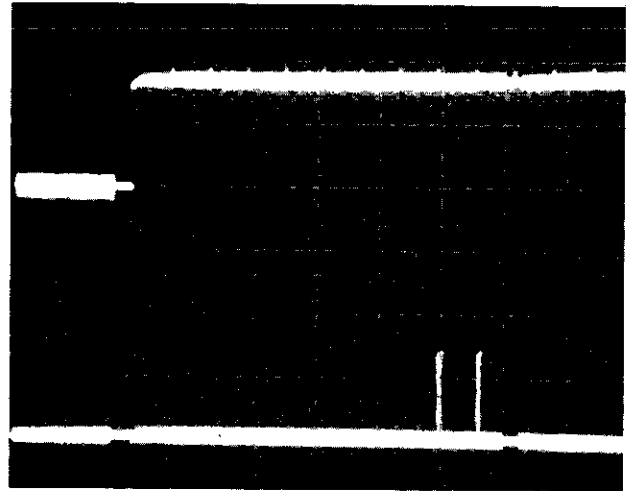

Vert. Drive/Cursor Home  
 1 Micro Sec/Div Clear Screen  
**WAVEFORM B**

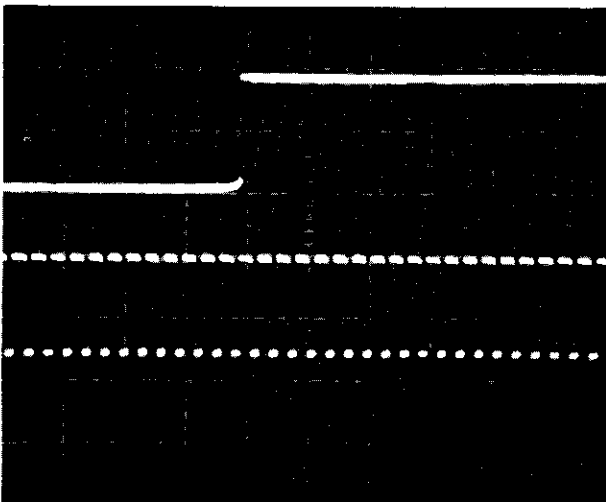

Horizontal Drive/Vert. Drive  
 2 M Sec/Div .2Volt/Div  
 Trigger Vert Drive Negative  
**WAVEFORM C**

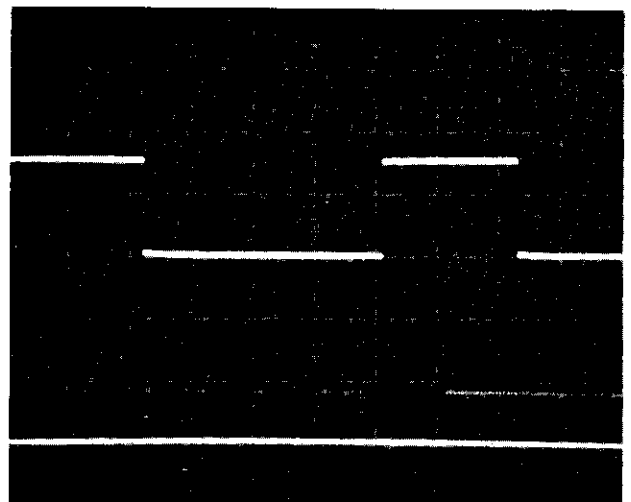

Horizontal Drive/Random Video  
 10 Micro Sec/Div .2Volts/Div  
 Trigger Horizontal Drive Positive  
**WAVEFORM D**

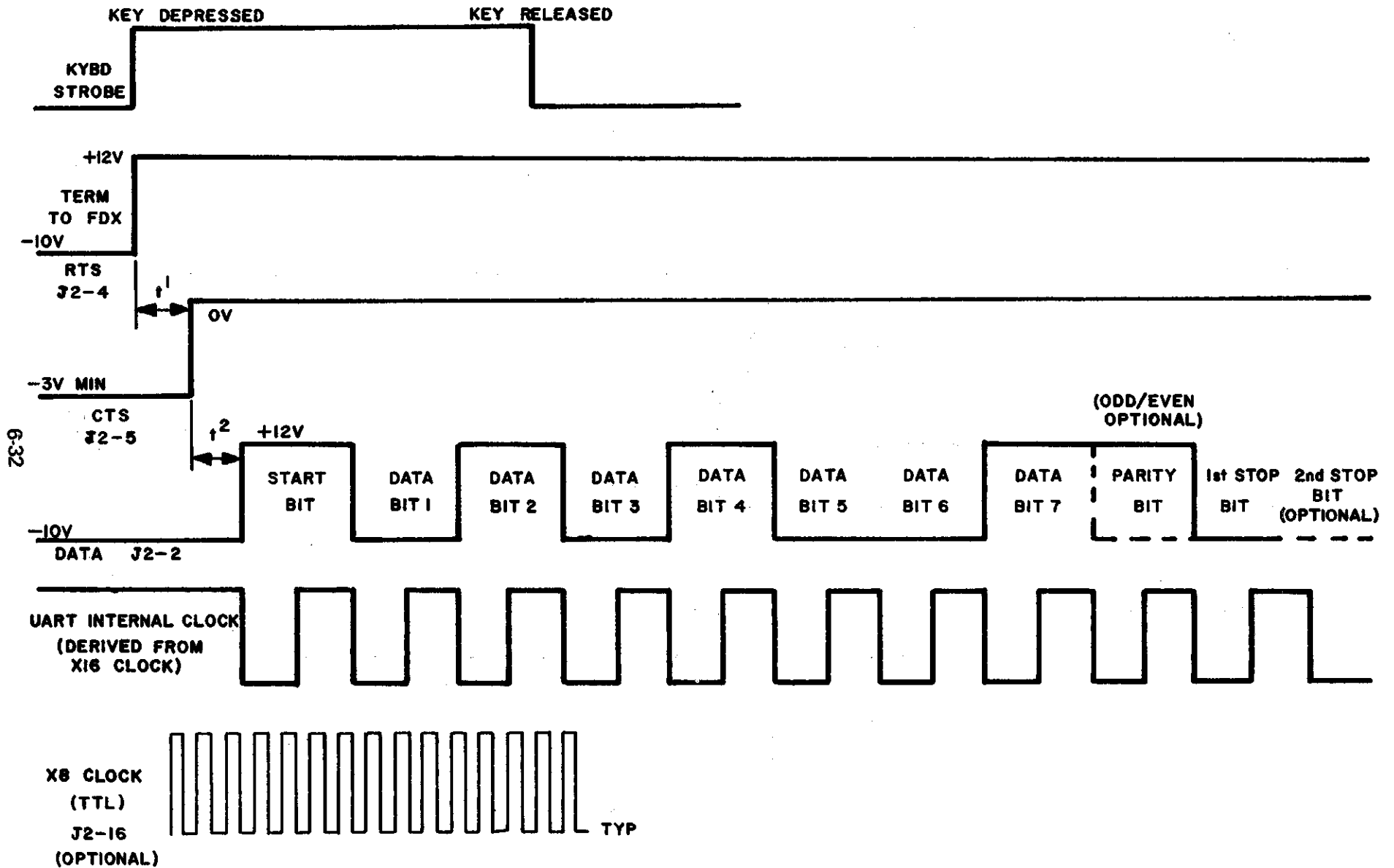

TERMINAL IN FDX  
 $t^1$  = DETERMINED BY MODEM  $\approx$  200 MSEC  
 $t^2$  = 0 MIN 9MSEC MAX  
 DATA = THE NUMBER FIVE

TIMING DIAGRAM  
 F

6-33

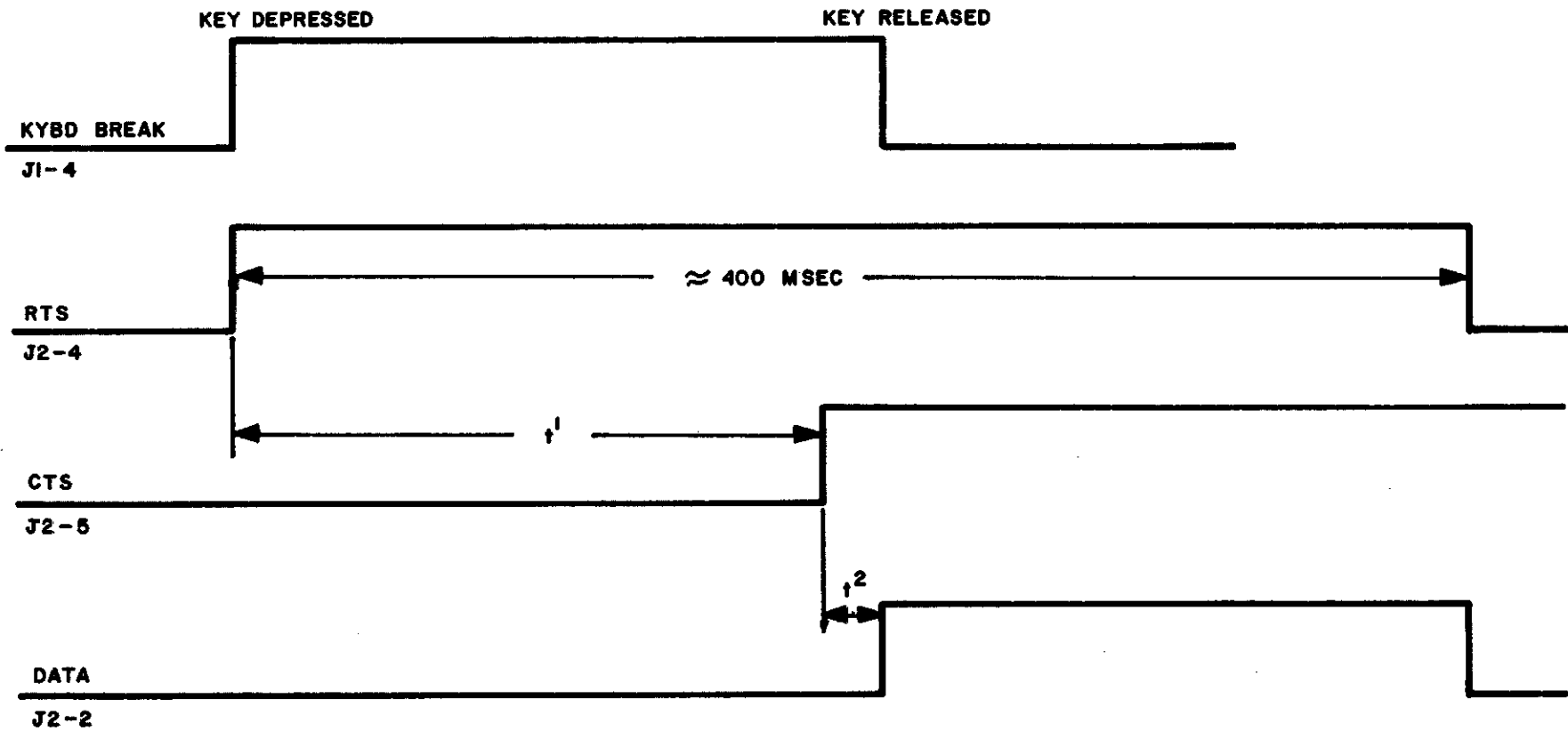

TERMINAL IN HDX AND ONLINE

$t^1 = \approx 200 \text{ MSEC}$  (DETERMINED BY MODEM)

$t^2 = 0 \text{ SEC TO } 9 \text{ MSEC}$  (DETERMINED BY UART INTERNAL CLOCK)  
BAUD RATE

TIMING DIAGRAM

G

# KEYBOARD INTERFACE TIMING DIAGRAM

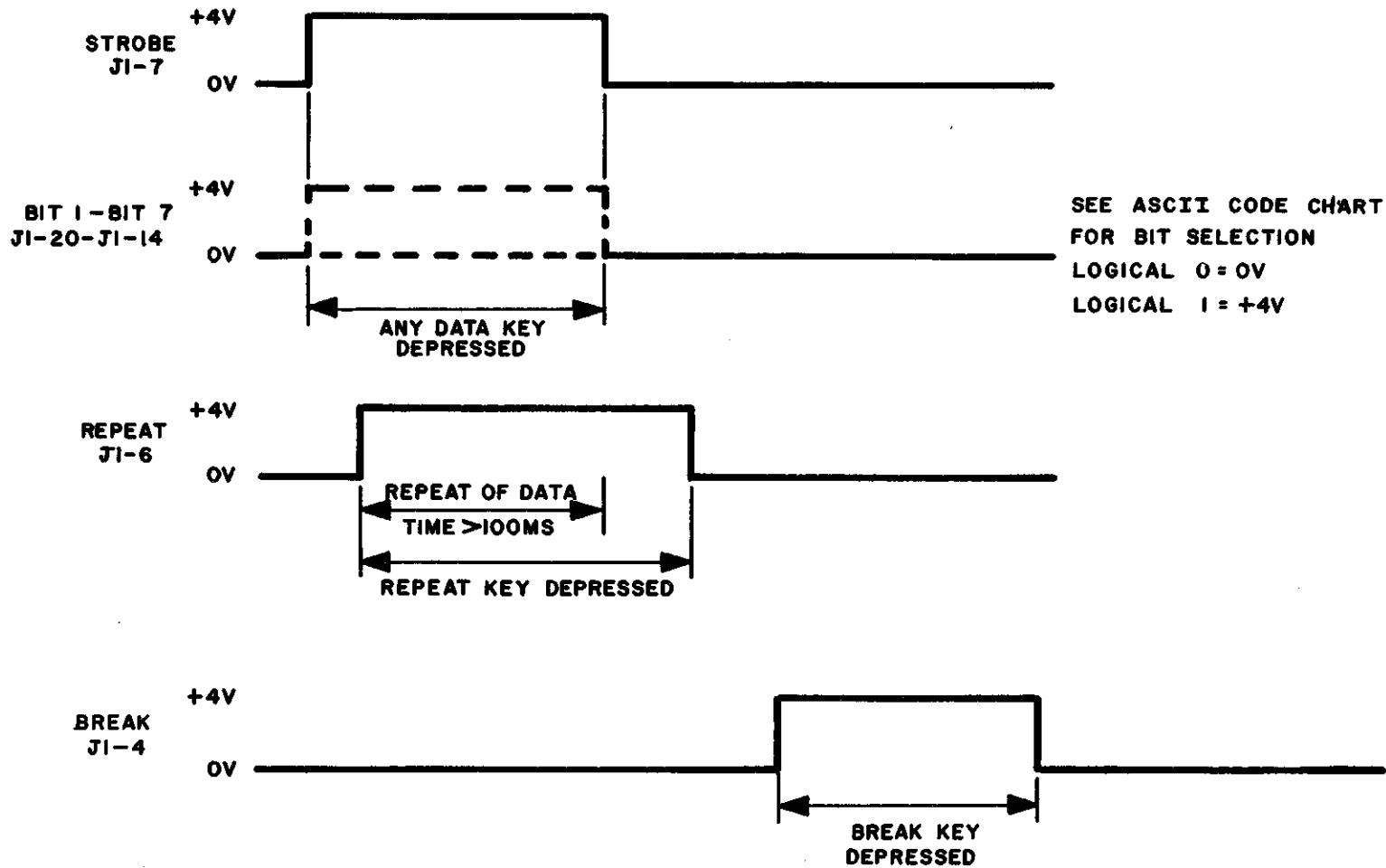

6-34

TIMING DIAGRAM  
E

NOTE: VOLTAGES INDICATED ARE  
 NOMINAL AND MAY VARY  
 ±1.0 VOLTS.

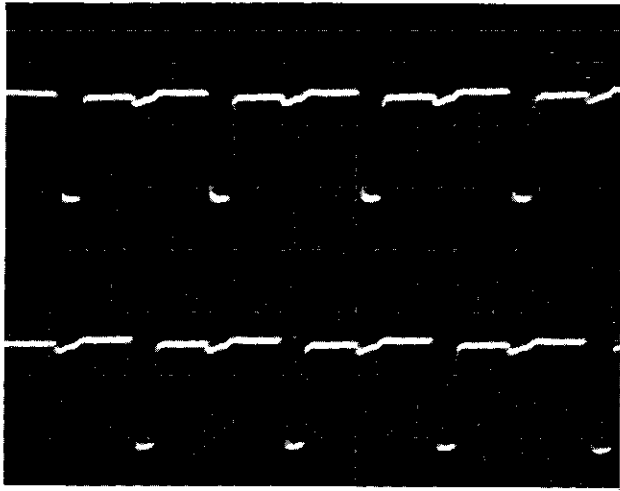

01 Clock/02 Clock  
 .5 Micro Sec/Div  
 1 Volt/Div  
**WAVEFORM H**

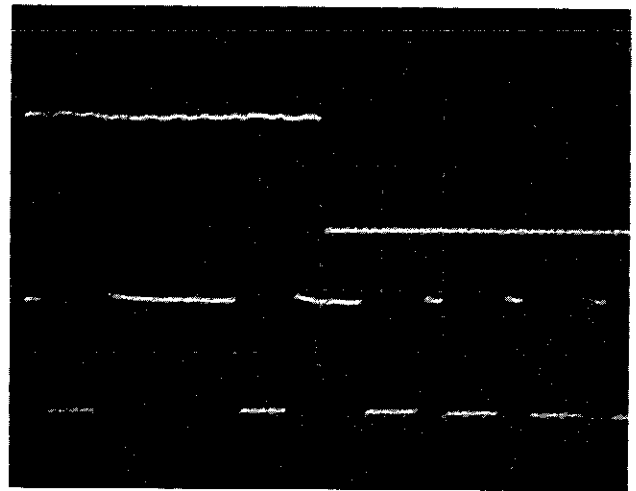

Soco-79/MRC CLK  
 Slow to Fast Clk. Rate  
 Transition  
 .2 Micor Sec/Div.  
 Delayed Sweep  
**WAVEFORM I**

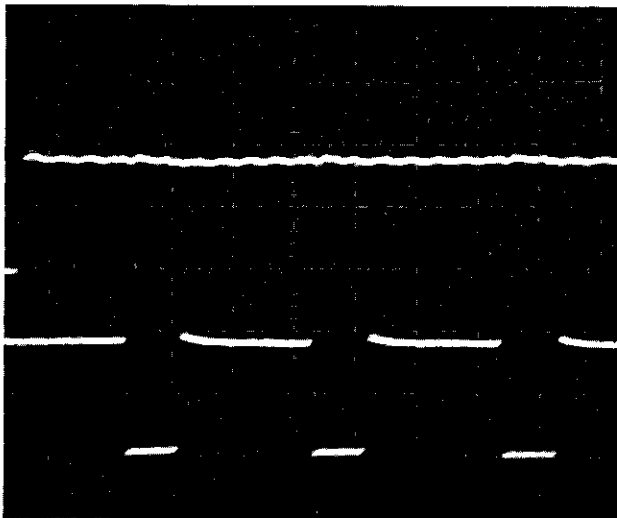

Soco-79/MRC Clock  
 Slow  
 .2 Micro Sec/Div.  
**WAVEFORM J**

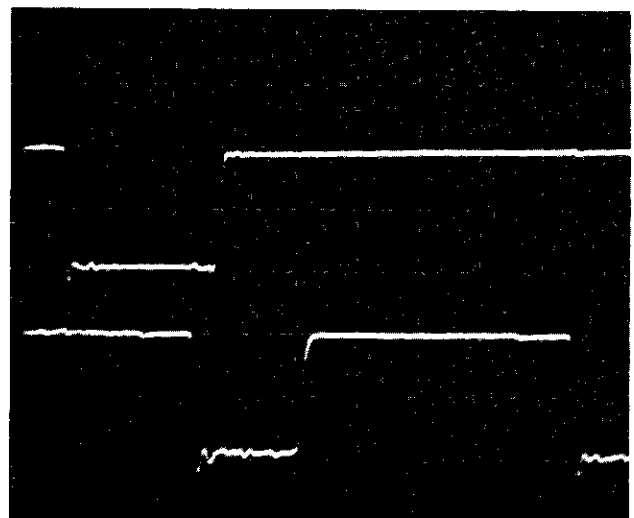

Colo/Dot 6/0  
 .1 Micro Sec/Div.  
 .2 Volts/Divde  
**WAVEFORM K**

## **SECTION VII**

# **GLOSSARY OF TERMS**



## ADVANCE

Advance (Not) is a low going pulse moving the cursor one position to the right on the CRT screen. It is derived from the MEM LOAD SIGNAL.

## BELL

Bell (Not) is a low going signal, decoded from a control G, and triggers the bell one shot.

## BELL 70

Bell 70 (Not) is a low going pulse, decoded from character 70. It is a low to high transition that triggers the bell one shot.

## BREAK ONE SHOT

Break One Shot is triggered by a positive level from the keyboard break key and develops a 400 M sec. signal which is transmitted on the data and RTS EIA lines.

## C80

C80 is a high going pulse from the Character Counter that defines character 80 to character 100 time.

## C80

C80 (Not) is the inverse of C80 used to inhibit the clock of the line memory.

## CCW

Counter-clockwise

## CHARACTER COUNTER

The Character Counter is made up of two decade counters with a modulus of 100, and it defines the characters on the line. Each character is 7 dots wide.

## CHARACTER CURSOR

Character Cursor is a high going signal when a compare is made between the cursor location counter and the marker reference counter.

## CHECK PAR

Check Parity enables a parity check on incoming data when low no parity check is made.

## CLEAR

Clear (Not) is a low going signal used to clear the screen and move the cursor home, made up of turn or clear or the decode of escape E.

## CLEAR MEM

Clear Memory is a positive going signal used to clear all or part of the screen derived from clear or EOS (decode of escape J) or EL (escape K) or during a scroll. To clear the screen, space codes are loaded into the memory in the required locations.

## COLO

Character Zero Line Zero (Not) is a low going signal derived from coincidence between the rollover of the memory reference counter and the overflowing of the main timing chain. Character 0 line 0 signifies that the memory and the display are coincidence at the Home position.

## CONTROL DECODER

Control Decoder (Not) decodes a control character when the sixth and seventh bits are zeros.

## CURSOR COMPARITOR

Cursor Comparitor compares the marker reference counter outputs to the cursor location counter outputs. The compare signal is called the Character Cursor.

## CURSOR LOCATION COUNTER

Cursor Location Counter has the cursor location stored in it. Both line and character are stopped and are modified by home, advance,  $\Rightarrow$   $\Leftarrow$   $\Downarrow$   $\Uparrow$  etc.

## CW

Clockwise

## DISPLAY CURSOR

Display Cursor signal is generated by inverting Character Cursor twice for buffering. It is applied to the line memory, loaded into the line memory when it is coincident with SOCO-79, and then displayed as a blinking double underline on scans 8 and 9.

## DOT COUNTER

Dot Counter is a divid-by-7 ring oscillator having outputs which are two dots wide labeled  $\bar{6}$  and  $\bar{0}$ ,  $\bar{0}$  and  $\bar{1}$ ,  $\bar{1}$  and  $\bar{2}$ , etc.

## DOT $\bar{6}/\bar{0}$

Dot  $\bar{6}/\bar{0}$  (Not) is an output from the dot counter that is 2 dots wide and used to clock the dot shifter.

## DOT 1/2

Dot 1/2 (Not) is an output from the dot counter two dots wide, and used in conjunction with C80 to clock the line memories.

## EIA RCVR

Used to receive data at EIA levels transform them to TTL levels

## EIA XMTR

Used to raise the outgoing data from TTL to EIA levels.

## EL

Erase Line signal is generated by decoding an escape K and is used to erase the entire line the cursor is on.

## EOS

Erase to end of screen is a signal generated from escape J and used to erase the screen beginning with the line the cursor is on.

## HDX

Half-Duplex is a mode of communication in which the data entered from the keyboard is displayed on the screen and transmitted. The terminal will receive through the I/O connector, but not at the same time it is transmitting.

## HOME

Home (Not) is a signal used to reset the cursor location counters which sets the cursor to the first location on the first line.

## HZ DRIVE

Horizontal Drive to monitor is used for sync and to develop high voltage for the CRT. It is generated by decoding count 84 of the Character Counter and reset by count 20.

## IN DATA 1

Buffered bit 1 parallel data from UART. Applied to decoders and memory.

## IN DATA 2

Buffered bit 2 parallel data from UART. Applied to decoders and memory.

## IN DATA 3

Buffered bit 3 parallel data from UART. Applied to decoders and memory.

#### IN DATA 4

Buffered bit 4 parallel data from UART. Applied to decoders and memory.

#### IN DATA 5

Buffered bit 5 parallel data from UART. Applied to decoders and memory.

#### IN DATA 6

Buffered bit 6 parallel data from UART. Applied to decoders and memory.

#### IN DATA 7

Buffered bit 7 parallel data from UART. Applied to decoders and memory.

#### KBD BRK

Keyboard Break is a function from the keyboard and stays in a high or binary '1' state while the key is depressed.

#### KBD STRB

Keyboard Strobe is a high level from the keyboard occurring when any keys, except function, are depressed.

#### KBD RPT

Keyboard Repeat is a function key and stays high while 'REPT' key is depressed on keyboard in conjunction with another key.

#### KBD 1

Bit 1 from keyboard is set to a logic 1 or 0 when a key is depressed on the keyboard and remains until the key is released.

#### KBD 2

Bit 2 from keyboard is set to a logic 1 or 0 when a key is depressed on the keyboard and remains until the key is released.

#### KBD 3

Bit 3 from keyboard is set to a logic 1 or 0 when a key is depressed on the keyboard and remains until the key is released.

#### KBD 4

Bit 4 from keyboard is set to a logic 1 or 0 when a key is depressed on the keyboard and remains until the key is released.

#### KBD 5

Bit 5 from keyboard is set to a logic 1 or 0 when a key is depressed on the keyboard and remains until the key is released.

#### KBD 6

Bit 6 from keyboard is set to a logic 1 or 0 when a key is depressed on the keyboard and remains until the key is released.

#### KBD 7

Bit 7 from keyboard is set to a logic 1 or 0 when a key is depressed on the keyboard and remains until the key is released.

#### LF DECODER

Line Feed decodes a control J which is used to move the cursor to the next line down. If the cursor is on the bottom line, the terminal will scroll everything up one line and the top line will be lost.

#### LINE MEMORY

The line memory is used to synchronize the page memory with the monitor display. 80 characters are shifted into the line memory and then applied to the character generator at a different rate.

---

#### MEM LOAD

Memory Load (Not) signal is generated when any printable character is received from the keyboard or I/O port. It switches the multiplexer on the page memory from its usual recirculate path so that new data can be loaded.

#### LOCAL

The terminal uses this mode of operation for operator familiarization only. Characters are entered into memory and displayed, but not transmitted, from the keyboard. Also, anything received at the I/O port is ignored.

---

#### LOCAL SWITCH

Local Switch (Not) toggle switch located on the keyboard housing switches the terminal between online and local mode.

#### MARKER REFERENCE COUNTER

Marker Reference Counter will count to 2,048 in increments of 80 to define 25 line with 48 undefined locations. It identifies each of the 2,000 locations of the screen.

#### MRC CLK

Memory Reference Counter Clock is made up of slow and fast pulses used to clock the page memory shift registers.

## ON LINE

In On Line mode of operation, the terminal transmits and receives data VIA and EIA RS232 I/O connector.

## OSC

The Oscillator Signal is generated by a 11.34 MHTZ crystal oscillator and buffered by a 7404.

## PAGE MEMORY

Page Memory is a 2,048 x 6 bit recirculating shift register. It defines the 2,000 character locations on the screen with 48 left over.

## PARITY LIGHT

The Parity Light located on the keyboard housing is illuminated by receiving a parity error and is resetable by depressing any alphanumeric key on the keyboard.

## RCT

Carrier Signal Detect is an EIA RS232 signal. It must be high to receive data and is usually used with a modem. It indicates suitability of the signal presented to the data communications equipment.

## RECEIVER

Circuitry dedicated to converting a serial word into parallel data, also included in this section, would be the parity checking circuit, CTS & RTS circuits.

## REC DATA

Received Data is an EIA RS232 line that transfers data to the terminal. It is held in a marking condition when the line is idle.

## RTS

Request to Send is an EIA RS232 line that informs the external device that information is ready to be transmitted from the terminal. It is held in an on condition when in FDX.

## SCAN COUNTER

Scan Counter has a modulus of ten, thus defining 10 scans per line.

## SCROLL

Scroll signal is generated by the scroll latch and is used to modify MRC clock and scroll the display up one line when it is true.

---

## SCROLL SET

Scroll Set (Not) signal is generated and used to set the scroll latch when line 24 and a line feed are decoded at the same time.

## SOCO-79

Scan 0, Character 0 to 79 (Not) represents the first 80 characters of scan 0. It is used to generate slow clocks in MRC clock to transfer the page memory information into the line memory and is also used as timing signal for received data after it leaves the UART.

## SOCO-79

Inverse of SOCO-79 and used as load signal on the line memories.

## S1, S2, S4 and S8

Outputs of the scan counter are applied to the character generator to define the scans in the character matrix.

## TERM READY

Terminal Ready is an EIA RS232 line that goes high when the terminal is turned on.

## THRE

Transmitter Holding Register Empty is a high level indicating that the transmitter holding register is empty and may be loaded with a new character.

## TOC

Turn on Clear is a signal generated by power up initiated by the UART.

## TOC

Turn on Clear (Not) is a signal used on power up to clear the screen and home the cursor.

## THRL

Transmitter Holding Register Load (Not). When this signal is low, a character is entered into the transmitter holding register of the UART, and on a low to high transmission the character is moved to the transmitter register.

## TRC

Transmitter Register Clock is 16 x Baud rate.

## TRE

Transmitter Register Empty stays low while transmitting a character and goes high when completed.

## TRO

Transmitter Register Output. The start bit, data bits, parity bit, and stop bit(s) are serially shifted out this line. It remains at a high level when no data is

being transmitted.

## TRANSMITTER

The Transmitter circuitry is dedicated to converting parallel data into a serial word complete with start bit, data bits, parity bit and stop bit(s); also, RTS, terminal ready, are included in this section.

## UART

Universal Asynchronous Receiver/Transmitter, MOS/LSI Device. The transmitter section converts parallel data into a serial word which contains a start, parity, and stop bits. The receiver section converts a serial word into parallel data and checks parity.

---

## VERT DRIVE

Vertical Drive (Not) signal is derived by decoding count 30 from the line counter and the reset signal at count 32. It is used for synchronization in the monitor and blanking of the video signal.

## VIDEO

Data from the dot shifter with blanking added, that is, applied to the monitor. A low level yields a dark screen and a high level yields a bright screen.

## VIDEO RET

Video Return is the signal ground line for the monitor.

## XMIT DATA

Transmit Data is an EIA RS232 line used for transferring data from the terminal to the EXTERNAL DEVICE and held to a mark condition during idle time.

## X8 CLK

Times 8 Clock is a TTL signal required by some external equipment and is eight times the baud rate frequency. It is available at the I/O connector if strapped.

## X16 CLK

Times 16 Clock is required by the UART and is sixteen times the baud rate frequency.

## 1/2 STOP BIT

One or Two Stop Bit is a strap that enables the UART to attach one or two stop bits to a data word.

## Ø1, Ø 2

Phase 1, Phase 2 are clocks used to clock the page memory, derived from MRC Clock and level shifted with drivers to swing from -5V to +10V levels.



5V SENSE-  
5V SENSE+

5 Volt Sense Negative and 5-Volt Sense Positive are lines used by the power supply to regulate the voltage at a remote point. These lines must be tied to the power supply voltage in order for the power supply to regulate properly.



Cursor Down (Not) is a signal generated by the decode of an escape B or an LF decode and is applied to the cursor location counter to move the cursor to the next line down.



Cursor Up (Not) is a signal generated by an escape decode and is applied to the cursor location counter to move the cursor to the left one character position.



Cursor Left (Not) is a signal generated by the decode of an escape D or a control H decode and applied to the cursor location counter to move the cursor to the left one character position.



Cursor Right (Not) is a signal generated by the decode of an escape C and is applied to the cursor location counter to move the cursor one character position to the right.

**APPENDIX  
A  
BALL  
MONITOR  
(TVB 12)**

## CONTENTS

Section		Page
1	GENERAL INFORMATION	1-1
	1.1 Monitor Description	1-1
	1.2 Electrical Specifications	1-1
	1.3 Environmental Specifications	1-4
	1.4 Human Factors Specifications	1-5
	1.5 Controls	1-5
2	OPERATING PROCEDURES	2-1
	2.1 Installation	2-1
	2.2 Grounding Techniques	2-1
	2.3 Video Lead Routing	2-2
	2.4 Initial Turn-On Procedure	2-3
	2.5 Normal Monitor Operation	2-4
3	THEORY OF OPERATION	3-1
	3.1 Video Amplifier	3-1
	3.2 Vertical Deflection	3-1
	3.3 Horizontal Deflection	3-3
	3.4 Low Voltage Regulated Supply (Optional on some models)	3-6
4	PRELIMINARY ADJUSTMENTS	4-1
	4.1 Synchronization and Drive Signals	4-1
	4.2 Low Voltage Supply	4-1
	4.3 Brightness	4-1
	4.4 Video Contrast	4-2
	4.5 Vertical Adjustments	4-2
	4.6 Horizontal Adjustments	4-3
	4.7 Focus Adjustment	4-4
	4.8 Centering	4-5
5	TROUBLESHOOTING AND MAINTENANCE	5-1
	5.1 Troubleshooting Guide	5-1

CONTENTS (Cont.)

ILLUSTRATIONS

Figure		Page
1	Synchronization and Blanking Generator Waveforms	1-6
2	Voltage Waveform	5-2
3	Interconnecting Cabling Diagram	5-3
4	Circuit Board Components Location	5-4
5	Schematic, TV 9 and 12 With Power Supply	5-5
6	Schematic, TV5, 9 and 12 Without Power Supply	5-6

Section 1  
GENERAL INFORMATION

1.1 MONITOR DESCRIPTION

The TV monitor is a solid-state unit for use in industrial and commercial installations where reliability and high quality video reproduction are desired.

The monitor features printed circuit board construction for reliability and uniformity. All circuits of the TV monitor are transistorized. The synchronization circuits have been custom designed to accept vertical and horizontal drive signals thus enabling the interfacing of this monitor with industrial or simple sync sources. This feature simplifies the user's sync processing and mixing and allows the unit to operate without requiring composite sync. The electronic packaging has been miniaturized for compatibility with small volume requirements.

1.2 ELECTRICAL SPECIFICATIONS

Input Data Specifications

	Video	Vertical Drive Signal	Horizontal Drive Signal
Input Connector	(Necessary Accessory-Available) Printed circuit board card edge connector - Viking #2VK10S/1-2 or Amphenol #225-21031-101		
Pulse Rate or Width	Pulse Width: 100 nsec or greater	Pulse Rate: 47 to 63 pulses/ sec	Pulse Rate: 15,000 to 16,500 pulses/ sec
Amplitude	Low = Zero $+0.4$ $-0.0$ volts (See Section 1, para. 1.5) High = $4 \pm 1.5$ volts (See Section 4, para. 4.4)		
Signal Rise & Fall Times (10% to 90% amplitude)	Less than 20 nsec	Less than 100 nsec	Less than 50 nsec
Input Signal Format	See Fig. 1		

Data Display Specifications

## Input Impedance

	Minimum Shunt Resistance	Maximum Shunt Capacitance
(a) Video Input:	3.3 k ohms	40 pF
(b) Vertical Drive Input:	3.3 k ohms	40 pF
(c) Horizontal Drive Input:	470 ohms	40 pF

## Video Amplifier

(a) Bandwidth:	12 MHz (-3 dB)
(b) Rise and Fall Times (10% to 90% amplitude):	Less than 35 nsec. (linear mode)
(c) Storage Time:	15 nsec, maximum (linear mode)

## Retrace and Delay Times

(a) Vertical:	900 $\mu$ sec retrace, maximum
(b) Horizontal:	7 $\mu$ sec retrace plus 4 $\mu$ sec delay, maximum

Display Specifications

Cathode Ray Tube

Nominal Diagonal Measurement (inches)	Phosphor	*Resolution (TV Lines)	
		Center	Corner
5	P4	650 at 80 fL	550 at 80 fL
9	P4	750 at 40 fL	650 at 40 fL
12	P4	900 at 40 fL	800 at 40 fL
12	P39	900 at 20 fL	800 at 20 fL

\*Resolution is measured in accordance with EIA RS-375 except Burst Modulation (or Depth of Modulation) is adjusted for 100 percent.

Geometric Distortion

The perimeter of a full field of characters shall approach an ideal rectangle to within  $\pm 1.5\%$  of the rectangle height.

Power Requirements

Power Specifications for Monitors Incorporating a Low Voltage Power Supply

	CRT SIZE		
	5 inches	9 inches	12 inches
Input Connector	Receptacle, Molex #03-06-1041 Supplied with Unit Mating Plug, Molex #03-06-2041 - Necessary Accessory (Available)		
Input Voltage	105 V to 130 V rms (120 V nominal); 50/60 Hz Optional: 220 V/240 V rms $\pm 10\%$ , 50/60 Hz		
Input Power			24 W (Nominal)
Output Voltages	+15 V DC (short circuit protected) +12 kV DC; 12.6 V rms		

Power Specifications for Data Monitors Using an External DC Power Supply:  
 Note: Any power transformers must be well removed from the CRT and/or be of low external flux field design.

	CRT SIZE		
	5 inches	9 inches	12 inches
Input Voltage	12 ± 0.2 V DC	15 ± 0.2 V DC	
Ripple	Less than 10 millivolts p-p		
Input Current	650 mA DC, nominal		900 mA DC, nominal
	*1.0 A DC, maximum		*1.5 A DC, maximum
Output Voltages	+12 V DC +9 kV DC	+12.6 V DC, +12 kV DC	
*Brightness and Contract adjusted for worst case conditions.			

1.3 ENVIRONMENTAL SPECIFICATIONS

Temperature (Chassis or Custom Unit)

Operating Range: 5°C to 55°C Ambient  
 Storage Range: -40°C to 65°C

Humidity

5 to 80 percent (Noncondensing)

Altitude

Operating Range: Up to 10,000 feet



#### 1.4 HUMAN FACTORS SPECIFICATIONS

##### X-Ray Radiation

These units comply with DHEW Rules-42-CFR-Part 78

#### 1.5 CONTROLS

Customer Access - Necessary Accessories (Available)

- (1) Contrast, 500 ohm potentiometer carbon composition  
≥1/8 Watt
- (2) Brightness, 100 kilohm potentiometer ≥1/8 Watt  
Optional: The Brightness Control can be mounted  
on the printed circuit board as an  
internal set up control.

##### Internal Set Up Controls

- (1) Height
- (2) Vertical Linearity
- (3) Vertical Hold
- (4) Focus
- (5) Width
- (6) Low Voltage Adjust

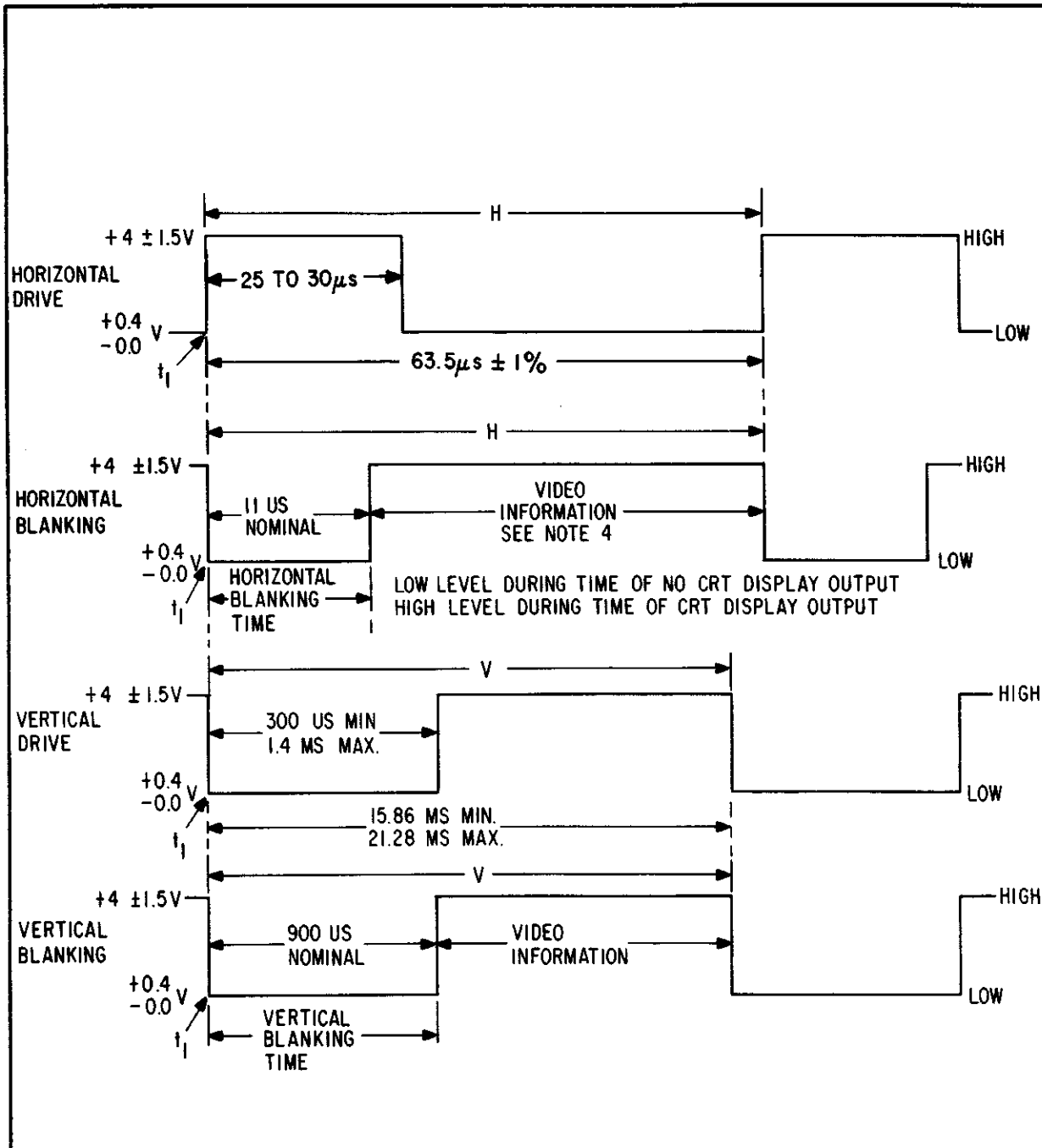

NOTES

1. The leading edges of Drive and Blanking waveforms must start at time  $t_1$ . Nominal Blanking times should be observed.
2. H = time from start of one line to start of next line.
3. V = time from start of one field to start of next field.
4. Video pulse width should be equal to or greater than 100 nsec.

Fig. 1 Synchronization and Blanking Generator Waveforms for the TV Series

## Section 2 OPERATING PROCEDURES

### 2.1 INSTALLATION

Power for the TV monitor series can be supplied in one of two methods, depending upon the model. For the model which has a self-contained, low voltage, power supply, plug the monitor into a 120 volt (220/240 V, optional) AC power source. For the model which requires external DC power, consult the schematic for terminal locations and voltage values.

The video and synchronization signals are fed to their appropriate connections as indicated on the schematic.

Mount the monitor so that the ambient temperature surrounding the monitor does not exceed 55°C.

### 2.2 GROUNDING TECHNIQUES

The method of interconnecting and grounding the equipment is a function of the signal frequency; any optimum grounding depends largely on the system in which the equipment is used.

The following grounding technique is recommended when installing a TV Data Display Monitor.

The vertical/video, horizontal drive, vertical drive, and CRT arc bypass are all returned to the TV chassis plate ground through single molex connections. Normally, it is assumed that the frame and chassis plate of the monitor will be installed in a system where they will be an integral part of system ground. If this is true,

then further grounding should not be necessary. However, the mating of the monitor's frame with the system or the generator's signal source ground must be electrically good. Good electrical metal-to-metal contact must be assured.

Where strong radiated noise and signal fields inhibit the monitors's operation or where a signal's waveform is deteriorated by long or poorly selected cabling, low or high frequency shielded cable should be used. When using shielded cable, careful attention must be given to proper grounding of the outer conductor. Improper grounding can cause annoying ground loops. In some cases, transistor failures can be traced to poor grounding techniques.

The TV monitor has provisions at the printed circuit board card edge connector to pick up the ground returns for the vertical/video, horizontal drive, and vertical drive circuits. If these connections must be used, it is likely that the single molex connection associated with each ground return may have to be opened to minimize ground loops. Reducing the number of ground connections reduces the number of possible ground loops with the ultimate being one system ground connection at the source.

IMPORTANT -- One pin on the printed circuit board edge connector is to be used specifically for the CRT arc bypass and must not be used as a signal ground return (see schematic).

### 2.3 VIDEO LEAD ROUTING

The video lead probably will carry high frequency signals and should be given the following considerations:

- A. To minimize distributed capacity and capacitive pickup of nearby radiated fields, route the video leads separately and away from all other wiring.
- B. Make the lead length as short as possible, consistent with the packaging requirements.
- C. Ideally, the video line should meet the requirements of a terminated coaxial system; i.e., the video line should exhibit a constant impedance from source to load. An effective method of testing the video line is as follows:
  - a. Establish a configuration and keep the foregoing requirements in mind.
  - b. Drive the source end of the video line with the output of TTL logic or an equivalent pulse generator capable of providing pulses with rise and fall times of typically 10 nanoseconds and pulse widths of approximately 100 nanoseconds. Any convenient duty cycle and repetition rate may be used. The generator should be capable of supplying +2.5 volt pulse into a shunt impedance of 3.3 k ohms (resistive) and 40 pF (capacitive).
  - c. Observe the pulse at the receiving end of the video line with a low capacitance (less than 5 pF) oscilloscope probe. Adjust the routing and termination of the video line to maintain rise and fall times of 20 nanoseconds or less and overshoots within 10 percent of the pulse amplitude.

#### 2.4 INITIAL TURN-ON PROCEDURE

The TV monitor was tested and aligned before shipment and should not require further adjustment after installation. First, connect the video and synchronization signals to the monitor; next apply power to the unit. Proceed as follows when turning the monitor on for the first time.

- (1) Place the power switch (external or internal) in the ON position. Adjust the brightness and contrast controls for desired effect and stabilize the picture with the vertical hold control. Allow the monitor to warm up for 15 minutes before proceeding to the next step.
  
- (2) Adjust the height control and width coil for the desired raster height and width. Adjust the focus control to produce optimum focus over the entire area of the CRT.

## 2.5 NORMAL MONITOR OPERATION

After the monitor has been adjusted, turn on the power and adjust contrast and brightness. Note that some models may have the brightness control as an internal setup control. In that case, make the adjustment as indicated in Section 2.4.

### Section 3 THEORY OF OPERATION

#### 3.1 VIDEO AMPLIFIER

The video amplifier consists of Q101 and its associated circuitry.

The incoming video signal is applied to the monitor through the contrast control through R109 to the base of transistor Q101.

Transistor Q101 and its components comprise the video output driver with a gain of about 17. Q104, operating as a class B amplifier, remains cutoff until a DC-coupled, positive-going signal arrives at its base and turns on the transistor. R111 adds series feedback which makes the terminal-to-terminal voltage gain relatively independent of transistor variations as well as stabilizes the device against voltage and current changes caused by ambient temperature variations.

The negative going signal at the collector of Q101 is DC-coupled to the cathode of the CRT. The class B biasing of the video driver allows a larger video output signal to modulate the CRT's cathode and results in a maximum available contrast ratio.

The overall brightness at the screen of the CRT is determined by the negative potential at the grid and is varied by the brightness control.

#### 3.2 VERTICAL DEFLECTION

Transistor Q102 is a programmable unijunction transistor, and together with its external circuitry, forms a relaxation oscillator

operating at the vertical rate. Resistor R115, variable resistor R116 and capacitors C105 and C106 form an RC network providing proper timing.

When power is applied, C105 and C106 charge exponentially through R115 and R116 until the voltage at the junction of R116 and C105 equals the anode "A" firing voltage. At this time, one of the unijunction's diodes that is connected between the anode and anode gate "G" becomes forward biased allowing the capacitors to discharge through another diode junction between the anode gate and the cathode "K" and on through R120.

R117 and R118 control the voltage at which the diode (anode-to-anode gate) becomes forward biased. This feature "programs" the firing of Q102 and prevents the unijunction from controlling this parameter. Therefore, the changing of firing points from one device to another, together with the temperature dependency of this parameter, is no longer a problem as it can be with conventional unijunction transistors.

The vertical oscillator is synchronized externally to the vertical interval from the vertical drive pulse at R113. At the time of the vertical interval, an external negative pulse is applied through R113, C104, and CR101 to the gate of Q102, causing the firing level of the unijunction to decrease.

The sawtooth voltage at the anode of Q102 is directly coupled to the base of Q103. Q103 is a driver amplifier and has two transistors wired as a Darlington pair; their input and output leads exit as a three-terminal device. This device exhibits a high input impedance to Q102, and thereby maintains excellent impedance isolation between Q102 and Q104.



The output waveform from the unijunction oscillator is not suitable, as yet, to produce a satisfactory vertical sweep. Such a waveform would produce severe stretching at the top of the picture and compression at the bottom. C105 and C106 modify the output waveform to produce satisfactory linearity. The sawtooth waveform output at Q103 is coupled through R122, the vertical linearity control R121, and on to C106 where the waveform is shaped into a parabola. This parabolic waveform is then added to the oscillator's waveform and changes its slope. Slope change rate is determined by the position of the variable resistor R121.

Q103 supplies base current through R123 and R124 to the vertical output transistor, Q104. Height control R124 varies the amplitude of the sawtooth voltage present at the base of Q104 and, therefore, varies the size of the vertical raster on the CRT.

The vertical output stage, Q104, uses a power type transistor which operates as a class A amplifier. No output transformer is required since the output impedance of the transistor permits a proper impedance match with the yoke connected directly to the collector. C107 is a DC-blocking capacitor which allows only AC voltages to produce yoke current. L1 is a relative high impedance compared to the yoke inductance. During retrace time, a large positive pulse is developed by L1 which reverses the current through the yoke and moves the beam from the bottom of the screen to the top. Resistor R126 prevents oscillations by providing damping across the vertical deflection coils.

### 3.3 HORIZONTAL DEFLECTION

To obtain a signal appropriate for driving Q106, the horizontal output transistor, a driver stage consisting of Q105 and T101,

is used. The circuitry associated with Q105 and Q106 has been designed to optimize the efficiency and reliability of the horizontal deflection circuits.

A positive going pulse is coupled through R127 to the base of Q105. The amplitude and duty cycle of this waveform must be as indicated in the electrical specifications (Section 1.2) for proper circuit operation.

The driver stage is either cut off or driven into saturation by the base signal. The output signal appears as a rectangular waveform and is transformer-coupled to the base of the horizontal output stage. The polarity of the voltage at the secondary of the driver transformer is chosen such that Q106 is cut off when Q105 conducts and vice versa.

During conduction of the driver transistor, energy is stored in the coupling transformer. The voltage at the secondary is then positive and keeps Q106 cut off. As soon as the primary current of T101 is interrupted due to the base signal driving Q105 into cut off, the secondary voltage changes polarity. Q106 starts conducting, and its base current flows. This gradually decreases at a rate determined by the transformer inductance and circuit resistance.

The horizontal output stage has five main functions: to supply the yoke with the correct horizontal scanning currents; develop a "C" VDC supply voltage for use with the CRT; develop a "B" VDC supply voltage for the video output stage; and develop a "D" VDC for the CRT bias.

Q106 acts as a switch which is turned on or off by the rectangular waveform on the base. When Q106 is turned on, the supply voltage

plus the charge on C113 causes yoke current to increase in a linear manner and moves the beam from near the center of the screen to the right side. At this time, the transistor is turned off by a positive voltage on its base which causes the output circuit to oscillate. A high reactive voltage in the form of a half cycle negative voltage pulse is developed by the yoke's inductance and the primary of T2. The peak magnetic energy which was stored in the yoke during scan time is then transferred to C109 and the yoke's distributed capacity. During this cycle, the beam is returned to the center of the screen.

The distributed capacity now discharges into the yoke and induces a current in a direction opposite to the current of the previous part of the cycle. The magnetic field thus created around the yoke moves the scanning beam to the left of the screen.

After slightly more than half a cycle, the voltage across C109 biases the damper diode CR103 into conduction and prevents the flyback pulse from oscillating. The magnetic energy that was stored in the yoke from the discharge of the distributed capacity is released to provide sweep for the first half of scan and to charge C113 through the rectifying action of the damper diode. The beam is then at the center of the screen. The cycle will repeat as soon as the base voltage of Q106 becomes negative.

C113, in series with the yoke, also serves to block DC currents through the yoke and to provide "S" shaping of the current waveform. "S" shaping compensates for stretching at the left and right sides of the picture tube because the curvature of the CRT face and the deflected beam do not describe the same arc.

L101 is an adjustable width control placed in series with the horizontal deflection coils. The variable inductive reactance allows a greater or lesser amount of the deflection current to flow through the horizontal yoke and, therefore, varies the width of the horizontal scan.

The negative flyback pulse developed during horizontal retrace time is rectified by CR104 and filtered by C110. This produces approximately "D" VDC which is coupled through the brightness control to the cathode of the CRT (V1).

This same pulse is transformer-coupled to the secondary of transformer T2 where it is rectified by CR2, CR106, and CR105 to produce rectified voltages of approximately 12 kV (9 and 12 inches) or 9 kV (5 inches), "C" VDC, and "B" VDC respectively. 12 kV or 9 kV is the anode voltage for the CRT, and "C" VDC serves as the source voltage for grids No. 2 and 4 (focus grid) of the CRT. The "B" VDC potential is the supply voltage for the video output amplifier, Q101.

#### 3.4 LOW VOLTAGE REGULATED SUPPLY (Optional on some models)

Some models use a series-pass, low voltage regulator designed to maintain a constant DC output for changes in input voltage, load impedance and temperature. Also included is a current limiting circuit designed to protect transistors connected to the "A" VDC output of the regulated supply from accidental output short circuits and load malfunctions.

The low voltage regulator consists of Q201, Q202, Q1, VR201, and their components. Q203 and its circuitry control the current limiting feature.

The 120 VAC primary voltage (220/240 V, optional) is stepped down at the secondary of T1 where it is rectified by a full wave bridge rectifier CR1. Capacitor C1 is used as a filter capacitor to smooth the rectified output of CR1. Transistor Q1 is used as a series regulator to drop the rectified voltage to "A" VDC and to provide a low output impedance and good regulation. Resistor network R207, R208 and R209 is used to divide down the "A" VDC voltage to approximately +6 VDC and apply this potential to the base of Q202. A reference voltage from zener diode VR201 is applied to the emitter of Q202. If the voltages applied to the base and emitter of Q202 are not in the proper relationship, an error current is generated through Q202. This error current develops a voltage across R202 which is applied to the base of emitter follower Q201 and then applied to the base of Q1 to bring the output voltage back to its proper level. R201 and C201 provide additional filtering of the rectified DC voltage.

Operation of this regulator may be better understood by assuming a certain operation condition has caused the output voltage to increase above normal. This positive increase of voltage is transferred to the base of Q202 where it is compared to the zener voltage of VR201. The increase of forward bias of Q202 causes the collector voltage to drop as a result of the increased collector current through R202. This voltage is directly coupled to the base of Q1 through Q201 where it causes Q1 to conduct less and brings the regulated voltage back to its proper state.

The short circuit protection or current limiting action can be explained as follows. Assume the "A" VDC bus becomes shorted to ground. This reduced output voltage is sensed by the base of Q202 turning that transistor off because of the reverse bias across its emitter and base junction. Simultaneously, the increased current

through R204 increases the forward voltage drop across the base and emitter junction of Q203 and turns it on. Prior to the short circuit condition, Q203 was cut off. The increased collector current through R202 decreases the collector voltage of Q203 which is detected by the base of Q201 and direct-coupled to the base of Q1 causing that conductor to conduct less. This closed loop operation maintains the current available to any transistor connected to the "A" VDC bus at a safe level during a short circuit condition. Circuit breakers and fuses are often used for this purpose; however, in the majority of cases, these devices are not fast enough to protect transistors.

## Section 4 PRELIMINARY ADJUSTMENTS

### 4.1 SYNCHRONIZATION AND DRIVE SIGNALS

Apply horizontal and vertical drive signals to the horizontal and vertical drive terminals as indicated on your schematic. Adjust their levels to a nominal +4 V peak-to-peak. The duty cycle of each signal must be adjusted as described in Section 1.2.

The horizontal drive signal is required to initiate horizontal scan and high voltage, and should be connected before applying power to the monitor.

### 4.2 LOW VOLTAGE SUPPLY

For units which have a self-contained, low voltage power supply, set the DC voltage by variable resistor R208 as indicated on the schematic. This voltage can be monitored at the junction of R114 and R130.

Monitors that use an external DC supply must supply the voltage as specified in Section 1.2.

### 4.3 BRIGHTNESS

Normally, the monitor will be used to display alphanumeric or other black and white information. Moreover, the video polarity is usually white characters on a black background.

The brightness control should be adjusted at a point where the white raster is just extinguished. The CRT will then be at its cutoff point, and a maximum contrast ratio can be obtained when a video signal is applied.

#### 4.4 VIDEO CONTRAST

Q101 is designed to operate linearly when a +2.5 V signal is applied to its base. Some models incorporate a 500 ohm external contrast control to maintain this level. This control, or a fixed resistor, should be adjusted for a typical signal level of +2.5 V peak-to-peak when measured at the video input terminal of the printed circuit board edge connector. (Refer to the schematic.)

In all cases, the output DC impedance of the video signal source must be 500 ohms, or less.

#### 4.5 VERTICAL ADJUSTMENTS

There is a slight interaction among the vertical frequency, height, and linearity controls. A change in the height of the picture may affect linearity.

- (1) Apply video and synchronization signals to the monitor.
- (2) Set the vertical frequency control, R116, near the mechanical center of its rotation.
- (3) Adjust the vertical height control, R124, for desired height.



- (4) Adjust the vertical linearity control, R121, for best vertical linearity.
- (5) Remove the vertical drive signal from the unit. Or, alternatively, use a short jumper lead, and short the vertical drive input terminal of the printed circuit card edge connector to ground.
- (6) Readjust the vertical frequency control, R116, until the picture rolls up slowly.
- (7) Restore vertical drive to the monitor.
- (8) Recheck height and linearity.

#### 4.6 HORIZONTAL ADJUSTMENTS

Raster width is affected by a combination of the low voltage supply, width coil L101, and the horizontal linearity sleeve located on the neck of the CRT beneath the yoke.

- (1) Apply video and synchronization signals to the monitor. Insert the horizontal linearity sleeve about  $\frac{2}{3}$  of its length under the yoke. (If you received a monitor from the factory in which the placement of the linearity sleeve has been determined, make a mark on the sleeve and reinsert the sleeve to this mark when removal of the yoke and linearity sleeve are required.)

If the linearity sleeve is inserted farther than necessary, excessive power will be consumed, and the horizontal output circuitry could be overstressed.

- (2) Adjust the horizontal width coil, L101, for the desired width.
- (3) Insert the linearity sleeve farther under the yoke to obtain the best linearity. Although this adjustment will affect the raster width, it should not be used solely for that purpose. The placement of the linearity sleeve should be optimized for the best linearity.
- (4) Readjust L101 for proper width.
- (5) Observe final horizontal linearity and width, and touch up either adjustment if needed.

No horizontal hold control is used in this monitor. The raster should be properly locked and centered when the horizontal drive signals as described in Section 1.2 are used.

#### 4.7 FOCUS ADJUSTMENT

The focus control, R107, provides an adjustment for maintaining best overall display focus. However, because of the construction of the gun assembly in the CRT, this control does not have a large effect on focus.

#### 4.8 CENTERING

If the raster is not properly centered, it may be repositioned by rotating the ring magnets behind the deflection yoke.

The ring magnets should not be used to offset the raster from its nominal center position because it would degrade the resolution of the display.

If the picture is tilted, rotate the entire yoke.

Section 5  
TROUBLESHOOTING AND MAINTENANCE

5.1 TROUBLESHOOTING GUIDE

<u>SYMPTOM</u>	<u>POSSIBLE REMEDY</u>
1. Screen is dark	Check "A" bus Q106, Q105, CR2
2. Loss of video	CR105, Q101
3. Power consumption is too high	Check horizontal drive waveform; Check proper placement of horizontal linearity sleeve; Q105, Q106
4. Low voltage bus incorrect (for units with a low voltage supply)	Q202, Q203, Q1 Note: Low voltage supply will indicate low or "0" volts due to its current limiting action if a short is evident in the "A" volt line.

The voltage waveforms are shown in Fig. 2, and Fig. 3 is the interconnecting cabling diagram. Figure 4 shows the circuit board component locations.

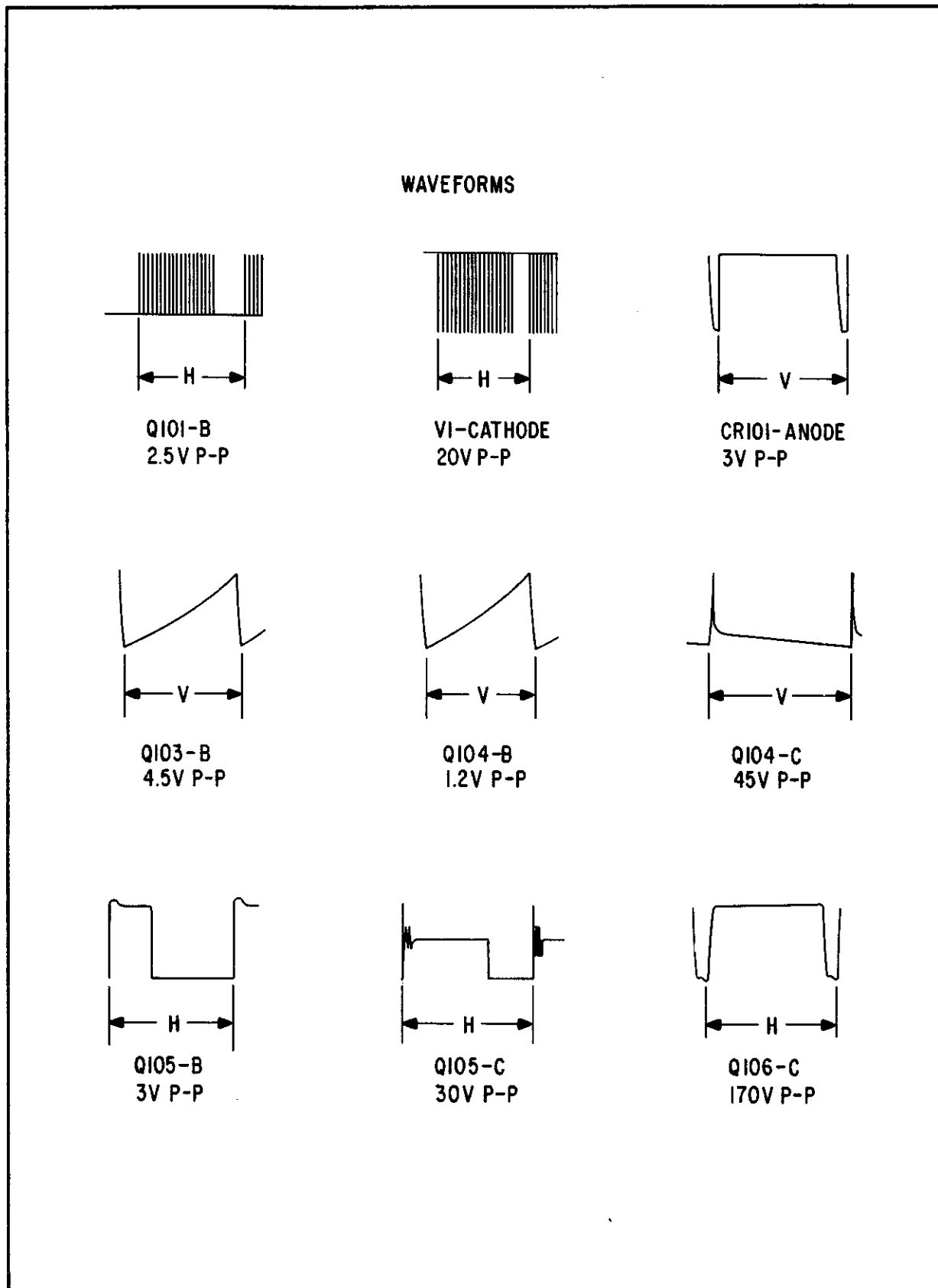

Fig. 2 Voltage Waveform

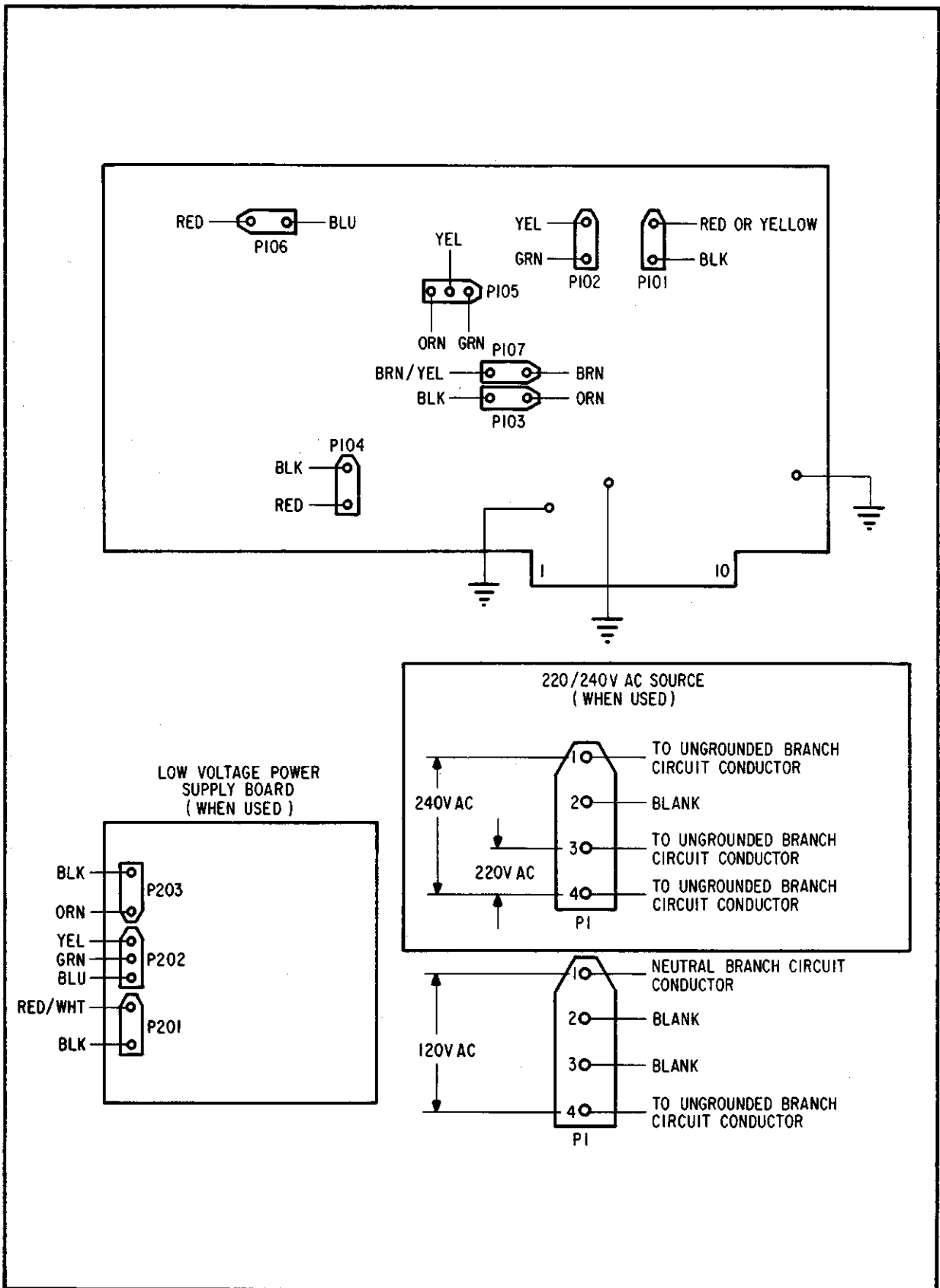

Fig. 3 Interconnecting Cabling Diagram

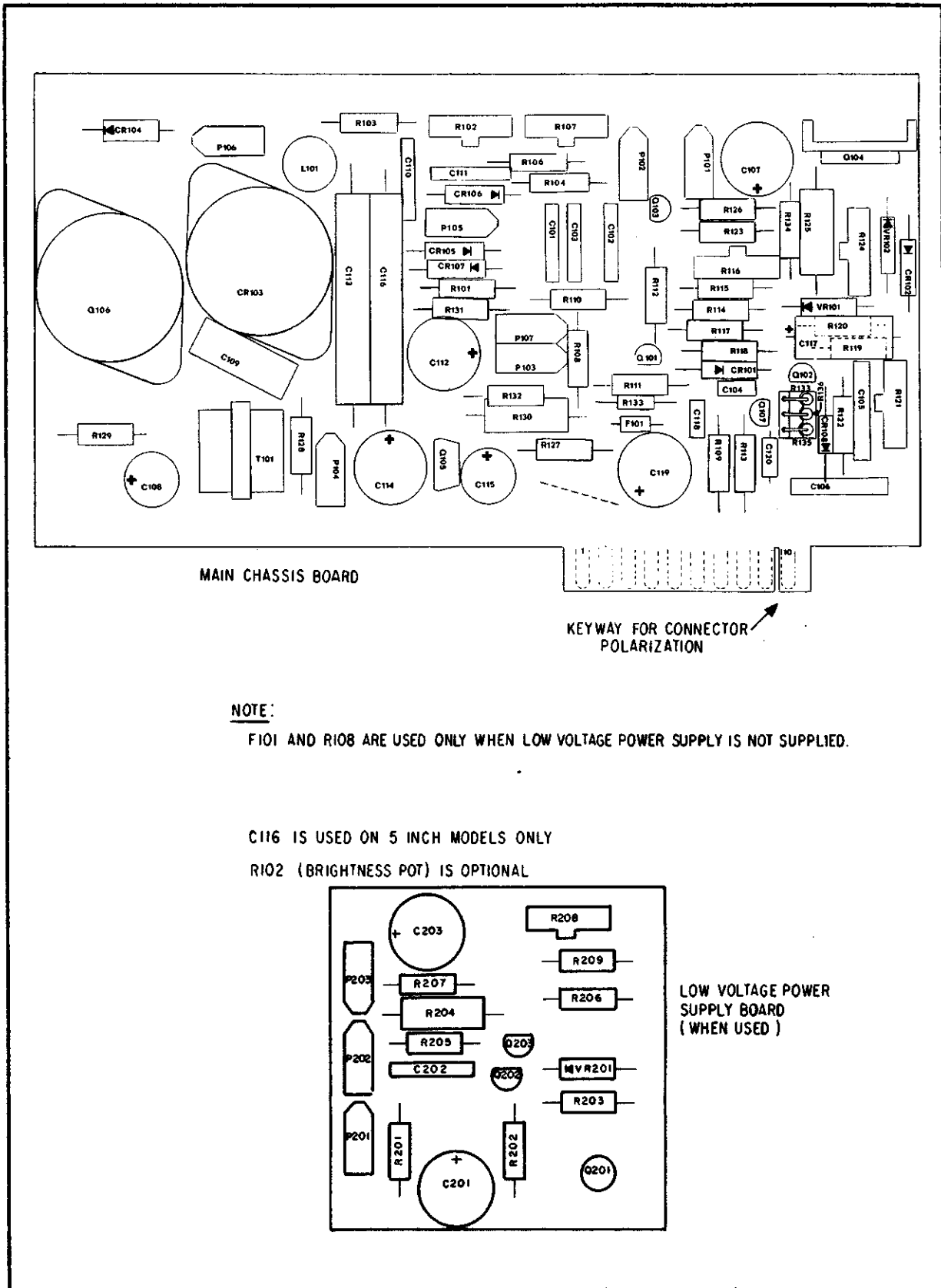

Fig. 4 Circuit Board Components Location

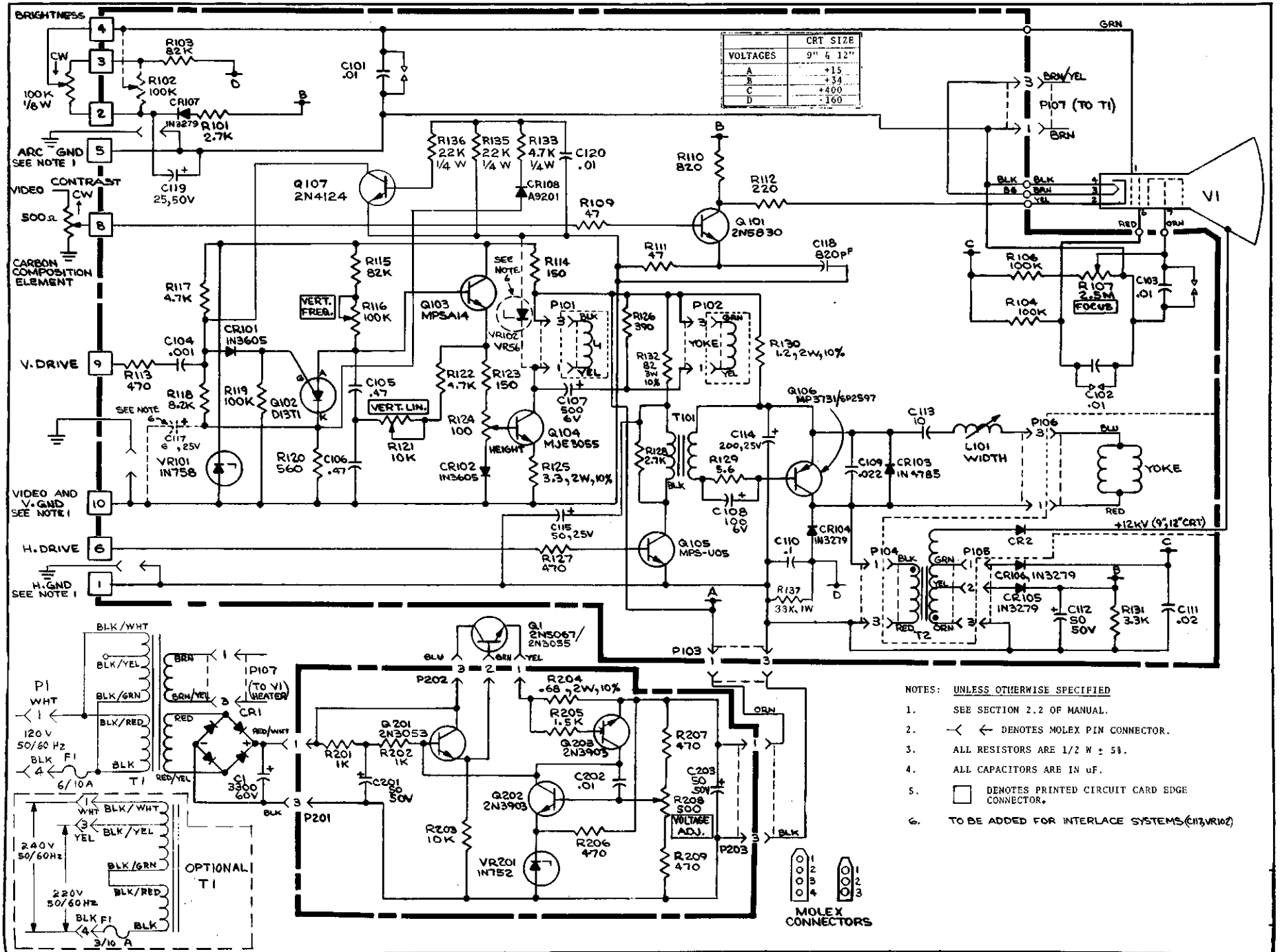
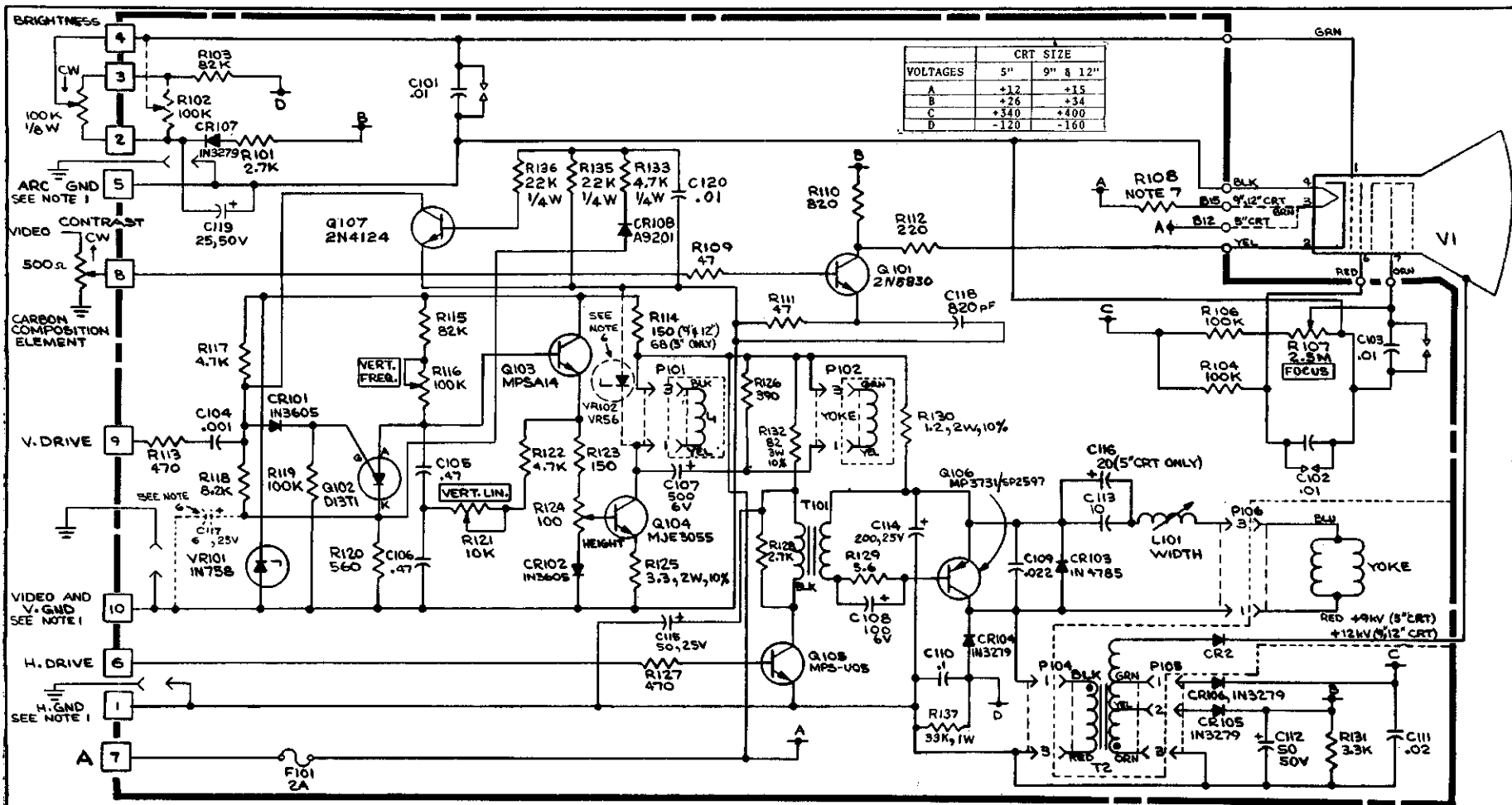

Fig. 5 Schematic, TV 9 and 12 With Power Supply

Not applicable to Mini Bee or Super Bee





- NOTES: UNLESS OTHERWISE SPECIFIED
- SEE SECTION 2.2 OF MANUAL.
  - ← ← DENOTES MOLEX PIN CONNECTOR.
  - ALL RESISTORS ARE 1/2 W ± 5%.
  - ALL CAPACITORS ARE IN μF.
  - DENOTES PRINTED CIRCUIT CARD EDGE CONNECTOR.
  - TO BE ADDED FOR INTERLACE SYSTEMS (417, 400)
  - FOR PROPER VALUE REFER TO PARTS LIST, SECTION 6 OF INSTRUCTION MANUAL.



Fig. 6 TV5, 9 and 12 Without Power Supply 5-6

## **APPENDIX B**

### **SCINTILLONICS POWER SUPPLY DESCRIPTION**

**TECHNICAL INFORMATION AND THEORY OF OPERATION  
POWERBEE**

**MANUFACTURER:** Scintillonics, Inc.  
P.O. Box 701  
600 Industrial Park  
Fort Collins, Colorado 80521  
Phone: (303) 482-4752

**Scintillonics, Inc. P/N: 1172-01**

**Beehive Medical Electronics, Inc. P/N: 610-0318-02**

## TABLE OF CONTENTS

1. General
2. Theory of Operation
3. Specifications
  - 3.1 Input Power
  - 3.2 Output Power
  - 3.3 Typical Output Parameters
  - 3.4 Dimensions
4. Mounting
5. Connections
6. Operation
  - 6.1 Sense Connection
  - 6.2 Voltage Adjustments
  - 6.3 Overvoltage Protection Circuit (OVP)
  - 6.4 Overload Protection
7. Maintenance
8. Corrective Maintenance

## 1. GENERAL

Powerbee is a series regulated multiple output power supply with overload and overvoltage protection. It is designed to operate without forced air cooling and features all silicon semiconductors. The components are mounted in a black anodized aluminum chassis.

## 2. THEORY OF OPERATION

The following description is for the +5 VDC supply, but can be applied directly to the +15 V and -12 V supplies.

Powerbee is built around three equivalent circuits, each one with its own raw filter supply consisting of a rectifier bridge, BR1, and filter capacitors (computer grade). A ceramic disc capacitor, C3, is used to bypass high frequency noise and transients. The positive output terminal is taken directly from the filter capacitors, C1 and C2, and fed to the load, which leaves the negative side with the series pass transistors, Q4, Q5 and Q6.

An operational amplifier, IC1, is used to compare the sampled output voltage with the reference voltage provided by zener diode, CR1. The sensor and temperature compensating block (ref. block diagram) consists of R7, R8, R9, R10 and CR2. CR2 is used forward biased and is in thermal equilibrium with zener diode CR1. R9 and R10 determine the rate of compensation. Output voltage adjustment is done with potentiometer R2 which divides the zener voltage of CR1. R1 is a biasing resistor. The output from IC1 is fed into an amplifier, Q1, which provides the base drive for the current regulator Q3. The constant current source and Q3 combined provide the driving element for the pass transistors.

The constant current source and the output current limit function are accomplished by resistor R5 and PNP transistor Q2. R5 determines the foldback point of the output current and together with Q2 supplies the base of Q4, Q5, Q6, and collector Q3, with a constant current.

In short circuit mode, Q2 is off and R6 supplies the base current to the pass transistors.

An electrolytic capacitor, C5, is connected across the output to prevent high frequency oscillations. The SCR crowbar, except for the zener diode CR3 which is connected to the + sense for the +5 V supply, is also tied directly across the output.

### 3. SPECIFICATIONS

Powerbee conforms to the Super Bee Power Supply specifications specified by B.M.E.I.

#### 3.1 INPUT POWER

Voltage: 103 - 127 VAC at 47 to 66 Hz  
or 207 - 253 VAC at 47 to 66 Hz

#### 3.2 OUTPUT POWER

Positive 5 VDC @ 7.0 A  
Positive 15 VDC @ 2.5 A  
Negative 12 VDC @ 2.5 A

#### 3.3 TYPICAL OUTPUT PARAMETERS

Monitored at output (DC) connector.

<u>Output</u>	<u>+5VDC</u>	<u>+15VDC</u>	<u>-12VDC</u>
Load regulation, 0-100%	1.5 mV	18.0 mV	18.0 mV
Line regulation, ±10%	1.0 mV	1.0 mV	1.0 mV
Ripple peak-to-peak	2.0 mVpp	2.0 mVpp	2.0 mVpp
Overvoltage protection trigger level	6.1 V	19.2 V	15.6 V
Short circuit current	1.3 A	1.2 A	1.1 A

#### 3.4 DIMENSIONS

Powerbee conforms to Scintillonics drawing no. 1172-201.  
The maximum physical size is 9.50" L X 10.00" H X 3.25" W.

### 4. MOUNTING

Powerbee is provided with two (2) sets of mounting holes, of which one set is used for the Mini Bee terminal and the other set for all other applications.

### 5. CONNECTIONS

As per B.M.E.I. drawing 610-0318-02 with AC input (connector 1, plug), and DC output (connector 2, receptacle).

Connector 1		Connector 2	
Pin	Function	Pin	Function
1	115 VAC (A)	1	Key
2	115 VAC (B)	2	Ground
3	Chassis ground	3	Ground
4	AC return (A)	4	-12 VDC
5	AC return (B)	5	+15 VDC
		6	Key
		7	5 VDC Sense -
		8	Blank
		9	Blank
		10	5 VDC Sense +
		11	+ 5 VDC
		12	+ 5 VDC

To connect for 230 VAC operation, connect Pin 2 to Pin 4, and connect 230 VAC high side to Pin 1 and AC return to Pin 5.

## 6. OPERATION

### 6.1 SENSE CONNECTION

Powerbee can not be operated without remote sensing.

Failure to connect sense will result in an output voltage of approximately 0.9 V at +5 V output pins. This is also a double test that the +5 V OVP circuit (overvoltage protection circuit) operates normally.

### 6.2 VOLTAGE ADJUSTMENTS

All outputs operate independently of each other and can be adjusted separately. The +5 V output is adjustable from approximately 4.7 V to maximum 6.5 V or until the OVP threshold is reached, through turning the potentiometer, R2, clockwise (CW). The +15 V output has a voltage range from 11.0 V to 16.0 V (potentiometer R22). The -12 V output is decreased from approximately -9.0 V to -14.0 V when adjusting R42 CW.

### 6.3 OVERVOLTAGE PROTECTION

Each output is protected with a SCR crowbar overvoltage protection (OVP) circuit with preset threshold voltages, typical values are in section 3.3.

In triggered condition, the OVP circuit reduces the output voltage to approximately 0.9 V and the output ripple increases to approximately 5 mV peak-to-peak.

Test procedure: Determination of trigger level for the +5 V output is accomplished simply through adjusting R2 CW until SCR1 triggers. On the +15 V (-12 V) output, adjust R22 (R42) CCW for an output voltage of approximately 13.0 V (-10.0 V). A 2.2K ohm resistor is thereafter paralleled with R28 (R48). The voltage will increase to approximately 16.5 V (decrease to -12.5 V). R22 (R42) can now be adjusted CW until the SCR's trigger and the threshold voltages measured.

NOTE: It is important to keep load current constant during test. If not kept constant, the foldback current limit circuit will reduce the output voltage which then will never reach threshold value.

#### 6.4 OVERLOAD PROTECTION

The output current is limited to 150% or less of rated load current, by a current limit foldback circuit. The foldback point (FB) is set by R5, R25 and R45. These resistor values are a function of the pass transistors gain and are determined in test by SCINTILLONICS, INC.

Short circuit protection is accomplished with the same FB circuit and the short circuit current is approximately 1.0 A.

Overload or short circuit operation over an extended period of time will not effect the power supply and the supply will recover instantly to normal operating mode when the overload conditions are removed.

#### 7. MAINTENANCE

The power supply is a long lasting supply designed to be maintenance free other than the general precautionary practices.

It should be noted, however, that as mechanical shock may damage the transformer shielding effectiveness, careful handling is of importance.

#### 8. CORRECTIVE MAINTENANCE

A malfunction will normally be detected at the output of the power supply by output parameters which are sub-standard to the power supply specifications.

Should repair become necessary, it is recommended to send the unit to SCINTILLONICS, INC., or an authorized repair agent for repair or replacement.



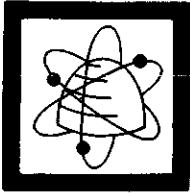

# Beehive Terminals

Beehive Medical Electronics, Inc.

Dear Customer:

To assist in the service and maintenance of your Beehive Computer Terminal, you are entitled to receive a one year subscription to THE BEELINE. This service is provided in conjunction with the purchase of your Beehive Terminal Maintenance Manual and Illustrated Parts Breakdown. The BEELINE will present the latest operation, maintenance and service information available, including:

- Service Updates and Tips
- Manual Updates and Changes
- Corrective Modification Kits and Documentation
- Recommended Spare Parts

To receive your copies of THE BEELINE, complete the following information and return this form to Beehive Terminals.

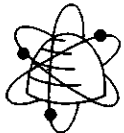

THE BEELINE

Subscription No. 10196

Name \_\_\_\_\_ Position or Title \_\_\_\_\_

Company \_\_\_\_\_ Address \_\_\_\_\_

Mailing Address (if other than company address) \_\_\_\_\_

Terminal Model  Mini Bee  Super Bee  Other (List) \_\_\_\_\_ Date Purchased \_\_\_\_\_

**NOTE:** This offer is subject to contractual agreements

**Beehive Terminals**  
Beehive Medical Electronics, Inc.  
870 West 2600 South  
Salt Lake City, Utah 84119

## WARRANTY

Beehive Medical Electronics, Inc. certifies that each terminal will be free from defective materials and workmanship for 90 days from date of shipment to the original customer.

B.M.E.I. agrees to correct any of the above defects when the terminal is returned to the factory prepaid. Return authorization must be obtained and confirmed in writing by the Field Service Department before returning the terminal to the factory.

Under this warranty, B.M.E.I. will provide the necessary components required by the customer to correct the terminal in the field. The components will be shipped, prepaid, on a billing memo which will be cancelled upon receipt of the defective components at the factory. When ordering components for repair or replacement, the model number and serial number must be included on the customer request.

This warranty is invalid if the terminal is subject to misuse, abuse, neglect, accident, improper installation or application, alteration or negligence in use, storage, transportation or handling and where the serial number has been removed, defaced or changed.

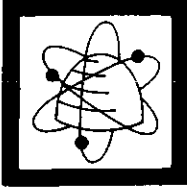

# Beehive Terminals

Beehive Medical Electronics, Inc.

## MALFUNCTION REPORT

Dear Customer :

We are trying to manufacture the most reliable product possible. You would do us a great courtesy by completing this form should you experience any failures.

1. Type Unit \_\_\_\_\_ Serial No. \_\_\_\_\_

Module (if applicable) \_\_\_\_\_

2. Part failed (Name and Number) \_\_\_\_\_

3. Cause of failure (If readily available)

\_\_\_\_\_  
\_\_\_\_\_  
\_\_\_\_\_

4. Approximate hours/days of operation to failure \_\_\_\_\_

5. Failure occurred during:

Final Inspection    Customer Installation    Field Use

6. Personal Comment:

\_\_\_\_\_  
\_\_\_\_\_  
\_\_\_\_\_

Customer \_\_\_\_\_

Address \_\_\_\_\_

Signed \_\_\_\_\_

Date \_\_\_\_\_

Beehive Medical Electronics, Inc.  
c/o Field Service Department  
870 West 2600 South  
P.O. Box 19244  
Salt Lake City, Utah 84120

RETURNING PARTS/EQUIPMENT  
FOR REPAIR

When the terminal requires service or repair in accordance with the enclosed warranty, unnecessary delays may be avoided when parts or equipment are returned to B.M.E.I. using the following procedures:

1. Contact B.M.E.I.'s Field Service Department for Return Authorization. An R.A. Number will be issued and used for future reference.
2. Package the unit or part in accordance with the method of shipment. Enclose a list of the material being returned and the reason for returning it. Reference the Return Authorization Number on the shipping label. If the number is not visible, the Receiving Department may refuse to accept the shipment.
3. Send the unit or part, transportation prepaid, to the address stipulated for returning parts and equipment.

All equipment and parts described in the warranty will be replaced provided B.M.E.I.'s examination discloses that the defects are within the limits of the warranty. If damages or defects are not within the limits of the warranty, the customer will be notified of the extent of repairs required and the cost. The unit will be repaired and returned upon agreement and receipt of a written purchase order number.

When returning parts and/or equipment for repair, please use the following address:

Beehive Medical Electronics, Inc.  
870 West 2600 South  
Salt Lake City, Utah 84119

OPTION CONFIGURATION FOR: \_\_\_\_\_

SERIAL NUMBER \_\_\_\_\_

FUNCTION	KEY BOARD	BACK PANEL	TERMINAL LOGIC PCB	VIDEO BOARD	INTERNAL
POWER OPTION					Jumper Lug 1-2 _____ Lug 3-4 115V _____ Lug 2-3 230V _____
DISPLAY FORMAT			12 line _____ 25 line _____		
STOP BIT 1/2 SELECT			Strap In _____ (1) Out _____ (2)		
PARITY CHECK			Strap In _____ (inact) Out _____ (act)		
PARITY SELECT			Strap In _____ (odd) Out _____ (even)		
HALF/FULL DUPLEX		Switch Half _____ Full _____			
I/O BAUD RATE SELECT		Switch 8 _____ 1 _____ 16 _____ 2 _____ 32 _____ 3 _____ 64 _____			
I/O BAUD RATE MULTIPLIER		Switch 110 _____ 150 _____			
8 x CLOCK			Strap In _____ Out _____		