

260XX
Programmer's
Reference Guide

Content

It is the policy of Applied Digital Data Systems Inc. (ADDS) to improve products as new technology, components, software, and firmware become available. ADDS, therefore, reserves the right to change specifications without prior notice.

All features, functions, and operations described herein may not be marketed by ADDS in all parts of the world. In some instances, photographs are of equipment prototypes. Therefore, before using this document, consult your ADDS representative or ADDS office for information that is applicable and current.

Copyright © 1994 by Applied Digital Data Systems Inc.
An NCR/AT&T Company
Hauppauge, New York
All Rights Reserved, Printed in U.S.A.

INTRODUCTION

OVERVIEW	
Control Codes & Escape Sequences	
7-bit & 8-bit sequences	
Visual Attributes	
Supported Emulations	

CHARACTER SETS

OVERVIEW	2
INTRODUCTION	2
CHARACTER SIZES	2
SOFT CHARACTER SETS	2
ANSI CHARACTER SETS	2
Mapping	2
ANSI Soft Characters	2
ASCII CHARACTER SETS	2-1
ASCII Soft Characters	2-1

FUNCTION & EDIT KEYS

OVERVIEW	3-
Storage Limits	3-
ASCII EMULATIONS	3-
Function Key Labels	3-
ANSI EMULATIONS	3-4
SCO CONSOLE & AT386 EMULATIONS	3-7

Contents

ASCII PROGRAMMING

GENERAL SETUP COMMANDS.....	4-1
COMMUNICATION COMMANDS.....	4-2
DISPLAY COMMANDS.....	4-5
SCROLL COMMANDS.....	4-6
CURSOR DISPLAY COMMANDS.....	4-7
ANSWERBACK COMMANDS.....	4-7
KEYBOARD COMMANDS.....	4-8
PROGRAM FUNCTION/EDIT KEYS.....	4-9
LABEL LINE COMMANDS.....	4-11
STATUS LINE COMMANDS.....	4-11
TAB COMMANDS.....	4-12
COLUMN COMMANDS.....	4-13
PAGE COMMANDS.....	4-13
SPLIT SCREEN COMMANDS.....	4-15
CURSOR MOVEMENT COMMANDS.....	4-16
EDIT COMMANDS.....	4-21
ATTRIBUTE COMMANDS.....	4-23
PROTECT COMMANDS.....	4-26
CHARACTER SIZE COMMANDS.....	4-28
CHARACTER SET COMMANDS.....	4-28
GRAPHICS COMMANDS.....	4-30
SEND COMMANDS.....	4-33
PRINT COMMANDS.....	4-35
WORDPERFECT GRAPHICS COMMANDS.....	4-37

ANSI PROGRAMMING

SUPPORTED C0 CONTROL CODES.....	5-1
---------------------------------	-----

Contents

SUPPORTED C1 CONTROL CODES.....	5-2
CURSOR COMMANDS.....	5-3
TAB COMMANDS.....	5-4
EDIT COMMANDS.....	5-5
SELECTIVE ERASE COMMANDS.....	5-5
CHARACTER SIZE COMMANDS.....	5-6
DISPLAY COMMANDS.....	5-6
KEYBOARD COMMANDS.....	5-8
CHARACTER SET COMMANDS.....	5-10
GRAPHICS COMMANDS.....	5-11
SEND AND PRINT COMMANDS.....	5-12
TERMINAL PERSONALITY.....	5-13
QUERY AND RESPONSE.....	5-13
RESET TERMINAL AND EMULATIONS.....	5-17
ANSI PAGING COMMANDS.....	5-18
GENERAL SETUP COMMANDS.....	5-19
WORDPERFECT GRAPHICS COMMANDS.....	5-19

SCO / A7386

SUPPORTED C0 CONTROL CODES.....	6-1
SUPPORTED C1 CONTROL CODES.....	6-1
CURSOR COMMANDS.....	6-2
TAB COMMANDS.....	6-3
EDIT COMMANDS.....	6-3
CHARACTER SIZE COMMANDS.....	6-4
DISPLAY COMMANDS.....	6-4
KEYBOARD COMMANDS.....	6-6
SEND COMMAND.....	6-7
RESET TERMINAL COMMAND.....	6-7

Contents

GENERAL SETUP COMMANDS	6-8
WORDPERFECT GRAPHICS COMMANDS	6-10

COLOR PROGRAMMING

OVERVIEW	7-1
ASCII COLOR MODE	7-1
Soft Palettes	7-1
WYSE 60 and WYSE 325 Emulation Commands	7-2
WYSE 50 and WYSE 350 Emulation Commands	7-3
PC-TERM and TVI 925 Emulation Commands	7-5
ADDS-VP Emulation Commands	7-6
Write-Protected Characters	7-6
ANSI COLOR MODE	7-7
Direct Mode	7-7
Palette Mode	7-9
Soft Palettes	7-10
Auto Mode	7-10
SCO CONSOLE EMULATION	7-10
Normal Replacement Colors	7-10
Reverse Replacement Colors	7-11
Graphics Replacement Colors	7-11
IGNORED COMMANDS	7-13

PALETTE DEFAULTS

OVERVIEW	8-1
WYSE 350	8-1 - 8-4
WYSE 325 AND WYSE 60	8-4 - 8-5

Contents

ALL OTHER EMULATIONS	8-5 - 8-8
----------------------------	-----------

DEFAULT STRINGS

OVERVIEW	9-1
CURSOR KEYPAD	9-1
NUMERIC KEYPAD (ASCII EMULATION)	9-2
NUMERIC KEYPAD (ANSI EMULATION-PC KYBD.)	9-3
NUMERIC KEYPAD (SCO CONSOLE EMUL.)	9-4
NUMERIC KEYPAD (ANSI EMULATION-ANSI KYBD.)	9-5
EDIT-KEYPAD (ASCII EMULATION-PC KYBD.)	9-6
EDIT-KEYPAD (ANSI EMULATION-PC KYBD.)	9-6
EDIT-KEYPAD (ASCII EMULATION - ANSI KYBD.)	9-7
EDIT-KEYPAD (ANSI EMULATION-ANSI KYBD.)	9-7
SPECIAL KEYS (ASCII EMULATION)	9-8
SPECIAL KEYS (ANSI EMULATION)	9-8
FUNCTION KEYS (ASCII-EMULATION)	9-9
FUNCTION KEYS (ANSI-EMULATION)	9-10
FUNCTION KEYS (SCO CONSOLE EMUL.)	9-11
FUNCTION KEYS (AT 386 EMUL.)	9-12
WYSE-60 APPLICATION KEYMODE	9-13
ADDS 4000 FAMILY OF KEYBOARDS	9-15
Languages Available	9-16
U.S. ENGLISH KEYBOARDS OFFERED	9-18
LAYOUTS OF THE FOREIGN ALPHANUMERIC KEYPADS	9-20
SELECTED CODES IN SCAN-CODE MODE	9-25
LOCAL KEYS IN SCAN-CODE MODE*	9-27

Contents

WP GRAPHICS

ALPHA MODE COMMAND SET.....	10-1
PIXEL MODE COMMAND SET.....	10-2

APPENDIX A

SCREEN / PAGE LENGTH.....	A-1
Bottom Status / Label Line Display.....	A-1
Visual Combinations.....	A-2
PAGE / SCREEN CONFIGURATIONS.....	A-3
Single Session Mode.....	A-3
Dual Session Mode.....	A-4

APPENDIX B

List of Tables

INTRODUCTION

Table 1-1: Common ANSI 8-bit Control Codes.....	1-2
Table 1-2: Supported Emulations.....	1-3

CHARACTER SETS

Table 2-1: The ANSI Character Sets.....	2-2
Table 2-2: ANSI Character Set Table.....	2-4
Table 2-3: Mapping Character Sets With Locking Shifts.....	2-5
Table 2-4: Mapping Character Sets With Single Shifts.....	2-5
Table 2-5: Converting Binary Code to an ASCII Character.....	2-8 - 2-10
Table 2-6: Character Matrix Sizes.....	2-13

FUNCTION & EDIT KEYS

Table 3-1: Function Key Specifiers.....	3-3
Table 3-2: Edit Key Specifiers.....	3-3
Table 3-3: ASCII Function Key Label Specifiers.....	3-4
Table 3-4: ANSI Function Key Specifiers.....	3-6
Table 3-5: Function Key Specifiers.....	3-8
Table 3-6: Edit Key Specifiers.....	3-8

COLOR PROGRAMMING

Table 7-1: Color Parameters for Mapping A Visual Attribute to a Color.....	7-2
Table 7-2: Visual Attribute Parameters for Mapping a Visual Attribute to a Color.....	7-2
Table 7-3: Attribute Parameters for Mapping an Attribute Entry of the Current Palette to a Particular Foreground Color and Another Attribute.....	7-3

List of Tables

Table 7-4: Color Parameters for Mapping an Attribute Entry of the Current Palette to a Particular Foreground Color and Another Attribute.....	7-4
Table 7-5: Assigned Attribute Parameters for Mapping an Attribute Entry of the Current Palette to a Particular Foreground Color and Another Attribute.....	7-4
Table 7-6: Color parameters for Mapping a Visual Attribute to a Color.....	7-6
Table 7-7: Visual Attribute Parameters to Select Color Rendition.....	7-8
Table 7-8: Color Parameters to Select Color Rendition.....	7-8
Table 7-9: Color Parameters to Select Replacement Character Color.....	7-9
Table 7-10: Commands Ignored by the Color Terminal.....	7-13

DEFAULT STRINGS

Table 9-1: Cursor Keypad Defaults.....	9-1
Table 9-2: Numeric Keypad Defaults (ASCII Emulation).....	9-2
Table 9-3: Numeric Keypad Defaults (ANSI Emulation - PC Kybd.).....	9-3
Table 9-4: Numeric Keypad Defaults (SCO Console Emulation).....	9-4
Table 9-5: Numeric Keypad Defaults (ANSI Emulation - ANSI Kybd.).....	9-5
Table 9-6: Edit-Keypad Defaults (ASCII Emulation - PC Kybd.).....	9-6
Table 9-7: Edit-Keypad Defaults (ANSI Emulation - PC Kybd.).....	9-6
Table 9-8: Edit-Keypad Defaults (ASCII Emulation - ANSI Kybd.).....	9-7
Table 9-9: Edit-Keypad Defaults (ANSI Emulation - ANSI Kybd.).....	9-7
Table 9-10: Special Keys Defaults (ASCII Emulation).....	9-8
Table 9-11: Special Keys Defaults (ANSI Emulation).....	9-8
Table 9-12: Function Keys Defaults (ASCII Emulation).....	9-9
Table 9-13: Function Keys Defaults (ANSI Emulation).....	9-10
Table 9-14: Function Keys Defaults (SCO Console Emulation).....	9-11
Table 9-15: Key Codes in Scan-Code Mode.....	9-25 - 9-27
Table 9-16: Local Keys in Scan-Code Mode.....	9-27

List of Tables

APPENDIX B

Table B-1: ASCII Chart.....	B-1
Table B-2: WYSE Native Character Set.....	B-2
Table B-3: PC Equivalent Character Set.....	B-3
Table B-4: Multinational Character Set.....	B-4
Table B-5: Multilingual Extended Character Set.....	B-5
Table B-6: PC French Canadian Character Set.....	B-6
Table B-7: PC Norwegian Character Set.....	B-7
Table B-8: ASCII Graphic Charts.....	B-8
Table B-9: ANSI Standard.....	B-9
Table B-10: ANSI Supplemental & ISO Latin-1 Supplemental.....	B-10
Table B-11: ANSI Scientific & ANSI Special Graphics.....	B-11
Table B-12: PC National Replacement Characters.....	B-12
Table B-13: ANSI National Replacement Characters.....	B-13
Table B-14: ASCII National Replacement Characters.....	B-14

PURPOSE AND AUDIENCE

The purpose of this 260xx Reference Guide is to provide the information general users, application programmers and customer engineers need to operate the 260 family terminals.

A NOTE TO THE USER

Thank you for purchasing our terminal. In purchasing this terminal, you chose a high quality product that supports the latest in terminal technology.

PREREQUISITE SKILLS AND KNOWLEDGE

To use this guide effectively, you need a working knowledge of the terminal or the system in which it is going to operate. This guide is designed to be used by the engineers, providing the detailed information needed to fully utilize the terminal's advanced features.

USAGE NOTES

The icons and typefaces listed below are used to convey special meanings in this manual:

Convention



Bold Italic

Key1-Key2

Key1, Key2

##h

Usage

This icon marks items or concepts that require special attention.

This typeface indicates keystrokes entered by the user from the keyboard.

Press Key2 while holding down Key1.

Press Key1 and then Key2.

The number ## is in hexadecimal format.

Introduction

OVERVIEW

This guide contains information about the entire 260xx product line. However, not all 260xx terminals are equipped with all the features in this publication, i.e. the chapters on color programming do not apply to the monochrome products such as the 260 terminal. For specific details reference the appropriate User's Guide.

CONTROL CODES & ESCAPE SEQUENCES

The 260 family of terminals, which includes 260, 260C, 260lf and 260lfc can be controlled by special sequences of characters. These sequences can be sent by the host or can be entered from the keyboard as a series of keystrokes. Each command begins with either a *control* or an *escape* character and contains a string of characters that specify the action to be taken.

7-BIT & 8-BIT SEQUENCES

Ordinarily, all data generated by the operating system of the terminal are stored in 8-bit data words. Depending on the terminal emulation setting and the number of data bits used to communicate with the host system, all control codes and escape sequences will be transmitted as 7-bit or 8-bit data words.

Control codes and escape sequences need to be converted to 7-bit format in one of two cases:

- The communications bandwidth or emulation setting of the terminal requires a 7-bit format, or
- Commands need to be entered from the keyboard.

In 7-bit environments (such as VT100, VT200-7, and VT300-7), the terminal maps any 8-bit CI control code to two 7-bit codes as follows:

- The first code will always be the Escape character (1Bh)
- The second code will be the value of the original 8-bit code minus 40h.

For example, consider the CSI 2 J command to clear the screen in an ANSI emulation. In a 7-bit environment (e.g. VT300-7 emulation), the terminal will map the first character of this command (CSI, with a hexadecimal value of 9B) to ESC [, which is 1Bh followed by 5Bh (9Bh - 40h). Therefore, the command will be transmitted as ESC [2 J.

Introduction

Some of the most common ANSI 8-bit control codes and their 7-bit equivalents are listed in the table below. For a complete listing, see the ANSI Programming Chapter.

Ctrl Code	Description	8-bit Code	7-bit Code
SS2	Single Shift G2	8Eh	ESC N
SS3	Single Shift G3	8Fh	ESC O
DCS	Device Control String	90h	ESC P
CSI	Control String Introducer	9Bh	ESC [
ST	String Terminator	9Ch	ESC \

Table 1-1: Common ANSI 8-bit control codes

VISUAL ATTRIBUTES

The 260 family of terminals offers both ASCII and ANSI emulations. Depending on the way screen attributes (bold, underline, etc.) are implemented, each emulation is classified as either a *parallel* or a *field* attribute emulation. See table 1-2 for a listing of all available emulations and their respective attribute implementation format.

- *Field attribute emulations* - the assigned visual attributes are displayed until the next field attribute or until the end of the page. The attribute marker occupies one character position.
- *Parallel attribute emulations* - once an attribute is set, all subsequently entered characters retain the assignment until the attribute is turned off or a new attribute is specified. The attribute does not occupy a character position, since attributes are mapped into an internal plane of memory "parallel" to the character display.

Introduction

SUPPORTED EMULATIONS

The following table lists all supported emulations on the 260 family of terminals.

Emulation	ANSI/ASCII	Field/Parallel	Host Edit of Color mapping ⁽¹⁾
ADDS-VP	ASCII	Field	N
AT386	ANSI	Parallel	Y
Intecolor ⁽²⁾	ANSI	Parallel	Y
PC-Term	ASCII	Parallel	N
SCO Console	ANSI	Parallel	Y
TV1925	ASCII	Field	N
VT100	ANSI	Parallel	N
VT200-7	ANSI	Parallel	N
VT200-8	ANSI	Parallel	N
VT300-7	ANSI	Parallel	N
VT300-8	ANSI	Parallel	N
Wyse 325 ⁽²⁾	ASCII	Parallel	Y
Wyse 350 ⁽²⁾	ASCII	Field	Y
Wyse 50+	ASCII	Field	N
Wyse 60	ASCII	Parallel	N

Table 1-2: Supported emulations

⁽¹⁾ The emulations marked by "Y" contain escape sequences that allow the host to edit the color map.

⁽²⁾ These emulations are only available in the 260 Color family of terminals.

Introduction

Character Sets

OVERVIEW

This chapter explains the procedure involved in loading and activating various character sets available with the 260 family of terminals. In addition, creation of custom-designed character sets (called *Soft Character Sets*) is discussed in detail.

INTRODUCTION

The 260 family of terminals is equipped with a number of built-in character sets (see Appendix B). To activate a character set, its font data must be loaded into one of four internal *font banks*. The loaded font bank is then selected as the active source of character information.

Soft character sets are activated in the same manner, with only one difference: the font data must be downloaded from the host before it can be loaded into a font bank.

CHARACTER SIZES

The terminal has the ability to display characters in four sizes: normal, double high, double wide, or double high and double wide.

The related commands affect characters one line at a time. To display characters that are double high, two duplicate lines of data are needed. The characters on the top line display only the top half of their characters while the characters on the lower line display only the lower half of the characters.

When displaying characters of double the normal width, the right-half of the line is removed from display memory, regardless of whether the text in those columns was write-protected. In an 80-column display, columns 41-80 are erased from the line, and on a 132-column display, columns 67-132 are erased.

See pages 4-28 and 5-6 for related commands.

SOFT CHARACTER SETS

The terminal allows you to create your own characters by specifying which pixels are turned on or off in a character cell. These *custom characters* are created differently in ASCII and ANSI emulations (as described in the following sections).

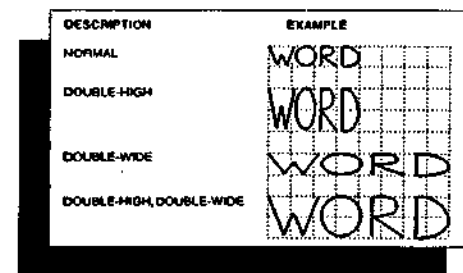

Figure 2-1: Supported Character Sizes

Character Sets

ANSI CHARACTER SETS

To understand how to select character sets in the ANSI emulations (such as VT300-7), you must first understand the function of the terminal's *in-use* table (Figure 2-2). The in-use table contains the character sets the terminal can currently access. You can place any two character sets in the terminal's in-use table. The in-use table consists of the *graphic left* (GL) and *graphic right* (GR) logical tables. The active sets of characters are grouped into four groups

Range	Group (Buffer)
00h - 1Fh	Control Left (CL)
20h - 7Fh	Graphics Left (GL)
80h - 9Fh	Control Right (CR)
A0h - FFh	Graphics Right (GR)

Table 2-1: The ANSI character sets

The GL buffer area is available to all ANSI emulations. The GR buffer area is accessible to all ANSI emulations (except VT100 emulation) through 8-bit codes.

MAPPING

You can select a different character set out of the ANSI Character Sets (Table 2-1) by following these two steps:

1. Designate the set as G0, G1, G2, or G3.

G0 through G3 are logical sets that the terminal uses to access character sets. You can designate up to four character sets and have them ready for use in the in-use table.

Example: ESC / A - Load G3 with ISO-Latin character set.

Note: When a new character set gets designated to one of the four font banks, (G0, G1, G2 or G3) its effects may not be noticed until it gets mapped to either GL or GR.

2. Map the designated set into the in-use table.

After you map the set into the in-use table, you can display or send to the host any character from that set by using 8-bit codes.

Example: ESC ! - Invoke G3 into GR.

Figure 2-2 is a graphic representation of this procedure.

Character Sets

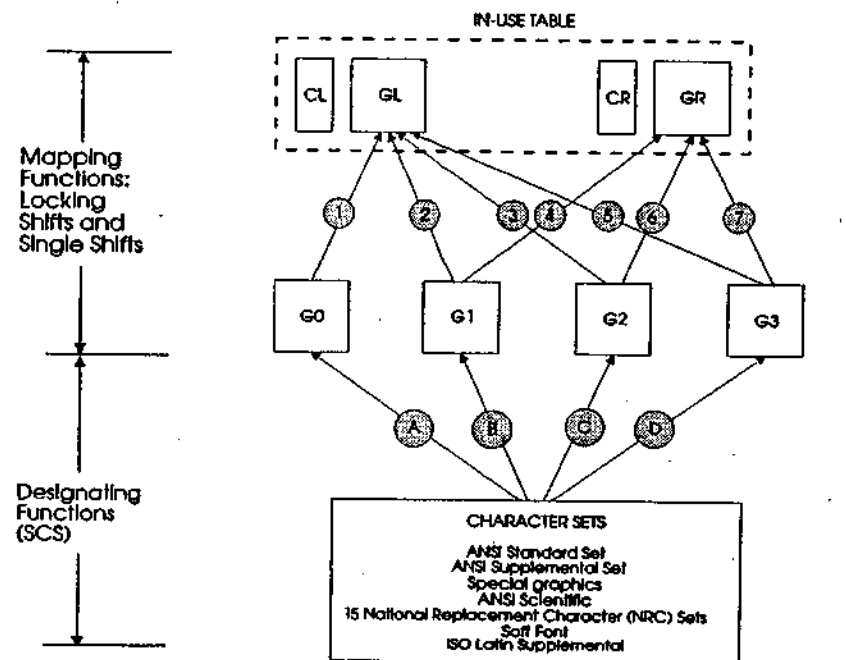

Designating functions

- A** ESC (Load G0 with 94-Char Set
- B** ESC) Load G1 with 94-Char Set
ESC - Load G1 with 96-Char Set
- C** ESC * Load G2 with 94-Char Set
ESC . Load G2 with 96-Char Set
- D** ESC + Load G3 with 94-Char Set
ESC / Load G3 with 96-Char Set

Mapping functions

- 1** LSO (S)
- 2** LS1 (SO)
- 3** LS2 (SS2)
- 4** LS1R
- 5** LS3 (SS3)
- 6** LS2R
- 7** LS3R

Figure 2-2: Designating and Mapping of Character Sets

Character Sets

CharSet	Character Set
B	ANSI Standard
<	User-preferred Supplemental
0.	ANSI Special Graphics
A	ISO-Latin Supplemental*
%5	ANSI Multinational
S	ANSI Scientific
CharSet	Character Set (National Mode)
A	UK
4	Dutch
5 or C	Finnish
R	French/Belgian Flemish
9 or Q	French Canadian
K	German
Y	Italian
^ or E or 6	Norwegian Danish
%6	Portuguese
Z	Spanish
7 or H	Swedish
=	Swiss
X	Latin American

Table 2-2: ANSI Character Set Table

* ISO Latin Supplemental character set is the only 96-character hard set available in the terminal. All other hard sets have 94 characters.

After you designate a character set as G0, G1, G2, or G3, you must map the set into the in-use table as GL or GR. You can control the duration of the mapping between the GL/GR buffers and the font banks. The mapping can be made active just to display the next character, or until another font bank is mapped into the buffer:

Character Sets

- **Lock-shift** - mapping is active permanently for screen display, or until the next lock-shift occurs.
- **Single-shift** - used to display a single character in the selected font, and then restore the previously-loaded font bank.

Code	Locking Shift	Function
Ctrl-O	LS0-Lock Shift G0	Map G0 into GL
Ctrl-N	LS1-Lock Shift G1	Map G1 into GL
Esc ~	LS1R-Lock Shift G1, Right	Map G1 into GR
Esc n	LS2-Lock Shift G2	Map G2 into GL
Esc j	LS2R-Lock Shift G2, Right	Map G2 into GR
Esc o	LS3-Lock shift G3	Map G3 into GL
Esc l	LS3R-Lock Shift G3, Right	Map G3 into GR

Table 2-3: Mapping Character Sets with Locking Shifts

Code	Single Shifts	Function
Esc N	SS2-Single Shift 2	Maps G2 to GL for next
Esc O	SS3-Single Shift 3	Maps G3 to GL for next

Table 2-4: Mapping Character Sets with Single Shifts

Character Sets

ANSI SOFT CHARACTERS

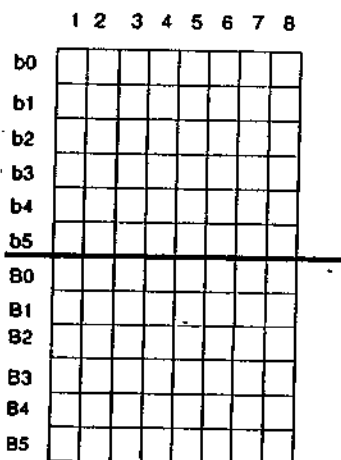

Figure 2-3: Blank grid for ANSI emulations

You can create custom characters and group up to 96 of them into a Dynamically Redefinable Character Set (DRCS). By loading this set into a font bank and then mapping the font bank to a buffer, you can display your characters on screen.

⚠ NOTE: Custom characters cannot be created in the VT100 emulation.

The character grid is 8x12 pixels, as shown in Figure 2-3. Each darkened cell corresponds to a binary 1, while a blank cell represents a binary 0 (zero).

To program the DRCS split the grid into two groups, the upper 8x6 group (*sixel*) and the lower 8x6 group.

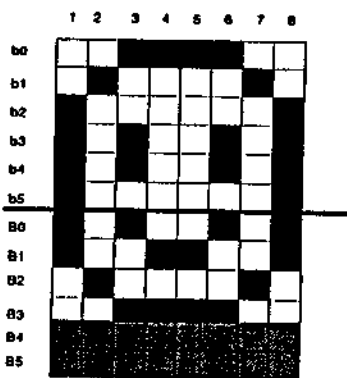

Figure 2-4: 8 x 10 Character Grid

Character Sets

Do the following to program each sixel (see Figures 2-5 and 2-6):

- 1) Begin with column 1 and compute the hexadecimal value of that column. Remember that the shaded cells represent binary 1s, and the unshaded cells 0s (zero). Next, perform the same calculation on the remaining columns.
- 2) Add an offset of 3Fh to each value you computed for each column. Your numbers will now range from 3Fh to 7Eh on the upper sixel and 3Fh to 4Eh on the lower sixel.
- 3) For each column value, find the corresponding character on the ASCII character chart (see Appendix B) with a hexadecimal index equal to the hex number you computed. This will range from '?' to '-' for the upper sixel and '?' to 'N' for the lower sixel.
- 4) When you have computed all eight characters that correspond to the eight columns in the sixel, make a "word" starting from the character for column 1 and moving right to the character for column 8 (see Figures 2-5 and 2-6). In our example, the ASCII translation is '{AX@@XA}' for the upper sixel and 'BCHHCB' for the lower sixel.

⚠ If any cell in the 8th column of the character grid is programmed, the adjacent cells in the neighboring character grid will also be turned on. This *pixel propagation* is due to hardware design, and is considered normal. It allows line graphic characters to connect.

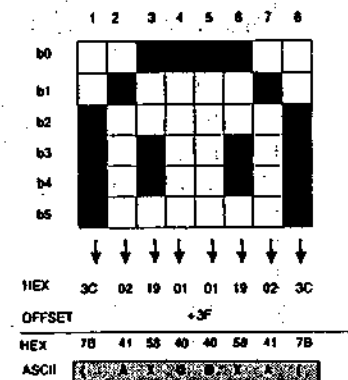

Figure 2-5: Top Sixel

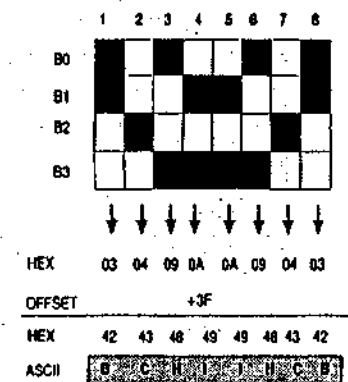

Figure 2-6: Bottom Sixel

Character Sets

Binary Value	Hex Value	Hex Value 3F Offset	Character Equivalent
000000	00	3F	?
000001	01	40	@
000010	02	41	A
000011	03	42	B
000100	04	43	C
000101	05	44	D
000110	06	45	E
000111	07	46	F
001000	08	47	G
001001	09	48	H
001010	A	49	I
001011	B	4A	J
001100	C	4B	K
001101	D	4C	L
001110	E	4D	M
001111	F	4E	N
010000	10	4F	O
010001	11	50	P
010010	12	51	Q
010011	13	52	R
010100	14	53	S
010101	15	54	T

Table 2-5: Converting Binary Code to an ASCII Character

Character Sets

Binary Value	Hex Value	Hex Value 3F Offset	Character Equivalent
010110	16	55	U
010111	17	56	V
011000	18	57	W
011001	19	58	X
011001	1A	59	Y
011011	1B	5A	Z
011100	1C	5B	[
011101	1D	5C	\
011110	1E	5D]
011111	1F	5E	^
100000	20	5F	_
100001	21	60	`
100010	22	61	a
100011	23	62	b
100100	24	63	c
100101	25	64	d
100110	26	65	e
100111	27	66	f
101000	28	67	g
101001	29	68	h
101010	2A	69	i
101011	2B	6A	j

Table 2-5: Converting Binary Code to an ASCII Character

Character Sets

Binary Value	Hex Value	Hex Value + 3E Offset	Character Equivalent
101100	2C	6B	k
101101	2D	6C	l
101110	2E	6D	m
101111	2F	6E	n
110000	30	6F	o
110001	31	70	p
110010	32	71	q
110011	33	72	r
110100	34	73	s
110101	35	74	t
110110	36	75	u
110111	37	76	v
111000	38	77	w
111001	39	78	x
111010	3A	79	y
111011	3B	7A	z
111100	3C	7B	{
111101	3D	7C	
111110	3E	7D	}
111111	3F	7E	~

Table 2-5: Converting Binary Code to an ASCII Character

Character Sets

Command: `<DCS>fb:bp:er:rw:tg:ch:ss:cn: [S: [C:G]:] [B:]`
`<ST>`

Description: This command is used to declare and load custom characters in VT300 emulation. Sixteen ASCII characters are required to represent every character created. The *rw*, *tg*, *ch*, and *ss* parameters may be omitted and will be defaulted. For a full listing of commands related to character sets, refer to page 5-10.

Parameters:

- fb:* font buffer designator. Only one font buffer may be used for downloading soft fonts at any time.
 0 = bank 0 1 = bank 1
- bp:* the position in which the first character of the font set is to be loaded. Valid values are 0 - 95.
- er:* specifies what part of the font bank should be erased.
 0, 2 = entire font set
 1 = only the characters that are loaded.
- rw:* character cell size. The default is 0.
 0 = 7 x 10 4 = 7 x 10 7 = 7 x 10
 2 = 5 x 10 5 = 5 x 10 8..15 = 8 x 10
 3 = 6 x 10 6 = 6 x 10
- fs:* font size. The default is 0.
 0,1 = 80 columns, 26 lines 2 - 132 = columns
 11,12,21,22 = 80 columns, 44 lines
- tg:* character type (text or graphics) - Graphics characters are not supported by the 260 family of terminals. The default is 0.
 0,1 = text 2 = graphics - not available
- ch:* maximum cell height. Default is 0.
 0..5 = 12 pixels (10 pixels VT200)
 6..12 = 6..12 pixels
- ss:* size of the character set. The default is 0.
 0 = 94-character set (21h-7Eh),
 1 = 96-character set (20h-7Fh).
- cn:* name of character set - the name should be unique and can be from one to three characters long. It consists of 0 to 2 intermediate characters and one final character. Intermediate characters must fall in the range of 20h to 2Fh, while the final character can range from 30h to 7Eh.
 For example, "< SPACE> @" is a valid name (space = 20h, and @ = 30h).

Character Sets

tsl: top sixel of character 1 - the eight ASCII characters that represent the top sixel of the first custom character.

bsl: bottom sixel of character 1 - the eight ASCII characters that represent the bottom sixel of the first custom character.

Example: `<DCS> 1;1;1;8 (<SPACE> @ (AX@@XA (/ BCIIHICB;
<ST>`
Load the character in Figure 2-4 as a single-character set starting at position 1 (21h) of font bank 1, while crasing only the characters that are reloaded. From the keyboard, instead of `<DCS>` type "`<ESC> P`" and instead of `<ST>` type "`<ESC> V`". To load this DRCS into font bank 0, enter the following sequence: `<ESC> (<SPACE> @`. Press the "!" key (exclamation point) and notice that the smiling face has been loaded into the "!" character. To restore the ANSI Standard character set to font bank 0, enter the following sequence: `<ESC> (B`

ASCII CHARACTER SETS

The mapping of character sets to fonts banks in ASCII emulations is very similar to that of the ANSI emulations (as depicted in Figure 2-2). In the ASCII emulations, the font banks are labeled *bank0 - bank3* (as opposed to *G0 - G3*), and the character sets currently in use are called the *Primary* and the *Secondary Set* (as opposed to *CL-GL* and *CR-GR*). See page 4-28 for related commands.

ASCII SOFT CHARACTERS

The ASCII command is designed to load one soft character into a specified position in one of the four font banks. The soft character is cleared when the terminal is powered off, or when the font bank is cleared or reloaded.

When designing characters, note that the cell size varies as a function of the number of lines and columns on the screen and the refresh rate selected (monochrome terminals only). The standard character matrix is 10 x 15 pixels in a 26-line screen, and 10 x 9 pixels in a 44-line or 49-line screen. Table 2-6 lists all available character matrix sizes according to the screen size (height x width) and refresh rate (monochrome terminals only).

Character Sets

Screen Size ↓	Character Cell Size (h x w)			
	Color Terminal	Monochrome Terminal		
		60Hz	70Hz	80Hz
26 x 80	10 x 15	10 x 15	10 x 13	10 X 13
26 x 132	9 x 15	9 x 15	9 x 13	9 X 13
44 x 80	10 x 9	10 x 9	N/A	N/A
44 x 132	9 x 9	9 x 9	N/A	N/A
49 x 80	10 x 8	10 x 8	N/A	N/A
49 x 132	9 x 8	9 x 8	N/A	N/A

Table 2-6: Character matrix sizes

Command: `<ESC> cA fb pp b1 b2 b3 ... b12 <Ctrl> Y`

Description: This command is used to define and load custom characters in ASCII emulations. Every character is designed using 32 bytes.

Parameters:

fb: the font bank where the character is to be loaded.
 0 = font bank G0 2 = font bank G2
 1 = font bank G1 3 = font bank G3.

pp: two bytes that specify the position of the character in the character set (using the ASCII character sets as a template). First, the position is noted as a hexadecimal number, with the first digit representing the row position on the chart and the second the column position. Then, the ASCII character representing each digit is entered as a separate byte. For example, to replace the character 'Z' (at a position value of 5Ah), the two ASCII characters representing the two bytes of *pp* would be '5' (35h) and 'A' (41h).

Parameters: Each row of the character grid is specified using 2 bytes. First, the state of each row is represented as a hexadecimal number of two digits: The first digit indicates the state of the left-most four pixels in that row (first *nibble*), and the next digit the state of the right nibble. Next, the ASCII character representing each digit of the hexadecimal number is entered as a separate byte in the sequence (see Example below). Since the largest cell size is 15 rows, 30 bytes are used. The last two bytes are ignored.

Character Sets

Example: To load (overlay) the 'smiling face' shown in Figure 7 at the same position in the character set as the character 'Z' (5Ah):

- send the following ASCII characters **from the keyboard:**
`<ESC>cA05A3C4281A5A581A599423C00000000
 0000<Ctrl>-Y.`
- send the following hexadecimal values **from the host:**
`1Bh 63h 41h 30h 35h 41h 33h 43h 34h 32h 38h 31h 41h 35h 41h 35h 38h
 31h 41h 35h 39h 39h 34h 32h 33h 43h 19h`

To see the results, press 'Shift-Z'.

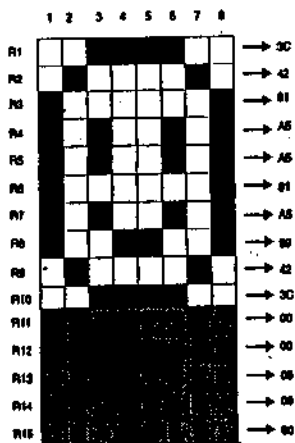

Figure 2-7: Sample ASCII Custom Character

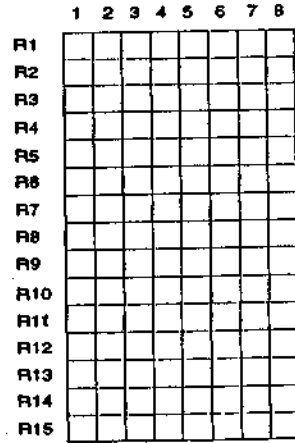

Figure 2-8: Blank Grid for ASCII Emulation

Function & Edit Keys

OVERVIEW

This chapter provides detailed information and examples for programming function and edit keys on the 260 family of terminals. The information is divided into three sections: 1) ASCII emulations, 2) ANSI emulations, and 3) SCO Console and AT386 emulations. Function and edit key defaults are listed separately in chapter 9.

STORAGE LIMITS

A total of 542 characters (*bytes*) of non-volatile permanent memory (RAM) are allocated for the answerback message and function key/label programming. When this storage limit is reached, the terminal will reject any attempts to store additional characters. As many as 255 characters can be programmed into any one key, and a maximum of 35 keys (in both their *normal* or *shifted* states) can be programmed for a total of 70 key definitions. In ASCII emulations, labels are limited to the function keys (edit keys do not have labels) with each label limited to 7 bytes (characters).

The storage capacity will vary depending on the "FkeySpeed" and "Emulation" parameters in Setup:

- If "Fkey Mode" in Emulation (F9) menu is set to *Fast*, only 8 bytes of storage per key are available.
- In SCO Console and AT386 emulations, a maximum of 29 characters can be programmed into any key by the host.

ASCII EMULATIONS

In ASCII emulations, both the function keys and their labels, and the edit keys can be programmed:

- **Function and Edit Keys:** both function and edit keys are programmable. The output of a programmed key can be redirected to the screen, to the host, or to the destination dictated by the value of the "Comm Mode" parameter in the Quick (F1) menu of Setup. Additional destination settings are available (manually) through the "Key Dir" parameter in the Program (F12) menu of Setup.
- **Function Key Labels:** the labels for normal and shifted function keys can be programmed. To display the programmed labels on the bottom status line, "Display NV Labels" in the Emulation (F9) menu of Setup should be set to *On*.



NOTE: For default setting see Chapter 9 Default Strings.

Function & Edit Keys

Command:	<code><ESC> Z dir keycode seq </code>
Description:	This command is used to program function or edit keys in ASCII emulations. The <i>dir</i> parameter allows you to specify the destination of the output of the programmed key. <code></code> may be replaced with <code><Ctrl>-8</code> when programming from the keyboard.
Parameters:	
<i>dir</i> :	Direction of the output data. 0 = dependent on the communication mode 1 = to host only 2 = to terminal only
<i>keycode</i> :	Specifies the key to be programmed. Select an Edit or Function Key Specifier from the table 3-1 and 3-2 on page 3-3.
<i>seq</i> :	The ASCII characters to be stored in the function or edit key. If this parameter is omitted, the function or edit key will be defaulted.
Example:	<code><ESC> Z 2 @ This is the F1 Key </code> This programs the F1 key with the text "This is the F1 Key".

Command:	<code><ESC> z Fkey seq </code>
Description:	This command is identical to the above command with one difference: This command cannot be used to specify a destination for the output of the programmed keys. By default, the destination is determined by the communication mode (as detailed by the value of the "Comm Mode" parameter).
Parameters:	
<i>Fkey</i> :	Specifies the key to be programmed. Select a Function Key Specifier from the table 3-1 on page 3-3.
<i>seq</i> :	The ASCII characters to be stored in the function key. If this parameter is omitted, the function key will be defaulted (see Chapter 9 for specific default values).
Example:	<code><ESC> z ` This is the Shifted F1 Key </code> This programs the shifted F1 key with the text "This is the Shifted F1 Key". The destination of the output data is determined by the communication mode of your terminal. If Comm Mode = Full Duplex, Fkey data will get sent to the host. If Comm Mode = Full Block, Fkey data will get displayed on the screen and not get sent to the host.

Function & Edit Keys

Function Key Specifiers		
Function Key	Normal	Shifted
F1	@	`
F2	A	a
F3	B	b
F4	C	c
F5	D	d
F6	E	e
F7	F	f
F8	G	g
F9	H	h
F10	I	i
F11	J	j
F12	K	k
F13	L	l
F14	M	m
F15	N	n
F16	O	o
F17	Q	w
F18	S	Y
F19	T	Z
F20	P	V

Table 3-1: Function Key Specifiers

Edit Key Specifiers		
Edit Key	Normal	Shifted
Esc	Space	%
Tab	!	&
Back Space	"	'
Delete/Remove	#	(
Return	\$)
Home/Select	*	/
↑	+	0
↓	,	1
←	-	2
→	.	3
Enter	s	4
Insert/PF4	q	p
Page Down	r	w
End	\]
Page Up	:	;
Print Screen	R	X
PF1	7	8
PF3]	z
PF2	5	6

Table 3-2: Edit Key Specifiers

FUNCTION KEY LABELS

Function key labels can be displayed on the bottom display line by setting the "Display NV Labels" parameter to *On* (the default setting for this parameter is *Off*). This can be done manually through the Emulation (F9) menu in Setup, or through escape sequences mentioned below. If "Save Labels" in the Emulation (F9) menu of Setup is set to *On*, the labels that are programmed will be saved.

Labels can hold up to 7 characters each. If shifted function key labels are programmed, the label line will display them only while the shift key is pressed (assuming that label line display is enabled.) Use the command below to program function key labels.

Function & Edit Keys

Command: <ESC> z *Label seq* <CR>

Description: This command is used to program function key labels. <CR> may be replaced by <Ctrl>-m when programming from the keyboard.

Parameters:

Label: Specifies the label to be programmed. Select a Function Key Label Specifier from the table 3-3 below.

seq: The ASCII characters to be stored in the function key label. If this parameter is omitted, the label will be cleared.

Example: <ESC> z P Shift-F1 <Ctrl> -m
This programs the shifted F1 function key label with "Shift-F1".

ASCII Function Key Label Specifiers					
Label	Normal	Shifted	Label	Normal	Shifted
F1	0	P	F10	9	Y
F2	1	Q	F11	:	Z
F3	2	R	F12	:	[
F4	3	S	F13	<	\
F5	4	T	F14	=]
F6	5	U	F15	>	^
F7	6	V	F16	?	_
F8	7	W	F17 - F20	Available only through Setup.	
F9	8	X			

Table 3-3: ASCII Function Key Label Specifiers



If the ADDS-VP emulation is used, "Enhanced" in the Quick (F1) menu must be set to On in order to access the following commands.

Command: <ESC> z / <CR>

Description: This command clears the label line display of normal (unshifted) function keys from the screen. The defined function key labels are not cleared. Entering and exiting Setup will re-display any programmed labels.

Function & Edit Keys

Command: <ESC> z | <CR>

Description: This command clears the label line display of shifted function keys from the screen. The defined function key labels are not cleared.

Command: <ESC> e K

Description: This command turns the "Save Labels" switch On.

Command: <ESC> e J

Description: This command turns the "Save Labels" switch Off.

Command: <ESC> e L <DELS>

Description: This command disables the display of labels programmed for shifted function keys when the Shift key is pressed. If a shifted function key label is programmed subsequent to this command, the display of shifted labels will be re-enabled.

ANSI EMULATIONS

The command listed below is used for all ANSI emulations except SCO Console and AT386 emulations. The commands for these emulations are listed on page 3-7.

Command: <DCS> Pc ; P1 / key1 / seq1 ; ... / keyn / seqn <ST>

Description: This command is used to program function keys in ANSI emulations. "Function Key Lock" in the Emulation (F9) menu of Setup must be Off (default setting) to program function keys from the host. Function keys F17-F20 and all edit keys cannot be programmed from the host; these keys can only be programmed through Setup. <DCS> and <ST> can be replaced by <ESC> P and <ESC> \, respectively, in a 7-bit environment such as VT100.

Parameters:

Pc: 0 = clear all key definitions
1 = clear only redefined keys

Function & Edit Keys

Command: <DCS> P; F1[Fkey] / seq1 ; ... ; Fkeyn / seqn <ST>

Pl: 0 = function keys locked: not programmable by the host
1 = function keys reprogrammable by host

Fkeyn: Specifies the key to be programmed. Select a Function Key Specifier from the table 3-4 below.

seqn: The data to be programmed into the function key. The data string consists of pairs of ASCII codes. Each pair represents the hexadecimal index of the desired character in the ASCII chart ranging from 00h to FFh (see Appendix B). Any invalid pair (for example, 1Gh) will abort the command. All subsequent characters will be ignored until the string terminator <ST> is received.

ANSI Function Key Specifiers					
Fkey	Normal	Shifted	Fkey	Normal	Shifted
F1	6	12	F11	43	23
F2	7	13	F12	44	24
F3	8	14	F13	45	25
F4	9	15	F14	46	26
F5	10	16	F15	48	28
F6	37	17	F16	49	29
F7	38	18	F17	51	31
F8	39	19	F18	52	32
F9	40	20	F19	53	33
F10	41	21	F20	54	34

Table 3-4: ANSI Function Key Specifier

Example: <DCS> I;1 38 / 54 69 6D 65 0D ; 15 / 49 6E 73 65 72 74 0D <ST>

This programs the F7 key with "Time<CR>" and Shift-F4 key with "Insert<CR>". F7 (Fkeyn = 38) and Shift-F4 (Fkeyn = 15) are first cleared and then programmed with the specified text. 'T' is 54h, 'I' is 69h, and so on. <CR> is 0Dh.

Function & Edit Keys

SCO CONSOLE & AT386 EMULATIONS

Command: <ESC> Q fn delim string delim

Description: This command is used to program function and edit keys in SCO Console and AT386 emulations. Each virtual terminal can store up to 542 characters (bytes), while each key can be programmed with a maximum of 29 characters. If an attempt is made to store more than 29 characters in a key, all characters are discarded, the sequence is terminated, and the key storage remains unchanged.

Parameters:

fn: Specifies the key to be programmed. Select a Function or Edit Key Specifier from the table 3-5 or 3-6.

delim: The character used to begin and terminate the string is '*'.

string: The data to be programmed into the function or edit key. To embed control codes into the string, use one of the following methods:

- Add 20h to the control code's ASCII value, and use the resulting number as an index into the ASCII chart. Place the resulting character in the string, preceded by a caret character (^). To embed a caret character, use '^_'. If the ASCII value of the character after the caret is less than 20h, the subtraction will wrap to the highest ASCII value.

Example: '^<US>' will be the character represented by OFFH.

- Embed control code directly into the string if programming from the keyboard. Care should be taken if you choose to use this method, since the control codes may be recognized by your system as a command, and acted upon immediately.

*Example: Esc Q 1 *this ^is the string* (F2 = this is the string)*

Function & Edit Keys

Function Key Specifiers				
Fkey	Normal	Shifted	Ctrl	Shift-Ctrl
F1	0	<	H	T
F2	1	=	I	U
F3	2	>	J	V
F4	3	?	K	W
F5	4	@	L	X
F6	5	A	M	Y
F7	6	B	N	Z
F8	7	C	O	[
F9	8	D	P	\
F10	9	E	Q]
F11	:	F	R	^
F12	;	G	S	-

Table 3-5: Function Key Specifier

Edit Key Specifiers	
Edit Key	Normal
Home	^
Insert	k
Page Down	j
Page Up	b
End	h
↑	a
↓	i
←	d
→	f

Table 3-6: Edit Key Specifiers

Example: `<ESC> Q | * * ; [2] ^ ; [H String in ^] ^key*`

This programs the F1 key with "<ESC> [2] <ESC> [H String in F1 Key." Asterisks (*) are used as string delimiters. When the F1 key is pressed, the screen is cleared, the cursor is homed, and the string "String in F1 Key" appears on the screen.

ASCII Programming

COMMAND

WYSE 60/325

WYSE 50+/350

ADDS VP

PC TERM

TVI925

GENERAL SETUP COMMANDS

Select personality

Esc - pers

Esc - pers

Esc - pers

Esc v pers

Esc - pers

Parameters	Description	Values			
pers	Personality specifier	pers	Personality	pers	Personality
		"	Wyse 50+	?	WP Graphics (Scan Code)
		\$	TVI925	Q	WP Graphics (ASCII)
		%	ADDS VP (A2)	a	AT386
		4	Wyse 60	s	SCO Console
		5	PC-Term	w	Wyse 325
		:	VT100	x	Wyse 350
		<	VT200/7	y	Intecolor
		=	VT200/8	-	previous personality

Enhanced mode off	ESC - SPACE	ESC - SPACE	ESC - SPACE	ESC - SPACE	ESC v SPACE
Enhanced mode on	ESC - !	ESC - !		ESC v !	ESC - !
Monitor mode on	ESC U	ESC U	ESC U	ESC U	ESC U
Monitor mode off	ESC u or ESC X	ESC u or ESC X	ESC u or ESC X	ESC u or ESC X	ESC u or ESC X
Send time to host				ESC SPACE 2	ESC SPACE 2
Load time	ESC c 8 hh mm	ESC c 8 hh mm	ESC c 8 hh mm	ESC SPACE 1 apm hpc mm CR	ESC SPACE 1 apm hpc mm CR



Commands in bold are available only when "Enhanced" parameter in the Quick (F1) menu of Setup is set to On.

ASCII Programming

COMMAND	WYSE 60/325	WYSE 50/350	ADDS VP	PC TERM	TV1925
Parameters	Description		Values		
apm	* a.m. or p.m. time specifier		a, A = a.m.	p, P = p.m.	
hpc	Hour specifier for PC-Term command		0 - 11		
hh	Hour specifier for other emulations		0 - 23		
mm	Minute specifier		0 - 59		

Load date **ESC_- P1/S1;** **ESC_- P1/S1;** **ESC_- P1/S1;** **ESC_- P1/S1;** **ESC_- P1/S1;**
 ...;Pn/Sn ESC \ ...;Pn/Sn ESC \ ...;Pn/Sn ESC \ ...;Pn/Sn ESC \ ...;Pn/Sn ESC \

Parameters	Description	Values	Parameters	Description	Values
P1 / S1	Display date	P1: 1 S1: 0 (off) 1 (on)	P4 / S4	Century setting	P4: 4 S4: 19 - 20
P2 / S2	Month setting	P2: 2 S2: 01 - 12	P5 / S5	Year setting	P5: 5 S5: 00 - 99
P3 / S3	Day setting	P3: 3 S3: 01 - 31			

Display date on top status line **ESC_-1/1 ESC ** **ESC_-1/1 ESC ** **ESC_-1/1 ESC ** **ESC_-1/1 ESC ** **ESC_-1/1 ESC **

COMMUNICATION COMMANDS

Half-duplex mode on **ESC C ESC D H** **ESC C ESC D H** **ESC C ESC D H** **ESC (** **ESC (**
 Full-duplex mode on **ESC C ESC D F** **ESC C ESC D F** **ESC C ESC D F** **ESC)** **ESC)**



Commands in bold are available only when "Enhanced" parameter in the Quick (F1) menu of Setup is set to On.

ASCII Programming

COMMAND	WYSE 60/325	WYSE 50/350	ADDS VP	PC TERM	TV1925
Block mode on	ESC B	ESC B	ESC B	ESC B	ESC B
Block mode off	ESC C	ESC C	ESC C	ESC C	ESC C
Enable transmission*	DC1 (Ctrl Q)	DC1 (Ctrl Q)	DC1 (Ctrl Q)	DC1 (Ctrl Q)	DC1 (Ctrl Q)
Disable transmission*	DC3 (Ctrl S)	DC3 (Ctrl S)	DC3 (Ctrl S)	DC3 (Ctrl S)	DC3 (Ctrl S)
Send ACK **	ENQ (Ctrl E)	ENQ (Ctrl E)	ENQ (Ctrl E)	ENQ (Ctrl E)	ENQ (Ctrl E)
ACK mode on	ESC e 7	ESC e 7			
*Enable and Disable transmission commands are setup selection dependent.					
**An ACK (05h) is transmitted in response to an ENQ, at the end of font loading and clearing, and upon completion of split screen, page print, and port configuring commands.					
ACK mode off	ESC e 6	ESC e 6			
Enable Host DTR protocol				SO (Ctrl N)	SO (Ctrl N)
Enable Host Xon/Xoff protocol				SI (Ctrl O)	SI (Ctrl O)
Set EIA as host and Aux as printer	ESC e 8	ESC e 8	ESC e 8		
This command is invalid in dual host (session) mode.					
Set EIA as printer and Aux as host	ESC e 9	ESC e 9	ESC e 9		
This command is invalid in dual host (session) mode.					
EIA Receive Protocol	ESC e 2 erp	ESC e 1 erp	ESC e 2 erp		



Commands in bold are available only when "Enhanced" parameter in the Quick (F1) menu of Setup is set to On.

ASCII Programming

COMMAND	WYSE 60/325	WYSE 50/350	ADDS VP	PC TERM	TVI 925
EIA Transmit Protocol	ESC c 4 <i>etp</i>	ESC c 4 <i>etp</i>	ESC c 4 <i>erp</i>		
Aux Receive Protocol	ESC c 3 <i>arp</i>	ESC c 3 <i>arp</i>	ESC c 3 <i>arp</i>		
Aux Transmit Protocol	ESC c 5 <i>atp</i>	ESC c 5 <i>atp</i>	ESC c 5 <i>atp</i>		

Parameters	Description	Values
<i>erp / etp</i> <i>arp / atp</i>	EIA receive protocol AUX receive protocol	0 = No protocol 1 = Xon / Xoff 2 = DTR / DSR 3 = Both Xon / Xoff & DTR / DSR

Set EIA communications **ESC c 0 ebr st ep db** **ESC c 0 ebr st ep db** **ESC c 0 ebr st ep db**
 Set Aux communications **ESC c 1 abr st ap db** **ESC c 1 abr st ap db** **ESC c 1 abr st ap db**

Parameters	Description	Values
<i>ebr</i>	EIA baud rate	D = 115,200 B = 76,800 C = 57,600 0 = 38,400 1 = 19,200 2 = 9,600 3 = 4,800 4 = 2,400 5 = 2000 6 = 1,800 7 = 1,200 8 = 600 9 = 300 : = 150 ; = invalid
<i>st</i>	Number of stop bits	0 = 1 stop bit 1 = 2 stop bits
<i>ep</i>	EIA Parity	0 = None 1 = Odd 2 = Mark 3 = Even
<i>db</i>	Number of data bits	0 = 7 data bits 1 = 8 data bits



Commands in bold are available only when "Enhanced" parameter in the Quick (F1) menu of Setup is set to On.

ASCII Programming

COMMAND	WYSE 60/325	WYSE 50/350	ADDS VP	PC TERM	TVI 925
<i>abr</i>	AUX baud rate	@ = 38,400 0 = 19,200 1 = 9,600 3 = 4,800	6 = 2,000 7 = 1,800 8 = 1,200 9 = 600	: = 150 < = 134.5 = = 110	
<i>ap</i>	AUX parity	0 = None 1 = Odd	2 = Mark 3 = Even	4 = Space	

Set maximum data transmit speed **ESC c 6 dr** or **ESC c 7 dr** **ESC c 6 dr** or **ESC c 7 dr** **ESC c 6 dr** or **ESC c 7 dr**

Parameters	Description	Values
<i>dr</i>	maximum data transmit speed	1 = 60 cps 2 = None 3 = 150 cps 4 = 33 cps

Accept received NULL characters **ESC e R** **ESC e R** **ESC e R**
 Ignore received NULL characters **ESC e S** **ESC e S** **ESC e S**

DISPLAY COMMANDS

Video off **ESC ' 8** **ESC ' 8** **ESC ' 8** **ESC O** **ESC O**



Commands in bold are available only when "Enhanced" parameter in the Quick (F1) menu of Setup is set to On.

ASCII Programming

COMMAND	WYSE 60/325	WYSE 501/350	ADDS VP	PC TERM	TVI 925
Video on	ESC '9	ESC '9	ESC '9	ESC N	ESC N
Screen saver off	ESC e P	ESC e P	ESC e P		
Screen saver on (5 min)	ESC e Q	ESC e Q	ESC e Q		
Reverse screen	ESC ^ 1	ESC ^ 1	ESC ^ 1	ESC b	ESC b
Normal screen	ESC ^ 0	ESC ^ 0	ESC ^ 0	ESC d	ESC d
Auto wrap mode off	ESC d .	ESC d .	ESC d .	ESC 0	ESC 0
Auto wrap mode on	ESC d /	ESC d /	ESC d /	ESC -	
Auto LF mode off	ESC e 4	ESC e 4	ESC e 4	ESC 9	ESC 9
Auto LF mode on	ESC e 5	ESC e 5	ESC e 5	ESC 8	ESC 8
Auto page mode off	ESC d *	ESC d *	ESC d *		
Auto page mode on	ESC d +	ESC d +	ESC d +		
Auto scroll mode off	ESC N	ESC N	ESC N	ESC H	
Auto scroll mode on	ESC O	ESC O	ESC O	ESC H	

SCROLL COMMANDS

Jump scroll	ESC '@	ESC '@	ESC '@		
Smooth scroll-1	ESC '<	ESC '<	ESC '<		



Commands in bold are available only when "Enhanced" parameter in the Quick (F1) menu of Setup is set to On.

4-6

ASCII Programming

COMMAND	WYSE 60/325	WYSE 501/350	ADDS VP	PC TERM	TVI 925
Smooth scroll-2	ESC '='	ESC '='	ESC '='		
Smooth scroll-4	ESC '>	ESC '>	ESC '>		
Smooth scroll-8	ESC '?'	ESC '?'	ESC '?'		

CURSOR DISPLAY COMMANDS

Cursor off	ESC '0	ESC '0	ESC '0 or ETB (Ctrl W)	ESC . 0	ESC . 0
Cursor on	ESC '1	ESC '1	ESC '1 or CAN (Ctrl X)	ESC . 1	ESC . 1
Steady block cursor	ESC '2	ESC '2	ESC '2	ESC . 2	ESC . 2
Blink line cursor	ESC '3	ESC '3	ESC '3	ESC . 3 or ESC . 6	ESC . 3 or ESC . 6
Steady line cursor	ESC '4	ESC '4	ESC '4	ESC . 4	ESC . 4
Blink block cursor	ESC '5	ESC '5	ESC '5	ESC . 5	ESC . 5

ANSWERBACK COMMANDS

Send terminal ID	ESC SPACE	ESC SPACE	ESC SPACE		
Response from terminal:	60 CR	60 CR	60 CR		



Commands in bold are available only when "Enhanced" parameter in the Quick (F1) menu of Setup is set to On.

CURSOR DISPLAY COMMANDS

4-7

ASCII Programming

COMMAND	WYSE 60/75	WYSE 50/750	ADDS-VF	PC TERM	TVI 925
Program answerback. <i>text</i> is a string of ASCII characters	ESC c ; <i>text</i> CTRL Y	ESC c ; <i>text</i> CTRL Y	ESC c ; <i>text</i> CTRL Y	ESC] <i>text</i> CR	ESC] <i>text</i> CR
Send answerback	ESC c <	ESC c <	ESC c <		
Conceal answerback	ESC c =	ESC c =	ESC c =		
Answerback mode on	ESC e !	ESC e !	ESC e !		
Answerback mode off	ESC e SPACE	ESC e SPACE	ESC e SPACE		

KEYBOARD COMMANDS

Sound bell	BEL (Ctrl G)	BEL (Ctrl G)	BEL (Ctrl G)	BEL (Ctrl G)	BEL (Ctrl G)
Unlock keyboard	ESC " or SO (Ctrl N)	ESC " or SO (Ctrl N)	ESC " or STX (Ctrl B) or ESC 6	ESC "	ESC "
Lock keyboard	ESC # or SI (Ctrl O)	ESC # or SI (Ctrl O)	ESC # or EOT (Ctrl D) or ESC 5	ESC #	ESC #
Keyclick off	ESC e \$	ESC e \$	ESC e \$	ESC >	ESC >
Keyclick on	ESC e %	ESC e %	ESC e %	ESC <	ESC <
Caps lock on	ESC e &	ESC e &	ESC e &		
Caps lock off	ESC e '	ESC e '	ESC e '		



Commands in bold are available only when "Enhanced" parameter in the Quick (F1) menu of Setup is set to On.

4-8

KEYBOARD COMMANDS

ASCII Programming

COMMAND	WYSE 60/75	WYSE 50/750	ADDS-VF	PC TERM	TVI 925
Margin bell on	ESC e M	ESC e M	ESC e M		
Margin Bell off	ESC e L	ESC e L	ESC e L	ESC n	ESC n
Set margin bell at cursor position	ESC ' J	ESC ' J	ESC ' J	ESC o	ESC o
Auto repeat on	ESC e -	ESC e -	ESC e -		
Auto repeat off	ESC e ,	ESC e ,	ESC e ,		
Define CAPS LOCK key as caps lock	ESC e T	ESC e T	ESC e T		
Define CAPS LOCK key as reverse	ESC e U	ESC e U	ESC e U		
Local edit key mode on	ESC k	ESC k		ESC k	ESC k
Duplex edit key mode on	ESC l	ESC l		ESC l	ESC l
Application key mode on	ESC ~ 3	ESC ~ 3	ESC ~ 3	ESC v 3	ESC ~ 3
Application key mode off	ESC ~ 2	ESC ~ 2	ESC ~ 2	ESC v 2	ESC ~ 2

PROGRAM FUNCTION/EDIT KEYS



The sequences listed under this section require usage of key specifier codes listed in the "Function & Edit Keys" chapter, starting on page 3-1. Please refer to the instructions and examples provided in that chapter for complete details.



Commands in bold are available only when "Enhanced" parameter in the Quick (F1) menu of Setup is set to On.

PROGRAM FUNCTION/EDIT KEYS

4-9

ASCII Programming

COMMAND	WYSE 60/325	WYSE 50/350	ADDS-VT	PC TERM	TV1925
Program/Clear function keys (to clear, omit <i>text</i>)	ESC z fkey text DEL	ESC z fkey text DEL	ESC z fkey text DEL		
Program key and direction	ESC Z dir key text DEL	ESC Z dir key text DEL	ESC I dir key text DEL	ESC I dir key text DEL	ESC I dir key text DEL
Clear function/edit key	ESC Z dir key DEL	ESC Z dir key DEL			
Read key programming. Response from terminal:	ESC Z - key <i>dir key text</i> DEL	ESC Z - key <i>dir key text</i> DEL			
Program function key label	ESC z label text CR	ESC z label text CR	ESC z label text CR		
Erase function key label field	ESC z fkey CR	ESC z fkey CR	ESC z fkey CR		

Parameters	Description	Values
fkey	Function key specifier	See tables in the "Function & Edit Keys" chapter.
key	Function or edit key specifier	See tables in the "Function & Edit Keys" chapter.
label	Function key label	See tables in the "Function & Edit Keys" chapter.
dir	Direction of output data	See tables in the "Function & Edit Keys" chapter.

Default programmable keys **ESC c U** **ESC c U** **ESC c U**



Commands in bold are available only when "Enhanced" parameter in the Quick (F1) menu of Setup is set to On.

4-10

ASCII Programming

COMMAND	WYSE 60/325	WYSE 50/350	ADDS-VT	PC TERM	TV1925
---------	-------------	-------------	---------	---------	--------

LABEL LINE COMMANDS

Save NV Labels: On	ESC e K	ESC e K	ESC e K		
Save NV Labels: Off	ESC e J	ESC e J	ESC e J		
Program unshifted label line	ESC z (text CR or ESC f text CR	ESC z (text CR or ESC f text CR	ESC z (text CR or ESC f text CR	ESC f text CR	ESC f text CR
Erase unshifted label line	ESC z (CR	ESC z (CR	ESC z (CR		
Program shifted label line	ESC z) text CR	ESC z) text CR	ESC z) text CR		
Erase shifted label line	ESC z) CR	ESC z) CR	ESC z) CR		
Set bottom status line label attribute	ESC A I attr	ESC A I attr	ESC A I attr	ESC A I attr	ESC A I attr
Enable display of shifted label line	ESC z P CR	ESC z P CR	ESC z P CR		
Disable display of shifted label line	ESC z DEL	ESC z DEL	ESC z DEL		

STATUS LINE COMMANDS

User message line display off				ESC e or ESC h	ESC e or ESC h
User message line display on				ESC g	ESC g



Commands in bold are available only when "Enhanced" parameter in the Quick (F1) menu of Setup is set to On.

ASCII Programming

COMMAND	WYSE 60/325	WYSE 50/350	ADDS VP	PC TERM	TVI 925
Extended status line on	ESC a	ESC a	ESC a		
Standard status line on	ESC b	ESC b	ESC b		
Status line off	ESC c	ESC c	ESC c		
Write bottom status line message, where <i>text</i> is an ASCII string	ESC f <i>text</i> CR	ESC f <i>text</i> CR	ESC f <i>text</i> CR	ESC f <i>text</i> CR	ESC f <i>text</i> CR
Set top status line attribute	ESC A 2 <i>attr</i>	ESC A 2 <i>attr</i>	ESC A 2 <i>attr</i>	ESC A 2 <i>attr</i>	ESC A 2 <i>attr</i>
Set host-writable (bottom) status line attribute	ESC A 3 <i>attr</i>	ESC A 3 <i>attr</i>	ESC A 3 <i>attr</i>	ESC A 3 <i>attr</i>	ESC A 3 <i>attr</i>
Enter host message on top status line, where <i>msg</i> is an ASCII string.	ESC F <i>msg</i> CR	ESC F <i>msg</i> CR	ESC F <i>msg</i> CR		

TAB COMMANDS

Set tab at cursor location	ESC 1	ESC 1	ESC 1	ESC 1	ESC 1
Clear tab stop at cursor location	ESC 2	ESC 2	ESC 2	ESC 2	ESC 2
Tab cursor	HT (Ctrl I) or ESC i	HT (Ctrl I) or ESC i	HT (Ctrl I) or ESC i	HT (Ctrl I)	HT (Ctrl I)
Field tab				ESC i	ESC i



Commands in bold are available only when "Enhanced" parameter in the Quick (F1) menu of Setup is set to On.

ASCII Programming

COMMAND	WYSE 60/325	WYSE 50/350	ADDS VP	PC TERM	TVI 925
Backtab	ESC I	ESC I	ESC I	ESC I	ESC I
Initialize tabs on	ESC e ;	ESC e ;	ESC e ;		
Initialize tabs off	ESC e :	ESC e :	ESC e :		
Clear all tab stops	ESC 0	ESC 0		ESC 3	ESC 3

COLUMN COMMANDS

80 column screen	ESC :	ESC :	ESC :		
132 column screen	ESC ;	ESC ;	ESC ;		
80-only mode off	ESC e F	ESC e F	ESC e F		
80-only mode on	ESC e G	ESC e G	ESC e G		
Width change clear: off	ESC e .	ESC e .	ESC e .		
Width change clear: on	ESC e /	ESC e /	ESC e /		

PAGE COMMANDS

Auto page mode on	ESC d +	ESC d +	ESC d +		ESC v
Auto page mode off	ESC d *	ESC d *	ESC d *		ESC w
24-data line base page	ESC e (ESC e (ESC e (



Commands in bold are available only when "Enhanced" parameter in the Quick (F1) menu of Setup is set to On.

ASCII Programming

COMMAND	WYSE 60/52	WYSE 50+/350	ADDS VP	PC TERM	TVI/925
25-data line base page	ESC e)	ESC e)	ESC e)	ESC ^	ESC ^
42-data line base page	ESC e *	ESC e *	ESC e *		
43-data line base page	ESC e +	ESC e + _l	ESC e +	ESC _	ESC _
Display next page	ESC w C or ESC K	ESC w C or ESC K	ESC w C or ESC K	ESC K	ESC K
Display previous page	ESC w B or ESC J	ESC w B or ESC J	ESC w B or ESC J		ESC J
Display page	ESC w pg	ESC w pg	ESC w pg		

Parameters	Description	Values
pg	Page identifier. The range of valid values differs with page configuration (See page A-3)	0 - 9

Set page length multiplier ESC w mul ESC w mul ESC w mul

Parameters	Description	Values
mul	Page length multiplier	G = 1 x base page size H = 2 x base page size I = 4 x base page size J = set page 0 to the base size, and page 1 to the maximum lines remaining.



Commands in bold are available only when "Enhanced" parameter in the Quick (F1) menu of Setup is set to On.

ASCII Programming

COMMAND	WYSE 60/52	WYSE 50+/350	ADDS VP	PC TERM	TVI/925
---------	------------	--------------	---------	---------	---------

SPLIT SCREEN COMMANDS



Split screen mode is only supported by the Wyse 50+ and Wyse 60 emulations. There are two split screen modes :

- 1) **Fixed Split:** In this mode, the size of the split window cannot be adjusted. When only a single page is available, the upper window will display the top portion of the page, and the lower window the bottom portion. If more than one page is available, the upper window will display the top portion of the current page, and the lower window the top portion of the next page. When split screen is turned off, the cursor is homed.
- 2) **Variable Split:** In this mode, the split can be adjusted, and the viewed page in each split can be changed. For a single page of display, the variable split page usage is like a fixed split. For multiple pages, the portions of pages displayed correspond to the cursor location on each page. In this mode, the size of the split window can be adjusted. When the split is turned off, the cursor position(s) are saved.

Split screen at row	ESC x A row	ESC x A row
Split screen at row after erasing screen	ESC x 1 row	ESC x 1 row
Split screen at row	ESC x C row	ESC x C row
Split screen at row after erasing screen	ESC x 3 row	ESC x 3 row

Parameters	Description	Values
row	Row specifier.	The values for this parameter are listed under the "Cursor Movement Commands" section, on page 4-17.

Activate upper window	ESC]	ESC]
Activate lower window	ESC }	ESC }



Commands in bold are available only when "Enhanced" parameter in the Quick (F1) menu of Setup is set to On.

ASCII Programming

COMMAND	WYSE 60/325	WYSE 50+/350	ADDS-VP	PC-TERM	TVI 925
Display previous window/toggle active window*	ESC J	ESC J	ESC J	ESC J	
Display next window/toggle active window	ESC K	ESC K		ESC K	
Lower horizontal split	ESC x P	ESC x P			
Raise horizontal split	ESC x R	ESC x R			
Window up in page	ESC w E	ESC w E			
Window down in page	ESC e F	ESC e F			
Split screen off	ESC x @	ESC x @			
Split screen off; erase text	ESC x 0	ESC x 0			

CURSOR MOVEMENT COMMANDS

Cursor left (wraps up)	BS (Ctrl H)	BS (Ctrl H)	BS (Ctrl H) or NAK (Ctrl U)	BS (Ctrl H)	BS (Ctrl H)
Cursor right (wraps down)	FF (Ctrl L)	FF (Ctrl L)	ACK (Ctrl F)	FF (Ctrl L)	FF (Ctrl L)
Cursor up (wraps down)	VT (Ctrl K)	VT (Ctrl K)	SUB (CTRL Z)	VT (Ctrl K)	VT (Ctrl K)
Cursor up with scroll	ESC j	ESC j	ESC j	ESC j	ESC j
Cursor down with scroll	LF (Ctrl J)	LF (Ctrl J)	LF (Ctrl J)	LF (Ctrl J)	LF (Ctrl J)
Cursor down				SYN (Ctrl V)	SYN (Ctrl V)



Commands in bold are available only when "Enhanced" parameter in the Quick (F1) menu of Setup is set to On.

4-16

CURSOR MOVEMENT COMMANDS

ASCII Programming

COMMAND	WYSE 60/325	WYSE 50+/350	ADDS-VP	PC-TERM	TVI 925
Cursor to start of line	CR (Ctrl M)	CR (Ctrl M)	CR (Ctrl M)	CR (Ctrl M)	CR (Ctrl M)
Cursor to start of next line	US (Ctrl _)	US (Ctrl _)	US (Ctrl _)	US (Ctrl _)	US (Ctrl _)
Cursor home SOH (in ADDS-VP) places cursor at lower left corner	RS (Ctrl ^) or ESC {	RS (Ctrl ^) or ESC {	RS (Ctrl ^) or ESC { or SOH (Ctrl A)	RS (Ctrl ^)	RS (Ctrl ^)
Move cursor to row			Ctrl K <i>row</i>		
Move cursor to column			Ctrl P <i>column</i>		

Parameters	Description	Values									
row	Row #	Code	row #	Code	row #	Code	row #	Code	row #	Code	row #
		NUL	1	DLE	17	SPACE33	0	49	@	65	
		SOH	2	DC1	18	!	34	1	50	A	66
		STX	3	CD2	19	"	35	2	51	B	67
		ETX	4	DC3	20	#	36	3	52	C	68
		EOT	5	DC4	21	\$	37	4	53	D	69
		ENQ	6	NAK	22	%	38	5	54	E	70
		ACK	7	SYN	23	&	39	6	55	F	71
		BEL	8	ETB	24	'	40	7	56	G	72
		BS	9	CAN	25	(41	8	57	H	73
		HT	10	EM	26)	42	9	58	I	74
		LF	11	SUB	27	*	43	:	59	J	75
		VT	12	ESC	28	+	44	:	60	K	76
		FF	13	FS	29	.	45	<	61	L	77
		CR	14	GS	30	-	46	=	62	M	78
		SO	15	RS	31	_	47	>	63	N	79
		SI	16	US	32	/	48	?	64	O	80



Commands in bold are available only when "Enhanced" parameter in the Quick (F1) menu of Setup is set to On.

ASCII Programming

COMMAND	WYSE 60/75	WYSE 50/350	ADDS VP	PC TERM	TVI 925	
Parameters	Description	Values				
win	Window selector, used in split screen modes (see page A-3.)	0 = select upper window 1 = select lower window				
pg	Page number. The range of valid values differs with page configuration (See page A-3.)	0 - 9				
col / row	Column and row positions	Code Position	Code Position	Code Position	Code Position	Code Position
		SPACE 1	4 21	H 41	\ 61	p 81
		! 2	5 22	I 42] 62	q 82
		* 3	6 23	J 43	^ 63	r 83
		# 4	7 24	K 44	~ 64	s 84
		\$ 5	8 25	L 45	· 65	t 85
		% 6	9 26	M 46	a 66	u 86
		& 7	: 27	N 47	b 67	v 87
		' 8	; 28	O 48	c 68	w 88
		(9	< 29	P 49	d 69	x 89
) 10	= 30	Q 50	e 70	y 90
		* 11	> 31	R 51	f 71	z 91
		+ 12	? 32	S 52	g 72	{ 92
		, 13	@ 33	T 53	h 73	93
		- 14	A 34	U 54	i 74	} 94
		. 15	B 35	V 55	j 75	~ 95
		/ 16	C 36	W 56	k 76	DEL 96
		0 17	D 37	X 57	l 77	
		1 18	E 38	Y 58	m 78	
		2 19	F 39	Z 59	n 79	
		3 20	G 40	[60	o 80	



Commands in bold are available only when "Enhanced" parameter in the Quick (F1) menu of Setup is set to On.

ASCII Programming

COMMAND	WYSE 60/75	WYSE 50/350	ADDS VP	PC TERM	TVI 925
EDIT COMMANDS:					
Insert mode on	ESC q	ESC q	ESC q	ESC Z	ESC Z
Insert mode off	ESC r	ESC r	ESC r	ESC r	ESC r
Page edit mode off	ESC e "	ESC e "	ESC e "		
Page edit mode on	ESC e #	ESC e #	ESC e #		
Insert character	ESC Q	ESC Q	ESC Q	ESC Q	ESC Q
Insert line	ESC E	ESC E	ESC E or ESC M	ESC E	ESC E
Insert a column of nulls	ESC c M	ESC c M	ESC c M		
Delete character	ESC W	ESC W	ESC W	ESC W	ESC W
Delete line	ESC R	ESC R	ESC R or ESC I	ESC R	ESC R
Delete column	ESC c J	ESC c J	ESC c J		
Erase page to nulls	ESC *	ESC *	ESC *	ESC *	ESC *
Erase page to spaces	ESC +	ESC +	ESC + or FF (Ctrl L)	ESC +	ESC +
Erase page to protected spaces	ESC ,	ESC ,	ESC ,	ESC ,	ESC ,
Erase unprotected page to spaces	ESC ; or SUB (Ctrl Z)	ESC ; or SUB (Ctrl Z)	ESC ;	ESC ; or SUB (Ctrl Z)	ESC ; or SUB (Ctrl Z)



Commands in bold are available only when "Enhanced" parameter in the Quick (F1) menu of Setup is set to On.

ASCII Programming

COMMAND	WYSE 60/325	WYSE 50+/350	ADDS-VF	PC/TERM	TVI 925
Erase unprotected page to nulls	ESC :	ESC :	ESC :	ESC :	ESC :
Erase unprotected page to character represented by <i>char</i>	ESC . <i>char</i>	ESC . <i>char</i>	ESC . <i>char</i>		
Erase unprotected from cursor to end of page with spaces	ESC Y	ESC Y	ESC Y or ESC k	ESC Y	ESC Y
Erase unprotected from cursor to end of page with nulls	ESC y	ESC y	ESC y	ESC y	ESC y
Erase unprotected foreground from cursor to end of page with spaces	ESC c P	ESC c P	ESC c P		
Erase unprotected foreground from cursor to end of page with nulls	ESC c Q	ESC c Q	ESC c Q		
Erase unprotected from cursor to end of line with spaces	ESC T or ESC c O	ESC T or ESC c O	ESC T or ESC c O or ESC K	ESC T	ESC T
Erase unprotected from cursor to end of line with nulls	ESC t or ESC c L	ESC t or ESC c L	ESC t or ESC c L	ESC t	ESC t
Erase unprotected foreground from cursor to end of line with spaces	ESC c R	ESC c R	ESC c R		



Commands in bold are available only when "Enhanced" parameter in the Quick (F1) menu of Setup is set to On.

4-22

EDIT COMMANDS:

ASCII Programming

COMMAND	WYSE 60/325	WYSE 50+/350	ADDS-VF	PC/TERM	TVI 925
Erase unprotected foreground from cursor to end of line with nulls	ESC c S	ESC c S	ESC c S		
Erase unprotected column with nulls	ESC c K	ESC c K	ESC c K		
Fill Screen with H's				ESC F	ESC F
Erase unprotected column with the character represented by <i>char</i>	ESC c I <i>char</i>	ESC c I <i>char</i>	ESC c I <i>char</i>		

ATTRIBUTE COMMANDS

Character attribute mode off	ESC e 0				
Character attribute mode on	ESC e 1				
Page attribute mode on	ESC e 2				
Line attribute mode on	ESC e 3				
Assign character attribute	ESC G <i>attr</i>			ESC G <i>attr</i>	
Assign field attribute		ESC G <i>attr</i>	ESC G <i>attr</i>		ESC G <i>attr</i>
Clear page to display attribute		ESC ! <i>attr</i>	ESC ! <i>attr</i>		



Commands in bold are available only when "Enhanced" parameter in the Quick (F1) menu of Setup is set to On.

ATTRIBUTE COMMANDS

4-23

ASCII Programming

COMMAND		WYSE 60/325	WYSE 50+/350	ADDS VP	PC TERM	TVI 925
Parameters	Description	Values				
attr	Attribute specifier	attr	Attribute	attr	Attribute	
		SPACE	normal	p	dim	
		0	normal	q	dim + inv	
		1	invisible (inv)	r	dim + blink	
		2	blink	s	dim + blink + inv	
		3	invisible	t	dim + rev	
		4	reverse (rev)	u	dim + rev + inv	
		5	rev + inv	v	dim + rev + blink	
		6	rev + blink	w	dim + rev + blink + inv	
		7	rev + blink + inv	x	dim + und	
		8	underline (und)	y	dim + und + inv	
		9	und + inv	z	dim + und + blink	
		:	und + blink	{	dim + und + blink + inv	
		<	und + blink + inv		dim + und + rev	
		=	und + rev	}	dim + und + rev + inv	
		>	und + rev + inv	~	dim + und + rev + blink	
		?	und + rev + blink	DEL	dim + und + rev + blink + inv	

Set attribute for message/field ESC A field attr ESC A field attr ESC A field attr ESC \ field attr ESC \ field attr

Parameters	Description	Values	
field	Screen field for which the attribute is being set.	0 = application screen	2 = top local status line
		1 = bottom status line	3 = top host status line



Commands in bold are available only when "Enhanced" parameter in the Quick (F1) menu of Setup is set to On.

4-24

ATTRIBUTE COMMANDS

ASCII Programming

COMMAND		WYSE 60/325	WYSE 50+/350	ADDS VP	PC TERM	TVI 925
Parameters	Description	Values				
attr	The attribute assigned to field as specified above. For application screen (when field = 0), only normal and reverse attributes are allowed (attr = 0 and attr = 4, respectively.)	See listing of attribute parameters and values on page 4-24 above.				

Assign attribute to protected character ESC wyattr ESC wyattr ESC wyattr or ESC 0 pattr ESC G pattr

Parameters	Description	Values			
wyattr	Attribute for protected characters in Wyse emulations. Parameters B-G have a cumulative effect.	wyattr	Attribute	wyattr	Attribute
		6	reverse only	C	add suppress
		7	dim only (default)	E	add underline
		A	normal only	F	add reverse
pcattr	Attribute for protected characters in PC-Term emulation.	B	add blink	G	add dim
		pcattr	Attribute	pcattr	Attribute
		p	dim	x	dim + underline (und)
		q	dim + invisible (inv)	y	dim + und + inv
		r	dim + blink	z	dim + und + blink
		s	dim + blink + inv	{	dim + und + blink + inv
		t	dim + reverse (rev)		dim + und + rev
u	dim + rev + inv	}	dim + und + rev + inv		
v	dim + rev + blink	~	dim + und + rev + blink		
w	dim + rev + blink + inv	DEL	dim + und + rev + blink + inv		



Commands in bold are available only when "Enhanced" parameter in the Quick (F1) menu of Setup is set to On.

ATTRIBUTE COMMANDS

ASCII Programming

PARAMETERS	DESCRIPTION	VALUES																						
vpatr	Attribute for protected characters in ADDS-VP emulation. If blink and invisible are set, blink will override invisible. The attributes are specified using five bits of a byte: bit 0: dim bit 1: blink bit 2: invisible bit 4: reverse bit 5: underline bits 3, 6, and 7 are don't-cares.	<table border="1"> <thead> <tr> <th>vpatr</th> <th>Attribute</th> </tr> </thead> <tbody> <tr><td>@, H</td><td>norm + dim</td></tr> <tr><td>B, F, J, N</td><td>blink</td></tr> <tr><td>C, G, K, O</td><td>dim + blink</td></tr> <tr><td>D, L, d</td><td>invisible (inv)</td></tr> <tr><td>E, M, e, m</td><td>dim + inv</td></tr> <tr><td>P, X</td><td>reverse (rev)</td></tr> <tr><td>Q, Y</td><td>rev + dim</td></tr> <tr><td>R, V, Z, ^</td><td>rev + blink</td></tr> <tr><td>S, W, !, _</td><td>rev + dim + blink</td></tr> <tr><td>T, \, t</td><td>rev + inv</td></tr> </tbody> </table>	vpatr	Attribute	@, H	norm + dim	B, F, J, N	blink	C, G, K, O	dim + blink	D, L, d	invisible (inv)	E, M, e, m	dim + inv	P, X	reverse (rev)	Q, Y	rev + dim	R, V, Z, ^	rev + blink	S, W, !, _	rev + dim + blink	T, \, t	rev + inv
vpatr	Attribute																							
@, H	norm + dim																							
B, F, J, N	blink																							
C, G, K, O	dim + blink																							
D, L, d	invisible (inv)																							
E, M, e, m	dim + inv																							
P, X	reverse (rev)																							
Q, Y	rev + dim																							
R, V, Z, ^	rev + blink																							
S, W, !, _	rev + dim + blink																							
T, \, t	rev + inv																							

Normal line background	ESC G H	ESC G H	ESC G H
Bold line background	ESC G G	ESC G G	ESC G G
Invisible line background	ESC G I	ESC G I	ESC G I
Dim line background	ESC G J	ESC G J	ESC G J

PROTECT COMMANDS



When write-protect is turned on, the characters that are subsequently written take on the attributes described in the Emulation (F9) menu of Setup. When Protect mode is on, write protected characters cannot be overwritten, and scroll modes are temporarily disabled. Protect mode also temporarily disables edit capabilities such as delete/insert line and page edit mode. Protect mode affects only the current page while write protect mode affects all pages.



Commands in bold are available only when "Enhanced" parameter in the Quick (F1) menu of Setup is set to On.

ASCII Programming

COMMAND	WVSE 60/325	WVSE 50/350	ADDS VP	ESC TERM	TVI 925
Stop write protect	ESC (ESC (ESC (or SI (Ctrl O)	ESC (ESC (
Start write protect	ESC)	ESC)	ESC) or SO (Ctrl N)	ESC)	ESC)
Protect mode on	ESC &	ESC &	ESC &	ESC &	ESC &
Protect mode off	ESC ' ESC ' (Enhanced)	ESC ' ESC ' (Enhanced)	ESC ' ESC ' (Enhanced)	ESC ' ESC ' (Enhanced)	ESC ' ESC ' (Enhanced)
Report attribute under the cursor				ESC D	ESC D
Response from terminal:				attr a	attr a

Parameters	Description	Value										
attr	Attribute of the character at the cursor. Each bit in this byte represents the state of an attribute. An attribute is on if the bit is 1, and off if the bit is 0.	<table border="1"> <thead> <tr> <th>Bit</th> <th>Attribute</th> </tr> </thead> <tbody> <tr><td>0</td><td>normal/dim</td></tr> <tr><td>1</td><td>underline</td></tr> <tr><td>2</td><td>blink</td></tr> <tr><td>3</td><td>invisible (suppress)</td></tr> </tbody> </table>	Bit	Attribute	0	normal/dim	1	underline	2	blink	3	invisible (suppress)
Bit	Attribute											
0	normal/dim											
1	underline											
2	blink											
3	invisible (suppress)											

Erase cursor column to protected spaces	ESC V	ESC V	ESC V
Lock line	ESC ' H	ESC ' H	ESC ' H

A locked line is not accessible with the cursor, and will not scroll out of its position. Locking lines temporarily disables smooth scroll and all commands to create box graphics.



Commands in bold are available only when "Enhanced" parameter in the Quick (F1) menu of Setup is set to On.

ASCII Programming

COMMAND	WYSE 60/325	WYSE 50+/350	ADDS VP	PC TERM	TVI 925
Unlock all lines on all pages*	ESC ' I	ESC ' I	ESC ' I		

CHARACTER SIZE COMMANDS

Single-high, single-wide	ESC G @	ESC G @	ESC G @
Single-high, double-wide	ESC G A	ESC G A	ESC G A
Double-high, single-wide tops	ESC G B	ESC G B	ESC G B
Double-high, single-wide bottoms	ESC G C	ESC G C	ESC G C
Double-high, double-wide tops	ESC G D	ESC G D	ESC G D
Double-high, double-wide bottoms	ESC G E	ESC G E	ESC G E

CHARACTER SET COMMANDS

Select primary character set	ESC c D	ESC c D	ESC c D
Select secondary character set	ESC c E	ESC c E	ESC c E
Auto font load off	ESC e N	ESC e N	ESC e N
Auto font load on	ESC e O	ESC e O	ESC e O
Define primary character set	ESC c B <i>bank</i>	ESC c B <i>bank</i>	ESC c B <i>bank</i>



Commands in bold are available only when "Enhanced" parameter in the Quick (F1) menu of Setup is set to On.

ASCII Programming

COMMAND	WYSE 60/325	WYSE 50+/350	ADDS VP	PC TERM	TVI 925
Define secondary character set	ESC c C <i>bank</i>	ESC c C <i>bank</i>	ESC c C <i>bank</i>		
Load font bank	ESC c @ <i>bank cs</i>	ESC c @ <i>bank cs</i>	ESC c @ <i>bank cs</i>		
Erase font bank	ESC c ? <i>bank</i>	ESC c ? <i>bank</i>	ESC c ? <i>bank</i>		
Define and load a custom character	ESC c A <i>bank pos</i> <i>bb...bb</i> CTRL Y	ESC c A <i>bank pos</i> <i>bb...bb</i> CTRL Y	ESC c A <i>bank pos</i> <i>bb...bb</i> CTRL Y		

Parameters	Description	Values
bank	Font bank number.	0 = font bank 0 1 = font bank 1 2: font bank 2 3: font bank 4
cs	Character set designator	@ = Wyse 60 Native A = Multinational B = Standard ASCII C = Graphics 1 D = PC Equivalent E = Graphics 2 F = Graphics 3 G = Standard ANSI ' = 44-line Wyse Native a = 44-line Multinational b = 44-line PC Equivalent c = 44-line ASCII d = 44-line ANSI
pos	Position in font bank where custom character is to be loaded	00h - 7Fh: position A - a, respectively
bb ... bb	32 bytes defining the appearance of the custom character	See "Character Sets" on page 2-12 for full detail on how to use this command.



Commands in bold are available only when "Enhanced" parameter in the Quick (F1) menu of Setup is set to On.

ASCII Programming

COMMAND	WYSE 60/75	WYSE 50/750	ADDSVP	PC TERM	VTI 925
---------	------------	-------------	--------	---------	---------

GRAPHICS COMMANDS

Graphics mode on	ESC H STX	ESC H STX	ESC H STX	ESC \$	ESC \$
Graphics mode off	ESC H ETX	ESC H ETX	ESC H ETX	ESC %	ESC %
Display character as graphic	ESC H <i>char</i>	ESC H <i>char</i>	ESC H <i>char</i>		

Parameters	Description	Values																																				
<i>char</i>	Graphic character designator	<table border="0"> <tr> <td>0, P, p:</td> <td>┌</td> <td>6, V, v:</td> <td>■</td> <td>< \ :</td> <td>≡</td> </tr> <tr> <td>1, Q, q:</td> <td>┐</td> <td>7, W, w:</td> <td>+</td> <td>=] :</td> <td>┌</td> </tr> <tr> <td>2, R, r:</td> <td>└</td> <td>8, X, x:</td> <td>+</td> <td>> ^ :</td> <td>┐</td> </tr> <tr> <td>3, S, s:</td> <td>┘</td> <td>9, Y, y:</td> <td>+</td> <td>? _ DEL:</td> <td>≡</td> </tr> <tr> <td>4, T, t:</td> <td>┘</td> <td>: Z, z:</td> <td>+</td> <td></td> <td></td> </tr> <tr> <td>5, U, u:</td> <td>┘</td> <td>; [{:</td> <td>+</td> <td></td> <td></td> </tr> </table>	0, P, p:	┌	6, V, v:	■	< \ :	≡	1, Q, q:	┐	7, W, w:	+	=] :	┌	2, R, r:	└	8, X, x:	+	> ^ :	┐	3, S, s:	┘	9, Y, y:	+	? _ DEL:	≡	4, T, t:	┘	: Z, z:	+			5, U, u:	┘	; [{:	+		
0, P, p:	┌	6, V, v:	■	< \ :	≡																																	
1, Q, q:	┐	7, W, w:	+	=] :	┌																																	
2, R, r:	└	8, X, x:	+	> ^ :	┐																																	
3, S, s:	┘	9, Y, y:	+	? _ DEL:	≡																																	
4, T, t:	┘	: Z, z:	+																																			
5, U, u:	┘	; [{:	+																																			



The following box drawing commands are ignored if a locked line is present on the page.

Draw <i>row x col</i> size box to right of cursor position	ESC c <i>N col row</i>	ESC c <i>N col row</i>	ESC c <i>N col row</i>
Draw box from cursor to <i>row</i> and <i>col</i> position on 80-column page	ESC c <i>G row col</i>	ESC c <i>G row col</i>	ESC c <i>G row col</i>
Draw box from cursor to <i>row</i> and <i>col</i> position on 132-column page	ESC c <i>G row - col</i>	ESC c <i>G row - col</i>	ESC c <i>G row - col</i>



Commands in bold are available only when "Enhanced" parameter in the Quick (F1) menu of Setup is set to *On*.

ASCII Programming

COMMAND	WYSE 60/75	WYSE 50/750	ADDSVP	PC TERM	VTI 925
---------	------------	-------------	--------	---------	---------

Draw box with <i>char</i> from cursor to <i>row</i> and <i>col</i> on 80-column page	ESC c <i>F row col char</i>	ESC c <i>F row col char</i>	ESC c <i>F row col char</i>
--	-----------------------------	-----------------------------	-----------------------------



The boxes will end at the last column and the page scroll boundary.

Erase unprotected box Draw box with <i>char</i> from cursor to <i>row</i> and <i>col</i> position on 132-column page.	ESC c <i>H row - col char</i>	ESC c <i>H row - col char</i>	ESC c <i>H row - col char</i>
---	-------------------------------	-------------------------------	-------------------------------



Commands in bold are available only when "Enhanced" parameter in the Quick (F1) menu of Setup is set to *On*.

ASCII Programming

COMMAND		WYSE 60/325	WYSE 50+/350	ADDS VP	HOSTERM	TVI925
Parameter	Description	Values				
col / row	Column and row positions for box coordinates.	Code Position SPACE1	Code Position	Code Position	Code Position	Code Position
		! 2	4 21	H 41	\ 61	p 81
		" 3	5 22	I 42] 62	q 82
		# 4	6 23	J 43	^ 63	r 83
		\$ 5	7 24	K 44	_ 64	s 84
		% 6	8 25	L 45	` 65	t 85
		& 7	9 26	M 46	a 66	u 86
		' 8	: 27	N 47	b 67	v 87
		(9	; 28	O 48	c 68	w 88
) 10	< 29	P 49	d 69	x 89
		* 11	= 30	Q 50	e 70	y 90
		+ 12	> 31	R 51	f 71	z 91
		, 13	? 32	S 52	g 72	{ 92
		- 14	@ 33	T 53	h 73	93
		. 15	A 34	U 54	i 74] 94
		/ 16	B 35	V 55	j 75	~ 95
		0 17	C 36	W 56	k 76	DEL 96
		1 18	D 37	X 57	l 77	
		2 19	E 38	Y 58	m 78	
		3 20	F 39	Z 59	n 79	
			G 40	[60	o 80	
char	The character used to draw the borders of the box	Any alphanumeric character.				



Commands in bold are available only when "Enhanced" parameter in the Quick (F1) menu of Setup is set to On.

4-32

ASCII Programming

COMMAND	WYSE 60/325	WYSE 50+/350	ADDS VP	HOSTERM	TVI925
---------	-------------	--------------	---------	---------	--------

SEND COMMANDS

Set print/send to start at top of page	ESC d'	ESC d'	ESC d'		
Set print/send start at top of viewing area	ESC d &	ESC d &	ESC d &		
Send character under cursor (including Ctrl codes)	ESC M	ESC M			
Send line	ESC 6	ESC 6		ESC 6	ESC 6

The "Send Line Term" and "Send Block Term" selections in the Host (F7) menu of Setup determine the terminator sent after each row and/or page. Locked lines are not transmitted. Graphic characters are transmitted as spaces. Write-protect fields and graphics are bracketed by ESC) and ESC (. A <CR> <LF> is performed by the cursor after each send.

Send page	ESC 7	ESC 7	ESC 7	ESC 7	ESC 7
-----------	--------------	--------------	--------------	--------------	--------------

The "Send Line Term" and "Send Block Term" selections in the Host (F7) menu of Setup determine the terminator sent after each row and/or page. Locked lines are not transmitted. Graphic characters are transmitted as spaces. Write-protect fields and graphics are bracketed by ESC) and ESC (. A <CR> <LF> is performed by the cursor after each send.

Send unprotected line	ESC 4	ESC 4		ESC 4	ESC 4
-----------------------	--------------	--------------	--	--------------	--------------

If protect mode is on, an FS code (ICh) is sent for blocks of write-protected characters or graphics. No locked lines are transmitted. A <CR> <LF> is performed by the cursor after each send.

Send unprotected page	ESC 5	ESC 5		ESC 5	ESC 5
-----------------------	--------------	--------------	--	--------------	--------------

If protect mode is on, an FS code (ICh) is sent for blocks of write-protected characters or graphics. No locked lines are transmitted. A



Commands in bold are available only when "Enhanced" parameter in the Quick (F1) menu of Setup is set to On.

ASCII Programming

<CR> <LF> is performed by the cursor after each send.

Send unprotected message ESC S ESC S ESC S ESC S ESC S

Transmits all text between STX and ETX. If neither code is found, the send occurs between the cursor or the home position and the first occurrence of an STX or ETX. All graphics characters are replaced by spaces; graphics and protected characters are bracketed by ESC (and ESC (. If protect mode is on, a Field Separator (FS) code (1Ch) is sent for blocks of write-protected characters or graphics. No locked lines are transmitted. A <CR> <LF> is performed by the cursor after each send.

Send message ESC s ESC s ESC s ESC s ESC s

Transmits all text between STX and ETX. If neither code is found, the send occurs between the cursor or the home position and the first occurrence of an STX or ETX. All graphics characters are replaced by spaces; graphics and protected characters are bracketed by ESC (and ESC (. Sends all text on page. If protect mode is on, protected fields and graphics are bracketed by ESC (and ESC), and graphic characters are replaced by spaces.

Display begin message mark (STX) ESC 8 ESC 8 ESC 8

Display end message mark (ETX) ESC 9 ESC 9 ESC 9

Transmit keyboard status
Response from terminal: ESC [ESC [res a res a

Parameters	Description	Values			
res	A byte returned from the terminal specifying the keyboard status. Each bit in this byte represents the status of a special key (see the Values column).	Bit set	Key pressed	Bit set	Key pressed
		0	CapsLock ON	4	ALT
		1	always 0	5	CTRL
		2	always 0	6	NumLock
		3	always 0	7	Shift



Commands in bold are available only when "Enhanced" parameter in the Quick (F1) menu of Setup is set to On.

ASCII Programming

Define delimiter to be used with page sends.

ESC x **delim** ch1
ch2 ESC x **delim** ch1
ch2

Parameters	Description	Values			
delim	Delimiter defined by the command.	delim	Delimiter	delim	Delimiter
		0	field separator	3	end of protected field
		1	line terminator	4	block terminator
		2	start of protected field		
ch1, ch2	ASCII characters assigned to the specified delimiter.	ASCII characters.			

PRINT COMMANDS

Print formatted page ESC P ESC P ESC P ESC P ESC P

Print unformatted page (graphic chars. sent as spaces if protect mode is on) ESC p or ESC L ESC p or ESC L ESC p or ESC L ESC p or ESC L

Print unprotected formatted page ESC @ ESC @ ESC @ ESC @ ESC @

All print modes off DC4 (Ctrl T) DC4 (Ctrl T) DC4 (Ctrl T) DC4 (Ctrl T) DC4 (Ctrl T)

Aux print on (Aux = port designated as the printer for current session) DC2 (Ctrl R) DC2 (Ctrl R) DC2 (Ctrl R) DC2 (Ctrl R) or ESC @ DC2 (Ctrl R) or ESC @



Commands in bold are available only when "Enhanced" parameter in the Quick (F1) menu of Setup is set to On.

ASCII Programming

COMMAND	WYSE 60/525	WYSE 50/350	ADDS VP	PC TERM	TY1925
Aux print off	DC4 (Ctrl T)	DC4 (Ctrl T)	DC4 (Ctrl T)	ESC Á	ESC A
Transparent print on	ESC d #	ESC d #	ESC 3 or ESC d #	ESC	ESC
Transparent print off	DC4 (Ctrl T)	DC4 (Ctrl T)	DC4 (Ctrl T)	ESC a	ESC a
Aux receive on (routes data from serial printer port to host; printer data is not displayed)	ESC d!	ESC d!	ESC d!		
Aux receive off	ESC d space	ESC d space	ESC d space		
Bi-directional print mode on (turns aux print & aux receive modes on)	ESC d%	ESC d%	ESC d%	DC2 (Ctrl-R)	DC2 (Ctrl-R)
Bi-directional print mode off	ESC d\$	ESC d\$	ESC d\$	DC4 (Ctrl-T) ESC p term	DC4 (Ctrl-T) ESC p term
Program print terminator for page print commands where term is any ASCII character				ESC L hh mm page	ESC L hh mm page
Print page with time					
<i>Response from terminal:</i>					
Prints all text on page up to the cursor. A terminator of CR, LF, NUL control codes is sent at the end of each line. ACK will be transmitted (if ACK mode is ON) upon completion. Null characters are not sent.					

Parameters	Description	Values
ap	Designates a.m. or p.m.	A = a.m. P = p.m.



Commands in bold are available only when "Enhanced" parameter in the Quick (F1) menu of Setup is set to On.

ASCII Programming

COMMAND	WYSE 60/525	WYSE 50/350	ADDS VP	PC TERM	TY1925
Parameters	Description	Values			
hh	Designates the hour	00 - 12			
mm	Designates the minutes	00 - 59			
page	The contents of the page.				

WORDPERFECT GRAPHICS COMMANDS

Enter WP-Graphics with ASCII key codes	ESC - Q	ESC ~ Q	ESC - Q	ESC v Q	ESC - Q
Enter WP-Graphics with SCAN key codes	ESC - ?	ESC ~ ?	ESC - ?	ESC v ?	ESC - ?



Commands in bold are available only when "Enhanced" parameter in the Quick (F1) menu of Setup is set to On.

ANSI Programming

SUPPORTED C0 CONTROL CODES

<u>CO Code</u>	<u>Hex</u>	<u>Keyboard Equivalent</u>	<u>Command</u>
NUL	00h	Ctrl-@	Ignored
ENQ	05h	Ctrl-E	Send answerback message if one is programmed, otherwise send nothing.
BEL	07h	Ctrl-G	Sound the bell.
BS	08h	Ctrl-H	Move cursor left to a maximum of left margin.
HT	09h	Ctrl-I	Move cursor to next tab stop. If no tab stops remain, move to line's last character position.
LF	0Ah	Ctrl-J	Perform a linefeed. Scrolling depends on Auto-Scroll and Auto-Page settings.
VT	0Bh	Ctrl-K	Vertical Tab - same as LF.
FF	0Ch	Ctrl-L	Form Feed - same as LF.
CR	0Dh	Ctrl-M	Perform carriage return (cursor to left margin of line). If "Recv <CR>" in Setup (F7 menu) is <CR><LF>, also performs a line feed.
SO	0Eh	Ctrl-N	Map G1 character set into the GL buffer.
SI	0Fh	Ctrl-O	Map G0 character set into the GL buffer.
DC1	11h	Ctrl-Q	Resumes terminal data transmission if enabled.
DC3	13h	Ctrl-S	Halts all terminal data transmission except for <i>Xon</i> and <i>Xoff</i> .
CAN	18h	Ctrl-X	Cancel an escape sequence in progress.
SUB	1Ah	Ctrl-Z	Same as CAN, and displays a reverse ?.
ESC	1Bh	Ctrl-[Introduce an escape sequence, canceling any in progress.
DEL	7Fh	Del (numeric keypad) or Ctrl-Shift-8	Ignored or performs a backspace, deleting the character under the new position depending on "Recv " selection in Setup (F7 menu).

ANSI Programming

SUPPORTED CI CONTROL CODES



The two keys which are the keyboard equivalent of the CI control code are to be pressed in succession. When forming an equivalent, the first character is always ESC (1Bh). The second character is the CI code minus 40h.

CI Code	Hex	Keyboard Equivalent	Command
IND	84h	ESC D	Cursor down one line, scrolling according to settings for Auto-Page and Auto-Scroll.
NEL	85h	ESC E	Cursor to first position of next line, scrolling according to settings for Auto-Page and Auto-Scroll.
HTS	88h	ESC H	Set horizontal tab at current column.
RI	8Dh	ESC M	Cursor up one line, scrolling according to settings for Auto-Page and Auto-Scroll.
SS2	8Eh	ESC N	Single-shift G2 into GL, (temporarily map the character set to display a single character).
SS3	8Fh	ESC O	Single-shift G3 into GL, (temporarily map the character set to display a single character).
DCS	90h	ESC P	Opening delimiter for a Device Control String.
CSI	9Bh	ESC	Opening delimiter for a Control String.
ST	9Ch	ESC \	String Terminator - ends device control strings started with DCS.
OSC	9Dh	ESC]	Operating System Command - all subsequent characters are ignored until ST.
PM	9Eh	ESC ^	Privacy Message - all subsequent characters are ignored until ST.
APC	9Fh	ESC _	Used for terminal configuration.

ANSI Programming

COMMAND	MNEMONIC	VT200/300 INTERCOLOR	VT100
---------	----------	----------------------	-------

CURSOR COMMANDS

Cursor on	DECTCEM	CSI ? 25 h	ESC [? 25 h
Cursor off	DECTCEM	CSI ? 25 l	ESC [? 25 l



In the following six commands, the cursor is bound by the scrolling region (if one has been set). If the cursor is outside of the scrolling region at the time the command is issued, the cursor is bound by the page.

Move cursor up P_n rows	CUU	CSI P_n A	ESC [P_n A
Move cursor down P_n rows	CUD	CSI P_n B	ESC [P_n B
	VPR	CSI P_n e	ESC [P_n e
Move cursor P_n columns to the right	CUF	CSI P_n C	ESC [P_n C
	HPR	CSI P_n a	ESC [P_n a
Move cursor P_n columns to the left	CUB	CSI P_n D	ESC [P_n D
Move cursor down P_n lines and 1st column	CNL	CSI P_n E	ESC [P_n E
Move cursor up P_n lines and 1st column	CPL	CSI P_n F	ESC [P_n F

Parameters	Description	Values
P_n	Number of lines/columns to move the cursor.	Any numeric value. If omitted, the value is defaulted to 1.



In the following three commands, the cursor is bound by the page. If a scrolling region is defined, the cursor is bound to that scrolling region.

Move cursor to row P_r	VPA	ESC [P_r d	CSI P_r d
Move cursor to column P_c	CHA	CSI P_r G	ESC [P_r G
	HPA	CSI P_c ^	ESC [P_c ^
Move cursor to row P_r and column P_c	CUP	CSI P_r ; P_c H	ESC [P_r ; P_c H
	IIVP	CSI P_r ; P_c f	ESC [P_r ; P_c f

Parameters	Description	Values
P_r , P_c	Row / column number to move the cursor to.	Numeric value. If omitted, the value defaults to 1.

ANSI Programming

COMMAND	MNEMONIC	VT200/300 INTERCOLOR	VT100
Save cursor state*	WYSC	CSI s	ESC s
	DECSC	ESC 7	ESC 7
Restore cursor state**	WTRC	CSI u	ESC u
	DECRC	ESC 8	ESC 8
Move cursor <i>Pn</i> pages forward	NP	ESC [<i>Pn</i> U	CSI <i>Pn</i> U
Move cursor <i>Pn</i> pages backward	PP	ESC [<i>Pn</i> V	CSI <i>Pn</i> V

* DECSC saves the following:

- cursor position,
- character attributes SGR command,
- character set assignments (GL & GR),
- wrap flag,
- origin mode (DECOM),
- selective Erase attribute,
- single shift2 (SS2) or single shift3 (SS3).

** DECRC restores to the following, if DECSC had not been sent:

- positions cursor home,
- resets origin mode,
- sets normal attribute for text,
- maps ASCII charset to GL & DEC supplemental to GR.

Parameters	Description	Values
<i>Pn</i>	Number of pages to move the cursor.	This numeric value depends on the page configuration of the terminal. See page A-3.

TAB COMMANDS

Tab cursor	HT	HT (Ctrl-I)	HT (Ctrl-I)
Set tab at column	HTS	HTS (ESC H)	ESC H
Set or clear tab stops	CTC	CSI <i>Pn</i> W	ESC <i>Pn</i> W
Clear one or all tab stops	TBC	CSI <i>Ps</i> g	ESC <i>Ps</i> g
Move cursor forward <i>Pn</i> tab positions	CHT	CSI <i>Pn</i> I	ESC <i>Pn</i> I
Move cursor backward <i>Pn</i> tab positions	CBT	CSI <i>Pn</i> Z	ESC <i>Pn</i> Z

Parameters	Description	Values
<i>Pn</i>	Number of tab positions	Numeric value. Default value is 1.
<i>Ps</i>	Clear tab stop at cursor. Clear all tab stops.	0 Default value is 0 3

ANSI Programming

COMMAND	MNEMONIC	VT200/300 INTERCOLOR	VT100
---------	----------	-------------------------	-------

EDIT COMMANDS

Insert <i>Pn</i> blank characters on current line	ICH	CSI <i>Pn</i> @	ESC [<i>Pn</i> @
Delete <i>Pn</i> characters on current line	DCH	CSI <i>Pn</i> P	ESC [<i>Pn</i> P
Insert <i>Pn</i> lines at cursor	IL	CSI <i>Pn</i> L	ESC [<i>Pn</i> L
Delete <i>Pn</i> lines at cursor	DL	CSI <i>Pn</i> M	ESC [<i>Pn</i> M
Erase <i>Pn</i> characters	ECH	CSI <i>Pn</i> X	ESC [<i>Pn</i> X

Parameters	Description	Values
<i>Pn</i>	Number of lines / characters to delete / insert.	Numeric value.

Erase from cursor to end of line	EL	CSI 0 K	ESC [0 K
Erase from beginning of line to cursor	EL	CSI 1 K	ESC [1 K
Erase entire line	EL	CSI 2 K	ESC [2 K
Erase from cursor to end of page	ED	CSI 0 J	ESC [0 J
Erase from beginning of page to cursor	ED	CSI 1 J	ESC [1 J
Erase entire page	ED	CSI 2 J	ESC [2 J

SELECTIVE ERASE COMMANDS



Selective erase leaves all DH/DW (double-high/double-wide) attributes intact. Although unprotected characters are erased, their visual attributes are also left intact.

Subsequent characters received are to be protected by DECSED and DECSEL commands.	DECSCA	CSI 1 " q	ESC [1 " q
Subsequent characters received are unprotected for DECSED and DECSEL commands.	DECSCA	CSI 0 " q CSI 2 " q	ESC [0 " q ESC [2 " q
Erase unprotected characters from cursor to end of line	DECSEL	CSI ? 0 K	ESC [? 0 K
Erase unprotected characters from beginning of line to cursor	DECSEL	CSI ? 1 K	ESC [? 1 K

EDIT COMMANDS

ANSI Programming

COMMAND	MNEMONIC	VT200/300 INTERCOLOR	VT100
Subsequent characters received are to be protected by DECSED and DECSEL commands.	DECSCA	CSI I " q	ESC I " q
Erase all unprotected characters on line	DECSEL	CSI ? 2 K	ESC ? 2 K
Erase unprotected characters from cursor to end of page	DECSED	CSI ? 0 J	ESC ? 0 J
Erase unprotected characters from beginning of page to cursor	DECSED	CSI ? 1 J	ESC ? 1 J
Erase all unprotected characters on page	DECSED	CSI ? 2 J	ESC ? 2 J

CHARACTER SIZE COMMANDS

Single-high / Single-wide characters	SWL	ESC # 5	ESC # 5
Single-high / Double-wide characters	DWL	ESC # 6	ESC # 6
Double-high / Single-wide tops	DHL	ESC # :	ESC # :
Double-high / Single-wide bottoms	DHL	ESC # ;	ESC # ;
Double-high / Double-wide tops	DHL	ESC # 3	ESC # 3
Double-high / Double-wide bottoms	DHL	ESC # 4	ESC # 4

DISPLAY COMMANDS

Monitor mode on	CRM	CSI 3 h	ESC [3 h
Monitor mode off	CRM	CSI 3	ESC [3
Disable execution and display of control characters unless monitor mode is turned on locally.	FEAM	CSI 13 h	ESC [13 h
Re-enable execution/display of control characters.	FEAM	CSI 13	ESC [13
Display alignment pattern of E's.	ALN	ESC # 8	ESC # 8
Set top and bottom of scrolling region.	DECSTBM	CSI P r ; P b r	ESC P r ; P b r

At least two rows are required to set up a scroll region. This command is ignored if the region exceeds the page or is invalid. Each page can have its own region.

ANSI Programming

COMMAND	MNEMONIC	VT200/300 INTERCOLOR	VT100
---------	----------	-------------------------	-------

Parameters	Description	Values
Pt, Pb	Row numbers of the top and bottom of the scroll region.	Any numeric value within page limits. Default value for Pt is 1. Default value for Pb is 24.

Reset scrolling region to full page.	DECSTB	CSI ; r	ESC [; r
Origin mode on	DECOM	CSI 6 h	ESC [6 h

Cursor is not allowed beyond the scrolling region. The first line of the region is now numbered 1.

Origin mode off	DECOM	ESC 6 h	CSI 6 h
-----------------	-------	-----------	---------

Cursor can be positioned outside the region with CUP command.

No status lines	DECSSDT	CSI 0 \$ ~	ESC [0 \$ ~
Host-writeable status line on	DECSSDT	CSI 2 \$ ~	ESC [2 \$ ~
Top status line on	DECSSDT	CSI 1 \$ ~	ESC [1 \$ ~
Both status lines on	DECSSDT	CSI 3 \$ ~	
Display text at main display	DECSASD	CSI 0 \$ }	ESC [0 \$ }
Display text at host-writeable line	DECSASD	CSI 1 \$ }	ESC [1 \$ }
Select smooth scroll rate	SCRATE	CSI P n z	ESC [P n z

This sequence is ignored if jump scroll is selected.

Parameters	Description	Values
Pn	Scroll rate designator.	1 = smooth rate 1 2 = smooth rate 2 3 = smooth rate 4 Default value is 1

Display LED messages	DECLL	CSI P l ; ... ; P n q	ESC [P l ; ... ; P n q
----------------------	-------	-----------------------	-------------------------

Parameters	Description	Values
P1 - Pn	LED designator.	0 = All LED's off 1 = LED #1 2 = LED #2 3 = LED #3 4 = LED #4 Default value is 0

Set base page size to 25 or 43	WYEXTDM	CSI 40 h	ESC [40 h
--------------------------------	---------	----------	------------

If the current page size is 24, 25 or its multiple, the base page size is set to 25. If the current page size is 42, 43 or its multiple, the base page size is set to 43.

ANSI Programming

COMMAND	MNEMONIC	VT240/300 INTERCOLOR	VT100
---------	----------	-------------------------	-------

Set base page size to 24 or 42 WYEXTDM CSI 40 I ESC [40 I
 If the current page size is 24, 25 or its multiple, the base page size is set to 24. If the current page size is 42, 43 or its multiple, the base page size is set to 42.

Set the base page size to 42 or 43 WYMAXDM CSI 41 h ESC [41 h
 If the current page size is 24 or 42, the base page size is set to 42. If the current page size is 25 or 43, the base page size is set to 43.

Set the base page size to 24 or 25 WYMAXDM CSI 41 I ESC [41 I
 If the current page size is 24 or 42, the base page size is set to 24. If the current page size is 25 or 43, the base page size is set to 25.

Select character visual attributes SGR CSI attr;...; attr m ESC [attr;...; attr m

Parameters	Description	Values	
attr	Attribute selector. Multiple declarations of the same parameter will overwrite previous ones.	0 = all attributes off 1 = bold intensity 4 = underline 5 = blink 7 = reverse	8 = invisible (suppress) 22 = suppress off 24 = underline off 25 = blink off 27 = reverse off

KEYBOARD COMMANDS

Lock Keyboard KAM CSI 2 h ESC [2 h

The terminal will still respond to Setup entry keystrokes and other local key strokes.

Unlock Keyboard KAM CSI 2 I ESC [2 I

Numeric keypad in application mode DECKPAM ESC = ESC =
 DECKNM CSI ? 66 h ESC [? 66 h

 Numeric keypad DECKPAM ESC > ESC >
 in numeric mode DECKNM CSI ? 66 I CSI ? 66 I

ESC > Program User DECPEX DCS Pc; P1
 ESC [? 66 I Defined Keys fkey1 / seq1; ...;
 (UDK's) fkeyn / seqn ST

 The above sequence requires usage of key specifier codes listed in the "Function & Edit Keys" chapter. Please refer to the instructions and examples provided in that chapter for complete details.

ANSI Programming

COMMAND	MNEMONIC	VT240/300 INTERCOLOR	VT100
---------	----------	-------------------------	-------

Parameters	Description	Values
Pc	Specifies what keys to clear when programming.	0 = clear all keys 1 = clear only redefined keys
Pl	Specifies the lock state of the programmed keys.	0 = keys are programmable by the host 1 = keys are not programmable by the host (locked)
fkey1 - fkeyn	Specifies the key to be programmed.	See tables in the "Function & Edit Keys" chapter.
seq1 - seqn	Specifies the sequence to program in the selected key.	See tables in the "Function & Edit Keys" chapter.

Cursor keypad in application mode DECCKM CSI ? I h ESC [? I h

Cursor keypad in cursor mode DECCKM CSI ? I I ESC [? I I

Key Usage = Data Processing DECKBUM CSI ? 68 h ESC [? 68 h
 When "Language = U.S." in the Quick (F1) menu of Setup, keys with two adjacent characters on the keypad will send the character printed on the right.

Key Usage = Typewriter DECKBUM CSI ? 68 I ESC [? 68 I
 When "Language = U.S." in the Quick (F1) menu of Setup, keys with two adjacent characters on the keypad will send the character printed on the left.

Newline mode on LNM CSI 20 h ESC [20 h
 Received LF, VT, and FF will also perform a <CR><LF>.

Newline mode off LNM CSI 20 I ESC [20 I
 Received LF, VT, and FF will perform a <LF>.

Delete key generates BS (08h) WYDELKM CSI 36 h ESC [36 h
 DECBKM CSI 67 h ESC [67 h

Delete key generates DEL (7Fh) WYDELKM CSI 36 I ESC [36 I
 DECBKM CSI 67 I ESC [67 I

 is treated according to "Recvd DEL" selection in the Host (F7) menu of Setup.

Received characters perform a destructive BS. WYDEL CSI 49 h ESC [49 h

Received characters are ignored. WYDEL CSI 49 I ESC [49 I

ANSI Programming

COMMAND	MNEMONIC	VT200/300 INTERCOLOR	VT100
---------	----------	-------------------------	-------

"Key Dir = Screen" for unshifted function keys DECEKEM CSI ? 16 h ESC [? 16 h

"Key Dir" parameter is adjustable through the Program (F12) menu of Setup.

"Key Dir = Host" for unshifted function keys DECEKEM CSI ? 16 l ESC [? 16 l

"Key Dir" parameter is adjustable through the Program (F12) menu of Setup.

CHARACTER SET COMMANDS

Load G0 with 94 character set Cs	SCS	ESC (Cs	ESC (Cs
Load G1 with 94 character set Cs	SCS	ESC) Cs	ESC) Cs
Load G2 with 94 character set Cs	SCS	ESC * Cs	ESC * Cs
Load G3 with 94 character set Cs	SCS	ESC + Cs	ESC + Cs
Load G1 with 96 character set Cs	SCS	ESC - Cs	
Load G2 with 96 character set Cs	SCS	ESC . Cs	
Load G3 with 96 character set Cs	SCS	ESC / Cs	

Parameters	Description	Values																																																
Cs	Character set designator	<p>For information on how to designate a soft character set refer to page 2-1</p> <table border="1"> <tbody> <tr> <td>Cs</td> <td>Character Set</td> <td>Cs</td> <td>Character Set</td> </tr> <tr> <td>A</td> <td>ISO-Latin-96</td> <td>0</td> <td>ANSI Special Graphic</td> </tr> <tr> <td>B</td> <td>ANSI Standard</td> <td><</td> <td>User-Preferred - 96</td> </tr> <tr> <td>S</td> <td>ANSI Scientific</td> <td>%5</td> <td>Supplemental</td> </tr> </tbody> </table> <p>if "Char Set = National" in Emulation (F9) menu of Setup:</p> <table border="1"> <tbody> <tr> <td>Cs</td> <td>NRC Set</td> <td>Cs</td> <td>NRC Set</td> </tr> <tr> <td>4</td> <td>Dutch</td> <td>A</td> <td>U.K.</td> </tr> <tr> <td>5 or C</td> <td>Finnish</td> <td>K</td> <td>German</td> </tr> <tr> <td>6 or E</td> <td>Norwegian / Danish</td> <td>R</td> <td>French / Belgian / Flemish</td> </tr> <tr> <td>7 or H</td> <td>Swedish</td> <td>X</td> <td>Latin American</td> </tr> <tr> <td>9 or Q</td> <td>French Canadian</td> <td>Y</td> <td>Italian</td> </tr> <tr> <td>=</td> <td>Swiss French/German</td> <td>Z</td> <td>14 Spanish</td> </tr> <tr> <td>%6</td> <td>Portuguese</td> <td></td> <td></td> </tr> </tbody> </table>	Cs	Character Set	Cs	Character Set	A	ISO-Latin-96	0	ANSI Special Graphic	B	ANSI Standard	<	User-Preferred - 96	S	ANSI Scientific	%5	Supplemental	Cs	NRC Set	Cs	NRC Set	4	Dutch	A	U.K.	5 or C	Finnish	K	German	6 or E	Norwegian / Danish	R	French / Belgian / Flemish	7 or H	Swedish	X	Latin American	9 or Q	French Canadian	Y	Italian	=	Swiss French/German	Z	14 Spanish	%6	Portuguese		
Cs	Character Set	Cs	Character Set																																															
A	ISO-Latin-96	0	ANSI Special Graphic																																															
B	ANSI Standard	<	User-Preferred - 96																																															
S	ANSI Scientific	%5	Supplemental																																															
Cs	NRC Set	Cs	NRC Set																																															
4	Dutch	A	U.K.																																															
5 or C	Finnish	K	German																																															
6 or E	Norwegian / Danish	R	French / Belgian / Flemish																																															
7 or H	Swedish	X	Latin American																																															
9 or Q	French Canadian	Y	Italian																																															
=	Swiss French/German	Z	14 Spanish																																															
%6	Portuguese																																																	

Map G0's character set into GL	LS0	SO (Cul-N)	SO (Cul-N)
Map G1's character set into GL	LS1	SI (Cul-O)	SI (Cul-O)

CHARACTER SET COMMANDS

ANSI Programming

COMMAND	MNEMONIC	VT200/300 INTERCOLOR	VT100
---------	----------	-------------------------	-------

Map G1's character set into GR	LSIR	ESC -	
Map G2's character set into GL	LS2	ESC n	ESC n
Map G2's character set into GR	LS2R	ESC)	
Map G3's character set into GL	LS3	ESC o	ESC o
Map G3's character set into GR	LS3R	ESC I	
Map G3's character set into GL for next character only	SS3	ESC O	ESC O
Map G2's character set into GL for next character only	SS2	ESC N	ESC N
Assign ANSI Supplemental Character set as the User-Preferred	DECAUPSS	DCS 0 ! u % 5 ST	
Assign ISO-Latin Character set as the User-Preferred	DECAUPSS	DCS 1 ! u A ST	
Load soft font	DECDLD	DCS fb; bp; er; cw; rw; tg; ch; ss / cn ts / bs1; ... ST	



For detailed information and examples on how to use this command, see the discussion in the "Character Sets" chapter, starting on page 2-6.

GRAPHICS COMMANDS

Draw box routine, where
 if Ps1=0, draw box relative from cursor,
 Ps2= # of rows down to draw and
 Ps3= # of columns to the right to draw;
 If Ps1=1, draw box absolute from cursor,
 Ps2= row of opposite corner of box
 Ps3= column of opposite corner of box

CSI Ps1;Ps2;
Ps3 p ESC [Ps1;Ps2;
Ps3 p

Erase box routine, where
 if Ps1=0 erase box relative from cursor,
 Ps2= # of rows down to erase and
 Ps3= # of columns to the right to erase;
 if Ps1=1 erase box absolute from cursor,
 Ps2= row of opposite corner of box
 Ps3= column of opposite corner of box

CSI Ps1;Ps2;
Ps3 o ESC [Ps1;Ps2
Ps3 o



The boxes will end at the maximum column and the page scroll bottom.

GRAPHICS COMMANDS

ESC [75 h
l

ANSI Programming

COMMAND	MNEMONIC	VT200/300 INTERCOLOR	VT100
---------	----------	-------------------------	-------

SEND AND PRINT COMMANDS



The state of the "Print" parameter in the Emulation (F9) menu of Setup affects the information routed to the printer as follows:

- 1 Print = National: No escape sequences are issued to the printer; control codes and ANSI Scientific characters are converted to '_' (5Fh). National mode is used if the printer is not DEC-compatible
- 2 Print = Line-Drawing: This mode has access to the Special Graphics sets and NRC (National Replacement Character) sets.
- 3 Print = Multinational: This mode has access to ASCII, line-drawing, multinational, and soft font character sets, as well as attributes.

Set send region to full page	WYTEXM	CSI 38 h	ESC [38 h
Set send region to scrolling region	WYTEXM	CSI 38 l	ESC [38 l
Set cursor as end point of send commands	TTM	CSI ? 16 h	ESC [? 16 h
Set the region (page/region for send region or line for send line) as the end point	TTM	CSI ? 16 l	ESC [? 16 l
Send page to host	MC	CSI 2 i	ESC [2 i
Send line to host	MC	CSI ? 3 i	ESC [? 3 i
Set FF as send page terminator	DECTCC	CSI 1 i	ESC [1 i
Reset send page terminator (set no terminator)	WYXCH	CSI 0 i	ESC [0 i
Erase-protected characters to be transmitted	WYGATM	CSI 1 h	ESC [1 h
Reset transmits of erase-protected characters (replaced with RS)	WYGATM	CSI 1 i	ESC [1 i
Autoprint mode on	MC	CSI ? 5 i ✓	ESC [? 5 i
Autoprint mode off	MC	CSI ? 4 i	ESC [? 4 i
Print controller mode on (cancels autoprint)	MC	CSI 5 i ✓	ESC [5 i
Print controller mode off	MC	CSI 4 i	ESC [4 i
Print receive mode on	MC	CSI 7 i	ESC [7 i
Print receive mode off	MC	CSI 6 i	ESC [6 i
Print page	MC	CSI i	ESC [i
Print cursor line	MC	CSI ? 1 i	ESC [? 1 i
Set print form feed	DECPFF	CSI ? 18 h	ESC [? 18 h

ANSI Programming

COMMAND	MNEMONIC	VT200/300 INTERCOLOR	VT100
---------	----------	-------------------------	-------

Reset print form feed	DECPFF	CSI ? 18 l	ESC [? 18 l
Set print to Full Screen	DECPEX	CSI ? 19 h	ESC [? 19 h
Reset print to Scrolling Region	DECPEX	CSI ? 19 l	ESC [? 19 l

TERMINAL PERSONALITY

Set emulation to VT100	<Marker>SCL	CSI 61 * p	ESC [61 * p
Set emulation to VT200/7	SCL	CSI 62;1 * p	ESC [62;1 * p
Set emulation to VT200/8	SCL	CSI 62;0 * p CSI 62;2 * p	ESC [62;0 * p ESC [62;2 * p
Set emulation to VT300/7	SCL	CSI 63;1 * p	ESC [63;1 * p
	S7C1T	ESC space F	ESC space F
Set emulation to VT300/8	SCL	CSI 63;0 * p	ESC [63;0 * p
	S7C1T	CSI 63;2 * p ESC space G	ESC [63;2 * p ESC space G

QUERY AND RESPONSE

Send cursor character to host	WYXCH	ESC 5	ESC 5
<i>Request:</i> Terminal operating status	DSR	CSI 5 n	ESC [5 n
<i>Response:</i> Good operating status		CSI 0 n	ESC [0 n
<i>Response:</i> Operating malfunction		CSI 3 n	ESC [3 n
<i>Request:</i> Cursor position	DSR	CSI 6 n	ESC [6 n
<i>Response:</i> Row <i>Pr</i> , Column <i>Pc</i>	CPR	CSI <i>Pr</i> ; <i>Pc</i> R	ESC [<i>Pr</i> ; <i>Pc</i> R

Parameters	Description	Values
Pr	Cursor's row position	Numeric value depending on the page configuration.
Pc	Cursor's column position	1 - 80 (or 132, depending on the page configuration. See page A-3.)

ANSI Programming

COMMAND	MNEMONIC	VT200/300 INTERCOLOR	VT100
<i>Request:</i> Printer status	DSR	CSI ? 15 n	ESC ? 15 n
<i>Response:</i> No printer		CSI ? 13 n	ESC ? 13 n
Printer ready		CSI ? 10 n	ESC ? 10 n
Printer not ready		CSI ? 11 n	ESC ? 11 n
Printer busy		CSI ? 18 n	ESC ? 18 n
Printer assigned to another session		CSI ? 19 n	ESC ? 19 n
<i>Request:</i> User defined keys status	DSR	CSI ? 25 n	ESC ? 25 n
<i>Response:</i> UDK's locked		CSI ? 21 n	ESC ? 21 n
UDK's modifiable by host (unlocked)		CSI ? 20 n	ESC ? 20 n
<i>Request:</i> Keyboard dialect	DSR	CSI ? 26 n	ESC ? 26 n
<i>Response:</i> Dialect is Pd		CSI ? 27; Pd n	ESC ? 27; Pd n

Parameters	Description	Values																																								
Pd	Keyboard dialect designator	<table border="1"> <thead> <tr> <th>Pd</th> <th>Dialect</th> <th>Pd</th> <th>Dialect</th> </tr> </thead> <tbody> <tr><td>1</td><td>U.S.</td><td>10</td><td>Swiss French</td></tr> <tr><td>2</td><td>U.K.</td><td>11</td><td>Swiss German</td></tr> <tr><td>3</td><td>Flemish</td><td>12</td><td>Swedish</td></tr> <tr><td>4</td><td>Canadian (French)</td><td>13</td><td>Norwegian</td></tr> <tr><td>5</td><td>Danish</td><td>14</td><td>French Belgian</td></tr> <tr><td>6</td><td>Finnish</td><td>15</td><td>Spanish</td></tr> <tr><td>7</td><td>German</td><td>16</td><td>Portuguese</td></tr> <tr><td>8</td><td>Dutch</td><td>30</td><td>Latin American</td></tr> <tr><td>9</td><td>Italian</td><td></td><td></td></tr> </tbody> </table>	Pd	Dialect	Pd	Dialect	1	U.S.	10	Swiss French	2	U.K.	11	Swiss German	3	Flemish	12	Swedish	4	Canadian (French)	13	Norwegian	5	Danish	14	French Belgian	6	Finnish	15	Spanish	7	German	16	Portuguese	8	Dutch	30	Latin American	9	Italian		
Pd	Dialect	Pd	Dialect																																							
1	U.S.	10	Swiss French																																							
2	U.K.	11	Swiss German																																							
3	Flemish	12	Swedish																																							
4	Canadian (French)	13	Norwegian																																							
5	Danish	14	French Belgian																																							
6	Finnish	15	Spanish																																							
7	German	16	Portuguese																																							
8	Dutch	30	Latin American																																							
9	Italian																																									

COMMAND	MNEMONIC	VT200/300	VT100
<i>Request:</i> Device Attributes	DA	CSI c	ESC c
<i>Response:</i> If in P9 Setup menu:		CSI ? 1; 2 c	ESC ? 1; 2 c
ANSI-ID = VT100		CSI ? 1; 0 c	ESC ? 1; 0 c
ANSI-ID = VT102		CSI ? 6 c	ESC ? 6 c
ANSI-ID = VT220		CSI ? 62; 1; 2; 6; 7; 8; 9; c	
ANSI-ID = VT300		CSI ? 63; 1; 2; 6; 7; 8; 9; c	

Parameters	Description	Values																
Pn	Supported attribute designator	<table border="1"> <thead> <tr> <th>Pn</th> <th>Attribute supported</th> <th>Pn</th> <th>Attribute supported</th> </tr> </thead> <tbody> <tr><td>1</td><td>132 columns</td><td>7</td><td>soft characters</td></tr> <tr><td>2</td><td>printer port</td><td>8</td><td>UKD's</td></tr> <tr><td>6</td><td>selective erase</td><td>9</td><td>NRC sets</td></tr> </tbody> </table>	Pn	Attribute supported	Pn	Attribute supported	1	132 columns	7	soft characters	2	printer port	8	UKD's	6	selective erase	9	NRC sets
Pn	Attribute supported	Pn	Attribute supported															
1	132 columns	7	soft characters															
2	printer port	8	UKD's															
6	selective erase	9	NRC sets															

ANSI Programming

COMMAND	MNEMONIC	VT200/300 INTERCOLOR	VT100
<i>Request:</i> Tab Stop Report	DECTABSR	CSI 2 \$ w	ESC 2 \$ w
<i>Response:</i> At columns P1..Pn		DCS 2 \$ u P1...;Pn ST	ESC P 2 \$ u P1...;Pn ESC
(Re)set tab stops to columns P1..Pn	DECRSPS	DCS 2 \$(P1...;Pn ST	ESC P 2 \$ l P1...;Pn ESC

Parameters	Description	Values
Pn	Tab's column position	1 - 80 (or 132, depending on the page configuration. See page A-3)

COMMAND	MNEMONIC	VT200/300	VT100
<i>Request:</i> Cursor Information	DECCIR	CSI I \$ w	ESC I \$ w
<i>Response:</i>		DCS I \$ u Pr; Pc; Pp; Pa; Pe; Pf; PGI; PGr; Ps; P0 P1 P2 P3 ST	ESC P I \$ u Pr; Pp; Pa; Pe; Pp; Pa; Pe; Pf; Pp; Pa; Pe; Pf; PGI; PGr; Ps; P0 P1 P2 P3 ST
Set (restore) cursor according to string	DECRSPS	DCS I \$(Pr; Pc; Pp; Pa; Pe; Pf; PGI; PGr; Ps; P0 P1 P2 P3 ST	ESC P I \$(Pr; Pc; Pp; Pa; Pe; Pf; PGI; PGr; Ps; P0 P1 P2 P3 ESC

Parameters	Description	Values																
Pr	Cursor's row position	Numeric values. These values depend on the page configuration of the terminal. See page A-3.																
Pc	Cursor's column position																	
Pp	Cursor's page location	1 - 10																
Pa	Attribute under the cursor. Each bit of this byte represents an attribute.	<table border="1"> <thead> <tr> <th>bit</th> <th>attribute</th> <th>bit</th> <th>attribute</th> </tr> </thead> <tbody> <tr><td>0</td><td>bold</td><td>3</td><td>reverse</td></tr> <tr><td>1</td><td>underline</td><td>4</td><td>suppress</td></tr> <tr><td>2</td><td>blink</td><td></td><td></td></tr> </tbody> </table>	bit	attribute	bit	attribute	0	bold	3	reverse	1	underline	4	suppress	2	blink		
bit	attribute	bit	attribute															
0	bold	3	reverse															
1	underline	4	suppress															
2	blink																	
Pe	Erasability of character under the cursor	64: non-erasable 65: selectively erasable																
Pf	Status flag. Each bit of this byte represents a state of the character under the cursor	<table border="1"> <thead> <tr> <th>bit</th> <th>state</th> <th>bit</th> <th>state</th> </tr> </thead> <tbody> <tr><td>0</td><td>slate origin mode</td><td>3</td><td>autowrap pending</td></tr> <tr><td>1</td><td>single-shift 2</td><td>4</td><td>always 0</td></tr> <tr><td>2</td><td>single-shift 3</td><td></td><td></td></tr> </tbody> </table>	bit	state	bit	state	0	slate origin mode	3	autowrap pending	1	single-shift 2	4	always 0	2	single-shift 3		
bit	state	bit	state															
0	slate origin mode	3	autowrap pending															
1	single-shift 2	4	always 0															
2	single-shift 3																	

ANSI Programming

COMMAND	MNEMONIC	VT200/300	VT100																																																
INTERCOLOR																																																			
Parameters	Description	Values																																																	
PGI, PGr	Font banks mapped to GL or GR buffers	0 = Font bank G0 1 = Font bank G1	2 = Font bank G2 3 = Font bank G3																																																
Ps	Character set size of Font bank. Each bit of this byte corresponds to the character set size of a font bank.	<table border="1"> <tr> <th>bit</th> <th>font bank</th> <th>bit=0</th> <th>bit=1</th> </tr> <tr> <td>0</td> <td>G0</td> <td>94 chars.</td> <td>96 chars.</td> </tr> <tr> <td>1</td> <td>G1</td> <td>94 chars.</td> <td>96 chars.</td> </tr> <tr> <td>2</td> <td>G2</td> <td>94 chars.</td> <td>96 chars.</td> </tr> <tr> <td>3</td> <td>G3</td> <td>94 chars.</td> <td>96 chars.</td> </tr> </table>	bit	font bank	bit=0	bit=1	0	G0	94 chars.	96 chars.	1	G1	94 chars.	96 chars.	2	G2	94 chars.	96 chars.	3	G3	94 chars.	96 chars.																													
bit	font bank	bit=0	bit=1																																																
0	G0	94 chars.	96 chars.																																																
1	G1	94 chars.	96 chars.																																																
2	G2	94 chars.	96 chars.																																																
3	G3	94 chars.	96 chars.																																																
P0, P1, P2, P3	Code specifying the character set in font banks G0, G1, G2, and G3.	<table border="1"> <tr> <th>Code</th> <th>Character set</th> <th>Code</th> <th>Character set</th> </tr> <tr> <td>A</td> <td>ISO-Latin - 96</td> <td>0</td> <td>ANSI Special Graphic</td> </tr> <tr> <td>B</td> <td>ANSI Standard</td> <td><</td> <td>User-Preferred-96 Supplemental</td> </tr> <tr> <td>S</td> <td>ANSI Scientific</td> <td>%5</td> <td></td> </tr> </table> <p>if "Char Set = National" in Emulation (F9) menu of Setup:</p> <table border="1"> <tr> <th>Code</th> <th>NRC set</th> <th>Code</th> <th>NRC set</th> </tr> <tr> <td>4</td> <td>Dutch</td> <td>A</td> <td>U.K.</td> </tr> <tr> <td>5 or C</td> <td>Finnish</td> <td>K</td> <td>German</td> </tr> <tr> <td>6 or E</td> <td>Norwegian / Danish</td> <td>R</td> <td>French / Belgian / Flemish</td> </tr> <tr> <td>7 or H</td> <td>Swedish</td> <td>X</td> <td>Latin American</td> </tr> <tr> <td>9 or Q</td> <td>French Canadian</td> <td>Y</td> <td>Italian</td> </tr> <tr> <td>=</td> <td>Swiss French / German</td> <td>Z</td> <td>Spanish</td> </tr> <tr> <td>%6</td> <td>Portuguese</td> <td></td> <td></td> </tr> </table>	Code	Character set	Code	Character set	A	ISO-Latin - 96	0	ANSI Special Graphic	B	ANSI Standard	<	User-Preferred-96 Supplemental	S	ANSI Scientific	%5		Code	NRC set	Code	NRC set	4	Dutch	A	U.K.	5 or C	Finnish	K	German	6 or E	Norwegian / Danish	R	French / Belgian / Flemish	7 or H	Swedish	X	Latin American	9 or Q	French Canadian	Y	Italian	=	Swiss French / German	Z	Spanish	%6	Portuguese			
Code	Character set	Code	Character set																																																
A	ISO-Latin - 96	0	ANSI Special Graphic																																																
B	ANSI Standard	<	User-Preferred-96 Supplemental																																																
S	ANSI Scientific	%5																																																	
Code	NRC set	Code	NRC set																																																
4	Dutch	A	U.K.																																																
5 or C	Finnish	K	German																																																
6 or E	Norwegian / Danish	R	French / Belgian / Flemish																																																
7 or H	Swedish	X	Latin American																																																
9 or Q	French Canadian	Y	Italian																																																
=	Swiss French / German	Z	Spanish																																																
%6	Portuguese																																																		

Request: Current User-Preferred character set DECRQPSS CSI & u ESC | & u

Response: UPSS = ANSI Supplemental DCS 0 ! u % 5 ST ESC P 0 ! u % 5
UPSS = ISO-Latin DCS ! ! u A ST ESC P ! ! u A

Request: Settings of command Pc DECRQSS DCS \$ q Pc ST

Response: DCS 0 \$ r string ESC A

Parameters	Description	Values
Pc	Command designator	\$ } DECSASD (Active status display, pg. 5-6) " q DECSCA (Character attribute command, pg. 5-5) " p DECSCL (Emulation command, pg. 5-11) \$ - DECSSDT (Status line type, pg. 5-6) r DECSTBM (Top and bottom margins, pg. 5-6) m SGR (Select graphic rendition command, pg. 5-7)

ANSI Programming

COMMAND	MNEMONIC	VT200/300	VT100
---------	----------	-----------	-------

Parameters	Description	Values
string	Settings related to the command specified by the Pc parameter are reported in this string.	See the description of each command.

Request mode (ANSI) DECRQM CSI Pm \$p

Request mode (Private) DECRPM CSI ? Pm \$p

Response (ANSI) DECRPM CSI Pm; Ps \$ y

Response (Private) CSI ? Pm; Ps \$ y

Parameters	Description	Values				
Pm (ANSI)	Particular mode setting	1	WYGATM	33	WYGATM	
		2	KAM	34	WYSTLINM	
		3	CRM	35	WYCRSAVM	
		4	IRM	36	WYSTCURM	
		12	SRM	37	WYULGURM	
		13	FEAM	38	WYTEXM	
		16	TTM	40	WYEXTDM	
		20	LNM	41	WYMAXDM	
		30	WYDSCM	42	WYASCII	
		31	WYCLRM	45	HOST MAP	
		32	WYDELKM	46	WYDEL	
Pm (Private)			1	DECKM	16	DECEKEM
			2	DECANM	18	DECPFF
			3	DECCOLM	19	DECPEX
			4	DECSCLM	25	DECTCEM
		5	DECSCNM	42	DECNRCM	
		6	DECOM	54	WYKCM	
		7	DECAWN	66	DECKNKM	
		8	DECCARM	67	DECBKM	
		10	DECEDM	68	DECKBUM	

RESET TERMINAL AND EMULATIONS

Delay processing for 250 ms WYDELAY ESC . ESC .

Set mode (up to 16 modes) SM CSI Pml ... ; Pml6 h ESC [Pml... ; Pml6 h

Reset mode (up to 16 modes) RM CSI Pml ... ; Pml6 l ESC [Pml... ; Pml6 l

RESET TERMINAL AND EMULATIONS

ANSI Programming

COMMAND	MNEMONIC	VT200/300 INTERCOLOR	VT100
Parameters	Description	Values	
Pm1 - Pm16	Mode designator. Depending on whether the listed values are used with the RM or SM commands, the corresponding mode is disabled (turned off) or enabled (turned on). Up to 16 mode designators can be specified in one command string.	Code Mode (ANSI) 1 transmit erase-protected characters 2 keyboard lock 3 monitor mode 4 insert mode 12 local echo 13 control code execution 16 send end mode 20 new line 30 screen display 31 status line display 32 screen saver 33 steady cursor 34 underline cursor 35 width change clear 36 redefine delete key 37 transmit erase-protected characters 38 transmit full screen 40 25/43 line display 41 set 43 line maximum with to WYSE60 emul. 45 set Aux port as host 49 DEL = destructive BS	Code Mode (Private) ?1 Cursor keypad = Application mode ?3 132 columns ?4 smooth scroll ?5 Reverse video screen ?6 origin mode ?7 autowrap mode ?8 autorepeat mode ?10 block mode ?16 normal Fkey direction is 'local' ?18 print terminator = <FF> (form-feed) ?19 print full page ?25 cursor display ?42 national character mode ?54 Keymode = ASCII ?66 Numeric keypad = Application mode ?67 Backspace key ?68 key usage = Data processing

Soft terminal reset	DECSTR	CSI ! p	ESC ! ! p
	WYSTR	ESC ! p	ESC ! p
Hard terminal reset (equiv. to power-up)	RIS	ESC c	ESC c

ANSI PAGING COMMANDS

Move forward Pn pages	CSI Pn U	ESC Pn U
Move backward Pn pages	CSI Pn V	ESC Pn V

Parameters	Description	Values
Pn	Number of pages to move forward or backward.	Numeric value depending on the page configuration. See page A-3). Default is a single page.

ANSI Programming

COMMAND	MNEMONIC	VT200/300 INTERCOLOR	VT100
Move to next page		CSI U	ESC U
Move to previous page		CSI V	ESC V

GENERAL SETUP COMMANDS

Load date	ESC _ - P1/S1; P2/S2;...;Pn/Sn ESC \
-----------	--

Parameters	Description	Values	
P1 - Pn	Mode specifiers. These parameters specify what part of the date is modified.	1 display of date 2 month setting 3 day setting	4 century setting 5 year setting
S1	Display of date	0 (display off) 1 (display on)	
S2	Month setting	01 - 12 (Jan, ..., Dec)	
S3	Day setting	01 - 31	
S4	Century setting	19 - 20	
S5	Year setting	00 - 99	

WORDPERFECT GRAPHICS COMMANDS

Enter WP-Graphics with ASCII key codes	CSI 30 -	ESC 30 -
Enter WP-Graphics with SCAN key codes	CSI 31 -	ESC 31 -

GENERAL SETUP COMMANDS

ANSI Programming

COMMAND	MNEMONIC	VT200/300	VT100
		INTERCOLOR	

SCO / AT386

SUPPORTED C0 CONTROL CODES

<u>C0 Code</u>	<u>Hex</u>	<u>Keyboard Equivalent</u>	<u>Command</u>
NUL	00h	Ctrl-@	Ignored
BEL	07h	Ctrl-G	Sound the bell.
BS	08h	Ctrl-II	Move cursor left to a maximum of left margin.
HT	09h	Ctrl-I	Move cursor to next tab stop. If no tab stops remain, move to line's last character position.
LF	0Ah	Ctrl-J	Perform a linefeed. Scrolling depends on Auto-Scroll and Auto-Page settings.
VT	0Bh	Ctrl-K	Vertical Tab - same as LF.
FF	0Ch	Ctrl-L	Form Feed. Homes cursor and erases screen.
CR	0Dh	Ctrl-M	Perform carriage return (cursor to left margin of line). If "Recv <CR>" in Setup (F7 menu) is <CR><LF>, also performs a line feed.
DC1	11h	Ctrl-Q	Resume transmission if Xon/Xoff mode is enabled.
DC3	13h	Ctrl-S	Halts transmission of all codes except Xon and Xoff if Xon/Xoff mode is enabled
CAN	18h	Ctrl-X	Cancel an escape sequence in progress.
SUB	1Ah	Ctrl-Z	Same as CAN, and displays a reverse ?.
ESC	1Bh	Ctrl-[Introduce an escape sequence, canceling any in progress.

SUPPORTED C1 CONTROL CODES



The two keys which are the keyboard equivalent of the C1 control code are to be pressed in succession. When forming an equivalent, the first character is always ESC (1Bh). The second character is the character with an ASCII code equal to the C1 code minus 40h.

<u>C1 Code</u>	<u>Hex</u>	<u>Key-Stroke</u>	<u>Command</u>
CSI	9Bh	ESC I	Control String Introducer - introduces a command.

SUPPORTED C0 CONTROL CODES

SCO / AT386

COMMAND	MNEMONIC	SCO Console	AT386
---------	----------	-------------	-------

CURSOR COMMANDS

Cursor on	DECTCEM	CSI ? 25 h	ESC ? 25 h
Cursor off	DECTCEM	CSI ? 25 I	ESC ? 25 I
Move cursor up <i>Pn</i> rows	CUU	CSI <i>Pn</i> A	ESC <i>Pn</i> A
Move cursor down <i>Pn</i> rows	CUD	CSI <i>Pn</i> B	ESC <i>Pn</i> B
	VPR	CSI <i>Pn</i> e	ESC <i>Pn</i> e
Move cursor <i>Pn</i> columns to the right	CUF	CSI <i>Pn</i> C	ESC <i>Pn</i> C
	HPR	CSI <i>Pn</i> a	ESC <i>Pn</i> a
Move cursor <i>Pn</i> columns to the left	CUB	CSI <i>Pn</i> D	ESC <i>Pn</i> D
Move cursor down <i>Pn</i> rows and position at left margin	CNL	CSI <i>Pn</i> E	ESC <i>Pn</i> E
Move cursor up <i>Pn</i> rows and position at left margin	CPL	CSI <i>Pn</i> F	ESC <i>Pn</i> F

Parameters	Description	Values
<i>Pn</i>	The number of rows or columns to move the cursor. _	Any numeric value.

Move cursor to line <i>Pn</i>	VFA	CSI <i>Pr</i> d	CSI <i>Pn</i> d
Move cursor to column <i>Pn</i>	DCH	CSI <i>Pc</i> G	CSI <i>Pn</i> G
	HPA	CSI <i>Pc</i> ^	CSI <i>Pn</i> ^
Move cursor to row <i>Pr</i> and column <i>Pc</i>	CUP	CSI <i>Pr</i> ; <i>Pc</i> H	CSI <i>Pr</i> ; <i>Pc</i> H
	HVP	CSI <i>Pr</i> ; <i>Pc</i> I	CSI <i>Pr</i> ; <i>Pc</i> I

Parameters	Description	Values
<i>Pr</i>	The row number to move the cursor to.	Any numeric value. If omitted, <i>Pr</i> will default to 1.
<i>Pc</i>	The column number to move the cursor to.	0 - 80 (or 132, depending on the page configuration.) If omitted, <i>Pc</i> will default to 1.

 Commands in bold are available only when "Enhanced" parameter in the Quick (F1) menu of Setup is set to *On*.

SCO / AT386

COMMAND	MNEMONIC	SCO Console	AT386
---------	----------	-------------	-------

Save cursor state	DECSC	CSI s	
	WYSC	ESC 7	
Restore cursor state	DECRC	CSI u	
	WTRC	ESC 8	

TAB COMMANDS

Tab cursor	HT	Ctrl-I	Ctrl-I
Set tab at column	HTS	ESC H	
Move cursor backward <i>Pn</i> tab positions	CBT	CSI <i>Pn</i> Z	CSI <i>Pn</i> Z

Parameters	Description	Values
<i>Pn</i>	The number of tab positions to move the cursor.	Any numeric value. Default value is 1.

EDIT COMMANDS

Turn insert mode on	IRM	CSI 4 h	CSI 4 h
Turn insert mode off	IRM	CSI 4 I	CSI 4 I
Insert <i>Pn</i> blank characters on current line	ICH	CSI <i>Pn</i> @	CSI <i>Pn</i> @
Delete <i>Pn</i> characters on current line	DCH	CSI <i>Pn</i> P	CSI <i>Pn</i> P
Insert <i>Pn</i> lines at cursor	IL	CSI <i>Pn</i> L	CSI <i>Pn</i> L
Delete <i>Pn</i> lines at cursor	DL	CSI <i>Pn</i> M	CSI <i>Pn</i> M
Erase <i>Pn</i> characters	ECH	CSI <i>Pn</i> X	CSI <i>Pn</i> X

Parameters	Description	Values
<i>Pn</i>	The number of characters or lines to insert or delete.	Any numeric value. Default value is 1.

 Commands in bold are available only when "Enhanced" parameter in the Quick (F1) menu of Setup is set to *On*.

SCO / AT386

COMMAND	MNEMONIC	SCO Console	AT386
---------	----------	-------------	-------

Erase characters on line	EL	CSI Pm K	CSI Pm K
Erase characters on page	ED	CSI Pm J	CSI Pm J

Parameters	Description	Values
Pm (EL)	From beginning of cursor to end of line.	0
	From beginning of row to cursor position.	1
	Entire Row.	2
Pm (ED)	From beginning of cursor to end of page.	0
	From beginning of page to cursor.	1
	Entire page.	2

CHARACTER SIZE COMMANDS

Set row to Single-high / Single-wide characters	SWL	ESC # 5	ESC # 5
Set row to Single-high / Double-wide characters	DWL	ESC # 6	ESC # 6
Set row to Double-high / Double-wide tops	DHIL	ESC # 3	ESC # 3
Set row to Double-high / Double-wide bottoms	DTIL	ESC # 4	ESC # 4

DISPLAY COMMANDS

Monitor mode on	CRM	CSI 3 h	CSI 3 h
Monitor mode off	CRM	CSI 3 I	CSI 3 I
Turn local echo on	SRM	CSI 12 J	CSI 12 J



Commands in bold are available only when "Enhanced" parameter in the Quick (F1) menu of Setup is set to On.

CHARACTERSIZECOMMANDS

SCO / AT386

COMMAND	MNEMONIC	SCO Console	AT386
---------	----------	-------------	-------

Turn local echo off	SRM	CSI 12 h	CSI 12 h
Display alignment pattern of E's. This command causes all line attributes to be cleared.	ALN	ESC # 8	ESC # 8
Display graphics character		CSI Pgc g	

Parameters	Description	Values
Pgc	Graphics character to be displayed. Characters are displayed from the PC Equivalent and PC Multinational character sets (See Appendix B).	0 - 255

Scroll screen up Pn lines	SU	CSI Pn S	CSI Pn S
Scroll screen down Pn lines	SD	CSI Pn T	CSI Pn T

Parameters	Description	Values
Pn	The number of lines to scroll.	Any numeric value.

Turn 132 column mode on	SRM	CSI ? 3 h	CSI ? 3 h
Turn 132 column mode off	SRM	CSI ? 3 I	CSI ? 3 I
Turn smooth scroll on	SRM	CSI ? 4 h	CSI ? 4 h
Turn smooth scroll off	SRM	CSI ? 4 I	CSI ? 4 I
Turn reverse video mode on	SRM	CSI ? 5 h	CSI ? 5 h
Turn reverse video mode off	SRM	CSI ? 5 I	CSI ? 5 I
Turn autowrap on	SRM	CSI ? 7 h	CSI ? 7 h
Turn autowrap off	SRM	CSI ? 7 I	CSI ? 7 I
Switch to page Pn	SRM	CSI n z	



Commands in bold are available only when "Enhanced" parameter in the Quick (F1) menu of Setup is set to On.

DISPLAY COMMANDS

6-5

SCO / AT386

COMMAND	MNEMONIC	SCO Console	AT386
---------	----------	-------------	-------

Parameters	Description	Values
Pn	The page number to switch to	Numeric value, depending on page configuration (See Appendix A). Default value is 1.

Select character visual attribute SGR CSI Ps;...Ps m CSI Ps;...Ps m

Parameters	Description	Values
Ps	Attribute selector. Multiple declarations of the same parameter will overwrite previous ones.	0 = All attributes off 5 = Blink 1 = Bold intensity 7 = Reverse 4 = Underline 8 = Invisible (suppress) 10 = Select primary character set (non-controls) 11 = Select primary character set (all characters except 1Bh and 9Bh) 12 = Display Extended character set (8-bit set)

KEYBOARD COMMANDS

Turn autorepeat on	SRM	CSI ? 8 h	CSI ? 8 h
Turn autorepeat off	SRM	CSI ? 8 i	CSI ? 8 i
Lock Keyboard (local keys still active)	KAM	CSI 2 h	CSI 2 h
Unlock Keyboard	KAM	CSI 2 i	CSI 2 i
Keyclick On (virtual terminal depend.)		CSI 0 k	CSI 0 k
Keyclick Off (virtual terminal depend.)		CSI 1 k	CSI 1 k



The sequence below requires usage of key specifier codes listed in the "Function & Edit Keys" chapter. Please refer to the instructions and examples provided in that chapter for complete details.

Program User Defined Keys	ESC Q Fn 'string'	ESCQ Fn 'string'
Scan code mode On (scan code set 1 PC-X7)	ESC - 5	
Scan code mode Off	ESC - 6	



Commands in bold are available only when "Enhanced" parameter in the Quick (F1) menu of Setup is set to On.

KEYBOARD COMMANDS

SCO / AT386

COMMAND	MNEMONIC	SCO Console	AT386
---------	----------	-------------	-------

SEND COMMAND

Autoprint mode on	MC	CSI ? 5 i	CSI ? 5 i
Autoprint mode off	MC	CSI ? 4 i	CSI ? 4 i
Print screen	MC	CSI i	CSI i
Print cursor line	MC	CSI ? 1 i	CSI ? 1 i
Send current screen to host. Each line is terminated by a LF (0Ah).	MC	CSI 2 i	CSI 2 i

RESET TERMINAL COMMAND

Set mode	SM	CSI Pm1; ...; Pm16 h	CSI Pm1; ...; Pm16 h
Reset mode	RM	CSI Pm1; ...; Pm16 i	CSI Pm1; ...; Pm16 i

Parameters	Description	Values
Pm1 - Pm16	Mode designator. Depending on whether the listed values are used with the RM or SM commands, the corresponding mode is disabled (turned off) or enabled (turned on).	30 = Display Disable 31 = Status Line Display 32 = Screen Saver 33 = Steady Cursor 34 = Underline Cursor

Hard terminal reset RIS ESC c ESC c

This command clears the current screen, homes the cursor, resets to primary font, and resets the Graphic Rendition (SGR).



Commands in bold are available only when "Enhanced" parameter in the Quick (F1) menu of Setup is set to On.

SEND COMMAND

6-7

SCO / AT386

COMMAND	MNEMONIC	SCO Console	AT386
---------	----------	-------------	-------

GENERAL SETUP COMMANDS

Set new line CSI 20 h CSI 20 h

Any received or (keyboard) generated <LF> will also perform a <CR>.

Reset new line CSI 20 I CSI 20 I

Any received or (keyboard) generated <LF> will not perform a <CR>.

Load date ESC _ ~ P1/S1; ESC _ ~ P1/S1;
P2/S2; ...; Pn/Sn P2/S2; ...; Pn/Sn
ESC / ESC /

Parameters	Description	Values	
P1 - Pn	Mode specifiers. These parameters specify what part of the date is modified.	1 = display of date 2 = month setting 3 = day setting	4 = century setting 5 = year setting
S1	Display of date	0 (display off) 1 (display on)	
S2	Month setting	01 - 12 (Jan, ..., Dec)	
S3	Day setting	01 - 31	
S4	Century setting	19 - 20	
S5	Year setting	00 - 99	

WORDPERFECT GRAPHICS COMMANDS

Enter WP-Graphics with ASCII key codes CSI 30 ~ CSI 30 ~

Enter WP-Graphics with SCAN key codes CSI 31 ~ CSI 31 ~



Commands in bold are available only when "Enhanced" parameter in the Quick (F1) menu of Setup is set to On.

Color Programming

OVERVIEW

This chapter contains the commands used to control the color capabilities of the color terminal. These color capabilities can be controlled in one of three ways:

1. By directly associating colors to visual attributes,
2. By selecting the active palette,
3. By defining the colors to be associated with a soft palette.

ASCII COLOR MODE

All ASCII emulations support color programming capabilities. The Wyse 325 emulation is basically the Wyse 60 emulation (its *base* emulation) with the addition of some escape sequences to support color programming. By the same token, the Wyse 350 is a *colorized* version of the Wyse 50+ emulation. For each emulation listed below, the color capabilities added to the base emulation are represented by the listed escape sequences.

SOFT PALETTES

In all ASCII and ANSI emulations supported by the color terminal, the Color Utility of the Desk Accessories may be used to change the color settings of each of the two soft palettes (color palettes that can be custom defined and downloaded from the host). In addition, any emulation that supports direct manipulation of the palette colors via escape sequences (e.g., Wyse 325 and Wyse 350) may be used to select color combinations for each soft palette. The changes made to any soft palette will not be saved unless a *Save Terminal* operation is performed through the Execute (F13) menu of Setup.

To define or change soft palette color settings, perform the following operations:

1. Select a soft palette:
 - a. From Setup, using the Display (F3) menu, or
 - b. By sending the escape sequences (see pages 7-2 through 7-9) from the keyboard (in local mode) or from the host.
2. Change the color settings of the selected soft palette:
 - a. Using the Color Utility of the Desk Accessories, or
 - b. By sending the escape sequences (see pages 7-2 through 7-9) from the keyboard (in local mode) or from the host.
3. Save your changes and selections by performing a *Save Terminal* from the Execute (F13) menu of Setup.

Color Programming

WYSE 60 AND WYSE 325 EMULATION COMMANDS

Command: < Esc> d y fcolor bcolor map
Description: Map a visual attribute to a color.
Parameters: Select parameters from tables 7-1 and 7-2 below.
 fcolor: Foreground color
 bcolor: Background color
 map: Attribute to be mapped with colors

fcolor/ bcolor	Color	fcolor/ bcolor	Color
1	Black	9	Dark Gray
2	Blue	:	Light Blue
3	Green	;	Light Green
4	Cyan	<	Light Cyan
5	Red	=	Light Red
6	Magenta	>	Light Magenta
7	Yellow (Brown)	?	Light Yellow
8	White	@	Light Grey

Table 7-1: Color parameters for Mapping a Visual Attribute to a Color

map	Attribute to map	map	Attribute to map
1	Normal	5	Underline
2	Reverse	6	Rev/Und
3	Intensity	7	Int/Und
4	Rev/Int	8	Rev/Int/Und

Table 7-2: Visual Attribute parameters for Mapping a Visual Attribute to a Color

Example: < Esc> d y 3 2 5
 Set underline text to green on a blue background.

Color Programming

Command: < Esc> d z palette
Description: Select a palette from the pre-defined or soft palettes (See chapter 8 for palette defaults.)
Parameters: palette: 0 - 9 for predefined palettes 0 - 9
 : for soft palette 1
 ; for soft palette 2
Example: < Esc> d z 5
 Select pre-defined color palette number 5.

WYSE 50 AND WYSE 350 EMULATION COMMANDS

Command: < Esc> m attr fcolor attrn
Description: Map an attribute entry of the current palette to a particular foreground color and another attribute. The standard background color is determined by the currently selected palette (See chapter 8 for palette defaults.) The second attribute parameter in the command allows an attribute type to be mapped to a color and another visual attribute.
Parameters: See the tables 7-3, 7-4 and 7-5 below for parameter values.
 attr: Attribute entry of current palette
 fcolor: Foreground color to use for mapping
 attrn: Additional attribute to map attr to.

attr	Attribute Association	attr	Attribute Association
0	Normal	8	Blink*
1	Rev	9	Blink/Rev*
2	Int	:	Blink/Int*
3	Und	;	Blink/Rev/Int*
4	Rev/Int	<	Blink/Und*
5	Rev/Und	=	Blink/Rev/Und*
6	Int/Und	>	Blink/Int/Und*
7	Rev/Int/Und	?	Blink/Rev/Int/Und*

Table 7-3: Attribute Parameters for Mapping an Attribute Entry of the Current Palette

* Attribute Associations for Wyse 50+. Ignored for Wyse 350.

Color Programming

Foreground Color	<i>fcolor</i>	Foreground Color	<i>fcolor</i>	Foreground Color	<i>fcolor</i>
Black	1	Light Blue	:	Light Red	r
Black	!	Light Blue	<	Light Red	s
Black)	Light Blue	'	Light Red	v
Black	\	Light Blue	b	Light Yellow	o
Blue	2	Light Blue	q	Light Yellow	p
Blue	9	Light Cyan	b	Light Yellow	l
Blue	"	Light Cyan	\$	Light Yellow	-
Blue	*	Light Cyan	e	Magenta	6
Blue	^	Light Gray	0	Magenta	?
Cyan	4	Light Gray	f	Magenta	&
Cyan	>	Light Gray	- m	Magenta	h
Cyan	.	Light Gray]	Magenta	t
Cyan	/	Light Green	+	Magenta	l
Dark Gray	(Light Green	c	Red	5
Dark Gray	z	Light Green	d	Red	%
Dark Gray	k	Light Green	g	Red	-
Dark Gray	l	Light Magenta	.	Red	u
Green	- 3	Light Magenta	n	Yellow (Brown)	7
Green	=	Light Magenta	w	Yellow (Brown)	i
Green	#	Light Magenta	x	Yellow (Brown)	y
Green		Light Magenta	[Yellow (Brown)	z
Green	space	Light Red	j	White	8

Table 7-4: Color Parameters for Mapping an Attribute Entry of the Current Palette

<i>attr</i>	Assigned Attribute
0	Normal*
.	Reverse
_	Underline
/	Rev/Und

Table 7-5: Assigned Attribute Parameters for Mapping an Attribute Entry of the Current Palette to a Particular Foreground Color and Another Attribute

* Accepted for Wyse 350 but ignored for Wyse 50+

Example: < Esc> m 0 / 0
Set normal text (foreground) to be cyan on the current background.

Color Programming

Command: < Esc> % *palette*
Description: Select a palette (See chapter 8 for palette defaults.)
Parameters: Wyse 350
palette: 0 - 9 for predefined palettes 0 - 9
: for predefined palette 10
: for predefined palette 11
< for predefined palette 12
= for predefined palette 13
> for predefined palette 14
? for predefined palette 15
A for soft palette 1
B for soft palette 2
0 - 9 for predefined palettes 0 - 9
A - F for predefined palettes 10 - 15
: for soft palette 1
; for soft palette 2

Example: < Esc> % <
Select predefined color palette 12.

Wyse 50+

PC-TERM AND TVI 925 EMULATION COMMANDS

Command: < Esc> Space \$ *palette*
Description: Select a palette (See chapter 8 for palette defaults.)
Parameters:
palette: 0 - 9 for predefined palettes 0 - 9
A - F for predefined palettes 10 - 15
: for soft palette 1
; for soft palette 2

Example: < Esc> Space \$ B
Select predefined color palette 11.

Command: < Esc> Space # *fcolor bcolor map*
Description: Map a visual attribute to a color.
Parameters: Select parameters from tables 7-1 and 7-2.
fcolor: Foreground color
bcolor: Background color
map: Attribute to be mapped with colors

Color Programming

ADDS-VP EMULATION COMMANDS

Command:	<code>< Esc> d y fcolor bcolor map</code>
Description:	Map a visual attribute to a color.
Parameters:	Select parameters from tables 7-2 and 7-6. <i>fcolor:</i> Foreground color <i>bcolor:</i> Background color <i>map:</i> Attribute to be mapped with colors

<i>fcolor/ bcolor</i>	Color	<i>fcolor/ bcolor</i>	Color
1	Dark Gray	9	Black
2	Light Blue	:	Blue
3	Light Green	;	Green
4	Light Cyan	<	Cyan
5	Light Red	=	Red
6	Light Magenta	>	Magenta
7	Light Yellow	?	Yellow (Brown)
8	Light Grey	@	White

Table 7-6: Color parameters for Mapping a Visual Attribute to a Color

WRITE-PROTECTED CHARACTERS

Write-protected characters in Wyse325 emulations can be assigned a color. Since the color terminal allows you to associate write-protected characters with a visual attribute (see Emulation (F9) menu in Setup), and each visual attribute is already mapped to a color combination, write-protected fields will simply take on the color combinations associated with their assigned visual attributes. In Wyse 350 and Wyse 50+, write protected characters take on the same colors as the field they reside in, with the write protected attribute.

Color Programming

ANSI COLOR MODE

In ANSI emulations, the "Color Mode" selection located in the General (F2) menu of Setup, defines the manner in which mapping of attributes and colors are handled. The possible settings for this selection are *Direct*, *Palette*, and *Auto*. This selection is available for all ANSI emulations except SCO Console emulation. In SCO Console emulation, "Color Mode" is permanently set to *Direct* (and therefore not available in Setup.) *Direct* and *Palette* Modes can be selected/set either manually through the General (F2) Setup menu or from host via the provided escape sequences (see below). *Auto* Mode can only be selected manually through the General (F2) Setup menu.

DIRECT MODE

In *Direct* Mode, colors and visual attributes are selected directly through the *Select Graphic Rendition* (SGR) command. No particular color is associated with a visual attribute as in *Palette* Mode. In addition, palette commands and access to *Local Palette* Mode are disallowed.

Command:	<code>< Esc> [J ; 0 % w</code>
Description:	Select <i>Direct Color</i> Mode. This command clears the screen and performs a page reset except when "Color Mode" in General (F2) menu is set to <i>Auto</i> , in which case the result of the command is different.

Command:	<code>< Esc> [P1 ; P2 ; ... ; Pn m</code>
Description:	Select <i>Graphic Rendition</i> (SGR). This command controls the visual attributes of data displayed on the screen, including their color (also see direct color commands.) Parameters may be concatenated into one command string, by separating each parameter with a <i>Parameter Separator</i> (;). If concatenated, each succeeding parameter will override any previous definition for the same attribute. Except for SCO Console emulation, <i>Suppress</i> can only be disabled by enabling a <i>normal</i> or <i>bold</i> attribute. In SCO Console emulation, <i>Suppress</i> combines with <i>Reverse</i> and cancels <i>Underline</i> . If the SGR command is used to define <i>fore/background</i> colors, the <i>Normal</i> , <i>Reverse</i> , and <i>Graphics Replacement</i> color are also redefined (see SCO Console section.)
Parameters:	Select parameters from the tables 7-6 and 7-7 P1 - Pn: numbers defining the color/attributes

Color Programming

Pn	Visual Attribute
0	All visuals off
1	Bold on
4	Underline on
5	Blink on
7	Reverse on

Pn	Visual Attribute
8	Suppress on
22	Bold off
24	Underline off
25	Blink off
27	Reverse off

Table 7-7: Visual Attribute Parameters to Select Color Rendition

Pn	Foreground Color
30	Black
31	Red
32	Green
33	Yellow
34	Blue
35	Magenta
36	Cyan
37	White

Pn	Background Color
40	Black
41	Red
42	Green
43	Yellow
44	Blue
45	Magenta
46	Cyan
47	White

Table 7-8: Color Parameters to Select Color Rendition

Example: < Esc > [0 ; 5 ; 40 ; 37 ; 31 m
Turn off all visual attributes, turn on blink, set background color to black, foreground color to white, reset foreground color to red.

Command: < Esc > [8 ; fcolor ; bcolor % w
Description: Select Replacement Character Color. This command will cause subsequently-introduced areas on the screen (through an erasure, scroll, insert, etc.) to be displayed in the defined color combination.
Parameters: Select parameters from the table below.
fcolor/bcolor: Fore/background color

Color Programming

fcolor/bcolor	Color
0	Black
1	Black
2	Blue
3	Green
4	Cyan

fcolor/bcolor	Color
5	Red
6	Magenta
7	Yellow
8	White

Table 7-9: Color Parameters to Select Replacement Character Color

Examples: < Esc > [8 ; 5 ; 7 % w
Set the attribute of any new text to be red on a yellow background.

Command: < Esc > [7 ; fcolor ; bcolor % w
Description: Select Status Line Color.
Parameters: Select parameters from the table above.
fcolor/bcolor: Status line fore/background color.
Example: < Esc > [7 ; 8 ; 2 % w
Set status line to white text on a blue background.

PALETTE MODE

In Palette Mode, all visual attributes are mapped to predefined palette colors (or soft palette colors, if selected). The SGR (Select Graphic Rendition) command is accepted but ignored.

Command: < Esc > [1 ; 1 % w
Description: Select Palette Color Mode. This command clears the screen and performs a page reset except when "Color Mode" in General (F2) menu is set to Auto, in which case the result of the command is different.

Command: < Esc > [2 ; Ps % w
Description: Select a color palette (See chapter 8 for palette defaults).
Parameters:
Ps: 0 - 15 Predefined palettes 0 - 15
16 Soft Palette 1
17 Soft Palette 2

Example: < Esc > [2 ; 17 % w
Select and activate Soft Palette 2.

Color Programming

SOFT PALETTES

Although escape sequences are provided to select a palette in ANSI emulations, no escape sequences are available to select color combinations for the soft palettes. Any alterations to the soft palette color combinations must be entered manually through the Color Utility of the Desk Accessories, using the procedure cited on page 7-1.

AUTO MODE

In Auto Mode, the terminal will automatically switch between Direct and Palette Modes, depending on the attribute command it receives from the host:

Palette Mode is enabled when:

- SGR command with attributes 0 or 1 is received,
- Select Palette Mode command is received (see Palette Mode section).

Direct Mode is enabled when:

- SGR command with attributes 30-37 or 40-47 is received,
- Select Direct Mode command is received (see Direct Mode section).

SCO CONSOLE EMULATION

The SCO Console emulation of this terminal is an implementation of the SCO Unix Color Console (version 3.2.2). When operating in the SCO Console emulation, the "Color Mode" option will be fixed to *Direct*. All Direct Mode color commands will operate in the same manner as with other ANSI emulations, unless specifically stated otherwise in this section. In addition, all Palette Mode commands will be ignored in this emulation.

In the SCO Console emulation, Replacement Color Schemes are used to determine the color of characters displayed in Primary Font, Alternate Font, and Reverse attribute.

NORMAL REPLACEMENT COLORS

Normal Replacement scheme is used when

- The Primary Font (activated via *CSI 10m* command) is in use, and
- Reverse attribute is *not* on, and
- Characters are *not* displayed using the *Display Graphics Character* command (see page 6-6).

Color Programming

Command:	< Esc> [= color G
Description:	Select normal background replacement color.
Parameters:	Select parameters from the table above.
Example:	< Esc> [= 1 G Select background color to be blue.

REVERSE REPLACEMENT COLORS

Reverse Replacement scheme is used when

- The Reverse attribute is on, and
- Characters are *not* displayed using the *Display Graphics Character* command.

Command:	< Esc> [= color H
Description:	Select reverse foreground replacement color.
Parameters:	Select parameters from the table above.
Example:	< Esc> [= 1 H Select reverse foreground color to be blue.

Command:	< Esc> [= color I
Description:	Select reverse background replacement color.
Parameters:	Select parameters from the table above.
Example:	< Esc> [= 5 I Select reverse background color to be magenta.

WRONG SCHEM
NO SUCH
TABLE
7.9

GRAPHICS REPLACEMENT COLORS

Graphics Replacement scheme is used when

- Either one of the Alternate Fonts (activated via *CSI 11m* or *CSI 12m* command) is in use, and
- Reverse attribute is *not* on, and
- Characters are displayed using the *Display Graphics Character* command.

Command:	< Esc> [= color J
Description:	Select graphics foreground replacement color.
Parameters:	Select parameters from table on page 7-10.

Color Programming

Command: < Esc > [= color J

Example: < Esc > [= 4 J
Select graphics foreground color to be red.

Command: < Esc > [= color K

Description: Select graphics background replacement color.
Parameters: Select parameters from the table on page 7-10.
Example: < Esc > [= 5 K
Select graphics background color to be magenta.

Command: < Esc > [= Ps L

Description: Fill Regions Attribute. All new regions introduced (erased, inserted, scrolled, etc.) will take on the background color specified by the parameter *Ps*.
Parameters: *Ps:* 0 Current Replacement Color Scheme
1 Normal Color Scheme
2 Black
Example: < Esc > [= 1 L
Set Fill Regions Attribute to Normal Color Scheme

Command: < Esc > [= Ps M

Description: Report Attribute Color Scheme
Parameters: *Ps:* 0 Normal Color Scheme
1 Reverse Color Scheme
2 Graphics Color Scheme
Example: < Esc > [= 2 M

With Graphics Color Scheme is defined as Red on White, the terminal will respond with "4 < SPACE > 7 < RETURN >".

Color Programming

IGNORED COMMANDS

The following commands -- used in Wyse 325 and Intecolor emulations, are ignored by the color terminal.

Wyse 325 Command	Intecolor Command	Intended Action	Reason Command is Ignored
Esc d)	Esc [6 ; ps % w	Designate color of overscan borders.	No overscan borders are available on the color terminal.
Esc d	Esc [4 % w	Designate color of blank attribute.	The color terminal can map colors to the blank attribute. Therefore, individual mapping is not necessary.
Esc d {	Esc [5 % w	Designate color of reverse attribute.	The color terminal can map colors to the blank attribute. Therefore, individual mapping is not necessary.
Esc c)	Esc [9 h	Enable intensity attribute.	The color terminal does not support this attribute.
Esc c	Esc [9 l	Disable intensity attribute.	The color terminal does not support this attribute.
Esc [3 ; Ps1 ; Ps2 % w		Redefine color map.	The color terminal supports all combinations
Esc [9 ; Ps % w		Reset color map pointer.	of colors and attributes, so these commands are not supported.

Table 7-10: Commands Ignored by the Color Terminal

Color Programming

Palette Defaults

OVERVIEW

This terminal is capable of displaying visual attributes (such as underline and blink) in combination with color. There are 16 predefined and 2 user-defined (*soft*) palettes available to the user. A predefined palette consists of various combinations of attributes and foreground colors on a single background color.

The following tables list the attribute and color assignments for each of the predefined and soft palettes. For each emulation of the terminal, the palette assignments are listed in tables with entries of the form:

Attribute Palette color Palette color Palette color



"Int" refers to bold intensity for an ANSI emulation (VT300, VT200, VT100, and Intecolor) and dim intensity for an ASCII emulation (Wyse 60, Wyse 50+, Wyse 25, Wyse 350, PC-Term).

WYSE 350

Attribute	Palette 0	Palette 1	Palette 2
Normal	Yellow/Black	Green/Black	White/Black
Rev	Black/White	Black/Lt Cyan	Black/Lt Yellow
Int	Red/Black	Cyan/Black	Red/Black
Rev, Int	Black/Red	Black/Cyan	Black/Red
Und	Lt Yellow/Black	Lt Green/Black	Yellow/Black
Und, Rev	Black/Lt Yellow	Black/Lt Green	Black/Yellow
Und, Int	Red/Black	Cyan/Black	Red/Black
Und, Rev, Int	Black/Red	Black/Cyan	Black/Red
Blink	Yellow/Black	Green/Black	White/Black
Rev, Blink	Black/White	Black/Lt Cyan	Black/Lt Yellow
Int, Blink	Red/Black	Cyan/Black	Red/Black
Int, Rev, Blink	Black/Red	Black/Cyan	Black/Red
Und, Blink	Lt Yellow/Black	Lt Green/Black	Yellow/Black
Rev, Und, Blink	Black/Lt Yellow	Black/Lt Green	Black/Yellow
Int, Und, Blink	Red/Black	Cyan/Black	Red/Black
Int, Und, Rev, Blink	Black/Red	Black/Cyan	Black/Red

Palette Defaults

WYSE 350 (Continued...)

Attribute	Palette 3	Palette 4	Palette 5
Normal	Cyan/Black	Magenta/Black	Lt Yellow/Black
Rev	Black/White	Black/Red	Black/Lt Red
Int	Lt Blue/Black	Dk Grey/Black	Red/Black
Rev, Int	Black/Lt Blue	Black/Dk Grey	Black/Red
Und	Green/Black	Blue/Black	Yellow/Black
Und, Rev	Black/Green	Black/Blue	Black/Yellow
Und, Int	Lt Blue/Black	Dk Grey/Black	Red/Black
Und, Rev, Int	Black/Lt Blue	Black/Dk Grey	Black/Red
Blink	Cyan/Black	Magenta/Black	Lt Yellow/Black
Rev, Blink	Black/White	Black/Red	Black/Lt Red
Int, Blink	Lt Blue/Black	Dk Grey/Black	Red/Black
Int, Rev, Blink	Black/Lt Blue	Black/Dk Grey	Black/Red
Und, Blink	Green/Black	Blue/Black	Yellow/Black
Rev, Und, Blink	Black/Green	Black/Blue	Black/Yellow
Int, Und, Blink	Lt Blue/Black	Dk Grey/Black	Red/Black
Int, Und, Rev, Blink	Black/Lt Blue	Black/Dk Grey	Black/Red

Attribute	Palette 6	Palette 7	Palette 8
Normal	Lt Blue/Black	Lt Grey/Black	Lt Yellow/Black
Rev	Black/Cyan	Black/Blue	Black/Lt Green
Int	Green/Black	Dk Grey/Black	Yellow/Black
Rev, Int	Black/Green	Black/Dk Grey	Black/Yellow
Und	Lt Green/Black	Lt Blue/Black	Green/Black
Und, Rev	Black/Lt Green	Black/Lt Blue	Black/Green
Und, Int	Green/Black	Dk Grey/Black	Yellow/Black
Und, Rev, Int	Black/Green	Black/Dk Grey	Black/Yellow
Blink	Lt Blue/Black	Lt Grey/Black	Lt Yellow/Black
Rev, Blink	Black/Cyan	Black/Blue	Black/Lt Green
Int, Blink	Green/Black	Dk Grey/Black	Yellow/Black
Int, Rev, Blink	Black/Green	Black/Dk Grey	Black/Yellow
Und, Blink	Lt Green/Black	Lt Blue/Black	Green/Black
Rev, Und, Blink	Black/Lt Green	Black/Lt Blue	Black/Green
Int, Und, Blink	Green/Black	Dk Grey/Black	Yellow/Black
Int, Und, Rev, Blink	Black/Green	Black/Dk Grey	Black/Yellow

Palette Defaults

WYSE 350 (Continued...)

Attribute	Palette 9	Palette 10	Palette 11
Normal	White/Black	White/Black	White/Black
Rev	Black/Yellow	Black/Lt Blue	Black/Red
Int	Lt Red/Black	Black/Cyan	Black/Blue
Rev, Int	Black/Lt Red	Black/Magenta	Black/Magenta
Und	Lt Grey/Black	Black/Lt Green	Black/Green
Und, Rev	Black/Lt Grey	Black/Lt Magenta	Black/Yellow
Und, Int	Lt Red/Black	Black/Yellow	Black/Cyan
Und, Rev, Int	Black/Lt Red	Black/White	Black/White
Blink	White/Black	White/Black	White/Black
Rev, Blink	Black/Yellow	Black/Lt Blue	Black/Red
Int, Blink	Lt Red/Black	Black/Cyan	Black/Blue
Int, Rev, Blink	Black/Lt Red	Black/Magenta	Black/Magenta
Und, Blink	Lt Grey/Black	Black/Lt Green	Black/Green
Rev, Und, Blink	Black/Lt Grey	Black/Lt Magenta	Black/Yellow
Int, Und, Blink	Lt Red/Black	Black/Yellow	Black/Cyan
Int, Und, Rev, Blink	Black/Lt Red	Black/White	Black/White

Attribute	Palette 12	Palette 13	Palette 14
Normal	Lt Green/Black	White/Black	Yellow/Black
Rev	Black/Lt Green	Black/White	Black/Yellow
Int	Green/Black	Lt Grey/Black	Red/Black
Rev, Int	Black/Green	Black/Lt Grey	Black/Red
Und	Lt Green/Black	White/Black	Yellow/Black
Und, Rev	Black/Lt Green	Black/White	Black/Yellow
Und, Int	Green/Black	Lt Grey/Black	Red/Black
Und, Rev, Int	Black/Green	Black/Lt Grey	Black/Red
Blink	Lt Green/Black	White/Black	Yellow/Black
Rev, Blink	Black/Lt Green	Black/White	Black/Yellow
Int, Blink	Green/Black	Lt Grey/Black	Red/Black
Int, Rev, Blink	Black/Green	Black/Lt Grey	Black/Red
Und, Blink	Lt Green/Black	White/Black	Yellow/Black
Rev, Und, Blink	Black/Lt Green	Black/White	Black/Yellow
Int, Und, Blink	Green/Black	Lt Grey/Black	Red/Black
Int, Und, Rev, Blink	Black/Green	Black/Lt Grey	Black/Red

Palette Defaults

Attribute	Palette 15	Soft Palette 1	Soft Palette 2
Normal	White/Black	Lt Yellow/Black	Yellow/Dk Grey
Rev	Red/Black	Black/Lt Yellow	Dk Grey/Yellow
Int	Blue/Black	Lt Green/Black	Lt Yellow/Dk Grey
Rev, Int	Magenta/Black	Black/Lt Green	Dk Grey/Lt Yellow
Und	Green/Black	Lt Cyan/Black	Cyan/Dk Grey
Und, Rev	Lt Yellow/Black	Black/Lt Cyan	Dk Grey/Cyan
Und, Int	Cyan/Black	Lt Red/Black	Lt Cyan/Dk Grey
Und, Rev, Int	Yellow/Black	Black/Lt Red	Dk Grey/Lt Cyan
Blink	White/Black	White/Black	Lt Red/Dk Grey
Rev, Blink	Red/Black	Black/White	Dk Grey/Lt Red
Int, Blink	Blue/Black	Lt Magenta/Black	Lt Green/Dk Grey
Int, Rev, Blink	Magenta/Black	Black/Lt Magenta	Dk Grey/Lt Green
Und, Blink	Green/Black	Cyan/Black	White/Dk Grey
Rev, Und, Blink	Lt Yellow/Black	Black/Cyan	Dk Grey/White
Int, Und, Blink	Cyan/Black	Lt Grey/Black	Lt Grey/Dk Grey
Int, Und, Rev, Blink	Yellow/Black	Black/Lt Grey	Dk Grey/Lt Grey

WYSE 325 AND WYSE 60

Attribute	Palette 0	Palette 1	Palette 2
Normal	Green/Black	Green/Black	Cyan/Black
Rev	Black/Yellow	Black/Red	Black/White
Int	Blue/Black	Yellow/Black	Red/Black
Rev, Int	Black/Blue	Black/Yellow	Black/Red
Und	Cyan/Black	Cyan/Black	Magenta/Black
Und, Rev	Black/Cyan	Black/Cyan	Black/Magenta
Und, Int	Red/Black	White/Black	Blue/Black
Und, Rev, Int	Black/Red	Black/White	Black/Blue

Attribute	Palette 3	Palette 4	Palette 5
Normal	Cyan/Black	Magenta/Black	Magenta/Black
Rev	Black/Blue	Black/Cyan	Black/Yellow
Int	White/Black	Blue/Black	White/Black
Rev, Int	Black/White	Black/Blue	Black/White
Und	Magenta/Black	Green/Black	Green/Black
Und, Rev	Black/Magenta	Black/Green	Black/Green
Und, Int	Yellow/Black	Red/Black	Cyan/Black
Und, Rev, Int	Black/Yellow	Black/Red	Black/Cyan

Palette Defaults

Attribute	Palette 6	Palette 7	Palette 8
Normal	Yellow/Black	Red/Black	White/Black
Rev	Black/Yellow	Yellow/Red	Black/White
Int	Red/Black	Magenta/Black	Red/Black
Rev, Int	White/Red	Yellow/Magenta	Black/Red
Und	Cyan/Black	Cyan/Black	Yellow/Black
Und, Rev	Red/Cyan	Red/Cyan	Black/Yellow
Und, Int	Magenta/Black	Green/Black	Magenta/Black
Und, Rev, Int	White/Magenta	Magenta/Green	Black/Magenta

Attribute	Palette 9	Soft Palette 1	Soft Palette 2
Normal	White/Black	Green/Black	Green/Black
Rev	Black/White	Black/Yellow	Black/Red
Int	Yellow/Black	Blue/Black	Yellow/Black
Rev, Int	Black/Yellow	Black/Blue	Black/Yellow
Und	Blue/Black	Cyan/Black	Cyan/Black
Und, Rev	Black/Blue	Black/Cyan	Black/Cyan
Und, Int	Cyan/Black	Red/Black	White/Black
Und, Rev, Int	Black/Cyan	Black/Red	Black/White

ALL OTHER EMULATIONS

Attribute	Palette 0	Palette 1	Palette 2
Normal	Lt Yellow/Black	Yellow/Dk Grey	Lt Yellow/Blue
Rev	Black/Lt Yellow	Dk Grey/Yellow	Blue/Lt Yellow
Int	Lt Green/Black	Lt Yellow/Dk Grey	Yellow/Blue
Rev, Int	Black/Lt Green	Dk Grey/Lt Yellow	Blue/Yellow
Und	Lt Cyan/Black	Cyan/Dk Grey	Lt Cyan/Blue
Und, Rev	Black/Lt Cyan	Dk Grey/Cyan	Blue/Lt Cyan
Und, Int	Lt Red/Black	Lt Cyan/Dk Grey	Cyan/Blue
Und, Rev, Int	Black/Lt Red	Dk Grey/Lt Cyan	Blue/Cyan
Blink	White/Black	Lt Red/Dk Grey	White/Cyan
Rev, Blink	Black/White	Dk Grey/Lt Red	White/Blue
Int, Blink	Lt Magenta/Black	Lt Green/Dk Grey	Blue/White
Int, Rev, Blink	Black/Lt Magenta	Dk Grey/Lt Green	Lt Grey/Blue
Und, Blink	Cyan/Black	White/Dk Grey	Blue/Lt Grey
Rev, Und, Blink	Black/Cyan	Dk Grey/White	Lt Green/Blue
Int, Und, Blink	Lt Grey/Black	Lt Grey/Dk Grey	Blue/Lt Green
Int, Und, Rev, Blink	Black/Lt Grey	Dk Grey/Lt Grey	Green/Blue
			Blue/Green

Palette Defaults

ALL OTHER EMULATIONS (Continued...)

Attribute	Palette 3	Palette 4	Palette 5
Normal	Yellow/Lt Blue	Black/Green	Blue/Lt Green
Rev	Lt Blue/ Yellow	Green/Black	Lt Green/Blue
Int	Lt Yellow/Lt Blue	Dk Grey/Green	Lt Blue/Lt Green
Rev, Int	Lt Blue/Lt Yellow	Green/Dk Grey	Lt Green/Lt Blue
Und	Lt Cyan/Lt Blue	White/Green	Black/Lt Green
Und, Rev	Lt Blue/Lt Cyan	Green/White	Lt Green/Black
Und, Int	Cyan/Lt Blue	Lt Cyan/Green	Dk Grey/Lt Green
Und, Rev, Int	Lt Blue/Cyan	Green/Lt Cyan	Lt Green/Dk Grey
Blink	White/Lt Blue	Blue/Green	Red/Lt Green
Rev, Blink	Lt Blue/White	Green/Blue	Lt Green/Red
Int, Blink	Lt Grey/Lt Blue	Lt Blue/Green	Lt Red/Lt Green
Int, Rev, Blink	Lt Blue/Lt Grey	Green/Lt Blue	Lt Green/Lt Red
Und, Blink	Lt Red/Lt Blue	Lt Yellow/Green	Magenta/Lt Green
Rev, Und, Blink	Lt Blue/Lt Red	Green/Lt Yellow	Lt Green/Magenta
Int, Und, Blink	Lt Magenta/Lt Blue	Red/Green	Lt Magenta/Lt Green
Int,Und,Rev,Blink	Lt Blue/Lt Magenta	Green/Red	Lt Green/Lt Magenta

Attribute	Palette 6	Palette 7	Palette 8
Normal	Black/Cyan	Blue/Lt Cyan	White/Red
Rev	Cyan/Black	Lt Cyan/Blue	Red/White
Int	Dk Grey/Cyan	Black/Lt Cyan	Lt Grey/Red
Rev, Int	Cyan/Dk Grey	Lt Cyan/Black	Red/Lt Grey
Und	Blue/Cyan	Red/Lt Cyan	Lt Yellow/Red
Und, Rev	Cyan/Blue	Lt Cyan/Red	Red/Lt Yellow
Und, Int	Lt Blue/ Cyan	Dk Grey/Lt Cyan	Yellow/Red
Und, Rev, Int	Cyan/Lt Blue	Lt Cyan/Dk Grey	Red/Yellow
Blink	White/Cyan	Lt Blue/Lt Cyan	Lt Cyan/Red
Rev, Blink	Cyan/White	Lt Cyan/Lt Blue	Red/Lt Cyan
Int, Blink	Lt Yellow/Cyan	Yellow/Lt Cyan	Cyan/Red
Int, Rev, Blink	Cyan/Lt Yellow	Lt Cyan/Yellow	Red/Cyan
Und, Blink	Lt Green/Cyan	Green/Lt Cyan	Lt Green/Red
Rev, Und, Blink	Cyan/Lt Green	Lt Cyan/Green	Red/Lt Green
Int, Und, Blink	Lt Cyan/Cyan	Lt Grey/Lt Cyan	Green/Red
Int,Und,Rev,Blink	Cyan/Lt Cyan	Lt Cyan/Lt Grey	Red/Green

Palette Defaults

ALL OTHER EMULATIONS (Continued...)

Attribute	Palette 9	Palette 10	Palette 11
Normal	Black/Lt Red	White/Magenta	Blue/Lt Magenta
Rev	Lt Red/ Black	Magenta/White	Lt Magenta/Blue
Int	Dk Grey/Lt Red	Lt Grey/Magenta	Lt Yellow/Lt Magenta
Rev, Int	Lt Red/Dk Grey	Magenta/Lt Grey	Lt Magenta/Lt Yellow
Und	Blue/Lt Red	Lt Yellow/Magenta	Black/Lt Magenta
Und, Rev	Lt Red/Blue	Magenta/Lt Yellow	Lt Magenta/Black
Und, Int	Lt Cyan/Lt Red	Yellow/Magenta	Dk Grey/Lt Magenta
Und, Rev, Int	Lt Red/Lt Cyan	Magenta/Yellow	Lt Magenta/Dk Grey
Blink	White/Lt Red	Lt Green/Magenta	Lt Green/Lt Magenta
Rev, Blink	Lt Red/White	Magenta/Lt Green	Lt Magenta/Lt Green
Int, Blink	Lt Green/Lt Red	Lt Cyan/Magenta	White/Lt Magenta
Int, Rev, Blink	Lt Red/Lt Green	Magenta/Lt Cyan	Lt Magenta/White
Und, Blink	Lt Yellow/Lt Red	Lt Magenta/Magenta	Lt Cyan/Lt Magenta
Rev, Und, Blink	Lt Red/Lt Yellow	Magenta/Lt Magenta	Lt Magenta/Lt Cyan
Int, Und, Blink	Lt Blue/Lt Red	Black/Magenta	Magenta/Lt Magenta
Int,Und,Rev,Blink	Lt Red/Lt Blue	Magenta/Black	Lt Magenta/Magenta

Attribute	Palette 12	Palette 13	Palette 14
Normal	Black/Yellow	Blue/Lt Yellow	Black/Lt Grey
Rev	Yellow/Black	Lt Yellow/Blue	Lt Grey/Black
Int	Dk Grey/Yellow	Black/Lt Yellow	Dk Grey/Lt Grey
Rev, Int	Yellow/Dk Grey	Lt Yellow/Black	Lt Grey/Dk Grey
Und	Blue/Yellow	Magenta/Lt Yellow	Blue/Lt Grey
Und, Rev	Yellow/Blue	Lt Yellow/Magenta	Lt Grey/Blue
Und, Int	Magenta/Yellow	Dk Grey/Lt Yellow	Lt Blue/Lt Grey
Und,Rev,Int	Yellow/Magenta	Lt Yellow/Dk Grey	Lt Grey/Lt Blue
Blink	Red/Yellow	Red/Lt Yellow	Red/Lt Grey
Rev, Blink	Yellow/Red	Lt Yellow/Red	Lt Grey/Red
Int, Blink	Lt Yellow/Yellow	Cyan/Lt Yellow	Magenta/Lt Grey
Int, Rev, Blink	Yellow/Lt Yellow	Lt Yellow/Cyan	Lt Grey/Magenta
Und, Blink	White/Yellow	Green/Lt Yellow	Lt Yellow/Lt Grey
Rev,Und,Blink	Yellow/White	Lt Yellow/Green	Lt Grey/Lt Yellow
Int, Und, Blink	Lt Cyan/Yellow	Yellow/Lt Yellow	White/Lt Grey
Int,Und,Rev,Blink	Yellow/Lt Cyan	Lt Yellow/Yellow	Lt Grey/White

Palette Defaults

ALL OTHER EMULATIONS (Continued...)

Attribute	Palette 15	Soft Palette 1	Soft Palette 2
Normal	Blue/White	Lt Yellow/Black	Yellow/Dk Grey
Rev	White/Blue	Black/Lt Yellow	Dk Grey/Yellow
Int	Lt Blue/White	Lt Green/Black	Lt Yellow/Dk Grey
Rev, Int	White/Lt Blue	Black/Lt Green	Dk Grey/Lt Yellow
Und	Magenta/White	Lt Cyan/Black	Cyan/Dk Grey
Und, Rev	White/Magenta	Black/Lt Cyan	Dk Grey/Cyan
Und, Int	Black/White	Lt Red/Black	Lt Cyan/Dk Grey
Und, Rev, Int	White/Black	Black/Lt Red	Dk Grey/Lt Cyan
Blink	Red/White	White/Black	Lt Red/Dk Grey
Rev, Blink	White/Red	Black/White	Dk Grey/Lt Red
Int, Blink	Dk Grey/White	Lt Magenta/Black	Lt Green/Dk Grey
Int, Rev, Blink	White/Dk Grey	Black/Lt Magenta	Dk Grey/Lt Green
Und, Blink	Yellow/White	Cyan/Black	White/Dk Grey
Rev, Und, Blink	White/Yellow	Black/Cyan	Dk Grey/White
Int, Und, Blink	Cyan/White	Lt Grey/Black	Lt Grey/Dk Grey
Int, Und, Rev, Blink	White/Cyan	Black/Lt Grey	Dk Grey/Lt Grey

Default Strings

OVERVIEW

This chapter lists the strings sent by function keys, edit keys, and the numeric keypad keys as well as special keys such as ESC, Tab, Shift, Ctrl, and Alt for the PC and ANSI keyboards. Depending on the emulation used (and sometimes on the state of the Shift or Num Lock keys), the default strings will vary.

CURSOR KEYPAD

PC/ ANSI KEY	WYSE-60 WYSE-50+	ADDS. VP	PC Term TV1925	VT-300/200-7 VT-100 SCO Console AT386		VT-300/200-3	
				Cursor*	App*	Cursor*	App*
↑	Ctrl-K	Ctrl-Z	Ctrl-K	Esc [A	Esc OA	CSI A	SS3 A
↓	Ctrl-J	Ctrl-J	Ctrl-V	Esc [B	Esc OB	CSI B	SS3 B
→	Ctrl-L	Ctrl-F	Ctrl-L	Esc [C	Esc OC	CSI C	SS3 C
←	Ctrl-H	Ctrl-U	Ctrl-H	Esc [D	Esc OD	CSI D	SS3 D

Table 9-1: Cursor Keypad Defaults



NOTE: Cursor defaults apply when "Cursor Keypad" = *Cursor* in the EMUL menu (F9) of Setup. App defaults apply when "Cursor Keypad" = *Application*.

Default Strings

NUMERIC KEYPAD (ASCII EMULATION)

PC/EEG/ANSI KEYBOARDS	NumLock OFF		NumLock ON
	Wyse 501, Wyse 60, Wyse 325, Wyse 350	ADDS-VP	ADDS-VP, Wyse 501, Wyse 60, Wyse 325, Wyse 350
/	/	/	/
*	*	*	*
-	-	-	-
+	+	+	+
....			
Enter	Ctrl-M	Ctrl-M	Ctrl-M
\Del	7FH	7FH	.
0\Ins	Esc r	Esc r	0
Shift-0\Ins	Esc q	Esc q	0
1\End	Esc T	Esc T	1
2\↓	Ctrl-J	Ctrl-J	2
3\PgDn	Esc K	Esc J	3
4\←	Ctrl-H	Ctrl-U	4
5			5
6\→	Ctrl-L	Ctrl-F	6
7\Home	Ctrl-^	Ctrl-A	7
Shift-7/Home	Esc {	Ctrl-A	7
8\↑	Ctrl-K	Ctrl-Z	8
9\PgUp	Esc J	Esc J	9

Table 9-2: Numeric Keypad Defaults (ASCII Emulation)



NOTE: ANSI keyboard: the codes from column labelled "Num Lock On" are sent out. In addition, the '*', '7', and '+' keys are not present on this keyboard. EPC keyboard: the '*' key is not present.

Default Strings

NUMERIC KEYPAD (ANSI EMULATION-PC KYBD.)

PC KEY	APPLICATION MODE		NUMERIC MODE		
	NumLock ON		NumLock OFF		NumLock ON
	7-bit	8-bit	7-bit	8-bit	7-bit/8-bit
/	/	/	/	/	/
*	Esc OI	SS3 I	*	*	*
-	Esc Om	SS3 m	-	-	-
+	+	+	+	+	+
.	Esc OI	SS3 I	.	.	.
Enter	Esc OM	SS3 M	Ctrl-M	Ctrl-M	Ctrl-M
\Del	Esc On	SS3 n	DEL	DEL	.
0\Ins	Esc Op	SS3 p	Esc OS	SS3 S	0
1\End	Esc Oq	SS3 q	nothing	nothing	1
2\↓	Esc Or	SS3 r	Esc [B	CSI B	2
3\PgDn	Esc Os	SS3 s	Esc [U	CSI U	3
4\←	Esc Ot	SS3 t	Esc [D	CSI D	4
5	Esc Ou	SS3 u	5	5	5
6\→	Esc Ov	SS3 v	Esc [C	CSI C	6
7\Home	Esc Ow	SS3 w	Esc [H	CSI H	7
8\↑	Esc Ox	SS3 x	Esc [A	CSI A	8
9\PgUp	Esc Oy	SS3 y	Esc [V	CSI V	9

Table 9-3: Numeric Keypad Defaults (ANSI Emulation - PC Kybd.)



NOTE: In this table, 7-bit refers to the VT300-7, VT200-7, and VT100. The 8-bit heading applies to Intecolor, VT300-8, and VT-200-8. The "NumLock OFF" column applies to both Application and Numeric modes. The ten strings in bold are exceptions. If Application mode is ON, these strings are sent regardless of the state of NumLock. Application and Numeric modes can be selected in Setup in the F9 menu. On the ANSI keyboard, the '*', '7', '+' keys are not present. On the EPC keyboard, the '*' key is not present.

Default Strings

NUMERIC KEYPAD (SCO CONSOLE EMUL.)

PC KEY	APPLICATION MODE		NUMERIC MODE
	NumLock ON	NumLock OFF*	NumLock ON
/	/	/	/
*	Esc OI	*	*
.	Esc Om	.	.
+	+	+	+
,	Esc OI	,	,
Enter	Esc OM	Ctrl-M*	Ctrl-M*
ADel	Esc On	DEL	.
0Ins	Esc Op	Esc [L	0
1End	Esc Oq	Esc [F	1
2L	Esc Or	Esc [B	2
3PgDn	Esc Os	Esc [G	3
4←	Esc Ot	Esc [D	4
5	Esc Ou	Esc [E	5
6→	Esc Ov	Esc [C	6
7Home	Esc Ow	Esc [H	7
8↑	Esc Ox	Esc [A	8
9PgUp	Esc Oy	Esc [I	9

Table 9-4: Numeric Keypad Defaults (SCO Console Emulation)



NOTE: The "NumLock OFF" column applies to both Application and Numeric modes. The five strings in bold are exceptions. If Application mode is ON, these strings are sent regardless of the state of NumLock. Application and Numeric modes can be selected in Setup in the F9 menu. On the EPC keyboard, the ',' key is not present. If the Shift key is pressed, it toggles the NumLock state for that keystroke.



NOTE: The function of the 'Enter' key is selectable through Setup.

Default Strings

NUMERIC KEYPAD (ANSI EMULATION-ANSI KYBD.)

PC KEY	APPLICATION MODE		NUMERIC MODE
	7-bit	8-bit	7- or 8-bit
-	Esc Om	SS3 m	-
Enter	Esc OM	SS3 M	Ctrl-M*
.	Esc On	SS3 n	.
0	Esc Op	SS3 p	0
1	Esc Oq	SS3 q	1
2	Esc Or	SS3 r	2
3	Esc Os	SS3 s	3
4	Esc Ot	SS3 t	4
5	Esc Ou	SS3 u	5
6	Esc Ov	SS3 v	6
7	Esc Ow	SS3 w	7
8	Esc Ox	SS3 x	8
9	Esc Oy	SS3 y	9

Table 9-5: Numeric Keypad Defaults (ANSI Emulation - ANSI Kybd.)



NOTE: In this table, 7-bit refers to the VT-300-7, VT-200-7, and VT-100. The 8-bit heading applies to Intecolor, VT-300-8, and VT-200-8. Application and Numeric modes can be selected in Setup in the F9 menu.



NOTE: The function of the 'Enter' key is selectable through Setup.

Default Strings

EDIT-KEYPAD (ASCII EMULATION-PC KYBD.)

PC KEY	WYSE 50+, WYSE 60 WYSE 325, WYSE 350, TVI 925 Shift State		ADDS VP Shift State	
	Off	On	Off	On
	Ins	Esq q	Esq r	Esq q
Home	Ctrl-^	Esc [Ctrl-A	Ctrl-A
Page-Up	Esc J	Esc J	Esc J	Esc J
Delete	Esc W	Esc R	Esc W	Esc I
End	Esc T	Esc Y	Esc K	Esc k
Page-Dn	Esc K	Esc K	Esc J	Esc J

Table 9-6: Edit-Keypad Defaults (ASCII Emulation - PC Kybd.)

EDIT-KEYPAD (ANSI EMULATION-PC KYBD.)

PC KEY	VT-300/200-7 VT-100	VT-300/200-8 INTECOLOR	SCO Console	AT386
Ins	Esc [2~	CSI 2~	Esc [L	Esc [@
Home	Esc [H	CSE H	Esc [H	Esc [H
Page-Up	Esc [5~	CSI 5~	Esc [I	Esc [V
Delete	DEL (7Fh)	DEL(7Fh)	DEL (7Fh)	DEL (7Fh)
Shift/Delete	BS	BS	BS	BS
End	Esc [1~	CSI 1~	Esc [F	Esc [Y
Page-Dn	Esc [6~	CSI 6~	Esc [G	Esc [U

Table 9-7: Edit-Keypad Defaults (ANSI Emulation - PC Kybd.)

Default Strings

EDIT-KEYPAD (ASCII EMULATION - ANSI KYBD.)

PC KEY	WYSE 50+, WYSE 60 WYSE 325, WYSE 350, TVI 925 Shift State		ADDS VP Shift State	
	Off	On	Off	On
	Find			
Insert Here	Esc Q	Esc E	Esc Q	Esc M
Remove	DEL (7Fh)	DEL (7Fh)	DEL (7Fh)	DEL (7Fh)
Select				
Prev Page	Esc J	Esc J	Esc J	Esc J
Next Page	Esc K	Esc K	Esc J	Esc J

Table 9-8: Edit-Keypad Defaults (ASCII Emulation - ANSI Kybd.)

EDIT-KEYPAD (ANSI EMULATION-ANSI KYBD.)

PC KEY	VT-300/200-7 VT-100	VT-300/200-8
Find	Esc [1~	CSI 1~
Insert Here	Esc [2~	CSI 2~
Remove	Esc [3~	CSI 3~
Select	Esc [4~	CSI 4~
Prev Page	Esc [5~	CSI 5~
Next Page	Esc [6~	CSI 6~

Table 9-9: Edit-Keypad Defaults (ANSI Emulation - ANSI Kybd.)

Default Strings

SPECIAL KEYS (ASCII EMULATION)

KEY	PC	WYSE 50+, WYSE 60, WYSE 325, WYSE 350, FYI 925		VP	
		Shift State		Shift State	
		Off	On	Off	On
	Esc	Ctrl-[Ctrl-[Ctrl-[Ctrl-[
Tab	Tab	Ctrl-I	Esc I	Ctrl-I	Esc O
<x)*	Backspace*	Ctrl-H	7Fh	Ctrl-H	7Fh
Return*	Enter*	Ctrl-M	Ctrl-M	Ctrl-M	Ctrl-M
	Print-Screen	Esc P	Esc 7	Esc P	Esc 7

Table 9-10: Special Keys Defaults (ASCII Emulation)

SPECIAL KEYS (ANSI EMULATION)

KEY	PC	VT-300/200-7, VT-100 SCO Console		VT-300/200-8 INTECOLOR	
		Shift State		Shift State	
		Off	On	Off	On
	Esc	Ctrl-[Ctrl-[Ctrl-[Ctrl-[
Tab	Tab	Ctrl-I	Esc [Z	Ctrl-I	CSI Z
<x)*	Backspace*	Ctrl-H	DEL (7Fh)	Ctrl-H	DEL (7Fh)
Return*	Enter*	Ctrl-M	Ctrl-M	Ctrl-M	Ctrl-M

Table 9-11: Special Keys Defaults (ANSI Emulation)

Default Strings

FUNCTION KEYS (ASCII-EMULATION)

PC/ANSI KEY	WYSE 50+, WYSE 60, WYSE 325, WYSE 350, TVI 925		ADDS VP	
	Shift State		Shift State	
	Off	On	Off	On
F1*	SOH @ CR	SOH ' CR	STX 1 CR	STX ! CR
F2*	SOH A CR	SOH a CR	STX 2 CR	STX " CR
F3*	SOH B CR	SOH b CR	STX 3 CR	STX # CR
F4*	SOH C CR	SOH c CR	STX 4 CR	STX \$ CR
F5*	SOH D CR	SOH d CR	STX 5 CR	STX % CR
F6	SOH E CR	SOH e CR	STX 6 CR	STX & CR
F7	SOH F CR	SOH f CR	STX 7 CR	STX ' CR
F8	SOH G CR	SOH g CR	STX 8 CR	STX (CR
F9	SOH H CR	SOH h CR	STX 9 CR	STX) CR
F10	SOH I CR	SOH i CR	STX : CR	STX * CR
F11	SOH J CR	SOH j CR	STX ; CR	STX + CR
F12	SOH K CR	SOH k CR	STX < CR	STX , CR
F13	SOH L CR	SOH l CR	STX = CR	STX - CR
F14	SOH M CR	SOH m CR	STX > CR	STX . CR
F15	SOH N CR	SOH n CR	STX ? CR	STX / CR
F16	SOH O CR	SOH o CR	STX @ CR	STX 0 CR
F17	SOH P CR	SOH p CR	STX A CR	STX 1 CR
F18	SOH Q CR	SOH q CR	STX B CR	STX 2 CR
F19	SOH R CR	SOH r CR	STX C CR	STX 3 CR
F20	SOH S CR	SOH s CR	STX D CR	STX 4 CR

Table 9-12: Function Keys Defaults (ASCII Emulation)



NOTE: On the ANSI keyboard, in the default state, these function keys are not available (they are local keys). To make these keys available, modify the setup selections in the F5:KEYS setup menu for "F1 through F5" to be Fkey. The keys F15 and F16 are labelled "Help" and "Do" on the ANSI keyboard. The PC/+ keyboard does not have F17 through F20 keys and the EPC does not have keys F13 through F20.

Default Strings

FUNCTION KEYS (ANSI-EMULATION)

PC/ ANSI KEY	VT-300/200-7		VT-300/200-8 INTECOLOR		VT-100	
	Shift State		Shift State		Shift State	
	Off	On	Off	On	Off	On
F1*	Esc OP	Esc OP	SS3 P	SS3 P	Esc OP	Esc OP
F2*	Esc OQ	Esc OQ	SS3 Q	SS3 Q	Esc OQ	Esc OQ
F3*	Esc OR	Esc OR	SS3 R	SS3 R	Esc OR	Esc OR
F4*	Esc OS	Esc OS	SS3 S	SS3 S	Esc OS	Esc OS
F5*	Esc [M	Esc [K	CSI M	CSI K		
F6	Esc [17~	Esc [31~	CSI 17~	CSI 31~		
F7	Esc [18~	Esc [32~	CSI 18~	CSI 32~		
F8	Esc [19~	Esc [33~	CSI 19~	CSI 33~		
F9	Esc [20~	Esc [34~	CSI 20~	CSI 34~		
F10	Esc [21~	Esc [35~	CSI 21~	CSI 35~		
F11	Esc [23~	Esc [1~	CSI 23~	CSI 1~	Esc	
F12	Esc [24~	Esc [2~	CSI 24~	CSI 2~	BS	
F13	Esc [25~	Esc [3~	CSI 25~	CSI 3~	LF	
F14	Esc [26~	Esc [4~	CSI 26~	CSI 4~	Esc [H	
F15	Esc [28~	Esc [5~	CSI 28~	CSI 5~		
F16	Esc [29~	Esc [6~	CSI 29~	CSI 6~		
F17	Esc [31~	Esc [7~	CSI 31~	CSI 7~		
F18	Esc [32~	Esc [8~	CSI 32~	CSI 8~		
F19	Esc [33~	Esc [9~	CSI 33~	CSI 9~		
F20	Esc [34~	Esc [10~	CSI 34~	CSI 10~		

Table 9-13: Function Keys Defaults (ANSI Emulation)



NOTE: On a PC keyboard, keys F1 through F4 serve as PFI through PF4 keys, respectively. On an ANSI keyboard, in the default state, function keys F1 through F5 are set up as local keys. The PC+/ keyboard does not have F17 through F20 keys. The EPC keyboard does not have keys F13 through F20.

Default Strings

FUNCTION KEYS (SCO CONSOLE EMUL.)

PC KEY	Normal	Shift	Key State Ctrl	Ctrl-Shift	All
F1	Esc [M	Esc [Y	Esc [k	Esc [w	Esc [0 z
F2	Esc [N	Esc [Z	Esc [l	Esc [x	Esc [1 z
F3	Esc [O	Esc [a	Esc [m	Esc [y	Esc [2 z
F4	Esc [P	Esc [b	Esc [n	Esc [z	Esc [3 z
F5	Esc [Q	Esc [c	Esc [o	Esc [@	Esc [4 z
F6	Esc [R	Esc [d	Esc [p	Esc [[Esc [5 z
F7	Esc [S	Esc [e	Esc [q	Esc [\	Esc [6 z
F8	Esc [T	Esc [f	Esc [r	Esc []	Esc [7 z
F9	Esc [U	Esc [g	Esc [s	Esc [^	Esc [8 z
F10	Esc [V	Esc [h	Esc [t	Esc [_	Esc [9 z
F11	Esc [W	Esc [i	Esc [u	Esc [`	Esc [9 z
F12	Esc [X	Esc [j	Esc [v	Esc [{	Esc [9 z
F13*	Esc [Y	Esc [k	Esc [w		
F14*	Esc [Z	Esc [l	Esc [x		
F15*	Esc [a	Esc [m	Esc [y		
F16*	Esc [b	Esc [n	Esc [z		

Table 9-14: Function Keys Defaults (SCO Console Emulation)



NOTE: These keys are only available on the PC+ (106/107-key) keyboard.

Default Strings

FUNCTION KEYS (AT 386 EMUL.)

PC KEY	Normal	Shift	Key State Ctrl	Ctrl-Shift	Alt
F1	Esc OP	Esc Op	Esc OP	Esc Op	Esc OP
F2	Esc OQ	Esc Oq	Esc OQ	Esc Oq	Esc OQ
F3	Esc OR	Esc Or	Esc OR	Esc Or	Esc OR
F4	Esc OS	Esc Os	Esc OS	Esc Os	Esc OS
F5	Esc OT	Esc Ot	Esc OT	Esc Ot	Esc OT
F6	Esc OU	Esc Ou	Esc OU	Esc Ou	Esc OU
F7	Esc OV	Esc Ov	Esc OV	Esc Ov	Esc OV
F8	Esc OW	Esc Ow	Esc OW	Esc Ow	Esc OW
F9	Esc OX	Esc Ox	Esc OX	Esc Ox	Esc OX
F10	Esc OY	Esc Oy	Esc OY	Esc Oy	Esc OY
F11	Esc OZ	Esc Oz	Esc OZ	Esc Oz	Esc OZ
F12	Esc OA	Esc Oa	Esc OA	Esc Oa	Esc OA
F13*	Esc Op	Esc OP	Esc Op		
F14*	Esc Oq	Esc OQ	Esc Oq		
F15*	Esc Or	Esc OR	Esc Or		
F16*	Esc Os	Esc OS	Esc Os		

Default Strings

WYSE-60 APPLICATION KEYMODE

KEYBOARD			KEYCODE (HEX)
PC+	EPC	ANSI	
↑	↑	↑	D3
Shift-↑	Shift-↑	Shift-↑	D8
↓	↓	↓	D2
Shift-↓	Shift-↓	Shift-↓	D7
→	→	→	D1
Shift-→	Shift-→	Shift-→	D6
←	←	←	D0
Shift-←	Shift-←	Shift-←	D5
Delete	Delete	Select	DD
Enter	Enter	Enter	BA
Shift-Enter	Shift-Enter	Shift-Enter	BA
Home	Home	Insert Here	D4
Shift-Home	Shift-Home	Shift-Insert Here	D9
Insert	Insert	Find	F5
Shift-Insert	Shift-Insert	Shift-Find	DF
Ctrl-F1	Ctrl-F1		80
Shift-Ctrl-F1	Shift-Ctrl-F1		90
Ctrl-F2	Ctrl-F2		81
Shift-Ctrl-F2	Shift-Ctrl-F2		91
Ctrl-F3	Ctrl-F3		82
Shift-Ctrl-F3	Shift-Ctrl-F3		92
Ctrl-F4	Ctrl-F4		83
Shift-Ctrl-F4	Shift-Ctrl-F4		93
Ctrl-F5	Ctrl-F5		84
Shift-Ctrl-F5	Shift-Ctrl-F5		94
Ctrl-F6	Ctrl-F6		85
Shift-Ctrl-F6	Shift-Ctrl-F6		95

Default Strings

WYSE-60 APPLICATION KEYMODE (cont.)

KEYBOARD			KEYCODE
PC/	EPC	ANSI	(HEX)
Ctrl-F7	Ctrl-F7	Ctrl-F7	86
Shift-Ctrl-F7	Shift-Ctrl-F7	Shift-Ctrl-F7	96
Ctrl-F8	Ctrl-F8	Ctrl-F8	87
Shift-Ctrl-F8	Shift-Ctrl-F8	Shift-Ctrl-F8	97
Ctrl-F9	Ctrl-F9	Ctrl-F9	88
Shift-Ctrl-F9	Shift-Ctrl-F9	Shift-Ctrl-F9	98
Ctrl-F10	Ctrl-F10	Ctrl-F10	89
Shift-Ctrl-F10	Shift-Ctrl-F10	Shift-Ctrl-F10	99
Ctrl-F11	Ctrl-F11	Ctrl-F11	8A
Shift-Ctrl-F11	Shift-Ctrl-F11	Shift-Ctrl-F11	9A
Ctrl-F12	Ctrl-F12	Ctrl-F12	8B
Shift-Ctrl-F12	Shift-Ctrl-F12	Shift-Ctrl-F12	9B
Ctrl-F13		Ctrl-F13	8C
Shift-Ctrl-F13		Shift-Ctrl-F13	9C
Ctrl-F14		Ctrl-F14	8D
Shift-Ctrl-F14		Shift-Ctrl-F14	9D
Ctrl-F15		Ctrl-Help	8E
Shift-Ctrl-F15		Shift-Ctrl-Help	9E
Ctrl-16		Ctrl-Do	8F
Shift-Ctrl-16		Shift-Ctrl-Do	9F
0/Ins (num)	0/Ins (num)	0 (num)	B0
Shift-0/Ins (num)	Shift-0/Ins (num)	Shift-0 (num)	B0
1/End (num)	1/End (num)	1 (num)	B1
Shift-1/End (num)	Shift-1/End (num)	Shift-1 (num)	B1
2/↓ (num)	2/↓ (num)	2 (num)	B2
Shift-2/↓ (num)	Shift-2/↓ (num)	Shift-2 (num)	B2
3-PgDn (num)	3-PgDn (num)	3 (num)	B3
Shift-3/PgDn (num)	Shift-3/PgDn (num)	Shift-3 (num)	B3
4/← (num)	4/← (num)	4 (num)	B4
Shift-4/← (num)	Shift-4/← (num)	Shift-4 (num)	B4

Default Strings

WYSE-60 APPLICATION KEYMODE (cont.)

KEYBOARD			KEYCODE
PC/	EPC	ANSI	(HEX)
5 (num)	5 (num)	5 (num)	B5
Shift-5 (num)	Shift-5 (num)	Shift-5 (num)	B5
6/→ (num)	6/→ (num)	6 (num)	B6
Shift-6/→ (num)	Shift-6/→ (num)	Shift-6 (num)	B6
7/Home (num)	7/Home (num)	7 (num)	B7
Shift-7/Home (num)	Shift-7/Home (num)	Shift-7 (num)	B7
8/↑ (num)	8/↑ (num)	8 (num)	B8
Shift-8/↑ (num)	Shift-8/↑ (num)	Shift-8 (num)	B8
9/PgUp (num)	9/PgUp (num)	9 (num)	B9
Shift-9/PgUp (num)	Shift-9/PgUp (num)	Shift-9 (num)	B9
, (num)	, (num)	, (num)	CC
Shift-, (num)	Shift-, (num)	Shift-, (num)	CC
- (num)	- (num)	- (num)	CD
Shift-- (num)	Shift-- (num)	Shift-- (num)	CD
/Del (num)	/Del (num)	, (num)	CE
Shift-/Del (num)	Shift-/Del (num)	Shift-, (num)	CE

Default Strings

ADDS 4000 FAMILY OF KEYBOARDS

ADDS offers a wide range of keyboard options to best meet individual customer need in the ASCII, ANSI and PC environments:

- **PC 101-key Keyboard** ideal for users who require a standard PC keyboard layout. A PC 102-key layout is also available for international use.
- **Compact PC 101 Keyboard** ideal for users in a space conscious environment.
- **PC/+ 106-key Keyboard** PS/2 style layout, ideal for users in the U.S. who require additional function keys. A 107-key PS/2 DIN style layout is available for use in the European marketplace.
- **ANSI Keyboard** vt220 style, ideal for use in the DEC environment.

	PC 101/102	Compact PC 101*	PC/+ 106/107	ANSI
4000/160**	X	-	X	X
4000/260**	X	-	X	X
4000/260C**	X	-	X	X
4000/260IC	X	X	-	-

* The Compact PC 101-key keyboard is only available with the 4000/260IC.

** The PC 101/102-key keyboards will be the standard PC keyboard shipped for these products as of 12/1/93. The ANSI keyboard remains unchanged and the PC/+ 106/107-key keyboards will continue to be available as an option.

Default Strings

Languages Available:

	PC 101/102	Compact PC 101	PC/+ 106/107	ANSI
US English	X	X	X	X
UK English	X	-	X	X
Belgian/Flemish	X	-	X	X
Danish	X	-	X	X
Dutch	X	-	X	X
Finnish	X	-	X	-
French	X	-	X	X
French Canadian	-	-	-	X
Fr. Canadian CSA	X	-	X	-
German	X	-	X	X
Italian	X	-	X	X
Latin American	X	-	X	-
Norwegian	X	-	X	X
Portuguese	X	-	X	-
Spanish	X	-	X	X
Swedish	X	-	X	X
Swiss	X	-	X	-
Swiss-French	-	-	-	X
Swiss-German	-	-	-	X

The PC 101-key and the PC/+ 106-key layouts are available in U.S. English only. For international use, the PC 102-key or the PC/+ 107-key keyboard are used. Individual language layouts are available upon request. Not all languages are available for all products. Please refer to individual product literature for specific language requirements.

Default Strings

U.S. ENGLISH KEYBOARDS OFFERED

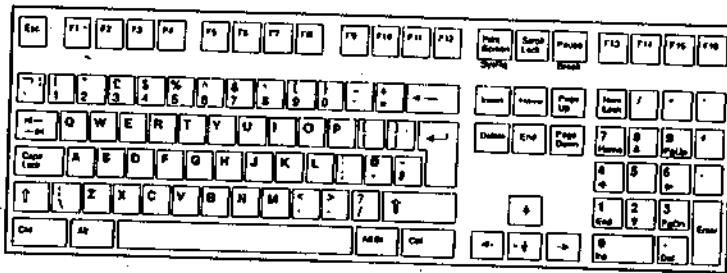

Figure 9-1: PC+/106 Keyboard

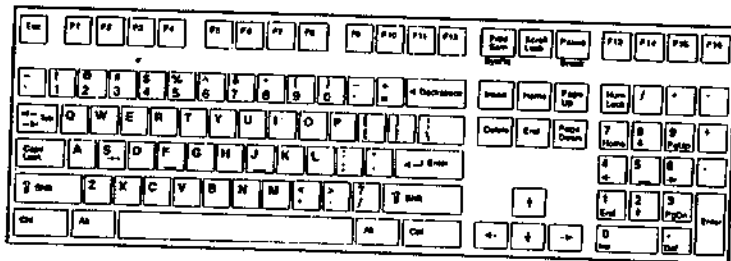

Figure 9-2: PC+/107 Keyboard

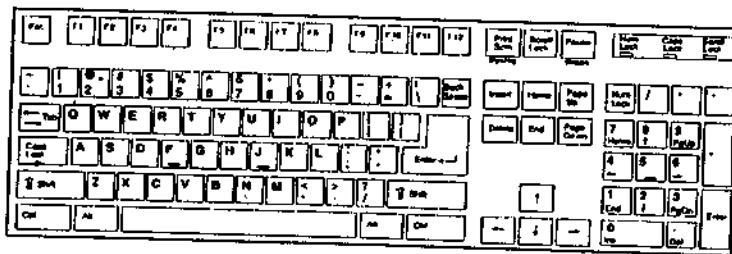

Figure 9-3: PC101 Keyboard

Default Strings

U.S. ENGLISH KEYBOARDS OFFERED (continued)

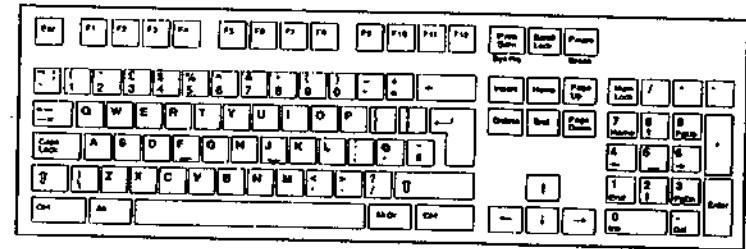

Figure 9-4: PC102 Keyboard

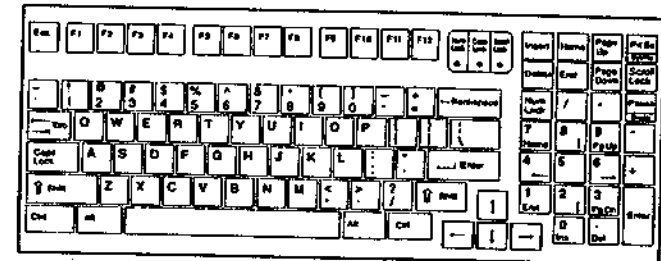

Figure 9-5: Compact PC101 Keyboard

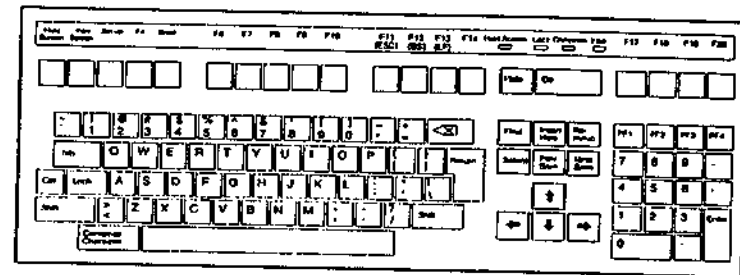

Figure 9-6: ANSI (VT-220 style) U.S. English Keyboard

Default Strings

LAYOUTS OF THE FOREIGN ALPHANUMERIC KEYPADS

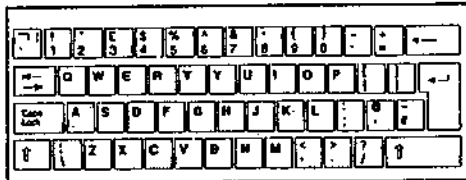

Figure 9-7: U.K. English Alphanumeric Keypad

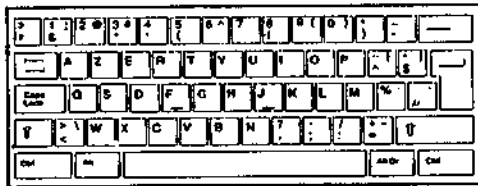

Figure 9-8: Belgian/Flemish Alphanumeric Keypad

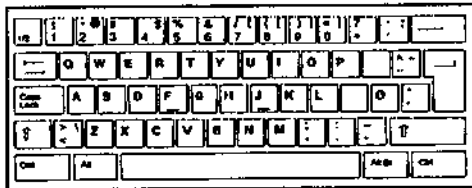

Figure 9-9: Danish Alphanumeric Keypad

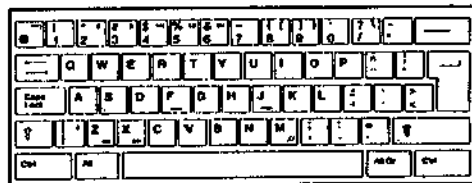

Figure 9-10: Dutch Alphanumeric Keypad

Default Strings

LAYOUTS OF THE FOREIGN ALPHANUMERIC KEYPADS

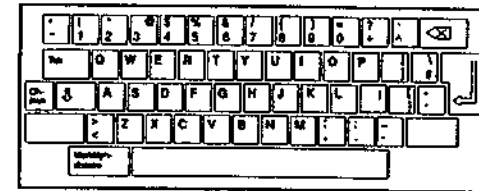

Figure 9-11: Finnish Alphanumeric Keypad

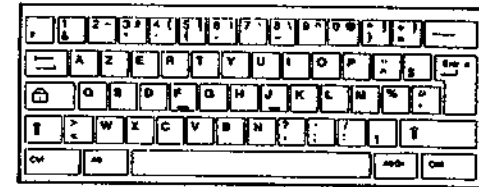

Figure 9-12: French Alphanumeric Keypad

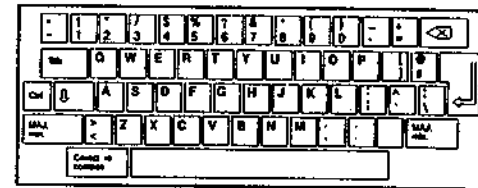

Figure 9-13: French Canadian Alphanumeric Keypad

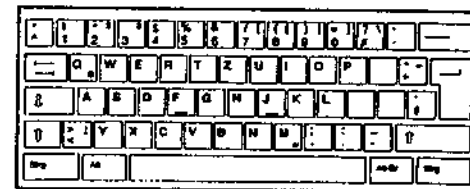

Figure 9-14: German Alphanumeric Keypad

Default Strings

LAYOUTS OF THE FOREIGN ALPHANUMERIC KEYPADS

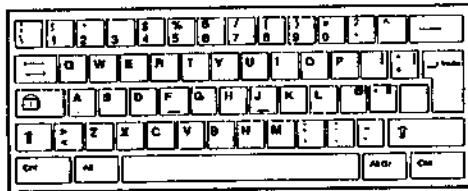

Figure 9-15: Italian Alphanumeric Keypad

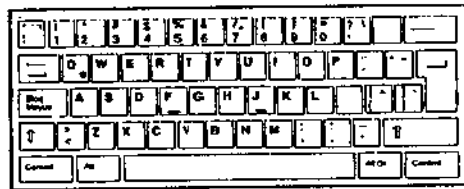

Figure 9-16: Latin American Alphanumeric Keypad

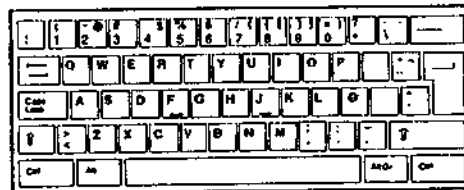

Figure 9-17: Norwegian Alphanumeric Keypad

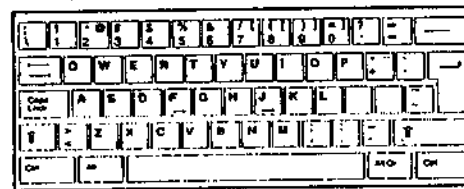

Figure 9-18: Portuguese Alphanumeric Keypad

Default Strings

LAYOUTS OF THE FOREIGN ALPHANUMERIC KEYPADS

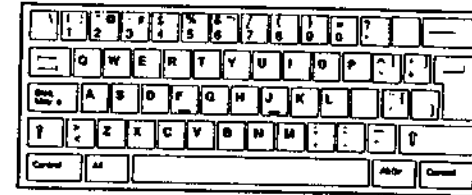

Figure 9-19: Spanish Alphanumeric Keypad

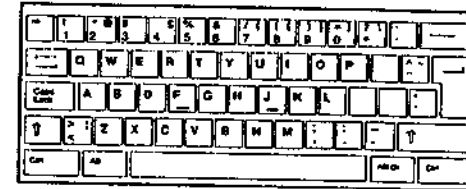

Figure 9-20: Swedish Alphanumeric Keypad

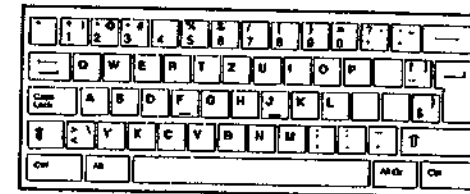

Figure 9-21: Swiss Alphanumeric Keypad

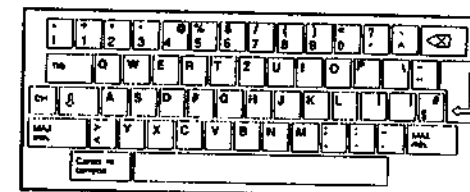

Figure 9-22: Swiss-French Alphanumeric Keypad

Default Strings

LAYOUTS OF THE FOREIGN ALPHANUMERIC KEYPADS

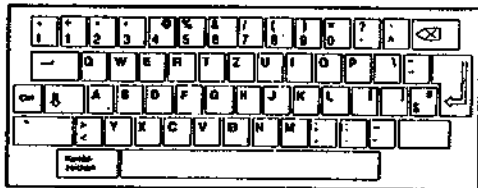

Figure 9-23: Swiss-German Alphanumeric Keypad

Default Strings

SELECTED KEY CODES IN SCAN-CODE MODE

KEYBOARD			HEX SCAN CODES	
PC/	EPC	ANSI	DOWN (Make)	UP (Break)
Alt (left)	Alt (left)	Compose	38	B8
Alt (right)	Alt (right)		E0 38	E0 B8
Backspace	Backspace	<XJ	0E	8E
Break	Break		E0 46	E0 C6
Caps Lock	Caps Lock	Lock	3A	BA
Ctrl (right)	Ctrl (right)	Ctrl	1D	9D
Ctrl (left)	Ctrl (left)		E0 1D	E0 9D
Enter	Enter	Return	1C	9C
Enter (num)	Enter (num)	Enter	E0 1C	E0 9C
Esc	Esc	F19	01	81
Num Lock	Num Lock	PF1	45	C5
Pause	Pause	F20	E1 1D 45 E1 9D C5	(none)
* (num)	* (num)	PF4	37	B7
Print Screen	Print Screen	F18	E0 2A E0 37	E0 B7 E0 AA
Scroll Lock	Scroll Lock	F17	46	C6
Shift (left)	Shift (left)	Shift (left)	2A	AA
Shift (right)	Shift (right)	Shift (right)	36	B6
Space	Space	Space	39	B9
Sys Rq	Sys Rq		E0 37	E0 B7
Alt-Print Scrn	Alt-Print Scrn		38 54	D4 B8
Tab	Tab	Tab	0F	8F
- (num)	- (num)	- (num)	4A	CA
+ (num)	+ (num)	, (num)	4E	CE
, (num)	, (num)		6A	EA

Table 9-15: Key Codes in Scan-Code Mode

Default Strings

SELECTED KEY CODES IN SCAN-CODE MODE (cont.)

KEYBOARD			HEX SCAN CODES	
PC/	EPC	ANSI	DOWN (Make)	UP (Break)
/ (num)	/ (num)	PF3	E0 35	E0 B5
/Del (num)	/Del (num)	. (num)	53	D3
(Delete)	(Delete)	Remove	E0 53	E0 D3
Delete	Delete		E0 2A E0 53	E0 D3 E0 AA
0/Ins (num)	0/Ins (num)	0 (num)	52	D2
(Insert)	(Insert)	Insert Here	E0 52	E0 D2
Insert	Insert		E0 2A E0 52	E0 D2 E0 AA
1/End (num)	1/End (num)	1 (num)	4F	CF
(End)	(End)	PF2	E0 4F	E0 CF
End	End		E0 2A E0 4F	E0 CF E0 AA
2/↓ (num)	2/↓ (num)	2 (num)	50	D0
(↓)	(↓)	↓	E0 50	E0 D0
↓	↓		E0 2A E0 50	E0 D0 E0 AA
3/PgDn (num)	3/PgDn (num)	3 (num)	51	D1
(Page Down)	(Page Down)	Next Scrn	E0 51	E0 D1
Page Down	Page Down		E0 2A E0 51	E0 D1 E0 AA
4/← (num)	4/← (num)	4 (num)	4B	CB
(←)	(←)	←	E0 4B	E0 CB
←	←		E0 2A E0 4B	E0 CB E0 AA
5 (num)	5 (num)	5 (num)	4C	CC
6/→ (num)	6/→ (num)	6 (num)	4D	CD
(→)	(→)	→	E0 4D	E0 CD
→	→		E0 2A E0 4D	E0 CD E0 AA

Table 9-16: Key Codes in Scan-Code Mode



NOTE: When a key is listed twice, the key shown in parentheses () sends the indicated code when Num Lock is off. The second longer code is sent when Num Lock is on.

Default Strings

SELECTED KEY CODES IN SCAN-CODE MODE (cont.)

KEYBOARD			HEX SCAN CODES	
PC/	EPC	ANSI	DOWN (Make)	UP (Break)
7/Home (num)	7/Home (num)	7 (num)	47	C7
(Home)	(Home)	Do	E0 47	E0 C7
Home	Home		E0 2A E0 47	E0 C7 E0 AA
8/↑ (num)	8/↑ (num)	8 (num)	48	C8
(↑)	(↑)	↑	E0 48	E0 C8
↑	↑		E0 2A E0 48	E0 C8 E0 AA
9/PgUp (num)	9/PgUp (num)	9 (num)	49	C9
(PageUp)	(PageUp)	Prev Scrn	E0 49	E0 C9
PageUp	PageUp		E0 2A E0 49	E0 C9 E0 AA
F14		Help	5A	DA
F16		Find	5B	DB

Table 9-17: Key Codes in Scan-Code Mode

LOCAL KEYS IN SCAN-CODE MODE*

LOCAL FUNCTION	KEYBOARD	
	PC	ANSI
Enter Setup	Ctrl-Scroll Lock	Ctrl-Select

Table 9-18: Local Keys in Scan-Code Mode



NOTE: "Local Leadin" selection in the Keys (F5) menu of Setup must be set to On in order to access other local functions listed in the User's Guide to Operation.

Default Strings

WP Graphics

COMMAND	ESCAPE SEQUENCE
---------	-----------------

ALPHA MODE COMMAND SET

Within WP-Graphics there are two modes of operation, Alpha and Pixel modes. Upon entering WP Graphics from its Context-Emulation, the Alpha mode is entered. Although the terminal will appear much like its Context-Emulation in Alpha mode, WP-Graphics does differ from its Context-Emulation in the commands set it supports. From within the Alpha mode, the following commands may be entered:

Clear screen	NUL @
Exit WP-Graphics and return to Wyse 60 emulation	NUL K
Enter Hercules Pixel mode (page 0)	NUL d *
Enter Hercules Pixel mode (page 1)	NUL d AAH
Display character	01h-FFH
Exit WP-Graphics and return to the emulation specified by <i>Param</i>	NUL ~ <i>Param</i>

Parameter	Description	Values
<i>Param</i>	Specifies the emulation that you want to return to after exiting the WP-Graphics	* Wyse 50+ 4 Wyse 60 < VT-220-7 ? WP-Graphics (SCAN) a AT-386 \$ TVI-925 5 PC-TERM = VT-200-8 Q WP-Graphics (ASCII) previous emulation % ADDS-VP ; VT-100 \$ SCO-CON



Commands in bold are available only when "Enhanced" parameter in the Quick (F1) menu of WP-Graphics is set to On.

WP Graphics

COMMAND	ESCAPE SEQUENCE
---------	-----------------

PIXEL MODE COMMAND SET

In Pixel mode, commands 93 through 97 followed by a NUL will display the commands as a byte. This allows the values which normally execute commands to be displayed on the terminal. For example, 93 NUL will display a 93 bit pattern on the terminal.

 **NOTE:** The 4000/260 does not support end-of-line/page wrap in Pixel mode. When the end-of-line/page is reached, data will not wrap to the appropriate location until a new address is received.

Although there is no physical cursor in pixel mode, there is a logical cursor defining the address where all write operations will take place. The logical cursor is described throughout the available Pixel mode commands below:

Exit Pixel mode and enter Alpha mode.

96h 64h 20h

Display byte. Displays the bit representation of the byte at the cursor location (MSB-LSB/Left-Right).

00h thru 92h

98h thru FFh

Set absolute video RAM address. Positions the cursor in the bitmap. Bit 7 of MSB is ignored but can be used to set the cursor address to 00000D-0255. These addresses are inaccessible if Bit 7 of MSB is 0.

93h *MSB Addr* *LSB Addr*

Set relative video address

94h *Signed Offset*

Where *Signed Offset* is an 8 bit signed integer (most significant bit determines the sign (1 is negative, 0 is positive)) which can alter the current address by + or - 127 bytes:

If *Signed Offset* = 1-7F then move forward.

If *Signed Offset* = 81-FF then move backward.

If *Signed Offset* = 80 then move backward 255 pixel positions.

Draw a horizontal short line. Write a pair of bytes (using the last two bytes displayed on the terminal) consecutively the number of times specified by *Length*. The cursor is set to the end of the drawn line.

95h *Length*

 Commands in **bold** are available only when "Enhanced" parameter in the Quick (F1) menu of Setup is set to *On*.

PIXELMODECOMMANDSET

WP Graphics

COMMAND	ESCAPE SEQUENCE
---------	-----------------

Draw a horizontal long line. Write a pair of bytes (using the last two bytes displayed on the terminal) for the length specified by *MSB* and *LSB*. *MSB* and *LSB* form the high and low order bytes of the 16 bit integer used to determine the number of byte pairs used to draw the line. The cursor is set to the end of the drawn line.

95h 01h *MSB LSB*

Clear graphics display. This command does not affect cursor address.

96h 40h

Sound bell.

96h 42h

Draw a vertical short line. Write a pair of bytes (using the last two bytes displayed on the terminal) consecutively the number of times specified by *Length*. The cursor is adjusted two bytes forward from its original position.

97h *Length*

Draw a vertical long line. Write a pair of bytes (using the last two bytes displayed on the terminal) for the length specified by *MSB* and *LSB*. *MSB* and *LSB* form the high and low order bytes of the 16 bit integer used to determine the number of byte pairs used to draw the line. The cursor is adjusted two bytes forward from its original position.

97h 01h *MSB LSB*

 Commands in **bold** are available only when "Enhanced" parameter in the Quick (F1) menu of Setup is set to *On*.

PIXEL MODE COMMAND SET

WP Graphics

COMMAND

ESCAPE SEQUENCE

Appendix A

SCREEN / PAGE LENGTH

BOTTOM STATUS/LABEL LINE DISPLAY

This terminal offers a variety of screen lengths including 26, 44, or 49 lines. These numbers include the top and bottom status line (or label line), as well as the lines used to display data.

With a screen length of 26 lines, the page lengths that are multiples of 24 allow the bottom status/label line to be displayed, while those that are multiples of 25 do not.

A "page" of terminal memory represents the total number of lines that can be accessed, whether or not they are all viewable on the screen at once. Refer to page A-3 for the number and lengths of pages available for your set-up.

The same concept applies with the 44 line screen size. A page length with 42 lines as a base page size will display a label line, while the 43 line base page length will not. An exception to this rule is the case where the screen length is significantly larger than the base page size. In that case, the label line will be displayed (e.g. a screen length of 44 lines and a page length of a multiple of 25).

The page length is comprised of a base page length multiplied by 1, 2, 4 or 8. For instance, in certain modes, 24 (24*), 48 (24 x 2), and 96 (24 x 4) are available, the same way that 25 (25 x 1), 50 (25 x 2), and 100 (25 x 4) are. The base page length and the screen size determine whether a bottom status line or label line is displayed or not.

The figure below represents the entire page memory of a 48 line page (24 base page length times a multiplier of 2) and the portion of the

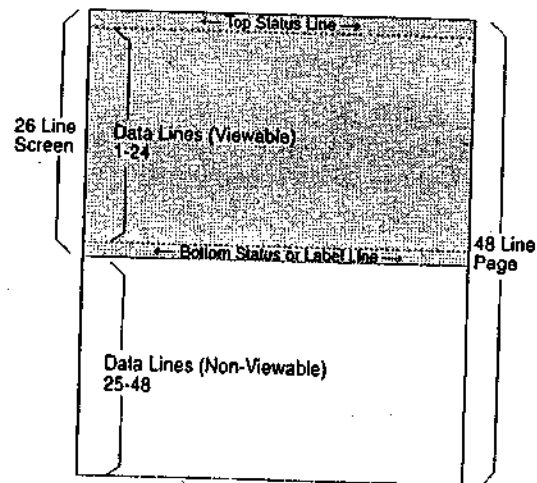

Figure A-1: Page Memory



Commands in bold are available only when "Enhanced" parameter in the Quick (F1) menu of Setup is set to On.

Appendix A

page that is viewable on the display screen, when 26 Lines are selected. Notice that the label line is visible in this mode.

VISUAL COMBINATIONS

The combination of page and screen lengths influence the number of displayable data lines. For example, if the page length is 50 (25 x 2), and the screen length is 44 lines, the number of data lines that are visible at any one time is 43, with no label line. The other line is used for the top status line. On a 49 line screen, 48 of the 50 data lines are visible at one time.

If the page length is shorter than the screen length, blank lines will be present below the data line or status/label line. If the page length is larger than the allowable number of data lines, some of the rows will be out of view. In order to bring them into view, "scrolling" or "panning" is used, if necessary.

Scrolling causes a new line to scroll into view when the cursor advances past the last row on the page. If the page is scrolled down, the top row of text is lost, and if scrolled up, the bottom row of text is lost (if "Auto Scroll" selection is set to On in Setup). Text scrolled off of the screen is not recoverable.

If the current page or portion of the page is longer than the screen display or window in which it is displayed, local keystrokes can be used to "pan" the window up or down (Ctrl-T and Ctrl-L). As a window is panned up, the page appears to be moving down, and the opposite is true when panning the window down. Text that is panned off the screen is out of view, but is not lost.

The figure below represents the display screen with a 48 line page length on a 44 line screen, after panning the window down 2 lines.

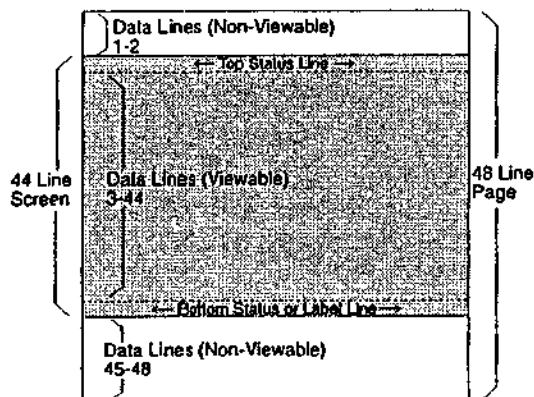

Figure A-2: Display Screen

Appendix A

PAGE / SCREEN CONFIGURATIONS

SINGLE SESSION MODE

Lines per Page	Field Attribute Emulations (ADDS-VP, WYSE-504)	Parallel Attribute Emulations: Wyse-60/PC Term, VT-300, VT-200, VT-100, SCO Console		
	Expanded or Standard Memory	Expanded Memory	Standard Memory	
	# of pages in 80/132 or 80-only column mode	# of pages in 80/132 or 80-only column mode	# of pages in 80-only column mode	# of pages in 80/132 column mode
24	10	10	4	2
48	5	5	2	1
96	2	2	1	-
192	1	1	-	-
*24	2(24/218)	2(24/218)	2(24/72)	2(24/32)
25	9	9	3	2
50	4	4	1	1
100	2	2	-	-
200	1	1	-	-
*25	2(25/217)	2(25/217)	2(25/71)	2(25/31)
42	5	5	2	1
84	2	2	1	-
168	1	1	-	-
*42	2(42/200)	2(42/200)	2(42/54)	-
43	5	5	2	1
86	2	2	1	-
172	1	1	-	-
*43	2(43/199)	2(43/199)	2(43/53)	-

Appendix A

DUAL SESSION MODE

Lines per Page	All Emulations (ADD5-VF, Wyse-50+, Wyse-60, PC-Term, VT-300, VI-200, VT-100, SCO Console)		
	Expanded Memory	Standard Memory	
	# of pages in 80/132 or 80-only column mode	# of pages in 80-only column mode	# of pages in 80/132 column mode
24	4	1	1
48	2	-	-
96	1	-	-
*24	2(24/94)	-	-
25	4	1	1
50	2	-	-
100	1	-	-
*25	2(25/93)	-	-
42	2	1	1
84	1	-	-
*42	2(42/76)	-	-
43	2	1	1
86	1	-	-
*43	2(43/75)	-	-



NOTE: When a page length (in the first column) is preceded by an asterisk (*), a total of two pages will be available. The first page contains the selected number of lines and the second page contains the remaining allowable lines in memory. The number of lines are listed on this chart as (first page/second page).

Appendix B

HEX	00h	10h	20h	30h	40h	50h	60h	70h
00h	NUL	DLE	SPACE	0	@	P	.	p
01h	SOH	DC1	!	1	A	Q	a	q
02h	STX	DC2	"	2	B	R	b	r
03h	ETX	DC3	#	3	C	S	c	s
04h	EOT	DC4	\$	4	D	T	d	t
05h	ENQ	NAK	%	5	E	U	e	u
06h	ACK	SYN	&	6	F	V	f	v
07h	BEL	ETB	'	7	G	W	g	w
08h	BS	CAN	(8	H	X	h	x
09h	HT	EM)	9	I	Y	i	y
0Ah	LF	SUB	*	:	J	Z	j	z
0Bh	VT	ESC	+	;	K	[k	[
0Ch	FF	FS	,	<	L	\	l	l
0Dh	CR	GS	-	=	M]	m]
0Eh	SO	RS	.	>	N	^	n	^
0Fh	SI	US	/	?	O	_	o	DEL

Table B-1: ASCII CHART

Appendix B

	00h	10h	20h	30h	40h	50h	60h	70h
00h	Nul	DLE T	Space	0	@	P	.	p
01h	SOH S _H	DC1 L	!	1	A	Q	a	q
02h	STX S _X	DC2 Γ	"	2	B	R	b	r
03h	ETX E _X	DC3 7	#	3	C	S	c	s
04h	EOT E _T	DC4	\$	4	D	T	d	t
05h	ENQ E _Q	NAK J	%	5	E	U	e	u
06h	ACK A _K	SYN I	&	6	F	V	f	v
07h	BEL B _L	ETB ≡	'	7	G	W	g	w
08h	BS B _S	CAN †	(8	H	X	h	x
09h	HT H _T	EM †)	9	I	Y	i	y
0Ah	LF L _F	SUB -	*	:	J	Z	j	z
0Bh	VT V _T	ESC ≡	+	;	K	[k	{
0Ch	FF F _F	FS =	.	<	L	\	l	
0Dh	CR C _R	GS ⊥	-	=	M]	m	}
0Eh	SO S _O	RS	.	>	N	^	n	~
0Fh	SI S _I	US ≡	/	?	O	_	o	DEL ?

Table B-2: WYSE NATIVE

Appendix B

HEX	00h	10h	20h	30h	40h	50h	60h	70h
00h		▶		0	@	P	.	p
01h	☺	◀	!	1	A	Q	a	q
02h	☹	↓	"	2	B	R	b	r
03h	♥	!!	#	3	C	S	c	s
04h	♦	‡	\$	4	D	T	d	t
05h	♣	§	%	5	E	U	e	u
06h	♠	—	&	6	F	V	f	v
07h	●	‡	'	7	G	W	g	w
08h	◻	↑	(8	H	X	h	x
09h	◯	↓)	9	I	Y	i	y
0Ah	◻	→	*	:	J	Z	j	z
0Bh	♂	←	+	;	K	[k	{
0Ch	♀	↳	.	<	L	\	l	
0Dh	♫	↔	-	=	M]	m	}
0Eh	♫	▲	.	>	N	^	n	~
0Fh	☀	▼	/	?	O	_	o	🏠

Table B-3: PC EQUIVALENT CHARACTER SET

Appendix B

HEX	80h	90h	A0h	B0h	C0h	D0h	E0h	F0h
00h	Ç	È	Á	⌘	Ł	⌌	α	≡
01h	Ù	æ	í	⌘	Ł	⌌	β	±
02h	é	Æ	ó	⌘	Ł	⌌	Γ	≥
03h	â	ô	ú		Ł	⌌	κ	≤
04h	ä	ö	ñ		Ł	⌌	Σ	ƒ
05h	à	ò	Ñ	⌌	Ł	⌌	σ	Ƶ
06h	á	ó	•	⌌	Ł	⌌	μ	+
07h	ç	ù	•	⌌	Ł	⌌	τ	×
08h	ê	ý	ı	⌌	Ł	⌌	φ	•
09h	è	ó	Γ	⌌	Ł	⌌	θ	•
0Ah	é	ü	⌌	⌌	Ł	⌌	Ω	•
0Bh	ı	€	½	⌌	Ł	■	δ	√
0Ch	ı	£	¼	⌌	Ł	■	∞	∞
0Dh	ı	¥	ı	⌌	Ł	■	∅	2
0Eh	Ä	Pl	«	⌌	⌌	■	€	■
0Fh	Å	ƒ	»	⌌	⌌	■	©	

Table B-4: PC MULTINATIONAL CHARACTER SET CODE PAGE 437

Appendix B

HEX	80h	90h	A0h	B0h	C0h	D0h	E0h	F0h
00h	Ç	È	Á	⌘	Ł	ø	Ó	—
01h	Ù	æ	í	⌘	Ł	Ð	β	±
02h	é	Æ	ó	⌘	Ł	É	Ò	=
03h	â	ô	ú		Ł	È	Ó	3/4
04h	ä	ö	ñ		Ł	È	ø	Ƶ
05h	à	ò	Ñ	⌌	Ł	ı	Ö	§
06h	á	ó	•	⌌	Ł	ı	ı	μ
07h	ç	ù	•	⌌	Ł	ı	ı	+
08h	ê	ý	ı	⌌	Ł	ı	ı	•
09h	è	ó	⊗	⌌	Ł	ı	ı	•
0Ah	é	ü	⌌	⌌	Ł	ı	ı	•
0Bh	ı	ø	½	⌌	Ł	■	ı	ı
0Ch	ı	£	¼	⌌	Ł	■	ı	ı
0Dh	ı	¥	ı	⌌	Ł	■	ı	ı
0Eh	Ä	x	«	⌌	⌌	ı	ı	ı
0Fh	Å	ƒ	»	⌌	⌌	ı	ı	ı

Table B-5: PC MULTILINGUAL EXTENDED CHARACTER SET CODE PAGE 850

Appendix B

HEX	80h	90h	A0h	B0h	C0h	D0h	E0h	F0h
00h	Ç	É	Ï	Ï	Ł	Ł	α	≡
01h	Ù	È	·	Ï	Ł	Ł	β	±
02h	é	Ê	ó	Ï	Ł	Ł	Γ	≥
03h	â	ô	ú	Ł	Ł	Ł	π	≤
04h	À	È	..	Ł	Ł	Ł	Σ	ƒ
05h	à	ì	.	Ł	Ł	Ł	σ	Ƶ
06h	ŕ	ó	3	Ł	Ł	Ł	μ	+
07h	ç	ù	·	Ł	Ł	Ł	ε	·
08h	e	ü	î	Ł	Ł	Ł	φ	°
09h	e	ô	Γ	Ł	Ł	Ł	θ	°
0Ah	e	ü	Γ	Ł	Ł	Ł	Ω	°
0Bh	ï	é	½	Ł	Ł	■	δ	√
0Ch	î	é	¼	Ł	Ł	■	ι	π
0Dh	ï	ø	¼	Ł	Ł	■	ø	2
0Eh	À	Ó	«	Ł	Ł	■	ε	■
0Fh	á	ſ	»	Ł	Ł	■	ç	

Table B-6: PC FRENCH CANADIAN CHARACTER SET

Appendix B

HEX	80h	90h	A0h	B0h	C0h	D0h	E0h	F0h
00h	Ç	É	á	Ï	Ł	Ł	α	≡
01h	ù	æ	í	Ï	Ł	Ł	β	±
02h	é	Æ	ó	Ï	Ł	Ł	Γ	≥
03h	â	ó	ú	Ł	Ł	Ł	π	≤
04h	á	ó	ñ	Ł	Ł	Ł	Σ	ƒ
05h	à	ó	Ñ	Ł	Ł	Ł	σ	Ƶ
06h	á	ó	·	Ł	Ł	Ł	μ	+
07h	ç	ó	°	Ł	Ł	Ł	ε	·
08h	e	y	¿	Ł	Ł	Ł	φ	°
09h	e	Ö	Γ	Ł	Ł	Ł	θ	°
0Ah	e	Ü	Γ	Ł	Ł	Ł	Ω	°
0Bh	ï	ø	½	Ł	Ł	■	δ	√
0Ch	î	£	¼	Ł	Ł	■	ι	π
0Dh	ï	ø	¼	Ł	Ł	■	ø	2
0Eh	À	Pl	«	Ł	Ł	■	ε	■
0Fh	À	ſ	»	Ł	Ł	■	ç	

Table B-7: PC NORWEGIAN CHARACTER SET

Appendix B

Graphics-1

Graphics-2

Graphics-3

HEX	30h	60h	70h	40h	50h	60h	40h	50h
00h	0	0	█	┌	┐	—		—
01h	1	1	—				┌	—
02h	2	2	▬				┐	◆
03h	3	3	▬				┐	■
04h	4	4	┌	┐	┌	┌	┐	■
05h	5	5	┌				┌	■
06h	6	6	┌				┌	■
07h	7	7	┌				┌	┌
08h	-8	8	┌	┌	┌	┌	┌	┌
09h	9	9					┌	┌
0Ah		┌	┌				┌	┌
0Bh		┌	┌				┌	┌
0Ch	▶	┌	┌	┌	┌		┌	┌
0Dh	◀	┌	┌				┌	┌
0Eh	▲	┌	■				┌	┌
0Fh	▼	┌					┌	┌

Table B-8: ASCII GRAPHIC CHARTS

Appendix B

Control Left

Graphics Left

HEX	00h	10h	20h	30h	40h	50h	60h	70h
00h	N	D	Blank	0	@	P	.	p
01h	S	D	!	1	A	Q	a	q
02h	S	D	"	2	B	R	b	r
03h	E	D	#	3	C	S	c	s
04h	E	D	\$	4	D	T	d	t
05h	E	N	%	5	E	U	e	u
06h	A	S	&	6	F	V	f	v
07h	B	E	'	7	G	W	g	w
08h	B	C	(8	H	X	h	x
09h	H	E)	9	I	Y	i	y
0Ah	L	█	*	:	J	Z	j	z
0Bh	V	E	+	;	K	[k	{
0Ch	F	F	,	<	L	\	l	
0Dh	C	G	-	=	M]	m	}
0Eh	S	R	.	>	N	^	n	~
0Fh	S	U	/	?	O	_	o	?

Table B-9: ANSI STANDARD

Appendix B

HEX	A0h	B0h	C0h	D0h	E0h	F0h	A0h	B0h	C0h	D0h	E0h	F0h
00h	°	◊	À	Ç	à	ç	NoBrSp	◊	À	Ð	à	ð
01h	ı	±	Á	Ñ	á	ñ	ı	±	Á	Ñ	á	ñ
02h	²	²	Â	Ò	â	ò	²	²	Â	Ò	â	ò
03h	£	³	Ã	Ó	ã	ó	£	³	Ã	Ó	ã	ó
04h	§	§	Ä	Ô	ä	ô	¶	·	Ä	Ô	ä	ô
05h	¥	µ	Å	Õ	å	õ	¥	µ	Å	Õ	å	õ
06h	¶	¶	Æ	Ö	æ	ö	ı	¶	Æ	Ö	æ	ö
07h	§	·	Ç	×	ç	×	§	·	Ç	×	ç	×
08h	¨	§	È	Ø	è	ø	¨	·	È	Ø	è	ø
09h	©	ı	É	Ù	é	ù	©	ı	É	Ù	é	ù
0Ah	°	°	Ê	Ú	ê	ú	°	°	Ê	Ú	ê	ú
0Bh	«	»	Ë	Û	ë	û	«	»	Ë	Û	ë	û
0Ch	§	¼	ı	Œ	ı	œ	¬	¼	ı	Œ	ı	œ
0Dh	§	½	ı	Ÿ	ı	ÿ	—	½	ı	Ÿ	ı	ÿ
0Eh	§	§	ı	ı	ı	ı	©	¾	ı	ı	ı	ı
0Fh	§	ı	ı	ı	ı	ı	ı	ı	ı	ı	ı	ı

Table B-10: ANSI SUPPLEMENTAL & ISO LATIN-1 SUPPLEMENTAL (ISO 8859 / 1.2)

Appendix B

HEX	20h	30h	40h	50h	60h	70h	20h	30h	40h	50h	60h	70h
00h		0	@	P	α	π		0	@	P	•	—
01h	!	1	A	Q	β	±	!	1	A	Q	⊞	—
02h	"	2	B	R	Γ	≥	"	2	B	R	H _T	—
03h	#	3	C	S	π	≤	#	3	C	S	F _F	—
04h	\$	4	D	T	Σ	∫	\$	4	D	T	C _R	⊞
05h	%	5	E	U	σ	∫	%	5	E	U	L _F	⊞
06h	&	6	F	V	μ	+	&	6	F	V	°	⊞
07h	'	7	G	W	τ	-	'	7	G	W	±	⊞
08h	(8	H	X	Φ	°	(8	H	X	N _L	
09h)	9	I	Y	θ	°)	9	I	Y	V _T	≤
0Ah	*	:	J	Z	Ω	·	*	:	J	Z	∫	≥
0Bh	+	;	K	[δ	√	+	;	K	[⊞	π
0Ch	,	<	L	\	∞	n	,	<	L	\	⊞	≠
0Dh	-	=	M]	ø	2	-	=	M]	L	£
0Eh	.	>	N	^	ε	n	.	>	N	^	+	·
0Fh	/	?	O		∩		/	?	O		—	

Table B-11: ANSI SCIENTIFIC & ANSI SPECIAL GRAPHICS

Appendix B

Keyboard Language	# 23h	< 3Ch	> 3Eh	@ 40h	! 50h	^ 5Ch	~ 5Dh	^ 5Eh	60h	(70h	7Ch) 7Dh	- 7Eh
Danish				Æ	Ø	Å			æ	ø	å		
Dutch	£			3/4	ij	1/2	;		..	f	1/4	'	
Finnish				Ä	Ö	Å	Ü	é	ä	ö	å	u	
Flemish (Belgian)/French	£			à	·	ç	§		é	ù	è	-	
French Canadian				à	á	ç	é	í	ó	é	ù	è	ó
German				§	Ä	Ö	Ü		ä	ö	ü	ß	
Italian	£			§	·	ç	é		ò	à	ò	è	ì
Latin American					í	Ñ	¿	á	é	í	ñ	ú	ü
Norwegian				Æ	Ø	Å			æ	ø	å	í	
Portuguese				Ä	Ç	Ö			ä	ç	ö		
Spanish					í	Ñ	¿		·	ñ	ç	í	
Swedish	-			É	Ä	Ö	Å	Ü	é	ä	ö	å	ü
Swiss (Fr/Ger)	£	í	í	ç	à	é	è		ü	ü	ü	-	
United Kingdom	£												

Table B-12: PC NATIONAL REPLACEMENT CHARACTERS

 NOTE: This NRC applies when Char Set Mode (in F4 menu of Setup) is PC. Characters shown in bold can only be generated by the host or compose sequence.

Appendix B

Keyboard Language	# 23h	@ 40h	! 50h	^ 5Ch	~ 5Dh	^ 5Eh	5Fh	60h	70h	7Ch	7Dh	7Eh
Danish/Norwegian			Æ	Ø	Å				æ	ø	å	
Dutch	£	3/4	ij	1/2	;				..	f	1/4	'
Finnish			Ä	Ö	Å	Ü		é	ä	ö	å	u
Flemish (Belgian)/French	£	à	·	ç	§			é	ù	è	-	
French Canadian		à	á	ç	é	í		ó	é	ù	è	ó
German		§	Ä	Ö	Ü			ä	ö	ü	ß	
Italian	£	§	·	ç	é			ò	à	ò	è	ì
Latin American			í	Ñ	¿	á		é	í	ñ	ú	ü
Portuguese			Ä	Ç	Ö			ä	ç	ö		
Spanish	£	§	í	Ñ	¿			·	ñ	ç		
Swedish		É	Ä	Ö	Å	Ü		é	ä	ö	å	ü
Swiss (Fr/Ger)	£	à	é	ç	è	í	è	ó	ä	ö	ü	ó
United Kingdom	£											

Table B-13: ANSI NATIONAL REPLACEMENT CHARACTERS

 This NRC applies when Char Set Mode (in F4 menu of Setup) is ANSI. Characters in bold can only be generated by the host.

Appendix B

Keyboard Language	13h	24h	40h	5Bh	5Ch	5Dh	5Eh	5Oh	7Bh	7Ch	7Dh	7Eh
Danish/Norwegian				Æ	Ø	Å			æ	ø	å	
Dutch	£		3/4	ij	1/2	i			..	f	1/4	'
Swedish/Finnish		α	É	Ä	Ö	Å	Ü	é	ä	ö	å	ü
Flemish (Belgian)/French	£		à	·	ç	§		..	é	ù	ê	
French Canadian			à	â	ç	ê	ï	ò	é	à	è	ó
German			§	Ä	Ö	Ü			ä	ö	ü	ß
Italian	£		§	·	ç	é		ò	à	ò	è	ì
Latin American				í	Ñ	¿	£	é	í	ñ	ú	ü
Portuguese/Spanish				í	Ñ	¿		°	ñ	ç	/	
Swiss (Fr/Ger)	£		ç	à	é	è			ä	ö	ü	..
United Kingdom	£											

Table B-14: ASCII NATIONAL REPLACEMENT CHARACTERS



NOTE: This NRC applies when Char Set Mode (in F4 menu of Setup) is ASCII. Characters shown in bold can only be generated by the host.

Index

A

- Address cursor 4-18
- ADDS 4000 family of keyboards 9-16
- ANSI
 - emulations 1-1, 1-2, 2-1, 3-5
 - emulatio 2-2
- ASCII
 - emulations 1-2, 2-1, 3-1, 7-1
- ASCII color mode 7-1
- Attribute
 - field 1-2
 - parallel 1-2
- Attribute commands 4-23
- Auto mode 7-10
 - direct mode 7-10
 - palette mode 7-10

B

- Bottom status/label line display A-1

C

- Character Sets
 - ANSI National Replacement .. B-12, B-13
 - ANSI Scientific B-11
 - ANSI Special Graphics B-11
 - ANSI Standard B-9
 - ANSI Supplemental B-10
 - ASCII 2-6, B-1
 - ASCII Graphics B-8
 - ASCII National Replacement B-14
 - graphics left 2-2
 - graphics right 2-2
 - ISO Latin-1 B-10
 - PC Equivalent B-3
 - PC French Canadian B-6
 - PC Multilingual B-5
 - PC Multinational B-4
- PC National Replacement B-12
- PC Norwegian B-7
- Wyse Native B-2
- Character set commands 4-28, 5-10
 - load character set 5-10
 - map character set 5-11
 - soft font 5-11
- Character Sets
 - ANSI 2-2
 - ANSI Soft Characters 2-6
 - ASCII Soft Characters 2-12
 - mapping 2-2
 - soft 2-1
 - Character size commands 4-28, 5-6, 6-4
- Character Sizes 2-12
 - double-high 2-1
 - double-high & double-wide 2-1
 - double-wide 2-1
 - normal 2-1
- Characters
 - custom, ANSI 2-2
 - custom, ASCII 2-12
 - write-protected 7-5
- Color Mode
 - ANSI 7-7
 - ASCII 7-1
- Communication commands 4-2
- Console
 - programming, ANSI 3-5
 - programming, ASCII 3-1
 - programming, SCO Console 3-7
- Control
 - left 2-2
 - right 2-2
 - string introducer 1-2
- Control codes 5-1
- Cursor commands
 - cursor state 5-4
 - move cursor 5-3, 6-2
- Cursor display commands 4-7
- Cursor keypad 9-1
- Cursor movement commands 4-16

Index

D

Date	4-2
Default strings	9-1
Delete	4-21
Device	
control string	1-2
Direct mode	7-7, 7-9
select a color palette	7-9
select direct color mode	7-7
select graphic rendition (SGR)	7-7
select replacement character color	7-8
select status line color	7-9
Display commands	4-5, 6-4
base page size	5-8
origin mode	5-7
scrolling region	5-6
status line	5-7

E

Edit commands	
delete	4-21, 5-5, 6-3
erase	4-21, 5-5, 6-3
insert	4-21, 5-5, 6-3
insert mode	6-3
Edit keypad	9-6, 9-7

F

Font	
banks	2-12
Function & Edit Keys	
labels	3-1, 3-3
programming, ANSI	3-5
programming, ASCII	3-1
programming, SCO Console	3-7
storage limits	3-1, 3-7
Function keys	9-9

G

Graphics commands	5-11
draw box	4-30
draw box routine	5-11
erase box routine	5-11
Graphics replacement colors	7-11

I

Insert	4-21
Intecolor	
- ignored commands	7-13

K

Keyboard commands	4-8, 5-8, 6-6
key usage	5-9
newline mode	5-9
Keyboards offered	9-18
Keycode	
cursor keypad	9-1
edit keypad, ANSI	9-6
edit keypad, ASCII	3-3, 9-6, 9-7
edit keypad, SCO Console	3-8
function ASCII	3-3
function key label, ASCII	3-3
function keys, ANSI	9-10
function keys, ASCII	9-9
function keys, SCO Console	9-11
function SCO Console	3-8
function, ANSI	3-6
function, SCO Console	3-7
numeric keypad, ANSI	9-3, 9-5
numeric keypad, ASCII	9-2
numeric keypad, SCO Console	9-4
special keys, ANSI	9-8
special keys, ASCII	9-8
Keymode	
Wyse 60 application	9-13

Index

L

Label line commands	4-11
Layouts of the foreign	
alphanumeric keypads	9-22
Line background	4-26
Load time	4-1
Local keys in scan-code mode	9-27

M

Map a visual attribute to a color	7-2, 7-5, 7-6
Map an attribute to a particular foreground color and another attribute	7-3

Mode

auto	7-10
direct	7-7, 7-10
palette	7-9

N

Normal replacement colors	7-10
Numeric keypad	9-2, 9-3, 9-4, 9-5

P

Page commands	4-13
Page/screen configurations	
dual session mode	A-4
single session mode	A-3
Paging commands	5-18
Palette	
Soft	8-1
Palette defaults	8-1
Palettes	
pre-defined	8-1
Wyse 325	8-4
Wyse 60	8-4

Print commands	4-35
Program function/edit keys	4-9
Protect commands	4-26

R

RAM	3-1
Read cursor address	4-18
Replacement Colors	
graphic	7-11
normal	7-10
reverse	7-11
Report attribute color scheme	7-12
Reset mode	5-17, 6-7
Reverse replacement colors	7-11

S

Scan Codes

EPC keyboard	9-18
Local Keys	9-27
SCO Console	3-7, 7-10
SCO	

emulation	3-7, 7-10
Screen/page length	A-1
Scroll commands	4-6
Select a palette	7-3, 7-5
select palette color mode	7-9
Selected keycodes in	
scan-code mode	9-25, 9-26
Selective erase commands	5-5
Send and print commands	5-12
Send commands	4-33, 6-7
Set mode	5-17, 6-7
Shift	
lock	2-5
single	2-5
Sixel	2-6
Soft palettes	7-1
Special keys	9-8
Split screen commands	4-15

Index

Status line commands4-11
String terminator1-2

T

Tab commands4-12, 5-4, 6-3

V

Visual combinationsA-2

W

Wyse 325 ignored commands7-13
Wyse 50+ emulation7-1
Wyse 60 emulation7-1
Wyse 60 application mode9-13

NOTES