

**SPRINT 3 PRINTER**

**MAINTENANCE/TRAINING MANUAL**

**Revision A**

**January 17, 1980**

**Copyright 1980 Vector Graphic Inc.**

**Copyright 1978 Qume Corporation**

Copyright 1980 by Vector Graphic Inc.  
Copyright 1978 by Qume Corporation

All rights reserved.

**Disclaimer**

Vector Graphic makes no representations or warranties with respect to the contents of this manual itself, whether or not the product it describes is covered by a warranty or repair agreement. Further, Vector Graphic reserves the right to revise this publication and to make changes from time to time in the content hereof without obligation of Vector Graphic to notify any person of such revision or changes, except when an agreement to the contrary exists.

Qume, Q, Q30, Q45, Sprint, Sprint 45, Sprint 55, Sprint Micro 0, Sprint Micro 3/35, Sprint Micro 3/45, Sprint Micro 3/55, Sprint 5, Sprint Micro 5, Sprint Micro 5/45, Sprint Micro 5/55, WideTrack, TwinTrack, PHD, SpeedFeed, Twintellect, Wedge, ActivityMotor, and MultiColor are Trademarks or Registered Trademarks of Qume Corporation.

# TABLE OF CONTENTS

## CHAPTER I INTRODUCTION AND DESCRIPTION

Scope and Organization of this Manual	1-1
Description of the Printer	1-1
S3/35, S3/45 and S3/55	1-2
S3/X30, S3/X40	1-3
S3/WideTrack	1-3
TwinTrack	1-3
Options and Features	1-3
Specifications	1-4
Control Signals	1-8
Basic Signal Inputs	1-10
Basic Signal Outputs	1-12
Timing Considerations	1-15
Typical Command Sequences	1-15

## CHAPTER II INSTALLATION

Introduction	2-1
Receiving	2-1

## CHAPTER III OPERATION

Turning on the Printer	3-1
Changing Ribbons	3-1
Changing Printwheels	3-2
Paper Controls	3-4
Customer Strappable Features	3-4
Queued/Direct Restore (JP-7)	3-5
Cover Open Interlock Enable/Disable (JP-4)	3-5
Sixteen Input Command Buffer (JP-1)	3-5
End of Ribbon Detect (JP-9)	3-5
External Program Mode	3-5
Top of Form Programming	3-9

## CHAPTER IV THEORY OF OPERATION

Introduction	4-1
Electrical Operation	4-3
Split-Phase Stepper Motors	4-3
Optical Servo Systems	4-5
The Servo Loop	4-6
Servo Compensation	4-9
Paper Feed	4-11
Ribbon Feed	4-11
Ribbon Lift	4-11
Hammer Driver	4-12
Check	4-12
Digital Control Section	4-13
What is a Microprocessor?	4-13
TwinTrack	4-15

## CHAPTER V MAINTENANCE

Monthly or as Required	5-1
Every Six Months or 300 Printing Hours	5-1
Support Equipment List	5-5
Tools and Equipment	5-5
Spares	5-5

## CHAPTER VI TROUBLESHOOTING & REPAIR

General	6-1
Diagnostic Procedures	6-1
Test Descriptions	6-2
ROM Test	6-2
I/O Lines Test	6-2
Restore Test	6-4
Carriage Test	6-4
Printwheel Test	6-5
Paper Feed Test	6-7
Error Routine	6-7
Test Points	6-7
Micro I/O Routine	6-11
Repair	6-13
Routine Procedures	6-13
Circuit Boards	6-14

**CHAPTER VI**  
**TROUBLESHOOTING & REPAIR**  
**(continued)**

Mechanical Alignment	6-17
Printhead	6-18
Printwheel Index Adjustment (HUB)	6-21
Platen Adjustments	6-23
Paper Feed Roller Adjustment	6-26
Carriage Cable Tension Adjustment	6-28
Left Margin Photo Sensor	6-28
Card Guide Adjustment	6-29
Ribbon Lift Height	6-30
Ribbon Drive Gear Adjustment	6-31
TwinTrack Carriage Synchronization	6-32
Ribbon Lift Spacing	6-32
Ribbon Tracking	6-33
Motherboard Alignment	6-33
Cover Interlock	6-34
Removal and Replacement Procedures	6-35
Cover Removal	6-35
Printed Circuit Board Removal	6-35
Motherboard Connections	6-39
Heat Sink Assembly Removal	6-40
Motherboard Removal	6-40
Paper Feed Motor Removal	6-41
Carriage Drive Cable Removal	6-42
Carriage Motor Assembly Removal	6-42
Carriage Assembly Removal	6-44
Ribbon Drive Clutch and Gear Removal	6-45
End of Ribbon Sensor Removal	6-45
Ribbon Lift Coil Removal	6-46
Print Hammer Armature Assembly Removal	6-46
Ribbon Drive Motor Removal	6-47
Front and Rear Feed Roll Removal	6-48



## LIST OF ILLUSTRATIONS

TITLE	PAGE
Power Connector (J2) Orientation	1-7
Control Connector (J1) Orientation	1-8
Interface Drivers and Receivers	1-8
Timing	1-14
Ribbon Cartridge	3-1
Ribbon Feed Switch	3-2
Unlock Button	3-2
Changing the Printwheel	3-3
Customer Strappable Features	3-4
Simplified Mechanical Cutaway	4-1
Stepper Motors	4-3
Overall Block Diagram	4-4
Optical Encoder (Simplified)	4-5
Acceleration Profile	4-6
Servo Loop	4-7
Encoder Related Signals	4-7
Direction Flip-Flop	4-8
Velocity Reference	4-9
Compensation Signals	4-10
Paper Feed	4-11
Ribbon Lift	4-12
Hammer Driver	4-12
Check	4-13
Digital Control	4-14
TwinTrack PCB Locations	4-15

**LIST OF ILLUSTRATIONS**  
**(continued)**

TITLE	PAGE
TwinTrack Coordination Logic	4-16
Sequential Interface Timing	4-17
Ribbon Bail Lubrication	5-2
Printhead Assembly	5-3
Carriage Control Signals	6-15
Printwheel Control Signals	6-16
Printhead Vertical Adjustment	6-19
Hammer Armature Core Adjustment	6-20
Printwheel Alignment Tools	6-21
Platen Adjustment Tool	6-24
Platen Adjustments	6-24
Platen Gear Drive Adjustment	6-25
Platen Latch Adjustment	6-25
Platen Release Adjustment	6-26
Feed Roller Depth	6-26
Feed Roller Disabling Lever	6-27
Carriage Cable Adjustment	6-28
Left Margin Sensor	6-29
Card Guide Adjustment	6-29
Ribbon Lift Height Adjustment	6-30
Ribbon Drive Gear	6-31
Dual Bearing Assembly	6-31
Ribbon Lift Space	6-32
Ribbon Tracking	6-33



# CHAPTER I

## INTRODUCTION AND DESCRIPTION

### SCOPE AND ORGANIZATION OF THIS MANUAL.

This manual provides information for installing, operating, and maintaining the Qume Sprint Micro 3 Series Printers. Complete procedures for repair are included with schematic diagrams and an illustrated parts list to aid the maintenance technician.

This chapter describes the printer from an external viewpoint. The description includes specifications, capabilities, and interface connections and requirements.

Chapter II describes unpacking, initial installation and performance checks, warranty information, and service and training policies.

Chapter III is a basic outline on the operation of the printer.

Chapter IV discusses the theory of operation. This includes circuit descriptions where the approach or concept may not be normally encountered by the average repair technician:

Chapter V outlines routine and preventative maintenance procedures. Chapter V also lists special tools, test equipment, spare parts, and miscellaneous items that are required to maintain, troubleshoot, and repair the printer.

Troubleshooting, repair, and adjustments are described in Chapter VI. Procedures are suggested to isolate problems to within the mechanical or electrical portions. Electrical faults can then be isolated to a board level.

Chapter VII contains an illustrated parts list of the mechanical portion of the printer. From this, repair parts can be identified for ordering purposes, or the illustrations can be used as an assembly guide during mechanical repair.

Chapter VIII is a complete wiring and schematic diagram with assembly, or component placement, drawings for each board.

### DESCRIPTION OF THE PRINTER.

The Sprint Micro 3 Series Printer is a high-performance, low-cost printer intended for use in automatic data systems. Its light weight and compactness, its ease of operation and dependability are important features in any application calling for a printer with intermediate output capacity. Such applications include small business systems in which printers constitute the principle output device, as well as larger data systems calling for a flexible terminal printer with high-quality print and word processing systems producing "camera ready" print. The printwheel provides a full 96-character set, including upper and lower case and special characters. Special models, such as the WideTrack and TwinTrack, add even greater dimension to the Sprint 3 series. The WideTrack expands the form width capabilities to 28 inches and retains all of the features of the Sprint 3 printer quality. The TwinTrack puts two complete printwheels on-line at the same time, expanding the character set to 192. The

TwinTrack can also be used to increase printing speed (over the center 15.3") to 75 cps by printing with both printwheels at the same time.

Printwheels are available in a variety of optional type styles and sizes.

On typical sequential text, the printer attains print speeds as high as 55 characters per second. The usefulness of the printer is not restricted to the line-sequential output, however. Both the vertical and horizontal placement of each character are under program control, with four degrees of freedom (right and left carriage movement; forward and reverse paper movement). A unique method of optical control permits accurate character placement. These features make the Sprint Micro 3 Series Printer suitable for X-Y plotting, and for applications where it is more convenient to have random output rather than conventional left-to-right or top-to-bottom operation. Character placement is done in increments of 1/120th inch horizontally and 1/48th inch vertically. Horizontal displacements up to the physical maximum of 13.1 inches and vertical displacements up to 21.3 inches may be programmed. The WideTrack and TwinTrack models will accept horizontal displacements up to the physical maximum of 26.3 inches.

The control and data interface is fully TTL-compatible. The printer uses a 13-bit binary weighted data bus and five unweighted strobe lines to enter the data into the printer input buffer. The strobe lines distinguish the operation to be performed and initiate the appropriate action on the part of the printer.

A significant feature of the printer is its mechanical simplicity. Mechanical functions have been replaced with electrical functions wherever possible, and the remaining inertia of the mechanism has been minimized by use of light-weight, low-moment components. By minimizing the number of moving parts, and by carefully optimizing the mechanical details, the designers have produced an exceptionally fast, quiet, and reliable serial printer. Mean time between failures exceeds 1,000 hours, and plug-in serviceability permits on-site repair with an absolute minimum of down time.

The Sprint 3 Micro Series printers have advantages for hard copy generation that are not shared by either the traditional slow speed serial printers or the expensive line printers. Print quality is equal to or better than that of the very best office typewriters. And they also have the ability to proportionately space. These basic characteristics, together with low cost, make the Sprint 3 Micro Series printers ideal for small systems that are "I/O bound" and larger systems that require a flexible terminal with a high readable output.

The new Qume Sprint Micro 3 Series printers incorporate a completely new electronics package based upon a true MOS microcomputer. This sharply reduces the number of electronic components and connections, and increases product reliability. The series includes a self-testing capability and self-compensating circuit boards that need no adjustments when they are replaced.

The Sprint Micro 3 Series has many models, options, and features. The basic models and options are introduced below.

### **S3/35, S3/45, and S3/55**

These are the standard line of high speed character printers with respective printing rates of 35, 45, and 55 characters per second for average English text.

They offer the systems designer an alternative to slow serial devices such as the teletype and automatic electric typewriter, and to the expensive high-speed devices such as the line printer.

### **S3/X30, S3/X40**

Offers the ultimate in print quality and printwheel life by using a special 88 or 92 character metalized printwheel.

### **S3/WIDE TRACK**

Offers all of the advantages of the S3 series with increased width to 26.4 inches of printed line on a 28 inch (maximum) form. The WideTrack lends itself to large forms or plotting, or it can be used where two or more forms are printed side-by-side.

### **S3/TWINTRACK**

Has two printing heads on a WideTrack frame. The dual print capability can be simultaneous, where both print stations are printing at the same time, or sequential (an option) where the second print station contains additional characters, and is moved into place automatically when needed. When printing simultaneously, speeds up to 75 characters per second can be achieved over the center 15.3". The TwinTrack interface requires the use of the D2048 bit in the character input, directing the character selection to the right or left print station. The two print stations can contain different type styles, different alphabets, or symbols, and can each or both use the Twintellect and MultiColor options.

The TwinTrack Sequential Interface option remembers which station printed last. And when the next character is to be printed, it tests the D2048 bit, comparing it with the last. The new character is then either printed by the head that is in place, or the carriage is automatically offset, and the character is printed by the other station. The carriage does not automatically return, but waits for the next character, and prints, or moves and prints, as the need may be.

The TwinTrack model lends itself to scientific formulas or foreign languages, where many special characters (up to 192) are needed on-line. In one of many uses, the TwinTrack can print English text on one half of the page while simultaneously typing a foreign language on the other half of the page.

## **OPTIONS AND FEATURES**

### ***Twintellect***

The Twintellect option within the Sprint 3 Series allows the user to manually select a special character ROM for non-standard printwheels. The selection is made by positioning a switch when the special printwheel is installed. The special character ROM then selects the proper printwheel address, ribbon advance, and impression (hammer) intensity for the non-standard printwheel.

### ***MultiColor***

The Sprint 3 Series also includes a dual color fabric ribbon option where more than one print color is needed. By using two dual color ribbons on the TwinTrack model, up to four colors can be printed.

## **MultiColor [continued]**

The MultiColor ribbon contains two colors. One is printed when the ribbon is in the lowered position, and one is printed with the ribbon in the raised position. A printer containing the MultiColor option is easily returned to normal ribbon operation by the operator. The ribbon lift guides are simply rotated 180° and a standard ribbon installed.

## **Self-Test**

The Sprint Micro 3 printer self test feature verifies printer operation and simplifies service. During self test the microprocessor conducts a checkout of itself and many other printer functions. The status of each test can be instantly displayed on Qume's palm size option, the Micro 3 ActivityMonitor.

## **SPECIFICATIONS**

### **Print Speed:**

Qume printer speed varies according to the sequence of characters being printed and whether the various capabilities of the printer (high speed electronic tab, printing right to left, etc.) are used properly. Speeds shown below are for average English text on one line, with electronic tab over spaces between words, and are shown in characters per second (cps).

Sprint Micro 3/35:	35 cps
Sprint Micro 3/45:	45 cps
Sprint Micro 3/55:	55 cps
Sprint Micro 3/X30:	30 cps (metallized wheel)
Sprint Micro 3/X40:	40 cps (metallized wheel)
Sprint Micro 3/WideTrack:	40 cps
Sprint Micro 3/TwinTrack:	75 cps (over 15.3" with simultaneous print)

### **Print:**

Full characters of electric typewriter quality, printed serially: variable intensity ballistic hammer automatically adjusts to one of six intensities according to character size. The six intensities can be externally programmed if desired.

### **Forms:**

Single sheets and continuous forms, with or without sprocket holes. The Sprint Micro 3 printer maximum forms width is 15 inches (38.1 cm). WideTrack and TwinTrack maximum forms width: 28 inches (71.1 cm).

### **Font:**

96 character positions on "daisy" printwheel: Wide variety of standard font styles in 10 and 12 pitch and proportional spacing. Special and custom printwheels available for use with the Twintellect model.

Format:

Horizontal:

Sprint Micro 3: 132 columns at 10 characters per inch; 158 columns at 12 characters per inch; proportional spacing in increments of 1/120 inch, left or right. Electronic tabbing and carriage return up to 13.1 inches (33.3 cm) at 400 ms maximum.

Sprint Micro 3 WideTrack and Sprint Micro 3 TwinTrack: 264 columns at 10 characters per inch; 316 columns at 12 characters per inch; proportional spacing in increments of 1/120 inch, left or right. Electronic tabbing and carriage return up to 26.3 inches (66.8 cm) at 680 ms maximum.

TwinTrack only: The left printwheel prints within the left 20.8 inches (columns 0 through 208 at 10 characters per inch) and the right printwheel prints within the right 20.8 inches (columns 55 through 263), making an area of 15.3 inches where both printwheels can print.

Vertical:

Spacing in increments of 1/48 inch up or down: slew rate at 5 inches (12.7 cm) per second.

Plotting:

Resolution of 5760 points per square inch.

Paper Feed:

Friction platen: pin feed platens, forms tractor, optional.

Ribbon:

Easy to handle cartridge with multi-strike carbon, single strike carbon, or fabric ribbon. Available in black, colors, or dual color fabric.

Printwheel:

Easily operator changeable. The TwinTrack model uses two printwheels.

Operator controls:

Horizontal forms positioning; vertical forms positioning; forms thickness, ribbon advance. The Twintellect option adds a switch for standard or non-standard printwheel.

Temperature:

Operating 50 to 105 degrees F (10 to 40 degrees C).  
Storage -40 to 170 degrees F (-40 to 76 degrees C).

Humidity:

Operating 10% to 90% RH (no condensation).  
Storage 2% to 98% RH (no condensation).

Physical:

Sprint Micro 3

Weight: 28 pounds (12.7 kg)  
Width: 23.63 inches (60 cm)  
Height: 7.11 inches (18 cm)  
Depth: 13.5 inches (34.3 cm)

### WideTrack

Weight: 37.2 pounds (16.9 kg)  
Width: 36.5 inches (92.8 cm)  
Height: 7.11 inches (18 cm)  
Depth: 13.5 inches (34.3 cm)

### TwinTrack

Weight: 40 pounds (17.2Kg)  
Width: 36.5 inches (92.8 cm)  
Height: 7.11 inches (18 cm)  
Depth: 13.5 inches (34.3 cm)

Data Input: 13-bit parallel TTL levels plus control lines.

Power Requirements: Sprint Micro 3 Models except TwinTrack.

+ 5 VDC $\pm$ 3%	3.5 amps DC
+15 VDC $\pm$ 10%	4.5 amps average (14 amps peak 20 ms max.)
-15 VDC $\pm$ 10%	4.5 amps average (14 amps peak 20 ms max.)

### TwinTrack

+ 5 VDC $\pm$ 3%	5.75 amps DC
+15 VDC $\pm$ 10%	4.5 amps DC average (16 amps peak/20 ms max.)
-15 VDC $\pm$ 10%	4.5 amps DC average (16 amps peak/20 ms max.)

All voltages must reach 90% of their final values in no less than 4 msec and no more than 100 msec. The absolute values of the +15 and -15 volt input must not differ by more than 2.0 volts during their rise or fall. The +5 volt input must reach 90% of its final value within 50 msec of the +15 and -15 volt input.

All power connections are made through a single connector (Molex #09-01-1121-1), that attaches to a corresponding connector on the left side of the printer, as viewed from the rear. Pin allocations on the power connector are shown on the next page. Note that separate lines for high and low current supply distributions must be provided for all three supplies to prevent noise from being coupled from the carriage and printwheel motor drive circuits into the signal processing circuits. It is suggested that the wire sizes recommended below be used for installation. For proper noise isolation, the +5 V logic supply return path must be isolated from the +15 V and -15 V supply ground return paths in the power supply and the power cable.

## POWER CONNECTOR

POWER	PIN	WIRE SIZE
+15V High Current	3,4	2x18 AWG
+15V Low Current	6	1x18 AWG
-15V High Current	1,2	2x18 AWG
-15V Low Current	5	1x18 AWG
+ 5V Logic Current	7,8	2x18 AWG
+ 5V Power Current	12	1x18 AWG
Ground	9, 10, 11	3x18 AWG (or 7/32" tinned copper braid)

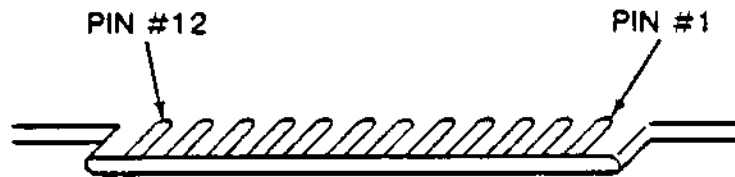

(As Viewed From Rear Of Printer)

POWER CONNECTOR (J2) ORIENTATION

## CONTROL SIGNALS

Control interface is provided through a dual 25-pin edge card connector (0.1" contact centers). Recommended connector is 3M #3415-0000. This mates with J1 (right side of the printer, as viewed from the rear). Recommended cable is 3M #3365, a 50-conductor ribbon type cable which has a 100 ohm characteristic impedance. All locations on the control connector are given in the table on the opposing page.

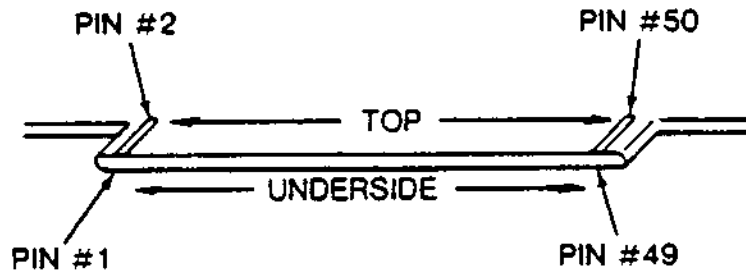

(As Viewed From Rear Of Printer)

### CONTROL CONNECTOR (J1) ORIENTATION

#### INTERFACE DRIVERS AND RECEIVERS

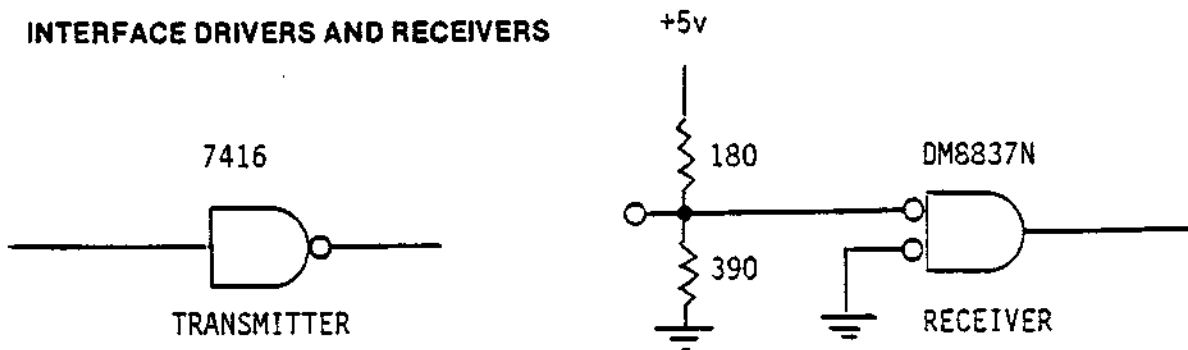

All input/output signals are active low.  
Logic 1: < 0.4v      Logic 0: > 2.4v  
Data 1/2 thru 2048 have 1K pull-up resistor and are received by 74412's.



# INTERFACE SIGNALS AND PIN ASSIGNMENTS

Connector: 3M #3415-0000

PIN	SIGNAL NAME	PIN	SIGNAL NAME
1	GND	26	TOP OF FORM STROBE (OPT)
2	DATA 1/2	27	GND
3	DATA 1	28	RIBBON LIFT COMMAND
4	DATA 2	29	GND
5	DATA 4	30	RIBBON OUT (OPT)
6	DATA 8	31	GND
7	DATA 16	32	PRINTER SELECT
8	DATA 32	33	GND
9	DATA 64	34	COVER INTERLOCK (OPT)
10	DATA 128	35	GND
11	DATA 256	36	GND
12	DATA 512	37	CHECK
13	DATA 1024	38	GND
14	DATA 2048	39	INPUT BUFFER READY (CHARACTER READY)
15	GND	40	GND
16	RESTORE	41	INPUT BUFFER READY (CARRIAGE READY)
17	GND	42	GND
18	CHARACTER STROBE	43	INPUT BUFFER READY (PAPER FEED READY)
19	GND	44	GND
20	CARRIAGE STROBE	45	INPUT BUFFER EMPTY
21	GND	46	GND
22	PAPER FEED MAIN STROBE	47	PRINTER READY
23	GND	48	GND
24	PAPER FEED AUXILIARY STROBE (OPT)	49	PAPER OUT (OPT)
25	GND	50	GND

## NOTES

In all but the TwinTrack model, the signals on pins 39, 41, and 43 are consolidated (but gate isolated) and occur simultaneously. Only one of these INPUT BUFFER READY lines needs to be tested prior to each and every CHARACTER STROBE, CARRIAGE STROBE, PAPER FEED MAIN STROBE, PAPER FEED AUXILIARY STROBE, TOP OF FORM STROBE, or Queued RESTORE command.

The TwinTrack model signals for pins 39, 41, and 43 are shown in parentheses. The CARRIAGE READY and PAPER FEED READY signals are simultaneous, but the CHARACTER READY signal is independent. The ready signal for the particular command must be tested before the command can be strobed into the buffer.

## BASIC SIGNAL INPUTS

The signals described below are the controlling inputs to the printer. Each signal line is briefly described by the action and interaction that it has on the printer. Signals that are output from the printer are described in later pages.

### PRINTER SELECT (Pin 32)

Enables the printer for operation. All input signals except RIBBON LIFT COMMAND are ignored until the PRINTER SELECT line is low. Some status lines are unaffected: CHECK, RIBBON OUT, COVER INTERLOCK, and PAPER OUT.

### RESTORE (Pin 16)

Initiates a restore sequence. Normally used before initial use if the printer has been idle for some time, or following a printer malfunction or power failure that caused a "check" condition (see BASIC SIGNAL OUTPUTS). The restore sequence consists of positioning the carriage at the leftmost position; synchronizing the printwheel; and resetting the carriage, printwheel, interface logic, and the internal "check" circuits. The microcomputer goes through its own reset sequence and begins program operation from the first byte of memory.

The printer can be strapped to provide either a direct or queued restore function. The direct restore command is executed immediately; any operation in progress is aborted and any command(s) held in the input command buffer is cleared out and never executed. The queued restore command, however, is normally converted into a command that is loaded into the input command buffer and forced to allow all previously received commands to be executed before the restore operation is begun. When the printer is in "CHECK", the queued restore is executed immediately. The queued/direct restore strap is on the #2 board (see the operation section of this manual). When strapping the TwinTrack model, both #2 boards must be queued restore, or both must be direct restore. Factory strapping is for queued restore.

Because the queued restore command is entered into the input command buffer, the INPUT BUFFER READY status line must be low prior to issuing a queued RESTORE command. While the INPUT BUFFER READY status is false (high), all commands issued, including a queued restore, will be ignored. When the printer is in "CHECK", the restore command can be issued regardless of the INPUT BUFFER READY status. Before issuing a queued restore in the TwinTrack model, any one, but at least one, of the ready signals (character, paper, or carriage) must be checked.

### DATA LINES (Pins 2 - 14)

These thirteen lines contain binary-coded information representing an ASCII character, a carriage movement command, a paper feed command, or a TOF form length programming command.

When representing an ASCII character, only seven lines (D1 through D64) are used; the remaining lines are ignored except by the TwinTrack model. The TwinTrack model uses the D2048 line to select the print station. If D2048 is low, the right

print station prints; if  $\overline{D2048}$  is high, the left print station prints. Further discussion of the ASCII code, printwheel address, and print intensities is given in the OPERATION Section of this manual.

When representing a carriage movement command,  $\overline{D172}$  through  $\overline{D512}$  designate the distance the carriage is to be moved in multiples of 1/60th of an inch. The  $\overline{D172}$  bit indicates 1/2 times 1/60th, or 1/120th of an inch. A value of six is required for one character at 10 characters/inch.  $\overline{D1024}$  determines the direction of carriage travel. If  $\overline{D1024}$  is high, the carriage travels to the right; if it is low, the carriage travels to the left. The  $\overline{D2048}$  bit is used in the WideTrack and TwinTrack models to represent 1024/60 inch.

When representing a paper feed command,  $\overline{D1}$  through  $\overline{D512}$  designate the number of vertical position increments to be moved, in multiples of 1/48th of an inch.  $\overline{D1024}$  determines the direction of paper movement; a high moves the paper upward, and a low moves the paper downward.  $\overline{D172}$  and  $\overline{D2048}$  are ignored.

See the OPERATION Section for using  $\overline{D172}$  through  $\overline{D2048}$  in a TOF form length define command and during the external program mode.

#### CHARACTER STROBE (Pin 18)

When this signal is pulled low and valid character bits are on the data lines, the character code will be transferred into the input command buffer. Timing considerations are given later in this section. CHARACTER STROBE is also used when programming the TOF length (see TOP OF FORM STROBE) and when using the external program mode. INPUT BUFFER READY status must be true (low) when the strobe is issued. In the TwinTrack model, CHARACTER READY must be true before the strobe is issued. TOF and external programming are described in the OPERATION Section.

#### CARRIAGE STROBE (Pin 20)

This signal, when pulled low, enters carriage movement data from the data lines into the input command buffer. Timing considerations are discussed later in this section. INPUT BUFFER READY status must be true when the strobe is issued. In the TwinTrack model, CARRIAGE READY is used instead of INPUT BUFFER READY.

#### RIBBON LIFT COMMAND (Pin 28)

This signal raises and lowers the ribbon. If the level on this line is high (false), the ribbon will drop to the lower position; if the level is low (true), the ribbon will be raised to the printing position. The MultiColor option allows the printer to print in both the raised and lowered positions. The MultiColor ribbon has two colors, making the raised position one color, and the lowered position the other color. The ribbon lift command simultaneously raises or lowers both ribbons of a TwinTrack.

### PAPER FEED MAIN STROBE (Pin 22)

When pulled low, this signal enters paper movement data into the input command buffer. In operations where a single platen is used, PAPER FEED MAIN STROBE drives the single platen. When the Dual Paper Drive option is installed, PAPER FEED MAIN STROBE drives the left platen. INPUT BUFFER READY status must be true when the strobe is issued. The TwinTrack uses PAPER FEED READY instead of the INPUT BUFFER READY signal.

### PAPER FEED AUXILIARY STROBE (Pin 24) (Optional)

When pulled low, this signal enters right platen paper movement data, assuming the Dual Paper Drive option is installed. INPUT BUFFER READY status must be true (low) when the strobe is issued. If the Dual Paper Drive is not installed, the right platen command will be entered into the input command buffer, but will be ignored by the printer when the attempt is made to execute the instruction. The TwinTrack model uses PAPER FEED READY instead of INPUT BUFFER READY.

### TOP OF FORM STROBE (Pin 26) (Optional)

This signal advances the paper to the beginning of the next form. There are sixteen programmable lengths of form feed available. The length of form to be used must be programmed prior to issuing the TOF strobe. If the form length is not programmed prior to the TOP OF FORM STROBE, the default length of eleven inches will be issued. TOF programming is discussed in the OPERATION Section of this manual. INPUT BUFFER READY status must be true when the strobe is issued. In the TwinTrack model, any one, but at least one, of the ready signals (character, paper, or carriage) must be true (low) before a TOP OF FORM STROBE can be issued.

## BASIC SIGNAL OUTPUTS

The output signals indicate the status of internal printer functions, and can be used by the external processor as flags for initiating data and control inputs.

### PRINTER READY (Pin 47)

This signal indicates that the printer is generally ready to accept data and control inputs, that it has been selected, has the correct power applied, and is not in "CHECK".

INPUT BUFFER READY (Pin 39) (CHARACTER READY)  
INPUT BUFFER READY (Pin 41) (CARRIAGE READY)  
INPUT BUFFER READY (Pin 43) (PAPER FEED READY)

These three lines are identical, but are gate isolated in all Sprint 3 models except the TwinTrack. The TwinTrack signal designations are shown in parenthesis. The input buffer must be ready before any print or move command can be given. In the TwinTrack model, the three lines are separate signals. The TwinTrack PAPER

## BASIC SIGNAL OUTPUTS (continued)

FEED READY and CARRIAGE READY signals are simultaneous, but with a different timing relationship to other signals than other Sprint 3 models. The CHARACTER READY signal is held false (high) during the complete paper move cycle.

For queued restore and top of form commands, any one of the ready lines being true (low) will allow the command to be strobed in.

### INPUT BUFFER EMPTY (Pin 45)

This signal indicates that the complete sixteen command input buffer is empty. It indicates that unless the customer strappable single command buffer is used, the printer will be able to accept a block of sixteen commands in quick succession (INPUT BUFFER READY, or the TwinTrack equivalent, must still be tested prior to each command being strobed into the printer).

### CHECK (Pin 37)

This signal indicates that a malfunction has occurred:

the carriage has been commanded to move, but the movement has not been completed; or

the printwheel has been commanded to move, but the movement has not been completed; or

the power supplies have failed.

Under these circumstances, the CHECK signal will be true (low) and no input commands will be accepted until the check condition has been cleared by correcting the malfunction and initiating either a RESTORE command or a power-up sequence. The CHECK signal disables the command input and generates the disable servo signal, turning off all high current devices.

### PAPER OUT (Pin 30) (Optional)

This signal indicates that the printer is out of paper. In printers not equipped with the paper out option, this line will always indicate a "paper available" (high) condition.

### RIBBON OUT (Pin 30) (Optional)

This signal indicates that the printer is out of ribbon. In printers not equipped with the ribbon out option, this line will always indicate a "ribbon available" (high) condition. A jumper allows the End of Ribbon detection (EOR) to indirectly inhibit the INPUT BUFFER READY status from being "true" until a new ribbon is installed. (See Customer Strappable Features in the OPERATION Section of this manual.)

## TIMING CONSIDERATIONS

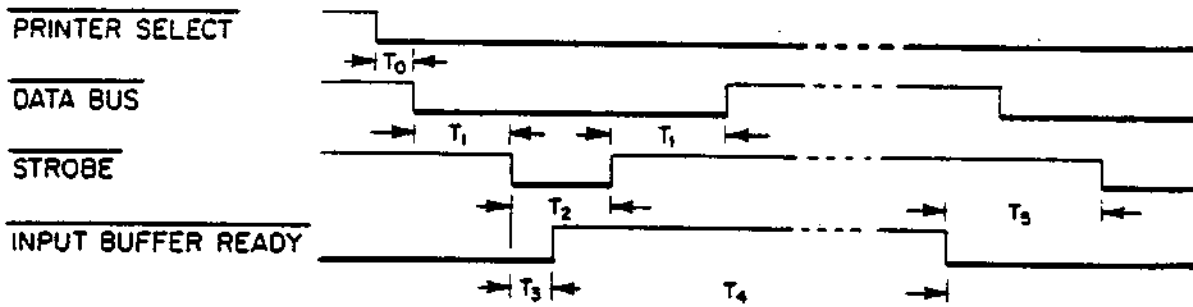

SPRINT 3

- $T_0 > 0 \text{ ns}$
- $T_1 > 200 \text{ ns}$
- $T_2 > 750 \text{ ns}$
- $T_3 < 250 \text{ ns} - 950 \text{ ns}$
- $T_4 > 20 \text{ usec}$
- $T_5 > 000 \text{ ns}$

\*Any STROBE arriving during the time that the INPUT BUFFER READY line is false ( $> 2.4 \text{ Volts}$ ) will be ignored.



- $T_1 \geq 200\text{ns}$
- $T_2 \geq 750\text{ns}$
- $T_3 \leq 250\text{ns} - 950\text{ns}$
- $T_4 \geq 20\text{us}$

SPRINT 3 TWINTRACK

- $T_5 \geq 10\text{ms}$
- $T_6 \geq 300\text{us}$
- $T_7 \geq 30\text{ms}$

$T_1$  through  $T_4$  times are the same relationship for all STB lines. The INPUT BUFFER READY lines will go false (high) for 20 to 800 usec after receiving any strobe. If the input buffer is full, INPUT BUFFER READY lines will remain false (high) until the command being executed is complete. Commands are executed in order of receipt.

## BASIC SIGNAL OUTPUTS (continued)

### COVER INTERLOCK (Pin 34) (Optional)

This signal indicates that the printer top cover is in place. In printers not equipped with the cover interlock, this line will always indicate the cover is in place. With this option installed, removing the top cover inhibits the inputs and stops the microprocessor from executing any new commands. (See Customer Strapable Features in the OPERATION Section of this manual.)

### TIMING CONSIDERATIONS

The timing diagram shown on the opposing page illustrates the relationships between the data lines, the strobe input, and the internal ready line for all Sprint 3 Printers except the TwinTrack model. Timing considerations for the TwinTrack are given as a separate illustration.

### TYPICAL COMMAND SEQUENCES

The Sprint Micro 3 printers have a sixteen command input buffer. The character, carriage, paper feed and TOF commands are first loaded into a single-command hardware buffer by their respective strobe input and are subsequently transferred, under program control, to a fifteen command first-in/first-out (FIFO) software buffer.

Commands sent to the printer are executed in order of receipt. A program controlled interlock routine decides which, if any, operations may occur simultaneously and controls the timing of the allowable "overlaps". The print cycle is divided into two parts:

- (1) Position the printwheel and advance the ribbon.
- (2) Fire the hammer.

In the TwinTrack model, both print stations can be positioning the printwheel or firing the hammer without interference to each other. However, as long as either print station is active within a print cycle, the print cycle interlock prevents new paper, carriage, or ribbon movement.

The Sprint 3 printer interlock program routine will always allow simultaneous paper movement and carriage motion. If the paper and/or the carriage motion mechanisms are executing a command and the microprocessor receives, from the input command buffer, a character print command, the interlock program routine will allow the first part of the print cycle to begin immediately. The second part of the print cycle, hammer fire, will begin only when there is no other operation in progress; all carriage, paperfeed, ribbon advance ribbon lift, or printwheel positioning operations must be completed before the hammer will fire. Once the microprocessor begins execution of the first part of a character print cycle, any new paper motion, carriage motion, TOF, or ribbon lift command will be deferred until the total print cycle is complete.

The interlock discussion on the previous page, and the example below describes the internal logic that is directed by the microprocessor within all Sprint 3 printers. While the logic circuits within the TwinTrack model remain the same as other Sprint 3 printers, command entry to the internal buffer is regulated differently. In the TwinTrack, there will never be printwheel positioning while the paper is moving. The TwinTrack immediately blocks character entry when a paper feed strobe or top of form is received. It will not accept characters until the paper move is completed. This restriction is true only for paper moves. The exact time relationship is different for the TwinTrack than for other Sprint 3 printers, but the sequence is the same. Both the normal Sprint 3 timing and the TwinTrack timing are shown following the example below.

EXAMPLE: Assume that the printer has just printed the last character of a writing line. The paper must now be advanced, the carriage returned to the left margin, type the first character on the new line, move the carriage to the right one character column width, print the second character, etc.

The commands might be received by the microprocessor from the sixteen command input buffer in the following sequence (we will discuss only the command sequence and not the specific data that would be unique for every situation).

paper feed  
carriage motion  
character print  
carriage motion  
character print  
etc.

After completing the print cycle for the last character on the writing line, the processor would receive and begin execution of the paper feed command. As long as several commands are in queue in the input command buffer, the microprocessor will be able to begin processing them, if allowed, long before any command presently being executed can finish. Shortly after beginning the paper feed command, the microprocessor will receive and begin execution of the carriage motion command. While both the paper and carriage are moving the microprocessor will receive the character print command. Since it is allowed to begin the print cycle while paper and/or carriage movement is taking place, the microprocessor will go ahead and advance the ribbon and, if necessary, reposition the printwheel. The paper, carriage, ribbon feed, and printwheel mechanisms are now all operating at the same time. The next operation to take place is hammer fire; however, hammer fire will not begin until all other motion has stopped. Until the hammer has been fired, the microprocessor will not begin any new operations. Once hammer fire is complete, the next command, carriage movement, will begin. While the carriage is being moved one character column to the right the next character print operation will begin, allowing ribbon advance and printwheel repositioning, but deferring hammer fire until the carriage motion is completed.



## CHAPTER II

### INSTALLATION

#### INTRODUCTION

This chapter describes installation of the Sprint Micro 3 Series printers, including receiving, quality assurance inspection, and electrical interface. Warranty, service, and training policies are also described at the end of the section.

#### RECEIVING

Each printer is shipped in an individual carton attached to a wooden pallet. The following items are also included:

Power Connector (Qume P.N. 80033)  
Hole Plugs (Printer with covers only)  
Interface Connector Hood (Qume P.N. 80034)

Unpack the printer as follows:

- . Inspect the container for external signs of damage. If any damage is observed, have the delivery agent note the damage on the shipping document. Some shippers may wish to be present when the container is opened if external damage is apparent.
- . Open the outer container and remove the inner carton.
- . Open the inner carton from the top and remove the cardboard spacer. The printer, bolted to its shipping pallet and wrapped in plastic, can now be withdrawn.
- . Remove the plastic bag surrounding the printer.
- . Using a 7/16" socket wrench, remove the four screws securing the printer to its shipping pallet.
- . Install hole plugs in the printer cover (if ordered) in holes vacated by pallet screws.
- . Remove any paper wrapped around the platen.
- . Remove the top front cover by lifting up at the operator side of the printer.
- . Using diagonal cutting pliers, cut and remove the two plastic ties securing the paper bail during shipping.
- . Cut and remove the plastic tie securing the carriage assembly to the printer chassis.

## RECEIVING (continued)

- . Examine the packing material closely to ensure that any small items ordered have been recovered (e.g. Power Connector Assembly Qume P.N. 80033 or Logic Connector Hood Assembly Qume P.N. 80034).
- . Retain all packing materials for possible reshipment.
- . Inspect the printer for scratches, dents, loose or damaged parts or other signs of damage. Note any evidence of such damage on the invoice, and file a claim with the carrier immediately, if the condition of the unit so warrants.
- . Remove the middle printer cover as follows:
  - . Remove the platen by grasping at each end, and depressing both latch mechanisms.
  - . Remove the three 8/32 screws at the rear of the unit.
  - . Unscrew the seven 10/32 captive screws inside the periphery of the cover.
  - . Lift the center cover free, being very careful to disconnect any associated wiring.
- . Inspect the interior of the entire unit. Look for loose or broken parts, evidence of electrical damage, or other signs of damage. Be sure that all printed circuit boards are seated securely in their sockets by pressing down on each one of the boards.
- . If damage that might impair printer operation is detected, do not attempt to operate the printer. Contact Qume for advice and instructions.
- . When the internal inspection is complete, replace the middle cover.
- . Install the platen, a printwheel, and ribbon cartridge.
- . Replace the top cover.
- . Connect the data cable.

Note: The ideal performance check uses the system with which the printer will operate, and executing a suitable exercise routine. However, if the system is not available, an alternate performance test for all Sprint 3 printers except the TwinTrack is given below.

- . Connect the printer to the power supply. Turn power on and verify that supply voltages are within specification. On S3 printers check +5 V supply at test point indicated on P.C.B. #2; check  $\pm 15$  V supply at the emitters of carriage drive transistors Q2 and Q1 (Q2 and Q1 are mounted on the heat sink at the right rear of the printer frame).

+ 5 VDC  $\pm$  3%  
+ 15 VDC  $\pm$  10%  
- 15 VDC  $\pm$  10%

## RECEIVING (continued)

- . Turn power off.
- . Connect the printer to a Printer Exerciser/Tester.
- . Apply power and verify that the carriage "restores" to the extreme left limit at a moderate velocity.
- . Press the ribbon advance switch on the printer and verify that the ribbon both lifts and advances correctly.
- . Insert a piece of paper into the platen.
- . Pull the feed roller release lever forward and verify that this allows the paper to be aligned. Push feed roller release lever to the rear.
- . On printers ordered with cover assemblies and cover interlock switch, verify that removing the top cover disables the printer (printer exerciser CHAR RDY, CARR RDY, PF RT RDY, and PF LFT RDY LED's will be OFF, only the PTR RDY LED will be ON).
- . Replace top cover.
- . If Top Of Form option has been ordered, verify that it works correctly. This function can be operated from the printer exerciser or, if ordered, from the "TOF" switch on the printer cover.
- . Print one line of Test 5-1 from the exerciser. (See exerciser instructions for test details.) Verify that the characters are printed evenly and are consistent from side to side and top to bottom.
- . Complete a 15 minute warm-up using printer exerciser Test 5-1 with vertical line spacing of six lines to the inch. Verify that print is equally dark through-out the printout (verifies proper ribbon advance).

In the Sprint Micro 3 Series printers the end of ribbon option is factory strapped so that it does not disable the printer and is only a status condition which provides a status signal to the interface. The Qume exerciser does not monitor this line. Only one of the two print stations and only part of the internal logic within the TwinTrack is exercised by the Printer Exerciser/Tester.

### Self Test (no exerciser available)

An alternate check may be performed by grounding pin 2 of the 40 pin test point strip on P.C.B. #2. The printer must be powered down when securing a jumper between ground and pin 2. In this test the printer relies on a diagnostic test stored in its own micro processor memory. Instead of grounding pin 2, this test may be monitored and controlled by the Sprint Micro 3 ActivityMonitor (Qume P.N. 80740). When the activity monitor is connected to the 40 pin test point strip, the ON/OFF switch on the activity monitor panel starts the test. Special consideration must be made when testing the TwinTrack model. These considerations are described at the end of this test.

The diagnostic test performs the following:

## RECEIVING (continued)

ROM test.

I/O lines.

Executes a restore.

Carriage moves 114 times back and forth in diminishing movements.

Printwheel moves 96 times clockwise and counter clockwise.

Executes various combinations of forward and reverse paper feeds.

Concludes test with "Self Test" printed vertically. Ribbon lift, hammer acutation and ribbon advance are exercised during this print cycle.

Some printers with certain options have an extended self test that continues after the test above by printing a single line of the complete ASCII character set from the printwheel that is installed. Manual intervention is not necessary for the extended test.

TwinTrack printers can be made to self test if both #2 boards are jumpered from pin 2 of the 40 pin test point strip to ground. The printer must be powered down when the connections are made. The test begins when printer power is applied. The test proceeds as listed above, but both printwheels will print the "self test" vertically. If the printer contains the extended self test, the single line of ASCII characters will overlap as the one printwheel reaches the area that was already printed by the other printwheel.

The Sprint Micro 3 ActivityMonitor can be used to monitor the self test in the TwinTrack. However, the #2 board that is not connected to the activity monitor must have pin 2 of the 40 pin test point strip grounded. Both the activity monitor connection and the pin 2 grounding must be done while the printer is powered down. The activity monitor must be ON before the printer is powered up. When the activity monitor is used in this way, only half of the circuits are being monitored. To check the other half of the circuits, power the printer down and connect the activity monitor to the other #2 board, and ground pin 2 of the 40 pin test point strip where the activity monitor was last connected.

If two Sprint Micro 3 ActivityMonitors are available, connect one to each of the #2 boards in the TwinTrack. This must be done while the printer is powered down. Before powering up the printer, set both activity monitors to ON. The self test will begin when the printer is powered up, and the activity of each circuit will be displayed on the monitor panel.

## CHAPTER III

### OPERATION

This chapter reviews the operator duties and functions, and describes the customer strappable features, the optional modes for external printwheel and hammer programming and Top of Form programming. For detailed printer operating instructions refer to the Operation Manual, Qume P.N. 32213.

#### TURNING ON THE PRINTER

Printer power comes from a separate power supply. The ON/OFF switch location for the power supply will vary with the system configuration unless the optional Qume power supply is used. The Qume switching regulator power supply attaches to the rear of the printer, and appears to be a part of the printer. If the Qume switching regulator power supply is attached to the printer, the power ON/OFF switch is located on the right side of the printer (from the operator position) near the rear. The switch is a "push-push" type. That is to say, pushing the button once will toggle the switch to the opposite state. Pushing the button again will return the switch to the first state. If the power is not already ON when the power cord is connected to the source outlet, pressing the button once will turn it ON.

#### CHANGING RIBBONS

Sprint 3 printers will accommodate a variety of ribbons. The three basic ribbon types are carbon (multi-strike or single strike), cloth (in a large number of colors), and MultiColor (a variety of two-color cloth ribbons that require an optional ribbon guide). Cloth ribbons are an endless loop and require changing only when the loss of print quality requires it. Carbon ribbons have a clear section at the beginning and end, and must be changed when the supply spool is depleted.

Changing the ribbon is an operator function, and is done as follows:

- . Remove the top printer cover by lifting up at the front edges.
- . Depress the red ribbon release lever shown as item D in the illustration.

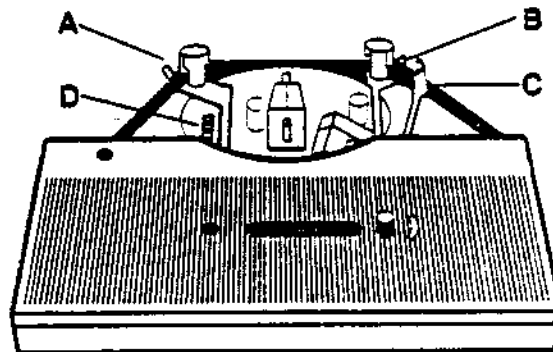

RIBBON CARTRIDGE

## CHANGING RIBBONS (continued)

- Lift out the cartridge and unthread from the two guides, A and B.
- Thread the new ribbon through the guides as shown, and around the outside of the tensioner, C, and snap the cartridge in place.
- Depress the ribbon feed switch (shown in the illustration below) until the clear leader disappears, or for a cloth ribbon, until it is feeding properly.

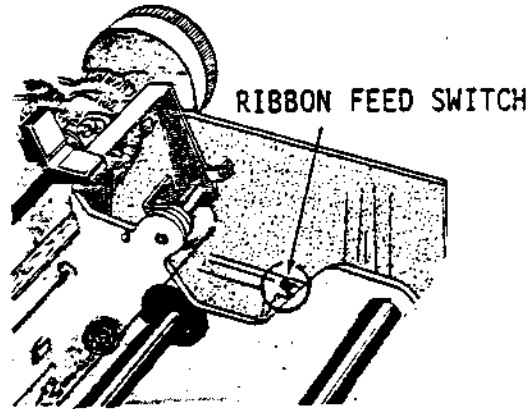

- Replace the top cover.

## CHANGING PRINTWHEELS

Changing the printwheel is an operator function, and can be done whenever a change in typeface is desired. The printwheel is changed as follows:

- Remove the top cover and ribbon as described in the paragraphs above.
- Unlock the printing mechanism by depressing the "0" (open) lever near the printwheel (see the illustration).

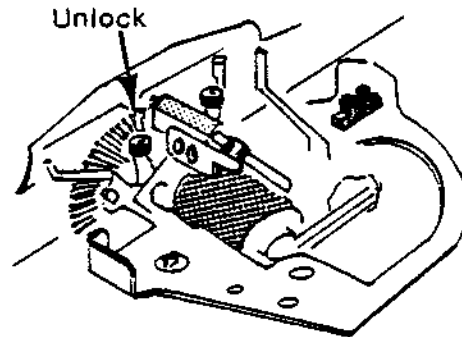

UNLOCK BUTTON

## CHANGING PRINTWHEELS (continued)

- Tilt the printing mechanism forward to an upright position.
- Lift the printwheel off by grasping firmly and pulling as shown in the illustration.

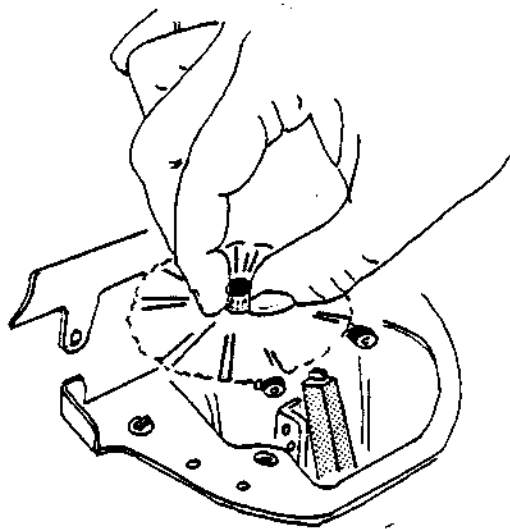

CHANGING THE PRINTWHEEL

- Place a new printwheel onto the hub, making sure that the hole in the printwheel engages the alignment stud (see the small illustration).

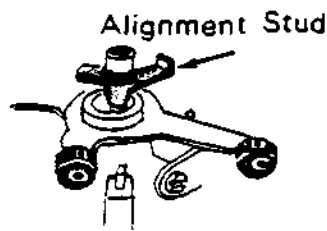

- Return the printing mechanism to the horizontal position.
- Lock the mechanism into place by depressing the lever marked "C" (close). There should be a definite "click" as the mechanism locks.
- Replace the ribbon cartridge and top cover as described previously.

## PAPER CONTROLS

The paper controls are similar to those of a standard office typewriter. The multicopy selector lever is on the left, from the operator position, and controls the distance between the printing mechanism and the platen. The multicopy selector lever should be in the forward position (toward the operator) for single part forms, and one or more notches toward the rear as needed for thicker forms.

The right hand lever (paper release) releases pressure on the paper when the lever is in the forward position. This allows the paper to be positioned for proper tracking and alignment. When the paper release lever is allowed to return to the rear, normal paper tension is resumed.

NOTE: When the optional pin feed platen or forms tractor is used, the paper release lever should remain in the forward (released) position.

The platen knobs at each end of the platen can be rotated to vertically position the paper. Fine adjustment can be made by pushing inward on the right-hand knob, releasing the platen from the drive motor gears. If the platen is not released from the motor when it is moved, manual paper movement will appear to "detent" every 1/12".

## CUSTOMER STRAPPABLE FEATURES

Sprint 3 printers have four customer strappable features for broader versatility in the end user system. The features select queued or direct restore, enable or disable the cover interlock, provide a sixteen input or single input command buffer, and select the action taken by the printer when the end of ribbon is detected. When printers are shipped from the factory, they are strapped for queued restore, cover interlock enabled, sixteen command input buffer, and if equipped with an End of Ribbon Detector, the ribbon out signal is sent to the interface only.

The location of the customer strappable features is shown in the illustration below. All are on the #2 board. A description of the exact action of each feature follows the illustration.

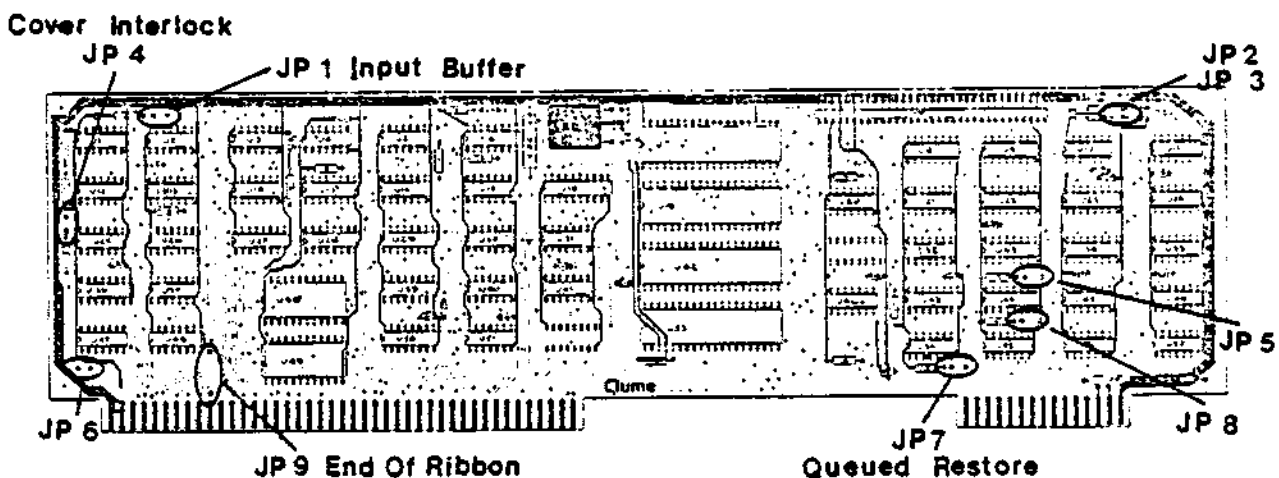

CUSTOMER STRAPPABLE FEATURES



### QUEUED/DIRECT RESTORE (JP-7)

When the JP-7 strap is in position, restore commands are entered into the input buffer as a normal command. Any commands that are not yet completed, and queued commands waiting in the input buffer will be completed before the restore is implemented. However, when the printer is in "check", a restore causes immediate cancellation of existing and queued commands, and the restore is executed immediately.

When the JP-7 jumper is not connected a restore command immediately aborts in-process commands, and initializes the printer. Any commands that may have been in the input buffer are lost.

### COVER OPEN INTERLOCK ENABLE/DISABLE (JP-4)

When JP-4 is not connected, the Cover Open Interlock prevents any new operation, but does not interrupt an already in-process command. For printers that are not purchased with the optional cover interlock switch, the customer must either install an interlock switch, connected to J20 on the side frame or J4 on the motherboard, or must disable the interlock circuit.

Jumper JP-4 disables the interlock circuit when the connection is made. An open cover will not disable the printer.

### SIXTEEN/SINGLE INPUT COMMAND BUFFER (JP-1)

The sixteen command input buffer can be disabled by connecting JP-1. When JP-1 is connected the input buffer becomes a single command input. Additional commands cannot be entered until the current command begins execution. Commands can be overlapped in execution, but only one will wait in queue in the input buffer.

### END OF RIBBON DETECT (JP-9)

For printers that contain the End of Ribbon Detect option, the detected signal is sent only to the interface when JP-9 is open.

Placing a jumper on JP-9 causes an inhibit to the ready status signals when the end of ribbon signal is detected. With the ready status signals disabled, all commands already in queue in the input buffer, and in-process commands will be completed, but no new commands can be entered. There is enough ribbon after the end of ribbon detection to complete the possible maximum number of print commands that could be in the input buffer.

### EXTERNAL PROGRAM MODE

Under normal operation the Sprint 3 printer is given a character to print, and the hammer intensity and ribbon advance are automatically calculated by the micro-processor. For special applications the hammer force and ribbon advance can be externally controlled. To do this the printer is given an ASCII S0 (shift out) character and a CHARACTER STROBE. All following characters must then contain the hammer intensity and ribbon advance information. The tables that follow show the additional bits that are needed and the normal intensities and ribbon advance. The ASCII character code is placed on the DI through D64 lines as always, and the remaining lines are used for the external programming information.

PROPORTIONAL RIBBON ADVANCE  
(RIBBON MOTOR STEPS)

CURRENT CHARACTER WIDTH (Ribbon Motor Steps)	LAST CHARACTER WIDTH (Ribbon Motor Steps)			
	5	4	3	2
5	5	4	4	3
4	4	4	3	3
3	4	3	3	3
2	3	3	3	2

EXTERNALLY PROGRAMMED  
RIBBON ADVANCE

Ribbon Advance Increments	Character Print Command Data Lines	
	$\overline{D1024}$	$\overline{D1/2}$
2	0	0
3	0	1
4	1	0
5	1	1

EXTERNALLY PROGRAMMED  
HAMMER INTENSITY

HAMMER INTENSITY	HAMMER "ON" TIME (ms)*	DATA LINES		
		D512	D256	D128
1	1.60	0	0	1
2	1.70	0	1	0
3	1.85	0	1	1
4	2.00	1	0	0
5	2.25	1	0	1
6	2.50	1	1	0

\* These standard intensities do not apply to "X" models, or if the optional Twintellect switch is in the SPECIAL CHARACTER position.

## ASCII CODE

CHAR- ACTER	ASCII BINARY CODE	ASCII HEX CODE	DECIMAL PRINTWHEEL ADDRESS	RELATIVE HAMMER FORCE	RIBBON ADVANCE
A	100001	41	022	5	4
B	100010	42	016	5	4
C	100011	43	020	4	3
D	1000100	44	044	5	4
E	1000101	45	030	4	3
F	1000110	46	018	4	3
G	1000111	47	048	5	4
H	1001000	48	034	5	4
I	1001001	49	040	4	3
J	1001010	4A	058	5	3
K	1001011	4B	056	5	4
L	1001100	4C	042	4	3
M	1001101	4D	012	6	4
N	1001110	4E	038	5	4
O	1001111	4F	036	5	4
P	1010000	50	052	4	3
Q	1010001	51	054	5	4
R	1010010	52	026	5	4
S	1010011	53	028	4	3
T	1010100	54	032	4	4
U	1010101	55	046	5	4
V	1010110	56	060	4	4
W	1010111	57	008	6	4
X	1011000	58	064	5	3
Y	1011001	59	050	4	4
Z	1011010	5A	014	4	4
a	1100001	61	168	4	4
b	1100010	62	156	4	3
c	1100011	63	158	4	3
d	1100100	64	152	4	3
e	1100101	65	166	3	3
f	1100110	66	178	3	3
g	1100111	67	148	4	3
h	1101000	68	174	4	3
i	1101001	69	170	3	3
j	1101010	6A	144	3	3
k	1101011	6B	186	4	3
l	1101100	6C	154	3	3
m	1101101	6D	142	6	4
n	1101110	6E	164	4	3
o	1101111	6F	160	4	3
p	1110000	70	180	4	4
q	1110001	71	184	4	4
r	1110010	72	162	4	3
s	1110011	73	176	4	3
t	1110100	74	172	4	3
u	1110101	75	182	4	3
v	1110110	76	146	3	4

ASCII CODE (continued)

CHAR- ACTER	ASCII BINARY CODE	ASCII HEX CODE	DECIMAL PRINTWHEEL ADDRESS	RELATIVE HAMMER FORCE	RIBBON ADVANCE
w	1110111	77	000	5	4
x	1111000	78	150	4	3
y	1111001	79	188	4	4
z	1111010	7A	190	4	3
0	0110000	30	074	4	3
1	0110001	31	066	3	3
2	0110010	32	068	4	3
3	0110011	33	070	4	3
4	0110100	34	072	4	3
5	0110101	35	076	4	3
6	0110110	36	078	4	3
7	0110111	37	080	4	3
8	0111000	38	082	4	3
9	0111001	39	084	4	3
e	0100000	20	004	4	3
!	0100001	21	136	3	2
"	0100010	22	140	2	3
#	0100011	23	092	4	3
\$	0100100	24	088	5	3
%	0100101	25	094	6	4
&	0100110	26	138	5	4
'	0100111	27	108	2	2
(	0101000	28	120	4	2
)	0101001	29	116	4	2
*	0101010	2A	122	3	3
+	0101011	2B	090	3	3
,	0101100	2C	006	1	2
-	0101101	2D	086	2	3
.	0101110	2E	010	1	2
/	0101111	2F	132	4	3
:	0111010	3A	024	1	2
;	0111011	3B	062	1	2
<	0111100	3C	114	3	3
=	0111101	3D	096	3	3
>	0111110	3E	100	3	3
?	0111111	3F	130	3	3
@	1000000	40	124	6	4
[	1011011	5B	106	4	2
\	1011100	5C	126	4	4
]	1011101	5D	102	4	2
^	1011110	5E	128	2	3
_	1011111	5F	110	1	5
`	1100000	60	112	2	2
{	1111011	7B	098	4	3
	1111100	7C	118	4	2
}	1111101	7D	134	4	3
~	1111110	7E	104	3	3
~	1111111	7F	002	2	3

## EXTERNAL PROGRAM MODE (continued)

The D2048 line is used only by the TwinTrack model to specify the left or right print station. The printer stays in the external program mode until an ASCII SI (shift in) character is received. It then returns to normal.

It is often possible to externally program a completely non-standard printwheel. The ASCII code table shows the normal printwheel address for the ASCII characters and the hammer intensities and ribbon advance. By using a software conversion table, printwheel addresses can be given for non-standard printwheels, and the hammer and ribbon information can be externally programmed (within the standard values). This procedure is much easier, however, if a ROM (read only memory) is available for the particular non-standard printwheel. If a ROM is available, the Twintellect option can be used, and the operation is automatic again.

### *Twintellect*

The Twintellect option switches an extra ROM in or out of use. The extra ROM is configured to handle a particular non-standard printwheel. All of the printwheel address information, hammer intensities and ribbon advance are pre-programmed into the ROM. When a standard printwheel is used on the printer, the operator manually switches to the standard program. This is a toggle switch that is located next to the ribbon advance switch.

Each non-standard printwheel type requires a unique ROM. Sprint 3 printers with the Twintellect option have the standard operating program, and an additional ROM for the special requirements of a particular printwheel. The TwinTrack model with two Twintellect options, however, can accept an additional ROM for each print station, making it possible to use one standard, and one non-standard printwheel, or two non-standard printwheels.

ROMs and printwheels are developed as needed. For the latest additions to the printwheel family, refer to the price catalog for printers and accessories (Qume P.N. 30032).

## TOP OF FORM PROGRAMMING

Sprint 3 printers contain a top of form feature that advances the paper to the next heading, or ejects a page when single sheets are used. The Top of Form feature can be used by issuing a TOP OF FORM strobe or depressing the optional TOF push button. A standard or default value of eleven inches is used when no other top of form value has been previously entered.

Form length information can be entered to define one of sixteen form lengths. This information must be re-entered after each restore or power up. To enter form length information, an ASCII form feed (FF) command is placed on lines D64 through D1. The ASCII FF code is 0001100 (MSD, or D64 line shown to the left). A binary value from the following table is also placed on the D1024 through D128 lines. With the FF and the binary code for the form length on the data lines, a CHARACTER STROBE is issued to enter the information.

<u>DATA BITS OF FF COMMAND</u>				<u>FORM LENGTH</u> <u>(INCHES)</u>
<u>D1024</u>	<u>D512</u>	<u>D256</u>	<u>D128</u>	
0	0	0	0	11 (Note 2)
0	0	0	1	3
0	0	1	0	3.5
0	0	1	1	4
0	1	0	0	5
0	1	0	1	5.5
0	1	1	0	6
0	1	1	1	7
1	0	0	0	8
1	0	0	1	8.5
1	0	1	0	9
1	0	1	1	10
1	1	0	0	11-2/3 (70 lines)
1	1	0	1	12
1	1	1	0	14
1	1	1	1	17

The data shown below will enter a form length of fourteen inches.

CHARACTER STROBE and

<u>DATA 1/2</u>	not used	
<u>DATA 1</u>	0	} ASCII FF (Form Feed)
<u>DATA 2</u>	0	
<u>DATA 4</u>	1	
<u>DATA 8</u>	1	
<u>DATA 16</u>	0	
<u>DATA 32</u>	0	
<u>DATA 64</u>	0	
<u>DATA 128</u>	0	
<u>DATA 256</u>	1	See Table 3-4
<u>DATA 512</u>	1	
<u>DATA 1024</u>	1	

# CHAPTER IV

## THEORY OF OPERATION

### INTRODUCTION

Mechanically the printer is similar and can be compared to a "fixed platen" typewriter originally marketed by the IBM Corporation and now produced by at least one other company. The paper is fed around a platen, using pinch rollers and the necessary guides exactly as in a typewriter. In the standard version of the printer, paper is friction fed. Options include a pin feed platen and an operator installed tractor feed mechanism. Paper is moved physically by a stepper motor, geared to drive the platen (and the tractor feed if it is attached). The stepper motor increments translate to 1/48 of an inch at the paper.

Just as it is in a fixed platen typewriter, the carriage with the printing element is positioned across the platen to the proper horizontal column on the paper. This is where the similarity ends. Carriage movement in the Qume printer is driven by a servo motor and a cable/pulley arrangement. (See the figure below.) Rigid guiderails and lightweight but rugged ball bearing assemblies allow the carriage to freely move horizontally with virtually no freedom in other directions. The entire carriage assembly design is aimed at low inertia and high rigidity for fast, accurate movement. The carriage servo system has stable positions every 1/120 of an inch at the paper.

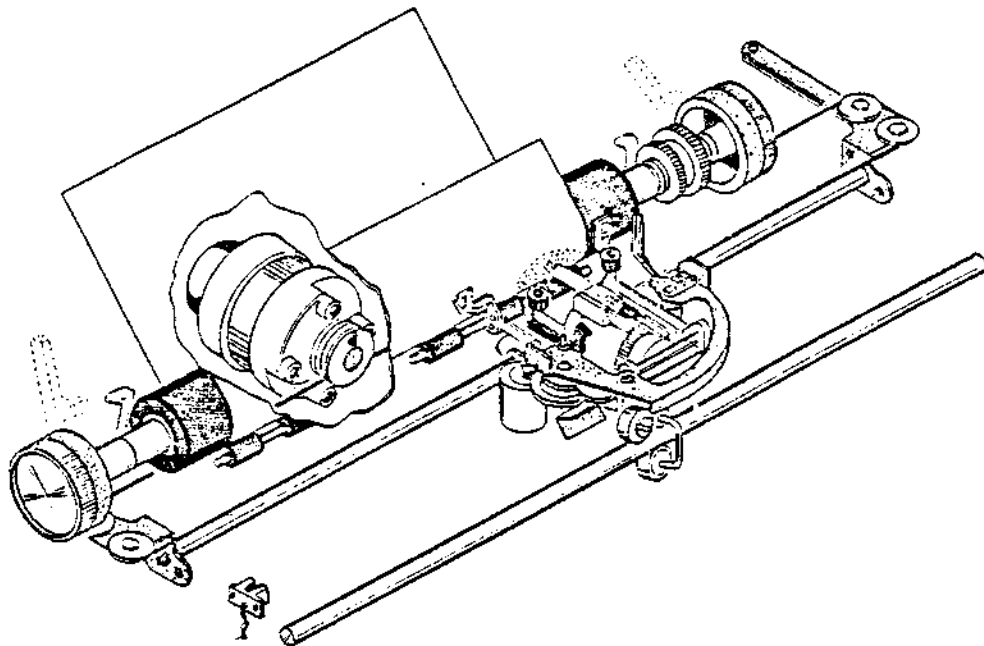

SIMPLIFIED MECHANICAL CUTAWAY

## INTRODUCTION (continued)

The print station on the carriage consists of a ribbon mechanism with a feed motor and lift solenoid, a printwheel motor and printwheel, and a printhead. The printwheel is lightweight plastic (sometimes metalized) with character dies at the end of individual spokes. When the proper character die is in position, the hammer strikes the rear of the die causing it to flex and strike the paper. The ribbon is between the paper and the printwheel, and is captured between the character die and the platen, depositing ink on the paper in the character form.

Mechanically the various models are similar enough that a basic understanding of one model will allow the reader familiarity with all of the models. Exact part exchangeability is obviously not possible in some cases, and is subtly impossible in other cases. But the basic mechanical function of the part is the same from one model to the next.

Ribbon lift and feed are separate sub-systems. Ribbon lift is a simple solenoid that is given a lift pulse, then a lower intensity hold current. The ribbon advance is a more complicated circuit (discussed in the electrical section of this chapter). Actual ribbon movement is driven by a small stepper motor that is a part of the carriage assembly.

From a mechanical standpoint, the printer works as follows:

- . The carriage motor is made to rotate, feeding the rotational information back into the electronic control circuits.
- . The rotation winds a cable onto a spool, or pulley, and unwinds another cable from the same spool.
- . These cables pass around pulleys at each end of the printer frame, and pull the carriage in the commanded direction.
- . When the electronic control circuits determine that the movement is correct, the motor is commanded to stop moving.
- . The printwheel motor moves independently, feeding back electronic information to the printwheel circuits. This movement can coincide with carriage movement.
- . When the proper character is in the print position, the motor is commanded to stop.
- . Either previously or during carriage movement, or during character positioning, the ribbon is lifted by activating the ribbon lift solenoid.
- . As another independent action, the ribbon is advanced the proper number of increments for best ribbon conservation.
- . When all other movement has stopped, the hammer is activated by the hammer solenoid.



## INTRODUCTION (continued)

- The hammer moves toward the platen, forcing the character die to impress the character through the ribbon onto the paper. The last portion of the hammer travel is "free-flight" in that the hammer is no longer being propelled. The impact energy is controlled by inertia, or most directly by the initial velocity (see the electrical explanation for velocity control).
- When the hammer, printwheel spoke (character die), and ribbon collide with the platen, the printhead is "bounced" back to its resting position. There is a small spring in the hammer assembly that keeps the hammer retracted when not in use. But by far the greatest return force is the "bounce" effect.
- Just before the next character is printed, the ribbon is advanced in proportion to the width of the character that was printed previously and the character that is about to be printed.

## ELECTRICAL OPERATION

The figure on the following page shows a simplified block diagram of the printer. As this discussion progresses, the individual blocks will be explained, and finally the overall flow from block to block.

## SPLIT-PHASE STEPPER MOTORS

The printer uses stepper motors for paper feed and ribbon feed. A short explanation of these conventional motors is given in the following paragraph for those who may not be familiar with them.

The motor can be explained as two pairs of field windings around a magnetic armature. The armature in the ribbon motor is a permanent magnet material for compactness. When the field coils are excited, the armature aligns to the magnetic field that is created. By changing the relationship of the fields, the motor armature aligns to one of four directions. The figure below is a simplified illustration of the relative fields and the direction of current flow to align the armature in each of the four directions.

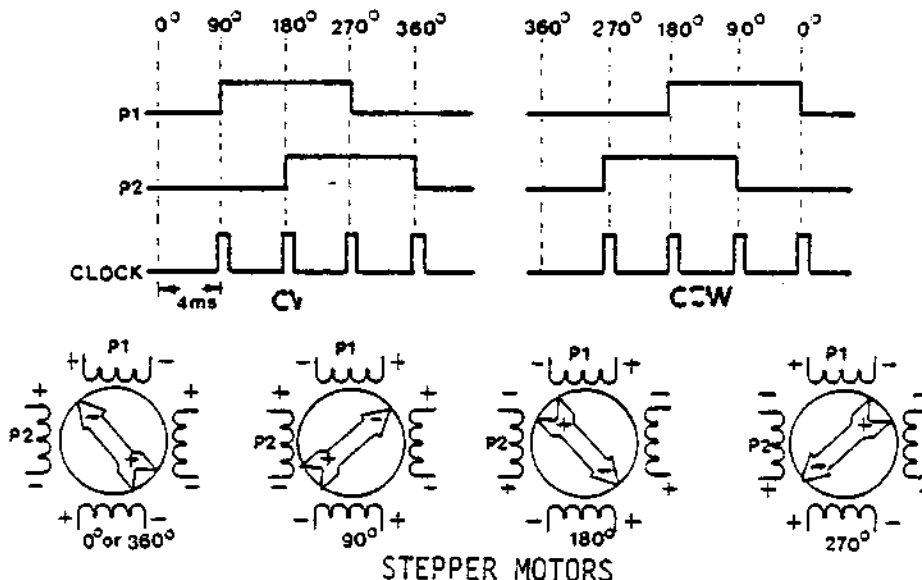

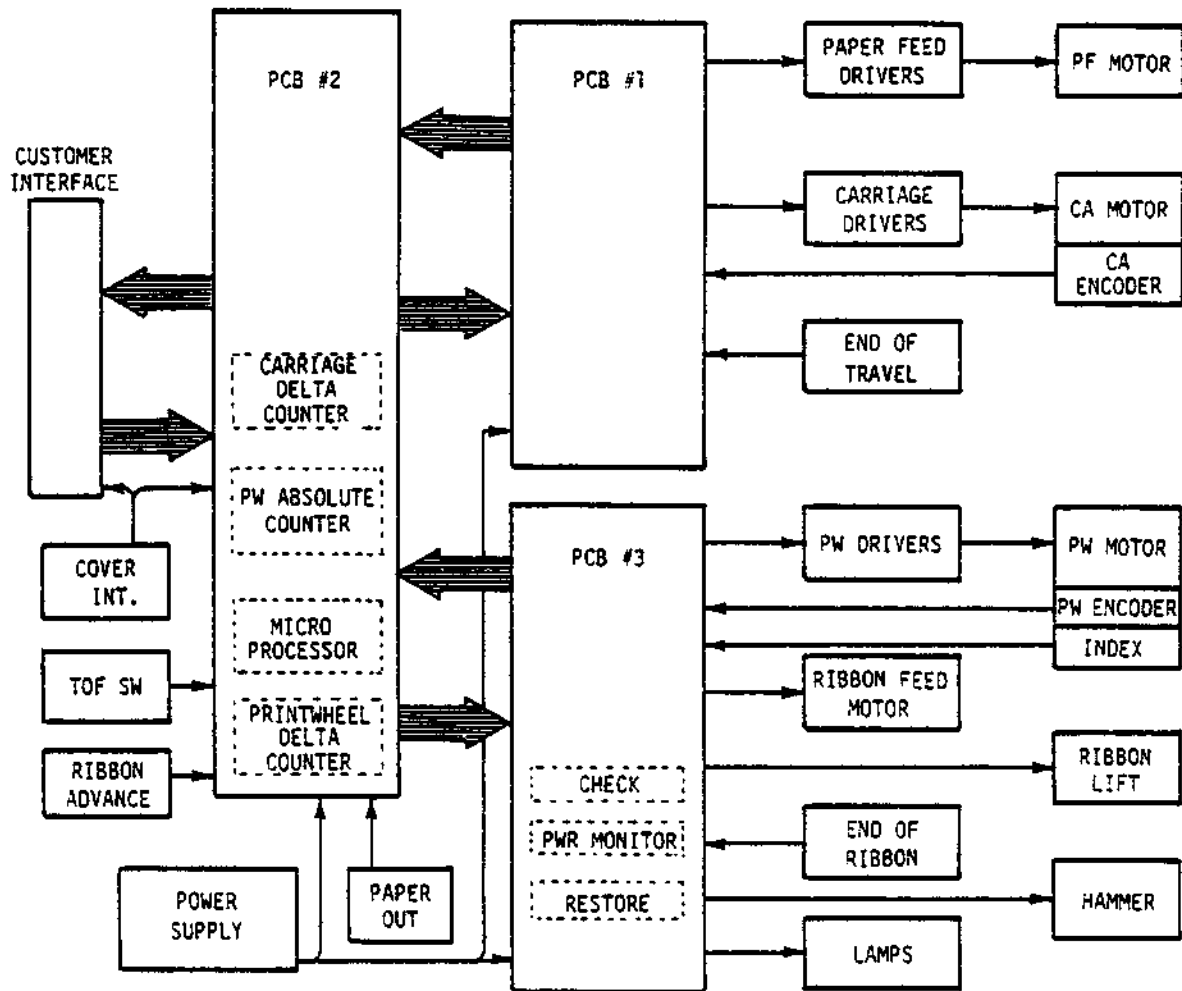

OVERALL BLOCK DIAGRAM

## SPLIT-PHASE STEPPER MOTORS (continued)

Control for the stepper motors comes from two sources, 1 and 2, for each motor. They are driven by a circuit that places the motor field current in the proper sequence to move in either direction or hold, whatever is desired.

## OPTICAL SERVO SYSTEMS

A servo system is a closed loop where a controlling circuit sends signals to a device that creates some kind of action. The resulting action in turn causes a change (is fed back) in the controlling input creating a new input to the action device. In this case, the action device is a servo motor and the action is rotation; the feedback from the the resulting action is from optical encoders on the motor shaft.

The printwheel and the carriage motors are DC servo motors. A DC servo motor is not essentially different from any ordinary motor except that it is designed for quick acceleration and deceleration and is part of a servo loop. Being a DC motor, it is reversible by changing the direction of flow in the field current.

The printwheel and carriage motors, while they are considerably different in size and duty, operate in the same manner. The printwheel motor has one addition that will be explained later.

The motor armature shaft extends from the rear of the motor. Attached to the extended shaft is an optical encoder disc. The disc is nothing more than a glass plate, silvered in radial patterns that appear similar to spokes of a wheel. Beneath the encoder disc are two photovoltaic cells spaced so that when one is exposed, the other is half covered by a silvered area. Above the encoder disc is a light emitting diode (LED). (See the illustration below.)

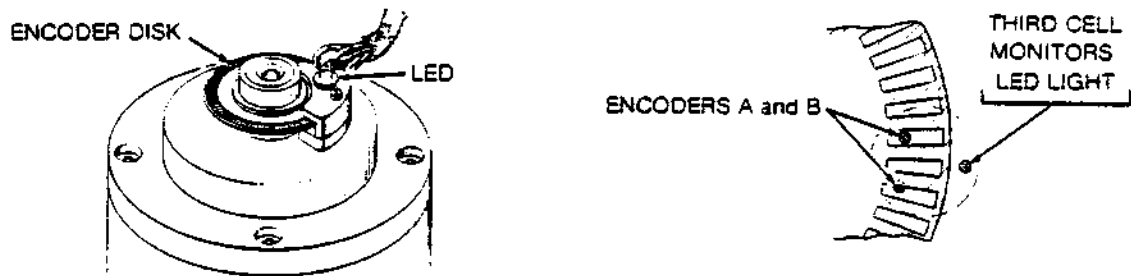

OPTICAL ENCODER

Photovoltaic cells produce a voltage when stimulated by light. One of the cells is called encoder A, the other is called encoder B. As the shaft is rotated, each of the two cells, illuminated by the LED, produces a sinewave output directly proportional in frequency to the rate of rotation. Because of the cell spacing, the two sinewaves are phased 90° apart. The light source (LED) is inherently unstable with temperature, and ideally the encoder output should not be affected by environment. So, a compensator is built into the system.

The temperature compensator consists of a third identical photovoltaic cell that is mounted outside of the influence of the encoder disc and is illuminated by the same light source. This cell is called the CLEAR cell. The output is taken from

## OPTICAL SERVO SYSTEMS (continued)

the CLEAR cell, is amplified, and compared with a standard voltage. If the light output from the LED changes, the voltage output from the CLEAR cell changes. The difference is then given to the LED source circuit, and compensation is made to the LED current until the CLEAR cell reports the proper output.

The encoder outputs are used basically for four separate, but related, purposes - direction, velocity, distance and position lock. The carriage has a delta ( $\Delta$ ) counter on board #2 that is loaded indirectly by the carriage move command, and decremented by the carriage clock signal as movement progresses. The printwheel has two counters, a delta counter and absolute position counter. The PW delta counter (also on board #2) is loaded from the microprocessor and is decremented by the PW clock signal. The delta number that is loaded relates to the printwheel position and the desired printwheel address.

The printwheel absolute position counter circuit is related to degrees of rotation, or circular distance from an index point. The index point is established by a second LED that is optically coupled to a photo transistor through a single slot in the encoder disc. The index pulse that is generated resets the printwheel absolute counter.

The carriage direction is loaded by the carriage move command, but for the printwheel circuit to count up or down, it must know which direction the motor is turning. If movement were always commanded electrically, there would be no problem. But motion is sometimes forced mechanically by the operator. The counter follows any movement, no matter how slow. The  $\bar{X}$ ,  $\bar{Y}$  and  $\bar{Z}$  signals are fed to flip-flops as shown in the simplified drawing below. The count up or count down signals are generated according to the relationship of the encoder signals.

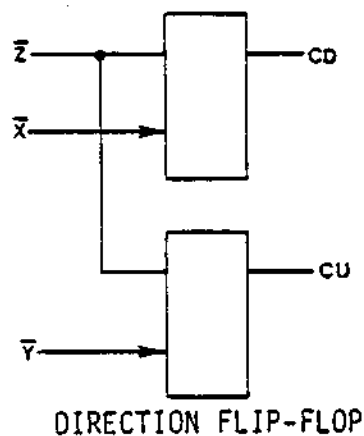

DIRECTION FLIP-FLOP

The delta counters, both printwheel and carriage, are loaded by the microprocessor. When a move is made, the extent of the move determines how much force is applied to the motor. Short moves would overshoot if full power were applied to the motor. As the movement progresses, the delta count decreases until the destination is near, and speed is then correspondingly reduced in steps. When the destination is reached, power is removed from the motor at a stable position. In practice this stable position appears to be a mechanical detent. As an attempt is made to move the motor, the force grows stronger, pushing it back to the stable position. With enough external force, the motor can be overcome, causing it to lock into another stable position. A visual representation of the acceleration/deceleration profile is shown on the next page.

## OPTICAL SERVO SYSTEMS (continued)

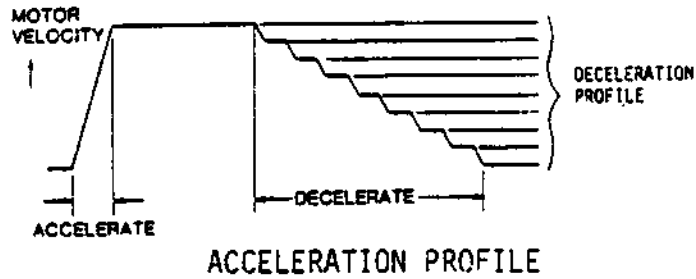

### THE SERVO LOOP

The figure below shows a block diagram of the carriage servo system. Both the carriage and printwheel servos are nearly identical, and the discussion below refers to both servo systems. The outputs of the A and B encoders are amplified, inverted, and digitized by Schmidt triggers. The Schmidt trigger remains at zero logic level

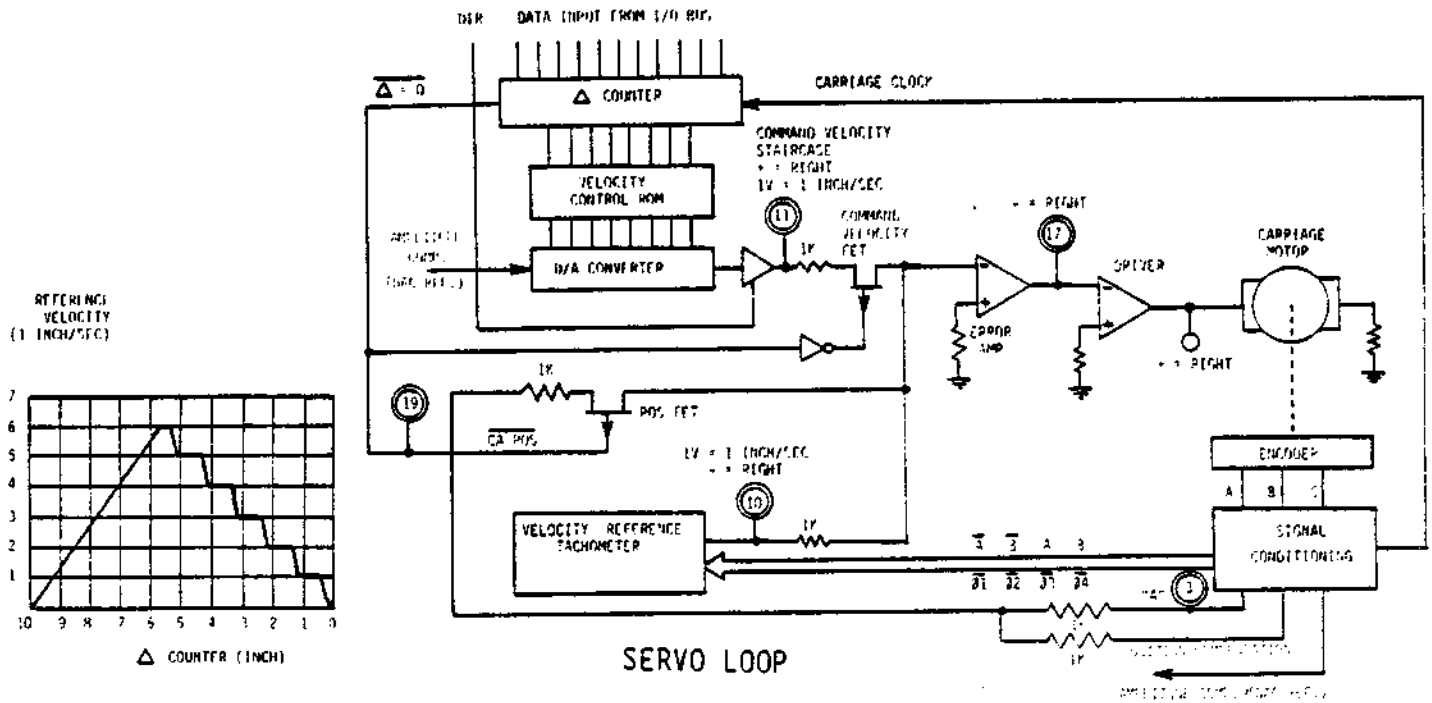

until the rising input reaches a critical voltage level. The output then quickly changes to full output. When the critical level is crossed by the decending portion of the sinewave, the logic level quickly returns to the opposite state. Three internal signals,  $\bar{X}$ ,  $\bar{Y}$  and  $\bar{Z}$  are generated this way. The figure on the next page shows the encoder sinewaves and the signals generated from them.  $\bar{X}$  is a portion of the positive peak of the encoder A sinewave.  $\bar{Y}$  is an equal portion of an inverted A encoder sinewave (corresponds to, but not derived from the negative peak of encoder A).  $\bar{Z}$  represents the most positive half of the excursion of the encoder B sinewave.

## THE SERVO LOOP (continued)

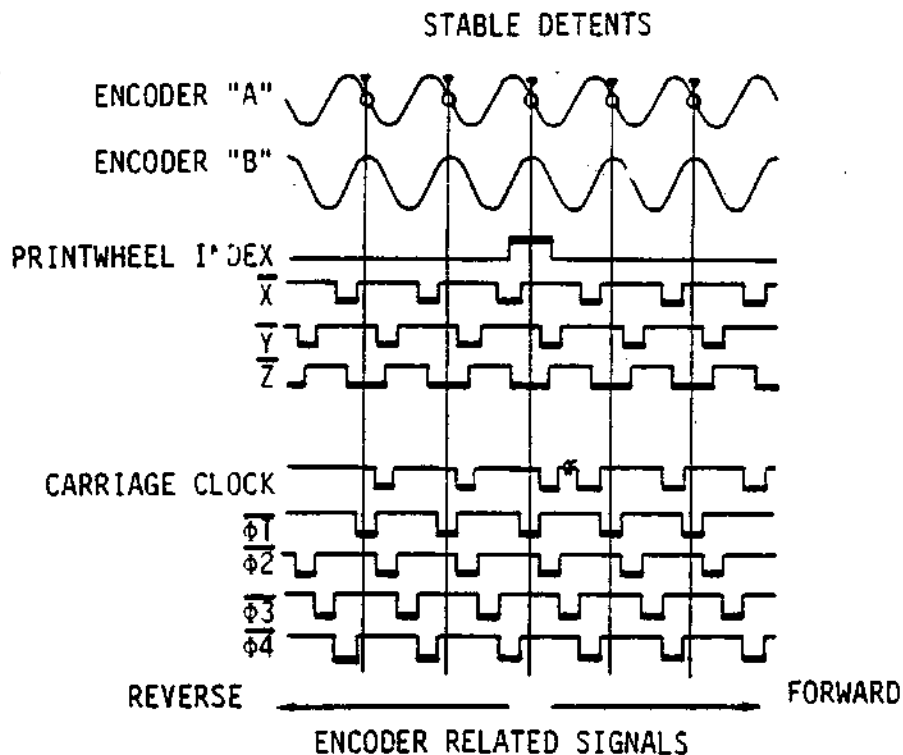

For accurate speed control, a series of timing signals must be generated. These timing signals are related to the exact axial position of the motor rather than to time itself.  $\phi_1$  ( is pronounced "fee") is the period between the end of  $\bar{X}$  and the beginning of  $\bar{Y}$ . Notice that  $\phi_1$  is the nearly straight portion of the decending encoder A sinewave. By differentiating the encoder A sinewave voltage during  $\phi_1$  time, the reference voltage for speed of rotation is obtained (faster rotation causes steeper angles and greater voltage). But,  $\phi_1$  is only a small portion of the revolution.  $\phi_2$  time is the same as  $\bar{Y}$ , and the natural phase relationship of the two encoder signals makes  $\phi_2$  the linear portion of the downward slope of the B encoder sinewave.  $\phi_3$  time is from the end of  $\bar{Y}$  to the beginning of  $\bar{X}$ , or the downward slope of the inverted encoder A sinewave.  $\phi_4$  is the same as  $\bar{X}$ , and samples the linear portion of the downward slope of the inverted encoder B sinewave. By sampling  $\phi_1$  through  $\phi_4$  the differentiation takes place over the entire 360 of motion. The differentiated level is returned to the servo loop for velocity control. A simplified illustration of the velocity reference is shown on the following page.

When the servomotor "locks" into a stable position, a voltage derived from the amplified encoder A sinewave influenced by a compensation voltage feeds an op amp in the motor drive. Voltage is applied to the motor if it is not positioned properly. The voltage is either positive or negative, according to the direction of error. The motor responds, and soon reaches a "detent" position where the feedback is neither positive or negative. This is the position mode, and is entered when the delta count reaches zero.

When it is necessary to re-position the motor, the position mode is suspended by the new count in the delta counter. As motion begins, clock pulses are generated and are given to the  $\Delta$  (delta) counter. The clock signals PW CLOCK AND CA CLOCK are generated directly or indirectly by the X, Y and Z signals. Both the carriage

## THE SERVO LOOP (continued)

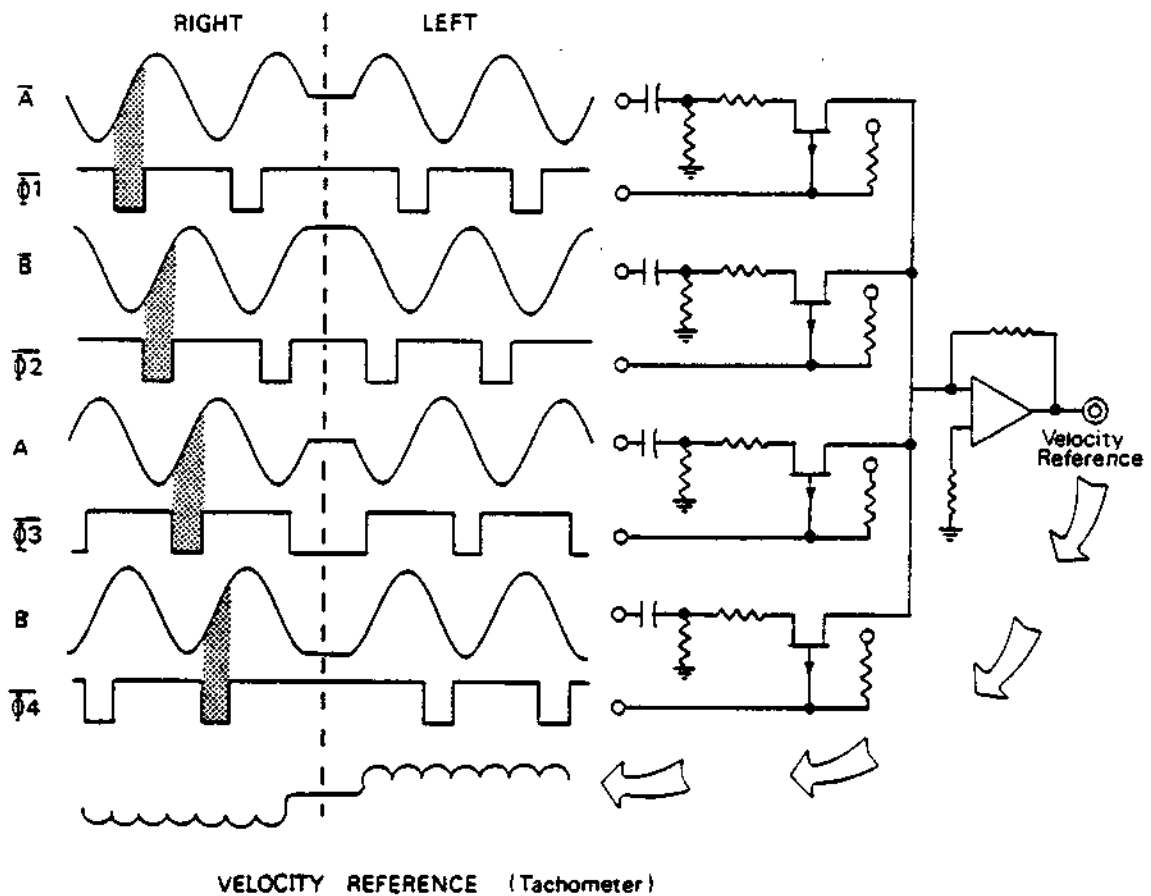

and printwheel delta counters are located on board 2. The delta count, is fed to a velocity control ROM and on to a digital-to-analog converter for the major control of the motor driver circuits. The delta count changing reduces the ROM command velocity, in steps, until the destination is reached. The position mode is again activated.

## SERVO COMPENSATION

To accomplish the accuracy needed for good print quality standards the servo signals must be closely controlled. Slight mechanical variations in the encoder disc, the output of the encoder cells, and the gain and offset of the operational amplifiers are electronically compensated. The Sprint 3 printer boards contain no manual adjustments.

## SERVO COMPENSATION (continued)

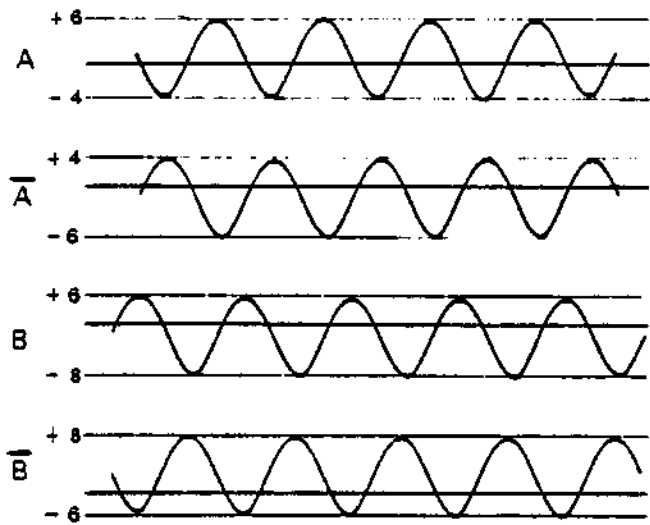

COMPENSATION SIGNALS

$$AP = +6$$

$$\bar{A}P = +4$$

$$\bar{A}P = -4$$

$$BP = +6$$

$$\bar{B}P = +8$$

$$A \text{ SUM} = \frac{AP + \bar{A}P}{2}$$

$$A \text{ SUM} = \frac{6 + 4}{2} = 5$$

Position  
Compensation

$$= \frac{AP + \bar{A}P}{2}$$

$$= \frac{6 + (-4)}{2} = 1$$

$$B \text{ SUM} = \frac{BP + \bar{B}P}{2}$$

$$= \frac{6 + 8}{2} = 7$$

Amplitude  
Compensation

$$= \frac{A \text{ SUM} + B \text{ SUM}}{2}$$

$$= \frac{5 + 7}{2} = 6$$

The amplified encoder sinewaves and the inverted encoder sinewaves are routed to peak detector circuits. Peak detectors are specialized applications for operational amplifiers. The peak detectors determine the highest positive value on the sinewave and generate signals shown in the illustrations on the following page as AP,  $\bar{A}P$ , BP and  $\bar{B}P$ . The illustration is actually an example, showing how the offset position compensation (for voltage offset) and amplitude compensation are calculated.

In the example the two encoder signals are, neither symmetrical about ground potential, or equal in amplitude, one to the other. To compensate for this the signals are processed as follows:

Position compensation develops an equalization that is used in the position mode. The compensation is made for any offset (from zero) in the average, or center, voltage of the A encoder signal. To do this, the A sinewave is inverted to create the  $\bar{A}$  sinewave (see the example). The positive peak voltage of A (expressed as AP) is averaged with the inverted positive peak voltage of  $\bar{A}$  (expressed as  $\bar{A}P$ ). In effect, AP is the negative peak voltage of A. The result is then inverted and electrically summed with the servo voltage (velocity reference) that controls the stable "detent" position.

Amplitude compensation develops an equalization for any difference between the peak-to-peak value of A and the peak-to-peak value of B. To do this AP is averaged with  $\bar{A}P$ , resulting in a signal called A SUM. BP is averaged with  $\bar{B}P$  to get B SUM. A SUM and B SUM are then averaged to get the amplitude compensation signal called DAC. REF. DAC. REF is given to the digital to Analog converter affecting the velocity control voltage that is sent to the servo drive.



## PAPER FEED

When paper is not feeding, the paper feed motor is held in a fixed position by a reduced current level. When paper is to be moved, the holding current is removed and heavy pulses of current are sent to the stepper motor coils. The figure below shows a simplified block diagram of the paper feed circuitry. The number of move increments and the direction of movement is converted by the microprocessor into signals called  $P1$  and  $P2$ . If  $P1$  leads  $P2$  the paper moves upward (normal). If  $P2$  leads  $P1$  the paper moves downward (reverse). The paper feed motor moves one step for each transition of  $P1$  or  $P2$ . Counting is done by the microprocessor on board 2 and sent to amplifier circuits on board 1. Shortly after the motor reaches the destination, the current is alternated between drive and hold levels. This continues for 28 ms, keeping a relatively high average holding current to prevent overshoot from the physical mass.

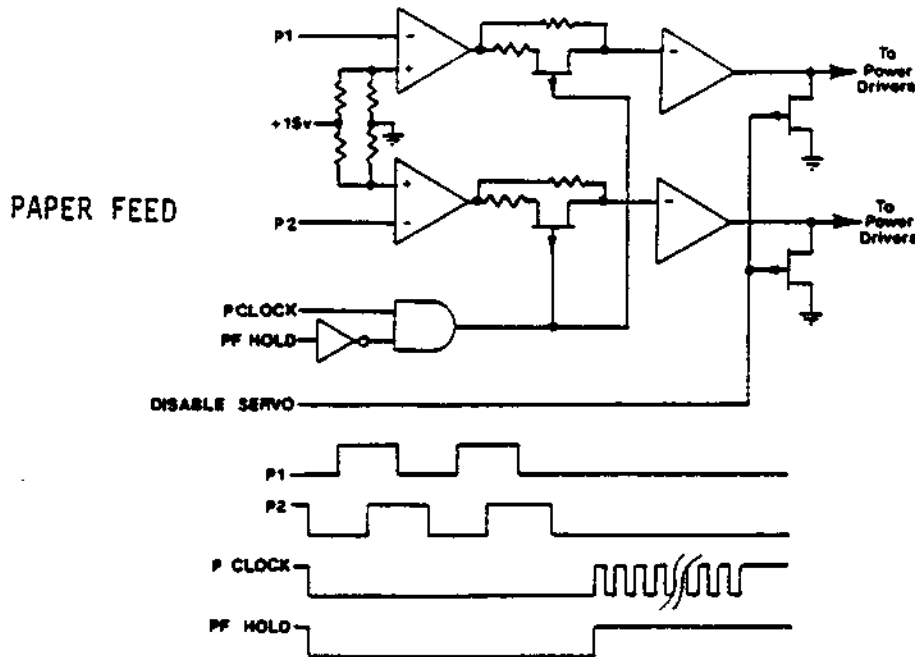

## RIBBON FEED

The ribbon feed is a stepper motor that is always fed in the same direction. The control signals are very similar to the paper feed circuits, but ribbon feed does not have the chopped interval. The controlling signals,  $R1$  and  $R2$ , are generated by the ROM circuit on board 2. The ribbon feed drivers are on board 3.

## RIBBON LIFT

The figure following shows a simplified diagram of the ribbon lift circuit. When the ribbon is in the lowered position it is at rest, with no current flowing through the lift solenoid. To raise the ribbon, two signals,  $RIB\ RAISE$  and  $RL\ HOLD$ , are generated on board 2 and sent to the driver circuitry on board 3. The ribbon lift hold current is enough to keep the ribbon in position once it is lifted, but is not strong enough to overcome the inertia of the mechanism for quick action. The ribbon raise current is strong enough to quickly lift the ribbon, but would overheat and destroy the coil if left on for extended periods.  $RIB\ RAISE$  is assured to be only a short duration by qualifying it with a short protection pulse signal (35 ms) from a "one-shot" on board 3.

## RIBBON LIFT (continued)

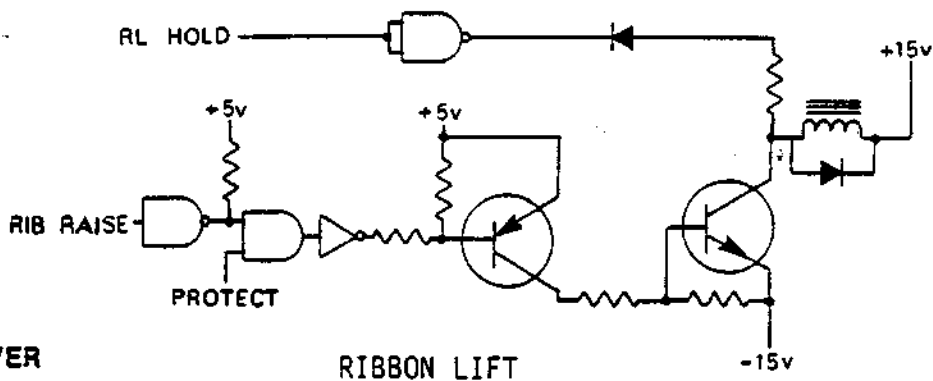

## HAMMER DRIVER

The hammer driver circuit is located on board 3, with the controlling signal coming from board 2. The figure below shows a simplified diagram of the hammer driver circuit. The HAMMER signal varies in length according to the intensity that is required for the particular character being printed. As the HAMMER signal is held ON longer, the hammer is driven through more of its travel distance, creating greater velocity and consequently more impact. The HAMMER signal duration is approximately 1.6 ms to 2.5 ms in six steps. Hammer driver current is much too high to remain for extended periods. The coil and circuit is protected by qualification with a "one-shot" that will turn off the signal after 35 ms in the events of a logic failure that would sustain hammer current for a longer time.

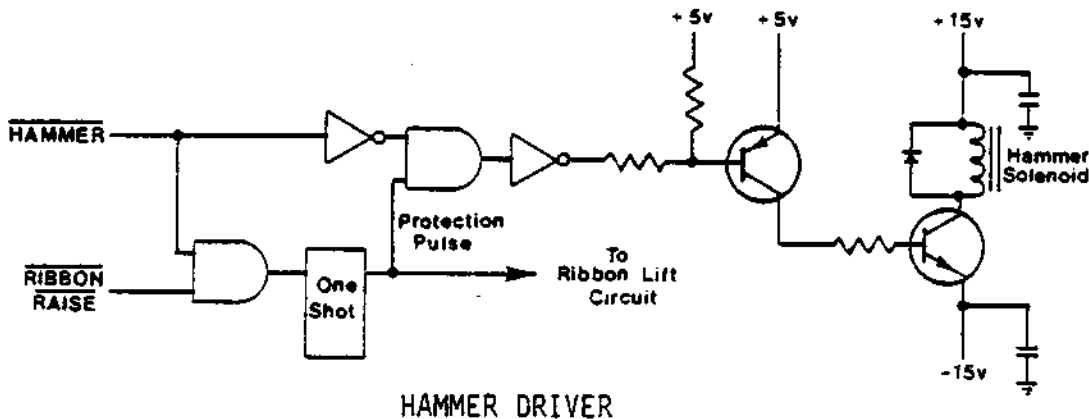

## CHECK

The check circuit is located on board 3, and is shown in simplified form on the next page. The +5 V, +15 V and -15 V power supplies are monitored by comparison circuits and precision Zener diodes. The +5 volt supply can not drop below 4.5 volts for more than one microsecond without setting the check flip-flop. The 15 volt supplies can drop 2 volts, but more than 2 volts for a period of 1 1/2 milliseconds sets check.

Carriage motion is monitored by the CA CLK and CA POS signals. The CA CLK signal is derived from carriage direction and the X, Y and Z signals on board 1. Whenever the carriage motor is moving, CA CLK will continue to change state. CA POS is high until the carriage reaches the proper destination. Both of these signals are used to re-trigger a "one-shot" with a 15 ms timeout. If the carriage is not in position, and a CA CLK (carriage movement) has not reset the "one-shot" before the 15 ms timeout, check is set. When the carriage reaches its position, the "one-shot" will timeout, but the output is blocked from setting check by the CA POS signal.

## CHECK (continued)

The printwheel signals PW POS and Ø1M operate to set check in exactly the same manner as the carriage signals when the printwheel is not in position, and is not moving. The DISABLE SERVOS signal is generated by check, and disables all high current devices.

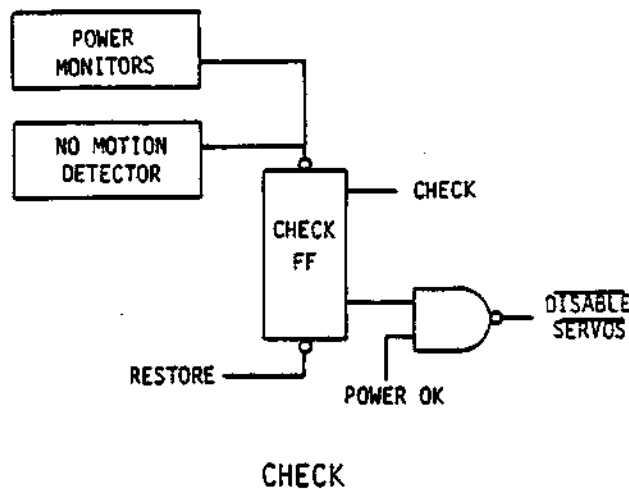

## DIGITAL CONTROL SECTION

Many of the various processes and operations within the Sprint 3 printer are coordinated and controlled by a microprocessor and some related support devices. The microprocessor is in part of central processing unit (CPU) chip, the 3850. The 3850 requires an accompanying program storage unit (PSU) or other equivalent device. The Sprint 3 printer uses the matching 3851 PSU. The figure on the opposing page shows the digital control section of the printer. All of the blocks shown are located on the #2 board.

Each PSU is a read-only memory (ROM) that has 1024 computer words of eight bits each. It also has two eight-bit input/output (I/O) ports. For those who are not familiar with ROM's. A ROM is a matrix of junctions. Each individual junction can be addressed as a unique point. Each junction may or may not be electrically connected. Those junctions that are connected are said to be "1" bits. Those that are not connected are zero bits.

A ROM can be thought of as being organized into sets. In this case eight sets are addressed identically and simultaneously. Each unique junction that is addressed contributes a "1" bit or "zero" toward the eight-bit computer word. It is common, though it is not a physical description, to refer to the computer word positions as columns and rows. One column and row designation forms a single address for the complete 8-bit computer word. By incrementing, decrementing, or substituting the address number, the microprocessor can read any word position sequentially or at random.

## WHAT IS A MICROPROCESSOR?

Large Scale Integration (LSI) technology has progressed to the point where a complete computer can now be put onto one or two chips. The microprocessor that is used in the Sprint 3 is one such device. It has all of the sections that are normal to a

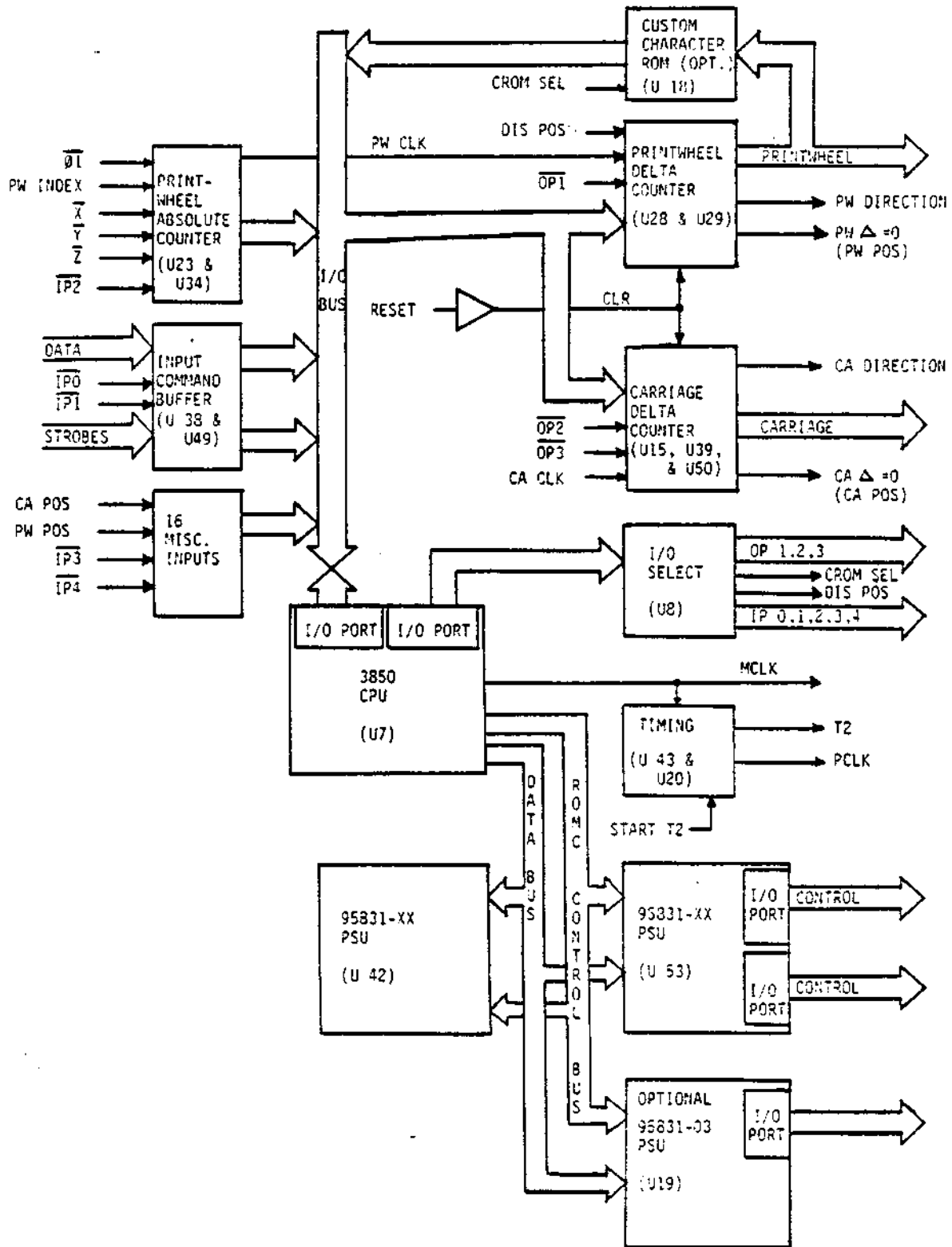

DIGITAL CONTROL

## WHAT IS A MICROPROCESSOR? (continued)

central processing unit (CPU). There is a 64 byte random access memory for temporary internal storage, an arithmetic logic unit, two I/O ports, control unit and instruction register, and an accumulator register. Memory addressing and timing comes from the PSU chip, but the clock signal is generated by the CPU.

The microprocessor program (contained in the PSU) is read by the CPU, and according to the states of the many variables, performs one or more actions. For example a series of instructions may control carriage velocity, or a single instruction may determine the hammer intensity.

## TWINTRACK

Unlike other Sprint 3 printers, the TwinTrack has two independent print stations. Each printwheel requires the complete servo system that is normally on board #3. Because of this the TwinTrack contains two #3 boards, one for the left printwheel, and one for the right printwheel. These servo boards must in turn be controlled by a microprocessor. Each printwheel can be doing different things at different times, so two microprocessors are necessary, requiring two #2 boards. The #2 and #3 boards that are used in the TwinTrack are basically interchangeable with other Sprint 3 boards of the same board number. We chose to continue calling these boards by their original Sprint 3 designations to avoid confusion. The TwinTrack PC board layout is shown below.

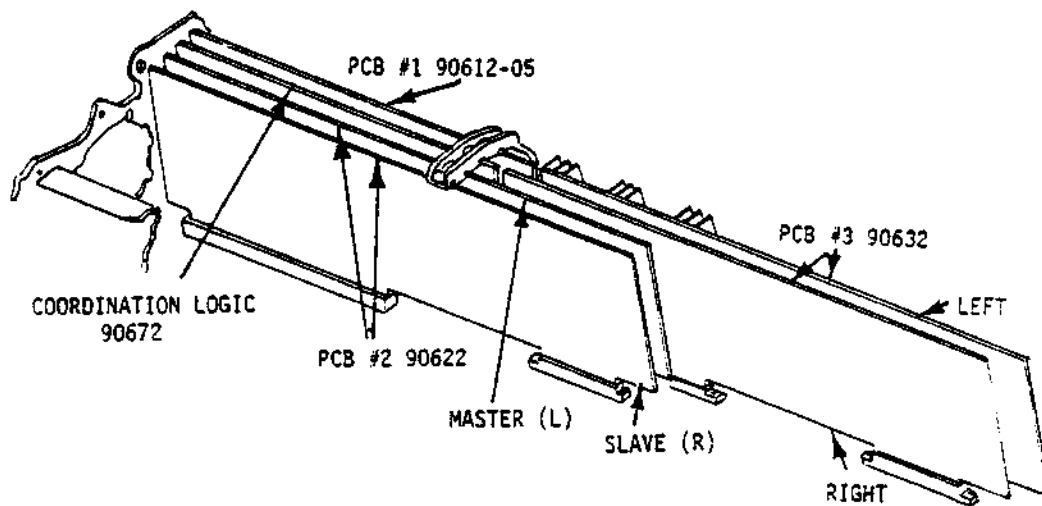

TWINTRACK PCB LOCATIONS

### *TwinTrack Coordination Logic*

With two microprocessors there must be some coordination between them, or chaos would result. The coordination logic board controls the interface lines, sending the incoming commands to the proper microprocessor. The two microprocessors have no interconnections with each other and are not aware that the other exists. Without coordination, one microprocessor could be printing a character, and the other, unaware of the in-process print cycle, might move the carriage or paper.

The coordination logic assigns a master/slave relationship to the two microprocessors. The controlling microprocessor for the left printwheel is the master, the other is the slave. Only the master receives paper move commands.

## TwinTrack Coordination Logic [continued]

Printwheel commands are given to the left or right controller as is designated by the  $\overline{D2048}$  bit in the command. Carriage commands are given to both microprocessors. Only the master microprocessor issues the delta count information to board #1, but both microprocessors must be ready to begin carriage movement to generate the CA POS signal that starts board #1 into action on the carriage move. In other words, neither can be busy completing a previous instruction.

As the carriage moves, the carriage clock (CA CLK) signals are returned to both microprocessors to decrement the delta count. Both delta counters must reach zero (which should be the same time) to have the CA POS signal low, indicating that the carriage is in position. The illustration shows a simplified block diagram of the coordination logic, and the basic logic flow.

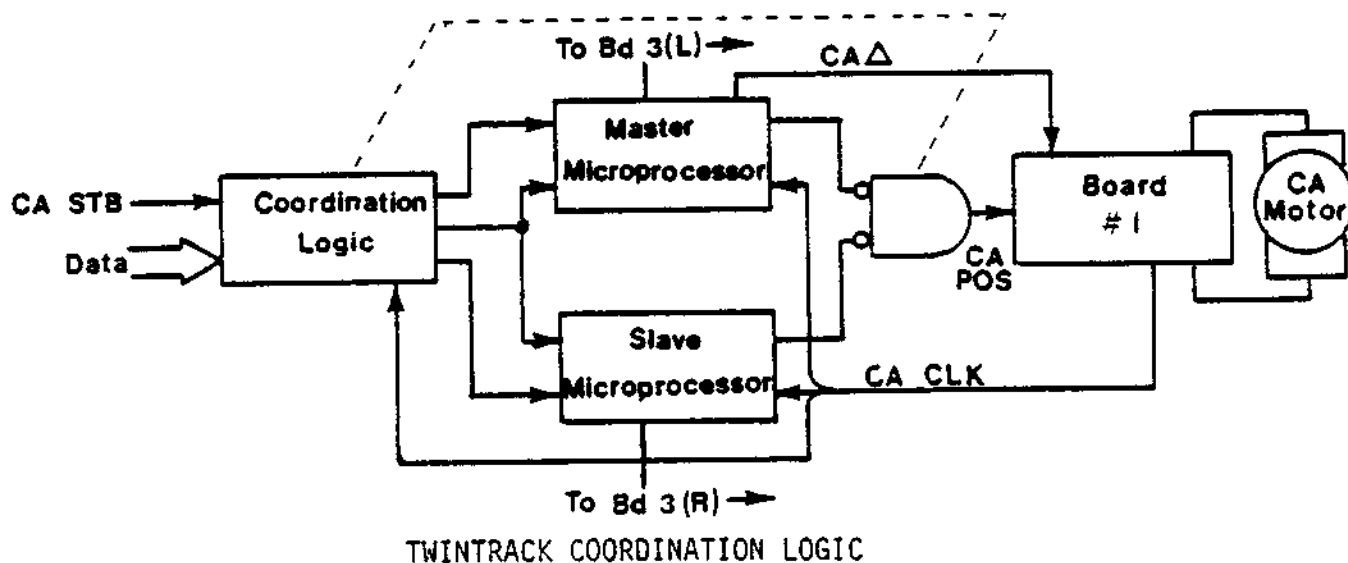

The coordination logic prevents carriage and paper feed commands from conflicting by allowing only one of either of those two instructions into the microprocessor input buffer at a time. For either a carriage or paper instruction to be strobed in, both microprocessor input buffers must be ready, and both must be empty. This does not mean that there could not be carriage, paper, or print instructions already in progress.

Any paper move command (except a zero increment) entering the coordination logic, inhibits subsequent print commands until the paper move is completed. Any in-process print cycle will be completed before the paper move is started. The paper clock enable signal is used to know when paper motion is complete. The PF HOLD current is chopped for 28 ms after movement is stopped to prevent overshoot and dampen the tendency to mechanically oscillate. At the end of this 28 ms period, the paper has completed all movement and settled into position. This is when the coordination logic will allow new print commands to be entered. However, a carriage move can be entered during a paper move execution or a paper move can be entered during a carriage move execution and the two processes will overlap to some extent.

## TwinTrack Coordination Logic [continued]

Print commands (character codes) can be strobed in at any time that both micro-processor input buffers are ready, and a paper feed is not in progress. Another print command or a carriage move can be in progress without affecting print command entry.

### Sequential Interface

The Sequential option to the TwinTrack adds to the complexity of the coordination logic. All portions of the sequential logic are within the Sequential option version of the coordination logic board. A timing diagram for this version is shown below.

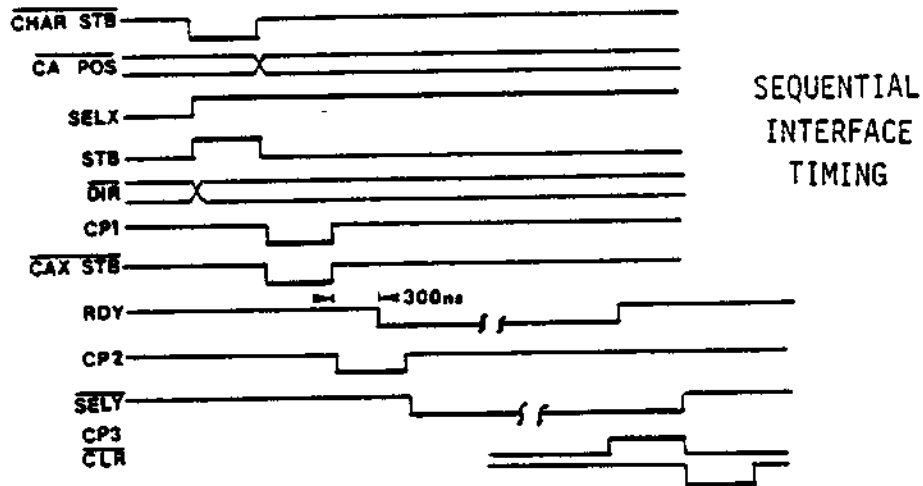

The sequential logic sets a flip-flop when a character for the right printwheel is strobed in. It resets the same flip-flop if the left print station is to print. If the character is for the same printwheel as the previous character (as determined by the state of the flip-flop) the strobe is sent directly to the proper #2 board. The character code is passed through the multiplexer by the SELY signal. The character and the strobe are then entered into the input buffer of that board for action when all else is ready.

If an incoming character reaches the coordination logic, and is not for the same printwheel as the last character, a delay and carriage move sequence is started. The character code is strobed into a holding register within the coordination logic. The SELX signal is generated, causing a set value (from jumpers on the coordination logic board) to be placed on the data lines. A carriage strobe is created, strobbing the set value to the #2 board. The left or right value (D1024) for the carriage move is generated by the Direction flip-flop. The Direction flip-flop is set or reset by the sequence between the previous left or right character command and the current character command.

The same circuits that generate the carriage strobe also generate the SELY signal to select the data input from the storage register. When the carriage movement is completed, the ready signal causes a character strobe, loading the stored character to be printed. After a small delay, the SELX and SELY flip-flop are cleared, making way for the next character.





## CHAPTER V

### MAINTENANCE

When properly maintained, the Qume Sprint 3 Series Printers will give excellent service for very long periods of time. The maintenance guidelines given below are for a normal office environment and normal or moderate use. If the environmental conditions are severe or if the use is heavier than moderate, the time between maintenance checks should be shortened accordingly.

As a general precaution when maintaining Qume printers, use only the solvents and lubricants that are recommended. Never over lubricate, expecting to stretch the time between maintenance periods. Over lubrication may cause immediate problems in the printhead area, and could cause serious problems in other areas.

#### MONTHLY OR AS REQUIRED

Check the printer each month or sooner for general cleanliness and accumulated fiber buildup from paper stock. Carefully clean the carriage assembly with a soft-bristle brush. Lightly moisten a soft cloth with one of the low-residue solvents listed below.

Formula 409  
Fantastik  
Zoom

Clean any ink residue or splatter from the plastic and metal parts with the moistened cloth. DO NOT SPRAY OR DRIP SOLVENT DIRECTLY INTO THE INTERIOR OF THE MACHINE.

#### *Printwheel*

After some length of service the printwheel will accumulate ink and paper fibers, making a noticeable difference in print quality. Before print deterioration is noticed, remove and clean the printwheel as follows.

Place the printwheel in a shallow dish or container. Pour a low-residue cleaner (one of those mentioned above) over the printwheel until it is barely covered. Let it soak for a minute or two. Using a type-cleaning brush or medium stiffness toothbrush, remove caked areas that have not dissolved.

**CAUTION:** This cleaning procedure can spatter ink on clothing and surrounding objects. Take the necessary precautions to avoid ruining clothing or other objects.

When the printwheel is clean, wipe lightly with a soft lint-free cloth and re-install it on the printer.

#### EVERY SIX MONTHS OR 1000 PRINTING HOURS

#### *Ribbon Lift*

Saturate the oiler pads within the ribbon lift mechanism and paper feed gear with a medium grade oil (Shell "Tellus 25" or equivalent). See the figure

**EVERY SIX MONTHS OR 1000 PRINTING HOURS (continued)**

below for the oiler pad location. Do not use "household" or "all purpose" oils for this purpose.

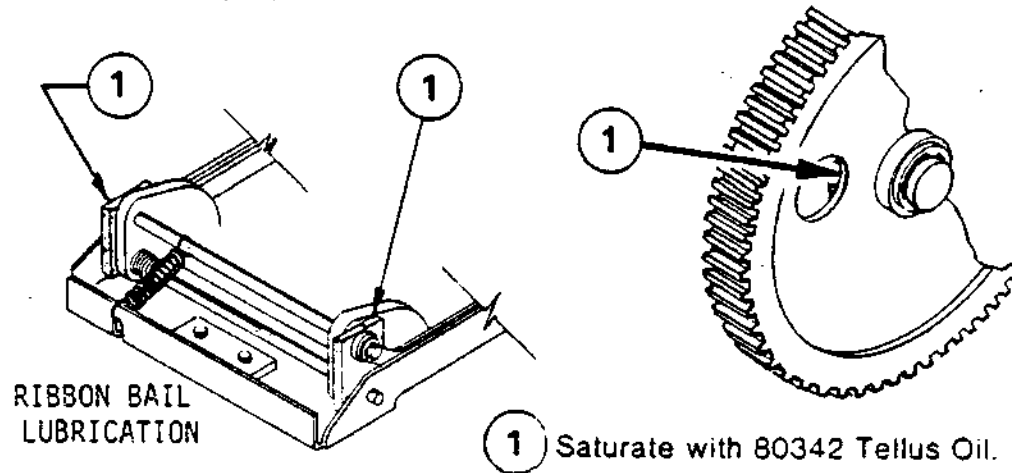

① Saturate with 80342 Tellus Oil.

**Platen**

Clean the platen surface or other rubber parts whenever necessary or as a general housekeeping maintenance.

- Remove the platen from the printer.
- With a soft cloth or tissue dampened with FEDRON platen cleaner, wipe all ink residue and accumulated soil from the platen.

**CAUTION**

Do not use or accidentally spill platen cleaner on any of the plastic parts.

**WARNING**

Use eye protection when handling cleaning solutions or solvents. The platen cleaner is flammable and toxic and must be used only in a well ventilated area. Read and observe all directions and cautions that are stated on the label.

- After cleaning, place one drop of Tellus oil, or equivalent, under each spacer sleeve adjacent to the platen knobs.

## EVERY SIX MONTHS OR 1000 PRINTING HOURS (continued)

- . Re-install the platen in the printer.

### **Hammer\***

- . Remove the rear hammer armature stop.
- . Carefully remove the hammer assembly. Be careful not to bend or loosen the return spring in the center of the hammer. (See the figure.)
- The "X" model has a round barrel, and the return spring is around the hammer.

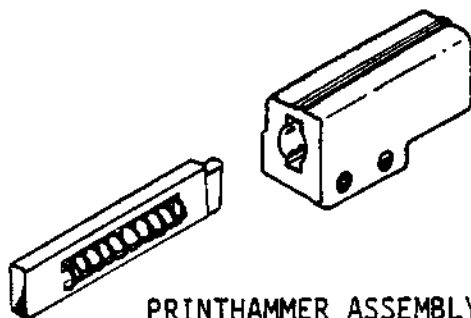

- . Remove the spring from the hammer and clean both the hammer and the spring by soaking in isopropyl alcohol. Use a cotton swab (Q-tip or other brand equivalent) to remove stubborn spots. DO NOT BEND OR DEFORM THE SPRING.
  - . Clean the inside of the hammer guide assembly with a cotton swab and isopropyl alcohol, being careful not to drip alcohol into the interior of the printer.
  - . Allow the parts to dry thoroughly.
  - . Place one or two drops of watch oil (80341) on the hammer.
  - . Spread the oil to a thin layer over the surface. A cotton swab or finger tip can be used for this.
- DO NOT OVER OIL.
- . Re-assemble the spring to the hammer.
  - . Replace and adjust the rear hammer armature stop as directed in the adjustment section of this manual.

\*Some early model wedge hammers should be cleaned and lubricated every 300 printing hours or six months, whichever comes first. See Sprint Micro 3 Series Tech Bulletin: Number 4 for identification of these parts.

**Printer Cover**

Clean soiled covers using a soft cloth moistened with one of the low-residue cleaners mentioned on the previous page. Do not spray the cleaner on the printer as the overspray will enter portions of the mechanism where it would be undesirable.

**Lower Carriage Bearings and Rails**

Lightly lubricate the lower carriage bearings and rails with Shell Darina-Ax grease, as shown in the illustration below. Wipe the rails first with a clean cloth and isopropyl alcohol. Place a thin layer of grease between the carriage bearing and the rail using a cotton-tipped applicator. Move the carriage by hand about six inches, keeping the applicator in contact with the bearing and rail. While moving the carriage, slowly rotate the applicator to apply a thin, consistent layer of grease. Remove any build-up of grease on either the bearing or rail. Repeat the procedure for the other lower carriage bearing.

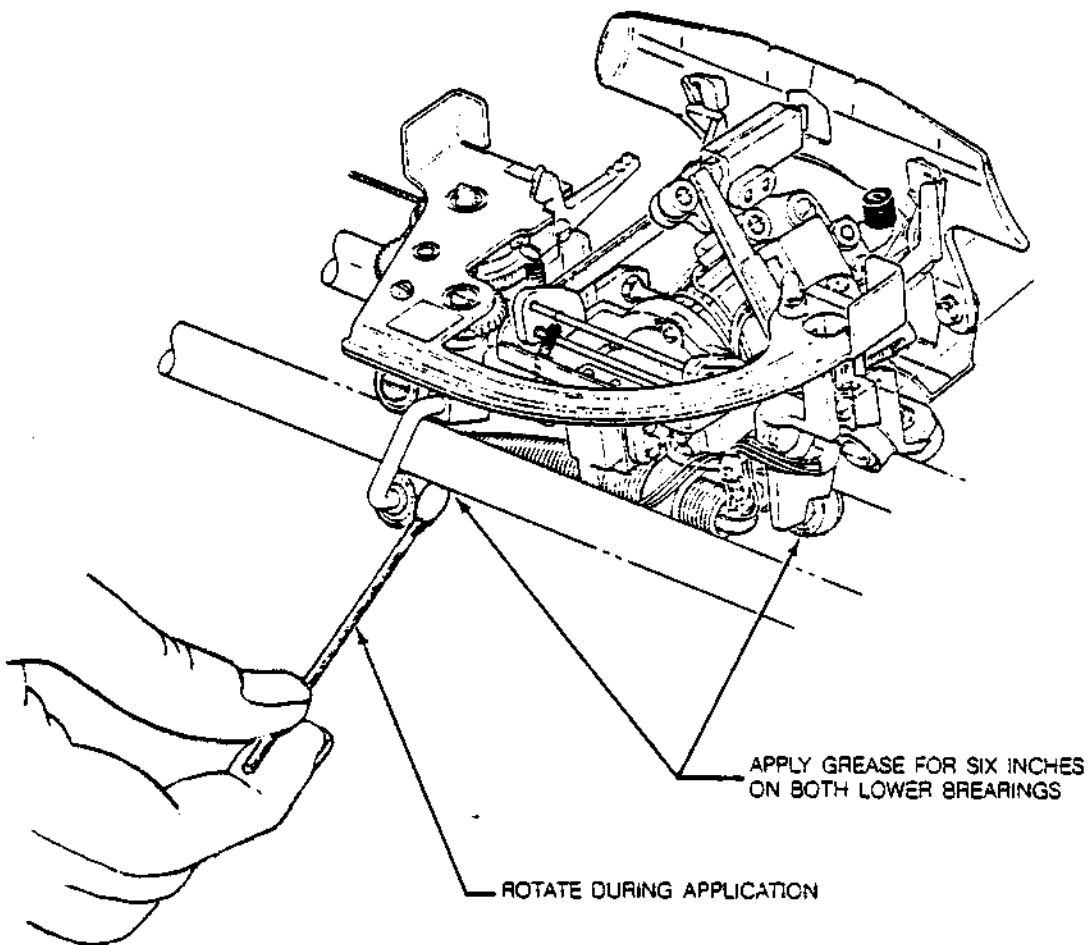

## SUPPORT EQUIPMENT LIST

The following is a consolidated listing of the supplies and equipment required to support the Sprint printers at the field service or depot maintenance levels.

### TOOLS AND TEST EQUIPMENT

The table on the following page lists the tools and test equipment that are required for maintenance and repair of Qume high-speed character printers. If equivalent items are available, they may be substituted for those listed. Repairmen on routine field service calls should be provided with one of each of the items in the table in addition to the normal complement of hand tools.

### SPARES

Repairmen making routine service calls should have one each of the complete sub-assemblies listed in the Field Service Spares listing in addition to a spare printwheel and ribbon cartridge.

### TOOLS AND TEST EQUIPMENT

<u>TOOLS</u>	<u>PART NUMBER</u>
Printwheel Adjustment Tool, Outer Collett	80471
Printwheel Adjustment Tool, Inner Collett	80472
Printwheel Adjustment Tool, Disc	80758
Platen Gauge Adjustment Tool	80751
Hammer Angle Adjustment Tool	80739
Printed Circuit Extender Set	99025-03
Cable Tension Gauge	80738
Ribbon Guide Adjustment Tool	80833
Return Limit Ring Gauge	73046
 <u>TEST EQUIPMENT</u>	
Printer Exerciser	99000
Portable Exerciser	80630
Oscilloscope	Tektronix 465
Multimeter	Simpson 260
ActivityMonitor	80740
 <u>LUBRICANTS</u>	
Watch Oil (Moebius Oil "Art. 8000")	80341
Tellus Oil (Shell Oil "Tellus 25")	80342
Polygrease	80346
Shell Darina-Ax Grease	-----
 <u>MISCELLANEOUS</u>	
Isopropyl Alcohol	-----
Platen Cleaning Fluid	Fedron
Heavy Duty Degreaser	Formula 409
Thread Locking Fluid, Loctite #222	85160-01
Loctite #06, Super Bonder Adhesive	85161-01
Dusting Brush, Soft Bristle	-----
Type Cleaning Brush, Stiff Bristle	-----
Lint-Free Cloths	-----

**RECOMMENDED FIELD SERVICE SPARES**

<u>Part #</u>	<u>Description</u>	<u>Printer Population</u>		
		<u>100</u>	<u>500</u>	<u>1000</u>
80023	Carriage Motor Final Asy	1	3	8
80028	Carriage Assembly	1	4	7
80032	Cradle Asy	1	1	2
80037	Pulley Asy - Idler	1	2	3
80046	Paper Feed Motor Asy	1	2	4
80057	Clutch Asy, Ribbon Drive	1	3	6
80142	Bail - Feed Roller	2	4	8
80160	Lever - Feed Roller Disable	1	2	3
80186	Lever - Impression Control	1	1	2
80202	Gear - Idler, Paper Drive	1	1	2
80207	Ribbon Drive, Stepper Motor	1	1	2
80336	P/W Motor - Encoded	1	4	7
80368	Photon Module - Carriage Home	2	5	8
80369	Armature Asy - Hammer	1	1	2
80374-01	Pad - P.W. Motor Stop	2	5	10
80374-02	Pad - Ribbon Bail Stop	2	5	10
80379	Coil Ribbon Lift	2	4	8
80380	Bail Asy - Ribbon Lift	1	1	2
80358	Link Asy - Guide Bearing	1	2	3
80610	Power Resistor 5 OHM	1	2	3
80686-02	Hammer	1	3	5
80687-02	Hammer Guide	1	1	2
80713	Spring Hammer	1	3	5
85127	Cable Carriage Drive	1	3	5
90612	P.C. Asy Card #1	1	3	5
90622	P.C. Asy Card #2	1	3	5
90632	P.C. Asy Card #3	1	3	5

## RECOMMENDED FIELD SERVICE SPARES

<u>Model 3/35</u>	<u>Part #</u>
Printed Circuit Board 1	90612-00
Printed Circuit Board 2	90622-00
Printed Circuit Board 3	90632-00
Carriage Assembly	80028-14

<u>Model 3/45</u>	<u>Part #</u>
Printed Circuit Board 1	90612-01
Printed Circuit Board 2	90622-00
Printed Circuit Board 3	90632-01
Carriage Assembly	80028-15

<u>Model 3/55</u>	<u>Part #</u>
Printed Circuit Board 1	90612-02
Printed Circuit Board 2	90622-00
Printed Circuit Board 3	90632-02
Carriage Assembly	80028-16

<u>Model 3/X30</u>	<u>Part #</u>
Printed Circuit Board 1	90612-03
Printed Circuit Board 2	90622-01
Printed Circuit Board 3	90632-02
Carriage Assembly	80028-17

<u>Model 3/X40</u>	<u>Part #</u>
Printed Circuit Board 1	90612-04
Printed Circuit Board 2	90622-01
Printed Circuit Board 3	90632-04
Carriage Assembly	80028-18

<u>Model 3/WideTrack</u>	<u>Part #</u>
Printed Circuit Board 1	90612-05
Printed Circuit Board 2	90622-00
Printed Circuit Board 3	90632-05
Carriage Assembly	80028-19

<u>Model 3/TwinTrack</u>	<u>Part #</u>
Printed Circuit Board 1	90612-05
Printed Circuit Board 2	90622-00
Printed Circuit Board 3	90632-02
Coordination Logic	90672
Carriage Assembly	80028-40





## CHAPTER VI

### TROUBLESHOOTING & REPAIR

#### GENERAL

Troubleshooting is complicated by the interrelationship between printer and controller. The printer obeys the commands of the external controller without question: If the carriage is commanded to move in the wrong direction, it will do so. Before attempting to troubleshoot the printer, be sure that the controller and interface are operating properly. If it is determined that the controller and interface are operating correctly, use the procedures below to isolate the problem so that you can either replace the defective board or be advised by Qume customer service personnel what action to take to correct the problem.

Troubleshooting is further complicated in the TwinTrack model by board duplication and the coordination logic. Special considerations for TwinTrack troubleshooting are discussed later in this section.

#### DIAGNOSTIC PROCEDURES

This procedure utilizes the optional Micro 3 ActivityMonitor to isolate faults. The other equipment required is a digital voltmeter capable of measuring the power supply voltages.

- . Remove the printer top and middle covers.
- . Disconnect the data cable from the printer.
- . Using a digital voltmeter, measure the power supply voltages at the test points on each board. They should be within the tolerances specified in below.

+ 5V	± 3%	- 4.85V	to	5.15V
+15V	±10%	- 13.5 V	to	16.5 V
-15V	±10%	- 13.5 V	to	16.5 V

- . Temporarily turn the printer OFF.
- . Connect the activity monitor cable to the 40 pin connector at the top of board 2. The cable connector is labeled FRONT on the side that must be toward the front (operator side) of the printer.
- . Place the ON/OFF switch on the activity monitor to ON.
- . Return power to the printer; the diagnostic will begin immediately. The activity lamps will show change, but the first two tests do not move the printer.
- . If the test stops prematurely, there will be a status indicator shown by the activity monitor lamps. The interpretation of these lamps is given on the bottom of the activity monitor and also in the table on page 6-3.

## DIAGNOSTIC PROCEDURES (continued)

If the lamps show that the test stopped during the carriage or printwheel tests, the CONTINUE button can be pressed to cause the logic to skip to the next test. A complete test description is given later in the text to aid troubleshooting.

- If the non-extended self test completes without problems, it will automatically restart. The test can be stopped by placing the activity monitor ON/OFF switch to the OFF position. With the switch in the OFF position, the printer will accept instructions from the interface lines.

The extended self test (automatically included in certain printer options) will complete only once. To make the extended self test repeat, depress either CONTINUE or the RESTART button on the activity monitor.

## TEST DESCRIPTIONS

### ROM TEST

This test is to determine if the 3851 PSU ROMs containing the diagnostic and the printer programs on board 2 is good. It adds all the bytes in the main program and the diagnostic program to develop a single-byte sum, excluding carries, which should be zero. The last byte in the diagnostic program is adjusted to be the two's complement of the sum of all the previous bytes.

Since the microprocessor is very fast, this test executes in a fraction of a second and will be seen as a fast blink on the TEST lights if the memory is OK.

A ROM failure causes the test to stop and the eight I/O bit lights display the actual sum. The CONTINUE button will not be active, since continuing the diagnostic may cause unusual things to occur if the main program or the diagnostic program is incorrectly stored in the ROM.

**IMPORTANT:** The test itself may not finish if the diagnostic program part of the ROM or the 3850 CPU or the power-up logic is defective.

### I/O LINES TEST

This test is to determine if the I/O lines are operating properly. These lines are used for data communication between the microprocessor and the 74S412 buffers, printwheel absolute counter, printer status, and printwheel and carriage delta counters. Any shorts to ground, +5V, or each other either directly or through faulty components will cause improper operation. Opens are also checked.

The test sends out a pattern which will light a single bit light, starting with bit zero and proceeding sequentially to bit 7. After each pattern is output, it is input and compared to the pattern output. If the two patterns are different, the test stops and the bit lights display the erroneous pattern input. The bit lights should be watched during the test so that if it fails the expected pattern (the pattern output), will be known. If the line is low (ground), the light lights.

## DIAGNOSTIC TEST PATTERN

TEST	TEST LIGHT PATTERN	OPERATION	IF TEST STOPS LAMPS INDICATE
ROM	0011	Adds all bytes of printer and diagnostic ROM programs. Sum must be zero.	Actual Sum.
I/O LINES	0001	Writes and reads each bit of I/O lines for isolating bus line shorts. Compares written pattern to read pattern.	Actual pattern that caused error. Expected pattern can be deduced from lighting sequence.
RESTORE	0110	Executes Restore part of Printer program.	Not meaningful. Malfunctions can be seen by visual inspection.
CARRIAGE	0010	Carriage moves 114 times, back and forth, in diminishing movements, and sent to home and Limit. All bit positions of carriage delta are checked.	00000001 - Check 00000010 - Timed Out 00000100 - Limit on home 00001000 - Limit not found
PRINT WHEEL	0100	Slowly moves printwheel and stops at position 00. Printwheel moves 96 times, clockwise and counter clockwise in diminishing movements, and sent to index. All bit positions of printwheel delta are checked.	00000001 - Counter 00000010 - Timed Out 00000100 - No index at end
PAPER FEED	0101	Executes various combinations of forward and reverse paper feeds and character printing. Ends with "Self Test" printed vertically.	Does not stop. Errors seen in visual inspection.
TEST OVER	0111		

NOTES: Continue test button is effective only after an error stop in either the CARRIAGE test, or the PRINTWHEEL test after the initial move to position 00. A second RESTORE is performed just before the PAPER FEED test. Restore, Paper feed, Ribbon Lift, Hammer, and Ribbon Advance errors are detected exclusively by visual inspection (during PAPER FEED test except RESTORE). Diagnostic does not test Ribbon Drop; nor does it test the external I/O interface which includes status lines, control lines, and data lines and associated circuitry.

## I/O LINES TEST (continued)

The CONTINUE button will not be active because the tests following are dependent on the I/O lines working satisfactorily.

### RESTORE TEST

This test is necessary at this time to establish a reference for the carriage and printwheel tests following it. It uses the actual Restore part of the printer program.

The carriage should be observed during this test. Failure to execute the Restore will cause the test to "hang up" in one of four program loops described below.

In the first loop, the carriage is slowly moved to the left until the carriage limit is sensed. The carriage may not move, in which case any one of a number of things can be wrong. Maybe the carriage delta counter is not receiving the data (hexadecimal 1007) or the counter output is not getting to the analog section, or the latter is inoperative, or the carriage limit sensing is faulty. If the carriage delta counter is not receiving the data, the port selection logic may be inoperative. OP2 and OP3 should be going low and high. The carriage may go in the wrong direction if the direction bit is lost. Or the carriage may travel at the wrong speed, indicating a faulty delta counter, velocity ROM, or analog section. Finally, the carriage may not find the limit and go into check, in which case maybe the carriage limit sensor is faulty or selection logic IP4 is inoperative or the connection between the limit sensor and the I/O lines is missing.

In the second loop, the carriage is sent to the right out of the limit. If the carriage doesn't move right, make sure it is not in check. The data output to the carriage delta counter is hexadecimal 0001.

In the third loop, a hexadecimal 07 is repeatedly sent to the printwheel delta counter until the printwheel passes position 00, the printwheel index position, at lower case "w". The printwheel may not turn, or it may turn too fast and/or it may never stop. Similar reasoning may be applied to the printwheel index which also uses IP4 selection.

In the fourth loop, printwheel position mode is sensed and the program loops until the condition is true. IP3 is selected for this sensing.

**IMPORTANT:** The CONTINUE button will not be active if the printer fails the Restore test, and the bit lights will not be relevant.

### CARRIAGE TEST

This test contains two program loops. The first and main loop does the following:

1. Removes and saves the direction bit from a RAM register containing the last carriage delta output to the carriage delta counter.
2. Subtracts a constant from the resulting delta magnitude of 1 above.

### CARRIAGE TEST (continued)

3. Tests the result of 2 above. If it is less than zero, the main loop is done and the program branches to the second loop.
4. Complements the direction bit saved in 1 above and combines it with the new delta of 2 above.
5. Sets a time limit for the carriage travel.
6. Outputs the delta of 4 above.
7. Tests position mode. If true, goes to step 1.
8. Tests the elapsed time. If it is over the value set in 5 above, sets bit light value and jumps to error routine (described later).
9. Tests if check occurred. If so, sets bit light value and jumps to error routine.
10. Jumps to step 7.

Initialization for the main loop is with the first carriage delta value and a jump to step 5.

After successfully completing the main loop, the program outputs a carriage delta which should send the carriage almost to home position, initializes a 1/2 step counter, and then jumps into the second loop at step 2. The second loop:

1. Outputs a hexadecimal 1001 (1/2 step left) to the carriage delta counter.
2. Tests for carriage position mode and carriage limit. If both are true, exists loop. If not in position, repeats this step.
3. If in position mode but not at limit, decrements 1/2 step counter and tests it. If it is not zero, jumps to step 1.
4. If the 1/2 step counter is at zero, sets bit light pattern and jumps to error routine.

After completing the second loop, the 1/2 step counter is tested. If it is at the value it was initialized to, the bit light pattern is set and program jumps to error routine. The carriage should not be at the limit on the 'home'.

**IMPORTANT:** Notice that the second loop does not test for a check condition. After passing the first loop without a check, the chances of having a check in the second loop are remote. A check in the second loop will "hang up" the test, and the bit lights will not be relevant. Furthermore, the CONTINUE button will not be operative.

### PRINTWHEEL TEST

This test also has two program loops, of which the second loop is the main one.

## PRINTWHEEL TEST (continued)

The first loop does one thing--send the printwheel to the index. It does this by testing whether the printwheel is in position 00, outputting a hexadecimal 01 to the printwheel delta counter if it is not at the index, briefly waiting, and then jumping to the beginning of the loop.

IMPORTANT: If the printwheel absolute position counter is faulty, the printwheel may not stop and will "hang up" at this point in the test. The bit lights will not be relevant if this happens and the CONTINUE button will not be effective.

After completing the first loop (not necessarily proving that the printwheel is really at the index), the program initializes the first printwheel delta value and the first value of the software-controlled printwheel absolute position counter and jumps into the main loop at step 7. The main loop:

1. Removes and saves the direction bit from a RAM register containing the last printwheel delta output to the printwheel delta counter.
2. Subtracts a constant from the resulting delta magnitude of 1 above.
3. Tests the result of 2 above. If it is less than zero, the main loop is done and the program branches to the final operation in this test.
4. Complements the direction bit saved in 1 above.
5. Updates the software-controlled printwheel absolute counter using the new delta in step 2 and based on the direction bit in 4 above (either adds or subtracts the delta to/from the counter).
6. Combines the new direction with the new delta.
7. Sets a time limit for the printwheel motion.
8. Outputs the delta of 6 above to the printwheel delta counter.
9. Checks for printwheel position mode. If false, tests elapsed time. If not over the value in 7 above, repeats this step. Otherwise, sets bit light pattern and branches to error routine (described later).
10. In position mode, the printwheel absolute position counter is input and compared to its software-controlled counterpart. If the two counters are not equal, sets bit light pattern and branch to error routine.
11. Jumps to step 1.

Following successful completion of the main loop, the program outputs a printwheel delta that should send the printwheel to the index. The index is tested after position mode is established and short delay. If the printwheel is not at the index, the bit light pattern is set and the program jumps to the error routine.

Another Restore is performed at this point to initialize the carriage to home, and to initialize the RAM registers for main printer program use for the following test.

## PAPER FEED TEST

This test uses the main printer program. Just prior to the command input part of the main program, the program branches to the diagnostic program if the Micro 3 ActivityMonitor is connected. The diagnostic then loads a printwheel or a paper feed command into the next available position in the software input buffer, tests the buffer to see if it is full, and sets an appropriate 'comeback code'. The diagnostic then jumps to the point in the main printer program which is just after where it stores a command into the software input buffer.

As long as the 'comeback code' is not a buffer full type, the above happens and the main program executes the commands in the buffer as though they came in through the external I/O interface.

When the software input buffer is full, the diagnostic ceases to load it until it becomes empty so it can adjust buffer pointers. It does this because four bytes at the end of that buffer are used by the diagnostic program.

The result of the paper feed test is a vertical printing of SELF TEST produced by a series of complex combinations of printwheel and paper feed commands. If the printer is working satisfactorily, the printing is reasonably evenly spaced (allowing for paper slippage) and spelled as above.

At the beginning of this test the ribbon should lift. It is not dropped at the conclusion of this test but is dropped at the beginning of the diagnostic. During the test, take note of the ribbon feed operating just prior to the printing of each letter.

**IMPORTANT:** This test has no internal checks and does not stop if a malfunction occurs. The results are seen during and after the test as mentioned above.

## ERROR ROUTINE

This routine is used for all tested error conditions. Just before the program branches to it, it sets the bit light pattern to be displayed in the bit lights for the identification of the error, and it also sets the address of where the program may jump when the CONTINUE button is depressed. The routine displays the bit light pattern, delays, tests the CONTINUE button, and either branches to the address set if it was depressed, or branches back to the beginning of the error routine.

In the case of the ROM Test and the I/O Lines Test, the address set is the error routine so the CONTINUE button is not effective. In the Carriage Test it is the start of the Printwheel Test, and in the Printwheel Test it is the start of the Paper Feed Test.

## TEST POINTS

The following three pages list the signals that are found on the printed circuit board test points. The lists are organized by printed circuit board numbers in numerical order.

SPRINT MICRO 3 PCB #1 TEST POINTS

<u>TEST POINT</u>	<u>SIGNAL NAME</u>
1	"AP" (A sine wave positive peak)
2	" $\bar{A}$ " (Inverted A sine wave)
3	"A" (A sine wave)
4	"A SUM"
5	AMPLITUDE COMPENSATION
6	" $\bar{A}P$ " (Inverted A sine wave positive peak)
7	" $\bar{B}$ " (Inverted B sine wave)
8	"B" (B sine wave)
9	POSITION COMPENSATION
10	VELOCITY REFERENCE (TACHOMETER)
11	COMMAND VELOCITY STAIRCASE
12	" $\bar{B}P$ " (Inverted B sine wave positive peak)
13	"BP" (B sine wave positive peak)
14	not used
15	"B SUM"
16	"Z THRESHOLD"
17	CAM DRIVER
18	CURRENT WAVEFORM
19	<u>CA POS</u>
20	not used



**SPRINT MICRO 3 PCB #2 TEST POINTS**

<u>TEST POINT</u>	<u>SIGNAL NAME</u>	<u>TEST POINT</u>	<u>SIGNAL NAME</u>
1	TEST CONT (Self Test)	18	$\overline{BI}$ (I/O BUS)
2	DIAG (Self Test)	19	I/O PORT 0 Bit 0
3	+5 VDC	20	I/O PORT 0 Bit 1
4	GROUND	21	I/O PORT 0 Bit 2
5	WRITE CLOCK	22	I/O PORT 0 Bit 3
6	GROUND	23	I/O PORT 4 Bit 7
7	MASTER CLOCK (2 MHz)	24	not used
8	DIAG RST (Self Test)	25	not used
9	I/O PORT 0 Bit 6	26	I/O PORT 5 Bit 1
10	I/O PORT 0 Bit 5	27	I/O PORT 4 Bit 6
11	$\overline{OP4}$ (Output 4)	28	$\overline{START T2}$
12	$\overline{B6}$ (I/O BUS)	29	not used
13	$\overline{B7}$ (I/O BUS)	30	not used
14	I/O PORT 0 Bit 7	31	GROUND
15	$\overline{B4}$ (I/O BUS)	32	$\overline{B2}$ (I/O BUS)
16	$\overline{B5}$ (I/O BUS)	33	$\overline{B3}$ (I/O BUS)
17	$\overline{B0}$ (I/O BUS)		

### SPRINT MICRO 3 PCB #3 TEST POINTS

<u>TEST POINT</u>	<u>SIGNAL NAME</u>
1	AMPLITUDE COMPENSATION
2	PWM DRIVE
3	" $\bar{A}P$ " (Inverted A sine wave positive peak)
4	"AP" (A sine wave positive peak)
5	CURRENT WAVEFORM
6	"PWM BASE"
7	" $\bar{A}$ " (Inverted A sine wave)
8	"A SUM"
9	COMMAND VELOCITY STAIRCASE
10	POSITION COMPENSATION
11	<u>PW POSITION</u>
12	"B" (B sine wave)
13	" $\bar{B}$ " (Inverted B sine wave)
14	VELOCITY REFERENCE (TECHOMETER)
15	not used
16	"BP" (B sine wave positive peak)
17	"B SUM"
18	"Z THRESHOLD"
19	-5 VDC (Regulated)
20	" $\bar{B}P$ " (Inverted B sine wave positive peak)
21	<u>"PW INDEX"</u>
22	"PWM"
23	"A" (A sine wave)
24	not used
25	not used

SPRINT MICRO 3  
MICRO I/O ROUTINE

A Sprint Micro 3 PCB #2 is a microcomputer, dedicated to controlling the SM3 printer mechanism and receiving commands from the customer's controller via the data interface (J1). The microcomputer chip set must receive data from the hardware input command buffer; the printwheel absolute position counter; sixteen miscellaneous inputs; and, optionally, the custom character ROM. The microcomputer must output data to the printwheel and carriage delta counters. These transfers of data are made via the 8 bit I/O bus. The following list indicates what data is passed from the I/O bus to a printer circuit or from which printer circuit to the I/O bus by the input (e.g. IP2) and output (e.g. OP3) commands.

I/O STATUS	I/O SIGNAL		
<u>IP 0</u>	CODED	+	<u>B7</u>
"	STROBE	+	<u>B6</u>
"	(see Note 1)	+	<u>B5</u>
"	D1024 (DIR)	+	<u>B4</u>
"	D2048 (or RIB LIFT)	+	<u>B3</u>
"	D512	+	<u>B2</u>
"	D256	+	<u>B1</u>
"	D128	+	<u>B0</u>
<u>IP 1</u>	D1/2	+	<u>B7</u>
"	D64	+	<u>B6</u>
"	D32	+	<u>B5</u>
"	D16	+	<u>B4</u>
"	D 8	+	<u>B3</u>
"	D 4	+	<u>B2</u>
"	D 2	+	<u>B1</u>
"	D 1	+	<u>B0</u>

Note 1:

The coded strobe indicates which customer or printer originated signal has loaded data into the input command buffer.

Strobe or Signal Name	U38 Pin #	3	5	7
	I/O Bus Line	<u>B7</u>	<u>B6</u>	<u>B5</u>
Paper Feed Auxiliary Strobe		1	0	1
Paper Feed Main Strobe		1	0	0
Top of Form Strobe		0	1	1
Character Strobe		0	1	0
Carriage Strobe		0	0	1
EN REST		1	1	1

I/O STATUS	I/O SIGNAL		
IP 2	PW ADDR 128	→	<u>B7</u>
"	PW ADDR 64	→	<u>B6</u>
"	PW ADDR 32	→	<u>B5</u>
"	PW ADDR 16	→	<u>B4</u>
"	PW ADDR 8	→	<u>B3</u>
"	PW ADDR 4	→	<u>B2</u>
"	PW ADDR 2	→	<u>B1</u>
"	PW ADDR 1	→	<u>B0</u>
IP 3	CHECK	→	<u>B7</u>
"	COVER INT (EOR)	→	<u>B6</u>
"	HEAVY PW	→	<u>B5</u>
"	MOVE RIBBON SW	→	<u>B4</u>
"	RIBBON LIFT	→	<u>B3</u>
"	T2	→	<u>B2</u>
"	PW POS	→	<u>B1</u>
"	STD ROM	→	<u>B0</u>
IP 4	RDY EN	→	<u>B7</u>
"	TOF	→	<u>B6</u>
"	TEST CONT	→	<u>B5</u>
"	DIAG	→	<u>B4</u>
"	Auxiliary PF	→	<u>B3</u>
"	PW INDEX	→	<u>B2</u>
"	CA LIMIT	→	<u>B1</u>
"	CA POS	→	<u>B0</u>
CROM SEL	CROM D08	→	<u>B7</u>
"	CROM D07	→	<u>B6</u>
"	CROM D06	→	<u>B5</u>
"	CROM D05	→	<u>B4</u>
"	CROM D04	→	<u>B3</u>
"	CROM D03	→	<u>B2</u>
"	CROM D02	→	<u>B1</u>
"	CROM D01	→	<u>B0</u>

I/O STATUS		I/O SIGNAL
OP 1	<u>B7</u> →	PW DIRECTION
"	<u>B6</u> →	PW Δ 64
"	<u>B5</u> →	PW Δ 32
"	<u>B4</u> →	PW Δ 16
"	<u>B3</u> →	PW Δ 8
"	<u>B2</u> →	PW Δ 4
"	<u>B1</u> →	PW Δ 2
"	<u>B0</u> →	PW Δ 1
OP 2	<u>B7</u> →	CA Δ 128
"	<u>B6</u> →	CA Δ 64
"	<u>B5</u> →	CA Δ 32
"	<u>B4</u> →	CA Δ 16
"	<u>B3</u> →	CA Δ 8
"	<u>B2</u> →	CA Δ 4
"	<u>B1</u> →	CA Δ 2
"	<u>B0</u> →	CA Δ 1
OP 3	<u>B7</u> →	-----
"	<u>B6</u> →	-----
"	<u>B5</u> →	-----
"	<u>B4</u> →	CA DIRECTION
"	<u>B3</u> →	CA Δ 2048
"	<u>B2</u> →	CA Δ 1024
"	<u>B1</u> →	CA Δ 512
"	<u>B0</u> →	CA Δ 256

## REPAIR

The following tells how to restore the high-speed printer to normal operation after replacing or repairing major parts and subassemblies. Step-by-step procedures are given for the mechanical alignment.

A preliminary word of caution is in order. Despite its apparent mechanical simplicity, the printer is a highly sophisticated piece of machinery. In many cases, the tolerances and adjustments that are carefully established on the assembly line are not obvious to the untrained eye. Yet, failure to observe these tolerances can result in degraded output quality, excessive stress, accelerated wear, and unnecessary premature failures. Only qualified personnel should attempt repair of high-speed character printers, and even these should be sure beforehand that they have read and understood the instructions thoroughly. Above all, resist the impulse to tamper with adjustments or to disassemble parts of the mechanism indiscriminately. If in doubt, contact Qume Technical Support for advice and instructions.

For the most part, the tools and equipment required for these adjustments are already available in the serviceman's tool kit. Whenever special tools, alignment fixtures, or test equipment are called for, they are noted prominently in the text. Section IV contains a consolidated listing of special tools and support equipment.

### **ROUTINE PROCEDURES**

#### ***Cover Removal***

The Sprint Micro 3 printer has a three-piece plastic cover. The uppermost section is a snap-on lid that protects the operator from carriage and printwheel movements during normal operation. To remove the top cover grasp the front edge firmly, and lift upward. The top cover snaps back into place in the same way.

Removing the top cover is an operator function, and must be done to replace the ribbon cartridge or exchange printwheels for various type styles. When replacing the top cover, be sure that the interlock switch is activated. The interlock switch is at the left-rear corner of the top cover, and disables the printer while the top is open (if this option is installed).

#### ***Middle Section***

- (1) Remove the platen by grasping at each end, and depressing both latch mechanisms.
- (2) Remove the three 8/32 screws at the rear of the unit.
- (3) Unscrew the seven 10/32 captive screws inside the periphery of the cover.
- (4) Lift the center cover section free of the printer chassis. Be careful to disconnect any associated wiring.
- (5) If the printer is to be run with the covers off, a jumper must be placed on J20 or J4, where the interlock switch connection was removed. The particular option configurations of the printer will determine which is the easiest to jumper.

## CIRCUIT BOARDS

Standard Sprint 3 control electronics are contained on three printed circuit boards, each having edge connectors that mate with corresponding connectors on the mother board.

For purposes of identification, these assemblies are numbered sequentially, beginning at the rear of the printer. The board at the rear of the unit is thus PCB #1; that nearest the front of the unit is PCB #3. The TwinTrack model uses the same printed circuit boards, but has a second #2 and #3 board. All of these boards (1, 2 and 3) are interchangeable between Sprint 3 models. In other words a #2 board can be used as a #2 board in all models including the TwinTrack. If the options are the same. Likewise with the #3 board, etc. The TwinTrack model has, however, one printed circuit board, and the mother boards (2 of them), that are not interchangeable except within the TwinTrack model.

Removing and replacing electronic assemblies is routine. Using extractors, however, makes this task easier and minimizes the possibility of damage to the printed circuit boards. Always turn power OFF before removing or replacing any assembly. Connectors on the mother board are staggered, making it impossible to insert a printed circuit board in the wrong mother board position. When replacing printed circuit boards, be certain that they are seated firmly in their mating connectors.

### **Selected Resistors**

Printed circuit boards #1 and #3 each have a factory selected resistor in the servo compensation circuit. These resistors are selected at the factory, and require no further attention unless some component within the circuit is changed. If the circuit is repaired or modified, the value of the selected resistor must be verified and/or re-selected. The selection procedure is outlined below.

Tools needed are: Oscilloscope - dual trace with 2 probes  
Resistance decade box  
Printer exerciser (P.N. 80630-04, -05, or 99000-00, -01)  
or a system that will operate the printer as given below

### Board #1:

- . Remove, by unsoldering, the selected resistor (see the specific revision level logic schematics for the R number and physical location).
- . In the place of the resistor, connect a resistance decade box, initially set to 1,000 OHMS.
- . Connect an oscilloscope probe to TP19 on circuit board #1 (CA POS).
- . Connect a second oscilloscope probe to TP3, circuit board #1 (Encoder A).
- . Using the printer exerciser, cause the carriage to move alternately right and left 0.1 inches (12 increments of 1/120 inches). This movement should be at the center of the carriage motion; directly in front of the motor pulley. The ribbon cartridge must be in place during this test.

### Selected Resistors [continued]

- Set the oscilloscope to trigger on the CA POS probe, and display the encoder A signal at nearly full screen in height and centered vertically.
- Vary the carriage strobe rate (on the exerciser) until the servo settling waveform is displayed on the screen (see the waveform below).

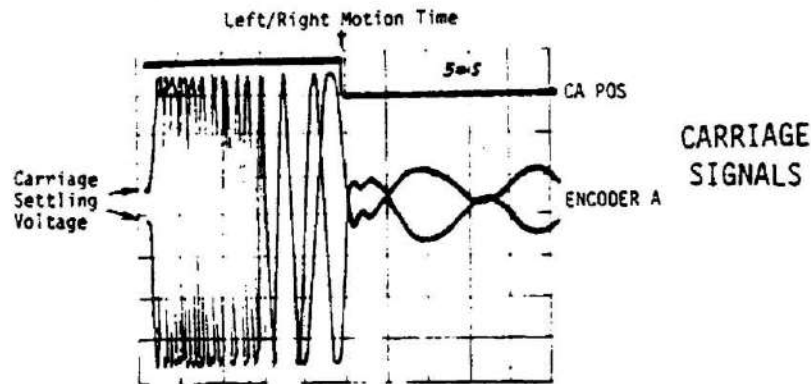

- Vary the resistance decade box (usually between 0.5k OHMS and 1.5k OHMS) to change the right to left and left to right carriage motion times.
- Adjust the resistance until both motions show identical times.
- Observe the encoder A waveform. The settling voltage may vary slightly, but must be within  $\pm 3$  volts of the average center voltage of the entire waveform. The settling voltage is easiest, and most accurately observed at the beginning of the waveform. The beginning point starts from the settled voltage of the previous cycle.
- If the settling voltage is not within  $\pm 3$  volts of the center, adjust the resistor decade box until it is within the specification.
- Observe the carriage travel time again. The left-to-right and right-to-left movements must be within 3 ms of the same time. In some cases the resistance must be varied to a compromise point. But the encoder A settling voltage must be within  $\pm 3$  volts of the center and the right/left left/right movements must be within 3 ms of each other.
- Boards that cannot be adjusted to the above specifications are defective, and must be repaired. Check all op-amps and associated components within the circuit.
- When a resistance value is found that allows both the settling voltage and the movement time to be within specifications, select a 1% resistor at the nearest value to that shown on the decade box.
- Insert and solder the selected resistor.
- Recheck the encoder A settling voltage ( $\pm 3$  volts) and the difference in travel time for the two directions (with 3 ms). If these values are not within specification, the resistor (R209) must be re-selected, repeating the steps above.

## Selected Resistors [continued]

### Board #3:

- Remove the resistor by unsoldering.
- In the place of the resistor, connect a resistance decade box, initially set to 1,000 OHMS.
- Connect an oscilloscope probe to TP11 on board #3 (PW position).
- Connect a second oscilloscope probe to TP23 on board #3 (encoder A).
- With the printer exerciser, alternately move the printwheel 47 characters clockwise, and 47 characters counterclockwise (w and % will do this).
- Vertically center the waveform on the screen.
- Vary the character strobe rate (on the exerciser) until the servo setting waveform is displayed on the screen (see the waveform below).

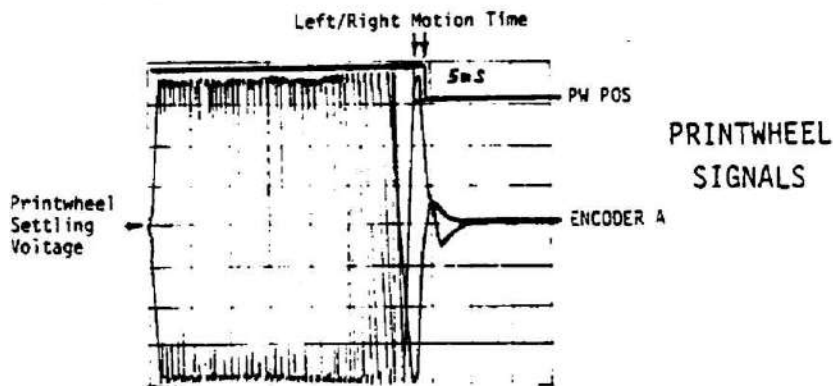

- Vary the resistance decade box to change the settling voltage level of the encoder A signal until the voltage is either centered in both directions or is symmetrical about center in both directions. The final settling voltage is most accurately reflected at the beginning of the following cycle, shown as the starting point on the oscilloscope.
- The encoder A display must be centered vertically on the screen during this test or the values are meaningless. The settling voltage must be within  $\pm 2$  volts of the average encoder voltage. The average encoder voltage will be the zero line in the middle of the oscilloscope graticule if the display is centered properly.
- Check the other trace for the difference in motion times between clockwise and counterclockwise. The difference between the two directions should not exceed 4 ms.
- If a selected resistance cannot be chosen that allows the encoder A settling voltage for each direction of travel to be within  $\pm 2$  volts of center, and the time difference between the two motions to be 4 ms or less, the board is defective, and must be repaired. Check the operational amplifier and associated components within the circuit.



### **Selected Resistors [continued]**

- . When a resistance value is found that allows both parameters to be within specification, select a 1% resistor of the nearest value to that shown on the decade box.
- . Insert and solder the selected resistor.
- . Re-check the settling voltage and the difference in the motion time. If the settling voltage is not within  $\pm 2$  volts and the difference in motion is not 4 ms or less, the resistor must be re-selected using the steps above.

### **MECHANICAL ALIGNMENT**

Although mechanical misalignment can result in noisy operation or in damage to the equipment, the first indication is usually a visible deterioration of the print quality. Symptoms frequently observed include characters that are too light or dark, characters that are heavier at the top or at the bottom edge, characters that appear to taper and become uneven at one or both extremes of carriage travel, and characters that seem to fade out at the horizontal line is scanned. Maladjustment occasionally produces positional inaccuracies that are most evident in the smeared appearance of overprinted characters or in the ragged "picket-fence" aspect of the horizontal lines.

Misalignment of the printer is seldom the result of ordinary wear. More often it is attributable to an accident, or to physical abuse of the printer. Any unit subject to a violent shock should be checked carefully for visible evidence of such maladjustment. However, re-adjustment will also be indicated as a matter of routine, whenever any of the following components and subassemblies are repaired or replaced:

- Printwheel carriage
- Printwheel servomotor
- Printhead solenoid
- Ribbon lift solenoid
- Carriage servomotor
- Paper feed stepper motor
- And/or platen drive gears
- Plastic card guide

A complete re-alignment will seldom be called for, but, you must be careful to restore any and all adjustments that may have been disturbed. We therefore recommend that you read the following section carefully before beginning any repair. The preface to each procedure enumerates the conditions that make the particular adjustment necessary.

Note that the alignment procedures are grouped, as follows:

- Printhead adjustments
- Platen adjustments
- Paper feed roller adjustments
- Carriage adjustments
- Ribbon adjustments
- Mother board alignment

## MECHANICAL ALIGNMENT (continued)

Some of the adjustments that are given have interaction. We therefore recommend that all the procedures in a given group be performed at the same time. Observe the order of adjustments carefully, and take special note of those few cases where adjustments in one group necessitate re-checking adjustments in another.

### PRINTHAMMER

Printhead misadjustment usually produces characters that are too light, too dark, or uneven. Occasionally, however, a faulty adjustment will cause noisy operation or printwheel breakage. Printhead adjustments should be made as a group, and in the given order. Check all adjustments first. Do not change hammer adjustments unless there is known trouble, or a check shows one or more dimensions out of specification. All platen adjustments must be correct and hammer cleaning and lubrication performed before the hammer adjustments are made.

Complete realignment of the printhead assembly is necessary whenever any of the following parts have been removed or replaced:

- Printhead
- Printhead actuating solenoid
- Armature limit bumpers
- Printwheel servomotor

#### Printhead Vertical Alignment

This procedure requires a special alignment tool (#80739), a screwdriver, and a 3/16" wrench or nut driver. The alignment tool gauges the angle and vertical position of the printhead. However, because of possible tolerance buildup, final adjustment must be made with print quality as the criteria.

- (1) Remove all power to the printer.
- (2) Remove the top cover.
- (3) Remove the platen by grasping at both ends, and depressing both latch mechanisms.
- (4) Remove the ribbon cartridge and printwheel.
- (5) Loosen the two printhead retaining screws (A) that secure the printhead housing to the carriage.

#### Most Sprint 3 Printers

- (6) Install the printhead alignment gauge (#80739), as shown in the figure. Be certain that the upper carriage is locked in its normal operating position. Check this by pushing down on the C (close) button near the end of the printwheel motor.
- (7) Move the printhead assembly into alignment. The movable hammer should contact the fixture lightly at both ends, as shown in the diagram.

### Printhammer Vertical Alignment [continued]

- (8) Hold the printwheel housing in the aligned position, and re-tighten the two retaining screws. This completes the vertical alignment.

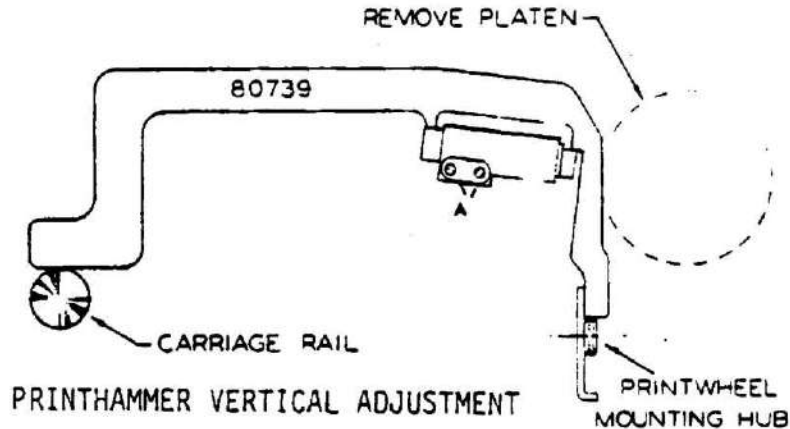

### S3/X30 and S3/X40 Models Only

- (6) Install the metalized printwheel on the printwheel motor hub. Be sure that the printwheel is correctly seated, and that the printwheel is not damaged or worn.
- (7) Verify that the printwheel motor assembly is locked into the normal operating position by pressing down on the "C" button.
- (8) Verify that the Multiple Copy Selector Lever is in the extreme forward position (toward the operator).
- (9) Gently push the hammer against the printwheel spoke until the font character lightly touches the platen.
- (10) Observe the contact between the hammer face and the back of the character font. When the character font is lightly touching the platen, the hammer face should be flat against the back side of the font. If there is space at the top or bottom, adjust the hammer angle for best contact.

After adjusting the printhammer vertical position, it is a good idea to run a print sample and check the evenness of the impression. Vertical misalignment produces characters that are darker at the top or bottom edge. If characters are heavier at the top or bottom, it may be necessary to raise or lower the adjustment slightly, so that the hammer is more nearly horizontal. Uniform appearance of the sample is the ultimate criterion to be applied. A small adjustment can be made by loosening only the screw closest to the printwheel, and moving the printhammer slightly. Before re-adjusting the hammer, however, be sure to check the platen height adjustment as described later in this section. Maladjustment of the platen can produce much the same result as faulty printhammer alignment, so the platen should be checked before concluding that the printhammer is to blame for a visible defect.

## Hammer Armature Core Adjustment

Before the hammer armature core is adjusted, the platen and hammer vertical adjustments must be made. Because this adjustment is made following the hammer vertical adjustment, it is assumed that the power is off, and the top cover and printwheel are both removed. Qume special tool, 80758, is used for this adjustment (see PRINTWHEEL INDEX ALIGNMENT for an illustration of this tool).

- (1) Install the alignment disc ( P.N. 80758) where the printwheel normally resides. With the printwheel motor tilted back to attach the alignment disc, "This Side Up" should be visible. This can be secured with a discarded printwheel center hub.
- (2) Rotate the disc until the notch on the flattened portion is toward the hammer. Be sure the alignment disc is securely seated on the printwheel motor shaft.
- (3) Using a 3/16" wrench, loosen the retaining nut at the opposite end of the eccentric forward limit bumper. (Item D in the figure below.)

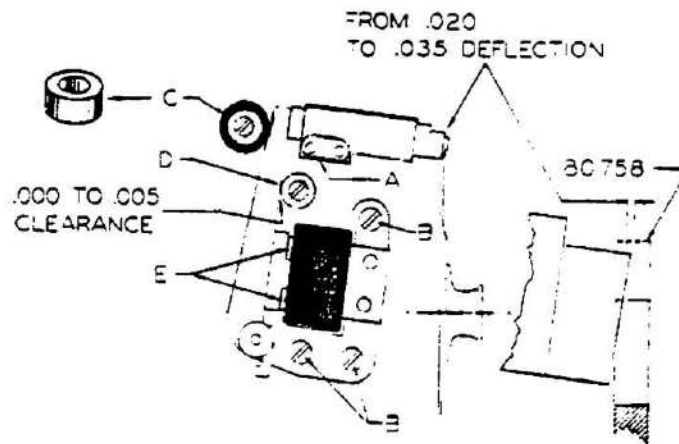

HAMMER ARMATURE CORE ADJUSTMENT

- (4) Rotate the bumper beneath screw D to the maximum possible clearance between the bumper and the armature. Do not re-tighten, this adjustment will be completed later.
- (5) Loosen the three screws (B) holding the armature core.
- (6) Pinch and hold the armature lever against the core piece, and position the entire assembly so that the hammer extends .020" to .035" into the slot on the alignment disc. There are two scribed lines on the flat edge of the alignment disc to aid this measurement.
- (7) While still holding the assembly in position, tighten the three screws (B).
- (8) Hold the armature core to the polepiece.
- (9) With a screwdriver, rotate the eccentric bumper (D) to within .000" to .005" of the hammer armature.

### Hammer Armature Core Adjustment [continued]

- (10) While holding the adjustment with a screwdriver, tighten the nut at the opposite end of D.
- (11) Loosen the retaining nut at the opposite end of screw (C).
- (12) Place the ring gauge (P.N. 73046) over the plastic bumper on C. If no ring gauge is available, use a .65" (.063" -.000 +.005) spacer or feeler gauge.
- (13) While holding the armature against the core, rotate the eccentric screw (E) until the ring gauge lightly touches the hammer armature.
- (14) Continue to hold the eccentric screw with the screwdriver; and tighten the retaining nut at the other end of the screw. The hammer armature will be held by the gauge during this part of the operation.
- (15) Remove the gauge from the bumper.

### PRINTWHEEL INDEX ADJUSTMENT (HUB)

Although the printwheel index adjustment is not technically a printhead adjustment, it should be checked when the printhead adjustments are made. Printhead maladjustment can produce symptoms ranging from poor print quality to physically breaking the printwheel spokes. The printwheel should not be adjusted until after all other adjustments are perfect, and then only if the misalignment is visible.

The printwheel index adjustment requires the special tools illustrated below. DO NOT ATTEMPT ADJUSTMENT WITHOUT THESE TOOLS.

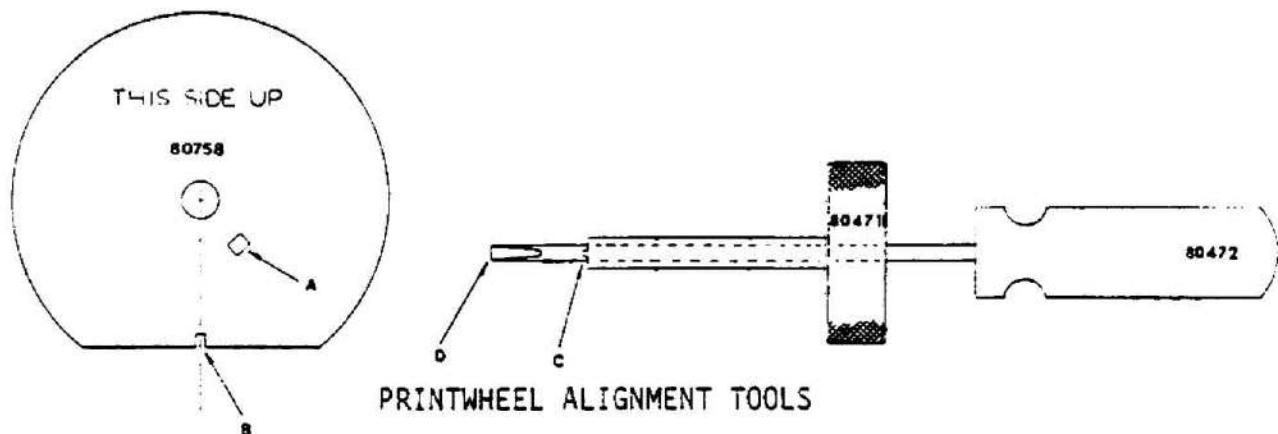

#### WARNING

This adjustment is made with the printer energized. Keep hands and tools clear of the carriage and printwheel, except as specifically instructed in the text.

- (1) Remove the top cover, if it is not already off.
- (2) Bypass the cover interlock switch if necessary by placing a small bit of folded paper into the opening to hold the switch lever. The interlock switch is located at the left rear of the top cover opening (as seen from the operator position).

## PRINTWHEEL INDEX ADJUSTMENT (HUB) (continued)

- (3) Disconnect the data cable from the printer unit, and apply power.
- (4) Extend the printhead and verify that the lower case "w" is squarely in front of the printhead. If it is aligned properly, skip the remaining procedure, otherwise continue.
- (5) Release the carriage locking lever by depressing the "0" button on the carriage.
- (6) Remove the printwheel by grasping firmly at the hub, and pulling away from the shaft.
- (7) Briefly activate the ribbon feed switch inside the lower right portion of the carrier travel area. The ribbon will raise and advance, then return to the lowered position. When the ribbon returns to the lowered position, the printwheel will index to a "home position", where the lower case 'w' is in the printing position (index pointer on the "X" models).
- (8) Using the collet adjusting tool and the concentric screwdriver, hold the shaft with the screwdriver and loosen the hub collet. The collet loosens by twisting the knurled knob of the tool counterclockwise.
- (9) Mount the alignment disc on the printwheel hub with the "UP" side away from the motor. The "UP" marking references the flat surface, not the rotation.
- (10) Place the ring gauge (P.N. 73046) over the plastic return stop bumper behind the armature, causing the printhead to extend.
- (11) While holding the motor shaft with the screwdriver portion of the adjustment tool, rotate the disc (but not the motor shaft) until the extended tip of the printhead engages (or aligns with) the cut in the flat edge of the disc.
- (12) Carefully tighten the collet hub by turning the knurled knob clockwise. DO NOT tighten with brut force. A very snug fit is sufficient.
- (13) Remove the alignment tools, the disc, and the ring gauge.
- (14) Re-mount the printwheel onto the motor shaft.
- (15) Briefly activate the ribbon feed switch again.
- (16) Verify that the lower case "w" is squarely in front of the printhead. If it is not, remove the printwheel and repeat the adjustment.  
\*For the "X" models, verify that the printwheel index pointer is exactly straight up.
- (17) When the adjustment is complete, return the carriage to the operating position, and press the "C" button to lock it into place.

## PLATEN ADJUSTMENTS

Platen misalignment usually causes variation in print quality over the width of the page, ragged lines, lines that taper, or lines that gradually fade from side to side. Difficulty in accurate overprinting may also indicate platen maladjustment. The platen should be aligned routinely when any of the following items are replaced:

- Paper Feed Stepper Motor
- Paper Feed Idler Gear
- Carriage
- Printwheel Servo Motor

Adjustments within this group are highly interdependent, and should be performed as a group, in the order that is given. These adjustments bring the platen alignment to within specifications, but the final criteria should be print quality.

### **Platen Depth**

- (1) Remove the top and middle cover sections. Cover removal instructions are given in the first portion of this section of the manual.
- (2) Place the multiple copy select lever in the extreme forward position. The forms thickness lever is behind the platen on the top left side. Be sure that the platen is properly seated and latched into position (the two platen releases have returned to the latched position).
- (3) Tilt the carriage forward, and remove the printwheel (as described in OPERATION).
- (4) Return the carriage to the operating position, and lock into place by depressing the "C" button.
- (5) Manually position the carriage to the end of travel on the side that is to be adjusted.
- (6) Place the alignment tool (80751) on the platen, printwheel hub, and front carriage rail as shown in the following illustration.

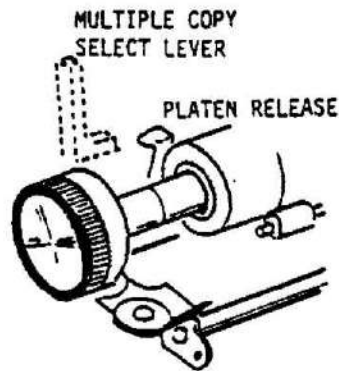

## PLATEN ADJUSTMENTS (continued)

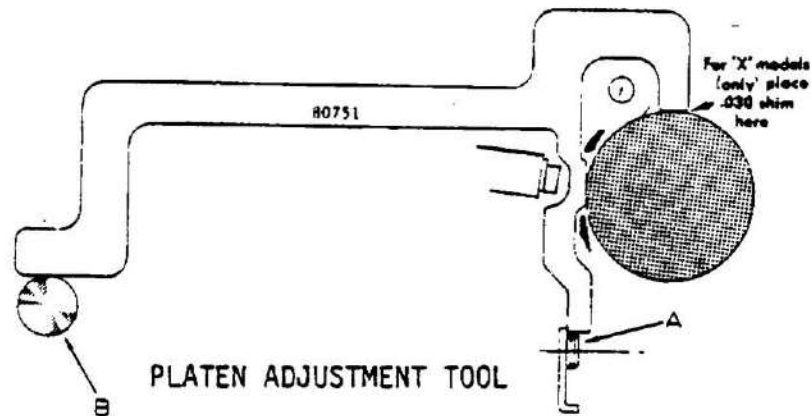

- (7) The figure below shows the adjustment on the platen frame assembly. The adjustment locations are the same for each end, and are "mirror images" of each other. Each adjustment has a slotted locking screw, and 5/8" hex adjustment eccentric. With a screwdriver, loosen, but do not remove, the two lock screws.

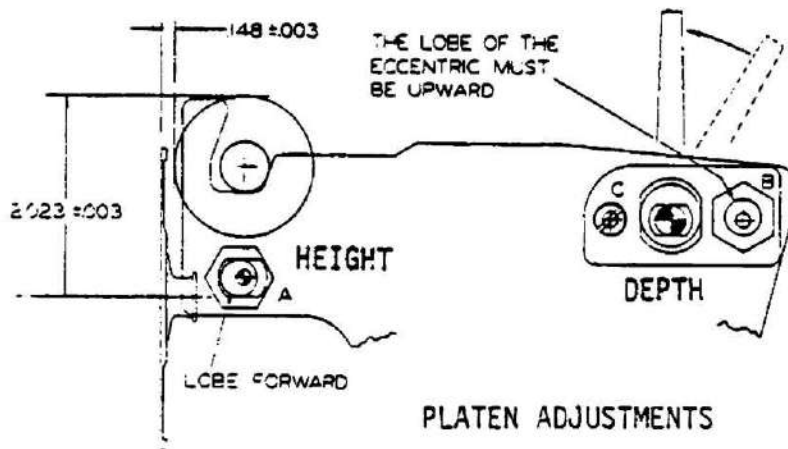

- (8) Using the hex eccentric, adjust the plate until the forward edge of the platen barely touches the flattened vertical edge of the alignment gauge.
- (9) When the adjustment is correct, tighten the lock screws, and repeat the procedure for the opposite end of the platen.

### Platen Height

- (1) Place the alignment gauge (80751) as shown on the previous page. This is the same tool, in the same place as for the depth adjustment. Note that the "X" models require a .030" shim beneath the gauge (the platen is adjusted .030" lower).
- (2) Loosen the locking screw for the eccentric. (See the illustration.)
- (3) Adjust until the top of the platen barely touches the gauge.
- (4) Re-tighten the locking screw, being careful not to change the adjustment.



## PLATEN ADJUSTMENTS (continued)

### Platen Drive Gear Adjustment

Adjust the platen drive gear for minimum backlash in the paper feed gear train. A drive mechanism that is too tight will bind, causing poor vertical positioning. A mechanism that is too loose causes poor registration and overprinting, or uneven lines.

The gear train is adjusted at the factory, but must be checked when any of the platen adjustments are made, or when a paper feed motor is replaced. The illustration below shows the location of the adjustment screws. Access to the screw labeled A is through a hole in the intermediate gear (the large black gear).

- (1) Loosen the two retaining screws, A and B. These should be loose enough to allow adjustment, but retain the position without being held.
- (2) Move the intermediate gear into both of the other gears. This should gently bottom without binding.
- (3) Re-tighten the securing screws, and check for backlash or binding. The large gear should be able to slide in and out on the shaft (within the limits of the endplay) but it should not have any rotation motion.
- (4) Rotate the platen knob to verify that there is no binding or backlash at some other point in the rotation. The paper feed motor will exert some resistance, even without power.
- (5) If the gear cannot be adjusted to eliminate backlash, the condition must be corrected by replacing worn parts. However, the quality of the print-out should determine if that is necessary.

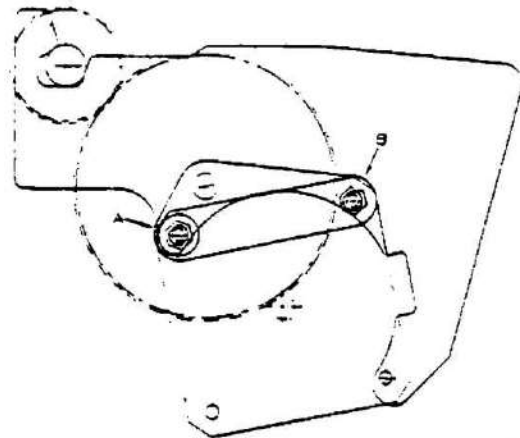

PLATEN GEAR DRIVE ADJUSTMENT

### Platen Latch Adjustment

- (1) Remove the platen by pressing both releases, and lifting the platen.
- (2) Loosen the locking screw (slot head). See the illustration for the screw location.
- (3) Adjust the eccentric slightly in the desired direction.

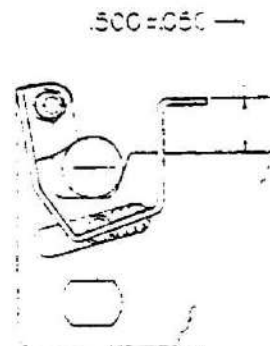

PLATEN LATCH ADJUSTMENT

### **Platen Latch Adjustment [continued]**

- (4) Replace the platen, and measure the distance shown in the illustration. If necessary, repeat steps (1), (2) and (3) until the adjustment is correct. Do NOT attempt to adjust with the platen in place.
- (5) Re-tighten the locking screw, and replace the platen.

### **Platen Release Adjustment**

The figure below shows the required spacings and tolerances for the platen release mechanism. Under normal circumstances this adjustment will not be required. If adjustment is required, remove the platen and adjust by loosening the set screws.

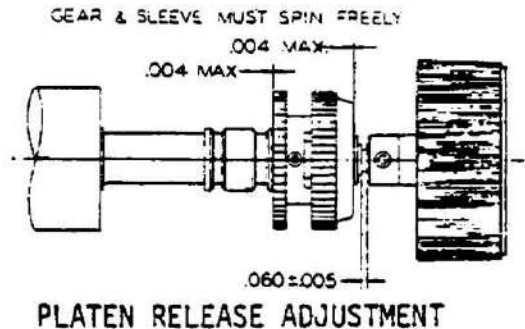

### **PAPER FEED ROLLER ADJUSTMENTS**

Feed rollers that are not properly adjusted may cause the paper to "creep" sideways or become misaligned as the paper passes through. All of the paper feed roller adjustments are interdependent, and should be performed as a group.

Remove all power from the unit when making these adjustments.

#### **Feed Roller Depth**

The figure below shows the mechanical details of one of the four feed roller arms. The arm is spring loaded from an adjustable pivot point. By moving the arm toward the front or rear, the roller alignment is adjusted. All four arms must be adjusted, one at a time, to assure proper tracking.

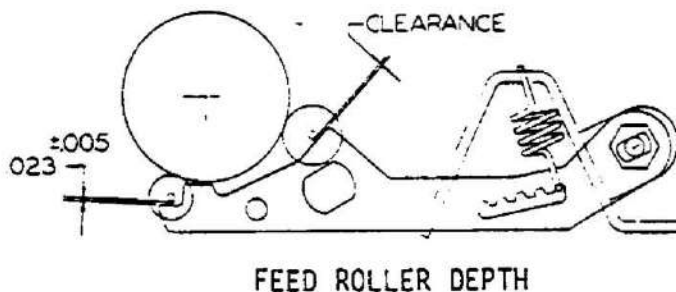

## PAPER FEED ROLLER ADJUSTMENTS (continued)

- (1) Using two wrenches, loosen the adjustment on one arm. Loosen only enough to allow movement with finger pressure.
- (2) Adjust the front clearance to the value shown. The front and rear clearance should be approximately equal.
- (3) Re-tighten the adjustment screws, being careful that the adjustment does not change when the screw is tightened.
- (4) Adjust the other three arms in the same manner. Before operating the unit, manually slide the carriage over the entire travel to verify that there is no interference between the front portion of the arm and the printwheel hub.

### Feed Roller Disabling Lever Adjustment

- (1) Remove the platen from the unit.
- (2) Carefully lift the cradle assembly (under the platen) and allow it to lay back, out of the way. Do not stretch the springs that are attached to the assembly.
- (3) Move the paper release all the way forward; replace the platen. Place a gauge between the platen and one lever arm. (See the illustration for the proper gauge thickness for friction platen or pin feed.)

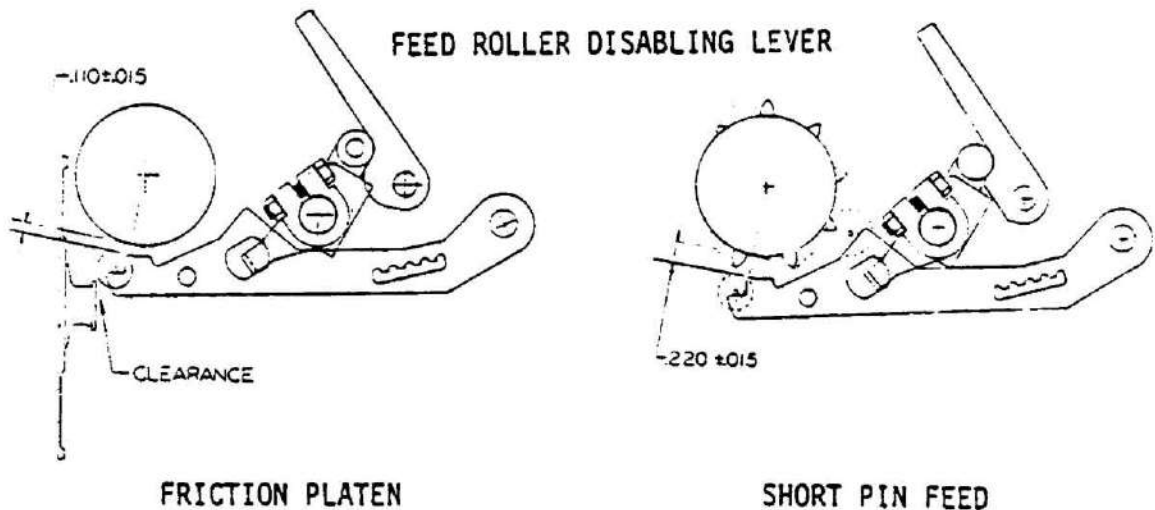

- (4) Adjust the arm for zero clearance by loosening the clamp, and changing the position of the lever.
- (5) Re-tighten the clamp, making sure that the adjustment does not change when doing so.
- (6) Adjust the other three arms in the same manner.
- (7) Re-install the cradle assembly and the platen.

## PAPER FEED ROLLER ADJUSTMENTS (continued)

- (8) With the paper release lever in the forward position, manually move the carriage over the entire range of movement. Check to be sure that there is adequate clearance between each of the paper feed rollers and the printwheel hub.
- (9) Return the paper release lever to the rear position, and check that all of the rollers engage the platen.

## CARRIAGE CABLE TENSION ADJUSTMENT

Cable tension should be checked routinely during preventive maintenance inspections or whenever the carriage is removed and replaced. Cable tension is maintained by spring tension on one idler pulley at the right side of the printer. Adjust the cable tension as follows:

### Most Sprint 3 Printers

- (1) Slide the adjustment tool, 80738, along the side frame as shown in the illustration.
- (2) Hold the cable (C in the illustration) and use a 3/16" wrench, to adjust the nut (A) until the bearing assembly (B) is centered in the gauge as shown. Either, or both ends of the cable may be adjusted, whichever is convenient, but DO NOT TWIST THE CABLE.

### S3/55, S3/WideTrack, and S3/TwinTrack

- (1) While holding the cable end (C), adjust at A until the bearing assembly (B) is centered in the hole of the side bracket as shown in the illustration.

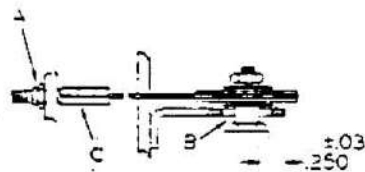
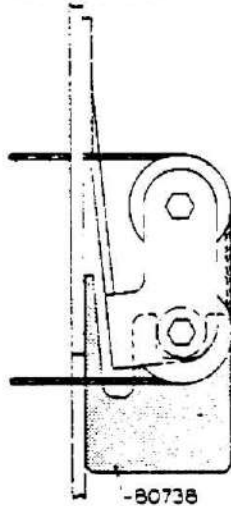

CARRIAGE CABLE ADJUSTMENT

## LEFT MARGIN PHOTO SENSOR

The optical sensor sets the beginning point for carriage travel. It is used only during the RESTORE sequence, which is issued in initialization and reset sequences.

- (1) Initialize the printer by removing power, then returning the power. The carriage should move to the left side of the travel.

## LEFT MARGIN PHOTO SENSOR (continued)

- (2) Using a graduated rule or other suitable measuring instrument, measure the distance from the printhead axis to the frame (see the illustration).
- (3) If the distance must be adjusted, loosen the two mounting screws on the photo sensor, and move the assembly.
- (4) When the adjustment has been moved, re-initialize the printer by power OFF/ON. The carriage will move to the adjusted location.

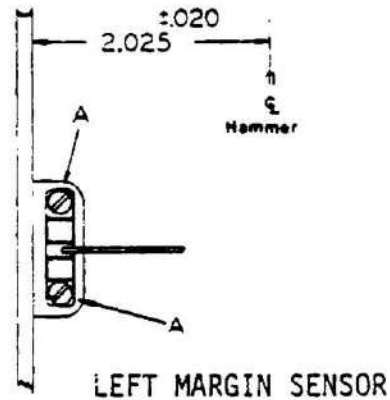

## CARD GUIDE ADJUSTMENT

The card guide must operate with both proper clearance and alignment. Adjust with power off and the multicopy select lever forward. Loosen the two mounting screws (B) shown in the illustration below. The card guide should lightly touch the platen along the entire working surface of the guide. Be sure that when the adjustment is made, there is clearance between the guide and the front platen rollers (see the lower illustration).

To set the card guide height, type several lines of capital I's at 6 lines per inch spacing. Adjust the guide by loosening the two screws (A) shown in the illustration. At 6 lines/inch, two lines should "rest" on the guide lines, while the center line is between the guide lines. The vertical mark, indicating the print position, should point directly at the center of the letter (see the illustration below).

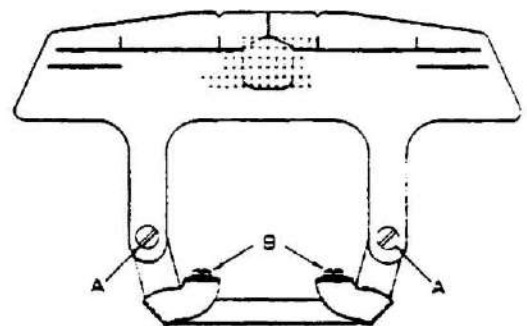
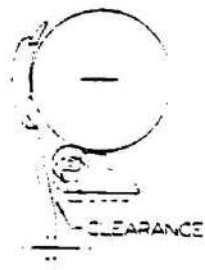
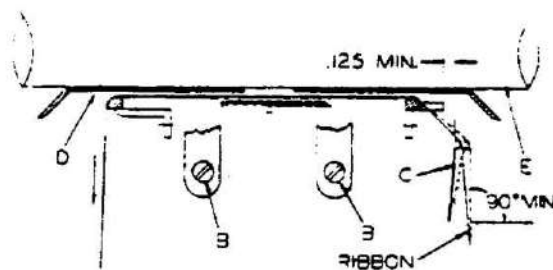

CARD GUIDE ADJUSTMENT

## RIBBON LIFT HEIGHT

- (1) Print a few characters, alternating between the apostrophe (') and the underscore (\_).
- (2) Examine the ribbon to be sure that the characters are centered on the ribbon. If the ribbon is a dual color, the characters will be centered on one of the two colors.

The illustration shows a single width ribbon, properly aligned. If adjustment is necessary proceed as follows.

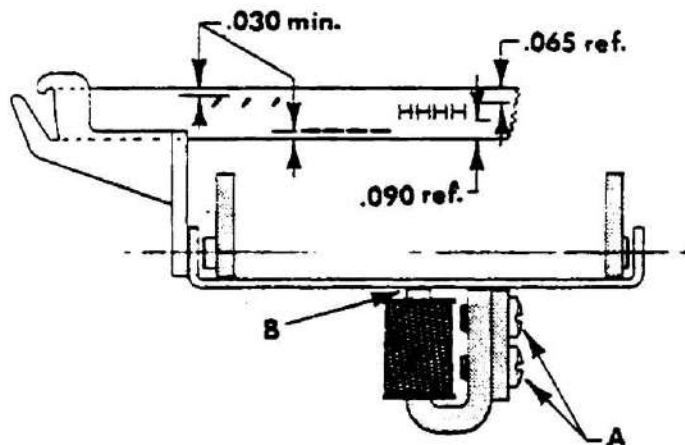

RIBBON LIFT HEIGHT ADJUSTMENT

- (1) Release the ribbon cartridge by depressing the red release lever.
- (2) The ribbon cartridge can either be removed or set askew so that the feed motor will not feed ribbon if it rotates. The ribbon can, but need not, be unthreaded from the lift guides.
- (3) Loosen the two coil mounting screws (A) shown in the drawing above.
- (4) Activate the ribbon lift by depressing and holding the ribbon advance button. The ribbon motor will also spin, but this is of no consequence.
- (5) Adjust the lift height while maintaining the coil-lift bail contact at B in the drawing. If, during the adjustment, the lift bail separates from the magnet, release the ribbon advance briefly, then re-activate. (The initial lift pulse is much greater, and will re-establish the magnetic contact.)
- (6) When the height is properly adjusted, re-tighten the coil mounting screws (A).
- (7) Release the ribbon advance button.
- (8) Replace the ribbon cartridge, and check the printing height.
- (9) Repeat the adjustment if necessary.

## RIBBON DRIVE GEAR ADJUSTMENT

The drive gear on the ribbon motor must rotate freely while meshing with the larger gear on the ribbon clutch. At the same time, only a minimum of back-lash is allowable. Adjust if necessary as follows:

- (1) Loosen, but do not remove, the two motor mounting screws (B).

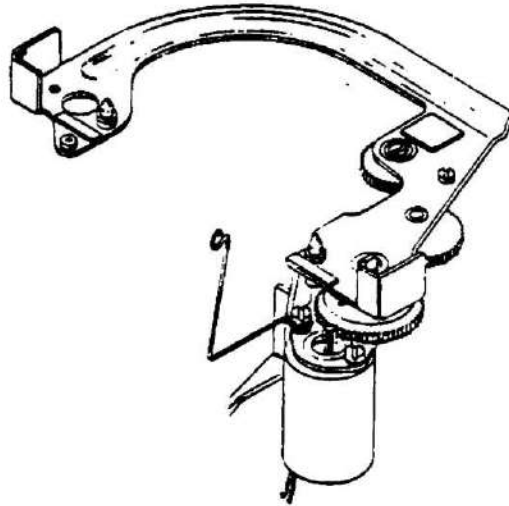

- (2) Adjust the motor position as necessary.
- (3) Re-tighten the two mounting screws (B).
- (4) If the motor mounting screws do not allow enough adjustment latitude, loosen the three screws at A, and re-position the plate.

## *TwinTrack Carriage Synchronization*

Test the two print heads of a TwinTrack printer for alignment as follows, and adjust if necessary.

- (1) Connect the TwinTrack printer to a commanding device that can cause the two print heads to alternately print at the same spot on the paper
- (2) Install identical printwheels on both print stations (i.e. print, move 5.50", print, move back 5.50", print, etc.).
- (3) Install ribbons of opposing (easy to distinguish from each other) colors.
- (4) Install paper and print identical characters from each print head at the same character column on the paper.
- (5) Observe the printed characters, they should exactly coincide (i.e. be superimposed).

### **TwinTrack Carriage Synchronization (Continued)**

- (6) Use the color difference between the two printed characters to determine direction of adjustment if the characters do not superimpose.
- (7) Adjust laterally by loosening or tightening the spring loaded screw (shown below).
- (8) Adjust for vertical misalignment by loosening the locknut (shown below) and rotating the eccentric stud. Be sure to re-tighten the locknut when the adjustment is complete.

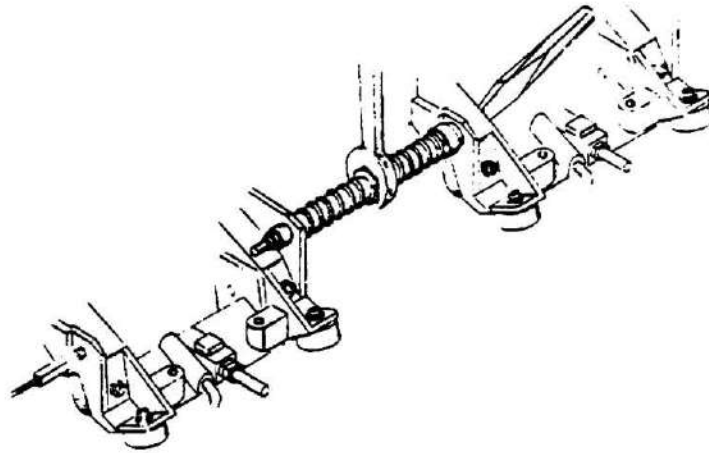

### **RIBBON LIFT SPACING**

- (1) Remove any paper from the printer. Remove the printer top cover.
- (2) Place the Multiple Copy Selector Lever in the extreme forward position (toward the operator).
- (3) Remove the ribbon cartridge.
- (4) Raise the ribbon lift guides by pressing downward on the bar portion of the bail assembly (over the lift coil).
- (5) Gently place a 0.15 inch thickness gauge between the card guide and one of the ribbon guides. (See the figure below.) The thickness gauge should touch both the card guide and the ribbon guide, but not deflect them. There may be a small movement within ribbon guide assembly, however, because of tolerances in the rivets.

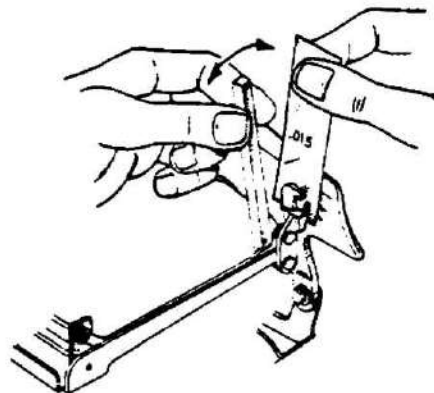



### RIBBON LIFT SPACING (continued)

- (6) Place the .015 inch thickness gauge between the card guide and the other ribbon guide. The gauge should touch both as described in the step above.

If either or both of the ribbon guides requires adjustment, proceed as follows:

- (1) Place the adjusting tool, Qume P.N. 80833, on the ribbon lift link that is to be adjusted (see the figure). The ribbon lift link is the inner of the two pieces of metal.
- (2) While holding pressure to keep the tool from slipping off, gently move the tool to adjust the ribbon lift guide. Lifting upward on the outer end of the tool decreases clearance between the card guide and ribbon lift guide. Downward increases clearance. DO NOT OVERFORM.
- (3) Re-check the clearance with the .015 inch thickness gauge.
- (4) When the ribbon lift guide properly clears the card guide, the ribbon to printwheel clearance should not be closer than .030 inches.

### RIBBON TRACKING

- (1) Replace the ribbon, but do not replace the printer top cover.
- (2) With power ON, depress the ribbon advance button, and observe the ribbon as it move across between the lift arms.
- (3) If any ribbon "curling" is present, determine which guide is causing it.
- (4) Carefully twist the arm to be adjusted outward to correct "curling" at the top of the ribbon, or inward to correct "curling" at the bottom of the ribbon. (See the illustration below.)
- (5) Check the adjustment by depressing the ribbon advance button again, and observing the ribbon as it travels across between the lift guides. Re-adjust if necessary.

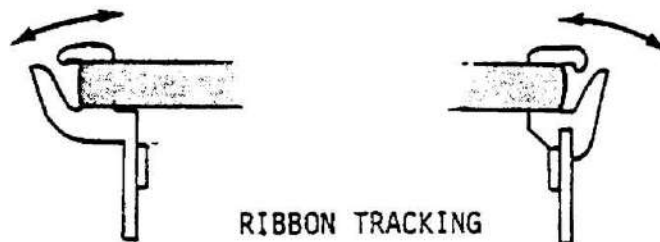

### MOTHERBOARD ALIGNMENT

If difficulty is encountered when inserting or removing the power and data connectors at the rear of the chassis, re-aligning the motherboard may help.

- (1) Remove all power from the unit.
- (2) Remove the top and middle cover sections.

## MOTHERBOARD ALIGNMENT (continued)

- (3) Remove the printed circuit boards from the inside of the printer.
- (4) Loosen, but do not remove, the eight pan-head screws that hold the motherboard.
- (5) Insert the power and data connectors. Be sure that both connectors are well seated onto the motherboard connector.
- (6) Tighten the jackscrews on the connectors.
- (7) Tighten the eight motherboard mounting screws.
- (8) Replace the printed circuit cards and the covers. Be sure that all printed circuit cards are securely seated, and the board switches are in the proper positions.

## COVER INTERLOCK

The cover interlock switch should be adjusted to faithfully disable the printer when the top cover is removed, while never falsely disabling the printer when the cover is in place. Adjust as follows:

- (1) Remove the top cover.
- (2) Lightly depress the interlock switch to its limit.
- (3) Slowly release the switch until a "click" is heard and felt. Note the position of the switch lever, it should be within .010" to .020" of resting against the intermediate cover.
- (4) If necessary slightly bend the switch lever to conform to the proper spacing.
- (5) After adjusting, check that the switch lever travels at least .035" from the resting position before the "click" is heard.

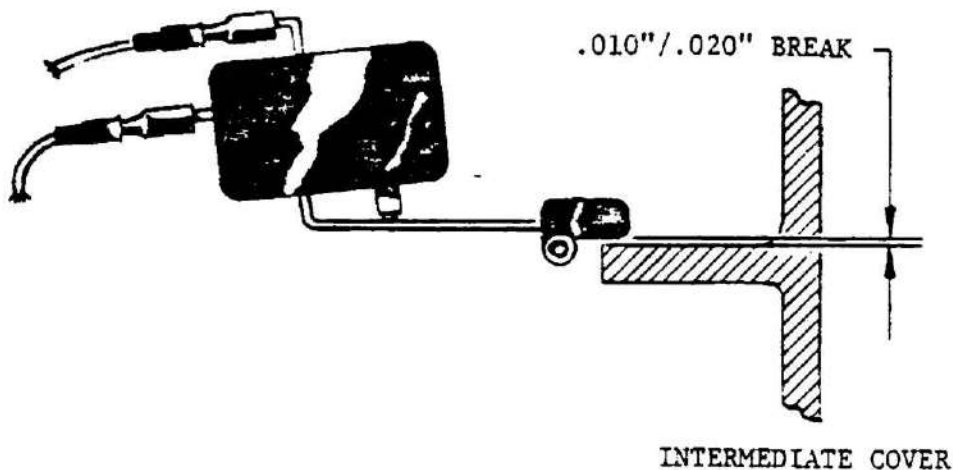

## SPRINT MICRO 3 REMOVAL AND REPLACEMENT PROCEDURES

The following procedures are to be used as a guide by the field or depot service technician when removing printer sub-assemblies for service or replacement. These procedures are written for Qume's standard Sprint Micro 3 printers and will vary slightly for the WideTrack and TwinTrack models and also for those printers with the Dual Paper Drive option installed. All adjustments referred to can be found in the earlier portions of this section. Read all pertinent procedures thoroughly before beginning.

### COVER REMOVAL

1. Refer to Illustration A. Remove the Top Cover (1) by grasping the forward corners and lifting up and toward you.
2. Pull the feed roll release lever and paper bail forward.
3. Remove the platen by releasing the latch at each end.
4. If the Cover Extension (2) is installed (e.g. covering Qume Switching Power Supply) remove the two screws (3). Complete removal of the Cover Extension requires powering down the printer and system and disconnecting both the 50 conductor data interface cable and the power cable from the printer.
5. To remove the Intermediate Cover (6), remove screws (4). There are five on the Receive Only Intermediate Cover and seven on the Keyboard Intermediate Cover. Screws (4) are located on the inside periphery of the cover.
6. Remove three screws (5) at the rear of the printer. Two of these will have already been removed if the Cover Extension was previously removed.
7. Disconnect any cables between the Intermediate Cover and the printer mechanism. Disconnection will be made at J4 on the motherboard or at J20 on the printer side frame depending upon which cable is in use.
8. Lift off the Intermediate Cover.
9. Remove the Bottom Cover (7) by removing the four screws (8) and the two nuts (8) inside the printer. Do not lose the two washers (10).

### PRINTED CIRCUIT BOARD REMOVAL

1. Remove the Top Cover, Intermediate Cover, and Cover Extension (if installed).
2. PCB #1 is at the rear of the printer; PCB #3 is nearest the operator.
3. Remove all power to the printer and system.
4. Remove the clamp that holds down the printed circuit boards.
5. Lift out the printed circuit board(s).

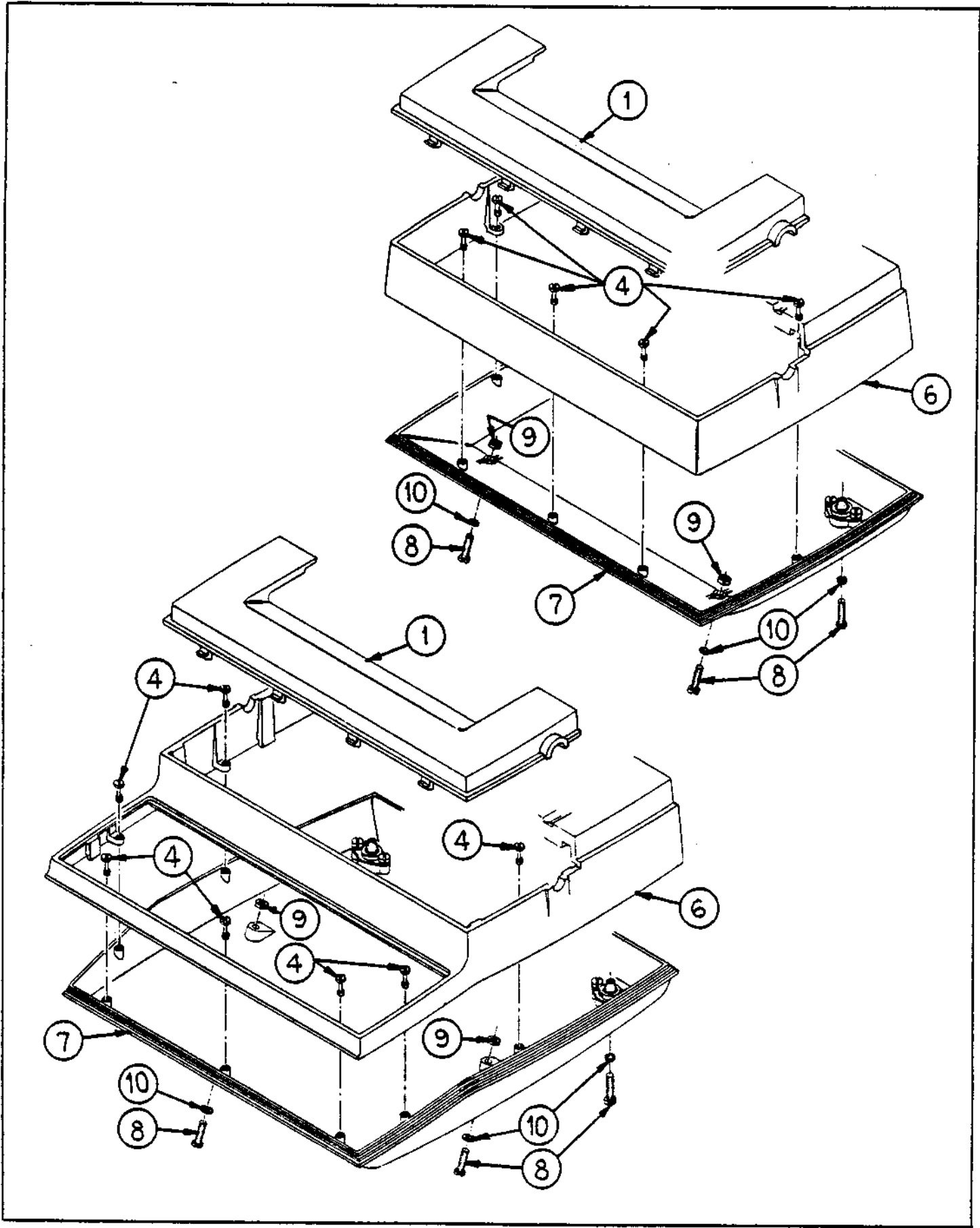

ILLUSTRATION A

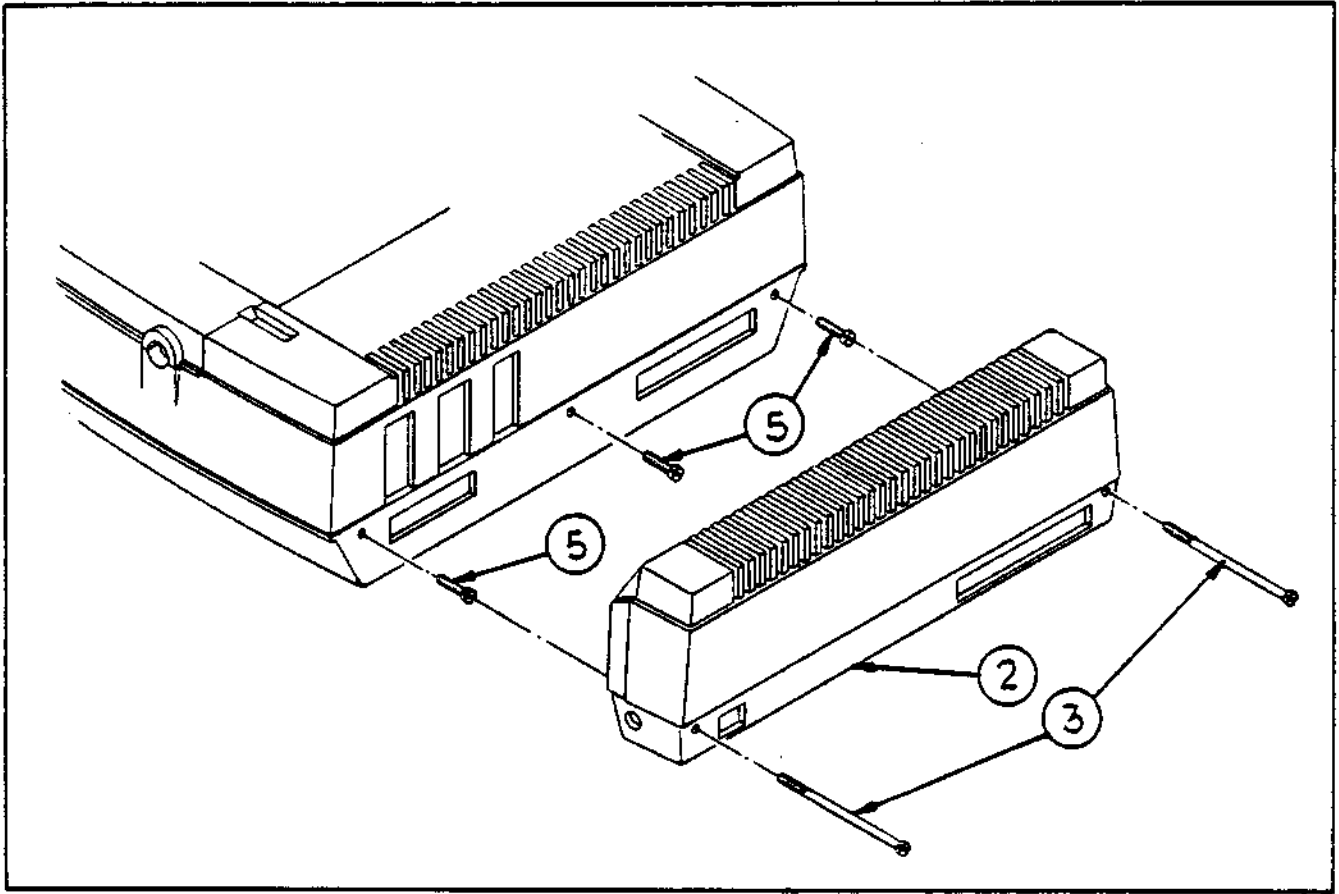

ILLUSTRATION A (Continued)

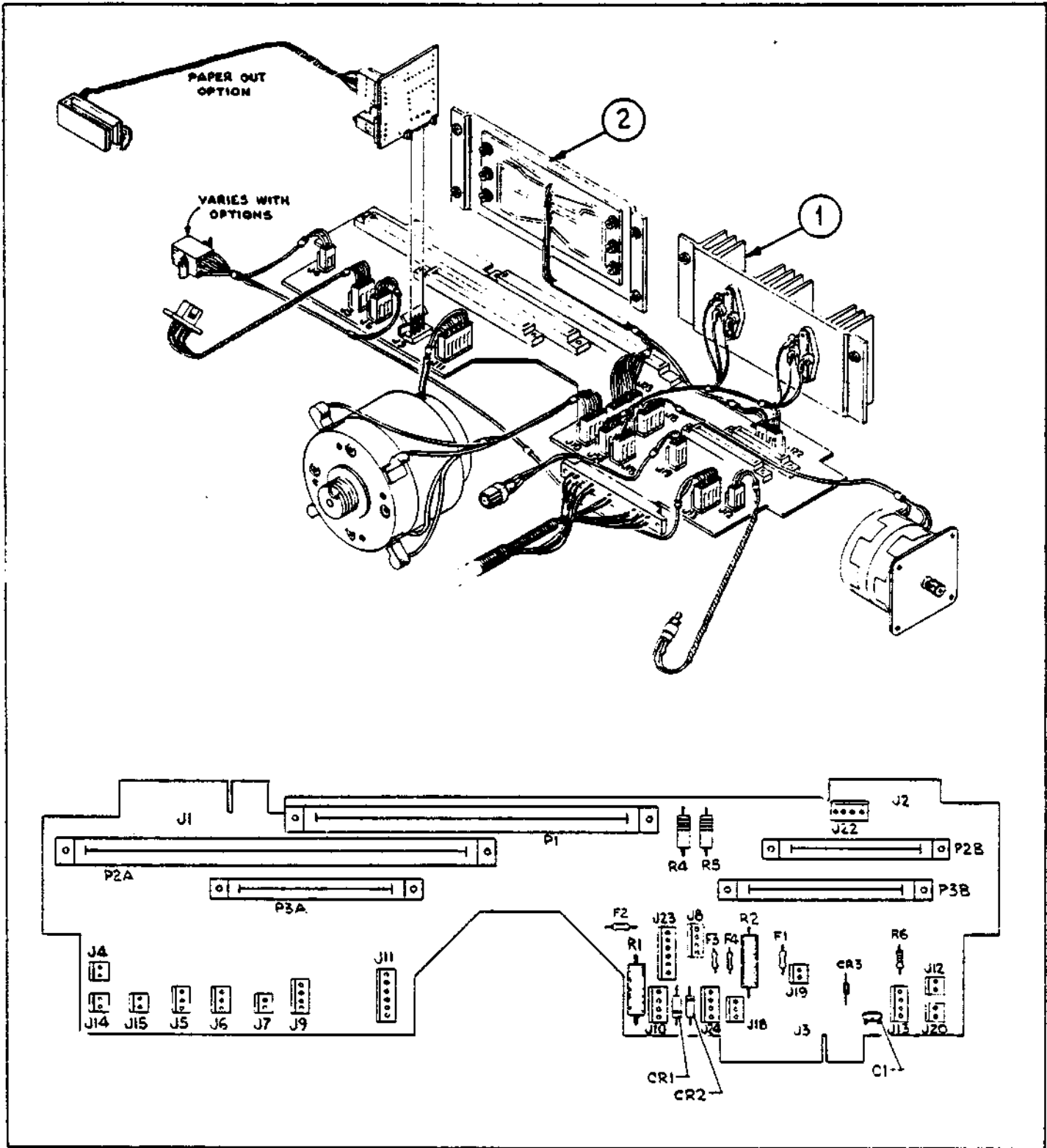

ILLUSTRATION B

## MOTHERBOARD CONNECTIONS

Most connectors are mechanically "keyed" to ensure correct assembly. If you have any questions, refer to the Motherboard Schematic (90600) for cable color coding and pin number assignments.

P1	Printed Circuit Board #1
P2A, P2B	Printed Circuit Board #2
P3A, P3B	Printed Circuit Board #3

J1	Data Interface Cable
J2	Power Cable
J3	Carriage Harness Assembly
J4	Cover Interlock Switch (may be directly connected to switch on intermediate cover or may be connected to J20 on printer left side frame)
J14	Unused
J15	Unused
J5	Carriage Left Limit Detector
J6	Form Advance (TOF) Pushbutton Switch (connected to J20 on printer left side frame)
J7	Unused
J9	Paper Out Printed Circuit Board
J11	Carriage Motor Encoder Assembly
J10	Carriage Drive Motor
J23	Paper Feed Drive Transistors (mounted on left rear heat sink assembly)
J24	Carriage Drive Transistors (mounted on right rear heat sink assembly)
J18	Printwheel Drive Transistors (mounted on left rear heat sink assembly)
J19	Hammer Fire Resistor
J13	Panel Lights (connected to J20 on printer left side frame)
J12	Move Ribbon Pushbutton
J20	Unused
J8	Paper Feed Motor
J22	+15V and -15V Power to both heat sink assemblies

F1	Fuse, Printwheel Motor
F2	Fuse, Carriage Motor
F3	Fuse, Paper Feed Motor
F4	Fuse, Paper Feed Motor

## HEAT SINK ASSEMBLY REMOVAL

1. Remove the Top and Intermediate Covers.
2. Remove all three printed circuit boards.
3. Refer to Illustration B. Looking from the front of the printer, the heat sink assembly on the right (1) contains the carriage drive transistors. The transistors themselves are socketed and can be replaced individually without removing the heat sink assembly.
4. Remove the carriage drive heat sink assembly by removing two screws and disconnecting the cables going to J24 and J22 on the motherboard.
5. The heat sink assembly (2) on the left (looking from the front) contains the paper feed and printwheel drive transistors. Remove it by removing four screws and disconnecting the cables going to J22, J23, and J18 on the motherboard.
6. When reinstalling either heat sink assembly, refer to Illustration B for cable placement.

## MOTHERBOARD REMOVAL

1. Remove the Top and Intermediate Covers.
2. Remove all three printed circuit boards.
3. Remove both heat sink assemblies.
4. Disconnect all cables from motherboard.
5. Remove the eight screws mounting the motherboard to the printer bottom pan.
6. When reinstalling the motherboard, perform the motherboard alignment adjustment given on page 6-33.
7. Refer to Illustration B and the Motherboard Connection list when reinstalling cables on the motherboard.



## PAPER FEED MOTOR REMOVAL

1. Remove the Top and Intermediate Covers.
2. Remove all three printed circuit boards.
3. Refer to Illustration C. Remove the paper feed idler gear (1) and the retaining clip (2).
4. Remove the three 8-32 hex headed screws (3), the associated washers (4), and the three spacers (5).
5. Disconnect the paper feed motor cable from the motherboard at J8. This cable may run underneath the motherboard but need not be reinstalled in the same manner as long as the routing does not interfere with any printer mechanism or removing and replacing the printed circuit boards.
6. Remove the paper feed motor (6) from the printer.
7. After reinstalling the paper feed motor, adjust the paper feed idler gear for proper gear mesh with the paper feed motor pinion gear and the platen drive gear (see Platen Drive Gear Adjustment, page 6-25).

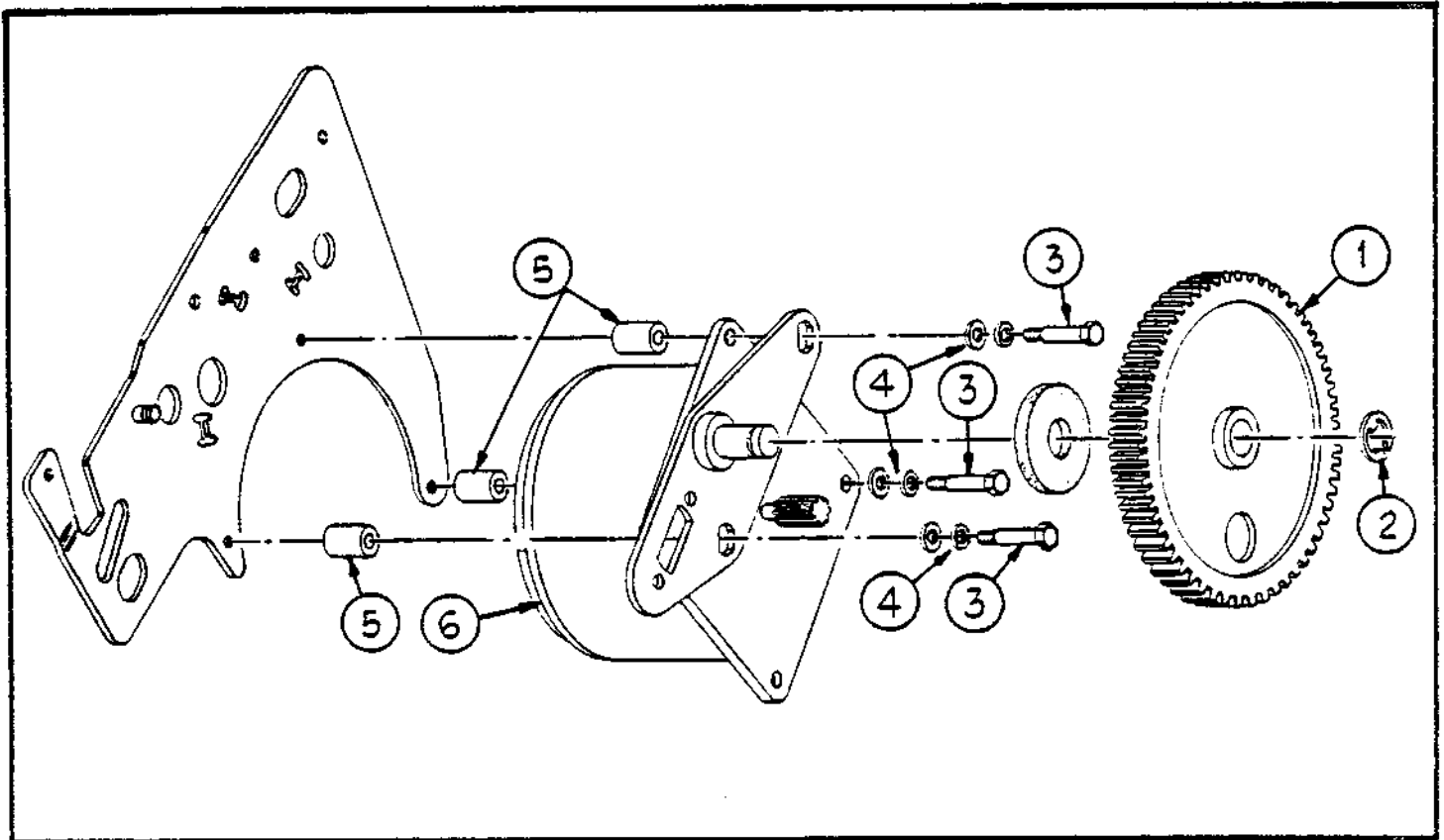

ILLUSTRATION C

## CARRIAGE DRIVE CABLE REMOVAL

1. Remove the Top and Intermediate Covers.
2. Remove the ribbon cartridge.
3. Remove the printwheel.
4. Refer to Illustration D. With the top carriage assembly tilted back, grasp the square swaged end (1) of one of the carriage drive cables with long nose pliers. Use a 3/16" wrench or nut driver and, while holding cable from twisting, back off the 3/16" self locking nut (2) until it is holding onto the last three or four threads of the cable end.
5. While holding the square end of the other carriage drive cable (1), remove the 3/16" self locking nut (2). Remove the 3/16" self locking nut loosened in step 4.
6. Both carriage drive cables are connected to the carriage drive motor pulley. Balls on the ends of the cables are retained by mating holes in the pulley.
7. Remove the drive cables from around the idler pulleys on each printer side frame and unhook the cables from the motor pulley.
8. When reinstalling the cables, note that they leave the pulley from the top side. See Illustration E. It is easiest to install the left drive cable first since it connects to the drive pulley at the end nearest the motor brace.
9. Remember to hold the square cable ends with long nose pliers to keep the cables from twisting when reinstalling the 3/16" self locking nuts.
10. Adjust carriage drive cable tension (page 6-28).

## CARRIAGE MOTOR ASSEMBLY REMOVAL

1. Remove Top, Intermediate, and Bottom Covers.
2. Remove all printed circuit boards.
3. Remove both heat sink assemblies.
4. Remove motherboard.
5. Remove carriage drive cables.
6. Refer to Illustration E. Using a 5/16" wrench, socket and ratchet, or nut driver, remove the four 1/2" long hex headed screws (1) and the associated washers.
7. Being careful not to disturb the plastic dust cap covering the carriage motor encoder assembly, remove the carriage motor through the square opening in the printer rear frame.
8. With some carriage motors, it will be necessary to remove the four conductor cable attached to the motor before it will fit through the rear frame. One of the motor terminals is marked with a red dot and the cable is color coded. A red cable is connected to the terminal marked with a red dot; the second red cable is connected to the terminal 180° on the opposite side of the motor. Individual cable length will help obtain correct orientation and electrical connection during reinstallation.

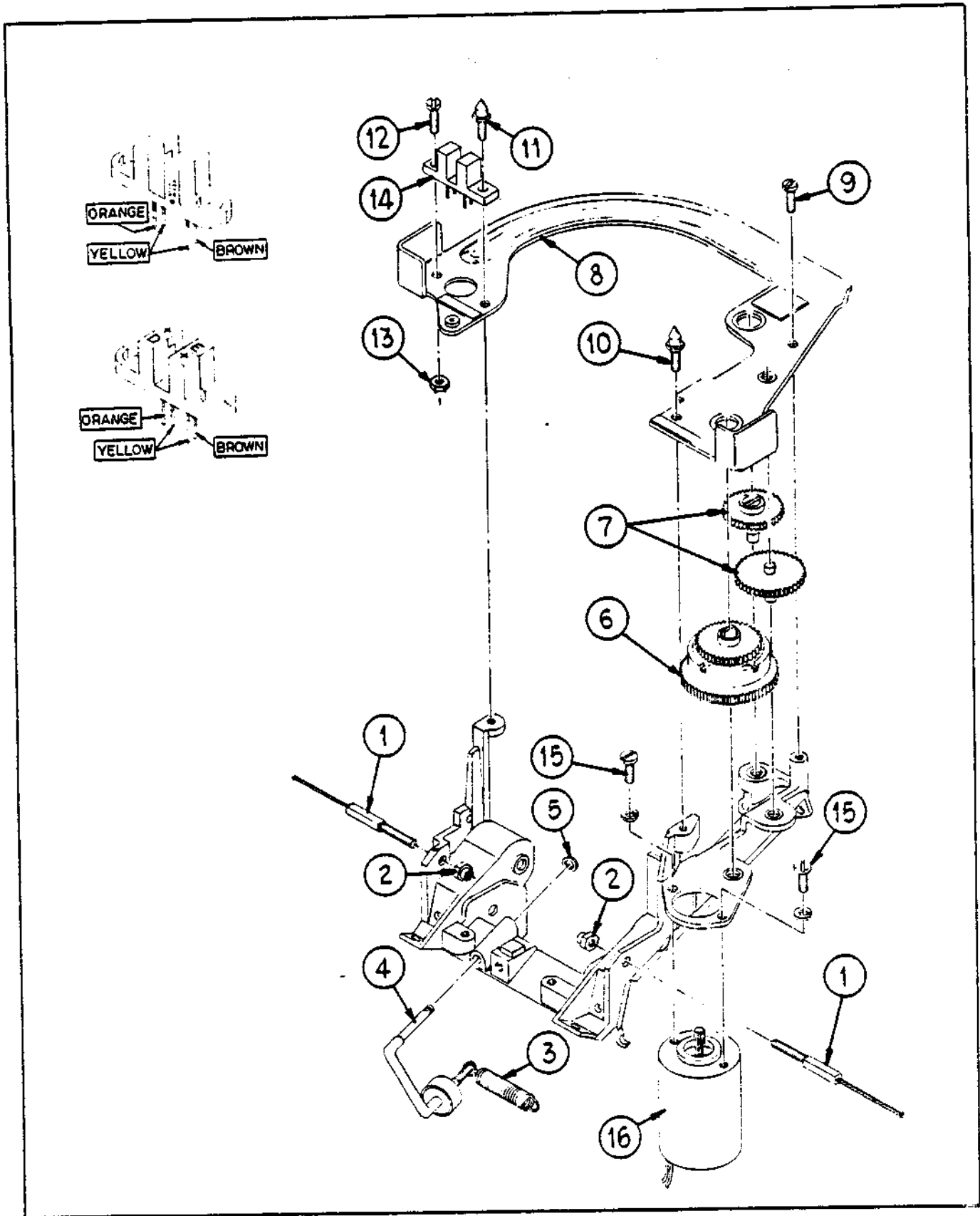

ILLUSTRATION D

## CARRIAGE ASSEMBLY REMOVAL

1. Remove the Top and Intermediate Covers.
2. Remove the carriage drive cables.
3. Disconnect the carriage harness cable from the motherboard at J3.
4. Remove the cable clamp holding the carriage harness cable to the printer bottom pan.
5. Remove any other fastener holding the carriage harness cable to the printer mechanism (e.g. nylon cable tie).
6. You can remove the carriage assembly from the carriage rails by either of two methods.
  - a. Method 1 -- The carriage rails are retained in the printer side frames by grip rings and screws. Remove the grip rings and screws on the right side only and slide both rails to the left until the carriage assembly can be reached from the printer.
  - b. Method 2 -- Refer to Illustration D. Remove the two springs (3) (only one shown in Illustration D) from the carriage assembly that load the two ball bearing assemblies (4) (only one shown in Illustration D) into contact with the bottom of the carriage rails. Remove the C-clip (5) that retains the bottom rear ball bearing assembly in the carriage. Remove the bottom rear ball bearing assembly. Remove the carriage assembly from the printer.
7. After reinstalling the carriage assembly and drive cables, adjust the carriage drive cable tension and check all print quality related adjustments (page 6-28).

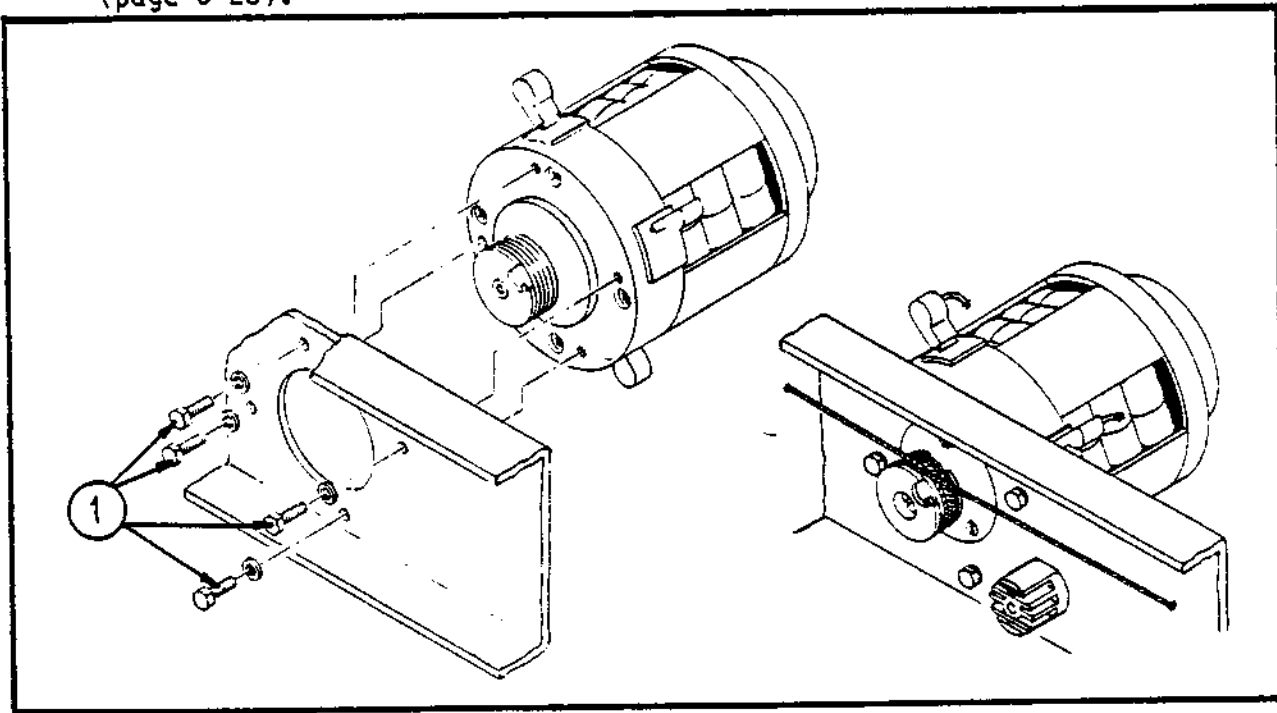

ILLUSTRATION E

## **RIBBON DRIVE CLUTCH AND GEAR REMOVAL**

1. Remove Top Cover.
2. Remove ribbon cartridge.
3. Refer to Illustration D.
4. To remove the ribbon drive clutch (6) or the ribbon drive idler gears (7), the ribbon drive plate (8) must be removed.
5. Remove screw (9) and the two studs (10) and (11). The ribbon drive plate, ribbon drive clutch, and idler gears can now be removed.
6. After reinstalling the clutch, idler gears, and drive plate, adjust the gear mesh between the ribbon drive motor and the ribbon drive clutch.

## **END OF RIBBON SENSOR REMOVAL**

1. Remove Top and Intermediate Covers.
2. In most cases it is advisable to remove the carriage assembly from the printer so that you will be able to perform the following steps easily and with little chance of accidentally causing additional damage.
3. Refer to Illustration D. Remove nut (13), screw (12), and stud (11).
4. The End of Ribbon Sensor (14) can be lifted up and the four wires cut as near to the sensor module pins as possible.
5. Remove any old heat shrink tubing from these four leads. Strip the insulation off the ends of these four leads for 1/4" to 1/2".
6. Slip a 1" long piece of 1/16" i.d. heat shrink tubing over each of the four leads.
7. Carefully solder the leads onto the correct pins of the new sensor module. See Illustration (D). Depending upon the vendor of the replacement sensor module, the module will either be marked with +, E, and D, or one of the pins will be marked with the white dot. Use Illustration (D) and the cable color coding to correctly install the new sensor module.
8. Slip the heat shrink tubing up to insulate the soldered connections and pins. Apply only enough heat to correctly shrink the tubing.

## **RIBBON LIFT COIL REMOVAL**

1. Remove the Top and Intermediate Cover.
2. In most cases it is advisable to remove the carriage assembly from the printer so that you will be able to perform the following steps easily and with little chance of accidentally causing additional damage.
3. Remove the two 1/4" long pan head screws that mount the ribbon lift coil assembly to the printer upper carriage assembly.
4. Cut the two wires going to the ribbon lift coil as close to the coil as possible.
5. Strip the insulation from these two leads for 1/4".
6. Slip a 1" long piece of 1/16" i.d. heat shrink tubing onto each lead.
7. Solder these leads to the new ribbon lift coil assembly.
8. Slip the heat shrink tubing up to insulate the soldered connections. Apply only enough heat to correctly shrink the tubing.
9. After complete reinstallation, adjust the ribbon lift coil assembly for correct ribbon lift height.

## **PRINT HAMMER ARMATURE ASSEMBLY REMOVAL**

1. Remove Top and Intermediate Covers.
2. In most cases it is advisable to remove the carriage assembly from the printer so that you will be able to perform the following steps easily and with little chance of accidentally causing additional damage.
3. Remove the three 1/4" long pan head screws that mount the hammer armature assembly to the printer upper carriage assembly.
4. To obtain enough slack in the hammer armature coil leads, it is usually necessary to cut and remove the two nylon wire ties that secure various leads exiting the carriage harness assembly to the upper carriage casting.
5. Cut the two hammer armature coil wires as close to the coil as possible.
6. Strip 1/4" of insulation from the end of each wire.
7. Slip a 1" long piece of 3/32" i.d. heat shrink tubing over each wire.
8. Solder these leads to the new hammer armature assembly.
9. Slip the heat shrink tubing up to insulate the soldered connection. Apply only enough heat to correctly shrink the tubing.

## PRINT HAMMER ARMATURE ASSEMBLY REMOVAL (Continued)

10. Reinstall the hammer armature assembly onto the upper carriage assembly.
11. Install two new nylon wire ties where they were previously removed.
12. Adjust the print hammer armature assembly and the rear and front eccentric hammer armature stops.
13. Print several lines of text. If necessary, further refine print quality associated adjustments.

## RIBBON DRIVE MOTOR REMOVAL

1. Remove Top and Intermediate Covers.
2. Remove carriage assembly from printer.
3. Refer to Illustration D. The four ribbon drive motor wires are protected for about 3" with plastic sleeving where they pass through the lower carriage casting. If your printer does not have the optional End of Ribbon sensor installed, the four EOR sensor wires may also be routed through this sleeving with the four unconnected ends near the ribbon drive motor.
4. Cut the four ribbon drive motor wires as close as possible to the motor.
5. Remove the two pan head screws (15) and washers that mount the ribbon drive motor to the lower carriage casting. Remove the defective ribbon drive motor (16).
6. Cut the wires on the replacement ribbon drive motor to a length of 1" to 1 1/2".
7. Strip 1/4" of insulation from the end of each of these wires and from the end of each of the ribbon drive motor wires exiting the protective sleeving.
8. Install the new ribbon drive motor on the lower carriage casting.
9. Slip a 1/4" to 1/2" long piece of 1/16" i.d. heat shrink tubing onto each ribbon drive motor wire.
10. Using the wire color coding as a guide, solder the replacement ribbon drive motor wires to the correct carriage harness cable wires.
11. Slip the heat shrink tubing over each of the soldered connections and apply only enough heat to correctly shrink the tubing.
12. Adjust ribbon drive motor to clutch gear mesh.

## FRONT AND REAR FEED ROLL REMOVAL

1. Remove Top Cover.
2. Remove platen by releasing the latch at each end.
3. The paper cradle is connected to the platen brace with two small springs. Remove the springs and the paper cradle.
4. See Illustration (F). Either front feed roll can be removed by gently spreading the feed roll arms.
5. To remove the rear feed roll, you must first remove the associated front feed roll. Then pivot the rear feed roll up and forward ninety degrees.
6. Gently spread the feed roll arms and remove the rear feed roll. See Illustration (F).

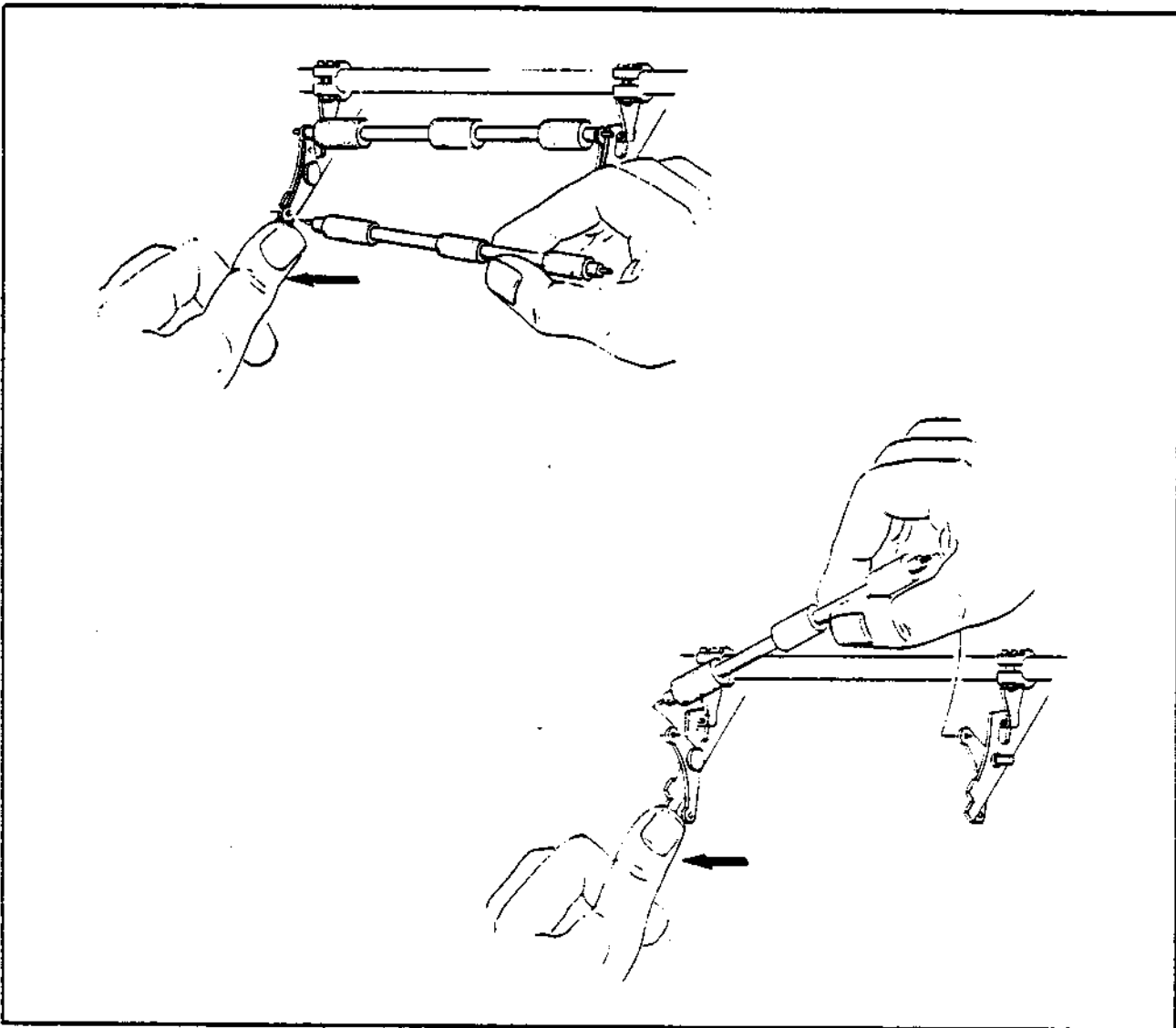

ILLUSTRATION F



## CHAPTER VII

### ILLUSTRATED PARTS LIST

The following pages contain illustrated parts lists for the various Sprint Micro 3 printer models. Each group is identified by the shaded portion in the overall printer drawing that is on the leading page. Where specific models require different parts, those parts are shown in separate illustrations, and sometimes identified in a separate list. These illustrated parts lists can be used as an assembly guide and to identify missing or broken parts when repairing a printer.

To order parts, visually locate the part on the drawing, then use the index number to locate the part number from the list on the accompanying page. For parts pricing, refer to Qume Catalog, Service and Spares (Qume P.N. 30030).

When replacing parts, refer to Section VI of this manual for alignment and adjustment procedures.

The following pages contain illustrated parts lists for the various Sprint Micro 3 printer models. Each group is identified by the shaded portion in the overall printer drawing that is on the leading page. Where specific models require different parts, those parts are shown in separate illustrations, and sometimes identified in a separate list. These illustrated parts lists can be used as an assembly guide and to identify missing or broken parts when repairing a printer.

To order parts, visually locate the part on the drawing, then use the index number to locate the part number from the list on the accompanying page. For parts pricing, refer to Qume Catalog, Service and Spares (Qume P.N. 30030).

When replacing parts, refer to Section VI of this manual for alignment and adjustment procedures.

# GENERAL STRUCTURE

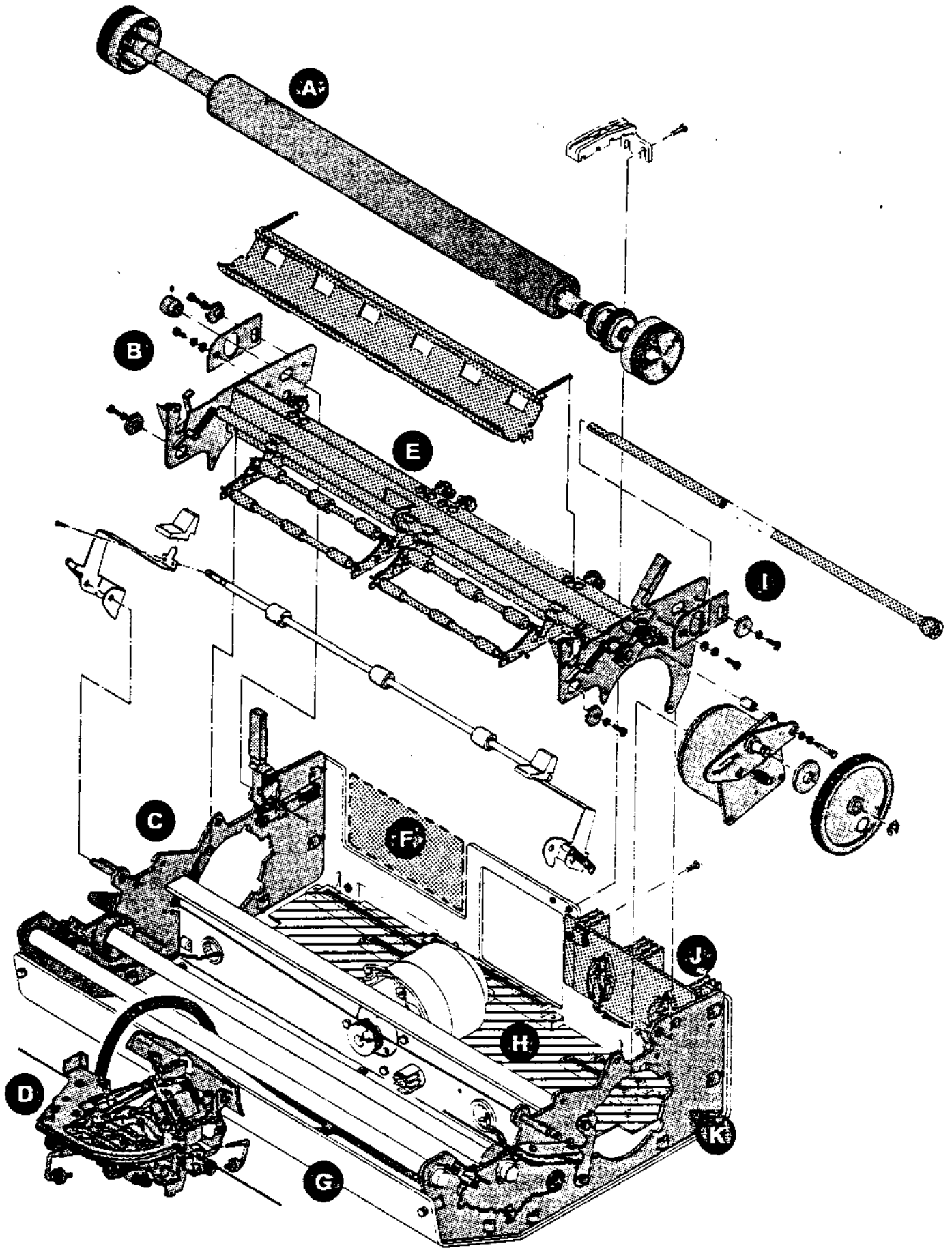

## GENERAL STRUCTURE

<u>DESCRIPTION</u>	<u>SEE PAGE</u>
A Platen Assembly, Friction (standard)	7-5
Platen Assembly, Friction (WideTrack/TwinTrack)	7-5
Platen Assembly, Pinfeed	7-7
B Platen Carrier, Left Side	7-11
C Structure Assembly, Left Side	7-9
D Carriage	
Upper	7-23
Lower	7-25
TwinTrack	7-27
E Platen Carrier, Center	7-21
F Paper and Printwheel Heatsink	7-29
G Structure, Common Parts	7-35
264 Col. Differences	7-15
TwinTrack Differences	7-17
H Motherboard (standard or WideTrack)	7-31
Motherboard (TwinTrack)	7-33
I Platen Carrier Assembly, Right Side	7-19
J Carriage Drive, Heatsink	7-29
K Structure, Right Side	7-13

# FRICION PLATENS

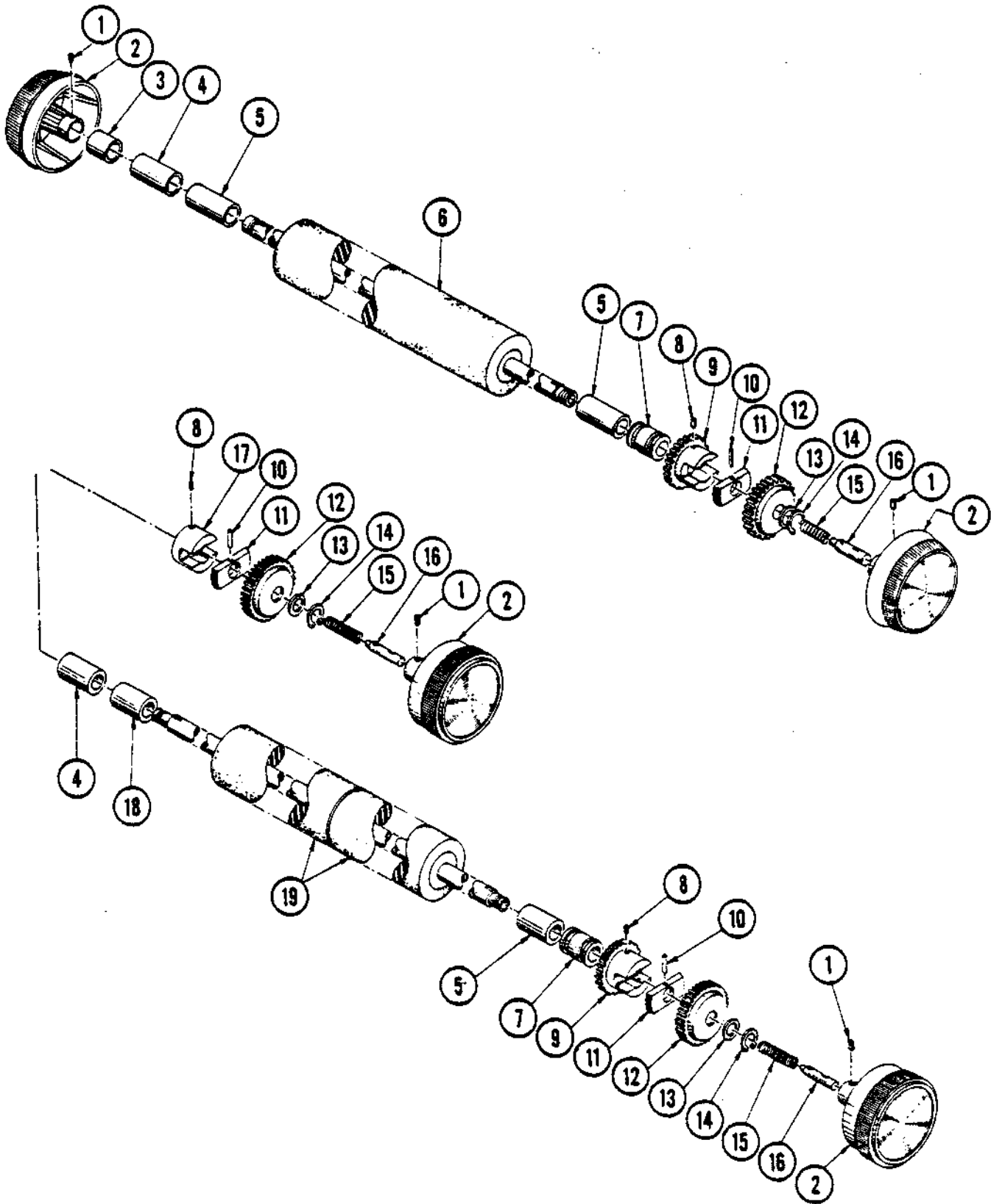

## FRICTION PLATENS

Platen Assembly Complete (Standard)	80022-01
Platen Assembly Complete (WideTrack/TwinTrack)	80022-03
Split Platen Assembly Complete (Requires dual paper feed option on printer)	80907-XX
(1) 85207-02	Set Screw 8-32X.125, Splined Socket
(2) 80045-01	Knob Asy, Platen, Charcoal Grey
80045-02	Knob Asy, Platen, Cordovan Brown
(3) 80513-02	Spacer, Platen (.620)
(4) 80515	Sleeve, Bearing
(5) 80513-01	Spacer, Platen (1.061)
(6) 80205-01	Platen Asy, 132 Col.
80205-03	Platen Asy, 264 Col.
(7) 80514	Sleeve, Right Platen
(8) 80206-04	Set Screw 6-32X.250, Splined Socket
(9) 80175	Gear, Tractor Drive
(10) 85000-03	Needle Roll, .062X.53
(11) 80176	Platen Driver
(12) 80177	Platen Gear
(13) 80857	Shim, Platen Asy
(14) 85145-31	Retaining Ring, 5100-31
(15) 80198	Spring, Compression
(16) 80594	Shaft, Push Platen
(17) 80720	Guide, Split Platen
(18) 80513-03	Spacer, Split Platen
(19) 80505-01	Platen Asy, Crt. Split, 132 Col.
88057-01	Platen Asy, Ctr. Split, 264 Col.

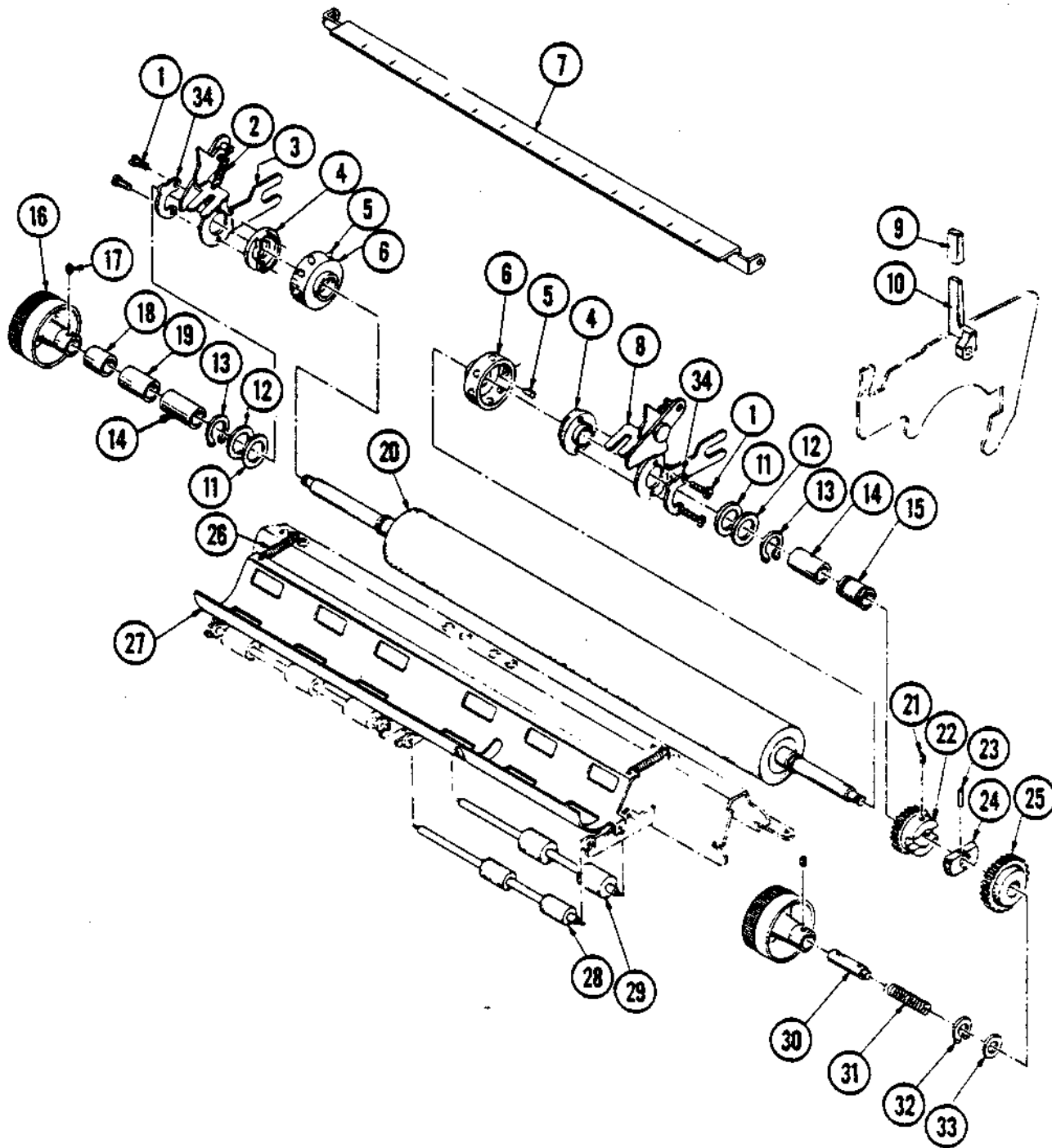

## PIN FEED PLATENS

	80012-01	14.375 Pin to Pin	(14)	80513-01	Spacer, Platen (1.061) Fill Hd.
	80012-02	13.125 Pin to Pin	(15)	80514	Sleeve, Right Pltn
	80012-03	8.000 Pin to Pin	(16)	80045-01	Knob Asy, Pltn, Char Grey
	80012-04	9.000 Pin to Pin	(17)	85207-02	Set Screw 8032X.125, Splined Socket
	80012-05	14.44 Pin to Pin	(18)	80513-02	Spacer, Pltn. (.620)
	80012-06	9.375 Pin to Pin	(19)	80515	Sleeve, Bearing
(1)	85014-03	Screw 4-40X.187, Slot, Fill Hd.	(20)	80497-01	P F Pltn Asy, 14.375
(2)	80516	Spring, Ext Paper Guide		80497-02	P F Pltn Asy, 13.125
(3)	80490-01	Bracket Asy, Left Side		80497-03	P F Pltn Asy, 8.000
(4)	80486	Cam, P F Pltn		80497-04	P F Pltn Asy, 9.000
(5)	80527	Pin, P F Pltn		80497-05	P F Pltn Asy, 14.449
(6)	80487	Pin Guide, P F Pltn		80497-06	P F Pltn Asy, 9.375
(7)	80443-03	Scale Asy For 13.125 (80012-02)	(21)	80497-07	P F Pltn Asy, 11.500
	88028-01	Scale Asy For 8.000 (80012-03)	(22)	85206-04	Set Screw 6-32X.250, Splined Socket
	88028-02	Scale Asy For 9.000 (80012-04)	(23)	80175	Gear, Tractor Drive
	88028-03	Scale Asy For 9.375 (80012-06)	(24)	85000-03	Needle Roll .062X.53
	88028-04	Scale Asy For 11.500 (80017-07)	(25)	80176	Pltn Driver
(8)	80490-02	Bracket Asy, R.S. For 14.375; 13.125; 14.44 (80012-01, -02, -05)	(26)	80177	Pltn Gear
	88030-01	Bracket Asy, R.S. For 8.000 (80012-03)	(27)	80334	Spring, Ext Cradle
	88030-02	Bracket Asy, R.S. For 9.000 (80012-04)		88027-01	Special Cradle Asy For 8.000 (80012-03)
	88030-03	Bracket Asy, R.S. For 9.375 (80012-06)		88027-02	Special Cradle Asy For 9.000 (80012-04)
	88030-04	Bracket Asy, R.S. For 11.500 (80012-07)	(28)	88027-03	Special Cradle Asy For 9.375 (80012-06)
(9)	80701-01	Cap, Lever, Char Grey	(29)	88027-04	Special Cradle Asy For 11.500 (80012-07), 80012-01, -02, -05, Use Std Cradle, 80032-03)
(10)	88026	Lever, Feed Roll Disable For 80012-03, -04, -06, -07,	(30)	88038	Shaft Asy, Front For 80012-03
(11)	85293-01	Washer, Nylon .015 Thick	(31)	88037	Shaft Asy, Rear For 80012-03
(12)	85293-02	Washer, Nylon .005 Thick	(32)	80594	Shaft, Push, Pltn
(13)	85145-56	External Retainer, 5100-56	(33)	80198	Spring, Compression
			(34)	85145-31	Retaining Ring 5100-31
				80857	Shim, Pltn Asy
				81949	Paper Guide Stop

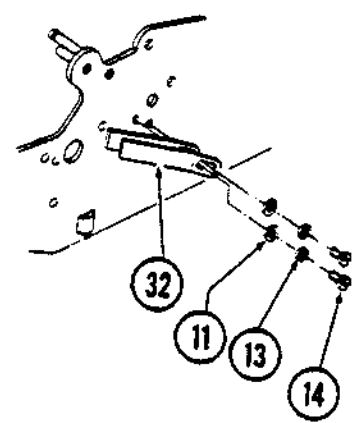
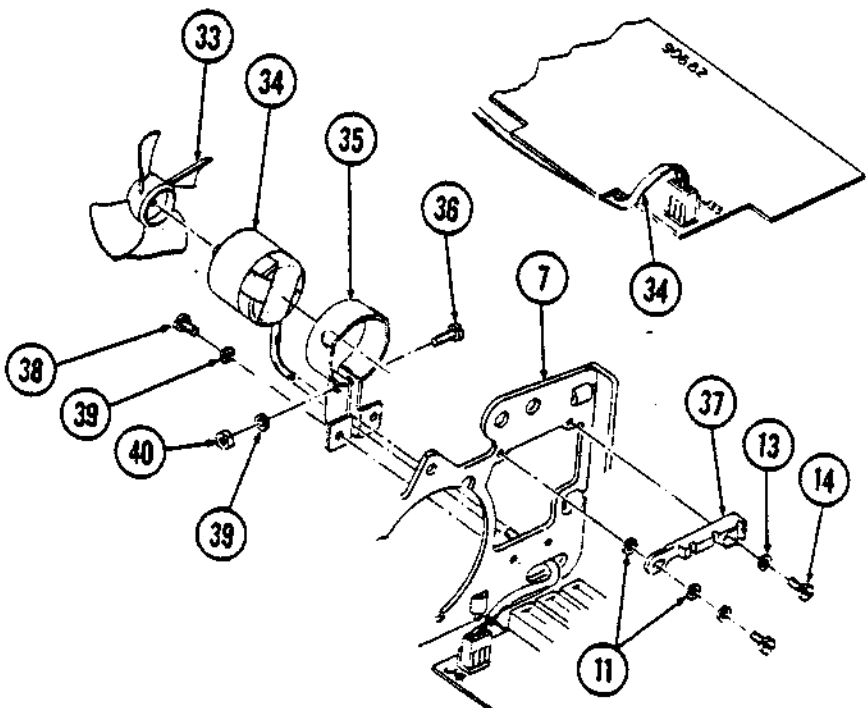
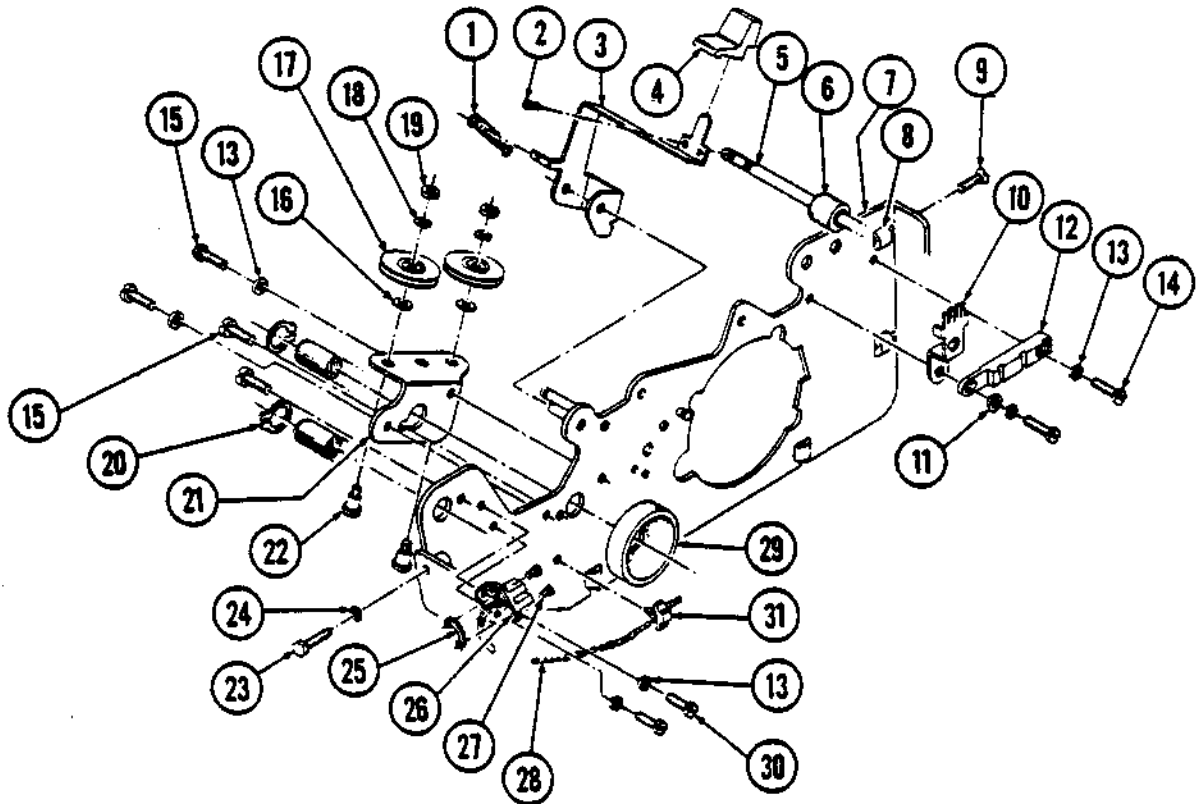



## STRUCTURE - LEFT SIDE

(1)	80237	Spring, Ext	(19)	85122-05	Nut 5-40, Hex
(2)	85074-04	Screw 4-40X.250, Slot Undercut Flat Hd	(20)	85129-50	Retaining Ring (5555-50)
(3)	80257-02	Arm, Bail Roller, Left Side	(21)	80106-02	Bracket, Pulley Mount Left
	80257-02	Arm, Bail Roller, Right Side	(22)	80523	Screw, Cable Pulley
(4)	80320-01	Lever, Pltn Bail, Chrome	(23)	85058-10	Screw, 10-32X.625, Hex Hd
	80320-02	Lever, Pltn Bail, Charcoal Grey	(24)	85124-10	Washer #10, Helical Lock
	80320-03	Lever, Pltn Bail, Cordovan Brown	(25)	80405	Bar Nut, Photo Sensor
(5)	80259-01	Shaft, Bail Rollers, 132 Col	(26)	80404	Bracket, Photo Sensor
	80259-02	Shaft, Bail Rollers, 264 Col	(27)	85004-04	Screw 4-40X.250, Pan Hd
(6)	80329	Roller Asy, Pltn Bail	(28)	99120	Photo Sensor Asy
(7)	80048	Frame Asy, Left Side, Excluding TwinTrack	(29)	80368-00	Photo Module (Part of 99120)
	81848	Frame Asy, Left Side, Excluding TwinTrack	(30)	80719	Bumper, Carriage Deceleration
(8)	80220	Nut, Frame Mounting	(31)	85006-04	Screw 6-32X.250, Pan Hd
(9)	85068-10	Screw 10-32X.625, Flat Hd	(32)	85159	Snap Grip, Wire Fastening
(10)	80187	Detent, Impression Control	(33)	80319	Spring, Carriage Deceleration For 264 Col
(11)	85125-06	Washer #6, Narrow	(34)	85414	Fan, C.W. Std. Mounting
(12)	80306	Guide, PCB Mounting	(35)	81815-01	Motor/Fan Cable Asy (Excluding TwinTrack)
(13)	85124-06	Washer #6, Helical Lock		81815-02	Motor/Fan Cable Asy (TwinTrack Only)
(14)	85006-05	Screw 6-32X.312, Pan Hd	(36)	81830	Bracket, Fan Motor
(15)	85056-04	Screw 6-32X.250, Hex Hd	(37)	85007-08	Screw 8-32X.500, Slot Pan Hd
(16)	80109	Washer, Pulley	(38)	81846	Guide, PCB Mounting S5 & TT
(17)	80037	Pulley Asy, Idler	(39)	85007-05	Screw 8-32X.312, Slot Pan Hd
(18)	85124-05	Washer #5, Helical Lock	(40)	85124-08	Washer #8, Helical Lock
				85122-08	Nut 8-32, Hex

# PLATEN CARRIER - LEFT SIDE

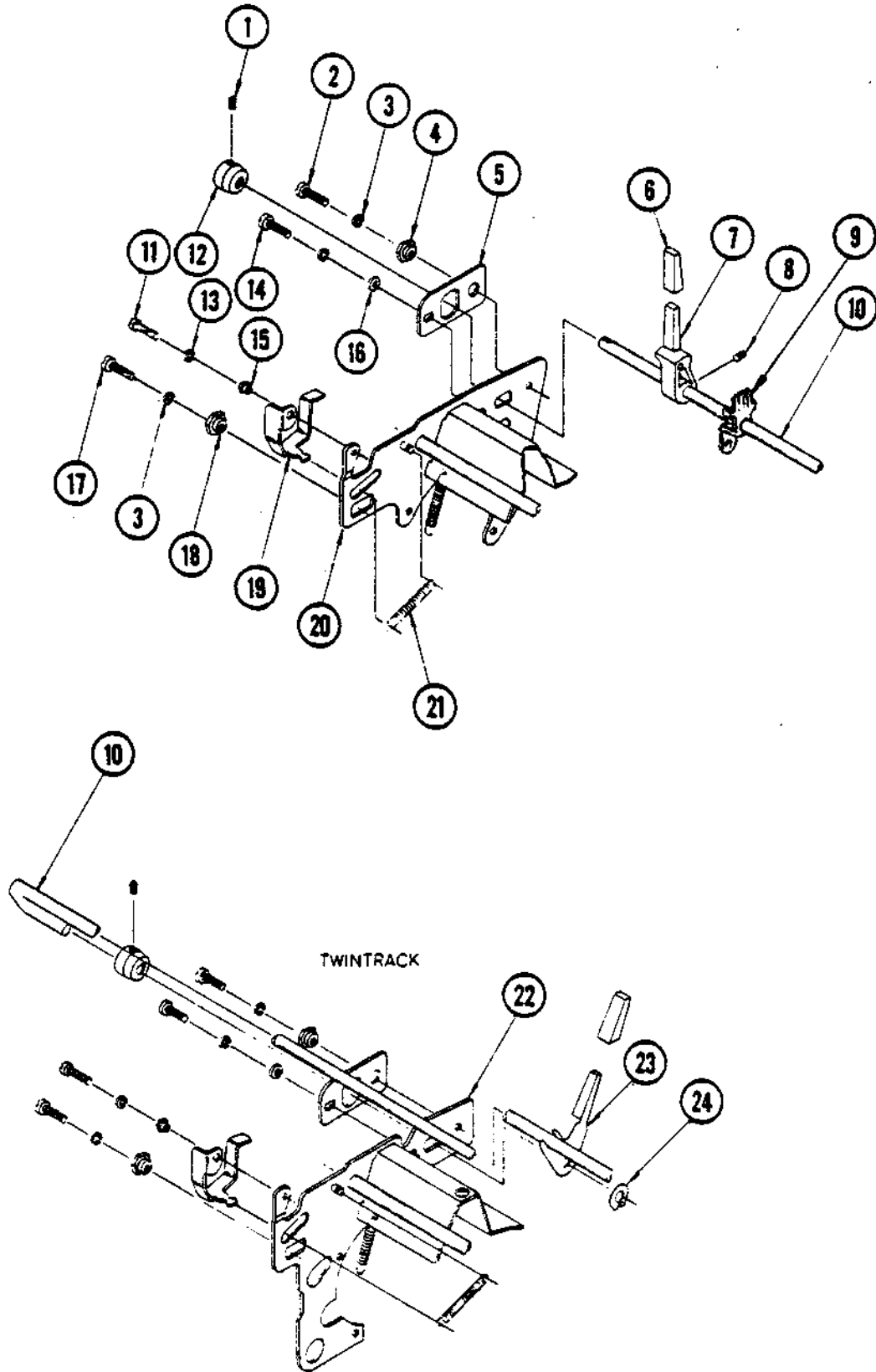

# PLATEN CARRIER - LEFT SIDE

- (1) 85207-03 Set Screw 8-32X.187, Splined Socket
- (2) 85007-06 Screw 8-32X.375, Slot Pan Hd
- (3) 85124-08 Washer #8, Helical Lock
- (4) 81081 Eccentric, Platen Rear
- (5) 80183 Plate, Impression Control Adjustment
- (6) 80707-01 Cap, Lever Char Grey
- 80707-02 Cap, Lever Cordovan Brown
- 80707-03 Cap, Lever Chrome Plated
- (7) 80186 Lever, Impression Cntl (Excluding TwinTrack)
- (8) 85207-04 Set Screw 8-32X.250, Splined Socket
- (9) Detent, Impression Cntl (Excluding TwinTrack)
- (10) 80185-01 Shaft, Impression Cntl, 132 Col
- 80185-02 Shaft, Impression Cntl, WideTrack
- 81828-02 Shaft, Impression Cntl, TwinTrack
- (11) 85006-05 Screw 6-32X.312, Slot Pan Hd
- (12) 80184 Eccentric, Impression Control
- (13) 85124-06 Washer #6, Helical Lock
- (14) 85007-05 Screw 8-32X.500, Slot Pan Hd
- (15) 80156 Eccentric, Pltn Latch
- (16) 85125-08 Washer #8, Narrow
- (17) 85007-08 Screw 8-32X.500, Slot Pan Hd
- (18) 80781 Eccentric, Pltn Front
- 80182 Replaced by 80781
- (19) 80141 Latch, Pltn
- (20) 80040 Frame Asy, Pltn (Excluding TwinTrack)
- (21) 80234 Spring, Ext, Pltn Latch
- (22) 81849 Frame Asy, Pltn Left (TwinTrack)
- (23) 81829 Impression Lever, (TwinTrack)
- (24) 85129-31 Gripping Ring (5555-31)

STRUCTURE - RIGHT SIDE

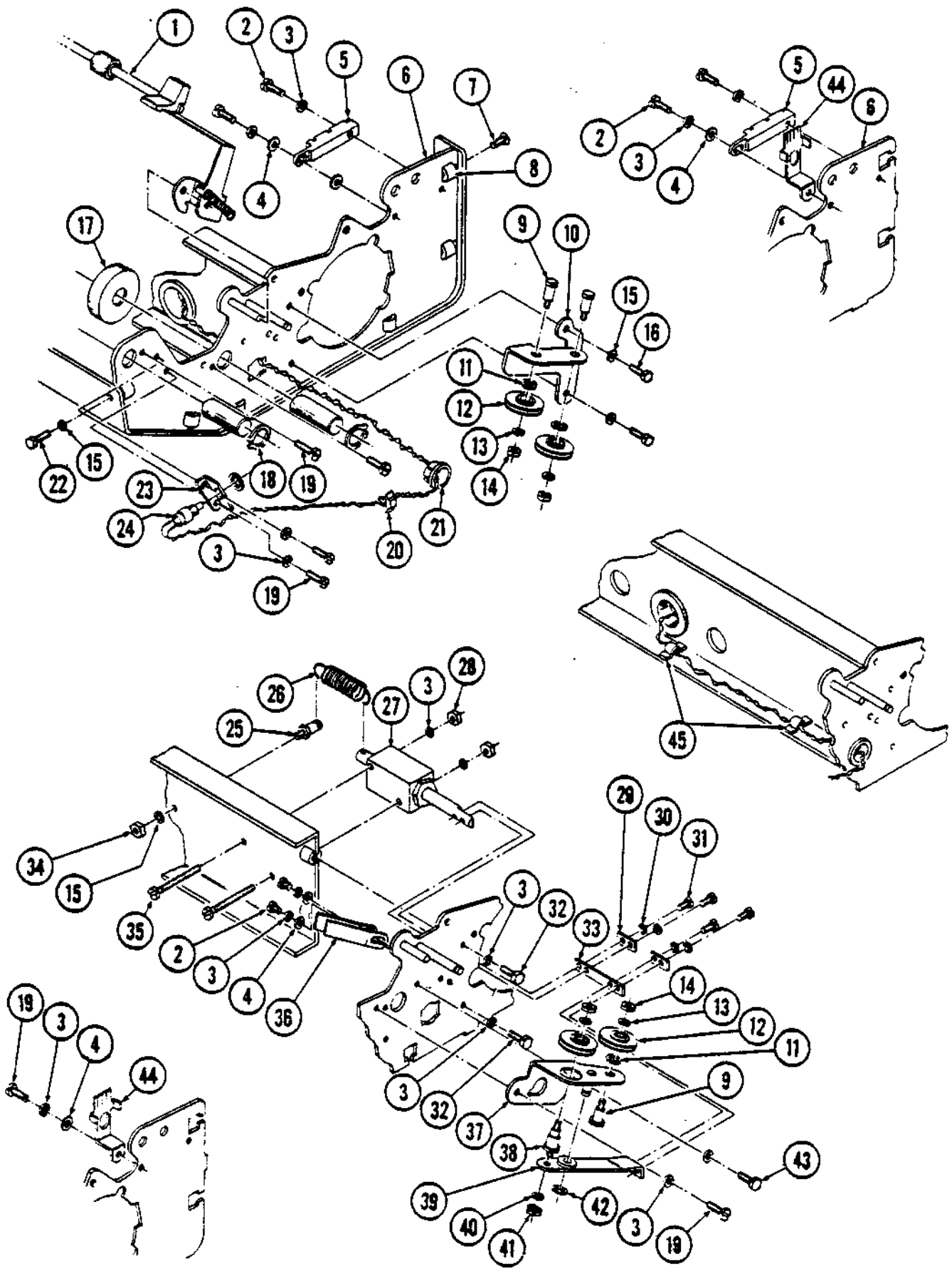

## STRUCTURE - RIGHT SIDE

(1)	80025-01	Bail Roller Asy, 132 Col	(25)	80666	Stud, Spring Dashpot
	80025-02	Bail Roller Asy, 264 Col (See Left Side Structure Asy for Bail Asy Parts)	(26)	81929	Spring, Dashpot
(2)	85006-05	Screw 6-32X.312, Pan Hd	(27)	80674	Dashpot, Cylinder Asy
(3)	85124-06	Washer #6, Helical Lock	(28)	85122-06	Nut 6-32, 1/4 Hex
(4)	85125-06	Washer #6, Narrow	(29)	80671	Plate, Flexure
(5)	80306	Guide, PCB Mounting	(30)	85124-04	Washer #4, Helical Lock
(6)	80050	Frame Asy, Right Side	(31)	85004-04	Screw 4-40X.250, Pan Hd
(7)	85068-10	Screw 10-32X.625, Flat Hd	(32)	85058-10	Screw 10-32X.625, Hex Hd
(8)	80220	Nut, Frame Mounting	(33)	80665	Flexure, Dashpot
(9)	80523	Screw, Cable Pulley	(34)	85122-10	Nut 10-32, Hex
(10)	80685	Bracket, Flexure Pulley	(35)	85006-20	Screw 6-32X1.250, Pan Hd
(11)	80109	Washer, Pulley	(36)	80319	Spring, Carriage Decel for 264 Col
(12)	80037	Pulley Asy, Idler	(37)	80684	Bracket and Stud Asy
(13)	85124-05	Washer #5, Helical Lock	(38)	80107	Stud, Pulley
(14)	85122-05	Nut 5-40, Hex	(39)	80673	Lever Asy, Dashpot
(15)	85124-10	Washer #10, Helical Lock	(40)	85124-08	Washer #8, Helical Lock
(16)	85058-12	Screw 10-32X.750, Hex Hd	(41)	85122-08	Nut 8-32, Hex
(17)	80719	Bumper, Carriage Decel	(42)	85128-25	Retaining Ring (5133-25)
(18)	85129-50	Retaining Ring (5555-50)	(43)	85056-04	Screw 6-32X.250, Hex Hd
(19)	85006-04	Screw 6-32X.250, Pan Hd	(44)	80187	Detent, Impression Cntl
(20)	85159	Snap Grip, Wire Fastening	(45)	85188-0	Press Clip
(21)	85157-04	Snap Bushing (SB-625-8)			
(22)	85058-10	Screw 10-32X.625, Hex Hd			
(23)	80404	Bracket, Photo Sensor			
(24)	99119-01	Switch Asy, Ribbon Ad- vance 132 Col			
	99119-02	Switch Asy, Ribbon Ad- vance 264 Col			

# 264 COL STRUCTURE DIFFERENCES

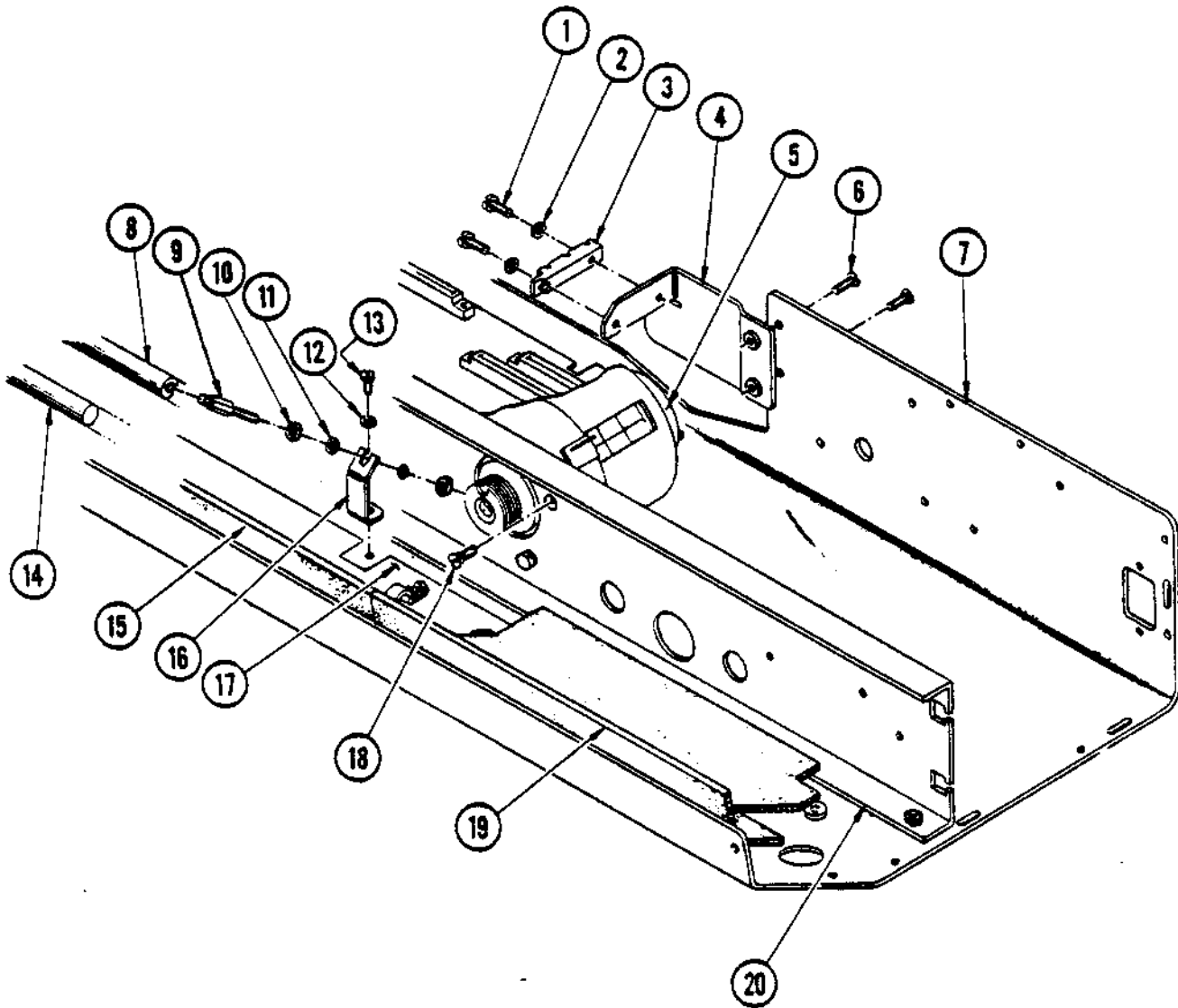

## 264 COL STRUCTURE DIFFERENCES

- (1) 85006-05 Screw 6-32X.312 Slot  
Pan Hd
- (2) 85124-06 Washer #6, Helical Lock
- (3) 88073 Guide PCB Mounting
- (4) 81852 Bracket Asy WideTrack
- (5) 80023-04 Motor/Encoder Asy 264 Col
- (6) 85068-06 Screw 10-32X.375 Slot  
Pan Hd
- (7) 88078-01 Pan Asy Bottom, Unslotted  
88078-02 Pan Asy Bottom, Slotted
- (8) 80852 Carriage Shaft Rear,  
264 Col
- (9) 80856 Post Rail Support
- (10) 85122-10 Nut 10-32, Hex
- (11) 85125-10 Washer #10, Narrow
- (12) 85124-10 Washer #10, Helical Lock
- (13) 85008-05 Screw 10-32X.312, Slot  
Pan Hd
- (14) 80116-02 Shaft Carriage Guide,  
264 Col
- (15) 81818 Pad Accoustical, Bottom  
Pan, Left
- (16) 80855 Sleeve
- (17) 81819 Shield, Bottom Pan
- (18) 85068-08 Screw 10-32X.500, Slot  
Flat Hd
- (19) 81817 Pad Accoustical, Bottom  
Pan Right
- (20) 88044 Brace Motor Mount, 264 Col

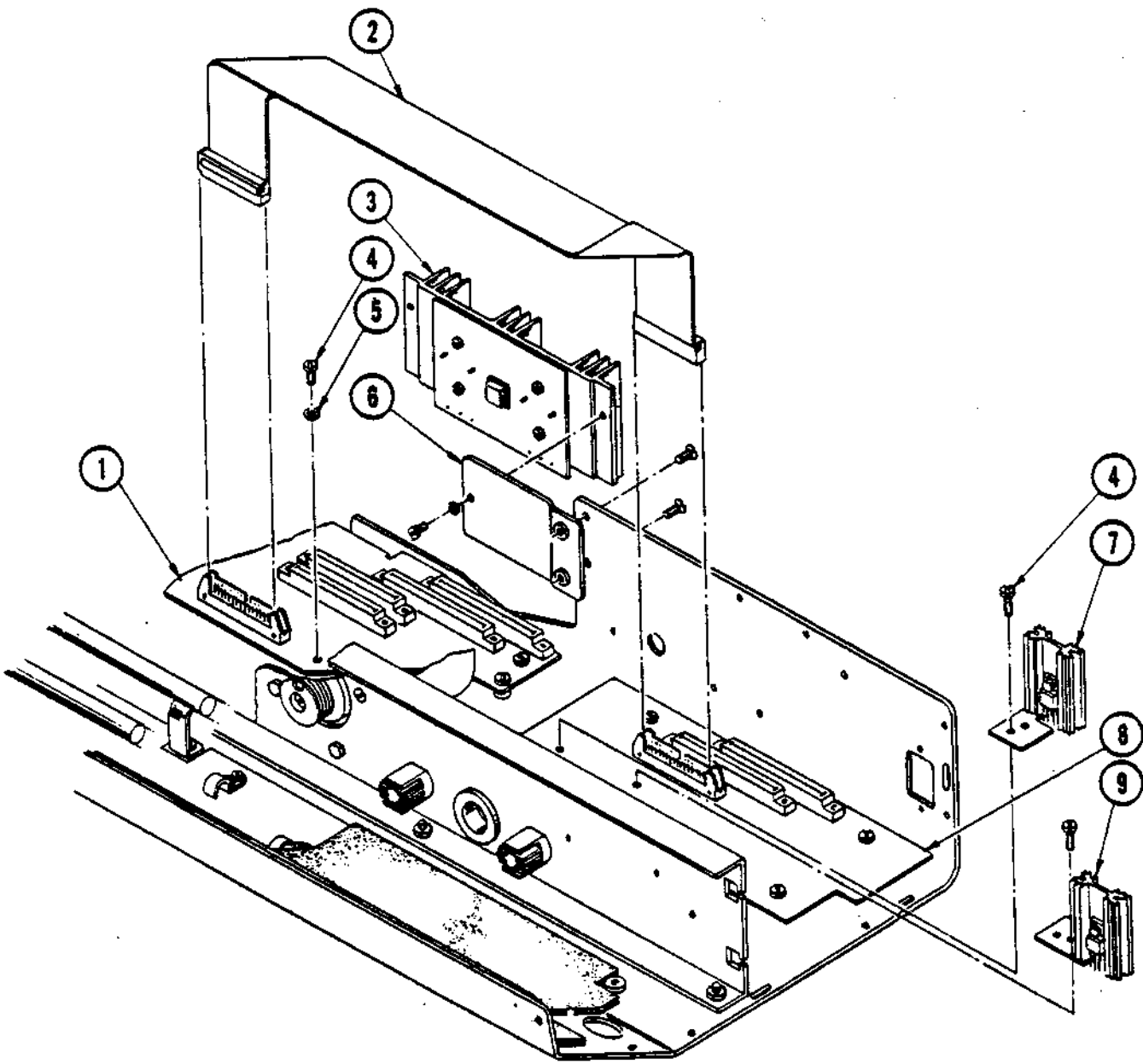

TWINTRACK



## TWINTRACK STRUCTURE DIFFERENCES

- (1) 90692 Motherboard Asy, Left, TwinTrack
- (2) 99114 Cable Asy, Motherboard, TwinTrack
- (3) 90752 Carriage Driver PCB Asy
- (4) 85008-09 Screw 10-32X.562 Slot Pan Hd
- (5) 85162-10 Washer #10, Internal Star
- (6) 81854 Bracket Asy, Bottom Pan
- (7) 81803-01 Printwheel Drive Asy, Left, TwinTrack
- (8) 90682 Motherboard Asy, Right, TwinTrack
- (9) 81803-02 Printwheel Drive Asy, Right, TwinTrack

# PLATEN CARRIER - RIGHT SIDE

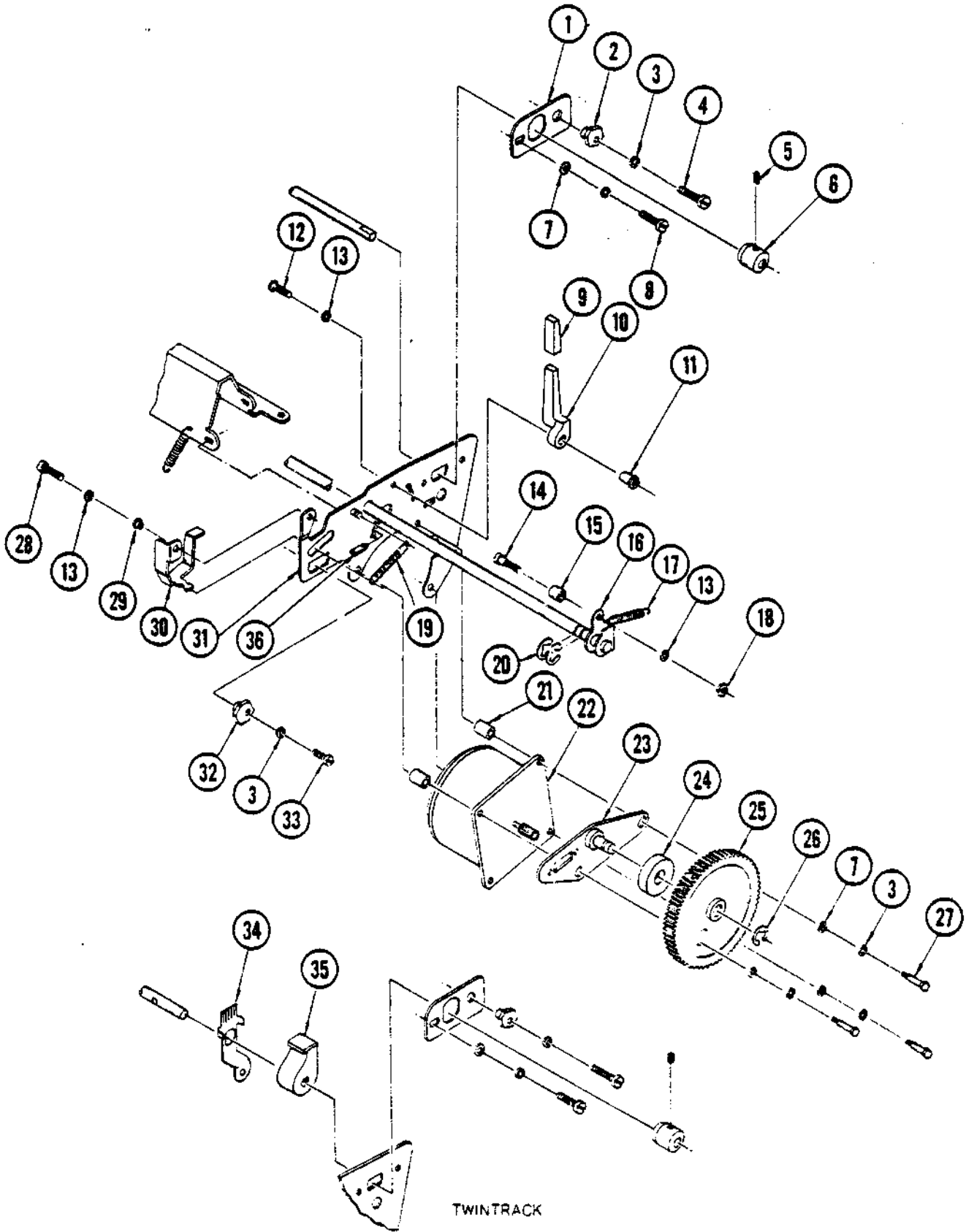

## PLATEN CARRIER - RIGHT SIDE

(1)	80183	Plate, Impression Cntl Adjustment	(18)	85122-66	Nut 6-32 Hex (5/16")
(2)	80181	Eccentric Pltn, Rear	(19)	80234	Spring, Extension, Platen Latch
(3)	85124-08	Washer #8, Helical Lock	(20)	85128-37	Retainer, E-Ring (X5133-37)
(4)	85007-06	Screw 8-32X.375, Slot, Pan Hd	(21)	80197-01	Spacer For .15 Thk Mtg Plate
(5)	85207-03	Set Screw 8-32X.187, Splined Socket		80197-02	Spacer For .08 Thk Mtg Plate
(6)	80184	Eccentric, Impression Control	(22)	80046-02	Paperfeed Motor, 132 Col
(7)	85125-08	Washer #8, Narrow		80046-08	Paperfeed Motor, 264 Col
(8)	85007-05	Screw 8-32X.312, Splined Socket	(23)	80339-00	Gear Plate Asy, R.H.
(9)	80707-01	Cap, Lever, Char Grey	(24)	80398	Washer, Lubrication
	80707-02	Cap, Lever, Cordovan Brwn	(25)	80202	Gear, Idler
	80707-03	Cap, Lever, Chrome Plated	(26)	85128-31	E-Ring Retainer (X5133-31)
(10)	80160	Lever, Feed Roller Disable	(27)	85057-14	Screw 8-32X.875, Hex Hd
(11)	80620	Shoulder Nut, Feed Roller Disable Lever	(28)	85006-05	Screw 6-32X.312, Slot Pan Hd
(12)	85056-07	Screw 6-32X.437, Hex Hd	(29)	80156	Eccentric, Pltn Latch
(13)	85124-06	Washer #6, Helical Lock	(30)	80141	Latch, Pltn
(14)	80149	Screw, Shoulder, Cam Follower	(31)	80040	Frame Asy, Pltn (All)
(15)	80150	Roller, Cam Follower	(32)	80781	Eccentric, Pltn Front
(16)	80036-01	Shaft Asy, Feed Roll Disable 132 Col	(33)	85007-08	Screw 8-32X.500, Slot Pan Hd
	80036-02	Shaft Asy, Feed Roll Disable 264 Col	(34)	80187	Detent, Impression Control TwinTrack
(17)	80333	Spring, Extension, Cam Follower	(35)	81839	Impression Control TwinTrack
			(36)	80132	Wedge

PLATEN CARRIER - CENTER PARTS

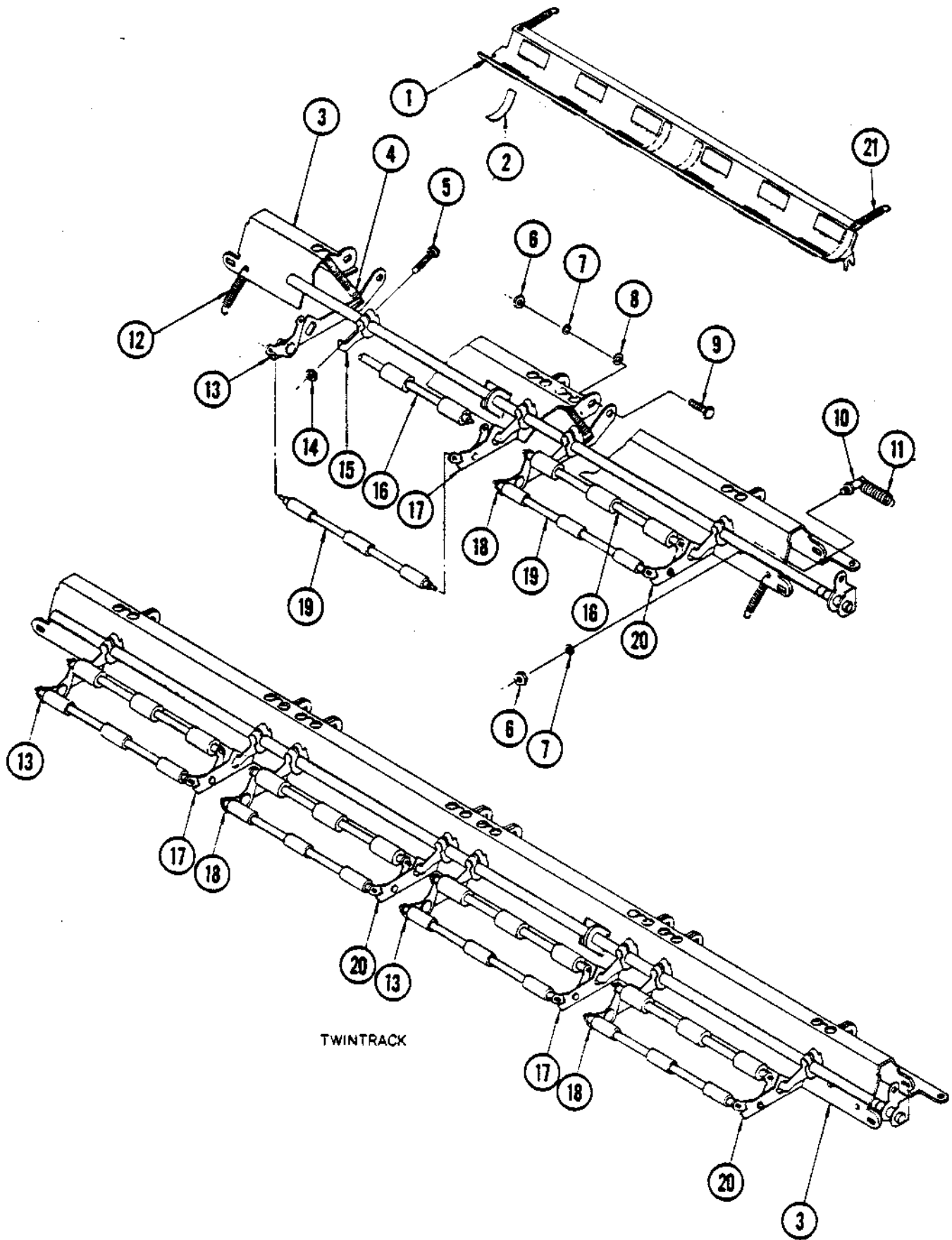

TWINTRACK

## PLATEN CARRIER - CENTER PARTS

- (1) 80032-03 Cradle Asy with Tape  
80012-01 Pinfeed (14.375")  
80012-02 Pinfeed (13.125")  
80012-03 Pinfeed (8")  
80012-04 Pinfeed (9")  
80012-05 Pinfeed (14.449")  
80012-06 Pinfeed (9.375")  
80012-07 Pinfeed (11.5")
- (2) 85185 *Film Tape, Clear*  
*(1/4" Wide X 1 1/2" Long)*
- (3) 80130 Brace, Pltn, 132 Col  
88043 Brace, Pltn, 264 Col
- (4) 80598 Spring, Ext, Feed Rollers
- (5) 85056-10 Screw 6-32X.562, Hex Hd
- (6) 85122-08 Nut #8, Hex
- (7) 85124-08 Washer #8, Helical Lock
- (8) 85125-08 Washer #8, Narrow
- (9) 80159 Screw, Shoulder, Feed  
Arm Roller
- (10) 80172 Screw Stud, Pltn Asy  
Spring
- (11) 80236 Spring, Extension
- (12) 80237 Spring, Extension
- (13) 80041 Arm Asy, Feed Roll,  
Left Outer
- (14) 85122-66 Nut #6, Hex (5/16")
- (15) 80142 Bail, Feed Roller
- (16) 80154 Shaft Asy, Rear Feed  
Roller
- (17) 80042 Arm Asy, Feed Roller,  
Left Inner
- (18) 80044 Arm Asy, Feed Roller,  
Right Inner
- (19) 80153 Shaft Asy, Front Feed  
Roller
- (20) 80043 Arm Asy, Feed Roller,  
Right Outer
- (21) 80334 Spring, Extension, Cradle

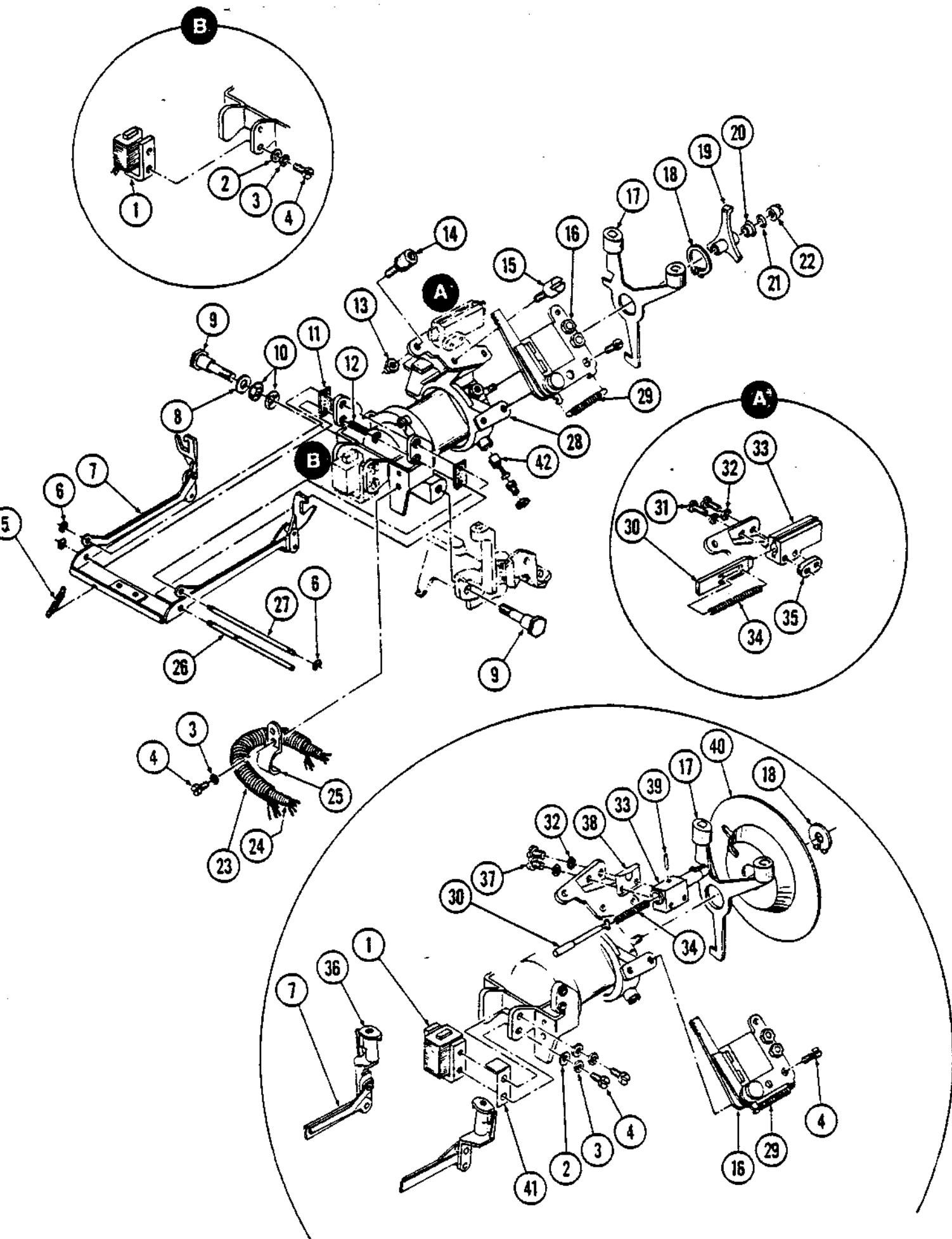

## UPPER CARRIAGE

(1)	81924	Coil & Core Asy, Single Color Rib.	(23)	80614	Spring, Carriage Conductors
	81943	Coil & Core Asy, Dual Color Rib.	(24)	80613	Spring, Inner, Carriage Conductors
(2)	85125-04	Washer #4, Narrow	(25)	80246	Clamp, Carriage Cable
(3)	85124-04	Washer #4, Helical Lock	(26)	80158	Shaft, Ribbon Bail
(4)	85004-04	Screw 4-40X.250, Slot Pan Hd	(27)	80155	Shaft, Ribbon Links
(5)	80476	Spring, Ribbon Bail	(28)	80336-01	Motor/Encoder Asy, PW S3/55, S5/55
(6)	85128-06	Retainer, E-Ring (Y 5133-6)		80336-02	Motor/Encoder Asy, PW All, Exc S3/55, S5/55, X Mod.
(7)	80380-01	Bail Asy, Ribbon Lift, Exc. Dual Color Ribbon		80336-03	Motor/Encoder Asy, X Models
	80819	Bail Asy, Ribbon Lift, Dual Color Ribbon	(29)	80387	Spring, Ribbon Tension Arm
(8)	85187-01	Shim (.188 I.D.)	(30)	80686-02	Hammer, All Exc X Models
(9)	80248	Pivot, Print Motor Housing		80717	Hammer, X Models
(10)	85140-01	Belleville Washer (.195 I.D.)	(31)	85003-10	Screw 3-48X.625, Slot Pan Hd
(11)	80403	Pad, Ribbon Lift Lubrication	(32)	85124-03	Washer #3, Helical Lock
(12)	80343	Spring, Compression, Ribbon	(33)	80687-02	Hammer Guide, All, Exc X Models
(13)	85137-05	Nut, Self Locking 5-40		80716	Hammer Guide, X Models
(14)	83605	Hammer Arm Stop Asy	(34)	80713	Spring, Hammer, All Exc X Models
(15)	80849	Eccentric, Hammer Arm Stop		80728	Spring, Hammer X Models
(16)	80369-02	Arm Asy, Hammer All, Exc X Models	(35)	80784	Nut Plate, Hammer (Not Required For X Models)
	80368-03	Arm Asy, Hammer, X Models	(36)	80797	Thimble, Ribbon (Dual Color)
(17)	80375-01	Latch Asy, Print Motor, All Exc X Models	(37)	85003-07	Screw 3-48X.437, Slot Pan Hd
	80375-02	Latch Asy, Print Motor, All X Models	(38)	80718	Retainer, Hammer Guide (X Models)
(18)	85145-50	Retainer, External (5100-50) All, Exc X Models	(39)	85000-01	Need Roll (.627 O.D.)
	85243-50	Retainer, External (5101-50) X Models	(40)	80766	Stabilizer, Printwheel (X Models)
(19)	80376	Hub, Print Disk	(41)	80401-00	Shim, Ribbon Magnet, X Models Only
(20)	80407	Collet, Print Disk Hub	(42)	80783-01	Brush Asy, Round Motor
(21)	85140-10	Belleville Washer (.126 I.D.)		80783-02	Brush Asy, Square Motor
(22)	80256	Pilot, Printwheel			

# LOWER CARRIAGE

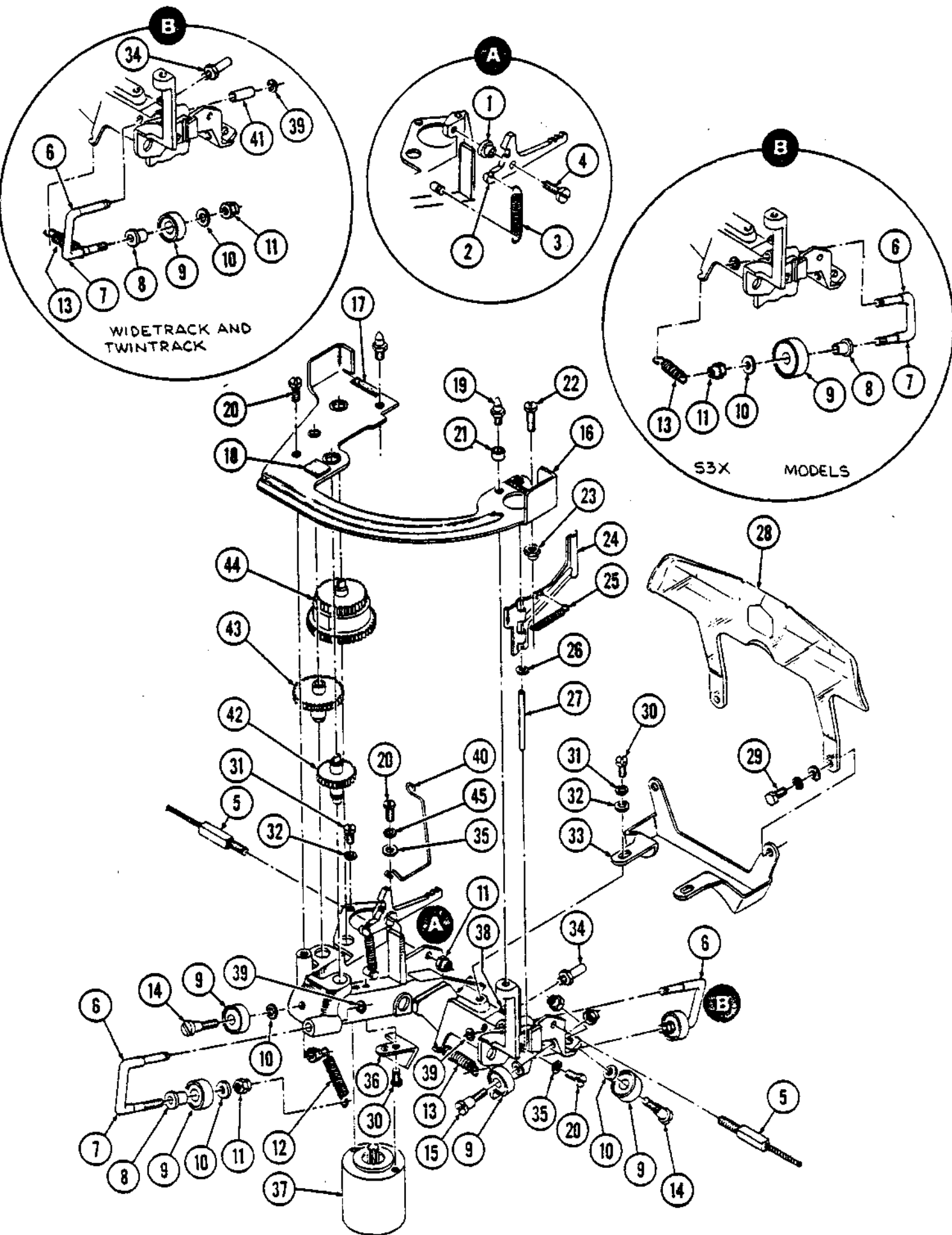



## LOWER CARRIAGE

(1)	80217	Bearing, Ribbon Latch	(14)	80104	Screw, Front Guide Bearing
(2)	80219-00	Latch, Ribbon, Exc. Multi-color	(15)	80103	Screw, Guide Bearing
	80219-01	Latch, Ribbon, Multicolor	(16)	80058	Plate Asy, Ribbon Drive
(3)	80304	Spring, Ribbon Box Latch	(17)	80410	Tape (.500X.500)
(4)	85004-05	Screw 4-40X.312, Slot Pan Hd	(18)	80409	Tape (.650X.150)
(5)	85127-01	Cable Carriage Drive R & L 132 Col	(19)	80296	Screw Stud, Ribbon Drive
	85127-02	Cable, Carriage Drive R WT	(20)	85004-04	Screw, 4-40X.250, Slot Pan Hd
	85127-03	Cable, Carriage Drive WT	(21)	80465	Spacer
	85127-04	Cable, Carriage Drive R TT	(22)	85004-06	Screw 4-40X.375, Slot Pan Hd
	85127-05	Cable, Carriage Drive TT	(23)	85137-04	Nut 4-40, Self Locking
(6)	80358	Guide Bearing Link Asy Front All, Rear S3/X30, S3/35, S3/45	(24)	80315	Tension Arm, All W/O Multi-color
	81917	Guide Bearing Link Asy, Rear WT & TT		81914	Tension Arm, All W/Multicolor
	81866	Guide Bearing Link Asy, Rear S/55, S3/55, S3/X40	(25)	80387	Spring, Ribbon Tension Arm, All, Requires 2, Merged, For Multicolor
(7)	80102	Link, Guide Bearing, For 80358 Asy	(26)	80386	Washer
	80853	Link, Guide Bearing, For 81917 Asy	(27)	80316	Shaft Tension Arm Pivot
	81865	Link, Guide Bearing, For 81866 Asy	(28)	80312-01	Line Card Guide
(8)	80330	Bushing, Guide Bearing, All Exc. 81866 Asy	(29)	85053-04	Screw 3-48X.250, Hex Hd
	81902	Busing, Guide Bearing 81866 Asy	(30)	85003-04	Screw 3-45X.250, Slot Pan Hd
(9)	85144-01	Ball Bearing, .500 OD, All Exc 81866 Asy	(31)	85124-03	Washer #3, Narrow Helical Lock
	85144-04	Ball Bearing, .750 OD, 81866 Asy	(32)	85125-03	Washer #3, Line Card Guide
(10)	80105	Washer, Guide Roller, All Exc. 81866 Asy	(33)	80357	Bracket Asy, Line Card Guide
	81901	Washer, Guide Roller, 81866 Asy	(34)	80253	Stud, Print Motor Latch, Exc. TT
(11)	85137-05	Nut, Self Locking 5-40, All		-----	Stud, Print Motor Latch, TT
(12)	80119	Spring, Guide Bearing Link, Front, All	(35)	85125-04	Washer #4, Narrow
(13)	80601	Spring, Guide Bearing Link, Rear, All Ex. S/55, S3/55, S3/X40	(36)	80406	Shutter, Photo Sensor
	81928	Spring, Guide Bearing Link, Rear, S/55, S3/55, S3/X40	(37)	80207	Stepper Motor, 45°
			(38)	80374-01	Pad, Carriage Stop, Square (.063 Thick)
			(39)	85138-12	Retainer, Guide Bearing Link (5103-12)
			(40)	81975	Left Hand Ribbon Tensioner For 80819-B
			(41)	80854	Sleeve For WT & TT
			(42)	80367	Gear Asy, 36T
			(43)	80218	Idler Gear, Ribbon Drive, 44T
			(44)	80057-01	Clutch Asy, Ribbon Drive
			(45)	85124-04	Washer #4, Hexical Lock

# CARRIAGES - TWINTRACK

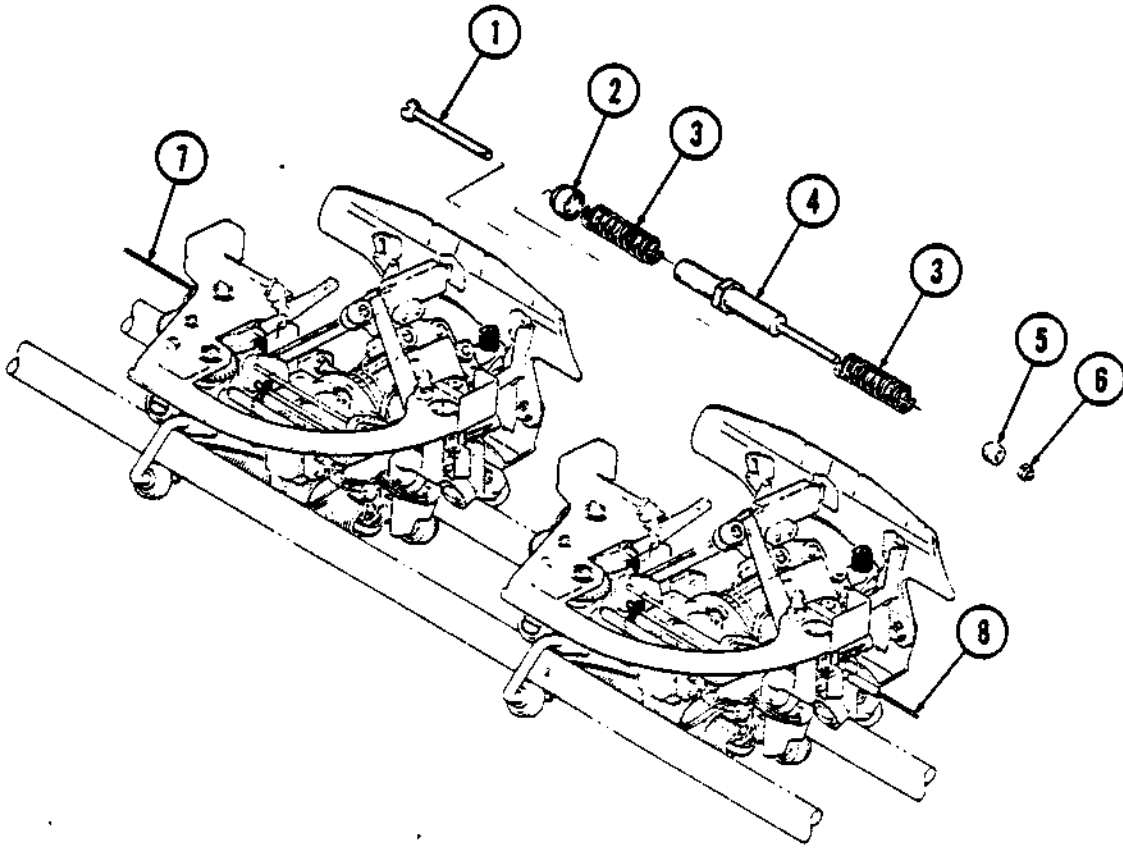

## CARRIAGES - TWINTRACK

- (1) 81871 Screw - Carriage
- (2) 81872 Spacer - Carriage
- (3) 81869 Spring - Carriage
- (4) 81870 Standoff - Carriage
- (5) 81859 Spherical Spacer
- (6) 85137-05 Nut - 5-40 Self Locking
- (7) 85127-05 Cable - Carriage Drive (48.25)
- (8) 85127-04 Cable - Carriage Drive (43.45)

### CARRIAGE DRIVER HEATSINK

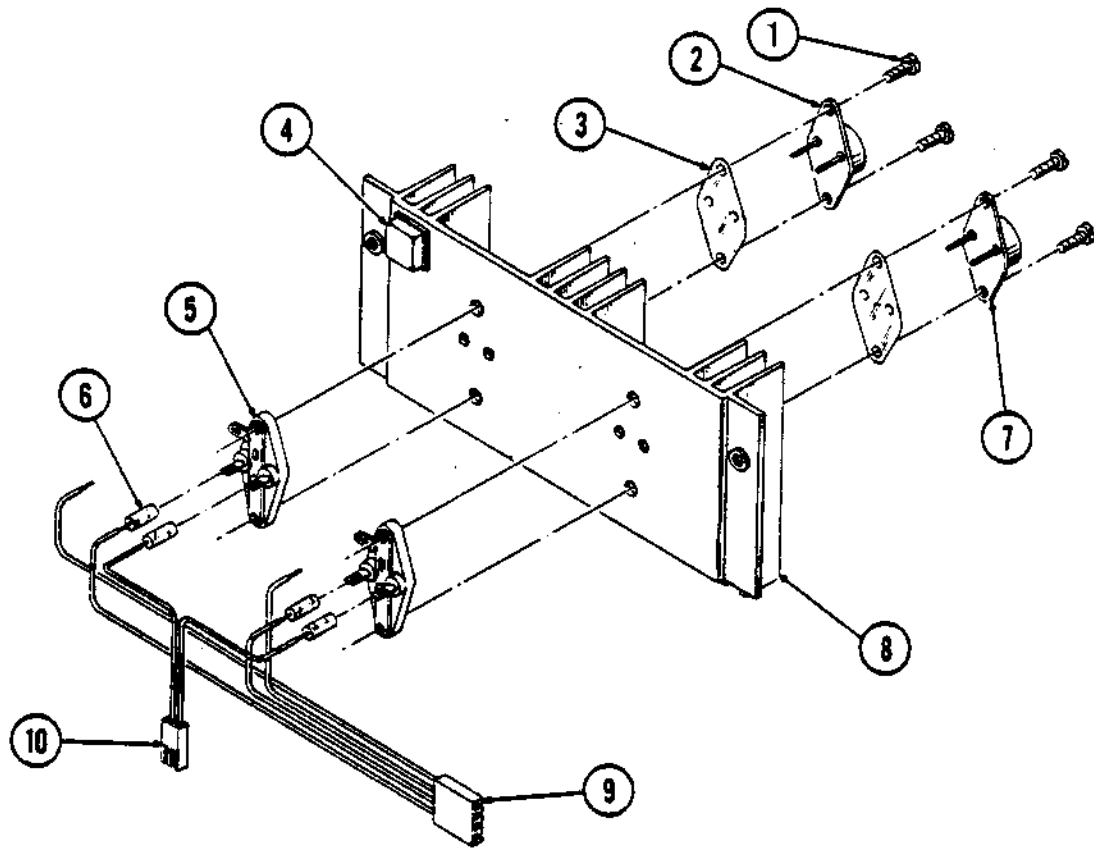

### PAPER AND PRINTWHEEL HEATSINK

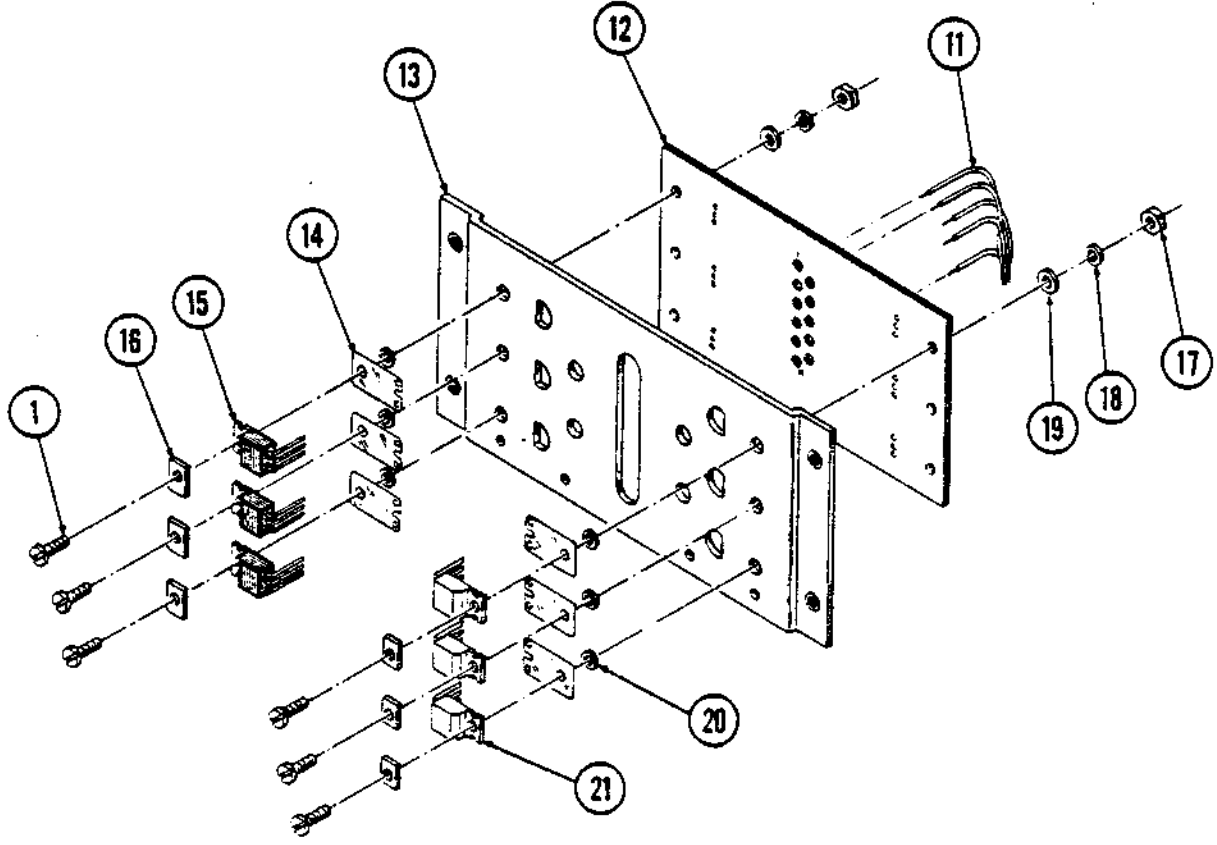

## CARRIAGE DRIVER HEATSINK

- (1) 85006-08 Screw #6-32X.500 Pan Hd.
- (2) 97028 Transistor PMD 10K
- (3) Mica Insulator (Part of Transistor 97028)
- (4) 85152-02 Foot
- (5) 94179 Transistor Waffer Socket
- (6) 94140-03 Shrink Tubing 3/16" Dia.
- (7) 97029 Transistor PMD 11K
- (8) 80711 Heatsink S3/S4 Series
- (9) 99073 Cable Asy.
- (10) 99074 Cable Asy. - Power

## PAPER AND PRINTWHEEL HEATSINK

- (1) 85006-08 Screw #6-32X.500 Pan Hd.
- (11) 99071 Cable - Paper Feed and Printwheel
- (12) 90091 Printed Circuit Board - Driver
- (13) 80709 Heatsink/Pen Nut Asy.
- (14) 94137 Mica Insulator - Large Rectangle
- (15) 97001 Transistor NPN
- (16) 94134 Rectangular Metal Washer
- (17) 85122-06 Nut #5-40 Full Hex Nut
- (18) 85124-06 Washer #6-32 Helical Lock
- (19) 85126-06 Washer #6-32 Regular Plain
- (20) 94228 Bushing - Nylon #6
- (21) 97013 Transistor PNP

# MOTHERBOARD CONNECTIONS (132 Column And WideTrack)

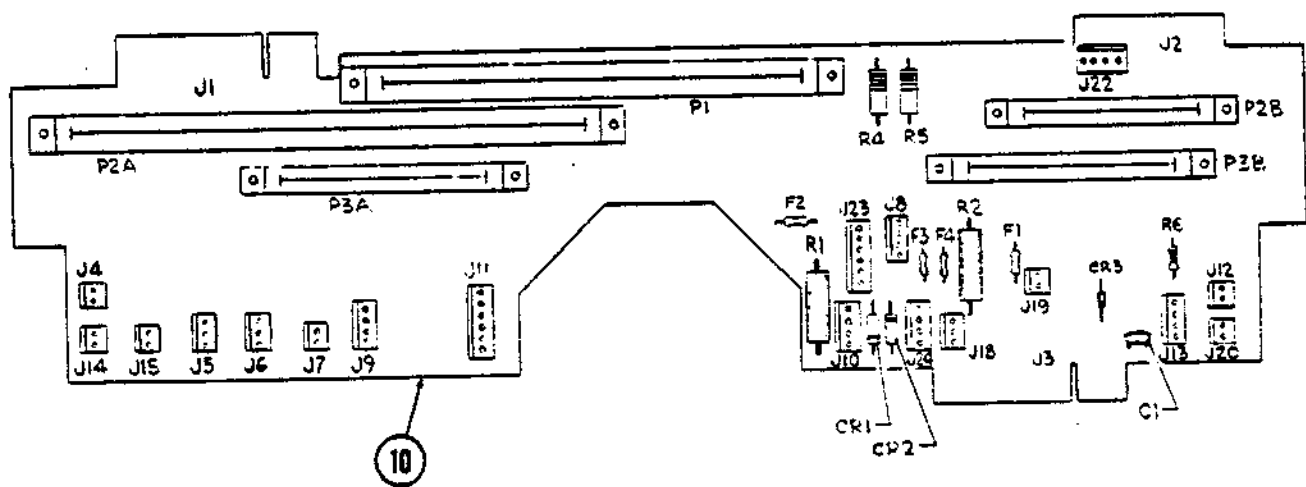
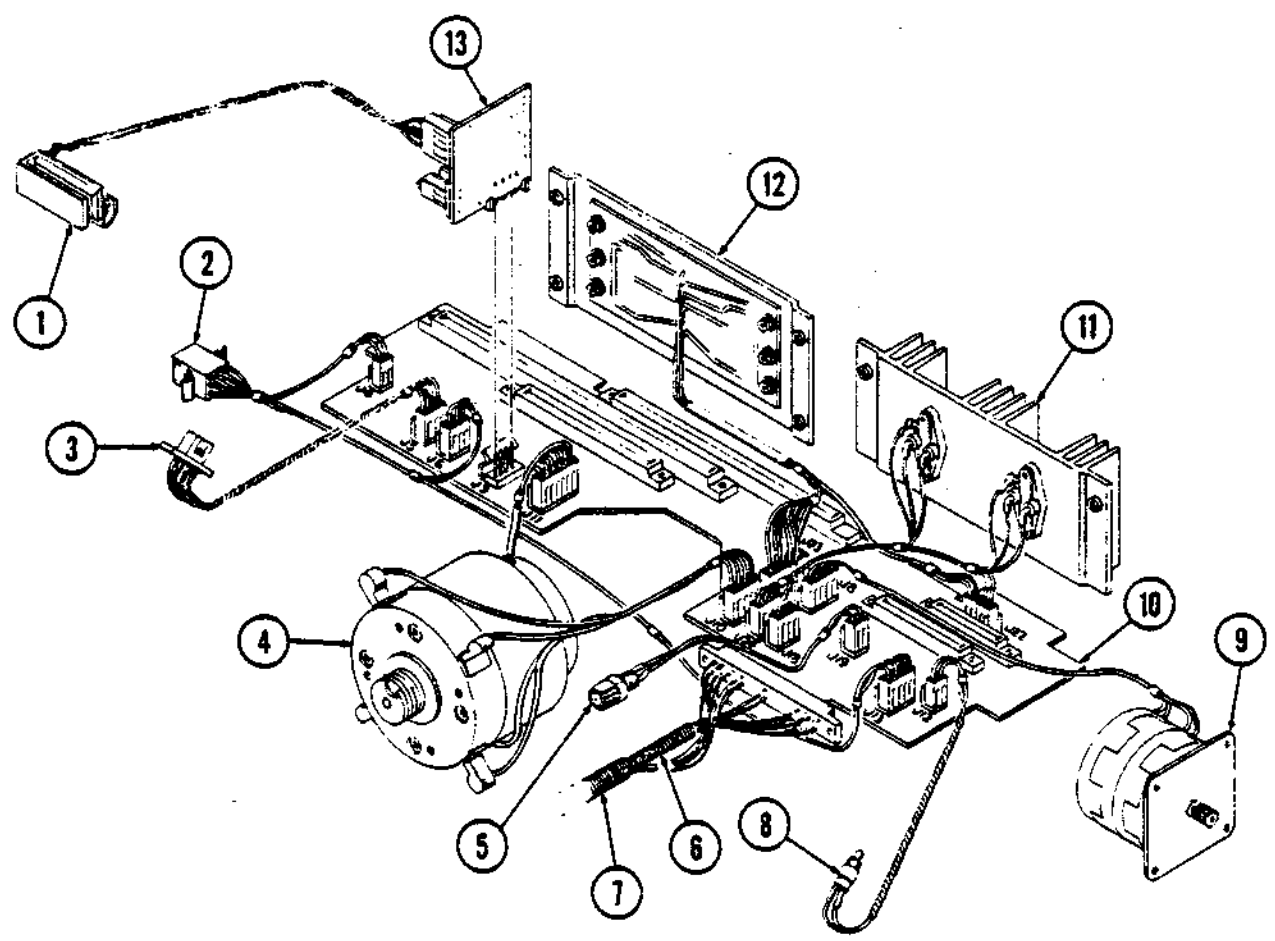

**MOTHERBOARD CONNECTIONS**  
**(132 Column And WideTrack)**

- (1) 80736 Sensor (Rear Out Of Paper)
- (2) 99007-01 Harness Asy. W/Int. W/Lights, W/T.O.F., 132 Col  
99007-03 Harness Asy. W/O Int. W/Lights, W/T.O.F., 132 Col  
99007-04 Harness Asy. W/Int. W/O Lights, W/O T.O.F., 132 Col  
99007-05 Harness Asy. W/O Int. W/Lights, W/O T.O.F., 132 Col
- (3) 99120 Photo Sensor
- (4) 80023-04 Motor/Encoder Asy. 132 Col
- (5) 80610-00 Resistor Asy.
- (6) 80613 Spring, Inner Carriage Conductors
- (7) 80614 Spring, Carriage Conductors
- (8) 99119-01 Switch Asy. Ribbon Adv. 132 Col  
99119-02 Switch Asy. Ribbon Adv.
- (9) 80046-01 Paper Feed Motor Asy. 132 Col (Low Current)  
80046-02 Paper Feed Motor Asy. 132 Col  
80046-07 Paper Feed Motor Asy. (Low Current)  
80046-08 Paper Feed Motor Asy.
- (10) 90602-00 Motherboard Asy. 132 Col
- (11) 80712 Carriage Driver Heatsink Asy. 132 Col
- (12) 90092-01 Paper/Printwheel Heatsink Asy.
- (13) 90592-01 PCB Rear Out Of Paper

# TWINTRACK MOTHER BOARD CONNECTIONS (RIGHT & LEFT)

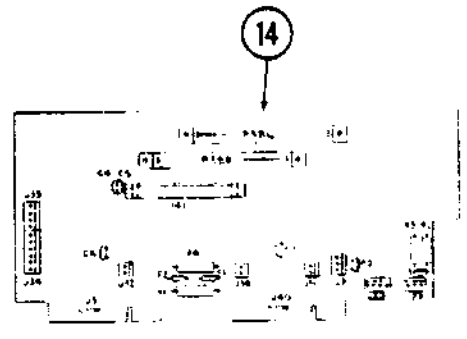
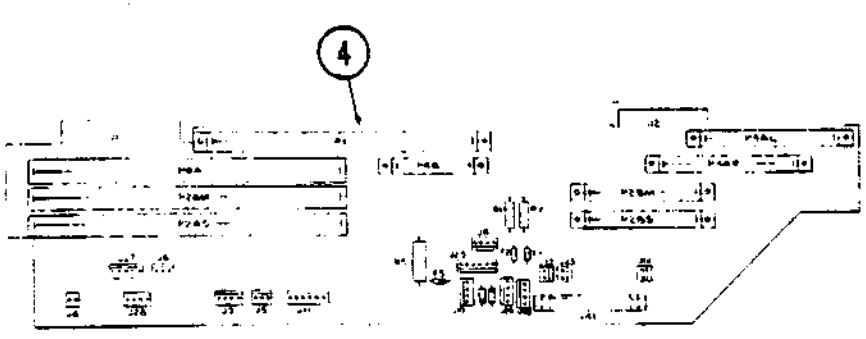
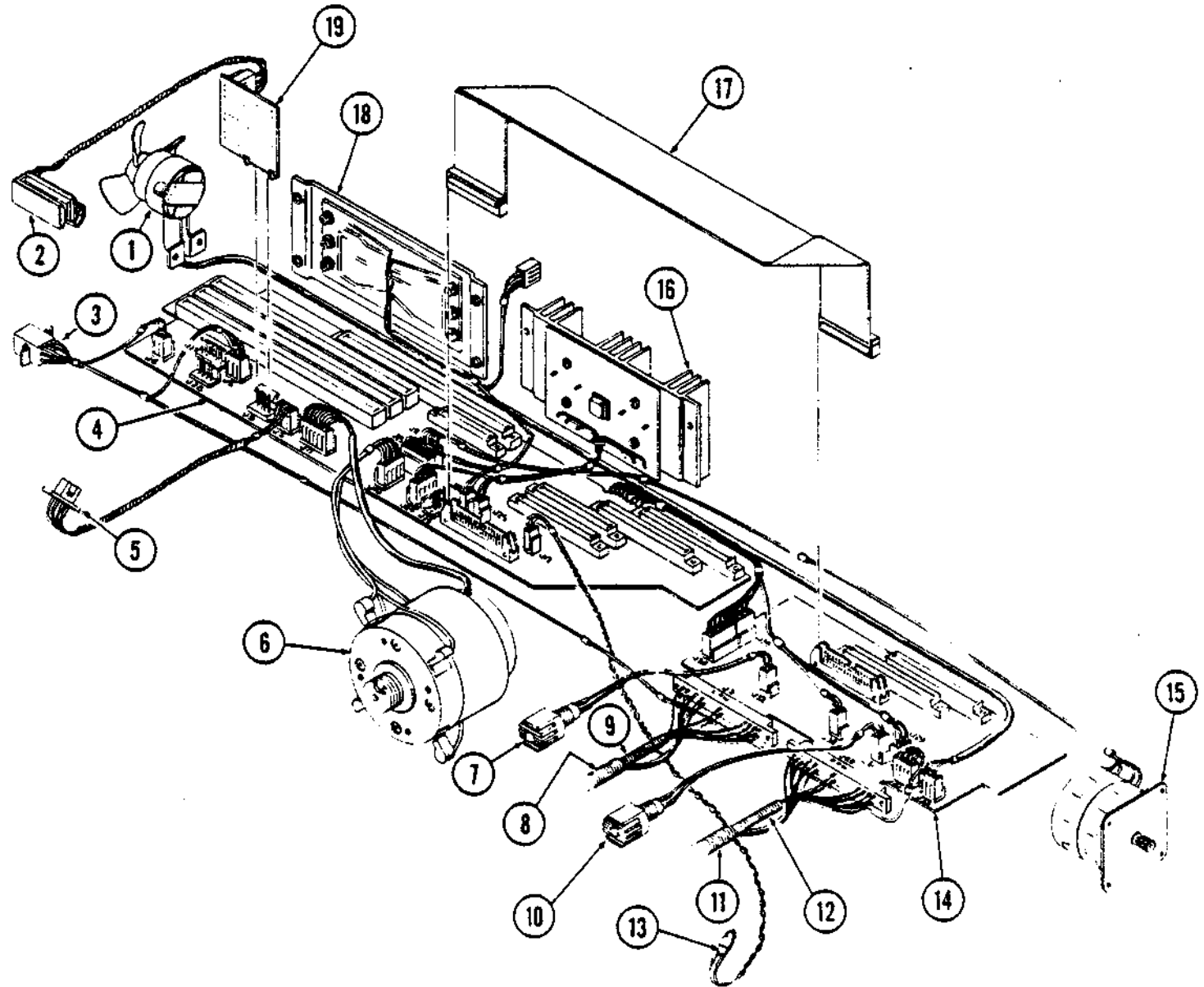



**TWINTRACK MOTHER BOARD CONNECTIONS  
(RIGHT & LEFT)**

- (1) 81815-02 Motor/Fan/Cable Asy.
- (2) 80736 Sensor/Rear Out of Paper
- (3) 99007-11 W/Int., W/Lights, W/T.O.F. Harness  
99077-13 W/O Int., W/Lights, W/T.O.F. Harness  
99077-14 W/Int., W/Lights, W/O T.O.F. Harness  
99077-15 W/O Int., W/Lights, W/O T.O.F. Harness
- (4) 90692 Mother Board Asy., Left Side
- (5) 99120 Photo Sensor
- (6) 80023-04 Motor/Encoder Asy., Carriage 264 Col.
- (7) 80610-99 Resistor Asy.
- (8) 80614 Spring, Carriage Conductors Left Side
- (9) 80613 Spring, Inner Carriage Conductors Left Side
- (10) 80610-00 Resistor Asy.
- (11) 80614 Spring, Carriage Conductors Right Side
- (12) 80613 Spring, Inner Carriage Conductors Right Side
- (13) 99119-02 Switch Asy., Ribbon Adv. 264 Col.
- (14) 90682 Mother Board Asy., Right Side
- (15) 80046-08 Paper Feed Motor Asy.
- (16) 90752 Carriage Heatsink Asy.
- (17) 99114 Flat Cable Asy.
- (18) 90092-02 Paper/Printwheel Heatsink Asy.
- (19) 90592-01 P.C.B. Rear Out of Paper

# STRUCTURE ASSEMBLY

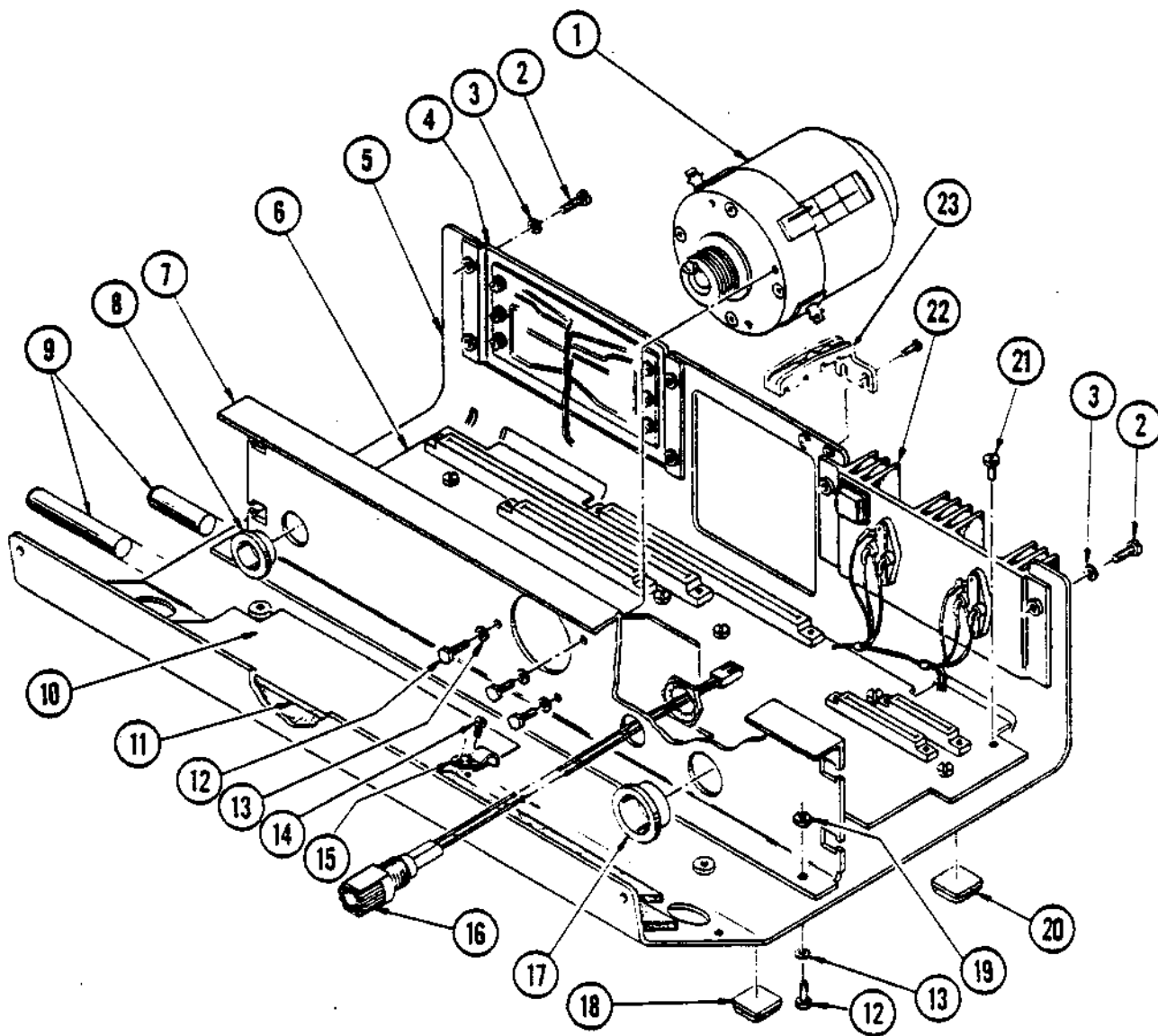

## STRUCTURE ASSEMBLY

- (1) 80023-01 Mtr./Enc. Asy. Car. S3/45.
- 80023-02 Mtr./Enc. Asy. Car. S3/35
- 80023-03 Mtr./Enc. Asy. Car. S3/55. S3X30, S3X40
- 80023-04 Mtr./Enc. Asy. Car. S3/WT
- 80023-05 Mtr./Enc. Asy. Car. S3/X30. S3/45. (128") Black
- 80023-06 Mtr./Enc. Asy. Car. S3/35 (128) Black
- 80023-07 Mtr./Enc. Asy. Car. S3/X40, S3/55 (128") Black
- 80023-09 Mtr./Enc. Asy. Car. S3/X30, S3/45 (144") Blue
- 80023-10 Mtr./Enc. Asy. Car. S3/35, (144) Blue
- 80023-11 Mtr./Enc. Asy. Car. S3/X40. S3/55 (144) Blue
- (2) 85006-05 Screw 6-32 X .312. Slot Pan Hd.
- (3) 85124-06 Washer #6, Helical Lock
- (4) 90092-02 Paper and Printwheel Heatsink Assembly
- (5) 80049-01 Pan Asy., Bot. 132 Col. Unslotted
- 80049-02 Pan Asy., Bot. 132 Col. Slotted
- (6) 90602-00 Motherboard S3 Including S3 WT
- (7) 80223 Motorbrace 132 Col.
- (8) 85157-02 Snap Bushing (SB-875-11) .687 I.D.
- (9) 80116-01 Shaft, Carriage Guide, 132 Col.
- (10) 80418 Shield, Bottom Pan, 132 Col.
- (11) 80449 Pad, Accoustical, Bottom Pan, 132 Col.
- (12) 85058-08 Screw 10-32 X .500, HEX HD.
- (13) 85124-10 Washer #10, Helical Lock
- (14) 85004-04 Screw 4-40 X .250, Slot Pan Hd.
- (15) 80246 Clamp, Carriage Cable
- (16) 80610-01 Resistor Assembly
- (17) 85157-03 Snap Busing (SB-1093-15) .937 I.D. Exc. S5
- (18) 85152-01 Foot, Rubber Front (SJ-5023) W/Covers
- 85152-02 Foot, Rubber Front (SJ-5025) W/O Covers
- (19) 85122-10 Nut 10-32, Hex
- (20) 85152-01 Foot, Rubber Rear (SJ-5023)
- (21) 85008-08 Screw 10-32 X .500, Slot Pan Hd.
- (22) 80712 Carriage Heatsink Assembly, All, Exc. TT
- 90752 Carriage Heatsink Assembly, TT
- (23) 81837 Clamp, P.C.B.



## CHAPTER VIII

### SCHEMATICS

#### SCHEMATIC INDEX

DESCRIPTION	PAGE
Motherboard (90600)	8-2
Printed Circuit Board #1 (90610)	8-4
Printed Circuit Board #2 (90620)	8-8
Printed Circuit Board #3 (90630)	8-14
TwinTrack Motherboard - Right (90680)	8-18
TwinTrack Motherboard - Left (90690)	8-19
TwinTrack Coordinating Logic (90670)	8-21
Auxiliary Paper Drive Option (90700)	8-26
Paper Out Option (90590)	8-27



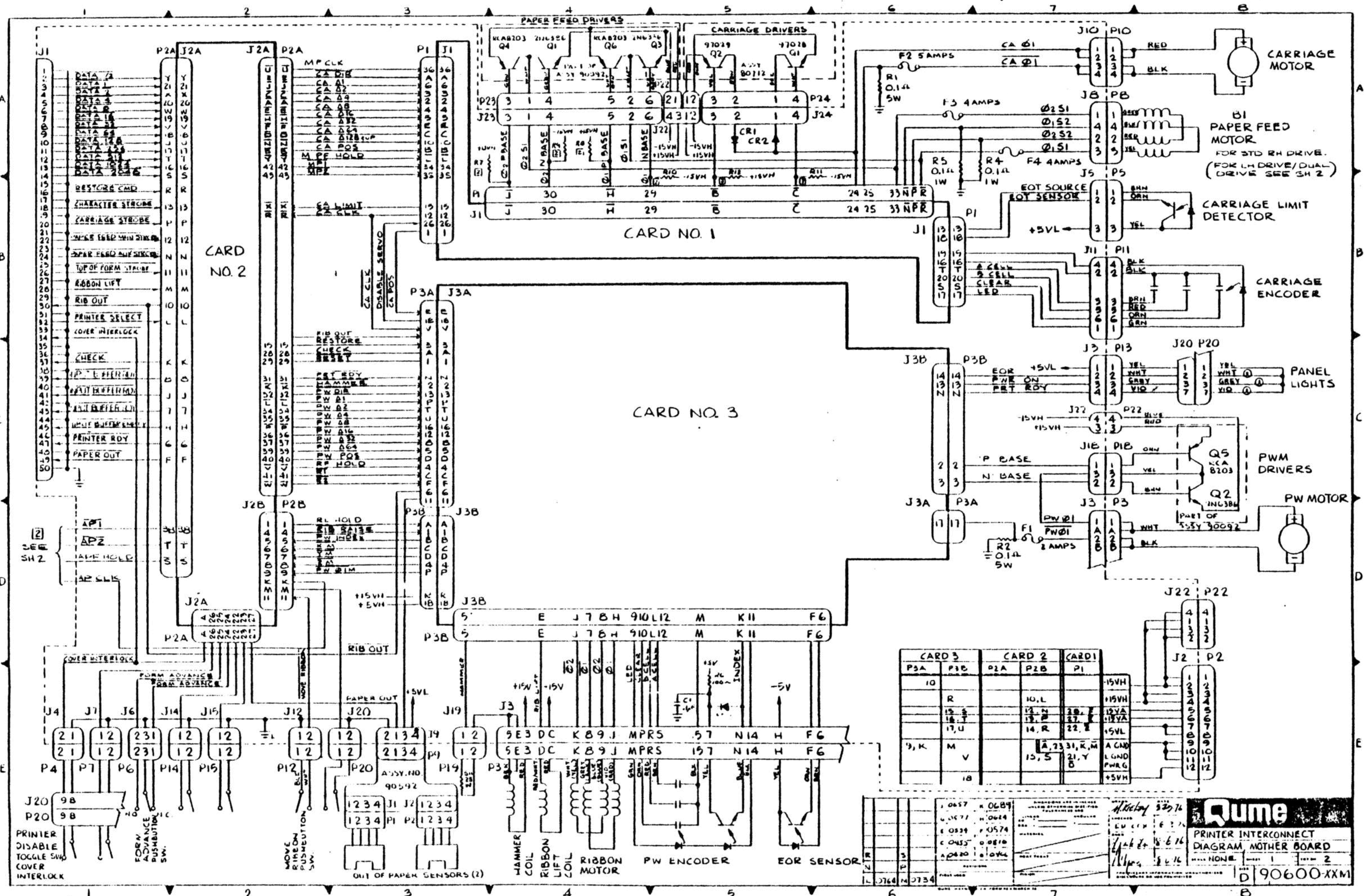

CARD NO. 2

CARD NO. 1

CARD NO. 3

	CARD 3	CARD 2	CARD 1	
P3A	P3B	P2A	P2B	P1
10				15VH
	R	10, L		15VH
	15, S	12, N	20, F	15VA
	16, T	13, P	27, Z	15VA
	17, U	14, R	22, E	15VL
3, K	M		A, 23, 31, K, M	ACND
	V		15, S	21, Y
			B	LGND
				PWR.G
				+5VH

J 0657	K 0684	DATE	1/26/76
L 0571	H 0614	REV	3
E 0539	F 0574	BY	J. Kelly
C 0453	D 0810	CHKD	J. Kelly
A 0420	B 0464	DATE	1/26/76

**Qume**  
 PRINTER INTERCONNECT  
 DIAGRAM MOTHER BOARD  
 NONE 1 2  
 90600-XXM

RESISTOR CHART			
DESIG	-00	-01	-02
R7	-	470Ω	-
R8	-	↑	-
R9	-	↑	-
R10	-	↑	-
R11	-	↑	-
R12	-	470Ω	-

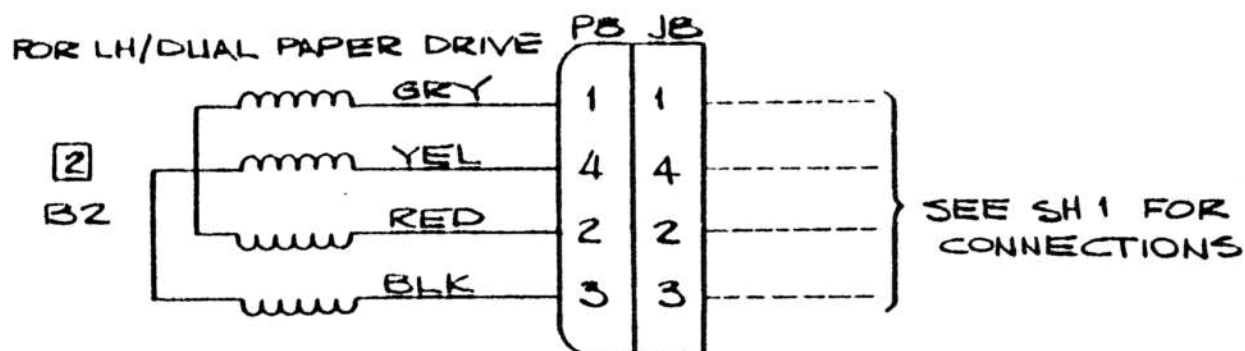
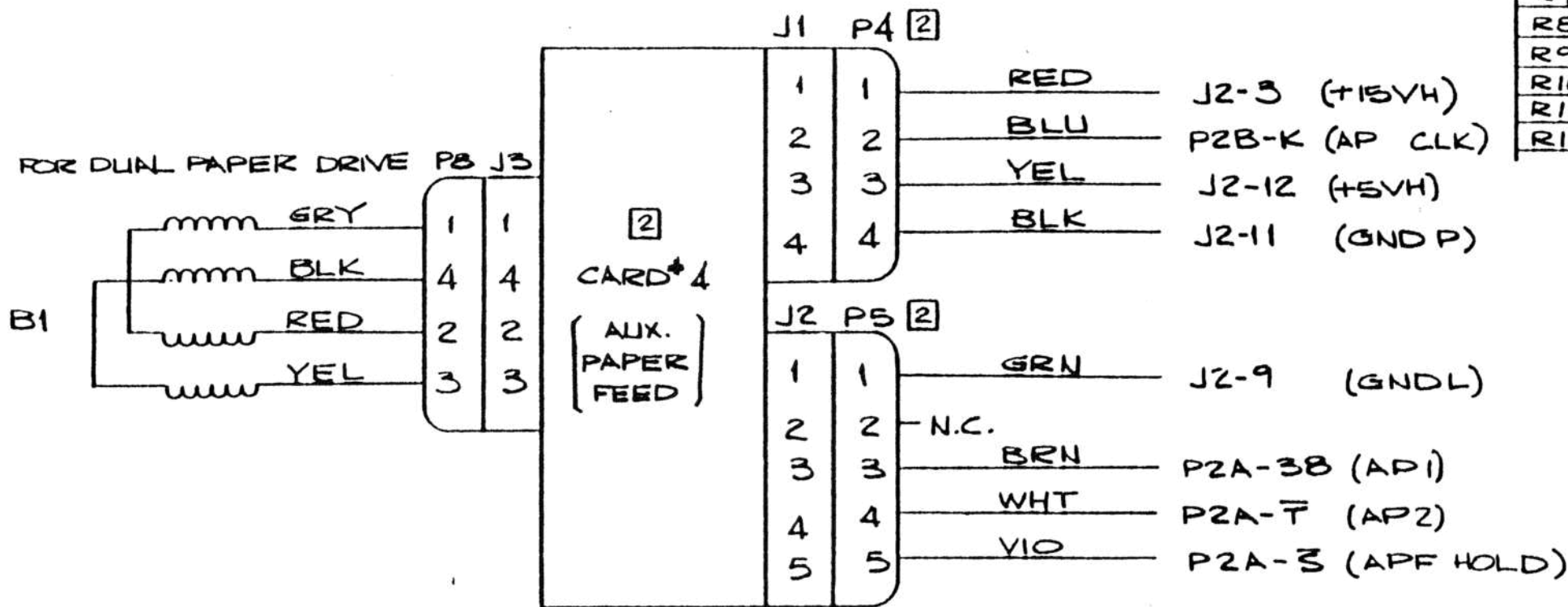

NOTES:

- THIS SCHEMATIC IS VALID FOR ASSY'S-  
90602-00 REV K ECN 0778  
90602-01 REV K ECN 0778  
90602-02 REV K ECN 0734

[2] DESIGNATED COMPONENTS ARE USED ON -02 ASSY'S ONLY.

DIMENSIONS ARE IN INCHES UNLESS OTHERWISE SPECIFIED TOLERANCES ARE		DRAWN	DATE	<b>Qume</b>
LINES AS SHOWN		FC	5/31/77	
MATERIAL		CHECKED	5/31/77	PRINTER INTERCONNECTION
HEAT TREAT		ENGR	6/17/77	DIAGRAM MOTHER BOARD
FINISH		MFG.		SCALE
REVISIONS		PROPRIETARY INFORMATION UNAUTHORIZED DISCLOSURE OR USE PROHIBITED.		SHEET 2
FIRST USED				100% 2
				90600-XX, M

90600-XX, M



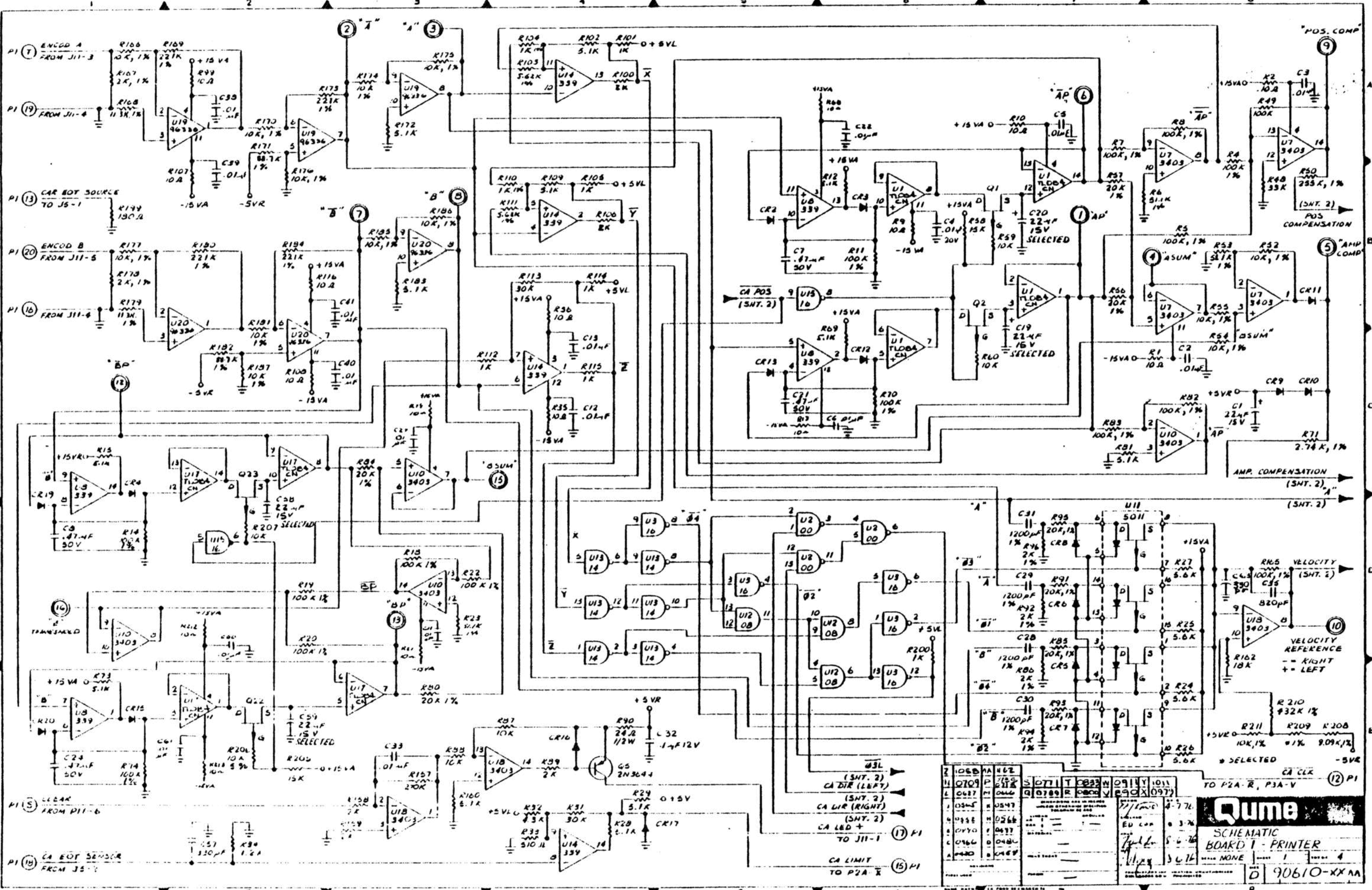

QTY	DESCRIPTION	QTY	DESCRIPTION	QTY	DESCRIPTION
1	106B	1	46Z	1	0911Y
1	0709	1	71S	1	1011
1	0487	1	0466	1	0977
1	0385	1	0547	1	0977
1	0750	1	0568	1	0977
1	0466	1	0488	1	0977
1	0480	1	0489	1	0977

1	0385	1	0547	1	0911Y
1	0750	1	0568	1	1011
1	0466	1	0488	1	0977
1	0480	1	0489	1	0977

1	0385	1	0547	1	0911Y
1	0750	1	0568	1	1011
1	0466	1	0488	1	0977
1	0480	1	0489	1	0977

1	0385	1	0547	1	0911Y
1	0750	1	0568	1	1011
1	0466	1	0488	1	0977
1	0480	1	0489	1	0977

1	0385	1	0547	1	0911Y
1	0750	1	0568	1	1011
1	0466	1	0488	1	0977
1	0480	1	0489	1	0977

1	0385	1	0547	1	0911Y
1	0750	1	0568	1	1011
1	0466	1	0488	1	0977
1	0480	1	0489	1	0977

1	0385	1	0547	1	0911Y
1	0750	1	0568	1	1011
1	0466	1	0488	1	0977
1	0480	1	0489	1	0977

**Qume**  
 SCHEMATIC  
 BOARD 1 - PRINTER  
 NONE 1 4  
 90610-KX AA

8-5

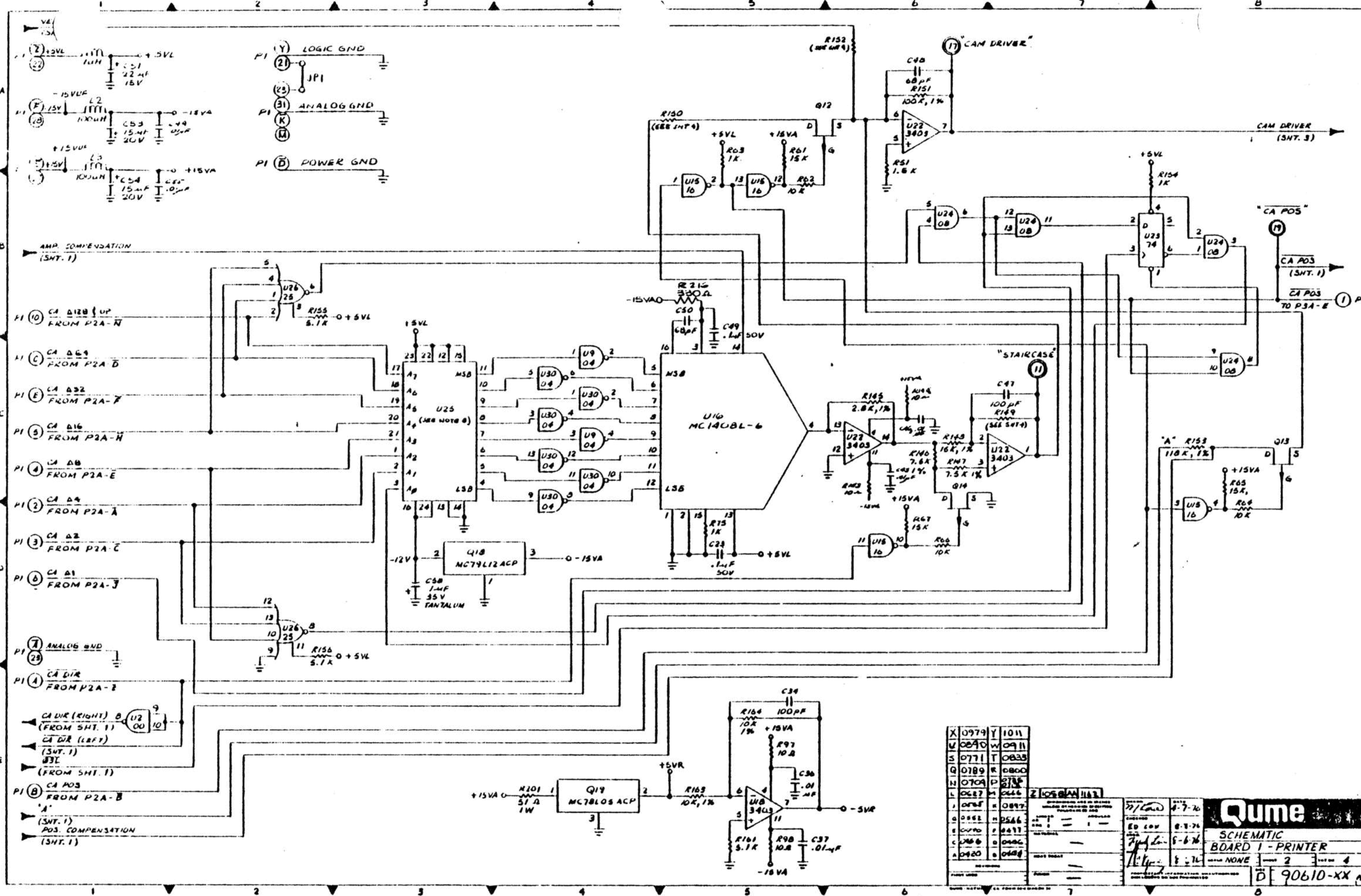

X	0979	Y	1011
V	0890	W	0911
S	0771	T	0833
Q	0789	R	0800
N	0709	P	0733
L	0627	M	0666
J	0547	K	0597
H	0467	J	0528
G	0387	I	0459
F	0307	H	0390
E	0227	G	0321
D	0147	F	0252
C	0067	E	0183
B	0000	D	0114
A	0000	C	0045

REV	1	DATE	4-7-76	
DESIGNED BY	W. J. L.	ENGINEER		
CHECKED BY		DATE	8-1-76	
APPROVED BY		DATE	5-6-76	
DATE	8-1-76	SCALE	NONE	
SHEET NO.		2	TOTAL SHEETS	4
PROJECT NO.				90610-XX

9-8

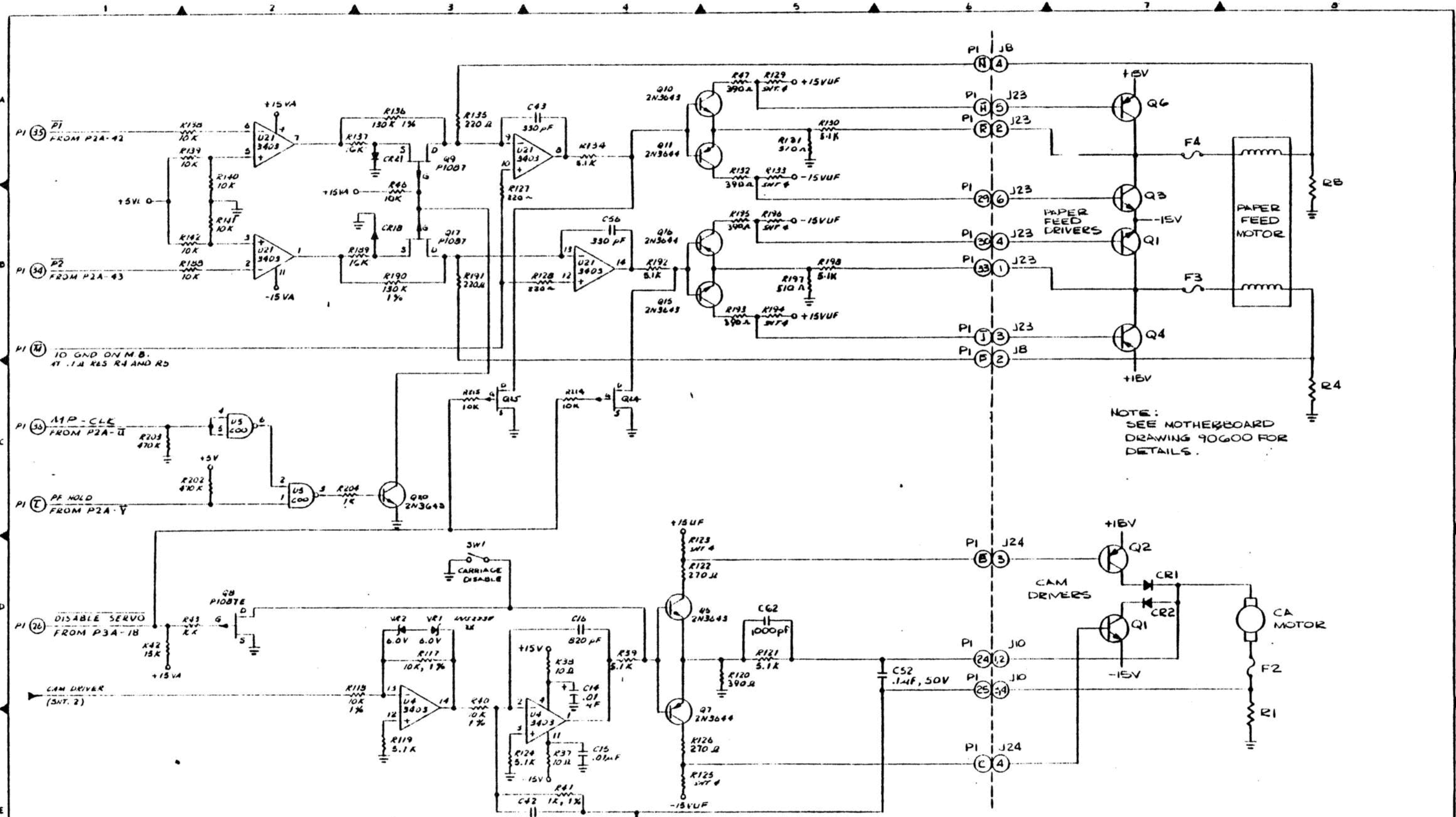

NOTE:  
SEE MOTHERBOARD  
DRAWING 90600 FOR  
DETAILS.

"CURRENT WAVEFORM"  
10 AMP / VOLT  
+ = LEFT  
- = RIGHT

Z	1058	A	1162	L	0627	F	0648	REVISED	DATE	BY	CHKD	APP'D	DATE	BY	CHKD	APP'D	DATE	BY	CHKD	APP'D
X	0979	Y	1011	E	2258	H	0566	DESIGNED	DATE	BY	CHKD	APP'D	DATE	BY	CHKD	APP'D	DATE	BY	CHKD	APP'D
M	0890	W	0911	C	0466	U	0468	DRAWN	DATE	BY	CHKD	APP'D	DATE	BY	CHKD	APP'D	DATE	BY	CHKD	APP'D
U	0771	T	0833	A	0410	B	0454	TESTED	DATE	BY	CHKD	APP'D	DATE	BY	CHKD	APP'D	DATE	BY	CHKD	APP'D
G	0789	R	0800																	
N	0709	J	0713																	

Qume  
SCHEMATIC  
BOARD I - PRINTER  
90610-XXAA

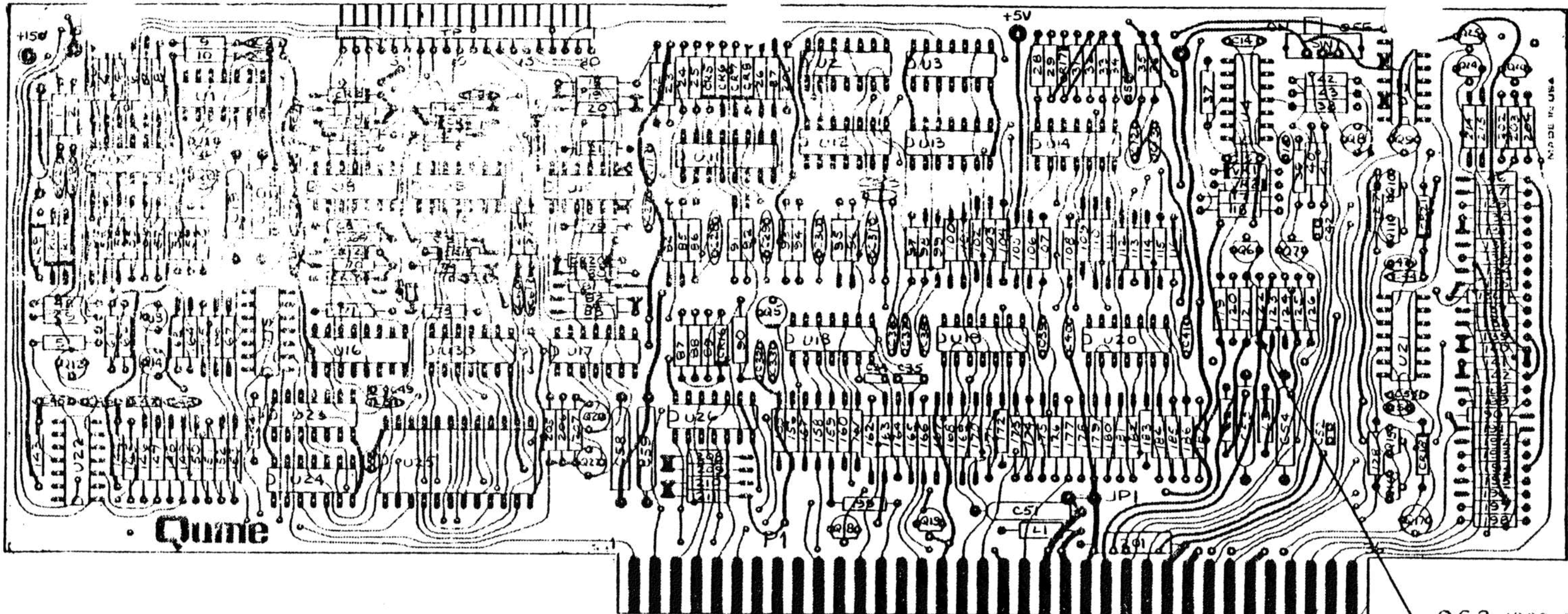

8-7

C62, 1000pF

CASH NUMBER	-00	-01	-02	-03	-04	-05	-06
MODEL USED ON	51/47	55/88	51/55	53/30	52/40	58/40W	55/88W
		32/75				23/75	SPECIAL
R150	4.12K, 1%	4.12K, 1%	SELECTED	8.6K, 1%	4.52K, 1%	SELECTED	SELECTED
R152	1.33K, 1%	1.74K, 1%	1.65K, 1%	1.65K, 1%	1.65K, 1%	1.54K, 1%	1.65K, 1%
R123	400Ω, 5%	400Ω, 5%	400Ω, 5%	470Ω, 5%	470Ω, 5%	470Ω, 5%	NONE
R125	↑	↑	↑	↑	↑	↑	↑
R129	↑	↑	↑	↑	↑	↑	↑
R133	↑	↑	↑	↑	↑	↑	↑
R134	↑	↑	↑	↑	↑	↑	↑
R136	470Ω, 5%	470Ω, 5%	470Ω, 5%	470Ω, 5%	470Ω, 5%	470Ω, 5%	NONE
U25	55/89	55/89	95/88	95/88	15/88	15/89	15/88
JPI	OPEN	OPEN	OPEN	OPEN	OPEN	OPEN	CLOSED
R149	15K, 1%	15K, 1%	SELECTED	15K, 1%	SELECTED	SELECTED	15K, 1%

NOTES  
 UNLESS OTHERWISE SPECIFIED  
 1. ALL .01μF CAPACITORS ARE 25V  
 2. ALL RESISTORS ARE 5% 1/4W  
 3. ALL 1% RESISTORS ARE 1/8W  
 4. ALL DIODES ARE IN454  
 5. ALL GROUNDS ARE ANALOG  
 6. ALL FET'S ARE P10B76  
 7. THIS SCHEMATIC IS VALID FOR THE FOLLOWING ASSEMBLY:  
 53/35 - 00 'X' ECN 0979  
 51/45 - 01 'W' ECN 0979  
 51/58 - 02 'X' ECN 1011  
 53/30 03 'X' ECN 1058  
 52/40 - 04 'W' ECN 0979  
 55/77, 55/40 - 05 'W' ECN 1162  
 SPECIAL - 06 'W' ECN 1011

X	C179	Y	1011	Z	1058	AA	1162
V	0890	W	0911	J	0563	K	0547
U	0771	T	0833	G	0332	H	0366
Q	0789	R	0800	E	0490	F	0477
M	0709	P	0713	D	0466	C	0486
L	0627	N	0666	A	0420	B	0454

DATE	7-13-76	DESIGNED BY	FNABONNE
ENGR	ED COV	DATE	8-1-76
CHKD	7/1/76	DATE	8-6-76
APP'D	7/1/76	DATE	8-6-76

**Quine**  
 SCHEMATIC BOARD 1 - PRINTER  
 NONE 4 4  
 D 90610-XY AM

8-8

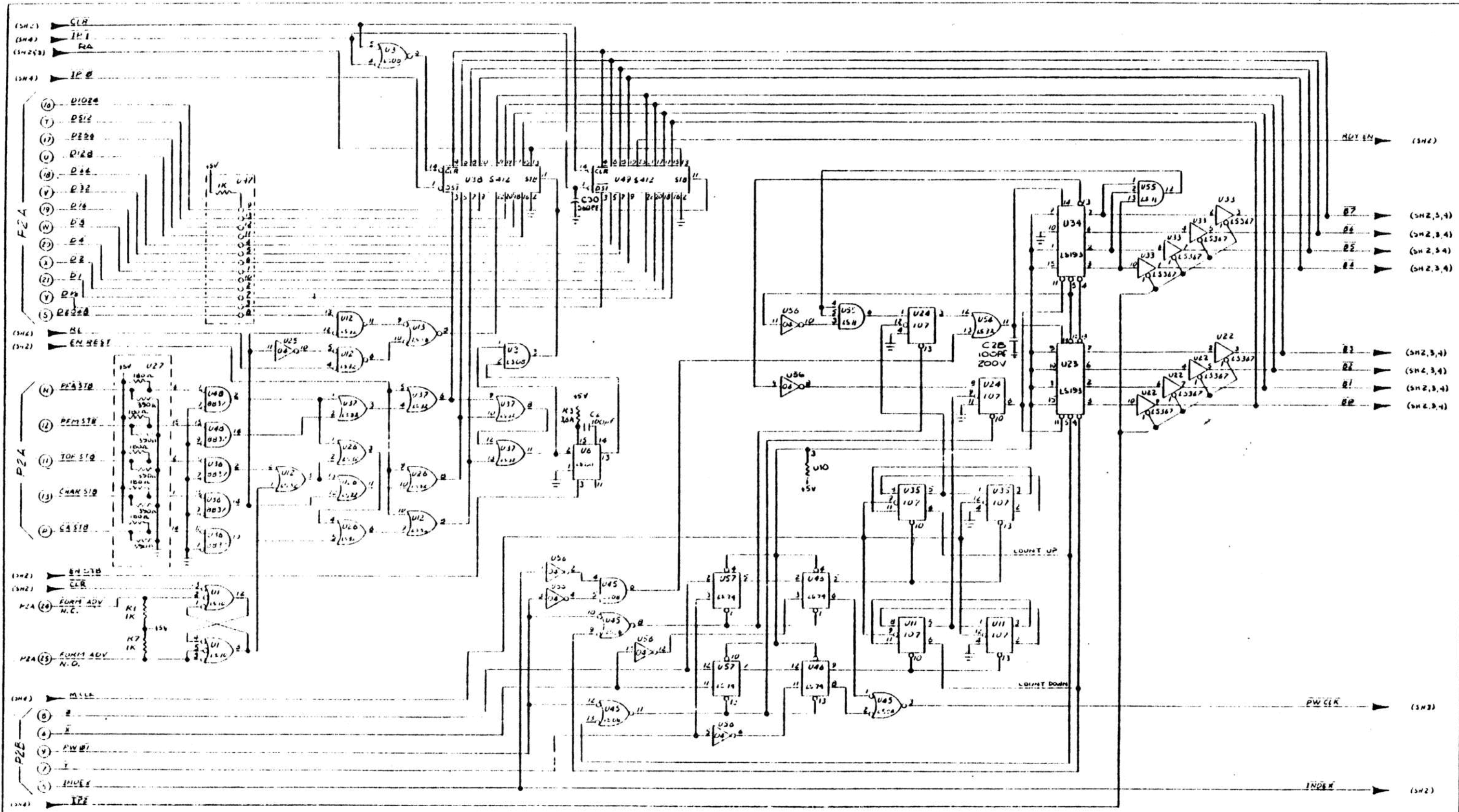

N	0873	P	0902
L	0666	M	0890
I	0566	K	0825
U	-	H	-
E	-	F	-
C	-	D	-
A	-	B	-

DRAWING NO. 19 DEC 76  
 NAME: NAJUNNE  
 DATE: 7 Jun 77  
 SCALE: NONE  
 SHEET: 1 OF 5  
 PROJECT: SPRINT 3-CARD #2  
 FILE: 90620-XX T

6-8

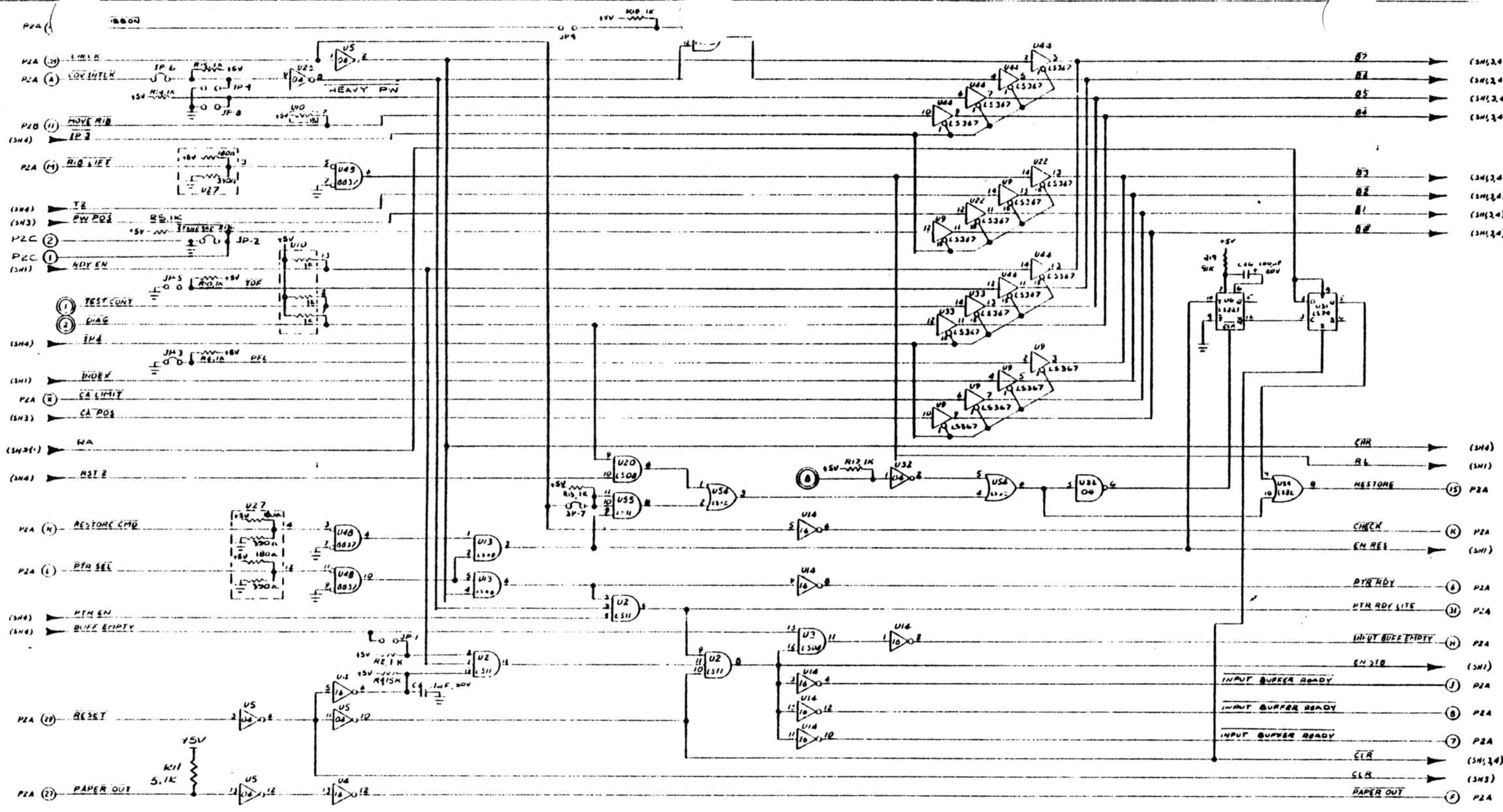

W 0973	P 0902
L 0826	M 0829
J 0826	A 0829
G -	H -
E -	F -
C -	D -
A -	B -

CHECKED BY: *[Signature]*  
 DATE: 12 DEC 77  
 NAME: NABONNE  
 PROJECT: SPRINT 3  
 SHEET: 2 OF 5  
 TITLE: SCHEMATIC  
 PART: 90620-XX T

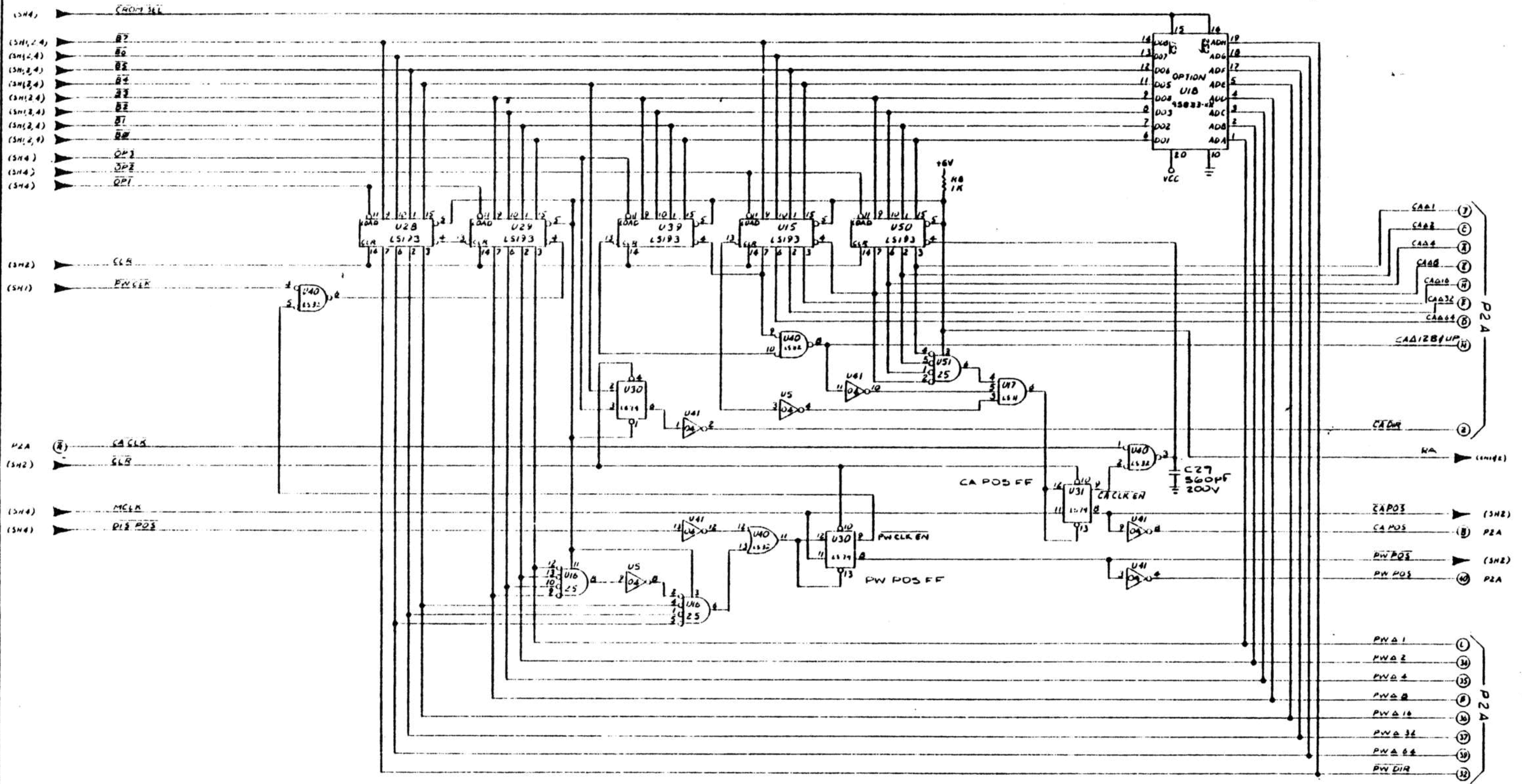

Y	0873P	0A02			
L	0666	0223			
J	0288	0642			
G					
F					
E					
D					
C					
B					
A					

REVISIONS	DATE	BY
1	1/2/71	WJF
2	1/10/71	WJF

DATE	1/2/71
TIME	10:30
BY	WJF
NO.	3
TITLE	SPRINT 3 - CARD #2
SCALE	NONE
PROJ.	90620-XXT

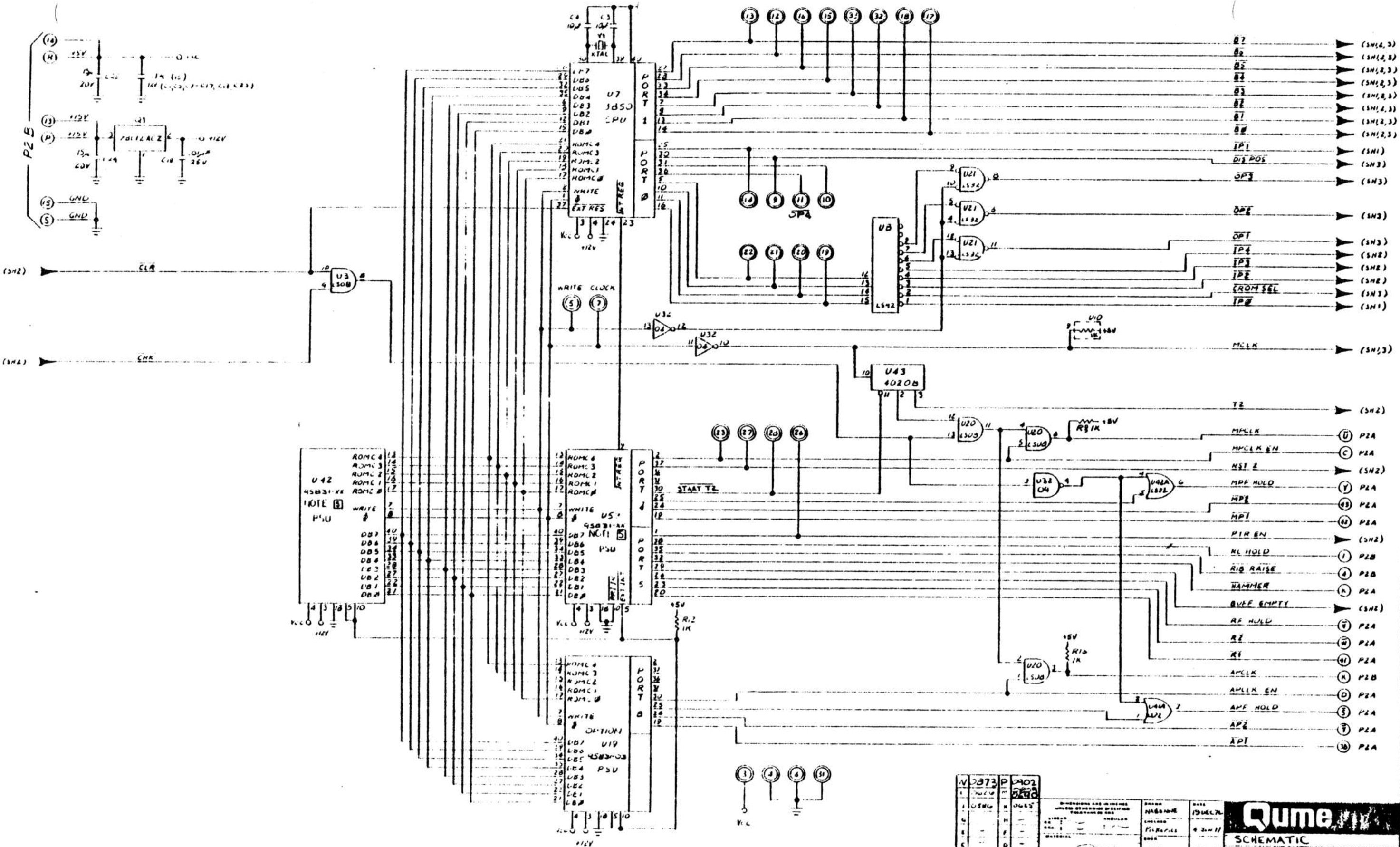

<b>Qume</b> SCHEMATIC SPRINT 3 - CARD #2		DATE: 4 Jun 77 DRAWN: [Signature] CHECKED: [Signature] APPROVED: [Signature]
T 1062 R 0909 5 1049	PROJECT: [Blank] SHEET: [Blank]	PARTS LIST: [Blank]



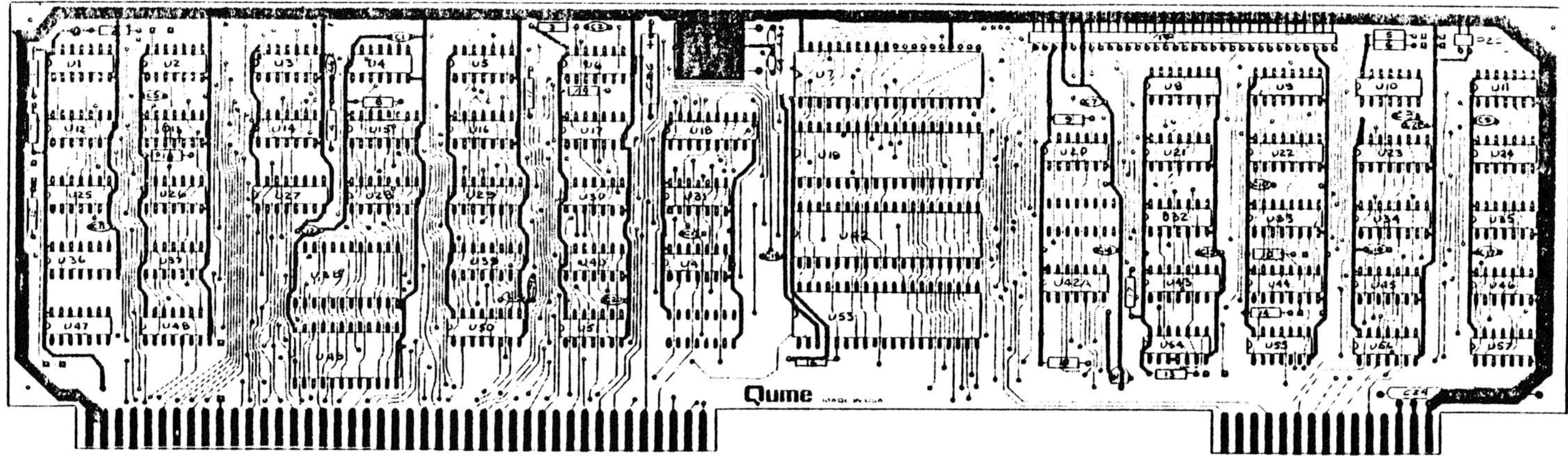

DASH No.			U18	U19	U42	U52	P2C
90622-00	-	-	-	95831-03	75831-02 OR 15831-05	75831-01 OR 75831-04	-
-01	-	-	95822-02	95831-02	15831-01	95831-04	-
-02	-	-	-	-	75831-02 OR 95831-05	95831-01 OR 95831-04	-
-03	-	-	75822-01	95831-03			-
-04	-	-	-	-			-
-05	-	-	-	95831-03			-
-06	-	-	-	-			-
-07	-	-	75822-01				P2C
N/A	-	-	-	-			-
-09	-	-	75833-04	95831-03	75831-05	95831-04	-

**NOTES:**

UNLESS OTHERWISE SPECIFIED:

1. ALL RESISTOR ARE 1/4W 5%
2. ALL DIODES ARE IN 4154.
3. ALL FILTER CAPS. .1MF; 12V.
4. THIS SCHEMATIC IS VALID FOR  
FOLLOWING ASSEMBLY  
REV "R" PCN 1062

Ⓜ X: MODELS MUST HAVE 95831-04 IN U52 ALL 95831-05 IN U52. ALL OTHERS CAN HAVE AS A SUB. 95831-04 IN U52 AND 95831-05 IN U42, OR 95831-01 IN U52 AND 95831-02 IN U42.

11	0373	12	0302
L	0626	M	0625
J	0371	K	0625
N			
E			
C			
A			

DRAWING USE IN THIS CASE UNLESS OTHERWISE SPECIFIED TOLERANCES ARE: DIMENSIONS IN INCHES: FRACTIONS (32ND-1/2) DECIMALS (10THS) ANGLES: DEGREES MINUTES SECONDS: NEAREST 10 MINUTES.

Qume  
 SCHEMATIC  
 SPRINT 3 - CARD #2  
 SCALE: NONE  
 SHEET: 5 OF 5  
 PART NUMBER: 90620-XYT

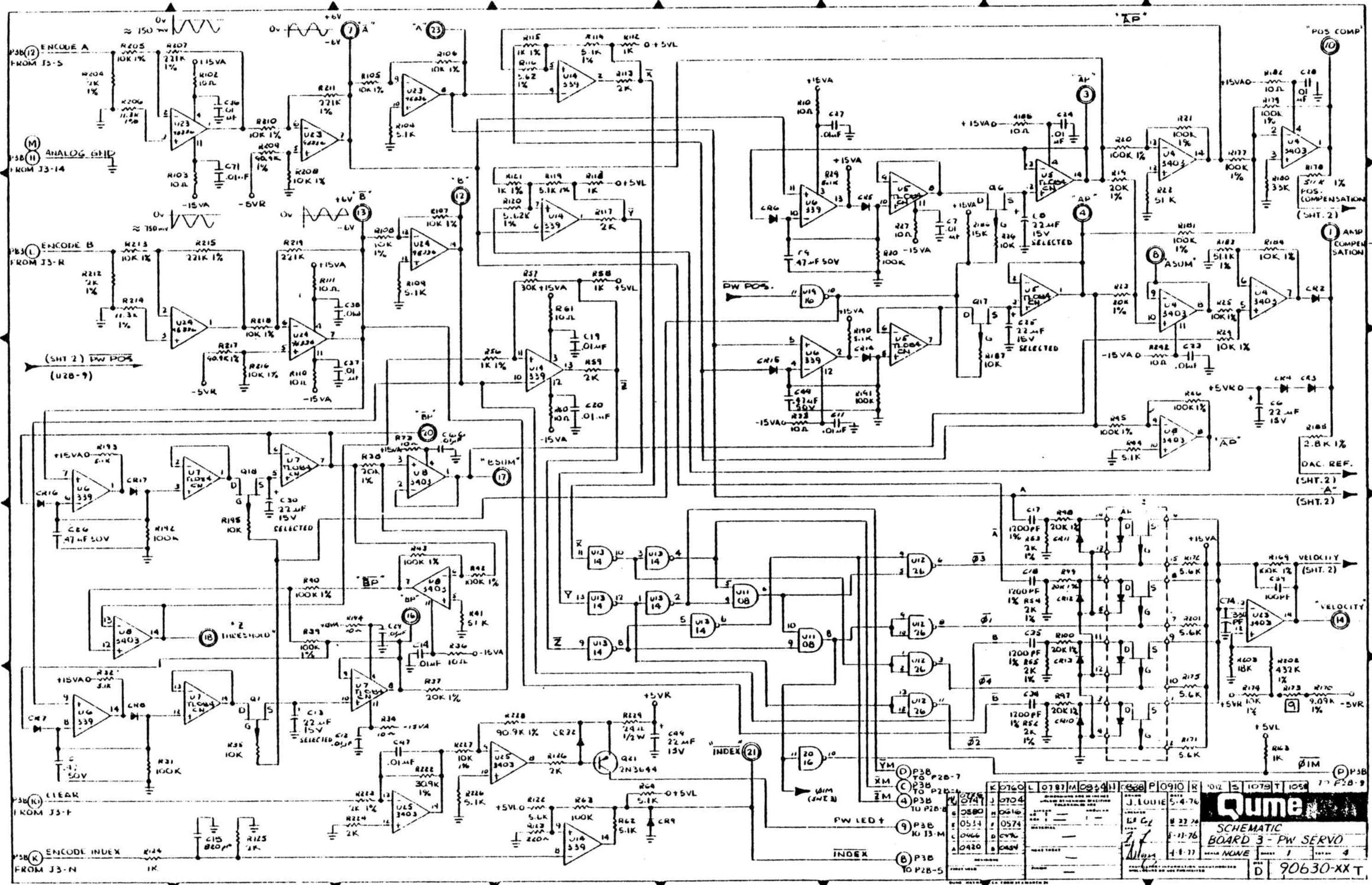

REV	DATE	BY	CHKD	APP'D
001	5-4-76	J. LOUIE		
002	8-23-76			
003	1-11-76			
004	4-8-77			

  

QUME	SCHEMATIC BOARD 3 - PW SERVO
90630-XX T	

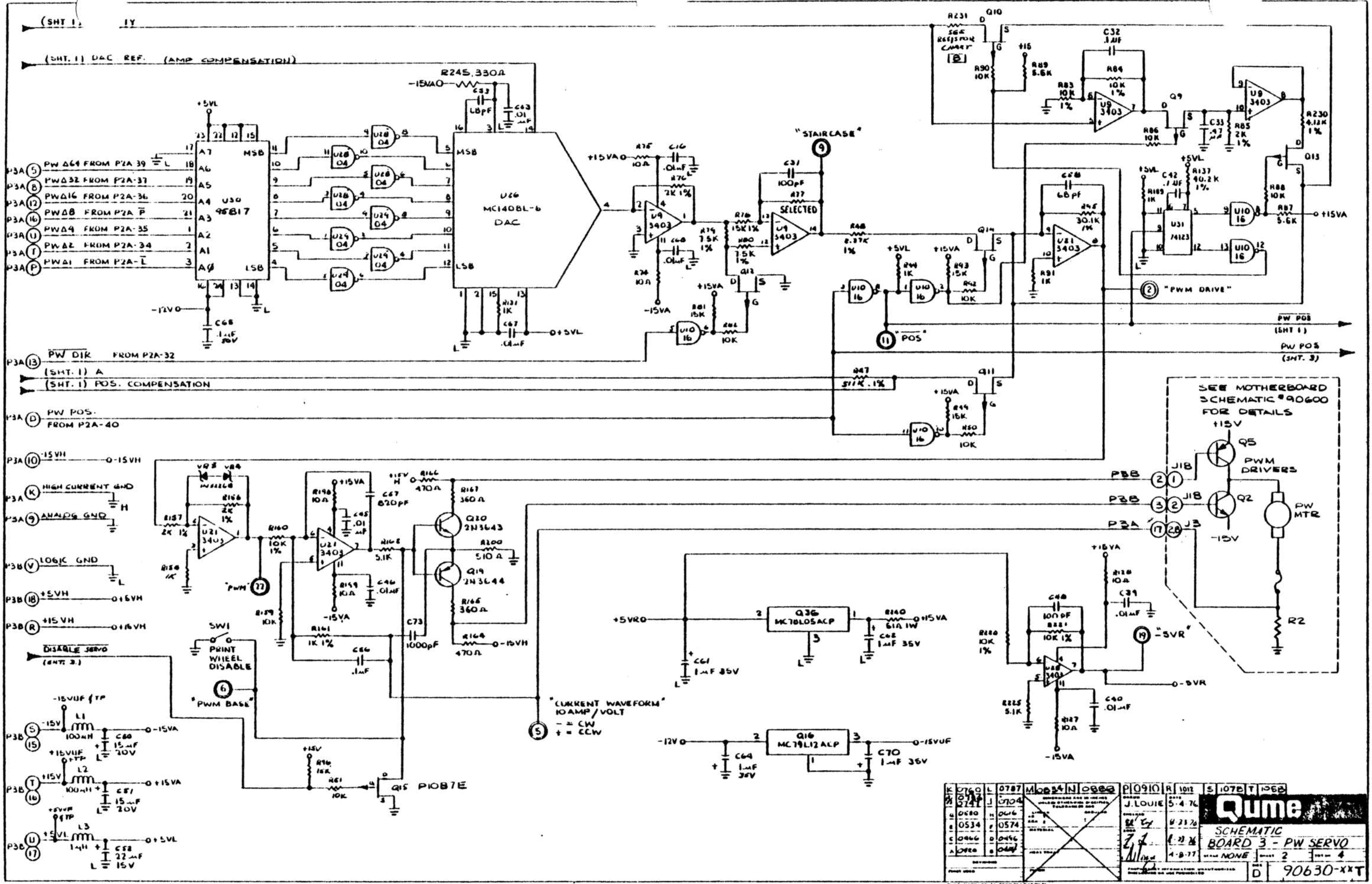

K 0760	L 0787	M 0824	N 0868	P 0910	R 1011	S 1078	T 1082
0747	0704			J. LOUIE	5-4-76		
0580	0516				4-21-76		
0534	0574				1-21-76		
0466	0456				4-8-77		
0480	0467						

**Qume**  
SCHEMATIC BOARD 3 - PW SERVO  
DATE: 1-8-77  
REV: 2  
D 90630-XXT

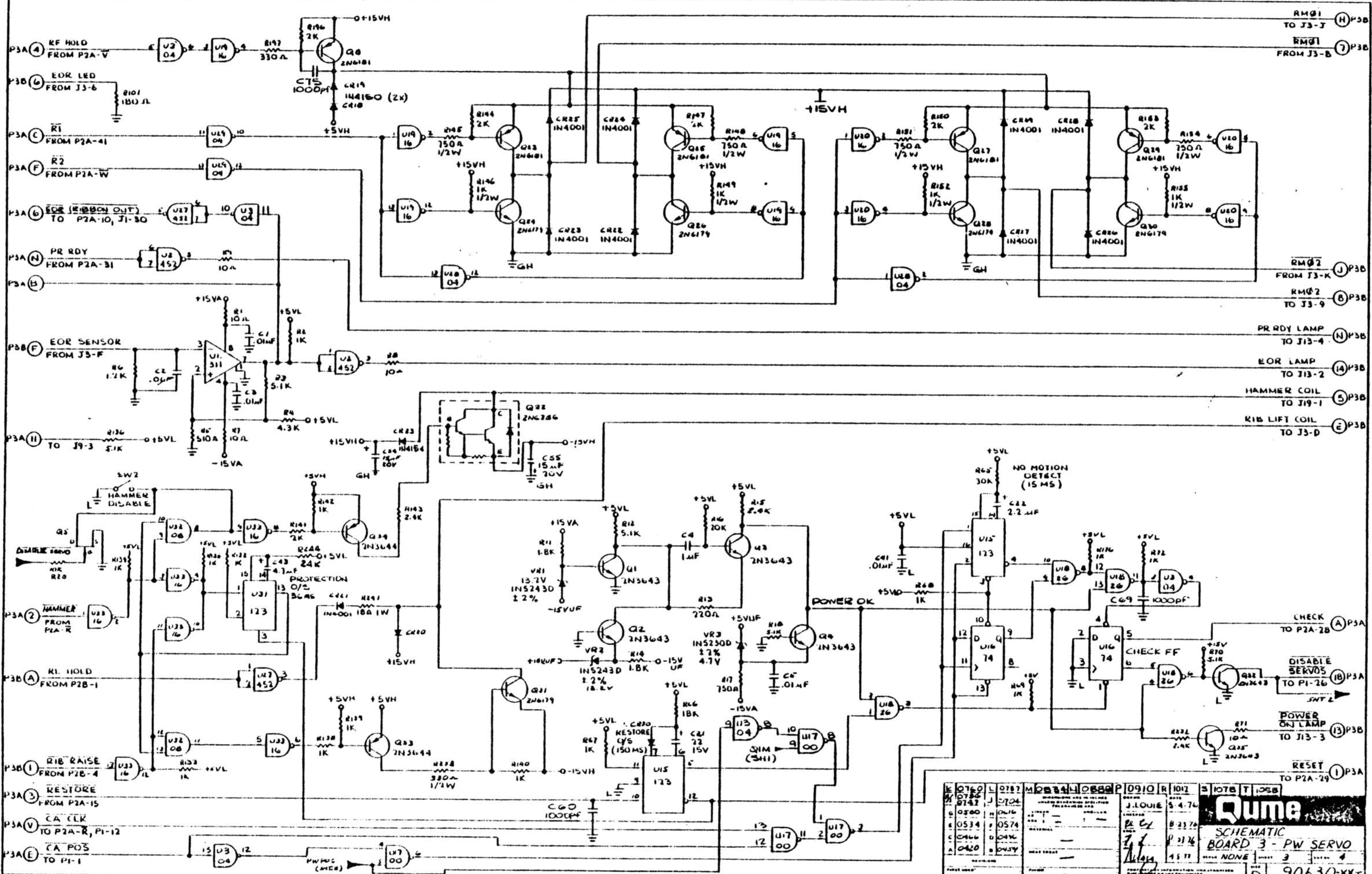

K	0760	L	0787	M	0844	N	0880	P	0910	R	1012	S	1078	T	1088				
Q	0785	J	0704	REVISIONS AND ALL CHANGES MADE BY REVISED SPECIFICATIONS FOR BOARD 300															
U	0500	V	0416	DESIGNED BY J. LOUIE															
E	0534	F	0574	DATE 5-4-74															
C	0466	D	0496	DRAWN BY B. C. 8-23-74															
A	0420	B	0434	CHECKED BY P. J. 8-21-74															
												MATERIAL		DATE 1-5-77		SCALE NONE		SHEET 3	
												PART NAME		90630-XXT		REV D			

**Qume**  
 SCHEMATIC  
 BOARD 3 - PW SERVO

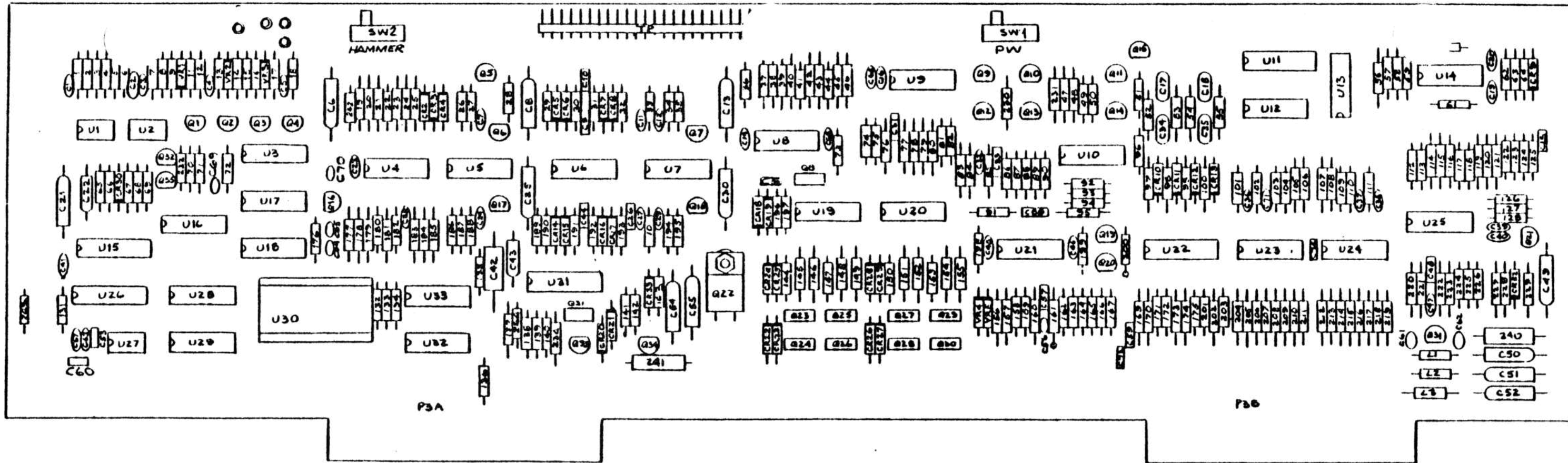

NOTES:

- 1. ALL RESISTORS IN OHMS, 1/4W, 5%. (Circled resistor symbol)
- 2. ALL DIODES ARE 1N4154.
- 3. ALL .01µF CAPACITORS ARE 25V.
- 4. ALL 1% RESISTORS ARE 1/8W.
- 5. ALL GROUNDS ARE ANALOG.
- 6. ALL FETS ARE P10B7E.
- 7. THIS SCHEMATIC IS VALID FOR THE FOLLOWING ASSEMBLIES.

53/26	-00	"R"	PCN 1078
53/27	-01	"R"	PCN 1078
53/28	-02	"R"	PCN 1078
53/29	-03	"S"	PCN 1058
53/30	-04	"R"	PCN 1078
WT 40	-05	"S"	PCN 1058

(Circled resistor symbol) SELECTED RESISTOR

RESISTOR CHART	
UNIT	RESISTOR
53/26 -00	R21, 1.27K, 1%
53/27 -01	R21, 1.35K, 1%
53/28 -02	R21, 1.54K, 1%
53/29 -03	R21, 1.27K, 1%
53/30 -04	R21, 1.27K, 1%
WT 40 -05	R21, 1.57K, 1%

1078	T	1068
0910	R	1018
0824	V	0868
0716	L	0787
0716	J	0704
0616		

		5 Jan 77	
		1/77	
SCHEMATIC		BOARD J - PW 16RVD	
1177		4	
90630-KY T		4	

R-17

8-18

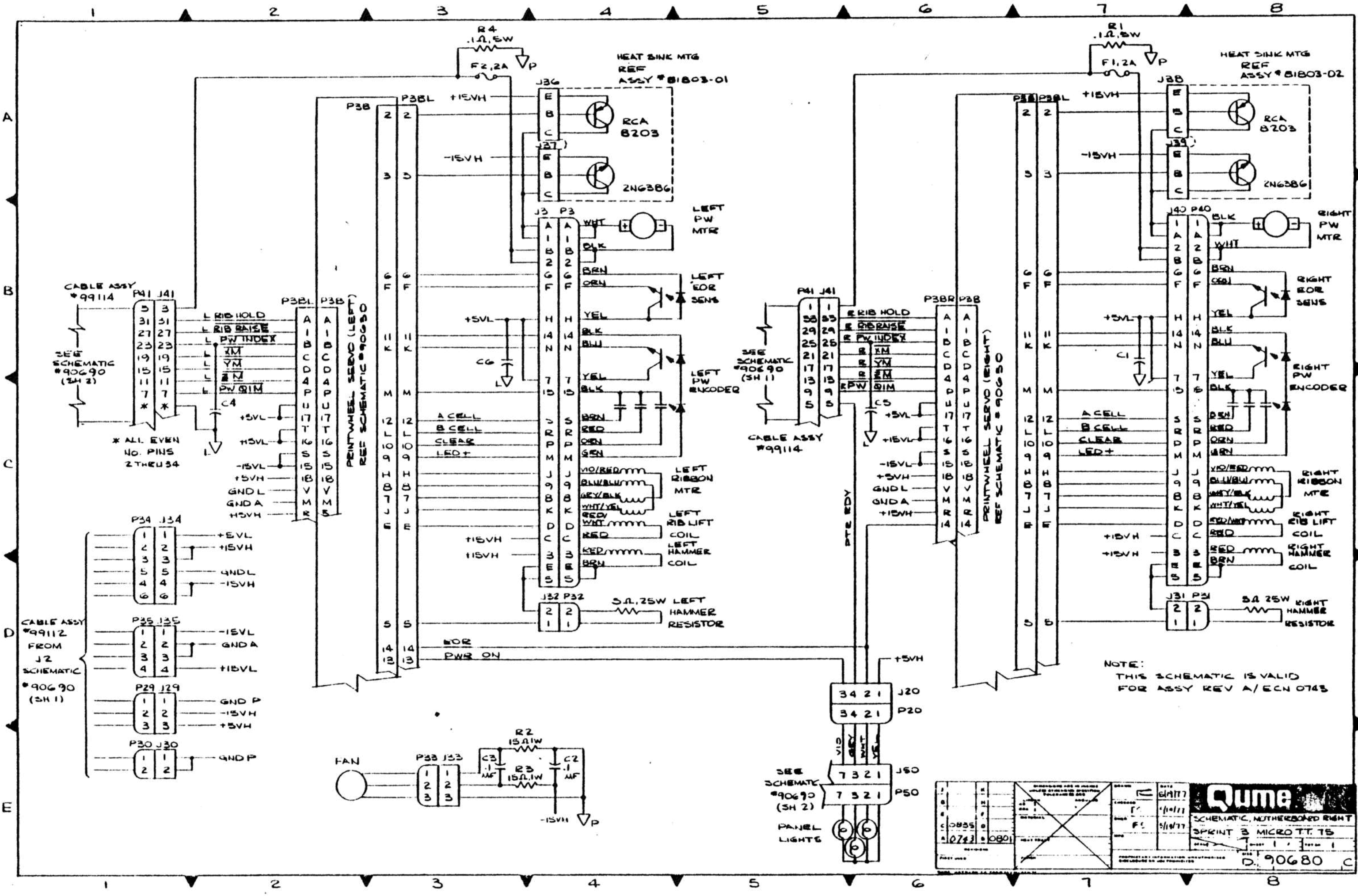

NOTE:  
THIS SCHEMATIC IS VALID  
FOR ASSY REV A/ECN 0743

APPROVED FOR RELEASE AUTHORITY: 68801 DATE: 10/19/2013 BY: 60355		DATE: 6/11/77 DRAWN: 4/11/77 CHECKED: F.S. PART NO.: 90680 C
Qume SCHEMATIC, MOTHERBOARD RIGHT SPRINT 3 MICRO T.T. 15		Qume 90680 C

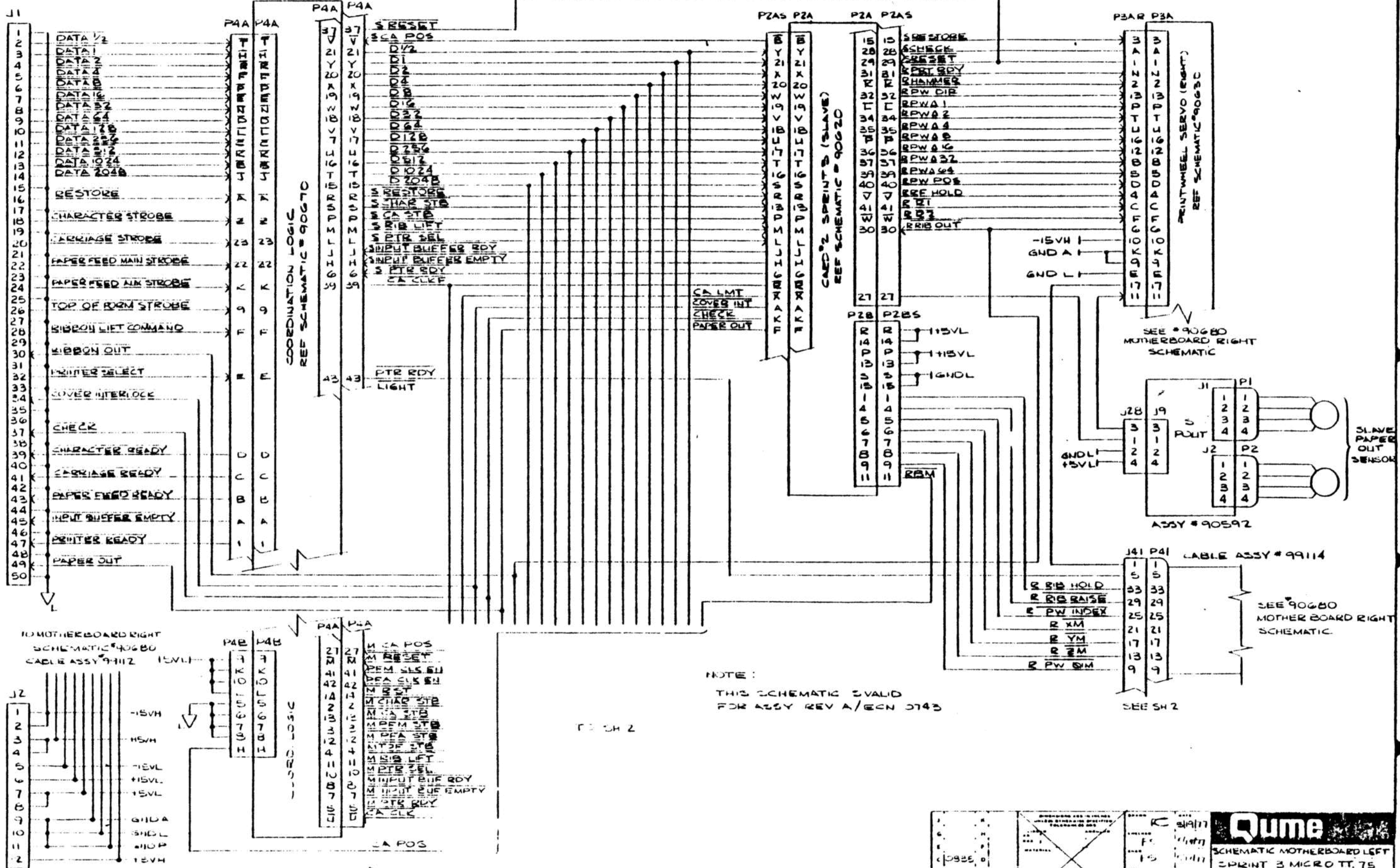

**Qume**

SCHEMATIC MOTHERBOARD LEFT  
SPRINT 3 MICRO TT. 75  
D 90690 C

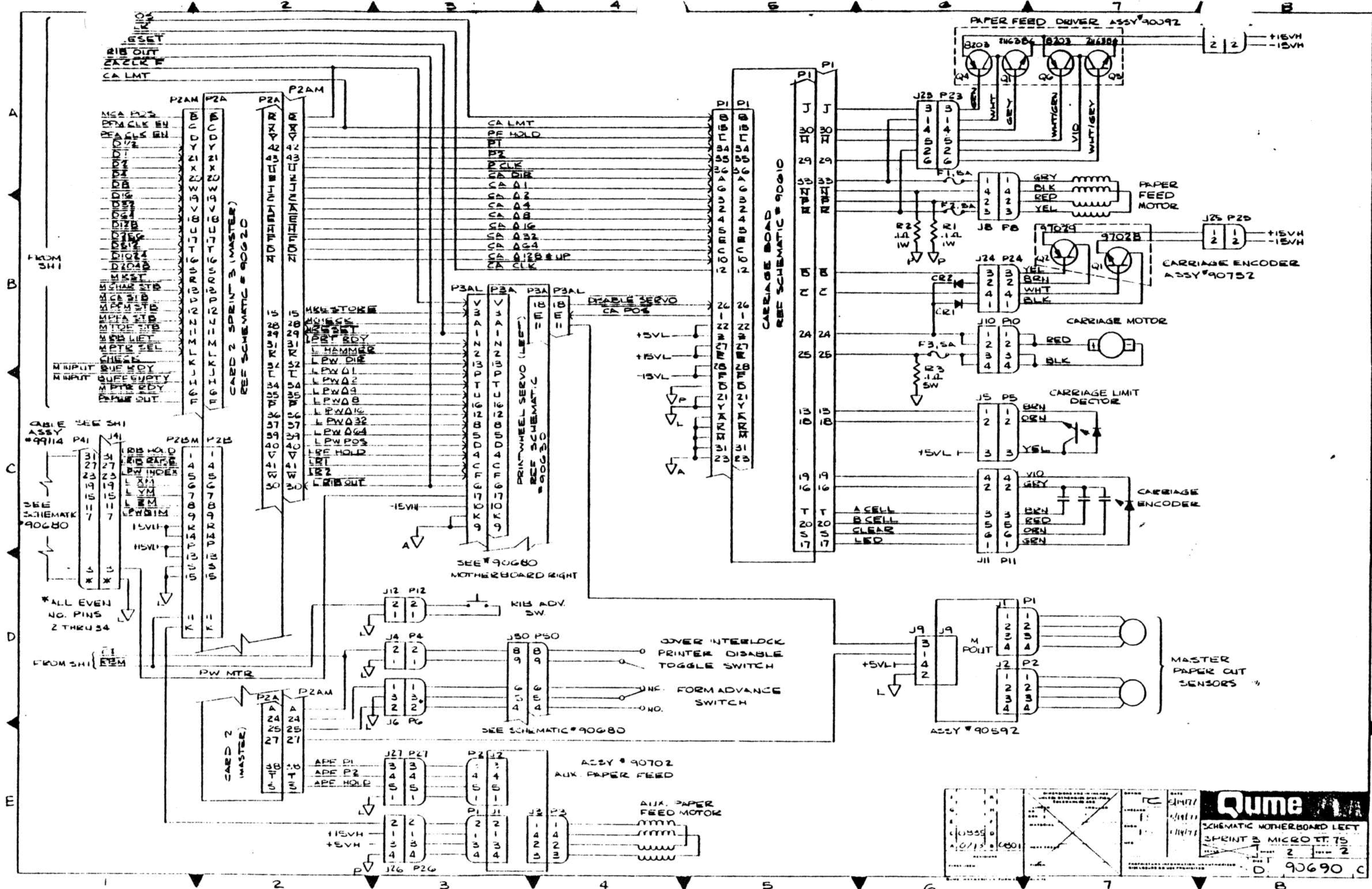

**Qume**

SCHEMATIC MOTHERBOARD LEFT

SPRINT 3 MICRO II 75

2 2

D. 90690 C



8-21

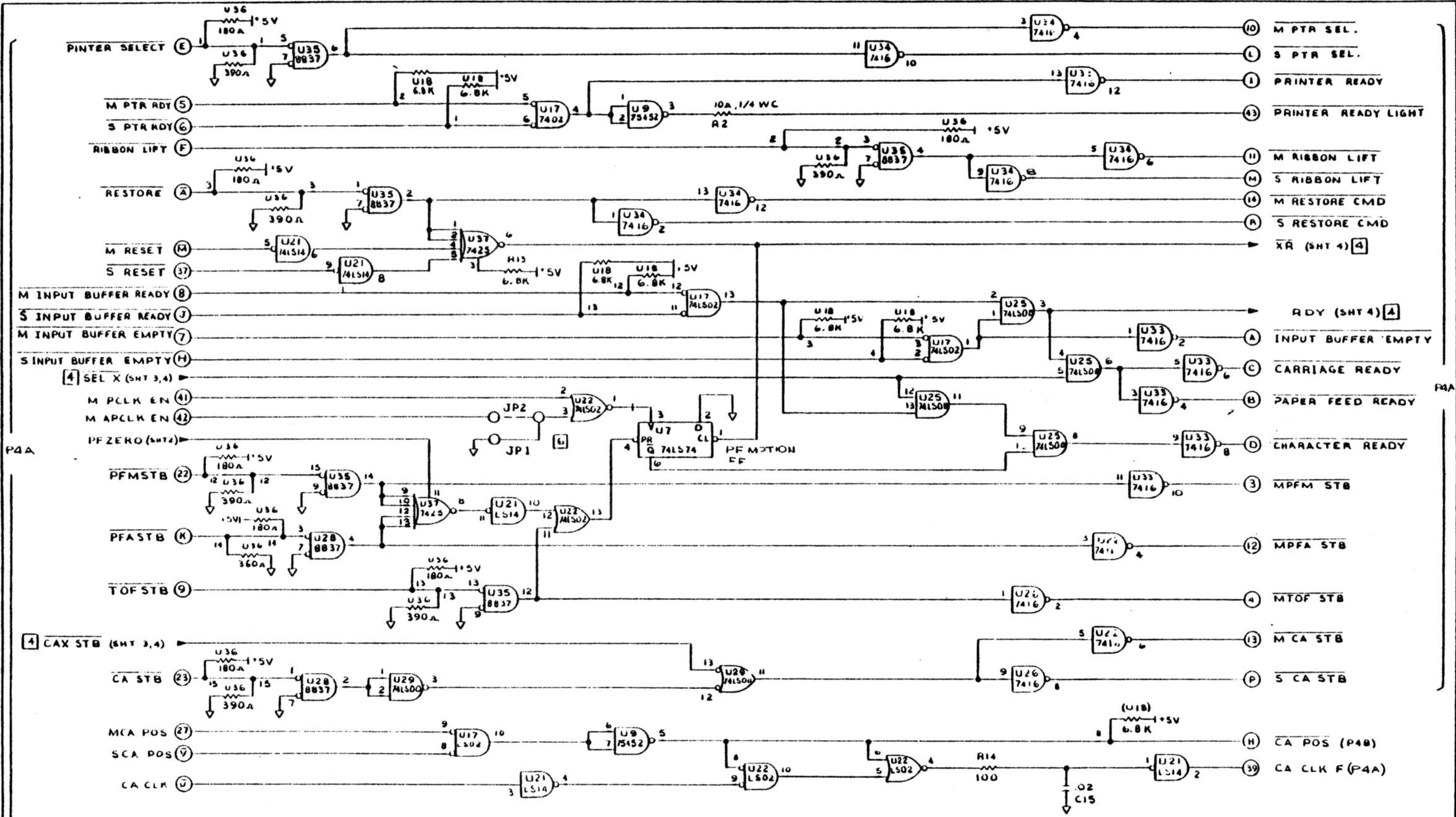

REV	DATE	BY	CHKD	APP'D
1	6/22/71	SMINYEN		
2	6/23/71	PC		
3	6/23/71	FS		
4	6/23/71			
5	6/23/71			

**Qume**  
 SCHEMATIC  
 SM31175 COORD LOGIC  
 SHEET 1 OF 5  
 90670 C

8-22

P4A

P4A

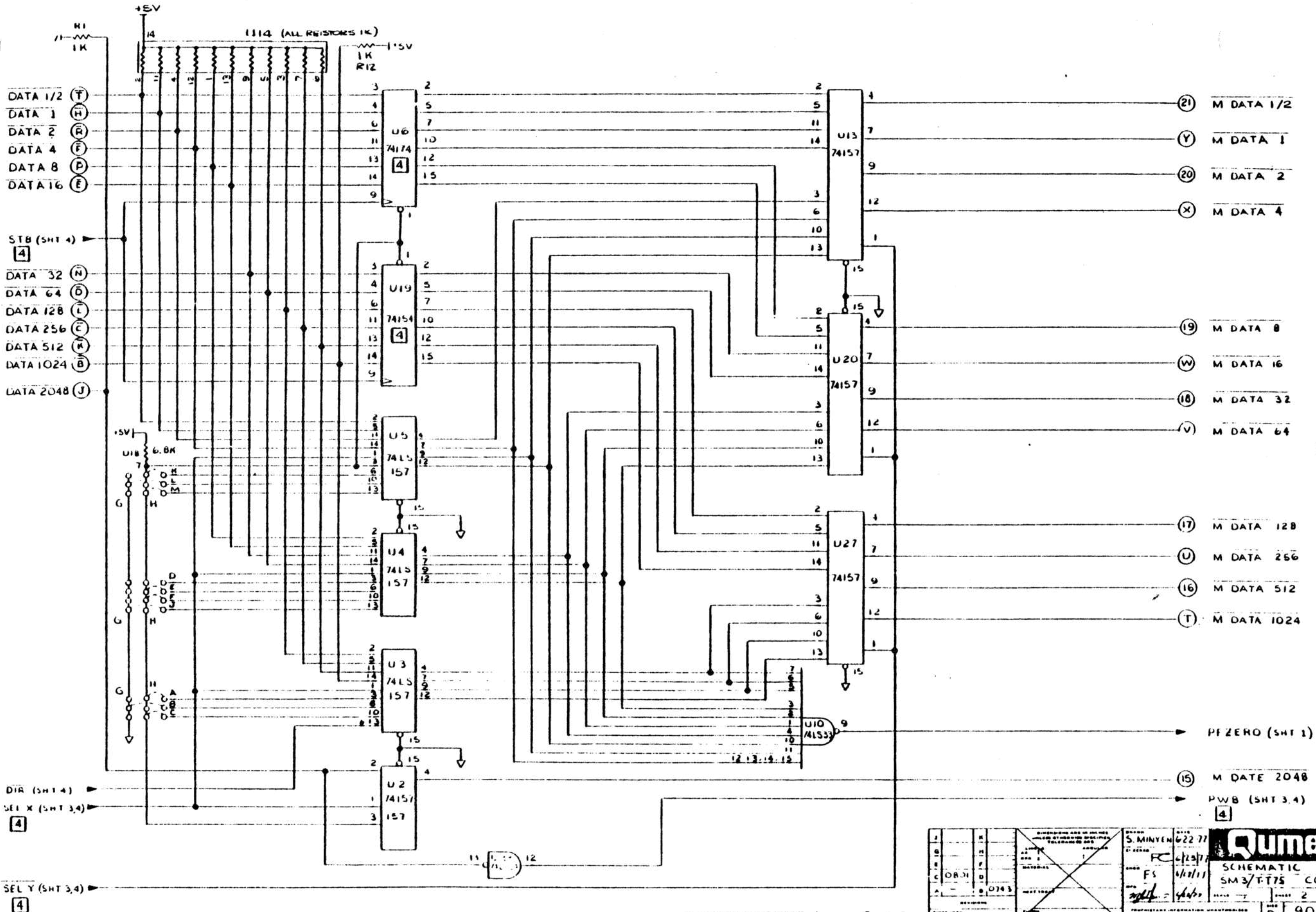

J	K	L	M	N	O	P	Q	R	S	T	U	V	W	X	Y	Z

**Qume**

SCHEMATIC  
SM3/T75 COORD LOGIC

DATE: 6/22/77  
DRAWN: FC  
CHECKED: FS  
APP'D: [Signature]

90670

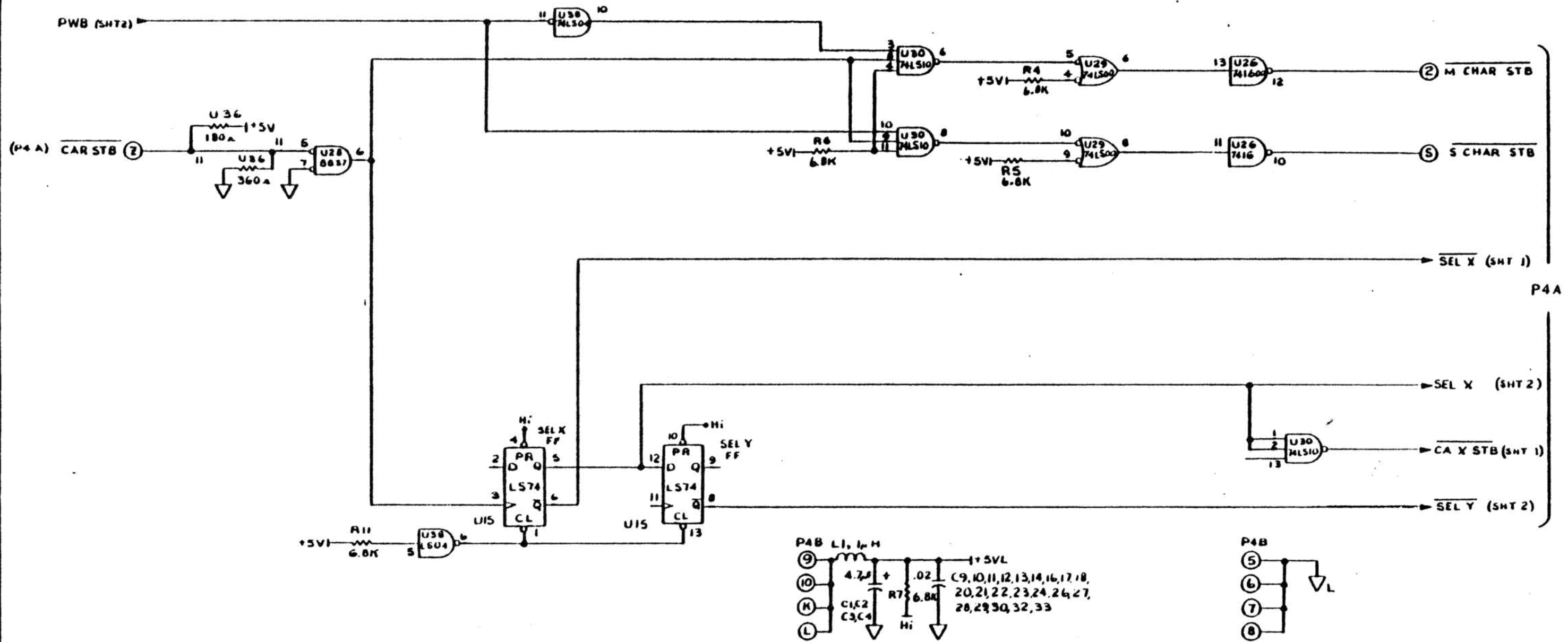

QUME SM3/T175 COORD LOGIC (PARALLEL OPTION) <b>A</b>		3 5 D 90670 C
--	--	------------------

8-24

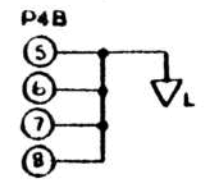
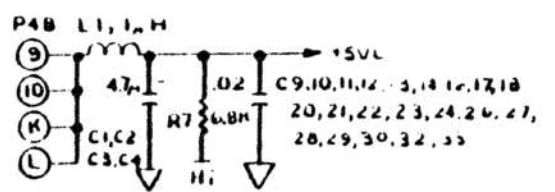
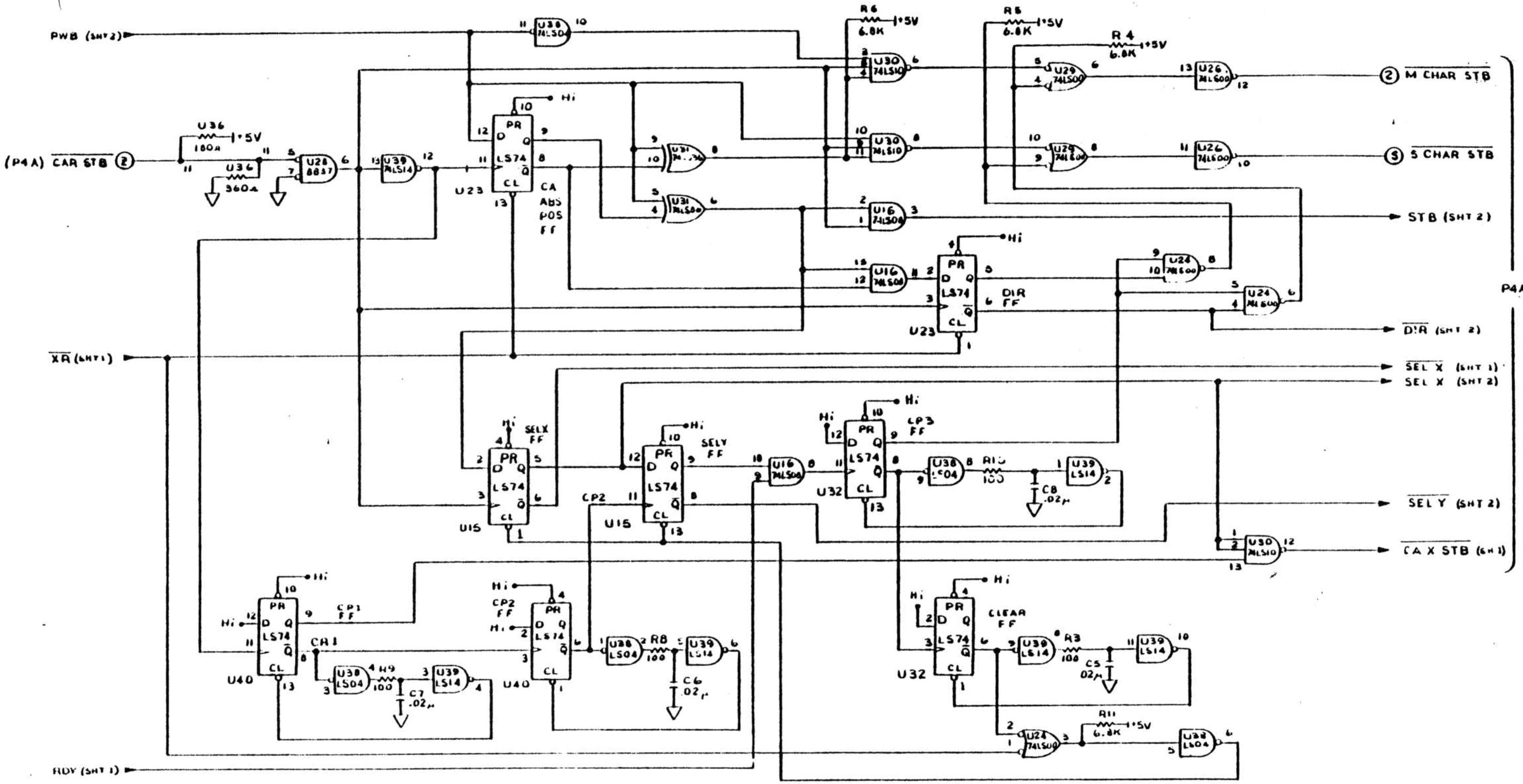

1	2	3	4	5	6	7	8	9	10	11	12	13

SMINYEN 423/77  
 424/77  
 M GREEN 4/29/77

SM3/TT75 COORD LOGIC (SEQUENTIAL OPTION)

90670 C

8-25

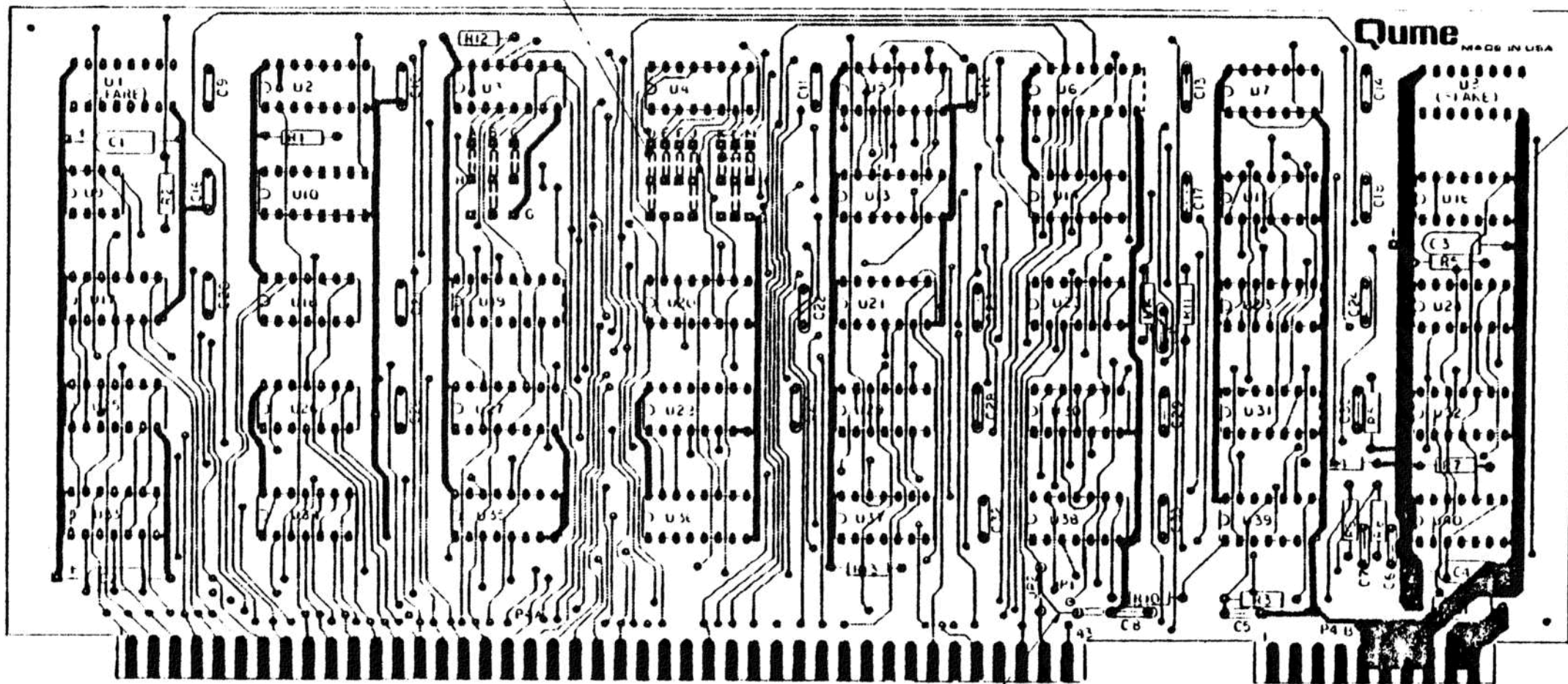

SEE NOTE 5

SEE NOTE 4

JP1  
SEE NOTE 6

LAST USED REF DESIGN.  
U40, C23, R13, L1, JP2

DASH NO. CHART

ASCY DASH NO.	-01 (SH 2)	-02 (SH 4)	-03 (SH 2) PARALLEL	-04 (SH 4) SEQUENTIAL
DESCR.	PARALLEL	SEQUENTIAL	DUAL DRIVE	DUAL DRIVE
U6	-	74174	-	74174
U9	-	74174	-	74174
U16	-	74LS08	-	74LS08
U23	-	74LS74	-	74LS74
U32	-	74LS74	-	74LS74
U40	-	74LS74	-	74LS74
U31	-	74LS24	-	74LS24
U39	-	74LS14	-	74LS14
U24	-	74LS00	-	74LS00
JPA-JPM	OPEN	CLOSED	OPEN	CLOSED
JP1	CLOSED	CLOSED	OPEN	OPEN
JP2	OPEN	OPEN	CLOSED	CLOSED

NOTES:

- UNLESS OTHERWISE SPECIFIED:
- 1. ALL RESISTORS ARE IN OHMS. 1/4W. 5%.
- 2. CAPACITORS C1, C2, C3 AND C4 ARE 4.7MFD. 10V, 20%.
- 3. ALL CAPACITORS ARE 0.02MFD. 50V, 20%.
- 4. SHEET 2 IS FOR PARALLEL LOGIC OPTION.
- 5. SHEET 4 IS FOR SEQUENTIAL LOGIC OPTION.
- SEE DASH NO. CHART.
- 6. ALL JUMPERS AS SHOWN ARE USED ON SEQUENTIAL -02 VERSION ONLY.
- 7. FOR DUAL DRIVE OPTION CUT JUMPER "JP1" INSTALL JUMPER JP2 (190672-03, -04)
- 7. THIS SCHEMATIC VALID FOR:
  - 90672-01 REV B PCN 0743
  - 90672-02 REV B PCN 0743
  - 90672-03 REV B PCN 0743
  - 90672-04 REV B PCN 0743

J K L M N O P Q R S T U V W X Y Z AA AB AC AD AE AF AG AH AI AJ AK AL AM AN AO AP AQ AR AS AT AU AV AW AX AY AZ BA BB BC BD BE BF BG BH BI BJ BK BL BM BN BO BP BQ BR BS BT BU BV BW BX BY BZ CA CB CC CD CE CF CG CH CI CJ CK CL CM CN CO CP CQ CR CS CT CU CV CW CX CY CZ DA DB DC DD DE DF DG DH DI DJ DK DL DM DN DO DP DQ DR DS DT DU DV DW DX DY DZ EA EB EC ED EE EF EG EH EI EJ EK EL EM EN EO EP EQ ER ES ET EU EV EW EX EY EZ FA FB FC FD FE FF FG FH FI FJ FK FL FM FN FO FP FQ FR FS FT FU FV FW FX FY FZ GA GB GC GD GE GF GG GH GI GJ GK GL GM GN GO GP GQ GR GS GT GU GV GW GX GY GZ HA HB HC HD HE HF HG HH HI HJ HK HL HM HN HO HP HQ HR HS HT HU HV HW HX HY HZ IA IB IC ID IE IF IG IH II IJ IK IL IM IN IO IP IQ IR IS IT IU IV IW IX IY IZ JA JB JC JD JE JF JG JH JI JJ JK JL JM JN JO JP JQ JR JS JT JU JV JW JX JY JZ KA KB KC KD KE KF KG KH KI KJ KK KL KM KN KO KP KQ KR KS KT KU KV KW KX KY KZ LA LB LC LD LE LF LG LH LI LJ LK LL LM LN LO LP LQ LR LS LT LU LV LW LX LY LZ MA MB MC MD ME MF MG MH MI MJ MK ML MM MN MO MP MQ MR MS MT MU MV MW MX MY MZ NA NB NC ND NE NF NG NH NI NJ NK NL NM NN NO NP NQ NR NS NT NU NV NW NX NY NZ OA OB OC OD OE OF OG OH OI OJ OK OL OM ON OO OP OQ OR OS OT OU OV OW OX OY OZ PA PB PC PD PE PF PG PH PI PJ PK PL PM PN PO PP PQ PR PS PT PU PV PW PX PY PZ QA QB QC QD QE QF QG QH QI QJ QK QL QM QN QO QP QQ QR QS QT QU QV QW QX QY QZ RA RB RC RD RE RF RG RH RI RJ RK RL RM RN RO RP RQ RR RS RT RU RV RW RX RY RZ SA SB SC SD SE SF SG SH SI SJ SK SL SM SN SO SP SQ SR SS ST SU SV SW SX SY SZ TA TB TC TD TE TF TG TH TI TJ TK TL TM TN TO TP TQ TR TS TT TU TV TW TX TY TZ UA UB UC UD UE UF UG UH UI UJ UK UL UM UN UO UP UQ UR US UT UU UV UW UX UY UZ VA VB VC VD VE VF VG VH VI VJ VK VL VM VN VO VP VQ VR VS VT VU VV VW VX VY VZ WA WB WC WD WE WF WG WH WI WJ WK WL WM WN WO WP WQ WR WS WT WU WV WW WX WY WZ XA XB XC XD XE XF XG XH XI XJ XK XL XM XN XO XP XQ XR XS XT XU XV XW XX XY XZ YA YB YC YD YE YF YG YH YI YJ YK YL YM YN YO YP YQ YR YS YT YU YV YW YX YZ ZA ZB ZC ZD ZE ZF ZG ZH ZI ZJ ZK ZL ZM ZN ZO ZP ZQ ZR ZS ZT ZU ZV ZW ZX ZY ZZ	APPROVED AND IN CHARGE DESIGN ENGINEER DATE 6-22-77 S. MINYEN CHECKED DATE 4-25-77 K DRAWN DATE 4-12-77 F. SHAW TITLE DESIGNED BY DATE 07-73 PART NO. 90670-XXC SHEETS 5 OF 5 Qume SCHEMATIC SM3/TT75 COORD. LOGIC PROPRIETARY INFORMATION UNAUTHORIZED DISCLOSURE OR USE PROHIBITED
---	--

8-26

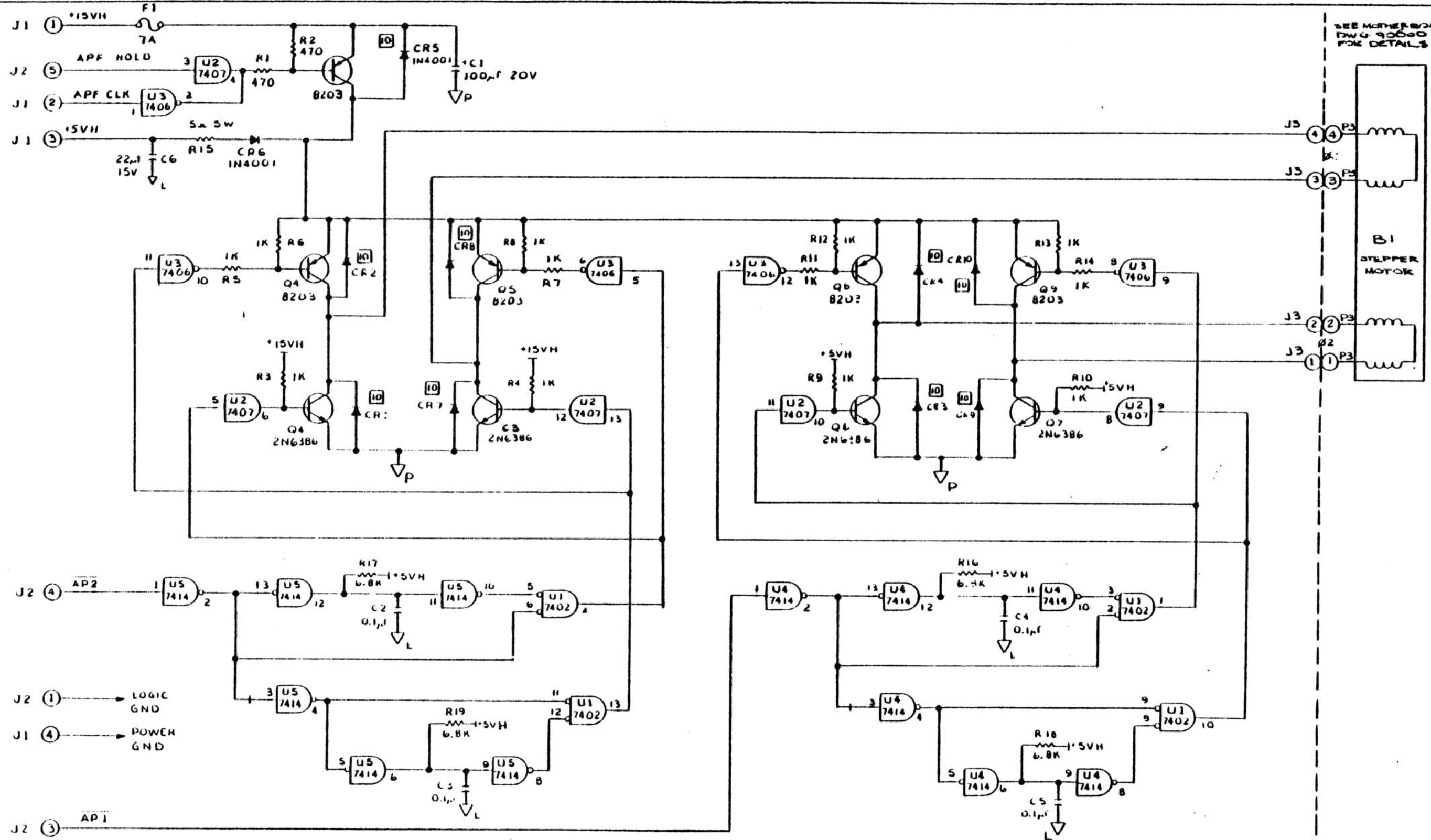

REV	DATE	BY	CHKD	APP'D
1	6/23/77	S. MINYEN		
2				
3				
4				
5				
6				
7				
8				
9				
10				
11				
12				
13				
14				
15				
16				
17				
18				
19				
20				
21				
22				
23				
24				
25				
26				
27				
28				
29				
30				
31				
32				
33				
34				
35				
36				
37				
38				
39				
40				
41				
42				
43				
44				
45				
46				
47				
48				
49				
50				
51				
52				
53				
54				
55				
56				
57				
58				
59				
60				
61				
62				
63				
64				
65				
66				
67				
68				
69				
70				
71				
72				
73				
74				
75				
76				
77				
78				
79				
80				
81				
82				
83				
84				
85				
86				
87				
88				
89				
90				
91				
92				
93				
94				
95				
96				
97				
98				
99				
100				

50702

Qume  
 SPRINT MICRO 3  
 AUXILIARY PAPER FEED (OPTION)

DATE: 6/23/77  
 BY: S. MINYEN  
 CHKD: FC  
 APP'D: [Signature]

REV: 1  
 DATE: 6/23/77  
 BY: [Signature]

REV: 2  
 DATE: 6/23/77  
 BY: [Signature]

REV: 3  
 DATE: 6/23/77  
 BY: [Signature]

REV: 4  
 DATE: 6/23/77  
 BY: [Signature]

REV: 5  
 DATE: 6/23/77  
 BY: [Signature]

REV: 6  
 DATE: 6/23/77  
 BY: [Signature]

REV: 7  
 DATE: 6/23/77  
 BY: [Signature]

REV: 8  
 DATE: 6/23/77  
 BY: [Signature]

REV: 9  
 DATE: 6/23/77  
 BY: [Signature]

REV: 10  
 DATE: 6/23/77  
 BY: [Signature]

REV: 11  
 DATE: 6/23/77  
 BY: [Signature]

REV: 12  
 DATE: 6/23/77  
 BY: [Signature]

REV: 13  
 DATE: 6/23/77  
 BY: [Signature]

REV: 14  
 DATE: 6/23/77  
 BY: [Signature]

REV: 15  
 DATE: 6/23/77  
 BY: [Signature]

REV: 16  
 DATE: 6/23/77  
 BY: [Signature]

REV: 17  
 DATE: 6/23/77  
 BY: [Signature]

REV: 18  
 DATE: 6/23/77  
 BY: [Signature]

REV: 19  
 DATE: 6/23/77  
 BY: [Signature]

REV: 20  
 DATE: 6/23/77  
 BY: [Signature]

REV: 21  
 DATE: 6/23/77  
 BY: [Signature]

REV: 22  
 DATE: 6/23/77  
 BY: [Signature]

REV: 23  
 DATE: 6/23/77  
 BY: [Signature]

REV: 24  
 DATE: 6/23/77  
 BY: [Signature]

REV: 25  
 DATE: 6/23/77  
 BY: [Signature]

REV: 26  
 DATE: 6/23/77  
 BY: [Signature]

REV: 27  
 DATE: 6/23/77  
 BY: [Signature]

REV: 28  
 DATE: 6/23/77  
 BY: [Signature]

REV: 29  
 DATE: 6/23/77  
 BY: [Signature]

REV: 30  
 DATE: 6/23/77  
 BY: [Signature]

REV: 31  
 DATE: 6/23/77  
 BY: [Signature]

REV: 32  
 DATE: 6/23/77  
 BY: [Signature]

REV: 33  
 DATE: 6/23/77  
 BY: [Signature]

REV: 34  
 DATE: 6/23/77  
 BY: [Signature]

REV: 35  
 DATE: 6/23/77  
 BY: [Signature]

REV: 36  
 DATE: 6/23/77  
 BY: [Signature]

REV: 37  
 DATE: 6/23/77  
 BY: [Signature]

REV: 38  
 DATE: 6/23/77  
 BY: [Signature]

REV: 39  
 DATE: 6/23/77  
 BY: [Signature]

REV: 40  
 DATE: 6/23/77  
 BY: [Signature]

REV: 41  
 DATE: 6/23/77  
 BY: [Signature]

REV: 42  
 DATE: 6/23/77  
 BY: [Signature]

REV: 43  
 DATE: 6/23/77  
 BY: [Signature]

REV: 44  
 DATE: 6/23/77  
 BY: [Signature]

REV: 45  
 DATE: 6/23/77  
 BY: [Signature]

REV: 46  
 DATE: 6/23/77  
 BY: [Signature]

REV: 47  
 DATE: 6/23/77  
 BY: [Signature]

REV: 48  
 DATE: 6/23/77  
 BY: [Signature]

REV: 49  
 DATE: 6/23/77  
 BY: [Signature]

REV: 50  
 DATE: 6/23/77  
 BY: [Signature]

8-27

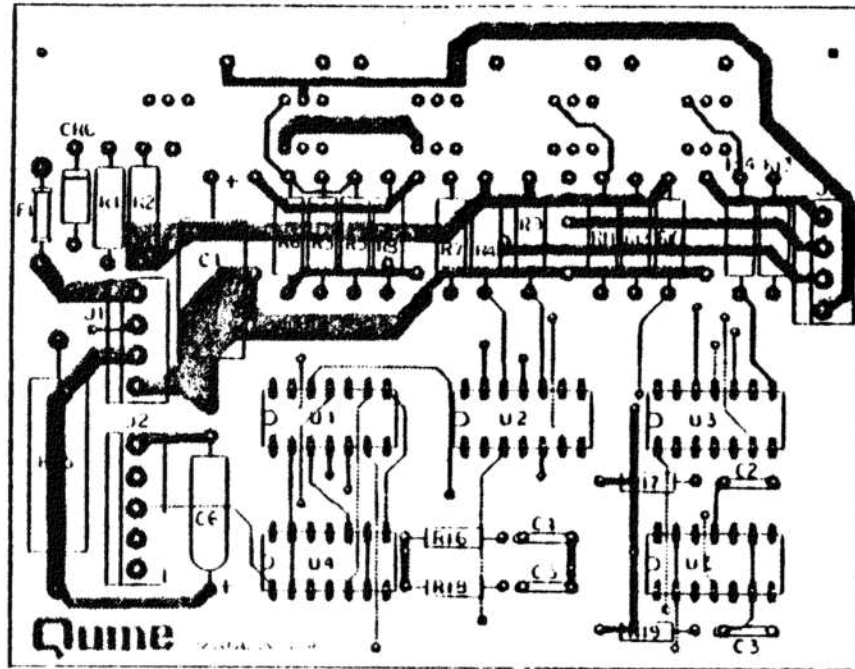

LAST USED  
C6, R19, CR6, F1,  
U5

NOTES:

- UNLESS OTHERWISE SPECIFIED:
1. ALL RESISTORS ARE 1/4 W, 5%.
  2. RESISTOR R1, R7, R11 AND R19 ARE 1/16 W, 5%, R12 \*W, 5%.
  3. ALL CAPACITORS ARE 0.1 MFD, 12V.
  4. CAPACITOR C1, 100 MFD, 20V, CAPACITOR C2, 22 MFD, 15V.
  5. ALL DIODES ARE IN4001.
  6. J1-1 "POWER GND"
  7. J2-1 "LOGIC GND"
  8. PROVISIONS MADE ON PC LAYOUT FOR IN4001 DIODES MAY BE LEFT OUT IF TRANSISTOR TYPES 2N6041 & 2N6044 ARE USED.
  9. THIS SCHEMATIC VALID FOR ASSY REV "A" PCN 0660
  10. DESIGNATES COMPONENTS ARE NOT USED.

J	K	REVISIONS AND IN INCLUDE UNLESS OTHERWISE SPECIFIED TOLERANCES AND DIMENSIONS	DATE 1-25-77	
G	H	LINEAR AND ANALOG	DATE 6/23/77	
E	F	MATERIAL SEE B/M 90702	DATE 4/11/77	SCHEMATIC - SPRINT MICRO 3 AUX. PAPERFEED BOARD.
C	D	HEAT TREAT	DATE 4/24/77	
A 0660	B 06-01	DESIGNER	DATE	SCALE 2X
FIRST LOGS	FINISH	PROPERTY INFORMATION	DATE	SHEET 2
QUME - STANDARD CA FORM 50-1 (MARCH 64)			DATE	TOTAL 2
			DATE	90700 B

E 90590

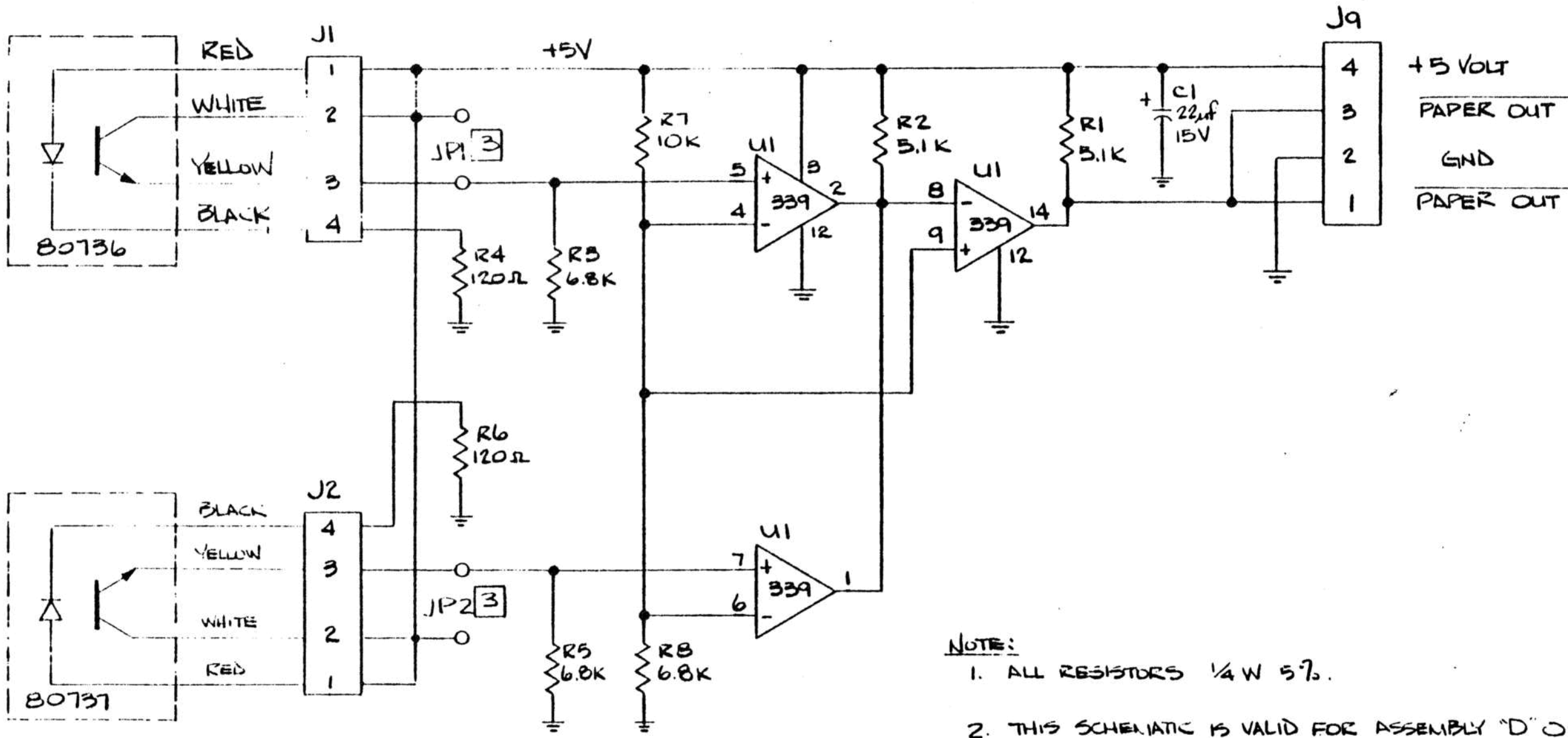

- NOTE:**
1. ALL RESISTORS 1/4 W 5%.
  2. THIS SCHEMATIC IS VALID FOR ASSEMBLY "D" 0845

3	DXEH No.	JP1	JP2
	-01	OPEN	CLOSED
	-02	CLOSED	OPEN
	-03	OPEN	OPEN

J	K	DIMENSIONS ARE IN INCHES UNLESS OTHERWISE SPECIFIED TOLERANCES ARE	DRAWN	DATE	<b>Qume</b>
G	H		DAN FONG	7-77	
E	F	LINEAR XX ± XXX ±	CHECKED	7/77	SCHEMATIC
C	D	MATERIAL	7-77	7-77	
A	B	HEAT TREAT	ENGR.	7/77	SCALE <i>1</i> SHEET / TOT SH /
REVISIONS		FINISH	MFG	7/77	
FIRST USED			PROPRIETARY INFORMATION. UNAUTHORIZED DISCLOSURE OR USE PROHIBITED.		SIZE B



DASH No.	DESCRIPTION	JPI	JP2
-01	REAR ONLY	OPEN	CLOSED
-02	BOTTOM ONLY	CLOSED	OPEN
-03	REAR & BOTTOM	OPEN	OPEN

REVISION TABLE	
ASSEMBLY	FABRICATION
B	A
C	E
D	B

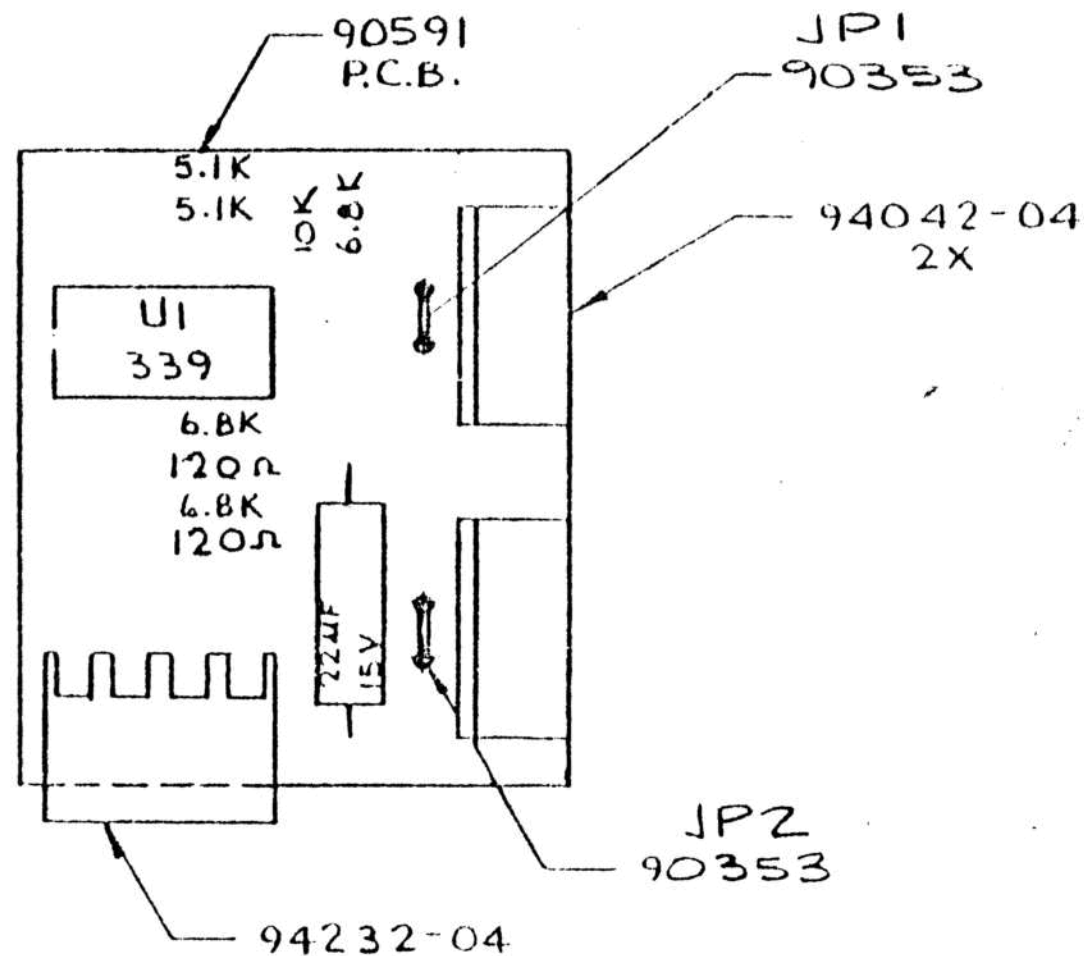

NOTE:  
ALL RESISTORS ARE 1/4 W 5%

J	K	DIMENSIONS ARE IN INCHES UNLESS OTHERWISE SPECIFIED TOLERANCES ARE	DRAWN	DATE	<b>QUMA</b>
G	H		J. LOUIE	4-19-76	
E	F	LINEAR XXX : — : — ANGULAR : — : —	CHECKED		PAPER OUT - PCB ASSEMBLY DRAWING
C	D	MATERIAL	ENGR		
A	B	HEAT TREAT	<i>Franklin</i>	<i>4-30-76</i>	SCALE 2 TO 1
REVISE		FINISH	PROPERTY INFORMATION UNAUTHORIZED DISCLOSURE OR USE PROHIBITED		SHEET 1
FIRST USED					TOT ON 1.
					SIZE B 90592 D

# ILLUSTRATIONS

■ Mechanical Adjustments

■ Lubrication Points

■ Recommended Lubricants & Cleaners

■ Game Printer Tools

■ General Hand Tools

# PLATEN CLUTCH RELEASE ADJUSTMENT

Adjust For  $.080" \pm .005"$

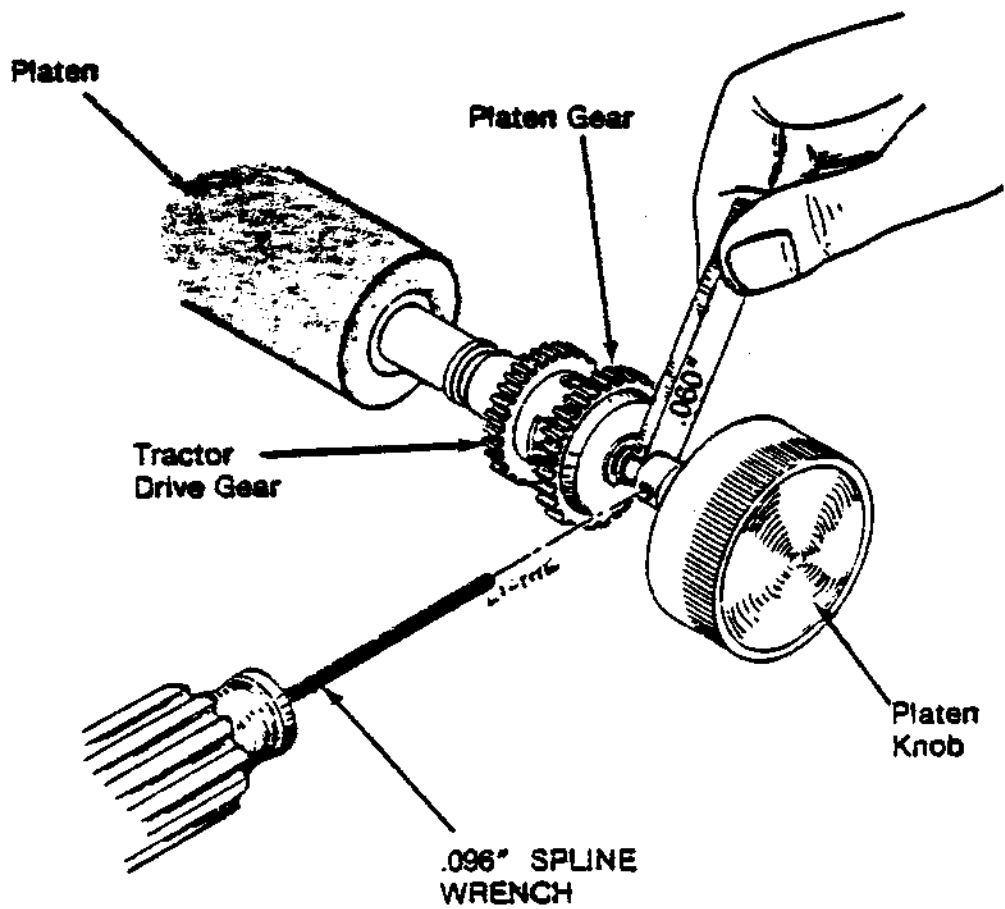

# PLATEN CLUTCH RELEASE ADJUSTMENT

Adjust For  $.060" \pm .005"$

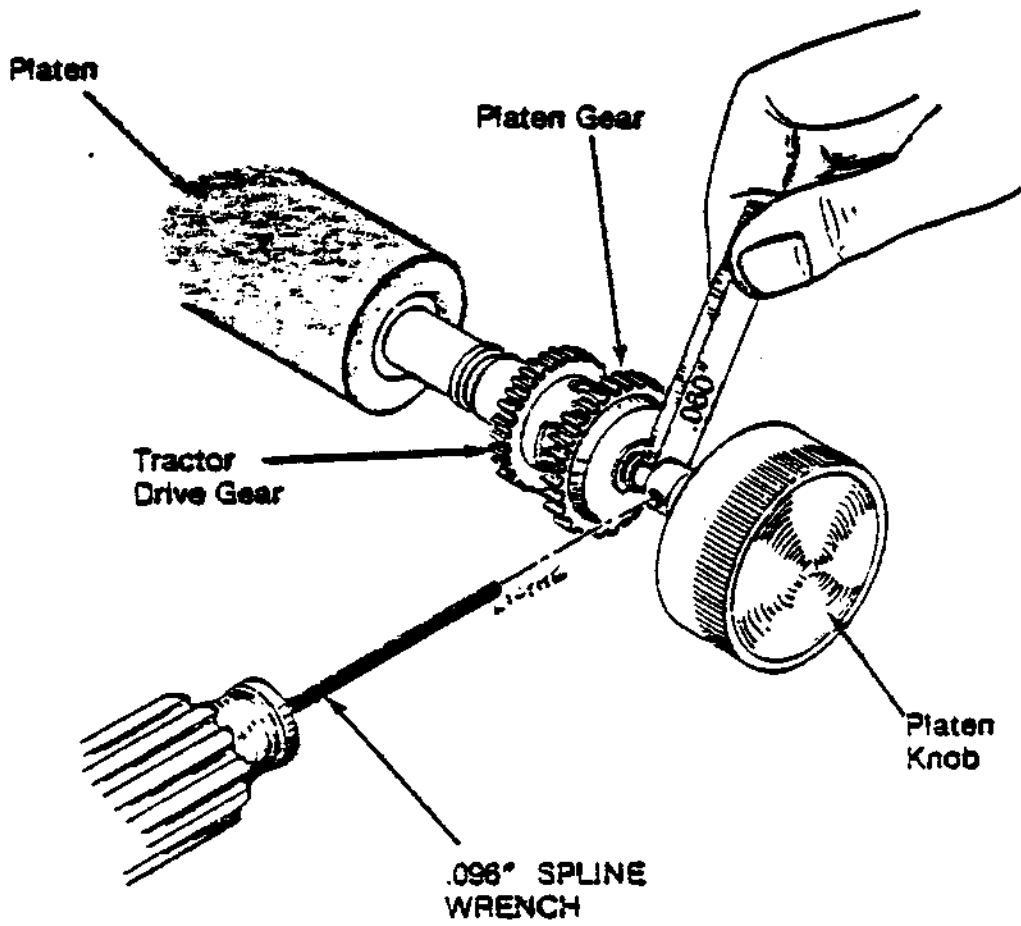

# TRACTOR DRIVE GEAR ADJUSTMENT

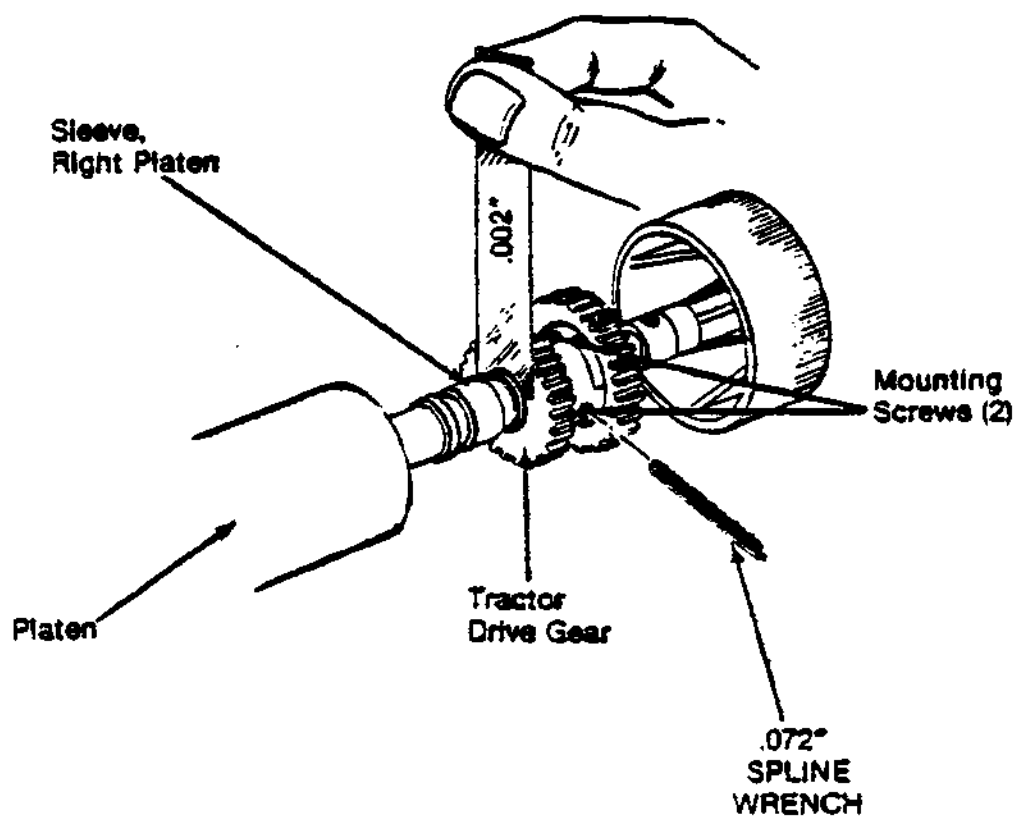

Adjust For Minimum Clearance  
(.004" Max, No Bind)

# PLATEN LATCH ADJUSTMENT

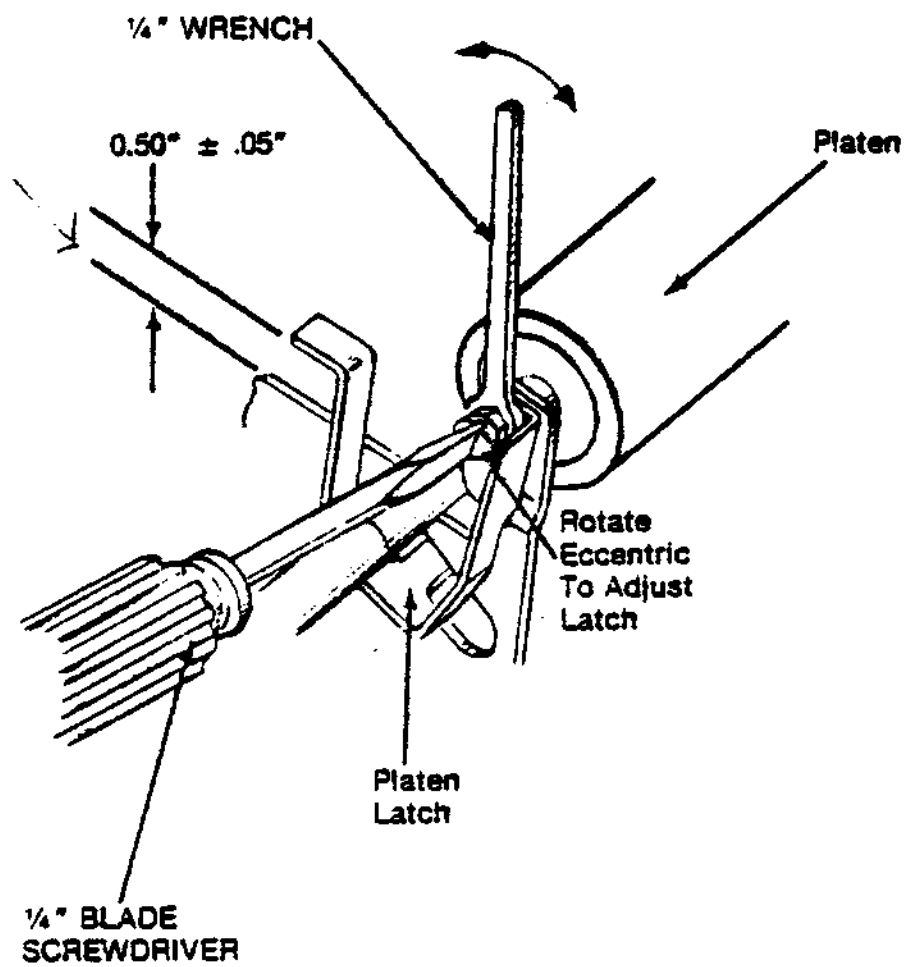

## PLATEN DRIVE IDLER GEAR ADJUSTMENT

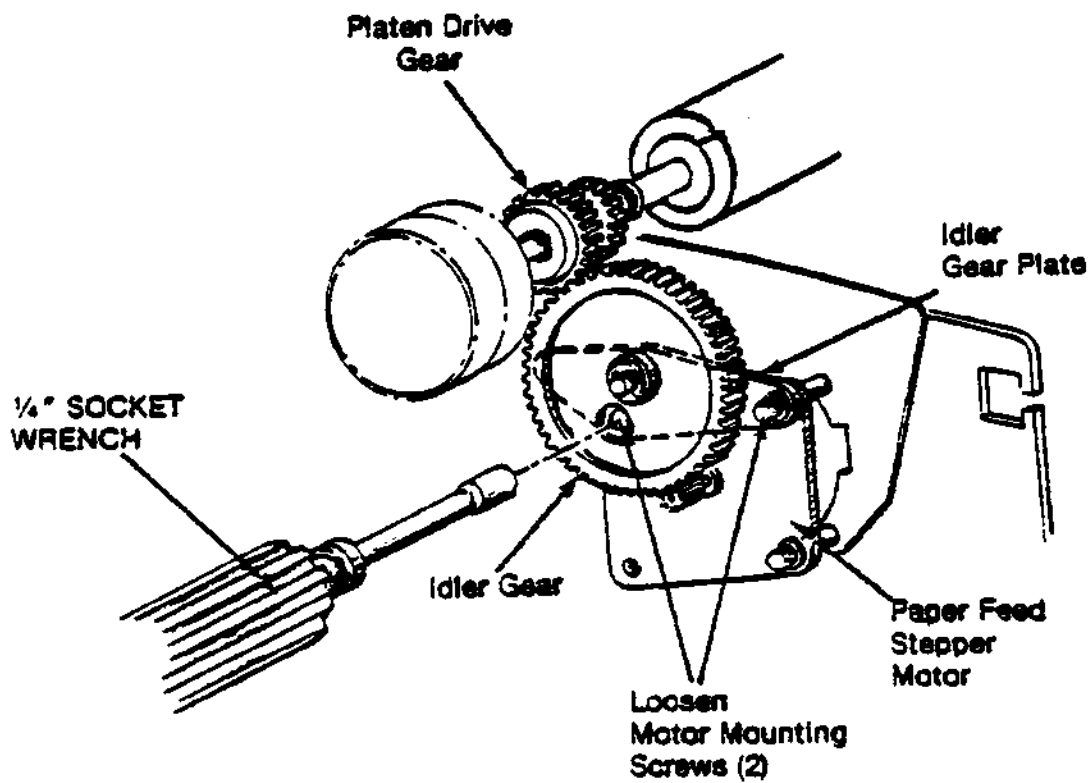

Adjust Idler Gear Plate  
For No Backlash, No Bind  
Between Gears

# PLATEN DEPTH AND HEIGHT ADJUSTMENT, STEP 1

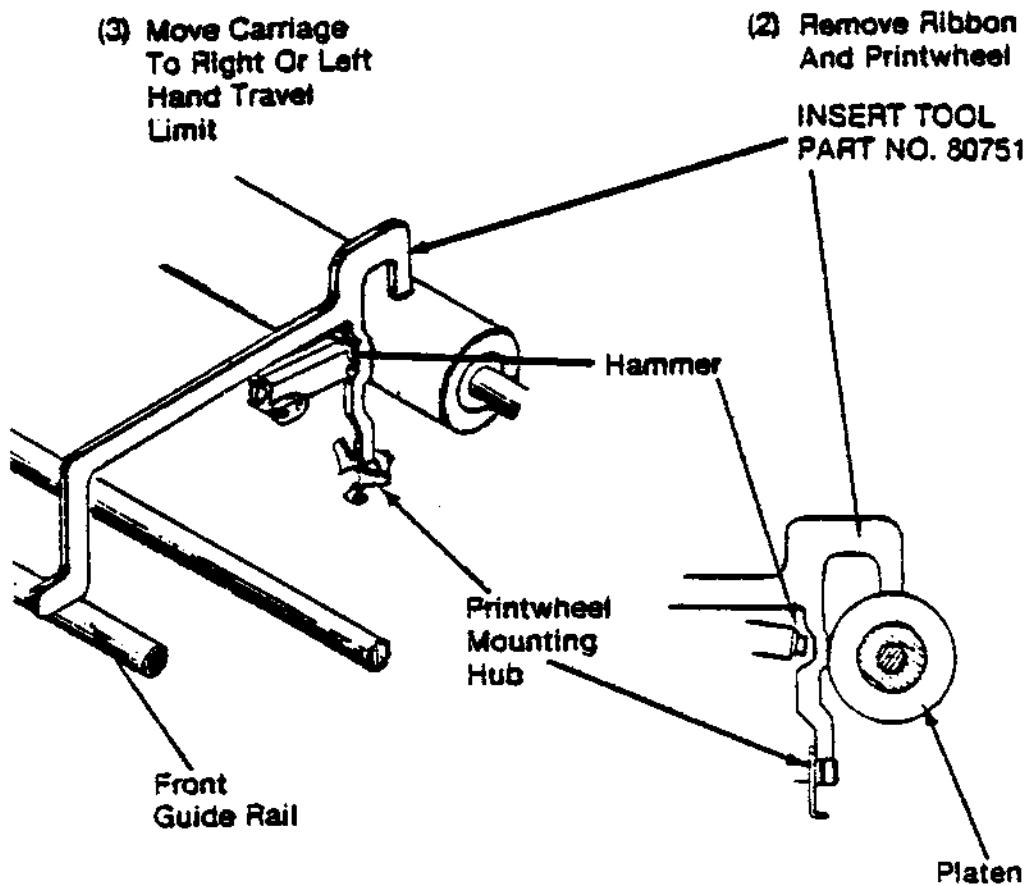
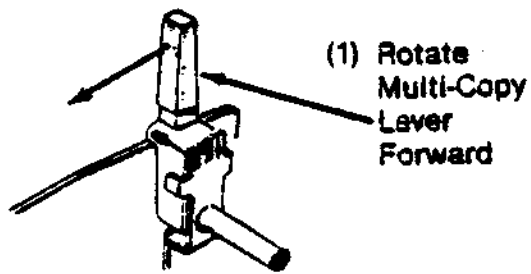



# PLATEN DEPTH AND HEIGHT ADJUSTMENT STEP 2

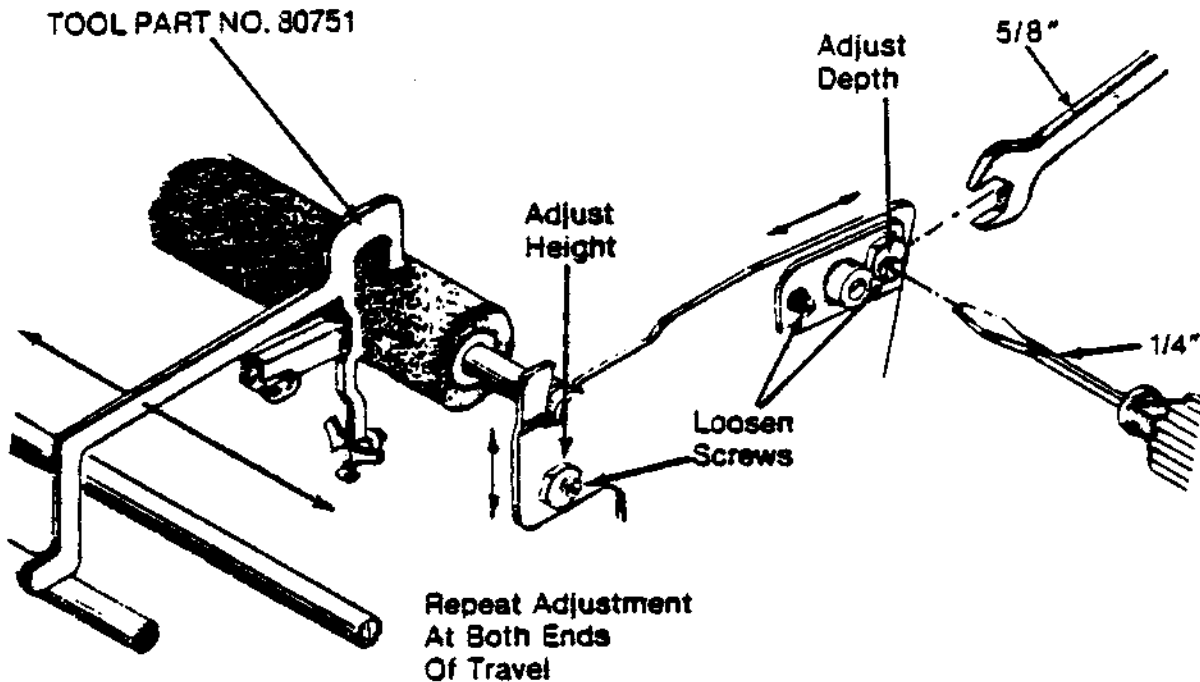

Insure That The High Point Of The Height Eccentric Faces Forward, And Faces Upward On The Depth Eccentric Prior To Making The Final Settings.

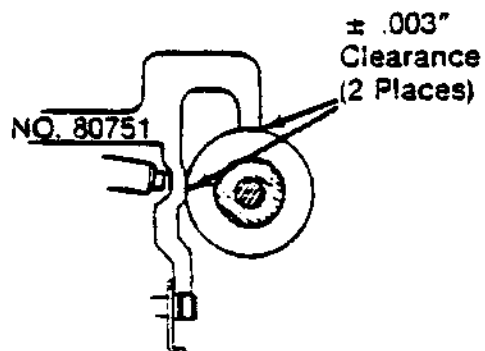

# FEED ROLLER DEPTH ADJUSTMENT

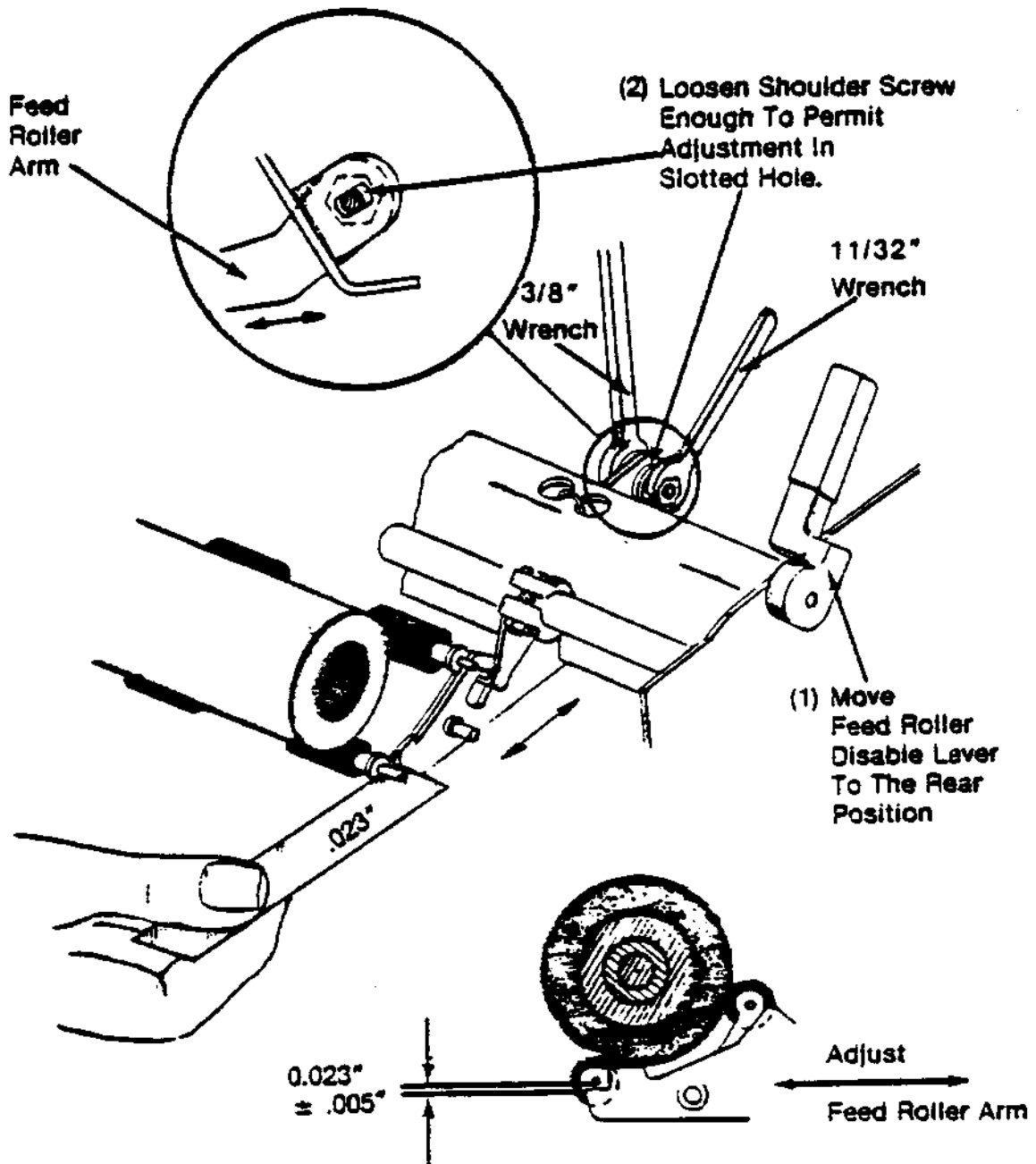

## FEED ROLLER DISABLE LEVER ADJUSTMENT

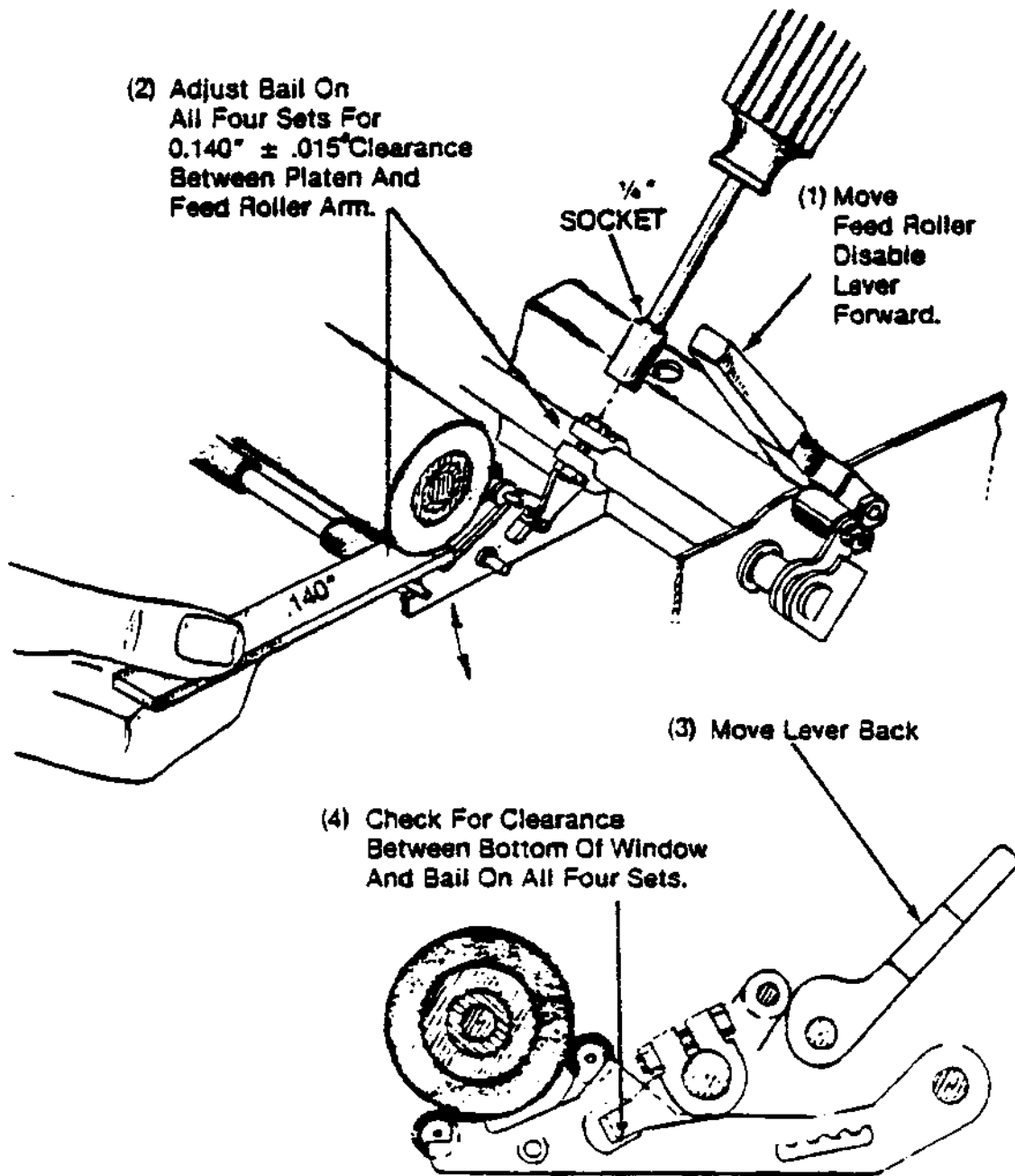

# CARD GUIDE FORWARD, HORIZONTAL, AND HEIGHT ADJUSTMENT

**NOTE: Platen  
Must Be Properly  
Adjusted Prior  
To Making This  
Alignment.**

**FORWARD ADJ.**

**Card  
Guide  
Should Rest  
Lightly On  
Platen**

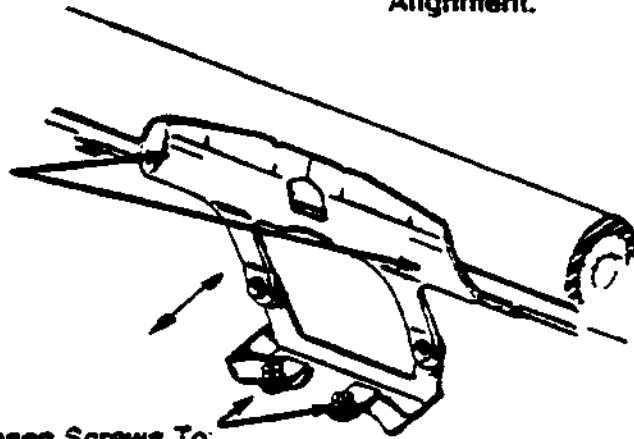

**Loosen Screws To  
Adjust.**

**Set Multi-Copy  
Lever Forward  
To Properly  
Locate The  
Platen Depth.**

**HORIZONTAL AND HEIGHT  
ADJUSTMENT**

**To Adjust,  
Loosen  
Shoulder  
Head Screws  
And Align  
Card Guide To  
Pre-Printed  
Upper Case I's.**

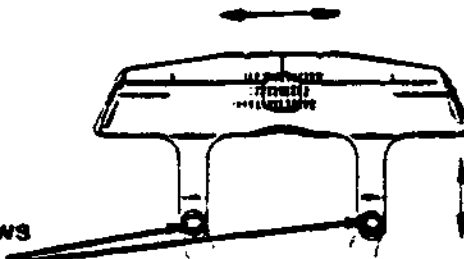

**After Adjustment, Slide  
Carriage Assembly Back  
And Forth, And Check For  
Clearance Between Feed  
Rollers And Card Guide.**

# RIBBON LIFT HEIGHT ADJUSTMENT

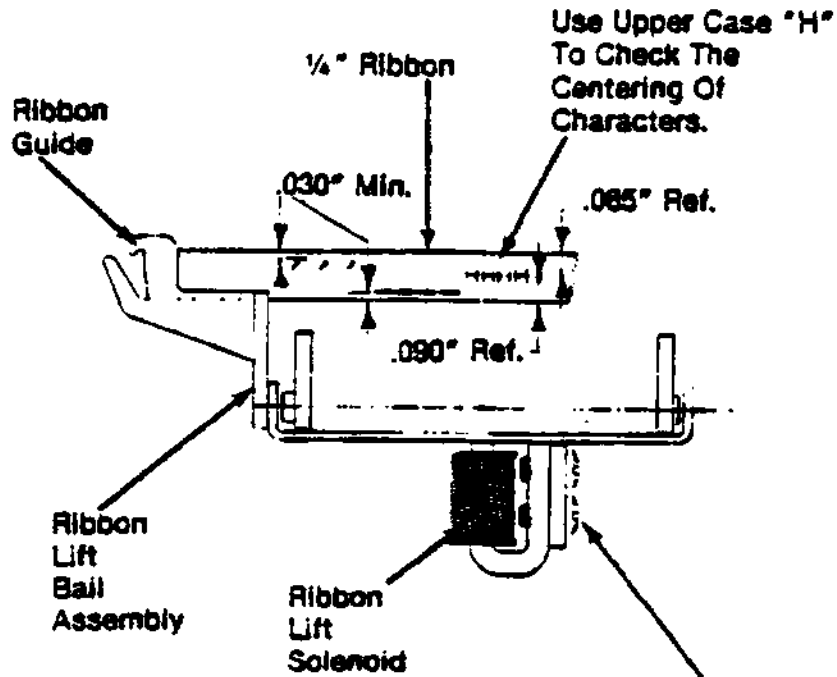

The APOSTROPHE And UNDERSCORE are Representative Of Characters That Print Near The Upper And Lower Edge Of The Ribbon.

Loosen The Solenoid Mounting Screws, Energize The Solenoid, And Adjust The Ribbon Height So That An "APOSTROPHE" Prints At Least 0.030" Below The Top Edge Of The Ribbon And An "UNDERSCORE" Prints At Least 0.030" Above The Bottom Edge Of The Ribbon.

# RIBBON LIFT HEIGHT ADJUSTMENT

## DUAL RIBBON OPTION

NOTE: The "APOSTROPHE" And "UNDERSCORE" Are Used As Examples Of Characters That Print Near The Top And Bottom Edge Of The Ribbon. Other Characters Could Be Used Where Applicable.

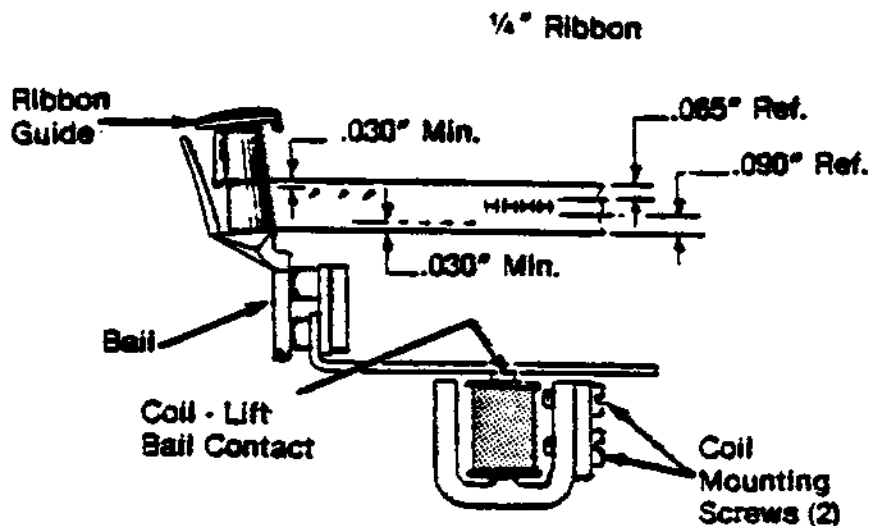

Loosen The Coil Mounting Screws,  
Energize The Coil  
Adjust The Ribbon Height So That  
An "APOSTROPHE" Prints At Least 0.030"  
Below The Top Edge Of The Ribbon, And  
An "UNDERSCORE" Prints At Least 0.030"  
Above The Bottom Edge Of The Ribbon.

# RIBBON LIFT SPACING ADJUSTMENT

**NOTE:** Platen And  
Card Guide Adjustment  
Must Be Made  
Prior To This  
Alignment.

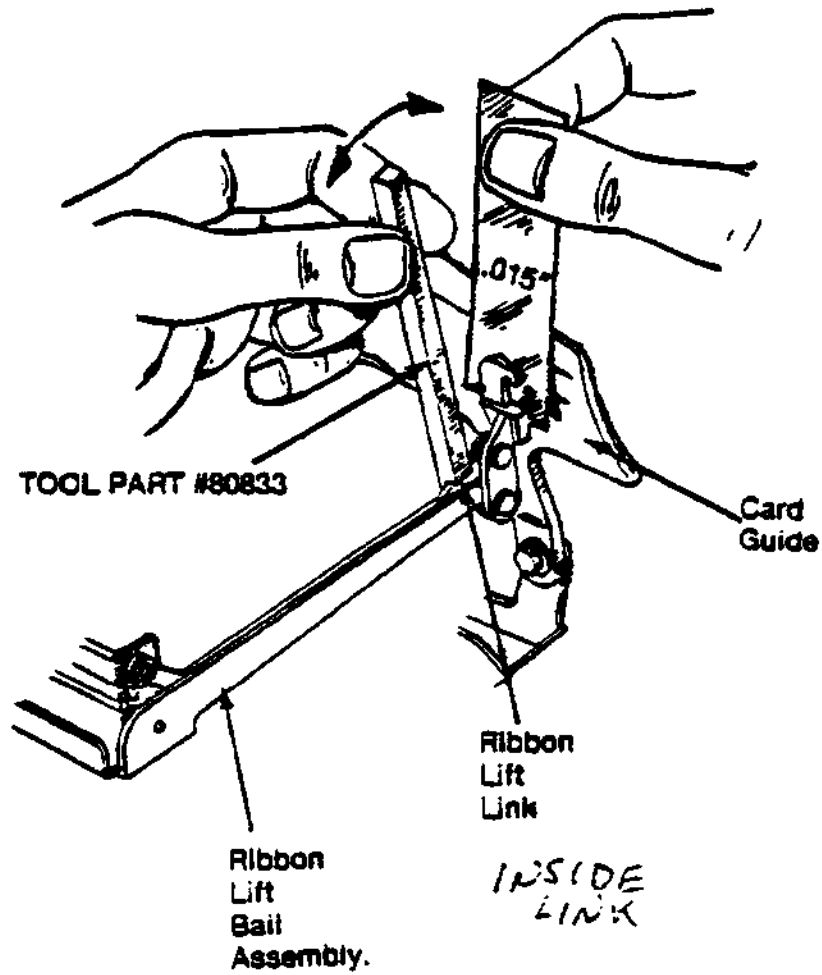

# RIBBON TRACKING ADJUSTMENT

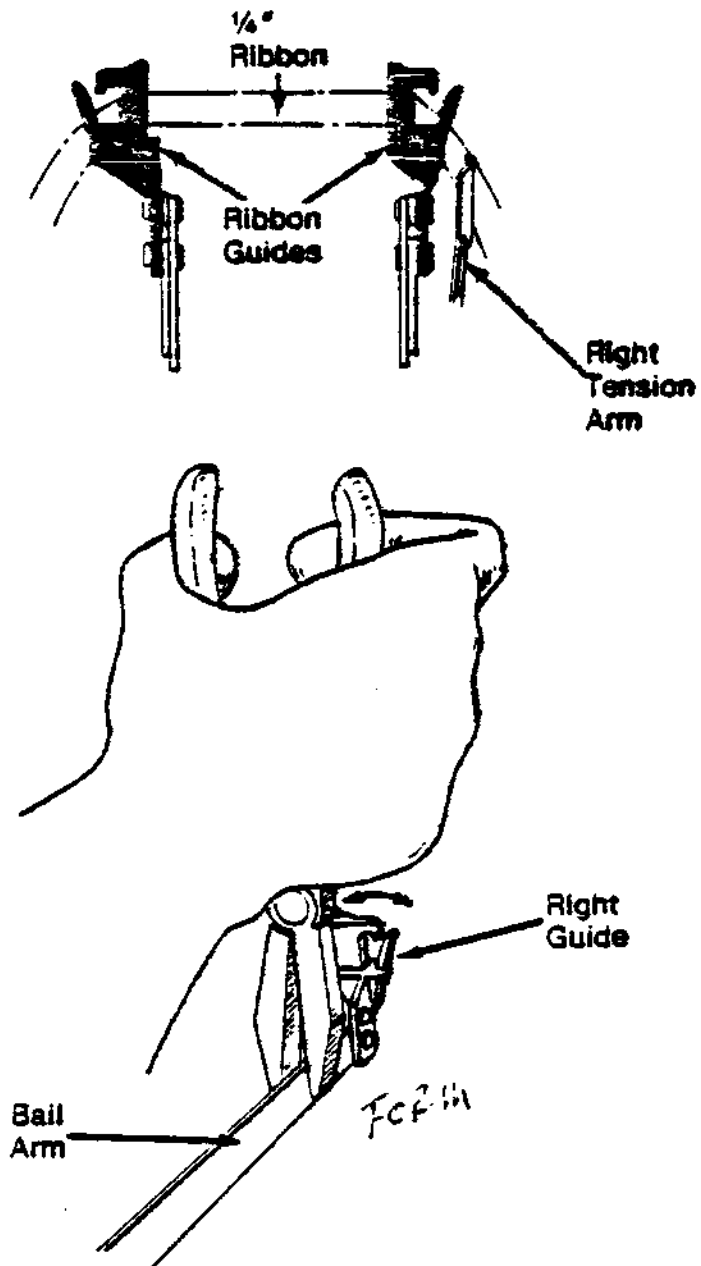

Adjust Ribbon Guides  
For Correct Tracking,  
No Ribbon Curling



# RIBBON DRIVE GEAR ADJUSTMENT

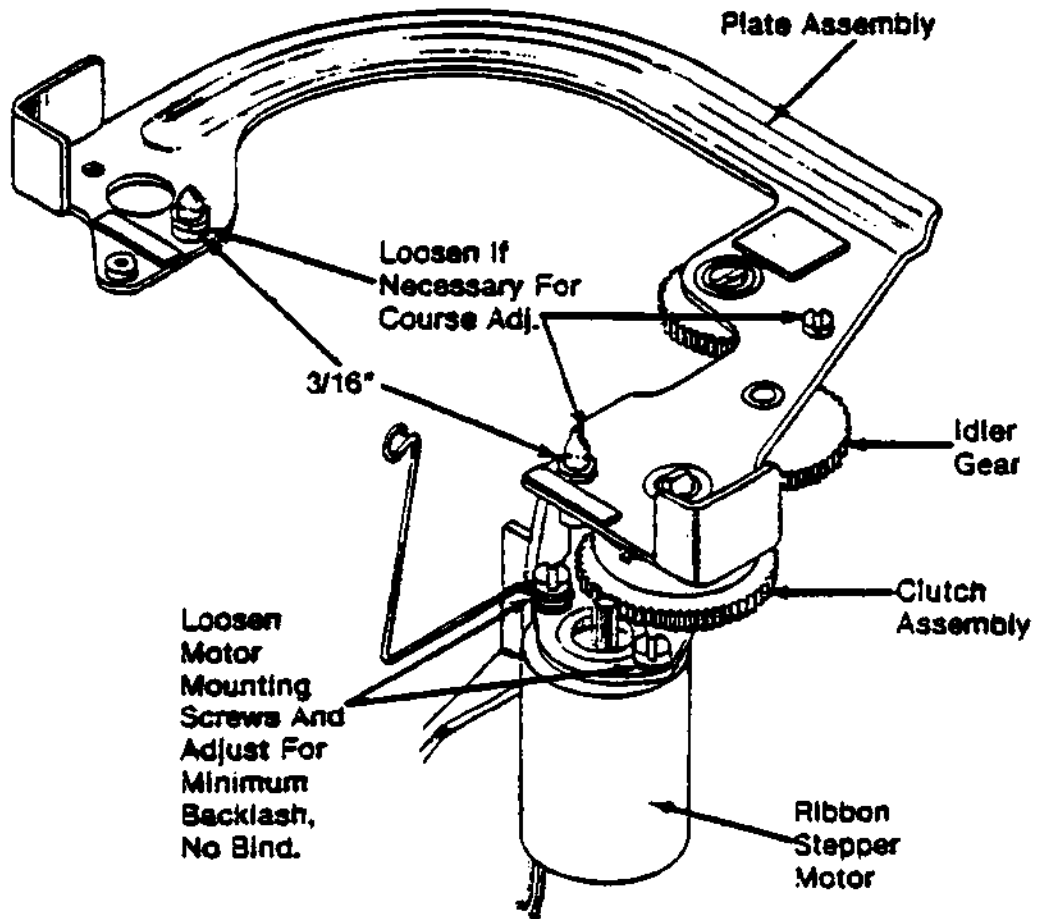

# CABLE TENSION ADJUSTMENT

(S5-45; SM3-35,-45)

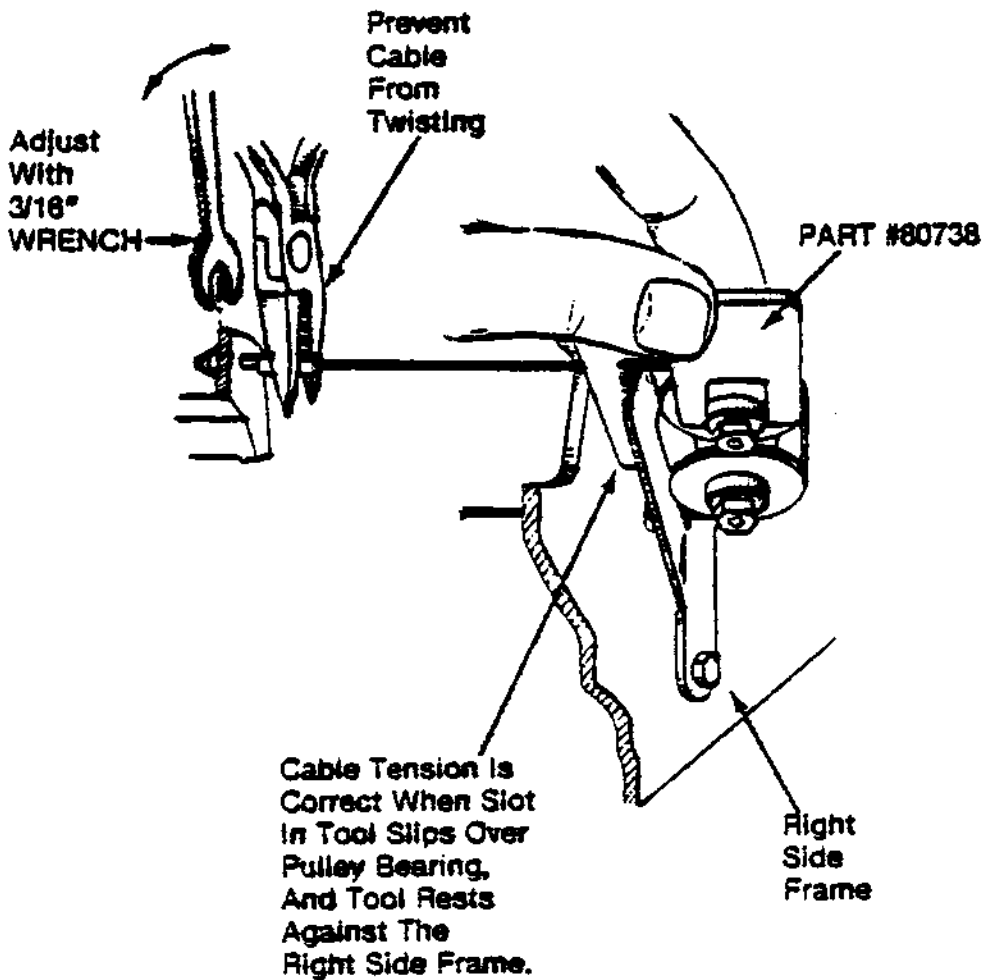

TENSIO-METER

WHEEL LINE MODEL - DXX-2 KG.  
ELECTROMATIC EQUIPMENT CORP.  
ROCKAWAY, N.Y.

MENT IN TEST REPORT

# CABLE TENSION ADJUSTMENT

(S5-55; SM3-55,-X30,-X40, WT, TT)

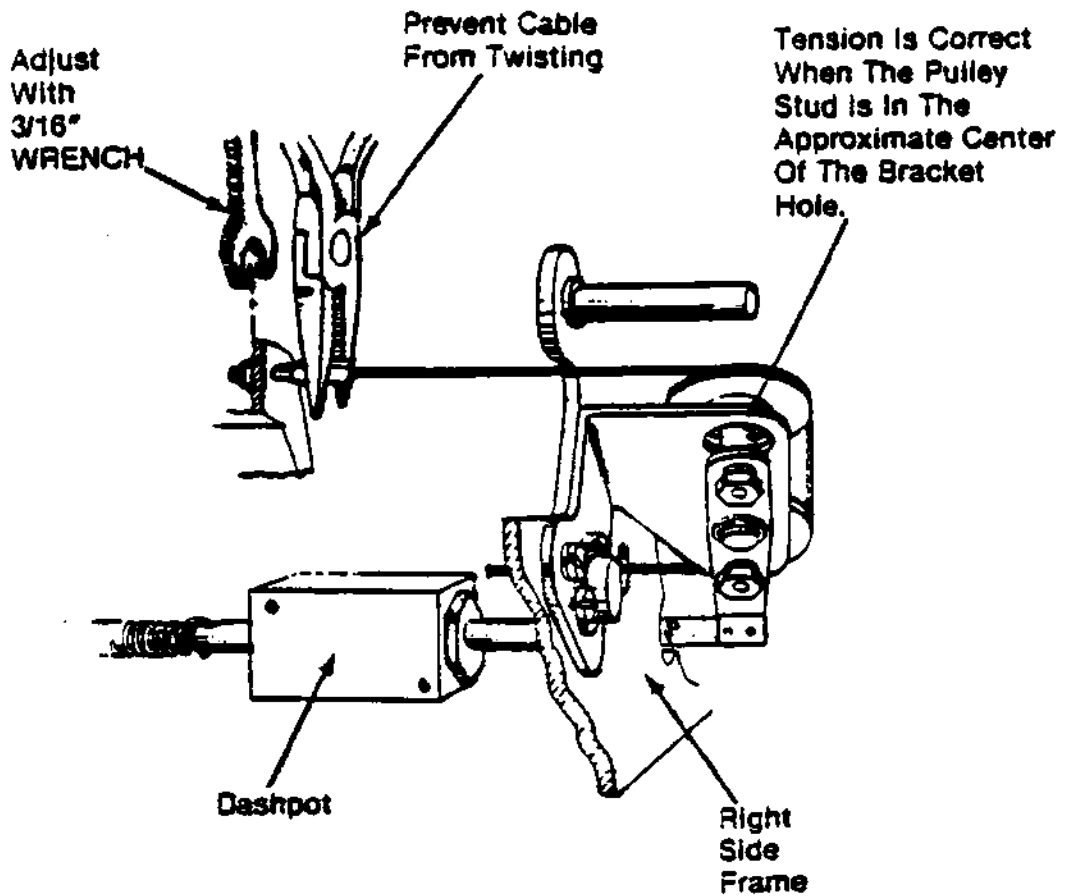

# CARRIAGE END-OF-TRAVEL SENSOR ADJUSTMENT

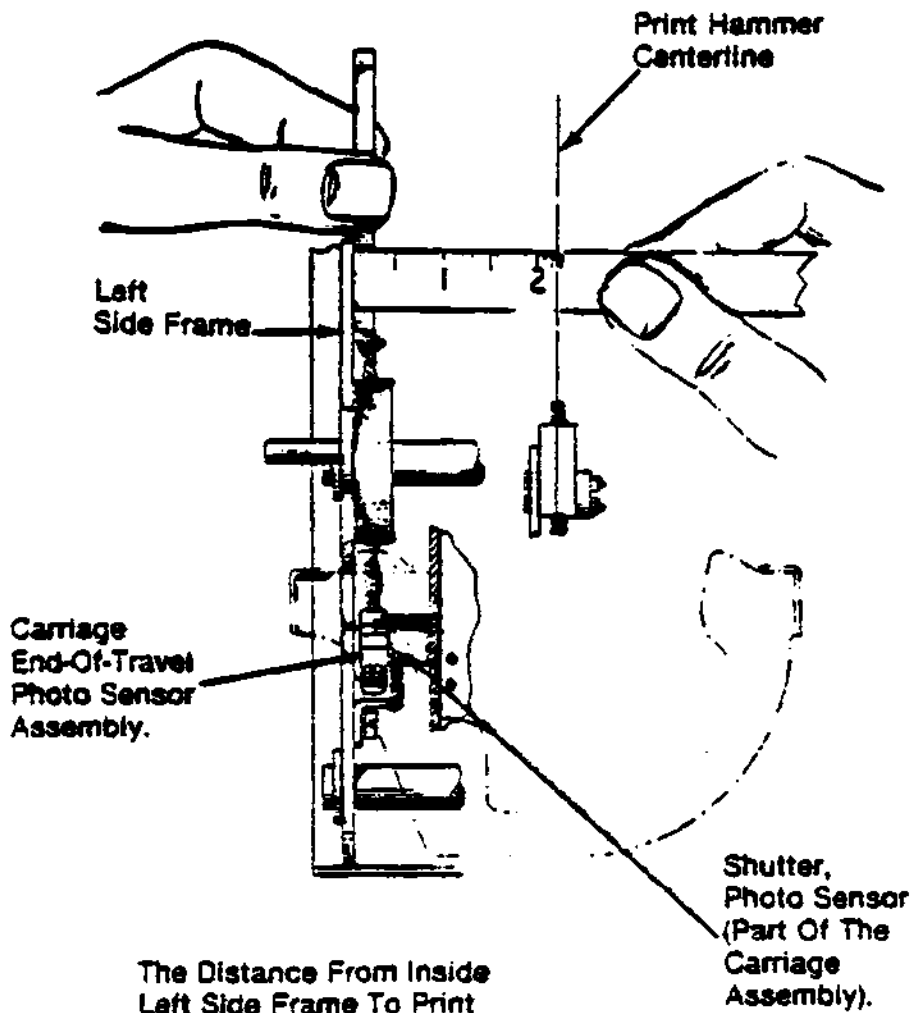

The Distance From Inside Left Side Frame To Print Hammer Centerline is  $2.025" \pm .020"$  After Printer is Initialized.

## PRINT HAMMER VERTICAL ADJUSTMENT (HEIGHT AND ANGLE)

Remove Ribbon, Printwheel  
And Platen.

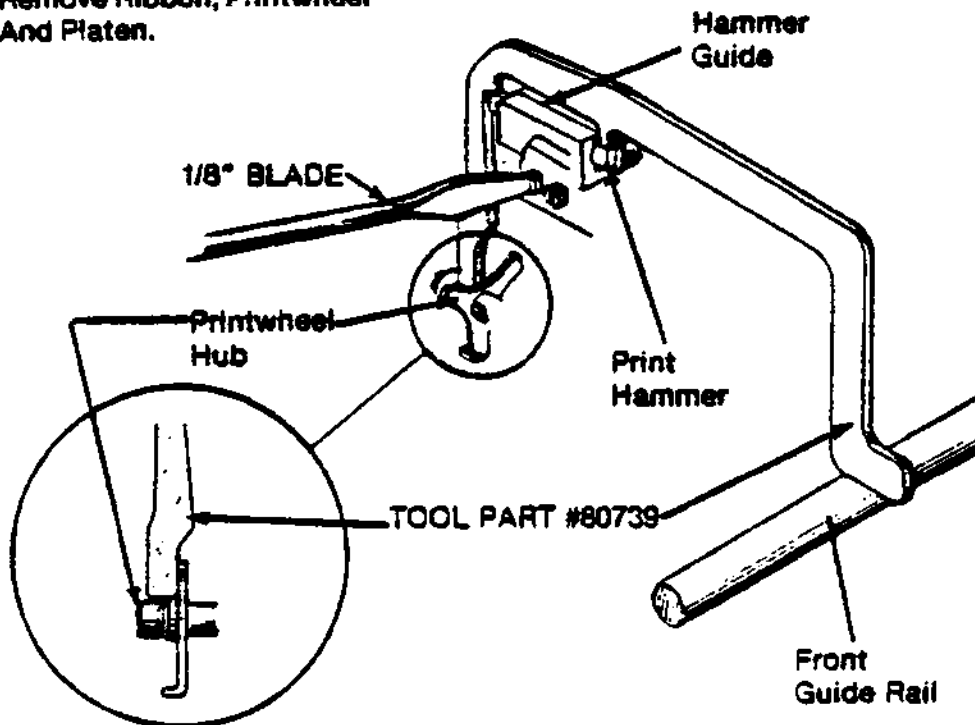

Loosen Hammer Assembly Mounting Screws.  
Use The #80739 Tool As Shown,  
For Making The Initial Settings.  
Final Adjustment Depends On The  
Quality Of A Print Sample.

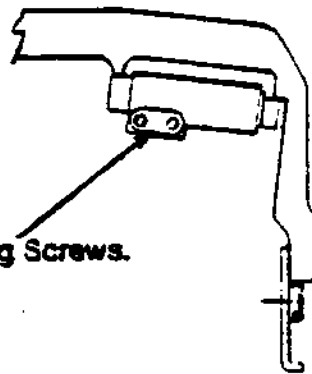

# HAMMER ARMATURE CORE ADJUSTMENT (PENETRATION), STEP 1

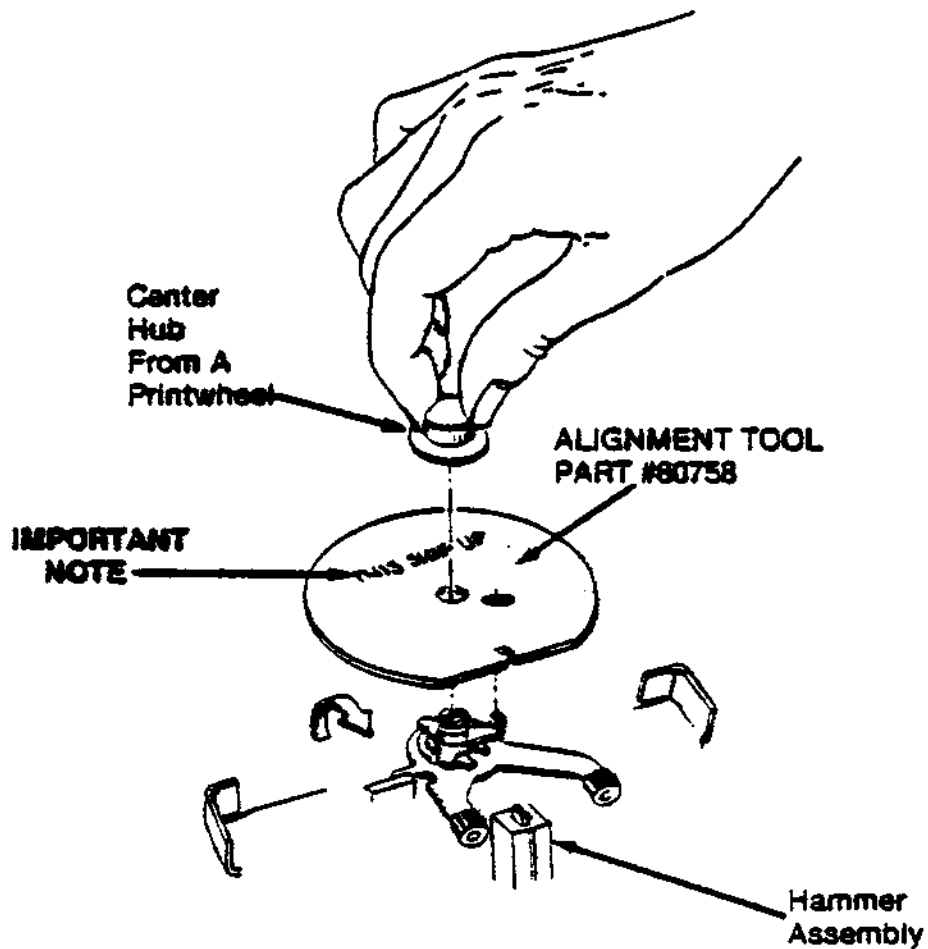

Remove Ribbon, Printwheel.  
Tilt Inner Carriage.  
Install Alignment Tool, #80758.

## HAMMER ARMATURE CORE ADJUSTMENT (PENETRATION), STEP 2

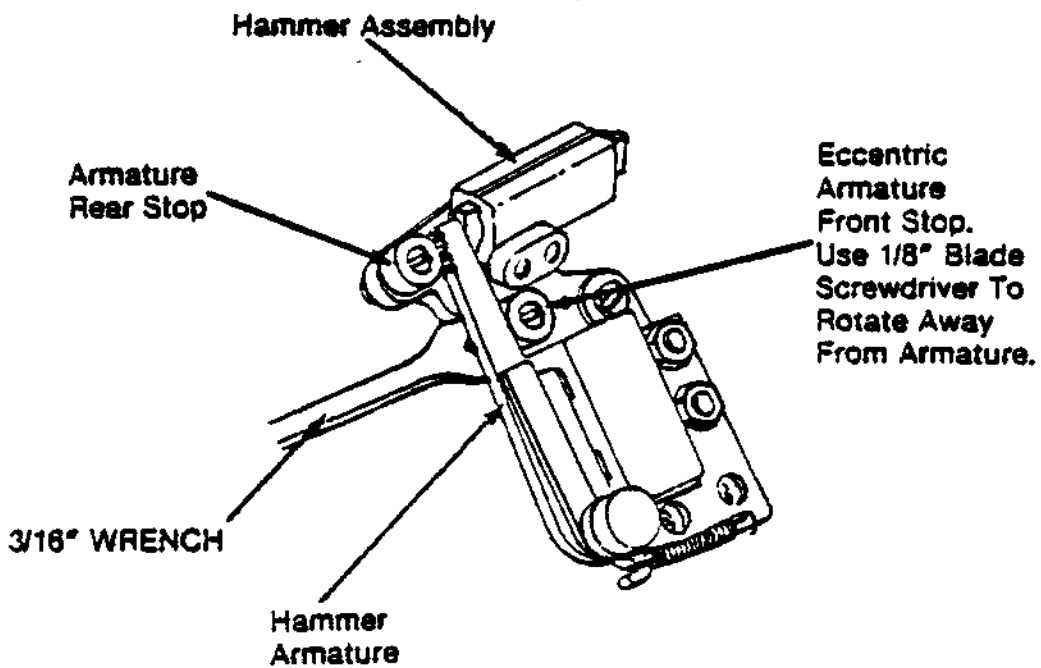

Rotate Front Stop Away From  
Armature Prior To Core Penetration  
Adjustment In Step 3.

# HAMMER ARMATURE CORE ADJUSTMENT (PENETRATION), STEP 3

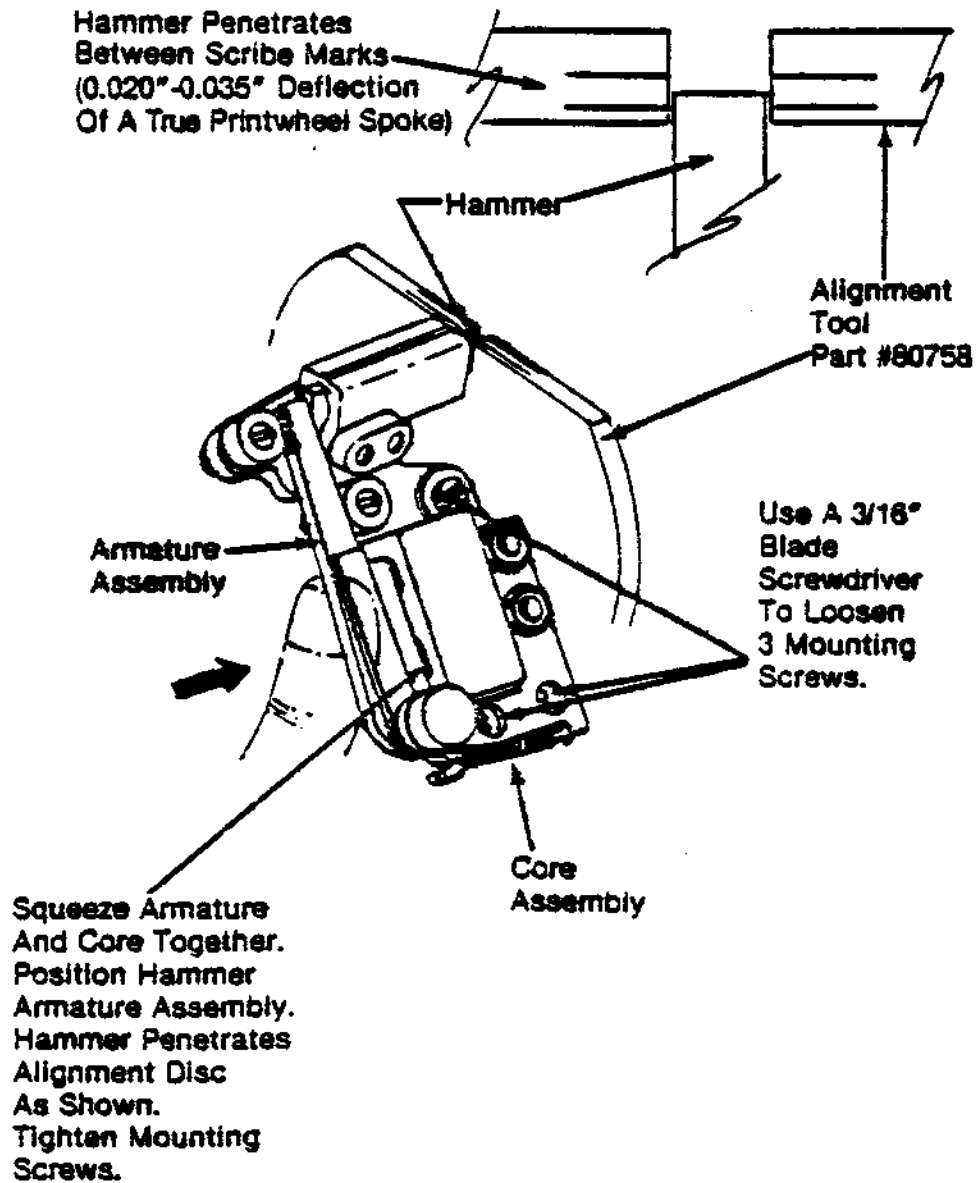



# HAMMER ARMATURE CORE ADJUSTMENT (FRONT STOP), STEP 4

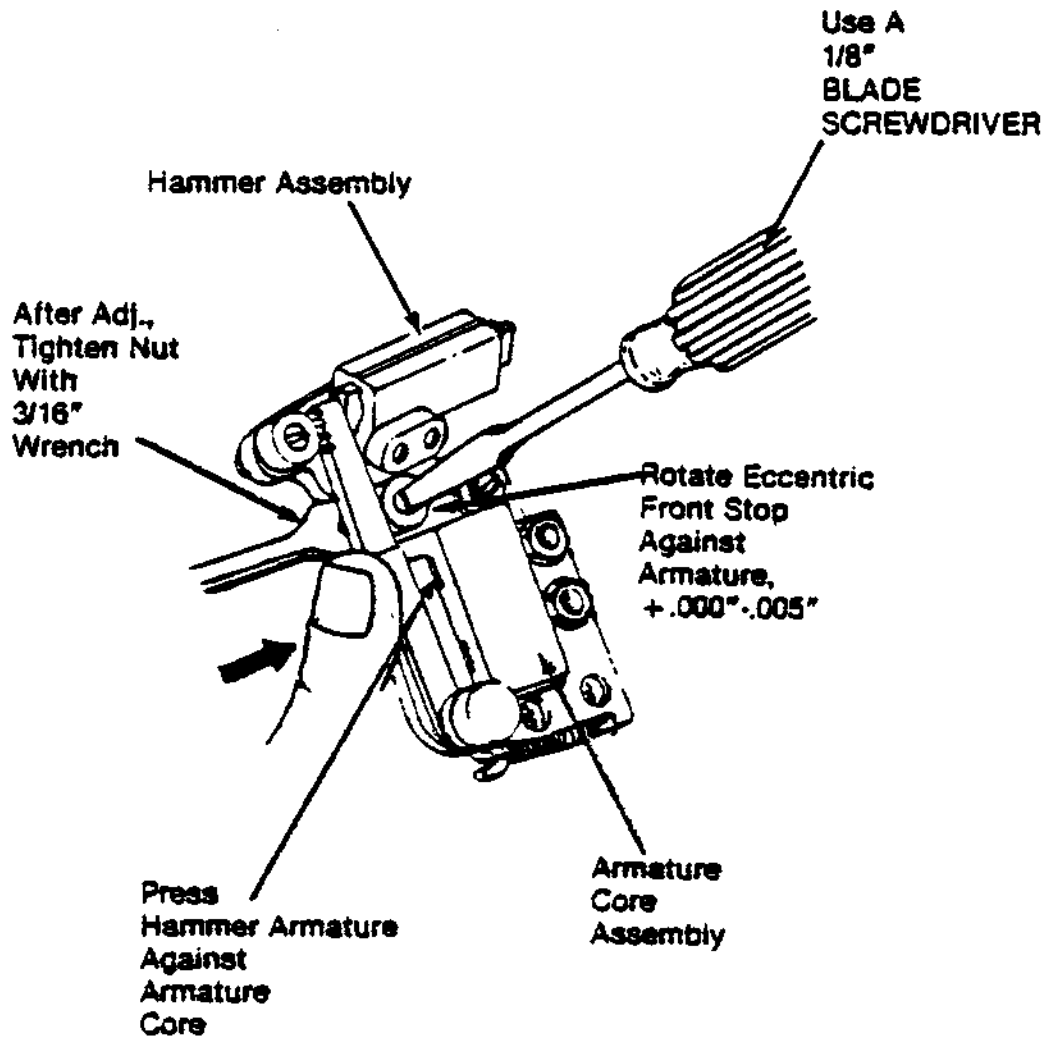

# HAMMER ARMATURE CORE ADJUSTMENT (REAR STOP), STEP 5

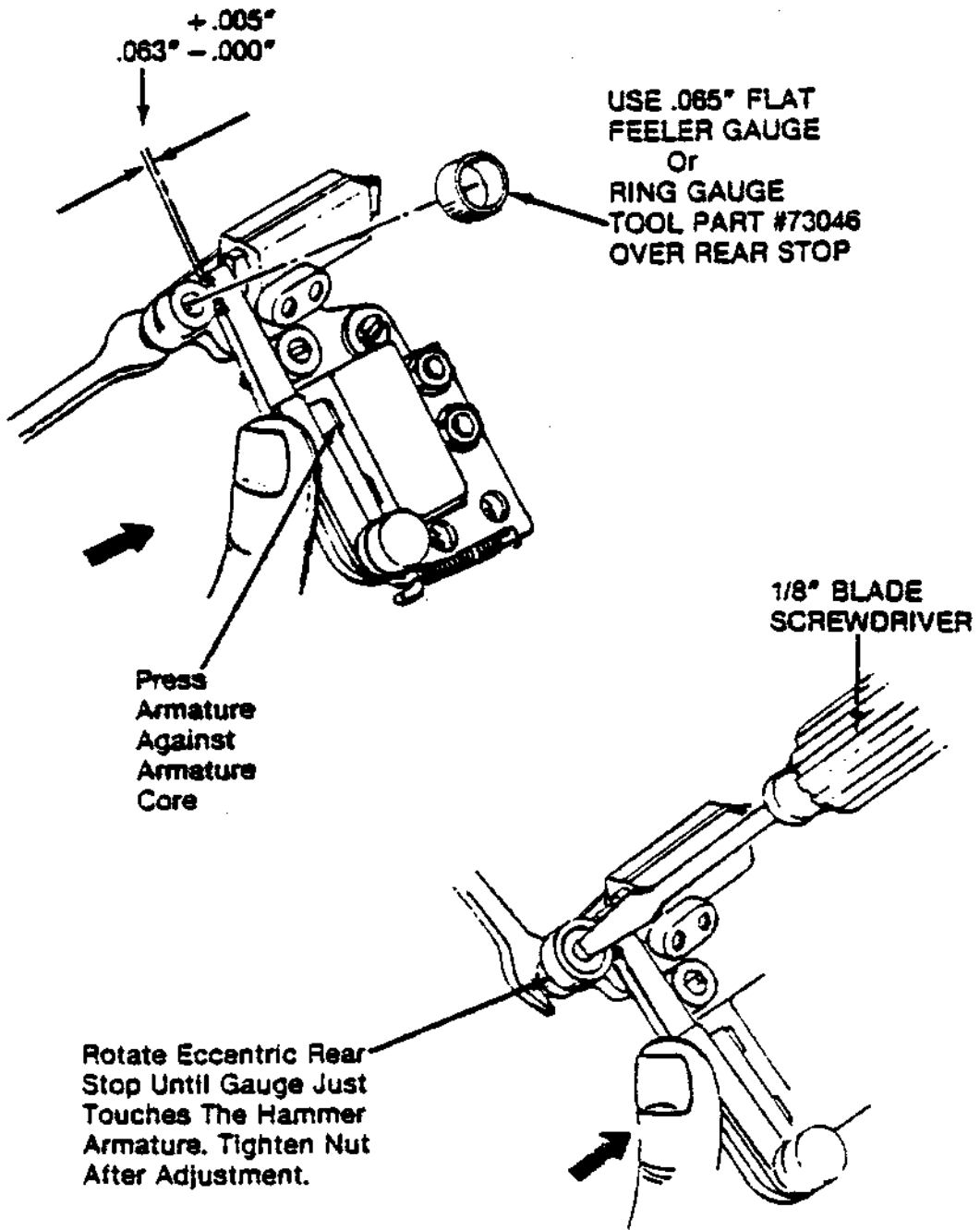

# PRINTWHEEL HUB (INDEX) ADJUSTMENT

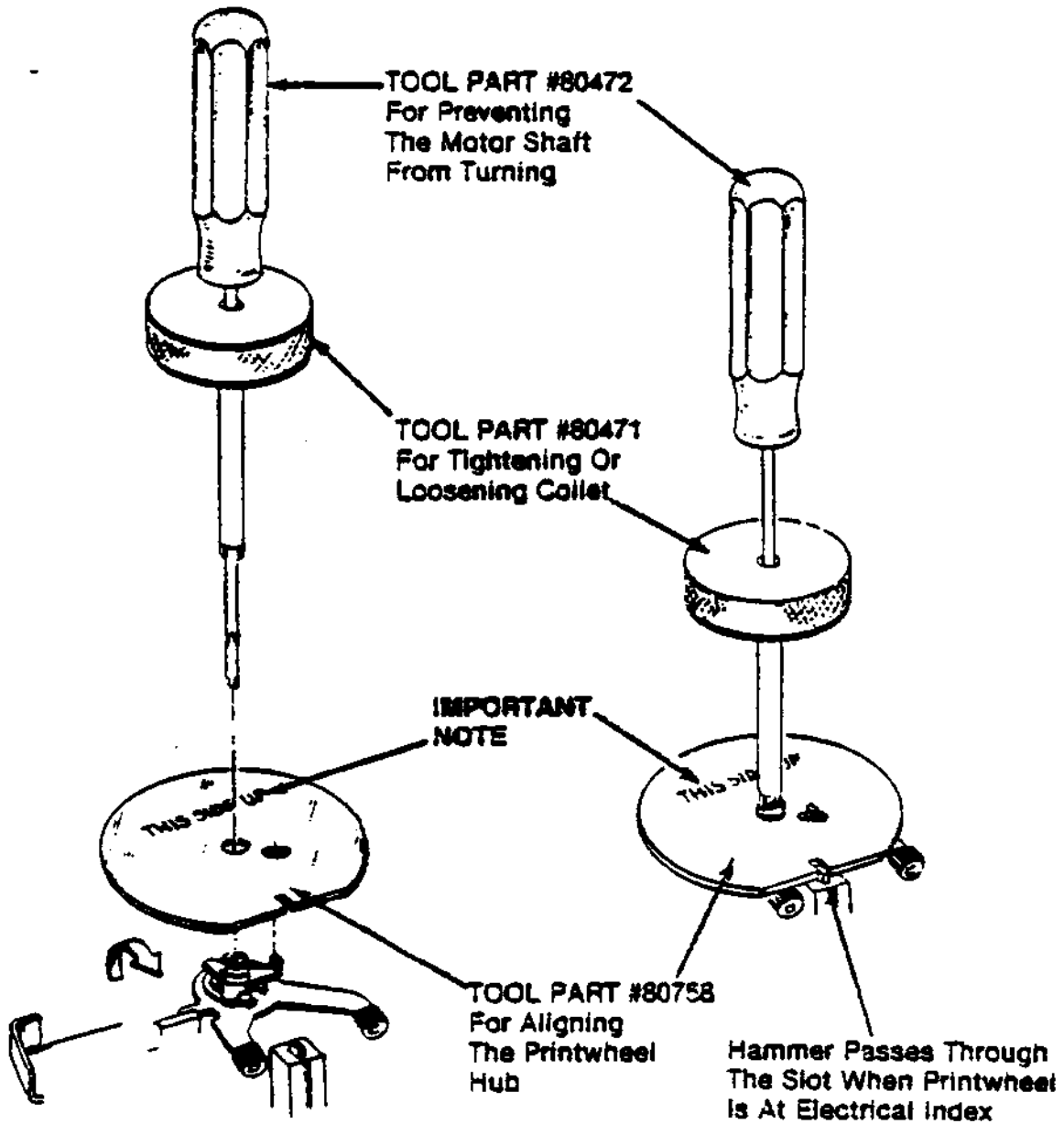

# TRACTOR FEED ADJUSTMENTS

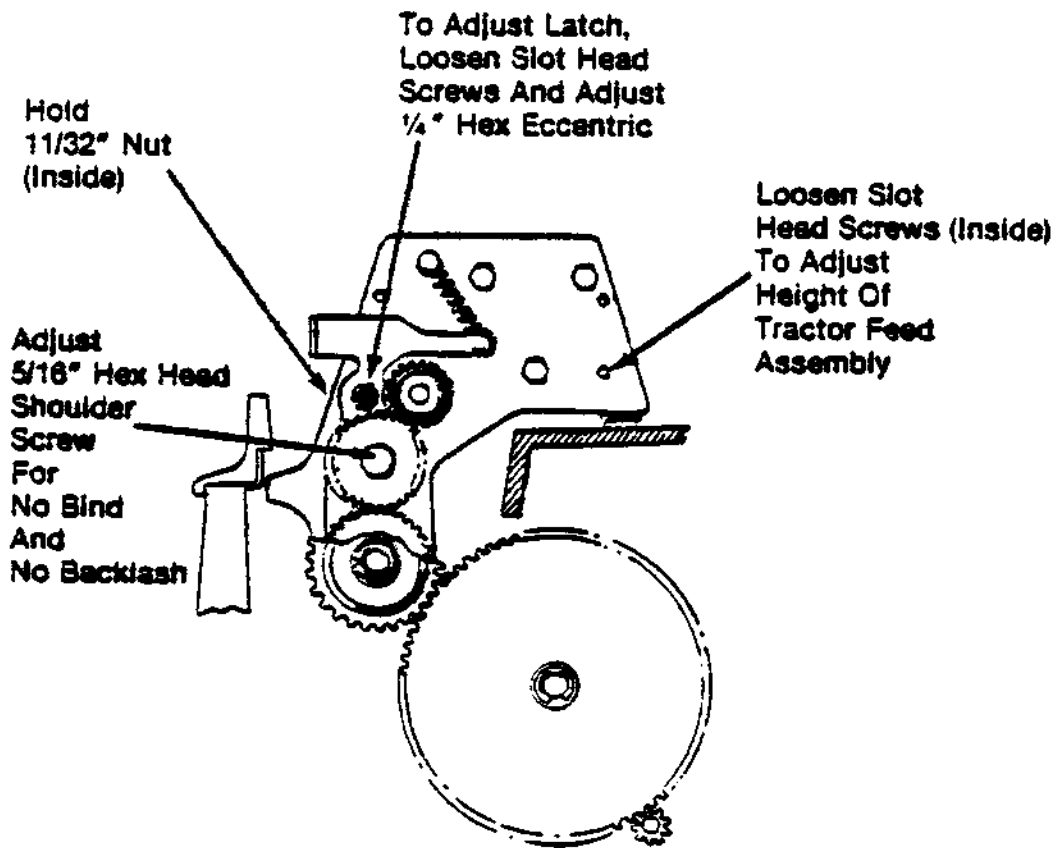

# COVER INTERLOCK SWITCH ADJUSTMENT

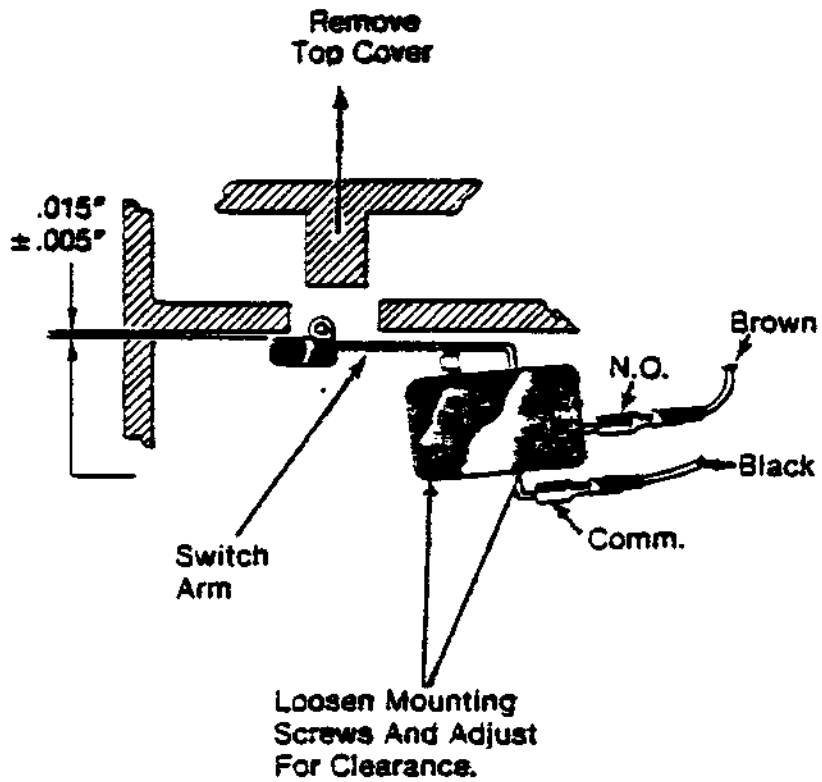

# 6 MONTH OR 1,000 HOUR LUBRICATION

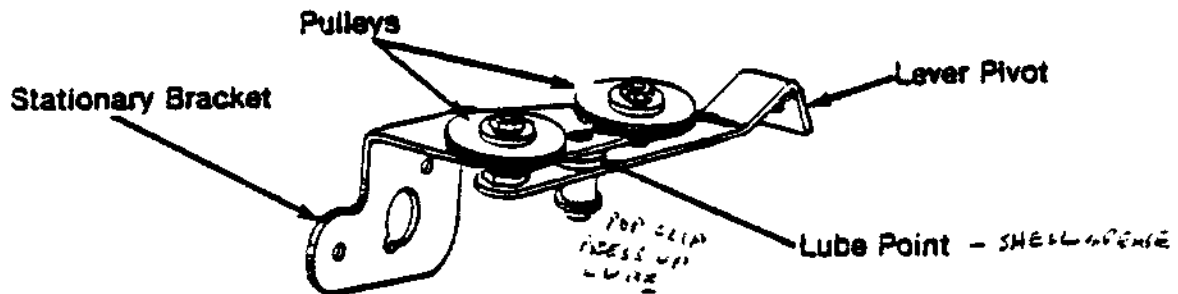

**CARRIAGE PULLEY LEVER LUBRICATION**  
(S5-55; SM3-55, -X30, -X40, WT, TT)

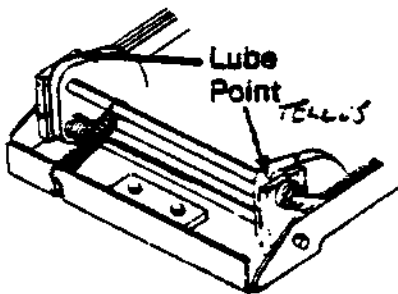

**RIBBON BAIL LUBRICATION**

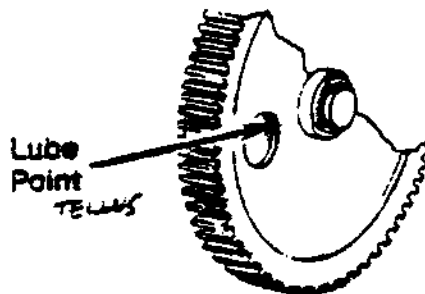

**PAPER FEED IDLER GEAR LUBRICATION**

**LUBE WITH ONE DROP TELLUS OIL #80342**

## 6 MONTH OR 1,000 HOUR LUBRICATION CARRIAGE BEARINGS

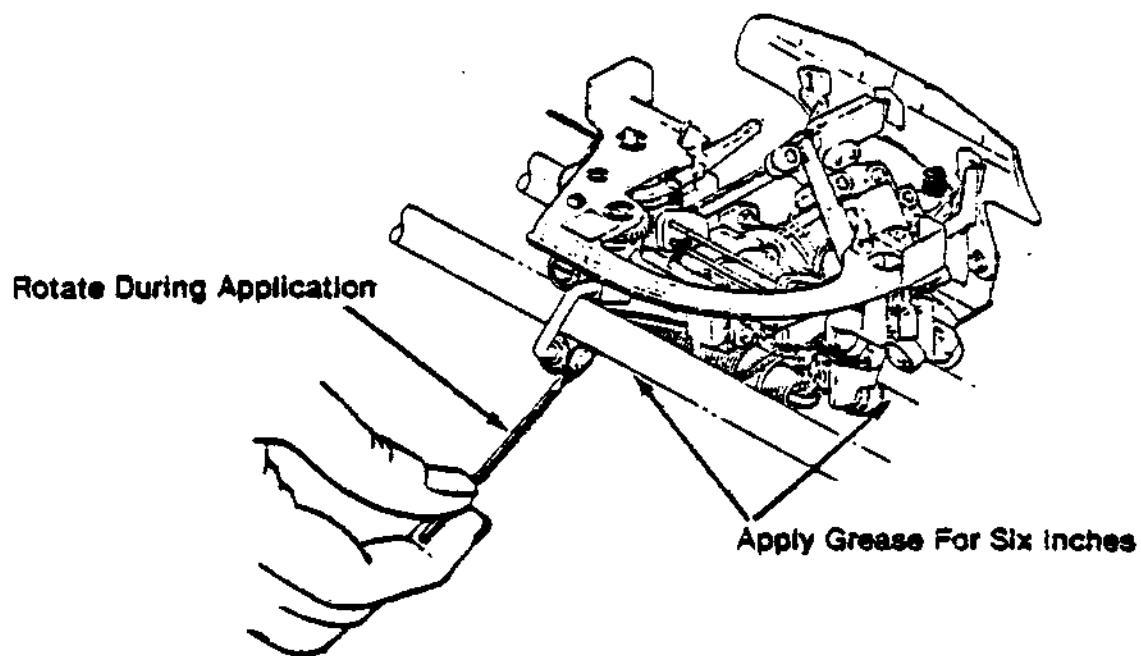

### LOWER CARRIAGE BEARINGS AND RAILS LUBRICATION

Clean With Isopropyl Alcohol. Apply  
a Light Coating Of Shell Darina-AX  
Grease #85179 As Shown.  
Remove Excess

# 6 MONTH OR 1,000 HOUR LUBRICATION PRINT HAMMER

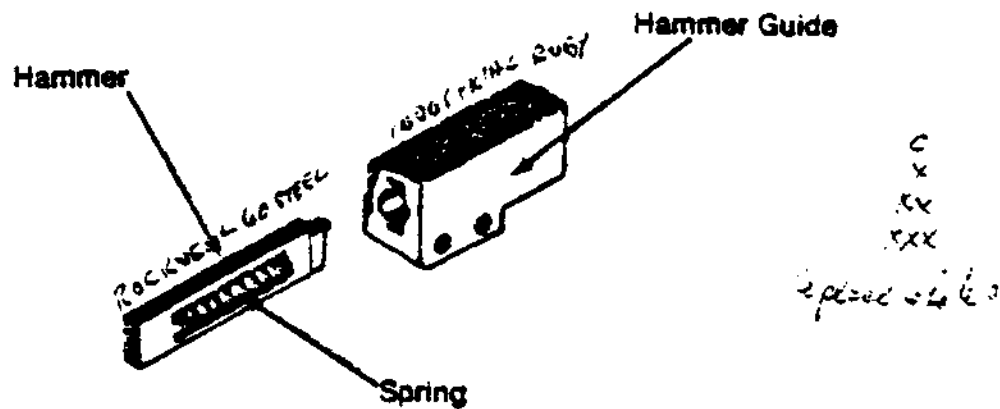

## PRINTHAMMER ASSEMBLY LUBRICATION

Clean Hammer And Hammer Guide  
With Isopropyl Alcohol. Lubricate  
Lightly With Watch Oil #80341  
And Re-Assemble.



# 12 MONTH OR 2,000 HOUR LUBRICATION

Lubricate With One Drop Of Tellus Oil #80342 At The Lube Points. Clean Off Excess.

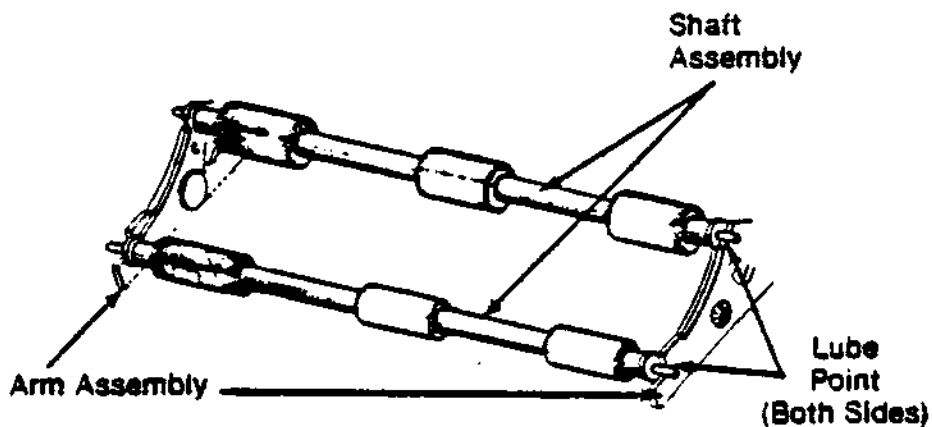

*AND BAIL ROLLERS*

## FEED ROLLER SHAFT LUBRICATION

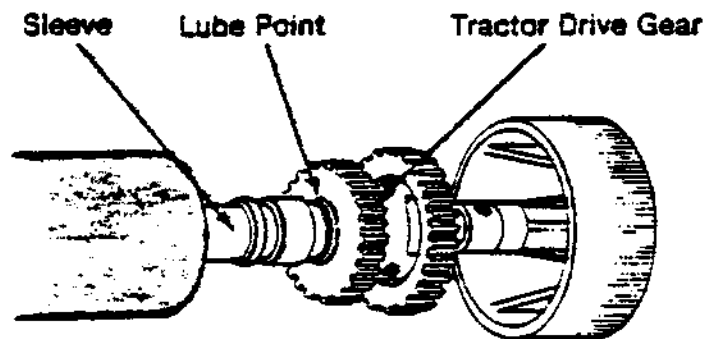

## PLATEN SLEEVE LUBRICATION

Lubricate Platen Sleeves (1 On Each End Of Platen) With One Drop Of Tellus Oil. Clean Off Excess.

# RECOMMENDED LUBRICANTS & CLEANERS

## LUBRICANTS

	QUME P/N
■ Watch Oil (Möbius Oil "Art. 8000")	85179-04
■ Tellus Oil (Shell Oil "Tellus 25")	80342-00
■ Polygrease	80346-00
■ Shell Darina-AX Grease	

*SALES*  
*55 (FULLY FIRST 10 LIT)*

## CLEANERS

- Isopropyl Alcohol (Metal Parts)
- Fedron (Platen, Feed Rollers, Bail Rollers)
- Zoom, Formula 409, Fantastic (Covers, Printwheel)
- Mild Soap and Warm Water (Column Scale, Card Guide)

# QUME TOOL KIT, #73054

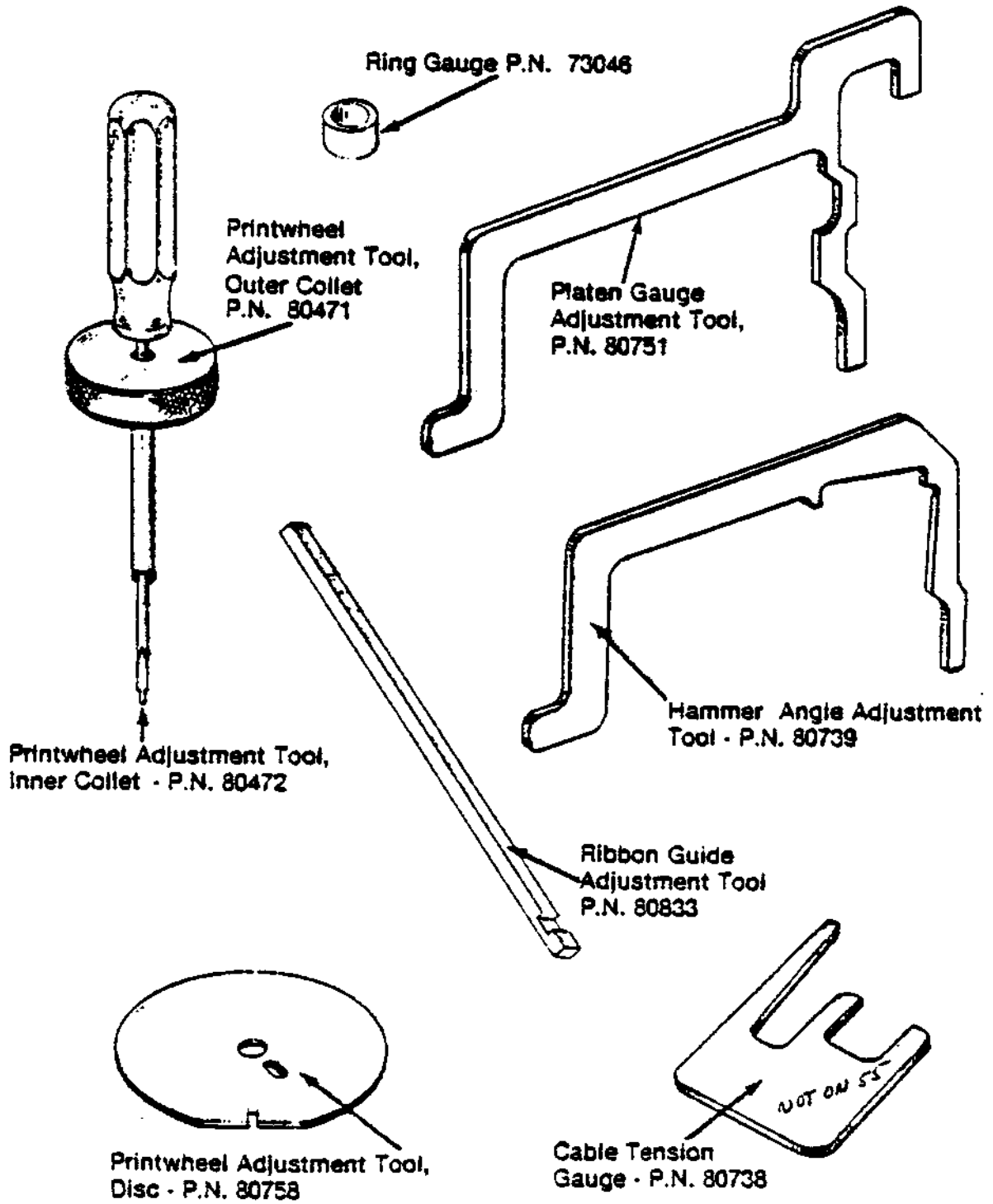

# RECOMMENDED HAND TOOLS

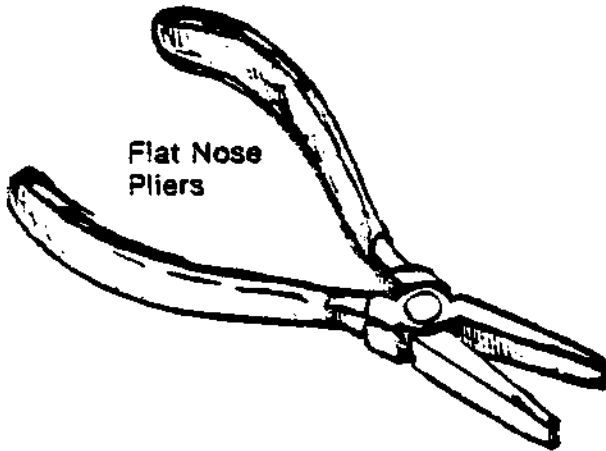

Flat Nose Pliers

Screwdriver

1/4"  
1/8"

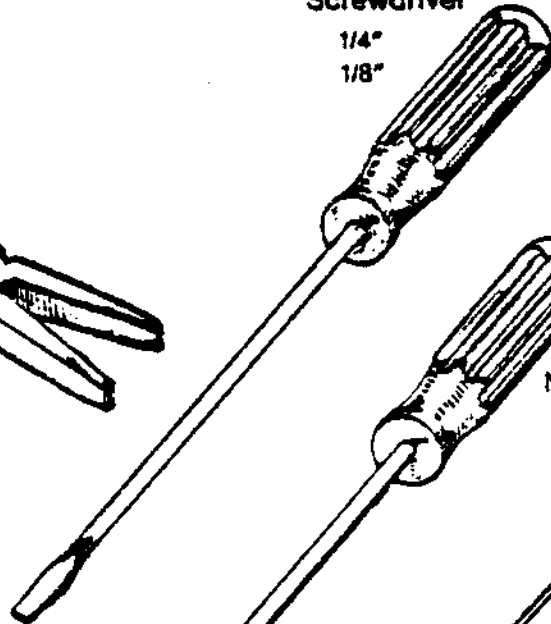

Nutdriver

1/4"  
3/16"

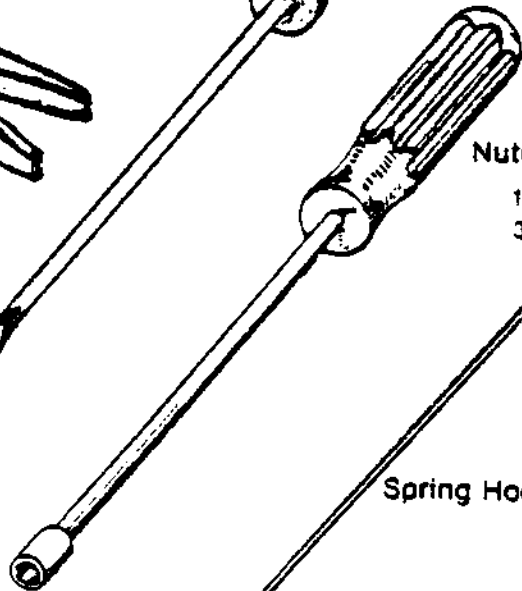

Feeler Gauge Set

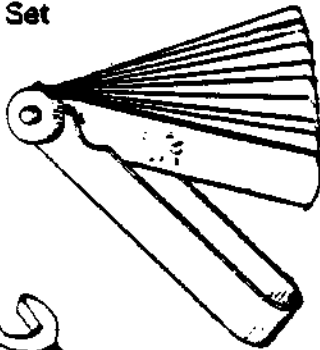

Spring Hook

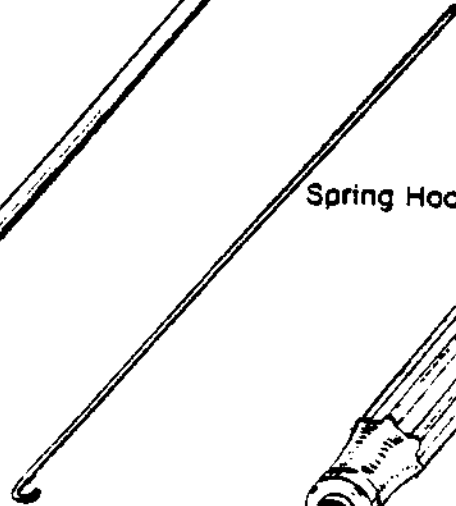

Open-end Wrench

5/8"  
11/32"  
5/16"  
3/8"  
1/4"  
3/16"

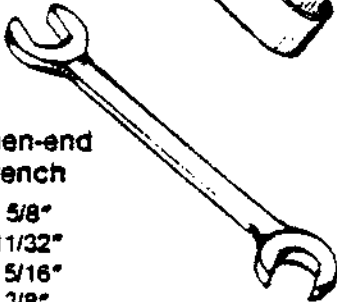

Spline Wrench

.096"  
.072"

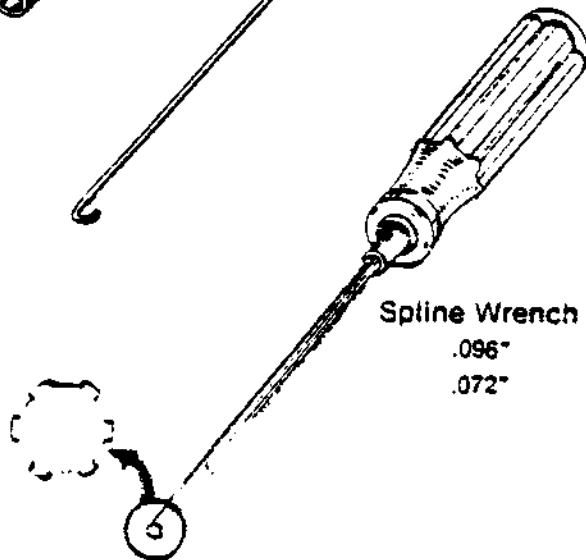

Scale

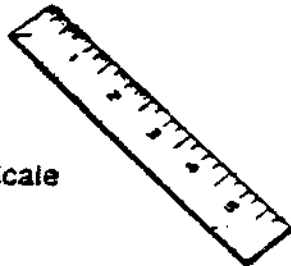

CARRIAGE CRASH (SLAM) PROBLEM

CARRIAGE MOTOR CONNECTOR

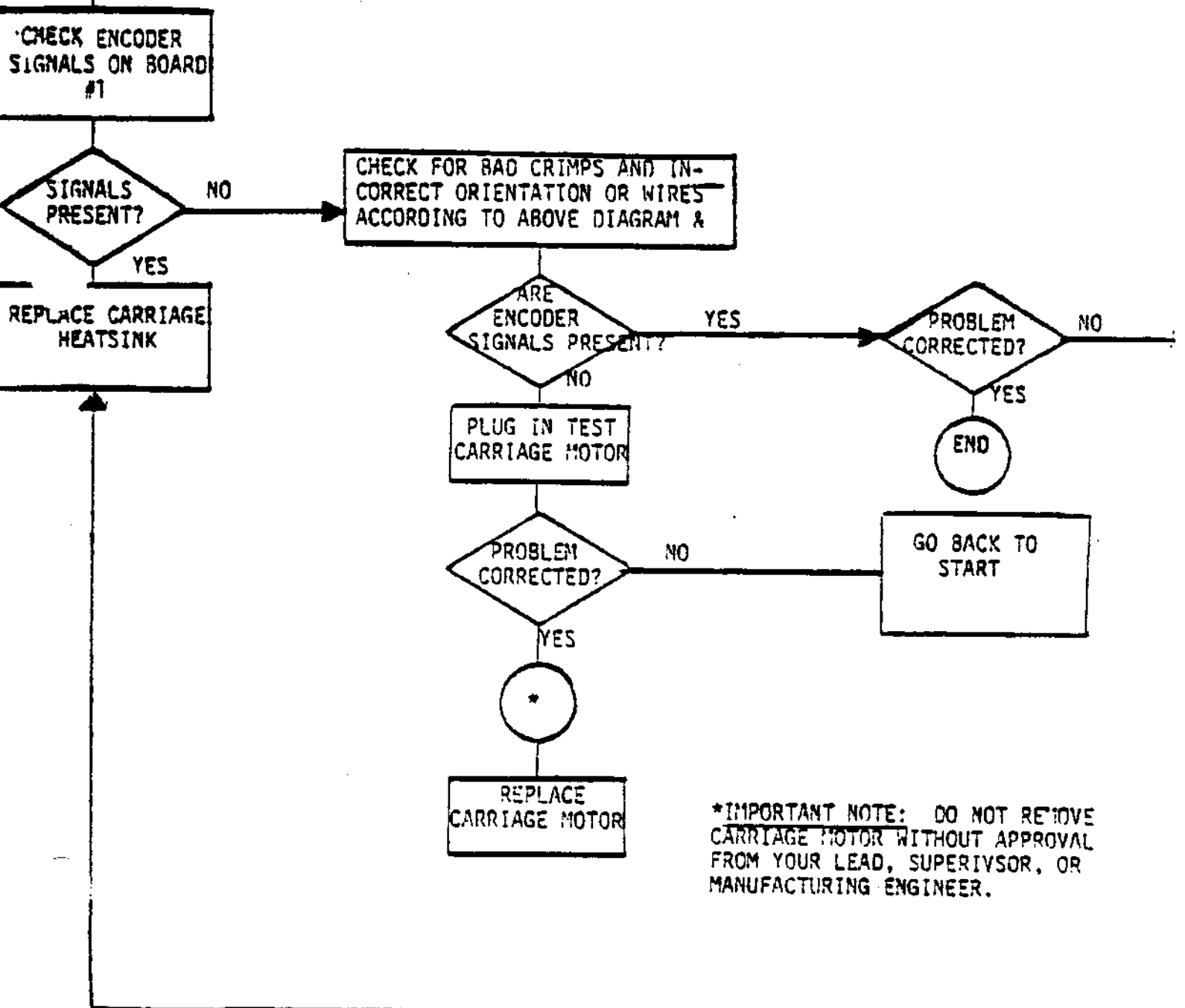
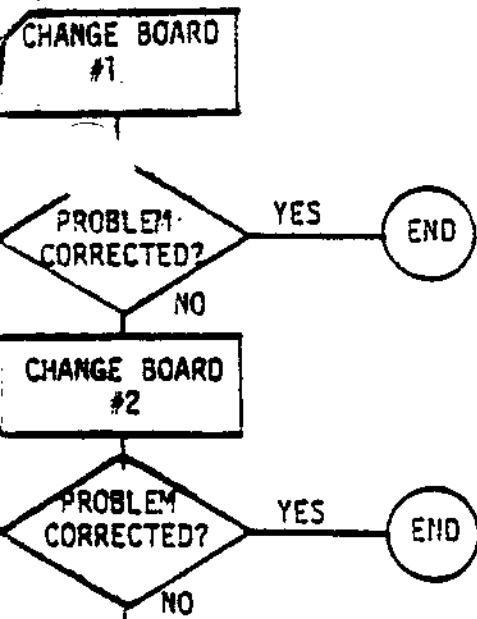
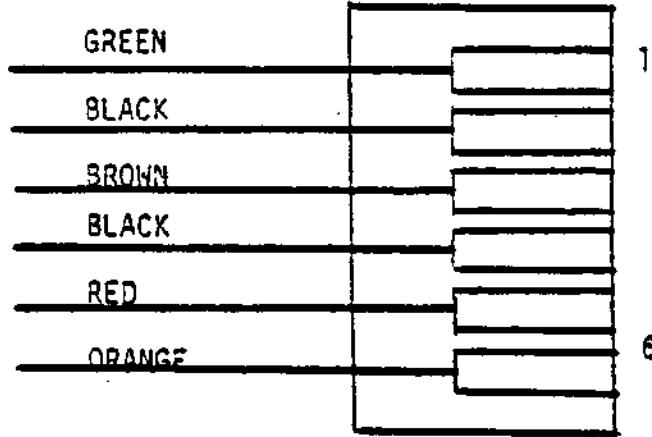

**\*IMPORTANT NOTE:** DO NOT REMOVE CARRIAGE MOTOR WITHOUT APPROVAL FROM YOUR LEAD, SUPERVISOR, OR MANUFACTURING ENGINEER.

RIBBON LIFT PROBLEM

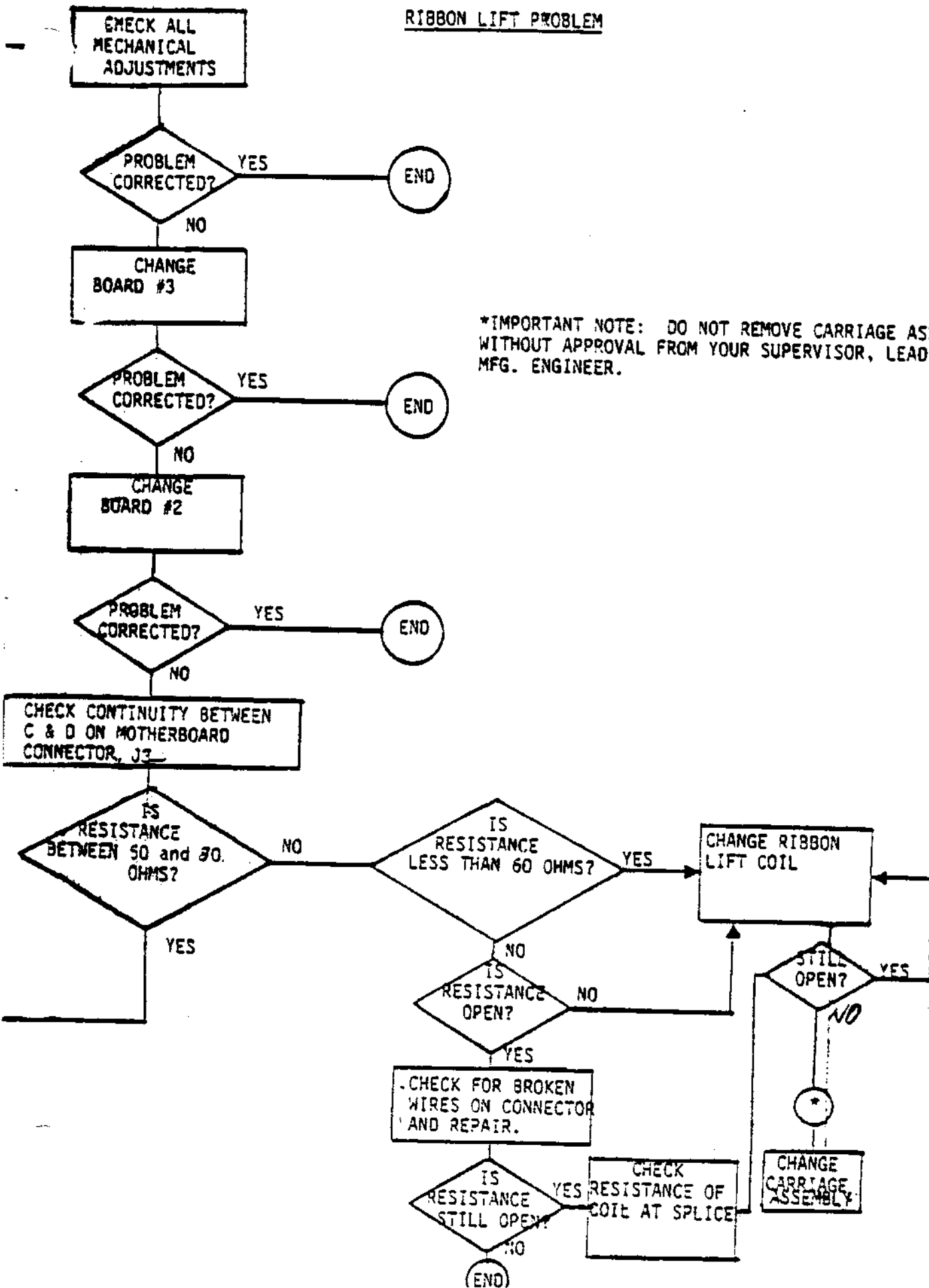

\*IMPORTANT NOTE: DO NOT REMOVE CARRIAGE ASSEMBLY WITHOUT APPROVAL FROM YOUR SUPERVISOR, LEAD OR MFG. ENGINEER.

# RIBBON-FEED PROBLEM

WIRE COLOR	PIN NUMBER	RESISTANCE
WHITE	K	29.6 - 37.6
BLUE	9	
PURPLE	J	29.6 - 37.6
GREY	8	

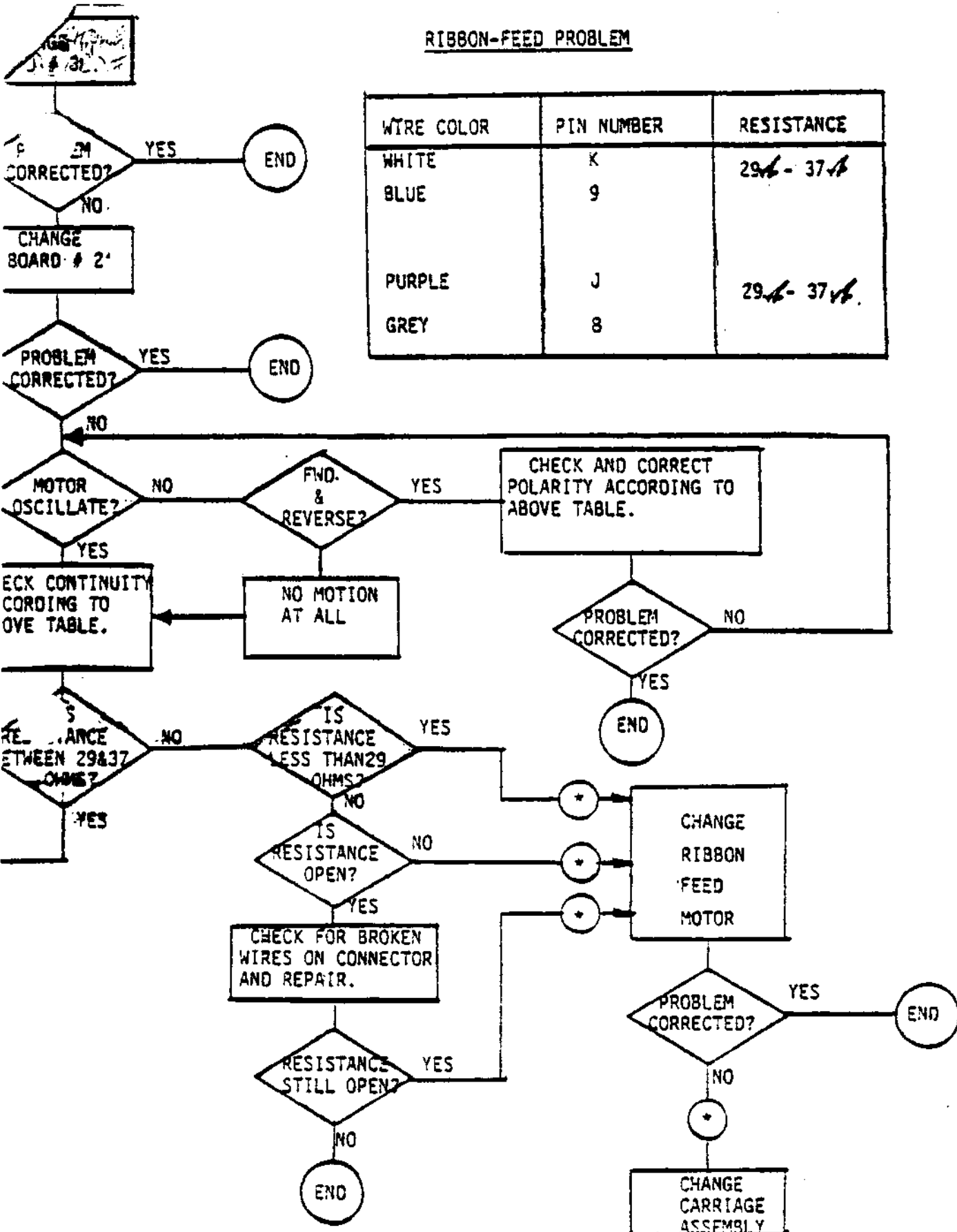

**\*IMPORTANT NOTE:** DO NOT REMOVE CARRIAGE ASSEMBLY WITHOUT APPROVAL FROM YOUR LEAD, SUPERVISOR OR MANUFACTURING ENGINEER.

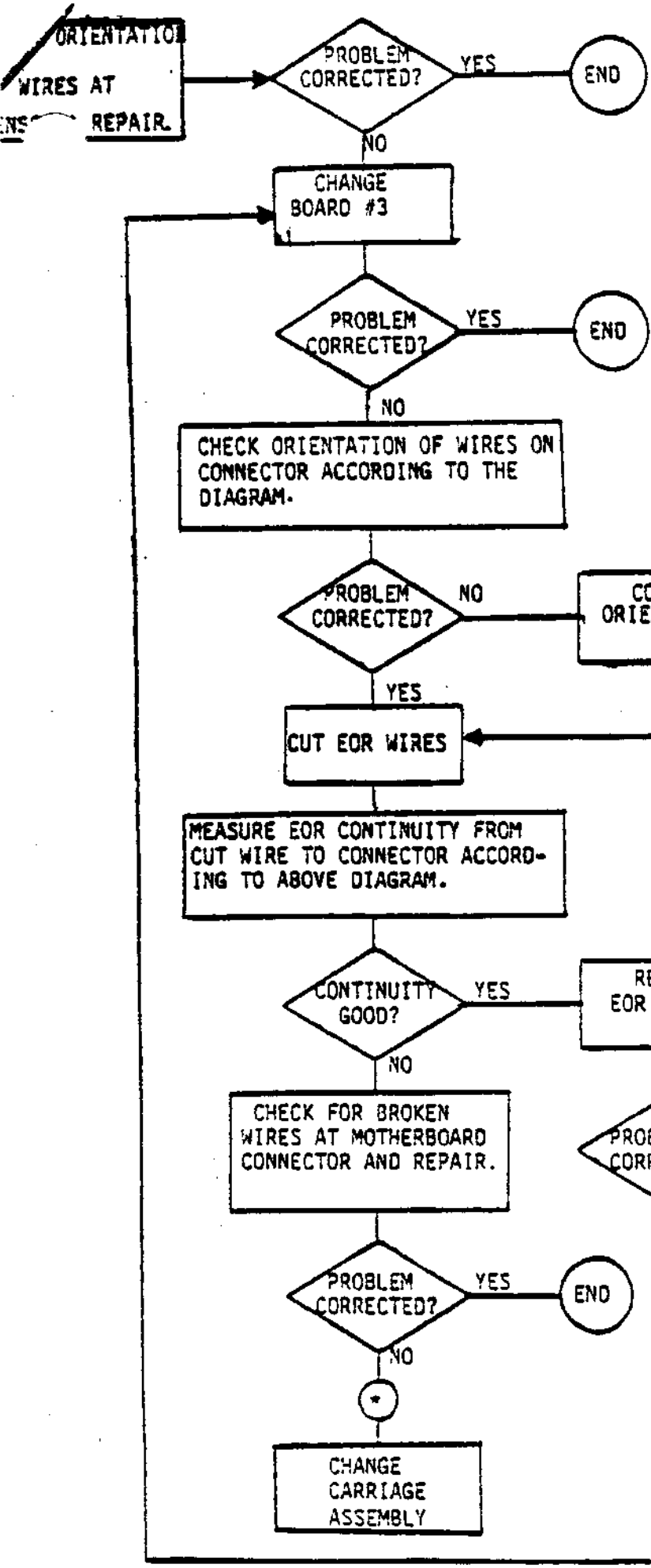

EOR PROBLEM

MOTHERBOARD CONNECTOR

WIRE COLOR	PIN NUMBER
YELLOW	H
YELLOW	H
BROWN	G
ORANGE	F

\*IMPORTANT NOTE: DO NOT REMOVE CARRIAGE ASSEMBLY WITHOUT THE APPROVAL FROM YOU SUPERVISOR, LEAD OR MFG. ENGINEER.



PAPERFEED PROBLEM

CHECK FUSES  
F4 and re-  
place if bad.

PROBLEM  
CORRECTED?  
YES → END

CHANGE  
BOARD #1

PROBLEM  
CORRECTED?  
YES → END

CHANGE  
BOARD #2

PROBLEM  
CORRECTED?  
NO

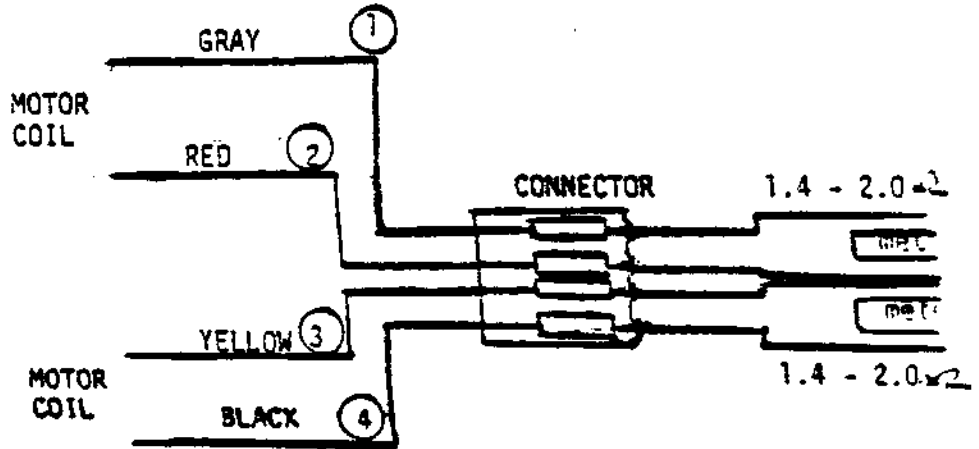

\*IMPORTANT NOTE: DO NOT REMOVE PAPERFEED MOTOR WITHOUT THE APPROVAL FROM YOUR LEAD, SUPERVISOR OR MANUFACTURING ENGINEER.

MOTOR  
OSCILLATE?  
NO → YES

MOTOR  
RUN IN  
REVERSE?  
YES → NO

CHECK AND CORRECT  
POLARITY ACCORD-  
ING TO THE ABOVE  
DIAGRAM.

PROBLEM  
CORRECTED?  
YES → END

NO MOTION  
AT ALL

CHECK CONTINUTY  
ACCORDING TO ABOVE  
DIAGRAM

RESISTANCE  
BETWEEN L4  
YES → NO

IS  
RESISTANCE  
LESS THAN  
1/4 Ω?  
YES → NO

IS  
RESISTANCE  
OPEN?  
NO → YES

USE  
TEST MOTOR

PROBLEM  
CORRECTED?  
YES → END

CHECK FOR BROKEN WIRES  
ON M.9. CONNECTOR AND  
REPAIR

RESISTANCE  
STILL  
OPEN?  
END

PROBLEM  
CORRECTED?  
YES → END

GO BACK TO  
START.

# HAMMER PROBLEM

CHECK POWER SUPPLY CONNECTIONS

CHECK ALL MECHANICAL ADJUSTMENTS & SWITCHES AND MAKE CORRECTIONS.  
(HAMMER SWITCH IS ON BOARD #3)

PROBLEM CORRECTED? YES → END

NO  
CHANGE BOARD #3

PROBLEM CORRECTED? YES → END

NO  
CHANGE BOARD #2

PROBLEM CORRECTED? YES → END

CHECK HAMMER RESISTOR (5 OHMS) FOR BAD CONNECTION OR WRONG RESISTANCE. CORRECT IF BAD.

PROBLEM CORRECTED? YES → END

CHECK CONTINUITY BETWEEN PINS 3 & 5 ON MOTHERBOARD CONNECTOR, J3.

IS RESISTANCE BETWEEN OHMS? YES → [ ] NO → [ ]

\* IMPORTANT NOTE: DO NOT REMOVE CARRIAGE ASSEMBLY WITHOUT APPROVAL FROM YOUR SUPERVISOR, LEAD OR MFG. ENGINEER.

