

**MODEL 630/630 ECS
PRINTERS/TERMINALS**

API INTERFACE

90440-01 Rev A

January 1984

DIABLO SYSTEMS, INC.

A XEROX COMPANY

FCC NOTICE

WARNING: This equipment generates, uses and can radiate radio frequency energy and, if not installed in accordance with the instructions manual, may cause interference to radio communications.

INSTRUCTIONS TO THE USER: This equipment has been type tested and found to comply with the limits for a Class B computing device in accordance with the specifications in subpart J of Part 15 of the FCC Rules, which are designed to provide reasonable protection against such interference in a residential installation. This equipment generates and uses radio frequency energy, and if not installed and used properly in strict accordance with the manufacturer's instructions, may cause interference to radio and television reception. There is, however, no guarantee that interference will not occur in a particular installation.

If equipment certified to meet Class B limits does cause interference to radio or television reception, which can be determined by turning the equipment off and on, the user is encouraged to try to correct the interference by one or more of the following measures:

- Reorient the receiving antenna.
- Relocate the equipment with respect to the receiver.
- Move the equipment away from the receiver.
- Plug the equipment into a different outlet so that the equipment and the receiver are on different branch circuits.

If necessary, the user should consult the dealer or an experienced radio/television technician for help. In addition, an FCC booklet, "How to Identify and Resolve Radio-TV Interference Problems", Stock No. 004-000-00345-4, is available from the U.S. Government Printing Office, Washington, D.C., 20402.

In equipment labeled Class B compliant a shielded and grounded I/O cable is necessary to achieve compliance with the FCC Rules regarding radio emissions from computers. Please consult your dealer or authorized Diablo sales representative for further details regarding such a cable.

Diablo®, HyType® and XEROX® are trademarks of XEROX CORPORATION.

©Copyright 1984 by Diablo Systems, Inc., Fremont, California, USA
Publication No. 90440-01 Rev A - First Edition.

Printed in the USA

PREFACE

This manual describes interfacing and operating considerations pertaining to the Model 630 API interface configurations. It is written presuming the reader has working knowledge of the type of interfaces described herein, or at least of the particular type of interface used in his system. In general, the discussion in this manual is limited to only those features of the subject interfaces that directly pertain to operation of the Diablo Model 630 API terminals.

This manual is one in a family of manuals covering the Model 630 printers and terminals. For a list of related publications, refer to any one of the manuals listed below:

- Model 630 Product Description Manual, Publication No. 90442-XX;
- Model 630 Communications Terminal Operator's Guide, Publication No. 90445-XX;
- Model 630 API/ECS Communications Terminal Operator's Guide, Publication No. 90466-XX;
- Model 630 ECS/IBM Operator's Guide, Publication No. 90302-XX.

Comments on all Diablo publications or their use are invited. Address your comments to:

Manager, Product Support Publications
Diablo Systems, Incorporated
P.O. Box 5030
Fremont, California 94537

Diablo Systems, Inc., reserves the right to make changes and/or improvements to its products without incurring any obligation to incorporate such changes or improvements in units previously sold or shipped.

WARRANTY

Diablo Model 630 printers and terminals are warranted against defects in materials and workmanship for 90 days from the date of purchase by the end user. Any questions regarding the warranty should be directed to your Diablo Sales Representative. All requests for repair should be directed to the Diablo or Xerox Service Center in your area. This will assure you of the fastest possible service. For a list of Service Center locations and description of available service options, refer to the Service Information Guide, Diablo Publication No. 90070-XX.

UL/CSA

UL recognized and listed under File No. E51242.
CSA certified as a component and printer under CSA File LR2196.

(For a complete list of pertinent standards and regulations, refer to section 1.5 in the Model 630 Product Description Manual, Publication No. 90442-XX.)

REVISION CONTROL RECORD

MODEL 630 API INTERFACE MANUAL - PUBLICATION No. 90440-01

Note: On revised pages of text, each area of new revision is marked by a heavy vertical bar in the margin.

<u>PAGE</u> / <u>REV</u>	<u>PAGE</u> / <u>REV</u>	<u>PAGE</u> / <u>REV</u>	<u>PAGE</u> / <u>REV</u>
Cover	A	3-1	A
ii	A	3-2	A
iii	A	3-3	A
iv	A	3-4	A
v	A	3-5	A
vi	A	3-6	A
vii	A	3-7	A
viii	A	3-8	A
ix	A	3-9	A
		3-10	A
1-0	A	3-11	A
1-1	A	3-12	A
1-2	A	3-13	A
1-3	A	3-14	A
1-4	A	3-15	A
1-5	A	3-16	A
1-6	A	3-17	A
1-7	A	3-18	A
		3-19	A
2-1	A	3-20	A
2-2	A	3-21	A
2-3	A	3-22	A
2-4	A	3-23	A
2-5	A	3-24	A
2-6	A	3-25	A
2-7	A	3-26	A
2-8	A	3-27	A
2-9	A	3-28	A
2-10	A	3-29	A
2-11	A	3-30	A
2-12	A	3-31	A
2-13	A	3-32	A
2-14	A	3-33	A
		3-34	A
		3-35	A
		3-36	A
		3-37	A
		3-38	A
		3-39	A
		3-40	A
		3-41	A
		3-42	A
		3-43	A
		3-44	A
		3-45	A
		3-46	A
		3-47	A
		3-48	A
		3-49	A
		3-50	A
		3-51	A
		3-52	A
		3-53	A
		3-54	A
		3-55	A
		3-56	A
		3-57	A
		3-58	A
		3-59	A
		3-60	A
		3-61	A
		3-62	A
		3-63	A
		3-64	A
		3-65	A
		3-66	A
		3-67	A
		3-68	A
		3-69	A
		3-70	A
		3-71	A
		3-72	A
		3-73	A
		3-74	A
		4-1	A
		4-2	A
		4-3	A
		4-4	A
		4-5	A
		4-6	A
		4-7	A
		4-8	A
		4-9	A
		4-10	A
		4-11	A
		4-12	A
		4-13	A
		4-14	A
		4-15	A
		4-16	A
		4-17	A
		4-18	A
		4-19	A
		4-20	A

TABLE OF CONTENTS

SECTION 1 - GENERAL DESCRIPTION

1.1	General Information	1-1
1.2	Signal Conventions	1-5
1.3	Serial RS-232-C Interface	1-5
1.4	IEEE-488 Interface	1-5
1.5	Centronics Interface	1-7

SECTION 2 - INTERFACE HARDWARE AND SIGNALS

2.1	General	2-1
2.2	The API Circuit Board	2-1
2.3	The Interface Connector	2-1
2.4	Selecting The Type Of Interface	2-2
2.5	RS-232-C Interface	2-4
2.5.1	Standard Diablo RS-232-C Interface Cable	2-4
2.5.2	Multihost Diablo RS-232-C Interface Cables	2-4
2.5.3	Pin Assignments In The Standard Cable	2-5
2.5.4	RS-232-C Signal Definitions	2-5
2.5.5	RS-232-C Interface Level Converter Circuits	2-6
2.5.5.1	Input Level Converter	2-6
2.5.5.2	Output Level Converter	2-6
2.6	IEEE-488 Interface	2-6
2.6.1	Cable	2-6
2.6.2	Pin Assignments	2-7
2.6.3	IEEE-488 Signal Definitions	2-8
2.7	Centronics-Type Interface	2-9
2.7.1	Cables	2-9
2.7.2	Pin Assignments	2-9
2.7.3	Centronics Signal Definitions	2-9
2.8	Feeder Interface	2-14

SECTION 3 - OPERATING CONSIDERATIONS

3.1	General	3-1
3.2	LCPN Operator Control Panel	3-1
3.2.1	Slide Switches	3-2
3.2.2	Command Switches	3-3
3.2.3	Indicator Lights	3-4
3.2.4	Control Panel Jumpers	3-4
3.3	FFCPN Operator Control Panel	3-5
3.3.1	General	3-5
3.3.2	The Mode Switches	3-5
3.3.3	The Operating Switches	3-8
3.3.4	The Front Panel Indicators	3-10
3.3.4.1	Audio Alarm	3-10
3.3.4.2	Indicator Lamps	3-10
3.4	Control Codes	3-11
3.5	Escape Code Sequences	3-12
3.6	Serial RS-232-C Communications Protocols	3-14
3.6.1	ETX/ACK Protocol	3-15
3.6.2	DC1/DC3 (X-ON/X-OFF) Protocol	3-15
3.6.3	Printer Ready Protocol	3-15
3.7	IEEE-488 Interface Protocol	3-16
3.8	Centronics Interface Protocol	3-16

(Table of Contents - cont'd)

3.9	Printing Format	3-16
3.9.1	Definition of Terms	3-16
3.9.2	Standard Formats	3-18
3.9.3	Proportional Space Printing	3-18
3.9.4	Optional Formats (Variable Indexing)	3-19
3.9.4.1	Variable HMI (Remote HMI Mode)	3-19
3.9.4.2	Variable VMI (Remote VMI Mode)	3-20
3.9.4.3	Lines Per Page	3-20
3.10	Forward/Backward Printing	3-20
3.10.1	Auto Backward Printing	3-20
3.10.2	Programmed Backward Printing	3-21
3.10.3	Inverted Horizontal Motion	3-21
3.11	Print Suppression	3-21
3.12	Control Of Margins	3-21
3.12.1	Horizontal Margins	3-21
3.12.2	Vertical Margins	3-22
3.13	Tabbing	3-22
3.13.1	Absolute Horizontal Tab	3-22
3.13.2	Absolute Vertical Tab	3-23
3.13.3	Normal Horizontal Tab	3-23
3.13.4	Normal Vertical Tab	3-24
3.14	Line Feed	3-24
3.15	Half-Line Feed	3-24
3.16	Form Feed	3-24
3.17	Carriage Return	3-24
3.18	Auto Carriage Return	3-24
3.19	Graphics	3-25
3.20	Two-Color Printing	3-25
3.21	Reset/Initialization	3-26
3.21.1	Limited Reset	3-26
3.21.2	Initialize	3-26
3.22	Print Wheel Table Download	3-27
3.22.1	General	3-27
3.22.2	Download Variations	3-28
3.22.3	Keys To Understanding The Download Function	3-29
3.22.4	Download Data Record Format	3-30
3.22.4.1	Record Start Character	3-31
3.22.4.2	Record Type Character	3-31
3.22.4.3	Byte Count	3-31
3.22.4.4	Load Address	3-32
3.22.4.5	Table Data	3-34
3.22.4.6	Checksum	3-35
3.22.5	The Download Sequence	3-36
3.22.6	Sample Download Structure	3-38
3.22.7	Manually Assembling the Print Table Data	3-39
3.22.7.1	The Data Sheet	3-39
3.22.7.2	The Universal Data Tables	3-40
3.22.7.3	The Download Worksheets	3-40
3.22.7.4	Assembling the Print Table	3-40
3.23	Remote Diagnostics	3-48
3.23.1	ESC SUB I	3-48
3.23.2	ESC SUB R	3-48
3.23.3	ESC SUB SO	3-48

3.23.4	ESC SUB 1	3-49
3.23.5	ESC SUB 3	3-49
3.24	Word Processing Features	3-49
3.24.1	Proportional Space Printing	3-50
3.24.2	Offset Selection	3-50
3.24.3	Auto Underscore	3-50
3.24.4	Bold Overprint	3-51
3.24.5	Shadow Print	3-51
3.24.6	Carriage Settling Time Control	3-51
3.24.7	Half-Unit Backspace	3-51
3.24.8	Program Mode	3-51
3.24.8.1	Spoke Position Data (first character)	3-52
3.24.8.2	Hammer Energy/Ribbon Advance (second character)	3-53
3.24.9	Auto Center	3-54
3.24.10	Auto Justify	3-54
3.24.11	Cancel Word Processing Features	3-55
3.25	HyPlot Vector Plotting	3-56
3.25.1	Scope	3-56
3.25.2	Definition Of Terms	3-56
3.25.3	Description Of HyPlot Vector Plotting	3-57
3.25.4	The HyPLOT Commands	3-58
3.25.5	Basic HyPLOT Procedure	3-60
3.25.6	Summary	3-62
3.26	Feeder Support	3-68
3.27	Self-Test	3-69
3.28	Print Speed Measurement	3-71
3.29	Extended Character Set (ECS)	3-71
3.29.1	Standard ECS Character Sets	3-71
3.29.2	Standard ECS 8-Bit ASCII Addressing	3-72
3.29.3	Standard ECS 7-Bit ASCII Addressing	3-72
3.29.4	ECS/IBM Character Set	3-73
3.29.5	8-Bit ASCII Addressing of the ECS/IBM Character Set	3-73
3.29.6	7-Bit ASCII Addressing of the ECS/IBM Character Set	3-73
3.30	Remote Print Wheel Selection	3-74

SECTION 4 - OPERATING REFERENCES

4.1	API Print Wheel Support	4-1
4.2	ASCII Coding System	4-2
4.3	Print Wheel ASCII Code Charts (Typical)	4-3
4.4	The Diablo Print Wheel Data Books	4-15
4.5	Decimal Value Tables	4-16
4.6	Tables For Character Proportional Space Units & Print Wheel Program Mode	4-19

ILLUSTRATIONS

<u>Figure</u>		<u>Page</u>
1-1	Diablo Model 630 API Terminals	1-0
1-2	Model 630 API Terminal Block Diagram	1-3
1-3	API Circuit Board Block Diagram	1-4
1-4	IEEE-488 Interface Timing	1-6
1-5	Centronics Interface Timing	1-7
2-1	API Circuit Board Layout	2-1
2-2	Model 630 API Interface Connector	2-2
2-3	RS-232-C Interface Cable	2-4
2-4	IEEE-488 Interface Cable	2-7
2-5	IBM Centronics Interface Cable	2-10
2-6	TRS-80 Models I/III Centronics Interface Cable	2-11
2-7	Apple II/III Centronics Interface Cable	2-12
2-8	Centronics 703 Interface Cable	2-13
2-9	Feeder Interface Connector	2-14
3-1	Model 630 LCPN Control Panel	3-2
3-2	Model 630 API FFCPN Control Panel	3-5
3-3	Page Layout And Printing Format	3-17
3-4	Download Variations	3-28
3-5	Download Record Format	3-30
3-6	Download Table Memory Map	3-33
3-7	Download Flow Chart	3-37
3-8	Sample Download Structure	3-38
3-9	Print Wheel Data Sheet	3-42
3-10	Download Table Worksheet (Xerox 96 - U.S. Pica 10 ASCII)	3-43
3-11	Download Structure For U.S. Pica 10 ASCII Print Wheel	3-44
3-12	Universal Download Data Tables	3-45
3-13A	Download Table Worksheet - Standard Print Wheels	
	- ECS Print Wheels Primary Character Set	3-46
3-13B	Download Table Worksheet - ECS Print Wheels Supplementary Character Set	3-47
3-14	Absolute/Relative Vector Plot Example	3-61
3-15	HyPlot Flowchart	3-67
3-16	Self-Test Printout - API (Firmware Levels Below -18)	3-69
3-17	Self-Test Printout - API (Firmware Level -18)	3-70
3-18	Self-Test Printout - API (Firmware Level -20)	3-70
4-1	ASCII Code Chart	4-2
4-2	96-Character Print Wheel (US) - Plastic	4-4
4-3	88-Character Print Wheel (US WP) - Metalized	4-5
4-4	92-Character Print Wheel (English WP) - Metalized	4-6
4-5	96-Character Print Wheel (US ASCII) - Metalized	4-7
4-6	96-Character Print Wheel (English WP) - Metalized	4-8
4-7	ECS Scientific Print Wheel	4-9
4-8	ECS Teletex Print Wheel	4-10
4-9	ECS Multipurpose Print Wheel	4-11
4-10	ECS Legal / Italic Print Wheel	4-12
4-11	ECS Dual Pitch Print Wheel	4-13
4-12	ECS PC Graphics Print Wheel	4-14

TABLES

<u>Table</u>		<u>Page</u>
1-1	Model 630 API Operating Features	1-2
2-1	Interface Selection	2-2
2-2	I/O Pin Assignments	2-3
2-3	RS-232-C Interface Cable Pin Assignments	2-5
2-4	IEEE-488 Interface Cable Pin Assignments	2-7
2-5	IBM Centronics Interface Cable Pin Assignments	2-10
2-6	TRS-80 Models I/III Interface Cable Pin Assignments	2-11
2-7	Apple II/III Centronics Interface Cable Pin Assignments	2-12
2-8	Centronics 703 Interface Cable Pin Assignments	2-13
2-9	Feeder Interface Connector Pin Assignments	2-14
3-1	Slide Switch And Jumper Assignments On The LCPN Control Panel	3-1
3-2	IEEE-488 Primary Listen Addresses	3-9
3-3	Standard Printing Formats	3-18
3-4	Feeder Identification	3-49
3-5	ASCII Characters For Values Of h And v	3-58
3-6	Conversion - X/Y Plot Increments Of Move To Binary Equivalents	3-59
3-7	Conversion - X/Y Plot Binary Equivalents To ASCII Byte Code	3-59
3-8	ASCII/Binary Code Chart	3-59
3-6A	Conversion - X/Y Plot Increments Of Move To Binary Equivalents (HyPlot Example A)	3-64
3-7A	Binary To ASCII (HyPlot Example A)	3-64
3-6B	Conversion - X/Y Plot Increments Of Move To Binary Equivalents (HyPlot Example B)	3-65
3-7B	Binary To ASCII (HyPlot Example B)	3-65
3-6C	Conversion - X/Y Plot Increments Of Move To Binary Equivalents (HyPlot Example C)	3-66
3-7C	Binary To ASCII (HyPlot Example C)	3-66
4-1	Hexadecimal-Decimal Conversion	4-3
4-2	Decimal Values Of ASCII Characters	4-16
4-3	ASCII Values For ESC Sequences (Set HMI/Set VMI)	4-17
4-4	ASCII Values For ESC Sequences (Set Lines/Page; Set Absolute Horizontal Tab; Set Absolute Vertical Tab)	4-18
4-5	Character Proportional Space Units - Metalized Print Wheels (US/UK)	4-19
4-6	Print Wheel Program Mode - Characters For Hammer Energy And Ribbon Advance	4-20

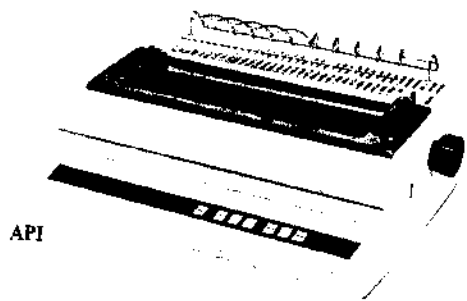

API

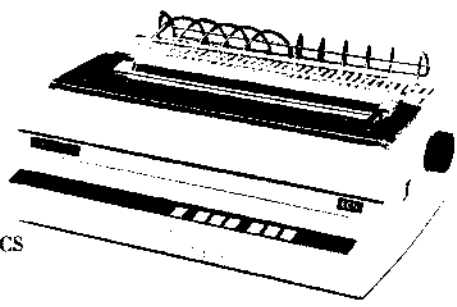

API/ECS

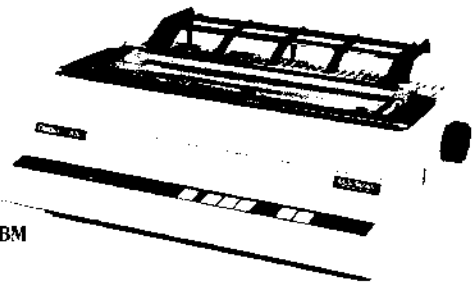

ECS/IBM

Figure 1-1. DIABLO MODEL 630 API TERMINALS

SECTION 1
GENERAL DESCRIPTION

1.1 GENERAL INFORMATION

This Interface Manual applies to both the ECS (Extended Character Set) and non-ECS versions of the Model 630 API (All Purpose Interface) communications terminal. This includes the Model 630 ECS/IBM which is simply a variation of the Model 630 API/ECS specially adapted for the IBM personal computer. For the ECS/IBM, the reader is referred also to the Diablo 630 ECS/IBM Operator's Guide, which contains information regarding the special features of Model 630 ECS/IBM. In most respects, the standard (non-ECS) Model 630 and the Model 630 ECS function the same. The differences that exist relate to print wheel addressing, ribbon lift, and the mechanics of print wheel shifting required to access the inner and outer character rows on the ECS print wheels. These differences are noted wherever pertinent throughout this manual. All of the features attributed to the standard API in this manual apply equally to the API/ECS, except for optional two-color ribbon capability which is not available in the ECS.

The standard Model 630 API is capable of operating with all Diablo and Xerox 88-, 92- and 96-character metalized print wheels, and 96-character plastic print wheels. The API/ECS Model 630 also operates with these print wheels, plus it can operate with Diablo's ECS print wheels which can contain two characters per spoke, or up to 192 characters per print wheel.

The Model 630 ECS/IBM operates with Diablo's specially designed ECS IBM print wheel for the IBM PC character set, as well as all of the 88-, 92- and 96-character print wheels. Although the Model 630 ECS/IBM does not contain the print wheel tables to operate the standard Diablo ECS print wheels, any one of these wheels can be used by assembling and downloading an appropriate print table from the host computer.

The Diablo Model 630 API terminals contain two major circuit boards:

1. The SCE (Servo Control Electronics) board.
2. The API (All-Purpose Interface) board.

The API circuit board can function in any one of three different interface configurations:

1. As a serial Receive-Only (RO) RS-232-C type interface. *
2. As a listen-only, PET-type IEEE-488 parallel interface. *
3. As a Centronics-type 8-bit parallel interface.

* ECS/IBM units operate only with the Centronics-type 8-bit parallel interface.

The interface type is selected by the wiring configuration of the Diablo-supplied external interface cable connected to the 50-pin interface connector at the rear of the Model 630. There are no on-board jumpers or switches to set when selecting the type of interface. A separate Interface Reference Manual (Publication No. 90410-XX) contains an extensive list of interface cable pin assignments for connecting the Model 630 API terminal to various mini/micro computer systems.

The only difference in operation of the API board for the three different types of interface is the way in which data is accepted from the interface. Once loaded into the input buffer, all data is acted on by a common control program.

Table 1-1 lists the standard and optional operating features of the Model 630 API terminals. Figure 1-2 shows a block diagram of the Model 630 API terminal, and Figure 1-3 contains a block diagram of the API circuit board.

**Table 1-1
MODEL 630 API OPERATING FEATURES**

<u>FEATURES</u>	<u>S / O</u> (STANDARD/OPTIONAL)	
Interface Types Supported: (Note 1)		
RS-232-C Serial	S	(Not available with ECS/IBM)
IEEE-488 Parallel	S	(Not available with ECS/IBM)
Centronics Parallel	S	
Print Buffer Capacity:		
1344 Characters	S	
Baud Rate Capability:		
300, 1200, 2400, 9600	S	(Note 2)
Protocols:		
ETX/ACK, DC1/DC3, Printer Ready	S	(Note 3) (Not avail. with ECS/IBM)
Parity Checking	S	(Not avail. with ECS/IBM)
Basic Control Panel (LCPN)	O	(Note 4) (Not avail. with ECS/IBM)
Fully-Featured Control Panel (FFCPN)	S	(Note 4)
Metal/Plastic Print Wheel Select	S	
Foreign Language and APL Capability	S	(Note 5)
Extended Character		
Set (ECS) Capability	S	(Note 6)
Character Spacing 10, 12, 15, PS	S	
Diablo Sheet Feed Accessory Support	S	
Forms Tractor	O	
Two-Color Ribbon Capability	O	(Note 7)
Self Test	S	
Remote Diagnostics	S	(Note 8)
Print Table Download Capability	S	
HyPlot Vector Plotting	S	
Auto Carriage Return	S	
Auto Line Feed	S	
Auto Backward Printing	S	
Programmed Backward Printing	S	
Inverted Horizontal Motion	S	
Print Suppression	S	
Margin Control	S	
Absolute Tabbing	S	
Normal Tabbing	S	
Line Feed	S	
Half-Line Feed	S	
Form Feed	S	
Graphics	S	
Carriage Settling Time Control	S	
Program Mode	S	
Offset Selection	S	
Auto Underscore	S	
Bold Overprint	S	
Shadow Print	S	
Half-Unit Backspace	S	
Auto Center	S	
Auto Justify	S	
Cover Open Detect	S	
End-of-Ribbon Detect	S	
Paper Out Detect	S	
VDE Compliance	S	
FCC B Compliance	S	

- Notes:**
- 1) Defined by interface cable configuration.
 - 2) Baud rate capability in early units is 110, 300, 1200, 2400 (check your control panel switches).
 - 3) ETX/ACK cannot be used in ECS 7-bit ASCII mode.
 - 4) Control panels shown on pages 3-2,3-5.
 - 5) Can be user defined thru print table download procedure.
 - 6) Standard on Model 630 ECS version only.
 - 7) Not available on ECS versions; optional on standard Model 630.
 - 8) Remote diagnostic status reporting capability is provided only by the RS-232-C interface.

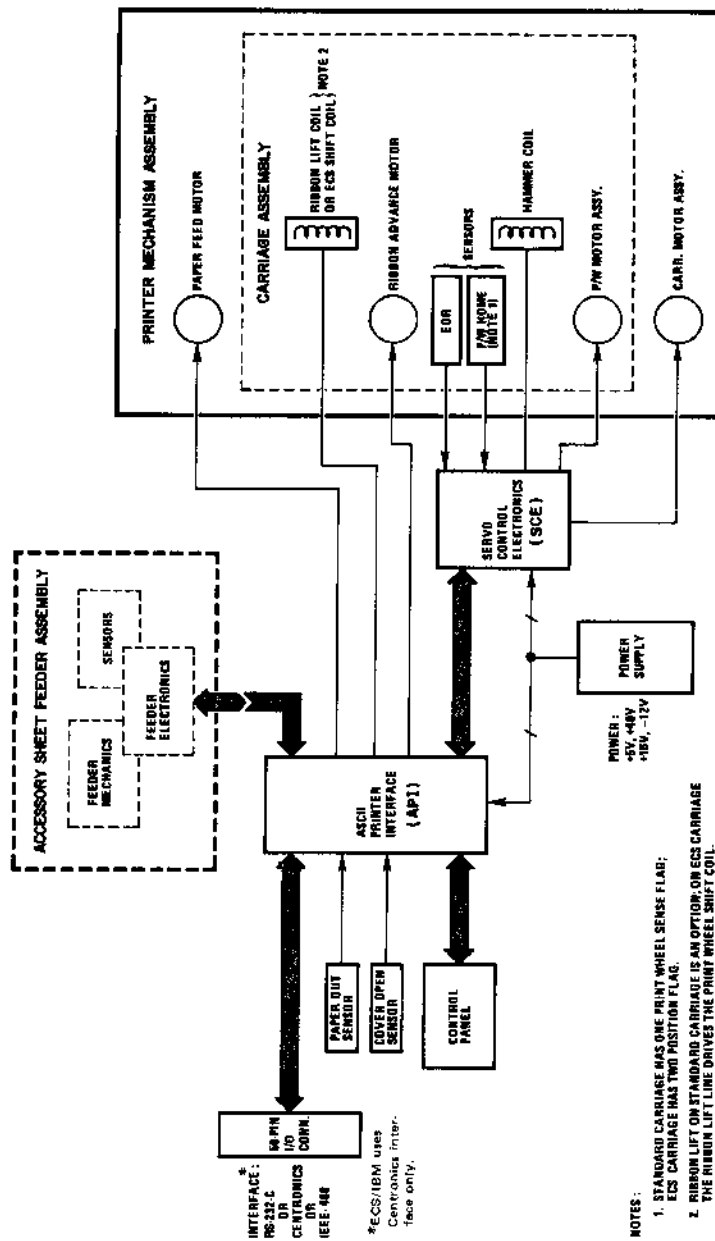

Figure 1-2. MODEL 630 API TERMINAL BLOCK DIAGRAM

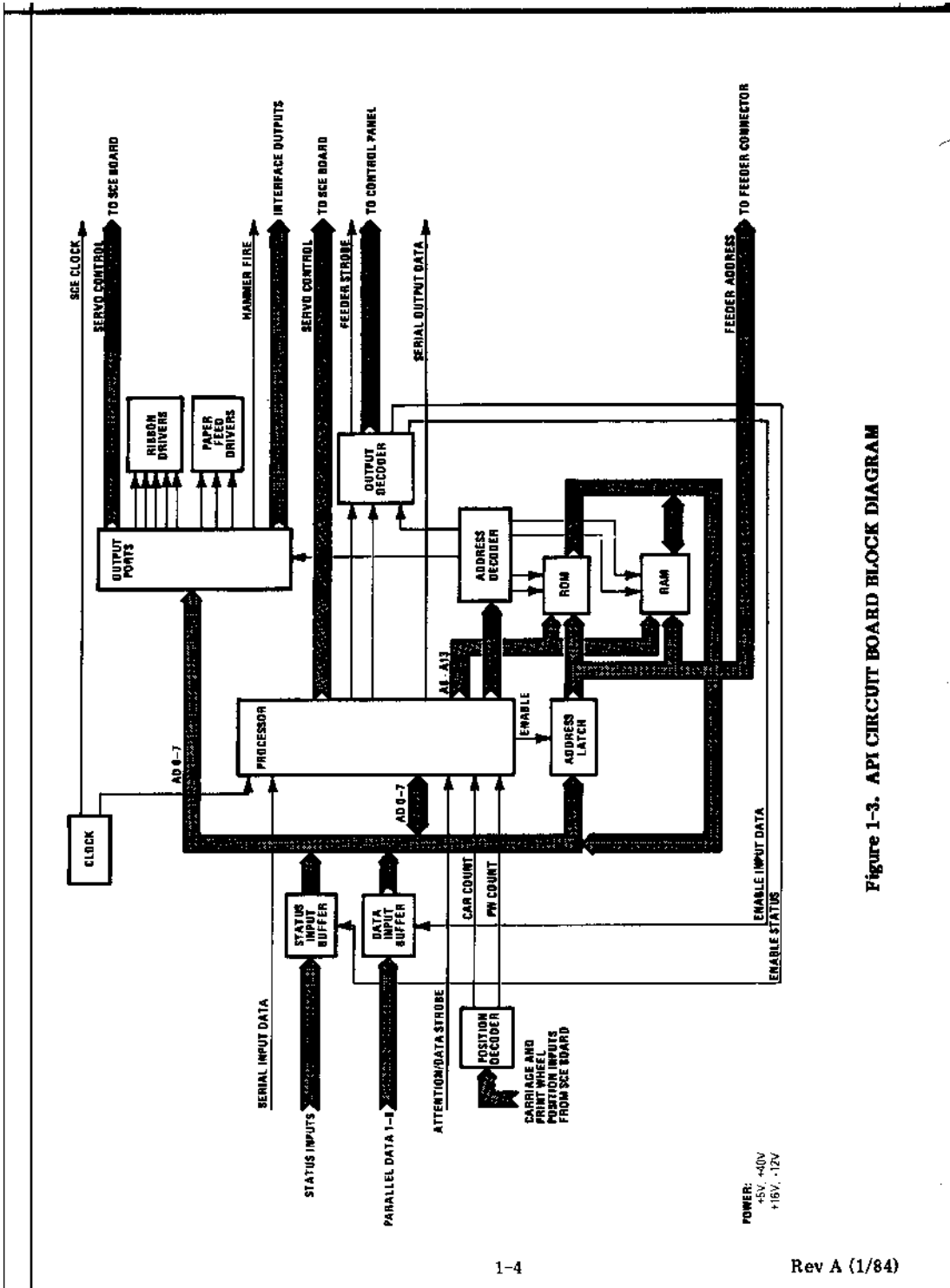

Figure 1-3. API Circuit Board Block Diagram

1.2 SIGNAL CONVENTIONS

All signal designations used in this manual comply with the following conventions.

- 1) A signal name prefixed by a "-" symbol (as in -Rx DATA) identifies a signal whose active state is a low electrical level.
- 2) A signal name prefixed by a "+" symbol (as in +DTR) identifies a signal whose active state is a high electrical level.
- 3) Electrical levels are indicated by "H" (HI) or "L" (LO). HI indicates an electrical level greater than 2.4 volts. LO indicates an electrical level less than 0.8 volts.
- 4) The "true" state of a signal is indicated by a logical "1", and the "false" state by a logical "0", regardless of electrical levels. For example, -Rx DATA = 1 = LO and +DTR = 1 = HI.

1.3 SERIAL RS-232-C INTERFACE

Typically, the RS-232-C configuration of the Model 630 API receives data from a remote terminal or a host computer through a communications link comprising telephone lines and a pair of modems. The API is capable of communicating over leased private lines and exchange dial networks, and through either frequency division multiplexed networks or time division multiplexed networks. Provision is made for connecting the terminal to a Bell 103A or equivalent modem. The API uses the USA Standard Code for Information Interchange (ASCII).

The API transmits and receives characters at switch selectable speeds of 300, 1200, 2400 and 9600 baud (later units). Each ASCII character code consists of a start bit, seven or eight data bits (selected through the FFCPN control panel), a parity bit, and one stop bit.

The API serial interface configuration is compatible with the Diablo Model 630 SPI terminal interface.

1.4 IEEE-488 INTERFACE (PET-Type)

The IEEE-488 type interface is commonly referred to as the GPIB (General-Purpose Interface Bus). The addressing feature of this type of interface allows connecting several devices to the host computer on the same interface bus. The API IEEE-488 interface functions as an address-to-listen, listen-only device. The API is always a "listener", while the host computer is always the "talker".

Note: The Model 630's IEEE-488 interface was designed to support the Commodore GPIB, which does not conform exactly to the standard IEEE-488 GPIB. (For example, the Commodore GPIB is sensitive to signal transitions and the standard GPIB is sensitive to voltage levels.)

The IEEE-488 interface consists of 24 parallel lines, allocated as follows:

- 8 lines on which to send parallel data.
- 8 ground lines.
- 5 bus management lines.
- 3 lines for "handshake" signals.

The three handshake signals are called Not Ready For Data (NRFD), Data Valid (DAV), and Not Data Accepted (NDAC). These signals provide the required protocol for operation with this type of interface. Figure 1-4 shows the timing relationships between these signals.

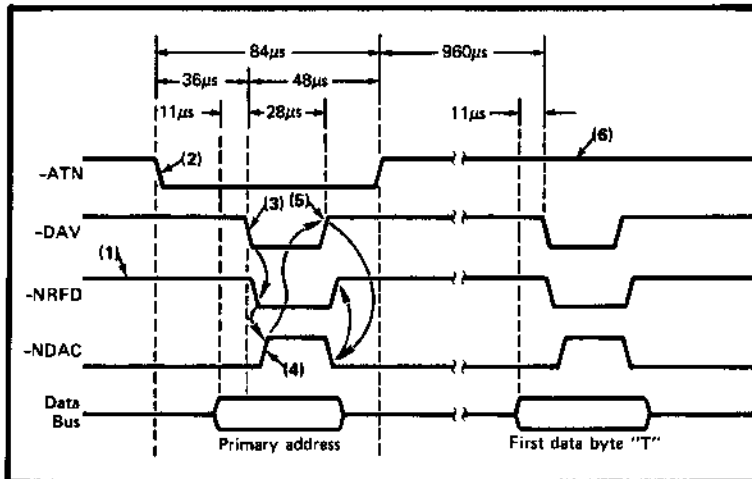

Figure 1-4. IEEE-488 INTERFACE TIMING

In operation, when the talker has data to send, it puts a LO on the -ATN line and waits until all listeners are ready. As each listener becomes ready, it releases the NRFD line. When all of the devices have released the line, the -NRFD signal is HI (point 1 in Fig. 1-4). This indicates to the talker that all of the devices are now ready to receive data. The talker drops the -ATN (attention) signal (2), puts the device address onto the data lines and sets -DAV (3), telling the listeners that data is ready to be sampled. The -ATN signal identifies the data on the data bus as a device address instead of regular data. The API compares the address on the data bus against the address switch settings on its control panel. If they match, the API enters the Listen state. The listener releases the NDAC line to indicate that it has read the data. When all listeners have released the NDAC line, the -NDAC signal goes HI (4) to tell the talker that all listeners have finished reading the data. The talker removes the data from the data bus and raises the -DAV signal (5) to indicate that the data bus no longer holds valid data. By repeating the address cycle, the talker can sequentially address multiple listeners to simultaneously receive the subsequent data string.

The addressed listener(s) remains in the listen state, ready to receive data. Subsequent data cycles proceed in the same manner as the address cycle except that the -ATN signal is not LO (6). The API terminates the listen state and enters the "Unlisten" state when -ATN goes LO, and a "UNL" code (hex 3F) is received on the data bus.

Since the API does not have any capability to send information back to the controller, it does not support the SRQ, Serial Poll and Parallel Poll features of the standard IEEE-488 interface.

1.5 CENTRONICS INTERFACE

The Centronics type interface is 8-bit parallel with simple handshake signals. This type of interface does not support device addresses, and thus only one API can be connected to the interface. Figure 1-5 shows the timing relationship of the signals that serve as protocol or handshake signals in the API Centronics type interface.

The API supports four versions of the Centronics interface, each selected by the type of connector and the wiring configuration of its corresponding external interface cable. The four versions are:

- IBM Personal Computer interface
- TRS-80 Models I and III interface
- Apple II and III interface
- Type 703 Centronics interface

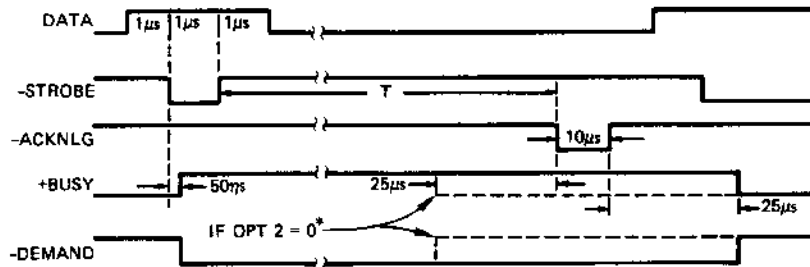

T = Depends on the program loop time.
* Refer to subsection 2.4.

Figure 1-5. CENTRONICS INTERFACE TIMING

The data transmission rate of the API Centronics type interface is 1000 characters per second nominal. The logic levels at the interface are TTL compatible.

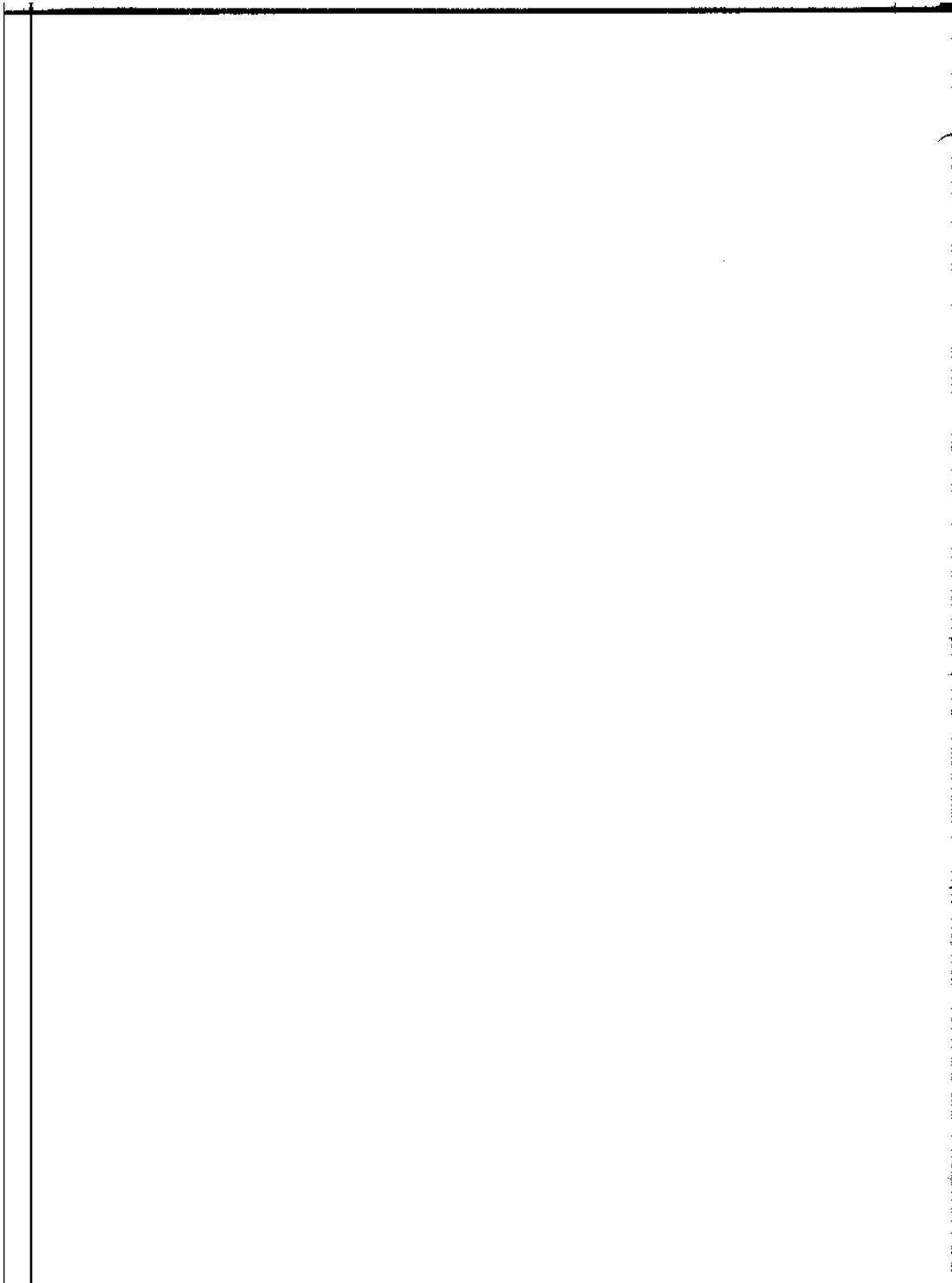

SECTION 2

INTERFACE HARDWARE AND SIGNALS

2.1 GENERAL

The information in this section pertains to the signal interface only. Information regarding power supplies, grounding requirements, ventilation and physical space requirements is contained in Section 2 of the Model 630 Product Description manual, Publication No. 90442-XX.

2.2 THE API CIRCUIT BOARD

The outline drawing in Figure 2-1 shows the locations of the processor, firmware and connectors on the API circuit board.

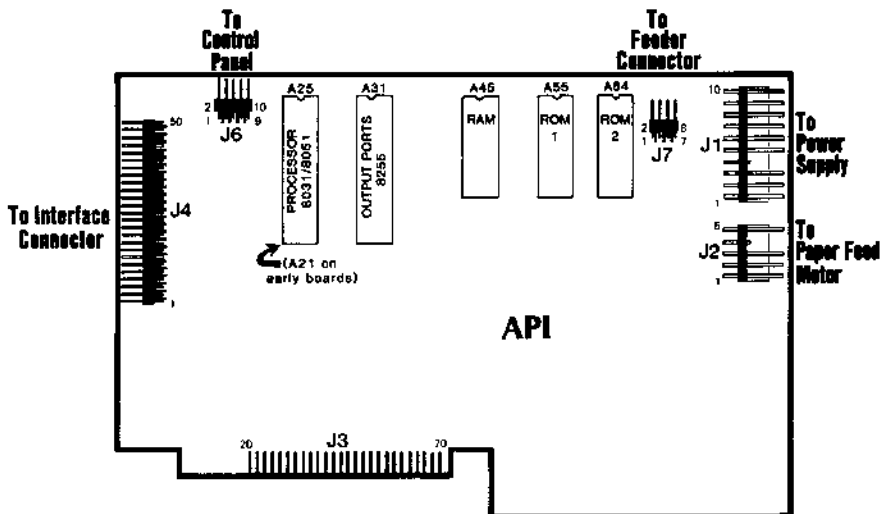

Figure 2-1. API CIRCUIT BOARD LAYOUT

2.3 THE INTERFACE CONNECTOR

The interface connector is a 50-position miniature ribbon cable connector mounted at the left-rear of the machine as shown in Figure 2-2. A 50-conductor internal interface cable connects from the interface connector to connector J4 on the API circuit board. Table 2-2 gives the pin assignments for the interface signals, both at J4 on the API board and at the interface connector. The table lists the signals associated with all of the types of interface supported by the API.

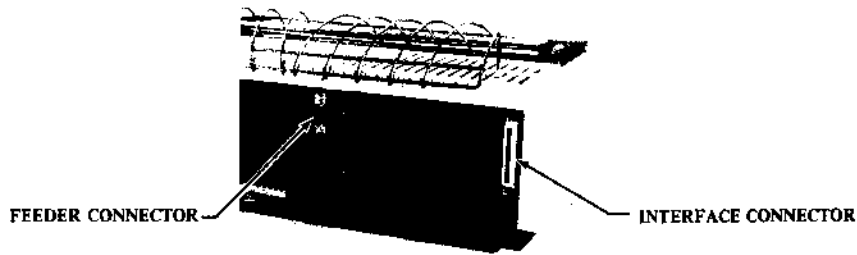

Figure 2-2. MODEL 630 API INTERFACE CONNECTOR

2.4 SELECTING THE TYPE OF INTERFACE

The appropriate Diablo interface cable will automatically configure the unit's interface circuits to support the appropriate signal protocols. This is controlled by the internal wiring arrangement at the 50-pin connector on the interface cable. It is the HI-LO combination of the interface signals -REN, -OPTION 1, and -OPTION 2, which configures the API board to a particular type of interface. The four versions of the Centronics type interface are differentiated further by the wiring arrangement of the other interface lines and by the type of connector installed at the computer end of the external interface cable. The HI-LO combinations of -REN, -OPTION 1, and -OPTION 2 are defined in Table 2-1. Also listed are the pin assignments for these signals at connector J4 on the API circuit board.

Table 2-1
INTERFACE SELECTION

<u>-OPTION 1</u> <u>Pin 15*</u>	<u>-OPTION 2</u> <u>Pin 14*</u>	<u>-REN</u> <u>Pin 26*</u>	<u>INTERFACE</u>
1	1	1	RS-232-C**
1	1	0	IEEE-488**
0	1	X	IBM-type Centronics
0	0	X	Centronics 737**

1 = HI, 0 = LO, X = Don't Care

* Pin numbers given are at connector J4 of the API circuit board.

** Not available with ECS/IBM.

The means of controlling signals -OPTION 1, -OPTION 2, and -REN varies with the type of interface. For RS-232-C these signal lines are left open and the signals are held HI via pullup resistors on the API board.

For the IEEE-488 type interface, the -REN signal is held LO by a ground line within the P2 connector of the external interface cable.

For the Apple II/III Centronics interface and TRS-80 Centronics interface the -OPTION 1 line is arranged in the interface cable such that it will be connected to an established ground in the host system.

For the IBM Centronics and Centronics 703 type interfaces, the -OPTION 1 signal is held LO by tying the -OPTION 1 line to a ground line within the P2 connector of the external interface cable. (Connector P2 is the one that connects to the 50-position interface connector mounted at the rear of the Model 630 - see Fig. 2-2.)

Table 2-2
I/O PIN ASSIGNMENTS

<u>API J4</u>	<u>I/O Pin</u>	<u>IEEE-488</u>	<u>CENTRONICS</u>	<u>RS-232-C</u>
1	1		+PE	
2	26		GND	
3	2		+5V	
4	27		GND	
5	3	N/C*		
6	28		GND	
7	4	N/C*		
8	29		GND	
9	5		+SELECT	
10	30		GND	
11	6		+BUSY	
12	31		GND	
13	7	-ATN	(Held HI)	
14	32		-OPTION 2	
15	8		-OPTION 1	
16	33	N/C* (Key)		
17	9	-DATA 1	+DATA 1	
18	34	-DATA 5	+DATA 5	
19	10	-DATA 2	+DATA 2	
20	35	-DATA 6	+DATA 6	
21	11	-DATA 3	+DATA 3	
22	36	-DATA 7	+DATA 7	
23	12	-DATA 4	+DATA 4	
24	37	-DATA 8	+DATA 8	
25	13	-EOI		
26	38	-REN		
27	14	-DAV	-DATA STROBE	
28	39	GND	GND	
29	15	-NRFD	-ACKNOWLEDGE	
30	40	GND	GND	
31	16	-NDAC	-DEMAND	
32	41	GND	GND	
33	17	-IFC	-INPUT PRIME	
34	42	GND	GND	
35	18	-SRQ	-FAULT	
36	43	GND	GND	
37	19	-ATN	-DATA STROBE	
38	44	GND	GND	
39	20	Shield		
40	45	Logic GND	GND	
41	21	N/C*		
42	46		GND	
43	22		Chassis GND	Chassis GND
44	47		Signal GND	Signal GND
45	23			RTS (+12V pullup)
46	48			-RX DATA
47	24			-TX DATA
48	49			+DSR
49	25			+DTR
50	50	N/C* (Key)		

* N/C means that position is open on the API board.

2.5 RS-232-C INTERFACE

2.5.1 Standard Diablo RS-232-C Interface Cable

The external interface cable for the RS-232-C type interface is illustrated in Figure 2-3. As supplied by Diablo, this is a 10-foot, 25-conductor cable, double-shielded for VDE/FCC emission compliance. At both ends of the cable only the seven lines that will actually be used are wired into the connectors. This cable is available from Diablo as part number 320781-01.

For the RS-232-C interface configuration, the API board requires that the signals -OPTION 1, -OPTION 2, and -REN be HI; thus these lines are open at connector P2 on this cable, and the signals are held HI via pullup resistors on the API board.

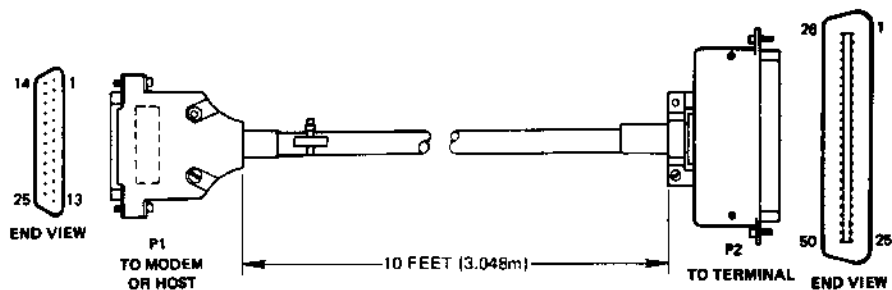

Figure 2-3. RS-232-C INTERFACE CABLE
DIABLO Part No. 320781-01

2.5.2 Multihost Diablo RS-232-C Interface Cables

The standard Diablo RS-232-C cable described above is the recommended cable for use in systems that are compatible with the wiring arrangement of this cable. Diablo also has available two different RS-232-C multihost interface cables which can be adapted to operate in many systems that deviate from the wiring arrangement of Diablo's standard RS-232-C cable. The multihost cables are equipped with miniature slide switches which enable you to set up the connector wiring arrangement to be compatible with that of your host system.

For further information regarding the multihost cables, or if you need assistance in determining whether the standard cable is suitable for your system, the following sources of assistance are recommended:

- Contact your local Diablo Sales Representative; or,
- Contact Diablo directly at the address or phone number listed below. If you make the contact by letter, please include a phone number where you can be reached.

Applications Support Center
M/S 323
Diablo Systems Incorporated
P.O. Box 5030
Fremont, California 94537

Phone No.: 415 498-4009

2.5.3 Pin Assignments In The Standard Cable

Table 2-3 lists the pin assignments in the standard Diablo RS-232-C interface cable used by the Model 630 API terminal. The arrows in the table indicate the direction of signal flow at the interface.

**Table 2-3
RS-232-C INTERFACE CABLE PIN ASSIGNMENTS**

Signal Flow		P1	P2			
Modem	Terminal	Pin	Pin	CCITT	TelCo	Signal
		1	22	101	AA	CHASSIS GND
←	←	2	24	103	BA	-TRANSMITTED DATA *
	→	3	48	104	BB	-RECEIVED DATA *
←	←	4	23	105	CA	+REQUEST TO SEND (+12V pullup)
	→	6	49	107	CC	+DATA SET READY *
	→	7	47	102	AB	SIGNAL GND
←	←	20	25	108	CD	+DATA TERMINAL READY

- * - In installations where the Model 630 will be cabled directly to the host system rather than thru a modem, the user must ensure the following conditions:
 1. The +DATA SET READY input must be held HI during data input to the terminal.
 2. All status conditions required by the host system must be satisfied.
 3. The transmitted data from the Model 630 must connect to the received data input of the host computer, and vice versa. In some cases, it may be necessary to alter the wiring at the P1 connector of the I/O cable to exchange the two wires connected to pins 2 and 3.

2.5.4 RS-232-C Signal Definitions

CHASSIS GND - Connects to chassis ground within the Model 630.

-TRANSMITTED DATA (-TxD) - This is the serial ASCII-coded digital data being transmitted by the Model 630. This signal is in the "mark" state (LO) between characters, rises for logic 0 and drops for logic 1.

-RECEIVED DATA (-RxD) - This is the serial ASCII-coded digital data being received by the Model 630. This signal must be held in the "mark" state (LO) between characters. It should go HI for logic 0, and LO for logic 1.

+REQUEST TO SEND (+RTS) - Held HI (+12V) on the API circuit board whenever power is on.

+DATA SET READY (+DSR) - Must be held HI by either the modem or the host computer during data input to the Model 630. If LO, no data can be received.

SIGNAL GROUND - Ground reference for all interface signals.

(continued)

+DATA TERMINAL READY (+DTR) - Always HI if Printer Ready protocol is not selected. If Printer Ready protocol is selected at the control panel, the terminal causes this signal to go LO under any of the following conditions:

- Cover open
- Paper out, and printing is attempted
- End of ribbon, and printing is attempted
- Printer in check, and printing is attempted
- Print buffer becomes nearly full (within 64 characters)

This signal will go true (HI) when the print buffer becomes nearly empty and all the other conditions listed above are corrected.

2.5.5 RS-232-C Interface Level Converter Circuits

2.5.5.1 Input Level Converter

The API circuit board uses type 75154 quad line receiver integrated circuits to convert the +/-12V modem signals into +5V and 0V for use by the TTL logic in the Model 630. These circuits are capable of handling the +/-25V maximum voltage swings allowed under EIA Standard RS-232-C. Input resistance is from 3K to 7K ohms, with 5K typical.

2.5.5.2 Output Level Converter

Type 75150 line driver integrated circuits are used to convert the TTL levels used within the Model 630 into +/-12V suitable for use on the RS-232-C interface. These circuits can withstand sustained output short circuits to any low-impedance voltage within the RS-232-C range (+/-25V).

2.6 IEEE-488 INTERFACE

2.6.1 Cable

The external interface cable for the IEEE-488 type interface is illustrated in Figure 2-4. As supplied by Diablo, this is a 10-foot, 25-conductor cable, double-shielded for VDE/FCC emission compliance. The computer end of this cable is equipped with a 24-position connector (P1) with cable wires connected at all 24 positions. The terminal end of this cable is equipped with the standard 50-position connector (P2) that mates with the interface connector at the rear of the terminal. This cable is available from Diablo as part number 320820-02. This version of the cable has the -REN signal tied to ground within the P2 connector as required for the IEEE-488 type interface (see subsection 2.4). With an earlier version (320820-01) of this cable, -REN is not tied to a ground line at the connector and thus must be held low by the host system. The maximum allowable interconnecting cable length is 4 meters (13.1 ft).

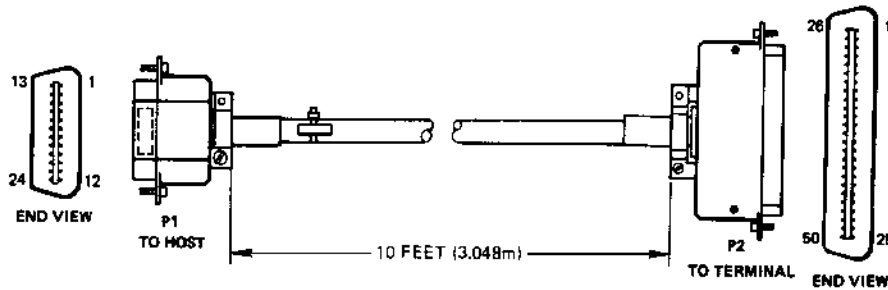

Figure 2-4. IEEE-488 INTERFACE CABLE
Diablo Part No. 320820-02

2.6.2 Pin Assignments

Table 2-4 lists the IEEE-488 interface cable pin assignments used by the Model 630 API terminal. The arrows in the table indicate the direction of signal flow at the interface.

Table 2-4
IEEE-488 INTERFACE CABLE PIN ASSIGNMENTS

Signal Flow		P1	P2	Signal
Computer	Terminal	Pin	Pin	
→	→	1	9	-DATA 1
→	→	2	10	-DATA 2
→	→	3	11	-DATA 3
→	→	4	12	-DATA 4
→	→	5	13	-EOI
→	→	6	14	-DAV
←	←	7	15	-NRFD
←	←	8	16	-NDAC
→	→	9	17	-IFC
←	←	10	18	-SRQ (always HI in API)
→	→	11	19/7	-ATN
→	→	12	20	CHASSIS GND
→	→	13	34	-DATA 5
→	→	14	35	-DATA 6
→	→	15	36	-DATA 7
→	→	16	37	-DATA 8
→	→	17	38	-REN (-01 cable only)
→	→	17	--	(unused in -02 cable only)
→	→	18	39/38	GND/-REN (GND alone in -01 cable)
→	→	19	40	GND
→	→	20	41	GND
→	→	21	42	GND
→	→	22	43	GND
→	→	23	44	GND
→	→	24	45	LOGIC GND

Note: Where more than one pin number (X/Y) is listed under P2, the interface line connects to the first pin, and is jumpered to the second pin at the connector.

2.6.3 IEEE-488 Signal Definitions

- DATA 1 - 8 - This is the parallel ASCII-coded data being received by the Model 630 API. The Data signals must be LO for a logic "1" and HI for a logic "0". A data byte received when the -ATN signal is LO represents device address, and data received when -ATN is HI represents print data and print commands.
- ATN (Attention) - This signal is issued by the controller to gain attention of the API and any other devices on the interface bus before beginning the handshake sequence. The controller must hold -ATN LO while it places the device address on the Data lines. While sending subsequent data bytes, -ATN must be HI. -ATN must again be LO when the controller sends the UNL (Unlisten) byte at the end of the data string.
- EOI (End Or Identify) - The API ignores this line. Typically this signal is issued by the talking device to notify the listening devices/s that the data byte currently on the data lines is the last one. Or it is issued by the controller together with ATN to initiate a parallel poll sequence. API does not support the parallel poll command, and it recognizes the end of a data string only by receiving the UNL (Unlisten) data byte with -ATN = LO.
- IFC (Interface Clear) - A LO signal initializes the API.
- REN (Remote Enable) - In the API, this line is used to configure the printer to IEEE-488 (-REN = LO) or RS-232-C (-REN = HI). For IEEE-488, -REN is held LO by a ground line within the P2 connector of the external interface cable.
- SRQ (Service Request) - This line is always HI in the API, except when being used for print speed measurement (see subsection 3.28).

The following three signals operate in a 3-line handshake process to transfer each data byte across the interface.

- DAV (Data Valid) - When LO, this signal indicates that valid data is present on the Data I/O lines.
- NRFD (Not Ready For Data) - LO indicates that the API is not ready to accept data from the interface bus.
- NDAC (Not Data Accepted) - Indicates whether the API has accepted the data byte currently on the Data I/O lines.

2.7 CENTRONICS-TYPE INTERFACE

2.7.1 Cables

The four variations of the Centronics interface offered by the Model 630 API are derived by the wiring and connector configurations of four different interface cables. These four configurations are illustrated in Figures 2-5 thru 2-8 on the following pages.

As supplied by Diablo, these cables are double-shielded for VDE/FCC emission compliance. Cable length is 10 feet except in the case of the Centronics 703 interface adaptor cable which is only 14 inches long. The IBM-Centronics interface cable contains 25 conductors; the others all contain 33 conductors.

2.7.2 Pin Assignments

Tables 2-5 thru 2-8 give the pin assignments of the four Diablo interface cables for the Centronics-type interfaces.

2.7.3 Centronics Signal Definitions

- DATA STROBE * - At the LO level of this signal, the API reads the data on the data bus.
- ACKNOWLEDGE - LO indicates that the printer has received data and is ready to accept next data.
- +BUSY - HI indicates that the printer can not receive data.
- +PE - HI indicates that the printer is out of paper.
- +SELECT - HI indicates that the printer is on line.
- DEMAND - The inverse of the BUSY signal.
- INPUT PRIME * - A LO pulse will initialize the printer.
- FAULT - LO indicates that the printer is in error mode.

* Signals generated by the host.

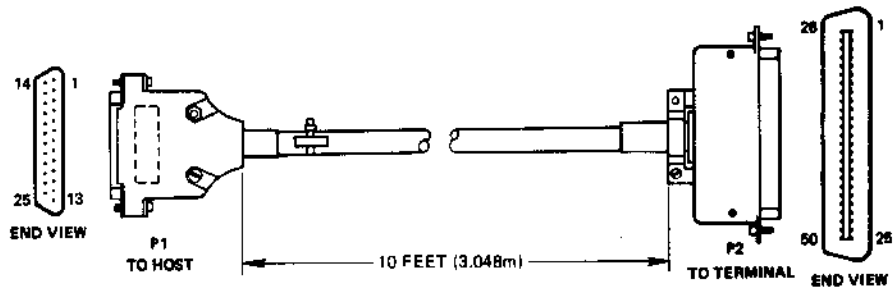

Figure 2-5. IBM CENTRONICS INTERFACE CABLE
DIABLO Part No. 320782-01

Table 2-5
IBM CENTRONICS INTERFACE CABLE PIN ASSIGNMENTS

Signal Flow	P1	P2	Signal
Computer	Pin	Pin	
→	1	14/19	-DATA STROBE
→	2	9	+DATA 1
→	3	10	+DATA 2
→	4	11	+DATA 3
→	5	12	+DATA 4
→	6	34	+DATA 5
→	7	35	+DATA 6
→	8	36	+DATA 7
→	9	37	+DATA 8
←	10	15	-ACKNOWLEDGE
←	11	6	+BUSY
←	12	1	+PE
←	13	5	+SELECT
←	14	—	(Unused)
←	15	18	-FAULT
→	16	17	-INPUT PRIME
→	17	26	GND
→	18	41	GND
→	19	22	Chassis GND
→	20	8/27	-OPTION 1 / GND
→	21	28	GND
→	22	29	GND
→	23	30	GND
→	24	39	GND
→	25	40	GND

Notes:

- 1) Where more than one pin number (X/Y) is listed under P2, the interface line connects to the first pin, and is then jumpered to the second pin at the connector.
- 2) -OPTION 2 signal is absent from the interface cable, thus allowing it to be pulled HI on the API board in order to select the Centronics-type interface configuration.

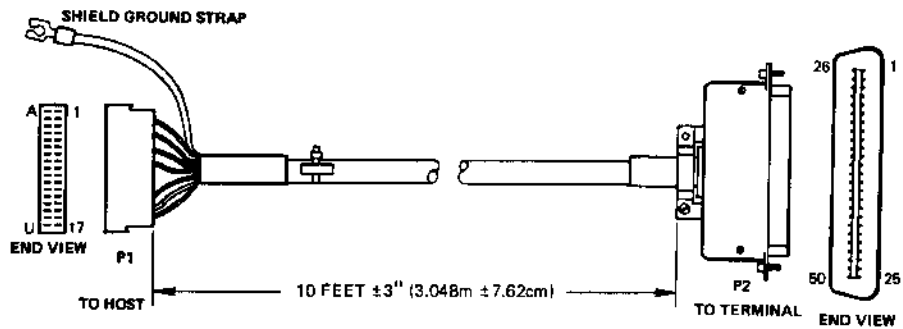

NOTE: Ground strap must be connected to chassis ground within the HOST system to achieve FCC-B compliance using the Interface cable.

Figure 2-6. TRS-80 MODELS I/III CENTRONICS INTERFACE CABLE
DIABLO Part No. 320837-01

Table 2-6
TRS-80 MODELS I/III INTERFACE CABLE PIN ASSIGNMENTS

Signal Flow	P1	P2	Signal
Computer Terminal	Pin	Pin	
→	1	14/19	-DATA STROBE
→	2	9	+DATA 1
→	3	10	+DATA 2
→	4	11	+DATA 3
→	5	12	+DATA 4
→	6	34	+DATA 5
→	7	35	+DATA 6
→	8	36	+DATA 7
→	9	37	+DATA 8
←	11	6	+BUSY
←	12	1	+PE
←	13	5	+SELECT
	14	46	GND
	A	45	GND
	B	27	GND
	C	28	GND
	D	29	GND
	E	30	GND
	F	31	GND
	H	39	GND
	J	40	GND
	K	41	GND
→	L	8	-OPTION 1
	M	26	GND
	N	42	GND
←	R	18	-FAULT
	U	43	GND

- NOTES:
- Where more than one pin number (X/Y) is listed under P2, the interface line connects to the first pin, and is jumpered to the second pin at the connector.
 - OPTION 2 is absent from the cable, allowing -OPTION 2 to be pulled HI on the API board to select Centronics-type interface configuration.
 - Unused pins on P1: 10, 15, 16, 17, P, S, T

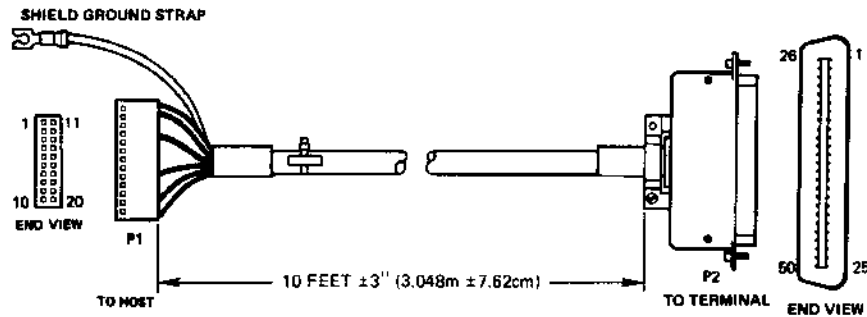

- NOTE:**
1. Ground strap must be connected to chassis ground within the HOST system to achieve FCC-B compliance using the Interface cable.
 2. P1 pin 1 must connect to pin 19 of the Printer interface connector on the APPLE Parallel Printer Card.

Figure 2-7. APPLE II/III CENTRONICS INTERFACE CABLE
DIABLO Part No. 320838-01

Table 2-7
APPLE II/III CENTRONICS INTERFACE CABLE PIN ASSIGNMENTS

Signal Flow	P1	P2	Signal
Computer	Pin	Pin	
	1	—	(Unused)
→	2	37	+DATA 8
→	3	35	+DATA 6
→	4	12	+DATA 4
→	5	10	+DATA 2
←	6	1	+PE
	7	—	(Unused)
	8	—	(Unused)
	9	—	(Unused)
→	10	8	-OPTION 1
→	11	42	GND
	12	—	(Unused)
→	13	36	+DATA 7
→	14	34	+DATA 5
→	15	11	+DATA 3
→	16	9	+DATA 1
→	17	14/19	-DATA STROBE
	18	—	(Unused)
	19	—	(Unused)
←	20	15	-ACKNOWLEDGE

Notes:

- 1) Where more than one pin number (X/Y) is listed under P2, the interface line connects to the first pin, and is then jumpered to the second pin at the connector.
- 2) -OPTION 2 signal is absent from the cable, allowing -OPTION 2 to be pulled HI on the API board in order to select the Centronics-type interface configuration.

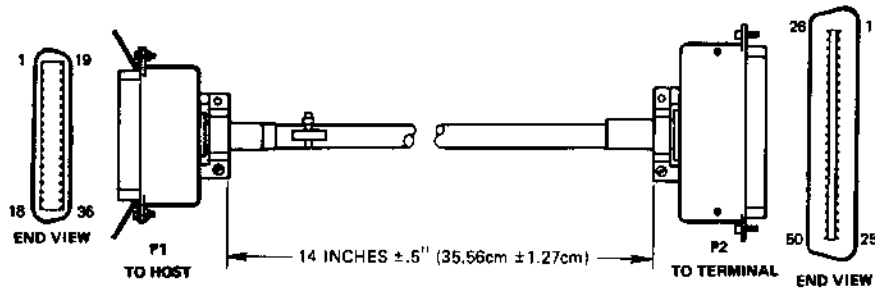

Figure 2-8. CENTRONICS 703 INTERFACE CABLE
 DIABLO Part No. 320839-01

Table 2-8
CENTRONICS 703 INTERFACE CABLE PIN ASSIGNMENTS

Signal Flow	P1	P2	Signal
Computer	Pin	Pin	
→	1	14/19	-DATA STROBE
→	2	9	+DATA 1
→	3	10	+DATA 2
→	4	11	+DATA 3
→	5	12	+DATA 4
→	6	34	+DATA 5
→	7	35	+DATA 6
→	8	36	+DATA 7
→	9	37	+DATA 8
←	10	15	-ACKNOWLEDGE
←	11	6	+BUSY
←	12	1	+PE
←	13	5	+SELECT
←	14	42	GND
←	15	44	GND
←	16	43	GND
←	17	22	Chassis GND
←	18	2	+5V
←	19	45	GND
←	20	27/8	GND / -OPTION 1
←	21	28	GND
←	22	29	GND
←	23	30	GND
←	24	31	GND
←	25	39	GND
←	26	40	GND
←	27	41	GND
←	28	46	GND
←	29	26	GND
←	30	47	Signal GND
←	31	17	-INPUT PRIME
←	32	18	-FAULT
←	36	21	N/C (This line left open on API circuit board)

NOTES:

- Where more than one pin number (X/Y) is listed under P2, the interface line connects to the first pin, and is jumpered to the second pin at the connector.
- OPTION 2 is absent from the cable, allowing -OPTION 2 to be pulled HI on the API board to select Centronics-type interface configuration.
- Unused pins on P1: 33, 34, 35

2.8 FEEDER INTERFACE

The API offers a feeder interface to operate the Diablo Models F32 and F33 accessory sheet feeders. Cables within the terminal bring the feeder control signals and power from the API circuit board (connector J7) and the power supply to an external feeder connector mounted at the center rear of the terminal, as shown in Figure 2-9.

Figure 2-9 also shows an outline drawing of the feeder interface connector and its pin arrangement. Table 2-9 lists the pin assignments for the feeder interface signals at the feeder interface connector.

Table 2-9
FEEDER INTERFACE CONNECTOR PIN ASSIGNMENTS

<u>Pin</u>	<u>Description</u>	<u>Pin</u>	<u>Description</u>
1	Chassis Ground	9	-FEED STATUS
2	-A0 (command signal)	10	-POWER DOWN
3	-A1 (command signal)	11	-FEED STROBE
4	-A2 (command signal)	12	(no connection)
5	(no connection)	13	(no connection)
6	(no connection)	14	+40V Signal Ground
7	+5V	15	+40V
8	+5V Signal Ground		

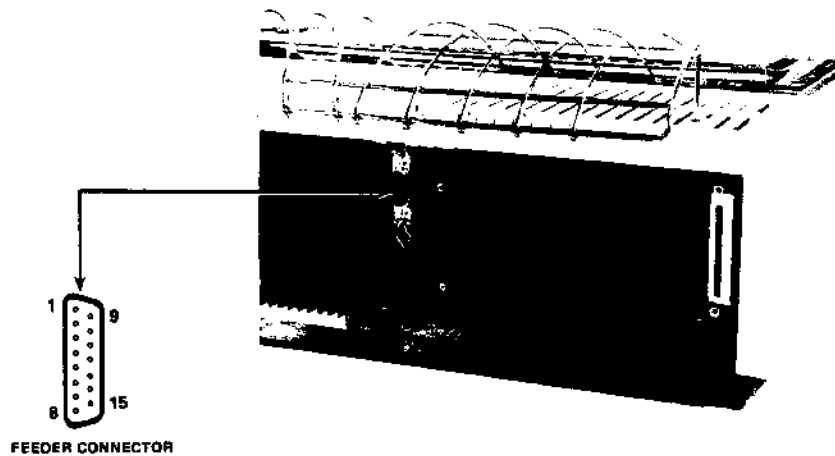

Figure 2-9. FEEDER INTERFACE CONNECTOR

SECTION 3
OPERATING CONSIDERATIONS

3.1 GENERAL

This section of the manual contains a detailed discussion of the operating features of the Model 630 API terminals. The procedures for routine operator duties, such as changing ribbons and print wheels, are given in detail in the Model 630 API/API ECS Operator's Guide, and thus are not repeated here.

3.2 LCPN OPERATOR CONTROL PANEL

The optional LCPN control panel used on the Model 630 API is the same as the standard control panel used on the Model 630 SPI terminal, although initially the switch labels differed in order to identify the additional switch functions on the API LCPN. Currently, a universal switch label is being used so that the API LCPN and SPI LCPN control panels are identical.

The layout of the LCPN control panel is shown in Figure 3-1. In addition to the switches and indicators, there is an easily-accessible jumper strip on the control panel. This permits selection of certain semi-permanent operating parameters by installation of jumper plugs between appropriate pins on the jumper strip. Table 3-1 lists the slide switch and jumper assignments on the LCPN control panel for each of the three different types of interface offered by the Model 630 API.

Table 3-1
SLIDE SWITCH AND JUMPER ASSIGNMENTS ON THE LCPN CONTROL PANEL

<u>Slide Switch</u>	<u>RS-232-C</u>	<u>IEEE-488</u>	<u>Centronics</u>
1	Wheel Type	Wheel Type	Wheel Type
2, 3	Spacing	Spacing	Spacing
4	Protocol	Primary	4 } Ignored
5	Baud Rate	Address	5 } Ignored
6, 7	Parity	Selection	6,7 } Ignored
8	Self Test	Self Test	Self Test
<u>Jumper</u>			
1	12" Page	12" Page	12" Page
2	Auto LF	Auto LF	Auto LF
3	Auto CR	Auto CR	Auto CR
	Disable	Disable	Disable
4, 5	Reserved	Reserved	Reserved

The function of each of the switches, indicators, and jumpers on the control panel is defined in the paragraphs that follow.

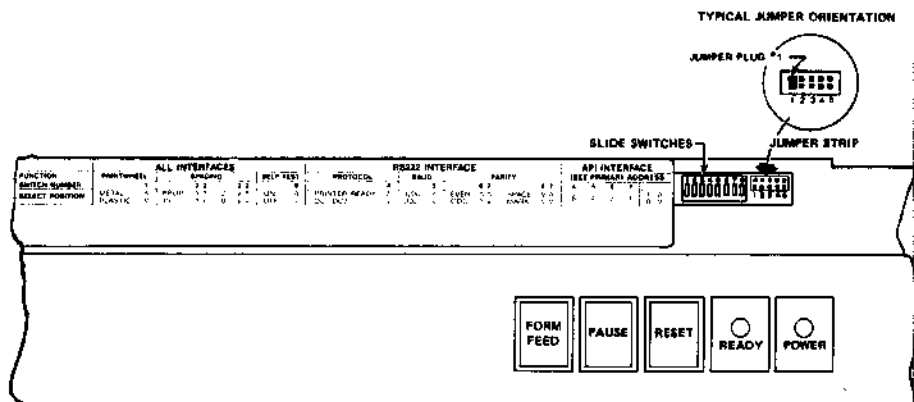

Figure 3-1. MODEL 630 LCPN CONTROL PANEL

3.2.1 Slide Switches

The label located to the left of the switch module identifies each switch by number and function, and lists the various settings for each switch. The arrowheads denote the position of the corresponding switch slider for each function.

Switch 1 - PRINT WHEEL Select

This switch sets the API to operate with either a Metal or Plastic print wheel. The switch setting selects between two internal lookup tables containing parameter values (hammer energies, PS units, spoke addresses) directly suitable for operation of the presently available Diablo print wheels listed below with their Diablo part numbers.

Part No.	96-Char. Plastic	Part No.	96-Char. Metalized
38101-01	Pica 10	311900-01	Titan 10
38102-02	Elite 12	311901-01	Cubic PS
38107-01	Courier 72	311903-01	Elite 12
38147	Forms Gothic S-10		
(-----)	(All equivalent UK print wheels)		

To accommodate print wheels that require parameter values different than those supplied by the two internal print wheel tables, a download procedure can be used to remotely load an appropriate print wheel table from the host computer to the Model 630 (see subsection 3.22).

Switches 2,3 - SPACING

The four combinations of settings of switches 2 and 3 provide selections for horizontal character spacing of 10, 12 and 15 characters/inch, and for proportional spacing. If the Horizontal Motion Index (HMI) is changed from its standard value, the SPACING switches are ignored.

Switch 4 - PROTOCOL (RS-232-C interface)

This switch selects between DC1/DC3 and Printer Ready protocols. (See subsection 3.6.) ETX/ACK protocol is also recognized under either position of this switch.

Switch 5 - BAUD (RS-232-C interface)

Selects either 300 or 1200 baud as the data transfer rate.

Switches 6,7 - PARITY (RS-232-C interface)

There are four combinations of settings for switches 6 and 7. Two combinations select Parity On - Odd or Even. The other two combinations select Parity Off - Mark or Space. The Mark and Space selections determine whether the parity bit transmitted by the Model 630 is always a mark or always a space when parity is Off.

Switches 4,5,6,7 - PRIMARY ADDRESS SELECTION (IEEE-488 interface)

When the API is configured for the IEEE-488 interface, these four switches set the device address of the terminal. The terminal will enter the "Listen" state and accept data thru the interface only after receiving an address character that matches the setting of the four address selection switches.

Switch 8 - SELF-TEST

If this switch is in the ON position when power is applied, the Model 630 enters the self-test mode. The self-test consists of a ROM test, a RAM test and 96 lines of swirl text. See subsection 3.27 for further information regarding Self-Test.

3.2.2 Command Switches

FORM FEED - When this switch is pressed, a local form feed operation occurs without causing a form feed code to be transmitted through the interface. The form feed operation causes the paper to be moved upward so that the print head is positioned at the first line of the next page, or at the top margin line if one has been set.

PAUSE - This switch allows the operator to interrupt terminal operation without loss of data. Any command in process when the switch is pressed will be completed, but no new commands will be dequeued from the print buffer. No commands will be lost as long as communication protocols (ETX/ACK, DC1/DC3 or PRINTER READY) are observed. When the PAUSE switch is pressed, the READY light turns OFF. The terminal will resume normal operation when the RESET switch is pressed if no error conditions are present.

RESET - When pressed, this switch causes a restore operation if a Check condition is present. The flashing READY light, indicating an error condition, is cleared to its steady ON state.

3.2.3 Indicator Lights

POWER - ON when power is applied to the terminal.

READY -ON when no error conditions are detected.

OFF when in pause mode, or when DATA SET READY is false.

FLASHING when any of the following error conditions are present:

1. The printer is in check and printing is attempted.
2. A cover-open condition has been detected.
3. A paper-out condition or end-of-ribbon condition has been sensed and printing is attempted.
4. Any of the following errors are detected:
 - Incorrect parity in received character.
 - A framing error (no stop bit) in received character.
5. Print Buffer overflow.

3.2.4 Control Panel Jumpers

The jumper positions are shown in Figure 3-1, along with an enlarged view showing the proper orientation of an installed jumper plug. Jumper plugs are available thru Diablo as part number 100398-01. In lieu of jumper plugs, a suitable jumper can also be formed by wire wrap connection.

<u>Position</u>	<u>Function</u>	<u>Jumper In/Out</u>	
1	12" PAGE SIZE	In	- Page size defaults to 12" (72 lines per page) when unit is initialized by: Power-up, ESC CR P, or ESC SUB I.
		Out	- Page size defaults to 11" (66 lines per page).
2	AUTO LINE FEED	In	- A line feed is performed with each carriage return (CR) character.
		Out	- Line feed occurs only on receipt of a line feed (LF) character.
3	AUTO CR DISABLE	In	- An automatic carriage return will <u>not</u> occur when attempting to print past the maximum right-hand horizontal position (i.e., 1572 1/120" increments).
		Out	- An automatic carriage return occurs when the carriage reaches the maximum horizontal position.
4	- RESERVED		
5	- RESERVED		

3.3 FFCPN OPERATOR CONTROL PANEL

3.3.1 General

The FFCPN (Fully-Featured Control Panel) is the standard operator control panel for the Model 630 API. It is basically the same as that used on the Model 630 HPRO5 terminals; although the switch labels differ corresponding to the function differences between the HPRO5 and API terminals. The API control panel uses an H5CPN circuit board assembly part number 302561-XX of -06 or higher design level. This circuit board is downward compatible with any H5CPN circuit board used on the Model 630 HPRO5 terminals. However, H5CPN circuit boards at design levels below 302561-06 cannot be used on the API control panel.

The layout of the switches and indicators on the FFCPN control panel is shown in Figure 3-2. The function of each of these items is described in the paragraphs that follow.

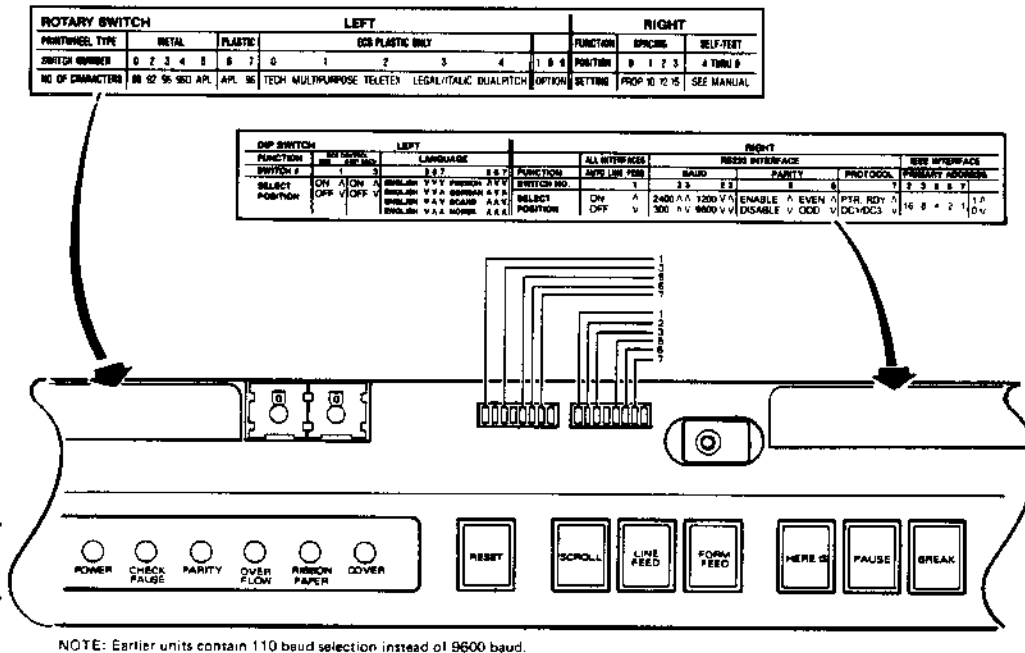

Figure 3-2. MODEL 630 API FFCPN CONTROL PANEL

3.3.2 The Mode Switches

The mode switches are located beneath the terminal's access cover. This group of switches comprises two rotary switches and two switch modules containing eight slide switches each.

Print Wheel Select (Left Rotary Switch)

Note: To prevent possible print wheel damage or excessive wear, this switch must be set to match the type of print wheel being used.

<u>Position</u>	<u>Selection (Non-ECS mode)</u>
0	88-character metal wheels - Xerox
2	92-character metal wheels - Rank Xerox
3	96-character metal wheels - Rank Xerox
4	96-character metal wheels - Diablo
5	APL metal wheels
6	APL plastic wheels
7	96-character plastic wheels
1,8,9	(Selection defaults to 88-character metal wheel - same as position 0)

<u>Position</u>	<u>Selection (ECS mode) *</u>
0	ECS Scientific (Tech) print wheel
1	ECS Multipurpose print wheel
2	ECS Teletex print wheel
3	ECS Legal / Italic print wheel
4	Dual Pitch print wheel

* ECS/IBM version offers only one ECS print wheel selection: ECS PC GRAPHICS

In addition to setting the Print Wheel Select switch, the three Language Select switches (5, 6 and 7 on left slide switch module) must be set to the proper language selection for the print wheel being used when operating in non-ECS mode. In ECS mode, the Language switches are ignored. Subsection 4.1 in this manual lists the print wheel language groups directly supported by the API firmware.

Spacing Select Switch (Right Rotary Switch)

This switch selects the horizontal spacing for character printout, or selects self-test mode.

<u>Position</u>	<u>Selection</u>
0	Proportional spacing
1	10-pitch spacing
2	12-pitch spacing
3	15-pitch spacing
4-9	Self-Test (The terminal enters self-test mode if the spacing select switch is in one of these positions at power-up.)

Left-Hand Slide Switch Module

Switch 1 - ECS SELECT

ON - The API is configured as an ECS (Extended Character Set) terminal.

OFF - The API is configured as a non-ECS terminal.

Switch 3 - 8-BIT ASCII

This switch is used to select 7 or 8 data bits in both received and transmitted ASCII bytes. See subsection 3.29 of this manual for additional information regarding use of this switch for ECS operation.

Switches 5,6,7 - LANGUAGE SELECT

These three switches work in conjunction with the Print Wheel Select switch to select the proper table of print wheel operating parameters to

match the print wheel being used. Language selection is as follows:

Switch			Language
5	6	7	
0	0	0	English
0	0	1	English
0	1	0	English
0	1	1	English
1	0	0	French
1	0	1	German
1	1	0	Scandia
1	1	1	Norsk

0=OFF, 1=ON

When the ECS Select switch is set to ON, the language select switches are ignored.

Right-Hand Slide Switch Module

Switch 1 - AUTO LINE FEED

When this switch is ON, a line feed occurs automatically on every carriage return.

The functions of switches 2, 3, 5, 6, and 7 differ as defined below, according to whether the API is configured for RS-232-C type interface or for IEEE-488 type interface. For the Centronics type interface, these switches are ignored.

Switches 2,3 - BAUD (RS-232-C Interface)

When the API is configured for RS-232-C interface, these two switches select the data transfer speed at which the API will operate, as defined below.

Switch		Baud	
		API Version I	API Version II
2	3		
0	0	110	9600
0	1	1200	1200
1	0	300	300
1	1	2400	2400

Switch 5 - PARITY ENABLE (RS-232-C Interface)

When the API is configured for RS-232-C interface, this switch enables parity checking.

Switch 6 - PARITY ODD/EVEN (RS-232-C Interface)

When the API is configured for RS-232-C interface, and the Parity Enable switch is ON, this switch selects either odd or even parity. If the Parity Enable switch is OFF, this switch determines whether the transmitted parity bit is always a space (odd) or always a mark (even).

Switch 7 - PROTOCOL (RS-232-C Interface)

When the API is configured for RS-232-C interface, this switch selects between DC1/DC3 and Printer Ready protocols (see subsection 3.6). ETX/ACK protocol is also recognized under either position of this switch.

Switches 2,3,5,6,7 - PRIMARY ADDRESS (IEEE-488 Interface)

When the API is configured for IEEE-488 type interface, these five switches set the device address (0-30) of the API terminal. In the idle state, the API is normally in the "unlisten" mode. To put the API into "listen" mode, the host system drops the -ATN signal and places on the data bus a device address code that matches the address set by the switches on the API control panel. To return the API to the unlisten mode, the host places a code 3F hex (0011 1111) on the data bus while holding the -ATN signal LO. Table 3-2 lists the available device addresses and corresponding address codes.

3.3.3 The Operating Switches

The seven Operating Switches are located in the right-hand area of the control panel, accessible to the operator with all covers on the machine. These are momentary-action, membrane-type switches, actuated by finger touch.

RESET - When pressed, this switch causes a restore operation if a Check condition is present. All of the error indicators are cleared. This switch also restarts the unit after the PAUSE switch interrupts operation.

SCROLL - When pressed and released, the Scroll switch causes the paper to advance a small amount to give the operator a clear view of the last printed line. Before printing resumes, the paper is automatically returned to the last printing position.

LINE FEED - Initiates a single line feed. If the switch is held depressed longer than 600 msec, the line feed will be repeated. It does not cause a line feed code to be transmitted thru the interface.

FORM FEED - Initiates a form feed to the next top-of-form position, without transmitting a form feed code. The form feed operation causes the paper to be moved upward so that the print head is positioned at the first line of the next page, or at the top margin line if one has been set.

HERE IS - (Not functional)

PAUSE - This switch allows the operator to interrupt terminal operation without loss of data. Any command in process when the switch is pressed will be completed, but no new commands will be dequeued from the print buffer. No commands will be lost as long as communication protocols (ETX/ACK, DC1/DC3 or PRINTER READY) are observed. The pause mode causes the PRINT CHK light to blink. Printer operation resumes and the PRINT CHK light turns OFF when the RESET switch is pressed if all error conditions are cleared.

BREAK - Causes a Break (250 msec space) to be transmitted over the communications link. Whenever the **BREAK** switch is pressed, the print buffers are emptied. Also, Graphics mode is cleared and Forward Printing mode is established. Red/black ribbon state and remote HMI are unchanged.

Table 3-2
IEEE-488 PRIMARY LISTEN ADDRESSES

Control Panel Switches (Binary)	Device Address (Decimal)	Address Code* (Hexadecimal)
16 8 4 2 1		
0 0 0 0 0 **	00	20
0 0 0 0 1	01	21
0 0 0 1 0	02	22
0 0 0 1 1	03	23
0 0 1 0 0	04	24
0 0 1 0 1	05	25
0 0 1 1 0	06	26
0 0 1 1 1	07	27
0 1 0 0 0	08	28
0 1 0 0 1	09	29
0 1 0 1 0	10	2A
0 1 0 1 1	11	2B
0 1 1 0 0	12	2C
0 1 1 0 1	13	2D
0 1 1 1 0	14	2E
0 1 1 1 1	15	2F
1 0 0 0 0	16	30
1 0 0 0 1	17	31
1 0 0 1 0	18	32
1 0 0 1 1	19	33
1 0 1 0 0	20	34
1 0 1 0 1	21	35
1 0 1 1 0	22	36
1 0 1 1 1	23	37
1 1 0 0 0	24	38
1 1 0 0 1	25	39
1 1 0 1 0	26	3A
1 1 0 1 1	27	3B
1 1 1 0 0	28	3C
1 1 1 0 1	29	3D
1 1 1 1 0	30	3E
1 1 1 1 1	UNL (Unlisten)	3F

* The Hexadecimal code that the host must send to select the device.

** 1 = ON or TRUE
0 = OFF or FALSE

3.3.4 The Front Panel Indicators

3.3.4.1 Audio Alarm

This device sounds briefly to indicate the occurrence of various errors or operating conditions. All error conditions cause the alarm to sound for 1/2 second when the error is first detected. The alarm will not sound again for that error until the RESET key is pressed, clearing the error. The alarm also sounds briefly each time one of the control panel operating switches is pressed. This provides audible feedback to the operator, confirming switch actuation.

3.3.4.2 Indicator Lamps

POWER - Indicates that AC power is applied to the machine.

PRINT CHK - In its steady ON state, this light indicates that a print operation has been called for while the printer is in a "check" condition. A check condition occurs when a print wheel or carriage command received by the printer cannot be successfully completed, due to a malfunction (possibly caused by a paper jam or bent print wheel). A print wheel check condition disables the print wheel servo, and a carriage check condition disables the carriage servo; both until a restore operation is performed.

When blinking, the PRINT CHK light indicates that the terminal is in the Pause mode.

PARITY - Indicates detection of either of the following types of errors:

- Incorrect parity sensed on a received character.
- A framing error (no stop bit) detected on a received nonbreak character.

A "?" character (ASCII code 3F) is substituted for the erroneous character. This light functions only if the PARITY ENABLE switch is ON.

OVFL - Indicates print buffer overflow.

RIBBON/PAPER - Indicates that either a paper-out or end-of-ribbon condition has been sensed and an attempt to print has been made.

COVER - The COVER light comes on immediately when the sound panel is opened.

3.4 CONTROL CODES

The Model 630 responds to a standard set of ASCII Control Codes. The control characters recognized by the Model 630 API are summarized below. The standard ASCII Code Chart shown in Figure 4-1 lists the control characters and their corresponding ASCII codes. The operator, however, normally need not be concerned with the actual codes for the control characters.

Several of the control characters listed here are used also in Escape code commands (see subsection 3.5).

- ACK - This code is used in conjunction with ETX for the ETX/ACK communications protocol. It is also used in download mode to acknowledge receipt of a valid download record.
- BEL - Sounds audible alarm buzzer (FFCPN control panel only) for 1/2 second. Updates all summarized motion and suspends processing of further characters until all printer activity is complete.
- BS - Backspaces the carriage one print position (HMI) in Normal mode, or 1/60 inch in Graphics mode. Direction of movement reverses in the Backward Print mode.
- CR - Causes a carriage return. If the AUTO LF switch is ON, the CR code also causes a line feed operation.
- DC1 - This code is used in conjunction with DC3 for communications protocol. (See subsection 3.6.2)
- DC3 - This code is used in conjunction with DC1 for communications protocol. (See subsection 3.6.2)
- DC4 - This code is used to exit from the print wheel table download mode.
- DEL - This code is ignored by the Model 630 API. It can be used as a buffer or "sluff" code the same as NUL.
- EM - Accesses the supplementary character set for one character selection in the range 80-FF hex when operating in 7-Bit ASCII mode. Access then reverts to the primary character set (00-7F).
- ETX - This code is used in conjunction with ACK for the ETX/ACK communications protocol. (See subsection 3.6.1)
- ESC - This code is always received as the first character of a 2- or 3-character command sequence. (See subsection 3.5)
- FF - Initiates form feed to the top of the next form (page), or to the top margin on the next form or page if one has been set.
- HT - Initiates movement of the carriage to the next previously-set horizontal tab stop.
- LF - Initiates movement of the paper up one line (one VMI). Movement changes to 1/48" per command in the Graphics mode.
- NAK - Transmitted by the Model 630 when certain error conditions occur. (See subsection 3.6.2) NAK is used also in download mode to indicate receipt of an invalid download record.

- NUL - This code is ignored by the Model 630 in all modes. It can be used as a buffer or "stuff" code.
- SI - 1) Causes exit from Program mode;
2) Operates ECS mode as follows:
 - 8-Bit ASCII mode: Blanks characters at ASCII 80-9F
 - 7-Bit ASCII mode: Selects primary character set (normal ASCII assignments of 00-7F)
- SO - Operates ECS mode as follows:
 - 8-Bit ASCII mode: Unblanks the characters at ASCII 80-9F
 - 7-Bit ASCII mode: Selects supplementary character set (characters assigned at 80-FF overlay the standard ASCII assignments of 00-7F)
- SP - Causes carriage movement of one print position (HMI) in Normal mode.
- VT - Initiates movement of the paper up to the next previously-set vertical tab stop.
- STX - Sent by 630 to indicate that the next byte it will send is a status byte; this occurs subsequent to a Remote Diagnostics status request (ESC SUB 1, ESC SUB 3) from the host.

3.5 ESCAPE CODE SEQUENCES

The Escape mode is entered by receiving the ESC control code over the communications interface. This code is always received as the first character of a 2- or 3-character "Escape Code Sequence". The ESC code conditions the Model 630 to receive the next one or two characters, uninterrupted by a CR, as commands and not print data. Upon receiving the last character in the ESC code sequence, the Model 630 executes the command, and then terminates the Escape mode.

The following list summarizes the complete set of ESC code command sequences recognized by the Model 630 API. (Some host systems may not be capable of generating all of the listed command codes.)

Characters			<u>Description of Command</u>
(1)	(2)	(3)	
<u>Margins & Formatting</u>			
ESC	T		Set top page margin at current paper position
ESC	L		Set bottom page margin at current paper position
ESC	C		Clear top and bottom margins
ESC	9		Set left margin at current carriage (print) position
ESC	0		Set right margin at current carriage (print) position
ESC	1		Set horizontal tab stop at current carriage (print) position
ESC	8		Clear horizontal tab stop at current carriage (print) position
ESC	-		Set vertical tab stop at current paper position
ESC	2		Clear all horizontal and vertical tab stops
ESC	FF	(n)	Set lines per page to (n)*

* See subsection 4.5, Table 4-4 for values on (n).

Carriage Movement

ESC	US	(n)	Set Horizontal Motion Index (HMI) to (n-1)**
ESC	S		Return HMI control to the SPACING switch
ESC	HT	(n)	Initiate absolute horizontal tab to print position (n)*
ESC	/		Enable Auto Backward Printing mode
ESC	\		Disable Auto Backward Printing mode
ESC	?		Enable Auto Carriage Return mode
ESC	!		Disable Auto Carriage Return mode
ESC	<		Enable Reverse Printing mode
ESC	>		Disable Reverse Printing mode
ESC	6		Enable Backward Printing mode (clear with CR)
ESC	5		Enable Forward Printing mode

Paper (Platen) Movement

ESC	RS	(n)	Set Vertical Motion Index (VMI) to (n-1)**
ESC	VT	(n)	Initiate absolute vertical tab to line (n)*
ESC	U		Perform half-line feed
ESC	D		Perform negative half-line feed
ESC	LF		Perform negative line feed

Printing Commands

ESC	3		Enable Graphics mode (cleared by CR)
ESC	4		Disable Graphics mode
ESC	A		Print in secondary color (Red) (Non-ECS option)
ESC	B		Print in primary color (Black) (Non-ECS option)
ESC	7		Enable Print Suppression (Cleared by CR)
ESC	Y		Print the print wheel character under ASCII code 20 hex
ESC	Z		Print the print wheel character under ASCII code 7F hex

Word Processing Commands

ESC	P		Enable Proportional Space Printing (ON) (cleared by ESC S)***
ESC	Q		Disable Proportional Space Printing (OFF)***
ESC	DC1	(n)	Set Offset to (n) (cleared by CR) See subsection 3.24.2
ESC	E		Auto Underscore ON
ESC	R		Auto Underscore OFF
ESC	O		Bold Print ON (cleared by CR)
ESC	W		Shadow Print ON (cleared by CR)
ESC	&		Bold/Shadow Print OFF
ESC	%		Extend carriage settling time for best print quality (must be used for proper registration of graphic characters with IBM PC print wheel)
ESC	N		Restore normal carriage settling time
ESC	M		Enable Auto Justify
ESC	=		Enable Auto Center (cleared by CR)
ESC	BS		Backspace 1/120"
ESC	SO	M	Enable Program mode
ESC	X		Cancel all WP modes except Proportional Space and Increased Carriage Settling Time.

* See subsection 4.5, Table 4-4 for values of (n).

** See subsection 4.5, Table 4-3 for values of (n).

*** See subsection 3.9.3 for additional details.

Feeder Control Commands

ESC	EM	E	Feed envelope
ESC	EM	1	Feed sheet 1
ESC	EM	2	Feed sheet 2
ESC	EM	R	Eject paper from printer

Note: See subsection 3.26 for definitions of embedded feeder control commands.

Remote Diagnostics Features

Also see subsection 3.23

ESC	SUB	1	Initialize the printer
ESC	SUB	R	Remote error reset
ESC	SUB	1	Request Status Byte 1
ESC	SUB	3	Request Status Byte 3
ESC	SUB	SO	Memory test

HyPlot Commands

ESC	G		HyPlot ON - Absolute Move (cleared by CR)
ESC	G	BEL	HyPlot ON - Absolute Plot (cleared by CR)
ESC	V		HyPlot ON - Relative Move (cleared by CR)
ESC	V	BEL	HyPlot ON - Relative Plot (cleared by CR)
ESC	.	'character'	Change plot character to 'character'
ESC	,	hv	Set plot precision (see subsection 3.25)
ESC	4		Exit HyPlot mode

Miscellaneous Commands

ESC	CR	P	Initiate Remote Reset (Allow 1 second for completion before next command.)
ESC	SO	DC2	Enter Print Wheel Table Download mode (Exit by DC4)
ESC	CAN	CAN	Toggles SRQ line for print speed timing (see subsection 3.28)
ESC	SYN	(n)	Remote print wheel selection (see subsection 3.30) ****
ESC	GS	A	Disables NAK error code response from API. ****
ESC	GS	B	Re-enables NAK error code response from API. ****

**** Functional only in units with firmware at revision level -18 or above.

3.6 SERIAL RS-232-C COMMUNICATIONS PROTOCOLS

The communications protocols prevent print buffer overflow when print data is being received faster than the print buffer is being emptied. The Model 630 requires a communications protocol at all baud rates above 300, and in some applications at baud rates of 300 and below.

The 2-position Protocol switch on the control panel enables selection of DC1/DC3 or Printer Ready communications protocol. ETX/ACK protocol can also be used simultaneous with either DC1/DC3 or Printer Ready. In addition to print buffer control, the DC1/DC3 and Printer Ready protocols also respond to error conditions within the Model 630.

3.6.1 ETX/ACK Protocol

The Model 630 API will respond also to this protocol when the Protocol switch is set for either DC1/DC3 or Printer Ready protocol. When the host computer sends a string of print data to the terminal, it includes an ETX control code character at the end of the data string. When the ETX character eventually is retrieved from the print buffer, the Model 630 transmits an ACK character back to the host. The ACK character indicates that the terminal is ready to accept more data. With this protocol, the host must ensure that any data string transmitted does not exceed the capacity of the print buffer, since the terminal does not send a response to indicate when the print buffer is nearly full.

3.6.2 DC1/DC3 (X-ON/X-OFF) Protocol

In DC1/DC3 protocol, a DC3 control code character is transmitted by the Model 630 under any of the following conditions:

1. Print buffer nearly full (within 64 bytes)
2. Cover Open
3. Paper Out *
4. End of Ribbon *
5. Printer in Check condition

* With Paper Out or End of Ribbon, a DC3 is sent only when printing is attempted.

With DC1/DC3 protocol enabled, a NAK character will also be transmitted (followed by DC3) for conditions 2 - 5 above. The NAK character thus distinguishes the "error" conditions from Print Buffer Full. NAK is also sent when a parity error is detected, if parity checking is enabled. In units equipped with firmware at revision level -18 or above, this NAK response can be disabled by receiving the sequence ESC GS A from the host computer. To re-enable the NAK response, the host computer must send the sequence ESC GS B.

Once a DC3 has been sent, the Model 630 will transmit a DC1 character when the print buffer is nearly empty (within 64 bytes) and conditions 2 thru 5 do not exist. Conditions 2 thru 5 can be cleared by pressing the RESET switch on the control panel, which also causes a DC1 character to be transmitted.

3.6.3 Printer Ready Protocol

The Printer Ready protocol uses a dedicated interface line instead of special control characters (as used with DC1/DC3 and ETX/ACK protocols). When the Protocol switch is set for Printer Ready, the Data Terminal Ready (+DTR) interface signal goes LO under any of the following conditions:

1. Print buffer becomes nearly full (within 64 bytes)
2. Cover Open
3. Paper Out*
4. End of Ribbon*
5. Printer in Check condition

* With Paper Out or End of Ribbon, +DTR goes LO only when printing is attempted.

The +DTR signal returns HI when the print buffer becomes nearly empty (within 64 bytes) and all the other conditions are corrected. When the Protocol switch is not set for Printer Ready protocol, the +DTR interface signal is at a continuous HI level.

3.7 IEEE-488 INTERFACE PROTOCOL

See subsection 1.4 of this manual.

3.8 CENTRONICS INTERFACE PROTOCOL

See subsection 1.5 of this manual.

3.9 PRINTING FORMAT

Printing format is dependent on three primary factors: Horizontal Character Spacing, Vertical Line Spacing, and number of Lines Per Page. Each of these factors can be independently controlled. An "index" is used to define the specific motion desired for both horizontal character spacing and vertical line spacing. Any point on a page can be defined in terms of a "horizontal position" and a "vertical position". The number of lines per page can easily be changed when necessary.

3.9.1 Definition of Terms

Figure 3-3 and the text below describe some of the points associated with a simple page layout.

ORIGIN: The position of the print head after a form feed (with no top margin set) and an absolute horizontal tab to print position 1 (horizontal position 0). The first print position on the first line of a page.

HORIZONTAL MOTION INDEX (HMI): Determines the distance, in multiples of 1/120", that the carriage moves after printing a character (or when spacing). Minimum HMI is 0, maximum is 125; thus, minimum distance is 0 x 1/120" and maximum is 125 x 1/120" (1.04" nominal).

VERTICAL MOTION INDEX (VMI): Determines the distance, in multiples of 1/48", that the paper (platen) moves for each line feed, negative line feed, etc. Minimum VMI is 0, maximum is 125; thus, minimum distance is 0 x 1/48" and maximum is 125 x 1/48" (2.6" nominal). When VMI = 0, no paper movement occurs.

ABSOLUTE HORIZONTAL POSITION: The horizontal distance, in 1/120 inch increments, between the print head position and the origin. Minimum absolute horizontal position is 0, maximum is 1572 (13.1" x 120).

ABSOLUTE VERTICAL POSITION: The vertical distance, in 1/48 inch increments, between the current print line and the first line on the page (the origin). Minimum absolute vertical position is 0, maximum is 15,750 (125 x 126 lines per page).

PRINT POSITION: The horizontal area capable of being occupied by a single printed character. This is similar to a print "column" on a line printer, except that it is variable. That is, the number of print positions per line is dependent on the HMI. The minimum number of print positions per line is 13 when HMI = 125; the maximum is 1573 when HMI = 1. The leftmost print position is position 1, which is the same as Absolute Horizontal Position 0. Print position may be calculated as follows:

$$\text{Print Position} = \frac{\text{Horizontal Position}}{\text{HMI}} + 1$$

LINE: The vertical distance capable of being occupied by a row of printed characters. The height of the line is equal to VMI. The top line on a page is designated as Line Number 1, which is the same as Absolute Vertical Position 0. Line number may be calculated as follows:

$$\text{Line Number} = \frac{\text{Vertical Position}}{\text{VMI}} + 1$$

LINES PER PAGE: The actual number of print lines per page of paper. Lines per page can be set to any number from 1 thru 126.

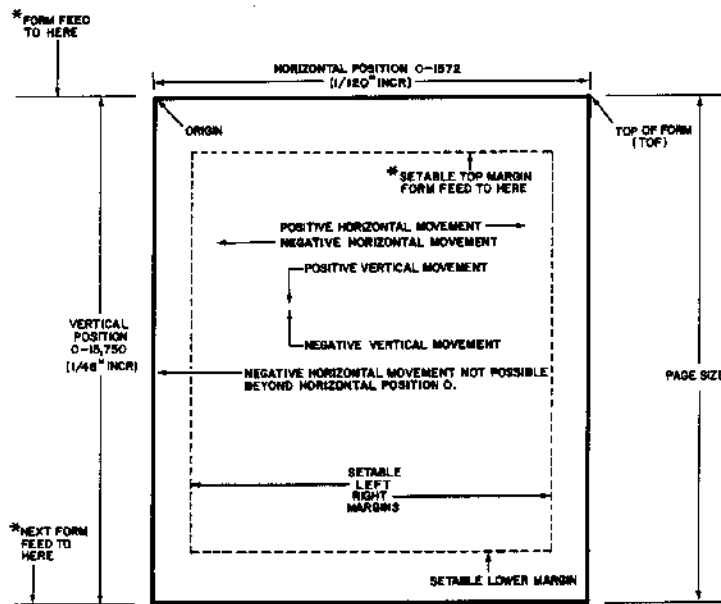

Width of Print Position = Horizontal Motion Index (HMI) and is variable from 0 to 125 (1/120") increments
 Print Position Number = $\frac{\text{Horizontal Position}}{\text{HMI}} + 1$ = Horizontal Tab Position. Tab Positions limited to first 160 Print Positions.
 Height of Line = Vertical Motion Index (VMI) and is variable from 0 to 125 (1/48") increments.
 Line Number = $\frac{\text{Vertical Position}}{\text{VMI}} + 1$ = Vertical Tab Position. Total number of lines can be specified from 1 to 126.
 Page Size = Number of lines x VMI.

* If a top margin is set, the Form Feed will advance beyond the Top of Form to the top margin.
 Note: Movement arrows depict carriage movement relative to paper and not actual paper movement direction.

Figure 3-3. PAGE LAYOUT AND PRINTING FORMAT

3.9.2 Standard Formats

Any one of three standard formats can be selected via the SPACING switch on the control panel. These formats are summarized in Table 3-3.

Whenever the SPACING switch is repositioned and an optional format has not been selected, the values listed in the table for the new position are used for horizontal and vertical spacing, and for lines per page.

Additional formats can be obtained by changing the HMI, VMI, or Lines Per Page. Such variable indexing overrides the SPACING switch function. Control can be restored to the SPACING switch by issuing the ESC S sequence.

Table 3-3
STANDARD PRINTING FORMATS

SPACING Switch	Horizontal Spacing			Vertical Spacing		
	Char/in.	Char/line	HMI	Lines/in.	Lines/page	VMI
10	10	132	12	6	66	8
12	12	156	10			
15	15	197	8			

3.9.3 Proportional Space Printing

This subsection describes how the 630 automatically handles the proportional spacing of simple text strings. Many host systems, however, elect to generate the proportional space commands within their own software, in which case the proportional space printing mode of the 630 is not activated.

The proportional space mode facilitates use of proportional space (PS) print wheels on the Model 630. The print wheel lookup tables stored in the memory of the Model 630 include PS unit values. These PS unit values represent one-half the width required by each proportionally spaced character. Carriage movement during proportional space printing is controlled by printing each character in the sequence: **Move - Print - Move**; where the amount of "Move" is specified by the PS unit value assigned to that character. The letter "V", for example, has a PS value of 6, which is one-half of the 12/120" spacing a "V" requires. The "V", therefore, would be printed in the sequence: Move 6/120" - Print - Move 6/120". The sequence for printing an "i" (PS value 3) following the "V" would be: Move 3/120" - Print - Move 3/120". The total distance between the centerline of the "V" and the centerline of the "i" would be 6/120" + 3/120" = 9/120".

In fixed pitch mode, the printing sequence is Print-before-Move. The size of the Move is determined by the current active HMI value, which is selected by the SPACING switch on the control panel, or by remote HMI mode (see subsection 3.9.4.1). **Note: You must not change remote HMI while the Model 630 is in PS mode; erratic printer action will result. If you wish to alter the spacing, use offset instead.**

The proportional space mode is selected by the SPACING switch on the control panel, unless the terminal is in the remote HMI mode, in which case the SPACING switch is ignored. When proportional spacing is selected by the SPACING switch, the HMI automatically goes to 12 pitch.

The proportional space mode may also be selected by the sequence ESC P, and turned off by the sequence ESC Q. Once the ESC P sequence has been received, the SPACING switch will be ignored and proportional spacing is used. When the ESC Q sequence is received, the Model 630 exits the proportional space mode, and horizontal spacing is then determined by the current HMI value until an ESC S sequence is received. An ESC S sequence returns control to the SPACING switch.

Entering and leaving proportional space mode via the Escape sequences does not change the HMI to 12 pitch as happens when proportional space selection is made by means of the SPACING switch. During proportional space mode, the HMI affects only tabbing and word space size (space and backspace).

There are times when certain data needs to be printed nonproportionally spaced even though a PS print wheel is being used; for example, when the display from a video terminal is to be printed to illustrate a document. If the data is printed proportionally spaced, the columnar alignment of the data is lost. To avoid this, you can issue the ESC Q sequence to exit the proportional space mode, and then issue an ESC US DLE sequence to set the HMI to 15, which is adequate to print all characters on the PS print wheel without any characters touching. When the nonproportionally spaced printing has been completed, revert to normal HMI by executing the ESC S sequence, and return to proportional space mode by executing an ESC P sequence.

All numeric characters have the same PS unit value (5). This allows numeric data to be printed aligned in columnar form without having to turn off proportional space printing. The starting position of the columns can be established by setting a tab at that position, and tabbing to it, or by using the absolute horizontal tab to move to the starting position (see subsection 3.13.1). If you are altering the value of the HMI during the print of each line, be sure that the HMI has the same value prior to each movement to the beginning of the column, to ensure that the starting position does not change.

3.9.4 Optional Formats (Variable Indexing)

Any of the three format factors can be altered by utilizing special escape (ESC) sequences. The ESC CR P (Remote Reset) sequence may also be used here to cancel all optional format factors and return to the format selected by the SPACING switch. Refer to subsection 3.5 for a detailed list of all ESC sequences.

Execution of any of these sequences does not immediately alter horizontal or vertical position. It does, however, change subsequent operations by redefining the variable format factors. It is recommended that a Form Feed (FF) and an Absolute Tab (see subsection 3.13) to location 0 be performed prior to changing any format factors.

3.9.4.1 Variable HMI (Remote HMI Mode)

The standard HMI can be altered by executing the 3-character sequence ESC US (ASCII character), where the binary value of the selected ASCII character is one (1) greater than the number of 1/120 inch increments the carriage will move after printing a character or when spacing. This places the terminal in the remote HMI mode.

$$\text{HMI} = (\text{ASCII character} - 1) \times 1/120 \text{ inch}$$

NUL and DEL characters cannot be used, therefore the minimum HMI is 0 increments, and the maximum is 125 increments. See subsection 4.5, Table 4.3, to determine the appropriate ASCII character for the ESC sequence. While the terminal is in remote HMI mode, the SPACING switch is ignored. An ESC S sequence will return control of HMI to the SPACING switch.

3.9.4.2 Variable VMI (Remote VMI Mode)

The standard VMI can be altered by executing the 3-character sequence ESC RS (ASCII character), where the binary value of the ASCII character is one (1) greater than the number of 1/48 inch increments the paper is to move for each line feed, negative line feed, etc.

$$\text{VMI} = (\text{ASCII character} - 1) \times 1/48 \text{ inch}$$

Minimum VMI is 0, maximum is 125. See subsection 4.5, Table 4-3, to determine the appropriate ASCII character for the ESC sequence.

3.9.4.3 Lines Per Page

Lines per page is automatically set at 66 (or 72 if so jumpered on LCPN control panel) when the terminal is initialized (restored at power up). **Note:** There is no provision for automatic default to 12" (72 lines) page size when the terminal is equipped with the FFCPN control panel.

The number of lines per page can be altered in ASCII mode by executing a 3-character sequence ESC FF (ASCII character) where the binary value of the ASCII character is equal to the number of lines per page desired. The minimum number of lines per page is 1, the maximum is 126.

The following two formulas can be used to compute the desired number of lines per page:

$$\text{Lines Per Page} = \text{Number of Lines Per Inch} \times \text{Page Size in Inches}$$

$$\text{Number of Lines Per Inch} = \frac{48}{\text{VMI}}$$

Once the desired number of lines per page is known, use the information in subsection 4.5, Table 4-4, to determine the appropriate character for the ESC sequence.

3.10 FORWARD/BACKWARD PRINTING

The Model 630 is capable of printing forward (left to right) or backward (right to left) with equal ease. It is capable of both Automatic and Programmed backward printing. It can also operate in an Inverted Horizontal Motion mode.

3.10.1 Auto Backward Printing

Auto backward printing is enabled by the sequence ESC /. It is disabled by the sequence ESC \. When the Model 630 is operating in the Auto Backward Printing mode, a line of text will be printed in the reverse direction only if all of the following conditions exist:

1. Auto backward printing is enabled.
2. Printing is a least one line behind print-queued data.
3. It is a shorter distance for the carriage to move to the right-hand end of the next line than to move to the left-hand end.
4. No ESC sequences are embedded within the line of text.

Programmed Backward Printing can override Auto Backward Printing for a single line.

3.10.2 Programmed Backward Printing

This mode is entered by receiving the sequence ESC 6 from the host. An ESC 5 sequence or a Carriage Return will re-establish the forward printing mode.

During Backward Printing, each character printed causes incremental carriage movement to the left, just opposite of carriage motion during forward printing. The action of the Space and Backspace keys and codes are also reversed in Backward Printing. Note, however, that tabbing operations, carriage return, and all paper movement functions are unaffected by being in the Backward Print mode.

3.10.3 Inverted Horizontal Motion

For foreign languages and any other application requiring reversal of the entire page horizontal format, the sequence ESC < will establish the Inverted Horizontal Motion mode. In this mode, all horizontal motion is inverted, including tabbing. The carriage home position is redefined as the rightmost carriage position. The starting point for each line is considered to be at the right margin instead of at the left margin.

Backward printing can also be performed when operating in the Inverted Horizontal Motion mode. In this case, backward printing is defined as printing from left to right. Normal left to right printing (Forward Printing) can be re-established by the sequence ESC > .

3.11 PRINT SUPPRESSION

Print suppression is initiated by the sequence ESC 7, and cancelled by a carriage return (CR) command. While this feature is enabled, all printable characters are replaced by spaces. Escape sequences and control characters are not affected.

3.12 CONTROL OF MARGINS

3.12.1 Horizontal Margins

Both left and right margins can be set remotely by positioning the carriage to the desired print position, and then sending an ESC 9 or ESC 0 (LEFT MAR or RIGHT MAR) sequence. Altering the left margin causes the carriage to return to the new print position setting following a carriage return (CR) command.

When the left margin is set at some print position other than 1, the carriage can be moved to the left of the margin by absolute horizontal tabbing, by backspacing, or by spacing in the Backward Print mode.

A power-on initialize or a remote reset operation will automatically clear the left margin to horizontal position 0 and the right margin to horizontal position 1572.

3.12.2 Vertical Margins

Both top and bottom vertical margins can be adjusted by first placing the paper in the top-of-form position, then moving the paper up with a series of LINE FEED operations or an absolute vertical tab to reach the desired top margin position. This "Top Margin" is then set by executing an ESC T sequence. Advancing the paper with LINE FEED operations or an absolute vertical tab to the desired "Bottom Margin" position, and then executing an ESC L sequence sets the bottom margin. The bottom margin must always be set below the upper margin, and both must be within the page size boundaries.

Whenever a lower page margin is crossed with a line feed, auto line feed or half line feed, paper movement automatically positions the print head at the top margin on the next page, eliminating the need for a form feed character. The area between the lower margin of one page and the top margin of the next page can be accessed through vertical tabs (absolute and normal), and through negative line feeds.

Top and bottom margins are reset to the top-of-form and bottom-of-page locations whenever page size (lines per page) is altered, or a remote Reset is received. They are also reset (or initialized) on power-up, or upon receipt of a remote ESC C command.

3.13 TABBING

There are two methods of tabbing for both horizontal and vertical motion. The first method, termed "Normal Tab", is similar to the traditional system used on typewriters in that tab stops are set at predetermined positions. The carriage or paper then moves to these positions sequentially on command. The second method, termed "Absolute Tab", is unique in that it does not require prior setting of tab stops. The carriage or paper is positioned directly to any one of 126 possible positions either horizontally or vertically from any other position. In the case of vertical tabbing, the paper should be moved "forward only", unless the unit is equipped with an optional bidirectional paper handling accessory.

Both methods of tabbing provide horizontal and vertical positioning to standard print positions or lines. This makes it possible, by using variable indexing, to print data out in any format desired without prior editing. For example, data that was originally formatted for 10 characters per inch, 6 lines per inch, can be printed out at 12 characters per inch, 4 lines per inch (or any other format), and all tabular material will remain in the same relative position.

The method of tabbing to be used is specified by the command character sequence used. The Horizontal Tab (HT) character or Vertical Tab (VT) character alone executes a normal Tab operation. An ESC HT or ESC VT sequence, plus an ASCII character executes an Absolute Tab.

Since tabbing provides positioning only to normal print positions and lines, finer positioning requires use of the Graphics mode. All tabbing functions are unchanged in Graphics mode.

3.13.1 Absolute Horizontal Tab

Using Absolute Tab, the carriage can be positioned directly to any of the first 126 print positions without the need for prior setting of tab stops. Since Absolute Tab Stops are not retained in memory, each stop must be commanded anew each time it is to be used. The command sequence for this is ESC HT (ASCII character), where the value of the ASCII character indicates the print position desired. See subsection 4.5, Table 4-4, to determine the appropriate ASCII character for the ESC sequence.

The leftmost print position is considered to be binary location 1. Any ASCII character other than NUL and DEL can be used, enabling direct tabbing to any of the first 126 print positions. This method of tabbing also permits tabbing leftward.

The horizontal position at the completion of an Absolute Tab operation is computed as follows:

$$\text{Horizontal Position} = (\text{ASCII character} - 1) \times \text{HMI}$$

Note that if you try to tab beyond the limit, the command is simply ignored and no movement occurs.

3.13.2 Absolute Vertical Tab

Using Absolute Vertical Tab, the paper can be moved to any of the 126 possible lines on the page from any other line on the page. Absolute Vertical Tab is initiated by executing the sequence ESC VT (ASCII character), where the value of the ASCII character chosen determines the number of the line to be reached. See subsection 4.5, Table 4-4, to determine the appropriate ASCII character for the ESC sequence. NUL and DEL are not used. The top line on the page is assigned the binary value of 1, with each succeeding line down the page assigned the next higher number. It is impossible to tab beyond the end of the page even if the number of lines per page is less than the maximum 126. The actual amount of paper movement is determined by: (a) the paper position before VT execution, (b) the ASCII character used, and (c) the Vertical Motion Index (VMI). The ultimate position reached is determined as follows:

$$\text{Vertical Position} = (\text{ASCII character} - 1) \times \text{VMI}$$

Note that if you try to tab beyond the limit, the command is simply ignored and no movement occurs.

3.13.3 Normal Horizontal Tab

Horizontal tab stops can be set at any print position up to position 160 by positioning the carriage to the desired print position and executing an ESC 1 sequence. Keeping in mind that tab stops can only be set at the first 160 print positions, the formula for determining a tab position is:

$$\text{Horizontal Tab Position (1 thru 160)} = \frac{\text{Horizontal Position}}{\text{HMI}} + 1$$

A TAB command automatically causes the carriage to move to the next sequential tab stop. Should a TAB move be commanded with no tab stop having been set to the right of the present carriage position, the carriage will not move and the alarm (FFCPN control panel only) will sound. Individual horizontal tab stops can be cleared by first positioning the carriage to that print position and then executing an ESC 8 sequence. All tab stops, both horizontal and vertical, can be cleared simultaneously by executing an ESC 2 sequence or a remote reset (ESC CR P).

3.13.4 Normal Vertical Tab

Vertical tabs are set with reference to the top-of-form position. This position, the first print line on the page, is reached by a keyboard FORM FEED command, followed by a manual adjustment of the paper location vertically to locate the paper in proper position. Vertical tab stops may then be set at any other line on the page by first moving the paper to the desired line by means of a series of LINE FEED commands, and then executing an ESC - sequence. This is repeated for each desired tab stop. The location of the vertical tab stop is defined as follows:

$$\text{Vertical Tab Position} = \frac{\text{Vertical Position}}{\text{VMI}} + 1$$

Once vertical tab stops are set, subsequent VT commands will cause the paper to be indexed upward to the next sequential vertical tab stop. If there are no more stops set between the present print line and the end of the form, the paper will not move and the audible alarm (FFCPN control panel only) will sound. Individual vertical tab stops cannot be cleared as can the horizontal tab stops. All tab stops, horizontal AND vertical, are cleared simultaneously by executing the ESC 2 sequence or a remote reset (ESC CR P).

3.14 LINE FEED

A LINE FEED (LF) command thru the interface will cause the form to be moved up one line (one VMI). An ESC LF sequence acts as a negative line feed, causing the paper to be moved down one line. A line feed is also performed automatically as a result of a carriage return operation when AUTO LF is ON.

3.15 HALF-LINE FEED

A Half-Line Feed (ESC U) causes the paper to move up 1/2 line (1/2 of the VMI). A Negative Half-Line Feed (ESC D) moves the paper down 1/2 line. These two commands are unchanged in Graphics mode. If the VMI is set to some odd number, the total paper movement during a half-line feed will be one increment (1/48 inch) less than 1/2 line.

3.16 FORM FEED

A FORM FEED command, issued either remotely or from the control panel, will cause the paper to be moved up to the first line of the next page, or to the top margin line if one has been set.

3.17 CARRIAGE RETURN

A CARRIAGE RETURN (CR) command thru the interface will cause the carriage to return to the left margin (Normal Printing Mode) or right margin (Reverse Printing Mode).

3.18 AUTO CARRIAGE RETURN

When the Auto Carriage Return mode is enabled, a carriage return occurs automatically when the carriage reaches print column 132 (in 10 pitch). The automatic carriage return also causes a line feed, regardless of whether the Auto LF mode is enabled.

The means of activating Auto Carriage Return mode differs between units equipped with the standard FFCPN control panel, and those with the optional LCPN control panel. With the LCPN, Auto Carriage Return is enabled when there is no jumper installed in jumper position 3 on the control panel. When the jumper is installed, Auto Carriage Return is disabled.

With the standard FFCPN control panel, Auto Carriage Return is enabled only by receiving the sequence ESC ? thru the interface. The sequence ESC ! disables Auto Carriage Return.

3.19 GRAPHICS

The API is placed into the Graphics mode by receiving an ESC 3 sequence thru the interface. A carriage return command (CR) or an ESC 4 sequence will return the unit to normal operation. While in the Graphics mode, carriage movement is completely divorced from printing; i.e., printing a character does not automatically move the carriage. The carriage can be moved only by executing a tab, space, backspace, or carriage return operation. The tab commands operate the same as they do in Normal mode. However, in Graphics mode the space and backspace commands move the carriage only 1/60" instead of the selected horizontal index (HMI) amount. Vertical Tab and Form Feed operations are unchanged in Graphics, but Line Feed and Negative Line Feed cause only 1/48" of paper movement instead of the full line (VMI) movement they effect in Normal mode. Half-Line Feed (ESC U) and Negative Half-Line Feed (ESC D) act the same in Graphics mode as in Normal mode.

The Graphics mode provides a rudimentary means of charting, graphing and plotting. It does, however, rely entirely on the host system software for control; in contrast to the more sophisticated HyPlot Vector Plotting feature additionally available. The HyPlot feature is described in subsection 3.25.

3.20 TWO-COLOR PRINTING (Available only on non-ECS units, as an option)

On units equipped with the two-color printing option, two-color printing can be achieved by installing a Diablo two-color ribbon cartridge. The mechanism initializes to print in the primary color (black). To print in the alternate color (red), execute an ESC A sequence. To return to the primary color, execute an ESC B sequence. The ribbon position should not be changed at a rate exceeding 3 times per second.

Note: Factory adjustment optimizes performance using a 5/16" multi-strike ribbon. Subsequent adjustment may be necessary if 2-color ribbon is going to be used.

3.21 RESET/INITIALIZATION

3.21.1 Limited Reset

This operation is initiated by either:

- The RESET switch on the control panel.
- An ESC SUB R sequence through the interface.

The results of the Limited Reset operation are:

- Any existing error indications are reset.
- A Restore operation occurs if the printer is in a Check condition.

3.21.2 Initialize

The Initialize operation is initiated by any of the following actions:

- Application of power to the Model 630.
- Execution of remote reset command (ESC CR P).
- Execution of command "Initialize Printer" (ESC SUB I)

(Subsection 3.23.1 points out the differences of execution between ESC CR P and ESC SUB I.)

The Initialize operation resets all the logic circuits, resets all program counters to zero, and sets the operating parameters of the unit as listed below. The unit will not respond to any input until the restore cycle is completed.

- Normal print mode
- Forward print mode
- Left-to-right forward print direction (Print Position 0 at leftmost carriage position)
- Carriage moved to Horizontal Position 0
- Vertical Position cleared to 0 (paper does not move)
- VMI set to 8 (8 lines/inch)
- Lines per page set to 66 (11" page) or 72 (12" page). (Note: 72 lines per page selected by jumper #1 on LCPN control panel only.)
- Print in black
- Auto Backward (Bidirectional) Printing enabled
- Left margin set to position 0
- Right margin set to position 1572
- Top margin set to position 0 (line 1)
- Bottom margin set to position 528 for 11" page, or 576 for 12" page (12" with LCPN only)
- All horizontal and vertical tab stops cleared
- Send and print buffers cleared
- ECS defaults to primary character set
- Print wheel selection defined by print wheel type switches on control panel (Discontinues use of downloaded print wheel parameters)

3.22 PRINT WHEEL TABLE DOWNLOAD

3.22.1 General

Print Wheel Table Downloading allows the user to specify a complete ASCII-to-spoke conversion table for any print wheel desired. This temporary conversion table is "downloaded" from the host computer to the read-write (RAM) memory of the API terminal. The downloaded table can then be used in place of the resident print wheel tables permanently stored in the read-only (ROM) of the API. For each ASCII code corresponding to a print character on the print wheel, the print wheel table specifies:

- hammer energy
- proportional space/ribbon advance units
- spoke position
- ribbon up/down (non-ECS), or print wheel up/down (ECS)
- whether this is a printable spoke position on this wheel

When the ASCII code for a particular character is received over the interface in the normal printing mode, the API's microprocessor refers to a particular location in the selected lookup table to obtain the proper print data for that character.

All non-ECS print wheel tables contain 96 table positions, corresponding to the maximum 96 character positions on a non-ECS print wheel. For 88- and 92-character print wheels, some of these table positions will specify a nonprinting status, corresponding to the absent spoke positions on those print wheels.

All ECS print wheel tables contain 224 table positions. In a downloaded ECS print wheel table, these table positions are utilized as follows:

- 96 positions for the 96 discrete print wheel characters contained in the primary character set.
- 128 positions for the supplementary character set.
The supplementary character set includes the remaining 96 discrete print wheel characters, plus any character duplications from the primary character set.

Note: Composite characters (constructed characters), which may be contained in the supplementary character set of a resident ECS print wheel table, cannot be included in a downloaded print wheel table. Table positions corresponding to unused ASCII codes or constructed characters must be loaded with 0's during the download operation.

The following paragraphs describe the format and protocol necessary for downloading a print wheel table to the API. However, host system software design for assembling the table and executing the download is the responsibility of the "Systems Integrator".

3.22.2 Download Variations

The diagrams in Figure 3-4 represent two variations of the download procedure: downloading the print table by a single record, and downloading by multiple records. The required record format is described in subsection 3.22.4.

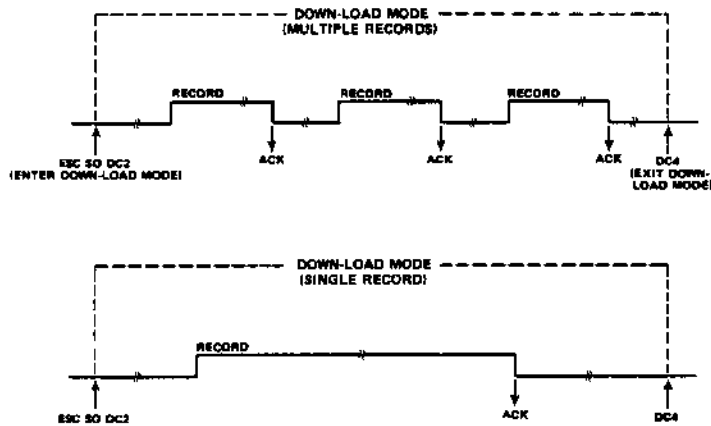

Note: The total amount of Table Data stored by a Download operation is 192 bytes for a non-ECS table (2 bytes for each possible character position on the print wheel); or 448 bytes for an ECS table (2 bytes for each possible printable character position in the primary and supplementary character sets).

Figure 3-4. DOWNLOAD VARIATIONS

The entire print wheel table can be downloaded within a single record (ECS print tables require at least two records), or the table can be loaded in segments by a series of records. Smaller records are more easily debugged if errors in data format are detected, but otherwise the multiple-record method has no significant advantage over single-record downloading. Typically, the user limits the length of the records so that when a hard copy printout is made of the record sequence it can be formatted on the printed page with one download record per line of printout. (See the download sample in subsection 3.22.6.)

Print wheel download mode is entered with the control sequence ESC SO DC2, and exited with the single control character DC4. After the download procedure has been completed successfully, the downloaded table is automatically selected for print wheel support. Reselection of one of the resident tables can be made by initializing the terminal (power off-on or remote reset), or by re-entering the download mode and sending an invalid record. (See subsection 3.22.4.2 to determine an appropriate invalid record.)

Note:

The download function as described here utilizes the ACK/NAK response capability of the RS-232-C interface. With this capability, following receipt of each downloaded record, the API transmits an ACK or NAK back to the host to indicate that the record has been received as either valid (ACK) or invalid (NAK). An ACK thus notifies the host that the API is ready to receive the next record, whereas a NAK signifies to the host that an invalid record has been received and the API has subsequently aborted the download mode.

To compensate for the lack of ACK/NAK capability with either the IEEE-488 or Centronics-type interface, the host should proceed with the download in the following manner:

- 1) Send the entire series of download records using the normal handshaking protocol for data transmission with the type of interface being used (see subsections 1.4, 1.5).
- 2) Send DC4 to take the API out of download mode.
- 3) Using the print wheel that matches the downloaded print wheel table, do a sample printout and examine the results. If the download executed properly, the printout should be correct for the print wheel being used.

Normally, if an invalid record occurs during download, the API will immediately abort the download and default to the print wheel table selected on the control panel. Subsequent download data will be recognized as print data and will immediately be printed. If this occurs during a download operation, it is a good indication that the download has been aborted.

3.22.3 Keys To Understanding The Download Function

Listed below are three important keys to understanding the download procedure described in the following paragraphs:

- It is important to carefully distinguish between "Hex" characters (4 bits) and ASCII characters (7 bits).
- Within both the host system and the API terminal, the print table data is stored and handled in the form of 4-bit hexadecimal (hex) characters.
- To transmit the table data, the host converts each 4-bit hex character into the corresponding 7-bit ASCII character. Upon receiving the 7-bit ASCII character, the terminal immediately converts it back to 4-bit hex form.

3.22.4 Download Data Record Format

The table data is downloaded within a character string called a "record". The record structure is depicted in Figure 3-5. This format is a common industry standard. The record consists of a record start character, a record type character, a byte count (two characters), a load address (four characters), the table data (four characters per table entry), and a checksum (two characters). Each of these elements is described in detail in the following paragraphs, and illustrated in subsection 3.22.6 by the printout of an actual download structure.

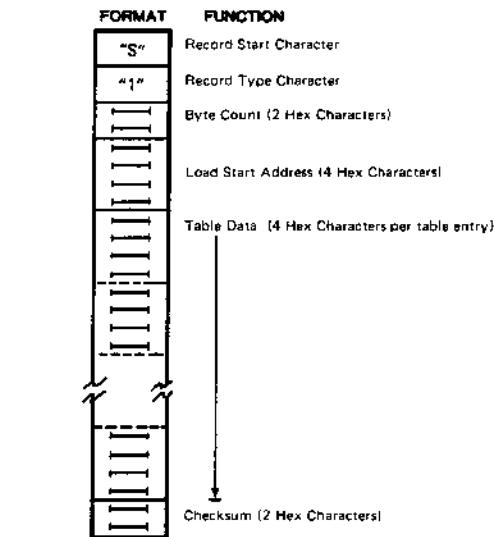

- Notes:
1. ← " One Hex Character
 2. The "Hex" characters designated in this diagram are ASCII characters, from the host, representing Hexadecimal values 0-9 and A-F.

Figure 3-5. DOWNLOAD RECORD FORMAT

If no error in data format is detected while receiving the record, the terminal will transmit an ACK control character immediately following receipt of the last character of the record (after verifying that the byte count and checksum are correct). An error in data format is detected if the terminal receives any character other than the hex characters 0 thru 9 and A thru F following the "S" record start character, or if the checksum does not compare correctly against the data received. If any error in data format is detected, the terminal immediately transmits a NAK control character, exits the download mode, and defaults table selection to the resident print wheel table selected by the print wheel switch on the control panel.

3.22.4.1 Record Start Character

The record start character is an ASCII "S". Any data encountered before the "S" will be ignored. This allows carriage returns and line feeds, or other characters, to be embedded before, after, or between records. These embedded characters will not affect the down-load process, but do allow appropriate formatting of the printout if a hard copy reference of the download records is required (see subsection 3.22.6).

3.22.4.2 Record Type Character

The record type character must be an ASCII "1" ("data record"). In other applications with similar download structures, the record type character is sometimes a "0" ("header record") or a "9" ("end-of-file record"). In the API terminal, a record identified as type 0 or 9 will simply be ignored. Any character other than a 0, 1 or 9 is detected as a download error, which causes the API to transmit a NAK control character and terminate the download mode. Print wheel table selection then defaults to the resident print wheel table selected on the control panel.

3.22.4.3 Byte Count

The byte count consists of two hex characters that specify the number of data bytes to follow, including the load address and checksum. Since each data byte contains two 4-bit hex characters, the record will contain twice the number of hex characters as the byte count value.

The maximum number that can be specified by the two 4-bit hex characters (8 bits) of the byte count is 255. Since the Load Address requires 2 bytes, and the Checksum requires 1 byte, this leaves a maximum of 252 bytes for actual table data. And with two data bytes per table entry, this sets a maximum limit of 126 print wheel table data entries that can be downloaded in a single record, as shown below:

$$(255 - 2 - 1) / 2 = 126 \text{ Print Wheel Table Entries}$$

This is more than adequate to allow sending the table data for a 96-character print wheel as a single-record download. Downloading the table data for an ECS (192 characters) print wheel, however, requires a minimum of two records.

Typically, the number of print wheel table entries per record is chosen to permit hard copy printout of each record within the margins of the paper width used. This allows the records to be printed within the sequence:

record (1) CR LF record (2) CR LF ... etc.

In this format, the records are printed as follows:

record (1)
record (2)
.
.
.
etc.

(Note: The "printout" being discussed is not a part of the download procedure; it is simply the print operation you would do to obtain a printed reference copy of a download structure you have assembled.)

If, for example, you wish to limit each line in the printout to a maximum of 74 characters, the maximum number of actual table entries that can be contained in each record is calculated as follows:

$$\begin{aligned}\text{No. of Table Entries} &= (74 - (1 \text{ Record Start char.} + 1 \text{ Record Type char.} + 2 \text{ Byte Count} \\ &\quad \text{chars.} + 4 \text{ Load Address chars.} + 2 \text{ Checksum chars.}))/4 \\ &= (74 - (1 + 1 + 2 + 4 + 2))/4 \\ &= 64/4 = 16 \text{ Table Entries}\end{aligned}$$

In this case, the Byte Count is calculated as follows:

$$\begin{aligned}\text{Byte Count (decimal)} &= (2 \text{ Load Address bytes}) + (16 \times 2 \text{ Table bytes}) + \\ &\quad (1 \text{ Checksum byte}) \\ &= 2 + 32 + 1 = 35 \text{ data bytes Total}\end{aligned}$$

When converted from decimal to hexadecimal, the Byte Count field for this example would contain the hex characters "23".

3.22.4.4 Load Address

The load address consists of four hex characters (16 bits/2 bytes) that specify the starting location in memory where the first byte of table data in this record is to be stored. The Most Significant (MS) hex character must be sent first. The diagram in Figure 3-6 illustrates the print wheel table memory layout.

The block of memory addresses allocated for the print wheel table extends from 0040 hex thru 00FF hex (non-ECS mode) and thru 01FF hex (ECS mode). If a load address outside this range is specified, it is interpreted as an error in data format and causes the API to abort the download mode and transmit a NAK control code.

The load address specified in the record must be equal to two times the hex value of the first ASCII character whose print data will be loaded into the table by this record. For example, if this is the second record of a multiple-record download, and the first table entry to be loaded by this record is for the ASCII character "B" (hex 42), the load address for this record is 0084 hex. The two bytes of table data associated with printing the "B" will actually occupy memory locations 0084 and 0085. Similarly, the two bytes of data associated with the ASCII character "C" (hex 43) will occupy memory locations 0086 and 0087, and so on for all subsequent characters in ASCII hex order. The load address for a single-record download, and for the first record of a multiple-record download is always 0040 hex; corresponding to two times the lowest hex code (20) that represents a printable character in the Model 630 API.

Note: The table data in memory locations 0040 and 0041 hex is the data accessed by an ESC Y sequence through the interface. Similarly, the table data in memory locations 00FE and 00FF hex is the print data for the character accessed by ESC Z.

**NON-ECS PRINT TABLE AND
ECS PRIMARY CHARACTER SET
PRINT TABLE**

**ECS SUPPLEMENTARY
CHARACTER SET
PRINT TABLE**

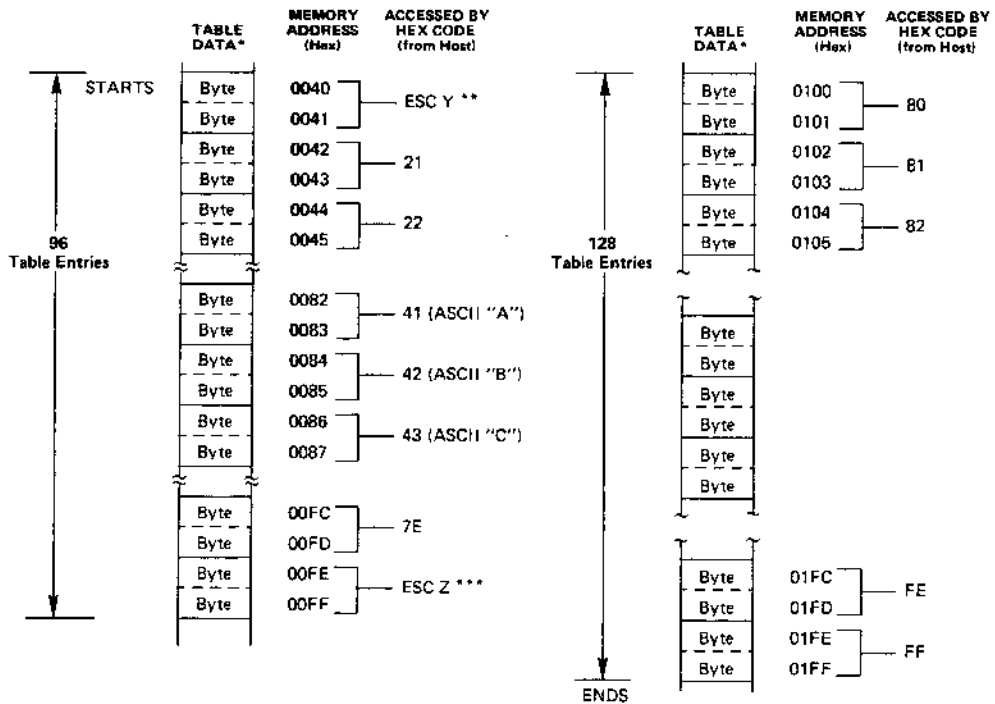

- NOTES:**
- * Each table entry is stored in memory as four 4-bit hex characters, comprising two 8-bit bytes as depicted above.
 - ** Table data for character under ASCII code 2D (hex) is accessed by ESC Y over the interface during normal print mode.
 - *** Table data for character under ASCII code 7F (hex) is accessed by ESC Z over the interface during normal print mode.
 - ♦ Any table positions corresponding to ASCII codes that are unused or assigned to constructed characters must be loaded with 0's. (Constructed characters cannot be addressed from a downloaded print table.)

Figure 3-6. DOWNLOAD TABLE MEMORY MAP

3.22.4.5 Table Data

Each print wheel table entry (four hex characters) occupies two bytes of memory space. The four hex characters comprising these two bytes in memory are recognized in the following order:

First hex character	- represents -	First byte, high 4 bits
Second hex character	-	First byte, low 4 bits
Third hex character	-	Second byte, high 4 bits
Fourth hex character	-	Second byte, low 4 bits

The format of the two bytes in memory is defined below.

	Bits							
	<u>7</u>	<u>6</u>	<u>5</u>	<u>4</u>	<u>3</u>	<u>2</u>	<u>1</u>	<u>0</u>
1st Byte -	P	H	H	H	ps	ps	ps	ps
2nd Byte -	R	S	S	S	S	S	S	S

Where: P = 1 if this is a printable position on this print wheel;
= 0* if this is a nonprinting position (such as with certain positions on 88- and 92-character print wheels.)
H = Hammer Energy 1 to 4 (0 = no hammer fire).
ps = Proportional Space value 0 to 15 (also used for ribbon advance if in PS mode)

R = 1 for ribbon up at print time (Non-ECS)
= 1 for inner row character (ECS)
= 0 for ribbon down at print time (Non-ECS)
= 0 for outer row character (ECS)
S = Absolute Electrical Spoke Position 0 thru 95.
(Spoke position specified greater than 95 will select spoke 0 and inhibit hammer fire.)

* **CAUTION** - Failure to assign nonprinting status (P=0) when needed may result in print wheel damage by allowing the hammer to fire against the print wheel flag on 88- and 92-character print wheels.

Diablo publishes Print Wheel Data Books (Publication Nos. 90044-XX) which contain the print wheel data that must be inserted by the host system when assembling a download print wheel table. (See subsection 4.4 in this manual.)

All of the locations in the table (96 for non-ECS/224 for ECS) must be loaded. For any non-printing print wheel positions, the "P" bit shown in the table data format (the highest bit in the first byte) must be a "0". The states of all other bits associated with that position are then irrelevant except for the "ps" bits (low 4 bits of the first byte). If this nonprinting position should ever be addressed in normal printing mode, the API will default to a space mode, in which the value specified by the "ps" bits for this character determines the amount of carriage movement that occurs.

Note: The most reliable policy is simply to load all 0's into the table in any unused positions and any positions corresponding to constructed characters. (Constructed characters cannot be addressed from a downloaded print table.)

Any downloaded table that will be used in a telecommunications environment must conform to the internationally accepted ASCII/ISO conventions regarding the specific hex code assigned to each ASCII character (see Fig. 4-1).

3.22.4.6 Checksum

The checksum (one data byte) consists of two hex characters generated by the host computer. The checksum data byte is the negation (i.e., the "1's" complement) of the sum of all data bytes (disregarding end-around carry), starting with the byte count. When all of the data bytes, starting with the byte count, are added together as received by the API, and the checksum is then added, the result must be FF hex. (No end-around carry is used when the check is calculated.)

If the check calculation result is not FF hex, a NAK control character is transmitted by the API, the download mode is aborted, and print wheel selection defaults to the control panel switch setting.

The example below uses an arbitrary record to illustrate the procedure for manual calculation of a checksum.

Example:

Record = S10500EF6C789B4
 —————
 ————— Checksum (Derived by calculation below)
 ————— Included in Checksum calculation

Checksum Calculation:

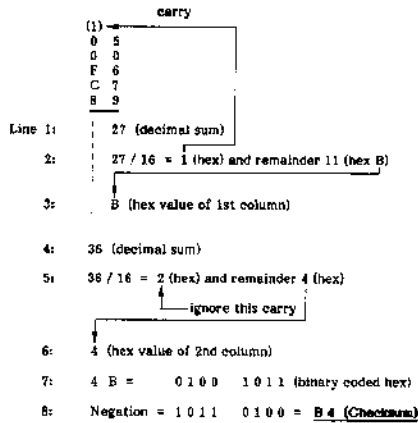

Explanation:

- Line 1: Add to obtain decimal sum of 1st column.
- Line 2: Divide decimal sum of 1st column by 16 to convert to hexadecimal.
- Line 3: The resultant hex character for the 1st column is B, and carry 1 to the 2nd column.
- Line 4: Add the 2nd column characters, plus the carry (1). The result is 36 decimal.
- Line 5: Divide decimal sum of 2nd column by 16 to convert to hexadecimal. Ignore the carry out during this conversion.
- Line 6: The resultant hex character for the 2nd column is 4.
- Line 7: Convert the hex sum (4 B) into binary coded hex.
- Line 8: Negate the binary codes (1's become 0's; 0's become 1's); then convert back to hexadecimal characters. The result is the proper checksum (B 4) for this record.

3.22.5 The Download Sequence

The following steps and the flow chart in Figure 3-7 describe the general sequence of events associated with the download procedure. The flow chart is keyed to the steps listed below by the boxed numbers that appear on the chart.

- 1) At power-up, remote reset (ESC CR P), or remote initialize (ESC SUB I), the download table memory locations are initialized to all zeroes, and the resident default print wheel table is selected according to the PRINT WHEEL switch selection on the control panel.
- 2) Print wheel selection must be made to match the print wheel table that is going to be downloaded and used. This can be done by means of the PRINT WHEEL switch on the control panel, or it can be done remotely by the control sequence ESC SYN (n). This is necessary because, although the downloaded table will supply the print data for subsequent printing, the print wheel selection still controls the critical servo timing differences required between plastic and metalized print wheels.
- 3) The host sends the command sequence ESC SO DC2 to put the API into the download mode.
- 4) The host sends the properly-formatted record(s) containing the table data, and the API responds as follows:
 - A) After each correctly-received record, the API transmits an ACK control character (RS-232-C interface only) to confirm acceptance of the data. The API then ignores all further data until it receives an "S" (start of next record) character, or a DC4 (end of data) control character.
 - B) Any error in data format detected while a record is being received, or as a result of the checksum calculation, will cause the API to transmit a NAK control character (RS-232-C interface only) and immediately abort the download mode. Table selection then reverts to the selection made by the PRINT WHEEL switch on the control panel.

Note: If the download mode is aborted for any reason, the host must send a new ESC SO DC2 command sequence in order to re-enter the download mode. If the abort was caused by an error, it is not necessary to resend the entire data table. The host may resume sending data starting from the last valid record.

When operating with an RS-232-C interface, it is important that the host wait for an ACK or NAK response from the API after sending a record. If your system does not have the facility to recognize ACK and NAK, the host must wait a minimum of 250 msec after sending a record; if the terminal has not then aborted download, the record has been accepted as valid.

- 5) After the last record has been received and confirmed as valid (by the API returning an ACK control character), the API waits for the host to send a DC4 (end of data) control character to terminate the download mode. The API terminal will now use the downloaded print wheel data for all ASCII-to-print wheel lookup parameters.

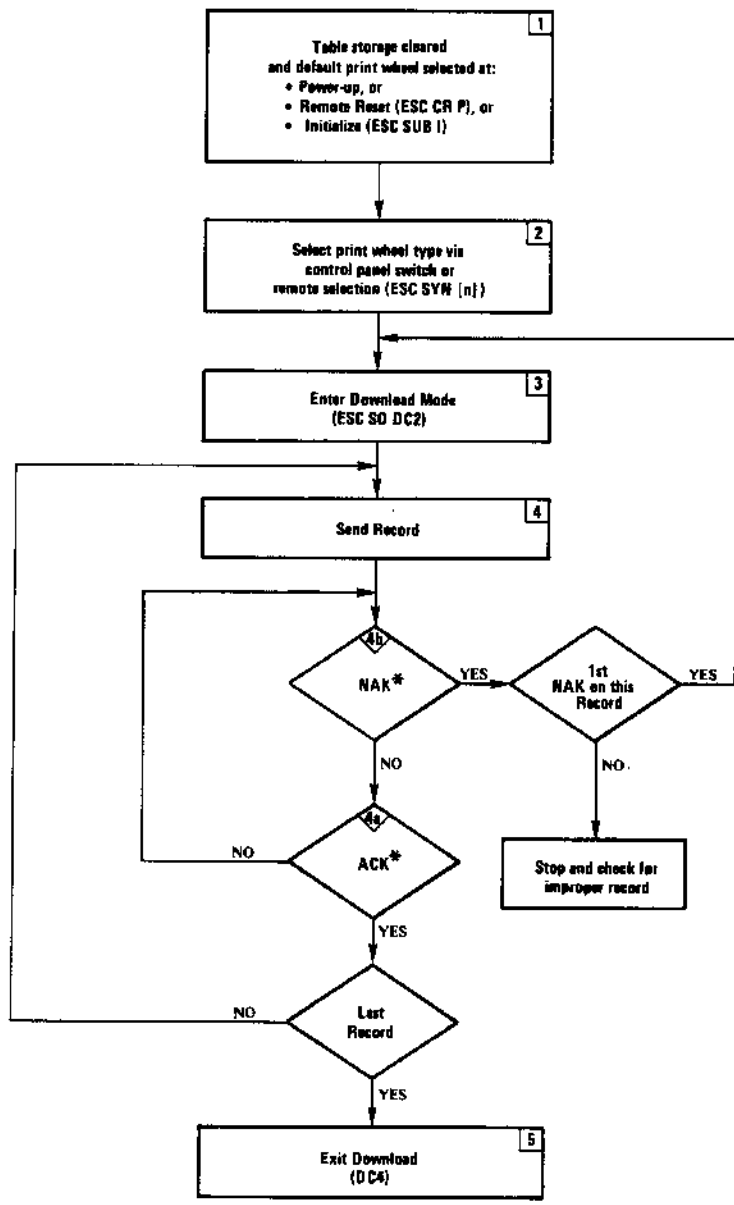

*ACK/NAK functional with RS-232-C interface only.

Figure 3-7. DOWNLOAD FLOW CHART

3.22.6 Sample Download Structure

Figure 3-8 shows a printout of the group of records comprising an actual print wheel download structure. Following the printout, each element of the first record is separated and defined. As stated earlier, this printout serves only as a hard-copy reference of the assembled download elements - it does not actually occur as part of the download process.

In this example, seven separate records are used to download the table data for a Pica 10, 88-character Xerox metalized print wheel. The number and length of the records in this example has no particular significance; it is simply the way the download was structured by this particular host system.

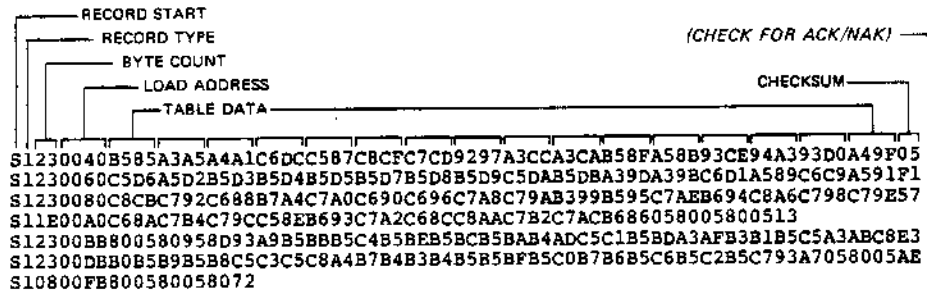

FIRST RECORD:

- S = Record Start
- 1 = Record Type
- 23 = Byte Count = 23₁₆ + 35₁₀
- 0040 = Load Address (Hex)

TABLE DATA: (First two entries)

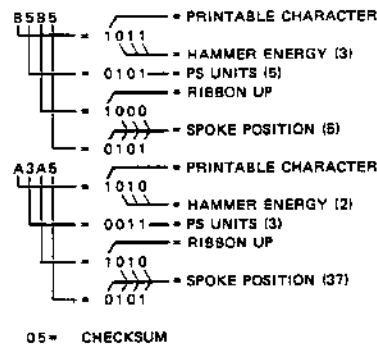

Figure 3-8. SAMPLE DOWNLOAD STRUCTURE

3.22.7 Manually Assembling the Print Table Data

Print table data for a particular print wheel need be assembled manually only once. The data can then be stored by the host and simply retrieved anytime thereafter for downloading. The material in this subsection demonstrates the procedure for manually assembling a print table for one particular print wheel. The print table for any other print wheel can be assembled in a similar manner.

The print wheel selected for this example is the **XEROX 96 - U.S. PICA 10 ASCII** print wheel. This is a 96-character metalized print wheel with a communications character set. The example presented here produces a print table that conforms to ISO/ASCII standards for character set/code assignments for this print wheel.

The Figures on the following pages contain the items listed below and explained in detail in subsequent paragraphs:

<u>Figure</u>	
3-9	- Revised Data Sheet for the XEROX 96 - U.S. PICA 10 ASCII print wheel
3-10	- A Download Table Worksheet, filled in with appropriate data extracted from the Data Sheet in Figure 3-9, and from the Universal Tables in Figure 3-12.
3-11	- Printout of a download structure for the U.S. PICA 10 ASCII print wheel
3-12	- Universal Tables of hex character combinations representing the entire range of combinations for downloaded print parameters.
3-13A, 3-13B	- Blank worksheets which can be used to make copies for assembling table data for other print wheels.

3.22.7.1 The Data Sheet

The data sheet shown in Figure 3-9 is a revised version of the XEROX 96 - U.S. PICA 10 ASCII print wheel data sheet contained in Diablo's Print Wheel Data Book-1 (Publication No. 90044-01). Because of the control panel setup and firmware used in printing the original data sheet, it contains several deviations from ISO/ASCII standard code assignments for this character set. The revised data sheet shown here (Fig. 3-9) contains the necessary changes (positions indicated by shading) to eliminate those deviations. Using this revised data sheet as reference, the download print wheel table developed in this example conforms to ISO/ASCII standards for this print wheel.

For each character on the print wheel, the data sheet lists the following:

- The ASCII hex code to address that character
- The spoke position of the character on the print wheel
- The proper proportional space/ribbon advance units for that character
- The proper hammer energy for printing that character

3.22.7.2 The Universal Data Tables

The Universal Data Tables in Figure 3-12 contain hex character combinations representing the entire range of possible print parameter combinations. From these universal tables you can extract the proper hex character combinations for each download table entry (4 hex characters) for any of the print wheels available for the Model 630 APL. The data in these tables is based on the print table data format defined in subsection 3.22.4.5. By using the tables, you can obtain the proper hex characters for the download table directly, without having to derive the download bytes bit-by-bit as presented in subsection 3.22.4.5.

3.22.7.3 The Download Worksheets

Figure 3-10 contains a filled-in worksheet to serve as a reference for the table assembly example described below. Figure 3-13 contains a blank 2-page worksheet which can be copied and used to assemble download tables for other print wheels. For standard print wheels (88-, 92-, 96-character) you will need only the first page of the worksheet; for ECS print wheels you will need both pages.

3.22.7.4 Assembling the Print Table

The following paragraphs describe the procedure used to fill in the worksheet in Figure 3-10. The same basic procedure may be used for any other print wheel, using the appropriate data sheet(s) for that print wheel.

Starting with code 20, the hex characters to be entered in the table are derived in the following manner:

1. On the Data Sheet (Fig. 3-9), locate Hex Address 20. There you will find listed the proper values for hammer energy, proportional space/ribbon advance, and spoke position for the print wheel character (e) we want to address with ASCII code 20. In this case, the values are: hammer energy = 3, proportional space/ribbon advance = 5, and spoke position = 1.
2. With the values just obtained from the Data Sheet, refer to the Universal Data Table - First Byte (Fig. 3-12). In this table, locate the box where proportional space/ribbon advance column 5 and hammer energy row 3 intersect. The two hex characters (B5) listed at this location in the table are the correct characters to enter as the first byte in the Download Table Worksheet (Fig. 3-10).
3. With the spoke position number (01) obtained from the Data Sheet in step 1 above, refer to the Universal Data Table - Second Byte (Fig. 3-12). In the area of this table designated for "Standard Wheels", locate the box where column 0 (tens digit) and row 1 (units digit) intersect. The two hex characters (81) listed in this box are the correct characters to enter as the second byte in the Download Table Worksheet (Fig. 3-10).
4. Repeat the same sequence for ASCII code 21, and for all subsequent codes listed on the Data Sheet. For ASCII code 21 (character " ! "), the associated values from the Data Sheet (Fig. 3-9) are hammer energy = 2, proportional space/ribbon advance = 3, and spoke position = 37. With these values, applied to the Universal Data Tables we obtain: First Byte = A3; Second Byte = A5; as listed in the worksheet (Fig. 3-10).

This being a 96-character print wheel table, all of the worksheet positions 20 - 7F are occupied. Had this been a download table for an 88- or 92-character print wheel, the unused worksheet positions would be blank and the corresponding positions in the actual download table should be

loaded with zeros (00 00). With the Download Worksheet completed, you have all of the proper hex table data for the download records.

Figure 3-11 shows the printout of a download structure wherein the table data assembled in this example is contained within six equal records.

For ECS print wheels, the procedure given above applies, along with the following additional instructions:

- Sheet 1 (codes 20-7F) of the Worksheet will take care of the primary character set, and sheet 2 (codes 80-FF) will take care of the supplementary character set.
- You must account for inner and outer character rows on the print wheel. The Data Sheet for an ECS print wheel will identify inner or outer row for each character. With that information for a given character, and the spoke position number, you simply refer to the appropriate section of the Universal Data Table - Second Byte.

XEROX 96 - U.S.
PICA 10 ASCII (96-Character Metalized) P/N 311950-01

(3)

CHARACTER(1)		!	"	#	\$	%	&	'	()	*	+	,	-	.	/	0	1
HEX Address	20	21	22	23	24	25	26	27	28	29	2A	2B	2C	2D	2E	2F	30	31
Elect. Spoke		37	33	92	7	79	77	23	76	74	15	11	78	35	80	31	86	82
Prop. Sp. Units		3	4	6	5	8	7	2	3	3	5	5	3	4	3	4	5	5
Ham. Energy(2)		2	2	4	4	4	4	1	2	2	3	2	1	1	1	2	4	2

2	3	4	5	6	7	8	9	:	;	<	=	>	?	@	A	B	C	D	E	F	G	H	I
32	33	34	35	36	37	38	39	3A	3B	3C	3D	3E	3F	40	41	42	43	44	45	46	47	48	49
83	84	85	87	88	89	90	91	29	27	41	9	39	17	75	18	8	36	32	16	22	40	26	25
5	5	5	5	5	5	5	5	3	3	5	5	5	5	8	7	6	7	7	6	6	7	7	3
3	3	3	3	3	3	4	3	2	2	2	2	2	2	4	4	4	3	4	4	4	4	4	3

J	K	L	M	N	O	P	Q	R	S	T	U	V	W	X	Y	Z	[\]	^	_	~	a
4A	4B	4C	4D	4E	4F	50	51	52	53	54	55	56	57	58	59	5A	5B	5C	5D	5E	5F	60	61
21	46	20	38	24	30	10	52	28	14	19	34	12	42	50	44	6	81	73	5	2	13	95	59
5	7	6	8	7	7	6	7	7	5	6	7	6	8	7	7	6	3	5	3	5	5	5	5
3	4	3	4	4	4	4	4	4	4	4	3	4	4	4	4	4	3	2	2	1	1	1	3

b	c	d	e	f	g	h	i	j	k	l	m	n	o	p	q	r	s	t	u	v	w	x	y
62	63	64	65	66	67	68	69	6A	6B	6C	6D	6E	6F	70	71	72	73	74	75	76	77	78	79
68	62	60	58	45	65	61	47	49	69	43	48	57	56	67	72	55	51	53	63	64	54	70	66
5	5	5	5	4	5	5	3	3	5	3	8	5	5	5	5	4	4	4	5	5	7	5	5
3	3	3	3	3	4	3	2	3	3	2	4	3	3	4	4	2	3	3	3	3	3	3	3

(4)

z	{		}	-	~
7A	7B	7C	7D	7E	7F
71	93	3	4	94	0
5	3	3	3	5	3
3	2	2	2	1	2

Figure 3-9. PRINT WHEEL DATA SHEET

20	21	22	23	24	25	26	27								
B5	81	A3	A5	A4	A1	C6	DC	C5	07	C8	CF	C7	CD	92	97
28	29	2A	2B	2C	2D	2E	2F								
A3	CC	A3	CA	B5	0F	A5	8B	93	CE	9A	A3	93	DO	A4	9F
30	31	32	33	34	35	36	37								
C5	D6	A5	D2	B5	D3	B5	D4	B5	D5	B5	D7	B5	D8	B5	D9
38	39	3A	3B	3C	3D	3E	3F								
C5	DA	B5	DB	A3	0D	A3	9B	A5	A9	A5	89	A5	A7	A5	91
40	41	42	43	44	45	46	47								
C8	C8	C7	92	C6	88	B7	A4	C7	A0	C6	90	C6	96	C7	AB
48	49	4A	4B	4C	4D	4E	4F								
C7	9A	B3	99	B5	95	C7	AE	B6	9A	C8	AG	C7	98	C7	9E
50	51	52	53	54	55	56	57								
C6	8A	C7	B4	C7	9C	C5	8E	B6	93	C7	A2	C6	8C	C8	AA
58	59	5A	5B	5C	5D	5E	5F								
C7	B2	C7	AC	B6	86	A3	D1	A5	C9	A3	B5	95	B2	95	8D
60	61	62	63	64	65	66	67								
95	DF	B5	BB	B5	CA	B5	BE	B5	BC	B5	BA	B4	AD	C5	C1
68	69	6A	6B	6C	6D	6E	6F								
B5	BD	A3	AF	B3	B1	B5	C5	A3	AB	C8	B0	B5	B9	B5	B8
70	71	72	73	74	75	76	77								
C5	C3	C5	C8	A4	B7	B4	B3	B4	B5	B5	BF	B5	C0	B7	B6
78	79	7A	7B	7C	7D	7E	7F								
B5	C6	B5	C2	B5	C7	A3	DD	A3	83	A3	84	95	DE	A3	80

LEGEND:

XX
XX XX

 = ASCII HEX CODE

XX	XX
----	----

 = TABLE DATA (INEX)

PRINT WHEEL TITLE Xerox 96 - U.S. PICA 10 ASCII PART NO. 311950-01 Sheet 1

Figure 3-10. DOWNLOAD TABLE WORKSHEET -
XEROX 96 - U.S. PICA 10 ASCII Print Wheel

S1230040B581A3A5A4A1C6DCC587C8CFC7CD9297A3CCA3CAB58FA58B93CE94A393D0A49F09
S1230060C5D6A5D2B5D3B5D4B5D5B5D7B5D8B5D9C5DAB5DBA39DA39BA5A9A589A5A7A5917D
S1230080C8C8C792C688B7A4C7A0C690C696C7A8C79AB399B595C7AEB694C8A6C798C79E57
S12300A0C68AC7B4C79CC58EB693C7A2C68CC8AAC7B2C7ACB686A3D1A5C9A3859582958DDA
S12300C095DFB5BB5C4B5BEB5BCB5B4ADC5C1B5BDA3AFB3B1B5C5A3ABC8B0B5B9B5B842
S12300E0C5C3C5C8A4B7B4B3B4B5B5BFB5C0B7B6B5C6B5C2B5C7A3DDA383A38495DEA38095

Figure 3-11. DOWNLOAD STRUCTURE FOR U.S. PICA 10 ASCII PRINT WHEEL

TABLE DATA - FIRST BYTE

HAMMER ENERGY	PROPORTIONAL SPACE/RIBBON ADVANCE														
	1	2	3	4	5	6	7	8	9	10	11	12	13	14	15
1	91	92	93	94	95	96	97	98	99	9A	9B	9C	9D	9E	9F
2	A1	A2	A3	A4	A5	A6	A7	A8	A9	AA	AB	AC	AD	AE	AF
3	B1	B2	B3	B4	B5	B6	B7	B8	B9	BA	BB	BC	BD	BE	BF
4	C1	C2	C3	C4	C5	C6	C7	C8	C9	CA	CB	CC	CD	CE	CF

TABLE DATA - SECOND BYTE

STANDARD WHEELS AND ECS WHEELS INNER ROW

TENS DIGIT	SPOKE POSITION									
	UNITS DIGIT									
	0	1	2	3	4	5	6	7	8	9
0	80	81	82	83	84	85	86	87	88	89
1	8A	8B	8C	8D	8E	8F	90	91	92	93
2	94	95	96	97	98	99	9A	9B	9C	9D
3	9E	9F	A0	A1	A2	A3	A4	A5	A6	A7
4	A8	A9	AA	AB	AC	AD	AE	AF	80	B1
5	B2	B3	B4	B5	B6	B7	B8	B9	BA	BB
6	BC	BD	BE	BF	C0	C1	C2	C3	C4	C5
7	C6	C7	C8	C9	CA	CB	CC	CD	CE	CF
8	D0	D1	D2	D3	D4	D5	D6	D7	D8	D9
9	DA	DB	DC	DD	DE	DF	E0	E1	E2	E3

ECS WHEELS OUTER ROW

UNITS DIGIT										
0	1	2	3	4	5	6	7	8	9	
00	01	02	03	04	05	06	07	08	09	
0A	0B	0C	0D	0E	0F	10	11	12	13	
14	15	16	17	18	19	1A	1B	1C	1D	
1E	1F	20	21	22	23	24	25	26	27	
28	29	2A	2B	2C	2D	2E	2F	30	31	
32	33	34	35	36	37	38	39	3A	3B	
3C	3D	3E	3F	40	41	42	43	44	45	
46	47	48	49	4A	4B	4C	4D	4E	4F	
50	51	52	53	54	55	56	57	58	59	
5A	5B	5C	5D	5E	5F	60	61	62	63	

Figure 3-12. UNIVERSAL DOWNLOAD DATA TABLES

20	21	22	23	24	25	26	27
28	29	2A	2B	2C	2D	2E	2F
30	31	32	33	34	35	36	37
38	39	3A	3B	3C	3D	3E	3F
40	41	42	43	44	45	46	47
48	49	4A	4B	4C	4D	4E	4F
50	51	52	53	54	55	56	57
58	59	5A	5B	5C	5D	5E	5F
60	61	62	63	64	65	66	67
68	69	6A	6B	6C	6D	6E	6F
70	71	72	73	74	75	76	77
78	79	7A	7B	7C	7D	7E	7F

LEGEND:

XX		= ASCII HEX CODE
XX	XX	= TABLE DATA (HEX)

PRINT WHEEL TITLE: _____ PART NO. _____ Sheet 1

Figure 3-13A, DOWNLOAD TABLE WORKSHEET

- Standard Print Wheels
- ECS Print Wheels Primary Character Set

B0	B1	B2	B3	B4	B5	B6	B7
B8	B9	BA	BB	BC	BD	BE	BF
B0	B1	B2	B3	B4	B5	B6	B7
B8	B9	BA	BB	BC	BD	BE	BF
A0	A1	A2	A3	A4	A5	A6	A7
AB	A9	AA	AB	AC	AD	AE	AF
B0	B1	B2	B3	B4	B5	B6	B7
B8	B9	BA	BB	BC	BD	BE	BF
C0	C1	C2	C3	C4	C5	C6	C7
CB	C9	CA	CB	CC	CD	CE	CF
D0	D1	D2	D3	D4	D5	D6	D7
D8	D9	DA	DB	DC	DD	DE	DF
E0	E1	E2	E3	E4	E5	E6	E7
E8	E9	EA	EB	EC	ED	EE	EF
F0	F1	F2	F3	F4	F5	F6	F7
F8	F9	FA	FB	FC	FD	FE	FF

PRINT WHEEL TITLE: _____ PART NO. _____ Sheet 2

Figure 3-13B. DOWNLOAD TABLE WORKSHEET
- ECS Print Wheels Supplementary Character Set

3.23 REMOTE DIAGNOSTICS

The remote diagnostics feature allows the interrogation of machine parameters and status through the interface. The following diagnostic commands are included in this feature:

ESC SUB I	Initialize the printer
ESC SUB R	Remote error reset
ESC SUB SO	Memory Test *
ESC SUB 1	Request status byte 1 *
ESC SUB 3	Request status byte 3 *

* Not functional with IEEE-488 and Centronics-type interfaces.

All diagnostic commands are processed immediately when received and are not queued. This means all status reported will be the status present at the time the command was received. Only the low 7 bits (bits 0 thru 6) of a status byte are significant. Their equivalent value may range from 0 to 127. The MSB (bit 7) will be a parity bit as defined by the PARITY ENABLE and PARITY EVEN/ODD switches. All commands that evoke a response from the Model 630 will result in a status byte being sent to the host computer preceded by an STX character. The STX identifies the following byte as a status byte. The rules for DC1/DC3, and Printer Ready protocols are applicable and should be used for sending status requests to the Model 630.

3.23.1 ESC SUB I

This command will cause the Model 630 to unconditionally execute an initialize sequence regardless of any error conditions that may exist within the printer. This command is executed immediately when received over the interface, unlike the corresponding remote reset sequence (ESC CR P) which is queued along with other commands. The Model 630 will default to the same conditions that exist at power-up. Before sending this command, the host should send a nonprinting character to cause the Model 630 to abort any multiple character sequence in progress.

3.23.2 ESC SUB R

This command causes the Model 630 to reset any error conditions. It produces essentially the same result as pressing the RESET switch on the control panel. If the unit is in check, it will execute a restore. Due to internal program latency, the minimum time necessary to reset all errors is 250 milliseconds.

In a situation where the terminal is being operated without a control panel, a series of up to eight automatic print wheel restores occurs if the terminal goes into a print wheel check condition. The ESC SUB R sequence causes the automatic restore counter to be reset to enable another series of automatic print wheel restore operations.

3.23.3 ESC SUB SO (RS-232-C only)

This command will cause the API to do a memory test and send the result through the interface. The true-state bit definitions in the result byte are:

Bit	Result	Bit	Result
0	ROM 1 bad	4	(not used)
1	ROM 2 bad	5	(not used)
2	Internal RAM bad	6	(not used)
3	External RAM bad	7	Parity bit *

* The state of bit 7 is defined by the two parity control switches on the control panel.

3.23.4 ESC SUB 1 (RS-232-C only)

This command will cause the Model 630 to send a status report byte (STATUS 1) thru the interface. The true-state bit definitions for this byte are:

<u>Bit</u>	<u>Status</u>
0	End of ribbon
1	10 pitch (This bit false if any other pitch is selected)
2	Paper out
3	Auto line feed enabled
4	Cover open
5	Printer idle (no motion, and print queue empty)
6	Printer in Check
7	Parity bit *

* The state of bit 7 is defined by the two parity control switches on the control panel.

3.23.5 ESC SUB 3 (RS-232-C only)

This command causes the Model 630 to send a status report byte (STATUS 3) thru the interface. This status byte pertains to a sheet feeder being used on the Model 630. The true-state bit definitions for this byte are:

<u>Bit</u>	<u>Status</u>
0	Insert not completed - denotes paper jam or out of paper
1	Exit not completed - denotes jam of paper during exit
2	Feeder present - Model F33 (dual tray plus envelopes) - see Table 3-4.
3	Feeder present - Model F32 (dual tray) or F33 - see Table 3-4.
4	(Not used)
5	(Not used)
6	Feeder in manual mode
7	Parity bit *

* The state of bit 7 is defined by the two parity control switches on the control panel.

**Table 3-4
FEEDER IDENTIFICATION**

<u>Bit</u>			<u>Feeder Installed</u>
2	3	5	
0	0	0	None
0	0	1	(Unused)
0	1	0	Model F32
1	1	0	Model F33

3.24 WORD PROCESSING FEATURES

The Word Processing (WP) feature set consists of several features that facilitate word processing applications of the API. Most of the WP functions are performed on a character by character basis. Those which require memory storage while being performed are: (1) Auto Line Center, and (2) Auto Justify. The WP features are compatible with all normal terminal operations except Graphics mode. All WP features are disabled during Graphics mode.

3.24.1 Proportional Space Printing

(See subsection 3.9.3)

3.24.2 Offset Selection

The normal way to change character spacing is to adjust HMI. However, for proportional space printing, HMI is ignored and table values are used. Thus, to add or subtract a constant to each table size value, the 3-character sequence ESC DC1 ("character") should be used. The binary value of the "character" is added to each table size value (or HMI if it is controlling size), as well as to the space character. This continues until another ESC DC1 (character) sequence is received, or until offset is cleared by a carriage return (CR) or the sequence ESC X.

The seven bits of the "character" are defined as follows:

- Bits 1-6 = Size of offset (63 units maximum; 1/120" per unit)
- Bit 7 = Sign of offset (1 = negative)

Note: Bit 8 (8-Bit ASCII) is a "Don't Care" (can be either 0 or 1).

If a negative offset (smaller character size) is desired, bit 7 should be set. If the resulting character size is zero or less, no carriage movement will occur. Note that because NUL and DEL cannot pass thru the serial receiver, positive offset values range from 1 thru 63 (0 000001 thru 0 111111), and negative values range from 0 thru 63 (1 000000 thru 1 111111). The negative 63 can be obtained only by sending the sequence ESC Z thru the interface in place of DEL (111111) since the DEL code cannot pass thru the serial receiver. Although the IEEE-488 and Centronics type interface configurations do not use the serial receiver, for the sake of consistency, the same limitations apply. Refer to Figure 4-1 in Section 4 of this manual for a Code Chart showing the ASCII characters corresponding to the range of offset values.

3.24.3 Auto Underscore

Automatic underscoring is initiated by the sequence ESC E. The present carriage position is stored in memory as the start location. When the end position is reached, the carriage will underscore the area between the start location and the end position. The printed underscore characters will overlap and the ribbon advance will increase to prevent fading. Auto Underscore should be invoked immediately preceding the first printable character to be underscored.

The end position is defined as the carriage position when one of the following events occurs:

- ESC R - The underscoring occurs, the carriage stops at the first position after the underscore, and the Model 630 exits the Auto Underscore mode.
- CR - The underscoring occurs, and the carriage returns to the left margin.
- LF - The underscoring occurs, the carriage stops at the first position following the underscore, and a line feed occurs.

Auto Underscore is cancelled by either sequence ESC R or ESC X. No underscoring will occur if the sequence ESC X is received, or if the area between the start and end locations is not positive.

3.24.4 Bold Overprint

Bold overprint is initiated by the sequence ESC O. Subsequent printable characters are struck twice with no intervening carriage motion. The normal ribbon advance occurs between character strikes. A carriage return (CR) or either of the sequences ESC & or ESC X will cause the Model 630 to exit the bold overprint mode. It is recommended that ESC % (carriage settling time control) be invoked in conjunction with this feature in order to optimize print registration.

Note: Bold Overprint and Shadow Print are mutually exclusive modes.

3.24.5 Shadow Print

Shadow print is initiated by the sequence ESC W. Subsequent printable characters are struck twice with 1/120" of carriage movement and normal ribbon advance between character strikes. This does not change the HMI or table size value for that character. Increased carriage settling time may improve shadow print quality on some units. A carriage return (CR) or either of the sequences ESC & or ESC X will cause the Model 630 to exit the shadow print mode. It is recommended that ESC % (carriage settling time control) be invoked in conjunction with this feature in order to optimize print registration.

3.24.6 Carriage Settling Time Control

The carriage settling time can be increased to 20 msec by issuing the sequence ESC %. This provides more time for mechanical vibrations to damp out before printing. Thus it produces improved print quality, at a small sacrifice in print speed. The sequence ESC N will restore the normal carriage settling time.

3.24.7 Half-Unit Backspace

The sequence ESC BS will produce a 1/120" backspace movement of the carriage.

3.24.8 Program Mode

Program mode enables user control of spoke position, hammer energy, and ribbon advance. This enables the use of special print wheels without modifications to the Model 630. In Program Mode, two characters are sent for each character to be printed. The first character selects the print wheel spoke; the second establishes the hammer energy and ribbon advance.

Note: To use Program Mode when operating in ECS mode, the system must be operating with 8-bit ASCII, wherein the 8th bit of the first character specifies inner or outer row character on the print wheel: 8th bit = 1 = Inner row selected

Program mode is initiated by the sequence ESC SO M. It is turned off by either the control character SI or the sequence ESC X.

The Diablo Print Wheel Data Books provide the print wheel data needed to operate the Model 630 in Program Mode. (See subsection 4.4 of this manual for information regarding the Data Books.) Table 4-6 in Section 4 of this manual provides a universal table of characters for Hammer Energy and Ribbon Advance units, which can be used in conjunction with the Print Wheel Data Books.

Fixed pitch spacing is controlled by HMI plus offset. This can be set by the SPACING switch on the control panel, or by the remote HMI command. If the Model 630 is in proportional space mode, spacing is controlled by the ribbon advance units (move RA, print, move RA) for each character, plus offset.

Program mode data format is shown below, and the two characters are defined in the paragraphs that follow.

		7	6	5	4	3	2	1	0
1st Character -	I/O*	SP	SP	SP	SP	SP	SP	SP	SP
2nd Character -	0*	HE	HE	HE	RA	RA	RA	RA	RA

* 8-bit mode only.

Where:

I/O = 1 = Inner row selected (ECS 8-bit mode only)
 = 0 = Outer row selected (ECS 8-bit mode only)

SP = Binary equivalent of the decimal sum of:
 (Electrical Spoke Position Number + 32)

HE = Hammer energy level (0 - 4) **Caution:**
 Never specify a hammer energy above level 4 (0100 XXXX).

RA = Ribbon advance / Proportional space units (0 - 15).
 Effective in proportional space mode only.

3.24.8.1 Spoke Position Data (first character)

The first character received is tested to determine if it is a control character or a spoke position character. If it is a control character, the normal processing of control characters will occur. If it is not a control character, it is assumed to be a spoke position character. The next character then will not be tested for control character parameters. The proper value to be sent for the first character is selected by applying the following formula according to the example given below:

Formula:

First Character = Binary equivalent of the decimal sum of:
 (Electrical Spoke Position Number + 32)

Example: (Addressing character "A" on 96-character metalized print wheel)

- 1) Refer to Figure 4-5 in this manual to determine the electrical spoke position number of the desired character (A). In this case, the number is 18.

- 2) Apply formula given above: $18 + 32 = 50$
- 3) Refer to Table 4-2 in this manual to determine the ASCII character that has a binary equivalent of decimal 50. The table shows that character to be a "2". The ASCII "2" then is the correct first character to send for addressing an "A" when operating in Program Mode with a Diablo 96-character metalized print wheel.

Note that only spokes 1 thru 94 can be distinguished from control characters. However, spokes 0 and 95 can be accessed by ESC Y and ESC Z respectively, followed by the second character.

If print wheels with less than 96 spokes are installed, ensure that the 88-92-96 print wheel selection switch is properly set (FFCPN control panel).

3.24.8.2 Hammer Energy/Ribbon Advance Data (second character)

The second character in the sequence is the hammer energy/ribbon advance character. This character contains 4 bits (0 - 3) for ribbon advance and 3 bits (4 - 6) for hammer energy. This provides 16 different size ribbon advances (0 to 15 steps) and 5 different hammer energy levels (0 to 4). The hammer energy level definitions are as follows:

- Level 0 - No hammer fire
- Level 1 - Lowest hammer energy
- Level 2 - Low hammer energy
- Level 3 - Medium hammer energy
- Level 4 - High hammer energy

Caution - Level 4 should be used only after it has been determined that the lower energy levels are inadequate for printing a particular character.

The Hammer Energy/Ribbon Advance character provides a means for the user to tailor print quality and ribbon economy as desired. The general criteria for selecting the proper amount of hammer energy and ribbon advance is to use the lowest hammer energy and the minimum ribbon advance that will produce a level of print quality suitable for the intended application. Excessive hammer energy levels will unnecessarily shorten the useful life of the affected print wheels.

The Print Wheel Data Books mentioned earlier are valuable aids for determining proper hammer energies and ribbon advance units for any of the Diablo or Xerox print wheels suitable for use on the Model 630. The Data Books list the recommended hammer energy for each print character on each of the different print wheels. For the metalized print wheels, the Data Book also lists a recommended proportional space (PS) unit for each character on the print wheel. In general, the recommended PS unit value for a particular character is also the appropriate ribbon advance unit value to use after printing that character. For the plastic print wheels, which are not assigned PS unit values, a standard ribbon advance unit value of 6 will prove satisfactory in most cases.

Table 4-6 in this manual contains a list of the appropriate ASCII characters to represent various combinations of hammer energy / ribbon advance .

3.24.9 Auto Center

Auto line centering is initiated by the sequence ESC =, which should precede the string of printable characters to be centered. Subsequent data is stored in a memory buffer until a carriage return (CR), form feed (FF), or line feed (LF) command is received. The data is then printed centered between the margins, and the Model 630 exits the auto center mode. Auto Center allows the line to extend beyond the left and right margins. If Auto Justify was enabled when Auto Center was entered, Auto Center will have precedence for that line only. The sequence ESC X will clear Auto Center without performing any printing. ESC X is not intended as a line terminator, however, and should not be embedded in a line of text to be auto centered.

3.24.10 Auto Justify

Automatic margin justification is initiated by the sequence ESC M. The ESC M should precede the first printable character in a line. Subsequent data is stored in a memory buffer until a carriage return (CR) or a line feed (LF) command is received. The data is then printed justified between the left and right margins. Auto Justify remains enabled until one of the following actions occurs:

- ESC X received from the host.
- ESC CR P or ESC SUB I received from the host.
- A Break is transmitted or received by the terminal.

The Model 630 then exits Auto Justify mode.

Auto Justify operates in fixed pitch or proportional space mode. Up to 256 data characters may be included in a line. Note that all communication protocols still function normally.

Auto Justify begins its justification calculations from the position of the first printable character after the carriage return (CR), line feed (LF), Horizontal Tab (HT), or ESC M sequence. This allows unjustified leading spaces or tabs and allows partial line justification. Auto Justify calculates the number of 1/120" offset units needed to fill out or to condense the line so that it will fit exactly between the first printable character and the right margin. The offset units are then applied, first to the word spaces, and then to the character and word spaces after the word spaces reach 150% of their normal size. If the offset added to the character spaces exceeds 7 units, the line is printed unjustified. The host system software should take this into account before calculating how many characters to insert on each line.

The following conditions are imposed on the use of ESC sequences while in the Auto Justify mode:

- Any graphics-related ESC sequences are not permitted. (WP features are not functional in graphics.)
- The following ESC sequences are permitted to be used within a line of text while in Auto Justify mode:

ESC U, ESC D	Half line Feed, Negative Half Line Feed (Exception: Half Line Feeds are not permitted across a page boundary.)
ESC HT (n)	Absolute horizontal tab
ESC US (n)	Set HMI
ESC Y, ESC Z	Printable ASCII characters

ESC A, ESC B	Print red ribbon, print black ribbon (Non-ECS units)
	Raise print wheel, drop print wheel (ECS units)
ESC E, ESC R	Auto Underscore ON, OFF
ESC W, ESC &	Shadow Print ON, OFF (CR clears)
ESC O, ESC &	Bold Print ON, OFF (CR clears)
ESC %,ESC N	Increased carriage settling time ON, OFF
ESC BS	Backspace 1/120"

- All other ESC sequences are permitted only at the beginning of a line of text (before the first printable character).

3.24.11 Cancel Word Processing Features

The sequence ESC X will cancel the following features:

Auto Underscore	Bold Overprint
Shadow Print	Program Mode
Offset Selection	Auto Justify
Auto Center	

Increased carriage settling time and proportional space mode are not cancelled by ESC X.

3.25 HYPLOT VECTOR PLOTTING

3.25.1 Scope

The HyPlot feature enables the Model 630 Terminal to recognize and execute the ESC and Plot command sequences unique to Diablo HyPLOT Vector Plotting. This subsection describes the operation of HyPLOT, and outlines the command sequences which must be supplied by the operator either thru a keyboard or from a host system to produce graphs or vectors.

3.25.2 Definition Of Terms

- Default - A "built-in" instruction or value for use by the unit in the absence of a user input on the subject.
- h - The number of increments of horizontal (X) movement (at 1/120" each) between print points along the vector line. Minimum value allowed is 0, maximum is 31. See Table 3-5.
- Plot Point - The basic X-Y coordinate location identified in the HyPLOT command sequence. Each successive plot point establishes the magnitude and direction for the intervening vector.
- Print Point - The individual points along a vector where the plot character is printed. Spacing between individual points, called the precision or resolution of the vector, is determined by the values selected for h and v. Note that the actual print point will be located at the nearest whole increment coincident value of both h and v, and not always exactly on the actual or intended "straight line" of the vector.
- Print Position - The position on the paper form directly in front of the print hammer where the next character may be printed.
- v - The number of increments of vertical (Y) movement (at 1/48" each) between print points along the vector line. Minimum value = 0, maximum = 31. See Table 3-5.
- Vector - A quantity having both magnitude and direction commonly represented by a directed line segment. In HyPLOT the line segment between successive plot points.
- X - Print position (carriage) movement in the horizontal direction (X coordinate), where:
+X = Relative movement to the RIGHT (cumulative total cannot exceed the physical limits of the printer - 1572 increments).
-X = Relative movement to the LEFT (remainder cannot be less than 0 or beyond the physical limits of the printer).
Absolute moves do not require a sign. The increment count, which is the horizontal print position address, simply increases to the RIGHT and decreases to the LEFT.

The minimum possible increment of horizontal movement is 1/120".

- Y
- Print line (paper) movement in the vertical direction (Y coordinate), where:
 - +Y = Relative movement DOWN (paper moves UP for positive line feed). If the movement exceeds either the limit set for lower margin, or 548 increments, a Form Feed will occur.
 - Y = Relative movement UP (paper moves DOWN for negative line feed). If the commanded paper movement exceeds the TOF or top margin, paper movement will stop.
- Absolute moves do not require a sign. The increment count, which is the print line address, simply increases DOWN (paper UP) and decreases UP (paper DOWN).

The minimum possible increment of vertical movement is 1/48".

3.25.3 Description Of HyPLOT Vector Plotting

HyPLOT action begins with the unit receiving a special pattern of ESC codes to enter HyPLOT mode and establish plot parameters. Once in the HyPLOT mode, the unit's print position can be moved to any (X-Y) plot point coordinate within the current page boundaries as defined by the unit's Printing Format instructions. Each such plot point requires a command sequence of not more than 6 bytes. The actual move from one plot point to the next is accomplished in one of two ways; either directly with no plot character printing along the vector, or by printing a series of plot characters along the vector between the two plot points. The vector is printed by executing a series of carriage and paper feed moves equal to the values of h (horizontal or X plot precision) and v (vertical or Y plot precision) defined in the HyPLOT Mode command sequence and printing the selected plot character at those print points where whole values of h and v occur near the actual "straight line vector" between the plot points. In short, the unit "fills in" the vector line between plot points by printing the plot character at each point along the line, with the characters spaced according to the values of h and v.

HyPLOT offers two methods of plotting - ABSOLUTE and RELATIVE, with the only difference being the manner in which each plot point is addressed. In the ABSOLUTE mode, each plot point is addressed in terms of its X/Y location relative to the page ORIGIN (X=0/Y=0). In the RELATIVE mode, each plot point is addressed in terms of its X/Y displacement from the X/Y location of the preceding plot point.

X-axis (carriage) movement consists of up to a maximum of 1572 total increments of 1/120" each, counting to the RIGHT from the ORIGIN. Y-axis (paper feed) movement consists of up to 528 increments of 1/48" each (for 11" long paper) counting DOWN from the ORIGIN. Note that the Y-axis increment count increases in value with the apparent downward movement of the print line, and that X-axis increment count increases in value as the carriage is moved rightward from the origin. Visualizing the vector plotting situation as it is normally perceived with X-Y coordinates, and remembering that all printer plotting is referenced from the origin (the top left corner of the printing format), then vector plotting is always done in the -Y/+X Quadrant, and therefore ALL Y values must be inverted. Note also that all vector plotting must be done within the confines of the four page margins (if any) defined by the unit's current Printing Format instructions, and that the unit assumes the 0/0 page origin print position upon entering HyPLOT mode, with both X and Y position counters at 0.

3.25.4 The HyPLOT Commands

ESC G	Enter HyPLOT ABSOLUTE Mode. All vector plot points are interpreted as absolute locations. Movement commands do not require the sign byte. Draw all vectors except the first, which is a move only.
ESC G BEL	Same as ESC G except draw all vectors including the first one.
ESC V	Enter HyPLOT RELATIVE Mode. All vector plot points are interpreted as relative locations. All movement commands must include a sign byte. Draw all vectors except the first, which is a move only.
ESC V BEL	Same as ESC V except draw all vectors including the first one.
ESC . (character)	Change the vector print character to the selected (character). The default character is the ".".
ESC , h v	<p>h = horizontal print point resolution or "precision" in increments of 1/120", with a default value of 2.</p> <p>v = vertical print point resolution or "precision" in increments of 1/48", with a default value of 1.</p> <p>Both h and v can be assigned values between 0 and 31 (see Table 3-5). If both h and v = 0, then only the plot points will be drawn (or printed). Values for both h and v must be sent, even if only one is to be changed.</p>
ESC A	Ribbon down to print in red (requires 2-color ribbon option).
ESC B	Ribbon up to print in black. (This command is needed only when operating non-ECS units equipped with 2-color ribbon option.)
ESC 4 (or CR)	Exit HyPLOT mode.

Table 3-5
ASCII CHARACTERS FOR VALUES OF h AND v

Value	ASCII	Value	ASCII
0	= Space	16	= 0
1	= !	17	= 1
2	= "	18	= 2
3	= #	19	= 3
4	= \$	20	= 4
5	= %	21	= 5
6	= &	22	= 6
7	= '	23	= 7
8	= (24	= 8
9	=)	25	= 9
10	= *	26	= :
11	= +	27	= ;
12	= ,	28	= <
13	= -	29	= =
14	= .	30	= >
15	= /	31	= ?

Table 3-6
CONVERSION - X/Y PLOT INCREMENTS OF MOVE TO BINARY EQUIVALENTS

Bit # → Binary Value	12	11	10	9	8	7	6	5	4	3	2	1	PLOT POINT VALUE ↓
X													=
Y													=
	MSB					IB					LSB		

Table 3-7
CONVERSION - X/Y PLOT BINARY EQUIVALENTS TO ASCII BYTE CODE

BYTE	BITS							ASCII
	7	6	5	4	3	2	1	
1. SIGN	0	1	x	x	x	Y sign	X sign	
2. HIY	0	1	5 MSBs of Y					
3. XLOY	1	1	0	2 LSBs of Y		2 LSBs of X		
4. LOY	1	1	5 Intermediate bits of Y					
5. HIX	0	1	5 MSBs of X					
6. LDX	1	0	5 Intermediate bits of X					

- Notes:
1. In the SIGN Byte, x = don't care; Bits 1 and 2 (X and Y sign) give negative movement if 1, positive movement if 0.
 2. The SIGN Byte must always be sent in RELATIVE mode.
 3. The SIGN Byte must not be sent in ABSOLUTE mode.
 4. If the 5 intermediate bits of Y (the LOY byte) are all ones, the sequence ESC Z should be used instead, to avoid using ASCII "DEL" as a data byte.

Table 3-8
ASCII/BINARY CODE CHART

Bits	b ₇ →	0	0	0	0	1	1	1	1
	b ₆ →	0	0	1	1	0	0	1	1
	b ₅ →	0	1	0	1	0	1	0	1
b ₄ b ₃ b ₂ b ₁	COLUMN →	0	1	2	3	4	5	6	7
0 0 0 0	0	NUL	DLE	SP	0	@	P	'	p
0 0 0 1	1	SOH	DC1	!	1	A	Q	o	q
0 0 1 0	2	STX	DC2	"	2	B	R	b	r
0 0 1 1	3	ETX	DC3	#	3	C	S	c	s
0 1 0 0	4	EOT	DC4	\$	4	D	T	d	t
0 1 0 1	5	ENQ	NAK	%	5	E	U	e	u
0 1 1 0	6	ACK	SYN	&	6	F	V	f	v
0 1 1 1	7	BEL	ETB	'	7	G	W	g	w
1 0 0 0	8	BS	CAN	(8	H	X	h	x
1 0 0 1	9	HT	EM)	9	I	Y	i	y
1 0 1 0	10	LF	SUB	*	:	J	Z	j	z
1 0 1 1	11	VT	ESC	+	;	K	[k	{
1 1 0 0	12	FF	FS	,	<	L	\	l	;
1 1 0 1	13	CR	GS	-	=	M]	m	}
1 1 1 0	14	SO	RS	.	>	N	^	n	~
1 1 1 1	15	SI	US	/	?	O	—	o	DEL

3.25.5 Basic HyPLOT Procedure

Following are the step by step procedures used to create the composite ABSOLUTE/RELATIVE Vector Plot Example shown in Figure 3-14. The reader is encouraged to use the forms shown as Tables 3-6, 3-7 and 3-8 as aids in gaining expertise in HyPLOT application. The HyPLOT Worksheet at the end of this subsection includes blank copies of Tables 3-6 and 3-7. The blank worksheet can be copied and used as an aid when formulating the command sequences required to produce a desired plot, as demonstrated in HyPLOT Example A and HyPLOT Example B.

The graph scale shown in Figure 3-14 is 35 character spaces wide x 12/120" increments per character (10 pitch) = 420/120" increments. It is 18 line spaces high x 8/48" increments per line space (6 lines per inch) = 144/48" increments. The graph scale is located on the page so that the 0/0 scale point ("A") is located at 21 x 12 = 252 increments horizontally (X) and 15 x 8 = 120 increments vertically (+Y) FROM the "x" in the top left corner which defines the 0/0 point or origin on the page. The printer assumes the "x" or 0/0 ORIGIN position upon entering the HyPLOT Mode, and the first vector plotting move must always be in a +Y or DOWNWARD direction and a +X direction RIGHTWARD away from the origin. The printer will not execute negative-going commands from the 0/0 page starting position.

1.0) FIRST PLOT - ABSOLUTE MODE

- 1.1) Initiate HyPLOT in ABSOLUTE Mode: **ESC G**
(The first plot is a MOVE ONLY from 0/0 ORIGIN to 0/0 SCALE - point "A".)
Set Plot Character to lower case "a": **ESC . a**
Set Plot Precision to 4x default or 8h and 4v: **ESC , (\$**
(Refer to Table 3-5 for ASCII characters)
Set Print in Black: **ESC B**

The resultant command sequence becomes **ESC G ESC . a ESC , (\$ ESC B**

- 1.2) Send plot command for MOVE ONLY vector to plot point "A".
The required move is 252 increments +X and 120 increments +Y. This is an ABSOLUTE HyPLOT Vector, therefore the sign byte must not be sent, and the increment count from the ORIGIN is the plot point address. Use of the forms in Tables 3-6 , 3-7 and 3-8 illustrates the development of the command sequence for plot point "A", which becomes the 5-byte sequence **SP ^ ~ ! _** (See HyPLOT Example A).

Upon receipt of the last command character (#6 in the required sequence - #1 not being sent) the printer will execute the command and move its print position to vector plot point "A".

- 1.3) Following this same procedure, vector commands are developed and sent for plot points "B", "C", "D" and "E". Following the initial no-print MOVE ONLY vector, the printer will print the selected plot character "a" along the vector between the several remaining plot points spaced according to the h and v values selected.

Send commands for vector to plot point 5/5, or "B" (use HyPLOT Worksheet):
SP ^ t]

Send commands for vector to plot point 7.5/10, or "C" (use HyPLOT Worksheet):
SP ^ j # L

x

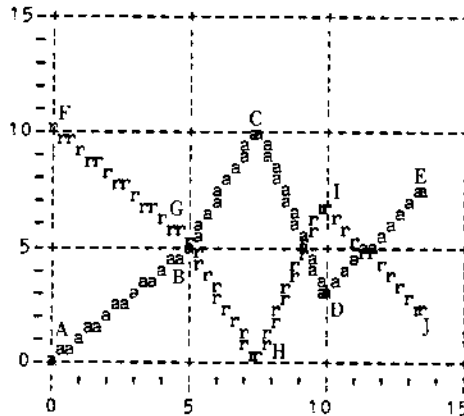

Figure 3-14. ABSOLUTE/RELATIVE VECTOR PLOT EXAMPLE

Send commands for vector to plot point 10/3, or "D" (use HyPLOT Worksheet):
`SP ` x # [`

Send commands for vector to plot point 13.5/7.5, or "E" (use HyPLOT Worksheet):
`SP ` o $ P`

It should be noted that in the ABSOLUTE mode, if bytes 2,3,4 or 5 do not change from one plot point to the next they need not be sent. Only the changed bytes AND byte 6 need be sent.

- 1.4) Exit HyPLOT Mode with a carriage return (CR). ESC 4 also works, but a CR exits HyPLOT and also moves the carriage to the left margin.
- 1.5) Send 7 negative line feed commands (ESC LF) and 1 negative half line feed (ESC D) to return the printer's print position to the 0/0 page ORIGIN position.

2.0) SECOND PLOT - RELATIVE MODE

- 2.1) Initiate HyPLOT in RELATIVE Mode: `ESC V`
(The first plot is a MOVE ONLY from 0/0 ORIGIN to 0/10 SCALE - point "F".)
Set Plot Character to lower case "r": `ESC . r`
Set Plot Precision to 4x default or 8h and 4v: `ESC , ($`
(Refer to Table 3-5 for ASCII Characters)
Set to print in black: `ESC B`

The resultant command sequence becomes `ESC V ESC . r ESC , ($ ESC B`

- 2.2) Send plot command for MOVE ONLY vector to plot point "F".
The required move is 252 increments of +X and 40 increments of +Y. This is a RELATIVE HyPLOT Vector Plot, and ALL 6 BYTES (including the sign byte) must be sent for each plot point. Again, the use of the forms in Tables 3-6, 3-7 and 3-8 illustrates the development of the command sequence for plot point "F", which becomes the 6 byte sequence `< SP ` j ! _` (see HyPLOT Example B).

Upon receipt of the last command (#6 in the required sequence) the printer will execute the command and move its print position to plot point "F".

- 2.3) Following this same procedure, vector commands are developed and sent for plot points "G", "H", "I" and "J". Note that these are RELATIVE moves, and each command includes ONLY the increments of + or -X and + or -Y needed to move to the next plot point. Following the initial no-print MOVE ONLY vector, the printer will print the selected plot character "r" along the vectors between the several remaining plot points spaced according to the h and v values selected.

Send commands for vector to plot point 5/5, or "G" (use HyPLOT Worksheet):
SP SP ` j SP ^

Send commands for vector to plot point 7.5/0, or "H" (use HyPLOT Worksheet):
SP SP ` j SP O

Send commands for vector to plot point 10/7, or "I" (use HyPLOT Worksheet):
" SP ` m SP O

Send commands for vector to plot point 13.5/2.5, or "J" (use HyPLOT Worksheet):
SP SP ` i SP U

- 2.4) Exit HyPLOT Mode with a carriage return (CR). ESC 4 works also, but leaves the carriage in the last plot point position. This would require backspaces as well as line feeds to move the print position to the next print line for any follow-on text.

Upon exiting HyPLOT Mode, the printer will "remember" its current print line relative to the TOF (Top Of Form).

3.25.6 Summary

HyPLOT LIMITS:

Attempts to plot beyond a format margin or mechanical printer limit are not allowed for the following reasons:

- +X beyond the right margin - the alarm sounds. Carriage movement and printing can continue, however.
- +X beyond 1572 increments - the carriage stops at the mechanical limit. Paper feed and printing can continue.
- X beyond the origin - carriage stops at the left limit. Paper feed and printing can continue.
- +Y beyond the lower margin or page end - printer automatically executes a FF to the top margin or TOF for the next page or form.
- Y beyond the origin - (ABSOLUTE MODE) - the printer does not recognize the sign byte and cannot be commanded to move negatively (up) beyond 0.
- Y beyond the origin - (RELATIVE MODE) - paper feed down stops at origin or TOF or top margin. Carriage movement and printing continue.

HyPLOT CHARACTER VARIATIONS:

The calculated plot point is always located in the center of the printer's character print space. Use of a "+" or "X" or similar character as the plot character will place the symbol's cross point at the calculated plot point. Use of a "." or a "," or other similar character places the center of the symbol somewhat below the calculated plot point. No set value can be given for this offset since it will vary between type styles and pitch settings. The user must determine this value for the print wheel to be used and include it when calculating the Y values for plot points.

DATA EXCHANGE FORMAT:

The X and Y values for each plot point must be reduced to corresponding incremental values by the host system. The host system must then operate on these values to render them in the required six byte series of HyPLOT commands acceptable to the HyPLOT-equipped Model 630 (see Tables 3-6 and 3-7). The Model 630 accepts HyPLOT data input in the form of the binary equivalent of ASCII characters making up 7-bit data bytes. The byte sequence given must be followed in either mode, except that in the ABSOLUTE Mode the sign byte must not be sent, and only those bytes which change from plot point to plot point need be sent - but EACH sequence MUST include the LOX byte (the last byte) whether it has changed or not. The printer reads the LOX byte as the execute command for the plot point being transmitted.

THE FULL ASCII COMMAND SEQUENCE FOR THE TWO PLOTS GIVEN:

ESC G ESC . a ESC , (\$ ESC B	= Set ABSOLUTE HyPLOT Mode & parameters
SP ^ ~ !	= Command Plot Point A; X=252/Y=120
SP ^ t " ^	= Command Plot Point B; X=372/Y=80
SP ^ j # L	= Command Plot Point C; X=432/Y=40
SP ^ x # [= Command Plot Point D; X=492/Y=96
SP ^ o \$ P	= Command Plot Point E; X=576/Y=60
ESC CTRL LF 7 times then ESC D	= Command Sequence to return Print Position to origin
ESC V ESC . r ESC , (\$ ESC B	= Set RELATIVE HyPLOT Mode & parameters
< SP ^ j !	= Command Plot Point F; X=252/Y=+40
SP SP ^ j SP ^	= Command Plot Point G; X=120/Y=+40
SP SP ^ j SP O	= Command Plot Point H; X=60/Y=+40
" SP ^ m SP O	= Command Plot Point I; X=60/Y=-56
SP SP ^ i SP U	= Command Plot Point J; X=84/Y=+36
CR	= Exit HyPLOT Mode

x

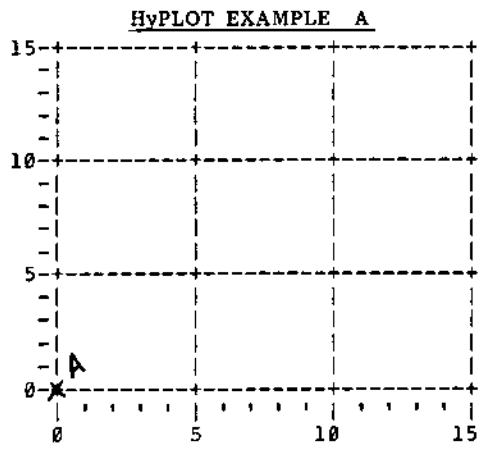

PLOT POINT A
 X = 252
 Y = 120
ABSOLUTE

TABLE 3-6A
 CONVERSION - X/Y PLOT INCREMENTS OF MOVE-TO-BINARY EQUIVALENTS

Bit # → Binary Value	12 2048	11 1024	10 512	9 256	8 128	7 64	6 32	5 16	4 8	3 4	2 2	1 1	PLOT POINT VALUE ↓
X	0	0	0	0	1	1	1	1	1	1	0	0	= 252
Y	0	0	0	0	0	1	1	1	1	0	0	0	= 120
	MSB					1B				LSB			

TABLE 3-7A
 BINARY TO ASCII

BYTE	BITS							ASCII
	7	6	5	4	3	2	1	
1. SIGN	0	1	x	x	x	Y sign	X sign	-
2. HIY	0	1	0	0	0	0	0	SP
3. XLOY	1	1	0	0	0	0	0	'
4. LOY	1	1	1	1	1	1	0	2
5. HIX	0	1	0	0	0	0	1	!
6. LOX	1	0	1	1	1	1	1	_

x = DON'T CARE

COMMAND: SP'~1_

HyPLOT EXAMPLE B

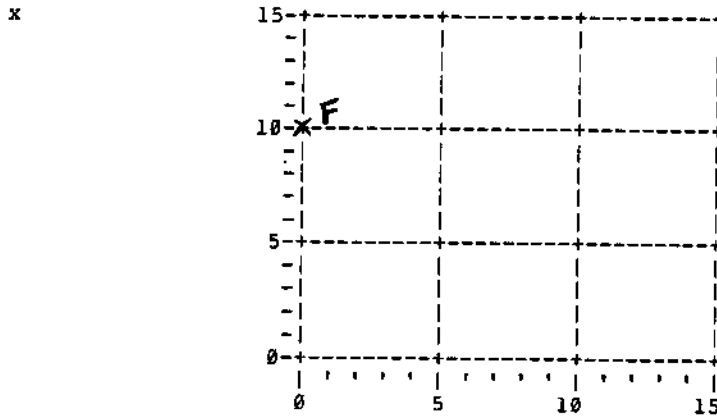

PLOT POINT F

X = 252

Y = 40

RELATIVE

TABLE 3-6B
CONVERSION - X/Y PLOT INCREMENTS OF MOVE-TO-BINARY EQUIVALENTS

Bit → Binary Value	12 2048	11 1024	10 512	9 256	8 128	7 64	6 32	5 16	4 8	3 4	2 2	1 1	PLOT POINT VALUE ↓
X	0	0	0	0	1	1	1	1	1	1	0	0	= 252
Y	0	0	0	0	0	0	1	0	1	0	0	0	= 40
	MSB					IB				LSB			

TABLE 3-7B
BINARY TO ASCII

BYTE	BITS							ASCII
	7	6	5	4	3	2	1	
1. SIGN	0	1	x	x	x	0	0	<
2. HIY	0	1	0	0	0	0	0	SP
3. XLOY	1	1	0	0	0	0	0	'
4. LOY	1	1	0	1	0	1	0	j
5. HIX	0	1	0	0	0	0	1	!
6. LOX	1	0	1	1	1	1	1	—

x = DON'T CARE

COMMAND: < SP ' j ! —

HyPLOT WORKSHEET

(Reproduce as needed)

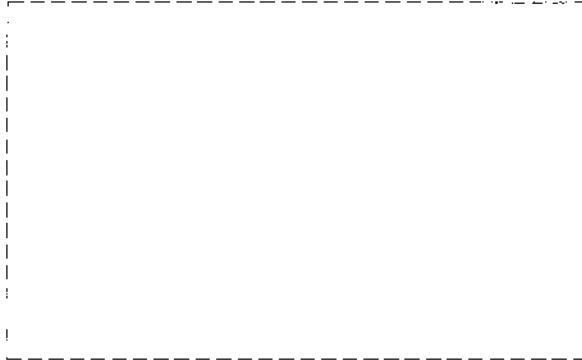

PLOT POINT

X = _____

Y = _____

User should make use of a grid scale which matches the intended vector plot.

TABLE 3-6C
CONVERSION - X/Y PLOT INCREMENTS OF MOVE-TO-BINARY EQUIVALENTS

Bit → Binary Value	12	11	10	9	8	7	6	5	4	3	2	1	PLOT POINT VALUE ↓
	2048	1024	512	256	128	64	32	16	8	4	2	1	
X													=
Y													=
	MSB					IB					LSB		

TABLE 3-7C
BINARY TO ASCII

BYTE	BITS							ASCII
	7	6	5	4	3	2	1	
1. SIGN	0	1	x	x	x	Y sign	X sign	
2. HIY	0	1						
3. XLDY	1	1	0					
4. LOY	1	1						
5. HIX	0	1						
6. LOX	1	0						

x = DON'T CARE

COMMAND: _____

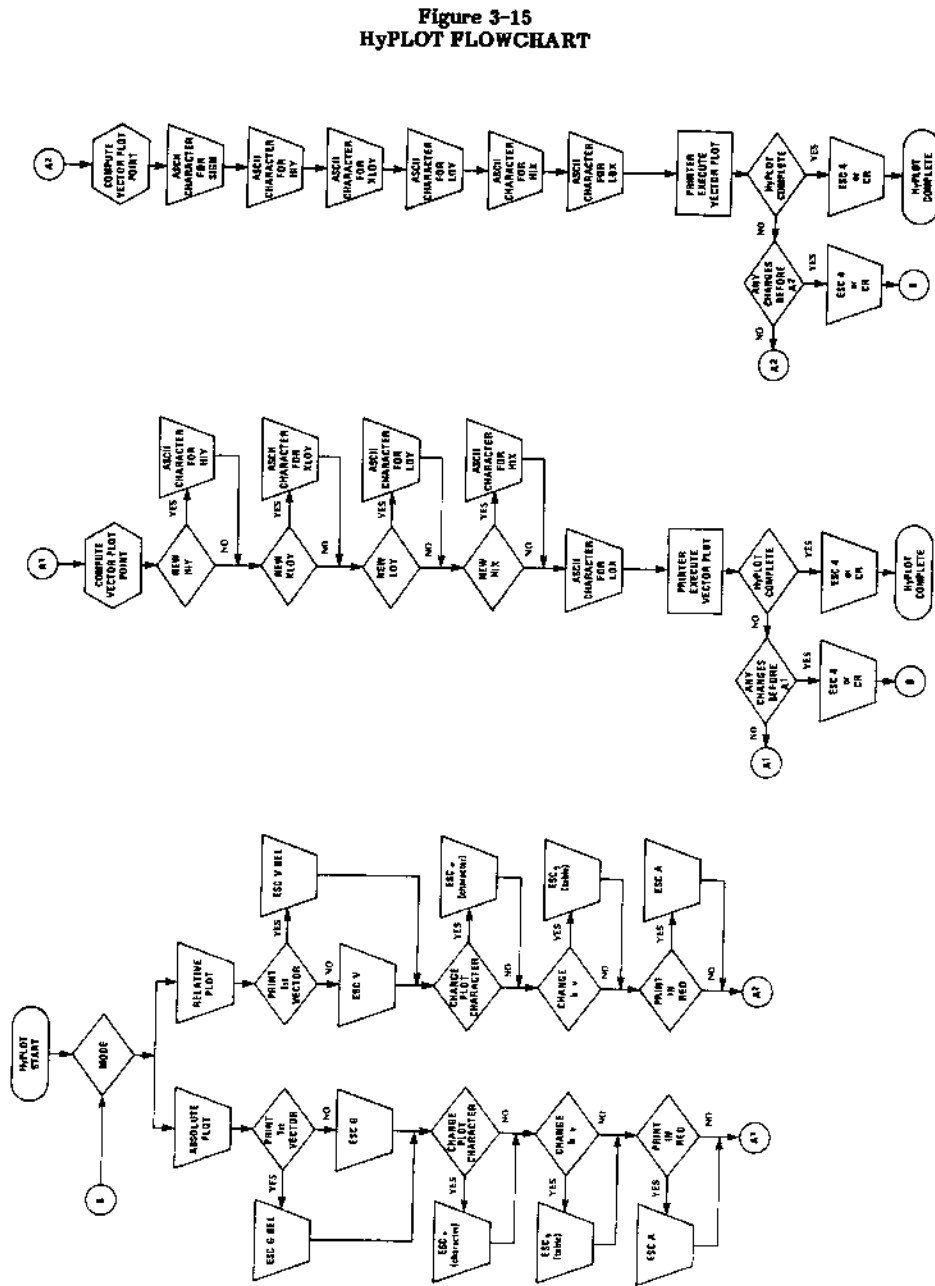

INITIATE HyPLOT - SET MODE & PARAMETERS

PLOT ABSOLUTE VECTORS

PLOT RELATIVE VECTORS

3.26 FEEDER SUPPORT

The API supports Diablo Models F32 and F33* feed-on-demand cut sheet feeders. The F32 is a two tray feeder, and the F33 a two tray plus envelope feeder. Both of these feeders operate with the same feeder interface hardware and firmware commands.

* F33 is supported only at firmware levels -18 and above.

The feeder is controlled by ESC sequences and embedded text commands. These commands are:

Escape Sequence Commands

ESC EM 1	Feed from tray 1 (upper tray)
ESC EM 2	Feed from tray 2
ESC EM E	Feed from envelope hopper
ESC EM R	Remove (eject) paper (does not cause a feed)

Embedded Commands (see Note 4 below)

//1//	Select tray 1 (upper tray)
//2//	Select tray 2
//E//	Select envelope
//R//	Select Remove (eject) (does not cause a feed)
//C//	Select tray 1 for first feed, then select tray 2 thereafter or until a new command is issued.

ESC CR P and ESC SUB I reset commands will also initialize the feeder. The status of the feeder can be obtained through Status Byte 3 in Remote Diagnostics (see subsection 3.23.5).

The following points pertain to operation of the API with a sheet feeder.

1. The ESC sequences and feeder control panel operations will act on the feeder immediately.
2. The ESC sequences and embedded text commands are both active at all times when the feeder is installed and not in manual mode.
3. The embedded text commands must be the only printable characters on a line (control codes are allowed). The line must start and finish with a CR or LF. Note that the line feed (LF) will be executed.
4. The embedded text commands select trays only. A subsequent form feed or line feed over a page boundary will cause the last selected tray to be fed.
5. Any feed command (//x// or ESC EM x) for a nonexistent tray will be ignored.
6. Any feed command (//x// or ESC EM x) will be ignored when there is no feeder installed, or if the feeder is in manual mode.
7. The API detects whether a feeder is present, and if so, which feeder it is.
8. Page size definition is the same, with or without a feeder. ESC FF (n) will define lines/page.
9. Vertical moves, such as a line feed, which cause movement beyond page boundaries will cause the system to automatically feed a sheet from the last tray fed or selected, so that the user perceives operation as with a continuous form.
10. When the API is in Graphics mode, crossing the bottom margin will not cause the next feed.
11. Reverse motion is not allowed across a page boundary or within the last 6 lines on a page.

12. Motion within the last 6 lines on a page is limited to minimum increments of 1/24 of an inch. Odd VMI increments will be rounded up to make them even.
13. When in auto mode, the feeder will center the printer's carriage for line feeds at the top of the page to facilitate entry of the paper into the outfeed chute.
14. If API is set for self-test with feeder installed, at power-up it will print self test with 84 columns of text and alternate between tray 1 and tray 2.

For complete instructions on operation of the feeder, refer to the Diablo Operator's Guide for the feeder being used.

3.27 SELF-TEST

The self-test mode is entered when the SELF TEST switch on the control panel is ON at power-on. The self-test consists of a ROM test, a RAM test and 96 lines of swirl text.

Figures 3-16, 3-17, and 3-18 show three variations of self-test printout; the only differences being in the first line of the printout. Figure 3-16 represents the self-test printout in units with firmware below the -18 design level. Starting at -18 firmware level (Fig. 3-17), the first line of the self-test printout identifies the firmware level ("ver18") installed in the unit. At later firmware levels (Fig. 3-18), the self-test printout also denotes F33 feeder support ("f33").

All of the tested ROM and RAM memory is located on the API circuit board; specific locations are identified on the API circuit board schematic in the Model 630 Maintenance Manual. The internal RAM listed in the printout ("INT.RAM.OK") is located in the 8031 CPU device on the API board.

With the Model 630 ECS/API, the entire extended character set will be included in the swirl text printout if the control panel switches are set for ECS operation. However, since the printout is only 132 columns wide, several lines of the text must be printed before all of the characters have actually appeared in the printout.

If a sheet feeder is installed on the API terminal, the self-test differs only in that the swirl text printout is 84 columns wide, and if it is a dual tray feeder, it will feed from alternate trays for each successive sheet of test printout.

```

630-API.SELFTEST
ROM1.OK
ROM2.OK
INT.RAM.OK
EXT.RAM.OK
96 LINES c!"#$%&'()*+,-./0123456789:;<=>?@ABCDEFGHIJKLMN
OPQRSTUVWXYZ[\]^_`
!"#$%&'()*+,-./0123456789:;<=>?@ABCDEFGHIJKLMN
OPQRSTUVWXYZ[\]^_`a
#$%&'()*+,-./0123456789:;<=>?@ABCDEFGHIJKLMN
OPQRSTUVWXYZ[\]^_`ab
$%&'()*+,-./0123456789:;<=>?@ABCDEFGHIJKLMN
OPQRSTUVWXYZ[\]^_`abc
%&'()*+,-./0123456789:;<=>?@ABCDEFGHIJKLMN
OPQRSTUVWXYZ[\]^_`abcd
&'()*+,-./0123456789:;<=>?@ABCDEFGHIJKLMN
OPQRSTUVWXYZ[\]^_`abcde
'()*+,-./0123456789:;<=>?@ABCDEFGHIJKLMN
OPQRSTUVWXYZ[\]^_`abcdef
()*+,-./0123456789:;<=>?@ABCDEFGHIJKLMN
OPQRSTUVWXYZ[\]^_`abcdefg
) *+,-./0123456789:;<=>?@ABCDEFGHIJKLMN
OPQRSTUVWXYZ[\]^_`abcdefgh
132 COLUMNS

```

Figure 3-16. SELF-TEST PRINTOUT - API
With Firmware Levels Below -18

```

630-APIϕver18.0ϕSELFTTEST
ROM1.OK
ROM2.OK
INT.RAM.OK
EXT.RAM.OK
96 LINES ϕ!"#$%&'()*+,-./0123456789:;<=>?@ABCDEFGHIJKLMNPOQRSTUVWXYZ[\]^_`
!"#$%&'()*+,-./0123456789:;<=>?@ABCDEFGHIJKLMNPOQRSTUVWXYZ[\]^_`a
"$%&'()*+,-./0123456789:;<=>?@ABCDEFGHIJKLMNPOQRSTUVWXYZ[\]^_`ab
#$%&'()*+,-./0123456789:;<=>?@ABCDEFGHIJKLMNPOQRSTUVWXYZ[\]^_`abc
$%&'()*+,-./0123456789:;<=>?@ABCDEFGHIJKLMNPOQRSTUVWXYZ[\]^_`abcd
%&'()*+,-./0123456789:;<=>?@ABCDEFGHIJKLMNPOQRSTUVWXYZ[\]^_`abcde
'()*+,-./0123456789:;<=>?@ABCDEFGHIJKLMNPOQRSTUVWXYZ[\]^_`abcdef
()*+,-./0123456789:;<=>?@ABCDEFGHIJKLMNPOQRSTUVWXYZ[\]^_`abcdefg
) *+,-./0123456789:;<=>?@ABCDEFGHIJKLMNPOQRSTUVWXYZ[\]^_`abcdefgh
132 COLUMNS

```

Figure 3-17. SELF-TEST PRINTOUT - API
With Firmware Level -18

```

630-APIϕver20.0ϕSELFTTESTϕ<f33>
ROM1.OK
ROM2.OK
INT.RAM.OK
EXT.RAM.OK
96 LINES ϕ!"#$%&'()*+,-./0123456789:;<=>?@ABCDEFGHIJKLMNPOQRSTUVWXYZ[\]^_`
!"#$%&'()*+,-./0123456789:;<=>?@ABCDEFGHIJKLMNPOQRSTUVWXYZ[\]^_`a
"$%&'()*+,-./0123456789:;<=>?@ABCDEFGHIJKLMNPOQRSTUVWXYZ[\]^_`ab
#$%&'()*+,-./0123456789:;<=>?@ABCDEFGHIJKLMNPOQRSTUVWXYZ[\]^_`abc
$%&'()*+,-./0123456789:;<=>?@ABCDEFGHIJKLMNPOQRSTUVWXYZ[\]^_`abcd
%&'()*+,-./0123456789:;<=>?@ABCDEFGHIJKLMNPOQRSTUVWXYZ[\]^_`abcde
'()*+,-./0123456789:;<=>?@ABCDEFGHIJKLMNPOQRSTUVWXYZ[\]^_`abcdef
()*+,-./0123456789:;<=>?@ABCDEFGHIJKLMNPOQRSTUVWXYZ[\]^_`abcdefg
) *+,-./0123456789:;<=>?@ABCDEFGHIJKLMNPOQRSTUVWXYZ[\]^_`abcdefgh
132 COLUMNS

```

Figure 3-18. SELF-TEST PRINTOUT - API
With Firmware Level -20

3.28 PRINT SPEED MEASUREMENT

The SRQ line in the IEEE-488 interface, which is unused by the API and held HI in normal operation, can be used as a start/stop flag for print speed measurement with a user-originated speed measurement text. To execute a print speed test, the host sends: **BEL, ESC CAN CAN, the print measurement text, BEL, ESC CAN CAN**. The SRQ signal will be toggled each time ESC CAN CAN is executed from the print buffer. The controller can use the state of SRQ to start and stop the timer.

It is not recommended that this feature be used in a system environment that supports the SRQ line for serial and parallel poll purpose.

3.29 EXTENDED CHARACTER SET (ECS)

The ECS mode is selected by switch 1 of the left DIP switch module on the FFCPN control panel. In ECS mode, the Model 630 is capable of operating with the ECS print wheels which can contain up to 192 separate print characters in two rows with two characters per print wheel spoke.

The character addressing and code assignments for the ECS/IBM Model 630 differ significantly from those of the standard ECS, thus the ECS/IBM extended character set addressing is covered separately below.

3.29.1 Standard ECS Character Sets

At the time of this writing, there are five families of ECS print wheels supported by the latest revision level of the standard ECS API firmware.* The print tables for these print wheels are stored internally in ROM and are selected by the left rotary switch on the control panel:

<u>Switch Position</u>	<u>Print Wheel Selection *</u>
0	Scientific
1	Multipurpose
2	Teletex
3	Legal/Italic
4	Dual Pitch

* The ECS/IBM version of the Model 630 supports only one ECS print wheel: the ECS PC GRAPHICS print wheel.

Figures 4-7 thru 4-11 in Section 4 of this manual contain the ASCII code charts for these five families of print wheels. The code charts list all of the discrete and constructed print characters and their ASCII code assignments as supported by the current level of standard API ECS firmware. The constructed characters are formed automatically by printing a combination of 2 or 3 discrete characters in sequence, with little or no carriage movement to separate the characters. The ASCII code assignments for the print characters are based on Teletex and Xerox character sets.

The print wheel characters are divided into a "primary" character set and a "supplementary" character set. The code charts illustrate the primary/supplementary character set address arrangement for each print wheel when operating in ECS mode. The primary character set includes print characters plus the full set of standard ASCII control characters. Note that two of the print wheel characters in the primary character set must be addressed by sending ESC Y and ESC Z. This is necessary because codes 20 hex and 7F hex are reserved for SP and DEL control codes, and thus are not available for print character addressing.

Note: The designations "primary character set" and "supplementary character set" do not necessarily correspond to "outer" and "inner" character row on the print wheel. "Primary" and "supplementary" relate to ASCII address arrangement as illustrated by the code charts.

It is also possible to download ECS print table data into RAM memory of the Model 630 from the host in the same manner in which standard print wheel tables are downloaded. For an ECS print wheel table, the firmware simply expands the RAM table size to 448 bytes to accommodate the 224 ECS address positions. If the print wheel table is supplied through the download procedure, the most significant bit (MSB) of the second byte of each table entry designates the outer or inner row character (see subsection 3.22). When the bit is 0, the outer row character is selected; when the bit is 1, the inner row character is selected.

3.29.2 Standard ECS 8-Bit ASCII Addressing

This is an expansion of the standard 7-bit ASCII method of print wheel addressing. The 8-Bit ASCII mode is selected by switch 3 of the left DIP switch module on the FCCPN control panel. When 8 bits are used for print wheel addressing, the code assignments expand to include codes 80 - FF, in addition to the codes 00 - 7F available with standard 7-bit ASCII, as shown in Figures 4-7 thru 4-11.

<u>Codes</u>	<u>Description</u>
00 - 7F . . .	Standard 7-bit ASCII code assignments for control codes and print characters. Codes in this range address the primary character set.
80 - FF . . .	Codes in this range address the supplementary character set.

Note: Codes 80 - 9F will be ignored at power-up or after SI is received from host. To access codes 80 - 9F, the host first must send SO. After the API receives SO, all codes are accessible in 8-bit ASCII mode.

3.29.3 Standard ECS 7-Bit ASCII Addressing

In the 7-bit ASCII mode of operation for ECS print wheels, ASCII codes 00 - 7F are used in conjunction with control codes SO and SI to address both the primary and supplementary character sets. The SI code selects the primary character set (including control codes), and the SO code selects the supplementary character set. The primary character set (including control codes) is selected automatically at power-up. To switch to the supplementary character set, the host must send an SO control code. While the supplementary character set is selected, SI and SP (space) are the only control codes recognized by the API.

A single-print shift from primary to supplementary character set and back can be done by using the EM control code. When the API receives the EM code, it switches to the supplementary character set, prints the next printable character, then automatically switches back to the primary character set.

3.29.4 ECS/IBM Character Set

The ECS/IBM version of the Model 630 internally supports only one ECS print wheel: the ECS PC GRAPHICS wheel. Other ECS print wheels can be supported by downloading an appropriate print wheel table from the host.

The ECS/IBM character set is selected on the Model 630 ECS/IBM printer by the following control panel switch settings:

Left Rotary Switch	-	Position 0 (192 IBM)
Right Rotary Switch	-	Position 2 (12 pitch)
Left DIP Switch 1	-	ON (ECS)
Left DIP Switch 3	-	ON for 8-Bit ASCII; OFF for 7-Bit ASCII

The ECS/IBM character set is illustrated by the code chart in Figure 4-12.

3.29.5 8-Bit ASCII Addressing of the ECS/IBM Character Set

Figure 4-12 shows all of the 8-bit ASCII code assignments for the ECS/IBM character set. To address the characters in the code range 00-1F hex, the following considerations apply:

- At power-up, all of the ASCII codes below 20 hex are preempted for standard ASCII control character functions. The printable characters assigned within this code range as shown in Figure 4-12 must be accessed by one of the following means:
 1. Host sends a GS code to single-shift for printing a single character from the ASCII range 00-1F. Following the single character print, codes 00-1F revert to their control character functions.
 2. Host sends an SO code to lock-shift codes 00-1F for access to the 20 print characters assigned within this code range. There are 12 codes within the range 00-1F that are not assigned to print characters; these codes retain their control character functions during the shift.

To shift back to the standard control character functions for codes 00-1F, the host must send the sequence ESC SI. (Although the standard SI code assignment, 0F hex, is shared with a printable character, the 0F is interpreted as an SI code any time it is preceded by an ESC code.)

3.29.6 7-Bit ASCII Addressing of the ECS/IBM Character Set

When operating in ECS 7-bit mode, the following considerations apply, in addition to those listed above for 8-bit mode:

- The "upper range" characters (see code chart) are addressable by codes 20-7F on a single-shift, nonlocking basis only. The control code EM must precede each character code sent for printing a character in this range. There is no locking shift because all code positions are assigned for printable characters, thus leaving no code to use for return to the "lower range".

3.30 REMOTE PRINT WHEEL SELECTION

The control code sequence ESC SYN (n) can be used to make remote print wheel type selections from the host computer without changing the setting of the PRINT WHEEL TYPE switch on the terminal's control panel. Typically, this feature will be used to select the proper print wheel type when a downloaded print table is going to be used. The 7-bit (n) character (3rd character in the sequence) determines the selection, as follows:

Bits							<u>Print Wheel Type</u>
<u>6</u>	<u>5</u>	<u>4</u>	<u>3</u>	<u>2</u>	<u>1</u>	<u>0</u>	
X	X	X	X	X	X	0	Plastic print wheel *
X	X	X	X	X	X	1	Metal print wheel
X	X	X	X	X	0	X	Non-ECS print wheel *
X	X	X	X	X	1	X	ECS print wheel

X = Don't Care condition (can be either 0 or 1)

* Note that the bit combination to select either the plastic or Non-ECS print wheels could theoretically be a zero value (null). However, since a null character is ignored by the printer, it is important that these be non-zero characters. The recommended hex codes for the four selections are:

30 hex (0110000) for Plastic print wheel
31 hex (0110001) for Metal print wheel
32 hex (0110010) for Non-ECS print wheel
33 hex (0110011) for ECS print wheel

To cancel the remote print wheel selection and return to the selection being made by the PRINT WHEEL TYPE switch on the control panel, you can use any of the following methods:

- Initialize the terminal by doing a power off-on cycle, or, preferably, by sending a remote reset command (ESC CR P) from the host computer.
Note: Any data remaining in the input buffer will be lost when ESC CR P is received. Similarly, any data received prior to completion of the restore sequence initiated by ESC CR P will also be lost.
- Put the terminal into download mode by sending ESC SO DC2 from the host, and then download an invalid record (refer to the Download description in this manual). When the invalid record is detected, the terminal aborts the download mode and reverts to the print wheel selection made at the control panel.

SECTION 4
OPERATING REFERENCES

This Section contains various charts and tables supporting Section 3, OPERATING CONSIDERATIONS.

4.1 API PRINT WHEEL SUPPORT

The print wheel groups listed below are directly supported by the firmware of the Model 630 APL.

Group I - Metalized Print Wheels

English; Xerox 88-Character (US)
English; Xerox 92-Character (United Kingdom)
English; Xerox 96-Character (United Kingdom)
English; Diablo 96-Character (Titan 10 - US, Elite 12 - US, Cubic PS - US)
Scandinavian 92-Character
Scandinavian 96-Character
Norsk 96-Character
French 92-Character
French 96-Character
German 92-Character
German 96-Character
APL 96-Character

Group II - Plastic Print Wheels

English 96-Character (US)
English 96-Character (UK)
Scandinavian 96-Character
Norsk 96-Character
French 96-Character
German 96-Character
APL 96-Character

Group III - ECS Plastic Print Wheels (-18 and later firmware) *

Scientific
Multipurpose
Teletex
Legal / Italic
Dual Pitch

Note: The ECS/IBM version of the Model 630 supports only one ECS print wheel: ECS PC GRAPHICS.

- * ECS units equipped with firmware EPROM's at design levels prior to -18 support only two types of ECS print wheels: the Scientific and the Teletex. You can determine the firmware level of your unit by initiating Self-Test (see subsection 3.27). In units equipped with firmware at level -18 or above, the firmware level is listed in the top line of the self-test printout.

4.2 ASCII CODING SYSTEM

The ASCII Coding System is based on the American National Standard Code for Information Interchange, Standard No. X3.4-1977 of the American National Standards Institute, Incorporated.

Bits		b ₇ →	0	0	0	0	1	1	1	1	
		b ₆ →	0	0	1	1	0	0	1	1	
		b ₅ →	0	1	0	1	0	1	0	1	
b ₄ ↓	b ₃ ↓	b ₂ ↓	b ₁ ↓	COLUMN →		ROW ←					
0	0	0	0	0	1	2	3	4	5	6	7
0	0	0	0	NUL	DLE	SP	0	@	P		p
0	0	0	1	SOH	DC1	!	1	A	Q	a	q
0	0	1	0	STX	DC2	"	2	B	R	b	r
0	0	1	1	ETX	DC3	#	3	C	S	c	s
0	1	0	0	EOT	DC4	\$	4	D	T	d	t
0	1	0	1	ENQ	NAK	%	5	E	U	e	u
0	1	1	0	ACK	SYN	&	6	F	V	f	v
0	1	1	1	BEL	ETB	'	7	G	W	g	w
1	0	0	0	BS	CAN	(8	H	X	h	x
1	0	0	1	HT	EM)	9	I	Y	i	y
1	0	1	0	LF	SUB	*	:	J	Z	j	z
1	0	1	1	VT	ESC	+	;	K	[k	{
1	1	0	0	FF	FS	,	<	L	\	l	
1	1	0	1	CR	GS	-	=	M]	m	}
1	1	1	0	SO	RS	.	>	N	^	n	~
1	1	1	1	SI	US	/	?	O	_	o	DEL

All characters in these two columns and SP (Space) are nonprinting. DEL (Delete) does not print in Remote mode. When a character is received with parity or framing error, the print wheel character addressed by ASCII code 3F (HEX) is printed in place of the received character.

Figure 4-1. ASCII CODE CHART

4.3 PRINT WHEEL ASCII CODE CHARTS (Typical)

The following print wheel code charts provide a general sample of technical data for the different types of print wheels. Specific technical data pertaining to each print wheel available from Diablo Systems for the Model 630 is contained in the Diablo Print Wheel Data Books 1 and 3 (see subsection 4.4 of this manual).

The codes 20 hex and 7F hex are interpreted as "space" and "delete" respectively by the Model 630 and thus are not available for print wheel addressing. In place of these two codes, the ESC sequences ESC Y and ESC Z are used to address certain characters and thus provide a complete set of 96 codes for print wheel addressing. ESC Y and/or ESC Z are listed on the following charts where applicable.

The hexadecimal code assignments shown on the print wheel code charts are based on ASCII and Teletex character code assignments. These are the proper codes for typical operation wherein the print characters are addressed via the print tables residing in firmware in the Model 630. The Hexadecimal-Decimal conversion table below is provided for the benefit of those users with systems that accept program code in decimal form instead of the hexadecimal form shown in the print wheel charts.

Table 4-1
HEXADECIMAL-DECIMAL CONVERSION

		H E X 1 6's															
		0	1	2	3	4	5	6	7	8	9	A	B	C	D	E	F
R	0	0	16	32	48	64	80	96	112	128	144	160	176	192	208	224	240
	1	1	17	33	49	65	81	97	113	129	145	161	177	193	209	225	241
E	2	2	18	34	50	66	82	98	114	130	146	162	178	194	210	226	242
	3	3	19	35	51	67	83	99	115	131	147	163	179	195	211	227	243
X	4	4	20	36	52	68	84	100	116	132	148	164	180	196	212	228	244
	5	5	21	37	53	69	85	101	117	133	149	165	181	197	213	229	245
U	6	6	22	38	54	70	86	102	118	134	150	166	182	198	214	230	246
	7	7	23	39	55	71	87	103	119	135	151	167	183	199	215	231	247
N	8	8	24	40	56	72	88	104	120	136	152	168	184	200	216	232	248
	9	9	25	41	57	73	89	105	121	137	153	169	185	201	217	233	249
I	A	10	26	42	58	74	90	106	122	138	154	170	186	202	218	234	250
	B	11	27	43	59	75	91	107	123	139	155	171	187	203	219	235	251
T	C	12	28	44	60	76	92	108	124	140	156	172	188	204	220	236	252
	D	13	29	45	61	77	93	109	125	141	157	173	189	205	221	237	253
S	E	14	30	46	62	78	94	110	126	142	158	174	190	206	222	238	254
	F	15	31	47	63	79	95	111	127	143	159	175	191	207	223	239	255



(MSB) b7				b6	b5	b4	b3	b2	b1														
b7				b6	b5	b4	b3	b2	b1														
b7				b6	b5	b4	b3	b2	b1														
b7				b6	b5	b4	b3	b2	b1														
0	0	0	0			0				37	59	@	62	34	P	26	70	,	56	40	p	90	6
0	0	0	1	!	88	28	1			33	63	A	11	85	Q	27	69	a	84	12	q	92	4
0	0	1	0	"	70	26	2			34	62	B	8	88	R	13	83	b	78	18	r	81	15
0	0	1	1	#	46	50	3			35	61	C	10	86	S	14	82	c	79	17	s	88	8
0	1	0	0	\$	44	52	4			36	60	D	22	74	T	16	80	d	76	20	t	86	10
0	1	0	1	%	47	49	5			38	58	E	15	81	U	23	73	e	83	13	u	91	5
0	1	1	0	&	69	27	6			39	57	F	9	87	V	30	66	f	89	7	v	13	23
0	1	1	1	'	54	42	7			40	56	G	24	72	W	4	92	g	74	22	w	0	0
1	0	0	0	{	60	36	8			41	55	H	17	79	X	32	64	h	87	8	x	75	21
1	0	0	1	}	58	38	9			42	54	I	20	76	Y	25	71	i	85	11	y	94	2
1	0	1	0	*	61	35	:			12	84	J	29	67	Z	7	89	j	72	24	z	95	1
1	0	1	1	+	45	51	;			31	65	K	28	68	[53	43	k	93	3	{	49	47
1	1	0	0	,	3	93	<			57	39	L	21	75	\	63	33	l	77	19	:	59	37
1	1	0	1	-	43	53	=			48	48	M	6	90]	51	45	m	71	25	}	67	29
1	1	1	0	.	5	91	>			50	46	N	19	77	^	64	32	n	82	14	~	52	44
1	1	1	1	/	66	30	?			65	31	O	18	78	_	55	41	o	80	16			

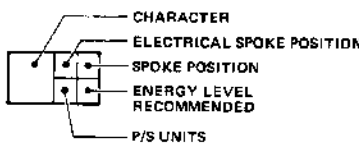

- NOTES:
1. USE ENERGY SWITCH POSITION M FOR NORMAL USE. FOR MULTISTACK.
 2. DESIGNATES RECOMMENDED LEVEL THAT DEVIATES FROM A STD HYTYPE II PRINTER
 3. CHARACTERS SHOWN ON THIS DRAWING DO NOT REFLECT AESTHETICS OF INDIVIDUAL TYPE STYLES.
 4. ELECTRICAL POSITION IS PRINTWHEEL SPOKE POSITION AS VIEWED FROM THE CHARACTER SIDE OF THE PRINTWHEEL.

Figure 4-2. 96-CHARACTER PRINT WHEEL (US) - PLASTIC

ESC Y



(MSE)				b7	0	0	1	1	1	1							
				b6	1	1	0	0	1	1							
				b5	0	1	0	1	0	1							
b4	b3	b2	b1														
0	0	0	0	0	86	10	@	75	21	P	10	86	41	18	p	67	29
0	0	0	1	!	37	59	1	82	14	A	18	78	52	44	a	59	37
0	0	1	0	"	33	63	2	83	13	B	8	88	28	68	b	58	28
0	0	1	1	#	82	4	3	84	12	C	35	60	14	82	c	62	34
0	1	0	0	\$	7	89	4	85	11	D	32	64	19	77	d	80	36
0	1	0	1	%	79	17	4	87	9	E	16	80	34	62	e	58	38
0	1	1	0	&	77	19	4	88	8	F	22	74	12	84	f	45	51
0	1	1	1	'	23	73	1	89	7	G	40	56	42	54	g	85	31
1	0	0	0	(78	20	2	90	6	H	26	70	50	46	h	61	35
1	0	0	1)	74	22	2	91	5	I	25	71	44	52	i	47	49
1	0	1	0	*	15	81	3	29	67	J	21	75	6	80	j	49	47
1	0	1	1	+	11	85	2	27	69	K	46	50			k	68	27
1	1	0	0	,	78	55	1	81	15	L	20	76			l	43	53
1	1	0	1	-	35	61	1	9	87	M	38	58			m	48	48
1	1	1	0	.	80	57	1	73	23	N	24	72			n	57	39
1	1	1	1	/	31	85	2	17	79	O	30	66	13	63	o	56	40

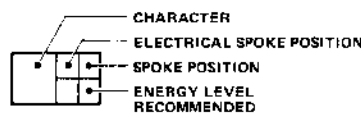

- NOTES:
1. USE ENERGY SWITCH POSITION M FOR NORMAL USE. FOR MULTISTACK.
 2. [Symbol] DESIGNATES RECOMMENDED LEVEL THAT DEVIATES FROM A STD. HY TYPE II PRINTER.
 3. CHARACTERS SHOWN ON THIS DRAWING DO NOT REFLECT AESTHETICS OF INDIVIDUAL TYPE STYLES.
 4. ELECTRICAL POSITION IS PRINTWHEEL SPOKE POSITION AS VIEWED FROM THE CHARACTER SIDE OF THE PRINTWHEEL.

Figure 4-3. 88-CHARACTER PRINT WHEEL (US WP) - METALIZED

ESC Y

5	91
3	

(MSB) b7				b6	b5	b4	b3	b2	b1
b4	b3	b2	b1						
0	0	0	0	0	0	0	0	0	0
0	0	0	1	0	0	0	0	0	0
0	0	1	0	0	0	0	0	0	0
0	0	1	1	0	0	0	0	0	0
0	1	0	0	0	0	0	0	0	0
0	1	0	1	0	0	0	0	0	0
0	1	1	0	0	0	0	0	0	0
0	1	1	1	0	0	0	0	0	0
1	0	0	0	0	0	0	0	0	0
1	0	0	1	0	0	0	0	0	0
1	0	1	0	0	0	0	0	0	0
1	0	1	1	0	0	0	0	0	0
1	1	0	0	0	0	0	0	0	0
1	1	0	1	0	0	0	0	0	0
1	1	1	0	0	0	0	0	0	0
1	1	1	1	0	0	0	0	0	0

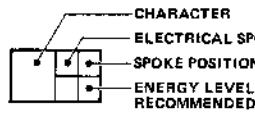

- NOTES:
1. USE ENERGY SWITCH POSITION M FOR NORMAL USE. FOR MULTISTACK
 2. DESIGNATES RECOMMENDED LEVEL THAT DEVIATES FROM A STD HYTYPE II PRINTER.
 3. CHARACTERS SHOWN ON THIS DRAWING DO NOT REFLECT AESTHETICS OF INDIVIDUAL TYPE STYLES.
 4. ELECTRICAL POSITION IS PRINTWHEEL SPOKE POSITION AS VIEWED FROM THE CHARACTER SIDE OF THE PRINTWHEEL.

Figure 4-4. 92-CHARACTER PRINT WHEEL (ENGLISH WP) - METALIZED (Rank Xerox)

ESC Y ESC Z

0	0	'	39	57
5	3		5	1

(MSB) b7				0	0	1	1	1	1						
b6				1	1	0	0	1	1						
b5				0	1	0	1	0	1						
b4	b3	b2	b1												
0	0	0	0	0	86 10 5 4	@	75 21 8 4	P	16 86 6 4	'	95 1 5 1	p	67 29 5 4		
0	0	0	1	!	37 59 3 2	1	82 14 5 2	A	18 78 7 4	Q	52 44 7 4	a	59 37 5 3	q	72 24 5 4
0	0	1	0	"	33 83 4 2	2	83 13 5 3	B	8 88 6 4	R	28 68 7 4	b	68 28 5 3	r	55 41 4 2
0	0	1	1	#	82 4 6 4	3	84 12 5 3	C	36 80 7 3	S	14 82 5 4	c	82 34 5 3	s	51 45 4 3
0	1	0	0	\$	7 89 5 4	4	85 11 5 3	D	32 84 7 4	T	19 77 6 3	d	80 36 5 3	t	53 43 4 3
0	1	0	1	%	79 17 8 4	5	87 9 5 3	E	16 80 6 4	U	34 82 7 4	e	58 38 5 3	u	63 33 5 3
0	1	1	0	&	77 19 7 4	6	88 8 5 3	F	22 74 6 4	V	12 84 6 4	f	45 51 4 3	v	64 32 5 3
0	1	1	1	'	23 73 2 1	7	89 7 5 3	G	40 56 7 4	W	42 54 8 4	g	65 31 5 4	w	54 42 7 3
1	0	0	0	(76 20 3 2	8	90 6 5 4	H	26 70 7 4	X	50 46 7 4	h	61 35 5 3	x	70 26 5 3
1	0	0	1)	74 22 3 2	9	91 5 5 3	I	25 71 3 3	Y	44 52 7 4	i	47 49 3 2	y	66 30 5 3
1	0	1	0	x	15 81 5 3	:	29 67 3 2	J	21 75 5 3	Z	6 90 6 3	j	48 47 3 3	z	71 25 5 3
1	0	1	1	+	11 85 5 2	;	27 69 3 2	K	46 50 7 4	[81 15 3 2	k	89 27 5 3	{	4 92 3 2
1	1	0	0	,	78 18 3 1	<	41 55 5 2	L	20 76 6 3	\	3 93 5 2	l	43 53 3 2	l	73 23 3 2
1	1	0	1	-	35 61 4 1	=	9 87 5 2	M	38 58 8 4]	1 95 3 2	m	48 48 8 4	}	93 3 3 2
1	1	1	0	.	80 16 3 1	>	5 91 5 2	N	24 72 7 4	^	2 94 5 1	n	57 39 5 3	~	94 2 5 1
1	1	1	1	/	31 65 4 2	?	17 79 5 2	O	30 66 7 4	_	13 83 5 1	o	56 40 5 3	DEL	

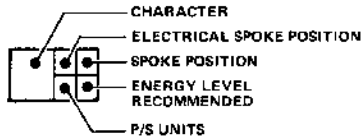

- NOTES:
1. USE ENERGY SWITCH POSITION M FOR NORMAL USE, FOR MULTISTACK.
 2. [Symbol] DESIGNATES RECOMMENDED LEVEL THAT DEVIATES FROM A STD HYTYPE II PRINTER.
 3. CHARACTERS SHOWN ON THIS DRAWING DO NOT REFLECT AESTHETICS OF INDIVIDUAL TYPE STYLES.
 4. ELECTRICAL POSITION IS PRINTWHEEL SPOKE POSITION AS VIEWED FROM THE CHARACTER SIDE OF THE PRINTWHEEL.

Figure 4-5. 96-CHARACTER PRINT WHEEL (US ASCII) - METALIZED (Diablo)

ESC Y		ESC Z	
5	91	3	0 0
5	2		5 2

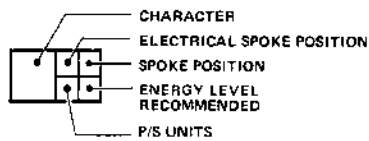

(MSB) b7	0	0	1	1	1	1									
b6	1	1	0	0	1	1									
b5	0	1	0	1	0	1									
b4	0	0	0	0	0	0									
b3	0	0	0	0	0	0									
b2	0	0	0	0	0	0									
b1	0	0	0	0	0	0									
0	0	0	0	0	0	0									
0	0	0	1	!	37 59 3 2	1	82 14 5 2	A	18 78 7 4	Q	52 44 7 4	a	59 37 5 3	q	72 24 5 4
0	0	1	0	"	33 63 4 2	2	83 13 5 3	B	8 88 6 4	R	28 68 7 4	b	68 28 5 3	r	55 41 4 2
0	0	1	1	μ	92 4 6 3	3	84 12 5 3	C	36 60 7 3	S	14 62 5 4	c	62 34 5 3	s	51 45 4 3
0	1	0	0	\$	7 89 5 4	4	85 11 5 3	D	32 64 7 4	T	19 77 6 3	d	60 36 5 3	t	53 43 4 3
0	1	0	1	%	79 77 8 4	5	87 9 5 3	E	16 80 6 4	U	34 62 7 4	e	58 38 5 3	u	63 33 5 3
0	1	1	0	&	77 79 7 4	6	88 8 5 3	F	22 74 6 4	V	12 84 6 4	f	45 51 4 3	v	64 32 5 3
0	1	1	1	'	23 73 2 1	7	89 7 5 3	G	40 56 7 4	W	42 54 8 4	g	65 31 5 4	w	54 42 7 3
1	0	0	0	(76 20 3 2	8	90 6 5 4	H	26 70 7 4	X	50 46 7 4	h	61 35 5 3	x	70 26 5 3
1	0	0	1)	74 22 3 2	9	91 5 5 3	I	25 71 3 3	Y	44 52 7 4	i	47 49 3 2	y	66 30 5 3
1	0	1	0	*	15 81 5 3	:	29 67 3 2	J	21 75 5 3	Z	6 80 6 3	j	49 47 3 3	z	71 25 5 3
1	0	1	1	+	11 85 5 2	;	27 68 3 2	K	46 50 7 4]	3 93 6 4	k	68 27 5 3	.	39 16 3 1
1	1	0	0	,	78 55 3 1	¼	81 15 6 4	L	20 76 6 3	£	4 92 5 4	l	43 53 3 2	<	1 95 6 2
1	1	0	1	-	35 61 4 1	=	9 87 5 2	M	38 58 8 4	°	93 3 5 1	m	48 48 8 4	2	2 94 5 2
1	1	1	0	.	80 57 3 1	½	73 23 6 4	N	24 72 7 4	¾	3 94 2 4 5 4	n	57 39 5 3	>	95 1 6 2
1	1	1	1	/	31 65 4 2	?	17 79 5 2	O	30 66 7 4	—	13 83 5 1	o	56 40 5 3	DEL	



- NOTES:
1. USE ENERGY SWITCH POSITION M FOR NORMAL USE. FOR MULTISTACK.
 2. □ DESIGNATES RECOMMENDED LEVEL THAT DEVIATES FROM A STD. HYTYPE II PRINTER.
 3. CHARACTERS SHOWN ON THIS DRAWING DO NOT REFLECT AESTHETICS OF INDIVIDUAL TYPE STYLES.
 4. ELECTRICAL POSITION IS PRINTWHEEL SPOKE POSITION AS VIEWED FROM THE CHARACTER SIDE OF THE PRINTWHEEL.

Figure 4-6. 96-CHARACTER PRINT WHEEL (ENGLISH WP) - METALIZED (Rank Xerox)

		PRIMARY CHARACTER SET							SUPPLEMENTARY CHARACTER SET								
ASCII HEX	HI LO	0	1	2	3	4	5	6	7	8	9	A	B	C	D	E	F
	0	NUL DLE SP	0	@	P	`	p		≠	BP	Π	e	π	o	o		
1	SOH DC1	!	1	A	Q	a	q	←	α	A	P	α	ρ	1	1		
2	STX DC2	"	2	B	R	b	r	→	∂	B	Σ	β	σ	2	2		
3	ETX DC3	#	3	C	S	c	s	↑		Γ	T	Υ	τ	3	3		
4	EOT DC4	\$	4	D	T	d	t	↓		Δ	T	δ	v	4	4		
5	ENO NAK	%	5	E	U	e	u	⊙		E	Φ	ε	φ	5	5		
6	ACK SYN	&	6	F	V	f	v	□		Z	X	ζ	χ	6	6		
7	DEL ETS	'	7	G	W	g	w	¨		H	Ψ	η	ψ	7	7		
8	BS CAN	(8	H	X	h	x	¶		Θ	Ω	θ	ω	8	8		
9	HT EM)	9	I	Y	i	y	†		I	Σ	ι	ℓ	9	9		
A	LF SUB	*	:	J	Z	j	z	£		K	∇	κ	•	±	+		
B	VT ESC	+	;	K	[k	}			Λ	(λ	✓	—	-		
C	FF FS	,	<	L	\	l				M)	μ	}	≤	x		
D	CR GS	-	=	M]	m	{	°		N	[v	{	≥	+		
E	SO RS	.	>	N	^	n	~	À		E]	ξ	.	-	∞		
F	SI US	/	?	O	_	o	DEL	See Note 2		O	ƒ	o	/	≈			



ESC Y ESC Z
 

See Note 2

- NOTES:
- ECS 7-bit ASCII Mode
 - Primary Character Set accessed by codes 00-7F after power-up/initialize or after SI received from host.
 - Supplementary Character Set accessed by codes 80-7F after SD received from host.
 - ECS 8-bit ASCII Mode
 - After power-up/initialize all characters can be accessed except those addressed by 80-9F.
 - After SD received from host, all characters can be accessed.
 - In ECS 7-bit ASCII Mode, code 0F represents SI control character in both Primary and Supplementary Character Set.
 - For spoke assignments, hammer energies, and PS unit values pertaining to ECS print wheels, refer to Print Wheel Data Book - 3 (Diablo Publication No. 90044-03).

Figure 4-7. ECS SCIENTIFIC PRINT WHEEL

		PRIMARY CHARACTER SET						SUPPLEMENTARY CHARACTER SET									
ASCII HEX	HI LO	0	1	2	3	4	5	6	7	8	9	A	B	C	D	E	F
	0	NUL DLE SP	0	@	P	`	p		°	ø	°	`	-	Ω	κ		
1	SOH DC1	!	1	A	Q	a	q	°	f	i	±	`	1	Æ	æ		
2	STX DC2	"	2	B	R	b	r	1	Φ	φ	2	'	⊙	Ð	ð		
3	ETX DC3	#	3	C	S	c	s	2	r	£	3	^	⊙	ä	ö		
4	EOT DC4	\$	4	D	T	d	t	3	"	\$	x	~	™	Ë	ë		
5	ENO NAK	%	5	E	U	e	u	4	5	¥	u	-	†	-	ı		
6	ACK SYN	&	6	F	V	f	v	5	6	#	¶	˘	'	Û	ü		
7	BEL ETB	'	7	G	W	g	w	6	7	\$.	.	.	L	ł		
8	BS CAN	(8	H	X	h	x	7	8	¤	+	˘	ç	Ł	ł		
9	HT EM)	9	I	Y	i	y	8	9	~	˘	˘	˘	Ø	ø		
A	LF SUB	*	:	J	Z	j	z	9	è	á	à	°	˘	œ	œ		
B	VT ESC	+	;	K	[k	{	l	é	<	>	.	^	Q	q		
C	FF FS	,	<	L	\	l		°	ı	,	¼	—	½	þ	þ		
D	CR GS	-	=	M]	m	}	ñ	ä	F	½	˘	¾	F	f		
E	SO RS	.	>	N	^	n	~	ã	ü	.	¾	˘	5/8	ŋ	ŋ		
F	SI US	/	?	O	_	o	DEL	ö	/	ı	˘	˘	7/8	'n			

ESC Y ESC Z
 

See Note 2

All characters
in column C
are non-spacing
diacritic marks.

- NOTES:
- ECS 7-bit ASCII Mode
 - Primary Character Set accessed by codes 00-7F after power-up/initialize or after SI received from host.
 - Supplementary Character Set accessed by codes 08-7F after SD received from host.
 - ECS 8-bit ASCII Mode
 - After power-up/initialize all characters can be accessed except those addressed by 80-9F.
 - After SD received from host, all characters can be accessed.
 - In ECS 7-bit ASCII Mode, code 0F represents SI control character in both Primary and Supplementary Character Set.
 - For spoke assignments, hammer energies, and PS unit values pertaining to ECS print wheels, refer to Print Wheel Data Book -3 (Diablo Publication No. 90044-03).

Figure 4-8. ECS TELETEX PRINT WHEEL

		PRIMARY CHARACTER SET						SUPPLEMENTARY CHARACTER SET									
ASCII HEX	HI LO	0	1	2	3	4	5	6	7	8	9	A	B	C	D	E	F
0	NU	DLE	SP	0	@	P	\	p		o	SP <small>Note 3</small>	0	\				
1	SOH	DC1	!	1	A	Q	a	q	0	f		1	a		a		
2	STX	DC2	"	2	B	R	b	r	1			2		®		r	
3	ETX	DC3	#	3	C	S	c	s	2		£	3		©	c	s	
4	EOT	DC4	\$	4	D	T	d	t	3	4	§		8	TM	d	t	
5	ENO	NAK	%	5	E	U	e	u	4	5	¥	μ	€	†	e		
6	ACK	SYN	&	6	F	V	f	v	5	6	¶		'				
7	BEL	ETB	'	7	G	W	g	w	6	7	§	•	γ	'		☒	
8	BS	CAN	(8	H	X	h	x	7	8	⊗	÷		x	h	🔔	
9	HT	EM)	9	I	Y	i	y	8	9	~	Σ	∴	σ	i	◆	
A	LF	SUB	*	:	J	Z	j	z	9	∅	△	▽	⋈			◻	
B	VT	ESC	+	;	K	[k	{	l	↑	⊥		Ⓟ	^		◻	
C	FF	FS	,	<	L	\	l		o	↓	⊙	¼		%	i	⊗	
D	CR	GS	-	=	M]	m	}	Sp	←	≠	½		¾	m	○	
E	SO	RS	.	>	N	^	n	~	⚡	→	•	¾	v	%	n	⊞	
F	SI	US	/	?	O	_	o	DEL	SP <small>Note 3</small>	↑	/	¢		≡	°		

ESC Y ESC Z
 

See Note 2



- NOTES:
- ECS 7-bit ASCII Mode
 - Primary Character Set accessed by codes 00-7F after power-up/initialize or after SI received from host.
 - Supplementary Character Set accessed by codes 00-7F after SO received from host.
 - While operating in Primary Character Set, Supplementary Character Set can be accessed for one character selection after EM received from host.
 - ESC 8-bit ASCII Mode
 - After power-up/initialize all characters can be accessed except those addressed by 80-9F.
 - After SO received from host, all characters can be accessed.
 - Control Codes SI and SP are assigned in both Primary and Supplementary Character Set.
 - For spoke assignments, hammer energies, and PS unit values pertaining to ECS print wheels, refer to Print Wheel Data Book-3 (Diablo Publication No. 90044-03).
 - The characters shown in this chart do not reflect the aesthetics of the actual characters on the print wheel.

Figure 4-9. ECS MULTIPURPOSE PRINT WHEEL

		PRIMARY CHARACTER SET (NON-ITALIC CHARACTERS)								SUPPLEMENTARY CHARACTER SET (ITALIC CHARACTERS (See Legend))								
ASCII HEX	HI LD	0	1	2	3	4	5	6	7	8	9	A	B	C	D	E	F	
	0	NA	DL	DF	0	@	P	\	p			SP	0	@	P	\	p	
	1	SCH	DC1	!	1	A	Q	a	q			!	1	A	Q	a	q	
	2	STX	DC2	"	2	B	R	b	r			"	2	B	R	b	r	
	3	ETX	DC3	#	3	C	S	c	s			£	3	C	S	c	s	
	4	EOF	DC4	\$	4	D	T	d	t			\$	4	D	T	d	t	
	5	ENQ	NAK	%	5	E	U	e	u			°	5	E	U	e	u	
	6	ACK	SYN	&	6	F	V	f	v			&	6	F	V	f	v	
	7	DEL	ETB	'	7	G	W	g	w			'	7	G	W	g	w	
	8	BS	CAN	(8	H	X	h	x			☺	(8	H	X	h	x
	9	HT	EM)	9	I	Y	i	y			☹)	9	I	Y	i	y
	A	LF	SUB	*	:	J	Z	j	z			◦	*	:	J	Z	j	z
	B	VT	ESC	+	;	K	[k	§			◦	+	;	K	[k	§
	C	FF	FS	,	¼	L	®	l	¶			◦	,	¼	L	®	l	¶
	D	CR	GS	-	=	M]	m	+			//	-	=	M]	m	+
	E	SO	RS	.	½	N	^	n	~			↳	.	½	N	©	n	™
	F	SI	US	/	?	O	_	o	DEL			↳	/	?	O	=	o	

ESC Y  See Note 2  ESC Z

LEGEND:

-  - Non-Italic Character Addressed in Supplementary Character Set
-  - See Character Glossary

CHARACTER GLOSSARY:

- ASCII 2D = Hyphen
- ASCII AD = Macron, lower case (Non-italic)
- ~ Tilde, lower case (Non-italic)
- Dot, lower case (Non-italic)
- ˘ Breve, lower case (Non-italic)
- ¨ Umlaut, lower case (Non-italic)
- ASCII 9A = Degree (Non-italic)
- ASCII 9B = Degree (Italic)
- ASCII 9C = Ring, lower case (Non-italic)
- ASCII 9E = Ring, lower case (Non-italic)
- ˆ Acute, lower case (Non-italic)
- ˆˆ Double Acute, lower case (Non-italic)
- ◌ Ogonek (Non-italic)
- ◌ Cedilla (Non-italic)
- ˘˘ Caron, lower case (Non-italic)

NOTES:

1. ECS 7-bit ASCII Mode
 - Primary Character Set accessed by codes 00-7F after power-up/initialize or after SI received from host.
 - Supplementary Character Set accessed by codes 00-7F after SD received from host.
 - While operating in Primary Character Set, Supplementary Character Set can be accessed for one character selection after EM received from host.
2. ESC 8-bit ASCII Mode
 - After power-up/initialize all characters can be accessed except those addressed by 80-9F.
 - After SD received from host, all characters can be accessed.
3. Control Codes SI and SP are assigned in both Primary and Supplementary Character Set.
4. For spoke assignments, hammer energies, and PS unit values pertaining to ECS print wheels, refer to Print Wheel Data Book-3 (Dialco Publication No. 90044-03).
5. The characters shown in this chart do not reflect the aesthetics of the actual characters on the print wheel.

Figure 4-10. ECS LEGAL / ITALIC PRINT WHEEL

		PRIMARY CHARACTER SET							SUPPLEMENTARY CHARACTER SET								
ASCII HEX	HI LD	0	1	2	3	4	5	6	7	8	9	A	B	C	D	E	F
0	NUL DLE SP	0	Ⓐ	P	°	p		=	SP Note 3	0	Ⓐ	P	°	p			
1	SOH DC1	!	1	A	Q	a	q	¹	¹	!	1	A	Q	a	q		
2	STX DC2	"	2	B	R	b	r	²	²	"	2	B	R	b	r		
3	ETX DC3	#	3	C	S	c	s	³	³	#	3	C	S	c	s		
4	EOT DC4	\$	4	D	T	d	t	=		\$	4	D	T	d	t		
5	ENO NAK	%	5	E	U	e	u	₂	₂	%	5	E	U	e	u		
6	ACK SYN	&	6	F	V	f	v	₃	₃	&	6	F	V	f	v		
7	BEL ETB	'	7	G	W	g	w	₄	₄	'	7	G	W	g	w		
8	BS CAN	(8	H	X	h	x	ϕ	ϕ	(8	H	X	h	x		
9	HT EM)	9	I	Y	i	y)	9	I	Y	i	y		
A	LF SUB	*	:	J	Z	j	z			*	:	J	Z	j	z		
B	VT ESC	+	;	K	[k	§			+	;	K	[k	§		
C	FF FS	,	<	L	Ⓜ	l	¶			,	<	L	Ⓜ	l	¶		
D	CR BS	-	=	M]	m	†			-	=	M]	m	†		
E	SO RS	.	>	N	Ⓒ	n	™			.	>	N	Ⓒ	n	™		
F	SI US	/	?	O	_	o	DEL	SI Note 3		/	?	O	_	o			

ESC Y ϕ	ESC Z 	See Note 2
← 10/12-PITCH CHARACTERS →		← 15-PITCH CHARACTERS →

- NOTES:**
1. ECS 7-bit ASCII Mode
 - Primary Character Set accessed by codes 00-7F after power-up/initialize or after SI received from host.
 - Supplementary Character Set accessed by codes 80-7F after SO received from host.
 - While operating in Primary Character Set, Supplementary Character Set can be accessed for one character selection after EM received from host.
 2. ESC 8-bit ASCII Mode
 - After power-up/initialize all characters can be accessed except those addressed by 80-9F.
 - After SO received from host, all characters can be accessed.
 3. Control Codes SI and SP are assigned in both Primary and Supplementary Character Set.
 4. For spoke assignments, hammer energies, and PS unit values pertaining to ECS print wheels, refer to Print Wheel Data Book-3 (Diablo Publication No. 90044-03).
 5. The characters shown in this chart do not reflect the aesthetics of the actual characters on the print wheel.

Figure 4-11. ECS DUAL PITCH PRINT WHEEL

		LOWER RANGE												UPPER RANGE																						
Note 1b		Note 1b																																		
ASCII HEX	HI LO	0	1	2	3	4	5	6	7	8	9	A	B	C	D	E	F	ASCII HEX	HI LO	0	1	2	3	4	5	6	7	8	9	A	B	C	D	E	F	
		0	1	2	3	4	5	6	7	8	9	A	B	C	D	E	F			0	1	2	3	4	5	6	7	8	9	A	B	C	D	E	F	
		0	1	2	3	4	5	6	7	8	9	A	B	C	D	E	F			0	1	2	3	4	5	6	7	8	9	A	B	C	D	E	F	
		1	2	3	4	5	6	7	8	9	A	B	C	D	E	F			1	2	3	4	5	6	7	8	9	A	B	C	D	E	F			
		2	3	4	5	6	7	8	9	A	B	C	D	E	F					2	3	4	5	6	7	8	9	A	B	C	D	E	F			
		3	4	5	6	7	8	9	A	B	C	D	E	F							3	4	5	6	7	8	9	A	B	C	D	E	F			
		4	5	6	7	8	9	A	B	C	D	E	F									4	5	6	7	8	9	A	B	C	D	E	F			
		5	6	7	8	9	A	B	C	D	E	F											5	6	7	8	9	A	B	C	D	E	F			
		6	7	8	9	A	B	C	D	E	F													6	7	8	9	A	B	C	D	E	F			
		7	8	9	A	B	C	D	E	F															7	8	9	A	B	C	D	E	F			
		8	9	A	B	C	D	E	F																	8	9	A	B	C	D	E	F			
		9	A	B	C	D	E	F																				9	A	B	C	D	E	F		
		A	B	C	D	E	F																						A	B	C	D	E	F		
		B	C	D	E	F																								B	C	D	E	F		
		C	D	E	F																										C	D	E	F		
		D	E	F																											D	E	F			
		E	F																													E	F			
		F																															F			

ESC Y ESC Z

NOTES:
1. ADDRESSING:
a. Lower-range characters addressed by 20-7F hex are accessible following power-on initialize.
b. Lower-range codes 00-1F hex are preempted for control characters at power-on. Access to printable characters assigned within the range 00-1F is controlled as follows:
 GS Code - Access any printable character in the range 00-1F hex on a single shift or nonlocking basis. The GS control code must precede each printable character code sent from the host.
 SC Code - Access the printable characters in the range 00-1F hex on a locking basis. The 20 printable characters in this range displace the ASCII control characters in the corresponding code positions. Control characters remain effective in the 12 code positions not assigned to printable characters in the range 00-1F.
 ESC SI Code Sequence - Terminates access to printable characters in the range 00-1F enabled by earlier SC code; restores control character functions to code positions 00-1F.
c. In 8-bit ASCII, all upper-range characters are addressed directly by the 8-bit codes listed on the chart.
d. In 7-bit ASCII, the upper-range characters are accessible on a single shift nonlocking basis only; an EM control code must precede each printable character code sent from the host.
e. ESC Y / ESC Z not used for addressing this print wheel.
2. ADDRESS DEVIATION: In the IBM PC, the left arrow character is addressed by hex code 16; in the Diablo ECS/IBM printer, the left arrow is addressed by hex code 1C (see code chart) in order to preserve code 1B for the ESC control character.
3. The characters shown in this chart do not reflect the aesthetics of the actual characters on the print wheel.
4. For spoke assignments, hammer energies, and PS unit values pertaining to ECS print wheels, refer to Print Wheel Data Book-3 (Diablo Publication No. 80044-03).

Figure 4-12. ECS PC GRAPHICS PRINT WHEEL

4.4 THE DIABLO PRINT WHEEL DATA BOOKS

The Data Books provide specific data pertaining to each Diablo/Xerox print wheel available for use on Diablo printers and terminals. At present there are three Data Books:

Print Wheel Data Book - 1 (Publication No. 90044-01) - covers the standard 88-, 92-, and 96-character print wheels.

Print Wheel Data Book - 2 (Publication No. 90044-02) - covers print wheels for the Diablo Model 820 printer.

Print Wheel Data Book - 3 (Publication No. 90044-03) - covers the ECS print wheels.

The excerpt below from a typical page in one of the Data Books shows the type of information provided. This type of information is essential when the Model 630 is going to be used with direct spoke addressing (Program Mode).

DIABLO 96 - U.S.
TITAN 10 (96-Character Metalized) P/N 311800-01

CHARACTER (1)	(3)															
	←	1	"	#	\$	%	&	'	()	*	+	,	-	.	/
HEX Address	20	21	22	23	24	25	26	27	28	29	2A	2B	2C	2D	2E	2F
Elect. Spoke	0	37	33	92	7	79	77	23	76	74	15	11	78	35	80	
Prop. Sp. Units	5	3	4	6	5	8	7	2	3	3	5	5	3	4	3	
Ham. Energy (2)	3	2	2	4	4	4	4	1	2	2	3	2	1	1		

2	3	4	5	6	7	8	9	:	;	<	=	>	?	@	A	B	C	D	E
32	33	34	35	36	37	38	39	3A	3B	3C	3D	3E	3F	40	41	42	43	44	45
83	84	85	87	88	89	90	91	29	27	41	9	5	17	75	18	8	36	32	
5	5	5	5	5	5	5	5	3	3	5	5	5	5	8	7	6	7		
3	3	3	3	3	3	4	3	2	2	2	2	2	2	4	4	4	3		

To order the Print Wheel Data Book/s, contact:

Diablo Systems, Incorporated
Retail Store
1510 Trimble Road
San Jose, California, USA 95131
(408) 263-7704

4.5 DECIMAL VALUE TABLES

The Decimal Value Tables are used to determine the third character (n) to use in 3-character sequences for setting format factors and for absolute tabbing. The associated procedures are covered in the following subsections.

- Setting HMI is covered in subsection 3.9.4.1
- Setting VMI is covered in subsection 3.9.4.2
- Lines Per Page is covered in subsection 3.9.4.3
- Absolute Horizontal Tab is covered in subsection 3.13.1
- Absolute Vertical Tab is covered in subsection 3.13.2

The following list summarizes the corresponding ESC code sequences:

- ESC US (n) Set HMI
- ESC RS (n) Set VMI
- ESC FF (n) Lines Per Page
- ESC HT (n) Absolute Horizontal Tab
- ESC VT (n) Absolute Vertical Tab

Table 4-2 gives a listing of decimal values for ASCII characters.

**Table 4-2
DECIMAL VALUES OF ASCII CHARACTERS**

TENS	UNITS									
	0	1	2	3	4	5	6	7	8	9
0		SOH	STX	ETX	EOT	ENQ	ACK	BEL	BS	HT
10	LF	VT	FF	CR	SO	SI	DLE	DC1	DC2	DC3
20	DC4	NAK	SYN	ETB	CAN	EM	SUB	ESC	FS	GS
30	RS	US	SP	!	"	#	\$	%	&	'
40	()	*	+	,	-	.	/	0	1
50	2	3	4	5	6	7	8	9	:	;
60	<	=	>	?	@	A	B	C	D	E
70	F	G	H	I	J	K	L	M	N	O
80	P	Q	R	S	T	U	V	W	X	Y
90	Z	[\]	^	_	`	a	b	c
100	d	e	f	g	h	i	j	k	l	m
110	n	o	p	q	r	s	t	u	v	w
120	x	y	z	{		}	~			

Table 4-4
ASCII VALUES FOR ESC SEQUENCES
Set Lines/Page
Set Absolute Horizontal Tab
Set Absolute Vertical Tab

Lines of Position	ASCII Character	Lines of Position	ASCII Character	Lines of Position	ASCII Character	Lines of Position	ASCII Character	Lines of Position	ASCII Character
1	CTRL A (SOH)	26	CTRL Z (SUB)	51	3	76	L	101	e
2	CTRL B (STX)	27	CTRL [ESC	52	4	77	M	102	f
3	CTRL C (ETX)	28	CTRL \ (FS)	53	5	78	N	103	g
4	CTRL D (EOT)	*29	CTRL] (GS)	54	6	79	O	104	h
5	CTRL E (ENQ)	**30	CTRL ^ (RS)	55	7	80	P	105	i
6	CTRL F (ACK)	31	CTRL _ (US)	56	8	81	Q	106	j
7	CTRL G (BEL)	32	SPACE	57	9	82	R	107	k
8	CTRL H BACKSPACE	33	!	58	:	83	S	108	l
9	CTRL I TAB	34	"	59	;	84	T	109	m
10	CTRL J LINEFEED	35	#	60	<	85	U	110	n
11	CTRL K (VT)	36	\$	61	=	86	V	111	o
12	CTRL L (FF)	37	%	62	>	87	W	112	p
13	CTRL M RETURN	38	&	63	?	88	X	113	q
14	CTRL N (SO)	39	.	64	@	89	Y	114	r
15	CTRL O (SI)	40	(65	A	90	Z	115	s
16	CTRL P (DLE)	41)	66	B	91	[116	t
17	CTRL Q (DC1)	42	*	67	C	92	\	117	u
18	CTRL R (DC2)	43	+	68	D	93]	118	v
19	CTRL S (DC3)	44	,	69	E	94	^	119	w
20	CTRL T (DC4)	45	-	70	F	95	_	120	x
21	CTRL U (NAK)	46	.	71	G	96	`	121	y
22	CTRL V (SYN)	47	/	72	H	97	a	122	z
23	CTRL W (ETB)	48	0	73	I	98	b	123	{
24	CTRL X (CAN)	49	1	74	J	99	c	124	
25	CTRL Y (EM)	50	2	75	K	100	d	125	}
								126	~

*Diablo Typewriter Paired keyboard uses ` (accent grave)
 **Diablo Typewriter Paired keyboard uses = (equals symbol)

4.6 TABLES FOR CHARACTER PROPORTIONAL SPACE UNITS & PRINT WHEEL PROGRAM MODE

Table 4-5
CHARACTER PROPORTIONAL SPACE UNITS - METALIZED PRINT WHEELS (US/UK)

PW POSITION	CHARACTER	PS UNIT	PW POSITION	CHARACTER	PS UNIT	PW POSITION	CHARACTER	PS UNIT	PW POSITION	CHARACTER	PS UNIT
1	()	(3)	25	I	3	49	i	3	73	%	6
2	()	(5)	26	H	7	50	X	7	74		3
3	% (\)	6 (5)	27	:	3	51	f	4	75	@	8
4	£ ((5 (3)	28	R	7	52	Q	7	76		3
5	# ()	5	29	:	3	53	l	4	77	&	7
6	Z	6	30	O	7	54	w	7	78	.	3
7	\$	5	31	/	4	55	r	4	79	%	8
8	B	6	32	D	7	56	o	5	80	.	3
9	"	5	33	~	4	57	r	5	81	%	8
10	F	6	34	U	7	58	e	5	82		5
11	+	5	35	-	4	59	e	5	83	2	5
12	V	6	36	C	7	60	d	5	84	3	5
13	^	5	37	I	3	61	b	5	85	4	5
14	S	5	38	M	8	62	c	5	86	0	5
15	*	5	39	.	3	63	u	5	87	5	5
16	E	6	40	G	7	64	v	5	88	6	5
17	?	5	41	.	3	65	e	5	89	7	5
18	A	7	42	W	8	66	y	5	90	8	5
19	T	6	43	I	3	67	p	5	91	9	5
20	L	6	44	Y	7	68	b	5	92	#	6
21	J	5	45	f	4	69	k	5	93	% ()	6 (3)
22	F	6	46	K	7	70	x	5	94	% (~)	6 (5)
23	.	2	47	i	3	71	z	5	95	()	(5)
24	N	7	48	m	8	72	q	5	0 (HOME)	{ }	(5)

NOTES:

- Units - 1/170 inch (212mm) carriage movement.
- Characters and PS unit values listed in this table represent 88-character Xerox "Titan 10", 92-character Xerox "Titan 10" (UK), and 96-character Diablo "Titan 10" print wheels. Parentheses () are used where characters and/or PS units of the 96-character wheel differ from those of the 88 and 92-character wheels. PW POSITION utilization is 5 thru 92 for 88-character wheels, 3 thru 94 for 92-character wheels, and 1 thru 0 for 96-character wheels. For similar data on other fonts refer to the appropriate Diablo Print Wheel Data Book, Publication No. 39044 XX (see subsection 4.4)

**Table 4-6
PRINT WHEEL PROGRAM MODE - CHARACTERS FOR HAMMER ENERGY AND RIBBON ADVANCE**

HAMMER ENERGY	RIBBON ADVANCE														
	1	2	3	4	5	6	7	8	9	10	11	12	13	14	15
1	DC1	DC2	DC3	DC4	NAK	SYN	ETB	CAN	EM	SUB	ESC	FS	GS	RS	US
2	!	"	#	\$	%	&	'	()	*	+	,	-	.	/
3	1	2	3	4	5	6	7	8	9	:	;	<	=	>	?
4	A	B	C	D	E	F	G	H	I	J	K	L	M	N	O

