

MODEL 630/630 ECS
PRINTERS & TERMINALS

MAINTENANCE MANUAL

90443-02 Rev A

March 1983

DIABLO SYSTEMS, INC.

A XEROX Company

FCC NOTICE

Warning: This equipment generates, uses and can radiate radio frequency energy and, if not installed in accordance with the instructions manual, may cause interference to radio communications. Because the different versions of this device meet different emissions standards, and because the same instructions manual covers all versions, all of the different applicable warnings are set forth below with the appropriate FCC Label installed on each unit.

As temporarily permitted by regulation, this equipment has not been tested for compliance with the limits for Class A computing devices pursuant to Subpart J of Part 15 of FCC Rules, which are designed to provide reasonable protection against such interference.

This equipment has been tested and found to comply with the limits for a Class A computing device pursuant to Subpart J of Part 15 of the FCC Rules, which are designed to provide reasonable protection against such interference when this device is operated in a commercial environment.

In either of the above cases, operation of this equipment in a residential area is likely to cause interference, in which case the user, at his own expense, will be required to take whatever measures are necessary to correct the interference.

This equipment has been type tested and found to comply with the limits for a Class B computing device in accordance with the specifications in subpart J of Part 15 of the FCC Rules, which are designed to provide reasonable protection against such interference in a residential installation. This equipment generates and uses radio frequency energy, and if not installed and used properly in strict accordance with the manufacturer's instructions, may cause interference to radio and television reception. There is, however no guarantee that interference will not occur in a particular installation.

If equipment certified to meet the Class B limits does cause interference to radio or television reception, which can be determined by turning the equipment off and on, the user is encouraged to try to correct the interference by one or more of the following measures: (a) Reorient the receiving antenna. (b) Relocate the computer with respect to the receiver. (c) Move the computer away from the receiver. (d) Plug the computer into a different outlet so that the computer and the receiver are on different branch circuits.

If necessary, the user should consult the dealer or an experienced radio/television technician for additional suggestions. In addition, an FCC booklet, "How to Identify and Resolve Radio-TV Interference Problems", Stock No. 004-000-00345-4, is available from the U.S. Government Printing Office, Washington, D.C., 20402.

In those versions of this equipment labeled Class A or B Compliant a shielded and grounded I/O cable is necessary to achieve compliance with the FCC Rules regarding radio emissions from computers. Please consult your authorized Diablo sales representative for further details regarding the cable.

Diablo® , HyType® and XEROX® are trademarks of XEROX CORPORATION.

©Copyright 1983 by Diablo Systems, Inc., Hayward, California, USA
Publication No. 90443-02 Rev A - Third Edition

Printed In The U.S.A.

PREFACE

This manual presents information pertaining to maintenance and repair of Diablo Model 630 and 630 ECS Printers and Terminals. It is one of several manuals that describe various aspects of the Model 630. All of the these manuals, and other related publications, are listed in subsection 1.6 of this manual, along with instructions for ordering them.

The information in this manual is divided into six sections entitled:

- 1 - General Information
- 2 - Preventive Maintenance
- 3 - Corrective Maintenance
- 4 - Removal & Replacement Procedures
- 5 - Adjustment Procedures
- 6 - Major Subassembly Replacement Parts
- 7 - Circuit Diagrams & Wiring Lists

Comments on all Diablo publications or their use are invited. Please address your comments to:

Manager, Product Support Publications
Diablo Systems, Incorporated
P.O. Box 5030
Fremont, California 94537

Diablo Systems, Inc., reserves the right to make changes and/or improvements to its products without incurring any obligation to incorporate such changes or improvements in units previously sold or shipped.

WARRANTY

Diablo Model 630 Printers and Terminals are warranted against defects in materials and workmanship for 90 days from the date of purchase by the end user. Any questions regarding the warranty should be directed to your Diablo Sales Representative. All requests for repair should be directed to the Diablo or Xerox Service Center in your area. This will assure you of the fastest possible service. For a list of Service Center locations and description of available service options, refer to the Service Information Guide, Diablo Publication No. 90070-XX.

UL/CSA

UL recognized and listed under File No. E51242.
CSA certified as a component and printer under CSA File LR2196.

(See the Model 630 Product Description manual for a complete list of pertinent Standards and Regulations)

REVISION CONTROL RECORD

MODEL 630 MAINTENANCE MANUAL - PUBLICATION NO. 90443-02

NOTE: On revised pages of text, each area of new revision is marked by a heavy vertical bar in the margin.

<u>PAGE/REV</u>	<u>PAGE/REV</u>	<u>PAGE/REV</u>	<u>PAGE/REV</u>	<u>PAGE/REV</u>	<u>PAGE/REV</u>
Cover A	3-1 A	4-1 A	5-1 A	7-1 A	
ii A	3-2 A	4-2 A	5-2 A	7-2 A	
iii A	3-3 A	4-3 A	5-3 A	7-3 A	
iv A	3-4 A	4-4 A	5-4 A	7-4 A	
v A	3-5 A	4-5 A	5-5 A	7-5 A	
vi A	3-6 A	4-6 A	5-6 A	7-6 A	
vii A	3-7 A	4-7 A	5-7 A	7-7 A	
viii A	3-8 A	4-8 A	5-8 A	7-8 A	
ix A	3-9 A	4-9 A	5-9 A	7-9 A	
x A	3-10 A	4-10 A	5-10 A	7-10 A	
1-0 A	3-11 A	4-11 A	5-11 A	7-11 A	
1-1 A	3-12 A	4-12 A	5-12 A	7-12 A	
1-2 A	3-13 A	4-13 A	5-13 A	7-13 A	
1-3 A	3-14 A	4-14 A	5-14 A		
1-4 A	3-15 A	4-15 A	5-15 A		
1-5 A	3-16 A	4-16 A	5-16 A		
2-1 A	3-17 A	4-17 A	5-17 A		
2-2 A	3-18 A	4-18 A	5-18 A		
2-3 A	3-19 A	4-19 A	5-19 A		
2-4 A	3-20 A	4-20 A	5-20 A		
2-5 A	3-21 A	4-21 A	5-21 A		
2-6 A	3-22 A	4-22 A	5-22 A		
2-7 A	3-23 A	4-23 A	5-23 A		
	3-24 A	4-24 A	5-24 A		
	3-25 A	4-25 A	6-1 A		
	3-26 A	4-26 A	6-2 A		
	3-27 A	4-27 A	6-3 A		
	3-28 A	4-28 A			
	3-29 A				
	3-30 A				
	3-31 A				
	3-32 A				
	3-33 A				
	3-34 A				
	3-35 A				

Circuit diagram revision levels are noted on each diagram.

TABLE OF CONTENTS

SECTION 1 - GENERAL DESCRIPTION

1.1	General	1-1
1.2	Maintenance Philosophy	1-1
1.3	Maintenance Precautions	1-2
1.4	Tools, Equipment and Spares	1-3
1.4.1	Level 1	1-3
1.4.2	Level 2	1-3
1.4.3	Level 3	1-4
1.4.4	Terminal Spares	1-4
1.4.5	Model 630 Tool Kits	1-5
1.5	Maintenance Training	1-5
1.6	Related Publications	1-5

SECTION 2 - PREVENTIVE MAINTENANCE

2.1	Preventive Maintenance Schedule	2-1
2.2	Cleaning The Print Wheel And Print Hammer	2-1
2.2.1	The Print Wheel	2-1
2.2.2	The Print Hammer	2-1
2.3	General Cleaning And Inspection	2-2
2.4	Lubrication	2-2
2.4.1	Carriage System - Non-ECS	2-2
2.4.2	Carriage System - ECS	2-4
2.4.3	Carrier System	2-6
2.4.4	Platen System	2-6
2.4.5	Lubrication of Optional Items	2-7

SECTION 3 - CORRECTIVE MAINTENANCE

3.1	Troubleshooting	3-1
3.2	Diagnostics - Models 630 PPI and HPRO6 Printers	3-1
3.3	Diagnostics - Model 630 SPI Terminal	3-2
3.3.1	SPI Self-Test	3-2
3.3.2	SPI Remote Diagnostics	3-3
3.3.2.1	ESC SUB I	3-3
3.3.2.2	ESC SUB R	3-3
3.3.2.3	ESC SUB 1	3-4
3.3.2.4	ESC SUB SO	3-4
3.4	Diagnostics - Model 630 HPRO5 Terminals	3-5
3.4.1	General Discussion	3-5
3.4.2	Confidence Test	3-6
3.4.2.1	Confidence Test On Model 630 Without Control Panel	3-7
3.4.2.2	Confidence Test On Model 630 With Control Panel - <u>Without</u> Jumper A60-1/2 On HPRO5 PCB	3-7
3.4.2.3	Confidence Test On Model 630 With Control Panel - <u>With</u> Jumper A60-1/2 on HPRO5 PCB	3-8
3.4.3	Individual Tests	3-8
3.4.3.1	Redefinition Of Control Panel Lights and Switches	3-9
3.4.3.2	Individual Test Selection and Operation	3-10
3.4.3.3	Individual Test Definitions	3-12
3.4.4	Remote Diagnostics - HPRO5	3-21
3.4.4.1	Diagnostic Commands	3-21
3.4.4.2	Diagnostics Interface Protocol	3-21
3.4.4.3	Diagnostic Command Definitions	3-22

3.5	Diagnostics - Model 630 API Terminals	3-24
3.5.1	API Self-Test	3-24
3.5.2	API Remote Diagnostics	3-24
3.5.2.1	ESC SUB T	3-25
3.5.2.2	ESC SUB R	3-25
3.5.2.3	ESC SUB SO	3-25
3.5.2.4	ESC SUB 1	3-25
3.5.2.5	ESC SUB 3	3-26
3.6	Test Operating References	3-27
3.6.1	ASCII Coding System	3-27
3.6.2	Print Wheel Code Charts (Typical)	3-28
3.6.3	ASCII-to-Decimal Equivalents	3-35

SECTION 4 - REMOVAL & REPLACEMENT PROCEDURES

4.1	General Instructions	4-1
4.2	Top Cover Removal	4-1
4.3	Platen Removal	4-2
4.4	Card Guide Removal	4-2
	(ECS card guide shield replacement)	4-3
4.5	Circuit Board Removals	4-4
4.5.1	PCE / PPI / SPI / API / HPRO5 / HPRO6 Circuit Boards Removal	4-4
4.5.2	SCE Circuit Board Removal	4-4
4.6	Power Supply Removal / Conversion	4-5
4.6.1	Regulator Circuit Board Removal	4-5
4.6.2	Power Supply Assembly Removal	4-6
4.6.3	Power Supply AC Input Conversion	4-7
4.7	SPI and API-1.5 Control Panel Removal	4-9
4.8	HPRO5 And API-2 Control Panel Removal	4-10
4.8.1	RO Control Panel Removal	4-10
4.8.2	KSR Control Panel Removal	4-11
4.9	Keyboard Assembly Removal	4-12
4.10	Print Mechanism Removal	4-12
4.11	Carriage Assembly Removal	4-14
4.12	Ribbon Deck Removal	4-16
4.13	Ribbon Latch Removal	4-17
4.14	Carriage Drive Motor Removal	4-17
4.15	Restringing The Carriage Drive Cable	4-17
4.16	Paper Feed Motor Removal	4-19
4.17	Bottom Feed Kit Installation	4-19
4.18	Wire Harness Removal	4-23
4.19	Accessory Pin Feed Platen Installation	4-23
4.20	ECS Solenoid Removal	4-25

SECTION 5 - ADJUSTMENT PROCEDURES

5.1	General Information	5-1
5.1.1	Adjustment Prerequisites	5-1
5.1.2	Summary of Adjustments	5-1
5.1.3	Conditions For Test and Alignment	5-2
5.1.4	Special Adjustment Tools	5-2
5.1.5	Print Quality Considerations	5-3
5.2	Platen Clutch Adjustment and Platen Bearing Check	5-4
5.3	Paper Release Actuator Adjustment	5-5
5.4	Top Paper Out Bail And Switch Adjustment	5-6
5.5	Bottom Paper Out Bail And Switch Adjustment	5-8

5.6	Paper Feed Gear Backlash Adjustments	5-9
5.6.1	In Units Without Anti-Backlash Mechanism	5-9
5.6.2	In Units With Anti-Backlash Mechanism	5-10
5.7	Print Wheel Home	5-11
5.8	Print Wheel To Hammer Alignment	5-15
5.9	Hammer Armature Adjustment	5-17
5.10	Ribbon Height Adjustment (Non-ECS units only)	5-18
5.11	Ribbon Lift Adjustment (Units with Ribbon Lift Option)	5-20
5.12	ECS Solenoid Adjustment	5-20
5.13	Card Guide Adjustments	5-21
5.14	Hammer Angles	5-23
5.14.1	Adjustable/Nonadjustable Print Hammer Assemblies	5-23
5.14.2	Hammer Angle Adjustments (Adjustable Hammer Assemblies Only)	5-23

SECTION 6 - MAJOR SUBASSEMBLY REPLACEMENT PARTS

6.1	General Information	6-1
6.2	Ordering Parts	6-1
6.3	Parts List	6-2

SECTION 7 - CIRCUIT DIAGRAMS & CABLE WIRING LISTS

7.1	General Discussion	7-1
7.2	Logic Symbology	7-1
7.3	Circuit Diagrams	7-1
7.4	Connector Wiring Lists	7-3

ILLUSTRATIONS

<u>Figure</u>		<u>Page</u>
1-1	Model 630 Printers And Terminals	1-0
2-1	Non-ECS Carriage System Lubrication Points	2-3
2-2	Non-ECS Carriage System Lubrication Points	2-3
2-3	ECS Carriage System Lubrication Points	2-5
2-4	Carrier System Lubrication Points	2-6
2-5	Zero-Backlash Platen Assembly	2-6
2-6	Early Style Platen System Lubrication Points	2-7
3-1	PPI Self-Test Printout	3-2
3-2	SPI Self-Test Printout	3-2
3-3	HPRO5 Circuit Board Self-Test Jumper and Switch	3-6
3-4	HPRO5 ROM and RAM Locations	3-6
3-5	Confidence Test Printout	3-7
3-6	HPRO5 Operator Control Panel - Self-Test Mode	3-9
3-7	API Self-Test Printout	3-24
3-8	ASCII Code Chart	3-27
3-9	96-Character Print Wheel - Plastic	3-28
3-10	88-Character Print Wheel - Metal	3-29
3-11	92-Character Print Wheel - Metal (Rank Xerox)	3-30
3-12	96-Character Print Wheel - Metal (Diablo)	3-31
3-13	96-Character Print Wheel - Metal (Rank Xerox)	3-32

3-14	ECS Elite 12 Scientific Print Wheel	3-33
3-15	ECS Pica 10 Teletex Print Wheel	3-34
4-1	Top Cover Shipping Screw	4-1
4-2	Top Cover Mounting Screws	4-2
4-3	Platen Latch Lever	4-2
4-4	Card Guides	4-3
4-5	ECS Card Guide Shield Replacement	4-3
4-6	Card Cage Cover	4-4
4-7	Circuit Board Locations	4-5
4-8	Mounting Screws For SCE and P/S Regulator Circuit Boards . .	4-5
4-9	Power Supply Assembly Mounting Screws	4-6
4-10	Rear Panel Feeder Connector Bracket	4-6
4-11	AC Input Wiring	4-8
4-12	Input Power Label Locations	4-9
4-13	SPI and API Control Panel Cable	4-9
4-14	HPRO5 and API-2 Control Panel Cable	4-10
4-15	Keyboard-Control Panel Removal	4-11
4-16	Ribbon Cable Shield Plate	4-13
4-17	Print Mechanism Front Retainers	4-13
4-18	Carriage Electrical Cable Assembly & Snubber	4-14
4-19	Rail Clip Removal	4-15
4-20	Securing Mismatched Carriage Cable Connectors	4-15
4-21	Ribbon Deck Cable Ties	4-16
4-22	Ribbon Deck Mounting Screws	4-16
4-23	Stringing The Drive Cable - Long Section	4-18
4-24	Stringing The Drive Cable - Short Section	4-18
4-25	Card Guides	4-19
4-26	Bottom Feed Kit	4-20
4-27	Bottom Feed Assembly	4-21
4-28	Routing Of The BPO Switch Wires	4-22
4-29	Paper Cradle	4-24
4-30	Pin Feed Platen Installation	4-24
4-31	ECS Carriage Cables	4-25
4-32	ECS Carriage Pivots	4-27
4-33	ECS Carriage Pivot Assembly	4-27
4-34	ECS Bell Crank Arm	4-28
5-1	Adjustment Tools 40795, 40795-02 and 301445-01	5-2
5-2	Fine Adjustment Shim	5-4
5-3	Platen Clutch Adjustment	5-5
5-4	Paper Release Actuator Adjustment	5-5
5-5	Top Paper Out Bail and Switch Adjustment	5-7
5-6	New Style Bail-Mounting Arms	5-7
5-7	Bottom Paper Out Bail and Switch Adjustment	5-8
5-8	Paper Feed Gear Adjustments (Without Anti-Backlash Mechanism)	5-9
5-9	Paper Feed Anti-Backlash Mechanism Adjustment	5-10
5-10	Print Wheel Home Alignment (Non-ECS Carriage)	5-13
5-11	Print Wheel Home Adjustment Waveforms (Non-ECS Carriage) . .	5-13
5-12	Print Wheel Home Alignment (ECS Carriage)	5-14
5-13	Print Wheel Home Adjustment Waveforms (ECS Carriage)	5-14
5-14	Print Wheel Home Sensor Waveforms	5-15
5-15	Print Wheel To Hammer Alignment	5-15
5-16	Adjusting The ECS Print Wheel Transducer	5-17
5-17	Hammer Armature Adjustments And Adjustment Tool	5-17
5-18	Ribbon Height Adjustment	5-19
5-19	ECS Solenoid Adjustment	5-21

5-20	Card Guides			5-21
5-21	Card Guide Adjustments			5-22
5-22	Nonadjustable Hammer Assembly			5-23
5-23	Print Hammer Top-To-Bottom Adjustment			5-24
5-24	Print Hammer Side-To-Side Adjustment			5-24
7-0	- - - - -	- - -	Circuit Diagram Notation	
7-1	- - - - -	- - -	Circuit Board Connector Locations	
7-2a	- - - - -	- - -	Interconnect Wiring Diagram - Model 630 PCE	
7-2b	- - - - -	- - -	Interconnect Wiring Diagram - Model 630 HPRO6	
7-2c	- - - - -	- - -	Interconnect Wiring Diagram - Model 630 PPI	
7-2d	- - - - -	- - -	Interconnect Wiring Diagram - Model 630 SPI	
7-2e	- - - - -	- - -	Interconnect Wiring Diagram - Model 630 HPRO5	
7-2f	- - - - -	- - -	Interconnect Wiring Diagram - Model 630 API	
7-3	302875-02	- - -	Sprint 3 Interface Adapting Connector	
7-4	302825-XX	Rev M	Power Supply Assembly	
7-4a	302825-XX	Rev P	Power Supply Assembly	
7-5	302604-02	Rev E	Carriage Transducer Preamp Assembly	
7-6	302880-01	Rev G	P/W Transducer Preamp PCB Assembly	
7-7	302670-09	Rev J	SCE PCB Assembly (w/o Heat Sink)	
7-8	"			
7-7a	302690-10	Rev P	SCE PCB Assembly (w/Heat Sink)	
7-8a	"			
7-7b	302690-11	Rev B	SCE PCB Assembly (w/Heat Sink)	
7-8b	"			
7-7c	302690-12	Rev A	SCE PCB Assembly	
7-8c	"			
7-9	302660-02	Rev L	PCE PCB Assembly	
7-10	"			
7-9a	302660-08/-09	Rev C	PCE PCB Assembly	
7-10a	"			
7-9b	302660-10/-11	Rev D	PCE PCB Assembly	
7-10b	"			
7-11	302779-XX	Rev T	HPRO5 PCB Assembly	
7-12	"			
7-13	"			
7-14	302840-01	Rev A	HPRO6 PCB Assembly	
7-15	320270-XX	Rev L	PPI PCB Assembly	
7-16	"			
7-17	(unassigned)			
7-15a	320270-XX	Rev P	PPI PCB Assembly	
7-16a	"			
7-17a	"			
7-18	320293-XX	Rev K	SPI PCB Assembly	
7-19	"			
7-18a	320293-XX	Rev Y	SPI PCB Assembly	
7-19a	"			
7-20	320462-XX	Rev J	API PCB Assembly	
7-21	"			
7-22	"			
7-20a	320462-XX	Rev K	API PCB Assembly	
7-21a	"			
7-22a	"			
7-23	302561-05	Rev A	H5CPN (HPRO5) Control Panel PCB Assembly	
7-23a	302561-06	Rev A	H5CPN (HPRO5/API-2) Control Panel Assembly	

7-24	302592-01	Rev C	Keyboard Circuit Diagram
7-25	320294-01	Rev D	LCPN (SPI/API-1.5) Control Panel PCB Assembly
7-26	320890-XX	Rev C	HPRO5-Feeder Interface PCB Assembly

TABLES

Table

3-1	Diagnostics Capabilities Of The HPRO5 Terminals	3-5
3-2	Feeder Identification	3-26
3-3	Decimal Values Of ASCII Characters	3-35
5-1	Summary Of Adjustments	5-1

**** LATE DEVELOPMENT ****

Diablo has now introduced the Model 630 ECS IBM printer. This is an API ECS printer that is specially adapted to operate with the IBM Personal Computer. With its special firmware set, and using the special Diablo ECS IBM print wheel, the ECS IBM printer is capable of printing all but two of the characters in the standard display screen character set of the IBM Personal Computer.

In addition to the special ECS IBM print wheel, the ECS IBM printer can also operate with the same standard 96-character plastic, and 88-, 92-, and 96-character metalized print wheels as the standard Model 630 API-2 printer.

Nearly all of the information in this manual (including circuit diagrams) that applies to the standard Model 630 API ECS applies also to the Model 630 ECS IBM, except as affected by the following differences:

- The ECS IBM firmware set on the API circuit board differs as necessary to support the special IBM character set and the slightly different functions of the ECS IBM control panel.
- The ECS IBM control panel does not include selections for standard ECS print wheels, or for RS-232-C and IEEE-488 type interfaces. (The ECS IBM printer uses the IBM Centronics type of interface.) Except for the differences in labeling, the ECS IBM control panel assembly is the same as that used in the standard Model 630 API-2 printer.



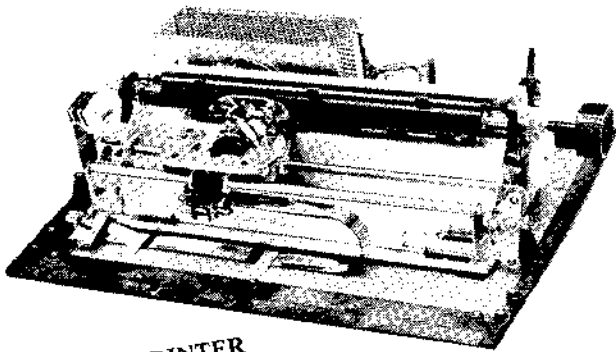

OEM PRINTER

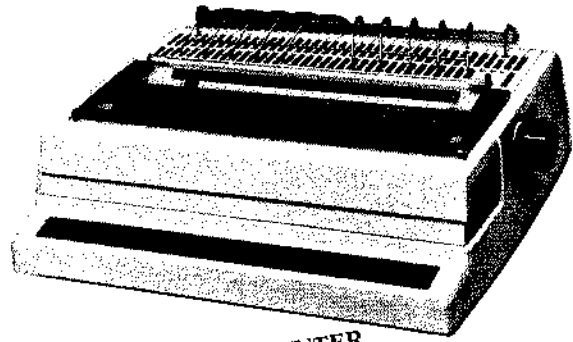

PPI/PPI ECS/HPRO6 PRINTER

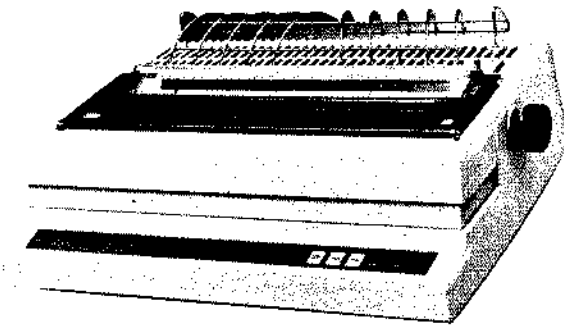

SPI/API-1.5 RO TERMINAL

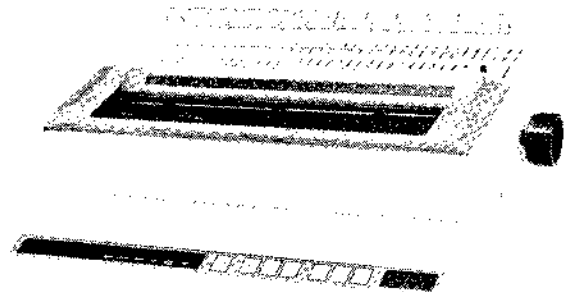

HPRO5/API-2 RO TERMINAL

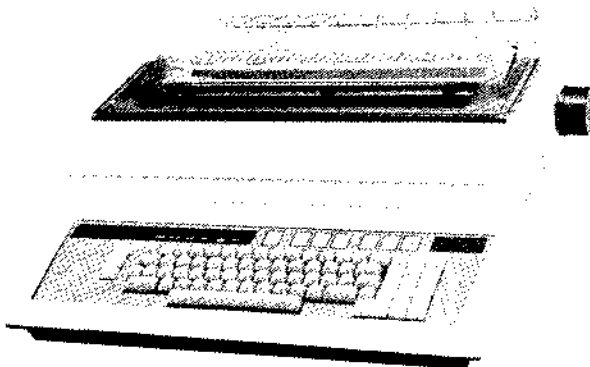

HPRO5 KSR TERMINAL

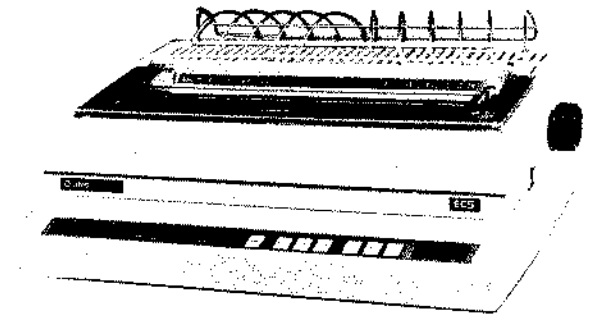

API-2 ECS RO TERMINAL

Figure 1-1. MODEL 630 PRINTERS AND TERMINALS

SECTION 1

GENERAL INFORMATION

1.1 GENERAL

A high degree of reliability has been achieved in the Model 630 through the simplicity of its daisy wheel printer and the extensive use of microelectronics. The Model 630 is designed for fast, easy subassembly replacement and a minimum number of adjustments, greatly reducing the amount of downtime required for unscheduled repairs. An internal diagnostic self-test is a standard feature in the terminal configurations. The Models 630 HPRO5 WP, HPRO5 Expanded, SPI, and API also have remote diagnostics capability.

Note: Throughout this manual, the term "Model 630" commonly encompasses both the standard Model 630 and the Model 630 ECS. Where it is necessary to differentiate between the two, "standard" or "ECS" will be specified.

1.2 MAINTENANCE PHILOSOPHY

There are two types of maintenance for the Model 630—Preventive Maintenance and Corrective Maintenance. Preventive maintenance consists of periodic cleaning and lubrication designed to minimize the need for unscheduled corrective maintenance. This preventive maintenance is relatively simple, and easily accomplished by the user. Corrective maintenance, on the other hand, requires certain minimum levels of technical expertise and facilities. Corrective maintenance capability will vary greatly from user to user.

Maintenance procedures for the Model 630 are categorized into three levels. The first level is primarily preventive maintenance, and may be accomplished by any user. The second level is corrective maintenance involving on-site exchange of subassemblies and printed circuit boards, and minor adjustments. The third level involves repair center and/or factory repair or refurbishment of assemblies and printed circuit boards.

- Level 1 - Ribbon cartridge and print wheel changes; some lubrication; surface cleaning.
- Level 2 - Includes Level 1 items, plus unit replacement, circuit board exchange, subassembly replacement, minor adjustments and alignments; minor assembly exchanges of platens and paper cradle.
- Level 3 - Includes Level 1 and 2 items, plus major disassembly and refurbishment of subassemblies, and repair of circuit boards.

NOTE: The user's service activity should be limited to only Level 1 procedures during the warranty period. The Diablo warranty is null and void when any Level 2 or Level 3 procedure has been unsuccessfully attempted. All time and material required to restore the printer to working order will be billed at prevailing rates. No adjustments should be attempted unless equipment malfunction indicates a specific need.

1.3 MAINTENANCE PRECAUTIONS

Observing the following precautions during service and maintenance activity will help prevent damage to the Model 630 and personal injury to the service technician.

1. Do Not remove or install circuit boards while the power is ON.
Do Not connect or disconnect any plug or cable while the power ON.
Do Not turn ON the power while the machine does not have its normal complement of circuit boards installed.
2. Before power is applied, make sure the carriage is free to move leftward. When power is applied, the printer executes a RESTORE sequence which includes leftward carriage movement.
3. Operating the Model 630 with its access cover removed and cover open interlock switch defeated is recommended only for qualified service technicians.
(In some units the interlock switch can be defeated by pulling the switch plunger out to its extended position after the access cover has been removed. In other units, the switch must be actuated by other means.)

WARNING:

High velocity carriage movement occurs during normal operations of the Model 630, and unpredictable carriage movement can occur during certain types of malfunctions. The technician should be careful to stay clear of the carriage travel path while operating the machine with its access cover removed.

4. Do not use alcohol to clean the platen or the paper feed rollers. Alcohol hardens the rubber, resulting eventually in paper feed problems. Use Fedron Platen Cleaner or its equivalent.

WARNING - Fedron Solvent

Fedron solvent is flammable, its vapor is harmful, it is harmful if swallowed, and it is irritating to the eyes and skin.

Keep away from heat, sparks and open flame.

Use only with adequate ventilation, synthetic rubber gloves, goggles and side shields.

Avoid prolonged breathing of vapors or contact with eyes or skin.

Do not drink.

In case of fire, use foam or CO₂.

First Aid:

In case of eye contact, flush with water and get medical attention.

For skin contact wash thoroughly.

If overcome by vapor, remove to fresh air.

If swallowed, call physician immediately. Do not induce vomiting.

Keep out of reach of children.

Keep container closed when not in use.

5. Do not use platen cleaner to clean plastic parts. These products are usually harmful to plastics, and may cause damage. Instead, you can use acetone, methyl ethyl ketone, "Formula 409", "Fantastik" or 91% isopropyl alcohol to clean the plastic parts.
6. Diablo provides a paper rack for holding paper away from the ventilation slots in the top cover. Use of the paper rack is required in all cases except:
 - When using a sheet feeder accessory.
 - When operating with bottom feed and a forms tractor.

Except for these two cases, use of fan-fold paper without a paper rack will cause overheating of the printer's electronics. OPERATION OF THE PRINTER IN SUCH A MODE WILL VOID WARRENTY GUARANTEES.

1.4 TOOLS, EQUIPMENT AND SPARES

1.4.1 Level 1

The following listed items should be available to personnel providing Level 1 maintenance on the Model 630:

- Fedron Platen Cleaner, or equivalent
- Acetone or Methyl Ethyl Ketone (available in hardware stores);
or "Formula 409" or "Fantastik" household cleaners
- Lint-free wipers
- No. 70655 Light oil, 1/4 oz. *
- No. 70654 Polyoil (light grease), 8cc *
- No. 70825-01 Multipurpose grease, 2 oz tube *
- No. 99000-01 Alcohol Pads (91% isopropyl alcohol) or equivalent
- Clean, low-pressure compressed air (optional)
- No. 100245-01 Silicone Grease (for ECS units) *

* Included in Diablo Model 630 tool kits #90011-04 (basic) and 90011-21 (deluxe).

CAUTION:

- 1) Observe all OSHA safety rules for use of compressed air, including safety goggles.
- 2) Do not use alcohol on rubber items or plastic print wheels.
- 3) Do not use platen cleaners on plastic items.
- 4) Use platen cleaners and alcohol with care. Alcohol and most platen cleaners are VERY flammable (low flash point, volatile, etc.).

1.4.2 Level 2

The following items, plus those listed for Level 1 should be available to persons performing corrective maintenance and/or repair of the Model 630 at Level 2:

- One set of circuit boards
- One platen (appropriate type)
- One platen knob
- One carriage assembly
- One paper feed motor
- One paper feed idler gear
- One carriage drive motor
- One carriage drive cable
- One snubber cable
- One snubber spring

- One DC power harness (appropriate type)
- One cover open switch
- One paper out switch
- One ribbon base plate assembly
- One forms tractor assembly, if appropriate
- Assortment of appropriate size fuses
- Assortment of hand tools adequate for electronic/mechanical repair.
- TORX tools: Screwdriver #T15 Diablo No. 70826-03 *
- Screwdriver #T9 Diablo No. 70826-04 *
- Print Wheel adjustment tools; Diablo No's. 40795 or 40795-01 or 40795-02 *;
40796 *, and 301445-01 *
- Thermal compound, Diablo No. 10549

* Included in Diablo Model 630 tool kits #90011-04 (basic) and 90011-21 (deluxe).

1.4.3 Level 3

The items listed below, plus those listed above for Levels 1 and 2 should be available to persons performing corrective maintenance and/or repair of the Model 630 at Level 3:

- One print wheel motor with hub assembly (standard carriage)
- One flat cable assembly (main interconnect cable harness)
- One bottom pan (bottom cover)
- ECS shift solenoid (for ECS units only)
- One PCB Extender Assembly Kit, Diablo No. 320048-02 (included in deluxe tool kit, 90011-21)
- Oscilloscope, vbw 15 mHz, vds 100 mV/cm, sweep speed 50 ns/cm

1.4.4 Terminal Spares

For service support of the Model 630 Terminals, the following spares are recommended in addition to those items listed above for Levels 1, 2 and 3.

- One top cover assembly
- One access cover assembly
- One power supply regulator circuit board, or one complete power supply assembly
- One AC power cord
- One control panel assembly
- One control panel cable
- One keyboard assembly (without control panel) - (KSR units only)
- One keyboard-to-control panel cable assembly - (KSR units only)
- One carriage motor power cable
- One interconnect cable, HPRO5 to PCE (for HPRO5 units only)
- One EIA interface connector assembly (for SPI and HPRO5 units only)
- One API interface connector assembly (for API units only)
- One side plate, left
- One side plate, right

1.4.5 Model 630 Tool Kits

Diablo's basic and deluxe tool kits for the Model 630 are the same except for the PCB Extender Kit which is included in the deluxe tool kit only.

Model 630 Basic Tool Kit No. 90011-04
Model 630 Deluxe Tool Kit No. 90011-21

<u>Part No.</u>	<u>Description</u>
40795-02	Combination Adjustment Tool
40796	Pin Gauge
70654	Polyoil
70655	Light Oil
70825-01	Multipurpose Grease
70826-03	Torx T15 Screwdriver
70826-04	Torx T9 Screwdriver
70826-05	Torx T15 Key**
70826-06	Torx T9 Key**
100245-01	Silicone Grease (for ECS units only)
100398-01	Jumper, Socket Plug
301445-01	Print Wheel Adjustment Tool
302710-03	PCB Extender Kit (Deluxe tool kit only)

** Included in Basic Kit but not required for Model 630. (Basic Kit serves for both Model 630 and HyType II models.)

1.5 MAINTENANCE TRAINING

Diablo offers regular scheduled classes, self-paced audio visual training programs and User Application Seminars. For further information, please call:

Diablo Product Support Training
(415) 786-5668 / 5085

1.6 RELATED PUBLICATIONS

There are several Diablo publications pertaining to the Model 630 printers and terminals, including Operator's Guides, a Product Description Manual, Interface Manuals, Parts Catalog, and others. All of these publications are listed and priced in the Model 630 Operator's Guides and Product Description Manual, which also contain ordering instructions and an order form. The Model 630 Product Description Manual (Publication No. 90442-XX) also contains a brief description of the contents of each of these publications.

In addition to the publications mentioned above, changes to a product which alter manual content are covered by publishing an Addenda to the affected manual. These Addenda are available to Diablo customers.

SECTION 2

PREVENTIVE MAINTENANCE

2.1 PREVENTIVE MAINTENANCE SCHEDULE

The Model 630 does not require scheduled periodic preventive maintenance. The few lubrication requirements that exist can be accomplished as needed when unscheduled maintenance is required. Under certain circumstances the print wheel may need periodic cleaning, as described below.

2.2 CLEANING THE PRINT WHEEL AND PRINT HAMMER

When a metal print wheel is being used with a fabric ribbon, occasional cleaning of the print wheel is required. If excessive ink buildup on the print wheel is permitted, the ink will migrate onto the print hammer and subsequently cause sticking of the hammer in its guide, and possible print wheel damage.

2.2.1 The Print Wheel

- 1) Rock the carriage to the service (print wheel changing) position.
- 2) Remove the print wheel.
- 3) Clean the print wheel with methyl ethyl ketone (MEK) or acetone (available in hardware stores) and a soft brush or cotton swab. Avoid getting the solvent on the vibration damper (metal wheels) or cap of the print wheel.

NOTE: Household cleaners "Formula 409" or "Fantastik" can be used in place of MEK or acetone, if desired.

Caution

- Do not soak print wheels in the cleaning solutions. This can alter characteristics of the print wheel.
 - Do not soak print wheels in either MEK or acetone. This can damage the vibration damper (on metal wheels) and the cap, or the petals on plastic wheels.
 - Clean the print wheel petals gently to prevent damage.
- 4) After using "Formula 409" or "Fantastik", rinse the print wheel with clear water.
 - 5) Blot dry the print wheel thoroughly with a soft cloth or tissue, replace it in the unit, and rock the carriage to the operating position.

2.2.2 The Print Hammer

- 1) Rock the carriage to the service position.
- 2) Remove the print wheel and print wheel shield.
- 3) With your fingers, push the hammer out of the hammer guide to expose the top and sides.
- 4) Use 91% isopropyl alcohol and a cotton swab or tissue to dissolve and remove any ink.
- 5) Dry the hammer with a clean swab or tissue; then install the print wheel shield and print wheel, and rock the carriage to its operating position.

2.3 GENERAL CLEANING AND INSPECTION (Qualified Service Personnel Only)

- 1) Remove power from the unit. Open and remove covers as required to gain access to the printer mechanisms.
- 2) Thoroughly inspect the printer for signs of wear and loose or broken hardware. Check the platen for looseness or wobble. Check the carriage system for looseness, wobble or accumulations of foreign material on the rails which might cause uneven carriage movement. Check the carriage drive cable system carefully for signs of wear.
- 3) Remove the platen, paper cradle, ribbon cartridge, and print wheel. Inspect these for signs of wear.
- 4) Clean the printer thoroughly, using alcohol saturated cleaning pads and wipers. Remove accumulations of paper residue, ink, dust, etc., with special attention to carriage rails and pulley grooves. Heavy deposits may be first removed by blowing with compressed air. Be sure to observe all safety precautions when using compressed air.

NOTE: Use of compressed air is NOT recommended when the printer is located close to other equipment that is sensitive to dirt and dust.

- 5) Clean the platen, platen pressure rollers, and paper bail rollers with a good platen cleaner which is noninjurious to rubber products, such as Fedron platen cleaner (see safety note pertaining to Fedron platen cleaner on page 1-2). Do not use alcohol on these items.

2.4 LUBRICATION

In normal operation there are only two critical lubrication points on the Model 630 printer mechanism: the carriage rail bearings, and the platen hubs (lube not required on late style friction platens with nylon bearing bushings). Typically, lubrication at these points may be required no more frequently than once every 500 usage hours or once per year, but at least once every 1000 usage hours or once every two years.

Several other moving parts in the printer mechanism also are lubricated during manufacture. In normal operation, these points do not require further lubrication unless the lubricant is removed during disassembly/reassembly, or if it is wiped off when the interior of the printer is being cleaned. If removed, the lubricant must be replaced as specified below. (Some of these points are accessible for lubrication only when the mechanism is disassembled.) Under extreme operating conditions, some of these points may require periodic lubrication. This determination is left to the judgement of the experienced service technician. All accessible lubrication points should be given a quick visual check during each service call on the machine.

Do not exceed the specified amounts of lubricant. Too much lubricant is often worse than none at all.

Lubrication requirements for the Model 630 printer mechanism are specified below. All of the lubricants called for are available from Diablo under the part numbers listed in subsection 1.4.1 of this manual.

2.4.1 Carriage System - Non-ECS

DO NOT lubricate the carriage drive cable.

Refer to Figures 2-1 and 2-2.

1. Carriage Rails (A) - Clean these with alcohol pads.
2. Carriage Rail Bearings (B) - Put 4 to 5 drops of light oil on each rail on each side of the carriage. Move the carriage back and forth slowly by hand, allowing the oil to saturate the lubrication felts inside each carriage bearing.

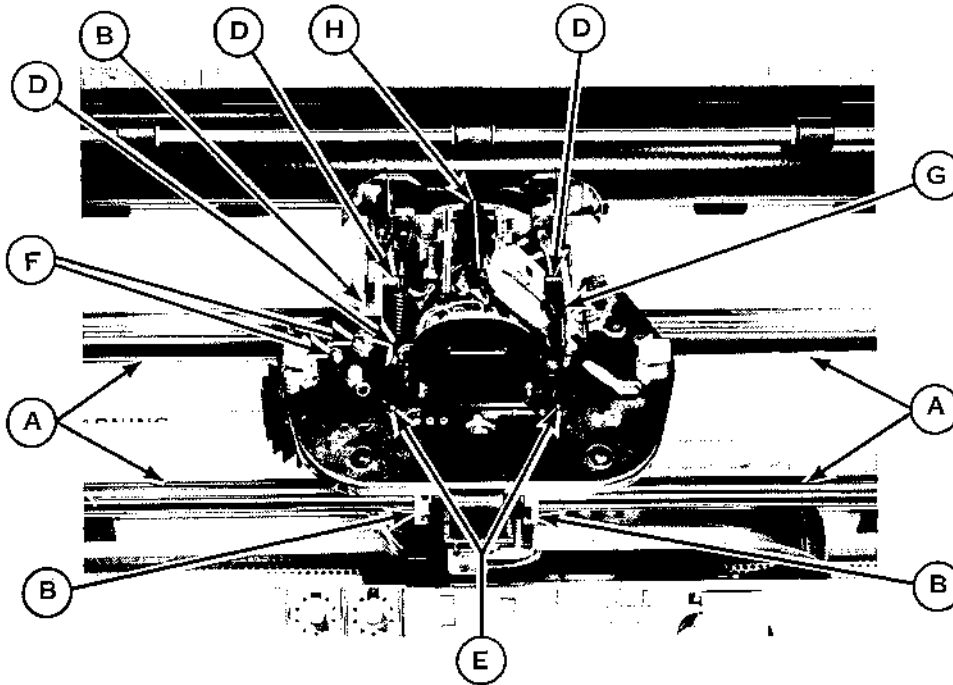

Figure 2-1. NON-ECS CARRIAGE SYSTEM LUBRICATION POINTS

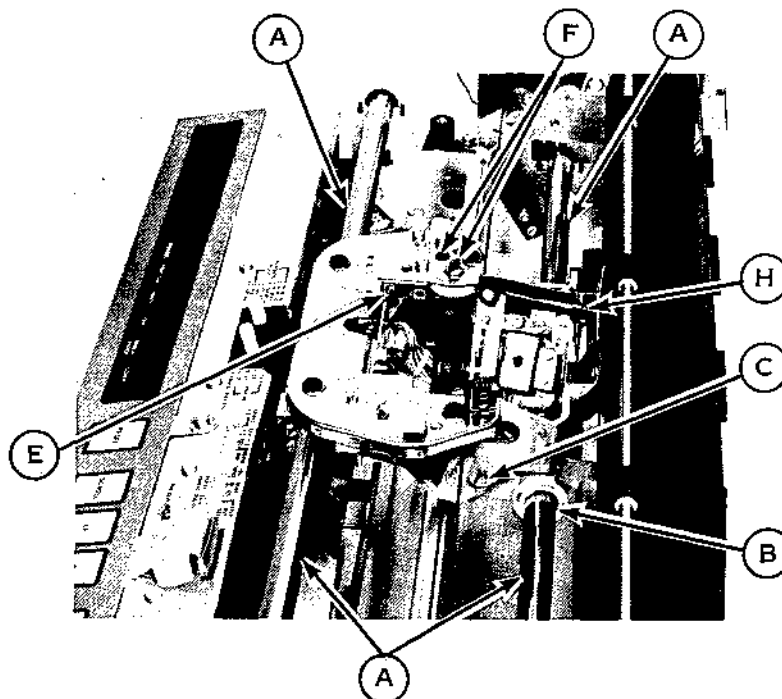

Figure 2-2. NON-ECS CARRIAGE SYSTEM LUBRICATION POINTS

3. Carriage Pivots (C) - Apply one drop of light oil to the pivot on each side of the carriage frame.
4. Carriage Pivot Spring Loops (D) - Lightly grease the end loops and posts of the pivot spring on each side of the carriage frame with multipurpose grease.
5. Ribbon Base Plate Pivots (E) - Saturate the felt washer on each of the base plate pivots with light oil.
6. Ribbon Drive System (F) - Apply one drop of light oil to the drive and idler gear shafts, and to the drive key slot.
7. Hammer Armature Pivots (G) - Remove the rubber cap covering the upper grease chamber, and fill the cup 1/4 to 1/2 full with Polyoil. Replace the rubber cap.
8. Print Hammer (H) - DO NOT lubricate this item. If a cloth ribbon is being used, make sure the hammer is clean.

2.4.2 Carriage System - ECS

DO NOT lubricate the carriage drive cable.

Refer to Figure 2-3.

1. Carriage Rails (A - Fig. 2-3) - Clean the rails with alcohol pads; then wipe dry.
2. Carriage Rail Bearings (B - Fig. 2-3) - Put 4 to 5 drops of light oil on each rail on each side of the carriage. Move the carriage back and forth slowly by hand, allowing the oil to saturate the lubrication felts inside each carriage bearing. (A properly lubricated bearing will leave a light film of oil on the carriage rail as the carriage is moved.)
3. Primary Slider (C - Fig. 2-3) - Apply silicone lubricant to the inside edges of the slot in the primary slider where it is contacted by the peg on the double crank.
4. Pivot Pins (D - Fig. 2-3) - Apply multipurpose grease to each of the two pivot pins before the pivot bushings are installed on the pins.
5. Bell Crank Pivot Shaft (E - Fig. 2-3) - Apply a film of multipurpose grease to the length of the shaft in contact before assembling each part on the shaft.
6. Steel Washer (F - Fig. 2-3) - Apply a film of multipurpose grease between the steel washer and the double crank during reassembly.
7. Bell Crank Return Spring (G - Fig. 2-3) - Press a light film of multipurpose grease between the coils of the spring. Apply a dab of multipurpose grease at one end of the spring where it contacts the bell crank, and at the other end where the spring contacts the pivot frame.
8. Bell Crank Arm (H - Fig. 2-3) - Apply a dab of multipurpose grease to the tip of the arm where it contacts the solenoid plunger.
9. Solenoid Plunger (I - Fig. 2-3) - The shaft of the plunger must be completely clean of any lubricant to ensure free movement of the plunger within the solenoid. (There will be a small amount of grease inside the notch of the plunger where it is contacted by the tip of the bell crank arm - H.)
10. Latch Pivot Shaft (J - Fig. 2-3) - Apply multipurpose grease to the pivot shaft before the latch lever is installed on the shaft.
11. Hammer Armature Pivots (K - Fig. 2-3) - Remove the two rubber caps covering the grease chambers, and fill the caps 1/4 to 1/2 full with Polyoil. Replace the rubber caps.
12. Print Hammer (L - Fig. 2-3) - DO NOT lubricate the print hammer. If a cloth ribbon is being used, make sure the hammer is clean.
13. Ribbon Drive System (M - Fig. 2-3) - Apply one drop of light oil to the idler gear shaft and to the bushing around the base of the drive key.
14. Solenoid Seat (N - Fig. 2-3) - When the solenoid is being installed, apply a layer of thermal compound on the seat that cradles the solenoid in the pivot assembly. This is critical to prevent overheating of the solenoid.

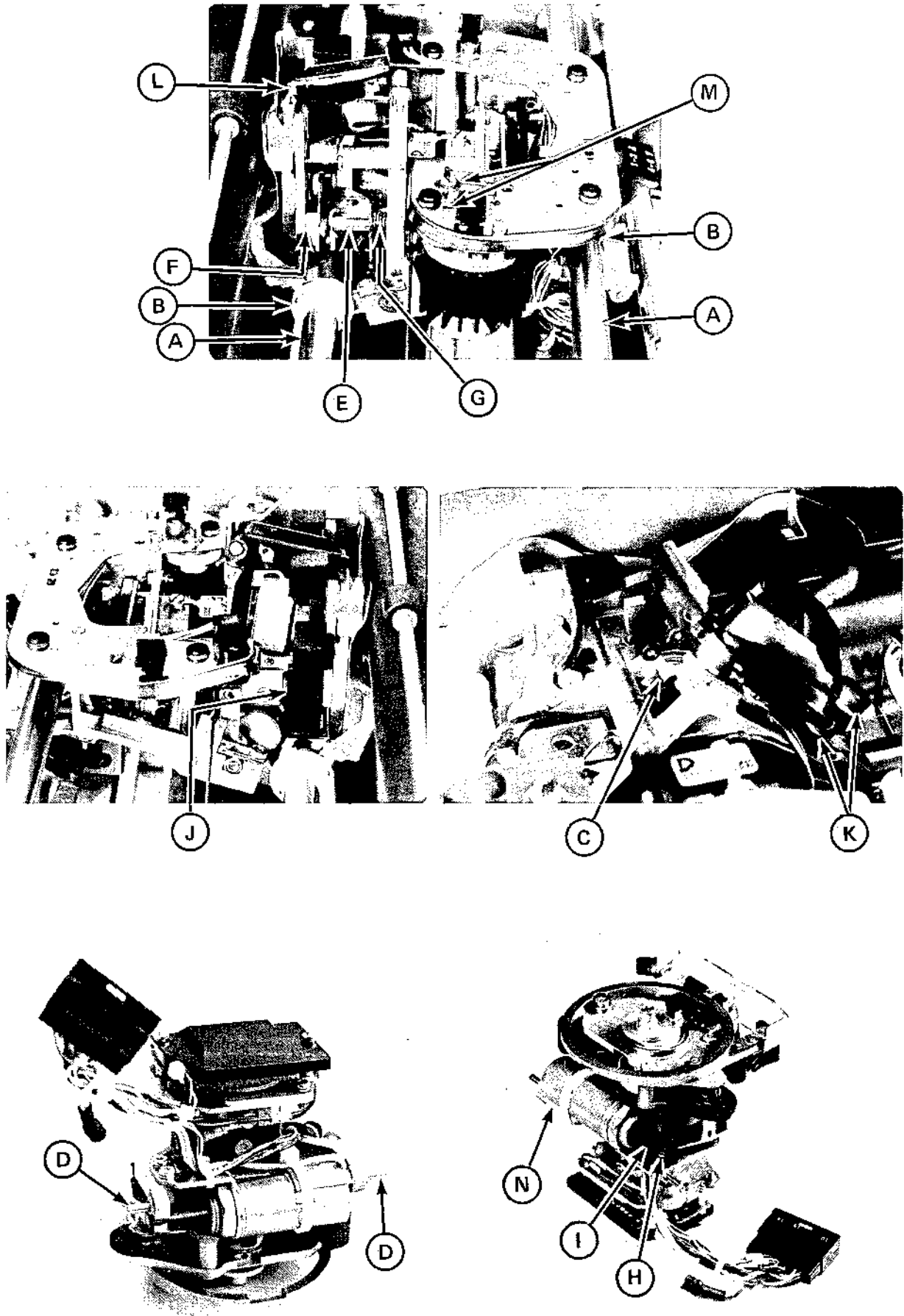

Figure 2-3. ECS CARRIAGE SYSTEM LUBRICATION POINTS

2.4.3 Carrier System

Refer to Figure 2-4.

1. Paper Feed Roller Shaft Pins (A) - Multipurpose grease (8 places).
2. Paper Release Lever Ramp (B) - Multipurpose grease.
3. Paper Feed Roller Assembly pivots (C) - One drop of light oil (4 places).

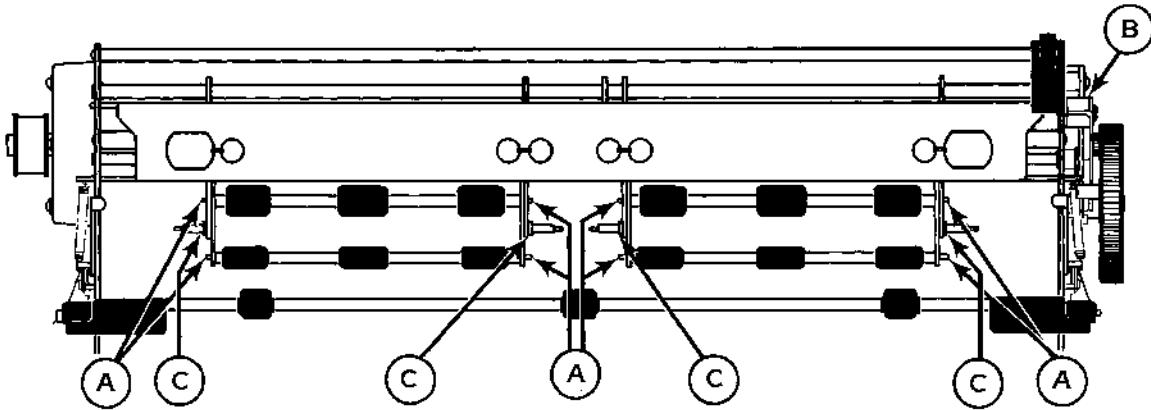

Figure 2-4. CARRIER SYSTEM LUBRICATION POINTS

2.4.4 Platen System

Note: Only the early style platens require lubrication. Zero-backlash platens, now being phased into production and which do not require lubrication, can be identified by the features shown in Figure 2-5. It is important to note that the early style platen knob will not properly operate the zero-backlash platen. The new style platen knob can be adjusted to operate either the early style or zero-backlash platen (see subsection 4.3, Platen Removal).

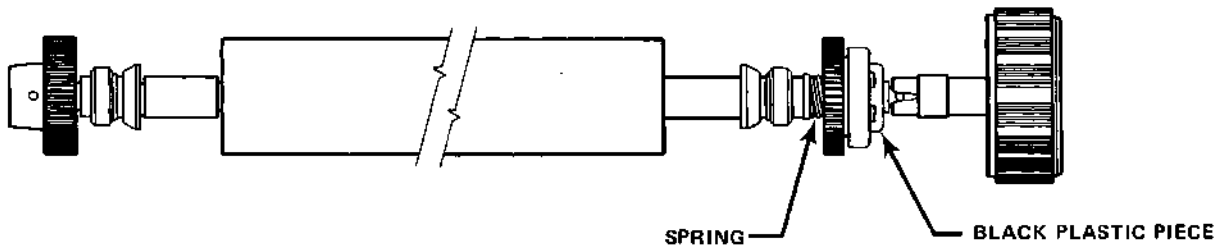

Figure 2-5. ZERO-BACKLASH PLATEN ASSEMBLY
(DO NOT LUBE)

(continued)

LUBRICATION OF EARLY STYLE PLATEN ASSEMBLY:

Refer to Figure 2-6.

Platen Hubs (A) - Apply one drop of light oil to the bore of the hub at each end of the platen.

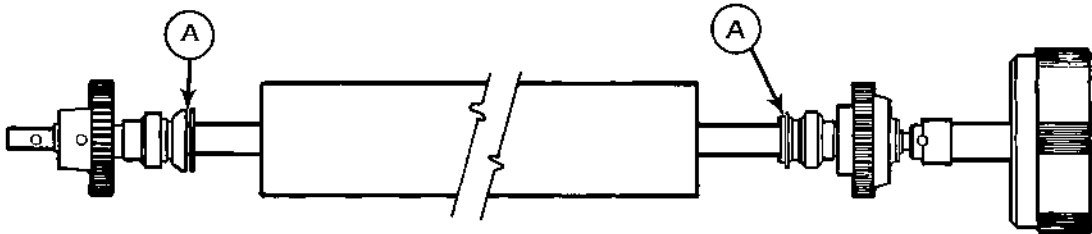

Figure 2-6. EARLY STYLE PLATEN SYSTEM LUBRICATION POINTS

2.4.5 Lubrication of Optional Items

Optional platen styles require only the lubrication of their hubs as outlined above. The pin feed sections of the pin feed platens are internally self-lubricating and do not require user attention. The optional Diablo forms tractors likewise do not require lubrication. Lubrication of the optional forms handling units is covered in their individual maintenance publications.

SECTION 3

CORRECTIVE MAINTENANCE

3.1 TROUBLESHOOTING

The first major task in troubleshooting the Model 630 printer or terminal is to determine that the problem is indeed in the Model 630, and not in some other element of the system. The diagnostic features in the Model 630 are designed to help isolate the problem by verifying operation of the Model 630 either in a self-test mode or by remote test commands from the host system. The diagnostic capabilities vary between versions of the Model 630; ranging from a simple self-test printing routine in the PPI/HPRO6 version to multiple self-tests and remote diagnostic routines in the Expanded HPRO5 versions.

The following subsections describe the function and operation of the diagnostic features in each version of the Model 630. Pertinent reference data in the form of charts and tables is contained on the last few pages of this section.

3.2 DIAGNOSTICS - Models 630 PPI and HPRO6 Printers

The Models 630 PPI and HPRO6 are equipped with a Self-Test mode. In this mode, a properly operating unit prints continuous swirl text at 10 pitch character spacing, 132 columns per line, and 6 lines per inch. Figure 3-1 shows a sample of PPI self-test print-out.

To put the Model 630 PPI into self-test mode, turn off the AC power, and install the self-test jumper on the PPI circuit board. The location of this jumper depends on the design level of the PPI circuit board etch as listed below. At power-up the unit enters self-test and remains in that mode until power is removed.

<u>PPI Board Etch</u>	<u>Self-Test Jumper Location</u>
320271-01	A3-5/7
320271-02	A65-5/6
320271-03	J5-9/10

Caution: With later levels of firmware on the PPI board, 88-character print wheels should not be used for self-test printout. If the firmware at location B30 on the PPI board is at or above level 100506-06 (EROM) or 100510-05 (MROM), the 88-character wheels are addressed from a 96-character lookup table. Thus, the print hammer will strike the print wheel flag during self-test when the missing spokes are addressed. This will also happen during normal operation if the host addresses the missing spoke positions.

The ECS PPI self-test does not include print wheel shifting; thus it prints only the outer row characters on the ECS print wheel.

For self-test on the HPRO6, set switch 8 on the HPRO6 circuit board to ON. Self-test is entered at power-up, and continues until power is removed.

```

CONTINUOUS
ϕ!"#$%&'()*+,-./0123456789:;<=>?@ABCDEFGHIJKLMN
OPQRSTUVWXYZ[\]^_
!"#$%&'()*+,-./0123456789:;<=>?@ABCDEFGHIJKLMN
OPQRSTUVWXYZ[\]^_
"#$%&'()*+,-./0123456789:;<=>?@ABCDEFGHIJKLMN
OPQRSTUVWXYZ[\]^_ a
#$%&'()*+,-./0123456789:;<=>?@ABCDEFGHIJKLMN
OPQRSTUVWXYZ[\]^_ ab
$%&'()*+,-./0123456789:;<=>?@ABCDEFGHIJKLMN
OPQRSTUVWXYZ[\]^_ abc
%&'()*+,-./0123456789:;<=>?@ABCDEFGHIJKLMN
OPQRSTUVWXYZ[\]^_ abcd
&'()*+,-./0123456789:;<=>?@ABCDEFGHIJKLMN
OPQRSTUVWXYZ[\]^_ abcde
'()*+,-./0123456789:;<=>?@ABCDEFGHIJKLMN
OPQRSTUVWXYZ[\]^_ abcdef
()*+,-./0123456789:;<=>?@ABCDEFGHIJKLMN
OPQRSTUVWXYZ[\]^_ abcdefg
)*+,-./0123456789:;<=>?@ABCDEFGHIJKLMN
OPQRSTUVWXYZ[\]^_ abcdefgh
132 COLUMNS

```

Figure 3-1. PPI SELF-TEST PRINTOUT

3.3 DIAGNOSTICS - Model 630 SPI Terminal

The Model 630 SPI has capability for both internal (self-test) and remote diagnostics as standard features.

3.3.1 SPI Self-Test

If the Self-Test switch on the control panel has been set to ON, the self-test begins execution immediately at power-up. The self-test comprises a ROM Test, a RAM Test and 96 lines of swirl text. The character spacing during self-test corresponds to the pitch selection made on the control panel. A sample of self-test printout is shown in Figure 3-2. The self-test repeats continuously until power is turned OFF.

If the ROM test fails, "ROM BAD" is printed, and the self-test stops; if the RAM test fails, "RAM BAD" prints, and the test stops. The tested ROM area includes: (1) the internal ROM of the UPI 8041A, and (2) either one or two EPROM's, or one masked ROM. The tested RAM includes the internal RAM of the UPI 8041A and the single RAM device on the SPI circuit board. All tested ROM and RAM is located on the SPI circuit board (specific locations are identified on the SPI circuit board schematic in Section 7 of this manual).

```

selftest!
romok
ramok
96 LINES
ϕ!"#$%&'()*+,-./0123456789:;<=>?@ABCDEFGHIJKLMN
OPQRSTUVWXYZ[\]^_
!"#$%&'()*+,-./0123456789:;<=>?@ABCDEFGHIJKLMN
OPQRSTUVWXYZ[\]^_
"#$%&'()*+,-./0123456789:;<=>?@ABCDEFGHIJKLMN
OPQRSTUVWXYZ[\]^_ a
#$%&'()*+,-./0123456789:;<=>?@ABCDEFGHIJKLMN
OPQRSTUVWXYZ[\]^_ ab
$%&'()*+,-./0123456789:;<=>?@ABCDEFGHIJKLMN
OPQRSTUVWXYZ[\]^_ abc
%&'()*+,-./0123456789:;<=>?@ABCDEFGHIJKLMN
OPQRSTUVWXYZ[\]^_ abcd
&'()*+,-./0123456789:;<=>?@ABCDEFGHIJKLMN
OPQRSTUVWXYZ[\]^_ abcde
'()*+,-./0123456789:;<=>?@ABCDEFGHIJKLMN
OPQRSTUVWXYZ[\]^_ abcdef
()*+,-./0123456789:;<=>?@ABCDEFGHIJKLMN
OPQRSTUVWXYZ[\]^_ abcdefg
)*+,-./0123456789:;<=>?@ABCDEFGHIJKLMN
OPQRSTUVWXYZ[\]^_ abcdefgh
132 COLUMNS

```

Figure 3-2. SPI SELF-TEST PRINTOUT

3.3.2 SPI Remote Diagnostics

The Remote Diagnostics feature allows the host computer to initiate diagnostic-type operations within the terminal by command through the serial interface. The diagnostic commands included in this feature are listed below, along with the ESC codes that initiate the commands. The commands are defined in the subsections that follow.

ESC SUB I	Initialize the terminal
ESC SUB R	Remote error reset
ESC SUB 1	Request status byte 1
ESC SUB SO	Perform self test

All diagnostic commands are executed immediately when received and are not queued. This means all status reported will be the status present at the time the command was received. Only the low 7 bits (bits 0 thru 6) of a status byte are significant. Their equivalent value may range from 0 to 127. The MSB (bit 7) will be a parity bit as defined by the parity switches on the control panel. All commands that generate a response from the Model 630 will result in a status byte being sent to the host computer preceded by an STX character. The STX identifies the next byte as a status byte. The rules for ETX/ACK and DC1/DC3 protocols are applicable and should be used for sending status requests to the Model 630.

3.3.2.1 ESC SUB I

The ESC SUB I command causes the Model 630 SPI to unconditionally execute an initialize sequence, regardless of error conditions that may exist within the printer. This command is executed immediately when received over the interface, unlike the corresponding remote reset sequence, ESC CR P, which is queued along with other commands. Before sending this command, the host should send a nonprinting character so that the terminal will abort any multiple character sequence that may be in progress.

With ESC SUB I, the Model 630 will be initialized to the same conditions produced by the remote reset command ESC CR P; specifically:

- Normal Print Mode (not Graphics)
- Forward Print Mode
- Print Head reset to print position 0
- Vertical Position cleared to 0 (paper does not move)
- VMI set to 8 (6 lines per inch)
- Lines per page set to 66 (11" page size) or 72 (12" page size) depending on whether Jumper #1 on control panel is OUT (11" page) or IN (12" page).
- Print in Black
- Auto backward printing enabled
- Left margin set to position 0
- Right margin set to position 1572
- Top margin set to position 0 (line 1)
- Bottom margin set to position 528 (line 66) for 11" page or position 576 (line 72) for 12" page.
- Send and Print buffers cleared

3.3.2.2 ESC SUB R

This command causes the Model 630 SPI to reset any error conditions. It produces essentially the same result as pressing the RESET switch on the control panel. If the unit

is in check, it will execute a restore. Due to internal program latency, the minimum time necessary to reset all errors is 250 milliseconds.

In a situation where the terminal is being operated without a control panel (not typical), a series of up to eight automatic restores occurs if the terminal goes into a check condition. The ESC SUB R sequence has the effect of resetting the automatic restore counter to enable another series of automatic restore operations.

3.3.2.3 ESC SUB 1

This command will cause the terminal to send a status report byte (STATUS 1) thru the interface. The true-state bit definitions of this status byte are:

<u>Bit</u>	<u>Status</u>
0	End of Ribbon
1	10 Pitch (This bit false if any other pitch is selected)
2	Paper Out
3	Auto Line Feed enabled (by jumper on control panel)
4	Cover Open
5	Printer Idle (print buffer empty and all printer motion complete)
6	Printer in Check
7	Parity Bit *

* The state of bit 7 is defined by the PARITY ENABLE and PARITY EVEN/ODD switches on the control panel.

3.3.2.4 ESC SUB SO

This command causes the terminal to execute a self-test. This self-test consists of the RAM Test and ROM CRC Test that are a part of the basic self-test routine of the Model 630 SPL. This command should not be issued when the terminal is busy, since it may cause data loss in some situations. No indication of test pass or failure is printed by the terminal. At the end of the self-test, the terminal sends a report byte to the host computer. The true-state bit definitions for this byte are:

<u>Bit</u>	<u>Condition</u>
0	Device 8041 internal RAM bad
1	Device 8041 internal ROM bad
2	6803 external RAM bad (location A65 on the SPI circuit board)
3	6803 external ROM #1 (4K) bad — upper half of 8K ROM memory *
4	6803 external ROM #2 (4K) bad — lower half of 8K ROM memory *
5	(unassigned)
6	(unassigned)
7	UART Parity Bit

* The 8K of external ROM memory associated with the 6803 processor consists of either two 4K EPROMS or one 8K masked ROM. The locations of these devices on the SPI circuit board can be determined from the SPI schematic in Section 7 of this manual.

3.4 DIAGNOSTICS - Model 630 HPRO5 Terminals

3.4.1 General Discussion

The HPRO5 circuit board provides internal diagnostic (Self-Test) capability and makes the Remote Diagnostics feature available as an option. All variations of the Self-Test mode are described in the subsections that follow. The Remote Diagnostics option is described in subsection 3.4.4. There are a few differences in the self-test between units equipped with -03 or later base firmware and those with earlier levels of the base firmware. Any diagnostic tests or features that are unique to the pre-03 firmware are denoted as such in the descriptions which follow. (The firmware ROM locations on the HPRO5 circuit board are identified in Figure 3-4.)

The features of the self-test mode vary according to whether the unit has a control panel, and whether the jumper plug is present at position A60-1/2 on the HPRO5 circuit board. In its most comprehensive form, the Self-Test mode allows the operator to initiate individual tests on specific elements of the Model 630, or to select a single "Confidence Test" that combines several of the individual tests. (See Table 3-1.)

Table 3-1
DIAGNOSTICS CAPABILITIES
OF THE HPRO5 TERMINALS

		<u>1</u>	<u>2</u>	<u>3</u>	
HPRO5 Basic	- with Control Panel	X	X*		1=Confidence Test 2=Individual Tests 3=Remote Diagnostics
	- w/o Control Panel	X			
HPRO5 WP	- with Control Panel	X	X*	X	
	- w/o Control Panel	X		X	
HPRO5 Expanded	- with Control Panel	X	X*	X	
	- w/o Control Panel	X		X	

* Requires Jumper A60-1/2 on HPRO5 circuit board

The Confidence Test is simple to use by even a nontechnical operator on units equipped with a control panel. Its purpose is to quickly test several major elements of the Model 630 and give a printed report of the results. This enables the operator to verbally relay the test results to a trained service technician to determine if a malfunction is occurring in the Model 630; and if so, the nature of the malfunction. The Confidence Test can be executed by all Model 630 configurations that include the HPRO5 circuit board.

The Individual Tests permit more extensive testing, and the test results are reported in greater detail than those of the Confidence Test. To enable individual test selection, the unit must be equipped with a control panel, and the jumper must be installed at location A60-1/2 on the HPRO5 circuit board (see Fig. 3-3). The individual tests are described in subsection 3.4.3.

In all cases, the character spacing in the test printout is 10 pitch.

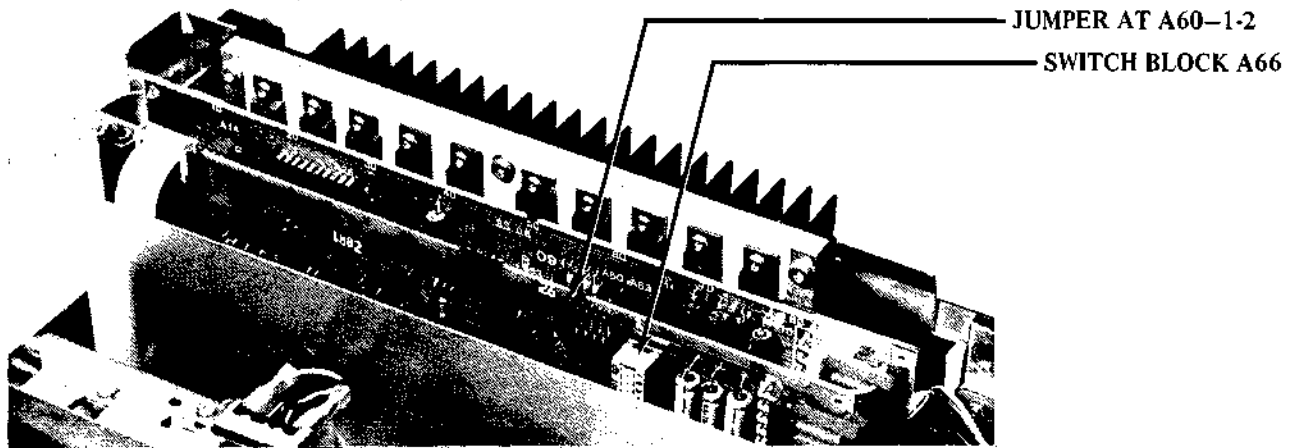

Figure 3-3. HPRO5 CIRCUIT BOARD SELF-TEST JUMPER AND SWITCH

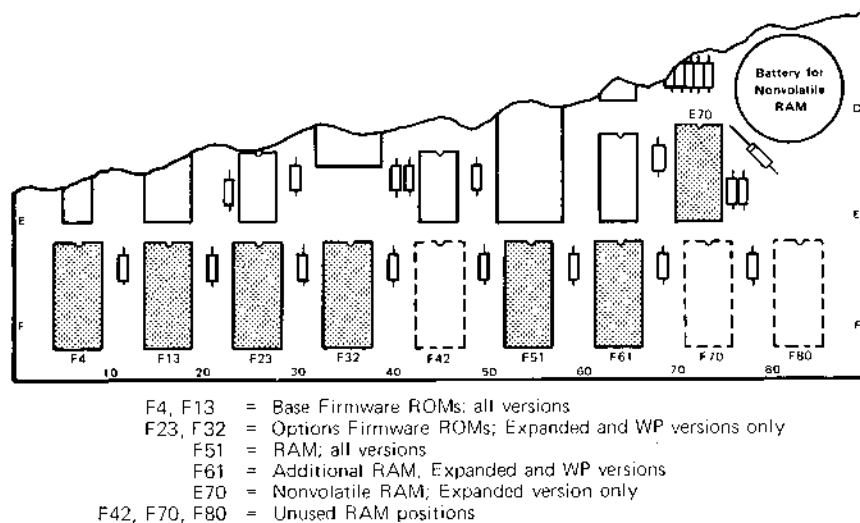

Figure 3-4. HPRO5 ROM AND RAM LOCATIONS

3.4.2 Confidence Test

This test is composed of several of the individual tests executed in sequence. The printed test results from a properly functioning unit are shown in Figure 3-5. Note that the shaded lines of the printout are present only when the HPRO5 board is equipped with pre-03 base firmware at locations F4 and F13 on the HPRO5 circuit board (see Fig. 3-4). The significance of each line in the printout is as follows:

- Line 1 - Announces the Self-Test mode.
- Line 2 - HPRO5 ROM Test result
- Line 3 - HPRO5 RAM Test result
- Line 4 - PCE ROM Test result
- Line 5 - Carriage Servo Test (132 columns)
- Line 6 - Result of Carriage Servo Test and subsequent Carriage Restore Test.
- Line 7 - Result of Print Wheel Servo Test (all spoke positions) and subsequent Print Wheel Restore Test.
- 96 Lines - Swirl Text Printout

PAUSE Switch - After the test has been stopped by the BREAK switch, this switch may be used to single-step through the test. Each time the switch is pressed, the test advances one step.

RESET Switch - When this switch is pressed, the test is interrupted and immediately starts again from the beginning.

3.4.2.3 Confidence Test On Model 630 With Control Panel - With Jumper A60-1/2 on HPRO5 Circuit Board

- 1) With the AC power switched OFF, set the SPACING switch on the control panel to position 7.
- 2) Turn ON the AC power. At power-up, the buzzer will sound briefly and the word "test" will be printed. The Model 630 is now in the Self-Test mode.
- 3) Press the RESET switch. This selects the Confidence Test (see Test X7 in subsection 3.4.3.3).
- 4) Press the BREAK switch to start the test.

Test Activity:

A properly functioning unit will print the test results as shown in Figure 3-5. In the Self-Test mode, the BREAK, PAUSE and RESET switches function as described below.

BREAK Switch - Serves as an alternate-action Start/Stop switch. After the test is first selected, the BREAK switch must be pressed to start test execution. Thereafter, successive actuations of the BREAK switch alternately stop and start the test. The test resumes each time from the point where it was stopped.

PAUSE Switch (see Fig. 3-6) - After the test has been stopped by the BREAK switch, this switch may be used to single-step through the test. Each time the switch is pressed, the test advances one step.

RESET Switch - When this switch is pressed, the test stops immediately. The test will then restart from the beginning when the BREAK switch is pressed.

3.4.3 Individual Tests

NOTE: The individual tests are accessible only on units equipped with a control panel and with jumper A60-1/2 installed on the HPRO5 circuit board.

The Self-Test mode for individual test selection is activated at power-up if the SPACING select switch on the control panel is set to the SELF TEST position. In this mode, the functions of all the control panel lights and switches are redefined. Individual diagnostic routines are selected by dialing in the proper test number on the two rotary switches (PRINT WHEEL SELECT and SPACING), and then pressing the RESET switch. The redefinition of all the remaining control panel switches and the control panel indicator lights is described below.

3.4.3.1 Redefinition Of Control Panel Lights and Switches

Figure 3-6 shows the standard designations, and in parentheses () the self-test designations, for the lights and switches on the Model 630 control panel. Figure 3-6 is followed by a list of control panel redefinitions that apply during the self-test mode.

The definition of the individual lights and switches is dependent on the individual test that is being executed. Three 16-bit data values are maintained by the self-test routine; one each for carriage motion, paper feed motion and print wheel data. These are used in various combinations by the individual test routines. Since there are only 8 data switches available (see list below), both the high data byte and the low data byte of each 16-bit value must be entered separately by pressing the appropriate "SELECT . . . DATA ENTRY" switch, followed immediately by the "ENTER HIGH DATA BYTE" or the "ENTER LOW DATA BYTE" switch, respectively. If the ENTER LOW DATA BYTE switch is not preceded immediately by the SELECT . . . DATA ENTRY switch, it becomes a test single-step switch when a test is not in the run mode.

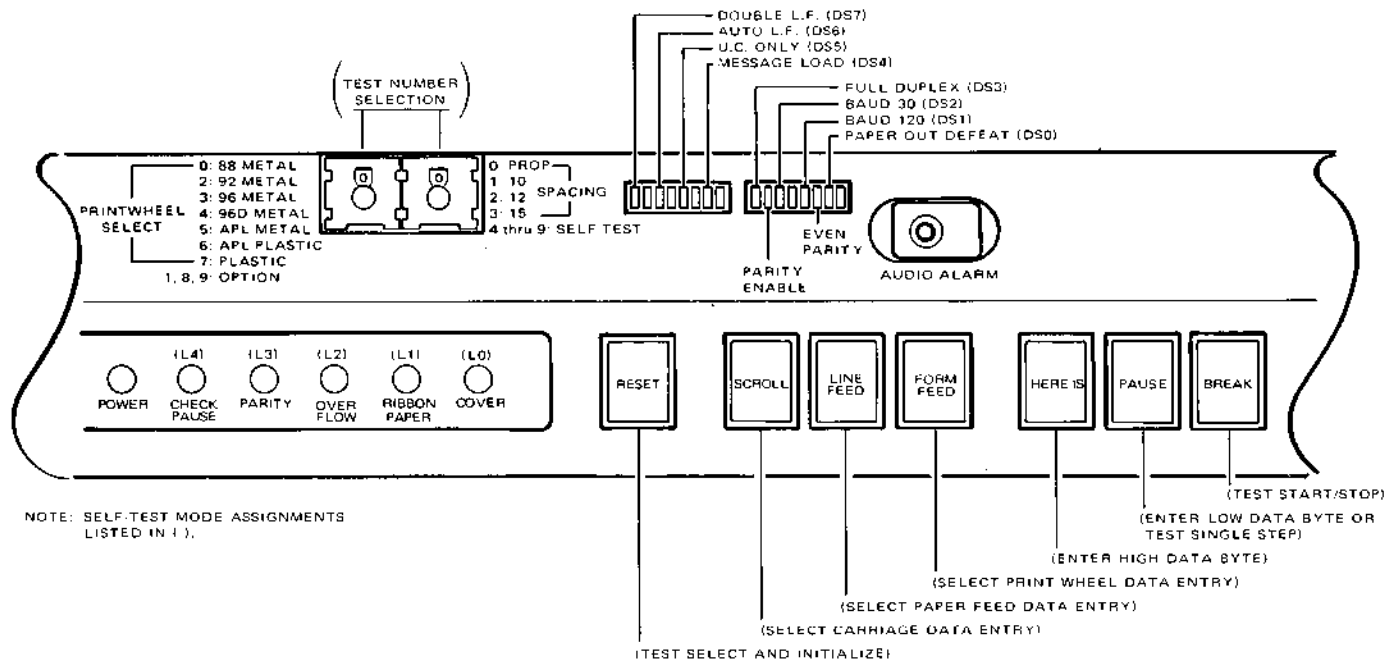

Figure 3-6. HPRO5 OPERATOR CONTROL PANEL - SELF-TEST MODE

LIGHTS

COVER OPEN
RIBBON/PAPER OUT
OVERFLOW
PARITY
CHECK/PAUSE

REDEFINED

L0
L1
L2
L3
L4

DATA SWITCHES

PAPER OUT DEFEAT DS0
SPEED 120 DS1
SPEED 30 DS2
FULL DUPLEX DS3
MESSAGE LOAD DS4
UPPERCASE ONLY DS5
AUTO LINE FEED DS6
DOUBLE LINE FEED DS7

FUNCTION SWITCHES

RESET	TEST SELECT AND INITIALIZE
SCROLL	SELECT CARRIAGE DATA ENTRY
LINE FEED	SELECT PAPER FEED DATA ENTRY **
FORM FEED	SELECT PRINT WHEEL DATA ENTRY
HERE IS	ENTER HIGH DATA BYTE
PAUSE *	ENTER LOW DATA BYTE (Acts as single-step switch if not preceded by "SELECT DATA ENTRY")
BREAK	TEST START/STOP (alternate action)

* The Pause function is not present in some units, and this switch may or may not be labeled. The switch is always present, however, and during the self-test mode it functions the same regardless of its labeling.

** In Test 31, the Line Feed switch serves to input the alternate Print Wheel Data Entry.

3.4.3.2 Individual Test Selection and Operation

The general procedure to select and initiate each test is given below, followed by a list giving the test number and title of each individual test available in the self-test mode. A complete explanation of each test is given in subsection 3.4.3.3, Individual Test Definitions.

Test Procedure:

- 1) With the AC power switched OFF, set the SPACING switch on the control panel to the Self-Test position (any position 4 - 9).
- 2) Turn ON the AC power. At power-up, the buzzer will sound briefly and the word "test" will be printed. The Model 630 is now in the Self-Test mode.
- 3) Use the two rotary switches on the control panel to select the test number desired. The left-hand switch selects the left digit of the test number and the right-hand switch selects the right digit.

- 4) Press the RESET switch. This loads the test selected by the two rotary switches.
- 5) Press the BREAK switch to start the test. The BREAK switch functions as an alternate-action start/stop switch; pressing this switch a second time will stop the test.
- 6) When the test has been stopped by the BREAK switch, the PAUSE switch can be used to single step the test. Each time the PAUSE switch is pressed, the test will advance one step.

Tests of HPRO5 and Associated Components

This series of tests is designed to verify the basic operation of the HPRO5 board, the serial interface, the control panel and the keyboard.

Test 00 - ROM TEST
 01 - RAM TEST
 03 - SERIAL INTERFACE WRAPAROUND TEST

PCE and SCE Tests

In this series of tests the PCE circuit board is tested first by verifying the functional capability of both 8041's. Once the PCE board has been verified, the SCE circuit board may be tested by exercising the print wheel and carriage servos to check for proper operation and alignment. Printer hardware status may also be read from the print wheel 8041. The automatic print wheel retry capability of the PCE board is inhibited during self-test to maximize the detection of any servo errors.

Test 20 - 8041 ROM TEST
 22 - PCE PRINTER STATUS TEST

 30 - PRINT WHEEL RESTORE TEST
 31 - PRINT WHEEL SERVO TEST

 40 - CARRIAGE RESTORE TEST
 41 - CARRIAGE SERVO TEST

 50 - SERVO DISABLE and DISPLAY CHECK STATUS
 51 - PAPER FEED TEST

Overall Printer Verification Tests

These are high level tests that require the correct print wheel to be selected on the control panel switch for proper printout. In all of these tests, both the carriage servo and the print wheel servo will be restored when the RESET switch is pressed. If any errors are detected, the test will halt and the error status will be displayed.

Note: "X" denotes an unspecified setting of the PRINTWHEEL SELECT switch on the control panel, but the setting must match the print wheel being used.

Test X4 - Combined HORIZONTAL MOTION TEST, VERTICAL MOTION TEST and PRINT TEST
 X5 - SWIRL TEXT PRINTOUT
 X7 - CONFIDENCE TEST

3.4.3.3 Individual Test Definitions

Test 00 - ROM Test

This test verifies the integrity of the data contained in the program ROMs by calculating a 16-bit checksum using the standard CRC-16 algorithm which has a specified high accuracy of error detection. All ROMs are checked individually. If an error is found, the test will halt and the number of the ROM that does not check correct will be displayed on the control panel lights. (See the HPRO5 schematic in Section 7 for ROM locations.) The definitions of the error lights are:

L4	L3	L2	L1	L0	
0	0	0	0	1	= ROM 1
0	0	0	1	0	= ROM 2
0	0	0	1	1	= ROM 3
0	0	1	0	0	= ROM 4

Note: 1 = ON
0 = OFF

Test 01 - RAM Test

This test verifies the ability of all RAM, including expanded RAM, to be written to and read from without any bit errors. A random bit pattern is generated by a pseudo-random number generator and written to each RAM location. The random number generator is reset and then used to verify that each RAM location contains the correct pattern. The number of passes will be displayed as the test executes. If an error is found, the test will halt and the number of the RAM that does not check correct will be displayed by the control panel lights. (See the HPRO5 schematic in Section 7 for RAM locations.) The definitions of the error lights are:

L4	L3	L2	L1	L0	
0	0	0	0	1	= SCRATCH RAM (resides in the 8155 IC)
0	0	0	1	0	= RAM 1
0	0	0	1	1	= RAM 2
0	0	1	0	0	= RAM 3

Note: 1 = ON
0 = OFF

Test 03 - Serial Interface Wraparound Test

This test checks operation of the USART, serial interface drivers and receivers, interface cabling and rear panel interface connector. This test requires that a special wraparound plug be installed in the 25-pin interface connector on the rear panel. The wraparound plug enables testing of the serial interface control lines by connecting the output lines directly to the appropriate input lines. An 8-bit data pattern is generated and sent out on the TRANSMIT DATA interface line. This data is received back in through the RECEIVE DATA interface line via the wraparound plug. The received data is then verified. During the test, the status of the USART on the HPRO5 circuit board is displayed by the control panel lights as defined below. Prior to selecting the test by pressing the RESET switch,

the desired baud rate and parity checking must be selected on the control panel. (At 1200 baud, control panel lights L3 and L4 give a good, rapid display of bits 6 and 7 of the test data being received.)

Definitions of the Control Panel lights while the test is in progress

- L0 - indicates state of the DSO control panel switch via the DATA TERMINAL READY (DTR) and DATA SET READY (DSR) interface lines.
- L1 - indicates state of the DS1 switch via the REQUEST TO SEND and CLEAR TO SEND interface lines.
- L2 - indicates state of the DS2 switch via the OPTION 1 (PRINTER READY) and CARRIER DETECT interface lines.
- L3 - RECEIVED DATA LIGHT BIT 6
- L4 - RECEIVED DATA LIGHT BIT 7 - MSB - (ALWAYS 0 IF PARITY ENABLED)

Note: L0, L1 and L2 are always ON if the current loop option is installed.

During the test, both firmware and hardware (the wraparound plug) serve to connect lights L0, L1 and L2 to their respective control panel switches, DS0, DS1 and DS2, via the control interface lines listed above. The condition of each of these interface loops can be verified by manipulating the switches and observing the response of the associated indicator lights.

Definitions of the Control Panel lights if an error is detected (test stops)

- L0 - PARITY ERROR (USART DETECTED)
- L1 - OVERRUN ERROR (USART DETECTED)
- L2 - FRAMING ERROR (USART DETECTED)
- L3 - BREAK ERROR (USART DETECTED)
- L4 - ERROR FOUND BY PROGRAM BUT NOT DETECTED BY USART

The Wraparound Plug

The wraparound plug can be assembled using a standard 25-pin EIA interface plug with its pins interconnected as listed below:

<u>Signal</u>	<u>Pin</u>	connects to	<u>Pin</u>	<u>Signal</u>
+DATA TERMINAL READY	20		6	+DATA SET READY
+REQUEST TO SEND	4		5	+CLEAR TO SEND
+PRINTER READY	11		8	+CARRIER DETECT
-XMIT DATA	2		3	-DATA RECEIVED
 (Current Loop only):				
RECEIVE SOURCE	23		10	RECEIVE DATA
+XMIT DATA	18		21	-RECEIVE DATA
-XMIT DATA	19		7	XMIT SINK

Test 20 - 8041 ROM Test

This test verifies the checksum for each 8041 UPI by using the 8041's built-in checksum routine. The number of passes through the test will be displayed by the control panel lights. If an error is found, the test will halt and the failing 8041 will be identified by the control panel lights. The error light definitions are:

- L0 - CARRIAGE 8041 ROM
- L1 - PRINT WHEEL 8041 ROM
- L2 - ALWAYS OFF DURING ERROR DISPLAY
- L3 - ALWAYS OFF DURING ERROR DISPLAY
- L4 - ALWAYS OFF DURING ERROR DISPLAY

Test 22 - PCE Printer Status Test

This test checks the hardware status sensors by reading printer status from the PW 8041 UPI and displaying it on the control panel lights. The Ribbon Out, Paper Out, Cover Open and Multicopy switches are checked. Actuating these switches during the test should cause a response by the corresponding indicator light on the control panel. The light definitions during this test are:

- L0 - Multicopy Lever Down (4-6 copies)
- L1 - Ribbon Out
- L2 - Paper Out
- L3 - Cover Open
- L4 - Always OFF

Test 30 - Print Wheel Restore Test

This test allows the print wheel to be restored alone. The carriage servo must not be in Check for this test to function properly. The PW 8041 automatic error retry function is inhibited.

Test 31 - Print Wheel Servo Test

This test allows exercising of the print wheel without affecting the other servos. The print wheel will alternately seek to the two spoke positions specified by the control panel switches. The hammer will fire with the energy specified by the control panel switches; if the specified hammer energy is zero, the hammer will not fire. The ribbon will advance the number of steps specified by the control panel switches; if the specified number of steps is zero, the ribbon will not advance. The ribbon lift position will be controlled by the MSB of the Low Byte, as defined below. The print wheel servo will be restored when the RESET switch is pressed. This test will not function if the carriage servo is in a Check condition.

The command bits are defined below, followed by the procedure for loading the commands. The eight bits of each command byte are set by use of the eight slide switches on the control panel. Each bit is controlled by the switch that occupies the same relative position in the row of switches.

PRINT WHEEL COMMAND

DS SWITCHES

	□ □ □ □ □ □ □ □				□ □ □ □ □ □ □ □				STEP	<u>TO LOAD, PRESS:*</u>
	<u>7</u>	<u>6</u>	<u>5</u>	<u>4</u>	<u>3</u>	<u>2</u>	<u>1</u>	<u>0</u>		
<u>High Byte</u> =	X	H	H	H	R	R	R	R	2)	FORM FEED - HERE IS
									4)	LINE FEED - HERE IS
<u>Low Byte</u> =	U	S	S	S	S	S	S	S	3)	FORM FEED - PAUSE
									5)	LINE FEED - PAUSE

X - DON'T CARE
H - HAMMER ENERGY (0 - 7)
R - RIBBON ADVANCE STEPS (0 - 15)
U - RIBBON UP (1) / RIBBON DOWN (0)
S - ABSOLUTE ELECTRICAL SPOKE # (0 - 95)

* Follow steps 1 thru 6 below for the proper sequence of loading this test.

- 1) With the Model 630 in the self-test mode, set the rotary switches for Test 31, and press the RESET switch to input the test selection.
- 2) Set the control panel switches as desired for the high byte of the first alternate print wheel command. Press the FORM FEED switch on the control panel, followed by the HERE IS switch.
- 3) Set the control panel switches as desired for the low byte of the first alternate print wheel command. Press the FORM FEED switch and then the PAUSE switch.
- 4) Set the control panel switches as desired for the high byte of the second alternate print wheel command. Press the LINE FEED switch and then the HERE IS switch.
- 5) Set the control panel switches for the low byte of the second print wheel command. Press the LINE FEED switch and then the PAUSE switch.
- 6) Press the BREAK switch to start the test.

Test 40 - Carriage Restore Test

This test allows the carriage to be restored alone. The test is not affected by the print wheel being in a Check condition.

Test 41 - Carriage Servo Test

This test allows exercising the carriage without affecting the other servos. The carriage will seek in the forward direction (rightward), in the reverse direction (leftward) or alternately as specified by the two bytes of the Carriage Data Command. The Carriage Data Command is entered in two stages (High Byte and Low Byte) similar to the procedure

used in Test 31. When alternate carriage movement is selected, the carriage will move back and forth between the carriage starting position and the carriage position specified in the carriage command

Note: There are some subtle characteristics of this test that the operator must keep in mind in order to avoid confusion:

1. If the test parameters are changed by altering one or more switch settings and loading a new Carriage Command while the test is in progress, there is a lag of one step between loading of the new command and a corresponding change in carriage motion.
2. The present position of the carriage must be such that the next commanded movement does not exceed the available distance for carriage travel, otherwise a Check condition will occur. For example, if the carriage is at its left limit and reverse (leftward) motion is commanded, the carriage contacts the left carriage stop, and a Check condition occurs.
3. When forward alternate carriage movement is specified the carriage motion will be displaced rightward from the starting position of the carriage. When reverse alternate carriage movement is specified, the carriage will be displaced leftward.

CAUTION: There is NO protection against a carriage crash during this test. Care must be used to avoid specifying a seek distance that exceeds the distance available for the carriage to move. Although the Carriage Command can generate a displacement of up to 4095 increments, the largest displacement that the carriage can ever safely move is 1572 increments (the distance from left-hand to right-hand limits of carriage travel).

The carriage servo will be restored when the RESET switch is pressed. The command bit definitions are listed below, followed by the procedure for loading the commands.

CARRIAGE COMMAND

DS SWITCHES

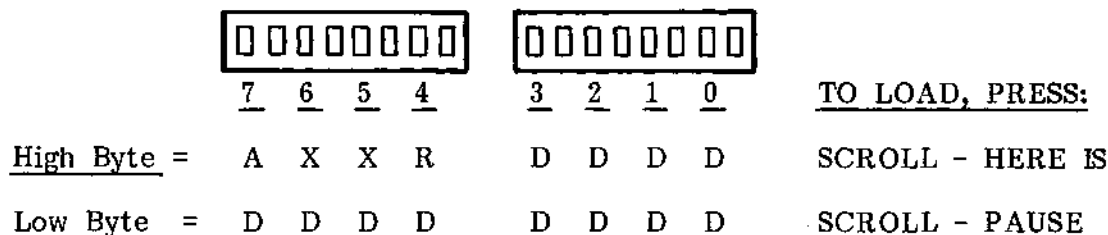

- A - ALTERNATE DIRECTION
- X - DON'T CARE
- R - REVERSE DIRECTION (0 = RIGHT, 1 = LEFT)
- D - CARRIAGE DISPLACEMENT (0 - 4095, 1572 MAXIMUM PERMISSABLE!)

- 1) With the Model 630 in the self-test mode, set the rotary switches for Test 41. Press the RESET switch to input the test selection.
- 2) Set the control panel switches as desired for the high byte of the carriage command. Press the SCROLL switch on the control panel, followed by the HERE IS switch.
- 3) Set the control panel switches as desired for the low byte of the carriage command. Press the SCROLL switch and then the PAUSE switch.
- 4) Press the BREAK switch to start the test.

Test 50 - Disable Servo and Display Check Status

In this test, the servos are disabled and a motion command is sent to both the print wheel servo and carriage servo to force a Check condition. This verifies that both servos can be disabled, and that a Check condition can be detected (indicated by lights L0 and L1). Upon being selected, this test will execute immediately when the RESET switch is pressed.

Both servos must be restored after this test to enable proper operation. This can be done in the self-test mode by executing a carriage restore (Test 40) and a print wheel restore (Test 30). The carriage servo must be restored first since the print wheel servo cannot be restored while the carriage servo is in Check.

In a properly operating unit, the test will execute as described above. This test can also be used to read and display the status of an existing Check condition. When the RESET switch is pressed for test selection, the existing Check condition will be detected by the presence of a status flag from the affected 8041 UPL. This causes the status byte to be read from the 8041, and the status displayed per the bit definitions given below. It is important to note that when the status byte is read, the status flag resets as in normal operation; however, the unit has not executed a normal restore operation, and thus the Check condition still exists. This Check condition must be cleared before normal operation or testing can be resumed.

The Check status definitions are:

- L0 - CARRIAGE
- L1 - PRINT WHEEL
- L2 - PRINT WHEEL AUXILIARY STATUS BIT*
- L3 - PRINT WHEEL AUXILIARY STATUS BIT*
- L4 - ALWAYS 0

* AUXILIARY STATUS BIT DEFINITIONS:

L3	L2	
0	0	- No Print Wheel Home Signal
0	1	- More Than 8 Retries Required
1	0	- Check With Auto Retry Inhibited
1	1	- Excessive Time Between +XING Signal

Note: 1 = ON
0 = OFF

Test 51 - Paper Feed Test

This test allows exercising of the paper feed drive without affecting the other servos. The paper feed will seek in the forward direction, in the reverse direction, or alternately as specified by the two bytes of the Paper Feed Command. The largest distance that the paper feed can move is 2047 increments. The definitions of the command bits are as follows:

PAPER FEED COMMAND

DS SWITCHES

	<table border="1"><tr><td>□</td><td>□</td><td>□</td><td>□</td><td>□</td><td>□</td><td>□</td><td>□</td></tr></table>	□	□	□	□	□	□	□	□	<table border="1"><tr><td>□</td><td>□</td><td>□</td><td>□</td><td>□</td><td>□</td><td>□</td><td>□</td></tr></table>	□	□	□	□	□	□	□	□	
□	□	□	□	□	□	□	□												
□	□	□	□	□	□	□	□												
	<u>7</u>	<u>6</u>	<u>5</u>	<u>4</u>	<u>3</u>	<u>2</u>	<u>1</u>	<u>0</u>	<u>TO LOAD, PRESS:</u>										
<u>High Byte</u> =	A	X	X	R	X	D	D	D	LINE FEED - HERE IS										
<u>Low Byte</u> =	D	D	D	D	D	D	D	D	LINE FEED - PAUSE										

A - ALTERNATE DIRECTION
X - DON'T CARE
R - REVERSE DIRECTION (0 = UP, 1 = DOWN)
D - PAPER FEED DISTANCE (2047 MAXIMUM)

- 1) With the Model 630 in the self-test mode, set the rotary switches for Test 51. Press the RESET switch to input the test selection.
- 2) Set the control panel switches as desired for the high byte of the Paper Feed Command. Press the LINE FEED switch and then the HERE IS switch.
- 3) Set the control panel switches as desired for the low byte of the Paper Feed Command. Press the LINE FEED switch and then the PAUSE switch.
- 4) Press the BREAK switch to start the test.

Test X4 - Combined Horizontal and Vertical Motion and Print Test

This test enables printing any two-character pattern in any direction at any resolution or pitch setting desired. The horizontal motion is controlled by the 16-bit value of the Carriage Command as described for Test 41. For this test, however, the carriage is "crash proof". Carriage motion is executed with left and right wraparound at either end of a line.

The vertical motion is controlled by the 16-bit value of the Paper Feed Command as described for Test 51. Paper feed motion is executed whenever horizontal motion wraps around at either end of a line.

The two printable characters are defined by the Low Byte (CHARACTER 1) and the High Byte (CHARACTER 2) of the Print Wheel Command. The procedure for print wheel character selection is similar to that in Test 31, however, the bit definitions given below for the Print Wheel Command reveal several differences. Most notable is the fact that in this test a single Print Wheel Data Entry specifies both print wheel characters, with the Low

Byte selecting the first character, and the High Byte selecting the second character. Another difference is that the print wheel characters are specified by their assigned ASCII code instead of by absolute addressing to a print wheel spoke. CHARACTER 1 will always be the first character printed after any paper motion. If CHARACTER 2 is a null (all zeros), then CHARACTER 1 will be repeated. If either character is nonprintable, a space will be substituted. The correct character font must be selected by the PRINT WHEEL SELECT switch.

The procedure for executing this test is given below, following the bit definitions for the associated command bytes.

PRINT WHEEL COMMAND

DS SWITCHES



TO LOAD, PRESS:

High Byte = R₂ D₂ D₂ D₂ D₂ D₂ D₂ D₂ FORM FEED - HERE IS

Low Byte = R₁ D₁ D₁ D₁ D₁ D₁ D₁ D₁ FORM FEED - PAUSE

- R₁ - RIBBON LIFT FOR CHARACTER 1 (1 = UP, 0 = DOWN)
- D₁ - ASCII CODE FOR CHARACTER 1
- R₂ - RIBBON LIFT FOR CHARACTER 2 (1 = UP, 0 = DOWN)
- D₂ - ASCII CODE FOR CHARACTER 2

CARRIAGE COMMAND

DS SWITCHES



TO LOAD, PRESS:

High Byte = A X X R D D D D SCROLL - HERE IS

Low Byte = D D D D D D D D SCROLL - PAUSE

- A - ALTERNATE DIRECTION
- X - DON'T CARE
- R - REVERSE DIRECTION (0 = RIGHT, 1 = LEFT)
- D - CARRIAGE DISPLACEMENT (0 - 4095)

PAPER FEED COMMAND

DS SWITCHES

	□□□□□□□□				□□□□□□□□				
	<u>7</u>	<u>6</u>	<u>5</u>	<u>4</u>	<u>3</u>	<u>2</u>	<u>1</u>	<u>0</u>	<u>TO LOAD, PRESS:</u>
<u>High Byte</u> =	A	X	X	R	X	D	D	D	LINE FEED - HERE IS
<u>Low Byte</u> =	D	D	D	D	D	D	D	D	LINE FEED - PAUSE

A - ALTERNATE DIRECTION
X - DON'T CARE
R - REVERSE DIRECTION (0 = UP, 1 = DOWN)
D - PAPER FEED DISTANCE (2047 MAXIMUM)

Note: The loading of the Print Wheel, Carriage and Paper Feed commands for this test are independent operations, and thus can be performed in any order desired. It is not necessary that they be loaded in the same order described below.

- 1) With the Model 630 in the self-test mode, set the rotary switches for Test X4. Press the RESET switch to input the test selection.
- 2) Set the control panel switches as desired for the high byte of the print wheel command defined above. Press the FORM FEED switch, followed by the HERE IS switch.
- 3) Set the switches as desired for the low byte of the print wheel command. Press the FORM FEED switch, followed by the PAUSE switch.
- 4) Load the carriage command according to steps 2 thru 4 of the procedure given under Test 41.
- 5) Load the paper feed command according to steps 2 thru 4 of the procedure given under Test 51.
- 6) Press the BREAK switch to start the test.

Test X5 - Swirl Text Printout

This pattern is an incrementing ASCII character string that is printed for a total of 132 characters followed by a carriage return - line feed. The first character of each succeeding line is incremented from the previous line. This generates the swirl or scrolling appearance. Thus each ASCII character is eventually printed at each character position. The printout is continuous.

Test X7 - Overall Confidence Test

This test is a combination of all of the above tests, except Paper Feed, executed in sequence. The results of each test are printed out on the printer, as shown in Figure 3-5. The tests will halt with all lamps lit before the swirl text printout if any errors are

are executed in the following order:

HPRO5 TESTS - 8085 ROM TEST
 - 8085 RAM TEST

PCE-SCE TESTS - 8041 ROM TEST

Only with -01 or -02
base firmware {
 - CARRIAGE SERVO TEST (132 character positions)
 - CARRIAGE RESTORE
 - PRINT WHEEL SERVO TEST (all spoke positions)
 - PRINT WHEEL RESTORE

SWIRL TEXT PRINTOUT (96 lines)

After the 96 lines of swirl text, the test repeats.

3.4.4 Remote Diagnostics - HPRO5

The remote diagnostics option allows the interrogation of machine parameters and status through the serial interface.

3.4.4.1 Diagnostic Commands

The following diagnostic commands are included in this option:

ESC SUB I	Initialize the printer (standard in Basic HPRO5)
ESC SUB R	Remote error reset (standard in Basic HPRO5)
ESC SUB 1	Request status byte 1
ESC SUB 2	Request status byte 2
ESC SUB U	Enter user (programmable) test mode
ESC SUB W (n)	Enter wraparound (echo) test mode
ESC SUB X	Exit test mode
DEL	Error correct backspace (user test mode only)
STX	Print buffer once (user test mode only)
SOH	Print buffer repeatedly (user test mode only)

3.4.4.2 Diagnostics Interface Protocol

Status information is not supplied to the interface of any keyboard-equipped Model 630 while it is in LOCAL mode. All diagnostic commands are processed immediately when received and are not queued. This means all status reported will be the status present at the time the command was received. Only the low 7 bits (bits 0 thru 6) of a status byte are significant. Their equivalent value may range from 0 to 127. The MSB (bit 7) will be a parity bit as defined by the PARITY ENABLE and PARITY EVEN/ODD switches. All commands that generate a response from the Model 630 will result in a status byte being sent to the host computer preceded by an STX character. The STX identifies the next byte as a status byte. The rules for ETX/ACK and DC1/DC3 protocols are applicable and should be used for sending status requests to the Model 630.

3.4.4.3 Diagnostic Command Definitions

ESC SUB I

This command causes the Model 630 to unconditionally execute an initialize sequence regardless of any error conditions that may exist within the printer. This command is executed immediately when received over the interface, unlike the corresponding remote reset sequence ESC CR P which is queued along with other commands. The Model 630 will default to the same conditions that exist at power up. Prior to sending this command, the host should send a nonprinting character to cause the Model 630 to abort any multiple character sequence in progress.

ESC SUB R

This command causes the Model 630 to reset any error conditions. It produces essentially the same result as pressing the RESET switch on the control panel. If the unit is in check, it will execute a restore. Due to internal program latency, the minimum time necessary to reset all errors is 250 milliseconds.

In a situation where the terminal is being operated without a control panel (not typical), a series of up to eight automatic restores occurs if the terminal goes into a check condition. The ESC SUB R sequence has the effect of resetting the automatic restore counter to enable another series of automatic restore operations.

ESC SUB 1

This command will cause the Model 630 to send a status report byte (STATUS 1) thru the interface. The true-state bit definitions for this status byte are:

<u>Bit</u>	<u>Status</u>
0	End of Ribbon
1	10 Pitch (This bit false if any other pitch is selected)
2	Paper Out
3	Auto Line Feed enabled (set by switch on control panel, or by ESC sequence if no control panel.)
4	Cover Open
5*	Printer Idle (no motion, and print queue empty)
6	Printer In Check
7	Parity Bit **

* Bit 5 represents "Buffer Full" if Options ROM at location F32 on HPRO5 board is at design level earlier than 302839-03 (or 100524-02 if EROM).

** The state of bit 7 is defined by the PARITY ENABLE and PARITY EVEN/ODD switches on the control panel.

ESC SUB 2

This command will cause the Model 630 to send a status report byte (STATUS 2) thru the interface. The true-state bit definitions for this status byte are:

0	Control Panel Option present	4	Reverse Print Mode enabled (inverted horizontal motion)
1	Diablo Keyboard Option present	5	Paper Out Defeat enabled (always 0 if no control panel)
2	Auto Carriage Return enabled	6	Full-Duplex enabled
3	Double Line Feed enabled (always 0 if no control panel)	7	Parity Bit *

* The state of bit 7 is defined by the PARITY ENABLE and PARITY EVEN/ODD switches on the control panel.

ESC SUB U

This command will cause the Model 630 HPRO5 to enter the USER (programmable) test mode. In this mode the user can enter any command sequence to the Model 630 up to within 5 characters from the end of the buffer. The Model 630 can then be commanded to execute the contents of the print buffer either once or repeatedly. All standard and optional ESC sequences are valid except REMOTE DIAGNOSTIC commands. Any REMOTE DIAGNOSTIC commands in the buffer will be ignored. Both ETX/ACK and DC1/DC3 protocols function normally when entering data into the buffer. During buffer execution an ACK will be sent thru the serial interface for each ETX encountered in the buffer, if enabled. DC1/DC3 does not function during buffer execution. USER test mode can be exited by issuing either ESC SUB X or ESC SUB I sequence. All other incoming commands will be ignored during buffer execution.

ESC SUB W (n)

This command will cause the Model 630 to enter the WRAPAROUND (echo) test mode. In this mode, the Model 630 sends back to the host computer each byte (n) that it receives, using the same protocol as status commands. The echoing starts with the first byte following the ESC SUB W sequence. The Model 630 will automatically exit WRAPAROUND mode when in LOCAL mode. WRAPAROUND mode may be exited by issuing either ESC SUB X or ESC SUB I sequence. The ESC SUB X sequence will be echoed back to the host computer.

ESC SUB X

This command will cause the Model 630 to exit both WRAPAROUND and USER test modes immediately. When in USER test mode, the Model 630 will finish the execution of the buffer if in progress when the ESC SUB X was received, and will simultaneously accept new data from the interface.

DEL

The DEL or RUBOUT character is used for error correction when entering data into the buffer in USER test mode. The buffer pointer will be backed up one position, and the previous character echoed on the printer for each DEL received. All control characters except SPACE, BACKSPACE, CARRIAGE RETURN and LINE FEED will be echoed as the uppercase ASCII equivalent preceded by an exclamation mark (!). An ESCAPE character will be echoed as a dollar sign (\$). The DEL character is ignored during an ESCAPE sequence, to prevent invalid ESC sequences. If the incoming data is received faster than the speed of the print mechanism, the entire RUBOUT and ECHO sequence will be transparent; that is, the buffer pointer will be backed up but the deleted character(s) may not be echoed on the printer.

STX

The STX character will cause the content of the print buffer to be executed one time only, when in USER test mode. If the buffer is being executed repeatedly (SOH character), receiving an STX character will cause the Model 630 to return to single cycle execution mode at the end of the buffer. The SOH and STX characters may still be used as the third character of a three character sequence in USER test mode. They will not cause the buffer to be executed when included within a valid ESCAPE sequence. Data may no longer be entered into or deleted from the buffer after receiving an SOH or STX execution character without first exiting and then reentering USER test mode. A BREAK in USER test mode will cause the Model 630 to go back to buffer entry mode which allows entering new test data without exiting USER test mode.

SOH

The SOH character will cause the content of the print buffer to be executed repeatedly. The Model 630 will continue buffer execution until being returned to single cycle execution mode (STX character), or exiting USER test mode (ESC SUB X or ESC SUB I).

3.5 DIAGNOSTICS - Model 630 API Terminals

3.5.1 API Self-Test

For all versions of the Model 630 API, the self-test mode is entered at power-on if the SELF TEST switch on the control panel is ON. The self-test consists of a ROM test, a RAM test and 96 lines of swirl text printed 132 columns wide. Figure 3-7 shows a sample of the API self-test printout. The internal RAM listed in the printout is located in the 8031 CPU device on the API board. All of the tested ROM and RAM memory is located on the API circuit board; specific locations are identified on the API circuit board schematic in Section 7 of this manual.

With the Model 630 ECS-API, the entire extended character set will be included in the swirl text printout if the control panel switches are set for ECS operation. However, since the printout is only 132 columns wide, several lines of the text must be printed before all of the characters have actually appeared in the printout.

If a sheet feeder is installed on the API terminal, the self-test differs only in that the swirl text printout is 84 columns wide, and if it is a dual tray feeder, it will feed from alternate trays for each successive sheet of test printout.

```
630-API.SELFTEST
ROM1.OK
ROM2.OK
INT.RAM.OK
EXT.RAM.OK
96 LINES  ¢! "#$%&'()*+,-./0123456789:;<=>?@ABCDEFGHIJKLMN
OPQRSTUVWXYZ[\]^_
!"#$%&'()*+,-./0123456789:;<=>?@ABCDEFGHIJKLMN
OPQRSTUVWXYZ[\]^_
"#$%&'()*+,-./0123456789:;<=>?@ABCDEFGHIJKLMN
OPQRSTUVWXYZ[\]^_`a
#$%&'()*+,-./0123456789:;<=>?@ABCDEFGHIJKLMN
OPQRSTUVWXYZ[\]^_`ab
$%&'()*+,-./0123456789:;<=>?@ABCDEFGHIJKLMN
OPQRSTUVWXYZ[\]^_`abc
%&'()*+,-./0123456789:;<=>?@ABCDEFGHIJKLMN
OPQRSTUVWXYZ[\]^_`abcd
&'()*+,-./0123456789:;<=>?@ABCDEFGHIJKLMN
OPQRSTUVWXYZ[\]^_`abcde
'()*+,-./0123456789:;<=>?@ABCDEFGHIJKLMN
OPQRSTUVWXYZ[\]^_`abcdef
()*+,-./0123456789:;<=>?@ABCDEFGHIJKLMN
OPQRSTUVWXYZ[\]^_`abcdefg
) *+,-./0123456789:;<=>?@ABCDEFGHIJKLMN
OPQRSTUVWXYZ[\]^_`abcdefgh
132 COLUMNS
```

Figure 3-7. API SELF-TEST PRINTOUT

3.5.2 API Remote Diagnostics

The remote diagnostics feature allows interrogation of machine parameters and status through the interface. The API remote diagnostic commands are:

ESC SUB I	Initialize the printer
ESC SUB R	Remote error reset
ESC SUB SO	Memory Test
ESC SUB 1	Request status byte 1
ESC SUB 3	Request status byte 3

All diagnostic commands are processed immediately when received and are not queued. This means all status reported will be the status present at the time the command was received. Only the low 7 bits (bits 0 thru 6) of a status byte are significant. Their equivalent value may range from 0 to 127. The MSB (bit 7) will be a parity bit as defined by the PARITY ENABLE and PARITY EVEN/ODD switches. All commands that evoke a response from the Model 630 will result in a status byte being sent to the host computer preceded by an STX character. The STX identifies the following byte as a status byte. The rules for DC1/DC3, and Printer Ready protocols are applicable and should be used for sending status requests to the Model 630.

3.5.2.1 ESC SUB I

This command will cause the Model 630 to unconditionally execute an initialize sequence regardless of any error conditions that may exist within the printer. This command is executed immediately when received over the interface, unlike the corresponding remote reset sequence ESC CR P which is queued along with other commands. The Model 630 will default to the same conditions that exist at power-up. Before sending this command, the host should send a nonprinting character to cause the Model 630 to abort any multiple character sequence in progress.

3.5.2.2 ESC SUB R

This command causes the Model 630 to reset any error conditions. It produces essentially the same result as pressing the RESET switch on the control panel. If the unit is in check, it will execute a restore. Due to internal program latency, the minimum time necessary to reset all errors is 250 milliseconds.

In a situation where the terminal is being operated without a control panel, a series of up to eight automatic restores occurs if the terminal goes into a check condition. The ESC SUB R sequence causes the automatic restore counter to be reset to enable another series of automatic restore operations.

3.5.2.3 ESC SUB SO

This command will cause API to do memory test and send the result through the interface. The true-state bit definitions in the result byte are:

0	ROM 1 bad	4	(not used)
1	ROM 2 bad	5	(not used)
2	Internal RAM bad	6	(not used)
3	External RAM bad	7	Parity bit

3.5.2.4 ESC SUB 1

This command will cause the Model 630 to send a status report byte (STATUS 1) through the interface. The true-state bit definitions for this byte are:

<u>Bit</u>	<u>Status</u>
0	End of ribbon
1	10 pitch (This bit false if any other pitch is selected)
2	Paper out

(continued)

- 3 Auto line feed enabled
- 4 Cover open
- 5 Printer idle (no motion, and print queue empty)
- 6 Printer in Check
- 7 Parity bit (Defined by the two parity control switches on the control panel.)

* The state of bit 7 is defined by the two parity control switches on the control panel.

3.5.2.5 ESC SUB 3

This command causes the Model 630 to send a status report byte (STATUS 3) thru the interface. This status byte pertains to a sheet feeder being used on the Model 630. The true-state bit definitions for this byte are:

<u>Bit</u>	<u>Status</u>
0	Insert not completed - denotes paper jam or out of paper
1	Exit not completed - denotes jam of paper during exit
2	Feeder present - Model F33 (dual tray plus envelopes) - see Table 3-2.
3	Feeder present - Model F32 (dual tray) or F33 - see Table 3-2.
4	(Not used)
5	Feeder present - Model F31 (single tray) - see Table 3-2.
6	Feeder in manual mode
7	Parity bit

* The state of bit 7 is defined by the two parity control switches on the control panel.

Table 3-2
FEEDER IDENTIFICATION

<u>Bit</u>			<u>Feeder Installed</u>
<u>2</u>	<u>3</u>	<u>5</u>	
0	0	0	None
0	0	1	F31
0	1	0	F32
1	1	0	F33

3.6 TEST OPERATING REFERENCES

The following charts contain reference data that is useful when implementing some of the diagnostic tests presented in the first part of this section.

3.6.1 ASCII Coding System

The ASCII Coding System is based on the American National Standard Code for Information Interchange, Standard No. X3.4-1977 of the American National Standards Institute.

Bits		b ₇ →	0	0	0	0	1	1	1	1		
		b ₆ →	0	0	1	1	0	0	1	1		
		b ₅ →	0	1	0	1	0	1	0	1		
b ₄ ↓	b ₃ ↓	b ₂ ↓	b ₁ ↓	COLUMN →	0	1	2	3	4	5	6	7
↓ ROW ↓				0	1	2	3	4	5	6	7	
0	0	0	0	0	NUL	DLE	SP	0	@	P	'	p
0	0	0	1	1	SOH	DC1	!	1	A	Q	a	q
0	0	1	0	2	STX	DC2	"	2	B	R	b	r
0	0	1	1	3	ETX	DC3	#	3	C	S	c	s
0	1	0	0	4	EOT	DC4	\$	4	D	T	d	t
0	1	0	1	5	ENQ	NAK	%	5	E	U	e	u
0	1	1	0	6	ACK	SYN	&	6	F	V	f	v
0	1	1	1	7	BEL	ETB	'	7	G	W	g	w
1	0	0	0	8	BS	CAN	(8	H	X	h	x
1	0	0	1	9	HT	EM)	9	I	Y	i	y
1	0	1	0	10	LF	SUB	*	:	J	Z	j	z
1	0	1	1	11	VT	ESC	+	;	K	[k	(
1	1	0	0	12	FF	FS	,	<	L	\	l	;
1	1	0	1	13	CR	GS	-	=	M]	m	}
1	1	1	0	14	SO	RS	.	>	N	^	n	~
1	1	1	1	15	SI	US	/	?	O	_	o	DEL

All characters in these two columns and SP (Space) are nonprinting. DEL (Delete) does not print in Remote mode. However, when DEL is entered on keyboard in Local mode, it prints the print wheel character addressed by ASCII code 7F (HEX) when operating with plastic print wheels, or 3F (HEX) when operating with metal print wheels. (This character is also printed in place of characters received with parity or framing error.) When UPPERCASE ONLY is used, shaded lowercase characters (columns 6 & 7) from keyboard are converted to their uppercase equivalents (columns 4 & 5) before being printed or transmitted.

Figure 3-8. ASCII CODE CHART

3.6.2 Print Wheel Code Charts (Typical)

These charts provide a general sample of technical data for the different types of print wheels. Specific technical data pertaining to each print wheel available from Diablo Systems is contained in the Diablo Print Wheel Data Book, Publication No. 90044-XX.

The codes 20 Hex and 7F Hex are interpreted as "space" and "delete" respectively by the Model 630 and thus are not available for print wheel addressing. In place of these two codes, the ESC sequences ESC Y and ESC Z are used to address certain characters and thus provide a complete set of 96 codes for print wheel addressing. ESC Y and/or ESC Z are listed on the following charts where applicable.

ESC Y
⌘ 2 94
3

ESC Z
⌘ 1 95
1

		(MSB) b ₇				b ₆		b ₅		b ₄		b ₃		b ₂		b ₁				
		0	0	1	1															1
0	0	0	0	0	0	0	0	0	0	0	0	0	0	0	0	0	0	0	0	0
0	0	0	0	0	0	0	0	0	0	0	0	0	0	0	0	0	0	0	0	0
0	0	0	0	1	0	0	0	0	0	0	0	0	0	0	0	0	0	0	0	0
0	0	0	0	1	1	0	0	0	0	0	0	0	0	0	0	0	0	0	0	0
0	0	0	0	1	1	1	0	0	0	0	0	0	0	0	0	0	0	0	0	0
0	0	0	0	1	1	1	1	0	0	0	0	0	0	0	0	0	0	0	0	0
0	0	0	0	1	1	1	1	1	0	0	0	0	0	0	0	0	0	0	0	0
0	0	0	0	1	1	1	1	1	1	0	0	0	0	0	0	0	0	0	0	0
0	0	0	0	1	1	1	1	1	1	1	0	0	0	0	0	0	0	0	0	0
0	0	0	0	1	1	1	1	1	1	1	1	0	0	0	0	0	0	0	0	0
0	0	0	0	1	1	1	1	1	1	1	1	1	0	0	0	0	0	0	0	0
0	0	0	0	1	1	1	1	1	1	1	1	1	1	0	0	0	0	0	0	0
0	0	0	0	1	1	1	1	1	1	1	1	1	1	1	0	0	0	0	0	0
0	0	0	0	1	1	1	1	1	1	1	1	1	1	1	1	0	0	0	0	0
0	0	0	0	1	1	1	1	1	1	1	1	1	1	1	1	1	0	0	0	0
0	0	0	0	1	1	1	1	1	1	1	1	1	1	1	1	1	1	0	0	0
0	0	0	0	1	1	1	1	1	1	1	1	1	1	1	1	1	1	1	0	0
0	0	0	0	1	1	1	1	1	1	1	1	1	1	1	1	1	1	1	1	0
0	0	0	0	1	1	1	1	1	1	1	1	1	1	1	1	1	1	1	1	1

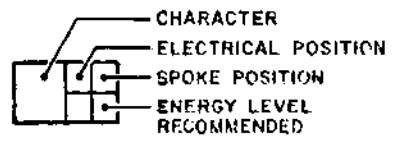

- NOTES:
1. USE ENERGY SWITCH POSITION M FOR NORMAL USE, FOR MULTISTACK.
 2. □ DESIGNATES RECOMMENDED LEVEL THAT DEVIATES FROM A STD. HYTYPE II PRINTER.
 3. CHARACTERS SHOWN ON THIS DRAWING DO NOT REFLECT AESTHETICS OF INDIVIDUAL TYPE STYLES.
 4. ELECTRICAL POSITION IS PRINTWHEEL SPOKE POSITION AS VIEWED FROM THE CHARACTER SIDE OF THE PRINTWHEEL.

Figure 3-9. 96-CHARACTER PRINT WHEEL - PLASTIC

ESC Y

⌘	5	91
		3

		(MSB) b7															
		b6	b5	b4	b3												
b4	b3	b2	b1														
				0	1	0	1	0	1	0	1	0	1	0	1	0	1
0	0	0	0	SP		0	86 10	@	75 21	P	10 86	,	41 18	p	67 29		
							4		4		4		1		4		
0	0	0	1	!	37 59	1	82 14	A	18 78	Q	52 44	a	59 37	q	72 24		
					2		2		4		4		3		4		
0	0	1	0	"	33 63	2	83 13	B	8 88	R	28 68	b	68 28	r	55 41		
					2		3		4		4		3		2		
0	0	1	1	#	92 4	3	84 12	C	36 60	S	14 82	c	62 34	s	51 45		
					4		3		3		4		3		3		
0	1	0	0	\$	7 89	4	85 11	D	32 64	T	19 77	d	60 36	t	53 43		
					4		3		4		3		3		3		
0	1	0	1	%	79 17	5	87 9	E	16 80	U	34 62	e	58 38	u	63 33		
					4		3		4		4		3		3		
0	1	1	0	&	77 19	6	88 8	F	22 74	V	12 84	f	45 51	v	64 32		
					4		3		4		4		3		3		
0	1	1	1	'	23 73	7	89 7	G	40 56	W	42 54	g	65 31	w	54 42		
					1		3		4		4		4		3		
1	0	0	0	(76 20	8	90 6	H	26 70	X	50 46	h	61 35	x	70 26		
					2		4		4		4		3		3		
1	0	0	1)	74 22	9	91 5	I	25 71	Y	44 52	i	47 49	y	66 30		
					2		3		3		4		2		3		
1	0	1	0	*	15 81	:	29 67	J	21 75	Z	6 90	j	49 47	z	71 25		
					3		2		3		3		3		3		
1	0	1	1	+	11 85	;	27 69	K	46 50			k	69 27	.	39 16		
					2		2		4				3		1		
1	1	0	0	,	78 55	1/4	81 15	L	20 76			l	43 53				
					1		4		3				2				
1	1	0	1	-	35 61	=	9 87	M	38 58			m	48 48				
					1		2		4				4				
1	1	1	0	.	80 57	1/2	73 23	N	24 72			n	57 39				
					1		4		4				3				
1	1	1	1	/	31 65	?	17 79	O	30 66		13 83	o	56 40	DEL			
					2		2		4		1		3				

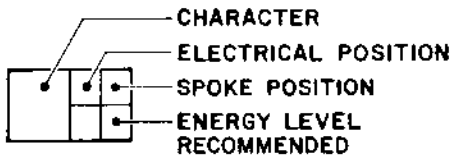

NOTES:

1. USE ENERGY SWITCH POSITION M FOR NORMAL USE, FOR MULTISTACK.
2. DESIGNATES RECOMMENDED LEVEL THAT DEVIATES FROM A STD HYTYPE II PRINTER.
3. CHARACTERS SHOWN ON THIS DRAWING DO NOT REFLECT AESTHETICS OF INDIVIDUAL TYPE STYLES.
4. ELECTRICAL POSITION IS PRINTWHEEL SPOKE POSITION AS VIEWED FROM THE CHARACTER SIDE OF THE PRINTWHEEL.

Figure 3-10. 88-CHARACTER PRINT WHEEL - METAL

ESC Y

5	91
3	

(MSB) b7				0	0	1	1	1	1						
b6				1	1	0	0	1	1						
b5				0	1	0	1	0	1						
b4	b3	b2	b1												
0	0	0	0	SP		0	86 10	@	75 21	P	10 86	,	41 18	p	67 29
0	0	0	1	!	37 59	1	82 14	A	18 78	Q	52 44	a	59 37	q	72 24
0	0	1	0	"	33 63	2	83 13	B	8 88	R	28 68	b	68 28	r	55 41
0	0	1	1	#	92 4	3	84 12	C	36 60	S	14 82	c	62 34	s	51 45
0	1	0	0	\$	7 89	4	85 11	D	32 64	T	19 77	d	60 36	t	53 43
0	1	0	1	%	79 17	5	87 9	E	16 80	U	34 62	e	58 38	u	63 33
0	1	1	0	&	77 19	6	88 8	F	22 74	V	12 84	f	45 51	v	64 32
0	1	1	1	'	23 73	7	89 7	G	40 56	W	42 54	g	65 31	w	54 42
1	0	0	0	(76 20	8	90 6	H	26 70	X	50 46	h	61 35	x	70 26
1	0	0	1)	74 22	9	91 5	I	25 71	Y	44 52	i	47 49	y	66 30
1	0	1	0	*	15 81	:	29 67	J	21 75	Z	6 90	j	49 47	z	71 25
1	0	1	1	+	11 85	;	27 69	K	46 50	2	3 93	k	69 27	.	39 16
1	1	0	0	,	78 55	1/4	81 15	L	20 76	£	4 92	l	43 53		
1	1	0	1	-	35 61	=	9 87	M	38 58	1/3	93 3	m	48 48		
1	1	1	0	.	80 57	1/2	73 23	N	24 72	3/4	94 2	n	57 39		
1	1	1	1	/	31 65	?	17 79	O	30 66	—	13 83	o	56 40	DEL	

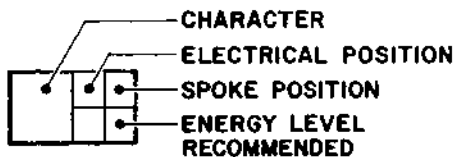

NOTES:

1. USE ENERGY SWITCH POSITION M FOR NORMAL USE, FOR MULTISTACK.
2. DESIGNATES RECOMMENDED LEVEL THAT DEVIATES FROM A STD HYTYPE II PRINTER.
3. CHARACTERS SHOWN ON THIS DRAWING DO NOT REFLECT AESTHETICS OF INDIVIDUAL TYPE STYLES.
4. ELECTRICAL POSITION IS PRINTWHEEL SPOKE POSITION AS VIEWED FROM THE CHARACTER SIDE OF THE PRINTWHEEL.

Figure 3-11. 92-CHARACTER PRINT WHEEL - METAL (Rank Xerox)

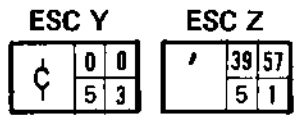

(MSB) b7				0	0	1	1	1	1						
b6				1	1	0	0	1	1						
b5				0	1	0	1	0	1						
b4	b3	b2	b1												
0	0	0	0	SP		0	86 10 5 4	@	75 21 8 4	P	10 86 6 4	'	95 1 5 1	p	67 29 5 4
0	0	0	1	!	37 59 3 2	1	82 14 5 2	A	18 78 7 4	Q	52 44 7 4	a	59 37 5 3	q	72 24 5 4
0	0	1	0	"	33 63 4 2	2	83 13 5 3	B	8 88 6 4	R	28 68 7 4	b	68 28 5 3	r	55 41 4 2
0	0	1	1	#	92 4 6 4	3	84 12 5 3	C	36 60 7 3	S	14 82 5 4	c	62 34 5 3	s	51 45 4 3
0	1	0	0	\$	7 89 5 4	4	85 11 5 3	D	32 64 7 4	T	19 77 6 3	d	60 36 5 3	t	53 43 4 3
0	1	0	1	%	79 17 8 4	5	87 9 5 3	E	16 80 6 4	U	34 62 7 4	e	58 38 5 3	u	63 33 5 3
0	1	1	0	&	77 19 7 4	6	88 8 5 3	F	22 74 6 4	V	12 84 6 4	f	45 51 4 3	v	64 32 5 3
0	1	1	1	'	23 73 2 1	7	89 7 5 3	G	40 56 7 4	W	42 54 8 4	g	65 31 5 4	w	54 42 7 3
1	0	0	0	(76 20 3 2	8	90 6 5 4	H	26 70 7 4	X	50 46 7 4	h	61 35 5 3	x	70 26 5 3
1	0	0	1)	74 22 3 2	9	91 5 5 3	I	25 71 3 3	Y	44 52 7 4	i	47 49 3 2	y	66 30 5 3
1	0	1	0	*	15 81 5 3	:	29 67 3 2	J	21 75 5 3	Z	6 90 6 3	j	49 47 3 3	z	71 25 5 3
1	0	1	1	+	11 85 5 2	;	27 69 3 2	K	46 50 7 4	[81 15 3 2	k	69 27 5 3	{	4 92 3 2
1	1	0	0	,	78 18 3 1	<	41 55 5 2	L	20 76 6 3	\	3 93 5 2	l	43 53 3 2		73 23 3 2
1	1	0	1	-	35 61 4 1	=	9 87 5 2	M	38 58 8 4]	1 95 3 2	m	48 48 8 4	}	93 3 3 2
1	1	1	0	.	80 16 3 1	>	5 91 5 2	N	24 72 7 4	^	2 94 5 1	n	57 39 5 3	~	94 2 5 1
1	1	1	1	/	31 65 4 2	?	17 79 5 2	O	30 66 7 4	_	13 83 5 1	o	56 40 5 3	DEL	

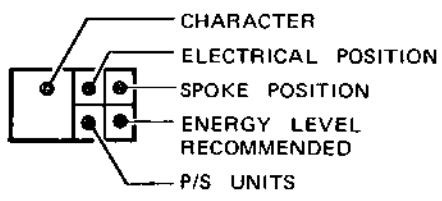

- NOTES-
1. USE ENERGY SWITCH POSITION M FOR NORMAL USE, FOR MULTISTACK.
 2. DESIGNATES RECOMMENDED LEVEL THAT DEVIATES FROM A STD HYTYPE II PRINTER.
 3. CHARACTERS SHOWN ON THIS DRAWING DO NOT REFLECT AESTHETICS OF INDIVIDUAL TYPE STYLES.
 4. ELECTRICAL POSITION IS PRINTWHEEL SPOKE POSITION AS VIEWED FROM THE CHARACTER SIDE OF THE PRINTWHEEL.

Figure 3-12. 96-CHARACTER PRINT WHEEL - METAL (Diablo)

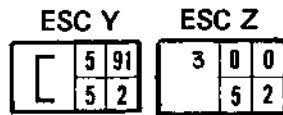

(MSB) b7				0	0	1	1	1	1						
b6				1	1	0	0	1	1						
b5				0	1	0	1	0	1						
b4	b3	b2	b1												
0	0	0	0	SP	0	86 10 5 4	@	75 21 8 4	P	10 86 6 4	,	41 18 3 1	p	67 29 5 4	
0	0	0	1	!	37 59 3 2	1	82 14 5 2	A	18 78 7 4	Q	52 44 7 4	a	59 37 5 3	q	72 24 5 4
0	0	1	0	"	33 63 4 2	2	83 13 5 3	B	8 88 6 4	R	28 68 7 4	b	68 28 5 3	r	55 41 4 2
0	0	1	1	μ	92 4 6 3	3	84 12 5 3	C	36 60 7 3	S	14 82 5 4	c	62 34 5 3	s	51 45 4 3
0	1	0	0	§	7 89 5 4	4	85 11 5 3	D	32 64 7 4	T	19 77 6 3	d	60 36 5 3	t	53 43 4 3
0	1	0	1	%	79 17 8 4	5	87 9 5 3	E	16 80 6 4	U	34 62 7 4	e	58 38 5 3	u	63 33 5 3
0	1	1	0	&	77 19 7 4	6	88 8 5 3	F	22 74 6 4	V	12 84 6 4	f	45 51 4 3	v	64 32 5 3
0	1	1	1	'	23 73 2 1	7	89 7 5 3	G	40 56 7 4	W	42 54 8 4	g	65 31 5 4	w	54 42 7 3
1	0	0	0	(76 20 3 2	8	90 6 5 4	H	26 70 7 4	X	50 46 7 4	h	61 35 5 3	x	70 26 5 3
1	0	0	1)	74 22 3 2	9	91 5 5 3	I	25 71 3 3	Y	44 52 7 4	i	47 49 3 2	y	66 30 5 3
1	0	1	0	*	15 81 5 3	:	29 67 3 2	J	21 75 5 3	Z	6 90 6 3	j	49 47 3 3	z	71 25 5 3
1	0	1	1	+	11 85 5 2	;	27 69 3 2	K	46 50 7 4]	3 93 6 4	k	69 27 5 3	.	39 16 3 1
1	1	0	0	,	78 55 3 1	¼	81 15 6 4	L	20 76 6 3	£	4 92 5 4	l	43 53 3 2	<	1 95 6 2
1	1	0	1	-	35 61 4 1	=	9 87 5 2	M	38 58 8 4	°	93 3 5 1	m	48 48 8 4	2	2 94 5 2
1	1	1	0	.	80 57 3 1	½	73 23 6 4	N	24 72 7 4	¾	94 2 6 4	n	57 39 5 3	>	95 1 6 2
1	1	1	1	/	31 65 4 2	?	17 79 5 2	O	30 66 7 4	—	13 83 5 1	o	56 40 5 3	DEL	

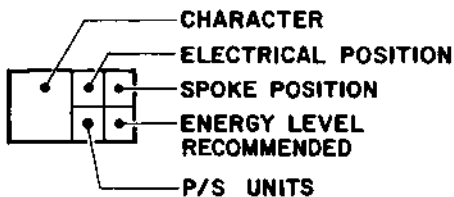

NOTES:

1. USE ENERGY SWITCH POSITION M FOR NORMAL USE, FOR MULTISTACK.
2. DESIGNATES RECOMMENDED LEVEL THAT DEVIATES FROM A STD HYTYPE II PRINTER.
3. CHARACTERS SHOWN ON THIS DRAWING DO NOT REFLECT AESTHETICS OF INDIVIDUAL TYPE STYLES.
4. ELECTRICAL POSITION IS PRINTWHEEL SPOKE POSITION AS VIEWED FROM THE CHARACTER SIDE OF THE PRINTWHEEL.

Figure 3-13. 96-CHARACTER PRINT WHEEL - METAL (Rank Xerox)

		PRIMARY CHARACTER SET								SUPPLEMENTARY CHARACTER SET							
ASCII HEX	HI LO	0	1	2	3	4	5	6	7	8	9	A	B	C	D	E	F
	0		NUL	DLE	SP	0	@	P	`	p		≠	SP	Π	e	π	o
1		SOH	DC1	!	1	A	Q	a	q	←	α			α	ρ	1	1
2		STX	DC2	"	2	B	R	b	r	→	∂		Σ	β	σ	2	2
3		ETX	DC3	#	3	C	S	c	s	↑		Γ		Υ	τ	3	3
4		EOT	DC4	\$	4	D	T	d	t	+		Δ	Τ	δ		4	4
5		ENO	NAK	%	5	E	U	e	u	⊙			Φ	ε	φ	5	5
6		ACK	SYN	&	6	F	V	f	v	□				ζ	χ	6	6
7		BEL	ETB	'	7	G	W	g	w	..			Ψ	η	ψ	7	7
8		BS	CAN	(8	H	X	h	x	¶		Θ	Ω	θ	ω	8	8
9		HT	EM)	9	I	Y	i	y	†			Σ	ι	ℓ	9	9
A		LF	SUB	*	:	J	Z	j	z	£			∇	κ	•	±	+
B		VT	ESC	+	;	K	[k	{			Λ	(λ	✓	—	-
C		FF	FS	,	<	L	\	l)	μ	}	≅	x
D		CR	GS	-	=	M]	m	}	°			[v	{	≅	÷
E		SO	RS	.	>	N	^	n	~		Å	Ξ]	ξ	.	-	8
F		SI	US	/	?	O	_	o	'	Note 3			f		/	≈	

ESC Y ESC Z

φ	'
---	---

See Note 2

NOTES :

1. ECS 7-bit ASCII Mode
 - Primary Character Set accessed by codes 00-7F after power-up/initialize or after SI received from host.
 - Supplementary Character Set accessed by codes 00-7F after SO received from host.
2. ECS 8-bit ASCII Mode
 - After power-up/initialize all characters can be accessed except those addressed by 80-9F.
 - After SO received from host, all characters can be accessed.
3. In ECS 7-bit ASCII Mode, code 0F represents SI control character in both Primary and Supplementary Character Set.

Figure 3-14. ECS ELITE 12 SCIENTIFIC PRINT WHEEL

		PRIMARY CHARACTER SET								SUPPLEMENTARY CHARACTER SET							
ASCII HEX	HI LO	0	1	2	3	4	5	6	7	8	9	A	B	C	D	E	F
	0	NUL	DLE	SP	0	@	P	`	p		°	SP	°	`	—	Ω	κ
1	SOH	DC1	!	1	A	Q	a	q	0	f	i	±	`	1	Æ	æ	
2	STX	DC2	"	2	B	R	b	r	1	Φ	φ	2	'	⊙	Ð	ð	
3	ETX	DC3	#	3	C	S	c	s	2	ϕ	£	3	^	⊙	á	ø	
4	EOT	DC4	\$	4	D	T	d	t	3	4	\$	x	~	™	Ë	ë	
5	ENO	NAK	%	5	E	U	e	u	4	5	¥	μ	—	†	—	ı	
6	ACK	SYN	&	6	F	V	f	v	5	6	#	¶	˘	'	Û	ÿ	
7	BEL	ETB	'	7	G	W	g	w	6	7	§	•	•	•	Ł	ł	
8	BS	CAN	(8	H	X	h	x	7	8	¤	÷	¨	ç	Ł	ł	
9	HT	EM)	9	I	Y	i	y	8	9	~	˘	¨	"	Ø	ø	
A	LF	SUB	*	:	J	Z	j	z	9	è	á	à	°	˘	Œ	œ	
B	VT	ESC	+	;	K	[k	{	l	é	<	>	,	^	º	ß	
C	FF	FS	,	<	L	\	l		°		,	¼	—	⅛	þ	þ	
D	CR	GS	-	=	M]	m	}	ñ	ä	F	½	"	⅜	ƒ	ƒ	
E	SO	RS	.	>	N	^	n	~	ã	ü	.	¾	˘	⅝	ŋ	ŋ	
F	SI	US	/	?	O	_	o	DEL	Note 3	ö	/	¿	˘	⅞	'n		

ESC Y



ESC Z



See Note 2

NOTES :

1. ECS 7-bit ASCII Mode
 - Primary Character Set accessed by codes 00-7F after power-up/initialize or after SI received from host.
 - Supplementary Character Set accessed by codes 00-7F after SO received from host.
2. ECS 8-bit ASCII Mode
 - After power-up/initialize all characters can be accessed except those addressed by 80-9F.
 - After SO received from host, all characters can be accessed.
3. In ECS 7-bit ASCII Mode, code 0F represents SI control character in both Primary and Supplementary Character Set.

Figure 3-15. ECS PICA 10 TELETYPE PRINT WHEEL

3.6.3 ASCII-to-Decimal Equivalents

Table 3-3
DECIMAL VALUES OF ASCII CHARACTERS

		Units									
		0	1	2	3	4	5	6	7	8	9
	0		SOH	STX	ETX	EOT	ENQ	ACK	BEL	BS	HT
	10	LF	VT	FF	CR	SO	SI	DLE	DC1	DC2	DC3
	20	DC4	NAK	SYN	ETB	CAN	EM	SUB	ESC	FS	GS
T	30	RS	US	SP	!	"	#	\$	%	&	'
	40	()	*	+	,	-	.	/	0	1
e	50	2	3	4	5	6	7	8	9	:	;
	60	<	=	>	?	@	A	B	C	D	E
n	70	F	G	H	I	J	K	L	M	N	O
	80	P	Q	R	S	T	U	V	W	X	Y
s	90	Z	[\]	^	_	`	a	b	c
	100	d	e	f	g	h	i	j	k	l	m
	110	n	o	p	q	r	s	t	u	v	w
	120	x	y	z	{		}	~			



SECTION 4

REMOVAL & REPLACEMENT PROCEDURES

4.1 GENERAL INSTRUCTIONS

The routine removal and replacement procedures for ribbons and print wheels are covered in the Model 630 Operator's Guides, and thus are not described in this manual.

WARNING:

1. Removing the top cover of the Model 630 exposes a safety hazard to unqualified personnel. Before performing any removal procedure on the Model 630, make sure that the AC power is switched OFF, and the power cord is unplugged.
2. DO NOT apply power to the machine while any of the circuit boards are disconnected; to do so can cause radical carriage movement and damage to the machine.

The removal procedures are arranged in this section in the logical sequence in which some of them must be performed. When one procedure refers to another, the section number of the referenced procedure is listed in parentheses; for example, "Remove the top cover (4.2)". For these procedures, it is assumed that any paper feed accessories such as a sheet feeder or forms tractor have already been removed if necessary.

In most cases, the reassembly procedure simply reverses the removal procedure, and thus is not described here. Any differences or special considerations required during reassembly are noted.

4.2 TOP COVER REMOVAL

- 1) Unplug the power cord.
- 2) Remove the platen knob by pulling it straight to the right.
- 3) Remove the access cover by grasping it at each end and rocking it up at the front to unlatch it. (Note: With the new style covers, considerably more force is required to unlatch the access cover.) After it is unlatched, the access cover can be removed by sliding it forward.
- 4) If not already done, loosen the shipping restraint screw from the rear of the top cover (Fig. 4-1). (The screw can be left loose when the cover is reinstalled, but it should be left in place for possible future use when shipping the machine.)
- 5) Loosen the two captive screws securing the top cover (Fig. 4-2).
- 6) Lift off the top cover.

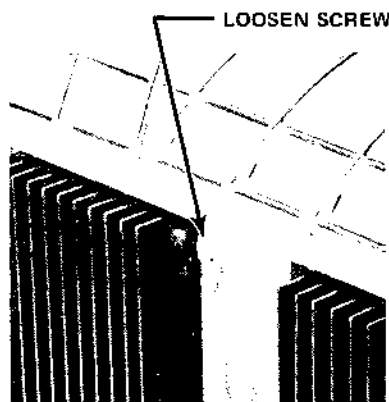

Figure 4-1. TOP COVER SHIPPING SCREW

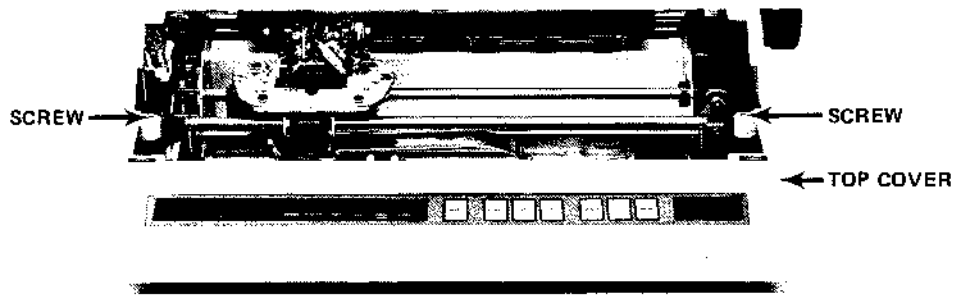

Figure 4-2. TOP COVER MOUNTING SCREWS

4.3 PLATEN REMOVAL

- 1) Turn the power switch OFF.
- 2) Remove the top cover (4.2).
- 3) Depress the platen latch lever (Fig. 4-3) at each end of the platen, and lift the platen out of the printer.

Platen Knobs:

The early style platen knob will not properly operate the new style (zero-backlash) platen. The new style platen knob, however, can be used on either early or late style platens by adjusting the position of the metal collar on the knob. To do this (with knob removed from platen), grasp the collar firmly and pull it out towards the end of the knob shank as far as it will go. Then install the knob on the platen shaft in the usual manner. When you push the knob onto the shaft, the collar will automatically slide to the proper position for the platen being used.

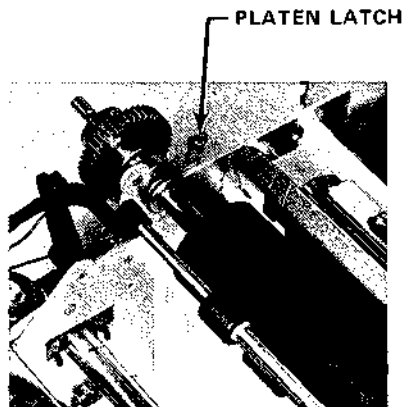

Figure 4-3. PLATEN LATCH LEVER

4.4 CARD GUIDE REMOVAL

Figure 4-4 identifies three different styles of card guides used on the Model 630. ECS units use the new style card guide 302935-01, but with a plastic shield (322598-03) affixed to it. The shield prevents occasional smudging by inner row print wheel characters when outer row characters are struck. If the shield becomes damaged it can be replaced as described below following card guide removal.

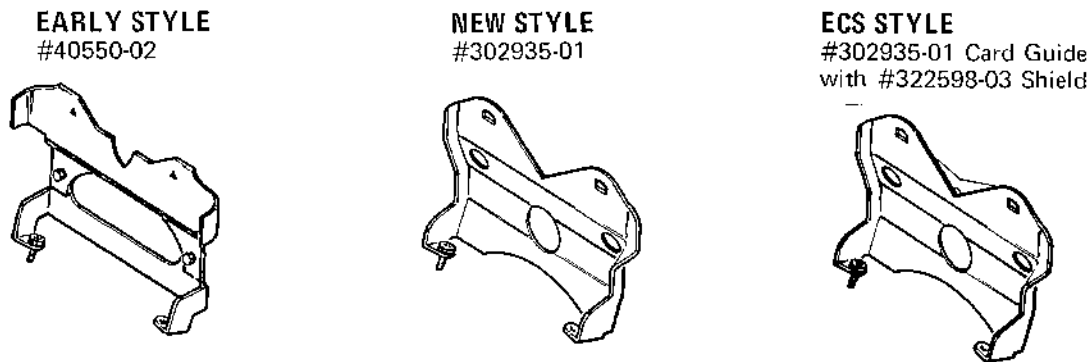

Figure 4-4. CARD GUIDES

- 1) Unplug the power cord.
- 2) Remove the top cover (4.2).
- 3) Remove the platen (4.3).
- 4) Tilt the carriage pivot assembly back away from the platen position.
- 5) Remove the two screws holding the card guide to the rear carriage bearings.
- 6) Remove the card guide.

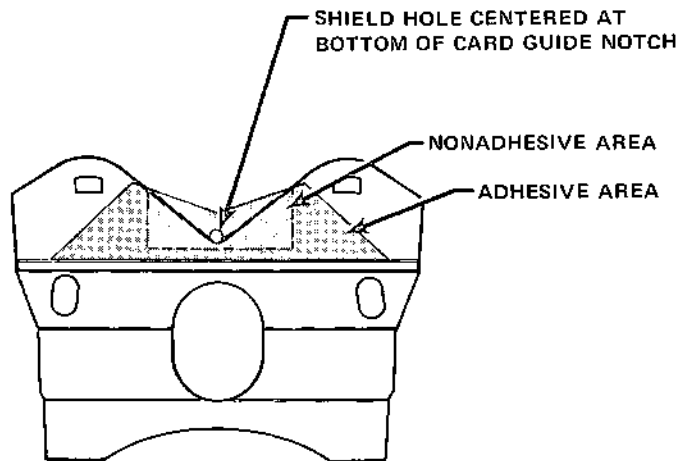

Figure 4-5. ECS CARD GUIDE SHIELD REPLACEMENT

Shield Replacement

- 1) With the card guide removed, peel the old shield off the card guide.
- 2) Clean the surface of the card guide to remove any residual adhesive or film of oil.
- 3) Remove the backing from the new shield and tack it lightly in position on the card guide as shown in Figure 4-5.
The shield should be square on the card guide, with the bottom edge of the hole in the shield centered at the bottom of the notch in the card guide. The adhesive area of the shield should not extend beyond the edges of the card guide, and all corners of the shield should be resting against the card guide.
- 4) When the shield is properly aligned on the card guide, press firmly over all of the adhesive area to bond it tightly to the card guide.

4.5 CIRCUIT BOARD REMOVALS

An electrostatic shield covers the circuit board compartment ("card cage") at the left rear of the unit. This card cage cover can be removed after loosening the two screws pointed out in Figure 4-6. The locations of the various Model 630 circuit boards are shown in Figure 4-7.

4.5.1 PCE / PPI / SPI / API / HPRO5 / HPRO6 Circuit Boards Removal

- 1) Unplug the power cord.
- 2) Remove the top cover (4.2).
- 3) Remove the card cage cover.
- 4) Carefully disconnect all of the cables connected along the left, right and top sides of the board.
- 5) Slide the board up out of its guides.

4.5.2 SCE Circuit Board Removal

- 1) Unplug the power cord.
- 2) Remove the top cover (4.2).
- 3) Remove the card cage cover.
- 4) Carefully disconnect the two cables from the right side of the SCE board.
- 5) Loosen the four screws (A) holding the SCE board assembly in position as shown in Figure 4-8.
- 6) Lift the SCE board up out of its edge connector and out of the machine.

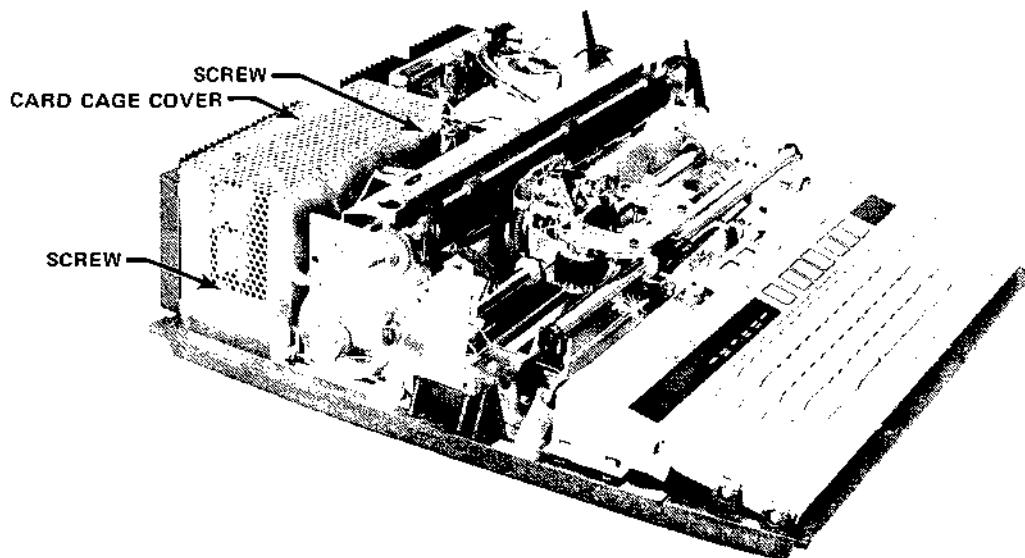

Figure 4-6. CARD CAGE COVER

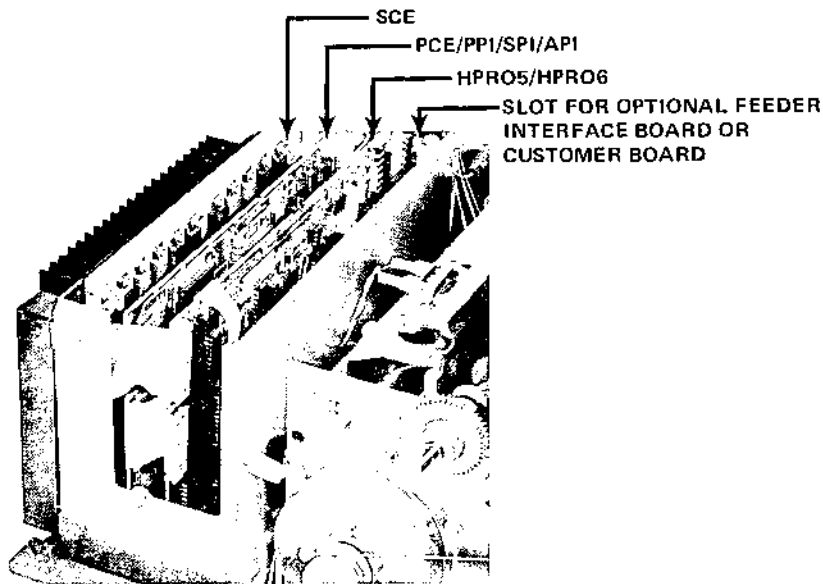

Figure 4-7. CIRCUIT BOARD LOCATIONS

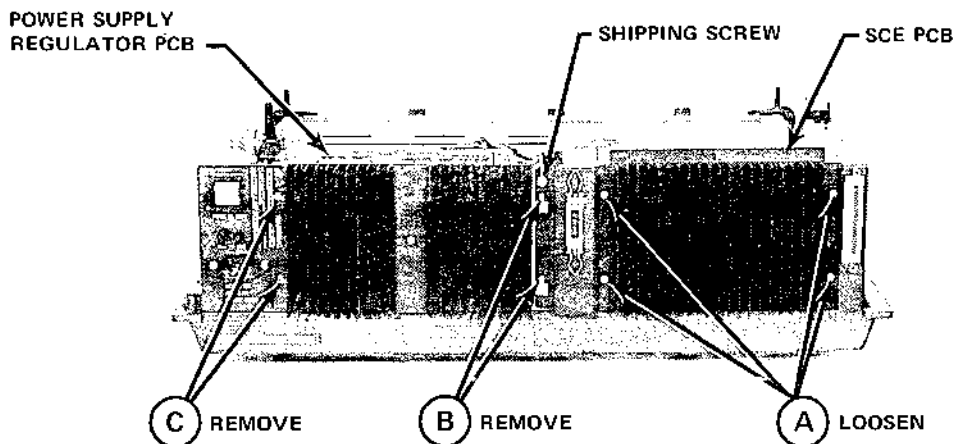

Figure 4-8. MOUNTING SCREWS FOR SCE AND P/S REGULATOR CIRCUIT BOARDS

4.6 POWER SUPPLY REMOVAL / CONVERSION

4.6.1 Regulator Circuit Board Removal

The power supply regulator circuit board can be removed separately as described here, or as part of the complete power supply assembly (4.6.2).

- 1) Unplug the power cord.
- 2) Remove the top cover (4.2).
- 3) Disconnect the two cables at the top edge of the regulator circuit board, and the one cable at the left edge of the board.
- 4) Refer to Figure 4-8.
Remove the two screws (B) holding the regulator board heat sink to the rear of the unit. Remove the two screws (C) at the other end of the heat sink near the ON-OFF switch. Remove the shipping screw.
- 5) Lift the regulator circuit board far enough to gain access to the cable connection at the lower right edge of the circuit board. Disconnect the cable, and then remove the circuit board from the machine.

4.6.2 Power Supply Assembly Removal

- 1) Unplug the power cord.
- 2) Remove the top cover (4.2).
- 3) Position the Model 630 so that you are facing the rear of the machine.
- 4) Remove the four mounting screws (A) and the ground strap screw (B) identified in Figure 4-9.
- 5) Referring to Figure 4-10, remove the feeder connector bracket (or trim plate) from the center rear panel of the machine.
To do this, loosen the four screws (C and D) that secure one side of the bracket to the SCE heat sink, and the other side to the power supply heat sink. Remove the shipping screw. Slide the feeder connector bracket up a little so it disengages from the screws on the power supply heat sink; then maneuver the bracket out from under the SCE heat sink. Let the bracket assembly hang loose on its feeder cable harness.
- 6) Disconnect the DC power cable from the top edge of the power supply regulator board.
- 7) Gently manipulate the power supply assembly out the rear of the machine. Avoid snagging and straining any of the cables.

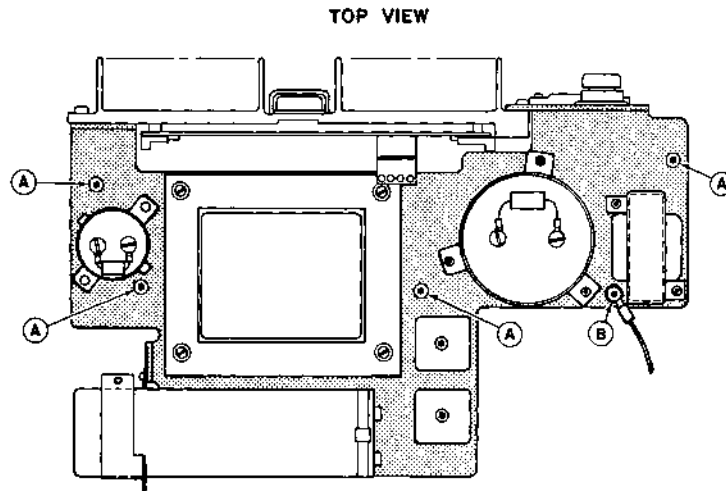

Figure 4-9. POWER SUPPLY ASSEMBLY MOUNTING SCREWS

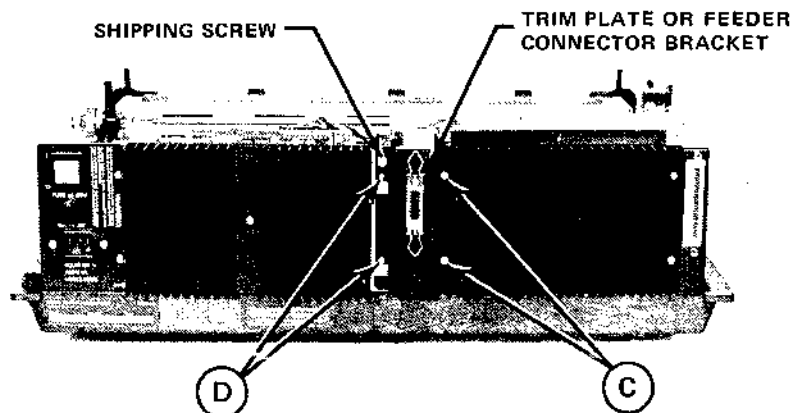

Figure 4-10. REAR PANEL FEEDER CONNECTOR BRACKET

4.6.3 Power Supply AC Input Conversion

The internal power supply of the Model 630 can be configured to operate from any one of four different input voltages: 100, 120, 220 or 240 VAC at 49 to 61 Hertz.

A universal conversion kit includes all parts required to convert from-to any of these voltages. Each part in the kit is also available separately, as listed below. Which of the parts are actually used in a particular conversion depends on the from-to configurations. For example, converting from a 100 VAC input to a 120 VAC input does not require a new line fuse since both configurations use a 4 amp fuse; however, when converting from 100 VAC to 220 VAC, the old 4 amp fuse must be replaced by a 2 amp fuse.

Figure 4-11 shows the required wiring configuration for each input voltage, and Figure 4-12 shows the locations of the associated label changes that may be required.

Parts List:

<u>Item</u>	<u>Part No.</u>	<u>Description</u>
	321344-01	Complete kit
1	302983-01	Label, Fuse, 4A (use with 100 and 120V input)
2	302970-01	Label, Fuse, 2A (use with 220 and 240V input)
3	302964-01	Label, Rating, 100V
4	302962-01	Label, Rating, 120V
5	302966-01	Label, Rating, 220V
6	302968-01	Label, Rating, 240V
7	10604-07	Fuse, 4A, Fast-Blow (use with 100 and 120V input)
8	10604-08	Fuse, 2A, Fast-Blow (use with 220 and 240V input)
9	10708	Jumper, Terminal Block

Conversion Procedure

- 1) Disconnect the AC power cord, and remove the top cover (4.2).
- 2) Remove the power supply assembly from the Model 630 (4.6.2).
- 3) Position the power supply assembly on its back so that the terminal block (TB1) on the bottom of the power supply assembly is accessible.
- 4) On the terminal block, reposition the terminal jumper(s) and line filter leads according to the appropriate diagram in Figure 4-11. It should be unnecessary to alter the position of the transformer leads; they are shown for reference only.

NOTE: The proper positions on the terminal block (TB1) for the brown and blue wires from the line filter depends on the wire colors on the top two terminals of the on-off switch. If the top left terminal has a brown wire and the top right terminal a blue wire (as viewed from the front of the machine), follow the colors listed in Figure 4-11; if the colors on the on-off switch are opposite, reverse the wire colors shown in Figure 4-11.

- 5) Turn the power supply right side up.
- 6) Check the value of the line fuse presently in the unit against the fuse requirement for the new input voltage, as shown in the Parts List above. Install the proper fuse.

- 7) Check the fuse label to see if it matches the fuse size that is now being used. If a new fuse label is required, select the proper label, remove the adhesive backing and apply the label to the location indicated in Figure 4-12. Make sure the label completely covers the existing fuse data printed on the panel.
- 8) Select the proper voltage rating label, remove the adhesive backing, and apply the label to the location indicated in Figure 4-12.
- 9) Connect the proper CSA-approved line cord (See Diablo Model 630 Parts Catalog, Publication No. 90444-XX), apply power and verify that the DC output voltages are correct.
- 10) Turn off power, disconnect the line cord, and reinstall the power supply assembly into the Model 630.

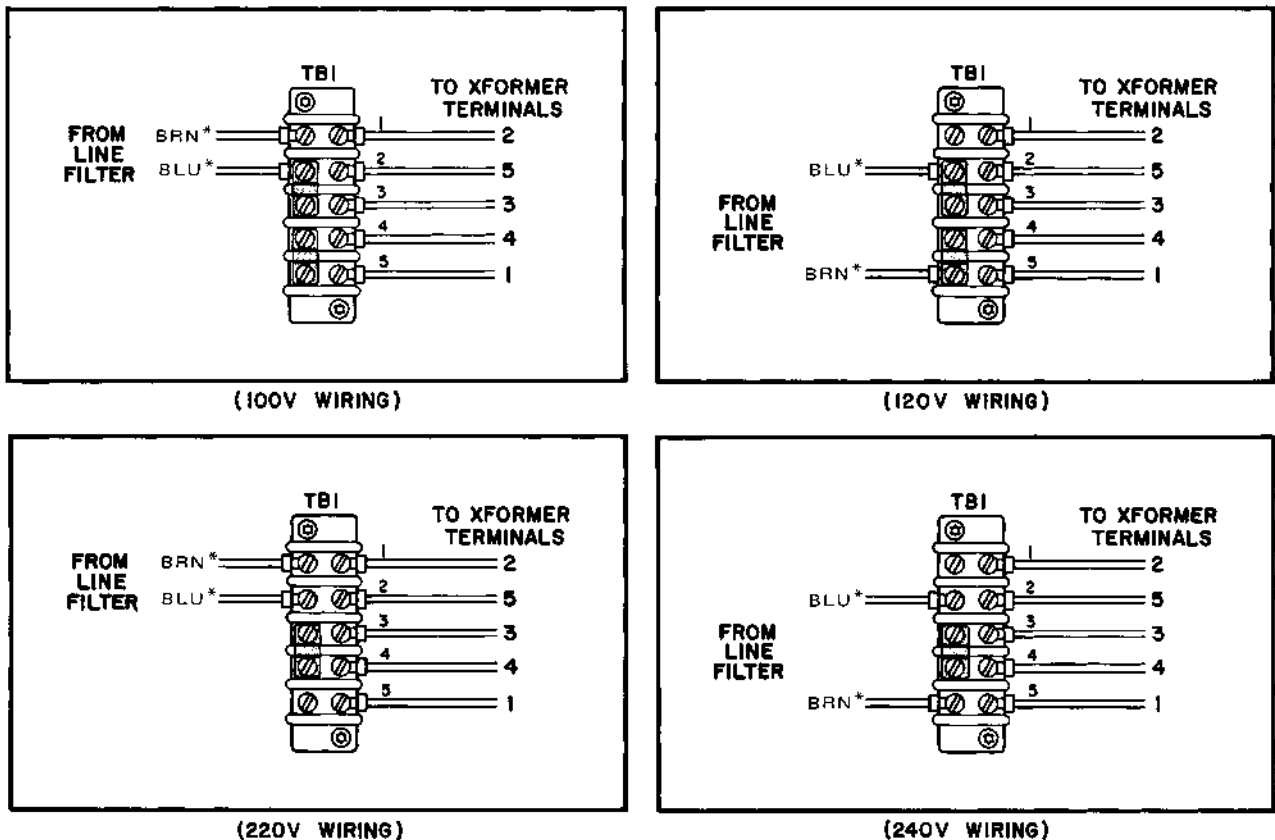

* The wire colors shown above apply if the on-off switch has a brown wire on the top left terminal and a blue wire on the top right terminal (viewed from front of machine). If the wire colors on the switch are opposite (brown on right, blue on left), the wire colors from the line filter to TBI must be opposite to that shown above.

Figure 4-11. AC INPUT WIRING

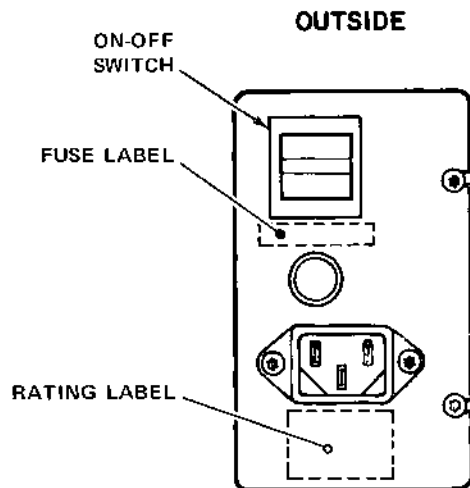

Figure 4-12. INPUT POWER LABEL LOCATIONS

4.7 SPI and API-1.5 CONTROL PANEL REMOVAL

- 1) Unplug the power cord.
- 2) Remove the top cover (4.2).
- 3) Remove the two screws holding the left end of the control panel to the bottom pan.
- 4) Loosen the two screws holding the right end of the control panel to the bottom pan.
- 5) Note carefully how the control panel cable connector is oriented (see Fig. 4-13). This connector is not keyed, and can easily be installed backwards. (This will not damage the machine, but will cause improper operation; among other things, the power indicator will not light when power is applied.)
- 6) Disconnect the control panel cable connector.
- 7) Turn the control panel over and slide the control panel cable out of the cable retainers on the bottom side of the control panel.

Reassembly Note: Be sure to reattach all ground straps that were disconnected during disassembly.

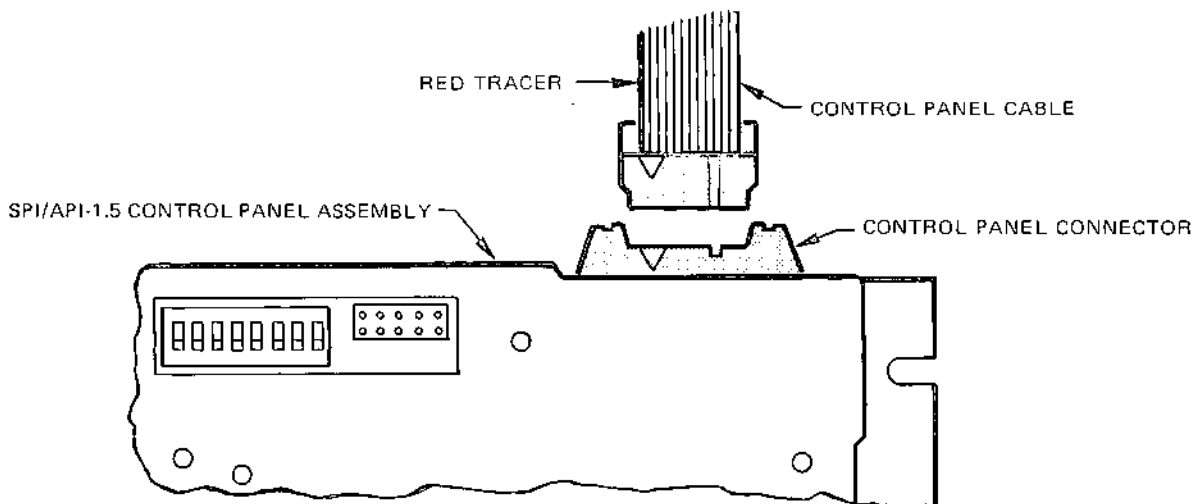

Figure 4-13. SPI and API CONTROL PANEL CABLE

4.8 HPRO5 AND API-2 CONTROL PANEL REMOVAL

The control panel removal procedure varies depending on whether the unit is an RO or a KSR, and on the type of ESD shielding used. The removal procedures for RO and KSR control panels are described separately. For ESD shielding on some early HPRO5 units, a metal plate is clipped in place across the bottom of the control panel. When the control panel is mounted, there are three screws holding the bottom edge of this plate to the bottom pan of the machine. On later units, a ground plane on the control panel circuit board provides ESD shielding, and the separate metal shield is not used.

Another aspect of the removal procedure subject to variation in HPRO5 terminals concerns the position of the cable that connects to the control panel from the HPRO5 circuit board. A design change to the control panel circuit board reversed the pin-outs on the connector, and thus requires that the cable be connected to the board just opposite of the way it is connected in earlier units. Figure 4-14 illustrates these two arrangements and identifies the circuit board etch level where the reversal occurs.

The HPRO5 and API-2 control panels can both use H5CPN control panel circuit boards (302561-XX) that are at design levels -06 or higher. H5CPN circuit boards at design levels below -06 can be used on HPRO5 control panel assemblies only.

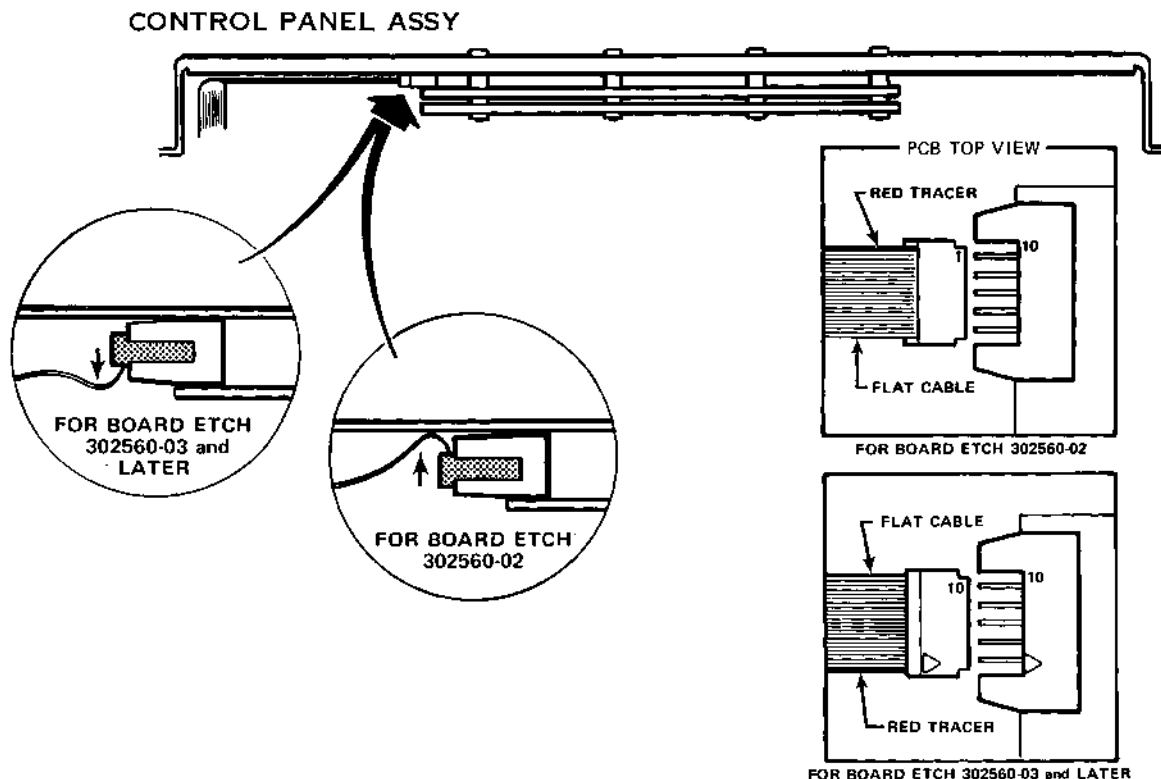

Figure 4-14. HPRO5 AND API-2 CONTROL PANEL CABLE

4.8.1 RO Control Panel Removal

- 1) Unplug the power cord.
- 2) Remove the top cover (4.2).
- 3) Loosen the 3 screws holding the control panel ESD shield (if present) to the bottom pan of the machine.

- 4) At each end of the control panel, remove the 2 screws holding the control panel to the bottom pan.
- 5) Disconnect the ground strap at each end of the control panel.
- 6) Slide the control panel forward to release the ESD shield from the bottom pan.
- 7) Tip the rear of the control panel upward to expose the cable connector on the bottom side of the panel.

NOTE: Note carefully how the connector is oriented (see Fig. 4-14). This connector is not keyed, and can easily be installed backwards. (This will not damage the machine, but will cause improper operation; among other things, the power indicator will not light when power is applied.)

- 8) Disconnect the cable.

Reassembly Notes:

1. Be sure to reattach the ground straps at each end of the control panel.
2. Be sure that the control panel cable is connected correctly before remounting the control panel assembly. (See explanation under 4.8.)

4.8.2 KSR Control Panel Removal

The KSR control panel can be removed either separately or as part of the keyboard assembly. This subsection describes its removal as a separate assembly. Subsection 4.9 describes removal of the complete keyboard-control panel assembly.

- 1) Unplug the power cord.
- 2) Remove the top cover (4.2).

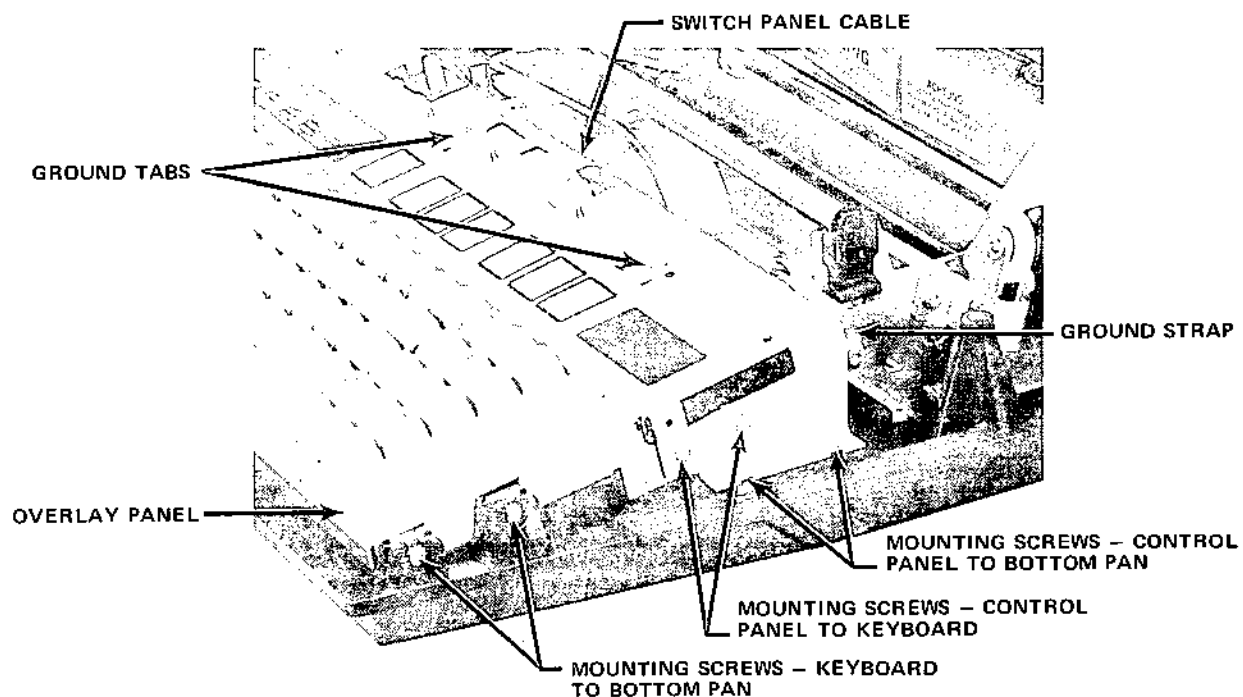

Figure 4-15. KEYBOARD-CONTROL PANEL REMOVAL

Refer to Figure 4-15.

- 3) Remove the two screws securing the ground tabs of the overlay panel.
- 4) Disconnect the short cable that connects the overlay switch panel to the control panel.
- 5) For reference during reassembly, look closely at how the overlay panel is fitted onto the keyboard; then lift the overlay panel off the keyboard.
- 6) Disconnect the ground strap at each end of the control panel.
- 7) At both ends of the control panel, remove the two screws that fasten the control panel to the keyboard assembly.
- 8) At both ends of the control panel, remove the two screws that secure the control panel to the bottom pan.
- 9) Rock the rear of the control panel upward to expose the cables on the bottom side of the control panel.
- 10) For reference during reassembly, carefully note the position of the cable connector at the left end of the control panel circuit board; then disconnect this cable.
- 11) Disconnect the cable that connects the control panel to the keyboard.
- 12) Remove the control panel.

4.9 KEYBOARD ASSEMBLY REMOVAL

- 1) Unplug the power cord.
- 2) Remove the top cover (4.2).

Refer to Figure 4-15.

- 3) Disconnect the ground strap at each end of the control panel.
- 4) Remove the two screws that secure each end of the control panel to the bottom pan.
- 5) Loosen the two screws that secure each end of the keyboard assembly to the bottom pan.
- 6) Lift the rear of the keyboard-control panel assembly to expose the control panel cable.
- 7) For reference during reassembly, note the way the control panel cable connects at the left end of the control panel circuit board; then disconnect the cable.
- 8) Lift the keyboard out of the machine.

NOTE: The membrane switch overlay panel is fastened down only at its rear edge. If the keyboard assembly must be inverted, support the overlay panel so that it doesn't fall free.

4.10 PRINT MECHANISM REMOVAL

- 1) Unplug the power cord.
 - 2) Remove the top cover (4.2).
 - 3) Remove the control panel (4.7 or 4.8) if this is an RO unit, or the entire keyboard-control panel assembly (4.9) if it is a KSR unit.
 - 4) Disconnect the two cable connectors mounted at the lower front of the carriage (Item A, Fig. 4-18).
 - 5) Loosen the screw (Item B, Fig. 4-18) that holds the carriage cable mounting bracket, and release the bracket from the carriage.
 - 6) Remove the two screws holding the cover open switch bracket to the bottom pan. Lay the bracket assembly out of the way at the left side of the machine.
 - 7) Loosen the two screws holding the cable shield plate on the left side of the bottom pan (Fig. 4-16). Slide the plate forward and lift it out.
- NOTE: Later units do not have this shield plate.

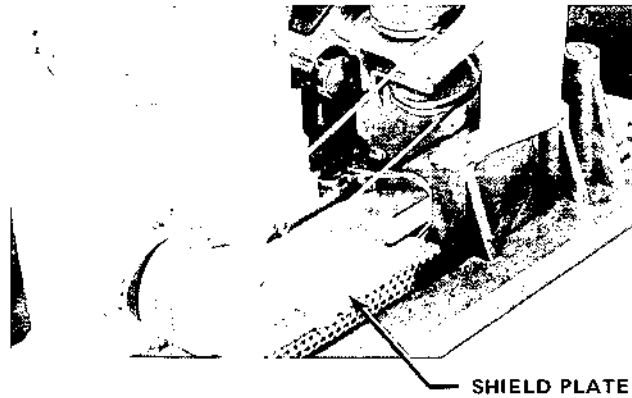

Figure 4-16. RIBBON CABLE SHIELD PLATE

- 8) Make note of the wire connections to the paper-out switch, and then disconnect the wires from the switch. (Yellow wire to left terminal, brown wire to right.)
- 9) Disconnect the ground straps located on the print mechanism at the left front corner, the right front corner, the left rear corner, and the center of the right side frame.

NOTE: Your unit may not have all of these ground straps.

- 10) Remove the card cage cover.
- 11) Disconnect the paper feed motor cable from either the PCE, PPI, SPI or API circuit board.
- 12) Disconnect the carriage drive motor cable from the SCE circuit board.

NOTE: On later units, the print mechanism is held in place at the rear by hooks on the mechanism which extend through two holes in the bottom cover. To satisfy UL certification requirements, two plastic plugs are used to fill the remaining hole space after the print mechanism is in place. Before the mechanism can be removed, the hole plug next to each hook must be pryed out from the bottom using a screwdriver or similar tool.

- 13) Unlatch the print mechanism from the bottom pan. The mechanism is held in place by two retainers located just inside the side frames of the mechanism, as shown in Figure 4-17. The retainers are unlatched by pulling the retainer slides toward the center of the mechanism. (A forceful tug may be required to overcome the detent.)

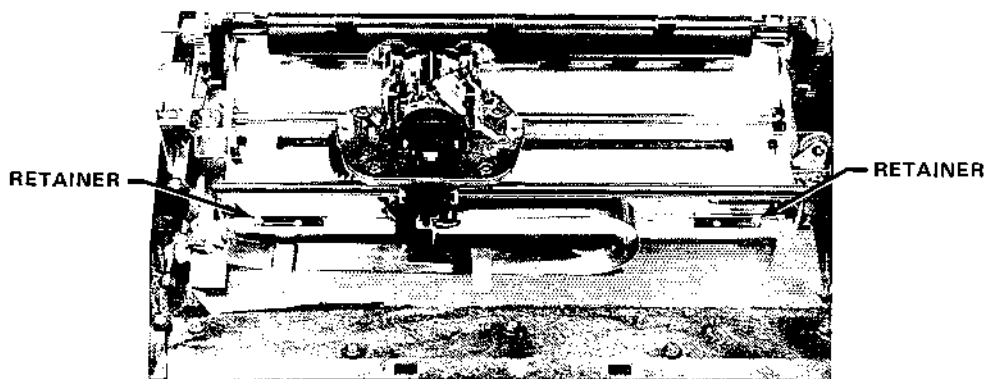

Figure 4-17. PRINT MECHANISM FRONT RETAINERS

- 14) Before the print mechanism can be removed completely from the machine, a cable that connects to the carriage drive motor from underneath must be disconnected as follows:
 - Carefully raise the front of the print mechanism above the retainer pins and slide it forward a short distance (approximately 3" / 76mm).
 - While holding the front of the mechanism up, reach underneath and disconnect the flat cable from the carriage drive motor.
- 15) Gently lift the mechanism out of the bottom pan.

Reassembly Notes:

To reinstall the print mechanism, simply reverse the removal procedure, with attention to the following details:

- Check that the rubber shock mount inserts (early style units only) are properly positioned in the mount brackets that hold the rear of the print mechanism in the bottom pan.
- Be sure to connect the flat cable to the carriage drive motor from underneath before latching the print mechanism in position.

4.11 CARRIAGE ASSEMBLY REMOVAL

- 1) Unplug the power cord.
- 2) Remove the top cover (4.2), platen, ribbon and print wheel.
- 3) Remove the control panel (4.7 or 4.8.)

Refer to Figure 4-18.

- 4) Disconnect the two cable connectors (A) mounted at the lower front of the carriage assembly.
- 5) Loosen the screw (B) that holds the carriage cable mounting bracket, and release the bracket from the carriage.
- 6) Loosen the lock screw (C) on the snubber eccentric (D) slightly, and rotate the eccentric 1/2 turn clockwise to release the tension on the carriage drive cable (E).

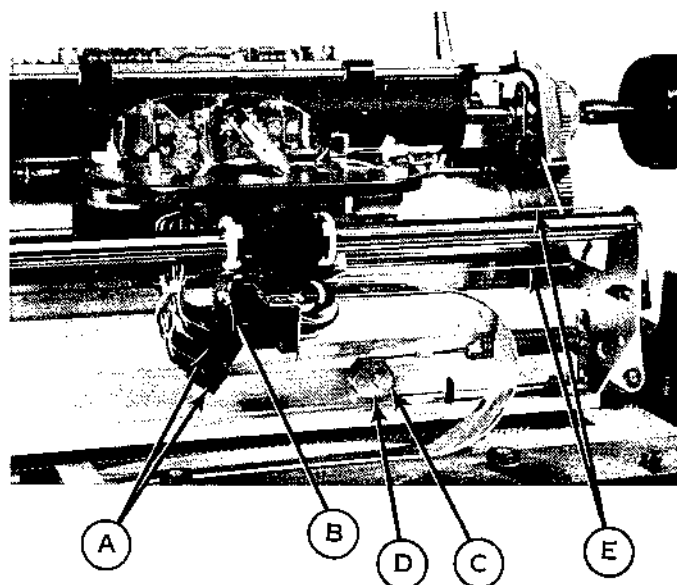

Figure 4-18. CARRIAGE ELECTRICAL CABLE ASSEMBLY & SNUBBER

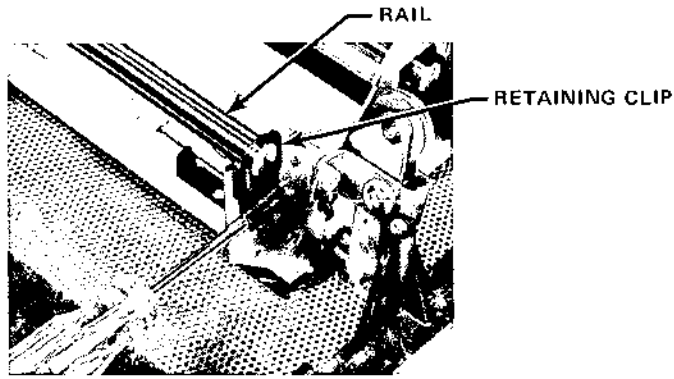

Figure 4-19. RAIL CLIP REMOVAL

- 7) Slip the drive cable off one of its pulleys; then unhook the two ends of the cable from their anchor slots on the carriage. The drive cable may now be completely removed from the machine, if desired. (To restring the cable, see subsection 4.15.)
- 8) Using a screwdriver or other suitable implement as shown in Figure 4-19, remove the retaining clips (4) from the ends of the two carriage rails. The clip is removed by rotating the screwdriver, not by prying. The shank of the screwdriver must be at least 8" long, and its blade must be narrow enough to insert through the clip but wide enough to force the clip open. (A 3/16" wide blade works well.)

CAUTION: After the clips are removed, the front rail is unrestrained. Take care that it does not fall free.

- 9) Lift one end of the rails and slide the carriage off.

Reassembly Notes:

- To install the carriage assembly, reverse the removal procedure.
- For restringing the carriage drive cable, see subsection 4.15.
- A replacement carriage assembly will be equipped with either jackscrew or self-locking type cable connectors. The self-locking type is designed with a detent feature to hold the two halves of the connector together. If it becomes necessary to mismatch the two halves of these connectors; i.e., a jackscrew type connector joined to a self-locking type connector; neither the detent feature nor the jackscrews are functional. In this case, it is recommended that the two halves of both connectors be held together with a cable tie to ensure a secure, reliable connection. Figure 4-20 shows one example of how this can be done. In this case, the unusable jackscrews have been completely removed to make space for the cable ties. Note that a cable tie is used on both sides of each connector.

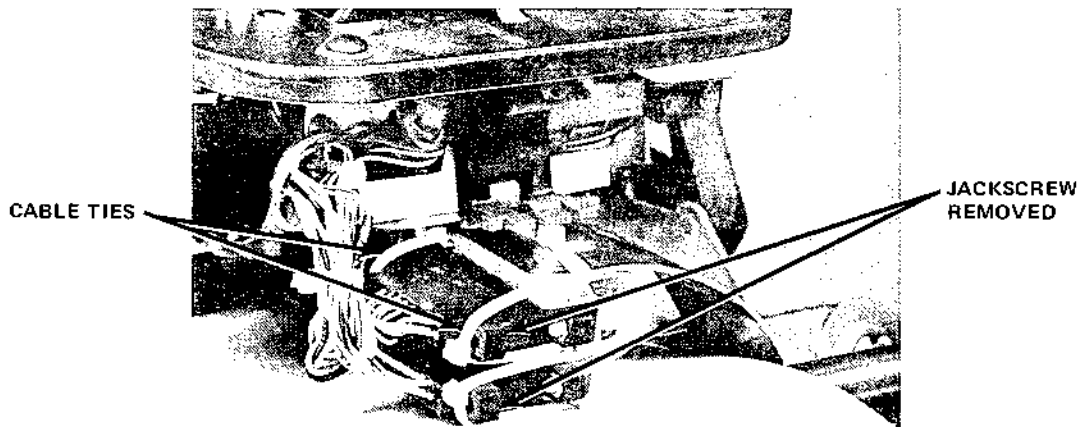

Figure 4-20. SECURING MISMATCHED CARRIAGE CABLE CONNECTORS

4.12 RIBBON DECK REMOVAL

- 1) Unplug the power cord.
- 2) Remove the access cover, ribbon and print wheel.
- 3) Remove the two cable ties located near the carriage cable connectors (Fig. 4-21). (In some units, only one cable tie is used here.)
- 4) Disconnect the top connector from the carriage. (In some cases, it may be helpful to remove the control panel before performing this step.)
- 5) On ECS units, unplug the ECS solenoid connector.
- 6) Remove the two TORX screws (Fig. 4-22) holding the ribbon deck to the carriage assembly.
- 7) Pivot the right side of the ribbon deck forward in order to clear the ribbon lift eccentric and then remove the ribbon deck.

Reassembly Note:

- When reconnecting the two halves of the ECS solenoid connector, be very careful to avoid bending the delicate pins in this connector.

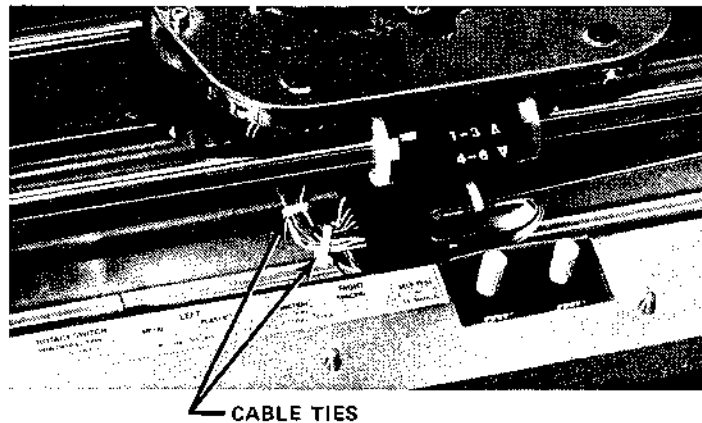
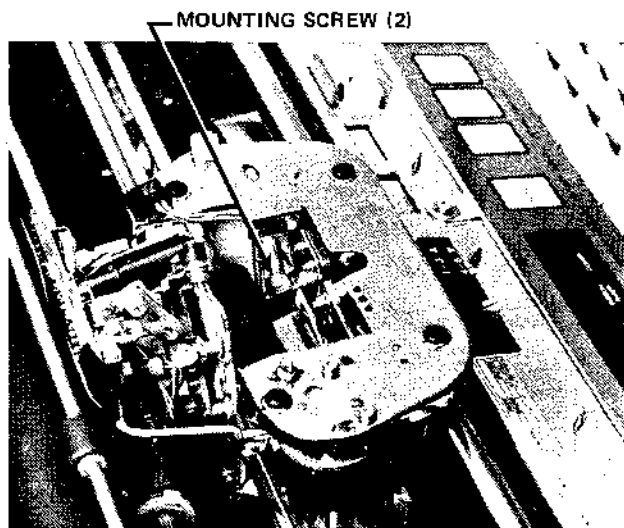
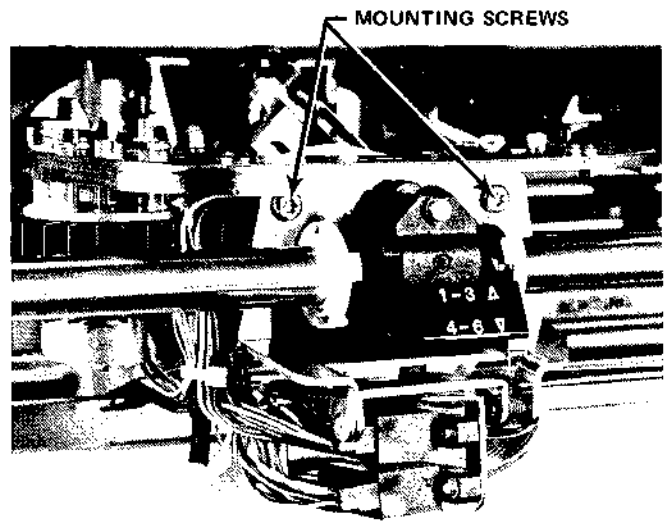

Figure 4-21. RIBBON DECK CABLE TIES



NON-ECS



ECS

Figure 4-22. RIBBON DECK MOUNTING SCREWS

4.13 RIBBON LATCH REMOVAL

Early style latches (using coil spring and taper pin pivot):

- 1) Unplug the power cord.
- 2) Remove the access cover, ribbon and print wheel.
- 3) Remove the ribbon deck (4.12).
- 4) Unhook the latch spring from the ribbon latch.
- 5) Using a pin punch, remove the retaining pin from the latch.
Note: For convenience when removing the left latch, the ribbon drive motor may be unfastened if desired.
- 6) Remove the latch and spring from the ribbon deck.

Late style latches (one-piece latch with mounting screw):

- 1) Unplug the power cord.
- 2) Remove the access cover and ribbon.
- 3) Remove the single screw holding the ribbon latch to the ribbon deck.
- 4) Lift the ribbon latch away from the ribbon deck.

4.14 CARRIAGE DRIVE MOTOR REMOVAL

- 1) Unplug the power cord.
- 2) Remove the top cover (4.2).
- 3) Remove the ribbon cartridge.
- 4) Remove the control panel (4.7 or 4.8).
- 5) Remove the print mechanism (4.10).
- 6) Remove the carriage drive cable (steps 6 and 7 of 4.11).
- 7) Remove the four motor mounting screws around the drive capstan.
- 8) Slide the motor out through the rear of the print mechanism.

Reassembly Notes:

- To install the carriage drive motor, reverse the removal procedure.
- To restring the carriage drive cable, refer to subsection 4.15.

4.15 RESTRINGING THE CARRIAGE DRIVE CABLE

The anchor ball fixed to the middle of the drive cable is not centered between the two ends. Consequently, the cable has a short section and a long section. The outer end of the long section connects to the right side of the carriage, and the outer end of the short section connects to the left side of the carriage.

Refer to Figure 4-23.

- 1) Position the carriage near the center of its travel.
- 2) Starting from outside the left frame of the printer mechanism, insert the end of the long cable section through the hole in the left frame, bring it across under the carriage and insert it through the hole in the right frame.
- 3) Bring the cable end up around the pulley on the right frame, and hook the anchor ball into the anchor slot in the right side of the carriage. Hereafter, continue to hold sufficient tension on the cable to prevent the anchor ball from slipping out of its anchor slot.
- 4) Grasp the free end of the cable and pull all of the cable slack out through the left frame so that the carriage begins moving rightward. Continue pulling until the carriage contacts the right end stop.

Refer to Figure 4-24.

- 5) Bring the cable rearward around the lower left pulley and under the capstan of the carriage drive motor.
- 6) Starting at the inner rim of the capstan, wind the cable four turns clockwise around the capstan. (Wind it snug but not tight.) This should bring the middle anchor ball on the cable to the capstan.

NOTE: Early production units require five turns around the capstan.

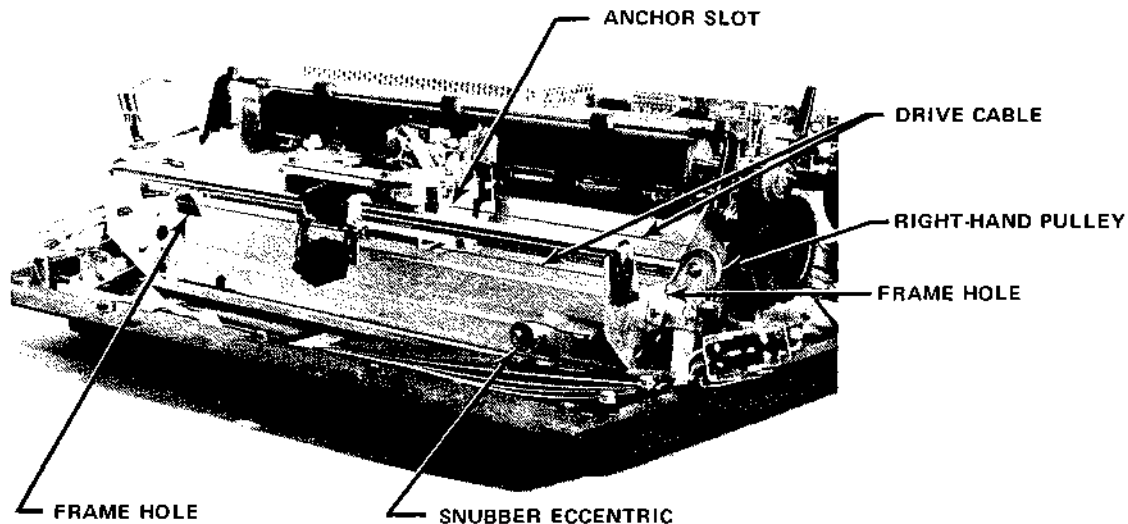
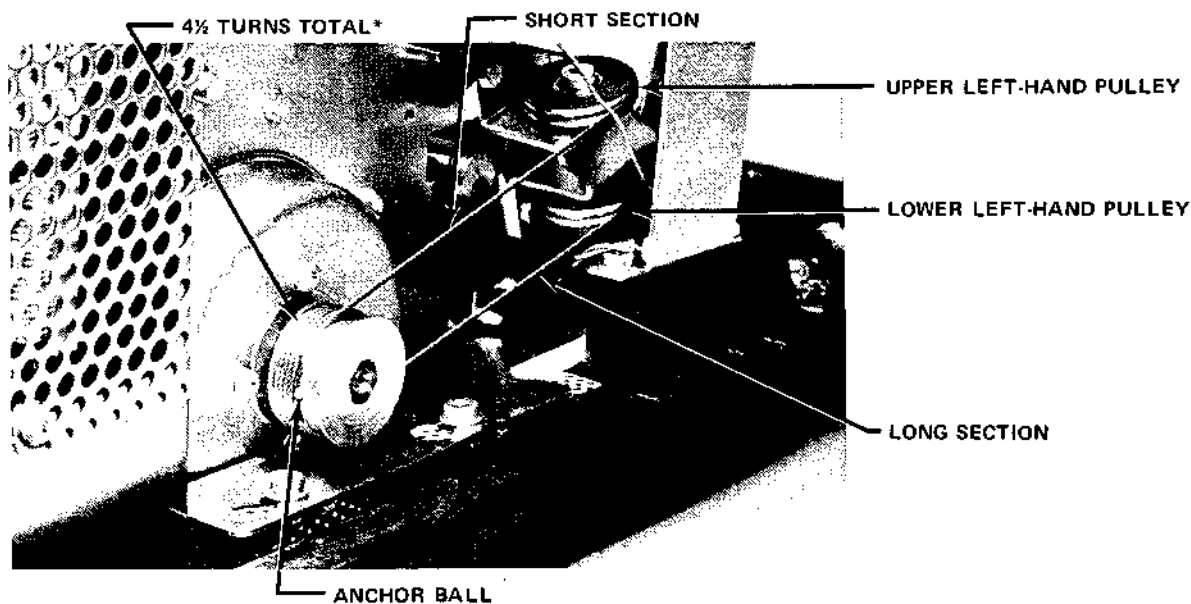

Figure 4-23. STRINGING THE DRIVE CABLE - LONG SECTION



*Early production units used a longer drive cable which requires 5 1/2 turns on the capstan.

Figure 4-24. STRINGING THE DRIVE CABLE - SHORT SECTION

- 7) Rotate the capstan within the windings to align the capstan anchor slot with the cable anchor ball. Seat the ball into the slot.
- 8) Wind 1/2 turn more cable onto the capstan (4-1/2 turns total), and then route the cable forward around the upper left pulley. (NOTE: Early production units used a longer drive cable which requires 5-1/2 total turns of cable on the capstan.)
- 9) Bring the end of the cable over to the carriage, and hook the anchor ball into the anchor slot in the left side of the carriage.
- 10) Slowly move the carriage from one end of the rails to the other a couple of times and check that the cable is properly seated on its pulleys, and that the cable windings on the capstan are not overlapping.
- 11) To tighten the cable, turn the cable snubber eccentric counterclockwise until it stops, using a 3/4" wrench.
- 12) Tighten the snubber eccentric lock screw.

4.16 PAPER FEED MOTOR REMOVAL

- 1) Unplug the power cord.
- 2) Remove the top cover (4.2).
- 3) Remove the platen (4.3).
- 4) Remove the card cage cover.
- 5) Unplug the paper feed motor cable from connector J2 on either the PCE, PPI, SPI or API circuit board.
- 6) Remove the three screws holding the paper feed motor to the right side frame. Note that of the three mounting spacers used, the one on the top screw is different from the other two.
- 7) The motor can now be slipped out through the hole in the side frame.

4.17 BOTTOM FEED KIT INSTALLATION

In addition to the parts included in the Bottom Feed Kit, some early Model 630 units require a new style one-piece card guide to replace the old two-piece card guide used on those early units (see Fig. 4-25). The new style card guide must be ordered separately, if needed.



Figure 4-25. CARD GUIDES

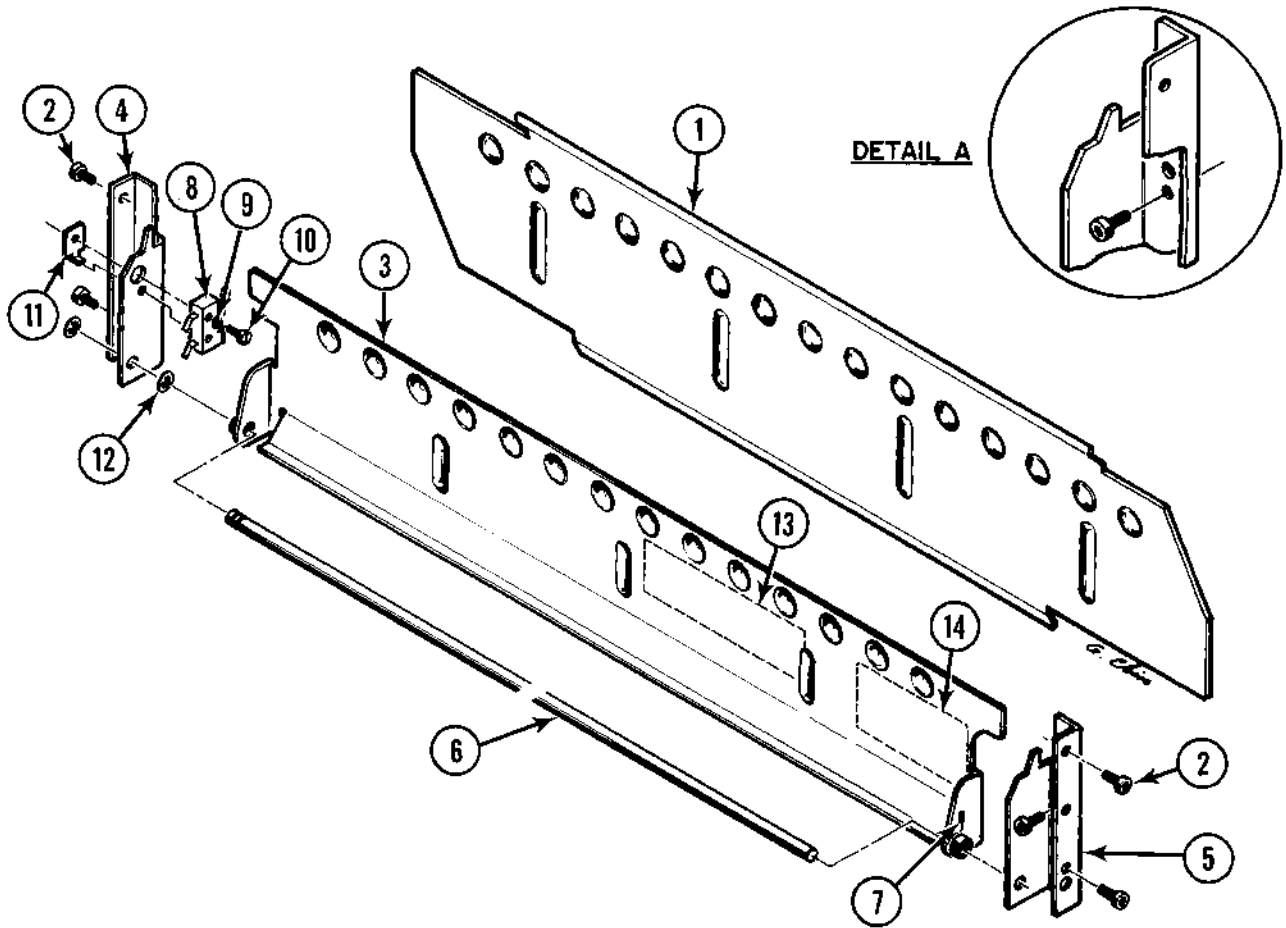

Figure 4-26. BOTTOM FEED KIT

PARTS LIST: (Reference Fig. 4-26)

<u>Item</u>	<u>Description</u>	<u>Qty</u>
1	Rear Plate, Paper Chute	1
2	Screw, 4-40 x .250 Pan Head Torx	6
3	Bail, Paper Chute	1
4	Support Bracket, Left	1
5	Support Bracket, Right	1
6	Shaft, Paper Chute	1
7	Setscrew, 6-32 x .187 Hex Skirt, Cup Point	2
8	Switch, Snap-Action	1
9	Lockwasher, #2	1
10	Screw, 2-56 x .500 Hex Washer Head	1
11	Nut Plate, 2-56	1
12	Retaining Ring	2
13	Warning Label, English	1
14	Warning Label, German	1

- 1) Check the contents of the Bottom Feed Kit to see that none of the parts are missing (see Figure 4-26 and associated parts list). If any parts are missing, refer to the Model 630 Parts Catalog (Publication No. 90444-XX) for the proper part numbers to order.
- 2) Unplug the power cord.
- 3) Remove any paper handling devices.
- 4) Remove the top cover (4.2).
- 5) Remove the ribbon, print wheel, platen and paper cradle.
- 6) Remove the card guide assembly by removing the two screws that fasten it to the rear carriage bearing.
- 7) Remove the large paper feed idler gear from the paper feed motor assembly.
- 8) Lift the front of the machine to expose the plate covering the paper feed slot in the bottom pan. Remove the cover plate by removing six screws from the metal cover (early units), or by snapping out the plastic cover (later units).
- 9) Remove the ribbon cable shield plate located along the left side of the unit (see Fig. 4-28). (Later units do not have this shield plate.)
- 10) Disconnect the wires from the Top Paper Out (TPO) switch.

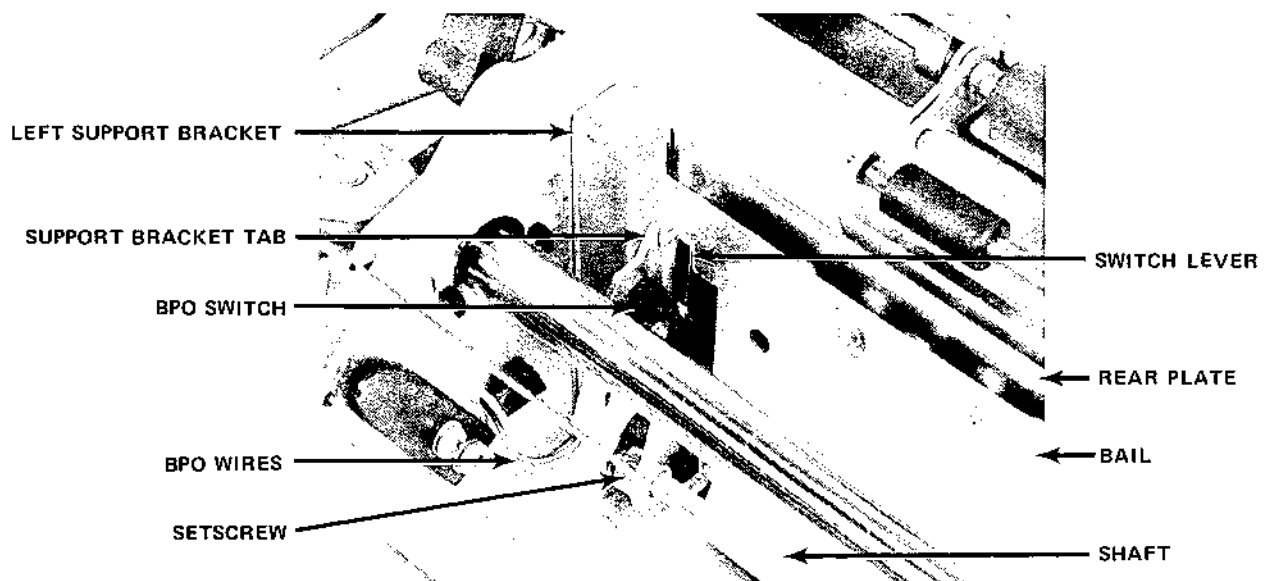

Figure 4-27. BOTTOM FEED ASSEMBLY

Refer to Figures 4-26 and 4-27 during the following steps.

- 11) Lower the paper chute rear plate (Item 1) into position flat against the printer frame as shown in Figure 4-27. The row of bumps on the plate must be at the top and projecting forward away from the printer frame. The plate rests on the printer frame on either side of the bottom slot. (Note — Installation will be easier with the carriage centered.)
- 12) Thread the two setscrews (7) part way into the collars on the paper chute bail (3).
- 13) Assemble the Bottom Paper Out (BPO) switch (8) to the left paper chute support bracket (4) using the new switch, one 2-56 x .500" hex washer head screw, one #2 lockwasher and a nut plate (do not tighten).

- 14) Thread a 4-40 x .250" Torx screw into the rear-facing hole in both the left and right support brackets, as shown in Detail "A" of Figure 4-26. After the screw has formed threads in the hole, back it out to the point where the screw tip is flush with the surface of the bracket.
- 15) Assemble the bottom paper chute bail (3) to the bottom paper chute shaft (6) and to the left and right support brackets (4 and 5), using the two retaining rings (12) at the left end of the shaft.
- 16) Install the bail/support bracket assembly down behind the rear carriage rail, directly in front of the rear plate (do not secure yet).
- 17) Center the bail (3) for equal contact against the left and right support bracket tabs (Fig. 4-27), and then tighten the two setscrews (7) to secure the bail to the paper chute shaft.
- 18) Route the two wires removed from the TPO switch into the cable trough on the left side of the printer. Pass these wires through the square cutout in the printer frame below the rear carriage rail.
- 19) Connect the paper out switch wires to the BPO switch (yellow wire to bottom terminal; brown wire to top terminal).
- 20) Reinstall the shield plate over the cable trough, with the paper out switch wires exiting near the same point as the cover open switch wires (Fig. 4-28).
- 21) Push the left and right support brackets against the rear plate, and fasten the brackets to the printer frame with two 4-40 x 1/4" Torx drive pan head screws (2) on each bracket.

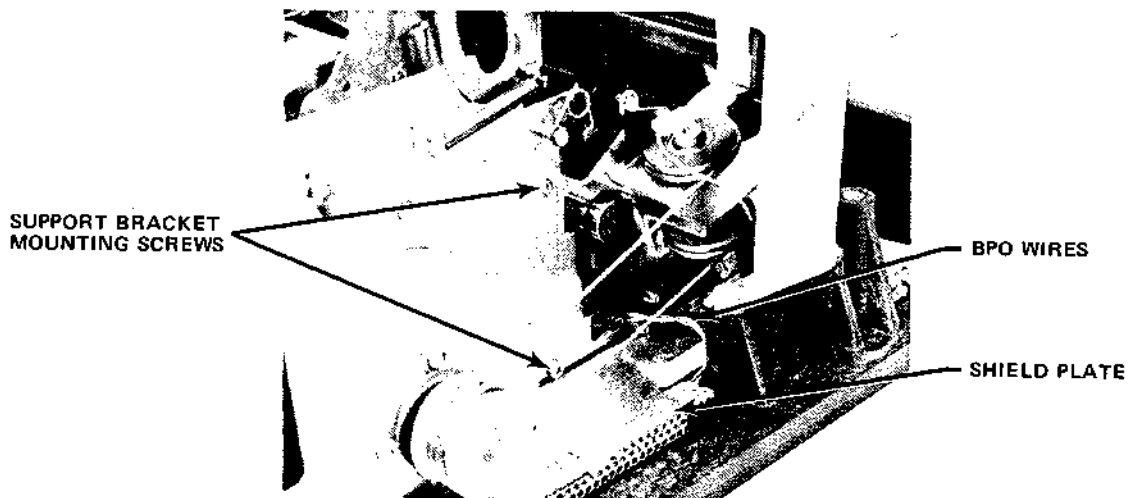

Figure 4-28. ROUTING OF THE BPO SWITCH WIRES

- 22) Thread the rear-pointing screw (Detail "A", Fig. 4-26) into each support bracket so that the tip of the screw pushes the rear plate (1) snugly against the printer frame.
- 23) Make sure that the actuator lever of the BPO switch is positioned on the front side of the paper chute bail, so that the switch actuates when the bail swings forward.
- 24) Adjust the BPO switch as follows:
 1. Start with the bail resting against the rear plate, and the BPO switch rocked away from the bail.
 2. Place a .035" shim between the bail and the BPO switch lever.

3. Push the switch toward the bail to the point where the switch actuates.
 4. Tighten the switch screw.
 5. Check for positive actuation/deactuation of the BPO switch when a standard sheet of printer paper is passed through the bottom feed paper path.
- 25) Attach the two warning labels (English and German) onto the front surface of the paper chute bail in the positions shown in Figure 4-26.
 - 26) Install the card guide. This must be the new style one-piece card guide to prevent the card guide from catching the leading edge of the paper during paper feed. The same mounting screws are used for both the old and new style card guides.
 - 27) Install the paper feed idler gear on the paper feed drive motor assembly.
 - 28) Install the paper cradle, platen, print wheel, ribbon, top cover, access cover and any paper handling device removed earlier.
 - 29) Connect the power cord, and apply power.

4.18 WIRE HARNESS REMOVAL

- 1) Unplug the power cord.
- 2) Remove the top cover (4.2).
- 3) Remove the print mechanism (4.10).
- 4) Remove the wires from the cover open switch and free them from the bracket.
- 5) Remove the two clips securing the carriage ribbon cable to the bottom pan.
- 6) Remove the card cage cover and all circuit boards from the card cage (4.5).
- 7) Remove the four screws securing the card cage housing, and remove the card cage and plastic cable clip that secures the ribbon cable to the bottom pan.
- 8) Note the orientation of the bracket and then remove the two screws and hold-down bracket securing the circuit board edge connectors.
- 9) Remove the wire harness.

Installation

- 1) Route the new harness properly.
- 2) Mount the circuit board edge connectors in place using the bracket and two screws. (Be sure to reattach any ground strap that was disconnected during removal.)
- 3) Install the two clips to secure the carriage ribbon cable to the bottom pan.
- 4) Connect the two wires to the cover open switch, and secure them to the bracket with a cable tie, or with the cable clip if present.
- 5) Install the card cage housing and plastic cable clip that secures the ribbon cable to the lower case.
- 6) Install the card cage circuit boards and card cage cover.
- 7) Install the print mechanism.

4.19 ACCESSORY PIN FEED PLATEN INSTALLATION

Installation Procedure

- 1) Remove the top cover (4.2).
- 2) Remove the friction feed platen, if installed (4.3).
- 3) Pull the paper bail and the paper release lever forward, toward the front of the unit.

- 4) Check that the paper cradle (Fig. 4-29) is properly positioned with the retaining forks of the cradle positioned over the locating pins.
- 5) Grasp the pin feed platen with one hand at each end, with the drive gear located at the righthand end of the platen, and the arm assembly at each end of the platen pointing upward.
- 6) Depress the platen latches on the printer, and lower the platen into place with the grooved collar at each end of the platen seated in the corresponding notch in the printer side frame. As the platen is being lowered, guide the arm assemblies so that the slot in each arm hooks over the paper bar, as shown in Figure 4-30. This locks the arm assemblies into proper position.
- 7) Release the platen latches, and then rotate the platen in both directions to see if it is clamped firmly in place.

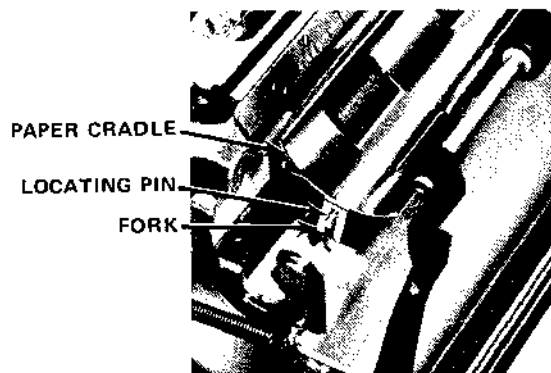

Figure 4-29. PAPER CRADLE

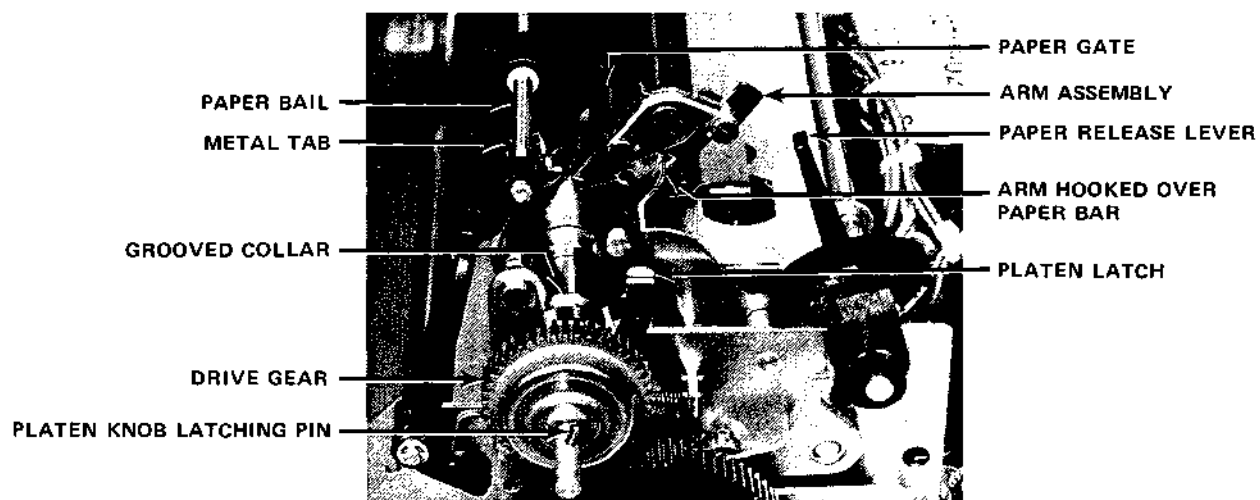

Figure 4-30. PIN FEED PLATEN INSTALLATION

- 8) Install the top cover and access cover. (The same sound panel is used with both the friction platen and pin feed platen.)
- 9) Install the platen knob by aligning the slot in the knob with the pin through the platen shaft, and then pushing firmly to latch the knob to the pin.

Loading Paper With The Pin Feed Platen

- 1) Pull the paper bail forward, away from the platen.
- 2) Push the paper release lever to its rear position.
- 3) Lift open the paper gate (Fig. 4-30) at each end of the platen. (The gate will remain open if lifted to its limit.)
- 4) Insert the leading edge of the paper down behind the paper bar (Fig. 4-30) and platen while manually turning the platen to feed the paper around and up in front of the platen.
- 5) Pull the paper release lever forward to release the paper. (This is the normal position for this lever when the pin feed platen is being used.)
- 6) Grasp the leading edge of the paper and pull it further around the platen so the pins on the platen engage the holes along the side edges of the paper. Ensure that the pins at both ends of the platen engage exactly opposite holes along the sides of the paper so that the paper will feed straight when the platen rotates.
- 7) Close the paper gates to lock the paper onto the feed pins.
- 8) Push the paper bail rearward. The bail will rest against the metal tab on each of the paper gates on the platen. This holds the bail rollers slightly out away from the platen surface.

4.20 ECS SOLENOID REMOVAL

- 1) Unplug the power cord.
- 2) Remove the top cover (4.2), platen, ribbon and print wheel.
- 3) Remove the card guide assembly by removing the two screws that fasten it to the rear carriage bearing.
- 4) Remove the control panel (4.8).

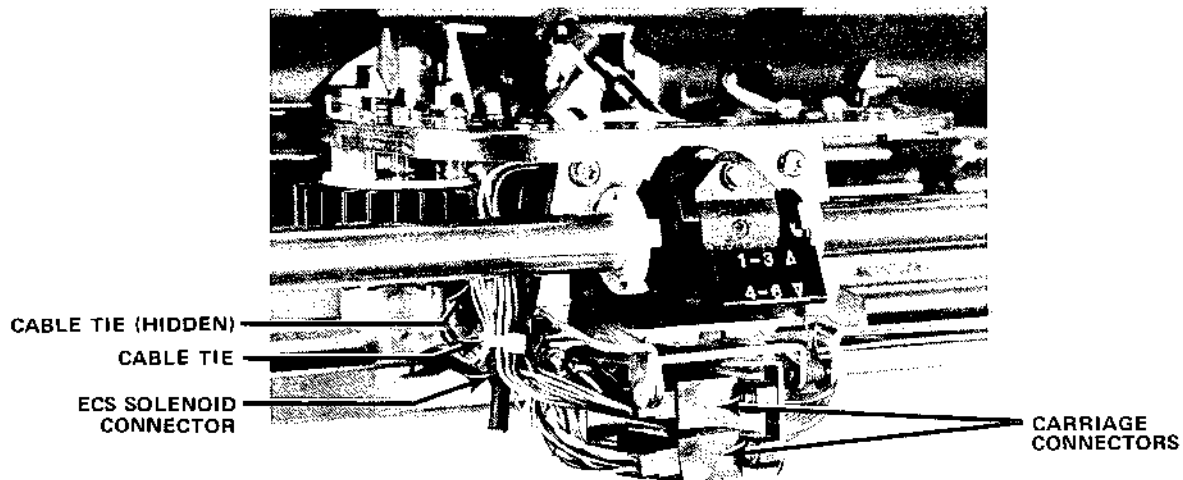

Figure 4-31. ECS CARRIAGE CABLES

- 5) Cut the cable tie that ties the two carriage cables together (Fig. 4-31).
- 6) Unplug the ECS solenoid connector (Fig. 4-31).
- 7) Unplug the two carriage connectors (Fig. 4-31).
- 8) Loosen the two pivot clamps (Fig. 4-32) holding the pivot assembly in place on the lower carriage assembly, and swing the clamps outward to release the pivot bushings.
- 9) Remove the bushings from the pivot pins so they don't accidentally drop off and become lost during removal of the pivot assembly. Set the bushings aside for later reinstallation.
- 10) Lift the pivot assembly out of the machine while guiding the cables to avoid snagging them on the lower carriage assembly.
- 11) Remove the two screws holding the ECS solenoid mounting bracket to the pivot assembly (Fig. 4-33).
- 12) Cut the cable tie holding the solenoid to the pivot assembly (Fig. 4-33), and remove the solenoid.

Reassembly:

- Note: - The pivot assembly is not interchangeable between lower carriage assemblies. Factory adjustments are precisely set for each combination of pivot assembly and lower carriage assembly operating together.
- A replacement ECS solenoid assembly does not include the mounting bracket.

- 1) Apply a coating of thermal compound to the solenoid seat on the pivot assembly (Fig. 4-33) where it will contact the solenoid.
- 2) Using an 11/16" wrench, remove the solenoid mounting bracket from the old solenoid assembly.
- 3) Install the mounting bracket onto the new solenoid assembly. Before tightening the mounting nut, ensure that the bracket extends out from the solenoid in the same direction as the solenoid wires (Fig. 4-33).
- 4) Ensure that the solenoid plunger is completely clean and free of any lubricant except in the notch that engages the tip of the bell crank arm (Fig. 4-34).
- 5) Ensure that there is a small dab of multipurpose grease on the tip of the bell crank arm where it will engage the notch in the solenoid plunger (Fig. 4-34).
- 6) With the plunger inserted into the solenoid, engage the bell crank arm in the slot in the plunger as you lower the solenoid into position on the pivot frame (Fig. 4-34).
- 7) Install and loosely tighten the two screws that hold the solenoid mounting bracket to the pivot frame (Fig. 4-33).
- 8) Install a large cable tie to loosely clamp the solenoid and solenoid wire to the solenoid mounting plate (Fig. 4-33). **DO NOT TIGHTEN THE CABLE TIE SECURELY OR CUT THE TAIL OFF THE CABLE TIE AT THIS TIME. THIS WILL BE DONE AFTER THE SOLENOID HAS BEEN ADJUSTED.**
- 9) Adjust the solenoid as described in subsection 5.12. When adjustment is finished, ensure that the solenoid-clamping cable tie has been tightened, that its tail has been cut off, and that its locking tab is positioned as shown in Figure 4-33.
- 10) Apply a light film of multipurpose grease to the pivot pins on the pivot assembly (Fig. 4-33), and slide the bushings onto the pivot pins. Be sure that the left bushing is installed with its flange outward as shown in Figure 4-32, to prevent interference with the solenoid plunger.
- 11) Lower the pivot assembly onto the lower carriage assembly and loosely tighten the bushing clamp plates (Fig. 4-32).
(Note: If the clamp plates have become bent during prior installation, simply turn them over when you install them so they are sure to clamp the bushings securely when tightened.)

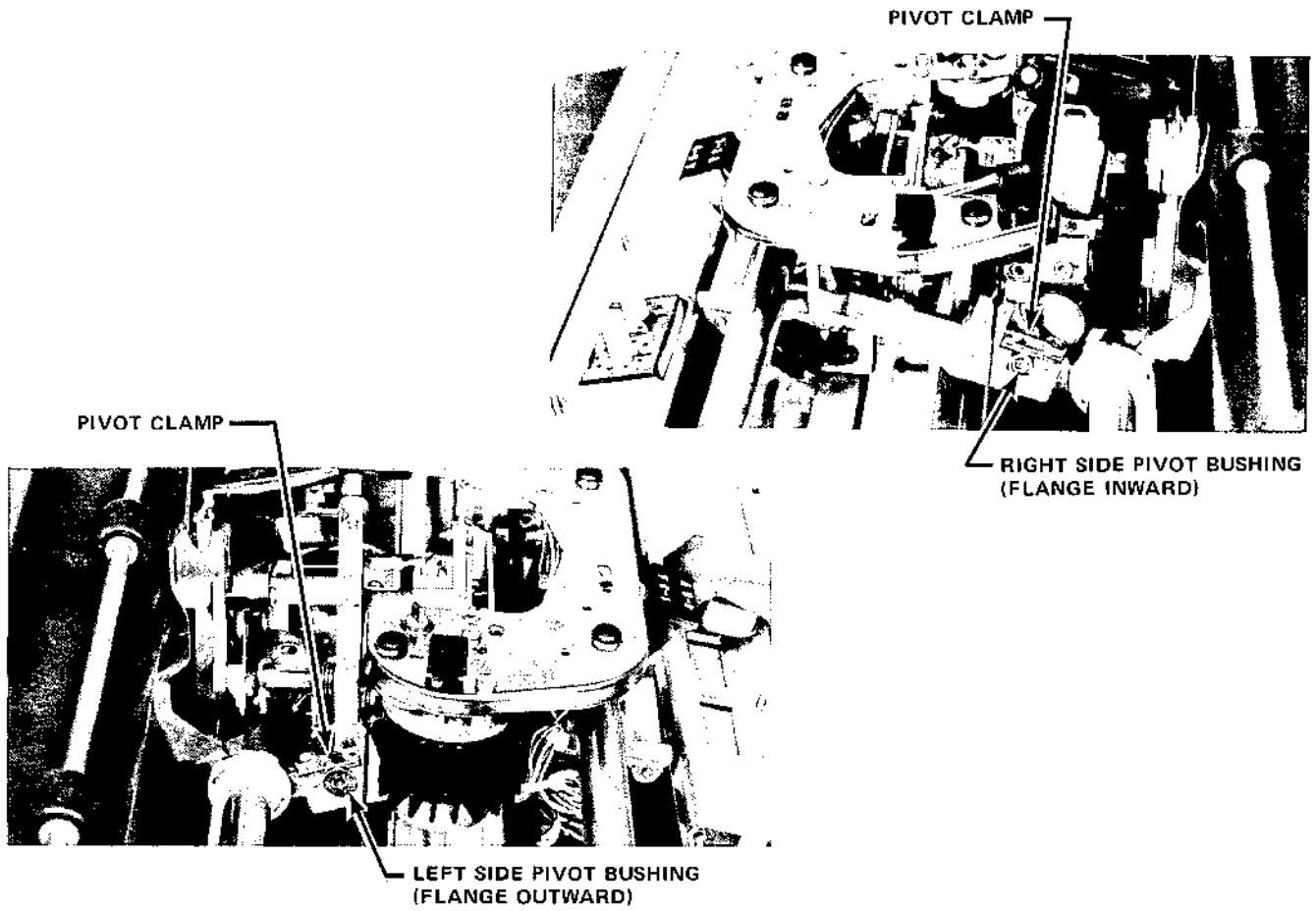

Figure 4-32. ECS CARRIAGE PIVOTS

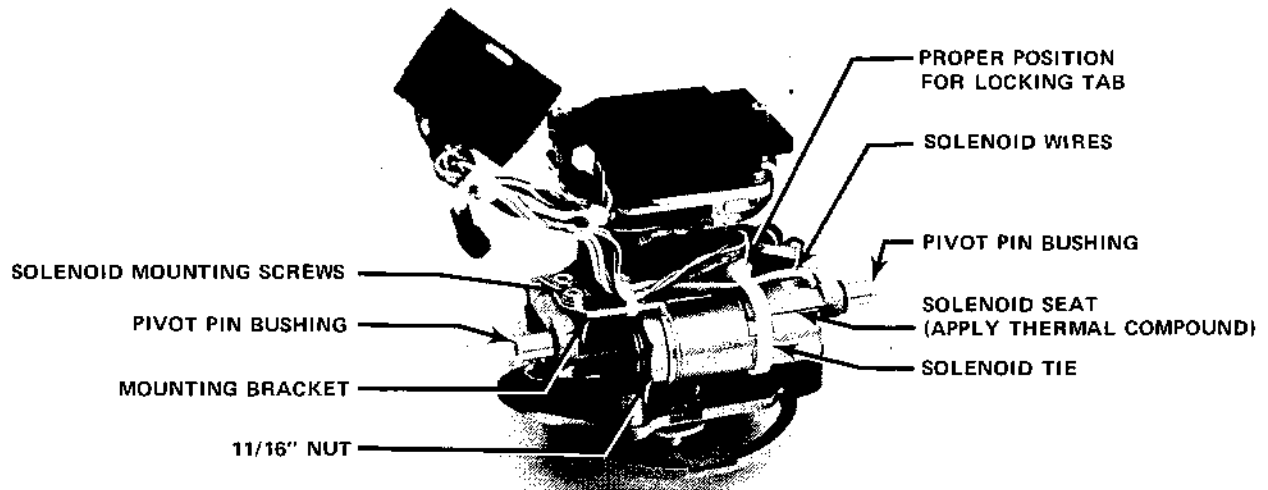

Figure 4-33. ECS CARRIAGE PIVOT ASSEMBLY

- 12) Hold the pivot assembly rightward (viewed from front of machine) on its pivots as far as it will go. This is done by pushing to the right on the flange of the left bushing. Tighten the pivot clamp screws.
- 13) Operate the pivot assembly latch several times to see if it latches properly and there is no noticeable right-to-left movement between the pivot assembly and the lower carriage. If movement is present, replace the clamp plates and repeat step 12.
- 14) Plug the solenoid wire connector together.
CAUTION: The two pins in this connector are very delicate, so be sure the pins are properly aligned before pushing the two halves of the connector together.
- 15) Connect the two carriage connectors.
- 16) Install two cable ties on the upper carriage cable as shown in Figure 4-31).
- 17) Install the control panel.
- 18) Install the card guide.
- 19) Install the platen, print wheel and ribbon.
- 20) Install the top cover and access cover.
- 21) Connect the power cord and turn on power.
- 22) Verify proper print wheel shifting when operating in ECS mode.

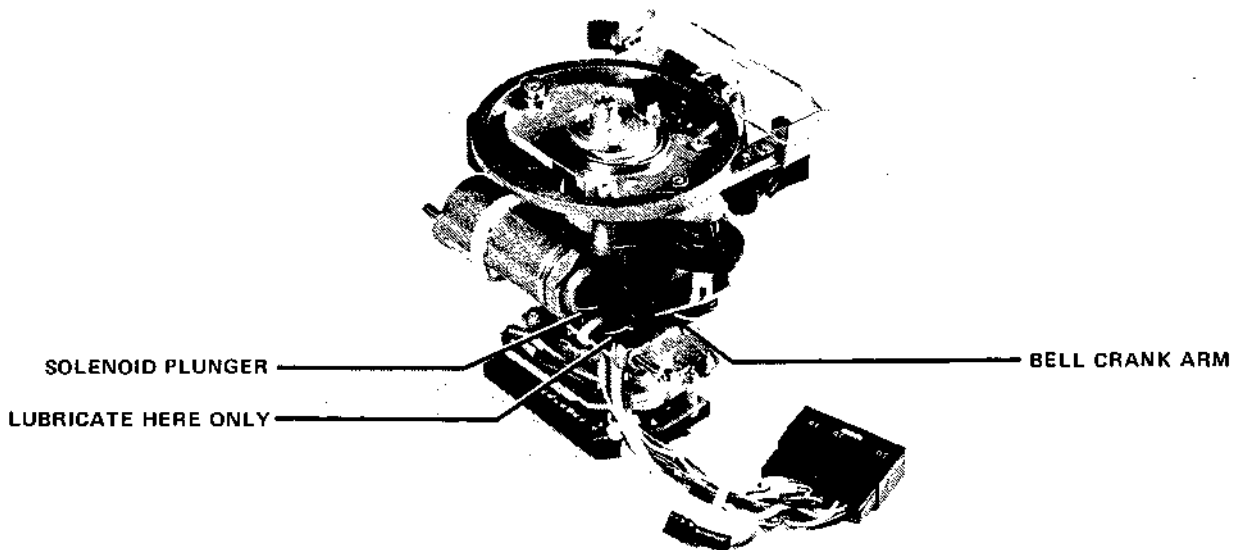

Figure 4-34. ECS BELL CRANK ARM

SECTION 5

ADJUSTMENT PROCEDURES

5.1 GENERAL INFORMATION

5.1.1 Adjustment Prerequisites

Adjustments should be performed on the Model 630 only after all lubrication and disassembly/assembly procedures have been completed. Since there is interaction between some of the adjustments, it is important that they be performed in the proper sequence, as they are presented here. This also is the proper sequence even when the adjustments are only being checked. Any mandatory prerequisites are specified with each adjustment procedure.

To maintain the best possible print quality, maximum usable print wheel life, and maximum reliability of the printer mechanism, the repair technician should make a practice of checking all of the adjustments during each service visit to the machine. On a machine that is not exhibiting any obvious symptoms of maladjustment, the adjustments can be validated quickly by visual and tactile observation. When any parts have been replaced on the mechanical assembly, it is important that all associated adjustments be checked thoroughly and carefully.

5.1.2 Summary of Adjustments

The adjustment procedures are listed below in their proper order. Some of the adjustments apply only to the standard carriage (marked *), some only to the ECS carriage (marked **), and some to both.

Table 5-1
SUMMARY OF ADJUSTMENTS

<u>Subsec.</u>	<u>Adjustment</u>	<u>Location</u>	<u>Printing Required</u>
5.2	Platen Clutch and Bearings	On Printer	No
5.3	Paper Release Actuator	Frame Assy.	No
5.4	Top Paper Out	"	No
5.5	Bottom Paper Out	"	No
5.6	Paper Feed Gear Backlash / Anti-Backlash Mechanism	"	No
5.7	Print Wheel Home	On Carriage Assy.	No
5.8	Print Wheel To Hammer Alignment	"	No
5.9	Hammer Armature	"	No
5.10	Ribbon Height *	"	No
5.11	Ribbon Lift (with ribbon lift option)	"	No
5.12	ECS Solenoid **	"	No
5.13	Card Guide	"	Yes
5.14	Hammer Angle * (nonadjustable with new style hammer assy)	"	Yes

5.1.3 Conditions For Test And Alignment

Power - Power is to be applied to the printer only when specified while making adjustments. It is used to electrically detent the print wheel and carriage servo motors, to hold the ribbon lift plate in operating position, and for cycling the printer through a RESTORE sequence when required.

Platen - When making adjustments that affect print quality, the platen used should be in good condition and free from wear or defects.

Ribbon - Ribbon adjustments are to be made using a carbon film ribbon cartridge.

Precautions - Always remove the special adjustment tool(s) from the print wheel motor shaft before initiating a RESTORE sequence, to prevent damage to the printer. Also, always ensure that the tool is properly seated prior to making any measurements.

5.1.4 Special Adjustment Tools

Some of the adjustments require special adjustment tools #40795, 40795-02 and 301445-01. (Note: Tool 40795-01 will also serve for any adjustment where tool 40795-02 is specified.) Tool #40796 is shown in subsection 5.9 (Fig. 5-17).

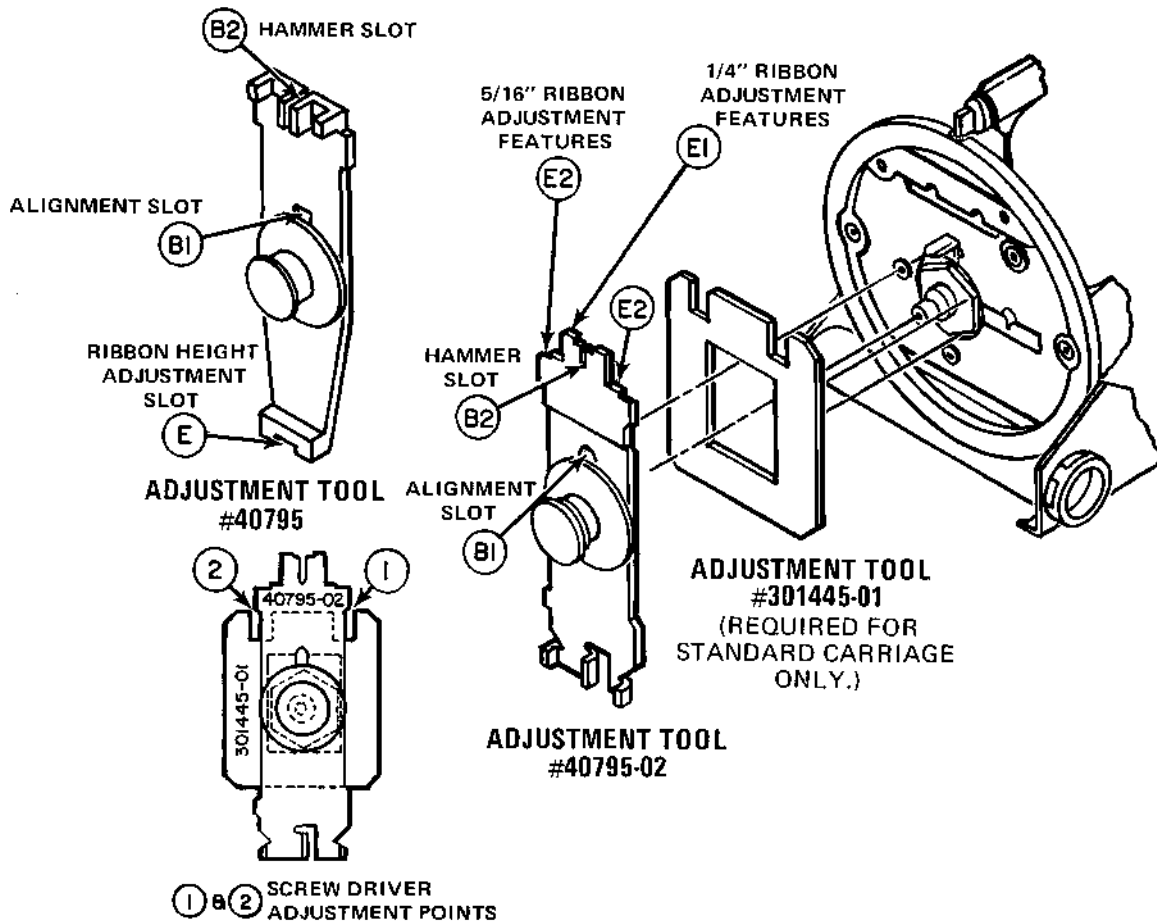

Figure 5-1. ADJUSTMENT TOOLS 40795, 40795-02 and 301445-01

Figure 5-1 identifies the tool features that are used for adjustments on the Model 630. Other features found on these tools, but not identified in Figure 5-1, are used for adjustments on Diablo HyType II printers. The illustration identifies the features by alphanumeric designators. In the adjustment procedures which call for the use of these tools, the features to be used are specified by these designators.

5.1.5 Print Quality Considerations

Print quality is dependent on several factors, one of which is proper adjustment of the printer. Adjustments to the Model 630 which directly affect print quality are:

- Print Wheel To Hammer Alignment
- Hammer Armature Adjustment
- Ribbon Height
- Card Guide Adjustments
- Hammer Angle Adjustments (not adjustable on later carriages)
- ECS Solenoid Adjustment

Other factors that affect print quality can be controlled entirely by the equipment operator. These factors are thoroughly discussed in a Diablo booklet entitled DIABLO SUPPLIES GUIDE, Publication No. 90071-XX.

Proper assessment of print quality requires that the print samples used for evaluation be obtained under standardized conditions. Therefore, tests should be made with a new print wheel and a multistrike ribbon, on a good grade of standard bond paper, with the multicopy lever on the carriage set for single copy. Print quality testing can be done as follows:

- 1) Print a full line of "H's".
- 2) Compare the test results with the examples shown here, in the following manner:

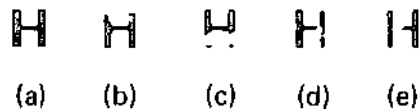

- Example (a) - Impressions similar to this with uniform density and good edge definition indicate proper printer adjustment.
- (b) - Impressions similar to this indicate HAMMER ANGLE * adjustment may be required to correct for hammer striking heavier at bottom.
- (c) - Impressions similar to this indicate HAMMER ANGLE * adjustment may be required to correct for hammer striking heavier at top.
- (d, e) - Impressions similar to these indicate that a PRINT WHEEL TO HAMMER or HAMMER ANGLE * adjustment may be required.

* Hammer Angle is not adjustable on later carriages (see subsection 5.14.1).

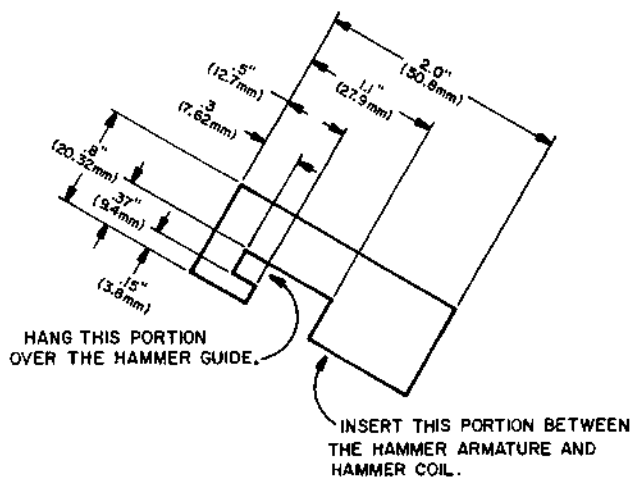

Figure 5-2. FINE ADJUSTMENT SHIM

To fine adjust the print quality, if desired, a .005" plastic shim, as shown in Figure 5-2, can temporarily be placed between the hammer armature and hammer coil. The shim decreases hammer energy significantly. This will in turn amplify nonuniform print density for easy adjustment. Be sure to remove the shim when adjustment is completed.

The fine-adjustment shim may be cut from .005" plastic shim stock (Diablo P/N 41144-07 or equivalent), using the pattern shown. In addition, always use a multistrike carbon film ribbon for print quality adjustments.

5.2 PLATEN CLUTCH ADJUSTMENT and PLATEN BEARING CHECK

The platen bearing check is valid for both early and late (zero-backlash) style platens; the platen clutch adjustment is required for early style platens only. Figure 2-5 in subsection 2.4.4 identifies the distinguishing features of the zero-backlash type platen.

Purpose

The Platen Bearing Check will detect unacceptable platen wobble that can prevent proper adjustment of the printer.

The Platen Clutch Adjustment (for early style platens only) sets the amount of clearance within the platen clutch.

Bearing Check

- 1) Remove the access cover and top cover.
- 2) Lift the platen out of its mounting slots and position it with its bearing collars resting on top of the closed platen latches.
- 3) Spin the platen manually while it is resting on the latches, and visually check for wobble of the platen. Any wobble indicates that the platen shaft has somehow become bent and must be replaced. Check also that the platen spins smoothly in its bearings.

Platen Clutch Check (early style platens only)

The platen clutch end play should be .003", +/- .001" (.076, +/- .025mm), as shown in Figure 5-3.

Adjustment Procedure (early style platens only)

- 1) Loosen the setscrews (A) in the platen clutch hub, and adjust the hub on its shaft to obtain the specified dimension.
- 2) Tighten the setscrews.

Figure 5-3
 PLATEN CLUTCH ADJUSTMENT

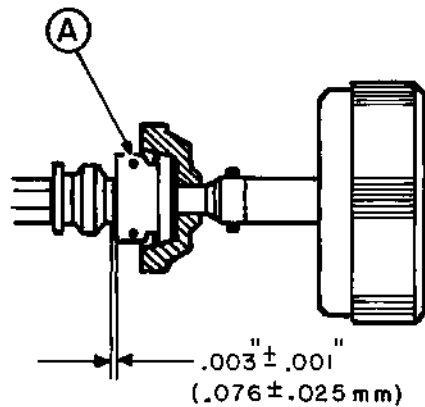

5.3 PAPER RELEASE ACTUATOR ADJUSTMENT

Refer to Figure 5-4.

Purpose

To ensure even and maximum pressure of the pressure rollers against the platen to give even paper movement.

Prerequisites

- Check for platen wobble (subsection 5.2).
- The paper release actuator (B) also actuates the top paper out bail actuator (F). To avoid interference during this adjustment, it may be necessary to loosen the top paper out bail actuator on its shaft, and then readjust it (see 5.4) after this adjustment has been completed.

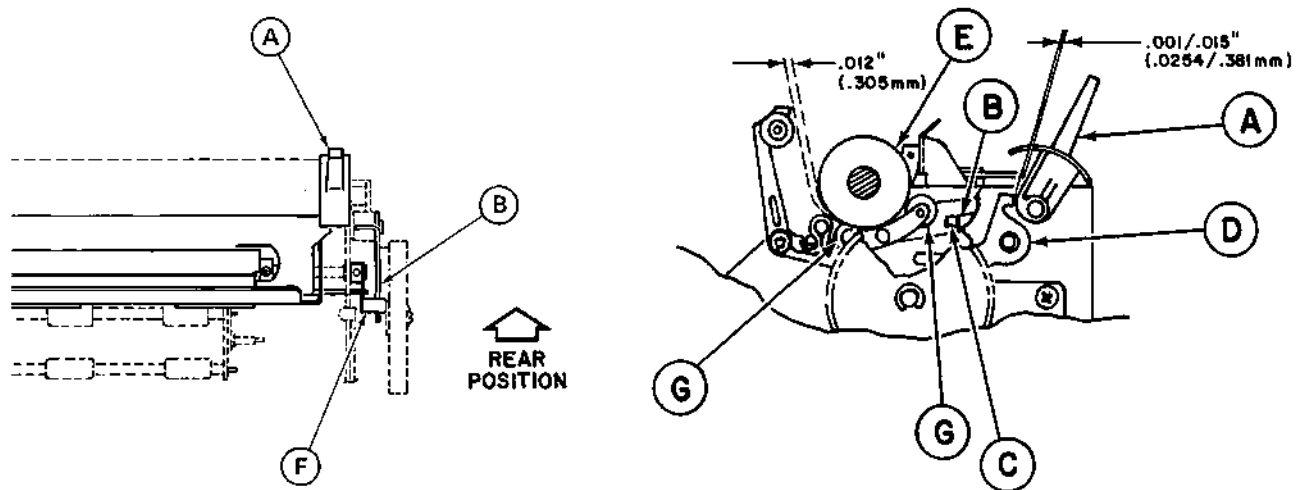

Figure 5-4. PAPER RELEASE ACTUATOR ADJUSTMENT

Adjustment Procedure

With the paper release lever (A) fully forward, the paper feed rollers (G) must clear the platen (E) by at least .070" (1.78mm). The system is adjusted as follows to achieve this:

- 1) Remove the access cover and top cover.
- 2) Insert 4 sheets of standard form paper (.012" / .305mm), and move the paper release lever (A) fully rearward.
- 3) Ensure that the torque shaft arm tab (B) is touching the lower edge of the pressure roller support arm slots (C).
- 4) Remove the 4 sheets of paper and reinsert 1 sheet. Ensure that the paper release actuator (D) clears the ramp on the paper release lever (A) by .001" to .015" (.025mm to .38mm). Loosen the 2 setscrews securing the actuator, and adjust the actuator to achieve this dimension.
- 5) Retighten the 2 setscrews.
- 6) Remove the sheet of paper. Insert a 6" (15.24cm) wide strip of standard form paper (.003" / .076mm thickness) between the platen (E) and each set (3 front and 3 rear) of pressure rollers (G). Check that both the platen and the rollers rotate when the strip is pulled free. If rotation does not occur, the torque shaft arm tab (B) has been pushed down too low, and the paper release actuator (D) should be readjusted.
- 7) If the top paper out bail actuator has been loosened, readjust it according to subsection 5.4.

5.4 TOP PAPER OUT BAIL AND SWITCH ADJUSTMENT

Purpose

To ensure proper sensing of a paper out condition when using continuous forms paper.

Prerequisites

Subsections 5.2, 5.3.

Adjustment Procedure

Refer to Figure 5-5.

- 1) Remove the access cover and top cover.
- 2) Set the paper release lever (A) to its forward position.
- 3) Gently push the top paper out bail (B) forward against the platen. The two ends of the bail should contact the platen simultaneously, within .015" (.38mm), and the tabs on the bail should pass freely through the notches in the paper bar (H).

(Steps 4 and 5 apply only to units with the old style setscrew-mounted bail arms. Figure 5-6 shows the features of a new style mounting arm.)

- 4) Loosen setscrews (C1) and (C2), and adjust the bail as necessary.
- 5) Retighten the setscrews.
- 6) Set the paper release lever (A) to its rear position.
- 7) Loosen setscrew (D) holding bail actuator (E) to the bail pivot shaft.
- 8) Rotate the bail actuator (E) so that its tab touches the top edge of the paper release actuator (G). While holding the actuator (E) in this position, adjust the bail (B) for a gap of .005/.035" (.127mm/.889mm) between the rear edge of the bail (B) and the comb (F).
- 9) Retighten setscrew (D).
- 10) Set the paper release lever (A) to its forward position.

11) Loosen the two mounting screws holding the top paper out switch (J).

NOTE: SPI units may have a hood over the switch for ESD shielding. Remove the hood to make the adjustment. On earlier units the hood is fastened by the switch mounting screws.

12) Adjust the switch so that it deactuates when the bail (B) approaches to within .060" to .010" (1.5mm to .254mm) of the platen, as measured from either end of the bail.

13) Retighten setscrew (D).

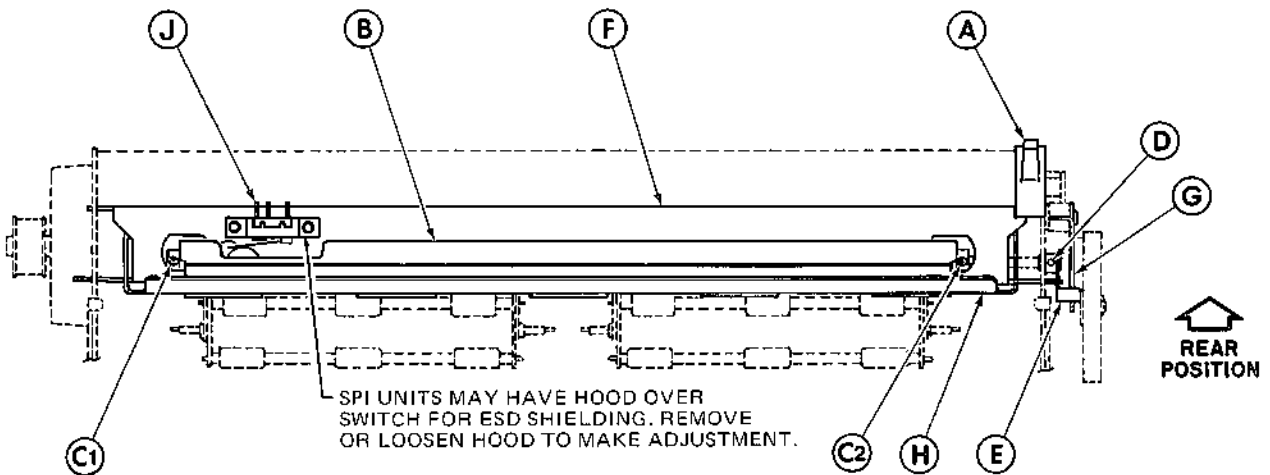

Figure 5-5. TOP PAPER OUT BAIL AND SWITCH ADJUSTMENT

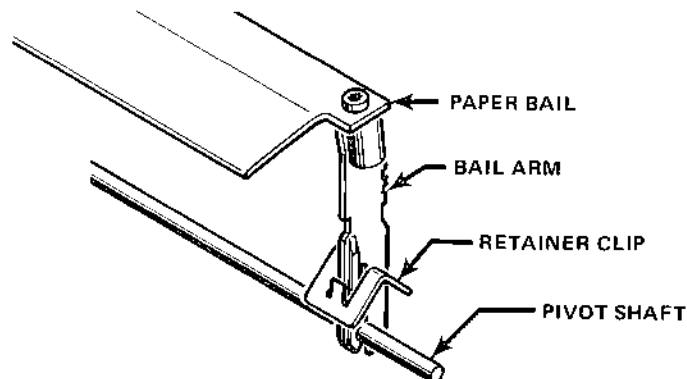

Figure 5-6. NEW STYLE BAIL-MOUNTING ARMS

5.5 BOTTOM PAPER OUT BAIL AND SWITCH ADJUSTMENT

Purpose

To ensure proper sensing of a paper out condition when using continuous forms paper with bottom feed.

Adjustment Procedure

Refer to Figure 5-7.

- 1) Remove the access cover and top cover.
- 2) Check to see that the bail is centered for equal contact against the tabs on the support brackets at both ends of the bail. If adjustment is necessary, loosen the two setscrews holding the bail to the paper bail shaft, slide the bail to its proper position, and then retighten the setscrews.
- 3) Check for positive actuation/deactuation of the BPO switch when a standard sheet of printer paper is passed through the bottom feed paper path.

If adjustment of the switch appears necessary, proceed as follows while referring to Figure 5-7.

- 4) Slightly loosen the screw/s holding the BPO switch. (Early versions use two screws.)
- 5) Start with the bail resting against the rear plate, and the BPO switch rocked away from the bail.
- 6) Place a .035" shim between the bail and the BPO switch lever.

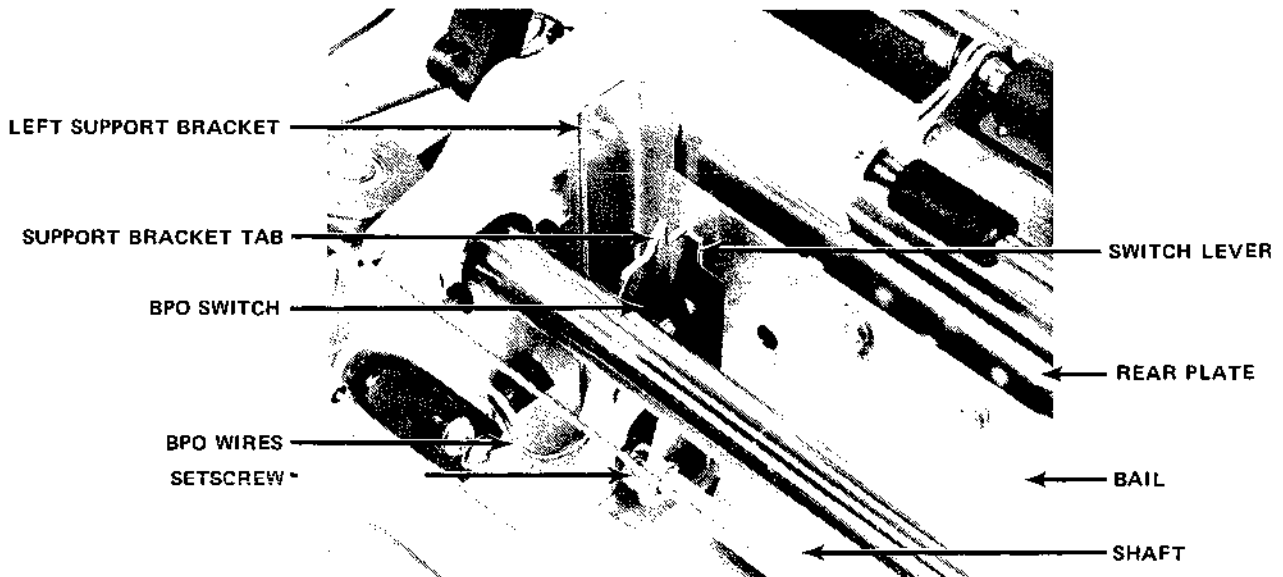

Figure 5-7. BOTTOM PAPER OUT BAIL AND SWITCH ADJUSTMENT

- 7) Push the switch toward the bail to the point where the switch actuates.
- 8) Tighten the switch screw/s.
- 9) Check again for proper operation of the switch when a sheet of paper is passed through the bottom feed paper path.

5.6 PAPER FEED GEAR BACKLASH ADJUSTMENTS

5.6.1 In Units Without Anti-Backlash Mechanism

Purpose

To prevent binding or excessive backlash of the paper feed gear train, and thus ensure consistent vertical print registration.

Prerequisites

Subsections 5.2, 5.3 and 5.4.

Adjustment Procedure

Refer to Figure 5-8.

- 1) Remove the access cover, top cover and platen.
- 2) On the inner side of idler gear (C), slightly loosen the locking nut that locks idler gear eccentric (E).
- 3) Turn idler gear eccentric (E) clockwise to move idler gear (C) away from motor pinion gear (A).
- 4) Move pinion gear (A) in and out (not side-to-side). While moving the pinion gear, rotate idler gear eccentric (E) counterclockwise until idler gear (C) starts to move with pinion gear (A). Back off (clockwise) on eccentric (E) to the point where the idler gear just stops moving.
- 5) Carefully tighten the locking nut on the inner side of idler gear (C).
- 6) Loosen the paper feed motor mounting screws (D).

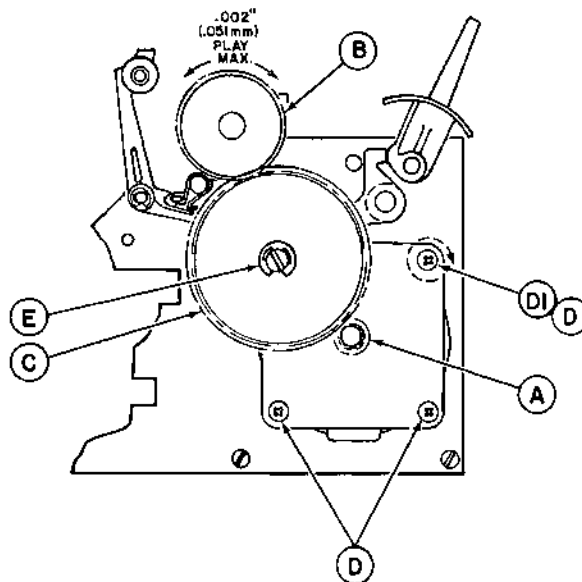

Figure 5-8. PAPER FEED GEAR ADJUSTMENTS
(Without Anti-backlash Mechanism)

- 7) Install the platen.
- 8) Rotate the paper feed motor clockwise around mounting screw (D1) until idler gear (C) and platen drive gear (B) can be held tightly together by hand.
- 9) While holding gears (B) and (C) together with one hand, tighten screws (D).

5.6.2 In Units With Anti-Backlash Mechanism

The paper feed anti-backlash mechanism (Fig. 5-9) is a standard feature on later units. This mechanism eliminates all backlash in the paper feed drive train to give precise control of paper registration.

Prerequisites

Subsections 5.2, 5.3 and 5.4.

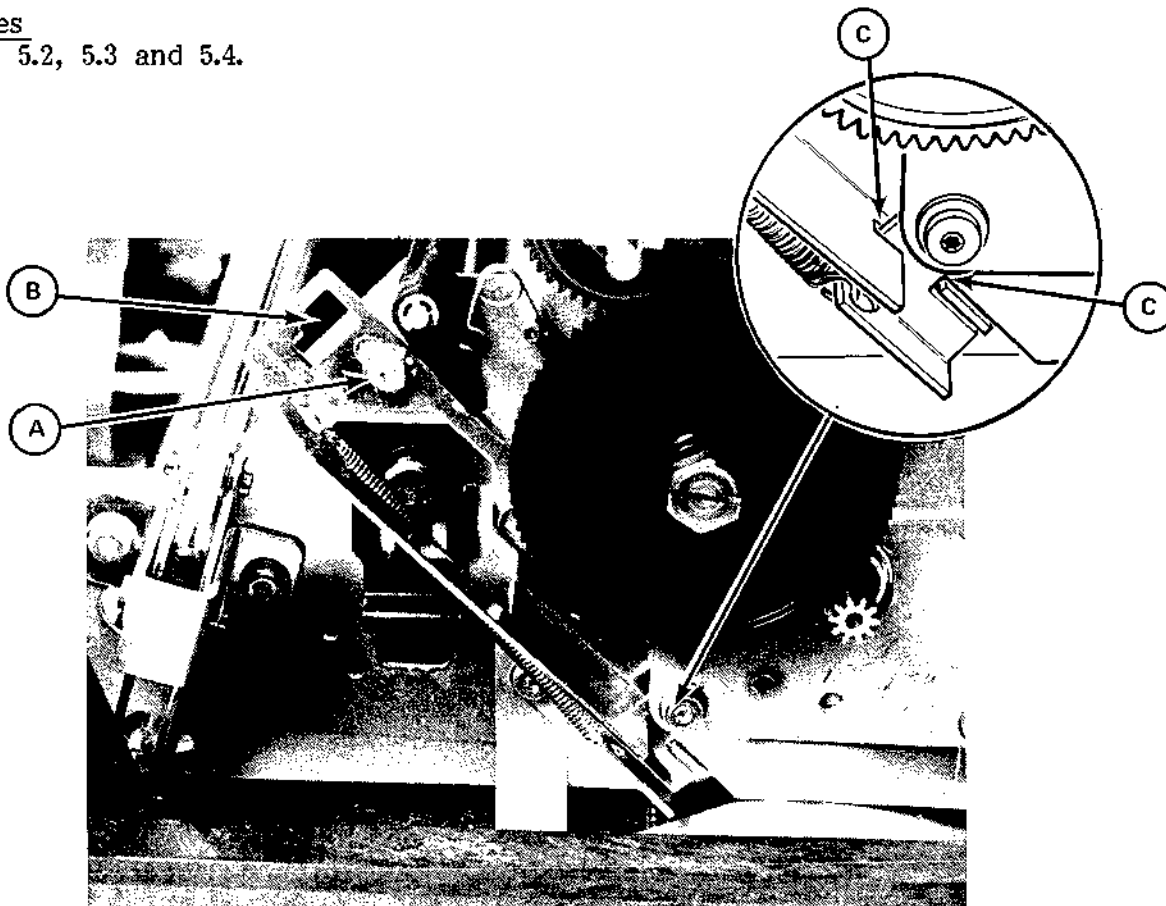

Figure 5-9. PAPER FEED ANTI-BACKLASH MECHANISM ADJUSTMENT

Adjustment Procedure

Refer to Figure 5-9.

- 1) Ensure that the platen is fully latched in place and the platen drive gears are properly meshed.
- 2) Loosen the tensioner bracket lock screw (A).
- 3) Insert a screwdriver blade into the adjustment slot (B), and adjust for equal clearance at points (C) shown in Figure 5-9.
- 4) Tighten the lock screw.

5.7 PRINT WHEEL HOME

Background

The printer logic locates the print wheel home position by sensing the flag that rotates with the print wheel motor shaft. The standard carriage uses a single flag; the ECS carriage uses a dual flag. On the ECS carriage, the first flag (clockwise flag rotation as viewed from front of machine) identifies Home position, and the second flag identifies the type of carriage (clockwise flag rotation as viewed from front of machine). The P/W HOME pulse produced by the Home flag triggers a timing window during which the printer logic watches for a second pulse. If a second pulse occurs during the detection period, the printer logic identifies the carriage as ECS. If there is no second pulse, the printer logic considers it to be a standard carriage.

Purpose

During print wheel seeks, the print wheel is allowed to stop, or "detent", only at a precise position in alignment with each print wheel spoke. If, during a Restore sequence, the print wheel fails to stop at this position, the print wheel logic will initiate a print wheel seek retry. If the print wheel logic is unable to obtain the correct condition after 8 consecutive retries, it will issue a CHECK command to stop the printer. This situation normally indicates that a "print wheel home" adjustment is needed.

Check Procedure

- 1) Remove the ribbon cartridge, and tilt the print wheel motor forward away from the platen.
- 2) Initiate a Restore sequence, and verify that the correct "home" character has been positioned squarely in front of the print hammer. Home characters for the various types of print wheels are:

Plastic 96 = w
Metal 88 = 90° vertical flag notch
Metal 92 = 90° vertical flag notch
Metal 96 - Xerox = Character at spoke position 0
Metal 96 - Diablo = Character at spoke position 0
ECS 192 = Character at spoke position 0

If the "home" character is displaced less than one character width, perform Print Wheel to Hammer Alignment (subsection 5.8).

If the "home" character is displaced one full character position, perform the "print wheel home" adjustment procedure outlined below.

If the "home" character is displaced more than one full character position, perform both the print wheel to hammer alignment and the home position alignment procedures. In this event, perform the wheel alignment first.

Adjustment Procedure

This procedure requires the use of the Model 630 PCB Extender Kit and an oscilloscope.

NOTE: The following procedure uses Test 30 in the self-test mode of the Model 630 HPRO5 to generate continuous print wheel restore cycles and thus facilitate the adjustment. For other versions of the Model 630, it will be necessary

to produce repeated print wheel restore cycles by means of the host system software.

- 1) Turn off the AC power to the Model 630.
- 2) Remove the access cover, top cover and card cage shield.
- 3) Mount the PCE (PPI, SPI or API) circuit board on the PCB Extender.
- 4) Set up the oscilloscope as follows:

Channel 1: 2V/Div Vertical
 Connect Probe to J3-48 (-PW HOME) on the PCE (PPI, SPI or API) circuit board

Channel 2: 2V/Div Vertical
 Connect Probe to J3-47 (+PW EVEN) on the PCE (PPI, SPI or API) circuit board

Trigger: Channel 1, negative slope

Horizontal Sweep: 100 usec/Div

- 5) For ECS units only:
 Remove the ribbon deck.
- 6) For HPRO5 units, set the unit for Self-Test mode and apply AC power.
 (Note: The cover open switch must be defeated.)
- 7) For HPRO5 units, select and start Test 30 - Print Wheel Restore.
 For other Model 630 versions, apply AC power, and initiate continuous print wheel restore cycles by means of the host system software.

Note: In the next step (8), to avoid the need for a delayed-sweep oscilloscope it is necessary to trigger the scope on the same signal edge that is used as the adjustment reference point (see Fig. 5-11/5-13). It is imperative that the scope be accurately triggered. Also, closely check the time span of one of the complete +PW EVEN pulses in the display so that the adjustment reference point (starting point of scope sweep at left edge of the display) can be accurately adjusted to coincide with the midpoint of a +PW EVEN high period, as shown in Figure 5-11/5-13.

- 8a) For Non-ECS units only:
 Using a 7/16" open-end wrench, adjust the home sensor eccentric (Item A, Figure 5-10) to obtain the timing relationship shown in Figure 5-11. The negative edge of -PW HOME should occur at the midpoint of a +PW EVEN high period.
- 8b) For ECS units only:
 - a. Using a 5/64" hex L-wrench, slightly loosen the two socket head screws (A) holding the home sensor assembly (Fig. 5-12).
 - b. With a screwdriver blade in the adjustment slot (E in Fig. 5-12), adjust the home sensor up or down to obtain the timing relationship shown in Figure 5-13. The negative edge of -PW HOME should occur at the midpoint of a +PW EVEN high period.
 - c. Tighten the two screws (A) and recheck the timing waveforms.

Refer to Figure 5-10 (non-ECS carriage) or Figure 5-12 (ECS carriage).

- 9) If the print wheel spins continuously (8 revolutions), the sensor (B) may be located too far from the print wheel home sensor flag (C). In this case, loosen nut (D) with a 5/16" open-end wrench, and rotate the sensor clockwise until the print wheel stops.
- 10) Use a plastic shim to verify .003" to .007" (.076mm to .178mm) clearance between the tip of the sensor and the edge of the flag (standard carriage) or the face of the dual flag (ECS carriage).
- 11) Retighten nut (D).

(continued)

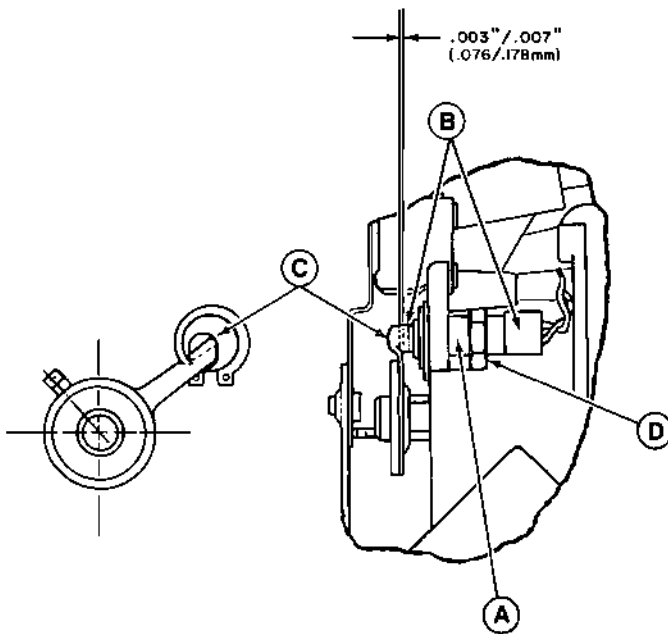

Figure 5-10.
PRINT WHEEL HOME ALIGNMENT
(Non-ECS Carriage)

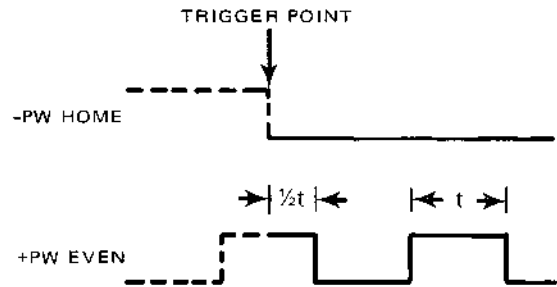

Figure 5-11.
PRINT WHEEL HOME
ADJUSTMENT WAVEFORMS
(Non-ECS Carriage)

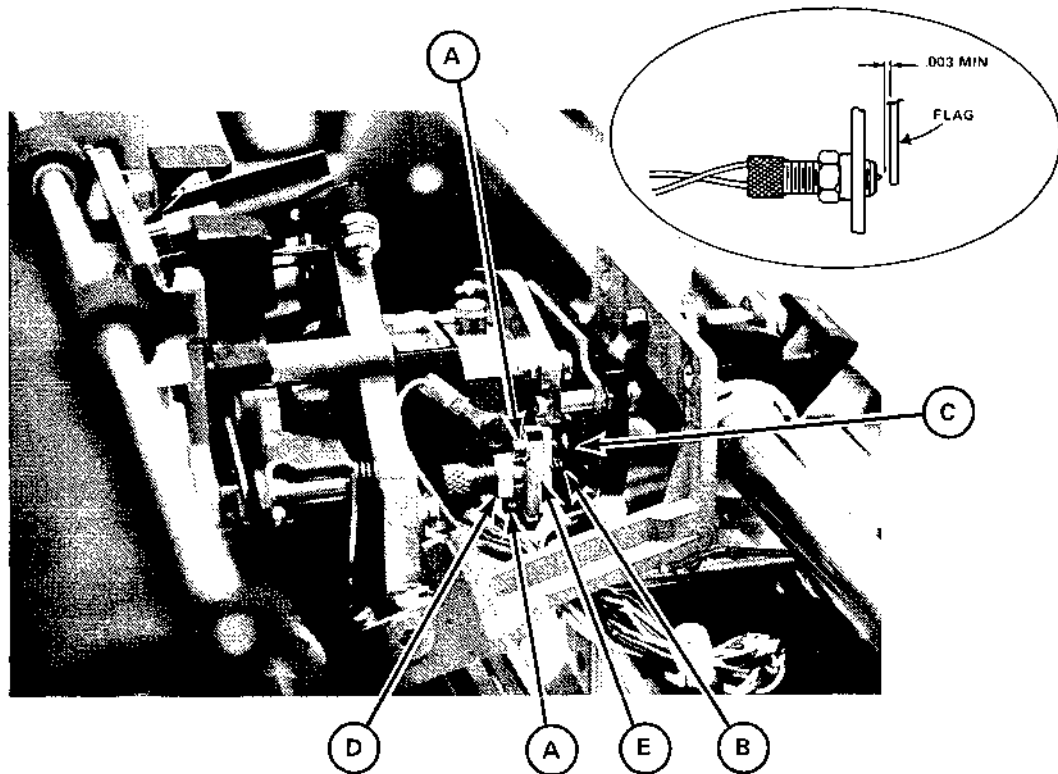

Figure 5-12. PRINT WHEEL HOME ALIGNMENT (ECS Carriage)

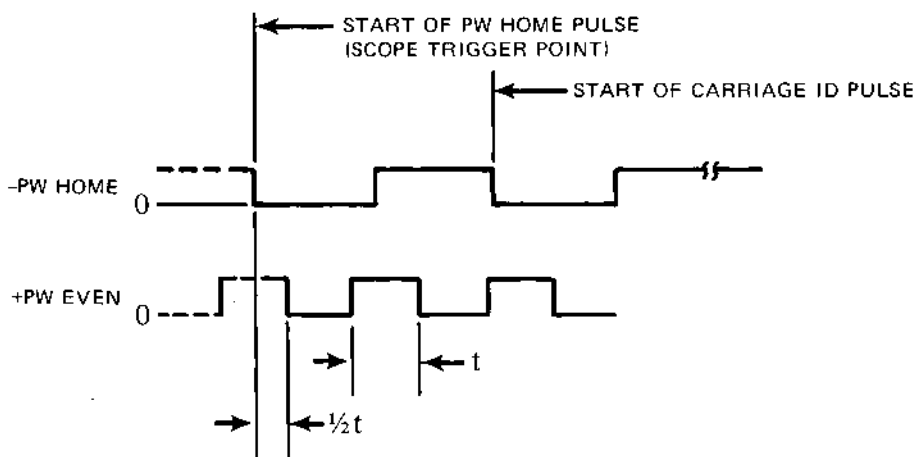

Figure 5-13. PRINT WHEEL HOME ADJUSTMENT WAVEFORMS (ECS Carriage)

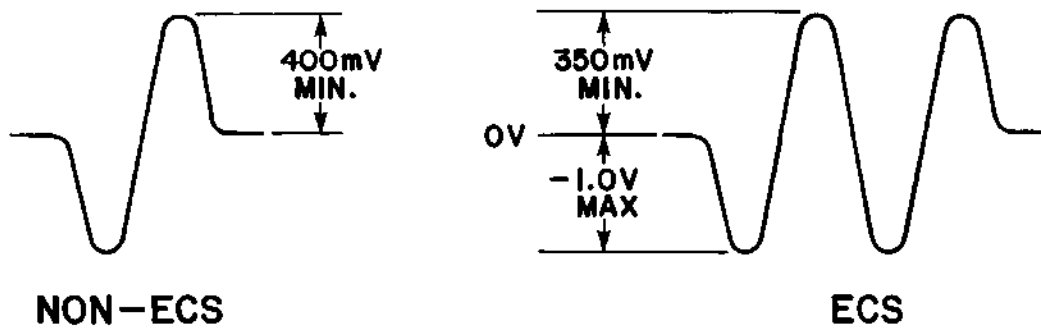

Figure 5-14. PRINT WHEEL HOME SENSOR WAVEFORMS

- 12) The electrical signal out of the sensor should be at least 400mV peak for non-ECS units, and 350mV peak for ECS units. Figure 5-14 illustrates this signal as seen at terminal J3-13 on the SCE circuit board.

Note: For sensor adjustment in ECS units with 302690-09 or earlier SCE PCB assembly, circuit board modification may be required. See FSA #54.

5.8 PRINT WHEEL TO HAMMER ALIGNMENT

Purpose

To set mechanical alignment of print wheel spoke to hammer position.

Adjustment Procedure

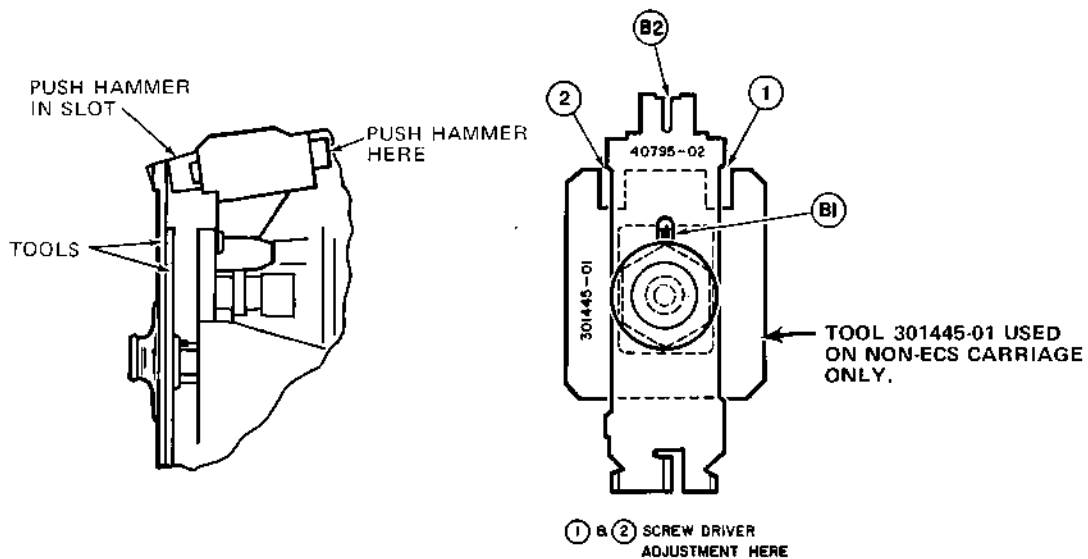

Figure 5-15. PRINT WHEEL TO HAMMER ALIGNMENT

Refer to Figures 5-15 and 5-1.

- 1) With power off, remove the paper, ribbon and print wheel from the printer.
- 2) For ECS Units Only:
Remove the ribbon deck from the carriage.
- 3) Apply power to the printer, and allow it to complete its RESTORE sequence.
- 4) For Non-ECS Units Only:
Install Adjustment Tool 301445-01 over the nut on the front of the print wheel hub as shown in Figure 5-15.
- 5) Install Adjustment Tool 40795, 40795-01 or 40795-02 firmly on the print wheel motor hub and ensure that it is properly seated with its alignment slot (B1) engaged over the tab on the hub's alignment plate.
- 6) Rotate the alignment tool to bring its hammer slot (B2) in front of the print hammer.
- 7) Push lightly against the carriage to activate the carriage and print wheel servos, and thereby detent the print wheel motor.

NOTE: This means of detenting the print wheel motor will not work with the Model 630 SPI, and possibly some other versions of the Model 630. Two other means of activating print wheel detent are as follows:

- 1 - SCE assemblies 302690-10 and below have a jumper plug at location F12. When this jumper is removed, the print wheel is detented.
 - 2 - SCE assemblies 302690-11 and above do not have jumper F12. In this case, mount the SCE board on Extender Board #320048-02. This extender board has a switch to open the -PW SMD line (pin 51 on J3) and cause print wheel detent.
- 8) With the print wheel detented, manually push the print hammer gently toward the alignment tool until its face enters the tool's hammer slot (B2). If the hammer face slides easily into the slot without contacting the sides of the slot, print wheel to hammer alignment is correct. If the hammer contacts the sides of the slot, or will not enter the slot at all, continue with this procedure.
- 9a) Non-ECS Units Only:
Place the tip of a blade screwdriver in either of points 1 or 2 (Fig. 5-15). The screwdriver may then be twisted to move the alignment plate in relation to the print wheel hub to achieve proper alignment.
 - 9b) ECS Units Only: (Refer to Fig. 5-16)
 - Slightly loosen the three screws (A) that hold the stationary transducer plate (B).
NOTE: To gain access to the lower right screw, on some early units it may be necessary to remove the black plastic cover (C) from the PW Preamp circuit board (D).
 - Grasp the edges of the PW Preamp circuit board (D), which is mounted on the stationary transducer plate (B), and rotate the board and plate very slightly. The electrically-detented print wheel motor shaft will follow the movement of the transducer plate, thus producing a relative change in print wheel to hammer alignment.
 - When proper alignment is achieved, tighten the three screws (A) that secure the stationary transducer plate; then check the alignment again.

NOTE: If a change of print wheel to hammer alignment was required, it will be necessary also to check the Print Wheel Home adjustment (subsection 5.7).

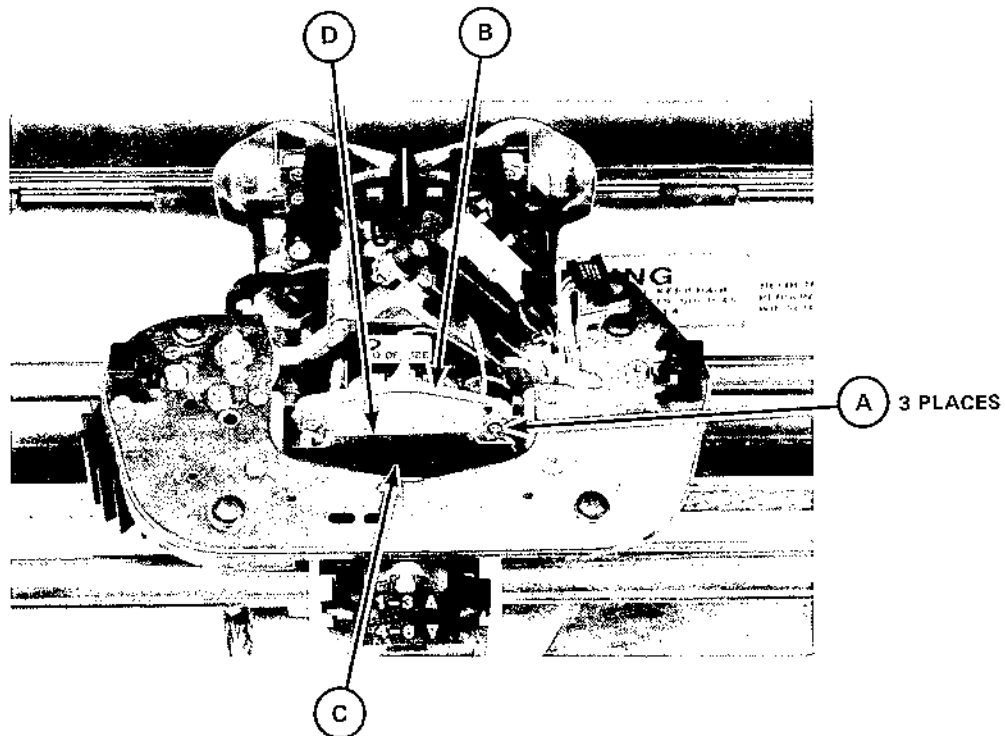

Figure 5-16. ADJUSTING THE ECS PRINT WHEEL TRANSDUCER

5.9 HAMMER ARMATURE ADJUSTMENT

Purpose

To obtain proper hammer striking force.

Prerequisites

Subsections 5.2, 5.7 and 5.8.

Also verify that the platen is in good condition and free of surface defects. If this is to be an adjustment for high print quality, it is advisable that a new platen be installed (even if only temporarily).

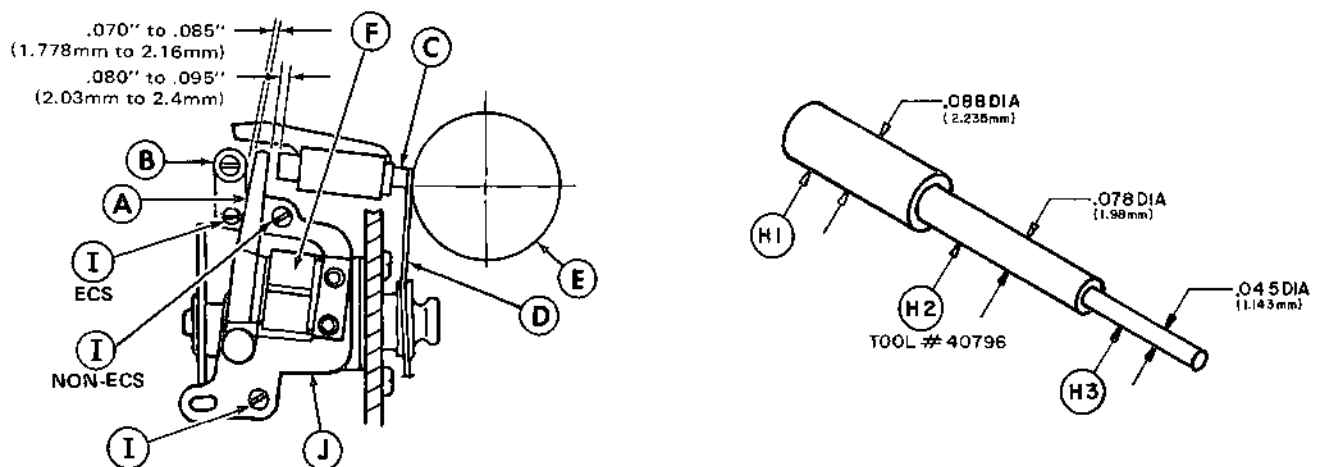

Figure 5-17. HAMMER ARMATURE ADJUSTMENTS AND ADJUSTMENT TOOL

Adjustment Procedure

NOTE: For optimum print quality on both standard and ECS type carriages, this adjustment is performed with a metal print wheel installed on the printer.

Refer to Figure 5-17.

- 1) Turn off power to the printer.
- 2) Remove access cover, ribbon, print wheel shield, print wheel and paper.
- 3) Hold the hammer armature (A) against the hammer coils (F), and check for no gap between the armature and coils.
- 4) While continuing to hold the hammer armature against the hammer coils, insert adjustment tool 40796 section H2 between the armature (A) and the armature stop eccentric (B). Adjust the eccentric (B) as necessary for a very light resistance to passage of the tool when slid along the side of the armature past the eccentric.
- 5) Set the multicopy lever on the carriage to its UP position.
- 6) Rotate the print wheel manually to position one of the larger characters (M, W, E, etc.) in front of the print hammer. (NOTE: If this is to be an adjustment for high print quality, it is advisable that a new print wheel be used, even if only temporarily).
- 7) Insert Adjustment Tool 40796 section H1 between the armature (A) and the anvil end of the print hammer (C). With the tool in place, lightly press in on the armature (A) until it stops against the hammer coils (F). This will drive the print hammer (C) in to nestle the selected print wheel petal (D) lightly against the platen (E). Gently rock the print wheel slightly back and forth, and verify that the petal can move with a very light drag. Repeat this check while rotating the platen and moving the carriage each time until the entire printing surface condition has been checked.

If adjustment is needed, loosen screws (I) and adjust the print hammer armature assembly (J) to achieve best hammer to platen dimensions. Retighten screws (I).

5.10 RIBBON HEIGHT ADJUSTMENT (Non-ECS units only)

Ribbon height adjustment is not required on ECS carriages.

The ribbon height adjustment procedure varies slightly depending on the following factors:

- Design level of the adjustment tool
- Ribbon width (1/4" or 5/16")
- Whether or not optional ribbon lift feature is installed

Purpose

To obtain proper height of the ribbon in relation to the level of the print line.

Prerequisites

On units equipped with the ribbon lift option, check the ribbon lift adjustment (5.11) before adjusting ribbon height. Since ribbon height and ribbon lift interact, if the setting of either of these is changed, the other one must be checked.

Check - Using Adjustment Tool 40795 (1/4" ribbons only)

Refer to Figure 5-18A.

- 1) Remove the access cover, print wheel shield, ribbon cartridge and print wheel.
- 2) Install the 40795 adjustment tool on the hub of the print wheel motor shaft, and rotate the tool to bring the ribbon height adjustment feature (E) to the top.
- 3) Tilt the print wheel motor into operating position, and install a multistrike carbon film ribbon cartridge.
- 4) Push up on the ribbon base plate tab "X" so the TOP edge of the exposed ribbon is brought near the top of the tool. (NOTE: In units without optional ribbon lift, the ribbon base plate is permanently fixed in the raised position.)
The top edge of the ribbon should be visible within the slot, as shown in Figure 5-18A.

Check - Using Adjustment Tool 40795-01/-02 (1/4" or 5/16" ribbons)

Refer to Figure 5-18B.

- 1) Remove the access cover, print wheel shield, ribbon cartridge and print wheel.

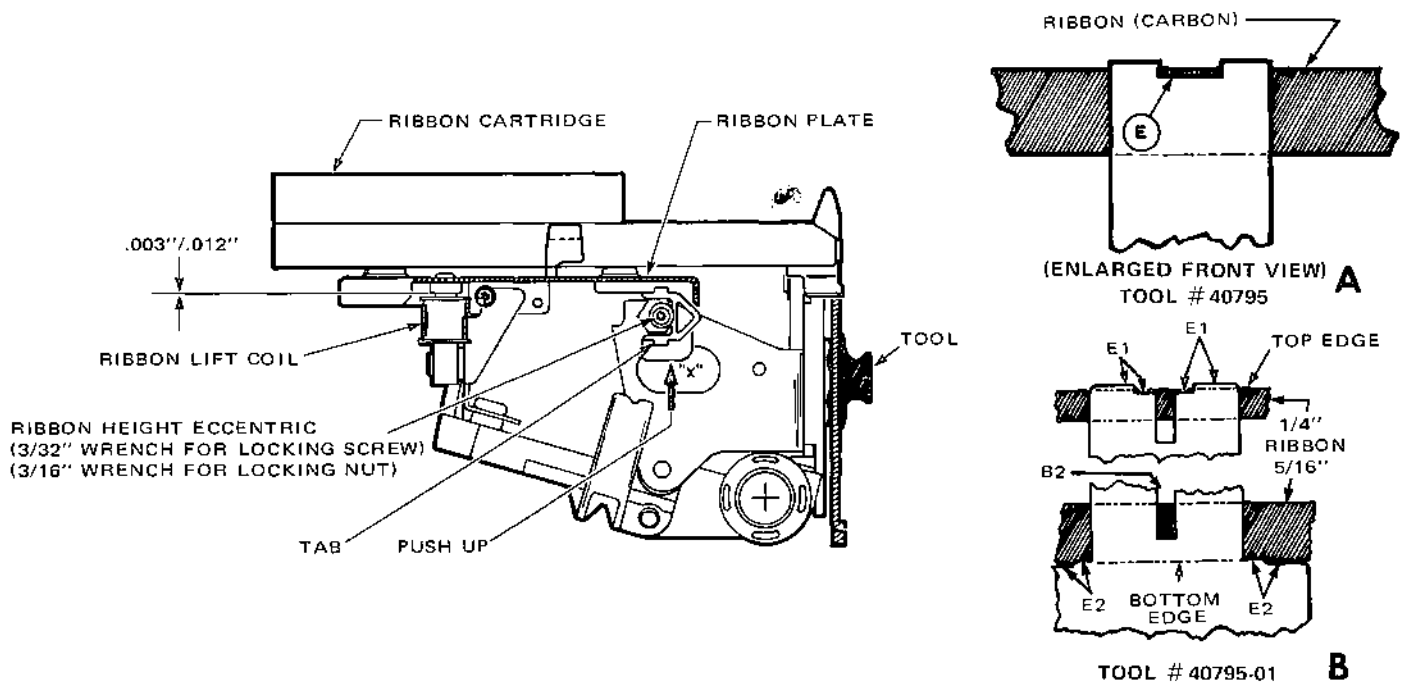

Figure 5-18. RIBBON HEIGHT ADJUSTMENT

- 2) Install the 40795-01 or -02 adjustment tool on the hub of the print wheel motor shaft, and rotate the tool to bring its hammer adjustment slot feature (B2) to the top.
- 3) Tilt the print wheel motor into operating position, and install a multistrike carbon film ribbon cartridge.
- 4) Push up on the ribbon base plate tab "X" so that the tab is held against the ribbon height eccentric. (NOTE: In units without optional ribbon lift, the ribbon base plate is permanently fixed in the raised position.)
- 5) Check the position of the exposed portion of the ribbon for proper height adjustment as follows:

1/4" ribbons -

The TOP edge of the ribbon must appear between the high and low planes of tool features (E1).

5/16" ribbons -

The BOTTOM edge of the ribbon must appear between the high and low planes of tool features (E2).

Adjustment Procedure

- 1) Loosen the ribbon height eccentric locking screw (or nut), and adjust the eccentric as required to set the ribbon at the proper level. (The screw version requires a 3/32" hex wrench; the nut version requires a 3/16" nut driver.)
- 2) Retighten the locking screw (or nut).
- 3) Remove the ribbon cartridge and tool. Replace the print wheel, print wheel shield and the operating ribbon cartridge.
- 4) If this unit is equipped with the ribbon lift option, check the ribbon lift adjustment (5.11).

5.11 RIBBON LIFT ADJUSTMENT (Units with Ribbon Lift option)

Purpose

To properly set the position of the ribbon lift coils in relation to the ribbon base plate pole piece.

Prerequisites

Since ribbon height and ribbon lift interact, if the setting of either of these is changed, the setting of the other one must be checked.

Check

Refer to Figure 5-18.

- 1) Remove the access cover and ribbon cartridge.
- 2) Push up on the ribbon base plate tab (X) so that the tab firmly contacts the ribbon height eccentric.
- 3) Check for .005" to .012" (0.12 to 0.30mm) gap between the ribbon lift coil laminations and the ribbon base plate pole piece.

Adjustment Procedure

Refer to Figure 5-18.

- 1) Loosen the two ribbon lift coil mounting screws.
- 2) Place a .005" plastic shim between the ribbon lift coil laminations and ribbon base plate pole piece.
- 3) Push up on the ribbon base plate tab (X) so that the tab firmly contacts the ribbon height eccentric.
- 4) Raise the ribbon lift coils so that the coil laminations are firmly and evenly seated against the shim and pole piece.
- 5) Retighten the coil mounting screws, and remove the shim.
- 6) Recheck the ribbon height adjustment (5.10). If ribbon height is readjusted, the ribbon lift adjustment must be checked again.

5.12 ECS SOLENOID ADJUSTMENT

Purpose

To position the ECS solenoid for proper actuation of the ECS print wheel lift mechanism.

Procedure

- 1) The two solenoid mounting screws should be loose enough to allow the solenoid assembly to move. The cable tie that clamps the solenoid to the solenoid plate should be snug only, and its tail should not have been cut off.

Refer to Figure 5-19.

- 2) Push the solenoid plunger to the bottom of the solenoid and hold it there (A).
- 3) Closely observe the double crank pin in the primary slider slot, and move the solenoid and plunger assembly just to the point where the pin contacts the end of the slot (B).
- 4) Without moving the solenoid further, tighten the solenoid mounting screws.
- 5) Tighten the solenoid cable tie, and cut off its tail.

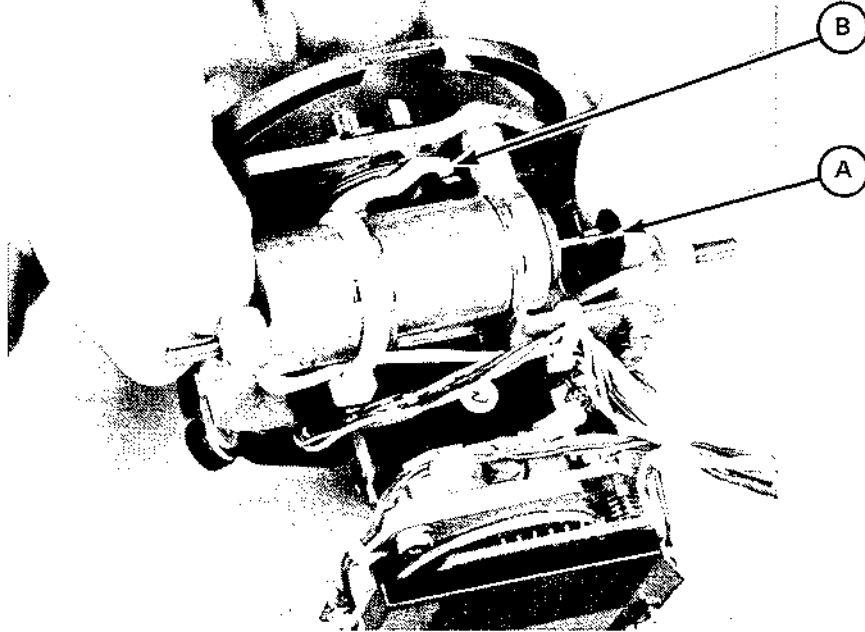

Figure 5-19. ECS SOLENOID ADJUSTMENT

5.13 CARD GUIDE ADJUSTMENTS

These adjustment procedures apply to the 2-piece card guide assembly originally used on the Model 630. The 1-piece card guide presently being used is designed to meet the same specifications without the need for adjustments. (See Fig. 5-20.)

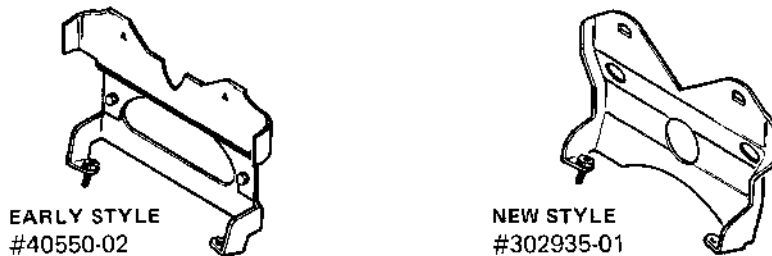

Figure 5-20. CARD GUIDES

Purpose

To ensure that the card guide does not interfere with ribbon movement or the leading edge of the paper.

Adjustment Procedure - Card Guide Height

Refer to Figure 5-21A.

- 1) Print a line of E's.
- 2) Remove the access cover.
- 3) Without rotating the platen, move the carriage to the left until characters are visible through both triangular openings in the card guide as shown.

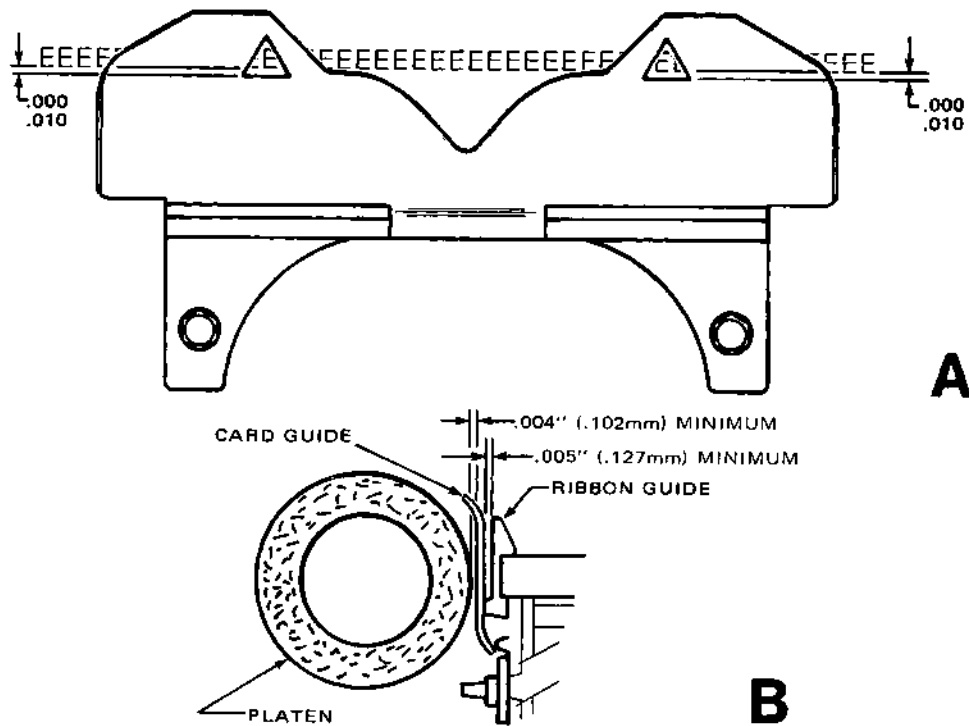

Figure 5-21. CARD GUIDE ADJUSTMENTS

- 4) The gap between the bottom of the characters and the bottom of each opening must be within the range .000" to .010" (.000mm to .254mm).
- 5) If adjustment is required, remove the ribbon, print wheel shield, and print wheel; then loosen the two 3/16" card guide mounting screws, and raise or lower the card guide to achieve the specified dimension.
- 6) Retighten the mounting screws.

Adjustment Procedure - Card Guide Clearance

Refer to Figure 5-21B.

- 1) Using a .005" plastic shim, check for no-drag shim clearance between the card guide and the ribbon guide posts on both sides of the carriage. Normally this dimension is set by the depth of the ribbon guide post tabs. Shim drag indicates that the card guide has become tilted, in which case its support arms should be gently reformed to achieve proper ribbon post clearance.
- 2) Using the .005" plastic shim, check for no-drag clearance between the card guide and the platen along the full length of the platen.

5.14 HAMMER ANGLES

5.14.1 Adjustable/Nonadjustable Print Hammer Assemblies

All hammer angle adjustments mentioned in this manual apply only to the early style carriages which use an adjustable-type hammer assembly as shown in Figure 5-23. Later style carriages use a nonadjustable hammer assembly as shown in Figure 5-22.



Figure 5-22. NONADJUSTABLE HAMMER ASSEMBLY

5.14.2 Hammer Angle Adjustments (Adjustable Hammer Assemblies Only)

CAUTION: The hammer angles are set by very sensitive adjustments at the factory. These adjustments should be changed only after thorough evaluation of the print quality strongly indicates that adjustment is necessary, and after all prerequisite adjustments have first been made.

Purpose

To correct for shading of printed characters, either top-to-bottom or side-to-side, caused by changes in the adjustments.

Prerequisites

Subsections 5.8 and 5.9.

Check

- 1) Print a line of "H's", using the largest print font available.
- 2) Visually check for shading of the printed characters.

Adjustment Procedure - To correct top-to-bottom shading

Refer to Figure 5-23.

- 1) Loosen screws (A) slightly on both sides of the hammer guide.
- 2) Using a small screwdriver in eccentric slot (B), adjust the hammer pitch angle.
- 3) Tighten screws (A).
- 4) Repeat the Check and this Adjustment Procedure until top-to-bottom shading is eliminated.
- 5) Check Print Wheel To Hammer Alignment (5.8) and Hammer Armature Adjustment (5.9).

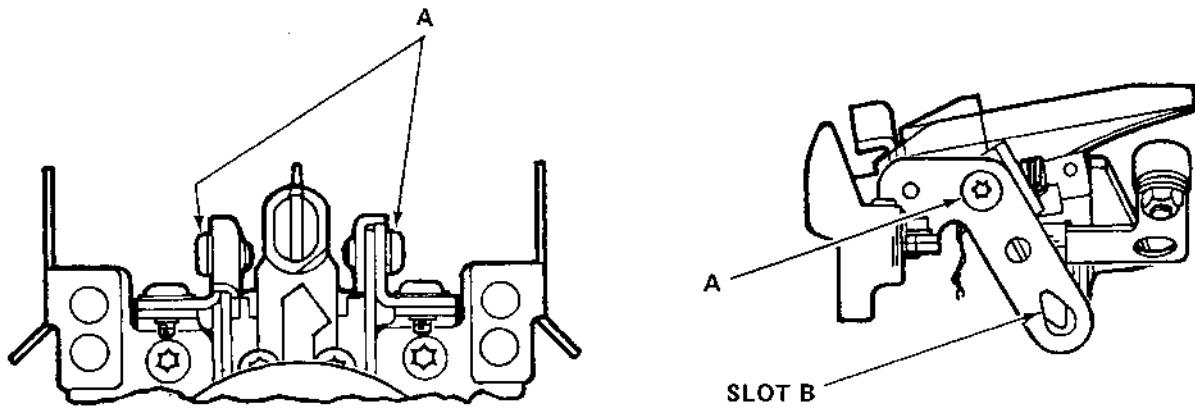

Figure 5-23. PRINT HAMMER TOP-TO-BOTTOM ADJUSTMENT

Adjustment Procedure - To correct side-to-side shading

Refer to Figure 5-24.

- 1) Loosen screws (C) on each side of the hammer adjustment bracket.
- 2) Using a small screwdriver in slot (D), adjust the hammer azimuth angle.
- 3) Tighten screws (C).
- 4) Repeat the Check and this Adjustment Procedure until side-to-side shading is eliminated.
- 5) Check Print Wheel to Hammer Alignment (5.8) and Hammer Armature Adjustment (5.9).

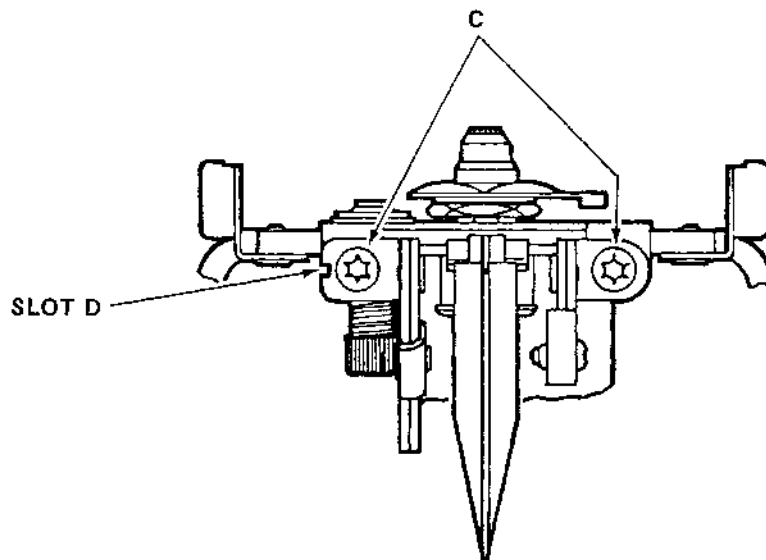

Figure 5-24. PRINT HAMMER SIDE-TO-SIDE ADJUSTMENT

SECTION 6

REPLACEMENT PARTS

6.1 GENERAL INFORMATION

This Section contains a basic list of most commonly ordered replacement parts for Model 630 printers/terminals. For a detailed parts breakdown, refer to the Model 630 Parts Catalog, Diablo publication No. 90444-XX.

6.2 ORDERING PARTS

The fastest way to obtain spare parts for your unit is to purchase them locally whenever possible. Parts that cannot be obtained locally may be ordered from Diablo as follows:

- | | | |
|--|---|--|
| All OEM
(Domestic & International) | - | Diablo Customer Administration
(415) 498-7192 |
| All Distributors
(Domestic & International)
and other orders for
quantities greater than 10 | - | Diablo Customer Administration
(415) 498-7218 |
| Internal Xerox only | - | Diablo Customer Administration
(415) 498-7215 |
| End Users and Other Orders
of quantity 10 or less
(as available basis only) | - | Diablo Retail Store
(408) 263-7704 |

Ordering addresses:

DIABLO SYSTEMS, INC.
Customer Administration, M/S-203
Post Office Box 5030
Fremont, CA 96537

-or-

DIABLO SYSTEMS, INC.
Retail Store/Service Center
1510 Trimble Road
San Jose, CA 95131

All parts fall into one of five categories or classes, identified as either "A", "B", "C", "D", or "E" in the CLASS column.

- | | | |
|----------------|---|---|
| <u>Class A</u> | - | Parts are either unique to this equipment or difficult to obtain through local sources. These parts are readily available from Diablo. |
| <u>Class B</u> | - | Parts are listed solely to assist in part location or component identification. These parts are common "off the shelf" items and should be purchased locally. |
| <u>Class C</u> | - | Parts are the same as Class B but should be purchased from recommended vendors. |

- Class D - Parts are either unique to this equipment or difficult to obtain through local sources. Parts are included in a higher Class A assembly and are not normally stocked by Diablo. Contact Diablo Customer Administration for minimum quantity, lead time and price.
- Class E - Parts, when listed, are for reference only and are not available as a spare part.

6.3 PARTS LIST

<u>Part No.</u>	<u>Description</u>	<u>Class</u>
100043-01	Switch, Power	A
100398-01	Jumper, Socket Plug (Jumper Module)	A
10961	Switch, Interlock (Cover Open Switch)	A
20424	Spring, Platen Latch	A
24074-02	Bail Arm, Right	A
24076-02	Bail Arm, Left	A
24075-03	Platen Assembly (early style)	A
24088-01	Spring, Bail Arm	A
24436-04	Switch, Snap Action (Top Paper Out)	A
301416-01	Shield, Print Wheel	A
302500-03S	Carriage Assembly, Std, with Ribbon Lift	A
302500-04S	Carriage Assembly, Std, without Ribbon Lift	A
302600-01S	Carriage Assembly, ECS, without Ribbon Lift	A
302640-03	Carriage Motor Assembly	A
302659-01	Knob, Platen (early style)	A
302736-01	I/O Interface Cable (internal)	A
302825-20	Power Supply Assembly, 120 Vac (Note 2)	A
152S24160	EIA Cable Assembly, 10 Ft.	A
152S24161	EIA Cable Assembly, 15 Ft.	A
152S24162	EIA Cable Assembly, 25 Ft.	A
152S24163	EIA Cable Assembly, 50 Ft.	A
302935-02	Card Guide	A
302945-06S	Control Panel Assembly, 7 Membrane Switches	A
302945-07S	Control Panel Assembly, 3 Membrane Switches	A
302955-01	Access Cover Assembly (magnetic latches)	A
320473-01	Lever, Paper Release	A
302637-02	Paper Feed Motor Assembly	A
320583-02	Paper Bail Assembly	A
302660-XXB	PCE PCB Assembly	A
302690-XXB	SCE PCB Assembly	A
302779-XXB	HPRO5 PCB Assembly	A
302840-XXB	HPRO6 PCB Assembly	A
320270-XXB	PPI PCB Assembly	A
320293-XXB	SPI PCB Assembly	A
320462-XXB	API PCB Assembly	A
302810-XXB	Power Supply PCB Assembly	A
24120	Latch, Ribbon Box (early style)	A
24147	Pin, Ribbon Box Latch (early style)	A
24146	Spring, Ribbon Box Latch (early style)	A
320484-01	Latch, Ribbon Box (new style)	A
100620-01	Screw, Latch, Pan Hd 4-40 x 1/4	A

24080-01	Roller Assembly, Front Pressure	A
24081-01	Roller Assembly, Rear Pressure	A
42665-01	Power Cord, 100/120V, 7.5 Ft, USA only	A
42665-02	Power Cord, 220/240V, 7.5 Ft, USA only	A
100448-01	Power Cord, 125V, 2 meters, International	A
100448-02	Power Cord, 250V, 2 meters, International	A

NOTES:

- (1) A part number followed by "-XX" means different configurations/revisions. Refer to the parts catalog.
- (2) Only the 120Vac version is available as a spare part. If another is required, Input Voltage Field Conversion Kit, Part No. 321344-01 must also be ordered.

SECTION 7

CIRCUIT DIAGRAMS & CABLE WIRING LISTS

7.1 GENERAL DISCUSSION

Diablo Systems logic diagrams emphasize the functions performed by the logic elements rather than the kinds of devices used. For example, a NAND gate may appear on a Diablo diagram as either a positive logic AND function with the output inverted (NAND), or as a negative logic OR function with the inputs inverted (NOR). This practice runs contrary to some logic drawing standards which require the use of the NAND symbol for both functions, but aids field service personnel in troubleshooting and system design engineers in understanding the principles of operation of the design.

This functional approach to logic symbology is basic to the logic documentation conventions employed by Diablo Systems. The conventions that govern logic symbology, signal nomenclature, and other drawing standards that may help the reader interpret Diablo logic diagrams, are discussed in the following paragraphs.

7.2 LOGIC SYMBOLOGY

The logic function symbols used in Diablo Systems logic diagrams conform closely to those set forth in MIL-STD-806 or ANSI Y32.14-1973. Small scale integration (SSI) circuits are represented by their function symbol. Medium scale (MSI) and large scale (LSI) integration devices, such as shift registers, RAM's, ROM's, etc., are represented by rectangles with function labels. Since both positive and negative logic conventions can appear in a single diagram, the unfilled-circle negation symbol specified by MIL-STD-806 or ANSI Y32.14-1973 is used to distinguish between LO true and HI true signals.

Usually, all logic symbols are drawn with inputs on the left and outputs on the right. Some device symbols, such as flip-flops, show inputs and other external connections on the top and bottom of the symbol for clarity. Also, the drawings themselves are usually drawn with major signal flows from left to right, top to bottom. However, drawing layout restrictions occasionally require the reverse of this, and that some symbols be drawn with a vertical orientation.

Figure 7-0 is a sample diagram, drawn to include examples of most, if not all, of the drawing conventions used. Note that in some cases two "grid coordinate" systems are used. One, shown on the perimeter of the diagram, is useful in locating a portion of a circuit or a particular component on the diagram itself, and has no other meaning. The other involves the component identifiers, such as "Resistor H35". The identifier is a "grid coordinate" code for locating that component on its printed circuit board. Further, textual reference to a device, such as a flip-flop, will usually further identify the device by its major output terminal. In the case of flip-flops, the "Q" output is usually used, i.e. FF B25-9.

7.3 CIRCUIT DIAGRAMS

The schematic diagrams in this manual represent the latest version of each circuit board in production at the time of this writing. Listed on the back of each diagram is the revision history of the circuit board, plus a listing of the solid state components used, and their component designator codes used for locating each device on its circuit board.

There are two important part numbers associated with each circuit board in the Model 630:

- 1) The PCB Assembly part number identifies the complete circuit board with components installed. This number is silk-screened onto the top (component side) of the PCB. The revision letter of the board assembly generally is marked on this side of the PCB also.
- 2) The PCB part number (etch number) is the part number of the blank PCB without components. This number is etched on the bottom side of the PCB.

7.4 CONNECTOR WIRING LISTS

The following wiring lists give the pin-to-pin wiring of the cable assemblies in the Model 630. The signal that appears at each pin is also identified. These lists should be used in conjunction with the interconnect diagrams shown in Figures 7-2a thru 7-2f.

Each row (read horizontally) lists all connector terminals that interconnect, and also lists the signal on those terminals.

<u>CONNECTORS</u>						<u>SIGNAL</u>	
<u>P1</u>	<u>P2</u>	<u>P3</u>	<u>P4</u>	<u>P5</u> (Power Harness)			P1, P2, P3, P4, P5
P1-1	P2-1	P3-1	P4-1	P5-1		-12V	1 <input type="checkbox"/> -12VDC
P1-2	P2-2	P3-2	P4-2	P5-2	P6-1	Chassis Gnd	2 <input type="checkbox"/> CHASSIS GROUND
P1-3	P2-3	P3-3	P4-3	P5-3	P6-7	+5V	3 <input type="checkbox"/> +5VDC
P1-4	P2-4	P3-4	P4-4	P5-4		(Key)	4 <input checked="" type="checkbox"/> KEY
P1-5	P2-5	P3-5	P4-5	P5-5	P6-8	Gnd	5 <input type="checkbox"/> SIGNAL GROUND
P1-6	P2-6	P3-6	P4-6	P5-6		Gnd	6 <input type="checkbox"/> SIGNAL GROUND
P1-7	P2-7	P3-7	P4-7	P5-7		+16V	7 <input type="checkbox"/> +16VDC
P1-8	P2-8	P3-8	P4-8	P5-8		-POWER DOWN	8 <input type="checkbox"/> -POWER DOWN
P1-9	P2-9	P3-9	P4-9	P5-9	P6-14	Gnd	9 <input type="checkbox"/> SIGNAL GROUND
P1-10	P2-10	P3-10	P4-10	P5-10	P6-15	+40V	10 <input type="checkbox"/> +40VDC

<u>P6 (Optional Feeder Connector)</u>							
P6-1	P1-2	P2-2	P3-2	P4-2	P5-2	Chassis Gnd	
P6-2						P31-4	-A0
P6-3						P31-5	-A1
P6-4						P31-6	-A2
P6-7	P1-3	P2-3	P3-3	P4-3	P5-3		+5V
P6-8	P1-5	P2-5	P3-5	P4-5	P5-5		Gnd
P6-9						P31-7	-FEEDER STATUS
P6-10						P31-8	-POWER DOWN
P6-11						P31-2	-FEEDER STROBE
P6-14	P1-9	P2-9	P3-9	P4-9	P5-9		Gnd
P6-15	P1-10	P2-10	P3-10	P4-10	P5-10		+40V

<u>P7 (Connects to SCE PCB J3)</u>		
P7-1	P9-8	HAMMER COIL RTN
P7-2	P9-17	VCCR
P7-3	P9-7	HAMMER COIL DRIVE
P7-4	P9-16	I OUT 1
P7-5	P9-6	PFM
P7-6	P9-15	VCCR
P7-7	P9-5	PRM
P7-8	P9-14	I OUT 2
P7-9	P9-4	PFM
P7-10	P9-13	+16V
P7-11	P9-3	PRM
P7-12	P9-12	Gnd
P7-13	P9-2	PW HOME SENSOR
P7-14	P9-11	PXDR1
P7-15	P9-1	SENSOR RETURN

P7-16	P9-10	PXDR2
P7-20	P11-1	VCCR
P7-21	- - -	Gnd
P7-22	P11-2	I OUT 4
P7-24	P11-3	VCCR
P7-26	P11-4	I OUT 3
P7-27	P10-4	Pulled HI to +5V
P7-28	P11-5	+16V
P7-29	P10-3	Gnd
P7-30	P11-6	Gnd
P7-31	P10-2	+16V
P7-32	P11-7	CXDR4
P7-33	P10-1	END-OF-RIBBON SENSOR
P7-34	P11-8	CXDR2
P7-37	P8-38	+PCMD1
P7-38	P8-37	+PCMD2
P7-39	P8-40	+PD5
P7-40	P8-39	+PD1
P7-41	P8-42	+PD4
P7-42	P8-41	+PD2
P7-43	P8-44	+PD3
P7-44	P8-43	+PD0
P7-45	P8-46	PW POS B
P7-46	P8-45	PW POS A
P7-47	P8-48	-PW HOME
P7-48	P8-47	+PW EVEN
P7-49	P8-50	-CAR. SMD
P7-50	P8-49	+HAMMER FIRE
P7-51	P8-52	-PW SMD
P7-52	P8-51	- - -
P7-53	P8-54	SCE CLK (5 MHz)
P7-54	P8-53	Gnd
P7-55	P8-56	+CD3
P7-56	P8-55	-END OF RIBBON
P7-57	P8-58	+CD1
P7-58	P8-57	+CD2
P7-59	P8-60	+CD4
P7-60	P8-59	+CD0
P7-61	P8-62	+CCMD1
P7-62	P8-61	+CD5
P7-63	P8-64	CAR. POS A
P7-64	P8-63	+CCMD2
P7-65	P8-66	+CAR. EVEN
P7-66	P8-65	CAR. POS B
P7-67	- - -	Chassis Gnd
P7-68	- - -	Chassis Gnd
P7-69	- - -	Chassis Gnd
P7-70	- - -	Chassis Gnd

P7, P8

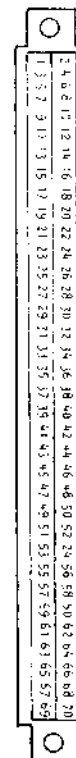

P8 (Connects to J3 of PCE, PPI, SPI or API PCB)

P8-20	P10-17	RIBBON MOTOR PHASE A
P8-22	P10-16	RIBBON MOTOR PHASE A
P8-24	P10-15	RIBBON MOTOR PHASE B
P8-26	P10-14	RIBBON MOTOR PHASE B
P8-28	P10-13	RIBBON LIFT RTN (PW LIFT RTN in ECS units)

P8-30	P10-12	+RIBBON LIFT (+PW LIFT in ECS units)
P8-32	P10-11	-SINGLE SHEET
P8-34	P10-10	Gnd
P8-37	P7-38	+PCMD2
P8-38	P7-37	+PCMD1
P8-39	P7-40	+PD1
P8-40	P7-39	+PD5
P8-41	P7-42	+PD2
P8-42	P7-41	+PD4
P8-43	P7-44	+PD0
P8-44	P7-43	+PD3
P8-45	P7-46	PW POS A
P8-46	P7-45	PW POS B
P8-47	P7-48	+PW EVEN
P8-48	P7-47	-PW HOME
P8-49	P7-50	+HAMMER FIRE
P8-50	P7-49	-CAR. SMD
P8-51	P7-52	- - -
P8-52	P7-51	-PW SMD
P8-53	P7-54	SCE CLK RETURN
P8-54	P7-53	SCE CLK
P8-55	P7-56	-END OF RIBBON
P8-56	P7-55	+CD3
P8-57	P7-58	+CD2
P8-58	P7-57	+CD1
P8-59	P7-60	+CD0
P8-60	P7-59	+CD4
P8-61	P7-62	+CD5
P8-62	P7-61	+CCMD1
P8-63	P7-64	+CCMD2
P8-64	P7-63	CAR. POS A
P8-65	P7-66	CAR. POS B
P8-66	P7-65	+CAR. EVEN
P8-67		To Paper Out switch (Common terminal)
P8-68		To Paper Out switch (N.C. terminal)
P8-69		To Cover Open switch (N.O. terminal)
P8-70		To Cover Open switch (Common terminal)

P9 (Connects to Carriage Assy P12)

P9-1	P7-15	PW HOME SENSOR RTN
P9-2	P7-13	PW HOME SENSOR
P9-3	P7-11	PRM
P9-4	P7-9	PFM
P9-5	P7-7	PRM
P9-6	P7-5	PFM
P9-7	P7-3	HAMMER COIL DRIVE
P9-8	P7-1	HAMMER COIL RTN
P9-10	P7-16	PXDR2
P9-11	P7-14	PXDR1
P9-12	P7-12	Gnd
P9-13	P7-10	+16V
P9-14	P7-8	I OUT 2
P9-15	P7-6	VCCR
P9-16	P7-4	I OUT 1
P9-17	P7-2	VCCR

P9

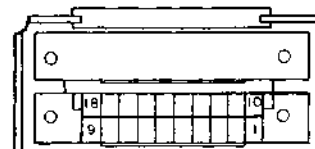

P10 (Connects to Carriage Assy P13)

P10-1	P7-33	END-OF-RIBBON SENSOR
P10-2	P7-31	+16V
P10-3	P7-29	Gnd
P10-4	P7-27	Pulled HI to +5V
P10-10	P8-34	Gnd
P10-11	P8-32	-SINGLE SHEET
P10-12	P8-30	+RIBBON LIFT (+PW LIFT in ECS units)
P10-13	P8-28	RIBBON LIFT RTN (PW LIFT RTN in ECS units)
P10-14	P8-26	RIBBON MOTOR PHASE B
P10-15	P8-24	RIBBON MOTOR PHASE B
P10-16	P8-22	RIBBON MOTOR PHASE A
P10-17	P8-20	RIBBON MOTOR PHASE A

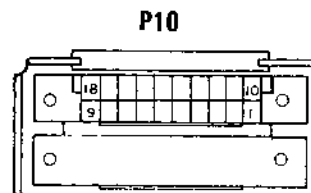

P11 (Connects to Carriage Motor Transducer)

P11-1	P7-20	VCCR
P11-2	P7-22	I OUT 4
P11-3	P7-24	VCCR
P11-4	P7-26	I OUT 3
P11-5	P7-28	+16V
P11-6	P7-30	Gnd
P11-7	P7-32	CXDR4
P11-8	P7-34	CXDR2

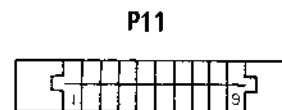

P12 (Connects Carriage Assy to P9 of Card Cage Harness)

P12-1	- To -	PW Home Sensor
P12-2		PW Home Sensor
P12-3		PW Motor
P12-4		PW Motor
P12-5		PW Motor
P12-6		PW Motor
P12-7		Hammer Coil
P12-8		Hammer Coil
P12-10		PW Transducer Preamp
P12-11		PW Transducer Preamp
P12-12		PW Transducer Preamp
P12-13		PW Transducer Preamp
P12-14		PW Transducer Preamp
P12-15		PW Transducer Preamp
P12-16		PW Transducer Preamp
P12-17		PW Transducer Preamp

P13 (Connects Carriage Assy to P10 of Card Cage Harness)

P13-1	- To -	EOR Sensor
P13-2		EOR Sensor
P13-3		EOR Sensor
P13-4		EOR Sensor
P13-10		Form Thickness Switch (Switch replaced by jumper in later units.)
P13-11		Form Thickness Switch (Switch replaced by jumper in later units.)
P13-12		Ribbon Lift Coil (PW Lift Coil in ECS units)
P13-13		Ribbon Lift Coil (PW Lift Coil in ECS units)
P13-14		Ribbon Drive Motor
P13-15		Ribbon Drive Motor
P13-16		Ribbon Drive Motor
P13-17		Ribbon Drive Motor

P14 (Connects to SCE PCB J2)

P14-2 To Carriage Motor
P14-3 To Carriage Motor

P15 (Connects to J2 of PCE, PPI, SPI or API PCB)

P15-1 To Paper Feed Motor
P15-2 To Paper Feed Motor
P15-3 To Paper Feed Motor
P15-5 To Paper Feed Motor

P17 - Model 630 PPI/HPRO6

Connects Sprint 3 adapting connector to J4 on either the PPI or HPRO6 PCB.
(Used only in units configured for Sprint 3 type interface.)

See Figure 7-3 for interconnect diagram.

P18 - Model 630 PCE
(Connects to PCE PCB J4)

P18-7	P19-4	+ADDR9
P18-8	P19-17	+ADDR8
P18-9	P19-5	+AD7
P18-10	P19-18	+AD6
P18-11	P19-6	+AD5
P18-12	P19-19	+AD4
P18-13	P19-7	+AD3
P18-14	P19-20	+AD2
P18-15	P19-8	+AD1
P18-16	P19-21	+AD0
P18-17	P19-9	(Key)
P18-18	P19-22	-WR
P18-19	P19-10	-RD
P18-20	P19-23	-PRINTER SELECT
P18-22	P19-24	-CLR
P18-23	P19-12	1 MS RTC RET
P18-24	P19-25	1 MS RTC
P18-25	P19-13	5 MHz CLK RET
P18-26		5 MHz CLK

P18 - Models 630 HPRO5 and HPRO6 (P18 connects to PCE PCB J4)

Note: P21 is required only when a customer PCB is installed.

P18-7	P20-7	P21-7	+ADDR9
P18-8	P20-8	P21-8	+ADDR8
P18-9	P20-9	P21-9	+AD7
P18-10	P20-10	P21-10	+AD6
P18-11	P20-11	P21-11	+AD5
P18-12	P20-12	P21-12	+AD4
P18-13	P20-13	P21-13	+AD3
P18-14	P20-14	P21-14	+AD2

P18-15	P20-15	P21-15	+AD1
P18-16	P20-16	P21-16	+AD0
P18-17	P20-17	P21-17	(Key)
P18-18	P20-18	P21-18	-WR
P18-19	P20-19	P21-19	-RD
P18-20	P20-20	P21-20	-PS
P18-21	P20-21	P21-21	
P18-22	P20-22	P21-22	-CLR
P18-23	P20-23	P21-23	1 MS RTC RET
P18-24	P20-24	P21-24	1 MS RTC
P18-25	P20-25	P21-25	5 MHz CLK RET
P18-26	P20-26	P21-26	5 MHz CLK

P19 - Model 630 PCE
(Interface connector)

P19-4	P18-7	+ADDR9
P19-5	P18-9	+AD7
P19-6	P18-11	+AD5
P19-7	P18-13	+AD3
P19-8	P18-15	+AD1
P19-9	P18-17	(Key)
P19-10	P18-19	-RD
P19-12	P18-23	1 MS RTC RET
P19-13	P18-25	5 MHz CLK RET
P19-17	P18-8	+ADDR8
P19-18	P18-10	+AD6
P19-19	P18-12	+AD4
P19-20	P18-14	+AD2
P19-21	P18-16	+AD0
P19-22	P18-18	-WR
P19-23	P18-20	-PS
P19-24	P18-22	-CLR
P19-25	P18-24	1 MS RTC

P19

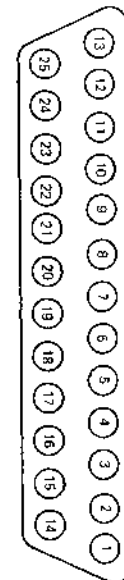

P19 - Model 630 PPI/HPRO6
(Adapting connector for Sprint 3 interface; see Figure 7-3.)

P19 - Models 630 SPI/HPRO5
(RS-232-C interface connector)

P19-1	P22-1	Chassis Gnd
P19-2	P22-3	-TRANSMITTED DATA
P19-3	P22-5	-RECEIVED DATA
P19-4	P22-7	+REQUEST TO SEND
P19-5	P22-9	+CLEAR TO SEND (unused)
P19-6	P22-11	+DATA SET READY
P19-7	P22-13	Signal Gnd
P19-8	P22-15	+CARRIER DETECT *
P19-11	P22-21	+PRINTER READY *
P19-12	P22-23	+OPTION 2
P19-20	P22-14	+DATA TERMINAL READY
P19-22	P22-18	+OPTION 3

* = HPRO5 only.

P19 - Model 630 HPRO5
(Current Loop interface connector)

P19-7	P22-13	XMIT SINK (Gnd)
P19-10	P22-19	+RECEIVE DATA (RCV A)
P19-13	P22-25	RECEIVE SINK (Gnd)
P19-17	P22-8	XMIT SOURCE
P19-18	P22-10	+XMIT DATA (XMIT B)
P19-19	P22-12	-XMIT DATA (XMIT A) (RTN)
P19-21	P22-16	-RECEIVE DATA (RCV B) (RTN)
P19-23	P22-20	RECEIVE SOURCE

P19 - Model 630 API

(See "P22 - API")

P20 - (Connects to HPRO5 PCB J5 or HPRO6 PCB J3)

P20-1	P21-1	+ADDR15	<u>Note:</u> P21 is required only when a Feeder Interface board or customer board is installed.
P20-2	P21-2	+ADDR14	
P20-3	P21-3	+ADDR13	
P20-4	P21-4	+ADDR12	
P20-5	P21-5	+ADDR11	
P20-6	P21-6	+ADDR10	
P20-7	P21-7	P18-7 +ADDR9	
P20-8	P21-8	P18-8 +ADDR8	
P20-9	P21-9	P18-9 +AD7	
P20-10	P21-10	P18-10 +AD6	
P20-11	P21-11	P18-11 +AD5	
P20-12	P21-12	P18-12 +AD4	
P20-13	P21-13	P18-13 +AD3	
P20-14	P21-14	P18-14 +AD2	
P20-15	P21-15	P18-15 +AD1	
P20-16	P21-16	P18-16 +AD0	
P20-17	P21-17	P18-17 (Key)	
P20-18	P21-18	P18-18 -WR *	
P20-19	P21-19	P18-19 -RD	
P20-20	P21-20	P18-20 -PRINTER SELECT *	
P20-21	P21-21	P18-21 +IO/-M	
P20-22	P21-22	P18-22 -CLEAR *	
P20-23	P21-23	P18-23 Gnd *	
P20-24	P21-24	P18-24 +1 MS RTC *	
P20-25	P21-25	P18-25 Gnd *	
P20-26	P21-26	P18-26 5 MHz CLK *	

* - Unused on Feeder Interface board

P21 - (Connects to Feeder Interface PCB J3, or Customer PCB J2)

P21-1	P20-1	+ADDR15
P21-2	P20-2	+ADDR14
P21-3	P20-3	+ADDR13
P21-4	P20-4	+ADDR12
P21-5	P20-5	+ADDR11

P21-6	P20-6		+ADDR10	
P21-7	P20-7	P18-7	+ADDR9	
P21-8	P20-8	P18-8	+ADDR8	
P21-9	P20-9	P18-9	+AD7	
P21-10	P20-10	P18-10	+AD6	
P21-11	P20-11	P18-11	+AD5	
P21-12	P20-12	P18-12	+AD4	
P21-13	P20-13	P18-13	+AD3	
P21-14	P20-14	P18-14	+AD2	
P21-15	P20-15	P18-15	+AD1	
P21-16	P20-16	P18-16	+AD0	
P21-17	P20-17	P18-17	(Key)	
P21-18	P20-18	P18-18	-WR *	
P21-19	P20-19	P18-19	-RD	
P21-20	P20-20	P18-20	-PRINTER SELECT *	
P21-21	P20-21	P18-21	+IO/-M	
P21-22	P20-22	P18-22	-CLEAR *	
P21-23	P20-23	P18-23	Gnd *	
P21-24	P20-24	P18-24	+1 MS RTC *	
P21-25	P20-25	P18-25	Gnd *	
P21-26	P20-26	P18-26	5 MHz CLK *	

* - Not used on Feeder Interface board.

P22 - RS-232-C Interface (SPI and HPRO5)
(Connects to SPI PCB J5 or HPRO5 PCB J4)

P22-1	P19-1	Chassis Gnd
P22-3	P19-2	-TRANSMITTED DATA
P22-5	P19-3	-RECEIVED DATA
P22-7	P19-4	+REQUEST TO SEND
P22-9	P19-5	+CLEAR TO SEND (unused)
P22-11	P19-6	+DATA SET READY
P22-13	P19-7	Signal Gnd
P22-14	P19-20	+DATA TERMINAL READY
P22-15	P19-8	+CARRIER DETECT
P22-17		(Key)
P22-18	P19-22	+OPTION 3
P22-21	P19-11	+PRINTER READY
P22-23	P19-12	+OPTION 2

P22 - Current Loop Interface
(Connects to HPRO5 PCB J4)

P22-8	P19-17	XMIT SOURCE
P22-10	P19-18	+XMIT DATA (XMIT B)
P22-12	P19-19	-XMIT DATA (XMIT A) (RTN)
P22-13	P19-7	XMIT SINK (Gnd)
P22-16	P19-21	-RECEIVE DATA (RCV B) (RTN)
P22-17		(Key)
P22-19	P19-10	+RECEIVE DATA (RCV A)
P22-20	P19-23	RECEIVE SOURCE
P22-25	P19-13	RECEIVE SINK (Gnd)

P22 - API - (Connects to API PCB J4)
P19 - (External Interface Connector)

<u>P22 Pin</u>	<u>P19 Pin</u>	<u>IEEE-488</u>	<u>CENTRONICS</u>	<u>RS-232-C</u>
1	1		+PE	
2	26		GND	
3	2		+5V	
4	27		GND	
5	3	N/C*		
6	28		GND	
7	4	N/C*		
8	29		GND	
9	5		+SELECT	
10	30		GND	
11	6		+BUSY	
12	31		GND	
13	7	-ATN	(Held HI)	
14	32		-OPTION 2	
15	8		-OPTION 1	
16	33	N/C* (Key)		
17	9	-DATA 1	+DATA 1	
18	34	-DATA 5	+DATA 5	
19	10	-DATA 2	+DATA 2	
20	35	-DATA 6	+DATA 6	
21	11	-DATA 3	+DATA 3	
22	36	-DATA 7	+DATA 7	
23	12	-DATA 4	+DATA 4	
24	37	-DATA 8	+DATA 8	
25	13	-EOI		
26	38	-REN		
27	14	-DAV	-DATA STROBE	
28	39	GND	GND	
29	15	-NRFD	-ACKNOWLEDGE	
30	40	GND	GND	
31	16	-NDAC	-DEMAND	
32	41	GND	GND	
33	17	-IFC	-INPUT PRIME	
34	42	GND	GND	
35	18	-SRQ	-FAULT	
36	43	GND	GND	
37	19	-ATN	-DATA STROBE	
38	44	GND	GND	
39	20	Shield		
40	45	Logic GND	GND	
41	21	N/C*		
42	46		GND	
43	22		Chassis GND	Chassis GND
44	47		Signal GND	Signal GND
45	23			RTS (+12V pullup)
46	48			-RX DATA
47	24			-TX DATA
48	49			+DSR
49	25			+DTR
50	50	N/C* (Key)		

* - N/C means that position is open on the API board

P23 - (Connects to Control Panel H5CPN PCB J3 from keyboard)

P24 - (Connects to Keyboard PCB J1 from control panel)

P23-1	P24-1	-SCAN 3
P23-2	P24-2	-SCAN 5
P23-3	P24-3	-SCAN 1
P23-4	P24-4	-SCAN 7
P23-5	P24-5	-SENSE 0
P23-6	P24-6	-SCAN 8
P23-7	P24-7	-SENSE 1
P23-8	P24-8	-SCAN 9
P23-9	P24-9	-SENSE 2
P23-10	P24-10	-SCAN 10
P23-11	P24-11	-SENSE 3
P23-12	P24-12	(Key)
P23-13	P24-13	-SENSE 4
P23-14	P24-14	-SCAN 0
P23-15	P24-15	-SENSE 5
P23-16	P24-16	-SCAN 2
P23-17	P24-17	-SENSE 6
P23-18	P24-18	-SCAN 4
P23-19	P24-19	-SENSE 7
P23-20	P24-20	-SCAN 6
P23-23	P24-23	Gnd
P23-24	P24-24	+5V
P23-25	P24-25	Gnd
P23-26	P24-26	+5V

P25 - (Connects to HPRO5 PCB J3 from Control Panel)

P26 - (Connects to Control Panel H5CPN PCB J1 from HPRO5 PCB)

P25-1	P26-1	-INIT SCAN
P25-2	P26-2	-LD SW & UPDATE SCAN
P25-3	P26-3	-SHIFT INPUT REG
P25-4	P26-4	-UPDATE OUTPUT REG
P25-5	P26-5	-CNTRL PNL STATUS
P25-6	P26-6	Gnd
P25-7	P26-7	+5V
P25-8	P26-8	Gnd
P25-9	P26-9	+5V
P25-10	P26-10	+16V

P27 - (Connects to HPRO5 PCB J2)

P28 - (Connects to Customer Board J2)

P27-1	P28-1	+HOLD
P27-2	P28-2	+HLDA
P27-3	P28-3	-XINTR (XIO)
P27-4	P28-4	-INTA
P27-5	P28-5	(Key)
P27-6	P28-6	+S1
P27-7	P28-7	+INTR
P27-8	P28-8	-RESTORE
P27-9	P28-9	- - -
P27-10	P28-10	- - -

P29 - (Connects to SPI or API PCB J6 from Control Panel)

P30 - (Connects to Control Panel LCPN PCB J1 from SPI PCB)

P29-1	P30-1	-CLR RDY
P29-2	P30-2	-LD SWITCHES
P29-3	P30-3	-SHIFT INPUT REG
P29-4	P30-4	-SET RDY
P29-5	P30-5	+CONTROL PANEL STATUS
P29-6	P30-6	Gnd
P29-7	P30-7	+5V
P29-8	P30-8	Gnd
P29-9	P30-9	+5V

P31 - (Connects to API PCB J7 or HPRO5-FEEDER Interface PCB J2 from feeder connector.)

P6 - (Connects to external feeder interface cable)

P31-2	P6-11	-FEEDER STROBE
P31-4	P6-2	-A0
P31-5	P6-3	-A1
P31-6	P6-4	-A2
P31-7	P6-9	-FEEDER STATUS
P31-8	P6-10	-POWER DOWN

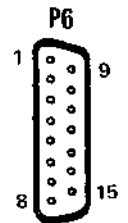

DETAIL

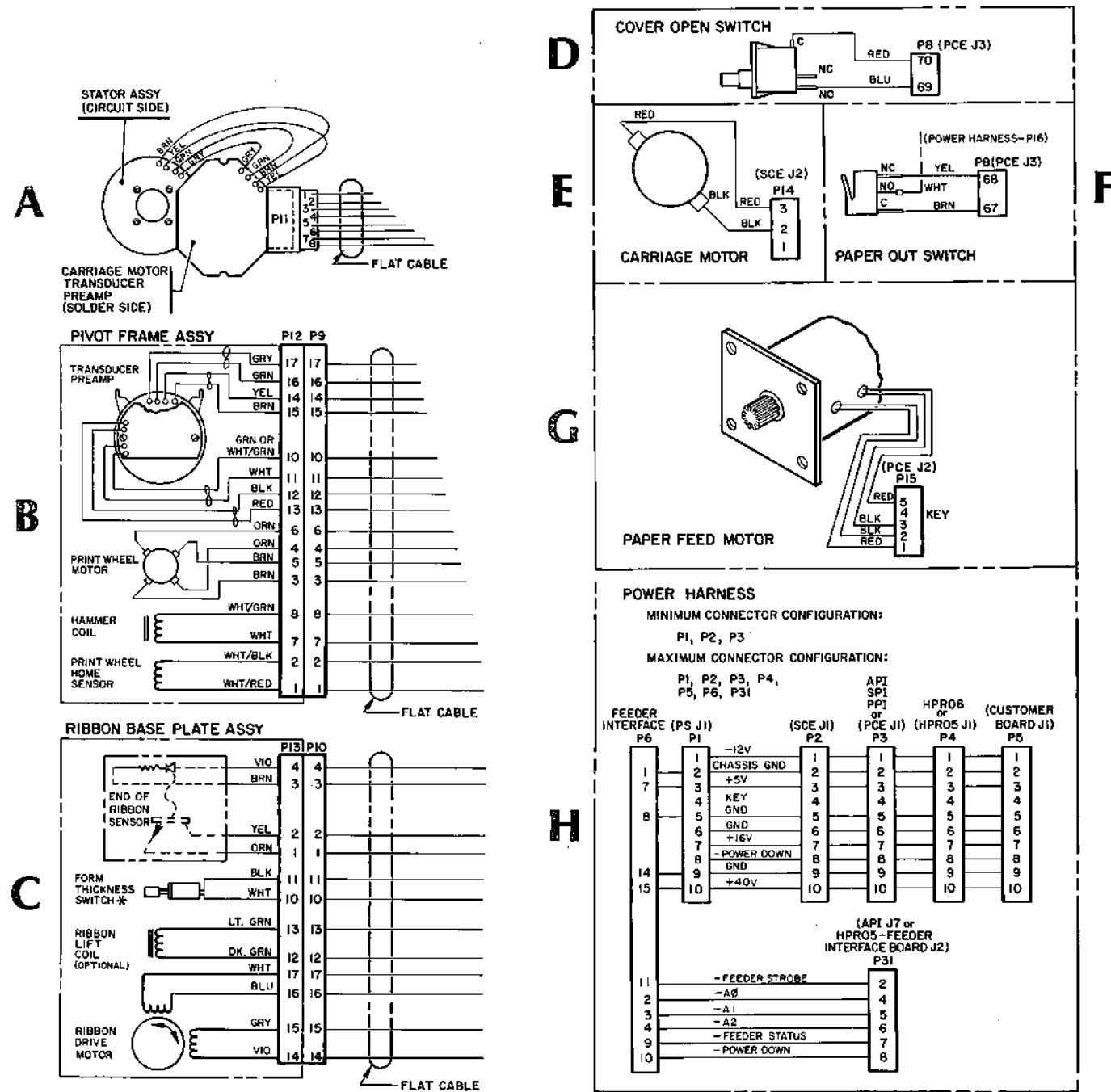

*FORM THICKNESS SWITCH REPLACED BY JUMPER IN LATER UNITS.

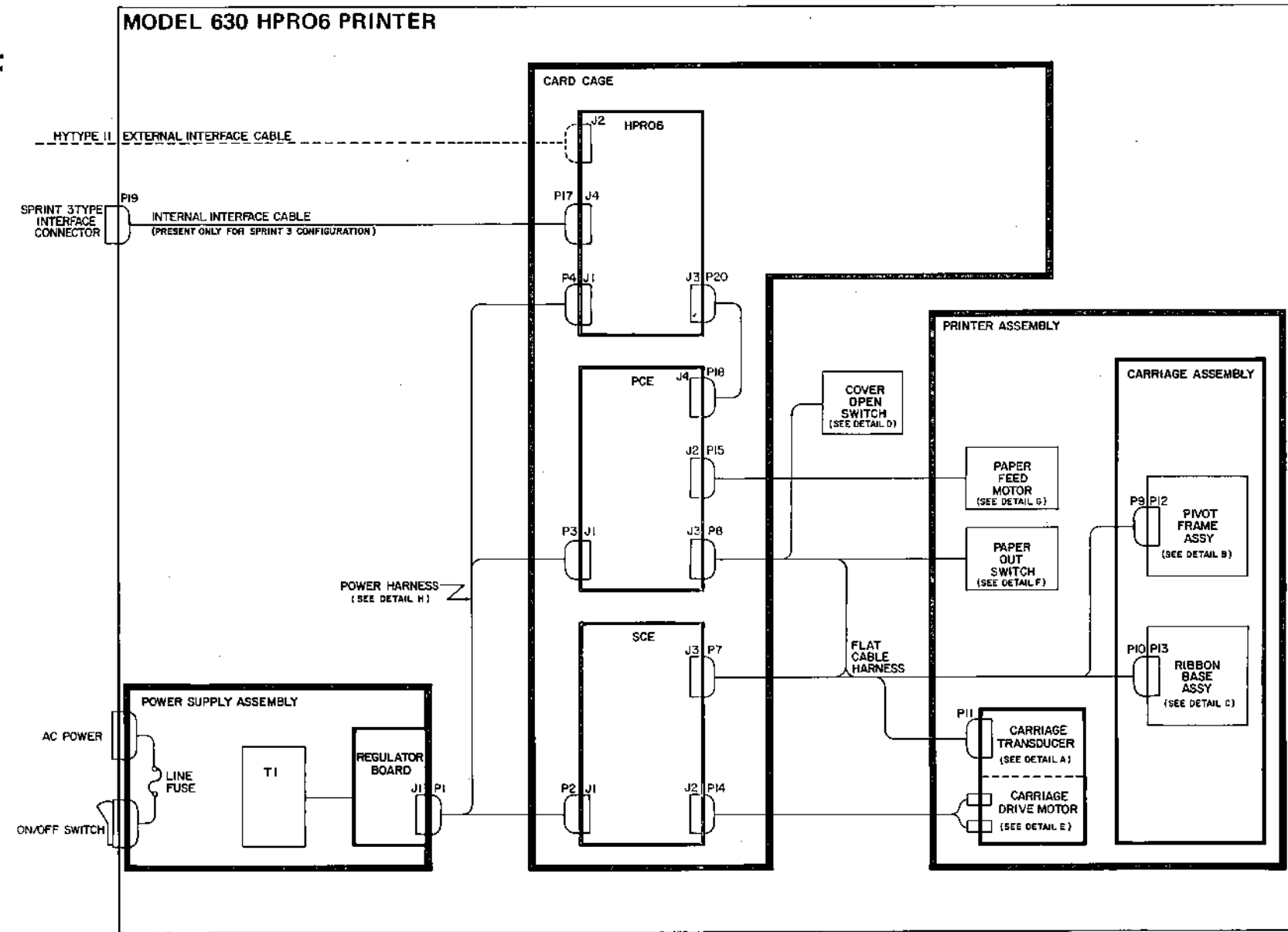
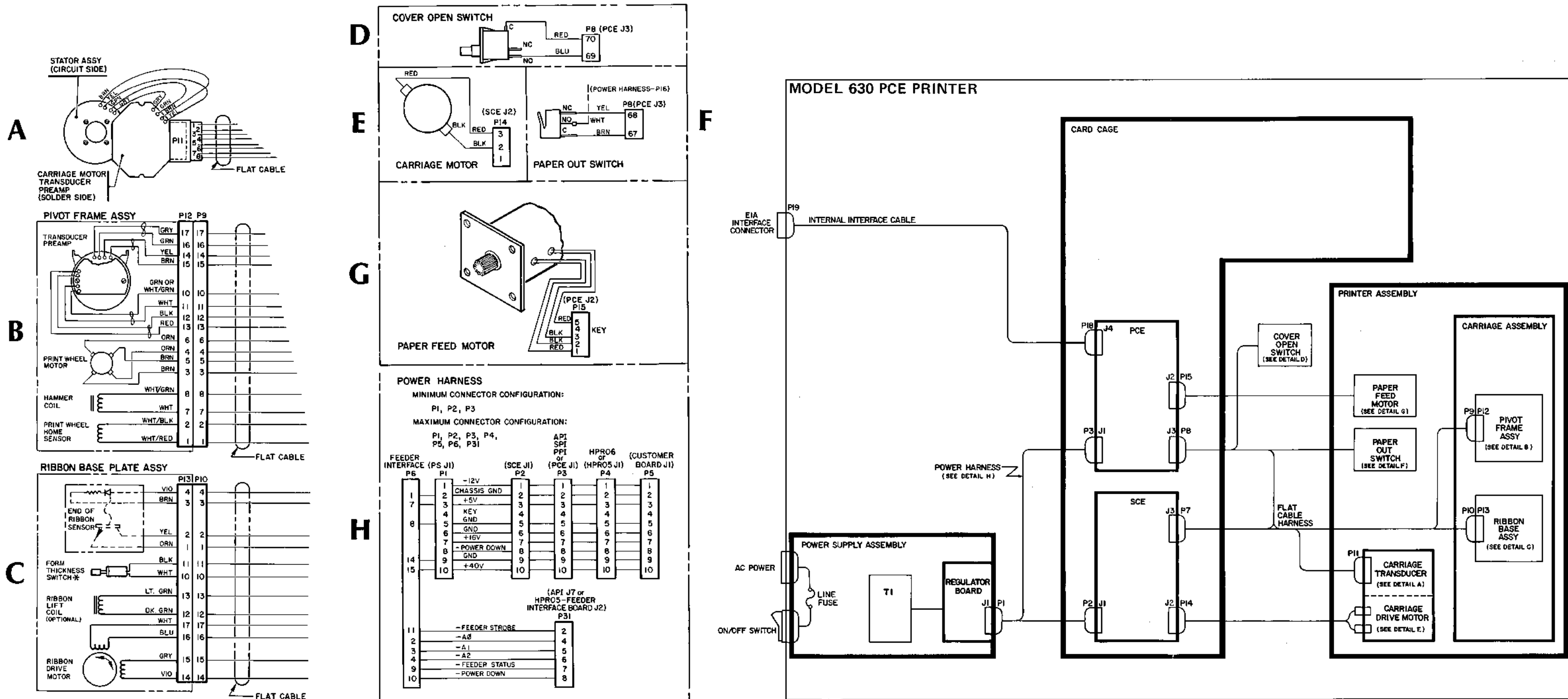

Figure 7-2b
INTERCONNECT WIRING DIAGRAM
MODEL 630 HPRO6

DETAIL



*FORM THICKNESS SWITCH REPLACED BY JUMPER IN LATER UNITS.

Figure 7-2a
INTERCONNECT WIRING DIAGRAM
MODEL 630 PCE

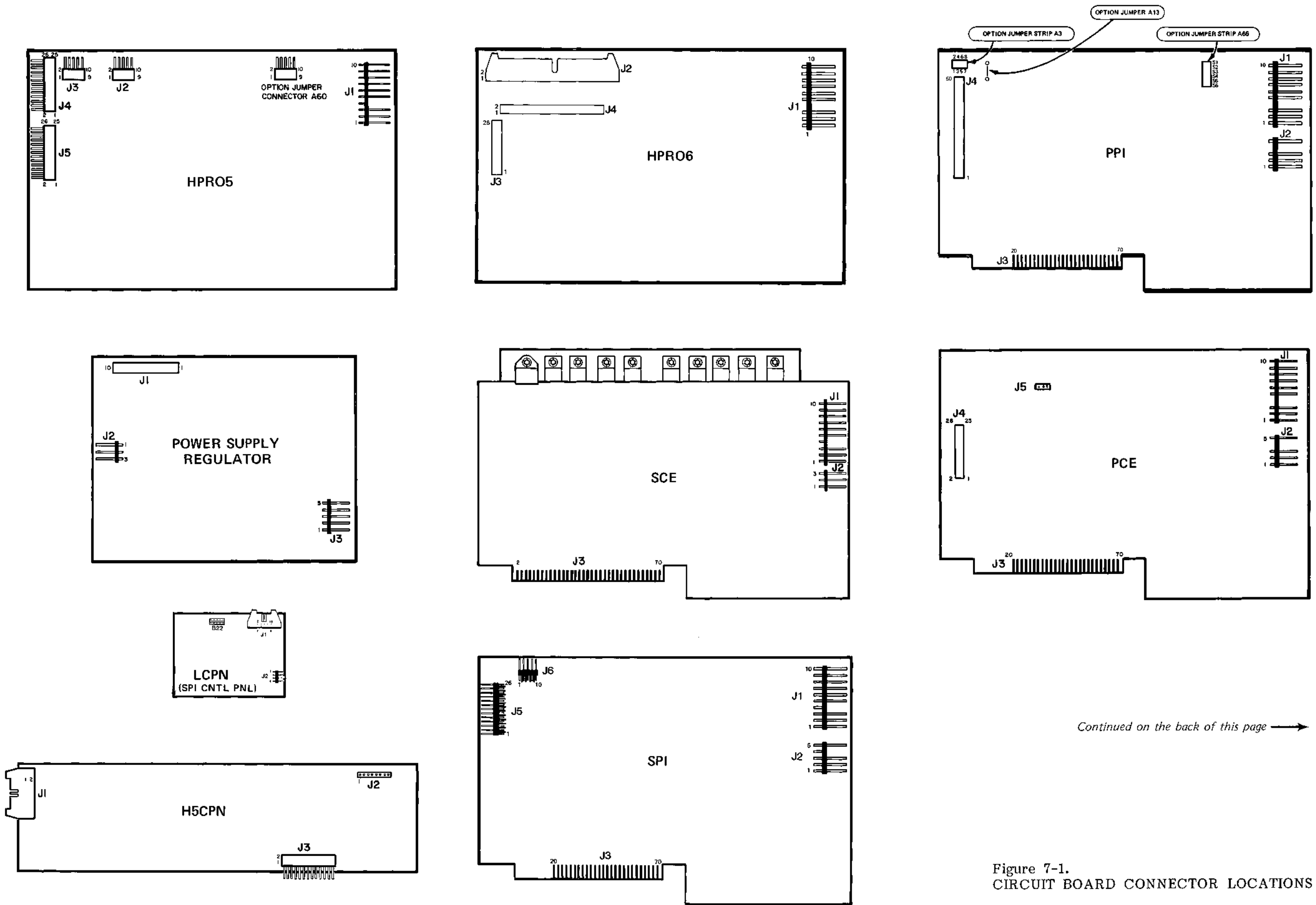

Continued on the back of this page →

Figure 7-1. CIRCUIT BOARD CONNECTOR LOCATIONS

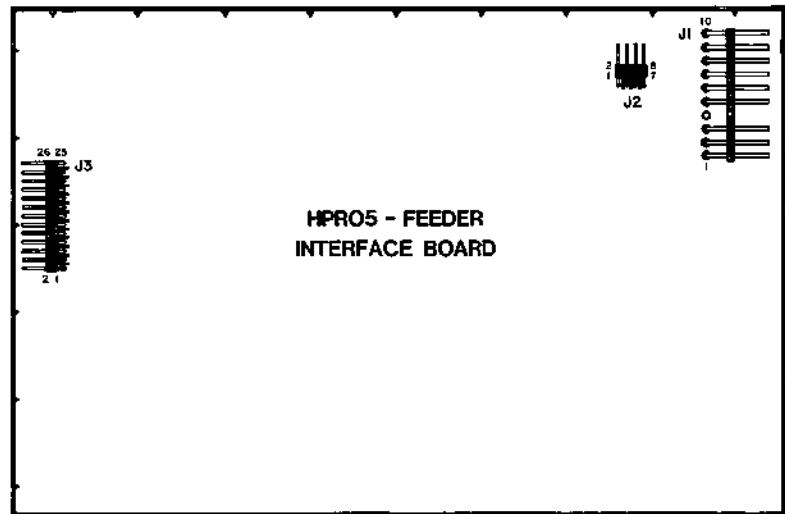
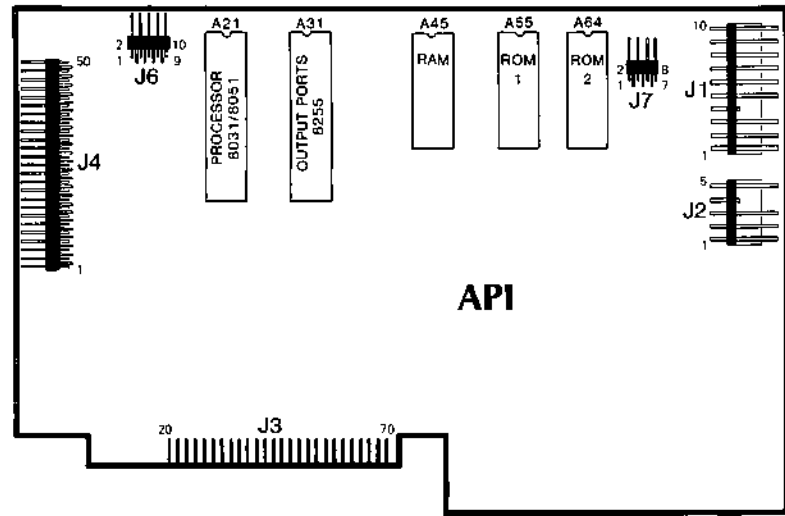

DETAIL

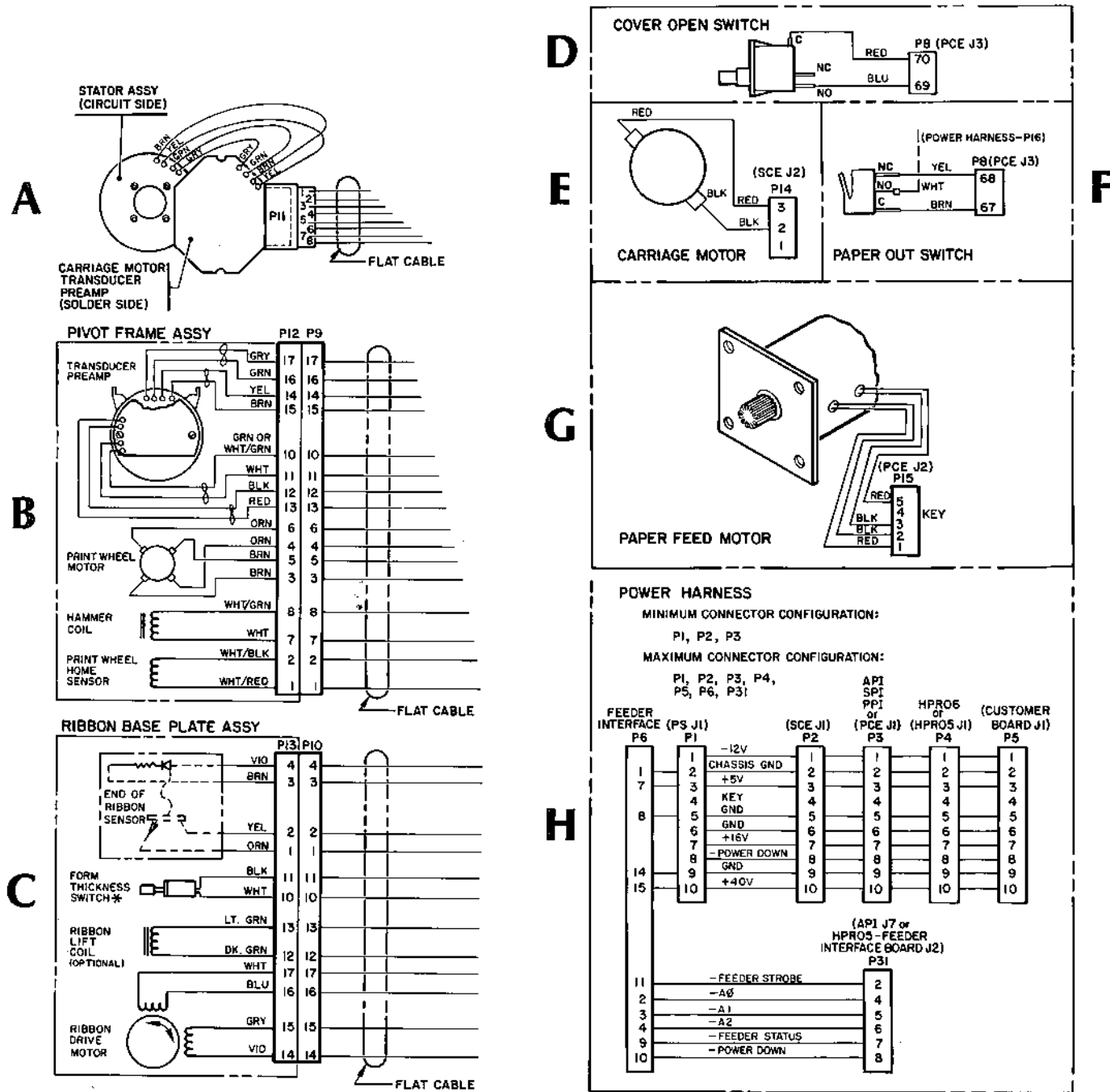

*FORM THICKNESS SWITCH REPLACED BY JUMPER IN LATER UNITS.

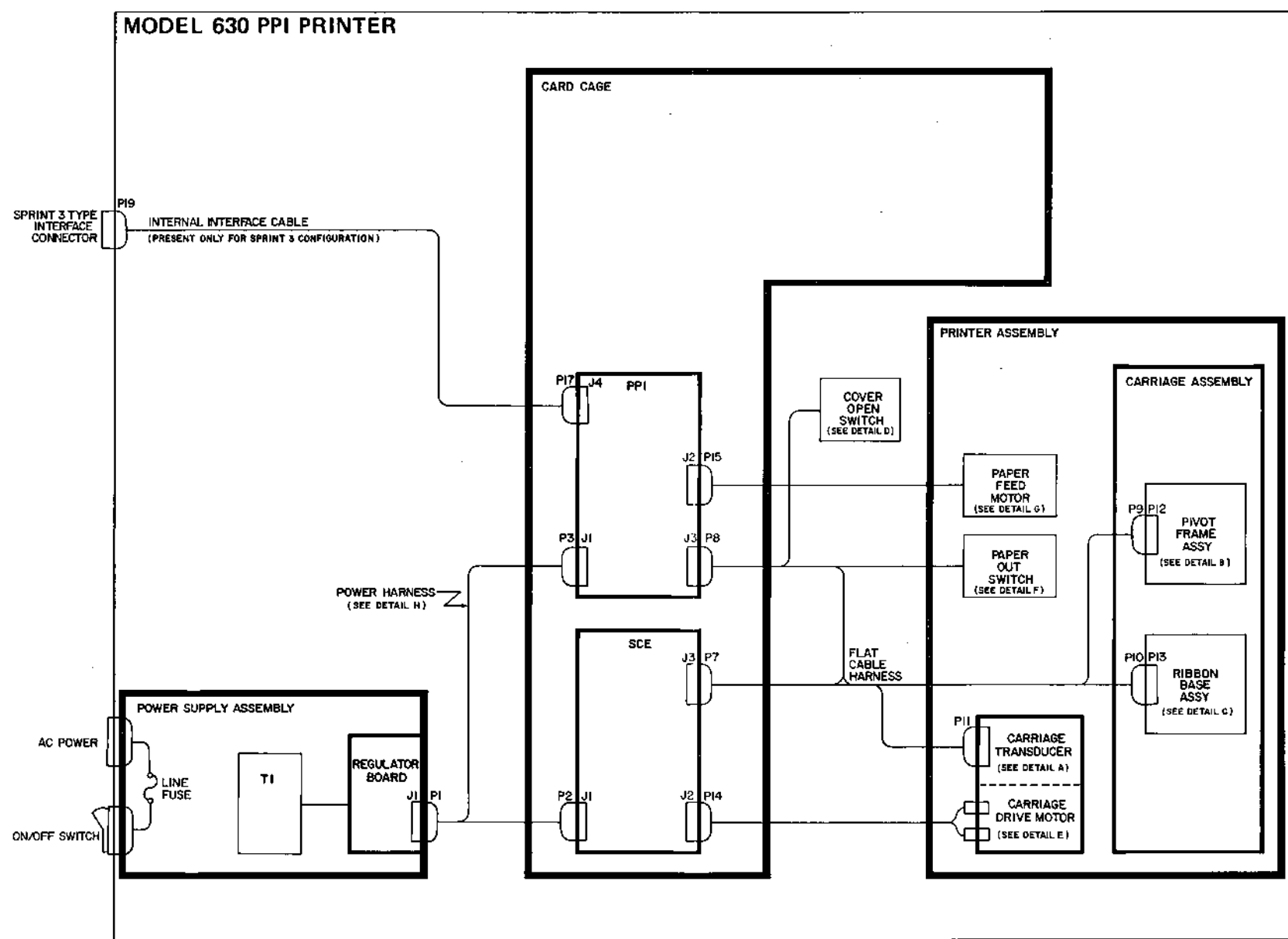
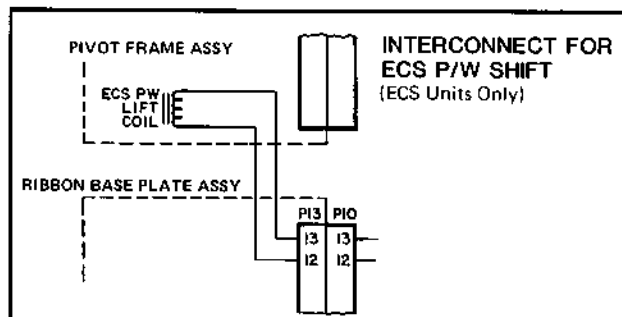
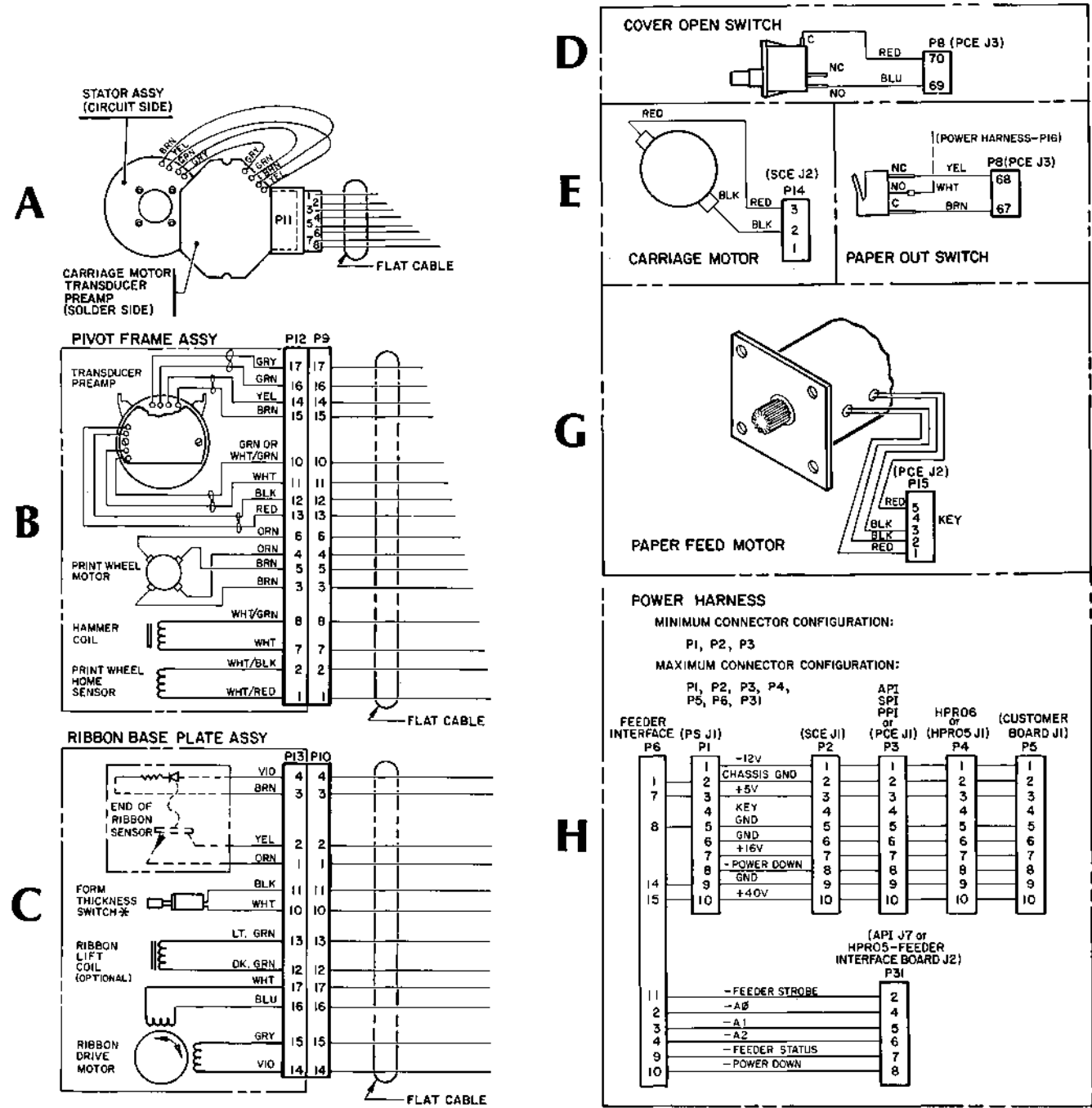

Figure 7-2c
INTERCONNECT WIRING DIAGRAM
MODEL 630 PPI

DETAIL



*FORM THICKNESS SWITCH REPLACED BY JUMPER IN LATER UNITS.

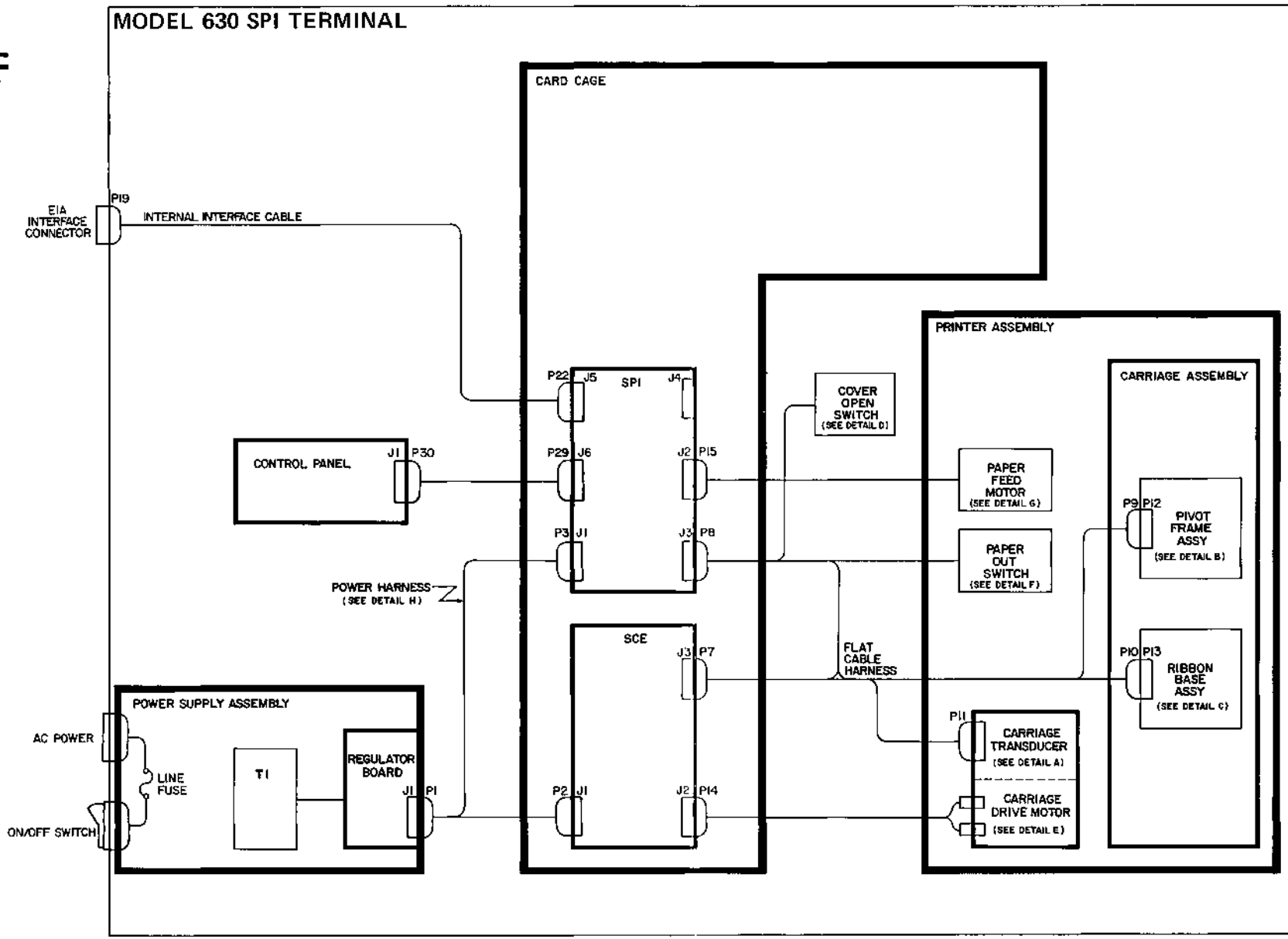

Figure 7-2d
INTERCONNECT WIRING DIAGRAM
MODEL 630 SPI

DETAIL

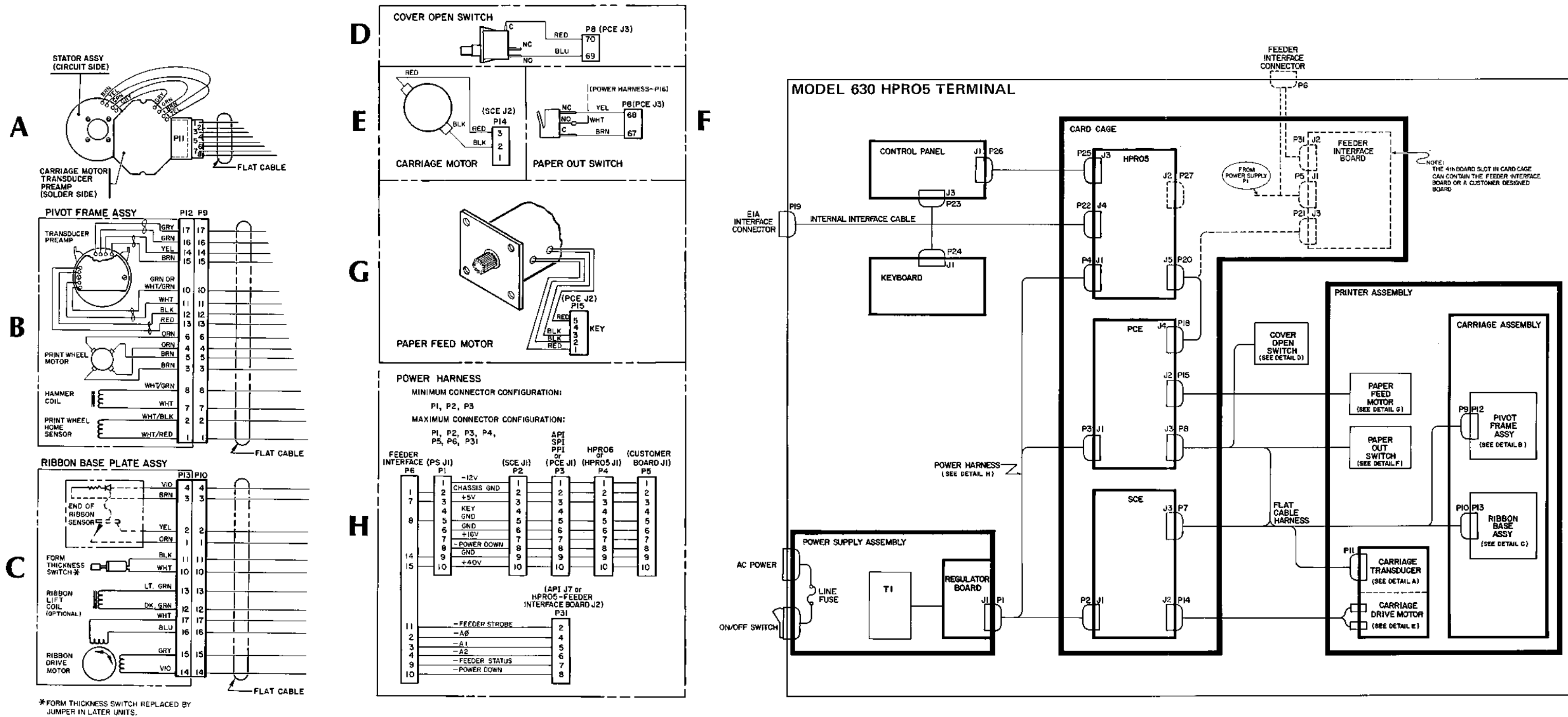
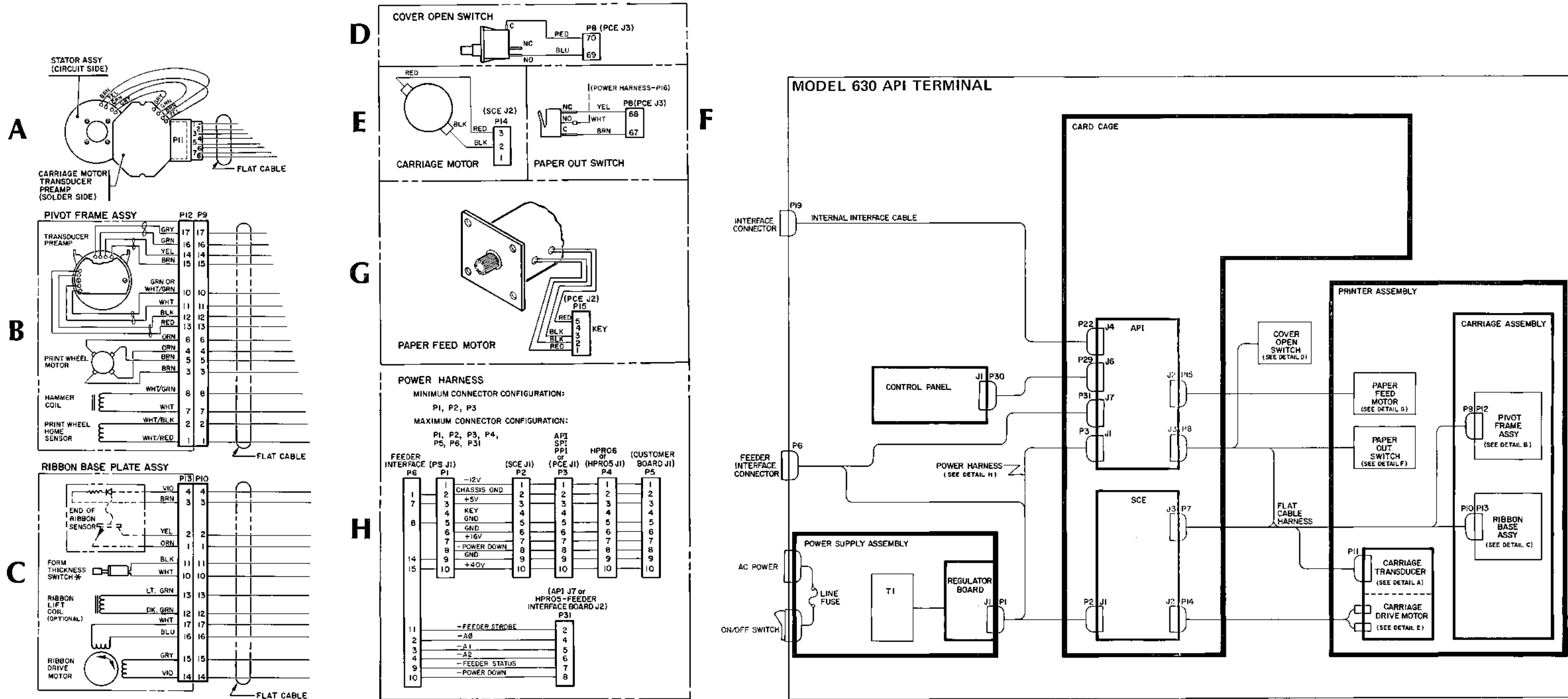

Figure 7-2e
INTERCONNECT WIRING DIAGRAM
MODEL 630 HPRO5

DETAIL



* FORM THICKNESS SWITCH REPLACED BY JUMPER IN LATER UNITS.

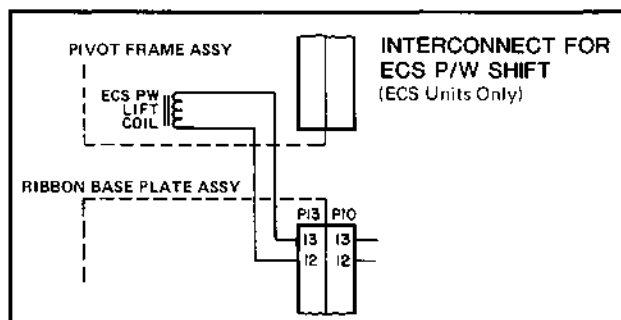

Figure 7-2f
INTERCONNECT WIRING DIAGRAM
MODEL 630 API

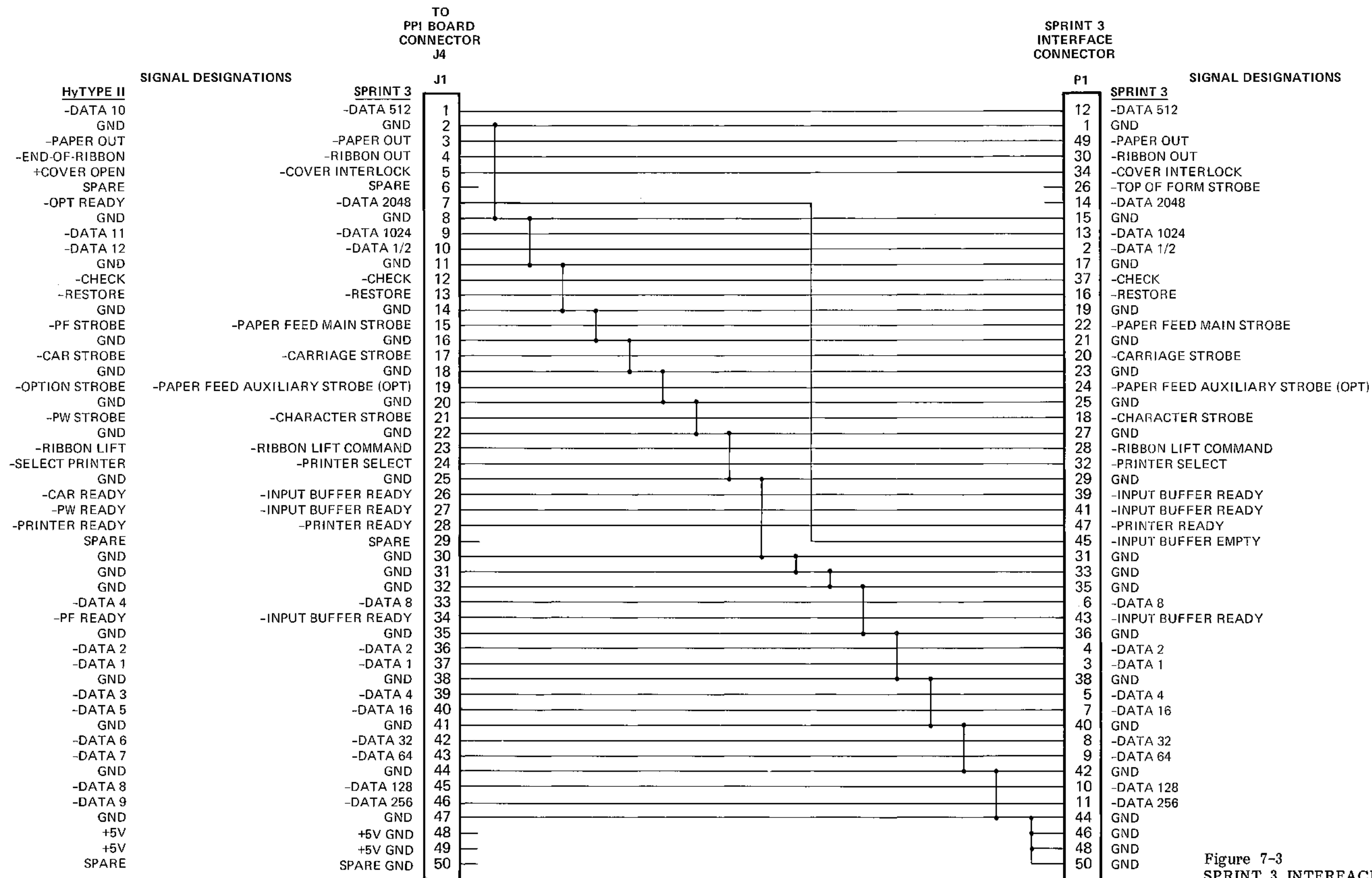
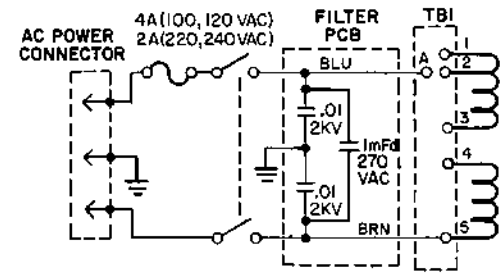

Figure 7-3
SPRINT 3 INTERFACE
ADAPTING CONNECTOR
302875-02

TAB CHART

Dash No.	Configuration
-05/-09/-13	100 VAC
-06/-10/-14	120 VAC
-07/-11/-15	220 VAC
-08/-12/-16	240 VAC



2 TBI WIRING

INPUT VOLTAGE	CONNECTIONS
100 VAC	A TO 2, 1 TO 4, 3 TO 5
120 VAC	A TO 1 and 4, 3 TO 5
220 VAC	A TO 2, 3 TO 4
240 VAC	A TO 1, 3 TO 4

TOP VIEW

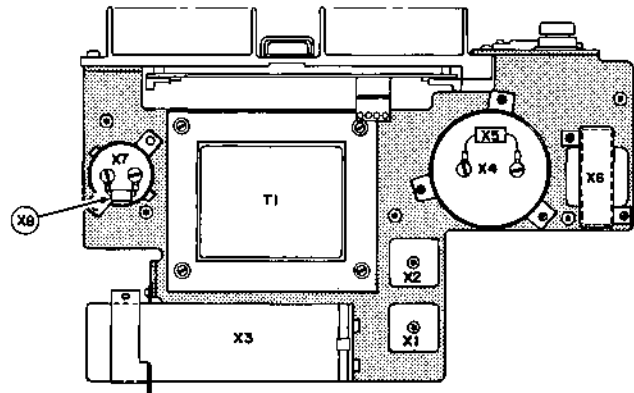

BOTTOM VIEW

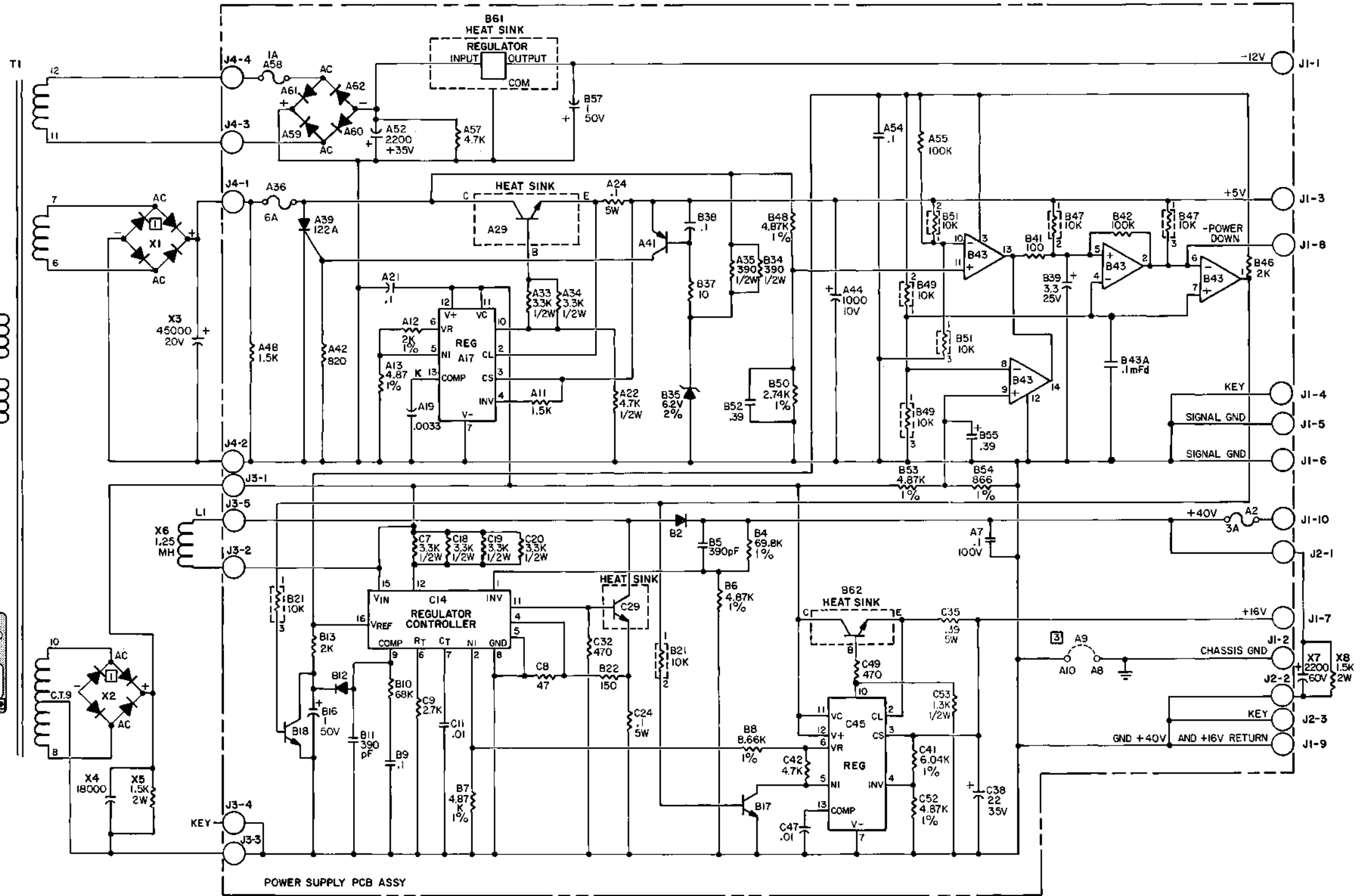
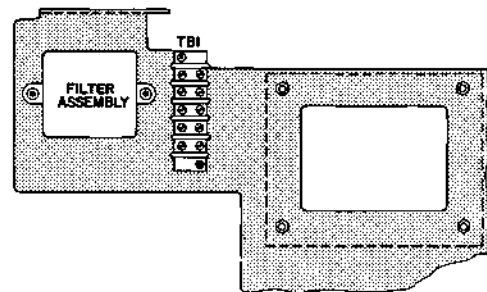

- NOTES:** (UNLESS OTHERWISE SPECIFIED)
- 1 POWER SUPPLY BRACKET REQUIRED AS HEAT SINK.
 - 2 TBI WIRING TABLE IS FOR REFERENCE ONLY. SEE SUBSECTION 5.5 FOR PROCEDURE TO CONVERT POWER SUPPLY VOLTAGE INPUT.
 - 3 WHEN RS-232-C REQUIRES THAT CHASSIS GND AND SIGNAL GND BE DISCONNECTED, REMOVE JUMPER A9 BETWEEN A8 AND A10.
 4. ALL RESISTORS ARE OHMS, 1/4, 2%.
 5. ALL CAPACITORS ARE μ F, 50V.

Figure 7-4.
POWER SUPPLY ASSEMBLY
302825-XX Rev M

POWER SUPPLY ASSEMBLY
302825-XX Rev M

For later revision levels of the Power Supply assembly, see Figure 7-4a.

REVISION HISTORY - P/S Assy 302825-XX

REV	ECO	ACTION
A	B1491	Releases Bill of Material (B/M).
B	B1637	B/M updated.
C	B1722	Schematic released.
D	B1829	Power Supply rear cover and heat sink altered.
E	B1886	Labels for P/S assembly released.
F	B2034	Incorporates changes to satisfy UL/CSA requirements.
G	B2262	Resistor A32, 470 ohms, replaced by two parallel 3.3K, 1/2W resistors at A33, A34 in +5V supply. Resistor C18, 820 ohms, replaced by 4 parallel 3.3K, 1/2W resistors at C7, C18, C19, C20 in +40V/+16V supply. Resistor at A37 in +5V supply moved to location A42. Resistor at C21 in +40V supply moved to location B22. 1A fuse in -12V supply moved from location A59 to A58. Resistor at A60 in -12V supply moved to location A57. Diodes at A63 and A64 in -12V supply moved to A59 and A60 respectively.
H	B2322	Capacitor B57 at -12V regulator (B61) output changed from 35V to 50V rating. Resistor A12 at pin 6 input of Regulator A17 in +5V supply changed to 1% rating. Capacitor B16 in +40V/+16V supply changes rating from 35V to 50V. Resistor A42 at overvoltage SCR in +5V supply changed from 1K to 820 ohms. Resistor A35 in +5V supply changed from 1K to 680 ohms 2% paralleled by 680 ohm 2% resistor at B34. Capacitor B39 in -POWER DOWN circuit changed from 3.9 mFd, 15V, to 3.3 mFd, 25V. Resistor A22 added to pin 10 output of Regulator A17 in +5V supply. Resistor C53 added to pin 10 output of Regulator C45 in +16V supply. Miscellaneous hardware changes; no effect on schematic.
J	B2337	Releases -09, -10, -11, -12 versions of PS Assembly; hardware changes to satisfy VDE/FCC requirements. No effect on schematic.
K	B2500	Hardware changes. No effect on schematic.
L	B2607	Hardware changes. No effect on schematic.
M	B2758	Releases -13, -14, -15, -16 versions of Power Supply Assembly, using Regulator Board 302810-06.

SOLID STATE COMPONENTS USED - P/S Assy 302825-XX

Bridge Rectifier, 100V X1, X2

REVISION HISTORY - P/S Circuit Board Assy 302810-XX (Includes heat sink)

REV	ECO	ASSY	ETCH	ACTION
A	B1491	-02	-01	Releases Bill of Material (B/M).
B	B1637	-02	-01	B/M updated.
C	B1735	-02	-01	B/M corrected. Assembly drawing released.
D	B2034	-02	-01	Changes incorporated to satisfy UL/CSA requirements.
A	B2262	-03	-02	Releases -03 assy and -02 etch.
A	B2322	-04	-03	Releases -04 assy and -03 etch.
B	B2346	-04	-04	PCB artwork changed to move connector J2 .100" into PCB.
C	B2362	-04	-05	Releases new etch to correct trace error on -04 etch.
D	B2337	-XX	-05	Releases -05 assy; changes to comply with VDE/FCC requirements. No effect on schematic. (-XX = -04/-05)
E	B2500	-XX	-05	Revises B/M. No effect on schematic.
F	B2578	-XX	-05	Replaces .01 mFd cap. at A19 with .0033 mFd to prevent 6 amp fuse blowing.
G	B2618	-XX	-05	Change from 5.6V to 6.2V zener diode at B35, and from 680 ohm to 390 ohm resistor at A35 and B34 to prevent 5 amp fuse blowing when on-off switch repeatedly cycled.
H	B2727	-XX	-05	Hardware change. No effect on schematic.
J	B2758	-XX	-05	Releases -06 assy with 0.1 mFd cap. between pins 4 and 12 of I.C. at B43A to stabilize Power Down circuit; prevents processor lockup in PPI units. (-XX = -04/-05/-06)

SOLID STATE COMPONENTS USED - P/S Circuit Board Assy 302810-XX

IC's	LM320T-12V	B61
	SG3524	C14
	339	B43
	723A (selected)	A17, C45
Diodes:	1N4002	A59, A60, A61, A62
	1N4454	B12
	1N5809	B2
	1N5234C, 6.2V	B35
	C122A (SCR)	A39
Transistors:	2N3906	A41
	2N4401	B17, B18
	2N6058	A29, C29
	TIP120	B62
Resistor Packs:	10K (SIP, 3-pin)	B21, B47, B49, B51

Dash No.	Configuration
-19	100VAC
-20	120VAC
-21	220VAC
-22	240VAC
-23	120VAC*
-24	220VAC*

*With capacitor link between chassis ground and signal ground at A7 on P/S circuit board.

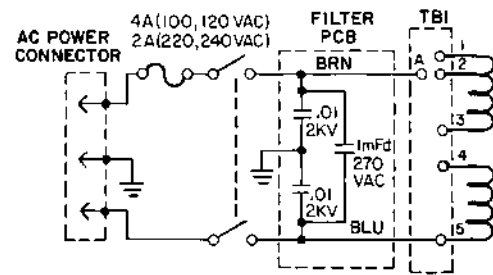

② TBI WIRING

INPUT VOLTAGE	CONNECTIONS
100 VAC	A TO 2, 1 TO 4, 3 TO 5
120 VAC	A TO 1 and 4, 3 TO 5
220 VAC	A TO 2, 3 TO 4
240 VAC	A TO 1, 3 TO 4

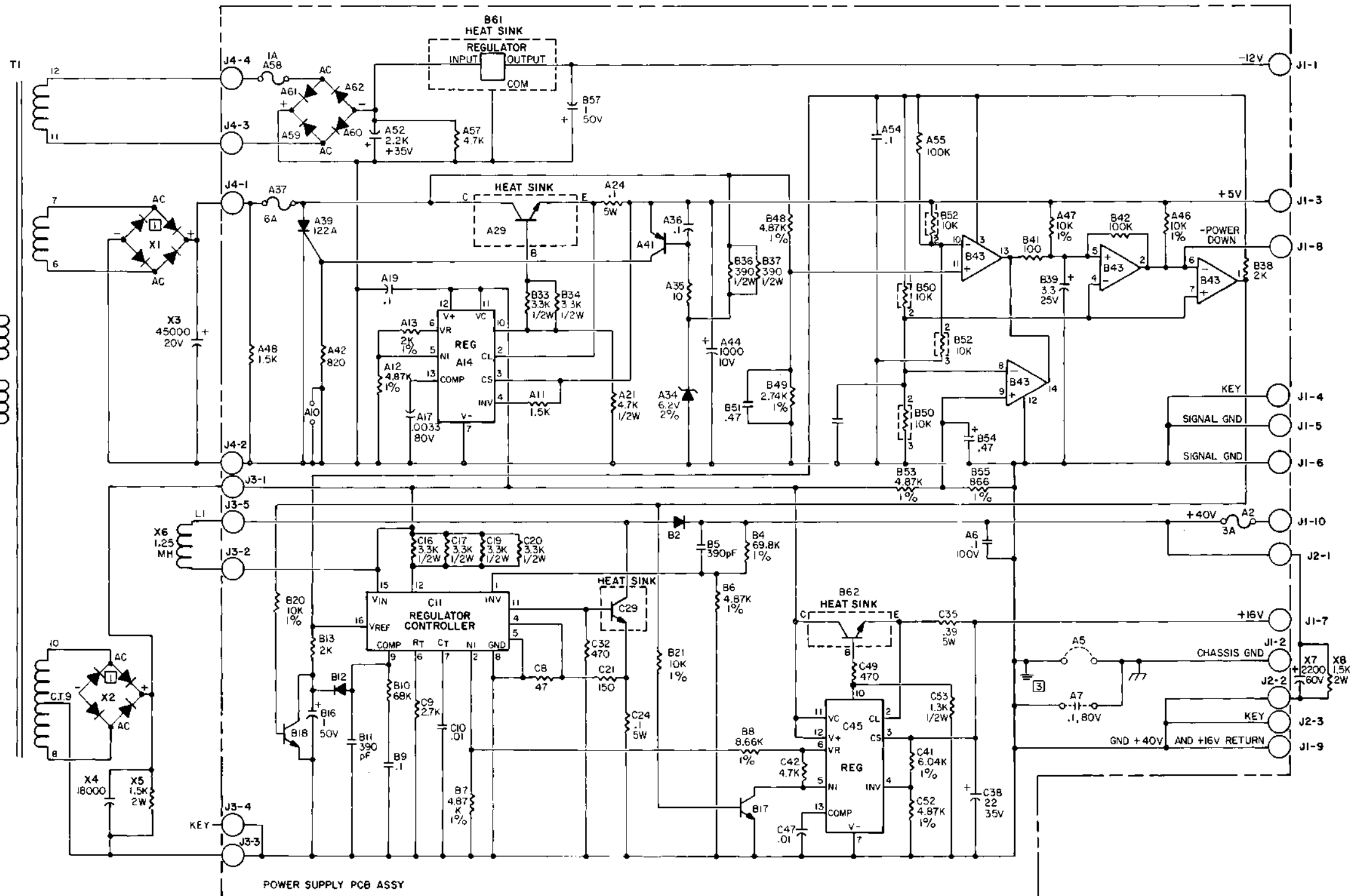

- NOTES: (UNLESS OTHERWISE SPECIFIED)
- ① - POWER SUPPLY BRACKET REQUIRED AS HEAT SINK.
 - ② - TBI WIRING TABLE IS FOR REFERENCE ONLY. SEE SECTION 4 FOR PROCEDURE TO CONVERT POWER SUPPLY VOLTAGE INPUT.
 - ③ - WHEN RS-232-C REQUIRES THAT CHASSIS GND AND SIGNAL GND BE DISCONNECTED, REMOVE JUMPER A5. FOR CAPACITIVE LINK BETWEEN CHASSIS GND AND SIGNAL GND, INSTALL CAPACITOR A7 AND REMOVE JUMPER A5.
 - 4 - ALL RESISTORS ARE OHMS, 1/4W, 2%.
 - 5 - ALL CAPACITORS ARE μ F, 50V.

Figure 7-4a
POWER SUPPLY ASSEMBLY
302825-XX Rev P

POWER SUPPLY ASSEMBLY
302825-XX Rev P

For earlier revision levels of the Power Supply assembly, see Figure 7-4.

REVISION HISTORY - P/S Assy 302825-XX

<u>REV</u>	<u>ECO</u>	<u>ACTION</u>
N	B2818	Obsoletes -09 thru -18 assys. Issues -19 thru -24 assys with changes to meet VDE 0730 requirements. Includes cost-reduced PCB and transformer.
P	B3133	Miscellaneous minor changes; no schematic change.

SOLID STATE COMPONENTS USED

Bridge Rectifier, 100V X1, X2

REVISION HISTORY - P/S Circuit Board Assy 302810-XX (Includes heat sink)

<u>REV</u>	<u>ECO</u>	<u>ASSY</u>	<u>ETCH</u>	<u>ACTION</u>
K	B2818	-08/-09	-06	Releases -08/-09 assys using new -06 etch. Obsoletes earlier assys and -05 etch.
L	B3053	-08/-09	-06	Changes transistor B62 from TIP120 to TIP121. Rivet replaces screw and nut for mounting SCR at A39.
M	B3072	-08/-09	-06	Minor hardware change; no schematic change.

SOLID STATE COMPONENTS USED

IC's:

LM320T-12V	B61
SG3524	C11
339	B43
723A (selected)	A14, C45

Diodes:

1N4002	A59, A60, A61, A62
1N4454	B12
1N5809	B2
1N5234C, 6.2V	A34
C122A (SCR)	A39

Transistors:

2N3906	A41
2N4401	B17, B18
2N6058	A29, C29
TIP121	B62

Resistor Packs:

10K (SIP, 3-pin)	B50, B52
------------------	----------

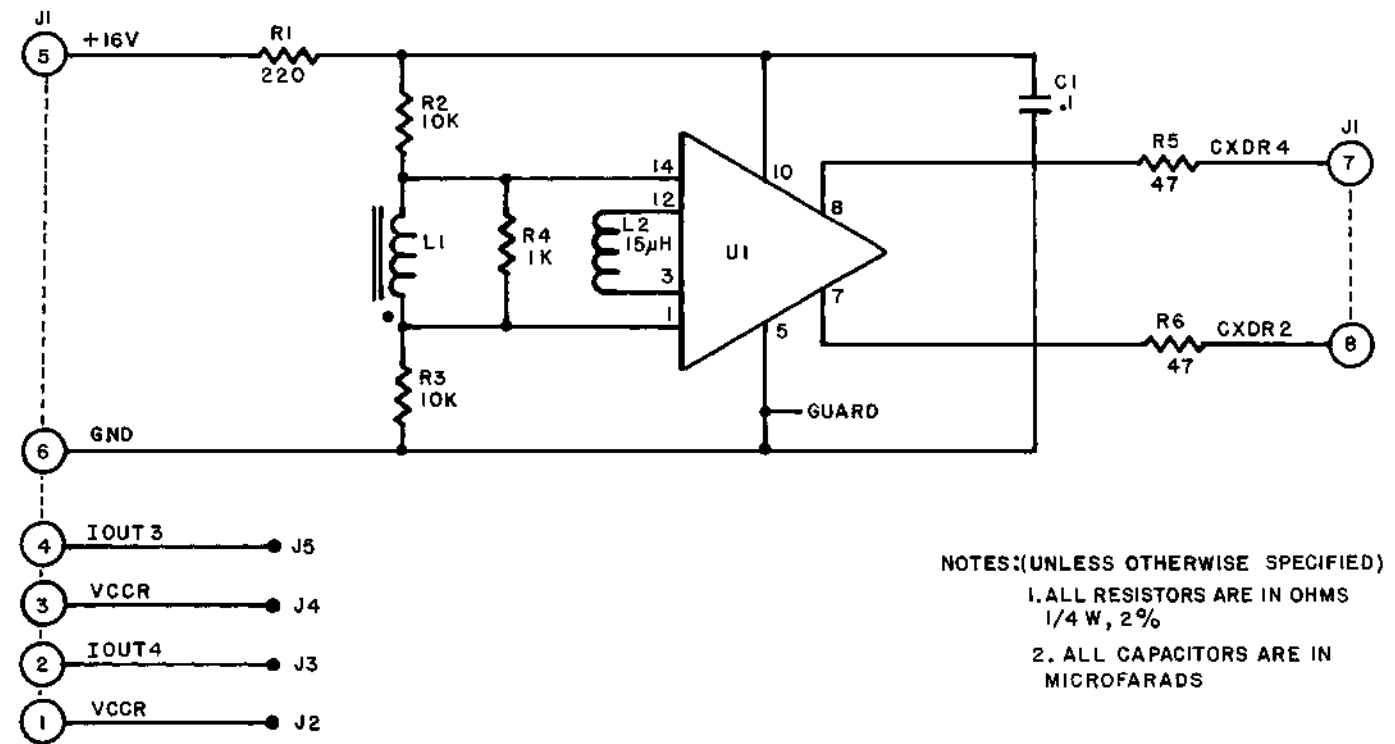
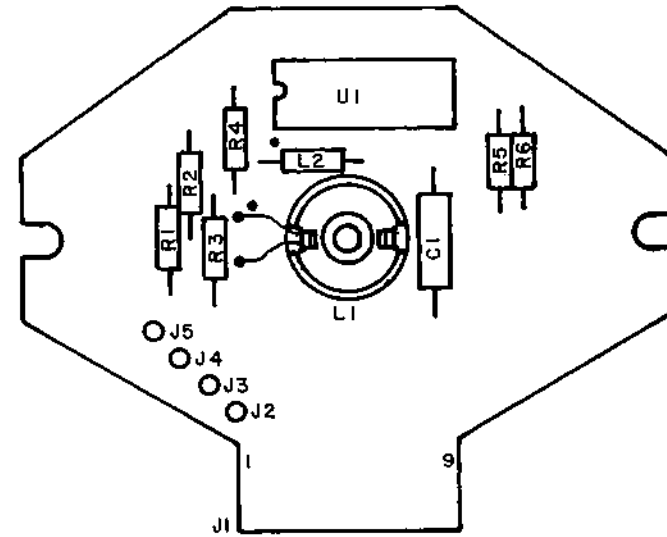

Figure 7-5.
 CARRIAGE TRANSDUCER PREAMP PCB ASSEMBLY
 302604-02 Rev E

CARRIAGE TRANSDUCER PREAMP PCB ASSEMBLY
302604-02 Rev E

REVISION HISTORY

<u>REV</u>	<u>ECO</u>	<u>ASSY</u>	<u>ETCH</u>	<u>ACTION</u>
A	B1390	-02	-02	Releases Bill of Material (B/M).
B	B1687	-02	-02	PCB released for production. Added schematic and assembly drawings.
C	B2038	-02	-02	Documentation change only. No schematic change.
D	B2191	-02	-03	Glue joints strengthened.
E	B2744	-02	-03	Minor hardware changes. No schematic change.

SOLID STATE COMPONENTS USED

IC's: 592A U1

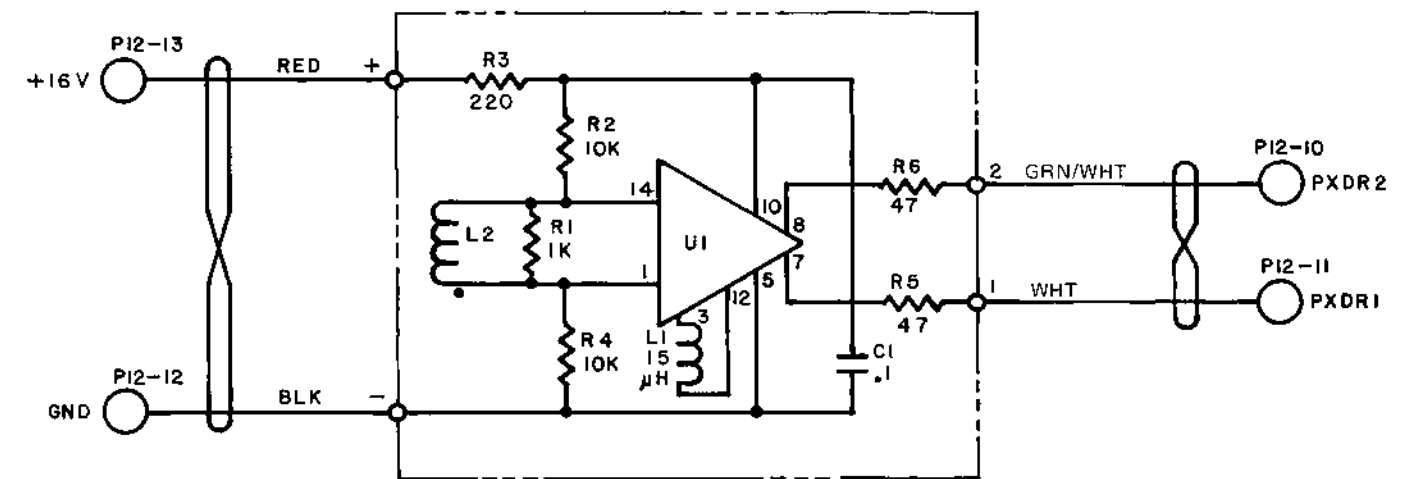
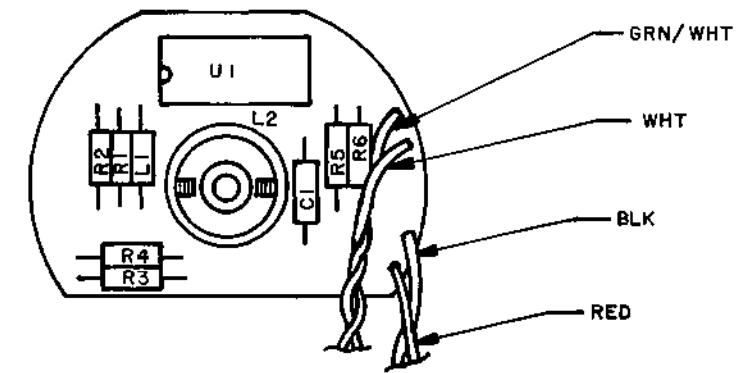

NOTES:(UNLESS OTHERWISE SPECIFIED)
 1. ALL RESISTORS ARE IN OHMS
 1/4W, 2%
 2. ALL CAPACITORS ARE IN
 MICROFARADS

Figure 7-6.
 P/W TRANSDUCER PREAMP PCB ASSEMBLY
 302880-01 Rev G

P/W TRANSDUCER PREAMP PCB ASSEMBLY
302880-01 Rev G

REVISION HISTORY

<u>REV</u>	<u>ECO</u>	<u>ASSY</u>	<u>ETCH</u>	<u>ACTION</u>
A	B1736	-01	-01	Released for production.
B	B1832	-01	-01	Change to larger pin contacts. Glue pot core to both PCB and pilot plug. Route wires out bottom of board instead of to side of board.
C	B2038	-01	-01	Documentation change only. No schematic change.
D	B2191	-01	-02	Glue joints strengthened.
E	B2325	-01	-02	Standoff changed.
F	B2468	-01	-02	Minor hardware change. No schematic change.
G	B2744	-01	-02	Minor hardware change. No schematic change.

SOLID STATE COMPONENTS USED

IC's: 592A U1

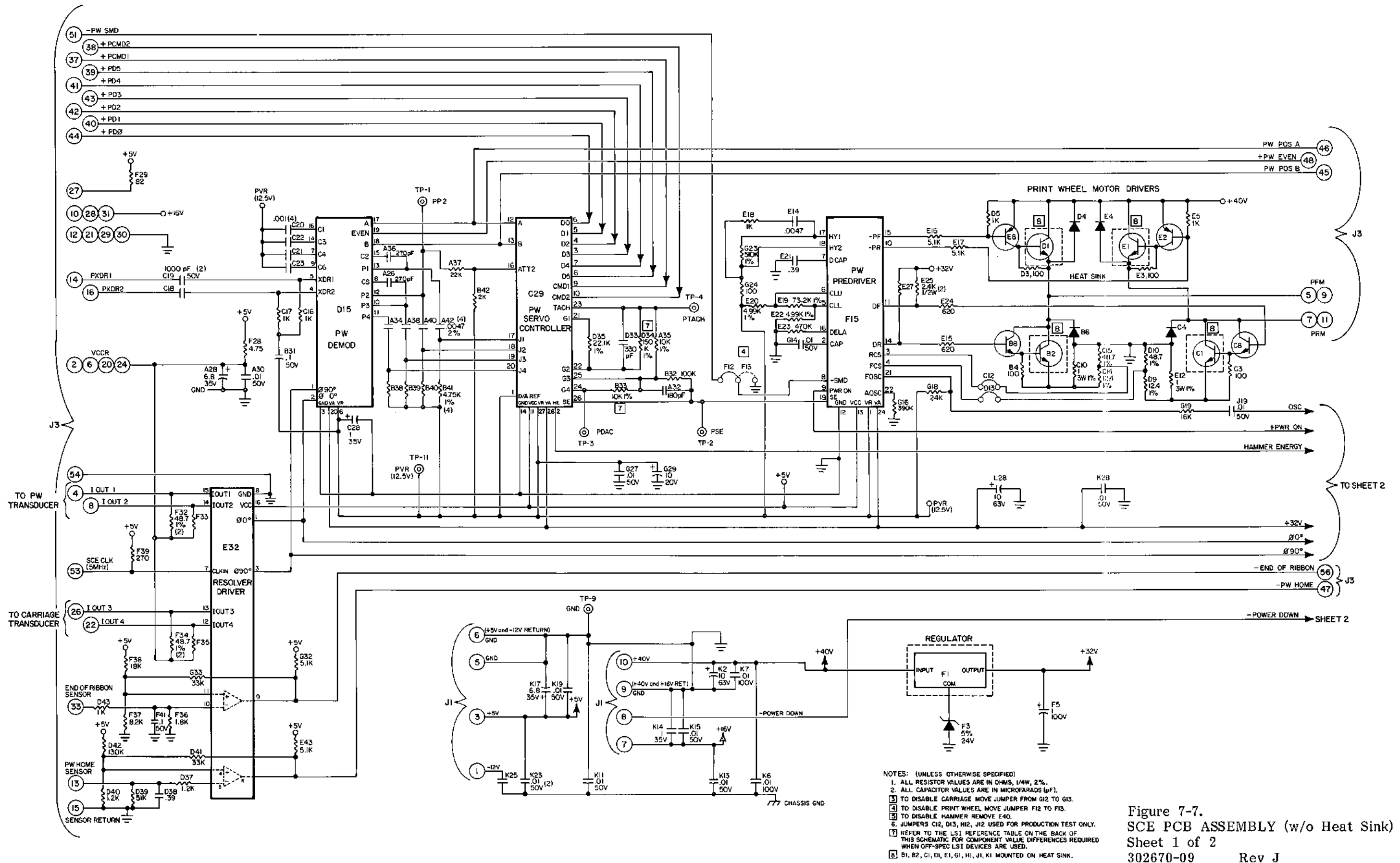

- NOTES: (UNLESS OTHERWISE SPECIFIED)
1. ALL RESISTOR VALUES ARE IN OHMS, 1/4W, 2%.
 2. ALL CAPACITOR VALUES ARE IN MICROFARADS (µF).
 3. TO DISABLE CARRIAGE MOVE JUMPER FROM G12 TO G13.
 4. TO DISABLE PRINT WHEEL MOVE JUMPER F12 TO F13.
 5. TO DISABLE HAMMER REMOVE E40.
 6. JUMPERS C12, D13, H12, J12 USED FOR PRODUCTION TEST ONLY.
 7. REFER TO THE LSI REFERENCE TABLE ON THE BACK OF THIS SCHEMATIC FOR COMPONENT VALUE DIFFERENCES REQUIRED WHEN OFF-SPEC LSI DEVICES ARE USED.
 8. B1, B2, C1, D1, E1, G1, H1, J1, K1 MOUNTED ON HEAT SINK.

Figure 7-7.
SCE PCB ASSEMBLY (w/o Heat Sink)
Sheet 1 of 2
302670-09 Rev J

For later revision levels of the SCE PCB assembly, see Figures 7-7a/7-8a, 7-7b/7-8b, and 7-7c/7-8c.

NOTE: Part number 302670-XX identifies the PCB assembly without heat sink.

REVISION HISTORY

REV	ECO	ASSY	ETCH	ACTION
A	B1390			Releases Bill of Material (B/M).
B	B1779	-02	-02	B/M updated. Schematic and assembly drawing added.
C	B1849	-02	-02	Resistor G20 changed from 6.19K to 4.99K 1%. Resistor G21 changed from 49.9K to 73.2K 1%. Resistor G25 changed from 6.19K to 4.99K 1%.
D	B1903	-02	-02	Part number correction and spec change.
E	B1983	-03	-03	Releases -03 PCB etch. Resistor J37, 28K ohms added. Capacitor designator C41 corrected to F41.
F	B2149	-05	-03	Resistor B11 changed from 470 ohms to 1K ohms. Resistor D34 changed from 140K ohms to 162K ohms. Resistor B32 changed from 270K ohms to 220K ohms. Resistors C14, D9 changed from 205 ohms to 12.4 ohms.
G	B2156	-05	-03	Resistors C15, D10 changed from 806 ohms to 48.7 ohms. Resistor J32 changed from 2% to 1% tolerance. Resistor D34 changed from 162K ohms to 150K ohms. Resistor B32 changed from 220K ohms to 100K ohms. Resistor G37, 150K ohms, deleted. Capacitor G36, .0068 mFd, deleted.
H	B2336	-07	-03	Remove .01 mFd caps. K16, K26 from carriage motor drive circuits to prevent spurious Check condition during Self-Test. Assembly advances to -07.
J	B2414	-09	-04	Releases -04 PCB etch. Assembly advances to -09.

SOLID STATE COMPONENTS USED

IC's:

78M08UC F1
747C A18
LM339 B15

(The remaining IC's on this PCB are custom LSI. Refer to the Model 630 Parts Catalog for Diablo part numbers.)

Diodes:

1N4002 B12
1N5416 D4, E4, J4, K4
1N5809 B13, B6, C4, G5, H5
1N4454 B17, B18, B22
1N5338A, 5.1V B14
1N5252B, 24V F3

Transistors:

TIP2955 B1
2N3644 A22
2N5320 B8, A12, C8, G8, H8
2N5322 A2, E8, E2, J9, K12
2N6101 B2, C1, D1, E1, G1, H1, J1, K1

DEVICE	IN-SPEC	OFF-SPEC	POSITION	ASSOCIATED RESISTORS		
				POSITION	VALUE	PART NO.
Demodulator:						
302477-03	X		L32	J37	28K Ohm	10004-44
	X		D15	D34	150K Ohm	10005-18
302477-03X		X	L32	J37	28.7K Ohm	10004-45
		X	D15	D34	133K Ohm	10005-15
320016-01		X	L32	J37	30.1K Ohm	10004-47
		X	D15	D34	140K Ohm	10005-15
320016-02		X	L32	J37	28.7K Ohm	10004-65
		X	D15	D34	147K Ohm	10005-17
Servo Controller:						
302478-03	X		C29	B33	10K Ohm	42005-12
				B26	10K Ohm	42005-12
302478-04	X		H32	J32	10K Ohm	42005-12
				J32	10K Ohm	42005-12
320066-01		X	C29	B33	10.7K Ohm	42005-13
				B26/B27*	10.7K Ohm	42005-13
320066-02		X	H32	J32	10.7K Ohm	42005-13
				J32	10.7K Ohm	42005-13
320066-03		X	C29	B33	10.5K Ohm	10004-03
				B26/B27*	10.5K Ohm	10004-03
320066-04		X	H32	J32	10.5K Ohm	10004-03
				J32	10.5K Ohm	10004-03
320066-05		X	C29	B33	11K Ohm	10004-05
				B26/B27*	11K Ohm	10004-05
320066-06		X	H32	J32	11K Ohm	10004-05
				J32	11K Ohm	10004-05
320066-07		X	C29	B33	10.2K Ohm	10004-02
		X	H32	J32	10.2K Ohm	10004-02
320066-08		X	H32	J32	10.2K Ohm	10004-02
				J32	10.2K Ohm	10004-02
320066-09		X	C29	B33	10K Ohm	42005-12
		X	H32	J32	10K Ohm	42005-12
320066-10		X	H32	J32	10K Ohm	42005-12

* = B27 on board etches -04 and later; B26 on earlier boards.

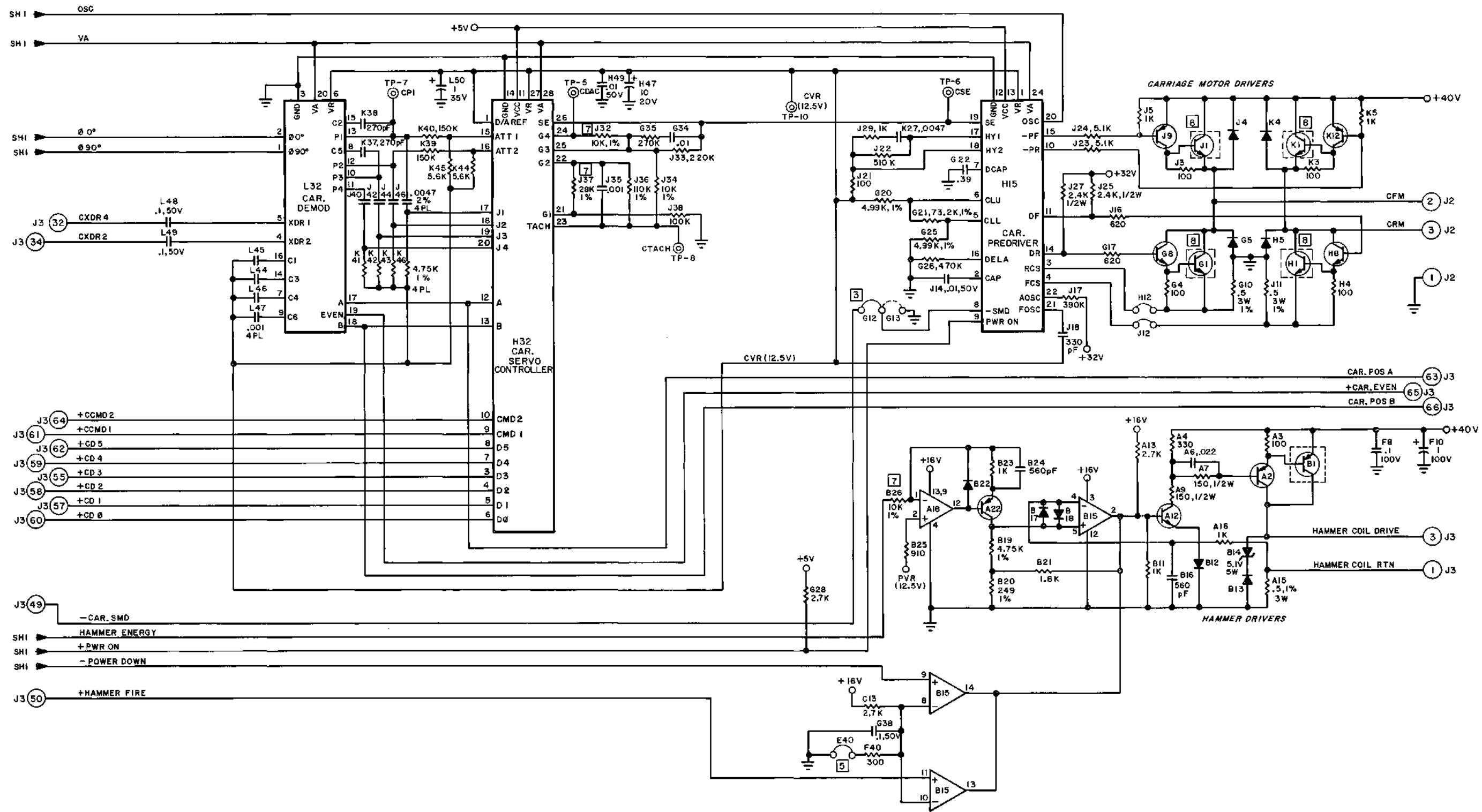
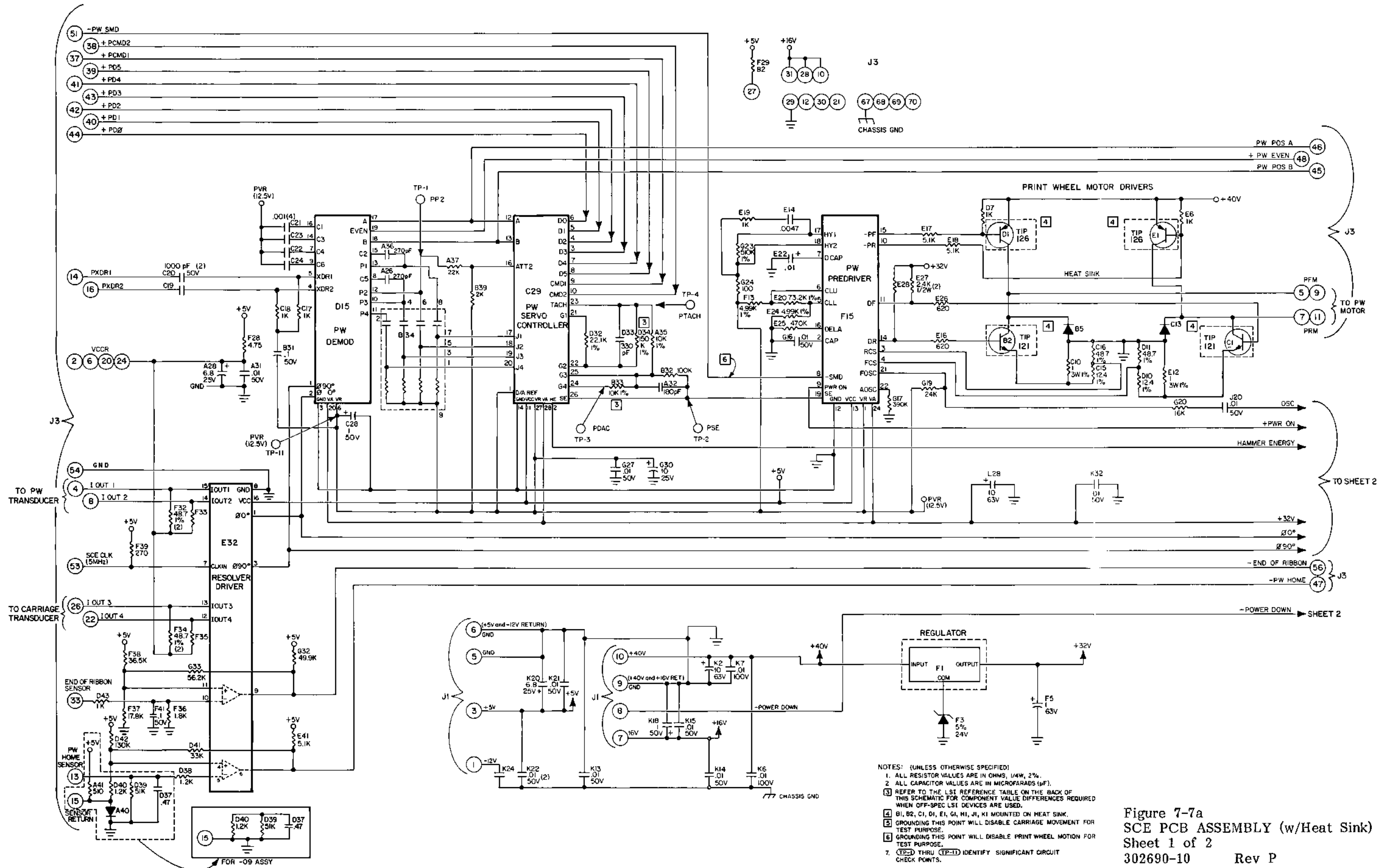

Figure 7-8.
 SCE PCB ASSEMBLY (w/o Heat Sink)
 Sheet 2 of 2
 302670-09 Rev J



- NOTES: (UNLESS OTHERWISE SPECIFIED)
1. ALL RESISTOR VALUES ARE IN OHMS, 1/4W, 2%.
 2. ALL CAPACITOR VALUES ARE IN MICROFARADS (µF).
 3. REFER TO THE LSI REFERENCE TABLE ON THE BACK OF THIS SCHEMATIC FOR COMPONENT VALUE DIFFERENCES REQUIRED WHEN OFF-SPEC LSI DEVICES ARE USED.
 4. B1, B2, C1, D1, E1, G1, H1, J1, K1 MOUNTED ON HEAT SINK.
 5. GROUNDING THIS POINT WILL DISABLE CARRIAGE MOVEMENT FOR TEST PURPOSE.
 6. GROUNDING THIS POINT WILL DISABLE PRINT WHEEL MOTION FOR TEST PURPOSE.
 7. (TP-1) THRU (TP-11) IDENTIFY SIGNIFICANT CIRCUIT CHECK POINTS.

Figure 7-7a
 SCE PCB ASSEMBLY (w/Heat Sink)
 Sheet 1 of 2
 302690-10 Rev P

SCE PCB ASSEMBLY (with heat sink)
302690-10 Rev P

LSI REFERENCE FOR SCE CIRCUIT BOARD

For earlier revision levels of the SCE PCB assembly, see Figures 7-7/7-8.
For later versions of the SCE PCB assembly, see Figures 7-7b/7-8b, and 7-7c/7-8c.

REVISION HISTORY

REV	ECO	ASSY	ETCH	ACTION
H	B2475	-09/-10	-04/-05	Combines B/M's for SCE PCB assy 302670-09 and SCE assy 302690-08 to create 302690-09 assy using -04 etch. Releases 302690-10 assy/-05 etch to replace -09 assy/-04 etch.
J	B2487	-10	-06	Releases -06 etch. Zener diode (5.1V) moved from B13 to B12 and standard diode from B12 to B13 to separate zener from hot power resistor.
K	B2572	-10	-06	Minor documentation changes. No schematic change.
L	B2776	-10	-06	Capacitors E22, G14 changed from .47 to .01. Diodes B5, C13, G4, H4 changed from 1N5809 to 1N5416.
M	B2885	-10	-06	Discontinue -10 assy and -06 etch. (Replaced by -11 assy and -07 etch.)
N	B2991	-10	-06	To allow auto insertion, change from diode 13054-01 to diode 100643-01. No schematic change.
P	B3053	-10	-06	For reliability improvement, change from transistor type TIP120 to TIP121, and TIP125 to TIP126.

SOLID STATE COMPONENTS USED

IC's:

78M08UC F1
747C A18
LM339 B15

(The remaining IC's on this circuit board are custom LSL. Refer to the Model 630 Parts Catalog for Diablo part numbers.)

Diodes:

1N4002 A6
1N5809 B5, B12 (in -09), B13 (in -10), C13, G4, H4
1N4454 B23, A40 (-10 only)
SES5002 B5, C13, G4, H4
1N5338A, 5.1V B12 (in -10), B13 (in -09)
1N5252, 24V F3

Transistors:

TIP121 B2, C1, G1, H1
TIP126 B1, D1, E1, J1, K1
2N3644 B28
2N4401 A10

R-C Network Pack B34, J39

DEVICE	IN-SPEC	OFF-SPEC	POSITION	ASSOCIATED RESISTORS		
				POSITION	VALUE	PART NO.
Demodulator:						
302477-03	X		L32	J37	28K Ohm	10004-44
	X		D15	D34	150K Ohm	10005-18
302477-03X		X	L32	J37	28.7K Ohm	10004-45
		X	D15	D34	133K Ohm	10005-15
320016-01		X	L32	J37	30.1K Ohm	10004-47
		X	D15	D34	140K Ohm	10005-15
320016-02		X	L32	J37	28.7K Ohm	10004-65
		X	D15	D34	147K Ohm	10005-17
Servo Controller:						
302478-03	X		C29	B33	10K Ohm	42005-12
				B26	10K Ohm	42005-12
	X		H32	J32	10K Ohm	42005-12
302478-04	X		H32	J32	10K Ohm	42005-12
320066-01		X	C29	B33	10.7K Ohm	42005-13
		X	H32	B26/B27*	10.7K Ohm	42005-13
		X	H32	J32	10.7K Ohm	42005-13
320066-02		X	H32	J32	10.7K Ohm	42005-13
320066-03		X	C29	B33	10.5K Ohm	10004-03
		X	H32	B26/B27*	10.5K Ohm	10004-03
		X	H32	J32	10.5K Ohm	10004-03
320066-04		X	H32	J32	10.5K Ohm	10004-03
320066-05		X	C29	B33	11K Ohm	10004-05
		X	H32	B26/B27*	11K Ohm	10004-05
		X	H32	J32	11K Ohm	10004-05
320066-06		X	H32	J32	11K Ohm	10004-05
320066-07		X	C29	B33	10.2K Ohm	10004-02
		X	H32	J32	10.2K Ohm	10004-02
320066-08		X	H32	J32	10.2K Ohm	10004-02
320066-09		X	C29	B33	10K Ohm	42005-12
		X	H32	J32	10K Ohm	42005-12
320066-10		X	H32	J32	10K Ohm	42005-12

* = B27 on board etches -04 and later; B26 on earlier boards.

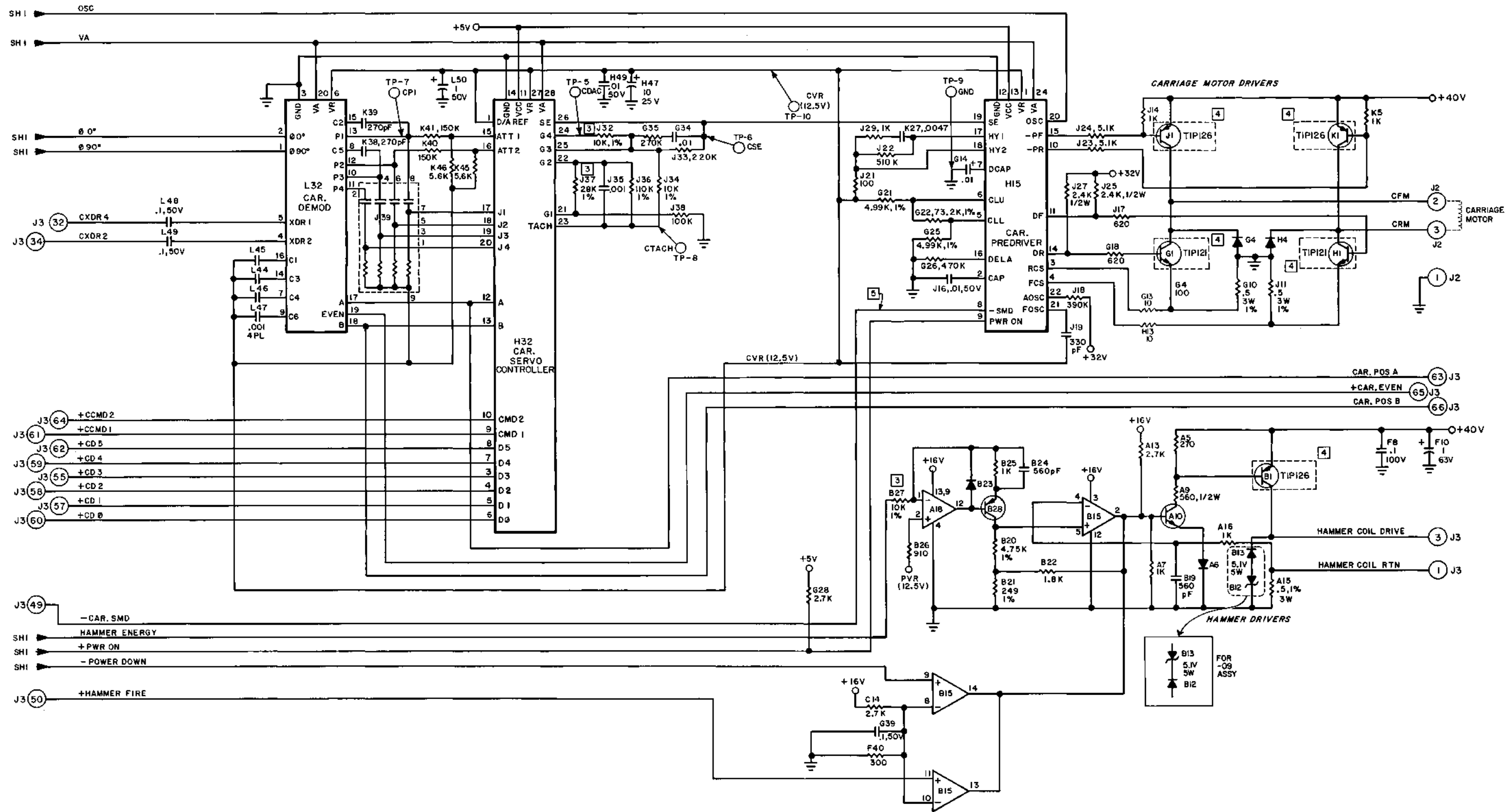

Figure 7-8a
 SCE PCB ASSEMBLY (w/Heat Sink)
 Sheet 2 of 2
 302690-10 Rev P

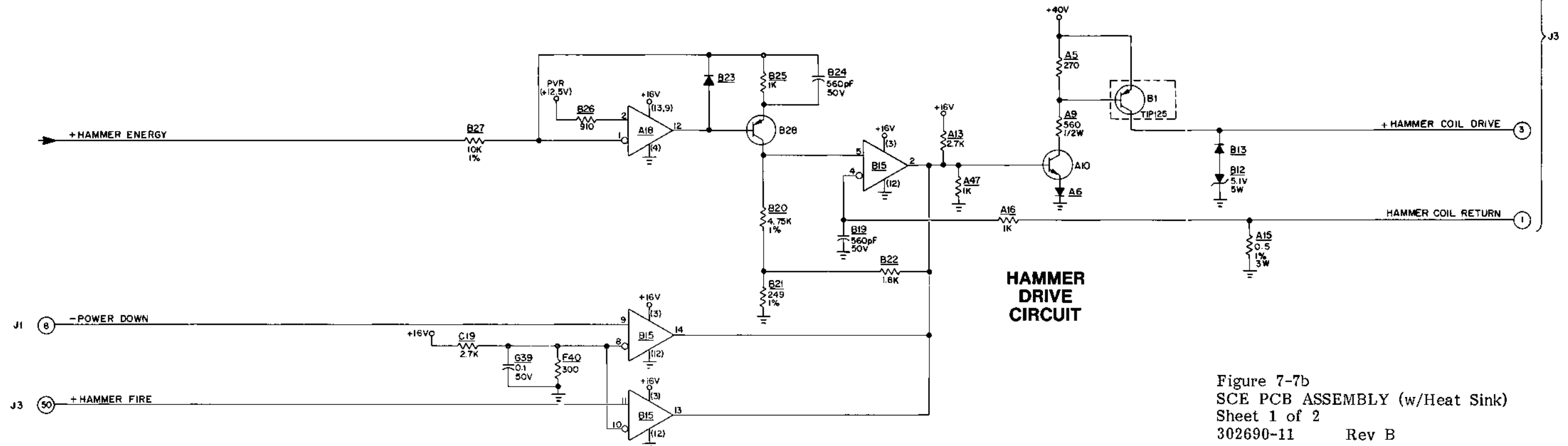
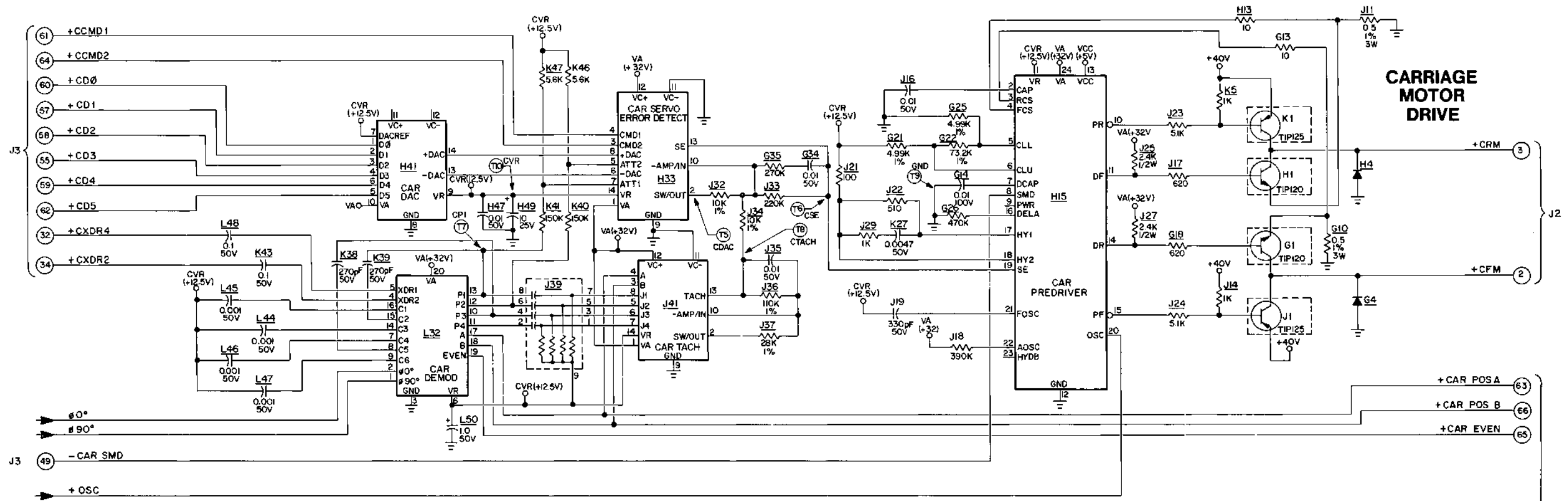

Figure 7-7b
 SCE PCB ASSEMBLY (w/Heat Sink)
 Sheet 1 of 2
 302690-11 Rev B

SCE PCB ASSEMBLY (with heat sink)
302690-11 Rev B

For earlier versions of the SCE PCB assembly, see Figures 7-7/7-8, 7-7a/7-8a.
For later version of the SCE PCB assembly, see Figures 7-7c/7-8c.

REVISION HISTORY

<u>REV</u>	<u>ECO</u>	<u>ASSY</u>	<u>ETCH</u>	<u>ACTION</u>
A	B2885	-11	-07	Releases -11 assy -07 etch to incorporate re-designed analog LSL.
B	B2991	-11	-07	To allow auto insertion, change from diode 13054-01 to diode 100643-01. No schematic change.
C	B3060	-11	-07	Discontinues -11 assy -07 etch; replaced by -12 assy -08 etch.

SOLID STATE COMPONENTS USED

IC's:

78M08UC	F1
747C	A18
LM339	B15

(The remaining IC's on this circuit board are custom LSL. Refer to the Model 630 Parts Catalog for Diablo part numbers.)

Diodes:

1N4002	A6
1N5809	B13
1N4454	B23, A40
SES5002	B4, C4, G4, H4
1N5338A, 5.1V	B12
1N5252, 24V	F3

Transistors:

TIP121	B2, C1, G1, H1
TIP126	B1, D1, E1, J1, K1
2N3644	B28
2N4401	A10

R-C Network Pack:

B34, J39

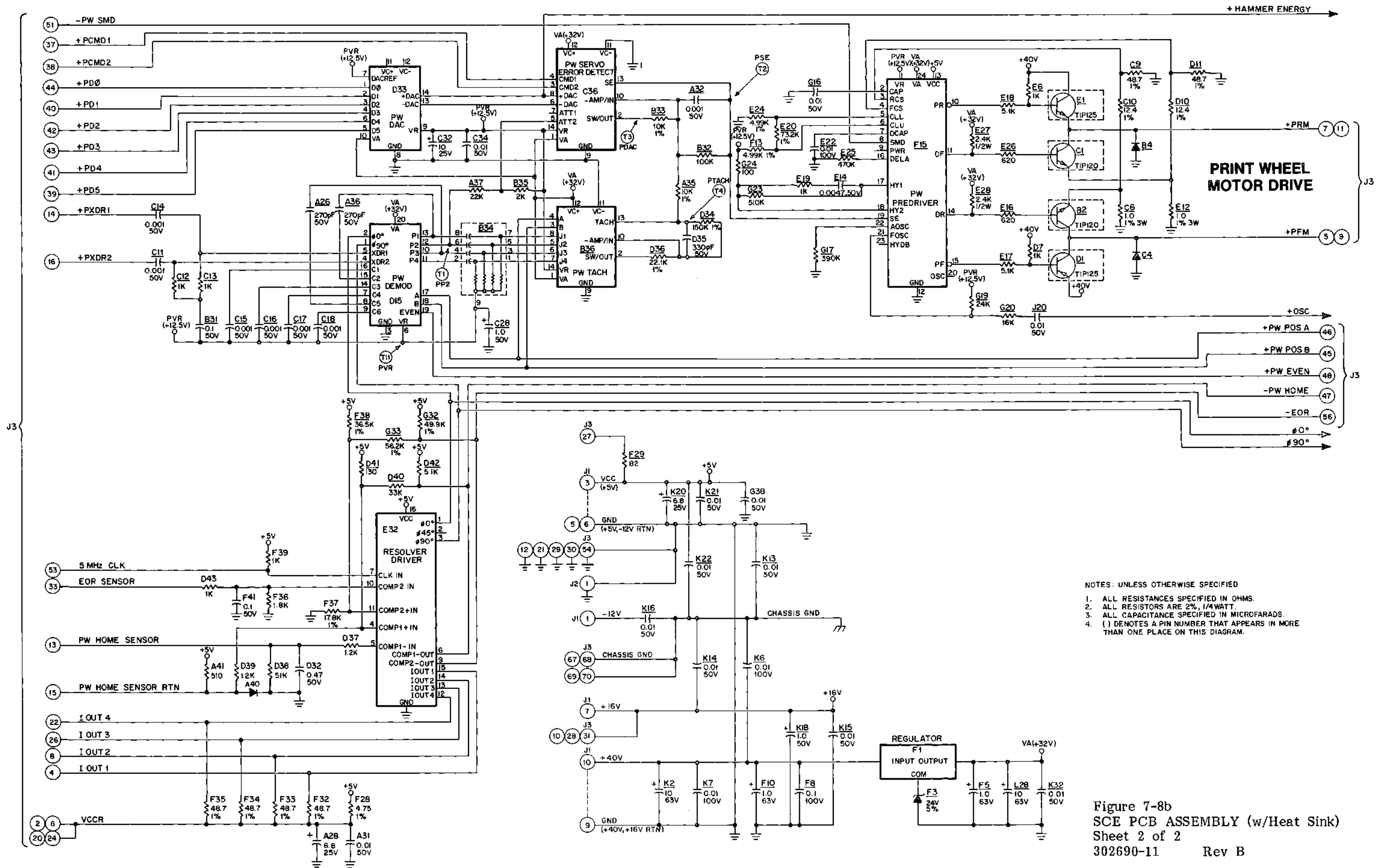

- NOTES: UNLESS OTHERWISE SPECIFIED
1. ALL RESISTANCES SPECIFIED IN OHMS.
 2. ALL RESISTORS ARE 2%, 1/4 WATT.
 3. ALL CAPACITANCE SPECIFIED IN MICROFARADS.
 4. () DENOTES A PIN NUMBER THAT APPEARS IN MORE THAN ONE PLACE ON THIS DIAGRAM.

Figure 7-8b
 SCE PCB ASSEMBLY (w/Heat Sink)
 Sheet 2 of 2
 302690-11 Rev B

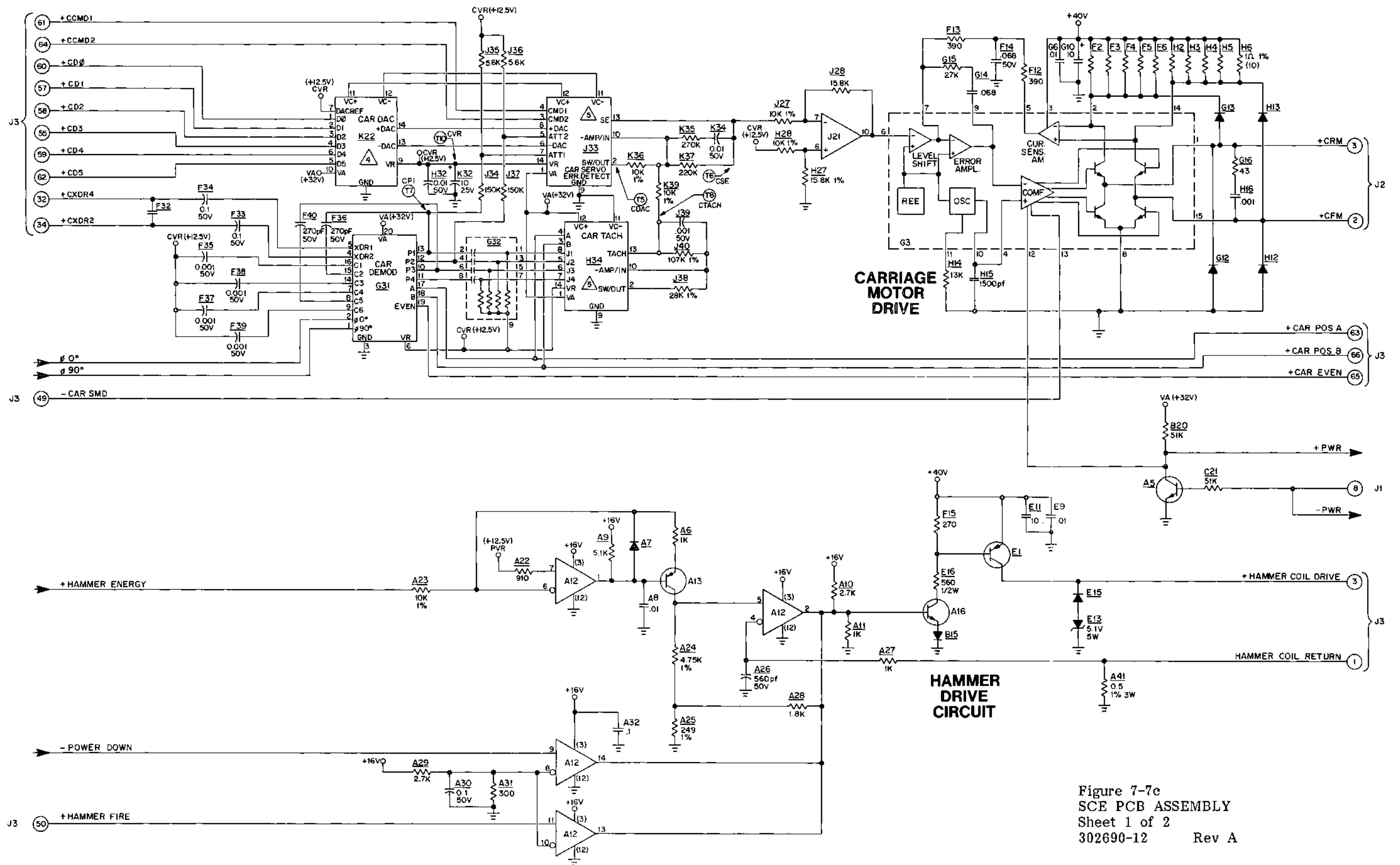

Figure 7-7c
 SCE PCB ASSEMBLY
 Sheet 1 of 2
 302690-12 Rev A

SCE PCB ASSEMBLY (with heat sink)
302690-12 Rev A

For earlier versions of the SCE PCB assembly, see Figures 7-7/7-8, 7-7a/7-8a, and 7-7b/7-8b.

REVISION HISTORY

<u>REV</u>	<u>ECO</u>	<u>ASSY</u>	<u>ETCH</u>	<u>ACTION</u>
A	B3060	-12	-08	Releases -12 assy -08 etch.

SOLID STATE COMPONENTS USED

IC's:

SGS L292	C3, G3
LM317	J4
747C	J21
LM339	A12

(The remaining IC's on this circuit board are custom LSL. Refer to the Model 630 Parts Catalog for Diablo part numbers.)

Diodes:

1N4002	B15, J5, J15
1N4454	A7, B36
1N5809	E15
SES5002	D12, C11, C12, D13, G11, G13, H12, H13
1N5338A, 5.1V	E13

Transistors:

TIP126	E1
2N3644	A13
2N4401	A5, A16

R-C Network Pack:

E23, G32

PRINT WHEEL MOTOR DRIVERS

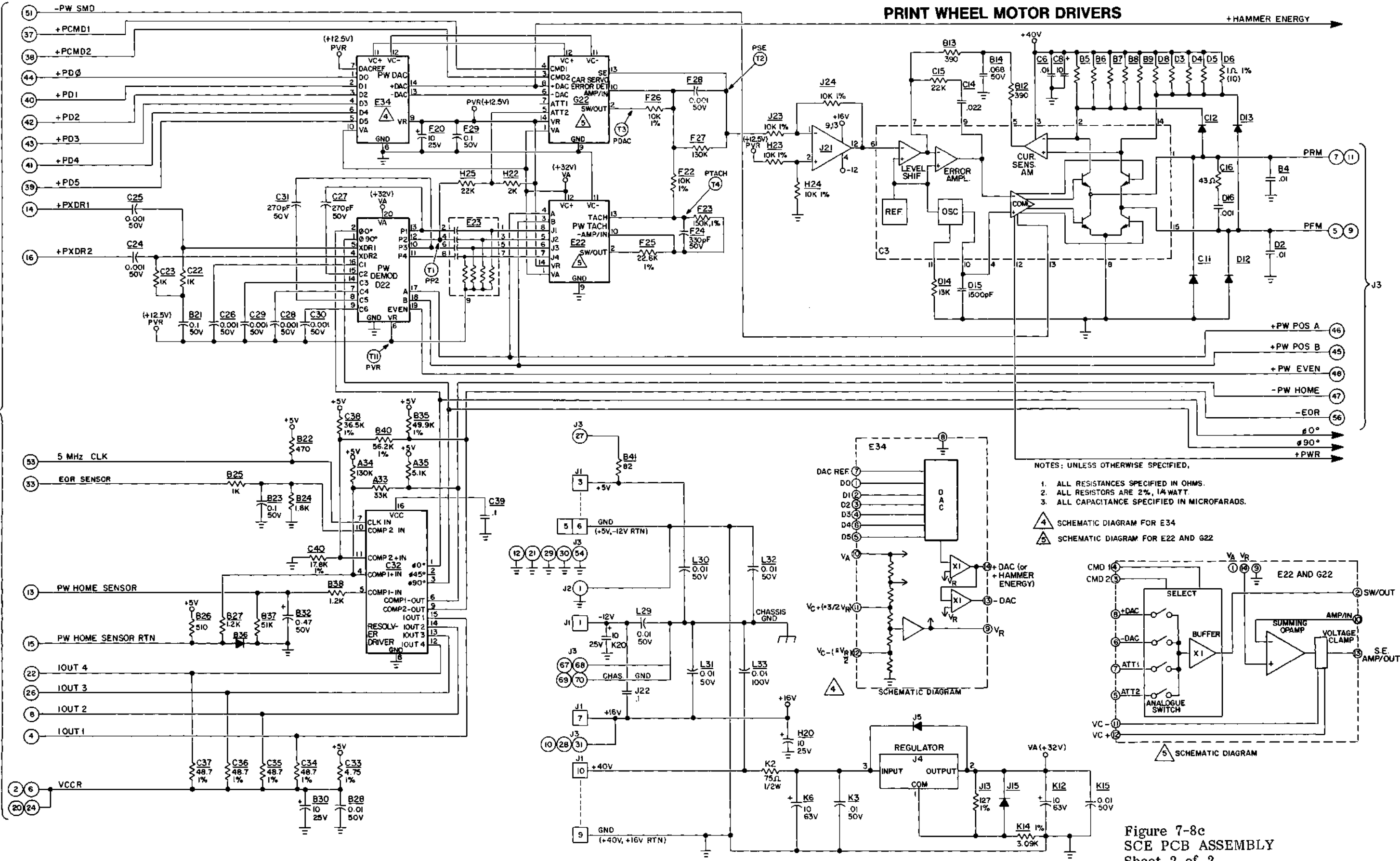

- NOTES: UNLESS OTHERWISE SPECIFIED,
1. ALL RESISTANCES SPECIFIED IN OHMS.
 2. ALL RESISTORS ARE 2%, 1/4 WATT.
 3. ALL CAPACITANCE SPECIFIED IN MICROFARADS.
- SCHEMATIC DIAGRAM FOR E34
 SCHEMATIC DIAGRAM FOR E22 AND G22

Figure 7-8c
 SCE PCB ASSEMBLY
 Sheet 2 of 2
 302690-12 Rev A

JUMPER LIST

B4 to B6	B4 to B5	
OUT	IN	Ties 1MS RTC RET line to ground.
IN	OUT	Ties 1MS RTC RET line to +5V.
D18	D17	
OUT	IN	Enables Cover Open response by PCE circuit board compliant with VDE requirements
IN	OUT	Disables VDE cover open response.

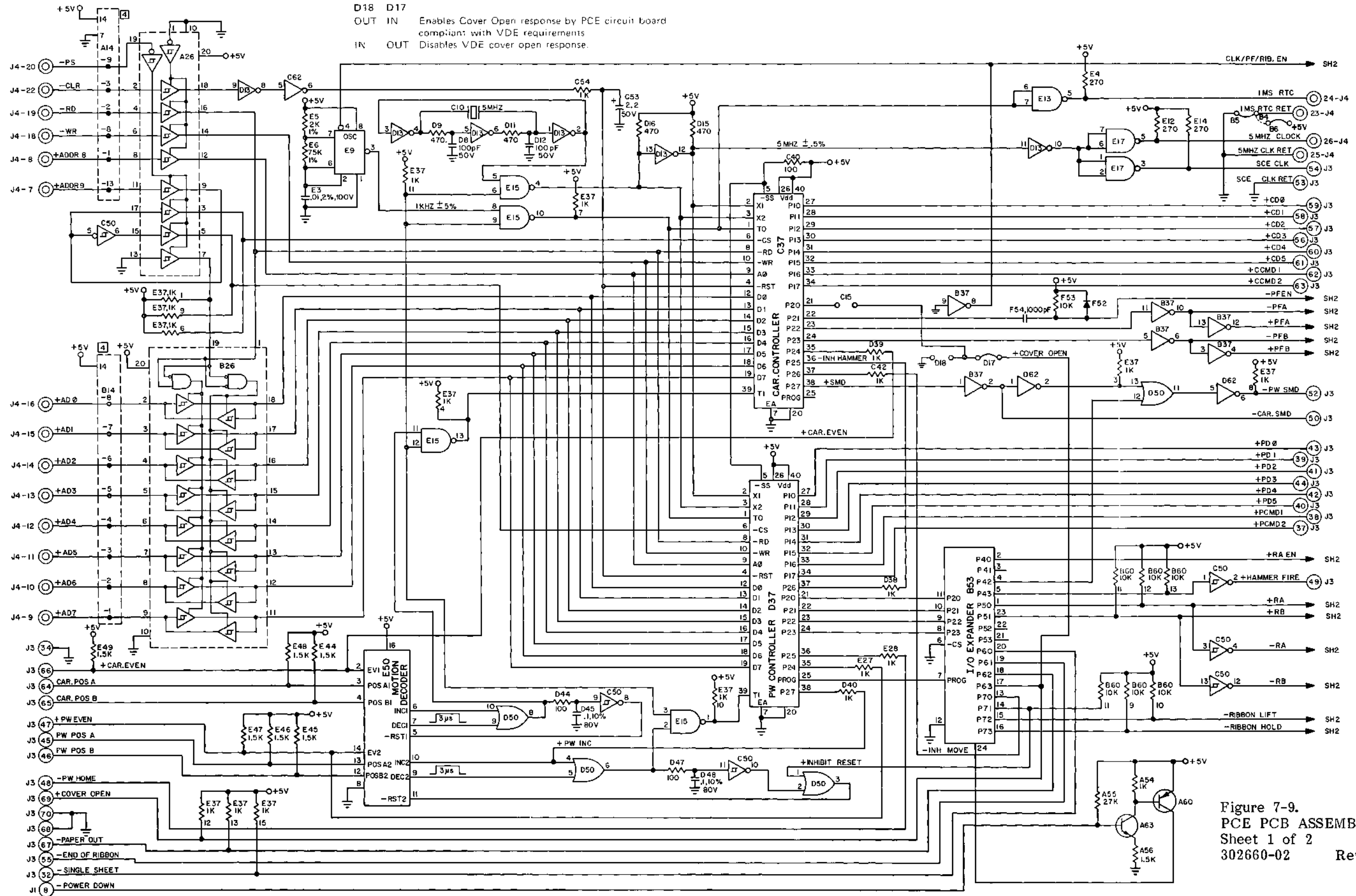

Figure 7-9.
PCE PCB ASSEMBLY
Sheet 1 of 2
302660-02 Rev L

For later revision levels of the PCE circuit board, see Figures 7-9a/7-10a and 7-9b/7-10b.

REVISION HISTORY

REV	ECO	ASSY	ETCH	ACTION
A	B1390			Releases Bill of Material (B/M)
B	B1747	-02	-02	B/M updated. PCB released for production. Schematic and assembly drawings added.
C	B1846	-02	-03	Releases -03 PCB etch. IC 7405 replaced by 7406. Added pullup resistors to outputs of 8243 IC (B53).
D	B1928	-02	-03	Following changes made to tighten tolerance of pulse width to paper feed motor driver: (Schematic sheet 2) Resistor F76 changed from 27K ohms to 330K ohms. Capacitor F66 changed from 0.1 mFd, 10%, 50V, to .01 mFd, 2%, 100V.
E	B1950	-02	-04	Releases -04 PCB etch.
F	B2007	-02	-04	Carriage Controller IC changed from 302995-01 to -02.
G	B2047	-02	-04	Following changes made to prevent spurious ribbon lift at power turn-off: Resistor C64 changed from 1K ohms to 470 ohms. Resistor D64 changed from 1K ohms to 300 ohms.
H	B2112	-02	-05	Releases -05 PCB etch.
J	B2323	-02	-06	Releases -06 PCB etch. Obsoletes -05 etch. (See Note 6 on Figure 7-10.) 1) Circuit controlling pin 21 input to CAR Controller (C37) modified to meet VDE requirement for Cover Open response. 2) Jumper positions B4, B5 and B6 added to allow selectable polarity for 1MS RTC RET signal.
K	B2411	-02	-06	Obsoletes -02 assembly. Releases -03 assembly/-06 etch (see Figures 7-9a/7-10a).
L	B2525	-02	-06	(-02 assembly obsoleted but still in production, thus requiring this change.) Transistor P/N 10105 replaced by P/N 13070 for more suitable thermal and moisture absorption properties.
M	B2609	-02	-06	-02 assembly discontinued; replaced by -XX assembly/-07 etch. (See Figures 7-9a/7-10a.)

74LS245 B26
75452 E17, E13
75472 J70, E70
8243 B53
555 E9, F70
Special IC's: C37, E50, D37 (Refer to the Model 630 Parts Catalog.)

Diodes:

1N4002 B61, D41, D53, E55, E56, E61, E63 E74, E75, E77, E78, E81, E82, G55, G56, G57, G58, G76, G78, G79, G84, G85
1N4454 E57, E60, E79, C70, F52, E83, G80, G59, G54, G83
1N5822 D76

Transistors:

2N3644 C63, G67, A60
2N4401 C66, E69, A63
2N5322 C74, G62, G72

Resistor Packs:

1K E37
10K (8-pin SIP) B60

SOLID STATE COMPONENTS USED

IC's:

2075	E62, E84, F62, F84
7401	E15
7404	B37, D13
7406	C62, C75, D62
74LS14	C50
74LS32	D50
74LS244	A26

(continued)

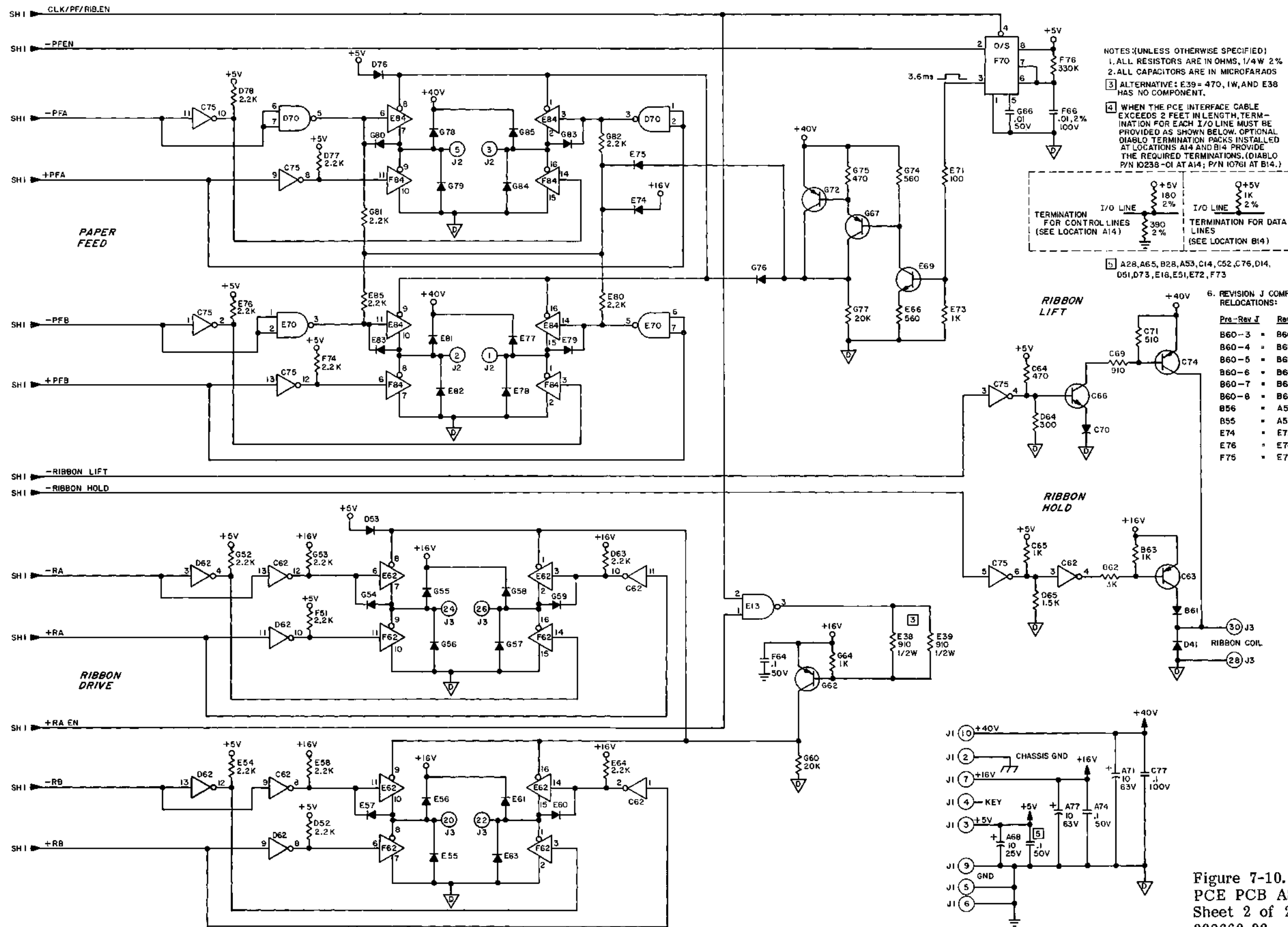

JUMPER LIST

- | | | |
|----------|----------|---|
| B4 to B6 | B4 to B5 | |
| OUT | IN | Ties 1MS RTC RET line to ground. |
| IN | OUT | Ties 1MS RTC RET line to +5V. |
| | | |
| D18 | D17 | |
| OUT | IN | Enables Cover Open response by PCE circuit board compliant with VDE requirements. |
| IN | OUT | Disables VDE cover open response. |

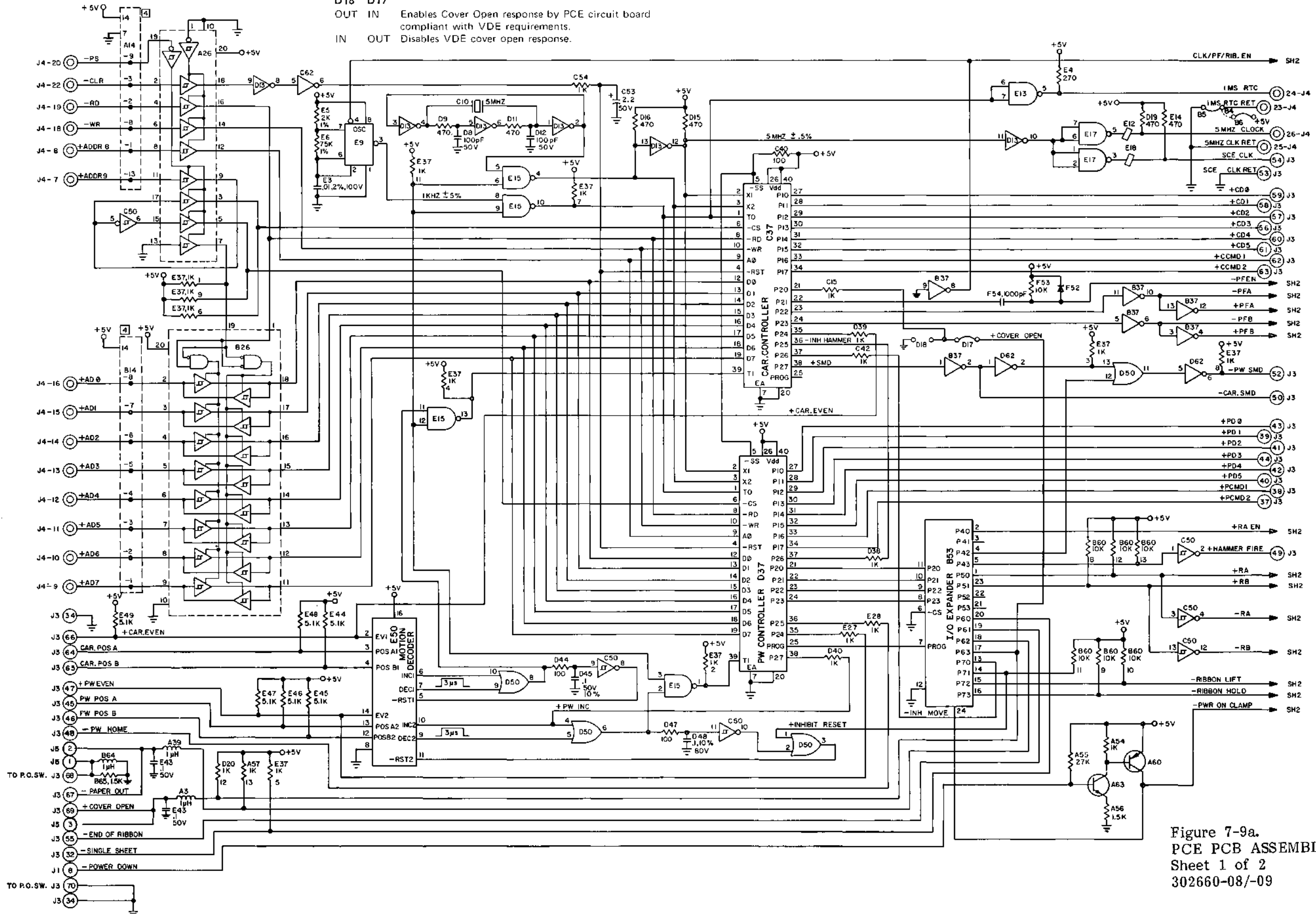

Figure 7-9a.
PCE PCB ASSEMBLY
Sheet 1 of 2
302660-08/-09 Rev C

For earlier revision levels of the PCE circuit board, see Figures 7-9/7-10; for later revision levels, see Figures 7-9b/7-10b.

REV	ECO	ASSY	ETCH	ACTION
A	B2411	-03	-06	Releases -03 assy/-06 etch equipped with revised firmware and circuit changes to achieve the following results: 1) Cover Open response compliant with VDE standards. 2) Slightly improved horizontal registration in some units. 3) Slight increase of print speed in some units.
B	B2427	-03	-06	Issues new firmware (302994-04 and 302995-04) to eliminate problem present in the -03 firmware which causes Check condition upon failure to detect the last count pulse within 128 msec.
C	B2525	-03	-06	Replaces transistor P/N 10105 with P/N 13070 to obtain better thermal and moisture absorption properties.
D	B2609	-03	-06	Discontinues -02 and -03 assemblies.
A	B2609	-XX	-07	Releases -XX assy/-07 etch, comprised of -04 assy (non-VDE/FCC) and -05 assy (VDE/FCC compliant).
B	B2769	-XX	-08	To prevent false energizing of the paper feed circuit at power-up, input pin 4 (Reset) of Timer F70 is changed to connect to the collector of A60 instead of connecting to the output of inverter B37-8. - Assemblies using -08 etch, which incorporates this change, are numbered -08 (non-VDE/FCC B) and -09 (VDE/FCC B). - -04/-05 assemblies reworked with this change are renumbered -08/-09 respectively. - -02 and -03 assemblies reworked with this change are renumbered -06 and -07 respectively.
C	B2845	-XX	-08	Component changes to improve manufacturability. No schematic change.

Diodes:

1N4002	B61, D41, D53, E55, E56, E61, E63, E74, E75, E77, E78, E81, E82, G55, G56, G57, G58, G78, G79, G84, G85
1N4454	C70, E57, E60, E79, E83, G54, G59, G80, G83
1N5822	D76, D78

Transistors:

TIP125	G67
2N3644	A60, C63, E68
2N4401	C66, E69, A63
2N5322	C74, G62

Resistor Packs:

1K	E37
10K (8-pin SIP)	B60

SOLID STATE COMPONENTS USED

IC's:

2075	E62, E84, F62, F84
7401	E15
7404	B37, D13
7406	C62, C75, D62
74LS14	C50
74LS32	D50
74LS244	A26
74LS245	B26
75452	E17, E13
75472	J70, E70
8243	B53
555	E9, F70
Special IC's:	C37, D37, E50 (Refer to the Model 630 Parts Catalog.)

(continued)

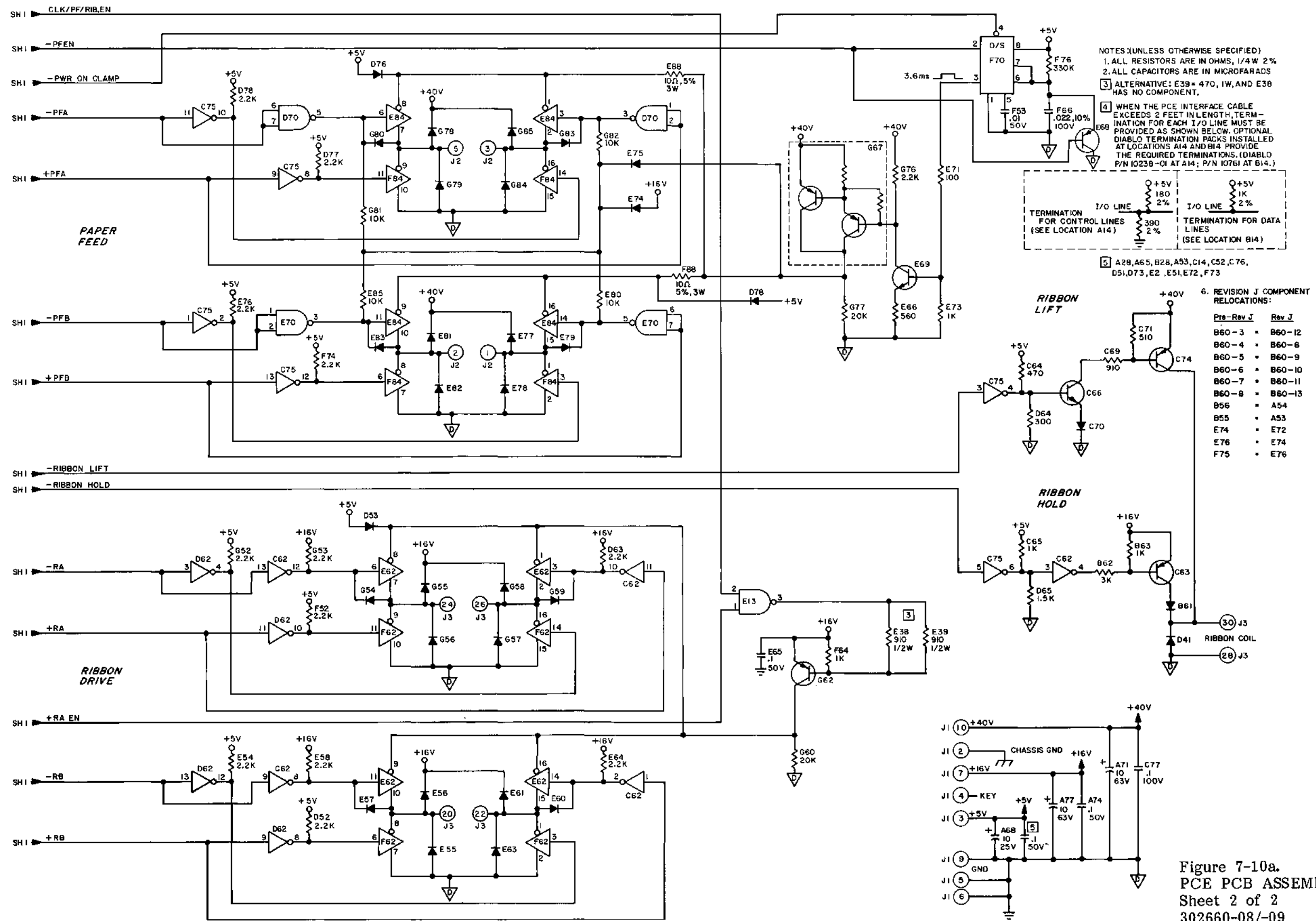

Figure 7-10a.
PCE PCB ASSEMBLY
Sheet 2 of 2
302660-08/-09 Rev C

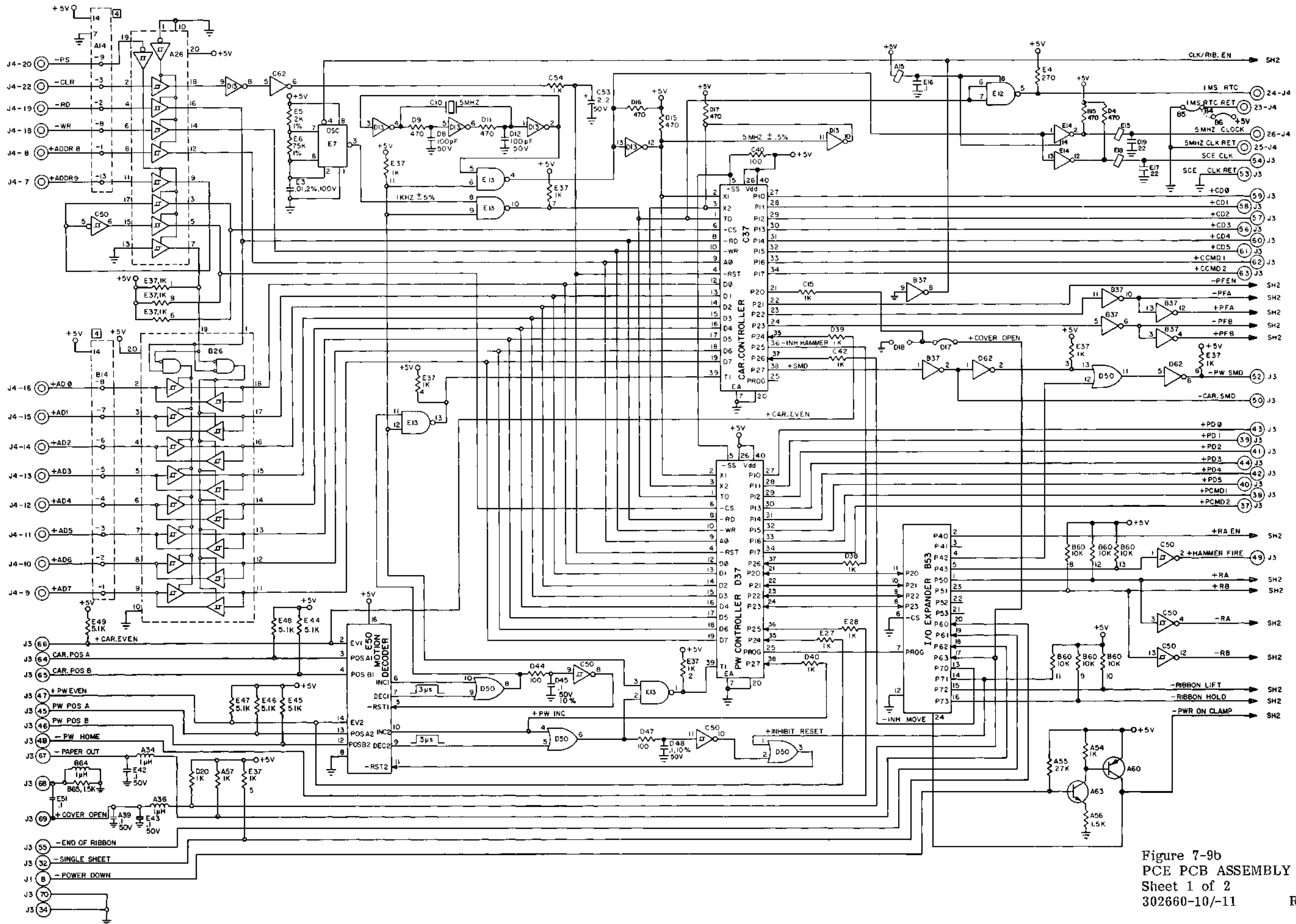

Figure 7-9b
PCE PCB ASSEMBLY
Sheet 1 of 2
302660-10/-11 Rev D

For earlier revision levels of the PCE circuit board, see Figures 7-9/7-10 and 7-9a/7-10a.

REV	ECO	ASSY	ETCH	ACTION
C	B2831	-XX	-09	Releases -10 -11 assy/-09 etch to assure FCC B compliance (-10 = non-VDE/FCC B; -11 = VDE/FCC B). Includes: 1) Protective blocking diodes C68 and E66 for collector circuits of G62 (Ribbon Advance) and C74 (Ribbon Lift). 2) Zener diode pullup (C71) to +16V for paper feed drivers.
D	B3053	-XX	-09	Change transistor type from TIP125 to TIP126 at location G67. Change to rivet mounting for transistor at G67.

SOLID STATE COMPONENTS USED

IC's:

2075	E62, E84, F62, F84
7401	E13
7404	B37, D13
7406	C62, C75, D62, E14
74LS14	C50
74LS32	D50
74LS244	A26
74LS245	B26
75452	E12
75472	D70, E70
8243	B53
555	E7, F70
Special IC's:	C37, D37, E50 (Refer to the Model 630 Parts Catalog.)

Diodes:

1N4002	B61, C68, D41, D53, E55, E56, E61, E63, E66 E74, E75, E77, E78, E81, E82, G55, G56, G57, G58, G78, G79, G84, G85
1N4454	C70, E57, E60, E79, E83, G80, G59, G54, G83
1N5819	D76, D78

Transistors:

TIP126	G67
2N3644	A60, C63, E68
2N4401	C67, E69, A63
2N5322	C74, G62

Resistor Packs:

1K	E37
10K (8-pin SIP)	B60

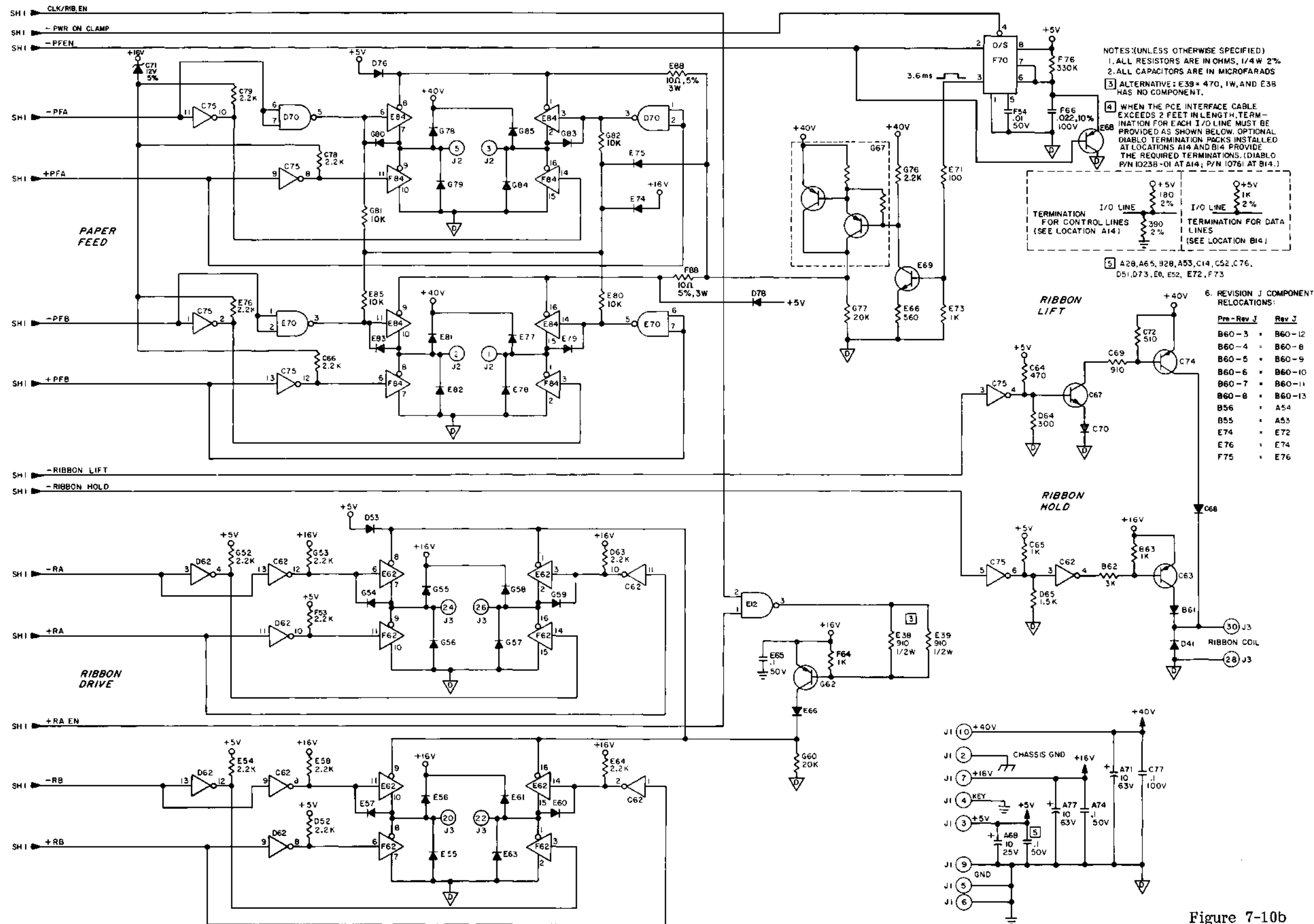
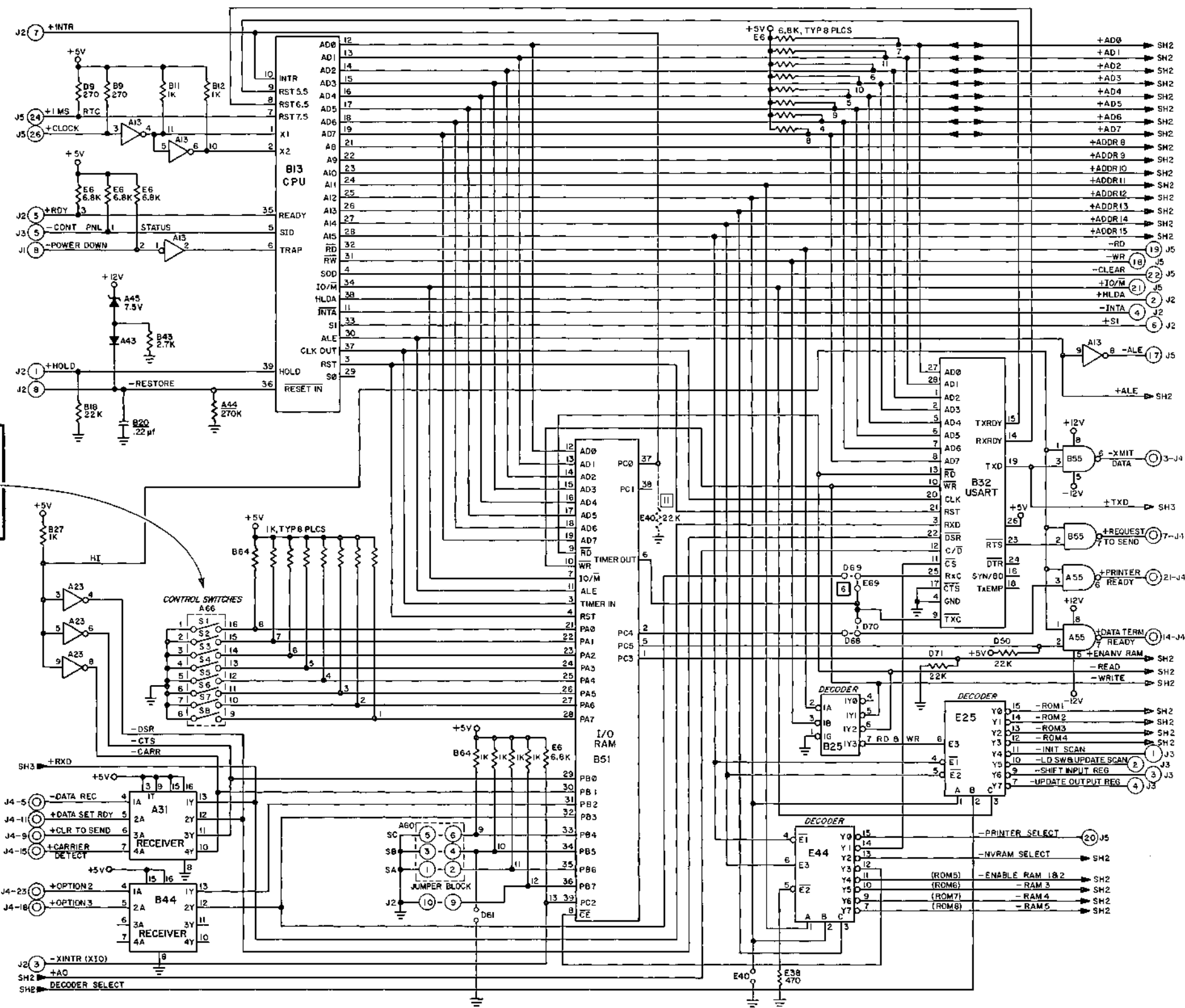

Figure 7-10b
PCE PCB ASSEMBLY
Sheet 2 of 2
302660-10/-11 Rev D



HPRO5 CONTROL SWITCH FUNCTIONS	
UNITS WITH CONTROL PANEL	UNITS WITHOUT CONTROL PANEL
S1 - ETX/ACK ENABLE	S1 - SELF TEST
S2 - DC/DCC (XON/XOFF) ENABLE	S2 - DC/DCC (XON/XOFF) ENABLE
S3, S4, S5 - OPTIONAL BAUD RATE SELECT*	S3 - TER. PITCH
S6, S7, S8 - LANGUAGE SELECT*	S4 - PARITY ENABLE
	S5 - EVEN PARITY
	S6 - FULL DUPLEX
	S7 - 120 SPEED BAUD SELECT†
	S8 - 30 SPEED BAUD SELECT†

*See HPRO5 Interface Manual for details.

- NOTES: Unless otherwise specified:**
- All resistors specified in ohms: 1/4 watt, 2%.
 - All capacitance specified in microfarads, 50V.
 - Location F42 is for 1K RAM. Locations F51, F61, F70, F80 are for RAMs or ROMs.
 - When 1K RAMs are used at F51 and F61, jumpers E21 and E86 must be in, and jumpers D29 and E77 must be out.
 - When 2K RAMs are used at F51 and F61, jumpers D29 and E77 must be in, and jumpers E21 and E86 must be out.
 - When 2K (E)ROMs are used at F4, F13, F23 and F32, jumpers A60-7/9 and A60-8/10 must be in, and jumpers E41 and E23 must be out.
 - When 4K ROMs are used at F4, F13, F23 and F32, jumpers A60-7/8 and A60-9/10 must be in, or jumpers E23 and E41 must be in.
 - For A60 jumper functions see Table 2-1 in Section 2.
 - For asynchronous operation, jumpers E69 and D68 must be installed; for synchronous operation, jumpers D69 and D70 must be installed.
 - For active half-duplex current loop or an active receiver current loop in full-duplex, jumper B37 must be installed or J4 pins 19 & 20 must be connected.
 - A61 = 750 ohms, 1 watt for 20 ma current loop.
 - A61 = 240 ohms, 1 watt for 60 ma current loop.
 - For an active transmitter current loop in full-duplex, jumper A52 must be installed, or J4 pins 8 & 10 must be connected.
 - A64 = 750 ohms, 1 watt for 20 ma current loop.
 - A64 = 240 ohms, 1 watt for 60 ma current loop.
 - For half-duplex current loop, jumper A51 must be installed, or J4 pins 10 & 16 must be connected.
 - A34, A53, B19, B36, B59, B81, D21, D30, D49, D60, E4, E30, E31, E39, D49, E61, E68, E76, F21, F50, F69
- Notes continued on page 2.

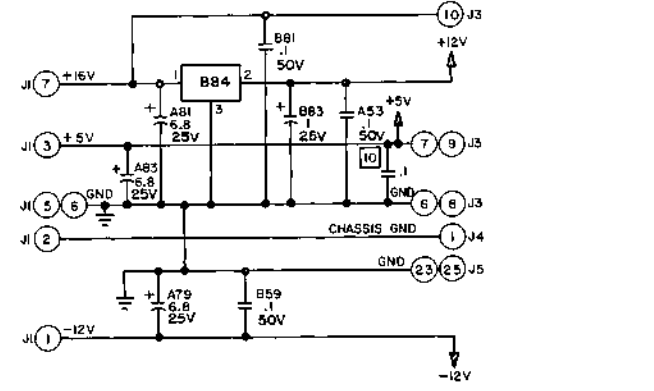

NOTE: See the back of this sheet for the -XX History Summary for this PCB.

Figure 7-11
 HPRO5 PCB ASSEMBLY
 Sheet 1 of 3
 302779-XX Rev T

REVISION HISTORY

(See -XX History Summary table to the right for the assembly dash number history.)

REV	ECO	ETCH	ACTION
A	B1390		Releases Bill of Material (B/M).
B	B1694	-03	B/M updated. Schematic and assembly drawing added.
C	B1939	-03	Firmware corrections. No schematic change. (See FSA #9.)
D	B2111	-04	Releases -04 PCB etch.
E	B2234	-05	Releases -05 PCB etch.
F	B2282	-05	B/M corrected to include capacitors A42, B28 and B81 on Basic Current Loop and Basic RS-232-C configurations of the HPRO5 PCB. Assys -01 and -03 without the caps. are replaced by assys -05 and -06 with the capacitors. Units without the caps. may experience intermittent Print Check conditions.
G	B2385	-05	Changes cap. at A42 from 0.1 to 0.22 mFd to delay drop of -RESTORE at power-down so CPU doesn't reset during parameter storage. (See FSA #11.)
H	B2407	-05	Releases new base firmware 302836-03, 302837-03; and new options firmware 302838-02, 302839-02. (See FSA #17.) The -03 base firmware includes provisions for VDE compliance.
J	B2564	-05	Battery circuit changed in Expanded HPRO5 to ensure normal battery shelf-life. (See FSA #23.)
K	B2647	-05	Revises circuit controlling -RESTORE signal to CPU to prevent power-up error condition. (See FSA #25.)
L	B2722	-05	Changes from 1K to 2K RAM devices. Changes ROM 4 firmware so bit 5 of ESC SUB 1 command in Remote Diagnostics represents "Printer Idle" instead of "Buffer Overflow".
M	B2775	-05	Releases new options firmware 302839-04 for Expanded HPRO5 to prevent problem wherein parameters are not saved in non-volatile RAM at power-down.
N	B2855	-05	Changes DIP switch to type that can be wave soldered.
P	B2911	-07	Etch -07 replaces etch -05. Releases revised HPRO5 assembly with new battery circuit, new restore line and some component changes for cost reduction and ease of manufacturing.
R	B2987	-07	B/M corrections; no schematic change.
S	B3033	-07	Jumper configuration change on special HPRO5. No effect on standard HPRO5 assemblies. No schematic change.
T	B3078	-07	Removes resistor from location E40 to compensate for board mis-layout at -07 etch (should be no component at location E40).

ASSY REVISION LETTER	=	B	E	F	G	H	J	K	L	M	N	P	R	S	T
NON	Basic RS232C	-01		05	05	05	05	18	18	18	18				
	Expnd RS232C	-02		02	02	02	13	19	x						
VDE	Basic Cur. Loop	-03		06	06	06	06	x							
	Expnd Cur. Loop	-04		04	04	04	16	20	20	x					
	Basic RS232C	-	-	-	-	07	07	21	21	21	21	31	31	31	31
	Expnd RS232C	-	-	-	-	08	14	22	22	26	26	32	32	32	32
VDE	Basic Cur. Loop	-	-	-	-	09	09	23	23	23	23	33	33	33	33
	Expnd Cur. Loop	-	-	-	-	10	15	24	24	24	24	34	34	34	34
	WP* RS232C	-	-	-	-	11	11	25	25	25	25	35	35	35	35

* - The "WP" (Word Processor) version is the same as Expanded RS232C except that it is not equipped with the nonvolatile RAM and battery for parameter storage and "Here Is . . ." .

x = "dropped"

SOLID STATE COMPONENTS USED

IC's:

8085A	B13
8155	B51
8251A	B32
MK4118 P3	F51, F61
5101L-1	E70
7406	A23
74LS14	A13
74LS138	E25, E44
74LS139	B25
74LS373	E64
75150P	A55, B55
75154	A31
78M12	B84
TIL117	A39, B39, B47

Masked ROM's: (Refer to Model 630 Parts Catalog)

ROM 1	F4
ROM 2	F13
ROM 3	F23
ROM 4	F32

Diodes:

1N4454	A43, D73, D75
1N5231B, 5.1V	E77
1N5236B, 7.5V	A45

Transistors:

2N2219A	A47
---------	-----

Resistor Packs:

1K, 14-pin	B64
6.8K, 14-pin	E6

(notes continued from page 1)

11 - Board layout changes at Rev P of this assembly result in the following component deletions, additions and location differences (schematic sheet 1):

Deleted: Resistor E40
Capacitors B28, F11, F30, F40, F59, F78 (see Note 10).

Added: Resistor E38
Capacitors A34, A53, B59, B81, E4, E31, E39, E61, E76, (see Note 10).

Jumper position D61

Location Differences:

	Pre Rev P	Rev P & Later
Sheet 1; -	A41 = A43, Diode	A42 = B43, Resistor
	A43 = A45, Zener Diode	A44 = D20, Resistor
	D11 = D9, Resistor	B73 = B84, Regulator
Sheet 3; -	B29 = B28, Resistor	B41 = A42, Resistor
	B43 = B40, Resistor	B50 = B52, Resistor
	B52 = B53, Resistor	

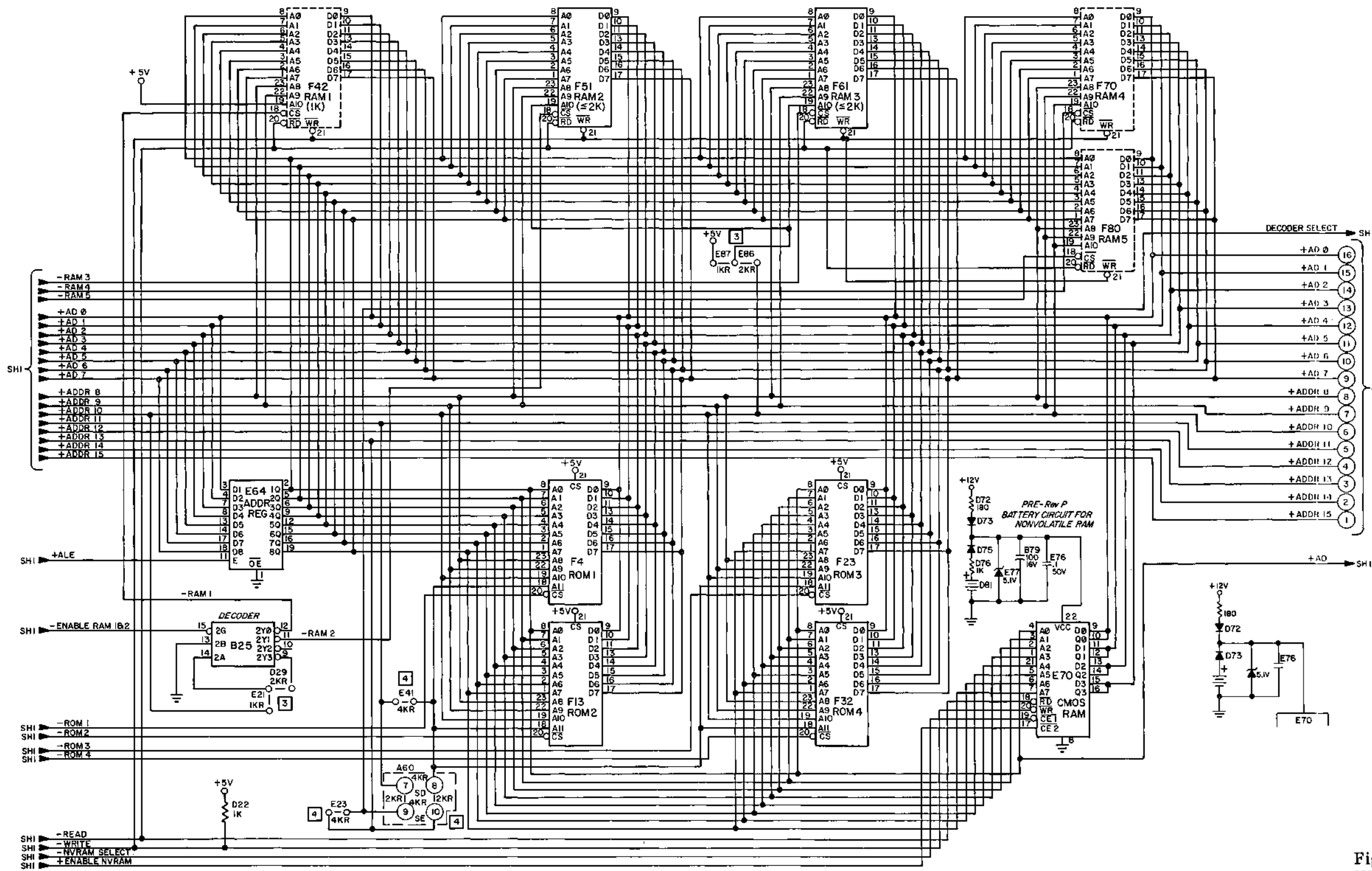

Figure 7-12
HPRO5 PCB ASSEMBLY
Sheet 2 of 3
302779-XX Rev T

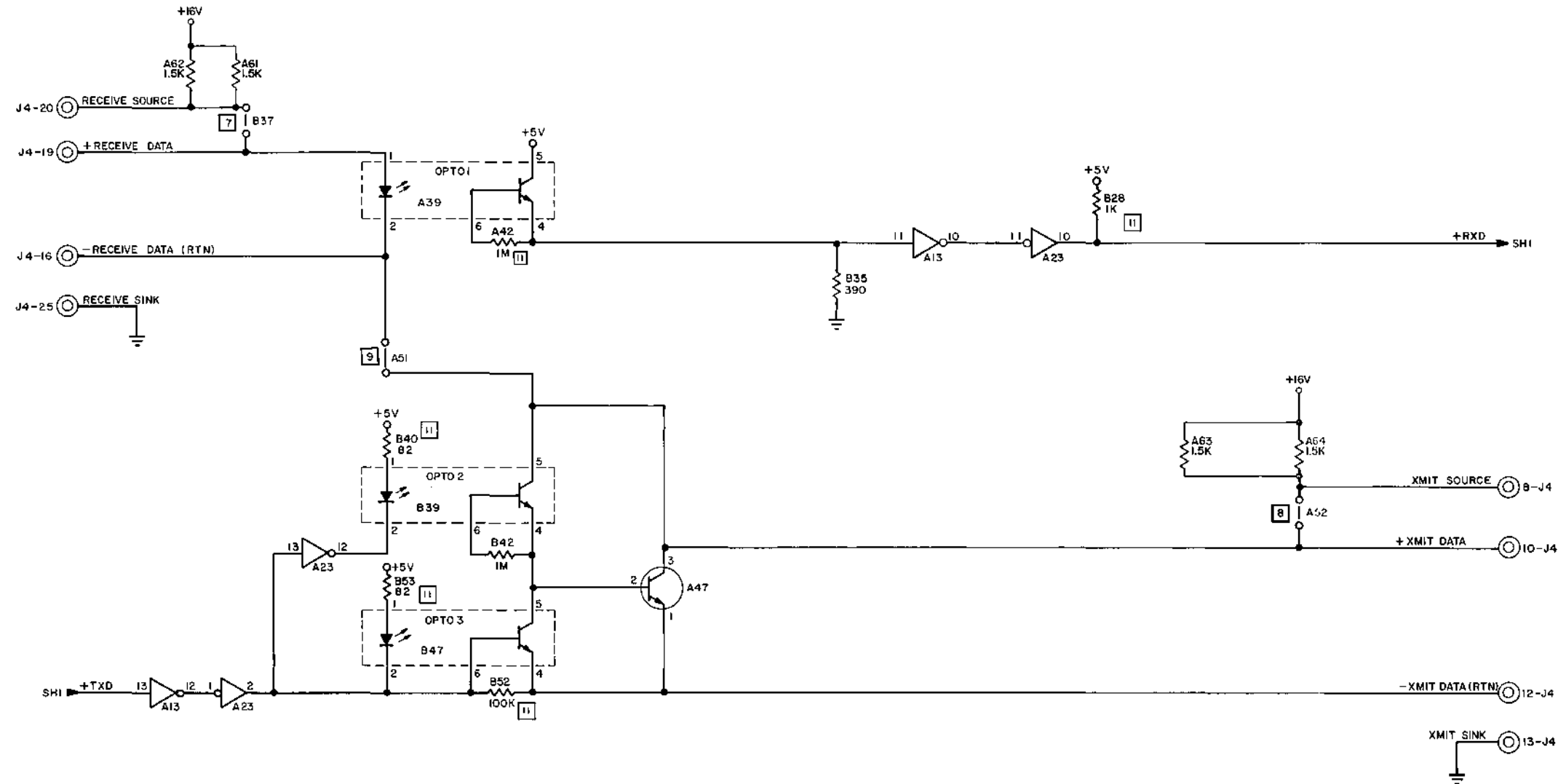
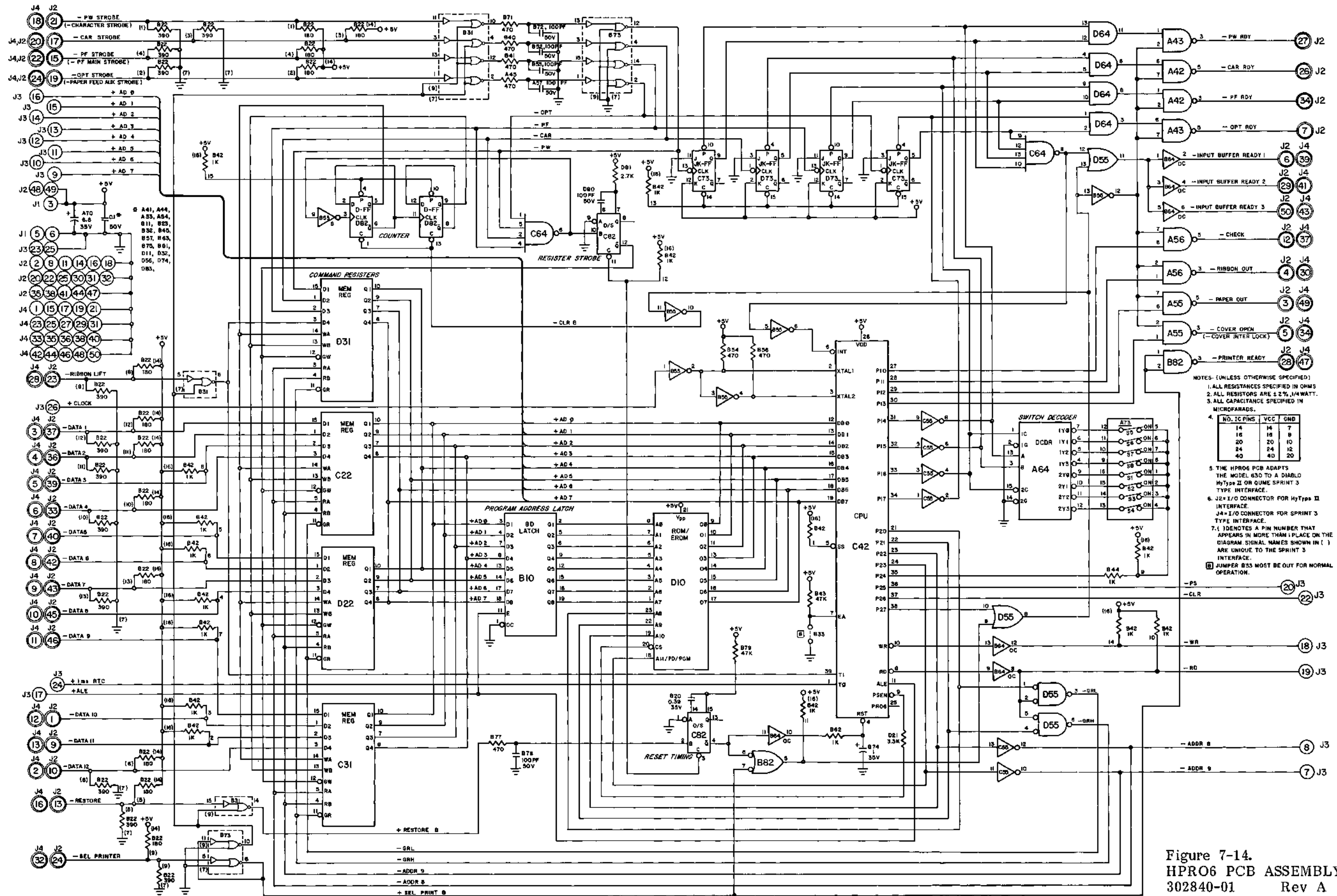

Figure 7-13
 HPRO5 PCB ASSEMBLY
 Sheet 3 of 3
 302779-XX Rev T



NOTES: (UNLESS OTHERWISE SPECIFIED)
 1. ALL RESISTANCES SPECIFIED IN OHMS
 2. ALL RESISTORS ARE $\pm 2\%$, 1/4 WATT
 3. ALL CAPACITANCE SPECIFIED IN MICROFARADS
 4.

NO. IC PINS	VCC	GND
14	14	7
16	16	8
20	20	10
24	24	12
40	40	20

5. THE HPRO6 PCB ADAPTS THE MODEL 830 TO A DIABLO HyType II OR QUME SPRINT 3 TYPE INTERFACE.
 6. J2= I/O CONNECTOR FOR HyType II INTERFACE.
 J4= I/O CONNECTOR FOR SPRINT 3 TYPE INTERFACE.
 7. () DENOTES A PIN NUMBER THAT APPEARS IN MORE THAN 1 PLACE ON THE DIAGRAM. SIGNAL NAMES SHOWN IN () ARE UNIQUE TO THE SPRINT 3 INTERFACE.
 (J) JUMPER B33 MUST BE OUT FOR NORMAL OPERATION.

Figure 7-14.
 HPRO6 PCB ASSEMBLY
 302840-01 Rev A

HPRO6 PCB ASSEMBLY
302840-01 Rev A

REVISION HISTORY

<u>REV</u>	<u>ECO</u>	<u>ASSY</u>	<u>ETCH</u>	<u>ACTION</u>
A	B2220	-01	-01	Releases HPRO6 circuit board assembly for production.

SOLID STATE COMPONENTS USED

IC's:

7404	B55
74LS04	C55
7407	B64
74LS08	D64
74LS20	C64
74LS32	D55
74LS74	D82
74LS112	C73, D73
74LS156	A64
74LS221	C82
74LS373	B10
74LS670	C22, C31, D22, D31
75452	A42, A43, A55, A56, B82
8035	C42
8837	B31, B73
ROM, 2K x 8 Bit	D10

Resistor Packs:

1K	B42
180/390 ohm	B22

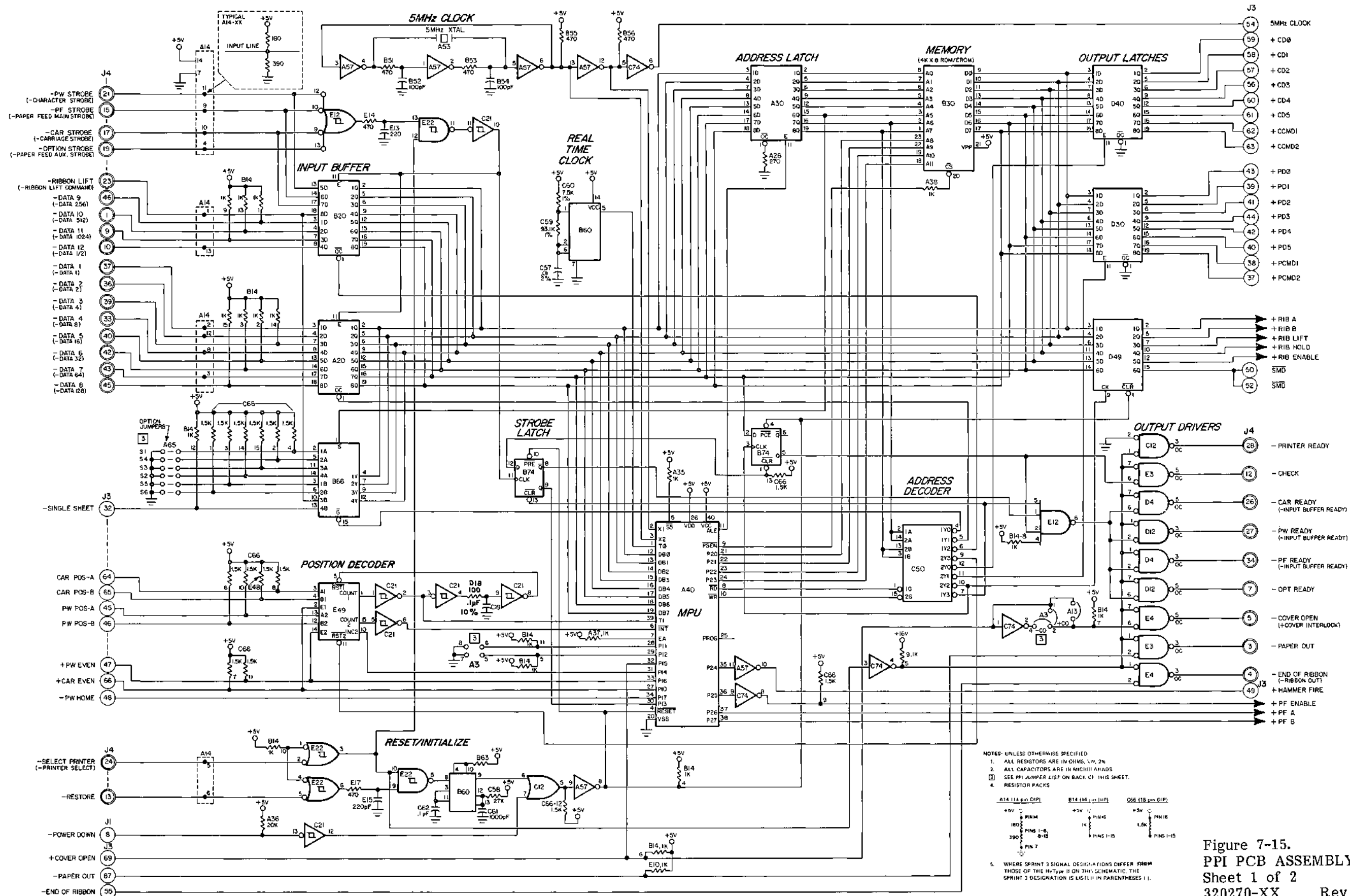

Figure 7-15.
PPI PCB ASSEMBLY
Sheet 1 of 2
320270-XX Rev L

For later revision levels of the PPI PCB assembly, see Figures 7-15a, 7-16a, and 7-17a.

REVISION HISTORY

REV	ECO	ASSY	ETCH	ACTION
A	B2294		-01	Releases Bill-of-Material (B/M) to production.
B	B2397	-01	-01	Releases schematic and assembly drawings.
C	B2400	-01	-01	Releases masked ROM to replace EROM for PPI control program.
D	B2436	-01	-02	Releases -02 etch; obsoletes -01 etch. Adds 270-ohm resistor at A26 for production test. Cap. at A70 changed from 0.1 to 6.8 mFd. Cap. at A68 changed from 6.8 to 0.1 mFd.
E	B2525	-01	-02	Transistors of Diablo P/N 10105 replaced by P/N 13070 for better thermal and moisture absorption properties.
F	B2583	-01/-02/ -03	-02	Releases -02 and -03 assemblies. Releases new firmware. On -01 assembly, resistor C59 changes to 97.6K to reduce audible noise from paper feed circuit.
G	B2619	-03	-02	Obsoletes -01 and -02 assemblies. Releases upgraded firmware (ROM P/N 100510-04 replaces 100510-01). No schematic change.
H	B2666	-04	-02	Releases -04 assembly; obsoletes -03 assembly. Adds wired-in 9.1K resistor to +16V from PF ENABLE line, replacing 1.5K resistor C66. See FSA #45 for recommended field correction procedure.
J	B2747	-04/-05	-02	Releases -05 version. (With -04, -COVER OPEN signal = LO when cover is opened; with -05, the polarity is reversed.)
K	B2845	-04/-05	-02	Component changes to improve manufacturability. No schematic change.
L	B2875	-06/-07	-02	Obsoletes -04/-05 assemblies. Releases -06/-07 assemblies with upgraded firmware 100506-06 (EROM) or 100510-05 (MROM). New firmware changes P/W tables as noted in PPI jumper list on this sheet. (See FSA #35B for change details.)

SOLID STATE COMPONENTS USED

IC's:

7404	A57	74LS257	B66
7406	C74, E55, E80	74LS373	A30
74LS13	E12	74LS374	A20, B20, D30, D40
74LS14	C21	75453B	C12, D4, D12, E3, E4
74LS74	B74	75472	E62, E74
74LS132	E22	2075 (Darlington)	D55, D80, F55, F80
74LS139	C50		
74LS174	D49	8039	A40
		556	B60

Masked ROM B30 (Refer to the Model 630 Parts Catalog)

Note: The IC at location E49 is custom I²L. Refer to the Model 630 Parts Catalog for the part number of this IC.

Diodes:

1N4002	D60, D62, D63, D65, D74, D76, D77, D79, E68, E69, F70, F71, G60, G62, G63, G65, G71, G74, G76, G77, G79, G82
1N4454	D61, D64, D75, D78, G61, G64, G75, G78, G83
1N5822	E66

Transistors:

2N3644	E76, F65
2N4401	E63, F73
2N5322	E73, F66, F74

Resistor Packs:

180/390, 14-pin	A14
1K, 16-pin	B14
1.5K, 16-pin	C66

PPI JUMPER LIST

Jumper Block A65

Note: This table (jumpers S1-S4) is for units with firmware at PPI board location B30 at or above level 100506-06 (EROM) or 100510-05 (MROM). (See Rev L in Revision History) For print wheel select table for earlier firmware, see the PPI Interface Manual.

A65	S1	S2	S3	S4	Print Wheel Selection
0 0 0 0	0	0	0	0	Plastic Pica 10 (See Note 3 below)
0 0 0 1	0	0	0	1	Plastic APL
0 0 1 0	0	0	1	0	Plastic KANA
0 0 1 1	0	0	1	1	Plastic German (Pica 10A only)
0 1 0 0	0	1	0	0	Plastic 96 WP Sort
0 1 0 1	0	1	0	1	Plastic French
0 1 1 0	0	1	1	0	Plastic NORSK
0 1 1 1	0	1	1	1	Plastic Scandia
1 0 0 0	1	0	0	0	Xerox Metal 96*
1 0 0 1	1	0	0	1	Metal APL
1 0 1 0	1	0	1	0	Diablo Metal 96 HyType II Sort
1 0 1 1	1	0	1	1	Metal German 96
1 1 0 0	1	1	0	0	Rank Xerox Metal 92 (U.K.) HyType II Sort**
1 1 0 1	1	1	0	1	Metal French 96
1 1 1 0	1	1	1	0	Diablo Metal 96
1 1 1 1	1	1	1	1	Diablo Metal 96 WP Sort

*Supports 88- and 92-character wheels, but to prevent printing on print wheel flag, missing spoke position should not be addressed. Do not use this selection during Self-Test.

**Supports 88-character wheels, but do not address missing spokes. Do not use this selection during Self-Test.

S5	S6	Function
0	0	Normal Operation
0	1	Option 1
1	0	Option 2
1	1	Option 3

Notes: 1) "1" = Jumper In
"0" = Jumper Out
2) S1 = 0 = Plastic Wheel
S1 = 1 = Metal Wheel
3) Jumper configuration 0000 is recommended for all plastic wheels except those listed separately above.
4) Jumper configuration 1000 is recommended for all 88-character metal wheels.

Jumper Block A3

Function
1-2 Sprint 3 Interface (Cover Open Signal +)
2-4 HyType II Interface (Cover Open Signal -)
5-7 Self-Test
6-8 VDE Feature (Affects response to cover open condition - See PPI Interface Manual)

Note: All other A3 jumper positions are unused.

Jumper A13

Soldered jumper A13 and pluggable jumper A3-1/2 perform the same function. Only one is required.

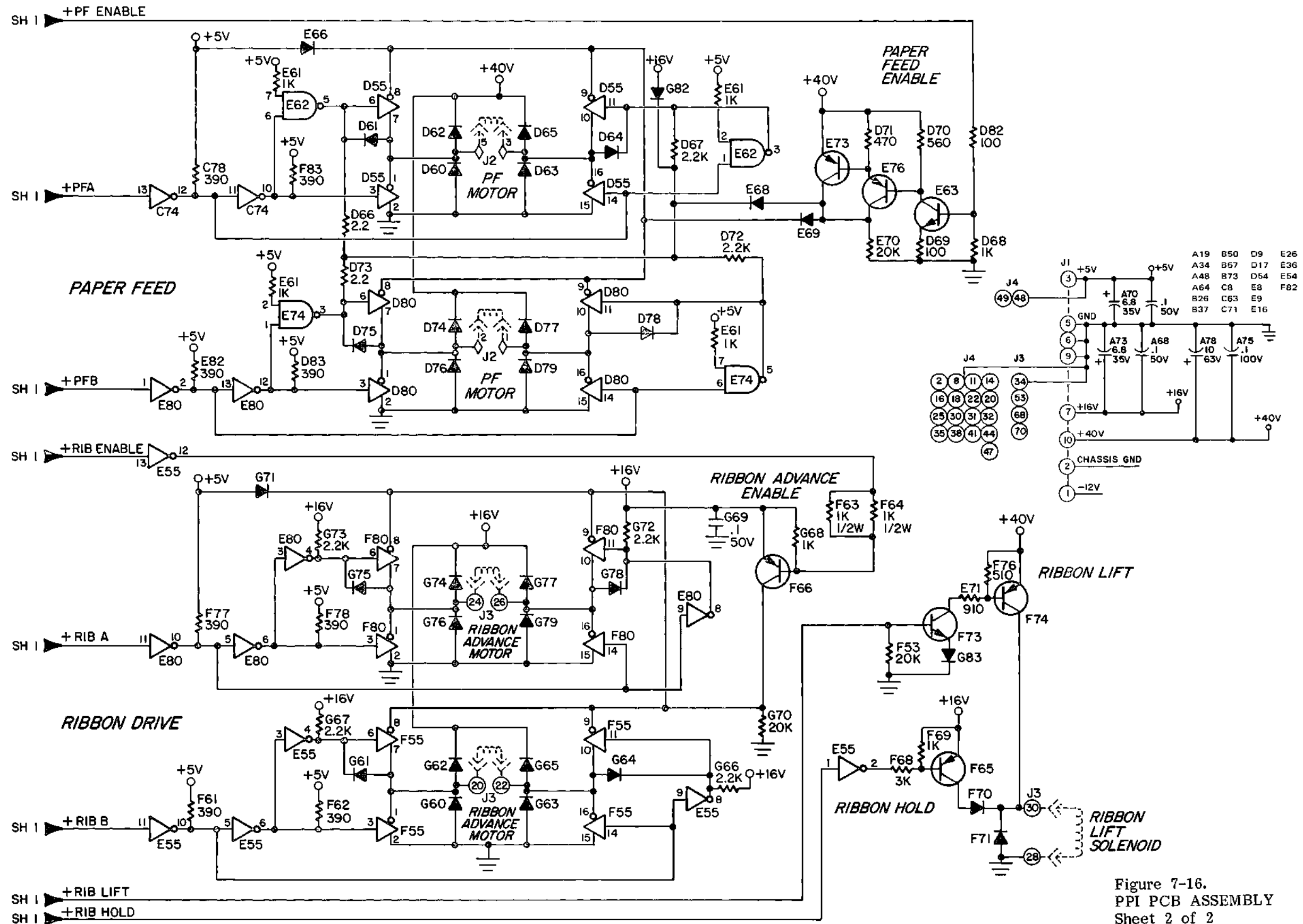

Figure 7-16.
 PPI PCB ASSEMBLY
 Sheet 2 of 2
 320270-XX Rev L

NOTES: UNLESS OTHERWISE SPECIFIED

1. ALL RESISTANCES SPECIFIED IN OHMS.
2. ALL RESISTORS ARE $\pm 2\%$, 1/4 WATT.
3. ALL CAPACITANCE SPECIFIED IN MICROFARADS.

NO.	I.C. PINS	VCC	GND
8	6	8	4
14	14	14	7
16	16	16	8
20	20	20	10
40	40	40	20

FOR +5V DRIVE ON \pm COVER OPEN, INSTALL A 1K, 1/4 WATT RESISTOR AT C8.

SEE PPI JUMPER LIST ON BACK OF THIS SHEET.

7. RESISTOR PACKS

A12 (14 PIN DIP)

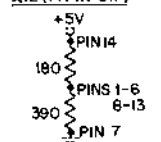

B12, B20 (14 PIN DIP)

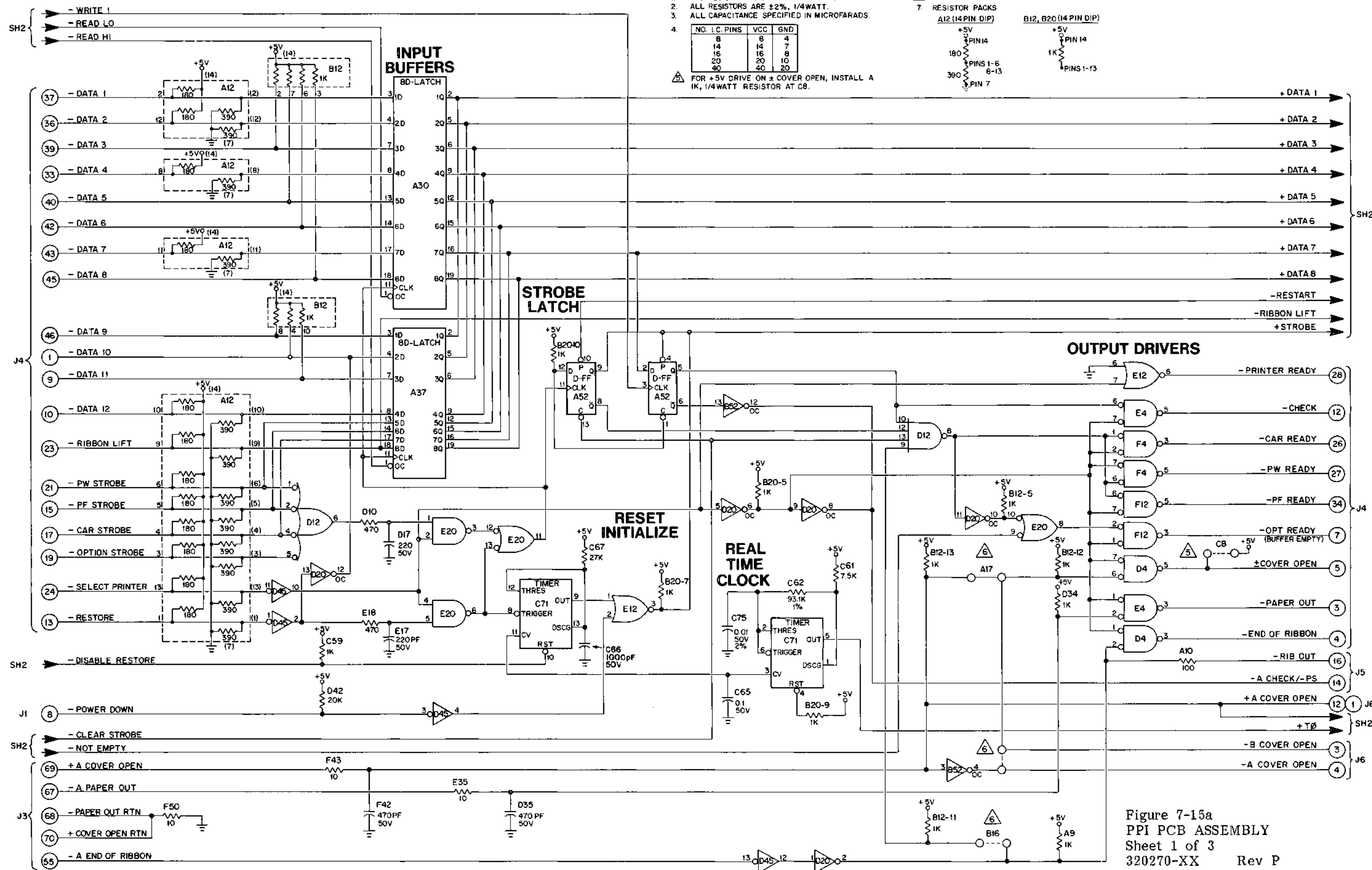
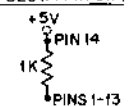

Figure 7-15a
PPI PCB ASSEMBLY
Sheet 1 of 3
320270-XX Rev P

For earlier revision levels of the PPI PCB assembly, see Figures 7-15 and 7-16.

REVISION HISTORY

REV	ECO	ASSY	ETCH	ACTION
M	B2941	-08/-09	-03	Releases -08/-09 assemblies and -03 etch. Discontinues -06/-07 assemblies and -02 etch. Changes are: - New paper feed circuit for increased torque - Control panel capability - Buffered Restore - ECS capability - BUFFER EMPTY signal - Platen backlash takeup
N	B3053	-08/-09	-03	Changes transistor type TIP125 to TIP126 at location F54, and changes from screw mount to rivet mount for this transistor.
P	B3315	-13/-14	-03	Releases -13/-14 assemblies with combined standard/ECS firmware set (EPROM P/N 100604-05). NOTE: This and higher levels of firmware should be used only on PPI boards with high torque paper feed circuitry. (A TIP transistor at location F54 identifies a <u>high torque board.</u>)

SOLID STATE COMPONENTS USED

IC's:

7404	B70
7406	D20, B52, E55, E80
74LS13	D12
74LS14	D45
74LS74	A52
74LS132	E20
74LS139	A45
74LS257	A20
74LS273	B28
74LS373	B45
74LS374	E28, E37, A30, A37
75453B	D4, E4, F4, F12
75454	E12
75472	E60, E76, F60
2075B (Darlington)	D55, D80, F55, F80
8039	A60
556	C71
Masked ROM	B30 (Refer to the Model 630 Parts Catalog)
Custom I ² L	E45 (Refer to the Model 630 Parts Catalog)

Diodes:

1N4002	C70, D60, D62, D63, D65, D71, D74, D77, D79, E63, E69, E70, G60, G62, G63, G65, G71, G74, G76, G77, G79
1N4454	D61, D64, D75, D78, G61, G64, G75, G78
1N4607	E81
1N5231, 5.1V	D68
VSK140	F69, F70

Transistors:

2N3644	F77
2N5322	E77, F76
TIP126	F54
MPS-A06	E78

Resistor Packs:

180/390, 14-pin	A14
1K, 14-pin	B12, B20

PPI JUMPER LIST

JUMPER BLOCK J5

JUMPER

1-2	3-4	5-6	7-8
0	0	0	0
0	0	0	1
0	0	1	0
0	0	1	1
0	1	0	0
0	1	0	1
0	1	1	0
0	1	1	1
1	0	0	0
1	0	0	1
1	0	1	0
1	0	1	1
1	1	0	0
1	1	0	1
1	1	1	0
1	1	1	1

Print Wheel Selection

Plastic Pica 10
Plastic APL
Plastic KANA GOTHIC
Plastic GERMAN Pica 10A
Plastic 96 WP Sort
Plastic FRENCH Pica 10
Plastic NORSEK Pica 10
Plastic SCANDIA
Metal 96 XEROX
Metal 96 APL
Metal 96 DIABLO HyType II Sort
Metal 96 GERMAN Pica 10
Metal 92 RANK XEROX (UK) HyType II Sort
Metal 96 FRENCH Pica 10
Metal 96 DIABLO
Metal 96 DIABLO WP Sort

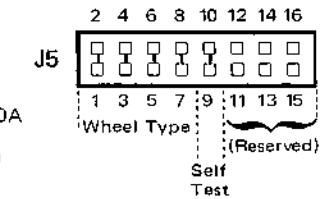

Note:

1 = Jumper In
0 = Jumper Out

9-10 IN: Self-Test

This jumper is read only during power-up or following a Restore sequence.

11-16 : (Reserved)

JUMPER BLOCK J6

2	4	6	8	1-3	3-4
□	□	□	□	□	□
1	3	5	7	5-6/	7-8

Function

Sprint 3 Interface (Cover Open Signal +)
HyType II Interface (Cover Open Signal -)
(Note that jumper at A17 must be removed)
"HyType II Options" (see Table below)

5-6	7-8	Function
0	0	Normal Operation
0	1	Option 1
1	0	Option 2
1	1	Option 3

"1" = Jumper In
"2" = Jumper Out

Note: See PPI Interface Manual for definition of HyType II Option

JUMPER A17

Soldered jumper A17 and pluggable jumper J6 - 1/2 perform the same function; only one is required.

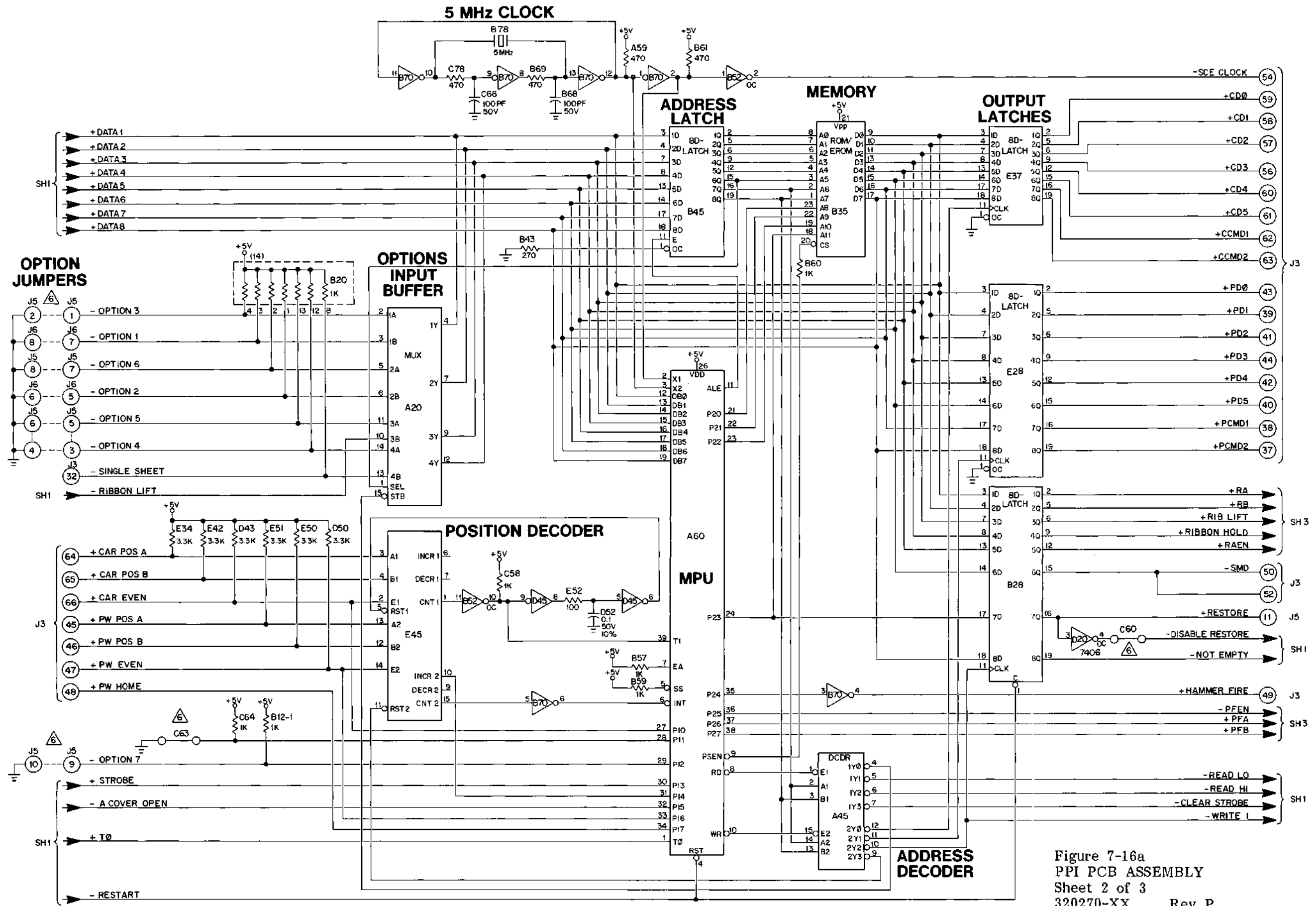

Figure 7-16a
PPI PCB ASSEMBLY
Sheet 2 of 3
320270-XX Rev P

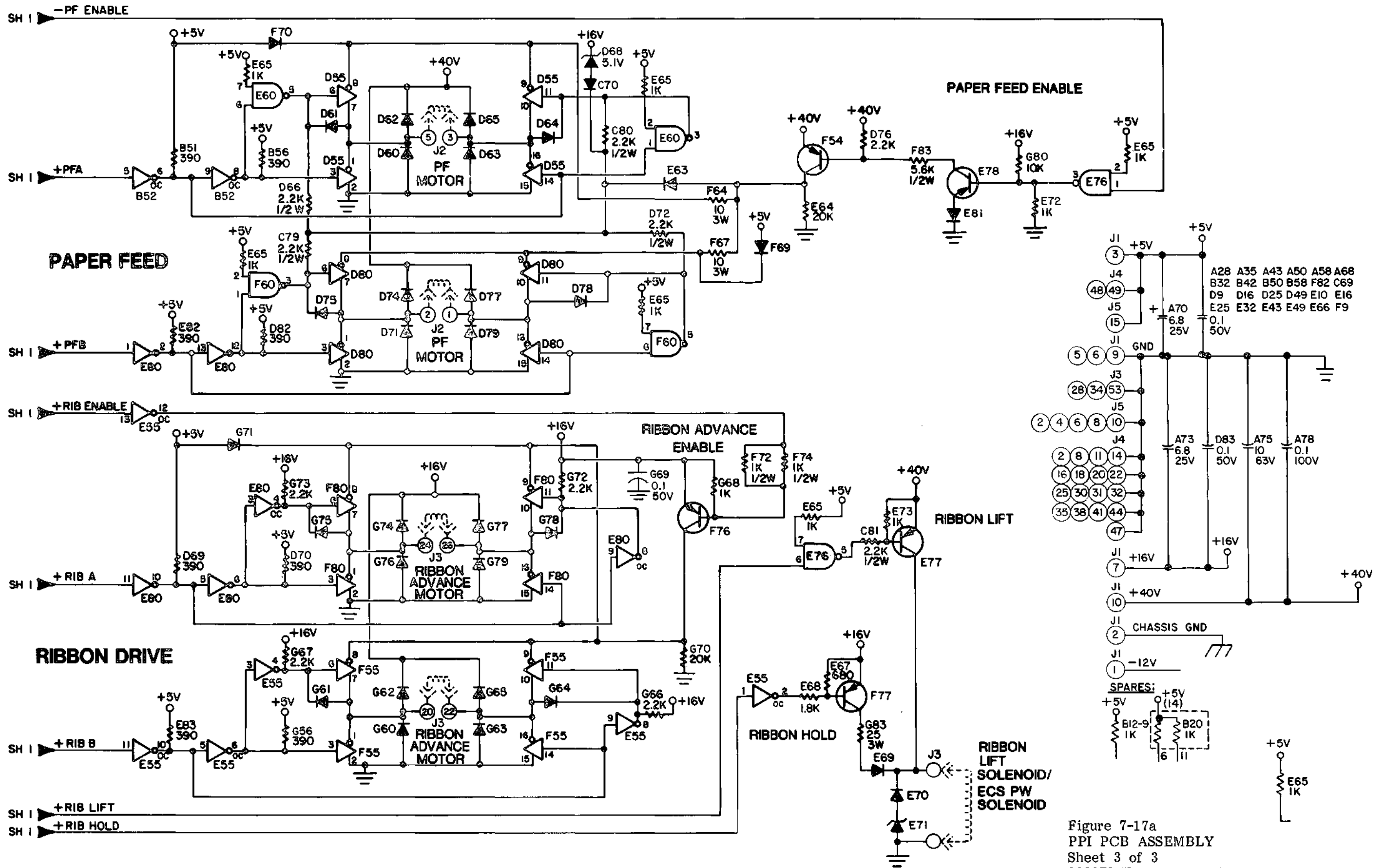
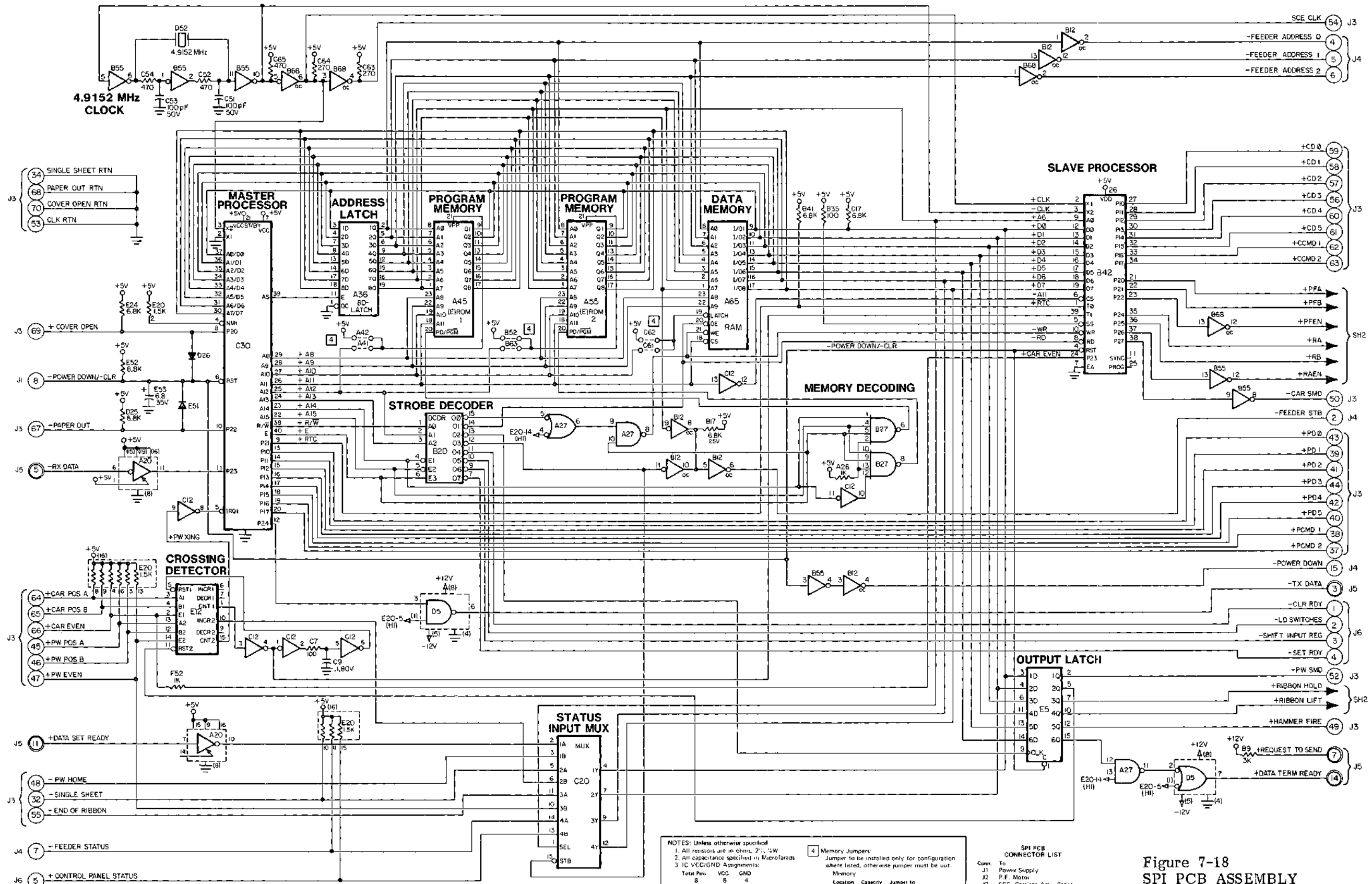

Figure 7-17a
PPI PCB ASSEMBLY
Sheet 3 of 3
320270-XX Rev P



NOTES: Unless otherwise specified

- All resistors are in ohms, 2% 1/8W
- All capacitance specified in Microfarads
- IC VCC/GND Assignments:

Total Pins	VCC	GND
8	8	4
14	14	7
16	16	8
20	20	10
24	24	12
40	40	20

Location	Capacity	Jumper to
A65	1K	C62
A66	2K	C61
A45	4K	A42
A46	8K	A41
A53	4K	B52
A55	8K	9B3

4 Memory Jumpers: Jumper to be installed only for configuration where listed, otherwise jumper must be out.

SPI PCB CONNECTOR LIST

Conn.	To
J1	Power Supply
J2	P.F. Motor
J3	SCE, Carriage Assy, Paper Out Switch, Cover Open Switch (Unused)
J4	I/O
J5	Control Panel

Figure 7-18
 SPI PCB ASSEMBLY
 Sheet 1 of 2
 320293-XX Rev K

SPI PCB ASSEMBLY
320293-XX Rev K

For later revision levels of the SPI circuit board, see Figures 7-18a and 7-19a.

REVISION HISTORY

REV	ECO	ASSY	ETCH	ACTION
A	B2324	-01		Releases Bill-of-Material (B/M) to production.
B	B2437	-01	-02	Releases firmware and -02 etch.
C	B2525	-01	-02	Transistor part number 10105 replaced by 13070 for better thermal and moisture absorption properties.
D	B2628	-01	-02	Releases upgraded SPI control program firmware.
E	B2648	-03	-02	Releases -03 assembly; obsoletes -01 assembly. Adds 7.5V zener diode between resistor C73 and +12V supply as part of pullup for PFEN line.
F	B2667	-03	-02	Modifies PFEN line pullup to delete 7.5V zener diode, change resistor C73 from 1K to 9.1K, and tie top end of C73 to +16V.
G	B2701	-03	-02	Hardware changes. No schematic change.
H	B2724	-05	-02	New firmware. No schematic change.
J	B2845	-05	-02	Component changes to improve manufacturability. No schematic change.
K	B2860		-02	Special firmware change. No schematic change.
	B2914			Discontinues -05 assy, -02 etch; replaced by -07 assy, -04 etch.
	B3012	-13	-02	Reworks -05 assy to -13 by adding capacitor to ground from base of transistor E63. This improves reliability of paper feed driver. See FSA #41A.

SOLID STATE COMPONENTS USED

IC's:

74LS00	A27
7404	B55
7406	B68, E55, E80
74LS14	C12
74LS20	B27
74LS138	B20
74LS174	E5
74LS257	C20
74LS373	A36
75150P	D5
75154	A20
75452	E62, E74
2075 (Darlington)	D55, D80, F55, F80
6803-1	C30
8041A	B42
ROM (8K byte)	A45
RAM (2K byte)	A65

Note: The IC at location E49 is custom I²L. Refer to the Model 630 Parts Catalog for part number.

(continued)

Diodes:

1N4002	D60, D62, D63, D65, D74, D76, D77, D79, G60, G62, G63, G65, G74, G76, G77, G79, G71, F70, F71, E68, E69, G82, E51, D26
1N4454	D61, D64, D75, D78, G61, G64, G75, G78, E83
1N5822	E66
1N4742, 12V	D4

Transistors:

2N3644	E76, F65
2N4401	E63, F73
2N5322	E73, F66, F74

Resistor Pack:

1.5K	E20
------	-----

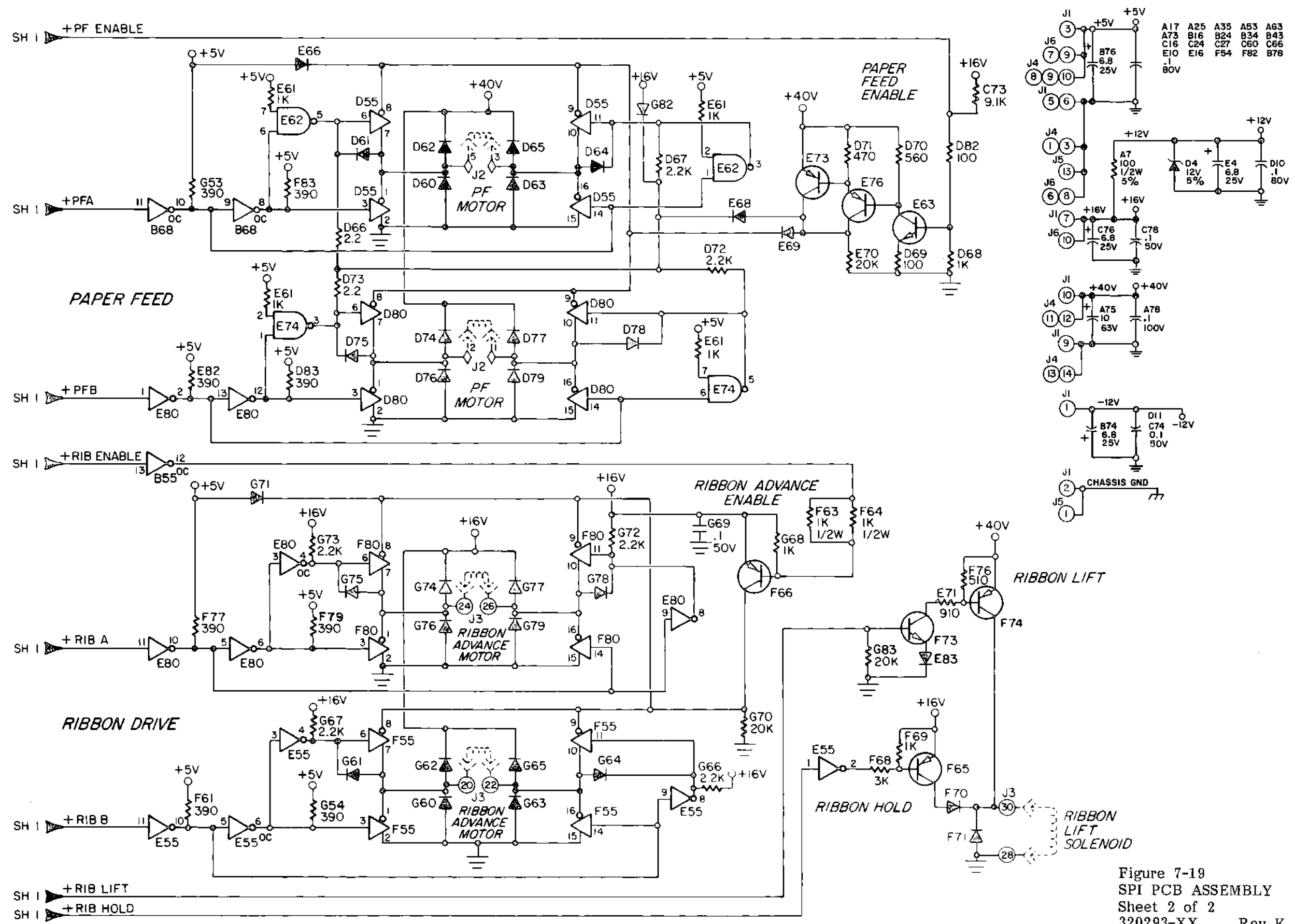

Figure 7-19
 SPI PCB ASSEMBLY
 Sheet 2 of 2
 320293-XX Rev K

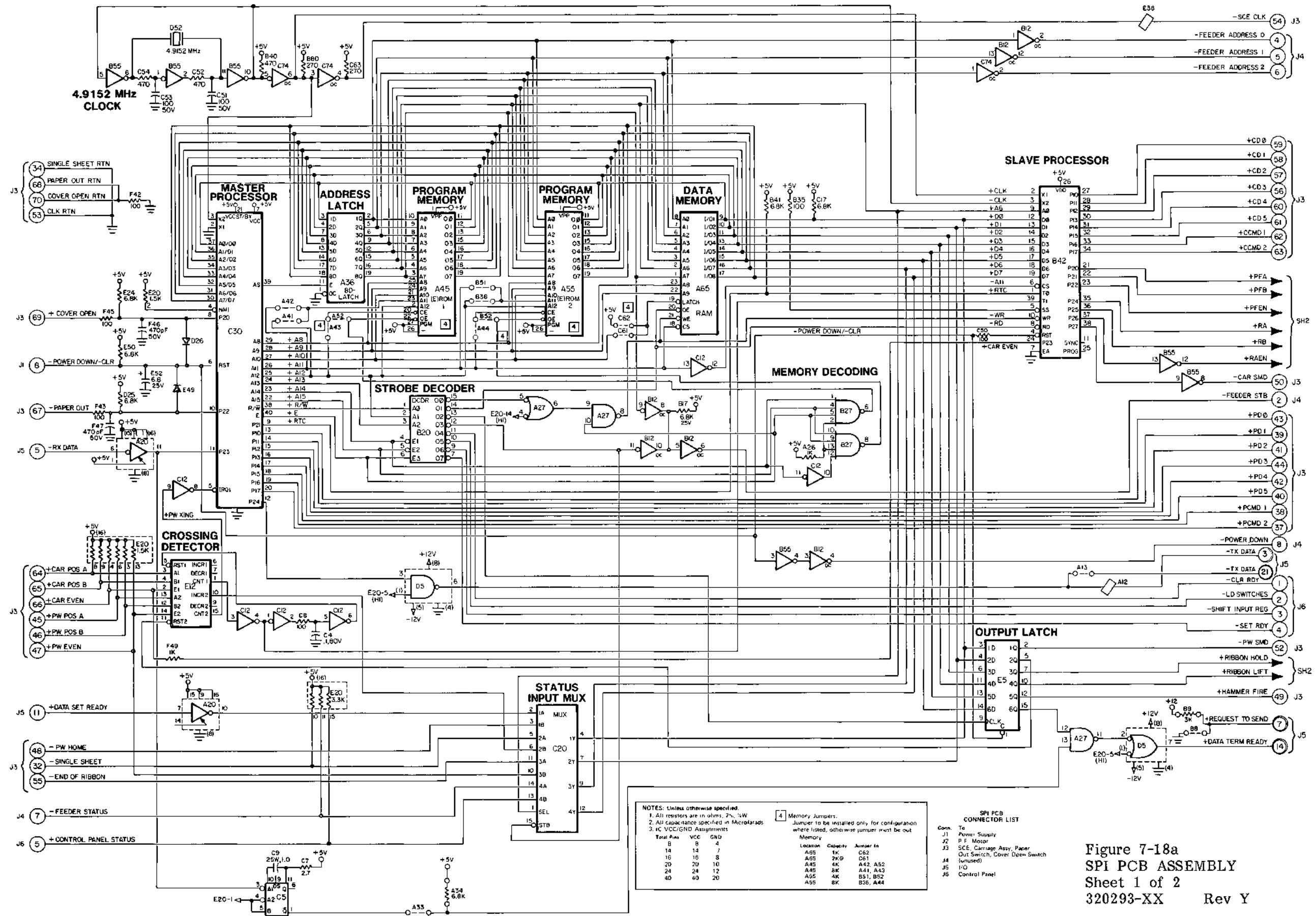

Figure 7-18a
 SPI PCB ASSEMBLY
 Sheet 1 of 2
 320293-XX Rev Y

SPI PCB ASSEMBLY
320293-XX Rev Y

For earlier revision levels of the SPI circuit board, see Figures 7-18 and 7-19.

REVISION HISTORY

<u>REV</u>	<u>ECO</u>	<u>ASSY</u>	<u>ETCH</u>	<u>ACTION</u>
L	B2914	-07	-04	Releases -07 assembly, -04 etch. Changes include: (See FSA #51 for greater detail.) - Control Program changes. - Improved RFI immunity. - Added RC network to improve ESD immunity. - Redesigned paper feed circuitry and firmware to provide higher paper feed torque.
N	B3007	-07	-04	Changes transistor at location F54 from a TIP125 to TIP126. Other changes affect SPI "specials" only. No effect on standard schematic.
P	B3012			Provides rework instructions for discontinued -05 assy in case of paper feed driver failure (see FSA #41A).
R	B3053	-07	-04	Changes from screw to rivet for mounting transistor at location F54.
S	B3079	-07	-04	Document changes; no schematic change.
T	B3173			Issues documentation for alternative memory arrangement for possible future use. No schematic change for present standard SPI PCB assembly.
V	B3178	-07	-04	Changes to special SPI PCB assembly; no change to standard SPI PCB assembly.
W	B3227	-07	-04	Releases firmware for special version Model 630. No schematic change.
Y	B3316	-41	-05	Releases -41 assembly using revised firmware to replace -07 assembly. Resistor pack at location E20 changes from 1.5K to 3.3K to prevent overdriving the SCE circuit board.

Diodes:

1N4002	D26, D60, D62, D63, D65, D68, D74, D76, D77, D79, E49, E63, E69, E70, G60, G62, G63, G65, G70, G74, G76, G77, G79
1N4454	D61, D64, D75, D78, G61, G64, G75, G78
1N5819	F69, F70
1N4742, 12V	C6

Transistors:

2N3644	F77
2N5322	F76, E77
TIP126	F54
MPS A06	E59

Resistor Pack:

1.5K	E20
------	-----

SOLID STATE COMPONENTS USED

IC's:

74LS00	A27
7404	B55
7406	C74, E55, E80
74LS14	C12
74LS20	B27
74LS138	B20
74LS174	E5
74LS257	C20
74LS373	A36

(continued)

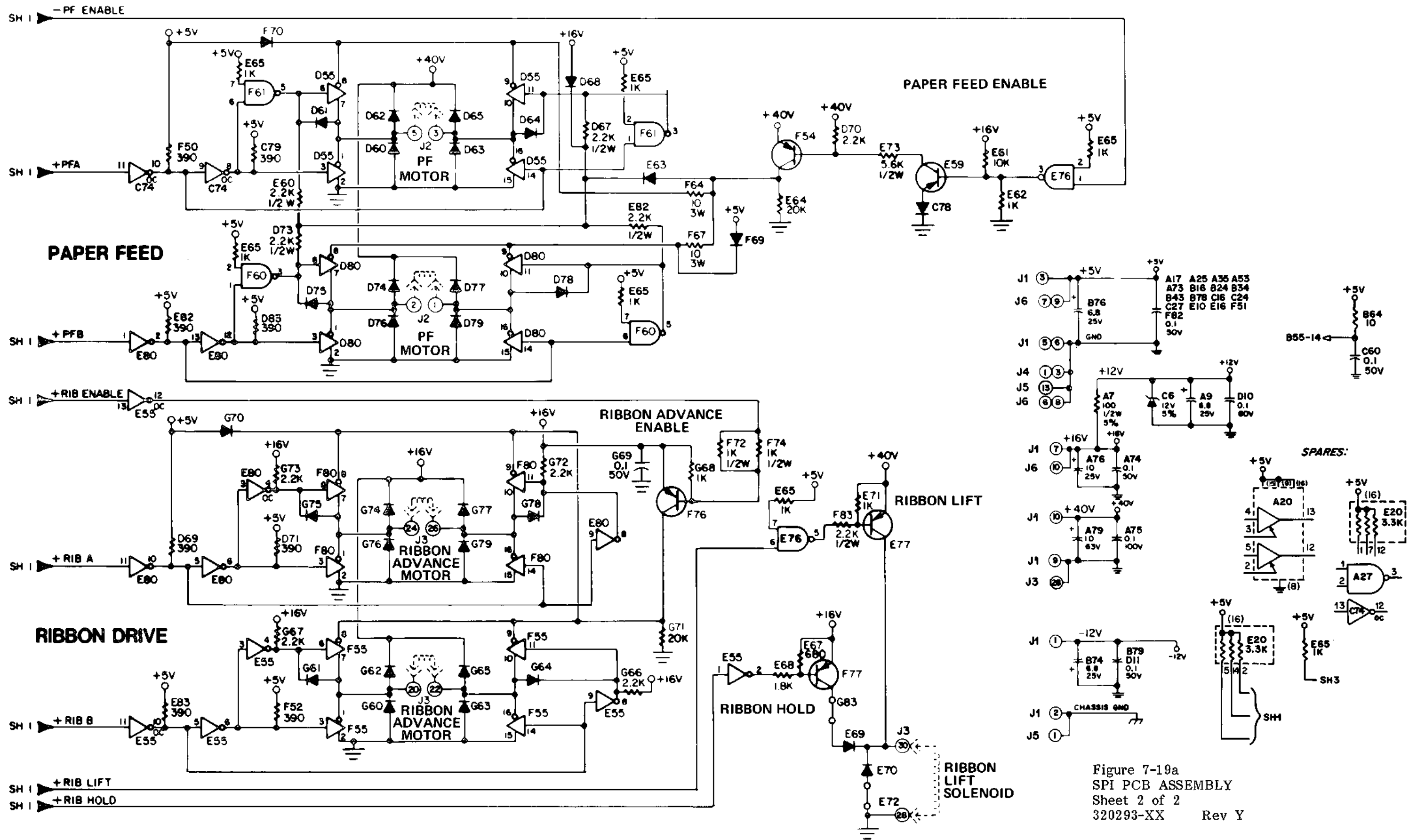

Figure 7-19a
 SPI PCB ASSEMBLY
 Sheet 2 of 2
 320293-XX Rev Y

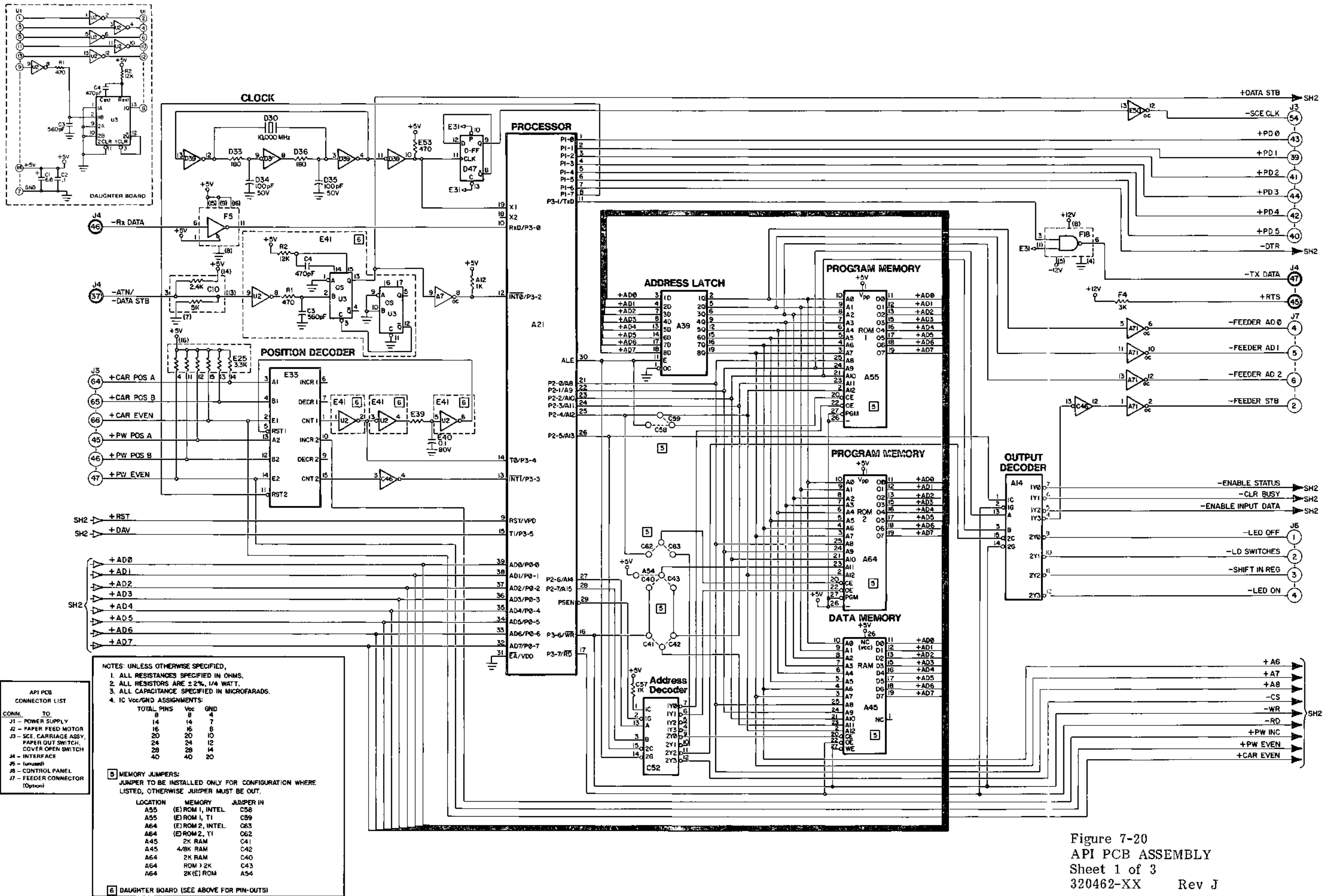

Figure 7-20
API PCB ASSEMBLY
Sheet 1 of 3
320462-XX Rev J

For later revision levels of the API circuit board, see Figures 7-20a, 7-21a and 7-22a.

REVISION HISTORY

REV	ECO	ASSY	ETCH	ACTION
J	B3208	-04	-04	Releases API-2 circuit board assembly with daughter board to production. Uses -13 firmware. (Not ECS compatible)

SOLID STATE COMPONENTS USED

IC's:

7404	D39
7405	E50
7406	A7, A71, E55, E80
74LS14	C46
7438	C66
74LS74	D47
74LS155	A14, C52
74LS257	D12, D20
74LS373	A39
74LS374	C15
75150	F18
75154	F5
75472	E76, F60, F61
2075B (Darlington)	D55, D80, F55, F80
8031	A21
8255A	A31
EPROM, 2764 (8K bytes)	A55
EPROM, 2764-2 (8K bytes)	A64

Note: The IC at location E33 is custom I²L. Refer to the Model 630 Parts Catalog for part number.

Diodes:

1N4002	D60, D62, D63, D65, D68, D74, D76, D77, D79, E63, E69, E70, G60, G62, G63, G65, G70, G74, G76, G77, G79
1N4454	D61, D64, D75, D78, G61, G64, G75, G78
1N4607	D54
1N4742A, 12V	F14
1N4745, 16V	E72
1N5231, 5.1V	E65
1N5819	F69, F70

Transistors:

2N5322	F76
TIP126	F54
GEX41K4-11	F77, E77
MPS-A06	E59

Resistor Packs:

3.3K, 16-pin	E25
2.4K/5K, 14-pin	C10

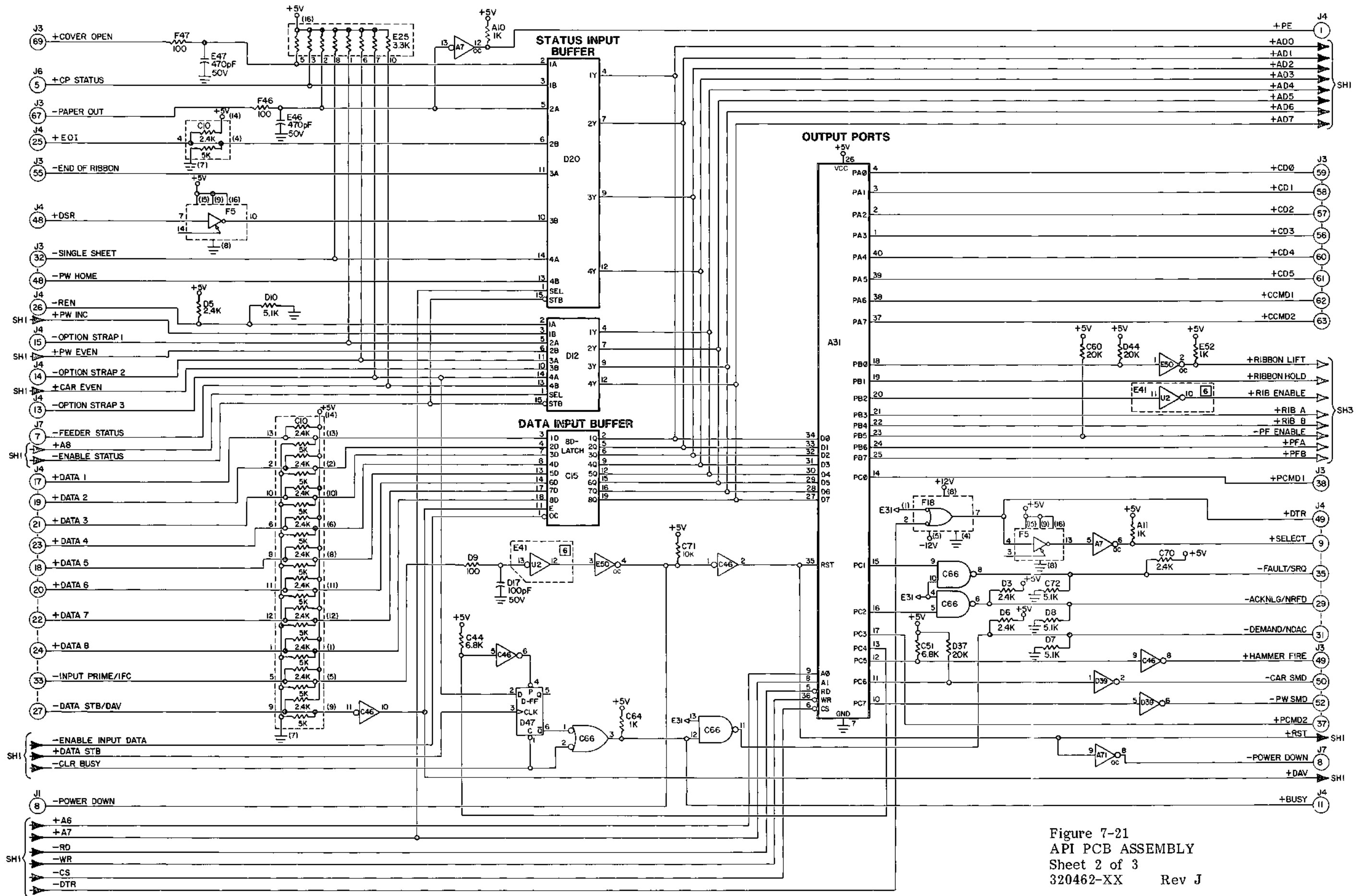

Figure 7-21
 API PCB ASSEMBLY
 Sheet 2 of 3
 320462-XX Rev J

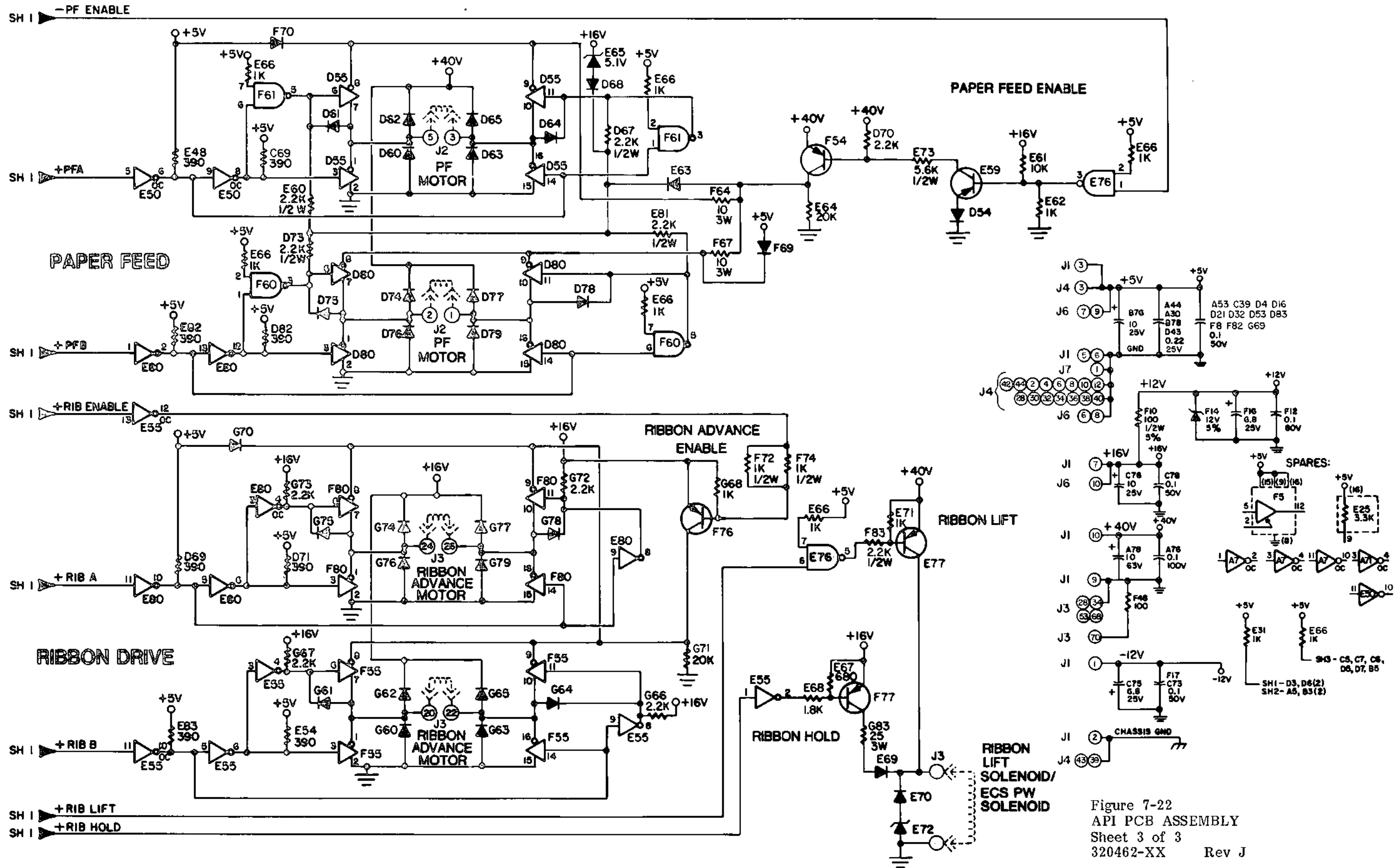
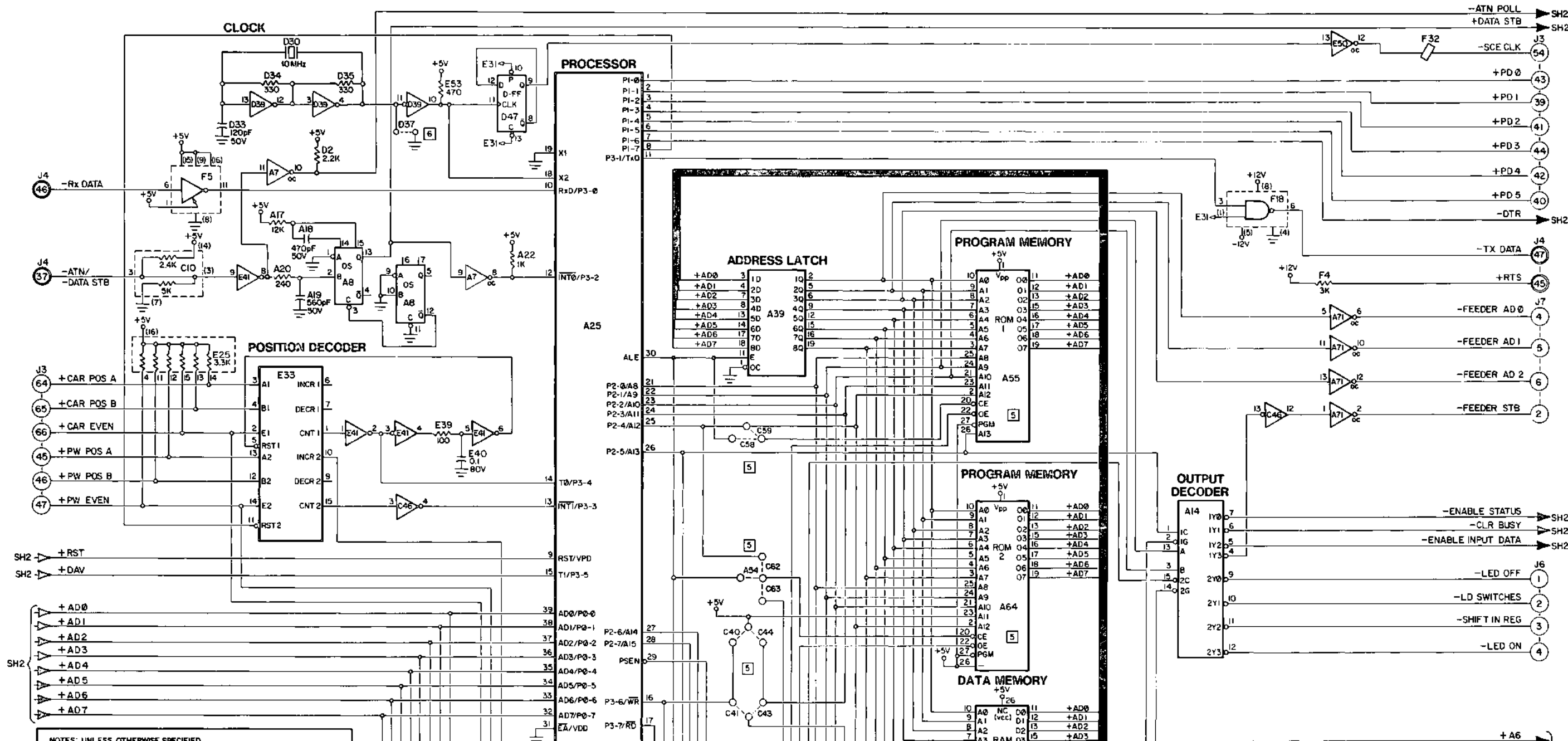

Figure 7-22
 API PCB ASSEMBLY
 Sheet 3 of 3
 320462-XX Rev J



NOTES: UNLESS OTHERWISE SPECIFIED,
 1. ALL RESISTANCES SPECIFIED IN OHMS.
 2. ALL RESISTORS ARE ±2%, 1/4 WATT.
 3. ALL CAPACITANCE SPECIFIED IN MICROFARADS.
 4. IC Vcc/GND ASSIGNMENTS:

TOTAL PINS	Vcc	GND
8	8	4
14	14	7
16	16	8
20	20	10
24	24	12
28	28	14
40	40	20

5 MEMORY JUMPERS:
 JUMPER TO BE INSTALLED ONLY FOR CONFIGURATION WHERE LISTED, OTHERWISE JUMPER MUST BE OUT.

LOCATION	MEMORY	JUMPER IN
A55	(E) ROM 1, INTEL	C58
A55	(E) ROM 1, TI	C59
A64	(E) ROM 2, INTEL	C63
A64	(E) ROM 2, TI	C62
A45	2K RAM	C41
A45	4/8K RAM	C43
A64	2K RAM	C40
A64	ROM > 2K	C44
A64	2K(E) ROM, 250ns	A54

6 OPTIONAL CAPACITOR - NOT IN USE.
 7 OPTIONAL JUMPER TO GROUND
 8 DATA BUS: + SIGN FOR CENTRONICS
 - SIGN FOR GPIB INTERFACE.

API PCB CONNECTOR LIST

CONN.	TO
J1	POWER SUPPLY
J2	PAPER FEED MOTOR
J3	SCE, CARRIAGE ASSY, PAPER OUT SWITCH, COVER OPEN SWITCH
J4	INTERFACE
J5	(unused)
J6	CONTROL PANEL
J7	FEEDER CONNECTOR (Optional)

Figure 7-20a
 API PCB ASSEMBLY
 Sheet 1 of 3
 320462-XX Rev K

API PCB ASSEMBLY
320462-XX Rev K

For earlier revision levels of the API circuit board, see Figures 7-20, 7-21, and 7-22.

REVISION HISTORY

REV	ECO	ASSY	ETCH	ACTION
K	B3292	-07	-04	Releases API-2 ECS compatible with -14 firmware minimum level.
		-06	-06	Releases new etch and assy for combined standard and ECS compatibility with no daughter board. Uses -16 firmware minimum level.

1N4742A, 12V	F14
1N4745, 16V	E72
1N5231, 5.1V	E65
1N5819	F69, F70

Transistors:

2N5322	F76
TIP126	F54
GEX41K4-11	E77, F77
MPS-A06	E59

Resistor Packs:

3.3K, 16-pin	E25
2.4/5K, 14-pin	C10

SOLID STATE COMPONENTS USED

IC's:

7404	D39
7405	E50
7406	A7, A71, E55, E80
74LS14	C46, E41
7438	C66
74LS74	D47
74LS155	A14, C52
74LS221	A8
74LS257	D12, D20
74LS373	A39
74LS374	C15
75150	F18
75154	F5
75472	E76, F60, F61
2075B (Darlington)	D55, D80, F55, F80
8031	A21 (-07 assy), A25 (-06 assy)
8255A	A31
RAM (2K bytes)	A45
EPROM,	
2764 (8K bytes)	A55
EPROM,	
2764 (-06 assy)	A64
2764-2 (-07 assy)	A64

Note: The IC at location E33 is custom I²L. Refer to the Model 630 Parts Catalog for part number.

Diodes:

1N4002	D60, D62, D63, D65, D68, D74, D76, D77, D79, E63, E69, E70, G60, G62, G63, G65, G70, G74, G76, G77, G79
1N4454	D61, D64, D75, D78, G61, G64, G75, G78
1N4607	D54

(continued)

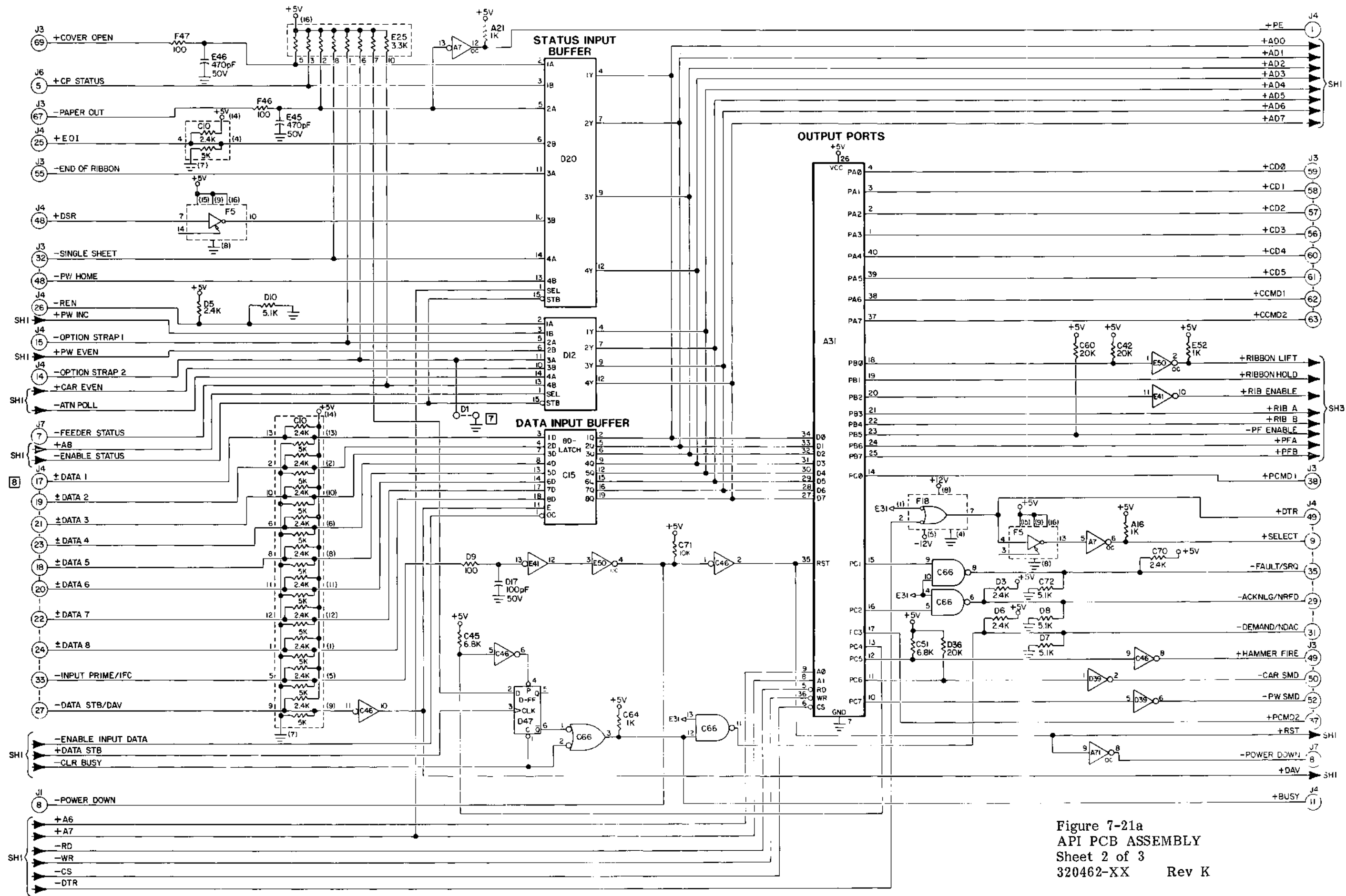

Figure 7-21a
 API PCB ASSEMBLY
 Sheet 2 of 3
 320462-XX Rev K

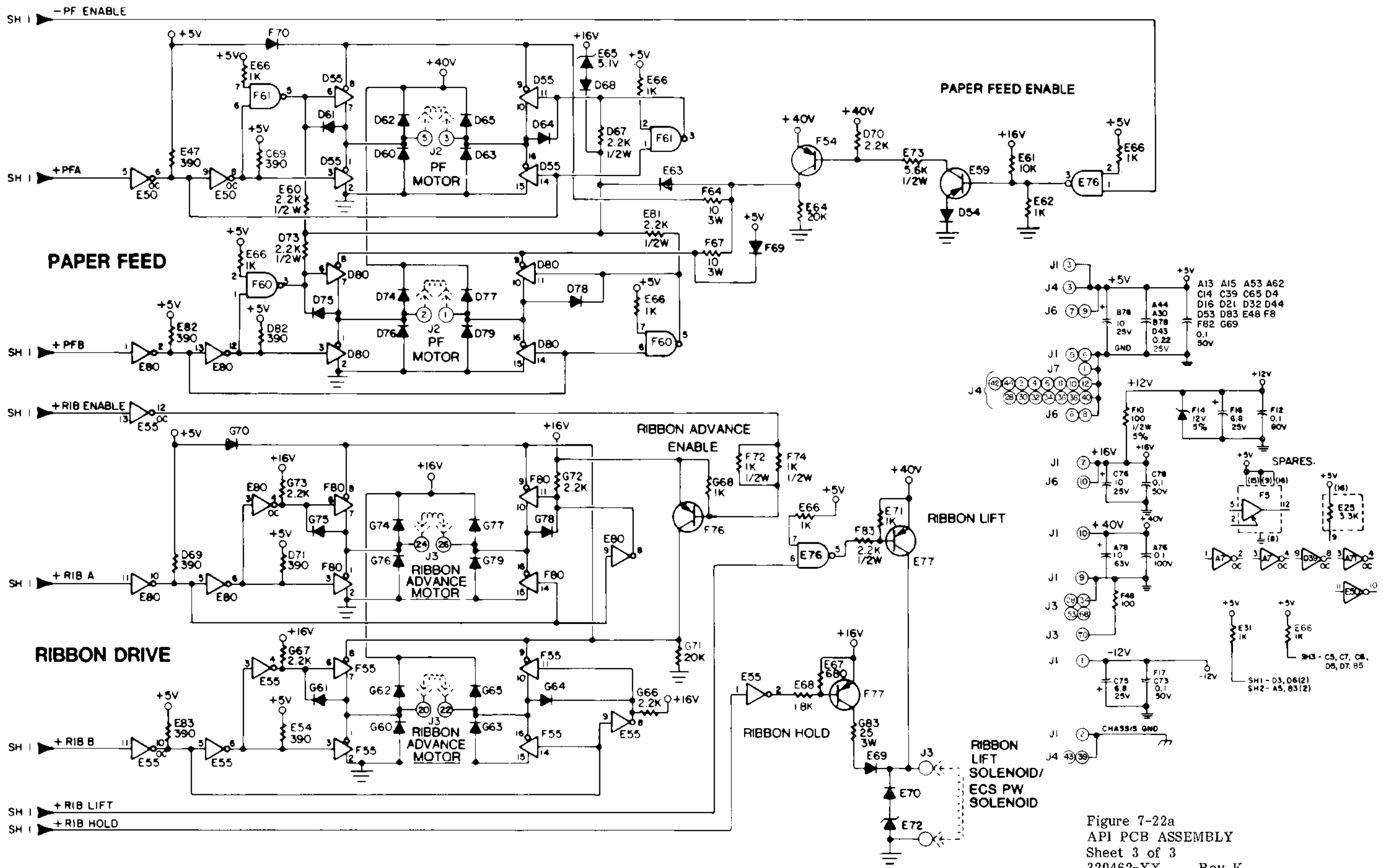
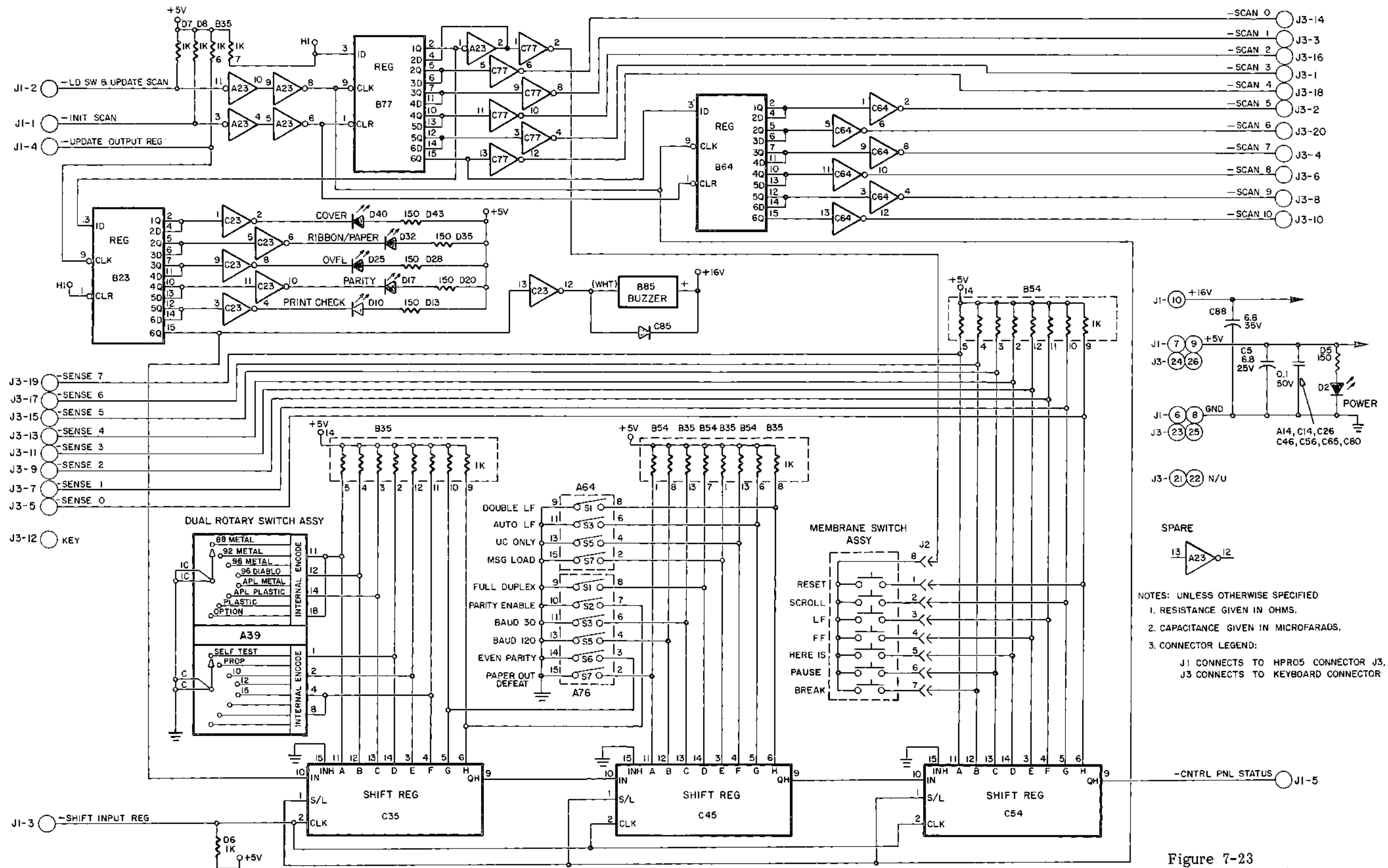

Figure 7-22a
 API PCB ASSEMBLY
 Sheet 3 of 3
 320462-XX Rev K



NOTES: UNLESS OTHERWISE SPECIFIED
 1. RESISTANCE GIVEN IN OHMS.
 2. CAPACITANCE GIVEN IN MICROFARADS.
 3. CONNECTOR LEGEND:
 J1 CONNECTS TO HPR05 CONNECTOR J3.
 J3 CONNECTS TO KEYBOARD CONNECTOR J1.

Figure 7-23
 H5CPN (HPR05) CONTROL PANEL
 PCB ASSEMBLY
 302561-05 Rev A

H5CPN (HPRO5) CONTROL PANEL PCB ASSEMBLY
302561-05 Rev A

Note: -05 and earlier versions of the H5CPN PCB assembly are suitable for use on Model 630 HPRO5 terminals only. -06 and later versions of the H5CPN PCB assembly can be used on both HPRO5 terminals and API-2 terminals.

For -06 and later versions of the H5CPN PCB assembly, see Figure 7-23a.

REVISION HISTORY

<u>REV</u>	<u>ECO</u>	<u>ASSY</u>	<u>ETCH</u>	<u>ACTION</u>
A	B1390			Releases Bill of Material (B/M) for -02 assembly.
B	B1694	-02	-02	B/M updated. Schematic and assembly drawing added.
C	B2356	-02	-03	Releases -03 etch; obsoletes -02 etch. Capacitor at C5 changed from 35V to 25V rating. Miscellaneous hardware changes with no effect on schematic.
A	B2518	-03	-03	Releases -03 assembly at Rev. A; obsoletes -02 assembly. No schematic change.
A	B2595	-04	-03	Releases -04 assembly; obsoletes -03 assembly. No schematic change.
A	B2745	-05	-04	Releases -05 assembly using -04 etch; obsoletes -04 assembly. -04 etch incorporates all previous cut-and-jump changes to -03 etch.

SOLID STATE COMPONENTS USED

IC's:

7406	C23, C64, C77
74LS14	A23
74LS165	C35, C45, C54
74LS174	B77, B64, B23

Diodes:

1N4454	C85
--------	-----

Resistor Pack:

1K, 14-pin	B35, B54
------------	----------