

REMEX
TECHNICAL MANUAL
TAPE READER
MODELS: RRS7300BEX/660/DRB

IMPORTANT INFORMATION

Changes to the equipment which are made between manual printings are listed in an addendum at the rear of the manual. As a convenience, a list of change pages is given as the last page in the manual. It is recommended that each of these pages be marked "Refer to Addendum" so that these changes can be identified.

EX-CELL-O CORPORATION

REMEX

1733 Alton St. • P.O. Box C-19533 • Irvine, CA 92713

TABLE OF CONTENTS

<u>Section</u>	<u>Title</u>	<u>Page</u>
I	GENERAL DESCRIPTION	1-1
1.1	<u>EQUIPMENT DESCRIPTION</u>	1-1
1.2	<u>EQUIPMENT SUPPLIED</u>	1-1
1.3	<u>MAINTENANCE EQUIPMENT REQUIRED BUT NOT SUPPLIED</u>	1-3
1.4	<u>EQUIPMENT WARRANTY</u>	1-3
1.5	<u>SPECIFICATIONS</u>	1-3
1.6	<u>MODEL NUMBER DESIGNATION AND OPTIONS</u>	1-4
1.7	<u>PHYSICAL DESCRIPTION</u>	1-5
1.8	<u>TAPE CHANNEL NUMBERING</u>	1-7
II	INSTALLATION AND INTERFACE	2-1
2.1	<u>UNPACKING</u>	2-1
2.2	<u>MOUNTING</u>	2-1
2.3	<u>INITIAL ADJUSTMENTS</u>	2-1
2.4	<u>POWER AND SYSTEM CONNECTIONS</u>	2-1
2.4.1	TRANSFORMER WIRING CHANGE FOR VOLTAGES OTHER THAN 115 VAC	2-3
2.5	<u>INTERFACE CIRCUITRY</u>	2-3
III	OPERATION	3-1
3.1	<u>INPUT-OUTPUT SIGNALS</u>	3-1
3.2	<u>CONTROL FUNCTIONS</u>	3-1
3.3	<u>OPERATING INSTRUCTIONS</u>	3-1
3.3.1	TAPE LOADING INSTRUCTIONS	3-1
3.3.2	TAPE DRIVE LOW SPEED, ASYNCHRONOUS OPERATION	3-2
3.3.3	TAPE DRIVE, HIGH SPEED, SYNCHRONOUS OPERATION	3-2
3.3.4	EXTERNAL INHIBIT	3-4
3.3.5	SPOOLER WIND MODE OPERATION	3-4
3.3.6	DATA OUTPUT MODE SELECTION	3-5
3.4	<u>OPERATIONAL MAINTENANCE</u>	3-11
3.5	<u>TAPE RECOMMENDATIONS AND AVAILABILITY</u>	3-11
3.6	<u>TAPE PREPARATION REQUIREMENTS</u>	3-12

TABLE OF CONTENTS, CONTINUED

<u>Section</u>	<u>Title</u>	<u>Page</u>
IV	THEORY OF OPERATION	4-1
4.1	<u>BLOCK DIAGRAM DESCRIPTION</u>	4-1
4.1.1	TAPE DRIVE	4-1
4.1.2	TAPE READING	4-2
4.1.3	SPOOLER BLOCK DIAGRAM	4-2
4.2	<u>CIRCUIT CARD DESCRIPTIONS</u>	4-7
4.2.1	READER CIRCUITRY	4-7
4.2.1.1	<u>Drive Circuits</u>	4-7
4.2.1.2	<u>Tape Reading Circuits</u>	4-9
4.2.2	SPOOLER CIRCUITRY	4-10
4.2.2.1	<u>Servo Mode Operation</u>	4-10
4.2.2.2	<u>Wind Mode Operation</u>	4-10
4.2.2.3	<u>Inhibit Mode</u>	4-12
4.2.3	POWER SUPPLY VOLTAGES	4-14
4.3	<u>LIGHT SOURCE</u>	4-14
V	MAINTENANCE	5-1
5.1	<u>GENERAL</u>	5-1
5.2	<u>PREVENTIVE MAINTENANCE</u>	5-1
5.2.1	CLEANING	5-2
5.2.1.1	<u>Readhead Assembly Cleaning</u>	5-4
5.2.1.2	<u>Sprocket Cleaning</u>	5-4
5.2.1.3	<u>Tape Inspection</u>	5-4
5.2.1.4	<u>General Cleaning</u>	5-4
5.2.2	LUBRICATION	5-5
5.3	<u>TROUBLE SHOOTING</u>	5-5
5.4	<u>READER ALIGNMENT</u>	5-10
5.5	<u>READER LAMP VOLTAGE ADJUSTMENT</u>	5-16
5.6	<u>SERVO ALIGNMENT</u>	5-16
5.7	<u>ARM SPRING TENSION ADJUSTMENT</u>	5-16
5.8	<u>WIND SPEED ADJUSTMENT</u>	5-17
5.9	<u>SPOOLER TAPE ARM AND ROLLER ALIGNMENT</u>	5-17
5.10	<u>TAPE SPLICING</u>	5-18

TABLE OF CONTENTS, CONTINUED

<u>Section</u>	<u>Title</u>	<u>Page</u>
5.11	<u>TAPE TENSIONING ASSEMBLY ADJUSTMENT</u>	5-18
VI	PARTS REPLACEMENT	6-1
6.1	<u>GENERAL</u>	6-1
6.2	<u>READER PARTS REPLACEMENT</u>	6-1
6.2.1	READHEAD MECHANISM DISASSEMBLY	6-1
6.2.2	READER CARD REPLACEMENT	6-2
6.2.3	LAMP ASSEMBLY REPLACEMENT	6-2
6.2.4	MOTOR AND/OR SPROCKET REPLACEMENT	6-3
6.2.5	TRANSFORMER REPLACEMENT	6-3
6.3	<u>SPOOLER PARTS REPLACEMENT</u>	6-4
6.3.1	POTENTIOMETER REPLACEMENT	6-4
6.3.2	FRONT PANEL AND CHASSIS	6-4
6.3.3	SERVO MOTOR REPLACEMENT	6-5
6.3.4	TAPE ARM REPLACEMENT	6-5
6.3.5	TAPE TENSION SOLENOID REPLACEMENT	6-5
VII	PARTS LIST	7-1
7.1	<u>GENERAL</u>	7-1
7.2	<u>KIT OF PARTS</u>	7-1
VIII	SCHEMATIC DRAWINGS	8-1/8-2
8.1	<u>GENERAL</u>	8-1/8-2

LIST OF ILLUSTRATIONS

<u>Figure</u>	<u>Title</u>	<u>Page</u>
1-1	REMEX Reader, Model RRS7300BEX/660/DRB	1-2
1-2	Installation Drawing, Model RRS7300BEX/660/DRB	1-5
1-3	Model Number Coding	1-6
1-4	Tape Channel Numbering	1-7/1-8
2-1	Reader Connections to External Equipment. See Table 3-1 for Signal Description	2-2
2-2	Recommended Interface Circuitry	2-4
3-1	Timing Diagram for RRS7300BEX/660/DRB	3-3
3-2	Tape Loading	3-3
4-1	Block Diagram, Reader Circuitry	4-3
4-2	Block Diagram, Spooler Circuitry	4-3
4-3	Timing Diagram, Reader Card 111121	4-5/4-6
4-4	Timing Diagram, Wind Speed Regulator Circuitry	4-11
4-5	Front View Showing Various Points of Tape Tension	4-13
5-1	Sprocket Relation to the Tape Riding Surface	5-11
5-2	Checking the Sprocket in Relation to Tape Riding Surface	5-11
5-3	Alignment of the Sprocket with the Light Columns	5-14
5-4	Adjustment of the Upper Tape Guide	5-14
5-5	Photocell Output Test Circuit	5-15
5-6	Tape Splicing Procedure	5-20
6-1	Tape Arm Assembly	6-6
7-1	Exploded View of Readhead Mechanism Assembly	7-7/7-8
7-2	Front View of Front Panel	7-9
7-3	Top View of Unit	7-10
7-4	Rear View of Front Panel from Bottom	7-11
7-5	Power Drive Card Assembly 111131-3	7-13
7-6	Reader Card Assembly 113191-1	7-18
8-1	System Schematic, RRS7300BEX/660/DRB	8-3/8-4
8-2	Schematic, P.C. Card 113191-1, Sheet 1 of 4	8-5/8-6
8-2	Schematic, P.C. Card 113191-1, Sheet 2 of 4	8-7/8-8
8-2	Schematic, P.C. Card 113191-1, Sheet 3 of 4	8-9/8-10
8-2	Schematic, P.C. Card 113191-1, Sheet 4 of 4	8-11/8-12
8-3	Some I.C. Modules Used in P.C. Card 113191-1	8-13/8-14
8-4	REMEX Standard Schematic Symbols, Sheet 1 of 2	8-15
8-4	REMEX Standard Schematic Symbols, Sheet 2 of 2	8-16

LIST OF TABLES

<u>Table</u>	<u>Title</u>	<u>Page</u>
1-1	Items Included with the RRS7300BEX/660/DRB	1-1
1-2	Specifications of the REMEX Reader, Model RRS7300BEX/660/DRB	1-3
3-1	Interface Signal Description	3-6
3-2	Front Panel Controls	3-10
3-3	Modes of Operation	3-10
3-4	Recommended Tapes	3-11
5-1	Maintenance Equipment Required	5-1
5-2	Preventive Maintenance Schedule and Log	5-3
5-3	Power Supply Voltage Locations, Reader Card	5-5
5-4	Trouble Shooting	5-6
6-1	Transformer Wire Connections	6-4
7-1	Recommended Spare Parts	6-2
7-2	Parts List, RRS7300BEX/660/DRB	7-3
7-3	Power Drive Card Assembly 111131-1	7-12
7-4	Reader Card Assembly 113191-1	7-14

SECTION 1

GENERAL DESCRIPTION

1.1 EQUIPMENT DESCRIPTION

This manual has been prepared to assist the user in interfacing, installing, operating and maintaining the REMEX Model RRS7300 series punched tape reader-spooler combination. See Figure 1-1. It is the purpose of this model series to provide tape reading at 300 characters/second speed along with spooling, all on a single chassis. Although the applications for punched tape readers are many and varied, they are generally used as input devices for digital computers, communication systems, numerical controls, and system checkout equipment.

The reader spooler card provides the logic control for tape movement in either direction from external signals. The outputs from the card control a step motor which drives the tape via a sprocket wheel. Data outputs are generated from the photocell readhead. As tape passes over the photocells, changes in light intensity are sensed by the photocells, amplified, and brought out to an external connector. The card contains the spooler control circuitry and also generates the required power supplies.

The function of the spooler is to payout tape to the reader and to take up the tape that has been read. During read mode, the fully proportional spooler senses the position of the tape arms and provides compensating reel movements that allow the arms to operate near the center of their travel areas. These movements maintain a constant tape tension across the readhead. During wind mode, the reader is inhibited and tape is reeled at high speed from one reel to the other under control of either external signals or front panel switches.

1.2 EQUIPMENT SUPPLIED

Several items are included with the reader-spooler for spare parts, installation, and maintenance. These items are listed in Table 1-1. No other equipment is required for the operation of the unit.

Table 1-1. Items Included with the RRS7300BEX/660/DRB

<u>Item</u>	<u>Remex Part No.</u>	<u>Quantity</u>
Brush, Soft Bristle	716003-101	1
Cap, Fuseholder (FI), Littlefuse 348007	705750-118	1
Connector, P1, Cannon DB25S	706510-211	1
Cover, Connector (P1)	706540-144	1
Fuse, 2A, Slo-Blo, (100, 115, 127 VAC Operation)	705710-139	1
Fuse, 1A, Slo-Blo, (220, 230 or 240 VAC Operation)	705710-118	1
Manual	112670-070	1
Reel, 7-1/2 inch dia.	①	2
Screw Lock Assembly, P1, Set of 2	706540-124	1
Power Cord, Belden 17250	708000-110	

① See page 7-6 for available reels.

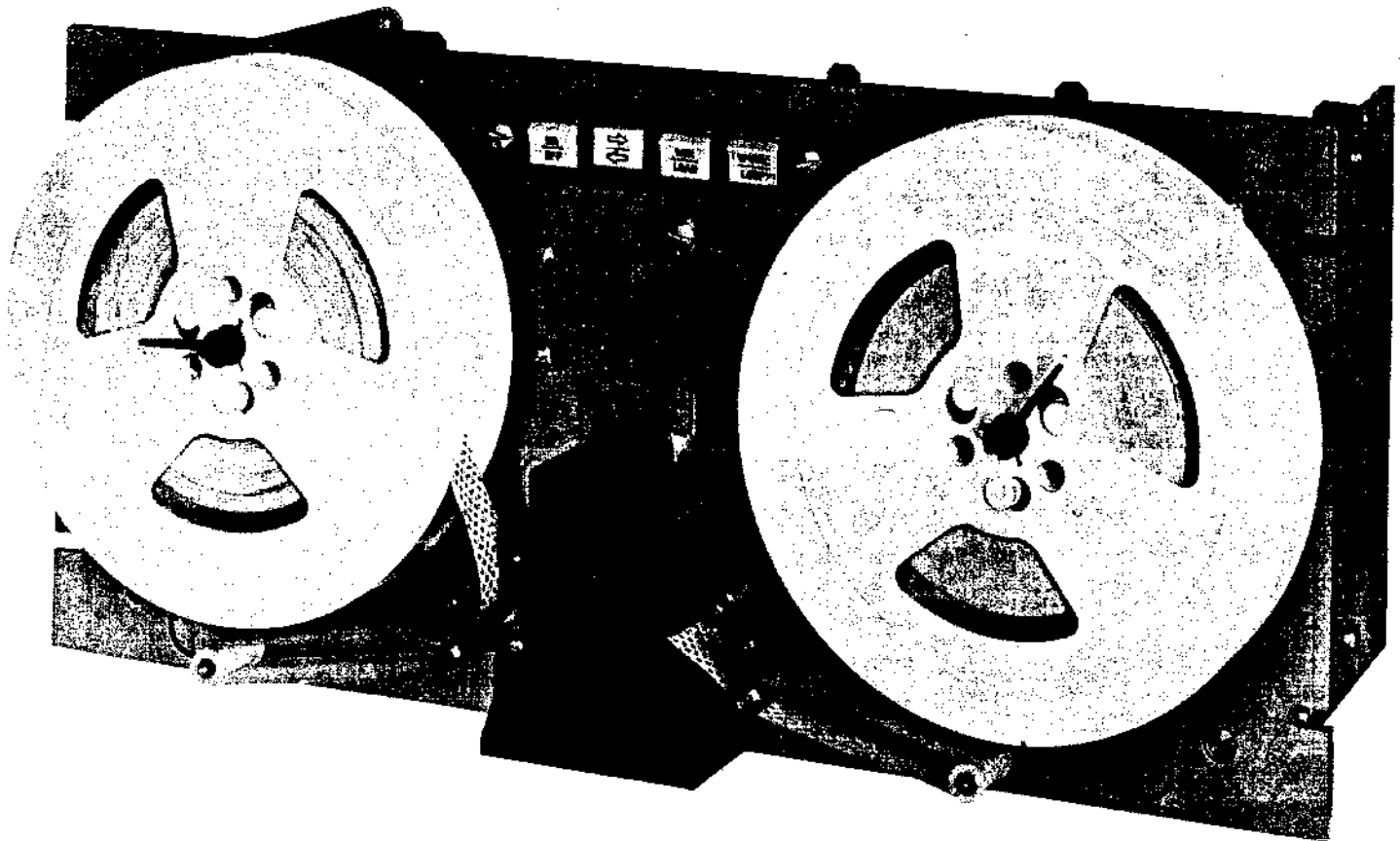

Figure 1-1. REMEX Reader, Model RRS7300BEX/660/DRB

1.3 MAINTENANCE EQUIPMENT REQUIRED BUT NOT SUPPLIED

The maintenance procedures in Section 5 require equipment that is not supplied. This equipment is listed in Table 5-1.

1.4 EQUIPMENT WARRANTY

A statement covering the warranty of this equipment is given on page iii (second page in book). It should be read and understood. All preventive maintenance procedures must be performed as outlined in Section 5.2 during the warranty period in order that the warranty remain in effect. Any questions arising concerning the warranty should be directed to the REMEX Service Department.

1.5 SPECIFICATIONS

The specifications for the REMEX tape reader, Model RRS7300BEX/660/DRB, are listed in Table 1-2. An X in a particular digit designator denotes any of the combinations given in Figure 1-3 can be used.

Table 1-2. Specifications of the REMEX Reader, Model RRS7300BEX/660/DRB

Characteristic	Specification
Tape Movement	Bidirectional (left-to-right or right-to-left).
Reading Speed	Low Speed Mode (Asynchronous): 0-150 characters/second. High Speed Mode (Synchronous): 300 characters/second. See Sections 3.3.2 and 3.3.3.
Tapes	Reads standard 8-track (1-inch) tapes with light transmissivity of 57% or less and thickness between 0.0027 and 0.0045 inch (oiled buff paper tape). Tapes must be punched as described in Section 3.6. Other tape sizes listed in Fig.1-4.
Input Power	100, 115, 127, 220 or 240 VAC (unless otherwise specified by customer, units are wired for 115 VAC), 47 to 63 Hz, single phase at 3.0 amps (100, 115 or 127 VAC) or 1.5 amp. (220 or 240 VAC), nominal voltage, maximum current.
Temperature	Operating: 0°C to +65°C, free air Non-operating: -55°C to +85°C
Weight	37 lbs.
Mounting Dimensions	8-3/4" high, 19" wide, 7-3/4" behind a 1/4" panel. 2-1/2" in front of panel. See Figure 1-2.
Modes of Operation	Two modes of operation are available: Low Speed (Asynchronous) and High Speed (Synchronous). See Sections 3.3.2 and 3.3.3.

Table 1-2. Specification of the REMEX Reader, Model RRS7300BEX/660/DRB
(Continued)

Characteristic	Specifications
Data Output	Data Mode Selectable (See Section 3.3.6): <u>Mode 5:</u> Hole: $+2.4 < V < +5.0 @ 0.2 \text{ ma. (source)}$ No Hole: $0 < V < +0.4 @ 16 \text{ ma. (sink)}$ <u>Mode 6:</u> Hole: $0 < V + 0.4 @ 16 \text{ ma. (sink)}$ No Hole: $+2.4 < V < +5.0 @ 0.2 \text{ ma. (source)}$
Timing	Timing Diagram given in Figure 3.1. Also see Sections 3.3.2 and 3.3.3.
Wind Operation	Bidirectional high speed wind at 1500 characters/sec.

1.6 MODEL NUMBER DESIGNATION AND OPTIONS

The REMEX model designation is used to code the basic functions and configurations of a particular product line. The model number codes for the RRS7300 series are shown in Figure 1-3. An X in a particular digit designator (as used in many parts of this manual, especially the parts list) denotes any of the combinations for that digit given in Figure 1-3 applies in the instance cited.

Always consult the serial number tag for proper voltage and frequency to be used and for model identification. Failure to do so could result in damage to the unit. The serial tag is located on one of the rear surfaces. In all correspondence, always refer to the complete model number, including the mode and the special number and the unit's serial number.

The last three digits of the model number denote either a standard unit (000 or 901 and higher) or a special (all other numbers). Units with 000 indicate standard units with no additional options other than those coded in the model number structure. Units with 901 and higher are used to indicate the number of standard options (used only on standard units) which are not coded in the model number. These are listed on the serial tag below the model number in the form of a series of three digit numbers depending upon the number of options used. For example, a unit with 902 would list two three digit numbers. Because the list of possible options is constantly changing, it is not included in the manual. Generally, this list consists of special customer requirements that do not affect the operation of the unit and include such things as special paint, no logo, mill edge panel, etc.

1.7 PHYSICAL DESCRIPTION

The REMEX punched tape reader is mounted on a 19-inch panel with a height of 8-3/4 inches for the RRS7300BEX/660. Detailed dimensions are shown in Figure 1-2. The front panel contains the tape reading and transport mechanism. The lamp is accessible from the rear of the front panel. The electronic chassis is mounted at the rear of the front panel and contains the two circuit cards.

112670-070A

1-5

SYM	ECO	EFFECT	REVISIONS	BY	DATE	APPRD
A	—	7-23-76	RELEASED	S.E.O.	7-23-76	

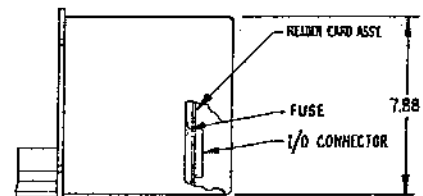
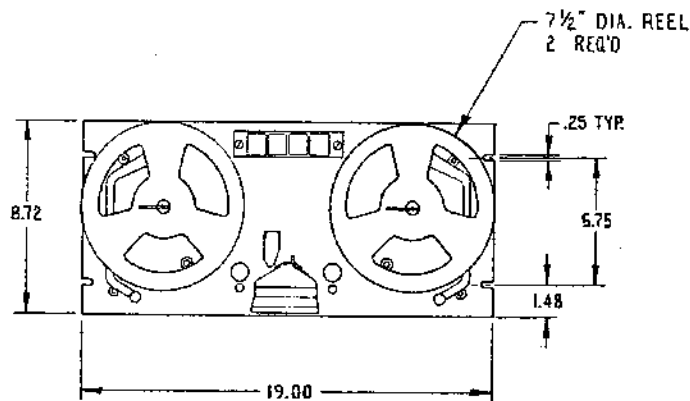
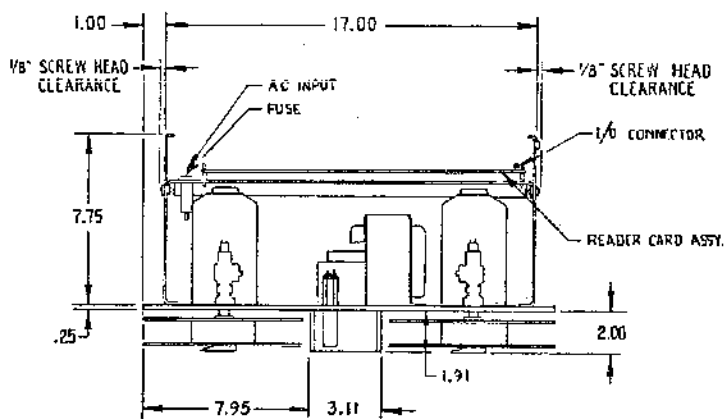

3. ALL DIMENSIONS ARE REF ONLY.
 2. FOR SCHEMATIC, SEE DWG. NO'S. 113190 & 113192.
 1. FOR FINAL ASSY., SEE DWG. NO. 113123-1.
- NOTES: UNLESS OTHERWISE SPECIFIED.

RECD	PART NUMBER	DESCRIPTION	DESIGNATION	NOTE	ITEM
LIST OF MATERIALS					
UNLESS OTHERWISE SPECIFIED DIMENSIONS ARE IN INCHES		DR S.E.O.	 <small>1733 ALTON STREET IRVINE, CALIF 92714</small>		
TOLERANCES: FRACTIONS DECIMALS ANGLES ± 1/32 XX & O2 ± 1/2 XXX & O1		DATE 7-1-76			
SURFACE ROUGHNESS BREAK SHARP EDGES 0.00 MAX		DATE 7-22-76	TITLE INSTALLATION DWG. RRS 7300BEX/660/DRB/UXXX		
MATERIAL		DATE 7-22-76			
FINISH		APPROVAL	CODE IDENT NO	SIZE	DWG NO
RRS 7300-D				C	113188
USED ON	NEXT ASSY		SCALE 1:4	DO NOT SCALE DRAWING	SHEET 1 OF 1

Figure 1-2. Installation Drawing, Model RRS7300BEX/660/DRB

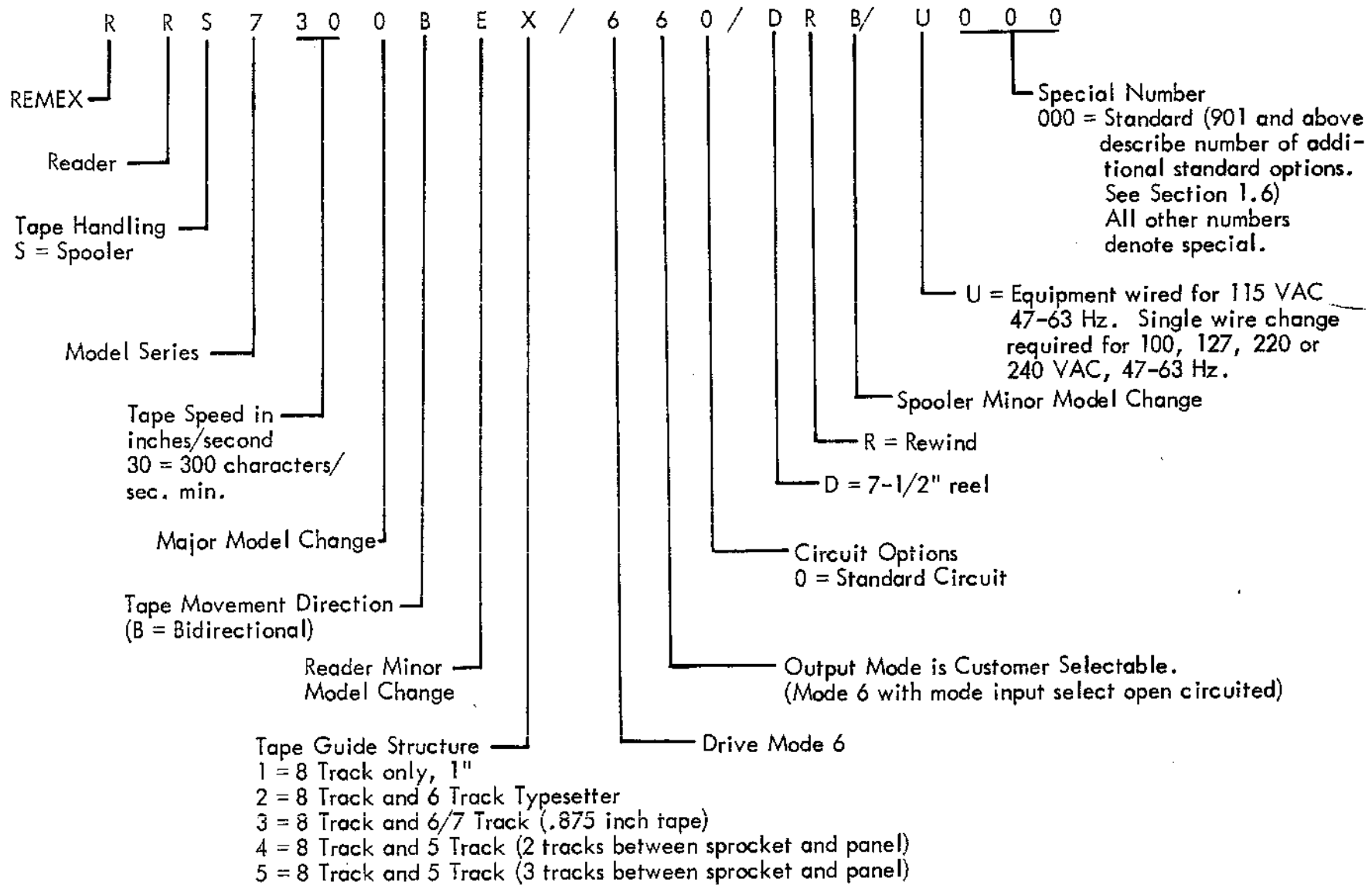
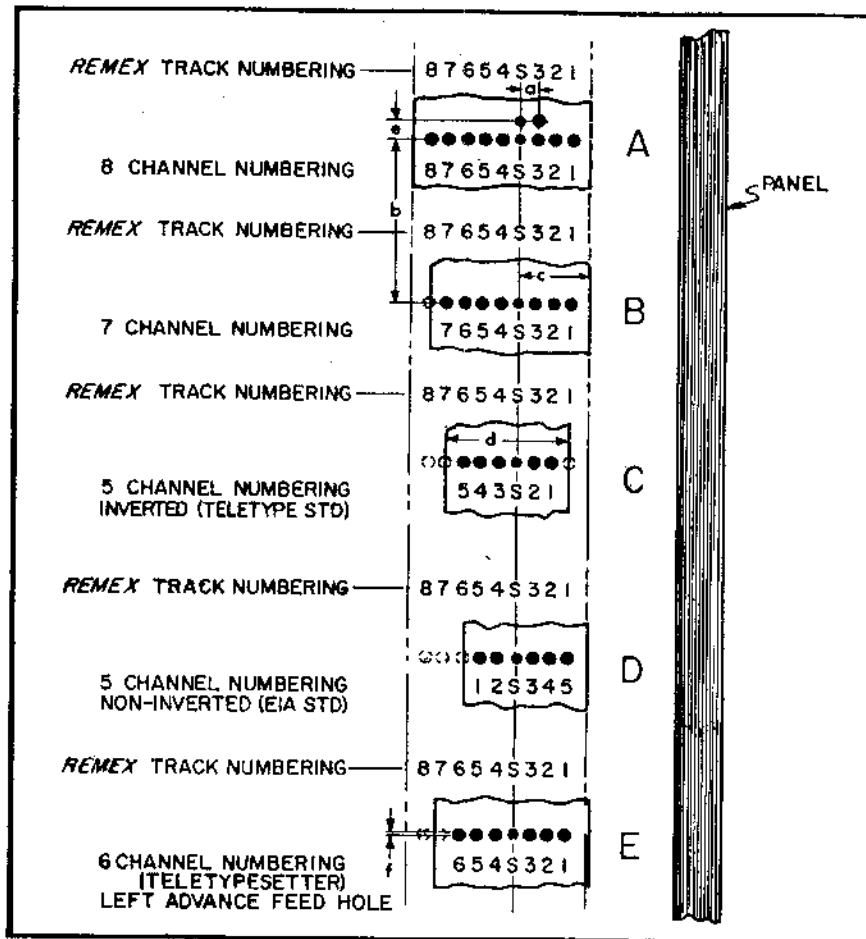

Figure I-3. Model Number Coding

TAPE CHANNEL NUMBERING

Figure 1-4 illustrates the tape channel numbering. The reader accepts one inch, eight channel tape and other width tapes, depending upon the tape guide structure used.



MMCT118A

Configuration	In All Configurations:		
	$\overset{c}{+0.003}$	$\overset{d}{+0.003}$	
A	0.392	1.000	In All Configurations: $a = 0.100 \pm 0.002$ b in any span of five inches is ± 0.025 $e = 0.100 \pm 0.001$ Data hole diameter is $0.072 \begin{matrix} +.001 \\ -.002 \end{matrix}$ Sprocket hole diameter is $+0.002$ $0.046 -0.001$
B	0.394	0.875	
C	0.293	0.687	
D	0.394	0.687	
E	0.441 Drive Right 0.434 Drive Left	0.875	

NOTE: The 6 channel teletypesetter has the sprocket hole center line advanced by 0.013 inch with respect to the data track center line (dimension f in illustration E).

Figure 1-4. Tape Channel Numbering

SECTION 11

INSTALLATION AND INTERFACE

2.1 UNPACKING

To provide the most protection during transit, specially designed and reinforced packing cartons are used to ship the REMEX punched tape reader. Those items listed in Table 1-1 are also packed with the unit. When removing the unit from the carton, the reader-spooler should be lifted with both hands under it. Never lift or attempt to carry the unit by any of the covers, drive assembly, arms or other delicate parts. Carefully inspect the unit for any apparent damage as soon as it is removed from the carton. Check the equipment supplied list in Table 1-1 against the kit of parts supplied with the reader. In the event the equipment has been damaged as a result of shipping, the carrier and REMEX must be notified as soon as possible.

2.2 MOUNTING

The reader mounts in a standard 19-inch rack with mounting holes provided. To ensure a minimum transmission of acoustical noise and vibration to other equipment, the reader should be securely mounted. When mounting the unit in a closed cabinet, adequate air circulation should be supplied so that the unit does not exceed the ambient temperature specification listed in Table 1-2.

2.3 INITIAL ADJUSTMENTS

Each reader has been accurately adjusted and aligned before leaving the factory. No adjustment or calibration should be required prior to installation or use. However, the proper fuse from the kit of parts requires installation. Refer to Section 2.4.

2.4 POWER AND SYSTEM CONNECTIONS

Input AC power (refer to Table 1-2) is applied through the A.C. connector at the rear.

CAUTION

All units come wired for 115 VAC, 47-63 Hz operation. If another voltage is to be used, a wire change on the transformer must be made as described in Section 2.4.1. In addition, before operating the system, the proper fuse value (as indicated in Table 1-1) must be inserted from the kit of parts. Discard the other fuse (unless, of course, a different voltage operation is anticipated).

All control signals and data track output signals are routed through J1. Figure 2-1 lists the detail routing of these signals and their description is given in Table 3-1. All wire sizes are 22 AWG unless otherwise noted in Figure 2-1. The proper mating connector for J1 has been supplied with the unit.

NOTE: All input and output logic signals are defined for positive logic, mode 5, i.e., logic 0 = 0V and logic 1 = +5V. Therefore, signals that are mode 6, 0V true for logic 1. (action condition) are written with a bar over the designation, e.g., Drive Right Input.

J1			
1			Data Track 1 Output
2			Data Track 2 Output
3			Data Track 3 Output
4			Data Track 4 Output
5			Data Track 5 Output
6			Data Track 6 Output
7			Data Track 7 Output
8			Data Track 8 Output
9			Data Ready Output
10			Data Mode Select Input
11, 12, 13, 24	20 AWG		Signal Ground 0V
14			<u>System Ready (SYSRDY) Output</u>
15			<u>External Inhibit Input</u>
16			<u>Drive Right (DR) Input</u>
17			<u>Drive Left (DL) Input</u>
18			<u>High Speed Enable (HISPD) Input</u>
19			Spare
20			<u>Wind Right External (WR) Input</u>
21			<u>Wind Left External (WL) Input</u>
22			<u>Winding (WDG) Output</u>
23			+5 VDC @ 200 ma Output
25	20 AWG		Chassis Ground

} To External Equipment

Figure 2-1. Reader Connections to External Equipment
See Table 3-1 for Signal Description

2.4.1 TRANSFORMER WIRING CHANGE FOR VOLTAGES OTHER THAN 115 VAC

All units come from the factory with a transformer which allows any of five input voltages to be used: 100, 115, 127, 220 or 240 VAC, 47-63 Hz. Unless otherwise directed by the customer, all units leave the factory wired for 115 VAC. If it becomes necessary to operate on one of the other four voltages, a simple wire change is required.

WARNING

Make sure the power plus is disconnected before making the change.

Power from the AC plug is applied through F101 and S1 to TB1-B5 via a white/green wire. See system schematic, Figure 8-1. It is necessary, then to change the white/green wire at TB1-C2 for 100 VAC, to TB1-B2 for 127 VAC, to TB1-A5 for 220 VAC or to TB1-A2 for 240 VAC. In addition a 1.5 amp fuse from the kit of parts must be substituted for the 3 amp fuse at F1 when using 220 or 240 VAC.

2.5 INTERFACE CIRCUITRY

Figure 2-2 illustrates suggested drive and output circuitry with which to interface with the REMEX circuitry. Note the termination network for the output signals. This should be incorporated into the user's equipment for maximum noise elimination. Table 3-1 lists which circuit is used with each input or output.

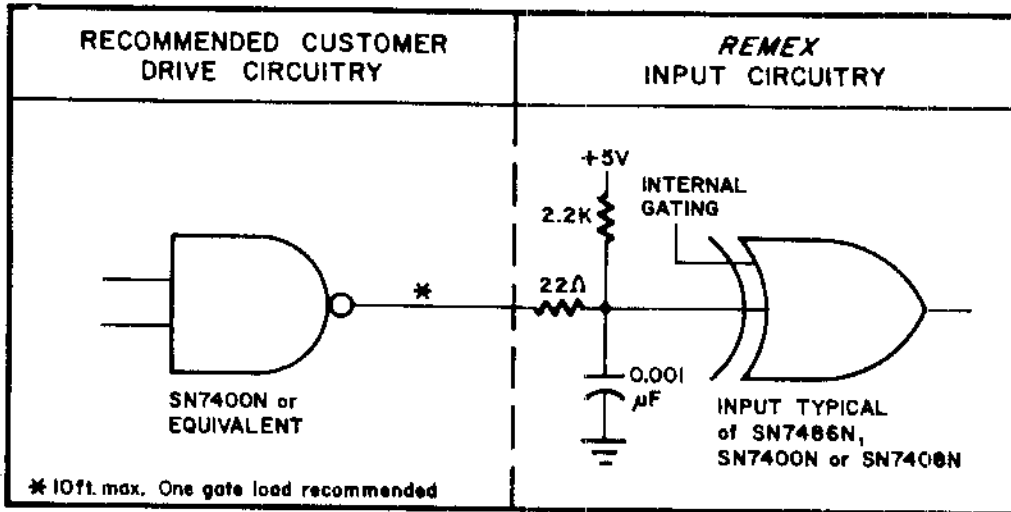

MMC 304A

CIRCUIT A

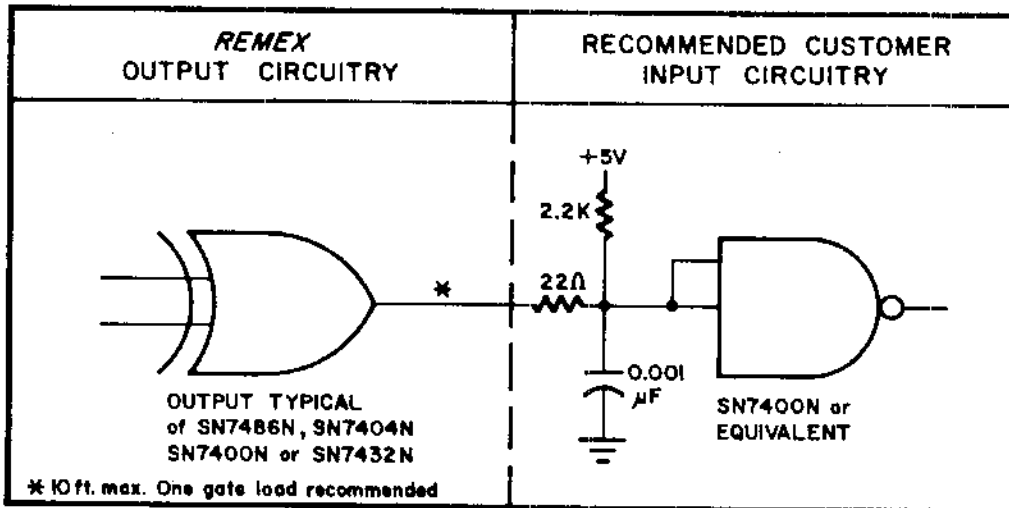

MMC 305A

CIRCUIT B

Figure 2-2. Recommended Interface Circuitry

SECTION 111

OPERATION

3.1 INPUT-OUTPUT SIGNALS

Table 3-1 lists those input and output signals which are routed through connector J1. The definition and/or usage of these signals are also included in table. Figure 3-1 shows the timing diagram for these signals.

3.2 CONTROL FUNCTIONS

Table 3-2 lists the operating controls located on the front panel. A description of the controls and their functions is also included.

3.3 OPERATING INSTRUCTIONS

The following procedure should be used when loading and reading a tape.

3.3.1 TAPE LOADING INSTRUCTIONS

- a. Connect J1/P1 and the line cord. See Caution in Section 2.4.
- b. Place the RUN-LOAD switch in the LOAD position.
- c. Place the ON-OFF switch into the ON position. This will apply power to the unit.

WARNING

Steps b and c should be performed in the order stated. If step c were performed first (ON-OFF in the ON position with SPOOL-LOOP in SPOOL), the spooler would be enabled and any movement of the tape arm could cause rapid rotation of the hub assembly resulting in possible personal injury.

- d. Raise the Upper Tape Guide allowing tape to be loaded. Install the reel of tape onto the hub and thread the tape through the spooler and readhead as shown in Figure 3-2. If a loop of tape is to be read, insert it into the reader and let it hang free of the tape arms.
- e. If a reel of tape is being used, place the SPOOL-LOOP switch in the SPOOL position. If a loop of take is to be used, place the switch in the LOOP position. Lower the Upper Tape Guide to its closed position. This will enable the spooler if the SPOOL-LOOP switch is in the SPOOL position.
- f. Place the RUN-LOAD switch in the RUN position.
- g. Make sure the System Ready output signal at J1-14 is in the true condition, i.e., $0 < V < +0.4$.
- h. Apply $0 < V < +0.4$ to J1-10 to select mode 5 data output and data ready signals or $+2.4 < V < +5.0$ (or open circuited) to select mode 6. See Section 3.3.6.

CAUTION

It is recommended that a reel of newly punched tape be driven through the reader once before attempting to use high speed wind. This will allow the tape to pack on the reel and hence avoiding possible tape breakage.

- i. The reader may now be operated in either of the three modes listed in Sections 3.3.2 and 3.3.3. See Section 3.3.4 for external inhibit operation and Section 3.3.5 for spooler wind mode operation.
- j. To unload tape, stop tape movement, raise the Upper Tape Guide and remove the tape.
- k. To remove power, place the ON-OFF switch in the OFF position.

3.3.2 TAPE DRIVE LOW SPEED, ASYNCHRONOUS OPERATION

In this mode of operation, tape is driven at 150 characters/sec., min., in either a continuous or a line-at-a-time step operation but the controller does not need to be synchronized with the reader outputs.

- a. Perform Section 3.3.1, steps a through h.
- b. Make sure the Data Ready signal at J1-9 is in the true condition depending upon the mode. See Table 3-1.
- c. Place the High Speed Enable input at J1-18 in its false condition ($+2.4 < V < +5.0$ or open circuited).
- d. Apply the following signal to the drive left (DL) line, J1-17 or the drive right (DR) line, J1-16:

STOP:	$+2.4 < V < +5.0$ (2.2K to +5V) or an open circuit
RUN:	$0 < V < +0.4$ @ 5 ma.

The drive signal can be either in the form of a pulse or a continuous DC level which must be removed within 750 μ sec after the leading edge of the true Data Ready signal to stop on character. A pulse must be maintained until the Data Ready signal goes false (typically less than 0.5 μ sec). The next pulse or D.C. level may be applied at any time after the Data Ready signal comes true. See Figure 3-1.

- e. If the drive direction is reversed and the spooler is enabled, all drive signals will be locked out for 500 ms max. to give the servo time to stabilize.
- f. Only one run signal must be present at one time. If both run signals are applied simultaneously, the reader will drive in the last previously commanded direction.

3.3.3 TAPE DRIVE, HIGH SPEED, SYNCHRONOUS OPERATION

In this mode of operation the reader is driven at 300 characters/sec., min., in a continuous mode but the controller must be completely synchronized with the Data Ready signal or else the drive signal can be locked out.

- a. Perform Section 3.3.1, step a through h.
- b. Make sure the Data Ready signal at J1-9 is in the true condition depending upon the mode. See Table 3-1.
- c. Place the High Speed Enable input at J1-18 in its true condition ($0 < V < +0.4$).

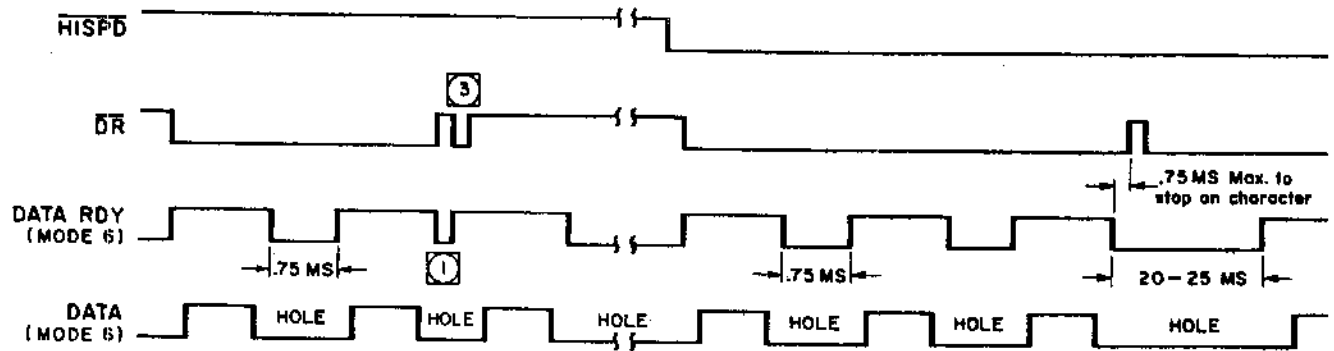

- NOTES:**
- ① IN LOW SPEED, THE DATA RDY SIGNAL GOES FALSE WHEN A NEW DR IS COMMANDED
 - ② IN BOTH MODES, THE MAX DELAY AFTER DATA RDY TO STOP ON CHARACTER IS 750 USEC
 - ③ DRIVE SIGNAL MUST REMAIN TRUE UNTIL DATA RDY GOES FALSE

MMC 402 A

Figure 3-1. Timing Diagram for RRS7300BEX/660/DRB

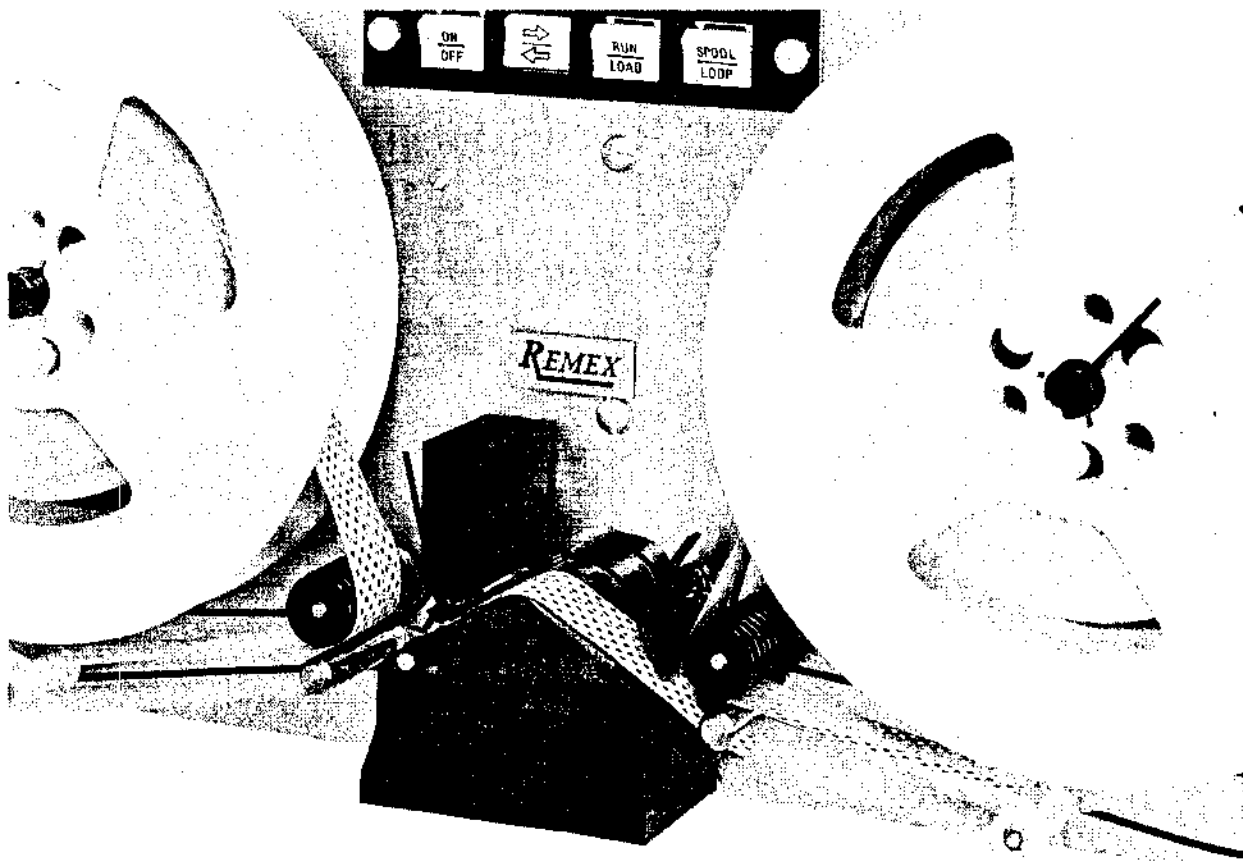

Figure 3-2. Tape Loading

- d. Apply the following drive signal to the Drive Left (\overline{DL}) line, J1-17, or the Drive Right (\overline{DR}) line, J1-16:

Stop: +2.4 < V < +5.0 (2.2K to +5V) or an open circuit
Run: 0 < V < +0.4 @ 5 ma.

The drive signal is a DC level input which drives tape at 300 characters/sec., min. Signal must be maintained until at least the next Data Ready signal goes true, but must be removed within 750 usec. after the leading edge of the true Data Ready signal to stop on that character. After the stop signal is applied, subsequent drive signals will be locked out for 20 to 25 ms before the reader can be driven again. See Timing Diagram, Figure 3-1.

Tape can be driven at high speed manually by depressing the \leftarrow switch for drive left or the \rightarrow switch for drive right. When the $\leftarrow \rightarrow$ switch is used, steps c and d can be eliminated. This operation can be used to wind tape onto either reel of the RRS7300.

- e. If the drive direction is reversed and the spooler is enabled, all drive signals will be locked out for 500 ms. max. from the time the previous drive signal is terminated to give the servo time to stabilize.
- f. Only one run signal must be present at one time. If both run signals are applied simultaneously, the reader will drive in the last previously commanded direction.

3.3.4 EXTERNAL INHIBIT

In this mode of operation, the reader and spooler are inhibited and the System Ready output (J1-14) and the Data Ready output (J1-9) are set to the false state. To place the reader in the inhibit mode apply the following signal to pin 15 of J1:

Reader Not Inhibited: +2.4 < V < +5.0 (2.2K to +5V) or an open circuit

Reader Inhibited: 0 < V < +0.4 @ 5 ma.

3.3.5 SPOOLER WIND MODE OPERATION

During wind mode operation, tape movement is completely controlled by the spooler. All reader drive circuits are inhibited until wind mode is completed. During the wind operation, the Data Ready output (J1-9) displays the sprocket signals as they are being read from the tape. The following procedure should be used during wind mode:

- a. Perform Section 3.3, steps a through h.
- b. Make sure the SPOOL-LOOP switch is in the SPOOL position.
- c. Wind mode is accomplished either from the front panel switch or by external signals as follows:

Front Panel Switches, Manual Wind Control

Depress the ← switch to wind tape onto the left reel or the → switch to wind tape onto the right reel. Release the switch when the desired amount of tape has been rewound. This switch can also be used to drive tape in excess of 300 characters/sec. when the LOAD-LOOP-SPOOL switch is in the LOOP position and a loop of tape is being used.

External Wind Control

Apply one of the following signals to J1-20 for wind right to J1-21 for wind left:

Wind: $0 < V < +0.4 @ 5 \text{ ma. (sink)}$

Stop Wind: $+2.4 < V < +5.0 @ 0.2 \text{ ma. (or open circuit)}$

The presence of both wind signals simultaneously will inhibit the wind function.

3.3.6 DATA OUTPUT MODE SELECTION

The output mode of both the data tracks and the Data Ready output is selectable for either Mode 5 (+5 volt true) or mode 6 (0 volt true) by applying one of the following signals to J1-10:

Mode 5: $0 < V < +0.4 @ 17 \text{ ma. max.}$

Mode 6: $+2.4 < V < +5.0 \text{ (or open circuit)}$

Table 3-i. Interface Signal Description

Connector Pin	Description	Interface Circuit (See Figure 2-2) & I. C. Type	Signal Levels	
			True Condition	False Condition
J1-1 thru J1-8	Data Track Outputs. True signal indicates data track hole and false condition indicates no hole condition. Output mode 5 or 6, selectable (see J1-10).	B SN7486N	<p>Mode 5: $+2.4 < V < +5$ @ 0.2 ma (source) Hole (or Data Ready)</p> <p>Mode 6: $0 < V < +0.4$ @ 16 ma (sink) Hole (or Data Ready)</p>	<p>Mode 5: $0 < V < +0.4$ @ 16 ma. (sink) No Hole (or Data Not Ready)</p> <p>Mode 6: $+2.4 < V < +5$ @ 0.2 ma (source) No Hole (or Data Not Ready)</p>
J1-9	Data Ready Output. True signal indicates data track outputs are in "on character" condition. Signal true with leading edge of feed hole and remains true until next drive signal is accepted. Data Ready signal is forced false by a load condition, external inhibit signal or out-of-tape signal. Output mode 5 or 6, selectable (see J1-10). During wind mode this output displays sprocket signals as they are being read from the tape.	B SN7486N		
J1-10	Data Mode Select Input. True signal places data outputs and data ready output in mode 6. False signal places data outputs and data ready output in mode 5.	A SN7486N	$+2.4 < V < +5.0$ (or open circuit) Data Track & Data Ready signals in <u>Mode 6.</u>	$0 < V < +0.4$ @ 17 ma. max. Data Track & Data Ready signals in <u>Mode 5.</u>

Table 3-1. Interface Signal Descriptions, Cont'd.

Connector Pin	Description	Interface Circuit (See Figure 2-2) & I. C. Type	Signal Levels	
			True Condition	False Condition
J1-11 thru J1-13, J1-24	Signal Ground (0V) to External Equipment. 0V ground reference for all inputs and outputs (isolated from chassis ground).			
J1-14	<p><u>System Ready (SYSRDY) Output.</u> True signal indicates the load switch is in its run position and none of the false condition signals are present (system ready). False signal indicates at least one of the following conditions is present: (1) <u>Load switch actuated</u>, (2) the <u>External Inhibit signal present</u>, (3) either of the tape arms is actuating its tape break switch with spooler enabled, (4) if a drive signal is accepted and a new feed hole is not sensed within 25 ms., this output indicates either no tape or torn tape and serves as the out-of-tape signal.</p>	B SN7400N	0 < V < +0.4 @ 16 ma (sink) System Ready	+2.4 < V < +5.0 @ 0.2 ma (source) System Not Ready
J1-15	<p><u>External Inhibit (EXT INH) Input.</u> True signal inhibits reader operation and causes System Ready and Data Ready signals to go false. False signal allows reader to operate in normal manner.</p>	A SN7408N	0 < V < +0.4 @ 16 ma (sink) Reader Inhibited. Data Ready and System Ready signals False.	+2.4 < V < +5.0 (or open circuit) Reader not externally inhibited.

Table 3-1. Interface Signal Descriptions (Cont'd)

Connector Pin	Description	Interface Circuit (See Figure 2-2) & I. C. Type	Signal Level	
			True Condition	False Condition
J1-16	<u>Drive Right</u> Input. True signal drives tape to right in either continuous mode or asynchronous mode. See Sections 3.3.1, 3.3.2 and 3.3.3.	A SN7400N	0 < V < 0.4 @ 5.0 ma max. Reader drives tape to right.	+2.4 < V < +5.0 (or open circuit) Reader does not drive tape to right.
J1-17	<u>Drive Left</u> Input. Same as drive right except drives to the left.			
J1-18	<u>High Speed Enable</u> Input. False condition and a true drive signal drives tape continuously at 150 characters/sec. True condition and a true drive signal drives tape at 300 characters/sec.	A SN7400N	0 < V < +0.4 @ 5 ma. max. Tape driven at 300 characters/sec.	+2.4 < V < +5.0 (or open circuit). Tape driven at 150 characters/sec.
J1-20	<u>Wind Right External</u> Input. True signal winds tape to right provided the LOOP-SPOOL is in the SPOOL position. False signal allows normal spooling.	A SN7400N	0 < V < +0.4 @ 5 ma. (sink) Spooler winds tape.	+2.4 < V < +5.0 (or open circuit) Spooler does not wind tape.
J1-21	<u>Wind Left External</u> Input. Same as for J1-20 except wind left.			

Table 3-1. Interface Signal Descriptions

Connector Pin	Description	Interface Circuit (See Figure 2-2) & I. C. Type	Signal Level	
			True Condition	False Condition
J1-22	Winding Output. True signal indicates the spooler is in wind mode by either external signal or wind switch and is not available for normal reading operation.	B SN7408N	$0 < V < +0.4$ @ 5 ma. (sink) Spooler in wind mode.	$+2.4 < V < +5.0$ @ 0.2 ma source (or open circuit) Spooler not in wind mode.
J1-23	+5V @ 200 ma output available to external equipment.			
J1-25	Chassis ground; isolated from signal ground.			

Table 3-2. Front Panel Controls

SWITCH	POSITION	FUNCTION
ON-OFF	OFF	Removes AC Power from reader-spooler
	ON	Applied AC Power to reader-spooler.
SPOOL-LOOP	LOOP	Disables the spooler allowing a tape loop to be read.
	SPOOL	Enables operation of the spooler and reader.
RUN-LOAD	LOAD	Inhibits reader and spooler and places <u>System Ready</u> output in false state.
	RUN	Allows reader and spooler to operate and places <u>System Ready</u> output in true state.
DRIVE CONTROL	 (Momentary)	When SPOOL-LOOP switch is in SPOOL, causes tape to be rapidly spooled onto left reel. When SPOOL-LOOP switch is in LOOP, drives tape loop to the left in excess of 300 characters/sec.
	 (Momentary)	When SPOOL-LOOP switch is in SPOOL, causes tape to be rapidly spooled onto right reel. When SPOOL-LOOP switch is in LOOP, drives tape loop to right in excess of 300 characters/sec.

Table 3-3. Modes of Operation

MODES OF OPERATION	DESCRIPTION
INHIBIT	System is in Inhibit mode (drive circuits inhibited when (1) RUN-LOAD switch is in LOAD, (2) External Inhibit input is true (3) either tape break switch is actuated when SPOOL-LOOP switch is in SPOOL, (4) End of Tape Sensor is true, or (5) Power is not up to operating level.
DRIVE	<p><u>Low Speed, Asynchronous Mode:</u> D.C. level or pulse input drives tape at 150 character/sec., min., under the conditions described in Section 3.3.2 and Figure 3-1.</p> <p><u>High Speed, Synchronous Mode:</u> D.C. level input drives tape at 300 characters/sec., min., under the conditions described in Section 3.3.3 and Figure 3-1.</p>

Table 3-3. Modes of Operation (Cont'd)

MODES OF OPERATION	DESCRIPTION
SPOOL	Placing the SPOOL-LOOP switch in the SPOOL position enables spooler to payout and take up tape.
WIND	External signal or front panel switch winds tape (left or right) from one reel to the other at speed of 150 inches/sec. (average mid-reel) provided spooler is enabled. Drive commands are inhibited in wind condition.

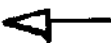
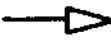
3.4 OPERATIONAL MAINTENANCE

After every 6 to 8 hours of use, the operator should check the tape transport area for cleanliness. This is extremely important since any dirt or foreign material covering the readhead can cause readout errors. For general cleaning, use the stiff bristle brush supplied. Cleaning of the photocell assembly area is described in Section 5.2.1.1. Make sure the tape remains clean at all times since any residue picked up by the tape can be deposited on the readhead. It has been found in certain cases that residue picked up by the tape comes from soiled hands. It is important that care be exercised when handling tape, especially in machining areas or other areas where grease, oil and sprays are present.

3.5 TAPE RECOMMENDATIONS AND AVAILABILITY

The tapes listed in Table 3-4 are among those recommended for use. Mylar tapes should be used in applications requiring continuous use.

Table 3-4. Recommended Tapes

Type	Manufacturer	Part Number
Paper, Unoiled or Oiled (except black carbon filled)	REMEX	715200-002 1000 ft. Roll
	Paper Manufacturers, Inc.	Perfection Series
	Crown Zellerbach	Paper Tape Series
	Bemis or Freiden	Paper Tape Series
Special Paper	Nova Tech	Syntosil Machine Tool Tape
Special Mylar	Arvey	RVCZ 60, RVCT 52
	Chase Foster	PMP 01151
	Numeridex	2000

NOTE: Black carbon tapes may be used but with reduced tape life.

NOT ACCEPTABLE: Arvey RVCP23, Numeridex #0500 and all vulcanized fiber tapes and Chase Foster MFM-153515 and MFM-103515. Also not acceptable: 3M Brand N/C Tape #401 or #301.

3.6 TAPE PREPARATION REQUIREMENTS

Proper tape reader operation requires that the maximum accumulated longitudinal error between feed hole centers in the punched tape be ± 0.025 inch within any span of 5 inches, as specified in the American National Standards Institute Standard X3.18-1967 (ANSI; formerly United States of America Standards Institute). In the event a user has, because of punching problems, a number of tapes which do not conform to this specification by an amount consistently out of tolerance, the reader may be set up as in Section 5.4 using one of these tapes rather than the type specified.

A tape gauge is available from REMEX (part number 110597) so that the ± 0.025 tolerance specification can be checked. To use the gauge, place the feed hole of one end of a 5-inch span (50 characters) at the single cross hair and swing the other end of the 5-inch span in the arc until one of the cross hairs is centered in the feed hole. Read the measurement adjacent to that cross hair (plus tolerances to the right and minus tolerances to the left). A second 5-inch gauge is printed at the bottom to check both longitudinal and perpendicular transverse center line spacing.

SECTION IV

THEORY OF OPERATION

4.1 BLOCK DIAGRAM DESCRIPTION

The REMEX punched tape reader-spooler combination performs three basic functions: (1) it drives tape in either direction over the read station, (2) converts the tape information into electrical signals and (3) spools tape on and off the tape reels. These three functions are described in block diagram form in Sections 4.1.1, 4.1.2 and 4.1.3 and illustrated in block diagram form in Figures 4-1 and 4-2.

4.1.1 TAPE DRIVE

Reader card 113191 contains the circuit logic used to operate the stepper drive motor in response to the drive inputs. The reader can be operated either at 150 characters/sec with the high speed (HISPD) input false or at 300 characters/sec. with HISPD true (at 0V). Operating at 150 characters/sec. will be described first followed by the 300 characters/sec. description. Refer to Figure 4-1 for the Reader Block Diagram. See Figure 8-1 for the overall system schematic.

Applying a 0V, true signal to the drive left (DL) or drive right (DR) input line sets the direction memory in the input logic to the desired state and establishes the direction of rotation for the motor by setting the three phase counter. The input logic also produces the true Drive Gate (DRVG) signal which triggers the Ready Circuit. It is the function of the Ready Circuit to make sure the reader is ready to accept a drive command and, when the drive command is accepted, to generate the motor clock (MCP). The MCP pulse is used to advance the three phase counter one count which steps the motor and, in turn, the tape to left or right one line depending upon the direction previously selected. The tape then stops on character and waits for the next MCP pulse. The Ready Circuit also locks out the sprocket signal for 2 ms after the MCP is generated so that any initial jitter in the sprocket is locked out as the tape starts up and the sprocket goes off character. At the end of the 2 ms time period, the Ready Circuit generates a 1 ms damping pulse which is applied to all three phases of the motor at once to minimize motor oscillations as the tape comes on character.

When the next sprocket hole is read, the sprocket output is amplified, delayed 140 μ s and sent to the Ready Circuit. Upon receipt of the sprocket signal, the Ready Circuit generates the following three signals: (1) a Data Ready signal for use in external equipment, (2) a strobe signal which latches up the data from the read head and (3) a 750 μ s delay to allow data to be examined and make the stop-go decision. At the end of the 750 μ s delay, if the drive has not been removed, the read-drive cycle will be repeated and the tape will advance another line.

In high speed operation (300 characters/sec. speed) the High Speed (HISPD) line is pulled down to 0V which sets the high speed flip-flop FF1. The drive sequence is similar to that

described for low speed operation with the following exceptions: (1) the damping pulse is inhibited and (2) after the initial MCP pulse starts the motor advancing, a second clock pulse is generated as soon as the tape goes off character. This sets the three phase counter one count ahead of the line to which the tape is advancing. When that line is reached, the motor will not stop, unless the drive signal is removed, but will continue rotating one line more. Again when the tape goes off character, the counter is again pulsed. In this manner, the counter is always one count ahead of the line being read on the tape. If, during the 750 us data sampling period the reader drive signal is removed, single-shot SS8 is triggered causing the counter to backup one count and the motor to stop on character. SS8 also triggers SS7 which inhibits the input memory via the Reverse Lock (REV LK) line to allow a settling time of 45 ms.

The reader can be inhibited by any one of four methods: (1) placing the RUN-LOAD switch S2 into LOAD causes both the true 0V Load Signal and the true 0V LDS to be generated, (2) a true, 0V, External Inhibit signal applied to J1-15, (3) either tape break switch in the spooler being actuated or (4) a true 0V Winding signal generated by the spooler indicating the spooler is wind mode. Items 1 and 2 are gated to form the Inhibit (INH) signal which inhibits both the High Speed Logic and the Ready Circuit and places the System Ready (SYSRDY) in the false state. The Winding signal is also applied to the Three Phase Counter and Amplifier to inhibit any motor phase signal and allow the sprocket to freewheel during a winding operation. The System Ready signal also goes false if, after receipt of a drive signal, no new sprocket is sensed within 25 ms, max., indicating that the reader is out of tape.

4.1.2 TAPE READING

The readhead is located under the lamp source and contains photovoltaic cells which are used to sense the punched tape perforations. As tape is advanced over the readhead by the sprocket drive, the photovoltaic cells are energized by the light source when the corresponding holes are present in the tape. Outputs from the readhead are then applied to the data track amplifiers and latch circuits. A 0V, Strobe signal locks up the two latch circuits, Z3 and Z4, thereby storing that line of data. The latch circuit outputs are applied to the Mode Select gates which produces either mode 5 or 6 outputs depending upon the level applied to the Mode Select input. At the same time, the Data Ready output signal goes true and it too is gated with the Mode Select signal.

4.1.3 SPOOLER BLOCK DIAGRAM

The tape spooler portion of the reader-spooler combination performs the following functions: (1) supplies and takes-up tape from the reader during servo mode operation, (2) provides high speed wind in either direction, and (3) provides gating and logic control for the spooler input and output signals. See Figure 4-2 for the Spooler Block Diagram. These modes of operation are discussed below in block diagram form.

Servo mode operation is achieved by the use of an output signal from an arm potentiometer which is proportional to the position of the tape arm. This signal is applied to a summing amplifier which controls a power amplifier that drives the servo motor. When the arm is in the center of its travel, the servo motor is not turned on. However, arm movement, caused by the movement of the tape turns on the motor in the direction which winds or unwinds the tape to bring the arm back to its center position.

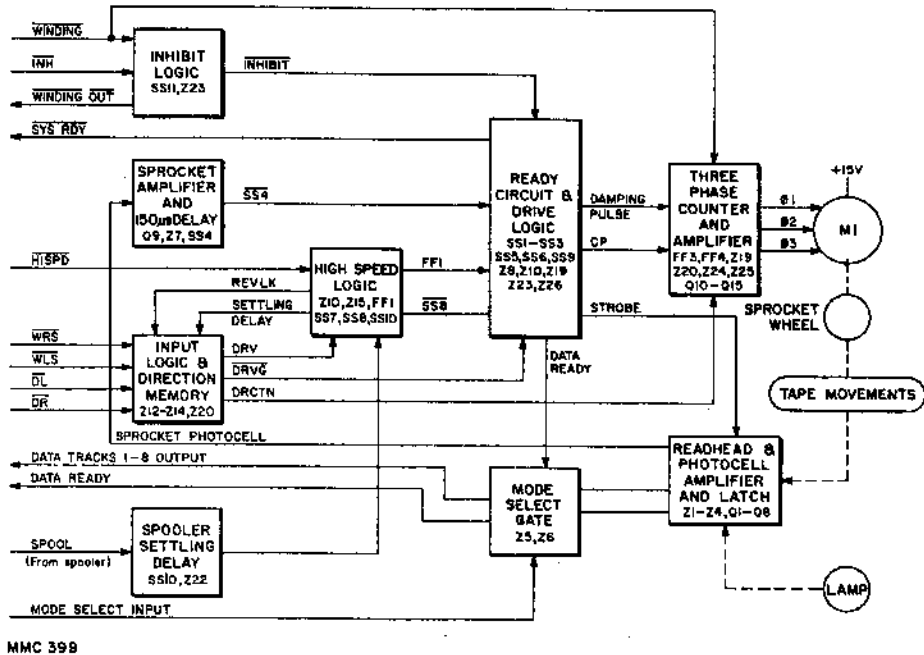

MMC 398

Figure 4-1. Block Diagram, Reader Circuitry

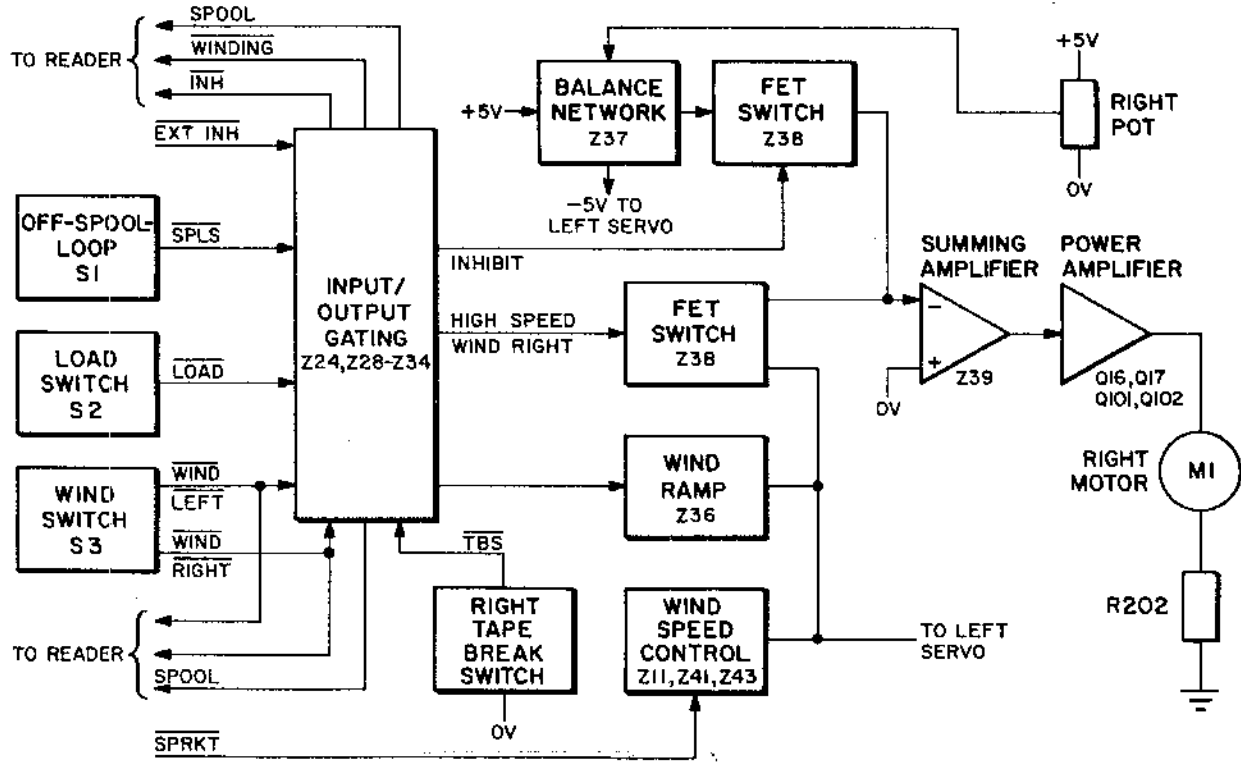

MMC 398

Figure 4-2. Block Diagram, Spooler Circuitry

Wind mode operation can be initiated from either a front panel switch or an external input which is applied to the Input/Output Gating circuitry provided the spooler is enabled. The resulting Wind signal closes a FET switch which allows the Wind Ramp and the Wind Speed Regulator signals to be summed at the input of the Summing Amplifier. Wind mode begins slowly as an increasing ramp from the Wind Ramp circuitry and gradually brings the servo up to a fixed speed. As the tape begins moving, the Sprocket signal from the reader is applied to the Wind Speed Regulator circuit. This circuit regulates the winding speed throughout wind mode by sampling the frequency of the sprocket and generating a second input to the summing amplifier which is proportional to the frequency. Normal Servo action occurs at the trailing side as the tape unwinds to meet the demand of the leading side. Wind operation also ends slowly allowing the spooler to gradually come to a stop.

In addition to the functions previously described, the Input/Output gating also performs the following functions:

- a. Wind switch inputs are gated with the external $\overline{\text{Wind}}$ inputs to generate a High Speed Wind signal for a given direction. If both direction wind signals are present at the same time, neither High Speed Wind signal becomes true.
- b. An $\overline{\text{External Inhibit}}$, Load, Broken Tape signal or the SPOOL-LOOP switch not being in the SPOOL position will inhibit both spool and wind operations.
- c. The $\overline{\text{Winding}}$ output, used by the reader, is held true until the winding operation is complete and the winding ramp has dropped to its original value.
- d. A Spool signal is generated whenever the SPOOL-LOOP switch is in the SPOOL position and is used by the reader to insert a delay when driving from one direction to the other.

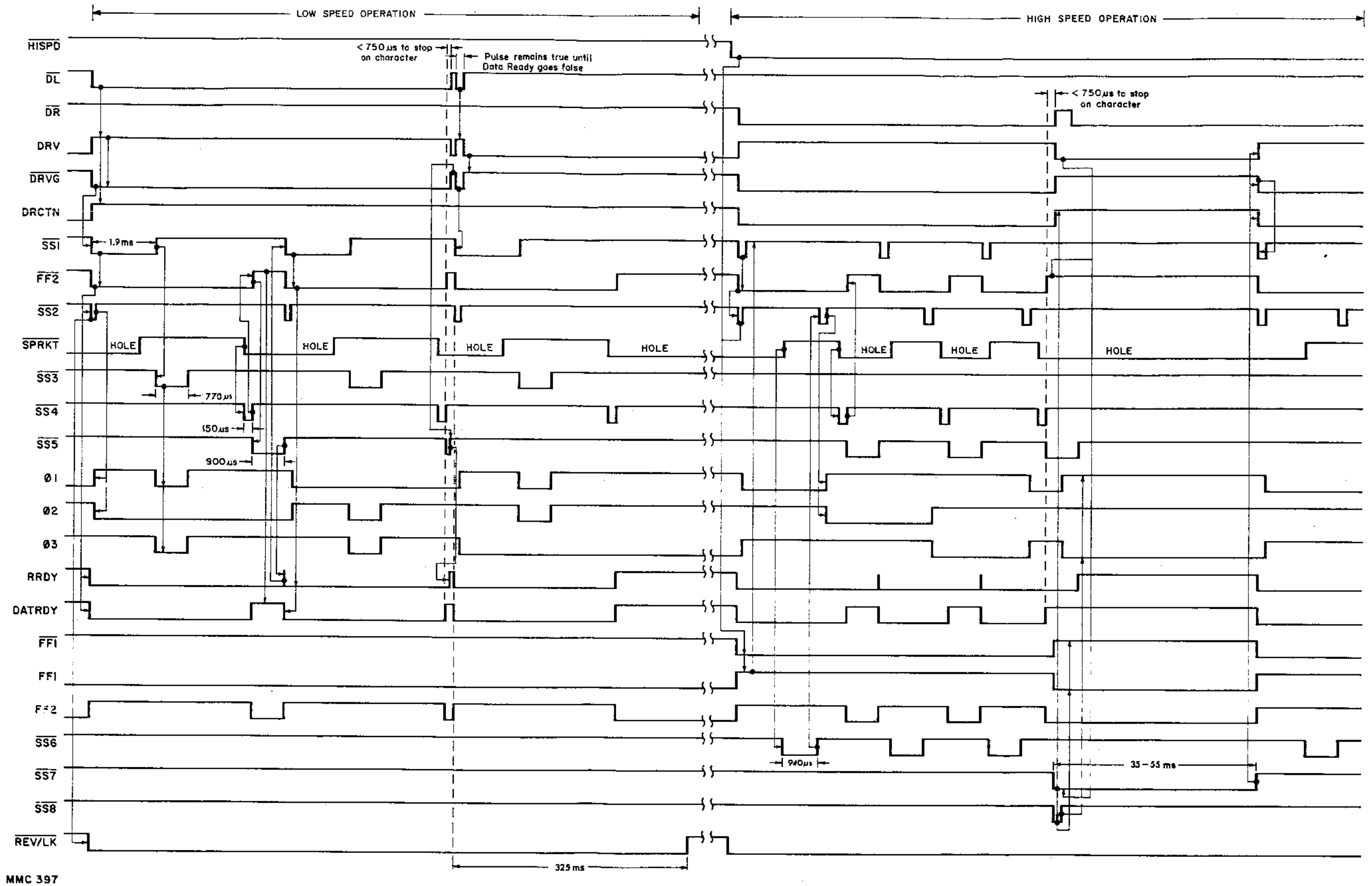

Figure 4-3. Timing Diagram, Reader Card 113191.

4.2 CIRCUIT CARD DESCRIPTIONS

4.2.1 READER CIRCUITRY

The reader circuitry on PC card 113191 is used: (1) to generate outputs to drive the three phases of the stepping motor in response to the drive inputs and (2) to provide amplification and gating of the readhead outputs.

4.2.1.1 Drive Circuits

Normal operation begins with the loading of the tape. Placing the RUN-LOAD switch into LOAD actuates S2, (sheet 1 of Figure 8-2), causing 0V (LDS) to be applied to Z28-13 and, in turn, placing both pins 11 and 6 (Inhibit line, INH) of Z28 at 0V. See sheet 3 of Figure 8-2. Notice also that the true INH signal can be generated by either a 0V, External Inhibit (EXT INH) or a Tape Break Switch (TBS). The INH signal is applied to Z23-2 (sheet 1 of Figure 8-2) which causes Z23-3 to go to 0V and perform four functions: (1) it clears and inhibits flip-flop FF2, thereby, preventing any sprocket from being recognized, (2) through Z23-11 and Z26-11, it causes the Reader Ready (RRDY) signal to drop to 0V which prevents any drive signal from being recognized, (3) through Z23-11, Z7-12 and Z8-3 places the Data Ready (DAT RDY) signal at 0V, thereby inhibiting data, and (4) through Z19-6 clears and inhibits flip-flop FF1 which prevents any High Speed (HISPD) signal from being recognized. The INH signal is also applied to Z8-9 causing a false (+5V) System Ready (SYSRDY) signal to be generated. After tape has been loaded, the RUN-LOAD switch is placed in RUN and the inhibiting effects of S2 are removed, making the reader operational.

During the following description, refer to Figure 4-3 which shows the waveforms and timing diagrams for the drive, step and high speed operations. This figure is intended as a guide to show the sequence of events and which signals initiate other signals. It must be cautioned that due to the wide range of pulse widths, no attempt has been made to draw the time axis to exact scale. Refer also to the schematic, Figure 8-2, sheet 1, during this description.

With the inhibiting signals removed, the $\overline{\text{SYSRDY}}$, $\overline{\text{DATRDY}}$ and internal RRDY signals are true allowing the drive signal to be recognized. The drive circuitry will be discussed first with a false HISPD input and then with a true 0V HISPD signal. Applying a true, 0V, DL signal at J1-17 sets the direction flip-flop, composed of Z12 and Z13, to the drive left state. This causes the clockwise (CW) line at Z13-6 to drop to 0V and the Direction (DRCTN) line at Z20-6 to rise to +5V (Z20-5 is at +5V since the high speed circuitry is not enabled). A +5V DRCTN signal sets up the three phase counter, composed of FF3, FF4, Z19 and Z20, to energize the motor phases in the sequence which drives tape to the left, i.e., phase 3, phase 2 and then phase 1 (drive right is the reverse order). The counter is advanced one count with each clock pulse received from S52 as described in a subsequent paragraph. The 0V CW line also causes Z48-6 to rise to +5V and turn on Q20 which energizes L1. During drive left the right roller L1 is released. L1 and L2 are solenoids which operate holding pins on the right and left tape rollers, respectively. During servo mode the roller on the take-up side does not rotate, causing friction to be applied to the tape, thereby producing tighter reel packing. The pin on the other side is released, allowing the roller to be free wheeling.

The 0V, DL signal also generates the 0V true Drive Gate ($\overline{\text{DRVG}}$) signal at Z14-8 which is used to trigger single-shot S51 at input A. Output S51 then goes to 0V which

sets flip-flop FF2, resulting in the negative going FF2 which triggers SS2. The negative going SS2, in turn, is applied to the three phase counter through Z19-3 causing it to step one count. A new motor phase is now energized which moves the tape one line to the left. FF2 also causes the DATRDY signal to go false (0V) through Z23-11, Z7-12 and Z8-3; FF2 causes the SYSRDY signal to go false (+5V) through Z8-11 and Z8-8. FF2 stays locked in the set condition until SS1 times out (approximately 2 ms). As a result, any noise or start-up jitter from the Sprocket signal is prevented from generating a true Data Ready signal. The positive going edge of FF2 also triggers SS9 which is a retriggerable single-shot timed for 25 ms, max. Output SS9 is combined with FF2 to produce an out-of-tape sensor at Z8-11. If SS9 is not retriggered within 25 ms and if no sprocket is sensed (FF2 remains high) then Z8-11 drops to 0V. This places the System Ready signal at Z8-8 in the +5 false state, indicating that the system is not ready.

At the end of the 2 ms period, FF2 is released, but by this time, the tape is up to speed and the only signal available to reset FF2 is the positive going edge of the Sprocket Delay single-shot output SS4. The positive going edge of SS1 at the end of the 2 ms period is used to trigger single-shot SS3. As a result, SS3 is held at 0V for 1 ms and is applied as a negative OR combination to Z24-1, Z24-12, Z24-9 causing the remaining two motor windings which are not energized during a given phase sequence to become energized for 1 ms. This momentary energizing of all three motor phases dampens the inherent oscillations present in all stepping motors as it moves on character. R20 controls the width of SS3 and is adjusted as described in Section 5.4.

When the next line is read, the negative going edge of the Sprocket signal triggers the 140 μ s Sprocket Delay single-shot SS4. This delay is required when using a feed hole advanced tape to electronically delay the feed hole and make sure all data is latched before the sprocket is recognized. With standard in-line feed holes this serves only to add an extra safety margin. At the end of the 140 μ s delay, the positive going edge of SS4 resets FF2. The resulting positive going edge of FF2 is used two places: (1) to trigger single-shot SS5 and (2) to generate the positive going DATRDY signal through Z23-11, Z7-12 and Z8-3 (and the only 0V Strobe 1 and Strobe 2 signals at Z7-4 and Z7-6). The inverse 0V, FF2 signal places the SYSRDY signal in the true 0V condition through Z8-11 and Z8-8. The function of SS5 is to provide a 750 μ s delay by holding the RRDY line at 0V. This allows the external equipment to examine the data and make the go/no-go decision. If the decision to stop is made, the DL input line must be taken high within 750 μ s (actually 900 but conservatively specified at 750 μ s). Otherwise, when SS5 times out, the positive going RRDY will trigger SS1 and repeat the tape advance cycle. If the drive line is taken false and then returned to the true state during the 750 μ s period of SS5, SS5 will be reset by the signal from Z10-6 applied to Z27-11 and the next drive sequence will begin immediately.

During low speed (150 cps) operation, the HIRSPD line is taken high (or open circuited). A 0V signal applied to J1-18 and a true drive input cause the reader to operate in excess of 300 characters/sec. Applying 0V to Z10-1 causes Z10-3 to go to +5V and in, turn, Z15-3 goes to +5V provided the drive signal is present (DRV is +5V at Z15-1). When the first MCP signal is generated, SS2 drops to 0V and is inverted to +5V at Z7-10. This signal, gated with the +5V at Z10-12, results in Z10-11 dropping to 0V and setting flip-flop FF1. This flip-flop is used to modify the previously described low speed drive sequence by performing the following functions: (1) FF1 inhibits the 1 ms damping pulse SS3, (2) FF1 enables gate Z10-8 so that as soon as flip-flop FF2 is set by SS1, the FF2 output, through Z10-8, clears SS1 and removes the 2 ms hold off, (3) after the first MCP is generated at Z27-4, FF1 at Z26-5 holds Z27-1 low so that the only trigger pulses applied to SS2 is via SS6 (discussed in the next paragraph), and (4) FF1 enables SS6 so that it is triggered on the positive going edge of the SPRKT signal.

When the tape moves off character, the positive going SPRKT signal triggers the 1 ms one-shot SS6. At the end of the 1 ms, the positive going SS6 signal triggers SS2 which generates a second clock pulse. The clock pulse is also applied to the counter and advances it one count ahead of the phase to which the motor is being advanced. Thus, when the next character is reached, if the reader has not been told to stop, the motor will continue advancing to the next character without stopping. Each time the tape goes off character, the counter will again be pulsed causing it to always be one count ahead. It should be noted that after the initial MCP is generated by FF2 going low, FF2 does not generate any more MCP pulses on subsequent lines since Z26-5 is held low. This coupled with the absence of the motor damping pulse SS3 allows the reader to drive tape in excess of 300 characters/sec.

If, during the period that FF2 is set, the drive signal is removed, the DRV signal will drop to 0V and trigger single-shot SS7. The resulting negative going SS7 performs the following functions: (1) provides a 45 ms inhibit to the REVLK line and therefore to the drive logic which allows the motor to settle before the next drive signal is recognized, (2) reverses the DRCTN line at Z20-6, (3) triggers single-shot SS8, and (4) inhibits any drive signal at Z14-9. With the DRCTN line reversed, the negative going SS8 signal causes the three phase counter to back up one count which puts it in phase with the existing motor position, causing it to stop. SS8 is also used to reset the High Speed flip-flop FF1. When SS7 times out, the REVLK signal returns to +5V and the reader is ready to accept the next drive signal.

Out of tape sensing is accomplished by combining the FF2 output with SS9 output at Z8-12 and 13. SS9 is triggered by the positive going edge of FF2 at the beginning of the drive sequence. If SS9 is not retriggered within approximately 25 ms and if no sprocket is sensed, then the positive going SS9 and the true FF2 signals are combined at pins 12 and 13 of Z8 to generate the true 0V End of Tape (EOT) signal at Z8-11. The System Ready signal at Z8-8 then rises to +5V false state, indicating that the system is not ready.

4.2.1.2 Tape Reading Circuits

Nine photovoltaic cells in the readhead assembly sense the perforations in the tape. Refer to Figure 8-2, sheet 2. An illumination system consisting of a lamp and fiber optics provides a continuous beam which covers the area of the photocells. The tape is driven over the top of the photocell block and when a hole appears between the photocell and the light source, the photocell becomes energized.

Each cell output is applied to an amplifier-latch circuit, Q1-Q8, Z3 and Z4. Track 1 is used in the following discussion since it is typical of tracks 1-8 (the Sprocket signal is developed differently as described in a subsequent paragraph). When track 1 becomes energized, the negative going signal at the cathode of the photocell turns off Q1. Q1 is interconnected with the D4 input and Q4 output of Z4 in a manner which allows Q1 and the first stage of Z4 to function as a Schmitt trigger. Z4 follows all changes in photocell output until the 0V strobe 1 signal (see Section 4.2.1.1) is generated which locks up Z4.

Track 1 output at Q4 is +5V true and is gated with the Mode Select signal at Z5-9 and 10. A 0V Mode Select input provides a mode 5 output at J1-1 (i.e., 0V for no hole and +5V for hole). Conversely, when the Mode Select signal is +5V, J1-1 will produce a Mode 6 output (i.e., +5V for no hole and 0V for hole). The DATRDY output is gated in the same manner as the track outputs at Z20, pins 1 and 2.

The sprocket track is somewhat different than the other eight tracks in that its Schmitt trigger uses an inverter, Z7, rather than part of a latch and is independent of either the Strobe or DATRDY signals. See Figure 8-2, sheet 1. It is also used only as an internal

logic signal and is not gated with the Mode Select signal. Both the SPRKT and $\overline{\text{SPRKT}}$ signals are generated and used in the internal logic.

4.2.2 SPOOLER CIRCUITRY

The spooler circuitry is used to perform three basic functions: (1) to control the payout and take-up of the spooler motors during servo mode operation, (2) to provide high speed wind in either direction and (3) to provide gating and logic control for the spooler input and output signals. Refer to Figure 8-2, sheet 3 during this description.

4.2.2.1 Servo Mode Operation

Because the 113191 card contains identical servo motor circuits for each side, the discussion will be confined to the right servo. Operational amplifier Z39 and the power amplifier consisting of Q16, Q17, Q101 and Q102 are used to control the right motor, M1. During servo mode, the only input to Z39 is from the right arm potentiometer which generates a signal proportional to the movement of the tape arm. This signal is biased by the -5V output from pin 6 of Z37 and summed with a feed back signal from R76. The FET switches at Z38-7 and Z42-7 are turned off when the SPOOL=LOOP switch is in SPOOL except during inhibit modes as described in Section 4.2.2.3. A +5V SPLS signal causes Z29-6 to go to +5V, Z28-8 to go to +5V, Z48-8 to go to 0V, and Z34-12 to go to +5V which shuts off Z38-7 and Z42-7. The potentiometer is adjusted so that when the arm is in the center of its travel area, the output of the summing amplifier Z39 causes no reel rotation, i.e., Q16 and Q17 are both turned off. The tape arm is spring loaded and follows the movement of the tape. When a tight tape situation occurs causing the tape arm to move in toward the readhead, the output at Z39-6 goes positive which turns on Q16 and Q101 and energizes the motor. As a result tape is payed out causing the arm to move back to the center which then shuts off the amplifier. Conversely, if a tape slack condition occurs, the spring loaded arm moves out toward the limit stop. The output of Z39-6 then becomes negative which turns on Q17 and Q102 and energizes the motor so that tape is taken up and the arm moves back toward the center. Refer to Section 4.2.2.4 for a discussion of the tape tension operations.

4.2.2.2 Wind Mode Operation

During wind mode, the payout side operates entirely in servo mode as described in Section 4.2.2.1. The take-up servo in wind uses the following two inputs in addition to the arm potentiometer: (1) a ramp generator input which gradually brings the take-up motor up to speed and (2) a wind speed regulator input which is produced by sensing the frequency of the sprocket holes. This circuit will be discussed in a subsequent paragraph.

Applying a 0V true, Right Wind signal from either the direction switch, S3, or an external input sets the direction memory composed of Z31 and Z32 and places Z32-3 at 0V and, in turn, Z29-8 at +5V. At this time, S1 is in the SPOOL position (SPLS at 0V) and the inhibit signal is +5V placing Z28-8 at +5V. This signal is then gated with the +5V at Z29-8 causing Z29-11 to drop to 0V. Operational amplifier Z36 switches on causing C26 to charge. Meanwhile Z32-11 has been set to +5V which places Z33-6 at +5V. This causes Z34-10 to drop to 0V which turns on FET Z38 at pin 2. The FET switch allows both the ramp generator output at Z36-6 and the speed regulator output at Z41-6 to be summed at Z39-2. Pin 6 of Z39 then goes negative causing the right reel to take-up tape. As C26 charges, the right motor gradually increases its rotational speed. Adjustable resistor R63 controls the level to which C26 charges and hence the wind speed and is adjusted as described in Section 5.8.

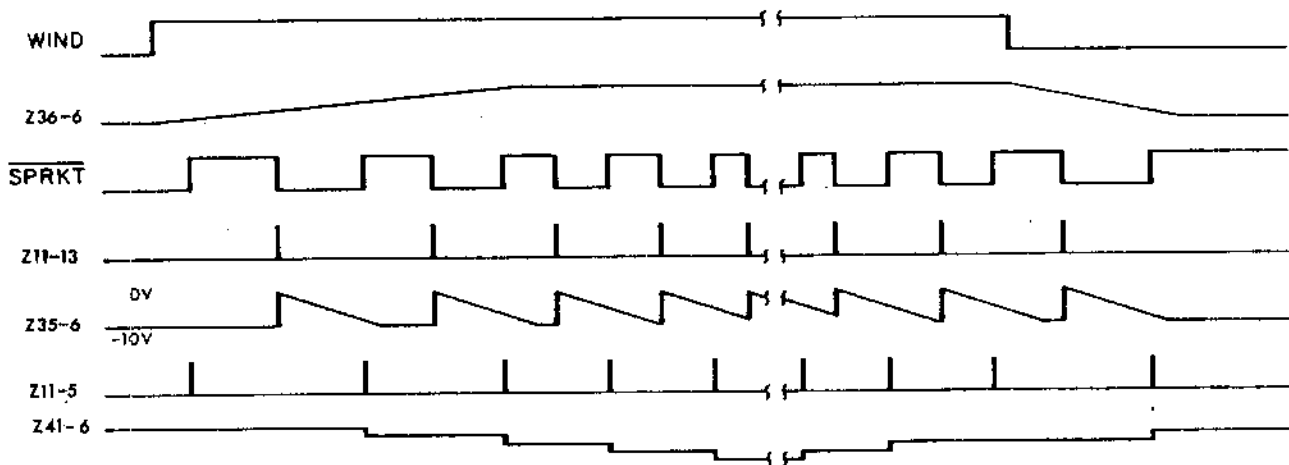

MMC 622

Figure 4-4. Timing Diagram, Wind Speed Regulator Circuitry

The ramp signal is also applied to Z33-10 which switches its output at Z33-8 to +5V. This in turn, switches Z34-6 to 0V and generates the Winding output at Z25-3 which is used to lock up the reader direction memory and inhibit the reader drive circuits. See Section 4.2.1.1. The Winding signal is also applied to pins 1 and 4 of Z48 (Figure 8-2, sheet 1) causing Q20 and Q21 to turn on and energize solenoids L1 and L2 which release the holding pins on the two tape rollers. During servo mode, the roller on the take-up side applies friction to the tape, thereby producing tighter reel packing. In wind, since the tape travels at a high speed, the drag on the tape is eliminated allowing the tape rollers to be free wheeling.

To maintain a constant wind speed, the frequency of the SPRKT signal is sampled and converted to a DC level and summed with the wind input signal at Z38-3. Figure 4-4 shows the timing diagram for the wind speed regulator circuitry, composed of Z11, Z34, Z35, Z41 and Z43 and the associated components. As the SPRKT output is generated, it is applied to both pins 1 and 10 of Z11 causing a positive going pulse at pin 13 on the negative going edge of the SPRKT and a positive going pulse at pin 5 on the positive going edge of the SPRKT. Z11-13 is inverted at Z34-2 and turns on Z43 at pin 2 for 35 us. With Z43 on, C42 discharges through R49 causing Z35-6 to rise to 0V. When Z43 turns off, C24 again charges through R46 resulting in a declining ramp at Z35-6 which drops to approximately -10 VDC.

Halfway thru the declining ramp, the pulse at Z11-5 is generated by the positive going edge of the SPRKT signal. This signal is, in turn, inverted at Z34-4 and turns on Z43 at pin 7. Pin 2 of Z41 at this time samples the ramp generated at Z35-6 which is biased by R48, R50, R51 and R52 to a level slightly above ground. The output at Z41-6 then is a negative DC level which is summed at Z38-3 with the winding ramp input. If the speed increases, the frequency of the SPRKT signal increases causing Z35-6 to be sampled earlier in the ramp. This increases the voltage at Z41-2 and, in turn, applies a more negative voltage at Z41-6 to offset the wind input. Conversely, a decrease in speed causes the ramp to be sampled later, resulting in a decrease in voltage at Z41-2 and a less negative voltage at Z41-6.

4.2.2.3 Inhibit Mode

Any of the following signals will inhibit the spooler: (1) a true 0V External Inhibit (EXT INH) signal present at J1-15, (2) the SPOOLER-LOOP switch not being in SPOOL, (3) a broken tape switch signal (TBS at 0V) or (4) a true, 0V LDS signal from S2.

Considering the EXTINH and LDS signals first, a 0V signal at Z28-12 or Z28-13 places 0V at Z28-11 and, in turn, at Z28-6 and Z28-8. A 0V signal at Z28-8 inhibits the spooler by causing Z48-8 to go to +5V and Z34-12 to go to 0V and turn on FET switches Z38 and Z42 at pin 7. This places R104 in the feedback loop of Z39 and causes the gain to drop below 1. Similarly, a +5V SPLS signal places Z29-6 and, subsequently, Z28-8 at 0V. When a tape break switch is actuated, the resulting 0V signal is inverted at Z48-11 and applied to both Z28-1 and Z30-2. Single-shot Z30 provides a 230 ms delay so that an accidental switch actuation is not recognized. If the switch is not actuated longer than 230 ms, Z48-11 will return to 0V before Z30-4 times out and no change will occur at Z28-3. However, if SPLS is longer than 230 ms, Z28-3 will go positive causing Z29-3 and subsequently Z28-6 to drop 0V and inhibit the spooler as previously described.

4.2.2.4 Tape Tension Description

Tape handling, at all speeds, requires that the proper tape tension be maintained. This is especially true when rapid, hi-torque starting, reversal of direction, and stopping is necessary. In addition, at times it is necessary to maintain different tape tensions at various points of travel throughout the tape transport mechanism due to the different and simultaneous requirements of the various tape mechanisms.

For example, in order for the tape to be moved over the readhead in a start-stop "geneva" mechanism fashion, the tape must have a certain tension applied in order to flow smoothly. At the same time, in order to insure proper packing on the take up reel, the tape must have a constant tension applied which is significantly different than the tension at the readhead. This is necessary to prevent uneven winding or loose pack on the take up reel.

The REMEX RRS7300D utilizes a unique combination of tape handling devices designed especially to maintain the required tape tension at each point of travel throughout the tape handling process. The tape travel and associated tension requirements are described in the following paragraphs and illustrated in Figure 4-5.

Assume that a full reel of tape is loaded on the right hand reel and an empty reel is placed on the left spindle. As the tape is moved from right to left during servo mode, it passes by a number of points which require different tension. As the tape is wound on the left hand reel, it starts winding on a small diameter since the reel is nearly empty. This means that the take up motor, if it were a fixed power or constant torque motor, would have a greater wind torque advantage when the reel was empty than when the reel was nearly full. To overcome this effect of varying tape diameter, a variable torque motion is used which is controlled by the position of the tape tension sensing arm. This arm indicates to the motor when and how much tape to take up by means of a potentiometer attached to the arm which controls a dc servo. When the reader stepper motor drives tape toward the left reel, the tape sensor arm senses the slack in the tape causing the take-up motor to rotate counterclockwise. This takes the slack out of the tape and moves the sensor arm back to its mid-range.

Thus, it can be seen that the tension applied to the tape by the sensor arm is the tension at which the tape passes the readhead or point (C). The tape sensor arms are adjusted so that with the stepper motor stopped, the torque applies just the amount of tension to the tape required to hold the tape sensor arms in their approximate mid-position. Since the take-up

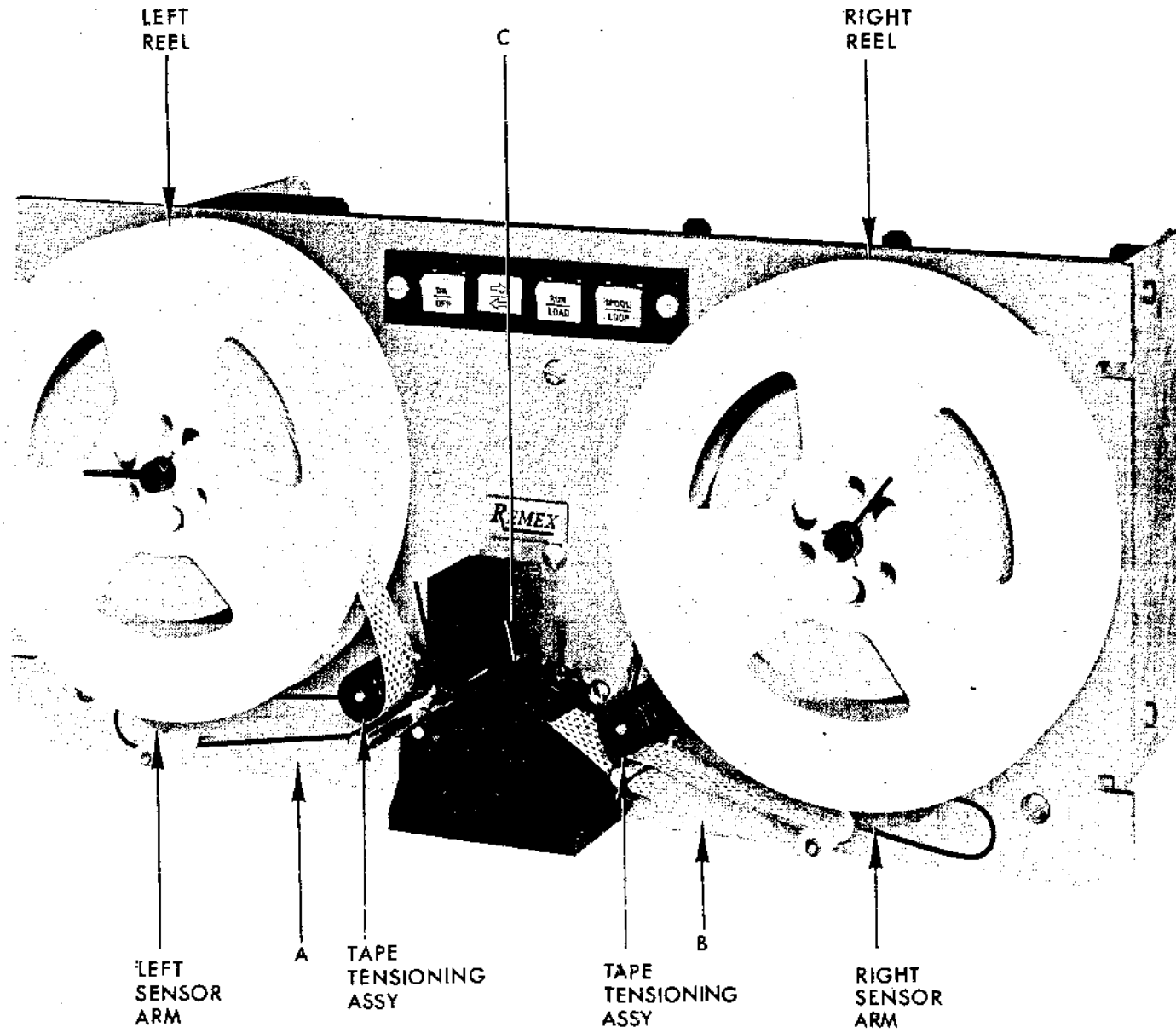

Figure 4-5. Front View Showing Various Points of Tape Tension

and supply motors always return their arm to the mid-position, it is evident that the tension applied to the tape across the read head is a function of the tape arm return spring tension.

The tape at point (A) where it winds onto the left reel must be kept at a higher tension than at point (C) and must be reasonably constant throughout the take-up process. This is accomplished by a special tape tensioning assembly which applies tension only when, in servo mode, its associated reel is taking up tape, eg., left tape tensioning assembly when tape moves to the left. The opposite assembly at this time is free wheeling. A solenoid clutch arrangement is used to accomplish this. The solenoid on the take-up side is turned off which causes the solenoid plunger to engage a frictionplate and thus apply a constant drag or tension on the tape as it winds up. See Section 4.2.2.2 for electronic description. Thus it can be seen that the tape at point (A) has a higher tension than at points (C) or (B) when tape is moving from right to left. Both solenoids are energized during wind to eliminate tape tension. Adjustments for the potentiometer, the tape sensor arm spring tension and the static torque on the tape tensioning assembly are given in Section 5.

4.2.3 POWER SUPPLY VOLTAGES

Five voltages are generated by the power supply section: +5VDC, +14VDC, 15VDC, and +24VDC. The +5 VDC is developed from the secondary winding on transformer T1 and is rectified by BR2 to produce approximately +15 VDC and -15 VDC unfiltered. The +15 VDC is used two places: (1) as the supply for the operational amplifiers (dropped to +14 VDC through R94) and (2) as the input to the +5 VDC regulator. Z101 and Z102 and their related circuitry comprise the two +5 VDC regulators. Z101, pin 2 is used for the +5 VDC IC requirement and Z102, pin 2 is used for the lamp voltage. R96 allows the lamp to be adjusted for the requirements described in Section 5.4. Z101 and Z102 are commercially packaged five volt regulators, LM309K, which are mounted on a heat sink external to the card. The +24 and -24 VDC supplies are generated by bridge rectifier BR1 and filtered by C102 and C103.

4.3 LIGHT SOURCE

A filament type lamp rated at 5.0 VDC is used as the light source. It is operated at approximately 15% below rated voltage to provide a long life expectancy. The lamp is mounted in a sleeve at the rear of the front panel. A lens contained in the lamp focuses the light to the fiber optics system which, in turn, conducts the light to the photocells.

SECTION V

MAINTENANCE

5.1 GENERAL

The REMEX punched tape reader-spooler has been designed to keep maintenance as simple and infrequent as possible. Table 5-1 lists the maintenance equipment required for the various procedures. To prolong the life of the equipment and minimize down-time, certain checks and preventive procedures are set up in Section 5.2 and Table 5-2 with suggested schedules. Section 5.3 outlines possible malfunctions along with probable causes and remedies. The remaining sections describe the required adjustment procedures. Replacement procedures are given in Section 6.

Table 5-1. Maintenance Equipment Required

ITEM	QUANTITY
* Frequency Counter, 10Hz to 1 MHz, 5V input	1
Miller-Stephenson MS-200 Magnetic Tape Head Cleaner (REMEX Part Number 716004-150)	1
* 0.010 and 0.0075 inch plastic shim stock. Available from Artus Corp., 201 So. Dean St., Englewood, N.J. 07631	
* Pulse Generator, 10 Hz to 1 KHz, up to +5V amplitude, 1 us to 100 ms width	1
* Oscilloscope, DC to 10 MHz, single sweep	1
Tape Gauge, REMEX Part Number 110597	1
* Torque Watch [®] , Waters Model 651C-1 or equivalent	1
* Voltmeter, Digital 0-0.1 ma, 0-100 mv dc, 0-100 V dc, 100 K impedance or greater	1
* These items are not available from REMEX	

5.2 PREVENTIVE MAINTENANCE

Preventive maintenance, which includes cleaning and lubrication, should be checked periodically in order to maintain peak performance. In addition, in order that the warranty remain in effect, the unit must be maintained in accordance with the instructions outlined below (see Section 1.4 and page iii). A preventive maintenance schedule and log are presented in Table 5-2 which indicates the item, frequency of action and references the maintenance paragraph in this section. For customer convenience the table is arranged so that a log can be kept of when each maintenance procedure was performed. Also refer to Section 3.4., Operational Maintenance.

NOTE

The frequency of cleaning as listed in Table 5-2 has been adopted for clean environmental conditions and usage. These items, however, may vary greatly from one installation to another. For example, a reader used in a machine shop to program numerical controls may require maintenance procedures considerably more frequently.

5.2.1 CLEANING

CAUTION

In all cleaning procedures, avoid using cleaning methods and materials other than those recommended in this manual. Certain cleaning compounds will damage parts of the reader, especially in the readout assembly area. REMEX primarily recommends the use of Miller-Stephenson MS-200 Magnetic Tape Head Cleaner (REMEX Part Number 716004-150) for most areas requiring cleaning. However, due to the degreasing nature of the cleaner, it should not be used in areas where the spray may come in contact with bearings or other oiled parts. This cleaner may be obtained from REMEX or directly from Miller-Stephenson Chemical Company at one of the following locations:

1001 East First Street
Los Angeles, California 90012

1350 W. Fullerton Avenue
Chicago, Illinois 60614

Route 7
Danbury, Connecticut 06810

To use the cleaner, hold the spray can 4 to 6 inches away from the area to be cleaned and allow spray to flush the dirt off. If a heavy buildup is present, loosen with the spray mist and scrub with a cotton swab. A 6-inch pin-point, spray nozzle extension is available for hard-to-reach areas or for delicate applications. Avoid spraying on lubricated surfaces or parts and on the lamp assembly and lens.

If the Miller-Stephenson cleaner is not available, a small amount of isopropyl alcohol applied to a clean, lint-free cloth or cotton swab may also be used. However, it should be used carefully and sparingly since damage to the photocell and the finish on the plastic cover may result. Use only clear, unadulterated isopropyl alcohol. Do not use ethyl alcohol or denatured alcohol as the denaturing agents vary and may damage the reader.

It is important that, whether the MS-200 cleaner or the isopropyl alcohol is used, only the amount required to clean the surfaces be applied. Never saturate or drench the areas to be cleaned. Never apply these materials to the lamp assembly.

Table 5-2. Preventive Maintenance Schedule and Log

Frequency* of Action Weeks	Date	Initial	Frequency* of Action Weeks	Date	Initial	5.2.1.1				5.2.1.5	5.2.3	5.4,5.5,5.6	5.7,5.8,5.9
						Cleaning							
2			28			X	X	X	X				
4			30			X	X	X	X				
6			32			X	X	X	X				
8			34			X	X	X	X				
10			36			X	X	X	X				
12			38			X	X	X	X				
14			40			X	X	X	X		X	X	X
16			42			X	X	X	X				
18			44			X	X	X	X				
20			46			X	X	X	X				
22			48			X	X	X	X				
24			50			X	X	X	X				
26						X	X	X	X		X	X	X
			52			X	X	X	X	X	X	X	X

*See Note on page 5-2.

5.2.1.1 Readhead Assembly Cleaning

The top surface of the readhead assembly should be cleaned every two weeks (for most installations having clean environments; dirtier environments which contain dust, oil and sprays, such as machining areas, may require cleaning as much as every eight hours). Cleaning is extremely important because any dirt or foreign material in this area can create errors in readout. Use the bristle brush supplied or the cleaning materials and methods described in Section 5.2.1 and clean the surfaces of the readhead assembly and the upper tape guide assembly. Care should be exercised so that no residue remains from the recommended cleaning materials when the cleaning operation is completed. Figure 5.0 illustrates the correct method of inserting the brush. Proper cleaning requires that the brush be rotated at least two revolutions and moved in and out. Remove the residue with compressed air.

5.2.1.2 Sprocket Cleaning

The sprocket wheel should be checked for cleanliness every two weeks. Depending upon tape conditions, accumulations may build up on the sprocket and be transferred to the sprocket holes in the tape which may cause readout errors. Use the recommended cleaning materials described in the caution in Section 5.2.1. Care should be taken so that the alignment of the sprocket wheel is not disturbed. If the sprocket wheel requires adjustment, refer to Section 5.4.

5.2.1.3 Tape Inspection

Repeated handling and usage of the tape leads to a build up of grease, oil and dirt on the tape. When the build up becomes excessive, this material will become lodged in the tape transport areas and could cause tape reading errors. To prevent this, the tape should be thoroughly inspected every two weeks and repunched as required.

5.2.1.4 General Cleaning

The entire reader should be cleaned every year. Use the following procedure:

Using the bristle brush supplied with the unit/or compressed air, remove all dust and dirt, paying particular attention to all moving parts. Use the recommended materials described in the caution in Section 5.2 to remove any grease or other accumulations. When cleaning, use care not to damage components on the circuit board.

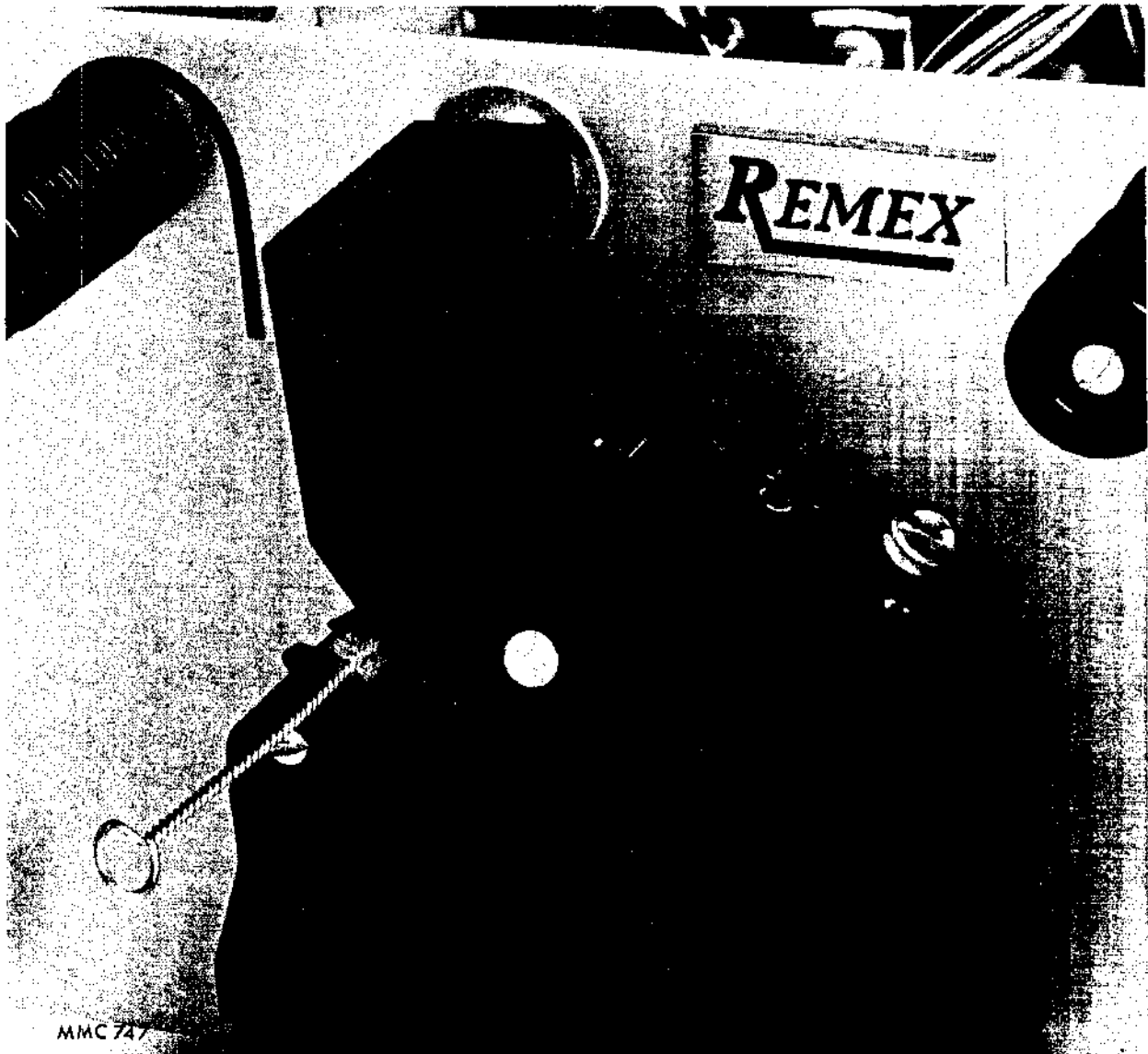

Figure 5-0. Proper brush insertion method. Proper cleaning requires that the brush be rotated and moved in and out.

5.2.2 LUBRICATION

All points of rotation have permanently lubricated bearings and should not require lubrication for the life of the part.

5.2.3 POWER SUPPLY VOLTAGES

Check all voltages on the reader card listed in Table 5-3 with a voltmeter once every three months. A change in voltage may be indicative of a gradual component failure. Before taking any measurements, allow a short period of time for warm up after turning on power.

Table 5-3. Power Supply Voltage Locations, Reader Card

<u>Voltage and Tolerance</u>	<u>From</u>	<u>Measure</u>	<u>To</u>
Lamp Voltage (See Section 5.5)	Across the lamp terminals		
+5 ± 0.25 VDC	TP2		TP1
+14 ± 1.4 VDC	C42+		TP1
-15 ± 1.5 VDC	C39-		TP1
+24 ± 2.4 VDC	F2		TP1
-24 ± 2.4 VDC	F3		TP1

5.3 TROUBLE SHOOTING

Trouble shooting is presented in the form of a chart, Table 5-4, which should be consulted whenever tape reader performance is unsatisfactory. The chart is divided into three columns; indication - the way in which the malfunction becomes evident; Probable Cause - the possible reason or reasons for the malfunction; and Remedy - the manner in which the malfunction may be corrected.

WARNING

The equipment described in this manual contains voltages hazardous to human life and may contain mechanical components capable of inflicting personal injury. The cautionary and warning notes are included in this manual to alert operator and maintenance personnel to the electrical and mechanical hazards and thus prevent personal injury and equipment damage.

Table 5-4. Trouble Shooting

Indication	Probable Cause	Remedy
1. No track outputs on any track	1. Readhead dirty	Clean Readhead Assembly as described in Section 5.2.1.
	2. Lamp Assembly misaligned	Check alignment of the Lamp Source as described in Section 5.4 and Lamp Voltage Adjustment, Section 5.5.
2. Outputs present on all but one track or one track intermittent.	1. Readhead dirty	Clean Readhead Assembly as described in Section 5.2.1.1
	2. Photocell defective	Check the output of the Photocell assembly as described in Section 5.4 and replace if defective as described in Section 6.2.1.
	3. Defective component on Reader Card	Check the components and IC modules associated with the particular track output.
3. Track output present with no hole punched in tape.	1. Tape transmissivity	Tape must have a transmissivity of 57% or less as specified in Table 1-2.
	2. Defective photocell	Check the output of the Photocell assembly as described in Section 5.4 and replace if defective as described in Section 6.2.1.
	3. Defective component on Reader Card	Check the components and IC models associated with the particular track output.
4. Upper Tape Guide closed, RUN-LOAD switch in RUN, correct drive signals present; tape does not move.	1. LOOP-SPOON switch, S4, defective.	Check switch S4 and replace if defective.
	2. RUN-LOAD switch, S2, defective	Check switch S5 and replace if defective as described in Section 6.2.6.
	3. Defective component on Reader Card	Check operation of Reader Card.
	4. Step Motor defective	Check Ø1 thru Ø3 outputs from Reader Card to see if they are present. If so, replace stepper motor as described in Section 6.2.4.

Table 5-4. Trouble Shooting, Continued

Indication	Probable Cause	Remedy
5. Tape does not stop on character	1. Improper reader alignment	Perform Section 5.4
	2. Defective component on Reader card	Check operation of Reader card.
6. Power switch in ON position; lamp does not turn on, no DC voltages.	1. No AC power	Make sure AC power cord is plugged into outlet.
	2. Fuse F1 blown	Check fuse and replace if required.
	3. ON-OFF switch, S1, defective	Check switch S1 and replace if defective.
	4. Power Supply defective	Check Reader card for proper operation of +5V power supply
	5. Defective Transformer, T1	Check T1 and replace if faulty as described in Section 6.2.5.
7. Continuous tape speed less than 150 characters/second	1. Tape out of registration	Check tape registration to make sure tape conforms to specifications as described in Section 3.6.
	2. Sprocket out of rotational alignment	Check alignment of reader as described in Section 5.4.
	3. Defective component	Check reader for proper operation of drive circuits and single-shot timings.
8. Irregular movement of tape	1. Drive system improperly adjusted	Perform Reader alignment as described in Section 5.4.
	2. Sprocket wheel bent or worn	Replace sprocket wheel as described in Section 6.2.4.
	3. Tape guide assembly worn.	Replace tape guide assembly.
9. +5V supply voltage too low or too high	1. Defective regulator	Check operation Z101 and replace if required.
	2. T1 malfunction	Check for presence of 24 VRMS across the green and blue terminals of T1. Replace T1 if not present.

Table 5-4. Trouble Shooting, Continued

Indication	Probable Cause	Remedy
10. Spooler spills tape when first turned on.	1. Improper threading	Thread tape as shown in Figure 1-1.
11. Tape sensor arms hit bumper during operation or arms act erratically.	1. Improper adjustment of tape arm pot.	Check tape arm potentiometer zero adjustment as described in Section 5.6.
	2. Improper adjustment of tape arm spring.	Check tape arm spring adjustment as described in Section 5.7.
	3. Reader card malfunction.	Check operation of servo circuitry on reader card.
12. Spooler does not go into wind mode when proper signals are applied.	1. Reader card malfunction.	Check operation of Reader card.
	2. Wind switch S3 malfunction.	Check S3 for proper operation and replace if defective as described in Section 6.2.6.
13. One spooler motor does not operate	1. Reader card malfunction	Check outputs from servo circuitry on Reader card and replace card if required.
	2. Servo motor faulty.	Check servo motor and replace if required as described in Section 6.3.3.
14. SPOOL-LOOP switch in SPOOL, reader drives tape, RUN-LOAD switch in RUN (S2). Neither spooler motor runs.	1. Switch S2 or S4 faulty.	Check S2 or S4 for proper operation and replace as described in Section 6.2.6.
	2. +24 or -24 VDC on Power Supply card faulty.	Check to see if proper power supply voltages are present on Reader card and replace card if required.
	3. Servo circuitry on reader card faulty.	Check Reader card for proper operation and replace if required.
	4. T1 faulty.	Check for presence of 36 VRMS across brown and red terminals of T1 and replace if not present.

Table 5-4. Trouble Shooting, Continued

Indication	Probable Cause	Remedy
15. Spooling motor is on when arm is in center of travel area.	1. Balance adjustment incorrect or arm pot out of adjustment.	Check balance adjustment as described in Section 5.5.
	2. Servo circuitry on Reader card faulty.	Check servo circuitry and replace card with spare if required.
16. Wind speed greater or less than 1500 characters/sec.	1. Wind speed adjustment faulty.	Check and adjust wind speed as described in Section 5.8.
17. Wind speed varies more than +20% during winding of a full reel of tape.	1. Wind regulator Circuitry faulty.	Check operation of Wind Regulator circuitry on Reader card and replace card if required.

Proper operation depends upon making and maintaining accurate adjustments. Although all adjustments are made at the factory, the following adjustments should be checked periodically (refer to Table 5-2) and should be performed only when the tape reader performance is unsatisfactory or when any of the following items is replaced: lamp, light source, readhead assembly, upper tape guide assembly, mechanism assembly, sprocket, step motor or circuit card. Letter designations in parenthesis refer to items called out in Figure 7-1.

Improper adjustment of this procedure will result in one or both of the following problems: (1) Reading errors, especially in computer applications and (2) Restriction of the tape tolerances capable of being read, i.e., either long or short tolerance tapes, not the +0.025 inch in either direction as specified in Section 3.6.

CAUTION

This is a factory set adjustment and should not require readjustment unless one of the aforementioned components has been replaced or the reader performance is unsatisfactory.

- a. Remove all power and control signals by disconnecting P1 and the power cord plug.

CAUTION

The procedure outlined in steps b through i should not be performed unless the readhead assembly, mechanism assembly, sprocket or step motor has been replaced or the reader performance is unsatisfactory. Prior to adjustment, steps b, d, e and f should be checked and corrective steps c and/or g, h, i and j performed only if necessary.

- b. Remove the Upper Tape Guide. Check the clearance between the readhead housing tape riding surface and the sprocket perimeter high point by placing the end of a small steel rule on the surface and rock the sprocket in both directions. See Figures 5-1 and 5-2. Observe that the perimeter high point clears the steel rule by a few thousandths. The sprocket teeth must have maximum penetration with no interference when driving tape. If the sprocket is not positioned as described in perform step c.
- c. If the conditions of step b do not exist, loosen two screws (D) which hold the motor heat sink to the panel. Adjust the height of the motor so that the conditions in step b exist. Tighten screws (D). On some units it may also be necessary to loosen the two 8-32 socket head screws (B) at the rear of the panel which hold the Mechanism Assembly to the Front Panel and move the Mechanism Assembly to achieve the required setting. This should only be attempted if the adjustment cannot be made with the motor only. Tighten screws (B) if required. Check the conditions in step b again and perform step c as required.

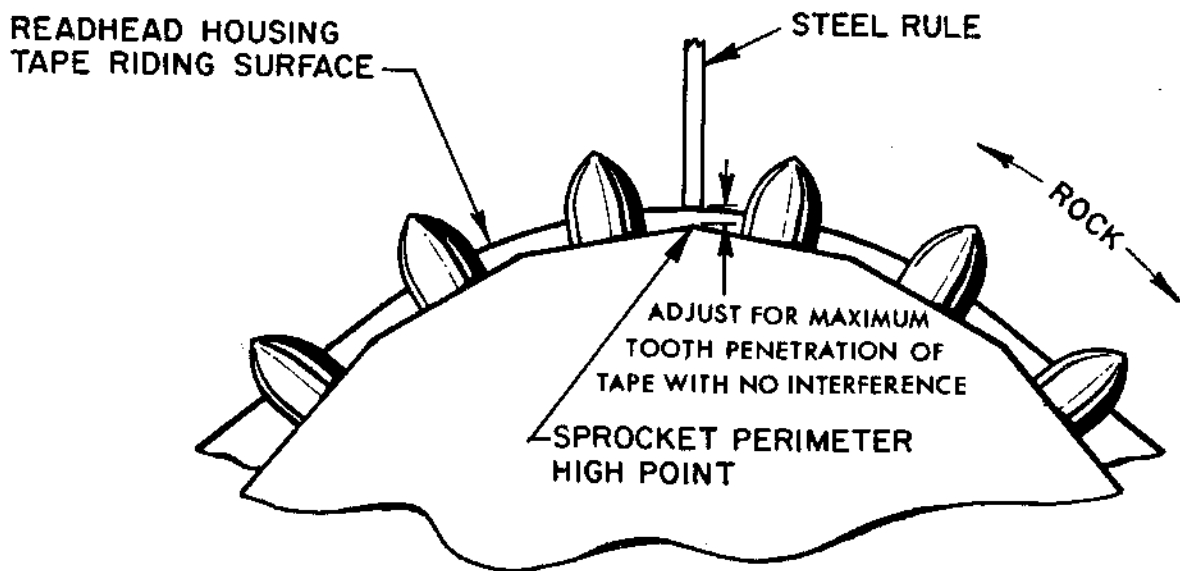

MMC 353B

Figure 5-1. Sprocket Relation to the Tape Riding Surface.

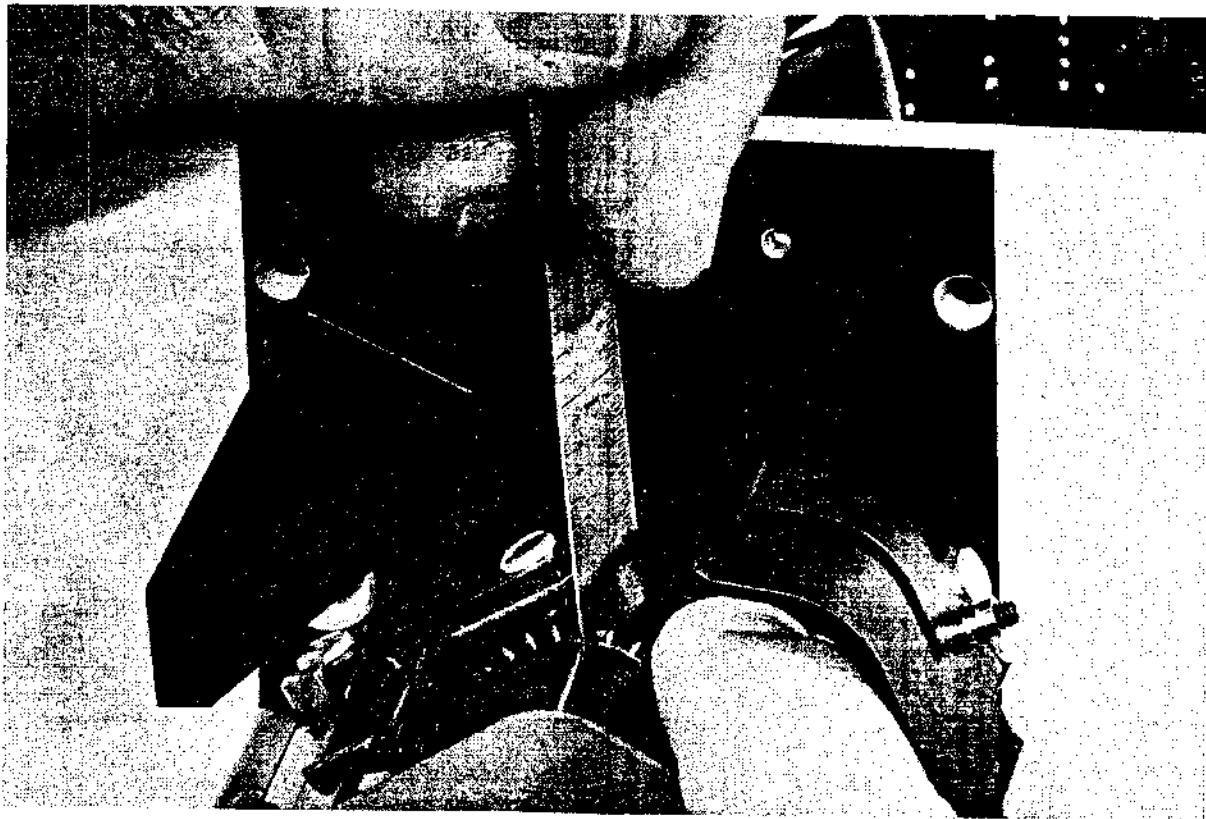

Figure 5-2. Checking the Sprocket in Relation to Tape Riding Surface.

WARNING

If the motor has been running for a period of time, it or the heat sink may be too hot to touch comfortably. Allow sufficient time for the motor and heat sink to cool before any adjustment or use a cloth or pair of gloves.

- d. Insert a loop of tape known to have been punched to within ± 0.0025 inch in a 5-inch span (0.05% error).

NOTE

Since repeatability of the feedhole placement in either direction is essential, a tape whose accumulated error in a 5-inch span is considerably better than ± 0.025 inches (as specified in Section 3.6) must be used in this procedure. Remex specifies a tape known to be punched to within ± 0.0025 inch in a 5-inch span ($\pm 0.05\%$ tolerance). Note that most Remex punches are specified at ± 0.025 and therefore these tapes should not be used for this adjustment unless the tape has been checked on a registration gauge and found to be within ± 0.0025 inch.

- e. Loosen nut (T) which holds the fiber optics light source to the reader panel and rotate the light source away from the light tunnels.
- f. With the rear edge of the tape parallel to the front panel, align the holes over the light columns in the readout assembly so that they are concentric. See Figure 5-3. The tape must remain parallel to the front panel so that no skew is present. With the tape in this position, the sprocket teeth should be centered in the sprocket holes in the tape. Skewing is indicated by tracks 1 and 8 not being concentric.
- g. If the condition of step f does not exist, loosen the set screw (J) which holds the sprocket to the motor shaft and move the sprocket in or out on the shaft until the teeth are centered in the feed holes and the tape holes remain concentric with the light tunnels. Tighten screw (J). Recheck the adjustment and readjust as required. Some models may have two set screws.
- h. Connect the power plug and place the POWER switch into the ON position. The motor should be energized. Place the SPOOL-LOOP switch in the LOOP position.
- i. Loosen the single screw (S) which holds the motor to the heat sink.
- j. Rotate the motor so that the holes, in the tape are concentric with the light columns in the readhead and the sprocket teeth are centered in the feed holes. Tighten the set screws. Recheck the adjustment and readjust as required.
- k. Remove the 0.05% tape.

- l. Place the POWER switch in the OFF position.
- m. make sure jack screw (E) is not protruding below the surface of the Upper Tape Guide.
- n. Insert three layers of 0.0037 mylar tape (approximately 0.011 inch) stapled together at one end or a piece of 0.010 plastic shim stock (see Table 5-1) between the Upper Tape Guide and the Readhead Assembly.
- o. Referring to Figure 5-4 use screws (H) and (N) to adjust the Upper Tape Guide so that there is maximum contact, firm pressure on the tape, and parallelism from A to B. Use screw (H) for lateral movement and screw (N) for rotational movement. From points B to C the Upper Tape Guide will not show this parallelism.
- p. Remove the three layers of tape.
- q. Insert two layers of tape between points A and B only or a strip of 0.0075 shim stock.
- r. Screw down jack screw (E) which will raise the Upper Tape Guide slightly. Adjust screw (E) until there is free movement of two layers of tape or shim stock between points A and B. This should provide a gap of between 0.009 and 0.011 inch.
- s. Remove the two layers of tape or shim stock.
- t. Connect P2 coming from the Readhead Assembly to a test circuit as shown in Figure 5-5. Connect a digital voltmeter in parallel with a 1K resistor. Place the POWER switch in its ON position.
- u. Place a digital voltmeter across the lamp terminals and adjust R96 on the reader card until the meter reads +4.3 VDC. This is a preliminary step. The final lamp voltage is adjusted in Step v.
- v. The nut (T) holding the fiber optic light source to the front panel should already be loose (step e). Rotate the fiber optic light source until the current through the 1K resistor is between 100 and 110 microamps for the sprocket cell. If the current is excessive reduce the lamp voltage. If the current is below the minimum requirements, loosen nut (U) which locks the lamp in the sleeve and screw the lamp in or out to obtain the required current. Tighten nut (U). If the current is still below the minimum requirement, increase the lamp voltage slightly to obtain the required current. Do not increase the lamp voltage above +4.7 VDC. When the required current is obtained for the sprocket, the minimum current for each of the data cells should be 80 microamps. The maximum output from any data cell should be 160 microamps so that tapes with the highest permitted transmissivity can be read without error.
- w. Place the POWER switch in the OFF position and reconnect P2.
- x. Place the POWER switch in the ON position and insert the 0.05% tape as described in step d. Place an oscilloscope across TP6 (SS3) and TP1 (0V). Drive tape to the right and adjust R20 for a 900 μ sec negative going pulse at TP6. This is a preliminary adjustment. The final adjustment is made in step aa.
- y. Connect a pulse counter to TP4 (Data Ready) and TP1 (0V) on the Reader Card.

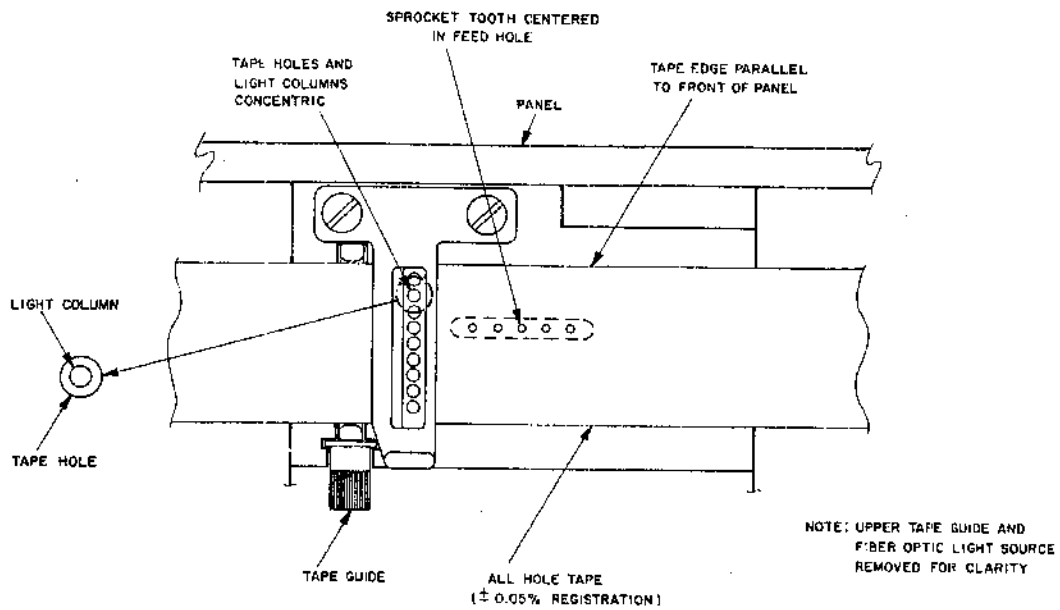

MMC 572

Figure 5-3. Alignment of the Sprocket with the Light Columns.

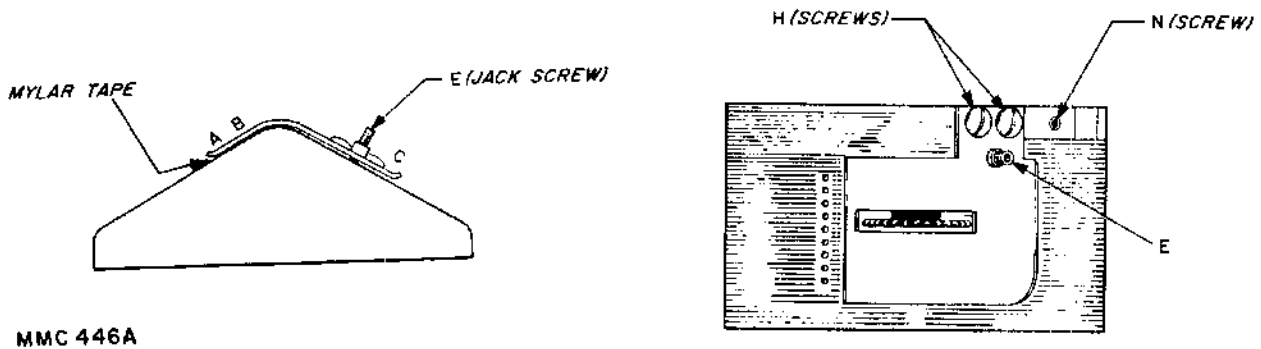

MMC 446A

Figure 5-4. Adjustment of the Upper Tape Guide.

- z. Measure the drive left speed using a \overline{DL} signal tied to 0V at J1-17. Repeat using a \overline{DR} signal tied to 0V at J1-16. If the lowest speed is more than 5% slower than the highest speed, loosen screw (S) which holds the motor to the heat sink. Rotate the motor slightly so that the difference in drive left and drive right speeds is less than 5%. Tighten screw (S). Repeat step z as required. When rotating the motor, make sure it is kept tight to the panel so that the adjustment in step g not disturbed. If steps g and j have been performed correctly only a slight adjustment of the motor should be necessary to obtain the 5% difference in speeds.

NOTE

The importance of steps y and z is not a specific interest in matching speeds, but rather that balancing speeds insures proper placement of the feedhole (via the sprocket) in relation to its aperture in the readhead. The 0.05% tape used virtually assures that there are no feedhole placement errors which are attributable to tape registration errors, but only to the position of the sprocket in relation to the feedhold aperture in the readhead. Thus, measuring and balancing the slew speed is only an accurate, electronic method of assuring that this relationship exists. When the speeds in the two directions are properly balanced, feedhole placement error will be minimal and independent of the direction of the tape, thereby increasing tape readability to a maximum.

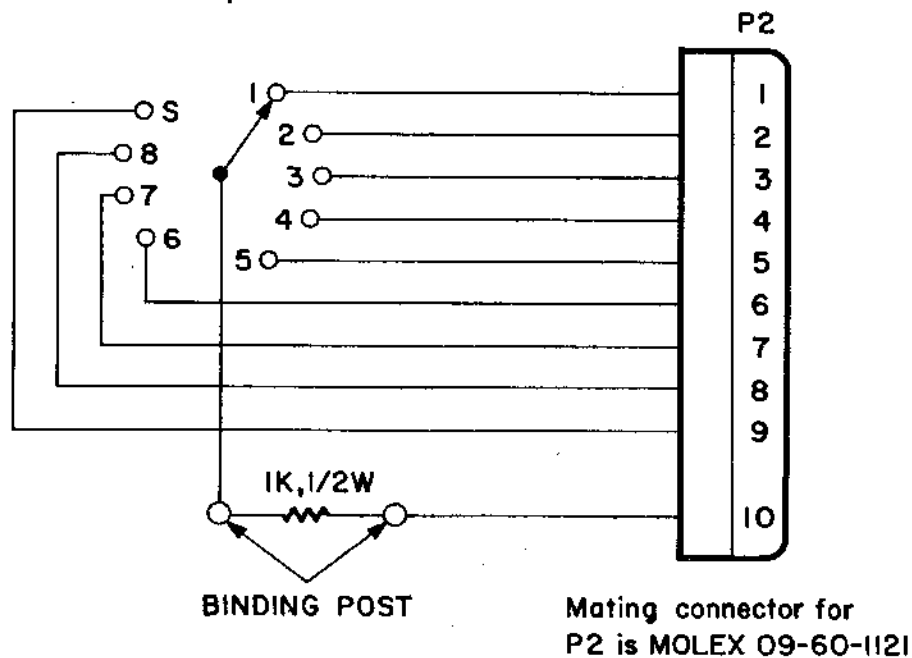

MMC 354

Figure 5-5. Photocell Output Test Circuit.

- aa. Connect an oscilloscope to the sprocket cell output at TP3 on the reader card and observe the jitter at the -0.3 Vdc level (do not be concerned about the jitter at the $+0.6$ Vdc level nor the time jitter in the leading or trailing edges of the waveform). Minimize the jitter by adjusting R20. The pulse width of $\overline{SS3}$ (TP6) should not be less than $750 \mu\text{sec}$ nor more than 1.05 milliseconds. Cycle the reader between 20 and 330 characters/sec and adjust for minimum jitter. Minimum jitter is defined as the interpulse noise between sprocket pulses as being less than 25% of pulse height. See Figure 5-6.

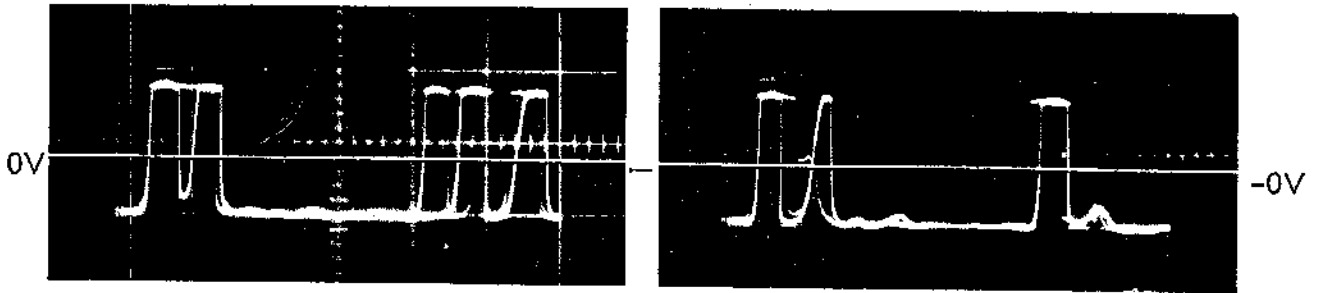

Two Examples of Misadjustment

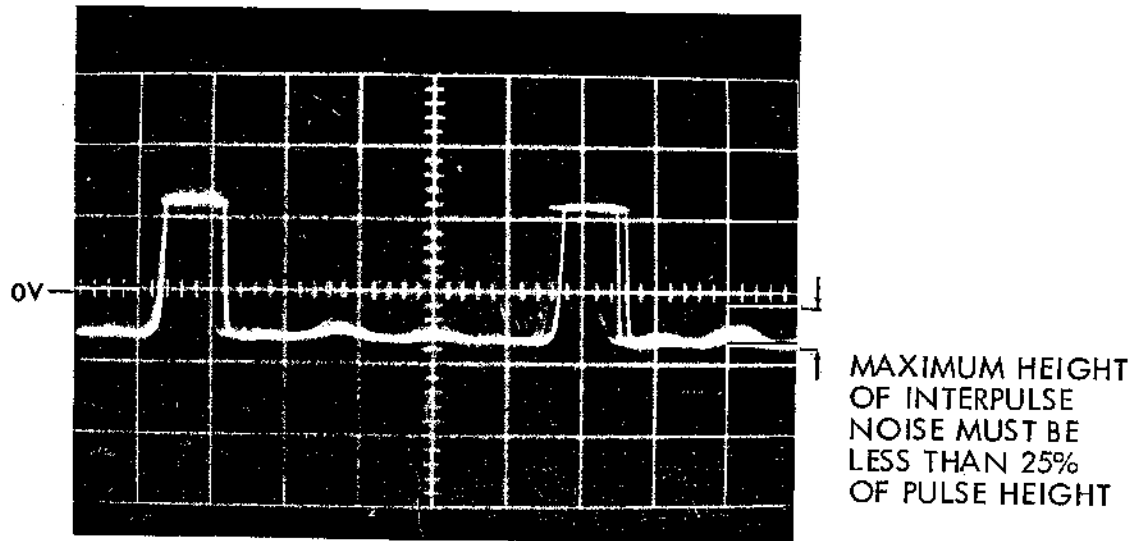

Upper Tape Guide and VMOT Properly Adjusted

MMC204A

Figure 5-6. Sprocket Cell Output Adjustment for Minimum Jitter.

5.5

READER LAMP VOLTAGE ADJUSTMENT

The reader lamp voltage is a function of the cell output and should be adjusted as described in Section 5.4, steps t, u and v.

5.6

SERVO ALIGNMENT

Alignment of the servo system is performed in the following manner:

- a. Place the ON-OFF switch in the OFF position.
- b. Remove all tape and reels from the reader-spooler.
- c. Place the SPOOL-LOOP switch in SPOOL and the ON-OFF switch in ON.
- d. Rotate the left and right tape sensing arms to the center of their travel arc. Secure the arm in this position with a rubber band loop around one of the tape rollers.
- e. If the left motor rotates when the arm is positioned in the center of its travel arc, perform steps f and g.
- f. Loosen the set screw (Item A, Figure 6-2) which holds the coupling to the potentiometer shaft.
- g. Rotate the shaft of the potentiometer until the left motor stops rotating. Tighten set screw (A).
- h. Place the ON-OFF switch in the OFF position.
- i. Place an ohmmeter across the C and NO contacts of the tape break switch.
- j. Move the left arm out until the arm is 0.12 inch from the outer bumper. At this point, the switch should actuate and the ohmmeter should change from infinite to zero ohms.
- k. If the condition of step j is not satisfied, loosen set screw (Item B, Figure 6-2) which holds the coupling to the switch assembly shaft and the potentiometer shaft.
- l. Rotate the collar until the conditions of step j are satisfied. Use care not to rotate the potentiometer shaft and disturb the setting made in step g.
- m. Tighten set screw (B).
- n. Repeat steps c, d, e, h, i and j to verify correct operation.
- o. Repeat steps c through n for the right servo using the right potentiometer, tape arm and tape break switch.

5.7

ARM SPRING TENSION ADJUSTMENT



Tension of the tape sensing arm spring is measured at the roller on the end of the arm.

- a. Place the ON-OFF switch in the OFF position.
- b. Attach tension gauge to the tape arm roller on the left arm using a piece of tape around the roller.

- c. Pull on the gauge perpendicularly to the tape arm and lift the arm up, off the outer stop. Note the gauge reading which should be $4 + 1/4$ ounces. Do not allow the tension of the arm on the switch to interfere with the measurements
- d. Move the arm to its inner limit. The tension gauge should read a maximum of $13 \pm 1/2$ ounces. Typically the reading is 8-10 ounces.
- e. If the tension measurements do not agree with the specifications noted in steps c and d, loosen the screw (A, Figure 7-2) which holds the arm-spring lug to the front panel and slide the lug until the conditions of steps c and d are satisfied. Tighten screw (A).
- f. Repeat steps b through e for the right arm.

5.8 WIND SPEED ADJUSTMENT

The nominal, mid-reel wind speed of the spooler should be set at 150 inches/second. This adjustment is performed as follows:

- a. Load the left side with a full reel of tape and thread the tape through the reader onto the left reel. The tape must have at least sprocket holes punched on every character.
- b. Connect a pulse counter to the sprocket test point TP5 on the Reader card.
- c. Place the following switches in the positions indicated: RUN-LOAD in RUN, the SPOOL-LOOP switch in SPOOL and the OFF-ON switch in ON.
- d. Place the  switch in the  position and note the number of sprocket holes changes per second at mid-reel wind (both reels containing approximately the same amount of tape). The number of sprocket holes should be approximately 1500 holes/second. If this is not the case, adjust R63 on the Reader card until the required speed is obtained.

5.9 SPOOLER TAPE ARM AND ROLLER ALIGNMENT

The tape rollers and the arm rollers should be positioned so that paper tape moves through the drive mechanism flat, in either direction, without wave. Mylar tape may have a slight wave. All tape should run through the head without excessive edge guiding, preferably with a slight tendency of guiding toward the panel.

To accomplish this alignment, a small amount of bending at the end of the tape arm may be required. However, the arm itself must be parallel to the panel over its entire length. In addition, the distance from the front surface of the arm to the inside edge of the roller must be between 0.190 and 0.205 inch. This is important when a new roller has been installed and is accomplished by placing 1 or 2 713600-149 washers between the spacer and roller as shown in Figure 6-1 and as described in Section 6.3.4. The roller must also remain perpendicular to the front panel.

5.10 TAPE SPLICING

If tape breakage occurs, this break may result in damage to one, two or possibly three characters. When splicing tape for this reader, great care should be used to ensure that the proper sprocket hole spacing be preserved. A lap splice should not be used; use only a butt type splice. To repair the tape without loss of characters, the process shown in Figure 5-7 is recommended and is accomplished as follows:

- a. Bring the tape ends together as shown in Figure 5-7A.
- b. Make a sketch of character(s) at the break (A-B-C) and five additional characters to the left (5-4-3-2-1) and five to the right (1-2-3-4-5) of the broken character(s) (A-B-C).
- c. Place the left end of the broken tape over a section of blank tape containing only feed holes so that at least eight or ten feed holes in each tape are aligned with one another as shown in Figure 5-7B. Cut the tapes at the third undamaged character (A-B-C). Use care to insure that feed holes are aligned and make cut through the center of the holes in the third undamaged character, Characters 5, 4, and half of 3 should remain on the broken tape.
- d. Place the right end of the broken tape over the section of blank tape so that at least eight or ten feed holes are aligned with one another. Feed holes for one-half of 3, 2, and 1 on the blank tape cut in step c should be visible to the left of the broken tape end as shown in Figure 5-7C. Cut the tapes at the third undamaged character to the right of the damaged character. Be sure that feed holes are aligned and make the cut through the center of the holes in the third undamaged character.

NOTE

One half of character 3 and characters 4 and 5 should remain in the broken tape.

- e. Place tape ends and new section on a flat surface with feed holes forward as shown in Figure 5-7D (tape is bottom side up). Using silver Scotch[®] tape, No. 852, splice the new section and the old tape ends as shown. That portion of tape that secures the old tape must cover the first two and a half characters (one-half of 3, 4 and 5) on the old tape ends. The edges of the tape should be between characters as shown. Use of 1/2-inch wide splicing tape is recommended as shown in Figure 5-7D.
- f. Repunch the characters recorded in step d.

5.11 TAPE TENSIONING ASSEMBLY ADJUSTMENT

The following adjustment should be performed when a tape tensioning assembly is replaced, loose packing on a reel is present, or too much tension is present on the tape.

- a. Place the ON-OFF switch in the OFF position.

[®]Registered Trademark of 3M Company.

- b. Loosen the set screw which holds the roller assembly to the tape tensioner shaft and remove the roller assembly. When replacing the roller assembly, slide it onto the shaft as far as it will go
- c. Attach a Torque Watch (Waters Model 651C-1 or equivalent) to the front of the shaft and measure the force required to make the friction plate slip. This force should be $1 \pm 1/4$ ounces.
If a Torque Watch is not available, an equivalent method is to use a string wound around the tape tension roller. The string should have approximately 10 turns around the roller in the clockwise direction for the left roller and counterclockwise for the right roller. Using a spring scale that is graduated in ounces, a reading of $3 \text{ oz.} \pm 1 \text{ oz.}$ should be obtained while the string is being pulled off the roller.
- d. If this is not the case, loosen the two set screws which hold the collar at the rear of the spring and move the collar in or out as required. Tighten the set screws.
- e. Repeat steps c and d as required until the $1 \pm 1/4$ ounce force is required to cause the friction plate to slip (or the $3 \text{ oz.} \pm 1 \text{ oz.}$ using the spring scale).
- f. Perform the reverse of steps b and then a.

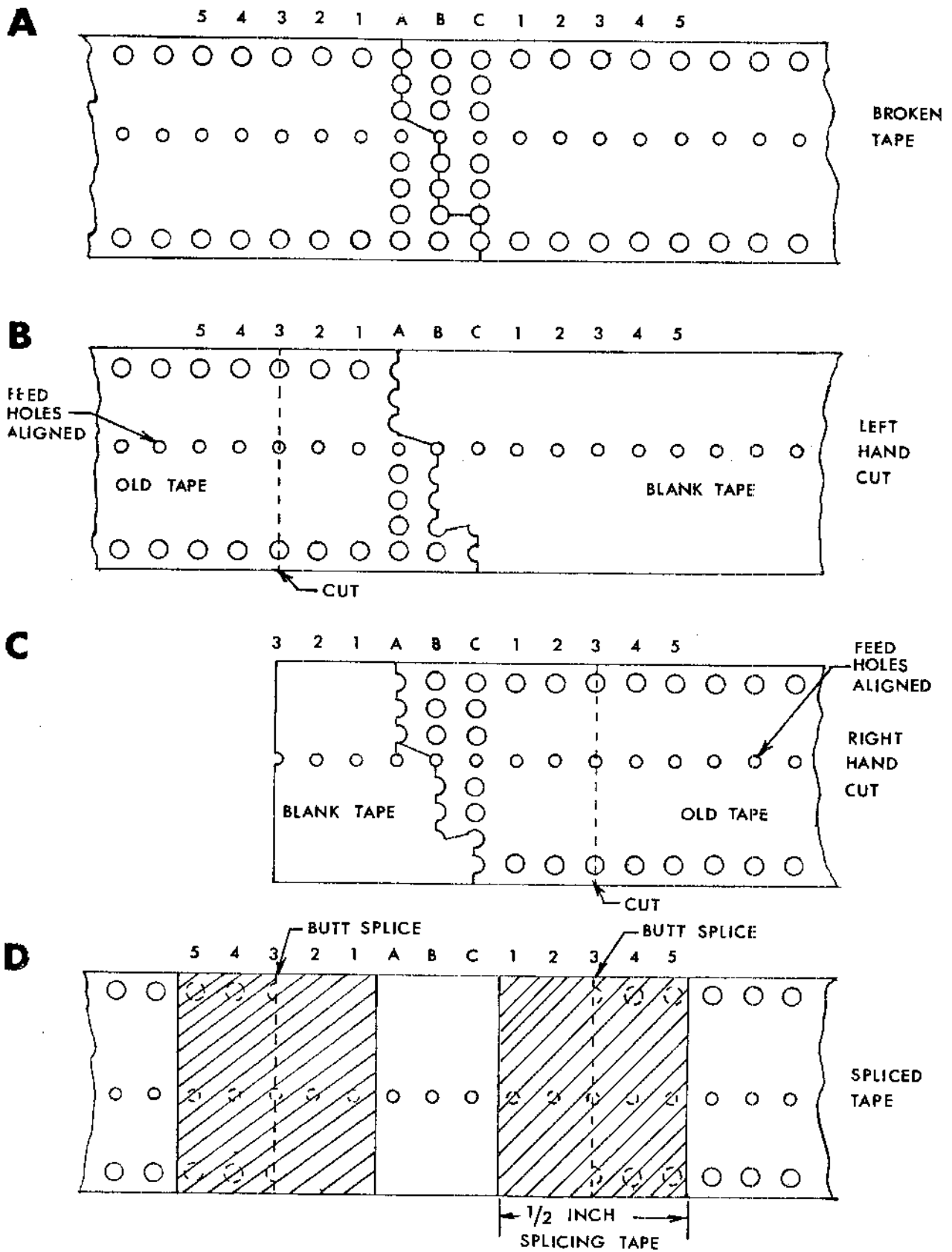

MMC 120A

Figure 5-7. Tape Splicing Procedure

SECTION VI

PARTS REPLACEMENT

6.1 GENERAL

REMEX maintains service facilities at its manufacturing location and at service centers in major population areas for repair or replacement of components for their products. It is recommended that one of these centers be contacted for assistance in case of equipment malfunction. For the locations of service facilities in any area, contact REMEX at the address or telephone listed on the title page of the manual. Please direct inquiries to the attention of the Service Department.

When any parts of the reader require replacement or disassembly, the procedure below should be followed closely. The warnings and cautions are included to protect personnel and equipment. Notes are included to assist persons unfamiliar with the equipment. Before attempting any procedure, all instructions for that disassembly should be read and understood.

Quantities of replaceable items suggested as spares are listed in Table 7-1. All system components are identified in Section VII of this manual along with illustrations showing part locations. This information may be used to locate parts below unit level if replacement is required.

WARNING

Potentially dangerous line voltage is applied to components within this equipment. If adjustments must be performed with power applied, these points must be located and avoided. High voltage can be accidentally contacted at TBI, at the OFF-ON switch/wiring connections, and on the circuit card (rear of the Unit). Always remove power before disconnecting internal plugs and removing cards.

6.2 READER PARTS REPLACEMENT

6.2.1 READHEAD MECHANISM DISASSEMBLY

This procedure is required when replacing the Upper Tape Guide Assembly, the Readhead Assembly (consisting of the Readhead Housing, Photocell Assembly and Light Columns), or the Mechanism Assembly. For ease of assembly, it is recommended that the Readhead Assembly (part number 113168-1) and Mechanism Assembly (part number 112346-1) be replaced as a complete assembly. Figure 7-1 should be folded out from Section 7 to follow during this procedure. The following procedure is recommended when replacing any of the above mentioned items:

- a. Remove all power and control signals by disconnecting P1 and the power cord.
- b. Disconnect P2 and P3 from the circuit card.
- c. Remove two 4-40 round head screws (C and F, Figure 7-1) which hold the Readhead Assembly to the Mechanism Assembly.
- d. Loosen the two 8-32 socket head screws (Item B, Figure 7-1) which hold the Mechanism Assembly to the Front Panel at the rear of the Front Panel. The entire Readhead Mechanism Assembly consisting of the Tape Guide Assembly, the Readhead Assembly, and the Mechanism Assembly is now free to be removed from the panel.
- e. Remove the two 4-40 binder head screws (Item H, Figure 7-1) which hold the Tape Guide Assembly to the Mechanism Assembly. If no further disassembly is required, install the new Upper Tape Guide Assembly and perform the reverse of steps e through c. Perform Section 5.4.
- f. From the underside of the Mechanism Assembly remove the two 4-40 round head screws (Item I, Figure 7-1) which hold the Readhead Assembly to the Mechanism Assembly. The Readhead Assembly and the Mechanism Assembly are now separated and can be replaced as individual assemblies. It is not recommended that Mechanism Assembly be disassembled beyond this level.
- g. Reassembly is the reverse of steps f, e, d and then c.
- h. Perform Section 5.4.

6.2.2 READER CARD REPLACEMENT

The following procedure is recommended when removing the Reader Card:

- a. Remove all power and control signals by disconnecting P1 and the power cord.
- b. Disconnect P2, P3, P4, P5, P6, P7 and P8.
- c. Remove the three 4-40 round head screws which hold the Reader Card to the Chassis and P.C. Board spacers. Four other snap on spacers also hold the card to the chassis.
- d. Reassembly is the reverse of steps c and b.
- e. Perform Sections 5.4, 5.5 and 5.8.

6.2.3 LAMP REPLACEMENT

The following procedure is recommended when replacing the lamp:

- a. Remove all power and control signals by disconnecting P1 and the power cord.
- b. Slide the two terminals off at the rear of the lamp.
- c. Unscrew nut (U) from the lamp and remove the lamp from the gasket and sleeve.

- d. Replacement is the reverse of steps c, b and then a.
- e. Perform Section 5.4, step t, u and v.

6.2.4 MOTOR AND/OR SPROCKET REPLACEMENT

The following procedure is recommended when replacing the motor and/or sprocket:

- a. Remove all power and control signals by disconnecting P1 and the power cord.

WARNING

If the motor has been running for a period of time, it or the heat sink may be too hot to touch comfortably. Allow sufficient time for the motor and heat sink to cool before adjusting or use a cloth or pair of gloves.

- b. Loosen the screw (item S, Figure 7-1) which holds the motor to the heat sink and back the motor out. Disconnect P4/J4.
- c. Loosen the set screw (item J, Figure 7-1) which holds the sprocket to the motor shaft. Some models may use two set screws.
- d. Install the new sprocket on the new motor and perform the reverse of steps c and b. The sprocket wheel is installed so that: (1) the distance from the rear of the sprocket to the front panel is 0.862 inch (see Figure 7-1) and (2) the 1/8 long set screw tightens on the flat of the motor shaft. This is a preliminary step. The final setting of the sprocket is performed in Section 5.4.
- e. Perform Section 5.4.

6.2.5 TRANSFORMER REPLACEMENT

The following procedure is recommended when replacing the transformer:

- a. Remove all power and control signals by disconnecting P1 and the power cord.
- b. Disconnect P7/J7 and the six transformer leads attached to TB1.
- c. Disconnect the four wires connected to terminals 1 and 2 of BR1 and BR2.
- d. Disconnect the orange transformer lead at the junction of C102 and C103 and the yellow wire at P7-4.
- e. Loosen the four 8-32 binder head screws which hold the transformer to the front panel and remove the transformer.
- f. Install the new transformer by performing the reverse of steps e, d, c, b and then a. Refer to Table 6-1 for transformer wire connections.

Table 6-1. Transformer Wire Connections

T1 Wire Color	TB2 Terminal	T1 Wire Color	Connections
White/Gray White/Violet White/Blue	TB1-A1 TB1-A4 TB1-B1	Brown Red Orange	BR1-2 BR1-1 C102, C103 junction
White/Green White/Yellow White/Orange	TB1-B4 TB1-C1 TB1-C4	Yellow Green Blue	P7-4 BR2-2 BR2-1

6.3 SPOOLER PARTS REPLACEMENT

6.3.1 POTENTIOMETER REPLACEMENT

The following procedure is recommended when replacing a potentiometer. Refer to Figure 7-4 for callout designations.

- a. Remove all power and control signals by disconnecting P1 and the power cord.
- b. Unsolder the wires at terminals 1-3 on the potentiometer (terminal 1 - yellow, terminal 2 - green, terminal 3 - red). Note the orientation of the terminals so the new potentiometer can be inserted the same way.
- c. Loosen set screw (A) which holds the coupling to the potentiometer shaft.
- d. Loosen nut (C) which holds the potentiometer to the bracket. Back the potentiometer out from the bracket.
- e. Install an ohmmeter across terminals 1 and 2 on the new potentiometer and rotate the shaft until the meter reads 5K.
- f. Install the new potentiometer into the coupling and bracket by performing the reverse of steps d and c. Care should be used so that the potentiometer shaft is not rotated and that the orientation of the terminals are as noted in step b.
- g. Perform Section 5.6.

6.3.2 FRONT PANEL AND CHASSIS

The following procedure is recommended when separating the front panel from the chassis.

- a. Remove all power and control signals by disconnecting P1 and the power cord.
- b. Disconnect the following connectors J2/P2, J3/P3, J4/P4, J5/P5, J6/P6, J7/P7, and J8/P8 on the Reader card.
- c. Disconnect the white/green wire at TB1-B5 and the gray wire at TB1-D1 which come from the power switch S1. Unlace these wires.
- d. Remove the four IO-32 screws which hold the front panel to the chassis.
- e. The front panel and chassis (with the Reader Card attached) can now be separated.

- f. Reassembly is the reverse of steps d, c, b and then a.

6.3.3 SERVO MOTOR REPLACEMENT

The following procedure is recommended when replacing either servo motor assembly. When replacing the motor, it is recommended that the entire 110829-1 motor assembly (including connector and hub assembly) be replaced.

- a. Separate the front panel and chassis. Refer to Section 6.3.2.
- b. Remove the two 10-32 x 3/8 binder head screws which hold each motor to the front panel. Note the orientation of the motor so that the new motor will be installed the same way.
- c. Install the new motor by performing the reverse of steps b and then a.

6.3.4 TAPE ARM REPLACEMENT

The following procedure is recommended when replacing the tape arm.

- a. Remove all power and control signals by disconnecting P1 and the power cord.
- b. Remove the 6-32 x 3/8 flat head screw (C) which holds the arm assembly to the tape arm shaft. See Figure 6-1.
- c. Remove the grip ring which holds the roller to the tape arm.
- d. The arm and roller are now free for replacement as required.
- e. Reassembly is the reverse of steps c, b and then a. When installing the roller, make sure the distance between the front of the arm and the rear of the roller is between 0.190 and 0.205 inches as shown in Figure 6-1. This is accomplished by placing 1 or 2 washers, (REMEX Part No. 713600-149) between the spacer and the roller to obtain the desired dimension.
- f. Perform Section 5.9.
- g. Check the adjustment in Section 5.6 and readjust as required.

6.3.5 TAPE TENSIONER AND SOLENOID ASSEMBLY REPLACEMENT

When replacing the tape tension solenoid, it is necessary to replace the entire 113216-1 assembly. The following procedure is recommended when changing the tape tensioner and/or the solenoid assembly:

- a. Remove all power and control signals by disconnecting P1 and the power cord.
- b. If the solenoid assembly is to be replaced, disconnect P8/J8 and remove the green and blue wires at pins 4 and 7, respectively, for the left solenoid or the green and blue wires at pins 5 and 8 respectively for the right solenoid. Unlace these wires. The wires are removed from the connector by using a pointed instrument and depressing the contact and sliding it out at the rear of the connector.

- c. Loosen the set screw which holds the Tape Tensioner Roller assembly to the Tape Tensioner shaft and slide the roller off the shaft.
- d. Unscrew the Tape Tensioner Assembly from the front panel. The solenoid assembly bracket and the tape tensioner assembly are now free for replacement. Mark the location of the Solenoid Assembly bracket so it can be replaced in the same spot.
- e. Install the new Solenoid Assembly or Tape Tensioner Assembly by performing the reverse of steps d, c, and then b.
- f. Perform Section 5.11.
- g. Perform the reverse of step a.

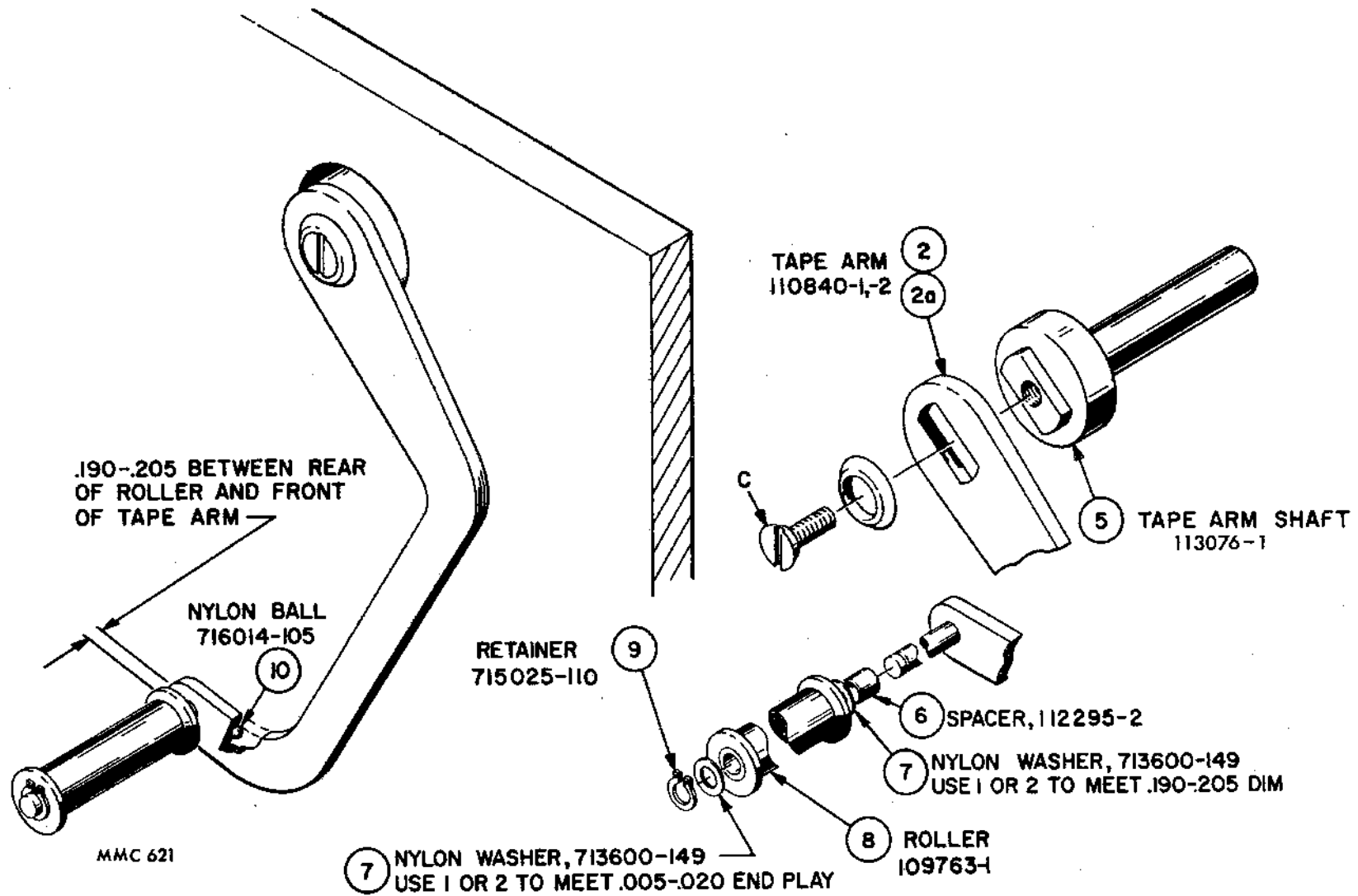

Figure 6-1. Tape Arm Assembly. Item no. 6 has been deleted on later models.

NOTE: WHEN ORDERING SPARE PARTS, CONTACT REMEX SPARES ORDER DESK AND REFERENCE COMPLETE MODEL AND SERIAL NUMBER OF UNIT. ALWAYS REFER TO ADDENDUM AT THE REAR OF THE MANUAL (IF APPLICABLE) FOR POSSIBLE PART NUMBER CHANGES.

Table 7-1. Recommended Spare Parts

Description and Manufacturer's Part No.	REMEX Part No.	Quantity	Reference Designation
Lamp, 5V, REMEX Specification	715071-141	1	DS1
Switch, ON-NONE-ON, C&K L21Z3X36	715063-111	1	S1, S2, S4
Switch, (ON)-OFF-(ON), C&K 5205Z3BX36	715063-114	1	S3
Switch, SPDT, Cherry E61-10H	715058-123	1	S5, S6
Solenoid, REMEX Specification	715067-106	1	L1, L2
Fuse 2A, Slo-Blo, 100, 115, or 127 VAC operation only, Bussman MDA	705710-	1	F1
Fuse 1A, Slo-Blo, 220, 240VAC operation only, Bussman MDA	705710-	1	F1
Printed Circuit Card Assembly, Power Driver Card	111131-3	1	PC2
Printed Circuit Card Assembly, Reader Card Assembly	113191-1	1	PCI

NOTE: WHEN ORDERING SPARE PARTS, CONTACT REMEX SPARES ORDER DESK AND REFERENCE COMPLETE MODEL AND SERIAL NUMBER OF UNIT. ALWAYS REFER TO ADDENDUM AT THE REAR OF THE MANUAL (IF APPLICABLE) FOR POSSIBLE PART NUMBER CHANGES.

Table 7-2. Parts List, RRS7300BEX/660/DRB

Description and Manufacturer's Part No.	REMEX Part No.	Quantity	Reference Designation
Top Assembly	113136-1	1	Ref.
Chassis Assembly	113183-1	1	Ref.
Bracket Side	113197-1	1	7-3;1
Cable Assembly, Power Supply	113184-1	1	(P7)
Connector, Housing, 6 pin, Violet Molex 09-50-7061	706510-265	1	P7
Contact, Connector, Female, Molex 08-50-0103	706530-137	6	(P7)
Terminal, Push-On, Amp 61167-1	715005-139	2	
Terminal Lug, Amp 31887	715005-110	3	
Capacitor Assembly	113198-1	1	(C102, C103)
Bracket, Side	113197-2	1	7-3;2
Capacitor, 9300 μ f, 40V, STM 71C40RC932	702313-107	1	7-3;C102,C103
Clamp, Capacitor, Mallory VR6	715045-148	2	(C102, C103)
① Cover, Capacitor, Sinclair & Rush 1.75-24 Black	716007-112	2	(C102, C103)
Printed Circuit Card Reader	113191-1	1	7-6;PC1
Refer to Table 7-3 for subassemblies			
Printed Circuit Card, Power Driver	111131-3	1	7-5;PC2
Refer to Table 7-4 for subassemblies			
Terminal Lug, Push-On, Amp 61167-1	715005-139	6	(F101, FL1, BR1)
Terminal Lug, Amp 31887	715030-110	4	(C102, C103)
Terminal, Molex 05-02-0048	706530-171	2	
Terminal, Lug, Amp 31885	715005-107	2	7-4;E1
Terminal, Lug, Ground #8, Amp 31888	715005-102	1	E2
Cover, Rear	113465-001	1	
Decal, Caution	111933-2	1	
Decal, Warning	110884-1	1	
Front Panel Assembly	113123-1	1	Ref.
Bumper, Rubbercraft 9114	715021-115	4	7-2;1
Clamp, Cable Thomas/Betts TC-342A	715040-141	1	7-3;4
Gasket, Welch Allyn 11200182	715018-104	1	7-1;3
Heat Sink, Stepper Motor	110448-1	1	7-1;5
Decal	113044-1	1	
Key, Terminal Block, Molex 15-04-0200	706540-155	16	(TB1)
Lamp, 5 volt, REMEX Specification	715071-141	1	7-1;DS1
Light Source, Fiber Optics, REMEX Specification	112297-1(P)	1	7-1,14
Lug, Spring Retainer	113087-1	2	7-3;12
Motor Assembly, Reader	110862-1	1	7-1;(M1)
Connector, Housing 6 pin, yellow, Molex 09-50-7061	706510-266	1	7-1;P4
Contact Connector, Female Molex 08-50-0108	706530-138	1	(P4)
Motor 28 Vdc, REMEX Specification	715075-158	1	7-1;M1
Motor Assembly Spooler	110829-1	2	
Connector, Housing, 3 pin, violet Molex 09-50-7031	706510-257	1	P11, P12
Contact, Connector, Female, Molex 08-50-0106	706530-137	3	(P11, P12)

① Deleted on Later Units.

NOTE: WHEN ORDERING SPARE PARTS, CONTACT REMEX SPARES ORDER DESK AND REFERENCE COMPLETE MODEL AND SERIAL NUMBER OF UNIT. ALWAYS REFER TO ADDENDUM AT THE REAR OF THE MANUAL (IF APPLICABLE) FOR POSSIBLE PART NUMBER CHANGES.

Table 7-2. Parts List, RRS7300BEX/660/DRB (Continued)

Description and Manufacturer's Part No.	REMEX Part No.	Quantity	Reference Designation
Hub Assembly It is recommended that all except the following item be replaced as a complete assembly.	105577	1	7-1;2
Spring Hub	109076	1	
Motor, 18 VDC, REMEX Specification	715075-183	1	7-3;M2, M3
Panel Front	113122-1	1	7-3,5
Readhead Mechanism Assembly	113173-1	1	7-1, Ref.
Ground Plate Assembly	112423-1	1	7-1;13
Lever, Upper Tape Guide	111797-1	1	7-1;1
Mechanism Assembly	112346-1	1	7-1;8
Readhead Assembly	113168-1(P)	1	7-1;11
Tape Guide Fixed	112329-1	1	7-1;15
Tape Guide Upper	112407-1	1	7-1;16
Roller Assembly, Tape Tensioner	113052-1	2	7-2;3
Shaft	112675-1	2	7-2;4
Sleeve, Lamp	112319-1	1	7-2;2
Solenoid Assembly, Tape Tensioner It is recommended that the entire 113216-1 assembly be replaced as a complete assembly.	113216-1	2	7-3;3
Spring, arm, Lee LE-037D-6	714090-106	2	7-3;6
Sprocket, REMEX Specification	716057-102	1	7-1;7
Switch Assembly, Tape Break, Left	113111-1	1	7-3;7
Bracket	113075-1	1	7-4;1
Connector, Housing, Green, 5 pin Molex 09-50-7051	706510-261	1	7-4;P6
Contact Connector Female, Molex	706530-137	5	(P6)
Collar	113077-1	2	7-4;2
Housing Bearing	113223-1	1	7-4;3
Potentiometer, REMEX Specification	701506-103	1	7-4;R203, R204
Retainer	112695-1	1	7-4;6
Ring, Retaining, Truarc 5133-37	715025-155	1	7-4;5
Shaft	113076-1	1	7-4;4
Switch, SPDT, Cherry E61-10H	715058-123	1	7-4, S5, S6
Switch Assembly Tape Break, Right Subassemblies are identical to 113111-1	113111-2	1	7-3;8
Switch Plate Assembly	113186-1	1	Ref.
Bezel, Black, C&K B7888-2	715063-201	4	(S1-S4)
Cap, ON/OFF, C&K 7922-1	715063-329	1	(S1)
Cap, RUN/LOAD, C&K 7922-1	715063-328	1	(S2)
Cap, ← / → C&K 7922-1	715063-321	1	(S3)
Cap, SPOOL/LOOP, C&K 7922-1	715063-326	1	(S4)
Connector, Housing, Orange 5 pin, Molex 09-50-7051	706510-308	1	P3
Connector, Housing, Gray, 8 pin, Molex 09-50-7081	706510-242	1	P8
Contact, Connector, Molex 08-50-0105	706530-137	9	(P3, P8)
Lug, Terminal, Molex 05-02-0048	706530-171	2	(S1)

NOTE: WHEN ORDERING SPARE PARTS, CONTACT REMEX SPARES ORDER DESK AND REFERENCE COMPLETE MODEL AND SERIAL NUMBER OF UNIT. ALWAYS REFER TO ADDENDUM AT THE REAR OF THE MANUAL (IF APPLICABLE) FOR POSSIBLE PART NUMBER CHANGES.

Table 7-2. Parts List, RRS7300BEX/660/DRB (Continued)

Description and Manufacturer's Part No.	REMEX Part No.	Quantity	Reference Designation
Lug, Terminal, Amp 75-7744	706530-163	2	(DS1)
Lug, Terminal, Amp 61454-1	715005-137	9	(S1-S3)
Plate, Switch	113105-1	1	7-3;9
Switch, ON-NONE-ON, C&K L21Z3X36	715063-111	3	7-3;S1,S2,S4
Switch, (ON(-OFF-(ON)), C&K 5205Z3BX 36	715063-114	1	7-3; S3
Tape Arm Assembly, Left	111088-2	1	7-2;5
Arm, Tape	110840-2	1	
Retaining, Ring, Truarc 5100-12	715025-110	2	
Roller, Tape	109763-1	1	
Spacer	112295-2	1	
Washer, Nylon, Flat, Amatom 2203-N129	713600-149	4	
Tape Arm Assembly, Right	111088-1	1	7-2;6
The subassemblies are identical to 111088-2 except:			
Arm, tape	110840-1	1	
Tape Tensioner Assembly, Left	113113-2	1	7-3;10
Tape Tensioner Assembly, Right	113113-1	1	7-3;11
Terminal Block, Molex 07-01-7051	706520-116	6	TB1
Transformer Assembly	113187-1	1	7-3;T1
Kit of Parts, See Table 1-1.	113189-1	1	
Nameplate, Patent	108546	1	
Tape Guide Assembly, RRS7300BE1	112411-1	1	7-1;12
Tape Guide Assembly, RRS7300BE2	112411-2	1	7-1;12
Tape Guide Assembly, RRS7300BE3	112411-3	1	7-1;12
Tape Guide Assembly, RRS7300BE4	112411-4	1	7-1;12
Tape Guide Assembly, RRS7300BE5	112411-4	1	7-1;12
<u>OPTIONS</u>			
Reel, 6-inch dia, 1/2 inch hub, Gray	107878-1	2	
Reel, 7-1/2 inch dia, 1/2 inch hub, Gray	107878-2	2	
Reel, 6-inch dia., 1/2 inch hub, White	107878-3	2	
Reel, 7-1/2 inch dia., 1/2 inch hub, White	107878-4	2	

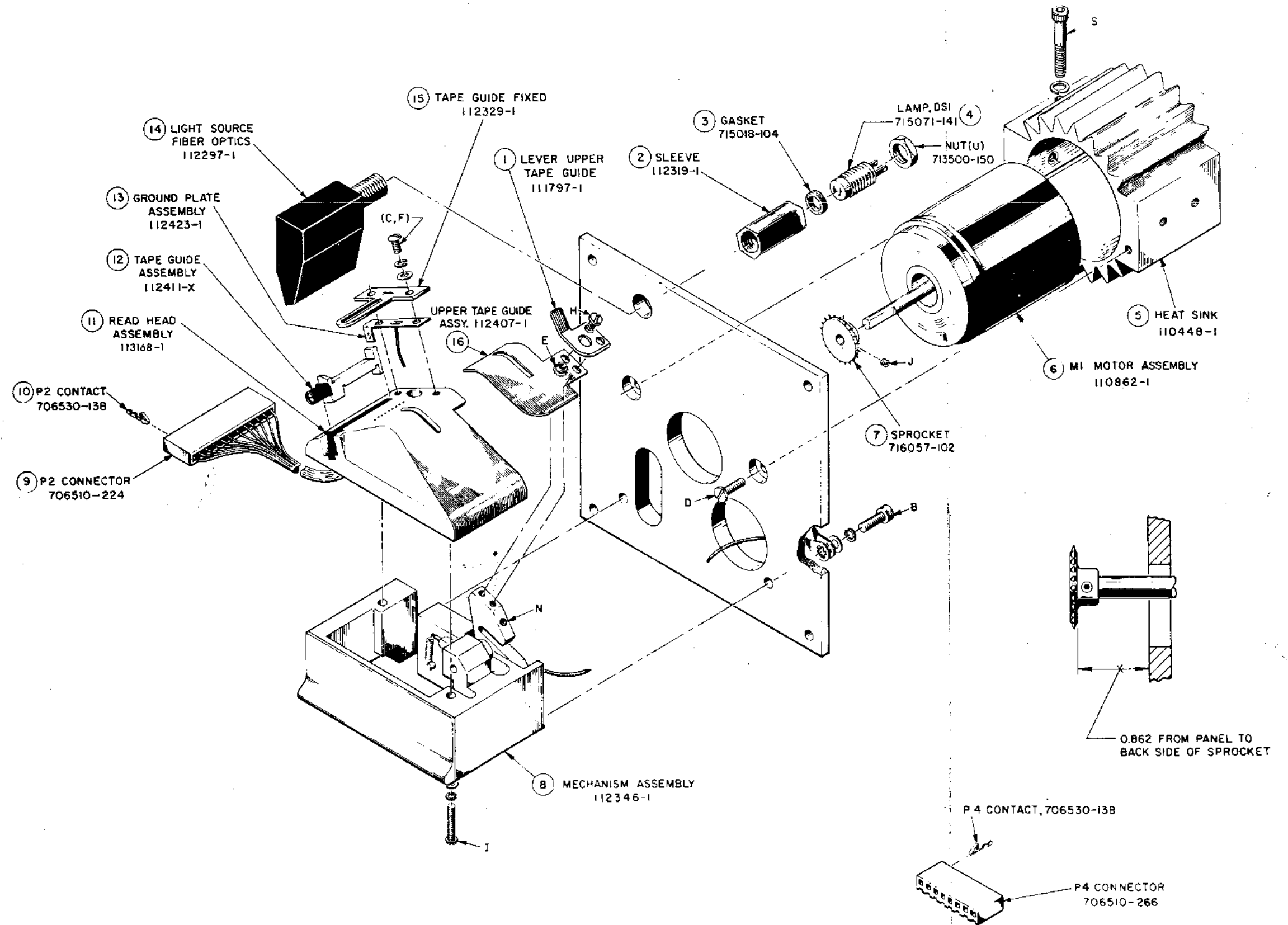

MMC 620

Figure 7-1. Exploded View of Readhead Mechanism Assembly.

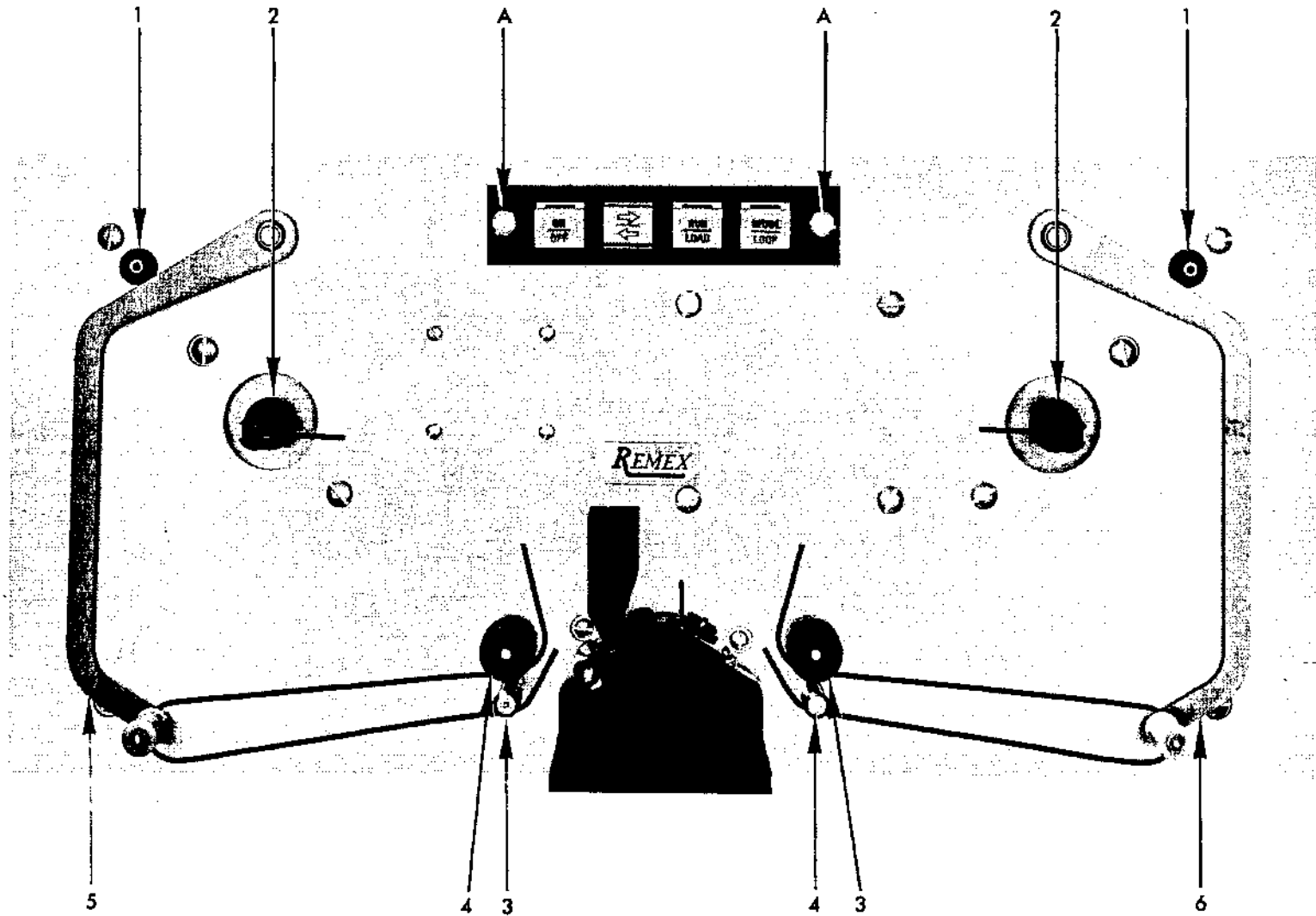

Figure 7-2. Front View of Front Panel. Two Lower Bumpers (Item 1) have been added since the unit was photographed.

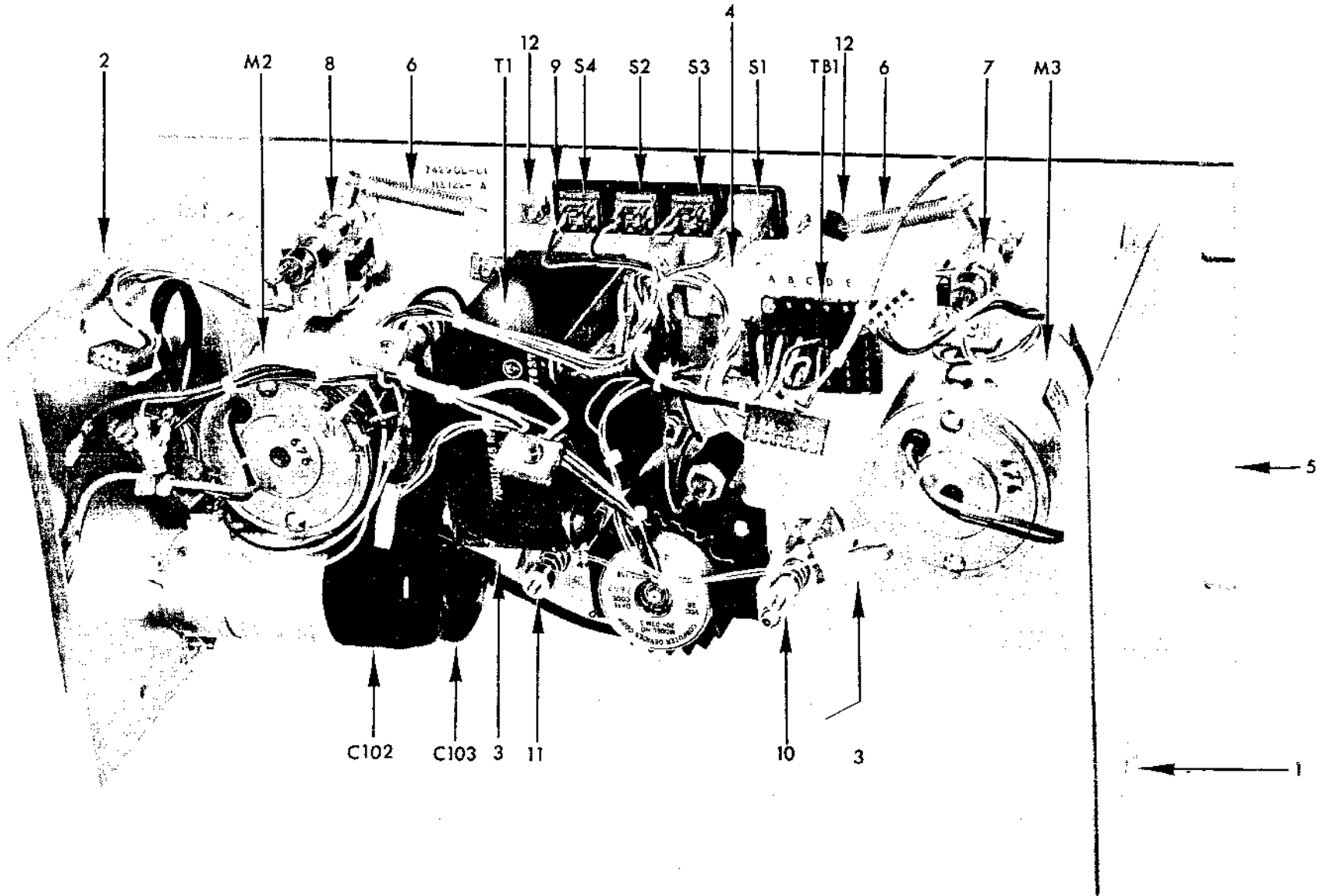

Figure 7-3. Rear View of Front Panel.

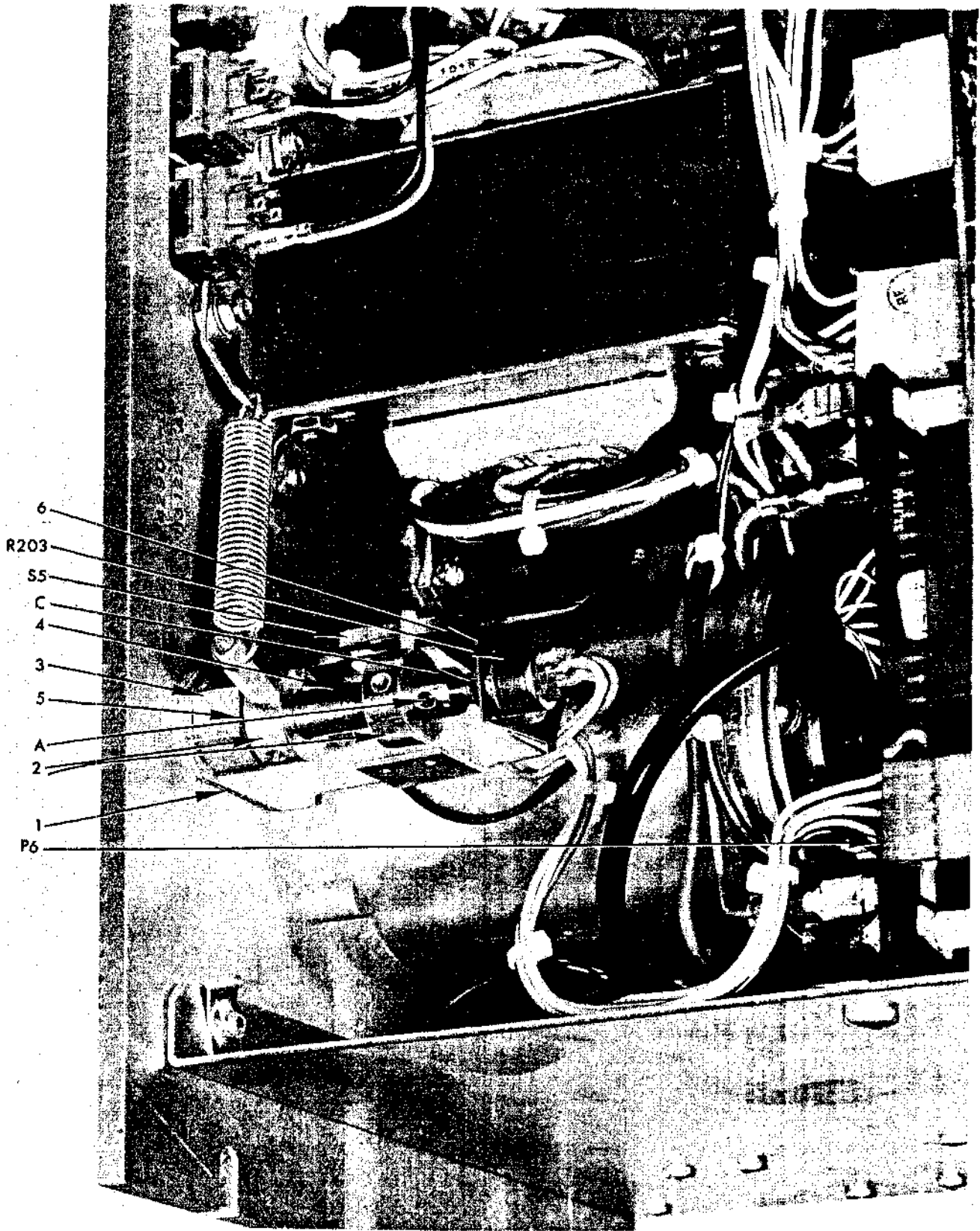

Figure 7-4. Tape Break Switch Assembly.

NOTE: WHEN ORDERING SPARE PARTS, CONTACT REMEX SPARES ORDER DESK AND REFERENCE COMPLETE MODEL AND SERIAL NUMBER OF UNIT. ALWAYS REFER TO ADDENDUM AT THE REAR OF THE MANUAL (IF APPLICABLE) FOR POSSIBLE PART NUMBER CHANGES.

Table 7-3. Power Drive Card Assembly 111131-3

Description and Manufacturer's Part No.	REMEX Part No.	Quantity	Reference Designation
Capacitor, 1.0 μ f, 50V, Ceramic, Sprague 7C Series	702131-105	2	C101, C102
Choke, R.F. Suppressor, Ferroxcube VK200-10/3B	702500-107	4	L1-L4
Connector, 8 pin, Orange, Molex 09-52-3082	706510-264	1	J9
Connector, 6 pin, Yellow, Molex 09-52-3062	706510-263	1	J10
Connector, 3 pin, Violet, Molex 09-60-1031	706501-037	2	J11, J12
Diode, 1N4003	704005-137	1	CR101
Filter, Corcom 6EF1-E1	702250-111	1	FL1
Fuseholder, Littlefuse 348870	705750-117	1	(F101)
Heat Sink, Ierc LA T03B5CB	715033-129	6	
Insulator, RCA 495320	715019-115	6	
Panel, Heat Sink	113199-1	1	
Rectifier, Motorola MDA3502	704005-144	2	BR1, BR2
Resistor, 2 ohm, 50W, \pm 3% Wire Wound Dale RH50-3%	701182-R00	2	R201, R202
Resistor, 35 Ω , 10W, \pm 5%	701017-350	1	R205
Transistor, Motorola MJ4032	704212-106	2	Q101, Q103
Transistor, Motorola MJ4035	704204-120	2	Q102, Q104
Voltage Regulator, National Semiconductor LM309K	704520-109	2	Z101, Z102

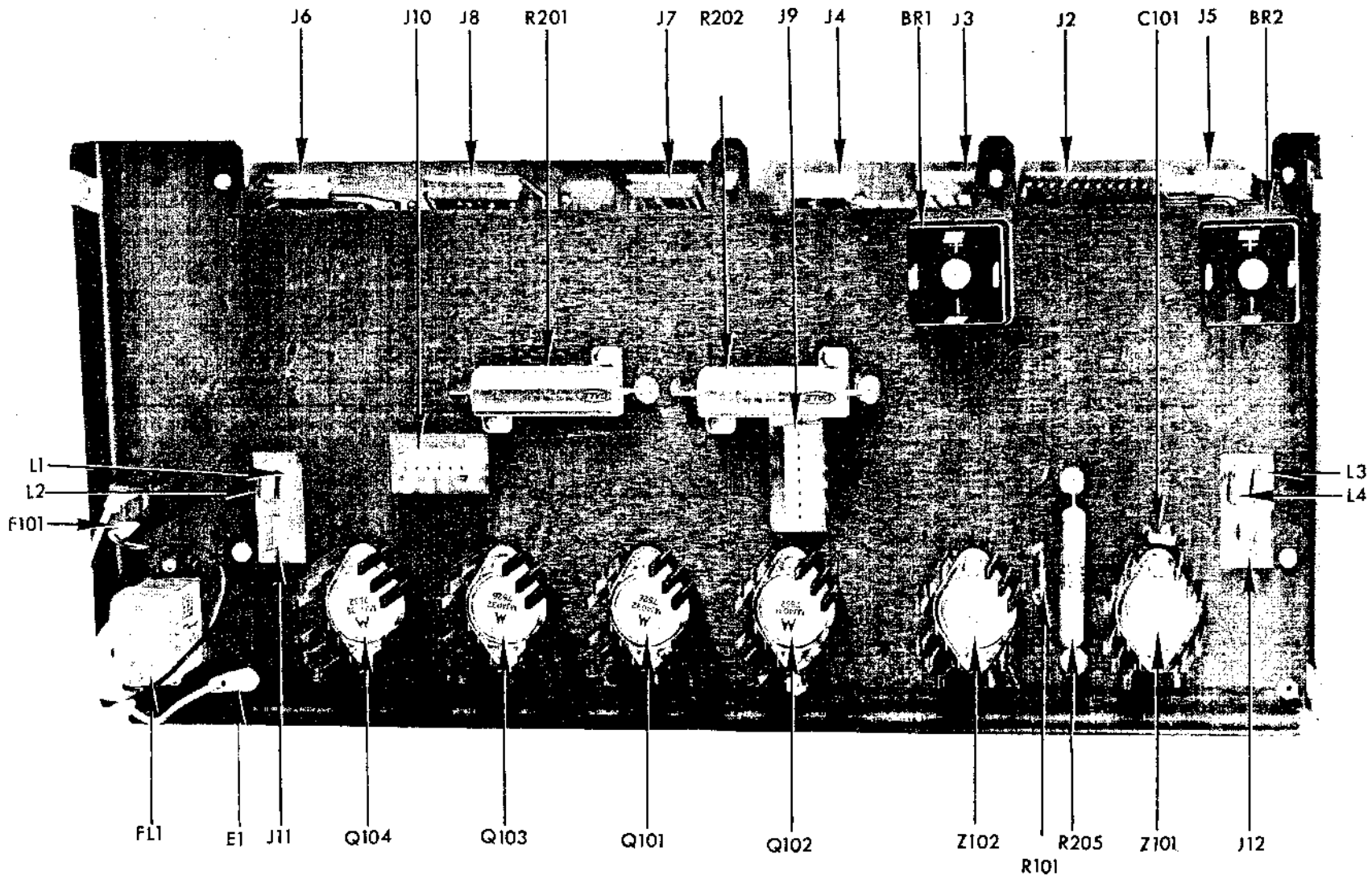

Figure 7-5. Power Drive Card Assembly 111131-3

NOTE: WHEN ORDERING SPARE PARTS, CONTACT REMEX SPARES ORDER DESK AND REFERENCE COMPLETE MODEL AND SERIAL NUMBER OF UNIT. ALWAYS REFER TO ADDENDUM AT THE REAR OF THE MANUAL (IF APPLICABLE) FOR POSSIBLE PART NUMBER CHANGES.

Table 7-4. Reader Card Assembly 113191-1

Description and Manufacturer's Part No.	REMEX Part No.	Quantity	Reference Designation
The following parts list was written for the F assembly of PC card 113191-1 and the G revision of schematic 113192. Previous revisions are listed on a PC card revision sheet on page 7-18A/7-18B and subsequent changes are listed in the addendum (if applicable).			
Capacitor, 100 pf, 200V, Ceramic, Type CK05	702128-101	5	C1,C7,C13 C36,C37
Capacitor, 470 pf, 200V, Ceramic, Type CK05	702128-471	2	C2,C24
Capacitor, 1.5 uf, 35V, Solid Tantalum, Sprague 196D155X9035JA1	702396-155	1	C3
Capacitor, 0.01 uf, 100V, Ceramic Disc, Erie 805X-5V1032	702121-103	41	C4,C5,C14,C16, C18,C22,C27, C41,C51-C73, C75,C77-C85
Capacitor, 47 uf, 10V, Electrolytic, Amperex, Model ET	702620-476	2	C6,C74
Capacitor, 3.3 uf, 15V, Solid Tantalum, Sprague 196D	702394-335	2	C8,C17
Capacitor, 0.022 uf, 100V, Metallized Mylar IMB X-P7B223X	702181-223	1	C9
Capacitor, 0.1 uf, 100V, Metallized Mylar IMB X-P7B104X	702181-104	2	C10,C15
Capacitor, 0.068 uf, 100V, Metallized Mylar IMB X-P7B683X	702181-683	2	C11,C12
Capacitor, 22 uf, 10V, Electrolytic, Mallory TAS 226M010P1	702386-226	1	C19
Capacitor, 0.0047 uf, 100V, Ceramic, Type CK06	702128-472	4	C20,C21,C30 C31
Capacitor, 220 uf, 10V, Electrolytic Amperex Model ET	702620-227	1	C23
Capacitor, 0.001 uf, 200V, Ceramic, Type CK05	702128-102	6	C25,C32-C35 C76
Capacitor, 1 uf, 100V, Metallized Mylar IMB X-P7B105X	702181-105	1	C26
Capacitor, 0.47 uf, 100V, Metallized Mylar IMB X-P7B474X	702181-474	2	C28,C29
Capacitor, 5000 uf, 25V, Electrolytic, STM61C	702349-102	3	C38-C40
Capacitor, 35 uf, 50V, Electrolytic, Sprague Type TE	702372-356	1	C42
Capacitor, 0.1 uf, 100V, Ceramic Disc, Erie 805X5V104Z	702121-104	2	C43,C44
Capacitor, 1 uf, 50V, Ceramic, Sprague 7C023105D8500E	702131-105	6	C45-C50
Connector, Cannon DB-25PV, 25 pin	706500-239	1	J1
Connector, 12 pin, Red, Molex 09-60-1121	706501-122	1	J2
Connector, 5 pin, Orange, Molex	706501-053	1	J3
Connector, 6 pin, Yellow, Molex 09-60-1061	706501-064	1	J4
Connector, 5 pin, Green, Molex 09-60-1051	706501-055	2	J5,J6

NOTE: WHEN ORDERING SPARE PARTS, CONTACT REMEX SPARES ORDER DESK AND REFERENCE COMPLETE MODEL AND SERIAL NUMBER OF UNIT. ALWAYS REFER TO ADDENDUM AT THE REAR OF THE MANUAL (IF APPLICABLE) FOR POSSIBLE PART NUMBER CHANGES.

Table 7-4. Reader Card Assembly 113191-1 (Continued)

Description and Manufacturer's Part No.	REMEX Part No.	Quantity	Reference Designation
Connector, 6 pin, Violet, Molex 09-60-1061	706501-067	1	J7
Connector, 8 pin, Grey, Molex 09-60-1081	706501-088	1	J8
Connector, 8 pin, Orange, Molex 09-64-1083	706500-254	1	P9
Connector, 6 pin, Yellow, Molex 09-64-1063	706500-253	1	P10
Diode, 1N4003	704005-137	5	CR1, CR2, CR7 CR8, CR9
Diode, FDH 6666	704000-110	7	CR3-CR6, CR11 CR12, CR13
Diode, 1N276	704000-100	2	CR10, CR14
Diode, 33V Zener, 1N4752	704014-130	1	CR15
Fuse, 200 ma, Bussman GMW	705725-101	1	F1
Fuse, 10A	705725-127	2	F2, F3
Fuse Connector, Cambion 3704-1-03	706515-129	2	(F1)
Fuse Connector	706515-141	4	(F2, F3)
Heat Sink	110854-1	1	(Q13-Q15)
I.C. Package, Resistor/Capacitor Network Beckman 1899-4102-0	701950-004	2	Z1, Z2
I.C. Package, SN7475N	704610-105	2	Z3, Z4
I.C. Package, SN7486N	704600-109	3	Z5, Z6, Z20
I.C. Package, SN7404N	704600-110	1	Z7
I.C. Package, SN7400N	704600-101	9	Z8, Z10, Z13, Z14, Z24, Z29, Z32, Z48, Z49
I.C. Package SN74221N	704610-165	6	Z9, Z11, Z16, Z21, Z27, Z30
I.C. Package SN74132N	704600-152	2	Z12, Z31
I.C. Package, SN7408N	704600-114	8	Z15, Z19, Z23, Z25, Z26, Z28, Z33, Z51
I.C. Package, SN7474N	704610-110	2	Z17, Z18
I.C. Package, SN74123N	704610-119	2	Z22, Z50
I.C. Package SN7406N	704600-111	1	Z34
I.C. Package, LM307N	704520-110	6	Z35-Z37, Z39, Z40, Z41
I.C. Package, IH 5019-CPA	704900-106	3	Z38, Z42, Z43
I.C. Package, Resistor, REMEX Specification	701900-004	1	Z44
I.C. Package, Resistor/Capacitor Network REMEX Specification	701950-007	3	Z45-Z47
Insulator, Thermalloy 43-77-2	715019-120	3	(Q13 - Q15)
Resistor, 4.7K, 1/4W, +5%	701003-472	10	R1, R34, R35 R37, R47, R52, R53, R55, R98, R107
Resistor, 100K, 1/4W, +5%	701003-104	1	R2
Resistor, 220 ohm, 1/4W, +5%	701003-221	1	R3
Resistor, 1.5K, 1/4W, +5%	701003-152	1	R4
Resistor, 22K, 1/4W, +5%	701003-223	1	R5

NOTE: WHEN ORDERING SPARE PARTS, CONTACT REMEX SPARES ORDER DESK AND REFERENCE COMPLETE MODEL AND SERIAL NUMBER OF UNIT. ALWAYS REFER TO ADDENDUM AT THE REAR OF THE MANUAL (IF APPLICABLE) FOR POSSIBLE PART NUMBER CHANGES.

Table 7-4. Reader Card Assembly 113191-1 (Continued)

Description and Manufacturer's Part No.	REMEX Part No.	Quantity	Reference Designation
Resistor, 330 ohm, 1/4W, $\pm 5\%$	701003-331	9	R6, R7, R25-R27, R82, R85, R86, R89
Resistor, 22 ohm, 1/4W, $\pm 5\%$	701003-220	6	R8, R17, R23, R43, R74, R99
Resistor 47 ohm, 1/4W, $\pm 5\%$	701003-470	3	R9, R19, R42
Resistor, 1K, 1/4W, $\pm 5\%$	701003-102	16	R10, R24, R31-R33, R39, R49, R78-R81, R92, R93, R100, R104, R105
Resistor, 27K, 1/4 W, $\pm 5\%$	701003-273	4	R11, R12, R22, R64
Resistor, 20K, 1/4W, $\pm 5\%$	701003-203	2	R13, R16
Resistor, 8.2K, 1/4W, $\pm 5\%$	701003-822	2	R14, R21
Resistor, 9.1K, 1/4W, $\pm 5\%$	701003-912	3	R15, R40, R41
Resistor 18K, 1/4W, $\pm 5\%$	701003-183	2	R18, R50
Resistor, 3.3K, 1/4W, $\pm 5\%$	701003-332	4	R28-R30, R101
Resistor, 2.2K, 1/4W, $\pm 5\%$	701003-222	1	R36
Resistor, 33K, 1/4W, $\pm 5\%$	701003-333	1	R38
Resistor, 10K, 1/4W, $\pm 5\%$	701003-103	10	R44, R45, R48, R51, R57-R59, R61, R66, R68, R46, R67, R97
Resistor, 1M, 1/4W, $\pm 5\%$	701003-105	3	R54
Resistor, 220K, 1/4W, $\pm 5\%$	701003-224	1	R56
Resistor, 5.6K, 1/4W, $\pm 5\%$	701003-562	1	R60
Resistor, 47K, 1/4W, $\pm 5\%$	701003-473	1	R62
Resistor, 8.2M, 1/4W, $\pm 5\%$	701003-825	1	R65
Resistor, 1.2K, 1/4W, $\pm 5\%$	701003-122	1	R69
Resistor, 910K, 1/4W, $\pm 5\%$	701003-914	1	R70, R71
Resistor, 330K, 1/4W, $\pm 5\%$	701003-334	2	R72, R73
Resistor, 180K, 1/4W, $\pm 5\%$	701003-184	2	R75
Resistor, 10 ohm, 1/4W, $\pm 5\%$	701003-100	1	R76, R77
Resistor, 2.2M, 1/4W, $\pm 5\%$	701003-225	2	R83, R84
Resistor, 820 ohm, 1/2W, $\pm 5\%$	701004-821	4	R87, R88
Resistor, 100 ohm, 1/4W, $\pm 5\%$	701003-101	2	R90, R91
Resistor, 47 ohm, 1/2W, $\pm 5\%$	701004-470	1	R94
Resistor, 330 ohm, 1/2W, $\pm 5\%$	701004-331	1	R95
Resistor, 390 ohm, 3W, $\pm 5\%$	701015-391	2	R102, R103
Resistor, 1.5 ohm, 2W, $\pm 5\%$	701014-1R5	1	R106
Resistor, Variable, 20K, 1/2W, Spectral 53-1-1-203	701659-203	1	R20
Resistor, Variable, 10K, 1/2W, Spectral 53-1-1-103	701659-103	1	R63
Resistor, Variable, 100 ohm, 1/2W, Spectral 54-1-1-101	701659-101	1	R96
Screw Lock (Set of 2) Female, Cannon D-20418-2	706540-123	1	(J1)
Standoff, Cambion 350-7409-10-19	715030-199	2	(J1)

NOTE: WHEN ORDERING SPARE PARTS, CONTACT REMEX SPARES ORDER DESK AND REFERENCE COMPLETE MODEL AND SERIAL NUMBER OF UNIT. ALWAYS REFER TO ADDENDUM AT THE REAR OF THE MANUAL (IF APPLICABLE) FOR POSSIBLE PART NUMBER CHANGES.

Table 7-4. Reader Card Assembly 113191-1 (Continued)

Description and Manufacturer's Part No.	REMEX Part No.	Quantity	Reference Designation
Test Point, Lerco 5025-B-1	715013-121	6	TP1-TP6
Transistor, 2N5088	704203-119	9	Q1-Q9
Transistor, Motorola MPSA56	704202-109	5	Q10-Q12, Q17, Q19
Transistor, Motorola MJE1100	704204-115	5	Q13-Q15, Q20, Q21
Transistor, Motorola MPSA06	704203-118	2	Q16, Q18

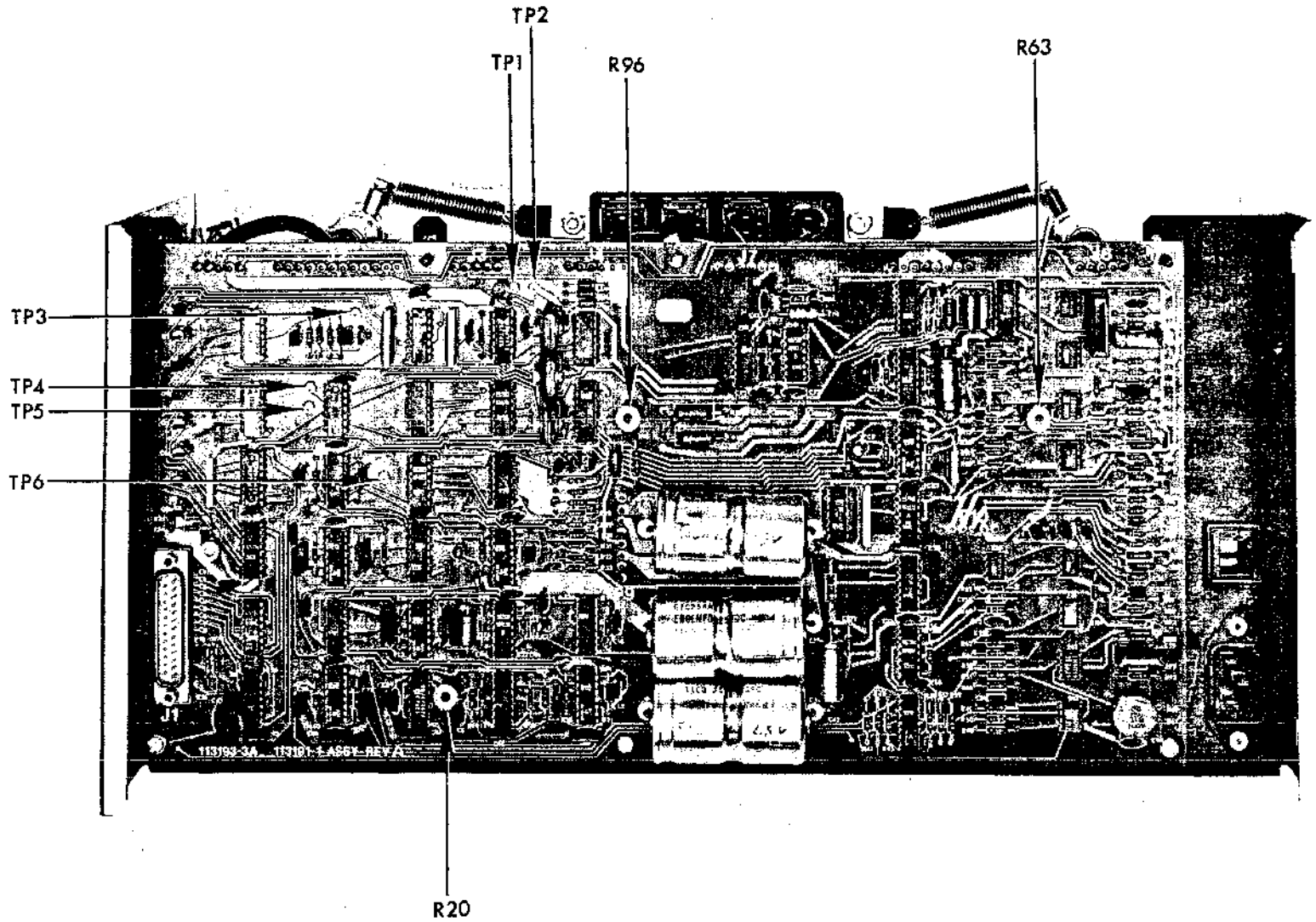

Figure 7-6. Reader Card Assembly 113191-1

SECTION VIII

SCHEMATIC DRAWINGS

8.1 GENERAL

Figure 8-1 contains the system schematic for the RRS73000BEX. Figure 8-2 contains the schematic (4 pages) for the 113191-1 reader card. Figure 8-3 illustrates the IC Module outlines and truth tables and is reproduced courtesy of Texas Instruments except for the 9602 which is reproduced courtesy of Fairchild Semiconductor.

SYM	ECO	EFFECT	REVISIONS	BY	DATE	APPD
A	—	—	RELEASED	Q.P.	11.17.74	—
B	16651	1.17.74	REVERSED: SEE WLS 33-P	S.E.O.	11.17.74	—
C	16721	2.19.74	CHANGED C.W. TO SWITCH C1	S.E.O.	2.19.74	—
D	16721	4.19.74	—	—	4.19.74	—
E	17016	5.7.74	ADDED 'E2 CHASSIS GND	S.E.O.	5.7.74	—
F	17176	6.20.74	ADDED NOTE 5	S.E.O.	6.20.74	—
G	18676	9.20.74	SEE ECO	S.E.O.	9.20.74	—

READER CARD ASSY 113191-001
SCHEMATIC 113192-000

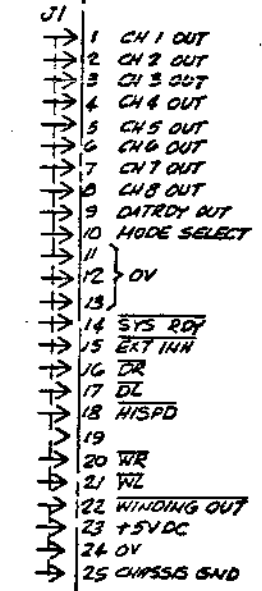
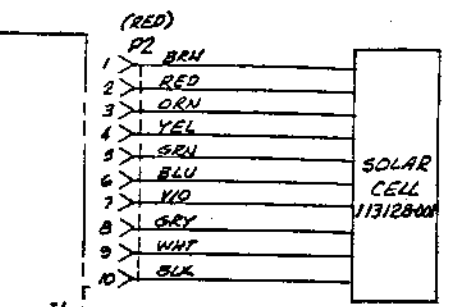

- NOTES: UNLESS OTHERWISE SPECIFIED.
1. C102 & C103 ARE 9.34F, 40V.
 2. R203 & R204 ARE 10K-Ω.
 3. BR1 & BR2 ARE MDA3302 (MOTOROLA) 35.0AMPS, 200V.
 4. SEE WIRE LIST W/L 113197-001.
 5. F101 IS 2 AMP, SLO-BLO FOR 110, 115, 127 VAC OPERATION.
F101 IS 1 AMP, SLO-BLO FOR 220, 240 VAC OPERATION.

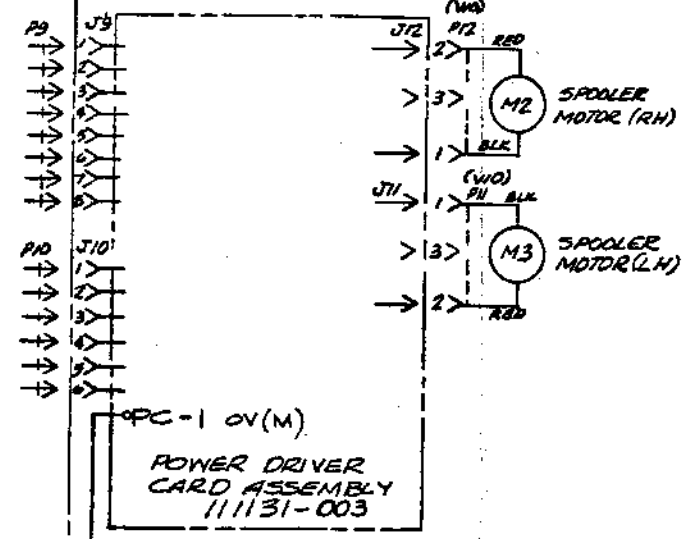

REV	ECO	REMARKS	DATE	BY
A		RELEASED		
B	11-27	EX-10 2'S HAS ECU		
C	11-27	EX-10 2'S HAS ECU		
D	12-29	EX-10 2'S HAS ECU		
E	12-29	EX-10 2'S HAS ECU		
F	12-29	EX-10 2'S HAS ECU		
G	12-29	EX-10 2'S HAS ECU		

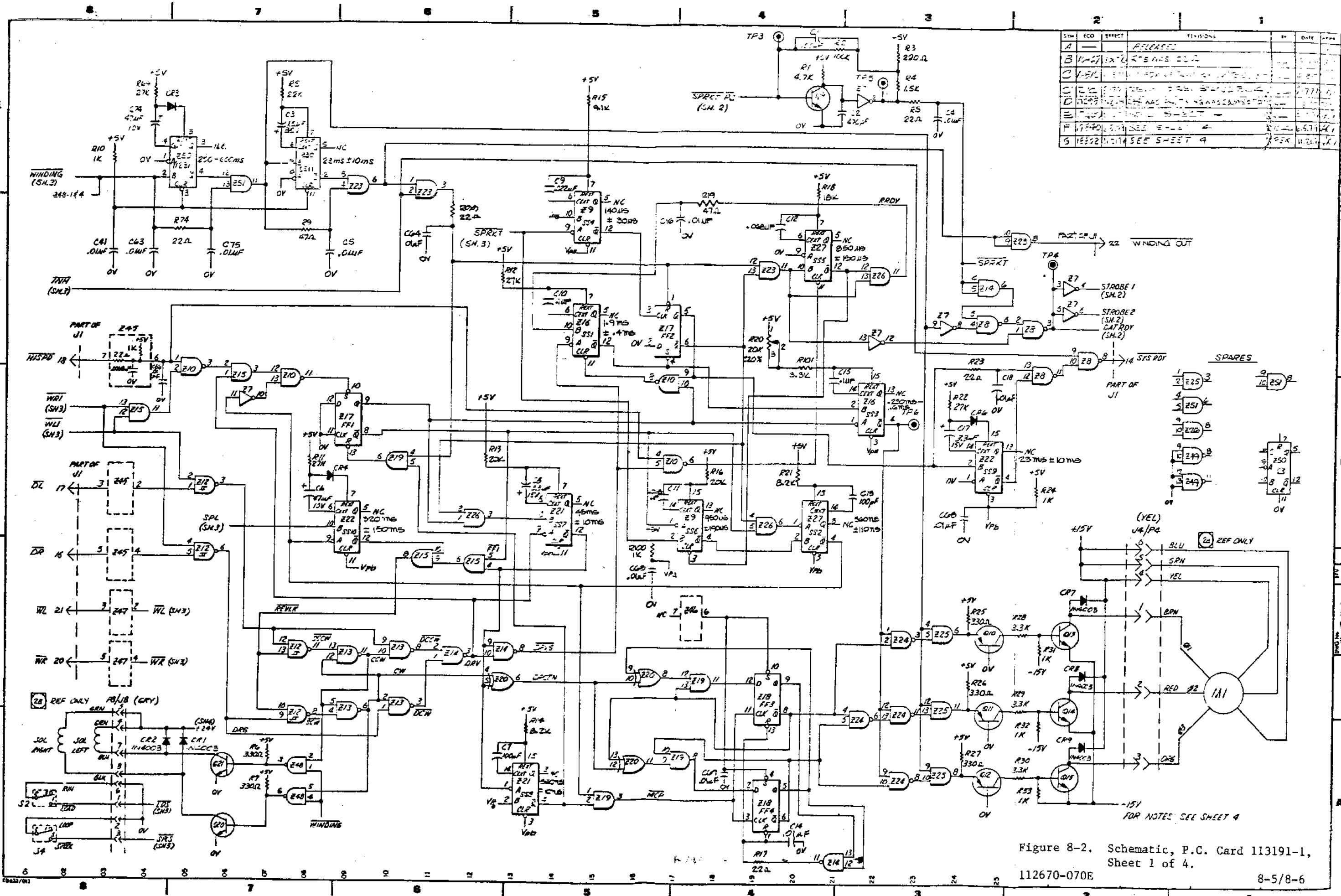
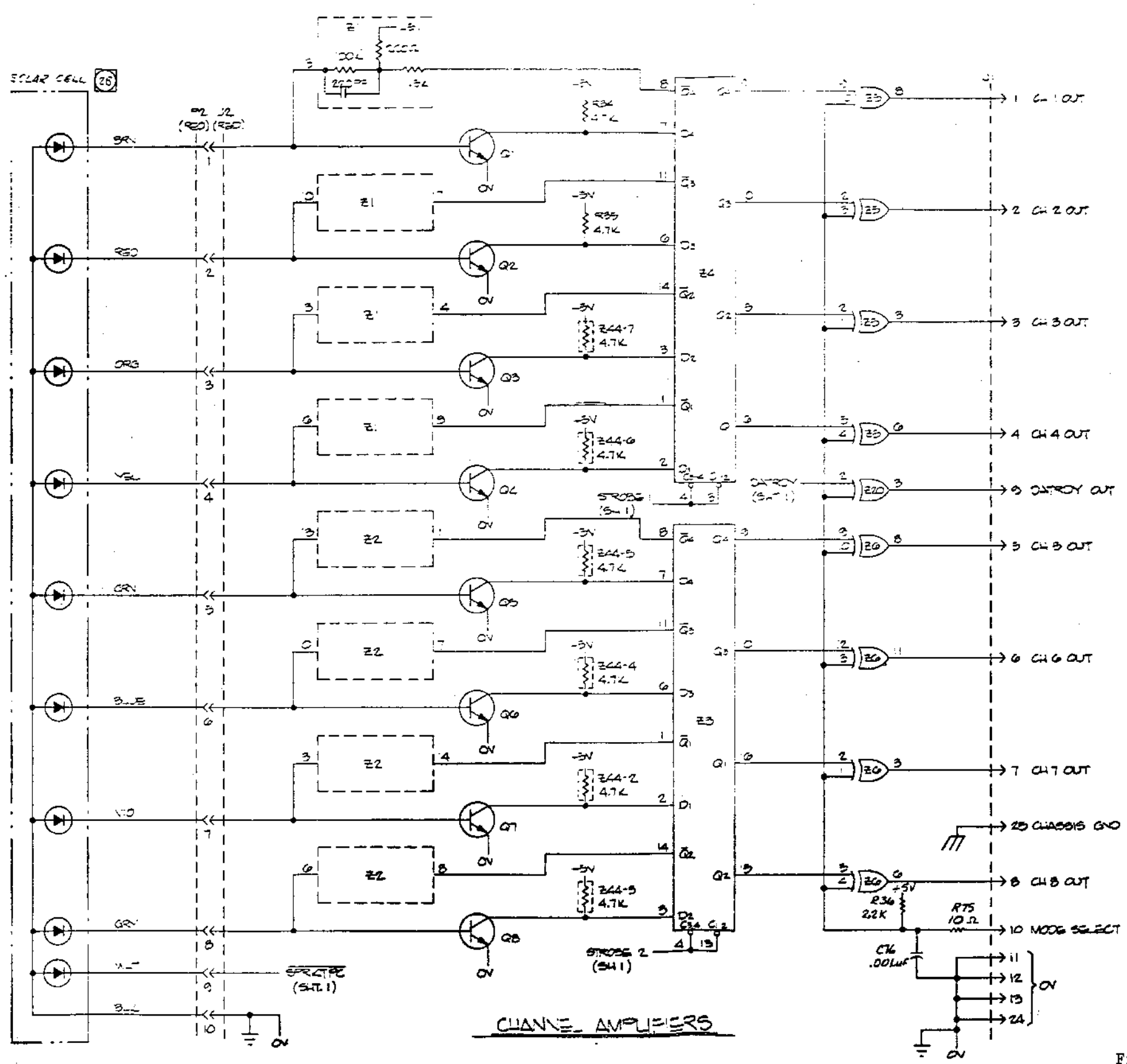

Figure 8-2. Schematic, P.C. Card 113191-1, Sheet 1 of 4.
112670-070E 8-5/8-6

SYM	ECO	EFFECT	REVISIONS	BY	DATE	APPR
5	18800	INITIAL	SEE SHEET 4	REK	11/21/84	JK



FOR GENERAL NOTES SEE SLI 4

Figure 8-2. Schematic, P.C. Card 113191-1, Sheet 2 of 4.

112670-070E

8-7/8-8

113191-1

REV	ECO	EFFECT	REVISIONS	DATE	APPROV
1		RELEASED			
2		REVISED			
3		REVISED			
4		REVISED			
5		REVISED			
6		REVISED			
7		REVISED			
8		REVISED			
9		REVISED			
10		REVISED			
11		REVISED			
12		REVISED			
13		REVISED			
14		REVISED			
15		REVISED			
16		REVISED			
17		REVISED			
18		REVISED			
19		REVISED			
20		REVISED			
21		REVISED			
22		REVISED			
23		REVISED			
24		REVISED			
25		REVISED			
26		REVISED			
27		REVISED			
28		REVISED			
29		REVISED			
30		REVISED			
31		REVISED			
32		REVISED			
33		REVISED			
34		REVISED			
35		REVISED			
36		REVISED			
37		REVISED			
38		REVISED			
39		REVISED			
40		REVISED			
41		REVISED			
42		REVISED			
43		REVISED			
44		REVISED			
45		REVISED			
46		REVISED			
47		REVISED			
48		REVISED			
49		REVISED			
50		REVISED			
51		REVISED			
52		REVISED			
53		REVISED			
54		REVISED			
55		REVISED			
56		REVISED			
57		REVISED			
58		REVISED			
59		REVISED			
60		REVISED			
61		REVISED			
62		REVISED			
63		REVISED			
64		REVISED			
65		REVISED			
66		REVISED			
67		REVISED			
68		REVISED			
69		REVISED			
70		REVISED			
71		REVISED			
72		REVISED			
73		REVISED			
74		REVISED			
75		REVISED			
76		REVISED			
77		REVISED			
78		REVISED			
79		REVISED			
80		REVISED			
81		REVISED			
82		REVISED			
83		REVISED			
84		REVISED			
85		REVISED			
86		REVISED			
87		REVISED			
88		REVISED			
89		REVISED			
90		REVISED			
91		REVISED			
92		REVISED			
93		REVISED			
94		REVISED			
95		REVISED			
96		REVISED			
97		REVISED			
98		REVISED			
99		REVISED			
100		REVISED			

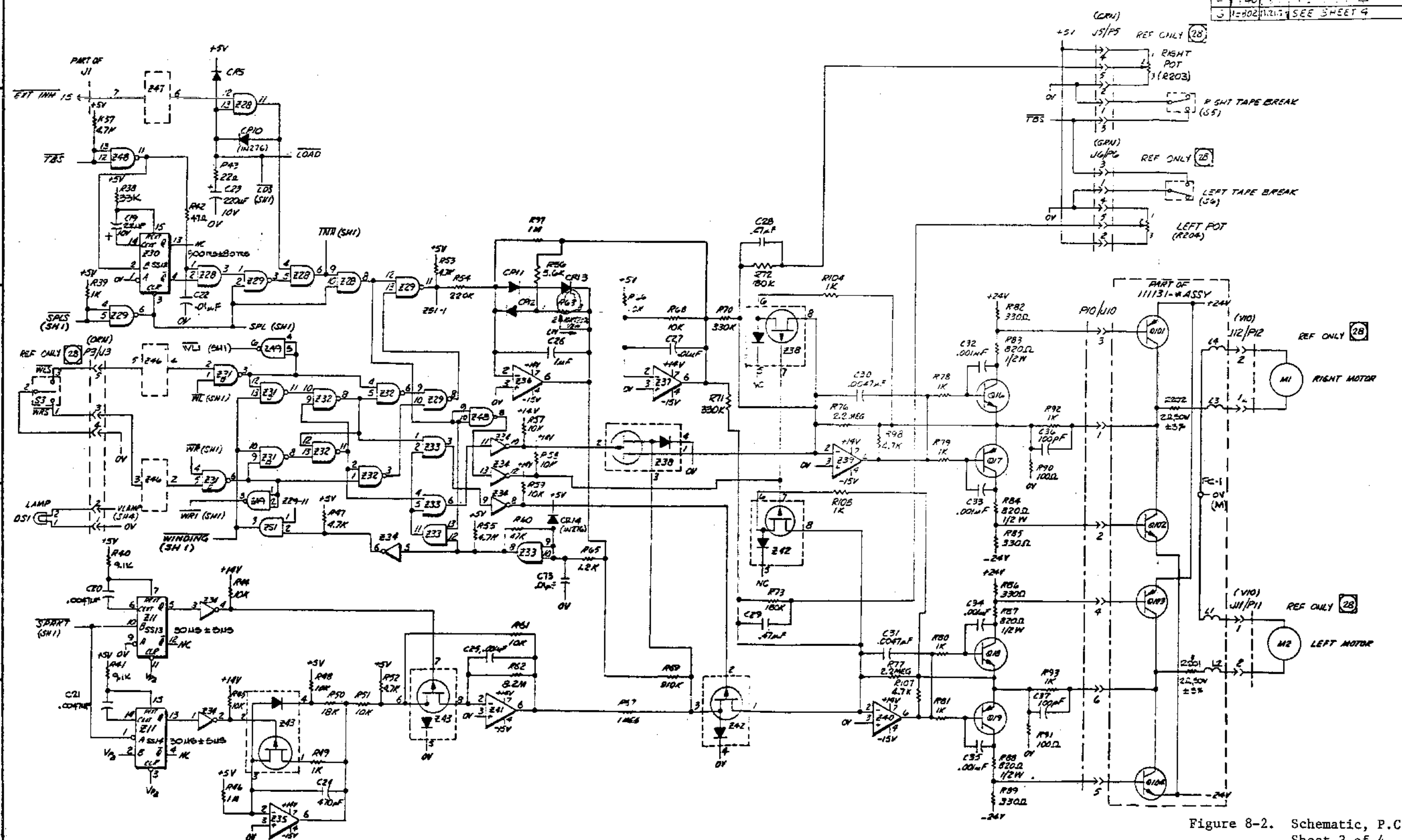
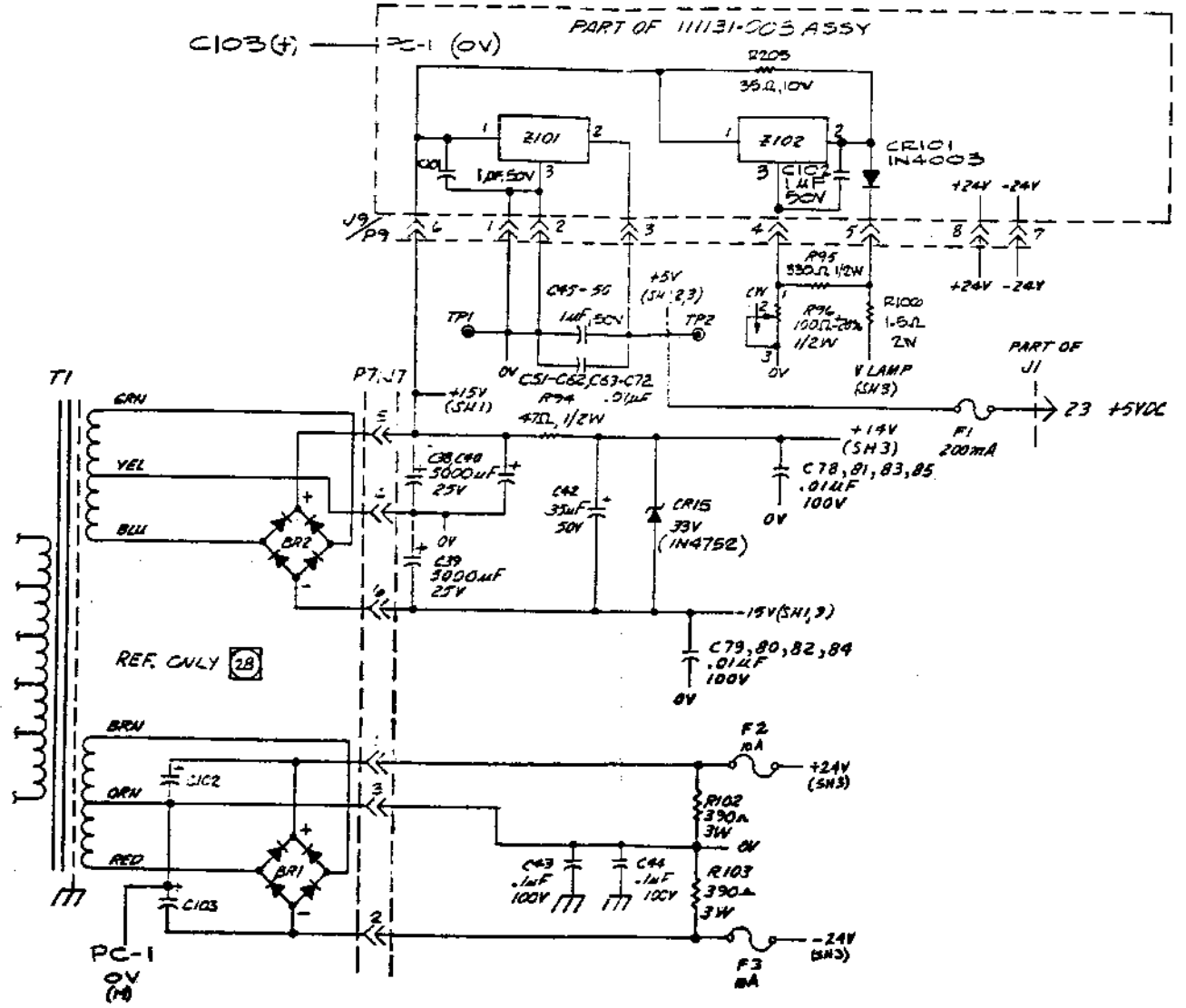

Figure 8-2. Schematic, P.C. Card 113191-1, Sheet 3 of 4.

11319200G

SYM	ECO	EFFECT	REVISIONS	BY	DATE	APPRO
A			RELEASED			
B	2427	ECO	REVISION 22 10	JL	10-7	JL
C	2501	ECO	REVISION 23 10	JL	10-7	JL
C	R/C	5/17/77	DEFINED REV STATUS	JL	5/17/77	JL
D	2295	ECO	REVISION 24 10	JL	5-78	JL
E	2407	ECO	REVISION 25 10	JL	3-78	JL
F	17140	ECO	REVISION 26 10	JL	6-79	JL
G	18802	ECO	REVISION 27 10	REK	11-27-79	REK



- NOTE-UNLESS OTHERWISE SPECIFIED
- RESISTORS ARE 1/4W, 5%.
 - 244 IS 701900-004 K0400A-472
 - REF ASSY DNG NO'S 113191-001 & 11131-003
 - 01-9 ARE 704203-119 (SN7402B)
 - 016, 218 ARE 704203-118 (MPS406)
 - 013-15, 20, 21 ARE 704204-115 (SN751100)
 - 010-12, 17, 19 ARE 704202-109 (MPS456)
 - CR1, 2, 7, 8, 9 ARE 704005-137 (IN4003)
 - CR16, 14 ARE 704000-100 (IN276)
 - CR15 IS 704014-130 (IN4752) 33V ZENER
 - CR3-6, 11 THEN 13 ARE 704000-110 (FDH6666)
 - 21, 2 ARE 701950-004 (1899-4152-0)
 - 23, 4 ARE 704610-105 (SN74751)
 - 25, 6, 20 ARE 704600-109 (SN74935N)
 - 27, 15 ARE 704600-110 (SN7409N)
 - 28, 10, 31, 24, 28, 32, 40, 44 ARE 704600-101 (SN7409N)
 - 29, 11, 3, 21, 27, 30 ARE 704610-105 (SN74751N)
 - 215, 12, 23, 25, 26, 28, 33, 51 ARE 704600-114 (SN7409N)
 - 217, 18 ARE 704610-110 (SN7474N)
 - 20, 23A IS 704600-111 (SN74065N)
 - 22, 50 ARE 704610-119 (SN74123N)
 - 212 & 31 ARE 704600-152 (SN74132N)
 - 245, 46, 47 ARE 701950-007
 - 2101, 102 ARE 704520-109 (LM209K)
 - 0101, 03 ARE 704212-106 (M44032)
 - 0102, 104 ARE 704204-120 (M44035)
 - 235-37, 39-41 ARE 704520-110 (LM307N)
 - REF SYSTEM SCHEMATIC 113190-000.
 - 238, 42, 43 ARE 704900-106 (1-5019-CPA)
 - PROGRAMMED FOR AUTOMATIC TEST

	0V	+5V
PIN -		PIN 11
12		5
7		14
7		14
7		14
8		16
7		14
7		14
7		14
8		16
7		14
7		14
PIN 1		PIN 8

LAST DESIGNATION USED	NOT USED
RESISTOR R107	R205
CAPACITOR C85	C102
DIODE CR15	CR101
TRANSISTOR Q21	Q104
I.C. 231	E102
113191-01	11131-003
ASSY	ASSY

F	E	H	D	G	F
F	E	H	C	F	E
F	E	H	B	E	D
F	D	H	B	D	D
F	C	G	E	C	C
F	C	F	B	C	B
E	B	E	B	B	B
E	A	E	B	A	A
F33	ECO	ASSY	F43	ECO	ASSY
113191-01	ASSY	113191-01	ASSY	113191-01	ASSY
REVISION STATUS	REVISION STATUS	REVISION STATUS	REVISION STATUS	REVISION STATUS	REVISION STATUS

Figure 8-2. Schematic, P.C. Card
113191-1, Sheet 4 of 4
112670-070E 8-11/8-12

SN7474

DUAL D-TYPE EDGE-TRIGGERED FLIP-FLOPS

TRUTH TABLE (Each Flip-Flop)

INPUT	OUTPUT	OUTPUT
0	0	0
1	1	1

NOTES: 1. t_{11} = bit time before clock pulse
2. t_{12} = bit time after clock pulse

positive logic: Low input to preset sets Q to logical 1
Low input to clear sets Q to logical 0
Preset and clear are independent of clock

SN74123

RETRIGGERABLE MONOSTABLE MULTIVIBRATORS WITH CLEAR

TRUTH TABLE (See Note A)

INPUTS	OUTPUTS
A B Q	Q
H X L H	H
X L L H	L
L L L L	L
L H L L	L

NOTES:
A. H = high level (steady state), L = low level (steady state), T = transition from low to high level, L = transition from high to low level, \downarrow L = one high-level pulse, \uparrow L = one low-level pulse, X = irrelevant (any input, including transition).
B. NC = No internal connection.
C. To use the internal timing resistor of SN54122/SN74123 (10 k Ω nominal), connect R_{int} to V_{CC}.
D. An external timing capacitor may be connected between C_{ext} and R_{int}/C_{ext} (positive).

TTL/MONOSTABLE 9602 RETRIGGERABLE RESETTABLE MONOSTABLE MULTIVIBRATOR

GENERAL DESCRIPTION — The TTL/Monostable 9602 is a dual retriggerable, resettable monostable multivibrator which provides an output pulse whose duration and accuracy is a function of external timing components. The 9602 has excellent immunity to noise on the V_{CC} and ground lines. The 9602 uses TTL inputs and outputs for high speed and high fanout capability and is compatible with all members of the Fairchild TTL family.

TRIGGERING TRUTH TABLE

PIN NO'S.	Operation
5(11)	4(12) 3(13)
H=L	L H Trigger
H	L→H H Trigger
X	X L Reset

H = HIGH Voltage Level
L = LOW Voltage Level
X = Don't Care
H→L = HIGH to LOW Voltage Level transition
L→H = LOW to HIGH Voltage Level transition

CONNECTION DIAGRAM DIP (TOP VIEW)

*Pins for external timing

SN7473, SN74107

DUAL J-K MASTER-SLAVE FLIP-FLOPS

TRUTH TABLE (Each Flip-Flop)

J	K	Q
0	0	Q _n
0	1	0
1	0	1
1	1	\bar{Q}_n

NOTES: 1. t_{11} = bit time before clock pulse.
2. t_{12} = bit time after clock pulse.

positive logic: Low input to clear sets Q to logical 0.
Clear is independent of clock.

SN7475, SN7477

8-BIT AND 4-BIT BISTABLE LATCHES

TRUTH TABLE (Each Latch)

t_{11}	t_{12}
0	1
1	1
0	0

NOTES: 1. t_{11} = bit time before clock pulse transition.
2. t_{12} = bit time after clock pulse transition.
NC = No Internal Connection.

positive logic: see truth table

SN74121

MONOSTABLE MULTIVIBRATORS

TRUTH TABLE (See Notes 1 thru 2)

t_{11} INPUT	t_{12} INPUT	OUTPUT
A1 A2 B	A1 A2 B	
0 1 0	0 1 0	Inhibit
0 1 1	0 1 1	Inhibit
0 1 0	1 1 0	One Shot
0 1 1	1 1 0	One Shot
1 1 0	0 1 0	One Shot
1 1 1	0 1 0	One Shot
0 0 1	0 1 0	Inhibit
0 0 1	1 1 0	Inhibit
0 1 1	1 1 1	Inhibit
1 1 1	1 1 1	Inhibit
1 1 0	0 1 0	Inhibit
1 1 0	0 1 1	Inhibit

1 = V_{CC} = 2V
0 = V_{INT} = 0.8V

NOTES: 1. t_{11} = time before input transition.
2. t_{12} = time after input transition.
3. X indicates that either a logical 0 or 1, may be present.
4. NC = No Internal Connection.

5. A1 and A2 are negative-edge triggered inputs, and will trigger the one shot when either or both go to logical 0 with B at logical 1.
6. B is a positive Schmitt-trigger input for few edges or level detection, and will trigger the one shot when B goes to logical 1 with either A1 or A2 at logical 0. (See Truth Table)

SN7400
SN7403 (Open Collector)
Positive Logic
NAND GATE

PIN NUMBERS

INPUT: 1,4,9,12
OUTPUT: 3,6,8,11
 $Y = \bar{A}\bar{B}$

A	B	Y
L	L	H
L	H	H
H	L	H
H	H	L

SN7402
Positive Logic
NOR GATE

INPUT: 3,6,9,12
OUTPUT: 1,4,10,13
 $Y = \overline{A+B}$

A	B	Y
L	L	H
L	H	L
H	L	L
H	H	L

SN7408
Positive Logic
AND GATE

INPUT: 1,4,9,12
OUTPUT: 3,6,8,11
 $Y = AB$

A	B	Y
H	H	H
H	L	L
L	H	L
L	L	L

SN7432
Positive Logic
OR GATE

INPUT: 1,4,9,12
OUTPUT: 3,6,8,11
 $Y = A+B$

A	B	Y
H	H	H
H	L	H
L	H	H
L	L	L

SN7486
Positive Logic
EXCLUSIVE-OR GATE

INPUT: 1,4,9,12
OUTPUT: 3,6,8,11
 $Y = A \oplus B$

A	B	Y
L	L	L
L	H	H
H	L	H
H	H	L

SN7410
Positive Logic
NAND GATE

INPUT: 1,3,9
OUTPUT: 2,4,6
 $Y = \bar{A}\bar{B}\bar{C}$

A	B	C	Y
L	L	L	H
L	L	H	H
L	H	L	H
L	H	H	H
H	L	L	H
H	L	H	H
H	H	L	H
H	H	H	L

SN7404
SN7406, SN7416 (Open Collector)
Positive Logic
HEX INVERTER

INPUT: 1,3,5
OUTPUT: 2,4,6
 $Y = \bar{A}$

A	Y
L	H
H	L

NOTE: Pin numbers are listed in the order in which they are related, for EXAMPLE, on SN7410, pins 1, 2, 13 and 12 function together on one gate. * Pin 7 is Gnd, Pin 14 is Vcc

Figure 8-3. Some I.C. Modules Used in P.C. Card 113191-1

COMPONENT I REF DESIGNATOR	SYMBOL	REMARKS	COMPONENT I REF DESIGNATOR	SYMBOL	REMARKS
SWITCH, 'S'	S1 S2 (N.C.) (N.O.)		INTEGRATED CIRCUIT PACKAGE	AND NOR AND OR EXCLUSIVE OR INVERTER AMPLIFIER	<p>2X1 - INDICATES I.C. PKG. LOCATION ON P.C. CARD. (LEFT TO RIGHT TOP TO BOTTOM SEQUENCE) (NUMBER)</p> <p>2X2 - INDICATES I.C. PKG. LOCATION ON P.C. CARD IN XY COORDINATE SYSTEM. (X=NUMBER, Y=LETTER)</p> <p>NOTE: EITHER NUMBERING SYSTEM SHOWN ABOVE MAY BE USED DEPENDING ON SIZE OR COMPLEXITY OF P.C. CARD</p>
SAFETY INTERLOCK	S1 S2 N.O. N.C. S3 S4 N.O. N.C. HELD CLOSED HELD OPEN		POSITIVE TRUE LOGIC SYMBOLS		
LIMIT SW	S1 N.O. S2 N.C. S3 N.O. S4 N.C. HELD CLOSED HELD OPEN				
POWER	S1 PWR ON				
PUSH BUTTON, 'PB'	PB1 N.O. N.C.				
TRANSFER	S1 S2 S3 S4 N.O. N.C. N.O. N.C. LND. CTR. OFF				
TIMER CONTACTS	S1 S2 S3 S4 N.O. N.C. N.O. N.C. DELAY OCCURS WHEN COIL IS ENERGIZED DE-ENERGIZED				
TRANSFORMER, 'T'	T1 T2 PWR. NPN				
UJT, 'U'	U1 U2 N-TYPE P-TYPE	ARROW POINTS TOWARD B1 FOR 'W' TYPE & AWAY FROM B1 FOR 'V' TYPE			
FET, 'Q'	Q1 Q2 N-TYPE P-TYPE				
DIODE 'CR' OR 'D'		*USE 'D' ON R/C APPLICATIONS			
ZENER DIODE 'CR'	XXV	V=VOLTS			
TRIAC		INDICATE TERMINALS 1 AND 2			
SCR					
BRIDGE RECTIFIER 'BR' 'D'		*USE 'D' ON R/C APPLICATIONS			
CABLE RUN (OPTIONAL)	X1 X2 X3 X4 X5 X6 X7 X8				
CABLE, 2 OR MORE CONDUCTORS		IF SHIELDED CONDUCTOR SHOW TERMINATION OF SHIELD			
TWISTED WIRES	P P T T PAIR TRIPPLE				
COAXIAL CABLE					

STANDARD SCHEMATIC SYMBOLS

107700

NOTE:
ALL SEMICONDUCTORS AND INTEGRATED CIRCUIT DEVICES ARE TO BE IDENTIFIED BY REMEX PART NUMBER ADJACENT TO DEVICE OR IN GENERAL NOTES. COMMERCIAL PART NUMBERS MAY ALSO BE SHOWN AT OPTION OF PROJECT ENGINEER

Figure 8-4. REMEX Standard Schematic Symbols, Sheet 1 of 2

01	COMPONENT 1 REF DESIGNATOR	SYMBOL	REMARKS	COMPONENT 2 REF DESIGNATOR	SYMBOL	REMARKS
02	CAPACITOR 'C'		DIVE VOLTAGE ON ELECTROLYTICS, MOTOR AND A.C. CAPACITORS IN A.C. CIRCUITS. VOLTAGE OPTIONAL ON ALL OTHERS.	TERMINAL 'E'		USE 'E', LOGICAL DESCRIPTION OR BOTH.
03	CELL - PHOTOSENSITIVE 'V'					
04	GND					
05	COIL RELAY 'K' OR NUMERICAL DESIGNATOR CONTACTS					
06	CONTACT CONNECTOR 'P', 'J'					
07	SEPARABLE CONNECTORS, ENGAGED		DEFINITION: PLUG USUALLY HORIZONTAL JACK USUALLY VERTICAL PLUG: ——— JACK: ———			
08	CONNECTORS, AC POWER 'P', 'J'					
09	FUSE - 'F'					
10	INDUCTOR, WINDING, SOLENOID, OR SOLENOID		LIVE INDUCTANCE OR COVER IN NOTES			
11	TRANSFORMER 'T'		POLARITY DOTS TO BE SHOWN IF NECESSARY TO CIRCUIT FUNCTION			
12	LAMP, INDICATING 'DS'					
13	CRYSTAL - 'Y'					
14	BOARD, TERMINAL 'TB' OR TAPPING STRIP 'TS'					
15	EYELET, PC CARD					
16	TEST POINT, 'TP'					
17	JUMPER - WIRE, PC		FOR OPTIONAL WIRING			
18	RESISTOR, FIXED, VARIABLE 'R'		OPTIONAL ADJUSTMENT SYMBOL: SCREW DRIVER AND TOLERANCE TO BE SHOWN OR PUT IN NOTES			
19	LAMP, GLOW 'N'					
20	LINE CROSS					
21	LINE CONNECT					

STANDARD SCHEMATIC SYMBOLS

107700-1

Figure 8-4. REMEX Standard Schematic Symbol, Sheet 2 of 2