

TECHNICAL MANUAL

TAPE READER

MODEL: RRS7200BEX/660/D-A

**IMPORTANT INFORMATION**

Changes to the equipment which are made between manual printings are listed in an addendum at the rear of the manual. As a convenience, a list of change pages is given as the last page in the manual. It is recommended that each of these pages be marked "Refer to Addendum" so that these changes can be identified.

**EX-CELL-O CORPORATION**

***REMEX***

1733 Alton St. • P.O. Box C-19533 • Irvine, CA 92713

Copyright © 1977 by REMEX, a Unit of Ex-Cell-O Corporation. Printed in the United States of America. All rights reserved. This book or parts thereof may not be reproduced in any form without permission of the publishers.

EX-CELL-O CORPORATION  
REMEX

# WARRANTY

The following section is part of the Standard Terms and Conditions and covers only the Warranty. The reader should refer to the complete Standard Terms and Conditions for the entire sales agreement.

The Seller warrants to the original Buyer only, that the Product, except as to software and firmware, is free from defects in workmanship and material under normal use and service. The Seller's obligation under this warranty shall be limited to furnishing a replacement for, or at the Seller's option repairing any Product or any part or parts thereof, which prove defective within 90 days\* from the date of shipment by the Seller, provided such Product or such part or parts are returned to the Seller transportation prepaid.

The Seller warrants, for a period of thirty (30) days from the date of shipment by the Seller to the original Buyer only, that the software and firmware Products are free from defects in workmanship and material. Seller's obligation under this warranty shall be limited to correcting any of said defects or replacing the software or firmware. Said warranty shall be void and of no effect whatsoever in the event that changes or additions have been made to the software or firmware (or in the event that the software or firmware product has been adapted by the Buyer) to serve a function not within the system specifications of the Seller.

All replacement Products or parts thereof furnished under this warranty will be invoiced in the usual manner and adjustments will be made after the Product or part thereof claimed to be defective has been returned to, and inspected at, the Seller's plant. Replacements shall be furnished under this warranty F.O.B. Buyer's plant, and the Seller shall not be responsible for installation costs. (For all international transactions, replacement shall be furnished F.O.B. Seller's plant and Buyer is responsible for all customs and brokerage fees.) The Buyer shall be liable for all freight inspection and handling costs if such Product or such part or parts do not prove to be defective. In no event will any claim for labor in removing or replacing a defective Product or part for incidental or consequential damages be allowed. No warranty is made as to any Product or part which has not been installed, operated, or maintained in accordance with Seller's instructions or the instructions contained in its operations or maintenance manuals, when furnished by the Seller, or which has been subject to misuse, abuse, accident, or alteration or to improper or negligent use, maintenance, storage, transportation or handling.

This warranty is in lieu of all other warranties expresses or implied, including any warranty of merchantability or fitness for a particular purpose, and the Seller neither assumes, nor authorizes any person or firm to assume for it, any other or further obligation or liability in connection with the sales, installation or use of any product.

**UNDER NO CIRCUMSTANCES SHALL SELLER OR ANY AFFILIATE OF SELLER HAVE ANY LIABILITY WHATSOEVER FOR LOSS OF USE OR FOR ANY INDIRECT, INCIDENTAL OR CONSEQUENTIAL DAMAGES.**

\*All paper tape products are covered under this warranty for a period of one year, excepting punch mechanisms, lamps and fuses which are warranted for a period of 90 days. Flexible disk drives are warranted for a period of 180 days.

# FOR YOUR SAFETY

Before undertaking any maintenance procedure, whether it be a specific troubleshooting or maintenance procedure described herein or an exploratory procedure aimed at determining whether there has been a malfunction, read the applicable section of this manual and note carefully the

**WARNING**

and

**CAUTION**

contained therein.

The equipment described in this manual contains voltages hazardous to human life and safety and may contain mechanical components capable of inflicting personal injury. The cautionary and warning notes are included in this manual to alert operator and maintenance personnel to the electrical and mechanical hazards and thus prevent personal injury and damage to equipment.



## TABLE OF CONTENTS

Section	Title	Page
I	GENERAL DESCRIPTION .....	1-1
1.1	EQUIPMENT DESCRIPTION .....	1-1
1.2	EQUIPMENT SUPPLIED .....	1-1
1.3	MAINTENANCE EQUIPMENT REQUIRED BUT NOT SUPPLIED .....	1-3
1.4	EQUIPMENT WARRANTY .....	1-3
1.5	SPECIFICATIONS .....	1-3
1.6	MODEL NUMBER DESIGNATION .....	1-4
1.7	PHYSICAL DESCRIPTION .....	1-4
1.8	TAPE CHANNEL NUMBERING .....	1-7
II	INSTALLATION AND INTERFACE .....	2-1
2.1	UNPACKING .....	2-1
2.2	MOUNTING .....	2-1
2.3	INITIAL ADJUSTMENTS .....	2-1
2.4	POWER AND SYSTEM CONNECTIONS .....	2-1
2.4.1	TRANSFORMER WIRING CHANGE FOR VOLTAGES OTHER THAN 115 VAC .....	2-3
2.5	INTERFACE CIRCUITRY .....	2-3
III	OPERATION .....	3-1
3.1	INPUT-OUTPUT SIGNALS .....	3-1
3.2	CONTROL FUNCTIONS .....	3-1
3.3	OPERATING INSTRUCTIONS .....	3-1
3.3.1	TAPE LOADING INSTRUCTIONS .....	3-1
3.3.2	TAPE DRIVE, ASYNCHRONOUS OPERATION .....	3-4
3.3.3	EXTERNAL INHIBIT .....	3-4
3.3.4	MANUAL DRIVE MODE OPERATION .....	3-4
3.3.5	WIND MODE OPERATION .....	3-5
3.3.6	DATA OUTPUT MODE SELECTION .....	3-6
3.4	OPERATIONAL MAINTENANCE .....	3-9
3.5	TAPE RECOMMENDATIONS AND AVAILABILITY .....	3-9
3.6	TAPE PREPARATION REQUIREMENTS .....	3-9

TABLE OF CONTENTS  
(CONTINUED)

Section	Title	Page
IV	THEORY OF OPERATION .....	4-1
4.1	BLOCK DIAGRAM DESCRIPTION .....	4-1
4.1.1	TAPE DRIVE .....	4-1
4.1.2	WIND OPERATION .....	4-1
4.1.3	READER INHIBIT 45 .....	4-3/4-4
4.1.4	TAPE READING .....	4-3/4-4
4.1.5	SPOOLER BLOCK DIAGRAM .....	4-3/4-4
4.2	LIGHT SOURCE .....	4-3/4-4
4.3	CIRCUIT CARD DESCRIPTIONS .....	4-7
4.3.1	READER CIRCUITRY .....	4-7
4.3.1.1	Drive Circuits .....	4-7
4.3.1.2	Wind Circuits .....	4-8
4.3.1.3	Tape Reading Circuits .....	4-9
4.3.2	SPOOLER CIRCUITRY .....	4-10
4.3.3	POWER SUPPLY .....	4-10
4.4	MECHANICAL THEORY OF OPERATION .....	4-11
4.4.1	TAPE TENSION .....	4-11
V	MAINTENANCE .....	5-1
5.1	GENERAL .....	5-1
5.2	PREVENTIVE MAINTENANCE .....	5-1
5.2.1	CLEANING .....	5-2
5.2.1.1	Readhead Assembly Cleaning .....	5-4
5.2.1.2	Sprocket Cleaning .....	5-4
5.2.1.3	Tape Inspection .....	5-4
5.2.1.4	General Cleaning .....	5-4
5.2.2	LUBRICATION .....	5-4
5.2.3	POWER SUPPLY VOLTAGES .....	5-5
5.3	TROUBLE SHOOTING .....	5-5
5.4	READER ALIGNMENT .....	5-9
5.5	READER LAMP VOLTAGE ADJUSTMENT .....	5-15
5.6	SERVO ALIGNMENT .....	5-15
5.7	ARM SPRING TENSION ADJUSTMENT .....	5-15

TABLE OF CONTENTS  
(CONTINUED)

Section	Title	Page
5.8	SPOOLER TAPE ARM AND ROLLER ALIGNMENT .....	5-16
5.9	TAPE SPLICING .....	5-16
VI	PARTS REPLACEMENT .....	6-1
6.1	GENERAL .....	6-1
6.2	READER PARTS REPLACEMENT .....	6-1
6.2.1	READHEAD MECHANISM DISASSEMBLY .....	6-1
6.2.2	READER CARD REPLACEMENT .....	6-2
6.2.3	READER LAMP REPLACEMENT .....	6-2
6.2.4	MOTOR AND/OR SPROCKET REPLACEMENT .....	6-3
6.2.5	TRANSFORMER REPLACEMENT .....	6-3
6.3	SPOOLER PARTS REPLACEMENT .....	6-4
6.3.1	POTENTIOMETER REPLACEMENT .....	6-4
6.3.2	FRONT PANEL AND CHASSIS SEPARATION .....	6-4
6.3.3	SERVO MOTOR REPLACEMENT .....	6-5
6.3.4	TAPE ARM PLACEMENT .....	6-5
VII	PARTS LIST .....	7-1
7.1	GENERAL .....	7-1
7.2	KIT OF PARTS .....	7-1
VIII	SCHEMATIC DRAWINGS .....	8-1/8-2
8.1	GENERAL .....	8-1/8-2

## LIST OF ILLUSTRATIONS

Figure	Title	Page
1-1	REMEX Reader Spooler, Model RRS7200BEX .....	1-2
1-2	Installation Drawing, Model RRS7200BEX .....	1-5
1-3	Model Number Coding for RRS7200 .....	1-6
1-4	Tape Channel Numbering .....	1-7
2-1	Reader Connections to External Equipment. See Table 3-1 for Signal Descriptions .....	2-2
2-2	Recommended Interface Circuitry .....	2-4
3-1	Timing Diagram for RRS7200 .....	3-2
3-2	Tape Loading, RRS7200 .....	3-3
4-1	Block Diagram Reader Circuitry .....	4-2
4-2	Block Diagram, Spooler Circuitry .....	4-2
4-3	Timing Diagram, Reader Card 112461-4 .....	4-5/4-6
5-0	Brush Insertion for Readheadhead Cleaning .....	5-5
5-1	Sprocket Relation to the Tape Riding Surface .....	5-11
5-2	Checking the Sprocket in Relation to Tape Riding Surface .....	5-11
5-3	Alignment of the Sprocket with the Light Columns .....	5-12
5-4	Adjustment of the Upper Tape Guide .....	5-12
5-5	Photocell Output Test Circuit .....	5-14
5-6	Tape Splicing Procedure .....	5-17
6-1	Tape Arm Assembly .....	6-6
7-1	Readhead Mechanism and Step Motor Assembly .....	7-7/7-8
7-2	RRS7200 Front View of Front Panel .....	7-9
7-3	RRS7200 Rear View of Front Panel .....	7-10
7-4	RRS7200 Chassis Assembly .....	7-11
7-5	RRS7200 Rear View .....	7-12
8-1	Schematic, RRS7200BEX, Sheet 1 of 3 .....	8-3/8-4
8-2	I.C. Module Outlines and Truth Tables .....	8-9/8-10
8-3	Standard Schematic Symbols, Sheet 1 of 2 .....	8-11

## LIST OF TABLES

Table	Title	Page
1-1	Items Included with the RRS7200 . . . . .	1-1
1-2	Specifications of the REMEX Reader, Model RRS7200BEX . . . . .	1-3
3-1	Interface Signal Description . . . . .	3-6
3-2	Front Panel Controls . . . . .	3-8
3-3	Modes of Operation . . . . .	3-8
3-4	Recommended Tapes . . . . .	3-9
5-1	Maintenance Equipment Required . . . . .	5-1
5-2	Preventive Maintenance Schedule and Log . . . . .	5-3
5-3	Power Supply Voltage Locations, Reader Card . . . . .	5-5
5-4	Trouble Shooting . . . . .	5-6
6-1	Transformer Wire Connections . . . . .	6-3
7-1	Recommended Spare Parts . . . . .	7-2
7-2	Parts List RRS7200BEX . . . . .	7-3
7-3	Parts List Reader Circuit Card 112461-4 . . . . .	7-13

25 JAN 1974

TO: DIRECTOR, FBI (100-442610)

FROM: SAC, NEW YORK (100-100000)

RE: MURDER OF MARTIN LUTHER KING, JR., 4/4/68

NY 100-100000-1000

## SECTION 1

### GENERAL DESCRIPTION

#### 1.1 EQUIPMENT DESCRIPTION

This manual has been prepared to assist the user in interfacing, installing, operating and maintaining the REMEX model RRS7200 punched tape reader/spooler combination. See Figure 1-1. It is the purpose of this model to provide tape reading at up to 200 characters/second speed along with spooling. Although the applications for punched tape readers are many and varied, they are generally used as input devices for digital computers, communication systems, numerical controls, and system checkout equipment.

The printed circuit card provides the logic control for tape movement in either direction from external signals. The outputs from the card control a step motor which drives the tape via a sprocket wheel. Data outputs are generated from the photocell readhead. As tape passes over the photocells, changes in light intensity are sensed by the photocells, amplified, and brought out to an external connector. The card contains the spooler control circuitry and also provides the required power.

The function of the spooler is to payout tape to the reader and take up the tape that has been read. During read mode, the fully proportional spooler senses the position of the tape arms and provides compensating reel movements that allow the arms to operate near the center of their travel areas. These movements maintain a constant tape tension across the readhead.

#### 1.2 EQUIPMENT SUPPLIED

Several items are included with the reader-spoolers for spare parts, installation, and maintenance. These items are listed in Table 1-1. No other equipment is required for the operation of the unit.

Table 1-1. Items Included With The RRS7200

Item		
Brush, Soft Bristle	716003-101	1
Cap, Fuseholder	705750-118	1
Connector, P1, Cannon DB25S	706510-211	1
Cover, Connector (P1)	706540-144	1
Fuse, 1A, Slow Blow (100, 115, 127 VAC Operation) F101	705710-118	1
Fuse, 1/2A, Slow Blow (220, 230 or 240 VAC Operation) F101	705710-113	1
Manual	112670-074	
Power Cord	708000-110	1
Reel, Selected by Customer	①	2
Screw Lock Assembly, P1, Set of 2	706540-124	1

① See Parts List, Page 7-6.

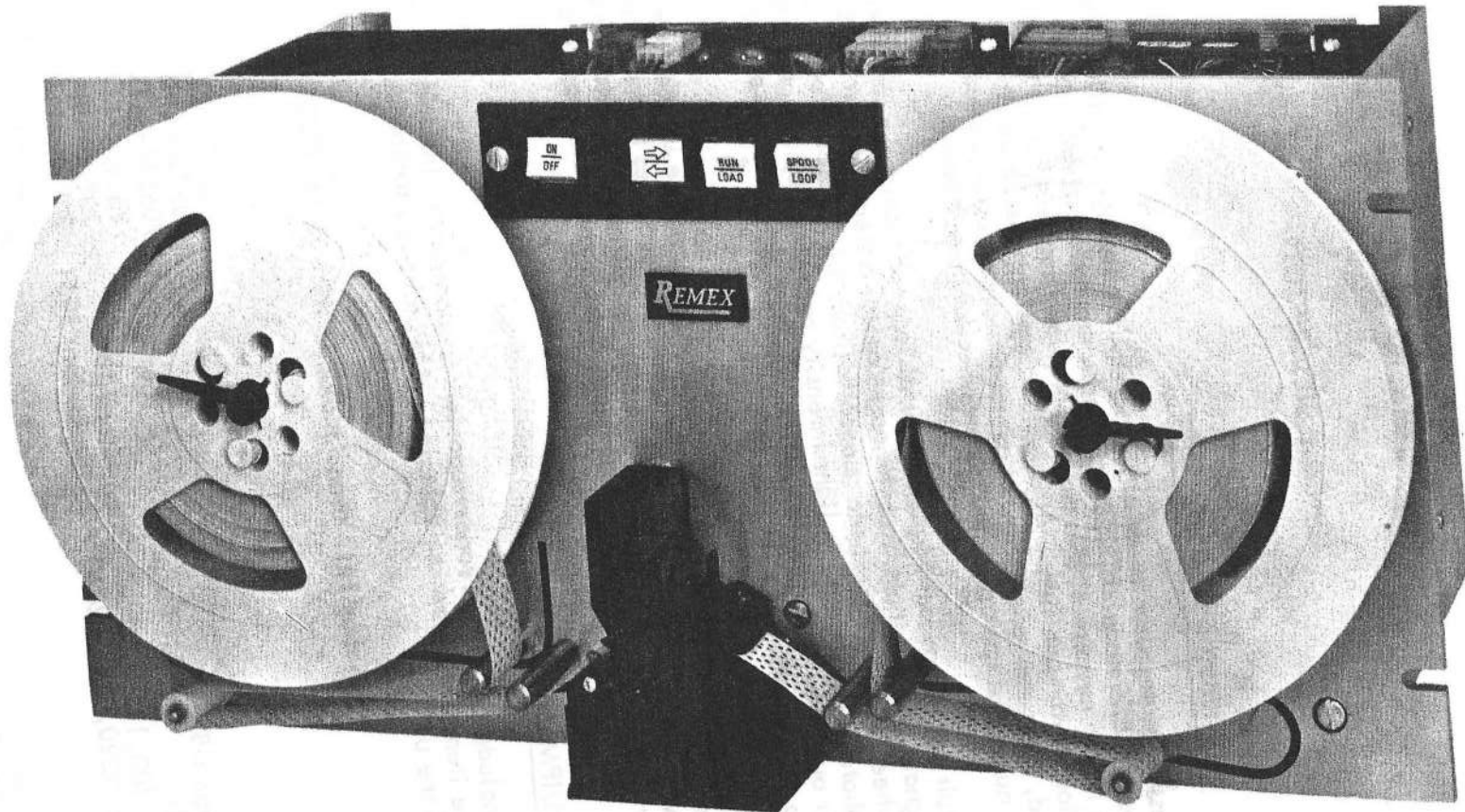

Figure 1-1. REMEX Reader Spooler, Model RRS7200BEX.



### 1.3 MAINTENANCE EQUIPMENT REQUIRED BUT NOT SUPPLIED

The maintenance procedures in Section 5 require equipment that is not supplied. This equipment is listed in Table 5-1.

### 1.4 EQUIPMENT WARRANTY

A statement covering the warranty of this equipment is given on page iii (second page in book). It should be read and understood. All preventive maintenance procedures must be performed as outlined in Section 5.2 during the warranty period in order that the warranty remain in effect. Any questions arising concerning the warranty should be directed to the REMEX Service Department.

### 1.5 SPECIFICATIONS

The specifications for the REMEX tape reader-spooler combination are listed in Table 1-2.

Table 1-2. Specifications of the REMEX Reader, Model RRS7200BEX

Characteristic	Specification
Tape Movement	Bidirectional (left-to-right or right-to-left).
Reading Speed	200 characters/second, nominal asynchronously.
Rewind Speed	300 characters/second, nominal.
Tapes	Reads standard 8-track (1-inch) tapes with light transmissivity of 57% or less and thickness between 0.0026 and 0.0045 inch (oiled buff paper tape). Tapes must be punched as described in Section 3.6. Other tape sizes listed in Figure 1-3.
Input Power	100, 115, 127, 220 or 240 VAC $\pm$ 15% (unless otherwise specified by customer, units are wired for 115 VAC), 47 to 63 Hz, single phase at 2.0 amps (100, 115 or 127 VAC) or 1.0 amps (220 or 240 VAC), nominal voltage, maximum current.
Temperature	Operating: 0°C to +65°C, free air Non-operating: -55°C to +85°C
Weight	29 lbs.
Mounting Dimensions	8-3/4" high, 19" wide, 7-3/4" behind a 1/4" panel 2-1/2" in front of panel. See Figure 1-2.
Data Output	Data Mode Selectable (See Section 3.3.6): Mode 5: Hole: +2.4 < V < +5.0 @ 0.2 mA (source) No Hole: 0 < V < +0.4 @ 16 mA (sink) Mode 6: Hole: 0 < V < +0.4 @ 16 mA (sink) No Hole: +2.4 < V < +5.0 @ 0.2 mA (source)
Timing	Timing Diagram given in Figure 3-1. Also see Section 3.3.2.

## 1.6

### MODEL NUMBER DESIGNATION

The REMEX model designation is used to code the basic functions and configurations of a particular product line. The model number codes for the RRS7200 are shown in Figure 1-3. An X in a particular digit designator (as used in many parts of this manual, especially in the parts list) denotes any of the combinations for that digit given in Figure 1-3 applies in the instance cited.

Always consult the serial number tag for proper voltage and frequency to be used and for model identification. Failure to do so could result in damage to the unit. The serial tag is located on one of the rear surfaces. In all correspondence, always refer to the complete model number, including the mode and the special number and the unit's serial number.

The last three digits of the model number denote either a standard unit (000 or 901 and higher) or a special (all other numbers). Units with 000 indicate standard units with no additional options other than those coded in the model number structure. Units with 901 and higher are used to indicate the number of standard options (used only on standard units) which are not coded in the model number. These are listed on the serial tag below the model number in the form of a series of three digit numbers depending upon the number of options used. For example, a unit with 902 would list two three digit numbers. Because the list of possible options is constantly changing, it is not included in the manual. Generally, this list consists of special customer requirements that do not affect the operation of the unit and include such things as special paint, no logo, mill edge panel, etc.

## 1.7

### PHYSICAL DESCRIPTION

The REMEX tape reader/spooler model RRS7200BE1 /660/D-A is mounted on a 19-inch panel with a height of 8-3/4 inches. Detailed dimensions are shown in Figure 1-2. The front panel contains the tape reading and transport mechanism. The lamp is accessible from the rear of the front panel. The electronic chassis is mounted at the rear of the unit.

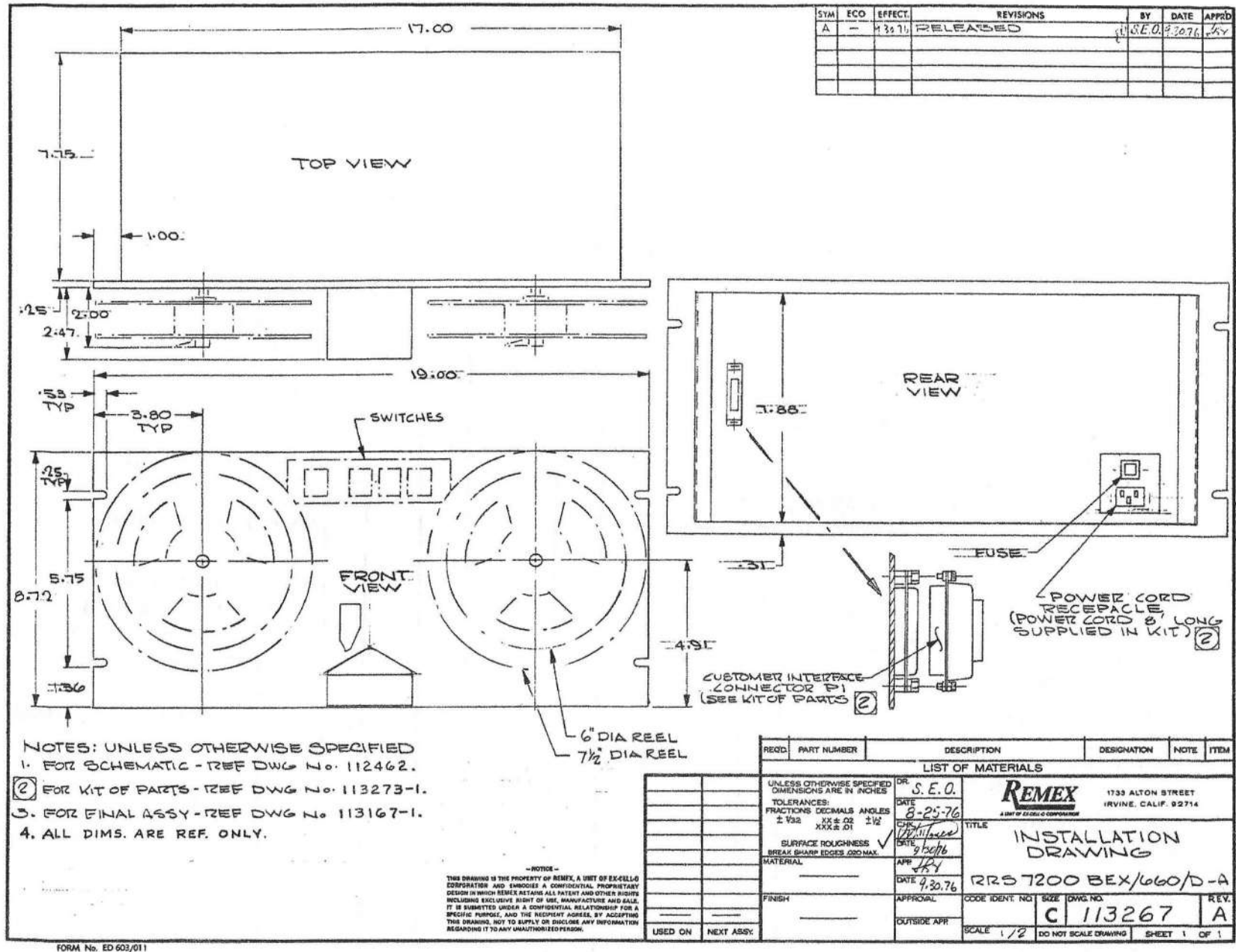

FORM No. ED 603/011

Figure 1-2. Installation Drawing, Model RRS7200BEX.

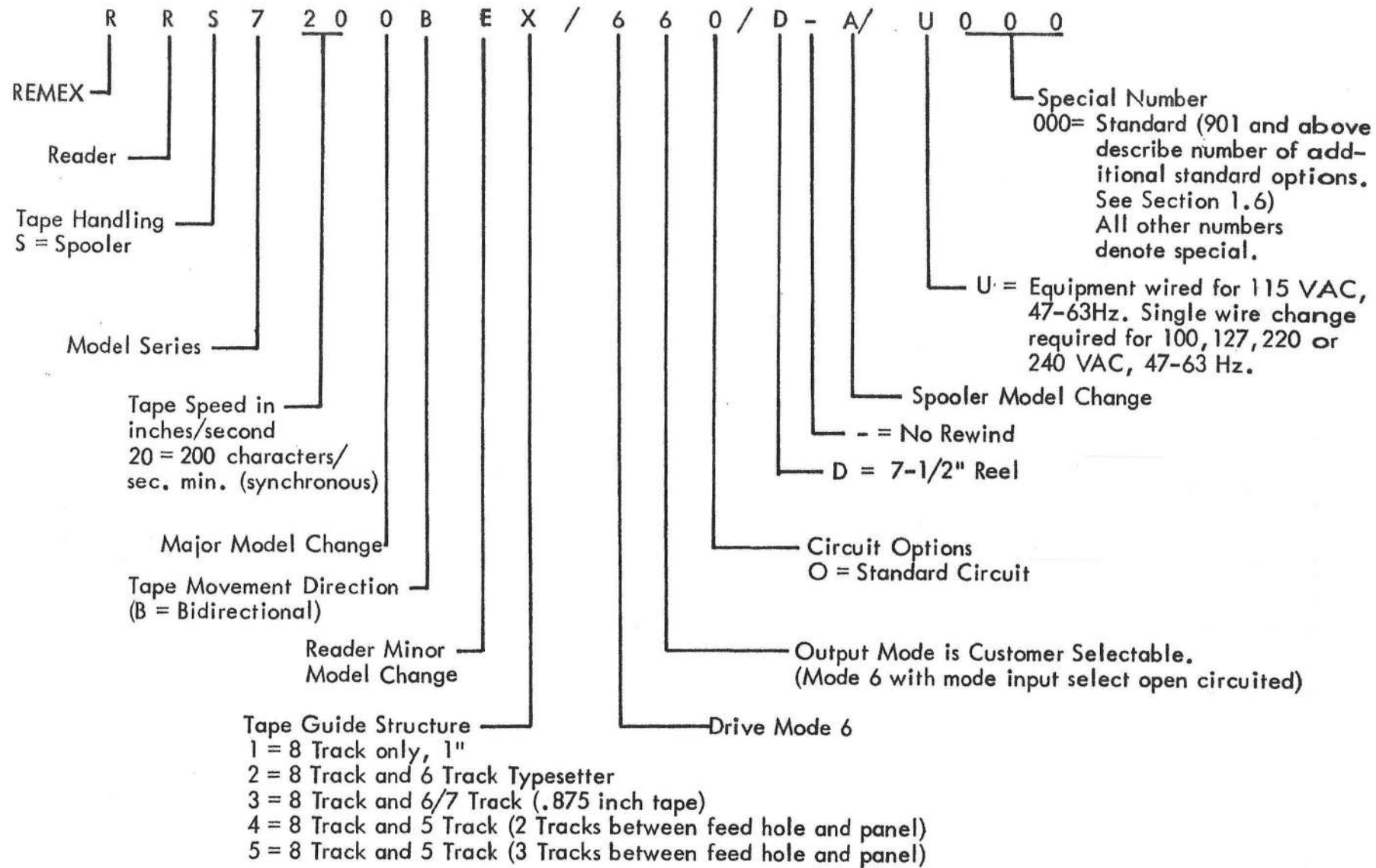
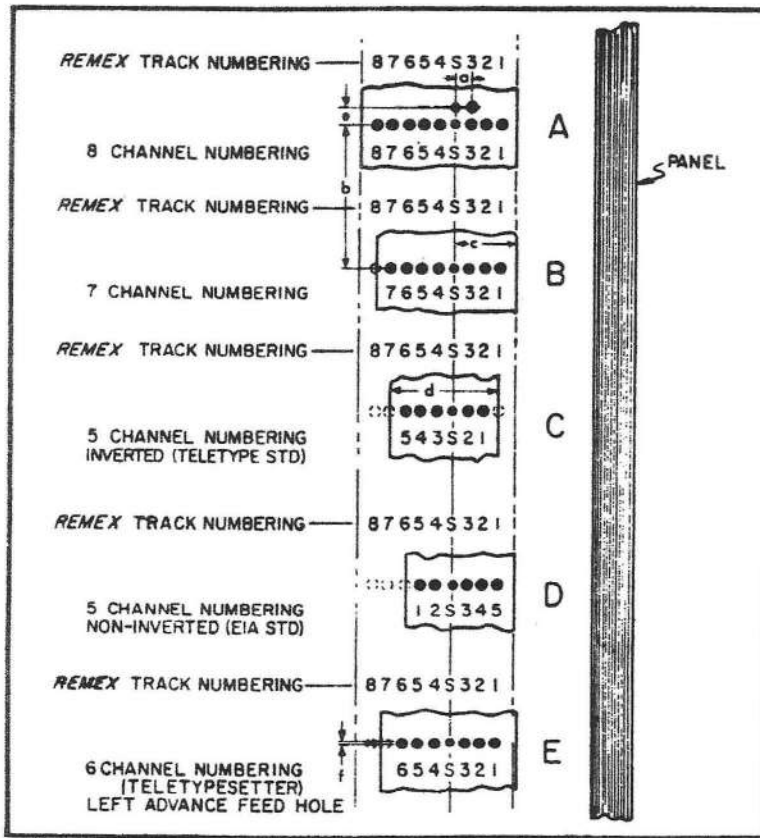

Figure 1-3. Model Number Coding For RRS7200.

1.8

TAPE CHANNEL NUMBERING

Figure 1-4 illustrates the tape channel numbering. The reader accepts one inch, eight channel tape and other width tapes, depending upon the tape guide structure used.



MMC118A

Configuration	$\pm 0.003$	$\pm 0.004$	
A	0.392	1.000	$a = 0.100 \pm 0.002$ b in any span of five inches is $\pm 0.025$ $e = 0.100 \pm 0.003$ Data hole diameter is $0.072 \begin{matrix} +.001 \\ -.002 \end{matrix}$ Sprocket hole diameter is $0.046 \begin{matrix} +0.002 \\ -0.001 \end{matrix}$
B	0.394	0.875	
C	0.293	0.687	
D	0.394	0.687	
E	0.441 Drive Right 0.434 Drive Left	0.875	

NOTE: The 6 channel teletypesetter has the sprocket hole center line advanced by 0.013 inch with respect to the data track center line (dimension f in illustration E).

Figure 1-4. Tape Channel Numbering.



## SECTION II

### INSTALLATION AND INTERFACE

#### 2.1 UNPACKING

To provide the most protection during transit, specially designed and reinforced packing cartons are used to ship the REMEX punched tape reader/spooler. Those items listed in Table 1-1 are also packed with the unit. When removing the unit from the carton, the reader-spooler should be lifted with both hands under it. Never lift or attempt to carry the unit by any of the covers, drive assembly, arms or other delicate parts. Carefully inspect the unit for any apparent damage as soon as it is removed from the carton. Check the equipment supplied list in Table 1-1 against the kit of parts supplied with the reader. In the event the equipment has been damaged as a result of shipping, the carrier and REMEX must be notified as soon as possible.

#### 2.2 MOUNTING

The reader/spooler mounts in a standard 19-inch rack with mounting holes provided. To ensure a minimum transmission of acoustical noise and vibration to other equipment, the reader should be securely mounted. When mounting the unit in a closed cabinet, adequate air circulation should be supplied so that the unit does not exceed the ambient temperature specification listed in Table 1-2.

#### 2.3 INITIAL ADJUSTMENTS

Each reader has been accurately adjusted and aligned before leaving the factory. No adjustment or calibration should be required prior to installation or use. However, the proper fuse from the kit of parts requires installation. Refer to Section 2.4.

#### 2.4 POWER AND SYSTEM CONNECTIONS

Input AC power (refer to Table 1-2) is applied through the A.C. connector at the rear.

#### **CAUTION**

All units come wired for 115 VAC, 47-63 Hz operation. If another voltage is to be used, a wire change on the transformer must be made as described in Section 2.4.1. In addition, before operating the system, the proper fuse value (as indicated in Table 1-1) must be inserted from the kit of parts. Discard the other fuse (unless, of course, a different voltage operation is anticipated).



All control signals and data track output signals are routed through J1. Figure 2-1 lists the detail routing of these signals and their description is given in Table 3-1. All wire sizes are 22 AWG unless otherwise noted in Figure 2-1. The proper mating connector for J1 has been supplied with the unit.

**NOTE:** All input and output logic signals are defined for positive logic, mode 5, i.e., logic 0 = 0V and logic 1 = +5V. Therefore, signals that are mode 6, 0V true for logic 1 (action condition) are written with a bar over the designation, e.g., Drive Right Input.

J1			
1			Data Track 1 Output
2			Data Track 2 Output
3			Data Track 3 Output
4			Data Track 4 Output
5			Data Track 5 Output
6			Data Track 6 Output
7			Data Track 7 Output
8			Data Track 8 Output
9			Data Ready Output
10			Data Mode Select Input
11, 12, 13, 24	20 AWG		Signal Ground 0V
14			<u>System Ready (SYSRDY) Output</u>
15			<u>External Inhibit EXT INH Input</u>
16			<u>Drive Right (DR) Input</u>
17			<u>Drive Left (DL) Input</u>
18			WIND ENABLE
19			Unused
20			Unused
21			Unused
22			Unused
23			+5V
25			Chassis Ground

To  
External  
Equipment

Unused

Figure 2-1. Reader Connections to External Equipment  
See Table 3-1 for Signal Descriptions



## 2.4.1 TRANSFORMER WIRING CHANGE FOR VOLTAGES OTHER THAN 115 VAC

All units come from the factory with a transformer which allows any of five input voltages to be used: 100, 115, 127, 220 or 240 VAC, 47-63 Hz. Unless otherwise directed by the customer, all units leave the factory wired for 115 VAC. If it becomes necessary to operate on one of the other four voltages, a simple wire change is required.

### WARNING

Make sure the power plug is disconnected before making the change.

Power from the AC plug is applied through S1 to TB1-B2 via a white/black wire. See system schematic, Figure 8-2. It is necessary, then to change the white/black wire at TB1-B2 to TB1-B5 for 100 VAC, to TB1-C5 for 127 VAC, to TB1-C1 for 220 VAC or to TB1-D1 for 240 VAC. In addition, the 1-1/2 amp fuse from the kit of parts must be substituted for the 3 amp fuse at F1 when using 220 or 240 VAC.

## 2.5 INTERFACE CIRCUITRY

Figure 2-2 illustrates suggested drive and output circuitry with which to interface with the REMEX circuitry. Note the termination network for the output signals. This should be incorporated into the user's equipment for maximum noise elimination. Table 3-1 lists which circuit is used with each input or output.

**NOTE:** All input and output logic signals are defined for positive logic (mode 5), i.e., logic 0 = 0V and logic 1 = +5V. Therefore, signals that are 0V true (mode 6) for logic 1 (action condition) are written with a bar over the designation, e.g., Drive Right Input.

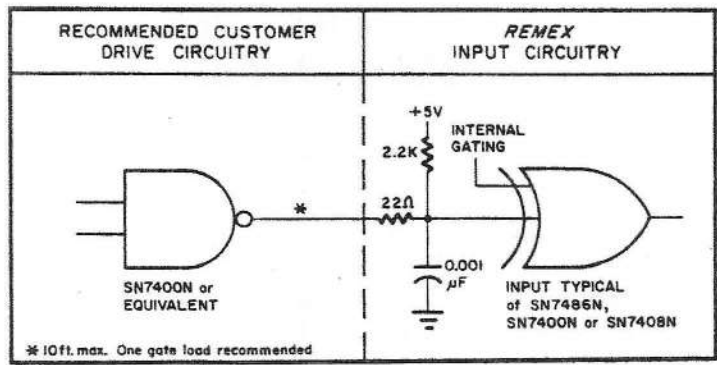

MMC 304A

CIRCUIT A

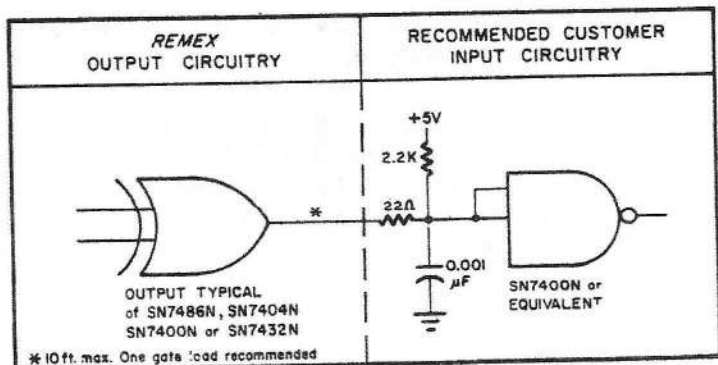

MMC 305A

CIRCUIT B

Figure 2-2. Recommended Interface Circuitry.

## SECTION III

### OPERATION

#### 3.1 INPUT-OUTPUT SIGNALS

Table 3-1 lists those input and output signals which are routed through connector J1. The definition and/or usage of these signals are also included in the table. Figure 3-1 shows the timing diagram for these signals.

#### 3.2 CONTROL FUNCTIONS

Table 3-2 lists the operating controls located on the front panel. A description of the controls and their functions is also included. It is recommended that the reader review the functions of these controls before operating the unit.

#### 3.3 OPERATING INSTRUCTIONS

The following procedure should be used when loading and reading a tape:

##### 3.3.1 TAPE LOADING INSTRUCTIONS

### CAUTION

All units come wired for 115 VAC, 47-63 Hz operation. If another voltage is to be used, a wire change on the transformer must be made as described in Section 2.4.1. In addition, before operating the system, the proper fuse value (as indicated in Table 1-1) must be inserted from the kit of parts. Discard the other fuse (unless, of course, a different voltage operation is anticipated).

- a. Connect J1/P1 and plug the line cord. See Caution in Section 2.4.

### WARNING

Steps b and c should be performed in the order stated. If step c were performed first (ON-OFF in the ON position with LOOP-SPOOL in SPOOL), the spooler would be enabled and any movement of the tape arms could cause rapid rotation of the hub assembly resulting in possible personal injury.

- b. Place the RUN-LOAD switch in the LOAD position.
- c. Place the ON-OFF switch into the ON position. This will apply power to the unit.

- d. Raise the Upper Tape Guide allowing tape to be loaded. Install the reel of tape onto the hub and thread the tape through the spooler and readhead as shown in Figure 3-2. If a loop of tape is to be read, insert it into the reader and let it hang free of the tape arms. Lower the Upper Tape Guide to its closed position.
- e. If a reel of tape is being used, place the SPOOL-LOOP switch in the SPOOL position. If a loop of tape is to be used place the switch in the LOOP position. Place RUN-LOAD switch in the RUN position. This will enable the spooler if the SPOOL-LOOP switch is in the SPOOL position.
- f. Make sure the System Ready output signal at J1-14 is in the true condition, i.e.,  $0 < V < +0.4$ .
- g. Apply  $0 < V < +0.4$  to J1-10 to select mode 5 data output and data ready signals or  $+2.4 < V < +5.0$  (or open circuited) to select mode 6. See Section 3.3.6.
- h. The reader may now be operated as described in Section 3.3.2. See Section 3.3.3 for external inhibit operation and Section 3.3.4 for manual drive mode operation and 3.3.5 for wind operation.
- i. To unload tape, stop tape movement, place the RUN-LOAD switch in LOAD, raise the Upper Tape Guide and remove the tape.
- j. To remove power, place the ON-OFF switch in the OFF position.

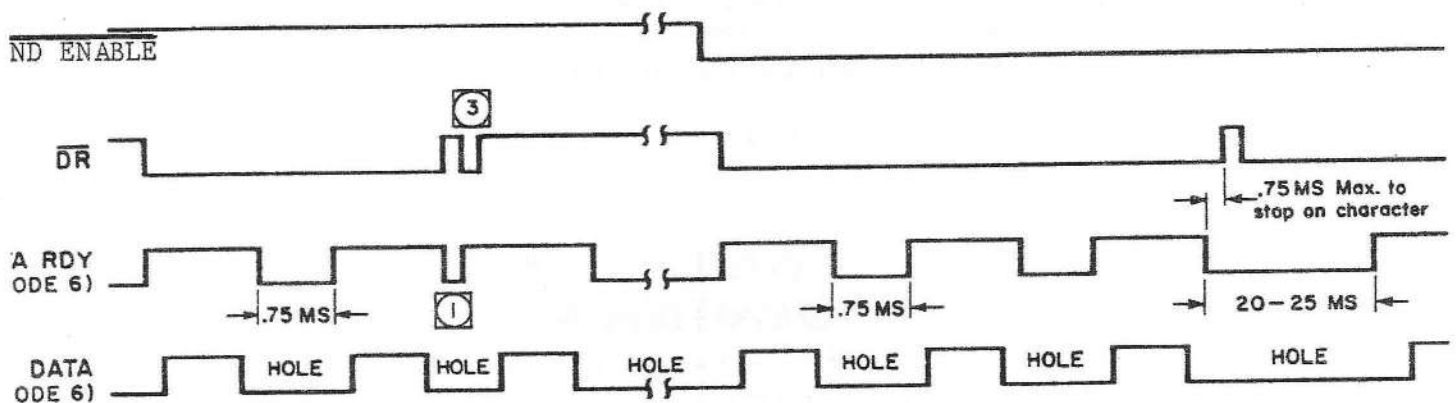

- NOTES:**
- ① IN LOW SPEED, THE DATA RDY SIGNAL GOES FALSE WHEN A NEW  $\overline{DR}$  IS COMMANDED
  - ② IN BOTH MODES, THE MAX DELAY AFTER DATA RDY TO STOP ON CHARACTER IS 750  $\mu$ SEC
  - ③ DRIVE SIGNAL MUST REMAIN TRUE UNTIL DATA RDY GOES FALSE

IC 402 A

Figure 3-1. Timing Diagram for RRS7200.

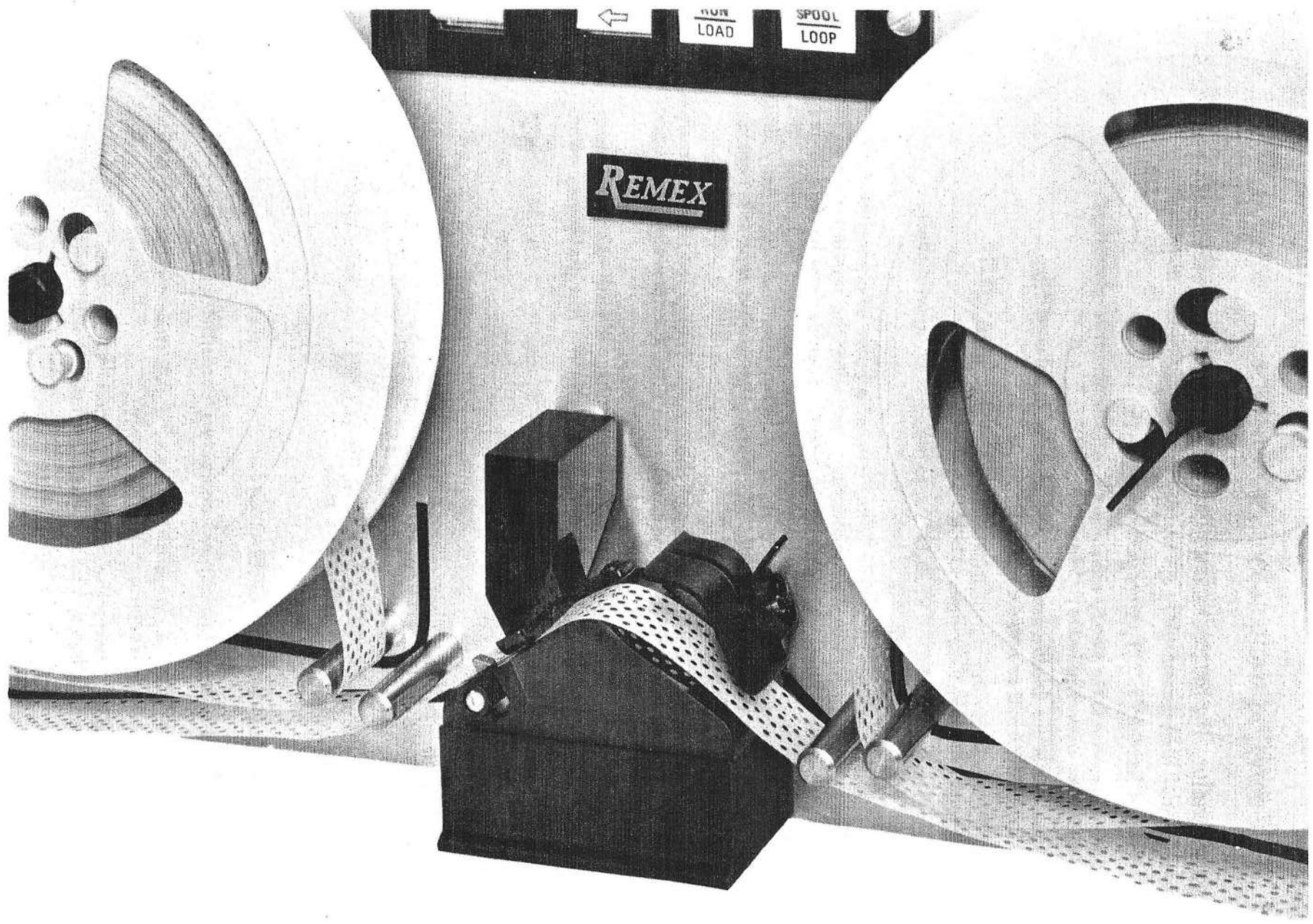

Figure 3-2. Tape Loading, RRS7200.

### 3.3.2 TAPE DRIVE, ASYNCHRONOUS OPERATION

In this mode of operation, the reader is controlled in either a continuous or a line-at-a-time step operation but is not completely synchronized with the reader outputs.

- a. Perform Section 3.3.1, steps a through g.
- b. Make sure the Data Ready signal at J1-9 is in the true condition depending upon the mode. See Table 3-1.
- c. Place the Wind Enable input at J1-18 in its false condition ( $+2.4 < V < +5.0$  or open circuited).
- d. Apply the following signal to the drive left (DL) line, J1-17 or the drive right (DR) line, J1-16:

Stop:  $+2.4 < V < +5.0$  (2.2K to +5V) or an open circuit  
Run:  $0 < V < +0.4 @ 5 \text{ mA}$ .

The drive signal can be either in the form of a pulse or a continuous DC level which must be removed within 440  $\mu\text{sec}$  after the leading edge of the true Data Ready Signal to stop on character. A pulse must be maintained until the Data Ready signal goes false (typically less than 0.5  $\mu\text{sec}$ ). The next pulse or DC level may be applied any time after the Data Ready signal comes true. See Figure 3-1. In this mode of operation tape is driven a nominal 200 characters/sec.

- e. If the drive direction is reversed and the spooler is enabled, all drive signals will be locked out for 500 ms max. from the time the previous drive signal is terminated to give the servo time to stabilize.
- f. Only one run signal must be present at one time. If both run signals are applied simultaneously, the reader will drive in the last previously commanded direction.



### 3.3.3 EXTERNAL INHIBIT

In this mode of operation, the reader and spooler are inhibited and the System Ready output (J1-14) and the Data Ready output (J1-9) are set to the false state. To place the reader in the inhibit mode apply the following signal to pin 15 of J1:

Reader Not Inhibited:  $+2.4 < V < +5.0$  (2.2K to +5V) or an open circuit  
Reader Inhibited:  $0 < V < +0.4 @ 5 \text{ mA}$ .

### 3.3.4 MANUAL DRIVE MODE OPERATION

Tape can be driven manually at a nominal 300 characters/sec either to the left or right as follows:

- a. Perform Section 3.3.1, steps a through g. 3.3.2 steps a through g or 3.3.3 steps a through g, depending upon the mode.
- b. Depress the  switch for drive left or the  switch for drive right as required. This option can be used to wind tape onto either reel.



## 3.3.5 WIND MODE OPERATION

In this mode of operation the winding of the left or right reel at 300 cps can be controlled in the following manner:

- a. Perform Section 3.3.1, steps a through g.
- b. Make sure the Data Ready signal at J1-9 is in the true condition depending upon the mode. See Table 3-1.
- c. Place the Wind Enable input at J1-18 in its active condition ( $0 < V < +0.4$ ).
- d. Apply the following signal to the drive left ( $\overline{DL}$ ) line, J1-17 or the drive right ( $\overline{DR}$ ) line, J1-16:

Stop:  $+2.4 < V < +5.0$  (2.2K to +5V) or an open circuit

Run:  $0 < V < +0.4$  @ 5 mA.

In this mode of operation the reader can be used to read (e.g. looking for a stop rewind character) but the reader is not guaranteed to stop on character nor is this mode advisable for step operation.

## 3.3.6 DATA OUTPUT MODE SELECTION

The output mode of both the data tracks and the Data Ready output is selectable for either Mode 5 (+5 volt true) or Mode 6 (0 volt true) by applying one of the following signals to J1-10:

Mode 5:  $0 < V < +0.5$  @ 17 mA max

Mode 6:  $+2.4 < V < +5.0$  (or open circuit).

Table 3-1. Interface Signal Description

Connector/ Pin	Description	Interface Circuit (See Figure 2-2)& I.C. Type	Signal Levels	
			True Condition	False Condition
J1-1 thru J1-8	Data Track Outputs. True signal indicates data track hole and false condition indicates no hole condition. Output mode 5 or 6, selectable (see J1-10).	B SN7486N	Mode 5: $+2.4 < V < +5$ @ 0.2 ma (source) Hole (or Data Ready)	Mode 5: $0 < V < +0.4$ @ 16 ma (sink) No Hole (or Data Not Ready)
J1-9	Data Ready Output. True signal indicates data track outputs are in "on character" condition. Signal true with leading edge of feed hole and remains true until next drive signal is accepted. Data Ready signal is forced false by a load condition, external inhibit signal or out-of-tape signal. Output mode 5 or 6, selectable (see J1-10).	B SN7486N	Mode 6: $0 < V < +0.4$ @ 16 ma (sink) Hole (or Data Ready)	Mode 6: $+2.4 < V < +5$ @ 0.2 ma (source) No Hole (or Data Not Ready)
J1-10	Data Mode Select Input. True signal places data outputs and data ready output in mode 6. False signal places data outputs and data ready output in mode 5.	A SN7486N	$+2.4 < V < +5.0$ (or open circuit) Data Track & Data Ready signals in mode 6.	$0 < V < +0.4$ @ 17 ma max. Data Track & Data Ready signals in mode 5.
J1-11 thru J1-13, J1-24	Signal Ground (OV) to External Equipment. OV ground reference for all inputs and outputs (isolated from chassis ground).			
J1-14	System Ready (SYSRDY) Output. True signal indicates the load switch is in its run position and none of the false condition signals are present (system ready). False signal indicates at least one of the following conditions is present: (1) LOAD/RUN switch in LOAD or upper tape guide open, (2) the External Inhibit signal present, (3) if a drive signal is accepted and a new feed hole is not sensed within 25 ms., this output indicates either no tape or torn tape and serves as the out-of-tape signal.	B SN7400N	$0 < V < +0.4$ @ 16 ma (sink) System Ready	$+2.4 < V < +5.0$ @ 0.2 ma (source) System Not Ready



Table 3-1. Interface Signal Description (Continued)

Connector/ Pin	Description	Interface Circuit (See Figure 2-2)& I.C. Type	Signal Levels	
			True Condition	False Condition
J1-15	<u>External Inhibit (EXT INH) Input.</u> True signal inhibits reader operation and causes <u>System Ready</u> and <u>Data Ready</u> signals to go false. False signal allows reader to operate in normal manner.	A SN7408N	0V<+0.4 @ 16 ma (sink) Reader Inhibited. <u>Data Ready</u> and <u>System Ready</u> signals False.	+2.4V<+5.0 (or open circuit) Reader not externally inhibited.
J1-16	<u>Drive Right Input.</u> True signal drives tape to right in asynchronous mode. See Section 3.3.2.	A SN7400N	0V<+0.4 @ 5.0 ma. max. Reader drives tape to right.	+2.4V<+5.0 (or open circuit) Reader does not drive tape to right.
J1-17	<u>Drive Left Input.</u> Same as drive right except drives to the left.			
J1-18	<u>Wind Enable Input.</u> True condition and a true drive signal causes tape to wind at 300 characters/sec.	A SN7400N	0V<+0.4 @ 5 ma. max. Tape winds at 300 characters/sec.	+2.4V<+5.0 (or open circuit) Tape drives at 200 characters/sec.
J1-19 thru J1-22	Not Used			
J1-23	+5V @ 200 ma output available to external equipment.			
J1-25	Chassis ground; isolated from signal ground.			

Table 3-2. Front Panel Controls



SWITCH	POSITION	FUNCTION
OFF-ON	OFF	Removes AC Power from reader-spooler.
	ON	Applies AC Power to reader-spooler.
LOOP-SPOOL	LOOP	Disables the spooler allowing a tape loop to be read.
	SPOOL	Enables operation of the spooler and reader.
RUN-LOAD	LOAD (guide raised)	<u>Inhibits reader and spooler and places System Ready output in false state.</u>
	RUN (guide lowered)	Allows <u>reader and spooler to operate and places System Ready output in true state.</u>
DRIVE CONTROL		Drives the tape to the left in excess of 300 characters/sec.
		Drives tape loop to right in excess of 300 characters/sec.

Table 3-3. Modes of Operation

MODES OF OPERATION	DESCRIPTION
INHIBIT	System is in Inhibit mode (drive circuits inhibited) when (1) Upper Tape Guide is raised, (2) External Inhibit input is true, or (3) End of Tape Sensor is true.
DRIVE	D.C. level or pulse input drives tape at 200 characters/sec., min., under the conditions described in Section 3.3.2 and Figure 3-1.
SPOOL	Placing the LOOP-SPOOL switch in the SPOOL position enables spooler to payout and take up tape.
WIND	An active WIND ENABLE and a drive command winds tape (left or right) from one reel to the other at a speed of 300 characters/sec as described in Section 3.3.5.

### 3.4 OPERATIONAL MAINTENANCE

After every 6 to 8 hours of use, the operator should check the tape transport area for cleanliness. This is extremely important since any dirt or foreign material covering the readhead can cause readout errors. For general cleaning, use the stiff bristle brush supplied. Cleaning of the photocell assembly area is described in Section 5.2.1.1. Make sure the tape remains clean at all times since any residue picked up by the tape can be deposited on the readhead. It has been found in certain cases that residue picked up by the tape comes from soiled hands. It is important that care be exercised when handling tape, especially in machining areas or other areas where grease, oil and sprays are present.

### 3.5 TAPE RECOMMENDATIONS AND AVAILABILITY

The tapes listed in Table 3-4 are among those recommended for use. Mylar tapes should be used in applications requiring continuous use.

Table 3-4. Recommended Tapes

Type	Manufacturer	Part Number
Paper, Unoiled or Oiled (except black carbon filled)	REMEX	715200-002 1000 ft. roll
	Paper Manufacturers, Inc.	Perfection Series
	Bemis	Paper Tape Series
Special Paper	Numeridex	0500
	Nova Tech	Syntosil Machine Tool Tape
Special Mylar	Arvey	RVCZ 60
	Chase Foster	PMP01151
	Numeridex	2000

NOTE: Black carbon tapes may be used but with reduced tape life.

### 3.6 TAPE PREPARATION REQUIREMENTS

Proper tape reader operation requires that the maximum accumulated longitudinal error between feed hole centers in the punched tape be  $\pm 0.025$  inch within any span of 5 inches, as specified in the American National Standards Institute Standard X3. 18-1967 (ANSI; formerly United States of America Standards Institute). In the event a user has, because of punching problems, a number of tapes which do not conform to this specification by an amount consistently out of tolerance, the reader may be set up as in Section 5.4 using one of these tapes rather than the type specified. However, unless absolutely necessary, the user should be encouraged not to do this since the reader performance may be compromised, especially in restricting the tape tolerances capable of being read. For ease of threading the recommended tape leader length is four feet.

A tape gauge is available from REMEX (part number 110597) so that the  $\pm 0.025$  tolerance specification can be checked. To use the gauge, place the feed hole of one end of a 5-inch span (50 characters) at the single cross hair and swing the other end of the 5-inch span in the arc until one of the cross hairs is centered in the feed hole. Read the measurement adjacent to that cross hair (plus tolerances to the right and minus tolerances to the left). A second 5-inch gauge is printed at the bottom to check both longitudinal and perpendicular transverse center line spacing.

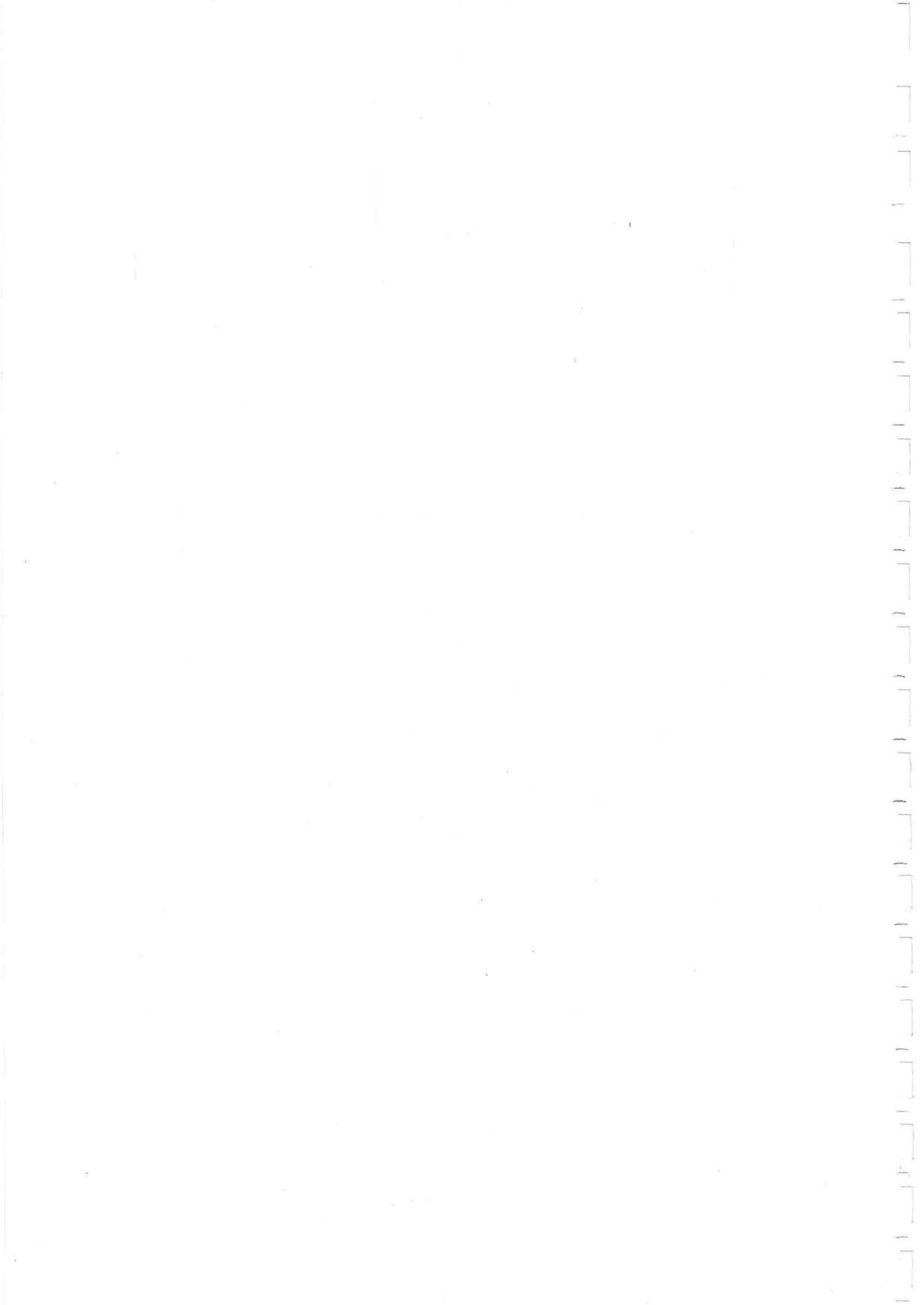

## SECTION IV

### THEORY OF OPERATION

#### 4.1 BLOCK DIAGRAM DESCRIPTION

The REMEX punched tape reader-spooler combination performs three basic functions: (1) it drives tape in either direction over the read station, (2) converts the tape information into electrical signals and (3) spools tape on and off the tape reels. These three functions are described in block diagram form in Section 4.1.1, 4.1.2 and 4.1.3 and illustrated in block diagram form in Figures 4-1 and 4-2.

##### 4.1.1 TAPE DRIVE

Reader Card 112461 contains the circuit logic used to operate the stepper drive motor in response to the drive inputs at 200 characters/sec. Refer to Figure 4-1 for the Reader Block Diagram. Applying a 0V, true signal to the drive left (DL) or drive right (DR) input line sets the direction memory in the input logic to the desired state and establishes the direction of rotation for the motor by setting the three phase counter. The input logic also produces the true Drive Gate (DRVG) signal which triggers the Ready Circuit. It is the function of the Ready Circuit to make sure the reader is ready to accept a drive command and, when the drive command is accepted, to generate the motor clock pulse (MCP). The MCP pulse is used to advance the three phase counter one count which steps the motor and, in turn, the tape to left or right one line depending upon the direction previously selected. The tape then stops on character and waits for the next MCP pulse. The Ready Circuit also locks out the sprocket signal for 2 ms after the MCP is generated so that any initial jitter in the sprocket is locked out as the tape starts up and the sprocket goes off character. At the end of the 1.9 ms time period, the Ready Circuit generates a 400  $\mu$ s damping pulse which is applied to all three phases of the motor at once to minimize motor oscillations as the tape comes on character.

When the next sprocket hole is read, the sprocket output is amplified, delayed 150  $\mu$ s and sent to the Ready Circuit. Upon receipt of the sprocket signal, the Ready Circuit generates the following three signals: (1) a Data Ready signal for use in external equipment, (2) a strobe signal which latches up the data from the read head and (3) a 440  $\mu$ s delay to allow data to be examined and make the stop-go decision. At the end of the 440  $\mu$ s delay, if the drive signal has not been removed, the read-drive cycle will be repeated and the tape will advance another line.

##### 4.1.2 WIND OPERATION

In wind mode operation, the Wind Enable line is pulled down to 0V which sets the flip-flop FF1. The drive sequence is similar to that described for tape drive operation with

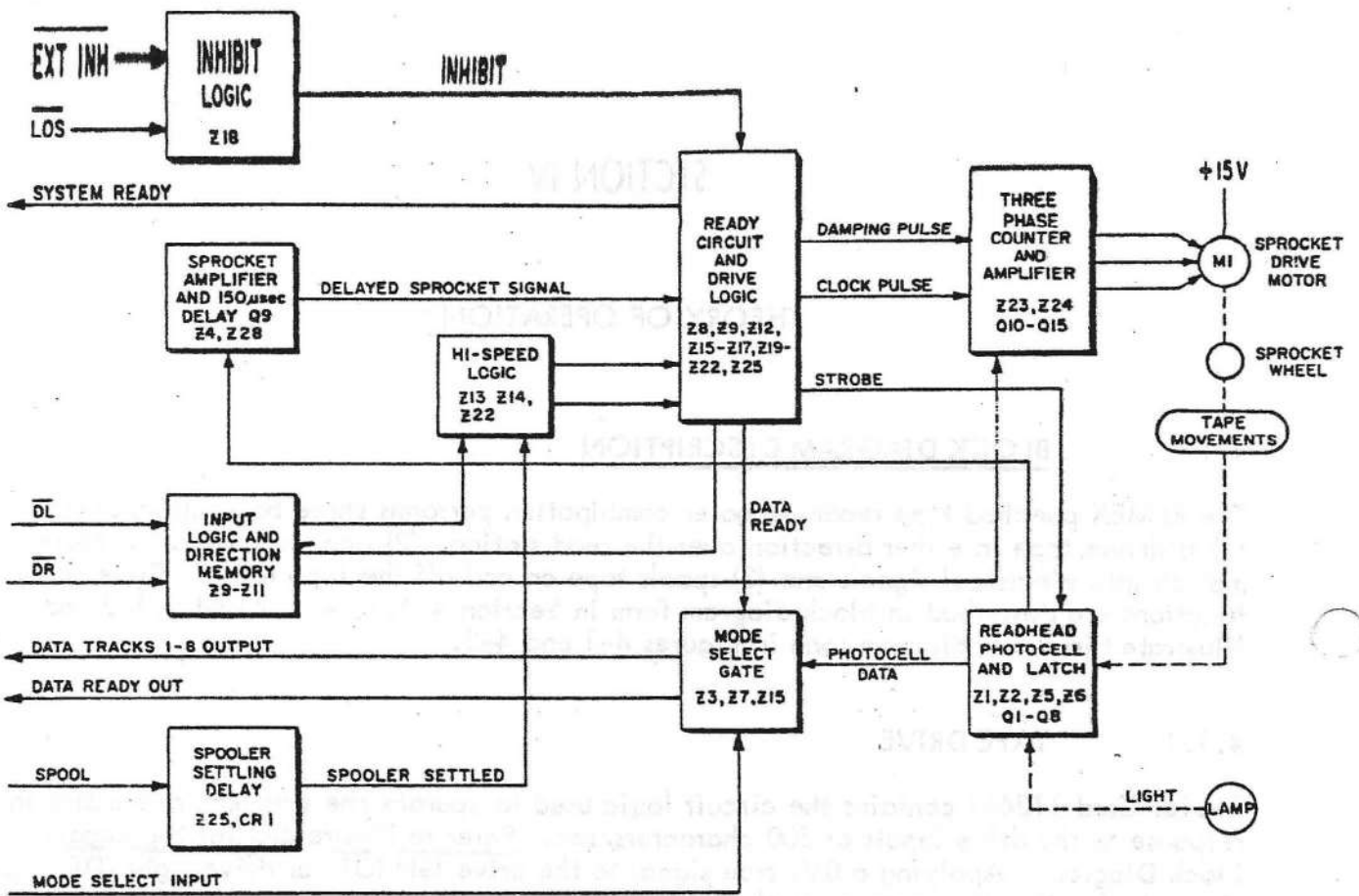

MMC 448

Figure 4-1. Block Diagram Reader Circuitry.

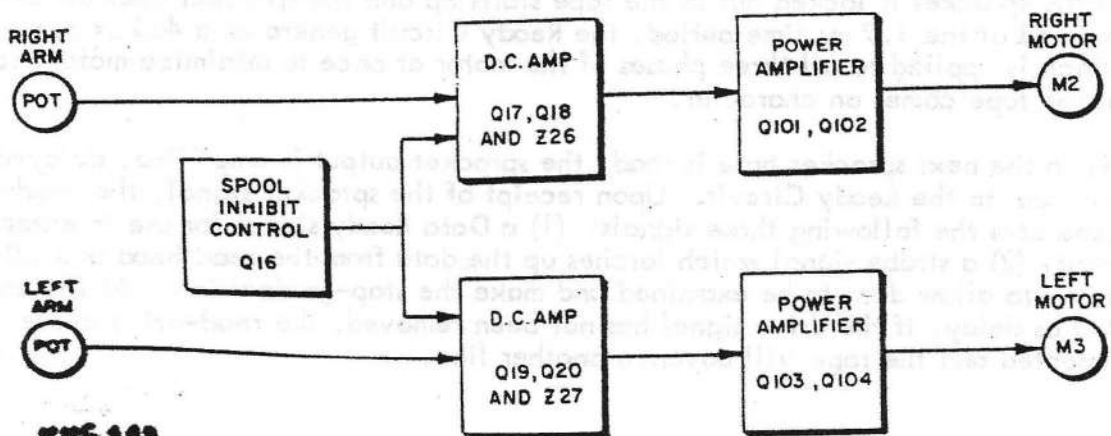

MMC 449

Figure 4-2. Block Diagram, Spooler Circuitry.



the following exceptions: (1) the damping pulse is inhibited and (2) after the initial MCP pulse starts the motor advancing, a second clock pulse is generated as soon as the tape goes off character. This sets the three phase counter one count ahead of the line to which the tape is advancing. When that line is reached, the motor will not stop, unless the drive signal is removed, but will continue rotating one line more. Again when the tape goes off character, the counter is again pulsed. In this manner the counter is always one count ahead of the line being read on the tape. If, during the 440  $\mu$ s data sampling period, the reader drive signal is removed, single-shot SS7 is triggered which inhibits the input memory via the Reverse Lock (REV LK) to allow a settling time of 45 ms. SS7 also triggers SS8 causing the counter to back up one count and the motor to stop on character.

#### 4.1.3 READER INHIBIT

The reader can be inhibited by any one of three methods: (1) placing the LOAD-RUN switch, S2, in LOAD, causing the LDS to be generated, (2) a true, 0V, External Inhibit signal applied to J1-15. Items 1 and 2 are gated to form the Inhibit (INH) signal which inhibits both the Wind Enable Logic and the Ready Circuit and places the System Ready (SYSRDY) in the false state. The System Ready also goes false if, after receipt of a drive signal, no new sprocket is sensed within 35 ms max, indicating that the reader is out of tape.

#### 4.1.4 TAPE READING

The readhead is located under the fiber optic light source and contains photovoltaic cells which are used to sense the punched tape perforations. As tape is advanced over the readhead by the sprocket drive, the photovoltaic cells are energized by the light source when the corresponding holes are present in the tape. Outputs from the readhead are then applied to the data track amplifiers and latch circuits. A true +5V, Strobe signal locks up the two latch circuits, Z2 and Z6, thereby storing that line of data. The latch circuit outputs are applied to the Mode Select gates which produces either mode 5 and 6 outputs depending upon the level applied to the Mode Select input. At the same time, the Data Ready output signal goes true and it too is gated with the Mode Select signal.

#### 4.1.5 SPOOLER BLOCK DIAGRAM

The tape spooler portion of the reader-spooler combination supplies and takes-up tape from the reader during operation. See Figure 4-2 for the Spooler Block Diagram. The operation is discussed below in block diagram form.

Servo mode operation is achieved by the use of an output signal from an arm potentiometer which is proportional to the position of the tape arm. This signal is applied to a summing amplifier which controls a power amplifier that drives the servo motor. When the arm is in the center of its travel the servo motor is not turned on. However, arm movement, caused by the movement of the tape, turns on the motor in the direction which winds or unwinds the tape to bring the arm back to its center position.

#### 4.2 LIGHT SOURCE

A filament type lamp rated at 5.0 Vdc is used as the light source. It is operated at approximately 15% below rated voltage to provide a long life expectancy. The lamp is





mounted in a sleeve at the rear of the front panel. A lens contained in the lamp focuses the light to the fiber optics system which, in turn, conducts the light to the photocells.

### 4.3 CIRCUIT CARD DESCRIPTIONS

#### 4.3.1 READER CIRCUITRY

The reader circuitry on PC card 112461 is used: (1) to generate output signals used to drive the stepping motor in response to the drive signal inputs and (2) to provide amplification and gating of the readhead data output signals.

##### 4.3.1.1 Drive Circuits

During the following description, refer to Figure 4-3 which shows the waveforms and timing diagrams for the drive, step and wind operations. This figure is intended as a guide to show the sequence of events and which signals initiate other signals. It must be cautioned that due to the wide range of pulse widths, no attempt has been made to draw the time axis to exact scale. Refer also to the schematic, Figure 8-1, sheet 1, during this description.

Normal operation begins with the loading of the tape. Placing the RUN/LOAD switch (S2) in the LOAD position causes 0V to be applied to Z18-1 and in turn places Z18-3 (the inhibit INH line) at 0V. An external inhibit signal applied to Z18-2 produces the same result.

The  $\overline{\text{INH}}$  signal is applied to Z18-4, Z12-9, and Z22-13 (FF2). The inhibit signal performs the following functions: (1) it clears and inhibits flip-flop FF2, thereby preventing recognition of any sprocket signal, (2) through Z18-6 and Z12-11 it causes the Reader Ready (RRDY) signal to drop to 0V thus preventing recognition of the Drive ( $\overline{\text{DRVG}}$ ) signal, (3) through Z18-6 it places the Data Ready ( $\overline{\text{DATRDY}}$ ) signal at 0V thereby inhibiting data, and (4) through FF2, which is held in the cleared state, and Z16-8, it clears and inhibits SS1, thus preventing recognition of any signal. The inhibit signal is also applied to Z12-9 causing a false System Ready ( $\overline{\text{SYSRDY}}$ ) to be generated. After the tape has been loaded, placing the RUN/LOAD switch in the RUN position makes the reader operational.

With the inhibiting signals removed, the  $\overline{\text{SYSRDY}}$ ,  $\overline{\text{DATRDY}}$ , and RRDY signals are true allowing the drive signal to be recognized. Application of a true 0V DL signal at J1-17 sets the direction flip-flop, composed of Z10 and Z11, to the drive-left state. This places the clockwise (CW) line at Z10-11 at 0V and the Direction (DRCTN) line at Z15-3 at +5V. A +5V DRCTN signal sets up the three phase counter, composed of FF3, FF4, Z19 to energize the motor phases in the sequence which drives the tape to the left, i.e., phase 3, phase 2 and then phase 1 (drive right is the reverse order). The counter is advanced one count with each clock pulse received from SS2 as described in a subsequent paragraph.

The 0V,  $\overline{\text{DL}}$  signal also generates the 0V true Drive Gate ( $\overline{\text{DRVG}}$ ) signal at Z9-6 which is used to trigger the single shot SS1 at input A. Output SS1 then goes to 0V which sets flip-flop FF2, resulting in the negative going FF2 signal which triggers SS2. The SS2 output, in turn, is applied to the three phase counter through Z19-11 causing the counter to step one count.

A new motor phase is now energized which moves the tape one line to the left.  $\overline{\text{FF2}}$  also causes the DATRDY signal to go false (0V) through Z18-6; FF2 causes the  $\overline{\text{SSYRDY}}$  signal to go false (+5V) through Z16-6 and Z12-8. FF2 stays locked in the set condition until SS1 times out (approximately 2 ms). As a result, any noise or start up jitter from the sprocket signal is prevented from generating a true Data Ready signal.

The positive going edge of the FF2 signal also triggers SS9 which is a retriggerable single-shot timed for 23 ms. Output  $\overline{\text{SS9}}$  is combined with FF2 to produce End of Tape signal at Z16-6. If SS9 is not retriggered within 23 ms and if no sprocket signal is sensed (FF2 remains high) then Z16-6 drops to 0V. This places the System Ready signal at Z12-8 in the +5V false state, indicating that the system is not ready.

At the end of the 2 ms period, FF2 is released, but by this time the tape is up to speed and the only signal available to reset FF2 is the positive going edge of the Sprocket Delay signal from SS4. The positive going edge of the  $\overline{\text{SS1}}$  signal is used to trigger single-shot SS3. As a result SS3 is held at 0V for 725  $\mu\text{s}$  and is applied as a negative OR combination to Z24-13, Z24-4, and Z24-1 causing the remaining two motor windings which are not energized during a given phase sequence to become energized for 1 ms. This momentary energizing of all three motor phases dampens the inherent oscillations present in all stepping motors as the tape moves on character.

When the next line is read, the negative going edge of the Sprocket signal triggers the 150  $\mu\text{s}$  Sprocket Delay single-shot SS4. This delay is required when using a feed hole advanced tape to electronically delay the feed hole and make sure all data is latched before the sprocket is recognized. With standard in-line feed holes this serves only to add an extra safety margin. At the end of the 150  $\mu\text{s}$  delay, the positive going edge of SS4 resets FF2. The resulting positive going edge of  $\overline{\text{FF2}}$  is used two places: (1) to trigger single-shot SS5 and (2) to generate the positive going DATRDY signal through Z18-6 (and the 0V Strobe 1 and Strobe 2 signals at Z4-2 and Z4-4). The inverse 0V, FF2 signal places the  $\overline{\text{SYSRDY}}$  signal in the true 0V condition through Z16-6 and Z12-8 and Z4-12. The functions of SS5 is to provide a 440  $\mu\text{s}$  delay by holding the RRDY line at 0V. This allows the external equipment to examine the data and make the go/no-go decision. If the decision to stop is made, the DL input line must be taken high within 440  $\mu\text{s}$  (actually 490 but conservatively specified at 440  $\mu\text{s}$ ). Otherwise, when SS5 times out, the positive going RRDY will trigger SS1 and repeat the tape advance cycle. If the drive line is taken false and then returned to the true state during the 440  $\mu\text{s}$  period of SS5, SS5 will be reset by the signal from Z9-8 applied to Z17-3 and the next drive sequence will begin immediately.

#### 4.3.1.2 Wind Circuits

During normal operation up to 200 cps the Wind Enable line is taken high (or open circuited). A 0V signal applied to J1-18 and a true drive input cause the reader to wind tape at a nominal 300 characters/sec. Applying 0V to Z13-5 causes Z13-6 to go to +5V and, in turn, Z14-3 goes to +5V provided the drive signal is present (DRV is +5V at Z14-2). When the first MCP signal is generated, SS2 drops to 0V and is inverted to +5V at Z13-11. This signal, gated with the +5V at Z13-2, results in Z13-3 dropping to 0V and setting flip-flop FF1.

This flip-flop is used to modify the previously described low speed drive sequence by performing the following functions: (1) FF1 inhibits the 725  $\mu\text{s}$  damping pulse SS3, (2) FF1 enables gate Z16-9 so that as soon as flip-flop FF2 is set by SS1, the FF2 output,

through Z16-9 clears SS1 and removes the 2 ms hold off, (3) after the first MCP is generated at Z21-12, FF1 at Z18-13 holds Z21-9 low so that the only trigger pulses applied to SS2 is via SS6 (discussed in the next paragraph) are recognized, and (4) FF1 enables SS6 so that it is triggered on the positive going edge of the SPRKT signal.

When the tape moves off character, the positive going SPRKT signal triggers the 1570  $\mu$ s one-shot SS6. At the end of SS6 time, the positive going SS6 signal triggers SS2 which generates a second clock pulse. The clock pulse is also applied to the counter and advances it one count ahead of the phase to which the motor is being advanced. Thus, when the next character is reached, if the reader has not been told to stop, the motor will continue advancing to the next character without stopping. Each time the tape goes off character, the counter will again be pulsed causing it to always be one count ahead. It should be noted that after the initial MCP is generated by FF2 going low, FF2 does not generate any more MCP pulses on subsequent lines since Z18-13 is held low. This coupled with the absence of the motor damping pulse SS3 allows the reader to drive tape in excess of 300 characters/sec.

If, during the period that FF2 is set, the drive signal is removed, the DRV signal will drop to 0V and trigger single-shot SS7. The resulting negative going SS7 performs the following functions: (1) provides a 45 ms inhibit to the REVLK line and therefore to the drive logic which allows the motor to settle before the next drive signal is recognized, (2) reverses the DRCTN line at Z15-3, (3) triggers single-shot SS8, and (4) inhibits any drive signal at Z9-5. With the DRCTN line reversed, the negative going SS8 signal causes the three phase counter to back up one count which puts it in phase with the existing motor position, causing it to stop. SS8 is also used to reset the High Speed flip-flop FF1. When SS7 times out, the REVLK signal returns to +5V and the reader is ready to accept the next drive signal.

#### 4.3.1.3 Tape Reading Circuits

Nine photovoltaic cells in the readhead assembly sense the perforations in the tape. Refer to Figure 8-1, sheet 2. An illumination system consisting of a lamp and fiber optics provides a continuous beam which covers the area of the photocells. The tape is driven over the top of the photocell block and when a hole appears between the photocell and the light source, the photocell becomes energized.

Each cell output is applied to an amplifier-latch circuit, Q1-Q8, Z2 and Z6. Track 1 is used in the following discussion since it is typical of tracks 1-8 (the Sprocket signal is developed differently as described in a subsequent paragraph). When track 1 becomes energized, the negative going signal at the cathode of the photocell turns off Q1. Q1 is interconnected with the D3 input and  $\overline{Q3}$  output of Z2 in a manner which allows Q1 and the first stage of Z2 to function as a Schmitt trigger. Z2 follows all changes in the photocell output until the 0V strobe 1 signal (see Section 4.3.1.1) is generated which locks up Z2.

Track 1 output at Q3 is +5V true and is gated with the Mode Select signal at Z3-1 and 2. A 0V Mode Select input provides a mode 5 output at J1-1 (i.e., 0V for no hole and +5V for hole). Conversely, when the Mode Select signal is +5V, J1-1 will produce a Mode 6 output (i.e., +5V for no hole and 0V for hole). The DATRDY output is gated in the same manner as the track outputs at Z15, pins 4 and 5.

The sprocket track is somewhat different than the other eight tracks in that its Schmitt trigger uses an inverter, Z4, rather than part of a latch and is independent of either the



Strobe or DATRDY signals. See Figure 8-1, sheet 1. It is also used only as an internal logic signal and is not gated with the Mode Select signal. Both the SPRKT and SPRKT signals are generated and used in the internal logic.

#### 4.3.2 SPOOLER CIRCUITRY

The spooler circuitry is designed to control the payout and take-up of the spooler motors during operation of the unit. Since there are two identical spooler motors and two identical control circuits only one side will be discussed. The following discussion pertains to the left side (refer to Figure 8-1, sheet 3) during the following description.

In operation, the RUN/LOAD switch is set to the LOAD position (see Figure 8-1, sheet 1) while the tape is loaded on the unit. This generates the Spool Inhibit (SPLINH) signal which is applied to Q16 (Figure 8-1, sheet 3). This in turn causes Q16 to clamp the inputs to Z27-3, the base of Q19 and the base of Q20 to a bias condition such that the motor drive transistors Q103 and Q014 produce 0V at their collectors. This condition produces 0V across the spooler motor M3 regardless of the position of the left arm potentiometer during the tape loading operation.

After the tape is loaded, the RUN/LOAD switch is placed in the RUN position, thereby removing the SPLINH signal. The tape arm potentiometer is now the controlling component for the motor control circuit. Assume for the purposes of this discussion that the tape arm is in the slack position. This will make the center arm of the potentiometer more positive and this positive voltage is applied to Z27-2 causing the operational amplifier output at Z27-6 to go in the negative direction. The negative going output of the operational amplifier tends to turn Q20 on while Q19 tends to turn off. When Q20 goes into conduction its collector goes in the positive direction and this in turn turns Q104 on, causing Q104's collector to move in the positive direction. At the same time Q19 is tending to conduct less and the Q19 collector goes in a positive direction, allowing Q103 to begin to turn off. The result is the negative going direction of the collector of Q103 and Q104. The motor M3 drives in the direction required to take the slack out of the tape and the tape arm is consequently moved to its center position. This reverses the off-center bias condition described above and the junction of the collectors of Q103 and Q104 moves toward zero. Since the purpose of the circuit and motors is to maintain a slight tension on the tape, a slight negative voltage remains on M3, sufficient to maintain the proper tension.

When the tape reader sprocket moves the tape in a direction that tightens the tape the process described is reversed, Q103 and Q104 collectors are driven in a positive direction, and M3 thus runs in the direction required to pay out tape.

#### 4.3.3 POWER SUPPLY

The power supply provides the regulated DC voltages required to operate the logic, the spooler drive circuits and the spooler motors. The major components of the power supply consists of power transformer T1 (Figure 8-1, sheet 3), bridge rectifier BR1, main filter capacitors C102 and C103, and the output regulators Z101 and Z102.

The transformer is a step-down transformer designed to convert the AC line voltage to approximately 33 VAC. The transformer is provided with a tapped primary winding to accommodate a variety of input voltages. The voltage from the transformer secondary is

rectified by BR1 and filtered by C102 and C103. The resultant +15 and -15 Vdc is used to provide power to the spooler circuit and motors. The +15 Vdc is also applied to the inputs of the 5V regulators Z101 and Z102. Z101 provides regulation of the 5 Vdc Logic power while Z102 provides the regulated voltage for the reader lamp. Z101 is not adjustable and provides regulated 5 Vdc for the logic circuitry. Z102 is provided with a voltage level adjustment R63 for varying the lamp brilliance. This makes it possible to adjust the lamp voltage to approximately 4.3 Vdc thereby extending lamp life expectancy. The lamp voltage should not be adjusted higher than 4.7 Vdc.

#### 4.4 MECHANICAL THEORY OF OPERATION

##### 4.4.1 TAPE TENSION

Tape handling, at all speeds, requires that the proper tape tension be maintained. This is especially true where rapid, hi-torque starting, reversal of direction, and stopping is necessary. For example, in order for the tape to be moved over the readhead in a start-stop "geneva" mechanism fashion, the tape must have a certain tension applied in order to flow smoothly.

Assume that a full reel of tape is loaded on the right hand reel and an empty reel is placed on the left spindle. As the tape is moved from right to left during servo mode, it passes by a number of points which require different tension. As the tape is wound on the left hand reel, it starts winding on a small diameter since the reel is nearly empty. This means that the take up motor, if it were a fixed power or constant torque motor, would have a greater wind torque advantage when the reel was empty than when the reel was nearly full. To overcome this effect of varying tape diameter, a variable torque motion is used which is controlled by the position of the tape tension sensing arm. This arm indicates to the motor when and how much tape to take up by means of a potentiometer attached to the arm which controls a dc servo. When the reader stepper motor drives tape toward the left reel, the tape sensor arm senses the slack in the tape causing the take-up motor to rotate counter-clockwise. This takes the slack out of the tape and moves the sensor arm back to its mid-range.

Thus it can be seen that the tension applied to the tape by the sensor arm is the tension at which the tape passes the readhead. The tape sensor arms are adjusted so that with the stepper motor stopped, the torque motor applies just the amount of tension to the tape required to hold the tape sensor arms in their approximate mid-position. Since the take-up and supply motors always return their arm to the mid-position, it is evident that the tension applied to the tape across the readhead is a function of the tape arm return spring tension.



## SECTION V

### MAINTENANCE

#### 5.1 GENERAL

The REMEX punched tape reader-spooler has been designed to keep maintenance as simple and infrequent as possible. Table 5-1 lists the maintenance equipment required for the various procedures. To prolong the life of the equipment and minimize down-time, certain checks and preventive procedures are set up in Section 5.2 and Table 5-2 with suggested schedules. Section 5.3 outlines possible malfunctions along with probable causes and remedies. The remaining sections describe the required adjustment procedures. Replacement procedures are given in Section 6.

Table 5-1. Maintenance Equipment Required

ITEM	QUANTITY
* Frequency Counter, 10Hz to 20 MHz, 5V input	1
Miller-Stephenson MS-200 Magnetic Tape Head Cleaner (REMEX Part Number 716004-150)	1
* Pulse Generator, 10Hz to 1MHz, up to +5V amplitude, 1 $\mu$ s to 100 ms width	1
* Oscilloscope, DC to 10 MHz, single sweep	1
Tape Gauge, REMEX Part Number 110597	1
* Torque Watch <sup>®</sup> , Waters Model 651C-1 or equivalent	1
* Voltmeter, Digital 0-0.1 ma, 0-100 mv dc, 0-100 V dc, 100 K impedance or greater	1
* Plastic Shim Stock, .010 Thick. Available from ARTUS Corp., 201 S. Dean St., Englewood, N.J. 07631	

#### 5.2 PREVENTIVE MAINTENANCE

Preventive maintenance, which includes cleaning and lubrication, should be performed periodically in order to maintain peak performance. In addition, in order that the warranty remain in effect, the unit must be maintained in accordance with the instructions outlined below (see Section 1.4 and page iii). A preventive maintenance schedule and log are presented in Table 5-2 which indicates the item, frequency of action and references the maintenance paragraph in this section. For customer convenience the table is arranged so that a log can be kept of when each maintenance procedure was performed. Also refer to Section 3.4., Operational Maintenance.

\* These items are not available from REMEX



## NOTE

The frequency of cleaning as listed in Table 5-2 has been adopted for clean environmental conditions and usage. These items, however, may vary greatly from one installation to another. For example, a reader used in a machine shop to program numerical controls may require maintenance procedures considerably more frequently.

### 5.2.1 CLEANING

#### **CAUTION**

In all cleaning procedures, avoid using cleaning methods and materials other than those recommended in this manual. Do not use ethyl alcohol or denatured alcohol as the denaturing agents vary and may damage the reader. Certain cleaning compounds will damage parts of the reader, especially in the readout assembly area. REMEX primarily recommends the use of Miller-Stephenson MS-200 Magnetic Tape Head Cleaner (REMEX Part Number 716004-150) for most areas requiring cleaning. However, due to the degreasing nature of the cleaner, it should not be used in areas where the spray may come in contact with bearings or other oiled parts. This cleaner may be obtained from REMEX or directly from Miller-Stephenson Chemical Company at one of the following locations:

1001 East First Street  
Los Angeles, California 90012

1350 W. Fullerton Avenue  
Chicago, Illinois 60614

Route 7  
Danbury, Connecticut 06810

To use the cleaner, hold the spray can 4 to 6 inches away from the area to be cleaned and allow spray to flush the dirt off. If a heavy buildup is present, loosen with the spray mist and scrub with a cotton swab. A 6-inch pin-point, spray nozzle extension is available for hard-to-reach areas or for delicate applications. Avoid spraying on lubricated surfaces or parts and on the lamp assembly and lens.

If the Miller-Stephenson cleaner is not available, a small amount of isopropyl alcohol applied to a clean, lint-free cloth or cotton swab may also be used. However, it should be used carefully and sparingly since damage to the photocell and the finish on the plastic cover may result. Use only clear, unadulterated isopropyl alcohol.

It is important that, whether the MS-200 cleaner or the isopropyl alcohol is used, only the amount required to clean the surfaces be applied. Never saturate or drench the areas to be cleaned. Never apply these materials to the lamp assembly.

Table 5-2. Preventive Maintenance Schedule and Log

Frequency* of Action Weeks	Date	Initial	Frequency* of Action Weeks	Date	Initial	5.2.1.1				5.2.1.2		5.2.1.3		5.2.1.4		5.2.1.5		5.2.3		5.4,5.5,5.6		5.7,5.8,5.9	
						Cleaning				Check		Adjust.											
2			28			X	X	X	X														
4			30			X	X	X	X														
6			32			X	X	X	X														
8			34			X	X	X	X														
10			36			X	X	X	X														
12			38			X	X	X	X														
14			40			X	X	X	X		X	X	X										
16			42			X	X	X	X														
18			44			X	X	X	X														
20			46			X	X	X	X														
22			48			X	X	X	X														
24			50			X	X	X	X														
26						X	X	X	X		X	X	X										
			52			X	X	X	X	X	X	X	X										

\* See Note on page 5-2.

### 5.2.1.1 Readhead Assembly Cleaning

The top surface of the readhead assembly should be cleaned every two weeks (for most installations having clean environments; dirtier environments which contain dust, oil and sprays, such as machining areas, may require cleaning as much as every eight hours). Cleaning is extremely important because any dirt or foreign material in this area can create errors in readout. Use the bristle brush supplied or the cleaning materials and methods described in Section 5.2.1 and clean the surfaces of the readhead assembly and the upper tape guide assembly. Care should be exercised so that no residue remains from the recommended cleaning materials when the cleaning operation is completed. Figure 5-0 shows the brush inserted between the readhead and tape guide when cleaning the readhead assembly. Proper cleaning requires that the brush be rotated at least two revolutions and moved in and out. Remove the residue with compressed air.

### 5.2.1.2 Sprocket Cleaning

The sprocket wheel should be checked for cleanliness every two weeks. Depending upon tape conditions, accumulations may build up on the sprocket and be transferred to the sprocket holes in the tape which may cause readout errors. Use the recommended cleaning materials described in the caution in Section 5.2.1. Care should be taken so that the alignment of the sprocket wheel is not disturbed. If the sprocket wheel requires adjustment, refer to Section 5.4.

### 5.2.1.3 Tape Inspection

Repeated handling and usage of the tape leads to a build up of grease, oil and dirt on the tape. When the build up becomes excessive, this material will become lodged in the tape transport areas and could cause tape reading errors. To prevent this, the tape should be thoroughly inspected every two weeks and repunched as required.

### 5.2.1.4 General Cleaning

The entire reader should be cleaned every year. Use the following procedure:

Using the bristle brush supplied with the unit and/or compressed air, remove all dust and dirt, paying particular attention to all moving parts. Use the recommended materials described in the caution in Section 5.2 to remove any grease or other accumulations. When cleaning, use care not to damage components on the circuit board.

## 5.2.2 LUBRICATION

Except for the bearing shaft assembly, all points of rotation have permanently lubricated bearings and should not require lubrication for the life of the part. The bearing should be lubricated every six months by applying one or two drops of cling oil to the inside surface of the bearing (part no. 112694-1).

### 5.2.3 POWER SUPPLY VOLTAGES

Check all voltages on the reader card listed in Table 5-3 with a voltmeter once every three months. A change in voltage may be indicative of a gradual component failure. Before taking any measurements, allow a short period of time for warm up after turning on power.

Table 5-3. Power Supply Voltage Locations, Reader Card

<u>Voltage and Tolerance</u>	<u>Test Location</u>	
	<u>From</u>	<u>To</u>
Lamp Voltage (See Section 5.5)	Across lamp terminals	
+5 $\pm$ 0.25 VDC	TP5	TP6
+14 $\pm$ 1.4 VDC	Cathode CR10	TP6
-15 $\pm$ 1.5 VDC	C103-	TP6
+15 $\pm$ 1.5 VDC	C102+	TP6

### 5.3 TROUBLE SHOOTING

Trouble shooting is presented in the form of a chart, Table 5-4, which should be consulted whenever tape reader performance is unsatisfactory. The chart is divided into three columns; Indication - the way in which the malfunction becomes evident; Probable Cause - the possible reason or reasons for the malfunction; and Remedy - the manner in which the malfunction may be corrected.

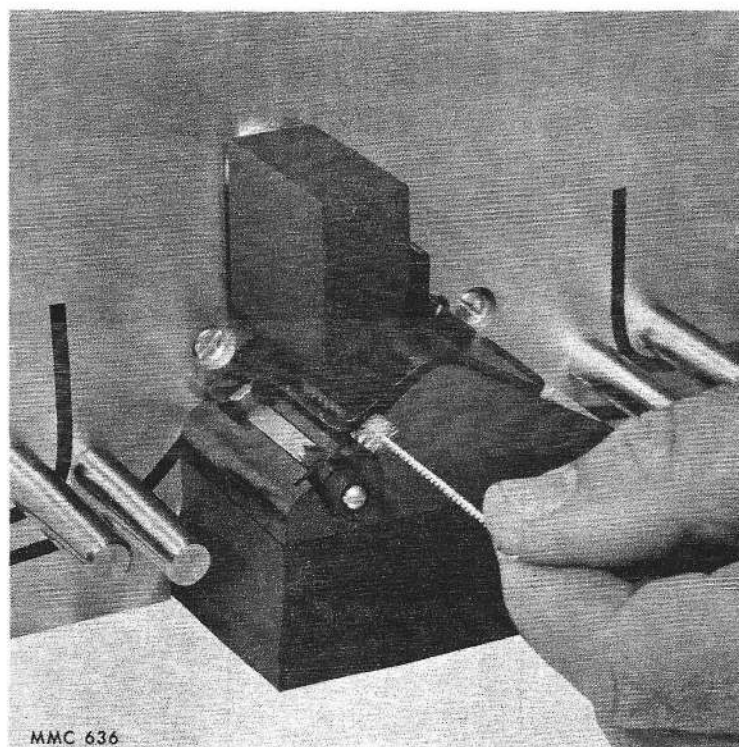

Figure 5.0. Brush Insertion for Readhead Cleaning.

Table 5-4. Trouble Shooting

Indication	Probable Cause	Remedy
1. No track outputs on any track.	1. Readhead dirty	Clean Readhead Assembly as described in Section 5.2.1.1.
	2. Lamp Assembly misaligned	Check alignment of the Lamp Source as described in Section 5.4. and Lamp Voltage Adjustment, Section 5.5.
2. Outputs present on all but one track or one track intermittent.	1. Readhead dirty	Clean Readhead Assembly as described in Section 5.2.1.1.
	2. Photocell defective	Check the output of the Photocell assembly as described in Section 5.4 and replace if defective as described in Section 6.2.1.
	3. Defective component on Reader Card	Check the components and IC modules associated with the particular track output.
3. Track output present with no hole punched in tape.	1. Tape transmissivity	Tape must have a transmissivity of 57% or less as specified in Table 1-2.
	2. Defective photocell	Check the output of the Photocell assembly as described in Section 5.4 and replace if defective as described in Section 6.2.1.
	3. Defective component on Reader Card	Check the components and IC models associated with the particular track output.
4. Upper Tape Guide closed, LOOP-SPOOL switch in SPOOL or LOOP, correct drive signals present; tape does not move.	1. LOOP-SPOOL switch, S4, defective.	Check switch S4 and replace if defective.
	2. LOAD-RUN switch, S2, defective	Check switch S2 and replace if defective as described in Section 6.2.6.
	3. Defective component on Reader Card	Check operation of Reader Card.
	4. Step Motor defective	Check $\phi 1$ thru $\phi 3$ outputs from Reader Card to see if they are present. If so, replace stepper motor as described in Section 6.2.4.



Figure 5-4. Trouble Shooting (Continued)

Indication	Probable Cause	Remedy
5. Tape does not stop on character	1. Improper reader alignment	Perform Section 5.4.
	2. Defective component on Reader card	Check operation of Reader card.
6. LOOP-SPOOL switch in SPOOL or LOOP; lamp does not turn on, no DC voltages	1. No AC power	Make sure AC power cord is plugged into outlet.
	2. Fuse F1 blown	Check fuse and replace if required.
	3. LOOP-SPOOL switch, S4, defective	Check switch S4 and replace if defective.
	4. Power Supply defective	Check Reader card for proper operation of +5V power supply.
	5. Defective Transformer, T1	Check T1 and replace if faulty as described in Section 6.2.5.
7. Continuous tape speed less than 180 characters/second	1. Tape out of registration	Check tape registration to make sure tape conforms to specifications as described in Section 3.6.
	2. Sprocket out of rotational alignment	Check alignment of reader as described in Section 5.4.
	3. Defective component on reader card	Check reader for proper operation of drive circuits and single shot timings.
8. Irregular movement of tape	1. Drive system improperly adjusted	Perform Reader alignment as described in Section 5.4.
	2. Sprocket wheel bent or worn	Replace sprocket wheel as described in Section 6.2.4.
	3. Tape guide assembly worn	Replace tape guide assembly.
9. +5V supply voltage too low or too high	1. Defective regulator	Check operation Z101 and replace if required.
	2. T1 malfunction	Check for presence of 24 VRMS across the green and blue terminals of T1. Replace T1 if not present.

Figure 5-4. Trouble Shooting (Continued)

Indication	Probable Cause	Remedy
10. Spooler spills tape when first turned on.	1. Improper threading	Thread tape as shown in Figure 1-1.
11. Tape sensor arms hit bumper during operation or arms act erratically.	1. Improper adjustment of tape arm pot.	Check tape arm potentiometer zero adjustment as described in Section 5.6.
	2. Improper adjustment of tape arm spring.	Check tape arm spring adjustment as described in Section 5.7.
	3. Reader card malfunction.	Check operation of servo circuitry on reader card.
12. Spooler does not go into wind mode when proper signals are applied.	1. Reader card malfunction.	Check operation of Reader card.
	2. Wind switch S3 malfunction.	Check S3 for proper operation and replace if defective as described in Section 6.2.6.
13. One spooler motor does not operate.	1. Reader card malfunction.	Check outputs from servo circuitry on Reader card and replace card if required.
	2. Servo motor faulty.	Check servo motor and replace if required as described in Section 6.3.3.
14. LOOP-SPOOL switch in SPOOL, reader drives tape, upper tape guide closed (S2 in run position) neither spooler motor runs.	1. Switch S2 or S4 faulty.	Check S2 or S4 for proper operation and replace as described in Section 6.2.6.
	2. +15 or -15 VDC on Power Supply card faulty.	Check to see if proper power supply voltages are present on Reader card and replace card if required.
	3. Servo circuitry on Reader card faulty.	Check Reader card for proper operation and replace if required.
	4. T1 faulty.	Check for presence of 36 VRMS across brown and red terminals of T1 and replace if not present.



READER ALIGNMENT

Proper operation depends upon making and maintaining accurate adjustments. Although all adjustments are made at the factory, the following adjustments should be checked periodically (refer to Table 5-2) and should be performed only when the tape reader performance is unsatisfactory or when any of the following items is replaced: distributor, readhead assembly, upper tape guide assembly, mechanism assembly, sprocket, step motor or circuit card. Letter designations in parenthesis refer to items called out in Figure 7-1.

Improper adjustment of this procedure will result in one or both of the following problems: (1) Reading errors, especially in computer applications and (2) Restriction of the tape tolerances capable of being read, i.e., either long or short tolerance tapes, not the  $\pm 0.025$  inch in either direction as specified in Section 3.6.

**CAUTION**

This is a factory set adjustment and should not require adjustment unless one of the aforementioned components has been replaced or the reader performance is unsatisfactory.

- a. Remove all power and control signals by disconnecting P1 and the power cord plug.

**CAUTION**

The procedure outlined in steps b through i should not be performed unless the readhead assembly, mechanism assembly, sprocket or step motor has been replaced or the reader performance is unsatisfactory. Prior to adjustment, steps b, d, e and f should be checked and corrective steps c and/or g, h, i and j performed only if necessary.

- b. Remove the Upper Tape Guide. Check the clearance between the readhead housing tape riding surface and the sprocket perimeter high point by placing the end of a small steel rule on the surface and rock the sprocket in both directions. See Figures 5-1 and 5-2. Observe that the perimeter high point clears the steel rule by a few thousandths of an inch. The sprocket teeth must have maximum tape penetration with no interference when driving tape. If the sprocket is not positioned as described perform step c.
- c. If the conditions of step b do not exist, loosen two screws (D) which hold the motor heat sink to the panel. Adjust the height of the motor so that the conditions in step b exist. Tighten screws (D). On some units it may also be necessary to loosen the four 8-32 socket head screws (B) at the rear of the panel which hold the Mechanism Assembly to the Front Panel and move the Mechanism Assembly to achieve the required setting. This should only be attempted if the adjustment cannot be made with the motor only. Tighten screws (B) if required. Check the conditions in step b again and perform step c as required.

## WARNING

If the motor has been running for a period of time, it or the heat sink may be too hot to touch comfortably. Allow sufficient time for the motor and heat sink to cool before any adjustment or use a cloth or pair of gloves.

- d. Insert a loop of tape known to have been punched to within  $\pm 0.0025$  inch in a 5-inch span (0.05% error).

### NOTE

Since repeatability of the feedhole placement in either direction is essential, a tape whose accumulated error in a 5-inch span is considerably better than  $\pm 0.025$  inches (as specified in Section 3.6) must be used in this procedure. Remex specifies a tape known to be punched to within  $\pm 0.0025$  inch in a 5-inch span ( $\pm 0.05\%$  tolerance). Note that most Remex punches are specified at  $\pm 0.025$  and therefore these tapes should not be used for this adjustment unless the tape has been checked on a registration gauge and found to be within  $\pm 0.0025$  inch.

- e. Loosen nut (T) which holds the fiber optics light source to the reader panel and rotate the light source away from the light tunnels.
- f. With the rear edge of the tape parallel to the front panel, align the holes over the light columns in the readout assembly so that they are concentric. See Figure 5-3. The tape must remain parallel to the front panel so that no skew is present. With the tape in this position, the sprocket teeth should be centered in the sprocket holes in the tape. Skewing is indicated by tracks 1 and 8 not being concentric.
- g. If the conditions of step f do not exist, loosen the two set screws (J) which hold the sprocket to the motor shaft and move the sprocket in or out on the shaft until the teeth are centered in the feed holes and the tape holes remain concentric with the light tunnels. Tighten screws (J). Recheck the adjustment and readjust as required.
- h. Connect the power plug and place the POWER switch into the ON position. The motor should be energized.
- i. Loosen the single screw (S) which holds the motor to the heat sink (some earlier models may have two sets screws).
- j. Rotate the motor so that the holes in the tape are concentric with the light columns in the readhead and the sprocket teeth are centered in the feed holes. Tighten the set screws. Recheck the adjustment and readjust as required.
- k. Remove the 0.05% tape.
- l. Place the POWER switch in the OFF position.

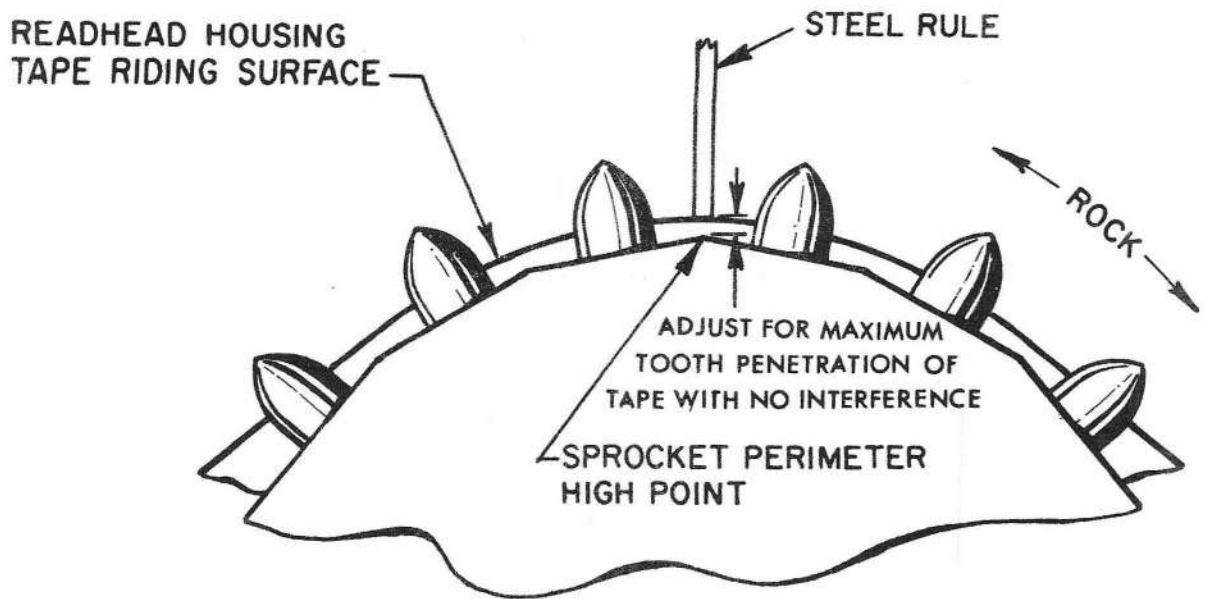

MMC 353B

Figure 5-1. Sprocket Relation to the Tape Riding Surface.

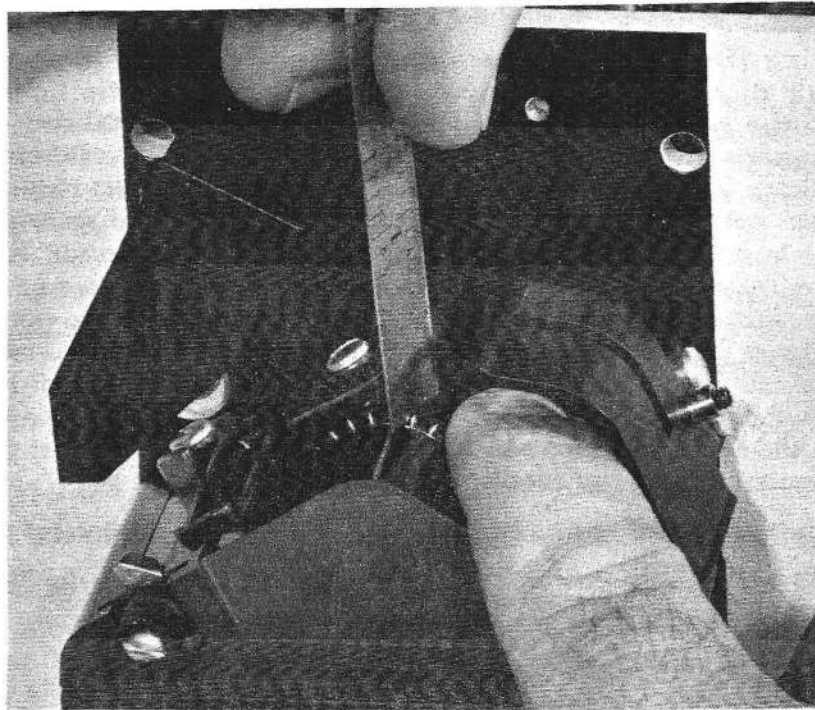
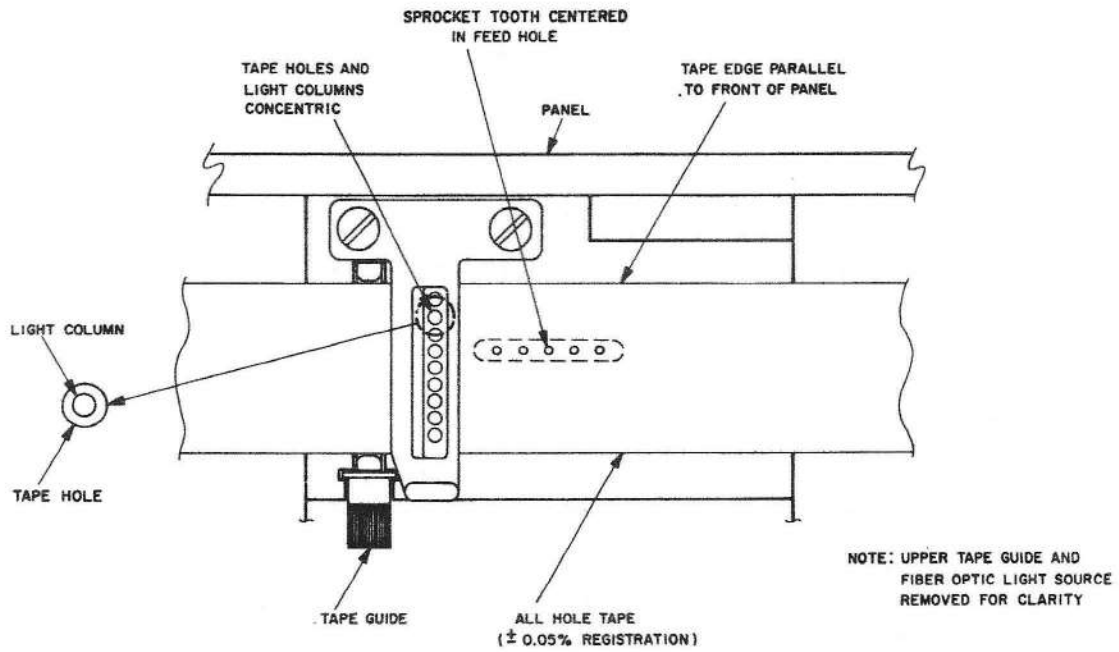

Figure 5-2. Checking the Sprocket in Relation to Tape Riding Surface.

- m. Make sure jack screw (E) is not protruding below the surface of the Upper Tape Guide.
- n. Insert three layers of 0.0037 mylar tape (approximately 0.011 inch) stapled together at one end or a piece of 0.010 plastic shim stock (see Table 5-1) between the Upper Tape Guide and the Readhead Assembly.
- o. Referring to Figure 5-4 use screws (H) and (N) to adjust the Upper Tape Guide so that there is maximum contact, firm pressure on the tape, and parallelism from A to B. Use screw (H) for lateral movement and screw (N) for rotational movement. From points B to C, the Upper Tape Guide will not show this parallelism.
- p. Remove the three layers of tape.
- q. Insert two layers of tape between points A and B only or a strip of 0.0075 shim stock.
- r. Screw down jack screw (E) which will raise the Upper Tape Guide slightly. Adjust screw (E) until there is free movement of two layers of tape or shim stock between points A and B. This should provide a gap of between 0.009 and 0.011 inch.
- s. Remove the two layers of tape or shim stock.
- t. Connect P2 coming from the Readhead Assembly to a test circuit as shown in Figure 5-5. Connect a digital voltmeter in parallel with a 1K resistor. Place the POWER switch in its ON position.
- u. Adjust the lamp voltage to +4.3 Vdc. See Section 5.6 for lamp voltage adjustment. This is a preliminary step. The final lamp voltage is adjusted in step v.
- v. The nut (T) holding the fiber optic light source to the front panel should already be loose (step e). Rotate the fiber optic light source until the current through the 1K resistor is between 100 and 110 microamps for the sprocket cell. If the current is excessive reduce the lamp voltage. If the current is below the minimum requirements, loosen nut (U) which locks the lamp in the sleeve and screw the lamp in or out to obtain the required current. Tighten nut (U). If the current is still below the minimum requirement, increase the lamp voltage slightly to obtain the required current. Do not increase the lamp voltage above +4.7 Vdc. When the required current is obtained for the sprocket, the minimum current for each of the data cells should be 80 microamps. The maximum output from any data cell should be 160 microamps so that tapes with the highest permitted transmissivity can be read without error.
- w. Place the POWER switch in the OFF position and reconnect P2.
- x. Place the POWER switch in the ON position and insert the 0.05% described in step d.
- y. Connect a pulse counter to TP3 (Data Ready) and TP6 (0V) on the Reader Card.



MMC 572

Figure 5-3. Alignment of the Sprocket with the Light Columns.

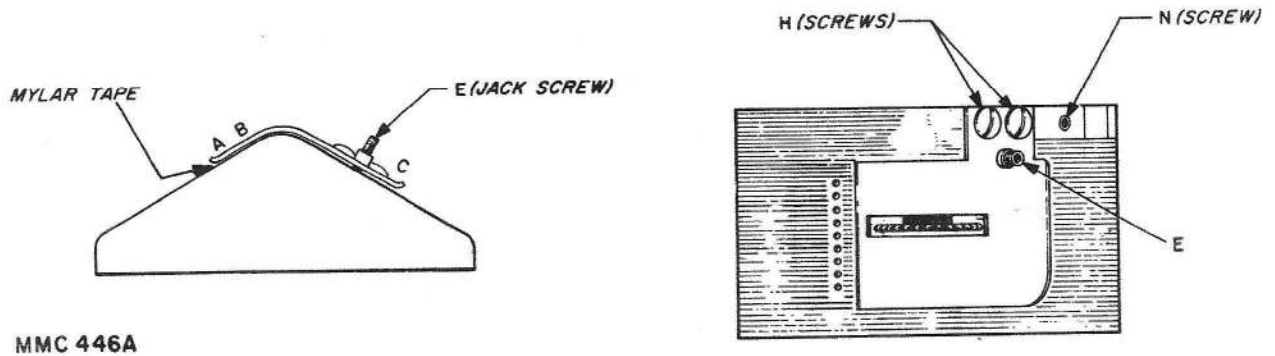

MMC 446A

Figure 5-4. Adjustment of the Upper Tape Guide.

- z. Measure the drive left speed using a DL\* signal tied to 0V at J1-17. Repeat using a DR\* signal tied to 0V at J1-16. If the lowest speed is more than 5% slower than the highest speed, loosen screw (S) which holds the motor to the heat sink. Rotate the motor slightly so that the difference in drive left and drive right speeds is less than 5%. Tighten screw (S). Repeat step z as required. When rotating the motor, make sure it is kept tight to the panel so that the adjustment in step g not disturbed. If steps g and j have been performed correctly only a slight adjustment of the motor should be necessary to obtain the 5% difference in speeds.

#### NOTE

The importance of steps y and z is not a specific interest in matching speeds, but rather that balancing speeds insures proper placement of the feedhole (via the sprocket) in relation to its aperture in the readhead. The 0.05% tape used virtually assures that there are no feedhole placement errors which are attributable to tape registration errors, but only to the position of the sprocket in relation to the feedhole aperture in the readhead. Thus measuring and balancing the slow speed is only an accurate, electronic method of assuring that this relationship exists. When the speeds in the two directions are properly balanced, feedhole placement error will be minimal and independent of the direction of the tape, thereby increasing tape readability to a maximum.

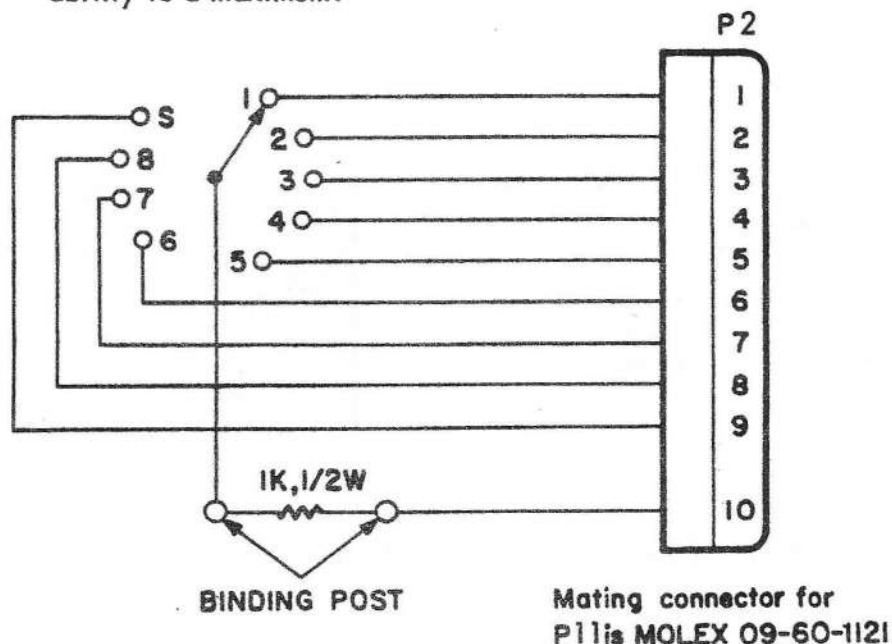

**MMC 354**

Figure 5-5. Photocell Output Test Circuit.



## 5.5 READER LAMP VOLTAGE ADJUSTMENT

The following procedure should be used when adjusting the reader lamp voltage:

- a. Place the ON-OFF switch to its ON position. The reader lamp should come on.
- b. Place a digital voltmeter across the lamp terminals.
- c. Adjust R63 on the Reader card until the meter reads  $+4.3 \pm 0.1$  Vdc.
- d. Remove the meter leads.

### NOTE

The reader lamp voltage may require further adjustment to increase the photocell outputs. See Section 5.4, step v. Do not increase the voltage above +4.7 Vdc.

## 5.6 SERVO ALIGNMENT

Alignment of the servo system is performed in the following manner:

- a. Place the ON-OFF switch in the OFF position.
- b. Remove all tape and reels from the reader-spooler.
- c. Place the SPOOL-LOOP switch in SPOOL and the OFF-ON switch in ON and place the RUN-LOAD switch in RUN position.
- d. Rotate the left and right tape sensing arms to the center of their travel arc. Secure the arms in this position with a rubber band loop around the tape rollers.
- e. If the left motor rotates when the arm is positioned in the center of its travel arc, perform steps f and g.
- f. Loosen the set screw which holds the coupling to the potentiometer shaft.
- g. Rotate the shaft of the potentiometer until the left motor stops rotating. Tighten set screw (A).
- h. Repeat steps e, f and g for the right arm.

## 5.7 ARM SPRING TENSION ADJUSTMENT

Tension of the tape sensing arm spring is measured at the roller on the end of the arm.

- a. Place the OFF-ON switch in the OFF position.
- b. Attach a tension gauge to the tape arm roller on the left arm using a piece of tape around the roller.
- c. Pull on the gauge perpendicularly to the tape arm and lift the arm up off the outer stop. Note the gauge reading which should be between 4 and 5 ounces. Do not allow the tension of the arm on the switch to interfere with the measurements.



- d. If the tension measurements do not agree with the specifications noted in step c, adjust the screw holding the arm spring up or down in the slotway until the conditions of step c is met.
- e. Repeat steps b through d for the right arm.

## 5.8 SPOOLER TAPE ARM AND ROLLER ALIGNMENT

The tape rollers and the arm rollers should be positioned so that paper tape moves through the drive mechanism flat in either direction, without wave. Mylar tape may have a slight wave. All tape should run through the head without excessive edge guiding, preferably with a slight tendency of guiding toward the panel.

To accomplish this alignment, a small amount of bending at the end of the tape arm may be required. However, the arm itself must be parallel to the panel over its entire length. In addition, the distance from the front surface of the arm to the inside edge of the roller must be between 0.190 and 0.205 inch. This is important when a new roller has been installed and is accomplished by placing 1 or 2 713600-149 washers between the spacer and roller as shown in Figure 6-1 and as described in Section 6.3.4. The roller must also remain perpendicular to the front panel.

## 5.9 TAPE SPLICING

If tape breakage occurs, this break may result in damage to one, two or possibly three characters. When splicing tape for this reader, great care should be used to ensure that the proper sprocket hole spacing be preserved. A lap splice should not be used; use only a butt type splice. To repair the tape without loss of characters, the process shown in Figure 5-6 is recommended and is accomplished as follows:

- a. Bring the tape ends together as shown in Figure 5-6A.
- b. Make a sketch of character(s) at the break (A-B-C) and five additional characters to the left (5-4-3-2-1) and five to the right (1-2-3-4-5) of the broken character(s) (A-B-C).
- c. Place the left end of the broken tape over a section of blank tape containing only feed holes so that at least eight or ten feed holes in each tape are aligned with one another as shown in Figure 5-6B. Cut the tapes at the third undamaged character (A-B-C). Use care to insure that feed holes are aligned and make cut through the center of the holes in the third undamaged character. Characters 5, 4 and half of 3 should remain on the broken tape.
- d. Place the right end of the broken tape over the section of blank tape so that at least eight or ten feed holes are aligned with one another. Feed holes for one-half of 3, 2 and 1 on the blank tape cut in step c should be visible to the left of the broken tape end as shown in Figure 5-6C. Cut the tapes at the third undamaged character to the right of the damaged character. Be sure that feed holes are aligned and make the cut through the center of the holes in the third undamaged character.

### NOTE

One half of character 3 and characters 4 and 5 should remain in the broken tape.

- e. Place tape ends and new section on a flat surface with feed holes forward as shown in Figure 5-6D (tape is bottom side up). Using silver Scotch tape, No. 852, splice the new section and the old tape ends as shown. That portion of tape that secures the old tape ends must cover the first two and a half characters (one-half of of 3, 4 and 5) on the old tape ends. The edges of the tape should be between characters as shown. Use of 1/2-inch wide splicing tape is recommended as shown in Figure 5-6D.
- f. Repunch the characters recorded in step d.

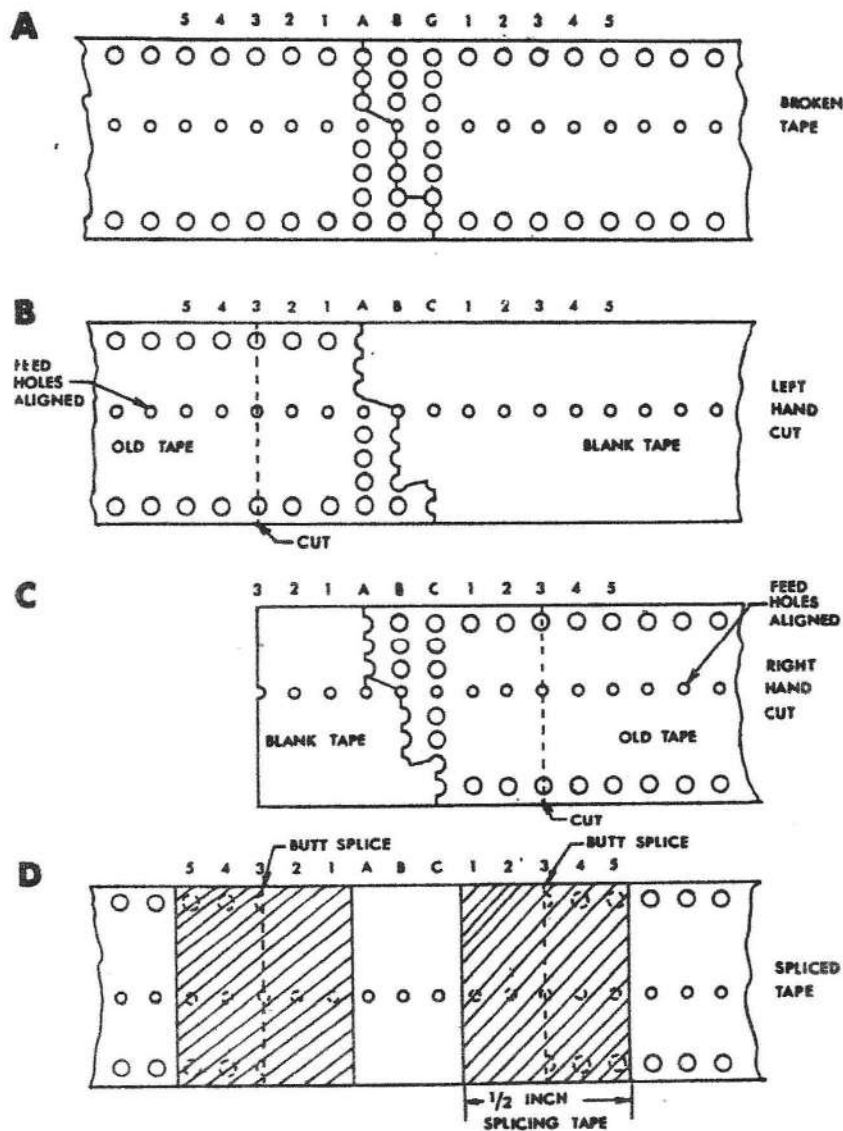

MMC 120A

Figure 5-5. Tape Splicing Procedure.



## SECTION VI

### PARTS REPLACEMENT

#### 6.1 GENERAL

REMEX maintains service facilities at its manufacturing location and at service centers in major population areas for repair or replacement of components for their products. It is recommended that one of these centers be contacted for assistance in case of equipment malfunction. For the locations of service facilities in any area, contact REMEX at the address or telephone listed on the title page of the manual. Please direct inquiries to the attention of the Service Department.

When any parts of the reader require replacement or disassembly, the procedures below should be followed closely. The warnings and cautions are included to protect personnel and equipment. Notes are included to assist persons unfamiliar with the equipment. Before attempting any procedure, all instructions for that disassembly should be read and understood.

Quantities of replaceable items suggested as spares are listed in Table 7-1. All system components are identified in Section VII of this manual, along with illustrations showing part locations. This information may be used to locate parts below unit level if replacement is required.

#### **WARNING**

Potentially dangerous line voltage is applied to components within this equipment. If adjustments must be performed with power applied, these points must be located and avoided. High voltage can be accidentally contacted at TB1, at the OFF-ON switch/wiring connections, and on the circuit card (rear of the Unit).

#### 6.2 READER PARTS REPLACEMENT

##### 6.2.1 READHEAD MECHANISM DISASSEMBLY

This procedure is required when replacing the Upper Tape Guide Assembly, the Readhead Assembly (consisting of the Readhead Housing, Photocell Assembly and Light Columns), or the Mechanism Assembly (consisting of the Mounting Block, Tape Guide Cam, Tape Tape Guide Actuator, Slide and Spring). For ease of assembly, it is recommended that the Readhead Assembly (part number 110459-3) and Mechanism Assembly (part number 112346-1) be replaced as a complete assembly. Figure 7-1 should be folded out from Section 7 to follow during this procedure. The following procedure is recommended when replacing any of the above mentioned items:

- a. Remove all power and control signals by disconnecting P1 and the power cord.
- b. Disconnect P2 and P3 from the circuit card.

- c. Remove two 4-40 round head screws (C and F, Figure 7-1) which hold the Readhead Assembly to the Mechanism Assembly.
- d. Loosen the two 8-32 socket head screws (Item B, Figure 7-1) which hold the Mechanism Assembly to the Front Panel at the rear of the Front Panel. The entire Readhead Mechanism Assembly consisting of the Tape Guide Assembly, the Readhead Assembly, and the Mechanism Assembly is now free to be removed from the panel.
- e. Remove the two 4-40 binder head screws (Item H, Figure 7-1) which hold the Tape Guide Assembly to the Mechanism Assembly. If no further disassembly is required, install the new Upper Tape Guide Assembly and perform the reverse of steps e through c. Perform the Upper Tape Guide adjustment Procedure.
- f. From the underside of the Mechanism Assembly remove the two 4-40 round head screws (Item I, Figure 7-1) which hold the Readhead Assembly to the Mechanism Assembly. The Readhead Assembly and the Mechanism Assembly are now separated and can be replaced as individual assemblies. It is not recommended that Mechanism Assembly be disassembled beyond this level.
- g. Reassembly is the reverse of steps g, f, e, d and c.
- h. Perform Section 5.4.

### 6.2.2 READER CARD REPLACEMENT

The following procedure is recommended when removing the Reader Card:

- a. Remove all power and control signals by disconnecting P1 and the power cord.
- b. Disconnect plugs from the circuit card and power driver board.
- c. Remove the 4-40 round head screws and nylon washers which hold the Reader Card to the Chassis and P.C. Board spacers.
- d. Reassembly is the reverse of steps c and b.
- e. Perform Section 5.5 and 5.6.

### 6.2.3 READER LAMP REPLACEMENT

- a. Remove all power and control signals by disconnecting P1 and the Power cord.
- b. Slide the two terminals off at the rear of the lamp.
- c. Unscrew the lamp from the sleeve.
- d. Replacement is the reverse of steps c, b and then a.
- e. Perform Section 5.4 steps t, u and v.

#### 6.2.4 MOTOR AND/OR SPROCKET REPLACEMENT

The following procedure is recommended when replacing the motor and/or sprocket:

- a. Remove all power and control signals.

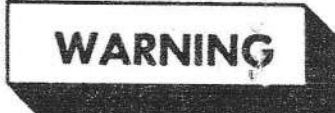

If the motor has been running for a period of time, it or the heat sink may be too hot to touch comfortably. Allow sufficient time for the motor and heat sink to cool before any adjustment or use a cloth or pair of gloves.

- b. Loosen the set screw (Item R, Figure 7-1) which holds the motor to the heat sink and back the motor out slightly.
- c. Loosen the two set screws (Item J, Figure 7-1) which hold the sprocket to the motor shaft and if only the sprocket needs replacing proceed to step e.
- d. Install the new motor by performing the reverse of step b. The motor should be up flush against the panel. Tighten set screw R.
- e. Install the sprocket wheel so that: (1) distance from the rear of the sprocket to the front panel is 0.862 inch (see Figure 7-1) and (2) the 1/8 long set screw tightens on the flat of the motor shaft. Tighten the set screws J.
- f. Perform Section 5.4.

#### 6.2.5 TRANSFORMER REPLACEMENT

The following procedure is recommended when replacing the transformer:

- a. Remove all power and control signals by disconnecting P1 and the power cord.
- b. Disconnect the transformer leads attached to TB1 and BR1.
- c. Loosen the four 10-24 binder head screws which hold the transformer to the chassis and remove the transformer.
- d. Install the new transformer by performing the reverse of steps c, b and then a. Refer to Table 6-1 for transformer wire connections.

Table 6-1. Transformer Wire Connections

T1 Wire Color	TB1 Terminal	T1 Wire Color	TB1 Terminal
White/Orange	TB1-A4	Brown	TB1-F5
White/Yellow	TB1-B5		
White/Green	TB1-B1	Orange	TB1-E5
White/Blue	TB1-C5	Yellow	BR1-2
White/Violet	TB1-C1		
White/Gray	TB1-D1		

## 6.3 SPOOLER PARTS REPLACEMENT

### 6.3.1 POTENTIOMETER REPLACEMENT

The following procedure is recommended when replacing a potentiometer. It is recommended that the entire potentiometer assembly 112857-1 be replaced (includes connector, contacts and retainer).

- a. Remove all power and control signals by disconnecting P1 and the power cord.
- b. Unsolder the wires at terminals 1, 2 and 3 on the potentiometer. Note orientation of terminals and which wires go to which terminals.
- c. Loosen set screw which holds the bearing shaft assembly to the potentiometer shaft.
- d. Loosen binder head 6-32 screw which holds the potentiometer assembly to the bracket. Back the potentiometer out from the bracket.
- e. Install an ohmmeter across terminals 2 and 2 on the new potentiometer and rotate the shaft until the meter reads 5K.
- f. Install the new potentiometer into the coupling and bracket by performing the reverse of steps d and c. Care should be used so that the potentiometer shaft is not rotated and that the orientation of the terminals as noted in step b are observed.
- g. Perform Section 5.6.

### 6.3.2 FRONT PANEL AND CHASSIS SEPARATION

The following procedure is recommended when separating the front panel from the chassis.

- a. Remove all power and control signals by disconnecting P1 and the power cord.
- b. Disconnect the following connectors J2/P2, J3/P3, J4/P4, J5/P5, J6/P6 and J7/P7 on the reader card.
- c. Disconnect J9/P9, J10/P10 and J11/P11 on the Power Driver card.
- d. Disconnect the two wires coming from the ON-OFF switch, S1, at TB1-1 and TB1-5.
- e. Remove the four screws which hold the front panel to the chassis.
- f. Remove the arm spring from the spring adjustment screw.
- g. The front panel and chassis (with the Reader Card attached) can now be separated.
- h. Reassembly is the reverse of steps e, f, d, c, b and then a. Perform Section 5.7.



### 6.3.3 SERVO MOTOR REPLACEMENT

The following procedure is recommended when replacing either servo motor assembly. When replacing the motor, it is recommended that the entire 110829-1 motor assembly (including connector and hub assembly) be replaced.

- a. Separate the front panel and chassis. Refer to Section 6.3.2.
- b. Remove the four 10-32 binder head screws which hold the motor to the front panel. Note the orientation of the motor so that the new motor will be installed the same way.
- c. Install the new motor by performing the reverse of steps b and then a.

### 6.3.4 TAPE ARM REPLACEMENT

The following procedure is recommended when replacing the tape arm.

- a. Remove all power and control signals by disconnecting P1 and the power cord.
- b. Remove the 6-32 x 3/8 flat head screw (C) which holds the arm assembly to the bearing shaft assembly. See Figure 6-1.
- c. Remove the grip ring which holds the roller to the tape arm.
- d. The arm and roller are now free for replacement as required.
- e. Reassembly is the reverse of steps c, b and then a. When installing the roller make sure the distance between the front of the arm and the rear of the roller is between 0.190 and 0.205 inch as shown in Figure 6-1. This is accomplished by placing 1 or 2 washers (Remex Part No. 713600-149) between the spacer and the roller to obtain the desired dimension. See Section 5.8.
- f. Check the adjustment in Section 5.6 and readjust as required.

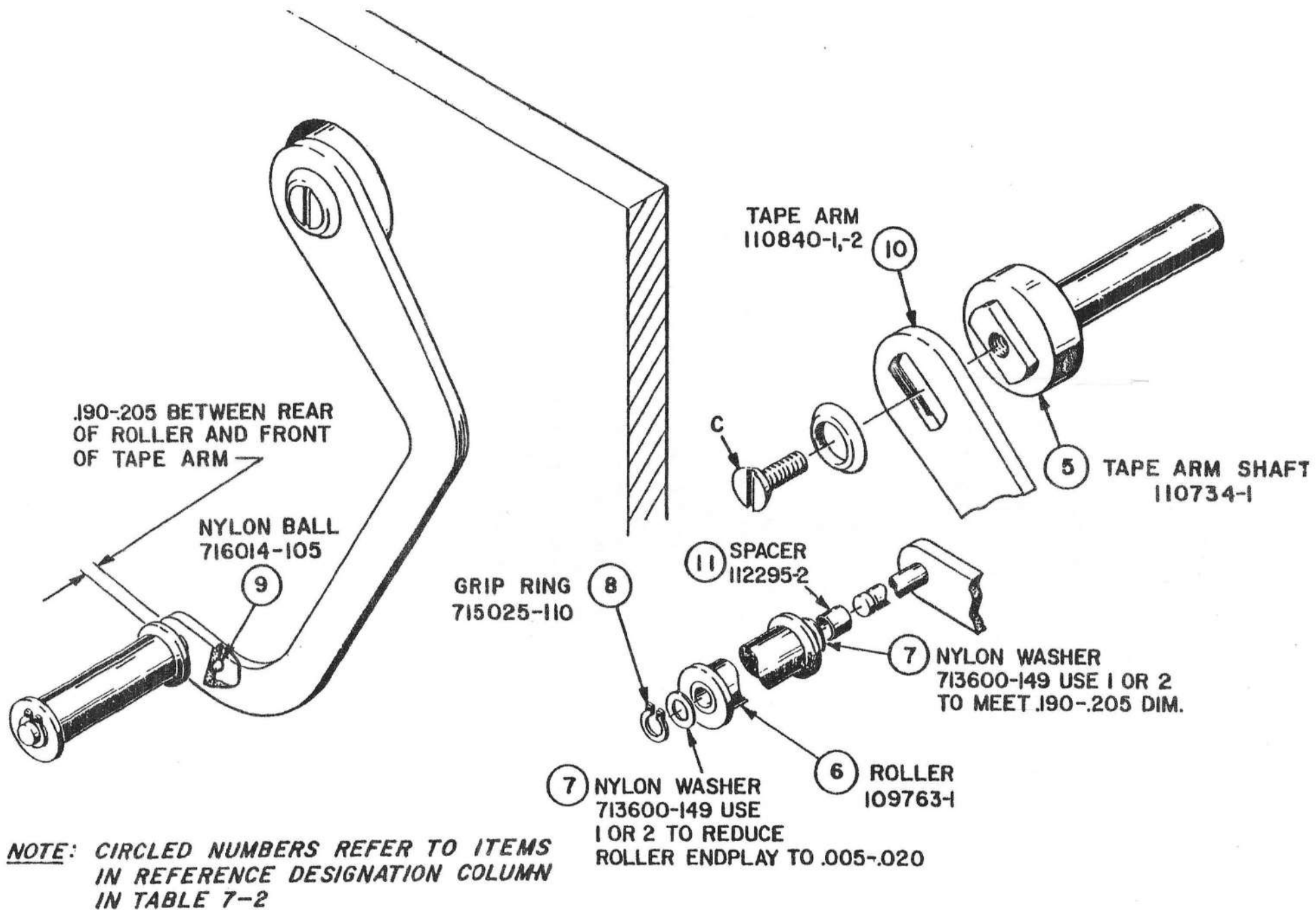

Figure 6-1. Tape Arm Assembly.

## SECTION VII

### PARTS LIST

#### 7.1 GENERAL

Listed in Table 7-2 are the electronic and mechanical parts used in the RRS7200BEX. Standard hardware items are not listed. Indented items are part of the assembly under which they are indented and the quantity of these items are per each assembly. Table 7-1 lists the recommended spare parts and the quantity column denotes the number recommended. Figures 7-1 through 7-4 illustrate the parts listed in Table 7-2. Those items identified by a broken arrow indicate the approximate location of parts not visible in the photograph.

Reference designations refer to the parts illustrated in Figures 7-1 through 7-4 (circled number designations in Figure 7-1; letter designations in Figure 7-1 refer to hardware items referenced in Sections 5 and 6). The reference designations include a figure number and a part designation number which appear on that figure to indicate the location of the part. For example, a 7-1; 12 appearing in the reference designation column indicates that the item listed in the description column can be located in Figure 7-1, Item 12. All electronic components are identified by letter-number combinations (such as S1 and T1) in the Reference Designation column and mechanical parts are identified by number. Reference designations contained in parenthesis are associated or function with the parenthical item. These items are generally individual items and are not part of an assembly but for reference are related back to the associated item. All items are available from Spares Order Desk, REMEX, 1733 Alton Street, P. O. Box C19533, Irvine, California 92713.

Table 7-3 contains the components used on the reader card.

#### 7.2 KIT OF PARTS

The kit of parts contains items used for installation and maintenance and is shipped with the unit. Refer to Table 1-1.

NOTE: WHEN ORDERING SPARE PARTS, CONTACT REMEX SPARES ORDER DESK AND REFERENCE COMPLETE MODEL AND SERIAL NUMBER OF UNIT. ALWAYS REFER TO ADDENDUM AT THE REAR OF THE MANUAL (IF APPLICABLE) FOR POSSIBLE PART NUMBER CHANGES.

Table 7-1. Recommended Spare Parts.

Description and Manufacturer's Part No.	REMEX Part No.	Quantity	Reference Designation
Card, Reader Circuit	112461-4	1	
Fuse, 1A, Slow Blow (100, 115, 127 VAC Operation)	705710-118	5	F101
Fuse, 1/2A, Slow Blow (220, 230 or 240 VAC Operation)	705710-113	5	F101
Lamp 5 V, REMEX Specification	715071-141	1	DS1
Lamp, Chicago Min. CM8536	715071-143	1	DS2
Rectifier, Motorola MDA 980-2	704005-143	1	BR1
Switch, ON-NONE-ON C&K L21Z3X36	715063-111	1	S1, S2, S4
Switch, (ON)-NONE-(ON) C&K L25Z3X36	715063-114	1	S3
Transistor, MJE1090, Motorola	704212-108	1	Q101, Q103
Transistor, MJE1100, Motorola	704204-115	1	Q102, Q104
Voltage Regulator, LM309K, National Semiconductor	704520-109	1	Z101, Z102

NOTE: WHEN ORDERING SPARE PARTS, CONTACT REMEX SPARES ORDER DESK AND REFERENCE COMPLETE MODEL AND SERIAL NUMBER OF UNIT. ALWAYS REFER TO ADDENDUM AT THE REAR OF THE MANUAL (IF APPLICABLE) FOR POSSIBLE PART NUMBER CHANGES.

Table 7-2. Parts List, RRS7200BEX

Description and Manufacturer's Part No.	REMEX Part No.	Quantity	Reference Designation
Top Assembly	113167-1	1	Ref.
Bracket Angle	716053-161	1	Ref.
Chassis Assembly	113272-1	1	Ref.
Bracket, Side	112684-1	2	7-4, 1
Capacitor, 10,000 $\mu$ fd, 25V, GE 86F139M	702310-118	2	7-4, C102, C103
Capacitor Harness Assembly	113157-1	1	(P13)
Connector, 3-pin, White, Molex 09-50-7031	706510-258	1	7-4, P13
Contact, Connector, Molex 08-50-0106	706530-137	3	(P13)
Contact, Terminal Lug, Molex 05-02-0048	706530-171	1	(TB1)
Contact, Push On, Amp 350176-1	715005-139	2	(BR1)
Terminal, Lug, Amp 2-31887-1	715005-110	4	(C102, C103)
Clamp, Capacitor, Sangamo DCM-06	715045-106	2	(C102, C103)
Connector/Fuseholder Assembly	113269-1	1	(J14, F101)
Capacitor, .01 $\mu$ f, 1000V, Ceramic Disk Erie 3848Z5U103M	702136-103	2	7-4, C101, C105
Connector, Switchcraft EAC-301	706500-296	1	7-5, J14
Contact, Terminal Lug, Molex 05-02-0048	706530-171	2	(TB1)
Contact, Push On, Amp 350176-1	715005-139	2	(F101)
Fuseholder, Littlefuse 348870	705750-117	1	7-5, F101
Lug, Ground, Amp. 31885	715005-107	1	7-4, E1
Plate, Connector	113274-1	1	(J14, F101)
Contact, Push On, Amp 350176-1	715005-139	1	(BR1)
Contact, Terminal Lug, Molex 05-02-0048	706530-171	1	(TB1)
Cover, Capacitor, Sincliar Rush 1.375-24	716007-111	2	(C102, C103)
Decal (A-F)	113044-1	1	(TB1)
Key, Terminal Block, Molex 15-040200	706540-155	10	(TB1)
Power Driver Panel Assembly	111201-2	1	Ref.
Capacitor, 1 $\mu$ f, 50V, Ceramic, Sprague 7C 023105D8500E	702131-105	2	7-4, C104, C105
Choke, Ferrocube VK200-10/3B	702500-107	1	7-4, L1-L4
Connector, 8-pin, Molex 09-52-3082	706510-264	1	7-4, J8
Connector, 6-pin, Molex 09-52-3062	706510-263	1	7-4, J9
Connector, 3-pin, Molex 09-60-1031	706501-037	2	7-4, J10, J11
Heat Sink Panel	112679-1	1	
Insulator, Thermalloy 43-77-2	715019-120	4	(Q101-Q104)
Insulator, RCA495320	715019-115	2	(Z101, Z102)
Resistor, 3-ohm, 25W, $\pm$ 3%	701173-R00	2	7-4, R101, R102
Transistor, Motorola MJE1090	704212-108	2	7-4, Q101, Q103
Transistor, Motorola MJE1100	704204-115	2	7-4, Q102, Q104
Voltage Regulator, National Semiconductor LM309K	704520-109	2	7-4, Z101, Z102

NOTE: WHEN ORDERING SPARE PARTS, CONTACT REMEX SPARES ORDER DESK AND REFERENCE COMPLETE MODEL AND SERIAL NUMBER OF UNIT. ALWAYS REFER TO ADDENDUM AT THE REAR OF THE MANUAL (IF APPLICABLE) FOR POSSIBLE PART NUMBER CHANGES.

Table 7-2. Parts List, RRS7200BEX (Continued)

Description and Manufacturer's Part No.	REMEX Part No.	Quantity	Reference Designation
<b>Chassis Assembly (Continued)</b>			
Printed Circuit Card Assembly, Reader See Table 7-3 for Assembly	112461-4	1	7-5,PC1
Rectifier, Motorola MDA 980-2	704005-143	1	7-4,BR1
Terminal Block, Molex 07-01-7051	706520-116	6	7-4,TB1
Transformer Assembly	113266-1	1	(T1)
Contact, Connector, Amp 350176-1	715005-139	1	(BR1)
Contact, Terminal, Molex 05-02-0048	706530-171	8	(TB1)
Transformer, REMEX Specification	703010-147	1	7-4,T1
Decal, Caution	111933-1	1	7-5,1
Decal, Warning	110884-1	1	7-5,2
Decal, Identification Label	716018-113	1	7-5,3
Decal, Patent	108546-1	1	7-5,4
Front Panel Assembly	113271-1	1	Ref.
Bearing /Shaft Assembly	114310-001	1	
Bearing	113223-001	1	
Bracket	114308-001	1	
Connector, Housing, 3 pin, Blue, Molex 09-50-7031	706510-255	1	7-3;P5,P6
Contact, Connector, Molex 08-50-0105	706530-137	3	(P1)
Potentiometer, 10K, Allen Bradley WA2G044S1030A	701506-103	1	7-3;R201,R20
Retaining Ring, Truarc 5133-37	715025-155	1	
Shaft	112690-001	1	
Stand Off	715030-231	1	
Bracket	112689-1	2	7-3,2
Bumper, Rubbercraft 9102-1	715021-113	2	7-2,2
Gasket, Welch Allyn 11200182	715018-104	1	7-1,3
Heat Sink	110448-1	1	7-1,5
Lamp, 5 volts, REMEX Specification	715071-141	1	7-1,DS1
Light Source, Fiber Optics	112297-1 (P)	1	7-1,14
Motor Assembly, Spooler	113118-1	2	(M2,M3)
Connector, Housing, Violet, 3-pin Molex 09-50-7031	706510-257	1	P10,P11
Contact, Connector, Female Molex 08-50-0106	706520-137	3	(P10,P11)
Hub Assembly	105577	1	7-2,3
Motor, REMEX Specification	715075-200	1	7-3,M2,M3
Motor Assembly, Stepper	110862-1	1	(M1,P4)
Connector, Housing, Yellow, 6-pin Molex 09-50-7151	706510-266	1	7-3,P4
Contact, Connector, Female Burndy 4823	706530-138	6	(P4)
Motor, REMEX Specification	715075-158	1	7-1,M1
Panel, Front	112677-1	1	7-2,4



NOTE: WHEN ORDERING SPARE PARTS, CONTACT REMEX SPARES ORDER DESK AND REFERENCE COMPLETE MODEL AND SERIAL NUMBER OF UNIT. ALWAYS REFER TO ADDENDUM AT THE REAR OF THE MANUAL (IF APPLICABLE) FOR POSSIBLE PART NUMBER CHANGES.

Table 7-2. Parts List, RRS7200BEX (Continued)

Description and Manufacturer's Part No.	REMEX Part No.	Quantity	Reference Designation
<b>Front Panel Assembly (Continued)</b>			
Readhead Mechanism	113173-1	1	7-1, Ref.
Clamp, Cable, Wechesser A-30	715040-139	1	
Ground Plate Assembly	112423-1	1	7-1, 13
Lever, Upper Tape Guide	111797-1	1	7-1, 1
Mechanism Assembly	112346-1	1	7-1, 8
The following parts are listed for reference only. It is recommended that the entire 112346-1 assembly be replaced as a complete unit.			
Actuator Assembly	110769-1	1	
Cam, Tape Guide	110438-1	1	
Ground Strap Assembly	110762-1	1	
Mounting Block, Readhead	112338-1	1	
Ring Retainer, Truarc 5013-25	715025-148	1	
Spring, Associated Spring Co. E0094-014-0620M	714090-127	1	
Readhead Assembly	113168-1(P)	1	7-1, 11
Except for the components listed below, the entire 113168-1 assembly must be replaced as a complete assembly.			
Connector, Housing, Red 12-pin, Molex 09-50-7121	706510-224	1	7-1, P2
Contact, Connector, Female Molex 08-50-0108	706530-138	10	(P2)
Tape Guide Assembly, Upper	112407-1	1	7-1, 16
Tape Guide, Fixed	112329-1	1	7-1, 15
Shaft	112675-1	4	7-2, 5
Sleeve	112319-1	1	7-1, 2
Sprocket, REMEX Specification	716057-102	1	7-1, 7
Switch Plate Assembly	113265-1	1	Ref.
Bezel, Black, C&K B7888-2	715063-201	4	(S1-S4)
Connector, Housing, Orange, 8-pin Molex 09-50-7081	706510-223	1	7-3, P3
Connector, 3-pin, gray Molex 09-50-7031	706510-256	1	7-3, P7
Contact, Connector, Molex 08-50-0105	706530-137	9	(P3, P7)
Lamp, Chicago Min. CM8536	715071-143	1	7-3, DS2
Lug, Terminal, Molex 05-02-0048	706530-171	4	(TB1)
Lug, Terminal, Amp 60436-2LP	706530-163	2	(DS1)
Lug, Terminal, Push On	715005-137	9	(S1-S4)
Plate, Switch	111840-3	1	7-2, 8
Rocker Cap, ON-OFF, C&K 7922-1	715063-329	1	(S1)
Rocker Cap,  , C&K 7922-1	715063-321	1	(S2)



NOTE: WHEN ORDERING SPARE PARTS, CONTACT REMEX SPARES ORDER DESK AND REFERENCE COMPLETE MODEL AND SERIAL NUMBER OF UNIT. ALWAYS REFER TO ADDENDUM AT THE REAR OF THE MANUAL (IF APPLICABLE) FOR POSSIBLE PART NUMBER CHANGES.

Table 7-2. Parts List, RRS7200BEX (Continued)

Description and Manufacturer's Part No.	REMEX Part No.	Quantity	Reference Designation
Switch Plate Assembly (Continued)			
Rocker Cap, RUN/LOAD, C&K 7922-1	715063-328	1	(S3)
Rocker Cap, SPOOL/LOOP, C&K 7922-1	715063-326	1	(S4)
Switch, ON-NONE-ON, C&K L21Z3X36	715063-111	3	7-3, S1, S2, S4
Switch, (ON)-NONE-(ON), C&K L25Z3X36	715063-114	1	7-3, S3
Tape Arm Assembly, Left	111088-2	1	7-2, 6
Arm, Tape	110840-2	1	6-1, 10
Ball, Nylon Prod. Components Corp. 1/8" nylon	716014-105	1	6-1, 9
Spacer	112295-2	1	6-1, 11
Retaining Ring, Truarc 5100-12	715025-110	1	6-1, 8
Roller, Tape	109763-1	1	6-1, 6
Washer Nylon, Amaron 2203-N129	713600-149	4	6-1, 7
Tape Arm Assembly, Right	111088-1	1	7-2, 7
The subassemblies for 111088-1 are identical to 111088-2 except:			
Arm, Tape	110840-1	1	
Fuse 3A, Slow Blow (100, 115, 127 VAC operation)	705710-126	1	7-5, F101
Fuse, 1-1/2A, Slow Blow (220 or 240 VAC operation)	705710-121	1	7-5, F101
Kit of Parts	113273-1	1	
See Table 1-1 for contents			
Nameplate, Logo	109782-6	1	7-2, 1
Spring, Arm, Associated Spring Co. E0240-026-2000M	714090-132	2	7-3, 3
Tape Guide Assembly, RRS7200BE1	112411-1	1	7-1, 12
Tape Guide Assembly, RRS7200BE2	112411-2	1	7-1, 12
Tape Guide Assembly, RRS7200BE3	112411-3	1	7-1, 12
Tape Guide Assembly, RRS7200BE4	112411-4	1	7-1, 12
Tape Guide Assembly, RRS7200BE5	112411-5	1	7-1, 12
OPTIONS			
Reel, 6-inch, Gray	107878-1	2	
Reel, 7-1/2 inch, Gray	107878-2	2	
Reel, 6-inch, White	107878-3	2	
Reel, 7-1/2 inch, White	107878-4	2	









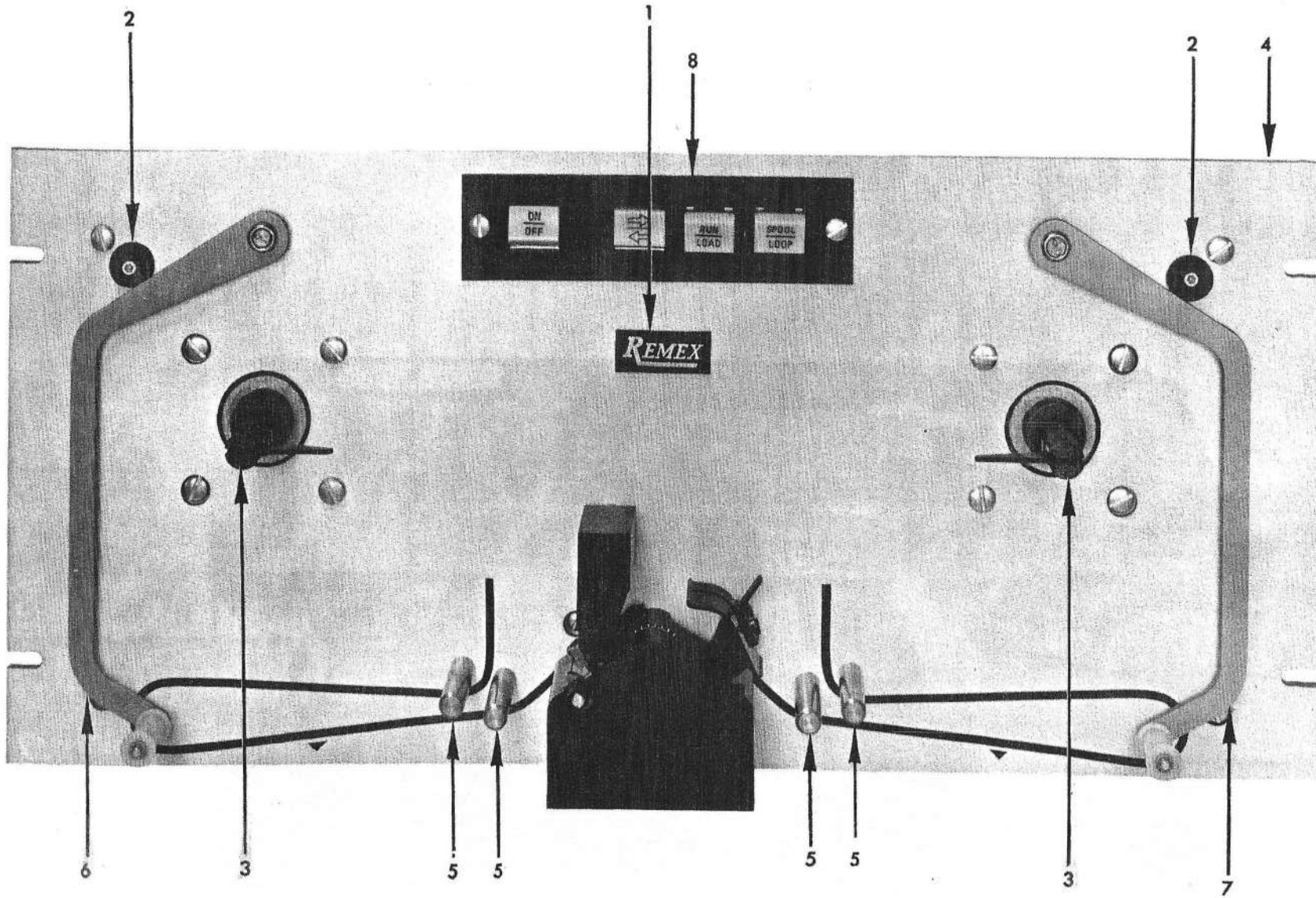

Figure 7-2. RRS7200 Front View of Front Panel.



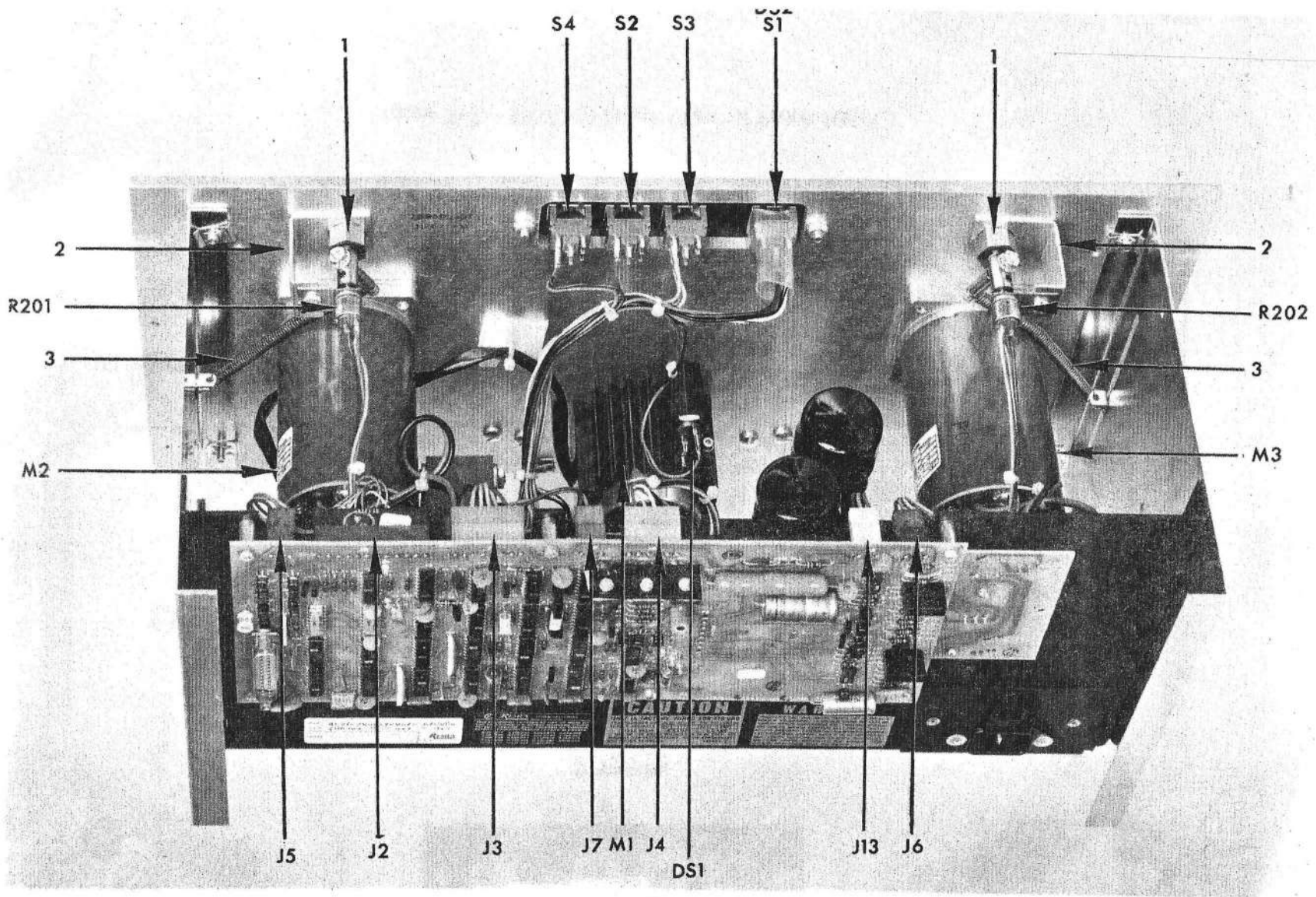

Figure 7-3. RRS7200 Rear View of Front Panel.

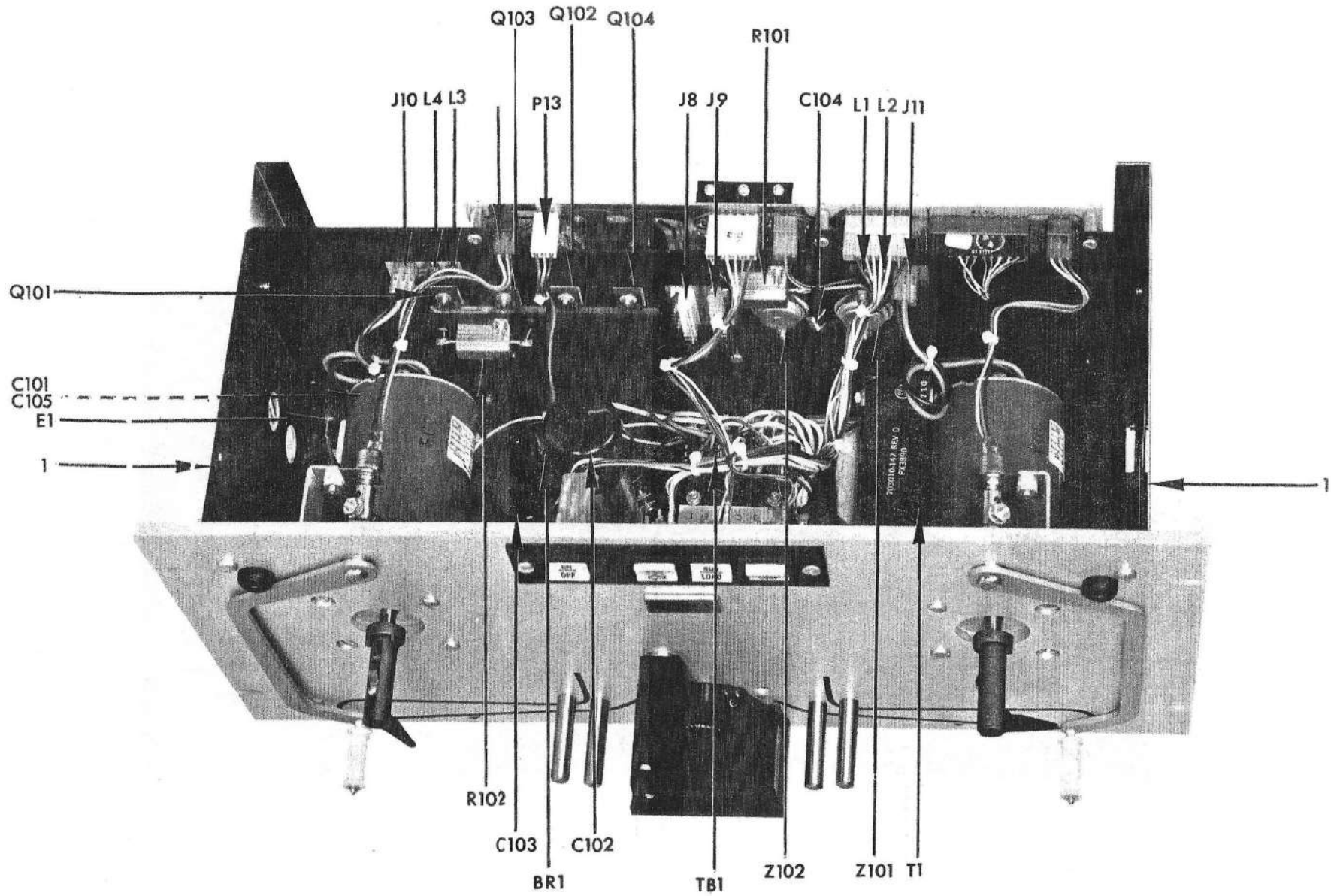

Figure 7-4. RRS7200 Chassis Assembly.

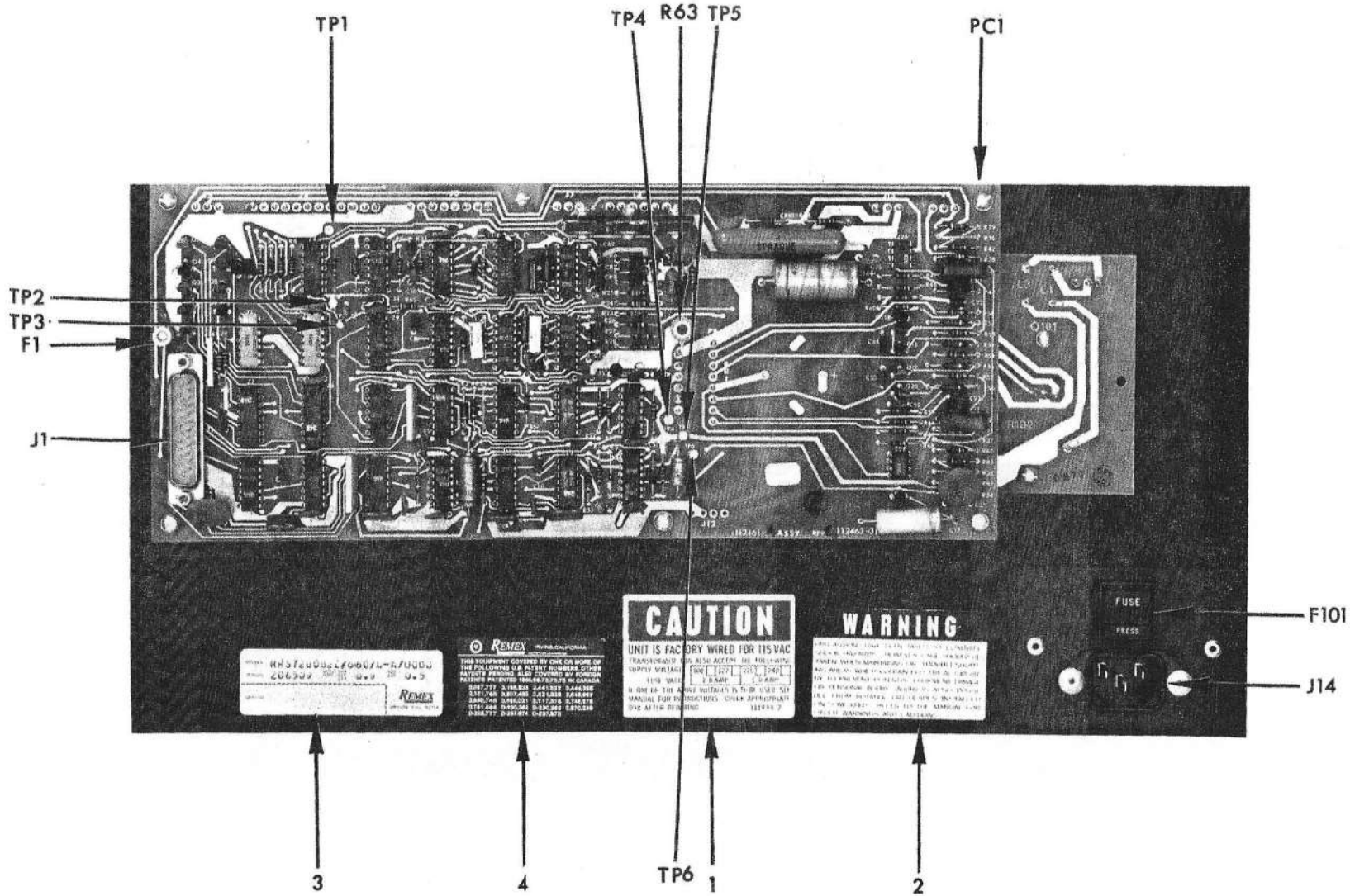

Figure 7-5. RRS7200 Rear View.

NOTE: WHEN ORDERING SPARE PARTS, CONTACT REMEX SPARES ORDER DESK AND REFERENCE COMPLETE MODEL AND SERIAL NUMBER OF UNIT. ALWAYS REFER TO ADDENDUM AT THE REAR OF THE MANUAL (IF APPLICABLE) FOR POSSIBLE PART NUMBER CHANGES.

Table 7-3. Parts List Reader Circuit Card 113541-1

This parts list is written for the G Assembly and the L schematic revisions. Subsequent revisions are contained on a P.C. Card Change Record form contained in the addendum.

Description and Manufacturer's Part No.	REMEX Part -No.	Quantity	Reference Designation
Capacitor, 470 pf, 200V, Ceramic, Type CK05	702128-471	1	C1
Capacitor, 100 pf, 200V, Ceramic, Type CK05	702128-101	3	C2, C9, C13
Capacitor, 47 $\mu$ f, 10V, Electrolytic, Amperex Model ET	702620-476	1	C3
Capacitor, 3.3 $\mu$ f, 15V, Solid Tantalum, Sprague 196D	702394-335	2	C4, C14
Capacitor, 220 $\mu$ f, 10V, Electrolytic, Amperex Model ET	702620-227	1	C5
Capacitor, 0.01 $\mu$ f, 100V, Metallized Mylar IMB XP7B103X	702181-103	1	C6
Capacitor, 0.1 $\mu$ f, 100V, Metallized Mylar IMB XP7B104X	702181-104	2	C7, C11
Capacitor, 0.15 $\mu$ f, 100V, Metallized Mylar IMB XP7B154X	702181-154	1	C8
Capacitor, 0.001 $\mu$ f, 200V, Ceramic, Type CK05	702128-102	8	C10, C15, C32, C52-C56
Capacitor, 0.047 $\mu$ f, 100V, Metallized Mylar IMB XP7B473X	702181-473	1	C12
Capacitor, 0.01 $\mu$ f, 100V, Ceramic Disk, Erie 805X-5V103Z	702121-103	21	C16, C25, C33-C51
Capacitor, 100 $\mu$ f, 25V, Polarized, Sprague TE Series	702370-107	1	C17
Capacitor, 0.47 $\mu$ f, 100V, Metallized Mylar, IMB XP7B474X	702181-474	2	C18, C19
Capacitor, 0.0022 $\mu$ f, 200V, Ceramic, Type CK05	702128-222	2	C20, C21
Capacitor, 330 pf, 200V, Ceramic, Type CK05	702128-331	2	C22, C23
Capacitor, 470 $\mu$ f, 40V, Polarized, Amperex Model ET	702650-477	1	C24
Capacitor, 1 $\mu$ f, 50V, Ceramic, Monolythic, Sprague 7CD231D8500E	702131-105	4	C26-C29
Capacitor, 0.1 $\mu$ f, 100V, Ceramic Disk, Erie 805X-5V104Z	702121-104	2	C30, C31
Connector, 25 pin, Cannon DB-25PV	706500-239	1	J1
Connector, 12 pin, Red, Molex 09-60-1121	706501-122	1	J2
Connector, 8 pin, Orange, Molex 09-60-1081	706501-083	1	J3
Connector, 6 pin, Yellow, Molex 09-60-1061	706501-064	1	J4
Connector, 3 pin, Blue, Molex 09-60-1031	706501-036	2	J5, J6
Connector, 3 pin, Gray, Molex 09-60-1031	706501-038	1	J7
Connector, 8 pin, Molex 09-64-1083	706500-254	1	P8
Connector, 6 pin, Molex 09-64-1063	706500-253	1	P9
Connector, 3 pin, White, Molex 09-60-1031	706501-039	1	J13
Diode, FDH 6666	704000-110	2	CR1, CR5
Diode, 1N4003	704005-137	8	CR3, CR6-CR8, CR11
Diode, 1N276	704000-100	1	CR4
Diode, 1N4752	704014-130	1	CR10
Fuse, 250 mA, Bussman GMW	705725-101	1	F1
Fuse Connector, Cambion 3704-1-03	706515-129	2	(F1)
Heat Sink	110854-1	1	(Q13-Q15)



NOTE: WHEN ORDERING SPARE PARTS, CONTACT REMEX SPARES ORDER DESK AND REFERENCE COMPLETE MODEL AND SERIAL NUMBER OF UNIT. ALWAYS REFER TO ADDENDUM AT THE REAR OF THE MANUAL (IF APPLICABLE) FOR POSSIBLE PART NUMBER CHANGES.

Table 7-3. Parts List Reader Circuit Card 112461-4 (Continued)

Description and Manufacturer's Part No.	REMEX Part No.	Quantity	Reference Designation
I. C. Package, Resistor/Capacitor Network, Beckman 1899-4102-0	701950-004	2	Z1, Z5
I. C. Package, SN7475N	704610-105	2	Z2, Z6
I. C. Package, SN7486N	704600-109	3	Z3, Z7, Z15
I. C. Package, SN7404N	704600-110	1	Z4
I. C. Package, SN74221N	704610-165	4	Z8, Z17, Z20 Z21
I. C. Package, SN7400N	704600-101	5	Z9, Z10, Z13 Z16, Z24
I. C. Package, SN74132N	704600-152	1	Z11
I. C. Package, SN7408N	704600-114	4	Z12, Z14, Z18, Z19
I. C. Package, SN7474	704610-110	2	Z22, Z23,
I. C. Package, SN74123N	704610-119	1	Z25
I. C. Package, LM 307N	704520-110	2	Z26, Z27
I. C. Package, Resistor, Remex Spec.	701900-004	1	Z28
I. C. Package, Resistor/Capacitor, Remex Spec.	701950-007	2	Z29, Z30
Insulator, Thermalloy 43-77-2	715019-120	3	(Q13-Q15)
Resistor, 4.7K, 1/4W, ± 5%	701003-472	7	R1, R29, R30 R39, R41-R43
Resistor, 100K, 1/4W, ± 5%	701003-104	1	R2
Resistor, 220 $\Omega$ , 1/4W, ± 5%	701003-221	1	R3
Resistor, 1.5K, 1/4W, ± 5%	701003-152	1	R4
Resistor, 27K, 1/4W, ± 5%	701003-273	2	R5, R17
Resistor, 20K, 1/4W, ± 5%	701003-203	1	R6
Resistor, 22 $\Omega$ , 1/4W, ± 5%	701003-220	3	R7, R8, R67
Resistor, 8.2K, 1/4W, ± 5%	701003-822	2	R9, R14
Resistor, 22K, 1/4W, ± 5%	701003-223	2	R10, R11
Resistor, 14.7K, 1/4W, ± 1 %	701211-472	1	R12
Resistor, 7.15K, 1/4W, ± 1%	701217-151	1	R13
Resistor, 12K, 1/4W, ± 5%	701003-123	1	R15
Resistor, 47 $\Omega$ , 1/4W, ± 5%	701003-470	5	R16, R18, R32 R64, R65
Resistor, 2.2K, 1/4W, ± 5%	701003-222	3	R19, R31, R34
Resistor, 330 $\Omega$ , 1/4W, ± 5%	701003-331	7	R20-R22, R50 R53, R54, R57
Resistor, 3.3K, 1/4W, ± 5%	701003-332	3	R23-R25
Resistor, 1K, 1/4W, ± 5%	701003-102	11	R26-R28, R33 R46-R49, R60 R61, R66
Resistor, 100 $\Omega$ , 1/4W, ± 5%	701003-101	3	R35, R58, R59
Resistor, 150K, 1/4W, ± 5%	701003-154	2	R38, R40

## SECTION VIII

### SCHEMATIC DRAWINGS

#### 8.1 GENERAL

Figures 8-1 through 8-3 contain the schematic diagrams for Model RRS7200. Note that only sheets 1, 3, 5 and 6 of drawing 112462 are applicable to the RRS7200 and appear in the manual on pages 8-3/8-4, 8-5/8-6, 8-7/8-8 and 8-9/8-10, respectively. Figure 8-2 contains the overall system schematic. Figure 8-3 illustrates the I.C. Module outlines and truth tables which are reproduced courtesy of Texas Instruments, except for 9602 which is reproduced courtesy of Fairchild Semiconductor.





LAST DESIGNATION USED	NOT USED
11241-A	111201-A, 11121-001
RESISTOR R72	R102
CAPACITOR C56	C105
TRANSFORMER G20	G104
DIODE CR11	CR2, 9
I.C. Z30	Z102

REVISION STATUS					
RRS 7150DD---G POWER DRIVER ASSY		READER CARD		RRS 7100BY---G POWER DRIVER ASSY	
111915 -001 FAB	111911 -001 ASSY	112463 -001 FAB	112462 -000 SCHEM	112464 -001 ASSY	111201 -001 FAB
A	D	A	A	A	B
A	D	A	D	A	E
B	E	D	C	D	F
D	E	D	C	C	F
D	E	D	C	C	G
B	E	D	C	C	H
D	E	D	P	D	C
D	E	D	G	E	H
D	E	D	H	E	C
D	E	B	J	F	J
B	E	B	K	F	C
B	E	B	K	F	J
-	-	C	-	-	-
B	E	D	L	G	C
-	-	-	-	D	K
-	-	-	-	D	L
-	-	D	M	H	D
-	-	D	N	J	D
-	-	D	P	J	D
-	-	D	R	K	D
-	-	D	R	K	D
-	-	E	-	-	-
-	-	F	S	L	E

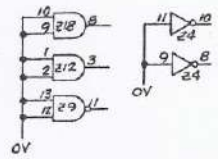

SHARES

ASSY CHART 3				SCHEMATIC SHEET				SYSTEM	
MODEL	FINAL ASSY	READER CARD ASSY	POWER DRIVER PANEL ASSY	NO. REQ'D / MODEL				SCHEMATIC	
RRS 7000DD---G	112414-001	112461-001	111201-001	1	2	3	4		
RR 7300 BDX---	112466-001	112461-002	111366-001	1	2	3	4		
RRS 7150 BDX---D	112434-001	112461-003	111511-001	1	2	3	4		
RRS 7100 BDX---D	112830-001	112461-004	111201-002	1	3	5	6		
RRS 700BEX---D	113167-001	112461-004	111201-002	1	3	5	6	113405-000	
RRS 7300 BEX---	113131-001	112461-005		1	3	5	7	113405-000	
RRS 7300 BEX---G	113100-001	112461-006	111201-003	1	3	5	6	113302-000	

R480	114022-001
R472	113447-000
R471	113446-000
R470	113445-000
R468	113444-000

UNIT	SCHEM NO.
OTHER SYSTEM	
SCHEMATIC AFFECTS	

BY	DATE	APPROV
A	4-10-70	GR
B	4-10-70	GR
C	4-10-70	GR
D	4-10-70	GR
E	4-10-70	GR
F	4-10-70	GR
G	4-10-70	GR
H	4-10-70	GR
I	4-10-70	GR
J	4-10-70	GR
K	4-10-70	GR
L	4-10-70	GR
M	4-10-70	GR
N	4-10-70	GR
P	4-10-70	GR
R	4-10-70	GR
S	4-10-70	GR

NOTES: UNLESS OTHERWISE SPECIFIED

- RESISTORS ARE 1/4W ± 5%.
- 201, 102 ARE 70420-109 (LM309K).
- FOR ASSEMBLY NUMBERS SEE CHART THIS SHEET.
- CR3, G-8, 11 ARE 70400B-07 (1N4003)
- CR10 IS 70401A-130 (1N4102)
- CR1 IS 70400B-189 (G7-0356) FOR 1001 ASSY.  
CR1 IS 70400B-162 FOR 1001 ASSY.
- G1-9 ARE 70420B-119 (2N5008)
- G10-12, 10, 20 ARE 704202-109 (MPS456)
- G13-15 ARE 704204-115 (MJE 1100)
- G16, 17, 19 ARE 704205-118 (MPS 400)
- G21, 5 ARE 701850-004 (1099-4102-D)
- G22, 6 ARE 704610-105 (5N7475N)
- G23, 7, 15 ARE 704600-109 (5N7486N)
- G24 IS 704600-110 (5N7404N)
- G25 IS 704610-119 (5N74123N)
- G26, 14, 13, 16, 24 ARE 704600-101 (5N7400N)
- G27, 14, 19, 19 ARE 704600-114 (5N7406N)
- G28, 23 ARE 704610-110 (5N7474N)
- G29, 27 ARE 704820-110 (LM307M)
- G30 IS 701900-004 (KD404A-472)
- G31, 30 ARE 701980-007
- F101 IS 1 AMP. 510-510 FOR 100, 115 127 VAC OPERATION } RRS  
F101 IS 1/2 AMP. 510-510 FOR 220, 240 VAC OPERATION } MODELS
- G101 & 103 ARE 704212-108 (MJE 1090) FOR 111201-# ASSY.  
G104 & 105 ARE 704212-109 (MU 4052) FOR 111511-001 ASSY.
- G102 & 104 ARE 704204-115 (MJE 1100) FOR 111201-# ASSY.  
G102 & 104 ARE 704204-120 (MU 4055) FOR 111511-001 ASSY.
- F101 IS 1/2 AMP. 510-510 FOR 220, 240 VAC OPERATION } RRS 7300  
F101 IS 1 AMP. 510-510 FOR 100, 115, 127 VAC OPERATION } RRS 7300
- NOTIFY APPLICATIONS OF CHANGES MADE TO THIS DRAWING.
- SEE COMPONENT VALUE BLOCK FOR RESISTOR VALUES.
- G3, 17, 20, 21 ARE 704610-105 (5N74221) PIN 5 IS ON, PIN 15 IS +5V.
- G11 IS 704600-152 (5N74152N) PIN 7 IS ON, PIN 14 IS +5V.
- FOR 111511-001 ASSY R101 & 102 ARE 2.0, FOR 111201-001 & 002 R101 & 102 ARE 1.0, FOR 111201-002 ASSY R101 & 102 ARE 5.0.
- PROGRAMMED FOR AUTOMATIC TEST.
- CR4 IS 704000-100 (1N4758)
- CR1 & 5 ARE 704000-110 (FDH6666)

Figure 8-1. Schematic, RRS7200BEX, Sheet 1 of 4.

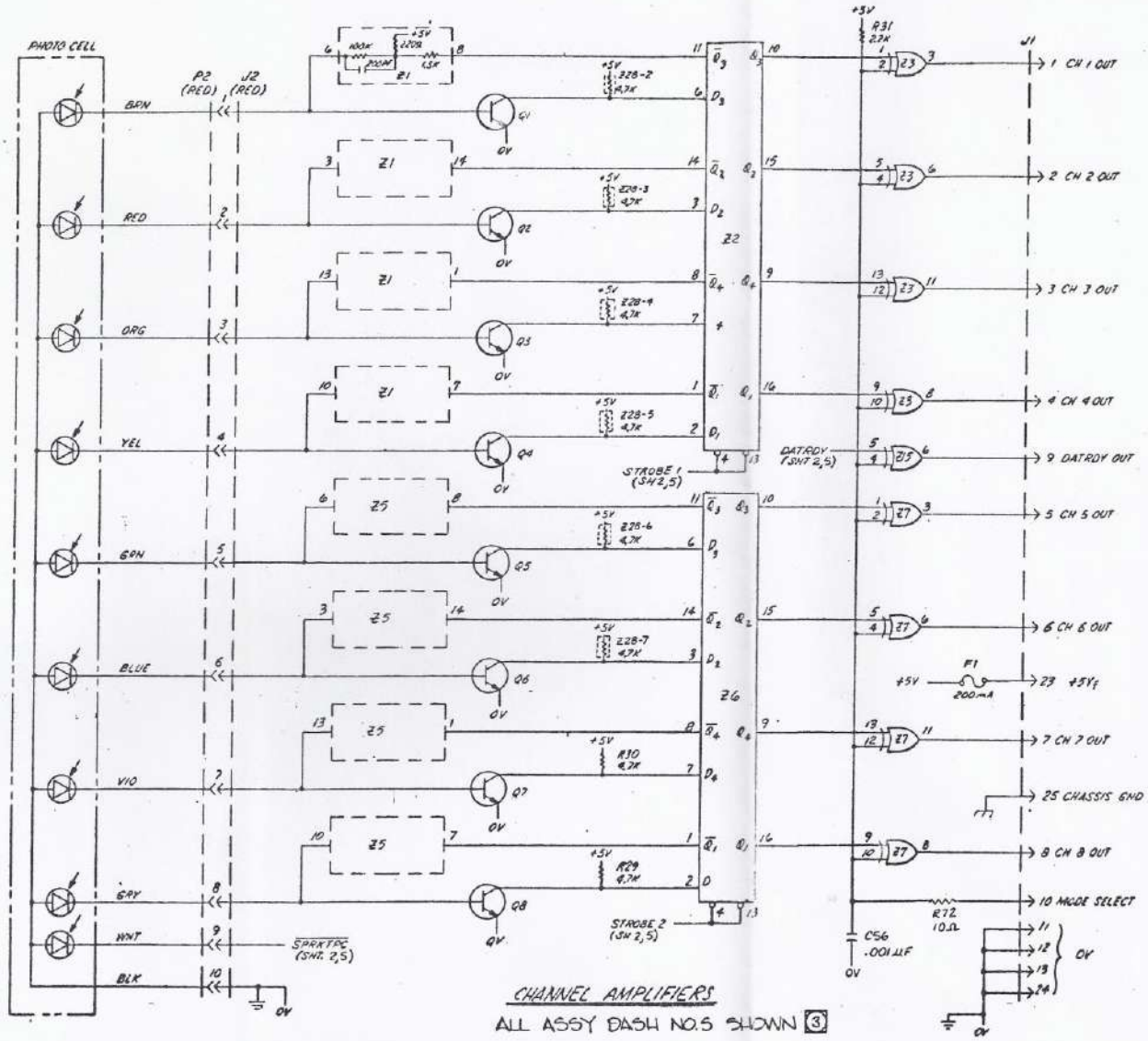

SYM	ECO	EFFECT	REVISIONS	BY	DATE
A		ADDED		GR	4.12.61
B		SEE SHEET 1		GR	4.12.61
C		SEE SHEET 1		GR	4.12.61
D		SEE SHEET 1		GR	4.12.61
E		SEE SHEET 1		GR	4.12.61
F		SEE SHEET 1		GR	4.12.61
G		SEE SHEET 1		GR	4.12.61
H		SEE SHEET 1		GR	4.12.61
I		SEE SHEET 1		GR	4.12.61
J		SEE SHEET 1		GR	4.12.61
K		SEE SHEET 1		GR	4.12.61
L		SEE SHEET 1		GR	4.12.61
M		SEE SHEETS 5 & 6		SEO	5.17.61
N		SEE SHEET 1		GR	5.17.61
P		SEE SHEET 1		JL	7.16.61
R		SEE SHEET 1		SEO	7.17.61

Figure 8-1. Schematic, RRS7200BEX, Sheet 2 of 4.





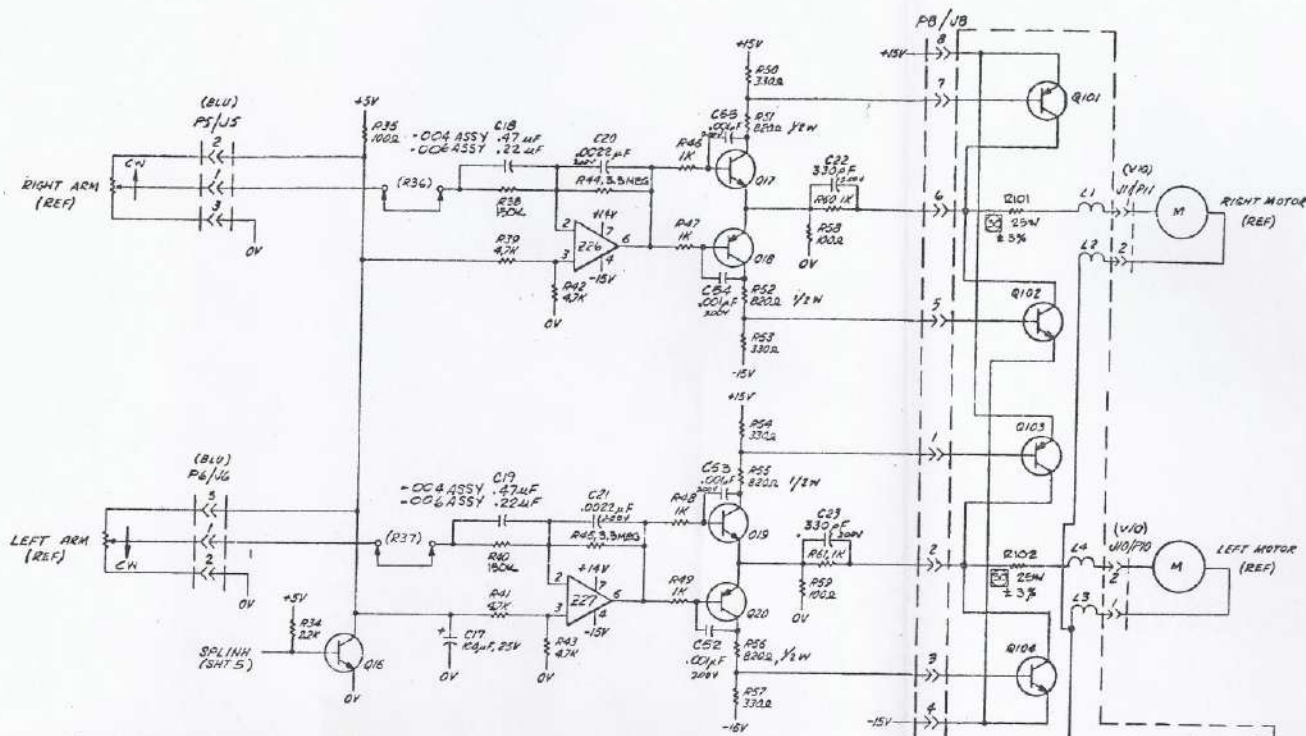

112461-004 & -006 ASSY SHOWN

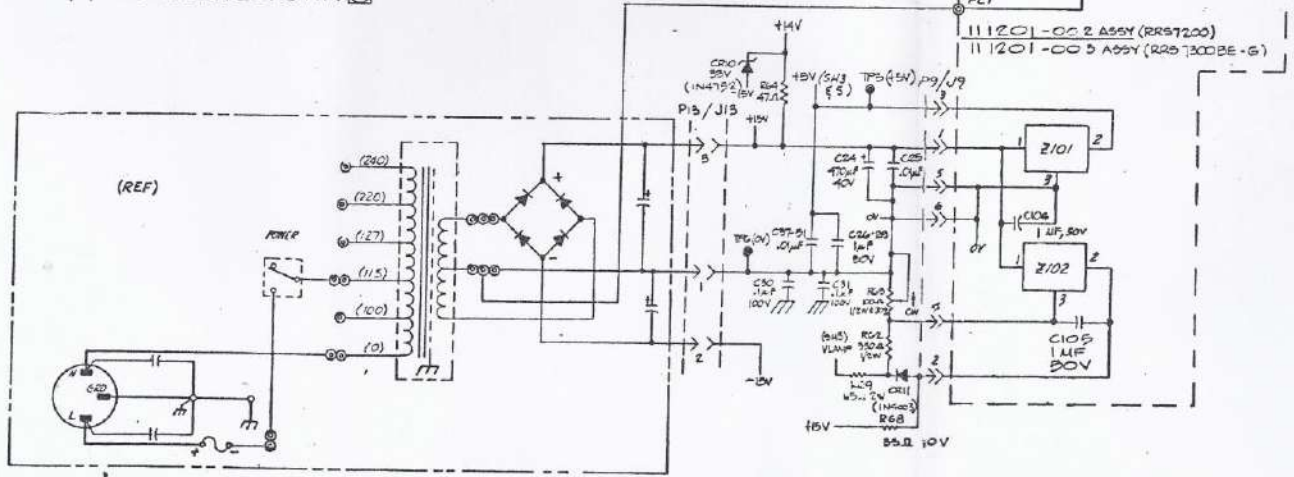

REV	ECO	DATE	REVISIONS	BY	DATE	APPROV
A		05-10-60	DESIGNED	SC	11-20-61	
B	15215	6-5-60	SEE SHEET 1		4-23-61	
C	15337	7-27-60	SEE SHEET 1		7-25-61	
D	15412	8-17-60	SEE SHEET 1	VEP	11-13-61	
E	15509	9-23-60	SEE SHEET 5	N.M.	5-28-62	
F	15666	10-27-60	SEE SHEETS 1-5 SEE CIR	N.M.	10-19-62	
G	15895	12-16-60	SEE SHEET 1	N.M.	1-21-63	
H	16009	1-19-61	SEE SHEET 1	N.M.	3-27-63	
J	16009	1-19-61	SEE SHEET 1	WC	3-27-63	
K	16140		SEE SHEET 1	N.M.	5-28-63	
L	16568		SEE SHEET 1	N.M.	7-21-63	
M	17165	1-1-61	ADDED WIRING CONNECTIONS FOR PCL	SEO	11-17-63	
N	17239	5-7-61	SEE SHEET 1	N.M.	11-27-63	
P	17370	7-18-61	SEE SHEET 1	JL	12-29-63	
R	17618	7-27-61	SEE SHEET 1	SEO	7-27-64	

FOR NOTES SEE SHEET 1.  
Figure 8-1. Schematic, RRS7200BEX, Sheet 4 of 4.



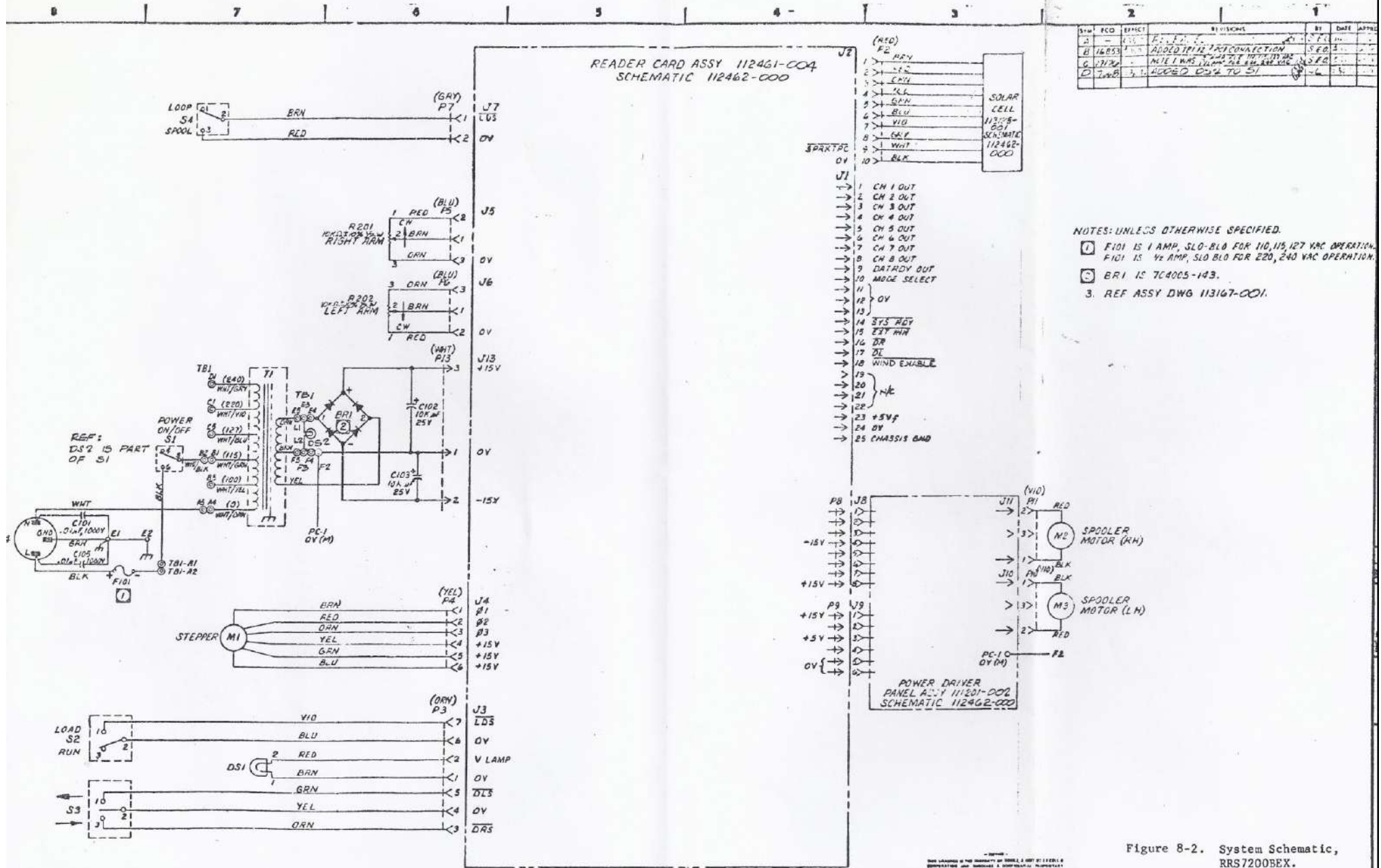

REV	ECO	EFFECT	REVISIONS	BY	DATE	APPROV
1			REVISED			
2			ADDED TITLE CONNECTION	SEA		
3			ADDED TITLE CONNECTION	SEA		
4			ADDED DATA TO S1	SEA		

NOTES: UNLESS OTHERWISE SPECIFIED.  
 1 F101 IS 1 AMP, SLO-BLO FOR 110, 115, 127 VAC OPERATION.  
 F101 IS 1/2 AMP, SLO-BLO FOR 220, 240 VAC OPERATION.  
 2 BR1 IS 7C4005-143.  
 3. REF ASSY DWG 113167-001.

Figure 8-2. System Schematic,  
 RRS7200BEX.  
 112670-074D 8-11/8-12