



TECHNICAL MANUAL

TAPE READER/SPOOLER COMBINATION

MODELS: RRS6500BEX/660/ARB  
RRS6500BEX/660/DRB

Peripheral  
Products

Ex-Cell-O Corporation

## TECHNICAL MANUAL

### TAPE READER/SPOOLER COMBINATION

MODELS: RRS6500BEX/660/ARB  
RRS6500BEX/660/DRB

## **IMPORTANT INFORMATION**

Changes to the equipment which are made between manual printings are listed in an addendum at the rear of the manual. As a convenience, a list of change pages is given as the last page in the manual. It is recommended that each of these pages be marked "Refer to Addendum" so that these changes can be identified.

**EX-CELL-O CORPORATION**

***REMEX***

1733 Alton St. • P.O. Box C-19533 • Irvine, CA 92713

Copyright © 1977 by REMEX, A Unit of Ex-Cell-O Corporation. Printed in the United States of America. All rights reserved. This book or parts thereof may not be reproduced in any form without permission of the publishers.

# WARRANTY

The Seller warrants to the original Buyer only that the Product to which this warranty applies is free from defects in workmanship and material under normal use and service. The Seller's obligation under this warranty shall be limited to furnishing a replacement for, or at the Seller's option repairing, any Product or any part or parts thereof which to the Seller's satisfaction, prove defective within one year (unless specifically excepted below\*) from the date of shipment by the Seller, provided such Product or such part or parts are returned to the Seller transportation prepaid. No Product or part may be returned without Seller's prior written approval. All replacement Products or parts thereof furnished under this warranty will be invoiced in the usual manner and adjustments will be made after the Product or part thereof claimed to be defective has been returned to, and inspected at, the Seller's plant.

Replacements shall be furnished under this warranty F.O.B. Buyer's city, and the Seller shall not be responsible for drayage or installation costs. The Buyer shall be liable for all freight and handling costs if such Product or such part or parts do not prove to be defective. In no event will any claim for labor in removing or replacing a defective Product or part or for incidental or consequential damages be allowed. No warranty is made as to any product or part which has not been installed, operated or maintained in accordance with Seller's instructions or the instructions contained in its operations or maintenance manuals, when furnished by the Seller, or which has been subject to misuse, abuse, accident or alteration or to improper or negligent use, maintenance, storage, transportation or handling. This warranty is in lieu of all other warranties, expressed or implied, including any warranty of merchantability or fitness for a particular purpose, and the Seller neither assumes, nor authorizes any person or firm to assume for it, any other or further obligation or liability in connection with the sale, installation or use of any product.

\*(Excludes lamps and fuses in all products. Excludes all punch mechanisms for material and labor in excess of 90 days or that have exceeded a use volume of 700 rolls (84 million characters) of REMEX recommended tape. Excludes Diskette and Cassette Drives or mechanisms for material or labor in excess of 180 days.)

# FOR YOUR SAFETY

Before undertaking any maintenance procedure, whether it be a specific troubleshooting or maintenance procedure described herein or an exploratory procedure aimed at determining whether there has been a malfunction, read the applicable section of this manual and note carefully the  and

 **CAUTION**

contained therein.

The equipment described in this manual contains voltages hazardous to human life and safety and may contain mechanical components capable of inflicting personal injury. The cautionary and warning notes are included in this manual to alert operator and maintenance personnel to the electrical and mechanical hazards and thus prevent personal injury and damage to equipment.

## TABLE OF CONTENTS

Section	Title	Page
I	GENERAL DESCRIPTION .....	1-1
1.1	<u>EQUIPMENT DESCRIPTION</u> .....	1-1
1.2	<u>EQUIPMENT SUPPLIED</u> .....	1-1
1.3	<u>MAINTENANCE EQUIPMENT REQUIRED BUT NOT SUPPLIED</u> .....	1-2
1.4	<u>EQUIPMENT WARRANTY</u> .....	1-2
1.5	<u>SPECIFICATIONS</u> .....	1-2
1.6	<u>MODEL NUMBER DESIGNATION</u> .....	1-8
1.7	<u>PHYSICAL DESCRIPTION</u> .....	1-8
1.8	<u>TAPE CHANNEL NUMBERING</u> .....	1-9
II	INSTALLATION AND INTERFACE .....	2-1
2.1	<u>UNPACKING</u> .....	2-1
2.2	<u>MOUNTING</u> .....	2-1
2.3	<u>INITIAL ADJUSTMENTS</u> .....	2-1
2.4	<u>POWER AND SYSTEM CONNECTION</u> .....	2-1
2.4.1	TRANSFORMER WIRING CHANGE FOR VOLTAGES OTHER THAN 115 VAC .....	2-3
2.5	<u>INTERFACE CIRCUITRY</u> .....	2-3
III	OPERATION .....	3-1
3.1	<u>INPUT-OUTPUT SIGNALS</u> .....	3-1
3.2	<u>CONTROL FUNCTIONS</u> .....	3-1
3.3	<u>OPERATING INSTRUCTIONS</u> .....	3-1
3.3.1	LOADING INSTRUCTION .....	3-1
3.3.1.1	<u>Tape Reel Loading</u> . RRS6500 Only .....	3-1
3.3.1.2	<u>Tape Loop Loading</u> .....	3-2
3.3.2	TAPE DRIVE, LOW SPEED, ASYNCHRONOUS OPERATION .....	3-5
3.3.3	TAPE DRIVE, HIGH SPEED, SYNCHRONOUS OPERATION .....	3-5
3.3.4	EXTERNAL INHIBIT .....	3-7
3.3.5	SPOOLER WIND MODE OPERATION (RRS6500 ONLY) ..	3-7
3.3.6	DATA OUTPUT MODE SELECTION .....	3-7

TABLE OF CONTENTS  
(CONTINUED)

Section	Title	Page
3.4	<u>OPERATIONAL MAINTENANCE</u> . . . . .	3-12
3.5	<u>TAPE RECOMMENDATIONS AND AVAILABILITY</u> . . . . .	3-12
3.6	<u>TAPE PREPARATION REQUIREMENTS</u> . . . . .	3-12
IV	THEORY OF OPERATION . . . . .	4-1
4.1	<u>BLOCK DIAGRAM DESCRIPTION</u> . . . . .	4-1
4.1.1	TAPE DRIVE . . . . .	4-1
4.1.3	SPOOLER BLOCK DIAGRAM . . . . .	4-2
4.2	<u>CIRCUIT CARD DESCRIPTIONS</u> . . . . .	4-9
4.2.1	READER CIRCUITRY . . . . .	4-9
4.2.1.1	<u>Inhibit Circuitry</u> . . . . .	4-9
4.2.1.2	<u>Drive Circuits, Low Speed Operation</u> . . . . .	4-9
4.2.1.3	<u>Drive Circuits, High Speed Operation</u> . . . . .	4-11
4.2.1.4	<u>Tape Reading Circuits</u> . . . . .	4-12
4.2.2	SPOOLER CIRCUITRY, RRS6500 Only . . . . .	4-12
4.2.2.1	<u>Servo Mode Operation</u> . . . . .	4-12
4.2.2.2	<u>Wind Mode Operation</u> . . . . .	4-13
4.2.2.3	<u>Inhibit Mode</u> . . . . .	4-14
4.2.2.4	<u>Tape Tension Description</u> . . . . .	4-15
4.2.3	POWER SUPPLY VOLTAGES . . . . .	4-17
4.3	<u>LIGHT SOURCE</u> . . . . .	4-17
V	MAINTENANCE . . . . .	5-1
5.1	<u>GENERAL</u> . . . . .	5-1
5.2	<u>PREVENTIVE MAINTENANCE</u> . . . . .	5-1
5.2.1	CLEANING . . . . .	5-2
5.2.1.1	<u>Readhead Assembly Cleaning</u> . . . . .	5-4
5.2.1.2	<u>Sprocket Cleaning</u> . . . . .	5-4
5.2.1.3	<u>Tape Inspection</u> . . . . .	5-4
5.2.1.4	<u>General Cleaning</u> . . . . .	5-4
5.2.2	LUBRICATION . . . . .	5-4
5.2.3	POWER SUPPLY VOLTAGES . . . . .	5-4
5.3	<u>TROUBLESHOOTING</u> . . . . .	5-5
5.4	<u>READER ALIGNMENT</u> . . . . .	5-10

TABLE OF CONTENTS  
(CONTINUED)

Section	Title	Page
5.5	<u>READER LAMP VOLTAGE ADJUSTMENT</u> . . . . .	5-18
5.6	<u>SERVO ALIGNMENT</u> . . . . .	5-18
5.7	<u>ARM SPRING TENSION ADJUSTMENT</u> . . . . .	5-20
5.8	<u>WIND SPEED ADJUSTMENT</u> . . . . .	5-20
5.9	<u>SPOOLER TAPE ARM AND ROLLER ALIGNMENT</u> . . . . .	5-21
5.10	<u>TAPE SPLICING</u> . . . . .	5-21
5.11	<u>TAPE TENSIONING ASSEMBLY ADJUSTMENT</u> . . . . .	5-22
VI	PARTS REPLACEMENT . . . . .	6-1
6.1	<u>GENERAL</u> . . . . .	6-1
6.2	<u>READER PARTS REPLACEMENT</u> . . . . .	6-1
6.2.1	UPPER COVER ASSEMBLY . . . . .	6-1
6.2.2	READHEAD MECHANISM DISASSEMBLY . . . . .	6-2
6.2.3	READER CARD REPLACEMENT . . . . .	6-2
6.2.4	LAMP ASSEMBLY REPLACEMENT . . . . .	6-3
6.2.5	MOTOR AND/OR SPROCKET REPLACEMENT . . . . .	6-3
6.2.6	TRANSFORMER REPLACEMENT . . . . .	6-3
6.2.7	SWITCH S1 REPLACEMENT . . . . .	6-4
6.2.8	SWITCHES S2 AND S3 REPLACEMENT . . . . .	6-4
6.3	<u>SPOOLER PARTS REPLACEMENT</u> . . . . .	6-5
6.3.1	POTENTIOMETER REPLACEMENT . . . . .	6-5
6.3.2	FRONT PANEL AND CHASSIS SEPARATION . . . . .	6-5
6.3.3	SERVO MOTOR REPLACEMENT . . . . .	6-6
6.3.4	TAPE ARM REPLACEMENT . . . . .	6-6
6.3.5	TAPE TENSION SOLENOID REPLACEMENT . . . . .	6-9/6-10
VII	PARTS LIST . . . . .	7-1
7.1	<u>GENERAL</u> . . . . .	7-1
7.2	<u>KIT OF PARTS</u> . . . . .	7-1
VIII	SCHEMATIC DRAWINGS . . . . .	8-1
8.1	<u>GENERAL</u> . . . . .	8-1



## LIST OF ILLUSTRATIONS

Figure	Title	Page
1-1	REMEX Reader-Spooler Combination, Model RRS6500BDX/600/DRB . . . . .	1-3
1-2	REMEX Tape Reader, Model RRS6500BDX/660/ARB . . . . .	1-4
1-3	Installation Drawing, Model RRS6500BDX/66X/DRB . . . . .	1-6
1-4	Model Number Coding . . . . .	1-7
1-5	Tape Channel Numbering . . . . .	1-9
2-1	Reader Connections to External Equipment . . . . .	2-2
2-2	Recommended Interface Circuitry . . . . .	2-4
3-1	Timing Diagram for RRS6500 . . . . .	3-3
3-2	Tape Loading, RRS6500 . . . . .	3-3
4-1	Block Diagram, Reader Circuitry . . . . .	4-3
4-2	Block Diagram, Spooler Circuitry, RRS6500 Only . . . . .	4-3
4-3	Timing Diagram, Reader Card 112041 Low Speed Operation . . . . .	4-5/4-6
4-4	Timing Diagram, Reader Card 112041, High Speed Operation . . . . .	4-7/4-8
4-5	Timing Diagram, Wind Speed Regulator Circuitry . . . . .	4-13
4-6	Front View Showing Various Points of Tape Tension . . . . .	4-16
5-1	Sprocket Relation to the Tape Riding Surface . . . . .	5-11
5-2	Setting of the Sprocket in Relation to the Tape Riding Surface . . . . .	5-11
5-3	Adjustment of the Upper Tape Guide . . . . .	5-12
5-4	Photocell Output Test Circuit . . . . .	5-16
5-5	Sprocket Cell Output Adjustment for Minimum Jitter . . . . .	5-17
5-6	Lock-Load and Switch Actuation Points for the Left Arm . . . . .	5-19
5-7	Tape Splicing Procedure . . . . .	5-23/5-24
6-1	Exploded Drawing of Servo Bracket Assembly 110742 and Tape Arm Assembly 110730 . . . . .	6-7/6-8
6-2	Exploded Drawing of the 110873 Assembly . . . . .	6-9/6-10
7-1	Exploded View of Readhead Mechanism Assembly . . . . .	7-9/7-10
7-2	Exploded View of Mounting Block Assembly . . . . .	7-11
7-3	Front View of Front Panel . . . . .	7-12
7-4	Rear View of Front Panel . . . . .	7-13
7-5	Power Driver Panel Assembly 111021-1 . . . . .	7-14
7-6	Reader Card Assembly 112041-2 . . . . .	7-20
8-1	Schematic, Models RRS6500BDX/660/DRB and RRS6500BDX/660/ARB. . . . .	8-3/8-4
8-2	Diagram of Some of the I.C. Modules Used . . . . .	8-17/8-18
8-3	REMEX Standard Schematic Symbols . . . . .	8-20

## LIST OF TABLES

Table	Title	Page
1-1	Items Included with the RRS6500 and RR-6500 . . . . .	1-2
1-2	Specifications of the REMEX Model RRS6500 . . . . .	1-5
2-1	Black/White Wire Connection . . . . .	2-3
2-2	Recommended Interface Circuitry . . . . .	2-4
3-1	Interface Signal Descriptions . . . . .	3-8
3-2	Front Panel Controls . . . . .	3-11
3-3	Modes of Operation . . . . .	3-11
3-4	Recommended Tapes . . . . .	3-12
4-1	Mnemonics Used On RRS6500 Schematics . . . . .	4-18
5-1	Maintenance Equipment Required . . . . .	5-1
5-2	Preventive Maintenance Schedule and Log . . . . .	5-3
5-3	Power Supply Voltage Locations . . . . .	5-5
5-4	Troubleshooting . . . . .	5-6
6-1	Transformer Wire Connections . . . . .	6-4
7-1	Recommended Spare Parts . . . . .	7-2
7-2	Parts List, RRS6500BDX/660/DRB/U000 . . . . .	7-3
7-3	Parts List, RRS6500BDX/660/ARB/U000 . . . . .	7-8
7-4	Power Driver Panel Assembly 111021-2 . . . . .	7-15
7-5	Parts List, Reader Card 112041-1 . . . . .	7-16

## SECTION I

### GENERAL DESCRIPTION

#### 1.1 EQUIPMENT DESCRIPTION

This manual has been prepared to assist the user in interfacing, installing, operating and maintaining the REMEX Model RRS6500BEX punched tape reader-spooler combination (Figure 1-1). It is the purpose of this model series to provide tape reading at 500 characters/second speed along with spooling, all on a single chassis. Although the applications for punched tape readers are many and varied, they are generally used as input devices for digital computers, communication systems, numerical controls and system checkout equipment.

The single printed circuit card provides the logic control for tape movement in either direction from external signals or from the front panel switches. The outputs from the card control a step motor which drives the tape via a sprocket wheel. Data outputs are generated from the photocell readhead. As tape passes over the photocells, changes in light intensity are sensed by the photocells, amplified, and brought out to an external connector. The P.C. Card also contains the required power supplies. The card also contains the spooler control circuitry.

The function of the spooler is to payout tape to the reader and to take up the tape that has been read. During read mode, the fully proportional spooler senses the position of the tape arms and provides compensating reel movements that allow the arms to operate near the center of their travel areas. These movements maintain a constant tape tension across the readhead. During wind mode, the reader is inhibited and tape is reeled at high speed from one reel to the other under control of either external signals or front panel switches.

#### 1.2 EQUIPMENT SUPPLIED

Several items are included with the reader and reader-spooler for spare parts, installation, and maintenance. These items are listed in Table 1-1. No other equipment is required for the operation of the unit.

Table 1-1. Items Included with the RRS6500 and RR-6500.

Item	REMEX Part No.	Quantity
Brush, Right Angle	716003-104	1
Brush, Soft Bristle	716003-101	1
Cap, Fuseholder	705750-118	1
Connector, P1, Cannon D825S	706510-211	1
Cover, Connector (P1)	706540-144	1
Fuse, 3A, Slow Blow (100, 115, 127 VAC Operation)	705710-126	1
Fuse, 1.5A Slow Blow (220, 230 or 240 VAC)	705710-138	1
Manual	112670-077	1
Power Cord	708000-110	1
Reel	①	2
Screw Lock Assembly, P1, Set of 2	706540-124	1

① See Page 7-7 for available reels for model RRS6500BEX/660/DRB. For model RRS6500BEX/660/ARB two 8-inch NAB reels, P/N 716028-101 are included.

### 1.3 MAINTENANCE EQUIPMENT REQUIRED BUT NOT SUPPLIED

The maintenance procedures in Section 5 require equipment that is not supplied. This equipment is listed in Table 5-1.

### 1.4 EQUIPMENT WARRANTY

A statement covering the warranty of this equipment is given on page iii (second page in book). It should be read and understood. All preventive maintenance procedures must be performed as outlined in Section 5.2 during the warranty period in order that the warranty remain in effect. Any questions arising concerning the warranty should be directed to the REMEX Service Department.

### 1.5 SPECIFICATIONS

The specifications for the REMEX reader-spooler combination RRS6500 are listed in Table 1-2. An X in a particular digit designator denotes any of the combinations given in Figure 1-4 can be used.

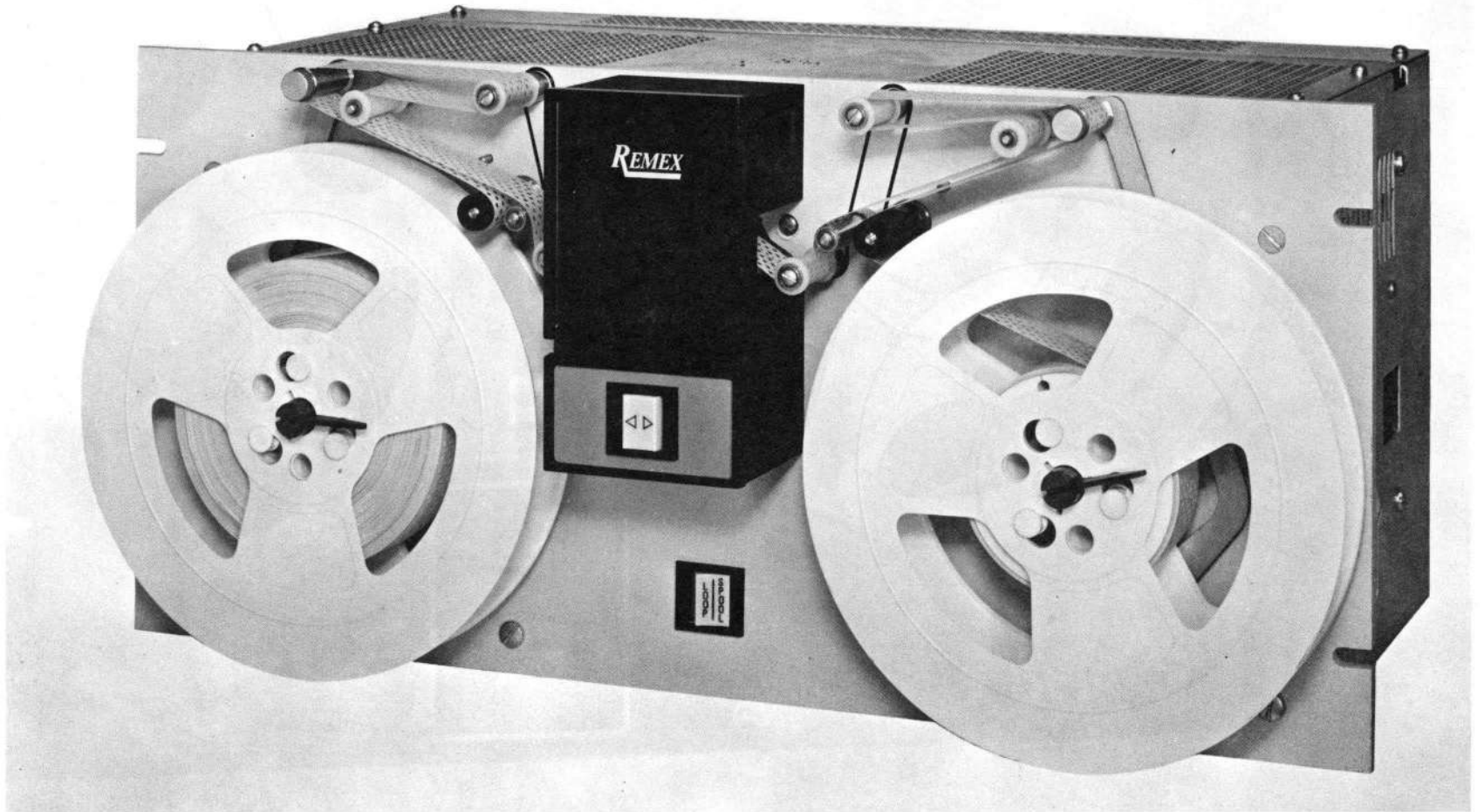

Figure 1-1. REMEX Reader/Spooler Combination, Model RRS6500BEX/600/DRB.

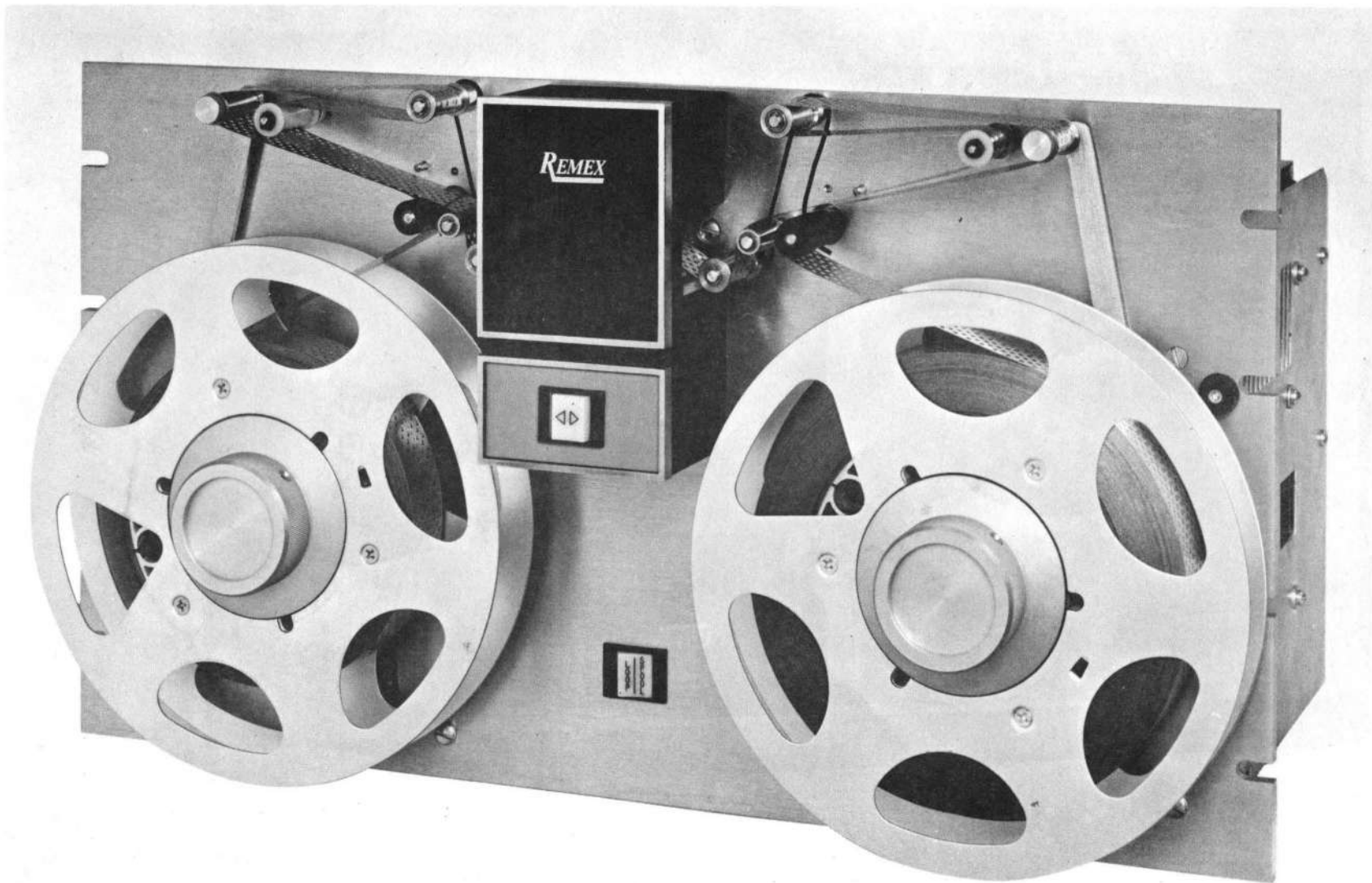
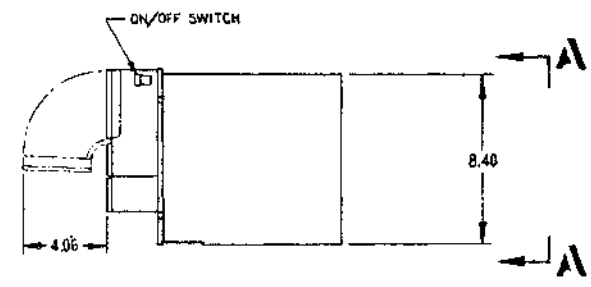
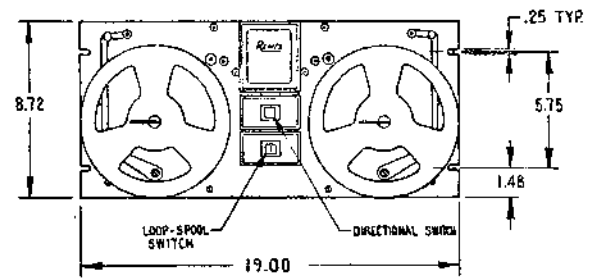
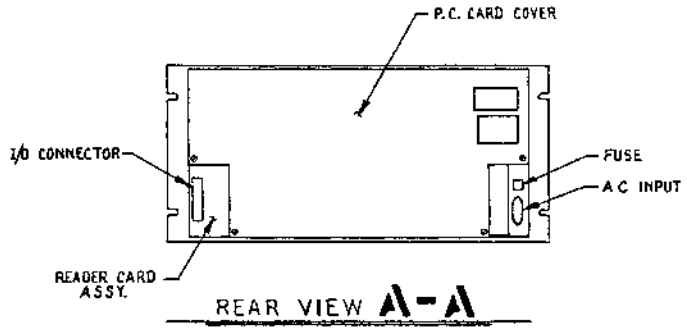
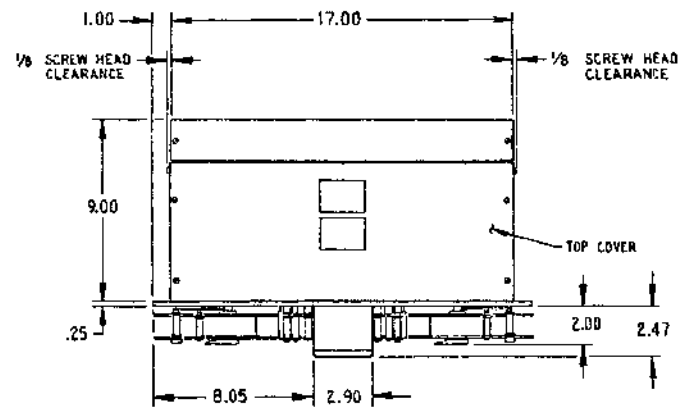

Figure 1-2. REMEX Tape Reader, Model RRS6500BEX/660/ARB.

Table 1-2. Specifications of the REMEX Model RRS6500.

Characteristic	Specification
Tape Movement	Bidirectional (left-to-right or right-to-left).
Reading Speed	0 to 300 characters per second asynchronously; greater than 500 characters/sec in synchronous mode.
Tapes	Reads standard 8-track (1-inch) tapes with light transmissivity of 57% or less and thickness between 0.0027 and 0.0045 inch (oiled buff paper tape). Tapes must be punched as described in Section 3.6. Other tape options available as shown in Figure 1-6.
Input Power	100, 115, 127 VAC operation, 47 to 63 Hz, single phase at 4.0 Amps max; 220 or 240 VAC operation, 47 to 63 Hz, single phase at 2.0 Amps max. Unless otherwise specified by customer, all units are wired for 115 VAC operation; easy wire change for any other specified voltage.
Temperature	Operating: 0°C to +55°C, free air Non-Operating: -55°C to +85°C
Weight	RRS6500BEX/660/DRB: 38 lbs; RRS6500BEX/660/ARB: 49 lbs.
Mounting Dimensions	RRS6500BEX/660/DRB: 8-3/4" high, 19" wide, 9" behind a 1/4" panel, 2-1/2" in front of panel. See Figure 1-3. RRS6500BEX/660/ARB: 10-1/2" high, 19" wide, 9" behind a 1/4" panel, 2-1/2" in front of panel.
Drive Control	The following signals are applied to J1, pin 17, for drive left or J1, pin 16, for drive right:  Stop: +2.4 < V < +5.0 or an open circuit Drive: 0 < V < +0.4 @ 5 ma.  Two modes of operation are available. See Sections 3.3.2 and 3.3.3.
Data Output	Data Output mode selectable. See Section 3.3.6. Mode 5: Hole: +2.4 < V < +5.0 @ 0.2 ma. (source) No Hole: 0 < V < +0.4 @ 16 ma. (sink) Mode 6: Hole: 0 < V < +0.4 @ 16 ma. (sink) No Hole: +2.4 < V < +5.0 @ 0.2 ma. (source)
Timing	Timing Diagram given in Figure 3-1.
Wind Operation	Bidirectional high speed wind at 1500 characters/sec. (mid-reel) with speed adjustment.

SYM	ECO	EFFECT	REVISIONS	BY	DATE	APPRD
A	-	9-23-76	RELEASED	S.E.O.	12-7-77	



- 3. DIMENSIONS ARE REF ONLY.
  - 2. FOR SCHEMATIC SEE DWG. NO. 113205.
  - 1. FOR FINAL ASSY. SEE DWG. NO. 113080-1.
- NOTES: UNLESS OTHERWISE SPECIFIED.

REQD	PART NUMBER	DESCRIPTION	DESIGNATION	NOTE	QTY
LIST OF MATERIALS					
UNLESS OTHERWISE SPECIFIED DIMENSIONS ARE IN INCHES		DR S.E.O.	1733 ALTON STREET IRVINE CALIF 92714		
TOLERANCES: FRACTIONS DECIMALS ANGLES		DATE 6-7-76			
± V32 XX ± 02 ± 1/2		DATE 3/20/76	TITLE INSTALLATION DWG. RRS 6500 BEX/660/DR3/UXXX		
SURFACE ROUGHNESS (BREAK SHARP EDGES DR20 MAX)		DATE 9-23-76			
MATERIAL		APP. S.E.O.	SCALE 1:4		
DESIGNER		APPROVAL	FIGURE IDENT. NO. C		SIZE (DWG. NO.) 113217
USED ON		NEXT ASSY	DO NOT SCALE DRAWING		SHEET 1 OF 1

113217 1A1

Figure 1-3. Installation Drawing, Model RRS6500BEX/66X/DRB. The dimensions for model RRS6500BEX/66X/ARB are identical except the 2.00 is 2.51, the 8.72 is 10.47 and the 5.75 is 7.50.



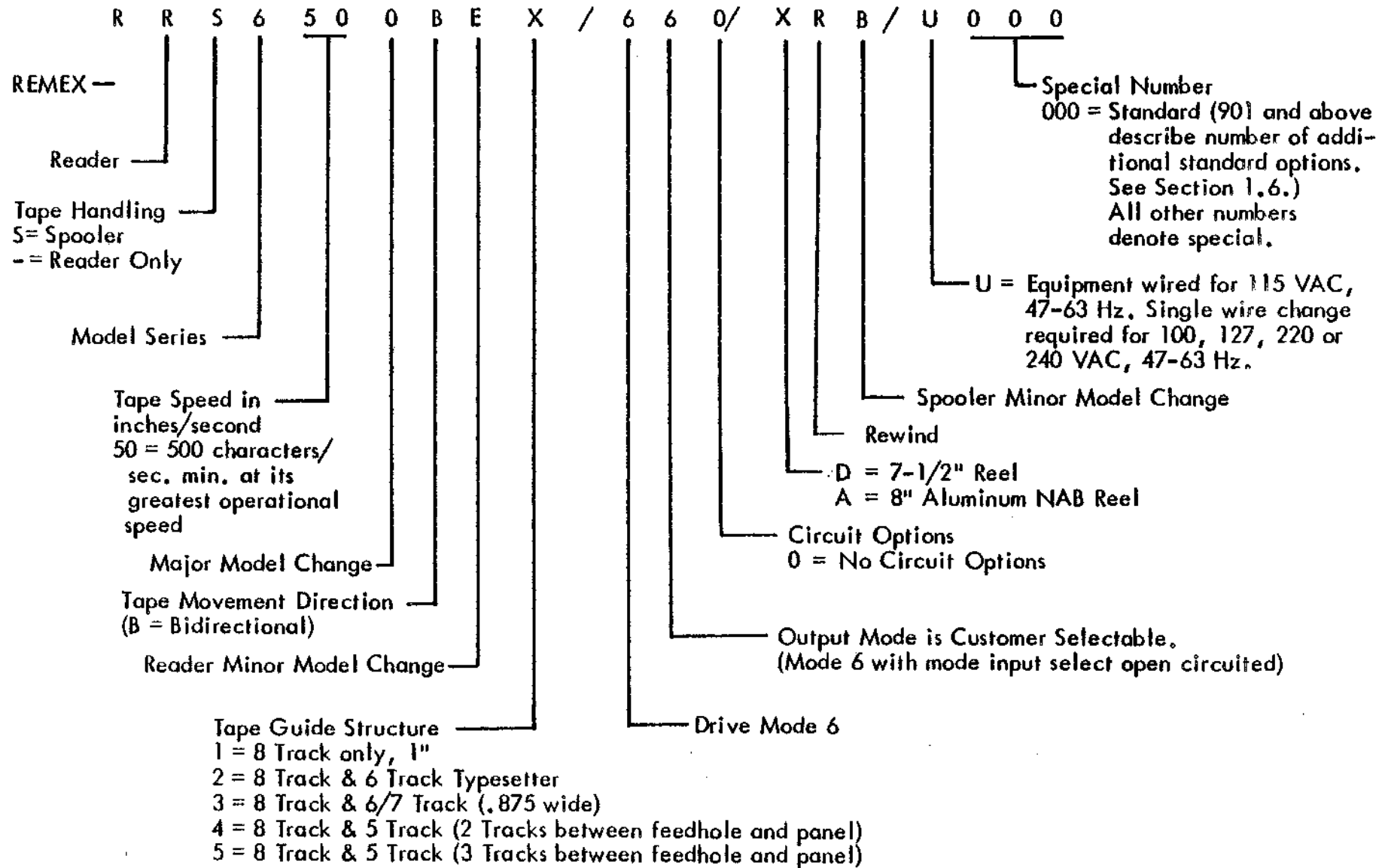

Figure 1-4. Model Number Coding

The REMEX model designation is used to code the basic functions and configurations of a particular product line. The model number codes for the RRS6500 series are shown in Figure 1-4. An X in a particular digit designator (as used in many parts of this manual, especially the parts list) denotes any of the combinations for that digit given in Figure 1-4 applies in the instance cited.

Always consult the serial number tag for proper voltage and frequency to be used and for model identification. Failure to do so could result in damage to the unit. The serial tag is located on one of the rear surfaces. In all correspondence, always refer to the complete model number, including the mode and the special number and the unit's serial number.

The last three digits of the model number denote either a standard unit (000 or 901 and higher) or a special (all other numbers). Units with 000 indicate standard units with no additional options other than those coded in the model number structure. Units with 901 and higher are used to indicate the number of standard options (used only on standard units) which are not coded in the model number. These are listed on the serial tag below the model number in the form of a series of three digit numbers depending upon the number of options used. For example, a unit with 902 would list two three digit numbers. Because the list of possible options is constantly changing, the complete list is not included in the manual. Generally, this list consists of special customer requirements that do not affect the operation of the unit and include such things as special paint, no logo, mill edge panel, etc. Table 1-3 lists those options and dash numbers which can be applied to all units.

The REMEX punched Tape Reader/Spooler is mounted on a 19-inch panel with a height of 8-3/4 inches. Detailed dimensions are shown in Figure 1-3. The front panel contains the tape reading and transport mechanism. The top front cover is removable and provides access to the fiber optics, readhead assembly and the sprocket drive assembly. The electronic chassis is mounted at the rear of the front panel and contains the circuit card. The reader lamp is located at the rear of the front panel.

Table 1-3. Options Used on RRS6500BEX

Option Number	Description	Change
001	No Logo	Removed Remex Logo from window on tape access door.

## 1.8 TAPE CHANNEL NUMBERING

Figure 1-5 illustrates the tape channel numbering. The reader accepts one inch, eight channel tape and other width tapes (see Figure 1-4) depending upon the tape guide structure used.

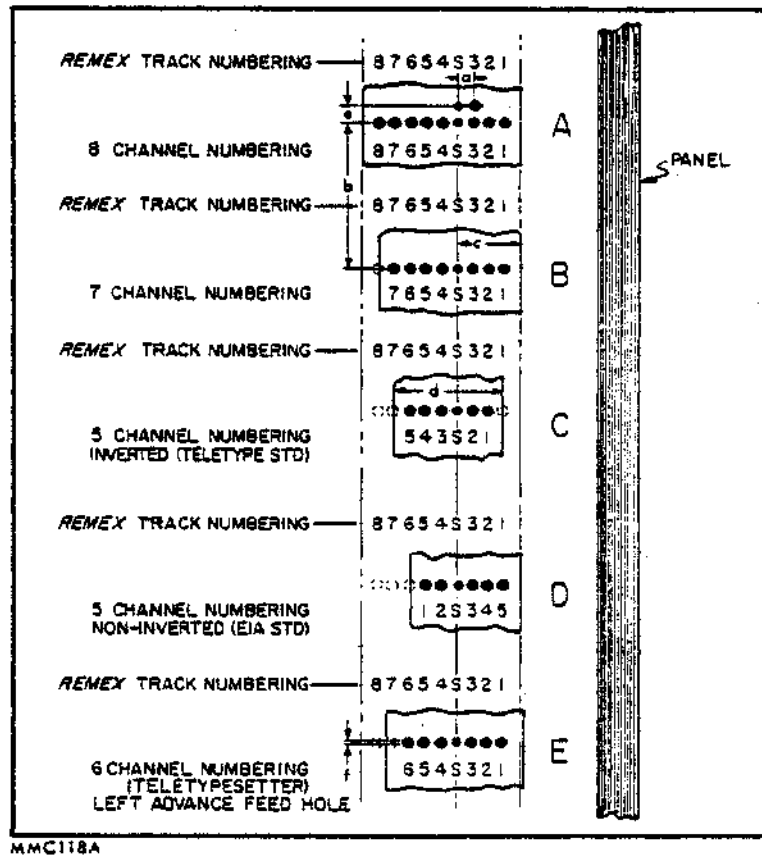

Tape Configuration	$c$ $\pm 0.003$	$d$ $\pm 0.003$	<u>In All Configurations</u> $a = 0.100 \pm 0.002$ $b$ in any span of five inches is $\pm 0.025$ $e = 0.100 \pm 0.001$ Data hole diameter is 0.072 $\begin{matrix} +.001 \\ -.002 \end{matrix}$ Sprocket Hole diameter is 0.046 $\begin{matrix} +0.002 \\ -0.001 \end{matrix}$
A	0.392	1.000	
B	0.394	0.875	
C	0.293	0.687	
D	0.394	0.687	
E	0.441 Right Drive 0.434 Left Drive	0.875	

NOTE: The 6 channel teletypesetter has the sprocket hole center line advanced by 0.013 inch with respect to the data track center line.

Figure 1-5. Tape Channel Numbering.



## SECTION II

### INSTALLATION AND INTERFACE

#### 2.1 UNPACKING

To provide the most protection during transit, specially designed and reinforced packing cartons are used to ship the REMEX punched tape reader. Those items listed in Table 1-1 are also packed with the unit. When removing the unit from the carton, the reader-spooler should be lifted with both hands under it. Never lift or attempt to carry the unit by any of the covers, drive assembly, arms or other delicate parts. Carefully inspect the unit for any apparent damage as soon as it is removed from the carton. Check the equipment supplied list in Table 1-1 against the kit of parts supplied with the reader. In the event the equipment has been damaged as a result of shipping, the carrier and REMEX must be notified as soon as possible.

#### 2.2 MOUNTING

The reader mounts in a standard 19-inch rack with mounting holes provided. To ensure a minimum transmission of acoustical noise and vibration to other equipment, the reader should be securely mounted. When mounting the unit in a closed cabinet, adequate air circulation should be supplied so that the unit does not exceed the ambient temperature specification listed in Table 1-2.

#### 2.3 INITIAL ADJUSTMENTS

Each reader has been accurately adjusted and aligned before leaving the factory. No adjustment or calibration should be required prior to installation or use. However, the proper fuse from the kit of parts requires installation. Refer to Section 2.4.

#### 2.4 POWER AND SYSTEM CONNECTIONS

Input AC power (refer to Table 1-2) is applied to the three prong power cord supplied.

#### **CAUTION**

All units come wired for 115 VAC, 47-63 Hz operation. If another voltage is to be used, a wire change on the transformer must be made as described in Section 2.4.1. In addition, before operating the system, the proper fuse value (as indicated in Table 1-1) must be inserted from the kit of parts. Discard the other fuse (unless, of course, a different voltage operation is anticipated).

All control signals and data track output signals are routed through J1. Figure 2-1 lists the detail routing of these signals and their description is given in Table 3-1. All wire sizes are 22 AWG unless otherwise noted in Figure 2-1. The proper mating connector for J1 has been supplied with the unit.

**NOTE:** All input and output logic signals are defined for positive logic, mode 5, i.e., +5V active and OV, inactive. Therefore, signals that are mode 6, OV active are written with an asterisk (\*), e.g., (Drive Right)\* Input.

J1		
1	_____	Data Track 1 Output
2	_____	Data Track 2 Output
3	_____	Data Track 3 Output
4	_____	Data Track 4 Output
5	_____	Data Track 5 Output
6	_____	Data Track 6 Output
7	_____	Data Track 7 Output
8	_____	Data Track 8 Output
9	_____	Data Ready Output
10	_____	Data Mode Select Input
11, 12, 13, 24	20 AWG	Signal Ground, OV
14	_____	(System Ready)* Output
15	_____	(External Inhibit)* Input
16	_____	(Drive Right)* Input
17	_____	(Drive Left)* Input
18	_____	(High Speed Enable)* Input
20	_____	(Wind Right External)* Input
21	_____	(Wind Left External)* Input
22	_____	Winding* Output
23	_____	+5VDC @ 200 mA Output
25	20 AWG	Chassis Ground

Figure 2-1. Reader Connections to External Equipment. See Table 3-1 for signal descriptions.

## 2.4.1 TRANSFORMER WIRING CHANGE FOR VOLTAGES OTHER THAN 115 VAC

All units come from the factory with a transformer which allows any of five input voltages to be used: 100, 115, 127, 220 or 240 VAC, 47-63 Hz. Unless otherwise directed by the customer, all units leave the factory wired for 115 VAC. If it becomes necessary to operate on one of the other four voltages, a simple wire change is required.

### **WARNING**

Make sure the power plug is disconnected before making the change.

Power from the AC plug is applied to FL1 and through F101 and S1 to TB1 via a white/black wire. See schematic, Figure 8-1, sheet 4. It is necessary, then, when changing from 115 VAC to another voltage, to change the white/black wire at TB1-5, to the required TB1 terminal as indicated in Table 2-1. This is the only wire to be moved; the fan must remain tied to the 115 VAC terminal. In addition, fuse F101 must be substituted as directed in Table 2-1.

Table 2-1. Black/White Wire Connection

VAC Required	RRS6500	
	Connection	Fuse 101
100 VAC	TB1-4	4 Amp
115 VAC	TB1-5	4 Amp
127 VAC	TB1-6	4 Amp
220 VAC	TB1-7	2 Amp
240 VAC	TB1-8	2 Amp

## 2.5 INTERFACE CIRCUITRY

Figure 2-2 illustrates suggested drive and output circuitry with which to interface with the REMEX circuitry. Note the termination network for the output signals. This should be incorporated into the user's equipment for maximum noise elimination. Table 3-1 lists which circuit is used with each input or output.

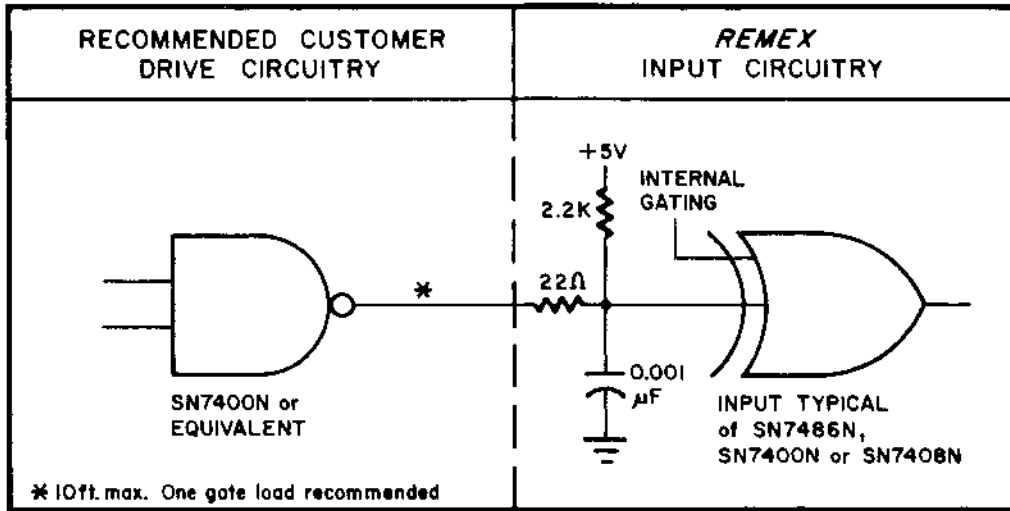

MMC 304A

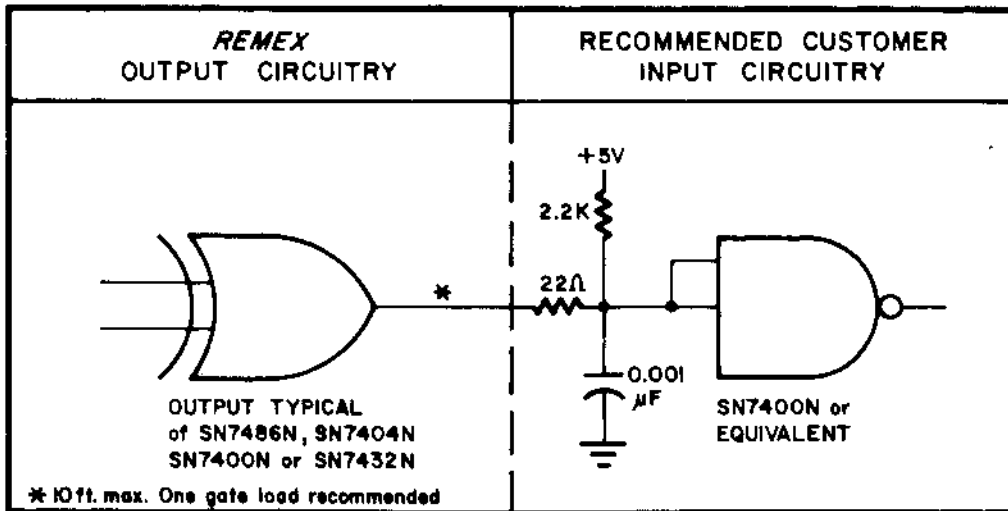

MMC 305A

Figure 2-2. Recommended Interface Circuitry.



## SECTION III

### OPERATION

#### 3.1 INPUT-OUTPUT SIGNALS

Table 3-1 lists those input and output signals which are routed through connector J1. The definition and/or usage of these signals are also included in the table. Figure 3-1 shows the timing diagram for these signals.

#### 3.2 CONTROL FUNCTIONS

Table 3-2 lists the operating controls located on the front panel. A description of the controls and their functions is also included.

#### 3.3 OPERATING INSTRUCTIONS

##### 3.3.1 LOADING INSTRUCTIONS

Loading instructions for the RRS6500 is divided into two parts: loading a reel of tape and loading a loop of tape.

##### 3.3.1.1 Tape Reel Loading

- a. Connect J1/P1 and plug the line cord into the proper AC outlet. Refer to the Caution in Section 2.4.
- b. Depress the power switch, S1, located on the right side of the cover assembly. Power is on when the lamp assembly is lit.

### **WARNING**

Always follow the exact procedure listed in steps c-j when loading tape. Operation of the tape arms with the LOOP-SPOOL switch in SPOOL and the door closed causes the hub assembly to rotate which could result in injury. An interlock system has been built into the spooler to prevent operation unless the exact procedure is followed. This has been done to protect the operator from possible injury and from breaking tape. To reset the interlock in event the exact procedure is not followed, it is necessary to open the tape access door and then close it.

- c. Pull forward and down on the Door Assembly. This will open the tape access door and raise the Upper Tape Guide allowing tape to be loaded.
- d. Place the LOOP-SPOOL switch in the LOOP position. See the warning following step b.

- e. Check the number showing on the Tape Guide. If a two-sided Tape Guide is being used and the other width of tape is required, depress and rotate the Tape Guide Latch 90°. The Tape Guide can now be removed and then reinserted with the other guiding edge up. One-sided guides, of course, do not need to be removed. The Tape Guide supplied with the unit is coded as part of the model number as indicated in Figure 1-3.
- f. Rotate the tape arms in past the locking pins so that they are held in the tape load position. See Figure 3-2.
- g. Install the reels of tape and thread the tape through the spooler arm rollers and reader as shown in Figure 3-2. The unit can be easily threaded if the tape threading path on the panel is followed. An eight-foot leader of tape should be provided at both ends of the tape to facilitate threading.
- h. Rotate the arms out past the locking pins to the center of their travel arc.
- i. Place the LOOP-SPOOL switch in the SPOOL position.
- j. Raise the Tape Access door to its closed position. This step must be performed last because of the interlock built into the spooler as described in the warning following step b.
- k. Make sure the (SYSTEM READY)\* output signal is  $0 < V < +0.4$ .
- l. Apply the proper signal to J1-10 to select either mode 5 or mode 6 data output and data ready signal. See Section 3.3.6.
- m. The unit may now be operated in either of the two modes listed in Section 3.3.2 or 3.3.3. See Section 3.3.4 for external inhibit operation and Section 3.3.5 for spooler wind mode operation.

### CAUTION

Always close the reader door when not in use. Accidental bumping of the door could break it off at the hinge and cause bodily injury.

- n. To unload tape, stop tape movement, place LOOP-SPOOL switch in LOOP, lower the Tape Access Door and remove the tape.
- o. To remove power, depress the power switch, S1. The lamp will turn off.

#### 3.3.1.2 Tape Loop Loading

- a. Connect J1/P1 and plug the line cord into the proper AC outlet. Refer to the Caution in Section 2.4.
- b. Depress the power switch, S1, located on the right side of the cover assembly. Power is on when the lamp assembly is lit.

**LOW SPEED OPERATION**

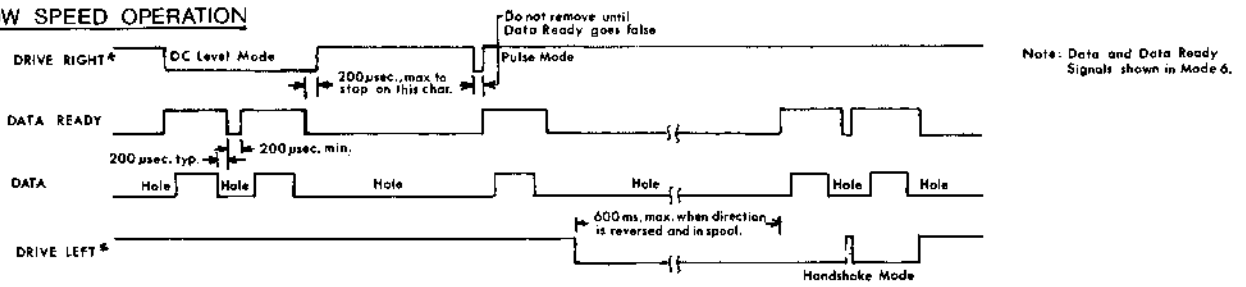

Note: Data and Data Ready Signals shown in Mode 6.

**HIGH SPEED OPERATION**

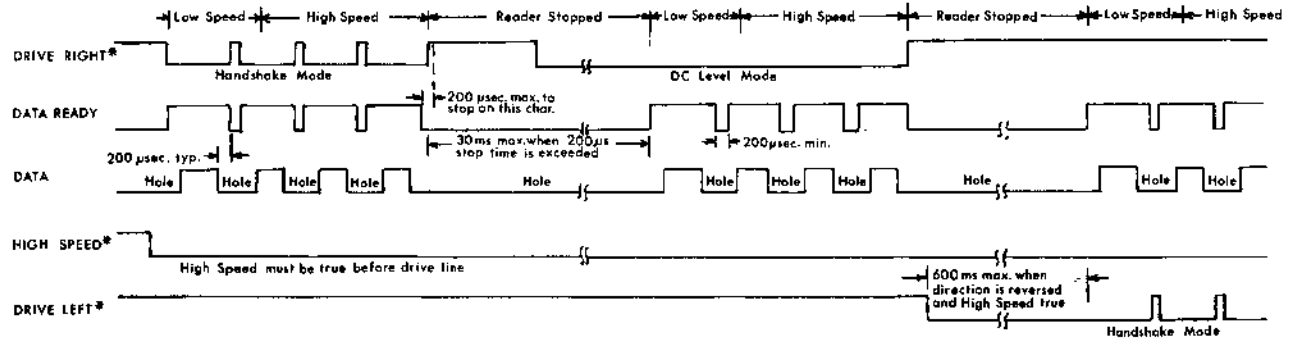

MMC 623

Figure 3-1. Timing Diagram for RRS6500.

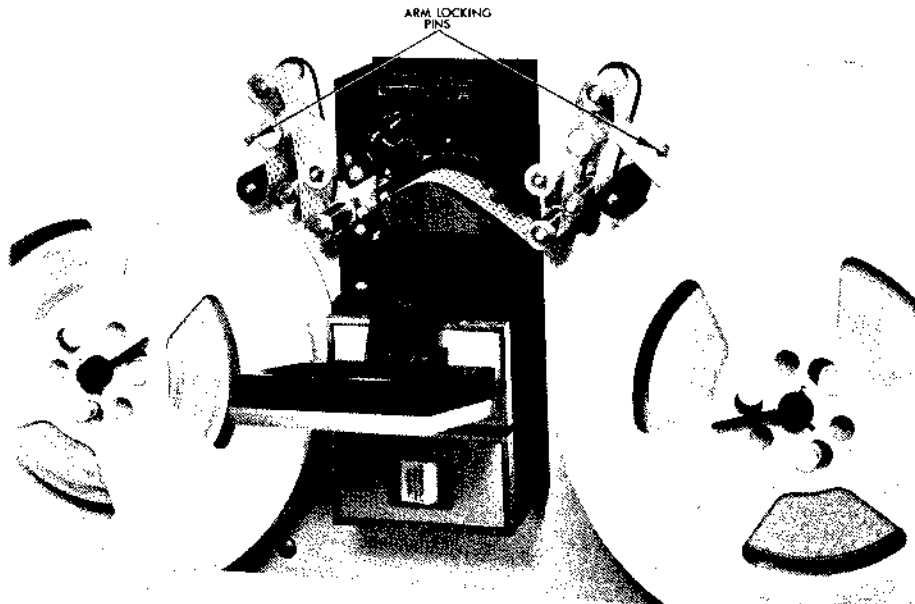

Figure 3-2. Tape Loading, RRS6500. The loading in the Tape door is the same for the RR-6500.

## WARNING

Always follow the exact procedure listed in steps c-i when loading tape. Operation of the tape arms with the LOOP-SPOOL switch in SPOOL and the door closed causes the hub assembly to rotate which could result in injury. An interlock system has been built into the spooler to prevent operation unless the exact procedure is followed. This has been done to protect the operator from possible injury and from breaking tape. To reset the interlock in event the exact procedure is not followed, it is necessary to open the tape access door and then close it.

- c. Pull forward and down on the Door Assembly. This will open the tape access door and raise the Upper Tape Guide allowing tape to be loaded.
- d. Place the LOOP-SPOOL switch in the LOOP position. See the warning following step b.
- e. Check the number showing on the Tape Guide. If a two-sided Tape Guide is being used and the other width of tape is required, depress and rotate the Tape Guide Latch 90°. The Tape Guide can now be removed and then reinserted with the other guiding edge up. One-sided guides, of course, do not need to be removed. The Tape Guide supplied with the unit is coded as part of the model number as indicated in Figure 1-3.
- f. Rotate the tape arms to the outer tape break position. When using a loop of tape, the arms must not be in the tight tape position inside the locking pins.
- g. Insert the loop of tape into the reader and let it hang free of the tape arms.
- h. Leave the LOOP-SPOOL switch in the LOOP position.
- i. Raise the Tape Access door to its closed position. This step must be performed last because of the interlock built into the spooler as described in the warning following step b.
- j. Make sure the (SYSRDY\*) output signal is  $0 < V < +0.4$ .
- k. Apply the proper signal to J1-10 to select either mode 5 or mode 6 data output and data ready signal. See Section 3.3.6.
- l. The unit may now be operated in either of the two modes listed in Section 3.3.2 or 3.3.3. See Section 3.3.4 for external inhibit operation.
- m. To unload tape, stop tape movement, place LOOP-SPOOL switch in LOOP, lower the Tape Access Door and remove the tape.
- n. To remove power, depress the power switch, S1. The lamp will turn off.

### 3.3.2 TAPE DRIVE, LOW SPEED, ASYNCHRONOUS OPERATION

In this mode of operation, tape is driven at 300 characters/sec., min., in either a continuous or a line-at-a-time step operation in which the controller does not need to be synchronized with the reader outputs.

- a. Perform Section 3.3.1 steps a through j. Note that a 350 ms delay is built into the unit when power is turned on to bring the power supply voltages to their proper levels.
- b. Make sure the Data Ready signal at J1-9 is in the true condition depending upon the mode. See Table 3-1.
- c. Place the (High Speed Enable)\* input at J1-18 in its false condition ( $+2.4 < V < +5.0$  or open circuited).
- d. Apply the following signal to the drive left (DL\*) line, J1-17 or the drive right (DR\*) line, J1-16:  
Stop:  $+2.4 < V < +5.0$  (2.2K to +5V) or an open circuit  
Run:  $0 < V < +0.4$  @ 5 ma.

The drive signal can either be in the form of a pulse (not less than 1  $\mu$ sec) or a continuous DC level which must be removed within 200  $\mu$ sec after the leading edge of the true Data Ready signal to stop on character. A pulse must be maintained until the Data Ready signal goes false (typically less than 0.5  $\mu$ sec). The next pulse or DC level may be applied at any time after the Data Ready signal comes true. See Figure 3-1. Handshake (synchronous) is the preferred mode of operation. In handshake mode, the drive signal is maintained until Data Ready comes true, is taken false while the data is examined and then, if required is taken true again until the next Data Ready comes true.

- e. If the direction is reversed and the spooler is enabled all drive signals will be locked out for approximately 200 ms, max. from the time the previous drive signal is terminated to give the servo time to stabilize.
- f. Only one run signal must be present at one time. If both run signals are applied simultaneously, the reader will drive in the last previously commanded direction.

### 3.3.3 TAPE DRIVE, HIGH SPEED, SYNCHRONOUS OPERATION

In this mode of operation the reader is driven in excess of 500 characters/sec, min., in a manner in which the controller must be completely synchronized with the Data Ready signal or else the drive signal can be locked out.

- a. Perform Section 3.3.1.1 steps a through l or 3.3.1.2, steps a through k. Note that a 350 ms delay is built into the unit when power is turned on to bring the power supply voltages to their proper level.
- b. Make sure the Data Ready signal at J1-9 is in the true condition depending upon the mode. See Table 3-1.

- c. Place the High Speed Enable (HISPD\*) input at J1-18 in its true condition ( $0 < V < +0.4$ ). This signal must be taken low before a drive signal is applied.
- d. Apply the following drive signal to the Drive Left (DL\*) line, J1-17, or the Drive Right (DR\*) line, J1-16:

Stop:  $+2.4 < V < +5.0$  (2.2K to +5V) or an open circuit  
Run:  $0 < V < +0.4$  @ 5 ma.

The following conditions and operating rules govern the use of the reader in high speed operation. Refer also to the timing diagram, Figure 3-1.

- (1) The drive signal is applied only when the Data Ready (DATRDY) signal is true.
  - (2) The drive signal can be either in the form of a pulse or a continuous D.C. level, both of which must be maintained until the DATRDY signal goes false. Figure 3-1 is illustrated first for synchronous pulse operation and then for D.C. operation.
  - (3) The reader operates in low speed (300 ch/sec) during the interval from the first drive signal to the leading edge of the next DATRDY signal.
  - (4) At each character, a 200  $\mu$ sec true DATRDY is present to permit the go/no go decision.
  - (5) To operate in high speed (500 ch/sec), the drive line must be taken true during the first DATRDY signal and held true until the DATRDY goes false. If no drive signal is applied within 200  $\mu$ sec after the leading edge of DATRDY, the reader will continue to operate in low speed and steps 3, 4 and 5 must be repeated to obtain high speed operation.
  - (6) Once the reader has attained high speed operation, the drive signal must be brought true with 200  $\mu$ sec after the leading edge of each DATRDY and held true until DATRDY goes false. If this condition does not happen, the reader will stop and all drive signals will be locked out for up to 30 ms (lock out condition).
  - (7) Anytime the reader goes into a lock-out condition, it reverts to low speed operation at the end of the lock out period. It is then necessary to repeat steps 3, 4, 5 and 6 to again bring it to high speed operation.
  - (8) To stop on character at any time, the drive signal must be removed within 200  $\mu$ sec after the leading edge of the DATRDY signal.
- e. If the drive direction is reversed and the spooler is enabled (RRS6500 only), all drive signals will be locked out for approximately 200 ms, max (from the time the previous drive signal is terminated) to give the servo time to stabilize.
  - f. Only one run signal must be present at one time. If both run signals are applied simultaneously, the reader will drive in the last previously commanded direction.

### 3.3.4 EXTERNAL INHIBIT

In this mode of operation, the reader and spooler are inhibited and the System Ready (SYSRDY\*) output (J1-14) and the DATRDY output (J1-9) are set to the false state. To place the reader in the inhibit mode apply the following signals to pin 15 of J1:

Reader Not Inhibited: +2.4<V<+5.0 (2K to +5V) or an open circuit



Reader Inhibited: 0<V<+0.4 @ 5 ma.

### 3.3.5 SPOOLER WIND MODE OPERATION

During wind mode operation, tape movement is completely controlled by the spooler. All reader drive circuits are inhibited until wind mode is completed. During wind operation, the DATRDY output (J1-9) displays the sprocket signals as they are being read from the tape. The following procedure should be used during wind mode:

- a. Perform Section 3.3, steps a through h.
- b. Depress the SPOOL switch.
- c. Wind mode is accomplished either from the front panel switch or by external signals as follows:

#### Front Panel Switches, Manual Wind Control

Depress the  switch to wind tape onto the left reel or the  switch to wind tape onto the right reel. Release the switch when the desired amount of tape has been rewound.

#### External Wind Control

Apply one of the following signals to J1-20 for wind right or to J1-21 for wind left:

Wind: 0<V<+0.4 @ 5 ma. (sink)

Stop Wind: +2.4<V<+5.0 @ 0.2 ma. (or open circuit)

Only one wind signal must be present at one time. The presence of both wind signals simultaneously will produce unpredictable behavior and is not an allowable operating condition.

### **CAUTION**

Do not try to rewind a reel of loosely packed tape (such as one directly from a punch) since the probability of tape breakage is high. It is recommended that a loose pack or a newly punched reel of tape be driven through the reader once before attempting high speed wind.

### 3.3.6 DATA OUTPUT MODE SELECTION

The output mode of both the data tracks and the DATRDY output is selectable for either mode 5 (+5 volt true) or mode 6 (0 volt true) by applying one of the following signals to J1-10:

Mode 5: 0<V<+0.4 @ 17 ma. max.

Mode 6: +2.4<V<+5.0 (or open circuit)

Table 3-1. Interface Signal Descriptions

Connector Pin	Description	Interface Circuit (See Figure 2-2) & IC Type	Signal Levels	
			True Condition	False Condition
J1-1 thru J1-8	Data Track Outputs. True signal indicates data track hole and false condition indicates no hole condition. Output mode 5 or 6, selectable (see J1-10).	B SN7486N	Mode 5: $+2.4 < V < +5$ @ 0.2 ma (source) Hole (or Data Ready)	Mode 5: $0 < V < +0.4$ @ 16 ma (sink). No Hole (or Data Not Ready)
			Mode 6: $0 < V < 0.4$ @ 16 ma (sink). Hole (or Data Ready)	Mode 6: $+2.4 < V < +5$ @ 0.2 ma (source) No Hole (or Data Not Ready)
J1-9	Data Ready Output. True signal indicates data track outputs are in "on character" condition. Signal true with leading edge of feed hole and remains true until next drive signal is accepted. Data Ready signal is forced false by a load condition, External Inhibit signal or out-of-tape signal. Output mode 5 or 6, selectable (see J1-10). During wind mode, this output displays sprocket signals as they are being read from tape.	B SN7486N		
J1-10	Data Mode Select Input. True signal places data outputs and data ready output in mode 6. False signal places data outputs and data ready output in mode 5.	A SN7486N	$+2.4 < V < +5.0$ (or open circuit) Data Track & Data Ready Signals in Mode 6.	$0 < V < +0.4$ @ 17 ma. max. Data Ready signals in Mode 5.
J1-11 thru J1-13, 24	Signal Ground (0V) to External Equipment. 0V ground reference for all inputs and outputs (isolated from chassis ground).			



Table 3-1. Interface Signal Descriptions (Continued)

Connector Pin	Description	Interface Circuit (See Figure 2-2) & IC Type	Signal Level	
			True Condition	False Condition
J1-14	System Ready (SYSRDY*) Output. True signal indicates RUN-LOAD switch is in RUN and none of the false condition signals are present (system ready). False signal indicates at least one of the following conditions is present: (1) Load switch actuated (door open), (2) the (EXT INH)* signal is present, (3) either of the tape arms is actuating its tape break switch with spooler enabled or (4) if a drive signal is accepted and a new feed hole is not sensed within 700 ms, this output indicates either no tape or torn tape and serves as the out-of-tape signal.	C SN7400N	$0 < V < +0.4$ @ 16 ma (sink) System Ready	$+2.4 < V < +5.0$ @ 0.2 ma (source) System Not Ready
J1-15	External Inhibit (EXT INH*) Input. True Signal inhibits reader operation and causes SYSRDY* and Data Ready signals to go false. False signal allows reader to operate in normal manner.	A SN7408N	$0 < V < +0.4$ @ 16 ma (sink) Reader Inhibited. Data Ready and System Ready signals False.	$+2.4 < V < +5.0$ (or open circuit) Reader not exter- nally inhibited.
J1-16	Drive Right (DR*) Input. True signal drives tape to right in either low speed (asynchronous) or high speed (synchronous) mode. See Sections 3.3.2 and 3.3.3.	A SN7400N	$0 < V < 0.4$ @ 5.0 ma. max. Reader drives tape to right.	$+2.4 < V < +5.0$ (or open circuit) Reader does not drive tape to right.
J1-17	Drive Left (DL*) Input. Same as drive right except drives to the left.			
J1-18	High Speed Enable (HISPD*) Input. False condition and a true drive signal drives tape continuously at 300 characters/second. True condition and a true drive signal drives tape at 500 characters/sec. This signal must be taken low before a drive signal is applied.	A SN7400N	$0 < V < +0.4$ @ 5.0 ma. max. Tape is driven at 500 charac- ters/sec.	$+2.4 < V < +5.0$ (or open circuit) Tape is driven at 300 characters/ sec.

Table 3-1. Interface Signal Descriptions (Continued)

Connector Pin	Description	Interface Circuit (See Figure 2-2) & IC Type	Signal Level	
			True Condition	False Condition
J1-20	Wind Right External (WR*) Input. True signal winds tape to right provided SPOOL switch is on. False signal allows normal spooling.	A SN7400N	0 < V < +0.4 @ 5 ma (sink) Spooler winds tape.	+2.4 < V < +5.0 (or open circuit) Spooler does not wind tape.
J1-21	Wind Left External (WL*) Input. Same as for J1-20 except wind left.			
J1-22	Winding Output (WINDING OUTPUT*). True signal indicates the spooler is in wind mode by either external signal or wind switch and is not available for normal reading operation. Causes Data Ready signal to show sprocket waveforms during winding.	B SN7408N	0 < V < +0.4 @ 5 ma (sink) Spooler in wind mode.	+2.4 < V < +5.0 @ 0.2 ma (source) (or open circuit) Spooler not in wind mode.
J1-23	+5 VDC @ 200 mA output available to external equipment.			
J1-25	Chassis ground, isolated from signal ground.			

Table 3-2. Front Panel Controls



SWITCH	POSITION	FUNCTION
POWER	ON	Applies AC power to reader.
	OFF	Removes AC power from reader.
RUN-LOAD (actuated by tape access door)	RUN (door closed)	Allows reader and spooler to operate and places SYSRDY* output in true state.
	LOAD (door open)	Inhibits reader and spooler and places SYSRDY* output in false state.
DRIVE CONTROL		Causes tape to be rapidly spooled onto the left reel if spooler is enabled. When LOOP-SPOOL switch is in SPOOL, causes tape to be wound at 1500 characters/sec onto the left reel. When LOOP-SPOOL switch is in LOOP, drives tape to left at 300 characters/sec or 500 characters if the HISPD* line is at OV.
		Same as for  except drives tape to right.
LOOP-SPOOL	LOOP	Disables spooler and allows a tape loop to be read.
	SPOOL	Enables the operation of the spooler.

Table 3-3. Modes of Operation

MODES OF OPERATION	DESCRIPTION
INHIBIT	System is in inhibit mode (drive circuits inhibited) when (1) RUN-LOAD switch is in LOAD, (2) EXINH* input is true, (3) either tape break switch is actuated when SPOOL switch is on, or (4) End of Tape sensor is true.
DRIVE	<u>Low Speed Asynchronous Mode:</u> Pulse or DC level drives tape at 300 characters/second as described in Section 3.3.2. <u>High Speed Synchronous Operation:</u> DC level drives tape at 500 characters/second as described in Section 3.3.3.
SPOOL	When LOOP-SPOOL switch is in SPOOL, spooler is enabled and will pay out and take up tape as required.
WIND	External signal or front panel switch winds tape (left or right) from one reel to the other at speed of 150 inches/sec. (average mid-reel) provided spooler is enabled. Drive commands are inhibited in wind condition.

### 3.4 OPERATIONAL MAINTENANCE

After every 6 to 8 hours of use, the operator should check the tape transport area for cleanliness. This is extremely important since any dirt or foreign material covering the readhead can cause readout errors. For general cleaning, use the stiff bristle brush supplied. Cleaning of the photocell assembly area is described in Section 5.2.1.1. Make sure the tape remains clean at all times since any residue picked up by the tape can be deposited on the readhead. It has been found in certain cases that residue picked up by the tape comes from soiled hands. It is important that care be exercised when handling tape, especially in machining areas or other areas where grease, oil and sprays are present.

### 3.5 TAPE RECOMMENDATIONS AND AVAILABILITY

The tapes listed in Table 3-4 are among those recommended for use. Mylar tapes should be used in applications requiring continuous use. There may be other tapes which are either acceptable or not acceptable but REMEX is not in the position to evaluate all tapes on the market.

Table 3-4. Recommended Tapes

TYPE	MANUFACTURER	PART NUMBER
Paper, Unoled or Oiled (except black carbon filled)	REMEX	715200-002 1000 ft. Roll
	Paper Manufacturers, Inc.	Perfection Series
	Bemis, Friden or Crown Zellerbach	Paper tape Series
Special Paper	Numeridex	1000
	Nova Tech	Syntosil Machine Tool Tape
Special Mylar	Arvey	RVCZ 60 or RVCT 52
	Numeridex	2000

NOTE: Black carbon tapes may be used but with reduced tape life.

### 3.6 TAPE PREPARATION REQUIREMENTS

Proper tape reader operation requires that the maximum accumulated longitudinal error between feed hole centers in the punched tape be  $\pm 0.025$  inch within any span of 5 inches, as specified in the American National Standards Institute Standard X3.18-1967 (ANSI; formerly United States of America Standards Institute). In the event a user has, because of punching problems, a number of tapes which do not conform to this specification by an amount consistently out of tolerance, the reader may be set up as in Section 5.4 using one of these tapes rather than the type specified.

A tape gauge is available from REMEX (part number 110597) so that the  $\pm 0.025$  tolerance specification can be checked. To use the gauge, place the feed hole of one end of a 5-inch span (50 characters) at the single cross hair and swing the other end of the 5-inch span in the arc until one of the cross hairs is centered in the feed hole. Read the measurement adjacent to that cross hair (plus tolerances to the right and minus tolerances to the left). A second 5-inch gauge is printed at the bottom to check both longitudinal and perpendicular transverse center line spacing.

## SECTION IV

### THEORY OF OPERATION

#### 4.1 BLOCK DIAGRAM DESCRIPTION

The REMEX punched tape reader-spooler combination performs three basic functions: (1) it drives tape in either direction over the read station, (2) converts the tape information into electrical signals and (3) spools tape on and off the tape reels. These three functions are described in block diagram form in Sections 4.1.1, 4.1.2 and 4.1.3 and illustrated in block diagram form in Figures 4-1 and 4-2. Table 4-1 which appears at the end of Section 4 lists the various mnemonics and descriptions for the various signals used in the manual and in the schematics.

##### 4.1.1 TAPE DRIVE

Reader card 112041 contains the circuit logic used to operate the stepper drive motor in response to the drive inputs. The reader/spooler can be operated either at 300 characters/sec with the high speed (HISPD\*) input inactive or at 500 characters/sec with HISPD\* at 0V. This card also contains the spooler circuitry and generates the required DC voltages. Refer to Figure 4-1 for the Reader Block Diagram.

With the HISPD\* at +5V or open circuited, applying a 0V signal to the drive left (DL\*) or drive right (DR\*) input line sets the direction memory, Z11-Z12, in the input logic to the desired state and establishes the direction of rotation for the motor by setting the four phase counter. The input logic also produces the active Drive (DRV) signal which triggers the Ready Circuit. It is the function of the Ready Circuit to make sure the reader is ready to accept a drive command and, when the drive command is accepted, to generate the motor clock pulse (MCP\*). The MCP\* pulse is used to advance the phase counter one count which steps the motor. Two phases of the four phase motor are energized at a time in a sequence which advances the sprocket and tape one line either to the left or right depending upon the sequence order of the phases. The tape then stops on character and waits for the next MCP\* pulse. The Ready Circuit also locks out the sprocket signal for 1.3 ms after the MCP\* is generated so that any initial jitter in the sprocket is locked out as the tape starts up and the sprocket goes off character.

When the next sprocket hole is read, the sprocket output is amplified, delayed 140  $\mu$ s and sent to the Ready Circuit. Upon receipt of the sprocket signal, the Ready Circuit generates the following three signals: (1) a Data Ready signal for use in external equipment, (2) strobe signal which latches up the data from the readhead and (3) a 200  $\mu$ s delay to allow data to be examined and make the stop-go decision. At the end of the 200  $\mu$ s delay, if the drive signal has not been removed, the read-drive cycle will be repeated and the tape will advance another line.

In high speed operation (500 characters/sec speed) the High Speed (HISPD\*) line is pulled down to 0V which enables the high speed circuitry. The drive sequence is similar to that described for low speed operation except that at the end of the first character, the reader determines if drive is still required and if it is, generates the drive sequence again but this time with an extra MCP\* pulse a short time after tape goes off character. This sets the motor counter one count ahead of the line to which the tape is advancing. When that line is reached, the motor will not stop, unless the drive signal is removed, but will continue rotating one more line. Again, when the tape goes off character, the counter is always one count ahead of the line being read on the tape. If, during the 200  $\mu$ s data

sampling period, the reader drive signal is removed, the high speed circuitry is reset. This causes another MCP\* pulse to be generated which now backs up the counter one count causing the motor to stop on character. The Reverse Lock (REVLK\*) line goes true at this time which lock out all drive signals to permit a 15 ms min. settling time.

The reader can be inhibited by any one of four methods: (1) raising the Upper Tape Guide to its upper position which actuates the Load Switch S2, causing the 0V Load Signal to be generated, (2) a 0V, (External Inhibit\*) signal applied to J1-15, (3) either tape break switch in the spooler being actuated or (4) a 0V (Winding\*) signal generated by the spooler indicating the spooler is in wind mode. Items 1 and 2 are gated to form the Inhibit (INH\*) signal which inhibits the Ready Circuit and places the System Ready (SYSRDY\*) in the false state. The Winding\* signal is also applied to the Four Phase Counter and Amplifier to inhibit any Motor phase signal and allow the sprocket to freewheel during a winding operation. The SYSRDY\* signal also goes false if, after receipt of a drive signal, no new sprocket is sensed within approximately 700 ms, indicating that the reader is out of tape.

#### 4.1.2 TAPE READING

The readhead is located under the fiber optic light source and contains photovoltaic cells which are used to sense the punched tape perforations. As tape is advanced over the readhead by the sprocket drive, the photovoltaic cells are energized by the light source when the corresponding holes are present in the tape. The outputs from the readhead are then applied to the data track amplifiers and latch circuits on the card. A true, 0V Strobe signal locks up the two latch circuits, Z3 and Z4, storing that line of data. The outputs of the latch circuits are applied to the Mode Select gates which produces either mode 5 or 6 outputs depending upon the level applied to the Mode Select input. At the same time, the Data Ready output signal goes true (+5V) and it too is gated with the Mode Select signal.

#### 4.1.3 SPOOLER BLOCK DIAGRAM

The tape spooler portion of the reader-spooler combination performs the following functions: (1) supplies and takes-up tape from the reader during servo mode operation, (2) provides high speed wind in either direction, and (3) provides gating and logic control for the spooler input and output signals. See Figure 4-2 for the Spooler Block Diagram. These modes of operation are discussed below in block diagram form.

Servo mode operation is achieved by the use of an output signal from an arm potentiometer which is proportional to the position of the tape arm. This signal is applied to a summing amplifier which controls a power amplifier that drives the servo motor. When the arm is in the center of its travel the servo motor is not turned on. However, arm movement, caused by the movement of the tape, turns on the motor in the direction which winds or unwinds the tape to bring the arm back to its center position.

Wind mode operation can be initiated from either a front panel switch or an external input which is applied to the Input/Output Gating circuitry provided the spooler is enabled. The resulting Wind signal closes a FET switch which allows the Wind Ramp and the Wind Speed Regulator signals to be summed at the input of the Summing Amplifier. Wind mode begins slowly as an increasing ramp from the Wind Ramp circuitry and gradually brings the servo up to a fixed speed. As the tape begins moving, the Sprocket signal from the reader is applied to the Wind Speed Regulator circuit. This circuit regulates the winding speed throughout wind mode by sampling the frequency of the sprocket and generating a second input to the summing amplifier which is proportional to the frequency. Normal Servo action occurs at the trailing side as the tape unwinds to meet the demand of the leading side. Wind operation also ends slowly allowing the spooler to gradually come to a stop.

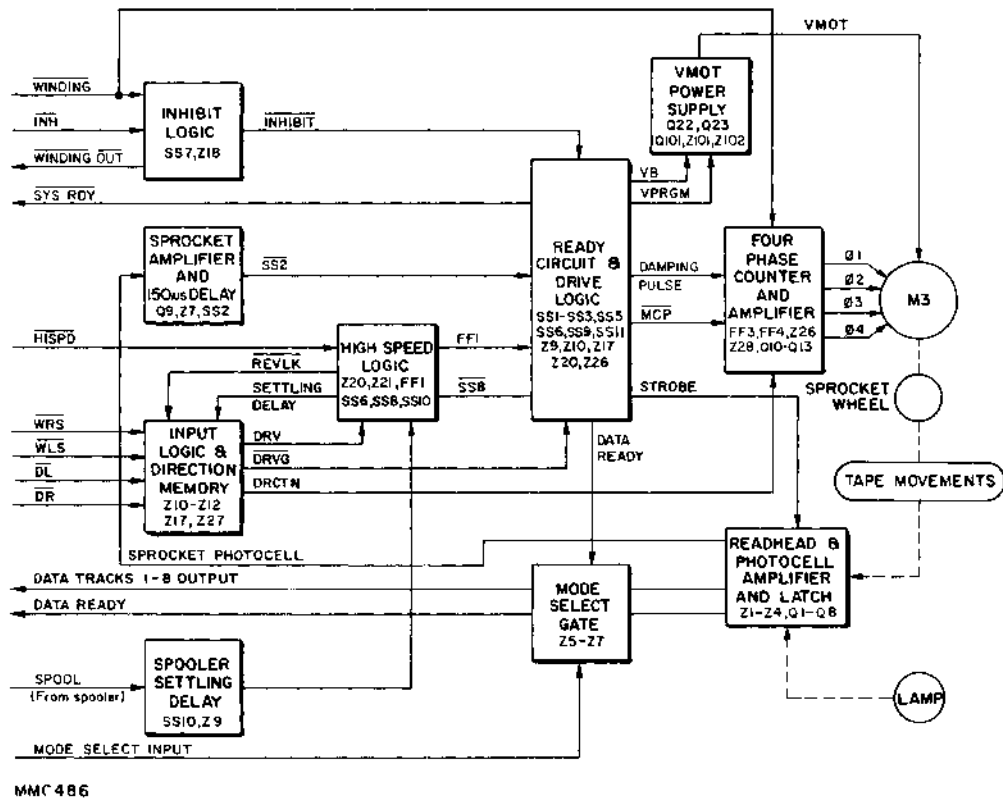

Figure 4-1. Block Diagram, Reader Circuitry. Component Designations listed are for RRS6500.

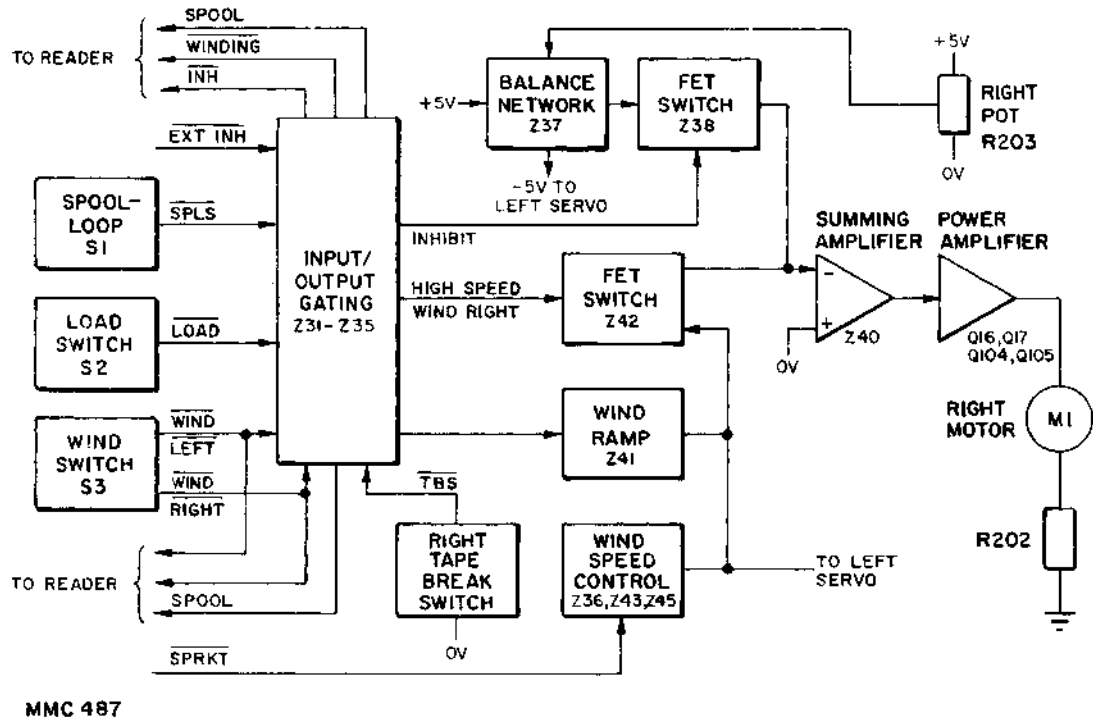
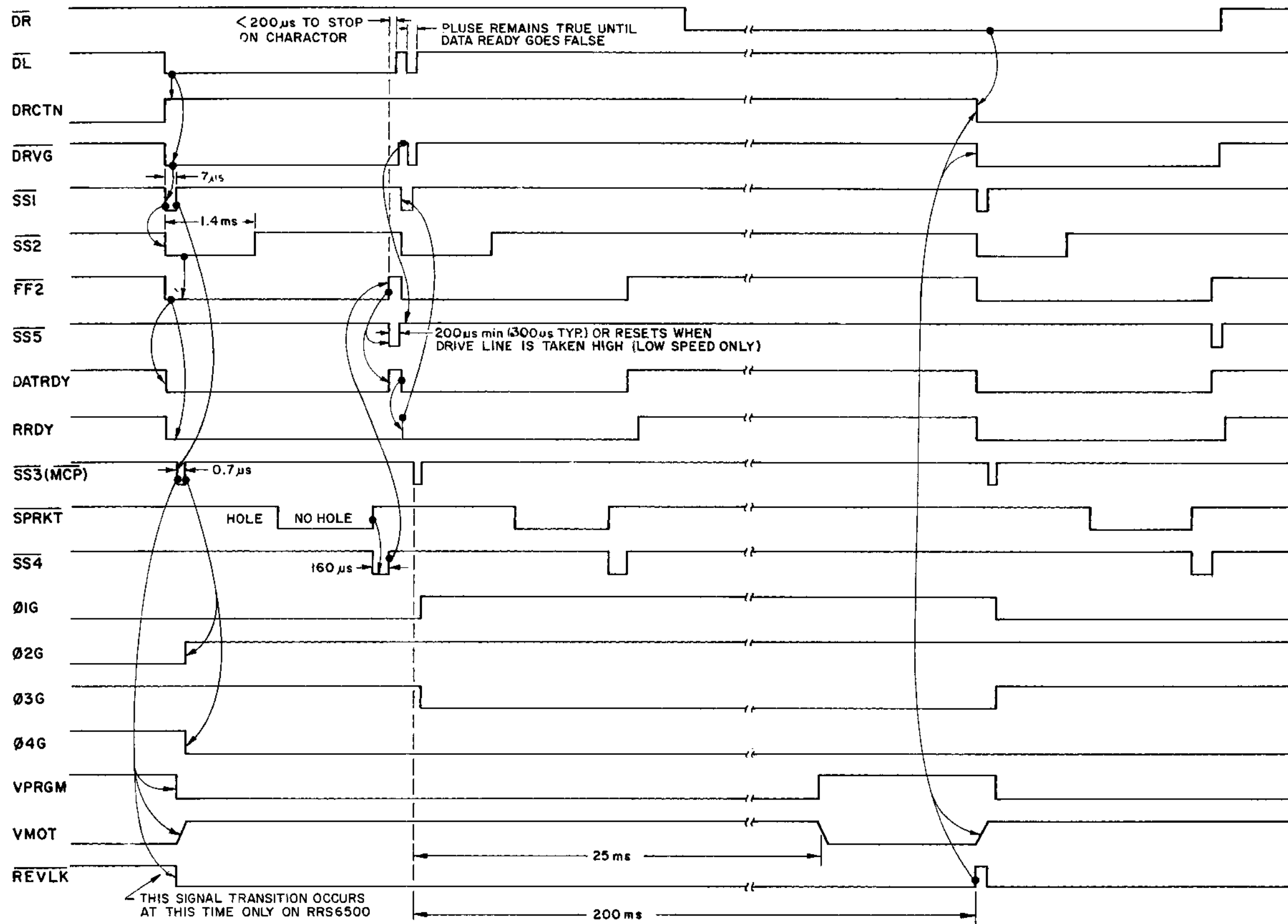

Figure 4-2. Block Diagram, Spooler Circuitry, RRS6500 Only.

In addition to the functions previously described, the Input/Output gating also performs the following functions:

- a. Wind switch inputs are gated with the external Wind inputs to generate a High Speed Wind signal for a given direction. If both direction wind signals are present at the same time, neither High Speed Wind signal becomes true.
- b. An External Inhibit, Load, or Tape Break signal or the LOOP-SPOOL switch not being in the SPOOL position will inhibit both spool and wind operations.
- c. The Winding output, used by the reader, is held true until the winding operation is complete and the winding ramp has dropped to its original value.
- d. A Spool signal is generated whenever the LOOP-SPOOL switch is in the SPOOL position and is used by the reader to insert a delay when driving from one direction to the other.





MMC 499

Figure 4-3. Timing Diagram, Reader Card 112041, Low Speed Operation.

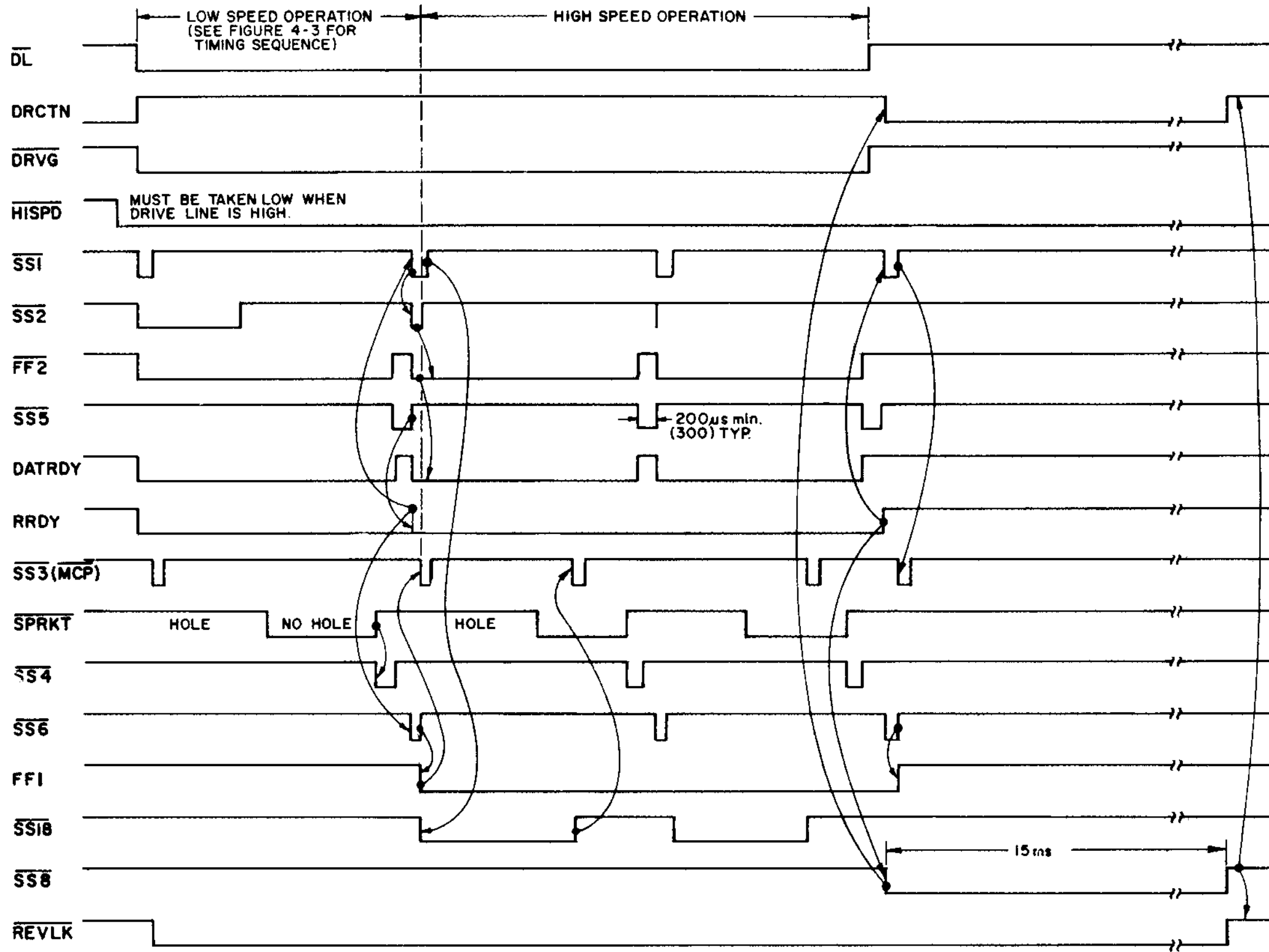

**MMC 500**

Figure 4-4. Timing Diagram, Reader Card 112041, High Speed Operation.

## 4.2 CIRCUIT CARD DESCRIPTIONS

### 4.2.1 READER CIRCUITRY

The reader circuitry on PC card 112041 is used: (1) to generate outputs to drive the four phases of the stepping motor in response to the drive inputs and (2) to provide amplification and gating of the readhead outputs.

#### 4.2.1.1 Inhibit Circuitry

Normal operation begins with the loading of the tape. Opening the tape access door actuates the Load switch, S2, causing 0V to be applied to the LOAD<sub>1</sub>\* line and in turn to Z51-8, 9 and Z30-2. Z30-3 and Z30-6, in turn, drop to 0V and place the Inhibit (INH\*) line at 0V. See Figure 8-1, sheet 3. Notice also that the true INH\* signal can be generated by either (1) a 0V, External Inhibit (EXT INH)\*, (2) a Tape Break Switch (TBS)\*, (3) by Z25-12 which is the Q\* output of the power on single shot (inhibits the system when power is first turned on to allow system to stabilize) or (4) the LOOP-SPOOL switch in LOOP position.

The INH\* signal is applied to Z18-13 (sheet 1 of Figure 8-1) which causes Z18-11 to go to 0V and perform three functions: (1) it clears and inhibits flip-flop FF2, thereby preventing any sprocket from being recognized, (2) through Z20-3 and Z17-6 it causes the Reader Ready (RRDY\*) signal to drop to 0V which prevents any drive signal from being recognized, and (3) through Z21-2 and Z22-11 places the Data Ready (DATRDY) at signal at 0V, thereby inhibiting data. The INH\* signal is also applied to Z22-5 causing a false (+5V) System Ready (SYSRDY\*) signal to be generated.

During loading, the tape arms are moved inward past the locking pins. See Section 3.3.1 step f. In this position Tight Loop switches S6 and S7 are actuated which removes the 0V from signals TLS<sub>1</sub> and TLS<sub>2</sub>. Removing either or both of these signals places Z51-13 at 0V and sets the flip-flop consisting Z52, pins 4-10. See Sheet 3 of Figure 8-1. This signal can also generate the INH\* signal through Z52-3, Q24 and Z30-3. When tape is loaded these arms are moved outward to their normal servo positions. This removes the set signal from flip-flop Z52. When the door is closed, the LOAD<sub>1</sub>\* rises to +5V which places Z52-11 at 0V and resets the Z52 flip-flop, thereby removing the inhibiting effects of INH\* and making the reader operational.

#### 4.2.1.2 Drive Circuits, Low Speed Operation

During the following description, refer to Figure 4-3 which shows the waveforms and timing diagrams for drive at low speed operations. This figure is intended as a guide to show the sequence of events and which signals initiate other signals. It must be cautioned that due to the wide range of pulse widths, no attempt has been made to draw the time axis to exact scale. Refer also to the schematic, Figure 8-1, sheet 1, during this description.

With the inhibiting signals removed, the SYSRDY\*, DATRDY and internal RRDY signals are true allowing the drive signal to be recognized. Operation of the drive circuits is first described using low speed (300 characters/sec) and then at high speed. During low speed, the HISP\* signal is +5V false, causing FF1 to be set. Applying a 0V, DL\* signal at J1-17 sets the direction flip-flop, composed of Z11 pins 8-13. This causes the direction line at Z7-8 to rise to +5V. A +5V RTDIR\* signal sets up the four phase counter, composed of FF3, FF4, and Z28 to energize two motor phases at a time in the sequence which drives,

tape to the left, i.e., phases 4 and 3, 3 and 2, 2 and 1, and then 1 and 4 (drive right is the reverse order). The counter is advanced one count with each clock pulse received from SS3\* (MCP\*) as described in a subsequent paragraph.

The output at either Z11-8 or Z11-11 of the direction flip-flop is also used to turn off either Q14 or Q15 depending upon the drive direction. A 0V Drive Left (DL\*) places Z11-8 at +5V which places Z17-8 at 0V (the WINDING\* signal is also +5V during Read mode). Q14 then turns off, thereby deenergizing the left solenoid on the tape tensioning assembly. See Figure 6-2. This causes the spring loaded solenoid pin to engage the friction plate and create a drag on the roller which produces a tighter tape pack in the take-up reel. In Wind mode, the WINDING\* signal is 0V which energizes both solenoids, causing the pin to disengage the friction plate. Both rollers then rotate freely during wind mode.

The 0V, DL\* signal also generates the +5V true Drive (DRV) signal at Z10-6 and, in turn, the 0V Drive Gate (DRVG\*) signal at Z10-3. This signal is used two places: (1) to trigger the 7  $\mu$ s single-shot SS1 and (2) to enable the 1.4 ms single-shot SS2. Output SS1\* in turn, is inverted at Z21-4 and used to trigger SS2 on the positive going edge and SS3 on the negative going edge at the end of the 7  $\mu$ s time period. The negative going SS3\* (MCP\*) is applied to the reverse lock single-shot SS10 which is a retriggerable single-shot and is used to lock out any drive signal in the reverse direction. It is also applied to SS9 and SS11 causing the motor voltage to come up to its full value. At the end of the 0.7  $\mu$ sec MCP\* pulse, the positive going edge is applied to the four phase counter causing the motor to move the tape one line to the left.

The SS2\* signal is used to set flip-flop FF2. This results in the negative going FF2\* output which causes the DATRDY signal to go false (0V) through Z20-3, Z21-2 and Z22-11. FF2 causes the SYSRDY\* signal to go false (+5V) through Z22-8 and Z22-6. FF2 stays locked in the set condition until SS2 times out (approximately 1.4 ms). As a result, any noise or startup jitter from the sprocket signal is prevented from generating a true Data Ready signal.

When the next line is read, the positive going edge of the Sprocket signal triggers the 140  $\mu$ s Sprocket Delay single-shot SS4. This delay is required when using a feed hole advanced tape to electronically delay the feed hole and make sure all data is latched before the sprocket is recognized. With standard in-line feed holes this serves only to add an extra safety margin. At the end of the 140  $\mu$ s delay, the positive going edge of SS4\* resets FF2. The resulting positive going edge of FF2\* is used two places: (1) to trigger single-shot SS5 and (2) to generate the positive going DATRDY signal through Z20-3, Z21-2 and Z22-11 (and the 0V Strabe signal at Z29-12). The function of SS5 is to provide a 200  $\mu$ s delay by holding the RRDY line at 0V. This allows the external equipment to examine the data and make the go/no-go decision. If the decision to stop is made, the DL\* input line must be taken high within 200  $\mu$ s (actually 300 but conservatively specified at 200 $\mu$ s). Otherwise, when SS5 times out, the positive going RRDY will trigger SS1 and repeat the tape advance cycle. If the drive line is taken false and then returned to the true state during the 200  $\mu$ s period of SS5, SS5 will be reset by the DRVG\* signal from Z10-8 applied to Z8-11 and the next drive sequence will begin as soon as the drive line returns to 0V.

Single-shot SS10 is a retriggerable single-shot with a period of approximately 200 ms. It is triggered by each negative going edge of SS3\* provided the reader is in spooling mode (SPL signal is +5V). The SS10 output places the REV/LK\* signal at 0V and prevents any change in drive direction for 200 ms after the last drive command by locking up the direction flip-flop at Z12, pins 10 and 13.

When the unit is in Wind mode, a 0V WINDING\* signal is generated from the spooler section. See Section 4.2.2.2. This signal is applied to the reader section at Z18-9 and Z19-10. Z18-8, in turn, drops to 0V which inhibits all the motor phase amplifiers at Z26, pins 1, 5, 9 and 12, allowing the step motor to be free-wheeling during wind. 0V is also applied to Z21-5 which places +5V at Z22-2. In this manner, the DATRDY signal subsequently generated during wind will be the result of the SPROCKET signal appearing at Z22-11. The 0V signal at Z18-8 is also applied to Z18-1 which produces a 0V inhibit signal at Z18-11 and prevents any drive signal from being recognized by locking up FF2 and SS5. Pin 3 of Z18 also generates the 0V (WINDING OUT)\* output at J1-22 through Z18-6.

At the end of Wind mode, the positive going edge of the WINDING\* signal triggers single-shot Z19 at Z19-10, placing pin 12 at 0V for approximately 350 ms. This maintains Z18-8 at 0V for 350 ms beyond the WINDING\* signal to make sure the spooler has stabilized. At the end of the 350 ms time period, the positive going Z19-12 signal triggers single-shot Z19 at Z19-2 for 25 ms. FF2 and SS5 remain inhibited during this 25 ms but the motor is no longer inhibited and assumes the phase position of the counter. At the end of 25 ms, the motor will be stabilized, all inhibits will be removed and the reader can accept a drive command.

#### 4.2.1.3 Drive Circuits, High Speed Operation

During high speed operation, HSPD\* is 0V which releases the set signal at FF1 (Z14-10). This flip-flop remains set, however, until the beginning of the second drive step as described later. During the stepping from the start character to the first new line to be read i. e., the first step, the reader is operated in low speed as previously described. At the end of the SS5, 300 ms time out (or shorter if the drive line has been taken false and returned true within the specified 200 $\mu$ s min.), the RRDY signals triggers SS1 to begin another step as described for low speed operation. RRDY also triggers SS6 which resets FF1 on the positive going edge at the end of 450 ns (SS6 is also triggered in low speed operation but since FF1 is held in the set state, SS6 has no effect). The negative going edge of FF1 triggers SS3 (since SS1 is still timing out, SS1\* is low and Z21-4 is high) producing the next MCP\* pulse. Note that the time period of SS1 is more than 10 times that of SS6 so that FF1 is able to trigger SS3 before SS1 times out. In addition, the 0V, FF1 signal at Z9-2 inhibits any further SS1 pulses from triggering SS3 during the time HSPD\* is active. The motor is now advancing to the second character as in low speed operation. FF1\* is now +5V so that when SS1 times out SS18 is triggered. At the end of the SS18 time, the positive going SS18\* signal triggers SS3 and another MCP\* is generated. This will occur approximately when the sprocket goes off character. The counter is now one count ahead of the phase to which the motor is being advanced. Thus when the next character is reached, if the reader has not been told to stop, the motor will continue advancing to the next character without stopping. The reader has now reached high speed operation. Each time SS1 times out as each new step is begun, the counter will again be pulsed causing it to always be one count ahead. In this manner, the reader is able to move tape in excess of 500 characters/sec. The time of SS18 is adjusted by R88 to compensate for the many variables in high speed operation and is set to provide a tape speed of 550  $\pm$  10 cps. It should also be noted that when the reader has entered high speed operation (FF1 is reset), R117 is placed in parallel with R89 which reduces the time of SS2 to 0.7 ms.

If during the SS5 time period, the drive signal is removed, the DRV signal will drop to 0V, enabling SS8. The DRVG\* will go positive and turn off SS5 causing the resulting positive going RRDY signal to trigger SS8. In turn the negative going edge of SS8\* performs the following functions: (1) provides a 15 ms inhibit to the REVLK\* line and therefore to the direction flip-flop to prevent any direction change from being recognized during the time the motor is stabilizing, (2) reverses the DRCTN line at Z7-9 and (3) inhibits any drive signal at Z10-2.

RRDY also triggers SS1 and with the DRCTN line reversed, the resulting MCP\* signal causes the counter to back up one count which puts it in phase with the existing motor position, causing it to stop. When SS8 times out, the REVLK\* signal returns to +5V, the direction line returns to the last commanded direction and the reader is ready to accept the next drive signal. Application of another drive signal will repeat the sequence just described. If the HISPDP\* is returned to +5V, FF1 is set and high speed operation is ended.

#### 4.2.1.4 Tape Reading Circuits

Nine photovoltaic cells in the readhead assembly sense the perforations in the tape. Refer to Figure 8-1, sheet 2. An illumination system consisting of a lamp and a fiber optic light conducting system provides a continuous beam which covers the area of the photocells. The tape is driven over the top of the photocell block and when a hole appears between the photocell and the light source, the photocell becomes energized.

Each cell output is applied to an amplifier-latch circuit, Q1-Q8, Z3 and Z4. Track 1 is used in the following discussion since it is typical of tracks 1-8 (the Sprocket signal is developed differently as described in a subsequent paragraph). When track 1 becomes energized, the negative going signal at the cathode of the photocell turns off Q1. Q1 is interconnected with the D4 input and Q4\* output of Z4 in a manner which allows Q1 and the first stage of Z4 to function as a Schmitt trigger. Z4 follows all changes in the photocell output until the 0V STROBE signal (see Section 4.2.1.1) is generated which locks up Z4.

Track 1 output at the Q4 of Z4 is +5V true and is gated with the Mode Select signal at Z5-9 and 10. A 0V Mode Select input provides a mode 5 output at J1-1 (i.e., 0V for no hole and +5V for hole). Conversely, when the Mode Select signal is +5V, J1-1 will produce a Mode 6 output (i.e., +5V for no hole and 0V for hole). The DATRDY output is gated in the same manner as the track outputs at Z7, pins 12 and 13.

The sprocket track is somewhat different than the other eight tracks in that its Schmitt trigger uses an inverter Q9 and an exclusive OR gate Z7, rather than part of a latch and is independent of either the Strobe or DATRDY signals. See Figure 8-1, sheet 1. It is also used only as an internal logic signal and is not gated with the Mode Select signal.

#### 4.2.2 SPOOLER CIRCUITRY, RRS6500 Only

The spooler circuitry is used to perform three basic functions: (1) to control the payout and take-up of the spooler motors during servo mode operation, (2) to provide high speed wind in either direction and (3) to provide gating and logic control for the spooler input and output signals. Refer to Figure 8-1, sheet 3 during this description.

##### 4.2.2.1 Servo Mode Operation

Because the 112041 card contains identical servo motor circuits for each side, the discussion will be confined to the right servo. Operational amplifier Z40 and the power amplifier consisting of Q16, Q17, Q104 and Q105 are used to control the right motor, M1. During servo mode, the only input to Z40 is from the right arm potentiometer, R203, which generates a signal proportional to the movement of the tape arm. This signal is biased by the -5V output from pin 6 of amplifier Z37 and applied through the FET switch at Z38-3 to Z40-2. The FET switch is turned on when the LOOP-SPOOL switch is in the SPOOL position except during inhibit modes as will be described later. The potentiometer is adjusted so that when the arm is in the center of its travel area, the output of the summing amplifier Z40 causes no reel rotation, i.e., Q16 and Q17 are both turned off.

The tape arm is spring loaded and follows the movement of the tape. When a tight tape situation occurs causing the tape arm to move in toward the readhead, the output at Z40-6 goes positive which turns on Q16 and Q104 and energizes the motor. As a result tape is payed out causing the arm to move back to the center which then shuts off the amplifier. Conversely, if a tape slack condition occurs, the spring loaded arm moves out toward the limit stop. The output of Z40-6 then becomes negative which turns on Q17 and Q105 and energizes the motor so that the tape is taken up and the arm moves back toward the center.

#### 4.2.2.2 Wind Mode Operation

During wind mode, the payout side operates entirely in servo mode as described in Section 4.2.3.1. The take-up servo in wind uses the following two inputs in addition to the arm potentiometer: (1) a ramp generator input which gradually brings the take-up motor up to speed and (2) a wind speed regulator input which is produced by sensing the frequency of the sprocket holes. This circuit will be discussed in a subsequent paragraph. Refer to Figure 4-5 during this discussion.

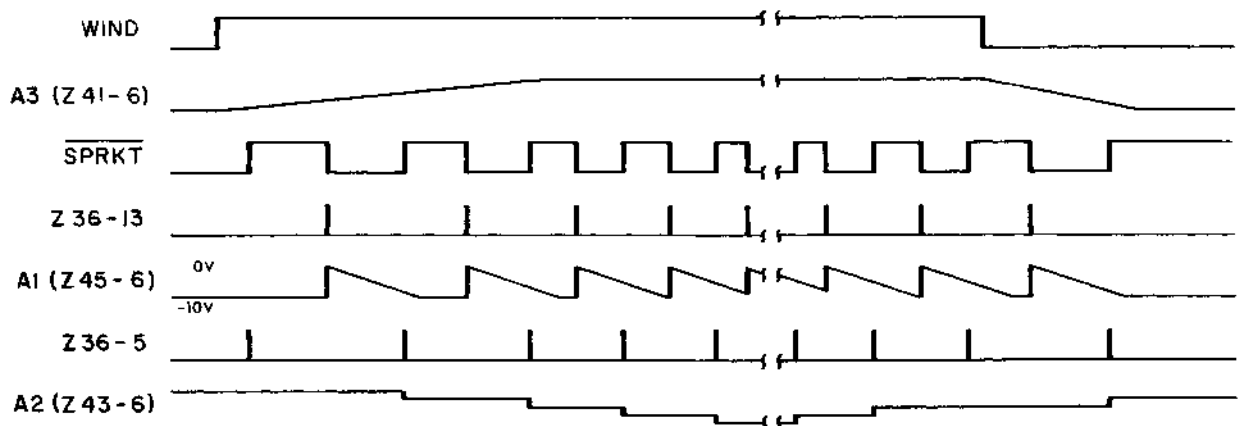

### MMC 502

Figure 4-5. Timing Diagram, Wind Speed Regulator Circuitry.

Applying a 0V, (Right Wind)\* signal from either the direction switch, S3, or an external input sets the direction memory composed of Z32 and places Z33-3 at 0V and, in turn Z33-6 at +5V. At this time, S1 is in the SPOOL position (SPLS\* at 0V) and the INHIBIT\* signal is +5V placing Z30-8 at +5V. This signal is then gated with the +5V from Z33-6 causing Z31-11 to drop to 0V. C20, in turn, begins to discharge which starts Z41-6 rising toward +5V. Meanwhile, Z32-6 has been set to +5V which places Z34-43 at +5V. This causes Z35-4 to drop to 0V which turns on FET Z42 at pin 2. The FET switch allows both the ramp generator output at Z41-6 and the speed regulator output at Z43-6 to be summed at Z40-2. Pin 6 of Z40 then goes negative causing the right reel to take-up tape. As C20 discharges, the right motor gradually increases its rotational speed.

The ramp signal is also applied to Z34-13 and 12 which switches its output at Z34-11 to +5V. This, in turn, switches Z29-10 to 0V and reinforces the Winding\* output which is used to lock up the reader direction memory and inhibit the reader drive circuits. See Section 4.2.1.1. When the (Wind Right)\* signal is removed the Winding\* signal which was generated from Z29-8 will be removed, but the Winding\* signal from Z29-10 will remain until the winding ramp drops below the point necessary to hold Z34-11 high.

To remain a constant wind speed, the frequency of the SPRKT\* signal is sampled and converted to a DC level and summed with the wind input signal at Z42-3. Figure 4-5 shows the timing diagram for the wind speed regulator circuitry, composed of Z36, Z35, Z44, Z45 and Z43, and the associated components. As the SPRKT output is generated, it is applied to both pins 1 and 10 of Z36 causing a positive going pulse at pin 5 on the positive going edge of the SPRKT and a positive going pulse at pin 13 on the negative going edge of the SPRKT. Z36-13 is inverted at Z35-10 and turns on Z44 at pin 7 for 30 $\mu$ s. With Z44 on, C18 discharges through R31 causing Z45-6 to rise to 0V. When Z44 turns off, C18 again charges through R27 resulting in a declining ramp at Z45-6 which drops to approximately -10 Vdc (Waveform A1, Figure 4-5).

Halfway thru the declining ramp, the pulse at Z36-5 is generated by the positive going edge of the SPRKT signal. This signal is, in turn, inverted at Z35-8 and turns on Z44 at pin 2. Pin 2 of Z43 at this time samples the ramp generated at Z45-6 which is biased by R29, R30, R32 and R33 to a level slightly above ground. The output at Z43-6 then is a negative DC level which is summed at Z42-3 with the winding ramp input. If the speed increases, the frequency of the SPRKT signal increases causing Z45-6 to be sampled earlier in the ramp. This increases the voltage at Z43-2 and, in turn, applies a more negative voltage at Z43-6 to offset the wind input (Waveform A2, Figure 4-5). Conversely, a decrease in speed causes the ramp to be sampled later, resulting in a decrease in voltage at Z43-2 and a less negative voltage at Z43-6. The bias level of Z43-6 is adjusted by R36 so that rewind speed can be set for 1500 characters/second.

#### 4.2.2.3 Inhibit Mode

Any of the following signals will inhibit the spooler: (1) a 0V External Inhibit (EXH INH)\* signal present at J1-15, (2) the LOOP-SPOOL switch not being in SPOOL, (3) a broken tape switch signal (TBS\* at 0V), (4) a tight tape switch condition (TLS<sub>1</sub> or TLS<sub>2</sub> at +5V), or (5) a 0V LOAD\* signal from S2.

Considering the EXTINH\* first, a 0V signal at Z20-9 places 0V at Z30-3 and, in turn, at Z30-6 and Z30-8. A 0V signal at Z30-8 inhibits the spooler by causing Z35-12 to go to +5V which turns off FET switches Z38 at pins 2 and 7. Similarly, a +5V SPLS\* signal places Z29-6 and, subsequently, Z30-8 at 0V. When a tape break switch is actuated, the resulting 0V signal is inverted at Z33-8 and applied to Z30-12. Single-shot SS17 provides a 350 ms delay so that an accidental switch actuation is not recognized. If the switch is not actuated longer than 350 ms, Z30-11 will return to 0V before Z24-12 times out and no change will occur at Z30-11. However, if TBS\* is longer than 350 ms, Z30-11 will go positive causing Z31-3 and subsequently Z30-6 to drop to 0V and inhibit the spooler as previously described.



#### 4.2.2.4 Tape Tension Description

Tape handling, at all speeds, requires that the proper tape tension be maintained. This is especially true where rapid, hi-torque starting, reversal of direction, and stopping is necessary. In addition, at times it is necessary to maintain different tape tensions at various points of travel throughout the tape transport mechanism due the different and simultaneous requirements of the various tape mechanisms.

For example, in order for the tape to be moved over the readhead in a start-stop "geneva" mechanism fashion, the tape must have a certain tension applied in order to flow smoothly. At the same time, in order to insure proper packing on the take-up reel, the tape must have a constant tension applied which is significantly different than the tension at the readhead. This is necessary to prevent uneven winding or loose pack on the take up reel.

The REMEX RRS6500 utilizes a unique combination of tape handling devices designed especially to maintain the required tape tension at each point of travel throughout the tape handling process. The tape travel and associated tension requirements are described in the following paragraphs and illustrated in Figure 4-6.

Assume that a full reel of tape is loaded on the right hand reel and an empty reel is placed on the left spindle. As the tape is moved from right to left during servo mode, it passes by a number of points which require different tension. As the tape is wound on the left hand reel, it starts winding on a small diameter since the reel is nearly empty. This means that the take up motor, if it were a fixed power or constant torque motor, would have a greater wind torque advantage when the reel was empty than when the reel was nearly full. To overcome this effect of varying tape diameter, a variable torque motion is used which is controlled by the position of the tape tension sensing arm. This arm indicates to the motor when and how much tape to take up by means of a potentiometer attached to the arm which controls a dc servo. When the reader stepper motor drives tape toward the left reel, the tape sensor arm senses the slack in the tape causing the take up motor to rotate counterclockwise. This takes the slack out of the tape and moves the sensor arm back to its mid-range.

Thus it can be seen that the tension applied to the tape by the sensor arm is the tension at which the tape passes the readhead at point (C). The tape sensor arms are adjusted so that with the stepper motor stopped, the torque motor applies just the amount of tension to the tape required to hold the tape sensor arms in their approximate mid-position. Since the take up and supply motors always return their arm to the mid-position, it is evident that the tension applied to the tape across the readhead is a function of the tape arm return spring tension.

The tape at point (A) where it winds onto the left reel must be kept at a higher tension than at point (C) and must be reasonably constant throughout the take up process. This is accomplished by a special tape tensioning assembly which applies tension only when, in servo mode, its associated reel is taking up tape, e.g., left tape tensioning assembly when tape moves to the left. The opposite assembly at this time is free wheeling. A solenoid clutch arrangement is used to accomplish this. The solenoid on the take up side is turned off which causes the solenoid plunger to engage a friction plate and thus apply a constant drag or tension on the tape as it winds up See Section 4.2.1.2 for electronic description. Thus it can be seen that the tape at point (A) has a higher tension than at points (C) or

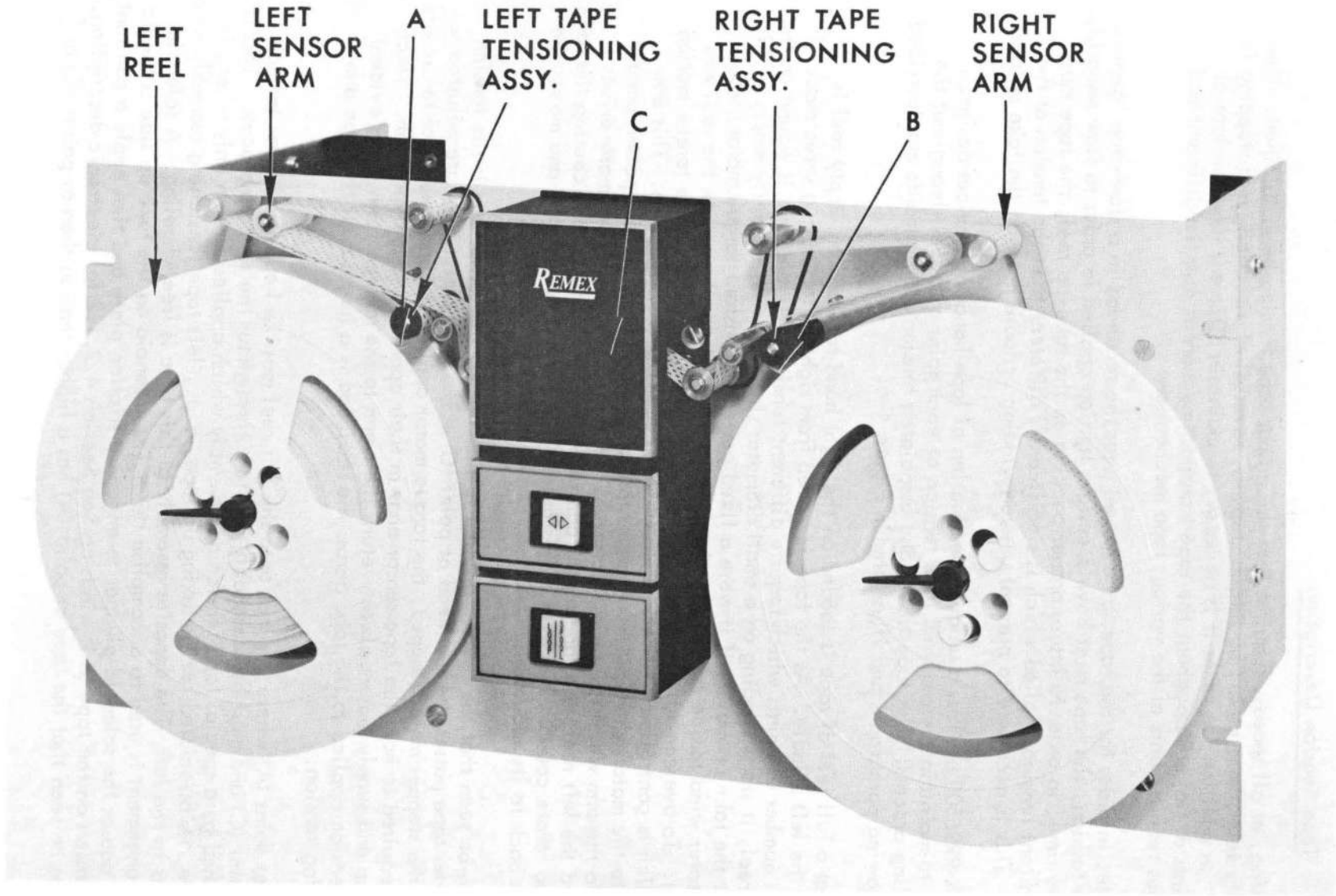

Figure 4-6. Front View Showing Various Points of Tape Tension.

(B) when tape is moving from right to left. Both solenoids are energized during wind to eliminate tape tension. Adjustments for the potentiometer, the tape sensor arm spring tension and the static torque on the tape tensioning assembly are given in Section 5.

#### 4.2.3 POWER SUPPLY VOLTAGES

Six voltages are generated by the power supply section: +5 Vdc,  $\pm 15$  Vdc,  $\pm 24$  Vdc, VMOT, VB and V Lamp. The  $\pm 24$  Vdc are developed from bridge rectifier BR1 and are used as the supply voltages for the servo motor power amplifiers. The +5 Vdc and V Lamp are produced from regulators Z101 and Z102. Their primary source is from rectifiers CR3 and CR4. R5 allows the lamp voltage to be adjusted as described in Section 5.5. Z101 and Z102 are commercially packaged five volt regulators, LM309K, which are mounted (along with Q101) on a heat sink external to the card.

CR1 and CR2 rectify the 75 VRMS from T1 to produce approximately 55 Vdc at the output of the filter network composed of C4, R2 and C5. This voltage is applied to the collector of the series pass transistor, Q101, and to a constant current source comprised of Q22 and its bias network. Q22 supplies the base drive for Q101. Control of Q101 is achieved by shunting some of the current from Q22 through Q23 instead of allowing it to reach the base of Q101. A resistive divider network composed of R10, R11 and R12 applies a voltage proportional to VMOT to the base of Q23. Q23 compares this voltage to the 6.2 volts developed by Zener diode CR9 and shunts more or less of Q101's base current as required to maintain VMOT constant.

When the step motor is moving, R12 is held at ground potential by the VPRGM line and VMOT is set by R11 for approximately +34 Vdc. During periods when the motor is stopped for longer than 700 ms, VPRGM appears as an open circuit and allows current to flow through R13. This change in the divider network forces VMOT to regulate at approximately 1/3 of the running potential, thereby conserving power during periods of inactivity.

#### 4.3 LIGHT SOURCE

A filament type lamp rated at 5.0 VDC is used as the light source. It is operated at approximately 15% below rated voltage to provide a long life expectancy. The lamp is mounted in a sleeve at the rear of the front panel. A lens contained in the lamp focuses the light to the fiber optics system which, in turn, conducts the light to the photocells.

Table 4-1. Mnemonics Used On RRS6500 Schematics.

Mnemonic	Definition
1. DLM, DRM	Memorized drive commands. Outputs of an R-S flip-flop which remembers the last DL or DR command.
2. DRV	Drive signals. Initiates or continues stepping operation.
3. DRVG*	Drive signal gated by another function. (STOP DLY in the RRX6500.)
4. FCHM (FF1)	First character memory. Stores fact that first character has been completed in HISPD clocked by FCHP. Enables SPKTIC path, indirectly disables SEQIC path; activates REVLK.
5. FCHP (SS6)	First character pulse. A pulse generated by RRDY at the termination of the first character step. Clocks a latch to allow high speed operation if reader is in HISPD mode.
6. HISPD*	An input connector signal which activates the high speed stepping mode.
7. INH*	A signal which inhibits reader operation. Activated by EXTINH* or load or tape error or any other malfunctions signal. Deactivates system ready.
8. MCP* (SS3)	Motor Clock pulse. Count input to motor phase counter.
9. OPRT	Signal enabling reader to respond to stepping drive commands. Inactivated by Inhibit or winding operations.
10. OPRTD (SS15)	A timer which delays OPRT at end of a winding operation. Follows WNDD*.
11. REVLK	Signal which prevents direction reversal. Active during SPLRVD or after first character in high speed mode or during STOP DLY in Loop mode.
12. RRDY (See SS5)	Reader ready. A signal which indicates reader is ready to start a new step sequence. RRDY is held inactive for a timed period after DATARDY goes active, to allow a stop-on-character decision to be made. (See SSEQIP.)
13. RTDIR	Signal which indicates stepping direction is to the right. Controls the motor phase counter.
14. SEQIC	Sequence initiated clock. Input to the motor clock pulse generator from SSEQIP.
15. SPKT	A signal which indicates the Sprocket (feed hole) signal is active.

Table 4-1. Mnemonics Used On RRS6500 Schematics. (Continued)

Mnemonic	Definition
16. SPKTD* (SS4)	A timed pulse which delays the response to a SPKT high transition. Purpose is to delay SPKT signal in readers using advanced feed hold tapes (typesetters).
17. SPKTGM (FF2)	A gated SPKT high memory which passes SPKT through to the remaining sequence path. SPKTGM requires presence of delayed sprocket (SPKTDLY) and the termination of the wait pulse.
18. SPKTIC	Sprocket initiated clock. Input to the motor clock pulse generator initiated by sprocket action. Used in Hi speed mode to advance motor clock pulse generation.
19. SPLMOD	Spool mode signal which turns on servo amplifiers.
20. SPLRVD*	Spool mode reversing delay. A timer which prevents instantaneous direction change in spool mode. Allows reel servos to smoothly stop and then change direction.
21. SSEQIP (SS1)	Step sequence initiating pulse. Indirectly removes DATRDY, locks out the sprocket (feedhole) signal, and may trigger the motor clock pulse (see MCP*). Initiated by RRDY going true or DRVG* going false.
22. STOPD* (SS8)	A timed pulse which prevents removing and immediately re-applying DRV command. Pulse is initiated by removal of DRV if RRDY is true, providing reader is in Hi speed mode.
23. STPRIN*	A signal which gates the stepper drive circuits off during winding operation, to allow stepper to free-wheel and not interfere with high speed wind.
24. STROBE	An inverted DATRDY signal used to strobe (clock) the data latches.
25. TACH	Analog output of frequency to voltage converter. Present only in spooler models.
26. TBSD* (SS17)	Delayed tape break signal.
27. TL*	Signal which indicates tape arms are in the tight loop position.
28. TLM*	Memorized tight loop indication. Inhibits reader operation until reset (operate load switch by opening door, or apply and remove EXTINH*).
29. VB (SS11)	Stepper motor voltage boost command. Boosts motor voltage for short period at start of each step. Increases speed of stepping action.

Table 4-1. Mnemonics Used on RRS 6500 and Schematics (Continued)

Mnemonic	Definition
30. VPRGM (SS9)	Stepper motor programmed voltage command. Reduces stepper motor voltage when not stepping to reduce motor dissipation. Applied after a timed delay following last step in a given reading operation.
31. WAITP* (SS2)	A timed delay-pulse at start of a step sequence. Indirectly removes DATRDY and locks out sprocket signal. Initiated by SSEQIP.
32. WLMG and WRMG	Gated WRM and WLM.
33. WLS, WRS	Wind left and wind right switch. Used for high speed rewind.
34. WND	Wind Signal. Puts the machine in fast wind mode.
35. WNDD* (SS14)	A timer which delays re-application of stepper motor voltage after conclusion of a winding operation. Gives reel servos time to settle out.
36. WNDG*	Wind signal gated by another function.
37. WNDOT*	Signal out which indicates the reader is in the re-wind mode. Stepper motor voltage is removed during this time.
38. WRM and WLM	Similar to DRM and DLM.

## SECTION V

### MAINTENANCE

#### 5.1 GENERAL

The REMEX punched tape reader-spooler has been designed to keep maintenance as simple and infrequent as possible. Table 5-1 lists the maintenance equipment required for the various procedures. To prolong the life of the equipment and minimize down-time, certain checks and preventive procedures are set up in Section 5.2 and Table 5-2 with suggested schedules. Section 5.3 outlines possible malfunctions along with probable causes and remedies. The remaining sections describe the required adjustment procedures. Replacement procedures are given in Section 6.

Table 5-1. Maintenance Equipment Required

ITEM	QUANTITY
* Frequency Counter, 10Hz to 20 MHz, 5V input	1
Miller-Stephenson MS-200 Magnetic Tape Head Cleaner (REMEX Part Number 716004-150)	1
* Pulse Generator, 10 Hz to 1 MHz, up to +5V amplitude, 1 $\mu$ s to 100 ms width	1
* Oscilloscope, DC to 10 MHz, single sweep	1
Tape Gauge REMEX Part Number 110597	1
* Voltmeter, Digital 0-0.1 ma, 0-100 mv dc, 0-100 V dc, 100K impedance or greater	1
* Plastic Shim Stock, 0.010 inch thickness, available from Artus Corp., Englewood, N.J. 07631	

#### 5.2 PREVENTIVE MAINTENANCE

Preventive maintenance should be checked periodically in order to maintain peak performance. In addition, in order that the warranty remain in effect, the unit must be maintained in accordance with the instructions outlined below (See Section 1.4 and page iii). A preventive maintenance schedule and log are presented in Table 5-2 which indicates the item, frequency of action and references the maintenance paragraph in this section. For customer convenience the table is arranged so that a log can be kept of when each maintenance procedure was performed. Also refer to Section 3.4, Operational Maintenance.

\* These items are not available from REMEX.

## NOTE

The frequency of cleaning as listed in Table 5-2 has been adopted for clean environmental conditions and usage. These items, however, may vary greatly from one installation to another. For example, a reader used in a machine shop to program numerical controls may require maintenance procedures considerably more frequently.

### 5.2.1 CLEANING

#### **CAUTION**

In all cleaning procedures, avoid using cleaning methods and materials other than those recommended in this manual. Certain cleaning compounds will damage parts of the reader, especially in the readout assembly area. REMEX primarily recommends the use of Miller-Stephenson MS-200 Magnetic Tape Head Cleaner (REMEX Part Number 716004-150) for most areas requiring cleaning. However, due to the degreasing nature of the cleaner, it should not be used in areas where the spray may come in contact with bearings or other oiled parts. This cleaner may be obtained from REMEX or directly from Miller-Stephenson Chemical Company at one of the following locations:

1001 East First Street  
Los Angeles, California 90012

1350 W. Fullerton Avenue  
Chicago, Illinois 60614

Route 7  
Danbury, Connecticut 06810

To use the cleaner, hold the spray can 4 to 6 inches from the area to be cleaned and allow spray to flush the dirt off. If a heavy buildup is present, loosen with the spray mist and scrub with a cotton swab. A 6-inch pin-point, spray nozzle extension is available for hard-to-reach areas or for delicate applications.

#### **CAUTION**

Avoid spraying on lubricated surfaces or parts and on the lamp and lens.

If the Miller-Stephenson cleaner is not available, a small amount of isopropyl alcohol applied to a clean, lint-free cloth or cotton swab may also be used. However, it should be used carefully and sparingly since damage to the photocell and the finish on the plastic cover may result. Use only clear, unadulterated isopropyl alcohol. Do not use ethyl alcohol or denatured alcohol as the denaturing agents vary and may damage the reader.

It is important that, whether the MS-200 cleaner or the isopropyl alcohol is used, only the amount required to clean the surfaces be applied. Never saturate or drench the areas to be cleaned. Never apply these materials to the lamp assembly.



Table 5-2. Preventive Maintenance Schedule and Log

Frequency* of Action Weeks	Date	Initial	Frequency* of Action Weeks	Date	Initial	5.2.1.1	5.2.1.2	5.2.1.3	5.2.1.4	5.2.1.5	5.2.3	5.4, 5.5, 5.6	5.7, 5.8, 5.9
						Cleaning					Check Adjust.		
2			28			X	X	X	X				
4			30			X	X	X	X				
6			32			X	X	X	X				
8			34			X	X	X	X				
10			36			X	X	X	X				
12			38			X	X	X	X				
14			40			X	X	X	X		X	X	X
16			42			X	X	X	X				
18			44			X	X	X	X				
20			46			X	X	X	X				
22			48			X	X	X	X				
24			50			X	X	X	X				
26						X	X	X	X		X	X	X
			52			X	X	X	X	X	X	X	X

\* See Note on page 5-2.

#### 5.2.1.1 Readhead Assembly Cleaning

The top surface of the readhead assembly should be cleaned every two weeks (for most installations having clean environments; dirtier environments which contain dust, oil and sprays, such as machining areas, may require cleaning as much as every eight hours). Cleaning is extremely important because any dirt or foreign material in this area can create errors in readout. Use the bristle brush supplied or the cleaning materials and methods described in Section 5.2.1 and clean the surfaces of the readhead assembly and the upper tape guide assembly. Care should be exercised so that no residue remains from the recommended cleaning materials when the cleaning operation is completed.

#### 5.2.1.2 Sprocket Cleaning

The sprocket wheel should be checked for cleanliness every two weeks. Depending upon tape conditions, accumulations may build up on the sprocket and be transferred to the sprocket holes in the tape which may cause readout errors. Use the recommended cleaning materials described in the caution in Section 5.2.1. Care should be taken so that the alignment of the sprocket wheel is not disturbed. If the sprocket wheel requires adjustment, refer to Section 5.4.

#### 5.2.1.3 Tape Inspection

Repeated handling and usage of the tape leads to a build up of grease, oil and dirt on the tape. When the build up becomes excessive, this material will become lodged in the tape transport areas and could cause tape reading errors. When this occurs the tape should be repunched.

#### 5.2.1.4 General Cleaning

The entire reader should be cleaned every year. Use the following procedure:

Using the bristle brush supplied with the unit and/or compressed air, remove all dust and dirt, paying particular attention to all moving parts. Use the recommended materials described in the caution in Section 5.2 to remove any grease or other accumulations. When cleaning, use care not to damage components on the circuit board.

### 5.2.2 LUBRICATION

All points of rotation have permanently lubricated bearings and should not require lubrication for the life of the part.

### 5.2.3 POWER SUPPLY VOLTAGES

Check all voltages listed in Table 5-3 with a voltmeter once every three months. A change in voltage may be indicative of a gradual component failure. Before taking any measurements, allow a short period of time for warm up after turning on power.

Table 5-3. Power Supply Voltage Locations

<u>Voltage and Tolerance</u>	Measure	
	<u>From</u>	<u>To</u>
VMOT (See Section 5.4)	TP2	TP6
Lamp Voltage (See Section 5.5)	Across Lamp Terminals	
+5 ± 0.25 Vdc (on Reader Card)	TP5	TP6
+15 Vdc ± 10%	Q20 Emitter	TP6
-15 Vdc ± 10%	Q21 Emitter	TP6
+24 Vdc ± 10%	BR1+	TP6
-24 Vdc ± 10%	BR1-	TP6

### 5.3 TROUBLESHOOTING

Trouble shooting is presented in the form of a chart, Table 5-4, which should be consulted whenever tape reader performance is unsatisfactory. The chart is divided into three columns: Indication – the way in which the malfunction becomes evident; Probable Cause – the possible reason or reasons for the malfunction; and Remedy – the manner in which the malfunction may be corrected.

Table 5-4. Troubleshooting

Indication	Probable Cause	Remedy
1. No track outputs on any track.	1. Readhead dirty	Clean Readhead Assembly as described in Section 5.2.1.1.
	2. Lamp Assembly misaligned	Check alignment of the Lamp Source as described in Section 5.4. and Lamp Voltage adjustment, Section 5.5.
2. Outputs present on all but one track or one track intermittent.	1. Readhead dirty	Clean Readhead Assembly as described in Section 5.2.1.1.
	2. Defective Photocell	Check the output of the Photocell assembly as described in Section 5.4 and replace if defective as described in Section 6.2.2.
	3. Defective component on Reader Card	Check the components and IC modules associated with the particular track output.
3. Track output present with no hole punched in tape.	1. Tape transmissivity	Tape must have a transmissivity of 57% or less as specified in Table 1-2.
	2. Defective photocell	Check the output of the Photocell assembly as described in Section 5.4 and replace if defective as described in Section 6.2.2.
	3. Defective component on Reader Card	Check the components and IC modules associated with the particular track output.
4. Tape Access Door closed, POWER switch in ON, correct drive signals present; tape does not move.	1. POWER switch, S1, defective	Check switch S1 and replace if defective as described in Section 6.2.7.
	2. RUN-LOAD switch, S2, defective	Check switch S2 and replace if defective as described in Section 6.2.8.
	3. Defective component on Reader Card	Check operation of Reader Card.
	4. Step Motor defective	Check $\overline{\phi 1}$ thru $\overline{\phi 4}$ outputs from Reader Card to see if they are present. If so, replace stepper motor as described in Section 6.2.5.

Table 5-4, Troubleshooting, Continued

Indication	Probable Cause	Remedy
5. Tape does not stop on character	1. Improper reader alignment	Perform Section 5.4.
	2. Defective component on Reader card	Check operation of Reader card.
6. POWER switch ON; lamp does not turn on, no DC voltages	1. No AC power	Make sure AC power cord is plugged into outlet.
	2. Fuse F1 blown	Check fuse and replace if required.
	3. POWER switch, S1, defective	Check switch S1 and replace if defective as described in Section 6.2.7.
	4. Power Supply defective	Check Reader card for proper operation of +5V power supply.
	5. Defective Transformer, T1.	Check T1 and replace if faulty as described in Section 6.2.6.
7. Low tape speed less than 330 characters/second	1. Tape out of registration	Check tape registration to make sure tape conforms to specifications as described in Section 3.6.
	2. Sprocket out of rotational alignment	Check alignment of reader as described in Section 5.4.
	3. Defective component on reader card	Check reader for proper operation of drive circuits and single shot timings.
8. Irregular movement of tape	1. Drive system improperly adjusted	Perform Reader alignment as described in Section 5.4.
	2. Sprocket wheel bent or worn	Replace sprocket wheel as described in Section 6.2.5.
	3. Tape guide assembly worn	Replace tape guide assembly.
9. +5V supply voltage too low or too high	1. Defective regulator	Check operation Z101 and replace if required.
	2. T1 malfunction	Check for presence of 26 VRMS across the brown and red terminals of T1. Replace T1 if not present.

Table 5-4. Troubleshooting, Continued

Indication	Probable Cause	Remedy
10. Spooler spills tape when first turned on.	1. Improper threading	Thread tape as shown in Figure 1-1.
11. Tape sensor arms hit bumper during operation or arms act erratically.	1. Improper adjustment of servo balance pot.	Check servo balance adjustment as described in Section 5.6.
	2. Improper adjustment of tape arm pot.	Check tape arm potentiometer zero adjustment as described in Section 5.6.
	3. Improper adjustment of tape arm spring.	Check tape arm spring adjustment as described in Section 5.7.
	4. Reader card malfunction	Check operation of servo on reader card.
12. Spooler does not go into wind mode when proper signals are applied.	1. Reader card malfunction.	Check operation of Reader card.
	2. Wind switch S3 malfunction.	Check S3 for proper operation and replace if defective.
13. One spooler motor does not operate.	1. Reader card malfunction.	Check outputs from servo circuitry on Reader card and replace card if required.
	2. Servo motor faulty.	Check servo motor and replace if required as described in Section 6.3.3.
14. Power switch on, reader drives tape, door closed (S2 in run position) neither spooler motor runs.	1. Switch S2 faulty.	Check S2 for proper operation and replace as described in Section 6.2.8.
	2. +24 or -24 VDC on Reader card faulty.	Check to see if proper power supply voltages are present and replace card if required.
	3. Servo circuitry on Reader card faulty.	Check Reader card for proper operation and replace if required.

Table 5-4. Troubleshooting, Continued

Indication	Probable Cause	Remedy
15. Spooling motor is on when arm is in center of travel area.	1. Balance adjustment incorrect or arm pot out of adjustment.	Check balance adjustment as described in Section 5.6.
	2. Servo circuitry on Reader card faulty.	Check servo circuitry and replace card with spare if required.
16. Reader does not go into high speed operation.	1. $\overline{\text{HISP}}$ line not pulled down to 0V.	Check to make sure $\overline{\text{HISP}}$ input at J1-18 is 0V.
	2. Reader card malfunction.	Check high speed circuitry on reader card. Make sure FFI is reset by $\overline{\text{SS6}}$ at the beginning of the second step. Note that the reader does not go into high speed until the command to advance to the second line is processed.
17. Wind speed greater or less than $1500 \pm 150$ characters/sec.	1. Wind speed adjustment faulty.	Check and adjust wind speed as described on Section 5.8.
	2. Spooler circuitry on Reader card malfunction.	Check rewind circuitry on reader card and replace card with spare if required.
18. Wind speed varies more than $\pm 20\%$ during winding of a full reel of tape.	1. Wind regulator circuitry faulty.	Check operation of Wind Regulator circuitry on Reader card and replace card if required.

Proper operation depends upon making and maintaining accurate adjustments. Although all adjustments are made at the factory, the following adjustments should be checked periodically (refer to Table 5-2) and should be performed only when the tape reader performance is unsatisfactory or when any of the following items is replaced: light source, readhead assembly, upper tape guide assembly, mechanism assembly, sprocket, step motor or circuit card. Letter designations in parenthesis refer to items called out in Figure 7-1.

Improper adjustment of this procedure will result in one or both of the following problems: (1) Reading errors, especially in computer applications and (2) Restriction of the tape tolerances capable of being read, i.e., either long or short tolerance tapes, not the  $\pm 0.025$  inch in either direction as specified in Section 3.6.

**CAUTION**

This is a factory set adjustment and should not require readjustment unless one of the aforementioned components has been replaced or the reader performance is unsatisfactory.

- a. Remove all power and control signals by disconnecting P1 and the power cord plug.
- b. Remove the Upper Cover Assembly (1) by loosening the two 6-32 round head screws (A), flat and lock washers at the rear of the front panel.
- c. Raise the Upper Tape Guide.

**CAUTION**

The procedure outlined in steps f through i should not be performed unless one of the components listed in the introductory paragraph above has been replaced or unless the reader performance is unsatisfactory. Prior to performing these steps, measure the clearance between the readhead housing tape riding surface and the sprocket perimeter high point as shown in Figure 5-1 and as described in step d and e. Perform steps f through i only if the distance is not within the tolerance specified in steps d and e.

- d. To check the clearance between the readhead housing tape riding surface and the sprocket perimeter high point, place the end of a small steel rule on the surface and between the teeth of the sprocket. See Figure 5-2.

**NOTE**

As shown in Figure 5-1, the sprocket perimeter is not round but is rather a surface comprised of 24 flat surfaces upon which the sprocket teeth are mounted.



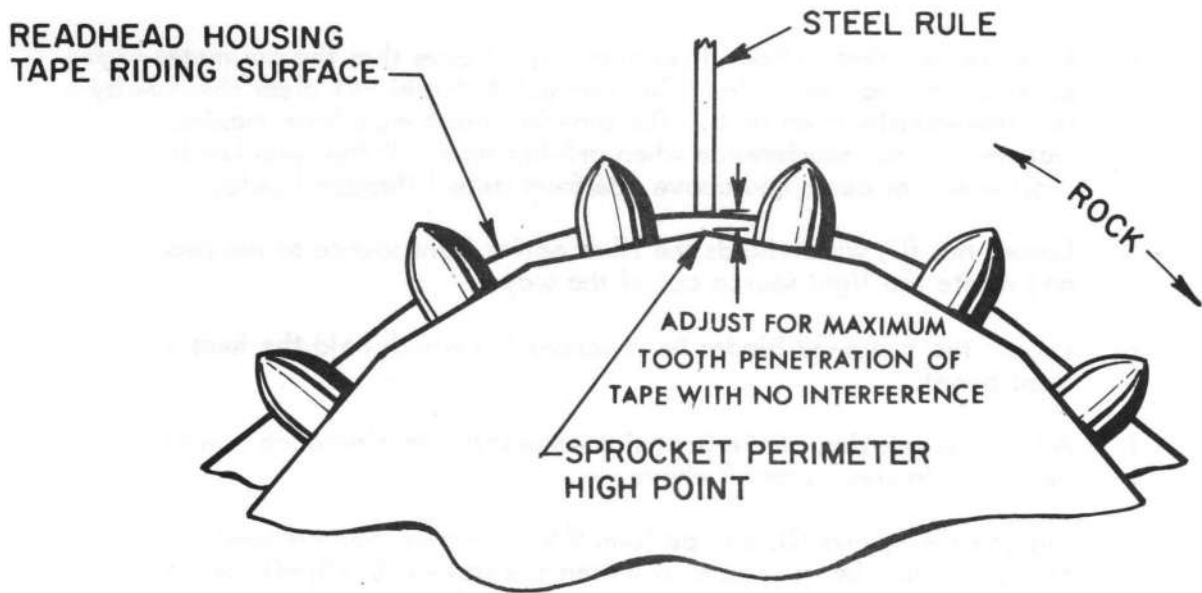

MMC 353B

Figure 5-1. Sprocket Relation to the Tape Riding Surface.

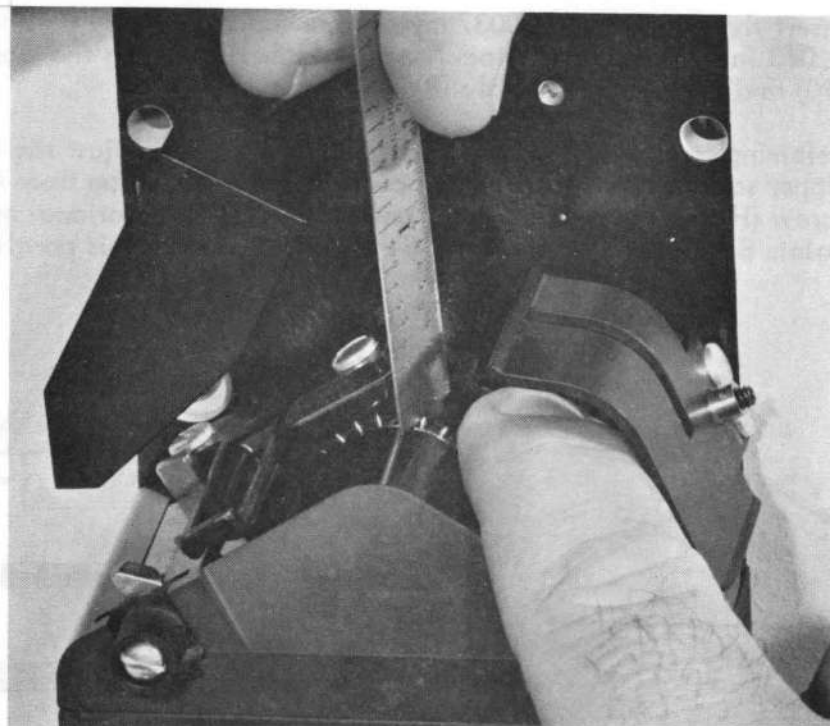

Figure 5-2. Setting of the Sprocket in Relation to the Tape Riding Surface.

- e. Rock the sprocket in both directions and observe that the perimeter high point clears the steel rule. The high point should just clear the rule by a few thousandths of an inch. The sprocket teeth must have maximum penetration with no interference when driving tape. If the sprocket is not positioned, as described above, perform steps f through i below.
- f. Loosen nut (U) which holds the fiber optics light source to the reader panel and rotate the light source out of the way.
- g. Loosen the two 6-32 binder head screws (D) which hold the heat sink to the front panel.
- h. Adjust the position of the heat sink to obtain the clearance conditions described in steps d and e above.
- i. Tighten the screws (D) and perform the clearance measurement in steps d and e. It may be necessary to loosen the screws (B) slightly and move the Mechanism Assembly slightly. Repeat the clearance measurement and adjustment as necessary to achieve proper clearance. This should only be attempted if the adjustment cannot be made with the motor only. Tighten screws (B).
- j. Apply AC power by plugging in the power cord and placing the LOOP-SPOOL switch in the LOOP position and the OFF-ON switch in the ON position.
- k. Make sure jack screw (E) is not protruding below the surface of the Upper Tape Guide (10).
- l. Insert three layers of 0.0037 mylar tape (approximately 0.011 inch) or a 0.010 inch plastic shim stock (see Table 5-1) between the Upper Tape Guide (10) and Readhead Assembly (8).
- m. Referring to Figure 5-3, use screws (H) and (N) to adjust the Upper Tape Upper so that there is maximum contact and parallelism from A to B. Use screw (H) for lateral movement and screw (N) for rotational movement. From points B to C, the Upper Tape Guide will not show this parallelism.

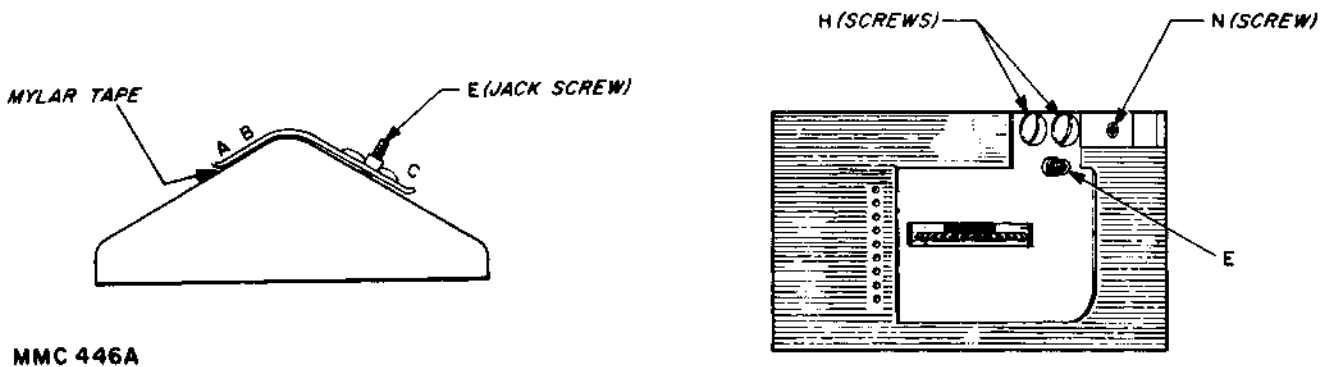

Figure 5-3. Adjustment of the Upper Tape Guide.

- n. Remove the three layers of tape.
- o. Insert two layers of tape between points A and B only or a strip of 0.0075 shim stock (Figure 5-3).
- p. Screw down jack screw (E) which will raise the Upper Tape Guide slightly. Adjust screw (E) until there is free movement of two layers of tape. This will provide a gap of between 0.008 and 0.012 inch.
- q. Insert a loop of tape known to have been punched to within  $\pm 0.0025$  inch in a 5-inch span (0.05% error).

### CAUTION

Since repeatability of the feedhole placement in either direction is essential, a tape whose accumulated error in a 5-inch span is considerably better than  $\pm 0.025$  inches (as specified in Section 3.6) must be used in this procedure. Remex specifies a tape known to be punched to within  $\pm 0.0025$  inch in a 5-inch span ( $\pm 0.05\%$  tolerance). Note that most Remex punches are specified at  $\pm 0.025$  and hence these tapes should not be used for this adjustment unless known to be within the  $\pm 0.05\%$  tolerance.

### NOTE

Some users may possess tapes which are outside the limits specified in Section 3.6. The reader may be adjusted using these tapes rather than the type specified. In doing so, only these tapes should be used. The reader must be readjusted using  $\pm 0.05\%$  tapes whenever the tapes specified in Section 3.6 are to be used.

- r. Turn on power. The motor should be energized.

### WARNING

If the motor has been running for a period of time, it or the heat sink may be too hot to touch comfortably. Allow sufficient time for the motor and heat sink to cool before any adjustment or use a cloth or a pair of gloves.

- s. With the rear edge of the tape parallel to the front panel, align the holes over the light columns in the readout assembly so that they are concentric. See Figure 5-3A. The tape must remain parallel to the front panel so that no skew is present. With the tape in this position, the sprocket teeth should be centered in the sprocket holes in the tape. Skewing is indicated by tracks 1 and 8 not being concentric. If this condition does not exist, loosen the screw (S) which holds the motor to the heat sink. Rotate the motor so that the holes in the tape are concentric with the light columns in the readhead and the sprocket teeth are centered in the feed holes. Tighten screw (S). It may also be necessary to loosen set screw (J) and move the sprocket to achieve this setting. Tighten set screw (J).

- u. The nut (U) holding the fiber optic light source to the front panel should already be loose (step f). Connect the digital voltmeter across the 1K resistor in the test circuit. Rotate the fiber optic light source until the current through the 1K resistor is between 100 and 110 microamps for the sprocket cell. If the current is excessive reduce the lamp voltage. If the current is below the minimum requirements, screw the lamp in or out to obtain the required current. Tighten nut (U). If the current is still below the minimum requirement, increase the lamp voltage slightly to obtain the required current. Do not increase the lamp voltage above +4.7Vdc. When the required current is obtained for the sprocket, the minimum current for each of the data cells should be 80 microamps. The maximum output from any data cell should be 160 microamps so that tapes with the highest permitted transmissivity can be read without error.
- v. Turn power OFF. Reconnect P2 and reload the tape.
- w. Apply AC power by plugging in the power cord and manually depressing the power switch S1. The lamp should come on.
- x. Drive tape in either direction using either the direction switch or the external drive line in continuous drive mode. Continuous drive is recommended rather than step mode operation since the tape speed must be above 60 cps.
- y. Place a digital voltmeter across TP2 (VMOT) and TP6 (0V) on the reader card and adjust R11 for +34 Vdc at TP2. This is a preliminary step. The final voltage is set in step dd.
- z. Connect a pulse counter to TP3 (Data Ready) and TP6 (0V) on the Reader Card.
- aa. Using a loop of 0.05% tape as specified in step d, apply a DL\* signal to J1-17 and measure the drive left speed in characters/sec with the pulse counter. Continuous drive is recommended rather than step mode operation since the tape speed must be above 60 cps. Repeat using a DR\* signal at J1-16. If the lowest speed is more than 5% slower than the highest speed, loosen screw (S) which holds the motor to the heat sink. Rotate the motor slightly so that the difference in the drive left and drive right speeds is less than 5%. Repeat steps z and aa as required. The motor should be rotated only slightly so that the conditions in step s are not disturbed. Also make sure the motor is kept tight to the panel so that the distance of the sprocket pins to the front panel as described in step s is not disturbed. Tighten screw (S). This screw should be tightened so that it firmly secures the heat sink to the motor assembly.

## NOTE

The importance of step aa is not a specific interest in matching speeds, but rather that balancing speeds insures proper placement of the feedhole (via the sprocket), in relation to its aperture in the readhead. The 0.05% tape used virtually assures that there are no feedhole placement errors which are attributable to tape registration errors, but only to the position of the sprocket in relation to feedhole aperture in the readhead. Thus measuring and balancing the slew speed is only an accurate, electronic method of assuring that this relationship exists. When the speeds in the two directions are properly balanced, feedhole placement error will be minimal and independent of the direction of the tape, thereby increasing tape readability to a maximum.

- bb. Apply a 0V DL\* signal to J1-17 and a 0V HISPD\* signal to J1-18 and measure the high speed which should be  $550 \pm 10\%$  characters/sec. If this is not the case adjust R88 on the Reader Driver card until this speed is achieved. Repeat for a 0V drive right signal to make sure it is also  $550 \pm 10\%$  cps.
- cc. Connect a pulse generator to the DR\* input, J1-16. Set the pulse generator for 300 pps.
- dd. Connect an oscilloscope to the sprocket cell output at TP1 and observe the jitter at the  $-0.3$  Vdc level (do not be concerned about the jitter at the  $+0.6$  Vdc level nor the time jitter in the leading or trailing edges of the waveform). Minimize the jitter by loosening the two set screws (R) which hold the collar to the motor shaft and move the collar in or out as required to obtain the least amount of jitter. See Figure 5-5. It may also be necessary to reduce the VMOT voltage set in step y in addition to moving the collar. VMOT should not, however, be adjusted lower than  $+30$  Vdc nor higher than  $+34$  Vdc. Cycle the reader between 20 and 500 characters and adjust for minimum jitter. Repeat steps bb and cc for the DL\* input, J1-17.
- ee. Repeat steps bb and cc using unbalanced reels (left full, right empty and then right full, left empty). Readjust as required.
- ff. Remove the pulse generator, oscilloscope and counter and perform the reverse of steps b and then a.

## 5.5. READER LAMP VOLTAGE ADJUSTMENT

The following procedure should be used when adjusting the reader lamp voltage:

- a. Place the power switch to its on position. The reader lamp should come on.
- b. Place a digital voltmeter across the lamp terminals.
- c. Adjust R5 on the Reader card until the meter reads  $+4.3$  Vdc.
- d. Remove the meter leads.

## NOTE

The reader lamp voltage may require further adjustment to increase the photocell outputs. See Section 5.4, step u. Do not increase the lamp voltage higher than  $+4.7$  Vdc.

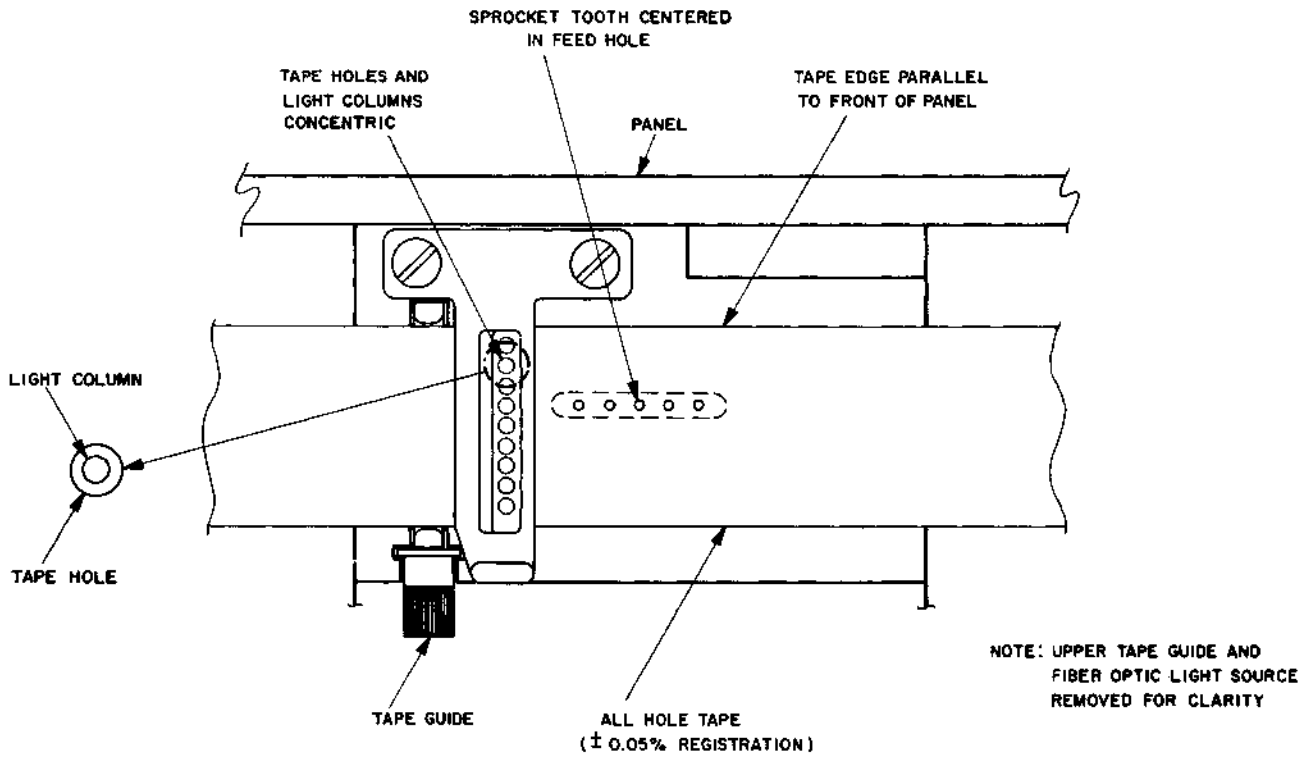

MMC 572

Figure 5-3A. Alignment of the Sprocket with the Light Columns.

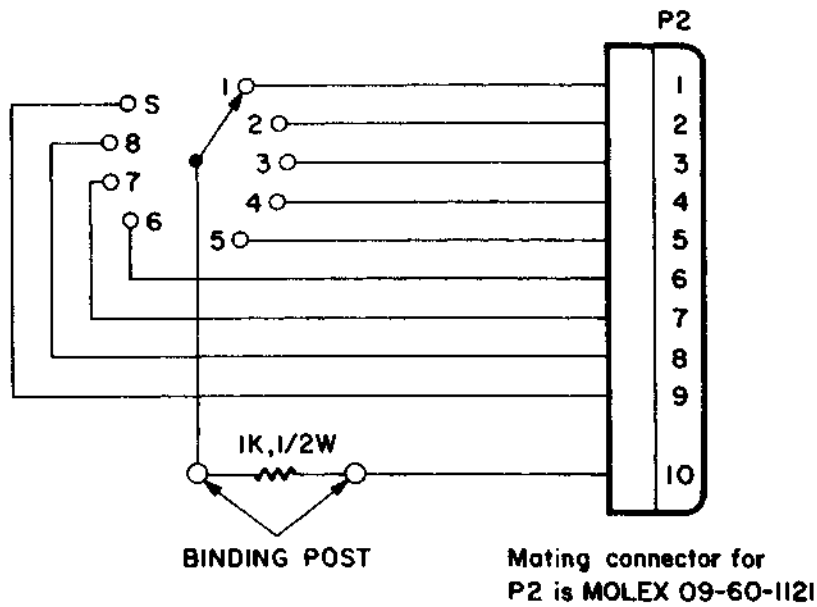

MMC 354

Figure 5-4. Photocell Output Test Circuit.

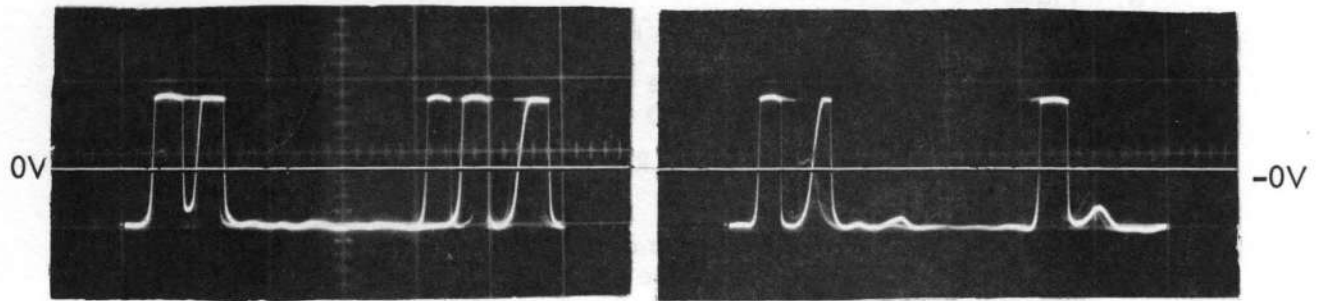

Two Examples of Misadjustment

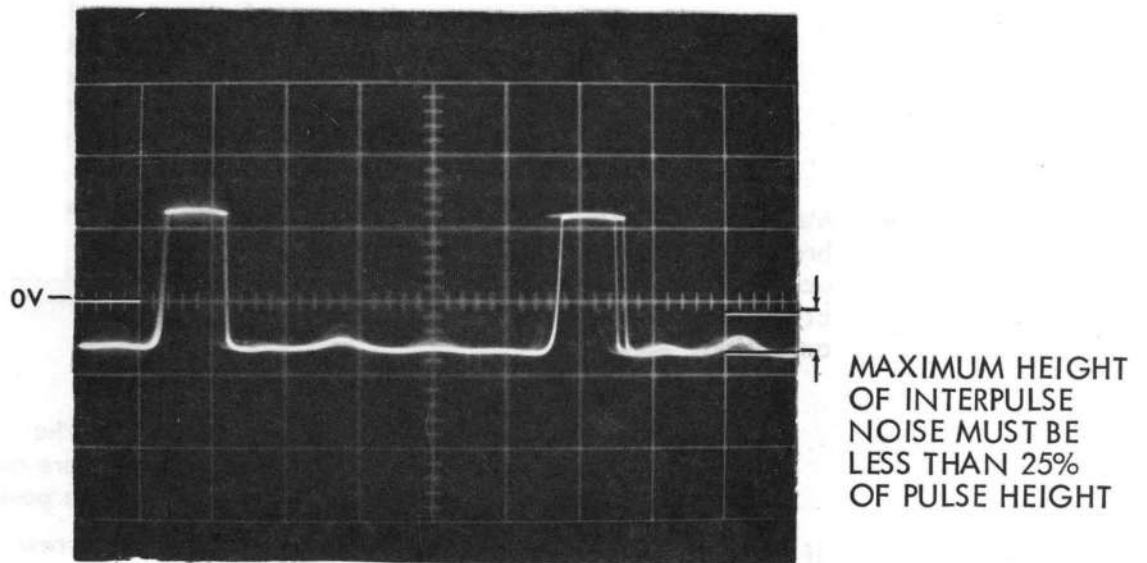

Upper Tape Guide and VMOT Properly Adjusted

MMC204A

Figure 5-5. Sprocket Cell Output Adjustment for Minimum Jitter.

Alignment of the servo system is performed in the following manner. Refer to Figures 5-6 and 6-1 during this procedure.

- a. Place the POWER switch in the OFF position.
- b. Remove all tape and reels from the Reader/Spooler.
- c. Place the POWER switch in the ON position, the SPOOL-LOOP switch in SPOOL and the RUN-LOAD in RUN (tape access door closed).
- d. Rotate potentiometers R52 and R103 on the circuit card to their center position.
- e. Position the left and right tape arms so that outside arm roller and top fixed roller center lines are  $2.75 \pm .375$ " as the arms are brought in towards the center of travel. See Figure 5-6. Secure the arms in this position. If the left motor rotates when the arm is in this position, perform steps f and g.
- f. Loosen the set screw (G, Figure 6-1) which holds the shaft to the potentiometer shaft.
- g. Rotate the shaft of potentiometer R204 until the left motor stops rotating.

### WARNING

Use care when making adjustments in the area of the chassis when power is ON, especially in the area of the large electrolytic capacitors and near T1 and TB1. Care should also be exercised when the motor shafts are rotating since the motors are of sufficient torque to cause injury.

- h. Move the left arm out toward the outer bumper. The switch (tape break) should actuate  $.120$ " to  $.250$ " from the bumper. When this occurs the motor will stop rotating. Use a  $.250$  shim for no tape break switch actuation and  $.120$  shim for tape break switch actuation.

### NOTE

Opening and closing the reader door will allow the motors to stop and start providing the tape arms are not in the tape load or tape break (broken or no tape position).

- i. If the condition of step h is not satisfied, loosen the screw (K, Figure 6-1) which holds the collar (7) to the shaft (1).
- j. Rotate the collar until pin D actuates S5 as described in step h. Use care not to rotate the potentiometer shaft and disturb the setting made in step g.
- k. Tighten set screw (K).



- l. With the motors running move the left tape arm in towards the tape load position. The motor should stop rotating somewhere between the point where the inboard side of the arm is flush with the inboard side of the locking pin and the point where the outboard side of the arm is flush with the outboard side of the locking pin. See Figure 5-6.
- m. If the condition of step l is not satisfied, loosen screw C (Figure 6-1) which holds the collar (7) to the shaft (1). Rotate the collar until pin D actuates S7 as described in step l. Use care not to rotate the potentiometer shaft and disturb the setting made in step g. Tighten screw C.
- n. Repeat steps e thru m to verify correct operation under dynamic conditions with full reels of tape.
- o. Repeat steps c through n for the right servo using the right potentiometer R203, right tape arm, the right tape break switch, S4, and the right tight tape switch S6.

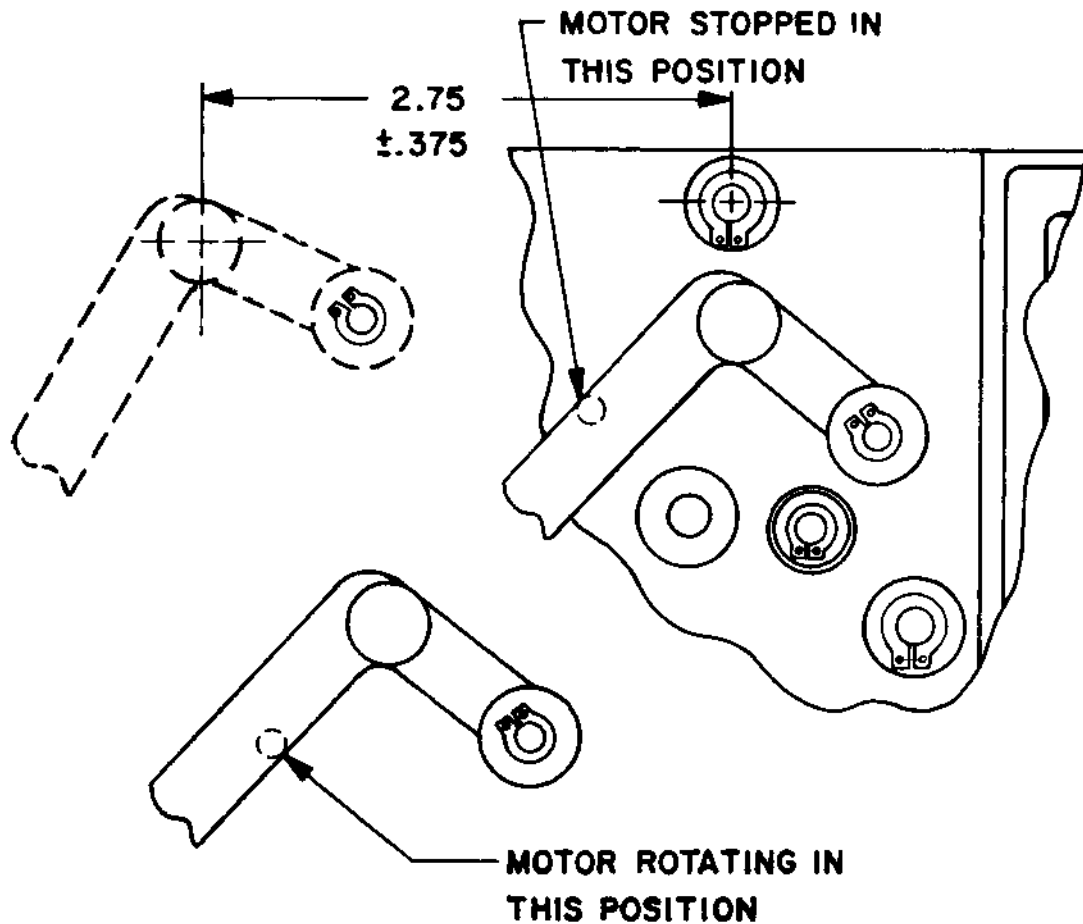

**MMC 501**

Figure 5-6. Switch Actuation Points for the Left Arm.

## 5.7 ARM SPRING TENSION ADJUSTMENT

Tension of the tape sensing arm spring is measured at the roller on the end of the arm. Refer to Figure 6-1 during this procedure.

- a. Place the POWER switch in the off position.
- b. Attach a tension gauge to the tape arm roller on the left arm using a piece of tape around the roller.
- c. Pull on the gauge perpendicularly to the tape arm and lift the arm off the outer stop. The gauge reading should be between 7.0 and 10.0 ounces throughout the range of the arm travel for the RRS6500BEX/660/DRB/UXXX. For the RRS6500BEX/660/ARB/UXXX the reading should be between 6.0 and 10.0 ounces.
- d. If the tension measurements do not agree with the specifications noted in step c, loosen the screw (E) which holds the collar (8) to the shaft (1), and rotate the collar until the condition of step c is satisfied. Tighten set screw (E).
- e. Repeat steps b through d for the right arm.

## 5.8 WIND SPEED ADJUSTMENT

The nominal, mid-reel wind speed of the spooler should be set at  $1500 \pm 10\%$  characters/second. This adjustment is performed as follows:

- a. Load the left side with a full reel of tape and thread the tape through reader onto the left reel. The tape must have at least sprocket holes punched on every character.
- b. Connect a pulse counter to the sprocket test point TP4 on the Reader card and TP6 (0V).
- c. Place the following switches in the positions indicated: POWER ON, RUN-LOAD in RUN (Reader door closed), LOOP-SPOOL in SPOOL and WIND switches OFF.
- d. Place the  $\triangleleft \triangleright$  switch in the  $\triangleright$  position and note the number of sprocket holes changes per second at mid-reel wind (both reels containing approximately the same amount of tape). The number of sprocket holes should be  $1500 \pm 10\%$  cps. If this is not the case, adjust R36 on the Reader card until the required speed is obtained.

### NOTE

The amount of tape transported after the removal of the wind command is a function of the wind speed. Some users may elect to reduce the wind speed in order to get shorter stopping distances.

### **CAUTION**

The wind speed should not be set below 1000 cps. Improper switch action occurs below 1000 cps. The wind speed should not be set greater than 1800 cps. Higher speeds can result in severe tape jerking during the stopping period.

The tape rollers and the arm rollers should be positioned so that the paper tape moves through the drive mechanism flat, in either direction, without any wave. Mylar tape may have a slight wave. All tape should run through the head without excessive edge guiding, preferably with a slight tendency of guiding toward the panel.

To accomplish this alignment, a small amount of bending at the end of the tape arm may be required. However, the long shaft of each arm must be parallel to the panel. In addition, the distance from the front surface of the arm to the inside edge of the roller must be between .190 and .205. This is important when a new roller has been installed and is accomplished by placing 1 or 2 713600-149 washers between the spacer and roller as shown in Figure 6.1 and as described in Section 6.3.4. The roller must also remain

If tape breakage occurs, this break may result in damage to one, two or possibly three characters. When splicing tape for this reader, great care should be used to ensure that the proper sprocket hole spacing be preserved. A lap splice should not be used; use only a butt type splice. To repair the tape without loss of characters, the process shown in Figure 5-7 is recommended and is accomplished as follows:

- a. Bring the tape ends together as shown in Figure 5-7A.
- b. Make a sketch of character(s) at the break (A-B-C) and five additional characters to the left (5-4-3-2-1) and five to the right (1-2-3-4-5) of the broken character(s) (A-B-C).
- c. Place the left end of the broken tape over a section of blank tape containing only feed holes so that at least eight or ten feed holes in each tape are aligned with one another as shown in Figure 5-7B. Cut the tapes at the third undamaged character to the left of damaged characters (A-B-C). Use care to insure that feed holes are aligned and make cut through the center of the holes in the third undamaged character. Characters 5, 4, and half of 3 should remain on the broken tape.
- d. Place the right end of the broken tape over the section of blank tape so that at least eight or ten feed holes are aligned with one another. Feed holes for one-half of 3, 2 and 1 on the blank tape cut in step c should be visible to the left of the broken tape end as shown in Figure 5-7C. Cut the tapes at the third undamaged character to the right of the damaged character. Be sure that feed holes are aligned and make the cut through the center of the holes in the third undamaged character.

## NOTE

One half of character 3 and characters 4 and 5 should remain in the broken tape.

- e. Place tape ends and new section on a flat surface with feed holes forward as shown in Figure 5-7D (tape is bottom side up). Using silver Scotch<sup>®</sup> tape, No. 852, splice the new section and the old tape ends as shown. That portion of tape that secures the old tape ends must cover the first two and a half characters (one-half of 3, 4 and 5) on the old tape ends. The edges of the tape should be between characters as shown. Use of 1/2-inch wide splicing tape if recommended as shown in Figure 5-7D.
- f. Repunch the characters recorded in step d.

<sup>®</sup>Registered Trademark of 3M Company.

## 5.11 TAPE TENSIONING ASSEMBLY ADJUSTMENT

The following adjustment should be performed when a tape tensioning assembly is replaced, loose packing on a reel is present, or too much tension is present on the tape.

- a. Place the ON-OFF switch in the OFF position.
- b. Remove the rubber roller from the shaft. The roller is press-fit onto the shaft but most can be removed by using a screwdriver to pry it off. If a torque watch is available with a chuck large enough to slip over the roller, this step may be eliminated.
- c. Attach a torque watch (Waters Model 651C-1 or equivalent) to the front of the shaft and measure the force required to cause the friction plate to slip. This force should be  $1 \pm 0.25$  ounces. Rotate the torque watch CCW for the left assembly and CW for the right assembly.  

If a torque watch is not available an equivalent method is to use a string wound around the tape tension roller. The string should have approximately 10 turns around the roller in the clockwise direction for the left roller and counterclockwise for the right roller. Using a spring scale that is graduated in ounces, a reading of 4 oz.  $\pm 1$  oz. should be obtained while the string is being pulled off the roller.
- d. If this is not the case, loosen the two set screws which hold the collar at the rear of the spring and move the collar in or out as required. Tighten the set screws.
- e. Repeat steps c and d as required until the  $1 \pm 0.25$  ounce force is required to cause the friction plate to slip (or the 4 oz.  $\pm 1$  oz. using the spring scale).
- f. Perform the reverse of steps b and then a.

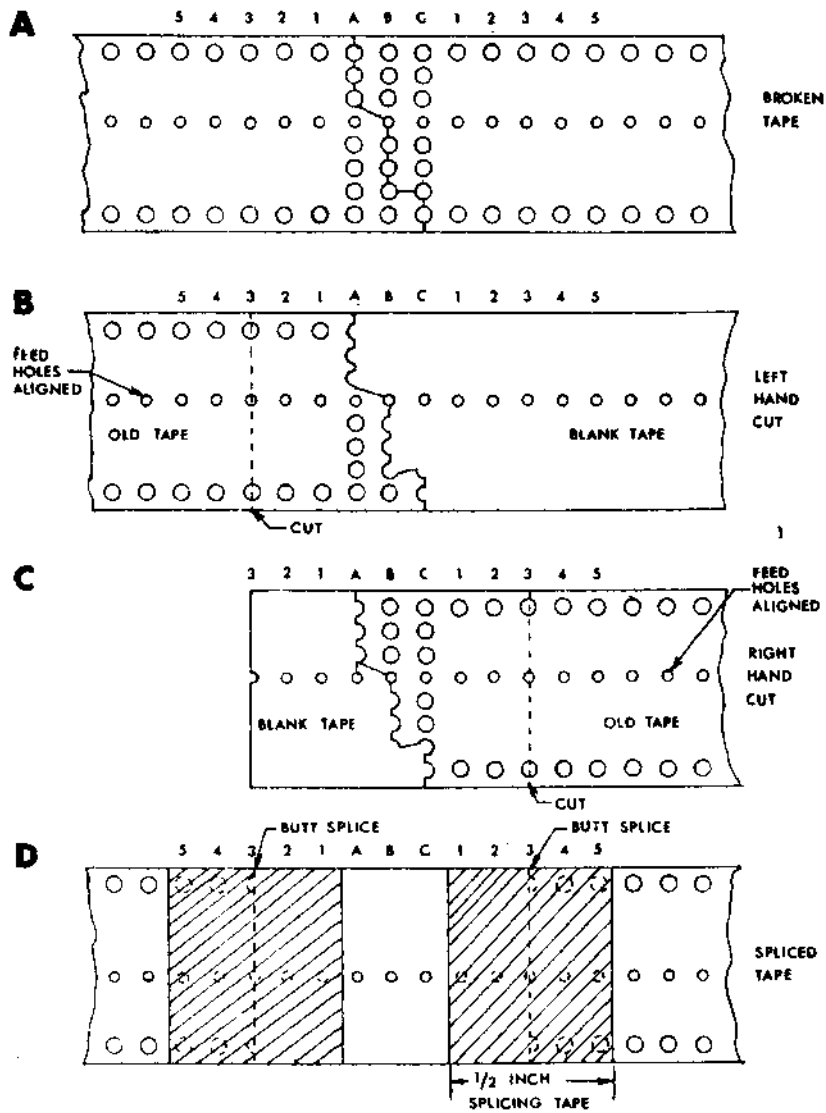

MMC 120A

Figure 5-7. Tape Splicing Procedure.



## SECTION VI

### PARTS REPLACEMENT

#### 6.1 GENERAL

REMEX maintains service facilities at its manufacturing location and at service centers in major population areas for repair or replacement of components for their products. It is recommended that one of these centers be contacted for assistance in case of equipment malfunction. For the locations of service facilities in any area, contact REMEX at the address or telephone listed on the title page of the manual. Please direct inquiries to the attention of the Service Department.

When any parts of the reader require replacement or disassembly, the procedures below should be followed closely. The warnings and cautions are included to protect personnel and equipment. Notes are included to assist persons unfamiliar with the equipment. Before attempting any procedure, all instructions for that disassembly should be read and understood.

Quantities of replaceable items suggested as spares are listed in Table 7-1. All system components are identified in Section VII of this manual, along with illustrations showing part locations. This information may be used to locate parts below unit level if replacement is required. Always reference the complete model number and serial number when making inquiries.

#### **WARNING**

Potentially dangerous line voltage is applied to components within this equipment. If adjustments must be performed with power applied, these points must be located and avoided. High voltage can be accidentally contacted at TBI, at the primary of T1, at the OFF-ON switch/wiring connections, and on the circuit card (rear of the unit).

#### 6.2 READER PARTS REPLACEMENT

##### 6.2.1 UPPER COVER ASSEMBLY

The Upper Cover Assembly (Item 1, Figure 7-1) is held to the front panel by two 6-32 round head screws (Item A, Figure 7-1). It should be replaced as a complete assembly which includes the switch actuator, cover and roll pin. When replacing the cover, check to make sure that the actuator properly operates S1.

### 6.2.2 READHEAD MECHANISM DISASSEMBLY

This procedure is required when replacing the Upper Tape Guide Assembly, the Readhead Assembly (consisting of the Readhead Housing, Photocell Assembly and Light Columns), or the Mechanism Assembly (consisting of the Door Mechanism Assembly, Tape Guide Cam, Tape Guide Actuator, Slide and Spring). For ease of assembly, it is recommended that the Readhead Assembly (part number 113168-1) and Mechanism Assembly (part number 113170-1) be replaced as a complete assembly. However, Figure 7-2 is provided for those desiring to order the subassemblies that comprise the Mechanism Assembly. Figure 7-1 should be folded out from Section 7 to follow during this procedure. Numbers in parenthesis refer to items called out in Figure 7-1. The following procedure is recommended when replacing any of the above mentioned items:

- a. Remove all power and control signals by disconnecting P1 and the power cord.
- b. Remove the Upper Cover Assembly by performing Section 6.2.1.
- c. Disconnect P2 and P3 from the circuit card.
- d. Remove two 4-40 round head screws (Items C and F, Figure 7-1) which hold the Readhead Assembly to the Mechanism Assembly.
- e. Loosen the four 8-32 socket head screws (Item B, Figure 7-1) which hold the Mechanism Assembly (5) to the Front Panel at the rear of the front panel. The entire Readhead Mechanism Assembly consisting of the Tape Guide Assembly, the Readhead Assembly, Lamp Assembly and the Mechanism Assembly is now free to be removed from the panel.
- f. Remove the two 4-40 binder head screws (Item H, Figure 7-1) which hold the Upper Tape Guide Assembly (10) to the Mechanism Assembly (5). If no further disassembly is required, install the new Upper Tape Guide Assembly and perform the reverse of steps f through c. Perform Section 5.4.
- g. From the underside of the Mechanism Assembly remove the two 4-40 round head screws (Item I, Figure 7-1) which hold the Readhead Assembly to the Mechanism Assembly. It is necessary first to remove the Filler Block Assembly to provide access to screws (I). The Readhead Assembly and the Mechanism Assembly are now separated and can be replaced as individual assemblies. It is not recommended that Mechanism Assembly be disassembled beyond this level. However, Figure 7-2 is provided for reference only should the customer desire to do so.
- h. Reassembly is the reverse of steps g, f, e, d and then c.
- i. Perform Section 5.4.

### 6.2.3 READER CARD REPLACEMENT

The following procedure is recommended when removing the Reader Card:

- a. Remove all power and control signals by disconnecting P1 and the power cord.
- b. Disconnect P2, P3, P4, P5, P6, P7, P8, P9 and P10.
- c. Remove the seven 4-40 round head screws and nylon washers which hold the reader card to the power driver panel spacers.
- d. Reassembly is the reverse of steps c and b.
- e. Perform Section 5.4 beginning with step g.



#### 6.2.4 LAMP ASSEMBLY REPLACEMENT

The following procedure is recommended when replacing the Lamp Assembly:

- a. Remove all power and control signals by disconnecting P1 and the power cord.
- b. Slide the two terminals off at the rear of the lamp.
- c. Unscrew the lamp from the sleeve.
- d. Replacement is the reverse of steps c, b and then a.
- e. Perform Section 5.4, steps t, u and v.

#### 6.2.5 MOTOR AND/OR SPROCKET REPLACEMENT

The following procedure is recommended when replacing the motor and/or sprocket:

- a. Remove all power and control signals.

### WARNING

If the motor has been running for a period of time, it or the heat sink may be too hot to touch comfortably. Allow sufficient time for the motor and heat sink to cool before any adjustment or use a cloth or pair of gloves.

- b. Loosen the screw (Item S, Figure 7-1) which holds the motor to the heat sink and back the motor out slightly.
- c. Loosen the set screw (Item J, Figure 7-1) which holds the sprocket to the motor shaft. If only the sprocket needs replacing proceed to step e.
- d. Install the new motor by performing the reverse of step b. The motor should be up flush against the panel. Tighten screw S.
- e. Install the sprocket wheel so that: (1) distance from the rear of the sprocket to the front panel is 0.862 inch (see Figure 7-1) and (2) the 1/8 long set screw tightens on the flat of the motor shaft. Tighten the set screw J. This is a preliminary setting of the sprocket. The final setting is made in step f.
- f. Perform Section 5.4.

#### 6.2.6 TRANSFORMER REPLACEMENT

The following procedure is recommended when replacing the transformer.

- a. Remove all power and control signals by disconnecting P1 and the power cord.
- b. Disconnect P8/J8 and the transformer leads attached to TB1.

- c. Loosen the four 6-32 round head screws which hold the transformer to the transformer mounting chassis and remove the transformer.
- d. Install the new transformer by performing the reverse of steps c, b and then a. Refer to Table 6-1 for transformer wire connection.

Table 6-1. Transformer Wire Connections

T1 Wire Color	TB1 Terminal	T1 Wire Color	P8-Pin No. RRS6500
White/Orange	TB1-3	Brown	P8-1
White/Yellow	TB1-4	Red	P8-2
White/Green	TB1-5	Orange	P8-3
White/Blue	TB1-6	Yellow	P8-4
White/Violet	TB1-7	Green	P8-5
White/Grey	TB1-8	Blue	P8-6
		Violet	P8-7
		Grey	P8-8
		White	P8-9

### 6.2.7 SWITCH S1 REPLACEMENT

When replacing switch S1, it is recommended that the entire 110474-3 switch assembly be replaced and the following procedure be used:

- a. Remove all power and control signals by disconnecting P1 and the power cord.
- b. Remove the Upper Cover Assembly by performing Section 6.2.1.
- c. Remove the knob (Item 3, Figure 7-1).
- d. Loosen the hex nut which holds switch shaft to the front panel. Remove the hex nut and lock washer.
- e. Remove the grey wire coming from S1 at TB-1 and the white/black wire at TB1-5. These terminals slide on and off the terminal strip.
- f. Remove the switch assembly.
- g. Install the anti-rotation washer and flat washer on new switch assembly.
- h. Perform the reverse of steps f, e, d, c, and then b.

### 6.2.8 SWITCHES S2 AND S3 REPLACEMENT

The following procedure is recommended when replacing either S2 or S3.

- a. Remove all power and control signals by disconnecting P1 and the power cord.
- b. Remove the two 4-40 round head screws (Item L, Figure 7-1) which hold lower cover frame to the mounting block assembly and drop the lower cover frame. It is necessary first to remove the Filler Block assembly to provide access to screws L.

- c. If the Direction Switch, S3, is to be replaced, unsolder the following wires: Orange at S3-1, Yellow at S3-2 and green at S3-3. If the LOAD switch, S2 is to be replaced proceed to step f.
- d. Snap out the old switch S3.
- e. Replacement is the reverse of steps d, c, b and then a.
- f. If the LOAD switch, S2, is to be replaced, loosen the two 2-56 screws (Item M, Figure 7-1) washers, and hex nuts which hold S2 to the Mounting Block Assembly.
- g. Unsolder the following wires: Blue at S3-C, and violet at S2-NC.
- h. Replacement of S2 is the reverse of steps g, f, b and then a.

### 6.3 SPOOLER PARTS REPLACEMENT

#### 6.3.1 POTENTIOMETER REPLACEMENT

The following procedure is recommended when replacing a potentiometer. Refer to Figure 6-1 for callout designations.

- a. Remove all power and control signals by disconnecting P1 and the power cord.
- b. Unsolder the wires at terminals 1-3 on the potentiometer (terminal 1-yellow, terminal 2-green, terminal 3-red).
- c. Loosen set screw (G, Figure 6-1) which holds the shaft to the potentiometer shaft.
- d. Loosen nut (B) which holds the potentiometer to the bracket. Back the potentiometer out from the bracket.
- e. Install an ohmmeter across terminals 1 and 2 on the new potentiometer and rotate the shaft until the meter reads 5K.
- f. Install the new potentiometer into the coupling and bracket by performing the reverse of steps d and c. Care should be used so that the potentiometer shaft is not rotated and that the orientation of the terminals are as shown in Figure 6-1.
- g. Perform Section 5.6.

#### 6.3.2 FRONT PANEL AND CHASSIS SEPARATION

The following procedure is recommended when separating the front panel from the chassis.

- a. Remove all power and control signals by disconnecting P1 and the power cord.
- b. Disconnect the following connectors J2/P2, J3/P3, J4/P4, J5/P5, J6/P6 J7/P7, J11/P11 and J12/P12.
- c. Disconnect the two wires at TB1-1 (grey) and TB1-5 (white/black) which come from S1. Unlace these wires.

- d. Remove the four 8-32 binder head screws which hold the front panel to the chassis at the bottom and the two 8-23 flat head screws at the top.
- e. The front panel and chassis can now be separated.
- f. Reassembly is the reverse of steps d, c, b and then c.

### 6.3.3 SERVO MOTOR REPLACEMENT

The following procedure is recommended when replacing either servo motor assembly. When replacing the motor, it is recommended that the entire 110829-1 for RRS6500BEX/660/DRB or 112201-1 for the RRS6500BEX/660/ARB motor assembly (including connector and hub assembly) be replaced.

- a. Separate the front panel and chassis. Refer to Section 6.3.2, steps a through d.
- b. Remove the four 10-32 x 1/2 binder head screws which hold the motor to the front panel. Note the orientation of the motor so that the new motor will be installed the same way.
- c. Install the new motor by performing the reverse of steps b and then a.

### 6.3.4 TAPE ARM REPLACEMENT

The following procedure is recommended when replacing the tape arm.

- a. Remove all power and control signals by disconnecting P1 and the power cord.
- b. Remove the 6-32 x 3/8 flat head arm retaining screw (L) which holds the arm assembly to the shaft (1). See Figure 6-1.
- c. Remove the grip ring which holds the roller to the tape arm.
- d. The arm and roller are now free for replacement as required.
- e. Reassembly is the reverse of steps c, b and then a. When installing the roller make sure the distance between the front of the arm and the rear of the roller is between 0.190 and 0.205 inch. This is accomplished by placing 1 or 2 713600-149 washers between the spacer and the roller to obtain the desired dimension.
- f. Check the adjustment in Section 5.6 and readjust as required.

112670-077A

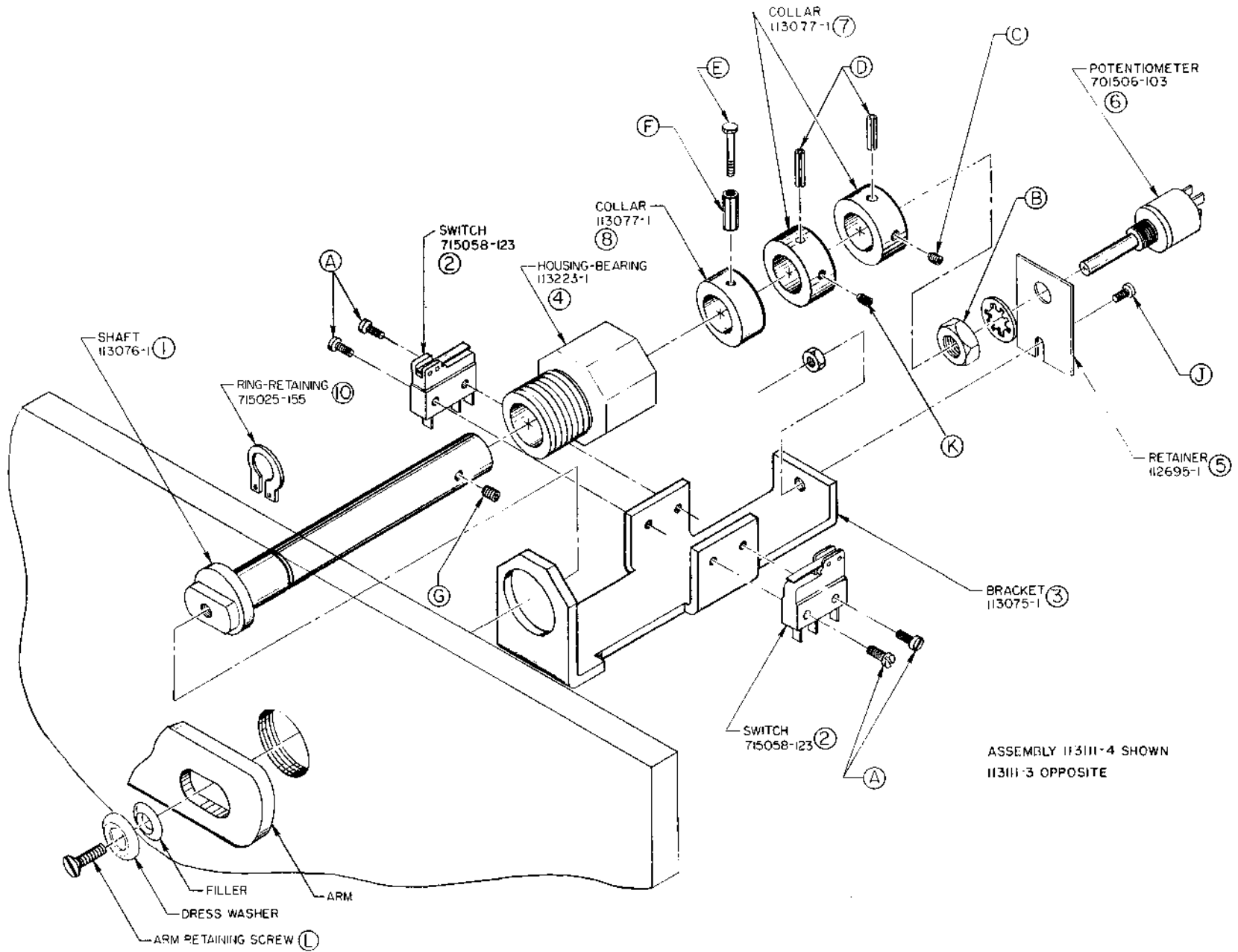

MMC 630

6-7/6-8

Figure 6-1. Exploded Drawing of Tape Break Switch Assembly 113111-3, -4.



## SECTION VII

### PARTS LIST

#### 7.1 GENERAL

Listed in Table 7-2 are the electronic and mechanical parts used in the RRS6500BEX/660/DRB. Table 7-3 lists those parts for the RRS6500BEX/660/ARB which are different from the RRS6500/BEX/660/DRB. Standard hardware items are not listed. Indented items are part of the assembly under which they are indented and the quantity of these items are per each assembly. Table 7-1 lists the recommended spare parts and the quantity column denotes the number recommended. Figures 7-1 through 7-4 illustrate the parts listed in Table 7-2. Those items identified by a broken arrow indicate the approximate location of parts not visible in the photograph.

Reference designations refer to the parts illustrated in Figures 7-1 through 7-4 (circled number designations in Figure 7-1; letter designations in Figure 7-1 refer to hardware items referenced in Sections 5 and 6). The reference designations include a figure number and a part designation number which appear on that figure to indicate the location of the part. For example, a 7-1; 12 appearing in the reference designation column indicates that the item listed in the description column can be located in Figure 7-1, Item 12. All electronic components are identified by letter-number combinations (such as S1 and T1) in the Reference Designation column and mechanical parts are identified by number. Reference designations contained in parenthesis are associated or function with the parenthetical item. These items are generally individual items and not part of an assembly but for reference are related back to the associated item. All items are available from Spares Order Desk, REMEX, 1733 Alton Street, P.O. Box C-19533, Irvine, California 92713.

Tables 7-4 through 7-5 and Figures 7-5 and 7-6 contain the components used on the power driver panel and the printed circuit card.

#### 7.2 KIT OF PARTS

The kit of parts contains items used for installation and maintenance and is shipped with the unit. Refer to Table 1-1.

NOTE: WHEN ORDERING SPARE PARTS, CONTACT REMEX SPARES ORDER DESK AND REFERENCE COMPLETE MODEL AND SERIAL NUMBER OF UNIT. ALWAYS REFER TO ADDENDUM AT THE REAR OF THE MANUAL (IF APPLICABLE) FOR POSSIBLE PART NUMBER CHANGES.

Table 7-1. Recommended Spare Parts.

Description and Manufacturer's Part No.	REMEX Part No.	Recomm. Quantity	Reference Designation
Fuse, 3A, Slow Blow (100, 115, 127 VAC Operation Only) Bussman MDA	705710-126	1	F101
Fuse, 1.5A, Slow Blow (220, 240 VAC Operation Only) Bussman MDA	705710-138	1	F101
Fuse, 4A, Bussman GMW, Reader Card	705725-112	1	F1
Fuse, 250 milliamp, Bussman GMW, Reader Card	705725-102	1	F2
Fuse, 200 milliamp, Bussman GMW, Reader Card	705725-101	1	F3
Lamp 5V, REMEX Specification	715071-141	1	DS1
Printed Circuit Card Assembly, Reader	112041-1	1	PC2
Readhead Assembly	113168-1	1	
Regulator, 5V, National Semiconductor, LM309K	704520-109	1	Z101, Z102
Solenoid with Plunger, REMEX Specification	715067-106	1	
Switch Assembly	110474-3	1	S1
Switch, SPDT, Cherry E61-00K	715058-120	1	S2
Switch, (ON) -OFF-(ON), C&K 5205	715063-104	1	S3
Switch, SPDT, Cherry E61-10H	715058-123	1	S4-S7
Switch, ON-NONE-ON, C&K 5201	715063-101	1	S8
Transistor, Motorola MJ4032	704212-106	1	Q102, Q104
Transistor, Motorola MJ4035	704204-120	1	Q101, Q103, Q105



NOTE: WHEN ORDERING SPARE PARTS, CONTACT REMEX SPARES ORDER DESK AND REFERENCE COMPLETE MODEL AND SERIAL NUMBER OF UNIT. ALWAYS REFER TO ADDENDUM AT THE REAR OF THE MANUAL (IF APPLICABLE) FOR POSSIBLE PART NUMBER CHANGES.

Table 7-2. Parts List, RRS6500BEX/660/DRB/U000

Description and Manufacturer's Part No.	REMEX Part No.	Quantity	Reference Designation
Top Assembly, RRS6500BEX/660/DRB	113080-1	1	Ref.
Chassis Assembly	113210-1	1	Ref.
Capacitor, 9300 $\mu$ f, 40V, STM 71C40RC932	702313-107	2	7-4; C102, C103
Chassis	113212-1	1	7-4; 1
Clamp, Capacitor, Stone City Products 1780-02	715045-149	2	7-4; (C102, C103)
① Cover, Capacitor, Sinclair-Rush 1.75-24 Black	716007-112	2	7-4; (C102, C103)
Decal, Terminal Block	113044-1	1	(TB1)
Fan Assembly	112068-1	1	7-4; (M4)
Bracket Fan	113214-1	1	
Bracket Fan Supporting	113213-1	2	
Fan, Howard 3-15-4450	716002-121	1	7-4; M4
Guard, Finger, Howard 6-182-033	716002-122	1	7-4; 2
Fuse, 3A, Slow Blow, (100, 115, 127 VAC Operation Only) Bussman MDA	705710-126	1	7-6; F101
Fuse, 1.5A, Slow Blow, (220, 240 VAC Operation Only) Bussman MDA	705710-138	1	7-6; F101
Key, Terminal Block	706540-155	14	(TB1)
Lug, Terminal, H.H. Smith, 1416-4	715000-108	1	7-5; E1
Lug, Capacitor Amp 31887	715005-110	5	7-5; (C102, C103)
Power Driver Panel Assembly See Table 7-4 for assembly and Figure 7-6 for component location	111021-3	1	7-5; PC1
Printed Circuit Card Assembly, Reader See Table 7-5 for assembly and Figure 7-7 for component location	112041-1	1	7-6; PC2
Terminal, Amp 350176-1	715005-139	2	7-6 (F101)
Terminal, Quick Disconnect Amp 42470-1	715005-125	2	7-4 (M4)
Terminal Lug, Aviel 05-02-0048	706530-171	19	7-4; (TB1)
Terminal Block, Molex 07-01-7051	706520-116	6	7-4; (TB1)
Transformer Assembly	113209-1	1	7-4; (T1)
Connector, Housing, 12 pin Yellow Molex 09-50-7121	706510-254	1	P8
Contact, Connector, Female, Molex 08-50-0106	706530-137	12	(P8)
Terminal Lug, Aviel 05-02-0048	706530-171	6	7-4; (T1)
Transformer, REMEX Specification	703010-150	1	7-4; T1
Cover, Assembly	113196-1	1	7-1; 1
Cover, P.C. Card	113208-1	1	
Cover, Top	113207-1	1	

① Deleted on later units.

NOTE: WHEN ORDERING SPARE PARTS, CONTACT REMEX SPARES ORDER DESK AND REFERENCE COMPLETE MODEL AND SERIAL NUMBER OF UNIT. ALWAYS REFER TO ADDENDUM AT THE REAR OF THE MANUAL (IF APPLICABLE) FOR POSSIBLE PART NUMBER CHANGES.

Table 7-2. Parts List, RRS6500BEX/660/DRB/U000 (Continued)

Description and Manufacturer's Part No.	REMEX Part No.	Quantity	Reference Designation
Decal, Caution Transformer Voltages	111933-3	1	These items are located on rear cover.
Decal, Hazard Warning	110884-1	1	
Decal, Nameplate	716018-113	1	
Decal, Patent Numbers	108546	1	
Decal, Warning, Line Voltages	111934-1	1	
Front Panel, Assembly	112426-1	1	Ref.
Block, Filler Assembly	111793-1	1	
Bracket, Cover	110765-1	1	
Bumper, Rubbercraft 91021	715021-113	2	7-3; 8, 15
Light Source, Fiber Optics	112297-1(P)	1	7-1; 20
Frame, Lower Cover	110440-3	1	7-1; 15
Gasket, Welch Allen 11200182	715018-104	1	7-1; 22
Heat Sink, Motor	110448-1	1	7-1; 11
Insert, Color	110441-3	2	7-1; 14
Knob, Microswitch 8Z0083	715065-113	1	7-1; 3
Lamp, 5 Volt REMEX Specification	715071-141	1	7-1; DS1
Motor Assembly, Reader	110473-3	1	7-1; (M3)
Collar	110866-1	1	7-1; 10
Collar, Spring	110869-1	1	7-1; 4
Connector, Housing, Molex 09-50-7051, Yellow	706510-221	1	P4
Contact, Connector, Female Molex 08-50-0108	706530-138	4	(P4)
Damper Assembly	110867-1	1	7-1; 9
Faceplate	111386-1	1	7-1; 7
Motor, 28 Vdc Stepper, REMEX Specification	715075-176	1	7-1; M3
Plate, Friction	111385-1	1	7-1; 8
Spring, Lee LC-032D-1 (MW)	714090-136	1	7-1; 5
Motor Assembly, Spooler	110829-1	2	(M2, M1)
Connector, Housing, Violet, 3 pin Molex 09-50-7031	706510-257	1	P11, P12
Contact, Connector, Female Molex 08-50-0106	706530-137	3	(P11, P12)
Hub Assembly	105577	1	7-3; 10, 14
Motor, 18 Vdc, 1600 RPM Howard S-70130	715075-183	1	7-4; M1, M2
Panel, Front	113066-3	1	7-3; 16
Readhead Mechanism Assembly	113171-1	1	7-1, 7-3; 12
See Figure 7-1 for location of parts			
Bezel, Black, C&K B7888-2	715063-201	1	(S3)
Cap, Rocker, ◁ ▷ C&K 7922-1	715063-319	1	(S3)
Clamp, Cable, Weckesser A-30	715040-139	1	
Connector, Housing, Orange, 8 pin Molex 09-50-7081	706510-223	1	7-1; P3
Contact, Connector, Female, Molex 08-50-0103	706530-137	7	7-1; (P3)

NOTE: WHEN ORDERING SPARE PARTS, CONTACT REMEX SPARES ORDER DESK AND REFERENCE COMPLETE MODEL AND SERIAL NUMBER OF UNIT. ALWAYS REFER TO ADDENDUM AT THE REAR OF THE MANUAL (IF APPLICABLE) FOR POSSIBLE PART NUMBER CHANGES.

Table 7-2. Parts List, RRS6500BEX/660/DRB/U000 (Continued)

Description and Manufacturer's Part No.	REMEX Part No.	Quantity	Reference Designation
Front Panel Assy. (Continued)			
Frame, Lower Cover	110440-5	1	7-1;15
Ground Plate Assembly	112423-1	1	7-1;19
Mechanism Assembly	113170-1	1	7-1;13
The following parts along with Figure 7-2 are listed for reference only. It is recommended that the entire 113170-1 assembly be replaced as a complete assembly.			
Actuator Assembly	110769-1	1	
Cam, Tape Guide	110438-1	1	
Door Mechism Assembly	110720-2	1	
Ground Strap Assembly	110762-1	1	
Ring, Retainer, Truarc 5103-25	715025-148	1	
Slide	110432-1	1	
Spring, Associate Spring E0094-014-0620M	714090-158	1	
Readhead, Assembly	113168-1(P)	1	7-1;16
Except for the components listed below, the entire 113168-1 assembly must be replaced as a complete assembly.			
Connector, Housing, Red, 12 pin Molex 09-50-7121	706510-224	1	7-1;P2
Contact, Connector, Female, Molex 08-50-0108	706530-138	10	7-1;(P2)
Switch, SPDT, Cherry E61-00K	715058-120	1	7-1;S2
Switch, (ON)-OFF-(ON) C&K 5205	715063-104	1	7-1;S3
Tape Guide, Fixed	112329-1	1	7-1;2
Tape Guide, Upper	112407-1	1	7-1;18
Roller Assembly, Tape Tensioner	113181-1	2	
Sleeve	112319-1	1	7-1;21
Solenoid Assembly	113216-1	2	
Bracket, Solenoid	113017-1	1	
Solenoid, REMEX Specification	715067-106	2	
Sprocket, REMEX Specification	716057-102	1	7-1;12
Spring, Arm	714090-106	2	7-4;3,4
Switch Assembly, Power	110474-3	1	S1
Switch Assembly, LOOP-SPOOL	111075-2	1	7-3;(S8)
Bezel, Black, C&K 87888-2	715063-201	1	7-3;(S8)
Cap, Rocker LOOP-SPOOL, C&K 7922-1	715063-323	1	7-3;(S8)
Connector, Housing, Blue, 2 pin Molex 09-50-7061	706510-225	1	P7

NOTE: WHEN ORDERING SPARE PARTS, CONTACT REMEX SPARES ORDER DESK AND REFERENCE COMPLETE MODEL AND SERIAL NUMBER OF UNIT. ALWAYS REFER TO ADDENDUM AT THE REAR OF THE MANUAL (IF APPLICABLE) FOR POSSIBLE PART NUMBER CHANGES.

Table 7-2. Parts List, RRS6500BEX/660/DRB/U000 (Continued)

Description and Manufacturer's Part No.	REMEX Part No.	Quantity	Reference Designation
Front Panel Assembly (Continued)			
Contact, Connector, Female, Molex 08-50-0106	706530-137	2	(P7)
Switch ON-NONE-ON C&K 5201	715063-101	1	7-3;S8
Tape Arm assembly, Left	110730-1	1	7-3;1
Arm, Left	111378-1	1	
Ball, Nylon, 1/8", Grade 1, Product Components Corp.	716014-105	1	
Bearing, Nippon Miniature SS-R1-5632ZZA3P15LG-20	714000-108	2	
Ring, Grip, Truarc 5100-12	715025-110	2	
Roller, Tape, Outer with Bearing	109763-1	1	
Roller, Tape, Inner	101837	1	
Shaft, Arm Roller	110849-1	1	
Spacer, .250 OD x .190 ID x 0.015 thick	715030-158	2	
Spacer	112295-2	1	
Spacer	112295-3	1	
Washer	713600-149	4	
Tape Arm Assembly, Right	110730-2	1	7-3;9
The subassemblies for 110730-2 are identical to 110730-1 except:			
Arm, Right	111378-2	1	
Tape Break, Switch Assembly, Left	113111-3	1	6-1;Ref.
Bracket	113075-1	1	6-1;3
Collar	113077-1	3	6-1;7,8
Connector Housing, Green Molex 09-50-7061	706510-222	1	P6
Contact, Connector, Female, Molex 08-50-0106	706530-137	6	(P6)
Housing, Bearing	113223-1	1	6-1;4
Potentiometer, REMEX Specification	701506-103	1	R204,6-1;6
Retainer	112695-1	1	6-1;5
Shaft	113076-1	1	6-1;1
Switch, SPDT, Cherry E61-10H	715058-123	2	S5,S7;6-1,-2
Tape Break Switch Assembly, Right	113111-4	1	6-1;Ref.
The subassemblies are the same as 113111-3			(P5,R203,S4,S6)
Tape Roller Assembly	108231	2	7-3;3,6
Bearing, Nippon Miniature SS-R1-F-5632ZZA3PLG-20	714000-127	2	
Ring, Retaining, Truarc 5100-18	715025-111	1	
Ring, Spacer, Gasket Mfg. Co. Die No. 128E	715030-158	1	
Roller, Tape	108232	1	
Shaft, Roller	101836	1	
Tape Roller Assembly	112606-1	4	7-3;2,4,5,7
Roller with Bearing	112605-1	1	
Shaft, Roller	112604-1	1	

NOTE: WHEN ORDERING SPARE PARTS, CONTACT REMEX SPARES ORDER DESK AND REFERENCE COMPLETE MODEL AND SERIAL NUMBER OF UNIT. ALWAYS REFER TO ADDENDUM AT THE REAR OF THE MANUAL (IF APPLICABLE) FOR POSSIBLE PART NUMBER CHANGES.

Table 7-2. Parts List, RRS6500BEX/660/DRB/U000 (Continued)

Description and Manufacturer's Part No.	REMEX Part No.	Quantity	Reference Designation
Front Panel Assembly (Continued)			
Tape Tensioning Assembly, Left It is recommended that the entire 113113-1 assembly be replaced as a complete assembly.	113113-1	1	7-4;5
Tape Tensioning Assembly, Right It is recommended that the entire 113113-2 assembly be replaced as a complete assy.	113113-2	1	7-4;6
Kit of Parts, RRS6500BEX/660/DRB See Table 1-1 for contents.	113204-1	1	
Kit of Parts, RRS6500BEX/660/ARB	113203-1	1	
Tape Guide Assembly, RRS6500EB1 Only	112411-1	1	7-1;17
Tape Guide Assembly, RRS6500EB2 Only	112411-2	1	7-1;17
Tape Guide Assembly, RRS6500EB3 Only	112411-3	1	7-1;17
Tape Guide Assembly, RRS6500EB4 Only	112411-4	1	7-1;17
Tape Guide Assembly, RRS6500EB5 Only	112411-5	1	7-1;17
Reel, 6" Diameter, Gray, Plastic RRS6500BEX/660/DRB Only	107878-1	2	
Reel, 7-1/2" diameter, Gray, Plastic RRS6500BEX/660/DRB Only	107878-2	2	
Reel, 6" diameter, White, Plastic RRS6500BEX/660/DRB Only	107878-3	2	
Reel, 7-1/2" diameter, White, Plastic RRS6500BEX/660/DRB Only	107878-4	2	
Reel, 8" diameter, Aluminum, NAB, RRS6500BEX/660/ARB Only	716028-101	2	

NOTE: WHEN ORDERING SPARE PARTS, CONTACT REMEX SPARES ORDER DESK AND REFERENCE COMPLETE MODEL AND SERIAL NUMBER OF UNIT. ALWAYS REFER TO ADDENDUM AT THE REAR OF THE MANUAL (IF APPLICABLE) FOR POSSIBLE PART NUMBER CHANGES.

Table 7-3. Parts List RRS6500BEX/660/ARB/U000

Description and Manufacturer's Part No.	REMEX Part No.	Quantity	Reference Designation
Top Assembly The subassemblies are the same as listed in Table 7-2 except for those parts listed below	113108-1	1	Ref.
Cover, Top	113206-1	1	
Front Panel Assembly The subassemblies are the same as listed in Table 7-2 except for those parts listed below.	113065-1	1	Ref.
Hub	109259	1	
Motor Assembly, Spooler	112201-1	1	(M1, M2)
Connector, Housing, Violet, 3 pin Molex 09-50-7031	706510-257	1	P11, P12
Contact, Connector, Female, Molex 08-50-0106	706530-137	3	(P11, P12)
Motor, 18 VDC, 1600 RPM Howard S-70130	715075-183	1	7-4; M1, M2
Panel, Front	113064-2	1	
Tape Arm Assembly, Left	112200-1	1	
Arm, Left	112217-1	1	
Ball, Nylon, 1/8", Grade 1, Product Components Corp.	716014-105	1	
Bearing, Nippon Miniature, SS-R1-563ZZA3PLG-20	714000-108	2	
Ring, Grip, Truarc 5555-12H	715025-115	2	
Ring, Retaining, Truarc 5100-18	715025-138	1	
Roller, Tape, Outer	109763-1	1	
Roller, Tape, Inner	101837	1	
Shaft, Arm Roller	110849-1	1	
Spacer, 0.250 O.D. x 0.190 ID x 0.015 thick	715030-158	2	
Tape Arm Assembly, Right The subassemblies are the same as 112200-1 except:	112200-2	1	
Arm, Right	112217-2	1	
Change Insert, Color, Black	110441-5	1	
Delete, Frame, Lower Cover	110440-3	1	

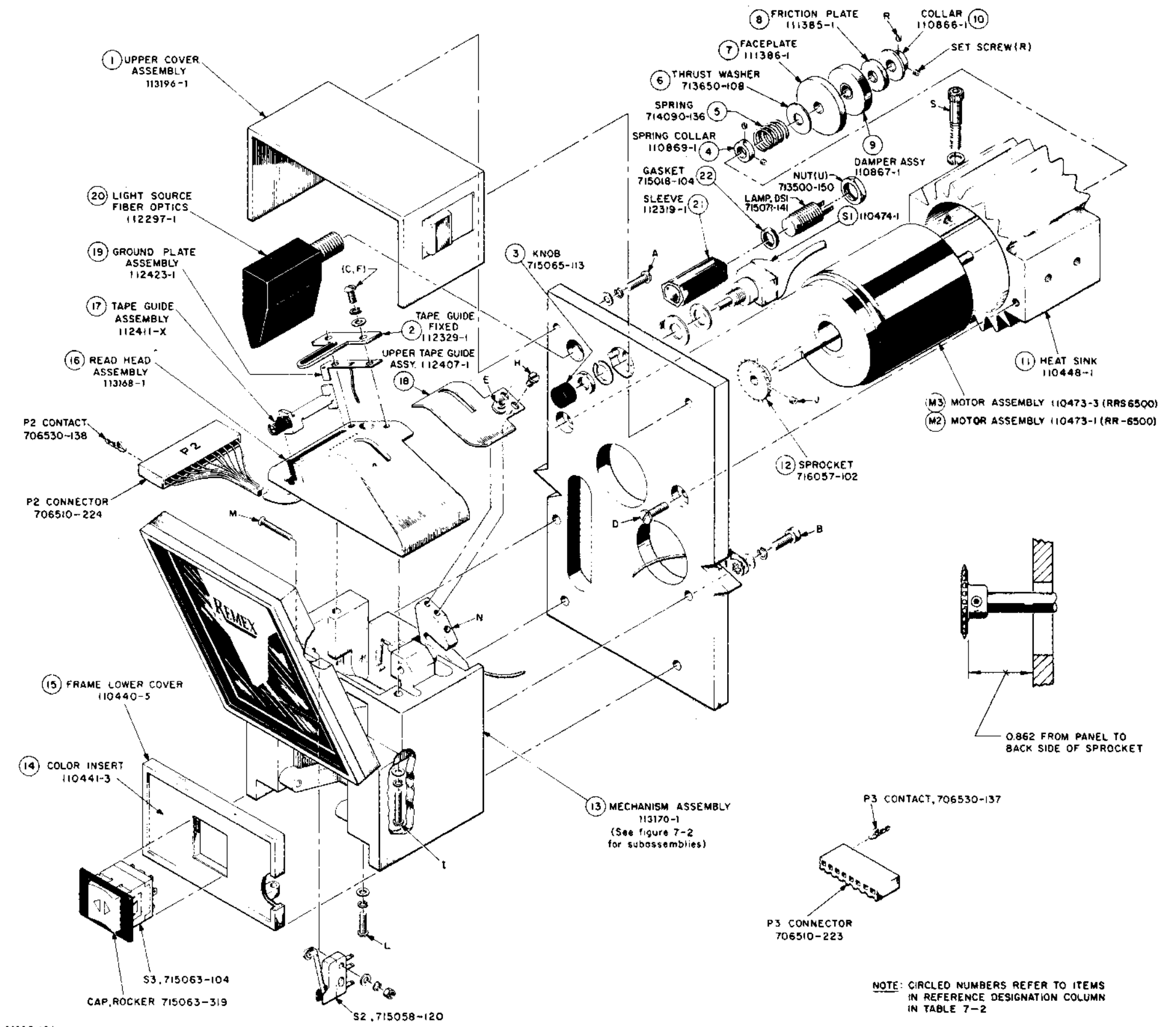

NOTE: CIRCLED NUMBERS REFER TO ITEMS IN REFERENCE DESIGNATION COLUMN IN TABLE 7-2

MMC 634

Figure 7-1. Exploded View of Readhead Mechanism Assembly

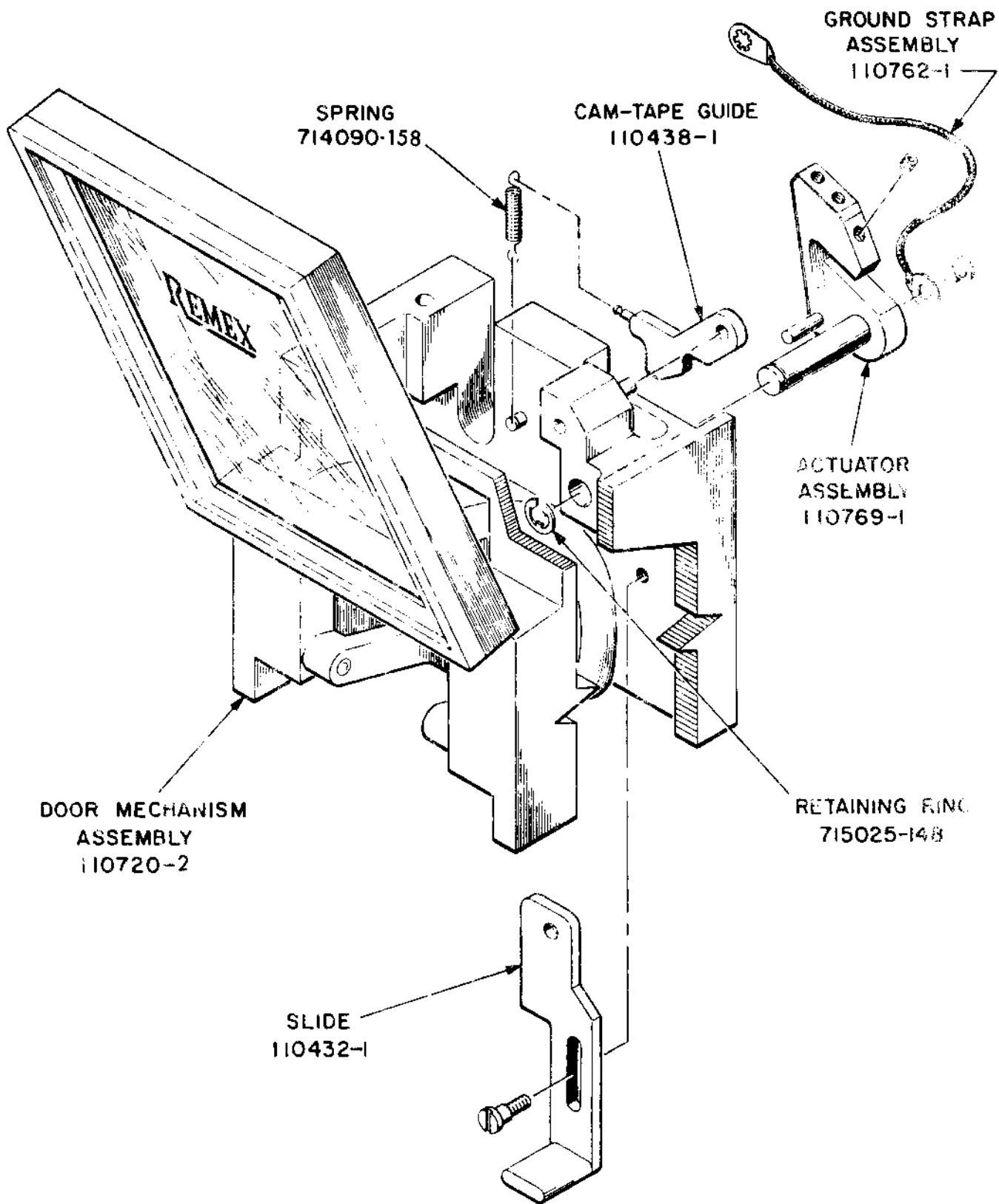

MMC 357

Figure 7-2. Exploded View of Mechanism Assembly, 113170-1.



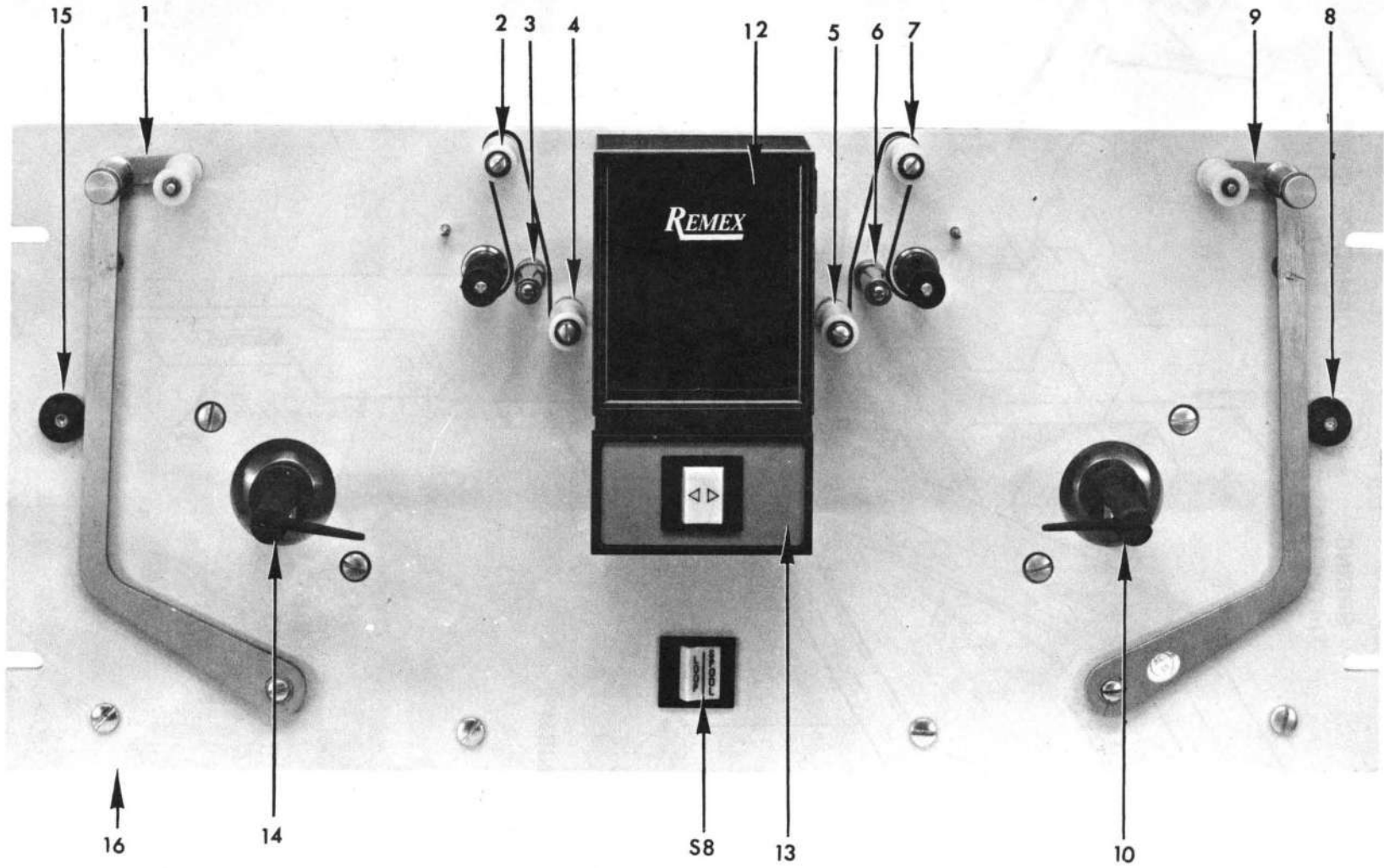

Figure 7-3. Front View of Front Panel.

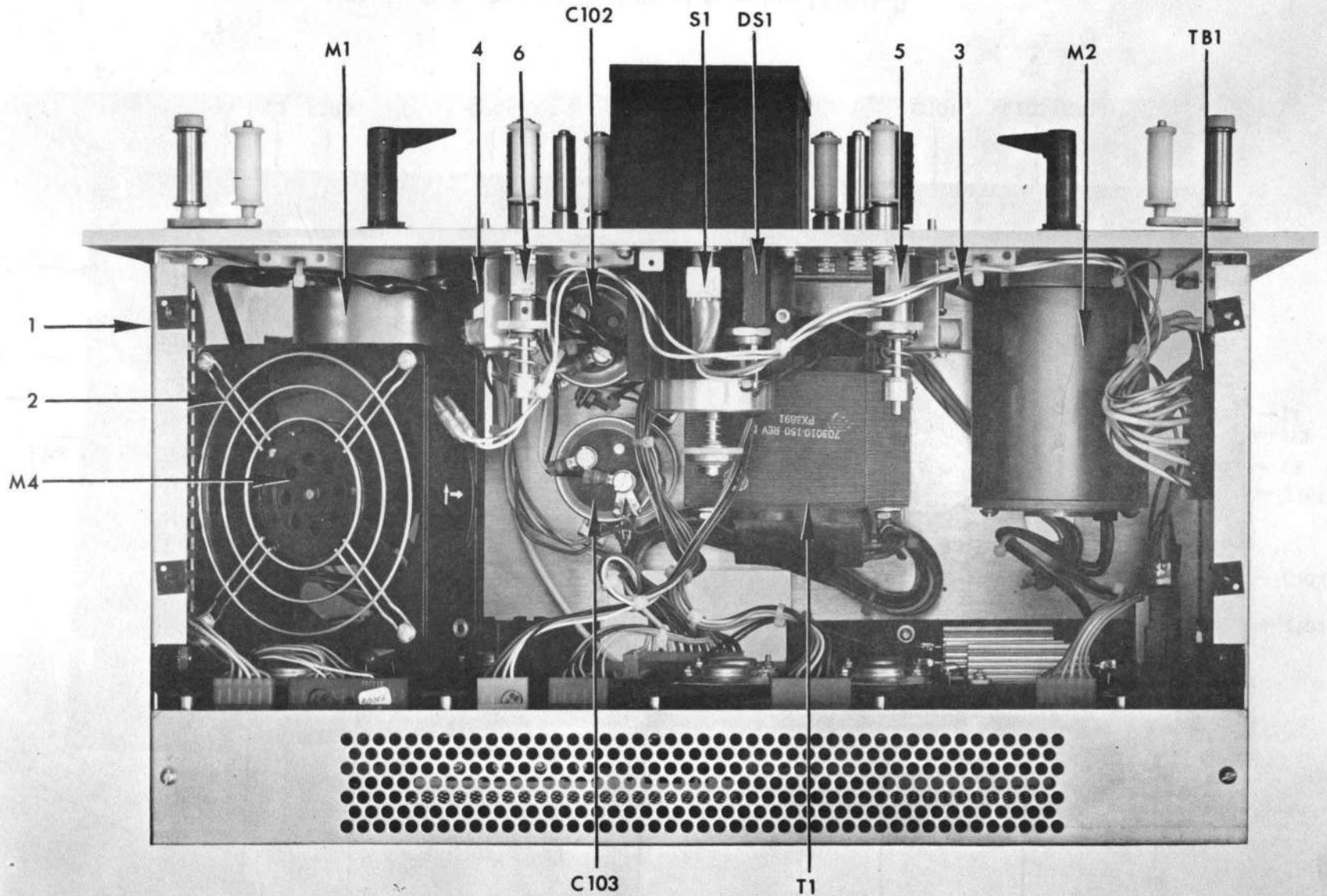

Figure 7-4. Rear View of Front Panel, RRS6500BEX/660/ARB. The location of components on the RRS6500BEX/660/DRB is approximately the same.

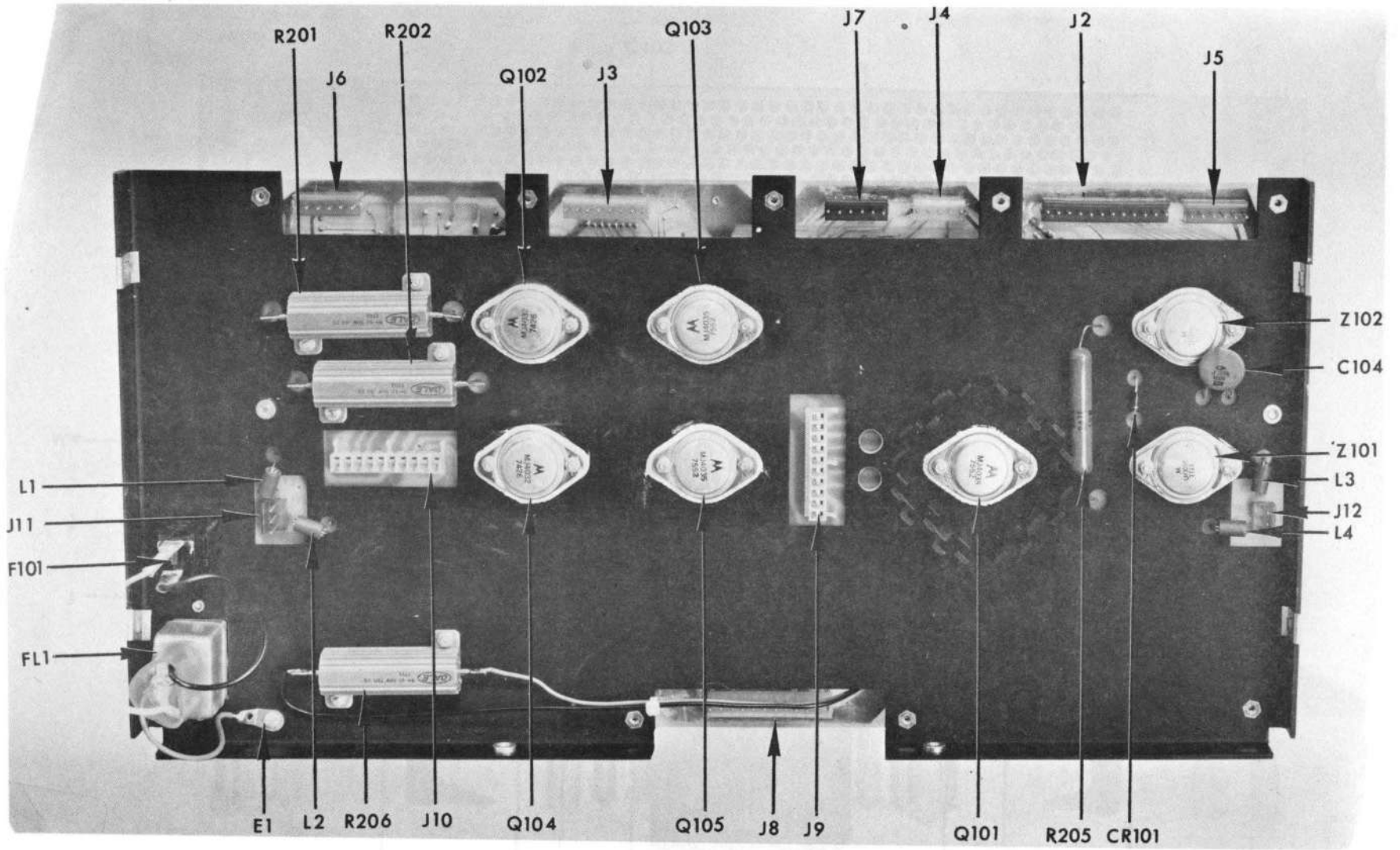

Figure 7-5. Power Driver Panel Assembly 111021-3.



Table 7-4. Power Driver Panel Assembly 111021-3

Description and Manufacturer's Part No.	REMEX Part No.	Quantity	Reference Designation
<b>NOTE</b>			
The following parts list has been written for the K <sub>1</sub> assembly revision and Z schematic revision. Subsequent changes are listed on a P.C. Card Change Record form inserted as an addendum at the end of the manual.			
Capacitor, 1 $\mu$ f, 50 Vdc, Ceramic, Monolithic Sprague 7C023105D8500E	702131-105	2	C104,C105
Choke, R.F. Suppressor, Ferroxcube VK200-10/3B	702500-107	4	L1-L4
Connector, 10 pin, White, Molex 09-52-3082	706510-262	2	J9, J10
Connector, 3 pin, Violet, Molex 90-60-1031	706501-037	2	J11, J12
Filter, Corcom 6EF1-E1	702250-111	1	F11
Fuseholder, Littlefuse 348870	705750-117	1	F101
Diode, 1N4003	704005-137	1	CR101
Heat Sink	715033-115	1	(Q101)
Insulator, RCA 495320	715019-115	7	(Q101-Q105, Z101,Z102)
Panel, Heat Sink	113144-1	1	
Resistor, 1/2 ohm, 50W, $\pm$ 3%	70118R-500	2	R201,R202
Resistor, 35 $\Omega$ , 10W, $\pm$ 5%	701017-350	1	R205
Resistor, 75 ohm, 50W	701187-5R0	1	R206
Transistor, Motorola MJ4035	704204-120	3	Q101, 103, 105
Transistor, Motorola MJ4032	704212-106	2	Q102, Q104
Voltage Regulator, National Semiconductor, LM309K	704520-109	2	Z101, Z102

Table 7-5. Parts List, Reader Card 112041-1

Description and Manufacturer's Part No.	REMEX Part No.	Quantity	Reference Designation
<p>NOTE: This parts list has been written for the G1 Assy. version of P.C. Card 112041-2 and Z version of Schematic 112042. Subsequent changes (if present) are itemized on a P.C. Card Change Record form inserted as an addendum at the rear of the manual.</p>			
Capacitor, 2500 $\mu$ f, 25V, Electrolytic	702345-258	1	C3
Capacitor, 2000 $\mu$ f, 75V, Electrolytic	702361-208	2	C4, C5
Capacitor, 100 $\mu$ f, 40V, Electrolytic, Solid Tantalum, Sprague 600D 107G040DGO	702382-107	2	C6, C7
Capacitor, 1 $\mu$ f, 50V, Ceramic, Monolithic Sprague 7C023105D8500E	702131-105	7	C8, C48-C53
Capacitor, 0.01 $\mu$ f, 100V, Ceramic Disk Erie 805X5V103Z	702121-103	42	C9, C15, C16, C21, C24, C25, C31, C35, C44, C54-C58, C60-C84, C86-C89
Capacitor, 0.1 $\mu$ f, 100V, Ceramic Disk Erie 805X5V104Z	702121-104	2	C10, C11
Capacitor, 82 $\mu$ f, 10V, Solid Tantalum Polarized, Sprague 196D	702393-826	1	C12
Capacitor, 220 $\mu$ f, 10V, Electrolytic, Amperex Model FT	702620-227	1	C13
Capacitor, 47 $\mu$ f, 10V, Electrolytic, Amperex Model FT	702620-476	3	C14, C28, C30
Capacitor, 0.001 $\mu$ f, 200V, Ceramic Type CK05	702128-102	2	C17, C19
Capacitor, 470 pf, 200V, Ceramic Type CK05	702128-471	2	C18, C29
Capacitor, 1 $\mu$ f, 100V, Metallized Mylar IMB XP7B105X	702181-105	4	C20, C22, C23
Capacitor, 100 pf, 200V, Ceramic, Type CK05	702128-101	4	C36, C26, C27, C32, C42
Capacitor, 220 pf, 200V, Ceramic, Type CK05	702128-221	1	C33
Capacitor, 3.3 $\mu$ f, 15V, Solid Tantalum Sprague 196D	702394-335	1	C34
Capacitor, 560 pf, 200V, Ceramic Type CK05	702128-561	1	C37
Capacitor, 0.22 $\mu$ f, 100V, Metallized Mylar IMB XP7B224X	702181-224	1	C38
Capacitor, 0.015 $\mu$ f, 100V, Metallized Mylar, IMB XP7B153X	702181-153	1	C39
Capacitor, 0.15 $\mu$ f, 100V, Metallized Mylar, IMB XP7B154X	702181-154	1	C40
Capacitor, 0.0047 $\mu$ f, 200V, Ceramic Type CK06	702128-472	4	C41, C59, C85, C90
Capacitor, 0.033 $\mu$ f, 100V, Ceramic Type CK06	702128-333	1	C43

Table 7-5. Parts List, Reader Card 112041-1 (Continued)

Description and Manufacturer's Part No.	REMEX Part No.	Quantity	Reference Designation
Capacitor, 100 $\mu$ f, 10V, Solid Tantalum Polarized Sprague 196D	702393-107	1	C45
Capacitor, 0.1 $\mu$ f, 100V, Metallized Mylar IMB XP78104X	702181-104	1	C46
Capacitor, 0.68 $\mu$ f, 100V, Metallized Mylar IMB XP78684X	702181-684	1	C47
Connector, Cannon DB-25PV, 25 pin	706500-239	1	J1
Connector, 12 pin, Red, Molex 09-60-1121	706501-122	1	J2
Connector, 8 pin, Orange, Molex 09-60-1081	706501-083	1	J3
Connector, 5 pin, Yellow, Molex 09-60-1051	706501-054	1	J4
Connector, 6 pin, Green, Molex 09-60-1061	706501-065	2	J5, J6
Connector, 6 pin, Blue, Molex 09-60-1061	706501-066	1	J7
Connector, 12 pin, Yellow, Molex 09-60-1121	706501-124	1	J8
Connector, 10 pin, Molex 09-64-1103	706500-251	1	P9, P10
Diode, Motorola MR1032B	704005-117	1	CR1, CR2
Diode, 1N5624	704005-138	2	CR3, CR4
Diode, 1N4003	704005-137	16	CR6-CR8, CR10, CR11 CR14, CR17- CR19, CR24- CR30 CR9
Diode, Zener 1N4735A	704014-116	1	CR12, CR13
Diode, Zener 1N4744A	704014-115	2	CR15, CR31, CR35-CR37
Diode, 1N276	704000-100	5	CR32, CR34 CR16, CR20-CR22
Diode, FDH6666	704000-110	6	
Fuse 4A, Bussman GMW	705725-112	1	F1
Fuse, 250 Milliamp, Bussman GMW	705725-102	1	F2
Fuse, 200 Milliamp, Bussman GMW	705725-101	1	F3
Fuse, 10A, Littlefuse 276	705725-127	2	F4, F5
Fuse, Connector	706515-141	4	(F4, F5)
Fuseholder, Cambion 3704-1-03	706515-129	6	(F1-F3)
Heatsink	109457-1	1	(Q10-Q13)
Heatsink, IERC PA1-1B	715033-109	2	(Q22, Q23)
Heatsink, Wakerfield NF-205	715033-113	2	(CR1, CR2)
Heatsink,	715033-133	1	(BR1)
I.C. Package, Resistor/Capacitor Network Beckman 1899-4102-0	701950-004	2	Z1, Z2
I.C. Package, SN7475N	704610-105	2	Z3, Z4
I.C. Package, SN7486N	704600-109	4	Z5-Z7, Z28
I.C. Package, SN74221N	704610-165	6	Z8, Z13, Z15, Z16, Z23, Z36

Table 7-5. Parts List, Reader Card 112041-1 (Continued)

Description and Manufacturer's Part No.	REMUX Part No.	Quantity	Reference Designation
I.C. Package, SN7408N	704600-114	6	Z9, Z18, Z20, Z26, Z30, Z34
I.C. Package, SN7400N	704600-101	7	Z10, Z11, Z17, Z22, Z32, Z33, Z52
I.C. Package, SN74132N	704600-152	2	Z12, Z31
I.C. Package, SN7474N	704610-110	2	Z14, Z27
I.C. Package, SN74123N	704610-119	3	Z19, Z24, Z25
I.C. Package, SN7404N	704600-110	1	Z21
I.C. Package, SN7406N	704600-111	2	Z29, Z35
I.C. Package, LM307N	704520-110	6	Z37, Z39-Z41, Z43, Z45
I.C. Package, Intersil I H5019CPA	704900-106	3	Z38, Z42, Z44
I.C. Package, Resistor, REMEX Specification	701900-004	1	Z46
I.C. Package, Resistor/Capacitor Network REMEX Specification	701950-007	3	Z47-Z49
I.C. Package, Resistor, REMEX Specification	701900-007	1	Z50
I.C. Package, SN7402N	704600-106	1	Z51
Insulator, Thermalloy 43-77-2	715019-120	4	(Q10-Q13)
Insulator, Thermalloy 43-77-1	715019-122	2	(Q22, Q23)
Rectifier, Bridge, International Rectifier 82-0103	704005-142	1	BR1
Resistor, 0.2 $\Omega$ , 3W, $\pm$ 5%	701015-R20	1	R1
Resistor, 0.5 $\Omega$ , 10W, $\pm$ 5%	701017-R50	1	R2
Resistor, 560 $\Omega$ , 1/2W, $\pm$ 5%	701004-561	2	R3, R4
Resistor, 330 $\Omega$ , 1/2W, $\pm$ 5%	701004-331	1	R6
Resistor, 2.2K, 2W, $\pm$ 5%	701014-222	1	R7
Resistor, 47 $\Omega$ , 1/4W, $\pm$ 5%	701003-470	5	R8, R26, R81, R87, R92
Resistor, 820 $\Omega$ , 3W, $\pm$ 5%	701015-821	1	R9
Resistor, 1.5K, 1/4W, $\pm$ 5%	701003-152	2	R10, R77
Resistor, 470 $\Omega$ , 1/4W, $\pm$ 5%	701003-471	2	R12, R118
Resistor, 10K, 1/4W, $\pm$ 5%	701003-103	8	R13, R29, R32, R43, R48, R49, R90, R111
Resistor, 4.7K, 1/4W, $\pm$ 5%	701003-472	16	R14, R15, R18, R19, R23, R24, R33, R38, R57, R58, R73, R74, R104, R112, R113, R115
Resistor, 2.2K, 1/4W, $\pm$ 5%	701003-222	6	R16, R22, R34, R100, R102, R116



Table 7-5. Parts List, Reader Card 112041-1 (Continued)

Description and Manufacturer's Part No.	REMEX Part No.	Quantity	Reference Designation
Resistor, 27K, 1/4W, ±5%	701003-273	4	R17, R21, R71, R94
Resistor, 22 Ω, 1/4W, ±5%	701003-220	6	R20, R72, R107, R114
Resistor, 3.9K, 1/4W, ±5%	701003-392	2	R23, R24
Resistor, 1M, 1/4W, ±5%	701003-105	3	R27, R40, R47
Resistor, 1K, 1/4W, ±5%	701003-102	10	R28, R31, R35, R69, R70, R93, R101, R105, R106, R108
Resistor, 18K, 1/4W, ±5%	701003-183	1	R30
Resistor, 8.2M, 1/4W, ±5%	701003-825	1	R37
Resistor, 33K, 1/4W, ±5%	701003-333	1	R39
Resistor, 47K, 1/4W, ±5%	701003-473	1	R41
Resistor, 5.1K, 1/4W, ±5%	701003-512	1	R42
Resistor, 1.2K, 1/4W, ±5%	701003-122	1	R45
Resistor, 1.8M, 1/4W, ±5%	701003-185	1	R46
Resistor, 180K, 1/4W, ±5%	701003-184	2	R50, R54
Resistor, 330K, 1/4W, ±5%	701003-334	2	R51, R53
Resistor, 2.2M, 1/4W, ±5%	701003-225	2	R55, R56
Resistor, 330 Ω, 1/4W, ±5%	701003-331	10	R59, R62, R66, R83, R84, R96-R99
Resistor, 820 Ω, 1/2W, ±5%	701004-821	4	R60, R61, R64, R65
Resistor, 100 Ω, 1/4W, ±5%	701003-101	2	R67, R68
Resistor, 100K, 1/4W, ±5%	701003-104	1	R75
Resistor, 220 Ω, 1/4W, ±5%	701003-221	1	R76
Resistor, 10K, 1/4W, ±1%	701211-002	1	R78
Resistor, 15K, 1/4W, ±5%	701003-153	1	R79
Resistor, 12K, 1/4W, ±5%	701003-123	2	R80, R95
Resistor, 22K, 1/4W, ±5%	701003-223	1	R82
Resistor, 39K, 1/4W, ±5%	701003-393	1	R85
Resistor, 13.3K, 1/4W, ±1%	701211-332	3	R86, R89, R91
Resistor, 390 Ω, 3W, ±5%	701015-391	2	R109, R110
Resistor, 8.2K, 1/4W, ±5%	701003-822	1	R117
Resistor, 2K, 1/4W, ±5%	701003-202	1	R119
Resistor, 1.5 Ω, 2W, ±5%	701014-1R5	1	R120
Resistor, 10 ohm, 1/4W, ±5%	701003-100	1	R121
Resistor, Variable, 100 Ω, 1/2W, Spectrol 53-1-1-101	701659-101	1	R5
Resistor, Variable, 2K, 1/2W, Spectrol 53-1-1-202	701659-202	1	R11
Resistor, Variable, 10K, 1/2W, Spectrol 53-1-1-103	701659-103	1	R36
Resistor, Variable, 100K, 1/2W, Spectrol 53-1-1-104	701659-104	2	R52, R103

Table 7-5. Parts List, Reader Card 112041-1 (Continued)

Description and Manufacturer's Part No.	REMEX Part No.	Quantity	Reference Designation
Resistor, Variable, 20K, 1/2W, Spectrol 53-1-1-203	701659-203	1	R88
Screw Lock, (Set of 2) Female Cannon D-10418-2	706540-123	1	(J1)
Standoff, Cambion 350-7409-10-19	715030-199	2	(J1)
Test Point, Phoenix Tool 23-1669-11	706530-170	11	TP1-TP11
Transistor, 2N5088	704203-119	9	Q1-Q9
Transistor, Motorola MJE1100	704204-115	6	Q10-Q15
Transistor, Motorola MPS-A06	704203-118	2	Q16, Q18
Transistor, Motorola MPS-A56	704202-109	2	Q17, Q19
Transistor, 2N5192	704204-109	1	Q20
Transistor, 2N5195	704212-107	2	Q21, Q22
Transistor, Motorola MJE803	704204-122	1	Q23
Transistor, 2N4401	704203-114	1	Q24



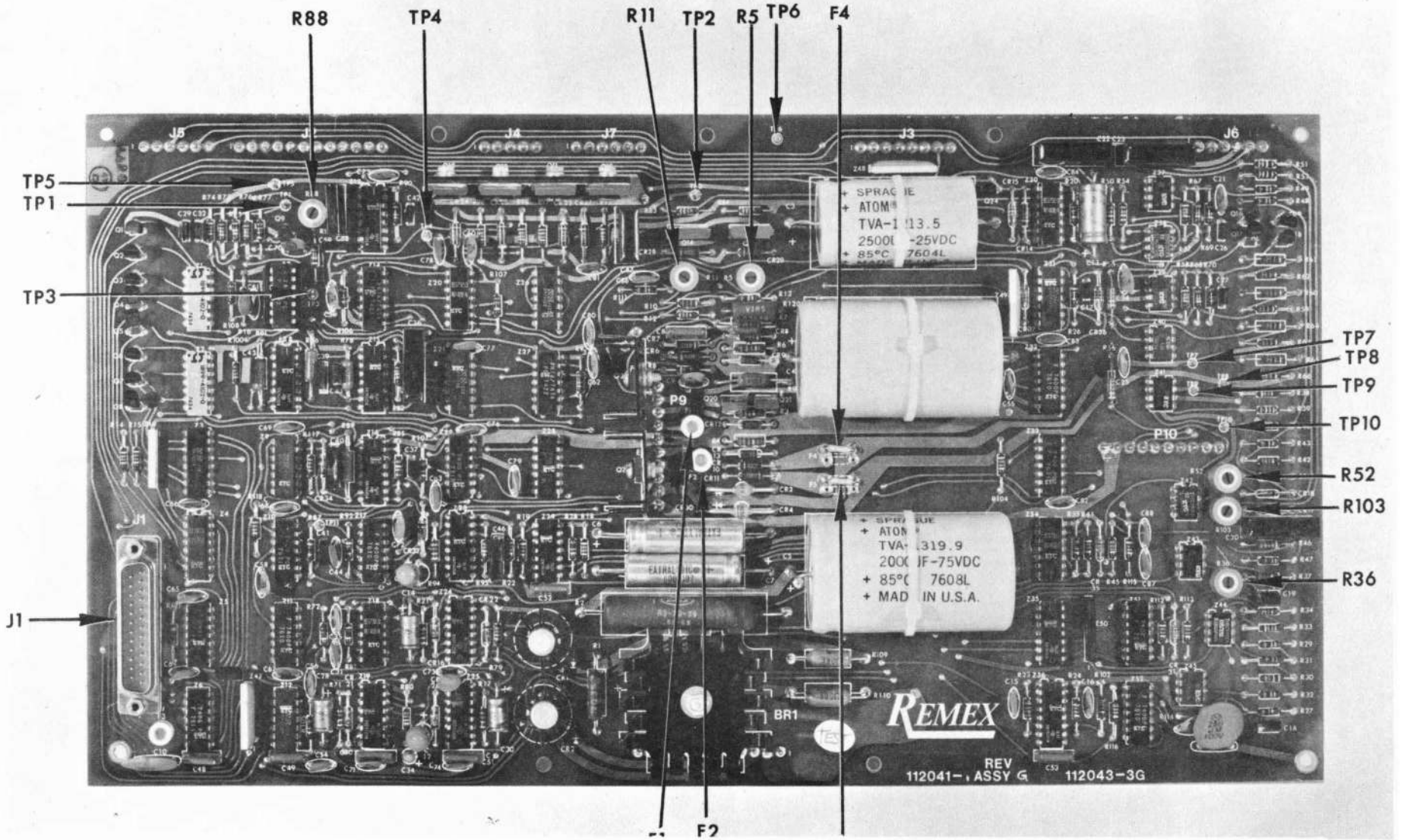

Figure 7-6. Reader Card Assembly, 112041-1.



## SECTION VIII

### SCHEMATIC DRAWINGS

#### 8.1 GENERAL

Figure 8-1 contains the schematic applicable to both the RRS6500BEX/660/DRB and the RRS6500BEX/660/ARB. Figure 8-2 contains many of the I.C. modules used in the reader. All I.C. Module outlines and truth tables are reproduced courtesy of Texas Instruments except for the 9602 which is reproduced courtesy of Fairchild Semiconductors.

SYM	ECO	EFFECT	REVISIONS	BY	DATE	APPROV	SYM	ECO	EFFECT	REVISIONS (CONT.)	BY	DATE	APPROV
Y	1734	7.75	SEE ECO	JL	2-27-76	TAC	T	1502	ATTN: CHG C20 VALUE, N.W. VALUE 2.2K		JL	2-27-76	TAC
Z	1737	2.76	ADD C105, C104 WAS 1.0K	JL	2-27-76	TAC	U	1510	ATTN: CHG REV. 1.5 VALUE OF C4 & ES. 1.5 A WAS 1.0 A - 240V		JL	2-27-76	TAC
							V	1558	ATTN: ADD TPT1-TPT4 & R21		JL	2-27-76	TAC
							W	1725	SEE ECO		ISEO	2-27-76	TAC

SYM	ECO	EFFECT	REVISIONS	BY	DATE	APPROV
A	1534	RELEASED		WEP	3-30-76	JL
B	1535	SEE ECO		WEP	3-30-76	JL
C	1536	REMOVED R105 & R106		WEP	3-30-76	JL
D	1537	SEE ECO		WEP	3-30-76	JL
E	1538	SEE ECO		WEP	3-30-76	JL
F	1539	SEE ECO		WEP	3-30-76	JL
G	1540	SEE ECO/REMOVED R107 & R108		WEP	4-16-76	JL
H	1541	SEE ECO		WEP	5-8-76	JL
I	1542	REMOVED R104 FROM INPUT OF UPT1		WEP	5-12-76	JL
J	1543	SEE ECO		WEP	5-12-76	JL
K	1544	SEE ECO		WEP	5-12-76	JL
L	1545	R19-1 WAS CONNECTED TO R23-1 ETC		N.M.		
M	1546	C33 WAS 22PF		N.M.	11-16-75	JL
N	1547	SEE SHEET 4		N.M.	11-16-75	JL
O	1548	SEE SHEET 4		WEP	12-5-75	JL
P	1549	SEE SHEET 4		WEP	3-17-76	JL
Q	1550	SEE SHEET 4		WEP	3-17-76	JL
R	1551	ADDED CR36 & 37, REVISED R26, 31		N.M.	7-17-76	JL
S	1552	SEE ECO		JL	11-26-76	JL

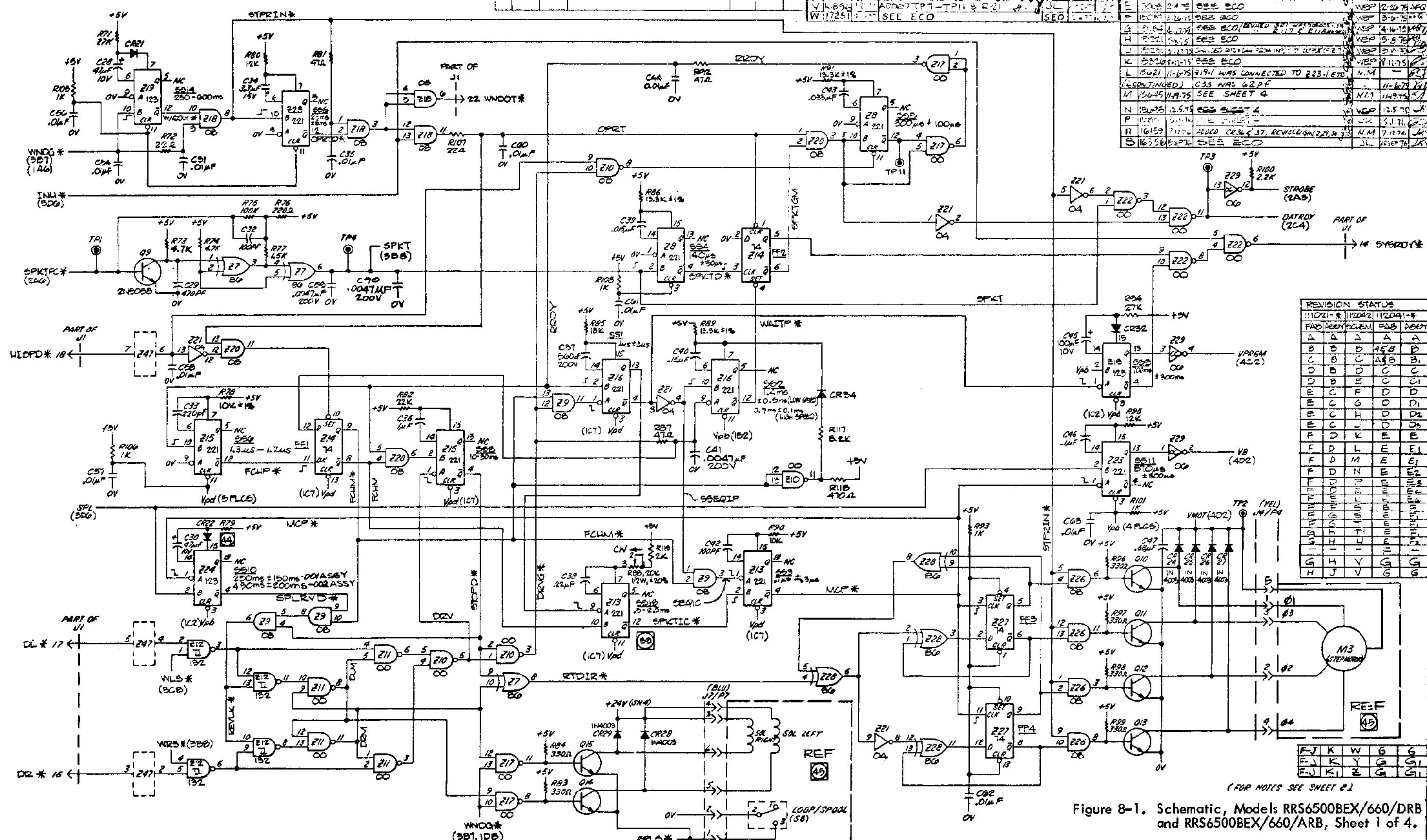

REVISION STATUS			
112021-*	112042	1120A1-*	
A	A	A	A
B	B	A	B
C	B	A	B
D	B	C	C
E	C	D	D
F	C	E	D
G	D	F	E
H	D	G	E
I	D	H	E
J	D	I	E
K	D	J	E
L	D	K	E
M	D	L	E
N	D	M	E
O	D	N	E
P	D	O	E
Q	D	P	E
R	D	Q	E
S	D	R	E
T	D	S	E
U	D	T	E
V	D	U	E
W	D	V	E
X	D	W	E
Y	D	X	E
Z	D	Y	E

Figure 8-1. Schematic, Models RRS6500BEX/660/DRB and RRS6500BEX/660/ARB, Sheet 1 of 4.

SYM	ECO	EFFECT	REVISIONS (CONT.)	BY	DATE	APPD.	SYM	ECO	EFFECT	REVISIONS	BY	DATE	APPD.
T	16502	217	SEE SHEET 1				A		RELEASED				
T	RC	222	SEE SHEET 1				B	14230	217	SEE SHEET 1			
U	16503	217	SEE SHEET 1				C	14230	217	SEE SHEET 1			
V	16504	217	SEE SHEET 1				D	14230	217	SEE SHEET 1			
W	17251	217	SEE ECO				E	15028	217	SEE SHEET 1			
Y	17349	217	SEE ECO				F	15027	217	SEE SHEET 1			
Z	17377	217	SEE SMT				G	15027	217	SEE SHEET 1			
							H	15221	217	SEE SHEET 1			
							I	15221	217	SEE SHEET 1			
							J	15221	217	SEE SHEET 1			
							K	15221	217	SEE SHEET 1			
							L	15021	217	SEE SHEET 1			
							M	15045	217	SEE SHEET 4			
							N	15021	217	SEE SHEET 4			
							O	15021	217	SEE SHEET 4			
							P	16059	217	SEE SHEET 1			
							Q	16059	217	SEE SHEET 1			

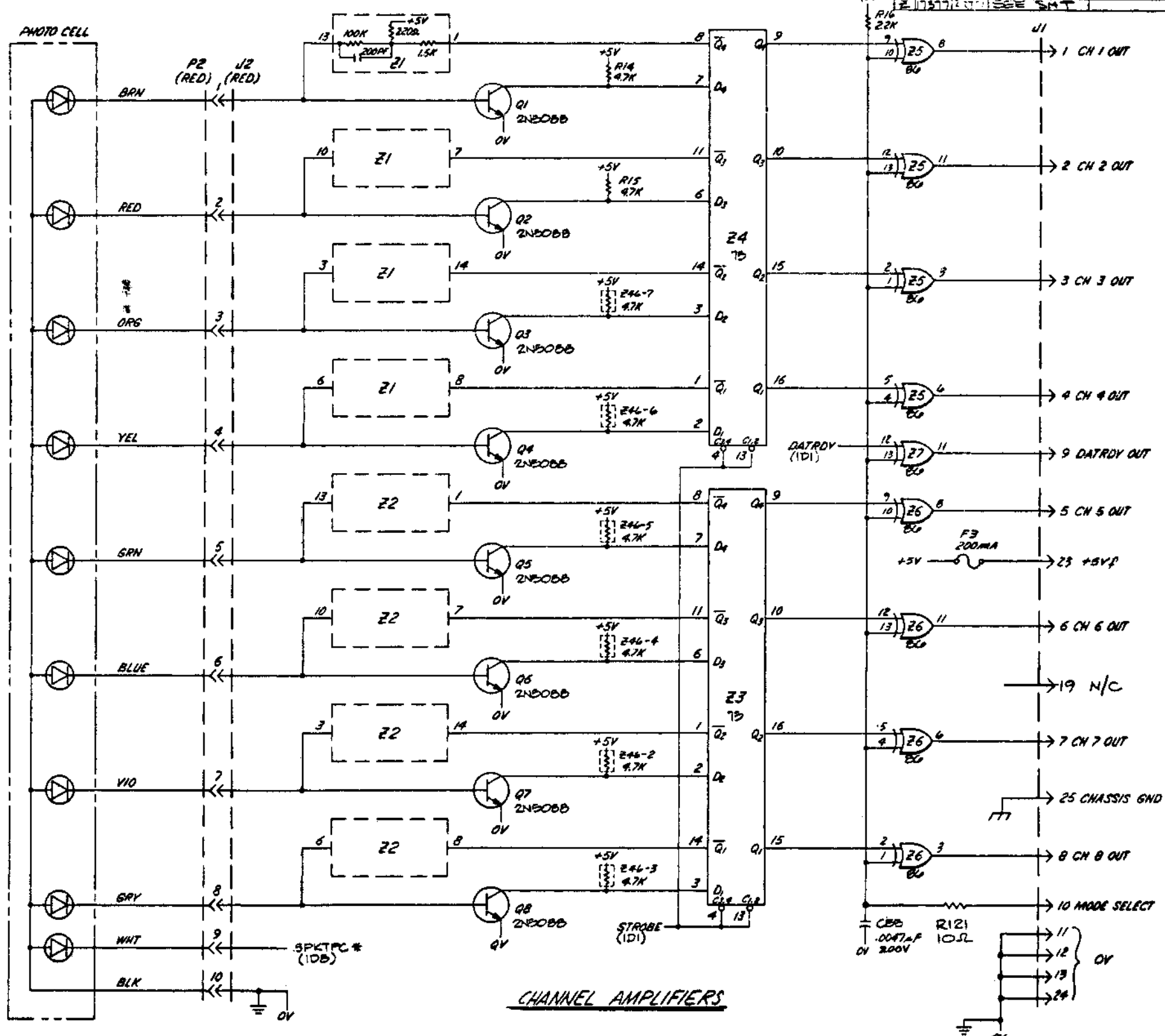

- NOTES: UNLESS OTHERWISE SPECIFIED
- RESISTORS ARE 1/4W ±5%
  - CR16, 20, 21, 22, 32, 34 ARE 704000-110 (FM4666)
  - REF ASSY DNG NO'S 112041-\*, AND 111021-\*
  - Q1-Q9 ARE 704203-19 (2N3088)
  - Q10-Q10 ARE 704204-115 (MJE1100)
  - Q16, 18 ARE 704203-118 (MPS206)
  - Q17, 19 ARE 704202-109 (MPS206)
  - R13, 24, 25 ARE 704610-119 (SNT423N)
  - R10, 11, 17, 22, 32, 33, 32 ARE 704600-101 (SNT400N)
  - R14, 27 ARE 704610-110 (SNT400N)
  - R1, 18, 20, 24, 30, 34 ARE 704600-114 (SNT400N)
  - R29, 35 ARE 704600-111 (SNT400N)
  - R3, 6, 7, 28 ARE 704600-109 (SNT400N)
  - R21, 15 704600-110 (SNT400N)
  - R1, 2 ARE 701930-004 (1899-A102-0)
  - R3, 4 ARE 704610-109 (SNT400N)
  - R47-49 ARE 701930-007
  - R46 IS 701930-004 (K0404A-472)
  - R30 IS 701930-007 (K0352-105), PIN 1 IS +5V
  - Q20 IS 704204-109 (2N5192)
  - Q21, 22 ARE 704212-107 (2N5195)
  - R38, 42, 44 ARE 704900-100 (115010-CPA)
  - F101 IS 4 AMP, 510-BLD FOR 100, 115, 127 VAC OPERATION
  - F101 IS 2 AMP, 510-BLD FOR 220, 240 VAC OPERATION
  - CR1, 2 ARE 704000-117 (MR1032B)
  - Q101, 103, 105 ARE 704204-120 (MJA035)
  - Q102, 104 ARE 704212-100 (MJA032)
  - CR3, 4 ARE 704000-158 (MJE24)
  - R101, 102 ARE 704520-109 (LM309K)
  - CR6-8, 10, 11, 14, 17, 18, 19, 24-30, 101 ARE 704000-137 (1M4003)
  - CR12, 13 ARE 704014-115 (1N4744A)
  - BRI IS 704000-142
  - CR9 IS 704014-116 (1N4755A)
  - R37, 39-41, 43, 45 ARE 704520-110 (LM307N) PIN 7 = +5V, PIN 4 = -5V
  - F11 IS 702250-110 (CORCOM-504)
  - CR2 IS 704204-122 (MJE205)
  - CR15, 31, 33, 36, 37 ARE 704000-100 (1N276)
  - R51 IS 704000-100 (SNT402N) PIN 7 = 0V, PIN 14 = +5V
  - SYMBOL \* MEANS THE SAME AS - OVER A LOGIC FUNCTION TO MAKE IT A COMPLEMENTARY FORM
  - R13, 39 IS ADJUSTED BY POT (R38) TO 850 ± 5% CHARACTERS PER SECOND AT HIGH SPEED
  - (1A3) MEANS SHEET NUMBER AND ZONE
  - PROGRAMMED FOR AUTOMATIC TEST
  - R12, 31 ARE 704600-152 (SNT4152N) PIN 7 = 0V, PIN 14 = +5V
  - R5, 13, 15, 16, 23, 30 ARE 704610-165 (SNT4221N) PIN 8 = 0V, PIN 16 = +5V
  - SEE TABULATION BLOCK FOR COMPONENT VALUES, SHT 3.
  - SEE TABULATION BLOCK, SHT 4, FOR MODEL NO'S.
  - NOTIFY APPLICATIONS ENGINEERING OF ANY CHANGES TO THIS SCHEMATIC.
  - Q24 IS 704203-114 (2N4401)
- | LAST DESIGNATION USED |      |          |          |                    |
|-----------------------|------|----------|----------|--------------------|
| 112041-*              | ASSY | NOT USED | 111021-* | ASSY & FRONT PANEL |
| RESISTOR              | R121 | R25, 44  | R206     |                    |
| CAPACITOR             | C90  | C12      | C103     |                    |
| TRANSISTOR            | Q24  | Q103     | Q103     |                    |
| DIODE                 | CR37 | CR23, 33 | CR101    |                    |
| I.C.                  | R52  | R102     |          |                    |

Figure 8-1. Schematic, Models RRS6500BEX/660/DRB and RRS6500BEX/660/ARB, Sheet 2 of 4.



SYMBOL	ECO	EFFECT	REVISIONS	BY	DATE	APPR
V	1009	SEE SHEET 1	JL		4-20-74	
W	1125	SEE ECO	SEO		11-12-74	
Y	1267	SEE ELD	JL		1-24-75	
Z	1301	SEE SHT 1	JL		2-4-75	
E	1506Y	SEE SHEET 1			2-25-75	
F	1507	SEE SHEET 1			3-6-75	
G	1508A	SEE SHEET 1			4-16-75	
H	15221	SEE SHEET 1			5-8-75	
J	15251	SEE SHEET 1			5-9-75	
K	15270	SEE SHEET 1			7-1-75	
L	1521	SEE SHEET 1			11-6-75	
M	15645	SEE SHEET 4			11-16-75	
N	15675	SEE SHEET 4			12-5-75	
R	1459	SEE SHEET 1			3-10-76	
S	162	SEE SHEET 1			10-27-76	
T	1602	SEE SHEET 1			10-17-76	
U	1602	SEE SHEET 1			12-3-76	
V	1650	SEE SHEET 1			5-6-77	

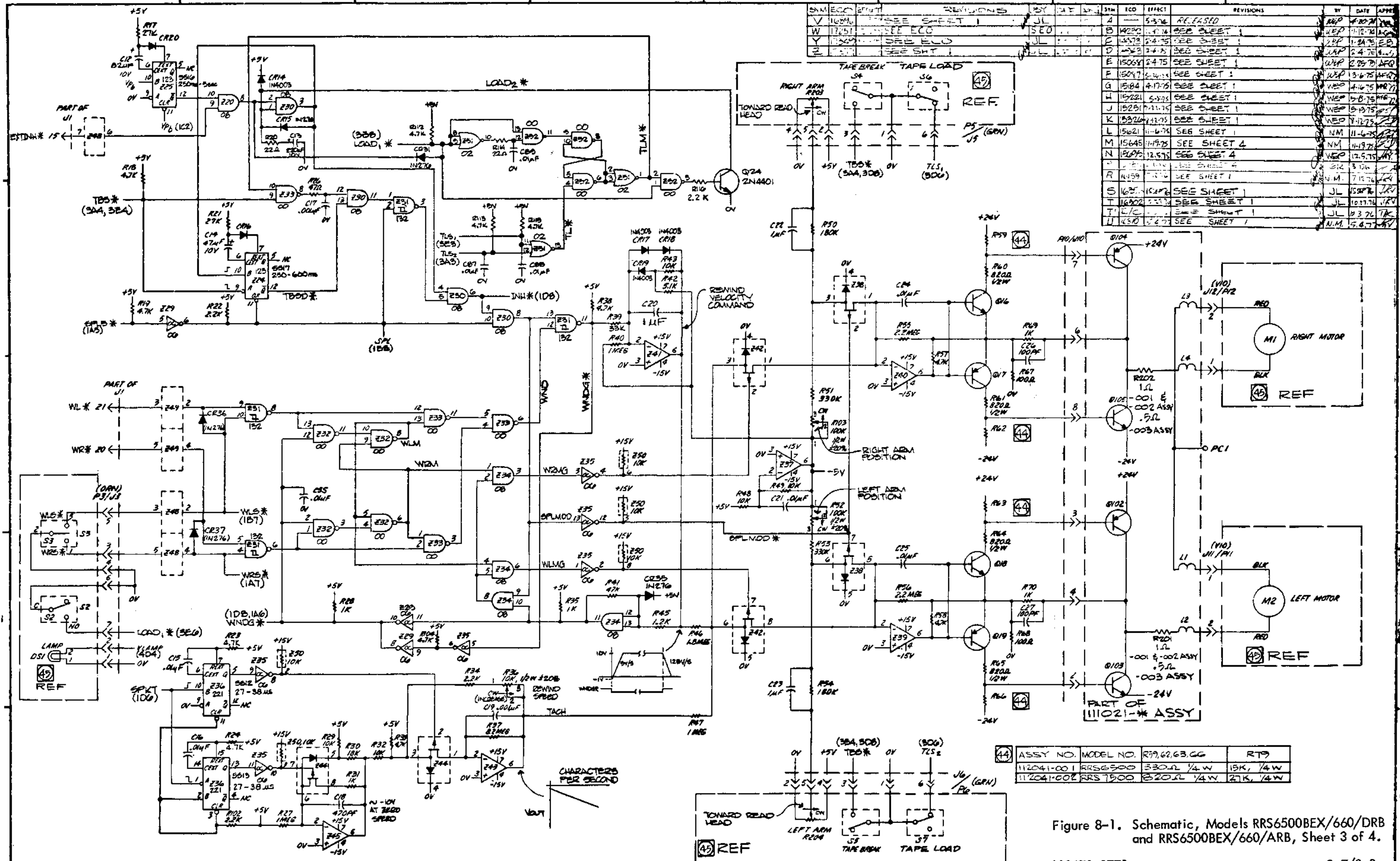

ASSY NO.	MODEL NO.	R59,62,63,GG	RT9
112041-001	RRS6500	530.0L 1/4W	15K, 1/4W
112041-002	RRS7500	520.0L 1/4W	27K, 1/4W

Figure 8-1. Schematic, Models RRS6500BEX/660/DRB and RRS6500BEX/660/ARB, Sheet 3 of 4.

SYM	ECO	EFFECT	REVISIONS	BY	DATE	APPRD
A	—	5.3.74	RELEASED	WEP	5.30.74	JL
B	14220	11.11.74	SEE SHEET 1	WEP	11.11.74	JL
C	14220	2.4.75	SEE SHEET 1	WEP	2.4.75	JL
D	14220	2.4.75	SEE SHEET 1	WEP	2.4.75	JL
E	15069	2.4.75	SEE SHEET 1	WEP	2.4.75	JL
F	15087	2.4.75	SEE SHEET 1	WEP	2.4.75	JL
G	15184	4.12.75	SEE SHEET 1	WEP	4.12.75	JL
H	15221	2.8.76	SEE SHEET 1	WEP	2.8.76	JL
J	15221	5.27.76	SEE SHEET 1	WEP	5.27.76	JL
K	15329	7.11.76	SEE SHEET 1	WEP	7.11.76	JL
L	15421	10.6.75	SEE SHEET 1	N.M.	10.6.75	JL
M	15465	11.19.75	DELETED 201A/2101B	N.M.	11.19.75	JL
N	15495	12.5.76	25-4 WMS CONNECTED TO OV	WEP	12.5.76	JL
P	15660	5.17.76	REMOVED CR5 ADDED R120	WEP	5.17.76	JL
R	16104	7.1.76	SEE SHEET 1	N.M.	7.1.76	JL
S	162	9.30.76	SEE SHEET 1	JL	9.30.76	JL
T	16502	10.27.76	SEE SHEET 1	JL	10.27.76	JL
T1	R/C	2.3.77	SEE SHEET 1	JL	2.3.77	JL
U	16610	3.27.77	SEE SHEET 1	N.M.	3.27.77	JL
V	16620	3.27.77	SEE SHEET 1	N.M.	3.27.77	JL
W	11261	3.27.77	SEE ECO	SEO	3.27.77	JL
Y	17349	3.27.77	SEE ECO	JL	3.27.77	JL
Z	17517	2.17.78	SEE SHEET 1	JL	2.17.78	JL

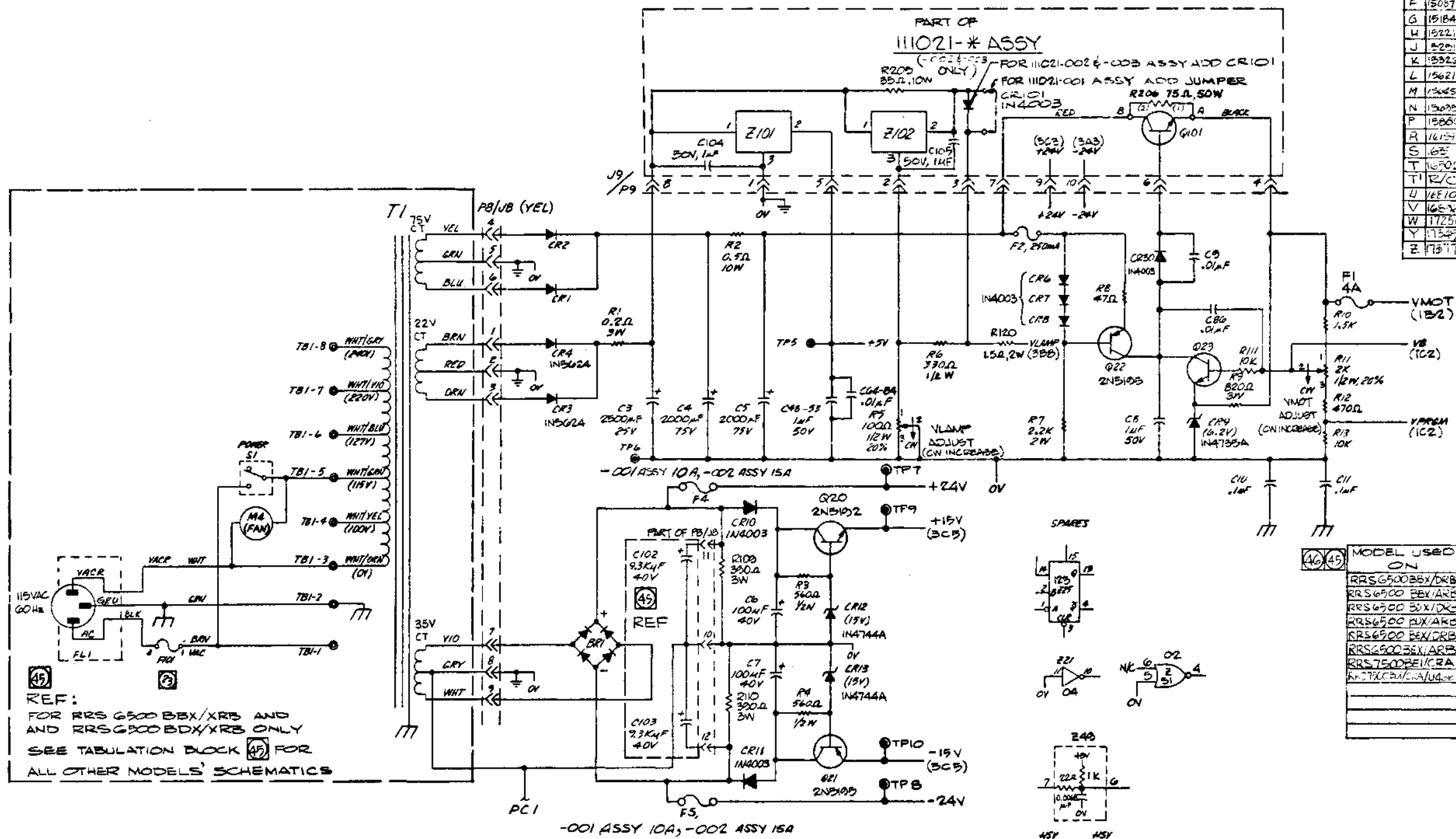

MODEL USED	READER	PWR DRIVER	FINAL ASSY	SYSTEM SCHEMATIC
RRS6500BEX/DRB	112041001	11021001	112044001	NONE
RRS6500BEX/ARB	-001	-001	112184001	NONE
RRS6500BEX/DRB	-001	-002	112425001	NONE
RRS6500BEX/ARB	-001	-002	112425001	NONE
RRS6500BEX/DRB	-001	003	113080001	113209000
RRS6500BEX/ARB	-001	-003	113103001	113209000
RRS7500BEX/ARB	-002	-003	113300001	113209000
RRS7500BEX/ARB	112041002	11021003	113145001	113162000

FOR GENERAL NOTES SEE SH2

Figure 8-1. Schematic, Models RRS6500BEX/660/DRB and RRS6500BEX/660/ARB, Sheet 4 of 4.

SYM	ECO	EFFECT.	REVISIONS	BY	DATE	APPR
A		4/22/76	RELEASED	S.E.O.	4/25/76	J.L.
B	16497	1/27/76	3/4" WIRE LIST WAS COR # 2 RIGHT	S.E.O.	10/21/76	J.L.
C	17176	4/26/77	ADDED NOTE 7	S.E.O.	10/21/77	J.L.

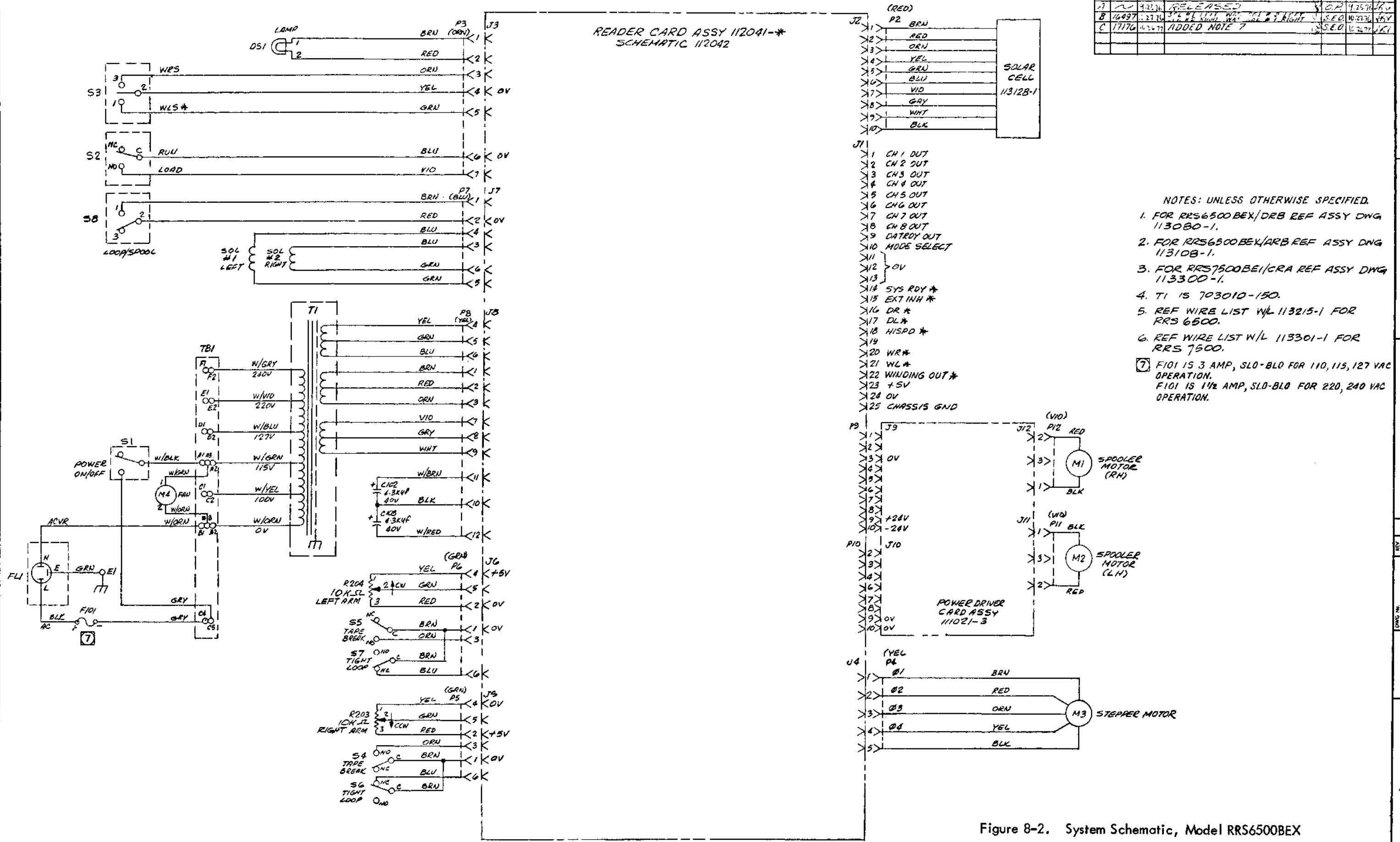

- NOTES: UNLESS OTHERWISE SPECIFIED.
- FOR RRS6500BEX/DRB REF ASSY DWG 113080-1.
  - FOR RRS6500BEX/ARB REF ASSY DWG 113108-1.
  - FOR RRS7500BEI/CRA REF ASSY DWG 113300-1.
  - T1 IS 703010-150.
  - REF WIRE LIST W/L 113215-1 FOR RRS 6500.
  - REF WIRE LIST W/L 113301-1 FOR RRS 7500.
  - F101 IS 3 AMP, SLO-BLO FOR 110, 115, 127 VAC OPERATION. F101 IS 1 1/2 AMP, SLO-BLO FOR 220, 240 VAC OPERATION.

Figure 8-2. System Schematic, Model RRS6500BEX

112670-077A

8-11/8-12

**SN7474**

TRUTH TABLE (Each Flip-Flop)

$t_n$	$t_{p1}$	INPUT	OUTPUT	OUTPUT
		D	Q	$\bar{Q}$
0	0	0	1	0
0	1	1	0	1

NOTES: 1.  $t_n$  = bit time before clock pulse.  
2.  $t_{p1}$  = bit time after clock pulse.

5 FLAT PACKAGE (TOP VIEW) | J OR N DUAL-IN-LINE PACKAGE (TOP VIEW)

positive logic: Low input to preset sets Q to logical 1. Low input to clear sets Q to logical 0. Preset and clear are independent of clock.

**DUAL D-TYPE EDGE-TRIGGERED FLIP-FLOPS**

**SN74123**

RETRIGGERABLE MONOSTABLE MULTIVIBRATORS WITH CLEAR

TRUTH TABLE (See Note A)

INPUTS		OUTPUTS	
A	B	Q	$\bar{Q}$
H	X	L	H
X	L	L	H
L	L	L	H
L	H	L	H

NOTES: A. H = high level (steady state), L = low level (steady state), T = transition from low to high level, F = transition from high to low level, J = one high level pulse, U = one low level pulse, X = irrelevant (any input, including transitions).  
B. NC = No Internal Connection.  
C. To use the internal timing resistor of SN54123/SN74123 (110 k $\Omega$  nominal), connect  $R_{int}$  to  $V_{CC}$ .  
D. An external timing capacitor may be connected between  $C_{ext}$  and  $R_{int}/C_{ext}$  (positive).

J OR N DUAL-IN-LINE OR W FLAT PACKAGE (TOP VIEW)

positive logic: Low input to clear resets Q to low level and inhibits data inputs.

TTL/MONOSTABLE 9602 RETRIGGERABLE RESETTABLE MONOSTABLE MULTIVIBRATOR

GENERAL DESCRIPTION - The TTL/Monostable 9602 is a dual retriggerable, resettable monostable multivibrator which provides an output pulse whose duration and accuracy is a function of external timing components. The 9602 has excellent immunity to noise on the  $V_{CC}$  and ground lines. The 9602 uses TTL inputs and outputs for high speed and high fanout capability and is compatible with all members of the Fairchild TTL family.

TRIGGERING TRUTH TABLE

PIN NO.'S	Operation
5(1) 4(1) 3(1)	
H-L	L H Trigger
H	L-H H Trigger
X	X L Reset

H = HIGH Voltage Level  
L = LOW Voltage Level  
X = Don't Care  
H-L = HIGH to LOW Voltage Level transition  
L-H = LOW to HIGH Voltage Level transition

CONNECTION DIAGRAM DIP (TOP VIEW)

\*Pins for external timing.

**SN74121**

TRUTH TABLE (See Note 1 thru 3)

$t_n$	INPUT	$t_{p1}$	INPUT	OUTPUT
	A1	A2	B	
0	X	1	X	0
0	X	1	X	0
0	X	0	X	1
0	X	0	X	1
1	1	1	X	0
1	1	1	X	0
1	1	0	X	1
1	0	1	1	0
1	0	1	1	0
1	0	0	1	1
1	0	0	1	1
1	1	0	X	0
1	1	0	X	0

1 =  $V_{in(1)}$   $\geq 2V$   
0 =  $V_{in(0)}$   $\leq 0.8V$

NOTES: 1.  $t_n$  = time before input transition.  
2.  $t_{p1}$  = time after input transition.  
3. X indicates that either a logical 0 or 1 may be present.  
4. NC = No Internal Connection.

5 FLAT PACKAGE (TOP VIEW) | J OR N DUAL-IN-LINE PACKAGE (TOP VIEW)

positive logic: see truth table and notes 5 and 6.

**MONOSTABLE MULTIVIBRATORS**

**SN7473, SN74107**

TRUTH TABLE (Each Flip-Flop)

$t_n$	$t_{p1}$	J	K	Q
0	0	0	0	0
0	1	0	0	0
1	0	1	0	1
1	1	1	1	0

NOTES: 1.  $t_n$  = Bit time before clock pulse.  
2.  $t_{p1}$  = Bit time after clock pulse.

J OR N DUAL-IN-LINE PACKAGE (TOP VIEW) | J OR N DUAL-IN-LINE PACKAGE (TOP VIEW)

positive logic: Low input to clear sets Q to logical 0. Clear is independent of clock.

**DUAL J-K MASTER-SLAVE FLIP-FLOPS**

**SN7475, SN7477**

TRUTH TABLE (Each Latch)

$t_n$	$t_{p1}$	D	Q
0	0	0	0
1	0	1	1

NOTES: 1.  $t_n$  = bit time before clock pulse transition.  
2.  $t_{p1}$  = bit time after clock pulse transition.  
NC = No Internal Connection.

J OR N DUAL-IN-LINE OR W FLAT PACKAGE (TOP VIEW) | J OR N DUAL-IN-LINE PACKAGE (TOP VIEW)

positive logic: see truth table.

**8-BIT AND 4-BIT BISTABLE LATCHES**

**SN74121**

TRUTH TABLE (See Note 1 thru 3)

$t_n$	INPUT	$t_{p1}$	INPUT	OUTPUT
	A1	A2	B	
0	X	1	X	0
0	X	1	X	0
0	X	0	X	1
0	X	0	X	1
1	1	1	X	0
1	1	1	X	0
1	1	0	X	1
1	0	1	1	0
1	0	1	1	0
1	0	0	1	1
1	0	0	1	1
1	1	0	X	0
1	1	0	X	0

1 =  $V_{in(1)}$   $\geq 2V$   
0 =  $V_{in(0)}$   $\leq 0.8V$

NOTES: 1.  $t_n$  = time before input transition.  
2.  $t_{p1}$  = time after input transition.  
3. X indicates that either a logical 0 or 1 may be present.  
4. NC = No Internal Connection.

5 FLAT PACKAGE (TOP VIEW) | J OR N DUAL-IN-LINE PACKAGE (TOP VIEW)

positive logic: see truth table and notes 5 and 6.

5. A1 and A2 are negative edge-triggered inputs, and will trigger the one shot when either or both go to logical 0 with B at logical 1.  
6. B is a positive Schmitt-trigger input for slow edges of level detection, and will trigger the one shot when B goes to logical 1, with either A1 or A2 at logical 0. (See Truth Table).

**MONOSTABLE MULTIVIBRATORS**

**SN7400**  
**SN7403 (Open Collector)**  
Positive Logic  
NAND GATE

PIN NUMBERS

INPUT: A (1,4,9,12), B (2,5,10,13)  
OUTPUT: Y (3,6,8,11)  
 $Y = \overline{AB}$

A	B	Y
L	L	H
L	H	H
H	L	H
H	H	L

**SN7402**  
Positive Logic  
NOR GATE

INPUT: A (3,6,9,12), B (2,5,8,11)  
OUTPUT: Y (1,4,10,13)  
 $Y = \overline{A+B}$

A	B	Y
L	L	H
L	H	L
H	L	L
H	H	L

**SN7408**  
Positive Logic  
AND GATE

INPUT: A (1,4,9,12), B (2,5,10,13)  
OUTPUT: Y (3,6,8,11)  
 $Y = AB$

A	B	Y
H	H	H
H	L	L
L	H	L
L	L	L

**SN7432**  
Positive Logic  
OR GATE

INPUT: A (1,4,9,12), B (2,5,10,13)  
OUTPUT: Y (3,6,8,11)  
 $Y = A+B$

A	B	Y
H	H	H
H	L	H
L	H	H
L	L	L

**SN7486**  
Positive Logic  
EXCLUSIVE-OR GATE

INPUT: A (1,4,9,12), B (2,5,10,13)  
OUTPUT: Y (3,6,8,11)  
 $Y = A \oplus B$

A	B	Y
L	L	L
L	H	H
H	L	H
H	H	L

**SN7410**  
Positive Logic  
NAND GATE

INPUT: A (1,3,9), B (2,4,10), C (13,5,11)  
OUTPUT: Y (12,6,8)  
 $Y = \overline{ABC}$

A	B	C	Y
L	L	L	H
L	L	H	H
L	H	L	H
L	H	H	H
H	L	L	H
H	L	H	H
H	H	L	H
H	H	H	L

**SN7404**  
**SN7406, SN7416 (Open Collector)**  
Positive Logic  
HEX INVERTER

INPUT: A (1,3,5,9,11,13)  
OUTPUT: Y (2,4,6,8,10,12)  
 $Y = \overline{A}$

A	Y
L	H
H	L

NOTE: Pin numbers are listed in the order in which they are related, for EXAMPLE, on SN7410, pins 1, 2, 13 and 12 function together on one gate. \* Pin 7 is Gnd, Pin 14 is  $V_{CC}$

Figure 8-3. Diagram and Truth Tables of I.C. Modules Used.

COMPONENT 4 REF DESIGNATOR	SYMBOL	REMARKS	COMPONENT 4 REF DESIGNATOR	SYMBOL	REMARKS
SWITCH, 'S'	S1 S2 (N.C.) (N.O.)		INTEGRATED CIRCUIT PACKAGE		* Z XY INDICATES I.C. PKG. LOCATION ON P.C. CARD. (LEFT TO RIGHT TOP TO BOTTOM SEQUENCE) NUMBER)
SAFETY INTERLOCK			POSITIVE TRUE LOGIC SYMBOLS		 * ZXY INDICATES I.C. PKG. LOCATION ON P.C. CARD IN XY COORDINATE SYSTEM (X=NUMBER, Y=LETTER)  A B C D 1 2 3 4 2 3 4 3 4
LIMIT SW.	S1 S2 N.O. N.C. S3 S4 NO HELD CLOSED NO HELD OPEN				
POWER	S1 PWR ON				
PUSH BUTTON, 'PB'	PB1 PB2 N.C. N.O.				
TRANSFER	S7 S5 NO1 C FREQ OFF SPOT 3 POSITION CENTER OFF				
TIMER CONTACTS	DELAY OCCURS WHEN COIL IS ENERGIZED DE-ENERGIZED NO N.C. NO N.C.				
TRANSISTOR, 'Q'	Q1 Q2 PNP NPN				
VJT, 'Q'	 'N' TYPE 'P' TYPE	ARROW POINTS TOWARD BI FOR 'N' TYPE & AWAY FROM BI FOR 'P' TYPE			
FET, 'Q'	 'N' TYPE 'P' TYPE				
DIODE 'CR' or 'D'		* USE 'D' ON N/C APPLICATIONS			
ZENER DIODE 'CR'	 KV V	V=VOLTS			
TRIAC		INDICATE TERMINALS 1 AND 2			
SCR					
BRIDGE RECTIFIER 'BR' 'D'		* USE 'D' ON N/C APPLICATIONS			
CABLE RUN (OPTIONAL)					
CABLE, 2 OR MORE CONDUCTORS	 SHIELD	IF SHIELDED CONDUCTOR SHOW TERMINATION OF SHIELD			
TWISTED WIRES	 PAIR TRIPPLE				
COAXIAL CABLE					

STANDARD SCHEMATIC SYMBOLS  
107700

NOTE:  
ALL SEMICONDUCTORS AND INTEGRATED CIRCUIT DEVICES  
ARE TO BE IDENTIFIED BY REMEX PART NUMBER ADJACENT  
TO DEVICE OR IN GENERAL NOTES. COMMERCIAL PART  
NUMBERS MAY ALSO BE SHOWN AT OPTION OF PROJECT  
ENGINEER

Figure 8-4. REMEX Standard Schematic Symbols (Sheet 1 of 2)

COMPONENT # REF DESIGNATOR	SYMBOL	REMARKS	COMPONENT # REF DESIGNATOR	SYMBOL	REMARKS
CAPACITOR 'C'	C10      C7 100      100 600V      200 pF 100V	GIVE VOLTAGE ON ELECTROLYTICS. MOTOR AND A.C. CAPACITORS IN A.C. CIRCUITS, VOLTAGE OPTIONAL ON ALL OTHERS.	TERMINAL 'T'		USE 'E' FOR LOCAL DESCRIPTION OR BOTH.
CELL, PHOTOSENSITIVE 'V'					
GROUND	DC RETURN      CHASSIS (EARTH)				
COIL RELAY 'K' OR NUMERICAL DESIGNATOR CONTACTS					
CONTACT, CONNECTOR 'K', 'J'					
SEPARABLE CONNECTORS, ENGAGED	PI J1      PI J1 	DEFINITION: PLUG: USUALLY MOVABLE JACK: USUALLY STATIONARY NON-POLARIZED POLAR: —→ JACK: ←—			
CONNECTORS, AC POWER 'P', 'J'	MALE      FEMALE 				
FUSE, 'F'					
INDUCTOR, WINDING, REACTOR, OR SOLENOID	L1      L2 AIR CORE      IRON CORE	GIVE INDUCTANCE OR COVER IN NOTES.			
TRANSFORMER 'T'		POLARITY DOTS TO BE SHOWN IF NECESSARY TO CIRCUIT FUNCTION.			
LAMP, INDICATING 'DS'	DS (COLOR) (FUNCTION)				
CRYSTAL, 'Y'	Y1 10 MHz				
BOARD TERMINAL 'TB1' OR PANNING STRIP 'FS'	TB1-1      TB1 				
EYELET, PC CARD	PC-23				
TEST POINT, 'TP'	TPT 1.5 V				
JUMPER WIRE, PC		FOR OPTIONAL WIRING			
RESISTOR, FIXED, VARIABLE 'R'	R10      R15 56 K      10 K	OPTIONAL ADJUSTMENT SYMBOL:  SCREEN DRIVER KNOB VOLTAGE AND TOLERANCE TO BE SHOWN OR PUT IN NOTES.			
LAMP, GLOW 'N'	N2      N3 DC CATH      AC				
LINE CROSS					
LINE CONNECT					

Figure 8-4. REMEX Standard Schematic Symbols (Sheet 2 of 2)



REMEX is constantly evaluating and improving its existing equipment so that you, the user, will always have equipment which is the "state-of-the-art".

Changes, when they occur, are incorporated into the next printing of the manual. In order to make current manuals as up-to-date as possible, all changes to date are contained in this section in the form of addendum sheets. Individual pages which are affected are, in addition, marked REFER TO ADDENDUM. Addendum sheets are also used to list changes to the manuals for special, non-standard units.

We are endeavoring to make our technical manuals as useful and practical as possible. Any comments or suggestions concerning its contents should be addressed to:

REMEX  
Technical Manual Supervisor

EX-CELL-O CORPORATION  
**REMEX**  
1733 Alton St. • P.O. Box C-19533 • Irvine, CA 92713



CHANGE PAGES

The following pages in the manual have been changed since the original printing. Please refer to the addendum and mark the pages accordingly.

1-8  
7-3  
7-4  
7-5  
7-6

ADDENDUM SHEET

The following changes in the manual are required:

1. On page 1-8, Table 1-3, add 006 option number. This option provides for a 600 us data ready time out and replaces circuit card 112041-001 with 113831-001. 113831-001 is identical to 112041-001 except R91 is 27K instead of 13.3K. Thus in Figure 3-1, in Section 3.3.2, step e, Section 3.3.3, steps d (4), (6) and (8) and step e, Figures 4-3 and Figure 4-4 all references to 200 us min. data ready signal should be approximately 600 us. Make this change in Section 4.2.1.3 also.
2. On page 7-3, make the following changes:  
Delete Lug, Terminal, P/N 715000-108.  
Change quantity of Key, Terminal Block, P/N 706540-155 from 14 to 6.  
Change quantity of Lug, Capacitor, P/N 715005-110 from 5 to 2.  
Change quantity of Terminal Lug, P/N 706530-171 from 19 to 4.  
Change P/N of Cover Assembly from 113196-1 to 112406-001.
3. On page 7-4, make the following changes:  
Change the P/N of Front Panel Assembly from 112426-1 to 113067-001.  
Delete Frame, Lower Cover.  
Change quantity of Insert Color from 2 to 1.  
Change quantity of Contact, P/N 706530-138 from 4 to 5.
4. On page 7-5, make the following changes:  
Change the P/N of Spring (part of Mechanism Assembly) from 714090-158 to 714090-127.  
Change the quantity of Solenoid from 2 to 1.
5. On page 7-6, change the quantity of Ring, Grip, P/N 715025-110 from 2 to 1.  
Change the quantity of Spacer, P/N 715030-158 from 2 to 1.



Ex-Cell-O Corporation

---

*REMEX* DIVISION