



TECHNICAL MANUAL
TAPE READER

MODELS: RR-6300BAX/66X
RR-6300BBX/66X
RR-6300BDX/66X

Peripheral
Products

Ex-Cell-O Corporation

Copyright© 1973 by REMEX, A Unit of Ex-Cell-O
Corporation. Printed in the United States of America.
All rights reserved. This book or parts thereof may not
be reproduced in any form without permission of the
publishers.

TECHNICAL MANUAL
TAPE READER

MODELS: RR-6300BAX/66X
RR-6300BBX/66X
RR-6300BDX/66X

EX-CELL-O CORPORATION
REMEX

1733 Alton St. • P.O. Box 11926 • Santa Ana, CA 92711

Copyright© 1973 by REMEX, A Unit of Ex-Cell-O
Corporation. Printed in the United States of America.
All rights reserved. This book or parts thereof may not
be reproduced in any form without permission of the
publishers.

WARRANTY

Remex warrants to the original buyer that this product is free from defects in workmanship and material under normal use and service. Unless otherwise agreed to in writing, Remex's obligation under this warranty shall be limited to furnishing a replacement for, or at Remex's option, repairing this product or any part or parts thereof which, to Remex's satisfaction, prove defective within one year (unless specifically excepted below*) from the date of shipment by Remex, provided all warranty stipulations of Remex Standard Terms and Conditions are complied with. No product or part may be returned without Remex's prior approval. In no event will any claim for labor in removing or replacing a defective product or part or for consequential damages be allowed.

NOTE:

No warranty is made as to this product or part which has not been registered, installed, operated or maintained in accordance with instructions conveyed by Remex or the instructions contained in this technical manual or which has been subject to misuse, abuse, accident or alteration or to improper or negligent use, maintenance, storage, transportation or handling.

This warranty is in lieu of all other warranties, expressed or implied, and Remex neither assumes, nor authorizes any person or firm to assume for it, any other or further obligations or liability in connection with the sale, installation or use of this product.

A Warranty Registration Card is included with each unit which must be completed and mailed within (30) days after receipt of the product.

*(Excludes lamps and fuses in all products. Excludes all punch mechanisms for material and labor in excess of 90 days or that have exceeded a use volume of 700 rolls (84 million characters) of Remex recommended tape.)

FOR YOUR SAFETY

Before undertaking any maintenance procedure, whether it be a specific troubleshooting or maintenance procedure described herein or an exploratory procedure aimed at determining whether there has been a malfunction, read the applicable section of this manual and note carefully the

WARNING

and

CAUTION

contained therein.

The equipment described in this manual contains voltages hazardous to human life and safety and may contain mechanical components capable of inflicting personal injury. The cautionary and warning notes are included in this manual to alert operator and maintenance personnel to the electrical and mechanical hazards and thus prevent personal injury and damage to equipment.

TABLE OF CONTENTS

<u>Section</u>	<u>Title</u>	<u>Page</u>
I	GENERAL DESCRIPTION	1-1
1.1	<u>EQUIPMENT DESCRIPTION</u>	1-1
1.2	<u>EQUIPMENT SUPPLIED</u>	1-1
1.3	<u>MAINTENANCE EQUIPMENT REQUIRED BUT NOT SUPPLIED.</u>	1-1
1.4	<u>EQUIPMENT WARRANTY</u>	1-4
1.5	<u>SPECIFICATIONS</u>	1-4
1.6	<u>MODEL NUMBER DESIGNATION</u>	1-5
1.7	<u>PHYSICAL DESCRIPTION</u>	1-6
1.8	<u>TAPE CHANNEL NUMBERING</u>	1-8
II	INSTALLATION AND INTERFACE	2-1
2.1	<u>UNPACKING</u>	2-1
2.2	<u>MOUNTING.</u>	2-1
2.3	<u>INITIAL ADJUSTMENTS</u>	2-1
2.4	<u>POWER AND SYSTEM CONNECTIONS</u>	2-1
2.4.1	TRANSFORMER WIRING CHANGE FOR VOLTAGES OTHER THAN 115 VAC	2-3
2.5	<u>INTERFACE CIRCUITRY</u>	2-3
III	OPERATION	
3.1	<u>INPUT-OUTPUT SIGNALS</u>	3-1
3.2	<u>CONTROL FUNCTIONS.</u>	3-1
3.3	<u>OPERATING INSTRUCTIONS.</u>	3-1
3.3.1	TAPE DRIVE, ASYNCHRONOUS MODE	3-4
3.3.2	TAPE DRIVE, CONTINUOUS MODE	3-4
3.3.3	EXTERNAL INHIBIT	3-6
3.4	<u>OPERATIONAL MAINTENANCE</u>	3-6
3.5	<u>TAPE RECOMMENDATIONS AND AVAILABILITY.</u>	3-6
3.6	<u>TAPE PREPARATION REQUIREMENTS</u>	3-7

TABLE OF CONTENTS (Continued)

<u>Section</u>	<u>Title</u>	<u>Page</u>
IV	THEORY OF OPERATION	4-1
4.1	<u>BLOCK DIAGRAM DESCRIPTION</u>	4-1
4.1.1	TAPE DRIVE	4-1
4.1.2	TAPE READING	4-5
4.2	<u>CIRCUIT DESCRIPTION, READER CARD 110271</u>	4-5
4.2.1	DRIVE CIRCUITS	4-5
4.2.2	TAPE READING CIRCUITS	4-6
4.2.3	POWER SUPPLY	4-7
4.3	<u>LIGHT SOURCE</u>	4-7
V	MAINTENANCE	5-1
5.1	<u>GENERAL</u>	5-1
5.2	<u>PREVENTIVE MAINTENANCE</u>	5-1
5.2.1	CLEANING	5-2
5.2.1.1	<u>Readhead Assembly Cleaning</u>	5-3
5.2.1.2	<u>Lamp and Lens Cleaning</u>	5-3
5.2.1.3	<u>Sprocket Cleaning</u>	5-3
5.2.1.4	<u>Tape Cleaning</u>	5-3
5.2.1.5	<u>General Cleaning</u>	5-3
5.2.2	LUBRICATION	5-7
5.3	<u>TROUBLESHOOTING</u>	5-7
5.4	<u>READER ALIGNMENT (UNITS WITHOUT DAMPER COMPONENTS)</u>	5-7
5.4A	<u>READER ALIGNMENT (UNITS WITH DAMPER COMPONENTS)</u>	5-12
5.5	<u>TAPE SPLICING</u>	5-16
5.6	<u>LAMP VOLTAGE ADJUSTMENT</u>	5-18
VI	PARTS REPLACEMENT	6-1
6.1	<u>GENERAL</u>	6-1
6.2	<u>READER PARTS REPLACEMENT</u>	6-1
6.2.1	UPPER COVER ASSEMBLY	6-1
6.2.2	READHEAD MECHANISM DISASSEMBLY	6-1

TABLE OF CONTENTS (Continued)

<u>Section</u>	<u>Title</u>	<u>Page</u>
6.2.3	READER CARD REPLACEMENT	6-2
6.2.4	LAMP ASSEMBLY REPLACEMENT	6-2
6.2.5	MOTOR AND/OR SPROCKET REPLACEMENT	6-3
6.2.6	TRANSFORMER REPLACEMENT	6-3
6.2.7	SWITCH S1 REPLACEMENT	6-4
6.2.8	SWITCH S2 AND S3 REPLACEMENT	6-4
VII	PARTS LIST	7-1
7.1	<u>GENERAL</u>	7-1
7.2	<u>KIT OF PARTS</u>	7-1
VII	SCHEMATIC DRAWINGS	8-1
8.1	<u>GENERAL</u>	8-1/8-2

LIST OF ILLUSTRATIONS

<u>Figure</u>	<u>Title</u>	<u>Page</u>
1-1	REMEX Reader, Model RR-6300BBX/66X	1-2
1-2	RR-6300BBX/66X with Tape Tank Accessory	1-3
1-3	Installation Drawing, Model RR-6300BBX/66X	1-7
1-4	Model Number Coding	1-8
1-5	Tape Channel Numbering	1-9
2-1	Reader Connections to External Equipment	2-2
2-2	Recommended Interface Circuitry	2-3
3-1	Timing Diagram for RR-6300BXX	3-5
3-2	Tape Loading	3-5
4-1	Block Diagram RR-6300	4-2
4-2	Timing Diagram, Reader Card Assembly 110271	4-3
5-1	Setting of the Sprocket in Relation to the Readhead Assembly.	5-9
5-2	Photocell Output Test Circuit	5-9
5-3	Alignment of the Lamp Assembly	5-10
5-4	Sprocket Cell Output Adjustment for Minimum Jitter	5-13
5-4A	Adjustment of the Upper Tape Guide	5-15
5-5	Tape Splicing Procedure	5-17

LIST OF ILLUSTRATIONS (Continued)

<u>Figure</u>	<u>Title</u>	<u>Page</u>
7-1	Front Panel Assembly	7-7
7-2	Mounting Block Assembly	7-9
7-3	Top View of the Reader	7-10
7-4	Printed Circuit Card Assembly 110271-1	7-13
7-4A	Printed Circuit Card Assembly 110271-1, Fabrication Board 110273-3C	7-14
7-4B	Printed Circuit Card Assembly 110271-1, Fabrication Board 110273-3D	7-15
7-4C	Printed Circuit Card Assembly 110271-1, Fabrication Board 110273-3E	7-16
8-1	Schematic, RR-6300BXX	8-3
8-1B	Schematic, RR-6300BBX, Sheet 1 of 2, Card Fabrication 110273-E	8-5C/8-6C
8-1B	Schematic, RR-6300BBX, Sheet 2 of 2, Card Fabrication 110273-E	8-5D/8-6D
8-2	IC Modules Used in the RR-6300BXX	8-7/8-8
8-3	REMEX Standard Schematic Symbols, Sheet 1	8-9
8-3	REMEX Standard Schematic Symbols, Sheet 2	8-10

LIST OF TABLES

<u>Table</u>	<u>Title</u>	<u>Page</u>
1-1	Items Included with the REMEX Reader	1-1
1-2	Specifications of the REMEX Reader, Model RR-6300BXX/66X	1-4
1-3	Options Used On All Standard RR-6300	1-6
3-1	Interface Signal Descriptions	3-2
3-2	Front Panel Controls	3-4
3-3	Recommended Tapes	3-7
5-1	Maintenance Equipment Required	5-1
5-2	Preventive Maintenance Schedule and Log	5-4
5-3	Troubleshooting	5-5
6-1	Transformer Wire Connections	6-3
7-1	Recommended Spare Parts	7-2
7-2	Parts List, RR-6300BAX/66X and RR-6300BBX/66X	7-3
7-3	Fanfold Tank Option Assembly	7-6
7-4	Parts List, Reader Card 110271-1, -2 Assemblies	7-11
7-5	Parts List, Reader Card 112511-1 Assembly	7-12C

SECTION I

GENERAL DESCRIPTION

1.1 EQUIPMENT DESCRIPTION

The REMEX punched tape reader model RR-6300BBX/66X, Figure 1-1, has been designed to operate in data processing systems using 8 channel punched tape (special tape options available). This manual also covers the RR-6300BDX/66X which is identical to the RR-6300BBX/66X except for the change in light source and other parts changes as noted specifically throughout the manual. Figure 1-2 shows the RR-6300BBX/66X with the addition of the optional tape tanks. This manual covers the earlier RR-6300BAX/66X unit. Unless otherwise specifically noted, the material covered is applicable to all models. The function of the reader is to convert the information stored in the form of punched holes into electronic signals. Although the applications for punched tape readers are many and varied, they are generally used as input devices for digital computers, communication systems, numerical controls, and system checkout equipment.

A plug-in circuit card provides the logic control for tape movement in either direction from external signals or the front panel switches. The outputs from the card control a step motor which drives the tape via a sprocket wheel. Data outputs are generated from the photocell readhead. As tape passes over the photocells, changes in light intensity are sensed by the photocells, amplified, and brought out to an external connector. The card also contains the power supplies for the lamp, circuits and the step motor.

1.2 EQUIPMENT SUPPLIED

Certain items are included with the reader for spare parts, installation, and maintenance. These items are listed in Table 1-1. No other equipment is required for the operation of the unit.

Table 1-1. Items Included with the REMEX Reader

ITEM	REMEX PART NO.	QUANTITY
Cover Connector (PI)	706540-144	1
Brush, Soft Bristle	716003-101	1
Connector, (PI), Cannon DB25S	706510-211	1
Fuse, 2 A, Slow Blow (100, 115, 127 VAC Operation)	705710-123	1
Fuse, 1 Amp, Slow Blow (220, 230 or 240 Operation)	705710-142	1
Manual	- -	1
Screw Lock Assembly (PI)	706540-124	2
Power Cord-Units with AC connector only	708000-098	1

1.3 MAINTENANCE EQUIPMENT REQUIRED BUT NOT SUPPLIED

The maintenance procedures in Section 5 require equipment that is not supplied. This equipment is listed in Table 5-1.

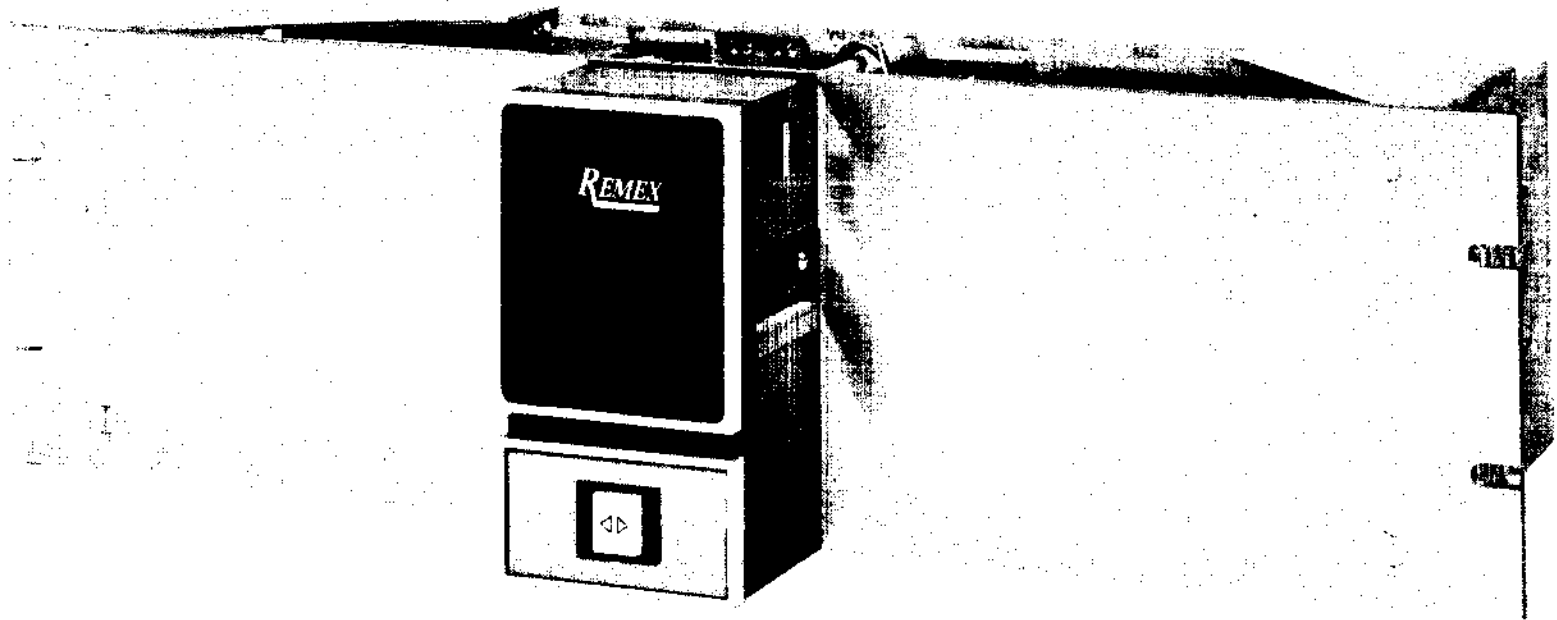

Figure 1.1 REMEX Reader, Model RR-6300BBX/66X.
Models RR-6300BAX/66X and RR-6300BDX/66X
are identical in appearance to this unit.

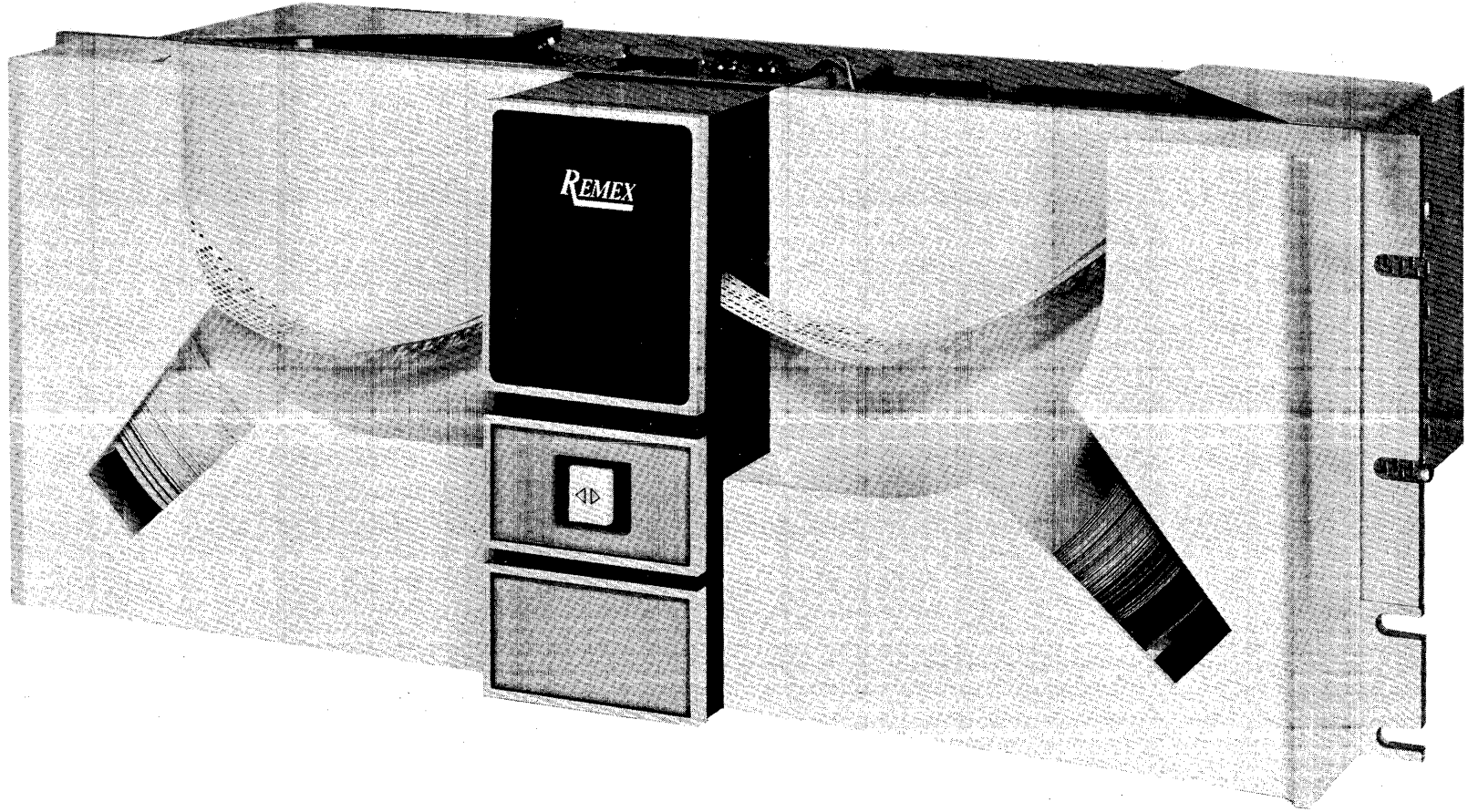

Figure 1-2. RR-6300BBX/66X with Tape Tank Accessory .

1.4 EQUIPMENT WARRANTY

A statement covering the warranty of this equipment is given on page iii (second page in book). It should be read and understood. All preventive maintenance procedures must be performed as outlined in Section 5.2 during the warranty period in order that the warranty remain in effect. Any questions arising concerning the warranty should be directed to the REMEX Service Department.

1.5 SPECIFICATIONS

The specifications for the REMEX tape reader, Model RR-6300BXX/66X, are listed in Table 1-2. An X in a particular digit designator denotes any of the combinations given in Figure 1-4 can be used.

Table 1-2. Specifications of the REMEX Reader, Model RR-6300BXX/66X

Characteristic	Specification
Tape Movement	Bidirectional (left-to-right or right-to-left).
Reading Speed	0 to 300 characters per second asynchronously (step pulse operation); greater than 300 char./sec. in continuous mode
Tapes	Reads standard 8-track (1-inch) tapes with light transmissivity of 57% or less and thickness between 0.0027 and 0.0045 inch (oiled buff paper tape). Options for other widths of tape available as coded in Figure 1-4. Tapes must be punched as described in Section 3.6.
Input Power	100, 115, 127, 220 or 240 VAC (unless otherwise specified by customer units are wired for 115 VAC), 47 to 63 Hz, single phase at 2.0 amps (100, 115 or 127 VAC) or 1.0 amp (220 or 240 VAC), nominal voltage, maximum current.
Temperature	Operating: 0°C to +55°C, free air Non-operating: -55°C to +85°C
Weight	RR-6300BXX: 19 lbs. Tape Tank Accessory: 7.5 lbs.
Mounting Dimensions	RR-6300BXX/66X: 5-1/4" high, 19" wide, 6 1/4" behind 1/4 panel, 2-1/2" in front of panel RR-6300BXX/66X: 7" high, 19" wide, 6 1/4" behind with tape tank 1/4 " panel, 2-1/2" in front of panel See Figure 1-3. Allow 3-1/4" at rear for cable service.
Drive Control	The following signals are applied to J1, pin 17, for drive left or J1, pin 16, for drive right: Stop: +2.4 < V < +5.0 or an open circuit Drive: 0 < V < +0.4 @ 5 ma. Two modes of operation are available. See Sections 3.3.1 & 3.3.2.

Table 1-2. Specifications of the REMEX Reader, Model RR-6300EXX/66X (Continued)

Characteristic	Specification
Data Output	Mode 5: Hole: $+2.4 < V < +5.0 @ 0.2 \text{ ma. (source)}$ No Hole: $0 < V < +0.4 @ 16 \text{ ma. (sink)}$
	Mode 6: Hole: $0 < V +0.4 @ 16 \text{ ma. (sink)}$ No Hole: $+2.4 < V < + 5 @ 0.2 \text{ ma. (source)}$
Timing	Timing diagram given in Figure 3-1.

1.6 MODEL NUMBER DESIGNATION

The REMEX model designation is used to code the basic functions, options, and configurations of a particular product line. Figure 1-4 illustrates the model code structure for the RR-6300 series and indicates the various options. An X in a particular digit designator (as used in many parts of this manual, especially the parts list) denotes any of the combinations given in Figure 1-4 can be used.

Nonstandard (special) units use the last three numbers of the model number to denote a special unit. The difference between any special unit and the standard unit is described in an addendum at the end of the manual. Units with 000 and 901 and higher are standards and are covered in this manual without addendums.

Standard options not shown in Figure 1-4 are used in the 901 and higher numbers (standard units only) and are listed on the serial tag below the model number in the form of a series of three digit numbers depending upon the number of options used. For example, a unit with 902 in the last three digits of the model number would list two three digit numbers. Because the list of possible options is constantly changing, it is not included in the manual. Generally, this list consists of special customer requirements that do not affect the operation of the unit and includes such things as special paint, no logo, mill edge panel, etc. Table 1-3 lists those dash numbers which are applicable to all units.

Always consult the serial number tag for proper voltage and frequency to be used and for model identification. Failure to do so could result in damage to the unit. The serial tag is located on one of the rear surfaces. In all correspondence, always refer to the complete model number including the mode, the last three numbers, and the unit's serial number. Refer to the CAUTION in Section 2.4.

Table 1-3. Options Used On All Standard RR-6300

Option Number	Description	Part Changed
004	Reader adjusted for 1% short registration tapes for drive left.	Reader adjusted per Section 5.4, step k, note. ①
006	Tape Spindle	Add 111444-1 to Top Assembly 110450-1. See Table 7-3A.

① A caution decal also appears above the motor to indicate a special alignment of the motor.

1.7 PHYSICAL DESCRIPTION

The REMEX punched tape reader is mounted on a 19-inch panel with a height of 5-1/4 inches for the RR-6300BBX/66X. Detailed dimensions are shown in Figure 1-3. The front panel contains the tape reading and transport mechanism. The top front cover is removable and provides access to the lamp, readhead assembly and the sprocket drive assembly. The electronic chassis is mounted at the rear of the front panel and contains the circuit card.

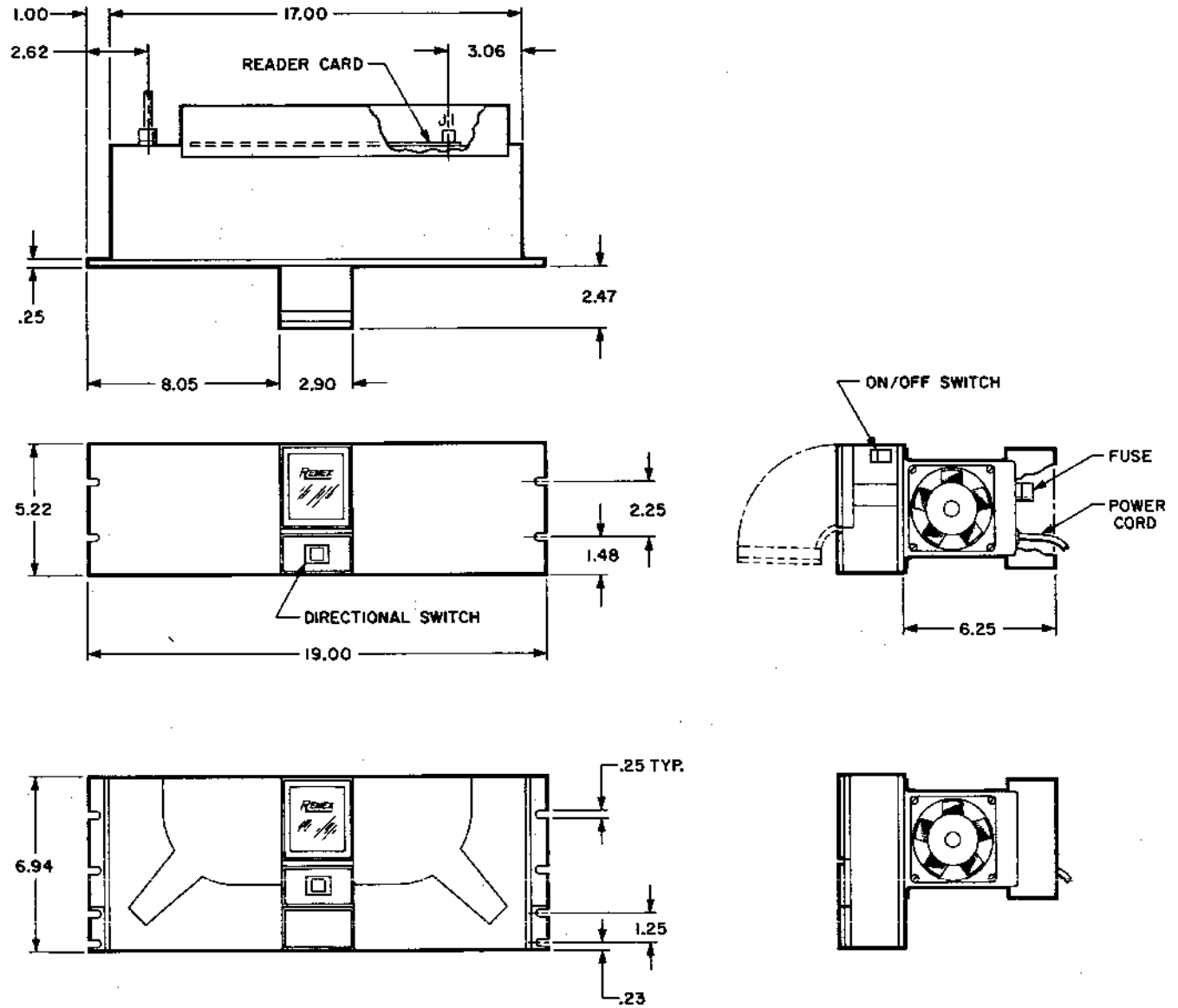

RR-6300BXI SHOWN WITH FANFOLD TANK ACCESSORY

Figure 1-3. Installation Drawing, Model RR-6300BBX/66X

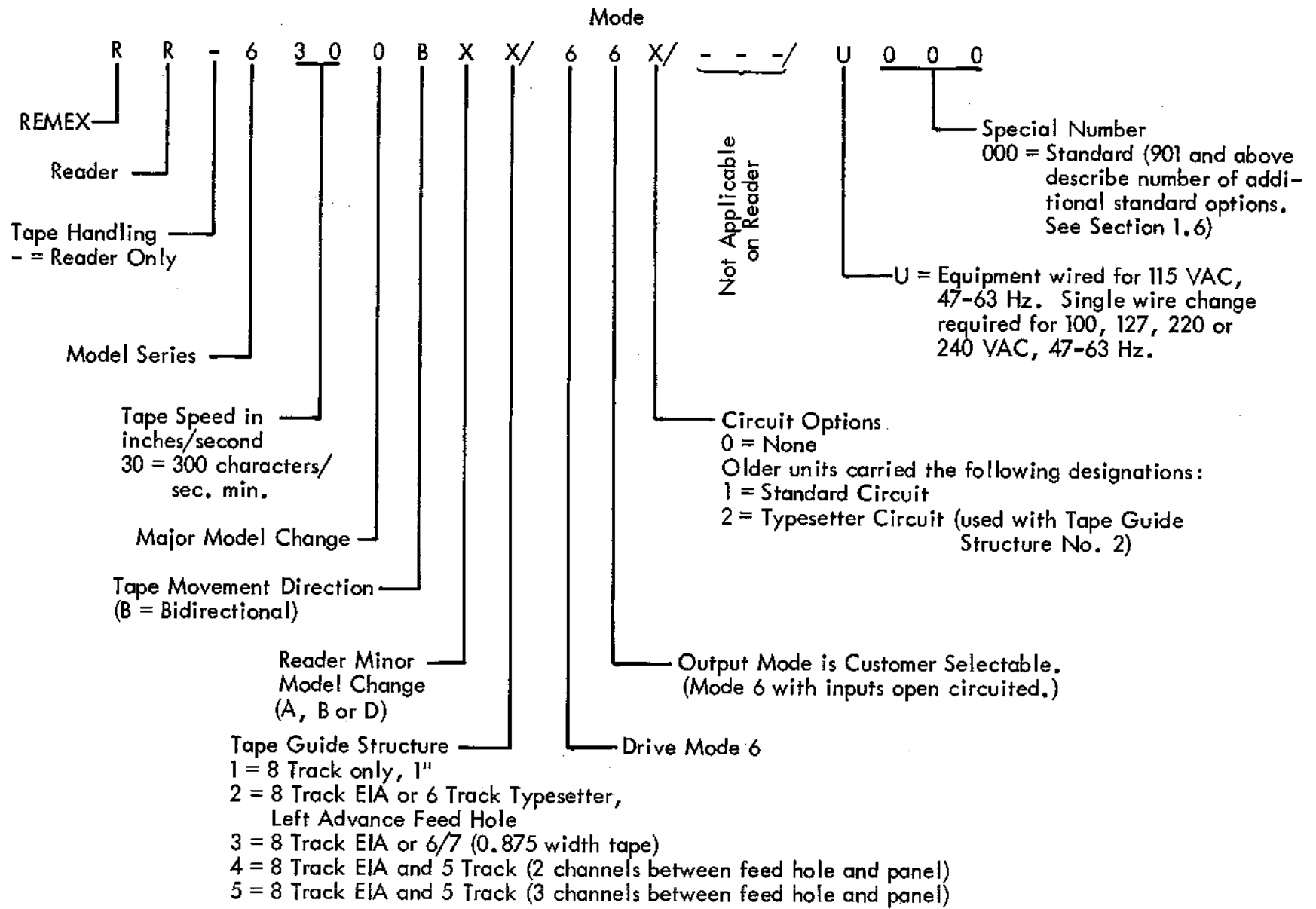
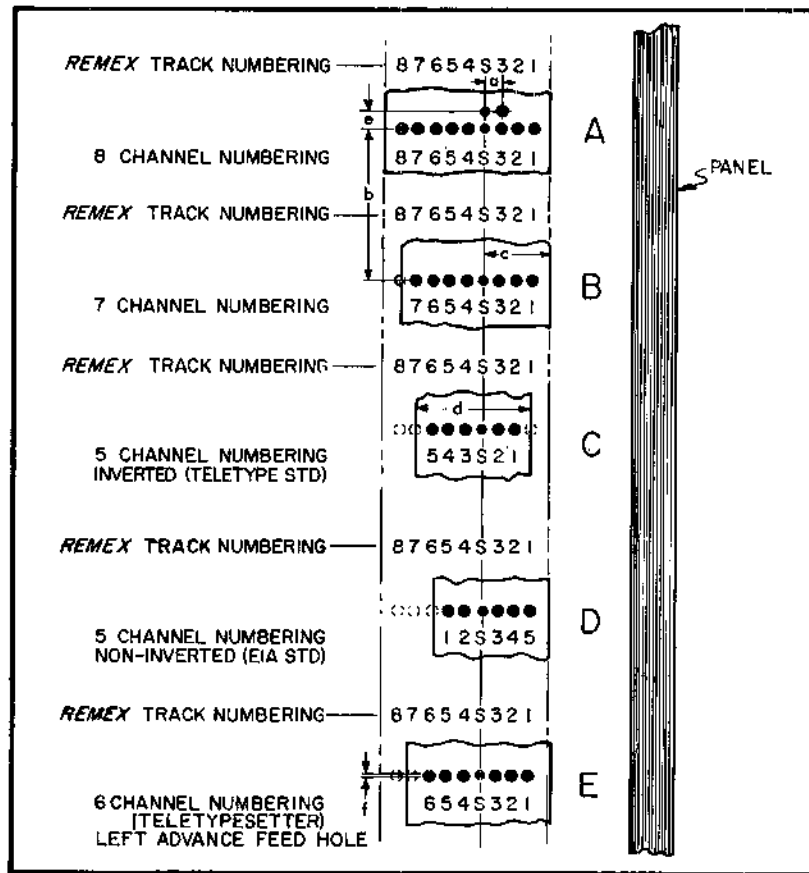

Figure 1-4. Model Number Coding

1.8 TAPE CHANNEL NUMBERING

Figure 1-5 illustrates the tape channel numbering. The reader accepts one inch, eight channel tape and other width tapes (see Figure 1-4) depending upon the tape guide structure used.



MMCI18A

Tape Configuration	c ± 0.003	d ± 0.003	In All Configurations:
A	0.392	1.000	$a = 0.100 \pm 0.002$ b in any span of five inches is ± 0.025 . $e = 0.100 \pm 0.001$ Data hole diameter is $0.072 \begin{smallmatrix} +.001 \\ -.002 \end{smallmatrix}$ Sprocket hole diameter is $0.046 \begin{smallmatrix} +0.002 \\ -0.001 \end{smallmatrix}$.
B	0.394	0.875	
C	0.293	0.687	
D	0.394	0.687	
E	0.441 Right Drive 0.434 Left Drive	0.875	

NOTE: The 6 channel teletypesetter has the sprocket hole center line advanced by 0.013 inch with respect to the data track center line.

Figure 1-5. Tape Channel Numbering

SECTION II INSTALLATION AND INTERFACE

2.1 UNPACKING

To provide the most protection during transit, specially designed and reinforced packing cartons are used to ship the REMEX punched tape reader. Those items listed in Table 1-1 are also packed with the unit. When removing the unit from the carton, the reader should be lifted with both hands under it. Never lift or attempt to carry the unit by any of the covers, drive assembly, or other delicate parts. Carefully inspect the unit for any apparent damage as soon as it is removed from the carton. Check the equipment supplied list in Table 1-1 against the kit of parts supplied with the reader. In the event the equipment has been damaged as a result of shipping, the carrier and REMEX must be notified as soon as possible.

2.2 MOUNTING

The reader mounts in a standard 19-inch rack with mounting holes provided. To ensure a minimum transmission of acoustical noise and vibration to other equipment, the reader should be securely mounted. When mounting the unit in a closed cabinet, adequate air circulation should be supplied so that the unit does not exceed the ambient temperature specification listed in Table 1-2.

2.3 INITIAL ADJUSTMENTS

Each reader has been accurately adjusted and aligned before leaving the factory. No adjustment or calibration should be required prior to installation or use. However, the proper fuse from the kit of parts requires installation. Refer to Section 2.4.

2.4 POWER AND SYSTEM CONNECTIONS

Input AC power (refer to Table 1-2) is applied to the three prong power cord supplied.

CAUTION

All units come wired for 115 VAC, 47-63 Hz operation. If another voltage is to be used, a wire change on the transformer must be made as described in Section 2.4.1. In addition, before operating the system, the proper fuse value (as indicated in Table 1-1) must be inserted from the kit of parts. Discard the other fuse (unless, of course, a different voltage operation is anticipated).

All control signals and data track output signals are routed through J1. Figure 2-1 lists the detail routing of these signals and their description is given in Table 3-1. All wire sizes are 22 AWG unless otherwise noted in Figure 2-1. The proper mating connector for J1 has been supplied with the unit.

NOTE: All input and output logic signals are defined for positive logic, mode 5, i.e., logic 0 = 0V and logic 1 = +5V. Therefore, signals that are mode 6, 0V true for logic 1 (action condition) are written with a bar over the designation, e.g., System Ready Output.

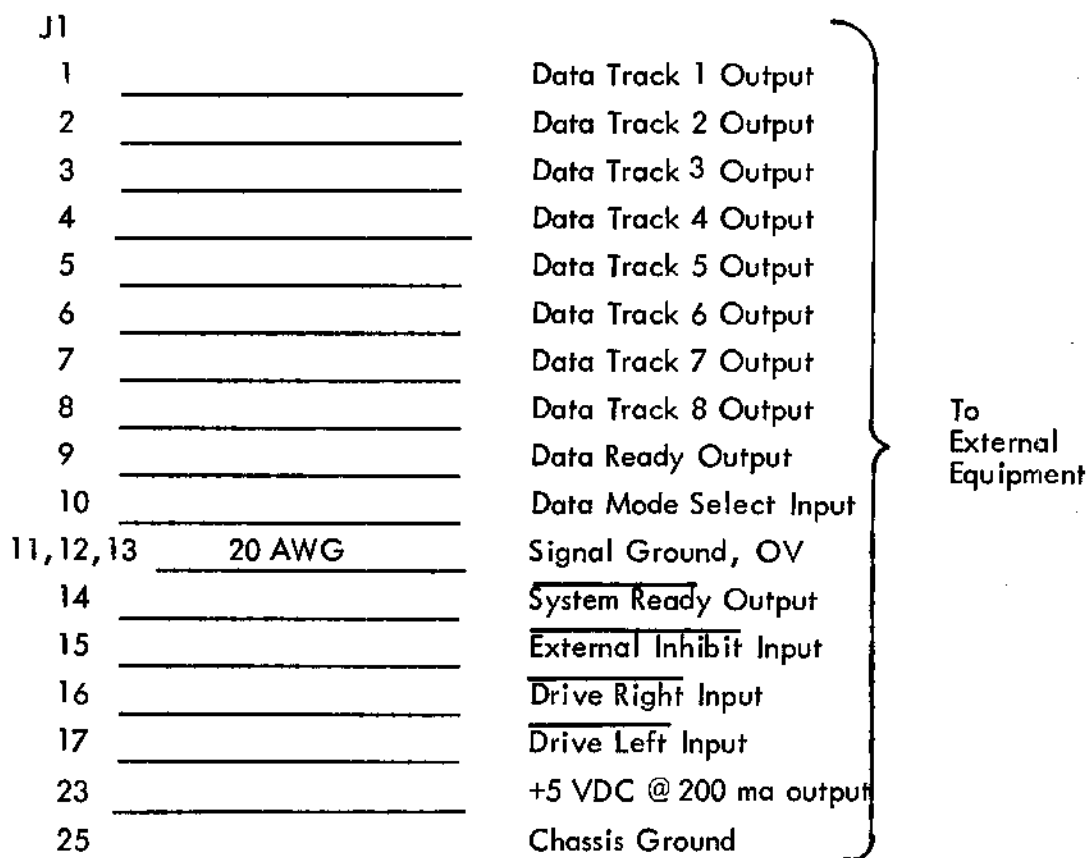

Figure 2-1. Reader Connections to External Equipment
See Table 3-1 for signal descriptions.

2.4.1 TRANSFORMER WIRING CHANGE FOR VOLTAGES OTHER THAN 115 VAC

All units come from the factory with a transformer which allows any of five input voltages to be used: 100, 115, 127, 220 or 240 VAC, 47-63 Hz. Unless otherwise directed by the customer, all units leave the factory wired for 115 VAC.

WARNING

Disconnect the power plug before making this change

If it becomes necessary to operate on one of the other four voltages, a simple wire change is required. Power from the AC plug is applied through S1 to TB1-6 via a white/black wire. See schematic, Figure 8-1, sheet 1. It is necessary, then, to change only the white/black wire at TB1-6 to TB1-5 for 100 VAC, to TB1-7 for 127 VAC, to TB1-8 for 220 VAC or to TB1-9 for 240 VAC. The fan must remain tied to TB1-6. In addition a 1.5 Amp fuse must be substituted for the 3 Amp fuse at F1 when using 220 or 240 VAC.

2.5 INTERFACE CIRCUITRY

Figure 2-2 illustrates suggested drive and output circuitry with which to interface with the REMEX circuitry. Note the termination network for the output signals. This should be incorporated into the user's equipment for maximum noise elimination.

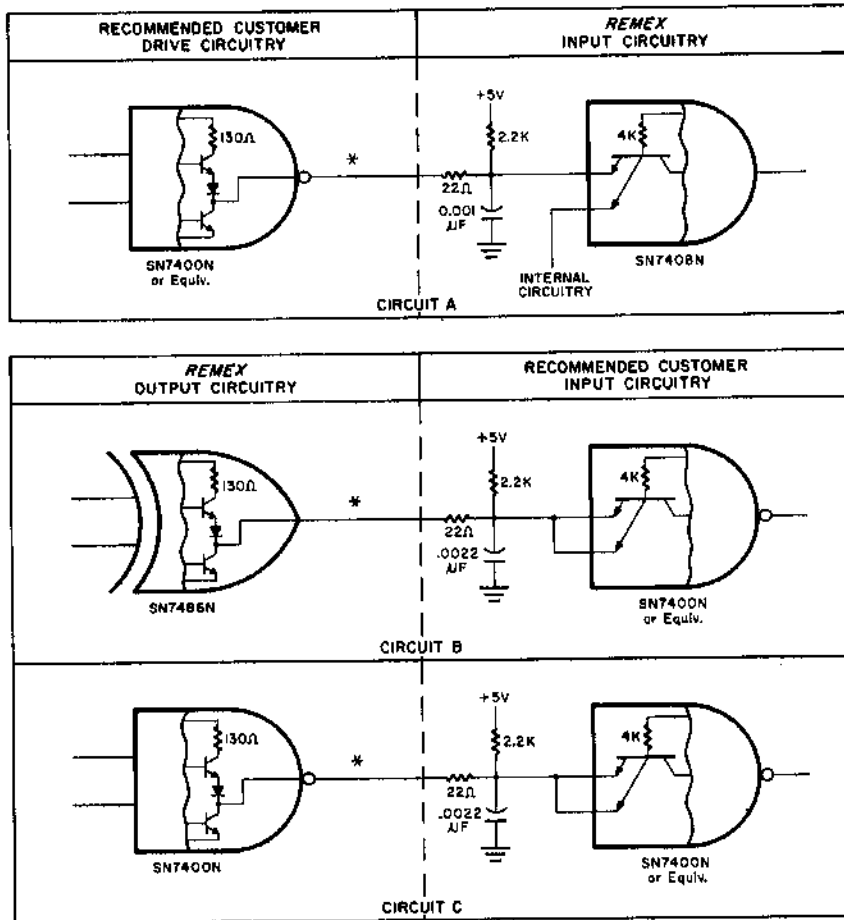

* 10 FT. MAX. ONE GATE LOAD RECOMMENDED

Figure 2-2. Recommended Interface Circuitry

SECTION III

OPERATION

3.1 INPUT-OUTPUT SIGNALS

Table 3-1 lists those input and output signals which are routed through connector J1. The definition and/or usage of these signals are also included in the table. Figure 3-1 shows the timing diagram for these signals.

3.2 CONTROL FUNCTIONS

Table 3-2 lists the operating controls located on the front panel. A description of the controls and their functions is also included.

3.3 OPERATING INSTRUCTIONS

The following procedure should be followed when reading a tape. Refer to Figure 3-2 during the following descriptions.

- a. Connect J1/PI and plug the line cord into the proper AC outlet. See Caution in Section 2.4.
- b. Depress switch S1 actuator located on the right side of the cover assembly. This will place the power switch, S1, in the on position. Power is on when the lamp assembly is lite.
- c. Pull forward and down on the Door Assembly. This will raise the Upper Tape Guide allowing tape to be loaded.
- d. Check the number showing on the Tape Guide. If a two sided Tape Guide is supplied and the other width of tape is required, depress and rotate the Tape Guide Latch 90°. The Tape Guide can now be removed and then reinserted with the other guiding edge up. One sided guides, of course, do not need to be removed. The Tape Guide supplied with the unit is coded as part of the model number as indicated in Figure 1-4.
- e. Insert the tape as shown in Figure 3-2.
- f. Raise the Door Assembly up to its closed position.
- g. Make sure the System Ready output signal is in the true condition, i.e., $0 < V < +0.4$.
- h. The reader may now be operated as described in Section 3.3.1. See Section 3.3.2 for external inhibit operation.
- i. To unload tape, stop tape movement, lower the Door Assembly and remove the tape.
- j. To remove power, depress switch S1 actuator. The lamp will turn off.

CAUTION

Close reader door when not in use. Accidental bumping of the door could break it off at the hinge.

Table 3-1. Interface Signal Descriptions

Connector Pin	Description	Interface Circuit-See Figure 2-2	Signal Levels	
			True Condition	False Condition
J1-1 thru J1-8	Data Track Outputs. True signal indicates data track hole and false condition indicates no hole condition. Output mode 5 or 6, selectable (see J1-10).	B	<u>Mode 5:</u> $+2.4 < V < +5$ @ 0.2 ma (source) Hole (or Data Ready)	<u>Mode 5:</u> $0 < V < +0.4$ @ 16 ma (sink). No Hole (or Data Not Ready)
J1-9	Data Ready Output. True signal indicates data track outputs are in "on character" condition. Signal true with leading edge of feed hole and remains true until next drive signal is accepted (minimum Data Ready time is 50 usec.). Data Ready signal is forced false by a load condition, external inhibit signal or out-of-tape signal. Output mode 5 or 6, selectable (see J1-10).	B	<u>Mode 6:</u> $0 < V < +0.4$ @ 16 ma (sink) Hole (or Data Ready)	<u>Mode 6:</u> $+2.4 < V < +5$ @ 0.2 ma (source) No Hole (or Data Not Ready)
J1-10	Data Mode Select Input. True signal places data outputs and data ready output in mode 6. False signal places data outputs and data ready output in mode 5.	A	$+2.4 < V < +5.0$ (or open circuit) Data Track & Data Ready signals in Mode 6.	$0 < V < +0.4$ @ 17 ma max. Data Track & Data Ready signals in Mode 5.
J1-11 thru J1-13	Signal Ground (OV) to External Equipment. OV ground reference for all inputs and outputs (isolated from chassis ground).			



3-2

TRM-301AF-2

Table 3-1. Interface Signal Descriptions

Connector Pin	Description	Interface Circuit-See Figure.2-2	Signal Levels	
			True Condition	False Condition
J1-14	System Ready (SYSRDY) Output. True signal indicates RUN-LOAD switch is in RUN and power is on (system ready). False signal indicates RUN-LOAD switch is in LOAD or if drive signal is accepted and new feed hole is not sensed within 10 ms., indicates either no tape or torn tape and serves as the out-of-tape signal (system not ready).	C	0V<+0.4 @ 16 ma (sink) System Ready	+2.4V<+5.0 @ 0.2 ma (source) System Not Ready
J1-15	External Inhibit (EXT INH) Input. True signal inhibits reader operation and causes System Ready and Data Ready signals to go false. False signal allows reader to operate in normal manner.	A	0V<+0.4 @ 16 ma (sink) Reader inhibited. Data Ready and System Ready signals false.	+2.4V<+5.0 (or open circuit) Reader not externally inhibited.
J1-16	Drive Right Input. True signal drives tape to right in either continuous mode or asynchronous mode. See Sections 3.3.1 and 3.3.2.	A	0V<+0.4 @ 5.0 ma. max. Reader drives tape to right	+2.4V<+5.0 (or open circuit) Reader does not drive tape to right
J1-17	Drive Left. Same as drive right except drives to the left.	A		
J1-23	+5 VDC @ 200 ma output available to external equipment.			
J1-25	Chassis Ground. Output connection to chassis ground (isolated from signal ground).			

Table 3-2. Front Panel Controls

SWITCH	POSITION	FUNCTION
POWER	ON	Applies AC power to reader.
	OFF	Removes AC power from reader.
RUN-LOAD (actuated by tape access door)	RUN (door closed)	<u>Allows</u> reader to operate and places System Ready output in true state.
	LOAD (door open)	<u>Inhibits</u> reader and places System Ready output in false state.
DIRECTION CONTROL		Drives tape to the left in continuous mode.
		Drives tape to the right in continuous mode.

3.3.1 TAPE DRIVE, ASYNCHRONOUS MODE

In this mode of operation, the reader is controlled in a line-at-a-time step mode. Each pulse input steps the tape one line. This mode is performed as follows:

- a. Perform Section 3.3, steps a through g.
- b. Apply the following drive signal to the drive left (\overline{DL}) line, pin 17 of J1, or the drive right (DR) line, pin 16 of J1 as follows. Make sure the Data Ready signal at pin 9 of J1 is in the true condition depending upon mode and that the External Inhibit input signal at J1, pin 15, is false ($+2.4V < +5.0$ or open circuited). See Table 3-1 and Figure 3-1.

Stop: $+2.4V < +5.0$ (2K to +5V) or an open circuit
 Run: $0V < +0.4$ @ 5 ma.

Pulse or D.C. level to be maintained until Data Ready signal goes false (1 μ sec typ). Tape will be driven in excess of 300 characters/sec. Signal to be removed within 50 μ sec. after leading edge of Data Ready signal to stop on that character.

- c. Only one run signal must be present at one time. If both run signals are present, the reader will drive to the left.
- d. The reader may also be driven either right or left in the continuous mode by the front panel direction switch S3. Operation of this switch in conjunction with external drive signals is not an allowed operating condition and should be avoided.

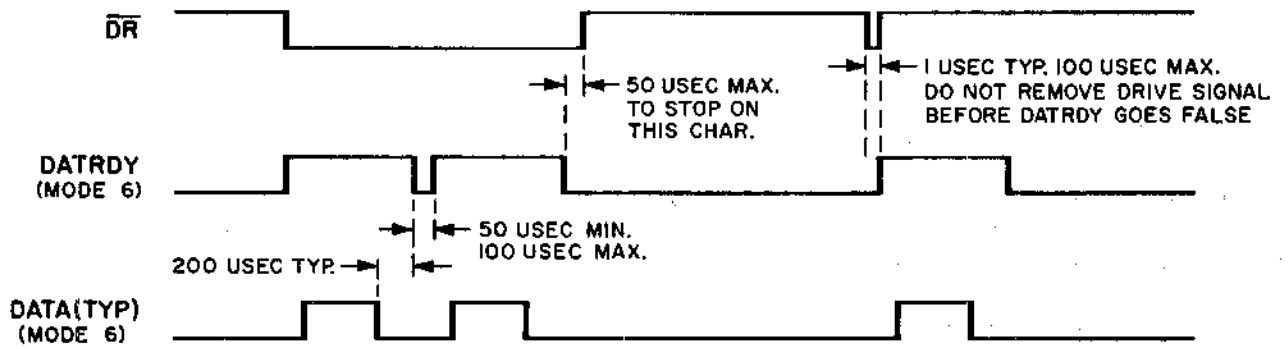

Figure 3-1. Timing Diagram for RR-6300BXX.

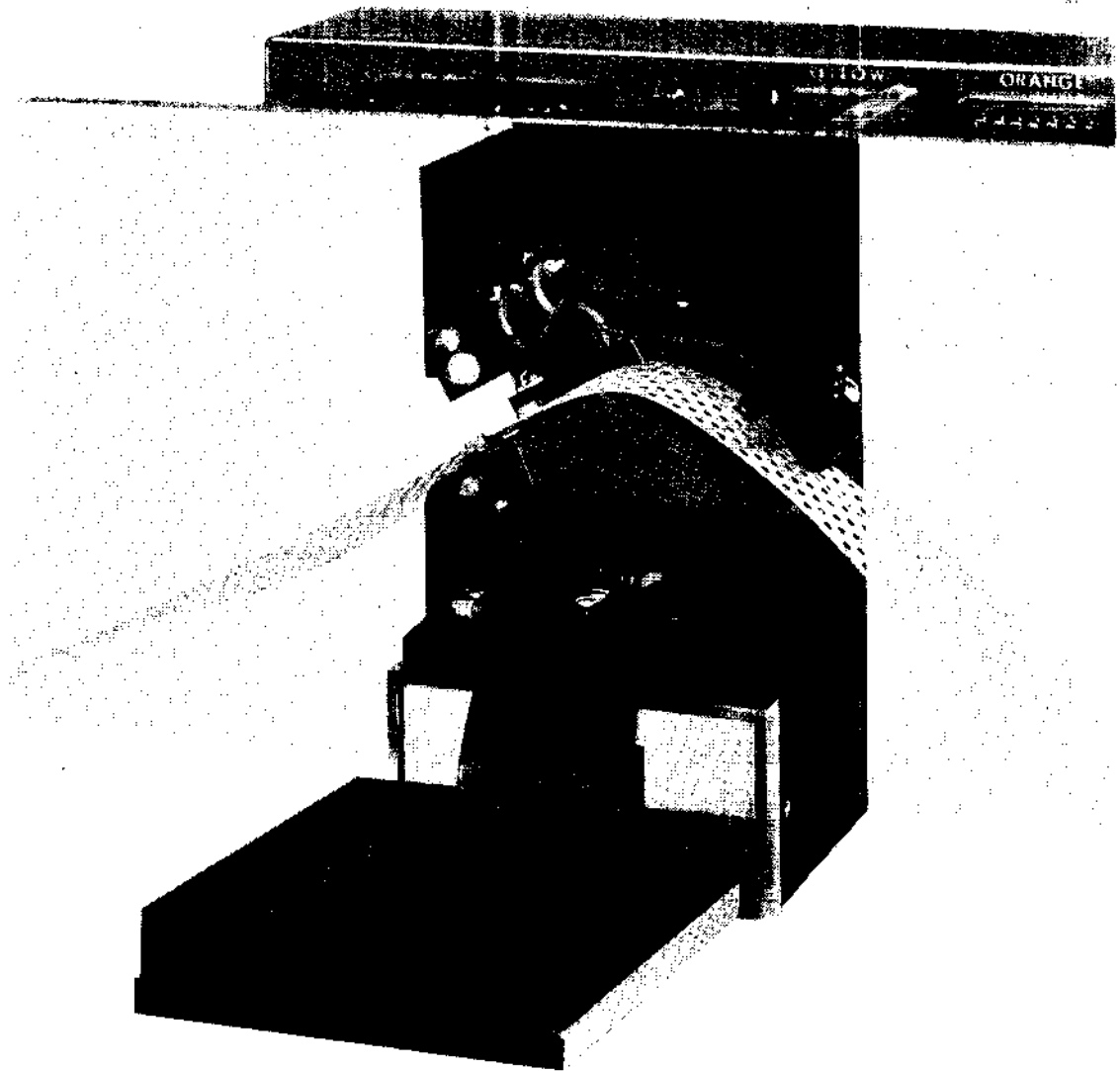

Figure 3-2. Tape Loading.

3.3.2 EXTERNAL INHIBIT

In this mode of operation, the reader is inhibited and the System Ready output (J1-14) and the Data Ready output (J1-9) are set to the false state. To place the reader in the inhibit mode apply the following signal to pin 15 of J1:

Reader Not Inhibited: $+2.4 < V < +5.0$ (2K to +5V) or an open circuit

Reader Inhibited: $0 < V < +0.4 @ 5 \text{ ma.}$

3.4 OPERATIONAL MAINTENANCE

After every 6 to 8 hours of use, the operator should check the tape transport area for cleanliness. This is extremely important since any dirt or foreign material covering the readhead can cause readout errors. For general cleaning, use the stiff bristle brush supplied. Cleaning of the photocell assembly area is described in Section 5.2.1.1. Make sure the tape remains clean at all times since any residue picked up by the tape can be deposited on the readhead. It has been found in certain cases that residue picked up by the tape comes from soiled hands. It is important that care be exercised when handling tape, especially in machining areas or other areas where grease, oil and sprays are present.

3.5 TAPE RECOMMENDATIONS AND AVAILABILITY

The tapes listed in Table 3-3 are among those recommended for use. Mylar tapes should be used in applications requiring continuous use.

Table 3-3. Recommended Tapes

Type	Manufacturer	Part Number
Paper, Unoled or Oiled (except black carbon filled)	REMEX	715200-001 1000 ft. Box Fanfolded 715200-002 1000 ft. Roll
	Paper Manufacturers, Inc.	Perfection Series
	Bemis	
Special Paper	Numeridex	0500
	Nova Tech	Syntosil Machine Tool Tape
Special Mylar	Arvey	RVCZ 60
	3M Brand	N/C Tape #401

3.6 TAPE PREPARATION REQUIREMENTS

Proper tape reader operation requires that the maximum accumulated longitudinal error between feed hole centers in the punched tape be ± 0.025 inch within any span of 5 inches, as specified in the American National Standards Institute Standard X3.18-1967 (ANSI; formerly United States of America Standards Institute). In the event a user has, because of punching problems, a number of tapes which do not conform to this specification by an amount consistently out of tolerance, the reader may be set up as in Section 5.4 using one of these tapes rather than the type specified.

A tape gauge is available from REMEX (part number 110597) so that the ± 0.025 tolerance specification can be checked. To use the gauge, place the feed hole of one end of a 5-inch span (50 characters) at the single cross hair and swing the other end of the 5-inch span in the arc until one of the cross hairs is centered in the feed hole. Read the measurement adjacent to that cross hair (plus tolerances to the right and minus tolerances to the left). A second 5-inch gauge is printed at the bottom to check both longitudinal and perpendicular transverse center line spacing.

SECTION IV

THEORY OF OPERATION

4.1 BLOCK DIAGRAM DESCRIPTION

The REMEX punched tape reader performs two basic functions: (1) it drives tape in either direction over the read station and (2) converts the tape information into electrical signals. These two functions are shown in block diagram form in Figure 4-1.

4.1.1 TAPE DRIVE

The drive system consists of a four phase stepping motor which is directly coupled to the sprocket drive wheel. Two phases of the motor are energized at a time in a sequence which advances the sprocket and tape one line either to the left or right depending upon the sequence order of the phases. The tape then stops on character and waits for the energizing of the next two motor phases.

Reader card assembly 110271-1 is used to generate the required motor phase signals in response to the drive inputs. It also generates the required DC voltages. A OV true drive signal or step pulse applied to the drive left or drive right input line or a drive command from the direction drive switch, S3, will generate the first system clock pulse, CP. The input signal also establishes the direction of rotation for the motor through the motor phase control circuit. The CP is used to advance the motor control circuit which steps the motor. A 1.5 ms single-shot, SS2, is also triggered by the CP so that any initial jitter in the sprocket is locked out as the sprocket goes off character.

When the next sprocket hole is read (approximately 3 ms after the drive command), the Sprocket Sensing flip-flop FF2 is set which (1) latches up the data (through FF2 and the Data Ready line) and (2) triggers the 75 μ s single-shot, SS3. This allows the external equipment approximately 75 μ s (specified as 50 μ s max) to examine data and make the stop-go decision.

An additional function performed by the CP signal is to trigger the 15 ms delay SS4. This is a retriggerable type single-shot which is recycled by each CP pulse. SS4 is used to program the step motor supply voltage, VMOT, up and down in order to reduce the motor power dissipation during inactive periods. In addition, if no new sprocket is sensed (i.e., FF2 is not triggered) during the 15 ms, the System Ready signal goes false indicating the reader is at the end of tape.

The CP generator is inhibited by either the LOAD switch or a true OV External Inhibit signal. Either signal generates the Step Inhibit signal which clears and locks up SS1 and FF2, inhibits the Data Ready signal and places the System Ready in the false condition (system not ready).

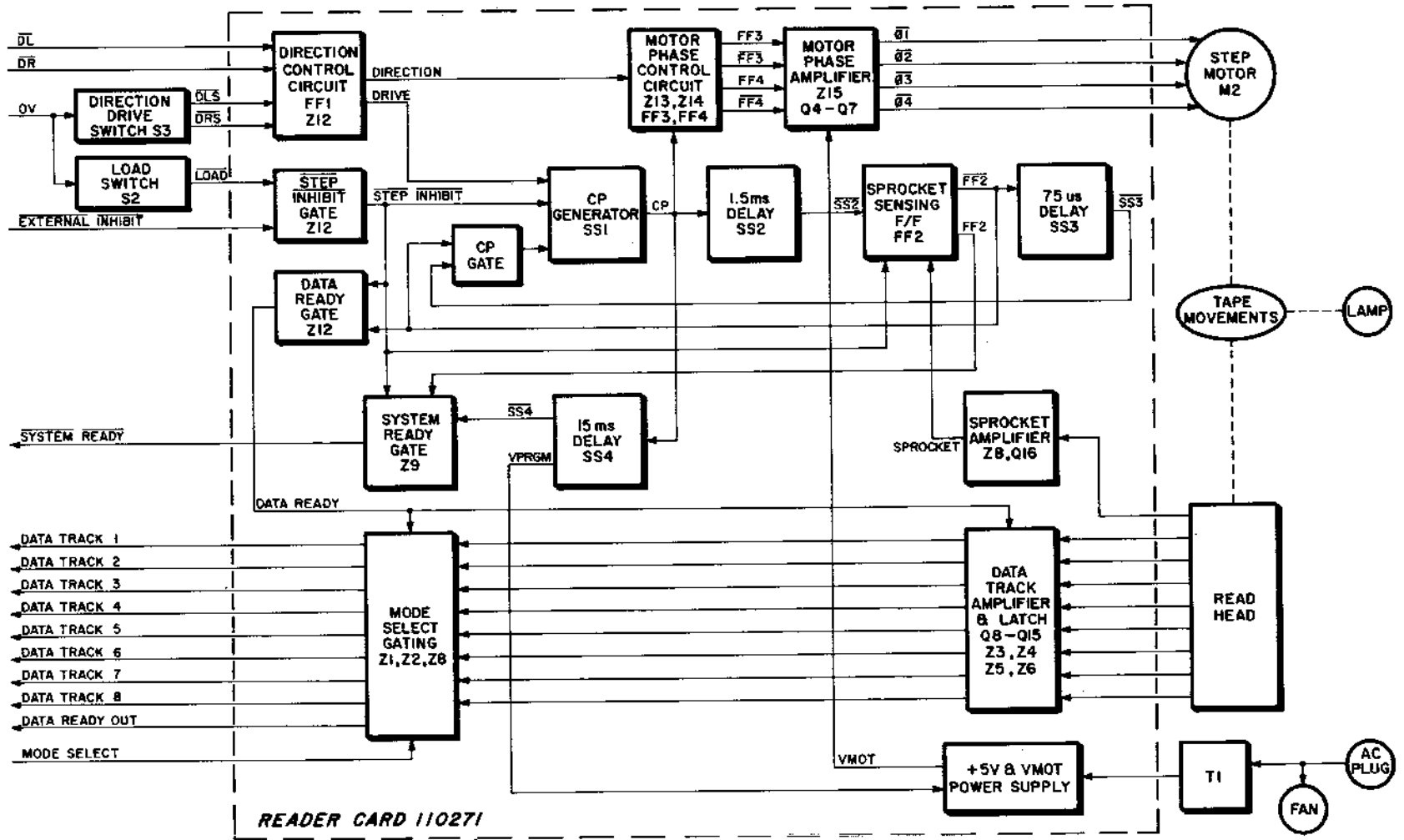

MMC 351

Figure 4-1. Block Diagram RR-6300

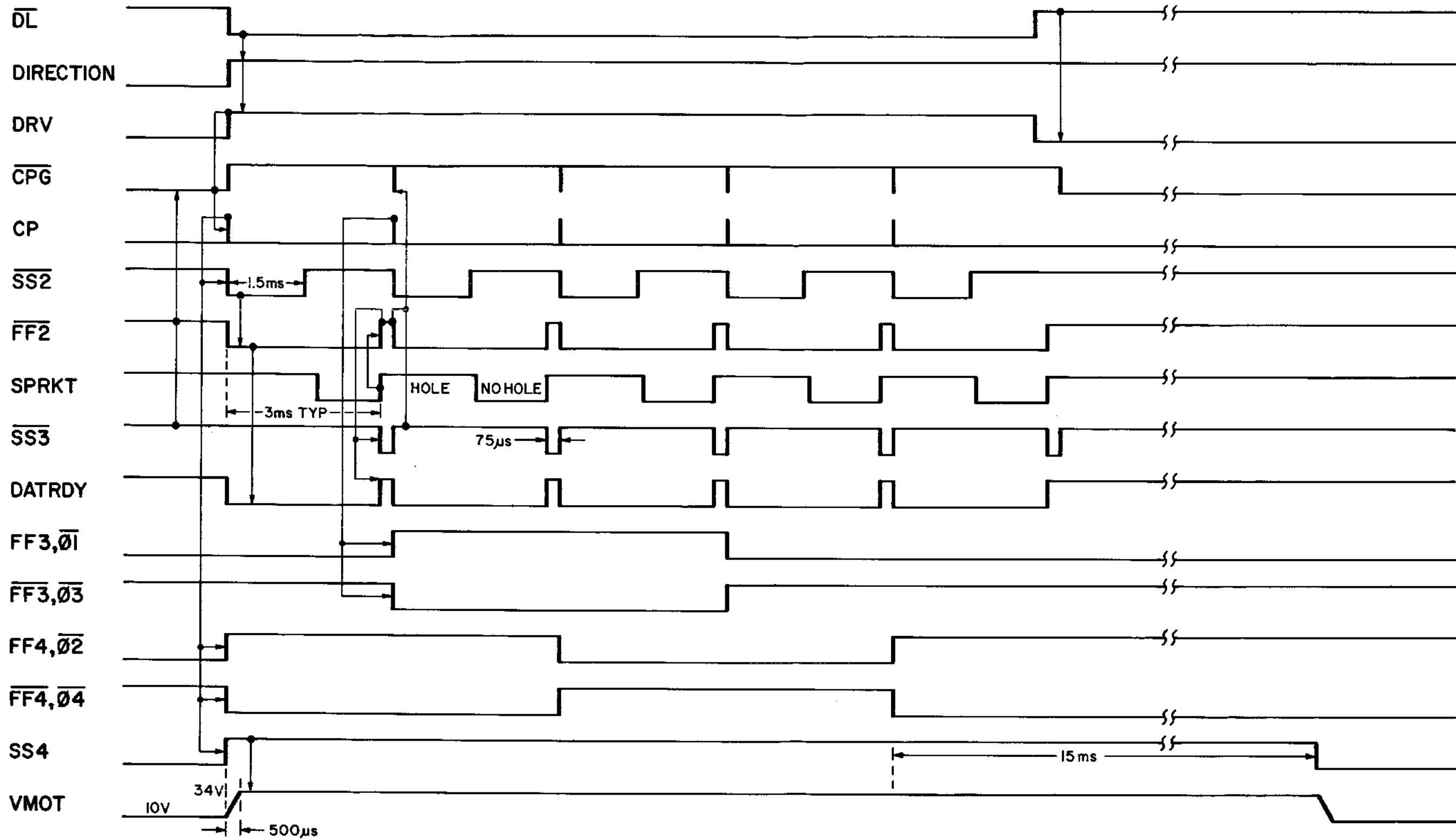

MMC 350

Figure 4-2. Timing Diagram, Reader Card Assembly 110271

4.1.2 TAPE READING

The readhead is located under the lamp source and contains photovoltaic cells which are used to sense the punched tape perforations. As tape is advanced over the readhead by the sprocket drive, the photovoltaic cells are energized by the light source when the corresponding holes are present in the tape. The outputs from the readhead are then applied to the data track amplifiers and latch circuits on the card. A true, +5V, Data Ready signal locks up the two latch circuits, Z3 and Z6 storing that line of data and causing the Data Ready output signal to go true. The outputs of the latch circuits are applied to the Mode Select gates which produces either mode 5 or 6 outputs depending upon the level applied to the Mode Select input.

4.2 CIRCUIT DESCRIPTION, READER CARD 110271

This card is used (1) to generate outputs to drive the four phases of the stepping motor in response to the drive inputs, (2) to provide amplification and gating of the readhead outputs, and (3) to generate the +5VDC required for the IC circuits and lamp and the step motor voltage, VMOT. Refer to the Schematic Figure 8-1, sheets 1 and 2 during this discussion.

4.2.1 DRIVE CIRCUITS

Normal operations begin with the loading of the tape. Opening the Door Mechanism Assembly actuates S2. This applies OV to pin 10 of Z12 causing Z12-8 (the Step Inhibit line, STPINH) to drop to its OV true state. See Figure 8-1 sheet 1. The STPINH line performs four functions: (1) it clears and inhibits single-shot SS1, thereby preventing any drive signal from being recognized, (2) it clears and inhibits flip-flop FF2, thereby preventing any sprocket from being recognized, (3) it places the Data Ready (DATRDY) line at Z12-11 in the false OV state and (4) it places the System Ready (SYSRDY) output at J1-14 in the +5V false state (not ready). Note also that a OV true External Inhibit (EXTINH) signal applied to J1-15 will also generate these same four conditions.

After tape has been loaded, the Door Mechanism Assembly is closed and the inhibit effects of S2 are removed allowing the drive signals to be applied. During the following description, refer to Figure 4-2 which shows the waveforms and timing diagrams for the drive and step operations. This figure is intended as a guide to show the sequence of events and which signals initiate other signals. It must be cautioned that due to the wide range of pulse widths, no attempt has been made to draw the time axis to scale. Refer also to the schematic, Figure 8-1, sheet 1 during this description.

With the reader stopped on character, the sprocket signal is +5V true which places the $\overline{FF2}$ and Data Ready (DATRDY) signals at +5V. This indicates the reader is ready to accept the next command. Applying a true, OV \overline{DL} signal at J1, pin 17, sets the direction flip-flop FF1 and places the Drive (DRV) line at +5V. Since $\overline{FF2}$ and $\overline{SS3}$ are +5V at this time, the positive going DRV signal triggers single-shot SS1, producing the CP signal (approximately 1 μ s width). The CP signal is used three places: (1) to trigger the 1.5 ms single-shot SS2, (2) to trigger the two motor phase control flip-flops FF3 and FF4, and (3) to trigger the programmed voltage single-shot SS4.

Single-shot output $\overline{SS2}$ sets the FF2 flip-flop causing the Sprocket signal to be locked out for 1.5 ms. Since $\overline{FF2}$ is held at OV, any noise or start-up jitter from the Sprocket signal is prevented from generating a true Data Ready signal. At the end of the 1.5 ms period, FF2 is released. By this time, the tape is up to speed and the only signal available to reset FF2 is the positive going true sprocket signal.

Flip-flops FF3 and FF4 are gated with Z13 to energize the phase windings of the motors in desired sequence. The order in which the windings are energized is determined by the direction line which places OV at pins 1, 10, 4 and 13 for drive right or +5V for drive left. Outputs FF3, $\overline{\text{FF3}}$, FF4 and $\overline{\text{FF4}}$ are connected through Z13 in such a manner that two phase (\emptyset) lines are true (OV) at a time. The sequencing order for drive left is $\emptyset 1$ and $\emptyset 4$, $\emptyset 4$ and $\emptyset 3$, $\emptyset 3$ and $\emptyset 2$, and the $\emptyset 2$ and $\emptyset 1$. Drive right is the reverse order.

SS4 is a retriggerable single-shot which is timed for 15 ms. The first CP signal to trigger SS4, places SS4 at +5V and, in turn, Z15-4 at OV. This has the effect of raising voltage VMOT from +10VDC to +34VDC. See Section 4.2.3. If SS4 is not retriggered within 15 ms, VMOT shuts down to conserve power when tape movement is not required. Output SS4 is combined with FF2 to produce an out-of-tape sensor. If SS4 is not retriggered within 15 ms (SS4 will go high) and if no sprocket is sensed (FF2 remains high) then the EOT signal at Z9-11 drops to OV. The System Ready signal at Z9-8 then rises to the +5V false state, indicating that the system is not ready.

When the tape comes back on character, the positive going sprocket signal resets FF2. The positive going output FF2 is, in turn, used three places: (1) to trigger single-shot SS3, (2) to generate the positive going Data Ready (DATRDY) signal at pin 11 of Z12, and (3) is applied to pin 4 of Z9 along with SS3 to hold the CPG line in the +5V false state during the SS3 time period. The function of SS3 is to provide a 75 μ s time delay so that the external equipment can examine the data and make the go/no-go decision. If the decision to stop is made, the DL input line must be taken high within 50 μ s. Otherwise, when SS3 times out, the positive going SS3 will cause CPG to go low, thereby generating the next CP and causing the tape to advance to the next character.

On units using the teletypesetter advanced feed hole tapes (110271-2 cards) Z20 is added and the jumper between terminals A and B is removed. Z20 is a single-shot which provides a 150 μ s delay of the leading edge of the sprocket. This gives the electronic appearance of a non-advance sprocket which then resets FF2 in the manner previously described.

4.2.2 TAPE READING CIRCUITS

Nine photovoltaic cells in the readhead assembly sense the perforations in the tape. An illumination system consisting of a lamp and focusing lens provides a continuous beam which covers the area of the photocells. The tape is driven over the top of the photocell block and when a hole in any track appears between the photocell and the light source, the light energizes the photocell.

Each cell output is applied to the amplifier-latch circuit Q8-Q16, Z3 and Z6. Track 1 is used in the following discussion since it is typical of tracks 1-8 (the Sprocket signal is developed differently as described in a subsequent paragraph). When track 1 becomes energized, the negative going signal at the cathode of the photocell turns off Q8. See Figure 8-1, sheet 2. Q8 is interconnected with the $2\overline{\text{Q}}$ output and 2D input of Z3 in a manner which allows Q8 and the first stage of Z3 to function as a Schmitt trigger. The latching circuit follows all changes in the photocell until the Data Ready (DATRDY) signal is +5V (see Section 4.2.1). The +5V true DATRDY signal is inverted at Z15-6 and locks up Z3 and Z6.

Track 1 output at 2Q is +5V true and is gated with the Mode Select signal at Z1, pins 9 and 10. A OV input Mode Select input will provide mode 5 outputs at J1, pin 1, i.e., when 2Q is OV for the no hole condition, J1-1 will be OV. When 2Q is +5V for the hole condition, J1-1 will be +5V. Conversely, when the Mode Select signal is +5V and 2Q is

OV, J1-1 will be +5V. The DATRDY output is gated in the same manner as the track outputs at pins 9 and 10 of Z8.

The sprocket track is somewhat different than the other eight tracks in that its Schmitt trigger uses an exclusive OR gate rather than part of a latch and appears to the logic circuitry independent of the DATRDY signal. It is also used only as an internal logic signal and is not gated with the Mode Select signal.

4.2.3 POWER SUPPLY

Two voltages are generated by the power supply section: +5VDC and VMOT. AC voltage from the secondary winding on transformer T1 is rectified by CR3 and CR4 to produce approximately 14VDC. This voltage is then applied to pin 1 of the +5VDC regulator, A1, causing the output at pin 2 to be +5VDC which is used for the IC and lamp requirements. A1 is a commercially packaged five volt regulator, LM309K, which is mounted (along with Q3) on a heat sink external to the card.

CR1 and CR2 rectify the 75VRMS from the transformer to produce approximately 55 VDC at the output of the filter network composed of C3, R2 and C4. This voltage is applied to the collector of the series pass transistor, Q3, and to a constant current source comprised of Q1 and its bias network. Q1 supplies the base drive for Q3. Control of the pass transistor, Q3, is achieved by shunting some of the current from Q1 through Q2 instead of allowing it to reach the base of Q3. A resistive divider network composed of R6, R7, R8 and R10 applies a voltage proportional to VMOT to the base of Q2. Q2 compares this voltage to the 6.2 volts developed in Zener diode CR8 and shunts more or less of Q3's base current as required to maintain VMOT constant.

When the step motor is moving, R8 is held at ground potential by the VPRGM line and VMOT is set by R7 for approximately 34 VDC. During periods when the motor is stopped for longer than 15 ms, VPRGM appears as an open circuit and allows current to flow through R22. This change in the divider network forces VMOT to regulate at approximately 1/3 of the running potential, thereby conserving power during periods of inactivity.

4.3 LIGHT SOURCE

A straight line filament lamp rated at 5.8 VDC @ 520 milliamps is used as the light source. It is operated at approximately 15% below rated voltage to provide a long life expectancy in excess of 13,000 hours. The lamp is mounted along with the lens in an assembly, 110453-1, which is replaced in the event of a lamp failure. The lamp assembly replacement is described in Section 6.2.4.

SECTION V MAINTENANCE

5.1 GENERAL

The REMEX punched tape reader has been designed to keep maintenance as simple and infrequent as possible. Table 5-1 lists the maintenance equipment required for the various procedures. To prolong the life of the equipment and minimize down-time, certain checks and preventive procedures are set up in Section 5.2 and Table 5-2 with suggested schedules. Section 5.3 outlines possible malfunctions along with probable causes and remedies. The remaining sections describe the required adjustment procedures. Replacement procedures are given in Section 6.

Table 5-1. Maintenance Equipment Required

ITEM	QUANTITY
* Frequency Counter, 10 Hz to 20 MHz, 5V input	1
Miller-Stephenson MS-200 Magnetic Tape Head Cleaner (REMEX Part Number 716004-150)	1
* Pulse Generator, 10 Hz to 1 MHz, up to +5V amplitude, 1 us to 100 ms width	1
* Oscilloscope, DC to 10 MHz, single sweep	1
Tape Gauge REMEX Part Number 110597	1
* Voltmeter, Digital 0-0.1 ma, 0-100 mv dc, 0-100V dc, 100K impedance or greater	1
* These items not available from REMEX.	

5.2 PREVENTIVE MAINTENANCE

Preventive maintenance, which includes cleaning and lubrication, should be checked periodically in order to maintain peak performance. In addition, in order that the warranty remain in effect, the unit must be maintained in accordance with the instructions outlined below (see Section 1.4 and page iii). A preventive maintenance schedule and log are presented in Table 5-2 which indicates the item, frequency of action and references the maintenance paragraph in this section. For customer convenience the table is arranged so that a log can be kept of when each maintenance procedure was performed. Also refer to Section 3.4, Operational Maintenance.

NOTE

The frequency of cleaning as listed in Table 5-2 has been adopted for clean environmental conditions and usage. These items, however, may vary greatly from one installation to another. For example, a reader used in a machine shop to program numerical controls may require maintenance procedures considerably more frequently.

5.2.1 CLEANING

CAUTION

In all cleaning procedures, avoid using cleaning methods and materials other than those recommended in this manual. Certain cleaning compounds will damage parts of the reader, especially in the readout assembly area. REMEX primarily recommends the use of Miller-Stephenson MS-200 Magnetic Tape Head Cleaner (REMEX Part Number 716004-150) for most areas requiring cleaning. However, due to the degreasing nature of the cleaner, it should not be used in areas where the spray may come in contact with bearings or other oiled parts. This cleaner may be obtained from REMEX or directly from Miller-Stephenson Chemical Company at one of the following locations:

1001 East First Street
Los Angeles, California 90012

1350 W. Fullerton Avenue
Chicago, Illinois 60614

Route 7
Danbury, Connecticut 06810

To use the cleaner, hold the spray can 4 to 6 inches from the area to be cleaned and allow spray to flush the dirt off. If a heavy buildup is present, loosen with the spray mist and scrub with a cotton swab. A 6-inch pin-point, spray nozzle extension is available for hard-to-reach areas or for delicate applications. Avoid spraying on lubricated surfaces or parts.

If the Miller-Stephenson cleaner is not available, a small amount of isopropyl alcohol applied to a clean, lint-free cloth or cotton swab may also be used. However, it should be used carefully and sparingly since damage to the photocell and the finish on the plastic covers may result. Use only clear, unadulterated isopropyl alcohol. Do not use ethyl alcohol or denatured alcohol as the denaturing agents vary and may damage the reader.

It is important that, whether the MS-200 cleaner or the isopropyl alcohol is used, only the amount required to clean the surfaces be applied. Never saturate or drench the areas to be cleaned. Never apply these materials to the lamp assembly.

5.2.1.1 Readhead Assembly Cleaning

The top surface of the readhead assembly should be cleaned every two weeks (for most installations having clean environments; dirtier environments which contain dust, oil and sprays, such as machining areas, may require cleaning as much as every eight hours). Cleaning is extremely important because any dirt or foreign material in this area can create errors in readout. Use the bristle brush supplied or the cleaning materials and methods described in Section 5.2.1 and clean the surfaces of the readhead assembly and the upper tape guide assembly. Care should be exercised so that no residue remains from the recommended cleaning materials when the cleaning operation is completed.

5.2.1.2 Lamp and Lens Cleaning

The lamp and lens should be checked for cleanliness every two weeks and cleaned as required. To clean the lamp assembly and lens, use only a soft cloth. Do not use the items described in the caution in Section 5.2.1. Remove the upper cover and carefully clean the lamp and lens. Care should be taken so that the adjustment of the lamp is not disturbed. If the lamp requires adjustment, refer to Section 5.4.

CAUTION

Some lens are made of plastic and tend to scratch easily. Care should be exercised when cleaning the plastic lens. The reflective material on the lamp is easily damaged by strong solutions. Use care in cleaning this area.

5.2.1.3 Sprocket Cleaning

The sprocket wheel should be checked for cleanliness every two weeks. Depending upon tape conditions, accumulations may build up on the sprocket and be transferred to the sprocket holes in the tape which may cause readout errors. Use the recommended cleaning materials described in the caution in Section 5.2.1. Care should be taken so that the alignment of the sprocket wheel is not disturbed. If the sprocket wheel requires adjustment, refer to Section 5.4.

5.2.1.4 Tape Cleaning

Repeated handling and usage of the tape leads to a build up of grease, oil and dirt on the tape. When the build up becomes excessive, this material will become lodged in the tape transport areas and could cause tape reading errors. To prevent this, the tape should be thoroughly inspected every two weeks and repunched as required.

5.2.1.5 General Cleaning

The entire reader should be cleaned every year. Use the following procedure:

Using the bristle brush supplied with the unit and/or compressed air, remove all dust and dirt, paying particular attention to all moving parts. Use the recommended materials described in the caution in Section 5.2 to remove any grease or other accumulations. When cleaning, use care not to damage components on the circuit board.

Table 5-2. Preventive Maintenance Schedule and Log

Frequency* of Action Weeks	Date	Initial	Frequency* of Action Weeks	Date	Initial	5.2.1.1	5.2.1.2	5.2.1.3	5.2.1.4	5.2.1.5	5.2.3	5.4.			
						Cleaning					Check Adjustments				
2			28			X	X	X	X						
4			30			X	X	X	X						
6			32			X	X	X	X						
8			34			X	X	X	X						
10			36			X	X	X	X						
12			38			X	X	X	X						
14			40			X	X	X	X		X	X			
16			42			X	X	X	X						
18			44			X	X	X	X						
20			46			X	X	X	X						
22			48			X	X	X	X						
24			50			X	X	X	X						
26						X	X	X	X		X	X			
			52			X	X	X	X	X	X	X			

*See Note on page 5-2.

Table 5-3. Troubleshooting

Indication	Probable Cause	Remedy
1. No track outputs on any track.	1. Readhead dirty	Clean Readhead Assembly as described in Section 5.2.1.1.
	2. Lamp Assembly misaligned	Check alignment of the Lamp Source as described in Section 5.4.
2. Outputs present on all but one track or one track intermittent	1. Readhead dirty	Clean Readhead Assembly as described in Section 5.2.1.1.
	2. Defective Photocell	Check the output of the Photocell assembly as described in Section 5.4 and replace if defective as described in Section 6.2.2.
	3. Defective component on Reader Card	Check the components and IC modules associated with the particular track output. Refer to Tape Reading Circuit description, Section 4.2.2.
3. Track output present with no hole punched in tape	1. Tape transmissivity	Tape must have a transmissivity of 57% or less as specified in Table 1-2.
	2. Defective Photocell	Check the output of the Photocell assembly as described in Section 5.4 and replace if defective as described in Section 6.2.2.
	3. Defective component on Reader card	Check the components and IC modules associated with the particular track output. Refer to Tape Reading Circuit description, Section 4.2.2.
4. Window closed, POWER switch in ON, correct drive signals present; tape does not move.	1. POWER switch, S1, defective	Check switch S1 and replace if defective as described in Section 6.2.7.
	2. RUN-LOAD switch, S2, defective	Check switch S2 and replace if defective as described in Section 6.2.8.
	3. Defective component on Reader card	Check operation of Reader card. Refer to description of Driver Circuits, Section 4.2.1.
	4. Step Motor defective	Check $\bar{01}$ thru $\bar{04}$ outputs from Reader card to see if they are present. If so, replace stepper motor as described in Section 6.2.5.

Table 5-3. Troubleshooting (Continued)

Indication	Probable Cause	Remedy
5. Tape does not stop on character	1. Improper reader alignment	Perform Section 5.4.
	2. Defective component on Reader card	Check operation of Reader card. Refer to description of Driver Circuits, Section 4.2.1.
6. POWER switch ON; lamp does not turn on, no DC voltages	1. No AC power	Make sure AC power cord is plugged into outlet.
	2. Fuse F1 blown	Check fuse and replace if required.
	3. POWER switch, S1, defective	Check switch S1 and replace if defective as described in Section 6.2.7
	4. Power Supply defective	Check Reader card for proper operation of +5V power supply. See Power Supply description, Section 4.2.3.
	5. Defective Transformer, T1	Check T1 and replace if faulty as described in Section 6.2.6.
7. Continuous tape speed less than 330 characters/second	1. Tape out of registration	Check tape registration to make sure tape conforms to specifications as described in Section 3.6.
	2. Sprocket out of rotational alignment	Check alignment of reader as described in Section 5.4.
	3. Defective component on reader card	Check Reader card for proper operation of drive circuits and single shot timings. See Drive Circuit Discussion, Section 4.2.1 and timing diagram, Figure 4-2.
8. Irregular movement of tape	1. Drive system improperly adjusted	Perform Reader alignment as described in Section 5.4.
	2. Sprocket wheel bent or worn	Replace sprocket wheel as described in Section 6.2.5.
	3. Tape guide assembly worn	Replace tape guide assembly
9. +5V supply voltage too low or too high	1. Defective regulator 2. T1 malfunction	Check operation of A1 and replace if required Check for presence of 22 VRMS across the yellow and orange terminals of T1. Replace T1 if not present.

5.2.2 LUBRICATION

All points of rotation have permanently lubricated bearings and should not require lubrication for the life of the part.

5.2.3 POWER SUPPLY VOLTAGES

Check all voltages listed below with a voltmeter once every three months. A change in voltage may be indicative of a gradual component failure. Before taking any measurements, allow a short period of time for warm up after turning on power.

<u>Voltage and Tolerance</u>	Measure	
	<u>From</u>	<u>To</u>
VMOT (See Section 5.4)	TP6	TP1
+5.00 VDC ± 0.2	TP5	TP1

5.3 TROUBLE SHOOTING

Trouble shooting is presented in the form of a chart, Table 5-3, which should be consulted whenever tape reader performance is unsatisfactory. The chart is divided into three columns: Indication - the way in which the malfunction becomes evident; Probable Cause - the possible reason or reasons for the malfunction; and Remedy - the manner in which the malfunction may be corrected.

5.4 READER ALIGNMENT (UNITS WITHOUT DAMPER COMPONENTS)

Earlier models which do not contain the Collar, Collar Spring, Damper Assembly, Faceplate and Friction Plate components on the rear of the reader motor shaft (see Figure 7-1) must have their reader aligned using this procedure. Units containing these components must be adjusted using Section 5.4A.

Proper operation depends upon making and maintaining accurate adjustments. Although all adjustments are made at the factory, the following adjustments should be checked periodically (refer to Table 5-2) and should be performed only when the tape reader performance is unsatisfactory or when any of the following items are replaced: light source, readhead assembly, upper tape guide assembly, mechanism assembly, sprocket, step motor or circuit card. Letter designations in parenthesis refer to items called out in Figure 7-1.

Improper adjustment of this procedure will result in one or both of the following problems: (1) Reading errors, especially in computer applications and (2) Restriction of the tape tolerances capable of being read, i.e., either long or short tolerance tapes, not the ± 0.025 inch in either direction as specified in Section 3.6.

CAUTION

This is a factory set adjustment and should not require re-adjustment unless one of the aforementioned components has been replaced or the reader performance is unsatisfactory.

- a. Remove all power and control signals by disconnecting P1 and the power cord plug.
- b. Remove the Upper Cover Assembly (5) by loosening the two 6-32 round head screws (A), flat and lock washers at the rear of the front panel.
- c. Check the distance from the back of the sprocket to the front panel. This distance should be 0.862 inch from panel to back side of sprocket as shown in Figure 7-1. If this is not the case, perform Section 6.2.5, steps b, c, f and h.

CAUTION

The following steps d, e, and f should be adjusted only if the 0.007 inch dimension described in step f is not correct.

- d. Loosen the four 8-32 socket head screws (B) which hold the Mechanism Assembly to the Front Panel at the rear of the panel and position the Mechanism Assembly so that it is centered in the black line on the panel and the bottom edge of the assembly is 1/32 higher than the bottom edge of the panel. Tighten screws (B). This is a preliminary step; the critical dimension is given in step f.
- e. Remove screw (C) which holds the left side of the Lamp Assembly to the Read-head Assembly.
- f. Loosen the two 6-32 binder head screws (D) which hold the heat sink to the front panel. Adjust the heat sink so that the perimeter of the sprocket is no more than 0.007 inch from the tape surface on the readhead assembly. This setting is difficult to make exactly but in no case should the sprocket and readhead assembly touch nor should this gap exceed 0.007 inch max. See Figure 5-1. Tighten two screws (D). A sprocket height alignment tool (REMEX part number 110608) is available for this alignment. It may be necessary to again perform step d, and move the Mechanism Assembly slightly to achieve the setting just described. This is the critical setting - not the 1/32 inch as described in step d.
- g. Apply AC power by plugging in the power cord and manually depressing the power switch S1. The lamp should come on. Make sure the lamp voltage has been adjusted for those units containing an adjustable lamp voltage supply. See Section 5.6.
- h. Place a jumper across R22 on the Reader card.
- i. Place a digital voltmeter across TP6 (VMOT) and TP1 (OV) on the Reader card and adjust R7 for +34 VDC at TP6.
- j. Loosen set screws (E and N) and the two machine screws (H). Place the Upper Tape Guide so that the side with the readout slot is flush against the cell side of the Readhead Assembly and the two outside edges are parallel. Tighten screws (H) while holding the Upper Tape Guide flush. If, after screws (H) are tightened, the left edge of the Upper Tape Guide has lifted, tighten screw (N) until the surfaces are again flush. Repeat by tightening screws (H) and then (N) as required until the Upper Tape Guide is flush on

the flat portion of the cell side of the Readhead Assembly and also flush onto the curved portion at the top. The Upper Tape Guide and Readhead need not be in contact at the top nor on the right side. This is a preliminary alignment; screws (E) and (N), if required, are again adjusted later in this procedure.

CAUTION

If screw (N) is tightened too much the Upper Tape Guide will not be in contact into the curved portion at the top. If this condition occurs, back off the set screw three turns and bend tape guide actuator (Figure 7-2) until set screw contact the lower portion of opening. Repeat procedure.

NOTE

On Models RR-6300BAX, the arrangement of the Upper Tape Guide is different. Screws (H) are not accessible and screw (N) does not exist. Adjustment is made only with screw E.

- k. Insert a loop of tape known to have been punched to within ± 0.0025 inch in a 5 inch span (0.05% error).

CAUTION

Since repeatability of the feedhole placement in either direction is essential, a tape whose accumulated error in a 5-inch span is considerably better than ± 0.025 inches (as specified in Section 3.6) must be used in this procedure. Remex specifies a tape known to be punched to within ± 0.0025 inch in a 5-inch span ($\pm 0.05\%$ tolerance). Note that most REMEX punches are specified at ± 0.025 and hence these tapes should not be used for this adjustment unless known to be within the $\pm 0.05\%$ tolerance. Some users possess tapes which are outside the limits specified in ANSI X3.18-1967 (see Section 3.6). The rotational position of the step motor may be set up (step m) using these tapes rather than the type specified. In doing so, only these tapes should be used. The reader must be readjusted using $\pm 0.05\%$ tapes whenever the tapes specified in Section 3.6 are to be used. The reader is set at the factory to handle tapes greater than 1% short registration if option 004 is shown on the serial tag. Refer to Section 1.6 and Table 1-3.

- l. With the power on, the motor should be energized. Loosen the two set screws (G) which hold the motor to the heat sink.

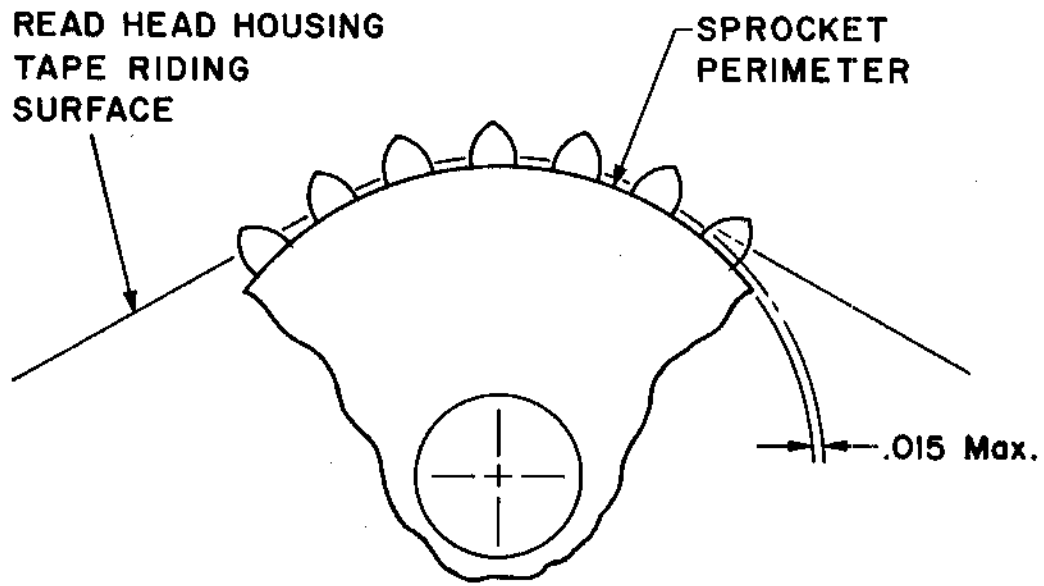

**NOTE: Upper tape guide
omitted for clarity**

MMC 353

Figure 5-1. Setting of the Sprocket in Relation to the Readhead Assembly

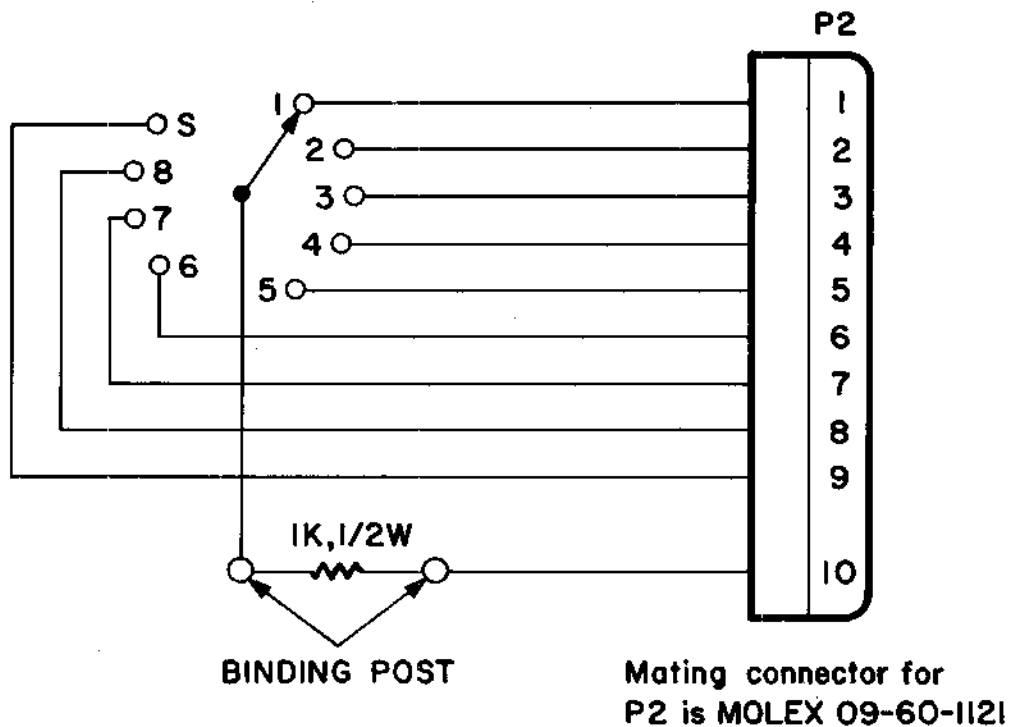

MMC 354

Figure 5-2. Photocell Output Test Circuit

- m. Rotate the motor so that the holes in the tape appear concentric with the light columns. Use care not to disturb the in or out setting of the sprocket made in step c. Tighten the set screws. Remove the jumper across R22.

WARNING

If the motor has been running for a period of time, it or the heat sink may be too hot to touch comfortably. Allow sufficient time for the motor and heat sink to cool before any adjustment or use a cloth or a pair of gloves.

- n. Turn power off and connect P2 coming from the Readhead Assembly to a test circuit as shown in Figure 5-2. Connect a μ meter in series with the 1K resistor. Turn power on.

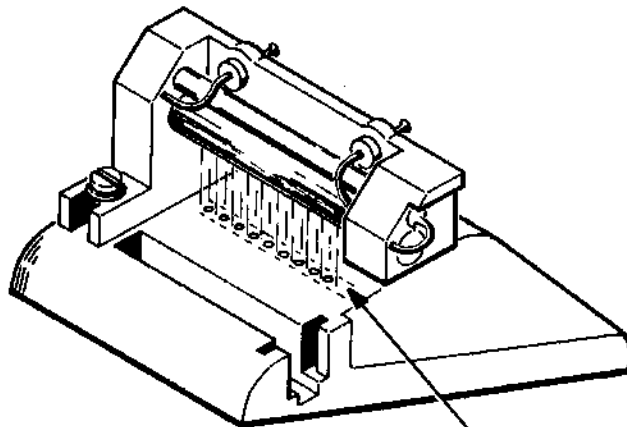

LIGHT BEAM ALIGNED
OVER DATA HOLES

MMC 355

Figure 5-3. Alignment of the Lamp Assembly

- o. Loosen the right screw (F) which holds the Lamp Assembly to the Readhead Assembly and adjust the Lamp Assembly as follows:
 - (1) Adjust the azimuth for alignment with the light columns. See Figure 5-3.
 - (2) Horizontally so that the light beam is centered over all nine columns.
 - (3) After these alignments, the reading on the ammeter should be $85 \mu\text{a}$ minimum for the sprocket track and $70 \mu\text{a}$ min. for each of the data tracks. If this is not true, increase the reader lamp voltage up to a maximum of +5.4 VDC. Refer to Section 5.6.

Tighten screws C and F being careful not to disturb the alignment.
- p. Reconnect P2/J2.
- q. Connect a pulse counter to TP4 and TP1 (OV) on the Reader Card.
- r. Place the direction switch, S3, in the drive left position and measure the drive left speed in char./sec. with the pulse counter by counting the negative going RCP signals.
- s. Repeat step r for the drive right position of S3. If the lowest speed is more than 5% slower than the highest speed, loosen the two set screws (G) which hold the motor to the heat sink. Rotate the motor slightly so that the difference in drive left and drive right speeds is less than 5%. Repeat steps q, r and s as required. When rotating the motor, make sure it is kept tight to the panel so that the distance of the sprocket pins to the front panel as described in step c is not disturbed. Tighten set screws (G). When tightening set screws (G), the torque should not be greater than 5 nor less than 3 inch pounds.

NOTE

The importance of step s is not a specific interest in matching speeds, but rather that balancing the speeds insures proper placement of the feedhole (via the sprocket) in relation to its aperture in the readhead. The 0.05% tape used virtually assures that there are no feedhole placement errors which are attributable to tape registration errors, but only to the position of the sprocket in relation to feedhole aperture in the readhead. Thus measuring and balancing the slew speed is only an accurate, electronic method of assuring that this relationship exists. When the speeds in the two directions are properly balanced, feedhole placement error will be minimal and independent of the direction of the tape, thereby increasing tape readability to a maximum.

- t. If the reader is to use fanfold tape, remove the tape loop and insert fanfold tape which has been punched to the standards described in "k" above. If fanfold tape is not to be used leave the tape loop in.
- u. Connect a pulse generator to the $\overline{\text{DR}}$ input, J1-16. Set the pulse generator for 200 pps.
- v. Connect an oscilloscope to the sprocket cell output at TP2 on the Reader Card and observe the jitter at the -0.3 VDC level (the jitter at the +0.6 VDC level and the time jitter in the leading or trailing edges of the waveform are not of concern). Minimize this jitter by adjusting VMOT and set screws (E and N). See Figure 5-4. Adjustment of the Upper Tape Guide may affect tape steering, especially with fanfold tape.

CAUTION

Do not adjust VMOT and screws (E and N) such that the continuous speed of the reader falls below 330 characters/sec.

Cycle the reader between 20 and 300 characters and check for minimum jitter. Jitter should not exceed 25% of pulse height with nominal registration tape.

- w. Repeat step v for the \overline{DL} input, J1-17.
- x. Remove the pulse generator, oscilloscope and counter.
- y. Perform the reverse of steps b and then a.

5.4A READER ALIGNMENT (UNITS WITH DAMPER COMPONENTS)

Later model units which contain the Collar, Collar Spring Damper Assembly, Faceplate and Friction Plate components on the rear of the reader motor shaft (See Figure 7-1), must have their reader aligned using this procedure. Units not containing these components must use Section 5.4.

Proper operation depends upon making and maintaining accurate adjustments. Although all adjustments are made at the factory, the following adjustments should be checked periodically (refer to Table 5-2) and should be performed only when the tape reader performance is unsatisfactory or when any of the following items are replaced: light source, readhead assembly, upper tape guide assembly, mechanism assembly, sprocket, step motor or circuit card. Letter designations in parenthesis refer to items called out in Figure 7-1 for model RR-6300BAX and RR-6300BBX and in Figure 7-1A for model RR-6300BDX.

Improper adjustment of this procedure will result in one or both of the following problems: (1) Reading errors, especially in computer applications and (2) Restriction of the tape tolerances capable of being read, i.e., either long or short tolerance tapes, not the ± 0.025 inch in either direction as specified in Section 3.6.

CAUTION

This is a factory set adjustment and should not require readjustment unless one of the aforementioned components has been replaced or the reader performance is unsatisfactory.

- a. Remove all power and control signals by disconnecting P1 and the power cord plug.
- b. Remove the Upper Cover Assembly (5) by loosening the two 6-32 round head screws (A), flat and lock washers at the rear of the front panel.
- c. Check the distance of the back of the sprocket to the front panel. This distance should be 0.862 inch from panel to back side of sprocket as shown in Figure 7-1. If this is not the case, perform Section 6.2.5, steps b, c, f and h.

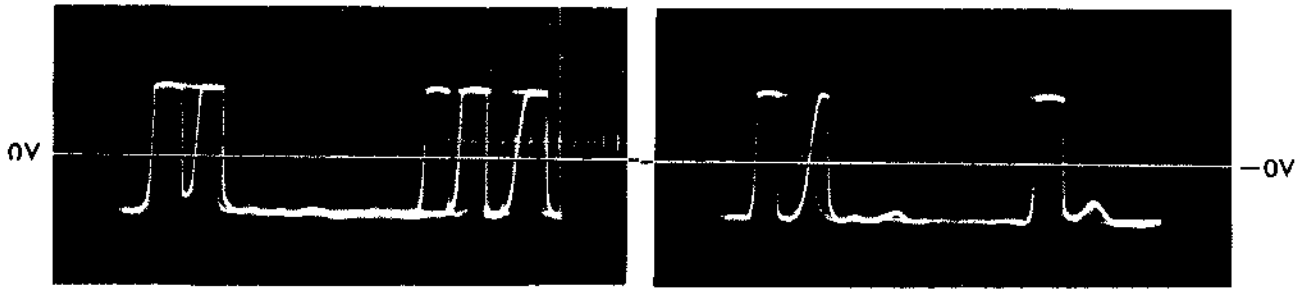

Two Examples of Misadjustment

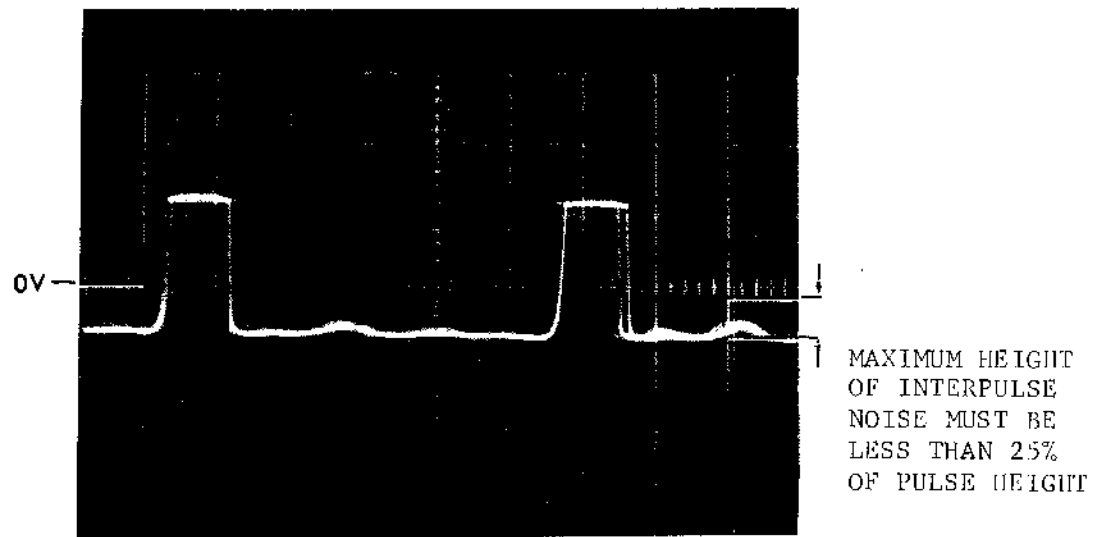

Upper Tape Guide and VMOT Properly Adjusted

MMC204A

Figure 5-4. Sprocket Cell Output Adjustment for Minimum Jitter

CAUTION

The following steps d, e, and f should be adjusted only if the 0.007 inch dimension described in step f is not correct.

- d. Loosen the four 8-32 socket head screws (B) which hold the Mechanism Assembly to the Front Panel at the rear of the panel and position the Mechanism Assembly so that it is centered in the black line on the panel and the bottom edge of the assembly is $1/32$ higher than the bottom edge of the panel. Tighten screws (B). This is a preliminary step; the critical dimension is given in step f.
- e. Remove screw (C) which holds the left side of the Lamp Assembly to the Readhead Assembly (RR-6300BAX and RR-6300BBX only). On model RR-6300BDX loosen nut T which holds the fiber optics to the front panel.
- f. Loosen the two 6-32 binder head screws (D) which hold the heat sink to the front panel. Adjust the heat sink so that the perimeter of the sprocket is no more than 0.007 inch from the tape surface on the readhead assembly. This setting is difficult to make exactly but in no case should the sprocket and readhead assembly touch nor should this gap exceed 0.007 inch max. See Figure 5-1. Tighten two screws (D). A sprocket height alignment tool (REMEX Part Number 110608) is available for this alignment. It may be necessary to again perform step d, and move the Mechanism Assembly slightly to achieve the setting just described. This is the critical setting - not the $1/32$ inch as described in step d.
- g. Make sure jack screw (E) is not protruding below the surface of the Upper Tape Guide.
- h. Insert three layers of 0.0037 mylar tape (approximately 0.011 inch) between the Upper Tape Guide (18) and Readhead Assembly (17).
- i. Referring to Figure 5-4A, use screws (H) and (N) to adjust the Upper Tape Guide so that there is maximum contact and parallelism from A to B. Use Screw (H) for lateral movement and screw (N) for rotational movement. From points B to C, the Upper Tape Guide will not show this parallelism.
- j. Remove the three layers of tape.
- k. Insert two layers of tape between points A and B only (Figure 5-4A).
- l. Screw down jack screw (E) which will raise the Upper Tape Guide slightly. Adjust screw (E) until there is free movement of two layers of tape.
- m. Insert a loop of tape known to have been punched to within ± 0.0025 inch in a 5 inch span (0.05% error).

CAUTION

Since repeatability of the feedhole placement in either direction is essential, a tape whose accumulated error in a 5-inch span is considerably better than ± 0.025 inches (as specified in Section 3.6) must be used in this procedure. Remex specifies a tape known to be punched to within ± 0.0025 inch in a 5-inch span ($\pm 0.05\%$ tolerance). Note that most REMEX punches are specified at ± 0.025 and hence these tapes should not be used for this adjustment unless known to be within the $\pm 0.05\%$ tolerance.

NOTE

Some users possess tapes which are outside the limits specified in ANSI X3.18 - 1967 (See Section 3.6). The rotational position of the step motor may be set up (step o) using these tapes rather than the type specified. In doing so, only these tapes should be used. The reader must be readjusted using the $\pm 0.05\%$ tapes whenever the tapes specified in Section 3.6 are to be used. The reader is set at the factory to handle tapes greater than 1% short registration if option 004 is shown on the serial tag. Refer to Section 1.6 and Table 1-3.

- n. With power on, the motor should be energized. Loosen the two set screws (G) which hold the motor to the heat sink.
- o. Rotate the motor so that the holes in the tape appear concentric with the light columns. Use care not to disturb the in or out setting of the sprocket mode in step b. Tighten the set screws.

WARNING

If the motor has been running for a period of time, it or the heat sink may be too hot to touch comfortably. Allow sufficient time for the motor and heat sink to cool before any adjustment or use a cloth or pair of gloves.

- p. Turn power off and connect P2 coming from the Readhead Assembly to a test circuit as shown in Figure 5-2. Connect a μ a meter in series with the 1K resistor. Turn power on.
- q. For Model RR-6300BDX/66X, loosen nut (T) which holds the fiber optic light source to the reader panel and rotate the fiber optics for maximum cell output. The reading on the ammeter should be $105 \pm 5\mu$ a minimum for the sprocket and 75μ a minimum for each of the data tracks. If necessary, increase the lamp voltage. Do not increase the lamp voltage above +4.7 Vdc. Tighten nut T.

On models RR-6300BAX and RR-6300BBX loosen the right screw (F) which holds the Lamp Assembly (DS1) to the Readhead Assembly and adjust the Lamp Assembly as described below:

- (1) Adjust the azimuth for alignment with the light columns. See Figure 5-3.
 - (2) Horizontally so that the light beam is centered over all nine columns.
 - (3) After these alignments, the reading on the ammeter should be 85μ a minimum for the sprocket track and 70μ a min. for each of the data tracks. If this is not, increase the reader lamp voltage up to a maximum of +5.4 Vdc. Refer to Section 5.6.
- r. Reconnect P2/J2 and reload the tape.
 - s. Apply AC power by plugging in the power cord and manually depressing the power switch S1. The lamp should come on.
 - t. Place a jumper across R22 on the Reader Card.
 - u. Place a digital voltmeter across TP6 (VMOT) and TP1 (OV) and adjust R7 for +34 VDC at TP6. Remove the jumper.
 - v. Connect a pulse counter to TP4 and TP1 (OV) on the Reader Card.

- w. Place the direction switch, S3, in the drive left position and measure the drive left speed in characters/sec. with the pulse counter. Repeat step using the drive right position. If the lowest speed is more than 5% slower than the highest speed, loosen the two set screws (G) which hold the motor to the heat sink. Rotate the motor slightly so that the difference in the drive left and drive right speeds is less than 5%. Repeat steps v and w as required. The motor should be rotated only slightly so that the conditions in steps r and t are not disturbed. Also make sure the motor is kept tight to the panel so that the distance of the sprocket pins to the front panel as described in step c is not disturbed. Tighten set screws (G). When tightening set screws (G), the torque should not be greater than 5 nor less than 3 inch pounds. Some later model units use a heat sink with a single screw (S). Tighten screw (S) until heat sink is secured about the motor.

NOTE

The importance of step w is not a specific interest in matching speeds, but rather that balancing the speeds insures proper placement of the feedhole (via the sprocket) in relation to its aperture in the readhead. The 0.05% tape used virtually assures that there are no feedhole placement errors which are attributable to tape registration errors, but only to the position of the sprocket in relation to feedhole aperture in the readhead. Thus measuring and balancing the slow speed is only an accurate, electronic method of assuring that this relationship exists. When the speeds in the two directions are properly balanced, feedhole placement error will be minimal and independent of the direction of the tape, thereby increasing tape readability to a maximum.

- x. Connect a pulse generator to the \overline{DR} input, J1-16. Set the pulse generator for 200 pps.
- y. Connect an oscilloscope to the sprocket cell output at TP2 on the Reader Card and observe the jitter at the -0.3 VDC level (do not be concerned about the jitter at the $+0.6$ VDC level and the time jitter in the leading or trailing edges of the waveforms). Minimize the jitter by loosening the two set screws (R) which hold the collar to the motor shaft and move the collar in or out as required to obtain the least amount of jitter. See Figure 5-4. Cycle the reader between 20 and 300 characters and adjust for minimum jitter. Repeat steps x and y for the \overline{DL} input, J1-17.

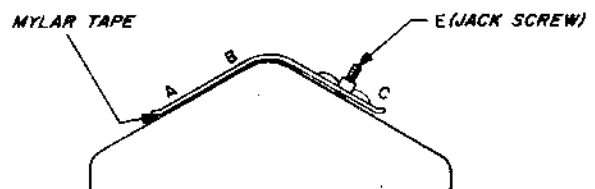
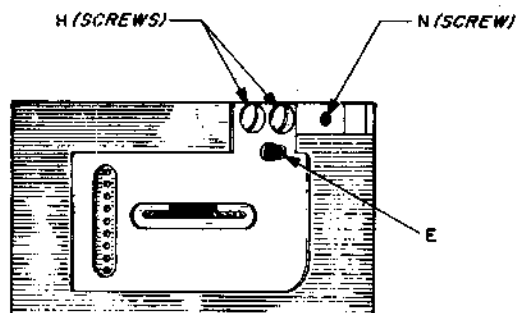

MMC 446

Figure 5-4A. Adjustment of the Upper Tape Guide

- z. Remove the pulse generator, oscilloscope and counter and perform the reverse of steps b and then a.

5.5 TAPE SPLICING

If tape breakage occurs, this break may result in damage to one, two, or possibly three characters. When splicing tape for this reader, great care should be used to ensure that the proper sprocket hole spacing be preserved. A lap splice should not be used; use only a butt type splice. To repair the tape without loss of characters, the process shown in Figure 5-5 is recommended and is accomplished as follows:

- a. Bring the tape ends together as shown in Figure 5-5A.
- b. Make a sketch of character(s) at the break (A-B-C) and five additional characters to the left (5-4-3-2-1) and five to the right (1-2-3-4-5) of the broken character(s) (A-B-C).
- c. Place the left end of the broken tape over a section of blank tape containing only feed holes so that at least eight or ten feed holes in each tape are aligned with one another as shown in Figure 5-5B. Cut the tapes at the third undamaged character to the left of damaged characters (A-B-C). Use care to insure that feed holes are aligned and make cut through the center of the holes in the third undamaged character. Characters 5, 4, and half of 3 should remain on the broken tape.
- d. Place the right end of the broken tape over the section of blank tape so that at least eight or ten feed holes are aligned with one another. Feed holes for one-half of 3, 2 and 1 on the blank tape cut in step c should be visible to the left of the broken tape end as shown in Figure 5-5C. Cut the tapes at the third undamaged character to the right of the damaged character. Be sure that feed holes are aligned and make the cut through the center of the holes in the third undamaged character.

NOTE

One half of character 3 and characters 4 and 5 should remain in the broken tape.

- e. Place tape ends and new section on a flat surface with feed holes forward as shown in Figure 5-5D (tape is bottom side up). Using silver Scotch® tape, No. 852, splice the new section and the old tape ends as shown. That portion of tape that secures the old tape ends must cover the first two and a half characters (one-half of 3, 4, and 5) on the old tape ends. The edges of the tape should be between characters as shown. Use of 1/2-inch wide splicing tape is recommended as shown in Figure 5-5D.
- f. Repunch the characters recorded in step d.

Registered Trademark of 3M Company.

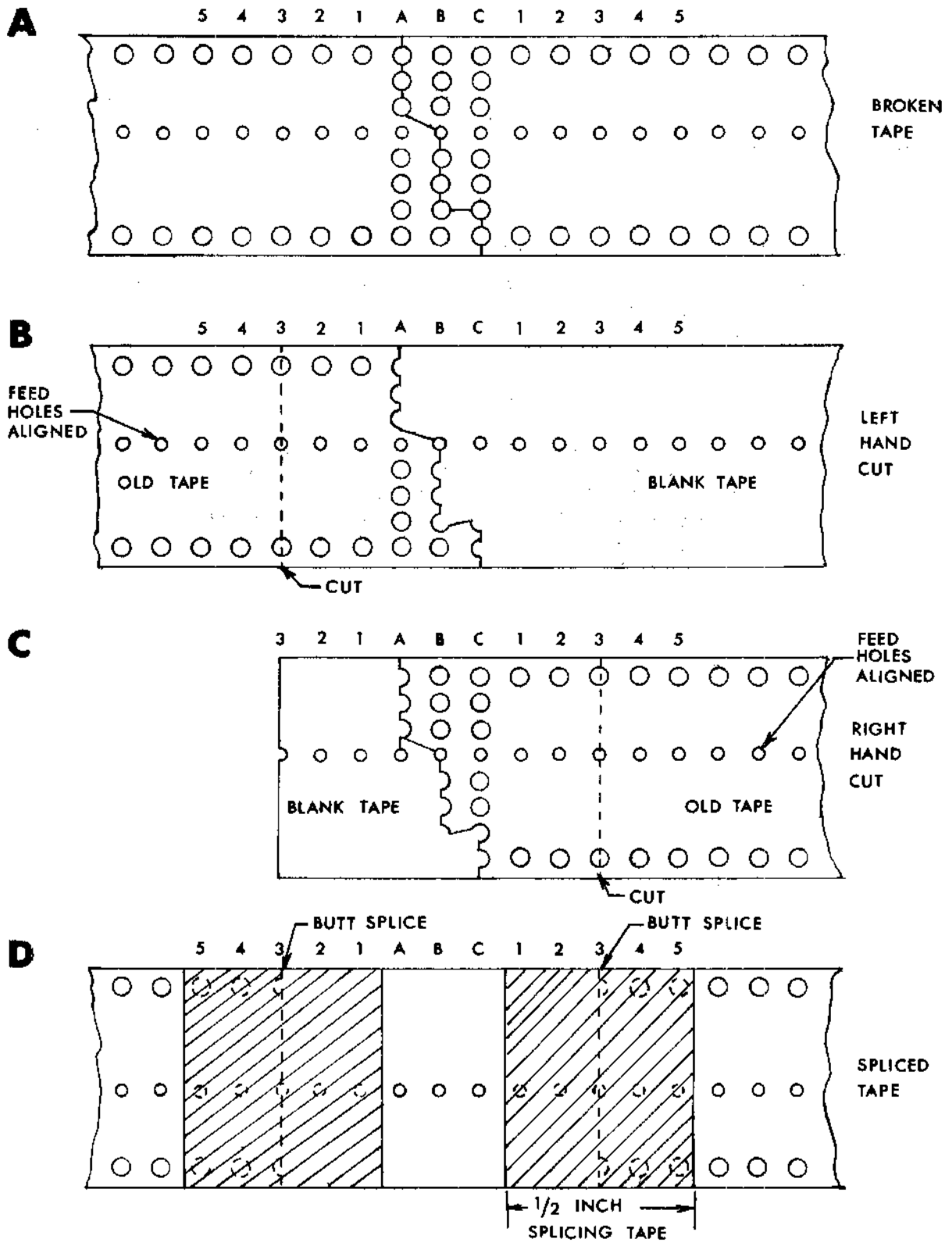

MMC 120A

Figure 5-5. Tape Splicing Procedure.

5.6 LAMP VOLTAGE ADJUSTMENT

The following procedure should be used when adjusting the reader lamp voltage: This procedure is applicable to those readers with the 110273-3E fabrication card or higher and model RR-6300BDX.

- a. Place the POWER switch in its ON position. The reader lamp should come on.
- b. Place a digital voltmeter across the lamp terminals.
- c. Adjust R27 until the meter reads +5.0 Vdc for model RR-6300BAX and RR-6300BBX. Adjust R27 for +4.3 Vdc for model RR-6300BDX.
- d. Remove the meter leads.

NOTE

The reader lamp may require further adjustment to increase the photocell outputs (step q (3) page 5-14). Do not increase the voltage above +5.4 Vdc for models RR-6300BAX and RR-6300BBX. Do not increase the voltage above +4.7 Vdc for model RR-6300BDX.

SECTION VI

PARTS REPLACEMENT

6.1 GENERAL

When any parts of the reader require replacement or disassembly, the procedures below should be followed closely. The warnings and cautions are included to protect personnel and equipment. Notes are included to assist persons unfamiliar with the equipment. Before attempting any procedure, all instructions for that disassembly should be read and understood.

6.2 READER PARTS REPLACEMENT

6.2.1 UPPER COVER ASSEMBLY

The Upper Cover Assembly is held to the front panel by two 6-32 round head screws (Item A, Figure 7-1). It should be replaced as a complete assembly which includes the switch actuator, cover and rollpin. When replacing the cover, check to make sure that the actuator properly operates S1.

6.2.2 READHEAD MECHANISM DISASSEMBLY

This procedure is required when replacing the Upper Tape Guide Assembly, the Readhead Assembly (consisting of the Readhead Housing, Photocell Assembly and Light Columns), or the Mechanism Assembly (consisting of the Door Mechanism Assembly, Tape Guide Cam, Actuator Assembly, Slide and Spring). For ease of assembly, it is recommended that the Readhead Assembly (part number 110459-1) and Mechanism Assembly (part number 110740-1) be replaced as a complete assembly. However, Figure 7-2 is provided for those desiring to order the subassemblies that comprise the Mechanism Assembly. Figure 7-1 should be folded out from Section 7 to follow during this procedure. The following procedure is recommended when replacing any of the above mentioned items:

- a. Remove all power and control signals by disconnecting P1 and the power cord.
- b. Remove the Upper Cover Assembly by performing Section 6.2.1.
- c. Disconnect P2 and P3 from the circuit card.
- d. Remove two 4-40 round head screws which hold the Lamp Assembly to the Readhead assembly.
- e. Loosen the four 8-32 socket head screws (Item B, Figure 7-1) which hold the Mechanism Assembly to the Front Panel at the rear of the front panel. The entire Readhead Mechanism Assembly consisting of the Tape Guide Assembly, the Readhead Assembly and the Mechanism Assembly is now free to be removed from the panel. On model RR-6300BDX, the grounding lug will have to be unsoldered before removing the readhead.

- f. Remove the two 4-40 binder head screws (Item H, Figure 7-1) which hold the Tape Guide Assembly to the Mechanism Assembly. If no further disassembly is required, install the new Upper Tape Guide Assembly and perform the reverse of steps f through c. Perform Section 5.4.
- g. From the underside of the Mechanism Assembly remove the two 4-40 round head screws (Item I, Figure 7-1) which hold the Readhead Assembly to the Mechanism Assembly. The Readhead Assembly and the Mechanism Assembly are now separated and can be replaced as individual assemblies. It is not recommended that Mechanism Assembly be disassembled beyond this level. However, Figure 7-2 is provided for reference only should the customer desire to do so.
- h. Reassembly is the reverse of steps g, f, e, d, and then c.
- i. Perform Section 5.4 or 5.4A.

6.2.3 READER CARD REPLACEMENT

The following procedure should be followed when removing the Reader Card:

- a. Remove all power and control signals by disconnecting P1 and the power cord.
- b. Disconnect P2, P3, P4, P5 and P6.
- c. Remove the six 4-40 binder head screws and nylon washers which hold the Reader Card to the Fan Mounting Chassis on the left, the P.C. Board Spacers in the middle and the Transformer Mounting Chassis on the right.
- d. Reassembly is the reverse of steps c and b.
- e. Perform Section 5.4 beginning with step g or Section 5.4A beginning with step s.

6.2.4 LAMP ASSEMBLY REPLACEMENT, RR-6300BAX AND RR-6300BBX ONLY

The following procedure should be followed when replacing the Lamp Assembly:

- a. Remove all power and control signals by disconnecting P1 and the power cord.
- b. Remove the Upper Cover Assembly by performing Section 6.2.1.
- c. Unsolder the red and brown wires at the two lamp terminals.
- d. Loosen the two 4-40 round head screws (items C and F, Figure 7-1) which hold the Lamp Assembly and Readhead Assembly to the Mechanism Assembly and remove the Lamp Assembly.
- e. Loosen the one screw which holds the bracket to the front panel (this bracket which holds the top of the Lamp Assembly to the Front Panel is not present on some earlier models; for those units disregard steps e, f, and g).
- f. Remove the Lamp Assembly and remove the other screw which holds the bracket to the Lamp Assembly.
- g. Install the bracket on the new Lamp Assembly.
- h. Reassembly is the reverse of steps e, d, and c.
- i. Perform Section 5.4, steps n and o or Section 5.4A, steps p and q.
- j. Perform the reverse of steps b and then a.

6.2.5 MOTOR AND/OR SPROCKET REPLACEMENT

The following procedure should be followed when replacing the motor and/or sprocket:

- a. Remove the Reader Card by performing Section 6.2.3, steps a through c.
- b. Remove the Mechanism Assembly by performing Section 6.2.2, steps a through e.
- c. Loosen the two set screws (Item J, Figure 7-1) which hold the sprocket to the motor shaft. If only the sprocket needs replacing proceed to step g.
- d. Loosen the two set screws (Item G, Figure 7-1) which hold the motor to the heat sink and back the motor out.
- e. Install the new motor by performing the reverse of step d. The motor should be up flush against the panel. Tighten set screws G.
- f. Install the sprocket wheel so that: (1) the distance from the panel to the back side of the sprocket is 0.862 inch; see Figure 7-1 (2) the 1/8 long set screw tightens on the flat of the motor shaft. Tighten the set screws J.
- g. Install the Reader Card by performing the reverse of step b.
- h. Install the Mechanism Assembly by performing the reverse of step a.
- i. Perform Section 5.4.

6.2.6 TRANSFORMER REPLACEMENT

The following procedure is recommended when replacing the transformer:

- a. Remove all power and control signals by disconnecting P1 and the power cord.
- b. Disconnect P5 and the transformer leads attached to TB1.
- c. Loosen the four 8-32 round head screws which hold the transformer to the transformer mounting chassis and remove the transformer.
- d. Install the new transformer by performing the reverse of steps c, b and then a. Refer to Table 6-1 for transformer wire connections.

Table 6-1. Transformer Wire Connections

TI Wire Color	TB1 Terminal	TI Wire Color	P5-Pin No.
White/Brown	TB1-5	Brown	P5-1
White	TB1-1	Red	P5-2
White/Red	TB1-6	Orange	P5-3
White/Orange	TB1-7	Yellow	P5-4
White/Yellow	TB1-8	Green	P5-5
White/Green	TB1-9	Blue	P5-6

6.2.7 SWITCH S1 REPLACEMENT

When replacing switch S1, it is recommended that the entire 110474-1 switch assembly be replaced and the following procedure be followed:

- a. Remove all power and control signals by disconnecting P1 and the power cord.
- b. Remove the Upper Cover Assembly by performing Section 6.2.1.
- c. Remove the knob (Item 23, Figure 7-1).
- d. Loosen the hex nut which holds switch shaft to the front panel. Remove the hex nut and lock washer.
- e. Remove the gray wire coming from S1 at TBI-4 and the white/black wire from TBI-6. These terminals slide on and off the terminal strip.
- f. Remove the switch assembly.
- g. Install the anti-rotation washer and flat washer on new switch assembly.
- h. Perform the reverse of steps f, e, d, c and then b.

6.2.8 SWITCHES S2 and S3 REPLACEMENT

The following procedure is recommended when replacing either S2 or S3.

- a. Remove all power and control signals by disconnecting P1 and the power cord.
- b. Remove the two 4-40 round head screws (Item L, Figure 7-1) which holds Lower Cover Frame to the Mounting Block Assembly and drop the Lower Cover Frame.
- c. If the Direction Switch, S3, is to be replaced, unsolder the following wires: Orange at S3-1, Yellow at S3-2 and green at S3-3. If the LOAD switch, S2, is to be replaced proceed to step f.
- d. Snap out the old switch S3.
- e. Replacement is the reverse of steps d, c, b and then a.
- f. If the LOAD switch, S2, is to be replaced, loosen the two 2-56 screws, (Item M, Figure 7-1) washers, and hex nuts which hold S2 to the Mounting Block Assembly.
- g. Unsolder the following wires: Blue at S2-C, and violet at S2-NC.
- h. Replacement of S2 is the reverse of steps g, f, b and then a.

6.2.9. LAMP REPLACEMENT, RR-6300BDX ONLY

- a. Remove all power and control signals by disconnecting P1 and the power cord.
- b. Slide the terminals off the lamp.
- c. Unscrew the lamp from the sleeve.
- d. Replacement is the reverse of steps c, b and then a.

SECTION VII

PARTS LIST

7.1 GENERAL

Listed in Table 7-2 are the electronic and mechanical parts used in the RR-6300BAX and the RR-6300BBX. Unless specifically noted all items are applicable to both models. Table 7-3 lists the parts for the fanfolded tape tank options. Standard hardware items are not listed. Indented items are part of the assembly under which they are indented and the quantity of these items are per each assembly. Table 7-1 lists the recommended spare parts and the quantity column denotes the number recommended. Figures 7-1 through 7-3 illustrate the parts listed in Tables 7-2 and 7-3.

Reference designations refer to the parts illustrated in Figures 7-1 through 7-4 (circled number designations in Figure 7-1; letter designations in Figure 7-1 refer hardware items referenced in Sections 5 and 6). All electronic components are identified by letter-number combinations in the Reference Designation column and mechanical parts are identified by number. Reference designations contained in parenthesis are associated or function with the parenthetical item. These items are generally individual items and not part of an assembly but for reference are related back to the associated item. All items are available from Spares Order Desk, REMEX, 1733 Alton Street, Santa Ana, California, 92705.

Table 7-4 and Figure 7-4 contain the components used on the printed circuit card. Note that the card parts list is on the left, the photograph on the right and, if required, the schematic can be folded out from Section 8, all in view at once.

7.2 KIT OF PARTS

The kit of parts contains items used for installation and maintenance and is shipped with the unit. Refer to Table 1-1.

NOTE: WHEN ORDERING SPARE PARTS, CONTACT REMEX SPARES ORDER DESK AND REFERENCE COMPLETE MODEL AND SERIAL NUMBER OF UNIT. ALWAYS REFER TO ADDENDUM AT THE REAR OF THE MANUAL (IF APPLICABLE) FOR POSSIBLE PART NUMBER CHANGES.

Table 7-1. Recommended Spare Parts.

Description and Manufacturer's Part No.	REMEX Part No.	Quantity	Reference Designation
Fuse, 3 Amp, 100, 110, 125 VAC Operation Only, Bussman Type MDA	705710-126	1	F1
Fuse, 1 1/2 Amp, 220 or 240 VAC Operation Only, Bussman Type MDA	705710-138	1	F1
Lamp Assembly, RR-6300BAX and RR-6300BBX Only	110453-1	1	DS1
Lamp, 5V, Welch Allyn 999079-6 Model RR-6300BDX Only	715071-141	1	DS1
Printed Circuit Card Assembly, Reader, RR-6300BAX and RR-6300BBX Only	110271-1		
Printed Circuit Card Assembly, Reader, Model RR-6300BDX Only	112511-1	1	
Readhead Assembly	110459-1	1	
Regulator, 5V, LM309K	704520-109	1	A1
Switch Assembly	110474-1	1	S1
Switch, SPDT, Cherry E61-00K	715058-120	1	S2
Switch, Basic	①	1	S3
Transistor, MJ4035	704204-120	1	Q3

① See Change Information Notice, Page 7-6A/7-6B.

NOTE: WHEN ORDERING SPARE PARTS, CONTACT REMEX SPARES ORDER DESK AND REFERENCE COMPLETE MODEL AND SERIAL NUMBER OF UNIT. ALWAYS REFER TO ADDENDUM AT THE REAR OF THE MANUAL (IF APPLICABLE) FOR POSSIBLE PART NUMBER CHANGES.

Table 7-2. Parts List, RR-6300BAX, RR-6300BBX and RR-6300BDX.

Description and Manufacturer's Part No.	REMEX Part No.	Quantity	Reference Designation
Top Assembly (Models A and B only)	110450-1	1	Ref.
Top Assembly (Model D only)	112416-1	1	Ref.
The subassemblies for 110450-1 and 112416-1 are identical except as noted for Models A, B or D only.			
Chassis, Fan Mounting (Models A and B only)	110460-1	1	1
Chassis, Fan Mounting (Model D only)	111505-1	1	
Chassis Assembly, Transformer Mounting	110469-1	1	2
Capacitor, Dual 0.01/.01 μ f, 1400 VAC Ceramic Sprague 36C219	702127-103	1	C19A/B
Chassis	110461-1	1	3
① Connector, 115 VAC, 3 pin, Switchcraft LAC3GD	706500-284	1	J7
Connector, Molex 09-50-7061 (Green)	706510-222	1	P5
Contact, Molex 08-50-0103	706530-137	1	(P5)
Fuseholder, Littlefuse 342004	705750-100	1	(F1)
Fuse, 3 Amp, Slow Blow (100, 115 or 125 VAC Operation Only), Bussman Type MDA	705710-126	1	F1
Fuse, 1-1/2 Amp, Slow Blow (220 or 240 VAC Operation Only), Bussman Type MDA	705710-138	1	F1
Grommet, Heyman SR-6P-1	715020-117	1	(4)
Marking Strip, Kulka MS-411-10	715007-128	1	(TB1)
Power Cord, Belden 17408-S (Hardwired)	708000-027	1	4
① Power Cord, Corcom 80-1255 (Detachable)	708000-098	1	4
Switch Assembly	110474-1	1	S1
Terminal Block, Kulka 511-10-KT11-KT12	715010-140	1	TB1
Terminal Lug, AMP 42470-1	715005-125	12	(TB1)
Transformer, REMEX Specification	703010-139	1	T1
Cover Assembly, Upper (Models A and B Only)	110452-1	1	5
Cover Assembly, (Model D Only)	112406-1	1	5
Decal, Identification	716018-113	1	6
Decal, Patents Pending	108546	1	7
Decal, Warning Line Voltages	111934-1	1	8
Decal, Warning, Hazard	110884-1	1	
Decal, Caution Transformer Voltages	111933-2	1	
Deflector, Fan (Model D only)	111504-1	1	
Fan Assembly	110472-1	1	9
Front Panel Assembly (Models A and B Only)	110468-1	1	Ref.
Front Panel Assembly (Model D Only)	112417-1	1	Ref.
The subassemblies for 110468-1 and 112417-1 are identical except as noted for Models A and B or Model D Only.			
① Bracket, Light Source (Model A and B Only)	111078-1	1	(DS1)
Gasket, Welch Allyn 11200182 (Model D Only)	715018-104	1	9A
Heat Sink, Motor	110448-1	1	10
Insert, Color (Model D Only)	110441-3	1	
Lamp, 5 Volt, Welch Allyn 999079-6 (Model D Only)	715071-141	1	DS1

① Not present on earlier models.

NOTE: WHEN ORDERING SPARE PARTS, CONTACT REMEX SPARES ORDER DESK AND REFERENCE COMPLETE MODEL AND SERIAL NUMBER OF UNIT. ALWAYS REFER TO ADDENDUM AT THE REAR OF THE MANUAL (IF APPLICABLE) FOR POSSIBLE PART NUMBER CHANGES.

Table 7-2. Parts List, RR-6300BAX, RR-6300BBX and RR-6300BDX (Continued)

Description and Manufacturer's Part No.	REMEX Part No.	Quantity	Reference Designation
Front Panel Assembly (Continued)			
Light Source, Fiber Optics (Model D only)	112297-1	1	10A
Motor Assembly, Reader	110473-1	1	(M3)
② Collar	110866-1	1	
② Collar, Spring	110869-1	1	
Connector, Housing, Yellow Molex 09-50-7051	706510-221	1	P4
Contact, Connector, Female, Molex 08-50-0108	706530-138	5	(P4)
② Damper Assembly	110867-1	1	
② Faceplate	111386-1	1	
Motor, 28 Vdc, Stepper, Computer Devices 20R-08B	715075-176	1	
② Plate, Friction	110385-1	1	
② Spring, Lee LC-032D-1 (MW)	714090-136	1	
Panel Front (Models A and B only)	110466-3	1	11
Panel Front (Model D only)	112418-3	1	11
Readhead Mechanism Assembly (Models A and B only)	110462-1	1	
Readhead Mechanism Assembly (Model D only)	112424-1	1	
The subassemblies for 110462-1 and 112424-1 are identical except as noted for Models A and B or Model D only. See Figure 7-1 (Models A and B only) or Figure 7-1A (Model D only)			
Bezel, Black	③		
Clamp, Cable, Weckesser A-30	715040-139	1	
Connector, Housing, Orange, 8 pin Molex 09-50-7081	706510-223	1	P3
Contact, Connector, Female, Molex 08-50-0103	706530-137	7	(P3)
Frame, Lower Cover	③	1	13
Ground Plate Assembly (Model D only)	112423-1	1	13A
Insert Color (Models A and B only)	③	1	14
Lamp Assembly (Models A and B only)	110453-1	1	15
Mechanism Assembly	110740-1	1	16
The following parts and Figure 7-2 are listed for reference only. It is recommended that the Mechanism assembly be replaced as a complete assembly.			
Actuator Assembly	110769-1	1	
Cam, Tape Guide	110438-1	1	
Door Mechanism Assembly	110720-1	1	
① Ground Strap Assembly	110762-1	1	
Ring, Retainer, Truarc 5103-25	715025-148	1	

① Not present on earlier models.

② Earlier 110473-1 assemblies did not contain these components. See Sections 5.4 and 5.4A.

③ See Change Information Notice, Page 7-6A/7-6B, Item 1.

NOTE: WHEN ORDERING SPARE PARTS, CONTACT REMEX SPARES ORDER DESK AND REFERENCE COMPLETE MODEL AND SERIAL NUMBER OF UNIT. ALWAYS REFER TO ADDENDUM AT THE REAR OF THE MANUAL (IF APPLICABLE) FOR POSSIBLE PART NUMBER CHANGES.

Table 7-2. Parts List, RR-6300BAX, RR-6300BBX and RR-6300BDX (Continued)

Description and Manufacturer's Part No.	REMEX Part No.	Quantity	Reference Designation
Mechanism Assembly (Continued)			
Slide	110432-1	1	
Spring, Associate Spring E0094-014-0620M	714090-127	1	
② Readhead Assembly	110459-1	1	17
Except for the components listed below the entire 110459-1 assembly must be replaced as a complete assembly.			
Connector, Housing, Red; 12 pin Molex 09-50-7121	706510-224		P2
Contact, Connector, Female Molex 08-50-0108	706530-138	10	(P2)
Rocker Cap,	③	1	(S3)
Switch, SPDT, Cherry E61-00K	715058-120	1	S2
Switch	③	1	S3
Tape Guide, Fixed (Model D only)	112329-1	1	17A
② Tape Guide, Upper (Models A and B only)	110537-1	1	18
Tape Guide, Upper (Model D only)	112407-1	1	18
Sleeve (Model D only)	112319-1	1	(18A)
Sprocket, LaVeZZi A24A25F	716057-102	1	19
Grommet, Hartwell H559-3-1	713656-124	1	20
Guard, Rail (Models A and B only)	110464-1	1	21
Guard, Rail (Model D only)	110464-2	1	21
Heat Sink Assembly	110471-1	1	(A1, Q3)
Connector, Housing, Molex 09-50-7061, Blue	706510-225	1	P6
Contact, Connector, Molex 08-50-0103	706530-137	6	(P6)
Heat Sink, IERC EC02-0611B	715033-121	1	22
Regulator, 5V, National Semiconductor LK309K	704520-109	1	A1
Transistor, Motorola MJ4035	704204-120	1	Q3
Knob, Microswitch 8Z0083	715065-113	1	23
Plunger, Hartwell H323-3-4-1	713656-123	1	24
Printed Circuit Card Assembly, Reader, Models RR-6300BAX/661 and RR-6300BBX/661 Only. See Table 7-4 for assembly and Figure 7-4 for component location.	110271-1	1	25
Printed Circuit Card Assembly, Reader, Model RR-6300BDX/661 Only	112511-1	1	25
Shield, Terminal Block	110467-1	1	26
Spacer, P.C. Board	110470-1	1	27
① Tape Guide Assembly, RR-6300BA1 and BB1 only	110454-1	1	28
① Tape Guide Assembly, RR-6300BA2 and BB2 only	110454-2	1	28
① Tape Guide Assembly, RR-6300BA3 and BB3 only	110454-3	1	28
① Tape Guide Assembly, RR-6300BA4 and BB4 only	110454-4	1	28
① Tape Guide Assembly, RR-6300BA5 and BB5 only	110454-5	1	28
① Tape Guide Assembly, RR-6300BD1	112411-1	1	28
① Tape Guide Assembly, RR-6300BD2	112411-2	1	28
① Tape Guide Assembly, RR-6300BD3	112411-3	1	28
① Tape Guide Assembly, RR-6300BD4	112411-4	1	28
① Tape Guide Assembly, RR-6300BD5	112411-5	1	28

① See Figure 1-4 for tape types applicable to each model number.

② See Item 2, Change Information Notice, page 7-6A/7-6B.

③ See Item 1, Change Information Notice, page 7-6A/7-6B.

NOTE: WHEN ORDERING SPARE PARTS, CONTACT REMEX SPARES ORDER DESK AND REFERENCE COMPLETE MODEL AND SERIAL NUMBER OF UNIT. ALWAYS REFER TO ADDENDUM AT THE REAR OF THE MANUAL (IF APPLICABLE) FOR POSSIBLE PART NUMBER CHANGES.

Table 7-3. Fanfold Tank Option Assembly

Description and Manufacturer's Part No.	REMEX Part No.	Quantity	Reference Designation
Top Assembly	110455-1	1	
Block, Filler	111632-1	1	
Frame, Lower Cover	110440-2	1	
Insert, Color	110441-2	1	
Panel, Fanfold Addition	110444-3	1	
Plate, Back, Left	110446-1	1	
Plate, Back, Right	110446-2	1	
Tank, Fanfold, Left	110445-1	1	
Tank, Fanfold, Right	110445-2	1	
Deflector, Tape	110777-1	2	
 <u>Table 7-3A Tape Spindle Option</u>			
Tape Spindle Option (used on -006 Option only; see Table 1-3).	111444-1	1	
Block	109809-1	1	
Plate, Access	109810-1	1	
Shaft	102815	1	
Standoff	715030-177	2	

NOTE: WHEN ORDERING SPARE PARTS, CONTACT REMEX SPARES ORDER DESK AND REFERENCE COMPLETE MODEL AND SERIAL NUMBER OF UNIT. ALWAYS REFER TO ADDENDUM AT THE REAR OF THE MANUAL (IF APPLICABLE) FOR POSSIBLE PART NUMBER CHANGES.

CHANGE INFORMATION PAGE

Description and Manufacturer's Part No.	REMEX Part No.	Quantity	Reference Designation
<p>1. Switch S3, the frame and the color insert on the readhead mechanism are identified as follows:</p> <p>A. If the switch mounting holes in the lower cover frame on the readhead mechanism are: .730" x .662", the following items apply:</p> <p>Frame, Lower Cover</p> <p>Insert, Color</p> <p>① Switch, Complete Assembly, Cutler Hammer SC2JX/-96</p> <p>① Base Switch, Cutler Hammer SC2JX</p> <p>Bezel, Cutler Hammer -96</p> <p>① Due to vendor availability, S3 may have been changed from a momentary switch 715061-400 to a latching 715061-300. The complete assembly would then be 715061-306. Reorder 715061-400 if available.</p> <p>B. If the switch mounting hole in the lower cover frame on the readhead mechanism is .750" x .750", the following items apply: These components also apply to all RR-6300BDX models.</p> <p>Bezel, Black, C&K B7888-2</p> <p>Cap, Rocker, ◀ ▶, C&K 7922-1</p> <p>Frame, Lower Cover</p> <p>Insert, Color</p> <p>Switch, (ON)-OFF-(ON), C&K 5205</p> <p>2. On RR-6300BAX units only, when replacing a Readhead Assembly order 110459-1 which is interchangeable although the configurations appear slightly different. When replacing the 110740-1 Mechanism Assembly on the RR-6300BAX it is also necessary to order a 110459-1 Readhead Assembly 110537-2 due to configuration differences.</p>	<p>110440-1</p> <p>110441-1</p> <p>715061-406</p> <p>715061-400</p> <p>715061-006</p> <p>716063-201</p> <p>715063-319</p> <p>110440-3</p> <p>110441-3</p> <p>715063-104</p>	<p>1</p> <p>1</p> <p>1</p> <p>1</p> <p>1</p> <p>1</p> <p>1</p> <p>1</p> <p>1</p> <p>1</p> <p>1</p> <p>1</p>	<p>13</p> <p>14</p> <p>(S3)</p> <p>S3</p> <p>(S3)</p> <p>(S3)</p> <p>S3</p>

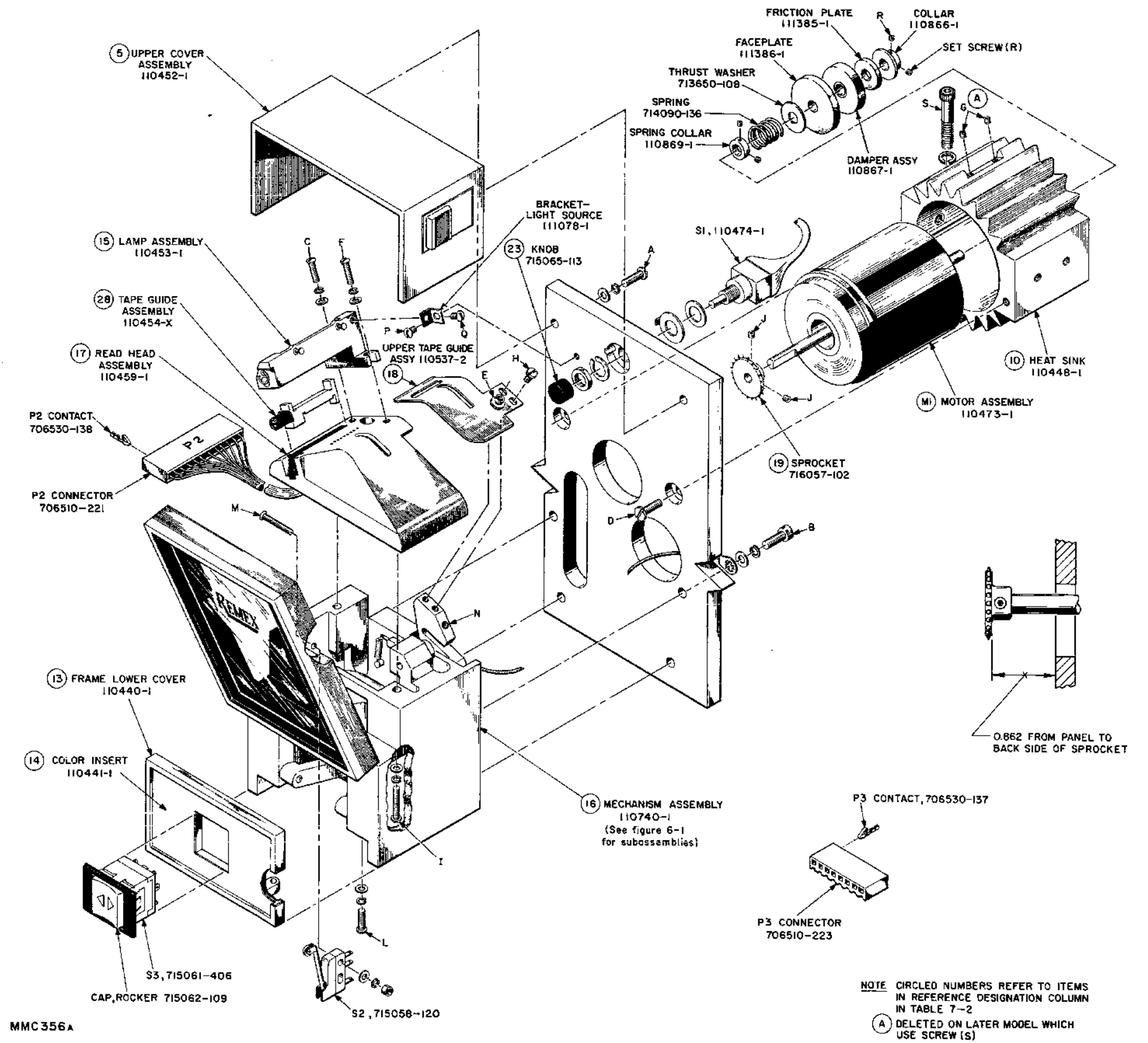

MMC 356A

Figure 7-1. Front Panel Assembly, Models A and B.

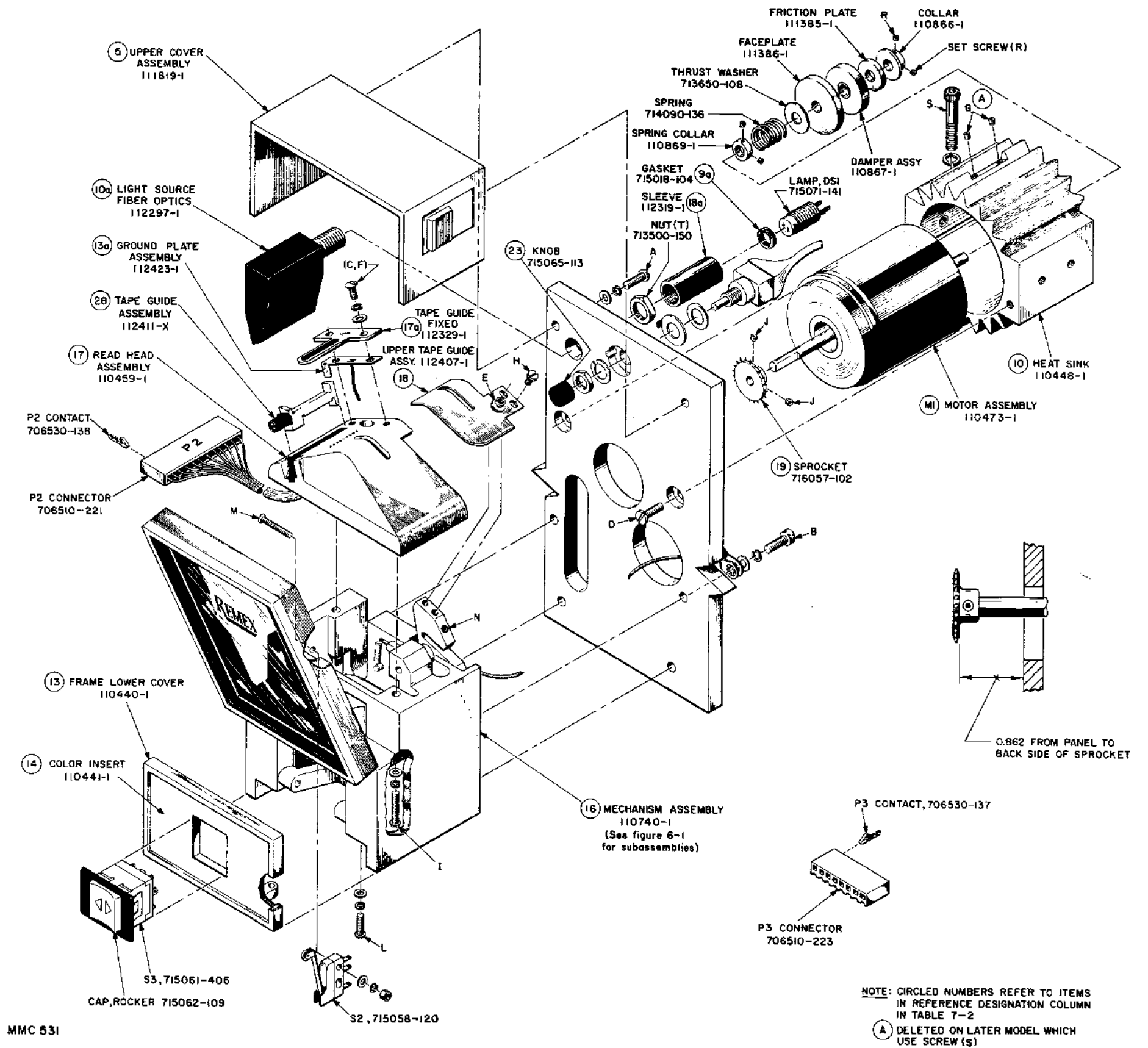
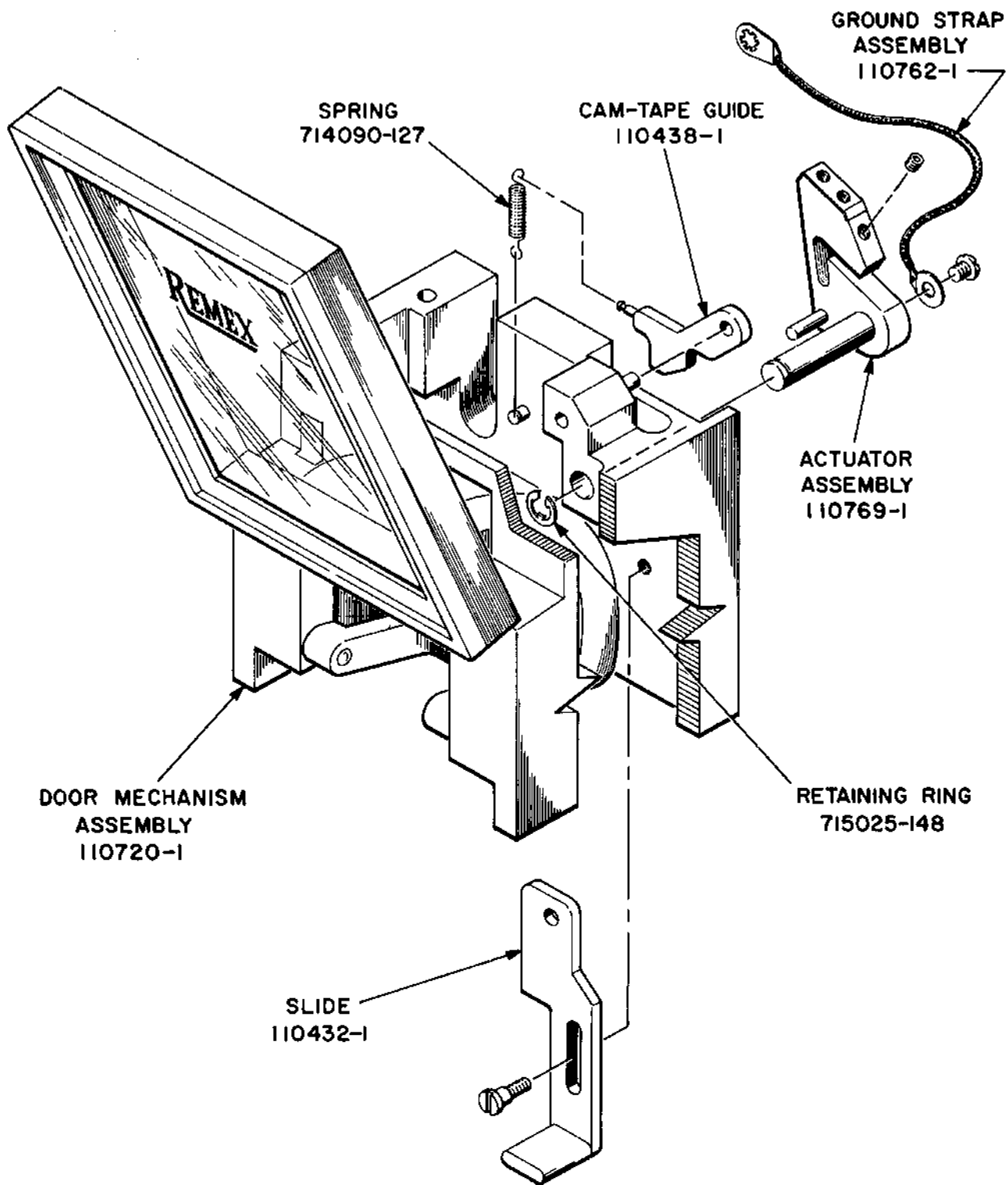

Figure 7-1A. Front Panel Assembly, Model D.



MMC 357

Figure 7-2. Mounting Block Assembly

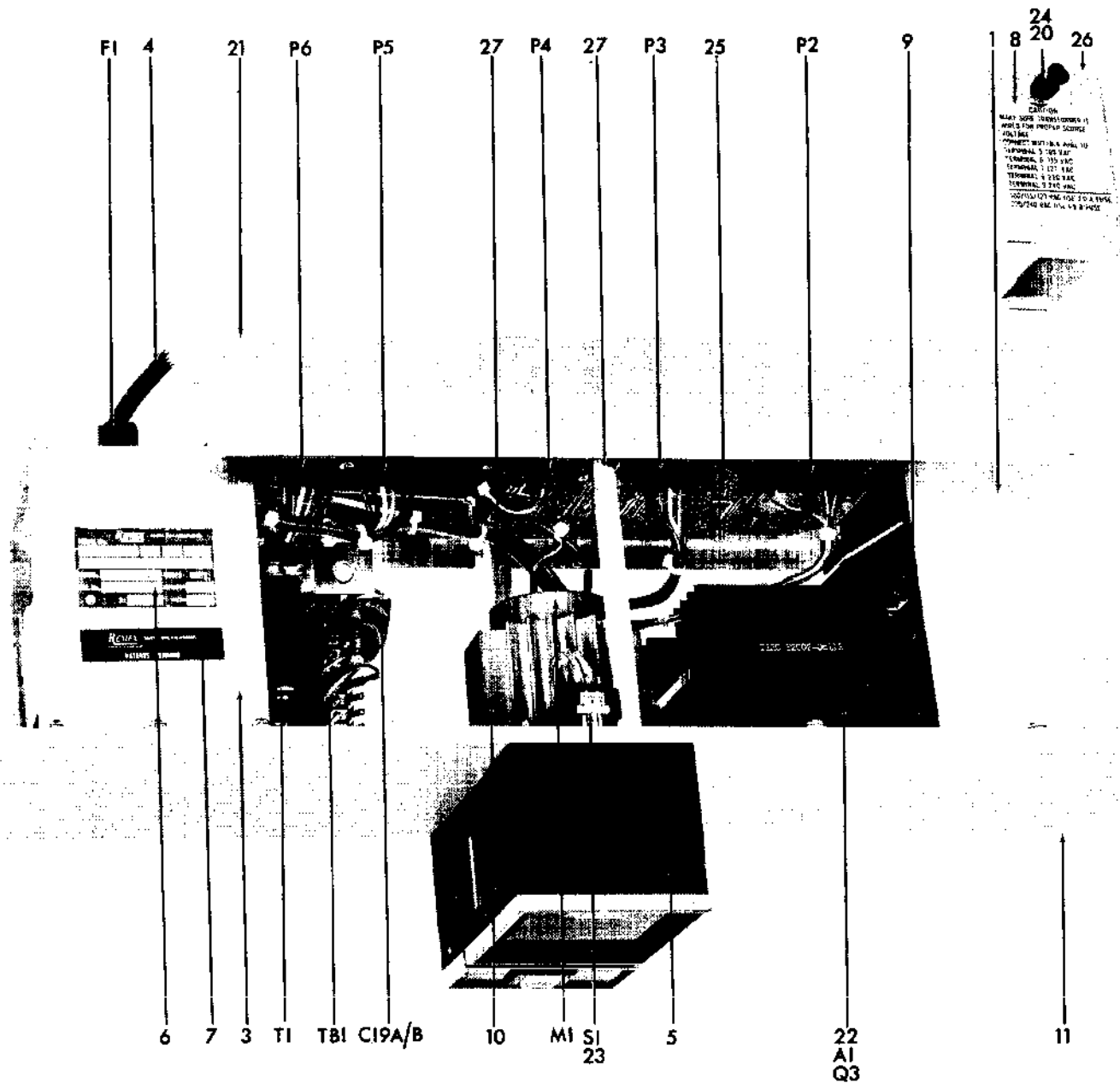

Figure 7-3. Top View of the Reader

NOTE: WHEN ORDERING SPARE PARTS, CONTACT REMEX SPARES ORDER DESK AND REFERENCE COMPLETE MODEL AND SERIAL NUMBER OF UNIT. ALWAYS REFER TO ADDENDUM AT THE REAR OF THE MANUAL (IF APPLICABLE) FOR POSSIBLE PART NUMBER CHANGES.

Table 7-4. Parts List, Reader Card 110271-1, -2 Assemblies
(Except as noted, all items apply to both assemblies)
Parts Lists are for current revision letter. See Page 7-12A/7-12B.

Description and Manufacturer's Part No.	REMEX Part No.	Quantity	Reference Designation
Capacitor, 3.5 μ f, 25V, Electrolytic, STM 61C25TA352	702349-101	1	C1
Capacitor, 0.1 μ f, 100V, Ceramic Disk, Sprague TG-P10	702121-104	2	C2, C2 ^①
Capacitor, 2.5 μ f, 75V, Electrolytic, Aluminum STM61C75HA252	702351-102	2	C3, C4
Capacitor, 1 μ f, 50V, Ceramic, Monolithic Sprague 71	702131-105	1	C5
Capacitor, 0.01 μ f, 100V, Metallized Mylar Electrocube 210B-1B103K	702191-103	3	C6, C11, C22
Capacitor, 220 μ f, 10V, Electrolytic Amperex ET	702620-227	1	C7
Capacitor, 0.01 μ f, 100V, Ceramic Disc, Erie 805-X5V103Z	702121-103	1	C8
Capacitor, 0.001 μ f, 200V, Ceramic, Type CK05	702128-102	1	C9
Capacitor, 100 pf, 200V, Ceramic Type CK05	702128-101	2	C10, C15
Capacitor, 0.15 μ f, 100V, Metallized Mylar Electrocube 217A1B154K	702181-154	1	C12
Capacitor, 1 μ f, 100V, Metallized Mylar IMB XP7B105X	702181-105	2	C13, C14
Capacitor, 1 μ f, 25V, Ceramic, Monolithic Sprague 5C	702130-105	3	C16-C18
Capacitor, 0.015 μ f, 100V, Metallized Mylar Electrocube 217A 1B153K	702181-153	1	C20*
Connector, Cannon DB-25PV	706500-239	1	J1
Connector, Molex 09-60-1121, Red	706501-122	1	J2
Connector, Molex 09-60-1081, Orange	706501-083	1	J3
Connector, Molex 09-60-1051, Yellow	706501-054	1	J4
Connector, Molex 09-60-1061, Green	706501-065	1	J5
Connector, Molex 09-60-1061, Blue	706501-066	1	J6
Connector, Jack, Cambion 3704-1-03	706515-129	6	(F2) (F3)(F4)
Diode, MR1032B	704005-117	2	CR1, CR2
Diode, 1N5059	704000-107	2	CR3, CR4
Diode, 1N4003	704005-137	10	CR5-7, 11-17
Diode, Zener, 6.2V, 1N4735A	704014-116	1	CR8
Diode, 1N276	704000-100	2	CR9, CR10
Fuse 4A, Bussman, Type GMW	705725-112	1	F2
Fuse, 250 ma, Bussman GMW	705725-102	1	F3
Fuse, 100 ma	705725-100	1	F4
Heat Sink, IERC TXBF-032-025-2B	715033-125	2	(CR1, CR2)
Heat Sink, IERC PA1-1B	715033-109	2	(Q1, Q2)
Heat Sink	109457	1	(Q4-Q7)
I.C. Package, SN7486N	704600-109	4	Z1, Z2, Z8, Z13
I.C. Package, SN7475N	704610-105	2	Z3, Z6
I.C. Package, SN74123N	704610-119	3, 2	Z7, Z11, Z20*
I.C. Package, SN7400N	704600-101	1	Z9
I.C. Package, SN7474N	704610-110	2	Z10, Z14

*C20, R26 and Z20 used on -2 assembly only. ① Not shown on Figure 7-4.

NOTE: WHEN ORDERING SPARE PARTS, CONTACT REMEX SPARES ORDER DESK AND REFERENCE COMPLETE MODEL AND SERIAL NUMBER OF UNIT. ALWAYS REFER TO ADDENDUM AT THE REAR OF THE MANUAL (IF APPLICABLE) FOR POSSIBLE PART NUMBER CHANGES.

Table 7-4. Parts List, Reader Card 110271-1, -2 Assemblies (Continued)

Description and Manufacturer's Part No.	REMEX Part No.	Quantity	Reference Designation
I.C. Package, SN7408N	704600-114	1	Z12
I.C. Package, SN7416N	704600-113	1	Z15
Potentiometer, 2K, 1/2W, Spectrol 53-1-1	701659-202	1	R7
Potentiometer, 100 ohm, 1/2W,	701659-101	1	R27
R/C Package, Beckman 1899-4102-0	701950-004	2	Z4, Z5
R/C Package, Keldron KD406	701950-001	2	Z18, Z19
Resistor Package, Keldron KD404A-472	701900-004	2	Z16, Z17
Resistor, 1/2 Ω , 3W, $\pm 5\%$	701015-R50	1	R1,
Resistor, 1/2 Ω , 10W, $\pm 5\%$	701017-R50	1	R2
Resistor, 2.2K, 2W, $\pm 5\%$	701014-222	1	R3
Resistor, 47 Ω , 1/4 W, $\pm 5\%$	701003-470	1	R4
Resistor, 820 Ω , 3W, $\pm 5\%$	701015-821	1	R5
Resistor, 1.5K, 1/4W, $\pm 5\%$	701003-152	2	R6, R25
Resistor, 470 Ω , 1/4W, $\pm 5\%$	701003-471	1	R8
Resistor, 22 Ω , 1/4 W, $\pm 5\%$	701003-220	4	R9-R11, R31
Resistor, 10K, 1/4W, $\pm 5\%$	701003-103	3	R12, R22, R30
Resistor, 22K, 1/4W, $\pm 5\%$	701003-223	1	R13
Resistor, 30K, 1/4W, $\pm 5\%$	701003-303	1	R14
Resistor, 1K, 1/4W, $\pm 5\%$	701003-102	2	R15, R23
Resistor, 47K, 1/4W, $\pm 5\%$	701003-473	1	R16
Resistor, 330 Ω , 1/4 W, $\pm 5\%$	701003-331	4	R17-R20, R28
Resistor, 100K, 1/4W, $\pm 5\%$	701003-104	1	R21
Resistor, 220 Ω , 1/4 W, $\pm 5\%$	701003-333	1	R24
Resistor, 3.3K, 1/4W, $\pm 5\%$	701003-333	1	R26*
Resistor, 0.75 Ω , 3W	701015-R75	1	R29
Standoff, Cambion 350-7409-10-19	715030-199	2	(J1)
Terminal Test Point, Lerco 5025-B-1	715013-121	7	TP1-TP7
Transistor, Motorola 2N5194	704212-107	1	Q1
Transistor, Motorola MJE803	704204-109	1	Q2
Transistor, Motorola MJE1100	704204-115	4	Q4-Q7
Transistor, Motorola 2N5088	704203-119	9	Q8-Q16

* C20, R26 and Z20 used on -2 assembly only.

CHANGE INFORMATION NOTICE

Table 7-4 lists this part for the current 110271-1 and -2 circuit card assemblies (fabrication board 110273-3G) check fabrication board revision letter. The following is a list of changes for each new fabrication letter change.

1. From D to E
Added fuse F4, 100 ma, REMEX Part No. 705725-100.
Increased the quantity of Connector, Jack, to 6 to include F4.
Added R27, Variable Resistor, 100 Ω , 1/2 W, REMEX Part No. 701659-101.
Added R28, Resistor, 1K, 1/4W, REMEX Part No. 701003-102.
Added R29, Resistor, 0.75 Ω , 3W, REMEX Part No. 701015-R75
C2 was 1 μ f, 25V, REMEX Part No. 702130-105.
Deleted C22 which was 0.1 μ f, 100V, REMEX Part No. 702121-104.
Added CR15, Diode 1N4003, REMEX Part No. 704005-137.
2. From C to D
Z14 was as SN74107N, REMEX Part No. 704610-117
C22 added.
Fuse F3 added.
C8 was .0022 μ f, 200V, REMEX Part No. 702121-103.
R10 was 68 ohm, 1/4 W, \pm 5%.
3. From B to C
C21 added.
Add -2 assembly.
4. Schematic for 110273-3C is shown on pages 8-3/8-4 and 8-5/8-6.
Schematic for 110273-3D is shown on pages 8-5A/8-6A and 8-5B/8-6B.
Schematic for 110273-3E is shown on pages 8-5C/8-6C and 8-5D/8-6D.
Schematic for 110273-G is shown on pages 8-5E/8-6E and 8-5F/8-6F.
5. From E to F
No component changes.
6. From F to G
Added C22
Added R16, CR16
Changed R5 from 680 Ω , 2W, \pm 5%, REMEX Part No. 701014-681
Added R30
Changed R28 from 1K, 1/4W, REMEX Part No. 701003-102
Deleted - 2 Requirements.
7. From G to H
C7 was 47 μ f
8. From H to J
Added R31
9. From J to K
Added J7, Deleted power cord.

NOTE: WHEN ORDERING SPARE PARTS, CONTACT REMEX SPARES ORDER DESK AND REFERENCE COMPLETE MODEL AND SERIAL NUMBER OF UNIT. ALWAYS REFER TO ADDENDUM AT THE REAR OF THE MANUAL (IF APPLICABLE) FOR POSSIBLE PART NUMBER CHANGES.

Table 7-5. Parts List, Reader Card 112511-1 Assembly

Description and Manufacturer's Part No.	REMEX Part No.	Quantity	Reference Designation
Capacitor, 2.5K μ f, 25V, Electrolytic, Sprague TVA (43D)	702345-258	1	C1
Capacitor, 0.1 μ f, 100V, Ceramic Disk, Sprague TG-P10	702121-104	2	C2,C21
Capacitor, 2.0K μ f, 75V, Electrolytic, Aluminum Sprague TVA	702361-208	2	C3,C4
Capacitor, 1 μ f, 50V, Ceramic, Monolithic Sprague 71	702131-105	1	C5
Capacitor, 0.01 μ f, 100V, Metallized Mylar Electrocube 210B-1B103K	702191-103	3	C6, C11,C22
Capacitor, 220 μ f, 10V, Electrolytic Ampere ET	702620-227	1	C7
Capacitor, 0.01 μ f, 100V, Ceramic Disk, Erie Erie 805-X5V103Z	702121-103	1	C8
Capacitor, 0.001 μ f, 200V, Ceramic, Type CK05	702128-102	1	C9
Capacitor, 100 pf, 200V, Ceramic Type CK05	702128-101	2	C10,C15
Capacitor, 0.068 μ f, 100V, Metallized Mylar Electrocube 217A1B683K	702181-683	1	C12
Capacitor, 1 μ f, 100V, Metallized Mylar IMB XP7B105X	702181-105	2	C13,C14
Capacitor, 1 μ f, 25V, Ceramic, Monolithic Sprague 5C	702130-105	3	C16-C18
Capacitor, 0.010 μ f, 100V, Metallized Mylar Electrocube 217A 1B103K	702181-103	1	C20
Connector, Cannon DB-25PV	706500-239	1	J1
Connector, Molex 09-60-1121, Red	706501-122	1	J2
Connector, Molex 09-60-1081, Orange	706501-083	1	J3
Connector, Molex 09-60-1051, Yellow	706501-054	1	J4
Connector, Molex 09-60-1061, Green	706501-065	1	J5
Connector, Molex 09-60-1061, Blue	706501-066	1	J6
Connector, Jack, Cambion 3704-1-03	706515-129	6	(F2) (F3)(F4)
Diode, MR1032B	704005-117	2	CR1,CR2
Diode, 1N5059	704000-107	2	CR3,CR4
Diode, 1N4003	704005-137	10	CR5-7, 11-17
Diode, Zener, 6.2V, 1N4735A	704014-116	1	CR8
Diode, 1N276	704000-100	2	CR9,CR10
Fuse 4A, Bussman, Type GMW	705725-112	1	F2
Fuse, 250 ma, Bussman GMW	705725-102	1	F3
Fuse, 100 ma	705725-100	1	F4
Heat Sink, IERC TXBF-032-025-2B	715033-125	2	(CR1,CR2)
Heat Sink, IERC PA1-1B	715033-109	2	(Q1,Q2)
Heat Sink	109457	1	(Q4-Q7)
I.C. Package, SN7486N	704600-109	4	Z1,Z2,Z8,Z13
I.C. Package, SN7475N	704610-105	2	Z3,Z6
I.C. Package, SN74221N	704610-165	2	Z7,Z20
I.C. Package, SN7400N	704600-101	1	Z9
I.C. Package, SN7474N	704610-110	2	Z10,Z14
I.C. Package, SN74123N	704610-119	1	Z11

NOTE: WHEN ORDERING SPARE PARTS, CONTACT REMEX SPARES ORDER DESK AND REFERENCE COMPLETE MODEL AND SERIAL NUMBER OF UNIT. ALWAYS REFER TO ADDENDUM AT THE REAR OF THE MANUAL (IF APPLICABLE) FOR POSSIBLE PART NUMBER CHANGES.

Table 7-5. Parts List, Reader Card 112511-1 Assembly (Continued)

Description and Manufacturer's Part No.	REMEX Part No.	Quantity	Reference Designation
I.C. Package, SN7408N	704600-114	1	Z12
I.C. Package, SN7416N	704600-113	1	Z15
Potentiometer, 2K, 1/2W, Spectrol 53-1-1	701659-202	1	R7
Potentiometer, 100 ohm, 1/2W,	701659-101	1	R27
R/C Package, Beckman 1899-4102-0	701950-004	2	Z4, Z5
R/C Package, Keldron KD406	701950-001	2	Z18, Z19
Resistor Package, Keldron KD404A-472	701900-004	2	Z16, Z17
Resistor, 1/2 Ω , 3W, \pm 5%	701015-R50	2	R1, R29
Resistor, 1/2 Ω , 10W, \pm 5%	701017-R50	1	R2
Resistor, 2.2K, 2W, \pm 5%	701014-222	1	R3
Resistor, 47 Ω , 1/4W, \pm 5%	701003-470	1	R4
Resistor, 820 Ω , 3W, \pm 5%	701015-821	1	R5
Resistor, 1.5K, 1/4W, \pm 5%	701003-152	2	R6, R25
Resistor, 470 Ω , 1/4W, \pm 5%	701003-471	1	R8
Resistor, 22 Ω , 1/4W, \pm 5%	701003-220	4	R9, R10, R11, R31
Resistor, 8.2K, 1/4W, \pm 5%	701003-822	1	R12
Resistor, 27K, 1/4W, \pm 5%	701003-273	2	R13, R14
Resistor, 1K, 1/4W, \pm 5%	701003-102	2	R15, R23
Resistor, 47K, 1/4W, \pm 5%	701003-473	1	R16
Resistor, 330 Ω , 1/4W, \pm 5%	701003-331	4	R17-R20, R28
Resistor, 100K, 1/4W, \pm 5%	701003-104	1	R21
Resistor, 10K, 1/4W, \pm 5%	701003-103	2	R22, R30
Resistor, 220 Ω , 1/4W, \pm 5%	701003-333	1	R24
Resistor, 20K, 1/4W, \pm 5%	701003-273	1	R26
Resistor, 20 Ω , 5W, \pm 5%	701016-200	1	R32
Standoff, Cambion 350-7409-10-19	715030-199	2	(J1)
Terminal Test Point, Lerco 5025-B-1	715013-121	7	TP1-TP7
Transistor, Motorola 2N5194	704212-107	1	Q1
Transistor, Motorola MJE803	704204-109	1	Q2
Transistor, Motorola MJE1100	704204-115	4	Q4-Q7
Transistor, Motorola 2N5088	704203-119	9	Q8-Q16

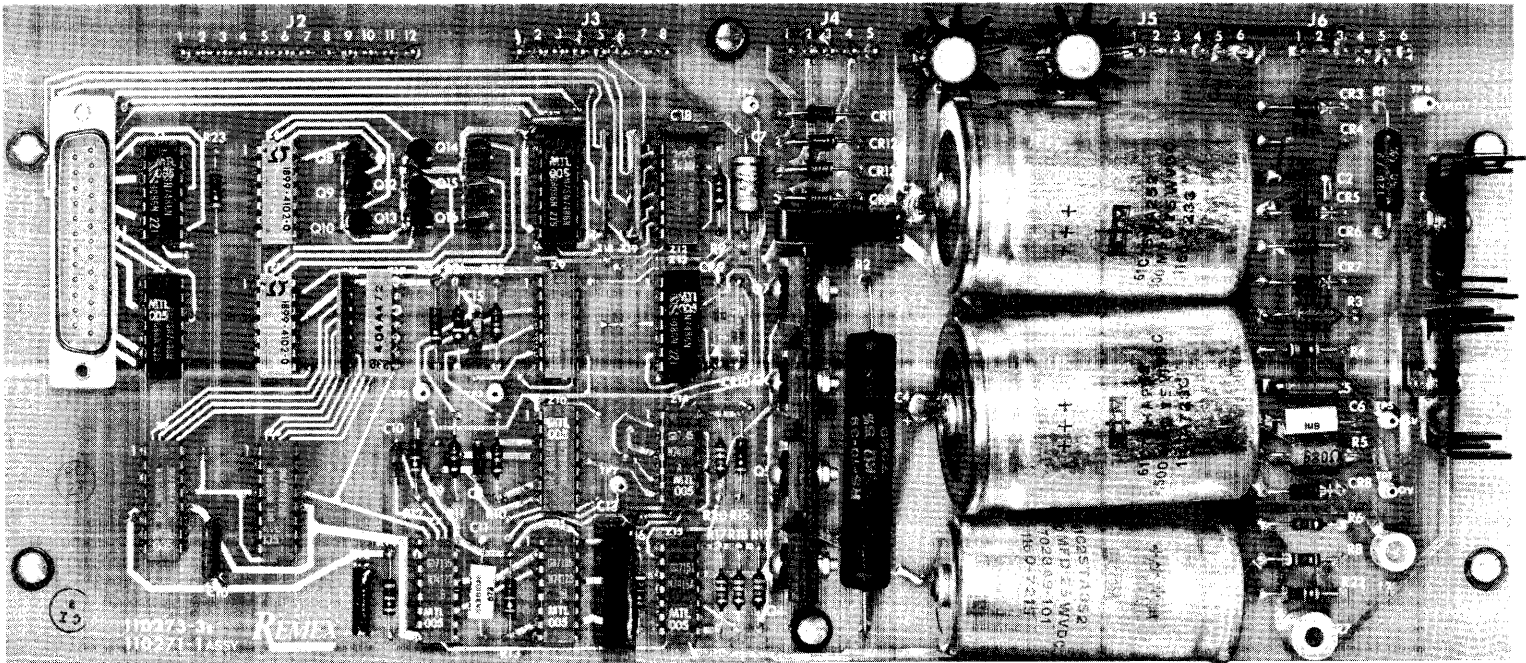

Figure 7-4. Printed Circuit Card Assembly 110271-1,
Fabrication Board 110273-3B

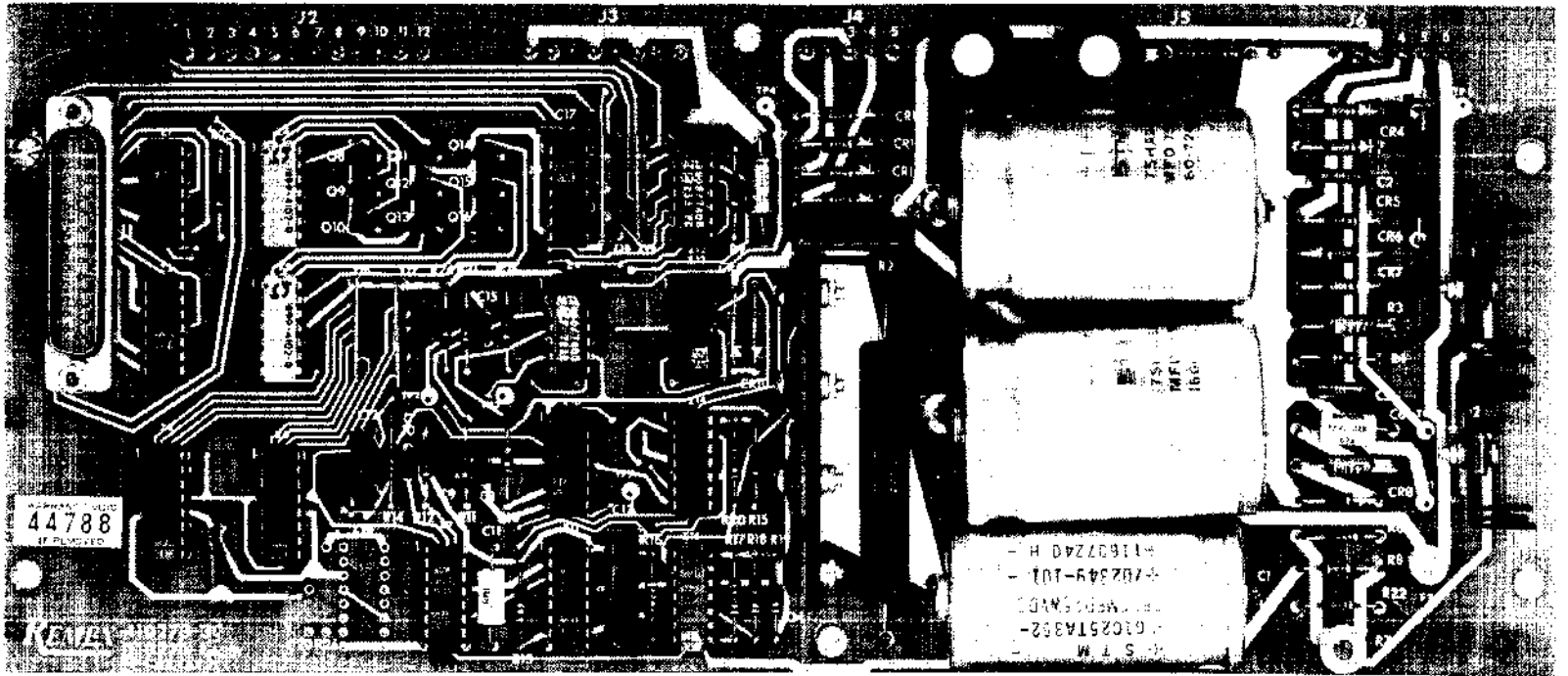

Figure 7-4A. Printed Circuit Card Assembly 110271-1,
Fabrication Board 110273-3C

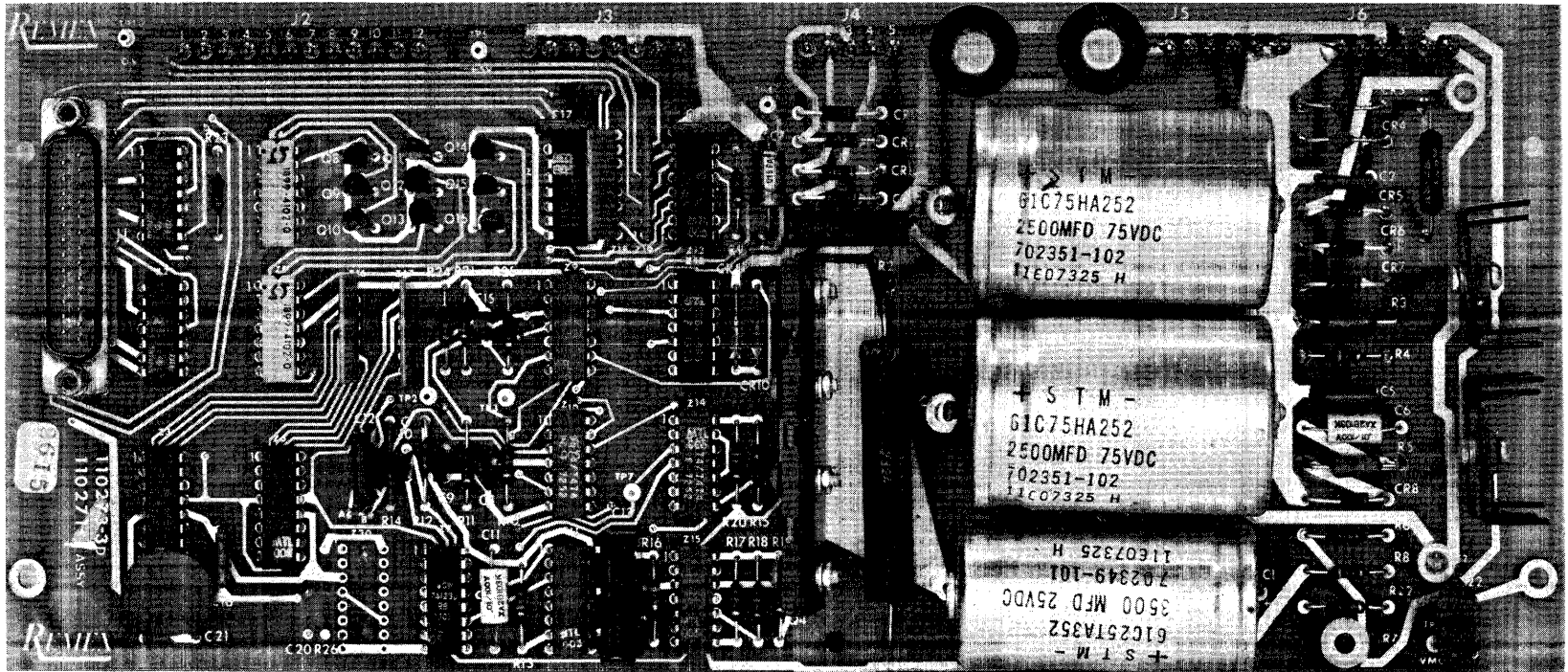

Figure 7-4B. Printed Circuit Card Assembly 110271-1, Fabrication Board 110273-3D.

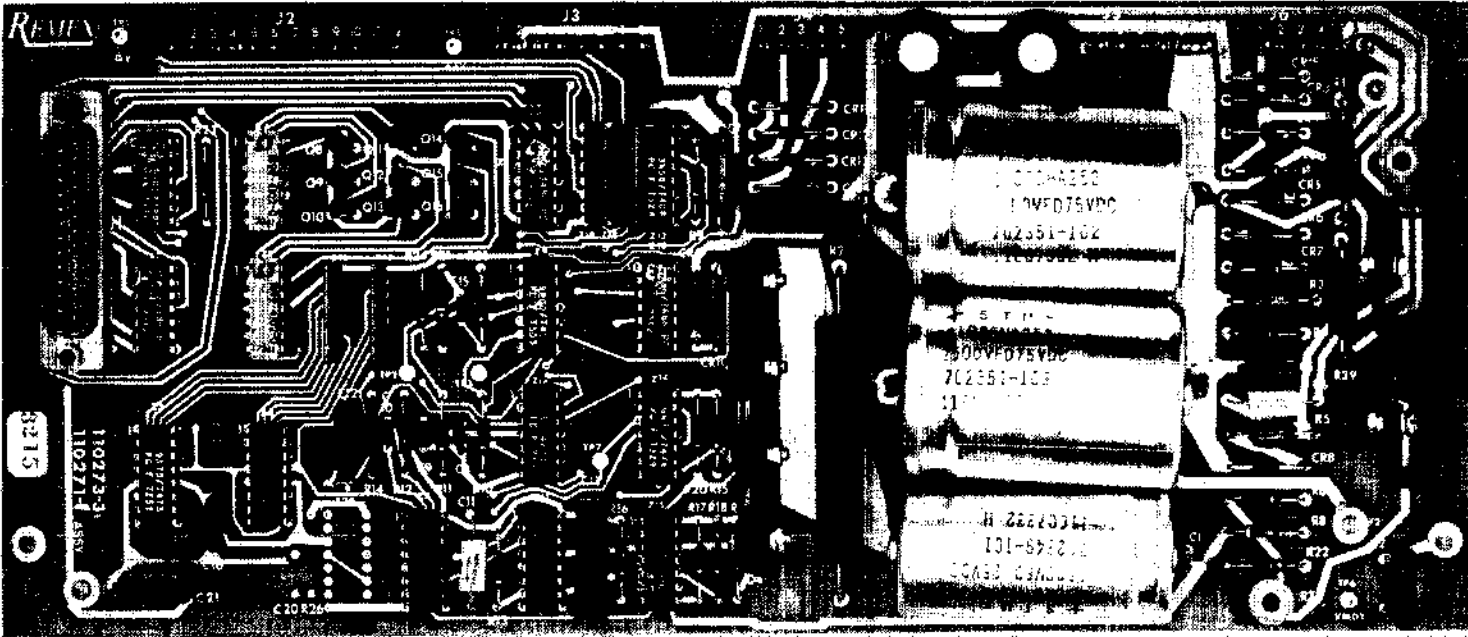

Figure 7-4C. Printed Circuit Card Assembly 110271-1,
Fabrication Board 110273-3E

SECTION VIII

SCHEMATIC DRAWINGS

8.1 GENERAL

Figures 8-1 through 8-3 contain the schematic and the pin connections for the IC Modules used in the reader. All IC Modules information has been reproduced with the permission of Texas Instruments except the Monostable 9602 which is reproduced with the permission of Motorola and LM300, LM307 and LM309 which are reproduced with the permission of National Semiconductor.

NOTE

Later schematics may contain terms using an asterisk (*). These terms have the same meaning as terms which are overscored (e.g. $\overline{DL} = DL^*$), i.e. 0V active, REMEX mode 6 logic.

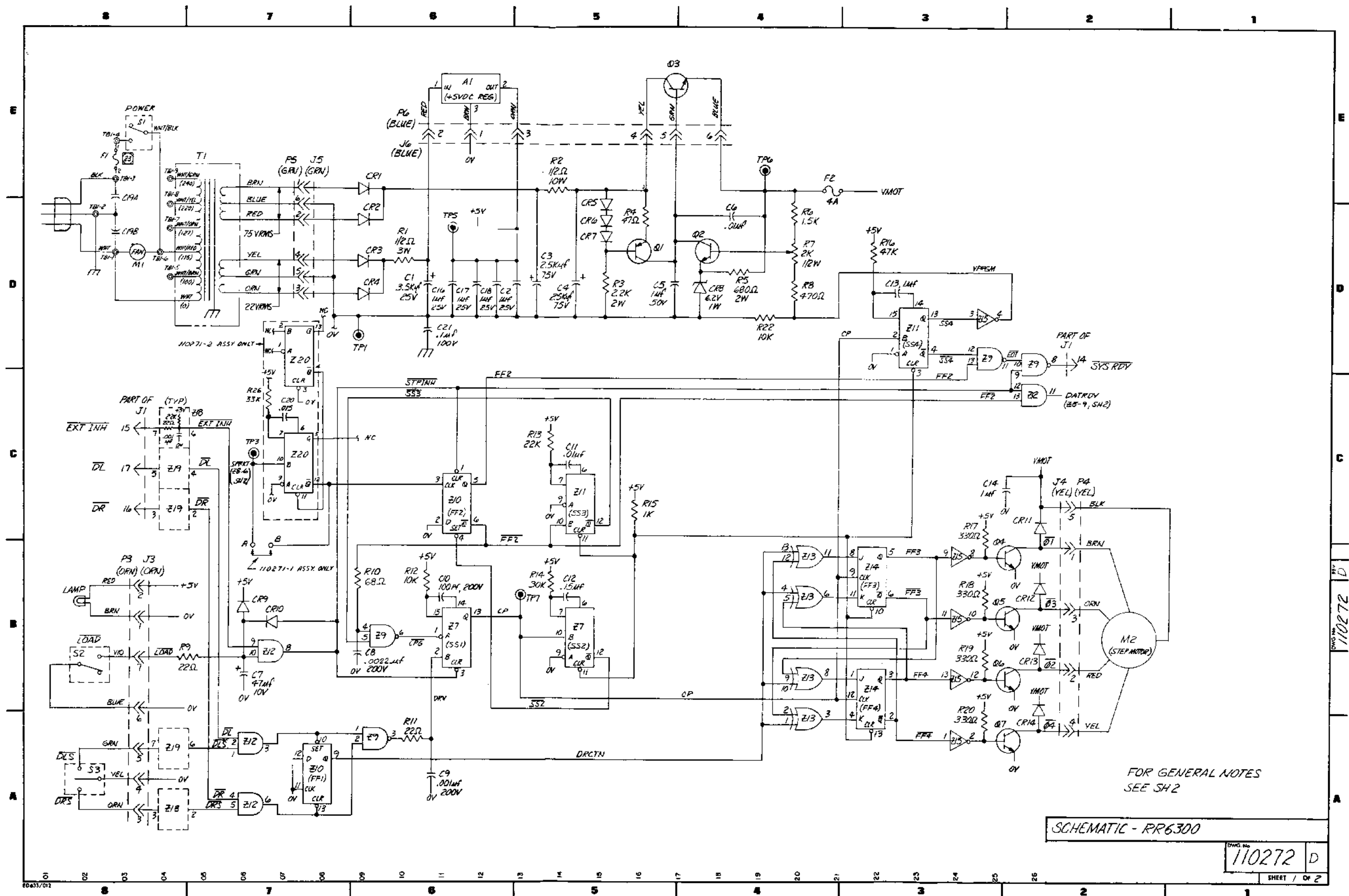

SCHMATIC - RR6300
 DWG No. 110272 D
 SHEET 1 OF 2

Figure 8-1. Schematic, RR-6300 BBX, Sheet 1 of 2, Card Fabrication 110273-1C. See page 7-12A/7-12B.

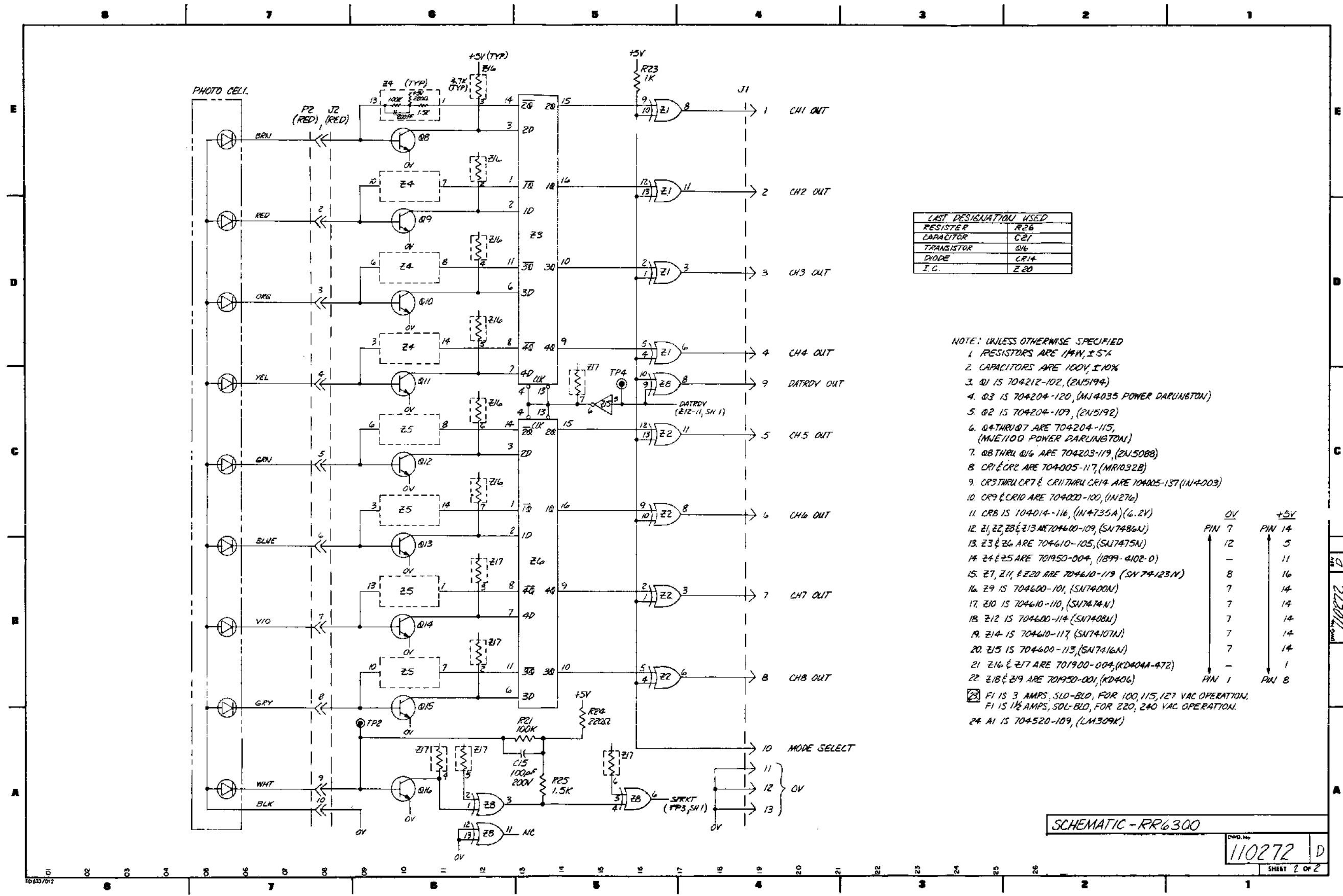

LAST DESIGNATION USED	
RESISTOR	R26
CAPACITOR	C21
TRANSISTOR	Q16
DIODE	CR14
I.C.	Z20

- NOTE: UNLESS OTHERWISE SPECIFIED
- RESISTORS ARE 1/4W, ±5%
 - CAPACITORS ARE 100V, ±10%
 - Q1 IS 704212-102, (2N5194)
 - Q3 IS 704204-120, (MJ4035 POWER DARLINGTON)
 - Q2 IS 704204-109, (2N5192)
 - Q4 THRU Q7 ARE 704204-115, (MJE1100 POWER DARLINGTON)
 - Q8 THRU Q16 ARE 704203-119, (2N5088)
 - CR1 & CR2 ARE 704005-117, (MR1032B)
 - CR3 THRU CR7 & CR11 THRU CR14 ARE 704005-137, (1N4003)
 - CR9 & CR10 ARE 704000-100, (1N276)
 - CR8 IS 704014-116, (1N4735A) (6.2V)
 - Z1, Z2, Z3 & Z13 ARE 704600-109, (SN7486N)
 - Z3 & Z6 ARE 704610-105, (SN7475N)
 - Z4 & Z5 ARE 701950-004, (1899-4102-0)
 - Z7, Z11, & Z20 ARE 704610-119, (SN74123N)
 - Z9 IS 704600-101, (SN7400N)
 - Z10 IS 704610-110, (SN7414N)
 - Z12 IS 704600-114, (SN7408N)
 - Z14 IS 704610-117, (SN74107N)
 - Z15 IS 704600-113, (SN7416N)
 - Z16 & Z17 ARE 701900-004, (KD404A-472)
 - Z18 & Z19 ARE 701950-001, (KD406)
 - F1 IS 3 AMPS, SLO-BLO, FOR 100, 115, 127 VAC OPERATION.
F1 IS 1 1/2 AMPS, SLO-BLO, FOR 220, 240 VAC OPERATION.
 - A1 IS 704520-109, (LM309K)

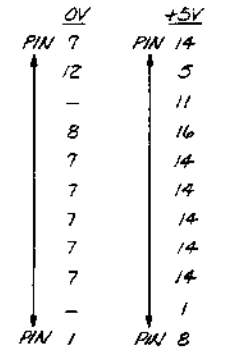

SCHEMATIC - RR6300
 DWG. NO. 110272 D
 SHEET 2 OF 2

Figure 8-1. Schematic, RR-6300 BBOX, Sheet 2 of 2, Card Fabrication 110273-1C. See page 7-12A/7-12B.

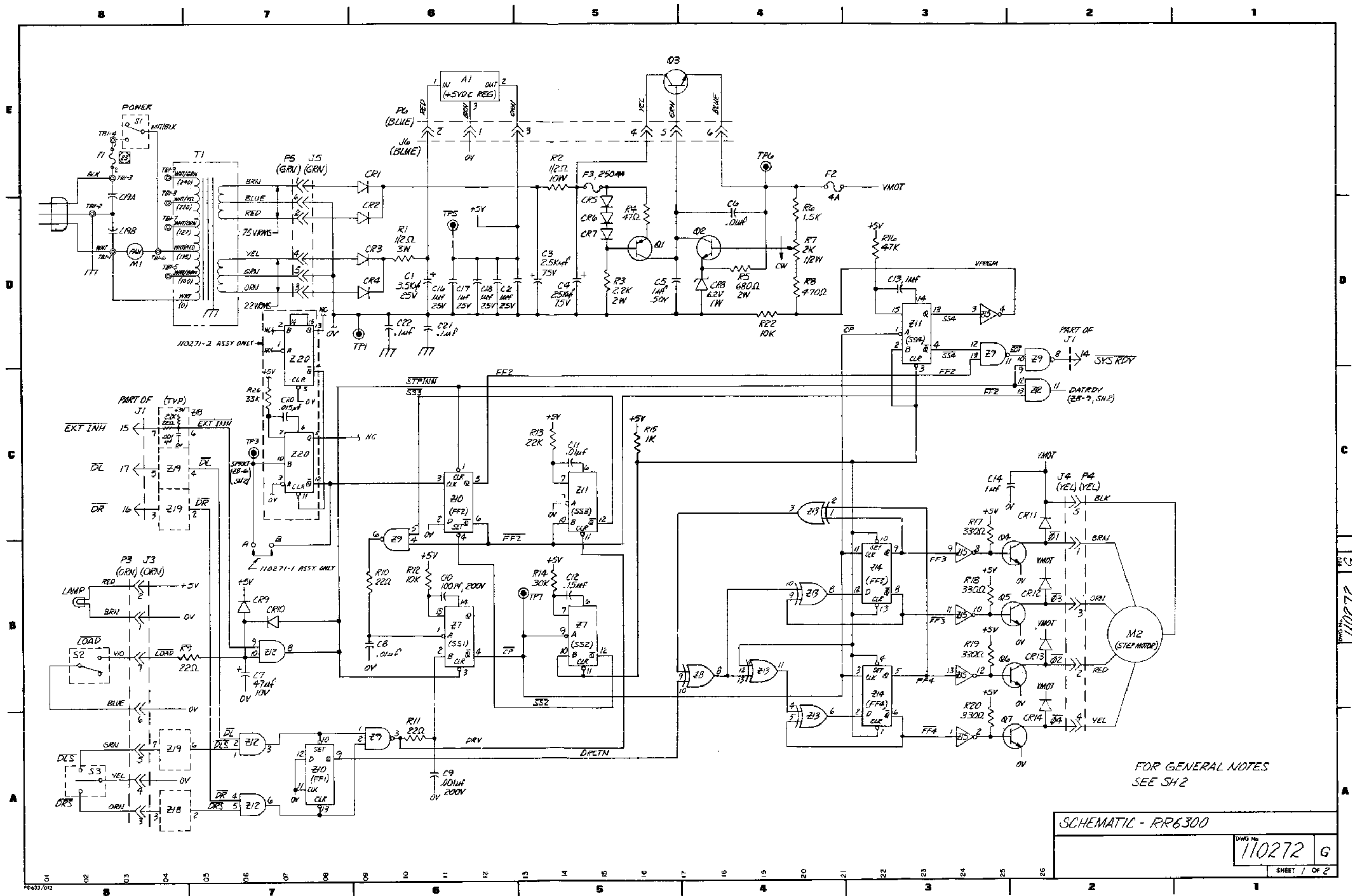

Figure 8-1A. Schematic, RR-6300 BBX, Sheet 1 of 2, Card Fabrication 110273-1D. See page 7-12A/7-12B.

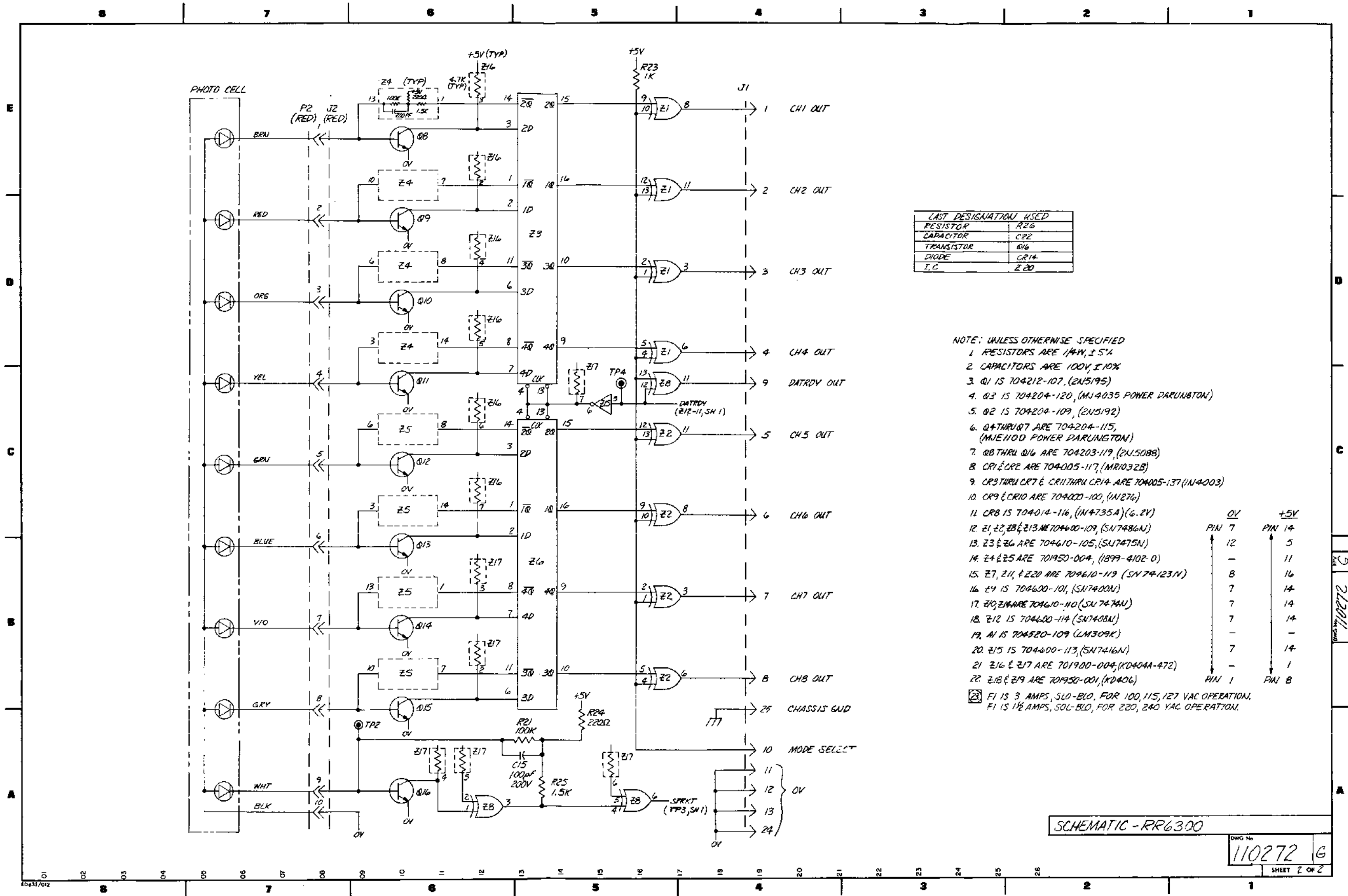

Figure 8-1. Schematic, RR-6300 BBOX, Sheet 2 of 2, Card Fabrication 110273-D. See page 7-12A/7-12B.

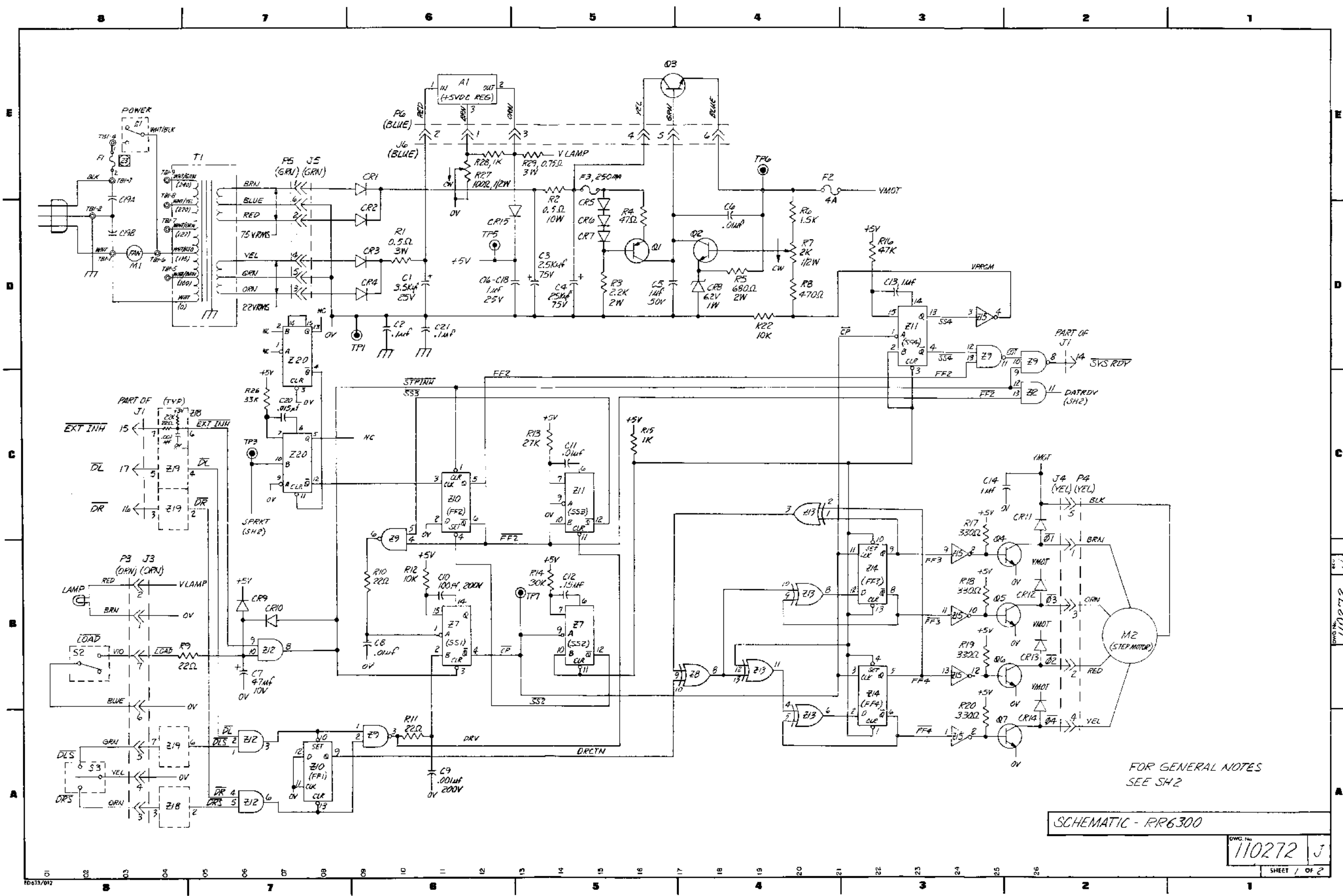
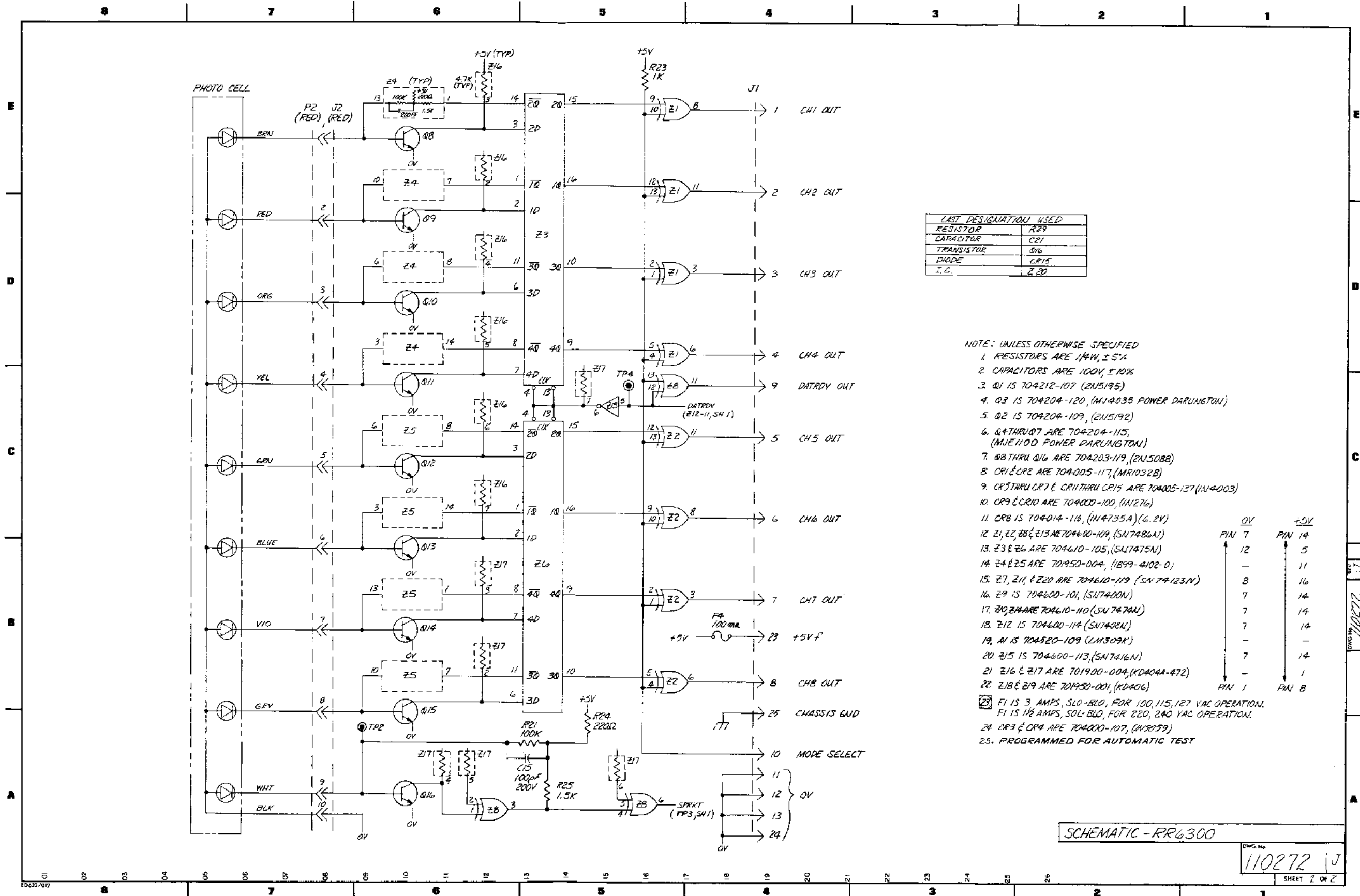
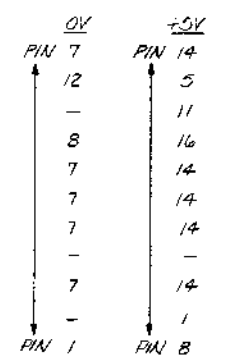

Figure 8-1B. Schematic, RR-6300BBX, Sheet 1 of 2, Card Fabrication 110273-E. See Page 7-12A/7-12B.



LAST DESIGNATION USED	
RESISTOR	Z29
CAPACITOR	C21
TRANSISTOR	Q16
DIODE	CR15
I.C.	Z20

- NOTE: UNLESS OTHERWISE SPECIFIED
- RESISTORS ARE 1/4W, ±5%
 - CAPACITORS ARE 100V, ±10%
 - Q1 IS 704212-107 (2N5195)
 - Q3 IS 704204-120 (MJ4035 POWER DARLINGTON)
 - Q2 IS 704204-109 (2N5192)
 - Q4 THRU Q7 ARE 704204-115 (MJ4100 POWER DARLINGTON)
 - Q8 THRU Q16 ARE 704203-119 (2N5088)
 - CR1 & CR2 ARE 704005-117 (MR1032B)
 - CR3 THRU CR7 & CR11 THRU CR15 ARE 704005-137 (1N4003)
 - CR9 & CR10 ARE 704000-100 (1N276)
 - CR8 IS 704014-116 (1N4735A) (6.2V)
 - Z1, Z2, Z8 & Z13 ARE 704600-109 (SN7486A)
 - Z3 & Z6 ARE 704610-105 (SN7475N)
 - Z4 & Z5 ARE 701950-004 (1B99-4102-0)
 - Z7, Z11 & Z20 ARE 704610-119 (SN74123N)
 - Z9 IS 704600-101 (SN7400N)
 - Z10, Z14 ARE 704610-110 (SN7474N)
 - Z12 IS 704600-114 (SN7408A)
 - Z18, Z19 ARE 701950-001 (K0406)
 - Z15 IS 704600-113 (SN7416N)
 - Z16 & Z17 ARE 701900-004 (K0404A-472)
 - Z18 & Z19 ARE 701950-001 (K0406)
 - Z1 IS 3 AMPS, SLO-BLO, FOR 100, 115, 127 VAC OPERATION.
Z1 IS 1/2 AMPS, SLO-BLO, FOR 220, 240 VAC OPERATION.
 - CR3 & CR4 ARE 704000-107 (1N5059)
 - PROGRAMMED FOR AUTOMATIC TEST



SCHEMATIC - RR-6300
 DWG. NO. 110272
 SHEET 2 OF 2

Figure 8-1B. Schematic, RR-6300BBX, Sheet 2 of 2, Card Fabrication 110273-E. See Page 7-12A/7-12B.

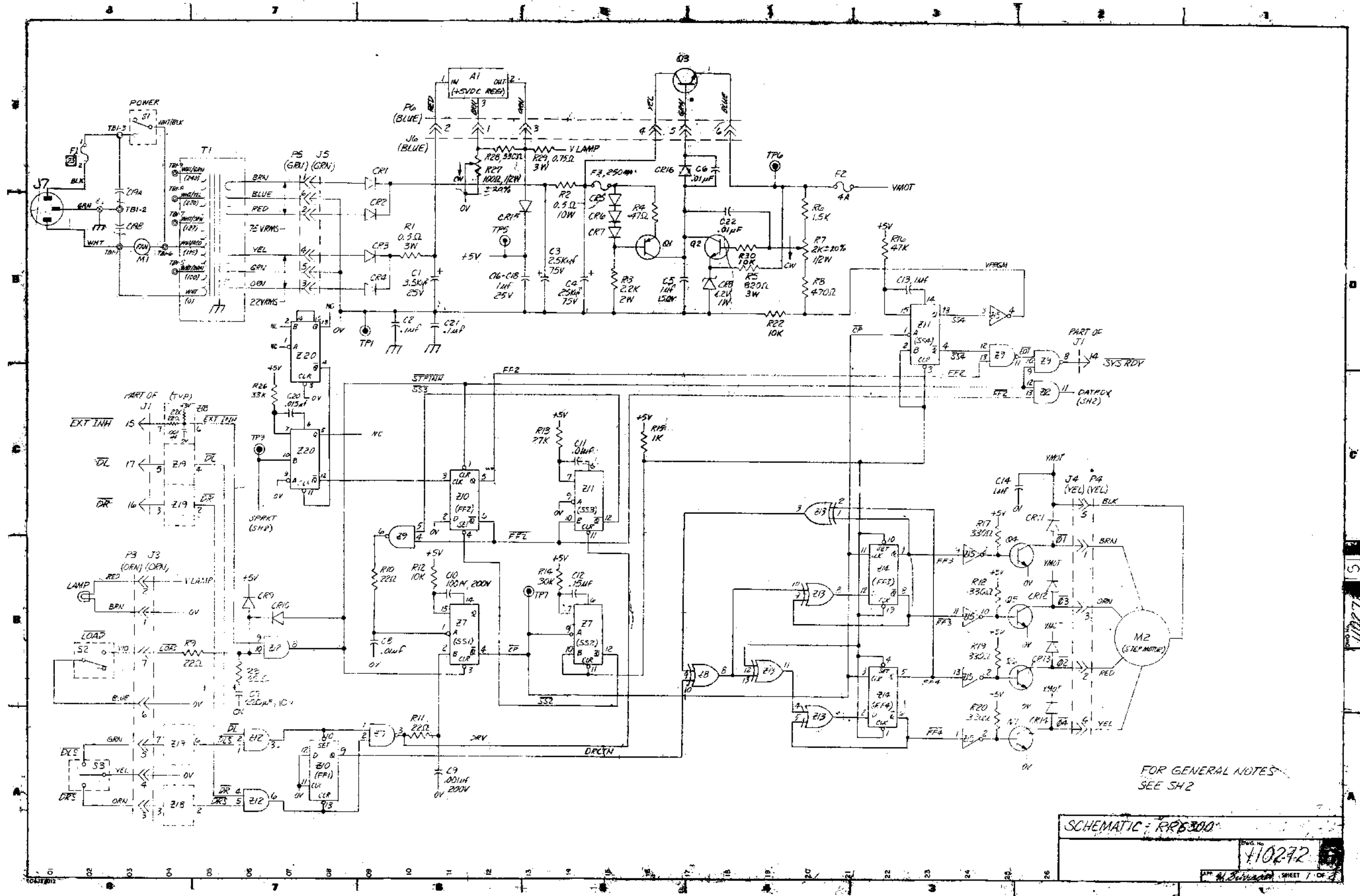
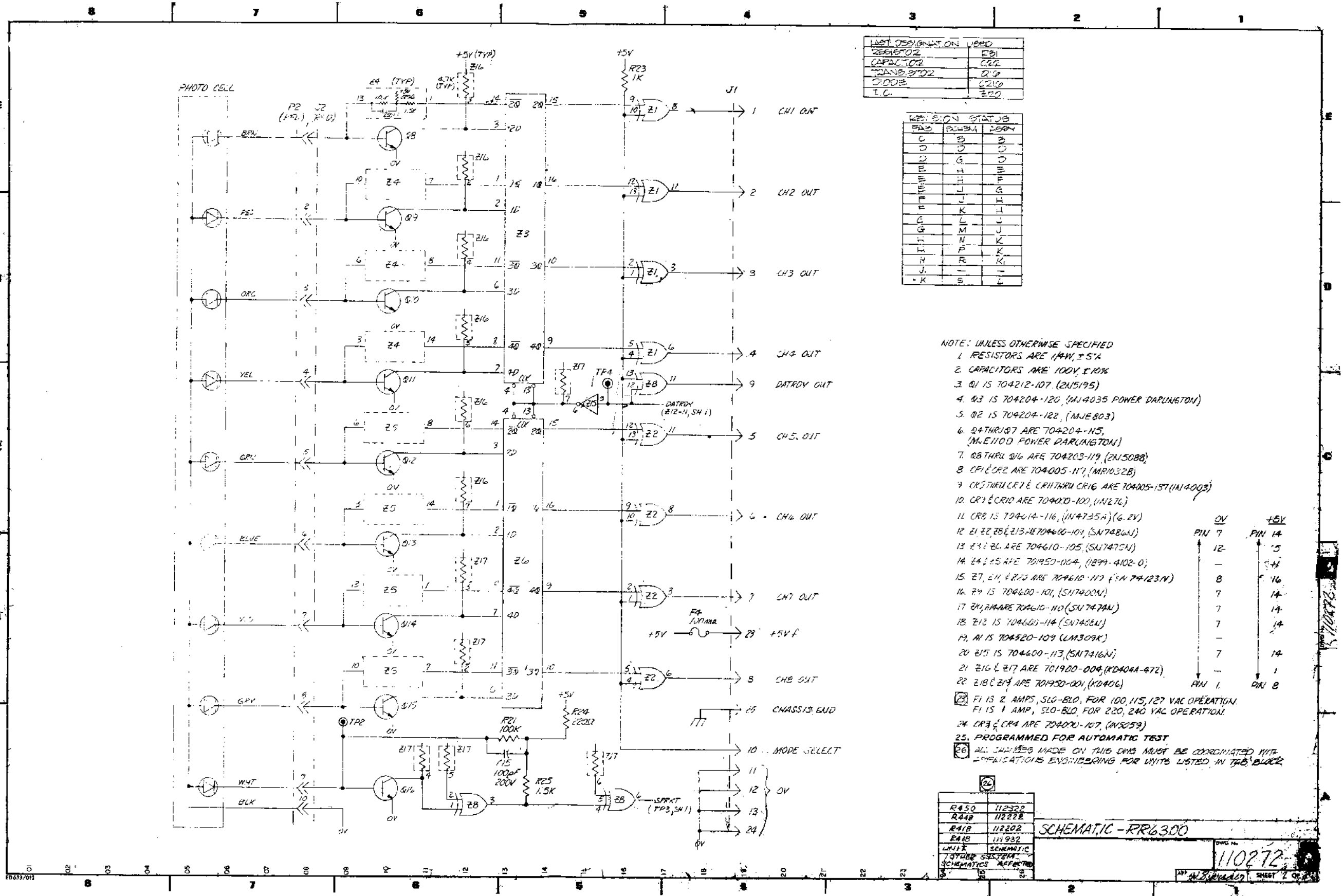

Figure 8-1C. Schematic, RR-6300BBX, Sheet 1 of 2. Card Fabrication 110273-K. See Page 7-12A/7-12B.



LAST DESIGNATION ON USED	
RESISTOR	R21
CAPACITOR	C22
TRANSISTOR	Q19
DIODE	C210
I.C.	Z20

DESIGNATION STATUS		
DES	POWER	DIODE
C	B	C
D	D	D
E	G	D
F	H	H
G	I	H
H	J	H
I	K	H
J	L	J
K	M	J
L	N	K
M	P	K
N	R	K
O	S	K
P	T	L
Q	U	L
R	V	L
S	W	L
T	X	L
U	Y	L
V	Z	L
W	AA	L
X	AB	L
Y	AC	L
Z	AD	L

- NOTE: UNLESS OTHERWISE SPECIFIED
- RESISTORS ARE 1/4W, 5%.
 - CAPACITORS ARE 100V, 5%.
 - Q1 IS 704212-107, (2N5195).
 - Q3 IS 704204-120, (MJE4035 POWER DARLINGTON).
 - Q2 IS 704204-122, (MJE803).
 - Q4THRU Q7 ARE 704204-115, (MJE1100 POWER DARLINGTON).
 - Q8THRU Q16 ARE 704203-119, (2N5088).
 - CR1 & CR2 ARE 704005-117, (M1R1032B).
 - CR3THRU CR7 & CR11THRU CR16 ARE 704005-137, (M14003).
 - CR7 & CR10 ARE 704020-100, (M1276).
 - CR8 IS 704014-116, (M14735A) (6.2V).
 - Z1, Z2, Z5 & Z13 ARE 704610-104, (SN7486N).
 - Z3 & Z6 ARE 704610-105, (SN7475N).
 - Z4 & Z15 ARE 704950-004, (1899-4102-0).
 - Z7, Z8, & Z12 ARE 704610-117, (SN74123N).
 - Z9 IS 704600-101, (SN7400N).
 - Z10, Z14 ARE 704610-110, (SN7474N).
 - Z12 IS 704600-114, (SN7485N).
 - Z11 IS 704520-109, (LM309K).
 - Z15 IS 704600-113, (SN7416N).
 - Z16 & Z17 ARE 701900-004, (KDA00A-472).
 - Z18 & Z19 ARE 701950-001, (KDA06).
 - F1 IS 2 AMP, SLO-BLO, FOR 100, 115, 127 VAC OPERATION.
F1 IS 1 AMP, SLO-BLO, FOR 220, 240 VAC OPERATION.
 - CR3 & CR4 ARE 704020-107, (M5059).
 - PROGRAMMED FOR AUTOMATIC TEST.
 - ALL CHANGES MADE ON THIS DMS MUST BE COORDINATED WITH COMMUNICATIONS ENGINEERING FOR UNITS LISTED IN THE BLOCK.

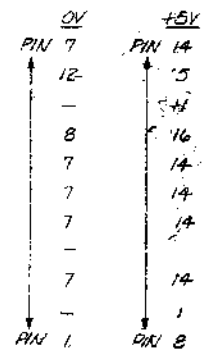

R450	112322
R448	112222
R418	112202
R415	111932
UNIT	SCHEMATIC
SYSTEM	SCHEMATIC
SCHEMATIC	SCHEMATIC

SCHEMATIC - RR6300
110272
SHEET 2 OF 2

Figure 8-1C. Schematic, RR-6300BBX, Sheet 2 of 2. Card Fabrication 110273-K. See Page 7-12A/7-12B.

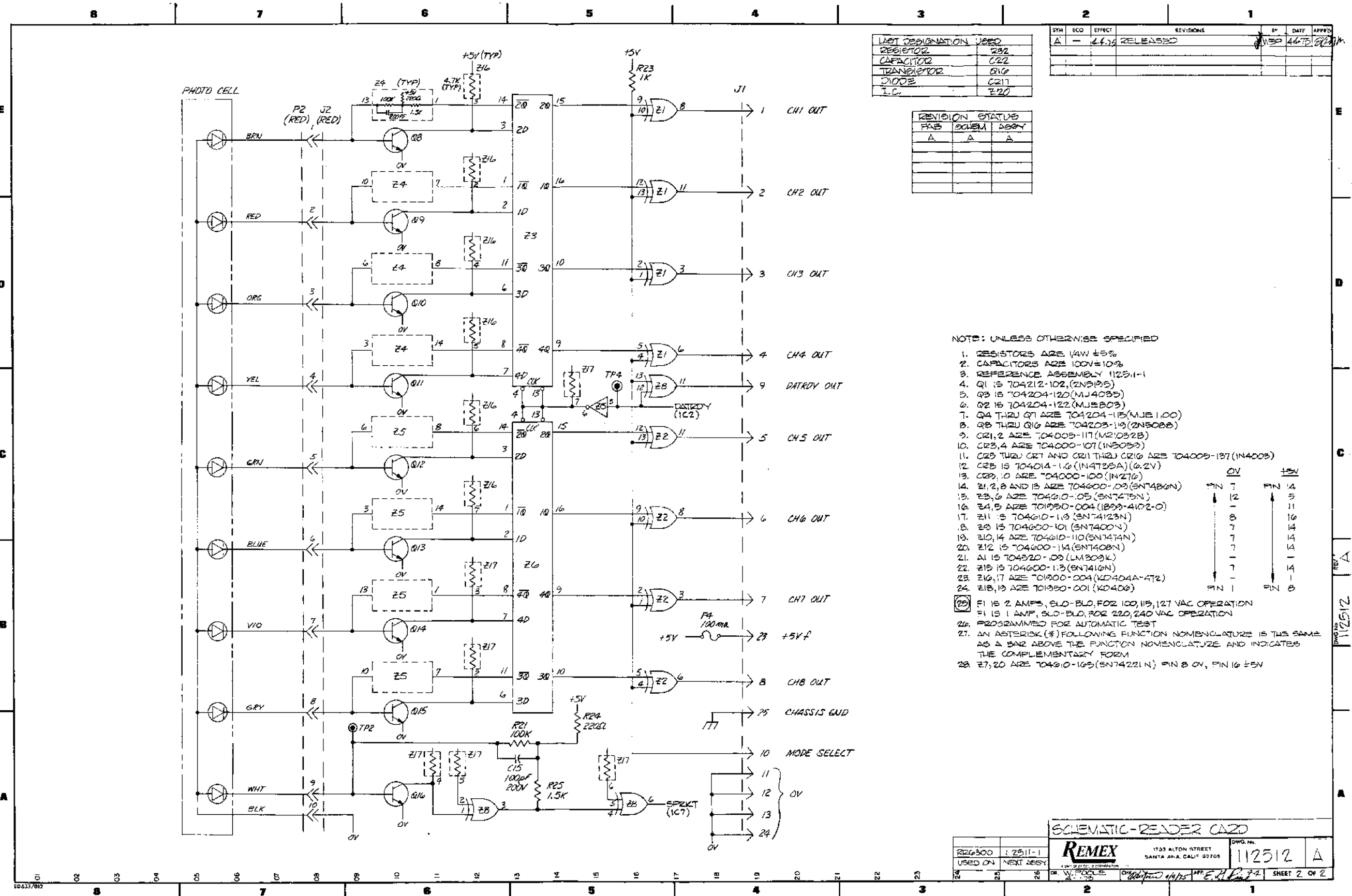

Figure 8-ID. Schematic, RR-6300BDX. (Sheet 1 of 2)

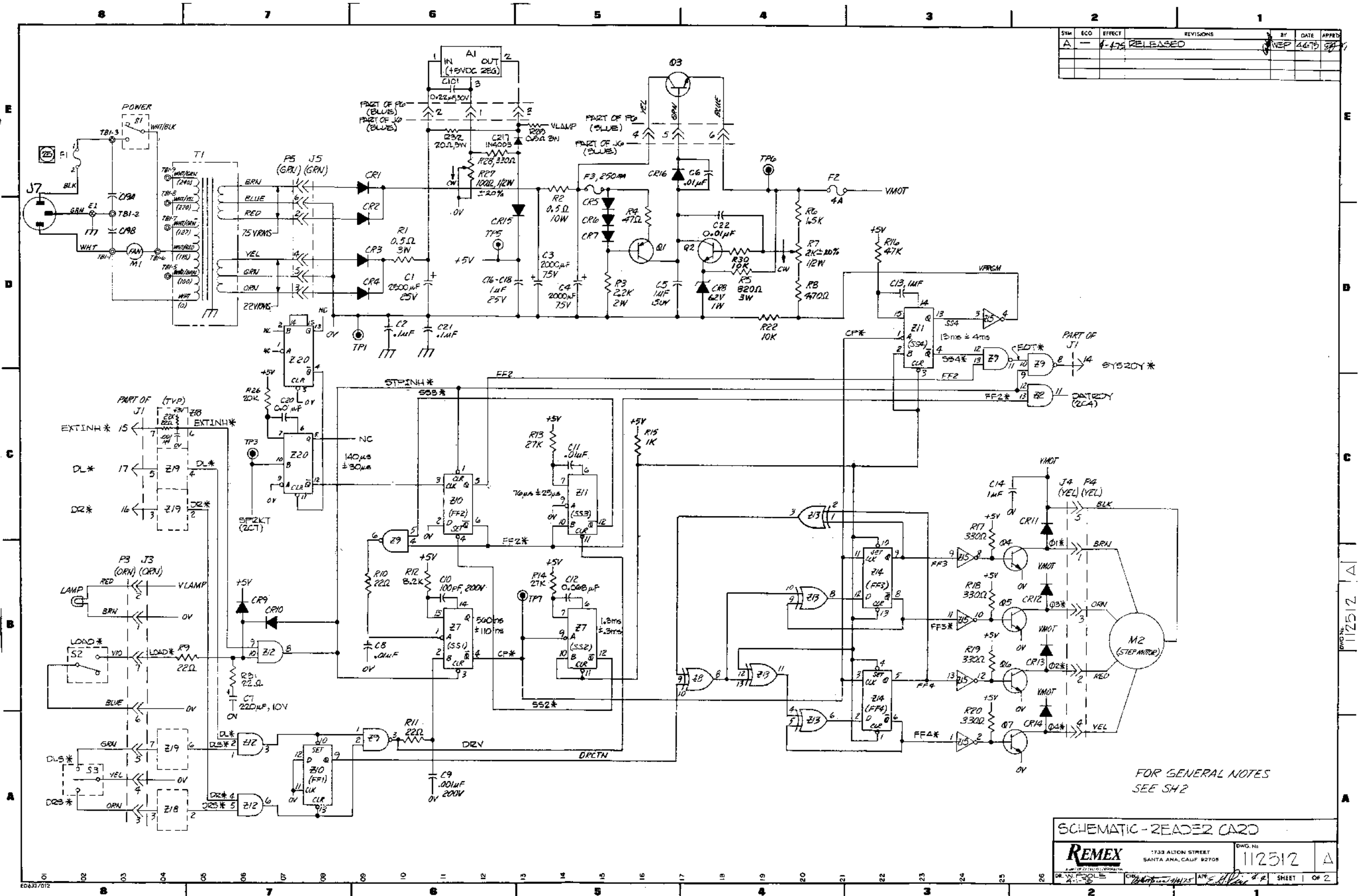

Figure 8-1D. Schematic, RR-6300BDX (Sheet 2 of 2)

SN7474

TRUTH TABLE (Each Flip-Flop)

t_n	INPUT	OUTPUT	t_{n+1}	OUTPUT
	D	Q		\bar{Q}
0	0	0	1	1
1	1	1	0	0

NOTES: 1. t_n = bit time before clock pulse.
2. t_{n+1} = bit time after clock pulse.

DUAL D-TYPE EDGE-TRIGGERED FLIP-FLOPS

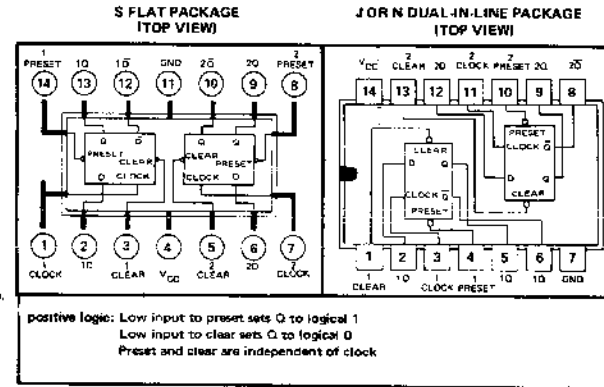

positive logic: Low input to preset sets Q to logical 1
Low input to clear sets Q to logical 0
Preset and clear are independent of clock

SN74123

RETRIGGERABLE MONOSTABLE MULTIVIBRATORS WITH CLEAR

TRUTH TABLE (See Note A)

INPUTS		OUTPUTS	
A	B	Q	\bar{Q}
H	X	L	H
X	L	L	H
L	↑	L	U
↓	H	U	U

NOTES:

- A. H = high level (steady state), L = low level (steady state), ↑ = transition from low to high level, ↓ = transition from high to low level, U = one high-level pulse, L = one low-level pulse, X = irrelevant (any input, including transitions).
- B. NC = No internal connection.
- C. To use the internal timing resistor of SN54122/SN74122 (10 kΩ nominal), connect R_{INT} to V_{CC} .
- D. An external timing capacitor may be connected between C_{EXT} and R_{EXT}/C_{EXT} (positive).

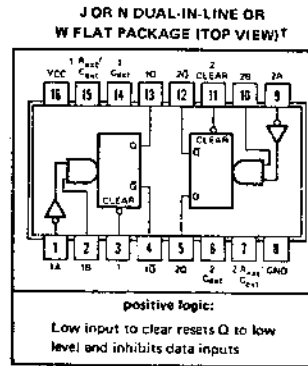

positive logic:
Low input to clear resets Q to low level and inhibits data inputs

TTL/MONOSTABLE 9602 RETRIGGERABLE RESETTABLE MONOSTABLE MULTIVIBRATOR

GENERAL DESCRIPTION - The TTL/Monostable 9602 is a dual retriggerable, resettable monostable multivibrator which provides an output pulse whose duration and accuracy is a function of external timing components. The 9602 has excellent immunity to noise on the V_{CC} and ground lines. The 9602 uses TTL inputs and outputs for high speed and high fanout capability and is compatible with all members of the Fairchild TTL family.

TRIGGERING TRUTH TABLE

PIN NO'S.	5(11)		Operation
	4(12)	3(13)	
H→L	L	H	Trigger
H	L→H	H	Trigger
X	X	L	Reset

H = HIGH Voltage Level
L = LOW Voltage Level
X = Don't Care
H→L = HIGH to LOW Voltage Level transition
L→H = LOW to HIGH Voltage Level transition

CONNECTION DIAGRAM DIP (TOP VIEW)

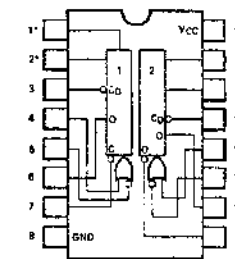

*Pins for external timing.

SN7473, SN74107

TRUTH TABLE (Each Flip-Flop)

t_n	J	K	Q
0	0	0	\bar{Q}_n
0	1	0	0
1	0	1	1
1	1	1	\bar{Q}_n

NOTES: 1. t_n = Bit time before clock pulse.
2. t_{n+1} = Bit time after clock pulse.

DUAL J-K MASTER-SLAVE FLIP-FLOPS

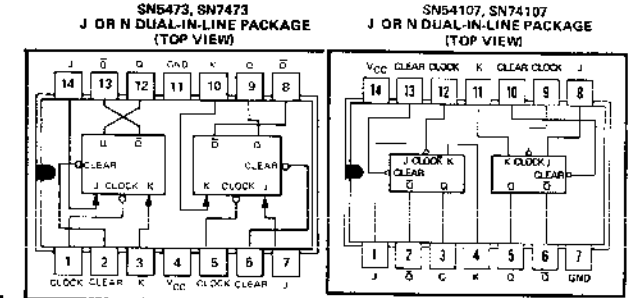

positive logic: Low input to clear sets Q to logical 0.
Clear is independent of clock.

SN7475, SN7477

TRUTH TABLE (Each Latch)

t_n	D	Q
1	1	1
0	0	0

NOTES: 1. t_n = bit time before clock pulse transition.
2. t_{n+1} = bit time after clock pulse transition.
NC - No Internal Connection

8-BIT AND 4-BIT BISTABLE LATCHES

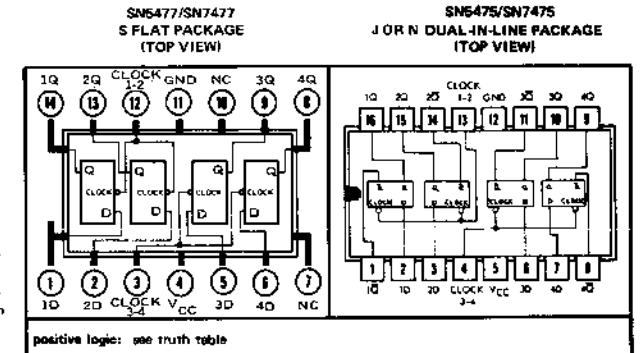

positive logic: see truth table

SN74121

TRUTH TABLE (See Notes 1 thru 3)

t_n	INPUT		t_{n+1}		OUTPUT
	A1	A2	A1	A2	B
1	1	0	1	1	Inhibit
0	X	1	0	X	0
X	0	1	X	0	0
0	X	0	0	X	1
X	0	0	X	0	1
1	1	1	0	X	1
1	1	1	0	X	1
X	0	0	X	1	0
0	X	0	1	X	0
X	0	1	1	1	1
0	X	1	1	1	1
1	1	0	X	0	0
1	1	0	0	X	0

$I = V_{in(1)} \geq 2V$
 $0 = V_{in(0)} \leq 0.8V$

NOTES: 1. t_n = time before input transition.
2. t_{n+1} = time after input transition.
3. X indicates that either a logical 0 or 1, may be present.
4. NC = No Internal Connection

MONOSTABLE MULTIVIBRATORS

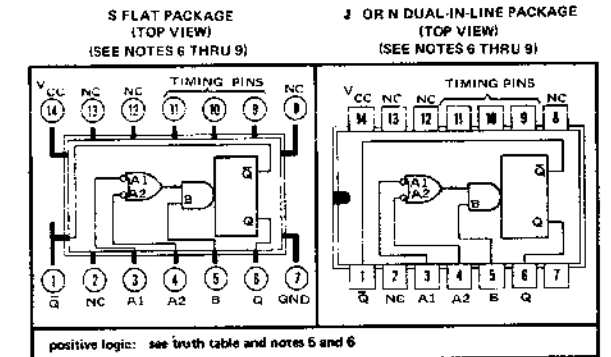

positive logic: see truth table and notes 5 and 6

- 5. A1 and A2 are negative-edge-triggered logic inputs, and will trigger the one shot when either or both go to logical 1 with B at logical 1.
- 6. B is a positive Schmitt-trigger input for slow edges or level detection, and will trigger the one shot when B goes to logical 1 with either A1 or A2 at logical 0. (See Truth Table)

SN7473, SN74107

TRUTH TABLE (Each Flip-Flop)

J	K	Q _n	Q _{n+1}
0	0	0	0
0	1	0	0
1	0	0	1
1	1	0	1

NOTES: 1. t_n = Bit time before clock pulse.
2. t_{n+1} = Bit time after clock pulse.

DUAL J-K MASTER-SLAVE FLIP-FLOPS

positive logic: Low input to clear sets Q to logical 0. Clear is independent of clock.

SN7475, SN7477

TRUTH TABLE (Each Latch)

D	Q
1	1
0	0

NOTES: 1. t_n = bit time before clock pulse transition.
2. t_{n+1} = bit time after clock pulse transition.
NC = No Internal Connection

8-BIT AND 4-BIT BISTABLE LATCHES

positive logic: see truth table

SN74121

TRUTH TABLE (See Notes 1 thru 3)

t _n INPUT			t _{n+1} INPUT			OUTPUT
A1	A2	B	A1	A2	B	
1	1	0	1	1	1	Inhibit
0	X	1	0	X	0	Inhibit
X	0	1	X	0	0	Inhibit
0	X	0	0	X	1	One Shot
X	0	0	X	0	1	One Shot
1	1	1	X	0	1	One Shot
1	1	1	0	X	1	One Shot
X	0	0	X	1	0	Inhibit
0	X	0	1	X	0	Inhibit
X	0	1	1	1	1	Inhibit
0	X	1	1	1	1	Inhibit
1	1	0	X	0	0	Inhibit
1	1	0	0	X	0	Inhibit

1 = V_{in(1)} ≥ 2V
0 = V_{in(0)} ≤ 0.8V

NOTES: 1. t_n = time before input transition.
2. t_{n+1} = time after input transition.
3. X indicates that either a logical 0 or 1, may be present.
4. NC = No Internal Connection.

MONOSTABLE MULTIVIBRATORS

positive logic: see truth table and notes 5 and 6

5. A1 and A2 are negative-edge-triggered logic inputs, and will trigger the one shot when either or both go to logical 0 with B at logical 1.
6. B is a positive Schmitt-trigger input for slow edges or level detection, and will trigger the one shot when B goes to logical 1 with either A1 or A2 at logical 0. (See Truth Table)

SN7400
SN7403 (Open Collector)
Positive Logic
NAND GATE

Y = \overline{AB}

A	B	Y
L	L	H
L	H	H
H	L	H
H	H	L

SN7402
Positive Logic
NOR GATE

Y = $\overline{A+B}$

A	B	Y
L	L	H
L	H	L
H	L	L
H	H	L

SN7408
Positive Logic
AND GATE

Y = AB

A	B	Y
H	H	H
H	L	L
L	H	L
L	L	L

SN7432
Positive Logic
OR GATE

Y = A+B

A	B	Y
H	H	H
H	L	H
L	H	H
L	L	L

SN7486
Positive Logic
EXCLUSIVE-OR GATE

Y = $A \oplus B$

A	B	Y
L	L	L
L	H	H
H	L	H
H	H	L

SN7410
Positive Logic
NAND GATE

Y = \overline{ABC}

A	B	C	Y
L	L	L	H
L	L	H	H
L	H	L	H
L	H	H	H
H	L	L	H
H	L	H	H
H	H	L	H
H	H	H	L

SN7404
SN7406, SN7416 (Open Collector)
Positive Logic
HEX INVERTER

Y = \overline{A}

A	Y
L	H
H	L

NOTE: Pin numbers are listed in the order in which they are related, for EXAMPLE, on SN7410, pins 1, 2, 13 and 12 function together on one gate. * Pin 7 is Gnd, Pin 14 is Vcc

Figure 8-2. IC Modules Used in the RR-6300BXX

COMPONENT & REF DESIGNATOR	SYMBOL	REMARKS	COMPONENT & REF DESIGNATOR	SYMBOL	REMARKS
SWITCH, 'S'	S1 (N.O.) S2 (N.C.)		INTEGRATED CIRCUIT PACKAGE	AND, NOR, AND, OR, EXCLUSIVE OR, INVERTER, AMPLIFIER	*2XX INDICATES I.C. PKG. LOCATION ON P.C. CARD. (LEFT TO RIGHT TOP TO BOTTOM SEQUENCE) (X=NUMBER)
SAFETY INTERLOCK					
LIMIT SW.	S1 (N.O.) S2 (N.C.) S3 (N.O. WELD CLOSED) S4 (N.C. WELD OPEN)				
POWER	PWR ON				
PUSH BUTTON, 'PB'	PB1 (N.C.) PB2 (N.O.)				*2YY INDICATES I.C. PKG. LOCATION ON P.C. CARD IN XY COORDINATE SYSTEM. (X=NUMBER, Y=LETTER)
TRANSFER	S1 (N.O.) S2 (N.C.) S3 (N.O.) S4 (N.C.)		POSITIVE TRUE LOGIC SYMBOLS		
TIMER CONTACTS	DELAY OCCURS WHEN COIL IS ENERGIZED DE-ENERGIZED				
TRANSISTOR, 'Q'	Q1 (PNP) Q2 (NPN)				
V.U.T., 'Q'	Q1 (N-TYPE) Q2 (P-TYPE)	ARROW POINTS TOWARD B1 FOR 'N' TYPE & AWAY FROM B1 FOR 'P' TYPE			
FET, 'Q'	Q1 (N-TYPE) Q2 (P-TYPE)				
DIODE 'CR' or 'D'		*USE 'D' ON M/C APPLICATIONS			
ZENER DIODE 'CR'	XXV	V=VOLTS			
TRIAC		INDICATE TERMINALS 1 AND 2			
SCR					
BRIDGE RECTIFIER 'BR' or 'D'		*USE 'D' ON M/C APPLICATIONS			
CABLE RUN (OPTIONAL)					
CABLE, 2 OR MORE CONDUCTORS		IF SHIELDED CONDUCTOR SHOW TERMINATION OF SHIELD			
TWISTED WIRES	PAIR TRIPPLE				
COAXIAL CABLE					

STANDARD SCHEMATIC SYMBOLS
107700

NOTE: ALL SEMICONDUCTORS AND INTEGRATED CIRCUIT DEVICES ARE TO BE IDENTIFIED BY REVEN PART NUMBER ADJACENT TO DEVICE OR IN GENERAL NOTES. COMMERCIAL PART NUMBERS MAY ALSO BE SHOWN AT OPTION OF PROJECT ENGINEER

Figure 8-3. REMEX Standard Schematic Symbols, Sheet 1 of 2

COMPONENT / REF DESIGNATOR	SYMBOL	REMARKS	COMPONENT / REF DESIGNATOR	SYMBOL	REMARKS
CAPACITOR 'C'		GIVE VOLTAGE ON ELECTROLYTICS, MOTOR AND A.C. CAPACITORS IN A.C. CIRCUITS. VOLTAGE OPTIONAL ON ALL OTHERS	TERMINAL 'E'		USE 'E', LOGICAL DESCRIPTION OR BOTH
CELL, PHOTOSENSITIVE 'V'					
GND					
COIL RELAY 'K' OR NUMERICAL DESIGNATOR CONTACTS					
CONTACT, CONNECTOR 'P', 'J'					
SEPARABLE CONNECTORS, ENGAGED		DEFINITION: PLUG: USUALLY INDICATE JACK: USUALLY STATIONARY HERMAPHRODITE: PLUG: → JACK: ←			
CONNECTORS, AC POWER 'P', 'J'					
FUSE, 'F'					
INDUCTOR, WINDING, REACTOR OR SOLENOID		GIVE INDUCTANCE OR COVER IN NOTES			
TRANSFORMER 'T'		POLARITY DOTS TO BE SHOWN IF NECESSARY TO CIRCUIT FUNCTION			
LAMP, INDICATING 'DS'					
CRYSTAL, 'Y'					
BOARD, TERMINAL 'TB' OR FANNING STRIP 'FS'					
EYELET, PC CARD					
TEST POINT, 'TP'					
JUMPER, WIRE, PC		FOR OPTIONAL WIRING			
RESISTOR, FIXED, VARIABLE 'R'		OPTIONAL ADJUSTMENT SYMBOL: ⊕ SCREW DRIVER, ⊙ KNIFE WATTAGE AND TOLERANCE TO BE SHOWN OR PUT IN NOTES			
LAMP, GLOW 'N'					
LINE CROSS					
LINE CONNECT					

Figure 8-3. REMEX Standard Schematic Symbols, Sheet 2 of 2

REMEX is constantly evaluating and improving its existing equipment so that you, the user, will always have equipment which is the "state-of-the-art".

Changes, when they occur, are incorporated into the next printing of the manual. In order to make current manuals as up-to-date as possible, all changes to date are contained in this section in the form of addendum sheets. Individual pages which are affected are, in addition, marked REFER TO ADDENDUM. Addendum sheets are also used to list changes to the manuals for special, non-standard units.

We are endeavoring to make our technical manuals as useful and practical as possible. Any comments or suggestions concerning its contents should be addressed to:

REMEX
Technical Manual Supervisor
1733 Alton Street
Santa Ana, California 92705

ADDENDUM SHEET

The following changes in the manual are required:

1. On page 7-7A/7-8A, the REMEX part number for item 5, Upper Cover Assembly, should be 112406-1.
2. On page 7-5, as part of the Heat Sink Assembly, add Capacitor C101 0.22uf, 50V, REMEX Part No. 702131-224.
3. On page 1-1, Table 1-1, add the following for RR-6300BDX units only:

Brush, Right Angle

716003-104

1

