



PCC PERTEC COMPUTER CORPORATION
6741 VAREL AVENUE - CANOGA PARK - CALIFORNIA 91303 - PHONE: (213) 348-1391
TELEX/TWX 910-494-2788

INTERFACING GUIDE FOR
iCOM MODEL FD360/CF360
FLOPPY DISK SYSTEM
AND FRUGAL FLOPPY FF36

Table of Contents

- I. General
- II. Physical Description
- III. Electrical Interface & Pin Configurations
- IV. Power Requirements
- V. Command and Data Structure
- VI. Operation Sequences and Timing
- VII. Data Format
- VIII. Typical Microprocessor Schematics
 - A. 8080 Interface
 - B. 6800 Interface

✓

✓

✓

I. GENERAL

The iCOM Model CF360 Controller/Formatter is designed for use by OEM's in industrial, commercial, and development applications. It is used in the iCOM FD360 series Floppy Disk System as well.

The CF360 can accommodate from one to four floppy disk drives and includes a general purpose interface compatible with most microprocessors and minicomputers.

The CF360 offers many features which reduce computer service overhead. For example, the controller is fully IBM 3740 and 3540 compatible, with all formatting and defragmenting accomplished automatically within the controller. The controller also performs track seek/verify, and CRC (Cyclic Redundancy Check) generation and verification automatically.

Independent 128 byte (full-sector) input and output buffers offer the possibility for DMA or programmed I/O operation. The ability to write-protect individual drives also is provided by the controller.

Interface signals to the CPU/MPU are TTL compatible and consist of independent input and output parallel data lines and an 8 bit parallel control port. Upon command, controller status data is presented to the CPU via the input data lines.

II. PHYSICAL DESCRIPTION

The CF360 is housed on two 7.25 X 15 inch (18.4 X 38.1 cm) printed circuit boards containing a total of about 125 IC's.

Interface connections are provided along one long edge of each board, obviating the need for back-plane wiring or a card cage.

III. ELECTRICAL INTERFACE

3.1 Signal Levels - All signals are standard TTL-compatible negative true. Positive true all ports available as an option.

3.1.1 Output to FD360 (negative true)

Logic "0": 2.0V min to +5V max

Logic "1": 0.0V min to 0.8V max

Standard load is 1 TTL Gate (7404 plus 680 ohms to +5V (see Fig. 1).

The two other input load variations as shown in Fig. 1 are available as options.

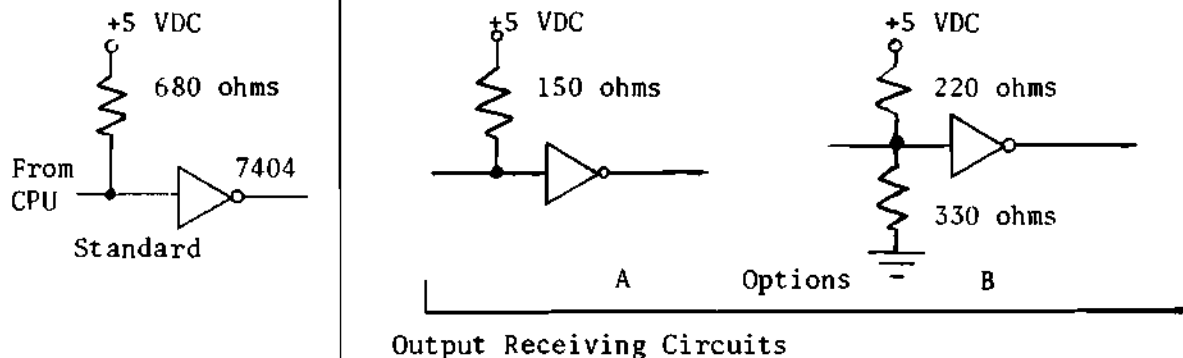
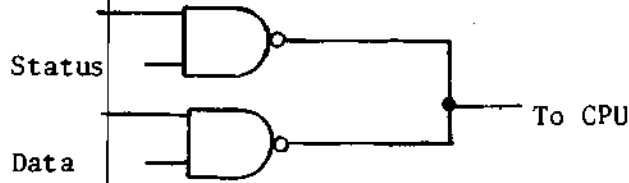

Fig. 1

- 3.1.2 Input from FD360 (negative true)
 Logic "0": 2.4V min
 Logic "1": 0.0V min to 0.4V max
 Current sink at logic "1" is 32 ma (See Fig. 2)



DM 8096 (Tri-State)

Input Status/Data Drive Circuits

Fig. 2

- 3.2 Pin Configuration - Two 40 conductor 3M-type ribbon cables with socket connectors on each end are normally used for interfacing the CF360. Connectors which mate with the CF360 are 3M #3432-2002 (solder tail) or 3432-4005 (wire wrap posts).

3.2.1 P4 Input Connector (to CPU)

<u>PIN#</u>	<u>PIN#</u>	<u>SIGNAL NAME</u>	<u>DESCRIPTION</u>
CPU Intf. end	CF360 end		
	P4 1-27	-	Not used
P9 8	P4 28	Key or Done	Connector Key Operation Done (option)
P9 9	P4 29	DI 0	Data In 0 (LSB)/Busy
P9 10	P4 30	DI 1	Data In 1/ UN0
P9 11	P4 31	DI 2	Data In 2/ UN1 Unit Select
P9 12	P4 32	DI 3	Data In 3/ CRC Error
P9 13	P4 33	DI 4	Data In 4/ Write Protected
P9 14	P4 34	DI 5	Data In 5/ Drive Fail
P9 15	P4 35	DI 6	Data In 6/ Not Used
P9 16	P4 36	DI 7	Data In 7/ Deleted Data Address Mark
P9 17-20	P4 37-40	GRD	Signal Ground

3.2.2 P5 Output Connector (from CPU)

<u>PIN#</u>	<u>PIN#</u>	<u>SIGNAL NAME</u>	<u>DESCRIPTION</u>	<u>PIN#</u>	<u>PIN#</u>	<u>SIGNAL NAME</u>	<u>DESCRIPTION</u>
CPU Intf. end	CF360 end			CPU Intf. end	CF360 end		
	P5 1-18	-	Not Used		P5 28	Not Used	
P9 29	P5 19	Key	Connector Key	P9 39	P5 29	CDO 0*	Data out Bit 0
P9 30	P5 20	CPU 0*	Command Strobe	P9 40	P5 30	CDO 1*	" " " 1
P9 31	P5 21	CPU 1*	Command Word	P9 41	P5 31	CDO 2*	" " " 2
P9 32	P5 22	CPU 2*	" "	P9 42	P5 32	CDO 3*	" " " 3
P9 33	P5 23	CPU 3*	" "	P9 43	P5 33	CDO 4*	" " " 4
P9 34	P5 24	CPU 4*	" "	P9 44	P5 34	CDO 5*	" " " 5
P9 35	P5 25	CPU 5*	" "	P9 45	P5 35	CDO 6*	" " " 6
P9 36	P5 26	CPU 6*	" "	P9 46	P5 36	CDO 7*	" " " 7
P9 37	P5 27	CPU 7*	" "	P9 47-50	P5 37-40	GRD	Signal Ground

3.2.3 P8 Power, Write Protect, Miscellaneous (connects to J8 on Board Z2).

<u>PIN#</u>	<u>SIGNAL NAME</u>	<u>DESCRIPTION</u>
P8 1	WP3*	Ground to Write Protect Unit 3
P8 2	WP1*	Ground to Write Protect Unit 1
Key		
P8 3	LDRFAL	LED Driver indicates Drive Fail Status
P8 4	LCRC	LED Driver indicates CRC Error
P8 5	LUN 1	LED Driver indicates Unit Select Bit 1 = 1
P8 6,7,8,9	+5 V	+5 V input
P8 10	-12 V	-12 V input
P8 A	WP2*	Ground to Write Protect Unit 2
P8 B	WP0*	Ground to Write Protect Unit 0
P8 C	L BUSY	LED Driver indicates Unit Busy
P8 D	LWRPR	LED Driver indicates Unit Write Protected
P8 E	LUN 0	LED Driver indicates Unit Select Bit 0 = 1
P8 F,H,J,K,L	GRD	Ground return for +5V and -12V

IV. POWER REQUIREMENTS

- 4.1 CF360 +5VDC, + 5% @ 6 Amps (Power requirements for connector J8 on the Z2 board.)
 -12VDC, + 5% @ 1 Amp
- 4.2 Disk Drive - The CF360 is ideally suited for use with the Pertec FD400 drive. The FD400 requires +24V +5% @ 2 Amps Avg, 4 Amps Peak.

V. COMMAND AND DATA STRUCTURE

5.1 Commands and Command Word Bits

<u>COMMAND</u>	<u>CPU BIT (NEGATIVE TRUE)</u>								<u>HEX CODE</u>
	7	6	5	4	3	2	1	0	
Examine Status	0	0	0	0	0	0	0	0	00
Read	0	0	0	0	0	0	1	1	03
Write	0	0	0	0	0	1	0	1	05
Read CRC	0	0	0	0	0	1	1	1	07
Seek	0	0	0	0	1	0	0	1	09
Clear Error Flags	0	0	0	0	1	0	1	1	0B
Seek Track 0	0	0	0	0	1	1	0	1	0D
Write with DDAM*	0	0	0	0	1	1	1	1	0F
Load Track Address	0	0	0	1	0	0	0	1	11
Load Unit/Sector	0	0	1	0	0	0	0	1	21
Load Write Buffer	0	0	1	1	0	0	0	1	31
Shift Read Buffer	0	1	0	0	0	0	0	1	41
Clear	1	0	0	0	0	0	0	1	81
Examine Read Buffer	0	1	0	0	0	0	0	0	40

* DDAM = Deleted Data Address Mark

Please refer to Fig. 3 for timing requirements of command and data outputs.

5.2 Status/Data Input Lines

DI0	Data In 0 / Busy
DI1	Data In 1 / UN 0 Unit Select Code Bit 0
DI2	Data In 2 / UN 1 Unit Select Code Bit 1
DI3	Data In 3 / Media Error or CRC Error
DI4	Data In 4 / Selected Unit Write Protected
DI5	Data In 5 / Drive Fail (not up to speed, etc.)
DI6	Data In 6 / No status Bit (Always Logic 1)
DI7	Data In 7 / Found Deleted Data Address Mark

Please refer to Figure 4 for timing of data and status inputs.

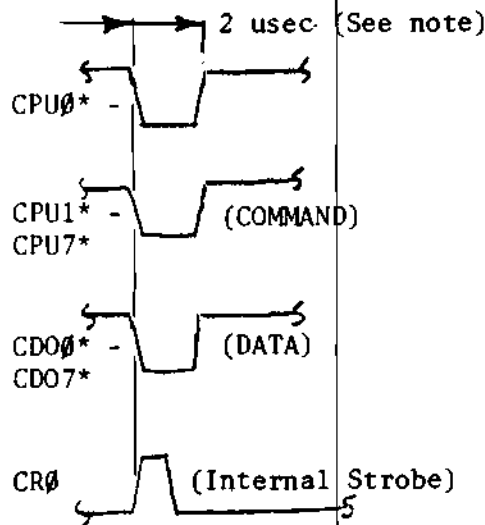

NOTE: Other data pulse widths can be accommodated, consult iCOM.

Output Command and Data Timing

Fig. 3

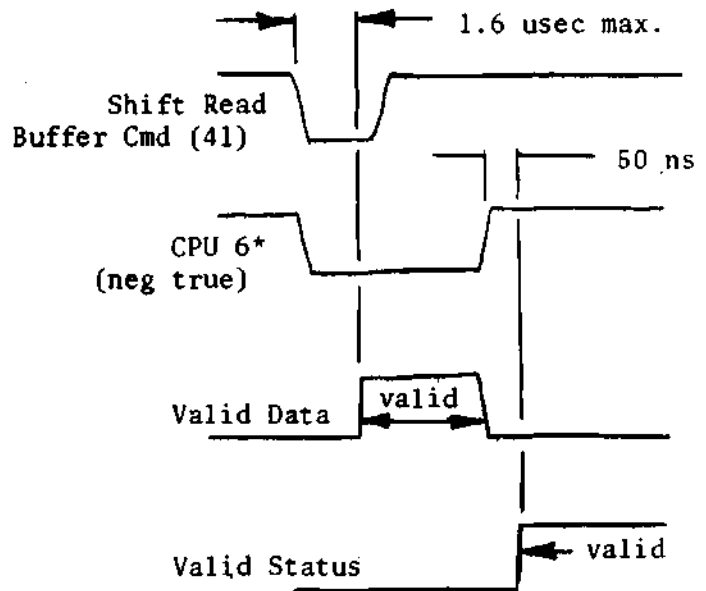

Input Status and Data Timing

Fig. 4

5.3 Data Output Lines

	CDO Bit								Range
	7	6	5	4	3	2	1	0	
Track Address	0	MSB						LSB	00 to 4C (HEX)
Unit/Sector	MSB	LSB	0	MSB	Sector			LSB	Unit 0-3 Sector 1-1A (HEX)
Write Buffer	MSB							LSB	00 to FF (HEX)

5.4 Operation Sequences

5.4.1 Seek

- a) Set up Data Out Bits 0-7 with Unit & Sector
- b) If track remains same, execute a load Unit/Sector Command (21). Otherwise, set up data out bits with Track Address
- c) Execute a load Track Address command (11)
- d) Execute a Seek command (09)
- e) If interrupt is used floppy will pulse "Done" when operation complete. More typically, the microcomputer should loop-on-busy as follows:
- f) Execute an Examine Status command
- g) Input the data lines and check the busy (=0 when done) and CRC bits.

5.4.2 Seek \emptyset

- a) Always used on power up
- b) No track address necessary
- c) Execute a Seek \emptyset command (0D)
- d) Loop-on-busy as above. Selected unit will go to track \emptyset .

5.4.3 Read

- a) After seek to the correct track, unit and sector, execute read (03)
- b) Loop-on-busy
- c) Check CRC, reread if $DI\bar{3} = 1$
- d) Execute examine read buffer (40)
- e) Input 1st character from data input lines
- f) Shift read buffer (41)
- g) Repeat (f) & (g) until 128 characters have been read.

5.4.4 Write

- a) Load write buffer by first setting up Data Out lines
- b) Execute Load Write Buffer (31)
- c) Repeat (a) and (b) above until 128 characters have been loaded
- d) Seek to correct track, unit, & sector
- e) Execute write (05)
- f) Execute read (CRC) (07) (Does not alter contents of read buffers) See also 6.1.2.
- g) Check CRC Bit and repeat (e) and (f) if CRC = 1. Write Buffer recirculates so it is not necessary to reload it to rewrite.

5.4.5 Write with Deleted Data Address Mark

- a) Same as write except that the data when written is automatically preceded by a Deleted Data Address Mark (DDAM) instead of by the standard Address Mark. When the same sector is later read, the Found Deleted Data Address Mark Status bit will be set on completion. This command can therefore be used to identify the data for some purpose. For example, a DDAM can be used to indicate the end of a long data field. It could also be used in some editing function.

5.4.6 Clear Error Flags

- a) Used to clear Deleted Data Address Mark and cyclic Redundancy Check status bits.
- c) Execute Clear Error Flags command (OB)

5.4.7 Clear

- a) Execute Clear command (81)
- b) Halts any operation in process. Clears Busy and pulses Done.

5.5 Status

5.5.1 7 Status Bits are returned on the Data Input Lines, DI \emptyset thru DI 7, when command Bit 6, CPU 6*, is logic \emptyset . All bits are negative true.

5.5.2 Busy. When logic "1", indicates that an operation is in process. When logic "0", indicates operation done. Busy is also cleared by Clear, Clear Error Flags, or the head unloading.

5.5.3 UN \emptyset , UN1 Unit Select Code Bits:

UN1	UN \emptyset	
0	0	= Unit 0 Selected
0	1	= Unit 1 Selected
1	0	= Unit 2 Selected
1	1	= Unit 3 Selected

5.5.4 Media Error or CRC Error. Indicates that the Read or Read (CRC) operation resulted in a data error. The status bit should be cleared by a Clear Error Flags command and the data should reread or rewritten.

5.5.5 Selected Unit Write-Protected. Each of the drives can be write-protected manually. If so protected this status bit will equal logic "1" when that unit is selected.

5.5.6 Drive Fail. Indicates that the selected drive is not ready because the door is open, or the drive is not up to speed, or no diskette is installed, or no drive is installed.

5.5.7 Found Deleted Data Address Mark. If on a Read command the data is preceded by a DDAM then this status bit is set. (See 5.4.5). Status bit is reset by the Clear Error Flags command.

VI. OPERATION SEQUENCES AND TIMING

6.1 Functional Sequences and Characteristics

6.1.1 Seeks - The FD360/CF360 starts a seek operation by reading its present location from the ID field preceding each sector. A comparison is then made with the desired track address and the head is stepped in the correct direction until the head should be at the right track. The track address is read again and if it compares to the desired track the operation is done.

In some formats the track address may not correspond to the physical track number, due to tracks being declared down. The FD/CF360 will handle this format by seeking until the correct track address is found

It should be noted that a seek is necessary only to change tracks. To change sectors only, the Load Unit/Sector command is used.

The seek Track 0 can be used to seek to track 0 without regard to the present track. It does not require a transfer of the Track Address. The Seek Track 0 should be used on power up and restart to initialize the head.

- 6.1.2 Read - A seek to the correct track is necessary unless the head is on the correct track already. A load Unit/Sector command selects the sector to be read, and the CF360 examines the ID Field preceding each Data Sector to find the correct sector. In a standard IBM format diskette, the sectors start at 1 following the index hole and increment to 26 (1A HEX) just before the index hole.

The CF360 automatically computes the CRC during the read and if an error is found the CRC status bit is set at the end of the read. Data from the sector is shifted into the Read Buffer at a 250 KHz rate. When the Read command is complete the first character of the sector is at the front of the read buffer. An examine Read Buffer command (40) will place the Read Buffer output on the Data Input Lines. A shift Read will shift the Read Buffer and place the Read Buffer output on the Data input lines. 127 shifts are thus required to read the 128 Bytes.

A read CRC does not load the data into the Read Buffer but merely tests CRC. This is commonly used following a Write to insure data integrity. Thus a Write operation can be executed and verified without destroying the Read Buffer. This is important in edit operations and for CPU's with small memory.

- 6.1.3 Write - A write operation writes the contents of the Write Buffer to the selected Unit/Sector. The location of the head while loading the Write Buffer does not matter. After the Write Buffer is loaded, a seek command will move the head to the desired track. The Write Command then causes the CF360 to begin examining each ID field for the correct sector. A field of 6 bytes of "0"'s will then be written preceding the intended location of the data sector. Next, the Address Mark is written (or DDAM if a Write Deleted Data Address Mark command). Then each byte of the Write Buffer is written out, followed by the CRC (2 Bytes) generated by the CF360. Finally, one byte of all zero's or all one's follows the CRC.

The data written should be read by a READ CRC command to insure the operation was valid.

6.2 Operation Timing

6.2.1 Seek

Track to Track	10 msec
Head Load & Settling Time	40 msec, maximum
Maximum Seek Time, 77 tracks	820 msec

6.2.2 Read/Write

Sector Read/Write Time	6 msec
Average Latency ($\frac{1}{2}$ Rev)	83 msec
Minimum Latency	1 msec
Read/Write Buffer Shift Rate:	DC to 500 KHz

VII. DATA FORMAT

7.1 The CF360/FD360 used standard IBM 33FD type diskettes such as those used in the IBM 3740 series equipment. It is completely media and format compatible. Type 33FD diskettes can be obtained from a number of sources, including iCOM.

7.2 Format Details (each Diskette)

77 tracks per diskette 00 thru 4C HEX
 26 Sectors per track 01 thru 1A HEX
 128 Bytes (8 Bits) per sector
 256,256 Bytes Diskette
 1,025,024 Bytes Per FD360 or CF360 using 4 drives.

VIII. TYPICAL MICROPROCESSOR INTERFACE SKETCH

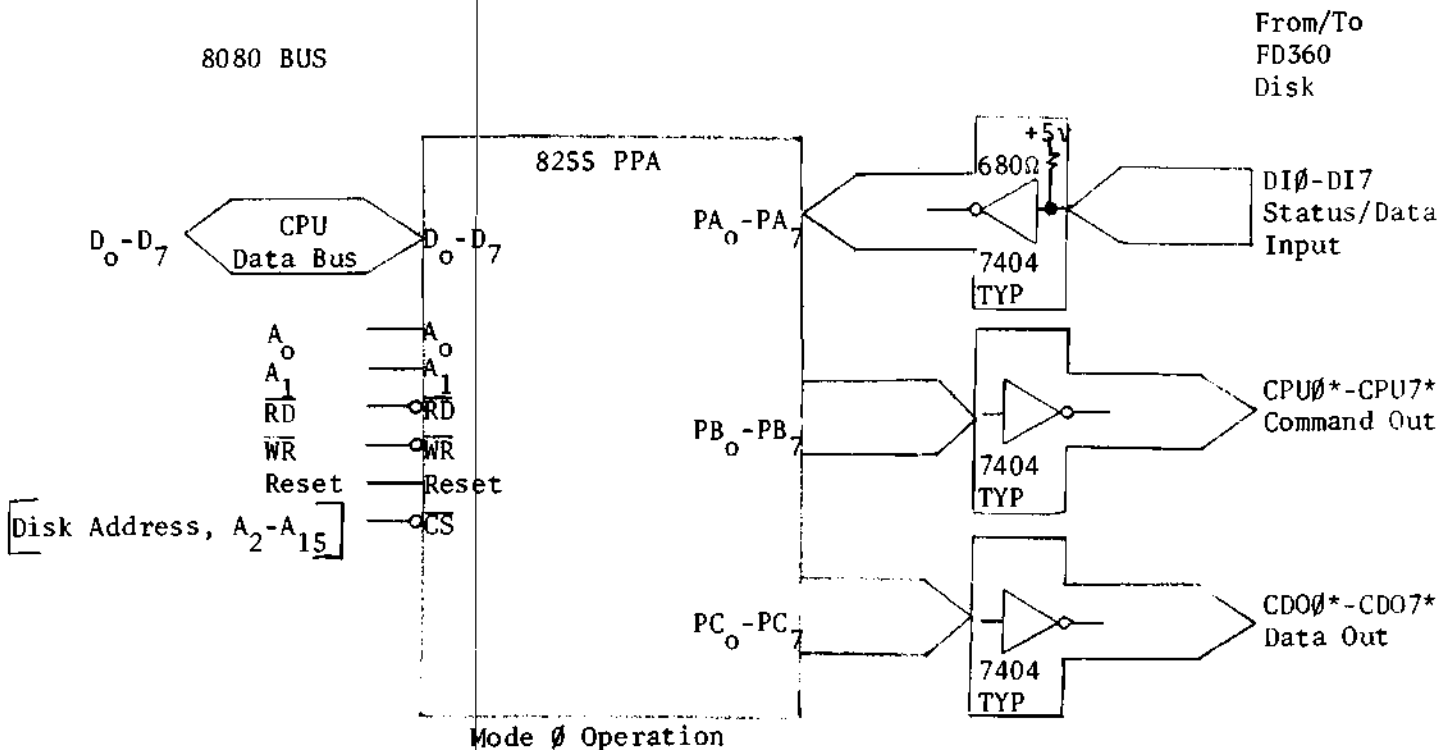

Fig. A-8080 Interface Sketch

VIII. CON'T

NOTE: Fig. A, page 8 is not compatible with iCOM's FDOS-II software, and is shown only as an alternative hardware interface arrangement for custom system designs. Use Fig B below with iCOM's FDOS-II/8080 OEM software.

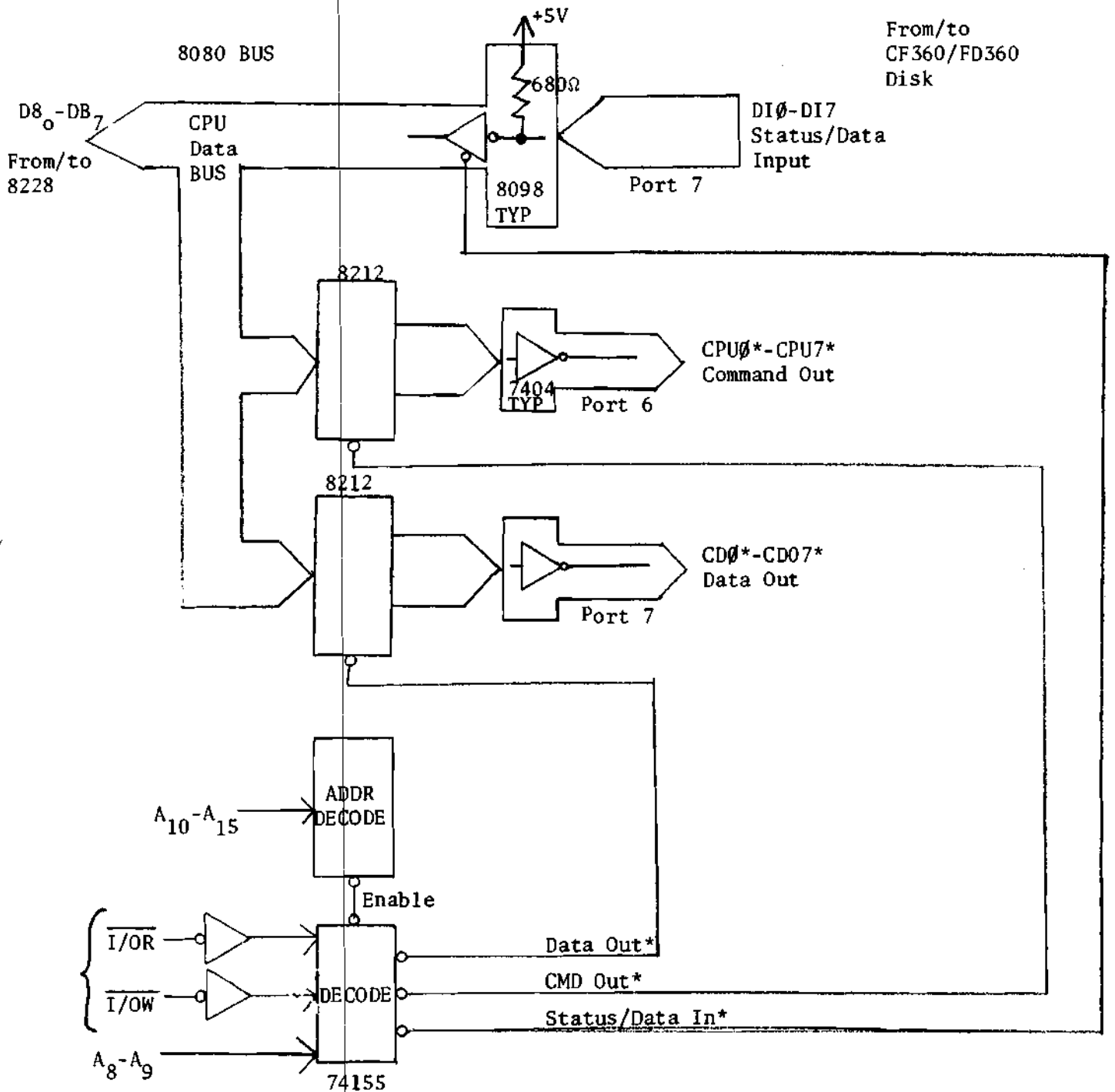

Fig. B 8080 Interface Sketch for use with iCOM FDOS-II/8080 OEM Software

VIII. CON'T

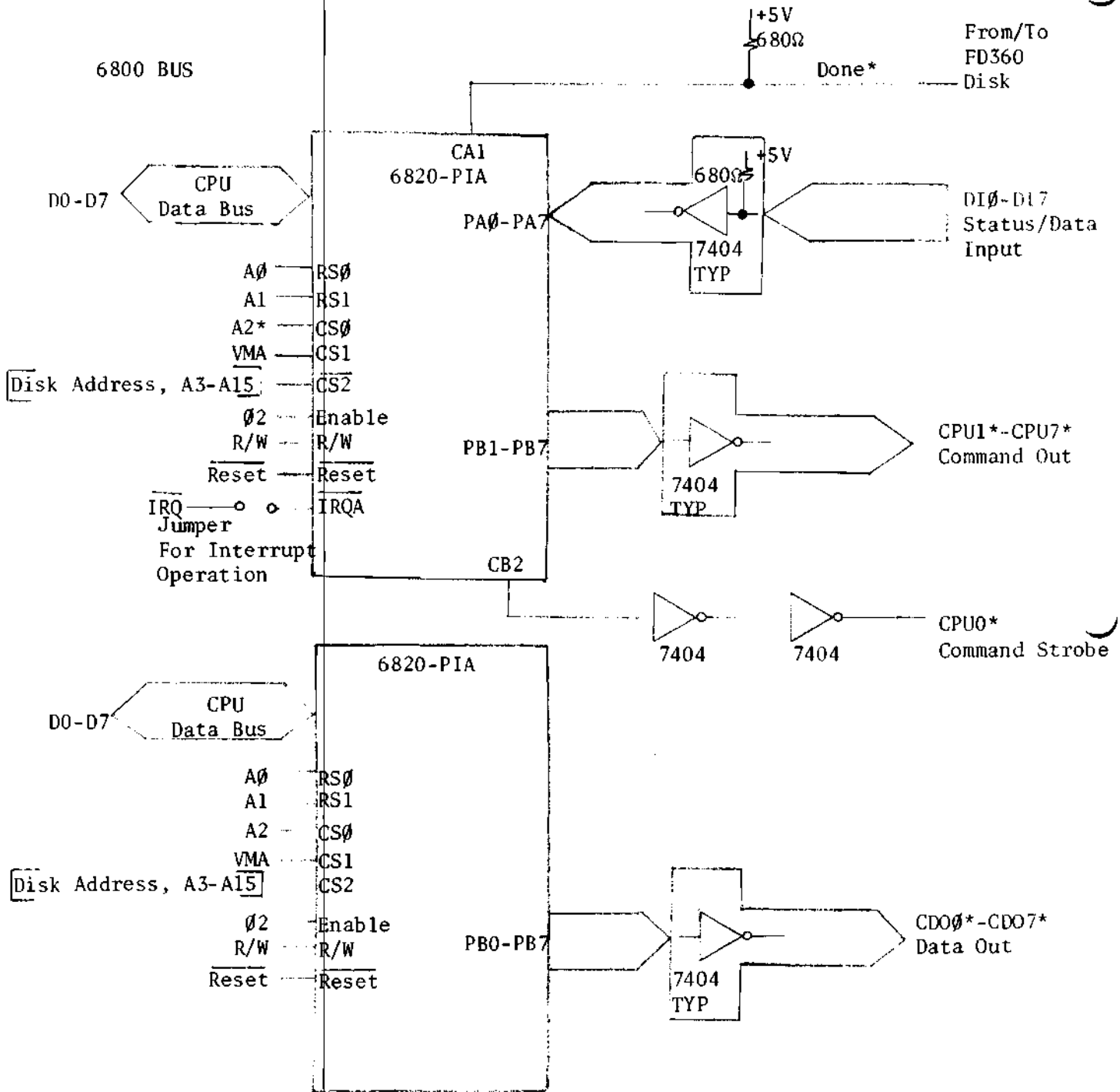

Fig. C-6800 Interface Sketch

APPENDIX A

Addendum for Frugal Floppy Model FF36

A.1 Add section 3.2.4 as follows:

3.2.4 P3 disk drive with remote mux power. (Connects to J3 on the remote mux board.)

<u>PIN#</u>	<u>SIGNAL NAME</u>	<u>DESCRIPTION</u>
P3 1	-12 V DC	-12 V Input
P3 2	-12 V RET	-12 V Return
P3 3	+5 V DC	+5 V Input
P3 4	+5 V RET	+5 V Return
P3 5	+24 V RET	+24 V Return
P3 E	+24 V RET	+24 V Return
P3 6	+24 V DC	+24 V Input
P3 F	+24 V DC	+24 V Input

A.2 Disregard Section 4.2 Use information as follows:

4.2 Disk Drive with Remote Mux

- * +24 V DC₊ 10% at 2 amps average, 4 amps peak.
+5 V DC₊ 5% at 1 amp maximum.
-12 V DC₊ 5% at 0.3 amps peak.

- * Power specified is for a single disk drive. If multiple drives are to be used, the power requirements must be multiplied by the number of drives used.

✓

✓

✓

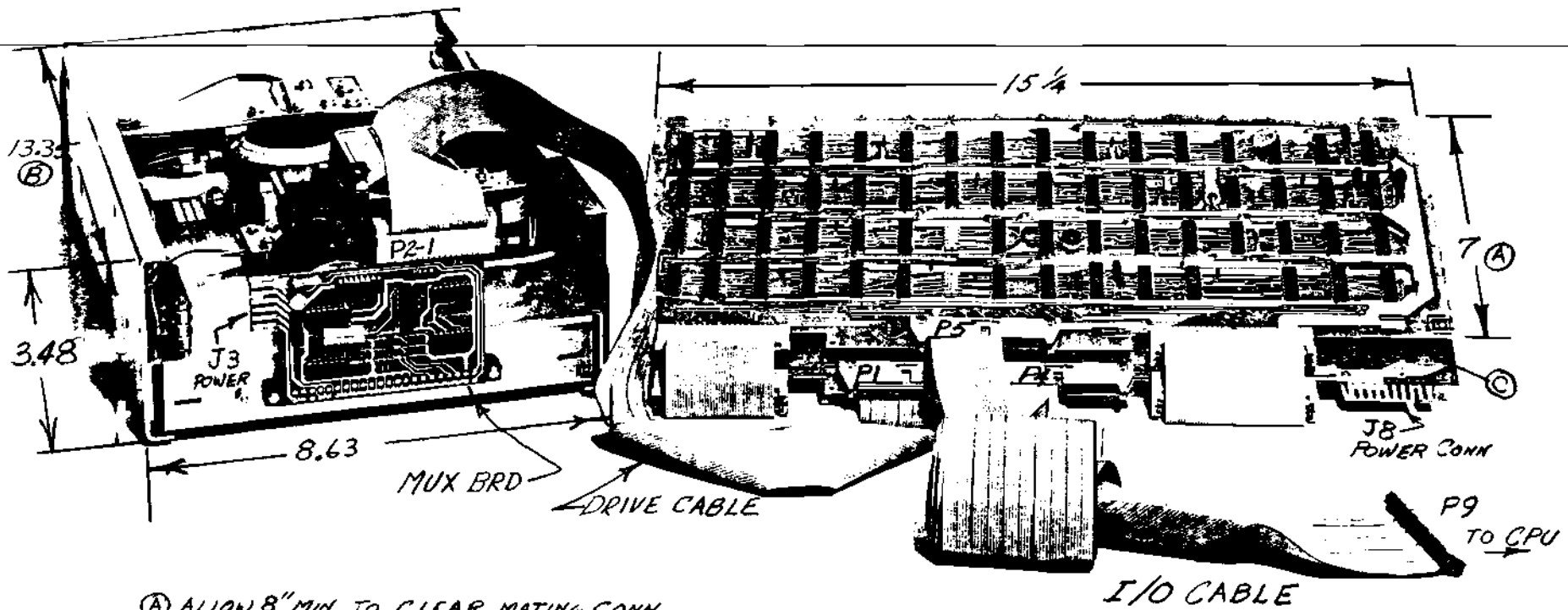
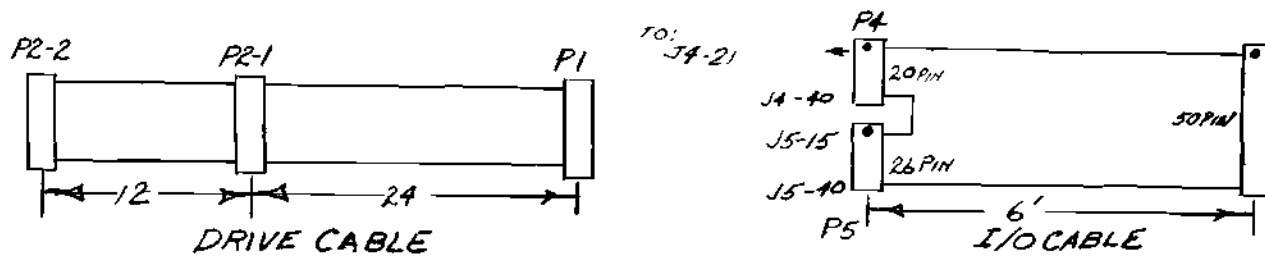

- (A) ALLOW 8" MIN TO CLEAR MATING CONN
- (B) ALLOW 14" MIN BEHIND BEZEL TO CLEAR MUX CARD
- (C) BOARD TO BOARD SPACING 1/2 MIN - 2 1/2 MAX

iCOM's Frugal Floppy.™
 your microprocessor's best friend.

✓

✓

✓