

6741 VARIEL AVENUE - CANOGA PARK - CALIFORNIA 91303 - PHONE: (213) 348-1391

FD360/CF360
MAINTENANCE MANUAL

This maintenance manual is intended as a trouble-shooting guide for isolating faults down to the replaceable subassembly level. Schematics are supplied as an aid in examining signals. No attempt is made to explain the operation fully enough to isolate faults down to the individual component level, however, it should be possible given the right test equipment and experience.

It is recommended that OEM customers who are maintaining large numbers of FD360/CF360 systems stock the subsystem level spares for use in field repairs. A recommended Spares List is given in the Appendix.

November 1975

SYMPTOM

POSSIBLE CAUSES (See Appendix for Signal Locations)

Drive Fail Status, Drive Motor does not run

1. Drive not up to speed yet. Software should allow 6-7 seconds after closing door.
2. Diskette jammed. Open door. Reinsert Diskette. Try again. Diskette may be out of tolerance. Try another Diskette.
3. Check +24 Volt supply. Pins E (+24V return) and F (+24V) on MUX PCB power connector. Voltage with both drives running s/b 24.0 Volts $\pm 10\%$.
4. Check cable connections. Ribbon connector. Power connector. Drive connector.
5. Try swapping MUX cards. If problem remains with drive, then check DRFAL signal. Should be low when door is open. Should go high 5 seconds after door is closed. Should hear motor start.
6. Is a valid unit selected? Check SEL 0*, SEL 1*, SEL2*, SEL 3*. Should be logic "0" for selected drive. All others should be logic "1". Check command load unit/sector and data in lines.

Head Loads, but does not seek

1. Head may be past track 76. Issue Seek 0 Command and retry.
2. Diskette may be bad. Try another.
3. Check -5V at pin A of MUX card. Check -12V supply at pin 1 of MUX card. Tolerance nominally $\pm 5\%$.
4. Check 10ms signal. When seeking, 10ms should be high for 10-11 msec, then low for about 1 us, then high, etc. Adjust frequency if necessary.
5. In a dual (or more) drive system, if one unit seeks OK and the other doesn't, try swapping MUX's. If problem now is in the other drive, replace the MUX. If the same drive is bad, replace drive.
6. If both drives will not seek, verify that the SEEK signal goes high. If the SEEK signal does not go high, check that the SEEK command, 05, is coming from the CPU on the CPU 0* - CPU 7* lines.

SYMPTOM	POSSIBLE CAUSES (CON'T.)
Head Loads, but does not seek (con't.)	7. If SEEK signal does go high, check for how long. 5-10 ms indicates CRC error in ID sector. 700 ms indicates no data being read from Diskette. Replace controller
CRC Errors	<ol style="list-style-type: none"> 1. Excessive wear on Diskette. Replace Diskette. 2. Diskette not seated. Reinsert and retry, put system in a read loop. 3. Sync scope on INDEX signal, positive edge. Look at two signals with two traces of the scope. On "A" trace look at the DAFLD signal. With the other trace look at CRCAZ signal. Twenty six DAFLD pulses should occur for each sync. At the end of each DAFLD, CRCAZ should go high momentarily. If the momentary high is not present, it is due to CRC error on Diskette or controller failure. Try a known good Diskette. If still bad, replace controller.
Seeks to wrong track	1. Bad controller. Replace.
One bit of data is bad on read	<ol style="list-style-type: none"> 1. Bad controller or interface. Write a pattern of all one's and examine input and output of read buffer. Inputs should be all ones during DAFLD time. Sync on NXDFD signal. Cycle on read. Output should be all one's also. Repeat with all zero pattern. 2. Check data in signals DIO-DI7 with data pattern above. Sync on GASTS signal. Data in lines should be one/zero during the time GASTS is logic zero.
One bit of data is bad on write	<ol style="list-style-type: none"> 1. Verify that data written previously can be read correctly. 2. Write all one's pattern continuously to one sector. Check inputs to write buffer D00-D07 and outputs of write buffer during NXDFD signal.
Reads wrong sector	1. Put system into continuous read loop on the correct sector. Examine NXDFD signal. It should be about 5 msec long. If it does not go high at all then the sector cannot be decoded from any ID field. Check SEC 0* - SEC 4* signals (negative true) to verify sector is being loaded correctly.

SYMPTOM

POSSIBLE CAUSES (CON'T.)

Reads wrong sector
(con't.)

2. If NXDFD is only about 100 us long, there is a CRC error in the ID field. Try a new Diskette.
3. If NXDFD is about 10 ms long, then the address mark at the beginning of the data field is not being detected. Try writing the sector again.
4. NXDFD is correct period but still wrong sector, check SEC 0* - SEC 4* (negative true)

Head seeks, but moves in two
or more stages

1. Put system into continuous loop of Seek 0 and Seek to track 4C (HEX). Check timing of 10MS signal. When seeking 10MS should be high for 10-11 ms and low for 1 us. Adjust timing if necessary.
2. Bad Diskette, try another.
3. Bad drive, check wear and friction of head stepper stage.
4. Check connectors, MUX to controller, MUX to drive.

Busy does not set

1. Check that Read, Write or Seek commands are being received.
2. Check 10MS signal. It should be a 10 MHz signal.

APPENDIX A
GLOSSARY OF SIGNALS

<u>SIGNAL</u>	<u>DESCRIPTION</u>	<u>SOURCE</u>
SEEK	Seek Command Latch	B1-10
SEEK 0	Seek 0 Command Latch	B1-12
READ	Read Command Latch	B1-2
READ CRC	Read CRC Command Latch	B1-7
WRITE	Write Command Latch	B1-5
WRDDA	Write Deleted Data Address Mark Command Latch	B1-15
Clear*	Clear Signal (Neg true)	C3-6
Gasts	Gate Status if True, Gate Read Data if False	A3-12
LDTRA	Load Track Address	B2-10
LDU.S	Load Unit/Sector	B2-8
LDWRD*	Load Write Buffer (Neg true)	B3-6
RBOU*	Shift Read Buffer (Neg true)	A6-11
CLREF*	Clear Error Flags	A5-1
BUSY	Controller Busy	D4-5
DONE	Controller Done Pulse (2 us)	D1-13
IDFLD	ID Field Time	F12-3
GAP2	Gap between ID and Data	F12-5
DAFLD	Data (Sector) Time	E9-3
Index	Index Hole Time	F14-1
GAP3	Gap between Data and ID	G15-10
WRTEN	Write Enable Time	F4-8
CO,1*	Write Clock Time	G4-6
C20,21*	Write Data Time	G4-8

APPENDIX A

GLOSSARY OF SIGNALS (CON'T.)

<u>SIGNAL</u>	<u>DESCRIPTION</u>	<u>SOURCE</u>
SDIN	Serial Data into CRC Register	E3-3
SDOUT	Serial Data out of CRC Register	D7-12
WDATA*	Write Data Composite (Neg true)	F1-13
ID*	ID Field Address Mark Detect	C12-12
Data*	Data Field Address Mark Detect	C6-8
Sep Clock*	Separated Clock (Neg true)	E7-3
Sep Data*	Separated Data (Neg true)	E16-6
HIGHI*	High Current Adjust Above Track 43	C13-10
10M	10 Megahertz Clock	C3-11
WBO-WB7	Write Buffer Output	A16,B16-14,4,12,
P8DO-P8D7	Read Buffer Output	D14,D15-14,4,12,7
FDDAM	Found Deleted Data Address Mark Latch	D6-5
10MS	10 msec Timing Signal for Head Step	A7-13
SLEW	Head Slew one shot	D1-5
STOUT*	Step Head out towards Track 0 (Neg true)	B7-3
STIN*	Step Head in towards Track 76 (Neg true)	B8-12
TRO	Track 0 Switch	E7-4
SEC 0*- SEC 4*	Sector Latch (Neg true)	A13-1, 14,11,8 A12-1
UN0	Unit Select Bit 0	A12-10
UN1	Unit Select Bit 1	A12-9
NXDFD	Next Data Field	D6-3
QHDL	Head Load Latch	D4-3

APPENDIX A
GLOSSARY OF SIGNALS (CON'T.)

<u>SIGNAL</u>	<u>DESCRIPTION</u>	<u>SOURCE</u>
SELO*	Select Unit 0 (Neg true)	E13-11
SEL1*	Select Unit 1 (Neg true)	E13-9
SEL2*	Select Unit 2 (Neg true)	E13-7
SEL3*	Select Unit 3 (Neg true)	E13-5
CRC	Cyclic Redundancy Check Latch	E9-5
WRPRO	Write Protect	E2-8
DRFAL	Drive Fail	E2-13
CRCAZ	CRC Register Equals Zero	D8-10
CPU0*- CPU7*	Command Output Bits 0-7 (Neg true)	A9-1,2,4,9,11,13 B9-11,13
CDO0*- CDO7*	Data Output Bits 0-7 (Neg true)	B9-1,3, A11-1,3,5, 9,11,13

APPENDIX B

RECOMENDED SPARES

iCOM MODEL FD360 FLOPPY DISK SYSTEM

<u>ITEM</u>	<u>MODEL</u>	<u>DESCRIPTION</u>	<u>UNIT PRICE</u>	<u>*</u>
1.	FD400	Pertec Floppy Disk Drive	\$ 650.00	4
2.	CF360	Controller/Formatter P.C. Board Set	850.00	2
3.	360-20	Multiplexer P.C. Card (MUX)	50.00	2
4.	360-22	2 Drive Cable from Controller to Drives	50.00	2
5.	360-24	4 Drive Cable	80.00	1
6.	360-25	50 Pin Jumper Cable between Controller Boards	30.00	3
7.	360-26	40 Pin Jumper Cable between Controller Boards	30.00	3
8.	360-27	Computer to FD360 Cable Assembly	50.00	5
9.	360-101	Power Supply Assembly +24V, +5V, -12V prewired	250.00	2
10.	225-20621-401-117	Connector - MUX power	5.00	10
11.	225-21021-401-117	Connector - Controller power	5.00	10

* Recommended inventory quantity per 100 installed FD360 units

NOTE: Prices shown valid at time of publication, but subject to change without notice.

Please ask for price quotation before ordering.



DISK DIAGNOSTICS

COMMAND	ACTION	COMMENTS	POSSIBLE ERROR MESSAGE
A	Send clear pulse to Floppy Disk Drive electronics.	May be used to halt disk operation provided key board response is available.	None
Bu,t	Seek to specified track and verifies proper track was attained.	Time required = \emptyset to .75 seconds (approximate)	None
Du,s	Reads from specified sector on current track to buffer.	Time required = .2 to 1 seconds (approximate)	$\emptyset 1$
Fu,s	Writes from buffer to specified sector on current track.	Continuous test - no physical indication of test progress	
Gu,s	Writes from buffer to specified sector on current track, then, checks by reading written data and compares to buffer.	Continuous test - no physical indication of test progress	$\emptyset 2$ $\emptyset 3$ $\emptyset 7$
Hu	Seeks track \emptyset to track 76 verifying that respective tracks were attained.	Continuous test - repetitive head movement to and from extremes of travel	None
I	Selects each of the four drives.	Checks electronics regardless of physical drives installed. No physical indication of test progress.	$\emptyset 4$
Ju	Seeks each track (\emptyset to 76) on unit specified. Writes track and sector number in each sector. Then reads to verify.	Approx. time required = 9 seconds per track for write cycle, 5 seconds per track for read cycle - total time = 17 minutes (approx.)	$\emptyset 1$ $\emptyset 2$ $\emptyset 5$
Ku	Repetitive J test.	Continuous test.	$\emptyset 1$ $\emptyset 5$ $\emptyset 2$
Lu	Repetitive J test read cycle only.	Continuous test.	$\emptyset 1$ $\emptyset 5$
Mu	Writes deleted data mark on each sector of current track, then, checks by reading.	Approx. time required = 15 seconds.	$\emptyset 6$

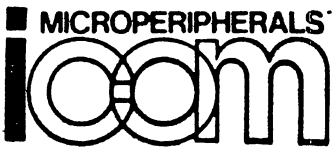

6741 VAREL AVENUE · CANOGA PARK · CALIFORNIA 91303 · PHONE: (213) 348-1391

SCHMATIC AND
LOGIC DIAGRAMS
MODEL FD360

The information contained herein is proprietary to iCOM, inc. and should not be reproduced, distributed, and/or disclosed outside your organization.

DRAWING NUMBERS PCS

Z1 200028-200

Z2 200028-201

Mux 200012-200

March 1976



REVISIONS				
ZONE	LTR	DESCRIPTION	DATE	APPROVED
B			1-14-76	

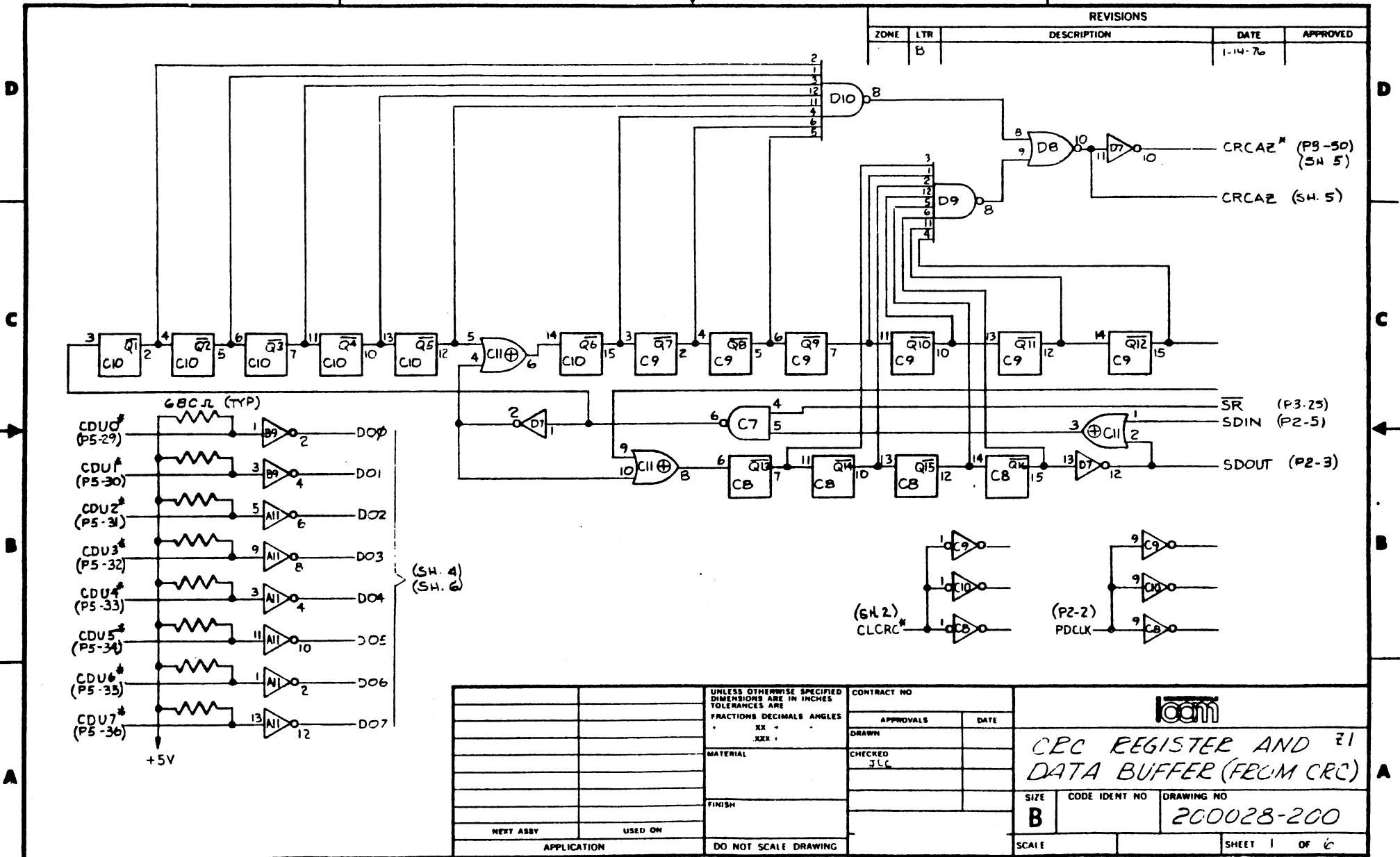

UNLESS OTHERWISE SPECIFIED DIMENSIONS ARE IN INCHES TOLERANCES ARE FRACTIONS DECIMALS ANGLES XX XXX		CONTRACT NO.			
MATERIAL		APPROVALS			
FINISH		DATE		CRC REGISTER AND 21 DATA BUFFER (FROM CRC)	
NEXT ASSY		DRAWN		SIZE	CODE IDENT NO
USED ON		CHECKED		B	200028-200
APPLICATION		DO NOT SCALE DRAWING		SCALE	SHEET 1 OF 6

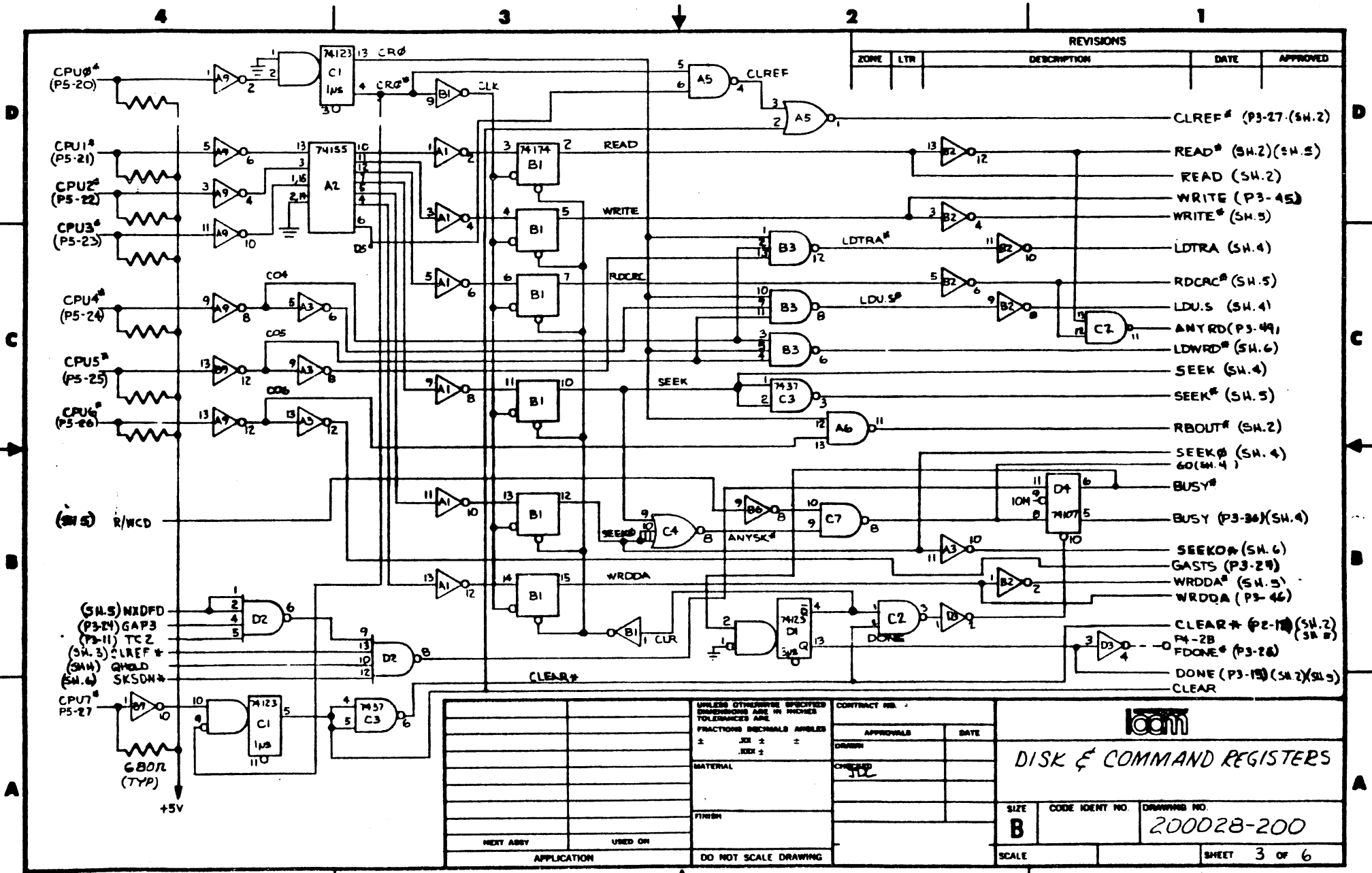

REVISIONS				
ZONE	LTR	DESCRIPTION	DATE	APPROVED

- CLREF* (P3-27)(SH.2)
- READ* (SH.2)(SH.5)
- READ (SH.2)
- WRITE (P3-45)
- WRITE* (SH.5)
- LDTRA (SH.4)
- RDCRC* (SH.5)
- LDUS (SH.4)
- ANYRD (P3-49)
- LDWRD* (SH.6)
- SEEK (SH.4)
- SEEK* (SH.5)
- RBOU* (SH.2)
- SEEK0 (SH.4)
- 60(SH.4)
- BUSY*
- BUSY (P3-36)(SH.4)
- SEEKA (SH.6)
- GASTS (P3-28)
- WRDDA* (SH.5)
- WRDDA (P3-46)
- CLEAR* (P2-17)(SH.2)
- P4-2B
- FDONE* (P3-26)
- DONE (P3-15)(SH.2)(SH.5)
- CLEAR

UNLESS OTHERWISE SPECIFIED DIMENSIONS ARE IN INCHES TOLERANCES ARE FRACTIONS DECIMALS ANGLES ± .01 ± .02 ±		CONTRACT NO.
MATERIAL		APPROVALS
FINISH		DATE
NEXT ASSY		CHECKED
USED ON		DATE
APPLICATION		DO NOT SCALE DRAWING

loom		
DISK & COMMAND REGISTERS		
SIZE	CODE IDENT NO.	DRAWING NO.
B		200028-200
SCALE	SHEET 3 OF 6	

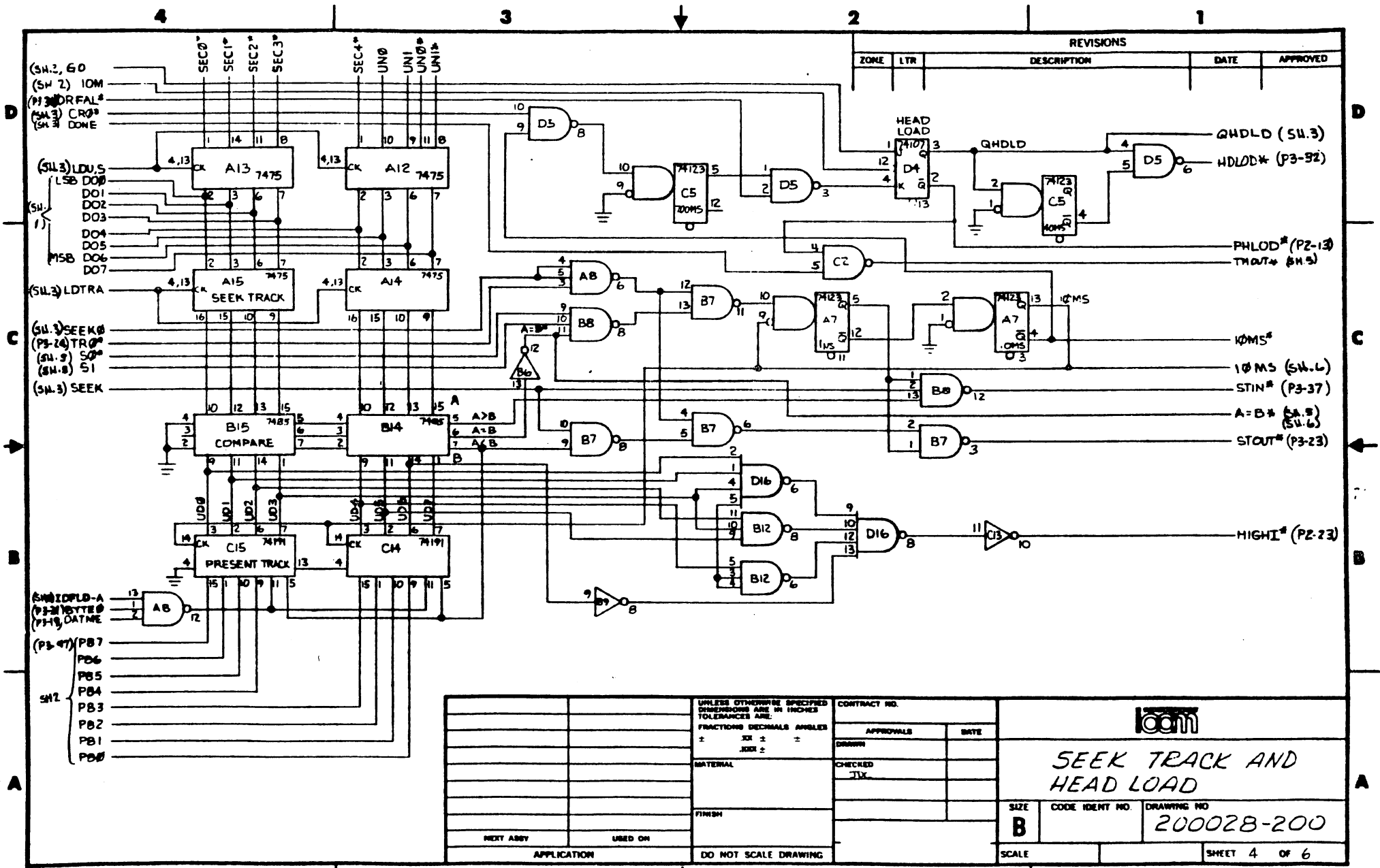

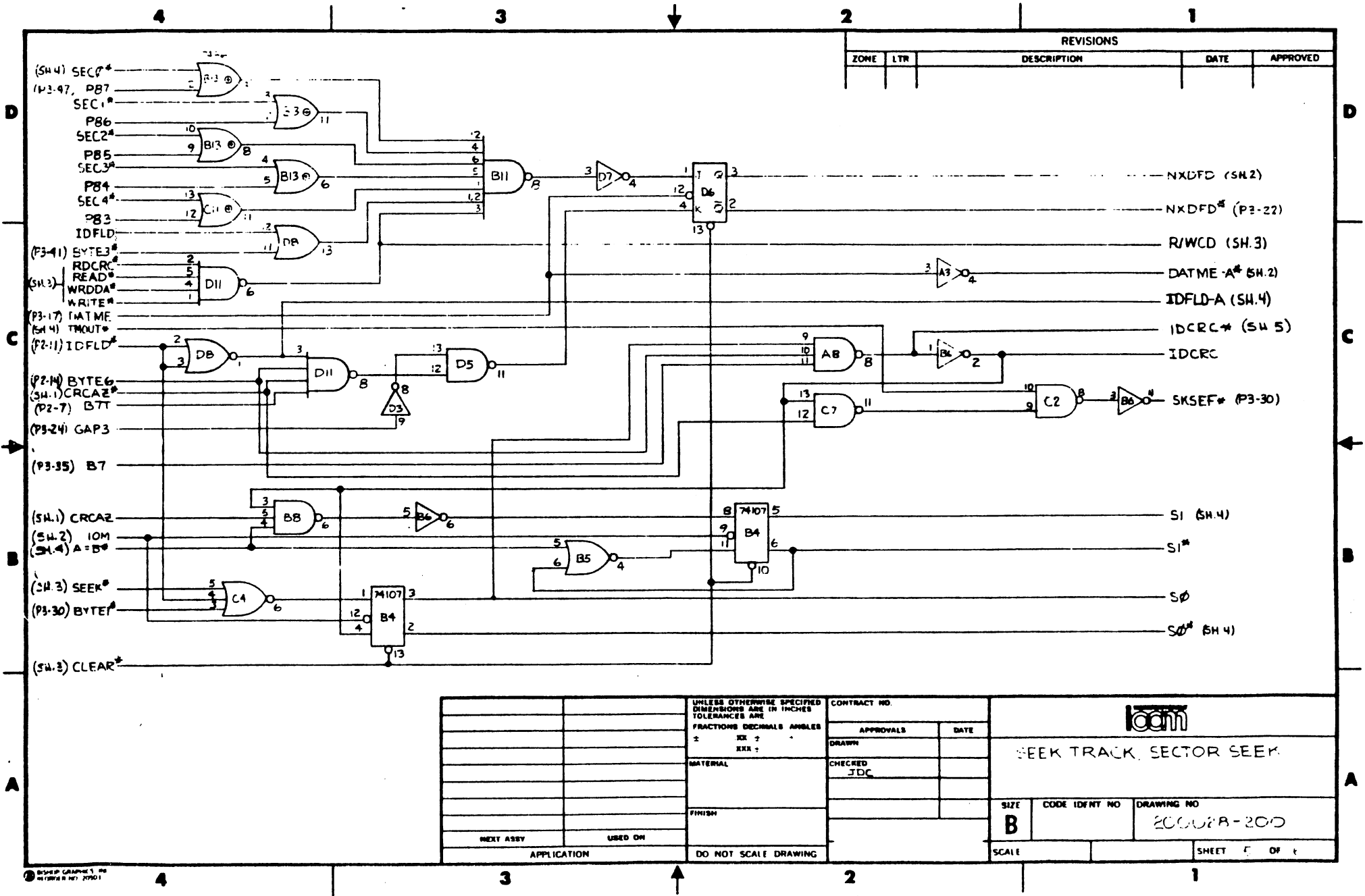

REVISIONS				
ZONE	LTR	DESCRIPTION	DATE	APPROVED

UNLESS OTHERWISE SPECIFIED DIMENSIONS ARE IN INCHES TOLERANCES ARE FRACTIONS DECIMALS ANGLES ± .XX ± XXX ±		CONTRACT NO.			
MATERIAL		APPROVALS	DATE		
FINISH		DRAWN	CHECKED	SEEK TRACK, SECTOR SEEK	
NEXT ASSY		USED ON	JDC		
APPLICATION		DO NOT SCALE DRAWING		SIZE	CODE IDENT NO
				B	200028-200
				SCALE	DRAWING NO
					200028-200
				SHEET 5 OF 6	

IBM CORPORATION
P.O. BOX 217
ARMONK, N.Y. 10501

REVISIONS				
ZONE	LTR	DESCRIPTION	DATE	APPROVED

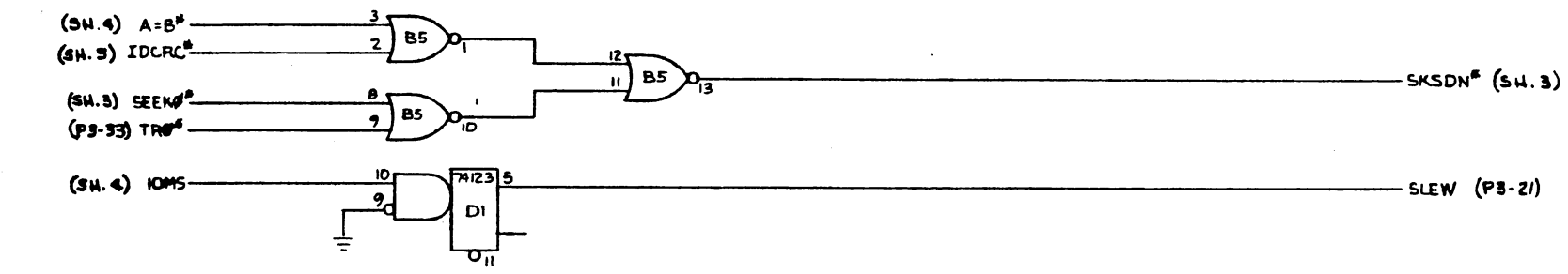
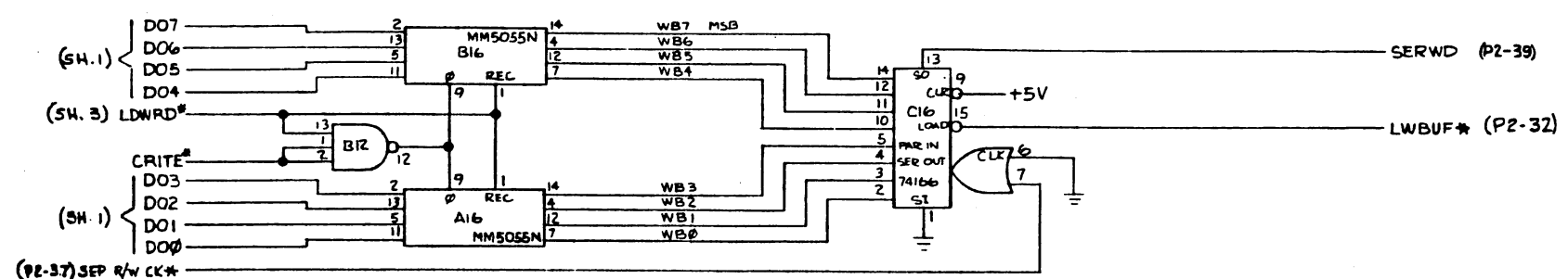

UNLESS OTHERWISE SPECIFIED DIMENSIONS ARE IN INCHES TOLERANCES ARE FRACTIONS DECIMALS ANGLES ± .XX + - .XXX +		CONTRACT NO.			
MATERIAL		APPROVALS	DATE		
FINISH		DRAWN	CHECKED	WRITE BUFFER AND COMMAND BUFFERS (FROM CPU)	
NEXT ASSY		USED ON	JDC	SIZE	CODE IDENT NO
APPLICATION		DO NOT SCALE DRAWING		B	200028-200
				SCALE	DRAWING NO
					200028-200
					SHEET 6 of 6

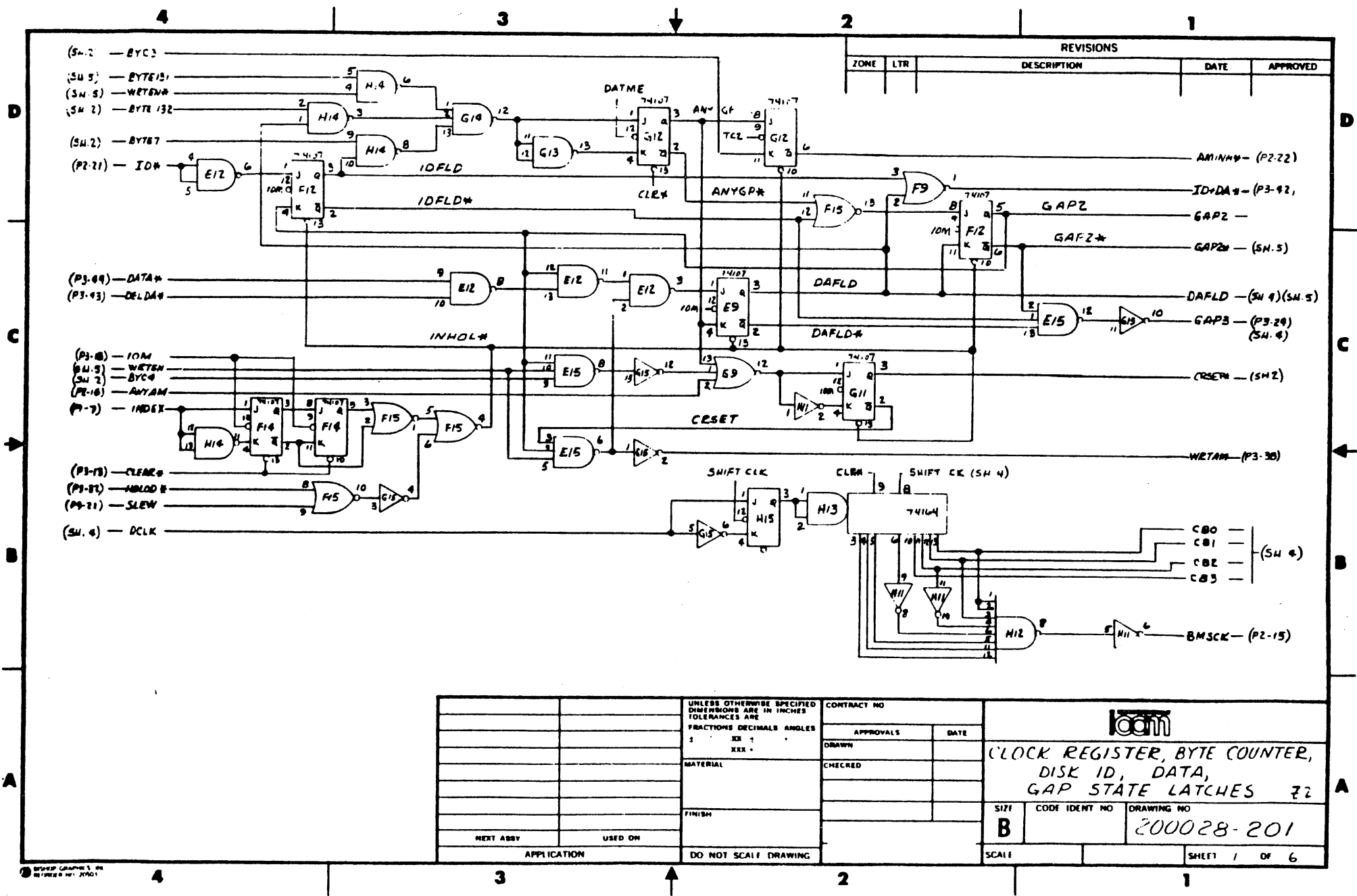

REVISIONS				
ZONE	LTR	DESCRIPTION	DATE	APPROVED

		UNLESS OTHERWISE SPECIFIED DIMENSIONS ARE IN INCHES TOLERANCES ARE FRACTIONS DECIMALS ANGLES 1 XXX 2 XXX 3	CONTRACT NO		
			APPROVALS	DATE	
		MATERIAL	CHECKED	CLOCK REGISTER, BYTE COUNTER, DISK ID, DATA, GAP STATE LATCHES ??	
		FINISH	SIZE B		CODE IDENT NO
NEXT ASSY		USED ON	DRAWING NO		200028-201
APPLICATION		DO NOT SCALE DRAWING	SCALE		SHEET 1 OF 6

REVISIONS				
ZONE	LTR	DESCRIPTION	DATE	APPROVED

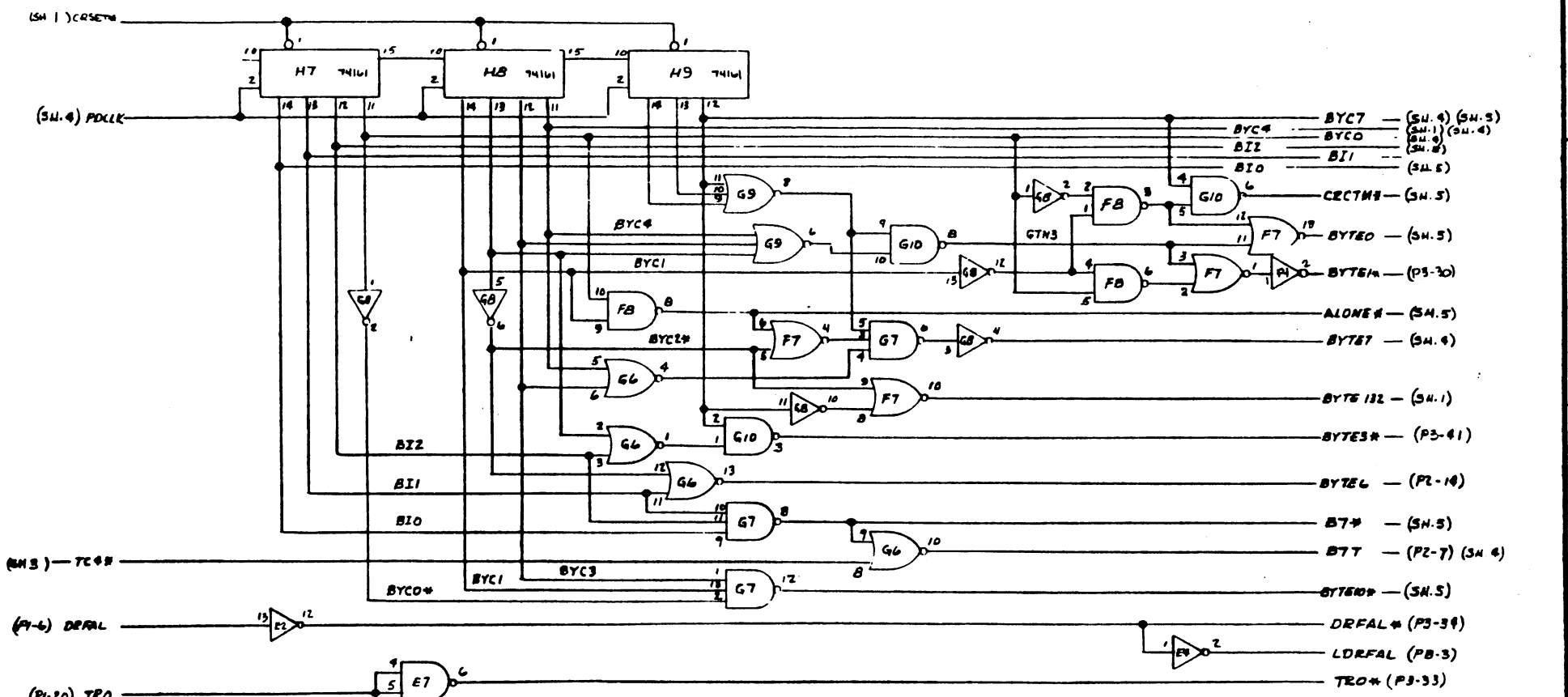

UNLESS OTHERWISE SPECIFIED DIMENSIONS ARE IN INCHES TOLERANCES ARE: FRACTIONS DECIMALS ANGLES ± .XX ± .2 .XXX ± .2		CONTRACT NO.		
MATERIAL		APPROVALS	DATE	
FINISH		DRAWN	CHECKED	BYTE COUNT DECODING
NEXT ASSY		DRAWING NO. 200028-201		
USED ON		SIZE B	CODE IDENT NO.	DRAWING NO. 200028-201
APPLICATION		SCALE	SHEET 2 OF 6	
DO NOT SCALE DRAWING				

REVISIONS				
ZONE	LTR	DESCRIPTION	DATE	APPROVED

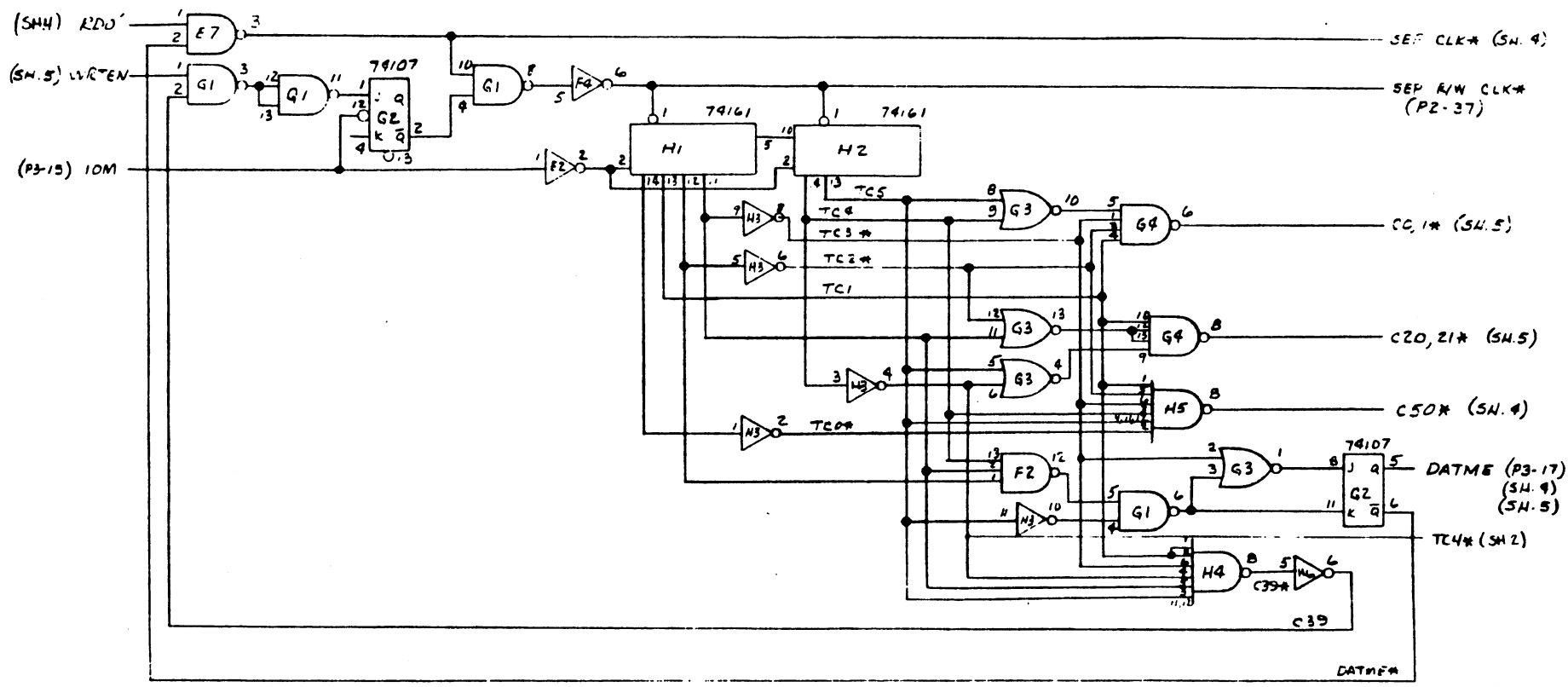

		UNLESS OTHERWISE SPECIFIED DIMENSIONS ARE IN INCHES FRACTIONS DECIMALS ANGLES • XX • XXX •	CONTRACT NO		
			APPROVALS	DATE	
		MATERIAL	DRAWN		DATA SEPARATOR
			CHECKED		
		FINISH			SIZE
					CODE IDENT NO
					DRAWING NO
					200028-201
					SCALE
					SHEET 3 OF 6

REVISIONS				
ZONE	LTR	DESCRIPTION	DATE	APPROVED

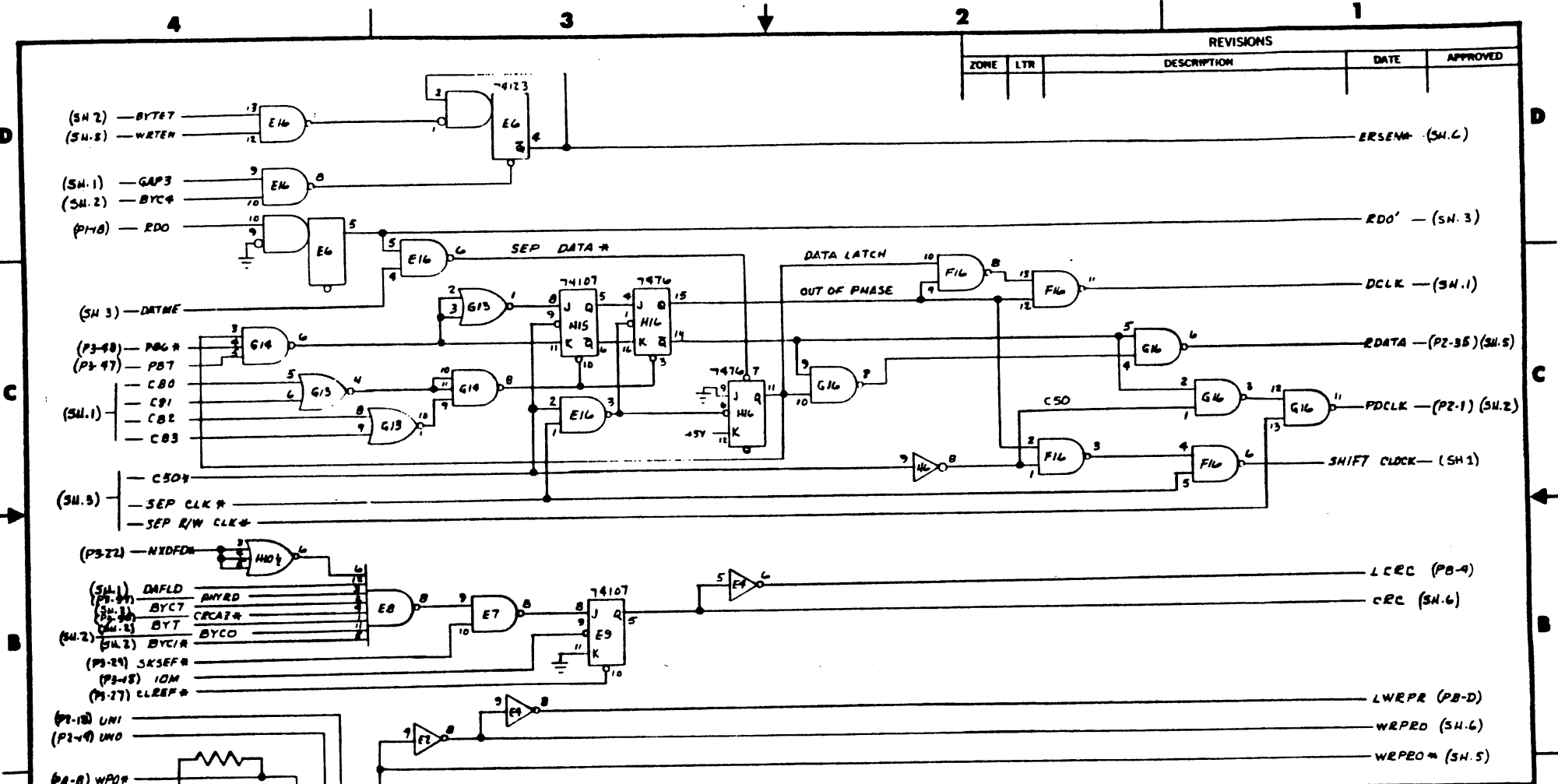

UNLESS OTHERWISE SPECIFIED DIMENSIONS ARE IN INCHES TOLERANCES ARE FRACTIONS DECIMALS ANGLES ± .010 .005 .005		CONTRACT NO.	
MATERIAL		APPROVALS	DATE
FINISH		DRAWN	
NEXT ASSY		CHECKED	
USED ON		SIZE	CODE IDENT NO
APPLICATION		B	200028-201
DO NOT SCALE DRAWING		SCALE	SHEET 4 OF 6

loom

**DATA LATCH,
ERASE TRIM,
CRC ERROR LATCH**

DRAWING NO
200028-201

REVISIONS				
ZONE	LTR	DESCRIPTION	DATE	APPROVED

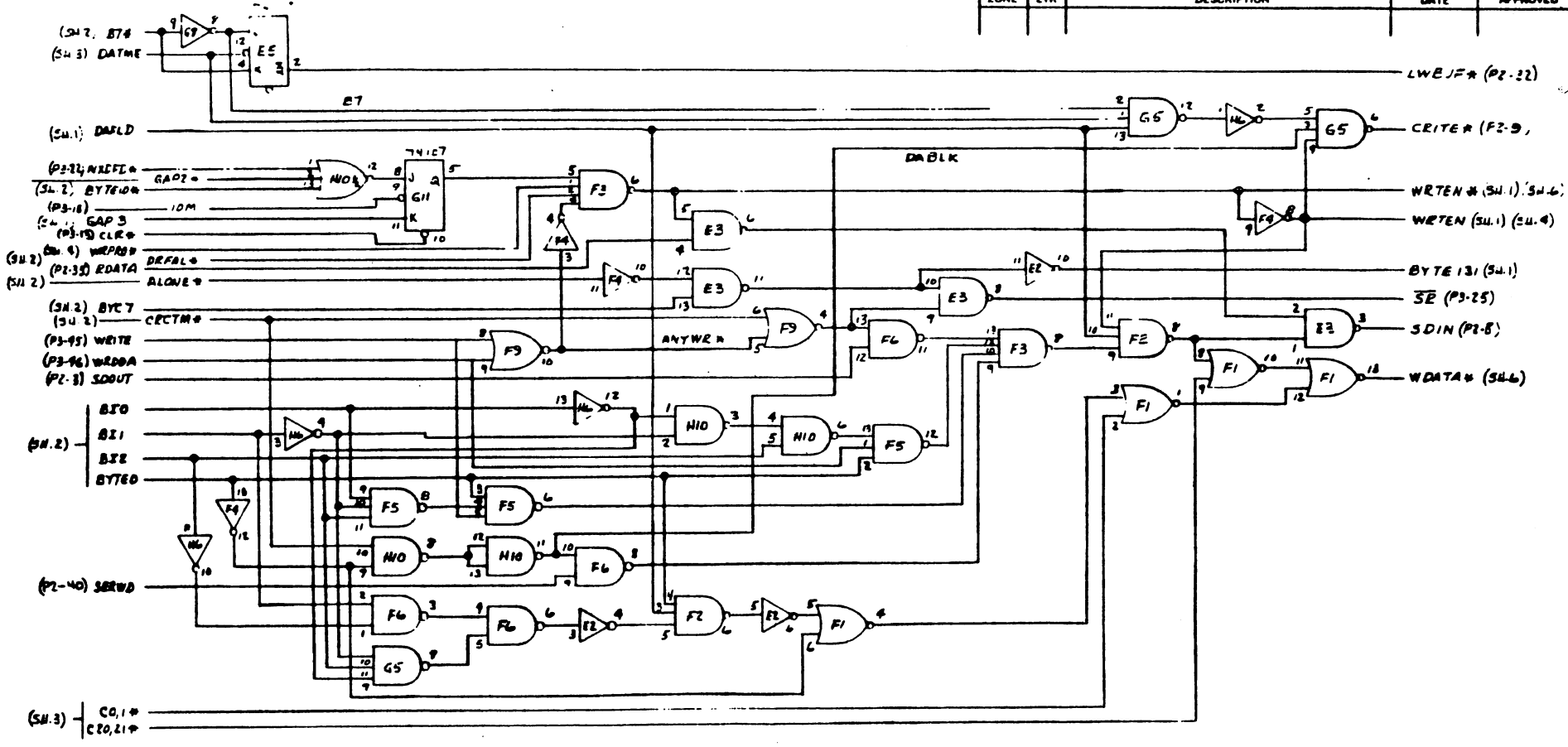

		UNLESS OTHERWISE SPECIFIED DIMENSIONS ARE IN INCHES TOLERANCES ARE FRACTIONS DECIMALS ANGLES + .XX + . XX.X + .	CONTRACT NO		
			APPROVALS	DATE	
		MATERIAL	DRAWN		DISK WRITE LOGIC
		FINISH	CHECKED		
NEXT ASSY	USED ON	DO NOT SCALE DRAWING	SIZE B	CODE IDENT NO	DRAWING NO 200028-201
APPLICATION			SCALE	SHEET 5 OF 6	

4

3

2

1

REVISIONS				
ZONE	LTR	DESCRIPTION	DATE	APPROVED

(P1-27) P226 — PBD1
 (P1-27) PBD0
 (P1-27) PBD2
 (P1-27) PBD3
 (P1-27) PBD4
 (P1-27) PBD5
 (P1-27) PBD6
 (P1-27) PBD7
 (P1-27) PBD8
 (P1-27) PBD9
 (P1-27) PBD10
 (P1-27) PBD11
 (P1-27) PBD12
 (P1-27) PBD13
 (P1-27) PBD14
 (P1-27) PBD15
 (P1-27) PBD16
 (P1-27) PBD17
 (P1-27) PBD18
 (P1-27) PBD19
 (P1-27) PBD20
 (P1-27) PBD21
 (P1-27) PBD22
 (P1-27) PBD23
 (P1-27) PBD24
 (P1-27) PBD25
 (P1-27) PBD26
 (P1-27) PBD27
 (P1-27) PBD28
 (P1-27) PBD29
 (P1-27) PBD30
 (P1-27) PBD31
 (P1-27) PBD32
 (P1-27) PBD33
 (P1-27) PBD34
 (P1-27) PBD35
 (P1-27) PBD36
 (P1-27) PBD37
 (P1-27) PBD38
 (P1-27) PBD39
 (P1-27) PBD40
 (P1-27) PBD41
 (P1-27) PBD42
 (P1-27) PBD43
 (P1-27) PBD44
 (P1-27) PBD45
 (P1-27) PBD46
 (P1-27) PBD47
 (P1-27) PBD48
 (P1-27) PBD49
 (P1-27) PBD50
 (P1-27) PBD51
 (P1-27) PBD52
 (P1-27) PBD53
 (P1-27) PBD54
 (P1-27) PBD55
 (P1-27) PBD56
 (P1-27) PBD57
 (P1-27) PBD58
 (P1-27) PBD59
 (P1-27) PBD60
 (P1-27) PBD61
 (P1-27) PBD62
 (P1-27) PBD63
 (P1-27) PBD64
 (P1-27) PBD65
 (P1-27) PBD66
 (P1-27) PBD67
 (P1-27) PBD68
 (P1-27) PBD69
 (P1-27) PBD70
 (P1-27) PBD71
 (P1-27) PBD72
 (P1-27) PBD73
 (P1-27) PBD74
 (P1-27) PBD75
 (P1-27) PBD76
 (P1-27) PBD77
 (P1-27) PBD78
 (P1-27) PBD79
 (P1-27) PBD80
 (P1-27) PBD81
 (P1-27) PBD82
 (P1-27) PBD83
 (P1-27) PBD84
 (P1-27) PBD85
 (P1-27) PBD86
 (P1-27) PBD87
 (P1-27) PBD88
 (P1-27) PBD89
 (P1-27) PBD90
 (P1-27) PBD91
 (P1-27) PBD92
 (P1-27) PBD93
 (P1-27) PBD94
 (P1-27) PBD95
 (P1-27) PBD96
 (P1-27) PBD97
 (P1-27) PBD98
 (P1-27) PBD99
 (P1-27) PBD100

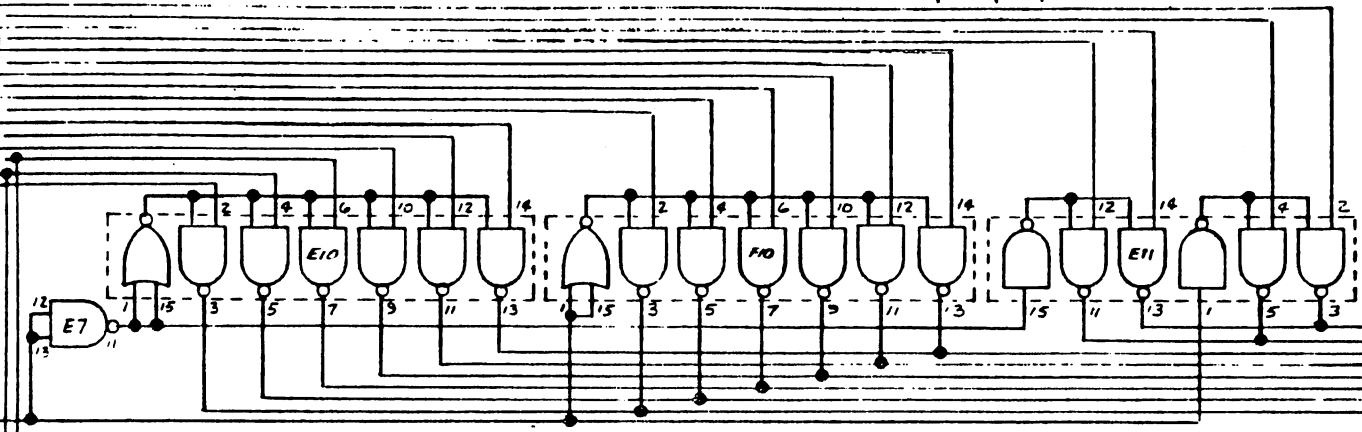

DI7 — DI6 — P1-35
 DI5 — P1-36
 DI4 — P1-37
 DI3 — P1-38
 DI2 — P1-39
 DI0 — P1-29

(P1-20) UNO* UN1*
 (SA.8) WDATA*
 (P1-27) STIN*
 (P1-23) PHLOD*
 (SA.5) WRENA*
 (P1-23) STOUT*
 (P1-23) HIGH I*
 (SA.5) ERSEN*

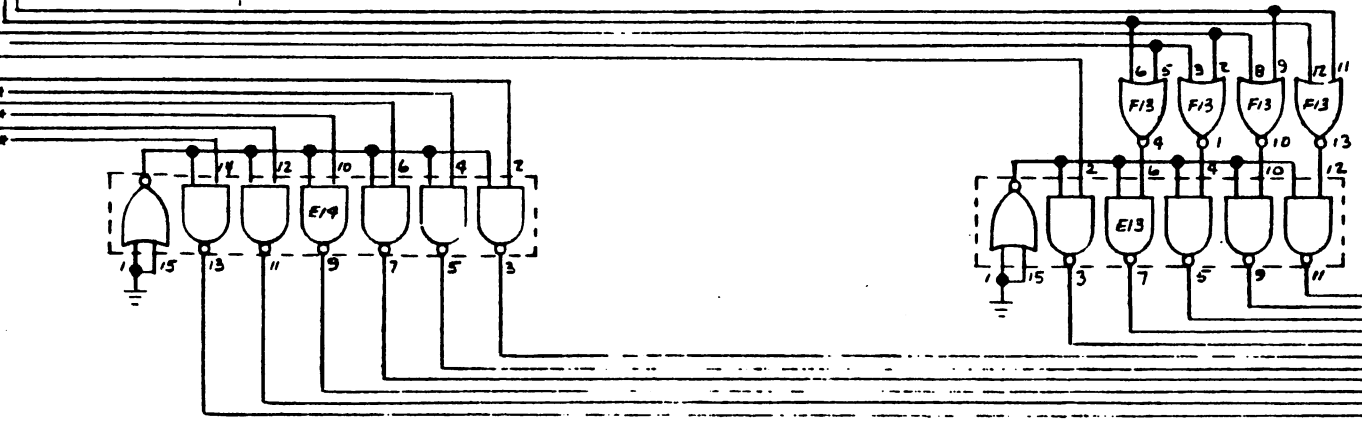

SEL1* — P1-10
 SEL2* — P1-11
 SEL3* — P1-12
 WDATA — P1-28
 STOUT — P1-34
 PHLOD — P1-32
 HIGH I — P1-24
 WRENA — P1-16
 ERSEN — P1-22

UNLESS OTHERWISE SPECIFIED DIMENSIONS ARE IN INCHES		CONTRACT NO			
FRACTIONS DECIMALS ANGLES		APPROVALS			
± XX +		DATE		OUTPUT DRIVERS	
XXX +		DRAWN			
MATERIAL		CHECKED		SIZE	
FINISH		JVL		CODE IDENT NO	
NEXT ASSY		USED ON		DRAWING NO	
APPLICATION		DO NOT SCALE DRAWING		B 200028-201	
				SCALE	
				SHEET 6 OF 6	

4

3

2

1

REVISIONS				
ZONE	LTR	DESCRIPTION	DATE	APPROVED
	A	REDRAWN WAS 'A' SIZE	5/5/76	<i>FS</i>

(ICOM)

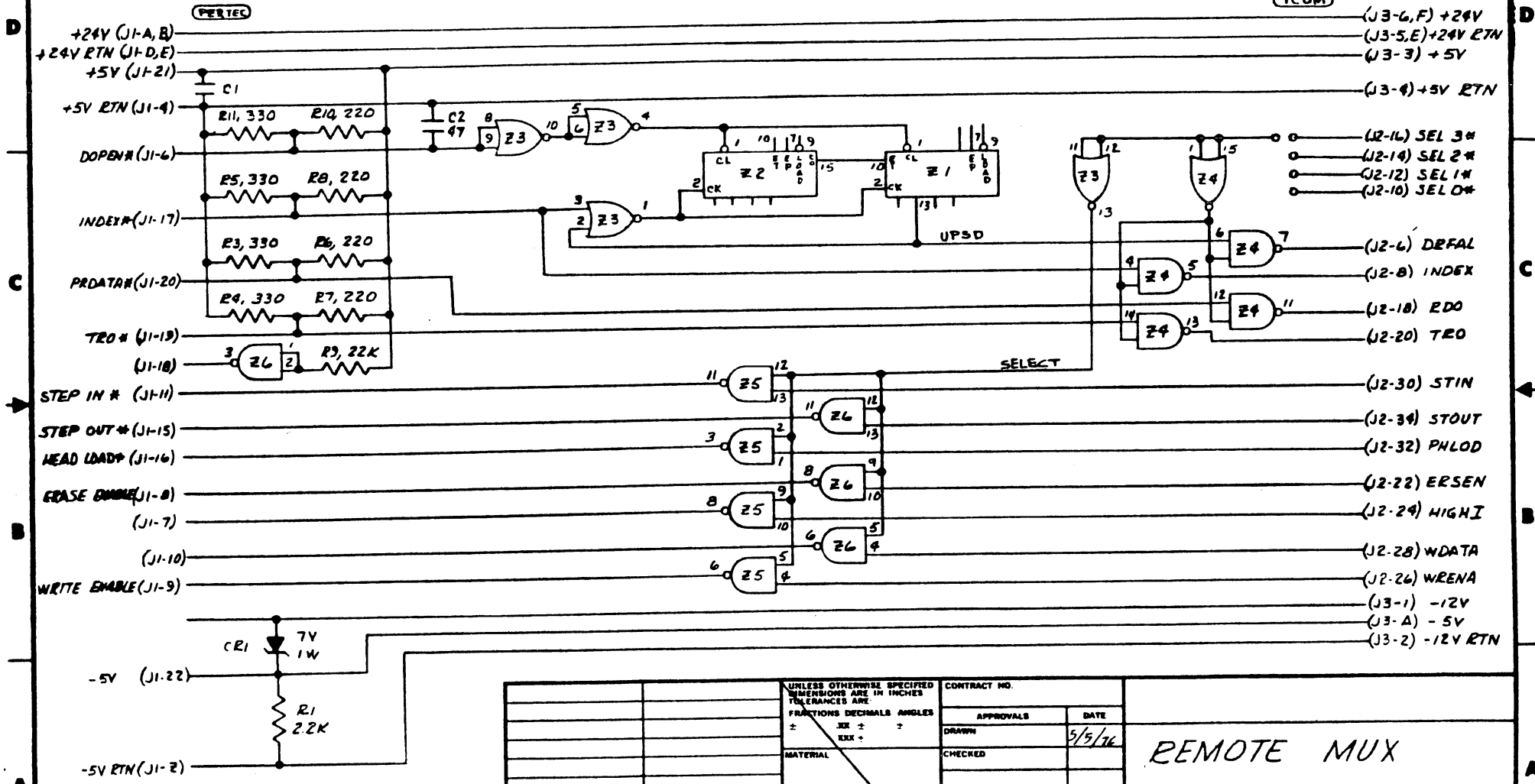

UNLESS OTHERWISE SPECIFIED DIMENSIONS ARE IN INCHES TOLERANCES ARE FRACTIONS DECIMALS ANGLES ± .XX ± .? XX ± .?		CONTRACT NO.		REMOTE MUX	
MATERIAL		APPROVALS	DATE		
FINISH		DRAWN	5/5/76		
NEXT ASSY		CHECKED			
APPLICATION	USED ON	DO NOT SCALE DRAWING		SIZE B	DRAWING NO 200012-200
				SCALE	SHEET 1 OF 1

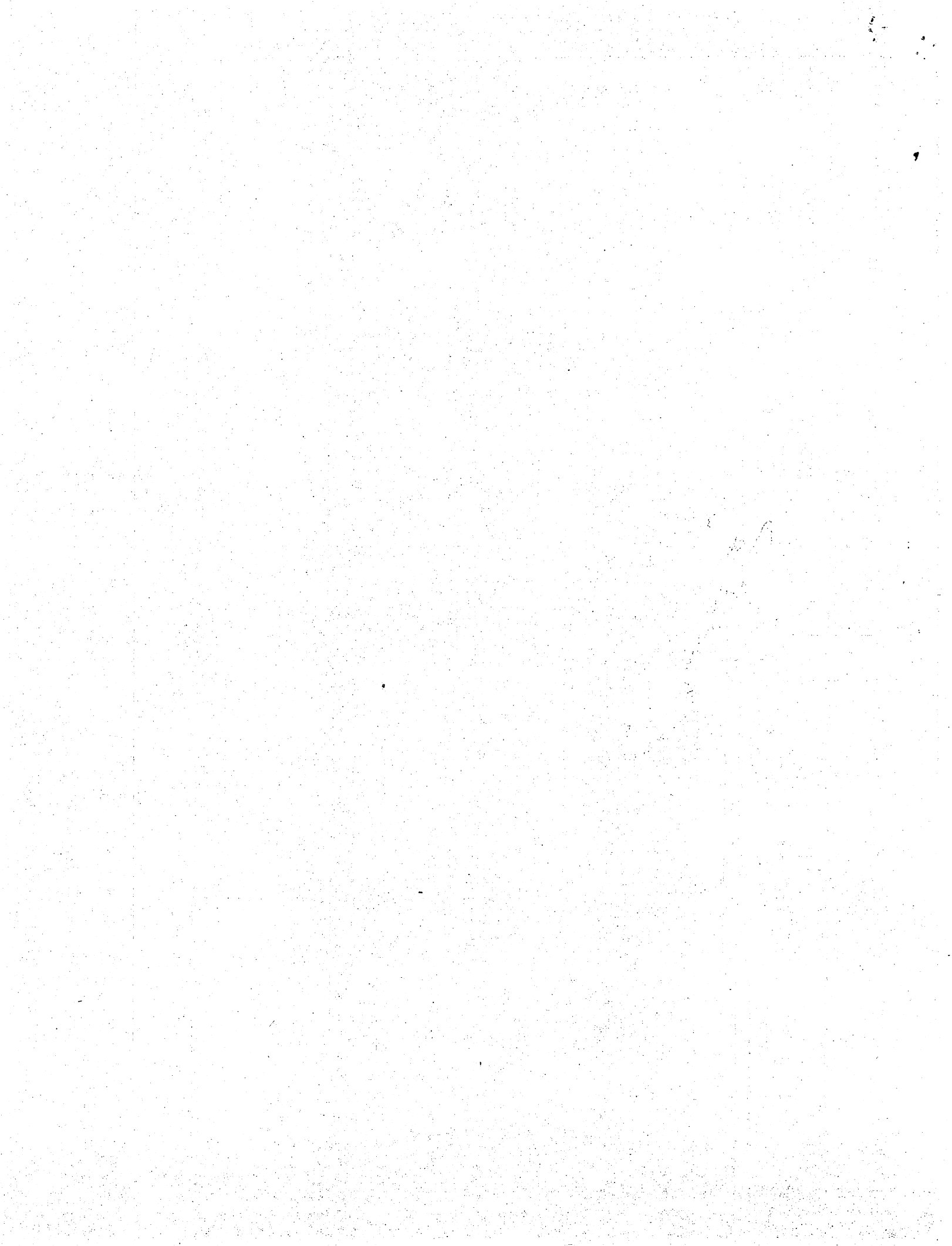

ZONE		LTS		REVISIONS		DATE	APPROVED

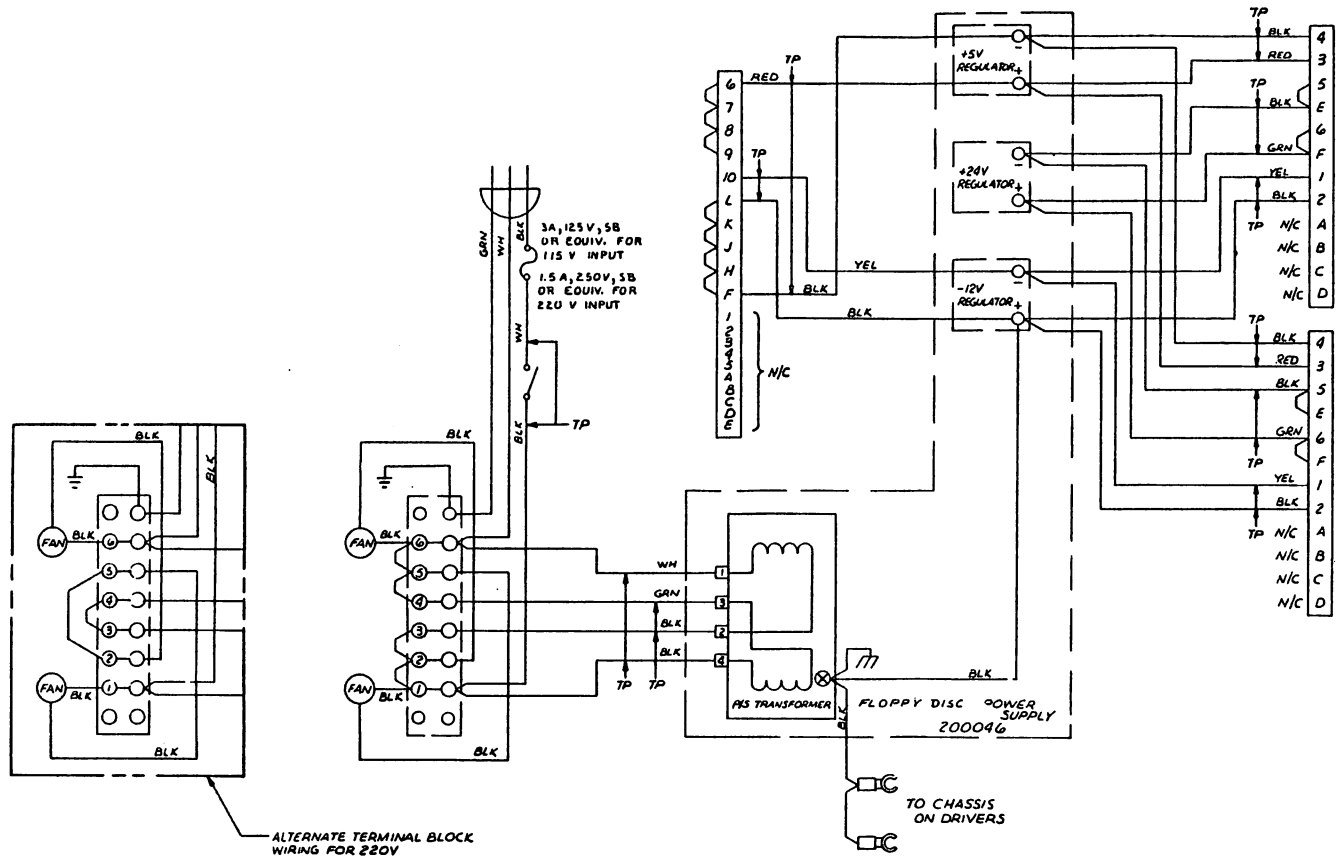

ALTERNATE TERMINAL BLOCK WIRING FOR 220V

1. "TP" INDICATES TWISTED PAIR WIRES.
 NOTES: UNLESS OTHERWISE SPECIFIED.

QTY REQD	CODE IDENT	PART OR IDENTIFYING NO.	NOMENCLATURE OR DESCRIPTION
PARTS LIST			
UNLESS OTHERWISE SPECIFIED DIMENSIONS ARE IN INCHES TOLERANCES ARE:		CONTRACT NO.	
FRACTIONS	DECIMALS	ANGLES	
°	±	±	
MATERIAL	APPROVALS	DATE	FD360 POWER SCHEMATIC
FINISH	DRAWN	DATE	
USED ON	CREATED BY	DATE	
APPLICATION			
DO NOT SCALE DRAWING			SIZE CODE IDENT NO DRAWING NO. D 200042-200
			SCALE NONE SHEET 1 OF 1

002-20002



REVISIONS				
ZONE	LTR	DESCRIPTION	DATE	APPROVED

8 7 6 5 4 3 2 1

D
C
B
A

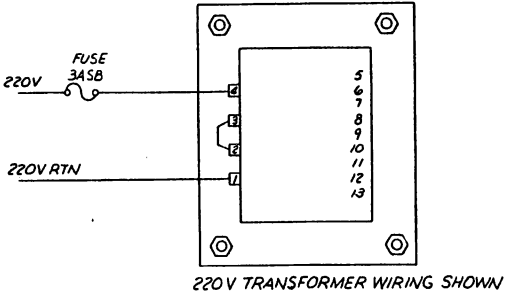
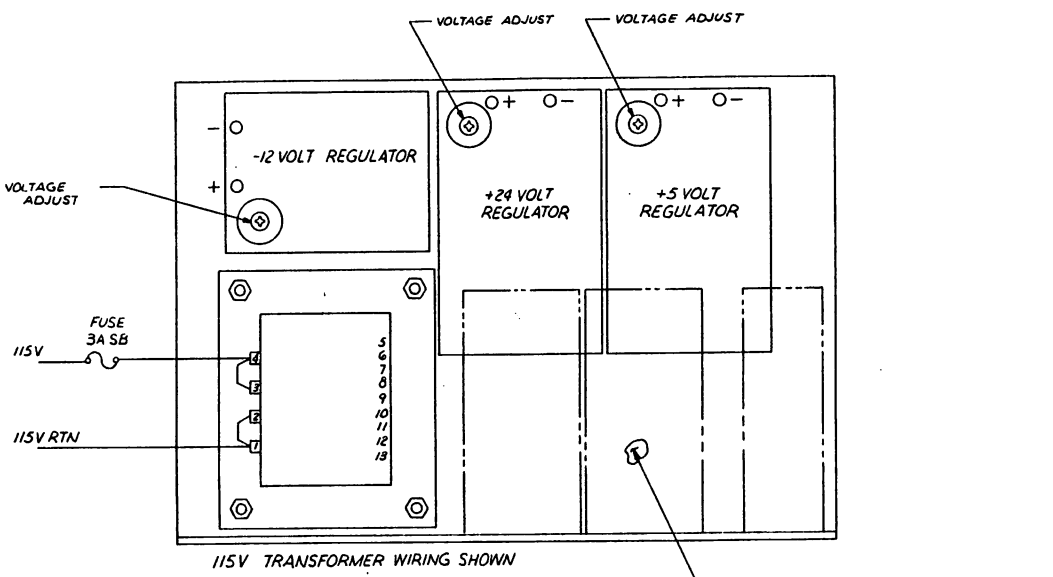

1. FOR WIRING DIAGRAM SEE ICOM DWG NO. 200042-200.
 NOTES: UNLESS OTHERWISE SPECIFIED

QTY	CODE	PART OR IDENTIFYING NO.	NOMENCLATURE OR DESCRIPTION
UNLESS OTHERWISE SPECIFIED DIMENSIONS ARE IN INCHES TOLERANCES ARE: FRACTIONS DECIMALS ANGLES			
MATERIAL		CONTRACT NO.	
FINISH		APPROVALS DATE	
NEXT ASSY USED ON		DRAWN <i>[Signature]</i> 5/20/76	
APPLICATION		CHECKED <i>[Signature]</i> 5/27/76	
DO NOT SCALE DRAWING		SCALE FULL	
PARTS LIST			ICOM
ASSEMBLY- FRUGAL FLOPPY POWER SUPPLY (ADTECH S171)			
SIZE CODE IDENT NO. DRAWING NO.		200046	
SHEET 1 OF 1			

200046

8 7 6 5 4 3 2 1



T1

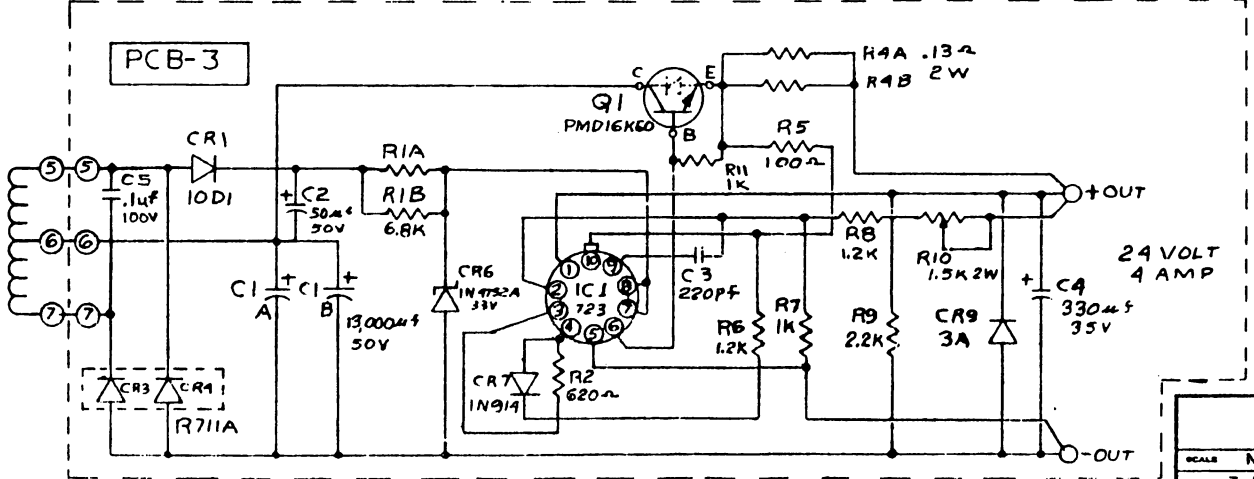
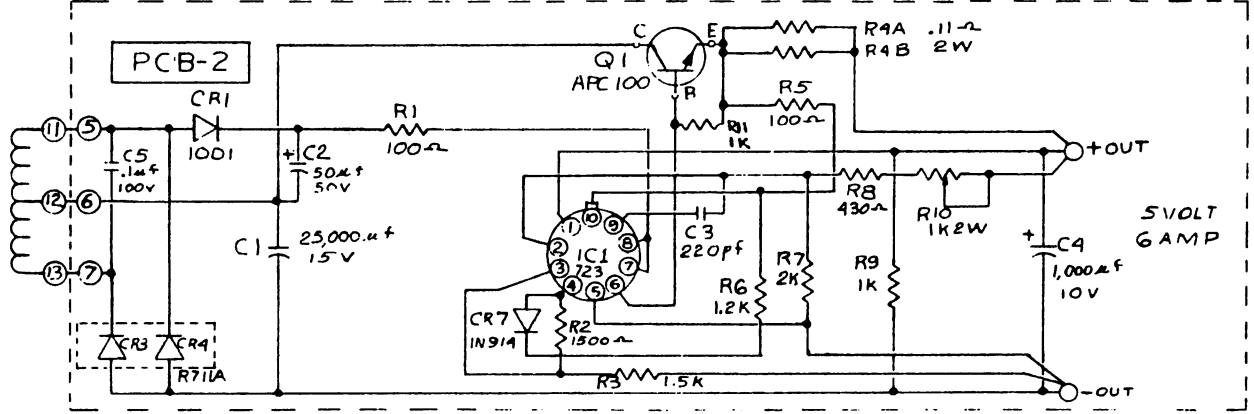
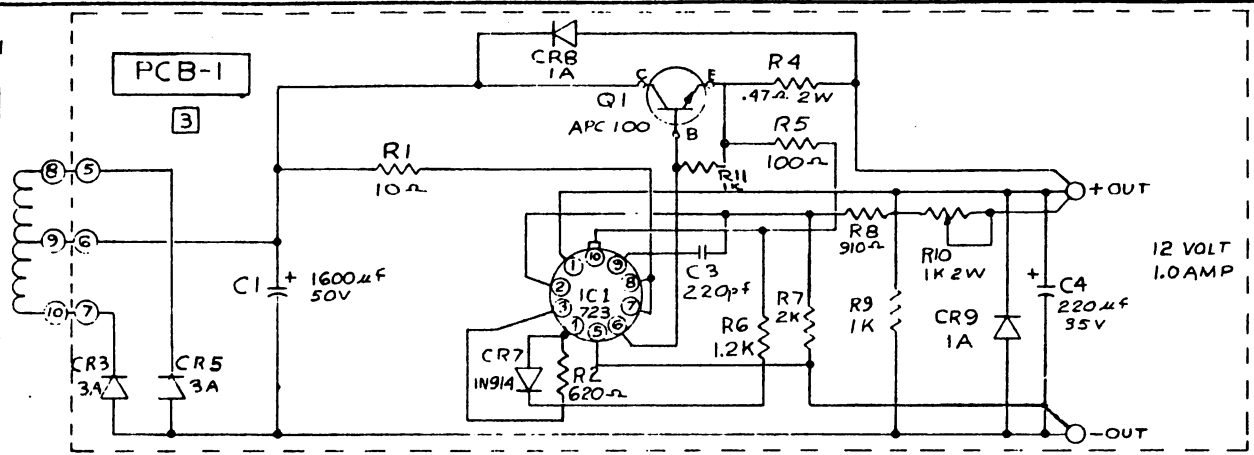

REV	REVISION RECORD	BY	APP
A	CR5 WAS CR4 (PCB-1) REF DES CHANGED TO AGREE WITH P.C. BOARD	PHH	BB
B	ADDED R11 TO PCB 1-2-3 ADDED C5 TO PCB 3	PHH	BB
C	RB 1.2K WAS 1K	PHH	BB
D	ADDED NOTE 3	PHH	BB

A.C. INPUT
 1 - 4
 FOR 115 VOLT JUMPER
 1-3 2-4
 FOR 230 VOLT JUMPER
 2-3 ONLY

NOTES: UNLESS OTHERWISE SPECIFIED:
 1. ALL RESISTORS ARE 1/8 W 5%, RESISTANCE IN OHMS
 2. SEE P/L 16-018 FOR PART LIST

3. ON PCB-1 (12V UNIT), DELETE C2, R3, CR1 & CR6
 REPLACE C2 WITH JUMPER

ADTECH POWER, INC.
 ANAHEIM, CALIF.

SCALE	N/A	APPROVED BY	CHKD	DRAWN BY	BB
DATE	7-10-75			REVISED	
SCHEMATIC, POWER SUPPLY					
WORK ON	SHAWING NO.	REV.	DATE		
S171	AP30-047	D	3-8-75		



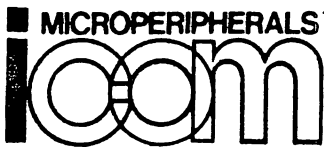

PCC PERTEC COMPUTER CORPORATION
6741 VARIEL AVENUE - CANOGA PARK - CALIFORNIA 91303 - PHONE: (213) 348-1391
TELEX/TWX 910-494-2788

INTERFACING GUIDE FOR
iCOM MODEL FD360/CF360
FLOPPY DISK SYSTEM
AND FRUGAL FLOPPY FF36

Table of Contents

- I. General
- II. Physical Description
- III. Electrical Interface & Pin Configurations
- IV. Power Requirements
- V. Command and Data Structure
- VI. Operation Sequences and Timing
- VII. Data Format
- VIII. Typical Microprocessor Schematics

Revision A

March, 1977

NOTICE

Information contained within this document may not be reproduced, distributed or disclosed in full or in part by any person without prior approval of iCOM.

I. GENERAL

The iCOM Model CF360 Controller/Formatter is designed for use by OEM's in industrial, commercial, and development applications. It is used in the iCOM FD360 series Floppy Disk System as well.

The CF360 can accommodate from one to four floppy disk drives and includes a general purpose interface compatible with most microprocessors and minicomputers.

The CF360 offers many features which reduce computer service overhead. For example, the controller is fully IBM 3740 and 3540 compatible, with all formatting and deformatting accomplished automatically within the controller. The controller also performs track seek/verify, and CRC (Cyclic Redundancy Check) generation and verification automatically.

Independent 128 byte (full-sector) input and output buffers offer the possibility for DMA or programmed I/O operation. The ability to write-protect individual drives also is provided by the controller.

Interface signals to the CPU/MPU are TTL compatible and consist of independent input and output parallel data lines and an 8 bit parallel control port. Upon command, controller status data is presented to the CPU via the input data lines.

II. PHYSICAL DESCRIPTION

The CF360 is housed on two 7.25 X 15 inch (18.4 X 38.1 cm) printed circuit boards containing a total of about 125 IC's.

Interface connections are provided along one long edge of each board, obviating the need for back-plane wiring or a card cage.

III. ELECTRICAL INTERFACE

3.1 Signal Levels - All signals are standard TTL-compatible negative true. Positive true all ports available as an option.

3.1.1 Output to FD360 (negative true)

Logic "0": 2.0V min to +5V max

Logic "1": 0.0V min to 0.8V max

Standard load is 1 TTL Gate (7404 plus 680 ohms to +5V (see Fig. 1).

The two other input load variations as shown in Fig. 1 are available as options.

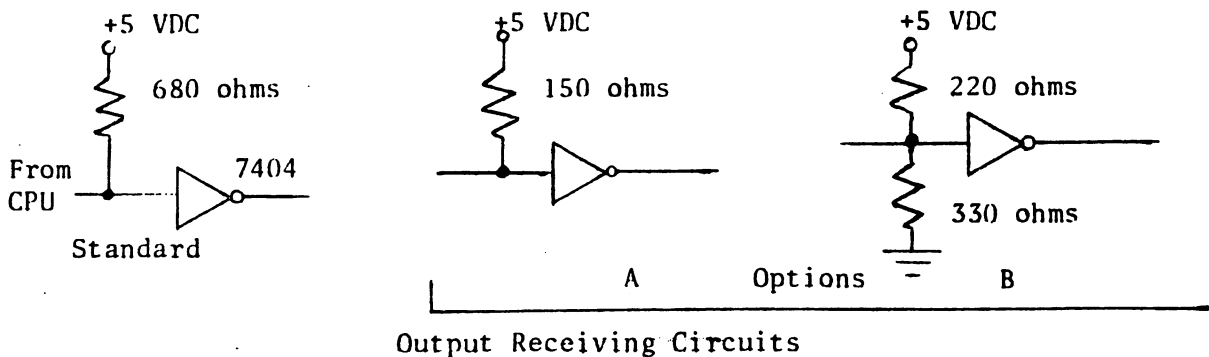
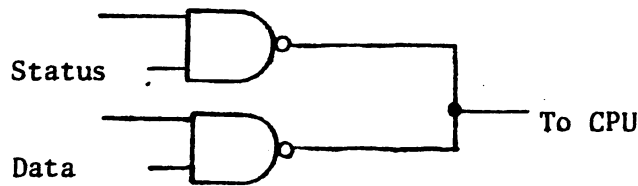

Fig. 1

- 3.1.2 Input from FD360 (negative true)
 Logic "0": 2.4V min
 Logic "1": 0.0V min to 0.4V max
 Current sink at logic "1" is 32 ma (See Fig. 2)



DM 8096 (Tri-State)

Input Status/Data Drive Circuits

Fig. 2

- 3.2 Pin Configuration - Two 40 conductor 3M-type ribbon cables with socket connectors on each end are normally used for interfacing the CF360. Connectors which mate with the CF360 are 3M #3432-2002 (solder tail) or 3432-4005 (wire wrap posts).

3.2.1 P4 Input Connector (to CPU)

<u>PIN#</u>	<u>PIN#</u>	<u>SIGNAL NAME</u>	<u>DESCRIPTION</u>
CPU Intf. end	CF360 end		
	P4 1-27	-	Not used
P9 8	P4 28	Key or Done	Connector Key Operation Done (option)
P9 9	P4 29	DI 0	Data In 0 (LSB)/Busy
P9 10	P4 30	DI 1	Data In 1/ UN0
P9 11	P4 31	DI 2	Data In 2/ UN1 Unit Select
P9 12	P4 32	DI 3	Data In 3/ CRC Error
P9 13	P4 33	DI 4	Data In 4/ Write Protected
P9 14	P4 34	DI 5	Data In 5/ Drive Fail
P9 15	P4 35	DI 6	Data In 6/ Not Used
P9 16	P4 36	DI 7	Data In 7/ Deleted Data Address Mark
P9 17-20	P4 37-40	GRD	Signal Ground

3.2.2 P5 Output Connector (from CPU)

<u>PIN#</u>	<u>PIN#</u>	<u>SIGNAL NAME</u>	<u>DESCRIPTION</u>	<u>PIN#</u>	<u>PIN#</u>	<u>SIGNAL NAME</u>	<u>DESCRIPTION</u>
CPU Intf. end	CF360 end			CPU Intf. end	CF360 end		
	P5 1-18	-	Not Used		P5 28	Not Used	
P9 29	P5 19	Key	Connector Key	P9 39	P5 29	CDO 0*	Data out Bit 0
P9 30	P5 20	CPU 0*	Command Strobe	P9 40	P5 30	CDO 1*	" " " 1
P9 31	P5 21	CPU 1*	Command Word	P9 41	P5 31	CDO 2*	" " " 2
P9 32	P5 22	CPU 2*	" "	P9 42	P5 32	CDO 3*	" " " 3
P9 33	P5 23	CPU 3*	" "	P9 43	P5 33	CDO 4*	" " " 4
P9 34	P5 24	CPU 4*	" "	P9 44	P5 34	CDO 5*	" " " 5
P9 35	P5 25	CPU 5*	" "	P9 45	P5 35	CDO 6*	" " " 6
P9 36	P5 26	CPU 6*	" "	P9 46	P5 36	CDO 7*	" " " 7
P9 37	P5 27	CPU 7*	" "	P9 47-50	P5 37-40	GRD	Signal Ground

3.2.3 P8 Power, Write Protect, Miscellaneous (connects to J8 on Board Z2).

<u>PIN#</u>	<u>SIGNAL NAME</u>	<u>DESCRIPTION</u>
P8 1	WP3*	Ground to Write Protect Unit 3
P8 2	WP1*	Ground to Write Protect Unit 1
Key		
P8 3	LDRFAL	LED Driver indicates Drive Fail Status
P8 4	LCRC	LED Driver indicates CRC Error
P8 5	LUN 1	LED Driver indicates Unit Select Bit 1 = 1
P8 6,7,8,9	+5 V	+5 V input
P8 10	-12 V	-12 V input
P8 A	WP2*	Ground to Write Protect Unit 2
P8 B	WP0*	Ground to Write Protect Unit 0
P8 C	L BUSY	LED Driver indicates Unit Busy
P8 D	LWRPR	LED Driver indicates Unit Write Protected
P8 E	LUN 0	LED Driver indicates Unit Select Bit 0 = 1
P8 F,H,J,K,L	GRD	Ground return for +5V and -12V

IV. POWER REQUIREMENTS

- 4.1 CF360 +5VDC, + 5% @ 6 Amps (Power requirements for connector J8 on the Z2 board.)
 -12VDC, + 5% @ 1 Amp
- 4.2 Disk Drive - The CF360 is ideally suited for use with the Pertec FD400 drive. The FD400 requires +24V +5% @ 2 Amps Avg, 4 Amps Peak.

V. COMMAND AND DATA STRUCTURE

5.1 Commands and Command Word Bits

<u>COMMAND</u>	<u>CPU BIT (NEGATIVE TRUE)</u>								<u>HEX CODE</u>
	7	6	5	4	3	2	1	0	
Examine Status	0	0	0	0	0	0	0	0	00
Read	0	0	0	0	0	0	1	1	03
Write	0	0	0	0	0	1	0	1	05
Read CRC	0	0	0	0	0	1	1	1	07
Seek	0	0	0	0	1	0	0	1	09
Clear Error Flags	0	0	0	0	1	0	1	1	0B
Seek Track 0	0	0	0	0	1	1	0	1	0D
Write with DDAM*	0	0	0	0	1	1	1	1	0F
Load Track Address	0	0	0	1	0	0	0	1	11
Load Unit/Sector	0	0	1	0	0	0	0	1	21
Load Write Buffer	0	0	1	1	0	0	0	1	31
Shift Read Buffer	0	1	0	0	0	0	0	1	41
Clear	1	0	0	0	0	0	0	1	81
Examine Read Buffer	0	1	0	0	0	0	0	0	40

* DDAM = Deleted Data Address Mark

Please refer to Fig. 3 for timing requirements of command and data outputs.

5.2 Status/Data Input Lines

DI0	Data In 0 / Busy
DI1	Data In 1 / UN 0 Unit Select Code Bit 0
DI2	Data In 2 / UN 1 Unit Select Code Bit 1
DI3	Data In 3 / Media Error or CRC Error
DI4	Data In 4 / Selected Unit Write Protected
DI5	Data In 5 / Drive Fail (not up to speed, etc.)
DI6	Data In 6 / No status Bit (Always Logic 1)
DI7	Data In 7 / Found Deleted Data Address Mark

Please refer to Figure 4 for timing of data and status inputs.

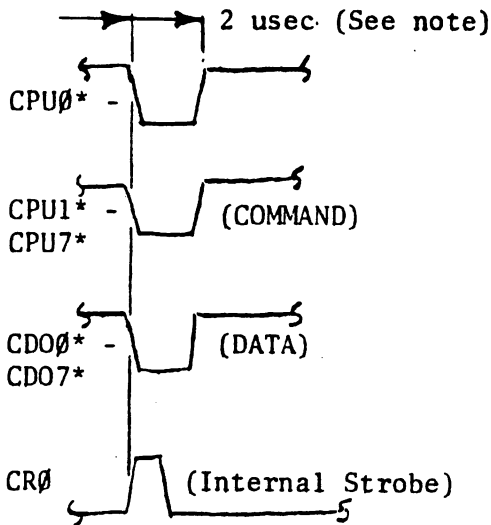

NOTE: Other data pulse widths can be accommodated, consult iCOM.

Output Command and Data Timing

Fig. 3

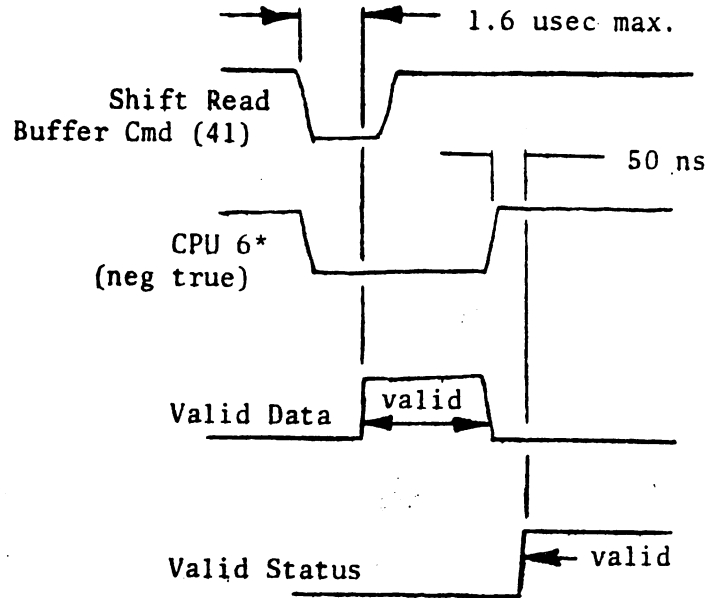

Input Status and Data Timing

Fig. 4

5.3 Data Output Lines

	CDO Bit								Range
	7	6	5	4	3	2	1	0	
Track Address	0	MSB						LSB	00 to 4C (HEX)
Unit/Sector	MSB	LSB	0	MSB	Sector			LSB	Unit 0-3 Sector 1-1A (HEX)
Write Buffer	MSB							LSB	00 to FF (HEX)

5.4 Operation Sequences

5.4.1 Seek

- a) Set up Data Out Bits 0-7 with Unit & Sector
- b) If track remains same, execute a load Unit/Sector Command (21). Otherwise, set up data out bits with Track Address
- c) Execute a load Track Address command (11)
- d) Execute a Seek command (09)
- e) If interrupt is used floppy will pulse "Done" when operation complete. More typically, the microcomputer should loop-on-busy as follows:
- f) Execute an Examine Status command
- g) Input the data lines and check the busy (=0 when done) and CRC bits.

5.4.2 Seek 0

- a) Always used on power up
- b) No track address necessary
- c) Execute a Seek 0 command (0D)
- d) Loop-on-busy as above. Selected unit will go to track 0.

5.4.3 Read

- a) After seek to the correct track, unit and sector, execute read (03)
- b) Loop-on-busy
- c) Check CRC, reread if DI# = 1
- d) Execute examine read buffer (40)
- e) Input 1st character from data input lines
- f) Shift read buffer (41)
- g) Repeat (f) & (g) until 128 characters have been read.

5.4.4 Write

- a) Load write buffer by first setting up Data Out lines
- b) Execute Load Write Buffer (31)
- c) Repeat (a) and (b) above until 128 characters have been loaded
- d) Seek to correct track, unit, & sector
- e) Execute write (05)
- f) Execute read (CRC) (07) (Does not alter contents of read buffers) See also 6.1.2.
- g) Check CRC Bit and repeat (e) and (f) if CRC = 1. Write Buffer recirculates so it is not necessary to reload it to rewrite.

5.4.5 Write with Deleted Data Address Mark

- a) Same as write except that the data when written is automatically preceded by a Deleted Data Address Mark (DDAM) instead of by the standard Address Mark. When the same sector is later read, the Found Deleted Data Address Mark Status bit will be set on completion. This command can therefore be used to identify the data for some purpose. For example, a DDAM can be used to indicate the end of a long data field. It could also be used in some editing function.

5.4.6 Clear Error Flags

- a) Used to clear Deleted Data Address Mark and cyclic Redundancy Check status bits.
- c) Execute Clear Error Flags command (OB)

5.4.7 Clear

- a) Execute Clear command (81)
- b) Halts any operation in process. Clears Busy and pulses Done.

5.5 Status

5.5.1 7 Status Bits are returned on the Data Input Lines, DI \emptyset thru DI 7, when command Bit 6, CPU 6*, is logic \emptyset . All bits are negative true.

5.5.2 Busy. When logic "1", indicates that an operation is in process. When logic "0", indicates operation done. Busy is also cleared by Clear, Clear Error Flags, or the head unloading.

5.5.3 UN \emptyset , UN1 Unit Select Code Bits:

UN1	UN \emptyset	
0	0	= Unit 0 Selected
0	1	= Unit 1 Selected
1	0	= Unit 2 Selected
1	1	= Unit 3 Selected

5.5.4 Media Error or CRC Error. Indicates that the Read or Read (CRC) operation resulted in a data error. The status bit should be cleared by a Clear Error Flags command and the data should reread or rewritten.

5.5.5 Selected Unit Write-Protected. Each of the drives can be write-protected manually. If so protected this status bit will equal logic "1" when that unit is selected.

5.5.6 Drive Fail. Indicates that the selected drive is not ready because the door is open, or the drive is not up to speed, or no diskette is installed, or no drive is installed.

5.5.7 Found Deleted Data Address Mark. If on a Read command the data is preceded by a DDAM then this status bit is set. (See 5.4.5). Status bit is reset by the Clear Error Flags command.

VI. OPERATION SEQUENCES AND TIMING

6.1 Functional Sequences and Characteristics

6.1.1 Seeks - The FD360/CF360 starts a seek operation by reading its present location from the ID field preceding each sector. A comparison is then made with the desired track address and the head is stepped in the correct direction until the head should be at the right track. The track address is read again and if it compares to the desired track the operation is done.

In some formats the track address may not correspond to the physical track number, due to tracks being declared down. The FD/CF360 will handle this format by seeking until the correct track address is found

It should be noted that a seek is necessary only to change tracks. To change sectors only, the Load Unit/Sector command is used.

The seek Track 0 can be used to seek to track 0 without regard to the present track. It does not require a transfer of the Track Address. The Seek Track 0 should be used on power up and restart to initialize the head.

- 6.1.2 Read - A seek to the correct track is necessary unless the head is on the correct track already. A load Unit/Sector command selects the sector to be read, and the CF360 examines the ID Field preceding each Data Sector to find the correct sector. In a standard IBM format diskette, the sectors start at 1 following the index hole and increment to 26 (1A HEX) just before the index hole.

The CF360 automatically computes the CRC during the read and if an error is found the CRC status bit is set at the end of the read. Data from the sector is shifted into the Read Buffer at a 250 Khz rate. When the Read command is complete the first character of the sector is at the front of the read buffer. An examine Read Buffer command (40) will place the Read Buffer output on the Data Input Lines. A shift Read will shift the Read Buffer and place the Read Buffer output on the Data input lines. 127 shifts are thus required to read the 128 Bytes.

A read CRC does not load the data into the Read Buffer but merely tests CRC. This is commonly used following a Write to insure data integrity. Thus a Write operation can be executed and verified without destroying the Read Buffer. This is important in edit operations and for CPU's with small memory.

- 6.1.3 Write - A write operation writes the contents of the Write Buffer to the selected Unit/Sector. The location of the head while loading the Write Buffer does not matter. After the Write Buffer is loaded, a seek command will move the head to the desired track. The Write Command then causes the CF360 to begin examining each ID field for the correct sector. A field of 6 bytes of "0"'s will then be written preceding the intended location of the data sector. Next, the Address Mark is written (or DDAM if a Write Deleted Data Address Mark command). Then each byte of the Write Buffer is written out, followed by the CRC (2 Bytes) generated by the CF360. Finally, one byte of all zero's or all one's follows the CRC.

The data written should be read by a READ CRC command to insure the operation was valid.

6.2 Operation Timing

6.2.1 Seek

Track to Track	10 msec
Head Load & Settling Time	40 msec, maximum
Maximum Seek Time, 77 tracks	820 msec

6.2.2 Read/Write

Sector Read/Write Time	6 msec
Average Latency ($\frac{1}{2}$ Rev)	83 msec
Minimum Latency	1 msec
Read/Write Buffer Shift Rate:	DC to 500 KHz

VII. DATA FORMAT

7.1 The CF360/FD360 used standard IBM 33FD type diskettes such as those used in the IBM 3740 series equipment. It is completely media and format compatible. Type 33FD diskettes can be obtained from a number of sources, including iCOM.

7.2 Format Details (each Diskette)

77 tracks per diskette 00 thru 4C HEX
 26 Sectors per track 01 thru 1A HEX
 128 Bytes (8 Bits) per sector
 256,256 Bytes Diskette
 1,025,024 Bytes Per FD360 or CF360 using 4 drives.

VIII. TYPICAL MICROPROCESSOR INTERFACE SKETCH

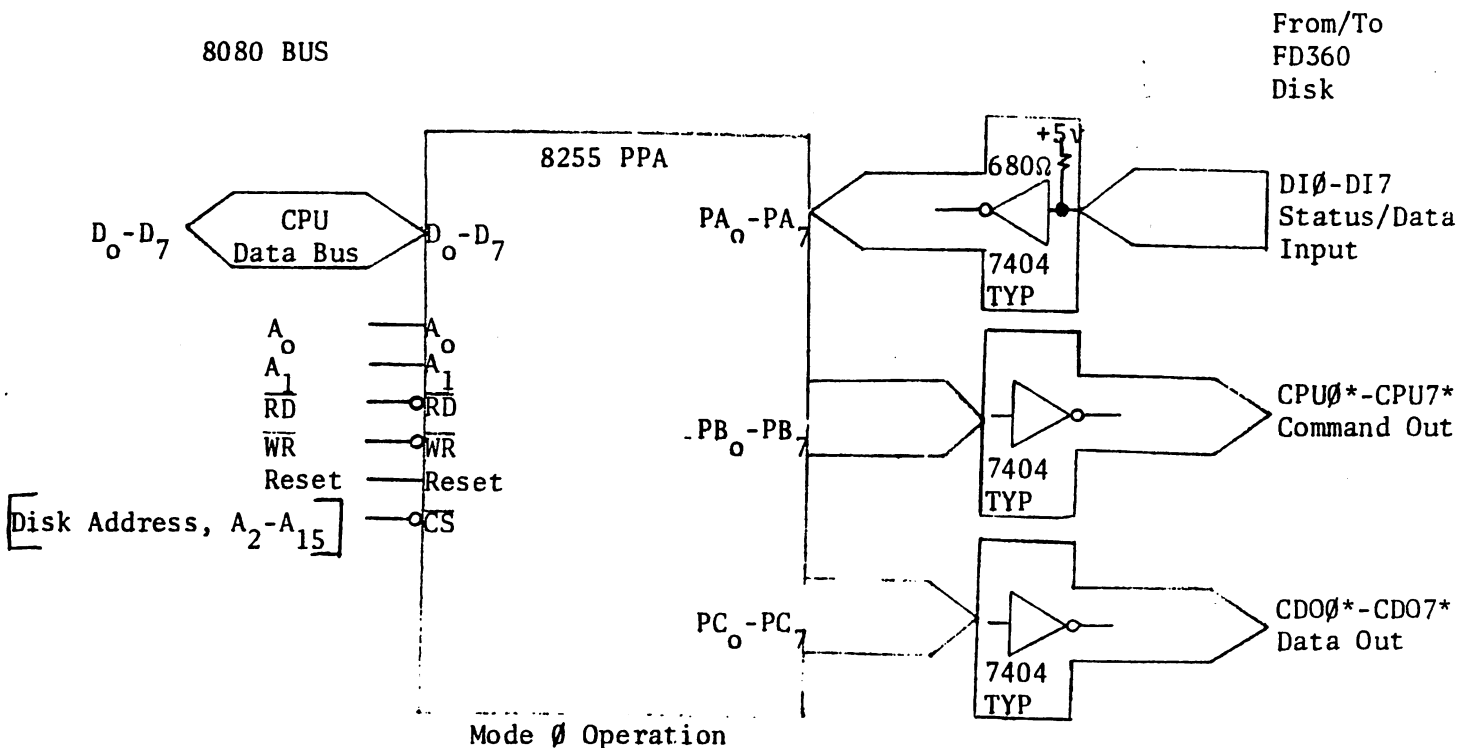

Fig. A-8080 Interface Sketch

VIII. CON'T

NOTE: Fig. A, page 8 is not compatible with iCOM's FDOS-II software, and is shown only as an alternative hardware interface arrangement for custom system designs. Use Fig B below with iCOM's FDOS-II/8080 OEM software.

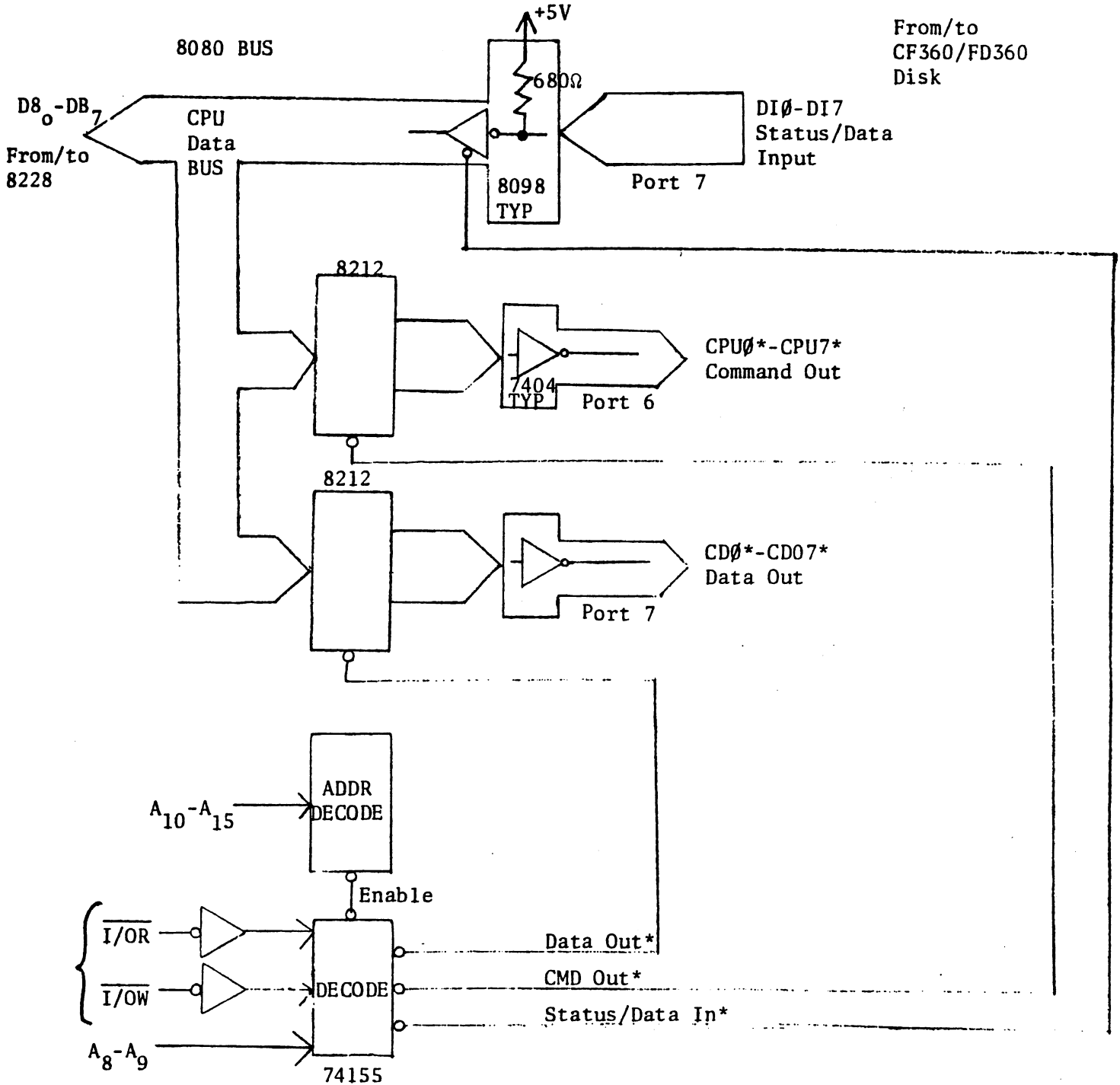

Fig. B 8080 Interface Sketch for use with iCOM FDOS-II/8080 OEM Software

VIII. CON'T

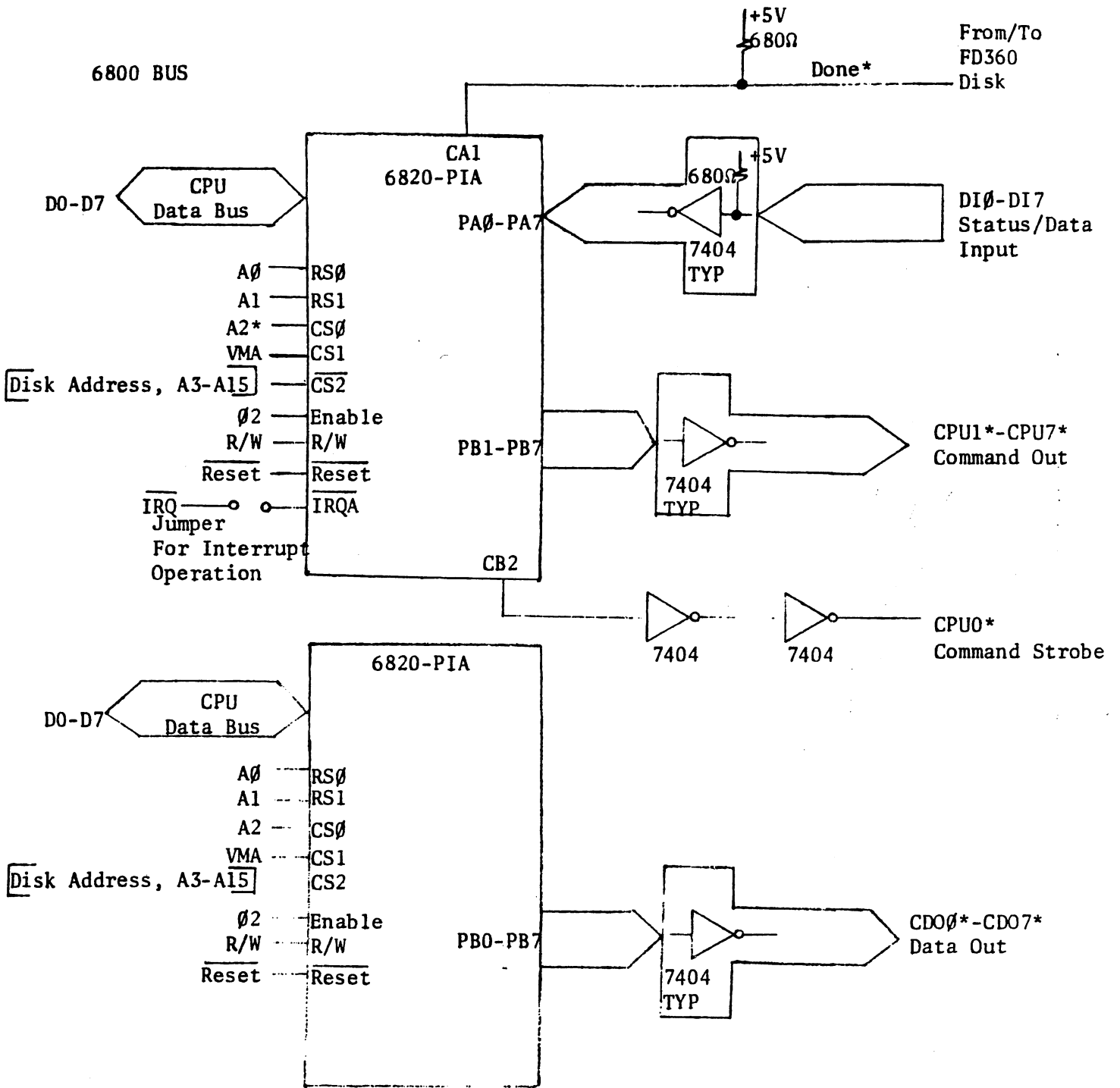

Fig. C-6800 Interface Sketch

VIII. Con't

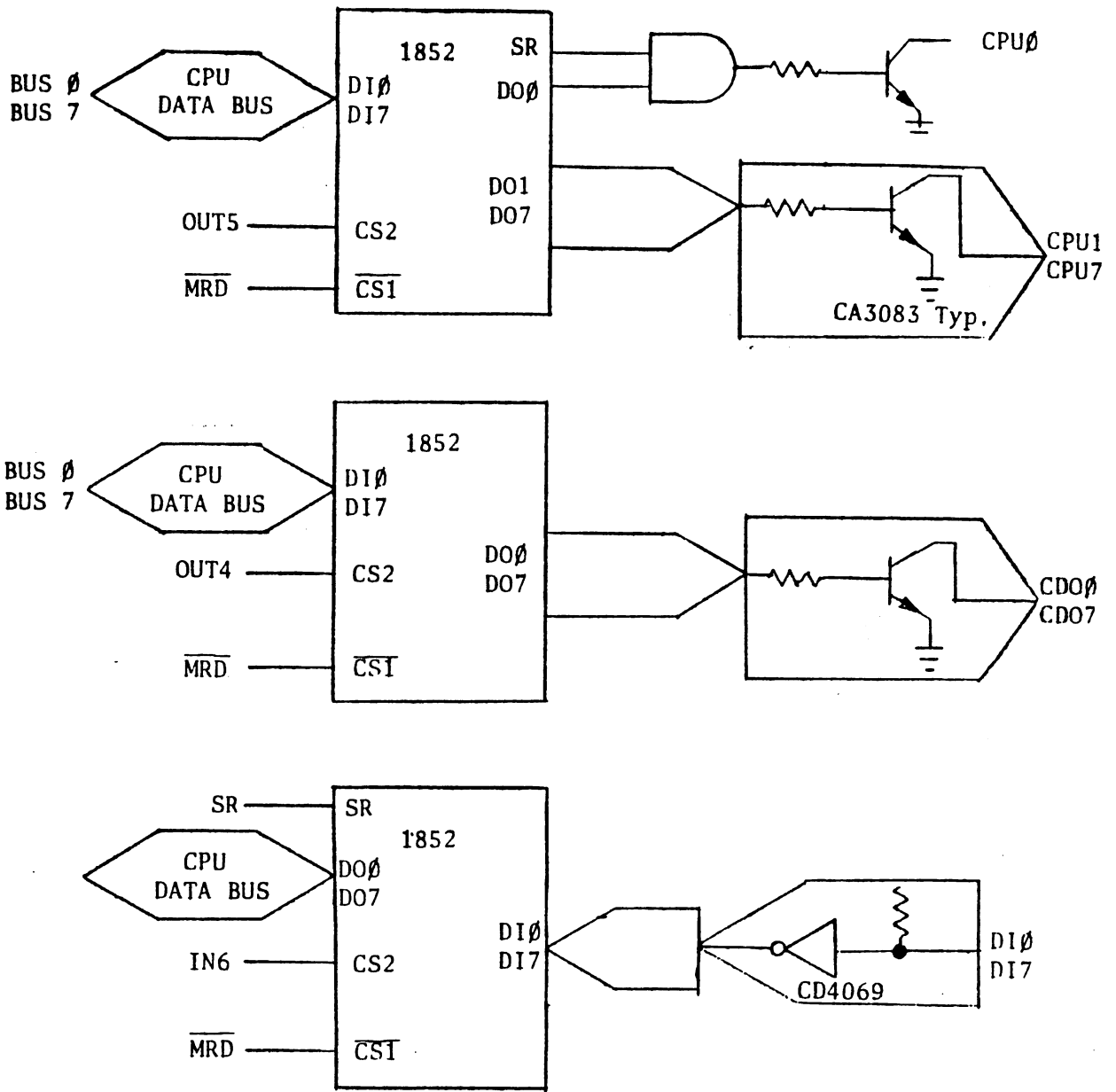
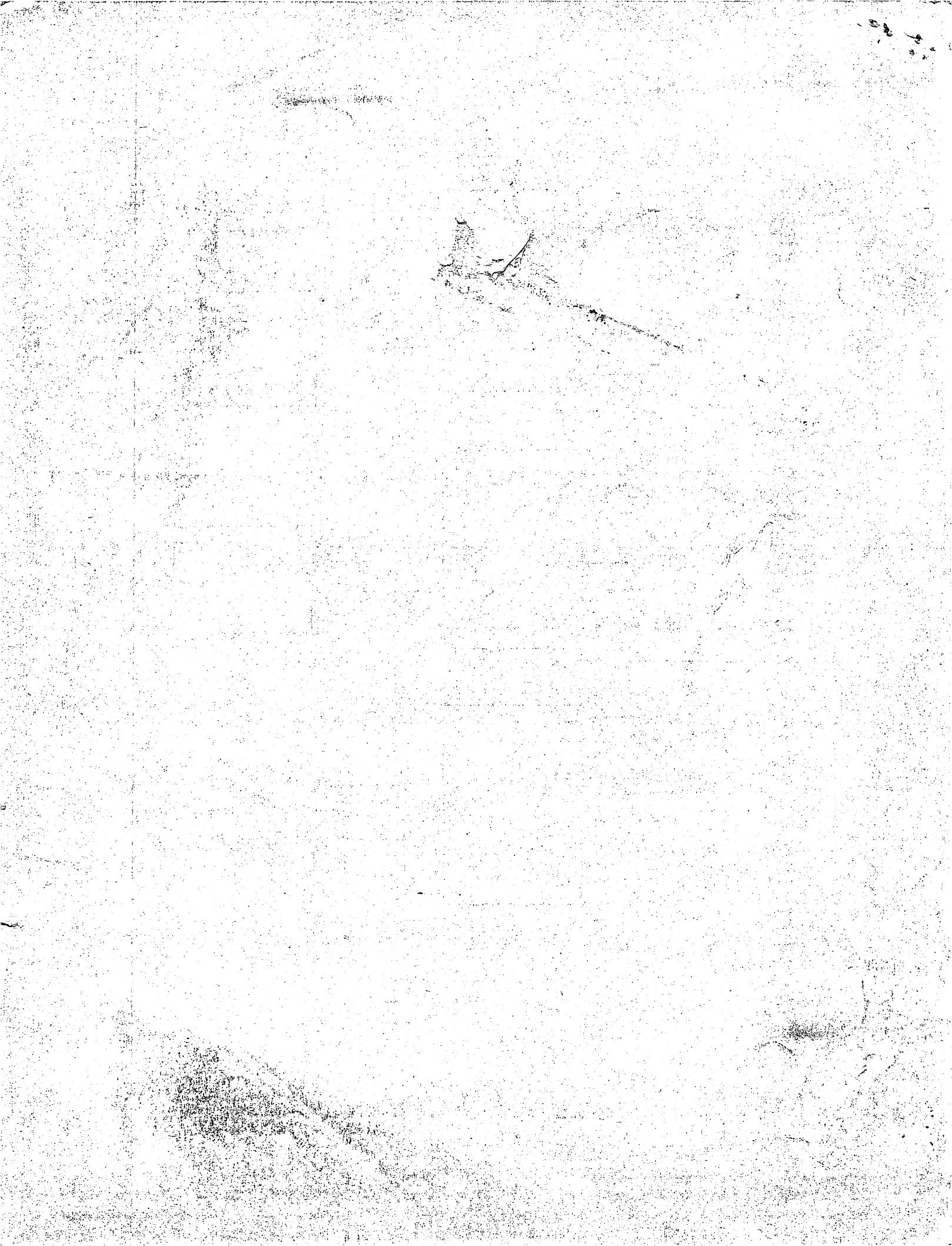

Fig. D 1852 Interface Sketch



APPENDIX A

Addendum for Frugal Floppy Model FF36

A.1 Add section 3.2.4 as follows:

3.2.4 P3 disk drive with remote mux power. (Connects to J3 on the remote mux board.)

<u>PIN#</u>	<u>SIGNAL NAME</u>	<u>DESCRIPTION</u>
P3 1	-12 V DC	-12 V Input
P3 2	-12 V RET	-12 V Return
P3 3	+5 V DC	+5 V Input
P3 4	+5 V RET	+5 V Return
P3 5	+24 V RET	+24 V Return
P3 E	+24 V RET	+24 V Return
P3 6	+24 V DC	+24 V Input
P3 F	+24 V DC	+24 V Input

A.2 Disregard Section 4.2 Use information as follows:

4.2 Disk Drive with Remote Mux

- * +24 V DC+ 10% at 2 amps average, 4 amps peak.
+5 V DC+ 5% at 1 amp maximum.
-12 V DC+ 5% at 0.3 amps peak.
- * Power specified is for a single disk drive. If multiple drives are to be used, the power requirements must be multiplied by the number of drives used.

