

TEAC

FD-55

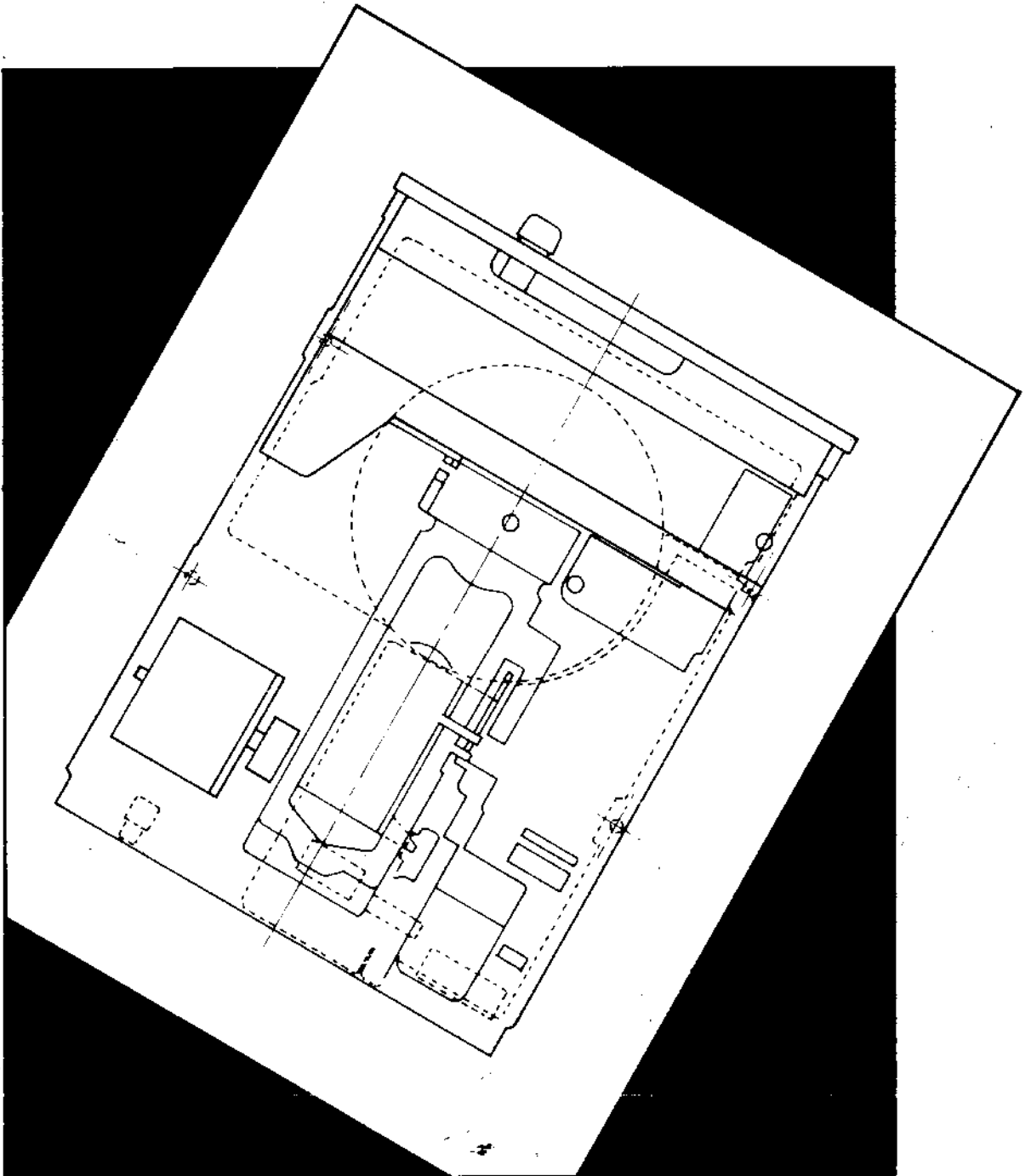

MINI FLEXIBLE DISK DRIVE MAINTENANCE MANUAL

TEAC FD-55 (L)
MINI FLEXIBLE DISK DRIVE
MAINTENANCE MANUAL

P/N 10180233-00 REV. B

TABLE OF CONTENTS

Title	Page
SECTION 3 THEORY OF OPERATION	300
3-1 CONSTRUCTION AND FUNCTION	301
3-1-1 General Block Diagram	301
3-1-2 Mechanical Section	302
3-2 CIRCUIT DESCRIPTIONS	307
3-2-1 Read Write Circuit	307
3-2-2 Control Circuit	315
3-2-3 Servo Circuit	321
3-3 FUNCTION OF TEST POINTS AND VARIABLE RESISTORS	322
3-3-1 Function of Test Points	323
3-3-2 Function of Variable Resistors	330

Title	Page
SECTION 4 MAINTENANCE	4000
4-1 GENERAL	4001
4-1-1 Periodic Maintenance	4001
4-1-2 Check and Adjustment	4002
4-1-3 Maintenance Parts Replacement	4004
4-1-4 Maintenance Jigs and Tools	4011
4-2 PRECAUTIONS	4014
4-2-1 Torque Applied to Screws and Locking Paint	4014
4-2-2 Handling of Connectors	4015
4-2-3 Head Cable Treatment	4020
4-2-4 Initial Setting of SKA	4022
4-2-4-1 Cable connection and setting of power supply voltage	4022
4-2-4-2 Setting of the maximum track number	4025
4-2-4-3 Setting of step rate and settling time	4026
4-2-4-4 Level disk calibration	4028
4-2-4-5 Alignment disk calibration	4030
4-2-4-6 Humidity setting	4033
4-2-4-7 Setting of SKA gain	4033
4-2-5 Others	4034
4-3 PREVENTIVE MAINTENANCE	4038
4-3-1 Cleaning of Magnetic Head by Cleaning Disk	4038
4-3-2 Direct Cleaning (Single sided FDD only)	4040
4-4 CHECK AND ADJUSTMENT	4042
4-4-1 Adjustment of Set Arm Position	4042
4-4-2 Adjustment of Clamp Arm Position	4044
4-4-3 Adjustment of Front Lever Position	4046
4-4-4 Adjustment of Arm Lifter	4048
4-4-4-1 Double sided FDD	4048
4-4-4-2 Single sided FDD	4058
4-4-5 Check of CSS Ass'y	4061
4-4-6 Check of File Protect Sensor	4065
4-4-7 Check and Adjustment of Disk Rotation Speed	4068
4-4-8 Check and adjustment of Erase Gate Delay	4071

Title	Page
4-4-9 Check and Adjustment of Head Touch	4074
4-4-10 Check and Adjustment of Asymmetry	4080
4-4-11 Check of Read Level	4085
4-4-12 Check of Resolution	4089
4-4-13 Check and Adjustment of Track Alignment	4093
4-4-14 Check and Adjustment of Track 00 Sensor	4102
4-4-15 Check and Adjustment of Track 00 Stopper	4109
4-4-16 Check and Adjustment of Index Burst Timing	4113
4-5 MAINTENANCE PARTS REPLACEMENT	4118
4-5-1 Replacement of Head Carriage Ass'y	4118
4-5-2 Replacement of Stepping Motor Ass'y	4122
4-5-3 Replacement of DD motor Ass'y (Spindle Motor)	4124
4-5-4 Replacement of Collet Ass'y	4126
4-5-5 Replacement of Head Load Solenoid	4127
4-5-6 Replacement of Track 00 Sensor Ass'y	4129
4-5-7 Replacement of PCBA MFD Control	4130
4-5-8 Replacement of PCBA Front OPT	4132
4-5-9 Replacement of Head Pad (Single sided only)	4133
4-5-10 Replacement of Front Bezel Ass'y	4135
4-5-11 Replacement of Front Lever Ass'y	4136
4-5-12 Replacement of CSS Ass'y	4137

Title	Page
SECTION 5 DRAWINGS & PARTS LIST	500
5-1 CONFIGURATION	501
5-2 MECHANICAL BREAK-DOWN AND PARTS LIST	507
5-2-1 FDD	507
5-2-2 Screw, Washer	512
5-3 PCBA PARTS LIST	513
5-3-1 PCBA MFD Control	514
5-3-2 PCBA Front OPT	520
5-4 SCHEMATIC DIAGRAMS AND PARTS LOCATION	521

SECTION 3

THEORY OF OPERATION

3-1. CONSTRUCTION AND FUNCTION

3-1-1. General Block Diagram

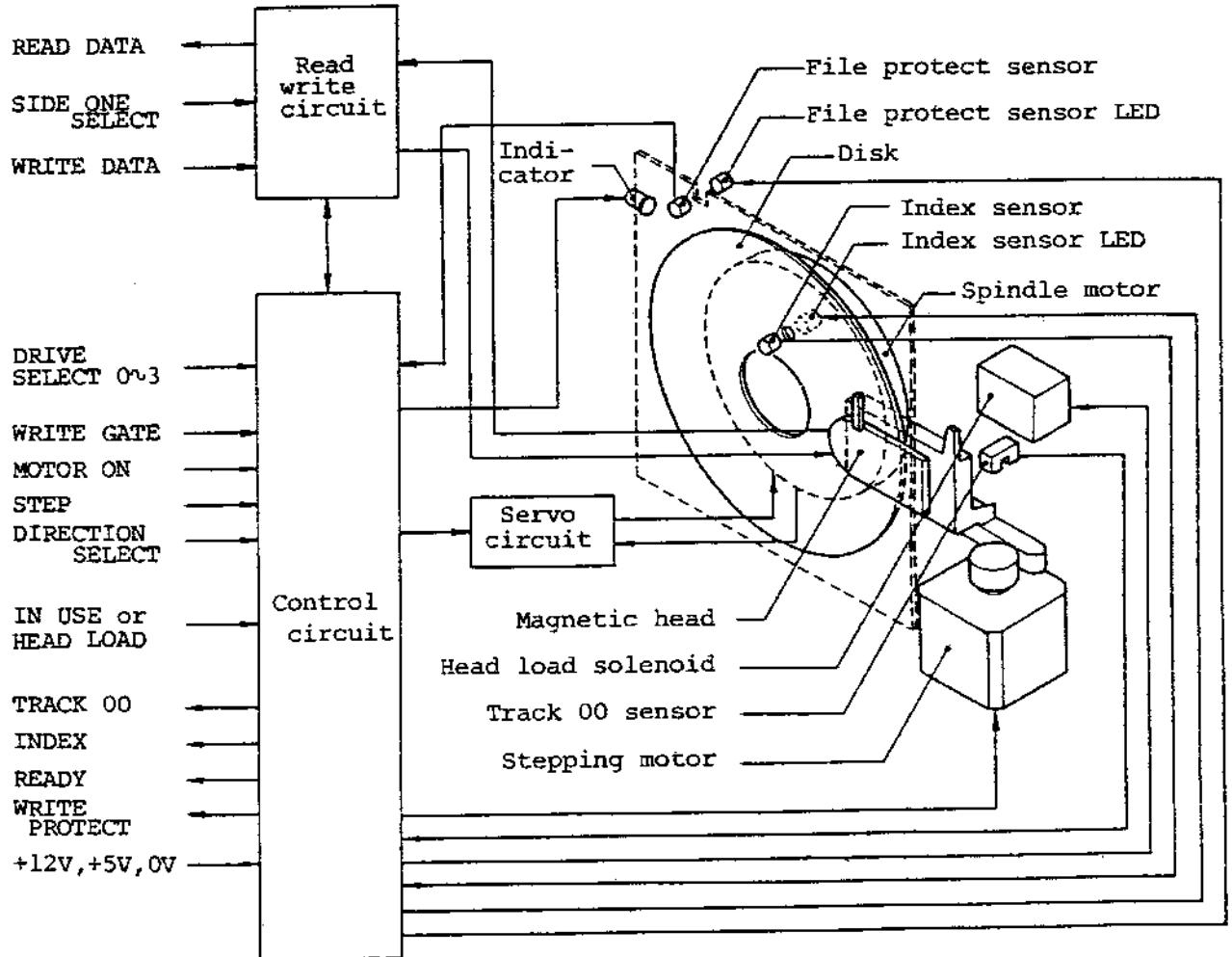

(Fig.301) General block diagram

3-1-2. Mechanical Section

Since the disk is a flexible recording media made of mylar film base and data interchangeability between disks and FDDs is required, the mechanical section of the FDD uses precision parts and it is also assembled with high precision. For this reason, only trained technicians can handle the internal mechanism. Never apply excessive impact nor drop the FDD down on the desk.

The mechanical section is constructed with frame, door mechanism, disk clamp mechanism, disk rotation mechanism, magnetic head and carriage, head load mechanism (or CSS mechanism), head seek mechanism, various detection mechanisms, etc.

(1) Frame

The main structure for mounting the various mechanisms and printed circuit boards. The frame is made of aluminum die cast to maintain the stability of the FDD in strength, precision, durability, and expansion coefficient.

(2) Door mechanism and disk clamp mechanism

The door mechanism is constructed with the main parts of set arm which forms the structure for installing the disk on the spindle; other parts of front lever, clamp arm, etc. The set arm is attached to the rear of the frame with leaf springs and on the tip of the set arm a collet, which forms the disk clamp mechanism, is attached.

When a disk is inserted and the door is closed, the tip of the collet is inserted in the central window of the disk and the window area is depressed to the spindle so that the center of the disk is clamped in the correct position along the outer circumference of the collet.

(3) Disk rotation mechanism

The disk rotation mechanism comprises DD motor Ass'y which includes spindle.

The DD motor is an outor-rotor type DC brushless motor which has the long life of 30,000 hours or more in continuous rotation.

The rotational speed is 300rpm (or 360rpm) and maintains stable rotational speed against load variations and environmental changes. This is achieved by a feedback signal from the internal AC tachometer.

The precisely combined collet and spindle are attached at the correct angle to maintain the center position correctly without damaging the center hole of the disk and so as to make the head be in contact with disk at the correct angle.

(4) Magnetic head and carriage

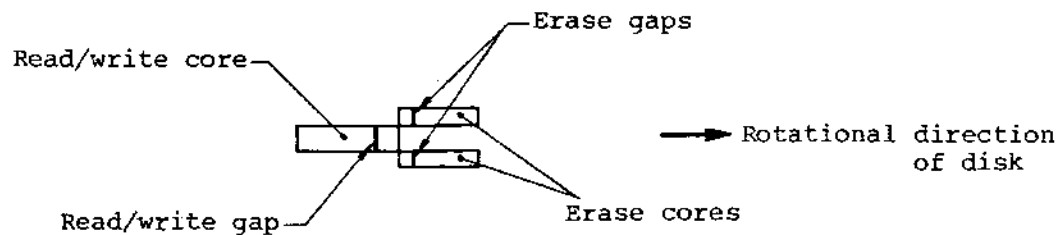

(Fig.302) External view of magnetic head core

For single sided FDDs, the external view of the magnetic head is button shaped and it is mounted on the carriage so that it is in contact with the SIDE 0 (the bottom side when the FDD is placed horizontally) head window area of the disk.

For double sided FDDs, both the SIDE 1 head and the SIDE 0 head are special flat type supported with the gimbaled mechanisms. The two magnetic heads are mounted across the disk on one carriage.

In both types of head, the surface is designed for minimum disk wear and maximum read output. The head itself is a long life type for improved head wear. Each head is constructed with a read/write gap used for data reading and data writing and two erase gaps to erase the recorded track edge immediately after the recording (tunnel erase). The magnetic head and the carriage on which the head is mounted form the

core section of the FDD and is specially assembled with high precision.

(5) Head load mechanism or CSS mechanism

The head load mechanism is used for models with head load solenoid and the CSS mechanism is used for double sided CSS model without head load solenoid. Neither of these mechanisms are used for single sided CSS model.

The head load mechanism functions to make the head in contact with the disk when only required so as to reduce disk and magnetic head wear. This mechanism is constructed with head load solenoid, arm lifter, etc. For a single sided FDD, the head pad attached to the pad arm of the head carriage is depressed against the SIDE 1 of the disk with appropriate pressure and the disk is held with head and head pad. For a double sided FDD, the SIDE 1 head is depressed with appropriate pressure instead of the head pad, as well as the single sided FDD.

In the CSS model, the magnetic head is always in contact with a disk as far as the disk is installed. In order to elongate the disk and head lives, it is required to make the disk rotate only when it is necessary. The CSS mechanism (double sided) is constructed with a CSS Ass'y which is designed to protect the contact of SIDE 0 and SIDE 1 heads when the front lever is closed if a disk is not installed. For the purpose of protecting the head being caught and damaged by the head window edge during disk insertion and ejection, the head protector to lift up the jacket a little is equipped to the CSS Ass'y. The head protector is also used in the models with head load solenoid.

(6) Head seek mechanism

The head seek mechanism consists mainly of stepping motor with a capstan (pooly), steel belt (band), guide shafts, and carriage. The carriage is connected to the capstan of the stepping motor through the steel belt

and is slid along the guide shafts.

The stepping motor rotates 2 steps (3.6°) for 48tpi and one step (1.8°) for 96tpi per one track space. To improve the continuity of the head seek operation and precision of head positioning, hybrid type 4-phase stepping motor is adopted. This special motor is driven in a unique manner which brought a success in reducing the head ratiation and to obtain a highly precise positioning.

The parallelism and the distance between the shafts and the center line of the disk, and shaft and disk themselves are precisely machined. Also the thermal expansion of the frame, steel belt, carriage, etc. are taken into consideration in the process of design so that they are mutually offset with the expansion of the disk.

(7) Detection mechanisms

(a) File protect detection mechanism

This mechanism is constructed with an LED and a photo-transistor to detect the existence of the write enable notch of the disk jacket. When a disk with the notch covered is installed and the light pass for detection is disturbed, no write or erase current will be supplied to the read/write and erase heads and the recorded information on the disk is protected from an erroneous input of a write command. The LED is mounted on the PCBA DD motor servo and the photo-transistor on the PCBA front OPT.

(b) Track 00 detection mechanism

This mechanism is constructed with a photo-interrupter for detecting the outermost track position (track 00) of the head and the track 00 stopper which is attached to the rear side of the head carriage. Inside tracks from the track 00 on the disk are used. Even if an erroneous step out command is input from the track 00 position, the command will be ignored by the internal circuit of the FDD.

If the head moves out from the track 00 by some reason (such as impact during transportation), the head carriage strikes the track 00 stopper to protect the head from moving out of the returnable range at a next power on.

When step-in commands are input from the innermost track, the head seeks toward inward and stops with an appropriate space left against the head window edge of the disk. In order to recalibrate the track from this position (returning operation to the track 00), it is required to input the step-out commands with several additional steps to the maximum track number.

(c) Index detection mechanism

LED and photo-transistor for the detection of the index hole are located at the index window area of the disk jacket. The LED is mounted on the PCBA DD motor servo and the photo-transistor on the PCBA front OPT. The index hole will be detected along the rotation of the disk.

3-2. CIRCUIT DESCRIPTIONS

The electronics of the FDD is constructed with three sections which are read write circuit, control circuit, and servo circuit. Read write circuit and control circuit are mounted on the PCBA MFD control, and servo circuit is on the PCBA DD motor servo.

3-2-1. Read Write Circuit

The read write circuit is constructed with read circuit, write circuit, and low voltage sensor. They are mostly packed in a read write LSI (bipolar).

Fig.303 shows the block diagram.

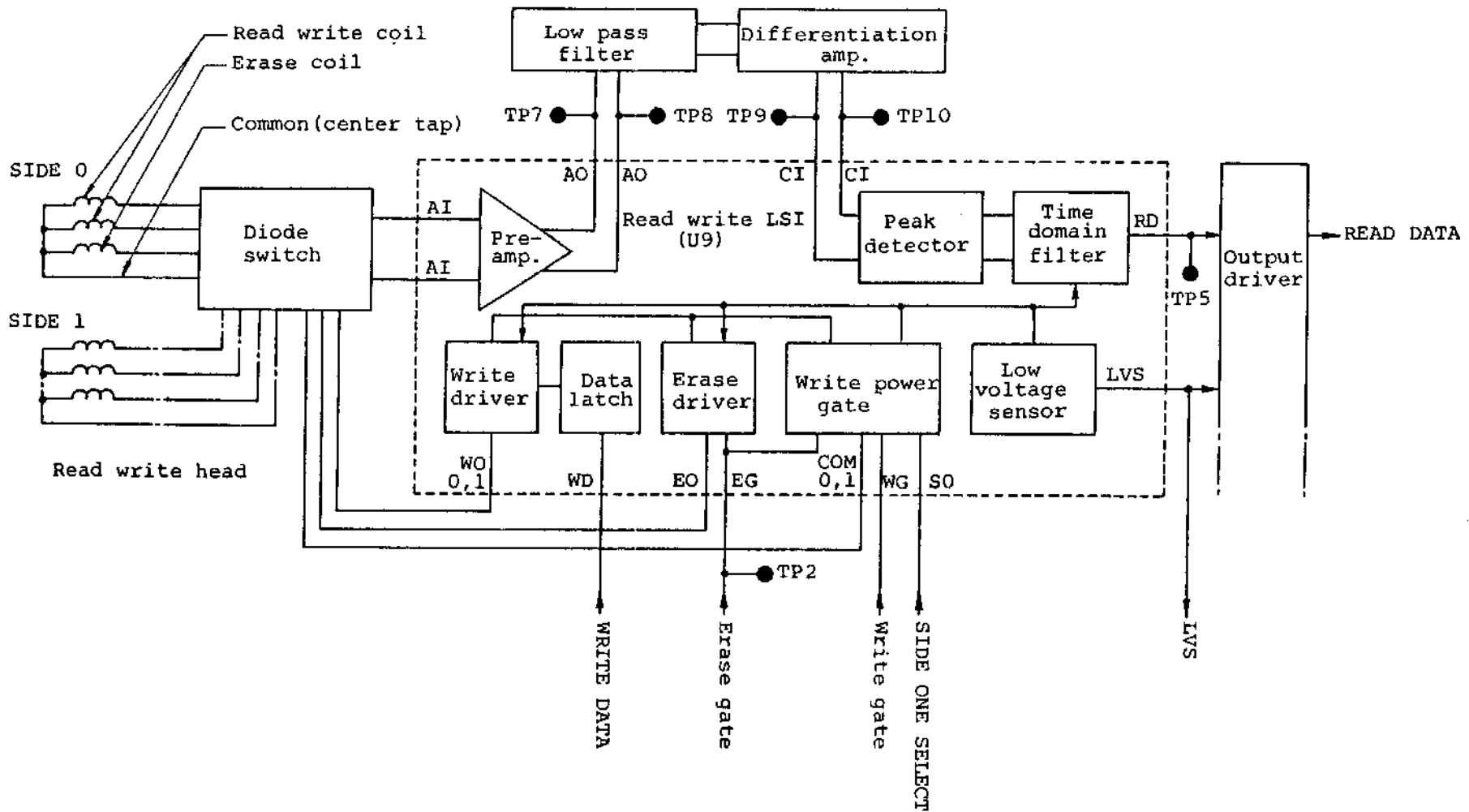

(Fig.303) Read write circuit block diagram

(1) Read circuit

The read circuit consists of pre-amplifier, low pass filter, differentiation amplifier, peak detector, time domain filter and read gate (output driver)

In read operation, the minute voltage induced by the read/write head is amplified about 30dB by the pre-amplifier which is constructed with a video band differential amplifier. Undesirable high frequency noise is eliminated by the low pass filter (L2,L3,C28,etc.) and the read signal is supplied to the differentiation amplifier (Q1,Q2,L1,C20, etc.)

The differentiation amplifier phase-shifts the peak position of the reproduced waveform to the zero cross point, and at the same time, further amplifies the signal about 20dB with the most appropriate equalization. The peak detector which is constructed with a comparator converts the differentiated output into a square wave.

The time domain filter eliminates a virtual pulse caused by the saddle in the low frequency area (LF area, 62.5KHz, approx. for models A ~ F, and 125KHz for model G) at outer tracks. The time domain filter is constructed with two edge detectors, 2.4 μ sec, delay single shot (LSI pin 7, RA9, C23), data latch, and 4 μ sec data single shot (LSI pins 8 and 9, RA9,C24)

Then the signal is output from the FDD through the read gate, U7 (pins 4 ~ 6, output driver)

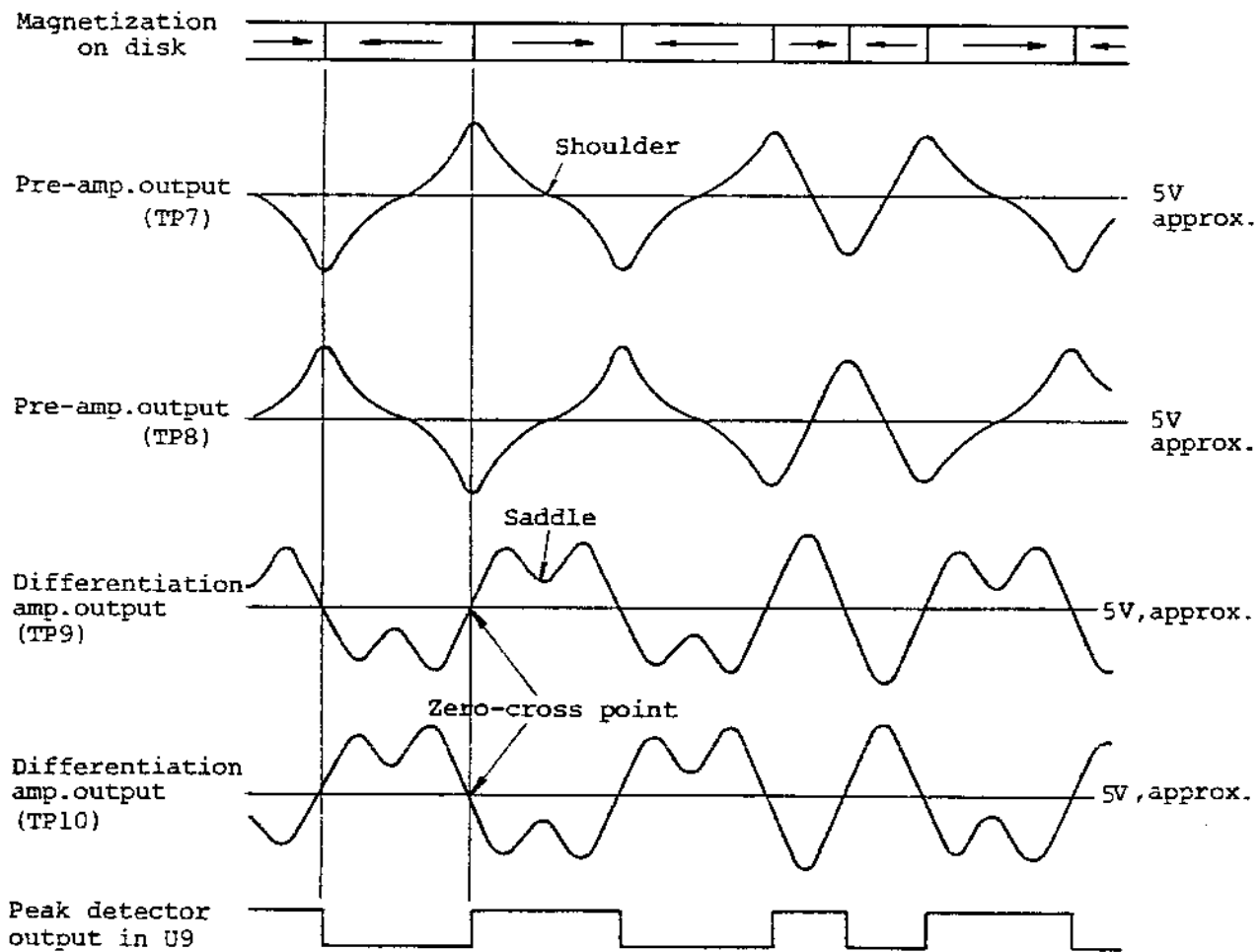

(Fig.304) Read amp. and peak detector waveforms

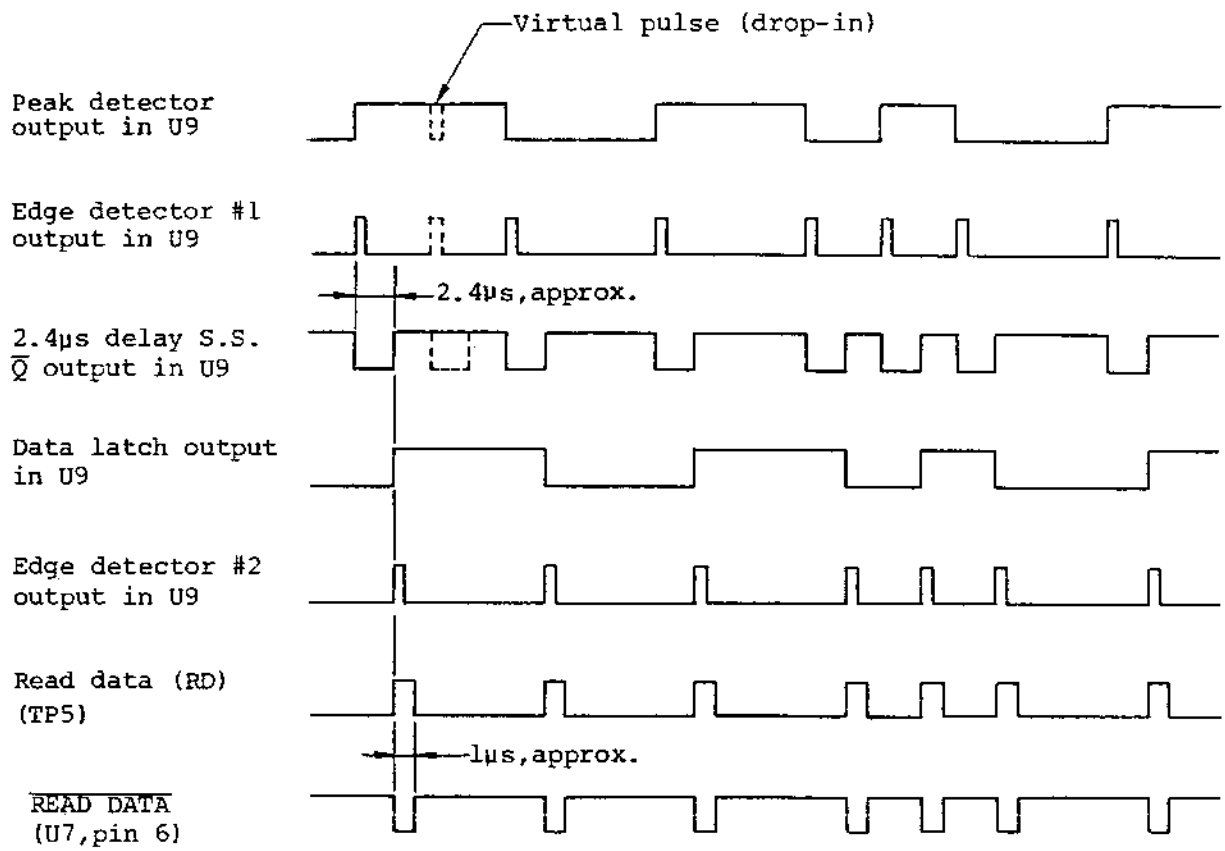

(Fig.305) Time domain filter and read gate waveforms

(2) Write circuit

The write circuit consists of write power gate (with side selector), select gate, data latch, write driver, and erase driver.

The write power gate output (COM0 or COM1) becomes high voltage when the write gate signal or the erase gate signal is TRUE (HIGH level). These signals are generated by the write/erase gate in the control circuit when all of the following three conditions are satisfied.

- (a) The file protect sensor detects the notch of the disk jacket (write enable condition).
- (b) The WRITE GATE input signal is TRUE.
- (c) MX strap is on or the DRIVE SELECT signal is TRUE (LOW).

The write power gate output is supplied to the common terminal of the head through the diode switch. Table 301 shows the output voltage of the write power gate in various operations.

Conditions	Write power gate output voltage	
	COM 0 (for Side 0)	COM 1 (for Side 1)
Side 0 write operation	High	Low
Side 1 write operation	Low	High
Side 0 read operation	Middle	Low
Side 1 read operation	Low	Middle

High: 10.5V, approx. Middle: 4V, approx. Low: 0V, approx.

(Table 301) Write power gate output voltage

The erase gate signal is delayed appropriately against the write gate signal. Since the erase gap is about 0.85mm (FD-55A ~ F models) or 0.585mm (FD-55G model) behind the read/write gap, it is necessary for the erase driver to delay the write gate signal so that the written data is completely trimmed by the erase head (tunnel erase). The

tunnel erase produces a guard band between the tracks preventing deterioration of the S/N ratio resulting from a off-track (positioning error). It also ensures disk interchangeability.

The WRITE DATA input pulse is latched by the data latch. And appropriate write current is supplied to the read/write head by turning on and off the two write drivers alternately. When the write driver is active, no read data pulse is generated by the read circuit.

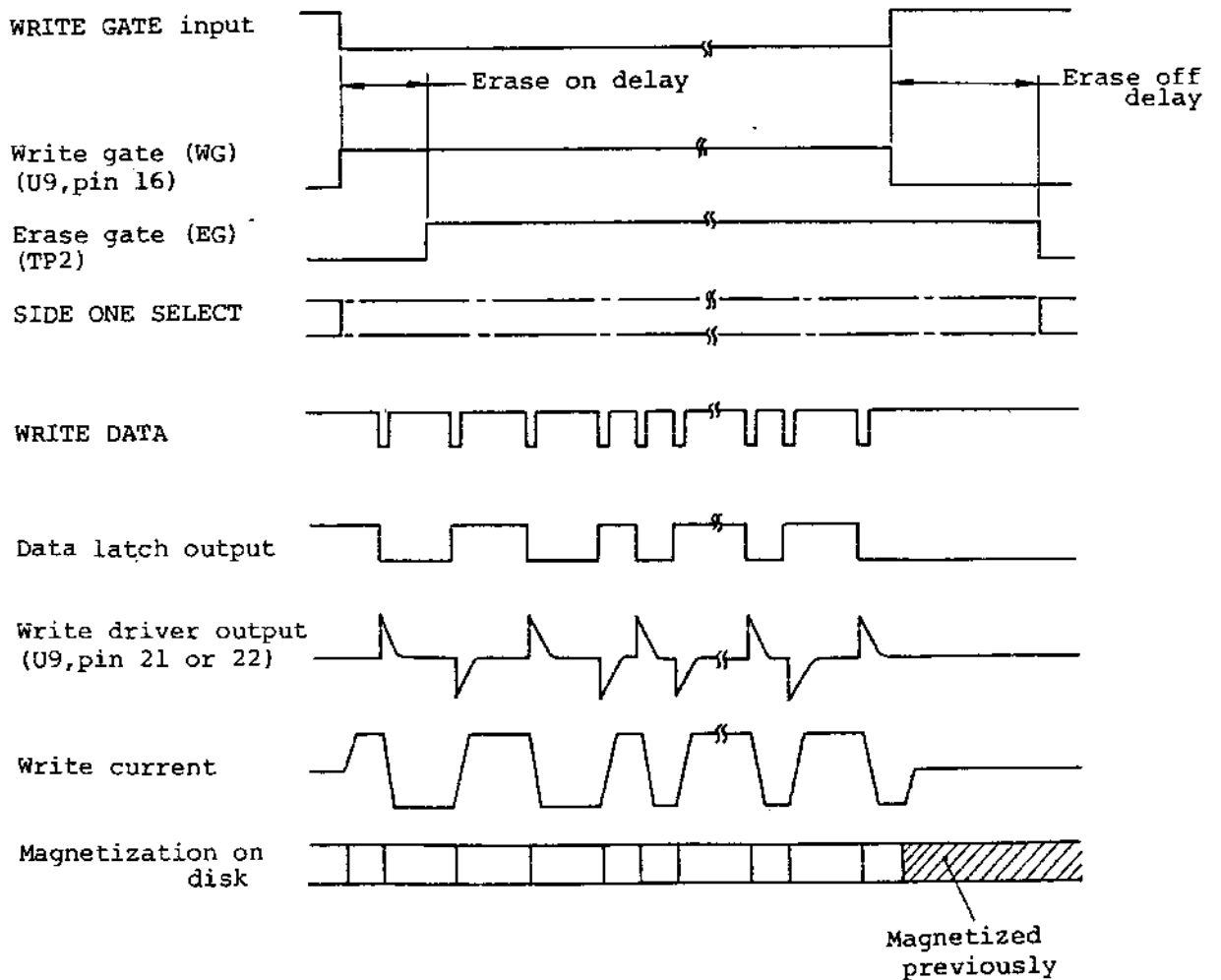

(Fig.306) Write circuit waveforms

(3) Low voltage sensor

The low voltage sensor is equipped to protect the FDD from erroneous operation due to the internal circuits construction of the FDD during unstable state of the supplied voltage such as at power on or off. The output of this sensor is ANDed to all the output drivers of the FDD. Therefore, in the unstable state of +5V and +12V power when the internal logic of the FDD does not function normally, it protects erroneous operations of write driver and erase driver, erroneous signal output to the host system, and etc.

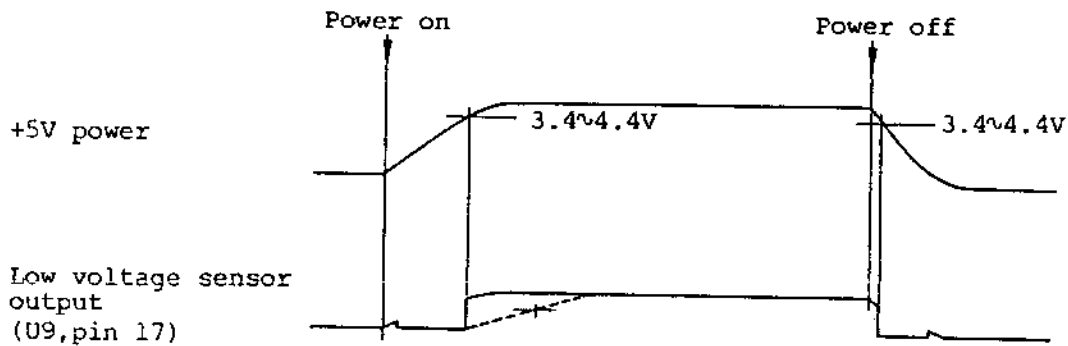

Note: Dotted line shows the LVS input pin 34 of U6, control LSI.

(Fig.307) Low voltage sensor waveforms

3-2-2. Control Circuit

The control circuit consists of gates, detectors, and the stepping motor control circuit. The gates are drive select gate to determine the drive select condition, head load gate to determine the head load condition (with head load solenoid models), spindle motor gate to determine the rotational condition of the spindle motor, write/erase gate to control the actual write operation, etc. The detectors are index/sector detector, track 00 detector, file protect detector, and ready detector. The former three detectors (photo-transistors) are mounted on the PCBA front OPT and the transport frame. And the other circuits are mounted on the PCBA MFD control (mostly packed in a control LSI (CMOS)).

Fig.308 shows the block diagram.

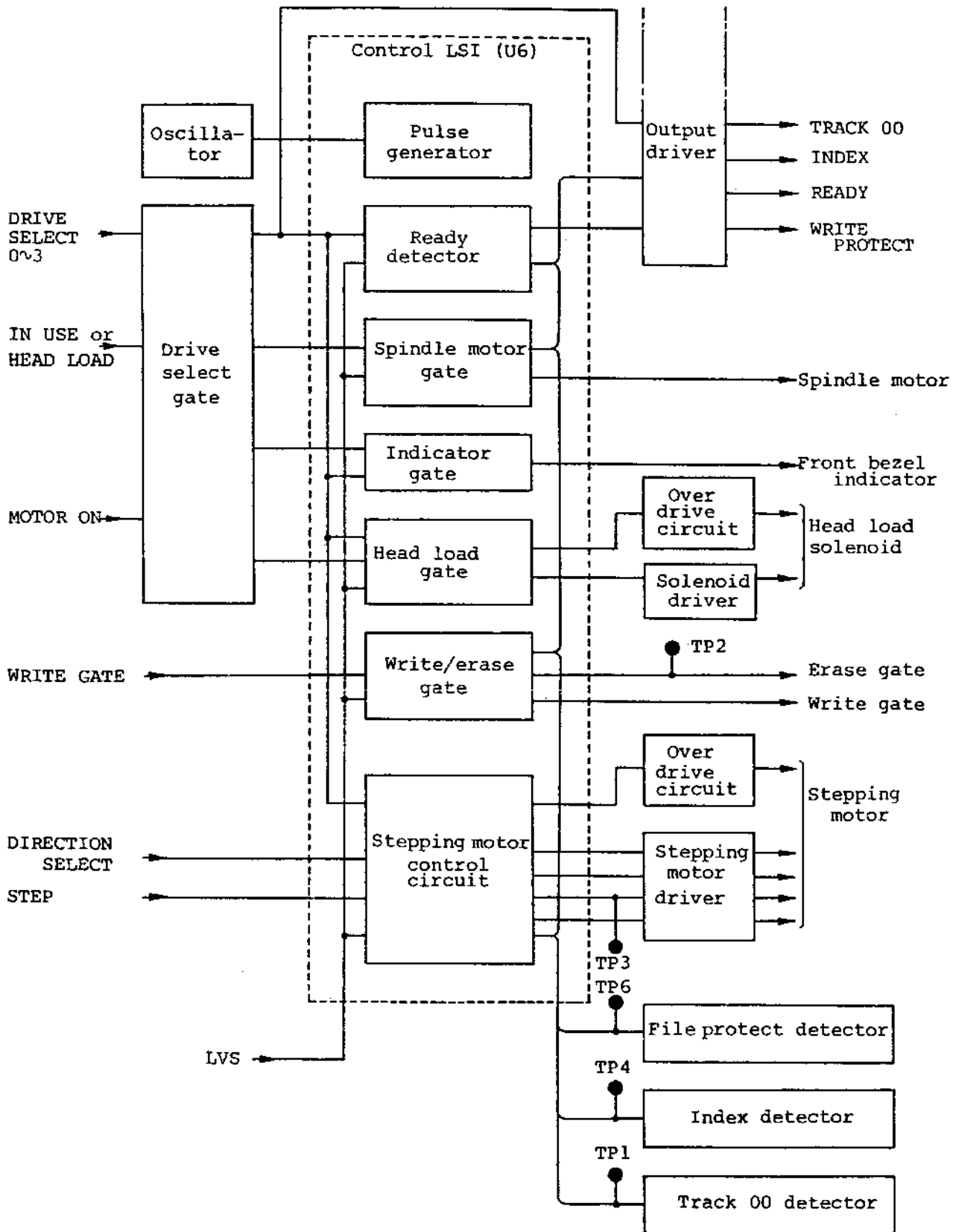

(Fig.308) Control circuit block diagram

Drive select gate classifies the external input signals into several functions and transmits them into the control LSI.

The selection of straps (short bars) determines the select condition of the drive, head load and spindle motor operating conditions, and turn-on condition of the front bezel indicator. Refer to items 1-11 and 1-12 of the Specification as to the detailed function of each strap.

The head load gate, adding the pre-ready condition to the selected head load command by the drive select gate, turns on the solenoid driver. The head load gate also triggers the internal over-drive timer constructed with a re-triggerable counter and maintains the over-drive circuit on for a determined period (26msec, approx.). During this period, +12V power is applied to the head load solenoid to execute the drawing action of the solenoid stably.

To protect the head positioning error by the impact of the head loading, the stepping motor is also over-driven. After the completion of the over-driving, both the head load solenoid and the stepping motor are maintained by +5V power to minimize the power loss.

The write/erase gate judges the FDD whether it can execute write operation or not and issues write gate and erase gate signals for the write circuit. A specified delay time is established in the erase gate signal by an internal counter (refer to Fig.306).

The ready detector consists of speed detector, pre-ready latch, and ready latch. The output of the speed detector which is constructed with a re-triggerable counter becomes always TRUE (HIGH) when the rotational speed of an installed disk (soft sectored) is more than 50%, approx. of the rated speed. The pre-ready latch detects the first index pulse (pre-ready condition) after the speed detector detects the 50% of the rated speed. The output of the ready latch becomes TRUE (HIGH) when the second index pulse after the 50% of the rated speed, then the READY condition is informed to the host system through the output driver, U2 (pin 1 ~ 3).

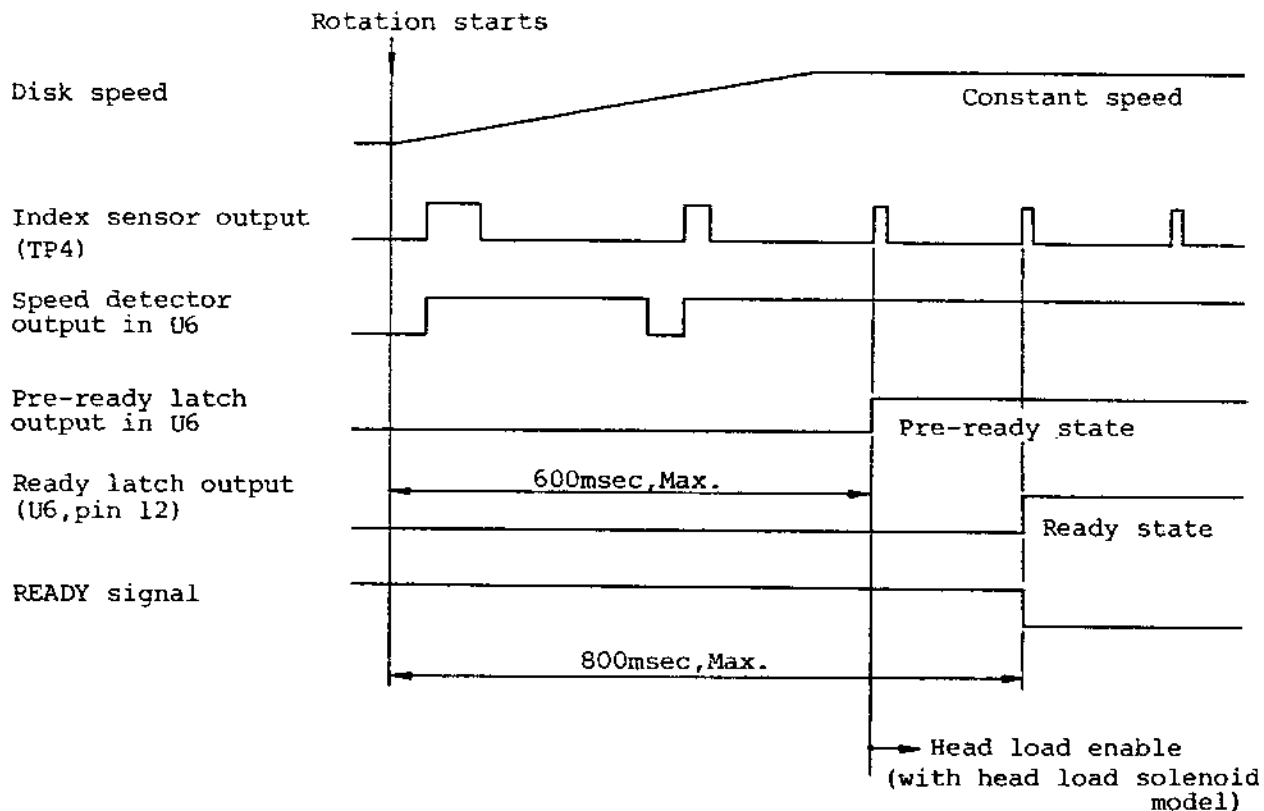

(Fig.309) Ready detector waveforms

Stepping motor control circuit is constructed with direction latch, internal step pulse generator, shift register, phase drive selector, overdrive timer, etc.

Direction latch is a circuit to sample and hold the head seek direction designated by the DIRECTION SELECT signal at every input of the STEP pulses.

The internal step pulse generator is constructed with a counter and a pulse generator. The counter is triggered at the trailing edge of the STEP input pulse, and the second internal step pulse is generated with a delay of 3msec, approx. from each STEP input pulse by the pulse generator. The internal step pulse generator functions only in a 48tpi FDD. It makes the stepping motor rotate for 2 steps (3.6°) in response to one STEP input pulse. In a 96tpi FDD, the stepping motor rotates for one step (1.8°) in response to one external STEP pulse.

Outputs of the direction latch and the internal step pulse generator are input to the shift register and phase drive selector, and they are converted to the appropriate timing signals for uni-polar one-phase drive (partially 2-phase drive) of the 4-phase stepping motor. These phase drive signals are supplied to the stepping motor driver, U8 (output pins 10 ~ 13). In order to improve the torque margin in the seek operation, partially 2-phase drive period is provided by the phase drive selector only in the initial stage when the drive phase is changed.

The output from the internal step pulse generator is also supplied to the over-drive timer constructed with a re-triggerable counter. During the active period of this timer (75msec, approx.), +12V power is supplied to the stepping motor coils through the over-drive circuit (Q3) to produce enough torque required for the head seek and the settling operations. After the completion of the settling, only +5V power is supplied to the stepping motor through the diode, CR3, which minimize the power loss by supplying only the required torque for the holding of the stop position. By the above consideration, heat radiation from the motor is depressed to the minimum level and the stepping motor power consumption of 0.25W, approx. at the stop condition is achieved.

DIRECTION SELECT

STEP

Direction latch output
in U6

48tpi FDD:

Internal step pulse gen.
output in U6

Overdrive timer output
(U6, pin 19)

Motor driver inputs
PHASE A (U8, pin 4)

PHASE B (U8, pin 5)
(TP3)

PHASE \bar{A} (U8, pin 6)

PHASE \bar{B} (U8, pin 7)

96tpi FDD:

Internal step pulse gen.
output in U6

Overdrive timer output
(U6, pin 19)

Motor driver inputs

PHASE A (U8, pin 4)

PHASE B (U8, pin 5)
(TP3)

PHASE \bar{A} (U8, pin 6)

PHASE \bar{B} (U8, pin 7)

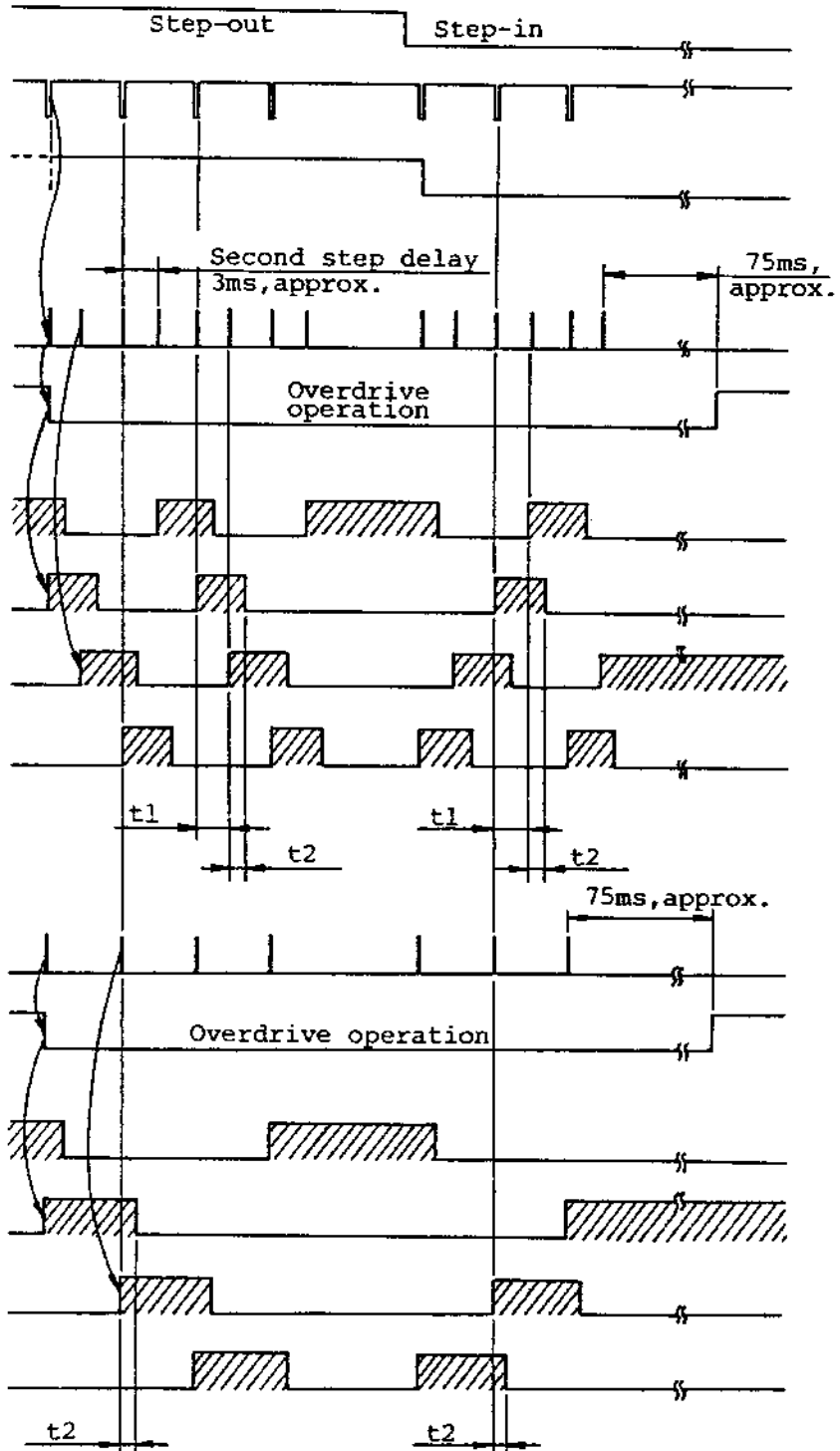

t_1 : Second step delay (3ms, approx.)

t_2 : Partial 2-phase magnetization (0.6ms, approx.)

(Fig.310) Stepping motor control circuit waveforms

3-2-3. Servo Circuit

The servo circuit aims to maintain the rotational speed of the spindle motor at 300rpm (or 360rpm), and the circuit is mounted on the PCBA assembled with the spindle motor.

Start and stop of the spindle motor (DD motor Ass'y) is controlled by the MOTOR ON signal supplied through the spindle motor gate in the control circuit.

The spindle motor is a long life DC brushless motor having 2-phase or 3-phase coils and bi-polar drive system. The coils are driven by the exclusive drive IC. Energization and magnetized direction of the coils are controlled by the signal from the hall elements mounted on the PCBA around the rotor so that they are changed corresponding to the designated rotational direction.

The rotational speed is maintained stably and precisely. The feedback signal from the AC tachometer in the rotor is converted into the drive voltage (F-V conversion) by servo IC, and supplied to the drive IC through the phase compensation circuit.

Several manufacturers' spindle motors are used in FD-55 series for the stable supply of the motor. Though these motors are almost the same in the function and performance, they are different in external view because of a little difference in the servo circuit, etc.

3-3. FUNCTION OF TEST POINTS AND VARIABLE RESISTORS

Fig.311 shows the mounting position of the test points and variable resistors.

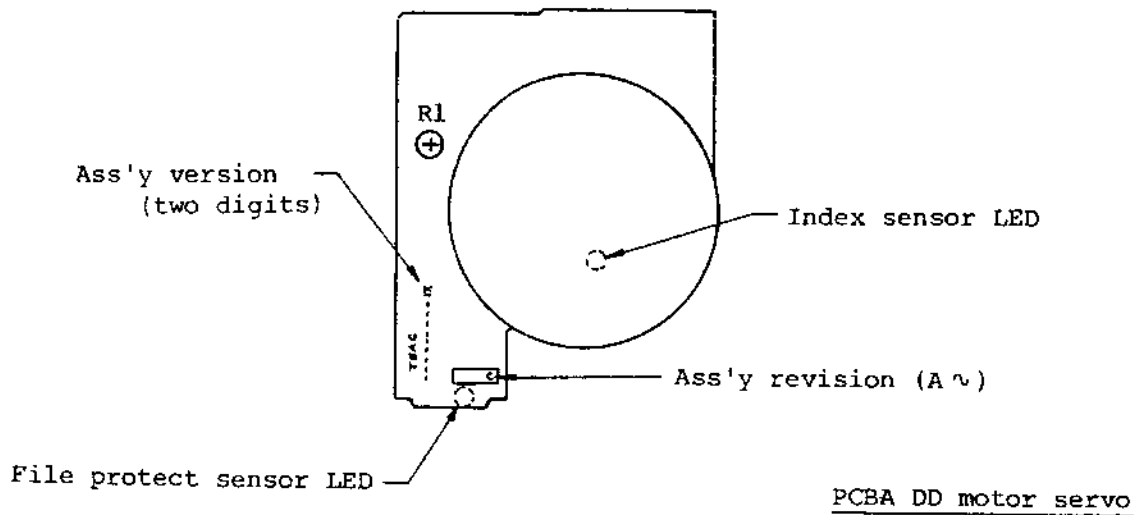
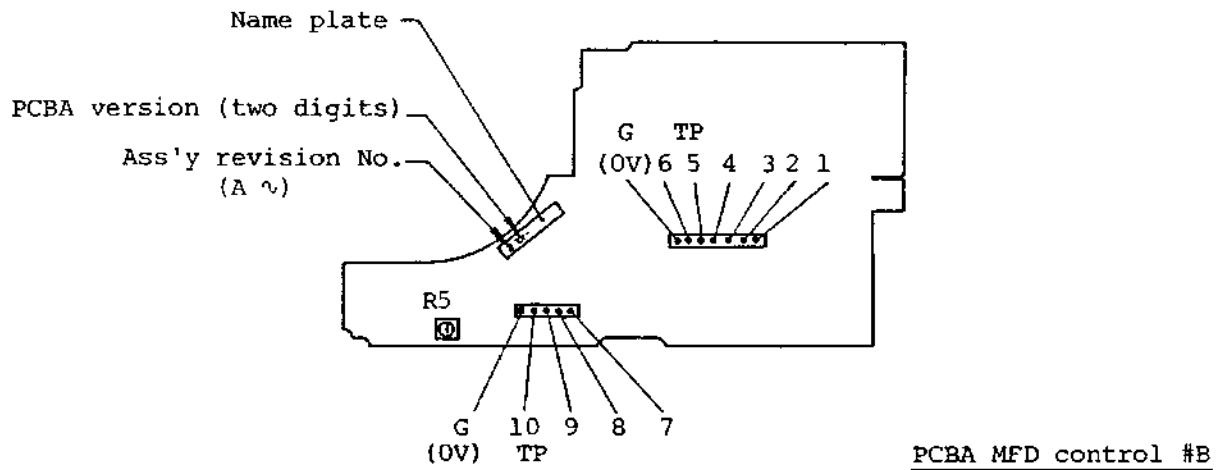

- Notes: 1. Some versions or some revision numbers of the PCBA MFD control #B have not the variable resistor R5.
 2. Some types of DD motor Ass'y have not the variable resistor R1.

(Fig.311) Location of test points and variable resistors'

3-3-1. Function of Test Points

Twelve test points (two for ground) are equipped on the PCBA MFD control for the check and adjustment of the FDD.

(1) TP1 (Track 00 sensor)

Test point to observe the output of the track 00 detection photo-transistor.

The signal level at this TP is opposite to that of the TRACK 00 output signal. When the head is on track 00 or around track 00 position, TP1 becomes HIGH level.

The voltage of TP1 should be more than 3V at track 00 and less than 0.5V at track 02 (48tpi) or track 04 (96tpi).

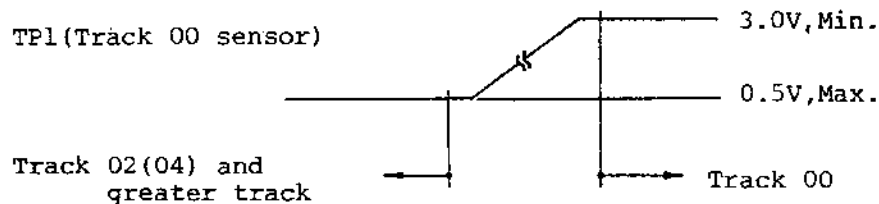

(Fig.312) Typical waveform of TP1

Note: The TRACK 00 output signal goes TRUE (LOW level) only when the phase A coil of the stepping motor is energized and the direction latch is set to the step-out direction (refer to Fig.310). Therefore, the level change timing of the TRACK 00 signal is not consistent with that of the TP1 signal.

(2) TP2 (ERASE gate)

Test point to observe the output of the erase gate.

When TP2 is HIGH level, erase current flows through the erase head.

This TP is used for the check of the required delay time of the erase

gate signal against the WRITE GATE input signal.

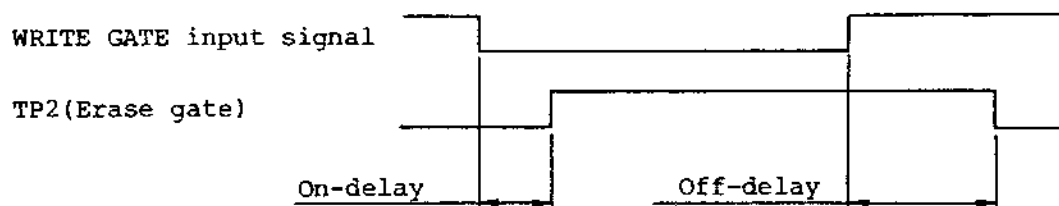

(Fig.313) Typical waveform of TP2

Delay	FD-55A ~ F	FD-55G
On-delay	200 ~ 320 μ s	175 ~ 210 μ s
Off-delay	860 ~ 950 μ s	500 ~ 550 μ s

(Table 302) Erase gate delay

(3) TP3 (Phase B)

Test point to observe the phase B magnetized period of the stepping motor. For the 48tpi FDD, it is also used for observing the delay time of the second step pulse which is produced automatically in the FDD. It is also used for all the FDDs, as the observation point of the partial 2-phase magnetization timing of the stepping motor.

For the 48tpi FDD, the stepping motor rotates for 2 steps in response to one STEP input pulse. Therefore, TP3 goes HIGH level for a specified time when a step-out command from an even track or a step-in command from an odd track is executed. Refer to Fig.310.

For the 96tpi FDD, the stepping motor rotates only for 1 step in response to one STEP input pulse by which one track space is moved. TP3 maintains HIGH level when the head is on the $1+4n$ ($n=0,1,2,---$) track (phase B magnetized) or for a specified time during step-in or

step-out operation from the above 1+4n track.

48tpi FDD:

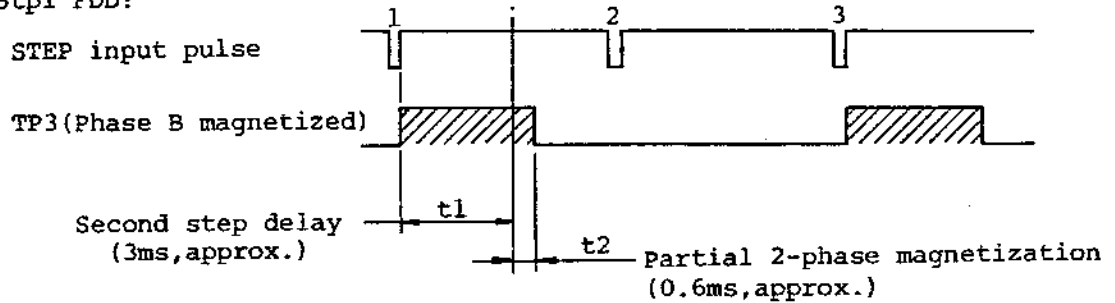

$$t_1+t_2= 3.6\pm 0.3\text{ms}$$

96tpi FDD:

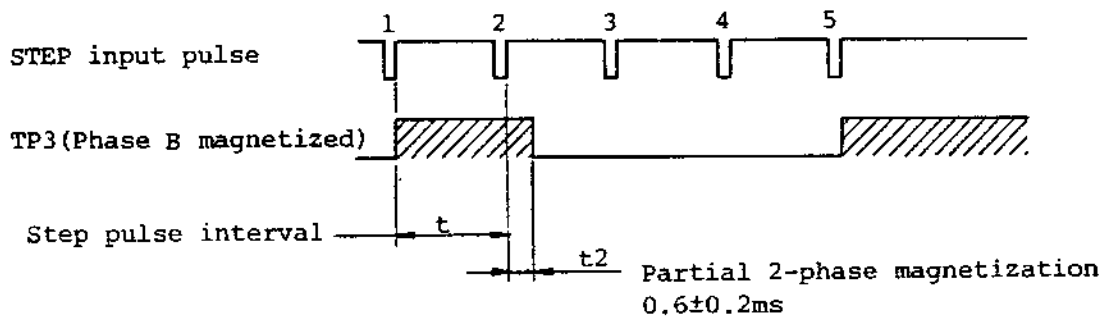

$$t+t_2=t+(0.6\pm 0.2)\text{ms}$$

(Fig.314) Typical waveform of TP3

(4) TP4 (Index)

Test point to observe the output of the index detection photo-transistor after inverting the level by the Schmitt inverter.

The signal level at this TP is opposite to that of the INDEX output signal. When the index hole or sector hole (hard sectored disk) is detected, HIGH going pulse is observed at TP4. The photo-transistor is mounted on the PCBA front OPT and the LED is mounted on the PCBA DD motor servo.

The test point is used for the following purposes.

(a) Confirmation and adjustment of the disk rotational speed. Speed is adjusted by the variable resistor R1 on the PCBA DD motor servo.

Note: Some types of DD motor Ass'y have not the variable resistor R1 for rotation speed adjustment. In such a DD motor Ass'y, no adjustment is required and the rotation speed is determined by an oscillation frequency of the ceramic oscillator mounted on the PCBA DD motor servo.

(b) Confirmation and adjustment of the index burst timing. Burst timing is adjusted by the fixing screws of the PCBA front OPT.

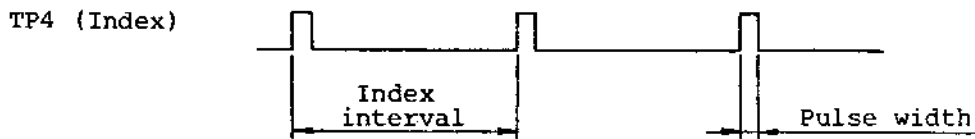

(Fig.315) Typical waveform of TP4 (Speed observation)

Items	FD-55A ~ F	FD-55G
Index interval	200±3ms	166.7±2.5ms
Pulse width	2 ~ 5.5ms	1 ~ 8ms
Burst delay	200±200µs	165±165µs

(Table 303) Index timing

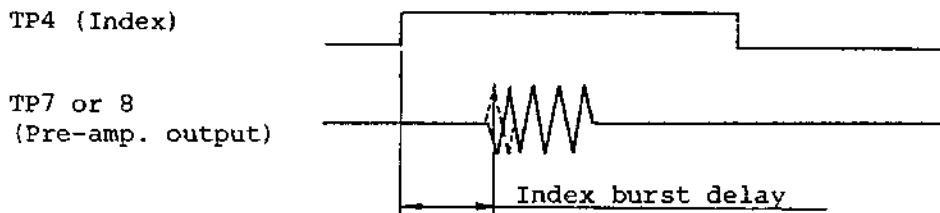

(Fig.316) Typical waveform of TP4 (Burst timing observation)

(5) TP5 (Read data)

Test point to observe the read data pulse.

The signal level at this TP is opposite to that of the READ DATA output signal.

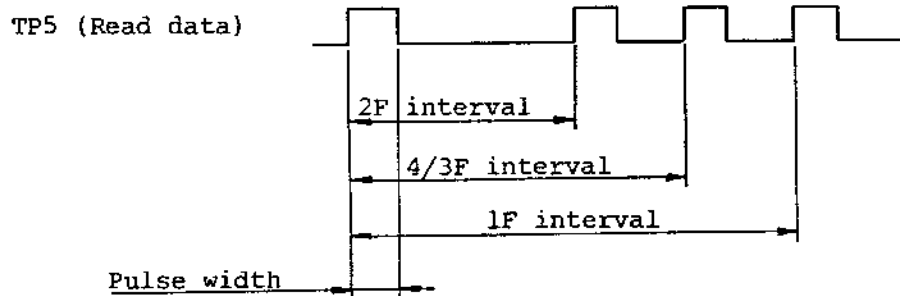

(Fig.317) Typical waveform of TP5

Fig.317 shows the waveform at TP5 in normal data read operation.

In the FM method, 2F and 1F intervals are observed, while 2F, 4/3F, and 1F intervals are observed in the MFM method.

Items	FD-55A ~ F	FD-55G
2F interval	4 μ s, Nom.	2 μ s, Nom.
4/3F interval	6 μ s, Nom.	3 μ s, Nom.
1F interval	8 μ s, Nom.	4 μ s, Nom.
Pulse width	1 \pm 0.5 μ s	0.5 \pm 0.25 μ s

(Table 304) Read data pulse timing

(6) TP6 (File protect sensor)

Test points to observe the output of the file protect detection photo-transistor.

The signal level at this TP is opposite to that of the WRITE PROTECT output signal. When a disk with the masked write protect notch (write

operation cannot be done) is installed, TP6 becomes HIGH level. The voltage of TP6 should be more than 3V at masked notch and less than 0.5V at open notch (write enable condition).

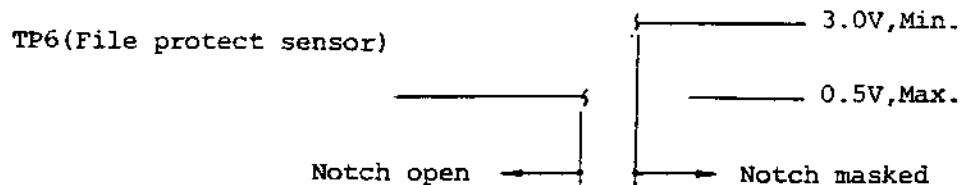

(Fig.318) Typical waveform of TP6

(7) TP7, TP8 (Pre-amplifier)

Test point to observe the read pre-amplifier output signals. The pre-amplifier has two outputs of the order of several dozen to several hundred mVp-p, and they differ in phase by 180° (opposite phase). Both outputs are observed at TP7 and TP8 respectively. For an accurate observation of the read waveforms, use two channels of an oscilloscope with one channel set to Invert mode and Add mode of both channels. Use G (0V) test point for the oscilloscope ground. TP7 and TP8 are used for checking various characteristics of the read/write head and also for the check and adjustment of the head seek mechanism such as track alignment.

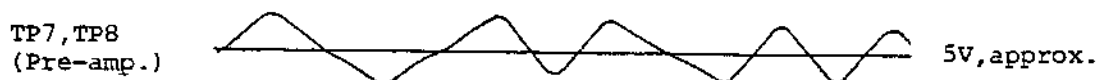

(Fig.319) Typical waveform of TP7 and TP8

(8) TP9, TP10 (Differentiation amplifier)

Test points to observe the differentiation amplifier output signals. Like the pre-amplifier, the differentiation amplifier also has two outputs of the order of several hundred mVp-p to several to several Vp-p which differ in phase by 180°. Both outputs are observed at TP9 and TP10 respectively.

For an accurate observation of the waveforms, use two channels of the oscilloscope with one channel set to Invert mode and Add mode of both channels.

Use G (0V) test point for the oscilloscope ground.

TP9 and TP10 are used for checking the total operation of the read/write head and the read amplifier and for the check and adjustment of the head seek mechanism such as track alignment.

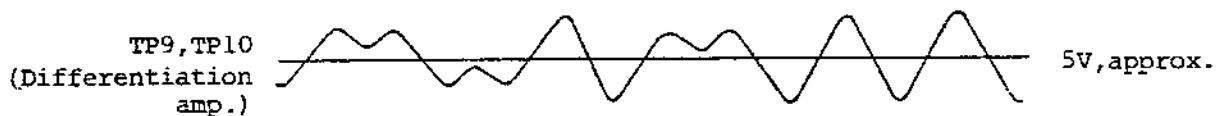

(Fig.320) Typical waveform of TP9 and TP10

(9) TP G (0V) -- PCBA MFD control, PCBA read write amp.

TP G is equipped respectively for two test point blocks (TP1 ~ 6 and TP7 ~ 10). They are used as the ground terminals for measurement equipment. Be sure to use a small size clip to obtain a probe ground of the equipment.

3-3-2. Function of Variable Resistors

On the PCBA MFD control and the PCBA DD motor servo, maximum two variable resistors are mounted.

The PCBA MFD control of some PCBA versions and some revision numbers has not the variable resistor R5. Also some types of DD motor Ass'y have not the variable resistor R1 on the PCBA DD motor servo.

However, there is interchangeability in function and performance between these PCBAs with the variable resistor and without the variable resistor as far as they have the same parts number (8 digits) and the same version number (2 digits). It is not necessary to identify one from another as the spare parts.

The variable resistors are correctly adjusted before the shipment of the FDD and fundamentally they shall not be readjusted except for by a trained technicians.

(1) R1 on PCBA DD motor servo (Disk rotational speed adjustment)

Variable resistor for adjusting the rotational speed of the disk.

It is adjusted so that the index pulse interval at TP4 or at the INDEX output signal is $200\text{msec} \pm 3\text{msec}$ for FD-55A ~ F and $166.7\text{msec} \pm 2.5\text{msec}$ for FD-55G (see Fig.315).

For the DD motor Ass'y without the variable resistor R1, the rotation speed of the motor is fixed by the ceramic oscillator in the servo circuit and no adjustment is required.

(2) R5 on PCBA MFD control (Read data asymmetry adjustment)

Variable resistor for adjusting the asymmetry of the read data pulse. Some PCBAs have this variable resistor and others have fixed resistor instead of it.

For a PCBA with the variable resistor, R5, write LF data and observe the pulse intervals at TP5 or at the READ DATA output signal during read operation. Then adjust the variable resistor so that the read

data asymmetry in Fig.321 takes the minimum value. For a double sided FDD, repeat this operation alternately for side 0 and side 1 heads to obtain the minimum asymmetry for both sides.

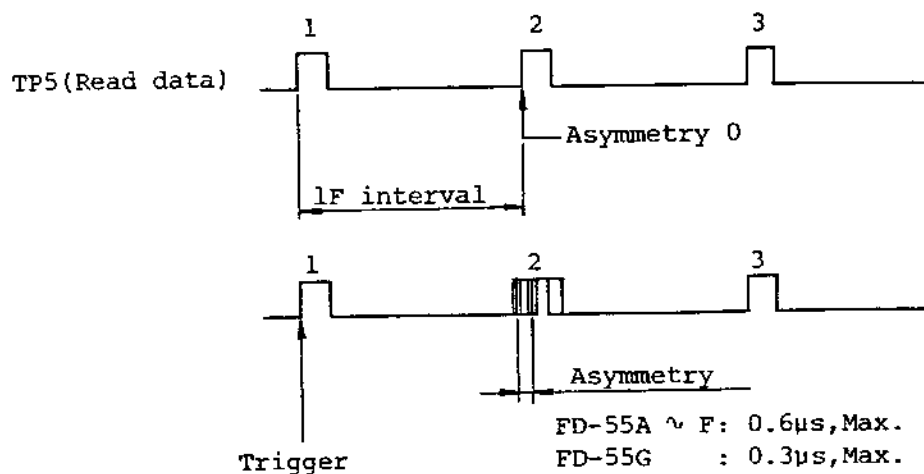

(Fig.321) Read data asymmetry

SECTION 4

MAINTENANCE

4-1. GENERAL

4-1-1. Periodic Maintenance

The FDD is designed to be free from periodic maintenance such as replacement of parts, grease-up, etc. when it is operated at a normal operation duty.

However, cleaning of the magnetic head using a cleaning disk is recommended since it is effective to improve the reliability of the data. If some of the parts in the FDD are operated at a specially heavy duty condition, or if the FDD is operated over 5 years, it is recommended to replace the wear parts according to Table 403.

Periodic maintenance items	Recommended cycle	Required time	Referred items
Cleaning of magnetic head	Refer to 4-3-1 and 4-3-2	5 min.	4-3-1
Replacement of wear parts	Refer to 4-1-3 and 4-5.		

(Table 401) Periodic maintenance items

4-1-2. Check and Adjustment

Table 402 shows all of the check and adjustment items.

Following items do not require periodic maintenance. Check and adjustment should be done when required during replacement of the maintenance parts or during trouble shooting referring to items 4-2 and 4-3.

The numbered procedure in Table 402 shows a typical procedure of the general check and adjustment all over the FDD.

Steps	Check and adjustment items	Required time	Referred items
1	Adjustment of set arm position	5 minutes	4-4-1
2	Adjustment of clamp arm position	5 minutes	4-4-2
3	Adjustment of front lever	5 minutes	4-4-3
4	Adjustment of arm lifter (Model with head load solenoid only)	5 minutes	4-4-4
5	Check of CSS Ass'y (Double sided CSS model only)	5 minutes	4-4-5
6	Check of file protect sensor	5 minutes	4-4-6
7	Check and adjustment of disk rotational speed	5 minutes	4-4-7
8	Check of erase gate delay	5 minutes	4-4-8
9	Check and adjustment of head touch	5 minutes	4-4-9
10	Check and adjustment of asymmetry	5 minutes	4-4-10
11	Check of read level	5 minutes	4-4-11
12	Check of resolution	5 minutes	4-4-12
13	Check and adjustment of track alignment	10 minutes	4-4-13
14	Check and adjustment of track 00 sensor	5 minutes	4-4-14
15	Check and adjustment of track 00 stopper	5 minutes	4-4-15
16	Check and adjustment of index burst timing	5 minutes	4-4-16

(Table 402) Check and adjustment items

4-1-3. Maintenance Parts Replacement

It is recommended to replace the wear parts periodically if the FDD is operated at a specially heavy duty condition or if it is operated over five years. Periodic replacement is not required for the parts if the FDD is operated at a normal operation duty.

Table 403 shows all of the maintenance parts. Replace the wear parts according to the recommended replacement cycle. Periodic replacement is not required for parts without a recommended replacement cycle.

The replacement of the parts should be done according to each referred item in Table 403.

Notes for Table 403:

- (1) If two parts numbers are listed for one part, either of the two may be used. Fundamentally, parts without brackets are used at the shipment though parts with brackets may be used since they are interchangeable as spare parts.
- (2) Since the parts number versions of the PCBA MFD control #B and the PCBA front OPT vary depending on some factors such as signal interface condition, be sure to confirm the version by checking the name plate on the actual printed circuit board.
- (3) The head carriage Ass'y are used always in pair with two guide shafts. The head carriage Ass'y represented by listed parts number in Table 403 includes these guide shafts which parts number is different from that of a head carriage Ass'y itself without these guide shafts.
- (4) The listed parts numbers of the front bezel Ass'y and the front lever Ass'y are those of standard color (black). For designating other color, use the corresponding parts number.
- (5) The parts number version of the front bezel Ass'y and the front lever

Ass'y is -50 which is different from the version (-00) of the conventional FD-55 series listed in the Maintenance Manual. This difference indicates that the material is changed from ABS to PPHOX (Zyron). Both of the assemblies are interchangeable between -50 and -00.

- (6) The head load solenoid Ass'y applies only to the models with head load solenoid. The CSS Ass'y applies only to the double sided models without head load solenoid. The head load solenoid Ass'y and the CSS Ass'y will never be installed together in a model.
- (7) The parts number of the head load solenoid Ass'y is different from that (P/N 17766799-01) of the conventional FD-55 series listed in the Maintenance Manual. This is because of partial improvement of the Ass'y. Both new and old assemblies are interchangeable each other. The head load solenoid Ass'y of the listed parts number in this manual need not adjustment of head protector. Therefore, the explanation for it is deleted from this manual.
- (8) The parts number version of the head pad for single sided models is -01 which is different from the version (-00) of conventional FD-55 series listed in the Maintenance Manual. This is because that the diameter of the pad is decreased a little for improving the function. Be sure to note that the improved smaller pad has not interchangeability with the old type when it is attached to the pad arm (refer to item 4-5-11).
- (9) Periodic replacement is not required for parts without a recommended replacement cycle. Replace the parts when required such as during repair.
- (10) If two recommended cycles are listed, the cycle which the parts reach first should have priority.
- (11) The required time for replacement includes the time for basic check and adjustment after the replacement.

(Table 403-1) FD-55A (Single sided, 48tpi) Maintenance parts list

Maintenance parts			Replacement		
Parts name	Description	Parts No.	Replacement cycle	Required time	Referred items
Head carriage Ass'y	Note (3)	17966940-00	7,000 head load & motor on hrs. or 1×10^7 seeks	45 min.	4-5-1
Stepping motor Ass'y	Note (1)	14769070-50 or (-00)	1×10^7 seeks	30 min.	4-5-2
Steel belt		16792265-00	Replace with stepping motor Ass'y	-	4-5-2
Belt spring		16392008-00		-	4-5-2
DD motor Ass'y (Spindle motor)	Note (1)	14733730-10 or (-00)	30,000 motor on hrs.	20 min.	4-5-3
Collet Ass'y		17966793-00	3×10^5 clamps	15 min.	4-5-4
Head load solenoid Ass'y	Note (6), Note (7)	17966859-01	1×10^7 head loads	15 min.	4-5-5
Track 00 sensor Ass'y		17966805-00	-	10 min.	4-5-6
PCBA MFD control #B		15532001-XX	-	30 min.	4-5-7
	Note (2)				
PCBA front OPT		15531990-XX	-	10 min.	4-5-8
	Note (2)				
Front bezel Ass'y	Note (4), Note (5)	17966807-50	-	10 min.	4-5-9
Front lever Ass'y	Note (4), Note (5)	17966808-50	-	5 min.	4-5-10
Pad (Head pad)	Note (8)	16786634-01	3,000 head load & motor on hrs.	10 min.	4-5-11

(Table 403-2) FD-55B (Double sided, 48tpi) Maintenance parts list

Maintenance parts			Replacement		
Parts name	Description	Parts No.	Replacement cycle	Required time	Referred items
Head carriage Ass'y	Note (3)	17966941-00	7,000 head load & motor on hrs.or 1×10^7 seeks	45 min.	4-5-1
Stepping motor Ass'y	Note (1)	14769070-50 or (-00)	1×10^7 seeks	30 min.	4-5-2
Steel belt		16792265-00	Replace with stepping motor Ass'y	-	4-5-2
Belt spring		16392008-00		-	4-5-2
DD motor Ass'y (Spindle motor)	Note (1)	14733730-10 or (-00)	30,000 motor on hrs.	20 min.	4-5-3
Collet Ass'y		17966793-00	3×10^5 clamps	15 min.	4-5-4
Head load solenoid Ass'y	Note (6), Note (7)	17966859-01	1×10^7 head loads	15 min.	4-5-5
Track 00 sensor Ass'y		17966805-00	-	10 min.	4-5-6
PCBA MFD control #B	Note (2)	15532001-XX	-	30 min.	4-5-7
PCBA front OPT	Note (2)	15531990-XX	-	10 min.	4-5-8
Front bezel Ass'y	Note (4), Note (5)	17966807-50	-	10 min.	4-5-9
Front lever Ass'y	Note (4), Note (5)	17966808-50	-	5 min.	4-5-10
CSS Ass'y	Note (6)	17966900-00	6×10^5 clamps	10 min.	4-5-12

(Table 403-3) PD-55E (Single sided, 96tpi) Maintenance parts list

Maintenance parts			Replacement		
Parts name	Description	Parts No.	Replacement cycle	Required time	Referred items
Head carriage Ass'y	Note (3)	17966942-00	7,000 head load & motor on hrs.or 1×10^7 seeks	45 min.	4-5-1
Stepping motor Ass'y		14769070-00	1×10^7 seeks	30 min.	4-5-2
Steel belt		16792265-00	Replace with stepping motor Ass'y	-	4-5-2
Belt spring		16392008-00		-	4-5-2
DD motor Ass'y (Spindle motor)		14733730-00	30,000 motor on hrs.	20 min.	4-5-3
Collet Ass'y		17966793-00	3×10^5 clamps	15 min.	4-5-4
Head load solenoid Ass'y	Note (6),Note (7)	17966859-01	1×10^7 head loads	15 min.	4-5-5
Track 00 sensor Ass'y		17966805-00	-	10 min.	4-5-6
PCBA MFD control #B	Note (2)	15532001-XX	-	30 min.	4-5-7
PCBA front OPT	Note (2)	15531990-XX	-	10 min.	4-5-8
Front bezel Ass'y	Note (4),Note (5)	17966807-50	-	10 min.	4-5-9
Front lever Ass'y	Note (4),Note (5)	17966808-50	-	5 min.	4-5-10
Pad (Head pad)	Note (8)	16786634-01	3,000 head load & motor on hrs.	10 min.	4-5-11

(Table 403-4) FD-55F (Double sided, 96tpi) Maintenance parts list

Maintenance parts			Replacement		
Parts name	Description	Parts No.	Replacement cycle	Required time	Referred items
Head carriage Ass'y	Note (3)	17966944-00	7,000 head load & motor on hrs.or 1×10^7 seeks	45 min.	4-5-1
Stepping motor Ass'y		14769070-00	1×10^7 seeks	30 min.	4-5-2
Steel belt		16792265-00	Replace with stepping motor Ass'y	-	4-5-2
Belt spring		16392008-00		-	4-5-2
DD motor Ass'y (Spindle motor)		14733730-00	30,000 motor on hrs.	20 min.	4-5-3
Collet Ass'y		17966793-00	3×10^5 clamps	15 min.	4-5-4
Head load solenoid Ass'y	Note (6), Note (7)	17966859-01	1×10^7 head loads	15 min.	4-5-5
Track 00 sensor Ass'y		17966805-00	-	10 min.	4-5-6
PCBA MFD control #B		15532001-XX	-	30 min.	4-5-7
	Note (2)				
PCBA front OPT		15531990-XX	-	10 min.	4-5-8
	Note (2)				
Front bezel Ass'y	Note (4), Note (5)	17966807-50	-	10 min.	4-5-9
Front lever Ass'y	Note (4), Note (5)	17966808-50	-	5 min.	4-5-10
CSS Ass'y	Note (6)	17966900-00	6×10^5 clamps	10 min.	4-5-12

(Table 403-5) FD-55G (Double sided, High density, 96tpi) Maintenance parts list

Maintenance parts			Replacement		
Parts name	Description	Parts No.	Replacement cycle	Required time	Referred items
Head carriage Ass'y	Note (3)	17966943-00	7,000 head load & motor on hrs.or 1×10^7 seeks	45 min.	4-5-1
Stepping motor Ass'y		14769070-00	1×10^7 seeks	30 min.	4-5-2
Steel belt		16792265-00	Replace with stepping motor Ass'y	-	4-5-2
Belt spring		16392008-00		-	4-5-2
DD motor Ass'y (Spindle motor)		14733730-50	30,000 motor on hrs.	20 min.	4-5-3
Collet Ass'y		17966793-00	3×10^5 clamps	15 min.	4-5-4
Head load solenoid Ass'y	Note (6), Note (7)	17966859-01	1×10^7 head loads	15 min.	4-5-5
Track 00 sensor Ass'y		17966805-00	-	10 min.	4-5-6
PCBA MFD control #B	Note (2)	15532001-XX	-	30 min.	4-5-7
PCBA front OPT	Note (2)	15531990-XX	-	10 min.	4-5-8
Front bezel Ass'y	Note (4), Note (5)	17966807-50	-	10 min.	4-5-9
Front lever Ass'y	Note (4), Note (5)	17966808-50	-	5 min.	4-5-10
CSS Ass'y	Note (6)	17966900-00	6×10^5 clamps	10 min.	4-5-12

4-1-4. Maintenance Jigs and Tools

The following are the jigs and tools required for adequate maintenance of the FDD.

(1) Equipment

(A) When Simulator KA (off-line exerciser, abbreviated to SKA) is used:

(a) Two different models of SKA are used for the maintenance of FD-55A through F, and for FD-55G. For FD-55G, designate SKA(-G).

The following accessories are necessary for operating the SKA (the accessories are supplied with the SKA).

i) SKA/FFD interface cable (-00)

ii) Check cable #1 (for observation of control signals)

iii) Check cable #2 (for observation of read amp. output signals)

iv) SKA/FDD power cable

(b) Oscilloscope (two channel)

(c) DC power supply (+12V, 1.2A and +5V, 2A) or SKA power supply.

The following accessory is required for the power supply (The accessory is supplied with the SKA power supply).

i) Power cable (4P)

(d) Thermometer and hygrometer

(B) When SKA is not used:

(a) FDD controller and DC power supply (user's system)

(b) Oscilloscope (two channel)

(c) Frequency counter

- (d) Digital volt meter
- (e) DC clip-on ammeter
- (f) Thermometer and hygrometer

(2) Tools

- (a) Cross-point screwdrivers, M2.6 and M3
- (b) Common screwdriver, small size
- (c) Hexagon wrench key, 1.5mm
- (d) A pair of tweezers
- (e) Round nose pliers
- (f) Cutting pliers
- (g) Solder and soldering iron
- (h) Cutter knife

(3) Special jigs

- (a) Max. media jig (Jig C, P/N 17890746-00)
- (b) Alignment adjustment jig (P/N 17851100-00)

(4) Disks

- (a) Work disk (commercially available disk)
- (b) Cleaning disk (commercially available cleaning disk)
 - i) Single sided type
 - ii) Double sided type
- (c) Alignment disk (CE disk)
 - i) Single sided, 48tpi type (P/N 14900016-20)
 - ii) Double sided, 48tpi type (P/N 14900016-21)
 - iii) Single sided, 96/100tpi type (P/N 14900016-23)

iv) Double sided, 96/100tpi type (P/N 14900016-24)

(d) Level disk (P/N 14900015-00)

(5) Other articles used during maintenance

(a) Absolute alcohol (Ethanol)

(b) Cotton swab or gauze

(c) Locking paint (3 Bond, 1401B)

(d) Screws and washers (Refer to item 5-2-2)

Note: Be sure to use well calibrated equipment and disks.

4-2. PRECAUTIONS

4-2-1. Torque Applied to Screws and Locking Paint

The following torque should be applied to screws, unless otherwise specified.

Size of screws	Torque
M2	2kg.cm
M2.6	4.5kg.cm
M3	6kg.cm
M3 set screw	4.5kg.cm
M3 plastic screw	1.5kg.cm

(Table 404) Torque applied to screws

For tightening or loosening M3 set screws for adjustment and parts replacement, the following procedure should be followed.

- (1) For adjustment, remove out the set screw and also remove the locking paint which had applied to the screw itself and around it.
- (2) Apply fresh locking paint to the first three threads of the set screw with some narrow object such as a pair of tweezers.
- (3) Adjust or tighten the set screw with the specified torque.

For other screws than set screws, apply a drop of locking paint to the designated points after tightening them.

4-2-2. Handling of Connectors

(1) Types of connectors

The following connectors are used for the FDD.

- (a) J1: Interface connector
- (b) J2: Power connector
- (c) J3: IC socket for terminator (resistor network)
- (d) J4: Head load solenoid & track 00 connector
- (e) J5: PCBA front OPT connector
- (f) J6: Stepping motor connector
- (g) J7: Spindle motor (DD motor Ass'y) connector
- (h) J8: (Option) Disk sensor connector
- (i) J9: Head connector
- (j) J10: (Option) 1/1 size front bezel indicator connector
- (k) J11: (Option) Door close switch connector or HD sensor connector
- (l) J12: (Option) PCBA VFO OPT connector
- (m) J13: (Option) Door lock solenoid connector

(2) Connection and disconnection of the connectors

Be sure to turn the power off before connecting and disconnecting the connectors. Connection or disconnection should be done straightly and correctly without applying excessive force to the cables and the post pins.

(3) Precautions for handling the white connectors (J6, J7, J11, J13)

(a) Disconnection of the connector

As shown in Fig.402, carefully pull up the edges of the upper protruding area of the connector little by little with the finger nails or with a screwdriver.

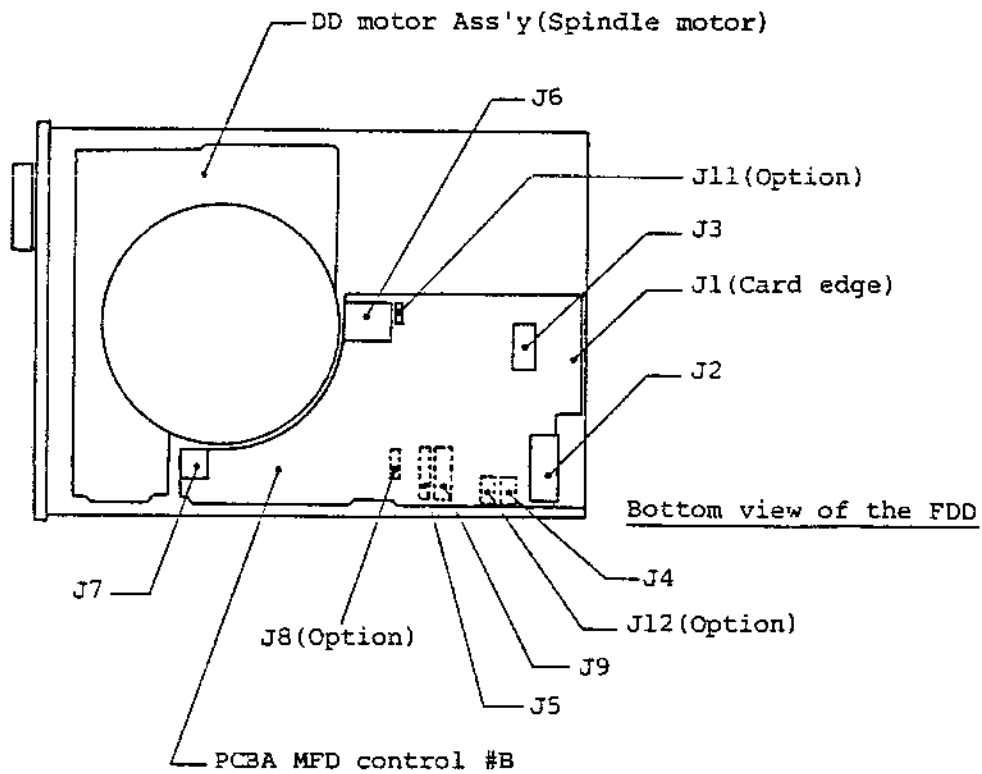
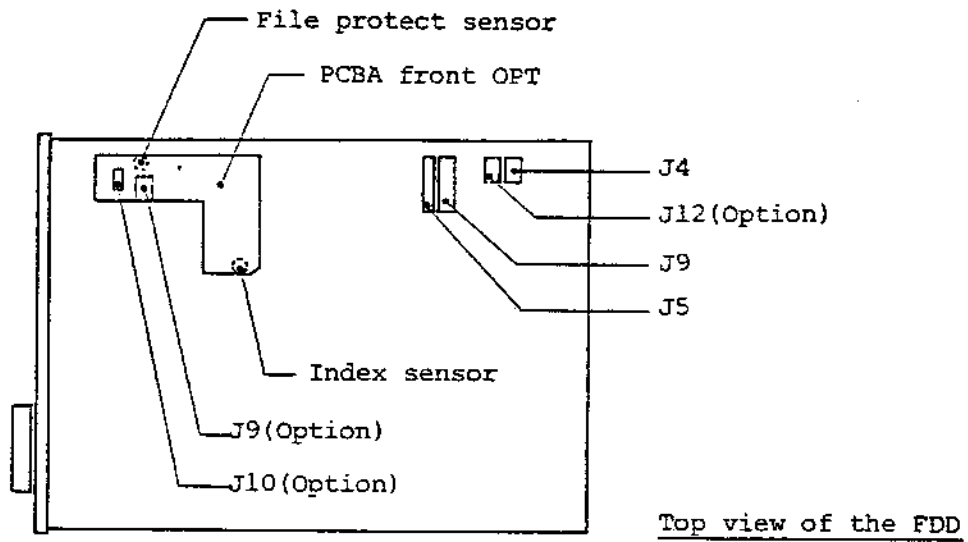

(Fig.401) Types of connectors

Connector J11 (option) is installed upright on the PCB. Though the shape of J11 is little different from the connector below in the figure, pull up the edges of the upper protruding area in the same manner.

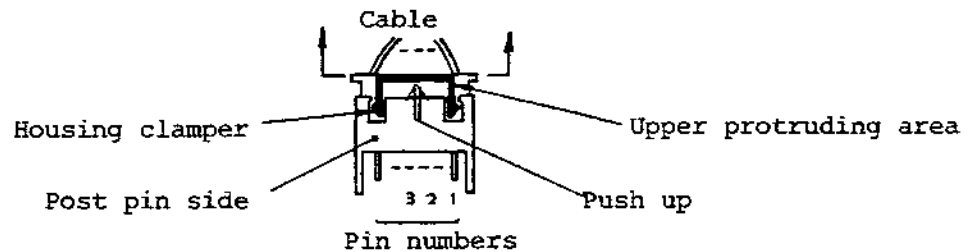

(Fig.402) Disconnection of white connector

(b) Connection of the connector

Push the connector into the post pin on the PCBA with the housing clamper up.

For the connector J11 (option), bring the hole of the pin onto the post pin position and push it. It will not be pushed in an opposite location.

(c) Removal of the pin (for reference)

Refer to Fig.403.

Depressing the stopper of the pin lightly with a narrow object such as a pair of tweezers, pull the cable in the direction indicated by the arrow.

(d) Insertion of the pin (for reference)

Before insertion, check the following three points.

- i) Confirm that the sheath and the core of the cable are securely clamped.

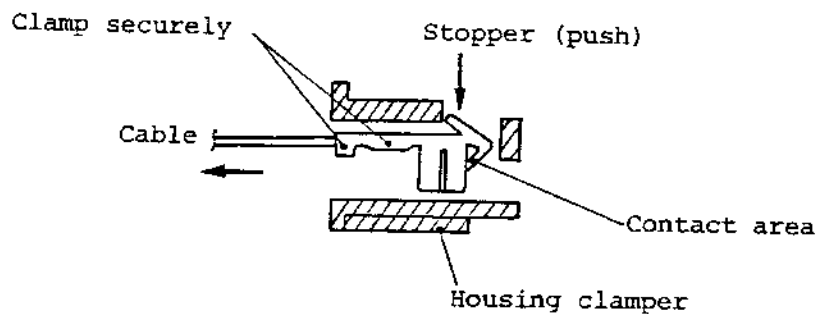

(Fig.403) Sectional view of white connectors

- ii) Confirm that the stopper is lifted as in Fig.403 and it inhibits accidental removal.
- iii) No tarnish or contamination should be on the contact area of the pin or the PCB side post pin. If there is, remove it.

Contact failure may happen if any of these three points is not satisfied.

When you insert the pin, it should be so inserted that the stopper faces the opening side of the housing.

After the insertion, check the connection by pulling the cable lightly.

(4) Precautions for handling the black connectors (J4, J5, J9, J10, J11)

(a) Disconnection of the connector

- i) Pull out J4 connector (head load solenoid and track 00 connector) slowly holding the cable with a pair of tweezers or a round nose pliers carefully.
- ii) For pulling out J5 (PCBA front OPT connector) and J9 (head connector), remove the screw fixing the cord guide (see Fig.501, No.1) and pull the connector holding the cable and housing slowly. Be sure not to apply tension to the fine cables of the J9 (head connector).

iii) For J10 (option) and J12 (option), pull out slowly in the same manner as in item i) and ii).

(b) Connection of the connector

Make the polarizing key position of the housing correspond with the lack of the post pin, and push the housing carefully with the fingers.

(c) Removal of the pin

Lifting up the stopper of the housing with a narrow object such as cutter knife, pull the cable with a pair of tweezers in the direction indicated by the arrow. Refer to Fig.404.

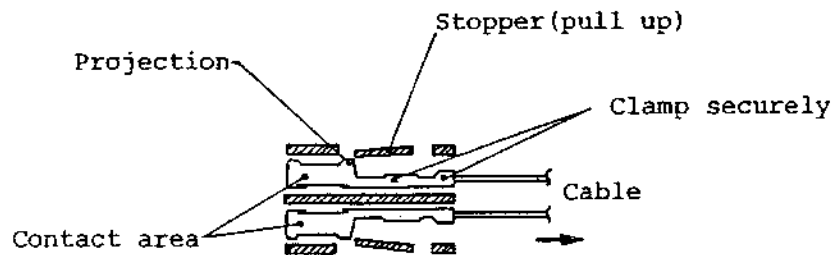

(Fig.404) Sectional view of black connectors

(d) Insertion of the pin

Before insertion, check the pins according to item (3)-(d), i) through iii).

When you insert the pin, it should be so inserted that the projection side faces the stopper of the housing. After the insertion, pull the cable with a pair of tweezers softly in order to confirm whether it is securely connected.

4-3-2. Head Cable Treatment

Head cable should be arranged correctly by the clampers with appropriate margin in length so that the head carriage can move on the guide shafts smoothly.

- (1) Clamp the head cable with cable clamber B so that the cable has appropriate looseness when the head carriage is set to track 00 (rear end of the moving area). The appropriate length of the head cable from the head carriage output to the first cable clamber is approximately 90mm.

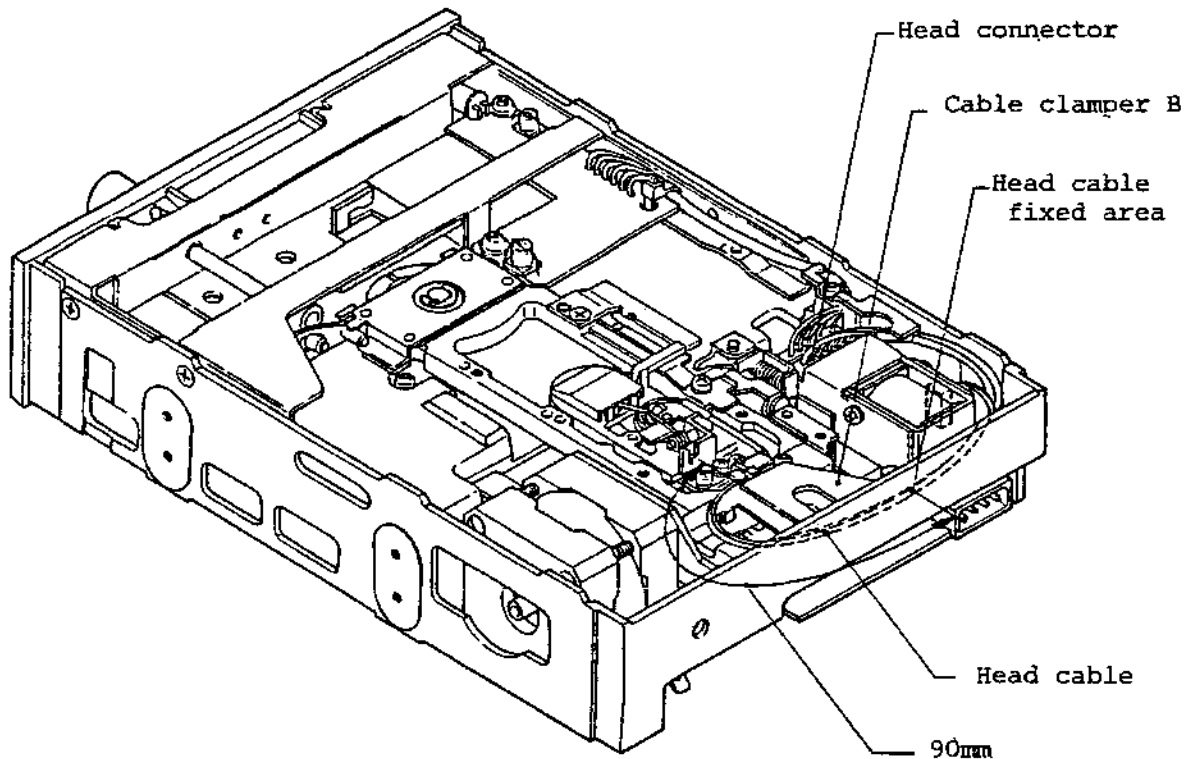

Note: The figure uses the double sided FDD. The same cable arrangement is applied to the single sided FDD.

(Fig.405) Head cable arrangement

(2) Form the cable not to have excessive looseness in the area from the head connector to the cable clamper B.

4-2-4. Initial Setting of SKA

Following initial setting is required for operating the SKA.

4-2-4-1. Cable connection and setting of power supply voltage

- (1) Set the output voltage of DC power supply to +12V and +5V, approx.
- (2) Turn the DC power off and connect the power cable to the PSA (SKA PWR) connector of the SKA.
- (3) Set the FD PWR switch of the SKA to the OFF position.
- (4) Connect the FD PWR OUTPUT of the SKA and the FDD with the SKA/FDD power cable.
- (5) Connect the SKA/FDD interface cable. Pay attention to the identification mark of the connector (V) so that it locates at the pin 1 and 2 side.

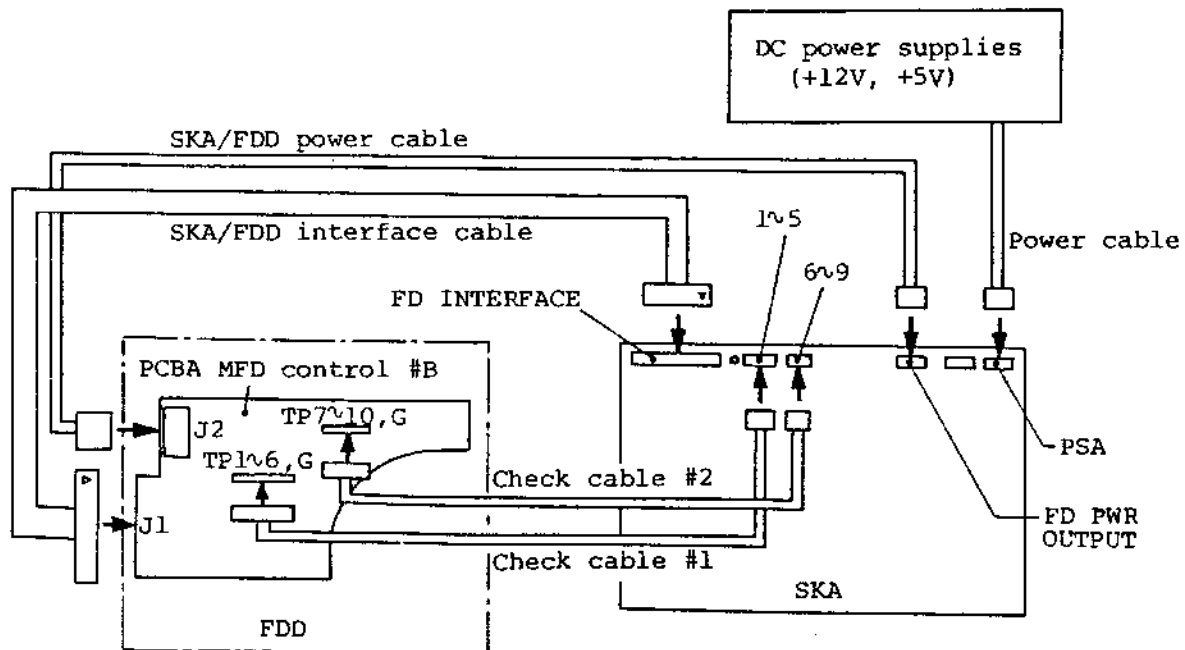

(Fig.406) Connection of SKA cable

- (6) Connect the check cable #1 (Flat cable, brown 7P connector at the FDD side and white 5P connector at the SKA side) between the terminals 1 ~ 5 of the SKA and TP1 ~ TP6, G of the FDD. For the SKA side, be sure to match the pin numbers of the connector housing and the terminal numbers of the connector. For the FDD side, cable connection side pins should be connected to the TP1 ~ 5 side.
- (7) Connect the check cable #2 (shield cable is used partially, 5P connectors at both ends) between the terminals 6 ~ 9, G of the SKA and TP7 ~ TP10, G of the FDD. Be sure to match the pin numbers of the connector housing and the terminal numbers of the SKA as in Fig.407. The shield cable side is TP7, 8, and terminals 6, 7 of the SKA.

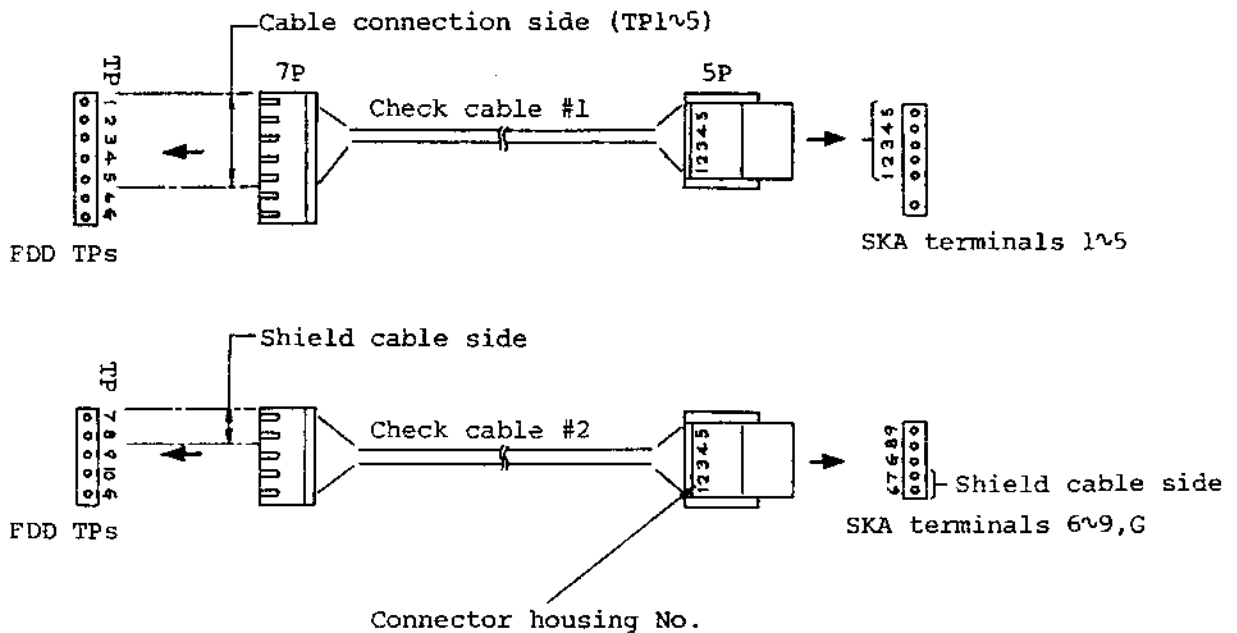

(Fig.407) Connection of check cable

- (8) Turn the DC power on. Set the FD PWR switch of the SKA to the PSA side.
- (9) Key in "CB". (+5V VOLTAGE)
- (10) Adjust the DC power voltage so that the DATA indicator of the SKA (V) indicates the value within the range of $5.00 \pm 0.1V$.

(11) Key in "F". (STOP)

(12) Key in "CC". (+12V VOLTAGE)

(13) Adjust the DC power voltage so that the DATA indicator of the SKA
[] [] [] (V) indicates the value within the range of $12.00 \pm 0.24V$.

(14) Key in "F". (STOP)

Note: The above items (1), (2), (9) ~ (14) may be omitted for replacement of the FDD or a temporary FDD power off. Remain DC power on and control the FDD power by the SKA PWR switch.

4-2-4-2. Setting of the maximum track number

Before the check and the adjustment of the FDD, set the maximum track number according to the following instructions.

The setting will be maintained until the main DC power (for SKA) is turned off or until the RESET switch of the SKA is depressed. Since The FD PWE switch is independent of this setting, it is convenient to maintain the main DC power on for the successive operations.

The initial setting of the following is not required if the maximum track number is the same as the initial value (79) of the SKA.

- (1) Key in "CF". (SET TMAX)
- (2) The maximum track number set at that time is indicated with the latter two digits of the DATA indicator (track).

Note: If there is no change in the maximum track number in item (2), depress "F" key.

- (3) Key in a new maximum track number (two digits) in decimal notation.

e.g. 48tpi: CF 39 (for 40 cylinders)

96tpi: CF 79 (for 80 cylinders)

96tpi (High density): CF 76 (for 77 cylinders)

4-2-4-3. Setting of step rate and settling time

Before check and adjustment of the FDD, set the step rate and the settling time according to the following instructions.

The setting will be maintained until the main DC power (for SKA) is turned off or until the RESET switch of the SKA is depressed.

If the step rate and the settling time are the same as the initial values of the SKA (step rate: 6msec, settling time: 15msec), the initial setting of the following is not required. This case is applied to 48tpi FDDs.

(1) Key in "DB". (SET STEP RATE)

(2) Step rate set at that time is indicated by 0.1msec scale on the DATA indicator (ms).

e.g. DATA indicator indicates 6.0msec.

(3) Key in a new step rate down to one decimal place (unit: msec).

Note: If there is no change in step rate in item (2), omit item (3) and forward to item (4).

(4) Key in "F". (STOP -- Setting of the step rate completes.)

(5) Settling time at that time is indicated by 0.1msec scale on the DATA indicator (ms)

e.g. DATA indicator indicates 15.0msec.

(6) Key in new settling time down to one decimal place (unit: msec).

Note: If there is no change in settling time in item (5), omit item (6) and depress "F" key to complete the operation.

(7) Depress "F" key. (STOP -- Setting of the settling time completes.)

e.g. 48tpi FDD: DB 60 F 150 F

(Step rate: 6msec, settling time: 15msec)

96tpi FDD: DB 30 F 150 F

(Step rate: 3msec, settling time: 15msec)

4-2-4-4. Level disk calibration

Setting of the following calibration value is required for accurate measurement before the check of the read level or the resolution. Use a level disk with a calibration value (100% center) written on the label. The setting will be maintained until the main DC power (for SKA) is turned off or until the RESET switch of the SKA is depressed. If the calibration value is the same as the initial value (100%) of the SKA, the initial setting of the following is not required.

(1) Innermost track read level

- (a) Key in "D0". (CALIBRATION READ LEVEL)
- (b) Calibration value set at that time is indicated in the latter three digits of the DATA indicator (%).
- (c) Key in a new calibration value written on the level disk label (three digits, Max.)
- (d) Key in "F". (STOP)

Note: If there is no calibration change in item (b), omit item (c) and depress "F" key.

(2) Innermost track resolution

- (a) Key in "D1". (CALIBRATION RESOLUTION)
- (b) Calibration value set at that time is indicated in the latter three digits of the DATA indicator (%).
- (c) Key in a new calibration value written on the level disk label (three digits, Max.)

(d) Key in "F". (STOP)

Note: If there is no calibration change in item (b), omit item (c) and depress "F" key.

e.g. READ LEVEL 103%, RESOLUTION 96%: D0 103 F, D1 96 F

4-2-4-5. Alignment disk calibration

Setting of the following calibration value is required for accurate measurement before the check and adjustment of the track alignment. Use a correctly calibrated (0% center) alignment disk with a calibration value written on the label. The setting will be maintained until the main DC power (for SKA) is turned off or until the RESET switch of the SKA is depressed.

If the calibration value is the same as the initial value (0%) of the SKA, the initial setting of the following is not required.

(1) SIDE 0 alignment

(a) Key in "E0". (CALIBRATION SIDE 0 ALIGNMENT)

(b) The calibration value set at the time is indicated in the latter two digits of the DATA indicator (%) , and the polarity is indicated in the initial digit. If a "0" is indicated, the polarity is positive. Polarity indication: plus + , minus -

(c) Key in a polarity and a new calibration value (two digits, Max.) written on the alignment disk label.
Designation of polarity: Depress "B" key only for minus designation.
(No designation is required for plus).

(d) Key in "F". (STOP)

(2) Side 1 alignment (Double sided only)

(a) Key in "E1". (CALIBRATION SIDE 1 ALIGNMENT)

(b) The same as in item (1)-(b) ~ (d).

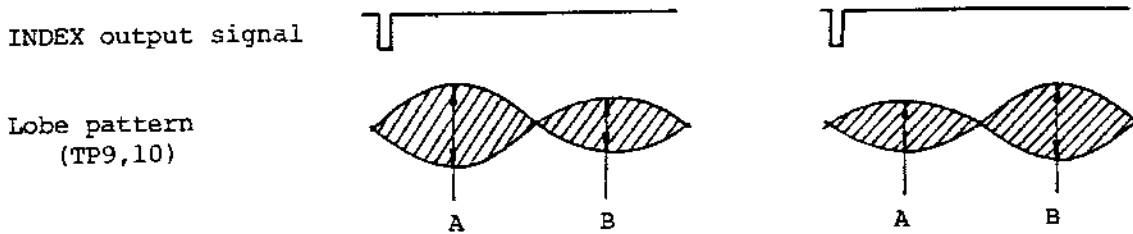

Notes: 1. The lobe pattern ratio is calibrated in the SKA according to the following expression.

$$\text{Lobe pattern ratio} = \frac{A-B}{\text{Larger one of A \& B}} \times 100 - \text{Calibration value}(\%)$$

after calibration

2. If the calculated value with the above expression is positive, the polarity is plus, while the polarity is minus when the value is negative.

(Fig.408) Calibration of alignment lobe pattern

(3) Index burst timing

(a) Key in "E5". (CALIBRATION INDEX TIMING)

(b) The calibration value set at that time is indicated in the latter three digits of the DATA indicator (μ s), and the polarity is indicated in the initial digit. (Refer to item (1)-(b)):

If a "0" is indicated, the polarity is positive.

(c) Key in a polarity and a new calibration value (three digits, Max.) written on the alignment disk label. Refer to item (1)-(c) for the polarity designation.

(d) Key in "F". (STOP)

Note: If there is no change in the calibration value in item (b), omit

item (c) and depress "F" key.

e.g. Double sided FDD, SIDE 0 ALIGNMENT +3%, SIDE 1 ALIGNMENT -5%,

INDEX TIMING -25 μ s:

E0 3 F, E1 B 5 F, E5 B 25 F

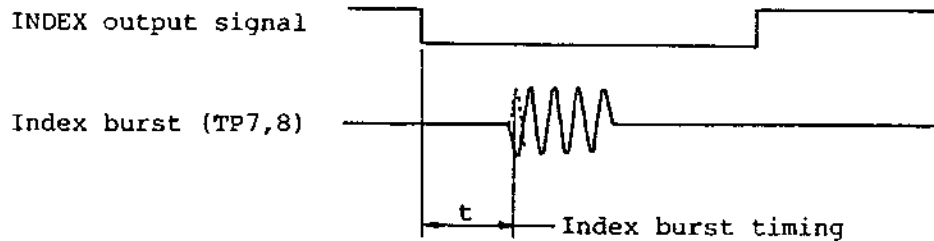

Notes: 1. The index timing is calibrated in the SKA according to the following expression.

Calibrated timing = t - calibration value (μ s)

2. If the calculated value with the above expression is positive, the polarity is plus, while the polarity is minus when the value is negative.

(Fig.409) Calibration of index burst timing

4-2-4-6. Humidity setting

For the check and adjustment of the track alignment using an alignment disk, set the environmental relative humidity to the SKA in order to improve the precision of measurement.

This setting is important when the relative humidity is considerably different from 50% at the 96tpi FDD.

The initial setting of the following is not required if the relative humidity is the same as the initial value (50%) of the SKA.

- (1) Key in "E2". (CALIBRATION RH ALIGNMENT)
- (2) The relative humidity set at that time is indicated in the latter two digits of the DATA indicator (%).
- (3) Input the relative humidity percentage in the measurement environment (two digits, Max.).
e.g. 96tpi, RH 58%: E2 58

4-2-4-7. Setting of SKA gain

Following setting is required for the check and adjustment of the 96tpi FDD.

- (1) Key in "DD" and confirm that the H GAIN indicator is on.

Note: Above setting shall not be done for 48tpi. If the H GAIN indicator is on, turn it off by keying in "DD".

4-2-5. Others

(1) Total error test

In the check and adjustment in item 4-4, read/write error test is not included. After the adjustment or the replacement of the maintenance parts, it is recommended to perform a data error test by connecting the FDD to the user's system or the TEAC simulator KB. The window margin test is the most recommended item.

(2) Setting of FDD straps and SKA special keys

It is required to confirm before the operation that the straps (short bars) on the PCBA MFD control are at the appropriate position for the system to be used in the check and adjustment.

For the purpose of simplifying the explanation, it is recommended to set the following straps on when you use the SKA. However, if you can set the straps correctly referring to Specification, Instruction Manual, Schematic diagrams, and SKA Instruction Manual, you need not to follow this recommendation.

(a) FDD with head load solenoid:

Set HS, DS 0, and SM straps on. No restriction for the straps IU, PM, and RE. Other straps should be set to off-state.

(b) CSS model (without head load solenoid) FDD:

Set DS 0 strap on. No restriction for the straps IU, PM, and RE. Other straps should be set to off-state.

Note: The signal level of the interface connector pin 4 (IN USE/HEAD LOAD) can be alternately changed between TRUE and FALSE by depressing "A" (IN USE) key of the SKA. When it becomes TRUE, "A" indicator of the SKA turns on. Refer to the Specification as to the function of the signal and straps.

If the strap position of the FDD is changed from the initial setting at the system installation, be sure to change it back to the initial position after maintenance.

(3) Terminator

When you check each FDD with a maintenance system such as the SKA, it is necessary to put the terminator network into the IC socket J3 on the PCBA MFD control. The terminator shall be returned to the initial condition after completion of the maintenance.

(4) Connection of the probe ground

Connect the probe ground of the equipment as follows:

(a) For the observation at the test points (TP) 7 ~ 10:

Connect the probe ground to the G test point (0V) on the PCBA MFD control.

(b) For the observation at the other test point:

Connect the probe ground to the G test point (0V) on the PCBA MFD control. Or GND (0V) terminal of the system power supply unit, or the SKA GND terminal may be used.

(c) For the observation of the SKA test point:

Connect the probe ground to the SKA GND terminal.

Note: When you use the SKA, almost all checks including the read amp. output at TP7 ~ TP10 of the FDD will be done automatically through the check cables #1 and #2 and interface cable. Also these signals can be observed by an oscilloscope using the test points on the SKA.

(5) Maintenance environment

Maintenance of the FDD should be done on a clean bench at room temperature and humidity. It is recommended to execute the check and adjustment of the track alignment after leaving the FDD for at least 2 hours at room temperature and humidity. The magnetic head, disk, steel belt, etc. might suffer from dust and dirt if the maintenance is not undertaken in a clean environment.

(6) Orientation of the FDD

Position the FDD as shown in Fig.410 unless otherwise specified. Horizontal and vertical orientations with lever side up should be used.

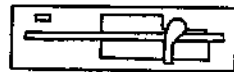

Horizontal setting

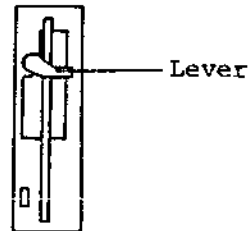

Vertical setting

(Fig.410) General orientation of the FDD during maintenance

(7) Head load of the CSS model

For the CSS model (without head load solenoid), the FDD is always in head load condition as far as a disk is inserted and the front lever is closed.

(8) Work disk

When you use the SKA, use a soft sectored disk.

(9) Disks for high density FDD (FD-55G)

For the check and adjustment of the high density FDD, it is required to use a high density disk (HD disk) as a work disk or as the level disk. The high density disks look more transparent when viewed through than the ordinary disk.

4-3. PREVENTIVE MAINTENANCE

4-3-1. Cleaning of Magnetic Head by Cleaning Disk

When you use the FDD in dusty environment, it is recommended to clean the magnetic head surface periodically (e.g. once a month) with a commercially available cleaning disk. Especially for a double sided FDD, it is difficult to clean the head surface, be sure to use the cleaning disk.

For typical usage under typical environmental condition, the cleaning is recommended when data errors often occur.

(A) Equipment

- (1) Cleaning disk
- (2) SKA or user's system

(B) Cleaning procedure

(1) General method

- (a) Start the spindle motor and install an appropriate cleaning disk.

- Notes:
1. Do not use a damaged cleaning disk on the surface.
 2. For a single sided FDD, be sure to install a single sided cleaning disk. The cleaning surface of the disk should be in contact with the head surface.
When the FDD is placed horizontally, the magnetic head is located down and it faces the back side of the disk.
If a double sided cleaning disk is installed in a single sided FDD, it may damage the head pad.
 3. For a double sided FDD, a double sided cleaning disk should be used. Side 0 (lower side) and side 1 (upper side) heads are cleaned simultaneously.

- (b) Execute head loading and clean the head at a suitable track position for 10 ~ 30 seconds, approx. In order to avoid the concentration on a specific track, it is a good way to make the head move between track 00 and the innermost track during cleaning.

Note: The most appropriate cleaning time is different for each type of cleaning disk used.

Excessively long cleaning time is not effective but has possibility to accelerate the head wear.

- (c) Remove the cleaning disk.

(2) SKA method

- (a) Connect the SKA referring to item 4-2-4 and set the FD PWR switch to the PSA side.
- (b) Start the spindle motor by key "5". (MON indicator turns on).
- (c) Execute drive select by key "0". (DS0 indicator turns on).
- (d) Key in "C0" and confirm that the TRACK indication of the SKA becomes "00". (RECALIBRATE)
- (e) Install an appropriate cleaning disk. See item (1)-(a), "Notes".
- (f) Key in "C6". (SEEK TEST)
- (g) After 10 ~ 30 seconds, depress "F" key.
- (h) Eject the cleaning disk.

4-3-2. Direct Cleaning (Single sided FDD only)

This cleaning method is applied only to a single sided FDD.

If this method is applied to a double sided FDD, gimbaled mechanism might be damaged.

If visible dirt is on the head surface when the head pad arm is lifted up manually during maintenance, perform direct cleaning as follows:

(A) Equipment

- (1) Absolute alcohol (Ethanol)
- (2) Cotton swab or gauze

(B) Cleaning procedure

- (1) Lightly dampen a cotton swab or a gauze with alcohol.
- (2) Lift up the pad arm (see Fig.411) and clean the head surface carefully with the cotton swab or the gauze.
Note: Do not touch the pad surface.
- (3) Wipe the head surface with clean dry cloth after the evaporation of the alcohol.
- (4) After confirming that the dirt is cleaned off and no fluff is left on the head surface, let the pad arm down carefully.

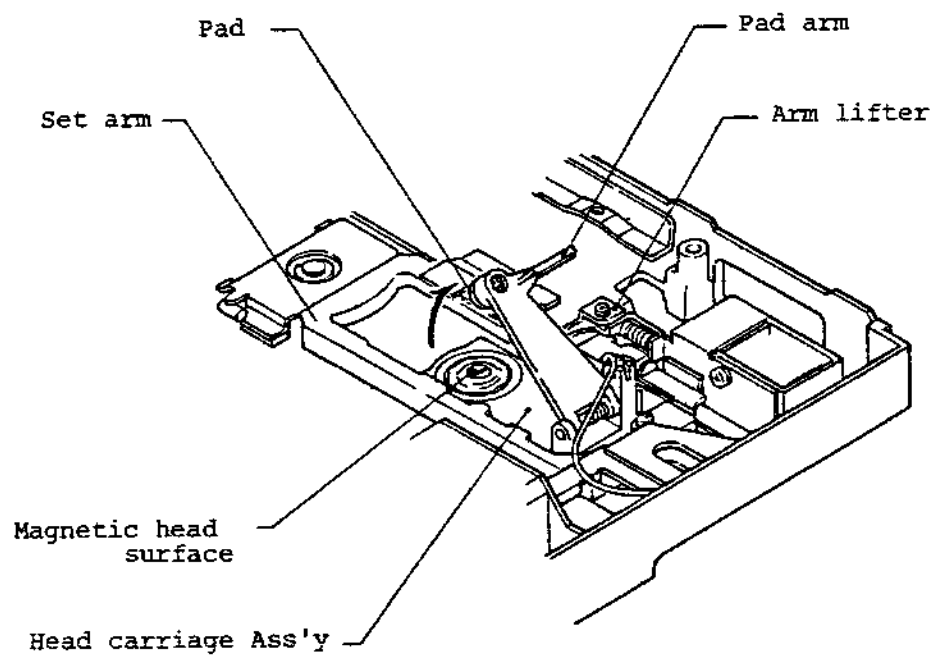

(Fig.411) Direct cleaning of the magnetic head (Single sided only)

4-4. CHECK AND ADJUSTMENT

4-4-1. Adjustment of Set Arm Position

(A) Equipment

- (1) Cross point screwdriver, M3
- (2) Locking paint

(B) Adjustment procedure

- (1) Loosen two fixing screws of the set arm (see Fig.412) so that the set arm can be moved manually without getting out of place.
- (2) Close the set arm by turning the front lever.
- (3) In this condition (item (2)), adjust the set arm so that the visual distance of the gap between the collet shaft and the set arm hole becomes even.
- (4) Tighten the installing screws of the set arm with the specified torque, apply a drop of locking paint on the screw head.
- (5) Open and close the set arm by turning the front lever and confirm that it does so smoothly.

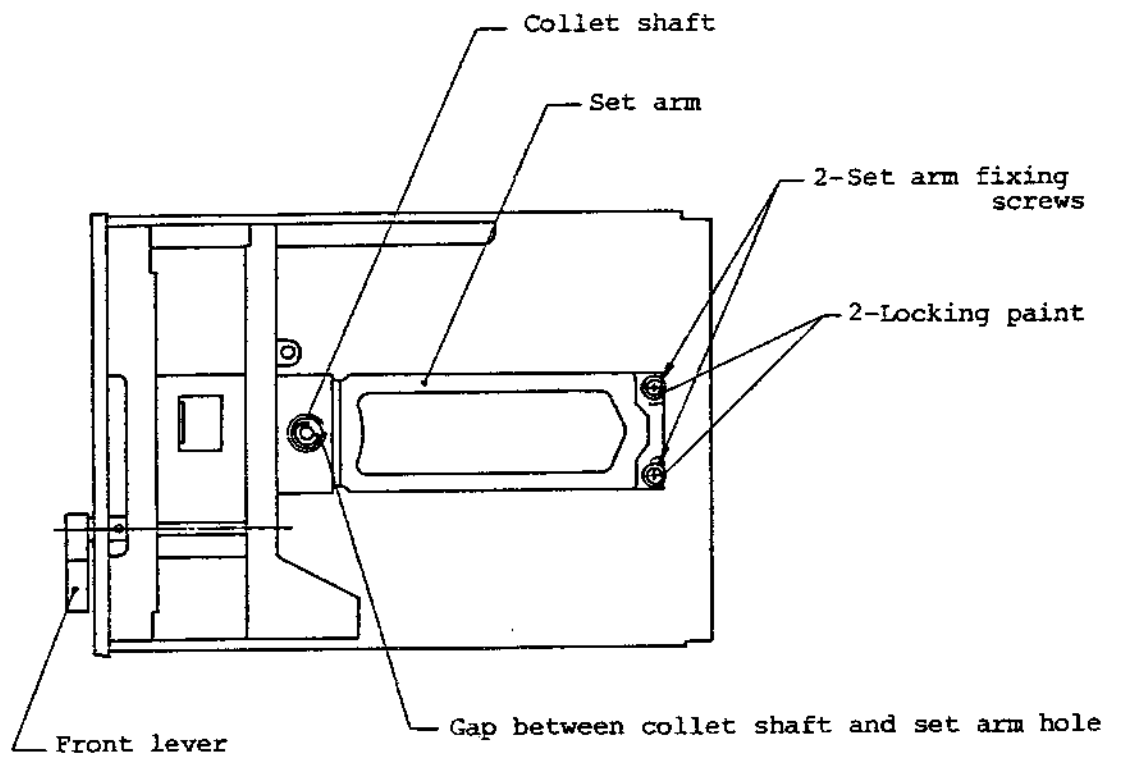

(Fig.412) Adjustment of set arm position

4-4-2. Adjustment of Clamp Arm Position

(A) Equipment

- (1) Cross point screwdriver, M3
- (2) SKA or user's system
- (3) Work disk

(B) Adjustment procedure

- (1) Loosen four holder fixing screws (see Fig.413) so that the holder can be moved manually without getting out of place.
- (2) Close the set arm by turning the front lever.
- (3) Push down the holder against the frame so that narrow gap is spaced between the E-ring on the collet shaft and the set arm plate, then tighten the four screws at both sides.
Narrow gap should be confirmed by a very easy manual turning of the E-ring.
•
- (4) Install a work disk.
- (5) Start the spindle motor and confirm that the disk rotates smoothly.
When the SKA is used, connect the SKA referring to item 4-2-4 and set the FD PWR switch to the PSA side. Then start the spindle motor by key "5". (MON indicator turns on).
- (6) Place the FDD vertically (refer to Fig.410).
- (7) Nip the disk edge firmly with fingers which appears a little from the front bezel, and confirm that the rotor of the spindle motor stops.
- (8) If the spindle motor does not stop completely, push down the holder

further against the frame at item (3). Then execute the procedure from item (4) through (7) again.

(9) Eject the work disk.

(10) Adjust the front lever position according to item 4-4-3.

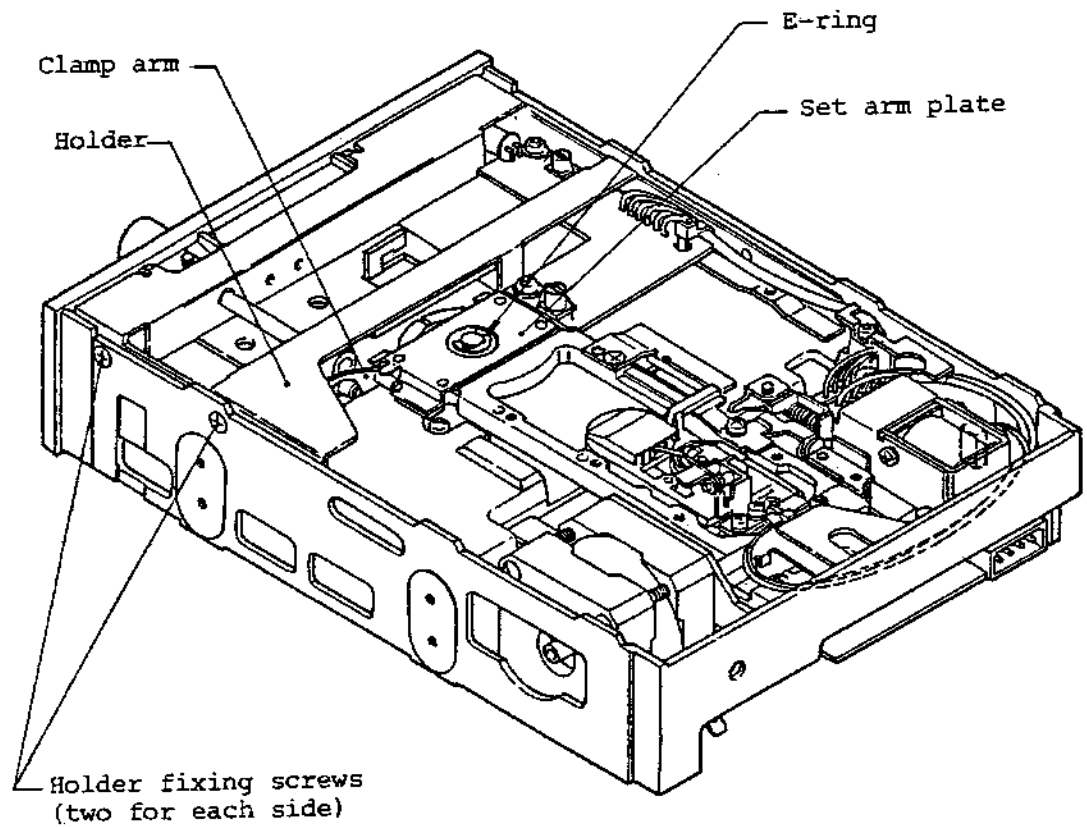

(Fig.413) Adjustment of clamp arm position

4-4-3. Adjustment of Front Lever Position

(A) Equipment

- (1) Hexagon wrench key, 1.5mm
- (2) MAX media jig

(B) Adjustment procedure

- (1) Turn the front lever to open position and loosen a lever fixing set screw (see Fig.414).
- (2) Turn the front lever to close position and loosen another fixing screw. Then pull out the lever for 0.5mm, approx.
- (3) Tighten the screw in item (2).
- (4) Open the front lever and insert the MAX media jig from the notch side. (See Fig.414).
- (5) Turn the front lever to close position and loosen the lever fixing screw again. Then push the lever against the MAX media jig.
- (6) Position the handle of the front lever forms right angle against the longitudinal side of the front bezel. And tighten the set screw with the specified torque. (see Fig.415).
- (7) Turn the front lever to open position and tighten another set screw in the same manner.
- (8) Close the front lever and confirm that the blade of the lever does not nip the MAX media jig.
- (9) Open the front lever and remove the jig.

Note: Refer to item 4-2-1 as to handling of the set screws.

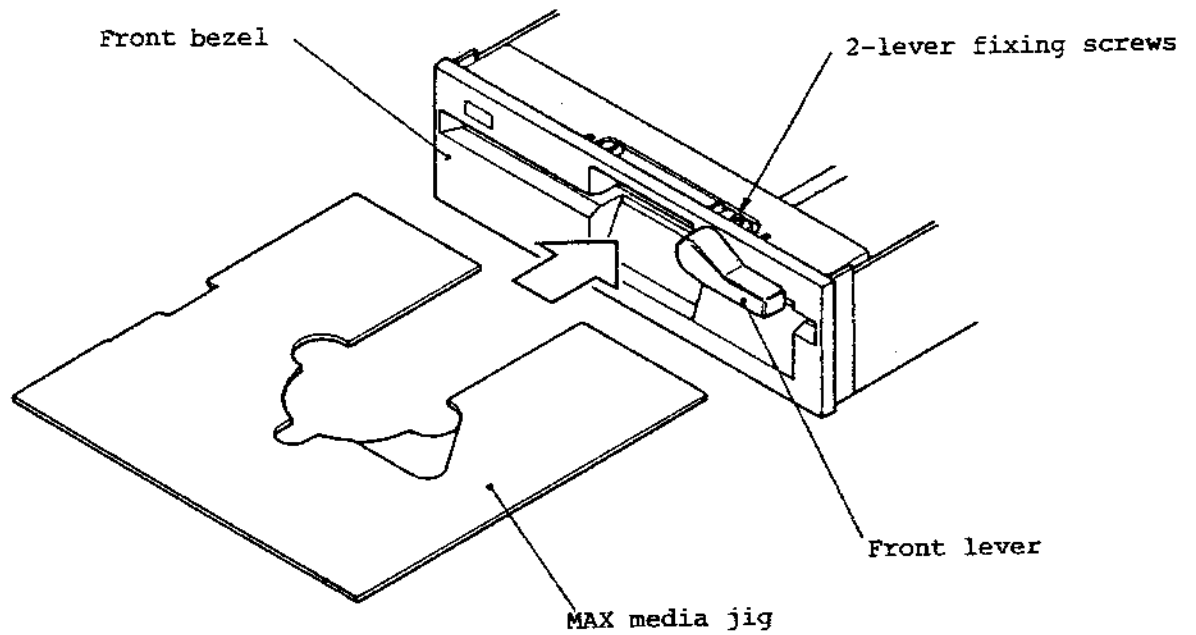

(Fig.414) Adjustment of front lever

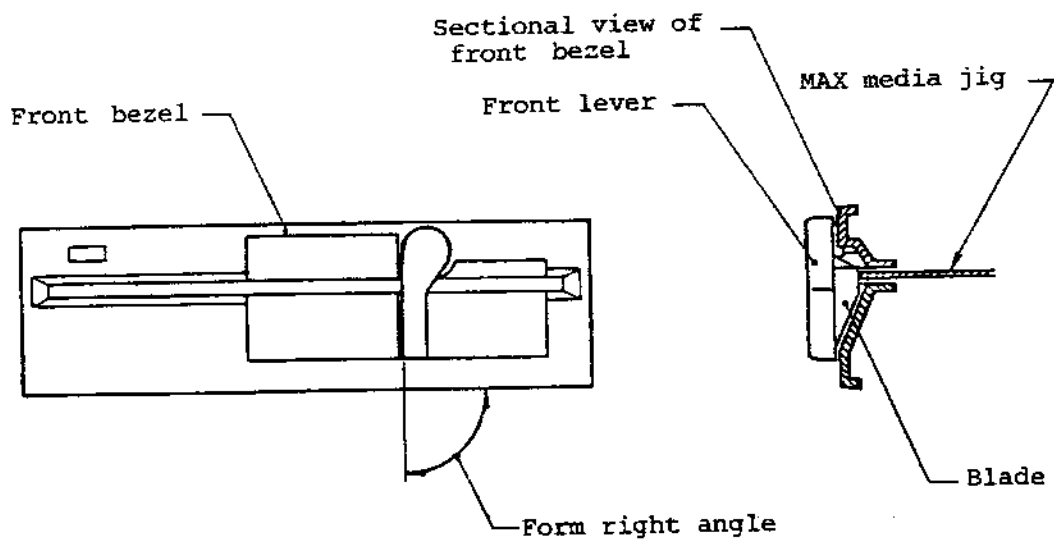

(Fig.415) Front lever position

4-4-4. Adjustment of Arm Lifter

This item applies only for the FDD with the head load solenoid.
The adjusting method is different between the single sided FDD and the double sided FDD.

4-4-4-1. Double sided FDD (Adjustment of arm lifter)

(A) Equipment

- (1) Hexagon wrench key, 1.5mm
- (2) Work disk
- (3) SKA or user's system
- (4) Oscilloscope
- (5) Locking paint

(B) Adjustment procedure

(1) General method

- (a) Start the spindle motor and insert a work disk.
- (b) Set the head to track 00.
- (c) Execute head loading.
- (d) Turn the adjusting screw (set screw) of the arm lifter so that the gap between the upper arm and the arm lifter becomes 0.2mm, Min.
(See Figs. 416 and 417).
- (e) Unload the head.
- (f) Confirm that the upper arm is lifted slightly by the arm lifter.

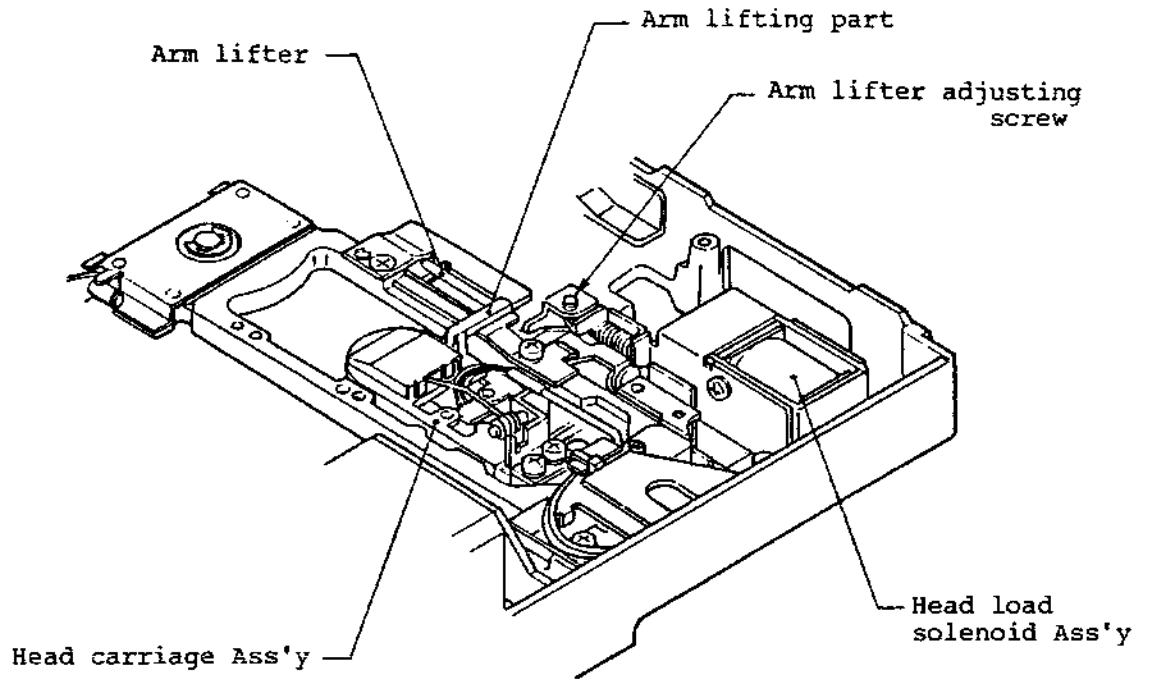

(Fig.416) Adjustment of arm lifter

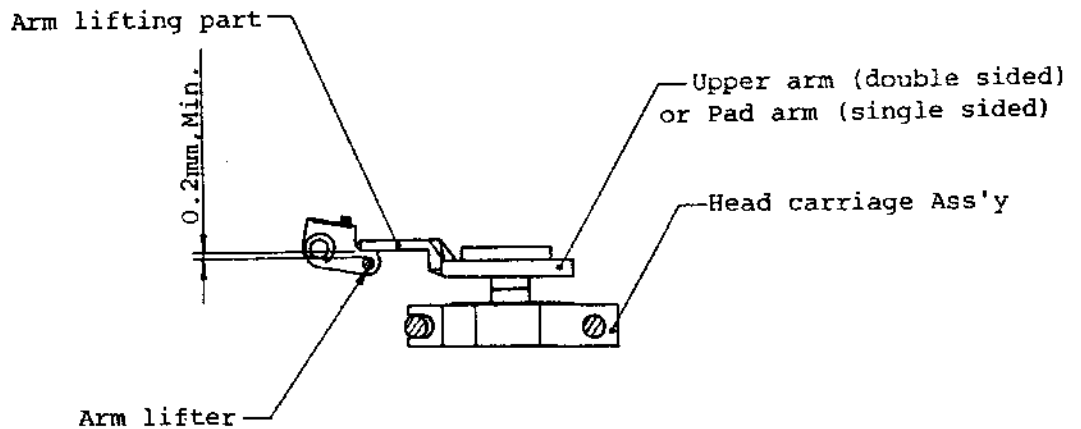

Note: Viewed from front bezel side

(Fig.417) Gap of arm lifter

- (g) Use two channels of oscilloscope. Connect the 1st channel to the head load command signal and the 2nd channel to TP9 or TP10 on the PCBA MFD control. Triggering is done by the head load command.

Oscilloscope range

The 1st channel: DC mode, 2V, 10msec

The 2nd channel: AC mode, 0.5V, 10msec

Note: For example, when you execute the head loading using a DRIVE SELECT signal, it is required to set DS (one of 0 through 3), HS, and SM straps on.

For the purpose of check and adjustment in this item, it is not proper to execute the head loading by the MOTOR ON signal with HM and SM straps on. Use either of the DRIVE SELECT signal or the IN USE/HEAD LOAD signal. (See the Specification item 1-12-3).

- (h) Select the side 1 head.
- (i) Execute head loading
- (j) Execute 2F write operation for one rotation of the disk (250KHz of WRITE DATA frequency for FD-55A ~ F, 500KHz for FD-55G).
- (k) Unload the head.
- (L) Repeat the head loading and unloading alternately (tapping operation) and observe the waveform of TP9 or TP10 by the oscilloscope. (See Fig.418).
- (m) Set the oscilloscope trigger to the positive mode and observe the read waveform at TP9 or TP10 after the input of an unload command. Confirm that there is no big spike noise (excludes a small one) or there is not a continuous unload level (excludes the noise level) as shown by dotted line in Fig.418.

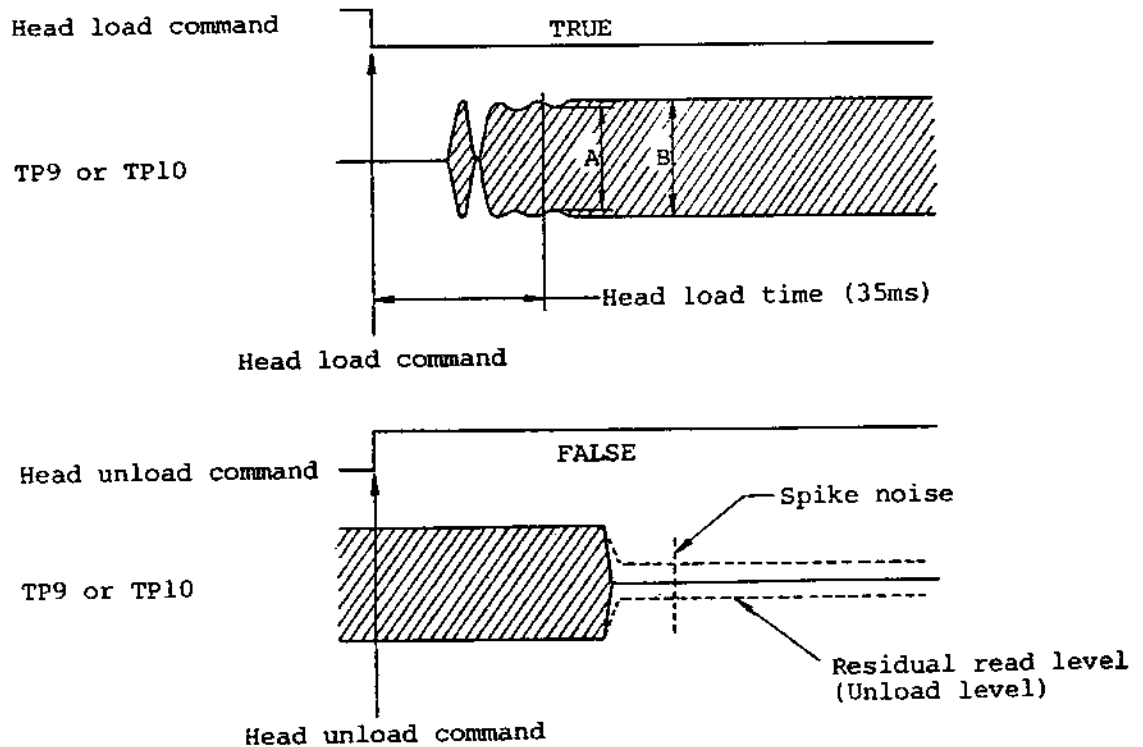

(Fig.418) Read waveforms at head loading/unloading

In such event that either of the spike noise or continuous unload level is observed in the waveform, fine adjust the set screw of the arm lifter.

Note: This item should be executed when the side 1 head is selected.
 If the side 1 head is lifted too high during unload operation, spike noise will be observed, while unload level will be observed when it is too low.

(n) Set the oscilloscope trigger to the negative (-) mode and observe the waveform at TP9 or TP10 after the input of a head load command. Confirm that the read waveform more than 35msec after the head load command is almost static.

As a detail, bottom "A" of the read level more than 35msec after the input of the head load command should be more than 0.7 against the average read level "B". ($A/B \geq 0.7$ in Fig.418)

- (o) Make the head move to the innermost track.
- (p) Repeat the procedure from item (i) to (n) and adjust so that the items (m) and (n) are satisfied at track 00 and at the innermost track.
- (q) The items (m) and (n) are applied to the side 0 head. However, as to the unload level in item (m) will be excluded unless it is the same read level as the head load condition.
Confirm in the same manner by selecting the side 0 head.
- (r) Again set the head to track 00.
- (s) After opening the front lever, draw out the disk slowly. In the process of drawing out, the side 0 and side 1 heads shall not catch the head window edge of the disk jacket (opening area of the jacket to make the head be in contact with the disk surface). The jacket can be drawn out smoothly with appropriate space margin.
- (t) Insert the disk slowly and confirm that the disk jacket does not touch the side 0 nor side 1 head and goes into the FDD smoothly with appropriate space margin.
- (u) If the items (p), (g), (s), or (t) is out of the specification, following causes are assumed.
 - i) Inferior disk:
Disk and/or jacket is deformed or the disk may have drop-outs.
In such event, replace the work disk with a new one.

ii) Inferior head carriage Ass'y:

Replace the head carriage Ass'y according to item 4-5-1.

iii) Inferior head load solenoid:

Replace the head load solenoid Ass'y according to item 4-5-5.

iv) Inferior PCBA MFD control:

Replace the PCBA MFD control according to item 4-5-7. (No relation to items (s) and (t)).

Note: Refer to item 4-2-1 as to handling of the set screw.

If the strap setting is changed, back it to the initial setting after the adjustment.

(2) SKA method

- (a) Connect the SKA according to item 4-2-4 and set the FD PWR switch to the PSA side.
- (b) Start the spindle motor by key "5". (MON indicator turns on).
- (c) Install a work disk.
- (d) Execute drive select by key "0". (DSO indicator turns on).
- (e) Key in "C0" and confirm that the TRACK indication becomes "00".
(RECALIBRATE)
- (f) Turn the adjusting screw (set screw) of the arm lifter so that the gap between the arm lifting area of the upper arm and the arm lifter becomes 0.2mm, Min. (See Figs. 416 and 417).
- (g) Release the drive select by key "0". (DSO indicator turns off).
- (h) Confirm that the upper arm is lifted slightly by the arm lifter.
- (i) Use two channels of oscilloscope. Connect the 1st channel to the DOUT terminal and the 2nd channel to the DIF terminal of the SKA. Apply negative trigger by the DOUT terminal.

Oscilloscope range

The 1st channel: DC mode, 2V, 10msec

The 2nd channel: AC mode, 0.5V, 10msec

Note: For the check and adjustment in this item, it is required to set on the straps DS 0, HS, and SM of the FDD. (See item 4-2-5 (2)).

- (j) Key in "BC F". (DRIVE SELECT observation)

- (k) Select side 1 head by key "4". (SIDE 1 indicator turns on).
- (L) Execute drive select by key "0". (DS0 indicator turns on).
- (m) Key in "C9". (HEAD LOAD TIME)
- (n) Observe the waveform of the DIF terminal at head unloading using the oscilloscope.

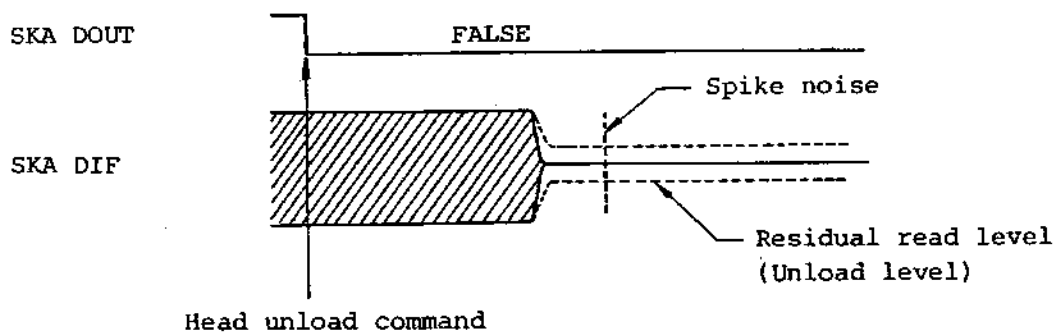

(Fig.419) Read waveform at head unloading

- (o) Confirm that there is no big spike noise (excludes a small one) or there is not a continuous unload level (excludes the noise level) as shown by dotted line in Fig.419.
In such event that either of the spike noise or continuous unload level is observed in the waveform, fine adjust the set screw of the arm lifter.

Note: This item should be executed when the side 1 head is selected (SIDE 1 indicator turns on).

If the side 1 head is lifted too high during unload operation, spike noise will be observed, while unload level will be observed when it is too low.

- (p) Confirm that the DATA indicator (%) of the SKA indicates a value within the following range.

Head load settling level after 35msec: 70%, Min.

- (q) Key in "F". (STOP)
- (r) If the DSO indicator of the SKA is off, execute drive select by key "0". (DSO indicator turns on).
- (s) Key in "Cl". (SEEK TMAX).
- (t) Repeat the procedure from items (m) to (p) and adjust so that the items (o) and (p) are satisfied at track 00 and at the innermost track.
- (u) Key in "F". (STOP)
- (v) The items (o) and (p) are applied to the side 0 head. However, as to the unload level in item (o) will be excluded unless it is the same read level as the head load condition.
Depress key "4" to turn off the SIDE 1 indicator of the SKA and confirm in the same procedure of items (L) through (u) for the side 0 head.
- (w) Key in "C0" and confirm that the TRACK indication becomes "00".
(RECALIBRATE)
- (x) After opening the front lever, draw out the disk slowly. In the process of drawing out, the side 0 and side 1 heads shall not catch the head window edge of the disk jacket (opening area of the jacket to make the head be in contact with the disk surface). The jacket can be drawn out smoothly with appropriate space margin.
- (y) Insert the disk slowly and confirm that the disk jacket does not touch the side 0 nor the side 1 head and goes into the FDD smoothly with appropriate space margin.
- (z) If the items (t), (v), (x), or (y) is out of the specification, refer to item (u) of "General method".

Note: Refer to item 4-2-1 as to handling of the set screw.

4-4-4-2. Single sided FDD (Adjustment of arm lifter)

(A) Equipment

- (1) Hexagon wrench key, 1.5mm
- (2) Work disk
- (3) SKA or user's system
- (4) Locking paint

(B) Adjustment procedure

(1) General method

- (a) Start the spindle motor and insert a work disk.
- (b) Set the head to track 00.
- (c) Execute head loading.
- (d) Turn the adjusting screw (set screw) of the arm lifter so that the gap between the pad arm and the arm lifter becomes 0.2mm, Min. (See Figs.416 and 417).
- (e) Unload the head.
- (f) Confirm that the pad arm is lifted slightly by the arm lifter.
- (g) Make the head move to the innermost track.
- (h) Load the head and repeat the procedure from item (d) to (f).
- (i) Again set the head to track 00.

(j) Repeat the procedure from item (c) to (f).

Note: Refer to item 4-2-1 as to handling of the set screw.

(2) SKA method

- (a) Connect the SKA according to item 4-2-4 and set the FD PWR switch to the PSA side.
- (b) Start the spindle motor by key "5". (MON indicator turns on).
- (c) Install a work disk.
- (d) Execute drive select by key "0". (DS0 indicator turns on).
- (e) Key in "CO" and confirm that the TRACK indicator becomes "00". (RECALIBRATE).
- (f) Turn the adjusting screw (set screw) of the arm lifter so that the gap between the pad arm and the arm lifter becomes 0.2mm, Min. (See Figs. 416 and 417).
- (g) Release the drive select by key "0". (DS0 indicator turns off).
- (h) Confirm that the pad arm is lifted slightly by the arm lifter.
- (i) Execute drive select by key "0". (DS0 indicator turns off).
- (j) Key in "C1" (SEEK TMAX).
- (k) Repeat the procedure from item (f) to (i).
- (L) Key in "CO" (RECALIBRATE).
- (m) Repeat the procedure from item (f) to (i).

Note: Refer to item 4-2-1 as to handling of set screw.

4-4-5. Check of CSS Ass'y

This item applies only to the double sided CSS model (without head load solenoid).

(A) Equipment

- (1) Work disk
- (2) SKA or user's system

(B) Check procedure

(1) General method

- (a) Open and close the front lever with no insertion of a disk.
- (b) Confirm that the side 1 head is lifted even if the front lever is close and it has enough gap against the side 0 head. (See Fig.420).

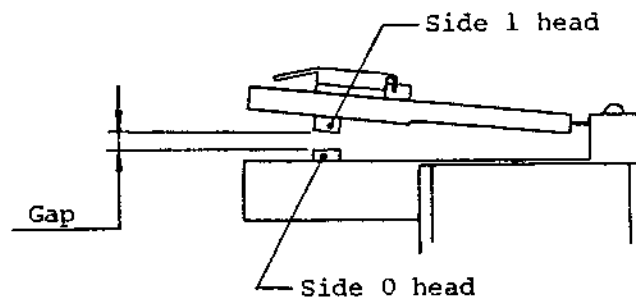

(Fig.420) Gap between side 0 and side 1 heads

- (c) After opening the front lever, insert a work disk slowly.
Confirm that the disk jacket does not touch the side 0 nor side 1 head and goes into the FDD smoothly with appropriate space margin.

- (d) Draw out the disk slowly. Confirm that the side 0 and side 1 heads do not catch the head window edge of the disk jacket (opening area of the jacket to make the head be in contact with the disk surface) and that the jacket can be drawn out smoothly with appropriate space margin.
- (e) Confirm that the cam (natural color) of the CSS Ass'y attached to the left side of the head carriage moves as in Fig.421 by opening/closing of the front lever and insertion/ejection of the disk.

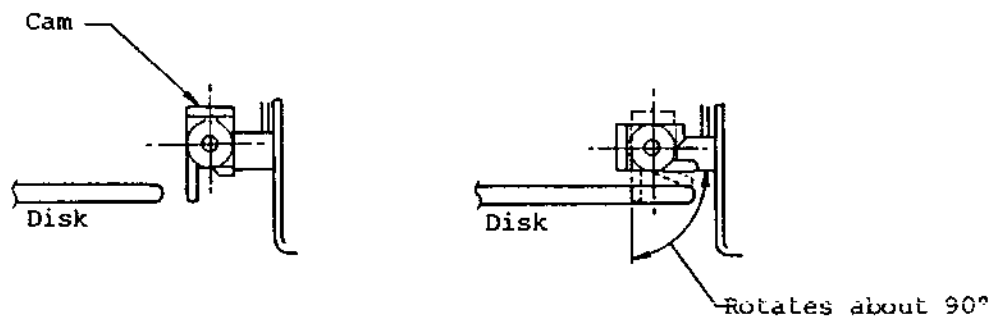

- i) Disk is not fully inserted. ii) Disk is fully inserted and front lever is close.

(Fig.421) Rotation of CSS Ass'y cam

- (f) Start the spindle motor and insert a work disk.
- (g) Set the head to track 00.
- (h) In the close condition of the front lever, confirm that the gap between the upper arm (double sided) or the pad arm (single sided) and the arm lifter is 0.2mm, Min. See Fig.418.
- (i) Make the head move to the innermost track.
- (j) Confirm as in item (h).

(2) SKA method

- (a) Open and close the front lever with no insertion of a disk.
- (b) Confirm that the side 1 head is lifted even if the front lever is close and it has enough gap against the side 0 head. (See Fig.420).
- (c) After opening the front lever, insert a work disk slowly.
Confirm that the disk jacket does not touch the side 0 nor side 1 head and goes into the FDD smoothly with appropriate space margin.
- (d) Draw out the disk slowly. Confirm that the side 0 and side 1 heads shall not catch the head window edge of the disk jacket (opening area of the jacket to make the head be in contact with the disk surface) and that the jacket can be drawn out smoothly with appropriate space margin.
- (e) Confirm that the cam (natural color) of the CSS Ass'y attached to the left side of the head carriage moves as in Fig.421 by opening/closing of the front lever and insertion/ejection of the disk.
- (f) Connect the SKA according to item 4-2-4 and set FD PWR switch to PSA side.
- (g) Start the spindle motor by key "5". (MON indicator turns on).
- (h) Execute drive select by key "0". (DS0 indicator turns on).
- (i) Key in "CO" and confirm that the TRACK indication becomes "00".
(RECALIBRATE)
- (j) In the close condition of the front lever, confirm that the gap between the upper arm (double sided) or the pad arm (single sided) and the arm lifter is 0.2mm, Min. See Fig.418.

(k) Key in "C1". (SET TMAX).

(L) Confirm as in item (j).

4-4-6. Check of File Protect Sensor

(A) Equipment

- (1) MAX media jig
- (2) Digital voltmeter (or oscilloscope)
- (3) SKA or user's system

(B) Check procedure

(1) General method

- (a) Place the FDD on the work bench with the LED indicator up and the front lever down. (See Fig.422).
- (b) Connect a digital voltmeter or an oscilloscope (DC range, 1V/div) to TP6 (File protect sensor) on the PCBA MFD control.
- (c) Install the MAX media jig from the notch side and set it so that the notch A area is located on the light pass from the file protect sensor LED. (See Fig.422).
- (d) Adjust the orientation of the FDD so that it is not exposed with strong light outside.
- (e) Confirm that the voltage measured at TP6 when power is supplied to the FDD is within the following range.
Notch A position TP6 voltage: 3.0V, Min.
- (f) Pull out the jig a little so that the notch B area is located on the light pass.
- (g) Confirm that the voltage measured at TP6 when power is supplied to the FDD is within the following range.

Notch B position TP6 voltage: 0.5V, Max.

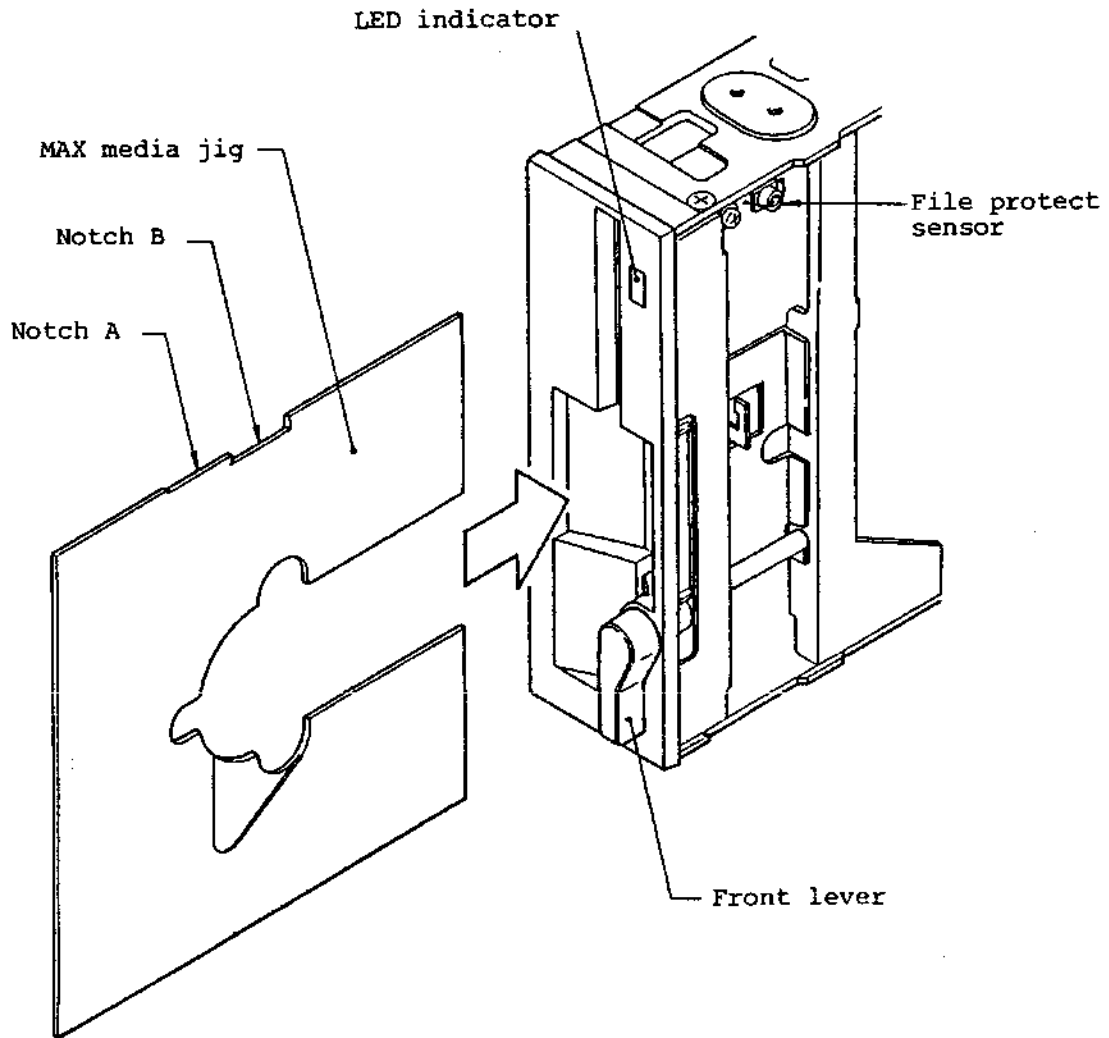

(Fig.422) Check of file protect sensor

(2) SKA method

- (a) Connect the SKA according to item 4-2-4 and set the PD PWR switch to the PSA side.
- (b) Execute the general method described in item (1)-(a) through (e).
WRRROT indicator of the SKA turns on when drive selection is executed by key "0". (DSO indicator turns on).
- (c) Execute the general method described in item (1)-(f) and -(g).
WRRROT indicator of the SKA turns off.

4-4-7. Check and Adjustment of Disk Rotation Speed

This item is only applied to the FDD which has a DD motor Ass'y with the variable resistor R1 for adjusting the rotational speed of the disk on the PCBA DD motor servo. Refer to Fig.311 as to the mounting position of the variable resistor R1.

For the DD motor Ass'y without the variable resistor, the rotation speed is fixed by the ceramic oscillator in the servo circuit and no adjustment is required.

(A) Equipment

- (1) Common screwdriver, small size
- (2) SKA or user's system
- (3) Frequency counter (not required when the SKA is used)
- (4) Work disk (soft sectored)

(B) Check and adjustment procedure

(1) General method

- (a) Connect the frequency counter to TP4 (Index) of the PCBA MFD control or to the INDEX interface signal line.
- (b) Start the spindle motor and install a work disk.
- (c) Set the head to track 00.
- (d) Execute the head loading.
- (e) Confirm that the pulse interval at TP4 is within the following range.
FD-55A ~ F: 200 ± 3 msec
FD-55G : 166.7 ± 2.5 msec

(f) If the value in item (e) is out of the specified range, adjust the variable resistor R1 on the PCBA DD motor servo to obtain the median value in the specified range in item (e).

(2) SKA method

- (a) Connect the SKA referring to item 4-2-4 and set the FD PWR switch to PSA side.
- (b) Start the spindle motor by key "5". (MON indicator turns on).
- (c) Insert a soft sectored work disk.
- (d) Execute drive select by key "0". (DS 0 indicator turns on).
- (e) Key in "C0" and confirm that TRACK indication becomes "00".
(RECALIBRATE)
- (f) Key in "C3". (INDEX PERIOD)
- (g) Confirm that the DATA indicator (ms) indicates a value within the following range.
FD-55A ~ F: 200.0±3.0msec
FD-55G : 166.7±2.5msec
- (h) If the value in item (g) is out of the specified range, adjust the variable resistor R1 on the PCBA DD motor servo to obtain the median value in the specified range in item (g).

4-4-8. Check and Adjustment of Erase Gate Delay

(A) Equipment

- (1) Common screwdriver, small size
- (2) Work disk
- (3) SKA or user's system
- (4) Oscilloscope (not required when the SKA is used)

(B) Check and Adjustment procedure

(1) General method

- (a) Use two channels of oscilloscope. Connect the trigger channel to WRITE GATE interface line and the other channel to TP2 (Erase gate delay) on the PCBA MFD control.

Oscilloscope range: For both channels, DC mode, 5V, 100 μ sec

- (b) Start the spindle motor and install a work disk.
- (c) Execute head loading.
- (d) Set the oscilloscope to the negative trigger (-) mode. Make the WRITE GATE signal TRUE (write command).
- (e) Confirm that "t" (Erase on delay) in Fig.423 is within the following range.
t(Erase on delay): 200 \sim 320 μ sec (FD-55A \sim F)
175 \sim 210 μ sec (FD-55G)
- (f) Set the oscilloscope to the positive trigger (+) mode. Make the WRITE GATE signal FALSE.

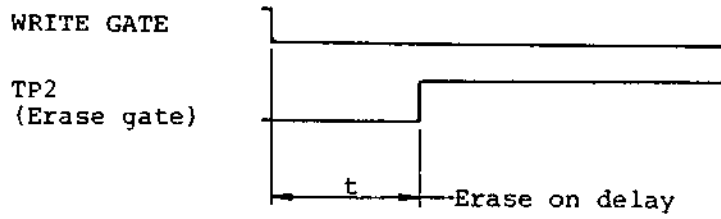

(Fig.423) Erase on delay

(g) Confirm that "t" (Erase off delay) in Fig.424 is within the following range.

t(Erase off delay): 860 ~ 950 μ sec (FD-55A ~ F)
 500 ~ 550 μ sec (FD-55G)

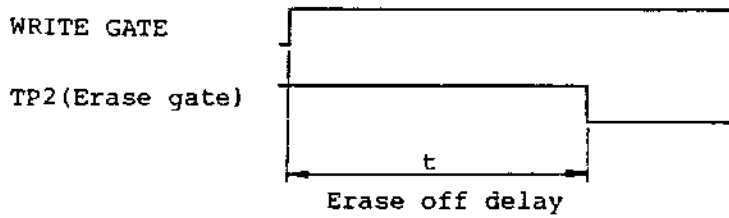

(Fig.424) Erase off delay

(2) SKA method

(a) Connect the SKA according to item 4-2-4 and set the FD PWR switch to PSA side.

(b) Execute drive select by key "0". (DS0 indicator turns on).

(c) Key in "7". (WRITE GATE ON)

(d) Confirm that the DATA indicator (μ s) shows a value within the following range.

Erase on delay: 200 ~ 320 μ sec (FD-55A ~ F)

175 ~ 210 μ sec (FD-55G)

(e) Key in "7" again. (WRITE GATE OFF)

(f) Confirm that the DATA indicator (μ s) shows a value within the following range.

Erase off delay: 860 ~ 950 μ sec (FD-55A ~ F)

500 ~ 550 μ sec (FD-55G)

4-4-9. Check and Adjustment of Head Touch

Note: The adjustment applies to a single sided FDD only.

(A) Equipment

- (1) Work disk
- (2) Common screwdriver, small size
- (3) SKA or user's system
- (4) Oscilloscope (not required when the SKA is used)
- (5) DC clip on ammeter (not required when the SKA is used)
- (6) Locking paint

(B) Adjustment procedure

(1) General method

- (a) Connect an oscilloscope to TP9 or TP10 (Differentiation amp.) on the PCBA MFD control.

Oscilloscope range 48tpi: AC mode, 0.2V

 96tpi: AC mode, 0.1V

- (b) Start the spindle motor and install a work disk.
- (c) Set the head to the innermost track.
- (d) Execute head loading.
- (e) Repeat the cycle of one write rotation and one read rotation.
Write data should be the fixed pattern of 2F(250KHz of WRITE DATA frequency for FD-55A ~ F, 500KHz for FD-55G).
- (f) Write down the average read level measured during the read operation of item (e).

- (g) Execute item (e) and (f) with a slight depression (very slight depression easy to release: 10 ~ 20g) by a finger on the top of the upper head (double sided) or of the pad arm (single sided), and measure the average read level as in item (f).
- (h) Confirm that the read level measured in item (f) is greater than 80% of that in item (g).
- (i) For a double sided FDD, execute items (e) through (h) respectively for side 0 and side 1 heads.
- (j) After making the head move to track 00, execute items (e) through (i).
- (k) Head touch adjustment for a single sided FDD:
 - i) At the innermost track, turn the groove on the upper side of the head pad by 30° steps, approx. with a common screwdriver (see Fig.425). At each turning of the groove, execute write and read operations in item (e).
Be sure to take apart the common screwdriver from the head pad during write or read operation.
Note: Be careful not to push the head pad strongly with the common screwdriver. Also do not touch the pad surface to which a disk will be in contact.
 - ii) After turning the pad position around 360°, set the position again to the position where the highest read level was obtained. Then execute items (e) through (h) at the innermost track.
 - iii) Continue the operation until the items (h) and (j) are sufficiently satisfied. Following causes are assumed for the insufficient result in item (h) or (j) after fine adjustment of the pad position.

① Inferior head pad:

Replace the pad according to item 4-5-9.

② Inferior disk:

Disk and/or jacket is deformed or damaged. Replace the work disk with a new one.

③ Inferior pressure of the jacket pads:

The jacket pad attached under the set arm (see Fig.506, No.8, 9A and 9B) does not touch the disk jacket surface. If item (h) is improved when the jacket surface is touched by a common screwdriver very lightly, execute the adjustment of the clamp arm position according to item 4-4-2, or replace the pad 9B to P/N 16787076-02 (Disk pad 2.5t).

Caution: If the jacket surface is excessively pressed, it might be deformed or the spindle motor might be overloaded because of increasing the rotation torque. If item ③ is done, measure the +12V current consumption of the FDD and confirm that the current does not exceed 300mA by an DC clip-on ammeter. For a commercially available general disks, the desirable current is 250mA, Max.

④ Inferior head:

Replace the head carriage Ass'y according to item 4-5-1.

iv) Remove the work disk and apply a drop of locking paint around the rotating area of the head pad. Be careful not to smear the groove for common screwdriver with the locking paint.

(L) Possible causes for the insufficient head touch in a double sided FDD:

Following causes are assumed for the insufficient result in items (h) through (j) on a double sided FDD.

i) Inferior disk:

Disk and/or jacket is deformed or damaged. Replace the work disk with a new one.

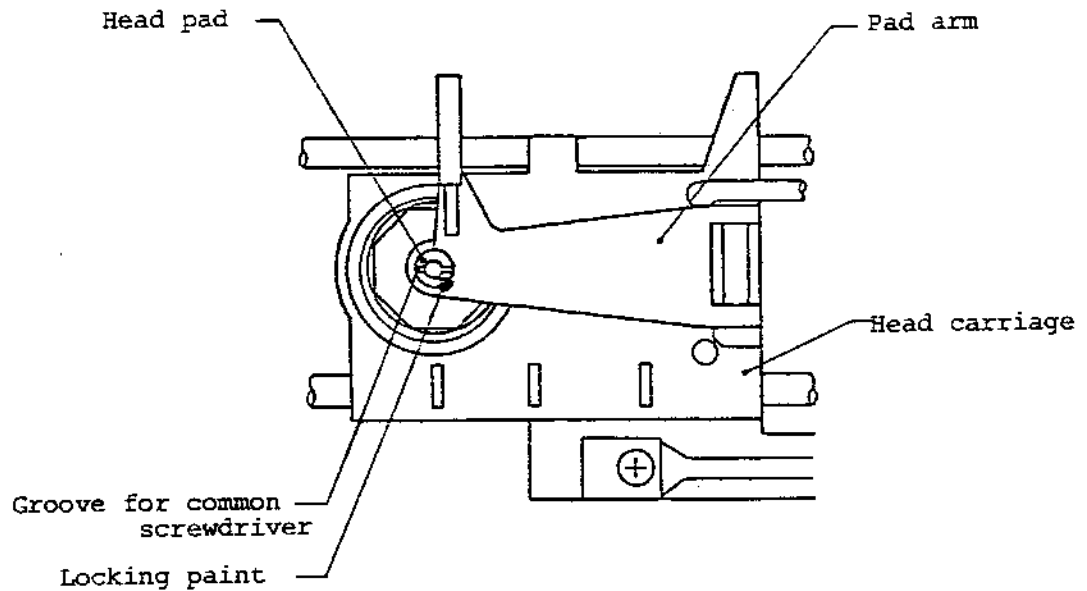

(Fig.425) Adjustment of head pad position (single sided FDD)

ii) Inferior head flexture:

Because of the failed performance of the arm lifter in item 4-4-4 (model with head load solenoid) or the failed performance of the CSS Ass'y in item 4-4-5 (CSS model without head load solenoid), the flexture on which the head piece is located may be deformed. Remove the disk. Then open and close the front lever slowly to observe the gap between the side 1 and side 0 heads from the front bezel. If the two head surfaces are not in parallel each other, it is considered to be the deformation.

Replace the head carriage Ass'y according to item 4-5-1.

iii) Inferior pressure of the jacket pads:

Refer to item (k)-iii)- ① ~ ③ and "Caution".

(2) SKA method

- (a) Connect the SKA according to item 4-2-4 and set the FD PWR switch to the PSA side.
- (b) Start the spindle motor by key "5". (MON indicator turns on). Install a work disk and execute drive select by key "0". (DSO indicator turns on).
- (c) Key in "C0" and confirm that the TRACK indicator becomes "00". (RECALIBRATE)
- (d) Key in "C1" (SEEK TMAX)
- (e) Key in "D3". (WRITE/READ LEVEL PRE 2F)
- (f) Write 2F and read operations are repeated.
The DATA indicator (mV) indicates the average read level of TP7 and TP8 (Pre-amp.) after each cycle of operation (one rotation of write and one rotation of read) is finished.
- (g) Observe the DATA indicator (mV) with a slight depression (very slight depression easy to release: 10 ~ 20g) by a finger on the top of the upper head (double sided) or of the pad arm (single sided).
- (h) Confirm that the read level measured in item (f) is more than 80% of that in item (g).
- (i) For a double sided FDD, depress "F" key to stop and then depress "4" key to execute items (e) through (h) for side 0 and side 1 heads respectively. The side is changed alternately by a depression of "4" key. If side 1 is selected, SIDE 1 indicator of the SKA turns on.

(j) Key in "CO" (RECALIBRATE) and execute items (e) through (i) in the similar way.

(k) Head touch adjustment for a single sided FDD:

Refer to item (k) of "General method".

+12V current consumption in item (k)-iii), "Caution" should be as follows.

i) Stop all the commands already input by depressing "F" key.

ii) Key in "DF". (+12V CURRENT)

iii) Measure the +12V current consumption at that time by the DATA indicator (mA).

iv) Key in "F" after the measurement completes. (STOP)

(L) Possible causes for the inferior head touch in a double sided FDD:

Refer to item (L) of "General method".

4-4-10. Check and Adjustment of Asymmetry

(A) Equipment

- (1) Work disk
- (2) SKA or user's system
- (3) Oscilloscope

(B) Check and adjustment procedure

(1) General method

- (a) Connect an oscilloscope to TP5 (Read data) on the PCBA MFD control or to the READ DATA interface line.

Oscilloscope range FD-55A ~ F: DC mode, 2V, 1 μ sec
 FD-55G : DC mode, 2V, 0.5 μ sec

- (b) Start the spindle motor and install a work disk.
- (c) Set the head to the innermost track.
- (d) Execute head loading.
- (e) Execute 1F write operation (125KHz of WRITE DATA frequency for FD-55A ~ F, 250KHz for FD-55G).
- (f) Measure the asymmetry referring to Fig.426.

Note: Oscilloscope should be so set that three read data pulses can be observed. Asymmetry width should be measured at the second read data pulse from the trigger pulse.

- (g) Confirm that the asymmetry is within the following range.

Innermost track 1F asymmetry FD-55A ~ F: 0.6 μ sec, Max.
 FD-55G : 0.3 μ sec, Max.

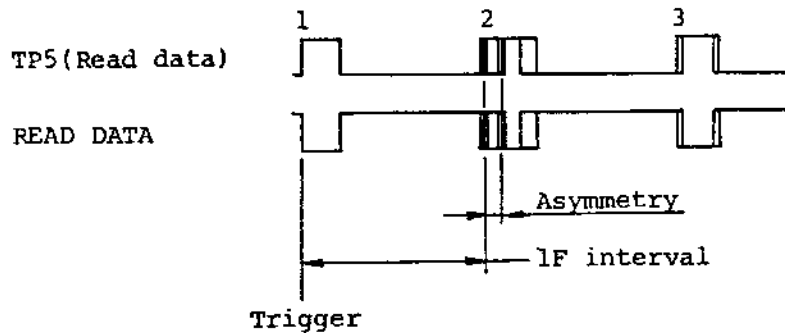

(Fig.426) Measurement of asymmetry

- (h) For a double sided FDD, execute items (e) through (g) for side 0 and side 1 heads respectively.
- (i) If the value in item (g) or (h) is out of the specified range, adjust according to the following procedure.
The adjustment can be done only for the PCBA versions or the PCBA revision numbers with the variable resistor R5 on the PCBA MFD control. No adjustment can be done without R5.
 - i) Adjust the variable resistor R5 so that the asymmetry takes the minimum value while repeating 1F write and 1F read operations alternately.
 - ii) For a double sided FDD, repeat the operation in item i) for side 0 and side 1 heads alternately. The variable resistor shall be so adjusted that both asymmetry for side 1 and side 0 heads take the minimum value.
- (j) If the values in items (g) and (h) are out of the specified range in the PCBA without the variable resistor R5, or if the adjustment in item (i) cannot be done sufficiently even if R5 is mounted, following causes are assumed.
 - i) Leakage flux density in the environmental condition of the FDD

is high:

If there is some flux source near the FDD such as magnet, transformer, motor, Brown tube, magnetized iron plate, etc., take it apart from the FDD. Then measure the asymmetry and adjust again.

ii) Inferior disk:

Replace the work disk.

iii) Inferior head:

Replace the head carriage Ass'y according to item 4-5-1.

iv) Inferior PCBA MFD control:

Replace the PCBA according to item 4-5-8.

(2) SKA method

- (a) Connect the SKA according to item 4-2-4 and set the FD PWR switch to the PSA side.
- (b) Key in "BlF". (lF DUTY)
- (c) Connect an oscilloscope to the DOUT terminal of the SKA.
Oscilloscope range FD-55A ~ F: DC mode, 2V, 0.2 μ sec
 FD-55G : DC mode, 2V, 0.1 μ sec
- (d) Start the spindle motor by key "5". (MON indicator turns on).
- (e) Install a work disk.
- (f) Execute drive select by key "0". (DSO indicator turns on).
- (g) Key in "C0" and confirm that the TRACK indicator becomes "00".
(RECALIBRATE)
- (h) Key in "C1". (SEEK TMAX)
- (i) Key in "D4". (WRITE/READ LEVEL PRE lF)
- (j) Measure the asymmetry as in Fig.427.

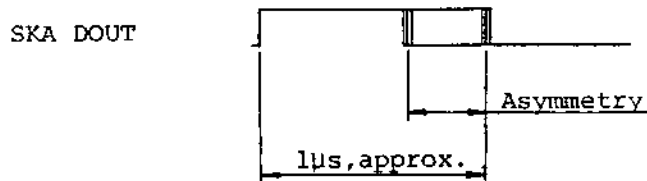

(Fig.427) Measurement of asymmetry (SKA)

- (k) Confirm that the asymmetry is within the following range.
- | | | |
|------------------------------|-------------|-----------------|
| Innermost track 1F asymmetry | FD-55A ~ F: | 0.6μsec, Max. |
| | FD-55G | : 0.3μsec, Max. |
- (L) For a double sided FDD, depress "4" key and execute items (i) through (k) for side 0 and side 1 heads respectively. The side is changed alternately by a depression of "4" key. If side 1 is selected, SIDE 1 indicator of the SKA turns on.
- (m) If the value in item (k) or (L) is out of the specified range, adjust according to the following procedure. The adjustment can be done only for the PCBA versions or the PCBA revision numbers with the variable resistor R5 on the PCBA MFD control. No adjustment can be done without R5.
- i) Adjust the variable resistor R5 so that the asymmetry takes the minimum value by keying in "D4".
 - ii) For a double sided FDD, execute the operation in item i) for both sides alternately by changing the side by key "4". The variable resistor shall be so adjusted that both asymmetry for side 1 and side 0 heads take the minimum value.
- (n) If the values in items (K) and (L) are out of the specified range in the PCBA without the variable resistor R5, or if the adjustment in item (m) cannot be done sufficiently even if R5 is mounted, refer to item (j) of "General method".

4-4-11. Check of Read Level

(A) Equipment

- (1) Level disk
- (2) SKA or user's system
- (3) Oscilloscope (not required when the SKA is used)

(B) Check procedure

(1) General method

- (a) Use two channels of an oscilloscope and connect them to TP9 and TP10 (Differentiation amp.) on the PCBA MFD control.
Oscilloscope range 48tpi: AC mode, 0.5V
 96tpi: AC mode, 0.2V
Set both channels, 1 and 2 to the above range. Set either of the channels to Invert mode and ADD both channels.
- (b) Start the spindle motor and install a level disk.
- (c) Make the head move to the innermost track.
- (d) Execute head loading.
- (e) Execute 2F write operation for one rotation of the disk (250KHz of WRITE DATA frequency for DD-55A ~ F, 500KHz for FD-55G).
- (f) Measure the average amplitude (V_{p-p}) of the read waveform as in Fig.428.
- (g) Calculate the read level by substituting the following expression with the measured value in item (f) and READ LEVEL calibration value (see level disk label).

$$\text{Read level (true value)} = \text{Measured value} \times \frac{100}{\text{Calibration value}}$$

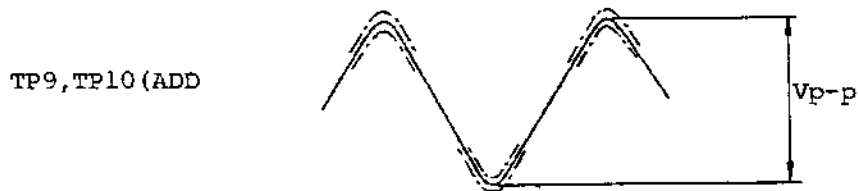

(Fig.428) Measurement of average read level (2F)

(h) Confirm that the true value of the read level is within the following range.

Innermost track read level 48tpi: 1.4Vp-p, Min.

96tpi: 0.6Vp-p, Min.

(i) For a double sided FDD, execute items (e) through (h) for side 0 and side 1 heads respectively.

(j) If the value in item (h) or (i) is out of the specified range, following causes are assumed.

i) Inferior disk:

Disk and/or jacket is deformed or damaged. Replace the level disk with a new one.

ii) Abnormal disk rotational speed:

Check and adjust according to item 4-4-7.

iii) Inferior head touch:

Check and adjust according to item 4-4-9.

iv) Inferior head:

Replace the head carriage Ass'y according to item 4-5-1.

v) Inferior PCBA MFD control:

Replace the PCBA MFD control according to item 4-5-7.

(k) Eject the level disk and release the Invert and ADD modes of the oscilloscope.

4-4-12. Check of Resolution

(A) Equipment

- (1) Level disk
- (2) SKA or user's system
- (3) Oscilloscope (not required when the SKA is used)

(B) Check procedure

(1) General method

- (a) Use two channels of an oscilloscope and connect them to TP7 and TP8 (Pre-amp.) on the PCBA MFD control.

Oscilloscope range 48tpi: AC mode, 50mV ~ 0.1V

 96tpi: AC mode, 20mV ~ 50mV

Set both channels, 1 and 2 to the above range. Set either of the channels to Invert mode and ADD both channels.

- (b) Start the spindle motor and install a level disk.
- (c) Make the head move to the innermost track.
- (d) Execute head loading.
- (e) Execute 1F write operation for one rotation of the disk (125KHz of WRITE DATA frequency for FD-55A ~ F, 250KHz for FD-55G).
- (f) Measure the average amplitude (V1F) as in Fig.429.
- (g) Execute 2F write operation as in item (e) (double in frequency to that in item (e)).
- (h) Measure the average amplitude (V2F) as in Fig.429.

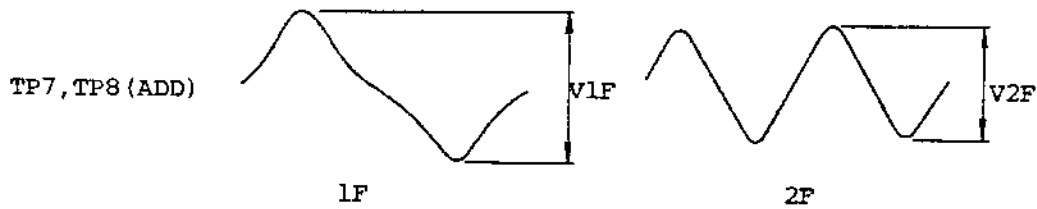

(Fig.429) Measurement of resolution

- (i) Calculate the resolution by substituting the following expression with the measured values $V1F$, $V2F$, and RESOLUTION calibration value (see level disk label).

$$\text{Resolution (true value)} = V2F/V1F \times 100/\text{Calibration value (\%)}$$

- (j) Confirm that the true value is within the following range.
Innermost track resolution: 55%, Min.
- (k) For a double sided FDD, execute items (e) through (j) for side 0 and side 1 heads respectively.
- (L) If the value in item (j) or (k) is out of the specified range, following causes are assumed.
- i) Inferior disk:
Disk and/or jacket is deformed or damaged. Replace the level disk with a new one.
 - ii) Inferior disk rotational speed:
Check and adjust according to item 4-4-7.
 - iii) Inferior head touch:
Check and adjust according to item 4-4-9.
 - iv) Inferior head: Replace the head carriage Ass'y according to item 4-5-1.
 - v) Inferior PCBA MFD control:

Replace the PCBA MFD control according to item 4-5-7.

(m) Eject the level disk and release the Invert and Add modes of the oscilloscope.

(2) SKA method

- (a) Connect the SKA referring to item 4-2-4 and set the FD PWR switch to the PSA side.
- (b) Start the spindle motor by key "5". (MON indicator turns on).
- (c) Install a level disk.
- (d) Execute drive select by key "0". (DSO indicator turns on).
- (e) Key in "C0" and confirm that the TRACK indication becomes "00".
(RECALIBRATE)
- (f) Key in "C1". (SEEK TMAX)
- (g) Key in "D8" (RESOLUTION)
The calibration value of the level disk should be set previously in the SKA.
- (h) Confirm that the DATA indicator (%) indicates the value within the following range.
Innermost track resolution: 55%, Min.
- (i) For a double sided FDD, depress key "4" and execute items (g) and (h) for side 0 head and side 1 head respectively. The side is changed alternately by a depression of "4" key. If side 1 is selected, SIDE 1 indicator of the SKA turns on.
- (j) If the value in item (h) or (k) is out of the specified range, refer to item (L) of "General method".
- (k) Eject the level disk.

4-4-13. Check and Adjustment of Track Alignment

(A) Equipment

- (1) Cross point screwdriver, M3
- (2) Alignment disk
- (3) Alignment adjustment jig or M3 screw of 15mm long
- (4) SKA or user's system
- (5) Oscilloscope
- (6) Hygrometer.
- (7) Locking paint

(B) Check and adjustment procedure

Note: Check and adjustment of track alignment should be done in an environment of general room temperature and humidity. Even if the environmental condition is within the specified operational condition, extremely high or low temperature, or extremely high or low humidity should be avoided. Check and adjustment should be done after two hours, Min. of storing in the above mentioned condition.

It is recommended that the orientation of the FDD for the track alignment check is the same as when the FDD is actually installed in the user's system.

(1) General method

- (a) Use two channels of an oscilloscope and connect them to TP9 and TP10 (Differentiation amp.) on the PCBA MFD control. Also connect the external trigger of the oscilloscope to TP4 (Index) and apply positive trigger.

Oscilloscope range 48tpi: AC mode, 0.5V, 20msec

 96tpi: AC mode, 0.2V, 20msec

Set both channels, 1 and 2 to the above range. Set either of the channels to Invert mode and Add both channels.

- (b) Start the spindle motor and install an alignment disk.
- (c) Execute head loading.
- (d) Set the head to the following alignment check track.
 - 48tpi: track 16
 - 96tpi: track 32
- (e) Confirm that two lobe patterns as in Fig.430 can be observed (it is not necessary that the levels of VA and VB are equal).

If only one lobe pattern can be observed or if two lobes become one pattern, the head is not on the alignment check track.

In such event, execute step-out or step-in as mentioned below to obtain the most similar waveform to that in Fig.430.

 - 48tpi: 2 tracks
 - 96tpi: 4 tracks

Note: The above number of tracks to be stepped is required to make the alignment track position be fit with the magnetized condition of the basic magnetized phase "A" of the stepping motor. If the stepped track numbers are inassured, set it again from track 00 (TRACK 00 output signal becomes TRUE).

For a 48tpi FDD, the lobe pattern as in Fig.430 should be observed at the track of even number. For a 96tpi FDD, the lobe pattern should be observed at the track of multiple number of four (4).

- (f) After one or several step-outs from the check track, step in the head to the check track again and measure VA and VB at that time.
- (g) Calculate the true value of misalignment by substituting the value in item (f) and ALIGNMENT calibration value (see alignment disk label, attention to the side).

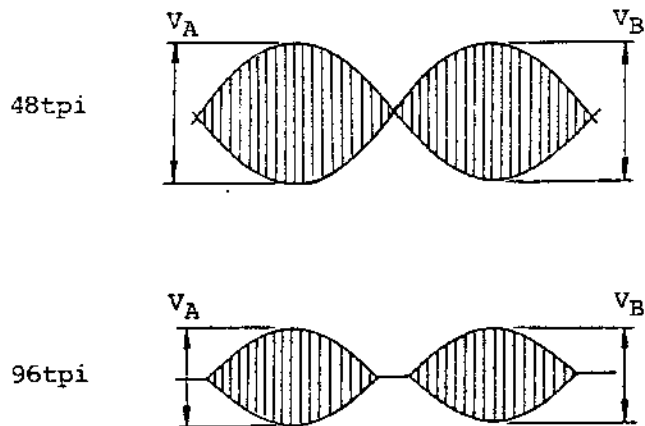

(Fig.430) Alignment check lobe pattern

$$\text{Misalignment (true value)} = \frac{V_A - V_B}{\text{Larger value in } V_A \text{ \& } V_B} \times 100$$

$$- \text{Calibration value} - (\text{Relative humidity} - 50) \times K$$

K is humidity compensation factor.

48tpi: K=0.26

96tpi: K=0.42

e.g. $V_A=0.58V$, $V_B=0.61V$, Calibration value=-6(%)

Relative humidity=65%, 96tpi:

$$\text{Misalignment (true value)} = \left\{ \frac{0.58 - 0.61}{0.61} \times 100 - (-6) \right\} - (65 - 50)$$

$$\times 0.42 \approx -5.2(\%)$$

If the calculated value is positive, the magnetic head is shifted inward from the reference position, while the head is shifted outward from the reference position when the value is negative.

(h) Conversely, measure V_A and V_B when the head is on the alignment check track by stepping-out after one or several step-ins.

(i) Calculate the true value of misalignment as described in item (g).

(j) Confirm that both of the calculated values in items (g) and (i) are within the following range.

True value of misalignment: 30%, Max.

(k) For a double sided FDD, execute items (d) through (j) for side 0 and side 1 heads respectively.

(L) If the value in item (j) or (k) is out of the specified range, adjust the track alignment according to the following procedure:

- i) Loosen two fixing screws of the stepping motor a little.
- ii) Insert the alignment adjustment jig or M3 screw from the back side of the FDD as shown in Fig.431.
- iii) Repeat step-in and step-out operations and adjust the misalignment to be the smallest on the alignment check track during both step-in and step-out operations by turning the jig or the screw (stepping motor moves little by little).

Note: When you adjust the alignment by observing the lobe pattern using the oscilloscope, pay attention to the calibration value on the alignment disk label and the ambient relative humidity.

① Calibration value + (Relative humidity - 50) x K \geq 0:

When the left side lobe pattern level, VA is assumed as "1", lobe pattern ratio should be so adjusted that the right side lobe pattern level VB takes the following value:

$$VB = 1 - \frac{\text{Calibration value} + (\text{Relative humidity} - 50) \times K}{100}$$

② Calibration value + (Relative humidity - 50) x K \leq 0:

When the right side lobe pattern level, VB is assumed as "1", lobe pattern ratio should be so adjusted that the left side lobe pattern level VA takes the following value.

$$VA = 1 - \frac{\text{Calibration value} + (\text{Relative humidity} - 50) \times K}{100}$$

e.g. Calibration value = -6%, Relative humidity = 35%, 96tpi:

$$-6 + (35 - 50) \times 0.42 = -12.3 < 0$$

$$VA = 1 - \frac{-6 + (35 - 50) \times 0.42}{100} = 0.88$$

Therefore, the target value of VA when VB is assumed as "1" is 0.88.

- iv) For a double sided FDD, repeat the adjusting operation in item iii) alternately for side 0 and side 1 heads until the both misalignment take the smallest value.
 - v) Tighten the two fixing screws of the stepping motor little by little for adjusting the true value of misalignment after tightening the screws with the specified torque to be within $\pm 20\%$.
 - vi) Remove the alignment disk.
 - vii) Apply a drop of locking paint to the head of the stepping motor fixing screws.
 - viii) Check and adjust the track 00 sensor according to item 4-4-14.
 - ix) Check and adjust the track 00 stopper according to item 4-4-15.
- (m) Release the Invert and Add modes of the oscilloscope.

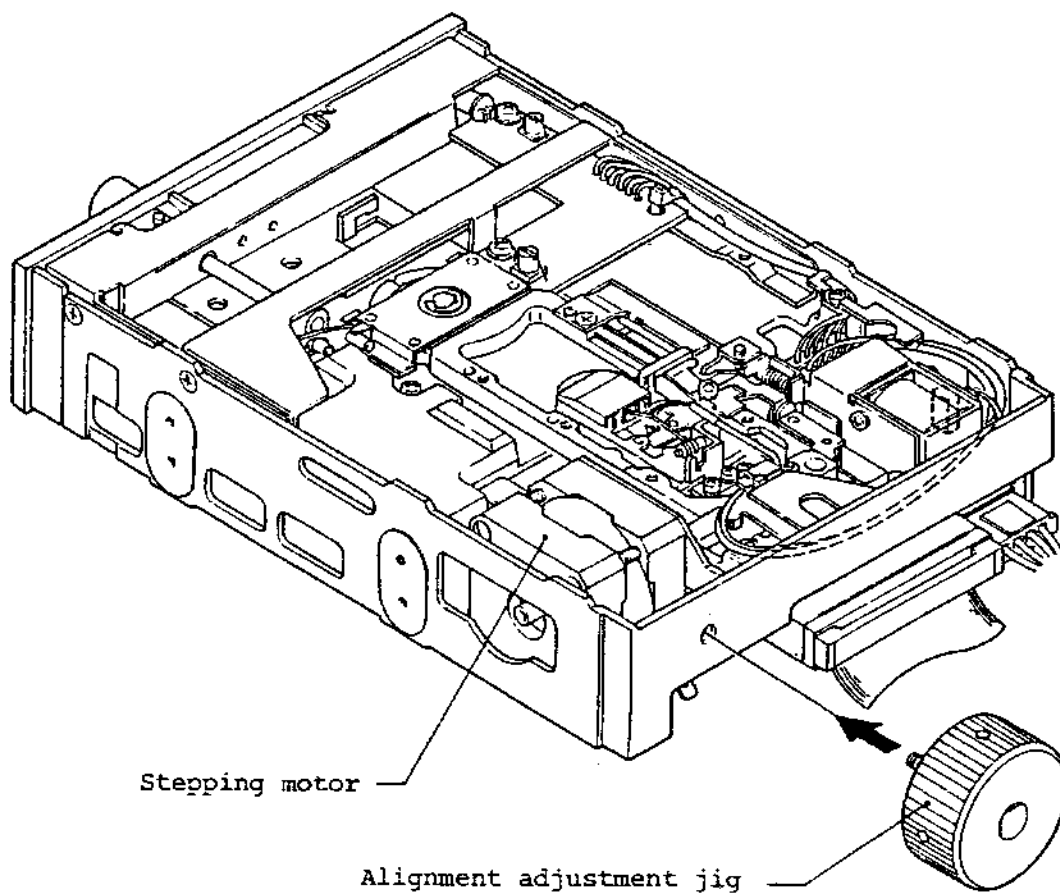

(Fig.431) Adjustment track alignment

(2) SKA method

- (a) Connect the SKA referring to item 4-2-4 and set the FD PWR switch to the PSA side.
- (b) Use two channels of an oscilloscope. Connect the 1st channel to the DOUT terminal of the SKA and the 2nd channel to the DIF terminal of the SKA. Apply positive trigger by DOUT terminal.
Oscilloscope range
 - The 1st channel: DC mode, 2V, 20msec
 - The 2nd channel 48tpi: AC mode, 1V, 20msec
 - 96tpi: AC mode, 0.5V, 20msec
- (c) Key in "B9F" (INDEX observation)
- (d) Start the spindle motor by key "5". (MON indicator turns on).
- (e) Install an alignment disk.
- (f) Execute drive select by key "0". (DSO indicator turns on).
- (g) Key in "C0" and confirm that the TRACK indicator becomes "00".
(RECALIBRATE)
- (h) Set the head to the alignment check track.
 - 48tpi: Key in "C2 16" and confirm that the TRACK indication becomes "16".
 - 96tpi: Key in "C2 32" and confirm that the TRACK indication becomes "32".
- (i) Confirm that two lobe patterns as in Fig.430 can be observed by the oscilloscope (it is not necessary that the levels of VA and VB are equal).

If only one lobe pattern can be observed or if two lobes become one pattern, the head is not on the alignment check track.

In such event, execute step-in or step-out as follows to obtain the most similar waveform to that in Fig.430. Step operation can be done by key "8" (STEP-IN) and key "9" (STEP-OUT). By a depression of these keys, head will move for one track space.

48tpi: 2 tracks

96tpi: 4 tracks

Note: The above number of tracks to be stepped is required to make the alignment track position be fit with the magnetized condition of the basic magnetized phase "A" of the stepping motor.

For a 48tpi FDD, the lobe pattern as in Fig.430 should be observed at the track of even number. For a 96tpi FDD, the lobe pattern should be observed at the track of multiple number of four (4).

(j) For a 96tpi, confirm that the H GAIN indicator of the SKA turns on in order to improve the measurement accuracy and switching of humidity coefficient. If it is off, turn it on by depressing "DD" key.

(k) Key in "E3" (ALIGNMENT)

Calibration value of the alignment disk and environmental relative humidity should be set previously in the SKA.

(L) Confirm all the indications on the DATA (%) indicator are within $\pm 30\%$.

The initial digit of the DATA indicator is the symbol. \wedge (+) mark indicates that the head is shifted inward from the reference position, while - mark indicates that the head is shifted outward.

(m) For a double sided FDD, execute the same check for side 1 head according to the following procedure.

i) Key in "0" following the operation of item (L) (during execution of E3 command) and confirm that SIDE 1 indicator of the SKA turns on.

ii) Confirm as in item (L).

Note: In order to change the head to side 0, key in "0" again.
(SIDE 1 indicator turns off).

(n) Depress "F" key (STOP).

(o) If the value in items (L) or (m) is out of the specified range, adjust the track alignment according to the following procedure.

i) Loosen the two fixing screws of the stepping motor a little.

ii) Insert the alignment adjustment jig or M3 screw from the back side of the FDD as shown in Fig.431.

iii) Key in "E3" and adjust the jig or M3 screw so that the DATA indicator (4 digits) (%) shows the smallest value. The stepping motor moves little by little when the jig or the screw is turned.

iv) For a double sided FDD, repeat the adjusting operation in item iii) alternately for side 0 and side 1 heads until the both misalignment take the smallest value.

v) Tighten the two fixing screws of the stepping motor little by little to obtain the value within $\pm 20\%$ on the DATA indicator when the screws are tightened with the specified torque.

vi) Remove the alignment disk.

vii) Apply a drop of locking paint to the screw head of the stepping motor fixing screws.

viii) Check and adjust the track 00 sensor according to item 4-4-14.

ix) Check and adjust the track 00 stopper according to item 4-4-15.

(p) Release the Invert and Add modes of the oscilloscope.

4-4-14. Check and Adjustment of Track 00 Sensor

(A) Equipment

- (1) Cross point screwdriver, M3
- (2) Work disk
- (3) Alignment disk
- (4) SKA or user's system
- (5) Oscilloscope (or digital volt meter)
- (6) Locking paint

(B) Check and adjustment procedure

(1) General method.

- (a) Connect a digital volt meter or an oscilloscope to TPl (Track 00 sensor) on the PCBA MFD control.

Oscilloscope range: DC mode, 1V

- (b) Start the spindle motor and install a work disk.

- (c) Execute head loading

- (d) Confirm that the voltage at TPl is within the following range when the head is set to track 00.

Track 00 position TPl voltage: 3V, Min.

- (e) Turn the power off of the FDD and then turn it on again. Confirm that the stop position of the head carriage did not change at power off and on. This item aims to confirm that the track 00 position matches the basic magnetized phase A of the stepping motor.

- (f) Make the head move to the following track.

48tpi: 02 track

96tpi: 04 track

- (g) Confirm that the voltage at TP1 is within the following range at the track position in item (f).

TP1 voltage at track 02 (48tpi) or track 04 (96tpi): 0.5V, Max.

- (h) If the value in item (d), (e), or (g) is out of the specified range, adjust the position of the track 00 sensor according to the following procedure.

- i) Loosen the fixing screw of the track 00 stopper (see Fig.434) and shift the stopper in the step-out direction (make apart from the rear side of the head carriage).
- ii) Connect the oscilloscope to TP9 or TP10 (Differentiation amp.) of the PCBA MFD control.
Oscilloscope range: AC mode, 0.2V, 20msec
- iii) Install an alignment disk. The track alignment should be adjusted correctly according to item 4-4-13.
- iv) Make the head move to the position where the lobe pattern as in Fig.430 can be observed.
- v) Remove the alignment disk.
- vi) Connect the digital voltmeter or the oscilloscope to TP1 (Track 00 sensor) on the PCBA MFD control.
Oscilloscope range: DC mode, 1V
- vii) Step out the head for the following track space from the position where the normal lobe pattern is observed.
48tpi: 15 tracks (head will be on track 01)
96tpi: 30 tracks (head will be on track 02)
- viii) Install a work disk.
- ix) Loosen the fixing screws of the track 00 sensor (see Fig.432) and move the sensor a little so that the voltage at TP1 falls within the following range.
TP1 voltage at track 01 (48tpi), track 02 (96tpi):

0.5 ~ 3V (0.8 ~ 1.2V, approx. center)

- x) Confirm the items (d) through (g).
- xi) Adjust the track 00 sensor position so that the values in items (ix) and (x) satisfy the specification when the screw has been tightened with the specified torque.
- xii) Apply a drop of locking paint on the fixing screw head.
- xiii) Adjust the track 00 stopper according to item 4-4-15.

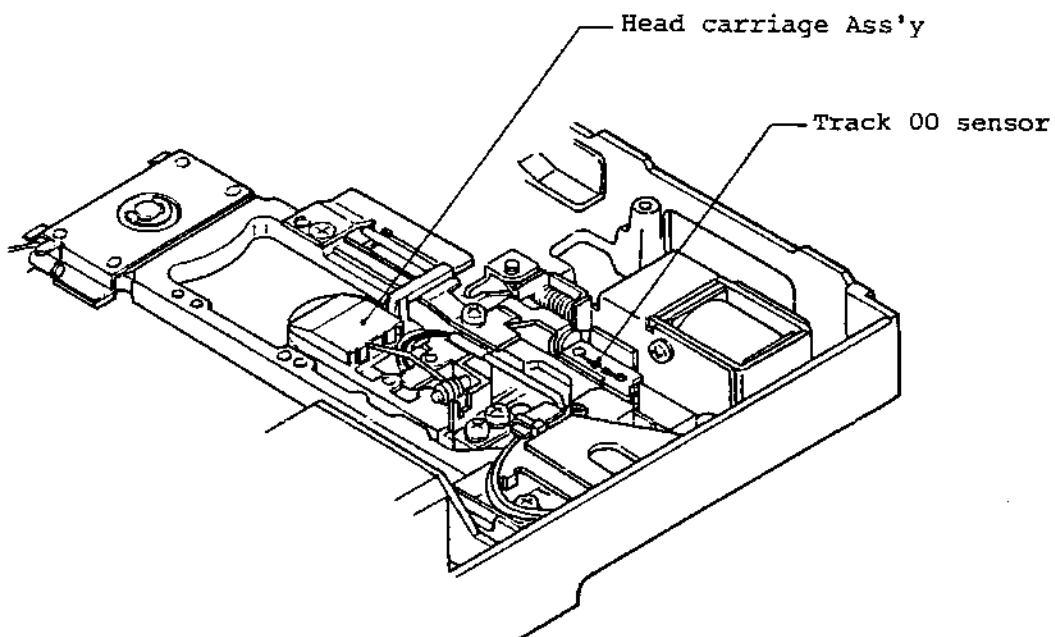

(Fig.432) Adjustment of track 00 sensor

(2) SKA method

- (a) Connect the SKA referring to item 4-2-4 and set the FD PWR switch to the PSA side.
- (b) Use two channels of oscilloscope and connect them as follows.
 - i) The 1st channel: SKA DOUT terminal
DC mode, 5V, 5 ~ 10msec
 - ii) The 2nd channel: PCBA MFD control TP1 (Track 00 sensor), 1V range
 - iii) External trigger: DIRECTION SELECT interface signal (Interface connector pin No.18) or Pin 3 of J3 (resistor network RAL for terminator) on the PCBA MFD control.
(+) trigger.
- (c) Key in "B8 F". (STEP observation)
- (d) Start the spindle motor by key "5". (MON indicator turns on).
- (e) Install a work disk.
- (f) Execute drive select by key "0". (DS0 indicator turns on).
- (g) Set the step rate and the settling time as follows referring to item 4-2-4-3.
 - 48tpi: Step rate 6msec, Settling time 15msec
 - 96tpi: Step rate 3msec, Settling time 15msec
- (h) Key in "C0" and confirm that the TRACK indicator becomes "00".
- (i) Key in "C5". (T00 TIMING, SEEK ±5)
- (j) Measure the timing of points A and B and the voltages VL and VH

referring to Fig.433. The values should be with the following range.

TP1 clip timing, A: t_A in Fig.433.

TP1 clip timing, B: t_B in Fig.433.

TP1 voltage, V_L : 0.5V, Max.

TP1 voltage, V_H : 3V, Min.

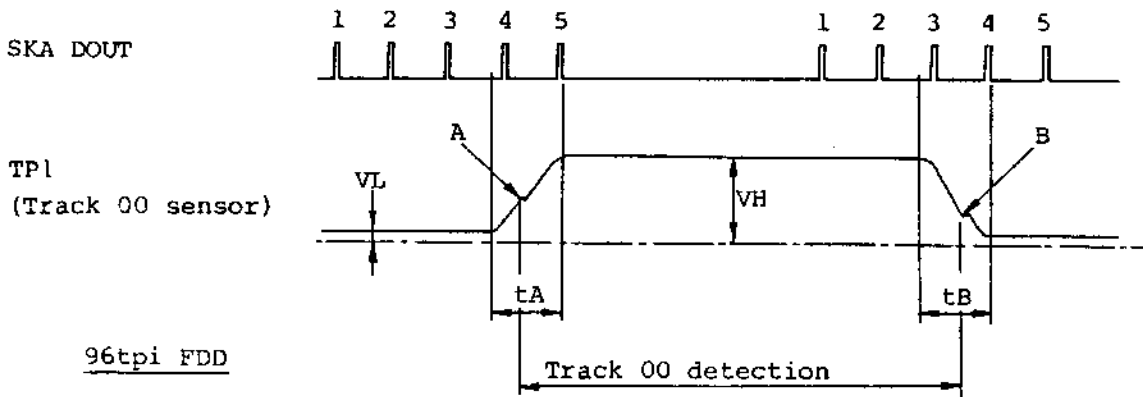
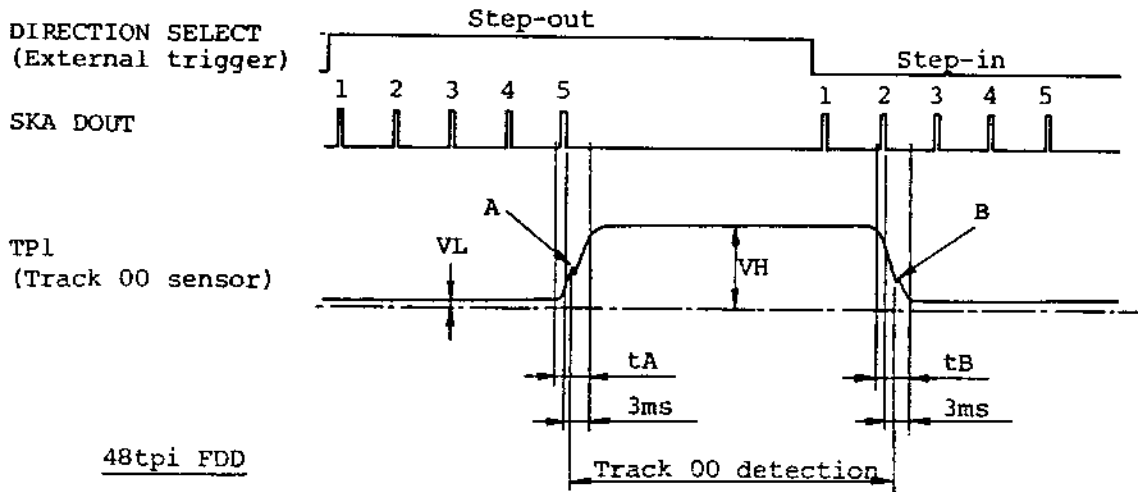

Note: V_L and V_H shall be smooth without undulations

(Fig.433) Track 00 sensor output waveform

(k) Key in "F". (STOP)

- (L) Turn the FD PWR switch of the SKA off at the track 00 position and then set it again to the PSA side. Confirm that the stop position of the head carriage did not change at power off and on.
- (m) If the value in item (j) or (L) is out of the specified range, adjust the position of the track 00 sensor according to the following procedure.
- i) Loosen the fixing screw of the track 00 stopper (see Fig.434) and shift the stopper in the step-out direction (make apart from the rear side of the head carriage).
 - ii) Connect the 2nd channel of the oscilloscope to TP9 or TP10 (Differentiation amp.) of the PCBA MFD control and change the trigger to this channel.
Oscilloscope range: AC mode, 0.2V, 20msec
 - iii) Install an alignment disk. The track alignment should be correctly adjusted according to item 4-4-13.
 - iv) Key in "C0" and confirm that the track indicator becomes "00".
(RECALIBRATE).
 - v) Key in the following code and confirm that two lobe patterns as in Fig.430 can be observed.
48tpi: C2 16
96tpi: C2 32
If normal lobe pattern cannot be observed, move the head to the track position where the typical lobe pattern can be observed by stepping in by key "8" or by stepping out by key "9".
 - vi) Remove the alignment disk.
 - vii) Key in the following code. (SET TRACK NUMBER)
48tpi: E4 16
96tpi: E4 32
 - viii) Key in "C2 00" (SEEK 00)
Don't key in "C0" (RECALIBRATE).
 - ix) Change the connection of the oscilloscope as in item (b).
 - x) Key in "C5". (T00 TIMING SEEK ±5)

- xi) Loosen the fixing screw of the track 00 sensor (see Fig.432) and adjust the sensor position where the requirements in item (j) are all satisfied.
- xii) Repeat the adjustment so that the values in item (j) fall within the specified range when the fixing screw has been tightened with the specified torque.
- xiii) Apply a drop of locking paint to the fixing screw head.
- xiv) Adjust the track 00 stopper according to item 4-4-15.

4-4-15. Check and Adjustment of Track 00 Stopper

(A) Equipment

- (1) Cross point screwdriver, M3
- (2) SKA or user's system
- (3) Locking paint

(B) Check and adjustment procedure

(1) General method

- (a) Set the head to track 00.
- (b) Step out the head from the track 00 position.
- (c) Confirm that the head carriage does not move by the step-out command (head carriage rests on track 00).
- (d) Confirm that the gap between the head carriage and the extreme end of the track 00 stopper is $0.1 \sim 0.4\text{mm}$. (See Fig.434).
- (e) Repeat step-in and step-out operations between track 00 and track 05. Confirm that no impact sound can be heard between the head carriage and the track 00 stopper.
- (f) Turn off the FDD power and depress the head carriage lightly against the track 00 stopper with fingers. (See Fig.434).
- (g) Confirm that the head carriage automatically returns to the initial position (track 00) when the power is turned on again.
- (h) If any one of the items (d), (e), and (g) is not satisfied, adjust the track 00 stopper position according to the following procedure.

- i) Set the head to track 00.
- ii) Loosen the fixing screw of the track 00 stopper. (See Fig.434).
- iii) Adjust the stopper position so that the gap between the stopper and the head carriage becomes 0.25mm, approx. And then tighten the screw with the specified torque.
- iv) Execute items (a) through (g).
- v) Apply a drop of locking paint on the fixing screw head.

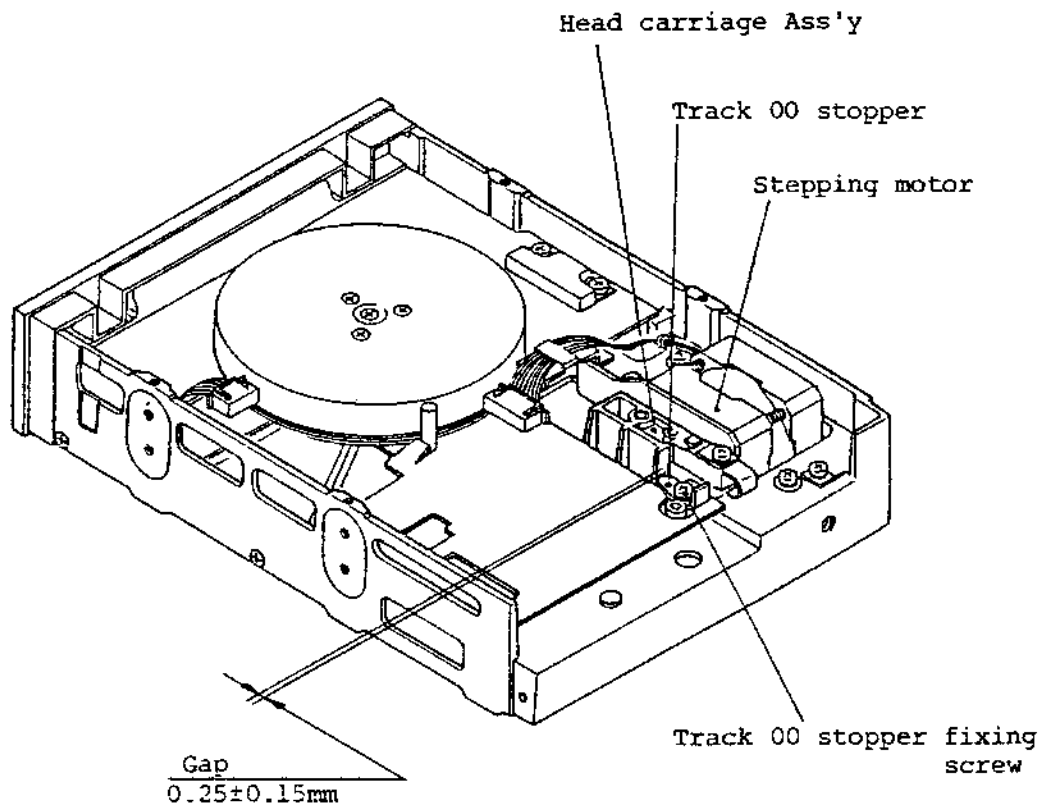

(Fig.434) Adjustment of track 00 stopper

(2) SKA method

- (a) Connect the SKA referring to item 4-2-4 and set the FD PWR switch to the PSA side.
- (b) Execute drive select by key "0". (DS0 indicator turns on).
- (c) Key in "C0" and confirm that the TRACK indicator becomes "00". (RECALIBRATE).
- (d) Set the step rate and the settling time as follows referring to item 4-2-4-3.
48tpi: Step rate 6msec, Settling time 15msec
96tpi: Step rate 3msec, Settling time 15msec
- (e) Key in "9". (STEP OUT)
- (f) Confirm that the head carriage does not move even if "9" is keyed in (head carriage rests on track 00).
- (g) Confirm that the gap between the head carriage and the extreme end of the track 00 stopper is 0.1 ~ 0.4mm. (See Fig.434).
- (h) Key in "C0" and key in "CS". (STEP TIMING, SEEK ±5)
- (i) Confirm that no impact sound can be heard between the head carriage and the track 00 stopper.
- (j) Turn off the FD PWR switch of the SKA and depress the head carriage lightly against the track 00 stopper. (See Fig.434).
- (k) Confirm that the head carriage automatically returns to the initial position (track 00) when the FD PWR switch is set to the PSA side again.

(L) If any one of the items (g), (i), and (k) is not satisfied, adjust the track 00 stopper position according to the following procedure.

- i) Key in "C0" and confirm that the TRACK indicator becomes "00"
(RECALIBRATE)
- ii) Loosen the fixing screw of the track 00 stopper. (See Fig.434).
- iii) Adjust the stopper position so that the gap between the stopper and the head carriage becomes 0.25mm, approx.
And then tighten the screw with the specified torque.
- iv) Execute items (a) ~ (k).
- v) Apply a drop of locking paint on the fixing screw head.

4-4-16. Check and Adjustment of Index Burst Timing

(A) Equipment

- (1) Cross point screwdriver, M3
- (2) Alignment disk
- (3) SKA or user's system
- (4) Oscilloscope (not required when the SKA is used)
- (5) Locking paint

(B) Check and adjustment procedure

(1) General method

- (a) Use two channels of the oscilloscope. Connect the 1st channel to TP4 (Index) on the PCBA MFD control and the 2nd channel to TP7 or TP8 (Pre-amp.). Apply positive trigger by TP4.

Oscilloscope range

The 1st channel: DC mode, 2V, 50 μ sec

The 2nd channel 48tpi: AC mode, 1V, 50 μ sec

96tpi: AC mode, 0.5V, 50 μ sec

- (b) Start the spindle motor and install an alignment disk.

- (c) Execute head loading.

- (d) Set the head to the following track.

48tpi: Track 01

96tpi: Track 02

- (e) Measure "t" in Fig.435.

- (f) Substitute the following equation with the measured value in item (e) and INDEX TIMING calibration value (see alignment disk label).

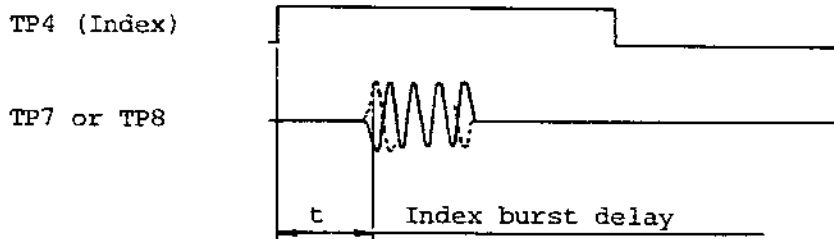

(Fig.435) Index burst timing

Index burst timing (true value) = Measured value - Calibration value (μs)

(g) Confirm that the true value of the index burst timing is within the following range.

FD-55A ~ F: $200 \pm 200 \mu\text{sec}$

FD-55G : $165 \pm 165 \mu\text{sec}$

(h) If the value in item (g) is out of the specified range, adjust the index sensor Ass'y position according to the following procedure.

i) Loosen the fixing screws (see Fig.436) of the PCBA front OPT and adjust its position to make the true value of the index burst timing fall in the specified range in item (g).

ii) Repeat the adjustment so that the true value of the index burst timing falls in the range of item (g) when the fixing screw has been tightened with the specified torque.

iii) Apply a drop of locking paint on the fixing screw head.

(i) Remove the alignment disk.

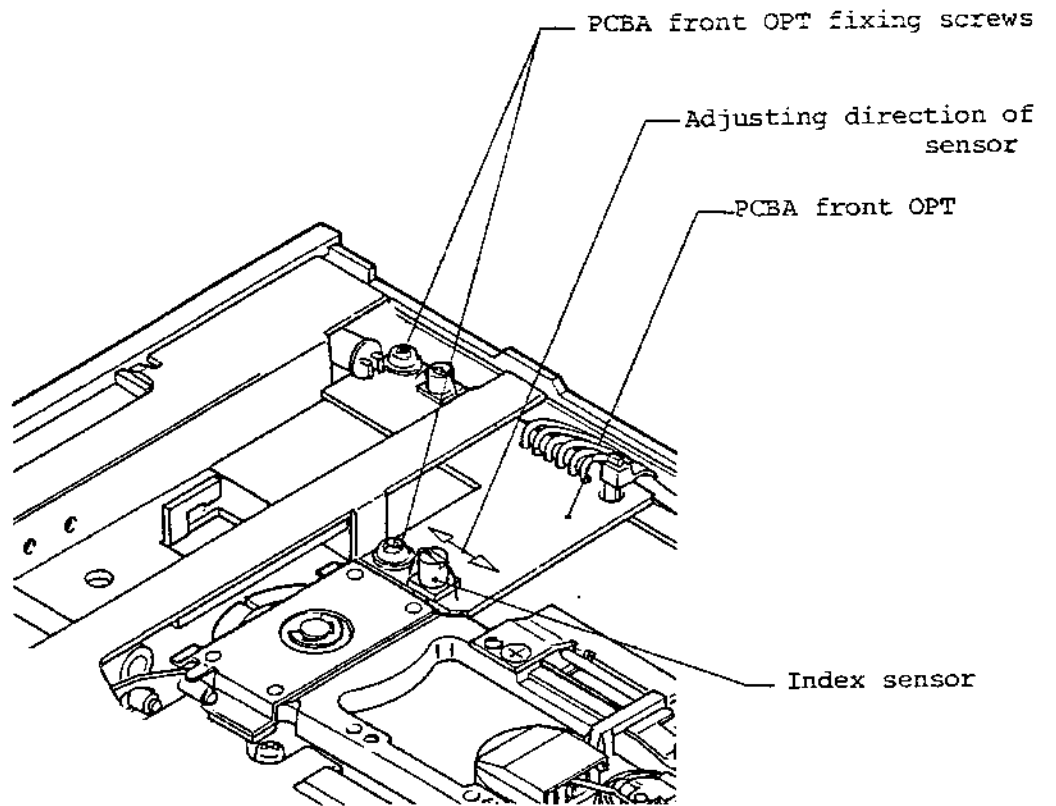

(Fig.436) Adjustment of index sensor

(2) SKA method

- (a) Connect the SKA referring to item 4-2-4 and set the FD PWR switch to the PSA side.
- (b) Start the spindle motor by key "5". (MON indicator turns on).
- (c) Install an alignment disk.
- (d) Execute drive select by key "0". (DSO indicator turns on).
- (e) Key in "C0" and confirm that the TRACK indicator becomes "00".
(RECALIBRATE)
- (f) Set the head to the index check track.
 - 48tpi: Key in "C2 01" and confirm that the TRACK indication becomes "01".
 - 96tpi: Key in "C2 02" and confirm that the TRACK indication becomes "02".
- (g) Key in "E6". (INDEX TIMING)
The calibration value of the index timing should be set previously in the SKA.
- (h) Confirm that the DATA indicator (μ s) indicates the value within the following range.
 - FD-55A ~ F: 200 \pm 200 μ sec
 - FD-55G : 165 \pm 165 μ sec
- (i) Key in "F". (STOP)
- (j) If the value in item (h) is out of the specified range, adjust the index sensor Ass'y position according to the following procedure.

- i) Loosen the fixing screws (see Fig.436) of the PCBA front OPT and its position so that the DATA indication under execution shows the median value in the specified range of item (h).
 - ii) Repeat the adjustment so that the DATA indication takes the median value when the fixing screw has been tightened with the specified torque.
 - iii) Depress "F" key. (STOP).
 - iv) Apply a drop of locking paint on the fixing screw head.
- (k) Remove the alignment disk.

4-5. MAINTENANCE PARTS REPLACEMENT

4-5-1. Replacement of Head Carriage Ass'y

(A) Tools

- (1) Cross point screwdriver, M3
- (2) Common screwdriver, small size
- (3) A pair of tweezers
- (4) Alcohol and gauze
- (5) Locking paint
- (6) SKA or user's system
- (7) Required equipment for each referring item

(B) Replacement procedure

- (1) Disconnect the head connector (J9) and remove the head cable from the cable clamper B (Fig.506, No.15).
- (2) Remove the plate (Fig.506, No.12) and shift lever (Fig.506, No.14) on the set arm by removing their fixing screws (Fig.506, S11, S3).
- (3) Remove the set arm (Fig.506, No.7) by removing the two fixing screws (Fig.506, S6).
- (4) Remove two screws (Fig.506, S3) fixing the head carriage Ass'y (Fig.506, No.24: the figure shows a double sided FDD) and the steel belt (Fig.506, No.28), and remove the steel belt and the belt spring (Fig.506, No.29) from the carriage.
- (5) Remove three screws (Fig.506, S3, S4) to remove the spring guides A and B (Fig.506, Nos. 25, 26) which fix two guide shafts (Fig.506, No.24).
- (6) Remove the head carriage Ass'y with the guide shafts. (See Fig.437).

- (7) Install a new head carriage Ass'y and two guide shafts in the reverse order of items (1) through (6).

Notes: 1. When replacing the head carriage Ass'y, replace the guide shafts at the same time because of matching the hole diameter of the carriage with that of the guide shaft. Guide shafts are to be designated in combination with the head carriage Ass'y. (Refer to item 4-1-3, (3)).

Guide shaft which goes through the hole of the head carriage smoothly with a little clearance is considered to be the best.

2. If there is dust or dirt on the surface of the steel belt, belt spring, capstan, etc. clean them carefully with alcohol and gauze.

- (8) After finishing the installation of head carriage Ass'y, loosen the screw (Fig.506, S1) which fixes the steel belt to the capstan of the stepping motor via the plate washer (Fig.506, No.30).
- (9) After moving the head carriage several times manually, tighten the fixing screw of the steel belt in item (8) carefully with the specified torque. At this time, be careful that the belt is tensioned straightly. Pay attention not to damage the surface of the belt or the capstan.
- (10) Loosen the fixing screw (Fig.506, S8) of the track 00 stopper (Fig.506, No.4) to shift the stopper toward the rear side of the FDD.
- (11) Adjust the set arm position according to item 4-4-1.
- (12) Check and adjust the clamp arm position according to item 4-4-2.
- (13) Check and adjust the front lever position according to item 4-4-3.
- (14) Check and adjust the arm lifter according to item 4-4-4. (Only for models with the head load solenoid).

- (15) Check and adjust the CSS Ass'y according to item 4-4-5. (Only for the double sided CSS models).
- (16) Execute head cable treatment according to item 4-2-3.
- (17) Make the head seek continuously between the track 00 and the innermost track and confirm that the steel belt does not meander nor undulate. When the SKA is used, key in "C6" for this check and key in "F" for stop.
If there is some abnormal running of the steel belt, readjust the belt with two screws in item (4) and one screw in item (8). After the adjustment tighten the screws carefully with the specified torque.
- (18) Check and adjust the head touch according to item 4-4-9.
- (19) Check and adjust the asymmetry according to item 4-4-10. (Adjustment is applied only for the models equipped with variable resistor, R5 on the PCBA MFD control).
- (20) Adjust the track alignment according to item 4-4-13.
- (21) Adjust the track 00 sensor position according to item 4-4-14.
- (22) Adjust the track 00 stopper position according to item 4-4-15.
- (23) Check and adjust the index burst timing according to item 4-4-16.
- (24) Check for the read level according to item 4-4-11.
- (25) Check for the resolution according to item 4-4-12.
- (26) It is recommended to connect the FDD to the system for overall test. (Refer to item 4-2-5, (1)).

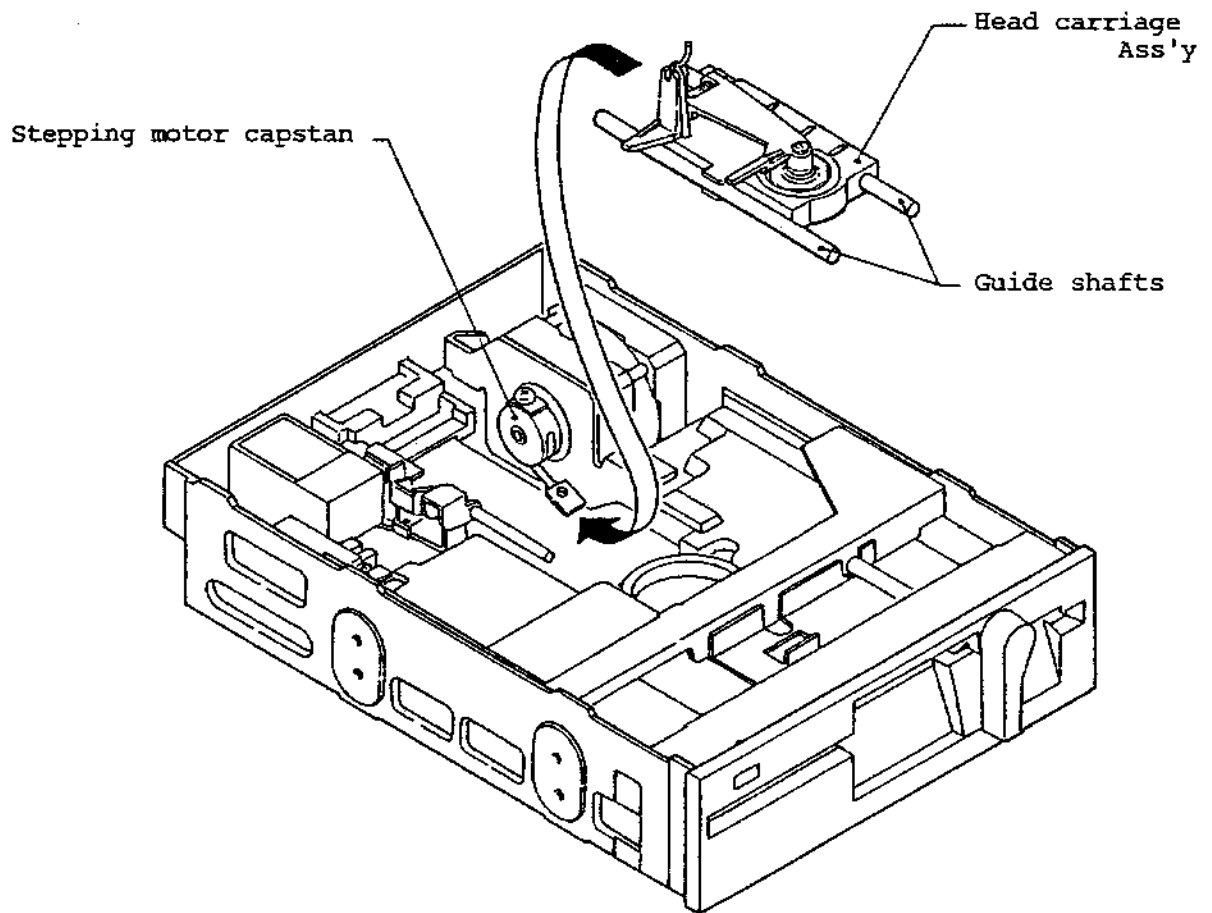

(Fig.437) Replacement of head carriage Ass'y

4-5-2. Replacement of Stepping Motor Ass'y

(A) Tools

- (1) Cross point screwdriver, M3
- (2) A pair of tweezers
- (3) Alcohol and gauze
- (4) Locking paint
- (5) SKA or user's system
- (6) Required equipment for each referring item

(B) Replacement procedure

- (1) Disconnect the stepping motor connector (J6).
- (2) Remove the cable holder (Fig.506, No.32) to make the stepping motor cable be free.
- (3) Remove two screws (Fig.506, S3) fixing the head carriage Ass'y (Fig.506, No.24) and the steel belt (Fig.506, No.28), and remove the steel belt and the belt spring (Fig.506, No.29) from the carriage.
- (4) Remove the two fixing screws (Fig.506, S7) of the stepping motor Ass'y (Fig.506, No.27) and remove the stepping motor with the steel belt.
- (5) Remove screw (Fig.506, S1) on the capstan of the stepping motor and remove the steel belt and the plate washer (Fig.506, No.30).
- (6) Fix a new steel belt temporarily to the capstan of a new stepping motor with the plate washer and the screw in item (5) as they were.

Notes: 1. Fundamentally, the steel belt and the belt spring should be replaced with the stepping motor. However, if there is no inferior points for these belt and spring, they may be used

after cleaning the surface carefully with alcohol and gauze.

2. Never remove the plate of the stepping motor Ass'y since they are combined each other.

- (7) Install the stepping motor in item (6) according to the reverse order of items (1) through (4).
- (8) Loosen the screw which fixes the belt to the capstan.
- (9) After moving the head carriage several times manually, tighten the fixing screw of the steel belt in item (8) carefully with the specified torque. At this time, be carefull so that the belt is tensioned straightly. Pay attention not to damage the surface of the belt or the capstan.
- (10) Loosen the fixing screw (Fig.506, S8) of the track 00 stopper (Fig.506, No.4) to shift the stopper toward the rear side of the FDD.
- (11) Make the head seek continuously between the track 00 and the innermost track and confirm that the steel belt does not meander nor undulate. When the SKA is used, key in "C6" for this check and key in "F" for stop. If there is some abnormal running of the steel belt, readjust the belt with two screws in item (4) and one screw in item (8). After the adjustment tighten the screws carefully with the specified torque.
- (12) If the steel belt is replaced, execute the continuous seek in item (11) for five minutes, approx.
- (13) Adjust the track alignment according to item 4-4-13.
- (14) Adjust the track 00 sensor position according to item 4-4-14.
- (15) Adjust the track 00 stopper position according to item 4-4-15.

4-5-3. Replacement of DD motor Ass'y (Spindle Motor)

(A) Tools

- (1) Cross point screwdriver, M3
- (2) Common screwdriver, small size
- (3) A pair of tweezers
- (4) Locking paint
- (5) SKA or user's system
- (6) Required equipment for each referring item

(B) Replacement procedure

- (1) Disconnect the spindle motor connector (J7).
- (2) Remove three screws (Fig.506, S2, S10) fixing the PCBA DD motor servo.
- (3) Remove three screws (Fig.506, S5) of spindle side fixing the DD motor Ass'y and draw out the DD motor Ass'y from the rotor side (PCBA side).
- (4) Remove the spacer (Fig.506, No.6) from the PCBA DD motor servo.
- (5) Install a new DD motor Ass'y in the reverse order.

- Notes:
1. Be sure to attach the spacer (Fig.506, No.6) to the correct position. Spacer is made of insulation material and if it is not inserted, the electric circuit will be damaged.
 2. The spindle area of the DD motor (clamping cup of the disk) is precisely machined. For installing the motor to the frame, place the spindle in parallel to the frame and push into the frame slowly. Handle the spindle very carefully not to damage the spindle surface.
 3. The installation screw (Fig.506, S10) of the spacer is made of plastic. Metallic screw will damage the electric circuit.

Do not tighten the plastic screw with larger torque than in specified in item 4-2-i.

- (6) Arrange the DD motor cable be in space between the PCBA MFD control and the frame.
- (7) Adjust the set arm position according to item 4-4-1.
- (8) Check and adjust the clamp arm position according to item 4-4-2.
- (9) Check for the file protect sensor according to item 4-4-6.
- (10) Adjust the disk rotational speed according to item 4-4-7.
- (11) Check and adjust the track alignment according to item 4-4-13.
- (12) Check and adjust the index burst timing according to item 4-4-16.

4-5-4. Replacement of Collet Ass'y

(A) Equipment

- (1) Cross point screwdriver, M3
- (2) A pair of tweezers
- (3) Round nose pliers
- (4) Locking paint
- (5) Required equipment for each referring item

(B) Replacement procedure

- (1) Remove the plate (Fig.506, No.12) and the shift lever (Fig.506, No.14) on the set arm by removing their fixing screws (Fig.506, S11, S3).
- (2) Remove the set arm (Fig.506, No.7) by removing the two fixing screws (Fig.506, S6).
- (3) Remove the E-ring (Fig.506, S15) which fixes the collet Ass'y (Fig.506, No.10) to the set arm and remove the collet and the spring (Fig.506, No.11).
- (4) Install a new collet Ass'y in the reverse order. Pay attention to the orientation of the spring. The spring is conical. The smaller diameter side faces the collet side and the larger diameter side faces the set arm side.
- (5) Adjust the set arm position according to item 4-4-1.
- (6) Check and adjust the clamp arm position according to item 4-4-2.
- (7) Check and adjust the track alignment according to item 4-4-13.

4-5-5. Replacement of Head Load Solenoid

This item applies only for the FDD with the head load solenoid.

(A) Tools

- (1) Cross point screwdriver, M3
- (2) Hexagon wrench key, 1.5mm
- (3) A pair of tweezers
- (4) Locking paint
- (5) Required equipment to each referring item

(B) Replacement procedure

- (1) Disconnect the head load solenoid and the track 00 connector (J4).
- (2) Pull out two solenoid pins (terminal Nos. 1 and 2) from the connector housing referring to item 4-2-2, (4).
- (3) Remove two fixing screws (Fig.506, S3) to remove the head load solenoid Ass'y (Fig.506, No.23).
- (4) Install a new head load solenoid Ass'y in the reverse order.

Note: Arrange the wiring connection of the head load solenoid so that the white lead wire is connected to pin 1 and the red wire to pin 2.
(See Fig.439).

- (5) Position the head load solenoid Ass'y so that the rod of $\phi 2\text{mm}$ be in parallel with the set arm. (See Fig.438).
And for a double sided FDD, the space between the head protector Ass'y and the arm lifter shall be more than 0.2mm.
Then tighten the screws with the specified torque.

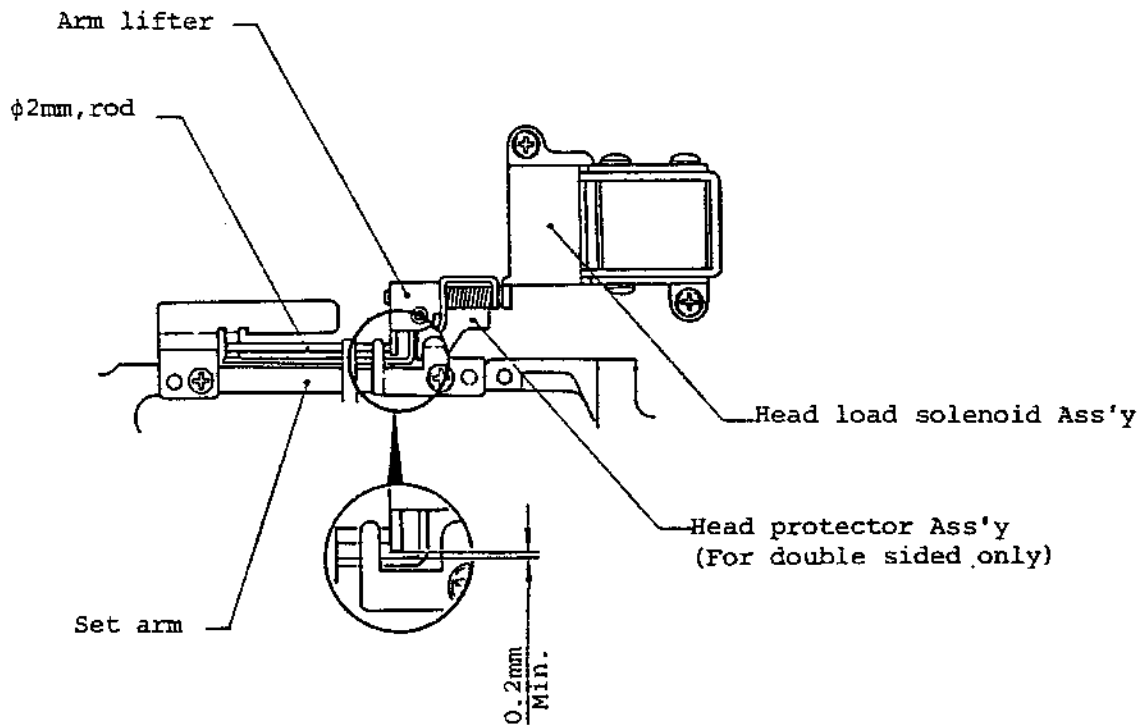

(Fig.438) Installation of the head load solenoid Ass'y

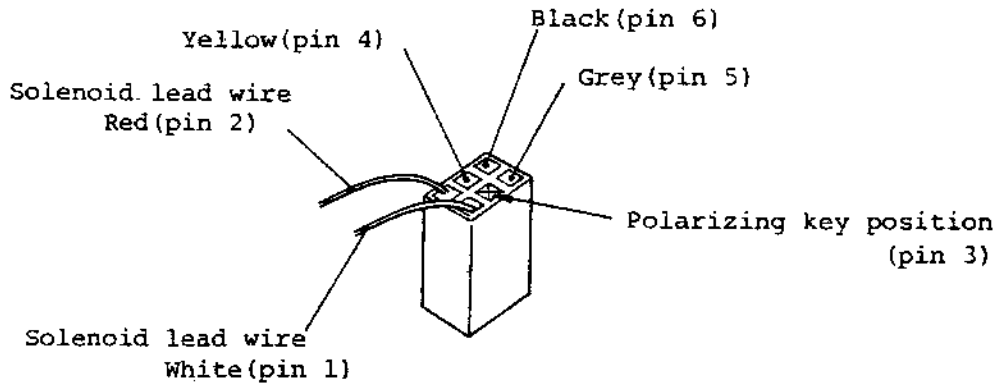

(Fig.439) Color identification of connector J4 wiring

(6) Check and adjust the arm lifter according to item 4-4-4.

4-5-6. Replacement of Track 00 Sensor Ass'y

(A) Tools

- (1) Cross point screwdriver, M3
- (2) A pair of tweezers
- (3) Locking paint
- (4) SKA or user's system
- (5) Required equipment for each referring item

(B) Replacement procedure

- (1) Disconnect the head load solenoid and the Track 00 connector (J4).
- (2) Pull out two solenoid pins (terminal Nos. 1 and 2) from the connector housing referring to item 4-2-2, (4).
- (3) Remove the fixing screw (Fig.506, S8) to remove the T00 sensor Ass'y (Fig.506, No.22).
- (4) Install a new T00 sensor Ass'y in the reverse order.

Note: Arrange the wiring connection of the head load solenoid so that the white lead wire is connected to pin 1 and red wire to pin 2. (See Fig.439).

- (5) Loosen the fixing screw (Fig.506, S8) of the track 00 stopper (Fig.506, No.4) to shift the stopper forward the rear side of the FDD.
- (6) Adjust the track 00 sensor position according to item 4-4-13.
- (7) Adjust the track 00 stopper position according to item 4-4-14.

4-5-7. Replacement of PCBA MFD Control

(A) Tools

- (1) Cross point screwdriver, M3
- (2) Common screwdriver, small size
- (3) SKA or user's system
- (4) Required equipment for each referring item

(B) Replacement procedure

- (1) Disconnect all of the connectors connected to the PCBA MFD control (Fig.506, No.34) referring to item 4-2-4.
- (2) Remove the PCBA by removing the three fixing screws (Fig.506, S2).
- (3) Install a new PCBA MFD control in the reverse order.
- (4) Set the straps and terminator as they were on the old PCBA.
- (5) Check for the file protect sensor according to item 4-4-6.
- (6) Check for the erase gate delay according to item 4-4-8.
- (7) Check and adjust the asymmetry according to item 4-4-10.
- (8) Check for the read level according to item 4-4-11.
- (9) Check for the resolution according to item 4-4-12.
- (10) Check for the track 00 sensor according to item 4-4-14.
- (11) Check for the index burst timing according to item 4-4-16.

(12) It is recommended to connect the FDD to the system for overall test.
(Refer to item 4-2-5, (1)).

4-5-8. Replacement of PCBA Front OPT

(A) Tools

- (1) Cross point screwdriver, M3
- (2) SKA or user's system
- (3) Required equipment for each referring item

(B) Replacement procedure

- (1) Disconnect PCBA front OPT connector (J5).
- (2) Remove the two fixing screws (Fig.506, S20) to remove the PCBA.
- (3) Install a new PCBA front OPT in the reverse order.
- (4) Check for the file protect sensor according to item 4-4-6.
- (5) Adjust the index burst timing according to item 4-4-16.
- (6) Check for the performance of the front bezel indicator.

4-5-9. Replacement of Head Pad (Single sided only)

This item applies only to the single sided FDD.

(A) Tools

- (1) A pair of tweezers
- (2) Required equipment for each referring item

(B) Replacement procedure

- (1) Lift up the pad arm manually and peel the pad carefully with a pair of tweezers. (See Fig.440).
- (2) Apply a new pad to the initial position. Be careful not to press the pad surface strongly.
- (3) Clean the magnetic head surface according to item 4-3-2.
- (4) Adjust the head pad position according to item 4-4-9.
- (5) Check for the read level according to item 4-4-11.
- (6) Check for the resolution according to item 4-4-12.

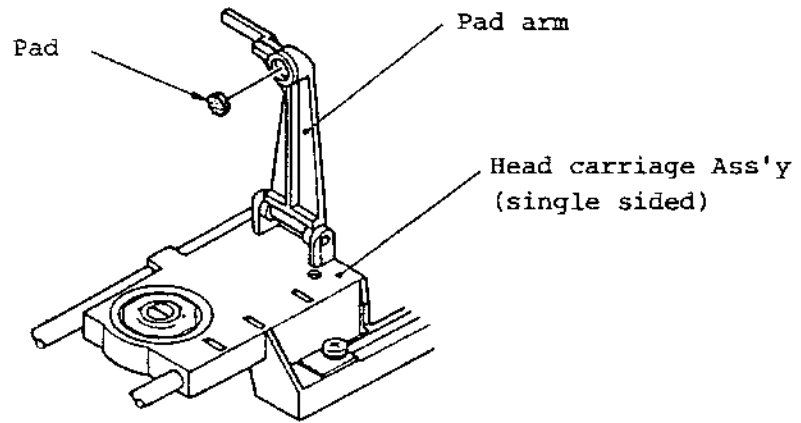

(Fig.440) Replacement of head pad

4-5-10. Replacement of Front Bezel Ass'y

(A) Tools

- (1) Cross point screwdriver, M3
- (2) Hexagon wrench key, 1.5mm
- (3) Required equipment for each referring item

(B) Replacement procedure

- (1) Turn the front lever to close position and remove a fixing set screw (Fig.506, S13).
- (2) Turn the front lever to open position and remove another fixing set screw. Then draw out the front lever Ass'y (Fig.506, No.37).
- (3) Remove the fixing screws (Fig.506, S7) of the front bezel Ass'y (Fig.506, No.36) and draw the front bezel out.
- (4) Install a new front bezel Ass'y in the reverse order. For the installation of the front bezel, press the longitudinal sides of the bezel against the frame and tighten the fixing screws with the specified torque.
- (5) Adjust the front lever position according to item 4-4-3.

4-5-11. Replacement of Front Lever Ass'y

(A) Tools

- (1) Hexagon wrench key, 1.5mm
- (2) Required equipment for each referring item

(B) Replacement procedure

- (1) Turn the front lever to close position and remove a fixing set screw (Fig.506, S13).
- (2) Turn the front lever to open position and remove another fixing set screw to draw out the front lever Ass'y (Fig.506, No.37).
- (3) Install a new front lever Ass'y in the reverse order.
- (4) Adjust the front lever position according to item 4-4-3.

4-5-12. Replacement of CSS Ass'y

This item applies only to the double sided CSS model (without head load solenoid).

(A) Tools

- (1) Cross point screwdriver, M3
- (2) Required equipment for each referring item

(B) Replacement procedure

- (1) Remove the fixing screw (Fig.506,S3) to remove the shift lever (Fig.506, No.14) from the set arm.
- (2) Remove the fixing screw (Fig.506,S3) to remove the CSS Ass'y (Fig.506, No.39) from the frame.
- (3) Install a new CSS Ass'y in the reverse order. Be careful to install the arm lifter area ($\phi 2\text{mm}$ rod) and the shift lever be in parallel to the set arm. The CSS Ass'y should be fixed with no contact to the set arm. (See Fig.441).
- (4) Check for the CSS Ass'y according to item 4-4-5.

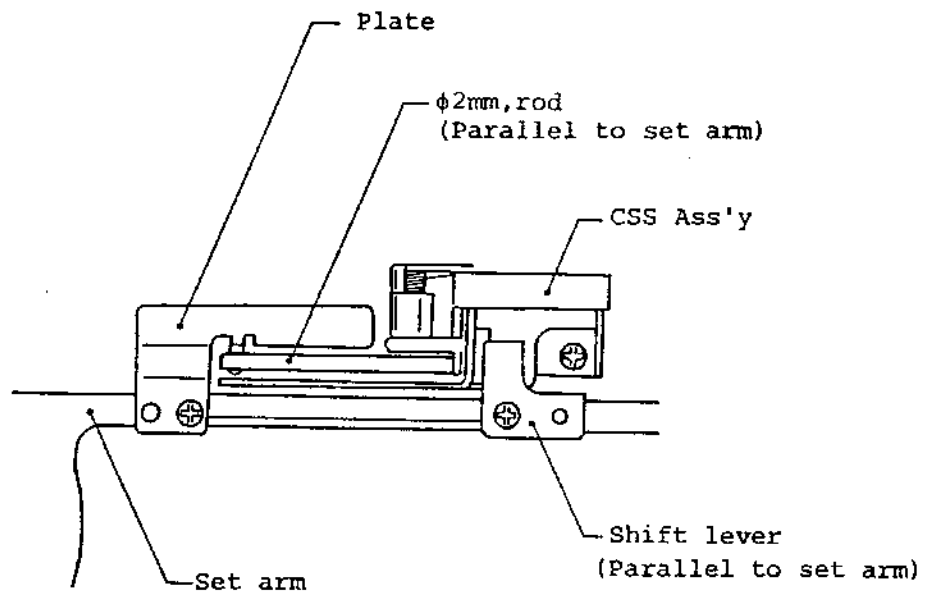

(Fig.441) CSS Ass'y and shift lever position

SECTION 5

DRAWINGS & PARTS LIST

5-1. CONFIGURATION

Following shows the configuration of the main parts of FD-55 (L). (Refer to Fig.501 ~ Fig.505). Refer to items 5-2 and 5-3 as to detailed break-downs.

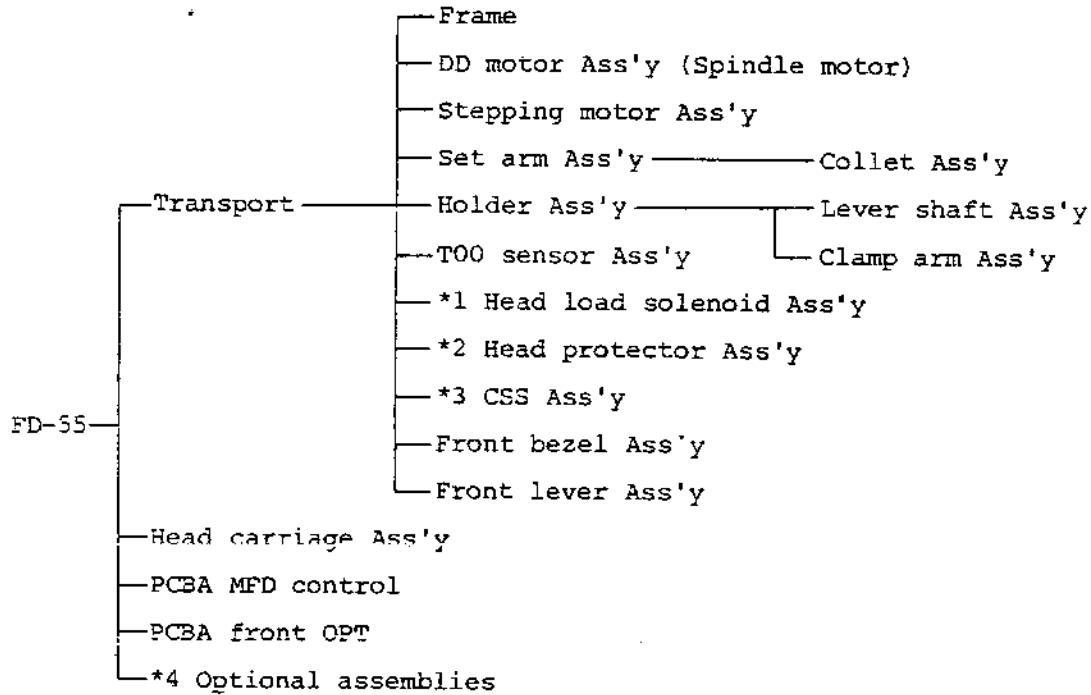

- Notes: *1: Applied only for models with head load solenoid (single and double sided).
 *2: Applied only for double sided models with the head load solenoid.
 *3: Applied only for double sided CSS models.
 *4: Refer to separate materials (SECTION 6).

(Table 501) Main parts configuration of FD-55(L)

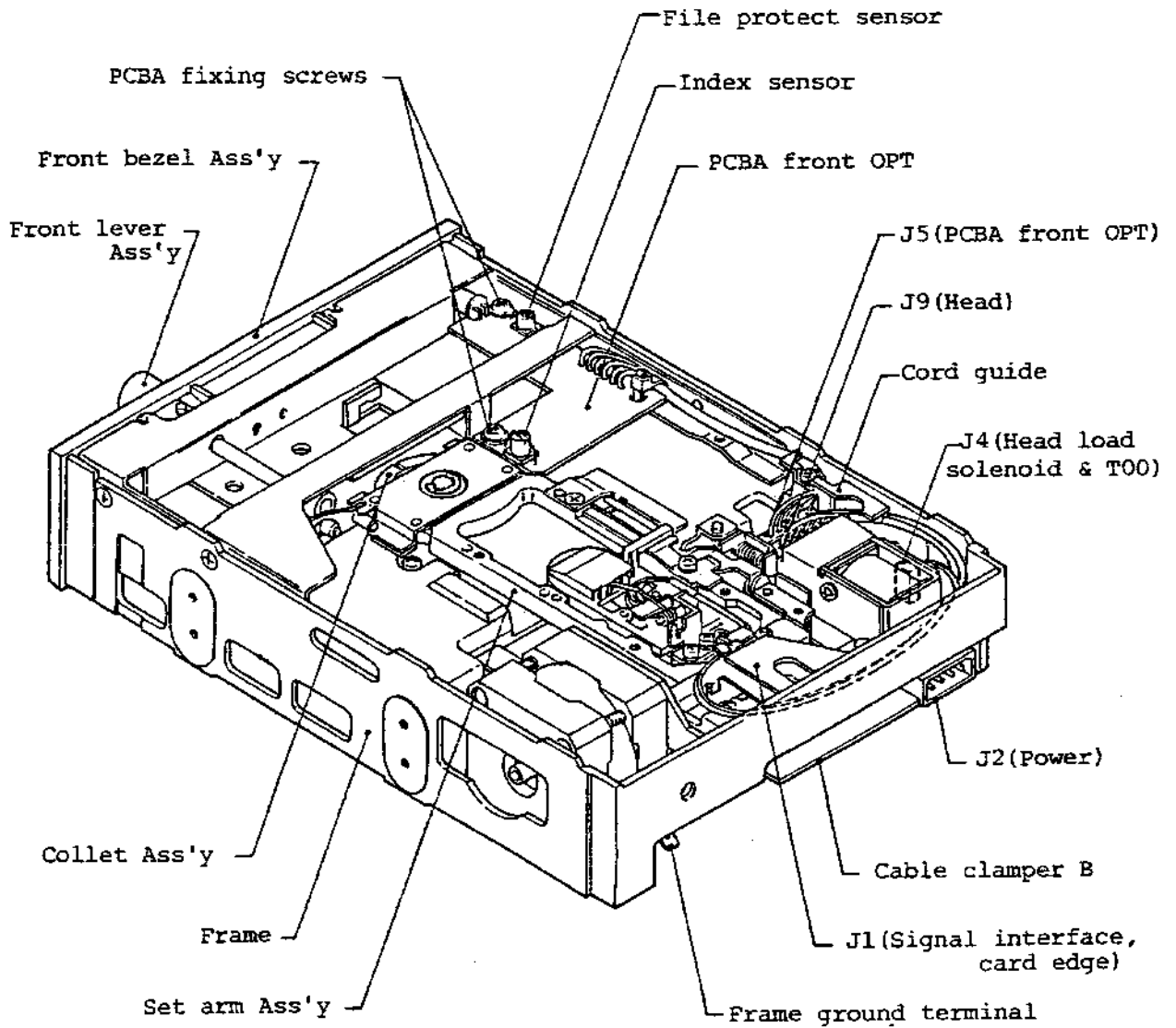

(Fig.501) External view (No.1)

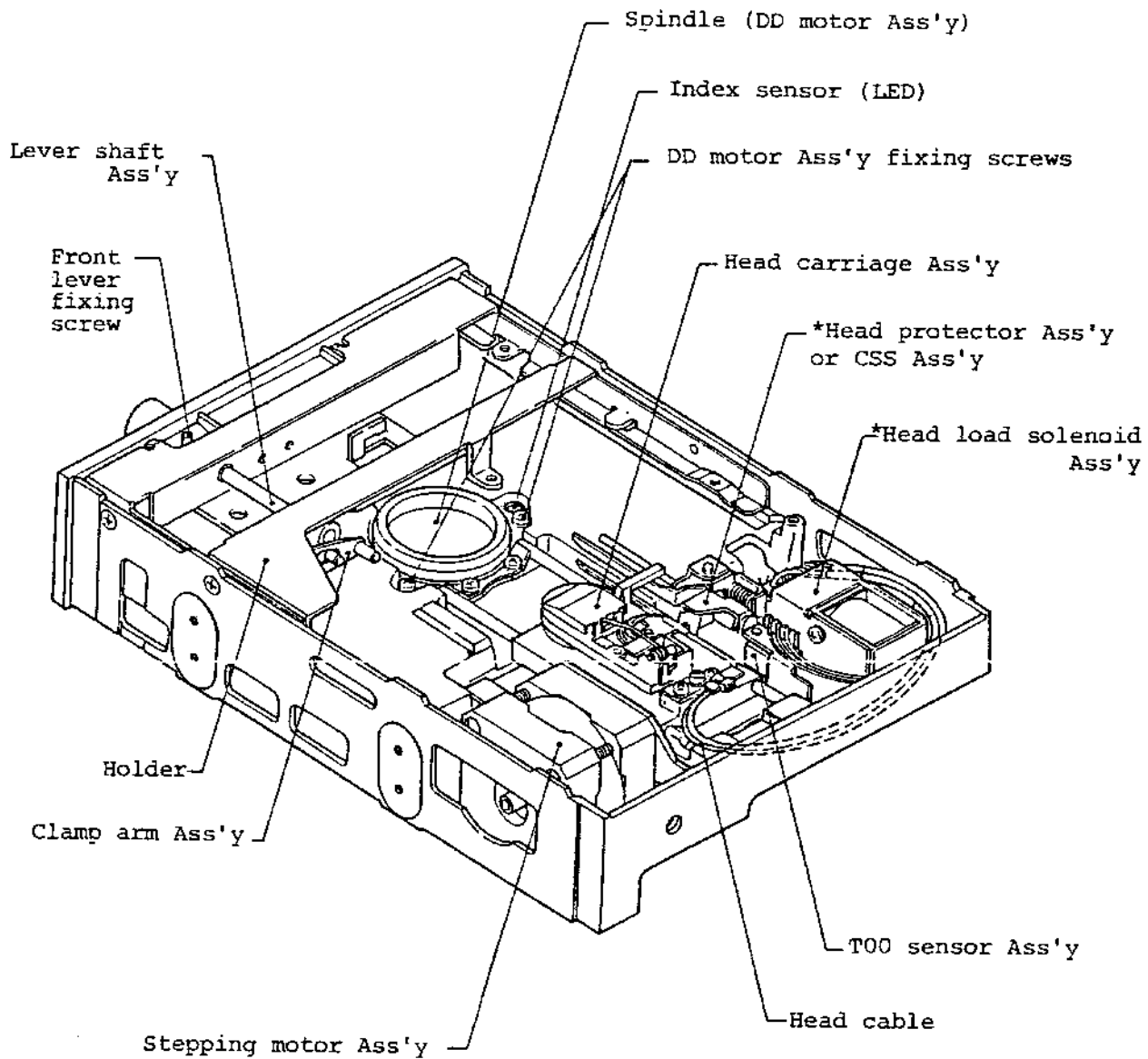

Note: Refer to Table 501 as to the assemblies with asterisks.

(Table 502) External view (No.2)

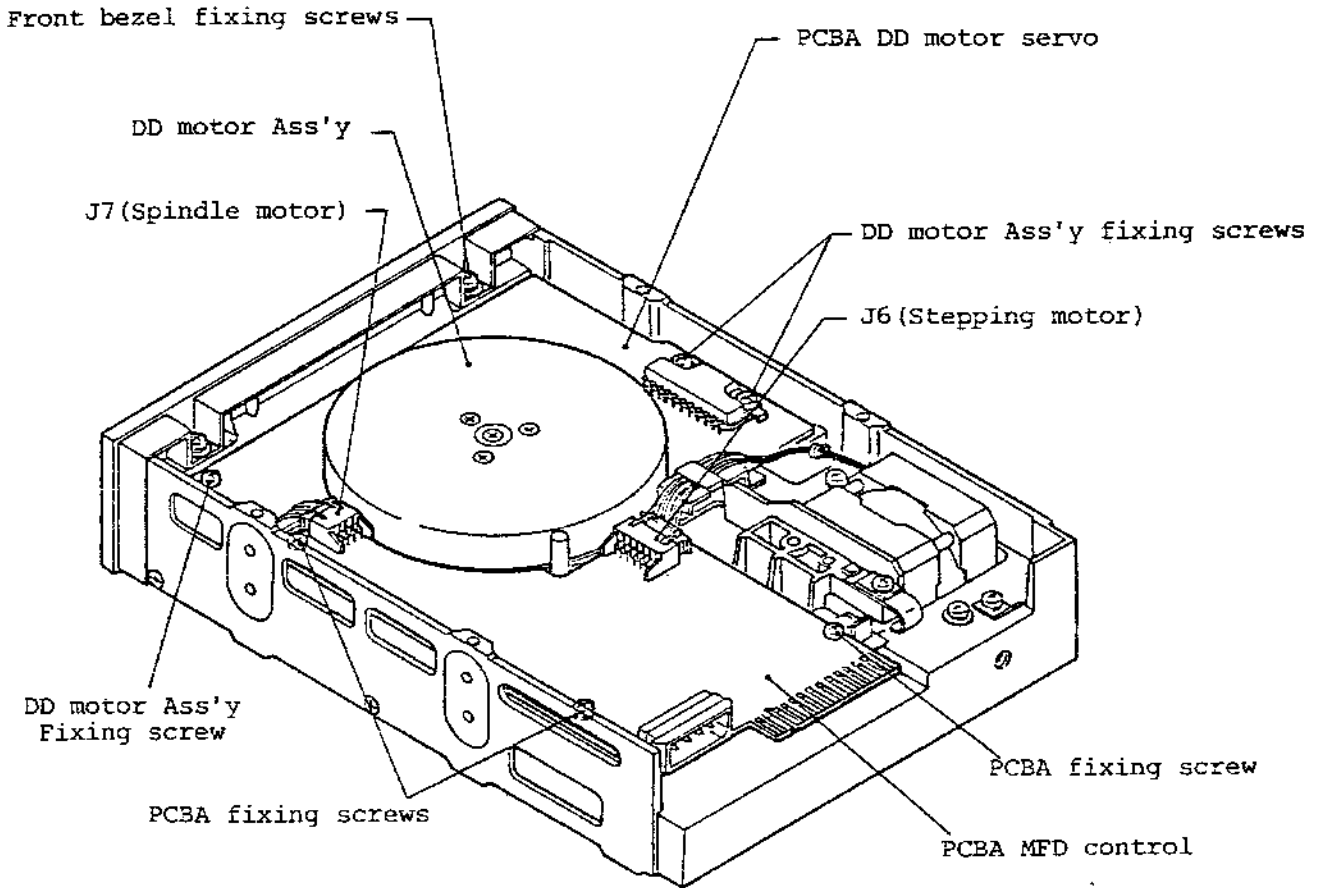

(Fig.503) External view (No.3)

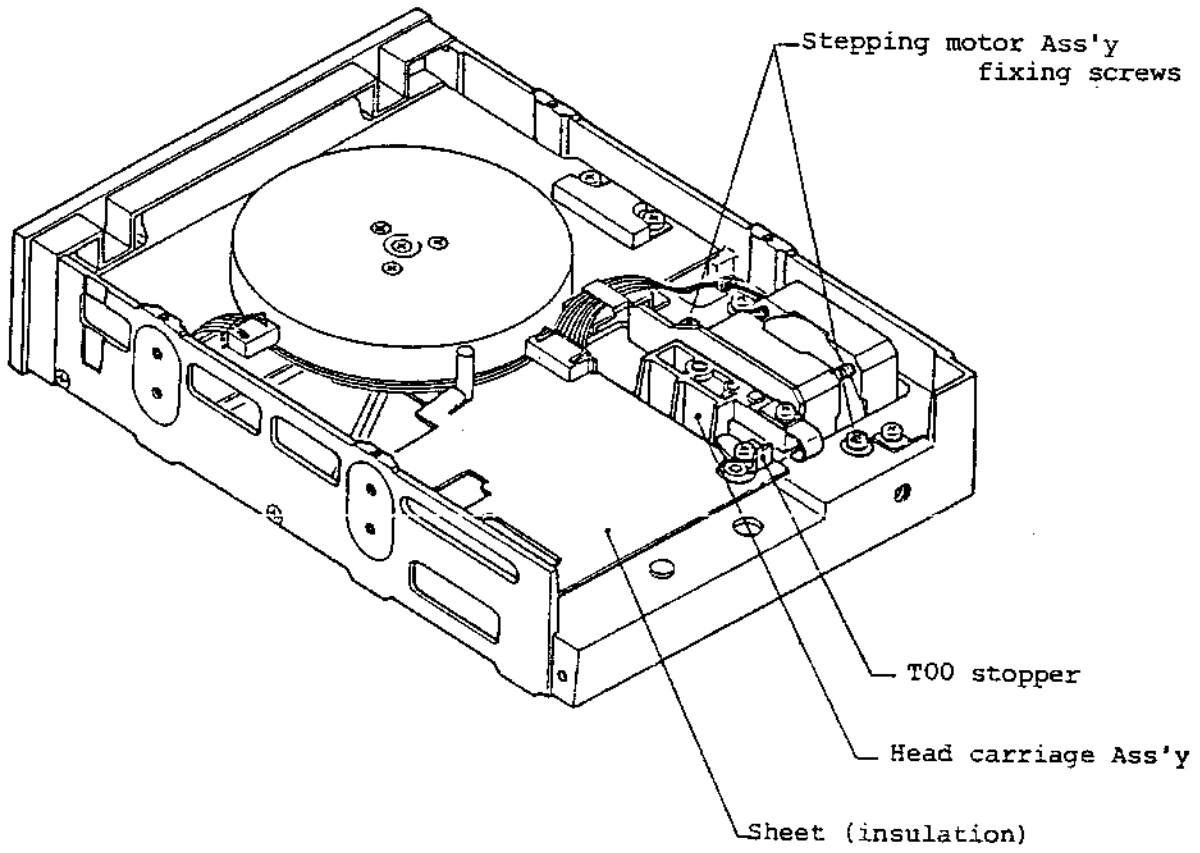

(Fig.504) External view (No.4)

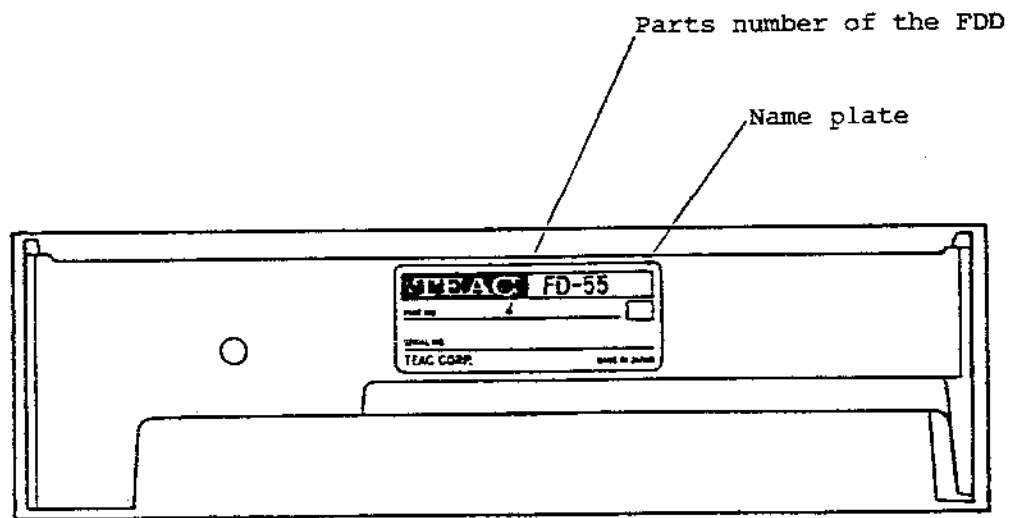

(Fig.505) External view (No.5)

5-2. MECHANICAL BREAK-DOWN AND PARTS LIST

5-2-1. FDD (Refer to Fig.506)

Nos.	Parts Nos.	Parts name	Q'ty	Description
1	16152803-00	Frame Ass'y	1	
2	16802602-00	Cord guide	1	
3	16787121-00	Sheet	1	
4	16802437-00	Stopper, T00	1	
5	14733730-00	DD motor Ass'y	*1	FD-55(L) A ~ F, Note 3
	14733730-10	DD motor Ass'y		FD-55(L) A,B
	14733730-50	DD motor Ass'y		FD-55(L) G
6	16786981-00	Spacer, IC	1	
7	17966790-01	Set arm sub Ass'y	*1	FD-55(L) A,E
	17966790-01	Set arm sub Ass'y		FD-55(L) B,F,G
8	16786984-00	Felt pad	1	
9A	16786984-00	Felt pad	1	
9B	16787076-02	Disk pad 2.5t	1	Note 4, FD-55(L) A,E
10	17966793-00	Collet Ass'y	1	
11	16385123-00	Spring, pressure	1	
12	16802440-00	Plate	1	
13	16786997-00	Pad, disk	1	
14	16802550-00	Shift lever	*1	Note 6
	16802592-00	Shift lever		FD-55(L) B,F,G:CSS
15	16802651-00	Cable clamper B	1	
16	17966806-00	Head protector Ass'y	1	Note 5
17	16792288-00	Holder	1	
18	16786990-00	Cushion, holder	1	
19	17966801-00	Lever shaft Ass'y	1	Note 7
20	17966802-00	Clamp arm Ass'y	1	
21	16389017-00	Spring, lever	1	
22	17966805-00	T00 sensor Ass'y	1	
23	17966859-01	Head load solenoid Ass'y	1	Note 8

(Table 502) Parts list of the FDD (1/2)

Nos.	Parts Nos.	Parts name	Q'ty	Description
24	17966940-00	Head carriage Ass'y	*1	FD-55(L) A, Note 9
	17966941-00	Head carriage Ass'y		FD-55(L) B, Note 9
	17966942-00	Head carriage Ass'y		FD-55(L) E, Note 9
	17966944-00	Head carriage Ass'y		FD-55(L) F, Note 9
	17966943-00	Head carriage Ass'y		FD-55(L) G, Note 9
25	16392009-00	Spring guide A	1	
26	16392010-00	Spring guide B	1	
27	14769070-00	Stepping motor Ass'y	*1	FD-55(L) A ~ G, Note 3
	14769070-50	Stepping motor Ass'y		FD-55(L) A, B
28	16792265-00	Steel belt A	1	
29	16392008-00	Spring, belt	1	
30	16496492-00	Washer, plate	1	
31	16802434-00	Cable guide	1	
32	16766580-00	Cable holder	1	
33	13189135	Terminal (Faston)	1	
34	15532001-XX	PCBA MFD control #B	1	Note 10
35	15531990-XX	PCBA front OPT	1	Note 10
36	17966807-50	Front bezel Ass'y	1	Note 11
37	17966808-50	Front lever Ass'y	1	Note 11
38	16389024-00	Arm spring	1	FD-55(L) B, F, G
39	17966900-00	CSS Ass'y	1	Note 8

(Table S02) Parts list of the FDD (2/2)

- Notes:
1. As to the parts with an asterisk in the Q'ty column, select appropriate one for the model.
 2. As to the parts with model name of FD-55(L) in the Description column, the parts is used only for the model.
 3. For the DD motor Ass'y of FD-55(L) A or B, either of 14733730-00 and -10 may be used. (Mainly -10 is used at shipment).
For the stepping motor Ass'y of FD-55(L) A or B, either of 14769070-00 and -50 may be used. (Mainly -50 is used at shipment).
 4. Pad 9B is attached for the adjustment of head touch (refer to item 4-4-9) and some models might not have it. Usually, double sided FDDs have not 9B pad.
 5. The head protector Ass'y applies only to the double sided models with head load solenoid.
 6. The shift lever (P/N 16802550-00) is used in all the models except for CSS models. P/N 16802592-00 is used only in the double sided CSS models.
 7. The parts number of the lever shaft Ass'y listed in the table is the standard length. Optional lever shaft Ass'y which length is different should be designated with other parts number.
 8. The head load solenoid Ass'y applies only to the models with head load solenoid. The CSS Ass'y applies only to the double sided models without head load solenoid. The head load solenoid Ass'y and the CSS Ass'y will never be used together in a model.
 9. The head carriage Ass'y is supplied in combination with two guide shafts. Be sure to replace the head carriage Ass'y with these guide shafts.
 10. The parts number versions of the PCBA MFD control #B and the PCBA front OPT vary depending on each model. Refer to the name plate of the actual PCBA mounted to designate the version.
 11. The parts numbers of the front bezel Ass'y and the front lever Ass'y are those of FD-55(L) standard color, black. For designating the other color, refer to the following table. Optional designation of colors than in the table or other forms, different parts numbers should be used.

Color	Front bezel Ass'y	Front lever Ass'y
Beige	17966807-52	17966808-52
Gray G4	17966807-53	17966808-53
Gray G12	17966807-55	17966808-55

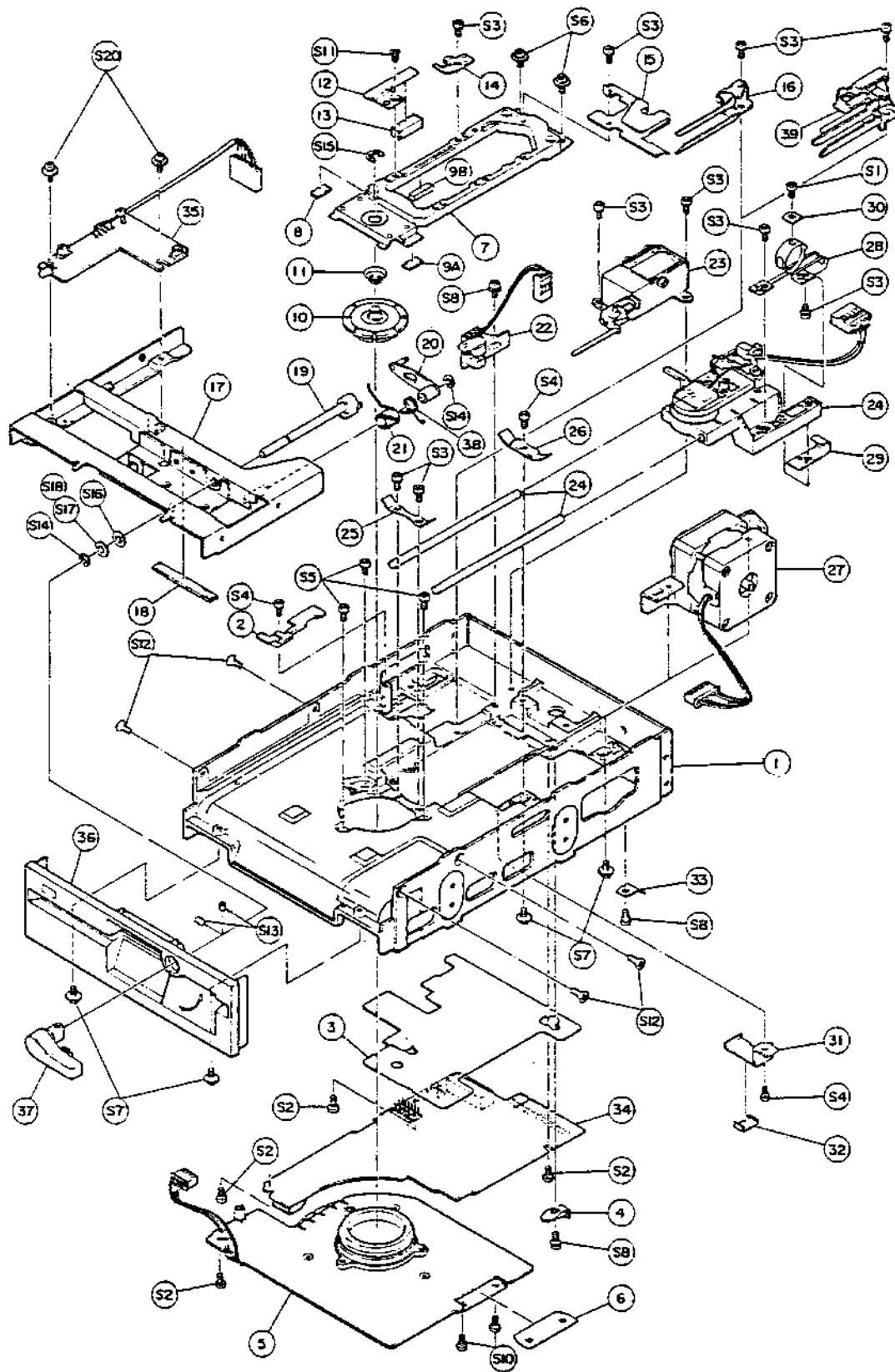

(Fig.506) Mechanical section break-down

5-2-2. Screw,Washer

Nos.	Parts Nos.	Parts name	Description
S1	16400304	Screw, pan, 3x4, S, ZMC	
S2	16400304	Screw, pan, 3x4, S, ZMC	
S3	16470305	Screw, pan, sems, 3x5, S, ZMC	
S4	16470306	Screw, pan, sems, 3x6, S, ZMC	
S5	16470308	Screw, pan, sems, 3x8, S, ZMC	
S6	16498579	Screw, pan, three pieces, 3x6, S, ZMC	
S7	16498580	Screw, pan, three pieces, 3x8, S, ZMC	
S8	16498712	Screw, pan, three pieces, 3x8	
S9	16400304	Screw, pan, 3x4, S, ZMC	
S10	16498296	Color screw, 3x6	Plastic screw
S11	16420005	Screw, flat, 2.6x5, S, ZMC	
S12	16420308	Screw, flat, 3x8, S, ZMC	
S13	16498260-00	Setscrew, 3x3	
S14	16351140	E-ring, 3J	
S15	16351160	E-ring, 4J	
S16	16496062-00	Mylar washer, 0.35Tx4.1x8	
S17	16496060-00	Mylar washer, 0.1Tx4.1x8	For adjustment
S18	16496061-00	Mylar washer, 0.2Tx4.1x8	For adjustment
S19	16496005	Flat washer, 5x12x0.8	
S20	16498711	Screw, triple, 3x4	
S21	16420305	Screw, pan, 3x5, S, ZMC	

(Fig.503) Parts list of screw & washer

5-3. PCBA PARTS LIST

Following shows all the parts mounted on the PCBAs of FD-55(L) series.

Notes for Tables 504 and 505:

1. Parts with an asterisk are different depending on the PCBA versions. Select either of them.
2. Parts with a double asterisks are not used in some PCBA versions.
3. Parts with a triple asterisks are different in quantity and location depending on the PCBA versions.
4. Refer to the schematic diagram of the PCBA as to the details of the parts with asterisks.
5. Name plate version is different depending on the PCBA version used.

5-3-1. PCBA MFD control #B (P/N 15532001-XX)

Parts Nos.	Parts name, rating	Location
13441922-00	LSI TEAC 1922-00	U6
13447358-00	LSI TEAC 7358-00] *U9
13447358-01	LSI TEAC 7358-01	
13441123	TTL IC 7438	U4,U7
13441235	TTL IC 74LS04	U3
13441510	TTL IC 74LS14	U1
13441515	TTL IC 74LS08	U2
13441245	TTL IC 74LS74A	U5,**U10
13428129	Transistor array, M54534P	U8
13423122 or 13421211	Transistor, 2SB 810 H/F-F or 2SA 881 Q,R	Q3,Q4
13424279 or 13424286	Transistor, 2SC 2785 F-F or 2SC 2021 R	Q1,Q2
1341378	Diode,pair MA154WA	CRA1,CRA3~CRA5,**CRA2 **CRA6
13411398	Diode,pair 1SS233-F,or MC921	CRA7,CRA8
13411243 or 13411407	Diode, 1S954 or 1SS92	CR1,CR3
13415184	Diode,zener,HZ7A2	CR2

(Table 504) PCBA MFD control parts list (1/6)

Parts Nos.	Parts name, rating	Location
13497297 13497296	Resistor network, 7-7 7-330Ω,J Resistor network, 7-1KΩ,J	*RA1
13497227-00 13497228-00 13497229-00 13497255-00 13497280 13497269 13497278 13497287	Resistor array,T-7227,7-12P,J Resistor array,T-7228,7-10P,G Resistor array,T-7229,7-10P,J Resistor array,T-7255,3-6P,J Resistor array,SA 7-47KΩ,J Resistor array,SA 6-4.7KΩ,J Resistor array,SA 5-47KΩ,J Resistor array,SC 4-2.2KΩ,J	RA8 RA9 RA7 RA5 RA2 RA3 RA4 RA6
11982479 11982497 11982508	Resistor,RN,1/4W,768Ω,F Resistor,RN,1/4W,1.24KΩ,F Resistor,RN,1/4W,1.69KΩ,F	*R17
11050121 11050151 11050241	Resistor,RN,1W,120Ω,J Resistor,RN,1W,150Ω,J Resistor,RN,1W,240Ω,J	*R20
11185104	Resistor,RD,1/4W,100KΩ,J	R10
11186331 11186471 11186100 11186473 11186102	Resistor,RD,1/5W,330Ω,J Resistor,RD,1/5W,470Ω,J Resistor,RD,1/5W,10Ω,J Resistor,RD,1/5W,47KΩ,J Resistor,RD,1/5W,1KΩ,J	*R13 **R14 ~ R16 **R18 ~ R19 **R11 ~ R12

(Table 504) PCBA MFD control parts list (2/6)

Parts Nos.	Parts name, rating	Location	
11186222	Resistor, RD, 1/5W, 2.2K Ω , J	*R21	
11186332	Resistor, RD, 1/5W, 3.3K Ω , J		
11186362	Resistor, RD, 1/5W, 3.6K Ω , J		
11186472	Resistor, RD, 1/5W, 4.7K Ω , J		
11186682	Resistor, RD, 1/5W, 6.8K Ω , J		
13256653	Trimmer, 1/2W, 20K Ω , M	**R5	
12903065	Capacitor, CE, 10V, 100 μ F, M	C2	
12903069	Capacitor, CE, 25V, 10 μ F, M	*C12 ~ C15	
12903220	Capacitor, CS, 16V, 33 μ F, K		
12903070	Capacitor, CE, 25V, 22 μ F, M	C3	
12903071	Capacitor, CE, 25V, 47 μ F, M	C33	
12902551	Capacitor, CS, 16V, 2.2 μ F, M	C17	*C6
12902553	Capacitor, CS, 16V, 4.7 μ F, M	**C35	*, **C7
12557334	Capacitor, CS, 35V, 0.33 μ F, M	C16	
12557474	Capacitor, CS, 35V, 0.47 μ F, M	C8	
12453152	Capacitor, CQ, 50V, 0.0015 μ F, G	*C20	
12453561	Capacitor, CQ, 50V, 560PF, G	*C28	
12453561	Capacitor, CQ, 50V, 560PF, G		
12453222	Capacitor, CQ, 50V, 0.0022 μ F, G		
12453332	Capacitor, CQ, 50V, 0.0033 μ F, G		

(Table 504) PCBA MFD control parts list (3/6)

Parts Nos.	Parts name, rating	Location
12454101	Capacitor, CQ, 100V, 100PF, G] *C23 C18] *C24
12902599	Capacitor, CC, 50V, CH, 27PF, G	
12902578	Capacitor, CC, 50V, CH, 22PF, J	
12901228	Capacitor, CC, 50V, CH, 8PF, J	
12902579	Capacitor, CC, 50V, CH, 24PF, J	
12902588	Capacitor, CC, 50V, CH, 56PF, J	
12900771	Capacitor, CC, 50V, SL, 180PF, J	C10, C11
12902983	Capacitor, CC, 50V, YA, 470PF, J] *C27] *C31] *, ** C29 ~ C30
12901417	Capacitor, CC, 50V, YB, 1000PF, K	
12901418	Capacitor, CC, 50V, YB, 1200PF, K	
12901421	Capacitor, CC, 50V, YB, 2200PF, K	
12901421	Capacitor, CC, 50V, YB, 2200PF, K	
12901417	Capacitor, CC, 50V, YB, 1000PF, K	
12902610	Capacitor, CC, 25V, YF, 0.022 μ F, Z	C4, C5, C9, C19, C21, C22, C32
12903080	Capacitor, CC, 25V, YU, 0.1 μ F, M	C25, C26
12902530	Capacitor, CC, 500V, YE, 0.01 μ F, Z	C1
14723570	Coil, chalk, 120 μ H, J] *L1] *L2 ~ L3 L4, L5
14723572	Coil, chalk, 330 μ H, J	
14723572	Coil, chalk, 330 μ H, J	
14723571	Coil, chalk, 150 μ H, J	
14723569	Coil, chalk, 39 μ H, K	

(Table 504) PCBA MFD control parts list (4/6)

Parts Nos.	Parts name, rating	Location
13295084-00	Ceramic oscillator, KBR-480B4	Y1
13299164	Socket, IC, 14P	J3 (for RA1)
13121109	Connector, 4P (172349-1)	J2
16322368	Connector, clamp, (172296-1)	For J2 installation
13121298	Connector, W6P, #80, polarizing	**J12
13121155	Connector, W6P, #75, polarizing	J4
13121234	Connector, S6P, #37, polarizing	*J9
13121235	Connector, W12P, #74, polarizing	*J5
13121296	Connector, S6P, #39, polarizing	
13121297	Connector, S8P, #39, polarizing	
13121191	Connector, 6P, (S6B-XH)	J6
13121189	Connector, 4P, (S4B-XH)	J7
13121299	Connector, 2P, (B3B-EH)	**J11
13121358	Connector, S2P	PM strap
13121359	Connector, S3P	**DC1 ~ 4 straps
13121361	Connector, S5P	TP7 ~ 10, G
13121363	Connector, S7P	TP1 ~ 6, G
13121332	Connector, W14P	HS ~ MX straps
13121333	Connector, W16P	UR ~ RE straps

(Table 504) PCBA MFD control parts list (5/6)

Parts Nos.	Parts name, rating	Location
13121149	Short bar	HS ~ MX, UR ~ RE, PM, DC1 ~ 4 straps
13000040	Plated wire, ϕ 0.5	***S1 ~ S18
16271169-XX	Name plate	Note 5

(Table 504) PCBA MFD control parts list (6/6)

5-3-2. PCBA Front OPT (P/N 15531990-XX)

Parts Nos.	Parts name, rating	Location
17966812-00	FPT sensor sub Ass'y	PQ51
17966906-00	Index sensor B sub Ass'y	PQ52
13423122	Transistor, 2SB510 H/F-F	**Q51
13411243	Diode, 1S954	**CR52
13413020	Diode, 1S953	**CR51
13419160	LED, GL-5HD5	*LED51
13419161	LED, GL-5NG6	
13121236	Connector, S3P, #38, polarizing	
11185151	Resistor, RD, 1/4W, 150Ω, J	**R51 ~ R52
11186222	Resistor, RD, 1/5W, 2.2KΩ, J	**R53 ~ R54
12903080	Capacitor, CC, 25V, YU, 0.1μF, M	C52
13121187	Connector, 2P	**J13
13061335-00	Harness OPT B Ass'y	
16362294	Cable tie	For fixing harness
16271169-XX	Name plate	Note 5

(Table 505) PCBA front OPT parts list

5-4. SCHEMATIC DIAGRAMS AND PARTS LOCATION

Notes for SCHEMATIC DIAGRAMS

1. Resistor (R) and resistor array (RA) values are in OHMS, 1/8W, $\pm 5\%$ (J), unless otherwise specified.
2. Capacitor (C) values are in Microfarads, 50V, $\pm 5\%$ (J), unless otherwise specified.
3. Tolerance symbols for R, RA, and C are:
F: $\pm 1\%$ G: $\pm 2\%$ J: $\pm 5\%$ K: $\pm 10\%$ M: $\pm 20\%$ Z: $+80-20\%$

PCBA DD MOTOR SERVO, PARTS LOCATION (Type S)

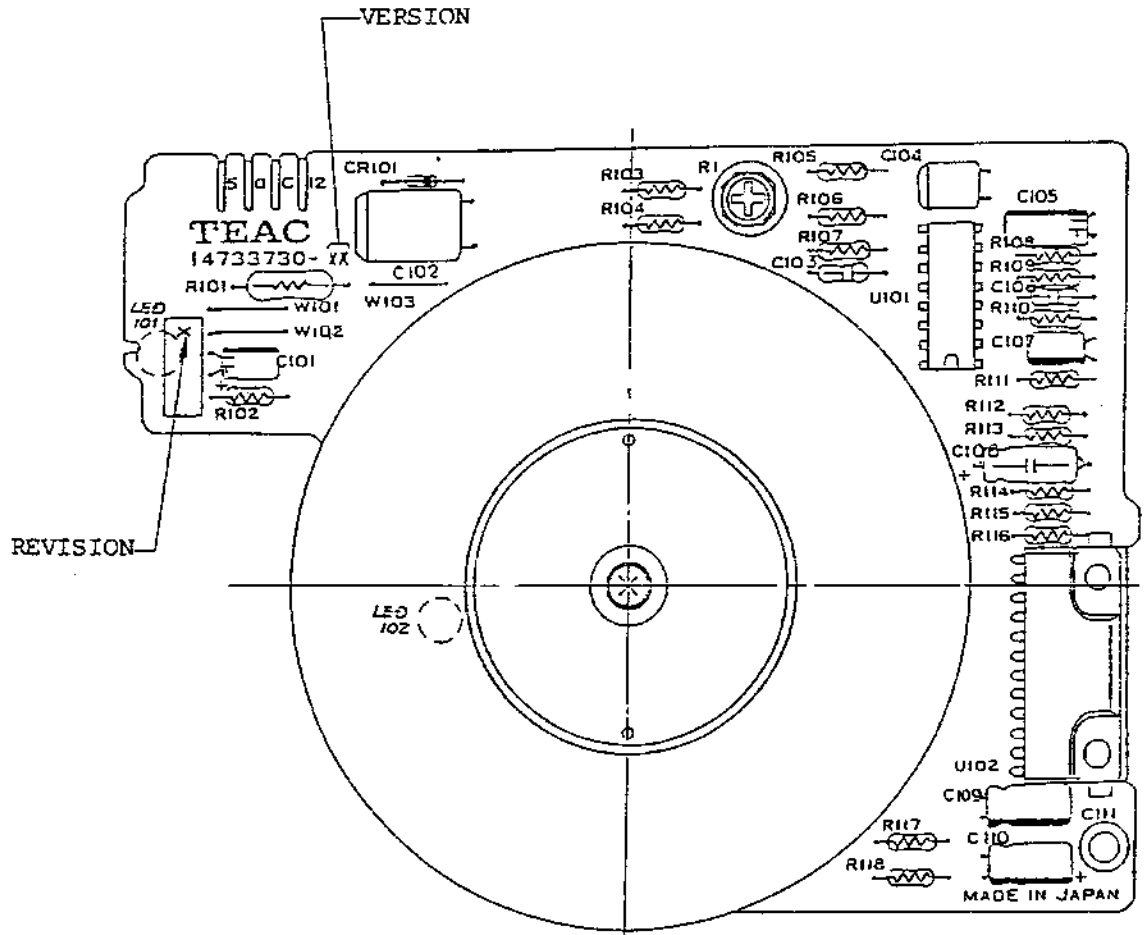

PCBA DD MOTOR SERVO, PARTS LOCATION (Type K)

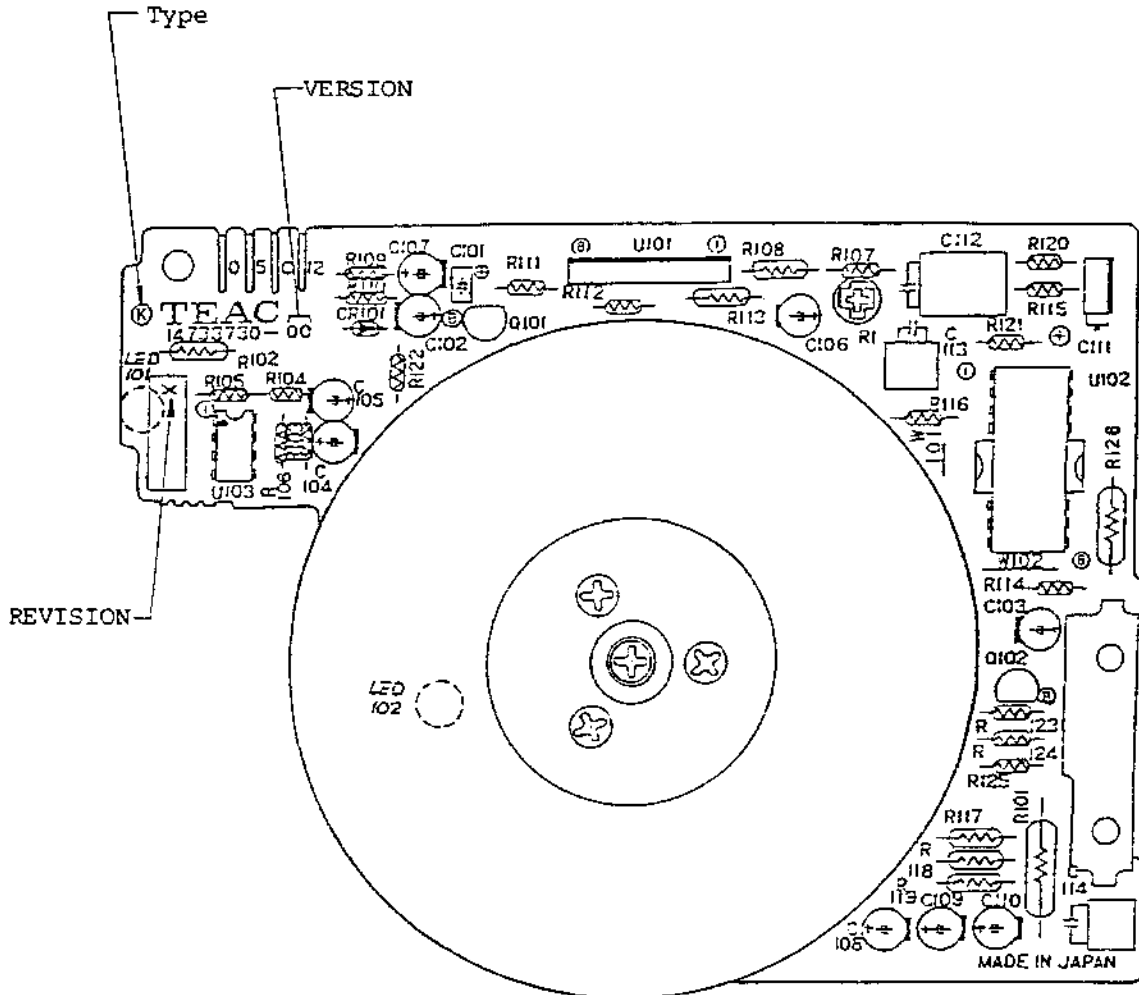

PCBA DD MOTOR SERVO, PARTS LOCATION (Type G)

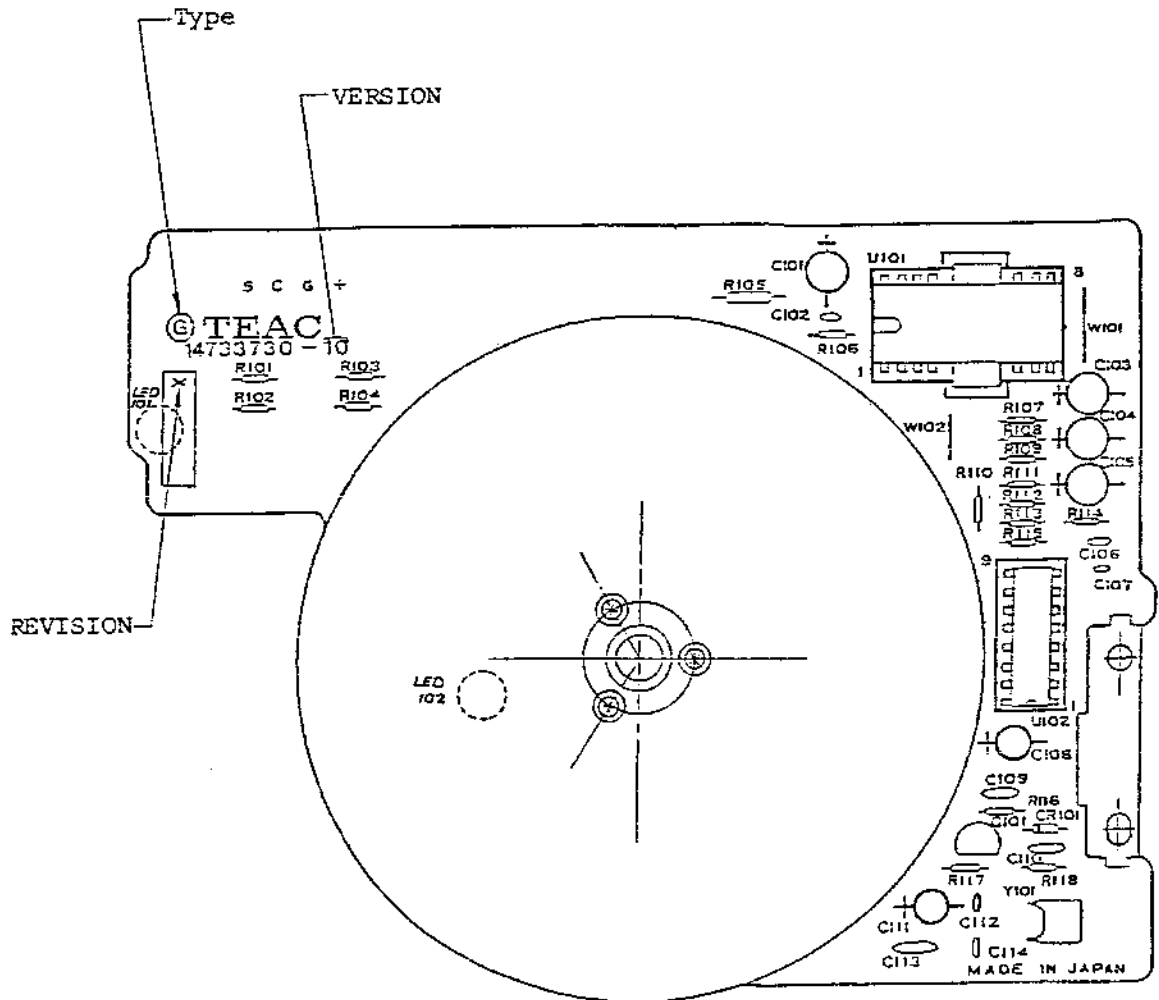

PCBA DD MOTOR SERVO, PARTS LOCATION (Type T)

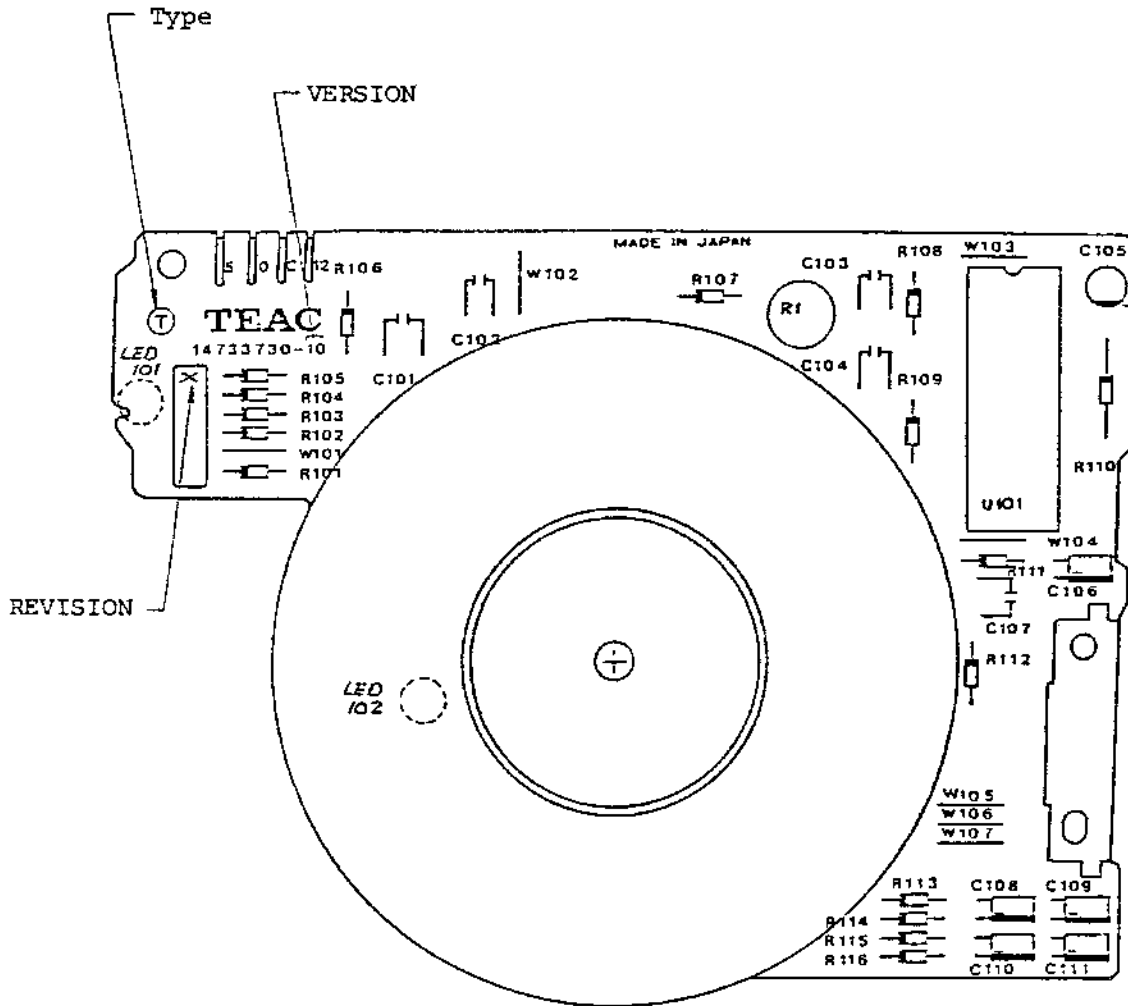

- 523A -

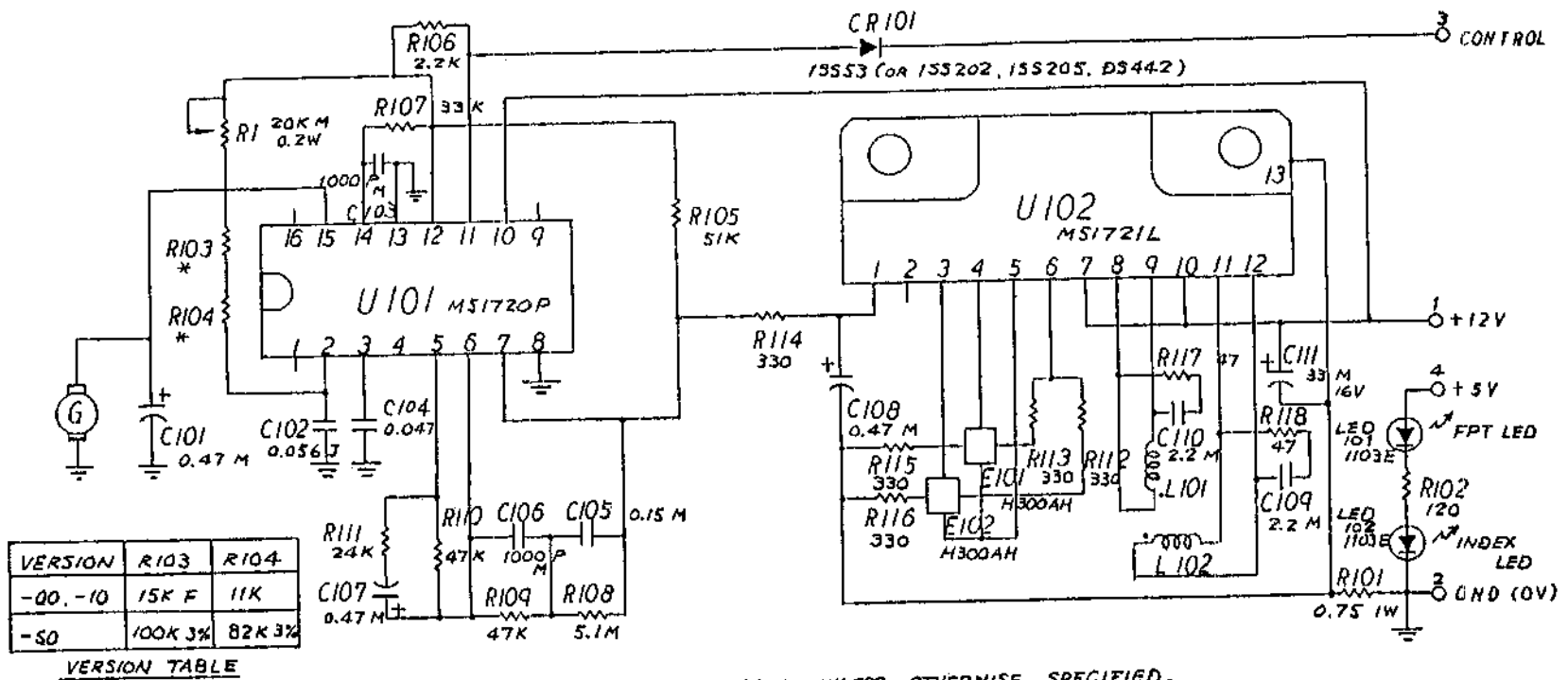

NOTE: RESISTORS ARE 1/4W, UNLESS OTHERWISE SPECIFIED.

PCBA DD MOTOR SERVO, SCHEMATIC (Type S)

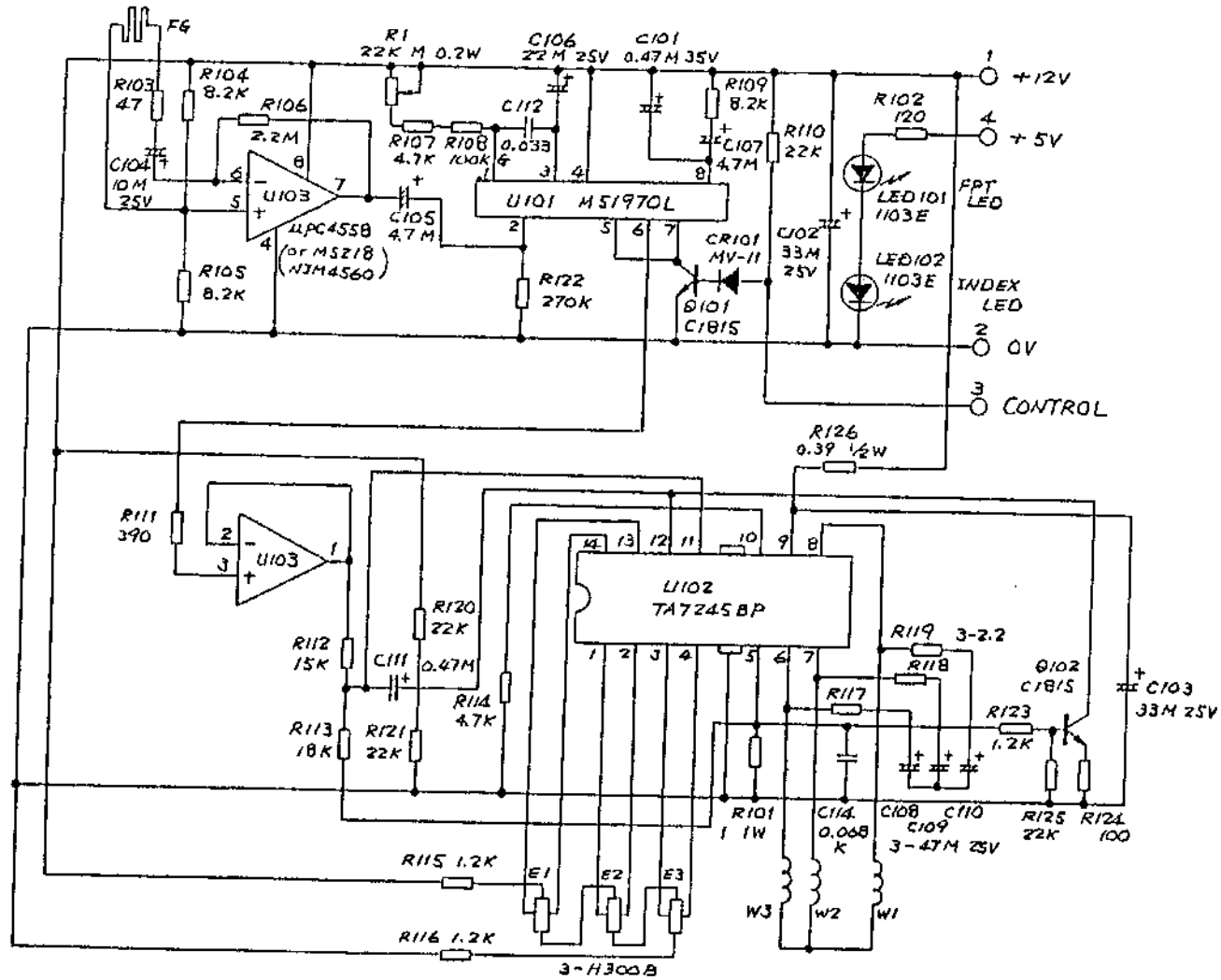

PCBA DD MOTOR SERVO, SCHEMATIC (Type K)

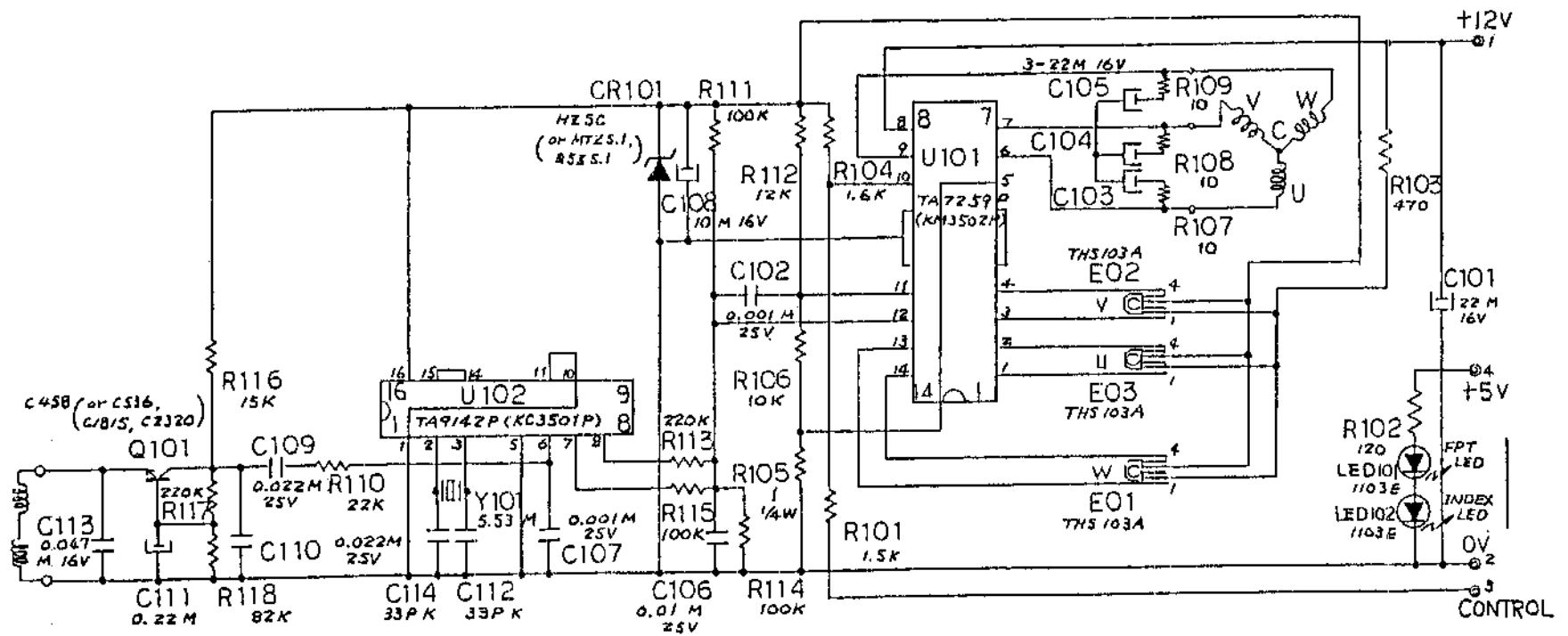

PACB DD MOTOR SERVO, SCHEMATIC (Type G)

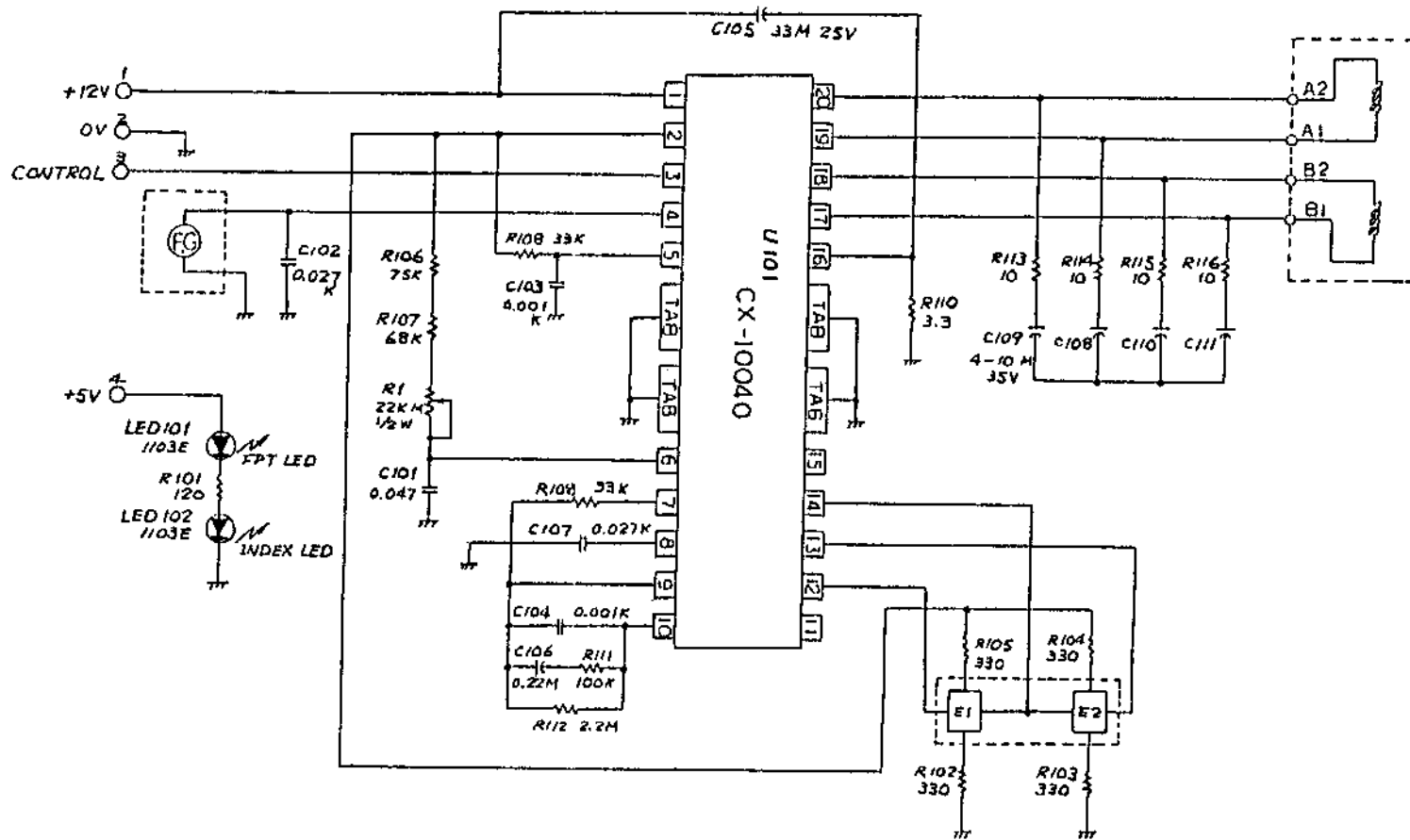

PCBA DD MOTOR SERVO, SCHEMATIC (Type T)

PCBA MFD CONTROL #B, PARTS LOCATION
 (PCB ISSUE H ~)

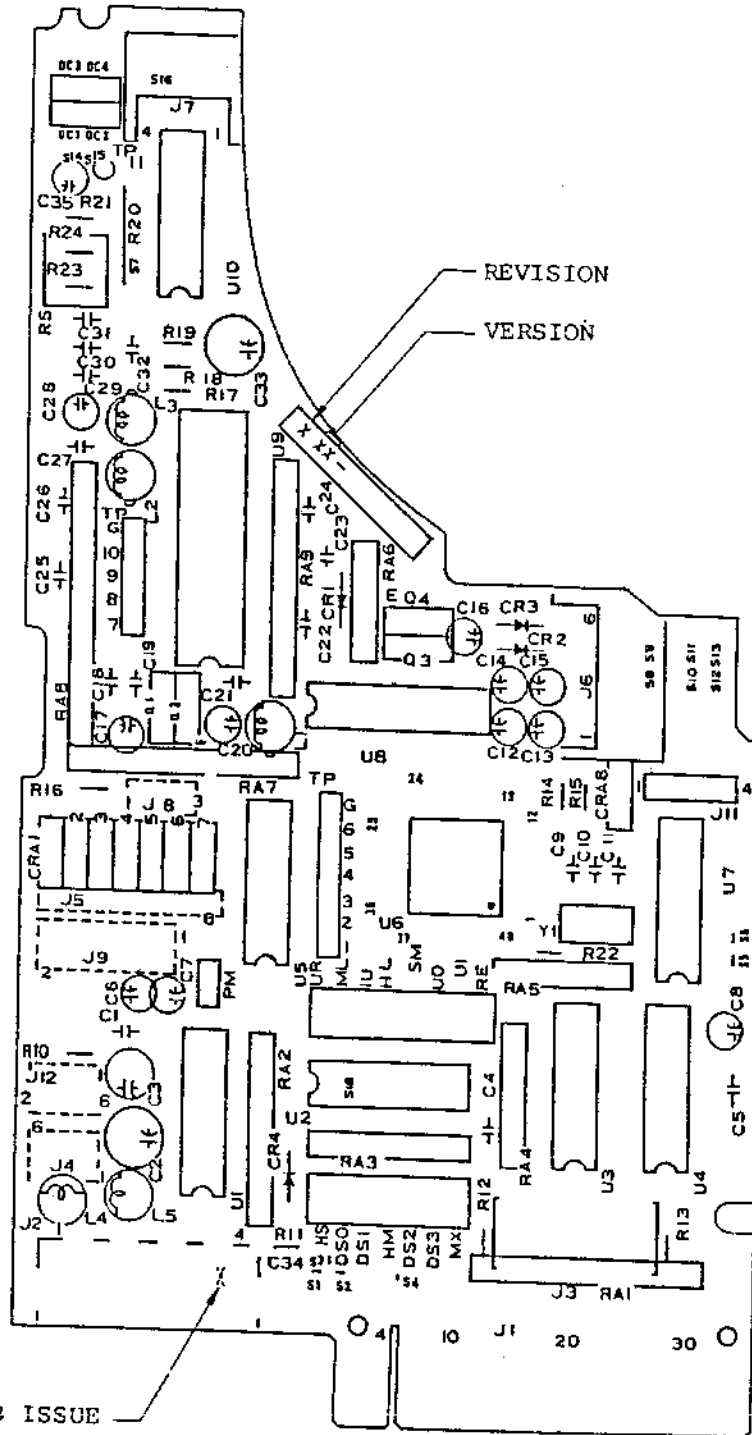

PCBA FRONT OPT, PARTS LOCATION

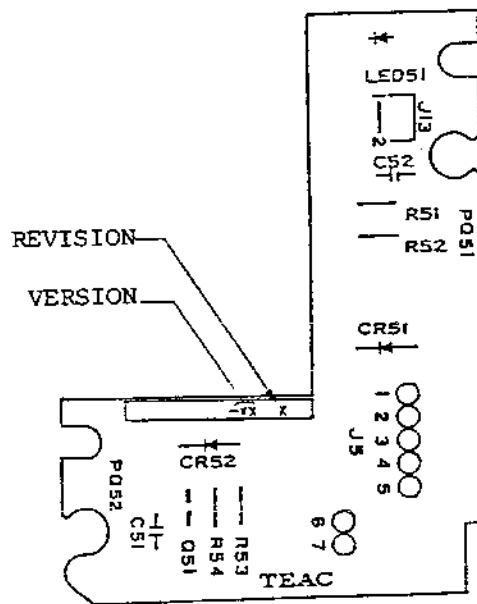

- ** RESERVED
- ** IN USE / HEAD LOAD
- ** DRIVE SELECT 3
- INDEX / SECTOR
- DRIVE SELECT 0
- DRIVE SELECT 1
- DRIVE SELECT 2
- MOTOR ON
- DIRECTION SELECT
- STEP
- WRITE DATA
- WRITE GATE
- TRACK 00
- WRITE PROTECT
- READ DATA
- SIDE ONE SELECT
- ** READY
- SIGNAL GND (000 NOS.)

PCBA
MFD CONTROL
15537001-XX

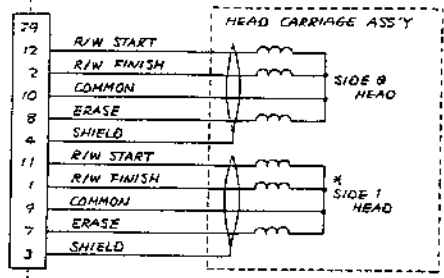

PCBA
MFD CONTROL
15532001-XX

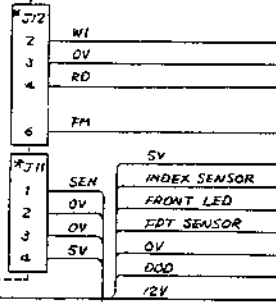

* PCBA VFO OPT
(SOP C)
15532010-XX

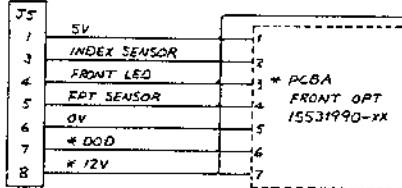
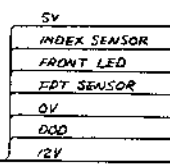

* J10

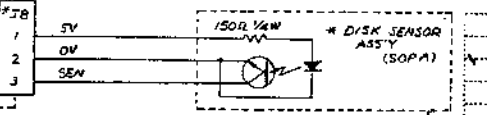
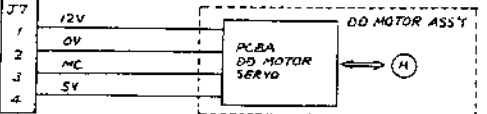
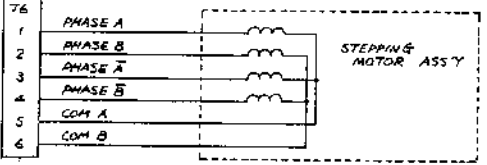
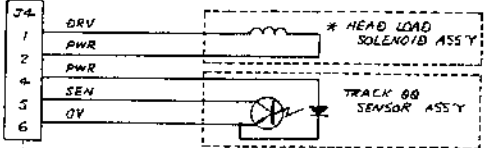
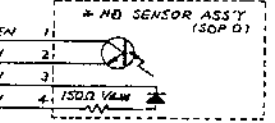
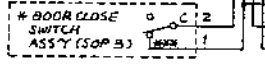
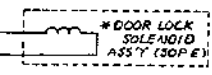
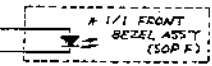

- +12V
- OV
- OV
- +5V

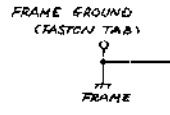

3. *** DOOR CLOSE SWITCH ASS'Y:
THERE ARE TWO VERSIONS IN DOOR CLOSE SWITCH ASS'Y. (REFER TO VERSION TABLE.)
FOR -00, PIN 2 OF J11 IS CONNECTED TO NORMAL CLOSE TERMINAL OF THE SWITCH,
WHILE IT IS CONNECTED TO NORMAL OPEN TERMINAL FOR -01.
2. SIGNALS WITH DOUBLE ASTERISKS (**) ARE CHANGED IN SOME OPTIONAL FDD
VERSIONS. REFER TO VERSION TABLE. UNLISTED SIGNALS ARE NOT CHANGED
IN THAT VERSION.
- NOTES 1. PARTS WITH AN ASTERISK (*) ARE USED IN SOME FDD VERSIONS.
REFER TO VERSION TABLE. UNLISTED PARTS ARE NOT USED IN THAT VERSION.

P/N 19307110-XX

材料	
仕上	指定以外のエッジはトメのこと
記号	訂正
承認	12月 83-12-26 R 度
検印	83-12-26
設計	(有友) (21.5.9) 第三角法
製図	単位 =

TEAC ティアック株式会社	
形式	
品名	FD-55
品番	TOTAL DIAGRAM 1/2
機番	10409218

No.19407

3024197

B
MIP

FOD VERSIONS	MAIN SPEC	* PARTS & SIGNALS	** SIGNALS
A-00, A-05 E-02, E-11	S SIDE, HL SOL	PCBA FO, HL SOL ASSY	
B-01, B-06, F91 F-03, G-04, F92	D SIDE, HL SOL	PCBA FO, HL SOL ASSY, SI HEAD	
A-19, E-21	S SIDE, CSS	PCBA FO	
B-20, B-29 F-22, G-23	D SIDE, CSS	PCBA FO, SI HEAD	
A-12, E-14	S SIDE, HL SOL 1/1	PCBA FO, HL SOL ASSY, 1/1 FB ASSY J10	
B-13, F-15	D SIDE, HL SOL 1/1	PCBA FO, HL SOL ASSY, SI HEAD, 1/1 FB ASSY, J10	
F-10	D SIDE, HL SOL ANR	PCBA FO, HL SOL ASSY, SI HEAD	
F-31	D SIDE, CSS ANR	PCBA FO, SI HEAD	
B-32, F-33, G-34	D SIDE, HL SOL, DL SOL	PCBA FO (WITH JS DOD & 12V), J13, HL SOL ASSY, SI HEAD, DL SOL ASSY	
B-37, F-38, G-39	D SIDE, CSS, DL SOL	PCBA FO (WITH JS DOD & 12V), J13 SI HEAD, DL SOL ASSY	
B-35 F-36	D SIDE, HL SOL DC SW (-00)	PCBA FO, HL SOL ASSY, SI HEAD, DC SW ASSY (-00), J11	J1 PIN 4 : DRIVE STATUS
B-40 F-41	D SIDE, CSS, DC SW (-00)	PCBA FO, SI HEAD, DC SW ASSY (-00) J11	J1 PIN 4 : DRIVE STATUS
F-42	D SIDE, HL SOL RDY6	PCBA FO, HL SOL ASSY, SI HEAD	J1 PIN 6 : READY
A-47 E-49	S SIDE, HL SOL VFO MASTER	PCBA VFO, HL SOL ASSY	J1 PIN 4 : FM J1 PIN 2 : WINDOW
B-48 F-50, G-51	D SIDE, HL SOL VFO MASTER	PCBA VFO, HL SOL ASSY, SI HEAD	J1 PIN 4 : FM J1 PIN 2 : WINDOW
A-52 E-54	S SIDE, HL SOL VFO SLAVE	PCBA FO, HL SOL ASSY	
B-53 F-55, G-56	D SIDE, HL SOL VFO SLAVE	PCBA FO, HL SOL ASSY	
E-53	S SIDE, CSS, ANR DC SW (-01)	PCBA FO, DC SW ASSY (-01) J11	J1 PIN 2 : DOOR CLOSED B J1 PIN 6 : DOOR CLOSED 1

VERSION TABLE

NOTE: ABBREVIATED NAMES ARE AS FOLLOWS:

- S SIDE : SINGLE SIDE
- HL SOL : HRA LOAD SOLENOID
- SI HEAD : SIDE 1 HEAD
- DC SW : DOOR CLOSE SWITCH
- HD SEN : HD SENSOR
- PCBA VFO : PCBA VFO OPT
- D SIDE : DOUBLE SIDE
- DL SOL : DOOR LOCK SOLENOID
- 1/1 FB : 1/1 FRONT BEZEL (FULL HEIGHT)
- D SEN : DISK SENSOR
- PCBA FO : PCBA FRONT OPT

P/N 19307110-XX

部品表 No. 19407

302497

材料		TEAC ティアック株式会社	
仕上		形式	
記号: 改訂番号 年月日: 標準: 承認		品名: FD-55	
承認: 樋井 83.12.26 R 様		図名: TOTAL DIAGRAM 2/2	
検印: 樋井 83.12.26		図番: 10409218	
設計 (当座): 83.5.9 第三角法		図名: 10409218	
製図:		図番: 10409218	

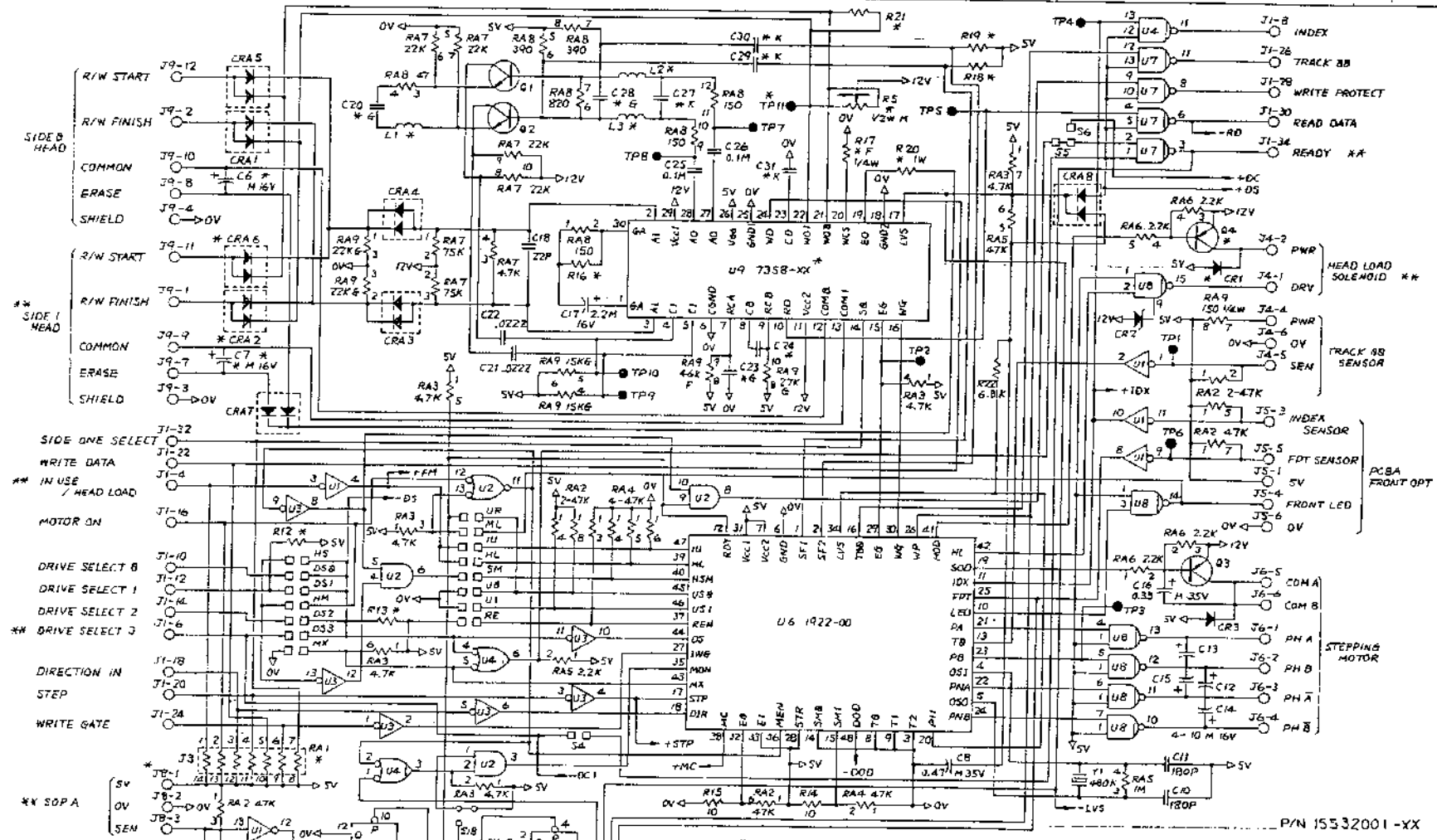

No. 19907

G. 19907 84 1'20 5+増大R		社上	標準以外のエッジレイタスのこと	形名	FD-S5
承認	2008 03-12-26	尺原		品名	PCBA* MFD CONTROL
検印	2008 03-12-26			図名	SCHEMATIC 1/3
設計	当座 (03-13)	項目判定		図番	10409180
校印		確認		数量	528

302480

Printed No. 17d07

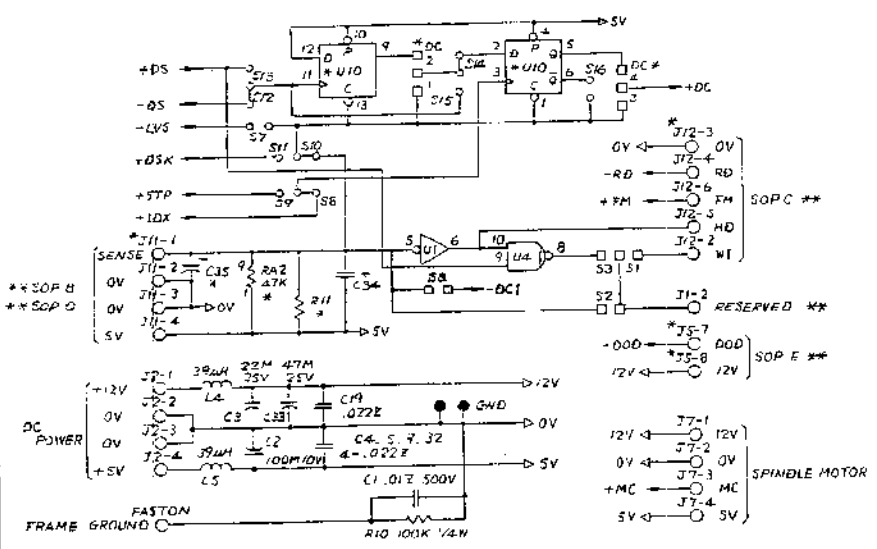

- 7 SIGNALS WITH DOUBLE ASTERISKS (***) ARE USED OR CHANGED IN SOME OPTIONAL FDD VERSIONS. REFER TO FD-55 TOTAL DIAGRAM AND ITS VERSION TABLE
- 6 POLARIZING KEY POSITIONS FOR CONNECTOR (J) ARE:
 J1: BETWEEN PIN4 AND6 J4: PIN3 J5: PIN2 J9: PIN6 J12: PIN1
- 5 REFER TO SHORT BAR SELECTION TABLE (HS~MX, UR~RE, PM) AS TO THE SIPPING POSITIONS AND THEIR FUNCTIONS.
- 4 TOLERANCE SYMBOLS FOR R, RA, AND C ARE:
 F: ±1% G: ±2% J: ±5% K: ±10% M: ±20% Z: +80-20%
- 3 CAPACITOR (C) VALUES ARE IN MICROFARADS, 50V OR HIGHER, ±5% (J), UNLESS OTHERWISE SPECIFIED.
- 2 RESISTOR (R) AND RESISTOR ARRAY (RA) VALUES ARE IN OHMS, 1/8W OR GREATER, ±5% (J), UNLESS OTHERWISE SPECIFIED.
- NOTES: 1. PARTS WITH AN ASTERISK (*) ARE DIFFERENT IN EACH PCBA VERSION. REFER TO VERSION TABLE. UNLISTED PARTS ARE NOT USED IN THAT VERSION.

図番 此 番 回 番 品 名 定 規 備 註 備考 通用

PCBA VERSIONS	MAIN SPEC.	# PARTS
-00	48tpL S. Side A STD.	Q4, CR1, RA1(330), R13(330), R14(10), R17(1.24K), R20(120), R21(7.2K), R5(20K) C6(4.7), C20(1500P), C23(100P), C24(56P), C27(1000P), C28(2200P), C31(2200P) L1~L3(330uH), U9(735B-00)
-01	48tpL D. Side B STD.	Q4, CR1, CRA2, CRA6, RA1(330), R13(330), R14(10), R17(1.24K), R20(120), R21(7.2K) C6~C7(4.7), C20(1500P), C23(100P), C24(56P), C27(1000P), C28(2200P), C31(2200P) L1~L3(330uH), R5(20K), U9(735B-00)
-02	96tpL S. Side E STD.	Q4, CR1, RA1(330), R13(330), R16(10), R17(1.69K), R20(240), R21(4.7K), R5(20K) C6(4.7), C20(1500P), C23(100P), C24(56P), C27(1000P), C28(2200P), C31(2200P) L1~L3(330uH), U9(735B-00)
-03	96tpL D. Side F STD.	Q4, CR1, CRA2, CRA6, RA1(330), R13(330), R16(10), R17(1.69K), R20(240), R21(4.7K) C6~C7(4.7), C20(1500P), C23(100P), C24(56P), C27(1000P), C28(2200P), C31(2200P) L1~L3(330uH), R5(20K), U9(735B-00)
-04	96tpL D. Side G STD.	Q4, CR1, CRA2, CRA6, RA1(330), R13(330), R15(10), R16(10), R17(768), R18~R19(4.7K) R20(150), R21(3.3K), R5(20K), C6~C7(2.2), C20(560P), C23(27P), C24(24P), C27(470P) C28(560P), C29~C30(2200P), C31(1200P), L1(120uH), L2 L3(150uH), U9(735B-01)
-05	48tpL S. Side NNA	RA1(1K), R13(470). THE OTHERS ARE THE SAME AS -00.
-06	48tpL D. Side NEB	RA1(1K), R12(1K), R13(470). THE OTHERS ARE THE SAME AS -01.
-07	F, ANR	C12~C15 (CHANGE TO 33K 16V). THE OTHERS ARE THE SAME AS -03.
-08	B, DL	J5 (CHANGE TO 8P). THE OTHERS ARE THE SAME AS -01.
-09	F, DL	J5 (CHANGE TO 8P). THE OTHERS ARE THE SAME AS -03.
-10	B, DL	J5 (CHANGE TO 8P). THE OTHERS ARE THE SAME AS -04.
-11	B, DC	J11, S5 CUT, S6 JUMPER, U10, R11(1K), C35(4.7M 16V), STRAP POST DC1~4 THE OTHERS ARE THE SAME AS -01. S7 CUT
-12	F, DC	J11, S5 CUT, S6 JUMPER, U10, R11(1K), C35(4.7M 16V), STRAP POST DC1~4 THE OTHERS ARE THE SAME AS -03. S7 CUT
-13	F, R0Y6	S4 JUMPER. THE OTHERS ARE THE SAME AS -03.
-14	A, VFO MASTER	S1 JUMPER, C24(8P), J12(6P). THE OTHERS ARE THE SAME AS -00.
-15	B, VFO MASTER	S1 JUMPER, C24(8P), J12(6P). THE OTHERS ARE THE SAME AS -01.
-16	E, VFO MASTER	S1 JUMPER, C24(8P), J12(6P). THE OTHERS ARE THE SAME AS -02.
-17	F, VFO MASTER	S1 JUMPER, C24(8P), J12(6P). THE OTHERS ARE THE SAME AS -03.
-18	G, VFO MASTER	S1 JUMPER, C24(8P), J12(6P). THE OTHERS ARE THE SAME AS -04.
-19	NEF	RA1(1K), R12(1K), R13(470), C28(3300P), C29(1000P), C30(1000P) THE OTHERS ARE THE SAME AS -03.

VERSION TABLE

P/N 15532001-XX

				材料	TEAC ティアック株式会社		
				仕上			
				南正以外のエッジは4ト4のこと		形式	FD-55
記号	改訂番号	年月日	担当	承認	品名		PCBA MFD CONTROL
	承認	183-12-26	尺塚	越前	国名		SCHEMATIC 2/3
	検印	183-12-26			国番		10409180
	設計	岩瀬 (83.3.23)	南三角送	普通	4番		10409180
	製図		単位 mm	寸法			

302430

PCBA VERSIONS	MAIN SPEC.	* PARTS
- 20	A. SLAVE	C24 (BP). THE OTHERS ARE THE SAME AS -00.
- 21	B. SLAVE	C24 (BP). THE OTHERS ARE THE SAME AS -01.
- 22	E. SLAVE	C24 (BP). THE OTHERS ARE THE SAME AS -02.
- 23	F. SLAVE	C24 (BP). THE OTHERS ARE THE SAME AS -03.
- 24	G. SLAVE	C24 (BP). THE OTHERS ARE THE SAME AS -04.
- 25	E. MIG	J11. 57 LUT. S8 (STRAP POST). S2 (STRAP POST). R11 (1K). R17 (1.50K) C12~C15 (CHANGE TO 33 K 16V). THE OTHERS ARE THE SAME AS -02.

VERSION TABLE (CONTINUED)

分社 資料 No. 19907

M P

P/N 15532001-XX

材料	TEAC ティアック株式会社	
仕上	形式	FD-55
記号: 改訂番号: 年月日: 標準: 承認	品名	PCBA MFD CONTROL 科目
承認: 12/26 83/12/26 尺度	図名	SCHEMATIC 3/3
検出: 12/26 83/12/26	図番	10409180
設計: 当座 (83.3.28) 第三角法	標準	330 3 3
製図	番付	TS-E (級)

3024430

TEAC Corporation of America
7733 Telegraph Rd., Montebello, CA 90640
(213) 726-0303