

**SA850/851  
Bi-Compliant™  
Double Sided  
Diskette Storage Drive**

**Service Manual**

 **Shugart**

# TABLE OF CONTENTS

1.0 Theory of Operations .....	1
1.1 General Operations .....	1
1.1.1 Head Positioning .....	1
1.1.2 Diskette Drive Spindle .....	1
1.1.3 Read/Write Heads .....	2
1.2 Recording Format .....	3
1.2.1 Bit Cell .....	3
1.2.2 Byte .....	3
1.2.3 Recording Format (Double Density) .....	4
1.2.3.1 Rules of Encoding .....	5
1.2.4 Tracks .....	6
1.2.5 Track Format .....	6
1.2.5.1 Sector Recording Format .....	6
1.2.5.2 Soft Sector Recording Format .....	6
1.2.6 Typical Track Index Format .....	6
1.2.6.2 .....	12
1.3.0 Track Accessing .....	13
1.3.1 .....	13
1.3.2 .....	13
1.3.2.1 .....	13
1.3.3 Actuator Control Logic (Figure 21) .....	13
1.3.3.1 Power On Reset .....	13
1.3.3.2 Forward Seek .....	13
1.3.3.3 Reverse Seek .....	14
1.3.4 Track Zero Indicator .....	14
1.4.0 Read/Write Operations .....	17
1.4.1 .....	17
1.4.2 .....	17
1.4.3 .....	17
1.4.4 .....	17
1.4.5 .....	17
1.5.0 Read/Write Head .....	19
1.5.1 .....	19
1.5.2 .....	19
1.5.3 .....	19
1.5.4 .....	19
1.6.0 Write Current Operation (Figure 32) .....	20
1.6.1 .....	20
1.6.2 .....	20
1.6.3 .....	20
1.6.4 .....	20
1.7.0 Read Circuit Operation (Figure 33) .....	21
1.7.1 .....	21
1.7.2 .....	21
1.7.3 .....	21
1.8.0 Interface .....	22
1.8.1 J1/P1 Connector .....	22
1.8.2 AC Power .....	22
1.8.3 DC Power .....	22
1.8.4 Output Lines .....	22

2.0 Maintenance Section	25
2.1.0 Maintenance Features	25
2.1.1 Alignment Diskette	25
2.1.2 SA809 Exerciser	25
2.1.3 Special Tools	25
2.2.0 Diagnostic Techniques	25
2.2.1 Introduction	25
2.2.2 "Soft Error" Detection and Correction	26
2.2.3 Write Error	26
2.2.4 Read Error	26
2.2.5 Seek Error	26
2.2.6 Test Points SA850/851	27
2.2.7 Connectors	27
2.2.7.1	27
2.2.7.2	28
2.2.7.3 J3/P3	28
2.2.7.4	29
2.2.7.5 J5/P5	29
2.2.7.6 J6/P6	29
2.3.0 Preventative Maintenance	29
2.3.1 Introduction	29
2.3.2 Preventive Maintenance Procedures	29
2.3.3 Cleanliness	30
2.3.4 Cautions	30
2.4.0 Removals, Adjustments	30
2.4.1 Motor Drive	30
2.4.1.1 Drive Motor Assembly: Removal and Installation	30
2.4.1.2 Motor Drive Pulley	30
2.4.2 Head Cover Shield Removal	30
2.4.3 Cartridge Guide Access	31
2.4.4 Sector/Index LED Assembly: Removal and Installation	31
2.4.5 Write Protect Detector	31
2.4.5.1 Write Protect Detector: Removal and Installation	31
2.4.5.2 Write Protect Detector Adjustment	31
2.4.6 Head Load Mechanism Assembly	32
2.4.6.1 Head Load Mechanism: Removal and Installation	32
2.4.6.2 Head Load Mechanism Adjustment	32
2.4.7 Index/Sector Photo Transistor Assembly	34
2.4.7.1 Index/Sector Photo Transistor Assembly: Removal and Installation	34
2.4.7.2 Index/Sector Adjustment	34
2.4.8 Spindle Assembly	34
2.4.8.1 Clamp Hub Removal	35
2.4.9 Cartridge Guide	35
2.4.9.1 Cartridge Guide Removal	35
2.4.9.2 Cartridge Guide Adjustment	35
2.4.10 Head Amplitude Check	36
2.4.10.1 Head Actuator Assembly: Removal and Installation	36
2.4.10.2 Head Penetration Adjustment	37
2.4.10.3 Head Radial Alignment	43
2.4.10.4 Read/Write Heads Azimuth Check	43
2.4.11 Door Lock Solenoid and In Use LED Assembly Removal	44
2.4.12 Track 00 Detector: Removal and Installation	46
2.4.12.1 Track 00/76 Stop Adjustment	46
2.4.12.2 Track 00 Detector Assembly Adjustment	46
2.4.13 Door Lock Solenoid and In Use LED Assembly Removal	46

# LIST OF ILLUSTRATIONS

Figure	1. SA850/851 Functional Diagram .....	2
	2. Bi-Compliant Read/Write Head .....	2
	3. Data Pattern .....	3
	4. Bit Cell .....	3
	5. Byte .....	4
	6. Data Bytes .....	4
	7. FM, MFM and M <sup>2</sup> FM Encoding .....	5
	8. SA801 Sector Recording Format .....	6
	9. Track Format .....	7
	10. MFM Track Format Comparison .....	8
	11. Index Address Mark FM .....	8
	12. ID Address Mark FM .....	9
	13. Data Address Mark FM .....	9
	14. Deleted Data Address Mark FM .....	9
	15. MFM Index Address Mark .....	10
	16. MFM ID Address Mark .....	10
	17. MFM Data Address Mark .....	10
	18. MFM Deleted Data Address Mark .....	11
	19. MFM Index Pre Address Mark .....	11
	20. MFM Pre ID/Data Address Mark .....	11
	21. Activator Control Logic .....	15
	22. Count 0 .....	16
	23. Count 1 .....	16
	24. Count 2 .....	16
	25. Count 3 .....	16
	26. Byte .....	17
	27. Basic R/W Head .....	18
	28. Recorded Bit .....	18
	29. Reading a Bit .....	18
	30. 1F and 2F Recording Flux and Pulse Relationship .....	19
	31. Read/Write Heads .....	19
	32. Write Circuit Functional Diagram .....	20
	33. Read Circuit Functional Diagram .....	21
	34. Data Separation Timing Diagram .....	22
	35. Interface Connections .....	23
	36. Interface Signal Driver/Receiver .....	24
	37. Head Load Mechanism Adjustment .....	33
	38. Head Load Timing .....	33
	39. Head Penetration Tools .....	37
	40. Dial Indicator .....	38
	41. Penetration Plate Installation .....	39
	42. Dial Indicator Installation .....	40
	43. Installation Check .....	41
	44. Correct Penetration .....	41
	45. Penetration Adjustment .....	42
	46. Head Radial Alignment .....	44
	47. Motor Plate .....	44

48. Azimuth Burst Patterns .....	45
Flow Charts .....	47
Logic Diagrams .....	53
Physical Locations .....	57
49. (1 of 2) .....	61
49. (2 of 2) .....	62
Illustrated Parts Catalog .....	63
50.....	64
51.....	67
Schematic Diagrams .....	68

## **1.0 THEORY OF OPERATIONS**

### **1.1 GENERAL OPERATIONS**

The SA850/851 Diskette Drive consists of read/write and control electronics, drive mechanism, read/write heads, track positioning mechanism, and removable Diskette. These components perform the following functions:

- Interpret and generate control signals.
- Move read/write heads to the desired track.
- Read and write data.

The relationship and interface signals for the internal functions of the SA850/851 are shown in Figure 1.

The Head Positioning Actuator positions the read/write heads to the desired track on the Diskette. The Head Load Actuator loads the read/write heads against the Diskette and data may then be recorded or read from the Diskette.

The electronics are packaged on the PCB. The PCB contains:

1. Index Detector Circuits (Sector/Index for SA851).
2. Head Position Actuator Driver
3. Head Load Solenoid Driver
4. Read/Write Amplifier and Transition Detector.
5. Data/Clock Separation Circuits (SA851).
6. Write Protect
7. Drive Ready Detector Circuit.
8. Drive Select Circuits.
9. Side Select Circuit.
10. In Use and Door Lock Circuits
11. Write Current Switching/Read Compensation

#### **1.1.1 HEAD POSITIONING**

The read/write heads are accurately positioned by a Fasflex™ metal band/stepping motor actuator system. A precision stepping motor is used to precisely position the head/carriage assembly through the use of a unique metal band/capstan concept. Each 3.6° rotation of the stepping motor moves the read/write head one track in discrete increments.

#### **1.1.2 DISKETTE DRIVE SPINDLE**

The Diskette drive motor rotates the spindle at 360 rpm through a belt-drive system. 50 or 60 Hz power is accommodated by changing the drive pulley and belt. A registration hub, centered on the face of the spindle, positions the Diskette. A clamp that moves in conjunction with the latch handles fixes the Diskette to the registration hub.

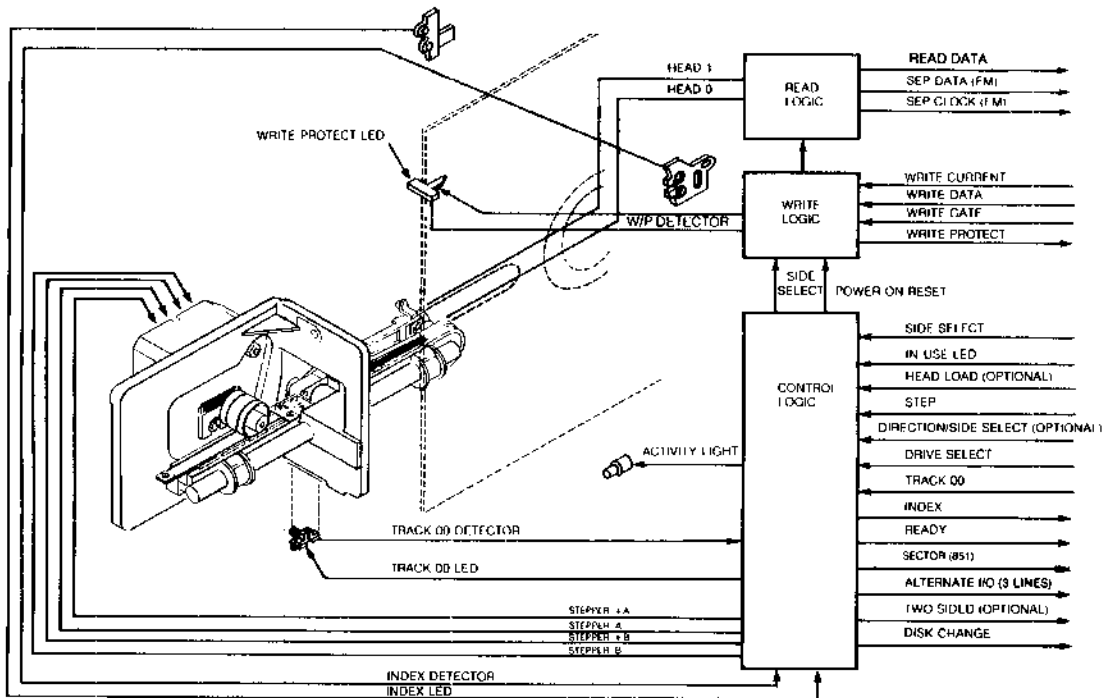


FIGURE 1. SA850/851 FUNCTIONAL DIAGRAM

### 1.1.3 READ/WRITE HEADS

The proprietary heads are a single element ceramic read/write head with straddle erase elements to provide erased areas between data tracks. Thus normal interchange tolerances between media and drives will not degrade the signal to noise ratio and insures diskette interchangeability.

The read/write heads are mounted on a carriage which is positioned by the Fasflex™ actuator. The head carriage assembly utilizes a combination flexured/rigid head mounting system. This allows the flexured head to load the media against its rigidly mounted counterpart (see Figure 2).

The diskette is held in a plane perpendicular to the read/write head by a platen located on the base casting. This precise registration assures perfect compliance with the read/write heads. The read/write heads are in direct contact with the diskette. The head surface has been designed to obtain maximum signal transfer to and from the magnetic surface of the diskette.

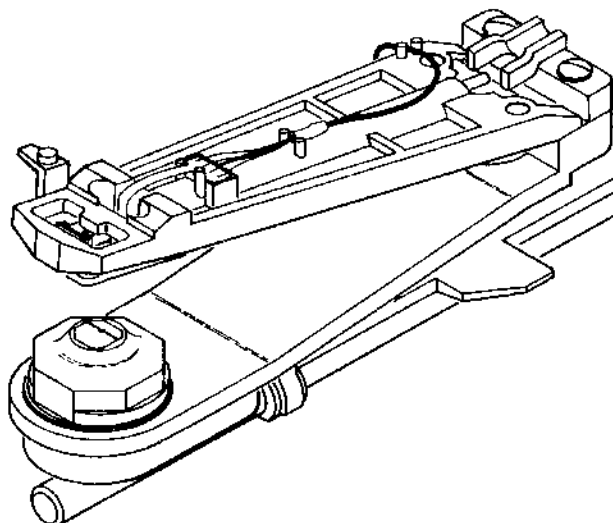


FIGURE 2. BI-COMPLIANT READ/WRITE HEAD

## 1.2 RECORDING FORMAT

The format of the data recorded on the Diskette is totally a function of the host system. Data is recorded on the diskette using frequency modulation as the recording mode, i.e., each data bit recorded on the diskette has an associated clock bit recorded with it, this is referred to as FM encoding. Data written on and read back from the diskettes takes the form as shown in Figure 3. The binary data pattern shown represents a 101.

### 1.2.1 BIT CELL

As shown in Figure 4, the clock bits and data bits (if present) are interleaved. By definition, a Bit Cell is the period between the leading edge of one clock bit and the leading edge of the next clock bit.

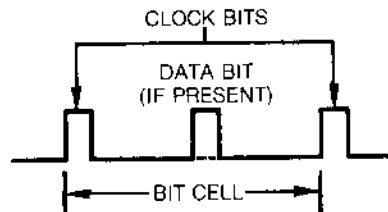


FIGURE 3. DATA PATTERN

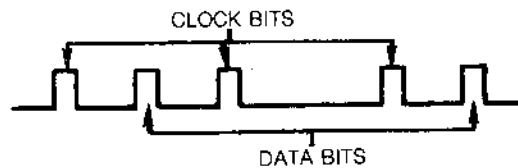


FIGURE 4. BIT CELL

### 1.2.2 BYTE

A Byte, when referring to serial data (being written onto or read from the disk drive), is defined as eight (8) consecutive bit cells. The most significant bit cell is defined as bit cell 0 and the least significant bit cell is defined as bit cell 7. When reference is made to a specific data bit (i.e., data bit 3), it is with respect to the corresponding bit cell (bit cell 3).

During a write operation, bit cell 0 of each byte is transferred to the disk drive first with bit cell 7 being transferred last. Correspondingly, the most significant byte of data is transferred to the disk first and the least significant byte is transferred last.

When data is being read back from the drive, bit cell 0 of each byte will be transferred first with bit cell 7 last. As with reading, the most significant byte will be transferred last from the drive to the user.

Figure 4 illustrates the relationship of the bits within a byte and Figure 6 illustrates the relationship of the bytes for read and write data.



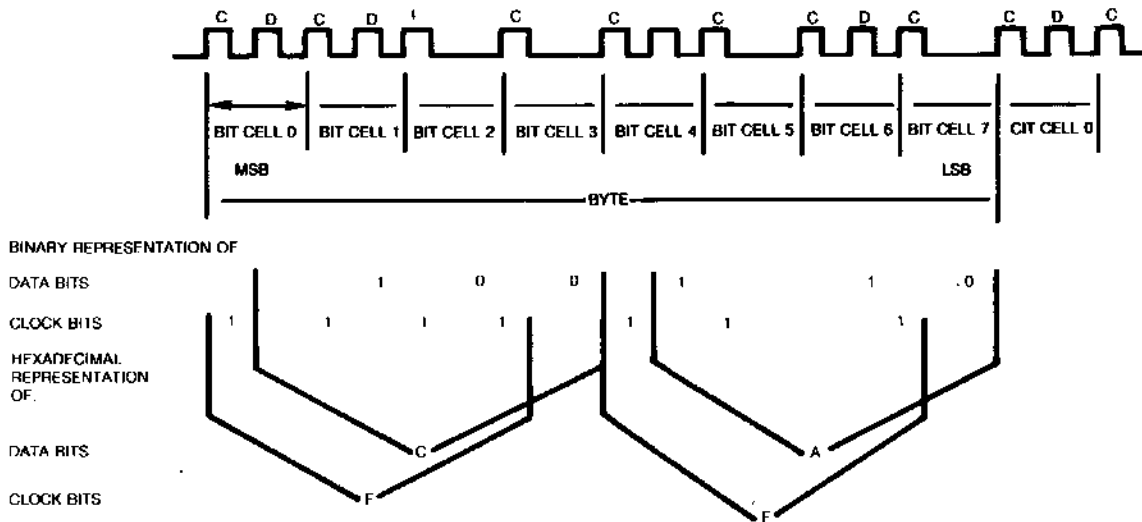


FIGURE 5. BYTE

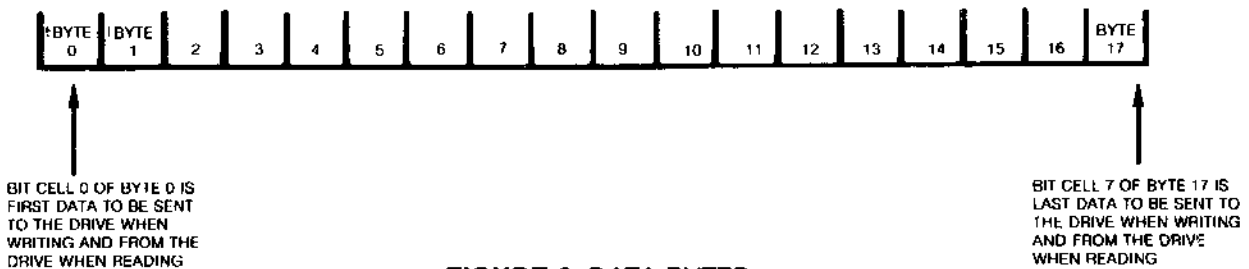


FIGURE 6. DATA BYTES

### 1.2.3 RECORDING FORMAT (DOUBLE DENSITY)

Double capacity can be obtained by use of MFM (modified frequency modulation) and M<sup>2</sup>FM (modified, modified frequency modulation) rather than FM (frequency modulation) which is the standard method of encoding data on the diskette.

The differences between FM, MFM and M<sup>2</sup>FM encoding are shown in Figure 7. Note that MFM and M<sup>2</sup>FM result in a 1 to 1 relationship between the "flux changes per inch" and the bits per inch recorded on the diskette. This also results in a doubling of the data transfer rate, from 250 to 500 KBS, when compared to FM.

Data error rate performance equal to standard capacity diskettes using FM encoding can be achieved by using:

- The SA850/851 diskette drive with its proprietary ceramic/ferrite read/write head.
- Phase locked loop (VFO) data separator
- Write precompensation.

Provision of the phase locked loop data separator and write precompensation circuitry is the responsibility of the user of the SA850/851 diskette drive.

Shugart Associates will provide design information, as required, to SA850/851 users who desire to incorporate double capacity diskette drives in their products.

The bit cell for MFM and M<sup>2</sup>FM encoded data is one half the duration of the bit cell for FM encoded data. Also, unlike FM, and MFM and M<sup>2</sup>FM bit cell does not always contain a clock bit at its leading edge. This lack of clock bit makes data separation more complex. Also, the window size is half the FM window size, which results in less tolerance to bit shift. The only reliable method to separate MFM and M<sup>2</sup>FM encoded data is through use of a phase locked loop (VFO) type of data separator. The VFO, once synchronized, tracks the data and generates clock and data windows, improving the bit shift tolerance over the conventional "hard" data separators commonly used in FM recording, which use windows of fixed timing.

### 1.2.3.1 RULES OF ENCODING

FM Encoding:

- Write data bits at the center of the bit cell.
- Write clock bits at the leading edge of the bit cell.

MFM Encoding:

- Write data bits at the center of the bit cell.
- Write clock bits at the leading edge of the bit cell if:
  - 1) There is no data bit written in the previous bit cell, and
  - 2) There will be no data bit written in the present bit cell.

M<sup>2</sup>FM Encoding:

- Write data bits at the center of the bit cell.
- Write clock bits at the leading edge of the bit cell if:
  - 1) There is no data bit or clock bit written in the previous bit cell, and
  - 2) There will be not data bit written in the present bit cell.

NOTE: In M<sup>2</sup>FM/MFM, the write oscillator frequency is doubled, while maintaining the same flux changes per inch as FM. Thus, the bit cell in M<sup>2</sup>FM/MFM is 1/2 that in FM. Data transfer rate is also doubled, since a 1 to 1 relationship exists between flux changes per inch and bits per inch (2 to 1 in FM).

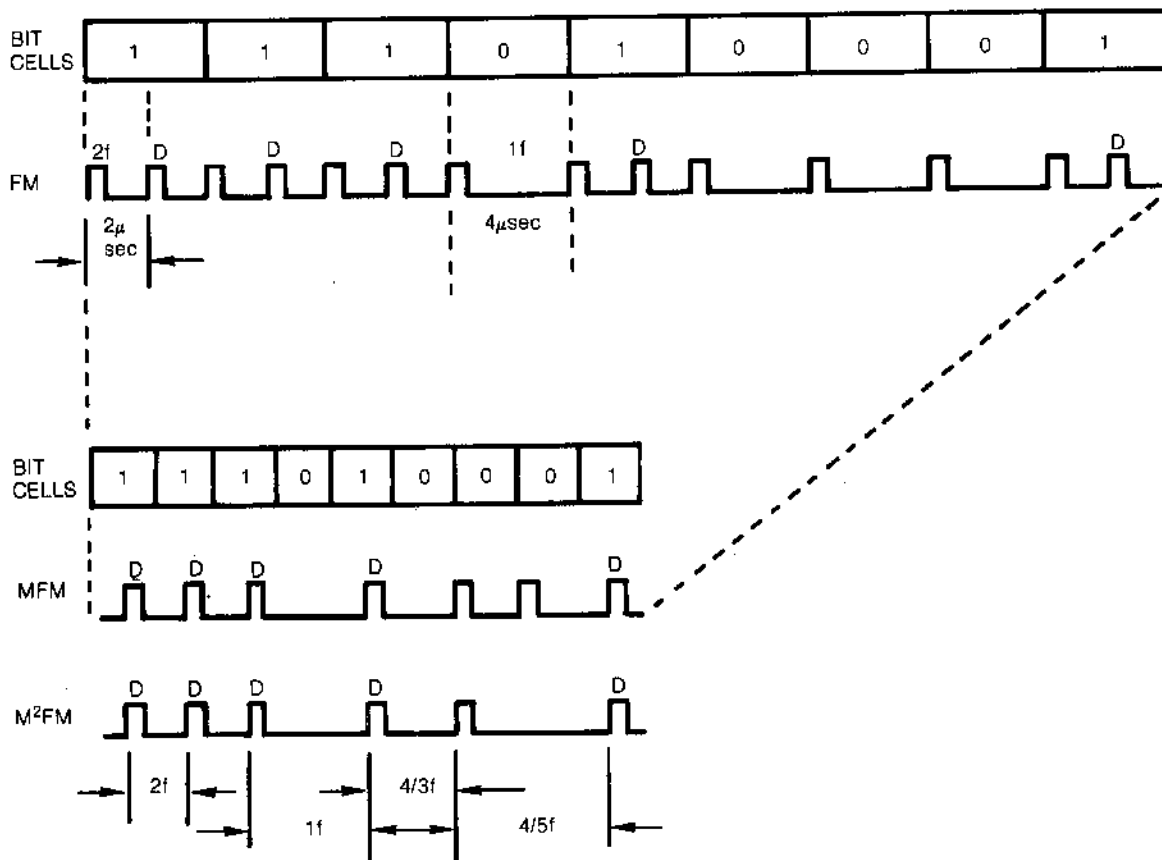


FIGURE 7. FM, MFM AND M<sup>2</sup>FM ENCODING

## 1.2.4 TRACKS

The SA850/851 drive is capable of recording up to 154 tracks of data. The tracks are numbered 0-76 for each side. Each track is made available to the read/write heads by accessing the head with a stepper motor and carriage assembly and selecting the desired side of the diskette. Track accessing will be covered in Section 3.

### Basic Track Characteristics:

No. Data bits/track Single Density	41,300 bits
No. Data bits/track Double Density	82,600 bits
Index Pulse Width	$1.8 \pm .6$ ms
Index/Sector Pulse Width (SA851 only)	$.4 \pm .2$ ms

## 1.2.5 TRACK FORMAT

Tracks may be formatted in numerous ways and is dependent on the using system. The SA850/851 use index and sector recording formats respectively.

### 1.2.5.1 SECTOR RECORDING FORMAT

In this Format, the using system may record up to 32 sectors (records) per track. Each track is started by a physical index pulse and each sector is started by a physical sector pulse. This type of recording is called hard sectoring. Figure 8 shows a typical Sector Recording Format for 1 of 32 sectors.

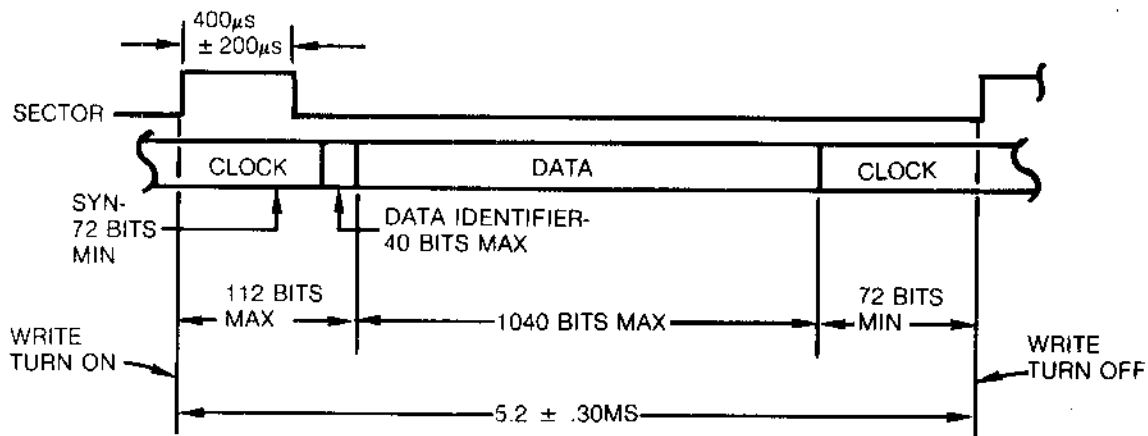


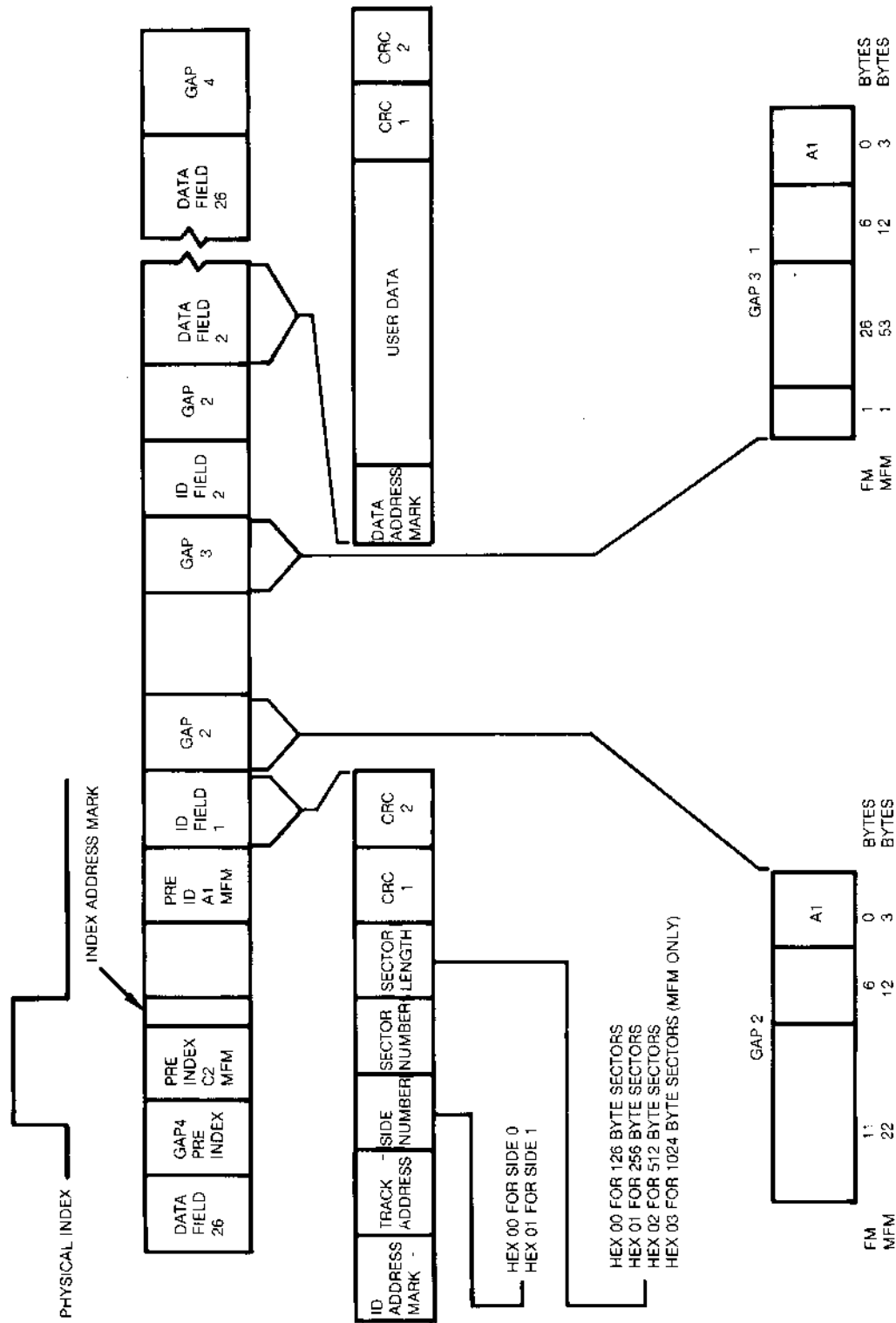
FIGURE 8. SA801 SECTOR RECORDING FORMAT

### 1.2.5.2 SOFT SECTOR RECORDING FORMAT

In this Format, the using system may record one long record or several smaller records. Each track is started by a physical index pulse and then each record is preceded by a unique recorded identifier. This type of recording is called soft sectoring.

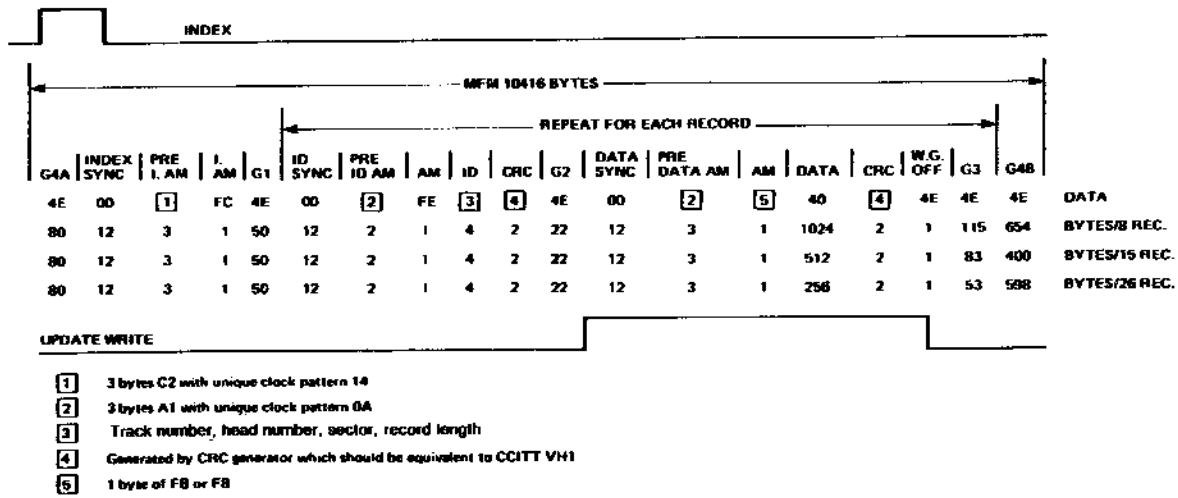
## 1.2.6 TYPICAL TRACK INDEX FORMAT

Figure 9 shows a track Format, which is IBM compatible, using index Recording Format with soft sectoring.

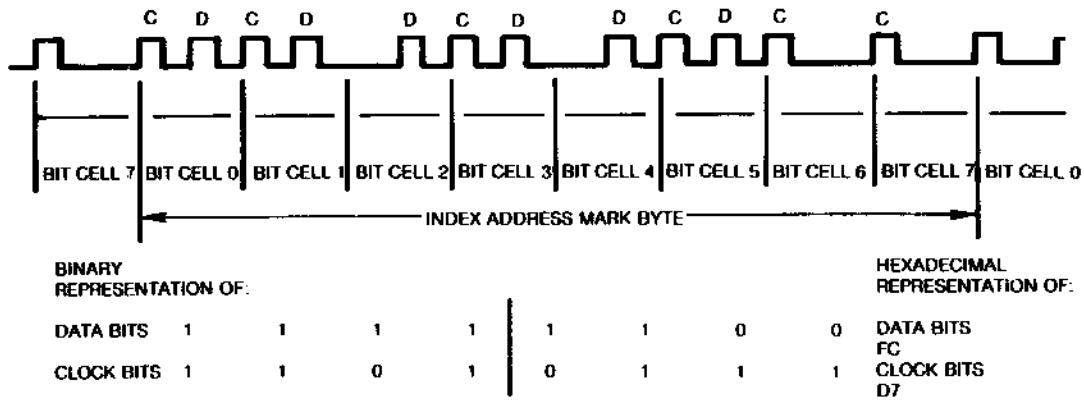


1 Note byte count is for 26 records.  
Gap 3 change byte count with record length.

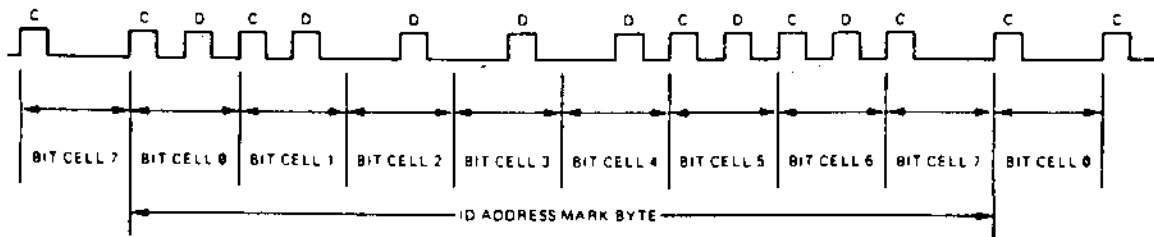
**FIGURE 9. TRACK FORMAT**



**FIGURE 10. MFM TRACK FORMAT COMPARISON**



**FIGURE 11. INDEX ADDRESS MARK FM**



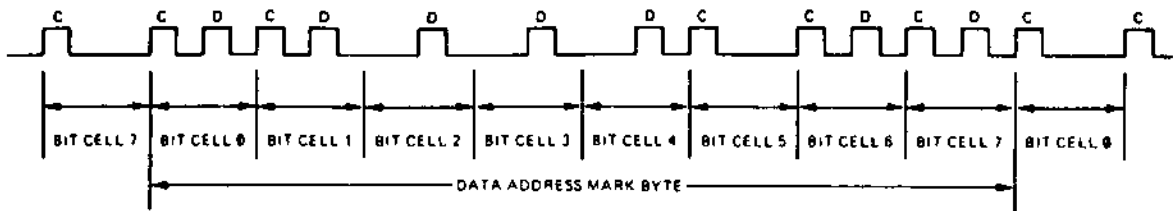
BINARY REPRESENTATION OF:

DATA BITS	1	1	1	1	1	1	1	0
CLOCK BITS	1	1	0	0	0	1	1	1

HEXADECIMAL REPRESENTATION OF:

DATA BITS  
FE  
CLOCK BITS  
C7

FIGURE 12. ID ADDRESS MARK FM.



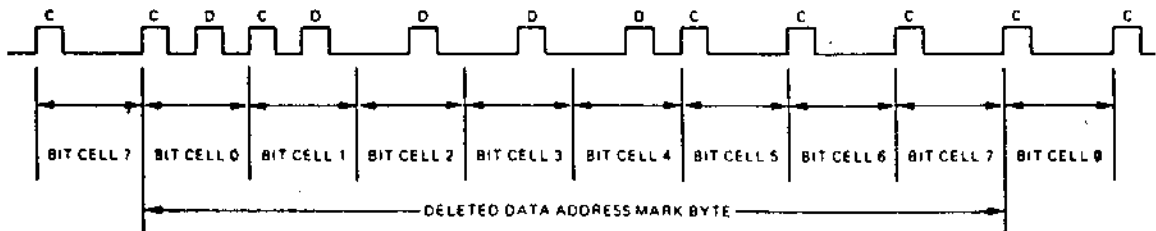
BINARY REPRESENTATION OF:

DATA BITS	1	1	1	1	1	0	1	1
CLOCK BITS	1	1	0	0	0	1	1	1

HEXADECIMAL REPRESENTATION OF:

DATA BITS  
FB  
CLOCK BITS  
C7

FIGURE 13. DATA ADDRESS MARK FM



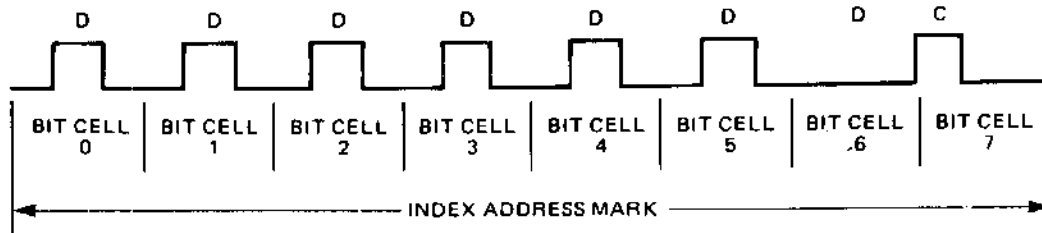
BINARY REPRESENTATION OF:

DATA BITS	1	1	1	1	1	0	0	0
CLOCK BITS	1	1	0	0	0	1	1	1

HEXADECIMAL REPRESENTATION OF:

DATA BITS  
FB  
CLOCK BITS  
C7

FIGURE 14. DELETED DATA ADDRESS MARK FM



BINARY REPRESENTATION OF:

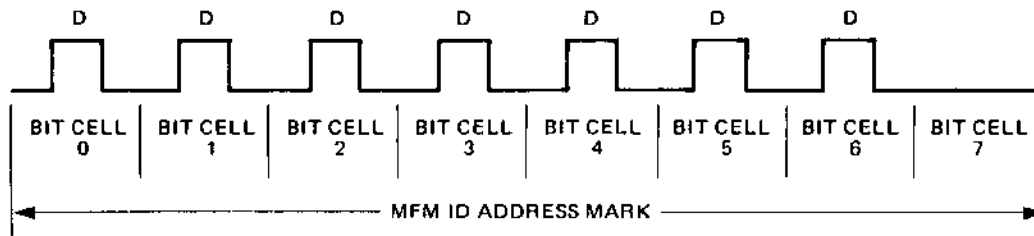
DATA BITS  
CLOCK BITS

1 1 1 1 1 1 1 0  
0 0 0

HEXADECIMAL REPRESENTATION OF:

FC  
01

FIGURE 15. MFM INDEX ADDRESS MARK



BINARY REPRESENTATION OF:

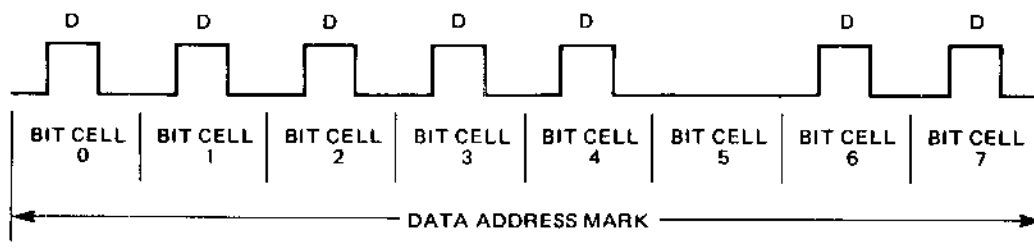
DATA BITS  
CLOCK BITS

1 1 1 1 1 1 1 0  
0 0 0 0 0 0 0 0

HEXADECIMAL REPRESENTATION OF:

FE  
00

FIGURE 16. MFM ID ADDRESS MARK



BINARY REPRESENTATION OF:

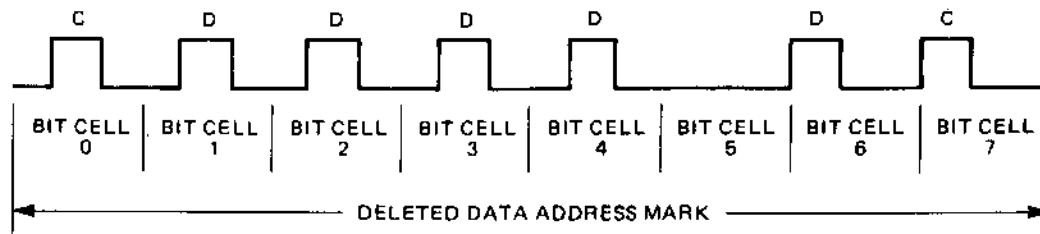
DATA BITS  
CLOCK BITS

1 1 1 1 1 0 1 1  
0 0 0 0 0 0 0 0

HEXADECIMAL REPRESENTATION OF:

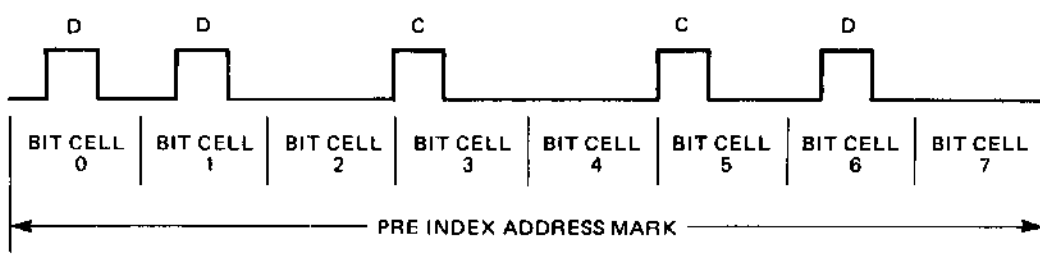
FB  
00

FIGURE 17. MFM DATA ADDRESS MARK



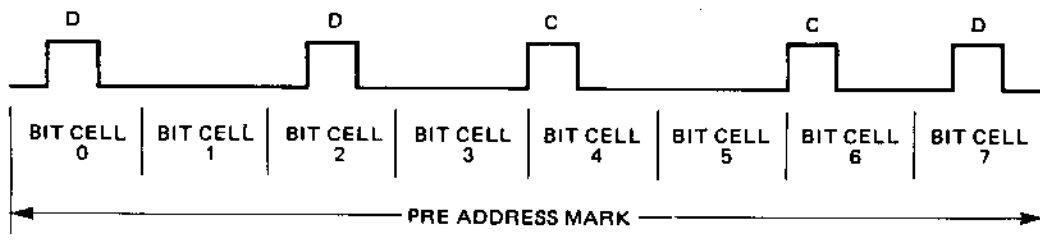
BINARY REPRESENTATION OF:									
DATA BITS	1	1	1	1	1	0	0	0	F8
CLOCK BITS	0	0	0	0	0	0	1	1	03

**FIGURE 18. MFM DELETED DATA ADDRESS MARK**



BINARY REPRESENTATION OF:									
DATA BITS	1	1	0	0	0	0	1	0	C2
CLOCK BITS	0	0	0	1	0	1	0	0	14

**FIGURE 19. MFM INDEX PRE ADDRESS MARK**



BINARY REPRESENTATION OF:									
DATA BITS	1	0	1	0	0	0	0	1	A1
CLOCK BITS	0	0	0	0	1	0	1	0	0A

**FIGURE 20. MFM PRE ID/DATA ADDRESS MARK**



**1.2.6.1** Index is the physical detector indicating one revolution of the media and is used to initiate format operations, generate the Ready signal in the storage device, insure one complete revolution of the media has been searched, and for a deselect storage device signal after a certain number of revolutions.

Gap 1- **G4A** is from the physical index address mark sync and allows for physical index variation, speed variation and interchange between Storage Devices.

**Sync** is a fixed number of bytes for Separator synchronization prior to the address mark. It includes a minimum of two bytes plus worst case Separator sync up requirements.

**Index Pre Address Mark (MFM)** - Three bytes of C2 with unique clock bits not written per the encode rules. Refer to Figure 19.

**Index Address Mark (FM)** - is a unique byte to identify the index field and is not written per the encode rules. Refer to Figure 11.

**Index Address Mark (MFM)** - is one byte of FC and it is written per the encode rules. Refer to Figure 15.

**G1** is from index address mark to ID field address mark sync.

ID Field - **Sync** is a fixed number of bytes for Separator synchronization prior to AM. Includes a minimum of two bytes plus worst case Separator sync up requirements.

**ID Pre Address Mark (MFM)** - Three bytes of A1 with unique clock bits not written per the encode rules. Refer to Figure 19.

**ID Address Mark (FM)** - is a unique byte to identify the ID field and not written per the encode rules. Refer to Figure 12.

**ID Address Mark (MFM)** - is one byte of FE and it is written per the encode rules. Refer to Figure 16.

**ID** - is a four byte address containing track number, head number, record number, and record length.

**CRC** - is two bytes for cyclic redundancy check.

Gap 2 - **Gap** from IDCRC to data AM sync and allows for speed variation, oscillator variation and erase core clearance of IDCRC bytes prior to write gate turn on for an update write.

Data field - **Sync** is a fixed number of bytes for Separator synchronization prior to the AM. Includes a minimum of two bytes plus worst case separator sync up requirements.

**Pre Data Address Mark (MFM)** - Three bytes of A1 with unique clock bits not written per the encode rules. Refer to Figure 20.

**Data Address Mark (FM)** - is a unique byte to identify the Data Field and it is not written per the encode rules. Refer to Figure 13.

**Data Address Mark (MFM)** - is one byte of FB or F8 and it is written per the encode rules. Refer to Figure 18.

**Data** - is the area for user data.

**CRC** - is two bytes for cyclic redundancy check.

**WG OFF (Write Gate Off)** - is one byte to allow for the Write Gate turn off after an update write.

- Gap 3 - Gap from WG OFF to next ID AM sync and allows for the erase core to clear the Data Field CRC bytes, speed and write oscillator variation, read preamplifier recovery time and system turn around time to read the following ID Field.
- Gap 4 - **G4B** is the last gap prior to physical index and allows for speed and write oscillator variation during a format write and physical index variation.

### 1.3.0 TRACK ACCESSING

- Carriage Actuator Motor
- Actuator Control Logic
- Reverse Seek
- Forward Seek
- Track 00 Flag

**1.3.1** Seeking the read/write heads from one track to another is accomplished by selecting the desired direction utilizing the Direction Select interface line, loading the read/write heads, and then pulsing the Step line. Multiple track accessing is accomplished by repeated pulsing of the Step line until the desired track has been reached. Each pulse on the Step line will cause the read/write heads to move one track either in or out depending on the Direction Select line.

**1.3.2** The Carriage Actuator Motor used on the SA850/851 is a four phase, 3.6 degree, permanent magnet stepper motor.

**1.3.2.1** There are four stator poles with four teeth per pole extending axially the length of the rotor. The rotor contains 25 teeth per half, spaced 14.4 degrees apart, with each being displaced one tooth pitch relative to each other. The rotor is permanently magnetized with one gear (half) being the north pole and the other the south pole. The four winding per phase are those which when energized will magnetize the poles causing the rotor to move  $\frac{1}{4}$  of a gear tooth pitch or 1 step.

### 1.3.3 ACTUATOR CONTROL LOGIC (FIGURE 21)

#### 1.3.3.1 POWER ON RESET

The Step Counter (FF A and FF B) is a modified Gray Code counter that counts 0, 1, 3 and 2. At power on, the Step Counter is reset causing the not outputs to be active. When the door is closed and the heads loaded the not outputs actuate the 1 and 4 drivers. With these drivers active the position zero windings are excited causing the rotor to align as shown in Figure 22. (Note, depending on the previous state of the stator windings, the heads may move up to two tracks).

#### 1.3.3.2 FORWARD SEEK

- Seek forward five tracks.
- Assuming:
  - Present position of the read/write heads to be track 00.
  - Direct Select at a minus level (from the host system).
  - Write Gate inactive.
  - Five Step pulses to be received (from the host system).
  - Step Counter reset (drivers 1 and 4 active).

Minus Direction Select is inverted and becomes + Direction Select. Since the Step Counter is reset (low), a high is at one input of Exclusive OR A and a low at Exclusive OR B. + Direction Select is high and inverts both signals present at Exclusive OR's A and B, causing the input to FFB to be high.

When the first Step pulse is sent to the control logic, it is ANDed with -Read Gate and then clocks FF A off and FF B on. this enables drivers 1 and 3 causing the Actuator Motor to move 3.6° in a clockwise direction, which in turn moves the carriage assembly one track towards the center of the diskette. Figure 21 (Track 01, Count 1).

With FF A off and FF B on, a low is presented to Exclusive OR A and B allowing + Direction Select to pass to both FFS. Upon receipt of the next Step pulse both FFS are clocked on, enabling drivers 2 and 3. Figure 22 (Track 02, Count 3).

With both FFS on, a low is at Exclusive OR A and a high at Exclusive OR B which presents + Direction Select to FF A. The next Step pulse clocks FF A on and FF B off enabling drivers 2 and 4. Figure 25 (Track 03, Count 2).

This process is continued until the host system stops sending step pulses at Track 05. At that time FF A is off and FF B on enabling drivers 1 and 3. Figure 23 (Count 1).

### 1.3.3.3 REVERSE SEEK

- Seek in a reverse direction five tracks.
- Assuming:
  - Present position of the read/write heads to be track 05. Direction Select at a positive level (from the host system).
  - Write Gate inactive.
  - Five step pulses to be received.
  - FF A is off and FF B is on, drivers 1 and 3 active.

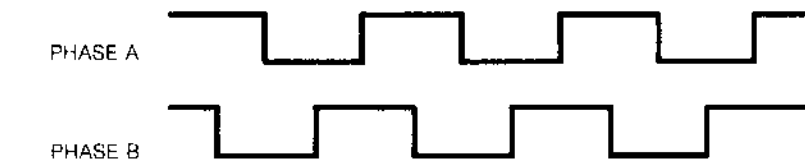
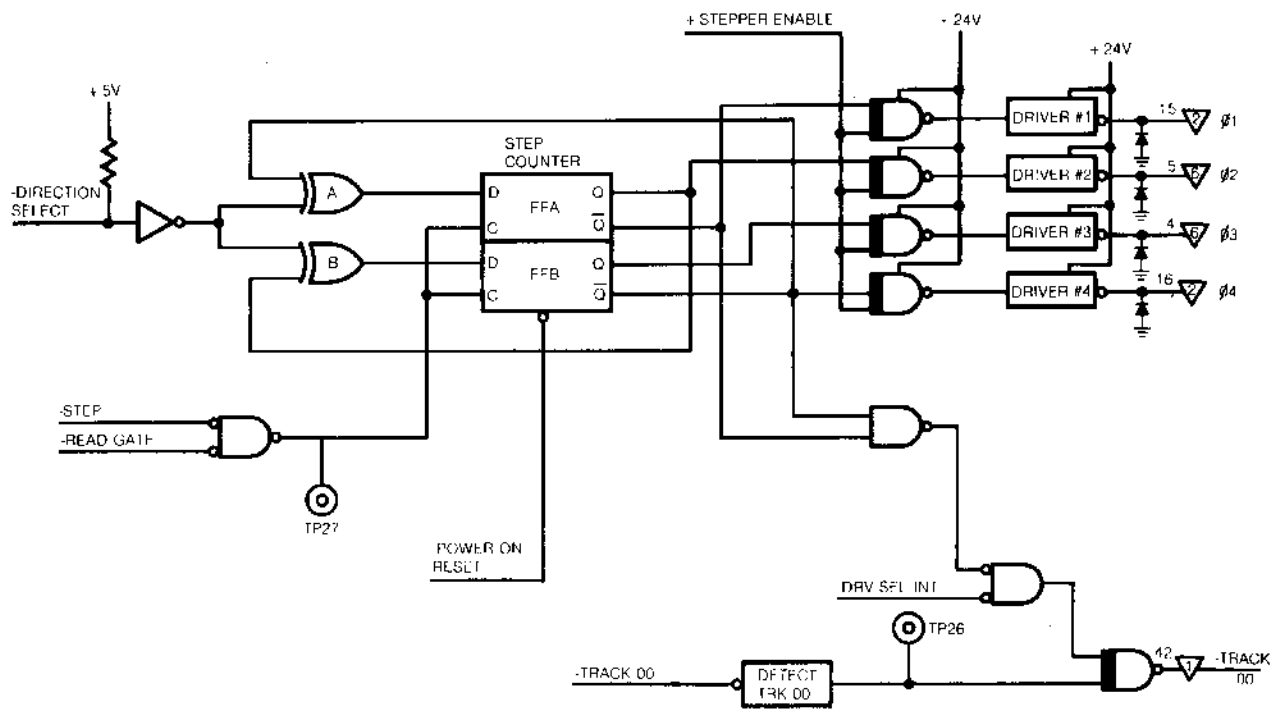
Plus Direction Select is inverted and becomes -Direction Select. With FF A off and FF B on lows are presented to Exclusive ORs A and B. With the first step pulse the FFS are clocked off enabling the 1 and 4 drivers causing the actuator motor to move 3.6 degrees in a counter-clockwise direction, moving the carriage one track towards the outside of the diskette. Figure 22 (Track 04, Count 0).

With both FFS off a high is presented to Exclusive OR A and a low to Exclusive OR B. the next Step pulse clocks FF A on and FF B off enabling drivers 2 and 4. Figure 25 (Track 03, Count 2).

This process continues until the fifth Step pulse. With lows at the Exclusive ORs, and FF's are clocked off enabling drivers 1 and 4. Figure 21 (Track 00, Count 0).

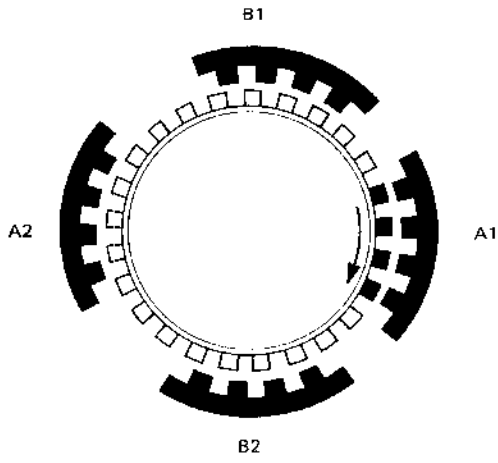
### 1.3.4 TRACK ZERO INDICATOR

Track 00 Pin 42 is provided to the host system to indicate the read/write heads are at track zero. The Track Zero Flag on the carriage assembly is adjusted so that the flag covers the photo transistor at track one. When FF A and B are clocked off the actuator moves to track zero, the Q outputs and Drive Select Internal are ANDed together and then ANDed with the Track Zero detect to send the Track Zero indication to the host system. (Figure 21)

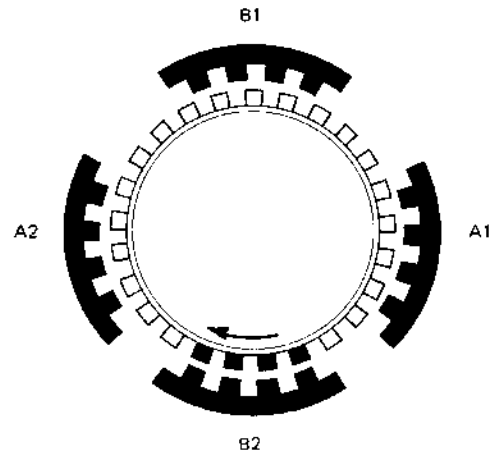


TRACK	00	01	02	03	04	05	06	07	08	09	10	11
STEP COUNT	0	1	3	2	0	1	3	2	0	1	3	2

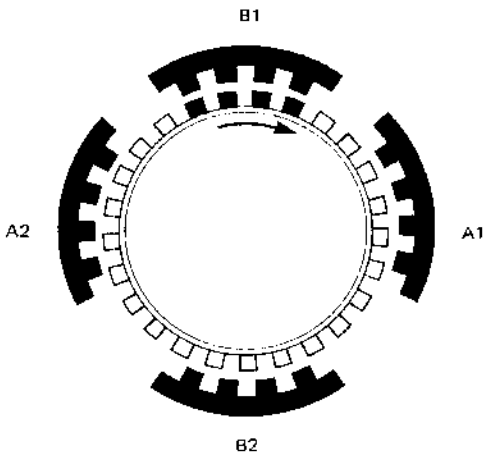
**FIGURE 21. ACTIVATOR CONTROL LOGIC**



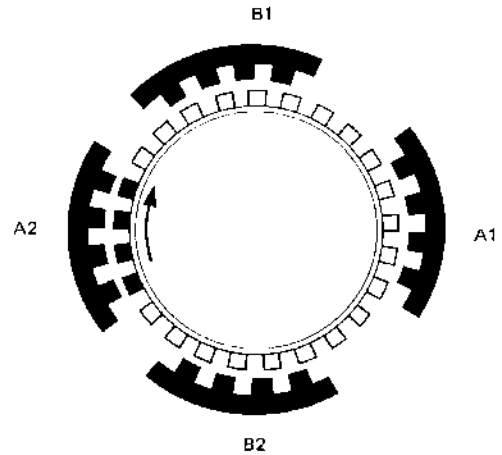
**FIGURE 22. COUNT 0**



**FIGURE 23. COUNT 1**



**FIGURE 24. COUNT 2**



**FIGURE 25. COUNT 3**

### 1.4.0 READ-WRITE OPERATIONS

- SA850/851 uses double frequency NRZI recording method.
- The read/write heads are similar to a ring with a gap and a coil wound at some point on the ring.
- During a write operation, a bit is recorded when the flux direction in the ring is reversed by rapidly reversing the current in the coil.
- During a read operation, a bit is read when the flux direction in the ring is reversed as a result of a flux reversal on the diskette surface.

**1.4.1** The SA850/851 drive uses the double-frequency (2F) horizontal non return to zero (NRZI) method of recording. Double frequency is the term given to the recording system that inserts a clock bit at the beginning of each bit cell time thereby doubling the frequency of recorded bits. This clock bit, as well as the data bit, are provided by the using system. See Figure 26.

**1.4.2** The read/write heads are similar to a ring with a gap and a coil wound some point on the ring. When current flows through the coil, the flux induced in the ring fringes at the gap. As the diskette recording surface passes by the gap, the fringe flux magnetizes the surface in a horizontal direction. See Figure 27.

**1.4.3** During a write operation, a bit is recorded when the flux direction in the ring is reversed by rapidly reversing the current coil. The fringe flux is reversed in the gap and hence the portion of the flux flowing through the oxide recording surface is reversed. If the flux reversal is instantaneous in comparison to the motion of the diskette, it can be seen that the portion of the diskette surface that just passed under the gap is magnetized in one direction while the portion under the gap is magnetized in the opposite direction. This flux reversal represents a bit. See Figure 28.

**1.4.4** During a read operation, a bit is read when the flux direction in the ring is reversed as a result of a flux reversal on the diskette surface. The gap first passes over an area that is magnetized in one direction, and a constant flux flows through the ring coil. The coil registers no output voltage at this point. When a flux transition passes under the gap, the flux flowing through the ring and coil will make a 180° reversal. This means that the flux reversal in the coil will cause a voltage output pulse. See Figure 29.

**1.4.5** Figure 30 shows the 1F and 2F recording flux transitions with pulse relationship.

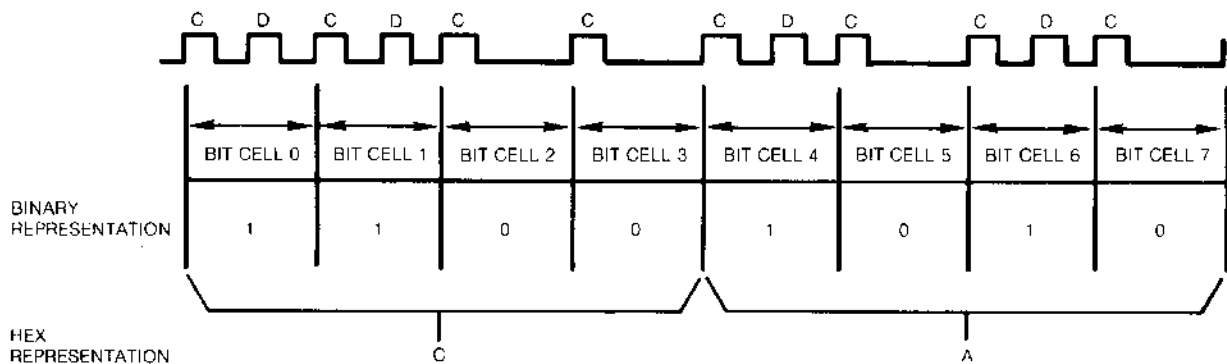
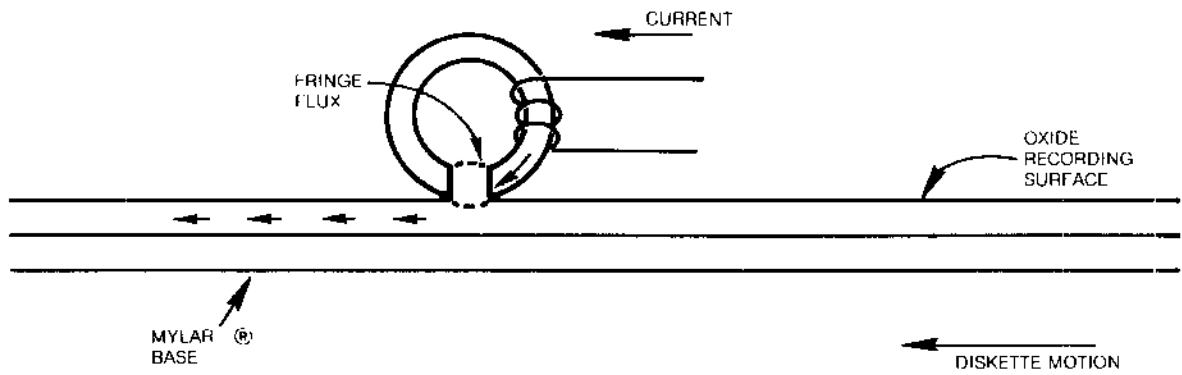
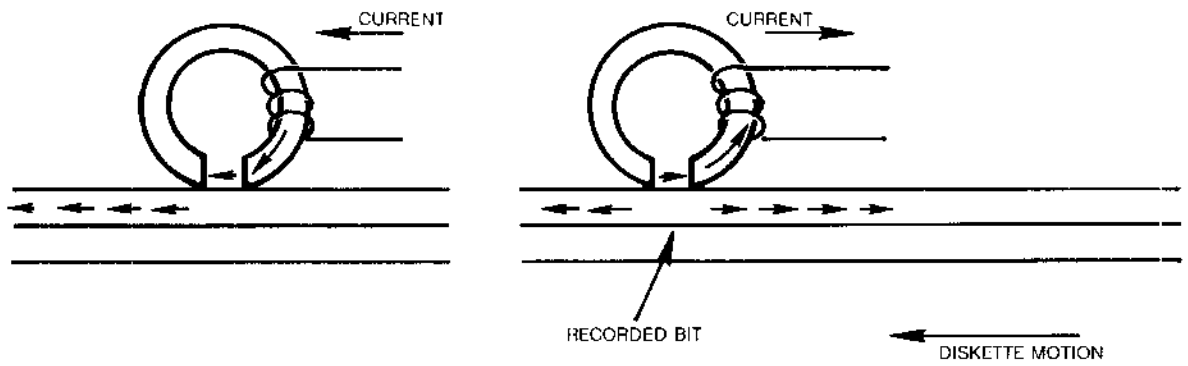


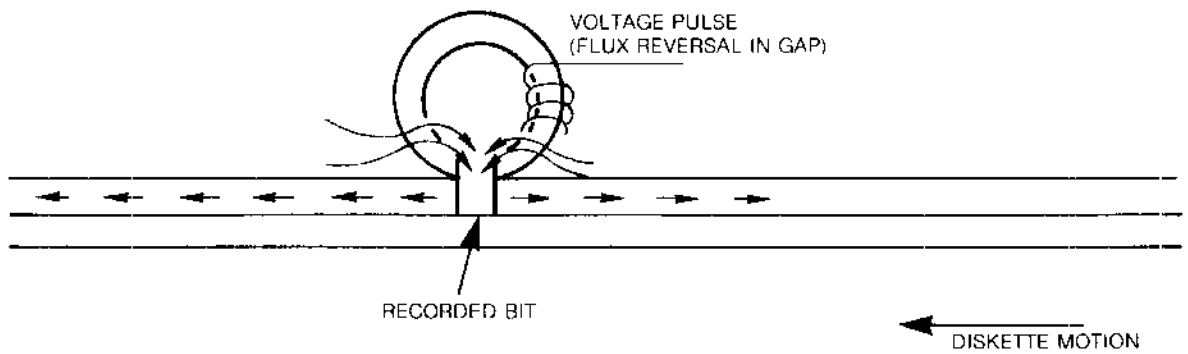
FIGURE 26. BYTE



**FIGURE 27. BASIC R/W HEAD**



**FIGURE 28. RECORDED BIT**



**FIGURE 29. READING A BIT**

### 1.5.0 READ/WRITE HEAD

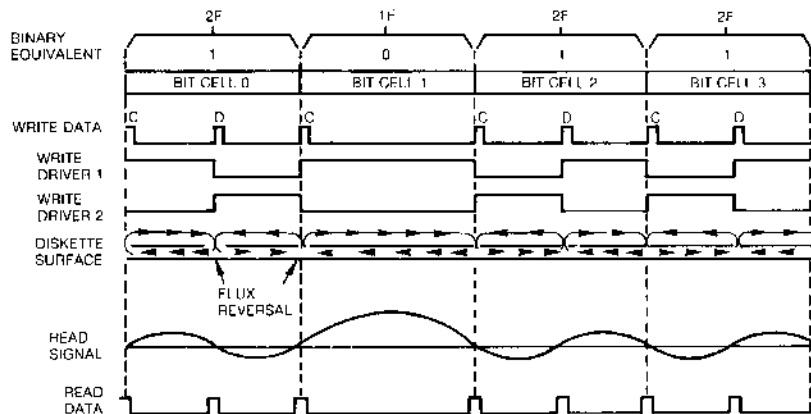
- The read/write heads contain two coils each.
- When writing, the head erases the outer edges of the track to insure there is erased areas between adjacent tracks.

**1.5.1** Each of the read/write heads contain two coils. Two read/write coils are wound on a single core, center tapped and one erase coil is wound on a yoke that spans the track being written. The read/write and erase coils are connected as shown in Figure 31.

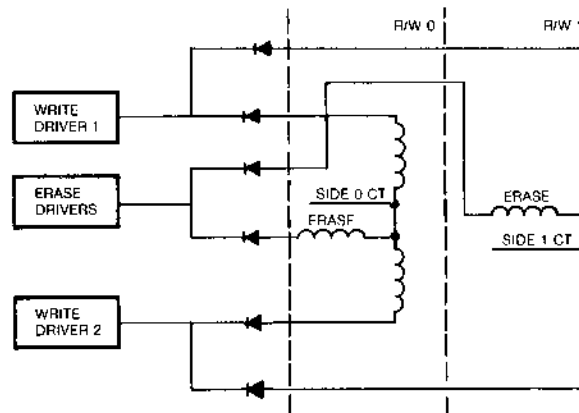
**1.5.2** On a write operation, the erase coil is energized. This causes the outer edges of the track to be trim erased so as the track being recorded will not exceed the .012" track width. The trim erasing allows for minor deviations in read/write head current so as one track is recorded, it will not "splash over" to adjacent tracks.

**1.5.3** Each bit written will be directed to alternate read/write coils, thus causing a change in the direction of current flow through the read/write head. This will cause a change in the flux pattern for each bit. The current through either of the read/write coils will cause the old data to be erased as new data is recorded.

**1.5.4** On a read operation, as the direction of flux changes on the diskette surface as it passes under the gap, current will be induced into one of the windings of the read/write head. This will result in a voltage output pulse. When the next data bit passes under the gap, another flux change in the recording surface takes place. This will cause current to be induced in the other coil causing another voltage output pulse.



**FIGURE 30.** 1F AND 2F RECORDING FLUX AND PULSE RELATIONSHIP



**FIGURE 31.** READ/WRITE HEADS



### 1.6.0 WRITE CIRCUIT OPERATION (FIGURE 32)

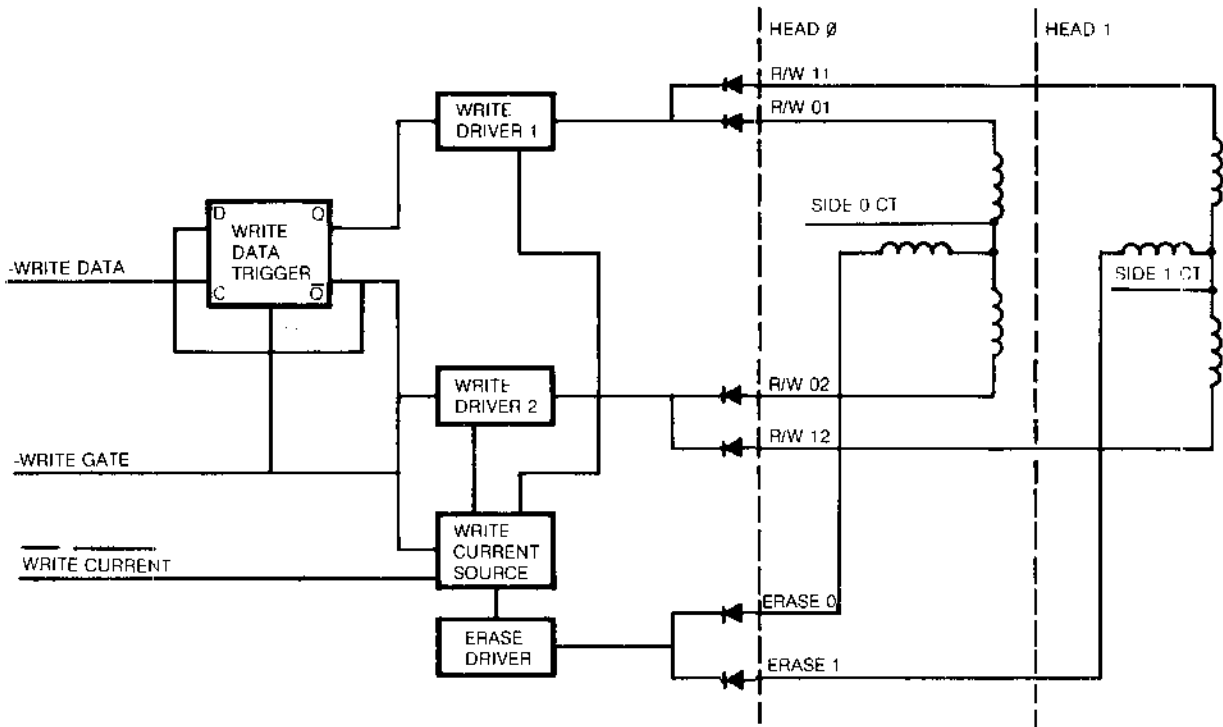
- The binary connected Write Data Trigger toggles with each pulse on the Write Data line.
- The Write Data Trigger alternately drives one or the other of the Write Drivers.
- Write Gate allows write current to flow to the Write Driver circuits.
- Write Current sensed allows Erase Coil current.
- Heads are selected by grounding the appropriate center tap.

**1.6.1** Write data pulses (clock & data bits) are supplied by the using system. The Write Trigger “toggles” with each pulse. The Q and  $\bar{Q}$  outputs are fed to alternate Write Drivers.

**1.6.2** Write Gate, from using system, and not Write Protect, are anded together to provide write current.

**1.6.3** The output of one of the Write Drivers allows write current to flow through one-half of the read/write coil of each head. When the Write Data Trigger toggles, the other Write Driver provides the write current to the other half one the read/write coils.

**1.6.4** When write current is sensed flowing to the Write Drivers, a signal is generated to provide trimmer erase coil current.



**FIGURE 32. WRITE CIRCUIT FUNCTIONAL DIAGRAM**

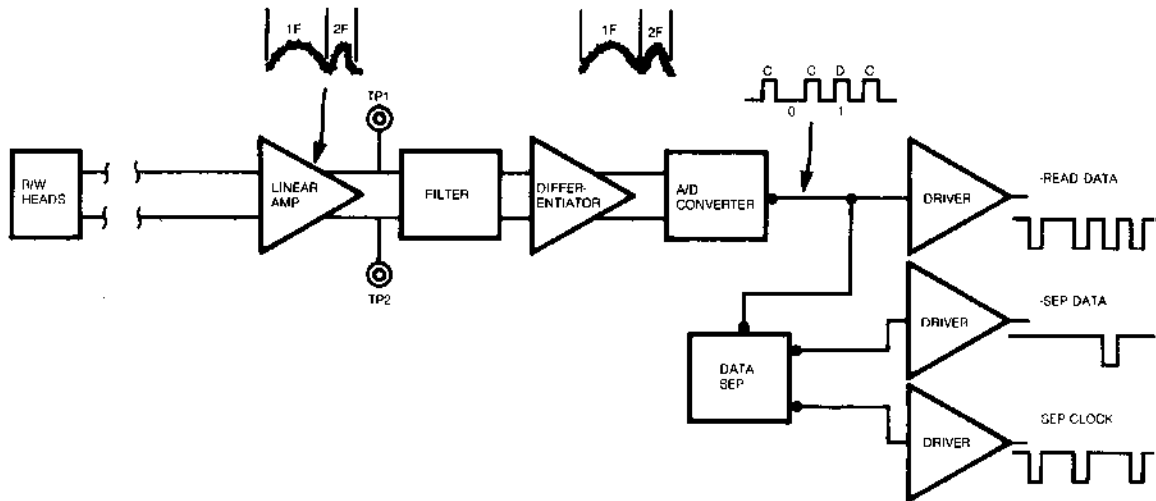
### 1.7.0 READ CIRCUIT OPERATION (FIGURE 33)

- Duration of all read operations is under control of the using system.
- When the heads are loaded, the read signal amplitude becomes active and is fed to the amplifier.
- As long as the heads are loaded and write gate is not active, the read signal is amplified and shaped, the square wave signals are sent to the host system.
- The data separator separates the read data into clock pulses and data pulses (SA851 only).

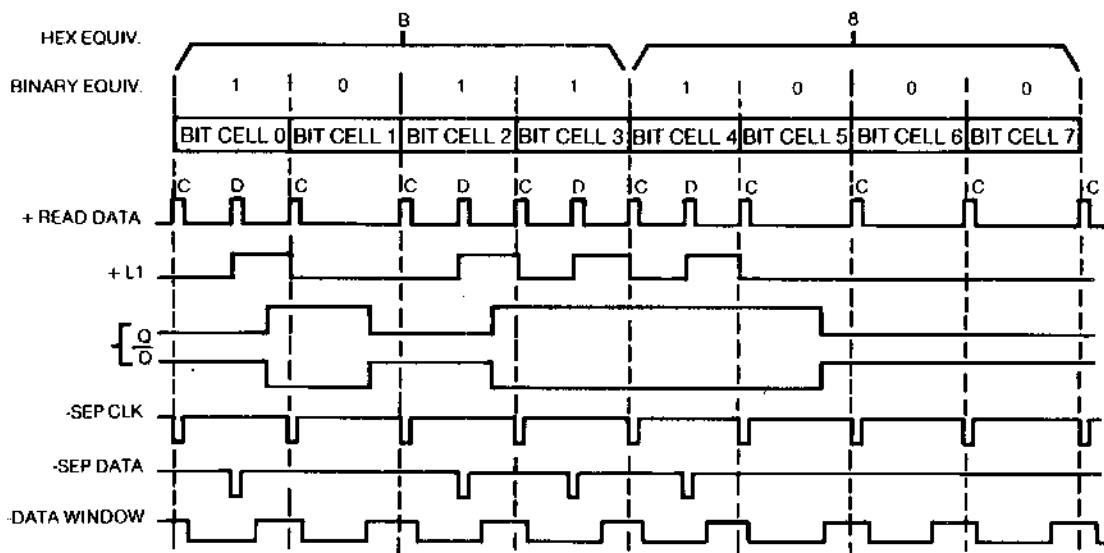
**1.7.1** When the using system requires data from the diskette drive, the using system must first load the heads and select the side. With loading of the heads and write gate being inactive, the read signal is fed to the amplifier section of the read circuit. After amplification, the read signal is fed to a filter where noise spikes are removed. The read signal is then fed to the differential amplifier.

**1.7.2** Since a pulse occurs at least once every  $4\mu\text{s}$  and when data bits are present once every  $2\mu\text{s}$ , the frequency of the read data varies. The read signal amplitude decreases as the frequency increases. Note the signals on Figure 31. The differential amplifier will amplify the read signals to even levels and make square waves out of the read signals (sine waves).

**1.7.3** The data separator (SA851 only) is a single time constant separator, that is, the clock and data pulses must fall within pre-specified time frames or windows (single density only).



**FIGURE 33. READ CIRCUIT FUNCTIONAL DIAGRAM**



**FIGURE 34. DATA SEPARATION TIMING DIAGRAM**

## 1.8.0 INTERFACE

The Electrical interface between the SA850/851 drive and the host system is via three connectors. The first connector, J1, provides the signal interface; the second connector, J5, provides the DC power; and the third connector, J4, provides the AC power and frame ground.

### 1.8.1 J1/P1 CONNECTOR

Connection to J1 is through a 50 pin PCB edge card connector. The pins are numbered 1 through 50 with the even numbered pins on the component side of the PCB and the odd numbered pins on the non-component side. Pin 2 is located on the end of the PCB connector closest to the AC motor capacitor and is labeled 2. A key slot is provided between pins 4 and 6 for optional connector keying. Refer to Figure 35.

### 1.8.2 AC POWER (REFER TO TABLE 1)

The AC power to the drive is via the connector P4/J4 located to the rear of the drive and below the AC motor capacitor. The P4/J4 pin designations are outlined in Table 1 for standard as well as optional AC power.

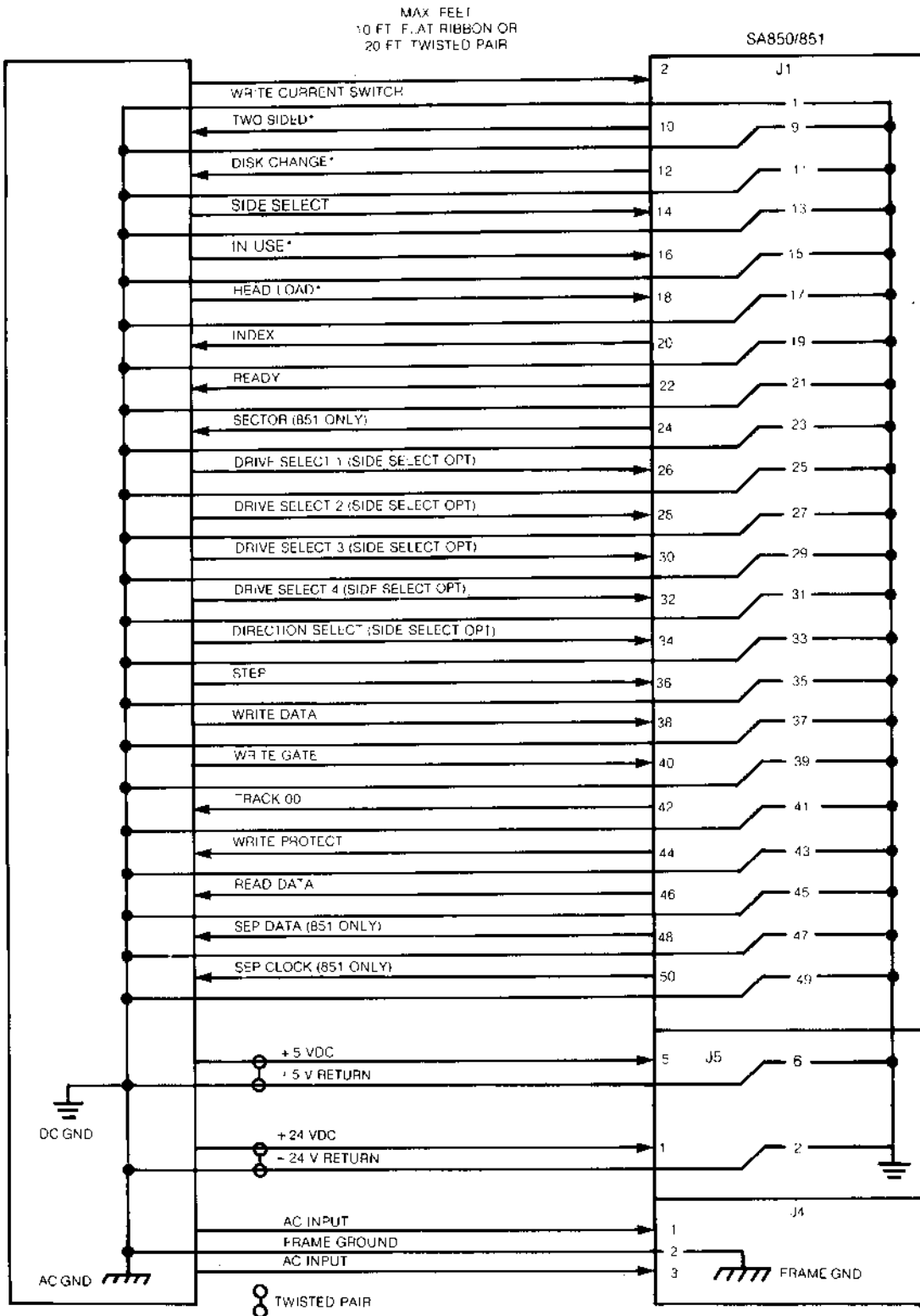
### 1.8.3 DC POWER (REFER TO TABLE 2)

DC power to the drive is via connector P5/J5 located on the non-component side of the PCB near the P4 connector. The two DC voltages and their specifications along with their P5/J5 pin designators, are outlined in Table 2.

### 1.8.4 OUTPUT LINES

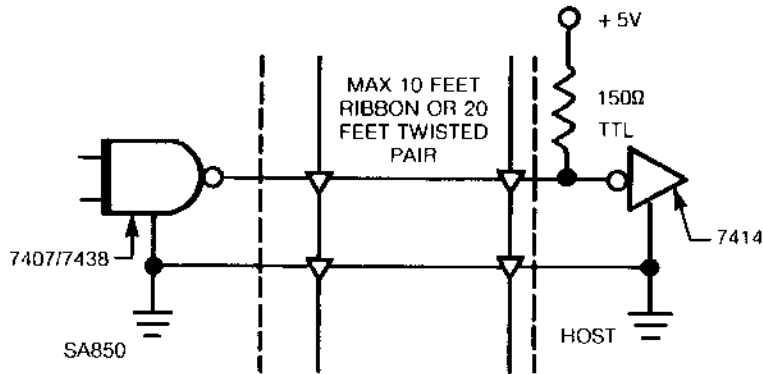
There are five standard output lines from the SA850, and eight standard output lines from the SA851. Also, there are two optional output lines and eight alternate outputs available from either the SA850 or SA851. The output signals are driven with an open collector output stage capable of sinking a maximum of 40 ma at a logical zero level or true state with a maximum voltage of 0.4V measured at the driver. When the line driver is in a logical one or false state, the driver is off and the collector current is a maximum of 250 microamperes.

Refer to Figure 36 for the recommended circuit.



\* These lines are alternate input/output lines and they are enabled by jumper plugs. Not shown are pins 4, 6 and 8 which are alternate I/O pins.

**FIGURE 35. INTERFACE CONNECTIONS**



**FIGURE 36. INTERFACE SIGNAL DRIVER/RECEIVER**

P4 PIN	60 Hz		50 Hz	
	115 V (Standard)	208/230 V	110V	220V
1	85-127 VAC	170-253 VAC	85-127 VAC	170-253 VAC
2	Frame Gnd	Frame Gnd	Frame Gnd	Frame Gnd
3	85-127 V Rtn	170-253 V Rtn	85-127 V Rtn	170-253 V Rtn
MAX CURRENT	0.35 Amps	0.25 Amps	0.35 Amps	0.25 Amps
FREQ TOLERANCE	± 0.5 Hz		± 0.5 Hz	

**TABLE I.**

P5 PIN	DC VOLTAGE	TOLERANCE	CURRENT	MAX RIPPLE (p to p)
1	+ 24 VDC	± 2.4 VDC	1.0A Max* 0.85A Typ	100 mv
2	+ 24 V Return			
6	+ 5 V Return			
5	+ 5 VDC	± 0.25 VDC	1.1A Max 1.0A Typ	50 mv

\*If either customer installable option described in sections 7.1 and 7.3 are used, the current requirement for the + 24-VDC is a multiple of the maximum + 24V current times the number of drives on the line

**TABLE 2**

## **2.0 MAINTENANCE SECTION**

### **2.1.0 MAINTENANCE FEATURES**

#### **2.1.1 ALIGNMENT DISKETTE**

The SA122 Alignment Diskette is used for alignment of the SA850/851. The following adjustments can be made using the SA122. Adjustments are checked on head zero and head one. The drive under test should be jumpered to the 850 position.

1. R/W Head radial alignment using track 38.
2. Index Photo-Detector Adjustment using tracks 01 and 76.
3. Track 00 is recorded with standard IBM 3740 format.
4. TK 75 has 1f + 2f signal.

**NOTE:** Caution should be exercised in using the SA122 Alignment Diskette. Tracks 00, 01, 36, 37, 38, 39, 40, 75, and 76 should not be written on. To do so will destroy pre-recorded tracks.

#### **2.1.2 SA809 EXERCISER**

The SA809 Exerciser is built on a PCB whose dimensions are 8" x 8". The exerciser PCB can be used in a stand alone mode or it can be built into a test station or used in a tester for field service.

The Exerciser is designed to enable the user to make all adjustments and check outs required on the SA850/851 drives, when used with the SA122 Alignment Diskette.

The exerciser has no intelligent data handling capabilities but can write both 1f and 2f frequencies. The exerciser can enable read in the drive to allow checking of read back signals.

#### **2.1.3 SPECIAL TOOLS**

The following special tools are available for performing maintenance on the SA850/851.

<b>Description</b>	<b>Part Number</b>
Alignment Diskette	SA122
Cartridge Guide Adj. Tool	50377-1
Exerciser	50619-0
Spanner Wrench	50752-0
Head Penetration Tool Set	51218-0

### **2.2.0 DIAGNOSTIC TECHNIQUES**

#### **2.2.1 INTRODUCTION**

Incorrect operating procedures, faulty programming, damaged diskettes, and "soft errors" created by airborne contaminants, random electrical noise, and other external causes can produce errors falsely attributed to drive failure or misadjustment.

Unless visual inspection of the drive discloses an obvious misalignment or broken part, attempt to repeat the fault with the original diskette, then attempt to duplicate fault on second diskette.

## **2.2.2 "SOFT ERROR" DETECTION AND CORRECTION**

Soft errors are usually caused by:

1. Airborne contaminants that pass between the read/write head and the disk. Usually these contaminants can be removed by the diskette self-cleaning wiper.
2. Random electrical noise that usually last for a few microseconds.
3. Small defects in the written data and/or track not detected during the write operation that may cause a soft error during a read.

The following procedures are recommended to recover from the above mentioned soft errors:

1. Reread the track ten (10) times or until such time as the data is recovered.
2. If data is not recovered after using step 1, access the head to the adjacent track in the same direction previously moved, then return to the desired track.
3. Repeat Step 1.
4. If data is not recovered, the error is not recoverable.

## **2.2.3 WRITE ERROR**

If an error occurs during a write operation, it will be detected on the next revolution by doing a read operation, commonly called a "write check". To correct the error, another write and write check operation must be done. If the write operation is not successful after ten (10) attempts have been made, a read operation should be attempted on another track to determine if the media or the drive is failing. If the error still persists the diskette should be replaced and the above procedure repeated. If the failure still exists, consider the drive defective. If the failure disappears, consider the original diskette defective and discard it.

## **2.2.4 READ ERROR**

Most errors that occur will be "soft" errors. In these cases, performing an error recovery procedure will recover the data.

## **2.2.5 SEEK ERROR**

1. Actuator malfunction.

To recover from a seek error recalibrate to track 00 and perform another seek to the original track.

## 2.2.6 TEST POINTS 850/851

1. Read data signal
2. Read data signal
5. Signal ground
6. Signal ground
7. Signal ground
11. + Head load
12. -Index and 851 sector pulses (single sided disk)
13. -Index and 851 sector pulses (double sided disk)
16. + Read data
17. -Data separator timing (long data window)
18. -Data separator timing (short data window)
25. + Write protect
26. + Detect track 00
27. + Gated step pulses
28. Signal ground
- I. -Separated index (interface)
- R. -Ready (interface)
- S. -Separated sector 851 (interface)

## 2.2.7 CONNECTORS

**2.2.7.1** J1/P1 provide the signal interface to the host system. The pin designators are as listed below.

2. Write Current Switch
4. Alternate I/O
6. Alternate I/O
8. Alternate I/O
10. Two Sided (optional)
12. Disk Change (optional)
14. Side Select
16. In Use (optional)
18. Head Load (optional)
20. Index
22. Ready
24. Sector (851 only)
26. Drive Select 1 (or Side Select Option)
28. Drive Select 2 (or Side Select Option)
30. Drive Select 3 (or Side Select Option)
32. Drive Select 4 (or Side Select Option)
34. Direction Select (or Side Select Option)
36. Step
38. Write Data
40. Write Gate
42. Track 00
44. Write Protect
46. Read Data
48. FM Sep Data (851 only)
50. FM Sep Clock (851 only)

NOTE: All odd numbered pins are ground.



**2.2.7.2 J2/P2** provide control signals and power to the Head Load Actuator, the Head Position actuator dropping resistors, In Use LED and Door Lock solenoid and the detector assemblies. The pin designators are as listed below:

- A. Key
- B. + In Use LED
- C. + Track 00 LED
- D. + Write Protected
- E. + Index LED
- F. + Door Closed
- H. -Door Closed
- J. Not used
- K. -Door Locked
- L. -Track 00
- M. + Write Protected
- N. + Index/Sector 0 Detector
- P. + Index/Sector 1 Detector
- R. Key
- S. + Stpr Wndg/Res A
- T. + Stpr Wndg/Res B
- U. -Head Load
- 1. Key
- 2. Ground
- 3. Ground
- 4. Ground
- 5. Ground
- 6. Ground
- 7. Not Used
- 8. Not Used
- 9. + 24V Door Lock
- 10. + 5V Track 00 Detector
- 11. + 5V Write Protect
- 12. + 5V Index (0 & 1) Detector
- 13. Not Used
- 14. Key
- 15. + Stpr Res A
- 16. + Stpr Res B
- 17. + 24V Head Load

**2.2.7.3 J3/P3** provides to interface to the Read/Write coils and the trim erase coils of the magnetic recording heads. The pins are listed below:

- 1. Shield 0
- 2. Key
- 3. Read/Write 01
- 4. Side 0 CT
- 5. Read/Write 02
- 6. Erase 0
- 7. Erase 1
- 8. Read/Write 12
- 9. Side 1 CT
- 10. Read/Write 11
- 11. Key
- 12. Shield 1

**2.2.7.4** J4/P4 provide AC power and ground as listed below:

1. -AC Motor Power A
2. -Frame Ground
3. AC Motor Power B

**2.2.7.5 J5/P5** J5/P5 provide DC power and ground as listed below:

1. + 24 Volts DC
2. + 24 Volt Ground Return
3. Not Used
4. Not Used
5. + 5 Volts DC
6. + 5 Volts Ground Return

**2.2.7.6 J6/P6** J6/P6 provide power to the Head Positioning actuator as listed below:

1. + Stpr Wndg/Res B
2. Key
3. + Stpr Wndg/Res A
4. + Stpr Wndg B
5. + Stpr Wndg A

## 2.3.0 PREVENTATIVE MAINTENANCE

### 2.3.1 INTRODUCTION

The prime objective of any preventive maintenance activity is to provide maximum machine availability to the user. Every preventative maintenance operation should assist in realizing this objective. Unless a preventative maintenance operation cuts machine downtime, it is unnecessary.

Visual inspection is the first step in every scheduled maintenance operation. Always look for corrosion, dirt, wear, binds, and loose connections. Noticing these items during PM may save downtime later.

Remember, do not do more than recommended preventative maintenance on equipment that is operating satisfactorily.

### 2.3.2 PREVENTIVE MAINTENANCE PROCEUDRES

Details of preventative maintenance operations are listed in Table 3. During normal perventative maintenance, perform only those operations listed on the chart for that preventative maintenance period. Observe all safety procedures.

UNIT	FREQ. MONTHS	CLEAN	OBSERVE
Read/Write Heads	N/A	No maintenance required	Do not touch or clean
Actuator band, capstan and shaft	12	Clean all oil, dust, and dirt only if necessary	
Belt	12		Frayed or weakened areas
Base	12	Clean base	Inspect for loose screws connectors, and switches
Read/Write Head	12		Check for proper alignment

**TABLE 3**

### **2.3.3 CLEANLINESS**

Cleanliness cannot be overemphasized in maintaining the SA850/851. Do not lubricate the SA850/851; oil will allow dust and dirt to accumulate. To prevent damage the read/write heads should not be cleaned or touched.

### **2.3.4 CAUTIONS**

The heads should never touch each other. Whenever removing or installing the heads insure a clean piece of lens tissue is inserted between the heads to prevent them from touching.

- a. Never open the cartridge guide access without first unloading the heads from the load bail (Section 2.4.3).
- b. Insure the up stop is in proper adjustment so the diskette will clear the heads when it is inserted (Section 4.6.2).
- c. Make sure the door lock is functioning properly so as not to remove a diskette while the heads are loaded.
- d. The Read/Write heads are factory aligned with a four track offset. Loosening the head mounting screw will destroy the alignment and the actuator assembly will have to be returned to the factory for alignment.

### **2.4.0 REMOVALS, ADJUSTMENTS**

NOTE: Read the entire procedure before attempting a removal and/or adjustment.

#### **2.4.1 MOTOR DRIVE**

##### **2.4.1.1 DRIVE MOTOR ASSEMBLY: REMOVAL AND INSTALLATION**

- a. Extract 3 contacts to disconnect motor from AC connector (J4).
- b. Loosen two screws holding capacitor clamp to the base. Remove rubber boot and disconnect motor leads from capacitor.
- c. Remove connectors from PCB and remove PCB.
- d. Remove belt from drive pulley.
- e. Remove 4 screws holding the motor to the base casting and remove motor.

##### **2.4.1.2 MOTOR DRIVE PULLEY**

- a. Remove connectors from PCB and remove PCB.
- b. Remove belt from drive pulley.
- c. Loosen set screw and remove pulley.
- d. Reverse procedure for installation.

NOTE: When installing a new pulley, the drive pulley must be aligned with the spindle pulley so that the belt tracks correctly.

##### **2.4.2 HEAD COVER SHIELD REMOVAL**

- a. Loosen the two screws holding cover to the guide opening assembly.
- b. Slide cover back toward drive and remove the cover.

### **2.4.3 CARTRIDGE GUIDE ACCESS**

- a. Remove head cover shield (Section 2.4.2).
- b. Position head to approximately track 00 by turning the actuator shaft.
- c. Open cartridge guide by pressing pushbar on front of drive.
- d. Insert a clean piece of lens tissue between the heads to prevent them from touching each other and gently lower the moveable head arm assembly.
- e. Loosen the two screws holding the cartridge to door latch plate.

CAUTION: Insure the head load arm is off the load bail first.

- f. Release safety catch on guide open assembly by pressing it towards the back of the drive.
- g. Swing cartridge guide out.
- h. To restore the cartridge guide to its normal position reverse the procedure and adjust per Section 2.4.9.2.

### **2.4.4 SECTOR/INDEX LED ASSEMBLY: REMOVAL AND INSTALLATION**

- a. Disconnect the wires to LED terminals (solder joints).
- b. Remove the screw holding the LED assembly to the cartridge guide.
- c. Reverse the procedure for installation.
- d. Check index timing and readjust if necessary. Refer to Section 2.4.7.2.

### **2.4.5 WRITE PROTECT DETECTOR**

#### **2.4.5.1 WRITE PROTECT DETECTOR: REMOVAL AND INSTALLATION**

- a. Remove connectors from PCB and remove PCB.
- b. Extract wires from P2 connector, pins 4, D, 11, and M.
- c. Remove cable clamps.
- d. Remove head cover shield (Section 2.4.2).
- e. Remove screw holding the detector bracket and remove assembly.
- f. Reverse procedure for reinstalling. Connect the wires to P2 by the following: Red to (4), Black to (D), White to (11), and Gray to (M).

#### **2.4.5.2 WRITE PROTECT DETECTOR ADJUSTMENT**

- a. Insert a diskette into drive. Write protect notch or hole must be open.
- b. Set oscilloscope to AUTO sweep, 2V/div. and monitor TP25.
- c. Loosen screw on detector assembly and adjust until maximum amplitude is achieved. Tighten screw. Be sure the detector assembly is not too far forward as to restrict the diskette when it is inserted.

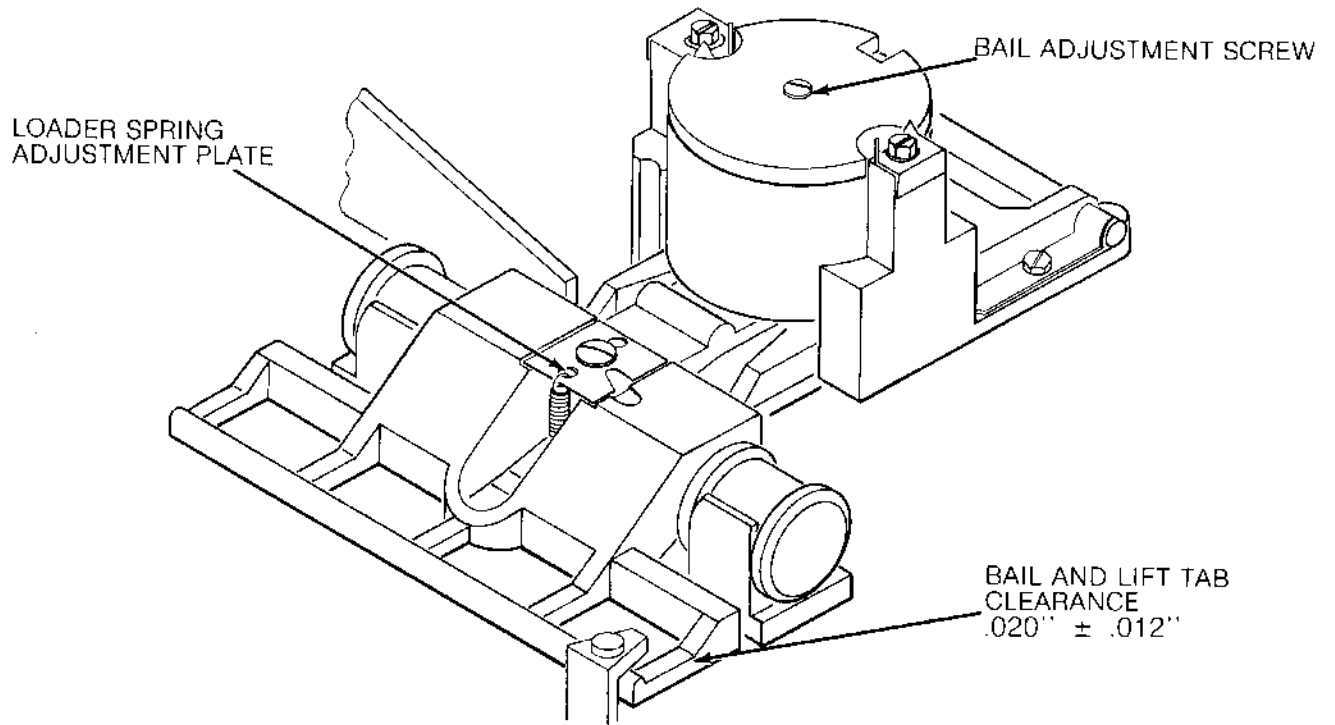
## 2.4.6 HEAD LOAD MECHANISM ASSEMBLY

### 2.4.6.1 HEAD LOAD MECHANISM: REMOVAL AND INSTALLATION

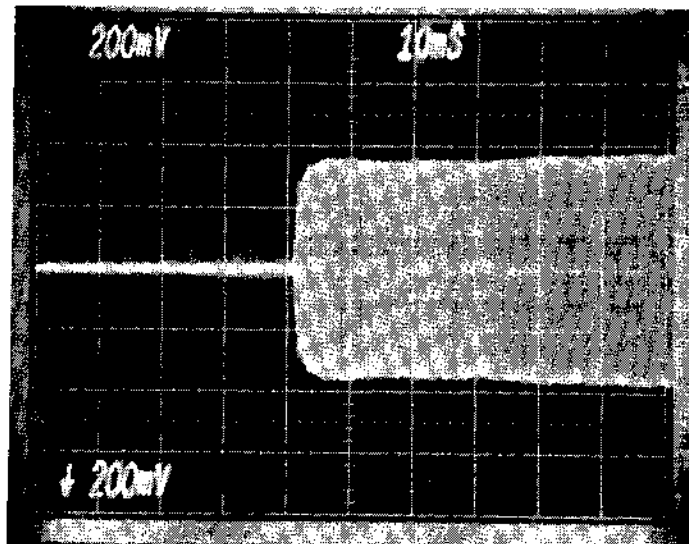
- a. Install a diskette.
- b. Remove head cover shield (section 2.4.2).
- c. Extract wires from P2 connector pins 17 and U.
- d. Unfasten the four mounting screws and remove the actuator assembly.
- e. To install, reverse the above procedure. Reference section 2.4.6.2 to adjust.
- f. When installing, make sure that the fasteners for mounting the solenoid body do not interfere with the armature.

### 2.4.6.2 HEAD LOAD MECHANISM ADJUSTMENT

- a. Apply power to the drive and insert a double-sided diskette (SA150). Step to track 00 and select side 1 head.
- b. Select the drive and insure the head is loading. With the head loaded a clearance of  $.020'' \pm .012''$  should be obtained between the bail on the head load solenoid and the lift tab on the head arm (see Figure 37). To adjust this clearance turn the screw located on top of the armature (see Figure 37). Clockwise will decrease the clearance and counter-clockwise will increase the clearance.  
  
Load the head a couples of times and reverify the clearance required.
- c. Step to track 76 and load the head, check the clearance between the bail and the lift tab. Lift tab *must* not be in contact with the bail, and clearance must be a minimum of  $.008''$  and no greater than  $.032''$ .
- d. Return to track 00.
  - (1) Sync oscilloscope on TP 11 (+ Head Load). Set time base to 10 msec/division. Connect one probe to TP1 and the other to TP2. Ground the probes on TP5. Set the inputs to AC couple, add and invert one input. Set the vertical deflection to 200 mv/division.
  - (2) Select the side 1 head, energize the head load solenoid and observe the read signal on the oscilloscope. The read signal should begin between 35 and 45 msec (see Figure 38).
  - (3) If the read signal begins sooner than 35 msec loosen screw holding the loader spring adjustment plate. Slide plate towards the solenoid body (see Figure 37). If the read signal begins after 50 msec, slide the plate away from the solenoid body.  
*\*When energizing the head load solenoid do not exceed one per second.*
- e. A properly adjusted head load mechanism should load between 35 and 45 msec and the read signal should settle out in 50 msec. There should be no read signal between 0 and 30 msec.



**FIGURE 37. HEAD LOAD MECHANISM ADJUSTMENT**



**FIGURE 38. HEAD LOAD TIMING**

## **2.4.7 INDEX/SECTOR PHOTO TRANSISTOR ASSEMBLY**

### **2.4.7.1 INDEX/SECTOR PHOTO TRANSISTOR ASSEMBLY: REMOVAL AND INSTALLATION**

- a. Disconnect P2 connector from PCB.
- b. Remove wires from Door Closed switch ORG Common, Grey N/C, and Red N/O. Extract wires from P2 connector Pins 12 BLK, N GREEN, P BRN, 6 ORG, F GRAY, and H RED.
- c. Remove the cable clamp holding wires for detector.
- d. Remove screw holding detector to the base plate and remove assembly.
- e. To install reverse procedure.

### **2.4.7.2 INDEX/SECTOR ADJUSTMENT**

- a. Insert Alignment Diskette (SA122).
- b. Step carriage to track 01.
- c. Sync oscilloscope, external negative, on TP12 (-Index). Set time base to 50 $\mu$ sec/division.
- d. Connect one probe TP1 and the other to TP2. Ground probes to the PCB. Set the inputs to AC. Add and invert one channel. Set vertical deflection to 500MV/division.
- e. Observe the timing between the start of the sweep and the first data pulse. This should be 200  $\pm$  100 $\mu$ sec. If the timing is not within tolerance, continue on with the adjustment.
- f. Loosen the holding screw in the Index Transducer until the transducer is just able to be moved.
- g. Observing the timing, adjust the transducer until the timing is 200  $\pm$  100 $\mu$ sec. Insure that the transducer assembly is against the registration surface on the base casting.
- h. Tighten the holding screw.
- i. Recheck the timing.
- j. Seek to track 76 and reverify that the timing is 200  $\pm$  100 $\mu$ sec.

## **2.4.8 SPINDLE ASSEMBLY**

- a. Remove head cover shield (Section 2.4.2).
- b. Switch out cartridge guide (Section 2.4.3).
- c. Remove drive belt.
- d. Remove the nut and 2 spring washers holding the spindle pulley. The Spanner Wrench 50752 must be used to hold spindle.

CAUTION: The pre-loaded rear bearing may fly out when spindle pulley is removed.

- e. Withdraw spindle hub from opposite side of baseplate.
- f. Reverse the procedure for installation.
- g. Tighten nut to 20 in./lbs., insuring that the spring washers are compressed. Add a drop of LOCTITE #290 to the threads.

### **2.4.8.1 CLAMP HUB REMOVAL**

- a. Remove hub clamp plate.
- b. Remove clamp hub and spring.
- c. To install, reverse the procedure. No adjustment necessary.

### **2.4.9 CARTRIDGE GUIDE**

#### **2.4.9.1 CARTRIDGE GUIDE REMOVAL**

- a. Perform steps, 2.4.3, 2.4.4, 2.4.5 and 2.4.6.1.
- b. Loosen cartridge guide stop.
- c. Remove E-ring from pivot shaft.
- d. Remove pivot shaft.
- e. Tilt the cartridge guide slightly, and remove it from the upper pivot.
- f. To install the cartridge guide, reverse the procedure.
- g. Perform steps 2.4.5.2 and 2.4.5.2.

#### **2.4.9.2 CARTRIDGE GUIDE ADJUSTMENT**

- a. Insert the shoulder screw (tool P/N 50377-1) through the adjustment hole in the cartridge guide and screw completely into the base casting (hand tight).
- b. Move the handle into the latched position and hold lightly against the latch.
- c. Tighten two screws holding the cartridge guide to the latch plate.
- d. Remove the tool and check to determine if the flange on the clamp hub clears the cartridge guide when the spindle is rotating. If the clamp hub rubs on the cartridge guide, repeat the adjustment procedure.
- e. Adjust the cartridge guide stop so that it is within .005 inch of the base casting.
- f. Check index alignment (Sector 2.4.7.2).
- g. Insert diskette, close and open door, then check for proper operation.



## 2.4.10 HEAD AMPLITUDE CHECK

These checks are only valid when writing and reading back as described below. If the amplitude is below the minimum specified, before re-writing and re-checking, insure that the diskette is not "worn" or otherwise shows evidence of damage on either side. Insure head load down stop is properly adjusted (Section 2.4.6.2).

- a. Install good media.
- b. Select the drive and step to TK 76.
- c. Sync the oscilloscope on TP12 (-Index) for single sided diskettes, TP13 for double sided diskettes, connect one probe on TP2 and one on TP1, on the drive PCB. Ground the probes to the PCB and invert one input. Set volts per division to 50mv and time base to 20 Msec per division.
- d. Write the entire track with 2F signal (all one's).
- e. The average minimum read back amplitude peak to peak, should be 130 millivolts for side 0 and 130 millivolts for side 1.

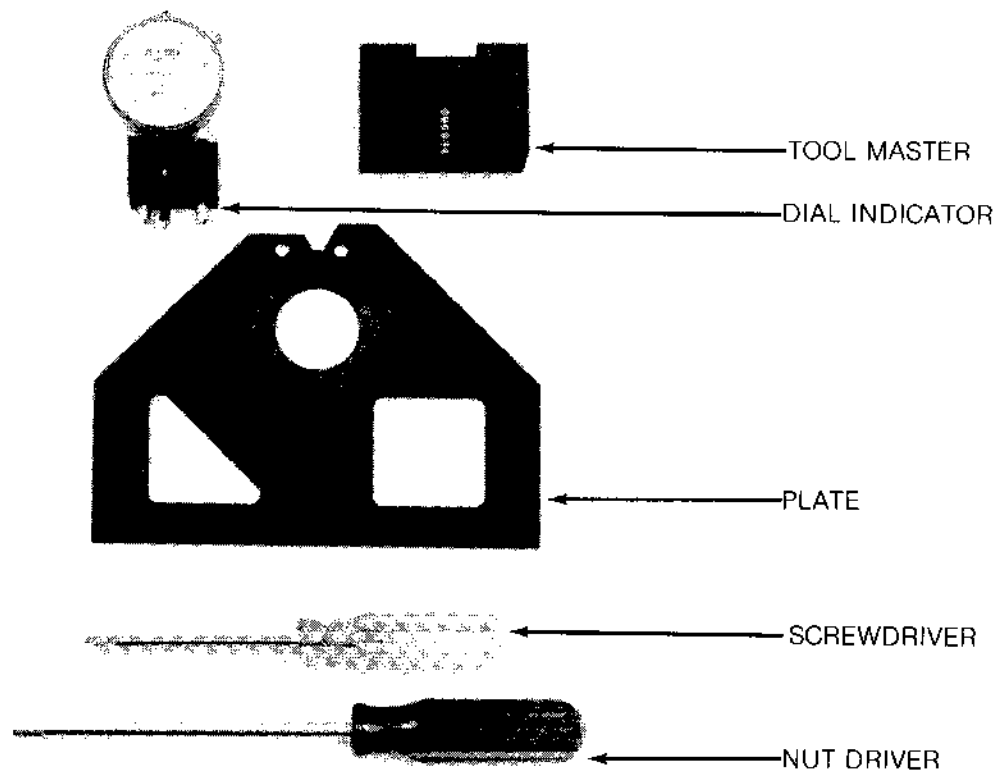
If the output is below minimum and different media is tried and the output is still low, it will be necessary to install a new head and actuator assembly.

### 2.4.10.1 HEAD ACTUATOR ASSEMBLY: REMOVAL AND INSTALLATION

- a. Remove the connectors and the PCB.
- b. Remove cable clamp holding R/W head cable on PCB side of drive.
- c. Remove the grommet from the cable bracket on head side.
- d. Unload heads (Refer to Section 2.4.3, Steps D & E).
- e. Remove the two or four screws holding actuator assembly to the base casting.
- f. Carefully remove heads and actuator assembly from the drive. Take care as not to snag the heads, load arms, or read/write head cable on the casting.
- g. To install, procede as follows:
  - (1) Hold assembly at a slight angle towards you when installing (approximately 15°CCW viewed from rear).
  - (2) Rotate actuator into position against the ledge while simultaneously lifting the arm tab with the bail so that the heads are separated and the protective paper between them falls free.
  - (3) Position the actuator casting firmly and squarely against the ledge on the base casting and secure with two or four screws and washers (install the locating screw nearest the ledge first).

### 2.4.10.2 HEAD PENETRATION ADJUSTMENT

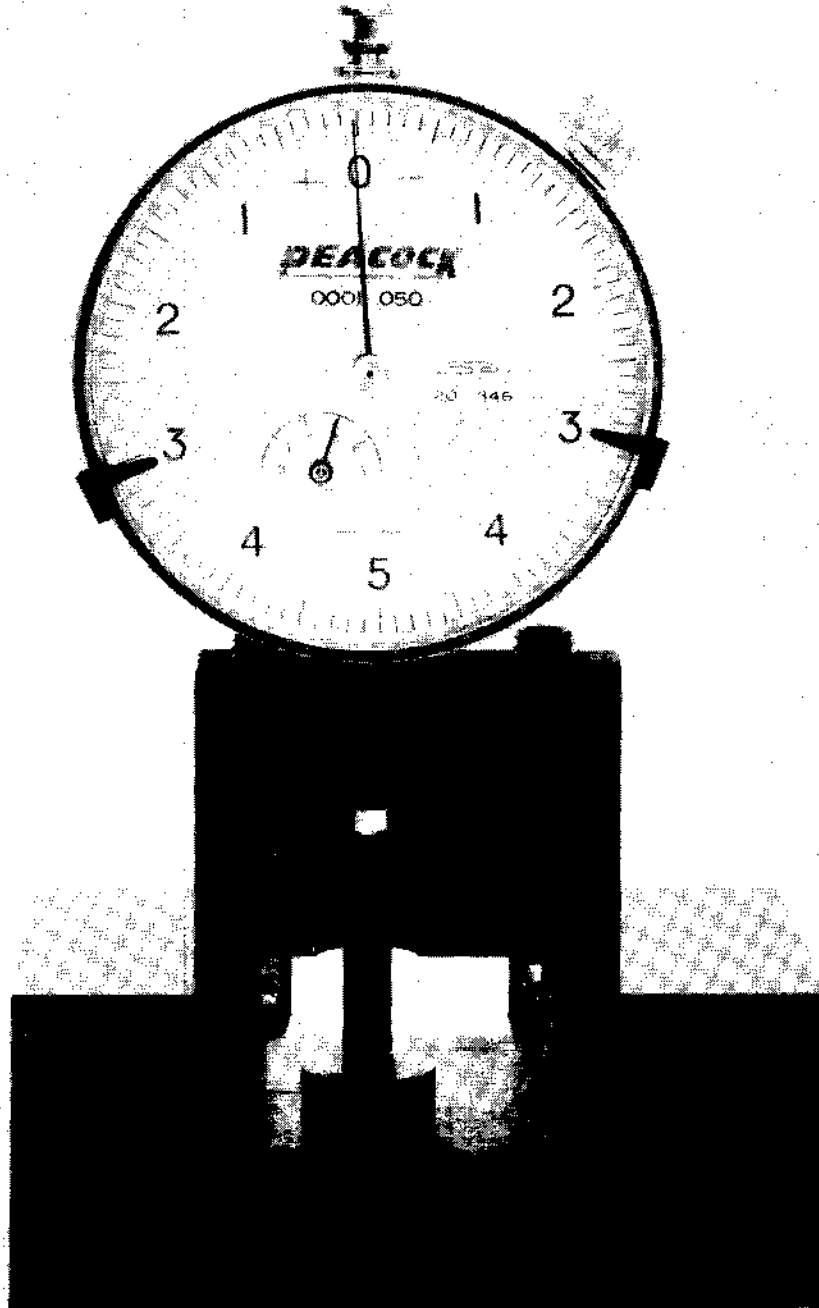
- a. The tools necessary to perform this alignment procedure will consist of penetration gauge tool set, screwdriver and 1/4" nut driver (see Figure 39).



**FIGURE 39. HEAD PENETRATION TOOLS**

- b. Set up the penetration dial indicator on the penetration tool master. Check penetration tool to make sure it's indicating surfaces are clean and properly set: (long hand on zero and small hand on three) while it's resting on the penetration tool master. See Figure 40.

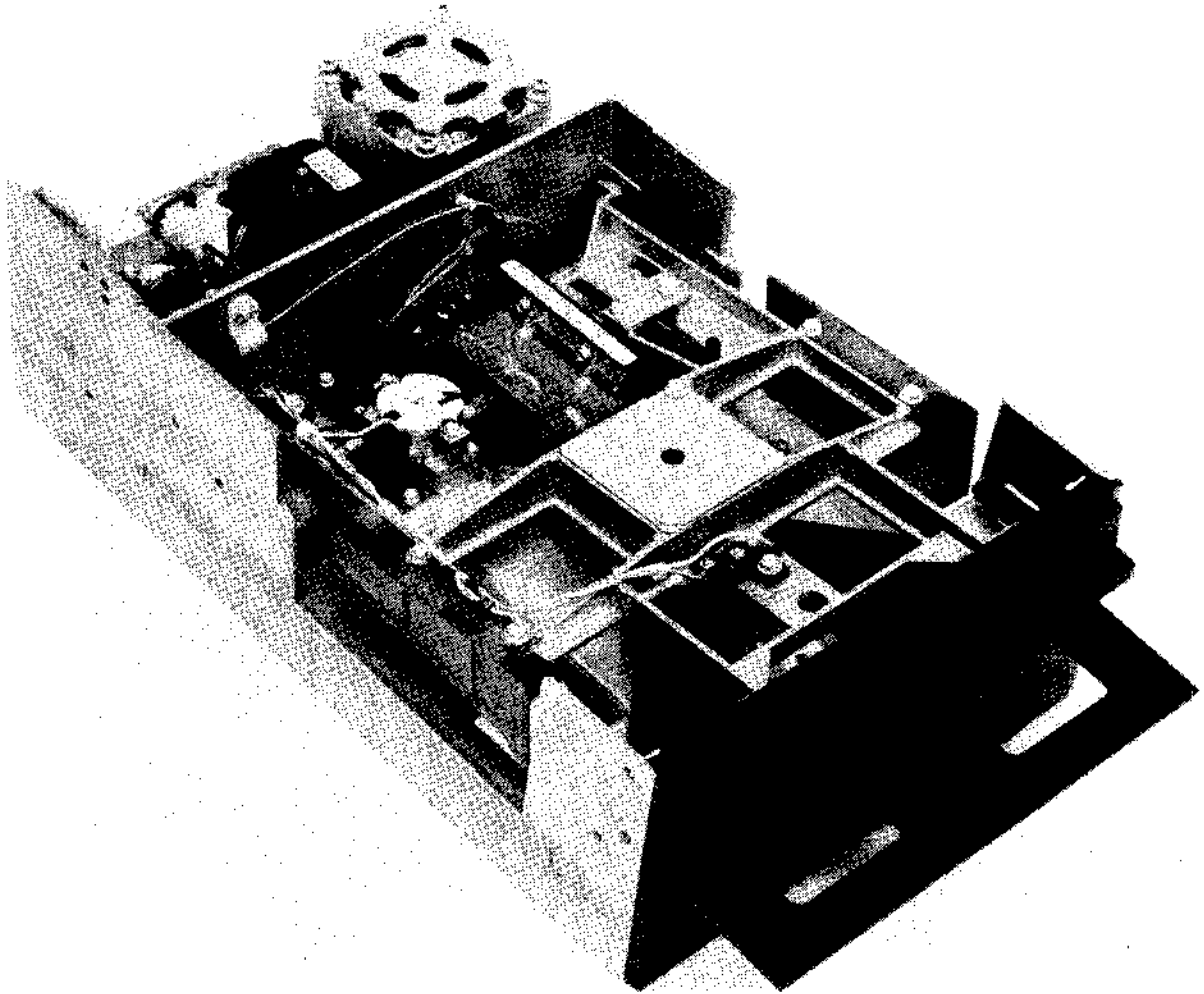
**NOTE:** When the tool is not being used, it should be kept where it won't be dropped or knocked off the work bench.



**FIGURE 40.** DIAL INDICATOR

- c. With the drive in the horizontal position, remove HAC shield and door open, slide the penetration plate into the drive with the tapered end in first and counter bore side up. Slide the plate up and over the spindle until it's squarely over the spindle and close the door. See Figure 41.

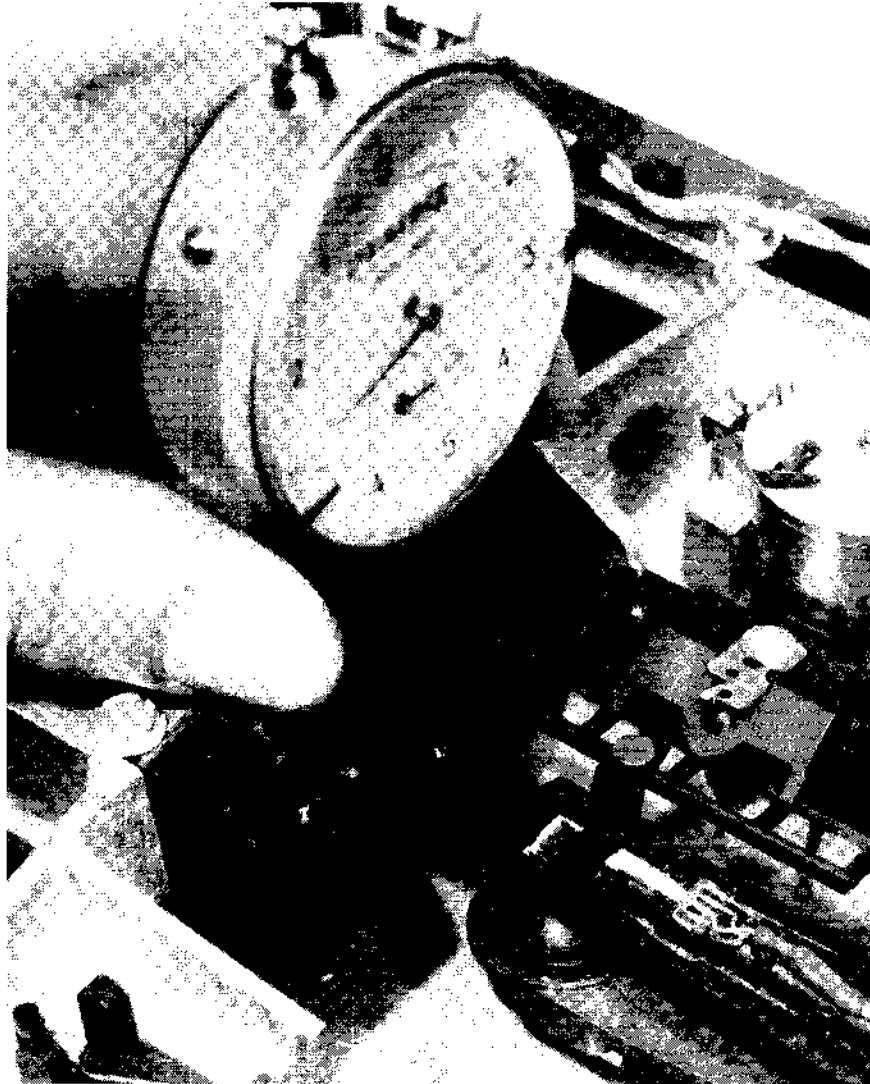
**NOTE:** The penetration plate is made of harden tool steel and care should be used not to damage spindle or any other part of the drive during insertion of extraction.



**FIGURE 41. PENETRATION PLATE INSTALLATION**

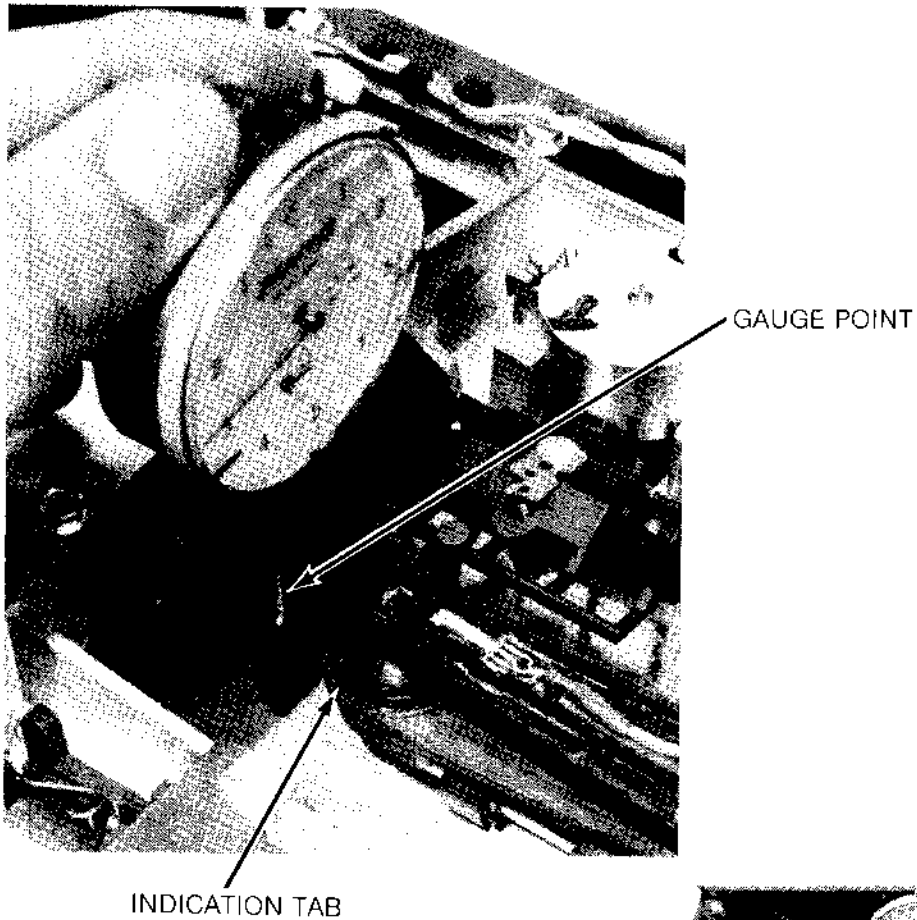
- d. Next install the indicator block into the penetration plate until you feel the block snap into place. See Figure 42.

**NOTE:** Make sure all surfaces are clean, the block is squarely and fully snapped onto the plate. Also avoid handling the block by the indicator.

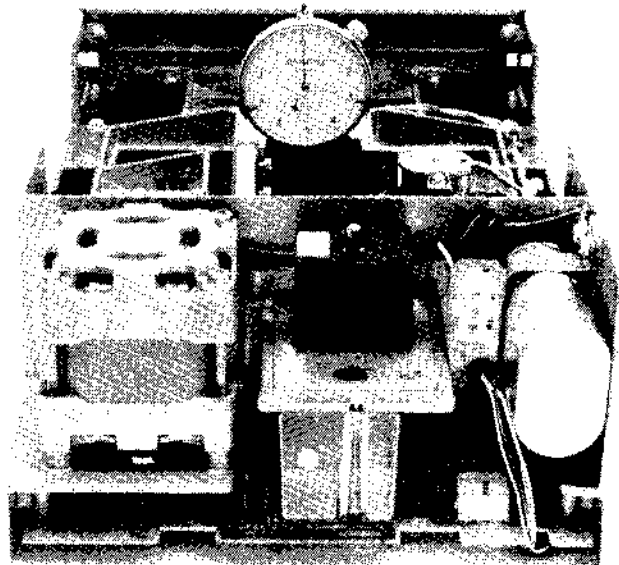


**FIGURE 42. DIAL INDICATOR INSTALLATION**

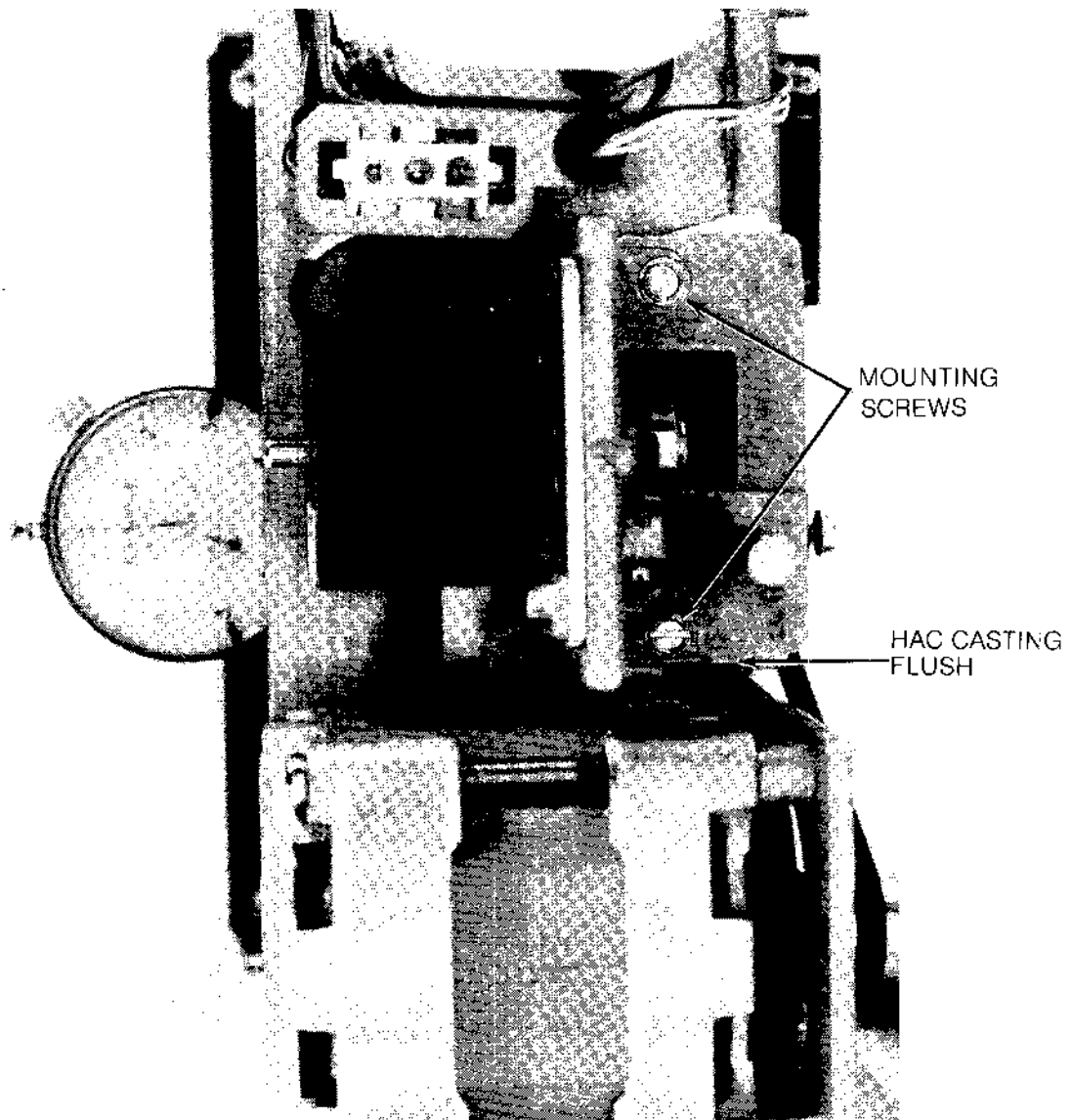
- e. The shaft that extends from the stepper motor can be used to move the head up far enough so the gauge point is indicating off the tab, on the side zero head as shown in Figure 43.
- f. Check the dial indicator for the proper setting. The long hand should be between +3 and -3 with the short hand pointing at three. If penetration setting is out of this range then continue with procedure starting at step 7. See Figure 44.



**FIGURE 43. INSTALLATION CHECK**



**FIGURE 44. CORRECT PENETRATION**



**FIGURE 45. PENETRATION ADJUSTMENT**

- g. With the penetration gauge installed set the drive up in the vertical position, the AC motor should be closest to the bench.
- h. Loosen the two or four mounting screws using a ¼" nut driver.
- i. Adjust HAC assembly left to right until the reading on the penetration gauge reads; small hand on three and long hand on zero  $\pm$  .003.
  - A. If small hand is on the left side of three, the HAC assembly must go to the right.
  - B. If small hand is on the right side of three, the HAC assembly must go to the left.
- j. When penetration is set tighten the two or four mounting screws using a ¼" nut driver.
- k. As you tighten the two mounting screws, make sure the HAC casting is flush (making contact) with the machined lip on the base casting.
- l. Check penetration gauge again to insure proper alignment. If not return to procedure step 7.
- m. Remove the indicator block (remember to handle with care). Open the door and remove the penetration gauge.
- n. Replace the HAC shield.

### 2.4.10.3 HEAD RADIAL ALIGNMENT

NOTE: The actuator assembly is aligned at the factory and adjustment is not normally required after replacing a head and actuator assembly. If after checking and the lobes are within 70% of each other, alignment is not recommended.

- a. Insert Alignment Diskette (SA122).

NOTE: Alignment diskette should be at room conditions for at least 1 hour before alignment checks.

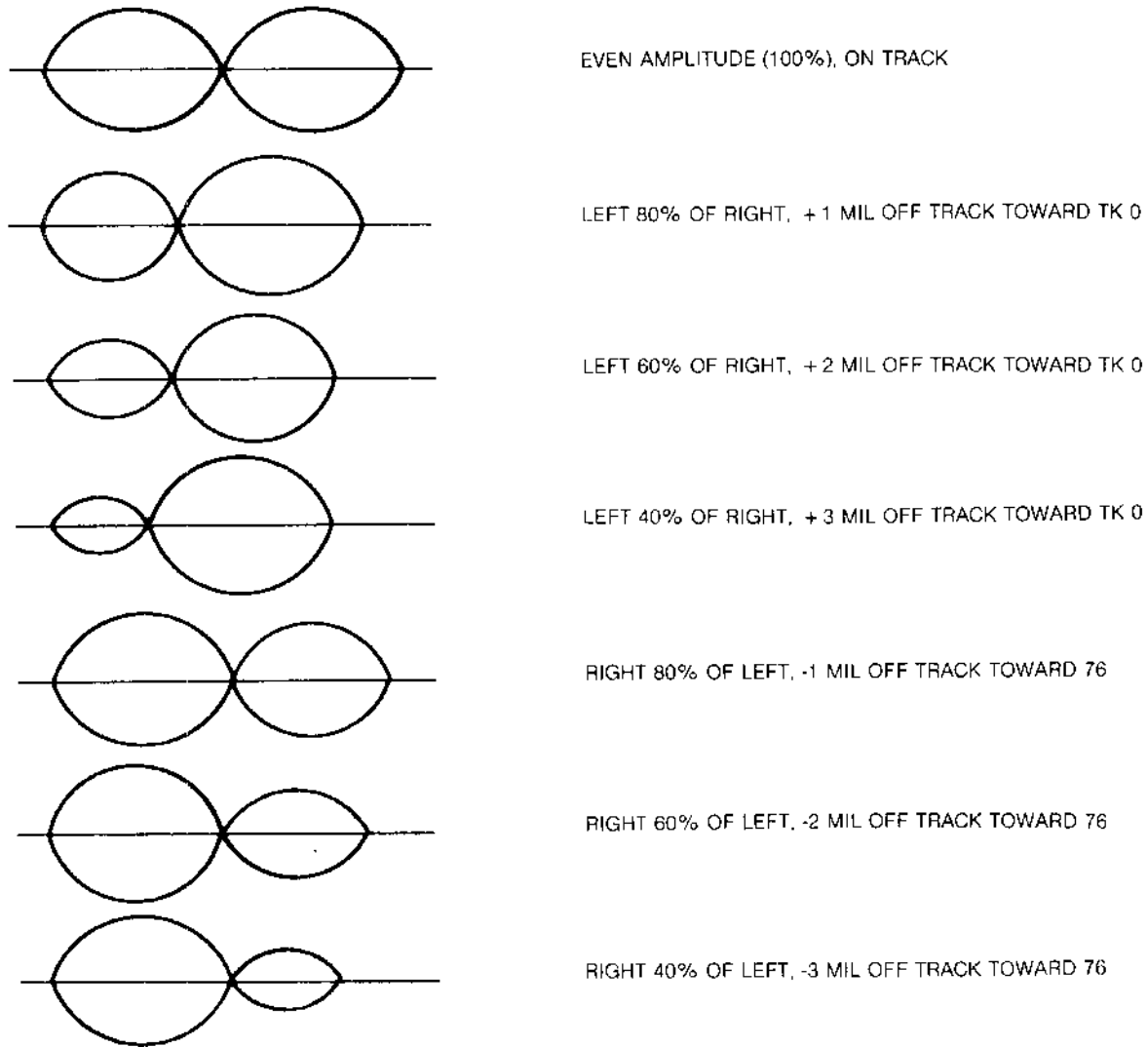
- b. Steps the heads to track 38.
- c. Sync the oscilloscope, external negative, on TP12 (-Index). Set the time base to 20Msec per division. This will display over one revolution.
- d. Connect one probe to TP1 and the other to TP2. Ground the probes to the PCB. Set the inputs to AC, Add and invert one channel. Set the vertical deflection to 100MV/division.
- e. The amplitude of the two lobes must be within 70% of each other. If the lobes do not fall within this specification continue on with the procedure (Refer to Figure 46).
- f. Loosen the two or four mounting screws, which hold the motor plate to the support bracket (Refer to Figure 47).
- g. Move the plate, by rotating the eccentric adjusting nut.
- h. When the lobes are of an equal amplitude, tighten the motor plate mounting screws (Refer to Figure 47).
- i. Check the adjustment by stepping off track and returning. Check in both directions and readjust as required.
- j. Whenever the Head Radial Alignment has been adjusted the Track 00 detector adjustment must be checked. (Section 2.4.11.2).

### 2.4.10.4 READ/WRITE HEADS AZIMUTH CHECK

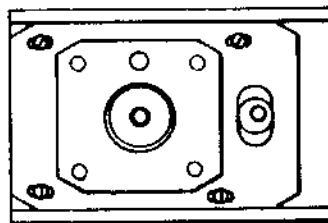
The azimuth is not field adjustable. If, after performing this check the waveform on the oscilloscope is not within +18' replace the Head Actuator Assembly.

- a. Install Alignment Diskette SA122. Select the drive and step to track 76. (114<sub>P</sub>)
- b. Sync the scope external negative on TP12, set time base to .5 MSec per division.
- c. Connect one probe to TP1 and the other to TP2. Invert one channel and ground the probes to TP5 & 6. Set the inputs to AC, ADD, and 50 MV per division.
- d. Compare waveform to Figure 48. If not within the range shown replace the Head Actuator Assembly 2.4.10.1





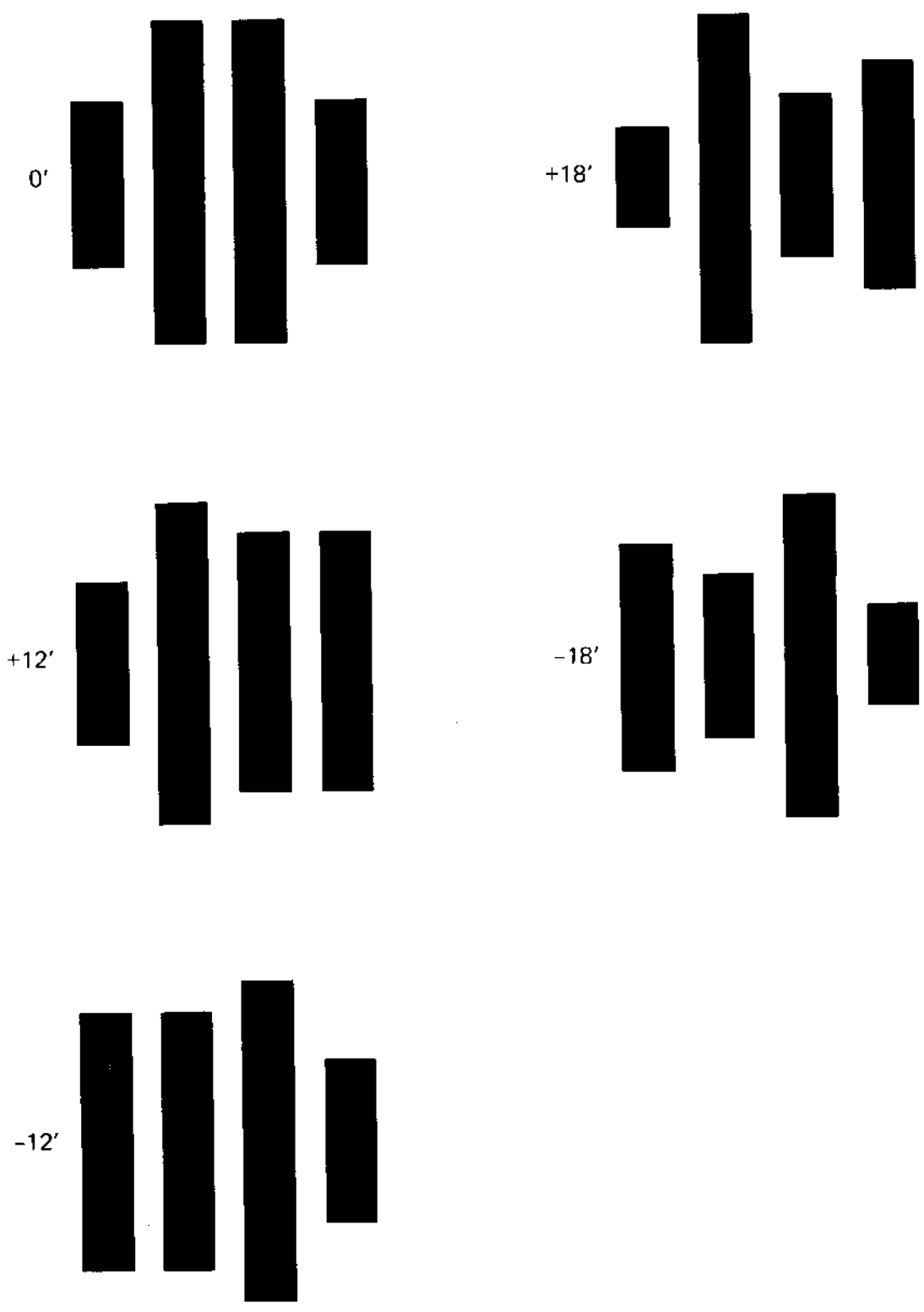
**FIGURE 46. HEAD RADIAL ALIGNMENT**



**FIGURE 47. MOTOR PLATE**

#### **2.4.11 DOOR LOCK SOLENOID AND IN USE LED ASSEMBLY REMOVAL**

- a. Perform steps 2.4.12a and 2.4.12h.
- b. Remove door lock assembly
- c. Reverse procedure to install new assembly.
- d. Adjust of the door lock should not be necessary. If it has to be, the gap between the armature tab and the latch should be  $.015 \pm .010$ . This adjustment can be made by loosening the two screws on the armature.



**FIGURE 48. AZIMUTH BURST PATTERNS**

#### **2.4.12 TRACK 00 DETECTOR: REMOVAL AND INSTALLATION**

- a. Remove head cover shield (Section 2.4.2).
- b. Swing cartridge guide open (Section 2.4.3).
- c. Manually rotate stepper shaft and move carriage to track 77.
- d. Remove screw holding bracket to base casting and remove bracket and detector.
- e. Remove PCB connector and remove PCB.
- f. Extract cable from P2 connector; Pin 3 BRN, C BLACK, 10 ORANGE, and L RED.
- g. Remove cable clamps and remove Detector assembly.
- h. To install, reverse the procedure.
- i. Adjust according to Section 2.4.11.2.

#### **2.4.12.1 TRACK 00/76 STOP ADJUSTMENT**

- a. Not field adjustable.

#### **2.4.12.2 TRACK 00 DETECTOR ASSEMBLY ADJUSTMENT**

- a. Check head radial alignment and adjust if necessary before making this adjustment.
- b. Insert diskette.
- c. Connect oscilloscope to TP26. Set vertical deflection of 1v/division and sweep to continuous.
- d. Step carriage to track 02. TP26 should go low. Adjust the detector assembly towards the actuator assembly if not low.
- e. Check the adjustment by stepping the heads between tracks 00 and 02, observing that TP26 is low at track 02 and high at track 00. A perfect adjustment is if you have a square wave on a scope.

#### **2.4.13 FRONT PLATE ASSEMBLY REMOVAL**

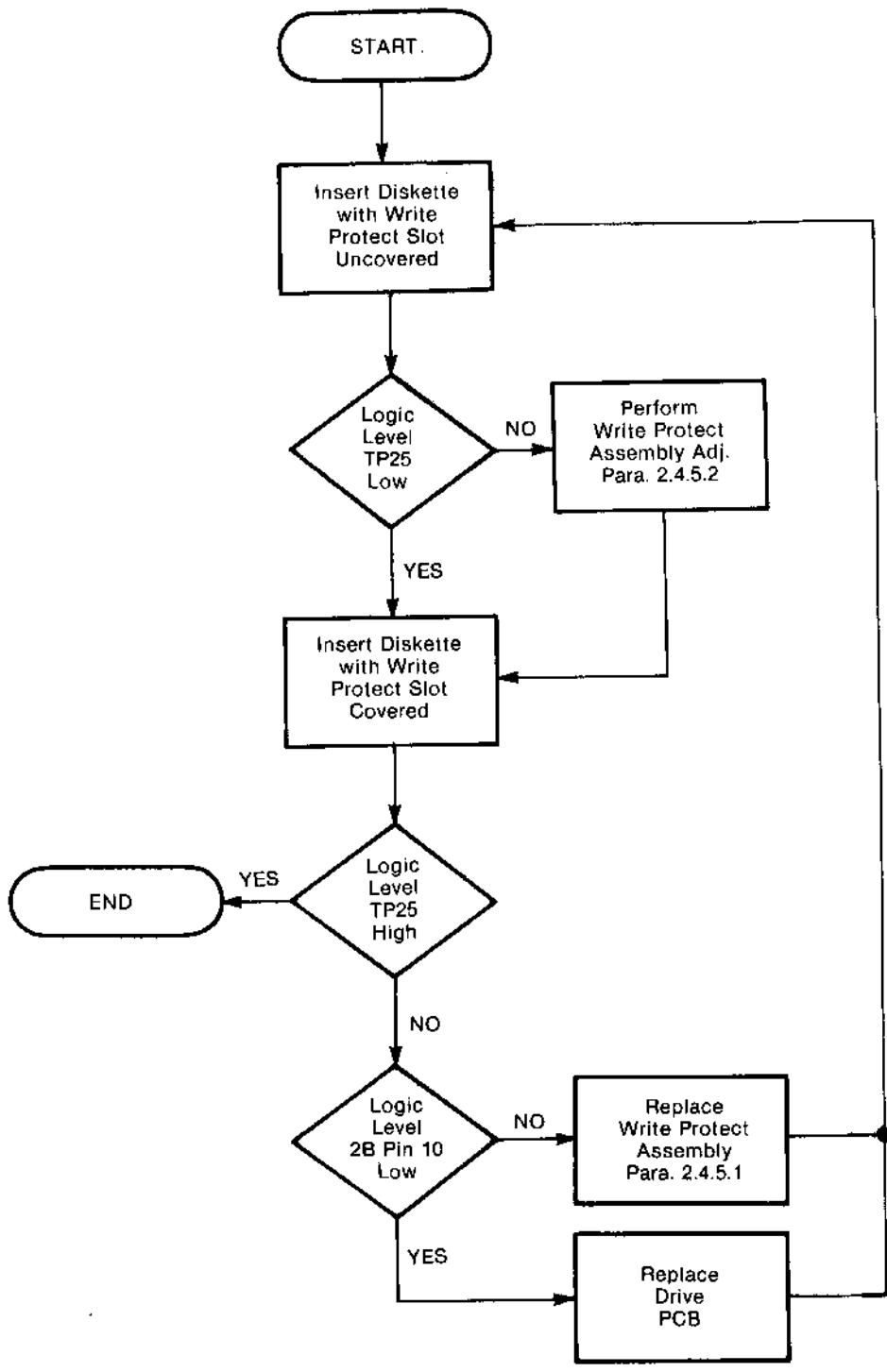
- a. Insert the cartridge guide adjustment tool (P/N 50377-1) through the adjustment hole in the cartridge guide and screw completely into the base hold casting (hand tight).
- b. Remove the door lock wires from P2, Pin 2-black, B-brown, 9-violet and K-blue.
- c. Remove the cable clamp holding the door lock wires.
- d. Remove the two allen head screws holding the handle to the front plate and remove the handle.
- e. Remove the four screws holding the front plate to the base casting.
- f. Remove two screws holding door lock assembly to the front plate.
- g. Remove two allen head screws holding the In Use LED to the door lock assembly.
- h. Grasp both ends of the push button and bow outwards to remove LED.
- i. Reverse procedure to install.
- j. Check Index adjustment (Section 2.4.7.2).

# Flow Charts

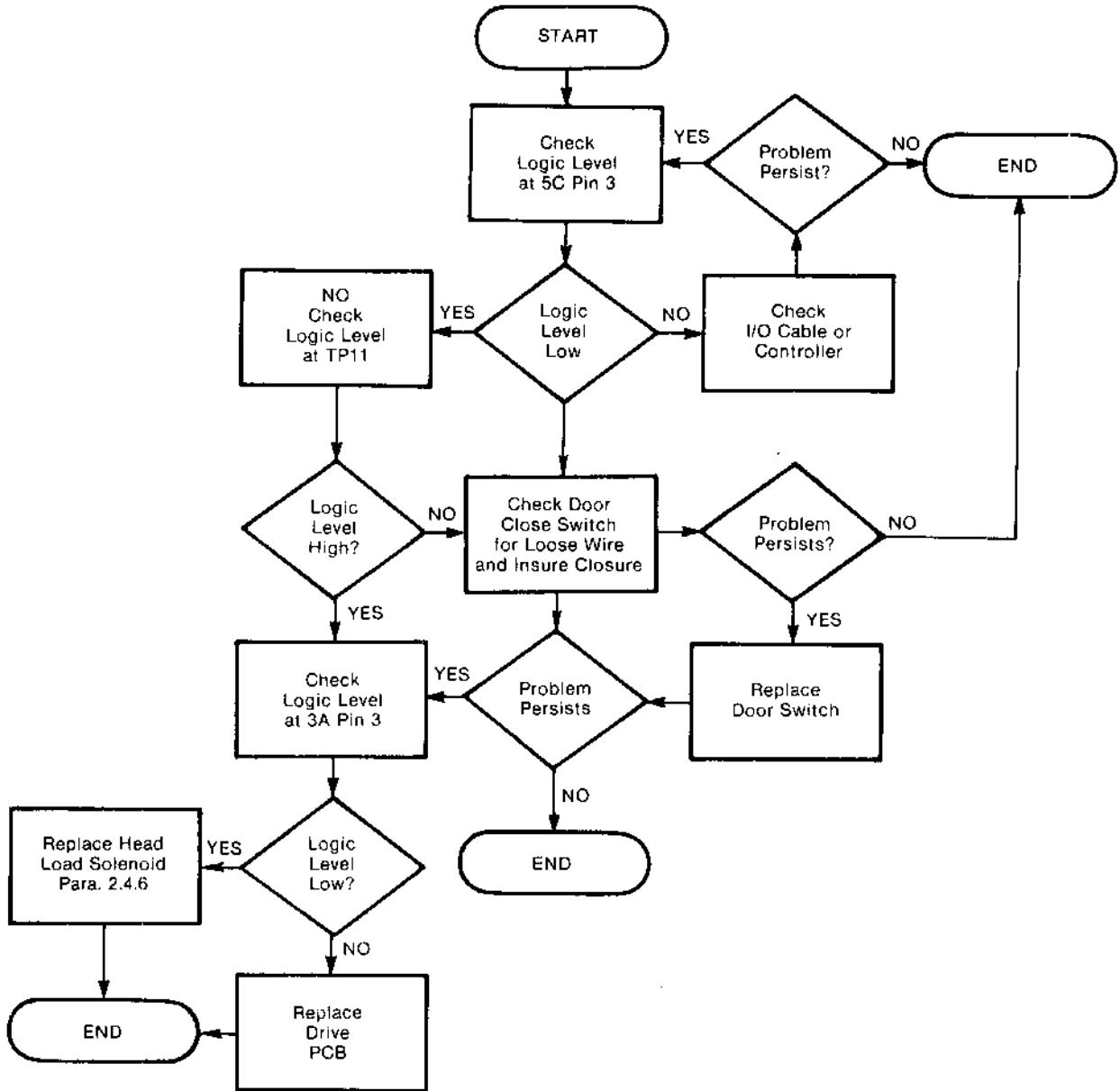
---

1. 1/16  
2. 1/16  
3. 1/16

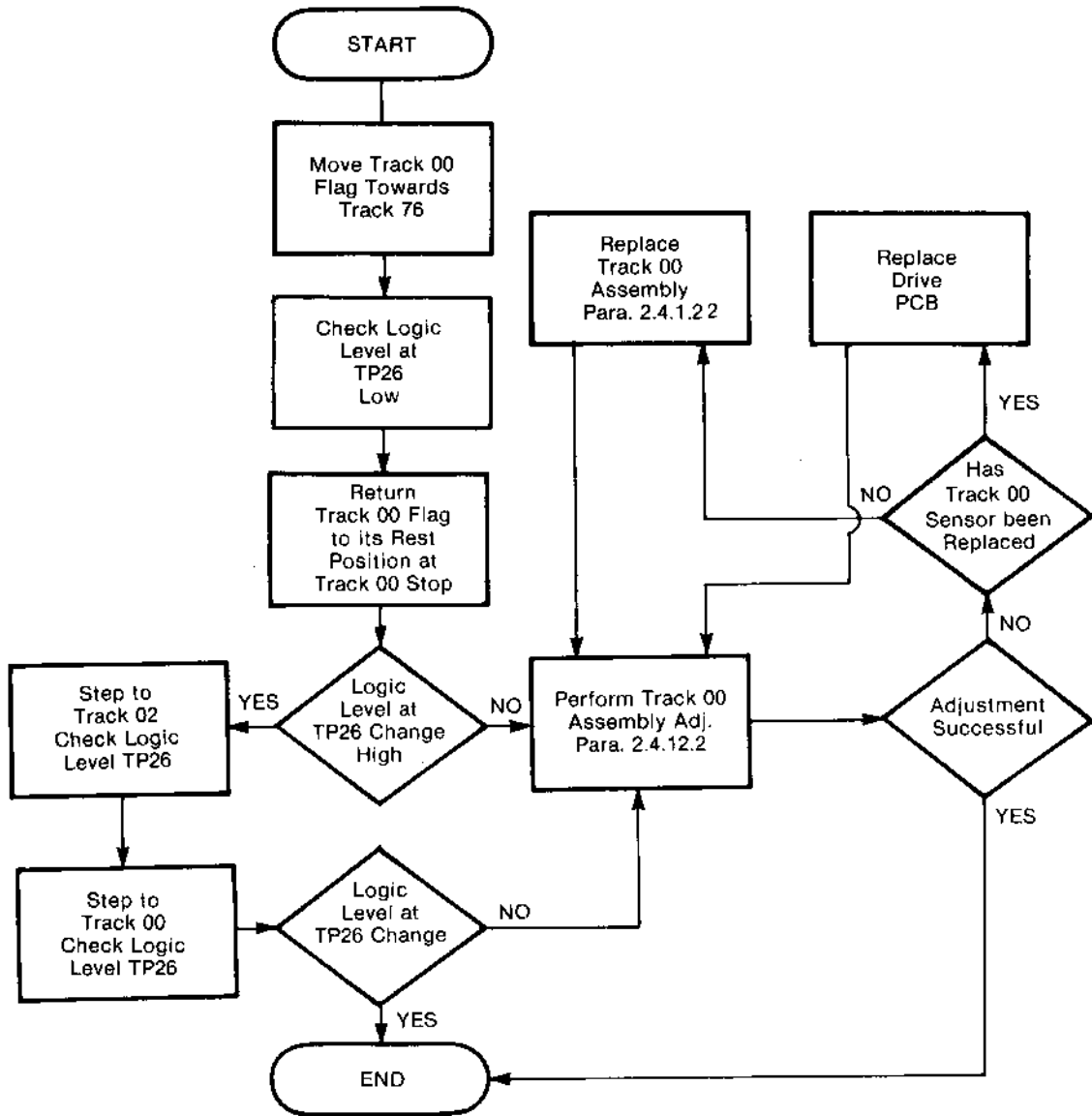
# WRITE PROTECT INOPERATIVE



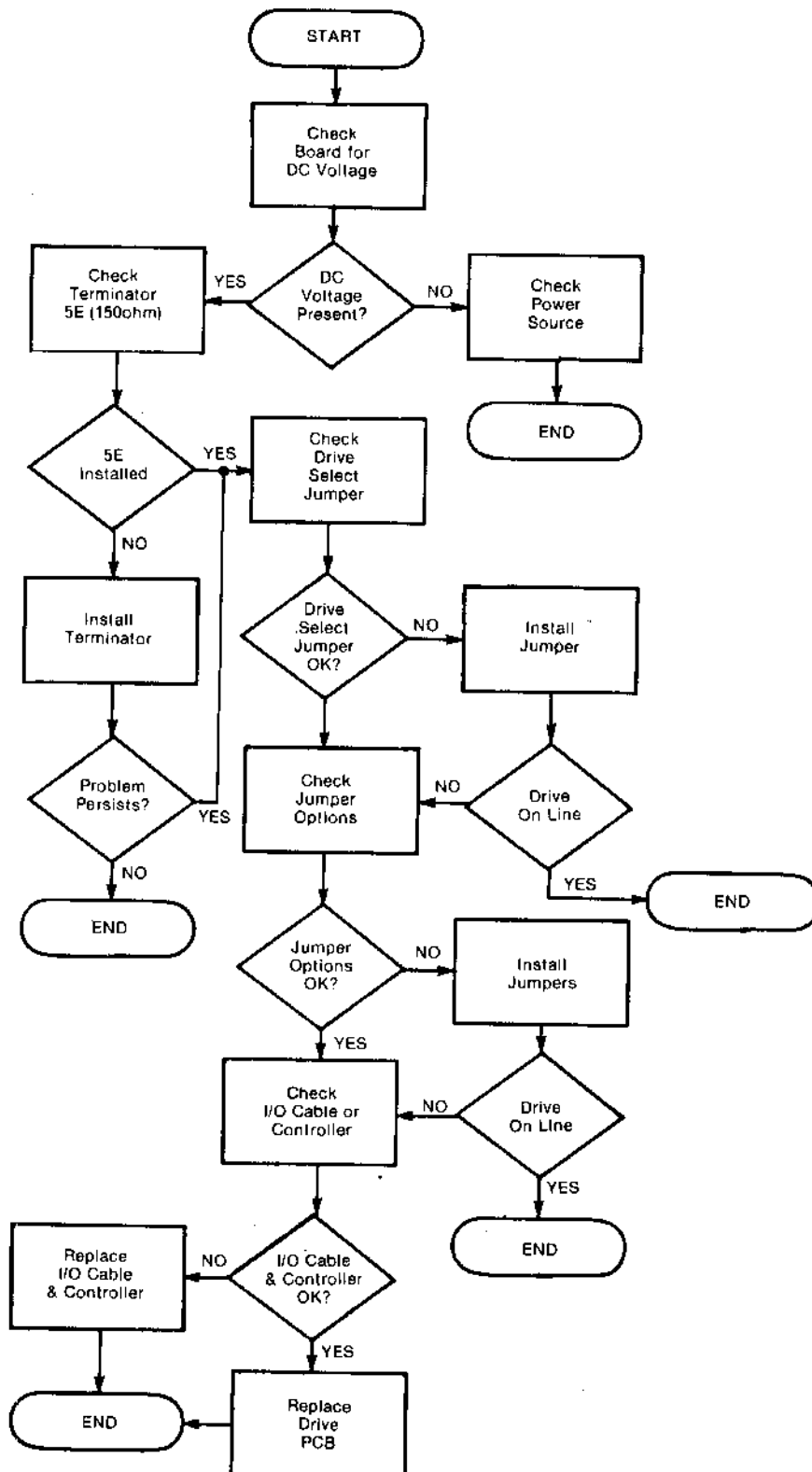
# HEAD LOAD INOPERATIVE



## TRACK 00 INDICATOR INOPERATIVE

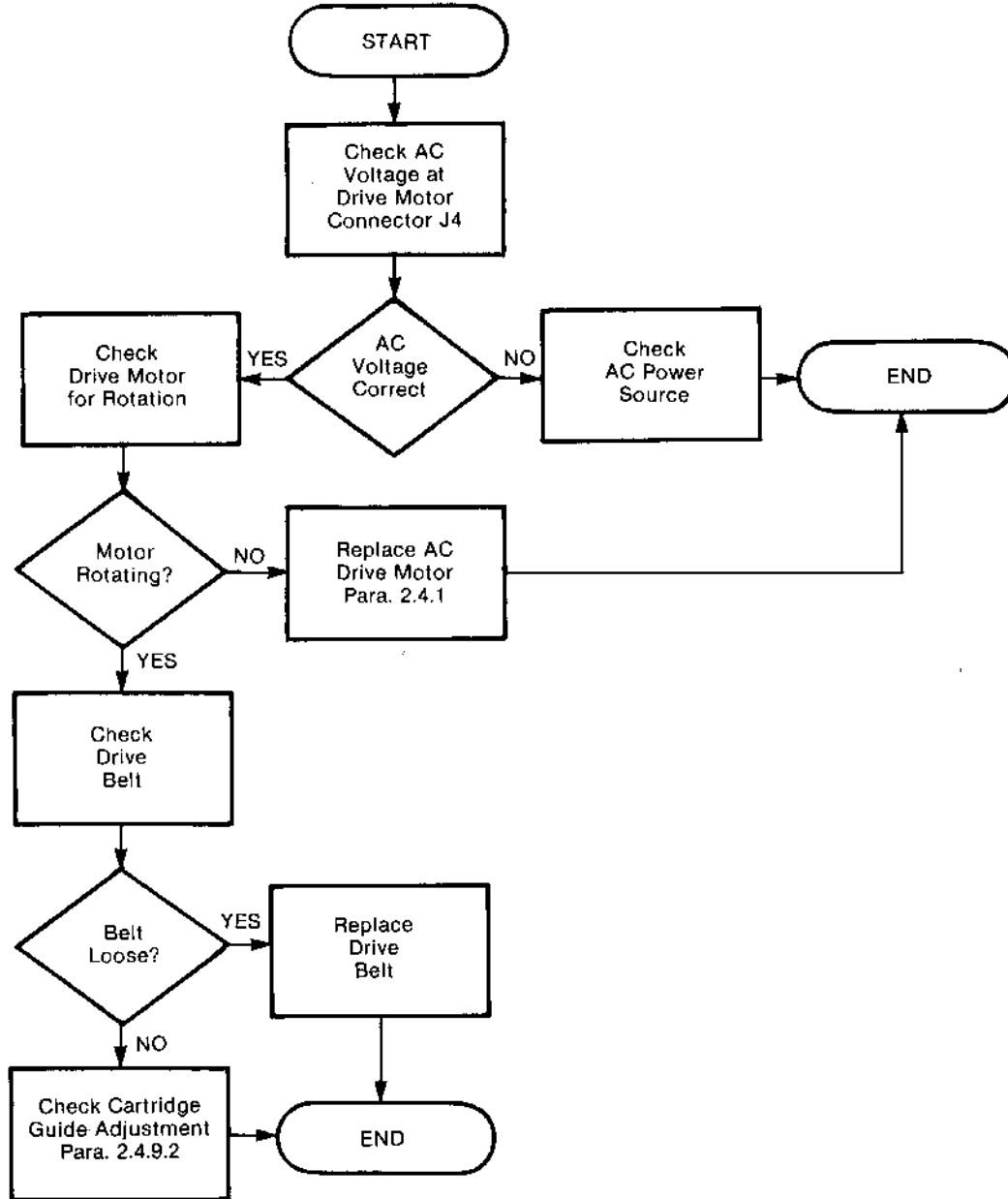


## DRIVE NOT COMING ON LINE

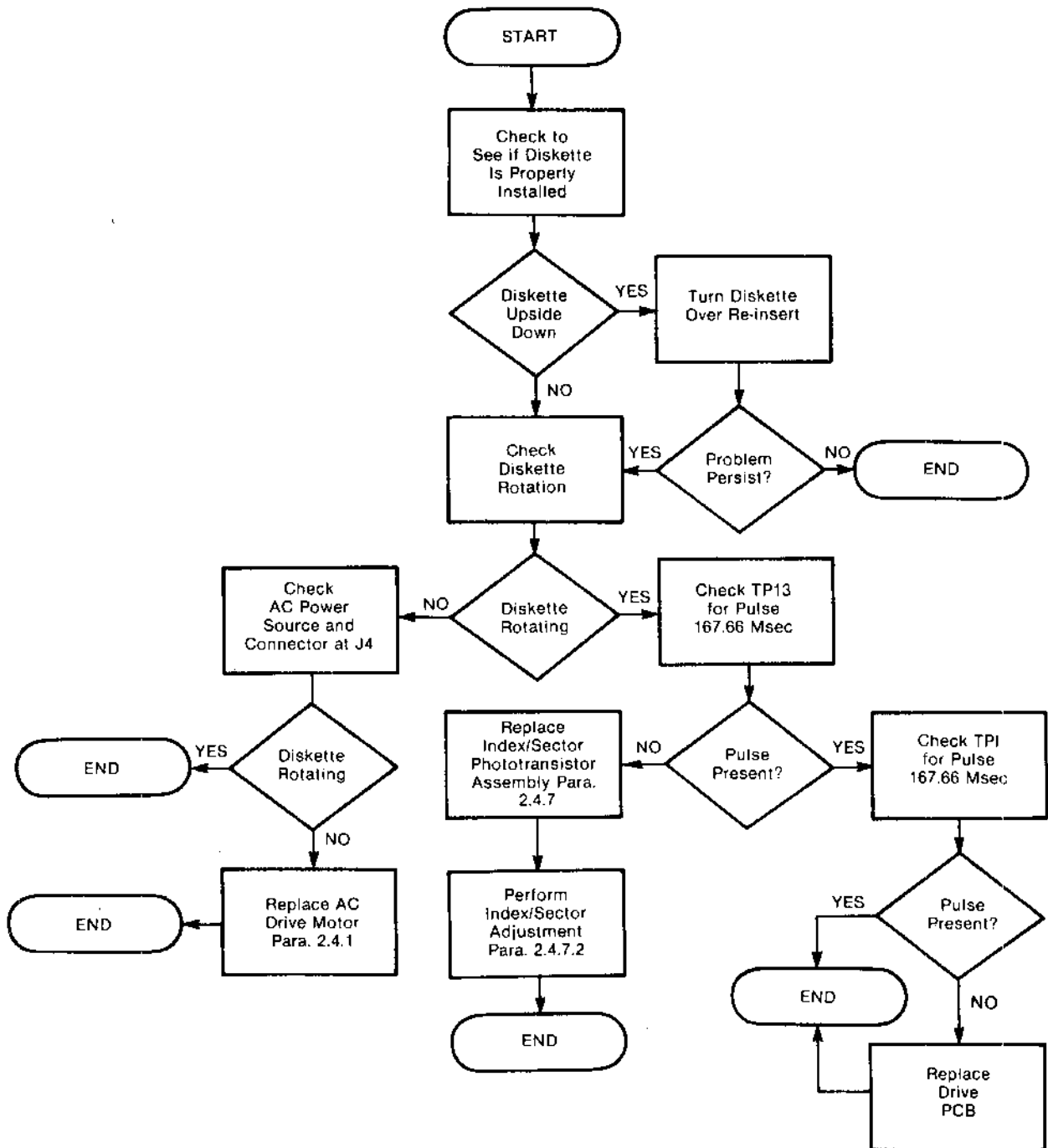




# DISKETTE NOT ROTATING

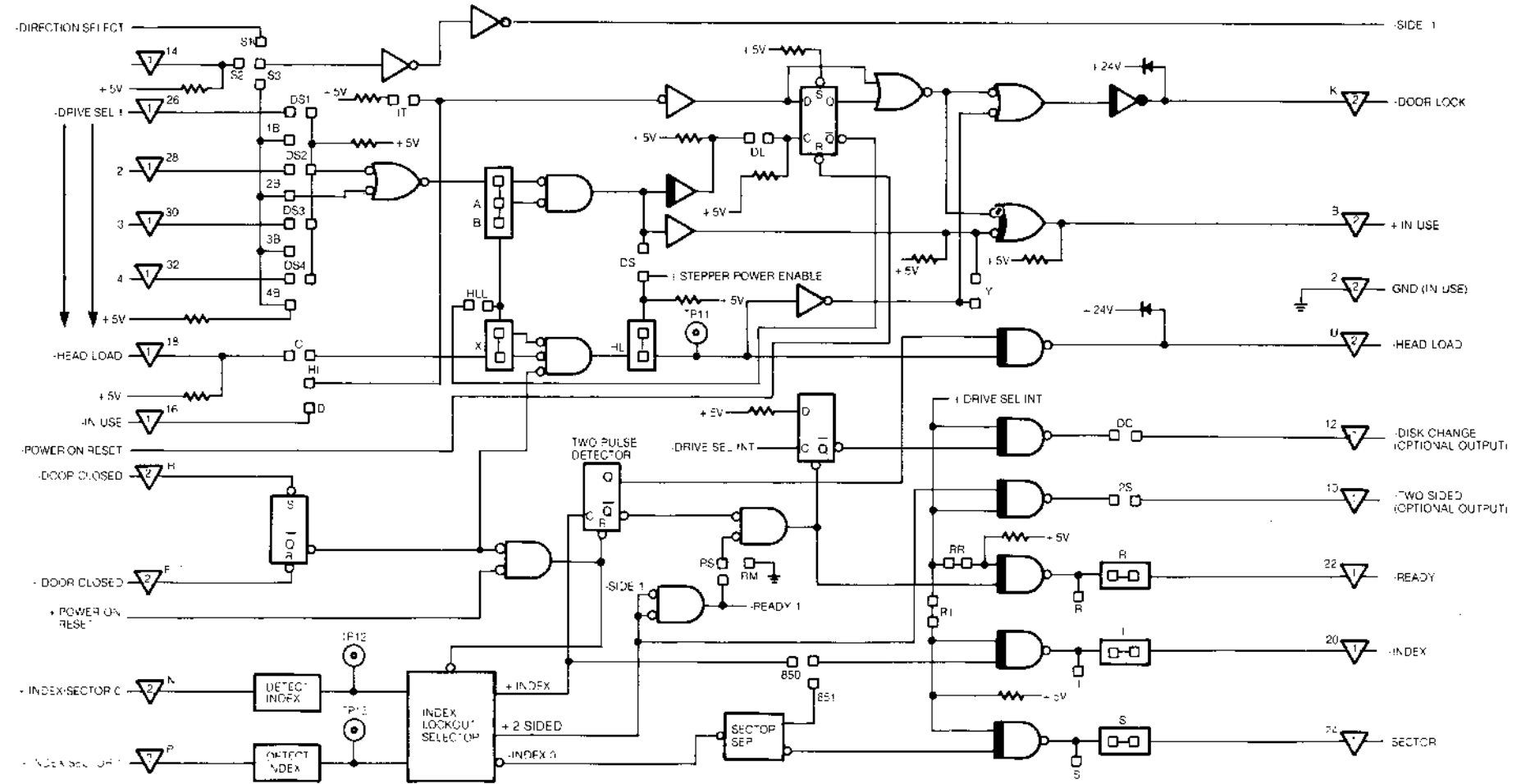
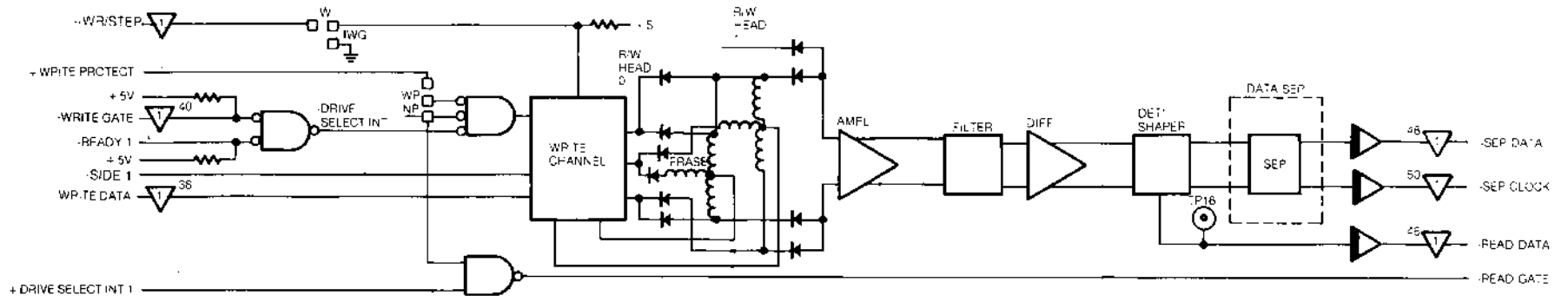


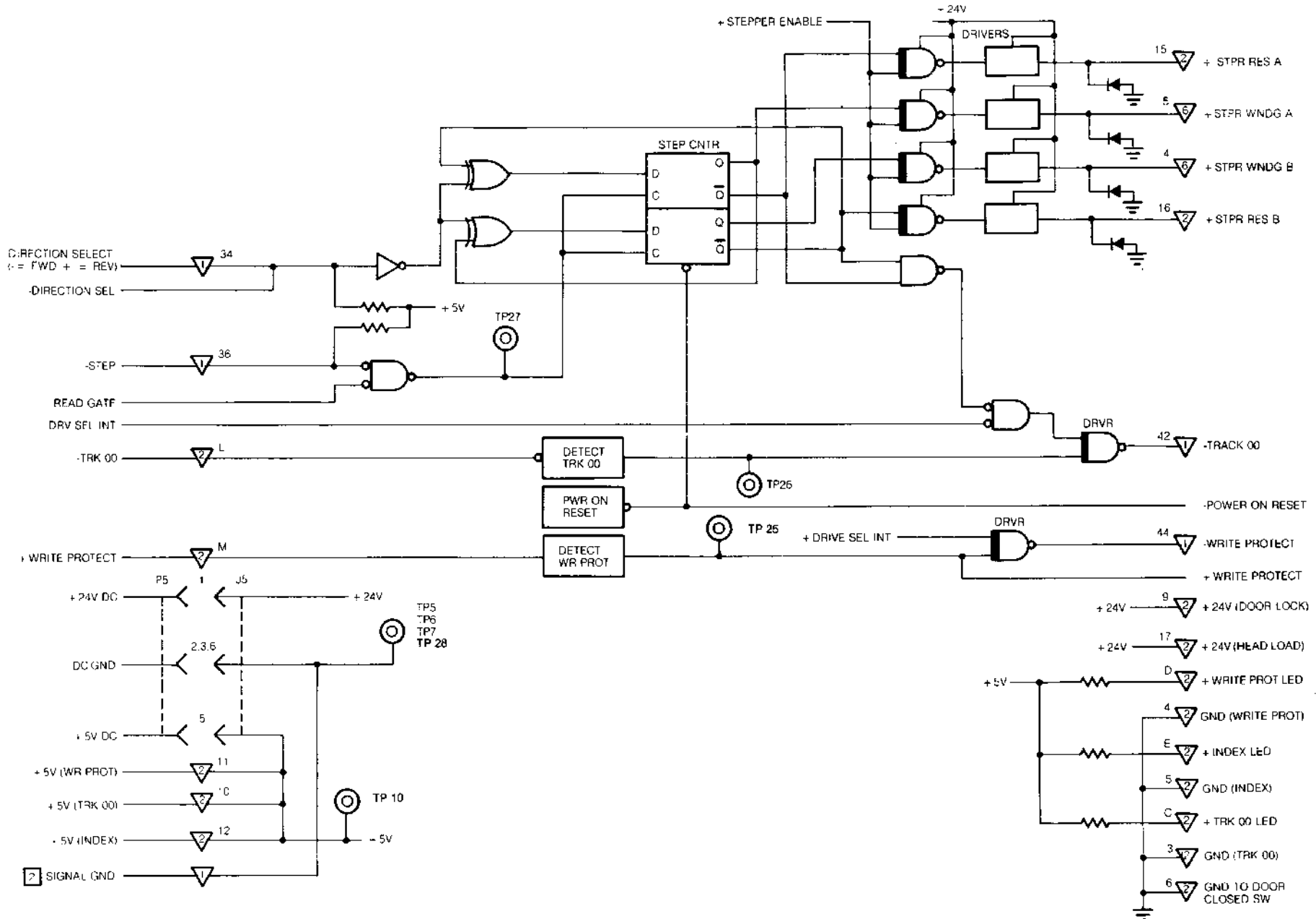
## INDEX PULSE INOPERATIVE



# Logic Diagrams

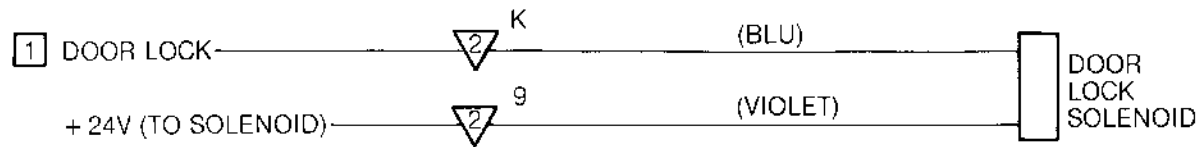
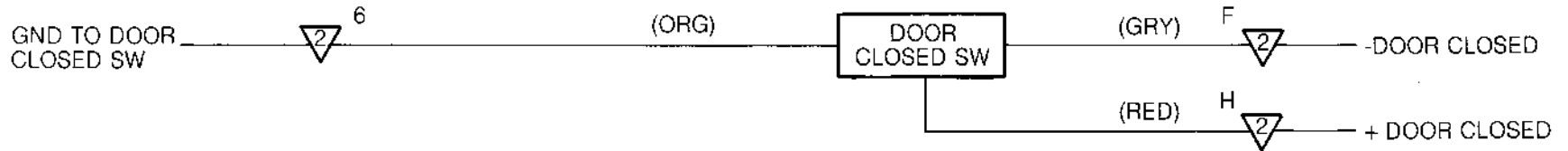
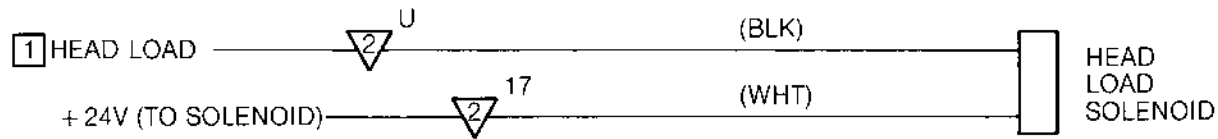
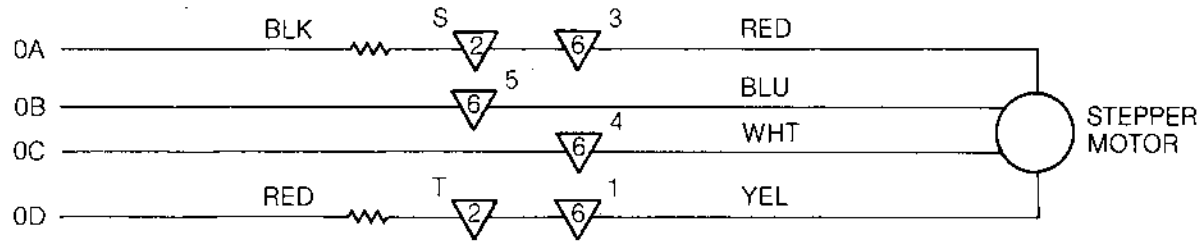
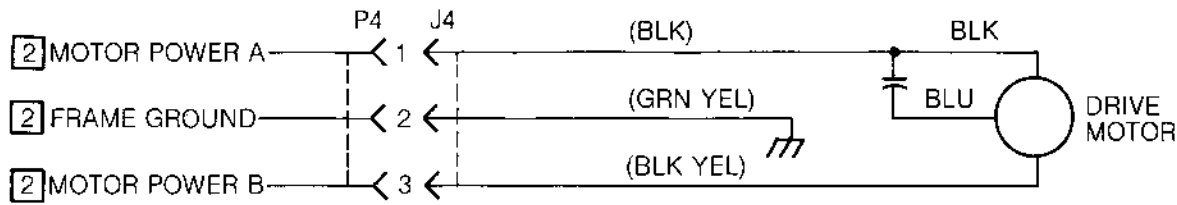
---





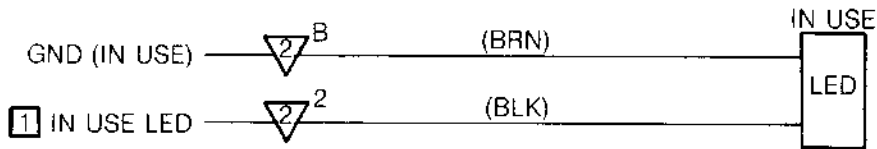
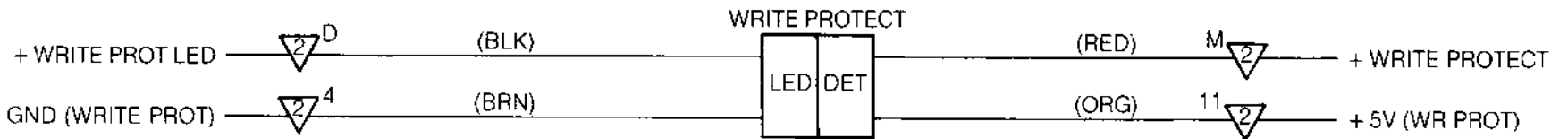
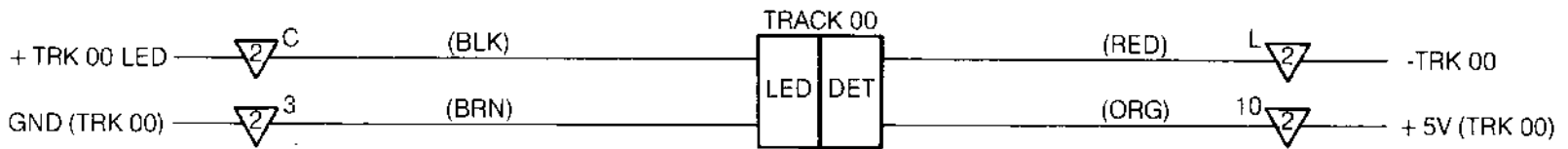
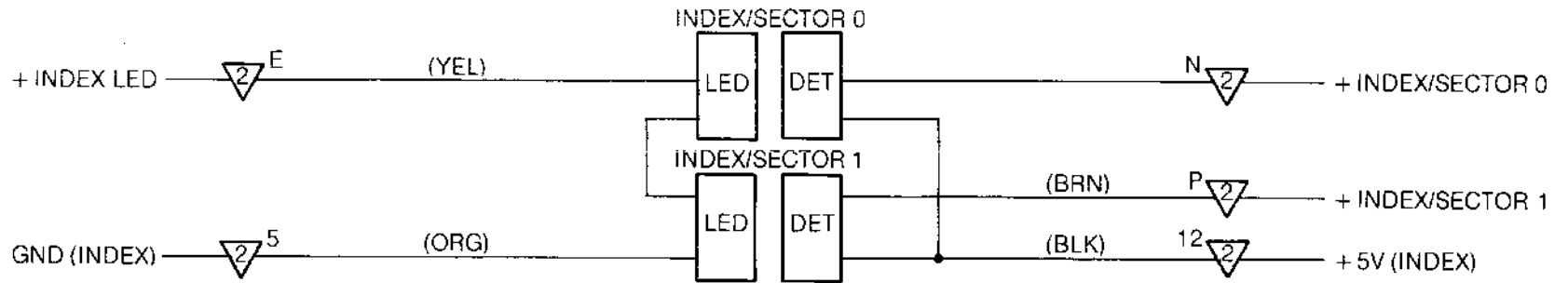
**NOTES:**

- 1 CONNECTOR SYMBOL REFERENCE 1 = J1, 2 = J2, 5 = J5
- 2 ALL ODD NUMBERED PINS ON J1 CONNECTOR ARE GROUND.



**NOTES:**

- 1** GND WHEN ACTIVE AND + 24 WHEN INACTIVE.
- 2** 115 OR 230 VAC.



**NOTES:**

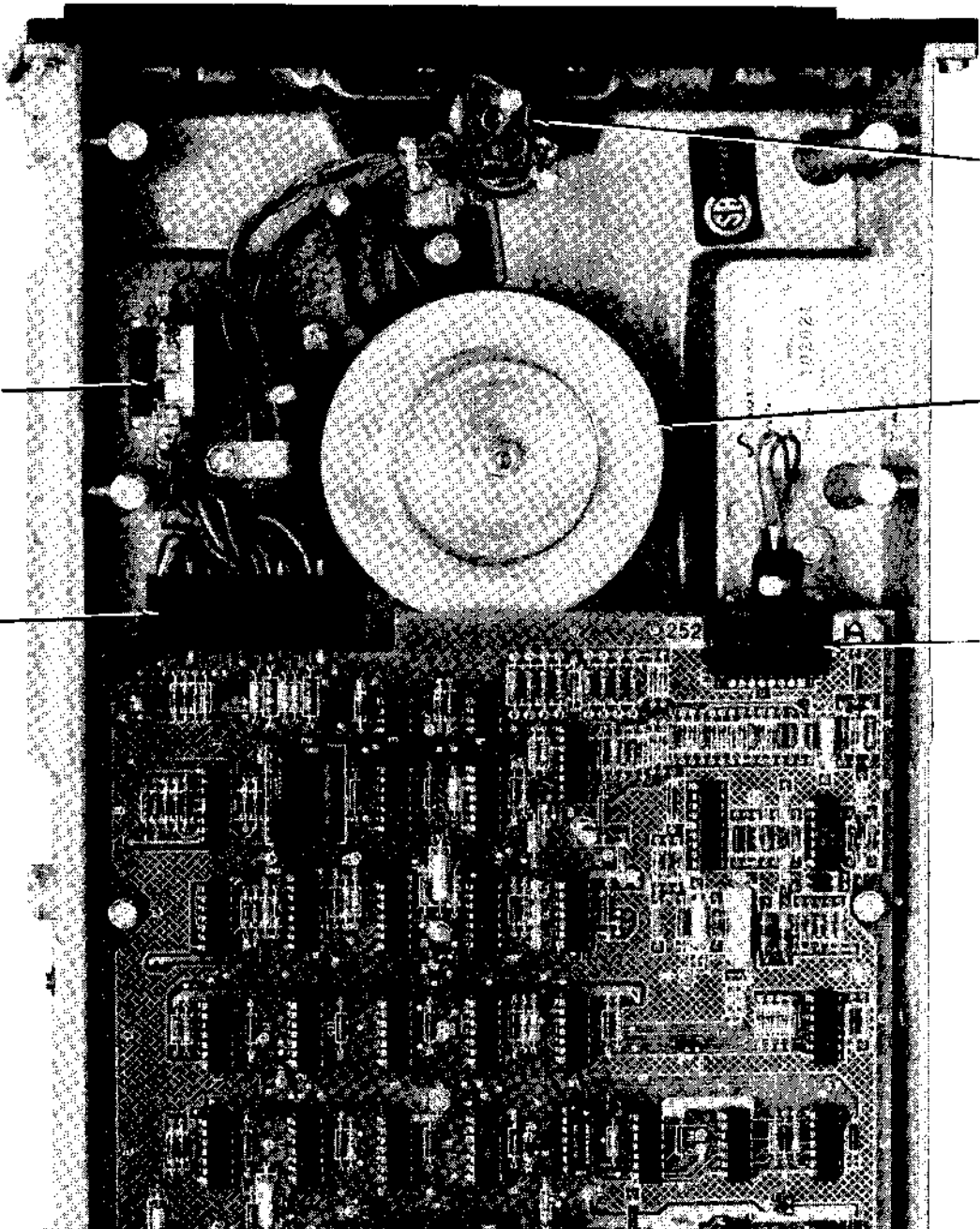
[1] GND WHEN INACTIVE AND +1.5VDC WHEN ACTIVE.

# Physical Locations

---



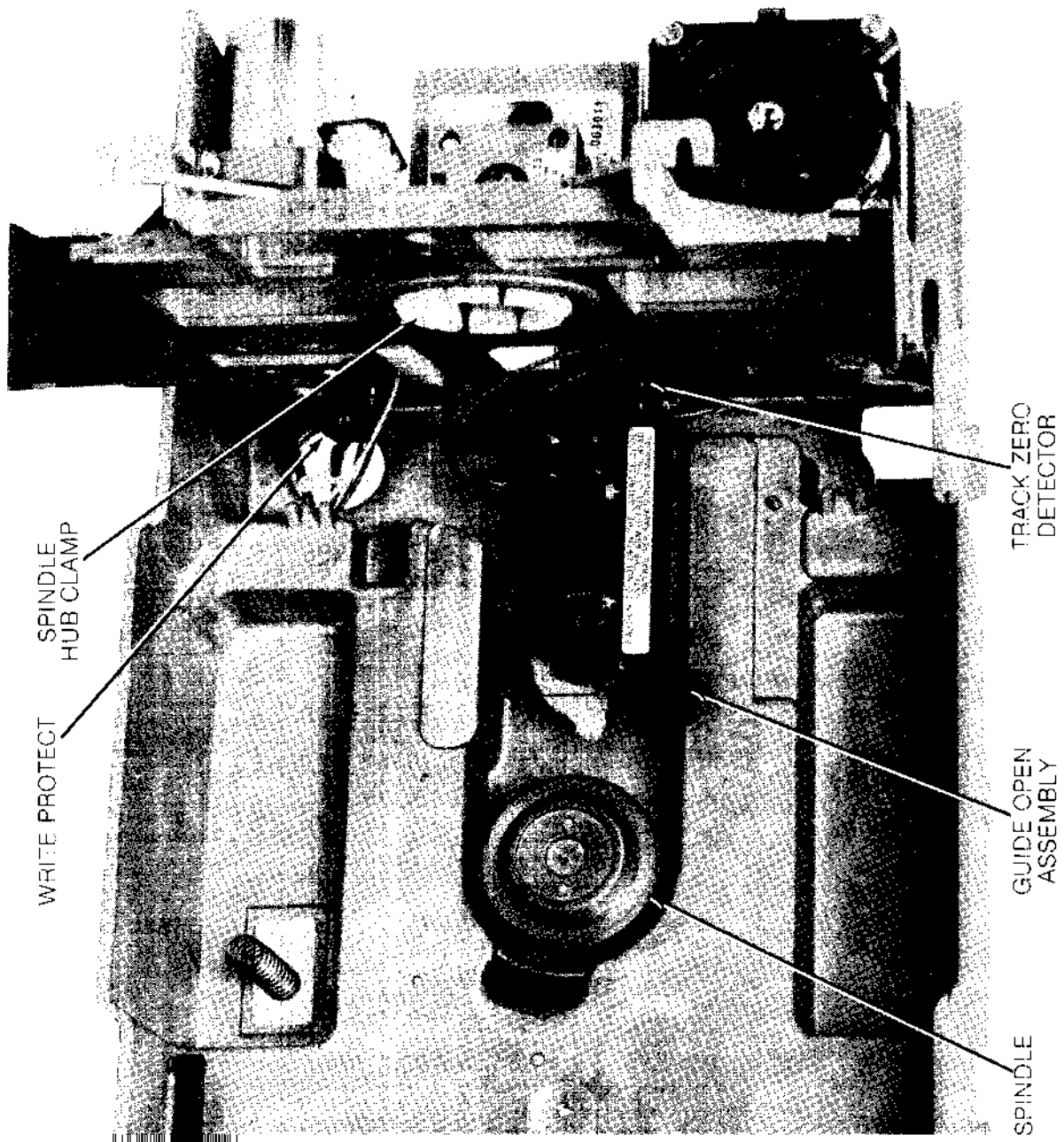
P2 CONNECTOR  
DOOR CLOSED SWITCH



DOOR LOCK SOLENOID

SPINDLE PULLEY

P3 CONNECTOR



WRITE PROTECT

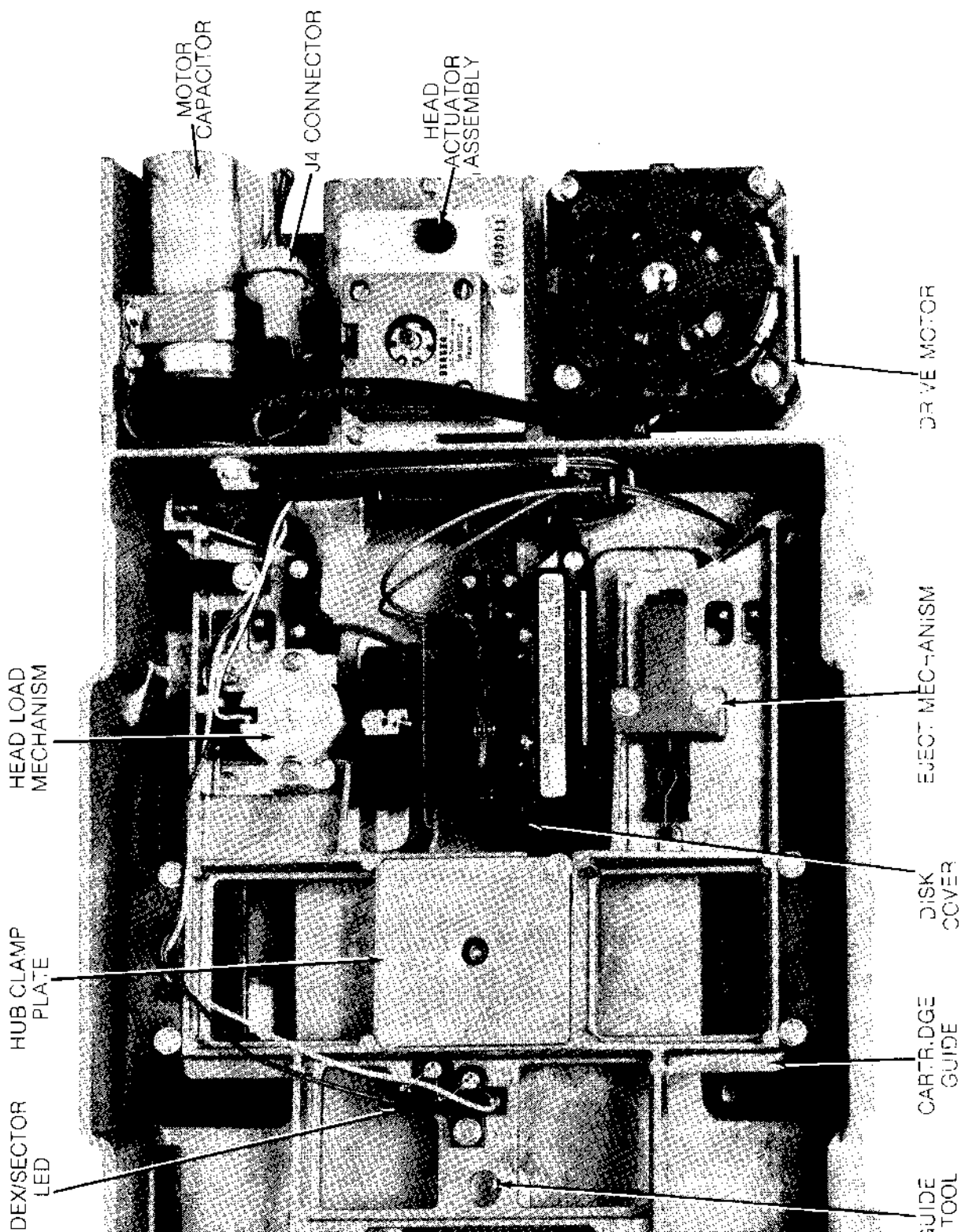
SPINDLE HUB CLAMP

TRACK ZERO DETECTOR

GUIDE OPEN ASSEMBLY

SPINDLE

903811



DEX/SECTOR  
LED

HUB CLAMP  
PLATE

HEAD LOAD  
MECHANISM

MOTOR  
CAPACITOR

J4 CONNECTOR

HEAD  
ACTUATOR  
ASSEMBLY

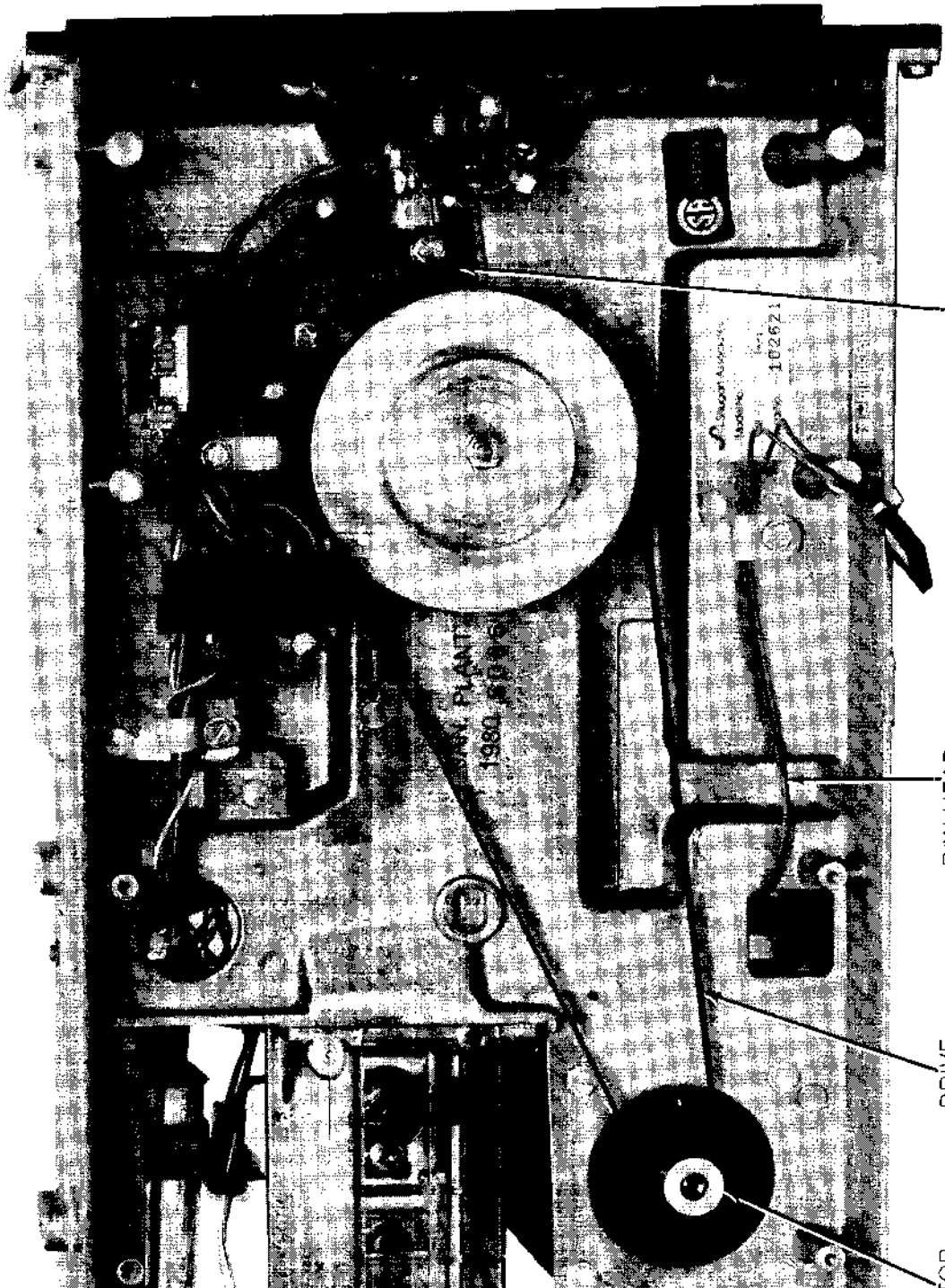
DRIVE MOTOR

EJECT MECHANISM

DISK  
COVER

CARTRIDGE  
GUIDE

GUIDE  
TOOL



INDEX/SECTOR  
PHOTO TRANSISTOR

R/W HEAD  
CABLE

DRIVE  
BELT

TOR

# **Illustrated Parts Catalog**

---

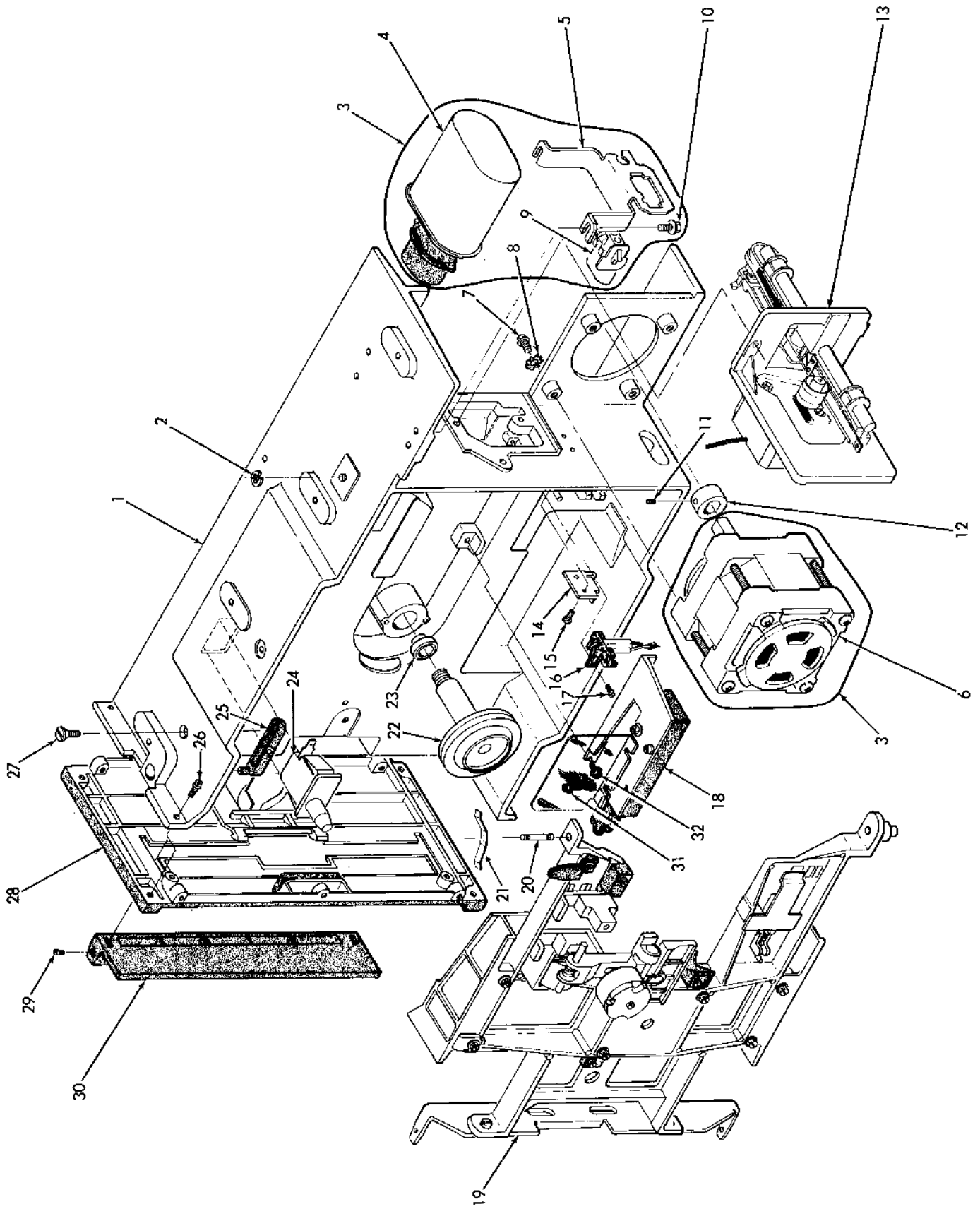


FIGURE 49. (1 of 2)

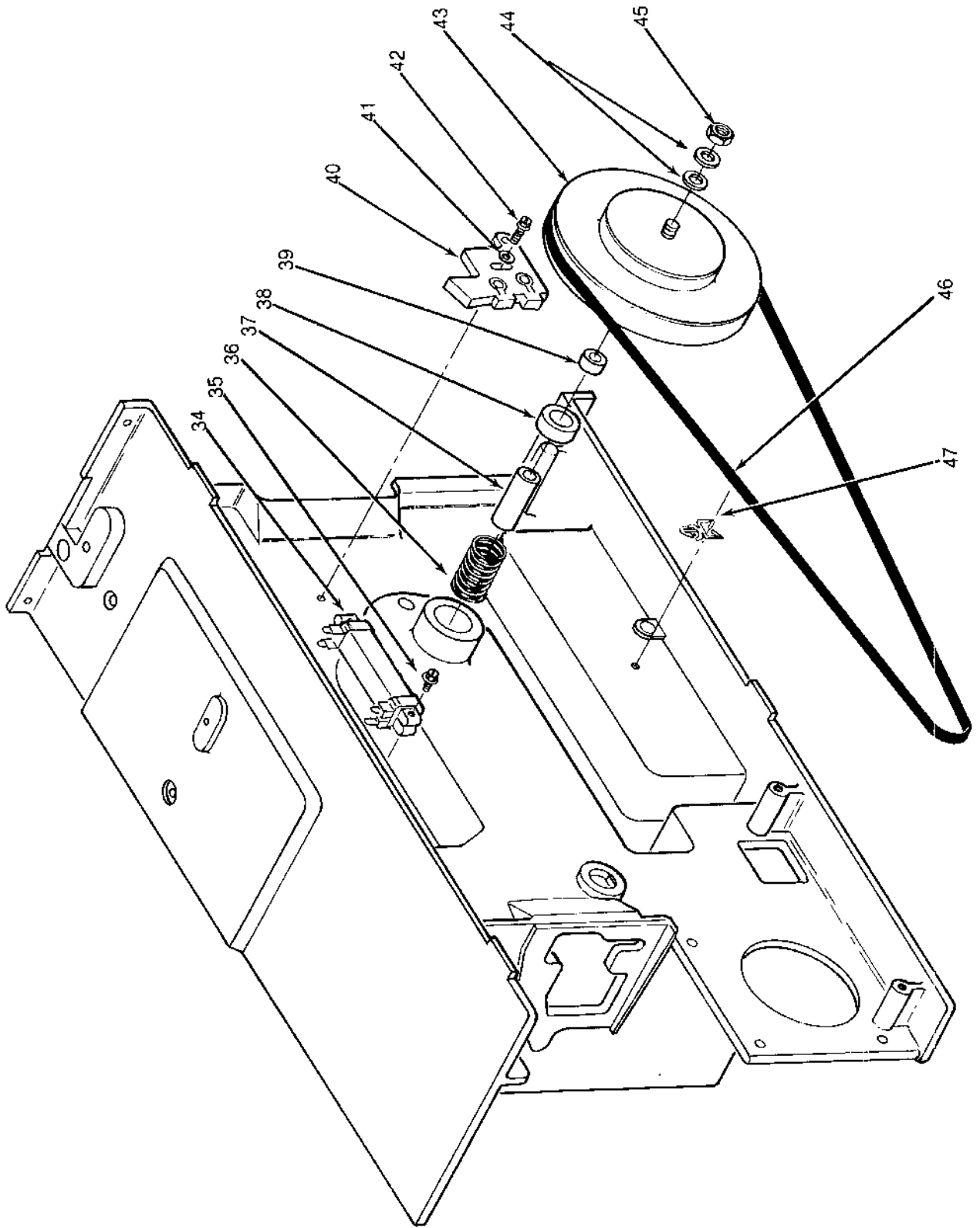


FIGURE & REF NUMBER	PART NUMBER	DESCRIPTION	QTY PER ASM
49-1		DRIVE ASSEMBLY SA850/851	
2	11305	CLIP (RETAINING RING)	1
3	50747	MOTOR ASSEMBLY, 115V, 50/60 HZ	1
	50748	MOTOR ASSEMBLY, 230V, 50/60 HZ	1
4	15004	CAPACITOR	1
5	50746	BRACKET	1
6	50744	MOTOR 115V, 50/60 HZ	1
	50745	MOTOR 230V, 50/60 HZ	1
7	12028	SCREW HEX HEAD 8-32 x .75	4
8	10013	WASHER	4
9	15669	HOUSING, 3 PIN CONNECTOR	1
10	12015	SCREW, 8-32 x .312	2
11	11904	SCREW, SET 6-32 x .125	1
12	50358	PULLEY, 60 HZ	1
	50357	PULLEY 50 HZ	1
13	51127	HEAD ACTUATOR ASSEMBLY	1
14	51056	BRACKET, TRACK 00	1
15	12013	SCREW, 6-32 x .312	2
16	51027	TRACK 00 ASSEMBLY	1
17	12053	SCREW	1
18	51063	GUIDE OPEN ASSEMBLY	1
19	51134	CARTRIDGE GUIDE ASSEMBLY (SEE FIGURE 50)	1
20	50167	PIVOT	1
20	50670	PIVOT (RACK MOUNT)	1
21	50168	BIAS SPRING	1
22	51198	SPINDLE	1
23	10801	FLANGED BEARING, SPINDLE	1
24	17200	DOOR OPEN SWITCH	1
25	50559	DEFLECTOR	2
26	12013	SCREW 6-32 x .438	4
27	12032	SCREW #8 x .50 2	2
28		FRONT PLATE ASSEMBLY (SEE FIGURE 51)	
29	11905	SCREW	2
30	50142	HANDLE	1
31	12011	SCREW, HEX HD 4-40	4
32	12053	SCREW	2
33	51058	COVER	1
34	51028	RESISTOR ASM	1
35	12026	SCREW	2
36	50166	SPRING, SPINDLE	1
37	50018	SPACER, SPINDLE LONG	1
38	10800	BALL BEARING	1
39	50019	SPACER SPINDLE SHORT	1
40	51046	PHOTO XSTR ASM	1
41	12026	SCREW	2
42	12036	SCREW	1
43	50016	PULLEY SPINDLE	1
44	12509	WASHER, SPRING #8	2
45	10025	NUT 8-32	1
46	50356	BELT, 60 HZ	1
46	50355	BELT, 50 HZ	1
47	10426	CABLE CLAMP	1



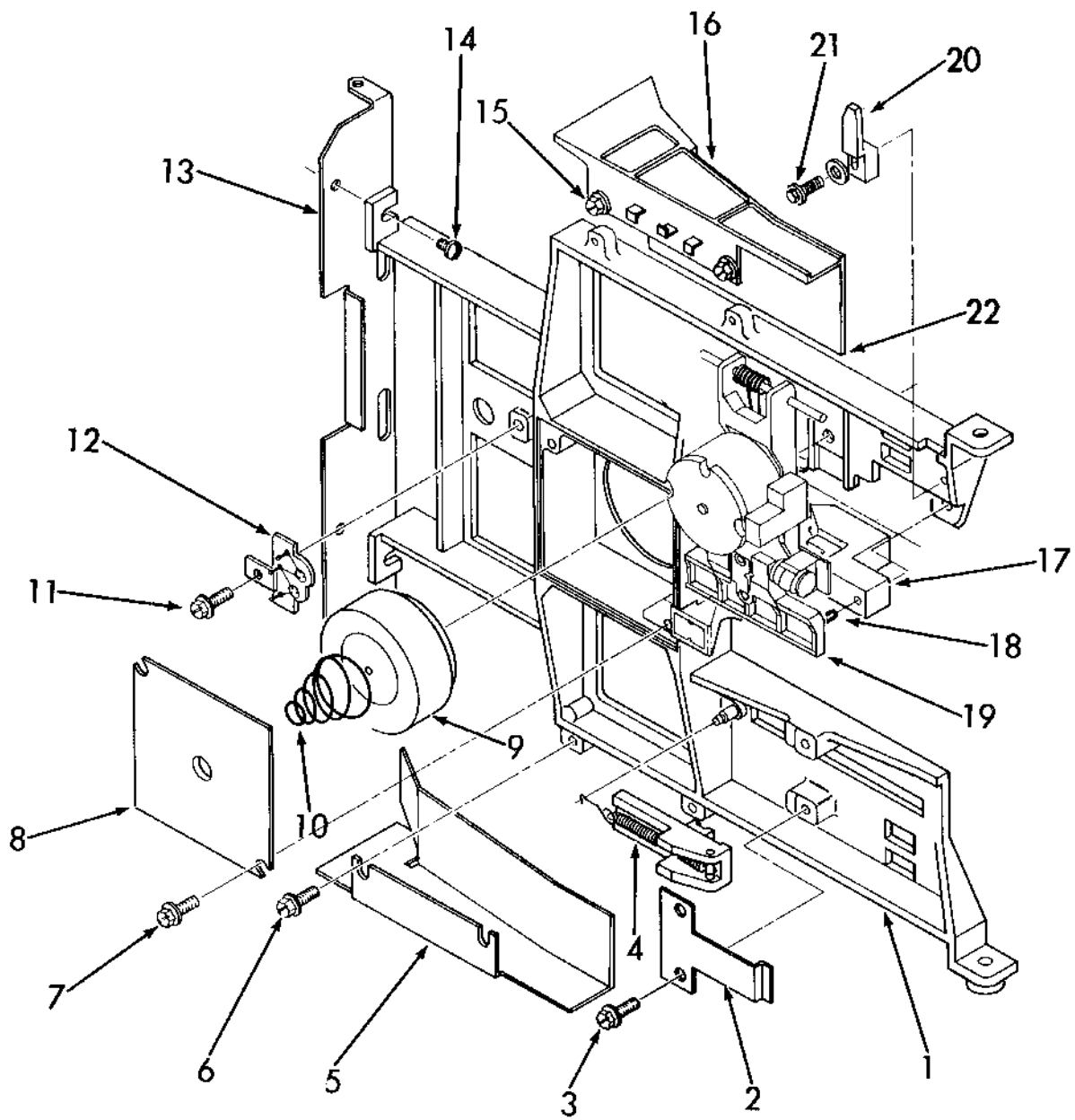


FIGURE 50.

FIGURE & REF NUMBER	PART NUMBER	DESCRIPTION	QTY PER ASM
50-1	51134	CARTRIDGE GUIDE ASSEMBLY	1
2	50555	SPRING, EJECTOR	1
3	12015	SCREW, 8-32	2
4	50609	EJECTOR ASSEMBLY	1
5	51062	STRIPPER BOTTOM	1
6	12015	SCREW, 8-32	2
7	12020	SCREW, 8-32	2
8	50546	PLATE, HUB CLAMP	1
9	50254	HUB ASSEMBLY	1
10	50031	SPRING, CLAMP	1
11	12016	SCREW, 8-32	1
12	51029	LED ASSEMBLY	1
13	50151	LATCH	1
14	10187	SCREW 6-32	2
15	12015	SCREW 8-32	2
16	51061	STRIPPER, TOP	1
17	50313	WRITE PROTECT ASSEMBLY	1
18	12026	SCREW	1
19	51176	HEAD LOAD MECHANISM	1
20	51075	LIMITER	1
21	10014	#8 WASHER	1
22	12020	SCREW 8-32	1

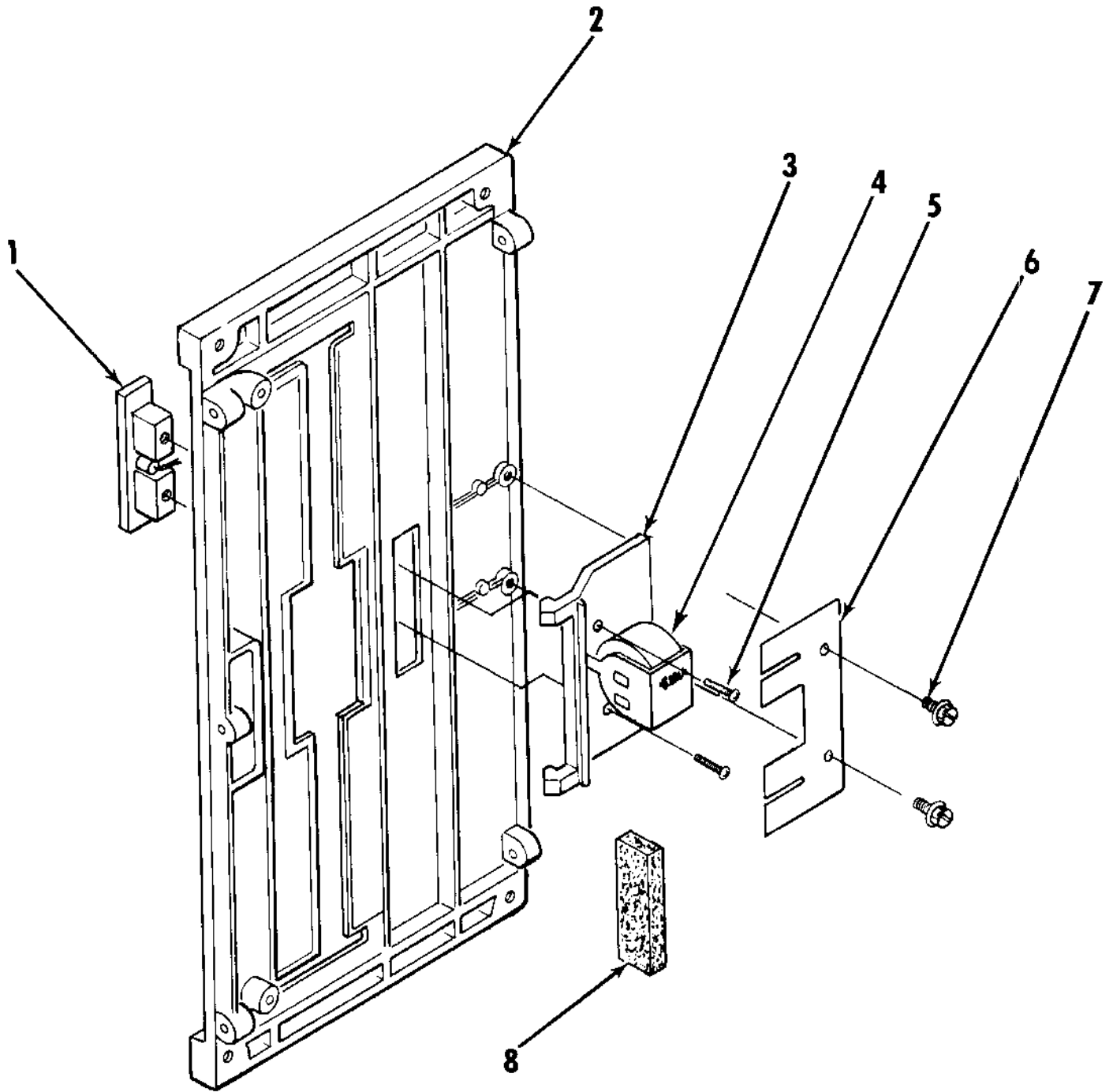
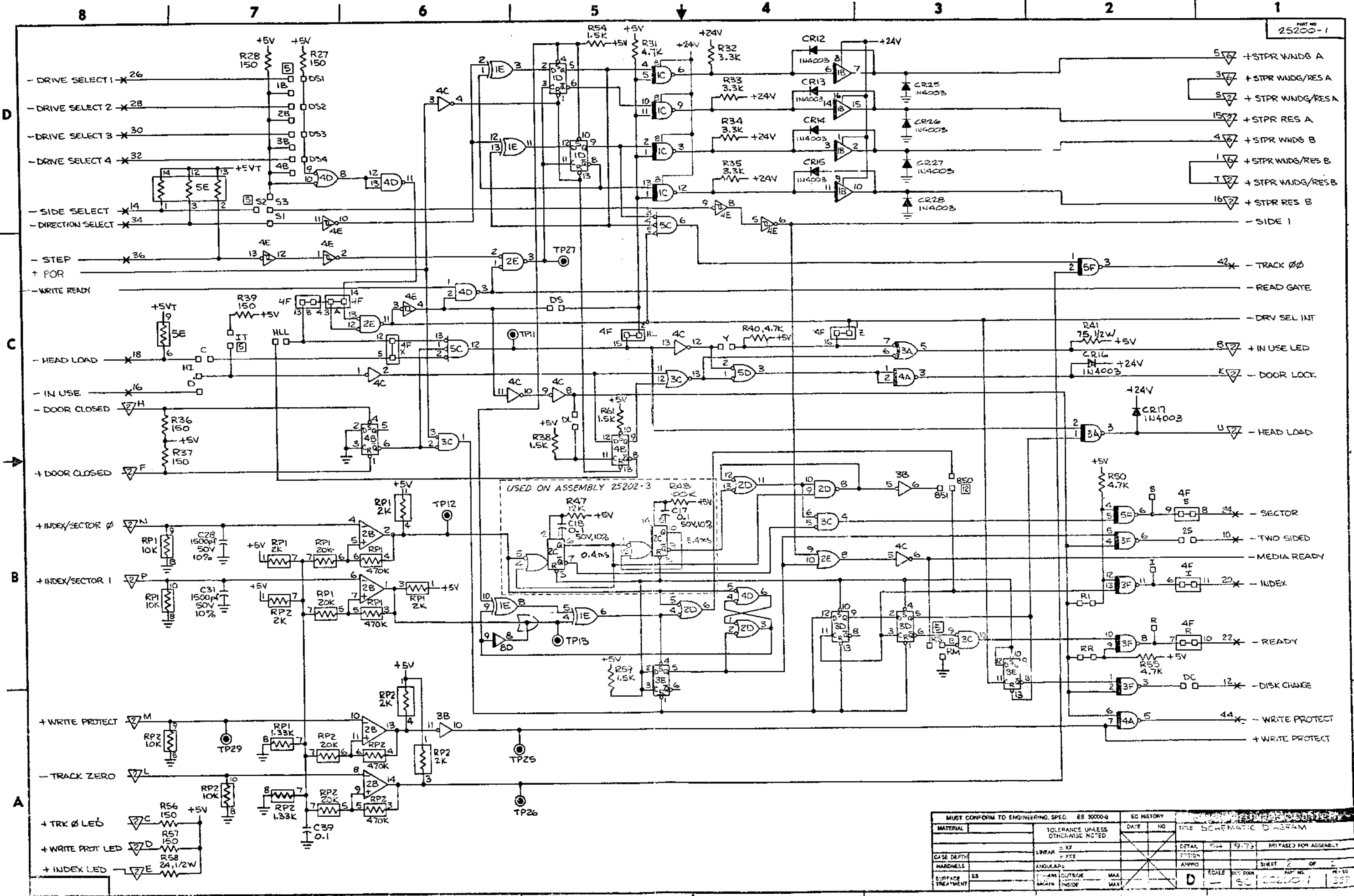


FIGURE 51

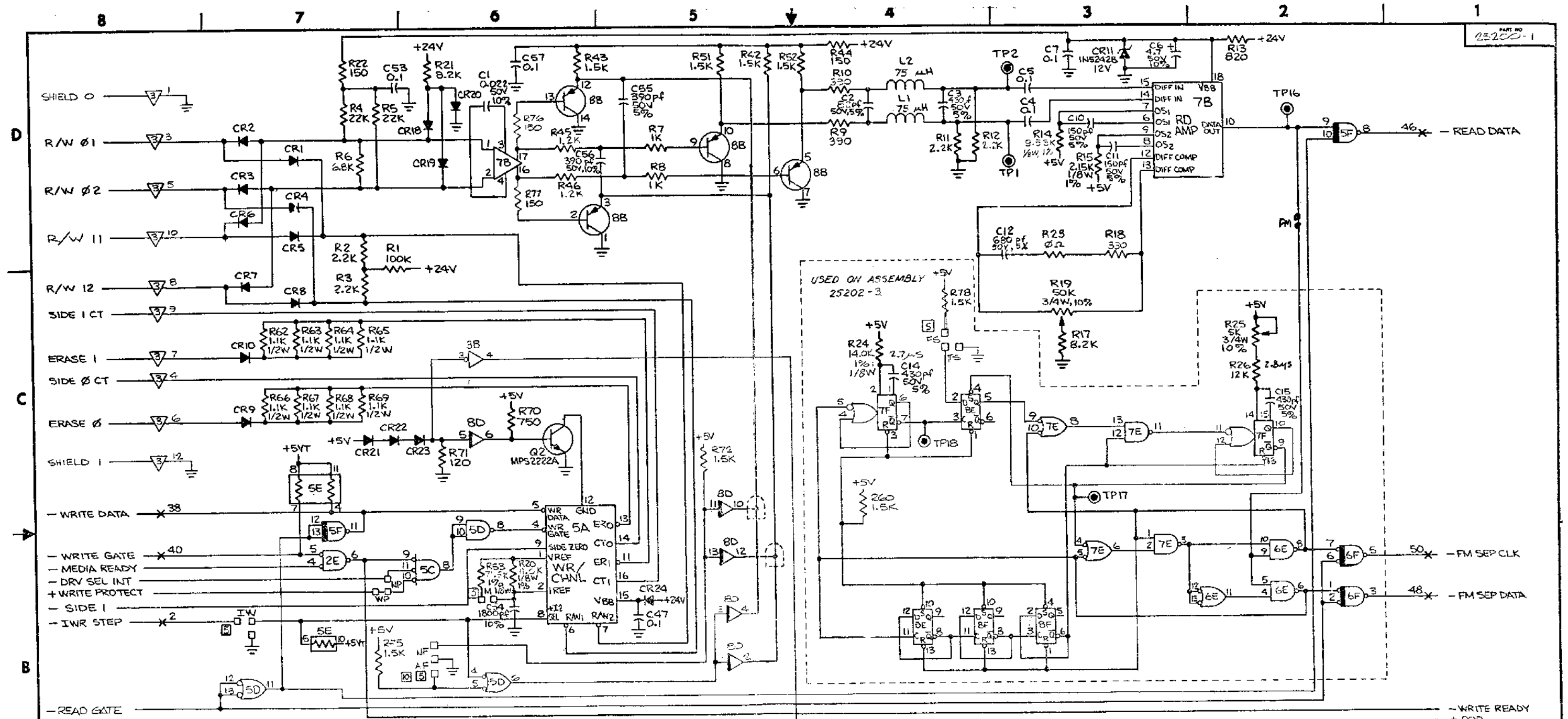
FIGURE & REF NUMBER	PART NUMBER	DESCRIPTION	QTY PER ASM
51	51037	FRONT PLATE ASSEMBLY LITE/LOCK	
	51043	FRONT PLATE ASSEMBLY LITE/LOCK (RACK MOUNT)	
-1	50587	PUSH BAR	1
-2	50349	FRONT PLATE	1
	50667	FRONT PLATE (RACK MOUNT)	1
-3	51038	LATCH ASSEMBLY, DOOR LOCK	1
-4	10002	SOLENOID	1
-5	12035	SCREW 4-40 x .250	2
-6	50691	SPRING LATCH INTERLOCK	1
-7	12013	SCREW 6-32 x .312	2
-8	50183	BUMPER	1

# Schematic Diagrams

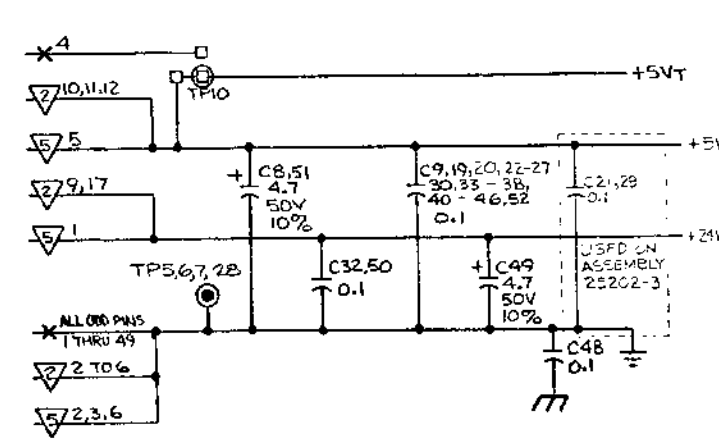
---



MUST CONFORM TO ENGINEERING SPEC. ES 3000-9		EC HISTORY		TITLE SCHEMATIC DIAGRAM	
MATERIAL	TOLERANCE UNLESS OTHERWISE NOTED	DATE	NO	DETAIL	REVISED FOR ASSEMBLY
CASE DEPTH	LINEAR = .002 RADIUS = .005			DETAIL	9-72
HARDNESS	ANODIZE			APPRO	SHEET 2 OF 2
SURFACE TREATMENT	FINISH OUTSIDE BRIGHT INSIDE	MAX		SCALE	200 000



PART NO. 25200-1



TYPE	POSITION	UNUSED ELEMENTS	+5V (PIN)	GND (PIN)
7400	2D, 4D, 5D, 6E, 7E	6E1	14	7
7402	3C		14	7
7404	3B, 4C	3B1, 4, 6	14	7
7407	8D		14	7
7427	5C		14	7
7432	2E		14	7
7439	3F, 5F		14	7
7474	4B, 1D, 3D, 3E, 8E, 8F		14	7
7486	1E		14	7
74LS14	4E		14	7
74LS02	2C, 7F		16	8
754538	6F		8	4
75462	3A, 4A		8	4
16270-1	5A		10	3
16278-0	7B		11	5
LM339	2B		3	12
RPK, 150Ω	5E		-	-
SHUNT	4F		-	-
TP0390x	8B		-	-
ULN2074B	1B		-	45, 20
LHP407	1C		14	7

NOTES: UNLESS OTHERWISE SPECIFIED

1. ALL CAPACITORS ARE IN MICROFARADS, 50V, ±20%.
2. ALL DIODES ARE IN 4148.
3. ALL INDUCTORS ARE IN MICROHENRYS, ±10%.
4. ALL RESISTORS ARE IN OHMS, 1/4W, ±5%.
5. SHORTING PLUGS INSTALLED.
6. CONNECTOR SYMBOL REFERENCE: \* = J1, ▽ = J2, ▽ = J3, ▽ = J4, ▽ = J5 & ▽ = J6.
7. - - - INDICATES CUT-TRACE OPTION.
8. □ □ INDICATES JUMPER OPTION.
9. □ ▭ INDICATES SHUNT JUMP/CUT-TRACE OPTION.
10. RECOMMENDED CONFIGURATION: SHORT AF FOR FM, MFM; SHORT NF FOR M<sup>2</sup>FM.
11. RPK INDICATES RESISTOR PACK
12. JUMPER OPTION \*R50/BS1 IS AS FOLLOWS: ASSEMBLY 25200-3 - B50 ASSEMBLY 25202-3 - JUMPER FOR APPROPRIATE DRIVE MODEL.

REFERENCE DESIGNATIONS	
LAST USED	NOT USED
C57	C13, 16
CR2	
L2	
Q2	Q1
R7B	R16, 19, 30, 49, 73, 74
TP29	TP3, 4, 8, 9, 14, 15, 19 TO 24
RPI	

USED ON ASSEMBLY 25200-1 25202-3

MUST CONFORM TO ENGINEERING SPEC ES 3000-0				EC HISTORY		TITLE SCHEMATIC DIAGRAM	
MATERIAL	TOLERANCE UNLESS OTHERWISE NOTED	DATE	NO.	DATE	NO.	SCALE	REVISE
CASE DEPTH	LINEAR 3.2X						RELEASED FOR ASSEMBLY
HARDNESS	ANQ/A APT						SHEET 2 OF 2
SURFACE TREATMENT	ES						SCALE: 1:1
				SCALE	REV CODE	PART NO	REV
				D	SC	25200-1	1359



Copyright 1977

475 Oakmead Parkway, Sunnyvale, California 94086  
Telephone: (408) 733-0100 TWX: 910 339 9355 SHUGART SUVL