

**SA800/801**  
**Diskette Storage**  
**Drive**

**Service Manual**

**Shugart**

© SHUGART 1982  
ALL RIGHTS RESERVED

# TABLE OF CONTENTS

	Page
TABLE OF CONTENTS .....	i
LIST OF FIGURES .....	iii
LIST OF TABLES .....	iv
ABBREVIATIONS/MNEMONICS .....	v
SECTION I INTRODUCTION .....	1-1
1.1 Description .....	1-1
1.2 SA800/801 Specification Summary .....	1-1
1.2.1 Performance Specifications .....	1-1
1.2.2 Functional Specifications .....	1-1
1.2.3 Physical Specifications .....	1-2
1.2.4 Reliability Specifications .....	1-2
1.3 Functional Characteristics .....	1-3
1.3.1 Read/Write and Control Electronics .....	1-3
1.3.2 Drive Mechanism .....	1-4
1.3.3 Positioning Mechanism .....	1-4
1.3.4 Read/Write Head .....	1-4
SECTION II ELECTRICAL INTERFACE .....	2-1
2.1 Signal Interface .....	2-1
2.1.1 Input Lines .....	2-1
2.1.2 Output Lines .....	2-3
2.2 Power Interface .....	2-3
2.2.1 AC Power .....	2-3
2.2.2 DC Power .....	2-3
2.3 Frame Ground .....	2-4
SECTION III PHYSICAL INTERFACE .....	3-1
3.1 Physical Interface .....	3-1
3.2 J1/P1 Connector .....	3-2
3.3 J5/P5 Connector .....	3-3
3.4 J4/P4 Connector .....	3-3
SECTION VI THEORY OF OPERATIONS .....	4-1
4.1 Track Accessing .....	4-1
4.1.1 Stepper Motor .....	4-1
4.1.2 Stepper Control Logic: Power-On Reset .....	4-2
4.1.3 Forward Seek .....	4-3
4.1.4 Reverse Seek .....	4-4
4.1.5 Track Zero Indicator .....	4-4
4.2 Read/Write Operations .....	4-5
4.3 Read/Write Head .....	4-7
4.4 Write Circuit Operation .....	4-8
4.5 Read Circuit Operation .....	4-9
4.6 LSI Theory of Operations (PCB P/N 25136 and 25229) .....	4-11
4.6.1 Drive Select and Head Load .....	4-11
4.6.2 Head Positioning .....	4-12
4.6.3 Index and Sector .....	4-12
4.6.4 Read and Write Operations .....	4-13
SECTION V MAINTENANCE .....	5-1
5.1 Maintenance Features .....	5-1
5.1.1 Alignment Diskette .....	5-1
5.1.2 SA809 Exerciser .....	5-1
5.1.3 Special Tools .....	5-1

# TABLE OF CONTENTS (CONT.)

5.2	Diagnostic Techniques	5-2
5.2.1	Introduction	5-2
5.2.2	“Soft Error” Detection and Correction	5-2
5.2.3	Write Error	5-3
5.2.4	Read Error	5-3
5.2.5	Seek Error	5-3
5.2.6	Test Points — SA800/801	5-3
5.3	Preventive Maintenance	5-4
5.4	Removals, Adjustments	5-4
5.4.1	Drive Motor Assembly Removal and Installation	5-4
5.4.2	Motor Drive Pulley Removal and Installation	5-4
5.4.3	Cartridge Guide Access	5-4
5.4.4	Sector/Index LED Assembly Removal and Installation	5-7
5.4.5	Write Protect Detector Removal and Installation	5-7
5.4.6	Write Protect Detector Adjustment	5-7
5.4.7	Head Load Actuator Removal and Installation	5-8
5.4.8	Head Load Actuator Adjustment	5-8
5.4.9	Head Load Actuator Timing	5-8
5.4.10	Index/Sector Photo Transistor Assembly Removal and Installation	5-9
5.4.11	Index/Sector Photo Transistor Potentiometer Adjustment	5-9
5.4.12	Index/Sector Adjustment	5-9
5.4.13	Belt and Pulley Removal and Installation	5-10
5.4.14	Spindle Assembly Removal and Installation	5-11
5.4.15	Hub Clamp Removal and Installation	5-11
5.4.16	Cartridge Guide Removal and Installation	5-11
5.4.17	Cartridge Guide Adjustment	5-11
5.4.18	Front Plate Assembly Removal and Installation	5-12
5.4.19	Head Amplitude Check	5-12
5.4.20	Stepper/Carriage Assembly Removal and Installation	5-12
5.4.21	Carriage Assembly Readjustment After Replacement	5-13
5.4.22	Head Radial Alignment	5-14
5.4.23	Read/Write Head Load Button Removal and Installation	5-15
5.4.24	Read/Write Head Load Button Adjustment	5-15
5.4.25	Head Penetration Adjustment	5-17
5.4.26	Track 00 Detector Removal and Installation	5-17
5.4.27	Track 00 Stop Adjustment	5-17
5.4.28	Track 00 Flag Adjustment	5-18
5.4.29	Read/Write Head Azimuth Alignment	5-18
5.4.30	Stepper Plate: Removal and Installation	5-19
5.4.31	Activity Light Removal and Installation (Standard)	5-20
5.4.32	Door Lock LED Removal and Installation	5-20
5.4.33	Activity Light (with Door Lock Option) Removal and Installation	5-20
5.5	Recommended Incoming Receiving Inspection	5-20
SECTION VI	SCHEMATIC DIAGRAMS	6-1
SECTION VII	ILLUSTRATED PARTS CATALOG	7-1
7.1	Description	7-1
7.2	Indented Level	7-1
7.3	Quantity Per Assembly	7-1
7.4	Door Lock	7-1
7.5	Recommended Spare Parts Stocking Guide	7-22

# LIST OF FIGURES

Figure		Page
1-1	SA800/801 Diskette Storage Drive .....	1-0
1-2	SA800/801 Functional Diagram .....	1-3
2-1	Interface Connections .....	2-2
2-2	Interface Signal Driver/Receiver .....	2-3
3-1	Interface Connectors - Physical Location Diagram .....	3-1
3-2	J1 Connector Dimensions .....	3-2
3-3	J5 Connector .....	3-3
3-4	J4 Connector .....	3-3
4-1	Stepper Motor .....	4-1
4-2	Position 1 (Trk 00) .....	4-1
4-3	Position 2 (Trk 01) .....	4-2
4-4	Position 3 (Trk 02) .....	4-2
4-5	Track Accessing (Stepper Control Logic) .....	4-2
4-6	Track Accessing .....	4-3
4-7	Stepper Motor At Trk 05 .....	4-4
4-8	Stepper Motor At Trk 02 .....	4-4
4-9	Track 00 Flag .....	4-4
4-10	Track 00 Timing .....	4-5
4-11	Bit Cell .....	4-6
4-12	Basic Read/Write Head .....	4-6
4-13	Recorded Bit .....	4-6
4-14	Reading A Bit .....	4-6
4-15	1F and 2F Recording Flux and Pulse Relationship .....	4-7
4-16	Read/Write Head .....	4-8
4-17	Write Circuit Functional Diagram .....	4-8
4-18	Read Circuit Functional Diagram .....	4-9
4-19	Data Separator Functional Diagram .....	4-10
4-20	Data Separation Timing Diagram .....	4-10
5-1	SA809 Exerciser Connection .....	5-2
5-2	Physical Locations (Sheet 1 of 3) .....	5-5
5-2	Physical Locations (Sheet 2 of 3) .....	5-6
5-2	Physical Locations (Sheet 3 of 3) .....	5-7
5-3	Head Load Actuator Upstop Adjustment .....	5-8
5-4	Head Load Actuator Downstop Adjustment .....	5-8
5-5	Head Load Actuator Timing .....	5-9
5-6	Index Timing .....	5-10
5-7	Cartridge Guide Adjustment .....	5-11
5-8	Cartridge Guide Removal .....	5-11
5-9	Carriage Assembly .....	5-13
5-10	Head Radial Alignment .....	5-15
5-11	Read/Write Head Radial Alignment .....	5-16
5-12	Read/Write Head Load Button Installation .....	5-16
5-13	Azimuth Burst Patterns .....	5-19
5-14	Drive Rear View .....	5-19
6-1	Schematic Diagram, P/N 2510X (Sheet 1 of 2) .....	6-2
6-1	Schematic Diagram, P/N 2510X (Sheet 2 of 2) .....	6-4
6-2	Schematic Diagram, P/N 2517X (Sheet 1 of 2) .....	6-6
6-2	Schematic Diagram, P/N 2517X (Sheet 2 of 2) .....	6-8
6-3	Schematic Diagram, P/N 25136 (Sheet 1 of 2) .....	6-10
6-3	Schematic Diagram, P/N 25136 (Sheet 2 of 2) .....	6-12
6-4	Schematic Diagram, P/N 25229 (Sheet 1 of 2) .....	6-14
6-4	Schematic Diagram, P/N 25229 (Sheet 2 of 2) .....	6-16
6-5	Door Lock Schematic .....	6-18
7-1	Drive Assembly SA800/801 Exploded View (Sheet 1 of 2) .....	7-3
7-1	Drive Assembly SA800/801 Exploded View (Sheet 2 of 2) .....	7-4

## LIST OF FIGURES (CONT.)

7-2	Stepper Carriage Assembly Exploded View .....	7-6
7-3	Cartridge Guide Assembly Exploded View .....	7-8
7-4	Front Plate Assembly Exploded View .....	7-10
7-5	PCB Component Locations P/N 2510X .....	7-12
7-6	PCB Component Locations P/N 2517X .....	7-15
7-7	PCB Component Locations P/N 25136 .....	7-18
7-8	PCB Component Locations P/N 25229 .....	7-20

## LIST OF TABLES

<b>Table</b>		<b>Page</b>
2-1	Voltage Specifications .....	2-4
2-2	AC Voltage/Frequency Conversion .....	2-4
3-1	Recommended P1 Connectors .....	3-2
6-1	Schematic Diagram Applicability .....	6-1
7-1	Spare Parts Stocking Guide .....	7-23
7-2	Part Number To Figure Reference Cross Reference .....	7-25

## ABBREVIATIONS / MNEMONICS

<b>CLK</b>	Clock	<b>NFO</b>	No Force Out
<b>CRC</b>	Cyclic Redundancy Check	<b>NHA</b>	Next Higher Assembly
<b>DDS</b>	Double Drive Select	<b>NRZI</b>	Non Return to Zero
<b>FM</b>	Frequency Modulation	<b>OUTEN</b>	Output Enable
<b>IPC</b>	Illustrated Parts Catalog	<b>PCB</b>	Printed Circuit Board
<b>LED</b>	Light-Emitting Diode	<b>PM</b>	Preventive Maintenance
<b>LSI</b>	Large Scale Integration	<b>STEN</b>	Step Enable
<b>MF</b>	Modified FM	<b>1F</b>	Single Frequency
<b>MLC</b>	Machine Level Code	<b>2F</b>	Double Frequency

## ABOUT THIS MANUAL

While every effort has been made to ensure that the information provided herein is correct, please feel free to notify us in the event of an error or inconsistency. Write any comments on the form at the back of this manual and send to:

Shugart  
Technical Publications  
475 Oakmead Parkway  
Sunnyvale, CA 94086  
(408) 733-0100

This manual (P/N 39025-1) supersedes and makes obsolete the previous edition of this manual (P/N 39025-0, dated 7/81). This manual incorporates all changes shown in errata #1, dated 9/17/81, to P/N 39025-0.

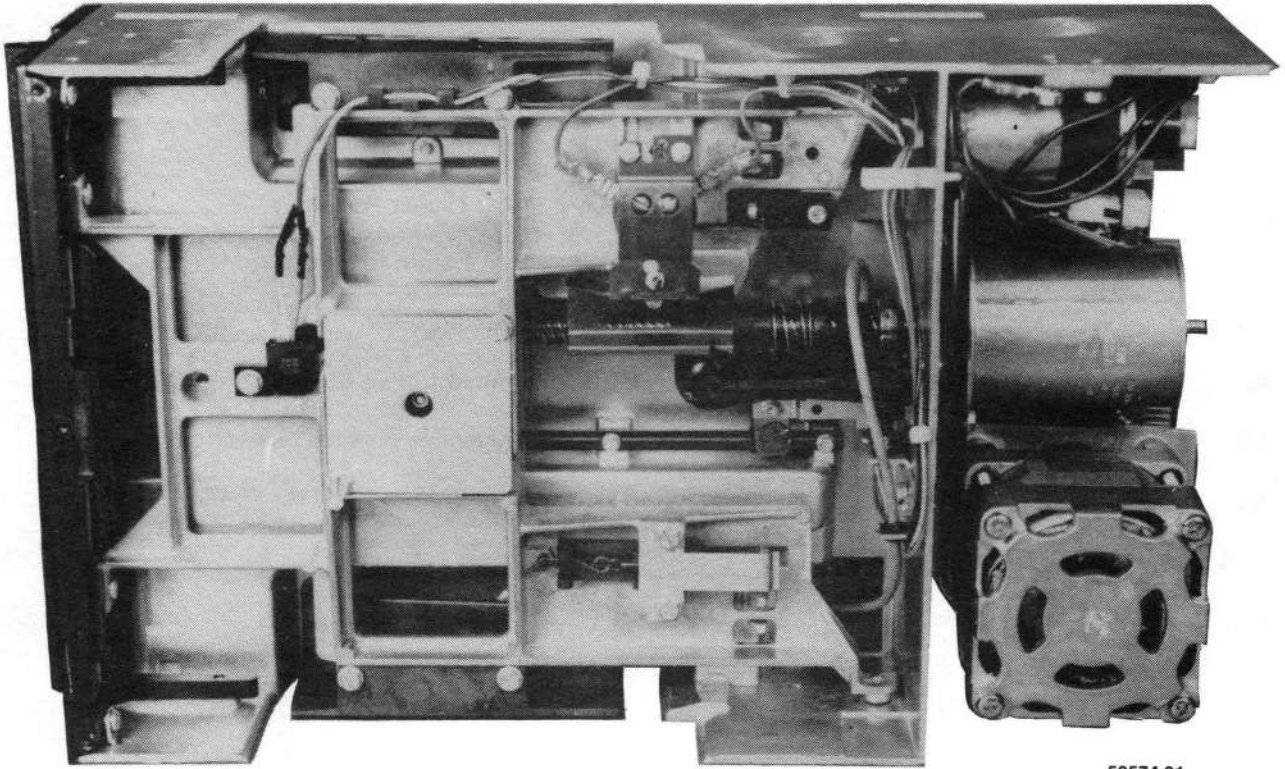

50574-01

FIGURE 1-1. SA800/801 DISKETTE STORAGE DRIVE



# SECTION I INTRODUCTION

## 1.1 DESCRIPTION

The SA800/801 Diskette Storage Drive provides the system designer solutions to his applications requirements with greater performance and reliability than cassette or cartridge drives, and lower cost with increased function over I/O and reel-to-reel tape drives.

The SA800/801 can read and write diskettes for interchange with other SA800's, the SA900, IBM 3741, 3742, or 3540, and with the IBM System 32.

The SA801 provides the same features as the SA800 with additional flexibility for those applications which do not require IBM compatibility.

The SA800/801R series is mechanically and electrically the same as the SA800/801, but has a narrower chassis width plus side and bottom mounting posts. This facilitates installation of two drives side by side in a standard 19-inch RETMA rack.

## 1.2 SA800/801 SPECIFICATION SUMMARY

### 1.2.1 Performance Specifications

	<b>Single Density</b>	<b>Double Density</b>
Capacity		
Unformatted		
Per Disk	500 k bytes	1 M bytes
Per Track	5.2 k bytes	10.4 k bytes
IBM Format		
Per Disk	250 k bytes	N/A
Per Track	3.3 k bytes	N/A
Transfer Rate	250 k bits/sec	500 k bits/sec
Latency (average)	83 ms	83 ms
Access Time		
Track to Track	8 ms	8 ms
Average	210 ms	210 ms
Settling Time	8 ms	8 ms
Head Load Time	35 ms	35 ms

### 1.2.2 Functional Specifications

	<b>Single Density</b>	<b>Double Density</b>
Rotational Speed	360 rpm	360 rpm
Recording Density		
(inside track)	3268 bpi	6536 bpi
Flux Density	6536 fci	6536 fci
Track Density	48 tpi	48 tpi
Tracks	77	77
Physical Sectors		
SA800	0	0
SA801	32/16/8	32/16/8

	Single Density	Double Density
Index	1	1
Encoding Method	FM	MFM
Media Requirements		
SA800	SA100/IBM Diskette	SA102 IBM/Diskette
SA801	SA101	SA103

### 1.2.3 Physical Specifications

Environmental Limits	Operating	Shipping	Storage
Ambient Temperature	40° to 115°F (4.4° to 46.1°C)	-40° to 144°F (-40° to 62.2°C)	-8 to 117°F (-22.2° to 47.2°C)
Relative Humidity	20 to 80%	1 to 95%	1 to 95%
Maximum Wet Bulb	85°F (29°C)	No Condensation	No Condensation

#### AC Power Requirements

50/60 Hz ± 0.5 Hz  
 100/115 V ac Installations = 85 to 127 V @ 0.4 A typical  
 200/230 V ac Installations = 170 to 253 V @ 0.2 A typical

#### DC Voltage Requirements

+24 V dc ± 5% 1.3 A typical  
 +5 V dc ± 5% 0.8 A typical  
 -5 V dc ± 5% 0.05 A typical (option -7 to -16) (Not required on LSI version)

#### Mechanical Dimensions

Height = 4.63 in. (11.75 cm)  
 Width = 9.50 in. (24.13 cm)  
           8.50 in. (21.72 cm) Rack  
 Depth = 14.25 in. (36.20 cm)  
 Weight = 13.0 lbs (5.90 kg)

Heat Dissipation = 271 BTU/hr typical

#### Mounting

Top Loading — Yes  
 Diskette Horizontal (Label Up) — Yes  
 Diskette Vertical (Label Left/Right) — Yes

### 1.2.4 Reliability Specifications

Mean Time Between Failure: 5000 POH under heavy usage  
 8000 POH under typical usage

Preventive Maintenance: 12 months

Mean Time To Repair: 30 minutes

Component Life: 15,000 POH

#### Error Rates:

Soft Read Errors: 1 per 10<sup>9</sup> bits read  
 Hard Read Errors: 1 per 10<sup>12</sup> bits read  
 Seek Errors: 1 per 10<sup>6</sup> seeks

#### Media Life:

Passes Per Track: 3.5 × 10<sup>6</sup>  
 Insertions: 30,000 +



### **1.3.2 Drive Mechanism**

The diskette drive motor continuously rotates a spindle at 360 rpm through a belt-drive system. Changing the drive pulley and belt accommodates 50 or 60 Hz power. Ordering the appropriate drive motor accommodates 110 V or 220 V power. A registration hub, centered on the face of the spindle, positions the diskette. A clamp moving in conjunction with the cartridge guide fixes the diskette to the registration hub.

### **1.3.3 Positioning Mechanism**

An electrical stepping motor (Head Position Actuator) and lead screw position the read/write head. The stepping motor rotates the lead screw clockwise or counterclockwise in 15° increments. A 15° rotation of the lead screw moves the read/write head one track position. The host system increments the stepping motor to the desired track.

### **1.3.4 Read/Write Head**

The SA800/801 head is a single element ceramic read/write head with straddle erase elements to provide erased areas between data tracks. Therefore, normal interchange tolerances between media and drives will not degrade the signal to noise ratio and diskette interchangeability is ensured.

The read/write head is mounted on a carriage located on the Head Position Actuator lead screw. The diskette is held in a plane perpendicular to the read/write head by a platen located on the base casting. This precise registration assures perfect compliance with the read/write head. The diskette is loaded against the head with a load pad actuated by the head load solenoid.

The read/write head is in direct contact with the diskette. The head surface has been designed to obtain maximum signal transfer to and from the magnetic surface of the diskette with minimum head/diskette wear.

## SECTION II ELECTRICAL INTERFACE

### 2.1 SIGNAL INTERFACE

The signal interface consists of two categories:

- a. Control
- b. Data Transfer

All lines in the signal interface are digital in nature and either provide signals to the drive (input) or provide signals to the host (output) via interface connector P1/J1. See figure 2-1 for all interface connections.

#### 2.1.1 Input Lines

There are ten signal input lines, eight are standard and two are user installable options (refer to SA800/801 OEM P/N 50574).

The input signals are of two types, those intended to be multiplexed in a multiple drive system and those which will perform the multiplexing. The input signals intended to do the multiplexing are:

- a. DRIVE SELECT 1
- b. DRIVE SELECT 2
- c. DRIVE SELECT 3
- d. DRIVE SELECT 4

The input signals which are intended to be multiplexed are:

- a. DIRECTION SELECT
- b. STEP
- c. WRITE DATA
- d. WRITE GATE
- e. HEAD LOAD (Alternate Input)
- f. IN USE (Alternate Input)

Input lines have the following electrical specifications:

True = logical zero:  $V_{in} = 0.0 \text{ V to } +0.4 \text{ V @ } I_{in} = 40 \text{ mA (max)}$   
False = logical one:  $V_{in} = +2.5 \text{ V to } +5.25 \text{ @ } I_{in} = 250 \mu\text{A (open)}$   
Input Impedance = 150 ohms

#### Input Line Termination

The SA800/801 has been provided with the capability of terminating the four input lines, which are meant to be multiplexed, by jumpering traces. The four lines and the respective jumpering traces are:

- a. DIRECTION SELECT . . . . . Trace "T3"
- b. STEP . . . . . Trace "T4"
- c. WRITE DATA . . . . . Trace "T5"
- d. WRITE GATE . . . . . Trace "T6"

In order for the drive to function properly, the last drive on the interface must have these four lines terminated. Termination of these lines can be accomplished by either of two methods.

- a. As shipped from the factory, jumpers are installed on the terminator posts T3, T4, T5, and T6. Remove these shorting plugs from all drives except the last one on the interface.
- b. External termination may be used, provided the terminator is beyond the last drive. Each of the four lines should be terminated by using a 150 ohm, 1/4 watt resistor, pulled up to +5 V dc.

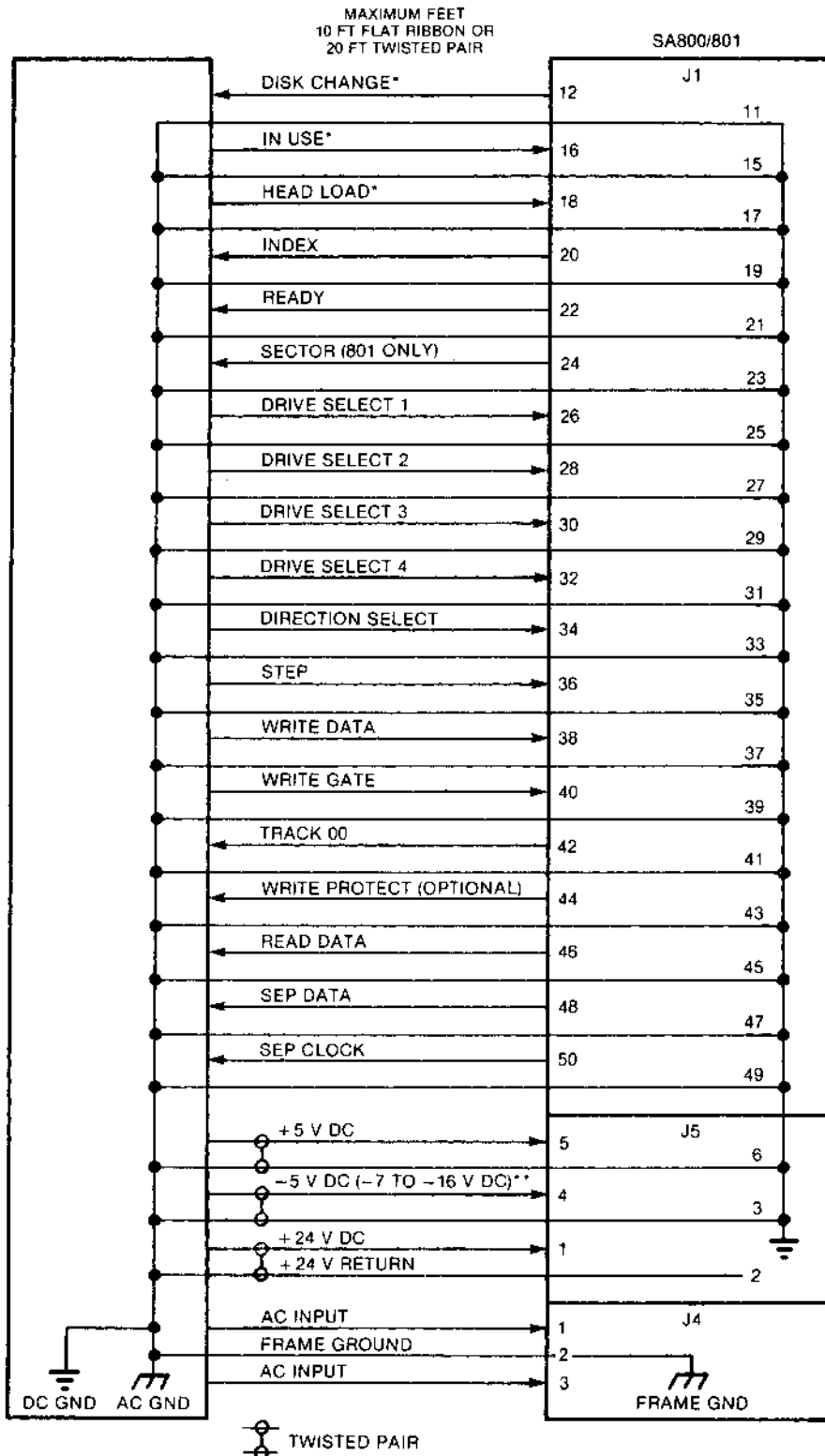

**NOTE:** Not shown are 5 of the 9 Alternate I/O connections. The connections for these lines are on pins 2, 4, 6, 8, 10, and 14. Signal return for these lines are on pins 1, 3, 5, 7, 9, and 13 respectively.

\*These lines are alternate input/output lines and are enabled by jumper plugs.

\*\*Not required on LSI PCB's.

50574-10

**FIGURE 2-1. INTERFACE CONNECTIONS**

### 2.1.2 Output Lines

There are seven output lines from the SA800 and eight from the SA801. There is also one optional output line from the SA800/801.

The output signals are driven with an open collector output stage capable of sinking a maximum of 40 mA at a logical zero level, or true state, with a maximum voltage of 0.4 V measured at the driver. When the line driver is in a logical one or false state, the driver is off and the collector current is a maximum of 250  $\mu$ A. The receiver should be a Schmidt trigger type device. See figure 2-2.

For a more detailed discussion of the signal interface, refer to the SA800/801 OEM Manual (P/N 50574).

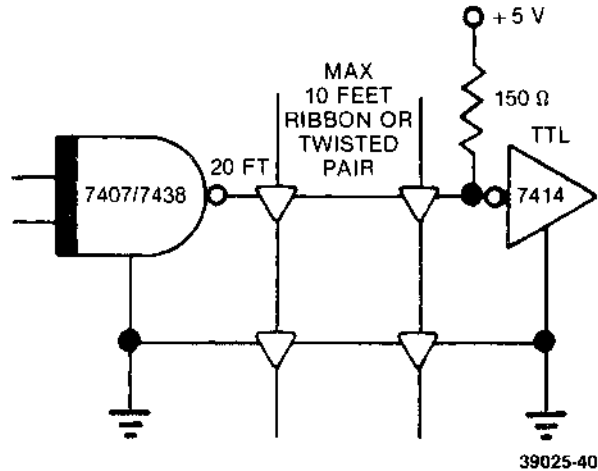

FIGURE 2-2. INTERFACE SIGNAL DRIVER/RECEIVER

## 2.2 POWER INTERFACE

The SA800/801 requires both ac and dc power for operation. The ac power is used for the spindle drive motor and the dc power is used for the electronics and the stepper motor.

### 2.2.1 AC Power

AC power to the drive is via the P4/J4 connector located to the rear of the drive and below the ac motor capacitor. The P4/J4 pin designations are outlined in table 2-1 along with the ac power specifications.

### 2.2.2 DC Power

DC power to the drive is via connector P5/J5 located on the non-component side of the PCB near the P4 connector. The three dc voltages and their specifications, along with their P5/J5 pin designators, are outlined in table 2-1.

**TABLE 2-1. VOLTAGE SPECIFICATIONS**

P4 PIN	60 Hz		50 Hz	
	110 V (Standard)	208/230 V	110 V	220 V
1	85 — 127 V AC	170 — 253 V AC	85 — 127 V AC	170 — 253 V AC
2	FRAME GND	FRAME GND	FRAME GND	FRAME GND
3	85 — 127 V RTN	170 — 253 V RTN	85 — 127 V RTN	170 — 253 V RTN
MAX CURRENT	0.35 AMPS	0.23 AMPS	0.35 AMPS	0.23 AMPS
FREQ TOLERANCE	± 0.5 Hz		± 0.5 Hz	

P5 PIN	DC VOLTAGE	TOLERANCE	CURRENT	MAX RIPPLE (p to p)
1	± 24 V DC	± 1.2 V DC	1.7 A MAX* 1.3 A TYP	100 mV
2	+ 24 V RETURN			
3**	- 5 V RETURN			
4**	- 5 V DC	± 0.25 V DC	0.07 A MAX 0.05 A TYP	50 mV
	OPTIONAL - 7 to - 16 V DC TRACE 'L'	NA	0.10 A MAX 0.07 A TYP	NA
5	+ 5 VDC	± 0.25 V DC	1.0 A MAX 0.8 A TYP	50 mV
6	+ 5 V RETURN			

\* The 24 V dc power requires a separate ground return line. The + 24 V return, other ground return lines, and frame ground must be connected together at the main power supply.

\*\* Not required on LSI PCB's.

39025-17

**TABLE 2-2. AC VOLTAGE/FREQUENCY CONVERSION**

PRIMARY VOLTAGE AND FREQUENCY	PART NUMBERS		
	MOTOR ASM*	MOTOR PULLEY	BELT
115 V AC, 60 HZ	50443	50358	50356
115 V AC, 50 HZ	50443	50357	50355
230 V AC, 60 HZ	50444	50358	50356
230 V AC, 50 HZ	50444	50357	50355

\* Motor assemblies include — motor, capacitor, and connector.

39025-41

### 2.3 FRAME GROUND

It is important that the drive be frame grounded to the host system by either the ac ground or frame ground. Failure to do so may result in drive noise susceptibility.



## SECTION III PHYSICAL INTERFACE

### 3.1 PHYSICAL INTERFACE

The electrical interface between the SA800/801 and the host system is via three connectors. The first connector, J1, provides the signal interface; the second connector, J5, provides the dc power; and the third connector, J4, provides the ac power and frame ground.

This section describes the physical connectors used on the drive and the recommended connectors to be used with them. See figure 3-1 for connector locations.

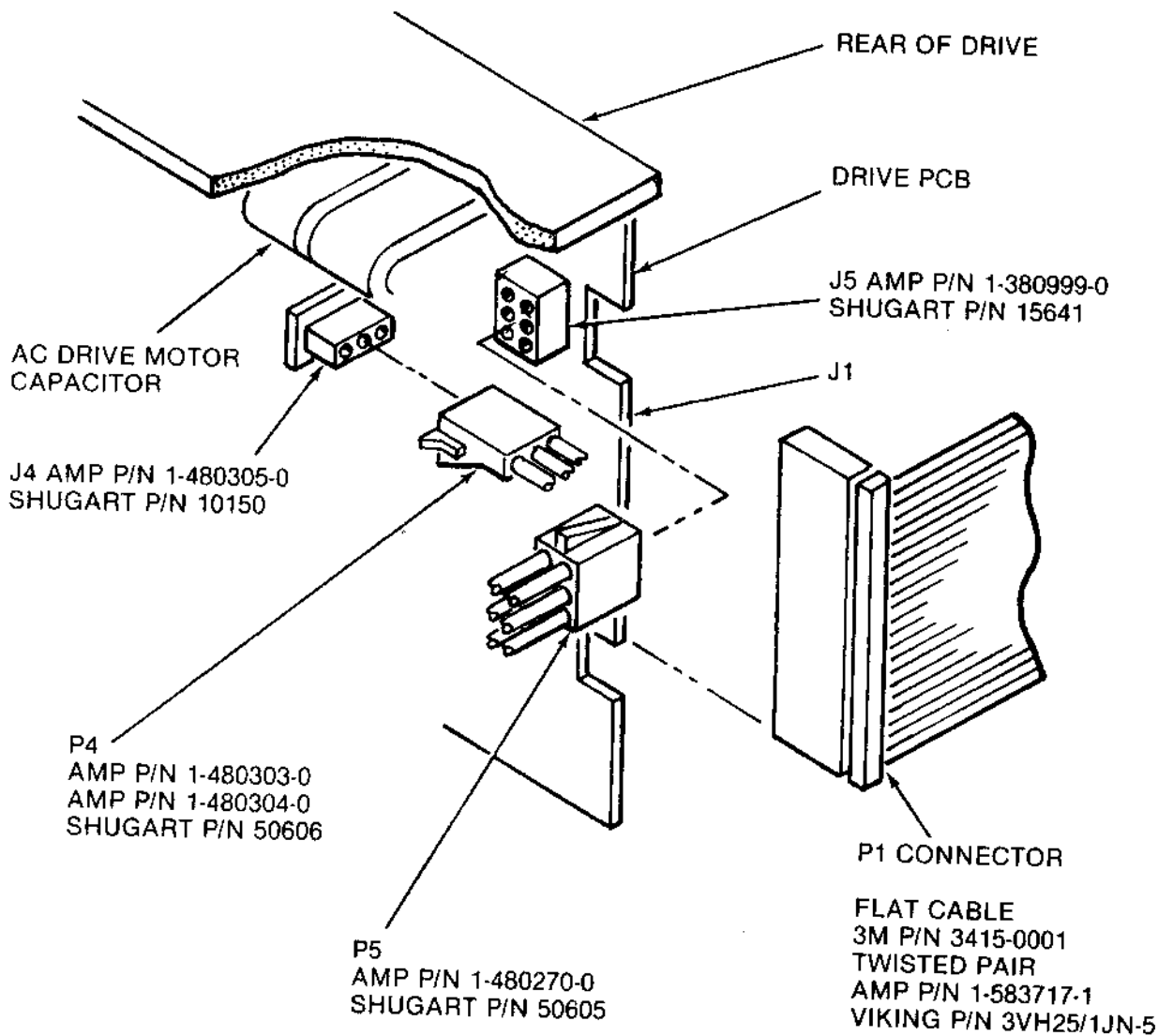

**FIGURE 3-1. INTERFACE CONNECTORS - PHYSICAL LOCATION DIAGRAM**

50574-18

### 3.2 J1/P1 CONNECTOR

Connection to J1 is through a 50 pin PCB edge card connector. The dimensions for this connector are shown in figure 3-2. The pins are numbered 1 through 50 with the even numbered pins on the component side of the PCB and the odd numbered pins on the non-component side. Pin 2 is located on the end of the PCB connector closest to the ac motor capacitor and is labeled "2." A key slot is provided between pins 4 and 6 for optional connector keying.

Table 3-1 lists the recommended P1 connectors.

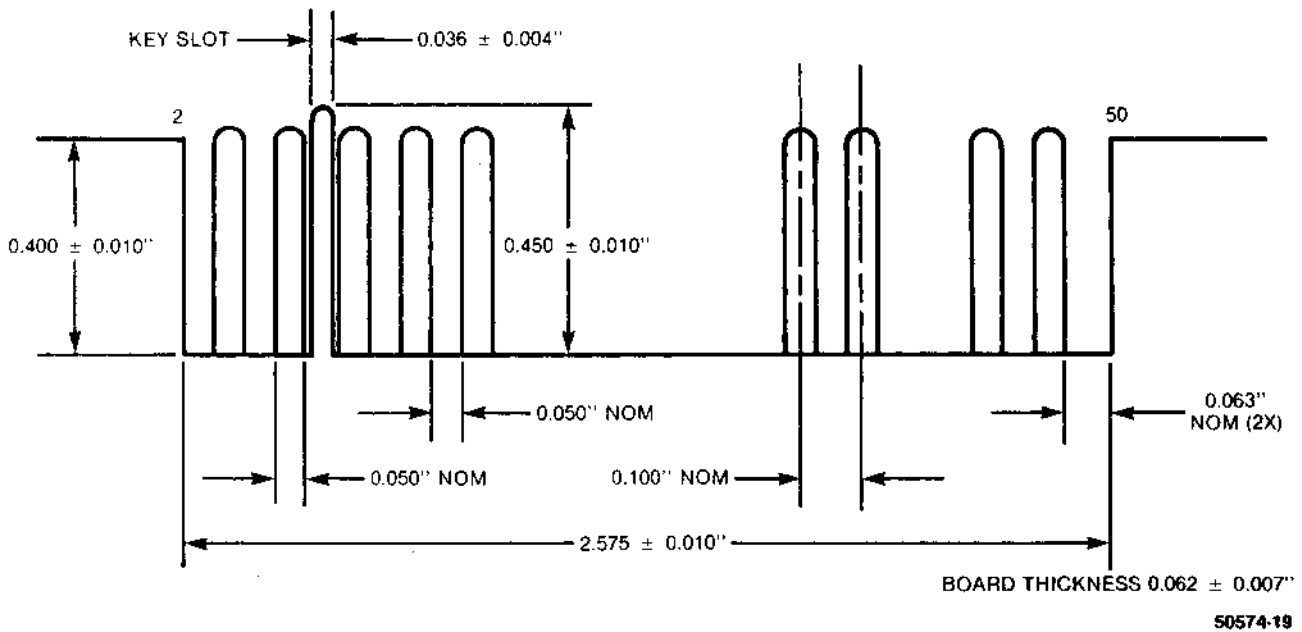

FIGURE 3-2. J1 CONNECTOR DIMENSIONS

TABLE 3-1. RECOMMENDED P1 CONNECTORS

TYPE OF CABLE	MANUFACTURER	CONNECTOR P/N	CONTACT P/N
TWISTED PAIR, #26 (CRIMP OR SOLDER)	AMP	1-583717-1	583616-5 (CRIMP) 583854-3 (SOLDER)
TWISTED PAIR, #26 (SOLDER TERM.)	VIKING	3VH25/1JN-5	N/A
FLAT CABLE	3M "SCOTCHFLEX"	3415-0001	N/A

50574-17

### 3.3 J5/P5 CONNECTOR

The dc power connector, J5, is mounted on the non-component side of the PCB below the ac motor capacitor. J5 is a 6 pin AMP Mate-N-Lok connector P/N 1-380999-0.

The recommended mating connector (P5) is AMP P/N 1-480270-0 utilizing AMP pins P/N 61117-1. J5 pins are labeled on the component side of the PCB with pin 5 located nearest J1/P1.

Figure 3-3 illustrates the J5 connector as seen on the drive PCB from the non-component side.

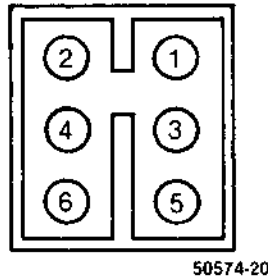

FIGURE 3-3. J5 CONNECTOR

### 3.4 J4/P4 CONNECTOR

The ac power connector, J4, is mounted on the ac motor capacitor bracket just below the capacitor. J4 connector is a 3 pin connector AMP P/N 1-480305-0 with pins P/N 60620-1.

The recommended mating connector (P4) is AMP P/N 1-480303-0 or 1-480304-0, both utilizing pins P/N 61117-1.

Figure 3-4 illustrates the J4 connector as seen from the rear of the drive.

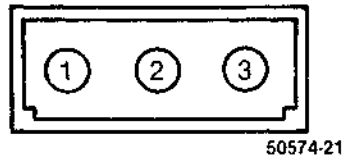

FIGURE 3-4. J4 CONNECTOR



## SECTION IV THEORY OF OPERATIONS

### 4.1 TRACK ACCESSING

- a. Stepper Motor
- b. Stepper Control Logic
- c. Forward Seek
- d. Reverse Seek
- e. Track 00 Indicator

Seeking the read/write head from one track to another is accomplished by selecting the desired direction utilizing the DIRECTION SELECT interface line, and pulsing the STEP line. Multiple track accessing is accomplished by repeated pulsing of the STEP line until the desired track has been reached. Each pulse on the STEP line will cause the read/write head to move one track either in or out depending on the DIRECTION SELECT line.

#### 4.1.1 Stepper Motor

The stepper motor used on the SA800/801 drive is a three phase, 15°, variable reluctance stepper motor. Figure 4-1 shows the logic diagram of the motor.

The stepper motor has 12 stator windings and a rotor with 8 teeth. The 12 stator windings are wired together in groups of four, 90° apart. Each group of stator windings is wired to one phase of the stepper control logic. The 8 teeth of the rotor are spaced 45° apart.

Figure 4-2 shows the stepper motor (rear view) with phase 1 of the stepper control logic active. Phase 1 is applied to the four stator windings at 0°, 90°, 180°, and 270°. This causes the four rotor teeth closest to those windings to move and line up with the stator windings.

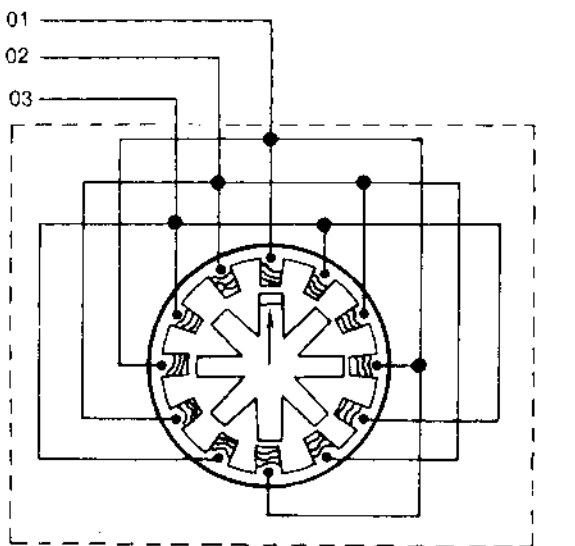

FIGURE 4-1. STEPPER MOTOR

39025-01

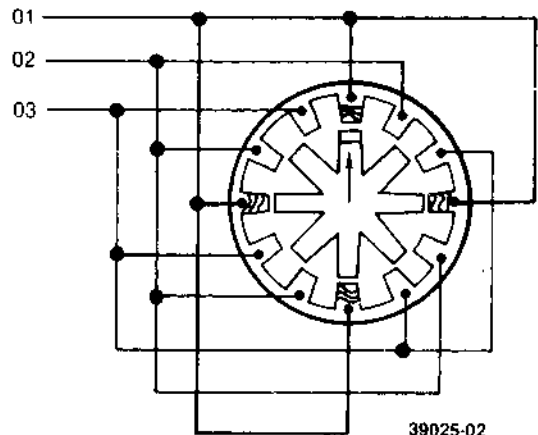

FIGURE 4-2. POSITION 1 (TRK 00)

39025-02

Figure 4-3 shows the stepper motor with phase 2 of the stepper control logic active. Phase 2 is applied to the stator windings at 30°, 120°, 210°, and 300°. This causes the four rotor teeth closest to those windings to move and line up with the stator windings. The result is a 15° turn of the stepper motor lead screw.

Figure 4-4 shows the stepper motor with phase 3 of the stepper control logic active. The result is another 15° turn of the stepper motor lead screw.

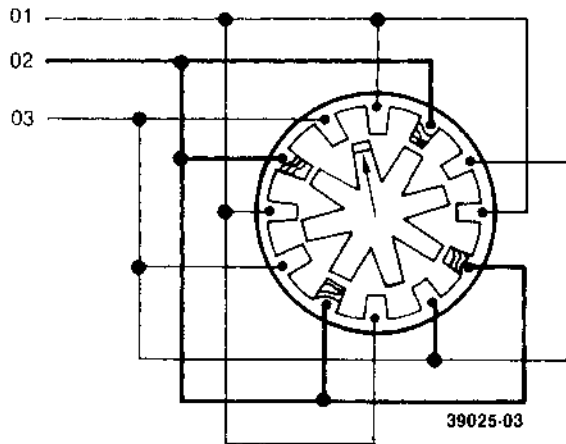

FIGURE 4-3. POSITION 2 (TRK 01)

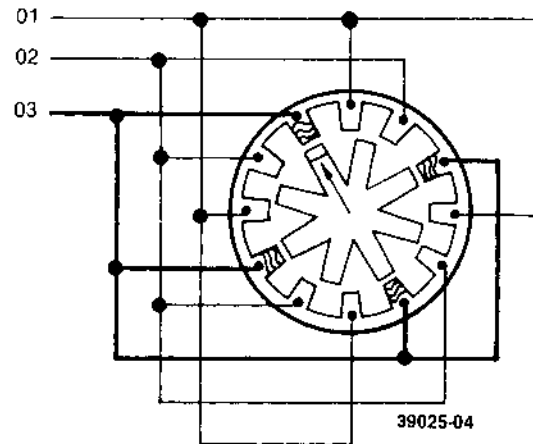

FIGURE 4-4. POSITION 3 (TRK 02)

#### 4.1.2 Stepper Control Logic: Power-On Reset

At power on, FF1 and FF2 are reset and the NOT outputs activate the 01 driver. With the 01 driver active, the position 1 windings in the stepper motor are excited and cause the rotor in the stepper motor to align as in figure 4-2. Stepper control logic determines forward and reverse seek as described below. See figure 4-5.

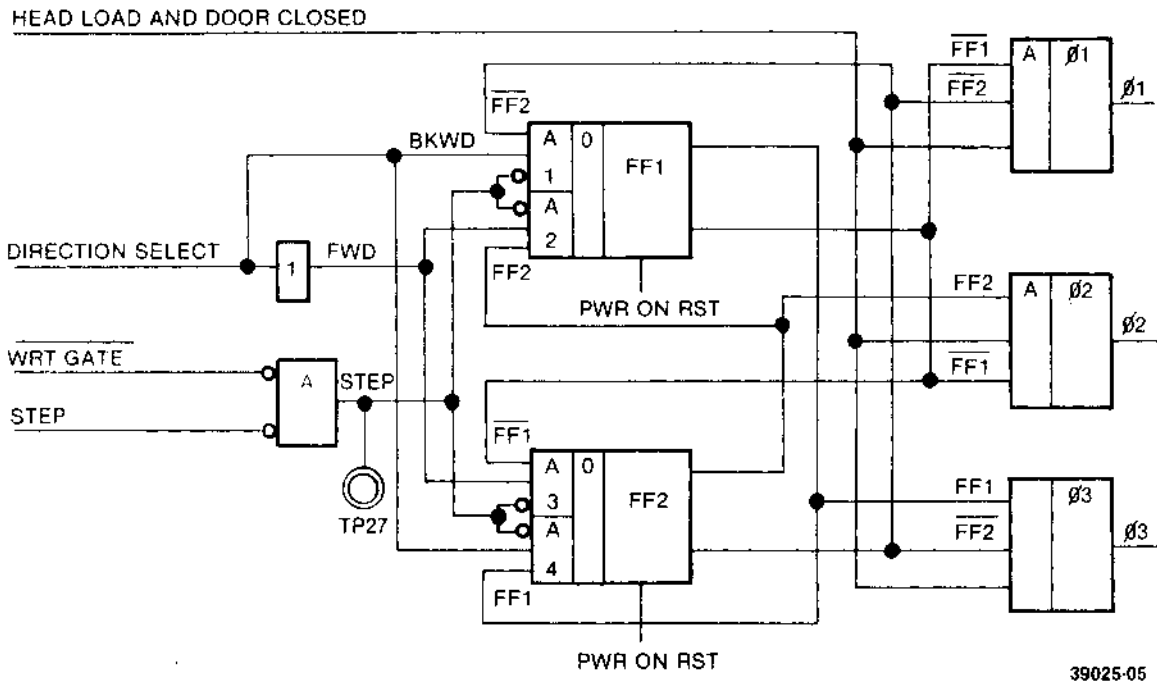

FIGURE 4-5. TRACK ACCESSING (STEPPER CONTROL LOGIC)

### 4.1.3 Forward Seek

- a. Seek a forward direction five tracks.
- b. Assume:
  - Present position of read/write head to be track 00.
  - DIRECTION SELECT at a minus level (from using system).
  - WRITE GATE is inactive.
  - Head is loaded and door is closed.
  - Five step pulses to be received (from using system).
  - FF1 and FF2 are reset, phase 1 driver active.

Figures 4-5 and 4-6 show the stepper control logic and timing diagram respectively. -DIRECTION SELECT is inverted and becomes +FORWARD; this enables A2 and A3 of FF1 and FF2. Since both FF1 and FF2 are reset at this point, the FF1 line further enables A3.

When the first step pulse is sent to the control logic, it is ANDed with NOT WRITE GATE and the step pulse clocks FF2 on. With FF2 on and FF1 off, the phase 2 driver is activated and the stepper motor moves 15° in a counter-clockwise direction, moving the carriage assembly one track towards the center of the diskette (track 01).

With FF2 on and FF1 off, AND blocks A2 and A3 are enabled. Upon receipt of the next step pulse, FF1 is clocked on and FF2 is clocked off. With FF1 on and FF2 off, the phase 3 driver is activated and the stepper motor moves 15° in a counter-clockwise direction. This moves the carriage assembly one more track towards the center (track 02).

With FF1 on and FF2 off, AND blocks A2 and A3 are disabled. Upon receipt of the next step pulse, FF1 is clocked off and FF2 remains off. This causes the phase 1 driver to be activated, the stepper motor to turn an additional 15° in the counter-clockwise direction, and the carriage assembly to move one more track closer to the center (track 03).

The above process is continued until the host system stops sending pulses (i.e., track 05). At that time, FF1 is on and FF2 is off, leaving the phase 3 driver active. Figure 4-7 shows the stepper motor in this position.

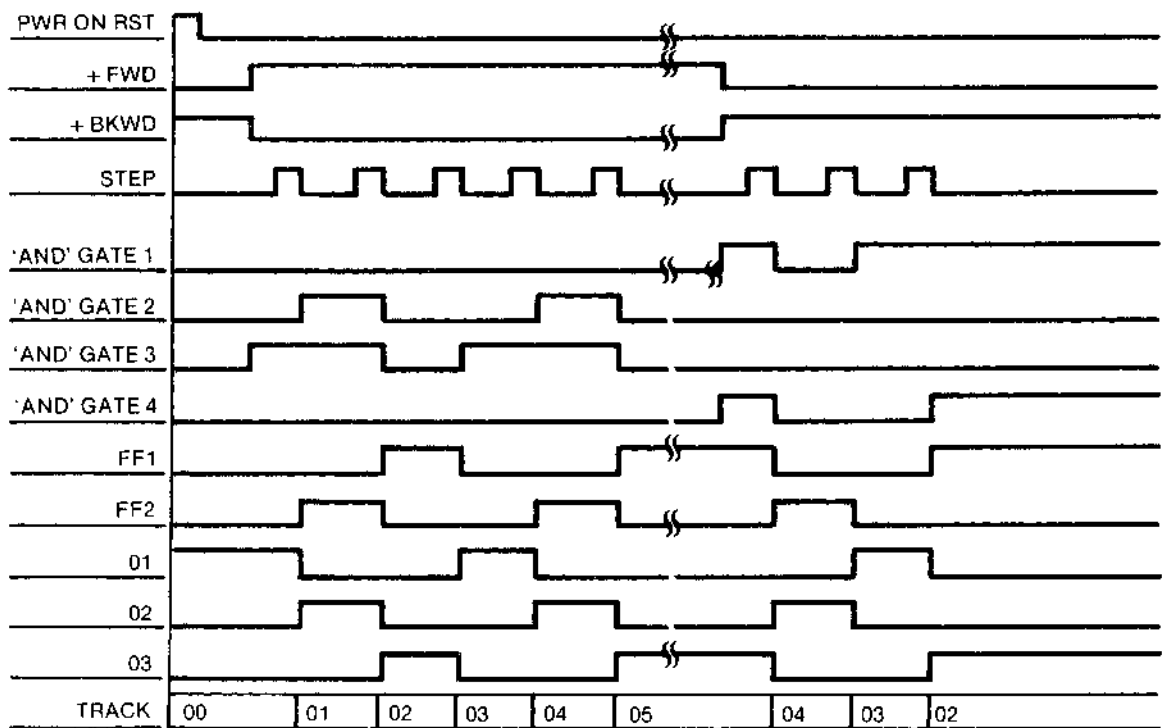

FIGURE 4-6. TRACK ACCESSING

39025-06

#### 4.1.4 Reverse Seek

- a. Seek a reverse direction three tracks.
- b. Assume:
  - Present position of read/write head to be track 05.
  - DIRECTION SELECT at a positive level.
  - WRITE GATE is inactive.
  - Head is loaded and door closed.
  - Three step pulses to be received.
  - FF1 is on. FF2 is off, phase 3 driver active.

The DIRECTION SELECT line, being positive, enables AND gates A1 and A4. With FF1 on and FF2 off, the first step pulse received is going to clock FF1 off and FF2 on. The phase 2 driver is activated by FF1 off and FF2 on, moving the stepper motor in a clockwise direction 15° or moving the carriage in a reverse direction one track.

The next step pulse received is going to clock FF2 off and leave FF1 off. This will cause the phase 1 driver to become active and move the stepper motor an additional 15° in the clockwise direction, moving the read/write head one more track in the reverse direction.

With FF1 off and FF2 off, AND gate A1 is enabled. The next step pulse received is going to clock FF1 on which in turn will activate the phase 3 driver. This will move the stepper motor in a clockwise direction 15° and the read/write head back to track 02. The stepper motor will end up in the position shown in figure 4-8.

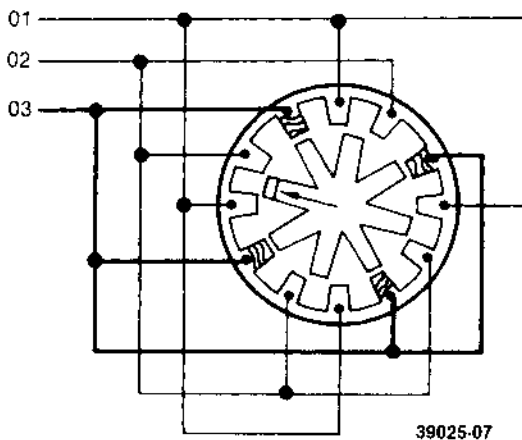

FIGURE 4-7. STEPPER MOTOR AT TRK 05

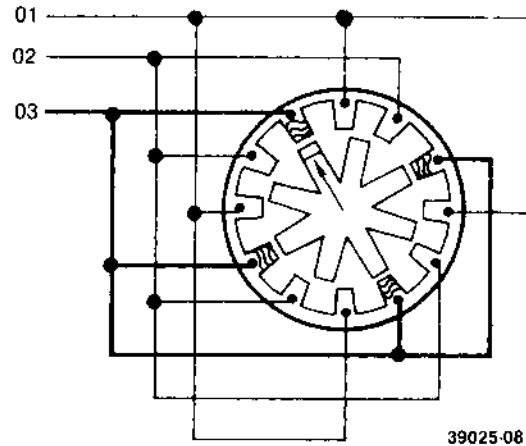

FIGURE 4-8. STEPPER MOTOR AT TRK 02

#### 4.1.5 Track Zero Indicator

TRACK 00 (pin 42) is provided to the using system to indicate when the read/write head is at track 00.

Figures 4-9 and 4-10 show the logic and timing for track 00 indication. The track 00 flag on the carriage assembly is adjusted so that the flag covers the photo transistor at track 01. When FF1 and FF2 are set off and the stepper moves to track 01, phase 1 is ANDed with DRV SEL INT and then is ANDed with track 00 detect. Track 00 indication is then sent to the using system.

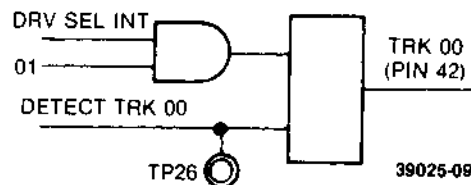

FIGURE 4-9. TRACK 00 FLAG



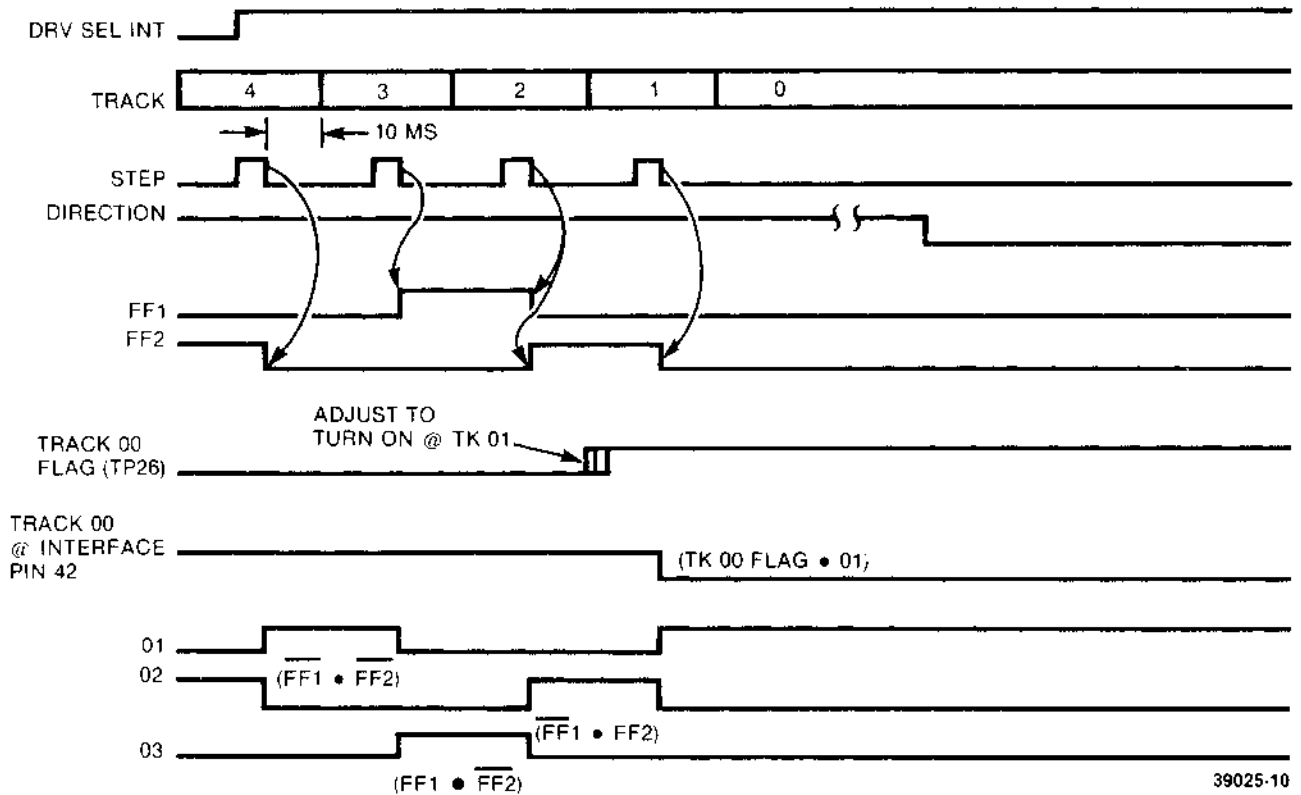

FIGURE 4-10. TRACK 00 TIMING

## 4.2 READ/WRITE OPERATIONS

- SA800/801 uses double frequency non return to zero (NRZI) recording method.
- The read/write head, in general, is a ring with a gap and a coil wound at some point on the ring.
- During a write operation, a bit is recorded when the flux direction in the ring is reversed by rapidly reversing the current in the coil.
- During a read operation, a bit is read when the flux direction in the ring is reversed as a result of a flux reversal on the diskette surface.

The SA800/801 drive uses a double-frequency (2F) horizontal non-return to zero (NRZI) method of recording. Double frequency is the term given to the recording system that inserts a clock bit at the beginning of each bit cell time thereby doubling the frequency of recorded bits. This clock bit, as well as the data bit, is provided by the using system. See figure 4-11.

The read/write head is a ring with a gap and a coil wound at some point on the ring. When current flows through the coil, the flux induced in the ring fringes at the gap. As the diskette recording surface passes by the gap, the fringe flux magnetizes the surface in a horizontal direction. See figure 4-12.

During a write operation, a bit is recorded when the flux direction in the ring is reversed by rapidly reversing the current in the coil. The fringe flux is reversed in the gap and hence the portion of the flux flowing through the oxide recording surface is reversed. If the flux reversal is instantaneous in comparison to the motion of the diskette, the portion of the diskette surface that just passed under the gap is magnetized in one direction while the portion directly under the gap is magnetized in the opposite direction. This flux reversal represents a bit. See figure 4-13.

During a read operation, a bit is read when the flux direction in the ring is reversed as a result of a flux reversal on the diskette surface. The gap first passes over an area that is magnetized in one direction, and a constant flux flows through the ring and coil. The coil registers no output voltage at this point. When a recorded bit passes under the gap, the flux flowing through the ring and coil will make a 180° reversal. This means that the flux reversal in the coil will cause a voltage output pulse. See figure 4-14.

Figure 4-15 shows the 1F and 2F recording flux transitions and corresponding pulse relationships.

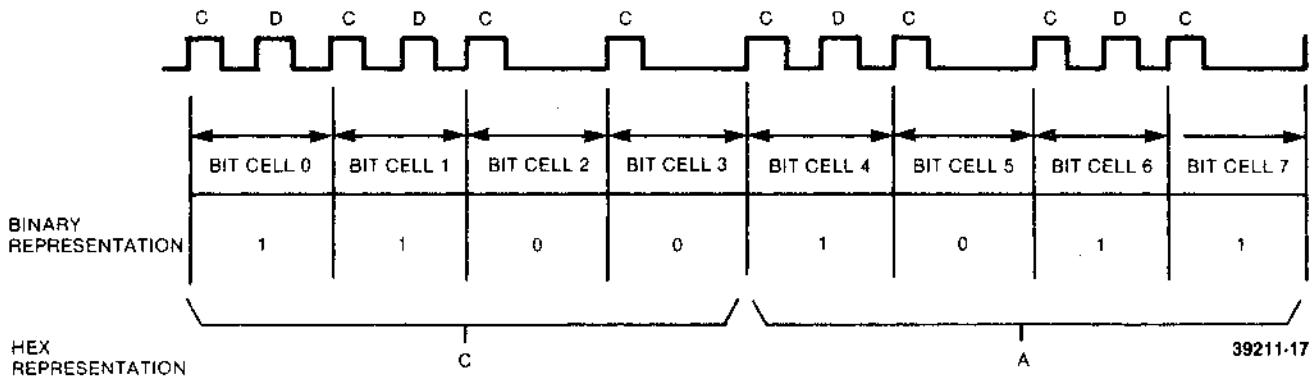

FIGURE 4-11. BIT CELL

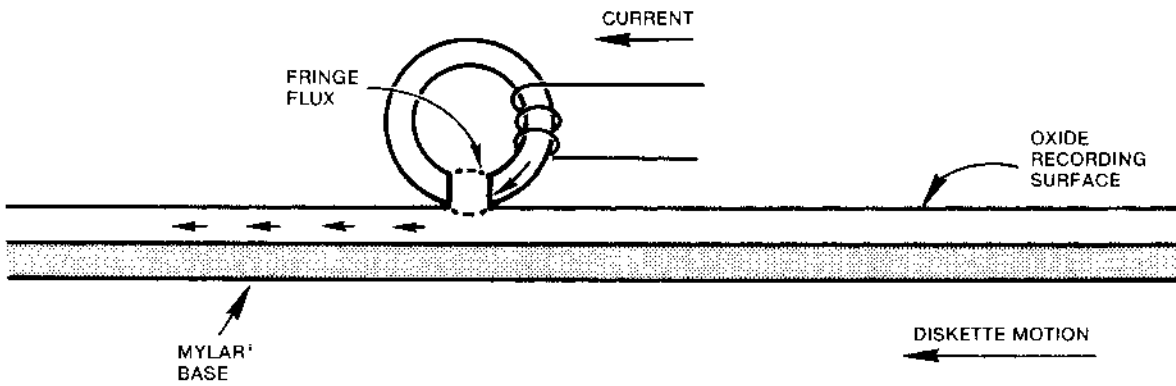

FIGURE 4-12. BASIC READ/WRITE HEAD

39211-18

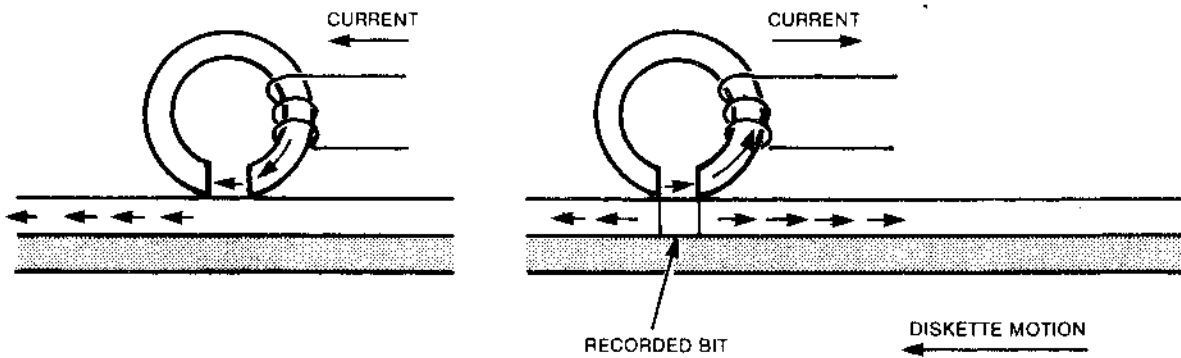

FIGURE 4-13. RECORDED BIT

39211-19

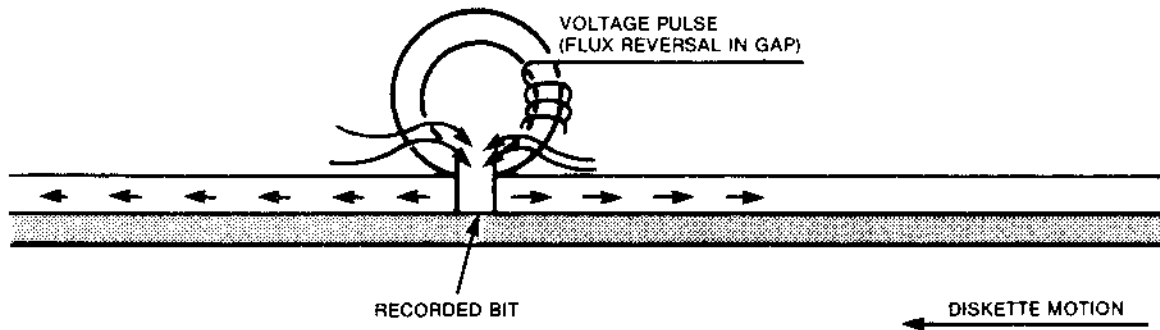

FIGURE 4-14. READING A BIT

39211-20

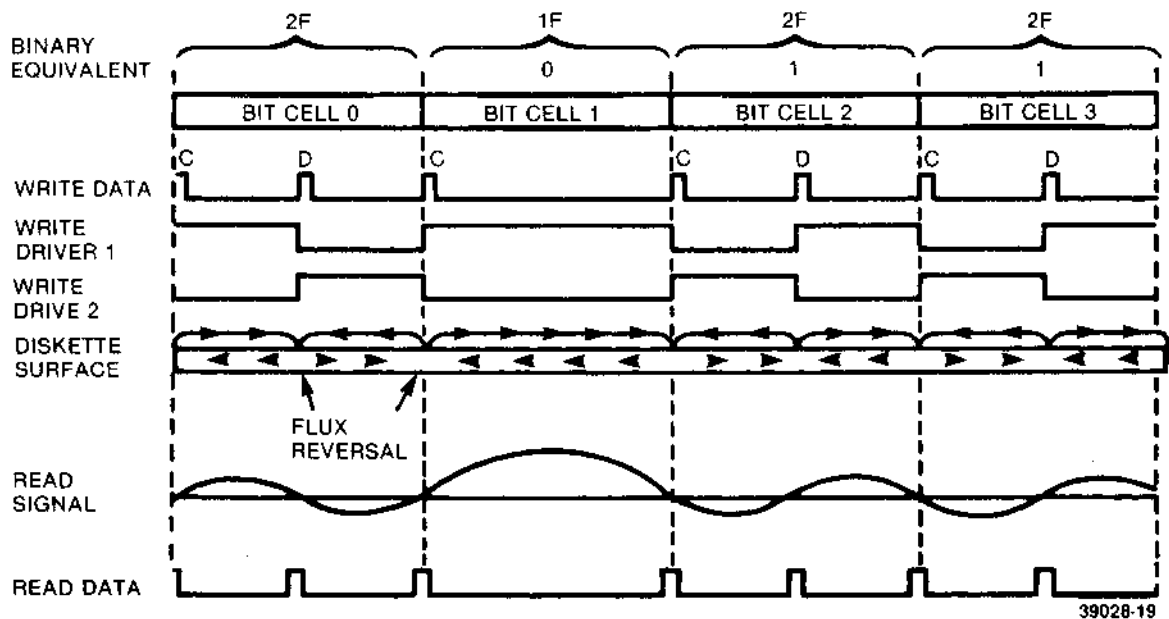

FIGURE 4-15. 1F AND 2F RECORDING FLUX AND PULSE RELATIONSHIP

### 4.3 READ/WRITE HEAD

- The read/write head contains three coils.
- When writing, the head erases the outer edges of the track to ensure data recorded will not exceed the 0.012 inch track width.
- The head is ceramic.

The read/write head contains three coils. Two read/write coils are wound on a single core, center tapped, and one erase coil is wound on a yoke that spans the track being written. The read/write and erase coils are connected as shown in figure 4-16.

During a write operation, the erase coil is energized. This causes the outer edges of the track to be trim erased. Therefore, as the track is being recorded, it will not exceed the 0.012 inch track width. The straddle erasing allows for minor deviations in read/write head current. Therefore, as one track is recorded, it will not "splash over" to adjacent tracks.

Each bit written will be directed to alternate read/write coils. This results in a change in the direction of current flow through the read/write head. This produces a change in the flux pattern for each bit. The current through either of the read/write coils will cause the old data to be erased as new data is recorded.

During a read operation, as the direction of flux changes on the diskette surface passing under the gap, current will be induced into one of the windings of the read/write head. This results in a voltage output pulse. When the next data bit passes under the gap, another flux change in the recording surface takes place. This causes current to be induced in the other coil producing another voltage output pulse.

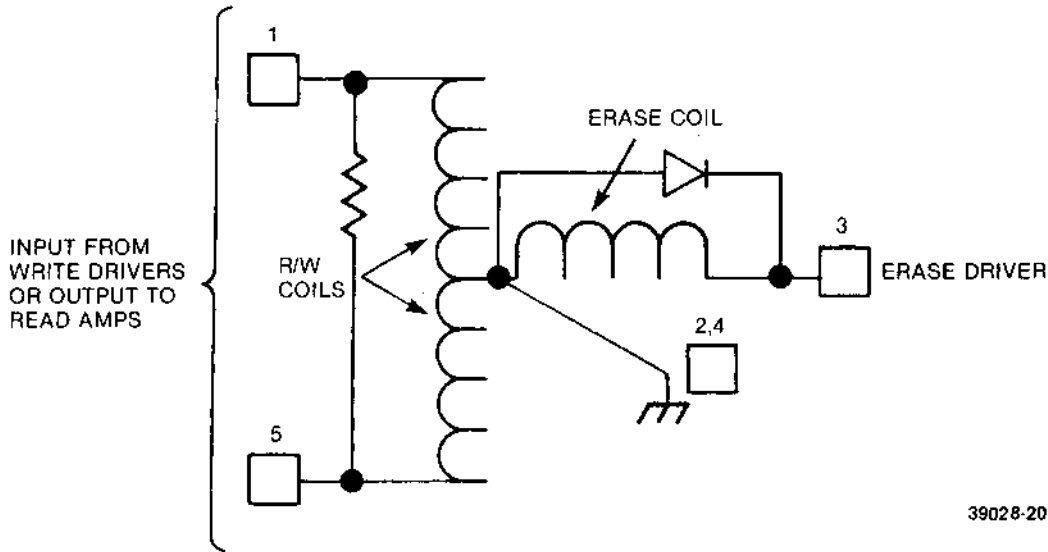

FIGURE 4-16. READ/WRITE HEAD

#### 4.4 WRITE CIRCUIT OPERATION

- The binary connected write data trigger flips with each pulse on the WRITE DATA line.
- The write data trigger alternately drives one or the other of the write drivers.
- WRITE GATE allows write current to flow to the write driver circuits.
- Write current sensed allows erase coil current.

WRITE DATA pulses (clock and data bits) are supplied by the using system. The write trigger "flips" with each pulse. The Q and  $\bar{Q}$  outputs are fed to alternate write drivers. See figure 4-17.

WRITE GATE from the using system and NOT WRITE PROTECT are ANDed together to provide write current.

The output of one of the write drivers allows write current to flow through one half of the read/write coil. When the write trigger "flips," the other write driver provides write current to the other half of the read/write coil.

When write current is sensed flowing to the write drivers, a signal is generated to provide erase coil current.

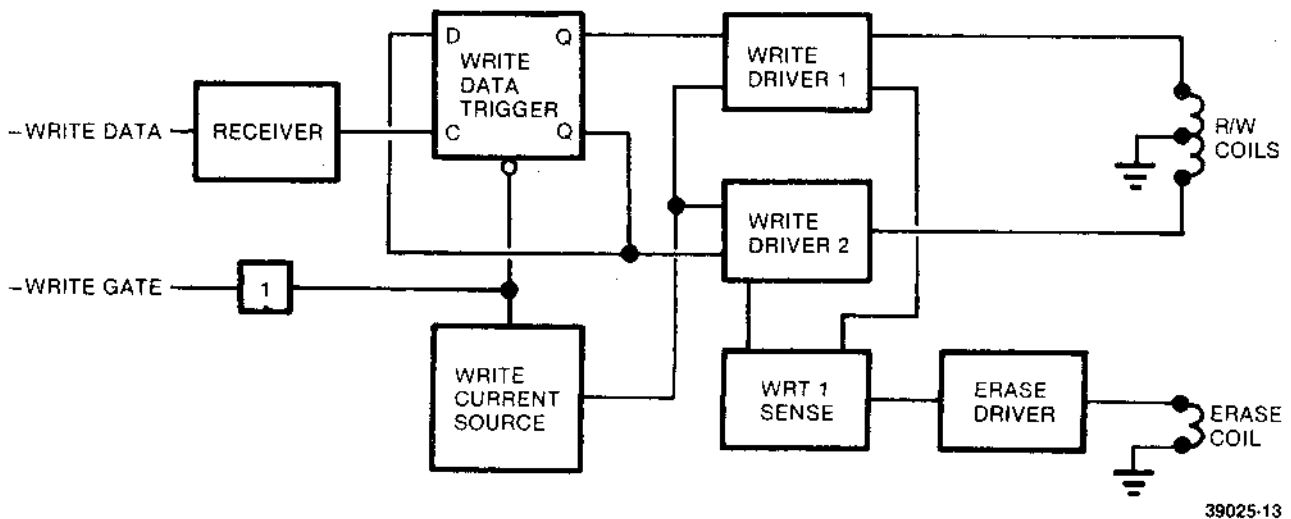

FIGURE 4-17. WRITE CIRCUIT FUNCTIONAL DIAGRAM

## 4.5 READ CIRCUIT OPERATION

- Duration of all read operations is under control of the using system.
- When the head is loaded, the read signal amplitude becomes active and is fed to the amplifier.
- As long as the head is loaded, WRITE GATE is not active, and the read signal is amplified and shaped, the square wave signals are sent to the data separator.
- The data separator separates the read data into clock pulses and data pulses (FM only).

When the using system requires data from the diskette drive, the using system must first load the head. With loading of the head and WRITE GATE being inactive, the read signal is fed to the amplifier section of the read circuit. After amplification, the read signal is fed to a filter where the noise spikes are removed. The read signal is then fed to the differential amplifier.

Since a clock pulse occurs at least once every  $4 \mu\text{s}$ , and data bits are present once every  $2 \mu\text{s}$ , the frequency of the read data varies. The read signal amplitude decreases as the frequency increases. Note the signals in figure 4-18. The differential amplifier will amplify the read signals to even levels and make square waves out of the read signals (sine waves).

The data separator is a two time constant separator, that is, the clock and data pulses must fall within pre-specified time frames or windows. The clock and data windows are developed in the data separation circuit. Figure 4-19 shows the functional diagram and figure 4-20 shows the timing diagram of the circuit.

Two data windows are supplied. The short window,  $2.9 \mu\text{s}$ , is used when the previous bit cell had a data pulse in it. The long window,  $3.1 \mu\text{s}$ , is used when the previous bit cell had no data pulse. If the data pulse initially falls in the data window, -SEPARATED DATA is sent back to the OR block that generates the data window to assure that the full data pulse is allowed through before the window falls. The clock windows will take up the remainder of the bit cell time, either  $1.1 \mu\text{s}$  or  $0.9 \mu\text{s}$ .

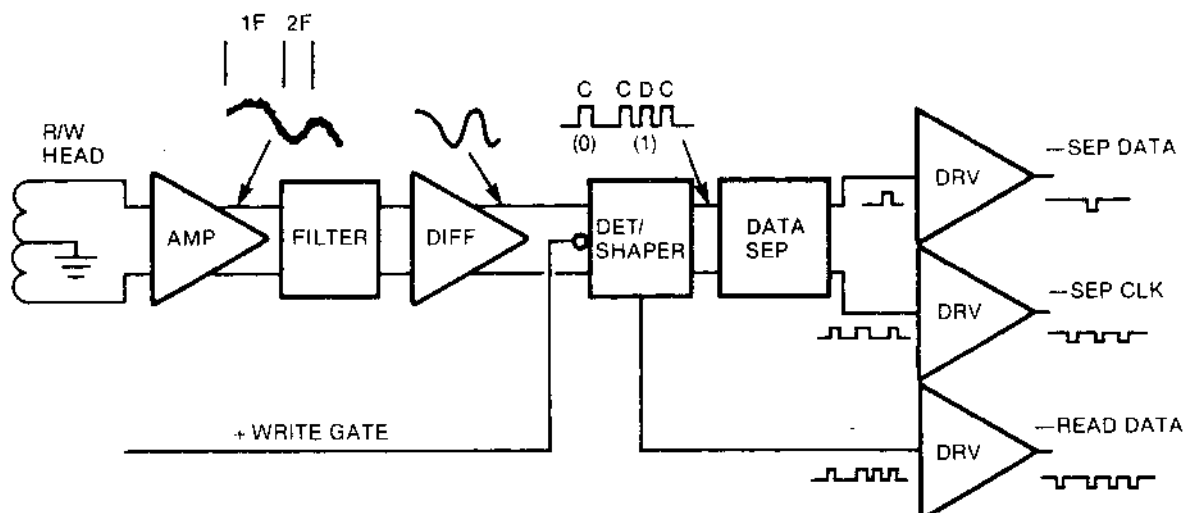

39025-14

FIGURE 4-18. READ CIRCUIT FUNCTIONAL DIAGRAM

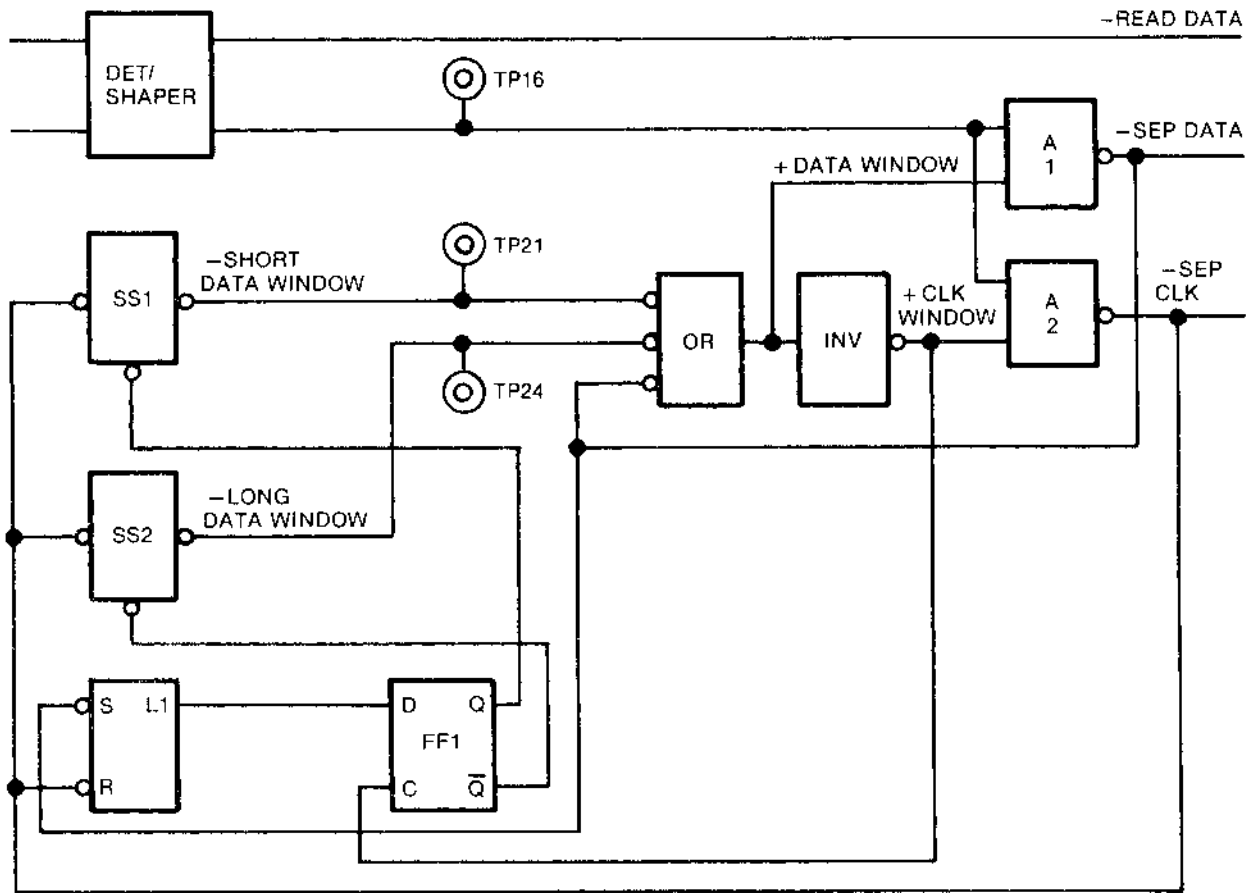

39025-15

FIGURE 4-19. DATA SEPARATOR FUNCTIONAL DIAGRAM

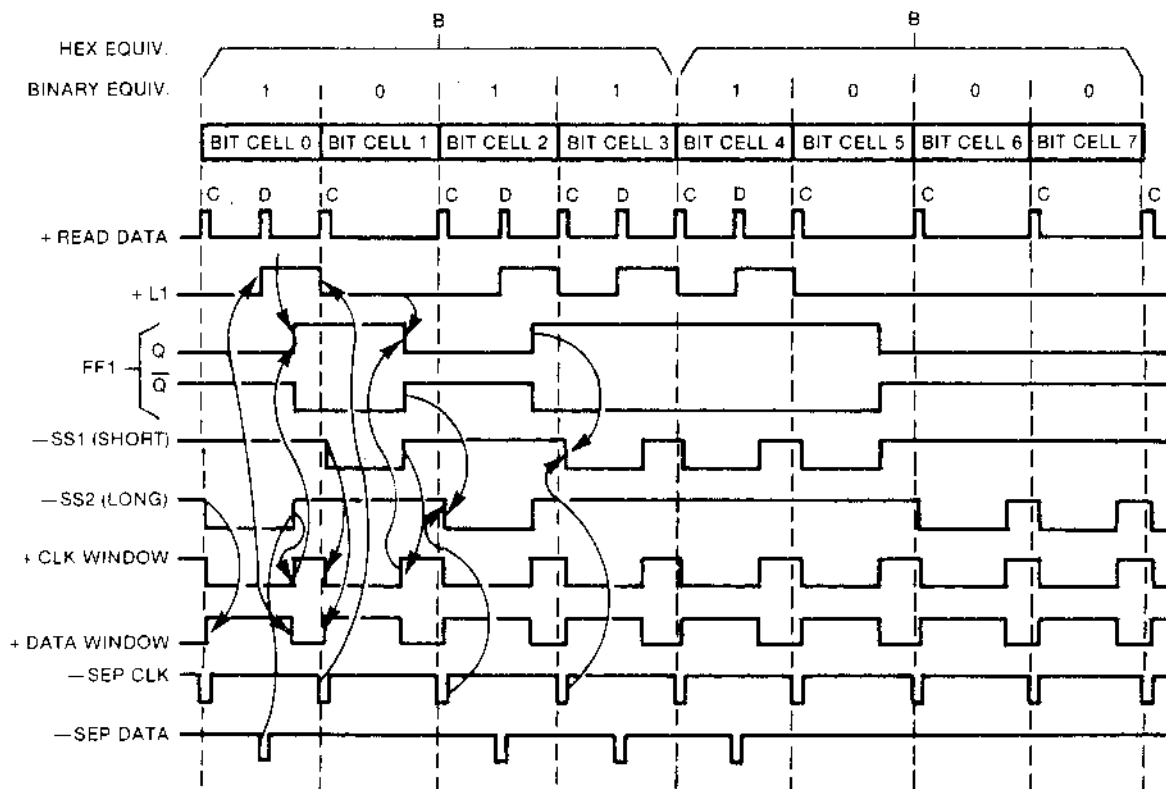

39025-16

FIGURE 4-20. DATA SEPARATION TIMING DIAGRAM

In discussing the data separator circuit (see figure 4-18), initially assume all circuits are reset (inactive) and that the +READ DATA line contains pulses shown in figure 4-20.

With both SS1 and SS2 off, +CLK WINDOW is active. The first READ DATA pulse will be allowed through AND A2 and sent out as -SEP CLK onto the interface line to L1, SS1, and SS2. Since FF1 is off, SS1 will be held reset. The -SEP CLK pulse will trigger SS2. The output of SS2 is sent to the OR block which in turn becomes +DATA WINDOW enabling AND A1. The next pulse on +READ DATA will be allowed through A1 becoming -SEPARATED DATA. -SEPARATED DATA sets L1 which in turn enables FF1. FF1 is clocked on by SS2 timing out (3.1  $\mu$ s) and +CLK WINDOW becoming active. The Q output of FF1 will hold SS2 reset and allow SS1 to trigger with receipt of the next clock pulse.

The next clock pulse, bit cell 1, is ANDed with +CLK WINDOW and becomes the next -SEP CLK. -SEP CLK will reset L1 and trigger SS1 on. When SS1 becomes active, +DATA WINDOW becomes active enabling AND A1. Since bit cell 1 has no data bit in it, L1 will remain reset enabling FF1 to be clocked off when +DATA WINDOW falls (2.9  $\mu$ s). When FF1 is clocked off, the Q output will hold SS1 reset and allow SS2 to be triggered.

The next clock pulse, bit cell 2, is ANDed with +CLK WINDOW and becomes -SEP CLK. -SEP CLK will further reset L1, which was off, and trigger SS2 on. When SS2 becomes active, +DATA WINDOW enables AND A1 allowing the data pulse in bit cell 2 to become -SEP DATA. -SEP DATA will set L1 which enables FF1 to be clocked on when +DATA WINDOW falls. When +DATA WINDOWS falls, the Q output will hold SS2 reset and allow SS1 to trigger. This procedure continues until the using system terminates the read operation by unloading the head.

#### **4.6 LSI THEORY OF OPERATIONS (PCB P/N 25136 AND 25229)**

This section describes the circuit functions of the LSI PCB's currently used on the SA800/801 Diskette Drive.

##### **4.6.1 Drive Select and Head Load**

Since the drive may be one of several sharing the same signal interface in a user's system, a means is provided to address or select the drive, allowing it sole use of the signal interface while selected. Four DRIVE SELECT lines, numbered 1 through 4, are available to address up to four drives in a system. Any one of the four lines may be connected through a jumper (DS1, DS2, DS3, or DS4) to the inputs of a DRIVE SELECT gate. A low level signal on the jumpered line will select the drive. Once selected, the drive can accept other input signals and issue output signals.

Output signals are driven with open collector output stages capable of sinking up to 40 mA at a logical zero level or true state (active low). All outputs and inputs are considered active low. All outputs and inputs on the last drive along a signal cable must be terminated to +5 V through 150  $\Omega$ . Jumpers are available for this purpose (T1 through T6).

An option is provided to allow up to eight drives to share the same signal cable. The normal drive select jumpers must be removed and the double drive select (DDS) trace added. Each drive is assigned a unique binary address, 0 through 7, with traces D1, D2, and D4 added appropriately. DRIVE SELECT lines 2, 3, and 4 are used to generate the binary address of the drive, and DRIVE SELECT 1 must be active (low). The customer-installed 74L85 magnitude comparator will activate the internal DRIVE SELECT line through DDS on the selected drive.

In order to allow reading and writing, the read/write head must be loaded against the surface of the diskette. The door must be closed and a solenoid activated to enable a load pad to press the diskette against the head. The PCB as shipped includes jumpers A, B, X, and T1 which enable the head load driver when the drive is selected and the door is closed. (When a switch is closed, -DOOR CLOSED line is grounded.) An open collector peripheral driver sinks current through the solenoid coil from +24 V and a diode connected across the coil suppresses the back emf generated when the solenoid is turned off. TP11 is +HEAD LOAD.

Options are available to control head load through the -HEAD LOAD input line when connected through the C jumper. Jumpers A, B, and X are selectively removed to load the head as a function of -HEAD LOAD, or -HEAD LOAD and DRIVE SELECT. The drive may also be selected as a function of -HEAD LOAD and DRIVE SELECT.

An activity light on the door of the drive is activated by an open collector peripheral driver. This driver turns off to allow current to flow from +5 V through 75  $\Omega$  and the LED to ground. The activity light will turn on when the drive is selected. As an option, the -IN USE input line may be connected through the D jumper to also control the LED. A jumper may also be moved from the Z position to the Y position to turn on the activity light when the head is loaded. A door lock option is available which locks the door whenever the activity LED is on. +5 V power for this option is taken from test pin DL.

### 4.6.2 Head Positioning

A stepper motor and lead screw position the read/write head. The head is mounted in a carriage which moves radially along the diskette. The stepper motor rotates the lead screw clockwise or counterclockwise in  $15^\circ$  increments, stepping the carriage in (forward) or out (reverse) track by track. Tracks are numbered 00 through 76, track 00 being the outermost track. Seeking the read/write head from one track to another is accomplished by selecting the desired direction with the DIRECTION line (low to step in, high to step out), loading the head and then pulsing the -STEP line. Each pulse on the -STEP line will cause the head to move one track either in or out depending on the direction line. A track counter is not provided. Therefore, the user's system is responsible for knowing the track position of the head at any time. Option No Force Out (NFO), when jumpered, will prevent the head from stepping out past track 00 (force out).

The stepper motor stator coils are organized in three phases: 01, 02, and 03. Only one phase is activated at a time. As each pulse is activated in turn, the motor rotates  $15^\circ$ , forcing the carriage to move one track position. If the phases are activated in the order 1, 2, 3, 1, 2, 3,....., the head will step in. The order 3, 2, 1, 3, 2, 1,..... will cause the head to step out.

After power is turned on, the user's system will recalibrate the drive by stepping out until the head reaches track 00, indicated by the -TRACK 00 output line being low. A metal flag mounted on the carriage interrupts a beam of light from the track 00 LED to the track 00 detector (a phototransistor). When the head is near track 00, the phototransistor turns off, and the voltage falls relatively slowly to ground. A voltage comparator acts as a Schmidt trigger inverter, squaring up the signal and providing some hysteresis. The positive transition threshold voltage is 2.2 V and the negative transition threshold is 2.1 V. TP26 is +TRACK 00 detected.

A second voltage comparator acts merely as an inverter to provide the correct polarity for the drive logic chip input. TRACK 00 output from the drive logic chip is only true when the track 00 detector is active and phase 1 of the stepper is selected internal to the chip. This allows the track 00 flag to be aligned so that -TRACK 00 detector is active at both tracks 00 and 01 providing some mechanical tolerance. However, the -TRACK 00 output will be active only at track 00.

After power on, a capacitor is charged up to +5 V through a resistor, giving a slowly rising voltage at -POR IN of the drive logic chip. Until this voltage crosses a threshold of about 1.8 V, a POWER ON RESET signal is active within the drive logic chip and can be seen at the -POR OUT output pin. At power on, the step logic is reset to select stepper phase 1. If the head is already positioned at track 00, the -TRACK 00 output will be true, making recalibration unnecessary.

Stepping will occur with each step pulse if the -STEP ENABLE (-STEN) and stepper motor +OUTPUT ENABLE (+OUTEN) inputs to the drive logic chip are true. -STEN is true when the drive is selected and not writing. +OUTEN is true when the head is loaded (using jumper HL), when the drive is selected (using jumper DS), or always with neither HL nor DS. If +OUTEN is false, the drive logic chip can internally step while the stepper motor remains off.

The -STEP pulse is unique in that action occurs on its trailing edge. For all other pulse signals (-READ DATA, -WRITE DATA, etc.) the leading edge is the active transition. Stepper motor outputs of the drive logic chip, as well as the TRACK 00 output, will change in response to the trailing edge of a step pulse after 5 to 15  $\mu$ s propagation delay.

The stepper motor outputs turn on Darlington switches and open collector drivers. These drivers can sink current from +24 V through a phase of the motor to ground. Diodes suppress back emf and voltages induced in an inactive phase by an active phase. TP27 is +STEP.

### 4.6.3 Index and Sector

To provide the user's system a time mark for controlling reading and writing, an index pulse is issued by the drive once per revolution of the diskette. An index LED and index detector phototransistor pair are mounted so that light can shine from the LED through a window in the diskette jacket to the phototransistor. Each time a small hole punched in the diskette rotates round to let light through, the phototransistor turns on and the +INDEX detector voltage rises. Since the transition is slow, a voltage comparator connected as a Schmidt trigger inverter is used to square up the signal and provide hysteresis. Voltage thresholds are the same as for the track 00 detector.

In some diskettes, 32 additional sector holes are punched along the same circumference as the single index hole, dividing one revolution in 32 equal parts called sectors. This is a feature of the SA801 model diskette drive. The user's system can read and write single records in each sector, using the -SECTOR output of the drive for timing. This is called a hard sector recording format. Soft sector recording format relies on the -INDEX signal only for timing, allowing the user's system to divide a revolution into an arbitrary number of sectors.



The drive logic chip can separate the index pulse from a stream of index and sector pulses by identifying the index pulse as the one which falls exactly between two of the 32 evenly spaced sector pulses. TP12 is -INDEX/SECTOR, TP10 is -INDEX.

The drive logic chip will either separate index from sector pulses or not, depending on the control inputs SS0 and SS1. With the 801 jumper in place, both control inputs are high and index/sector separation occurs. In this mode, output pulse widths will be 0.4 ms each. Using the 800 jumper position, both control inputs are low and no separation takes place. Even if a hard sector diskette is installed, all pulses will be routed to the -INDEX line without changing their pulse widths. (The pulse width is set with a potentiometer on the index detector within a 1.2 to 2.2 ms range.) Two other configurations are made possible by using the 801 jumper position. Cut trace 32, and add either trace 16 or trace 8 to divide down the sector output to 16 pulses or 8 pulses, each with a 50% duty cycle.

An option is available to output -INDEX and -SECTOR, whether the drive is selected or not. The RI trace is cut to always enable the output drivers. On all but one drive, the I and S traces must be cut and the outputs connected to unused signal lines (labeled "jumper-optionable I/O") so that each output of each drive will have its own line. This system configuration, called radial index, allows all index and sector outputs to be monitored at once.

The drive logic chip can generate a -READY output indicating that the drive spindle has reached a stable speed of 360 rpm. This output is reset at power on or when the door opens and becomes true after the door is closed and two index pulses are found. The RR and R cut-trace options allow a radial ready configuration similar to the radial index scheme.

The -DISK CHANGE output can be connected to the signal interface to alert the user's system to the possibility that the diskette has been removed since the drive was last selected. This output becomes true after the drive is deselected if the door opens.

#### 4.6.4 Read and Write Operations

The write chip forces write current through the read/write coil by raising the center tap of 24 V and drawing 3.0 mA through either one side of the coil or the other. As each -WRITE DATA pulse is received, the current is switched to the other side of the coil. The amount of current is set by a resistor at the current reference input of the chip (which is bypassed by a capacitor to ground to decouple WRITE DATA from write current), and damping (overshoot) is set by two resistors across the entire coil. Simultaneously, the erase output will be grounded, allowing 40 mA to flow from the center tap through the erase coil to ground. A diode is placed across the erase coil to suppress back emf when the current is switched off. Another diode in series with the +24 V input prevents the write chip from being the source of current into the +24 V bus when +5 V power is turned on first.

Writing will occur whenever -WRITE GATE is low, the drive is selected, and the diskette is not write protected. The write protect LED and write protect detector (phototransistor) sense whether a slot is cut out along the edge of the diskette jacket. If it is cut out:

- a. The phototransistor turns on,
- b. +WRITE PROTECT detector (TP25) is high,
- c. The signal is inverted by a Schmidt-trigger gate in the drive logic chip,
- d. -WRITE PROTECT is true on the interface and writing cannot occur. An option exists to cut trace WP and add trace NP to allow writing regardless of the write protect feature.

The drive is in a reading mode whenever it is not writing. The write chip pulls the center tap to ground. The alternating voltages across the read/write coil are pre-amplified differentially in the read chip. Two pairs of diodes isolate the read circuit from the write circuit. During writing, the center tap is at +24 V and the read/write coil outputs of the write chip are alternately pulling low to forward bias the write circuit diodes. At the same time, the read circuit diodes are reverse biased by being pulled down to 12 V at their anodes, thus protecting the read chip from overvoltages. During reading, the center tap is grounded, the two sides of the read/write coil are near ground and reverse biasing the write circuit diodes, and the read circuit diodes hold the pre-amplifier inputs to 0.7 V. Two resistors used to set the current through the diodes, plus a third resistor, damp the read/write head during reading.

Three additional diodes form a clamping circuit to offer limited protection from negative voltages at the differential inputs of the pre-amplifier. Input voltages less than -0.2 V may latch an integral circuit and destroy the read chip. During head degaussing, power should be turned off as a precaution.

Pre-amplifier gain is approximately 90 (within a wide tolerance), the differential outputs are approximately 3.0 V, and the low pass filter has an insertion loss of 2. This yields a gain from head to TP1 and 2 of 45, with 1.5 V dc at these test points. If the head output ranges from 3 mV to 25 mV, the amplified signal will range from 135 mV to 1125 mV peak to peak.

The signal is differentiated to transform voltage peaks (caused by flux transitions) into zero crossings. These crossings are detected and fire a 1330 ns one-shot IC. When this times out, the differentiated signal is sampled as being positive or negative. This is part of a time-domain filtering scheme which ignores extra zero crossings (excessive "droop") found in very high resolution drives. Transitions between positive and negative fire a 200 ns one-shot IC for the read data output. A potentiometer adjusts differentiator offset current to cancel out asymmetry produced in the read channel.

A transistor clamps -WRITE DATA to ground while reading to prevent it from introducing noise into the read channel. Read data is gated by -WRITE GATE since spurious read data are created while no signal is read from the head. TP16 is +READ DATA.

The drive logic chip separates read data into -SEPARATED DATA and -SEPARATED CLOCK for FM decoding. The first pulse is called a clock bit. Each clock bit generates a data window of  $2.60 \mu\text{s}$  during which any arriving read data pulse is recognized as a data bit. Ordinarily, clock bits will occur every  $4 \mu\text{s}$  with one exception: a unique pattern lacking up to three successive clock bits, called an address mark, is used to begin each data record. True separation, an option enabled by adding trace TS, maintains synchronization by internally inserting up to three successive missing clock bits and creating the proper data windows. TP8 is +DATA WINDOW. The standard false separation will lose synchronization at any missing clock bit.

All timing within the drive logic chip is derived from a 5 MHz crystal oscillator. The data window lasts exactly 13 clock periods and provides a good measure of the oscillator accuracy. Since the chip is a MOS device, its inputs are vulnerable to static discharge. Most test points are buffered from the chip, and probes should be grounded before measuring voltages at its pins.

## **SECTION V MAINTENANCE**

### **5.1 MAINTENANCE FEATURES**

#### **5.1.1 Alignment Diskette**

The SA120 alignment diskette is used for alignment of the SA800/801. The following adjustments can be made using the SA120.

- a. Read/write head radial alignment using track 38.
- b. Read/write head azimuth using track 76.
- c. Index Photo-Detector adjustment using tracks 01 and 76.
- d. Track 00 is recorded with standard IBM 3740 format.
- e. Track 75 has 1F and 2F signals for load pad adjustment.

Caution should be exercised in using the SA120 alignment diskette. Tracks 00, 01, 36, 37, 38, 39, 40, 75, and 76 should not be written on. Doing so will destroy pre-recorded tracks.

#### **5.1.2 SA809 Exerciser**

The SA809 exerciser is built on an 8 inch by 8 inch PCB. The exerciser PCB can be used in a stand alone mode, built into a test station, or used in a tester for field service.

The exerciser is designed to enable the user to make all adjustments and checkouts required on the SA800/801 drives when used with the SA120 alignment diskette.

The exerciser has no intelligent data handling capabilities but can write both 1F and 2F frequencies. The exerciser can enable read in the drive to allow checking of read back signals.

See figure 5-1 for SA809 exerciser connections. Refer to Section VI for schematics.

#### **5.1.3 Special Tools**

The following special tools are available for performing maintenance on the SA800/801.

<b>Description</b>	<b>Part Number</b>
Alignment Diskette	SA120
Cartridge Guide Adjustment Tool	50377
Head Penetration Gauge	50380
Load Bail Gauge	50391
Exerciser (SA809)	50619
Spanner Wrench	50752

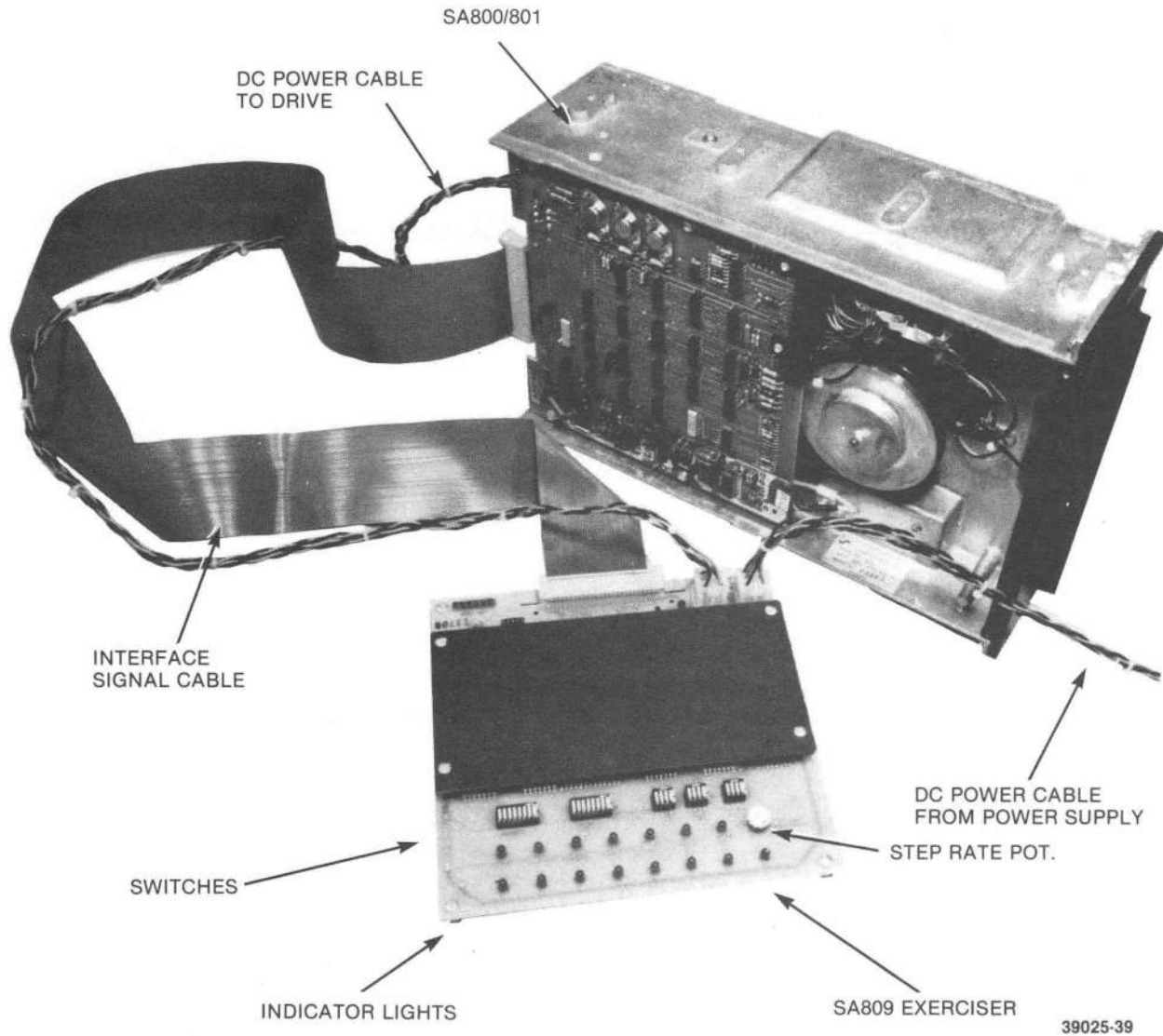

**FIGURE 5-1. SA809 EXERCISER CONNECTION**

## 5.2 DIAGNOSTIC TECHNIQUES

### 5.2.1 Introduction

Incorrect operating procedures, faulty programming, damaged diskettes, "soft errors" created by airborne contaminants, random electrical noise, and other external causes can produce errors falsely attributed to drive failure or misadjustment.

Unless visual inspection of the drive discloses an obvious misalignment or broken part, attempt to repeat the fault with the original diskette, then attempt to duplicate the fault on a second diskette.

### 5.2.2 "Soft Error" Detection and Correction

Soft errors are usually caused by:

- Airborne contaminants that pass between the read/write head and the disk. Usually these contaminants will be removed by the cartridge self-cleaning wiper.
- Random electrical noise that usually lasts for a few microseconds.

- c. Small defects in the written data and/or track of the diskette not detected during the write operation that may cause a soft error during a read.
- d. Worn or defective load pad.
- e. Dirty read/write head.

The following procedures are recommended to recover from soft errors:

- a. Reread the track 10 times or until such time as the data is recovered.
- b. If data is not recovered after using step (a), access the head to the adjacent track in the same direction previously moved, then return to the desired track.
- c. Repeat step (a).
- d. If data is not recovered, the error is not recoverable.

### 5.2.3 Write Error

If an error occurs during a write operation, it will be detected on the next revolution by doing a read operation, commonly called a "write check." To correct the error, another write and write check operation must be done. If the write operation is not successful after 10 attempts, a read operation should be attempted on another track to determine if the media or the drive is failing. If the error still persists, the diskette should be replaced and the above procedure repeated. If the failure still exists, consider the drive defective. If the failure disappears, consider the original diskette defective and discard it.

### 5.2.4 Read Error

Most errors that occur will be soft errors. In these cases, performing an error recovery procedure will recover the data.

### 5.2.5 Seek Error

- a. Stepper malfunction
- b. Improper carriage torque.

To recover from a seek error, recalibrate to track 00 and perform another seek to the original track.

### 5.2.6 Test Points – SA800/801

TP	1 Read Data Signal
	2 Read Data Signal
	3 Read Data (Differentiated; Not available on LSI PCB's.)
	4 Read Data (Differentiated; Not available on LSI PCB's.)
	5 Signal Ground
	6 Signal Ground
	7 Signal Ground
	10 -Index
	11 +Head Load
	12 -Index and 801 Sector Pulses
	16 +Read Data
	21 -Data Separator Time + 1 (Not available on LSI PCB's.)
	24 -Data Separator Time + 2 (Not available on LSI PCB's.)
	25 +Write Protect
	26 +Detect Track 00
	27 +Gated Step Pulses

### 5.3 PREVENTIVE MAINTENANCE

The prime objective of any preventive maintenance activity is to provide maximum machine availability to the user. Every preventive maintenance operation should assist in realizing this objective. Unless a preventive maintenance (PM) operation cuts machine downtime, it is unnecessary.

Visual inspection is the first step in every scheduled maintenance operation. Always look for corrosion, dirt, wear, binds, and loose connections. Noticing these items during PM may save downtime later.

Remember, do not do more than recommended preventive maintenance on equipment that is operating satisfactorily.

Cleanliness cannot be overemphasized in maintaining the SA800/801. Do not lubricate the SA800/801; oil will allow dust and dirt to accumulate. The read/write head should be cleaned only when signs of oxide build up are present.

### 5.4 REMOVALS, ADJUSTMENTS

For parts location, see figure 5-2 and refer to Section VII.

#### 5.4.1 Drive Motor Assembly Removal and Installation

- a. Extract three contacts to disconnect motor from ac connector.

#### NOTE

Drives at EC1376 and above do not have rubber boot.

- b. Loosen two screws holding capacitor clamp to base. Remove rubber boot and disconnect motor leads from capacitor.
- c. Remove connectors from PCB and remove PCB.
- d. Remove belt from drive pulley (paragraph 5.4.13).
- e. Remove four mounting screws holding motor to base casting and remove motor.
- f. Reverse procedure for installation.

#### NOTE

Ensure ground lead is installed between capacitor clamp and base.

#### 5.4.2 Motor Drive Pulley Removal and Installation

- a. Loosen set screw and remove pulley.
- b. Reverse procedure for installation.

#### 5.4.3 Cartridge Guide Access

- a. Position head to approximate center of head load bail (to prevent load arm damage).
- b. Loosen two screws holding cartridge guide to door latch plate.
- c. Swing cartridge guide out.
- d. When guide is swung in, it must be adjusted as per paragraph 5.4.16.

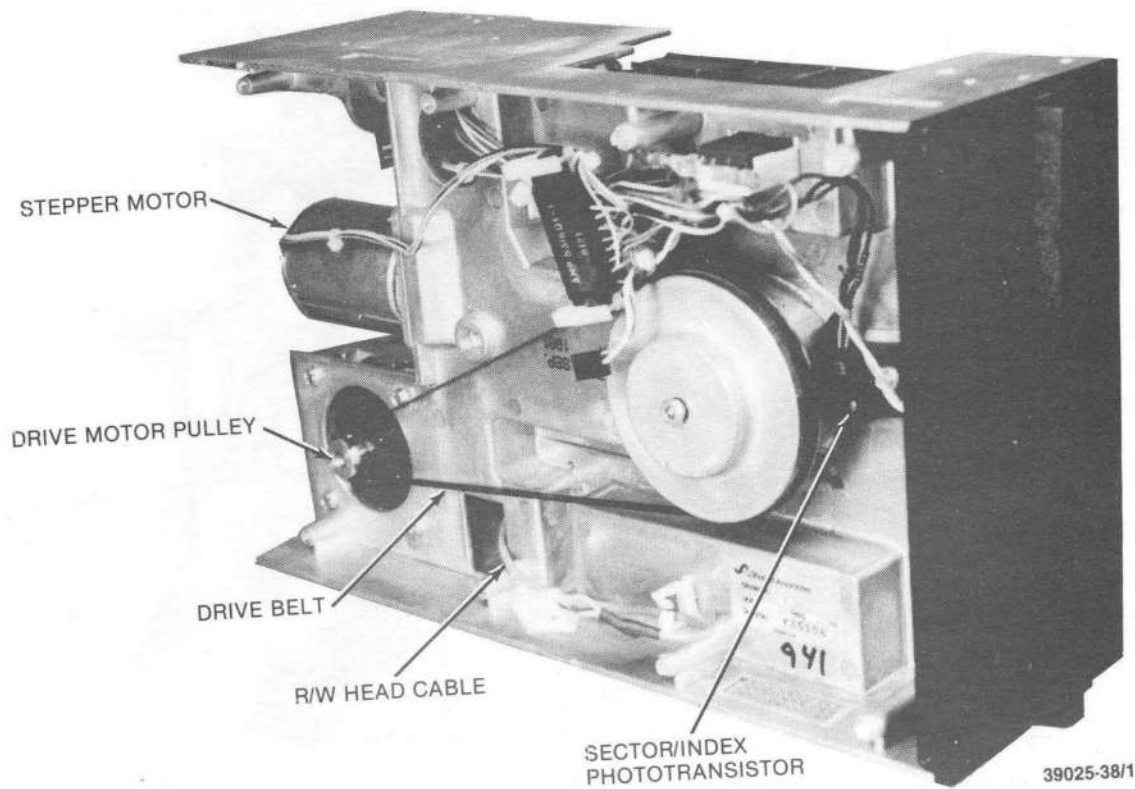
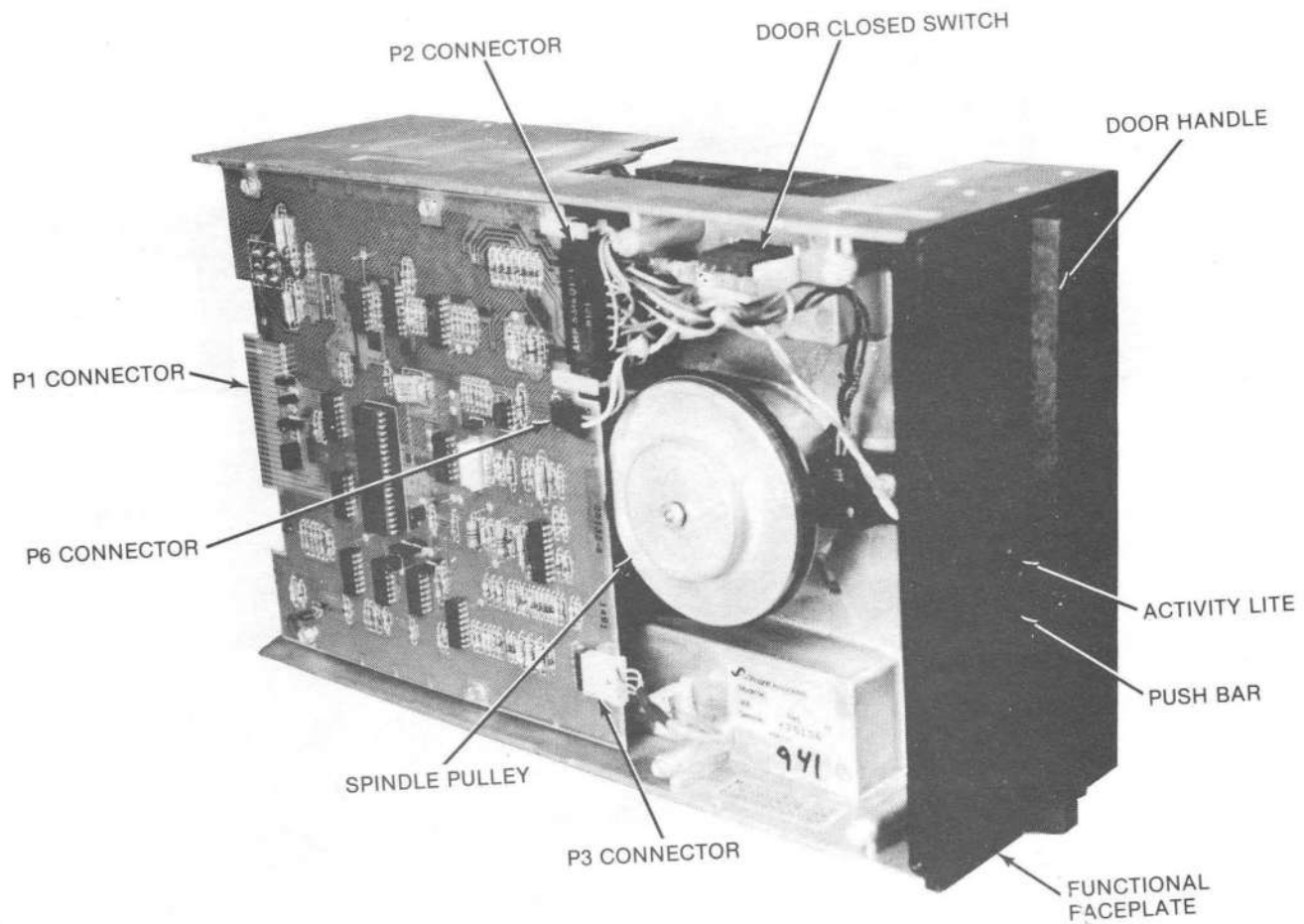
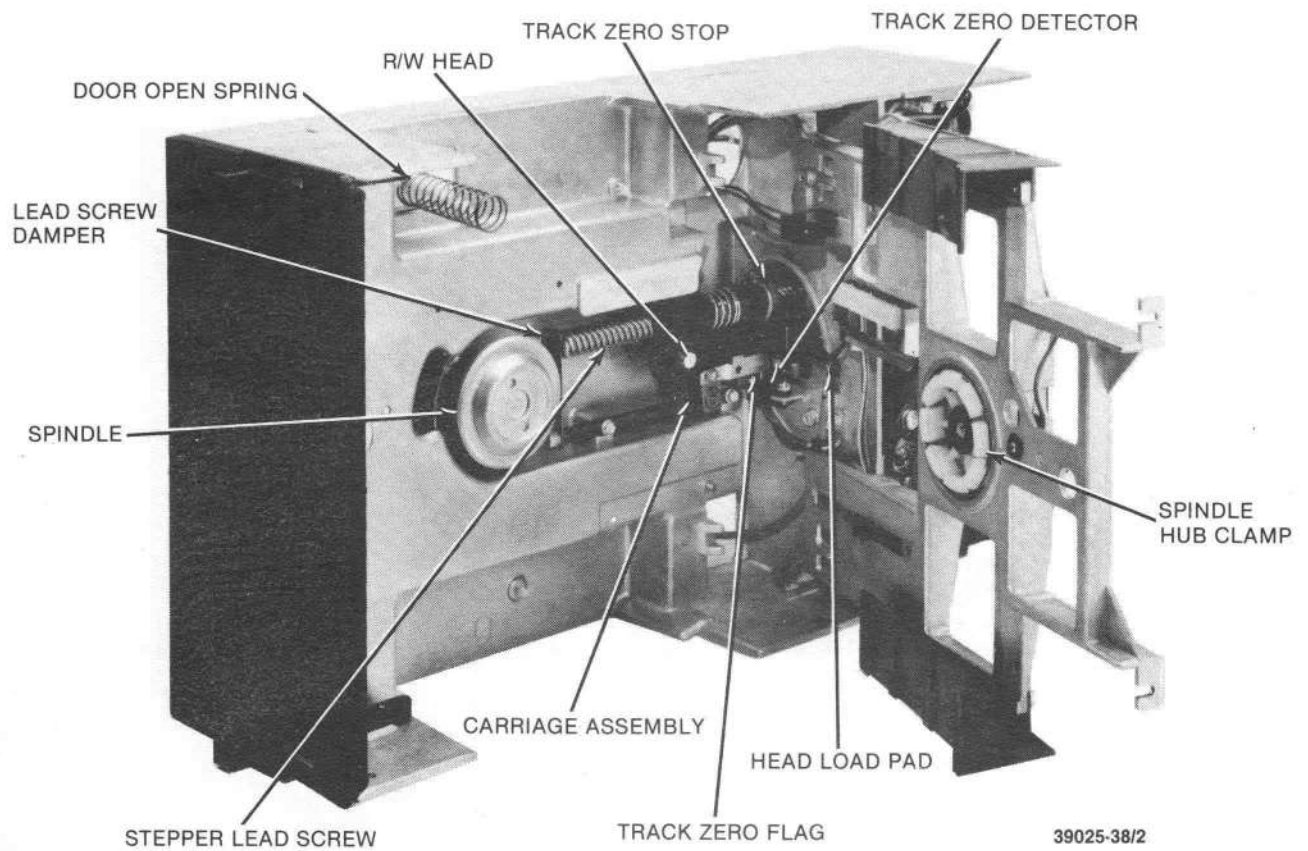
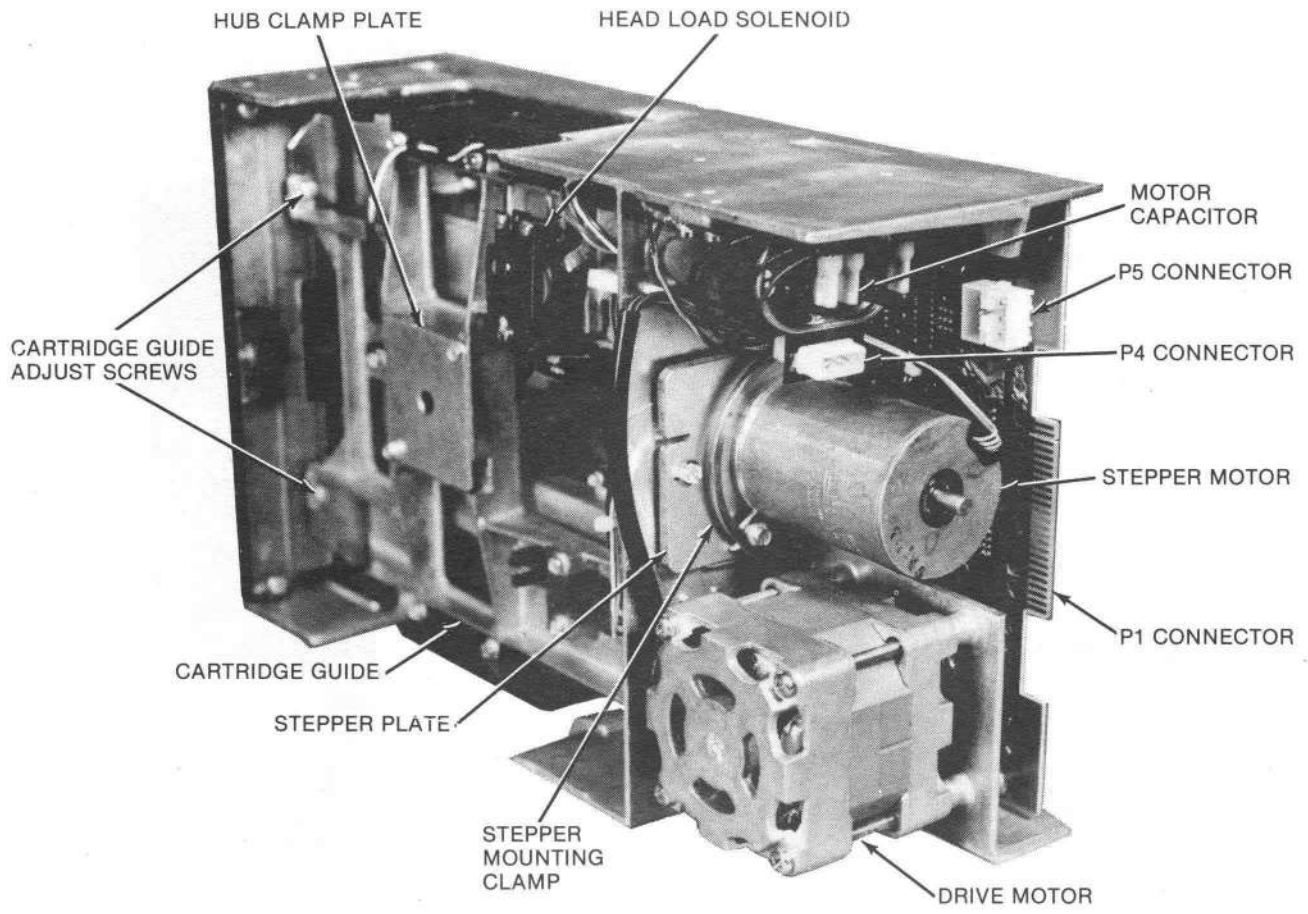

FIGURE 5-2. PHYSICAL LOCATIONS (SHEET 1 OF 3)



39025-38/2

FIGURE 5-2. PHYSICAL LOCATIONS (SHEET 2 OF 3)



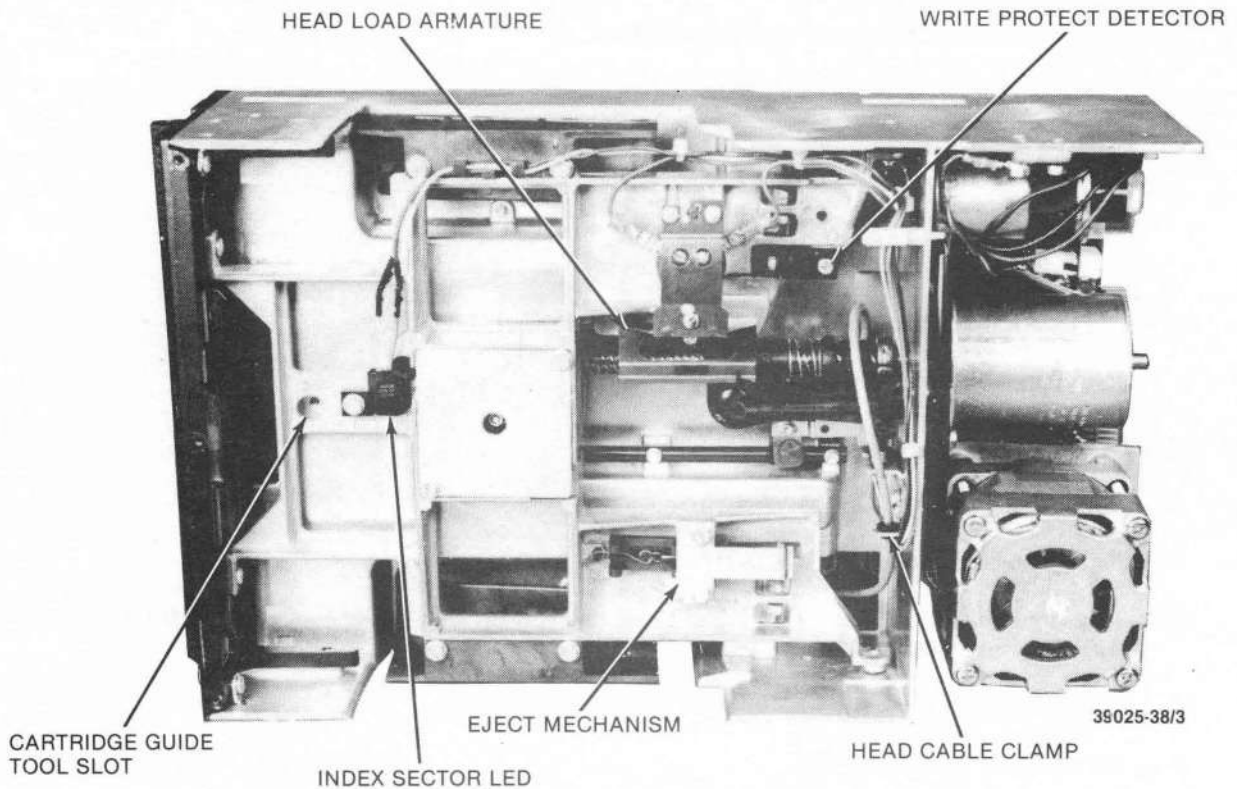

**FIGURE 5-2. PHYSICAL LOCATIONS (SHEET 3 OF 3)**

#### **5.4.4 Sector/Index LED Assembly Removal and Installation**

- a. Disconnect wires to LED terminals (solder joints).
- b. Remove screw holding LED assembly to cartridge guide.
- c. Reverse procedure for installation.
- d. Check index timing and readjust if necessary.

#### **5.4.5 Write Protect Detector Removal and Installation**

- a. Remove connectors from PCB and remove PCB.
- b. Extract wires from P2 connector, pin L3, L4, R5 (E), and R8 (S).
- c. Remove cable clamps.
- d. Remove screw holding detector bracket and remove assembly.
- e. Reverse procedure for reinstalling. Connect wires to P2 by following: Red to '3' (L3), Grey to '4' (L4), Black to 'E' (R5), and White to 'J' (R8).

#### **5.4.6 Write Protect Detector Adjustment**

- a. Insert SA120 diskette into drive. Write protect hole must be open.
- b. Set oscilloscope to auto sweep, 2 V/div, and monitor TP25.
- c. Loosen screw on detector assembly and adjust until maximum amplitude is achieved. Tighten screw.

### 5.4.7 Head Load Actuator Removal and Installation

- Disconnect wires to actuator terminals (solder joints).
- Swing out cartridge to guide assembly (paragraph 5.4.3).

#### CAUTION

Restrain head load arm to prevent its impact with head.

- Remove screw holding actuator to cartridge guide.
- Reverse procedure for installation.

### 5.4.8 Head Load Actuator Adjustment

- Energize Head Load Coil.
- Place Load Bail gauge (P/N 50391) on platen.
- Adjust down stop so that top of Head Load Bail is flush with top of tool within  $\pm 0.005$  inch at track 76. See figure 5-3.
- Step carriage to track 38.
- De-energize Head Load Coil.
- Place adjustment tool onto R/W Head and place load button in cup of tool.
- Adjust up stop on actuator so that bail just touches Head Load Arm or has 0.005 inch clearance or lifts load arm 0.005 inch. See figure 5-4.
- Energize Head Load Coil and step carriage between track 00 and 76. Ensure minimum clearance of 0.010 inch between Head Load Bail and Head Load Arm.

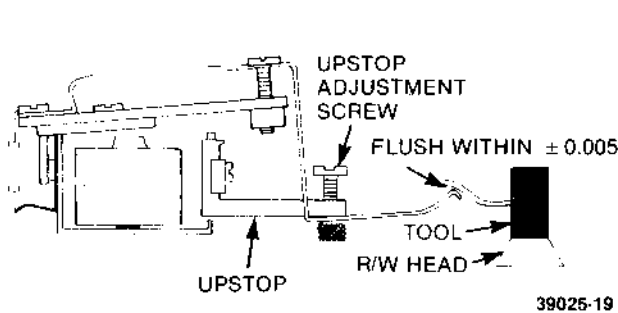

**FIGURE 5-3. HEAD LOAD ACTUATOR UPSTOP ADJUSTMENT**

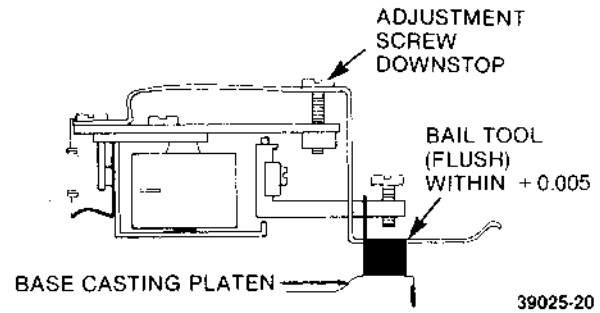

**FIGURE 5-4. HEAD LOAD ACTUATOR DOWNSTOP ADJUSTMENT**

### 5.4.9 Head Load Actuator Timing

- Insert alignment diskette (SA120)
- Step carriage to track 00.
- Sync oscilloscope on TP11 (+HEAD LOAD). Set time base to 10 msec/division.
- Connect one probe to TP1 and other to TP2. Ground probes to PCB. Set inputs to add and invert one input. Set vertical deflection to 50 mV/div.
- Energize head load solenoid and observe read signal on oscilloscope. Signal must be at 50% of full amplitude by 35 msec. See figure 5-5.

- f. If this is not met, continue with procedure.
- g. Check adjustments outlined in paragraph 5.4.8.

**NOTE**

In step (h), do not exceed 1/4 turn.

- h. If step “g” checks, adjust downstop screw (figure 5-4) clockwise until timing is met.

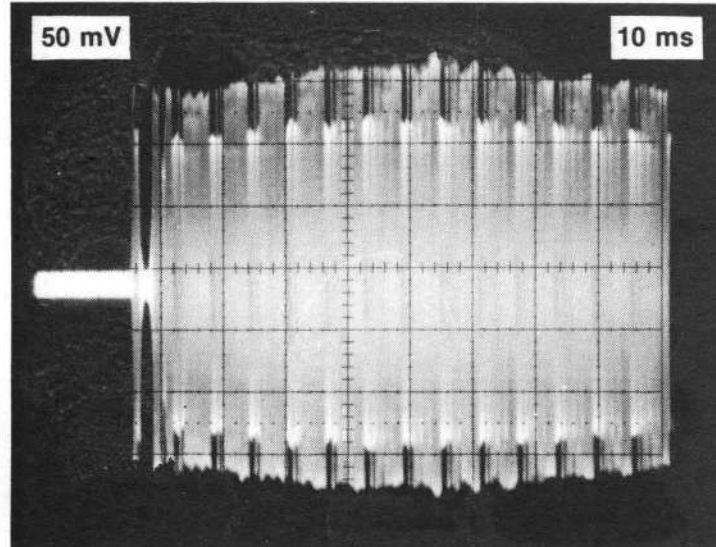

39025-21

**FIGURE 5-5. HEAD LOAD ACTUATOR TIMING**

**5.4.10 Index/Sector Photo Transistor Assembly Removal and Installation**

- a. Disconnect P2 connector from PCB.
- b. Remove wires from door closed switch and extract wires from P2 connector pin 9 (L9) Black, H (R7) Brown, 6 (L6) Red, and B (R2) Orange.
- c. Remove cable clamp holding wires from detector.
- d. Remove screw holding detector to base plate and remove assembly.
- e. To install, reverse procedure.

**5.4.11 Index/Sector Photo Transistor Potentiometer Adjustment**

- a. Insert alignment diskette (SA120).
- b. Using oscilloscope, monitor TP12 (-INDEX), sync internal negative, dc coupled, set vertical scale to 2 V/cm.
- c. Adjust potentiometer on Sector/Index Phototransistor to obtain pulse of 1.2 msec minimum to 2.2 msec maximum duration.
- d. Continue adjustment in paragraph 5.4.12.

**5.4.12 Index/Sector Adjustment**

- a. Insert alignment diskette (SA120).
- b. Step carriage to track 01.

- c. Sync oscilloscope, external negative, on TP12 (-INDEX). Set time base to 50  $\mu\text{sec}/\text{division}$ .
- d. Connect one probe to TP1 and other to TP2. Ground probes to PCB. Set inputs to ac. Add and invert one channel. Set vertical deflection to 500 MV/division.
- e. Observe timing between start of sweep and first data pulse. This should be  $200 \pm 100 \mu\text{sec}$ . If timing is not within tolerance, continue on with adjustment. See figure 5-6.

#### NOTE

Do not adjust potentiometer in Index/Sector phototransistor.

- f. Loosen holding screw in index transducer until transducer is just able to be moved.
- g. Observing timing, adjust transducer until timing is  $200 \pm 100 \mu\text{sec}$ . Ensure that transducer assembly is against registration surface of base casting.
- h. Tighten holding screw.
- i. Recheck timing.
- j. Seek to track 76 and reverify that timing is  $200 \pm 100 \mu\text{sec}$ .

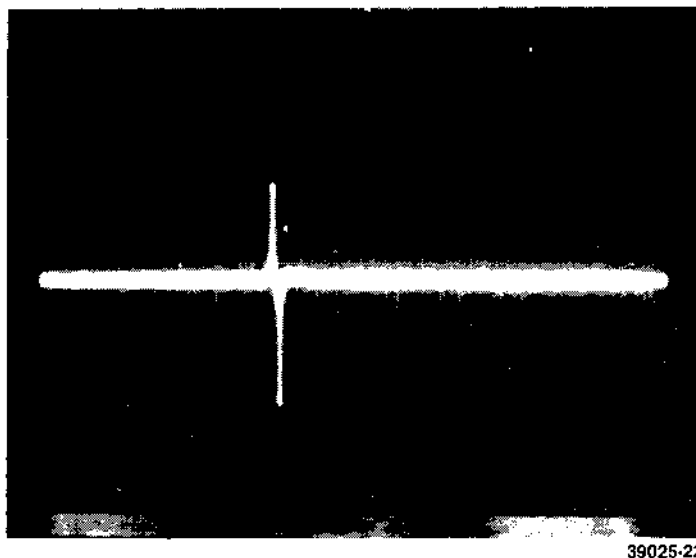

39025-22  
**FIGURE 5-6. INDEX TIMING**

#### 5.4.13 Belt and Pulley Removal and Installation

- a. Remove PCB.
- b. Remove belt by slowly rotating spindle pulley while guiding belt off pulley.
- c. Remove drive pulley by loosening set screw.
- d. Install new drive pulley to motor drive shaft with set screw. Position set screw over flat surface of shaft and press down firmly on pulley while tightening screw.
- e. Place new belt around drive pulley and guide belt onto rear of spindle pulley while slowly rotating spindle pulley until belt is on. Spin pulley to properly center belt.
- f. Reinstall PCB.

#### 5.4.14 Spindle Assembly Removal and Installation

- a. Swing out cartridge guide (paragraph 5.4.3).
- b. Remove nut and washer or two spring washers holding spindle pulley. On late level drives, Spanner Wrench 50752 may be used to hold spindle.

#### CAUTION

Pre-loaded rear bearing may fly out when spindle pulley is removed.

- c. Withdraw spindle hub from opposite side of baseplate.
- d. Reverse procedure for installation.
- e. Tighten nut to 20 in./lbs. If spring washers are used, ensure they are compressed. Add a drop of Loctite<sup>®</sup> #290 to threads.

#### 5.4.15 Hub Clamp Removal and Installation

- a. Remove hub clamp plate. See figure 5-7.
- b. Remove hub clamp and spring.
- c. To install, reverse procedure. No adjustment necessary.

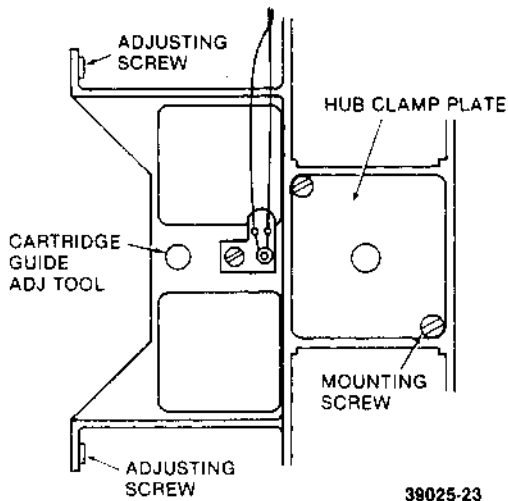

39025-23

FIGURE 5-7. CARTRIDGE GUIDE ADJUSTMENT

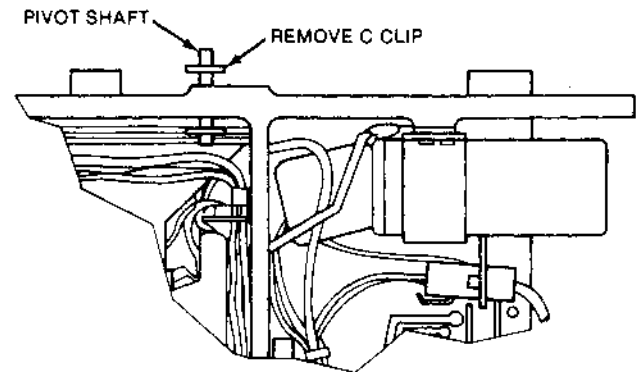

39025-24

FIGURE 5-8. CARTRIDGE GUIDE REMOVAL

#### 5.4.16 Cartridge Guide Removal and Installation

- a. Perform paragraphs 5.4.3 and 5.4.7.
- b. Remove C-clip from pivot shaft. See figure 5-8.
- c. Remove pivot shaft.
- d. Tilt cartridge guide slightly and remove it from upper pivot.
- e. To install cartridge guide, reverse procedure.

#### 5.4.17 Cartridge Guide Adjustment

- a. Insert Cartridge Guide Adjustment tool (P/N 50377-1) through adjustment hole in cartridge guide and screw completely into base casting (hand tight). See figure 5-7.

- b. Move handle into latched position and hold it lightly against latch.
- c. Tighten two screws holding cartridge guide to latch plate.
- d. Remove tool and check to determine flange on clamp hub clears cartridge guide when spindle is rotating. If clamp hub rubs on cartridge guide, repeat adjustment procedure.
- e. Check index alignment per paragraph 5.4.12.
- f. Insert diskette, close and open door, then check for proper operation.

#### **5.4.18 Front Plate Assembly Removal and Installation**

- a. Swing out cartridge guide assembly (paragraph 5.4.3).
- b. Remove four screws holding front plate assembly to base casting.
- c. To install, reverse procedure.
- d. Check index adjustment (paragraph 5.4.12).

#### **5.4.19 Head Amplitude Check**

These checks are only valid when writing and reading back as described below. If this amplitude is below the minimum specified, the load pad should be replaced and the head should be cleaned (if necessary) before rewriting and rechecking. Ensure the diskette used for this check is not "worn" or otherwise shows evidence of damage on either the load pad or head side.

- a. Install good media.
- b. Select drive and step to TK 76.
- c. Sync oscilloscope on TP12 (-INDEX). Connect one probe on TP2 and one on TP1 on drive PCB. Ground probes to PCB. Add and invert one input. Set volts per division to 50 mV and time base to 20 Msec per division.
- d. Write entire track with 2F signal (all ones).
- e. Average minimum read back amplitude, peak to peak, should be 110 mV (170 mV for LSI PCB's).

If output is below minimum, try a new load pad and different media. If output is still low, install new head and carriage assembly.

#### **5.4.20 Stepper/Carriage Assembly Removal and Installation**

- a. Remove cable clamp holding read/write head cable on PCB side of drive.
- b. Extract stepper cable contacts from P2 connector, Black 10 (L10), Red 2 (L2), Brown 5 (L5), and Orange 8 (8).

#### **NOTE**

This step is only necessary if stepper motor is to be replaced.

#### **CAUTION**

Do not loosen three screws coated with Glyptol.

- c. Loosen two screws and swing clamp down to allow withdrawal of motor.
- d. Remove grommet on cable that is inserted into slot on track 00 detector bracket.

- e. Turn stepper shaft until carriage runs off end of lead screw.
- f. To install stepper/carriage assembly, reverse procedure. Note steps "g" and "h."
- g. If installing a new carriage, set pre-load nut in #2 notch. See figure 5-9.
- h. When threading lead screw into carriage assembly, press pre-load nut slightly against spring in order to start thread. After threading, ensure there is a gap between pre-load nut and rear of carriage.

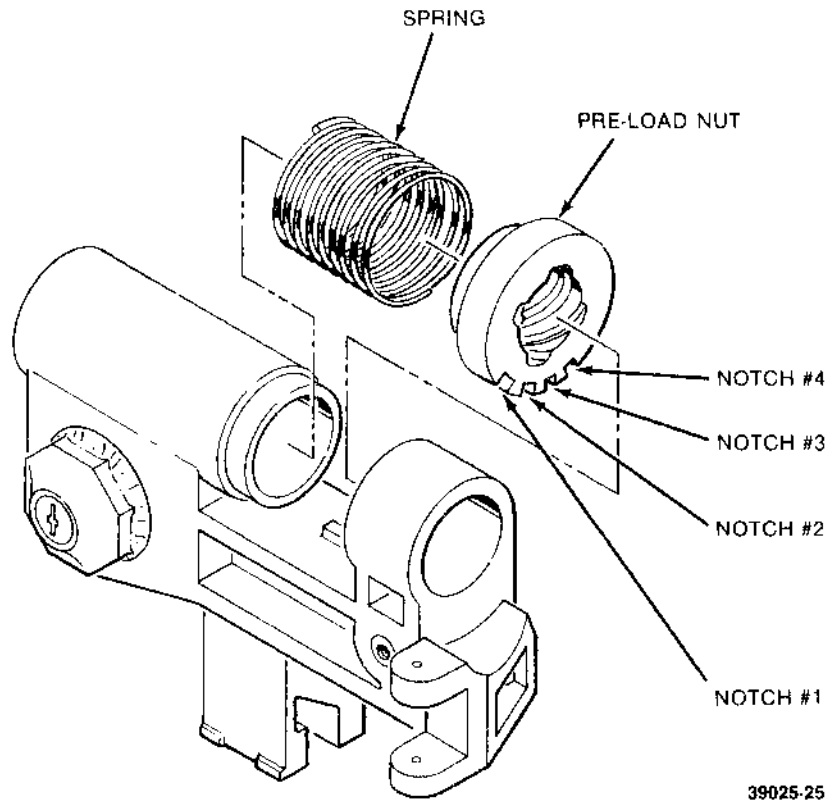

**FIGURE 5-9. CARRIAGE ASSEMBLY**

#### **5.4.21 Carriage Assembly Readjustment After Replacement**

- a. Loosen track 00 stop collar and manually move carriage towards stepper by rotating lead screw until carriage load arm tab is near edge of load bail. Tighten collar set screw.
- b. Position track 00 flag approximately in center of its slot and tighten screw. Move carriage towards spindle by rotating lead screw until flag is clear of detector.
- c. Insert SA120 alignment diskette and load head. Set scope as explained in paragraph 5.4.22, steps "c" and "d."
- d. Step carriage towards track 00 until track 00 signal is detected on interface pin 42.

#### **CAUTION**

Do not loosen three screws coated with Glyptol.

- e. Loosen two stepper motor mounting screws slightly and slowly rotate stepper motor case until Read Data Signal Off of track 00 appears. Continue rotation until maximum amplitude is obtained. This is only a rough adjustment.
- f. Step carriage to track 38 and proceed with head radial adjustments. Refer to paragraph 5.4.22.

- g. Adjust track 00 stop (paragraph 5.4.27).
- h. Adjust track 00 flag (paragraph 5.4.28).
- i. Adjust index (paragraph 5.4.12).
- j. Adjust azimuth (paragraph 5.4.29).

#### 5.4.22 Head Radial Alignment

##### NOTE

Head radial alignment should be checked prior to adjusting index/sector, track 00 flag, or carriage stop.

- a. Load alignment diskette (SA120).

##### NOTE

Alignment diskette should be at room conditions for at least twenty minutes before alignment.

- b. Step carriage to track 38.
- c. Sync oscilloscope, external negative, on TP12 (-INDEX). Set time base to 20 Msec per division. This will display over one revolution.
- d. Connect one probe to TP1 and other to TP2. Ground probes on PCB. Set inputs to AC. Add and invert one channel. Set vertical deflection to 100 MV/div.
- e. Two lobes must be within 70% amplitude of each other. If lobes do not fall within specification, continue with procedure. See figure 5-10.

##### CAUTION

Do not loosen three screws coated with Glyptol.

- f. Loosen two mounting screws which hold motor clamp to mounting plate.
- g. Rotate stepper motor to radially move head in or out. If left lobe is less than 70% of right, turn stepper motor counter-clockwise as viewed from rear. If right lobe is less than 70% of left lobe, turn stepper motor clockwise as viewed from rear. See figure 5-11.
- h. When lobes are of equal amplitude, tighten motor clamp mounting screws.
- i. Check adjustment by stepping off track and returning. Check in both directions and readjust as required.
- j. Whenever Head Radial Alignment has been adjusted, track 00 flag adjustment (paragraph 5.4.28), track 00 stop (paragraph 5.4.27), and read/write head azimuth (paragraph 5.4.29) must be checked.



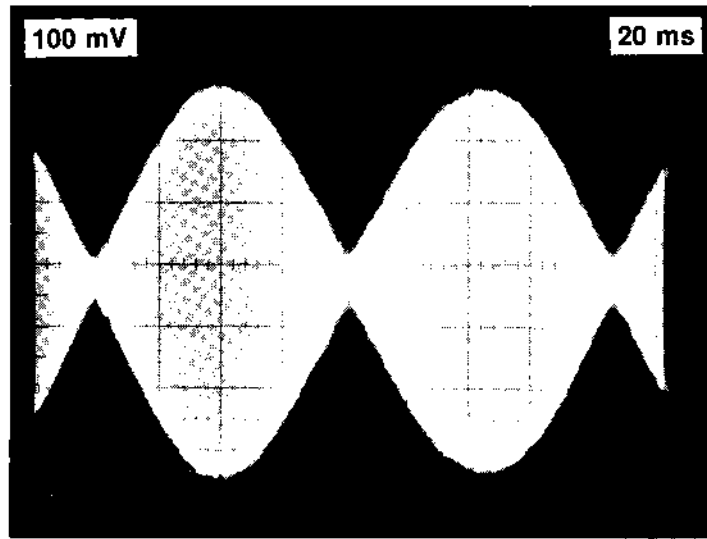

**FIGURE 5-10. HEAD RADIAL ALIGNMENT**

#### **5.4.23 Read/Write Head Load Button Removal and Installation**

##### **NOTE**

Load arm should never be opened over 90° from carriage assembly or while at track 00 to prevent possible damage to torsion spring.

- a. To remove old button, hold arm out away from head, squeeze locking tabs together with pair of needle nose pliers, and press forward.
- b. To install load button, press button into arm from head side, and snap in place. See figure 5-12.
- c. Adjust according to paragraph 5.4.24.

#### **5.4.24 Read/Write Head Load Button Adjustment**

- a. Insert alignment diskette (SA120).
- b. Connect oscilloscope to TP1 and 2. Add differentially and sync negative external on TP12 (-INDEX).
- c. Step carriage to track 75.
- d. Observing read signal on oscilloscope, rotate load button counter-clockwise in small increments (10°) until maximum amplitude is obtained.

##### **CAUTION**

Lift load arm off media. Use pliers, not screwdriver.

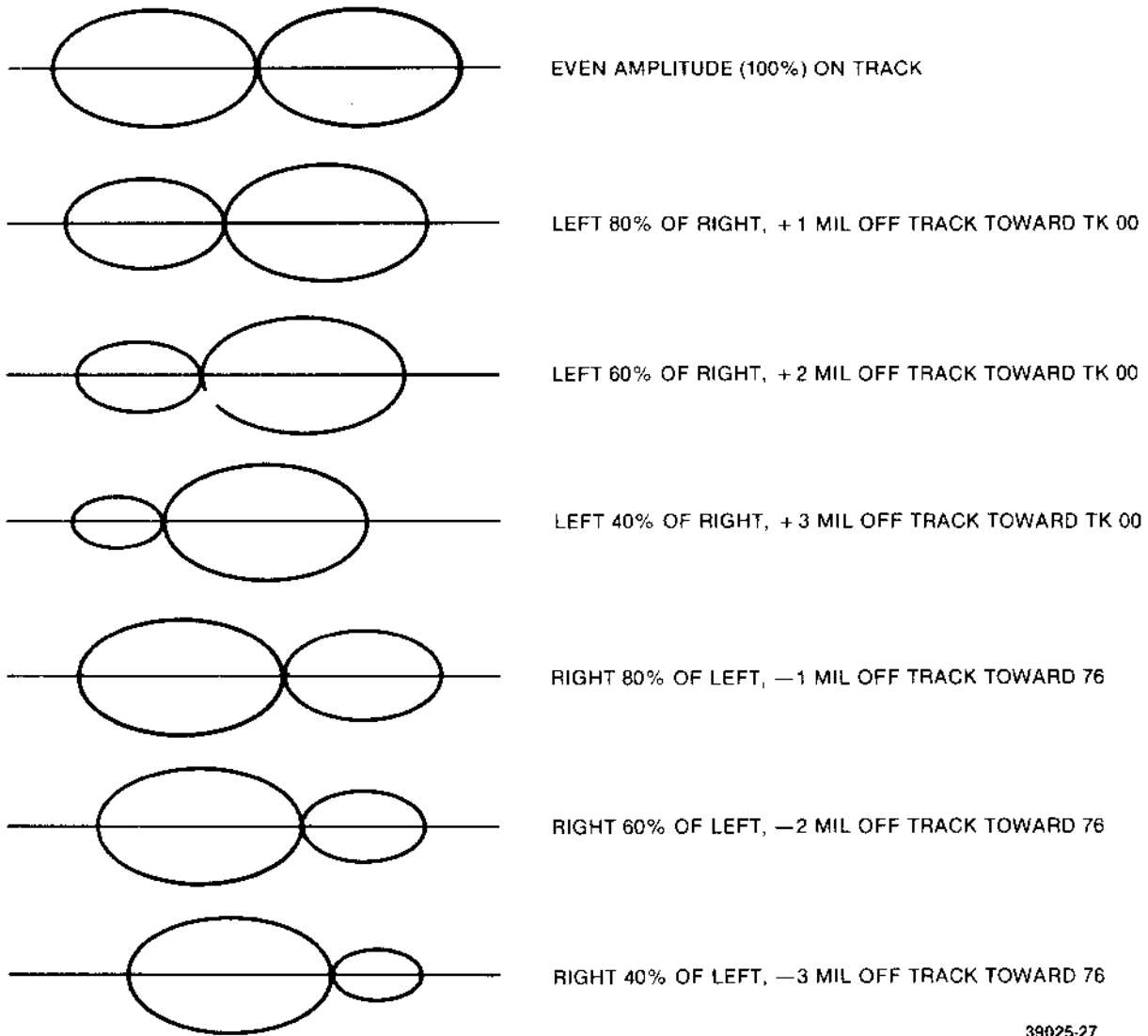

**FIGURE 5-11. READ/WRITE HEAD RADIAL ALIGNMENT**

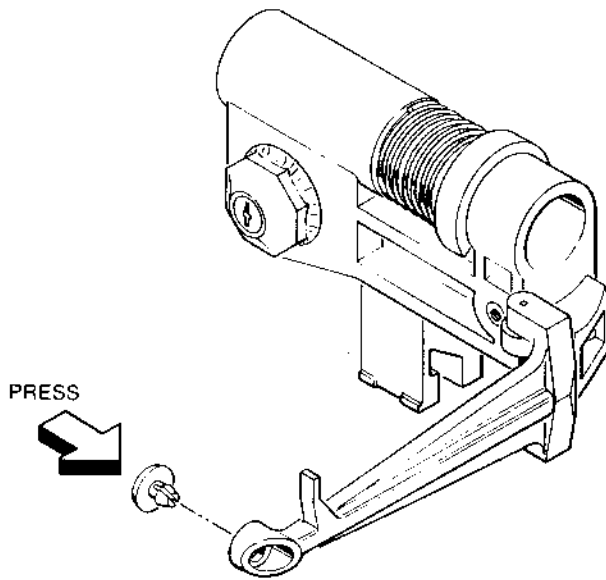

**FIGURE 5-12. READ/WRITE HEAD LOAD BUTTON INSTALLATION**

#### 5.4.25 Head Penetration Adjustment

##### NOTE

This adjustment is not normally done in field. The only time that this adjustment need be done is when stepper mounting plate has been loosened or removed.

- a. Place Head Penetration Gauge (P/N 50380) on gauge block. Ensure that gauge reads 0.030 inch (3 on the small hand) and zero dial for large hand. This results in a reading of 0.030 inch.
- b. Swing open cartridge as per paragraph 5.4.3.
- c. Place gauge on base assembly with short leg on platen, long leg on carriage guide bar, and plastic tip in center of read/write head.
- d. Head penetration should be  $0.030 \pm 0.004$  inch read on gauge.
- e. If head does not meet this adjustment, move stepper plate laterally until gauge reads 0.030 inch.
- f. Tighten screws and recheck adjustment.
- g. Return cartridge guide and adjust per paragraph 5.4.17.
- h. Adjust azimuth (paragraph 5.4.29).

#### 5.4.26 Track 00 Detector Removal and Installation

- a. Swing cartridge guide open (paragraph 5.4.4).
- b. Manually rotate stepper shaft and move carriage all the way in.
- c. Remove two screws holding bracket to base casting and remove bracket and detector.
- d. Remove PCB connector and remove PCB.
- e. Extract cable from P2 connector; Brown, A (R1); Black, C (R3); Red, F (R6); and Orange, K (R9).
- f. Remove cable clamps and remove detector assembly.
- g. To install, reverse procedure.
- h. Adjust according to paragraph 5.4.27.

#### 5.4.27 Track 00 Stop Adjustment

- a. Step carriage to track 00. Verify carriage is at track 00 by checking P1 pin 42 is minus (ground).
- b. Check stop is  $0.040 \pm 0.020$  inch between collar and carriage. Turn dc power off and manually rotate lead screw clockwise until carriage stops. Check stop is  $0.020 \pm 0.010$  inch between collar and carriage.
- c. If clearances are not within tolerance, continue on with adjustment procedure.
- d. Turn dc power on.
- e. Step carriage to track 02.
- f. Loosen track 00 stop collar.
- g. Grasp end of lead screw in back of stepper motor with pair of pliers. Manually turn lead screw clockwise to track 01 position (next detent position on stepper motor).

- h. Position stop collar axially along lead screw so there is  $0.020 \pm 0.010$  inch between collar and carriage. Rotate collar toward inside until stop on collar contacts carriage stop surface. Tighten screw.
- i. Turn dc power off and back on. Carriage should move to track 00. Verify data is at track 00.
- j. Step carriage between track 00 and 76. Check for any binding or interference between carriage, lead screw, stop, and head cable.

#### 5.4.28 Track 00 Flag Adjustment

- a. Check head radial alignment and adjust if necessary before making this adjustment.
- b. Connect oscilloscope probe to TP26. Set vertical deflection to 1 V/division and sweep to continuous.
- c. Step carriage to track 01. TP26 should be high (+5 volts).
- d. If TP26 is not high, loosen screw holding track 00 flag and move flag towards stepper until TP26 just goes high.
- e. Step carriage to track 2. TP26 should go low. Adjust flag towards spindle if not low.
- f. Check adjustment by stepping carriage between tracks 00 and 02, observing that TP26 is low at track 02 and high at tracks 01 and 00.

#### 5.4.29 Read/Write Head Azimuth Alignment

This adjustment can only be made on SA800/801's at MLC 3 or higher with a stepper plate marked 50112-4. This adjustment is only necessary when the stepper or carriage assembly has been replaced or if the stepper plate has been loosened.

- a. If stepper plate has been loosened or replaced, adjust head penetration (paragraph 5.4.24).
- b. Align read/write head (paragraph 5.4.22).
- c. Install alignment diskette SA120-1. Select drive and step to track 76.
- d. Sync scope external negative on TP12. Set time base to 0.5 Msec per division.
- e. Connect one probe to TP1 and other to TP2. Invert one channel and ground probes to TP5 and 6. Set inputs to AC and add 50 MV per division.
- f. Compare wave form to figure 5-13. If not within range shown ( $\pm 18$  minutes), head Azimuth will require adjustment. If required, proceed to next step.
- g. Slightly loosen two right hand stepper plate mounting screws only (see figure 5-14). Do not loosen left hand screw as this will effect head penetration adjustment.
- h. Push stepper down towards ac drive motor until first sector is larger than second sector.
- i. Pry right hand side of stepper plate up with medium screw driver until first and fourth sectors have equal or less amplitude than middle two sectors. See figure 5-13.
- j. Retighten two right hand screws. If either of outside two sectors increase in amplitude greater than inside two after retightening screws, perform adjustment again.
- k. Check and re-adjust index timing and head radial adjustment, if required.

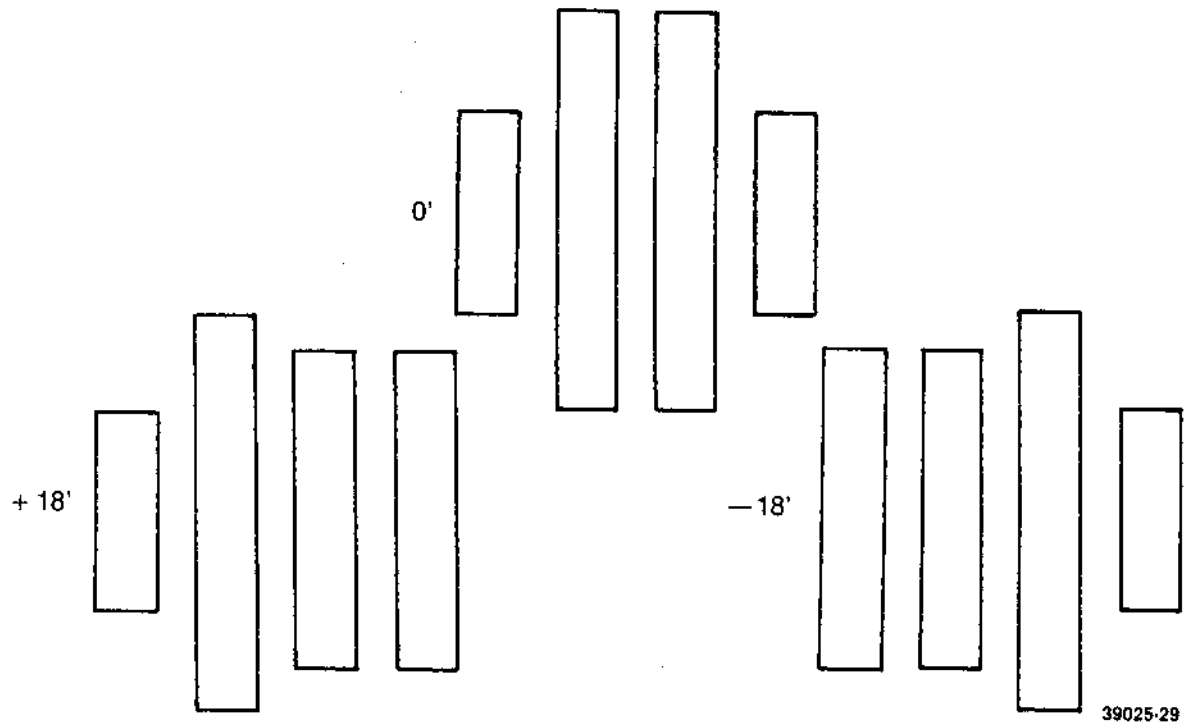
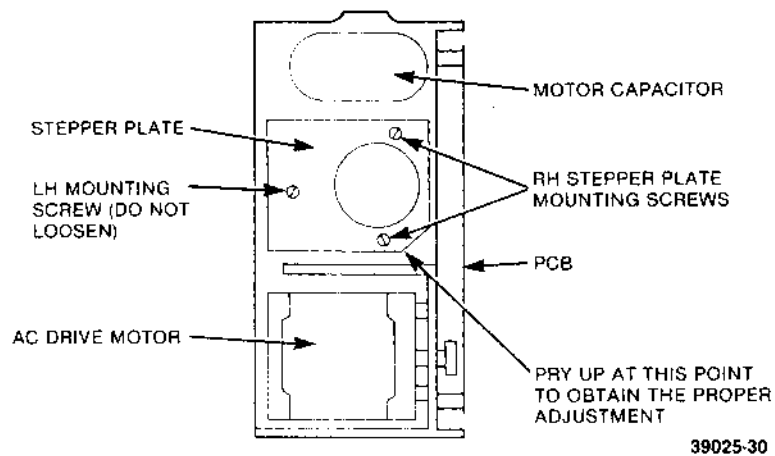

FIGURE 5-13. AZIMUTH BURST PATTERNS



39025-30

FIGURE 5-14. DRIVE REAR VIEW

#### 5.4.30 Stepper Plate: Removal and Installation

- a. Remove PCB.
- b. Remove head and carriage assembly from stepper lead screw (paragraph 5.4.20).
- c. Pull stepper motor out through stepper plate until lead screw is completely clear of plate.
- d. Remove three stepper plate mounting screws.
- e. Reinstall stepper plate.

## NOTE

If stepper plate is P/N 50112-4, there must be nylon bushing in left hand hole and all three screws must have flat washer and black spring washer.

- f. Reinstall head, carriage and stepper motor assemblies.
- g. Adjust penetration (paragraph 5.4.24).
- h. Readjust carriage assembly (paragraph 5.4.21).
- i. Check and adjust azimuth alignment (paragraph 5.4.29).

### 5.4.31 Activity Light Removal and Installation (Standard)

- a. Remove P6 connector from PCB.
- b. Remove cable clamp holding cable and remove cable from clamp.
- c. Remove two screws holding push button.
- d. Remove, as an entire assembly, push button and activity light from front.
- e. Install light and push button assembly by reversing removal procedure.
- f. No special orientation is required when installing P6 onto PCB. No adjustments are required on push button assembly.

### 5.4.32 Door Lock LED Removal and Installation

- a. Disconnect P6 connector.
- b. Disconnect red wire near IC 2G (TP DL on LSI PCB's).
- c. Remove front plate (paragraph 5.4.18).
- d. Remove two screws holding assembly to front plate.
- e. Remove two allen head screws holding assembly to push button.
- f. Grasp both ends of push button and bow outwards to remove LED.
- g. Reverse procedure to assemble.
- h. Adjustment of door lock should not be necessary. If adjustment is required, gap between armature tab and latch should be  $0.015 \pm 0.010$  inch. This adjustment can be made by loosening two screws on armature.

### 5.4.33 Activity Light (with Door Lock Option) Removal and Installation

Follow procedure in paragraph 5.4.32.

## 5.5 RECOMMENDED INCOMING RECEIVING INSPECTION

All Shugart drives are 100% adjusted and tested before leaving the factory. Therefore, it is only necessary to inspect for shipping damage on receipt of drives.

Inspection should be simple and test equipment kept to a minimum. Shugart recommends the following equipment:

- a. 800/801 Service Manual
- b. SA809 Exerciser

- c. Exerciser Instruction Manual
- d. Power Supply for Exerciser (+5 V, +24 V, -5 V not required on drives with an MLC 6 and above)
- e. Oscilloscope
- f. SA120 Alignment Diskette
- g. SA102 Diskette

The SA800/801 incoming receiving inspection procedure is as follows:

- a. Unpack drive.
- b. Make visual inspection for physical damage.
- c. Make sure all power is off, then attach exerciser cables to appropriate drive connectors and accord to P4 connector.
- d. Power up.
- e. Insert SA102 diskette.
- f. Set track addresses of 00 and 76 into exerciser, load head, and let drive seek automatically for 5 minutes. After 5 minutes, move address 76 to 00. Seeking should stop and track 00 indicator should be on.
- g. Push door open button while drive is seeking. Door must not open if door lock feature is provided.
- h. Using this Service Manual, SA120 alignment disk, and exerciser instruction manual as guides, perform the following checks:
  - Head Load Actuator Timing (paragraph 5.4.9).
  - Index Sector Adjustment (paragraph 5.4.12).
  - Head Radial Alignment (paragraph 5.4.22).
- i. Remove SA120 alignment disk and insert SA102 diskette.
- j. Seek to track 76 and write 2F on both sides. Minimum read back signal should be 110 mV (170 mV for LSI PCB's).
- k. Connect scope to TP12 and verify index timing is  $166.7 \pm 3.3$  msec.
- l. Power off.
- m. Remove connectors.

Completion of this procedure verifies that the critical functions of the drive are operating properly (i.e., the file will read and write, it will access, the disk is rotating at the proper speed, and critical adjustments are within specifications).





## SECTION VI SCHEMATIC DIAGRAMS

The following schematic diagrams are furnished as an aid to malfunction analysis. Table 6-1 shows the applicability of each diagram.

**TABLE 6-1. SCHEMATIC DIAGRAM APPLICABILITY**

<b>FIGURE</b>	<b>TITLE</b>	<b>APPLICABILITY</b>
6-1	Schematic Diagram for 800 Series (2 sheets)	25102-4 25103-4 25104-4 25105-4 25106-4 25107-4
6-2	Schematic Diagram for 800 Series (2 sheets)	25171-0 25172-0 25173-0 25174-0 25175-0 25176-0
6-3	Schematic Diagram for 800/801 Series (2 sheets)	25136-4
6-4	Schematic Diagram for 800L Series (2 sheets)	25229
6-5	Door Lock Schematic	All

39025-31



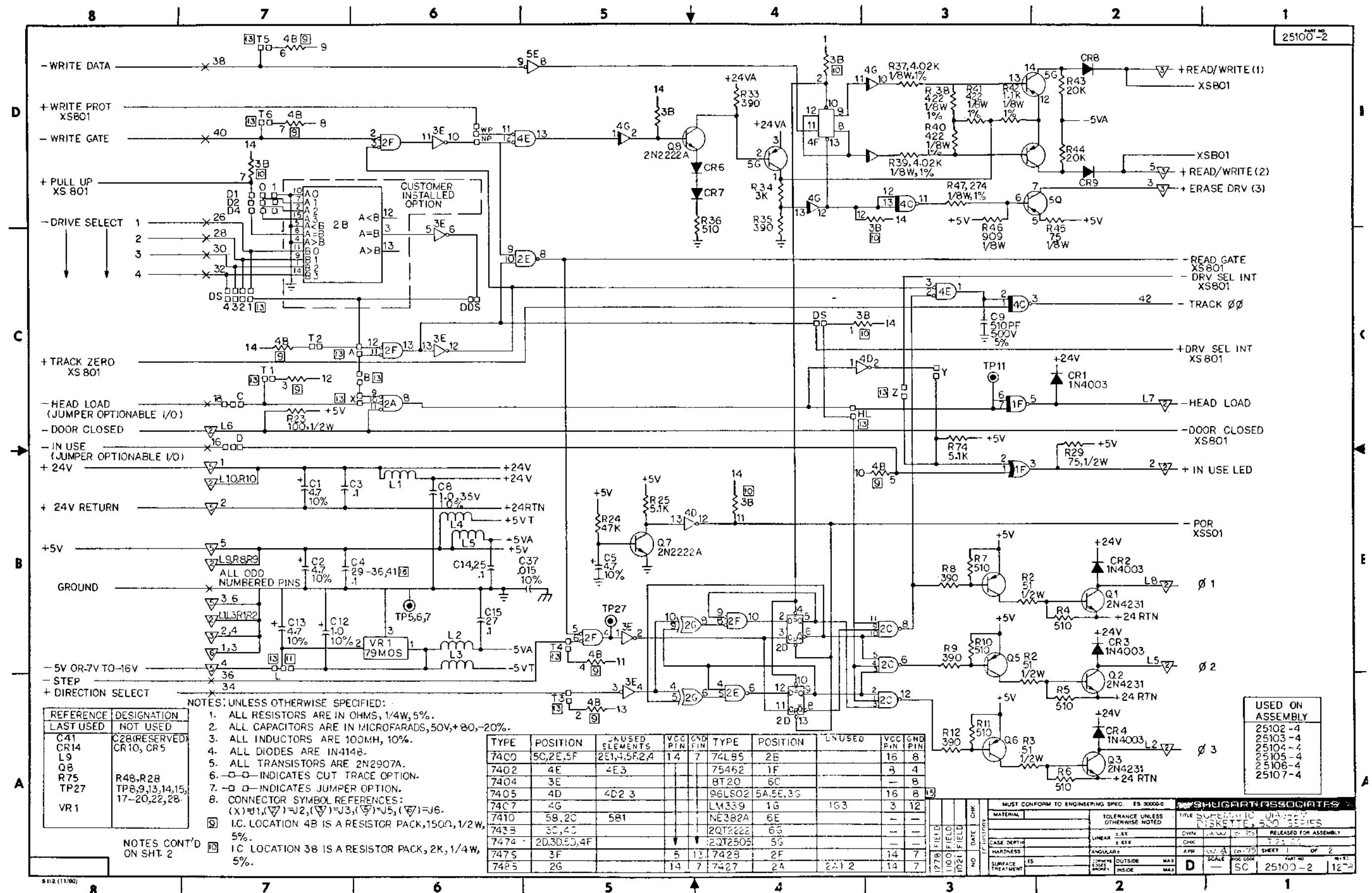
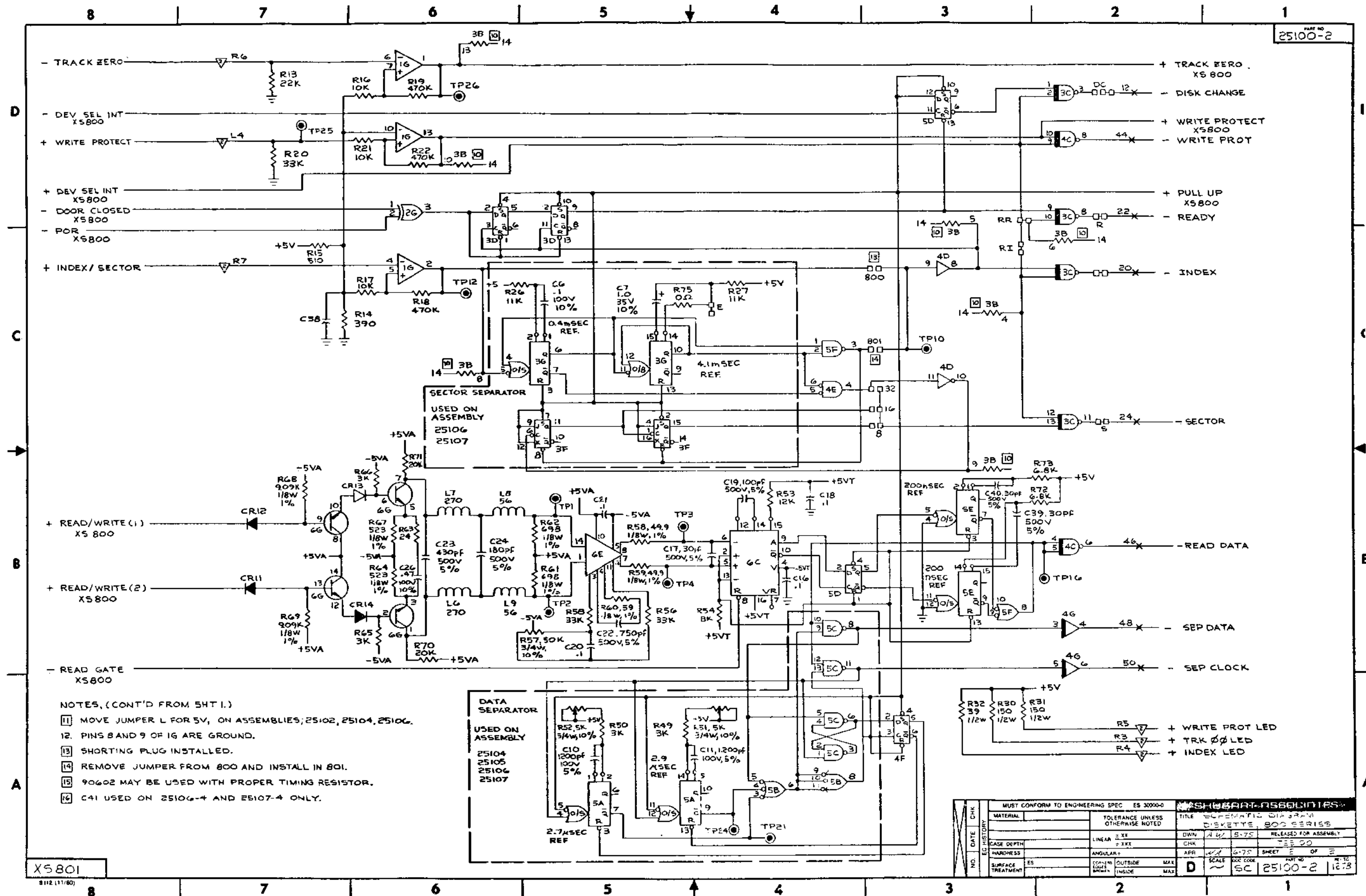
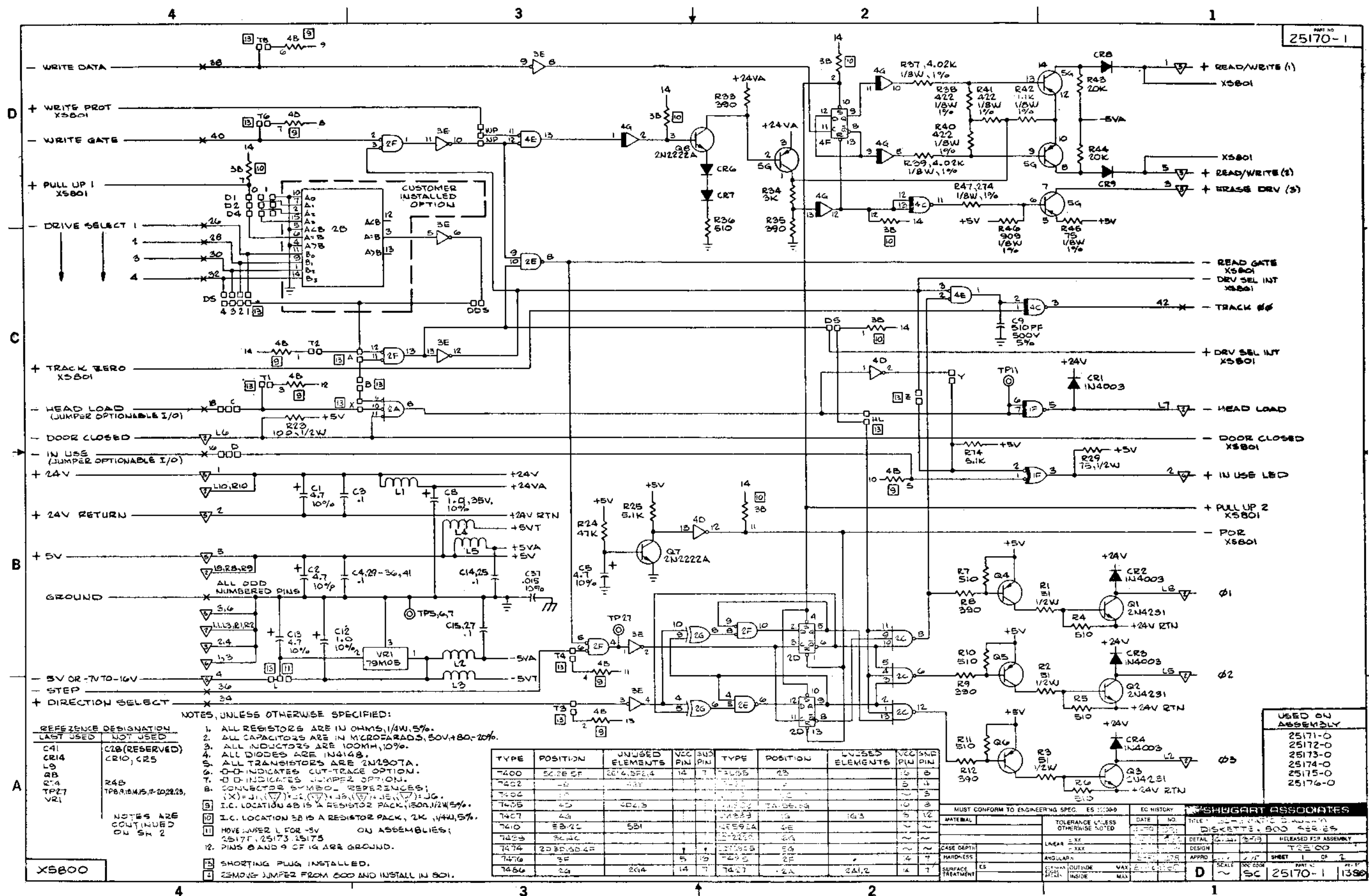

FIGURE 6-1. SCHEMATIC DIAGRAM, P/N 2510X (SHEET 1 OF 2)



- NOTES, (CONT'D FROM SHT 1.)
- 11 MOVE JUMPER L FOR 5V, ON ASSEMBLIES; 25102, 25104, 25106.
  - 12 PINS 8 AND 9 OF I6 ARE GROUND.
  - 13 SHORTING PLUG INSTALLED.
  - 14 REMOVE JUMPER FROM 800 AND INSTALL IN 801.
  - 15 90602 MAY BE USED WITH PROPER TIMING RESISTOR.
  - 16 C41 USED ON 25106-4 AND 25107-4 ONLY.

FIGURE 6-1. SCHEMATIC DIAGRAM, P/N 2510X (SHEET 2 OF 2)



REFERENCE DESIGNATION

LAST USED	NOT USED
C41	C28 (RESERVED)
CR14	CR10, CR5
L9	
RB	
RT4	
TP27	
VR1	

NOTES ARE CONTINUED ON SH 2

- NOTES, UNLESS OTHERWISE SPECIFIED:
1. ALL RESISTORS ARE IN OHMS, 1/4W, 5%.
  2. ALL CAPACITORS ARE IN MICROFARADS, 50V, ±20%.
  3. ALL INDUCTORS ARE 100MH, 10%.
  4. ALL DIODES ARE IN4148.
  5. ALL TRANSISTORS ARE 2N2904.
  6. -D- INDICATES CUT-TRACE OPTION.
  7. -D- INDICATES JUMPER OPTION.
  8. CONNECTOR SYMBOL REFERENCES: (X) = J1, (Y) = J2, (Z) = J3, (A) = J4, (B) = J5, (C) = J6, (D) = J7, (E) = J8, (F) = J9, (G) = J10, (H) = J11, (I) = J12, (J) = J13, (K) = J14, (L) = J15, (M) = J16, (N) = J17, (O) = J18, (P) = J19, (Q) = J20, (R) = J21, (S) = J22, (T) = J23, (U) = J24, (V) = J25, (W) = J26, (X) = J27, (Y) = J28, (Z) = J29, (A) = J30, (B) = J31, (C) = J32, (D) = J33, (E) = J34, (F) = J35, (G) = J36, (H) = J37, (I) = J38, (J) = J39, (K) = J40, (L) = J41, (M) = J42, (N) = J43, (O) = J44, (P) = J45, (Q) = J46, (R) = J47, (S) = J48, (T) = J49, (U) = J50, (V) = J51, (W) = J52, (X) = J53, (Y) = J54, (Z) = J55, (A) = J56, (B) = J57, (C) = J58, (D) = J59, (E) = J60, (F) = J61, (G) = J62, (H) = J63, (I) = J64, (J) = J65, (K) = J66, (L) = J67, (M) = J68, (N) = J69, (O) = J70, (P) = J71, (Q) = J72, (R) = J73, (S) = J74, (T) = J75, (U) = J76, (V) = J77, (W) = J78, (X) = J79, (Y) = J80, (Z) = J81, (A) = J82, (B) = J83, (C) = J84, (D) = J85, (E) = J86, (F) = J87, (G) = J88, (H) = J89, (I) = J90, (J) = J91, (K) = J92, (L) = J93, (M) = J94, (N) = J95, (O) = J96, (P) = J97, (Q) = J98, (R) = J99, (S) = J100, (T) = J101, (U) = J102, (V) = J103, (W) = J104, (X) = J105, (Y) = J106, (Z) = J107, (A) = J108, (B) = J109, (C) = J110, (D) = J111, (E) = J112, (F) = J113, (G) = J114, (H) = J115, (I) = J116, (J) = J117, (K) = J118, (L) = J119, (M) = J120, (N) = J121, (O) = J122, (P) = J123, (Q) = J124, (R) = J125, (S) = J126, (T) = J127, (U) = J128, (V) = J129, (W) = J130, (X) = J131, (Y) = J132, (Z) = J133, (A) = J134, (B) = J135, (C) = J136, (D) = J137, (E) = J138, (F) = J139, (G) = J140, (H) = J141, (I) = J142, (J) = J143, (K) = J144, (L) = J145, (M) = J146, (N) = J147, (O) = J148, (P) = J149, (Q) = J150, (R) = J151, (S) = J152, (T) = J153, (U) = J154, (V) = J155, (W) = J156, (X) = J157, (Y) = J158, (Z) = J159, (A) = J160, (B) = J161, (C) = J162, (D) = J163, (E) = J164, (F) = J165, (G) = J166, (H) = J167, (I) = J168, (J) = J169, (K) = J170, (L) = J171, (M) = J172, (N) = J173, (O) = J174, (P) = J175, (Q) = J176, (R) = J177, (S) = J178, (T) = J179, (U) = J180, (V) = J181, (W) = J182, (X) = J183, (Y) = J184, (Z) = J185, (A) = J186, (B) = J187, (C) = J188, (D) = J189, (E) = J190, (F) = J191, (G) = J192, (H) = J193, (I) = J194, (J) = J195, (K) = J196, (L) = J197, (M) = J198, (N) = J199, (O) = J200, (P) = J201, (Q) = J202, (R) = J203, (S) = J204, (T) = J205, (U) = J206, (V) = J207, (W) = J208, (X) = J209, (Y) = J210, (Z) = J211, (A) = J212, (B) = J213, (C) = J214, (D) = J215, (E) = J216, (F) = J217, (G) = J218, (H) = J219, (I) = J220, (J) = J221, (K) = J222, (L) = J223, (M) = J224, (N) = J225, (O) = J226, (P) = J227, (Q) = J228, (R) = J229, (S) = J230, (T) = J231, (U) = J232, (V) = J233, (W) = J234, (X) = J235, (Y) = J236, (Z) = J237, (A) = J238, (B) = J239, (C) = J240, (D) = J241, (E) = J242, (F) = J243, (G) = J244, (H) = J245, (I) = J246, (J) = J247, (K) = J248, (L) = J249, (M) = J250, (N) = J251, (O) = J252, (P) = J253, (Q) = J254, (R) = J255, (S) = J256, (T) = J257, (U) = J258, (V) = J259, (W) = J260, (X) = J261, (Y) = J262, (Z) = J263, (A) = J264, (B) = J265, (C) = J266, (D) = J267, (E) = J268, (F) = J269, (G) = J270, (H) = J271, (I) = J272, (J) = J273, (K) = J274, (L) = J275, (M) = J276, (N) = J277, (O) = J278, (P) = J279, (Q) = J280, (R) = J281, (S) = J282, (T) = J283, (U) = J284, (V) = J285, (W) = J286, (X) = J287, (Y) = J288, (Z) = J289, (A) = J290, (B) = J291, (C) = J292, (D) = J293, (E) = J294, (F) = J295, (G) = J296, (H) = J297, (I) = J298, (J) = J299, (K) = J300, (L) = J301, (M) = J302, (N) = J303, (O) = J304, (P) = J305, (Q) = J306, (R) = J307, (S) = J308, (T) = J309, (U) = J310, (V) = J311, (W) = J312, (X) = J313, (Y) = J314, (Z) = J315, (A) = J316, (B) = J317, (C) = J318, (D) = J319, (E) = J320, (F) = J321, (G) = J322, (H) = J323, (I) = J324, (J) = J325, (K) = J326, (L) = J327, (M) = J328, (N) = J329, (O) = J330, (P) = J331, (Q) = J332, (R) = J333, (S) = J334, (T) = J335, (U) = J336, (V) = J337, (W) = J338, (X) = J339, (Y) = J340, (Z) = J341, (A) = J342, (B) = J343, (C) = J344, (D) = J345, (E) = J346, (F) = J347, (G) = J348, (H) = J349, (I) = J350, (J) = J351, (K) = J352, (L) = J353, (M) = J354, (N) = J355, (O) = J356, (P) = J357, (Q) = J358, (R) = J359, (S) = J360, (T) = J361, (U) = J362, (V) = J363, (W) = J364, (X) = J365, (Y) = J366, (Z) = J367, (A) = J368, (B) = J369, (C) = J370, (D) = J371, (E) = J372, (F) = J373, (G) = J374, (H) = J375, (I) = J376, (J) = J377, (K) = J378, (L) = J379, (M) = J380, (N) = J381, (O) = J382, (P) = J383, (Q) = J384, (R) = J385, (S) = J386, (T) = J387, (U) = J388, (V) = J389, (W) = J390, (X) = J391, (Y) = J392, (Z) = J393, (A) = J394, (B) = J395, (C) = J396, (D) = J397, (E) = J398, (F) = J399, (G) = J400, (H) = J401, (I) = J402, (J) = J403, (K) = J404, (L) = J405, (M) = J406, (N) = J407, (O) = J408, (P) = J409, (Q) = J410, (R) = J411, (S) = J412, (T) = J413, (U) = J414, (V) = J415, (W) = J416, (X) = J417, (Y) = J418, (Z) = J419, (A) = J420, (B) = J421, (C) = J422, (D) = J423, (E) = J424, (F) = J425, (G) = J426, (H) = J427, (I) = J428, (J) = J429, (K) = J430, (L) = J431, (M) = J432, (N) = J433, (O) = J434, (P) = J435, (Q) = J436, (R) = J437, (S) = J438, (T) = J439, (U) = J440, (V) = J441, (W) = J442, (X) = J443, (Y) = J444, (Z) = J445, (A) = J446, (B) = J447, (C) = J448, (D) = J449, (E) = J450, (F) = J451, (G) = J452, (H) = J453, (I) = J454, (J) = J455, (K) = J456, (L) = J457, (M) = J458, (N) = J459, (O) = J460, (P) = J461, (Q) = J462, (R) = J463, (S) = J464, (T) = J465, (U) = J466, (V) = J467, (W) = J468, (X) = J469, (Y) = J470, (Z) = J471, (A) = J472, (B) = J473, (C) = J474, (D) = J475, (E) = J476, (F) = J477, (G) = J478, (H) = J479, (I) = J480, (J) = J481, (K) = J482, (L) = J483, (M) = J484, (N) = J485, (O) = J486, (P) = J487, (Q) = J488, (R) = J489, (S) = J490, (T) = J491, (U) = J492, (V) = J493, (W) = J494, (X) = J495, (Y) = J496, (Z) = J497, (A) = J498, (B) = J499, (C) = J500, (D) = J501, (E) = J502, (F) = J503, (G) = J504, (H) = J505, (I) = J506, (J) = J507, (K) = J508, (L) = J509, (M) = J510, (N) = J511, (O) = J512, (P) = J513, (Q) = J514, (R) = J515, (S) = J516, (T) = J517, (U) = J518, (V) = J519, (W) = J520, (X) = J521, (Y) = J522, (Z) = J523, (A) = J524, (B) = J525, (C) = J526, (D) = J527, (E) = J528, (F) = J529, (G) = J530, (H) = J531, (I) = J532, (J) = J533, (K) = J534, (L) = J535, (M) = J536, (N) = J537, (O) = J538, (P) = J539, (Q) = J540, (R) = J541, (S) = J542, (T) = J543, (U) = J544, (V) = J545, (W) = J546, (X) = J547, (Y) = J548, (Z) = J549, (A) = J550, (B) = J551, (C) = J552, (D) = J553, (E) = J554, (F) = J555, (G) = J556, (H) = J557, (I) = J558, (J) = J559, (K) = J560, (L) = J561, (M) = J562, (N) = J563, (O) = J564, (P) = J565, (Q) = J566, (R) = J567, (S) = J568, (T) = J569, (U) = J570, (V) = J571, (W) = J572, (X) = J573, (Y) = J574, (Z) = J575, (A) = J576, (B) = J577, (C) = J578, (D) = J579, (E) = J580, (F) = J581, (G) = J582, (H) = J583, (I) = J584, (J) = J585, (K) = J586, (L) = J587, (M) = J588, (N) = J589, (O) = J590, (P) = J591, (Q) = J592, (R) = J593, (S) = J594, (T) = J595, (U) = J596, (V) = J597, (W) = J598, (X) = J599, (Y) = J600, (Z) = J601, (A) = J602, (B) = J603, (C) = J604, (D) = J605, (E) = J606, (F) = J607, (G) = J608, (H) = J609, (I) = J610, (J) = J611, (K) = J612, (L) = J613, (M) = J614, (N) = J615, (O) = J616, (P) = J617, (Q) = J618, (R) = J619, (S) = J620, (T) = J621, (U) = J622, (V) = J623, (W) = J624, (X) = J625, (Y) = J626, (Z) = J627, (A) = J628, (B) = J629, (C) = J630, (D) = J631, (E) = J632, (F) = J633, (G) = J634, (H) = J635, (I) = J636, (J) = J637, (K) = J638, (L) = J639, (M) = J640, (N) = J641, (O) = J642, (P) = J643, (Q) = J644, (R) = J645, (S) = J646, (T) = J647, (U) = J648, (V) = J649, (W) = J650, (X) = J651, (Y) = J652, (Z) = J653, (A) = J654, (B) = J655, (C) = J656, (D) = J657, (E) = J658, (F) = J659, (G) = J660, (H) = J661, (I) = J662, (J) = J663, (K) = J664, (L) = J665, (M) = J666, (N) = J667, (O) = J668, (P) = J669, (Q) = J670, (R) = J671, (S) = J672, (T) = J673, (U) = J674, (V) = J675, (W) = J676, (X) = J677, (Y) = J678, (Z) = J679, (A) = J680, (B) = J681, (C) = J682, (D) = J683, (E) = J684, (F) = J685, (G) = J686, (H) = J687, (I) = J688, (J) = J689, (K) = J690, (L) = J691, (M) = J692, (N) = J693, (O) = J694, (P) = J695, (Q) = J696, (R) = J697, (S) = J698, (T) = J699, (U) = J700, (V) = J701, (W) = J702, (X) = J703, (Y) = J704, (Z) = J705, (A) = J706, (B) = J707, (C) = J708, (D) = J709, (E) = J710, (F) = J711, (G) = J712, (H) = J713, (I) = J714, (J) = J715, (K) = J716, (L) = J717, (M) = J718, (N) = J719, (O) = J720, (P) = J721, (Q) = J722, (R) = J723, (S) = J724, (T) = J725, (U) = J726, (V) = J727, (W) = J728, (X) = J729, (Y) = J730, (Z) = J731, (A) = J732, (B) = J733, (C) = J734, (D) = J735, (E) = J736, (F) = J737, (G) = J738, (H) = J739, (I) = J740, (J) = J741, (K) = J742, (L) = J743, (M) = J744, (N) = J745, (O) = J746, (P) = J747, (Q) = J748, (R) = J749, (S) = J750, (T) = J751, (U) = J752, (V) = J753, (W) = J754, (X) = J755, (Y) = J756, (Z) = J757, (A) = J758, (B) = J759, (C) = J760, (D) = J761, (E) = J762, (F) = J763, (G) = J764, (H) = J765, (I) = J766, (J) = J767, (K) = J768, (L) = J769, (M) = J770, (N) = J771, (O) = J772, (P) = J773, (Q) = J774, (R) = J775, (S) = J776, (T) = J777, (U) = J778, (V) = J779, (W) = J780, (X) = J781, (Y) = J782, (Z) = J783, (A) = J784, (B) = J785, (C) = J786, (D) = J787, (E) = J788, (F) = J789, (G) = J790, (H) = J791, (I) = J792, (J) = J793, (K) = J794, (L) = J795, (M) = J796, (N) = J797, (O) = J798, (P) = J799, (Q) = J800, (R) = J801, (S) = J802, (T) = J803, (U) = J804, (V) = J805, (W) = J806, (X) = J807, (Y) = J808, (Z) = J809, (A) = J810, (B) = J811, (C) = J812, (D) = J813, (E) = J814, (F) = J815, (G) = J816, (H) = J817, (I) = J818, (J) = J819, (K) = J820, (L) = J821, (M) = J822, (N) = J823, (O) = J824, (P) = J825, (Q) = J826, (R) = J827, (S) = J828, (T) = J829, (U) = J830, (V) = J831, (W) = J832, (X) = J833, (Y) = J834, (Z) = J835, (A) = J836, (B) = J837, (C) = J838, (D) = J839, (E) = J840, (F) = J841, (G) = J842, (H) = J843, (I) = J844, (J) = J845, (K) = J846, (L) = J847, (M) = J848, (N) = J849, (O) = J850, (P) = J851, (Q) = J852, (R) = J853, (S) = J854, (T) = J855, (U) = J856, (V) = J857, (W) = J858, (X) = J859, (Y) = J860, (Z) = J861, (A) = J862, (B) = J863, (C) = J864, (D) = J865, (E) = J866, (F) = J867, (G) = J868, (H) = J869, (I) = J870, (J) = J871, (K) = J872, (L) = J873, (M) = J874, (N) = J875, (O) = J876, (P) = J877, (Q) = J878, (R) = J879, (S) = J880, (T) = J881, (U) = J882, (V) = J883, (W) = J884, (X) = J885, (Y) = J886, (Z) = J887, (A) = J888, (B) = J889, (C) = J890, (D) = J891, (E) = J892, (F) = J893, (G) = J894, (H) = J895, (I) = J896, (J) = J897, (K) = J898, (L) = J899, (M) = J900, (N) = J901, (O) = J902, (P) = J903, (Q) = J904, (R) = J905, (S) = J906, (T) = J907, (U) = J908, (V) = J909, (W) = J910, (X) = J911, (Y) = J912, (Z) = J913, (A) = J914, (B) = J915, (C) = J916, (D) = J917, (E) = J918, (F) = J919, (G) = J920, (H) = J921, (I) = J922, (J) = J923, (K) = J924, (L) = J925, (M) = J926, (N) = J927, (O) = J928, (P) = J929, (Q) = J930, (R) = J931, (S) = J932, (T) = J933, (U) = J934, (V) = J935, (W) = J936, (X) = J937, (Y) = J938, (Z) = J939, (A) = J940, (B) = J941, (C) = J942, (D) = J943, (E) = J944, (F) = J945, (G) = J946, (H) = J947, (I) = J948, (J) = J949, (K) = J950, (L) = J951, (M) = J952, (N) = J953, (O) = J954, (P) = J955, (Q) = J956, (R) = J957, (S) = J958, (T) = J959, (U) = J960, (V) = J961, (W) = J962, (X) = J963, (Y) = J964, (Z) = J965, (A) = J966, (B) = J967, (C) = J968, (D) = J969, (E) = J970, (F) = J971, (G) = J972, (H) = J973, (I) = J974, (J) = J975, (K) = J976, (L) = J977, (M) = J978, (N) = J979, (O) = J980, (P) = J981, (Q) = J982, (R) = J983, (S) = J984, (T) = J985, (U) = J986, (V) = J987, (W) = J988, (X) = J989, (Y) = J990, (Z) = J991, (A) = J992, (B) = J993, (C) = J994, (D) = J995, (E) = J996, (F) = J997, (G) = J998, (H) = J999, (I) = J1000, (J) = J1001, (K) = J1002, (L) = J1003, (M) = J1004, (N) = J1005, (O) = J1006, (P) = J1007, (Q) = J1008, (R) = J1009, (S) = J1010, (T) = J1011, (U) = J1012, (V) = J1013, (W) = J1014, (X) = J1015, (Y) = J1016, (Z) = J1017, (A) = J1018, (B) = J1019, (C) = J1020, (D) = J1021, (E) = J1022, (F) = J1023, (G) = J1024, (H) = J1025, (I) = J1026, (J) = J1027, (K) = J1028, (L) = J1029, (M) = J1030, (N) = J1031, (O) = J1032, (P) = J1033, (Q) = J1034, (R) = J1035, (S) = J1036, (T) = J1037, (U) = J1038, (V) = J1039, (W) = J1040, (X) = J1041, (Y) = J1042, (Z) = J1043, (A) = J1044, (B) = J1045, (C) = J1046, (D) = J1047, (E) = J1048, (F) = J1049, (G) = J1050, (H) = J1051, (I) = J1052, (J) = J1053, (K) = J1054, (L) = J1055, (M) = J1056, (N) = J1057, (O) = J1058, (P) = J1059, (Q) = J1060, (R) = J1061, (S) = J1062, (T) = J1063, (U) = J1064, (V) = J1065, (W) = J1066, (X) = J1067, (Y) = J1068, (Z) = J1069, (A) = J1070, (B) = J1071, (C) = J1072, (D) = J1073, (E) = J1074, (F) = J1075, (G) = J1076, (H) = J1077, (I) = J1078, (J) = J1079, (K) = J1080, (L) = J1081, (M) = J1082, (N) = J1083, (O) = J1084, (P) = J1085, (Q) = J1086, (R) = J1087, (S) = J1088, (T) = J1089, (U) = J1090, (V) = J1091, (W) = J1092, (X) = J1093, (Y) = J1094, (Z) = J1095, (A) = J1096, (B) = J1097, (C) = J1098, (D) = J1099, (E) = J1100, (F) = J1101, (G) = J1102, (H) = J1103, (I) = J1104, (J) = J1105, (K) = J1106, (L) = J1107, (M) = J1108, (N) = J1109, (O) = J1110, (P) = J1111, (Q) = J1112, (R) = J1113, (S) = J1114, (T) = J1115, (U) = J1116, (V) = J1117, (W) = J1118, (X) = J1119, (Y) = J1120, (Z) = J1121, (A) = J1122, (B) = J1123, (C) = J1124, (D) = J1125, (E) = J1126, (F) = J1127, (G) = J1128, (H) = J1129, (I) = J1130, (J) = J1131, (K) = J1132, (L) = J1133, (M) = J1134, (N) = J1135, (O) = J1136, (P) = J1137, (Q) = J1138, (R) = J1139, (S) = J1140, (T) = J1141, (U) = J1142, (V) = J1143, (W) = J1144, (X) = J1145, (Y) = J1146, (Z) = J1147, (A) = J1148, (B) = J1149, (C) = J1150, (D) = J1151, (E) = J1152, (F) = J1153, (G) = J1154, (H) = J1155, (I) = J1156, (J) = J1157, (K) = J1158, (L) = J1159, (M) = J1160, (N) = J1161, (O) = J1162, (P) = J1163, (Q) = J1164, (R) = J1165, (S) = J1166, (T) = J1167, (U) = J1168, (V) = J1169, (W) = J1170, (X) = J1171, (Y) = J1172, (Z) = J1173, (A) = J1174, (B) = J1175, (C) = J1176, (D) = J1177, (E) = J1178, (F) = J1179, (G) = J1180, (H) = J1181, (I) = J1182, (J) = J1183, (K) = J1184, (L) = J1185, (M) = J1186, (N) = J1187, (O) = J1188, (P) = J1189, (Q) = J1190, (R) = J1191, (S) = J1192, (T) = J1193, (U) = J1194, (V) = J1195, (W) = J1196, (X) = J1197, (Y) = J1198, (Z) = J1199, (A) = J1200, (B) = J1201, (C) = J1202, (D) = J1203, (E) = J1204, (F) = J1205, (G) = J1206, (H) = J1207, (I) = J1208, (J) = J1209, (K) = J1210, (L) = J1211, (M) = J1212, (N) = J1213, (O) = J1214, (P) = J1215, (Q) = J1216, (R) = J1217, (S) = J1218, (T) = J1219, (U) = J1220, (V) = J1221, (W) = J1222, (X) = J1223, (Y) = J1224, (Z) = J1225, (A) = J1226, (B) = J1227, (C) = J1228, (D) = J1229, (E) = J1230, (F) = J1231, (G) = J1232, (H) = J1233, (I) = J1234, (J) = J1235, (K) = J1236, (L) = J1237, (M) = J1238, (N) = J1239, (O) = J1240, (P) = J1241, (Q) = J1242, (R) = J1243, (S) = J1244, (T) = J1245, (U) = J1246, (V) = J1247, (W) = J1248, (X) = J1249, (Y) = J1250, (Z) = J1251, (A) = J1252, (B) = J1253, (C) = J1254, (D) = J1255, (E) = J1256, (F) = J1257, (G) = J1258, (H) = J1259, (I) = J1260, (J) = J1261, (K) = J1262, (L) = J1263, (M) = J1264, (N) = J1265, (O) = J1266, (P) = J1267, (Q) = J1268, (R) = J1269, (S) = J1270, (T) = J1271, (U) = J1272, (V) = J1273,

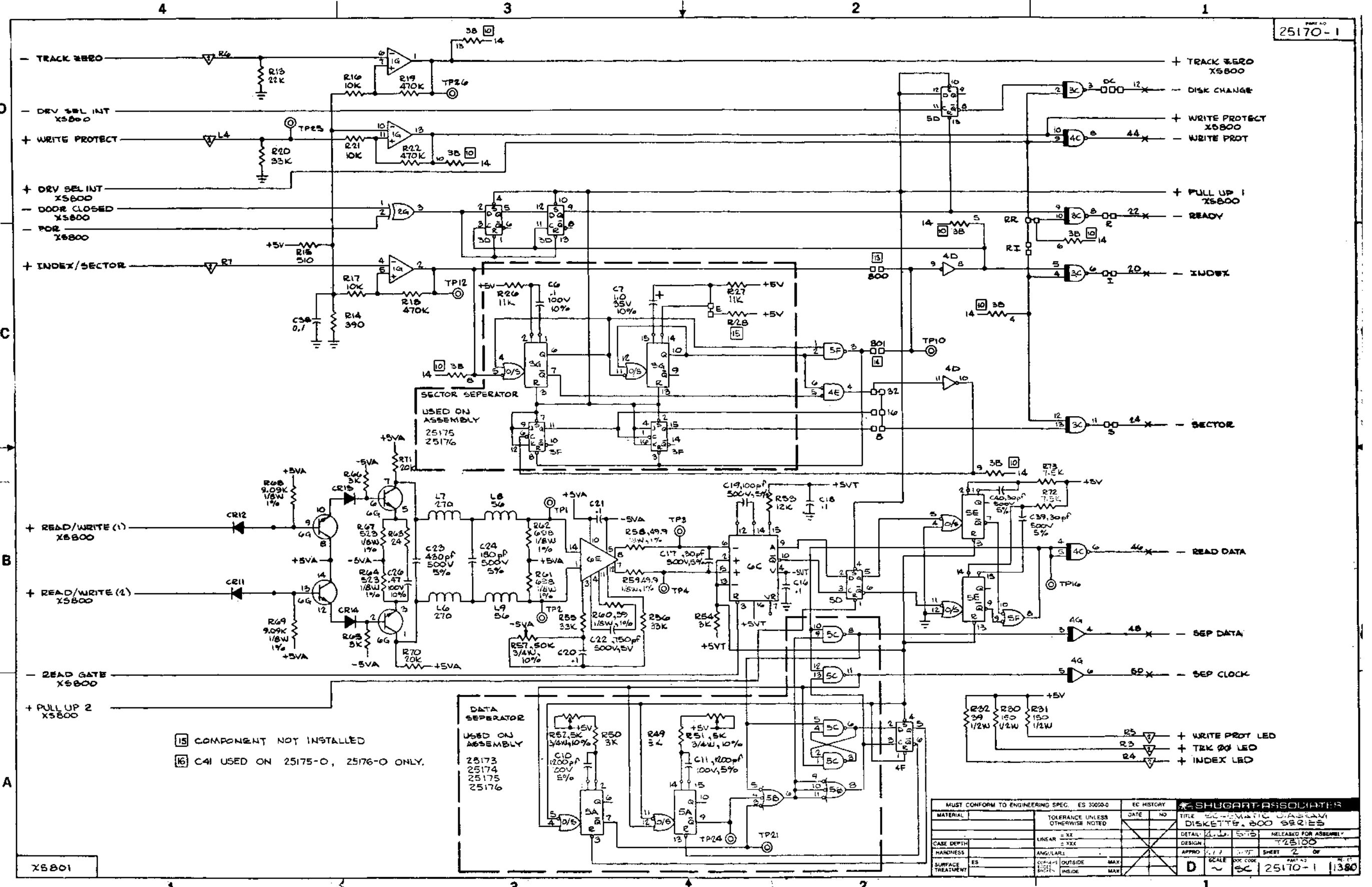
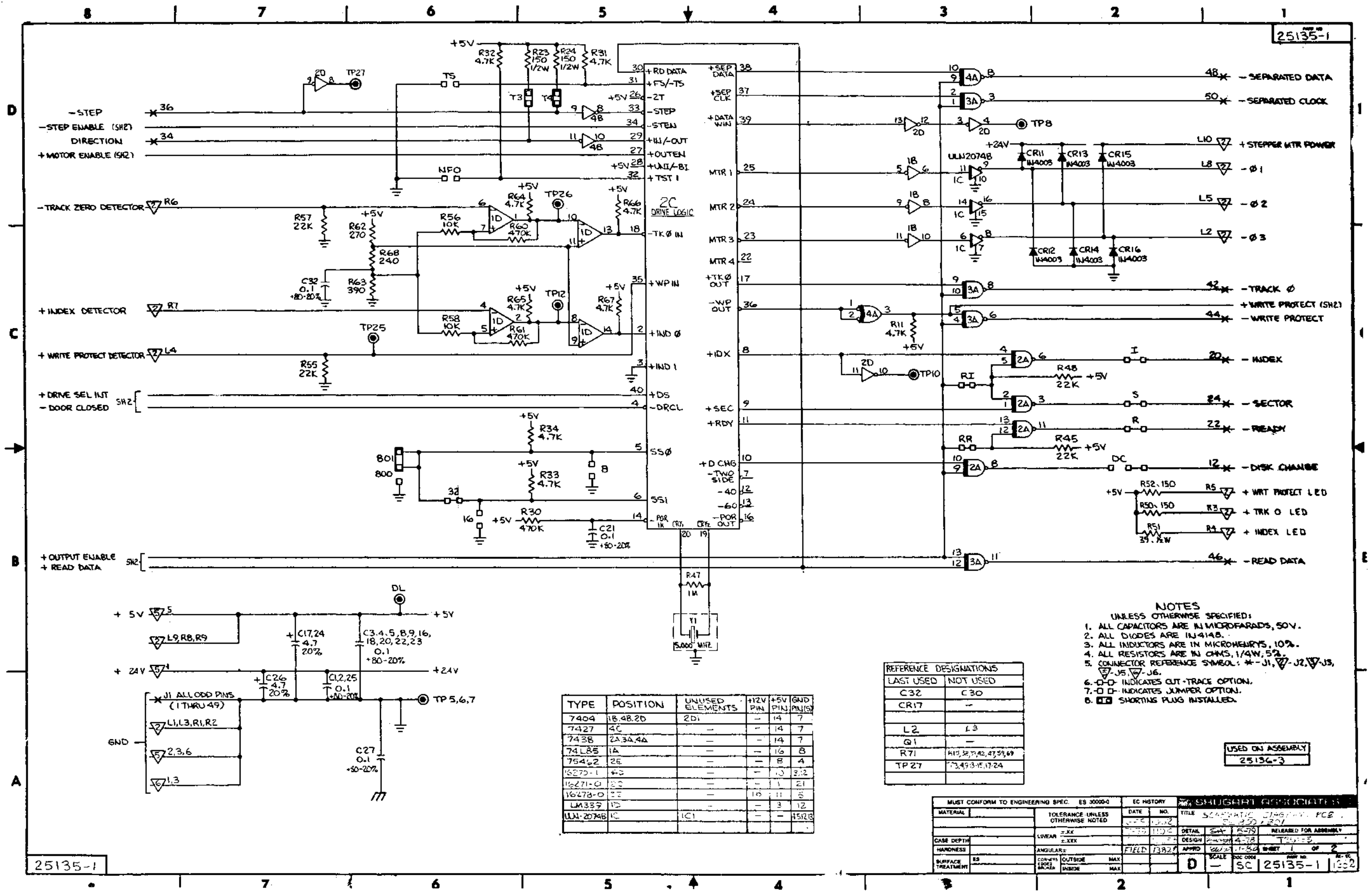

FIGURE 6-2. SCHEMATIC DIAGRAM, P/N 2517X (SHEET 2 OF 2)



25135-1

- NOTES**  
 UNLESS OTHERWISE SPECIFIED:  
 1. ALL CAPACITORS ARE IN MICROFARADS, SOV.  
 2. ALL DIODES ARE 1N4148.  
 3. ALL INDUCTORS ARE IN MICROHENRYS, 10%  
 4. ALL RESISTORS ARE IN OHMS, 1/4W, 5%  
 5. CONNECTOR REFERENCE SYMBOL: \*-J1, ▽-J2, ▽-J3, ▽-J5, ▽-J6.  
 6. -D-D- INDICATES CUT-TRACE OPTION.  
 7. -D-D- INDICATES JUMPER OPTION.  
 8. □ SHORTING PLUG INSTALLED.

**REFERENCE DESIGNATIONS**

LAST USED	NOT USED
C32	C30
CR17	-
L2	L3
Q1	-
R71	R15, R2, R42, 47, 59, 69
TP27	T3, 49, 51, 17, 24

TYPE	POSITION	UNUSED ELEMENTS	+12V PIN	+5V PIN	GND PIN(S)
7404	1B, 4B, 2D	2D1	-	14	7
7427	4C	-	-	14	7
7438	2A, 3A, 4A	-	-	14	7
74L85	1A	-	-	16	8
75462	2E	-	-	8	4
15272-1	6D	-	-	13	3, 12
15271-0	8C	-	-	1	21
16478-0	2E	-	-	16	11, 8
LM339	1D	-	-	3	12
ULN2074B	1C	1C1	-	-	15, 18

USED ON ASSEMBLY  
25136-3

MUST CONFORM TO ENGINEERING SPEC. ES 30000-0		EC HISTORY		SHUGART ASSOCIATES	
MATERIAL	TOLERANCE UNLESS OTHERWISE NOTED	DATE	NO.	TITLE	SCHEMATIC DIAGRAM PCB
CASE DEPTH	LINEAR Z-XXX	11/82	11/82	DETAIL	5-75 RELEASED FOR ASSEMBLY
HARDNESS	ANGULAR	FIELD	13827	DESIGN	4-78 TR-5
SURFACE TREATMENT	CONFORMS TO SPEC	OUTSIDE	MAX	APPD	1-83
		INSIDE	MAX	SCALE	1:1
				DOC CODE	SC 25135-1
				REV NO.	1 of 2

FIGURE 6-3. SCHEMATIC DIAGRAM, P/N 25136 (SHEET 1 OF 2)

6-11/6-12 (blank)

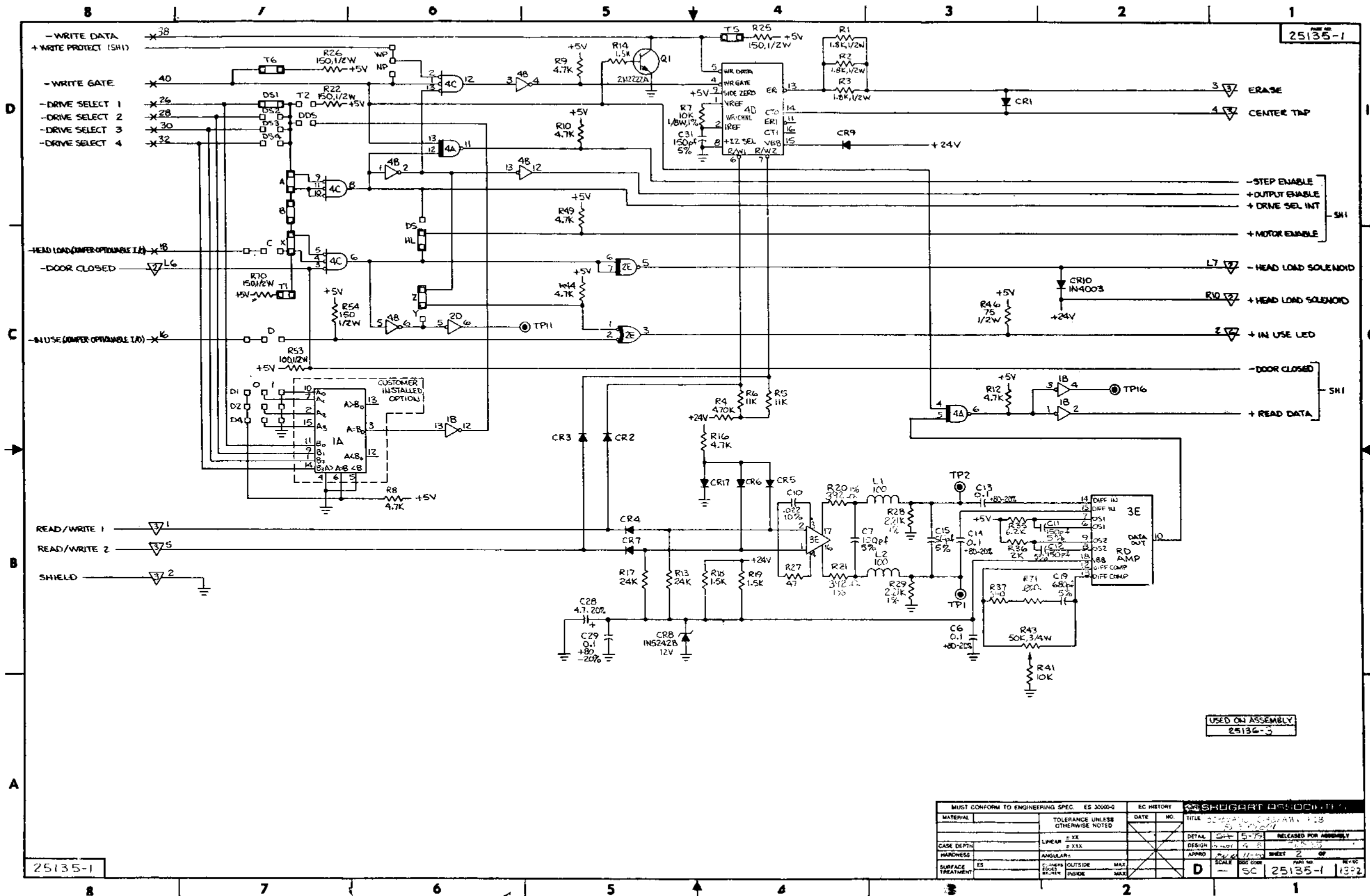
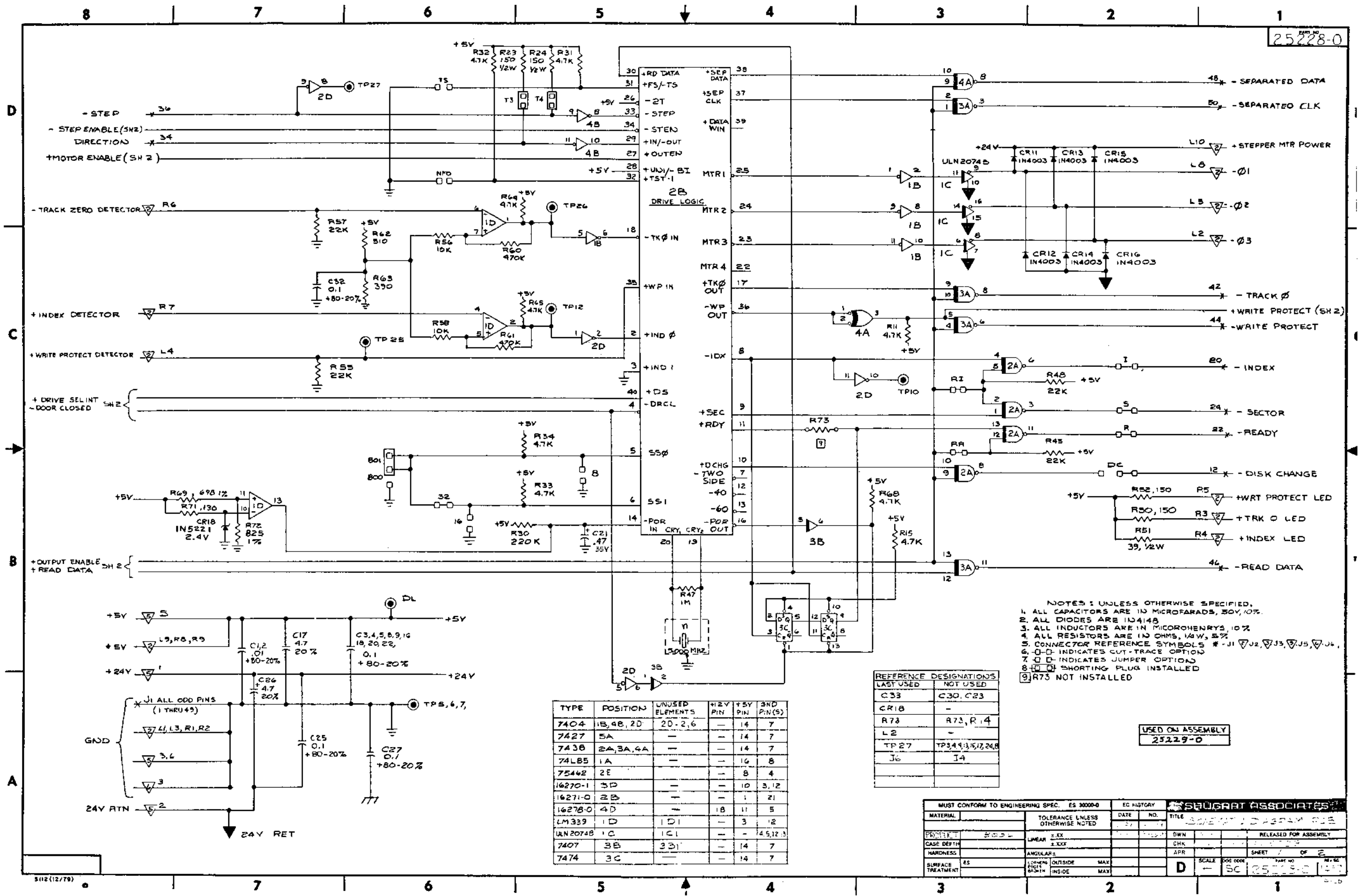

FIGURE 6-3. SCHEMATIC DIAGRAM, P/N 25136 (SHEET 2 OF 2)





25228-0

- NOTES: UNLESS OTHERWISE SPECIFIED,  
 1. ALL CAPACITORS ARE IN MICROFARADS, 50V, 10%.  
 2. ALL DIODES ARE 1N4148.  
 3. ALL INDUCTORS ARE IN MICRORHENRYS, 10%.  
 4. ALL RESISTORS ARE IN OHMS, 1/4W, 5%.  
 5. CONNECTOR REFERENCE SYMBOLS \* J1, J2, J3, J5, J4.  
 6. -O-O- INDICATES CUT-TRACE OPTION.  
 7. -O-D- INDICATES JUMPER OPTION.  
 8. -O-D- INDICATES SHORTING PLUG INSTALLED.  
 9. R73 NOT INSTALLED.

REFERENCE DESIGNATIONS	
LAST USED	NOT USED
C33	C30, C23
CR18	-
R73	R73, R14
L2	-
TP27	TP34, 33, 35, 12, 24, 8
J6	J4

USED ON ASSEMBLY  
25229-0

TYPE	POSITION	UNUSED ELEMENTS	+12V PIN	+5V PIN	3RD PIN(S)
7404	1B, 9B, 2D	20, 2, 6	-	14	7
7427	5A	-	-	14	7
7438	2A, 3A, 4A	-	-	14	7
74LS5	1A	-	-	14	8
75442	2E	-	-	8	4
16270-1	3D	-	-	10	3, 12
16271-0	2B	-	-	1	21
16278-0	4D	-	-	18	11, 5
LM339	1D	1D1	-	3	12
ULN2074B	1C	1C1	-	-	4, 5, 12, 13
7407	3B	3B1	-	14	7
7474	3C	-	-	14	7

MUST CONFORM TO ENGINEERING SPEC. ES 3000-0		EC HISTORY		SEUGART ASSOCIATES	
MATERIAL	TOLERANCE UNLESS OTHERWISE NOTED	DATE	NO.	TITLE	RELEASED FOR ASSEMBLY
PROJECT	503-			SCHEMATIC DIAGRAM P18	
CASE DEPTH	LINEAR ±.XXX			CHK	
HARDNESS	ANGULAR ±.XXX			APR	
SURFACE TREATMENT	CORNERS ±.XXX OUTSIDE MAX ±.XXX INSIDE MAX			SCALE	

FIGURE 6-4. SCHEMATIC DIAGRAM, P/N 25229 (SHEET 1 OF 2)  
6-15/6-16 (blank)

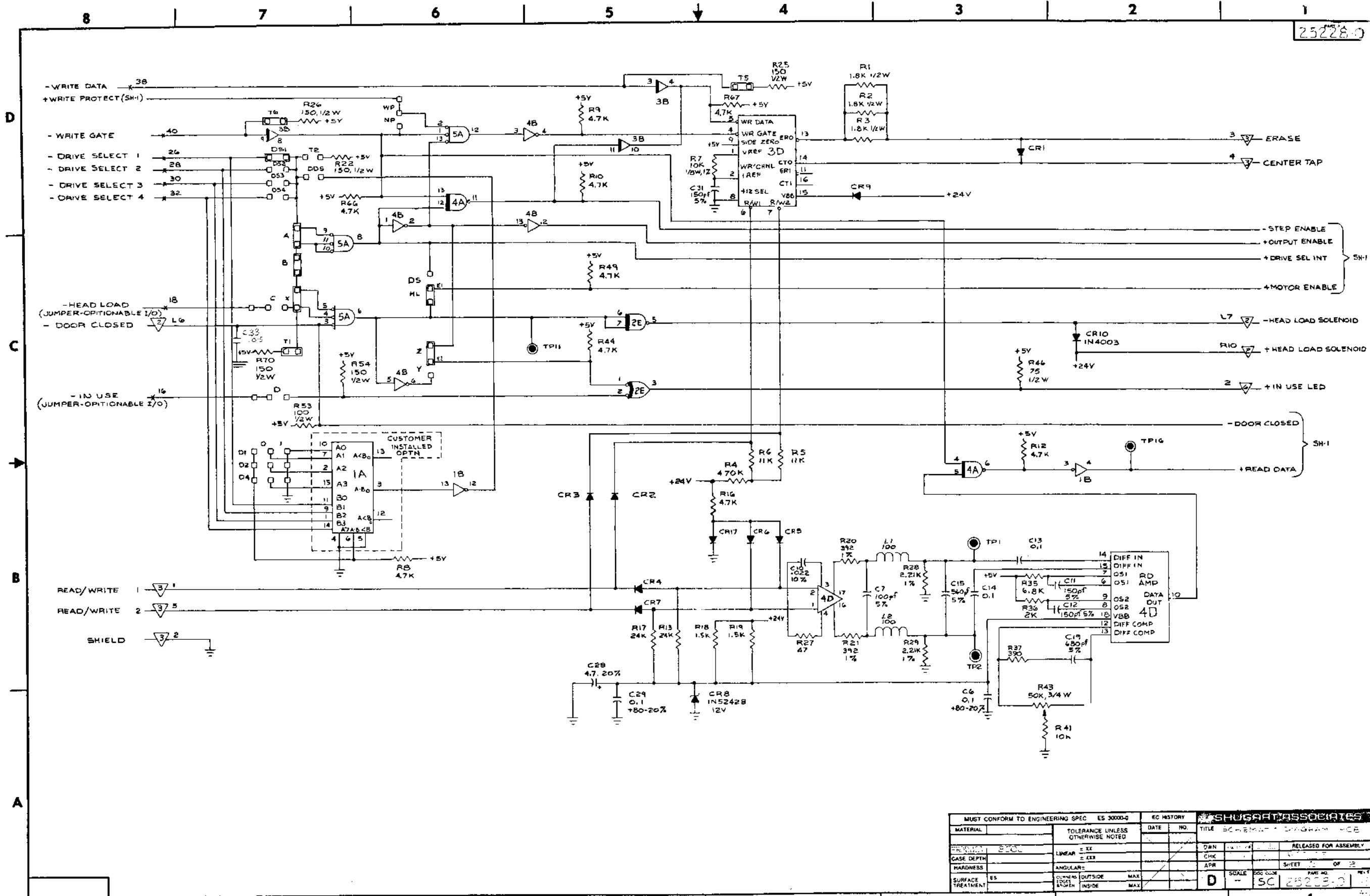
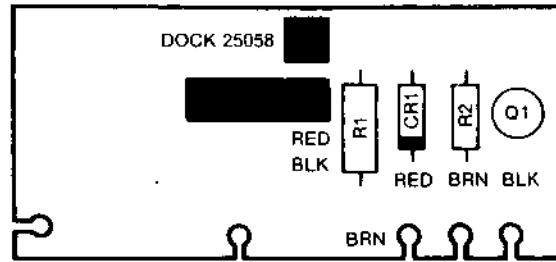
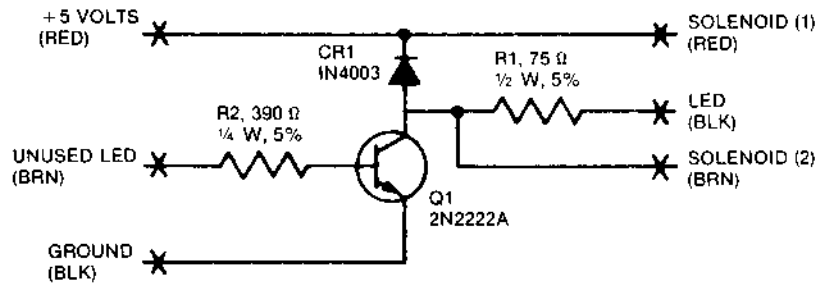

FIGURE 6-4. SCHEMATIC DIAGRAM, P/N 25229 (SHEET 2 OF 2)

6-17/6-18 (blank)



39025-32

FIGURE 6-5. DOOR LOCK SCHEMATIC



## **SECTION VII**

### **ILLUSTRATED PARTS CATALOG**

#### **7.1 DESCRIPTION**

The Illustrated Parts Catalog (IPC) is arranged so that the figure will always precede the parts listing and, when possible, will appear directly above the parts list or on the left hand page immediately preceding it.

The first number in the list will always refer to the figure number. The second number will refer to the reference number or the part within the figure.

Part numbers enclosed in parentheses refer to parts belonging to a Next Higher Assembly (NHA) and are of importance only to those customers with alternate assemblies. Following the descriptions of these parts, the designation NHA P/N \_\_\_\_\_ gives the part number of the assembly to which they pertain. When applicable to the customer's assembly, these alternate parts will be used in lieu of the part listed directly above them. Assume that the quantity per assembly for these alternate parts is the same unless otherwise listed.

When an assembly is referred to within a figure and a further breakdown is shown in another figure, then the referenced figure will be called out.

#### **7.2 INDENTED LEVEL**

The parts list is indented to show the levels of assembly within a figure. The major assembly will always be unindented. All parts or assemblies that attach to the assembly will be indented one space. Parts within these assemblies will be indented two spaces and so on.

#### **7.3 QUANTITY PER ASSEMBLY**

The quantity listed is the quantity used on the major assembly. Major assemblies themselves will never have a quantity listed.

#### **7.4 DOOR LOCK**

For door lock parts, see figure 6-5.



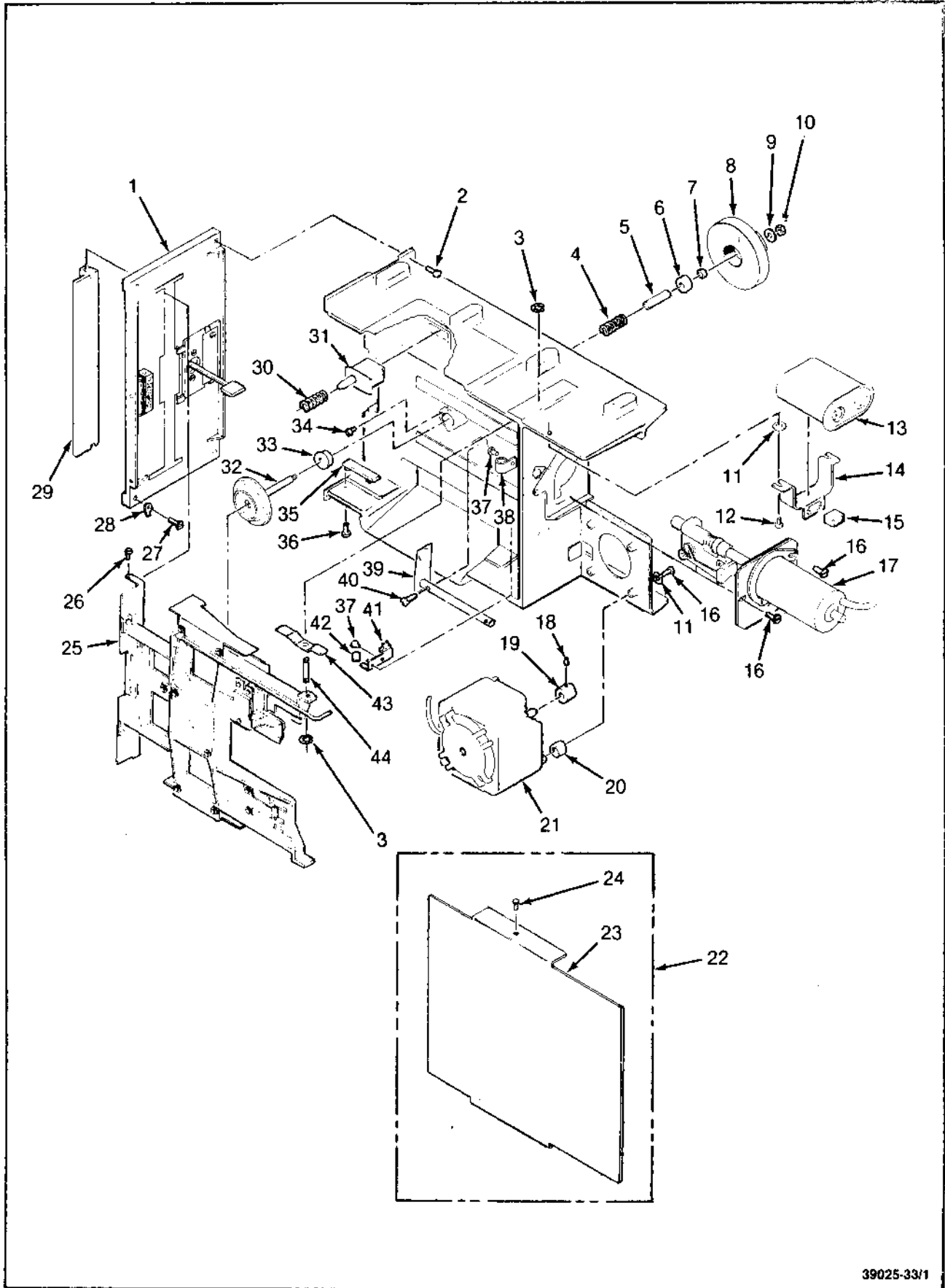

39025-33/1

FIGURE 7-1. DRIVE ASSEMBLY SA800/801 EXPLODED VIEW (SHEET 1 OF 2)

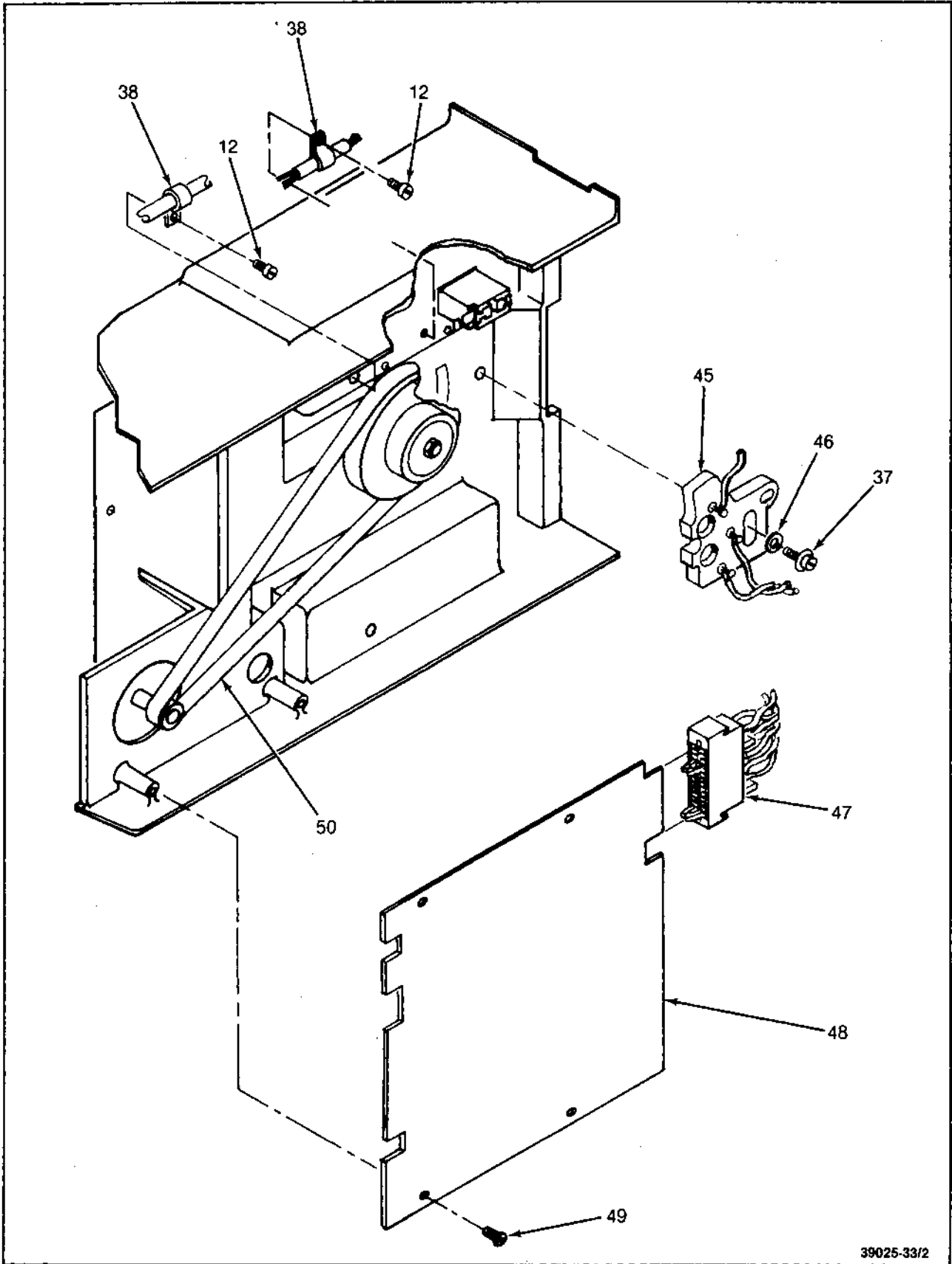

39025-33/2

FIGURE 7-1. DRIVE ASSEMBLY SA800/801 EXPLODED VIEW (SHEET 2 OF 2)



## DRIVE ASSEMBLY

FIGURE & REF NUMBER	PART NUMBER	DESCRIPTION	QTY PER ASM
1-		DRIVE ASSEMBLY SA800/801	
1		. FRONT PLATE ASSEMBLY (see figure 7-4)	1
2	12011	. SCREW, 4-40 × .250	1
3	11305	. CLIP	2
4	50166	. SPRING, Spindle	1
5	51231	. SPACER, Spindle-long	1
6	10800	. BEARING, Spindle	1
7	50019	. SPACER, Spindle-Short	1
8	50016	. PULLEY ASSEMBLY, Spindle	1
9	12509	. WASHER, Spring, #8	2
10	10025	. NUT, 8-32	1
11	12500	. WASHER, LOCK #8	6
12	12015	. SCREW, 8-32 × .312	4
13	15110	. CAPACITOR, AC Motor Run	1
14	50098	. BRACKET	1
15	10150	. HOUSING, (AMP P/N 1-480305-0)	1
16	12028	. SCREW, 8-32 × .750	8
17		. STEPPER/CARRIAGE ASSEMBLY (see fig. 7-2)	1
18	11904	. SCREW, Set 6-32 × .125	1
19	50358	. PULLEY, 60 Hz	1
	50357	. PULLEY, 50 Hz	1
20	50602	. SPACER	4
21	50443	. MOTOR 110 V, 50/60 Hz Kit	1
	50444	. MOTOR, 208/230/220 V, 50/60 Hz	1
22	50440	. DUST COVER KIT (Optional)	1
23	12023	. . SCREW, Thd. Form, Pan Hd.	2
24	50009	. . COVER	1
25	50550	. CARTRIDGE GUIDE ASSEMBLY (see fig. 7-3)	1
26	11928	. SCREW, Hex Head 4-40 × .250	2
27	12036	. SCREW, 8-32 × .438	3
	12139	. SCREW, 6-32 × .250 (SA800R)	2
28	50669	. CLIP, FACEPLATE MOUNT (SA800R)	2
29	50142	. HANDLE	1
30	50583	. SPRING, Door Open	1
31	17200	. SWITCH, Door Open	1
32	50561	. HUB ASSEMBLY Spindle	1
33	10801	. FLANGED BEARING, Spindle	1
34	12011	. SCREW, 4-40 × .250	1
35	50559	. DEFLECTOR	2
36	12032	. SCREW, 8-32 × .50	2
37	12013	. SCREW, 6-32 × .312	11
38	10426	. CABLE CLAMP, 1/8 Inch	4
39	50522	. SPRING/GUIDE ASSEMBLY	1
40	12012	. SCREW 4-40 × .375	2
41	50121	. DETECTOR ASSEMBLY, Track 00	1
42	50578	. HEAD CABLE GROMMET	1
43	50168	. SPRING, Bias	1
44	50167	. PIVOT TOP	1
	50670	. PIVOT TOP (Standard) (800R)	1
45	50128	. PHOTOTRANSISTOR AND CABLE ASSEMBLY	1
46	10014	. WASHER, #8 Flat	1
47	17701	. HOUSING CONNECTOR	2
48	25136	. PCB ASSEMBLY, 800/801 LSI	1
49	12014	. SCREW, Thd Frm, Hex Hd. 6-32 × .375	4
50	50356	. BELT (60 Hz)	1
	50355	. BELT (50 Hz)	1

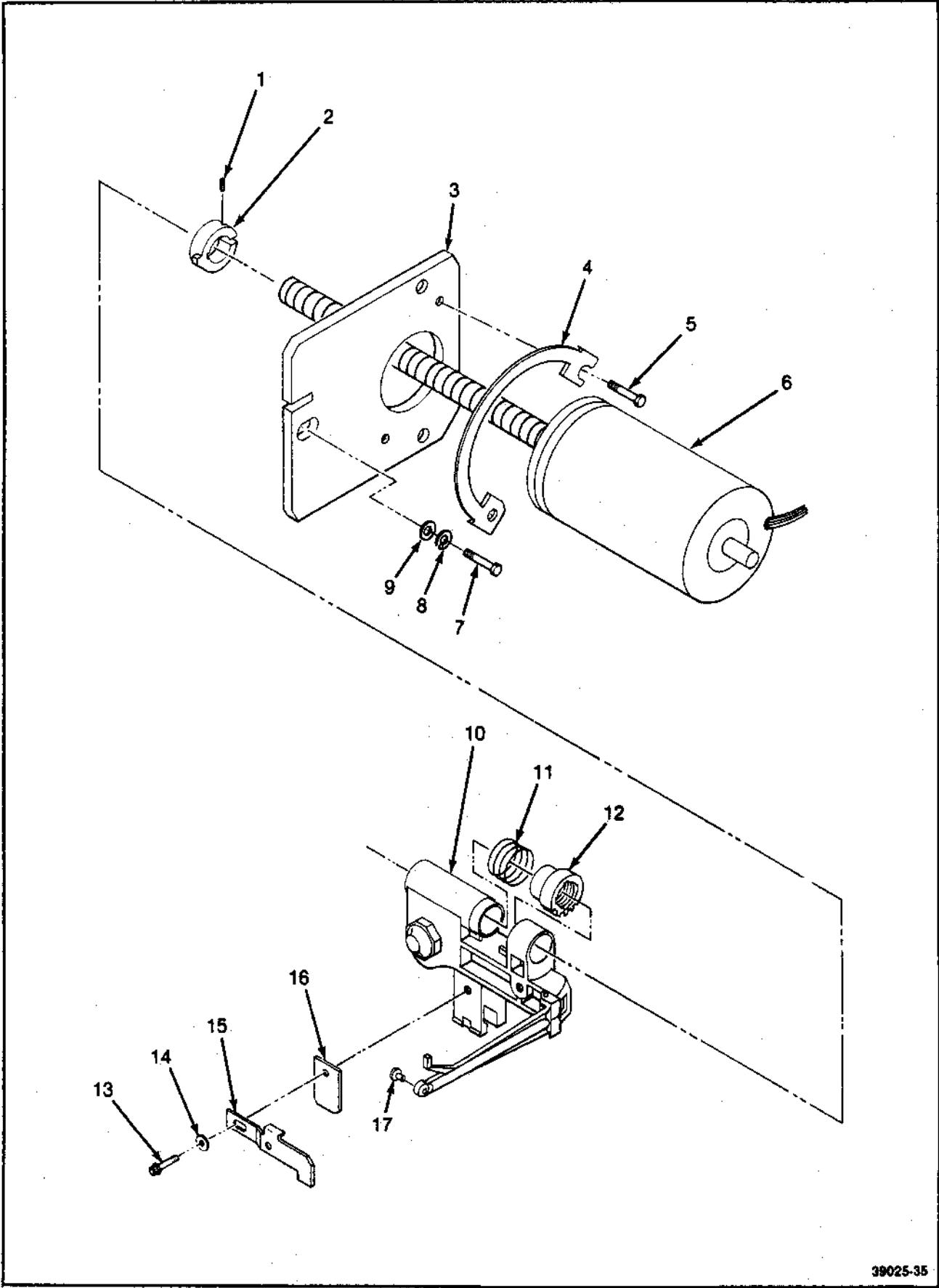

39025-35

FIGURE 7-2. STEPPER CARRIAGE ASSEMBLY EXPLODED VIEW

**STEPPER CARRIAGE ASSEMBLY**

<b>FIGURE &amp; REF NUMBER</b>	<b>PART NUMBER</b>	<b>DESCRIPTION</b>	<b>QTY PER ASM</b>
2-		STEPPER/CARRIAGE ASSEMBLY	
1	11903	. SCREW, Cap 2-56 x .250	1
2	50245	. STOP, Limit - Lead Screw	1
3	50112	. PLATE, Stepper Motor	1
4	50584	. MOUNTING CLAMP	1
5	12016	. SCREW, 8-32 x .375	2
6	50130	. STEPPER MOTOR ASSEMBLY	1
7	12027	. SCREW, 6-32 x .500	3
8	12510	. WASHER, Spring	3
9	10013	. WASHER, #6 Flat	3
10	50562	. CARRIAGE ASSEMBLY	1
11	50088	. . SPRING, Pre-load	1
12	50087	. . NUT	1
13	12055	. . SCREW, Hex Socket Hd, 4-40 x .312	1
14	10012	. . WASHER, #4 Flat	1
15	50529	. . FLAG, Track 00	1
16	50362	. . SPRING, Plate	1
17	50542	. . LOAD BUTTON	1

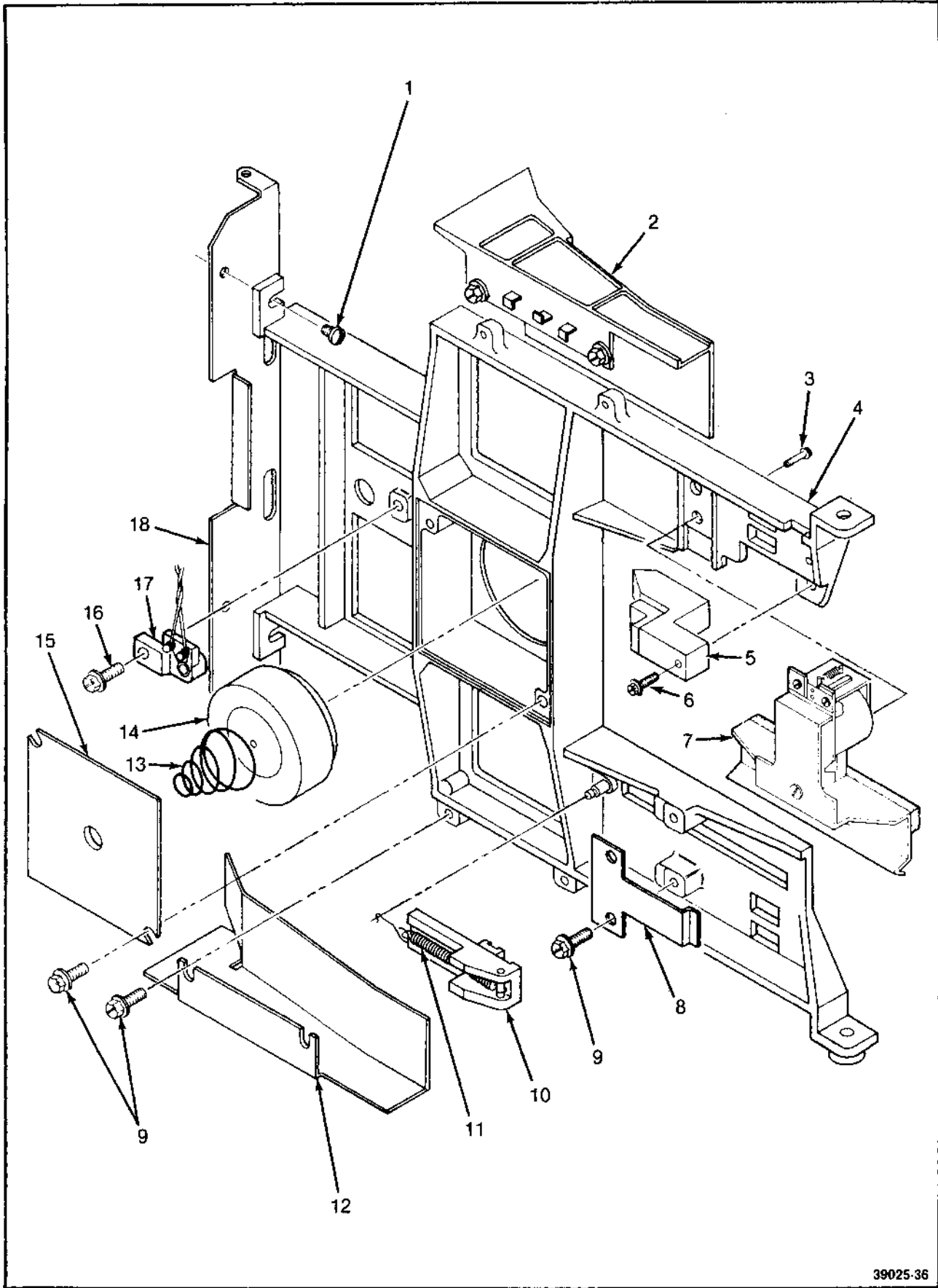

39025-36

FIGURE 7-3. CARTRIDGE GUIDE ASSEMBLY EXPLODED VIEW

### CARTRIDGE GUIDE ASSEMBLY

FIGURE & REF NUMBER	PART NUMBER	DESCRIPTION	QTY PER ASM
3-	50550	CARTRIDGE GUIDE ASSEMBLY	
1	12139	. SCREW, 6-32 × .250	2
2	51061	. STRIPPER, Top	1
3	12014	. SCREW, Thd. Form Hex Hd., 6-32 × .375	1
4	50544	. GUIDE	1
5	50313	. WRITE PROTECT DETECTOR ASSEMBLY	1
6	12012	. SCREW, 4-40 × .375	2
7	50558	. HEAD LOAD ACTUATOR ASSEMBLY	1
8	50555	. SPRING, Clamp, Ejector	1
9	12015	. SCREW, 8-32 × .312	7
10	50609	. EJECTOR ASSEMBLY	1
11	50556	. HOOK, Spring	1
12	51062	. STRIPPER, Bottom	1
13	50031	. SPRING, Hub Clamp	1
14	50254	. HUB CLAMP ASSEMBLY	1
15	50546	. PLATE, Hub Clamp	1
16	12016	. SCREW, 8-32 × .375	1
17	50557	. LED ASSEMBLY	1
18	50579	. LATCH PLATE	1

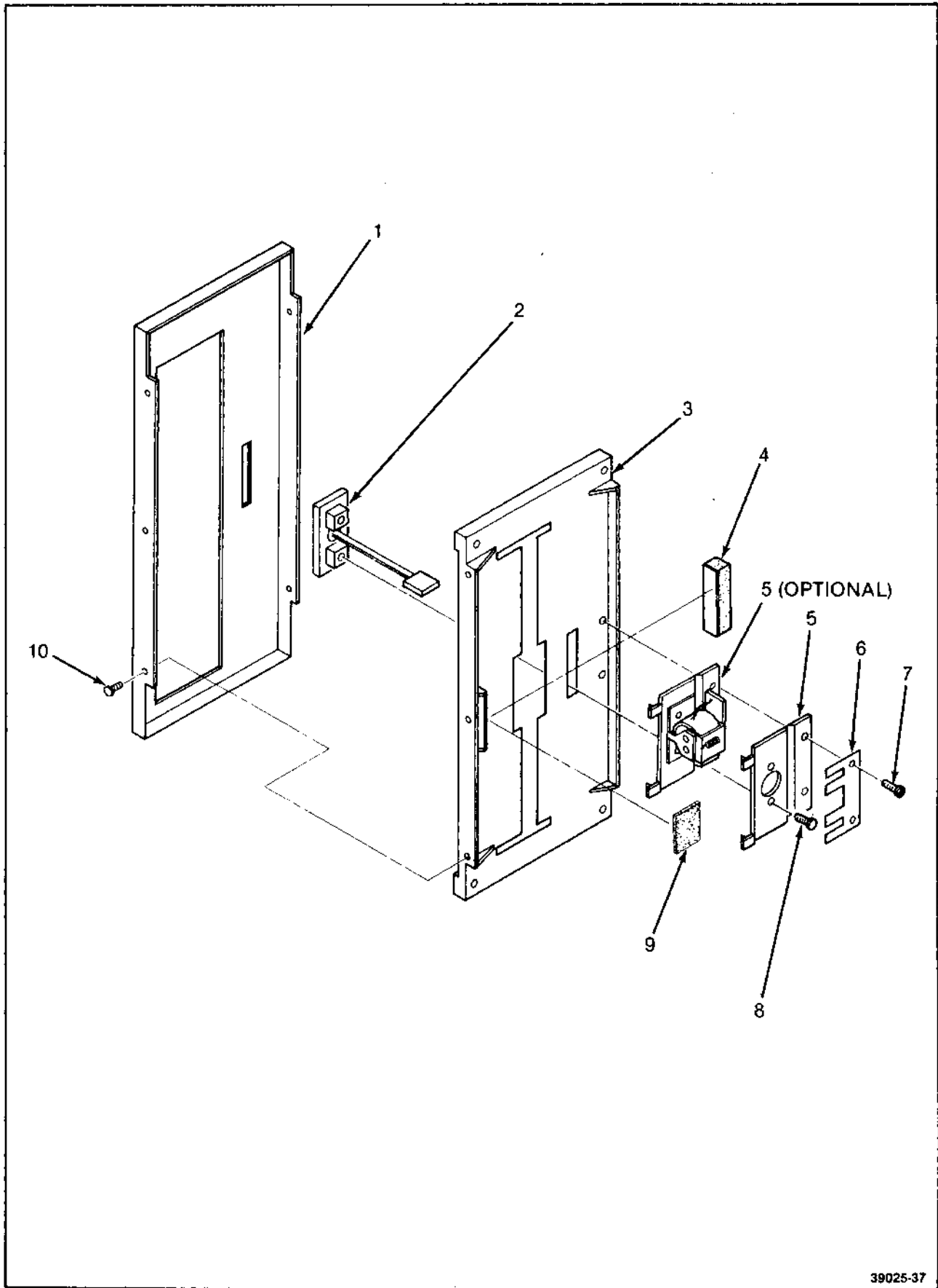

FIGURE 7-4. FRONT PLATE ASSEMBLY EXPLODED VIEW

**FRONT PLATE ASSEMBLY**

<b>FIGURE &amp; REF NUMBER</b>	<b>PART NUMBER</b>	<b>DESCRIPTION</b>	<b>QTY PER ASM</b>
4-			
Ref	50733	FRONT PLATE ASM (With Light)	
	50731	FRONT PLATE ASM (Without Light)	
	50735	FRONT PLATE ASM KIT (With Door Lock)	
	50679	FRONT PLATE ASM — 800R (Without Light)	
	50680	FRONT PLATE ASM — 800R (With Light)	
	50724	FRONT PLATE ASM — 800R (With Door Lock)	
1	50257	COVER, Front 5-1/4 × 11 White	1
	50258	COVER, Front 5-1/4 × 11 Tan	1
	50260	COVER, Front 5-1/4 × 10 White	1
	50261	COVER, Front 5-1/4 × 10 Tan	1
	50263	COVER, Front 4-5/8 × 10-1/2 White	1
	50264	COVER, Front 4-5/8 × 10-1/2 Tan	1
	50675	COVER, Front — 800R Tan	1
2	50727	PUSH BUTTON (With Light)	1
	50726	PUSH BUTTON, Door Lock Option	
	50728	PUSH BUTTON, (Without Light)	1
3	50729	FRONT PLATE	1
	50667	FRONT PLATE — 800R	1
4	50183	BUMPER	1
5	50156	LATCH	1
	50690	LATCH ASM, Door Lock Option	1
6	50691	SPRING PLATE	1
7	12013	SCREW, 6-32 × .312	2
8	12035	SCREW, 4-40 × .250	2
9	50580	SNATCH	1
10	10261	SCREW, Fl. Hd., 4-40 × .250	5

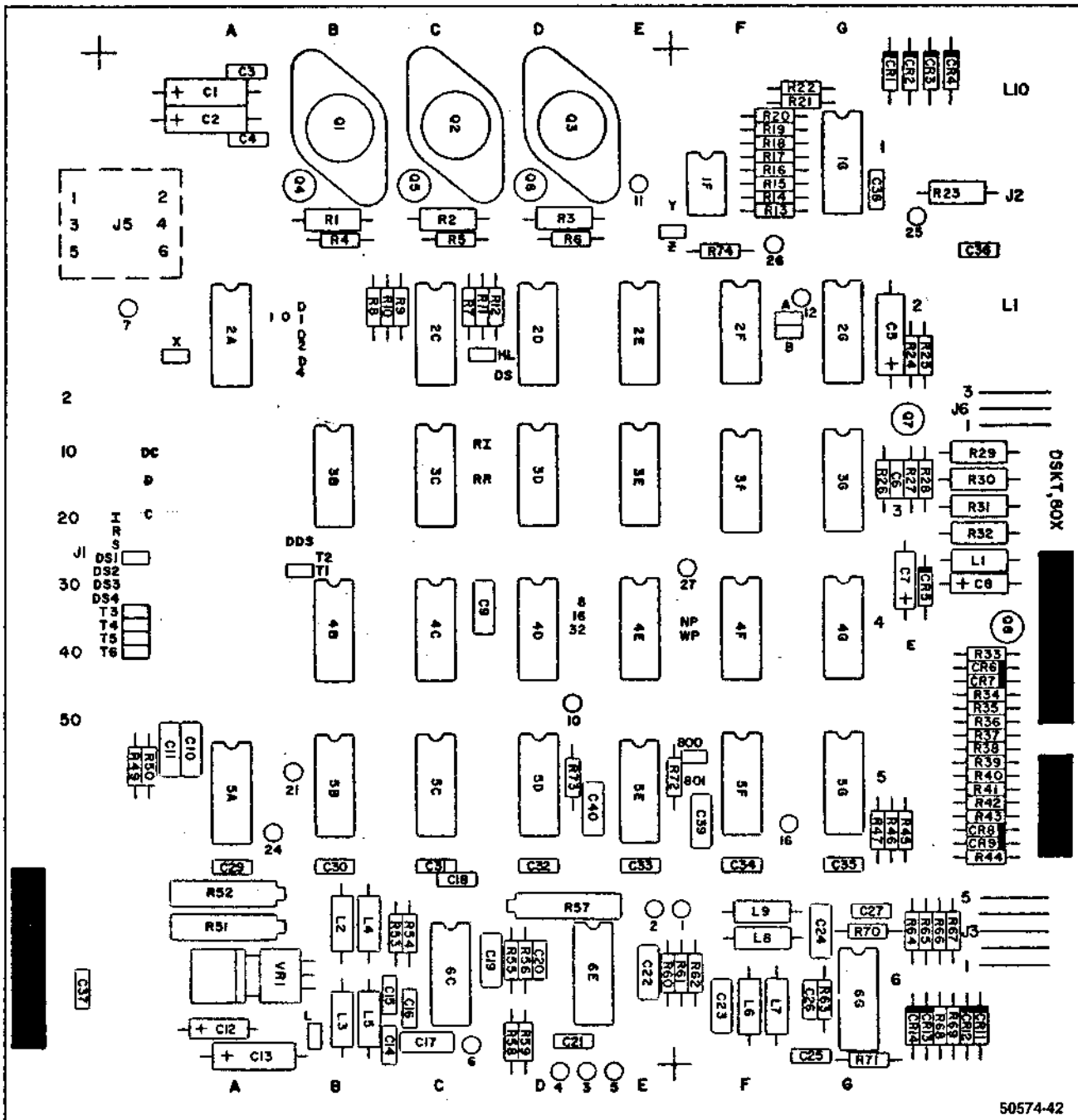

FIGURE 7-5. PCB COMPONENT LOCATIONS P/N 2510X



## PCB 2510X

REFERENCE DESIGNATOR	PART NUMBER	DESCRIPTION	QTY PER ASM
5-	2510X	PCB	1
C-1,2,5,13	10089	CAP., 4.7 $\mu$ F, 50 V, 10%	4
C-3,4,14,15, 16,18,20,21, 25,27,29-36, 38,41	15007	CAP., .01 $\mu$ F, 50 V, +80, -20%	19
C-6	15008	CAP., 0.1 $\mu$ F, 50 V, 10%	1
C-7,8,12	10088	CAP., 1.0 $\mu$ F, 35 V, 10%	3
C-9	10092	CAP., 510 pF, 500 V, 5%	1
C-10,11	10094	CAP., 1200 pF, 100 V, 5%	2
C-17,39,40	10090	CAP., 30 pF, 500 V, 5%	3
C-19	10091	CAP., 100 pF, 500 V, 5%	1
C-22	10096	CAP., 750 pF, 300 V, 5%	1
C-23	15015	CAP., 430 pF, 500 V, 5%	1
C-24	15018	CAP., 180 pF, 500 V, 5%	1
C-26	15003	CAP., 0.47 $\mu$ F, 50 V, 10%	1
C-37	15009	CAP., 0.015 $\mu$ F, 50 V, 10%	1
C-42	15005	CAP., 0.01 $\mu$ F, 200 V, 10%	1
CR-1-4	15900	DIODE, IN4003	4
CR-6-9,11-14	10062	DIODE, IN4148	8
L-1-5	10081	INDUCTOR, 100 $\mu$ H, 10%	5
L-6,7	10071	INDUCTOR, 270 $\mu$ H, 10%	2
L-8,9	16300	INDUCTOR, 56 $\mu$ H, 10%	2
Q-1,2,3	17605	TRANSISTOR, 2N4231	3
Q-4,5,6	10060	TRANSISTOR, 2N2907A	3
Q-7,8	10059	TRANSISTOR, 2N2222A	2
R-1,2,3	16765	RES., 51 $\Omega$ , 1/2 W, 5%	3
R-4-7,10, 11,15,36	10106	RES., 510 $\Omega$ , 1/4 W, 5%	8
R-8,9,12,14, 33,35	16749	RES., 390 $\Omega$ , 1/4 W, 5%	6
R-13	10131	RES., 22 K $\Omega$ , 1/4 W, 5%	1
R-16,17,21	10113	RES., 10 K $\Omega$ , 1/4 W, 5%	3
R-18,19,22	10114	RES., 470 K $\Omega$ , 1/4 W, 5%	3
R-20,55,56	16770	RES., 33k $\Omega$ , 1/4 W, 5%	3
R-23	10127	RES., 100 $\Omega$ , 1/2 W, 5%	1
R-24	16738	RES., 47 K $\Omega$ , 1/4 W, 5%	1
R-25,74	16768	RES., 5.1 K $\Omega$ , 1/4 W, 5%	2
R-26,27	16740	RES., 11 K $\Omega$ , 1/4 W, 5%	2
R-29	10126	RES., 75 $\Omega$ , 1/2 W, 5%	1
R-30,31	10130	RES., 150 $\Omega$ , 1/2 W, 5%	2
R-32	10128	RES., 39 $\Omega$ , 1/2 W, 5%	1
R-34,49,50,54, 65,66	10117	RES., 3 K $\Omega$ , 1/4 W, 5%	6
R-37,39	16754	RES., 4.02 K $\Omega$ , 1/8 W, 1%	2
R-38,40,41	16704	RES., 422 $\Omega$ , 1/8 W, 1%	3
R-42	16782	RES., 1.1 K $\Omega$ , 1/8 W, 1%	1
R-43,44,70,71	10119	RES., 20 K $\Omega$ , 1/4 W, 5%	4
R-45	16713	RES., 75 $\Omega$ , 1/8 W, 1%	1
R-46	16705	RES., 909 $\Omega$ , 1/8 W, 1%	1
R-47	16703	RES., 274 $\Omega$ , 1/8 W, 1%	1
R-51,52	16729	RES., Pot., 5 K $\Omega$ , 3/4 W, 10%	2
R-53	16714	RES., 12 K $\Omega$ , 1/4 W, 5%	1
R-57	16766	POT., 50 K $\Omega$ , 3/4 W, 10%	1
R-58,59	16712	RES., 49.9 $\Omega$ , 1/8 W, 1%	2
R-60	16801	RES., 59 $\Omega$ , 1/8 W, 1%	1

R-61,62	16800	RES., 698 $\Omega$ , 1/8 W, 1%	2
R-63	16774	RES., 24 $\Omega$ , 1/4 W, 5%	1
R-64,67	16776	RES., 523 $\Omega$ , 1/8 W, 1%	2
R-68,69	16711	RES., 9.09 K $\Omega$ , 1/8 W, 1%	2
R-72,73	10115	RES., 6.8 K $\Omega$ , 1/4 W, 5%	2
R-75	16887	ZERO OHM RESISTOR	1
VR-1	16242	I.C., 79M05	1
2A	16234	I.C., 7427	1
5A,5E,3G	12642	I.C., 96LS02	3
3B	16751	RES. PACK, 2 K $\Omega$ , 1/4 W, 5%	1
4B	16752	RES. PACK, 150 $\Omega$ , 1/2 W, 5%	1
5B,2C	10052	I.C., 7410	2
3C,4C	16207	I.C., 7438	2
5C,2E,5F	10050	I.C., 7400	3
6C	10055	I.C., 8T20	1
2D,3D,5D,4F	16203	I.C., 7474	4
4D	10064	I.C., 7405	1
3E	16201	I.C., 7404	1
4E	16204	I.C., 7402	1
6E	16244	I.C., NE592A	1
1F	12610	I.C., 75462	1
2F	16257	I.C., 7428	1
3F	10054	I.C., 7476	1
1G	16227	I.C., LM339	1
2G	16205	I.C., 7486	1
4G	16232	I.C., 7407	1
5G	16240	I.C., Q2T2905	1
6G	16241	I.C., Q2T2222	1

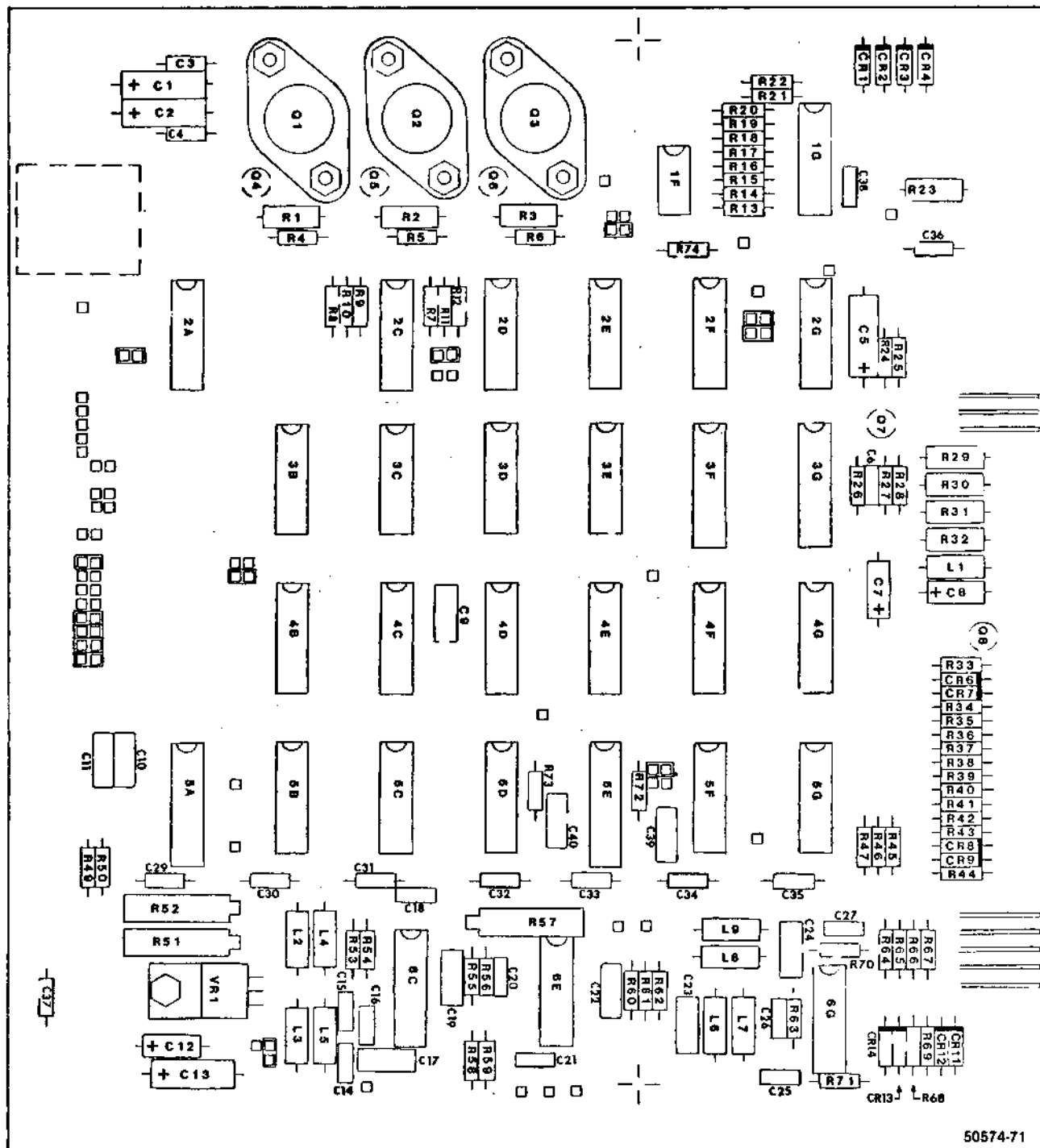

FIGURE 7-6. PCB COMPONENT LOCATIONS P/N 2517X

## PCB 2517X

REFERENCE DESIGNATOR	PART NUMBER	DESCRIPTION	QTY PER ASM
6-	2517X	PCB	1
C-1,2,5,13	10089	CAP., 4.7 $\mu$ F, 50 V, 10%	4
C-3,4,14,15, 16,18,20,21, 25,27,29-36, 38,41	15080	CAP., .01 $\mu$ F, 50 V, +80, -20%	19
C-6	15008	CAP., 0.1 $\mu$ F, 50 V, 10%	1
C-7,8,12	10088	CAP., 1.0 $\mu$ F, 35 V, 10%	3
C-9	10092	CAP., 510 pF, 500 V, 5%	1
C-10,11	10094	CAP., 1200 pF, 100 V, 5%	2
C-17,39,40	10090	CAP., 30 pF, 500 V, 5%	3
C-19	10091	CAP., 100 pF, 500 V, 5%	1
C-22	10096	CAP., 750 pF, 300 V, 5%	1
C-23	15015	CAP., 430 pF, 500 V, 5%	1
C-24	15018	CAP., 180 pF, 500 V, 5%	1
C-26	15003	CAP., 0.47 $\mu$ F, 50 V, 10%	1
C-37	15074	CAP., 0.015 $\mu$ F, 50 V, 10%	1
C-42	15005	CAP., 0.01 $\mu$ F, 200 V, 10%	1
CR-1,4	15900	DIODE, IN4003	4
CR-6,9,11-14	10062	DIODE, IN4148	8
L-1-5	10081	INDUCTOR, 100 $\mu$ H, 10%	5
L-6,7	10071	INDUCTOR, 270 $\mu$ H, 10%	2
L-8,9	16300	INDUCTOR, 56 $\mu$ H, 10%	2
Q-1,2,3	17605	TRANSISTOR, 2N4231	3
Q-4,5,6	10060	TRANSISTOR, 2N2907A	3
Q-7,8	10059	TRANSISTOR, 2N2222A	2
R-1,2,3	16765	RES., 51 $\Omega$ , 1/2 W, 5%	3
R-4,7,10, 11,15,36	10106	RES., 510 $\Omega$ , 1/4 W, 5%	8
R-8,9,12,14, 33,35	16749	RES., 390 $\Omega$ , 1/4 W, 5%	6
R-13	10131	RES., 22 K $\Omega$ , 1/4 W, 5%	1
R-16,17,21	10113	RES., 10 K $\Omega$ , 1/4 W, 5%	3
R-18,19,22	10114	RES., 470 K $\Omega$ , 1/4 W, 5%	3
R-20,55,56	16770	RES., 33k $\Omega$ , 1/4 W, 5%	3
R-23	10127	RES., 100 $\Omega$ , 1/2 W, 5%	1
R-24	16738	RES., 47 K $\Omega$ , 1/4 W, 5%	1
R-25,74	16768	RES., 5.1 K $\Omega$ , 1/4 W, 5%	2
R-26,27	16740	RES., 11 K $\Omega$ , 1/4 W, 5%	2
R-29	10126	RES., 75 $\Omega$ , 1/2 W, 5%	1
R-30,31	10130	RES., 150 $\Omega$ , 1/2 W, 5%	2
R-32	10128	RES., 39 $\Omega$ , 1/2 W, 5%	1
R-34,49,50,54, 65,66	10117	RES., 3 K $\Omega$ , 1/4 W, 5%	6
R-37,39	16754	RES., 4.02 K $\Omega$ , 1/8 W, 1%	2
R-38,40,41	16704	RES., 422 $\Omega$ , 1/8 W, 1%	3
R-42	16782	RES., 1.1 K $\Omega$ , 1/8 W, 1%	1
R-43,44,70,71	10119	RES., 20 K $\Omega$ , 1/4 W, 5%	4
R-45	16713	RES., 75 $\Omega$ , 1/8 W, 1%	1
R-46	16705	RES., 909 $\Omega$ , 1/8 W, 1%	1
R-47	16703	RES., 274 $\Omega$ , 1/8 W, 1%	1
R-51,52	16729	RES., Pot., 5 K $\Omega$ , 3/4 W, 10%	2
R-53	16714	RES., 12 K $\Omega$ , 1/4 W, 5%	1
R-57	16766	POT., 50 K $\Omega$ , 3/4 W, 10%	1
R-58,59	16712	RES., 49.9 $\Omega$ , 1/8 W, 1%	2
R-60	16801	RES., 59 $\Omega$ , 1/8 W, 1%	1

R-61,62	16800	RES., 698 $\Omega$ , 1/8 W, 1%	2
R-63	16774	RES., 24 $\Omega$ , 1/4 W, 5%	1
R-64,67	16776	RES., 523 $\Omega$ , 1/8 W, 1%	2
R-68,69	16711	RES., 9.09 K $\Omega$ , 1/8 W, 1%	2
R-72,73	16879	RES., 7.5 K $\Omega$ , 1/4 W, 5%	2
VR-1	16242	I.C., 79M05	1
2A	16234	I.C., 7427	1
5A,5E,3G	12642	I.C., 96LS02	3
3B	16751	RES. PACK, 2 K $\Omega$ , 1/4 W, 5%	1
4B	16752	RES. PACK, 150 $\Omega$ , 1/2 W, 5%	1
5B,2C	10052	I.C., 7410	2
3C,4C	16207	I.C., 7438	2
5C,2E,5F	10050	I.C., 7400	3
6C	10055	I.C., 8T20	1
2D,3D,5D,4F	16203	I.C., 7474	4
4D	10064	I.C., 7405	1
3E	16201	I.C., 7404	1
4E	16204	I.C., 7402	1
6E	16244	I.C., NE592A	1
1F	12610	I.C., 75462	1
2F	16257	I.C., 7428	1
3F	10054	I.C., 7476	1
1G	16227	I.C., LM339	1
2G	16205	I.C., 7486	1
4G	16232	I.C., 7407	1
5G	16240	I.C., Q2T2905	1
6G	16241	I.C., Q2T2222	1

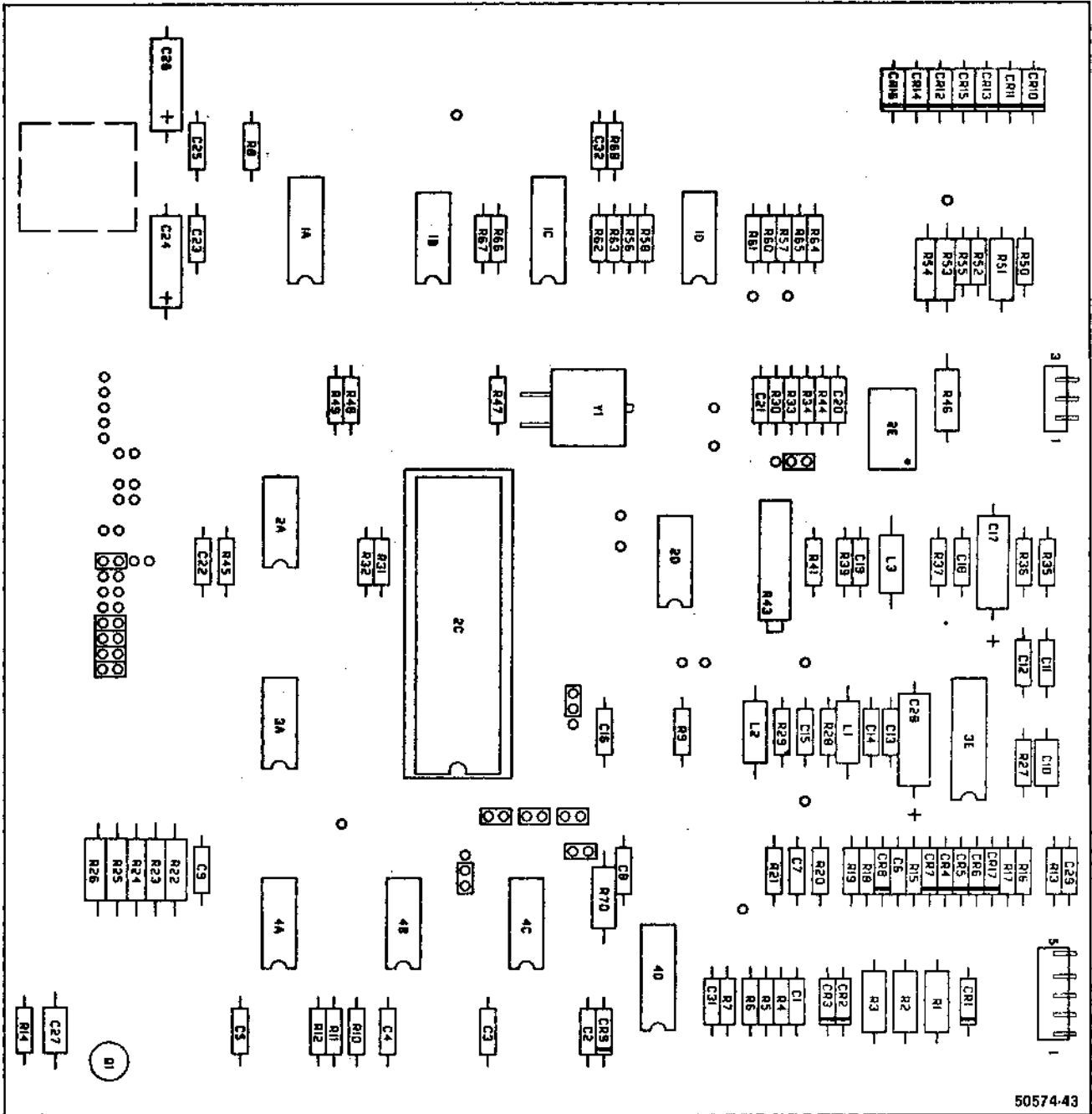

FIGURE 7-7. PCB COMPONENT LOCATIONS P/N 25136

## PCB 25136

REFERENCE DESIGNATOR	PART NUMBER	DESCRIPTION	QTY PER ASM
7-	25136	PCB	1
C-1-6,8,9,13,14, 16,18,20,22,23, 25,27,29,32	15080	CAP., 0.1 $\mu$ F, 50 V, +80, -20%	19
C-7	15054	CAP., 100 pF, 50 V, 5%	1
C-10	15075	CAP., 0.022 $\mu$ F, 50 V, 10%	1
C-11,12,31	15096	CAP., 150 pF, 50 V, 5%	3
C-15	15109	CAP., 560 pF, 50 V, 5%	1
C-17,24,26,28	15086	CAP., 4.7 $\mu$ F, 50 V, 20%	4
C-19	15064	CAP., 680 pF, 50 V, 5%	1
C-21	15003	CAP., 0.47 $\mu$ F, 50 V, 10%	1
CR-1-7,9,17	10062	DIODE, IN4148	9
CR-8	15922	DIODE, IN5242B, 12 V, Zener	1
CR-10-16	15900	DIODE, IN4003	7
L-1,2	10081	INDUCTOR, 100 $\mu$ H, 10%	2
Q1	17619	TRANSISTOR, 2N2222A, T092	1
R-1,2,3	16872	RES., 1.8 K $\Omega$ , 1/2 W, 5%	3
R-4,30,60,61	10114	RES., 470 K $\Omega$ , 1/4 W, 5%	4
R-5,6	16740	RES., 11 K $\Omega$ , 1/4 W, 5%	2
R-7	16829	RES., 10 K $\Omega$ , 1/8 W, 1%	1
R-8-12,16,31- 34,44,49, 64-67	10111	RES., 4.7 K $\Omega$ , 1/4 W, 5%	16
R-13,17	16787	RES., 24 K $\Omega$ , 1/4 W, 5%	2
R-14,18,19	16773	RES., 1.5 K $\Omega$ , 1/4 W, 5%	3
R-20,21	16916	RES., 392 $\Omega$ , 1/8 W, 1%	2
R-22-26,54,70	10130	RES., 150 $\Omega$ , 1/2 W, 5%	7
R-27	16863	RES., 47 $\Omega$ , 1/4 W, 5%	1
R-28,29	16917	RES., 2.21 K $\Omega$ , 1/8 W, 1%	2
R-35	16760	RES., 6.2 K $\Omega$ , 1/4 W, 5%	1
R-36	10109	RES., 2 K $\Omega$ , 1/4 W, 5%	1
R-37,63	16749	RES., 390 $\Omega$ , 1/4 W, 5%	2
R-41,56,58	10113	RES., 10 K $\Omega$ , 1/4 W, 5%	3
R-43	16766	RES., POT., 50 K, 3/4 W,	1
R-45,48,55,57	10131	RES., 22 K $\Omega$ , 1/4 W, 5%	4
R-46	10126	RES., 75 $\Omega$ , 1/2 W, 5%	1
R-47	16822	RES., 1 M $\Omega$ , 1/4 W, 5%	1
R-50,52	16777	RES., 150 $\Omega$ , 1/4 W, 5%	2
R-51	10128	RES., 39 $\Omega$ , 1/2 W, 5%	1
R-53	10127	RES., 100 $\Omega$ , 1/2 W, 5%	1
R-62	16741	RES., 270 $\Omega$ , 1/4 W, 5%	1
R-68	10104	RES., 240 $\Omega$ , 1/4 W, 5%	1
R-71	16887	RES., 0 $\Omega$	1
Y-1	15702	CRYSTAL, 5 MHz	1
2A,3A,4A	16207	I.C., 7438	3
1B,4B,2D	16201	I.C., 7404	3
1C	16267	I.C., ULN2074B	1
2C	16271	I.C., Drive Logic	1
4C	16234	I.C., 7427	1
1D	16227	I.C., LM339	1
4D	16270	I.C., 24 V, Wrt Chnl	1
2E	12610	I.C., 75462	1
3E	16278	I.C., Read Amp	1

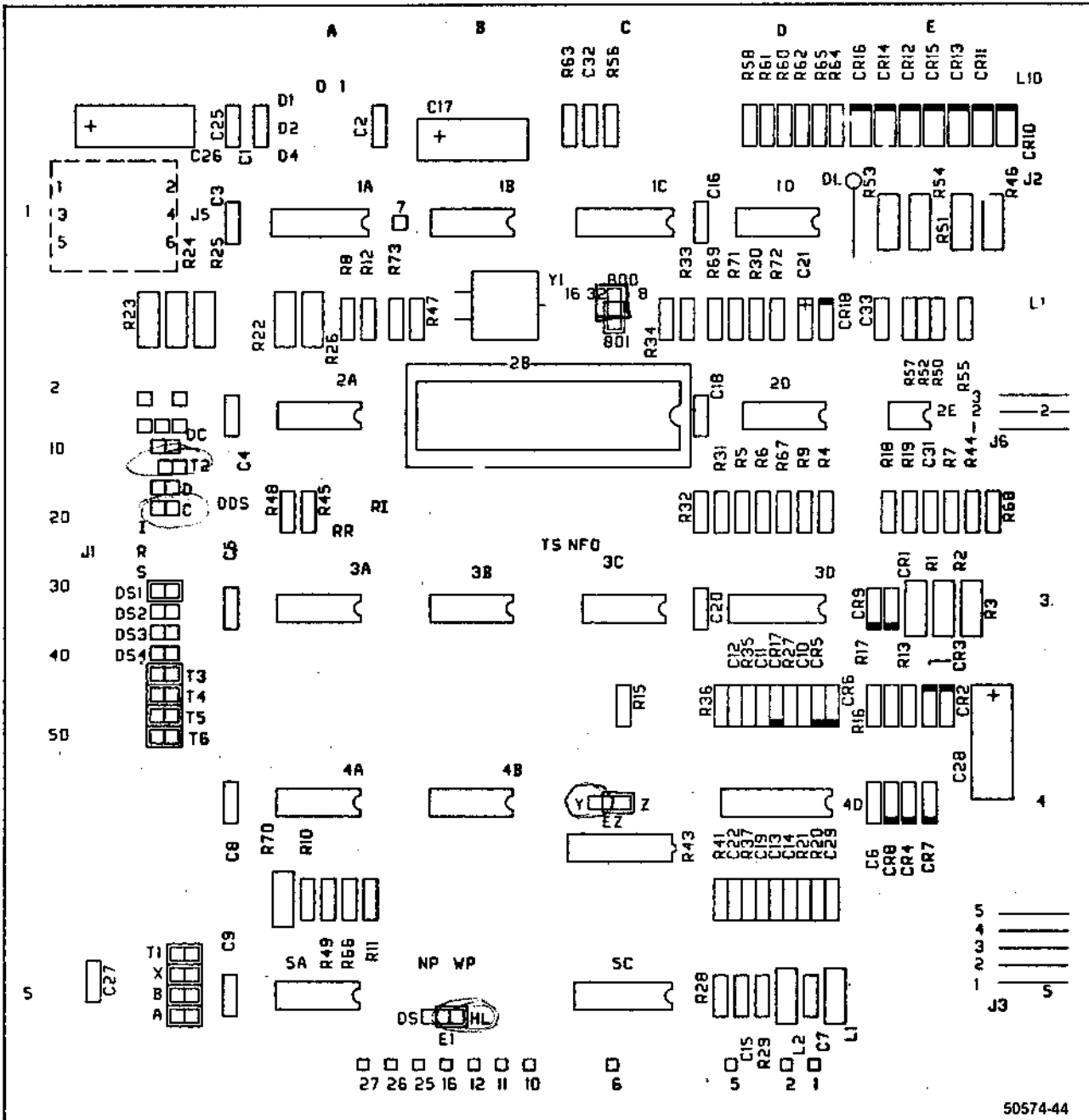

FIGURE 7-8. PCB COMPONENT LOCATIONS P/N 25229



## PCB 25229

REFERENCE DESIGNATOR	PART NUMBER	DESCRIPTION	QTY PER ASM
8-	25229	PCB ASSEMBLY, 800/801 LSI	1
C-1-6,8,9, 16,18,20,22, 25,27,29,32	15080	CAP., 0.1 $\mu$ F, 50 V, +80, -20%	16
C-7	15054	CAP., 100 pF, 50 V, 5%	1
C-10	15075	CAP., 0.022 $\mu$ F, 50 V, 10%	1
C-11,12,31	15096	CAP., 150 pF, 50 V, 5%	3
C-13,14	15106	CAP., 0.1 $\mu$ F, 50 V, 10%	2
C-15	15109	CAP., 560 pF, 50 V, 5%	1
C-17,26,28	15086	CAP., 4.7 $\mu$ F, 50 V, 20%	3
C-19	15064	CAP., 680 pF, 50 V, 5%	1
C-21	15093	CAP., 0.47 $\mu$ F, 35 V, 10%	1
C-33	15074	CAP., 0.015 $\mu$ F, 50 V, 10%	1
CR-1-7,9,17	10062	DIODE, IN4148	9
CR-8	15922	DIODE, IN5242B, 12 V, Zener	1
CR-10-16	15900	DIODE, IN4003	7
CR-18	15908	DIODE, IN5221B, 2.4 V, Zener	1
L-1,2	10081	INDUCTOR, 100 $\mu$ H, 10%	2
R-1,2,3	16872	RES., 1.8 K $\Omega$ , 1/2 W, 5%	3
R-4,60,61	10114	RES., 470 K $\Omega$ , 1/4 W, 5%	3
R-5,6	16740	RES., 11 K $\Omega$ , 1/4 W, 5%	2
R-7	16829	RES., 10 K $\Omega$ , 1/8 W, 1%	1
R-8-12,15,16,31- 34,44,49, 64,68	10111	RES., 4.7 K $\Omega$ , 1/4 W, 5%	18
R-13,17	16787	RES., 24 K $\Omega$ , 1/4 W, 5%	2
R-14,18,19	16773	RES., 1.5 K $\Omega$ , 1/4 W, 5%	3
R-20,21	16916	RES., 392 $\Omega$ , 1/8 W, 1%	2
R-22-26,54,70	10130	RES., 150 $\Omega$ , 1/2 W, 5%	7
R-27	16863	RES., 47 $\Omega$ , 1/4 W, 5%	1
R-28,29	16917	RES., 2.21 K $\Omega$ , 1/8 W, 1%	2
R-30	16923	RES., 220 K $\Omega$ , 1/4 W, 5%	1
R-35	10115	RES., 6.8 K $\Omega$ , 1/4 W, 5%	1
R-36	10109	RES., 2 K $\Omega$ , 1/4 W, 5%	1
R-37,63	16749	RES., 390 $\Omega$ , 1/4 W, 5%	2
R-41,56,58	10113	RES., 10 K $\Omega$ , 1/4 W, 5%	3
R-43	16766	RES., Pot., 50 K, 3/4 W, 10%	1
R-45,48,55,57	10131	RES., 22 K $\Omega$ , 1/4 W, 5%	4
R-46	10126	RES., 75 $\Omega$ , 1/2 W, 5%	1
R-47	16822	RES., 1 M $\Omega$ , 1/4 W, 5%	1
R-50,52	16777	RES., 150 $\Omega$ , 1/4 W, 5%	2
R-51	10128	RES., 39 $\Omega$ , 1/2 W, 5%	1
R-53	10127	RES., 100 $\Omega$ , 1/2 W, 5%	1
R-62	10106	RES., 510 $\Omega$ , 1/4 W, 5%	1
R-69	16800	RES., 698 $\Omega$ , 1/8 W, 1%	1
R-71	16839	RES., 130 $\Omega$	1
R-72	16700	RES., 825 $\Omega$ , 1/8 W, 1%	1
Y-1	15702	CRYSTAL, 5 MHz	1
2A,3A,4A	16207	I.C., 7438	3
5A	16234	I.C., 7427	1
1B,4B,2D	16201	I.C., 7404	3
2B	16271	DRIVE Logic	1
3B	16232	I.C., 7407	1
1C	16267	I.C., ULN2074 B	1
3C	16203	I.C., 7474	1
1D	16227	I.C., LM339	1
3D	16270	I.C., 24 V, Wrt Chnl	1
4D	16278	I.C., Read Amp	1
2E	12610	I.C., 75462 (8-pin)	1

## CONNECTORS FOR PCBs

REFERENCE DESIGNATOR	PART NUMBER	DESCRIPTION
See figures 3-1 and 5-13 for PCB connector locations.		
P1	15648	PLUGS, Jumper (Optional) (AMP P/N 531220-2)
	15644	HOUSING, DC, Twisted Pair (AMP P/N 1-583718-1)
	10143	. CONTACTS (50 x) (AMP P/N 531476-2)
P2		. CONNECTOR, Ribbon (AMP P/N 3415-0001) (3M P/N 15645)
	10140	HOUSING, DC, Control (AMP P/N 583859-9)
	10143	. CONTACTS (20 x) (AMP P/N 583616-3)
P3	17702	. CLIPS, Retaining (AMP P/N 530248-1)
	50160	HOUSING, DC, Connector, Head (AMP P/N 87668-1)
	17737	. CONTACTS (5 x) (AMP P/N 85969-6)
J3	15696	HEADER, PCB (AMP P/N 102357-2)
P4	10149	HOUSING, AC, Socket (AMP P/N 1-480303-0)
		. SOCKETS (3 x) (AMP P/N 60619-1)
J4	10150	HOUSING, Pin (AMP P/N 1-480305-0)
P5		. PINS (3x) (AMP P/N 60620-1)
	15642	HOUSING, DC, Socket (AMP 1-480270-0)
		. SOCKETS (6 x) (AMP 60619-1)
J5	15641	HOUSING, Pin (AMP P/N 1-380999-0)
P6/J6	15646	HOUSING, DC (AMP P/N 102210-2)
	17737	. CONTACTS (AMP P/N 85969-6)
	15696	HEADER, PCB (AMP P/N 102357-2)

### 7.5 RECOMMENDED SPARE PARTS STOCKING GUIDE

The spare parts stocking guide is broken down into three levels. These levels are Site or Field Support Engineer (level 1), Branch Office (level 2), and Depot or Headquarters (level 3). The quantities assume that Site is replenished by the Branch immediately, and Branch replenished by the Depot within 30 days.

The inventories that the levels can maintain are:

Site	1 to 20 machines
Branch	1 to 100 machines
Depot	
Depot only parts	Unlimited
Branch replenishment	Same as Branch ratio

Table 7-1 shows the spare parts required to support the 800/801 diskette drive in the field.

TABLE 7-1. SPARE PARTS STOCKING GUIDE

PART NUMBER	DESCRIPTION	QUANTITY PER LEVEL		
		SITE	BRANCH	DEPOT**
10800	BEARING, Spindle		3	3
10801	BEARING, Flanged, Spindle		3	3
15110	CAPACITOR (115/230 V), AC Motor Run		2	2
17200	SWITCH, Door Closed		1	1
25136*	PCB SA801	1	4	4
25175*	PCB SA801	1	4	4
25176*	PCB SA801 (—16 V Option)	1	4	4
25229*	PCB SA801	1	4	4
50016	PULLEY ASSEMBLY, Spindle			1
50019	SHORT SPACER, Spindle			1
50031	SPRING, Hub Clamp			1
50098	BRACKET			1
50121	DETECTOR ASSEMBLY, Track 00		1	1
50128	PHOTOTRANSISTOR ASSEMBLY		2	2
50130	STEPPER MOTOR		1	1
50142	HANDLE			1
50156	LATCH			1
50166	SPRING, Spindle			2
50183	BUMPER			2
50245	STOP, Limit - Lead Screw			1
50254	HUB CLAMP ASSEMBLY		1	1
50313*	WRITE PROTECT ASSEMBLY		2	2
50355*	BELT (50 Hz)	1	3	3
50356*	BELT (60 Hz)	1	3	3
50357	PULLEY, 50 Hz			1
50358	PULLEY, 60 Hz			1
50440*	MOTOR (110 V, 50/60 Hz)		1	1
50444*	MOTOR (208/220/230 V, 50/60 Hz)		1	1
50522	SPRING/GUIDE ASSEMBLY			1
50542	HEAD LOAD BUTTON	2	2	2
50557	LED ASSEMBLY		2	2
50558	HEAD LOAD ACTUATOR ASSEMBLY			1
50561	HUB ASSEMBLY, Spindle			1

TABLE 7-1. SPARE PARTS STOCKING GUIDE (CONT.)

PART NUMBER	DESCRIPTION	QUANTITY PER LEVEL		
		SITE	BRANCH	DEPOT**
50562	CARRIAGE ASSEMBLY		1	1
50579	LATCH PLATE			1
50584	MOUNTING CLAMP			1
50609	EJECTOR			1
50667	FRONT PLATE - 800R			1
50691	SPRING PLATE			2
50727	PUSH BUTTON (With Light)			1
50729	FRONT PLATE			1
51231	LONG SPACER, Spindle			1

\*Only stock items which reflect the machines installed.

\*\*Depot parts listed are only unique to the depot. Stocking levels to back up Branch stocks should be added.

50574 - 73

TABLE 7-2. PART NUMBER TO FIGURE REFERENCE CROSS REFERENCE

Part Number	Figure Reference
10012	2-14
10013	2-9
10014	1-46
10025	1-10
10050	5-5C
	6-5C
10052	5-5B
	6-5B
10054	5-3F
	6-3F
10055	5-6C
	6-6C
10059	5-Q7
	6-Q7
10060	5-Q4
	6-Q4
10062	5-CR6
	6-CR6
	8-CR1
10064	5-4D
	6-4D
10071	5-L6
	6-L6
10081	5-L1
	6-L1
	8-L1
	7-L1
10088	5-C7
	6-C7
10089	5-C1
	6-C1
10090	5-C17
	6-C17
10091	5-C19
	6-C19
10092	5-C9
	6-C9
10094	5-C10
	6-C10
10096	5-C22
	6-C22
10104	7-R68
10106	5-R4
	6-R4
	8-R62
10109	8-R36
	7-R36
10111	8-R8
	7-R8
10113	5-R16
	6-R16
	8-R41
	7-R41

Part Number	Figure Reference
10114	5-R18
	6-R18
	8-R4
	7-R4
10115	5-R72
	8-R35
10117	5-R34
	6-R34
10119	5-R43
	6-R43
10126	5-R29
	6-R29
	8-R46
	7-R46
10127	5-R23
	6-R23
	8-R53
	7-R53
10128	5-R32
	6-R32
	8-R51
	7-R51
10130	5-R30
	6-R30
	8-R22
	7-R22
10131	5-R13
	6-R13
	8-R45
	7-R45
10140	P2*
10143	P1**
10149	P4**
10150	1-15
	J4**
10261	4-10
10426	1-38
10800	1-6
10801	1-33
11305	1-3
11903	2-1
11904	1-18
11928	1-26
12011	1-2
12012	1-40
	3-6
12013	1-37
	4-7
12014	1-49
	3-3
12015	1-12
	3-9

Part Number	Figure Reference
12016	2-5
	3-16
12023	1-23
12027	2-7
12028	1-16
12032	1-36
12035	4-8
12036	1-27
12055	2-13
12139	1-27
	3-1
12500	1-11
12509	1-9
12510	2-8
12610	5-1F
	6-1F
	8-2E
	7-2E
12642	5-3G
	6-3G
15003	5-C26
	6-C26
	7-C21
15005	5-C42
	6-C42
15007	5-C3
15008	5-66
	6-C6
15009	5-C37
15015	5-C23
	6-C23
15018	5-C24
	6-C24
15054	8-C7
	7-C7
15064	8-C19
	7-C19
15074	6-C37
	8-C33
15075	8-C10
	7-C10
15080	6-C3
	8-C1
	7-C1
15086	8-C17
	7-C17
15093	8-C21
15096	8-C11
	7-C11
15106	8-C13
15109	8-C15
	7-C15
15110	1-13

\*See figure 5-13.

\*\*See figure 3-1.

TABLE 7-2. PART NUMBER TO FIGURE REFERENCE CROSS REFERENCE (CONT.)

Part Number	Figure Reference	Part Number	Figure Reference	Part Number	Figure Reference
15641	J5**	16267	8-1C	16770	5-R20
15642	P5**		7-1C		6-R20
15644	P1**	16270	8-3D	16773	8-R14
15645	P1**		7-4D		7-R14
15646	P6/J6**	16271	8-2B	16774	5-R63
15648	Ref		7-26		6-R63
15696	P6/J6*	16278	8-4D	16776	5-R64
15702	8-Y1		7-3E		6-R64
	7-Y1	16300	5-L8	16777	8-R50
15900	5-CR1		6-L8		7-R50
	6-CR1	16700	8-R72	16782	5-R42
	8-CR10	16703	5-R47		6-R42
	7-CR10		6-R47	16787	8-R13
15908	8-CR18	16704	5-R38		7-R13
15922	8-CR8		6-R38	16800	5-R61
	7-CR8	16705	5-R46		6-R61
16201	5-3E		6-R46		8-R69
	6-3E	16711	5-R68	16801	5-R60
	8-1B		6-R68		6-R60
	7-1B	16712	5-R58	16822	8-R47
16203	5-2D		6-R58		7-R47
	6-2D	16713	5-R45	16829	8-R7
	8-3C		6-R45		7-R7
16204	5-4E	16714	5-R53	16839	8-R71
	6-4E		6-R53	16863	8-R27
16205	5-2G	16729	5-R51		7-R27
	6-2G		6-R51	16872	8-R1
16207	5-3C	16738	5-R24		7-R1
	6-3C		6-R24	16879	6-R72
	8-2A	16740	5-R26	16887	5-R75
	7-2A		6-R26		8-R71
16227	5-1G		8-R5	16916	8-R20
	6-1G		7-R5		7-R20
	8-1D	16741	7-R62	16917	8-R28
	7-1D	16749	5-R8		7-R28
16232	5-4G		6-R8	16923	8-R30
	6-4G		8-R37	17200	1-33
	8-3B		7-R37	17605	5-Q1
16234	5-2A	16751	5-3B		6-Q1
	6-2A		6-3B	17619	7-Q1
	8-5A	16752	5-4B	17701	1-47
	4-4C		6-4B	17702	P2*
16240	5-5G	16754	5-R37	17737	P3*
	6-5G		6-R37		P6/J6*
16241	5-6G	16760	7-R35	251XX	5-Ref
	6-6G	16765	5-R1	25136	1-39
16242	5-VR1		6-R1		7-Ref
	6-VR1	16766	5-R57	2517X	6-Ref
16244	5-6E		6-R57	25229	7-Ref
	6-6E		8-R43	50009	1-24
16257	5-2F		7-R43	50016	1-8
	6-2F	16768	5-R25	50019	1-7
			6-R25	50031	3-13

\* See figure 5-13.

\*\* See figure 3-1.

TABLE 7-2. PART NUMBER TO FIGURE REFERENCE CROSS REFERENCE (CONT.)

Part Number	Figure Reference
50087	2-12
50088	2-11
50098	1-14
50112	2-3
50121	1-41
50128	1-45
50130	2-6
50142	1-29
50156	4-5
50160	P3*
50166	1-4
50167	1-44
50168	1-43
50183	4-4
50245	2-2
50254	3-14
50257	4-1
50258	4-1
50260	4-1
50261	4-1
50263	4-1
50264	4-1
50313	3-5
50355	1-50
50356	1-50
50357	1-19
50358	1-19
50362	2-16
50440	1-22
50443	1-21
50444	1-21
50522	1-39
50529	2-15
50542	2-17
50544	3-4
50546	3-15
50550	1-25
	3-Ref
50555	3-8
50556	3-11
50557	3-17
50558	3-7
50559	1-35
50561	1-32
50562	2-10
50578	1-42
50579	3-18
50580	4-9
50583	1-30
50584	2-4
50602	1-20
50609	3-10
50667	4-3

Part Number	Figure Reference
50669	1-28
50670	1-44
50675	4-1
50679	4-Ref
50680	4-Ref
50690	4-5
50691	4-6
50707	2-15
50724	4-Ref
50726	4-2
50727	4-2
50728	4-2
50729	4-3
50731	4-Ref
50733	4-Ref
50735	4-Ref
51061	3-2
51062	3-12
51198	1-34
51231	1-5

Part Number	Figure Reference
-------------	------------------

\*See figure 5-13.  
 \*\*See figure 3-1.





# Shugart

Copyright 1982

475 Oakmead Parkway Sunnyvale, California 94086  
Telephone: (408) 733-0100 TWX: 910 339 9355 SHUGART SUVL

P/N 39025-1 3/82

PRINTED IN U.S.A.