

SA410/460
96 TPI
Single/Double-sided
Minifloppy™ Diskette
Storage Drives

Service Manual

Shugart

**© SHUGART 1982
ALL RIGHTS RESERVED**

TABLE OF CONTENTS

	Page
TABLE OF CONTENTS	i
LIST OF FIGURES	iii
ABBREVIATIONS/MNEMONICS	iv
SECTION I INTRODUCTION	1-1
1.1 INTRODUCTION	1-1
1.2 SPECIFICATION SUMMARY	1-1
1.2.1 Performance Specifications	1-1
1.2.2 Functional Specifications	1-2
1.2.3 Physical Specifications	1-2
1.2.4 Reliability Specifications	1-2
1.3 FUNCTIONAL CHARACTERISTICS	1-4
1.3.1 Electronics	1-4
1.3.2 Drive Mechanism	1-4
1.3.3 Positioning Mechanism	1-4
1.3.4 Read/Write Head(s)	1-4
1.4 FUNCTIONAL OPERATIONS	1-4
1.4.1 Powering Sequencing	1-4
1.4.2 Drive Selection	1-5
1.4.3 Motor On	1-5
1.4.4 Track Accessing	1-5
1.4.5 Step Out	1-5
1.4.6 Step In	1-5
1.4.7 Side Selection (SA460 Only)	1-6
1.4.8 Read Operation	1-6
1.4.9 Write Operation	1-8
1.4.10 Sequence of Events	1-9
SECTION II ELECTRICAL INTERFACE	2-1
2.1 ELECTRICAL INTERFACE	2-1
2.2 SIGNAL INTERFACE	2-2
2.2.1 Input Lines	2-2
2.2.2 Input Line Terminations	2-3
2.2.3 Drive Select 1-4	2-3
2.2.4 Motor On	2-3
2.2.5 Direction Select	2-3
2.2.6 Step	2-3
2.2.7 Write Gate	2-4
2.2.8 Write Data	2-4
2.2.9 Side Select (SA460 Only)	2-4
2.2.10 In Use	2-4
2.2.11 Output Lines	2-4
2.2.12 Track 00	2-6
2.2.13 Index/Sector	2-5
2.2.14 Read Data	2-5
2.2.15 Write Protect	2-5
2.3 POWER INTERFACE	2-5
2.4 FRAME GROUND	2-5
SECTION III PHYSICAL INTERFACE	3-1
3.1 PHYSICAL INTERFACE	3-1
3.1.1 J1/P1 Connector	3-2
3.1.2 J2/P2 Connector	3-2
3.2 FRAME GROUNDING	3-2
SECTION IV THEORY OF OPERATION	4-1
4.1 THEORY OF OPERATION	4-1

TABLE OF CONTENTS (CONT.)

4.2	READ/WRITE OPERATIONS	4-1
4.3	READ/WRITE HEAD	4-3
4.4	WRITE CIRCUIT OPERATION	4-4
4.5	READ CIRCUIT OPERATION	4-4
4.6	DRIVE MOTOR CONTROL	4-5
4.7	INDEX DETECTOR	4-6
4.8	TRACK ZERO INDICATION	4-6
4.9	TRACK ACCESSING	4-7
	4.9.1 Stepper Motor	4-7
	4.9.2 Stepper Control	4-7
4.10	DRIVE SELECT	4-9
4.11	WRITE PROTECT	4-9
4.12	DOOR LOCK SOLENOID	4-10
4.13	DRIVE STATUS	4-10
SECTION V	MAINTENANCE	5-1
5.1	MAINTENANCE EQUIPMENT	5-1
	5.1.1 Alignment Diskette	5-1
	5.1.2 Exerciser PCB	5-1
	5.1.3 Special Tools	5-1
5.2	DIAGNOSTIC TECHNIQUES	5-2
	5.2.1 Introduction	5-2
	5.2.2 "Soft Error" Detection And Correction	5-2
	5.2.3 Write Error	5-2
	5.2.4 Read Error	5-2
	5.2.5 Seek Error	5-3
	5.2.6 Trouble-Shooting	5-3
SECTION VI	ADJUSTMENTS	6-1
6.1	HEAD RADIAL ALIGNMENT	6-1
6.2	READ/WRITE HEAD(S) AZIMUTH CHECK	6-2
6.3	HEAD AMPLITUDE CHECK	6-3
6.4	TRACK ZERO CARRIAGE LIMITER	6-3
6.5	TRACK ZERO DETECTOR ASSEMBLY ADJUSTMENT	6-4
6.6	INDEX/SECTOR TIMING ADJUSTMENT	6-4
6.7	MOTOR SPEED ADJUSTMENT	6-5
	6.7.1 Motor Speed Adjustment (Using A Frequency Counter)	6-5
	6.7.2 Motor Speed Adjustment (Fluorescent Light)	6-6
6.8	WRITE PROTECT SWITCH	6-6
SECTION VII	REMOVALS AND REPLACEMENTS	7-1
7.1	FACEPLATE REMOVAL AND INSTALLATION	7-1
7.2	DRIVE MOTOR ASSEMBLY REMOVAL AND INSTALLATION	7-1
7.3	HEAD AND CARRIAGE ASSEMBLY	7-1
7.4	STEPPER MOTOR AND ACTUATOR ASSEMBLY	7-2
7.5	INTERLOCK ARM REMOVAL AND INSTALLATION (SA460 Only)	7-2
7.6	SPINDLE HUB AND PULLEY ASSEMBLY	7-2
7.7	CLAMP HUB REMOVAL	7-2
7.8	HUB FRAME ASSEMBLY REMOVAL	7-3
7.9	HUB FRAME ASSEMBLY INSTALLATION AND ADJUSTMENT	7-3
7.10	WRITE PROTECT SWITCH REMOVAL	7-3
7.11	INDEX DETECTOR ASSEMBLY REMOVAL	7-3
7.12	INDEX LED REMOVAL	7-4
7.13	TRACK ZERO PHOTO DETECTOR REMOVAL	7-4

TABLE OF CONTENTS (CONT.)

SECTION VIII	ILLUSTRATED PARTS CATALOGS	8-1
	8.1 DESCRIPTION	8-1
	8.2 INDENTED LEVEL	8-1
	8.3 QUANTITY PER ASSEMBLY	8-1
SECTION IX	SCHEMATIC DIAGRAMS	9-1

LIST OF FIGURES

Figure		Page
1-1	SA410/460 96 TPI Minifloppy	1-0
1-2	SA410/460 Functional Diagram	1-3
1-3	Track Access Timing	1-5
1-4	Read Initiate Timing	1-6
1-5	Read Data Timing(FM)	1-7
1-6	FM and MFM Code Comparisons	1-7
1-7	Write Initiate Timing	1-8
1-8	Write Data Timing (FM)	1-8
1-9	General Control and Data Timing Requirements	1-9
2-1	Interface Connections	2-1
2-2	Interface Signal Driver/Receiver	2-2
2-3	Track Zero Circuit	2-4
2-4	Track Zero Timing	2-5
3-1	Interface Connectors - Physical Locations	3-1
3-2	J1 Connector Dimensions	3-2
3-3	J2 Connector	3-2
4-1	Byte	4-1
4-2	Basic Read/Write Head	4-2
4-3	Recorded Bit	4-2
4-4	Reading a Bit	4-2
4-5	1F and 2F Recording Flux and Pulse Relationship	4-3
4-6	Read/Write Heads	4-3
4-7	Write Circuit	4-4
4-8	Read Circuit	4-5
4-9	Drive Motor Control	4-6
4-10	Index Detector	4-6
4-11	Stepper Circuit	4-7
4-12	Stepper Timing	4-8
4-13	Power On Reset	4-8
4-14	Drive Select, Motor On, and In Use	4-9
4-15	Write Protect	4-9
4-16	Door Lock From In Use or Drive Select	4-10
4-17	Drive Status	4-11
5-1	Write Protect Inoperative	5-3
5-2	Diskette Not Rotating	5-4
5-3	Track 00 Indicator Inoperative	5-5
5-4	Drive Not Coming On Line	5-6
5-5	Index Pulse Inoperative	5-7
6-1	Alignment Lobes	6-1

LIST OF FIGURES (CONT.)

6-2	Motor Plate	6-2
6-3	Azimuth	6-2
6-4	Carriage Limiter	6-3
6-5	Track Zero Adjustment	6-4
6-6	Index Burst	6-5
6-7	Index Detector	6-5
6-8	Motor Speed Adjustment	6-6
8-1	SA410 Parts Break Down	8-2
8-2	Drive Motor Assembly	8-3
8-3	Drive Belt	8-4
8-4	Diskette Guide	8-5
8-5	Spindle Assembly	8-6
8-6	Stepper Motor Assembly	8-7
8-7	Hub Frame Assembly	8-8
8-8	SA460 Read/Write Carriage Assembly	8-10
8-9	SA410 Read/Write Carriage Assembly	8-11
8-10	Main Harness Assembly	8-12
8-11	Front Cover (Std)	8-14
8-12	Front Cover (Optional)	8-15
8-13	Drive PCB (MLC 4)	8-16
9-1	Main Harness Assembly	9-2
9-2	R/W Head Connector	9-3
9-3	Schematic Diagrams (3 Sheets)	9-5

ABBREVIATIONS / MNEMONICS

fci	Flux Changes Per Inch	NRZI	Non Return to Zero
FM	Frequency Modulation	PCB	Printed Circuit Board
ID	Identification	TP	Test Point
I/O	Input/Output	tpi	Tracks Per Inch
IPC	Illustrated Parts Catalog	V_{in}	Voltage In
LED	Light Emitting Diode	V_{out}	Voltage Out
MFM	Modified FM	2F	Double Frequency
NHA	Next Higher Assembly		

ABOUT THIS MANUAL

While every effort has been made to ensure that the information provided herein is correct, please notify us in the event of an error or inconsistency. Direct any comments to:

Shugart
Technical Publications, MS 3-14
475 Oakmead Parkway
Sunnyvale, CA 94086
(408) 733-0100

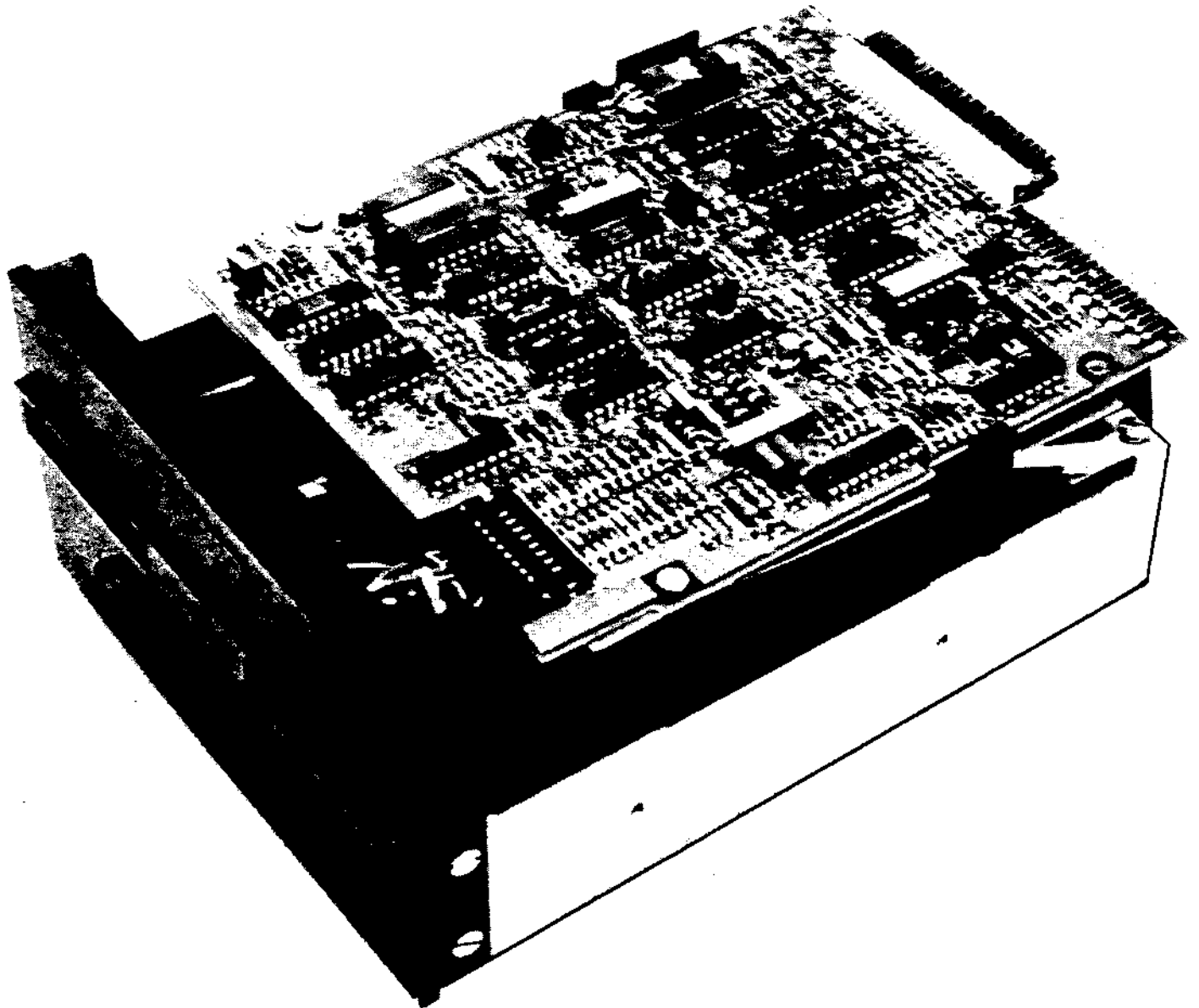

39211-01

FIGURE 1-1. SA410/460 96 TPI MINIFLOPPY

SECTION I INTRODUCTION

1.1 INTRODUCTION

This manual provides depot level maintenance information necessary to maintain, trouble-shoot, and repair the SA410/460 Minifloppy disk drive manufactured by Shugart. A separate OEM manual (SA410/460 OEM P/N 39024) is available which describes the installation, interface, and power requirements useful for the applications of our product.

The compact SA410/460 floppy drives have these standard features:

- a. Direct drive stepping motor actuator with precise HeliCam™ V-groove lead screw
- b. Single and double density capability
- c. 96 tracks per inch
- d. 0.5/1.0 M byte capacity (unformatted)
- e. 125/250 k bits/second transfer rate
- f. Low heat dissipation
- g. Positive media insertion to avoid media damage
- h. Rapid start dc drive motor (eliminates ac requirements) with precision servo speed control and integral tachometer
- i. Ball bearing anti-backlash
- j. Internal write protect circuitry
- k. Activity light
- l. Drive status
- m. Door lock solenoid (optional)
- n. Solid die cast chassis
- o. Shugart Bi-Compliant™ read/write head assembly on SA460

1.2 SPECIFICATION SUMMARY

1.2.1 Performance Specifications

	SA410	SA460
Capacity	Single/Double Density	Single/Double Density
Unformatted		
Per Disk	250/500 k bytes	0.5/1 M byte
Per Surface	250/500 k bytes	250/500 k bytes
Per Track	3.1/6.2 k bytes	3.1/6.2 k bytes
Formatted		
(10 Sectors/Track)		
Per Disk	204.8/409.6 k bytes	409.6/819.2 k bytes
Per Surface	204.8/409.6 k bytes	204.8/409.6 k bytes
Per Track	256/512 k bytes	256/512 k bytes
Transfer Rate	125/250 k bits/sec	125/250 k bits/sec
Latency (average)	100 msec	100 msec
Access Time (w/o settling)		
Track to Track	6 msec	6 msec
Side to Side	—	0.2 msec
Average	158 msec	158 msec
Settling Time	15 msec	15 msec
Motor Start Time	200 msec	200 msec

1.2.2 Functional Specifications

	SA410	SA460
Rotational Speed	300 rpm	300 rpm
Recording Density (inside track)	2788/5576 bpi	2961/5922 bpi
Flux Density	5576 fci	5922 fci
Track Density	96 tpi	96 tpi
Tracks	80	80
Index	1	1
Encoding Method	FM/MFM	FM/MFM
Media Requirements		
Soft sectored	SA114	SA164
16 sectors hard sectored	SA115	SA165
10 sectors hard sectored	SA117	SA167
Industry standard flexible diskette		
Oxide on 0.003 in. (0.08 mm) Mylar		
5.25 in. (133.4 mm) square jacket		

1.2.3 Physical Specifications

	Operating	Shipping
Environmental Limits		
Ambient Temperature:	40° to 115°F (4.4° to 46.1°C)	-40° to 144°F (-40° to 62°C)
Relative Humidity:	20% to 80%	1% to 95%
Maximum Wet Bulb:	85°F (25.6°C)	no condensation
	Storage	
	-8° to 117°F (-22° to 47°C)	
	1% to 95%	
	no condensation	

DC Voltage Requirements

- +12 V ± 5% @ 1.3A typical, 2.2A max
- + 5 V ± 5% @ 0.5A typical, 0.7A max

Mechanical Dimensions (exclusive of front panel):

- Width = 5.75 in. (146.1 mm)
- Height = 3.25 in. (82.6 mm)
- Depth = 8.25 in. (205 mm)
- Weight = 3 lbs 3 ozs (1.44 kg nominal)

Power Dissipation:

- 18.2 watts (62.1 BTU/hr) Continuous (typical)
- 14.6 watts (49.8 BTU/hr) Standby (typical)

1.2.4 Reliability Specifications

Mean Time Between Failure: 8000 Power on hours (POH) under typical usage*

* Assumes the duty cycle of the drive spindle motor to be 25%

Mean Time to Repair: 30 minutes

Component Life: 5 years

Error Rates:

- Soft Read Errors: 1 per 10⁸ bits read
- Hard Read Errors: 1 per 10¹² bits read
- Seek Errors: 1 per 10⁶ seeks

Media Life:

- Passes per Track: 3.0 × 10⁶
- Insertions: 30,000 +

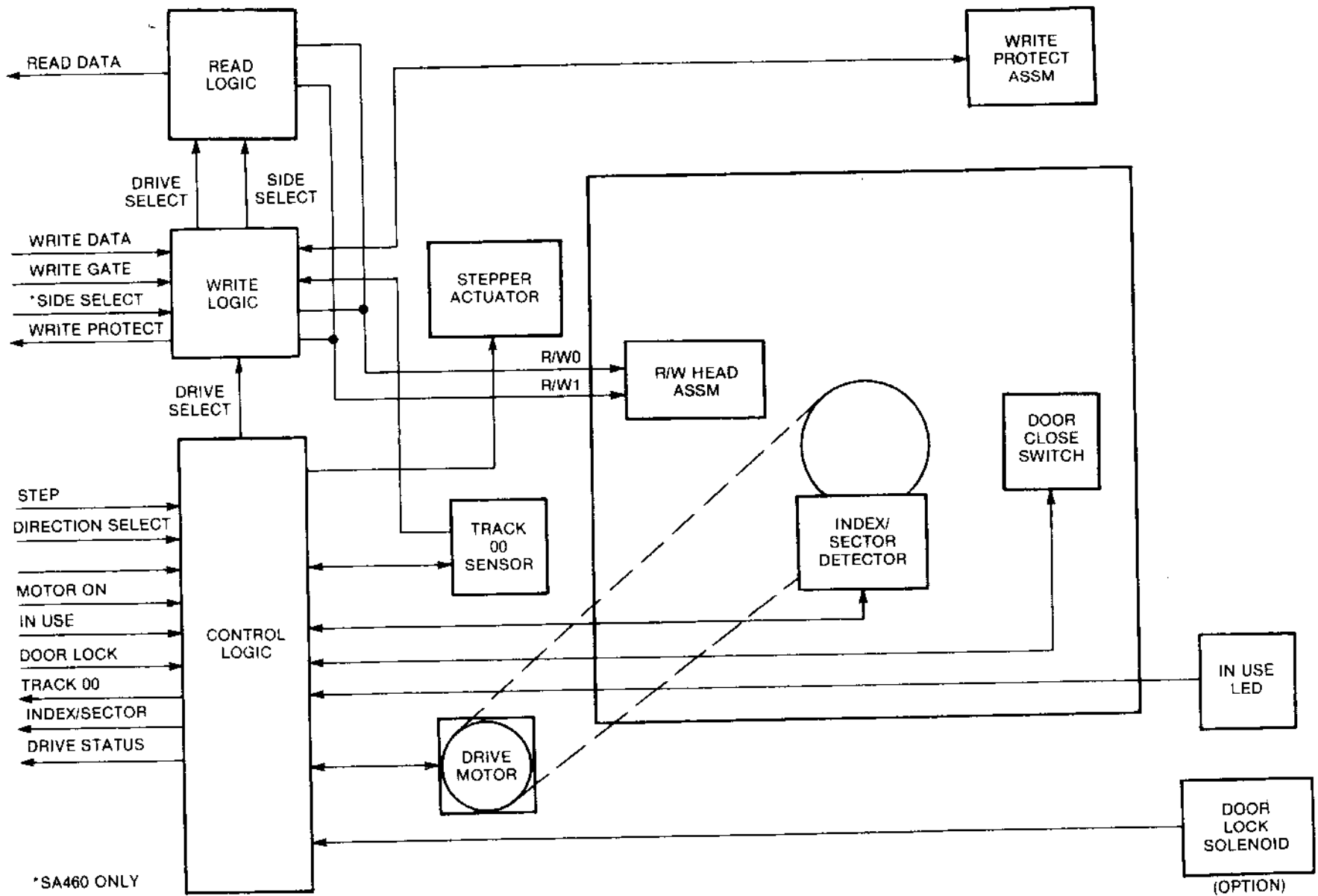

FIGURE 1-2. SA410/460 FUNCTIONAL DIAGRAM

1.3 FUNCTIONAL CHARACTERISTICS

The SA410/460 Minifloppy disk drives consist of:

- a. Read/Write and Control Electronics
- b. Drive Mechanism
- c. Precision Track Positioning Mechanism
- d. Read/Write Head(s)

See figure 1-2 for a functional diagram of the SA410/460.

1.3.1 Electronics

The electronics are packaged on one PCB which contains:

- a. Index Detector Circuits
- b. Head Position Actuator Driver
- c. Read/Write Amplifier and Transition Detector
- d. Write Protect
- e. Drive Select Circuits
- f. Spindle Motor Control

The head positioning actuator moves the read/write head(s) to the desired track on the diskette. The head(s) are loaded onto the diskette when the door is closed.

1.3.2 Drive Mechanism

The dc drive motor under servo speed control (using integral tachometer) rotates the spindle at 300 rpm through a belt-drive system. An expandable collet/spindle assembly provides precision media positioning to ensure data interchange. A mechanical interlock prevents door closure without proper media insertion, thus eliminating media damage.

1.3.3 Positioning Mechanism

The read/write head assembly is accurately positioned through the use of a precision HeliCam V-groove lead screw with a ball follower which is attached to the head carriage assembly. Precise track location is accomplished as the lead screw is rotated in discrete increments by a stepping motor.

1.3.4 Read/Write Head(s)

The glass bonded ceramic and ferrite read/write head(s) contains tunnel erase elements to provide erased areas between data tracks. Thus, normal interchange tolerances between media and drives will not degrade the signal to noise ratio and diskette interchangeability is ensured.

The read/write head(s) is mounted on a carriage which is located on precision carriage ways. The diskette is held in a plane perpendicular to the read/write head(s) by a platen located on the base casting. This precise registration assures perfect compliance with the read/write head(s). The read/write head(s) is in direct contact with the diskette. The head surfaces have been designed to obtain maximum signal transfer to and from the magnetic surface of the diskette with minimum head/diskette wear.

1.4 FUNCTIONAL OPERATIONS

1.4.1 Power Sequencing

Applying dc power to the SA410 or SA460 can be done in any sequence; however, during power up, the WRITE GATE line must be held inactive or at a high level. After application of dc power, a 100 ms delay should be introduced before any operation is performed. After powering on, initial position of the read/write heads is indeterminate with respect to the data tracks on the media. In order to assure proper positioning of the read/write heads after power on, a step out operation should be performed until the TRACK 00 line becomes active (recalibrate).

1.4.2 Drive Selection

Drive selection occurs when the DRIVE SELECT line of a drive is activated. Only the drive with this line active will respond to input lines or gate output lines. Under normal operation, the DRIVE SELECT line enables the input and output lines and lights the activity LED on the front of the drive.

1.4.3 Motor On

In order for the host system to read or write data, the dc drive motor must be activated. This is accomplished by activating the MOTOR ON line. A 200 ms delay must be introduced after activating this line to allow the motor to come up to speed before reading or writing. All motors in a daisy chain configuration are activated with MOTOR ON.

The motor must be turned off by the host system by deactivating the MOTOR ON line. This should be done if the drive has not received a new command within 2 seconds (10 revolutions of the diskette) after completing the execution of a command. This will ensure maximum motor and media life.

1.4.4 Track Accessing

Seeking the read/write heads from one track to another is accomplished by:

- Activating DRIVE SELECT line.
- Selecting desired direction utilizing DIRECTION SELECT line.
- WRITE GATE being inactive.
- Pulsing STEP line.

Multiple track accessing is accomplished by repeated pulsing of the STEP line until the desired track is reached. Each pulse on the STEP line will cause the read/write heads to move either one track in or one track out depending on the DIRECTION SELECT line. Head movement is initiated on the trailing edge of the STEP pulse.

1.4.5 Step Out

With the DIRECTION SELECT line at a plus logic level (2.5 V to 5.25 V), a pulse on the STEP line will cause the read/write heads to move one track away from the center of the disk. The pulse(s) applied to the STEP line must have the timing characteristics shown in figure 1-3.

1.4.6 Step In

With the DIRECTION SELECT line at minus logic level (0.0 V to 0.04 V), a pulse on the STEP line will cause the read/write heads to move one track closer to the center of the disk. The pulse(s) applied to the STEP line must have the timing characteristics shown in figure 1-3.

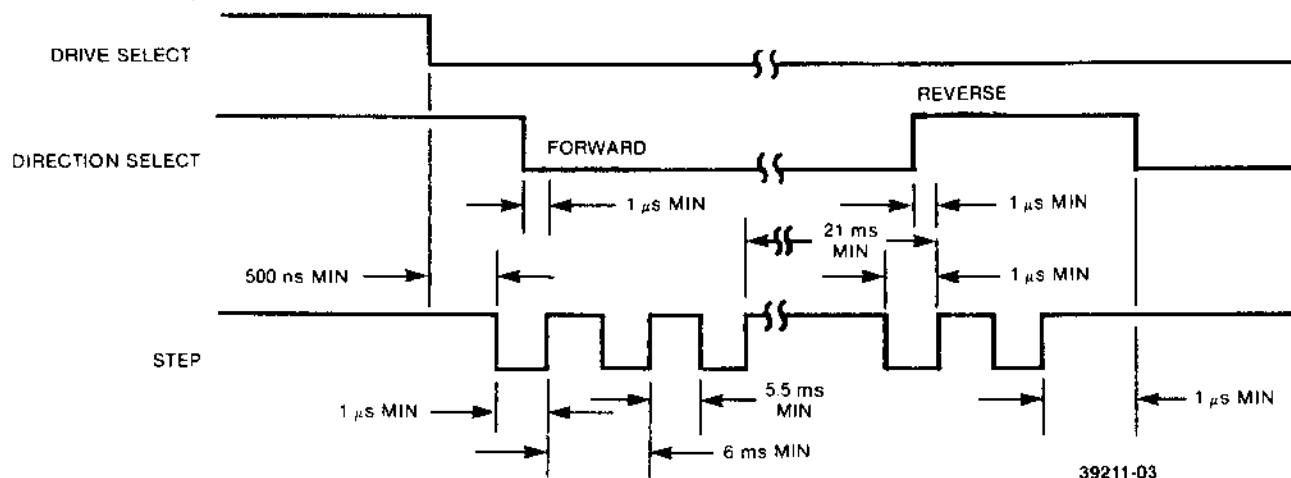
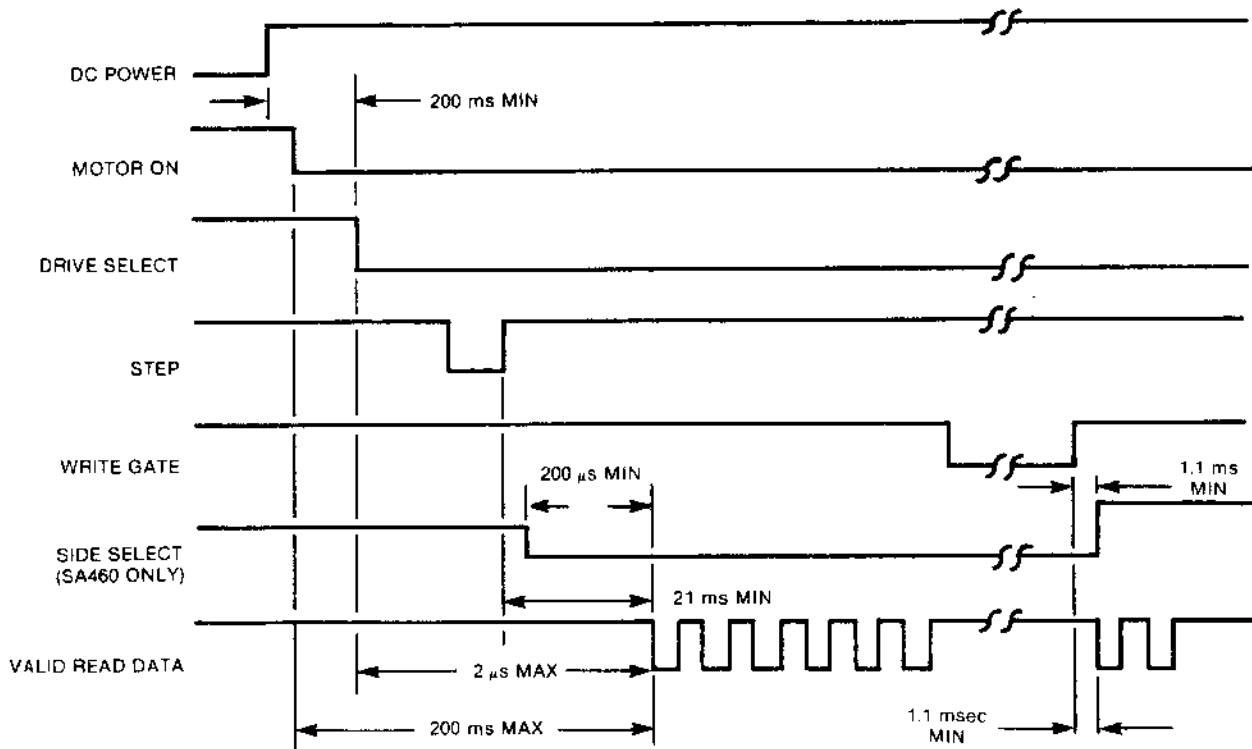

FIGURE 1-3. TRACK ACCESS TIMING

1.4.7 Side Selection (SA460 Only)

Head selection is controlled via the I/O signal line designated SIDE SELECT. A plus logic level on the SIDE SELECT line selects the read/write head on the side 0 surface of the diskette. A minus logic level selects the side 1 read/write head. When switching from one side to the other, a 200 μ s delay is required after SIDE SELECT changes state before a read or write operation can be initiated. SIDE SELECT should not change state for a minimum of 1.1 msec after WRITE GATE is terminated. Figure 1-4 shows the use of SIDE SELECT prior to a read operation.



39211-04

FIGURE 1-4. READ INITIATE TIMING

1.4.8 Read Operation

Reading data from the SA410/460 minifloppy drive is accomplished by:

- Activating DRIVE SELECT line.
- Selecting head (SA460 only).
- WRITE GATE being inactive.

The timing relationships to initiate a read sequence are shown in figure 1-4. These timing specifications are required in order to guarantee that the position of the read/write head has stabilized prior to reading.

The timing of READ DATA (FM) is shown in figure 1-5.

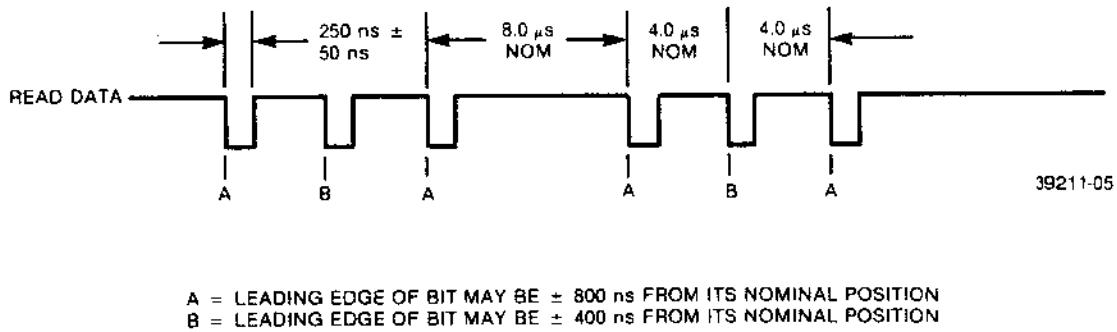

FIGURE 1-5. READ DATA TIMING (FM)

The encoding scheme of the recorded data can be either FM or MFM. FM encoding rules specify a clock bit at the start of every bit cell (see figure 1-6). MFM encoding rules allow clock bits to be omitted from some bit cells, with the following prerequisites:

- The clock bit is omitted from the current bit cell if either the preceding bit cell or the current bit cell contains a data bit. See figure 1-6.
- In the above mentioned encoding schemes, clock bits are written at the start of the respective bit cells and data bits at the centers of their bit cells.

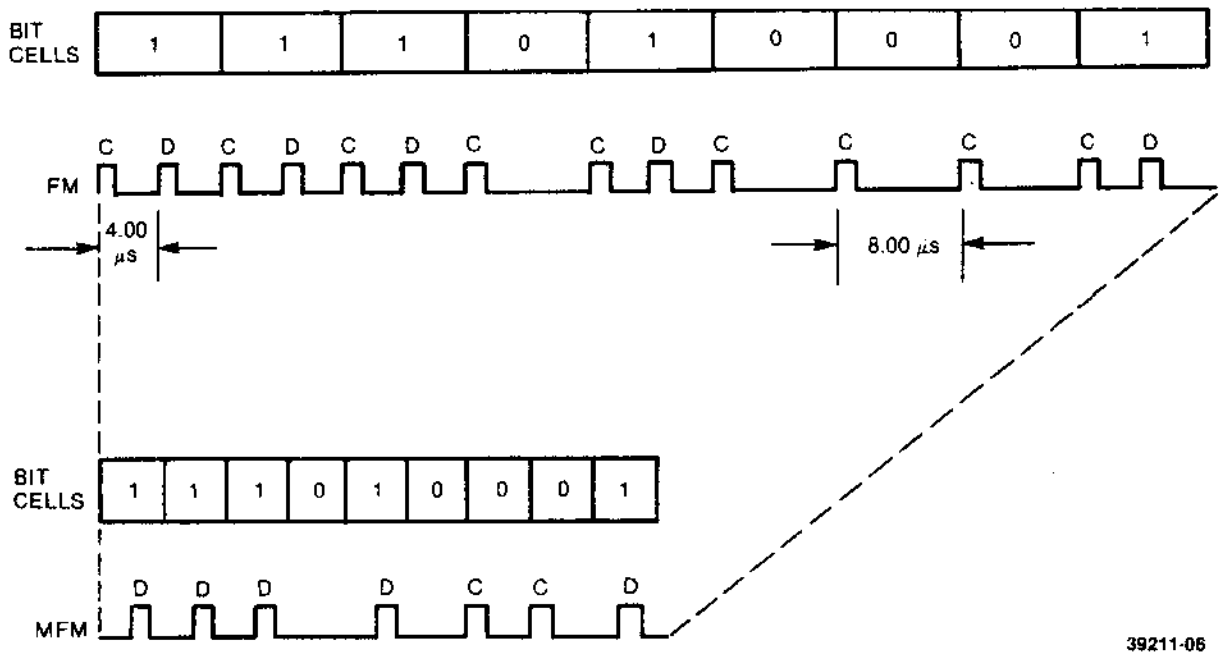

FIGURE 1-6. FM AND MFM CODE COMPARISONS

1.4.9 Write Operation

Writing data to the SA410/460 is accomplished by:

- Activating the DRIVE SELECT line.
- Selecting head (SA460 only).
- Activating the WRITE GATE line.
- Pulsing the WRITE DATA line with the data to be written.

The timing relationships required to initiate a WRITE DATA sequence are shown in figure 1-7. These timing specifications are required in order to guarantee that the position of the read/write head has stabilized prior to writing. DRIVE SELECT or SIDE SELECT (SA460) may not change, nor may a step command be issued, for a minimum of 1.1 msec after WRITE GATE is returned to an inactive state.

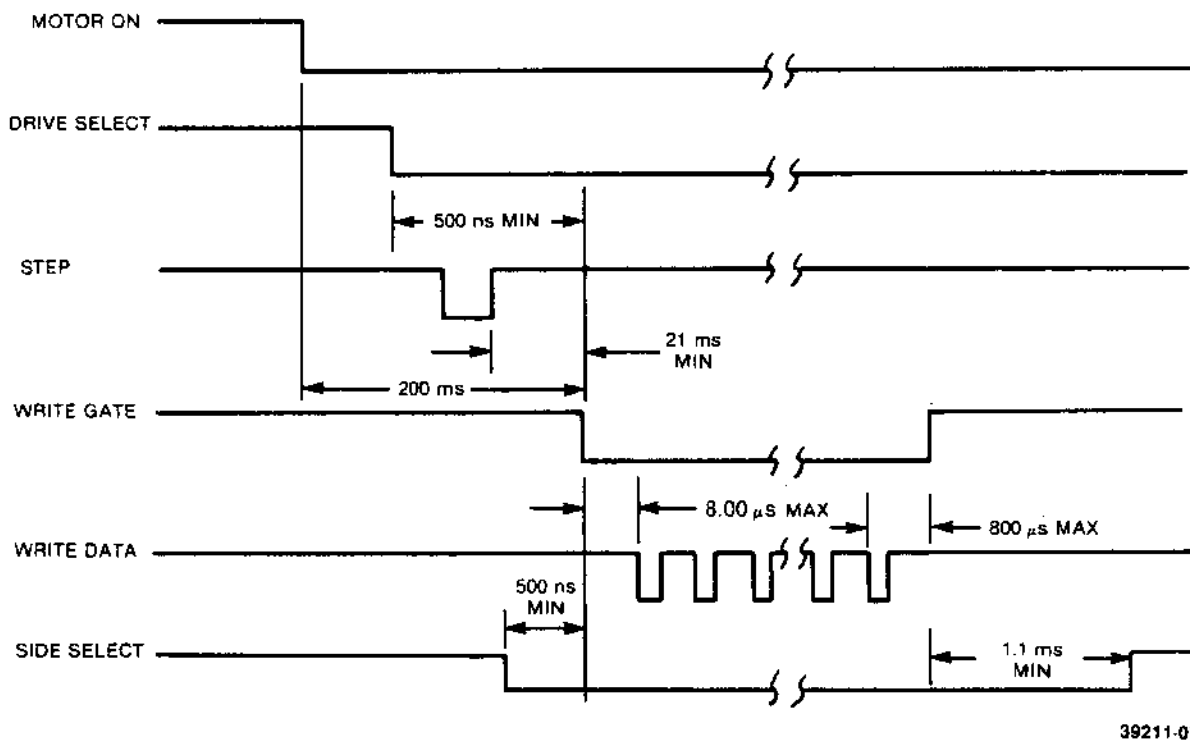

FIGURE 1-7. WRITE INITIATE TIMING

The timing specifications for the WRITE DATA pulses are shown in figure 1-8.

WRITE DATA encoding can be FM or MFM. The WRITE DATA should be precompensated 100 ns on all tracks to counter the effects of bit shift. The direction of compensation required for any given bit in the data stream depends on the pattern it forms with nearby bits.

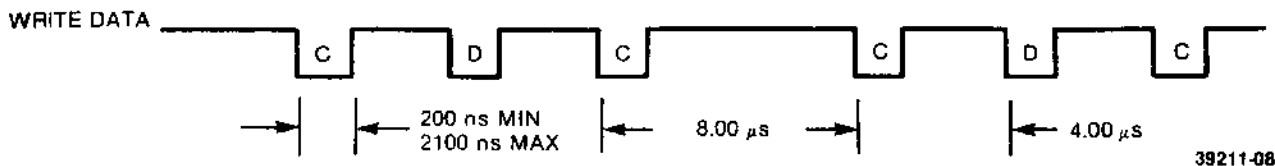

FIGURE 1-8. WRITE DATA TIMING (FM)

1.4.10 Sequence Of Events

The timing diagram shown in figure 1-9 shows the necessary sequence of events with associated timing restrictions for proper operation.

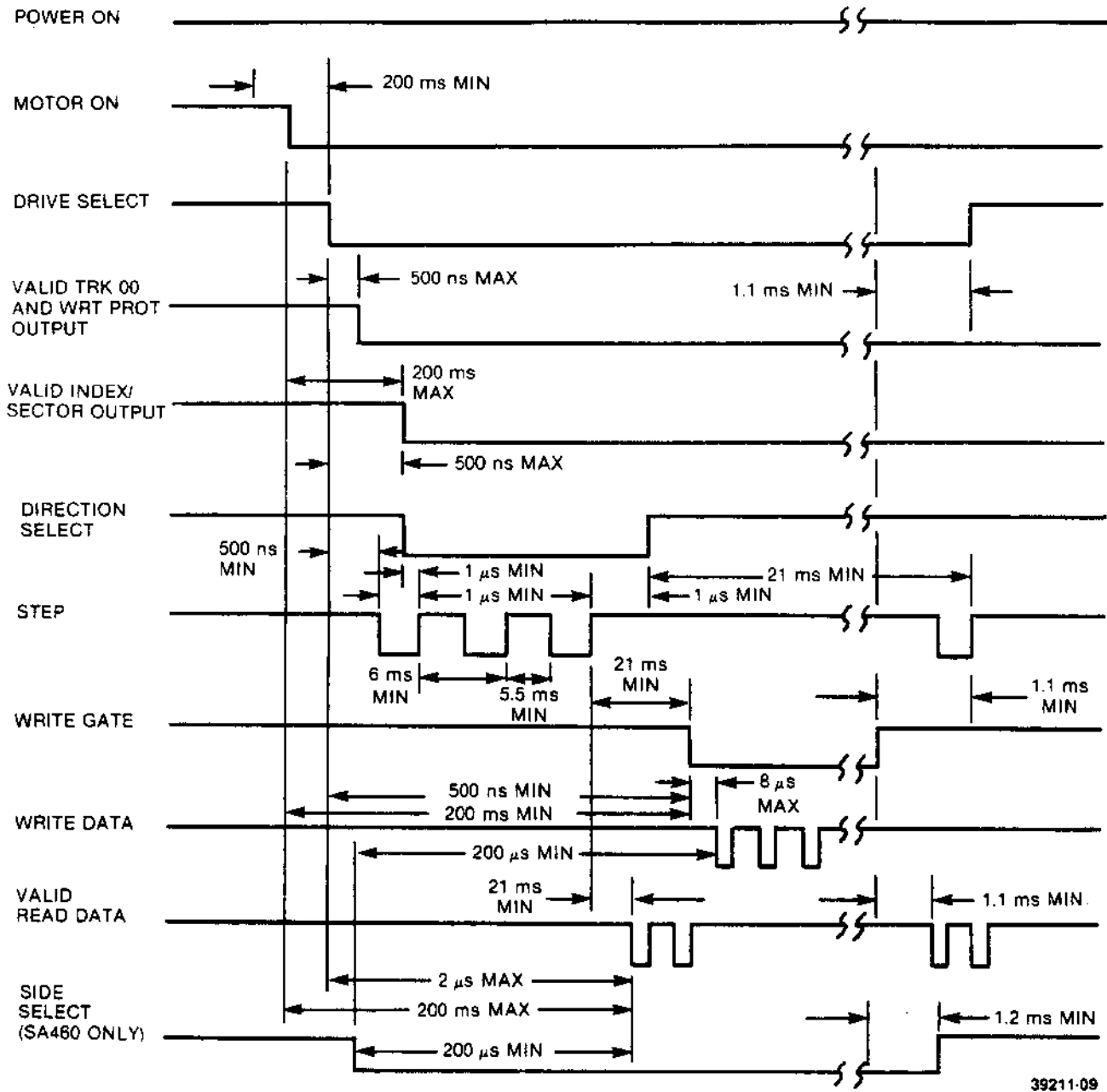

FIGURE 1-9. GENERAL CONTROL AND DATA TIMING REQUIREMENTS

SECTION II ELECTRICAL INTERFACE

2.1 ELECTRICAL INTERFACE

The interface of the SA410/460 minidiskette drives can be divided into two categories:

- a. Signal
- b. Power

The following sections provide the electrical definition for each line of the interface.

Refer to figure 2-1 for all interface connections.

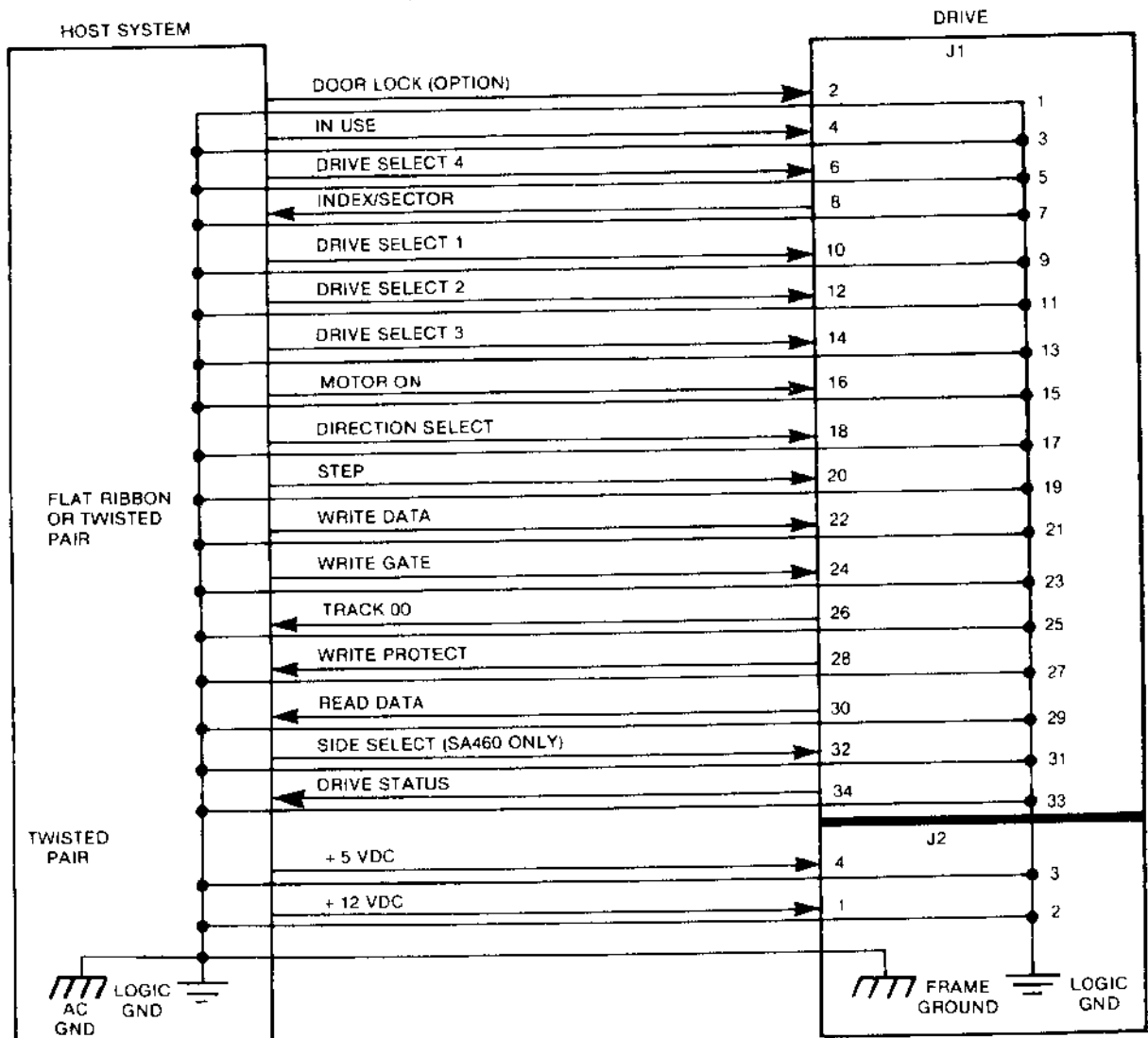

39211-10

FIGURE 2-1. INTERFACE CONNECTIONS

2.2 SIGNAL INTERFACE

The signal interface consists of two categories:

- a. Control
- b. Data Transfer

All lines in the signal interface are digital in nature and either provide signals to the drive (input) or provide signals to the host (output) via interface connector P1/J1.

2.2.1 Input Lines

The input signals are of three types, those intended to be multiplexed in a multiple drive system, those which will perform the multiplexing, and those signals which are not multiplexed and affect all the drives in a daisy chain system.

The input signals to be multiplexed are:

- a. DIRECTION SELECT
- b. STEP
- c. WRITE DATA
- d. WRITE GATE
- e. SIDE SELECT (SA460 only)

The input signals which are intended to do the multiplexing are:

- a. DRIVE SELECT 1
- b. DRIVE SELECT 2
- c. DRIVE SELECT 3
- d. DRIVE SELECT 4

The signals which are not multiplexed are IN USE and MOTOR ON.

Figure 2-2 shows the recommended circuit for the input lines with the following electrical specifications.

True = Logical Zero = V_{in} 0.0 V to +.04 V @ 40 mA (max)

False = Logical one = V_{in} + 2.5 V to +5.25 V @ 250 μ A (open)

Input impedance = 220/330 ohms

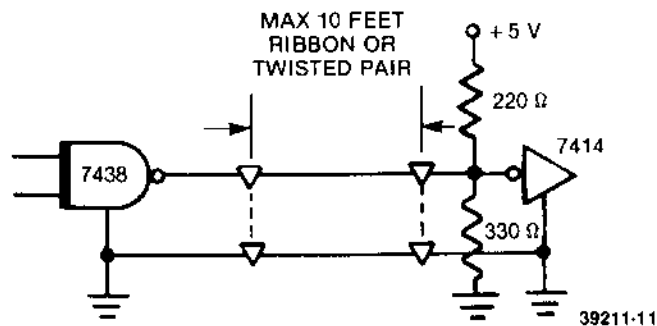

FIGURE 2-2. INTERFACE SIGNAL DRIVER/RECEIVER

2.2.2 Input Line Terminations

The SA410/460 has been provided with the capability of terminating the following eight input lines:

- a. MOTOR ON
- b. DIRECTION SELECT
- c. STEP
- d. WRITE DATA
- e. WRITE GATE
- f. SIDE SELECT (SA460 only)
- g. DOOR LOCK
- h. IN USE

These lines are terminated through a 220/330 ohm resistor pack installed in a dip socket.

In a single drive system, this resistor pack should be kept in place to provide proper terminations.

In a multiple drive system, only the last drive on the interface is to be terminated. All other drives on the interface must have the resistor pack removed. External terminations may also be used, but the user must provide the terminations beyond the last drive and each of the eight lines must be terminated to +5 Vdc through a 220/330 ohm 1/4 watt resistor.

2.2.3 Drive Select 1-4

The SA460 and SA410 are configured to operate with up to four drives in a multiplexed multiple drive system.

SINGLE DRIVE SYSTEM (MX shorting plug installed)

With the MS shorting plug installed, DRIVE SELECT, when activated to a logical 0 level, will turn the motor on. With MX shorted, the I/O lines are always enabled.

MULTIPLE DRIVE SYSTEM (MS shorting plug not installed)

Four separate input lines (DRIVE SELECT 1, DRIVE SELECT 2, DRIVE SELECT 3, and DRIVE SELECT 4) are provided so that up to four drives in a multiplexed system may have separate input pins. Only the drive with its unique DRIVE SELECT line active will turn on its motor, allow the drive to respond to multiplexed input lines, and enable the outputs to drive their respective signal lines. A logical 0 on the interface selects a unique drive select line for a drive.

2.2.4 Motor On

This input, when activated to a logical 0 level, will turn on the drive motor to allow reading or writing on the drive. After activating this line, a 0.2 second delay must be allowed before reading or writing. For maximum motor life, this line should be deactivated if no commands have been issued to the drive within 2 seconds nominal (10 revolutions of the media) after completion of a previous command. Depending on the application, this time may be varied by the host system to maximize system through-put and motor life.

2.2.5 Direction Select

This interface line defines the direction of motion the read/write heads will take when the STEP line is pulsed. An open circuit, or logical 1, defines the direction as "out" and if a pulse is applied to the STEP line, the read/write heads will move away from the center of the disk. Conversely, if this input is shorted to ground, or a logical 0 level, the direction of motion is defined as "in," and if a pulse is applied to the STEP line, the read/write heads will move towards the center of the disk.

2.2.6 Step

This interface line is a control signal which causes the read/write heads to move in the direction of motion defined by the DIRECTION SELECT line. This signal must be a logical 0 pulse with a minimum pulse width of 1 μ s and a logical 1 for 5.5 ms minimum between adjacent pulses. Each subsequent pulse must be delayed by 6 ms minimum from the preceding pulse.

The access motion is initiated on each logical 0 to logical 1 transition, or the trailing edge of the signal pulse. Any change in the DIRECTION SELECT line must be made at least 1 μ s before the trailing edge of the STEP pulse. The DIRECTION SELECT logic level must be maintained 1 μ s after the trailing edge of STEP pulse.

2.2.7 Write Gate

The active state of this signal, or logical 0, enables WRITE DATA to be written on the diskette. The inactive state, or logical 1, enables the READ DATA logic and stepper logic. Refer to figure 1-7 for timings.

2.2.8 Write Data

This interface line provides the data to be written on the diskette. Each transition from a logical 1 level to a logical 0 level will cause the current through the read/write heads to be reversed, thereby writing a data bit. This line is enabled by WRITE GATE being active. WRITE GATE must be inactive during a read operation. See figure 1-7 for timings.

2.2.9 Side Select (SA460 only)

This signal defines which side of a two-sided diskette is to be written to or read from. A logical 1 selects the side 0 head. When switching from one side to the other, a 200 μ s delay is required before a read operation can be initiated. A delay of 1.1 ms is required after a write operation before changing the state of SIDE SELECT.

2.2.10 In Use

Normally, the activity LED on the selected drive will activate when the corresponding DRIVE SELECT signal is active. The IN USE input can alternately activate the LED on all the drives in a daisy chain or separately in a radial configuration.

2.2.11 Output Lines

The output control lines have the following electrical specifications:

True = Logical 0 = $V_{out} + 0.0 \text{ V to } +0.04 \text{ V @ } 40 \text{ mA (max)}$

False = Logical 1 = $V_{out} + 5.25 \text{ V (open collector @ } 250 \mu\text{A max)}$

See figure 2-2 for the recommended circuit.

2.2.12 Track 00

The active, or logical 0 state of this interface signal indicates when the read/write heads of the drive are positioned at track 00 (the outermost track) and the stepper is locked on track. This signal is at a logical 1 level, or inactive state, when the read/write heads of the drive are not at track 00. When the heads are at track 00 and an additional step out pulse is issued to the drive, a mechanical stop will keep the read/write heads at track 00. See figures 2-3 and 2-4 for track 00 circuit and timing.

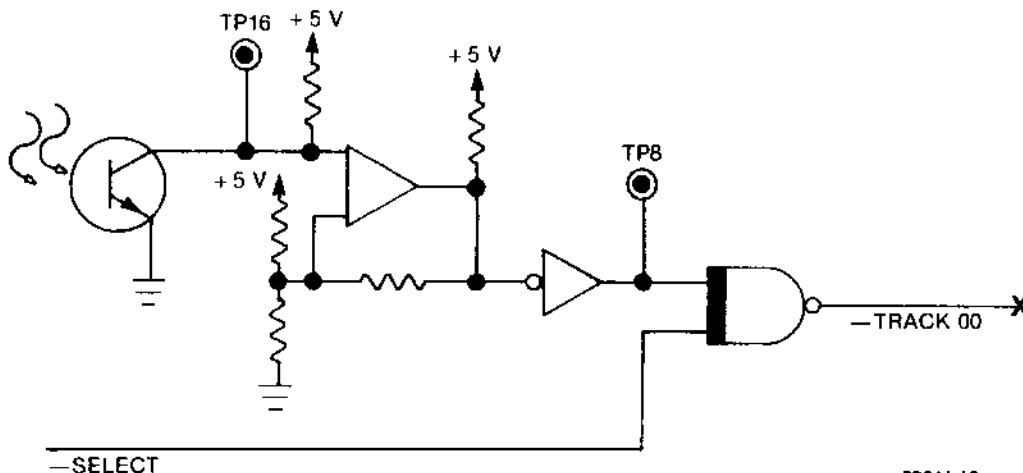

FIGURE 2-3. TRACK ZERO CIRCUIT

39211-12

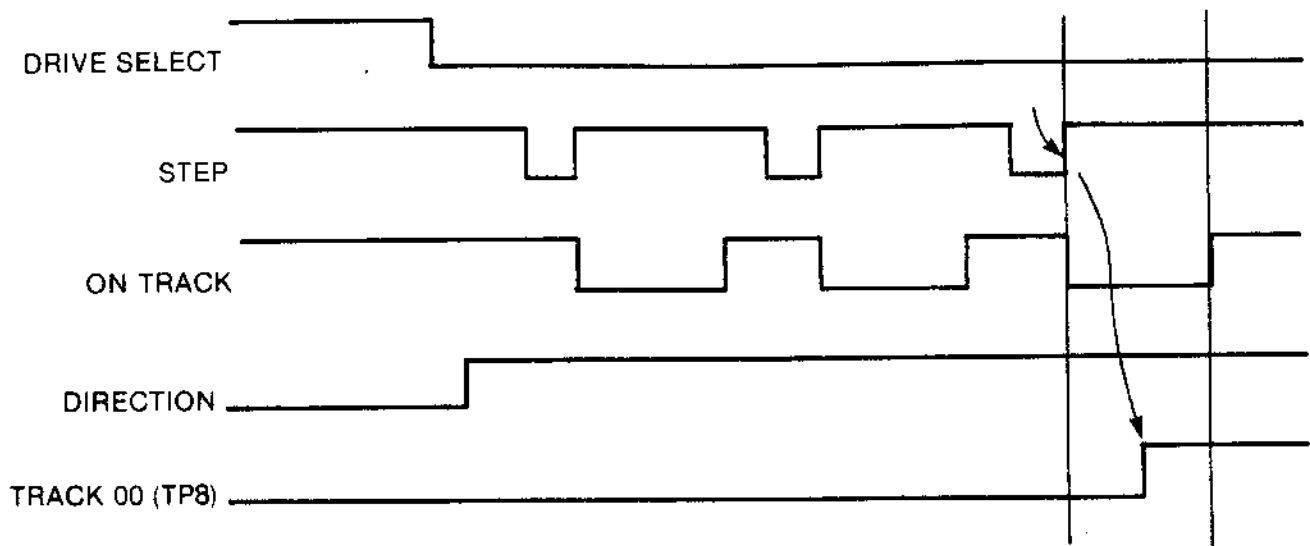

FIGURE 2-4. TRACK ZERO TIMING

39211-13

2.2.13 Index/Sector

This interface signal is provided by the drive each time an index or sector hole is sensed at the INDEX/SECTOR photo detector. Normally, this signal is at a logical 1 level and makes the transition to the logical 0 level each time a hole is sensed.

When using media soft sectored, there will be one pulse on this interface signal per revolution on the diskette (200 ms). This pulse indicates the physical beginning of a track.

When using the INDEX/SECTOR signal, look for an edge or transition rather than a level for determining its status. With no diskette inserted, this signal remains active or at a logical 0 level which is an erroneous status.

2.2.14 Read Data

This interface line provides the "raw data" (clock and data together) as detected by the drive electronics. Normally, this signal is a logical 1 level and becomes a logical 0 level for the active state.

2.2.15 Write Protect

This interface signal is provided by the drive to give the user an indication when a write protected diskette is installed. The signal is logical 0 level when it is protected with a label over the notch. The drive will inhibit writing with a protected diskette installed in addition to notifying the interface.

2.3 POWER INTERFACE

The SA410 or SA460 requires only dc power for operation. DC power to the drive is provided via P2/J2 located on the component side of the PCB near the spindle drive motor.

2.4 FRAME GROUND

It is important that the drive be frame grounded to the host system ac or frame ground. Failure to do so may result in drive noise susceptibility.

SECTION III PHYSICAL INTERFACE

3.1 PHYSICAL INTERFACE

The electrical interface between the SA410 or SA460 and the host system is via two connectors. The first connector, J1, provides the signal interface and the second connector, J2, provides the dc power.

This section describes the physical connectors used on the drive and the recommended connectors to be used with them. Refer to figure 3-1 for connector locations.

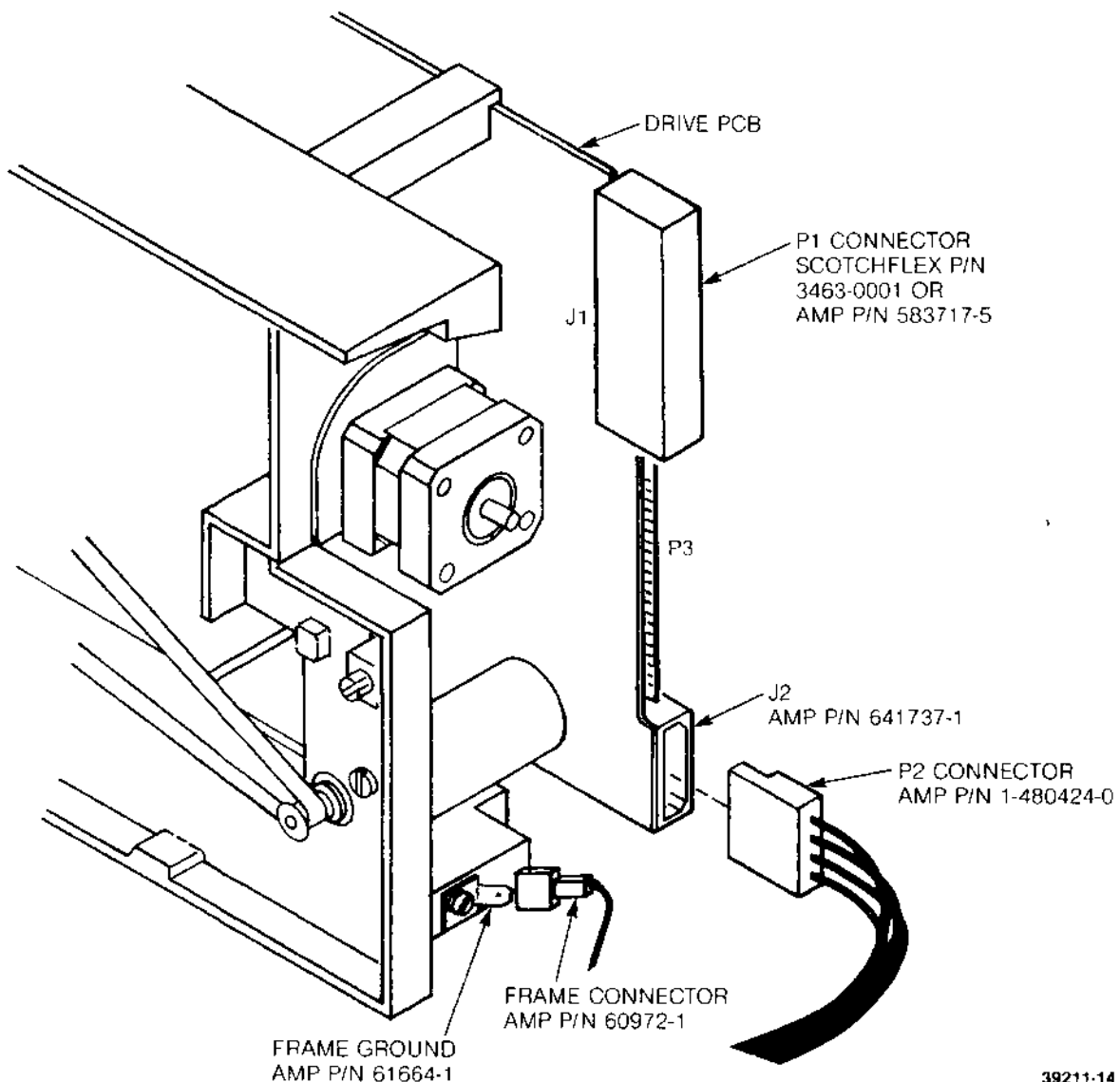

39211-14

FIGURE 3-1. INTERFACE CONNECTORS - PHYSICAL LOCATIONS

3.1.1 J1/P1 Connector

Connection to J1 is through a 34 pin PCB edge connector. The dimensions for this connector are shown in figure 3-2. The pins are numbered 1 through 34 with the even numbered pins on the component side of the PCB and the odd numbered pins on the non-component side. Pin 2 is located on the end of the PCB connector closest to the corner and is labeled 2. A key slot is provided between pins 4 and 6 for optional connector keying.

The recommended connectors for P1 are shown in figure 3-1.

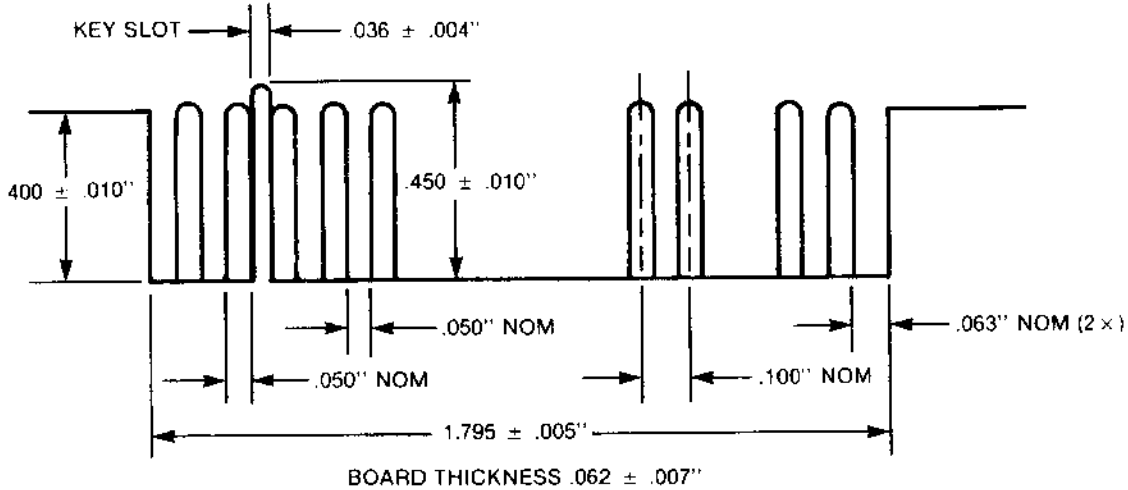

FIGURE 3-2. J1 CONNECTOR DIMENSIONS

39211-15

3.1.2 J2/P2 Connector

The dc power connector, J2, is mounted on the component side of the PCB and is located near the spindle drive motor. J2 is a 4 pin AMP Mate-N-Lok connector P/N 641737-1. The recommended mating connector (P2) is AMP P/N 1-480424-0 utilizing AMP pins P/N 61473-1. J2, pin 1, is labeled on the component side of the PCB. Wire used should be #18 AWG. Figure 3-3 illustrates the J2 connector as seen on the PCB from the rear of the drive.

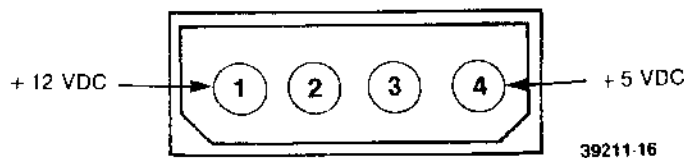

FIGURE 3-3. J2 CONNECTOR

39211-16

3.2 FRAME GROUNDING

The drive must be frame grounded to the host system to ensure proper operation. If the frame of the drive is not fastened directly to the frame of the host system with a good ac ground, a wire from the system ac frame ground must be connected to the drive. For this purpose, a faston tab is provided on the drive where a faston connector can be attached or soldered. The tab is AMP P/N 61664-1 and its mating connector is AMP P/N 60972-1.

SECTION IV THEORY OF OPERATION

4.1 THEORY OF OPERATION

The SA410/460 floppy diskette drive electronics are packaged on one PCB which contains:

- a. Read/Write Amplifier and Transition Detector
- b. Spindle Motor Control
- c. Drive Select Circuits
- d. Index Detector Circuits
- e. Track Zero Circuits
- f. Track Accessing Circuits
- g. Power On Reset Control
- h. Write Protect Circuits
- i. Door Lock Solenoid Circuits (optional)
- j. Drive Status Circuits

The head positioning actuator moves the read/write head(s) to the desired track on the diskette. The head(s) is loaded onto the diskette when the door is closed.

The following information describes each of the above functions in detail.

4.2 READ/WRITE OPERATIONS

- a. The SA410/460 uses double frequency non return to zero (NRZI) recording method.
- b. The read/write head, in general, is a ring with a gap and a coil wound at some point on the ring.
- c. During a write operation, a bit is recorded when the flux direction in the ring is reversed by rapidly reversing the current in the coil.
- d. During a read operation, a bit is read when the flux direction in the ring is reversed as a result of a flux reversal on the diskette surface.

SA410/460 drives use the double-frequency (2F) longitudinal NRZI method of recording. Double frequency is the term given to the recording system that inserts a clock bit at the beginning of each bit cell thereby doubling the frequency of recorded bits. This clock bit, as well as the data bit, is provided by the using system. See figure 4-1.

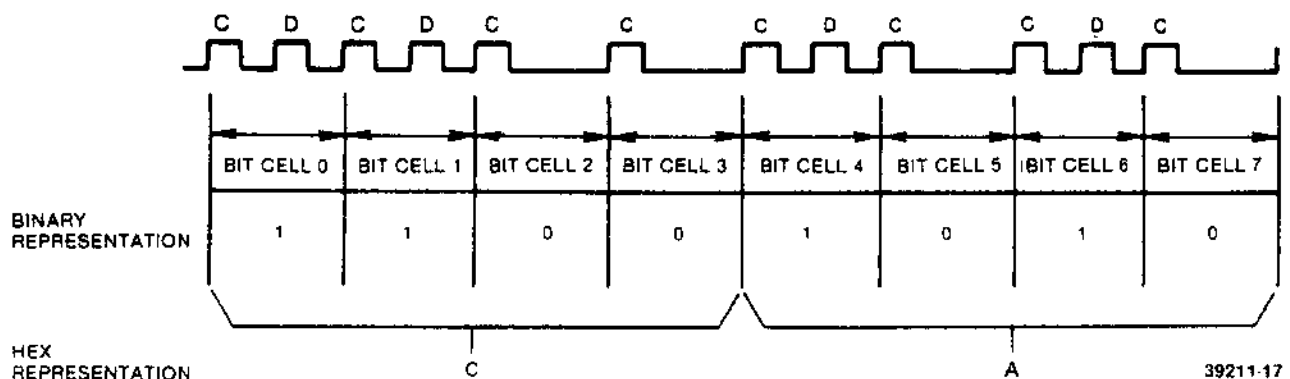

FIGURE 4-1. BYTE

The read/write head is a ring with a gap and a coil wound some point on the ring. When current flows through the coil, the flux induced in the ring fringes at the gap. As the diskette recording surface passes by the gap, the fringe flux magnetizes the surface in a longitudinal direction. See figure 4-2.

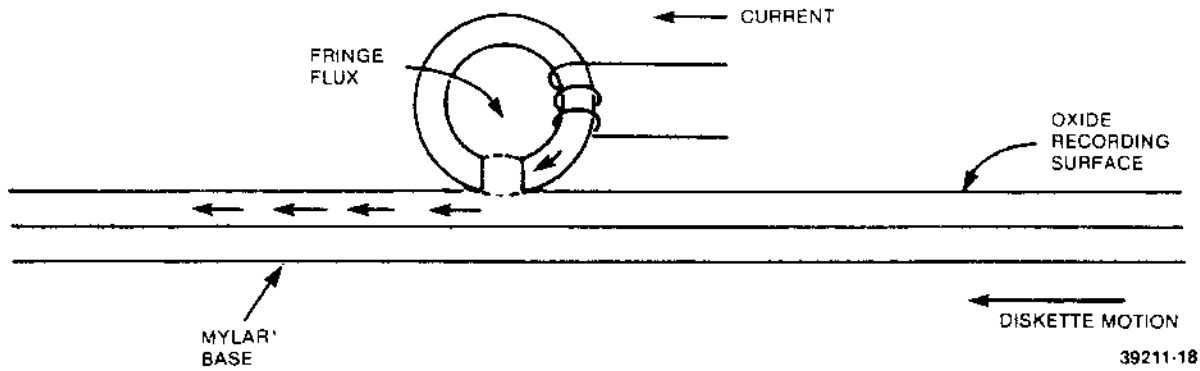

FIGURE 4-2. BASIC READ/WRITE HEAD

The drive writes two frequencies: 1F 62.5 k Hz and 2F 125 k Hz. During a write operation, a bit is recorded when the flux direction in the ring is reversed by rapidly reversing the current in the coil. The fringe flux is reversed in the gap and hence the portion of the flux flowing through the oxide recording surface is reversed. If the flux reversal is instantaneous in comparison to the motion of the diskette, it can be seen that the portion of the diskette surface that just passed under the gap is magnetized one direction while the portion under the gap is magnetized in the opposite direction. This flux reversal represents a bit. See figure 4-3.

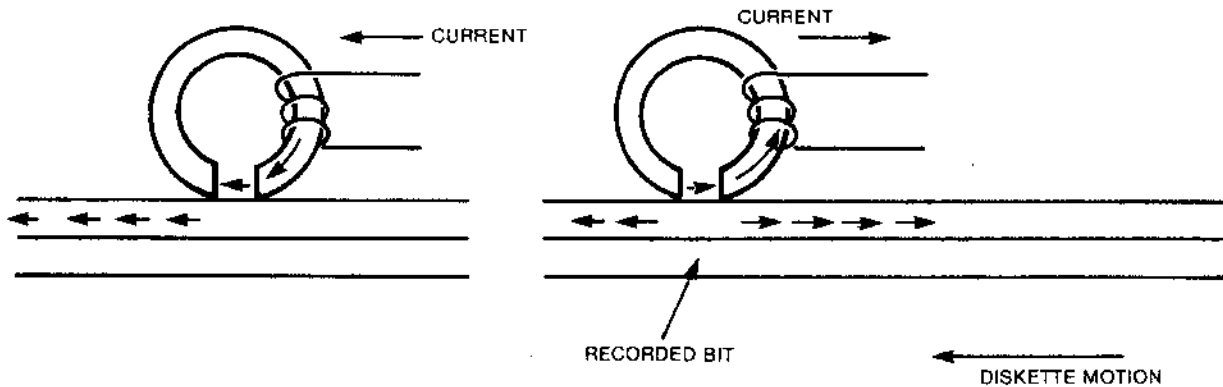

FIGURE 4-3. RECORDED BIT

39211-19

During a read operation, a bit is read when the flux direction in the ring is reversed as a result of a flux reversal on the diskette surface. The gap first passes over an area that is magnetized in one direction and a constant flux flows through the ring and coil. The coil registers no output voltage at this point. When a recorded bit passes under the gap, the flux flowing through the ring and coil will make a 180° reversal. This means that the flux reversal in the coil will cause a voltage output pulse. See figure 4-4.

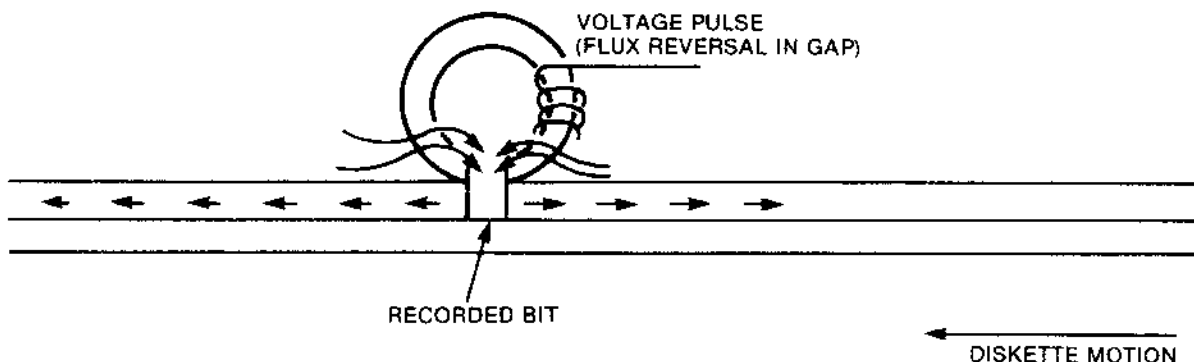

FIGURE 4-4. READING A BIT

39211-20

These flux reversals produce an FM waveform which transmits data to and from the diskette. See figure 4-5.

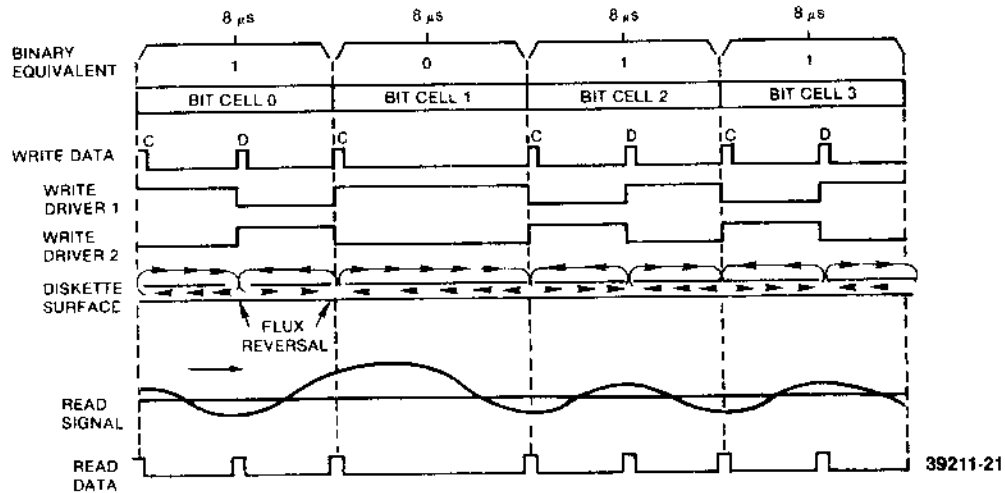

FIGURE 4-5. 1F AND 2F RECORDING FLUX AND PULSE RELATIONSHIP

4.3 READ/WRITE HEAD

- a. The ceramic read/write heads each contain three coils.
- b. When writing, the head erases the outer edges of the track to ensure that the data recorded will not exceed the .006 inch track width.

The read/write head contains three coils. Two read/write coils are wound on a single core, center tapped, and one erase coil is wound on a yoke that spans the track being written. The read/write and erase coils are connected as shown in figure 4-6.

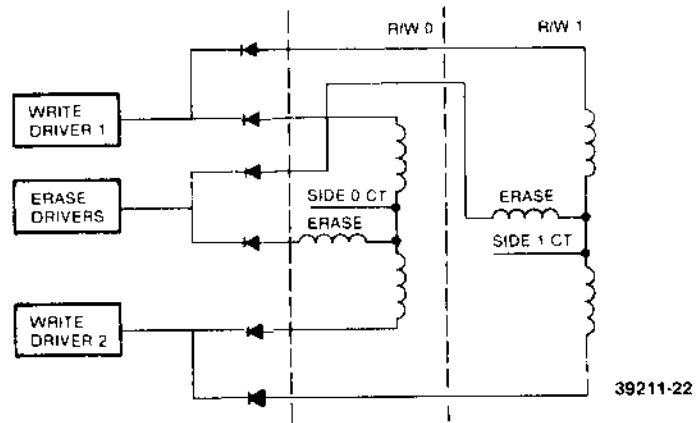

FIGURE 4-6. READ/WRITE HEADS

During a write operation, the erase coil is energized. This causes the outer edges of the track to be trim erased so that the track being recorded will not exceed the .006 inch track width. Tunnel erasing allows for minor deviations in read/write head current so as one track is recorded, it will not "splash over" to adjacent tracks.

Each bit written will be directed to alternate read/write coils, thus causing a change in the direction of current flow through the read/write head. This will cause a change in the flux pattern for each bit. The current through either of the read/write coils will cause the old data to be erased as new data is recorded.

During a read operation, the direction of flux changes on the diskette surface as it passes under the gap and current is induced into one of the windings of the read/write head. This results in a voltage output pulse. When the next data bit passes under the gap, another flux change takes place in the recording surface. This causes current to be induced in the other coil, producing another voltage output pulse of the opposite polarity.

4.4 WRITE CIRCUIT OPERATION

- The write data trigger flips with each pulse on the WRITE DATA line.
- The write data trigger alternately drives one or the other of the write drivers.
- WRITE GATE allows write current to flow to the write driver circuits if the diskette is not write protected.
- Write current sensed allows erase coil current.
- Heads are selected by grounding the appropriate center tap.

WRITE DATA pulses (clock and data bits) are supplied by the using system. The write trigger "flips" with each pulse. The outputs are fed to alternate write drivers.

WRITE GATE and NOT WRITE PROTECT are ANDed together and will cause write current to flow to the write driver circuits, which in turn causes the center tap switch to close and erase current to flow after the turn on delay of 400 μ sec.

The output of one of the write drivers allows write current to flow through one half of the read/write coil. When the write trigger "flips," the other write driver provides write current to the other half of the read/write coil.

The removal of WRITE GATE causes the turn off delay circuit to time out for 1.1 milliseconds. At the end of the delay, the center tap switch opens and the erase current source is turned off. See figure 4-7.

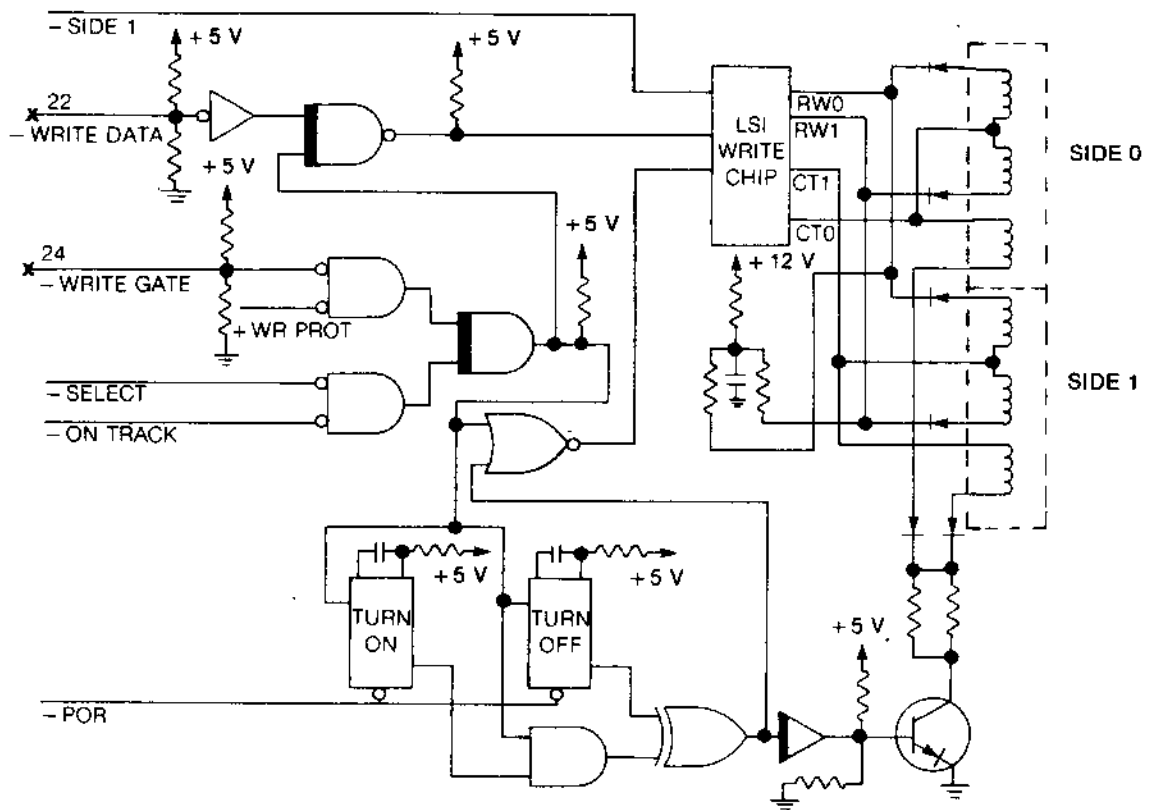

FIGURE 4-7. WRITE CIRCUIT

39211-23

4.5 READ CIRCUIT OPERATION

- Duration of all read operations is under control of the using system.
- As long as the drive is selected and WRITE GATE is not active, the read signal is amplified and shaped, and the square wave signals are sent to the interface as READ DATA.

When the using system requires data from the diskette drive, the using system must select the head and disable WRITE GATE. The read signal is then fed to the amplifier section of the read circuit. After amplification, the read signal is fed to a filter where the out of band noise is removed. The read signal is then fed to the differentiator amplifier.

Since a clock pulse occurs at least once every $8 \mu\text{s}$ and data bits are present once every $4 \mu\text{s}$, the frequency of the READ DATA varies (FM encoding only). The read signal amplitude decreases as the frequency increases. Note the signals in figure 4-8. The differential amplifier will amplify, differentiate, limit, and digitize the read signals (sine waves).

The drive has no data separator, only a pulse standardizer for the READ DATA signal.

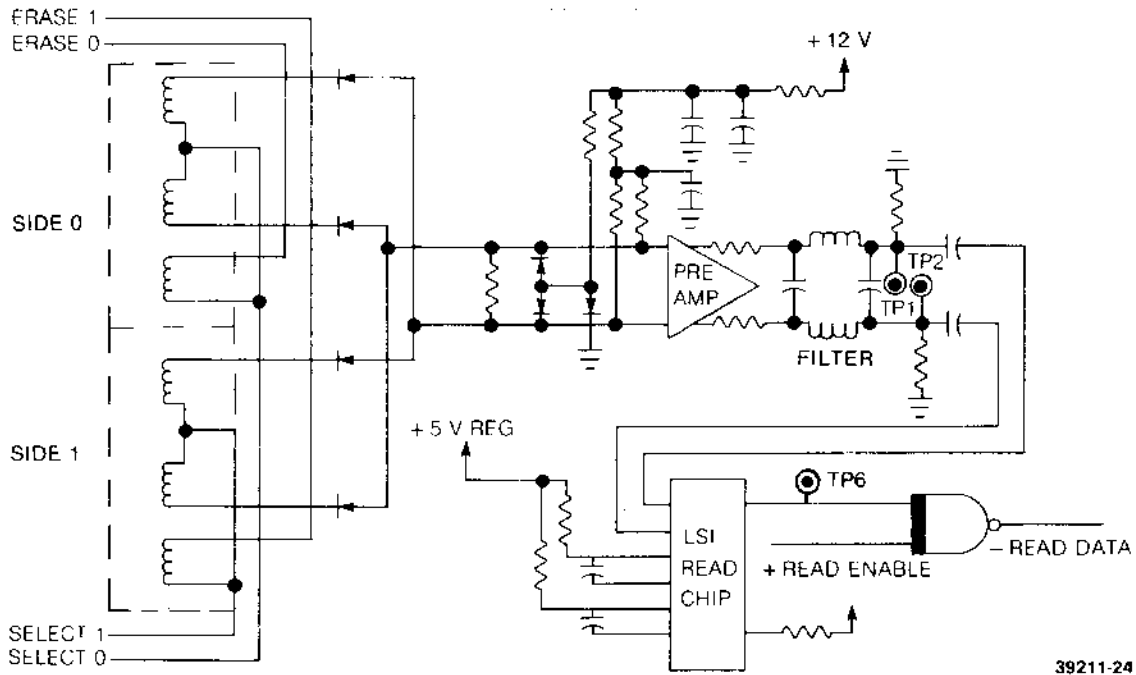

FIGURE 4-8. READ CIRCUIT

4.6 DRIVE MOTOR CONTROL

- a. Start/Stop
- b. Speed Control
- c. Over Current Protection
- d. Speed Adjust

The motor used in the SA410/460 is a dc drive motor with a separate motor on and off interface line. After activating the MOTOR ON line, a 200 ms delay must be introduced to allow proper motor speed before reading or writing.

When MOTOR ON is activated at pin 16 of the interface, the mode will start by means of current flow through the motor windings. Figure 4-9 shows the functional diagram of the motor speed control circuit. The motor speed control utilizes an integral brushless tachometer. The output voltage signal from this tachometer is compared to a voltage/frequency reference level. The output from the voltage/frequency comparator will control the necessary current to maintain a constant motor speed of 300 rpm. Motor speed adjustment changes the voltage reference through a potentiometer.

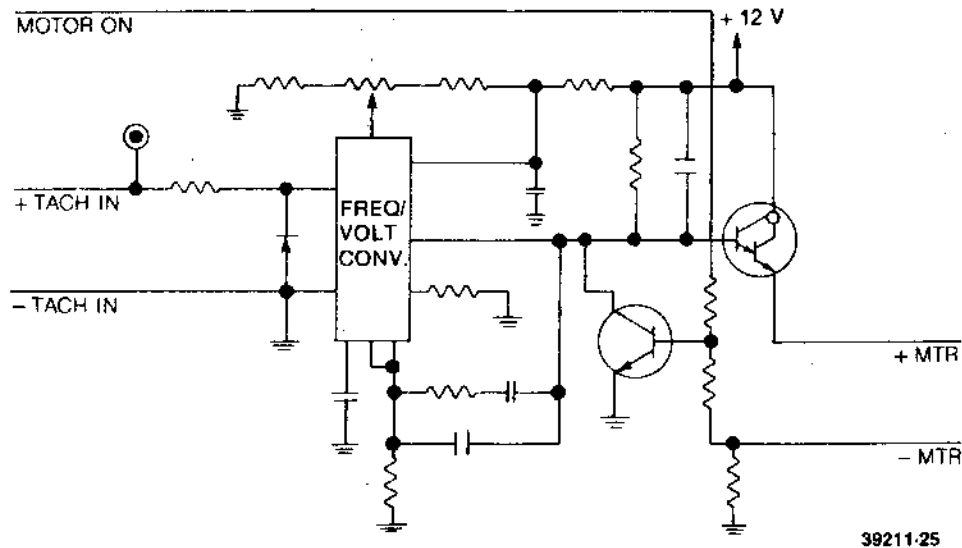

FIGURE 4-9. DRIVE MOTOR CONTROL

4.7 INDEX DETECTOR

Each time an index or sector hole is moved past the index photo detector, a pulse is formed. This pulse is present on the interface as index/sector pin 8. Without a diskette in the drive, the output line will be low and the using system must look for a transition to be a valid signal. The detector output is fed into a schmidt trigger with a level trigger latch back to maintain pulse stability while shaping the pulse. With output enable true, this pulse will be on the interface as a negative going pulse. See figure 4.10.

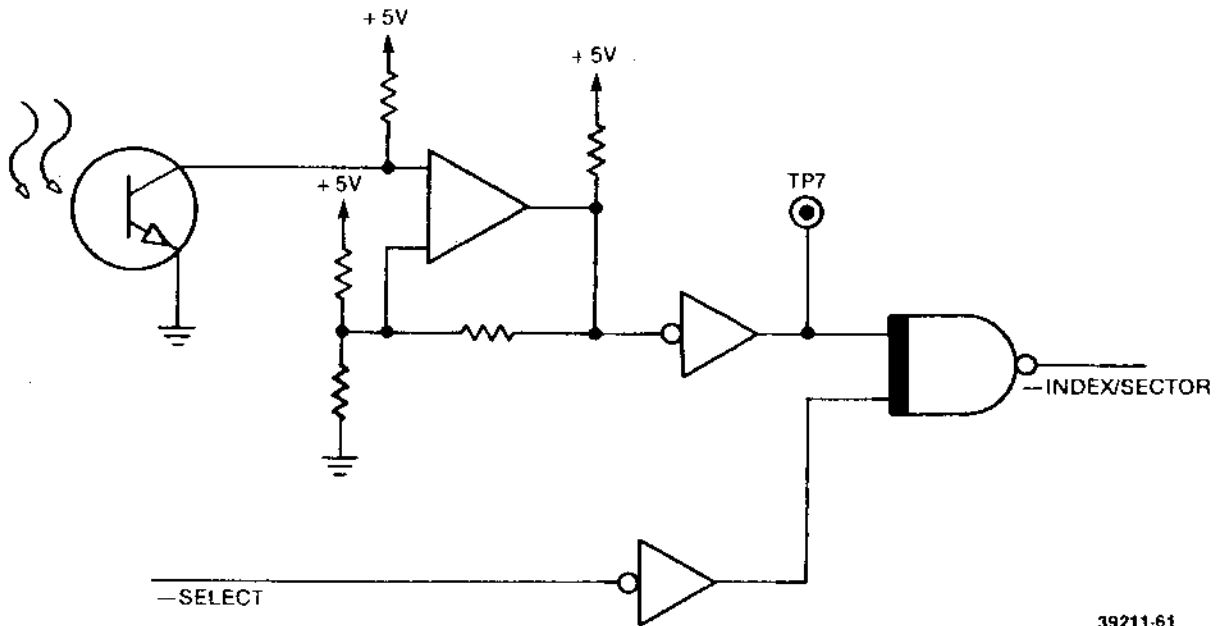

FIGURE 4-10. INDEX DETECTOR

4.8 TRACK ZERO INDICATION

Track 00 signal (pin 26) is provided to the using system to indicate when the read/write head is positioned on track 00. Figures 2-3 and 2-4 show the logic and timing for track 00 indication. The track 00 indication is provided when the flag attached to the head carriage passes between the photo transistor and the photo detector. On track., DRIVE SELECT is ANDed with the photo detector output. These conditions will cause a track 00 indication to the interface.

4.9 TRACK ACCESSING

- a. Stepper Motor (Four Phase)
- b. Stepper Control Logic
- c. Reverse Seek
- d. Forward Seek

Seeking the read/write head from one track to another is accomplished by selecting the desired direction utilizing the DIRECTION SELECT interface line, loading the read/write head, and pulsing the STEP line. Multiple track accessing is accomplished by repeated pulsing of the STEP line with WRITE GATE inactive until the desired track has been reached. Each pulse on the the STEP line will cause the read/write head to move one track either in or out, depending on the DIRECTION SELECT line.

4.9.1 Stepper Motor

The four phase stepper motor turns the head actuator cam in four step increments per track. Four increments will move the head one track via a ball bearing follower which is attached to the carriage assembly. This follower rides in a spiral groove in the HeliCam.

The stepper motor has four phases. Phase -A and -B are in their active position and are energized when the head is on track. The phases +A and +B are transient states. Two one shots to the stepper counter logic are used to provide four step pulses approximately 1.6 milliseconds apart.

Two current modes are automatically enabled. The first step pulse will enable full current to the stepper motor. Within 35 ms after that last step pulse is issued, stepper motor current is automatically decreased to approximately 50% of its full value.

4.9.2 Stepper Control

During power on reset time, the stepper control counter is reset to zero. This will cause phases -B and -A to be energized in the stepper. Figures 4-11 through 4-13 show the stepper control logic and timing.

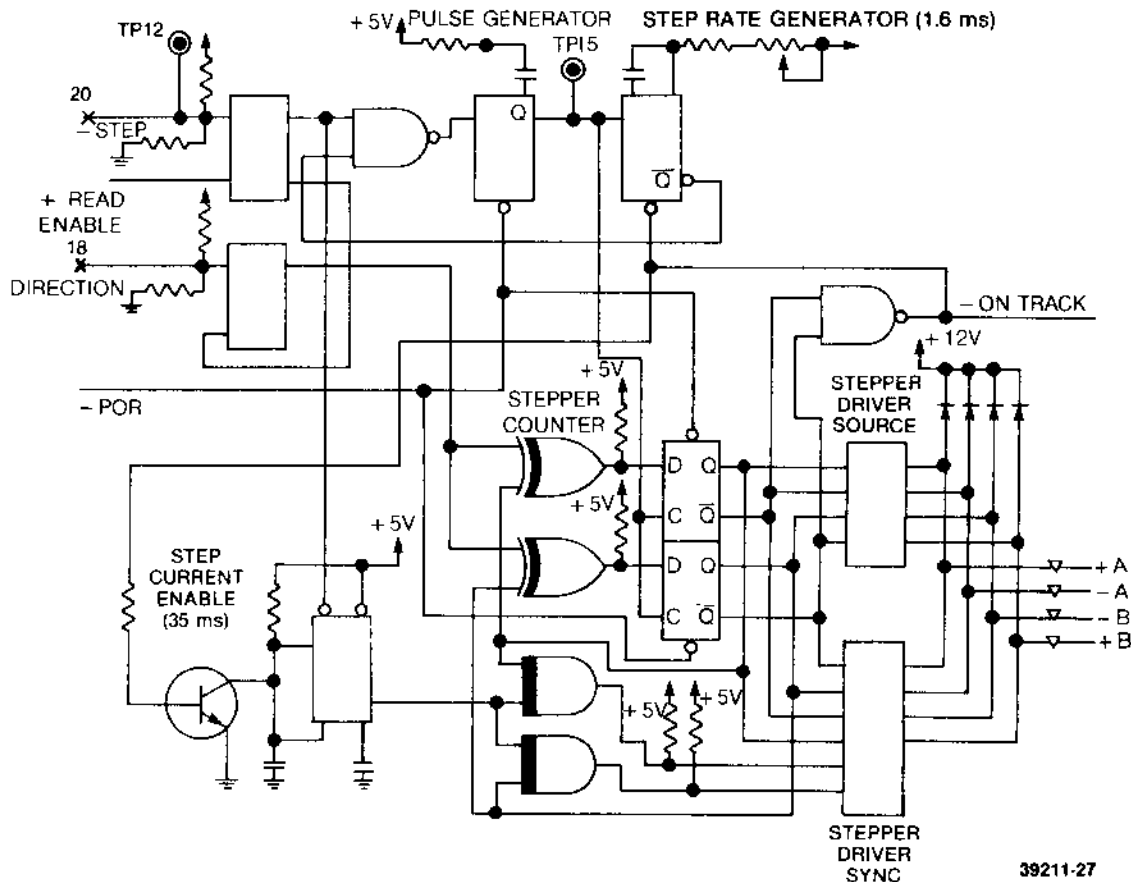

FIGURE 4-11. STEPPER CIRCUIT

39211-27

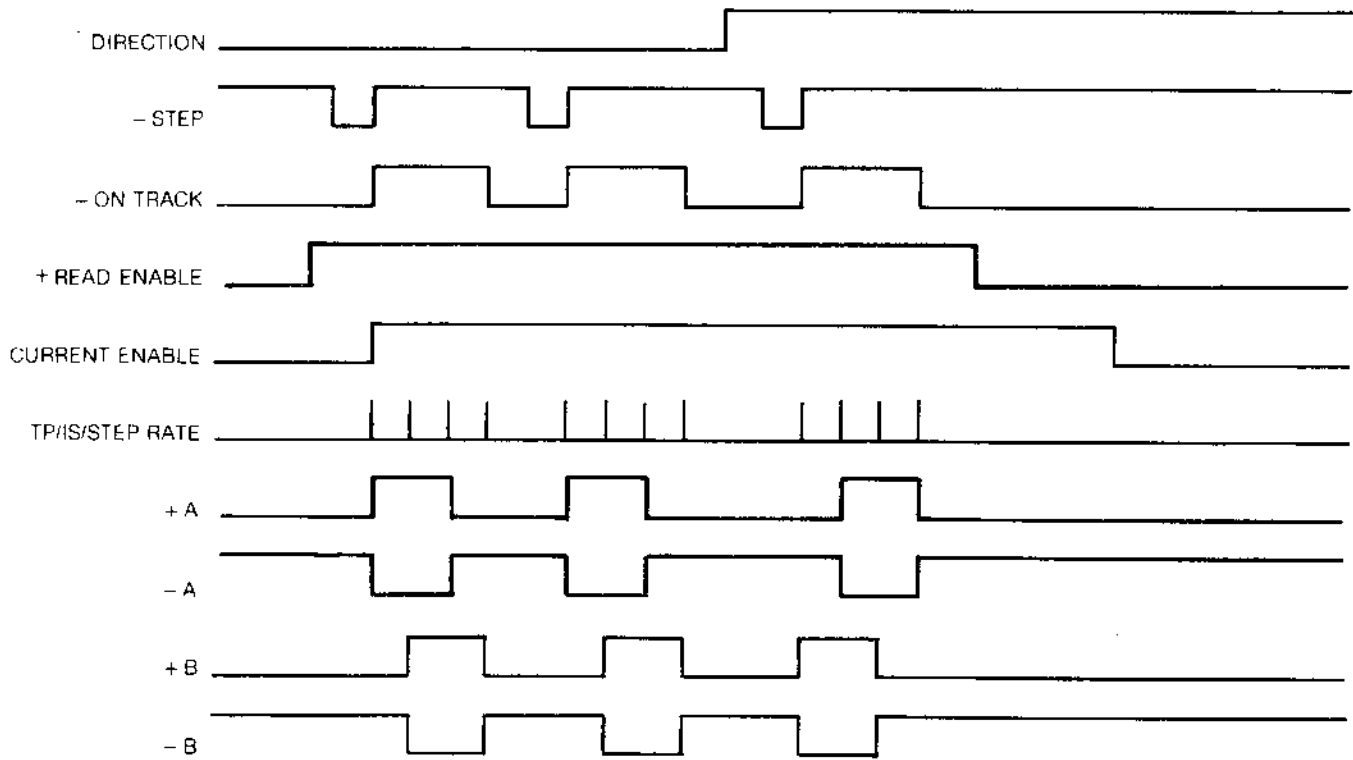

FIGURE 4-12. STEPPER TIMING

39211-28

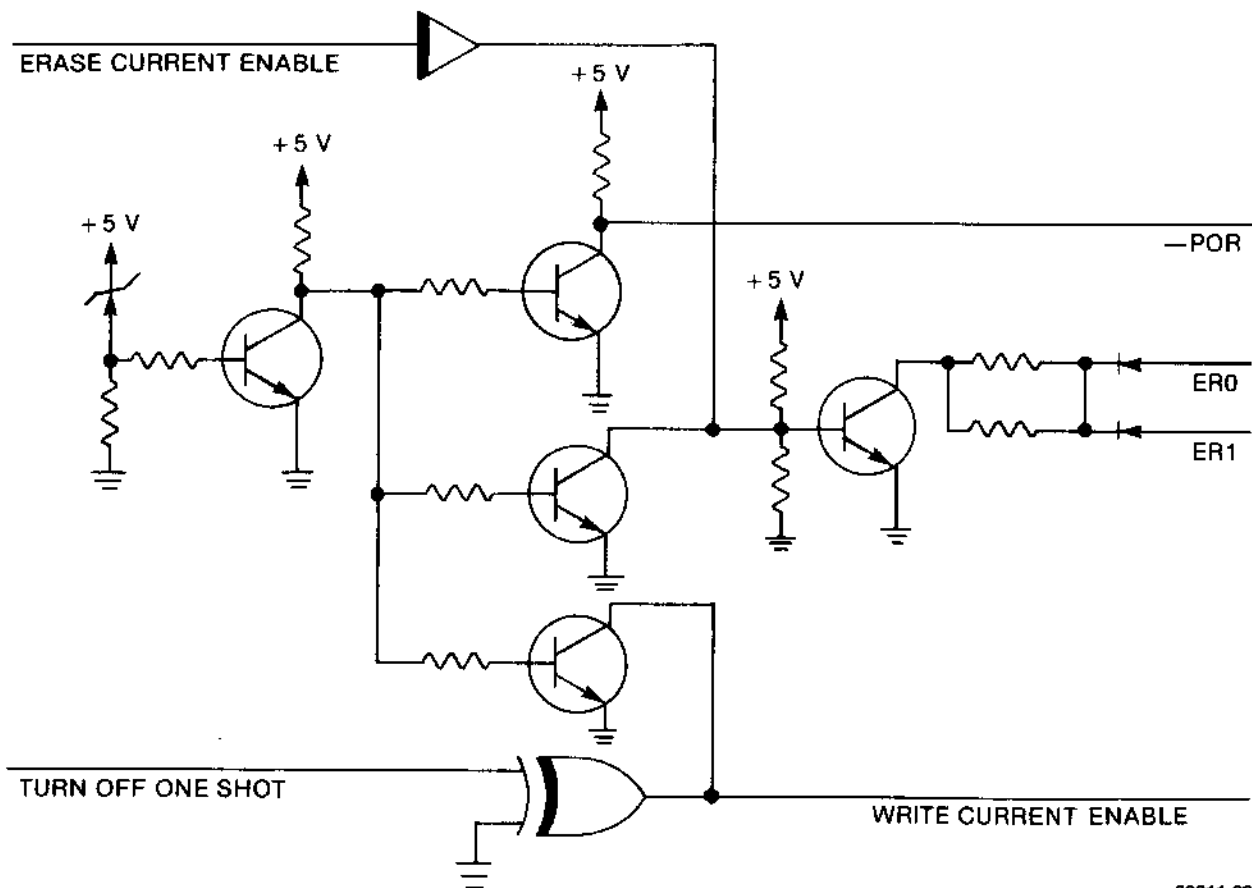

FIGURE 4-13. POWER ON RESET

39211-29

4.10 DRIVE SELECT

The SA410/460 is configured to operate alone in a single drive system. It can be easily modified to operate with other drives in a daisy chained multiplexed drive system. This is done by selecting the specific drive address and jumpering the appropriate DRIVE SELECT line. See figure 4-14.

The MX option is used for single drive systems. By shorting MX, the I/O lines are always enabled.

The MS option allows the motor to be enabled from DRIVE SELECT.

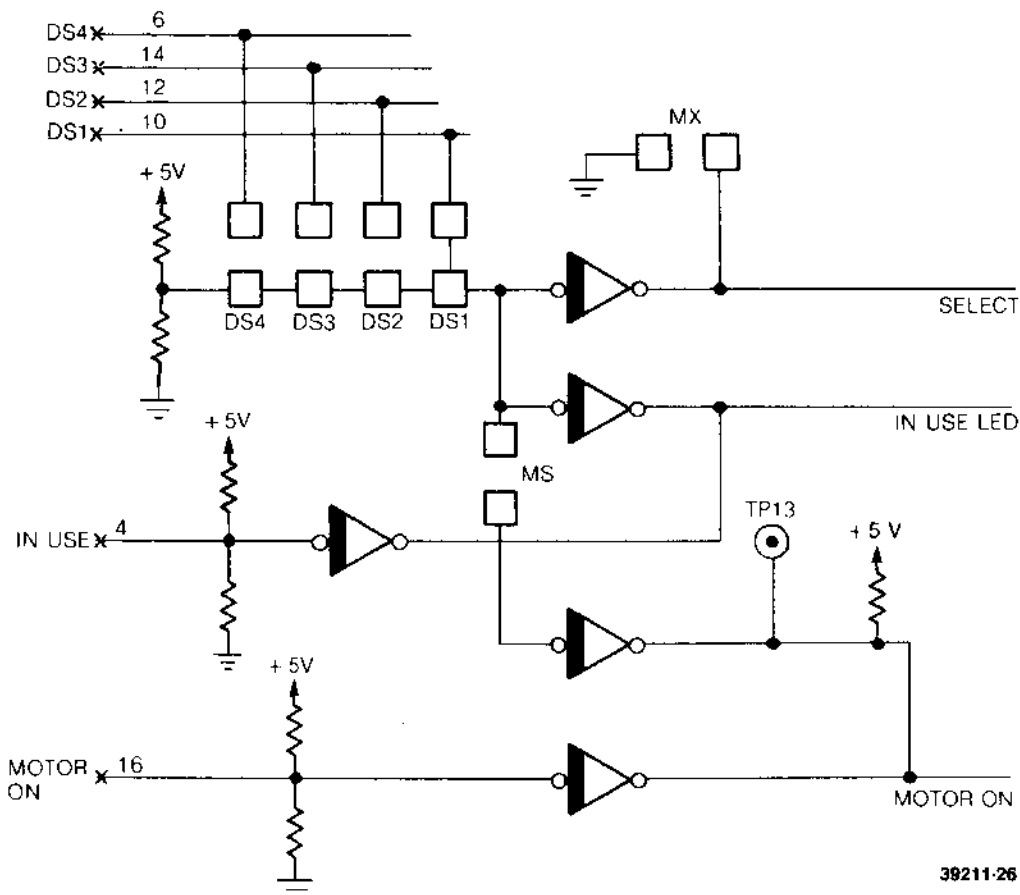

39211-26

FIGURE 4-14. DRIVE SELECT, MOTOR ON, AND IN USE

4.11 WRITE PROTECT

This interface signal is provided by the drive to indicate to the user when a write protected diskette is installed. The signal is logic 0 level when it is protected. Under normal operation, the drive will inhibit writing with a protected diskette installed in addition to notifying the interface. If the WP trace is cut, writing to the diskette is inhibited unless a write protect label is installed over the notch. See figure 4-15.

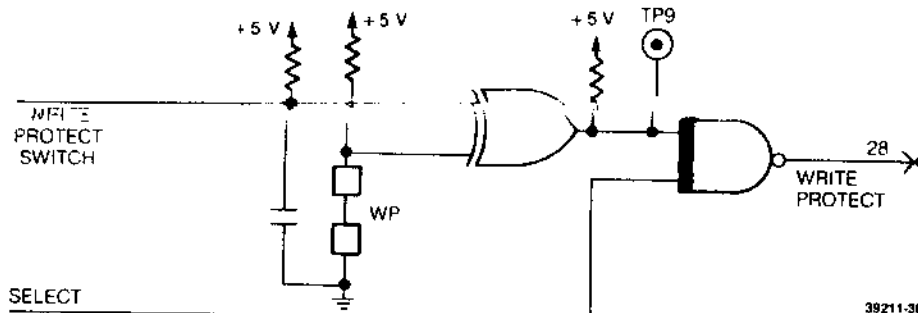

39211-30

FIGURE 4-15. WRITE PROTECT

4.12 DOOR LOCK SOLENOID

The door lock solenoid can be activated by the interface line provided on pin 2.

The DA option allows the door lock solenoid to be activated when the IN USE or DRIVE SELECT signal has been asserted to a logic low (see figure 4-16).

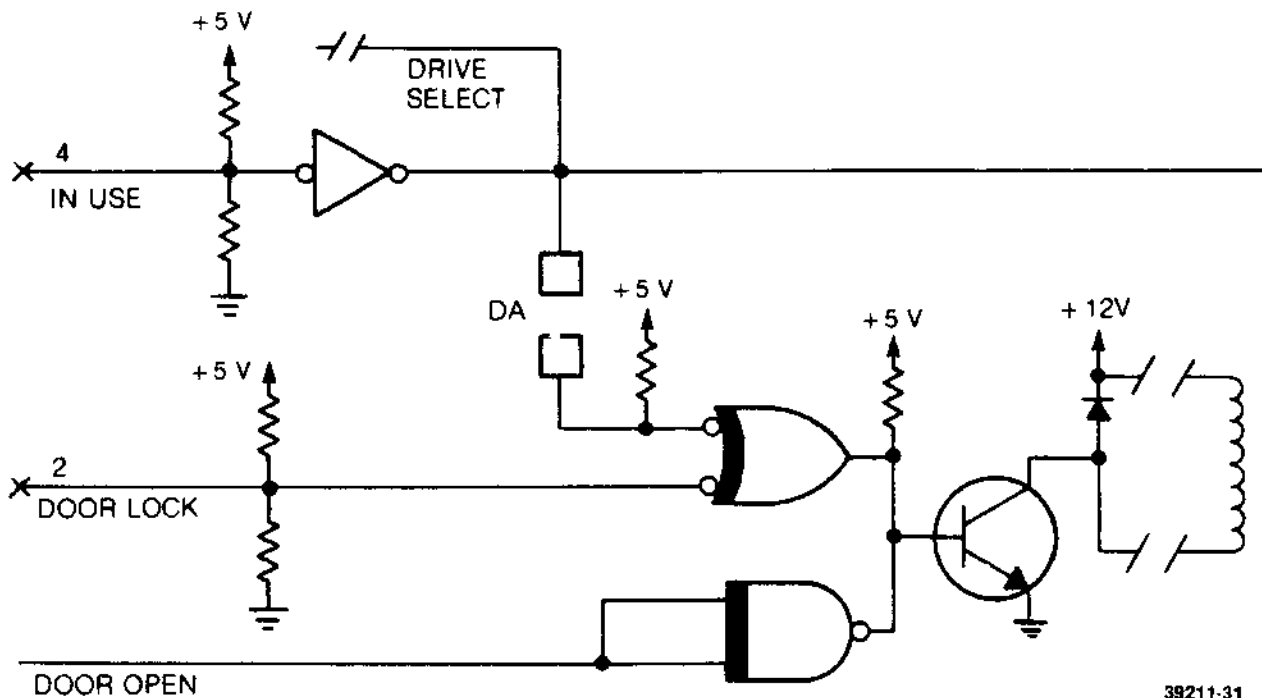

FIGURE 4-16. DOOR LOCK FROM IN USE OR DRIVE SELECT

4.13 DRIVE STATUS

This interface signal gives the user an indication that a diskette is inserted correctly in the drive and the door is closed. The DRIVE STATUS signal is active, at a logical 0 level, when all of the following conditions are met:

- a. The door is closed.
- b. The door has not been opened since the drive was last deselected
- c. An INDEX/SECTOR pulse has been sensed since the previous conditions were met.

If the DRIVE STATUS signal is inactive, the user may deselect and then select the drive to test DRIVE STATUS again; if the door had previously been disturbed but is now closed, DRIVE STATUS will activate upon sensing an INDEX/SECTOR pulse.

Condition (b) may optionally be eliminated by cutting trace DD and shorting trace DO. Conditions (b) and (c) may optionally be eliminated by cutting trace RI and shorting trace RD. One of these two options must be implemented if MX is shorted (see figure 4-17), since condition (b) will not be met.

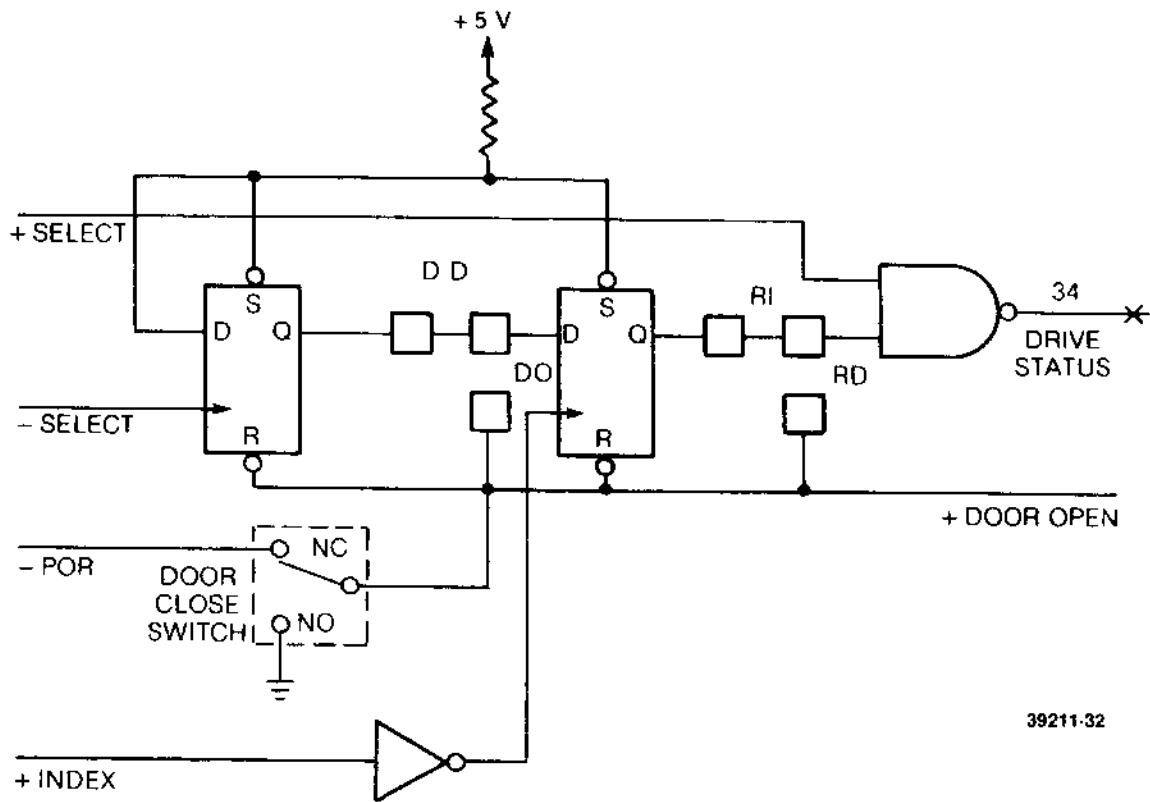

FIGURE 4-17. DRIVE STATUS

SECTION V MAINTENANCE

5.1 MAINTENANCE EQUIPMENT

5.1.1 Alignment Diskette

The alignment diskette is used for verifying and adjusting the SA410/460. Two alignment diskettes are available. The SA410 only requires written information on one surface and will utilize the SA144 alignment diskette. The SA460 has two read/write heads and requires written information on both surfaces. The SA148 alignment diskette should be utilized when performing service checks on the SA460. The following adjustments and checks can be made using the SA144/148.

- a. Track 00 is recorded with a 125 k Hz signal. This track is used to determine if the head is positioned over track 00 when the track 00 indication is active at the interface.
- b. Track 02 is recorded with a special data pattern to determine index photo detector alignment.
- c. Track 64 is recorded with a special data pattern to determine read/write head positioning.
- d. Track 76 is recorded with a special data burst pattern to determine azimuth angle.
- e. Track 79 is recorded with a 125 k Hz signal.

Caution should be used in order not to destroy prerecorded alignment tracks. The write protect tab should always be installed to prevent accidental writing on the alignment diskette, or if the write protect option is utilized, remove the write protect tab.

5.1.2 Exerciser PCB

The exerciser PCB can be used in a stand alone mode, built into a test station, or used in a test for field service.

The exerciser will enable the user to make all adjustments and check outs required on the SA410/460 minidiskette drive. It has no intelligent data handling capabilities but can write a 2F 125 k Hz signal which is the recording frequency used for amplitude checks in the SA410/460 drive. The exerciser can start and stop the drive motor, and enable read in the SA410/460 to allow checking for proper read back signals.

5.1.3 Special Tools

The following special tools are available for performing maintenance on the SA410/460.

Description	Part Number
SA410 Alignment Diskette	SA144 P/N 54298
SA460 Alignment Diskette	SA148 P/N 54296
Exerciser	54157
Head Cable Extender	54578

Allen Wrenches	1/16, 5/64, and 7/64 inches (1.59, 1.98, and 2.78 mm)
Screw Drivers	Medium and Small
Feeler Gauge	.015 inch (0.381 mm)
Oscilloscope	Textronix 465 or equivalent

5.2 DIAGNOSTIC TECHNIQUES

5.2.1 Introduction

Incorrect operating procedures, faulty programming, damaged diskettes, and "soft errors" created by airborne contaminants, random electrical noise, and other external causes can produce errors falsely attributed to drive failure or misadjustment. Unless visual inspection of the drive discloses an obvious misalignment or broken part, attempt to repeat the fault with the original diskette, then attempt to duplicate the fault on the second diskette.

5.2.2 "Soft Error" Detection And Correction

Soft errors are usually caused by:

- a. Airborne contaminants that pass between read/write heads and disk. Usually these contaminants can be removed by cartridge self-cleaning wiper.
- b. Random electrical noise that usually lasts for a few microseconds.
- c. Small defects in written data and/or track not detected during write operation may cause soft errors during read.
- d. Improper grounding of power supply, drive and/or host system. Refer to SA410/460 OEM manual for proper grounding requirements.
- e. Improper motor speed.

The following procedures are recommended to recover from the above mentioned soft errors:

- a. Reread track 10 times or until such time as data is recovered.
- b. If data is not recovered after using step (a), access head to adjacent track in same direction previously moved, then return to desired track.
- c. Repeat step (a).
- d. If data is not recovered, error is not recoverable.

5.2.3 Write Error

If an error occurs during a write operation, it will be detected on the next revolution by doing a read operation, commonly called a "write check." To correct the error, another write and check operation must be done. If the write operation is not successful after 10 attempts have been made, a read operation should be attempted on another track to determine if the media or the drive is failing. If the error still persists, the diskette should be replaced and the above procedure repeated. If the failure still exists, consider the drive defective. If the failure disappears, consider the original diskette defective and discard it.

5.2.4 Read Error

Most errors that occur will be "soft errors." In these cases, performing an error recovery procedure will recover the data.

5.2.5 Seek Error

- a. Stepper malfunction.
- b. Carriage binds.
- c. To recover from seek error, recalibrate to track 00 and perform another seek to original track or do a read ID to find what track head is on and compensate accordingly.

5.2.6 Trouble-Shooting

Figures 5-1 through 5-5 provide trouble-shooting procedures for the SA410/460.

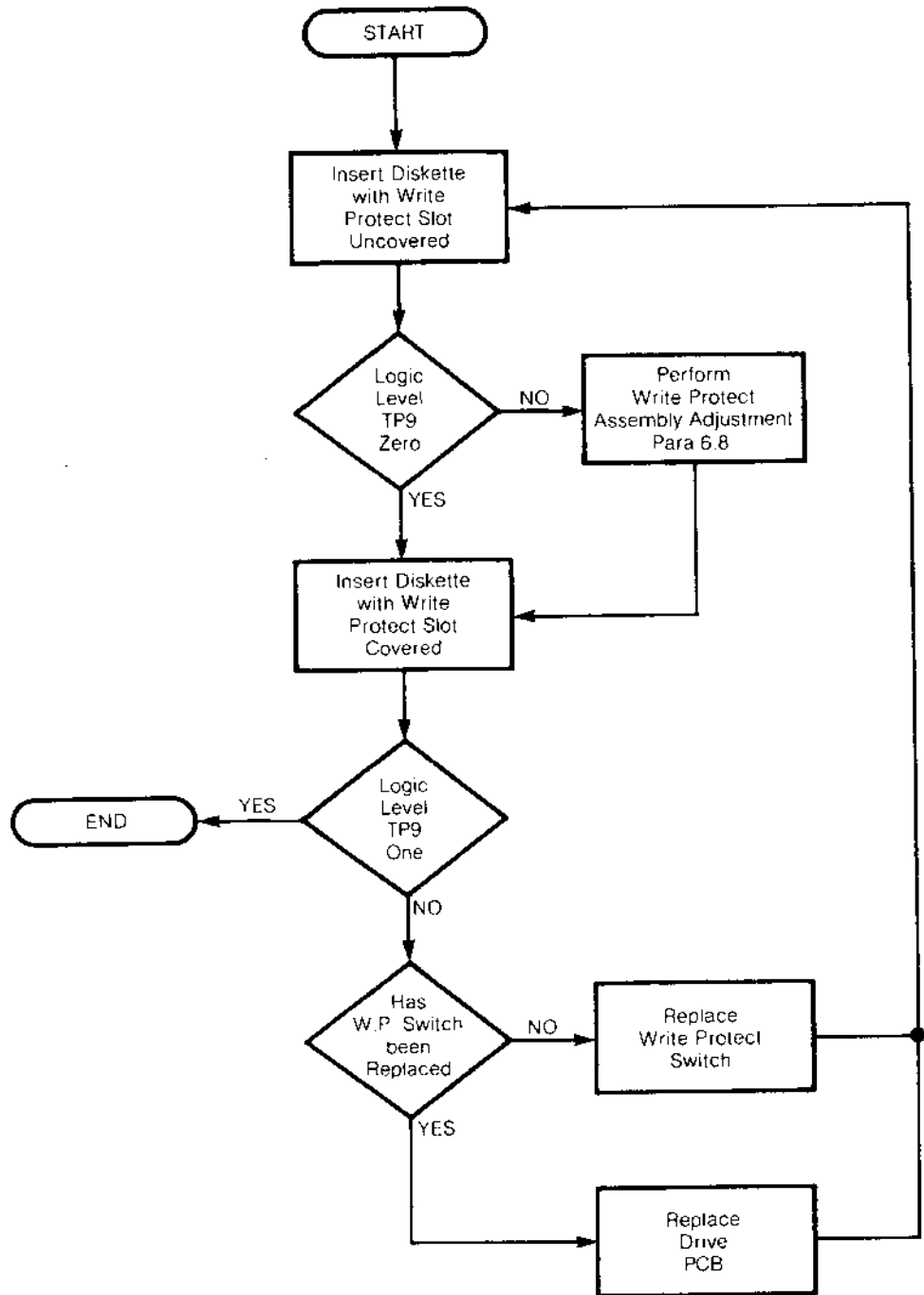

39211-33

FIGURE 5-1. WRITE PROTECT INOPERATIVE

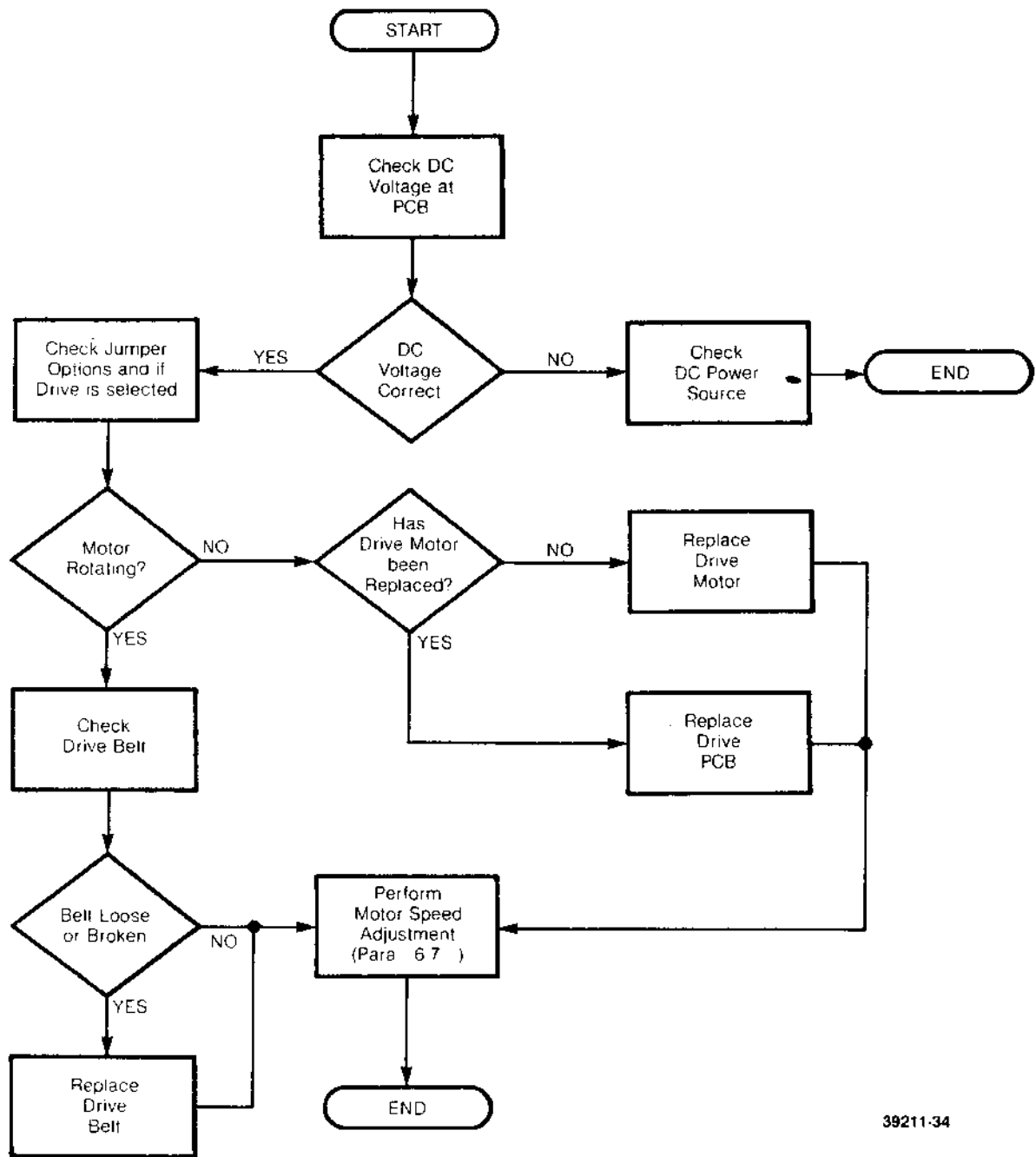

39211-34

FIGURE 5-2. DISKETTE NOT ROTATING

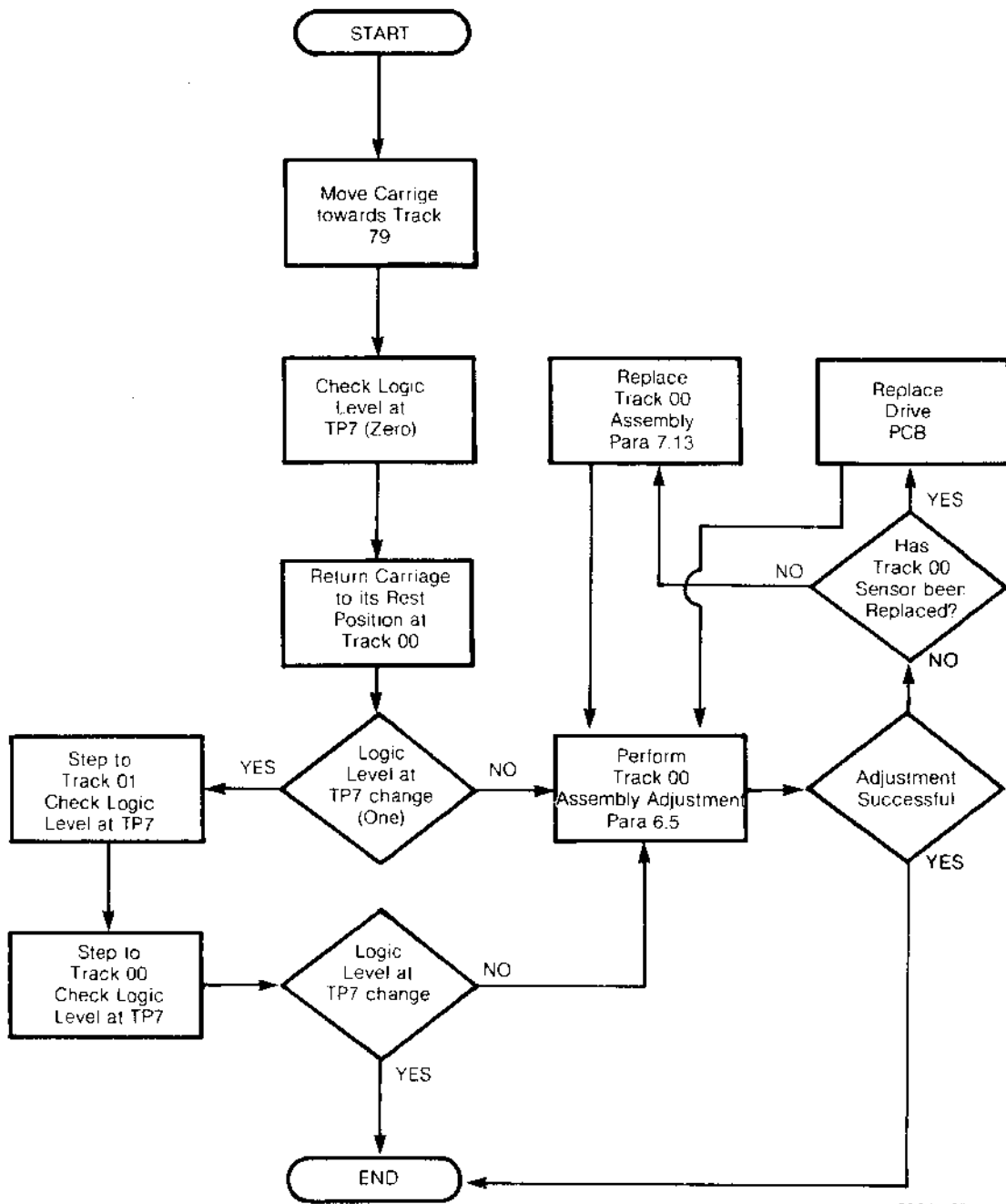

39211-35

FIGURE 5-3. TRACK 00 INDICATOR INOPERATIVE

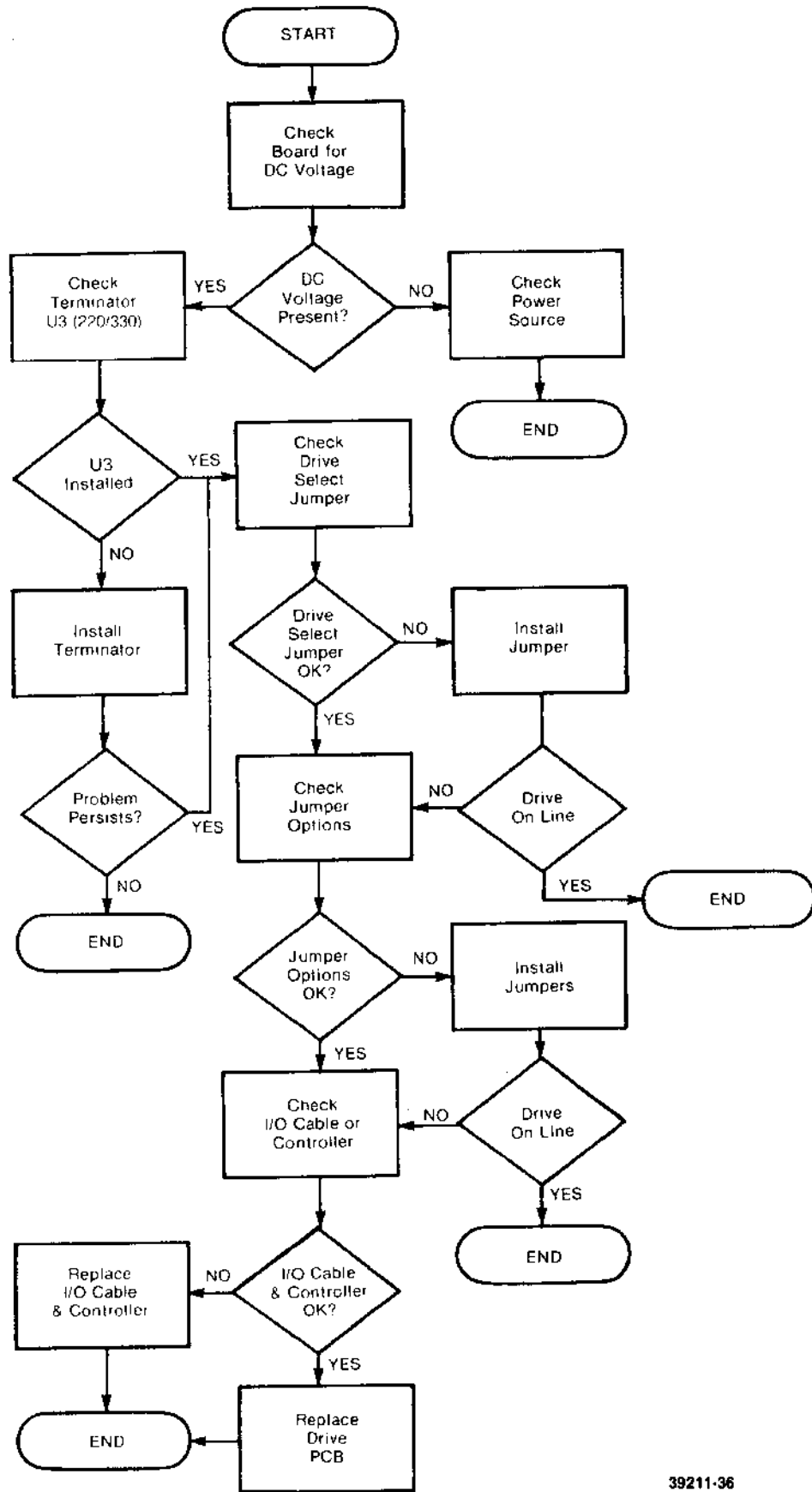

39211-36

FIGURE 5-4. DRIVE NOT COMING ON LINE

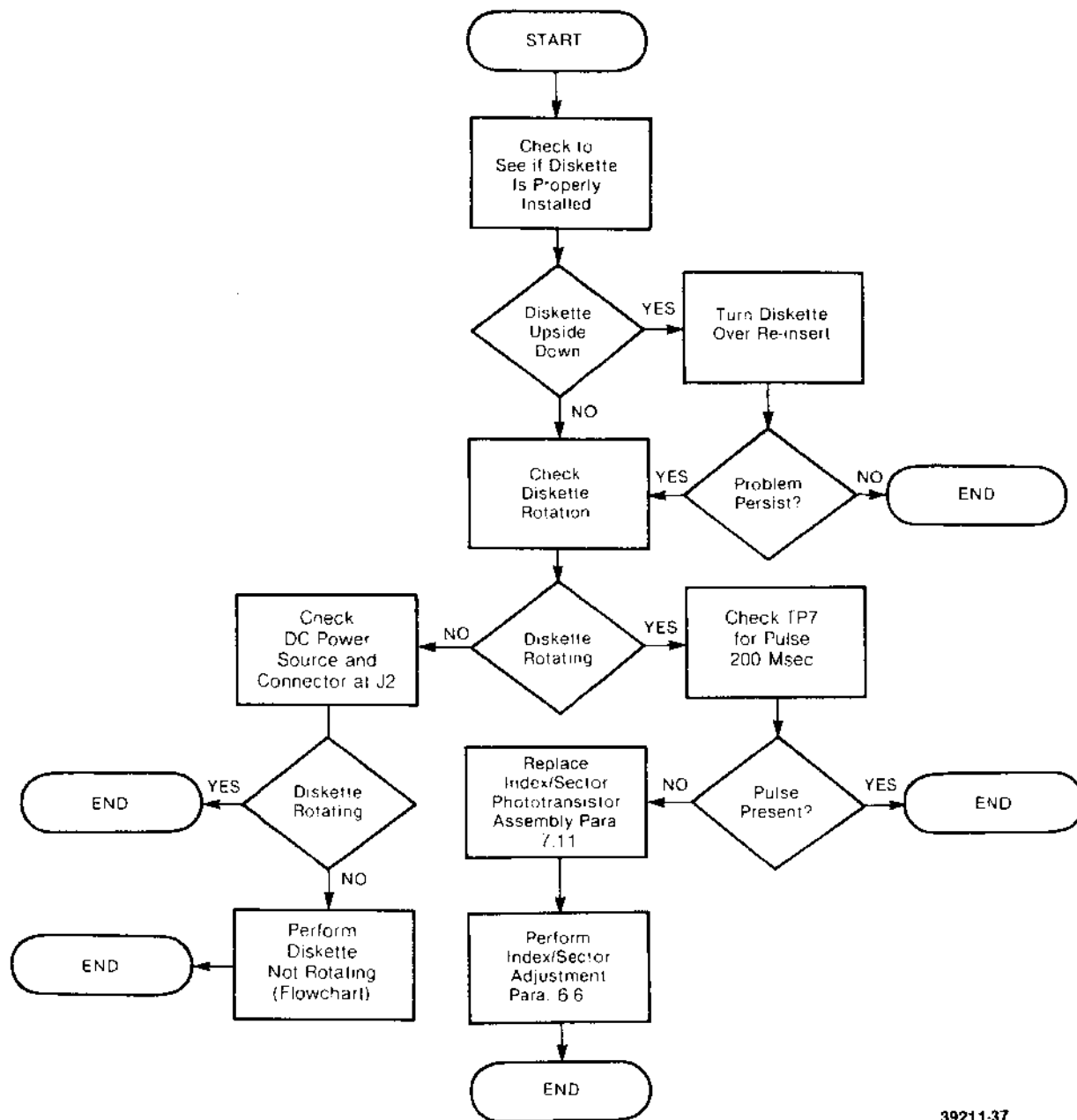

39211-37

FIGURE 5-5. INDEX PULSE INOPERATIVE

SECTION VI ADJUSTMENTS

6.1 HEAD RADIAL ALIGNMENT

NOTE

The SA460 read/write head assembly is aligned at factory and adjustment of head to head alignment is not field adjustable.

- a. Insert alignment diskette (SA410 = SA144) (SA460 = SA148).

NOTE

Alignment diskette should be at room conditions for at least 24 hours before alignment checks.

- b. Select drive and step head(s) to track 64.
- c. Sync oscilloscope external negative on TP7 (-INDEX). Set time base to 20 msec per division. This will display over one revolution.
- d. Connect one probe to TP1 and other to TP2. Ground probes to PCB. Set inputs to ac, ADD, and invert one channel. Set vertical deflection to 50 mV/division.
- e. Amplitude of two lobes must be within 80% of each other. If lobes do not fall within specification, continue on with procedure (see figure 6-1).

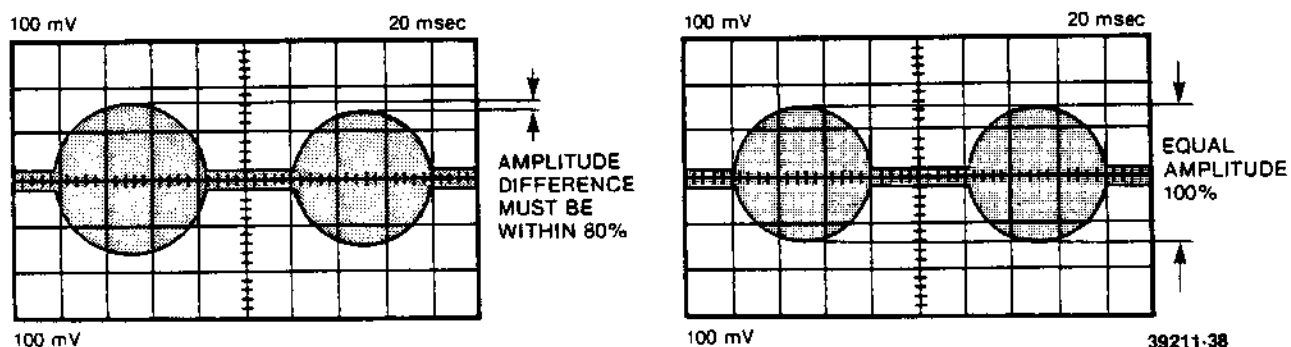
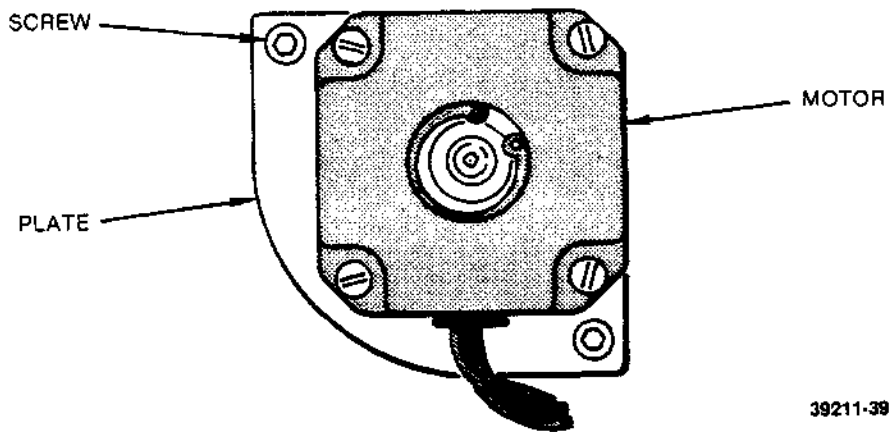

FIGURE 6-1. ALIGNMENT LOBES

- f. Loosen two mounting screws, which hold motor plate to base casting (see figure 6-2).
- g. Rotate stepper motor.
- h. When lobes are of equal amplitude, tighten motor plate mounting screws (see figure 6-2).
- i. Check adjustment by stepping off track and returning. Check in both directions and readjust as required.
- j. Whenever head radial alignment has been adjusted, track 00 detector and limiter adjustment must be checked (paragraph 6.4).



39211-39

FIGURE 6-2. MOTOR PLATE

6.2 READ/WRITE HEAD(S) AZIMUTH CHECK

The azimuth is not field adjustable. If after performing this check the waveform on the oscilloscope is not within ± 21 minutes, replace the read/write head(s) assembly.

- Install alignment diskette (SA410 = SA144) (SA460 = SA148).
- Select drive and step to track 76.
- Sync oscilloscope external negative on TP7, set time base to 0.5 msec per division.
- Connect one probe to TP1 and other to TP2. Invert one channel and ground probes to PCB. Set inputs to ac, ADD, and 50 mV per division.
- Compare waveform to figure 6-3. If not within range shown, replace read/write head assembly.

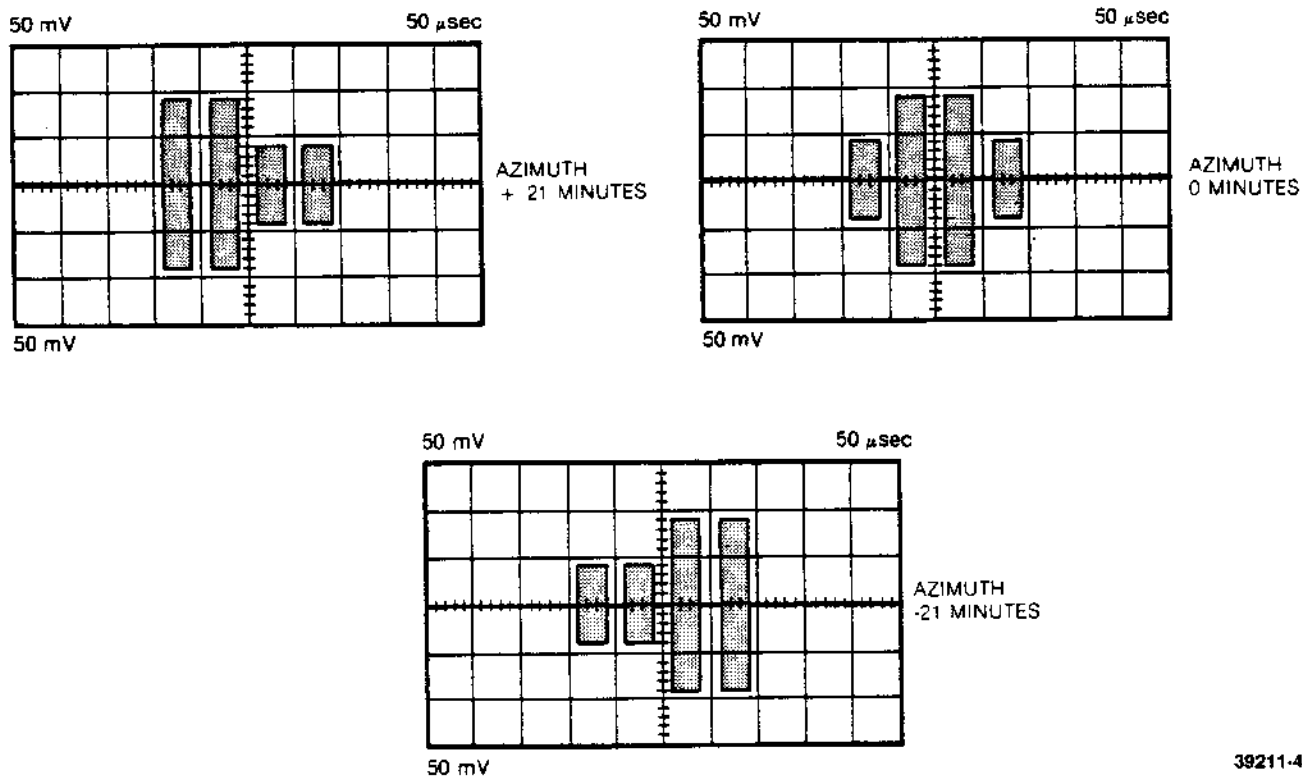

39211-40

FIGURE 6-3. AZIMUTH

6.3 HEAD AMPLITUDE CHECK

These checks are only valid when writing and reading back as described below. Ensure the diskette used for this check is not "worn" or otherwise shows evidence of damage on either side.

- a. Install good media.
- b. Start motor.
- c. Select drive and step to track 79.
- d. Sync oscilloscope external on TP7 (+ Index); connect one probe to TP2 and TP1 on drive PCB. Ground probes to PCB, ADD, and invert one input. Set volts per division to 50 mV and time base to 20 msec per division.
- e. Select head 0 and write a 2F pattern on entire track. Average minimum amplitude peak-to-peak should be 100 mV.
- f. Select head 1 and write a 2F pattern on entire track. Average minimum amplitude peak-to-peak should be 100 mV.
- g. If either head fails to meet minimum amplitude specifications, continue with procedure.
- h. Install fresh media and recheck.
- i. Check motor speed as per paragraph 6.7.
- j. With oscilloscope in 'chop' mode, verify that there is output at both TP1 and TP2. If one TP has no output, or significantly less output than other, turn head cable connector over at J4. Should same TP have little or no output, PCB is faulty and should be replaced. If opposite TP now exhibits problem, head assembly is at fault, and should be replaced. Reference paragraph 7.3.

6.4 TRACK ZERO CARRIAGE LIMITER

- a. Unplug head cable and remove PCB from drive leaving interface and PCB connector installed. Install head cable extension.
- b. Loosen set screw on limiter.
- c. Apply power to drive and step to track 00, leaving drive selected.
- d. Adjust track 00 carriage limiter until there is 0.015 ± 0.005 inch between limiter and carriage assembly (see figure 6-4).
- e. Reinstall drive PCB and remove head cable extension.

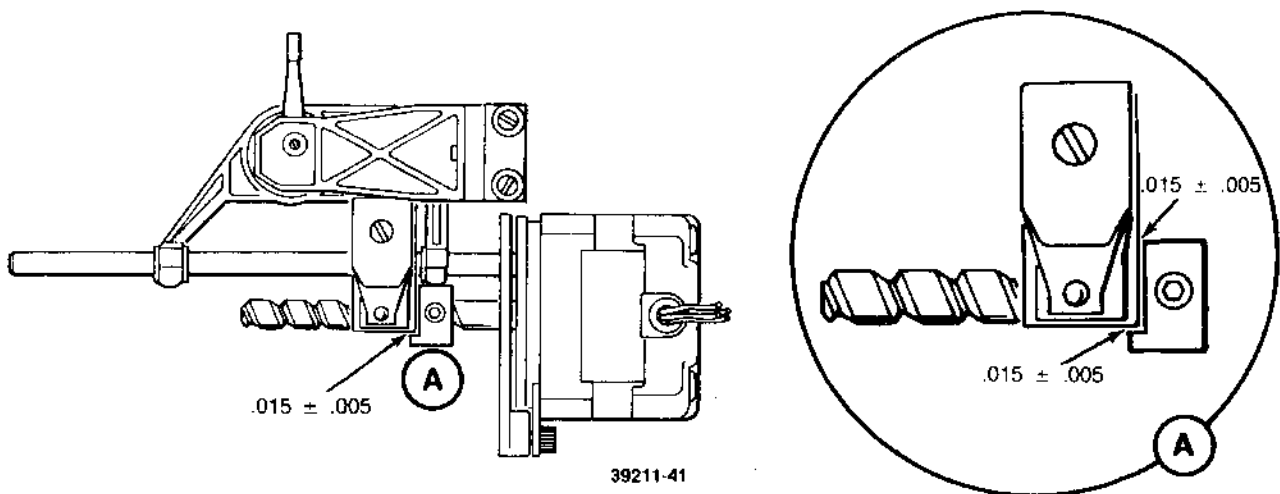

FIGURE 6-4. CARRIAGE LIMITER

6.5 TRACK ZERO DETECTOR ASSEMBLY ADJUSTMENT

- a. Disconnect head cable at J4 on PCB leaving interface and power connectors attached. Remove PCB from drive and install head cable extension.
- b. Apply power to drive and install alignment diskette SA144 or SA148.
- c. Select drive and step to track 00.
- d. Sync oscilloscope external negative on TP7 (-Index). Set time base to 20 msec per division.
- e. Connect one probe to TP1 and other to TP2. Ground probes to PCB. Set input to ac, ADD, and invert one channel. Set vertical deflection to 100 mV/division.
- f. The 125 k Hz signal recorded should be observed at this time.
- g. If 125 k Hz signal is not present, step forward one track at a time and verify 125 k Hz signal is present. Step only five tracks.
- h. Step back towards track 00 detector and verify presence of 125 k Hz signal. Repeat stepping until signal is found. If necessary, loosen carriage limiter and slide towards motor.
- i. Once 125 k Hz signal is present on oscilloscope, carriage is located at track 00. Disconnect probes from TP1, TP2, and TP7. Connect one channel to TP8 and set input to dc. Set the vertical deflection to 2 V per division. Trigger oscilloscope on selected input channel.
- j. Step to track 1 and verify that TP8 goes to zero.
- k. If not, loosen track 00 bracket.
- l. Set drive to seek alternately between tracks 00 and 01.
- m. Adjust eccentric until a 50% duty cycle is obtained (see figure 6-5).
- n. Tighten track 00 bracket and recheck timing.
- o. If same signal is obtained, remove alignment diskette, power down drive, and reinstall PCB. If same signal is not obtained, repeat steps k-n.

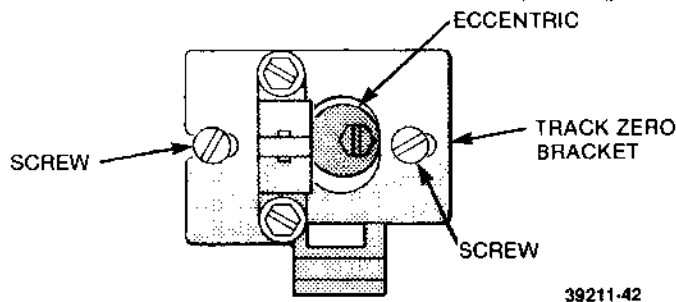

FIGURE 6-5. TRACK ZERO ADJUSTMENT

6.6 INDEX/SECTOR TIMING ADJUSTMENT

- a. Remove PCB and install head cable extender. Remove shield from hub frame. Leave PCB and interface connector installed.
- b. Insert alignment diskette SA144 or SA148.
- c. Start motor and select head 0.
- d. Step carriage to track 02.
- e. Sync oscilloscope external positive on TP7 (+Index). Set time base to 50 μ sec/division.

- f. Connect one probe to TP1 and other to TP2. Ground probes to PCB. Set inputs to ac, ADD, and invert one channel. Set vertical deflection to 500 mV/division.
- g. Observe timing between start of sweep and first data pulse. This should be $200 \pm 100 \mu\text{sec}$. If timing is not within tolerance, continue on with adjustment. See figure 6-6.

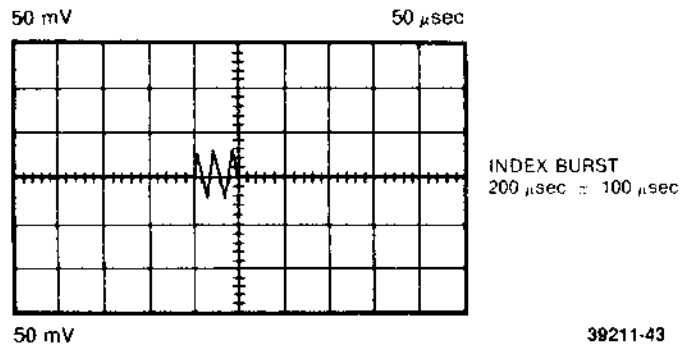

FIGURE 6-6. INDEX BURST

- h. Loosen mounting screw in index detector block until assembly is just able to be moved. See figure 6-7.

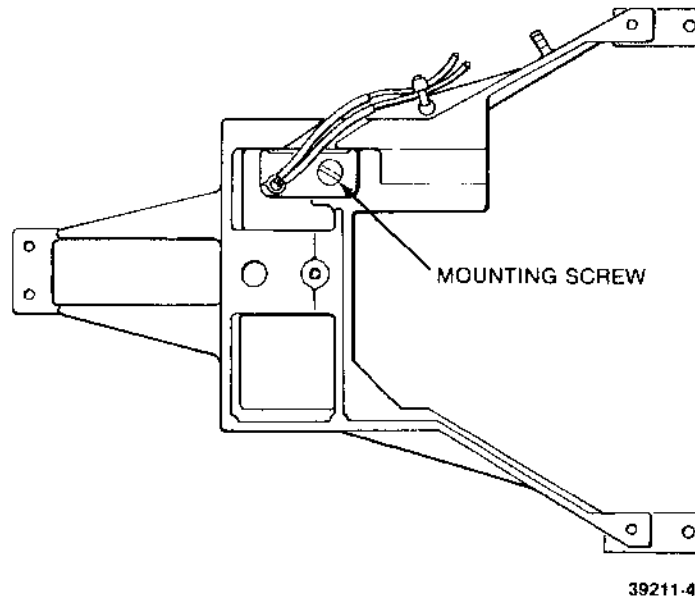

FIGURE 6-7. INDEX DETECTOR

- i. Observing timing, adjust detector until timing is $200 \pm 100 \mu\text{sec}$. Ensure that detector assembly is against registration surface on hub frame.
- j. Tighten mounting screw.
- k. Recheck timing.
- l. For SA460, repeat for head 1.

6.7 MOTOR SPEED ADJUSTMENT

6.7.1 Motor Speed Adjustment (Using A Frequency Counter)

- a. Install SA128 or SA154 diskette. start motor and step to track 32.
- b. Connect frequency counter to TP7 (+ Index) on drive PCB.
- c. Adjust pot R-53 located on the drive PCB for $5 \text{ Hz} \pm .05 \text{ Hz}$ (Period = $200 \pm 2 \text{ ms}$).

6.7.2 Motor Speed Adjustment (Fluorescent Light)

- a. Install diskette, close door, and start motor. Step to track 32.
- b. Turn pot R-53 located on drive PCB until dark lines on spindle pulley appear motionless. For 60 Hz use outside ring of lines. For 50 Hz, observe inside ring. See figure 6-8.

NOTE

This adjustment can be made only in area where there is fluorescent lighting.

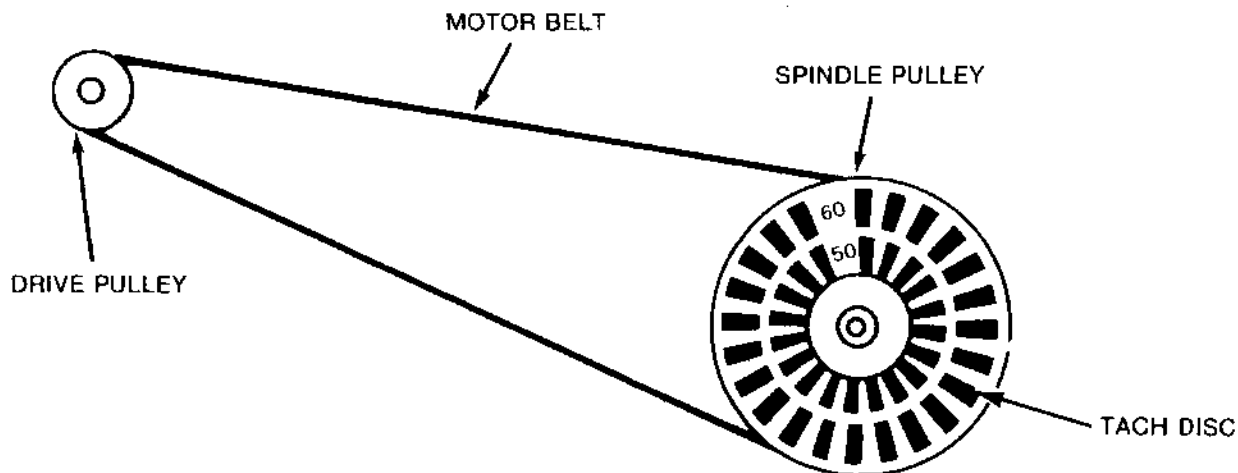

FIGURE 6-8. MOTOR SPEED ADJUSTMENT

39211-45

6.8 WRITE PROTECT SWITCH

- a. Insert diskette into drive. Write protect notch must be open.
- b. Set oscilloscope to AUTO SWEEP, 2 V/div, and monitor TP9.
- c. Check to see if logic level changes when diskette is removed.
- d. If not, loosen mounting screws on switch and adjust until logic level changes.

SECTION VII REMOVALS AND REPLACEMENTS

7.1 FACEPLATE REMOVAL AND INSTALLATION

- a. Open door.
- b. Remove mounting screw on each side of faceplate. Pull faceplate forward and away from drive casting.
- c. No re-adjustment is required after replacement.

7.2 DRIVE MOTOR ASSEMBLY REMOVAL AND INSTALLATION

- a. Remove drive motor belt.
- b. Disconnect drive motor connector from PCB.
- c. Remove PCB.
- d. Remove drive motor by unfastening two mounting screws.
- e. To reinstall, reverse above procedure.
- f. Motor speed must be adjusted as per paragraph 6.7.

7.3 HEAD AND CARRIAGE ASSEMBLY

- a. Remove drive PCB and disconnect head connector from PCB.
- b. Remove shield from hub frame.
- c. Unclamp head cable from diskette guide rail.
- d. Insert clean piece of bond paper between read/write heads and disengage interlock.
- e. Remove screws securing rod clamps to base casting.
- f. Pivot carriage away from base casting and remove.
- g. Locate ball bearing in channelled area of base casting. Remove and retain bearing for re-assembly. Do not lose ball.
- h. To re-install, reverse above procedure.

CAUTION

Ensure that after installing head cable there is enough slack to allow carriage full motion without causing binds.

- i. Check head alignment (paragraphs 6.1 through 6.3).
- j. Readjust track 00 limiter if new carriage is installed. (Refer to paragraph 6.4.)

7.4 STEPPER MOTOR AND ACTUATOR ASSEMBLY

- a. Remove drive PCB and remove connectors.
- b. Cut tie wraps around harness wires.
- c. Remove two screws from motor clamp.
- d. Pivot motor and retract from base casting.
- e. To reinstall, reverse above procedure.
- f. Loosen track 00 limiter.
- g. Adjust read/write head alignment (paragraph 6.1).
- h. Readjust track 00 limiter (paragraph 6.4).

7.5 INTERLOCK ARM REMOVAL AND INSTALLATION (SA460 ONLY)

- a. Remove drive PCB.
- b. Remove shield from hub frame.
- c. Remove platen/interlock arm assembly by removing motor (paragraph 7.2).
- d. Release retaining spring from interlock arm.
- e. Rotate arm 90° and remove it from platen keyway.
- f. To reinstall, reverse procedure.

7.6 SPINDLE HUB AND PULLEY ASSEMBLY

These assemblies are not field replaceable.

7.7 CLAMP HUB REMOVAL

- a. Remove faceplate (reference paragraph 7.1).
- b. Remove shield from hub frame.
- c. Remove drive PCB.
- d. Remove E-ring from hub shaft. Entire assembly can now be removed from hub frame. Care should be taken not to overstress hub frame mounting pivot springs.
- e. To re-install: Position hub clamp with spacer and spring in place onto spindle hub. (Large end of spring is placed against hub frame).
- f. Press hub frame down towards spindle until hub shaft protrudes through its mounting hole in hub frame.
- g. Reinstall faceplate. Readjustment is not required.

7.8 HUB FRAME ASSEMBLY REMOVAL

Removal of this assembly is not normally required or recommended. The only time that removal would be required in the field is to replace the entire assembly.

- a. Remove drive PCB.
- b. Remove index detector assembly.
- c. Remove two mounting screws that hold pivot springs to casting.
- d. Hub frame assembly can now be lifted clear of casting.
- e. When removing hub frame on SA460, use caution to free side and lift arm.

7.9 HUB FRAME ASSEMBLY INSTALLATION AND ADJUSTMENT

- a. Put hub frame onto drive and lightly tighten mounting screws removed in step (c) of removal procedures.
- b. Latch hub frame closed.
- c. Position hub frame until hub shaft is centered in its mounting hole in hub frame. Now tighten mounting screws for hub frame pivot springs.
- d. Check that door latch assembly does not bind in faceplate. If binding occurs, loosen door latch mounting screws and reposition until it is free of binds.
- e. Reinstall drive PCB.
- f. Check and readjust index timing. (Paragraph 6.6.)

7.10 WRITE PROTECT SWITCH REMOVAL

- a. Remove drive PCB.
- b. Remove two mounting screws for switch.
- c. Unsolder black wire from terminal and brown wire from N/C on switch.
- d. After reinstallation, adjust per paragraph 6.8.

7.11 INDEX DETECTOR ASSEMBLY REMOVAL

- a. Remove PCB.
- b. Remove shield from hub frame.
- c. Remove: orange wire from J3 Pin 10.
red wire from J3 Pin 9.
- d. Remove detector mounting screw from hub frame. This will free detector.
- e. When installing new assembly, ensure detector mounting block is flush against side of hub frame.
- f. Readjust index timing (paragraph 6.6).

7.12 INDEX LED REMOVAL

- a. Remove drive PCB.
- b. Remove: blue wire from J3 Pin 17.
violet wire from J3 Pin 24.
- c. Remove housing from base casting to which LED is mounted.
- d. Squeeze LED mounting block locking tabs together and press assembly out of mounting hole in platen.
- e. To reinstall, reverse removal procedure.
- f. When remounting housing, ensure it is flush with machine surface on casting. Position it laterally so diskette can be inserted without binding when door is closed.
- g. Readjust index timing (paragraph 6.6).

7.13 TRACK ZERO PHOTO DETECTOR REMOVAL

- a. Remove PCB from drive.
- b. Remove: brown wire from J3 Pin 11.
black wire from J3 Pin 12.
orange wire from J3 Pin 18.
red wire from J3 Pin 19.
- c. Remove two screws securing LED housing to track 00 plate.
- d. To reinstall, reverse above procedure.
- e. Adjust as directed in paragraph 6.5.

SECTION VIII ILLUSTRATED PARTS CATALOG

8.1 DESCRIPTION

The Illustrated Parts Catalog (IPC) is arranged so that the figure will always precede the parts listing and, when possible, will appear either directly above the list, or on the left hand page immediately preceding it.

The first number in the list will always refer to the figure number. The second number will refer to the reference number of the part within the figure.

Part numbers enclosed in parentheses refer to parts belonging to a Next Higher Assembly (NHA) and are of importance only to those customers with alternate assemblies. Following the descriptions of these parts, the designation NHA P/N _____ gives the part number of the assembly to which they pertain. When applicable to the customer's assembly, these alternate parts will be used in lieu of the part listed directly above them. Assume that the quantity per assembly for these alternate parts is the same unless otherwise listed.

When an assembly is referred to within a figure and a further breakdown is shown on another figure, then the referenced figure will be called out.

8.2 INDENTED LEVEL

The parts list is indented to show the levels of assembly within a figure. The major assembly will always be unindented. All parts or assemblies that attach to the assembly will be indented one space. Parts within these assemblies will be indented two spaces and so on.

8.3 QUANTITY PER ASSEMBLY

The quantity listed is the quantity used on the major assembly. Major assemblies themselves will never have a quantity listed.

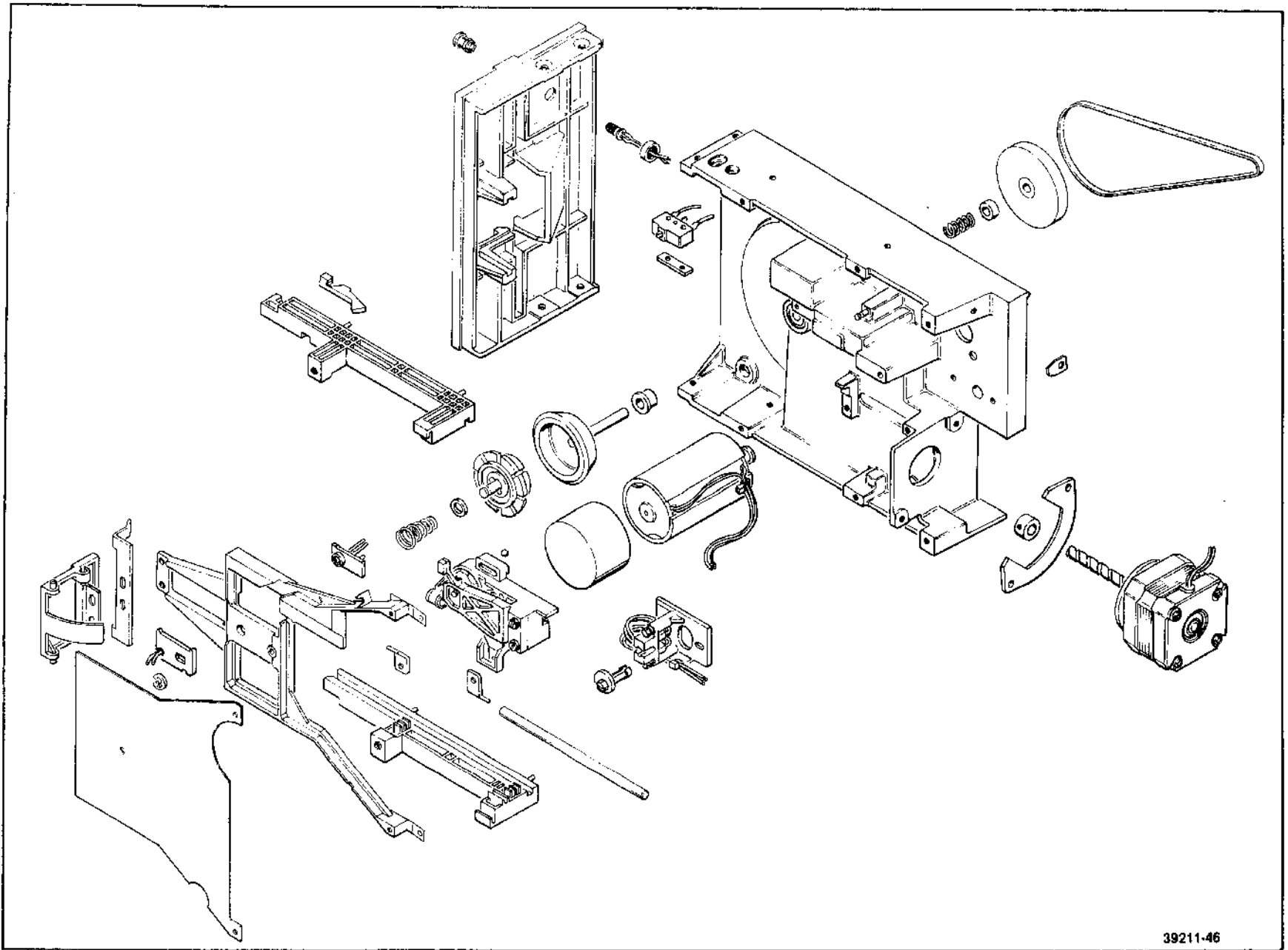

39211-46

FIGURE 8-1. SA410 PARTS BREAKDOWN

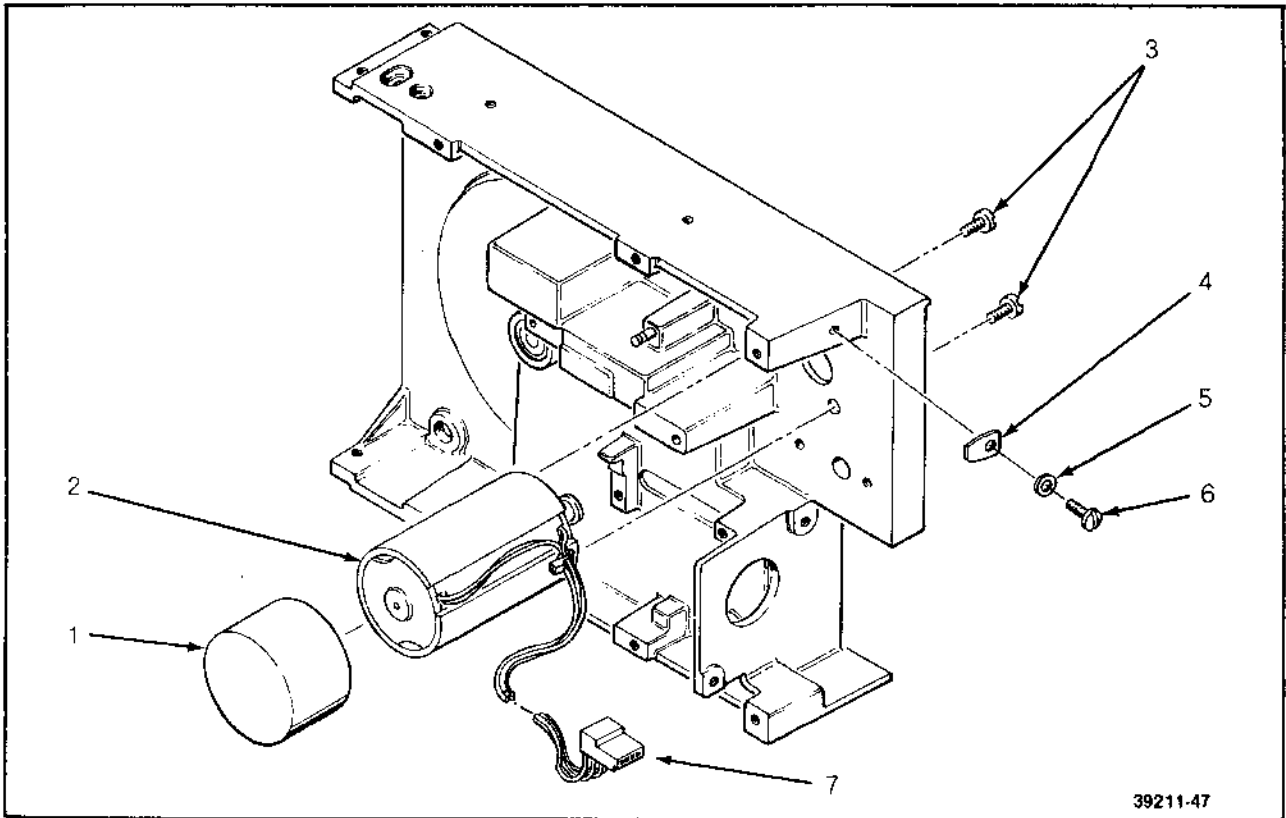

FIGURE 8-2. DRIVE MOTOR ASSEMBLY

DRIVE MOTOR ASSEMBLY			
Reference Designator	Description	Part Number	Qty Used
2-			
1	End Cap	19514	1
2	Drive Motor	54338	1
3	Screw #6-32 x .25	10187	2
4	Faston Tab	15663	1
5	Star Washer	12501	1
6	Screw #6-32 x .25	10187	1
7	Connector (Red)	17743	1

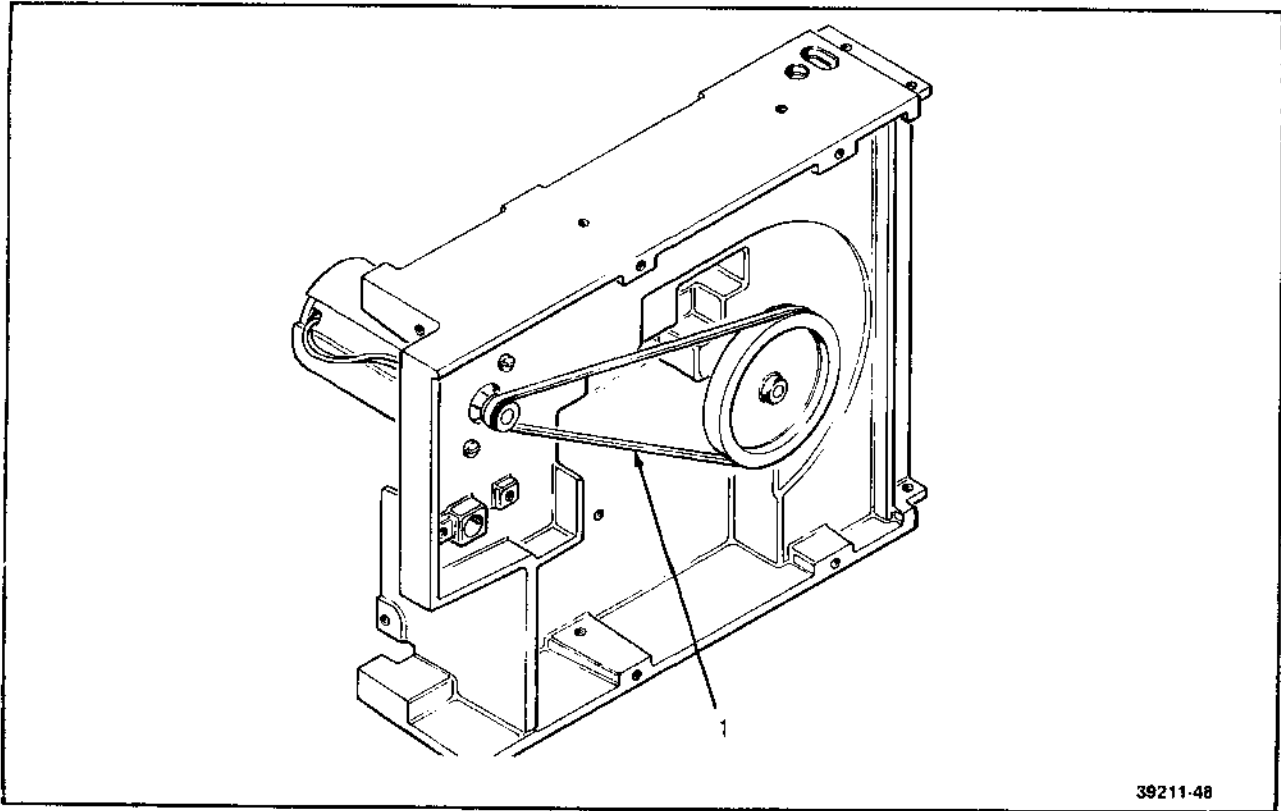

FIGURE 8-3. DRIVE BELT

DRIVE BELT			
Reference Designator	Description	Part Number	Qty Used
3-1	Drive Belt	54229	1

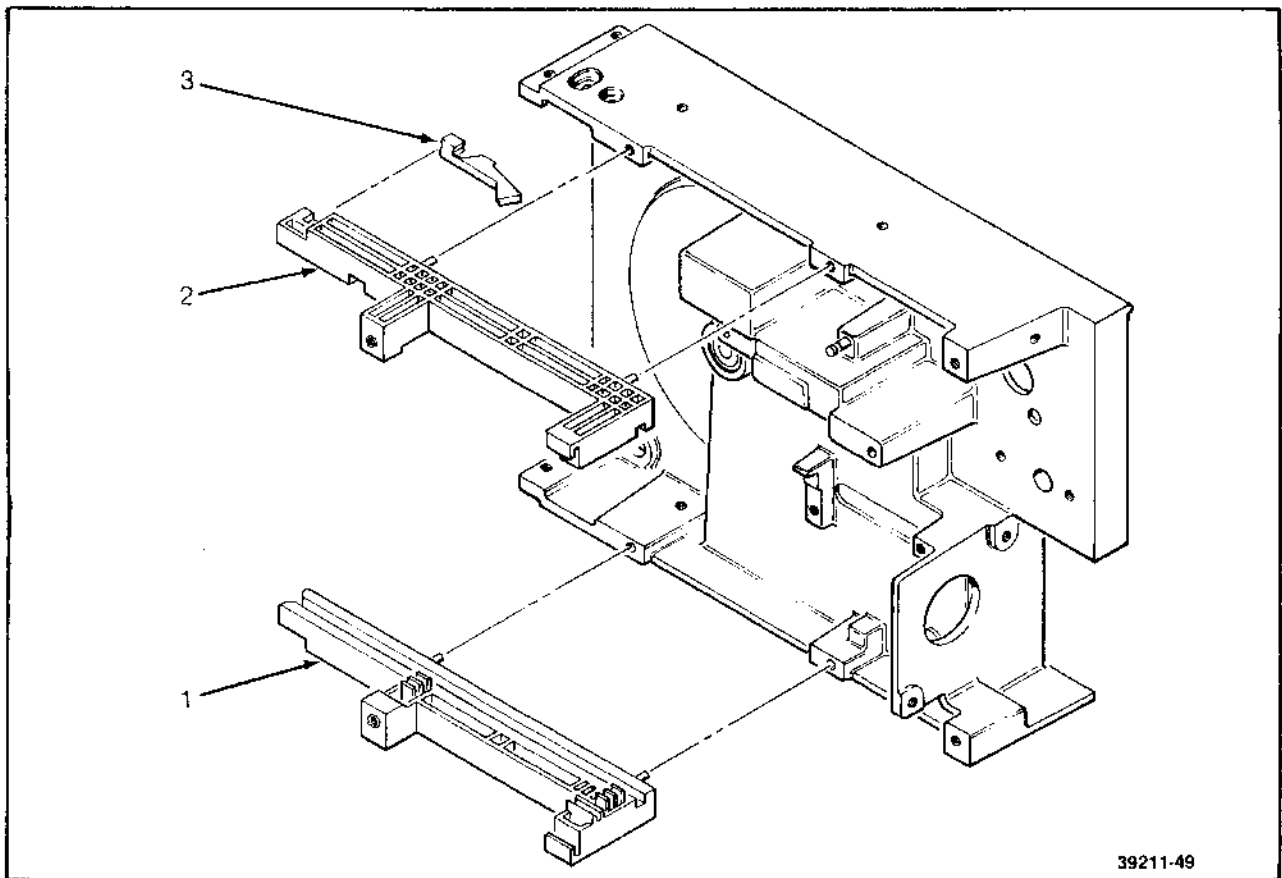
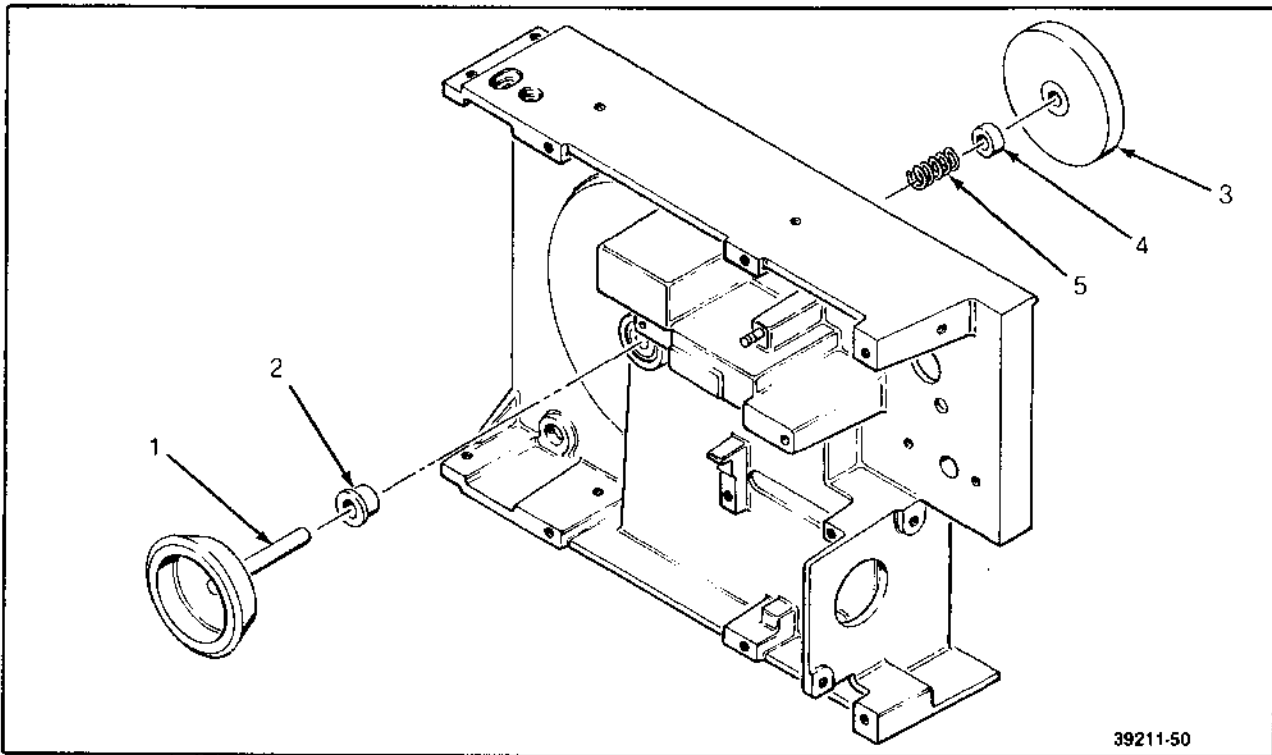

FIGURE 8-4. DISKETTE GUIDE

DISKETTE GUIDE			
Reference Designator	Description	Part Number	Qty Used
4-			
1	Diskette Guide Right	54516	1
2	Diskette Guide Left	54040	1
3	W.P. Actuator	54030	1



39211-50

FIGURE 8-5. SPINDLE ASSEMBLY

SPINDLE ASSEMBLY

Reference Designator	Description	Part Number	Qty Used
5-			
1	Spindle	54232-2	1
2	Ball Bearing	10805	1
3	Pulley	54138	1
4	Ball Bearing	10804	1
5	Spindle Spring	54328	1

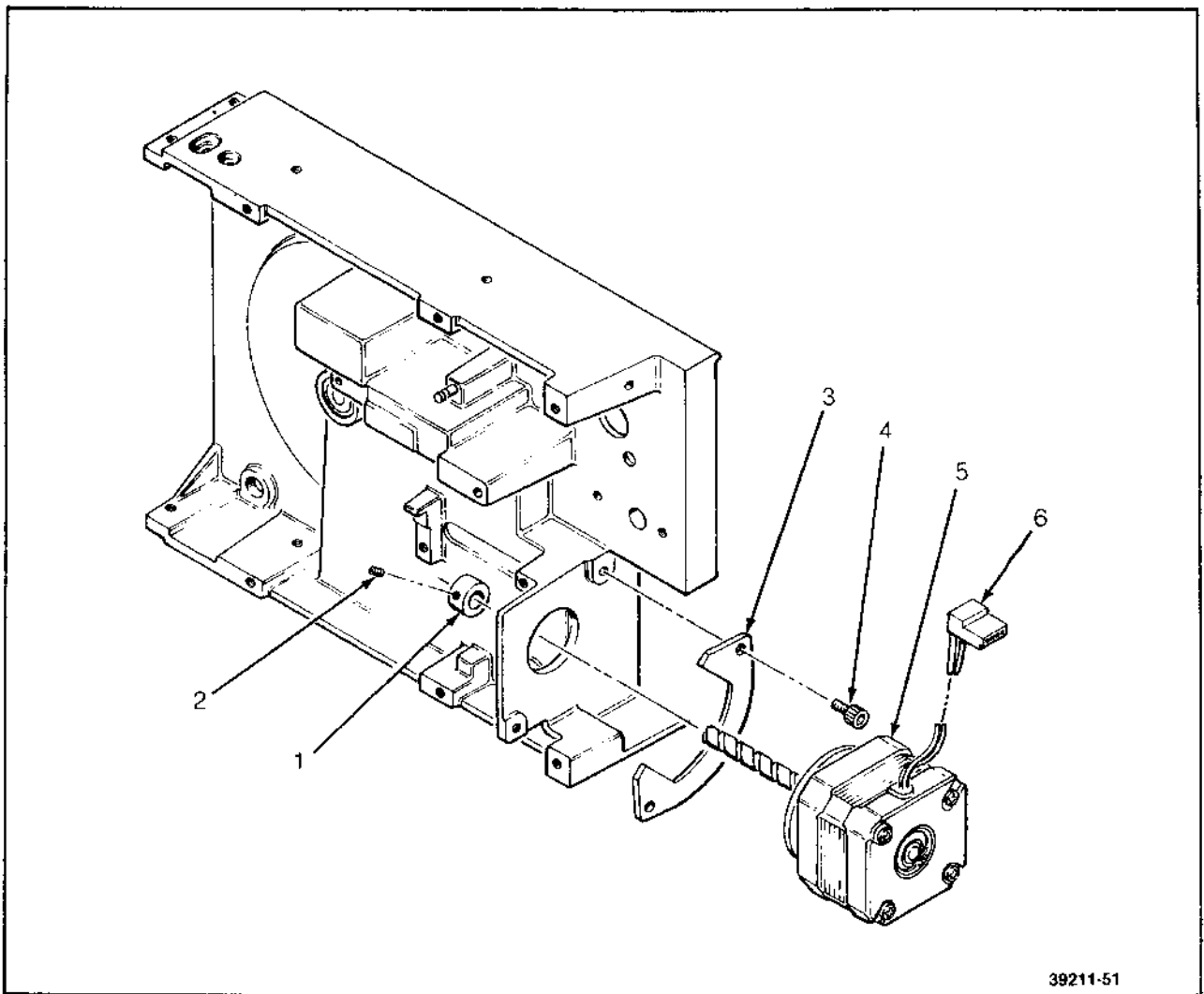

39211-51

FIGURE 8-6. STEPPER MOTOR ASSEMBLY

STEPPER MOTOR ASSEMBLY

Reference Designator	Description	Part Number	Qty Used
6-			
1	Track Zero Limiter	54330	1
2	Set Screw	11904	1
3	Motor Clamp	54231	1
4	Allen Screw 6-32	11942	2
5	Stepper Motor	54348	1
6	Connector (Blue)	17742	1

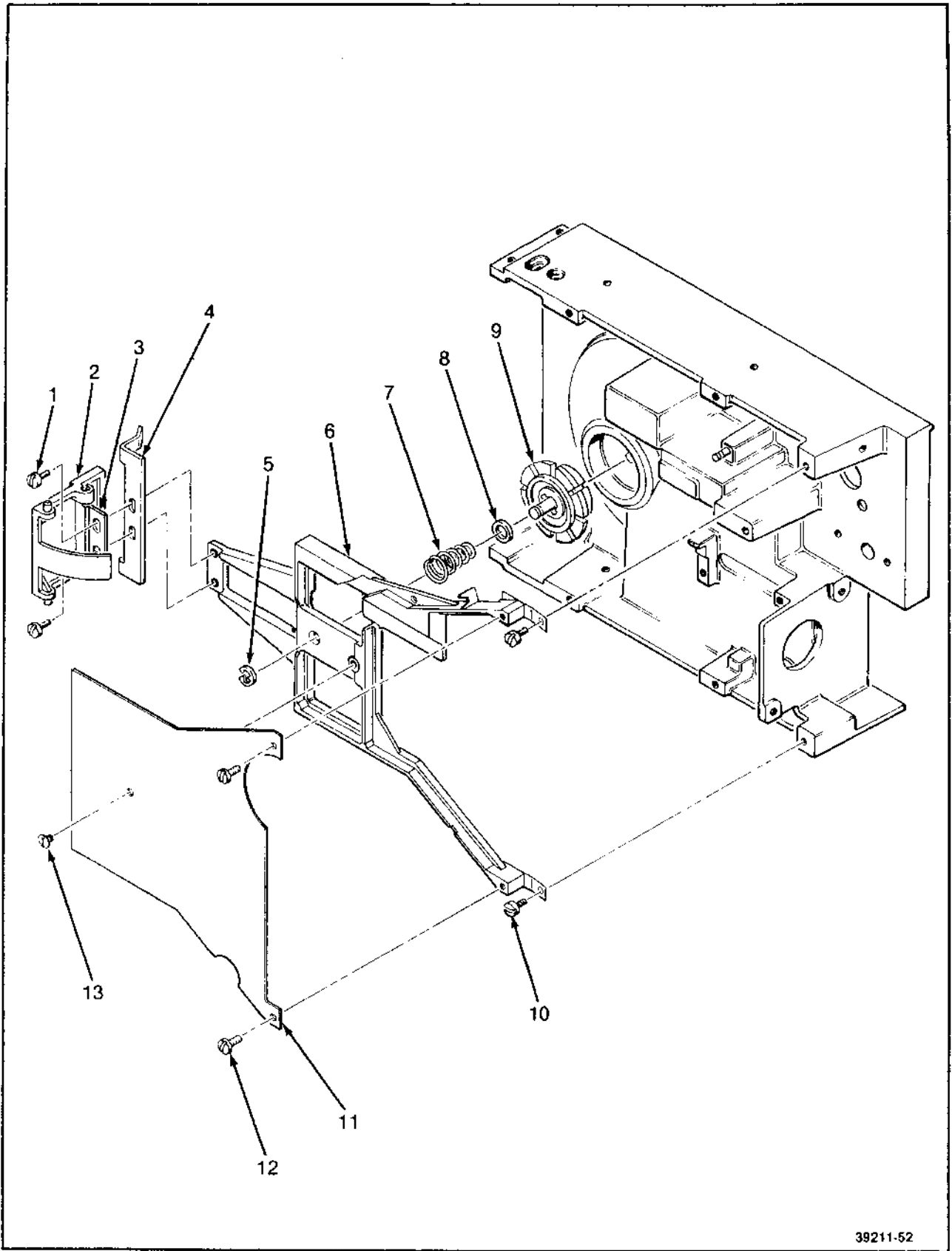

39211-52

FIGURE 8-7. HUB FRAME ASSEMBLY

HUB FRAME ASSEMBLY

Reference Designator	Description	Part Number	Qty Used
7-			
1	Screw #6-32 x .18	10186	2
2	Door	54334	1
3	Door Hinge	54039	1
4	Diskette Stop	54057	1
5	Retaining Ring	11305	1
6	Hub Frame	54347	1
7	Clamp Spring	54132	1
8	Hub Collar	54131	1
9	Hub Clamp Assembly	54242	1
10	Screw #6-32 x .25	10187	2
11	Shield	54339	1
12	Screw #6-32 x .18	10186	2
13	Screw #6-32 x .18 (Non-metallic)	12106	1

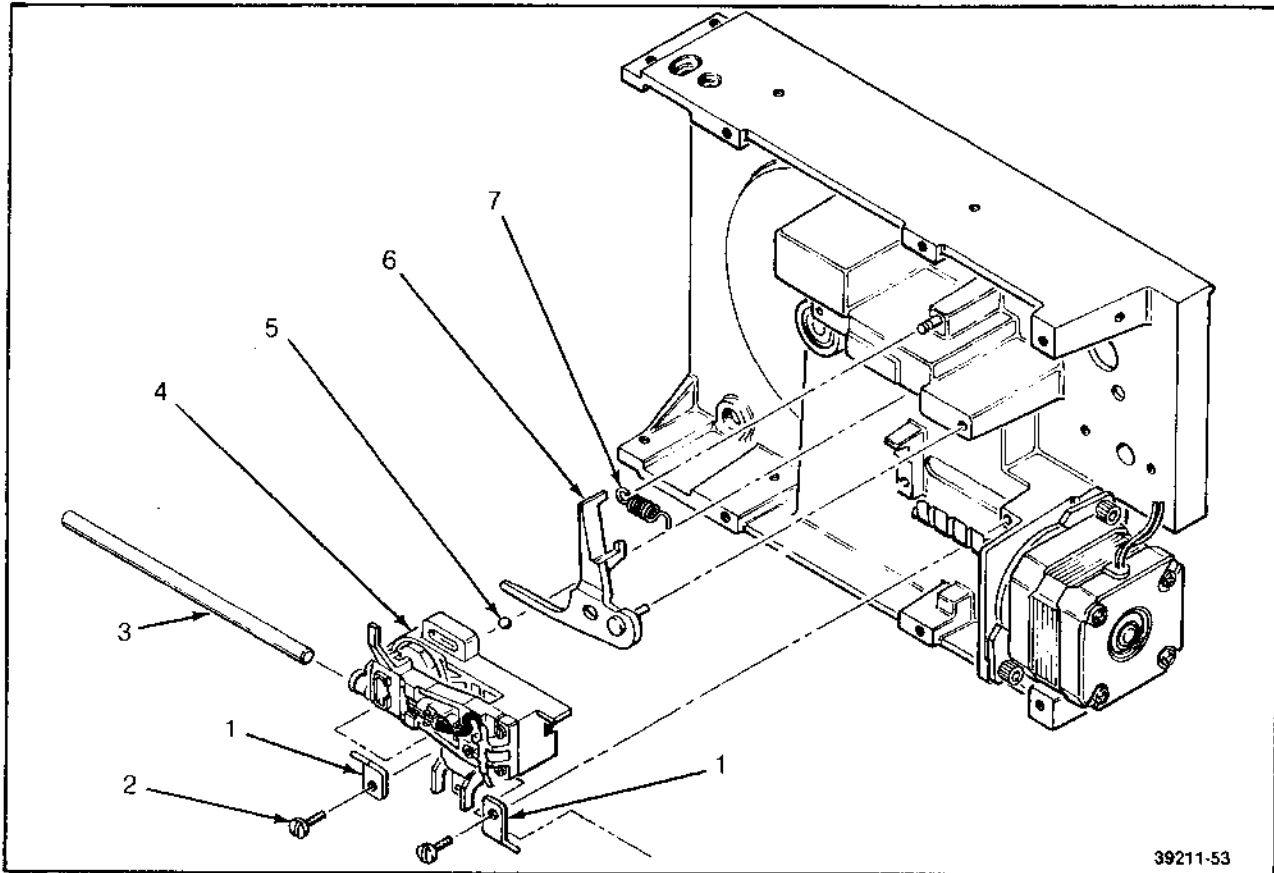
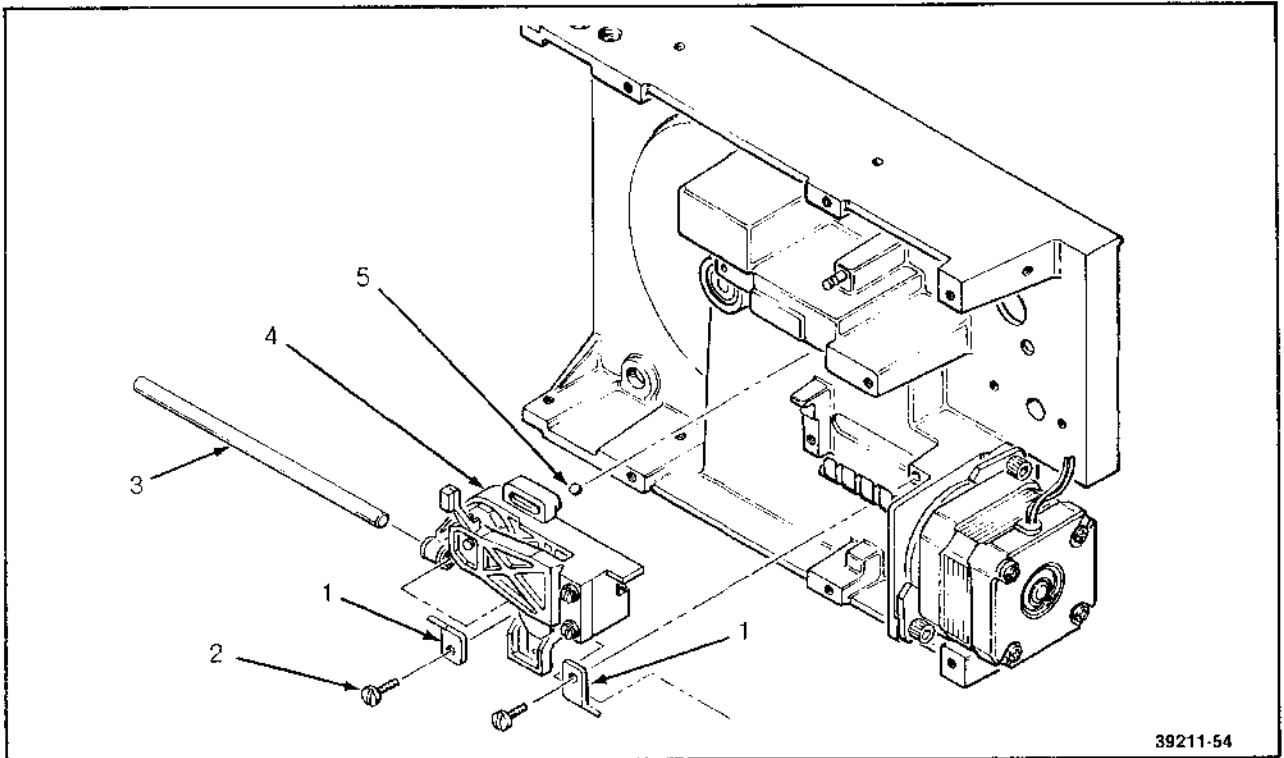

FIGURE 8-8. SA460 READ/WRITE CARRIAGE ASSEMBLY

SA460 READ/WRITE CARRIAGE ASSEMBLY

Reference Designator	Description	Part Number	Qty Used
8-			
1	Guide Rod Clamp	54230	2
2	Screw #6-32 x .25	10187	2
3	Guide Rod	54243	1
4	Carriage Assembly	54250	1
5	Chrome Ball	10813	1
6	Head Interlock Lever	54342	1
7	Interlock Spring	54563	1



39211-54

FIGURE 8-9. SA410 READ/WRITE CARRIAGE ASSEMBLY

SA410 READ/WRITE CARRIAGE ASSEMBLY

Reference Designator	Description	Part Number	Qty Used
9-			
1	Guide Rod Clamp	54230	2
2	Screw #6-32 x .25	10187	2
3	Guide Rod	54243	1
4	Carriage Assembly	54294	1
5	Chrome Ball	10813	1

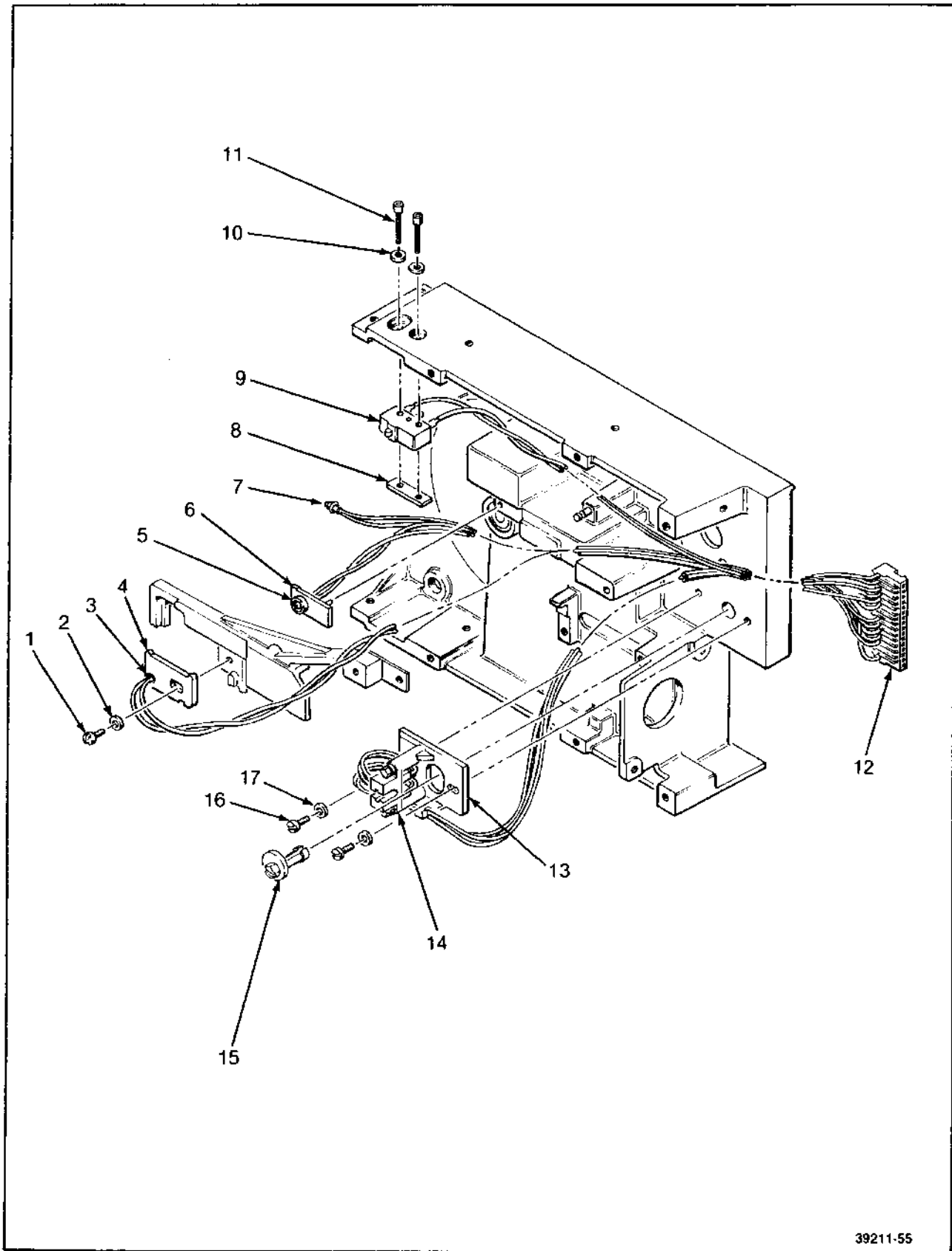

FIGURE 8-10. MAIN HARNESS ASSEMBLY

MAIN HARNESS ASSEMBLY

Reference Designator	Description	Part Number	Qty Used
10-			
1	Screw #6-32 × .25	10187	1
2	Washer #6	10013	1
3	Index Photo Transistor	10066	1
4	Photo Transistor Bracket	54023	1
5	Index LED	10065	1
6	LED Holder	54335	1
7	Activity LED	15915	1
8	Nut Plate	54062	1
9	W.P. Switch	17212	1
10	Washer #2	10011	2
11	Allen Screw #2-56 × .50	12039	2
12	Connector (Red)	17744	1
13	Track Zero Bracket	54227	1
14	Track Zero Photo Detector	10068	1
15	Eccentric	50818	1
16	Screw #6-32 × .25	10187	2
17	Washer #6	10013	2

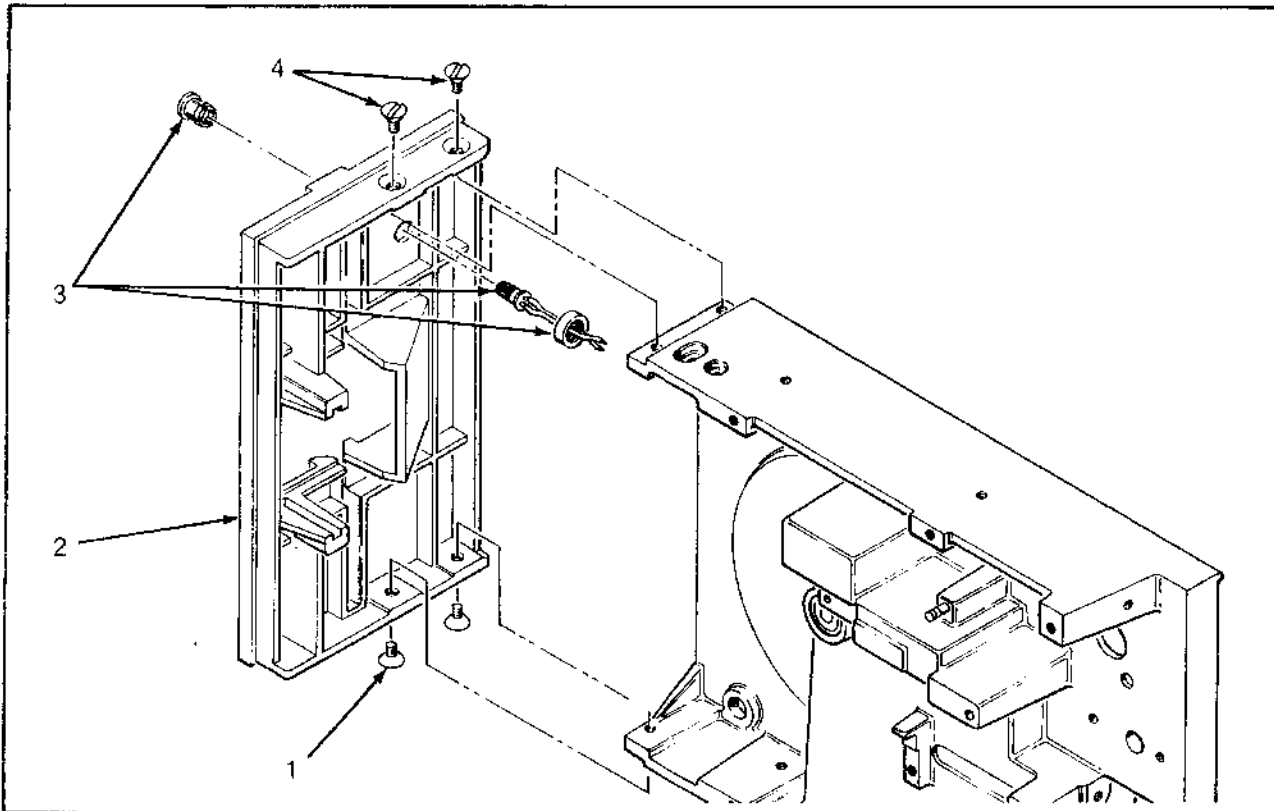

FIGURE 8-11. FRONT COVER (STD)

39211-56

FRONT COVER (STD)

Reference Designator	Description	Part Number	Qty Used
11-			
1	Screw #6-32 × .25	11900	2
2	Front Cover	54077-2	1
3	Activity LED	15915	1
4	Screw #6-32 × .25	11900	2

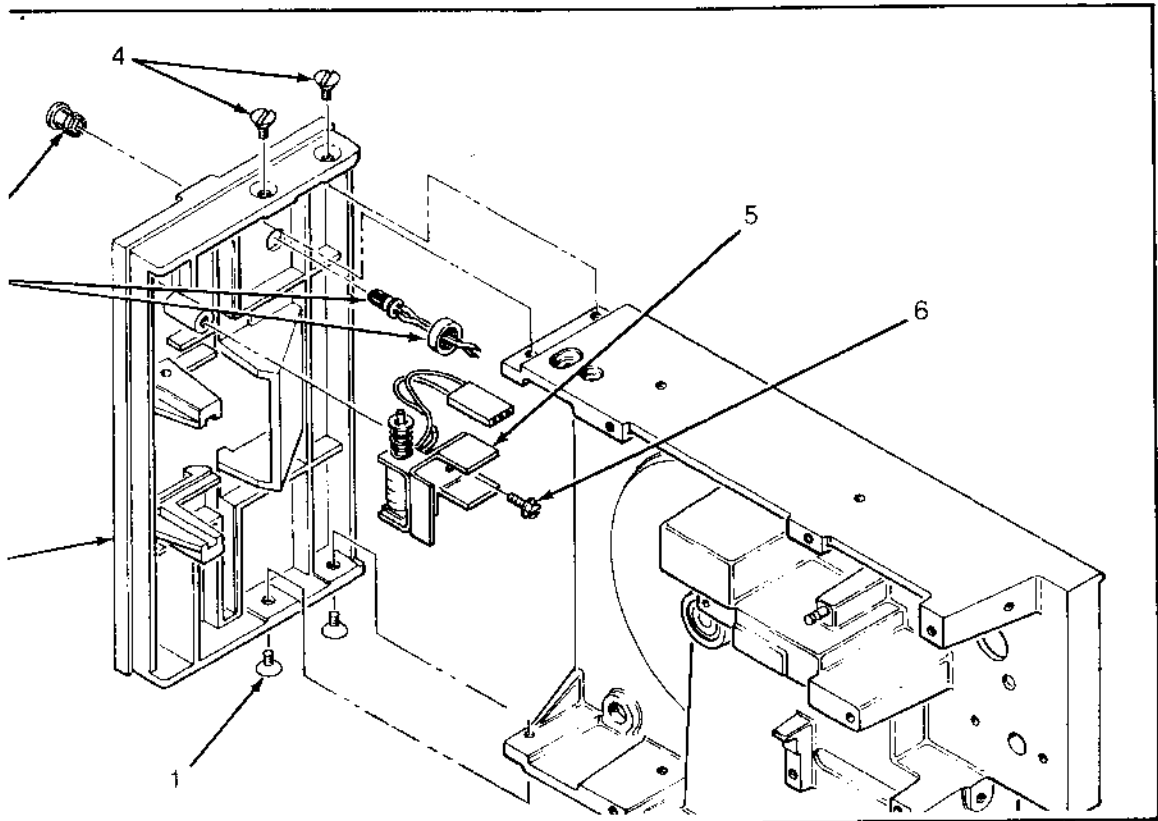

FIGURE 8-12. FRONT COVER (OPTIONAL)

39211-57

FRONT COVER (OPTIONAL)

Reference Indicator	Description	Part Number	Qty Used
2-			
1	Screw #6-32 x .25	11900	2
2	Front Cover	54077-4	1
3	Activity LED	15915	1
4	Screw #6-32 x .25	11900	2
5	Door Lock Solenoid	54374	1
6	Screw	12011	1

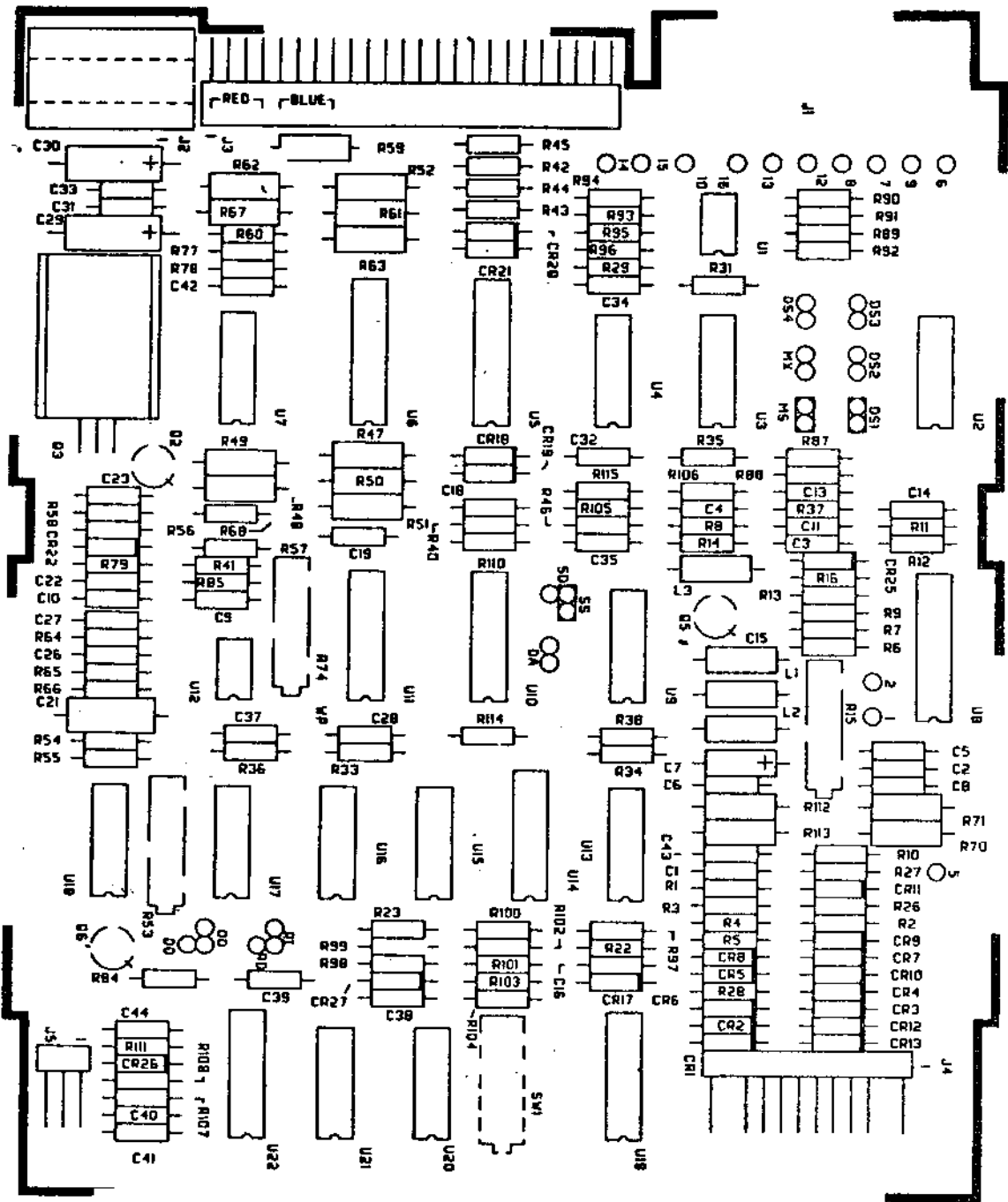

FIGURE 8-13. DRIVE PCB (MLC4)

39211-58

DRIVE PCB MLC4

Reference Designator	Part Number	Description	Qty
13-			
Ref.	25219	DRIVE PCB (MLC4)	1
C1,8-11,16,22, 23,28,31-35, 37-39,44	15080	CAP., 1 μ F	18
C-2,5,6,27	15106	CAP., 0.1 μ F, 50 V, 10%	4
C-3,13,14,18,42,43	15057	CAP., 200 pF, 50 V, 5%	6
C-4	15067	CAP., 1000 pF, 50 V, 5%	1
C-7	10088	CAP., 1.0 μ F, 35 V, 10%	1
C-15	15117	CAP., 2700 pF, 50 V, 5%	1
C-19,21,40,41	15091	CAP., .015 μ F, 50 V	4
C-26	15100	CAP., .047 μ F, 25 V	1
C-29,30	10089	CAP., 4.7 μ F, 50 V, 10%	2
CR-1-13,17,22	10062	DIODE, 1N4148	15
CR-18-21,26	15900	DIODE, 1N4003	5
CR-25	15902	DIODE 1N5231B, 5.1 V, 5%	1
CR-27	15924	DIODE 1N5226B, 3.3 V, 5%	1
DS-1,MS,SS	15648	PLUG Shorting	3
L-1,2	16314	INDUCTOR, 180 μ H, 10%	2
L-3	16313	INDUCTOR, 68 μ H, 10%	1
Q-2,5,6	17619	TRANSISTOR, 2222A	3
Q-3	17625	TRANSISTOR, D44E2	1
R-1	16889	RES., 4.87 k ohm, 1/8 w, 1%	1
R-2,4,23,34-38, 46,68,77,78, 84,92,96,97, 100,110	16773	RES., 1.5 k ohm, 1/4 w, 5%	18
R-3,5,16,33	10113	RES., 10 k ohm, 1/4 w, 5%	4
R-6,7	16916	RES., 392 ohm, 1/8 w, 1%	2
R-8,9,26,28	16917	RES., 2.21 k ohm, 1/8 w, 1%	4
R-10	16739	RES., 20 ohm, 1/4 w, 5%	1
R-11	16929	RES., 8.45 k ohm, 1/8 w, 1%	1
R-12,89,90,93	16706	RES., 2 k ohm, 1/8 w, 1%	4
R-13	16709	RES., 121 ohm, 1/8 w, 1%	1
R-14,40,79	16744	RES., 18 k ohm, 1/4 w, 5%	3
R-15	16766	RES., Pot, 50 k, 3/4 w, 10%	1
R-22	16913	RES., 12.1 k ohm, 1/8 w, 5%	1
R-27,31,115	16722	RES., 100 k ohm, 1/4 w, 5%	3
R-29	16738	RES., 47 k ohm, 1/4 w, 5%	1
R-41	16964	RES., 243 k ohm, 1/8 w, 1%	1
R-42,45	16777	RES., 150 ohm, 1/4 w, 5%	2
R-43,44,99	10100	RES., 75 ohm, 1/4 w, 5%	3
R-47,48,63,67	16966	RES., 39 ohm, 1 w, 5%	4
R-49-52,61,62	16932	RES., 22 ohm, 1/2 w, 5%	6
R-53	16795	RES., Pot, 10 k, 3/4 w, 10%	1
R-54,55	16829	RES., 10 k ohm, 1/8 w, 1%	2
R-56,66	10106	RES., 510 ohm, 1/4 w, 5%	2
R-57	16779	RES., 3.3 k ohm, 1/4 w, 5%	1

DRIVE PCB MLC4 (Cont.)

Reference Designator	Part Number	Description	Qty
13-			
R-58,102,105,106	10108	RES., 1 k ohm, 1/4 w, 5%	4
R-59	16786	RES., 1 ohm, 1/2 w, 5%	1
R-60	16756	RES., 1.2 k ohm, 1/4 w, 5%	1
R-64	10114	RES., 470 k ohm, 1/4 w, 5%	1
R-65	16907	RES., 97.6 k ohm, 1/8 w, 1%	1
R-70,71	16721	RES., 220 ohm, 1/2 w, 5%	2
R-74	16796	RES., Pot. 100 k, 3/4 w, 10%	1
R-85	16931	RES., 270 k ohm, 1/4 w, 5%	1
R-87	10103	RES., 220 ohm, 1/4 w, 5%	1
R-88	16838	RES., 330 ohm, 1/4 w, 5%	1
R-91	16787	RES., 24 k ohm, 1/4 w, 5%	1
R-94	16754	RES., 4.02 k ohm, 1/8 w, 1%	1
R-95	16770	RES., 33 k ohm, 1/4 w, 5%	1
R-98	16925	RES., 33 ohm, 1/4 w, 5%	1
R-101,103,104	10109	RES., 2 k ohm, 1/4 w, 5%	3
R-107	16897	RES., 71.5 k ohm, 1/8 w, 1%	1
R-108	16965	RES., 174 k ohm, 1/8 w, 1%	1
R-111	16832	RES., 180 ohm, 1/4 w, 5%	1
R-112	16727	RES., 360 ohm, 1/2 w, 5%	1
R-113	16785	RES., 680 ohm, 1/4 w, 5%	1
R-114	16768	RES., 5.1 k ohm, 1/4 w, 5%	1
SW-1	17214	SWITCH Door Open	1
U-1	12673	I.C., LM393	1
U-2,20	16207	I.C., 7438	2
U-3	16837	RES., Pack, 220/330 ohm	1
U-4	16265	I.C., 74LS14	1
U-5	12665	I.C., UDN2981A	1
U-6	12666	I.C., ULN2803A	1
U-7	12677	I.C., 74LS09	1
U-8	16278	I.C., Read Amplifier	1
U-9	16232	I.C., 7407	1
U-10	12676	I.C., 74LS75	1
U-11,22	12642	I.C., 92LS02	2
U-12	16260	I.C., 555	1
U-13,17	12607	I.C., 72LS74	2
U-14	12674	I.C., CA3083	1
U-15	16274	I.C., 74LS02	1
U-16	12675	I.C., 74LS136	1
U-18	12614	I.C., LM2917	1
U-19	16270	I.C., Write Channel	1
U-21	16273	I.C., 74LS00, 14 Pin Dip	1

RECOMMENDED SPARES

	Description	Part Number
1	PCB	25219
2	SA410 Head Load Pad	50542
3	SA410 Carriage Assembly	54294
4	SA460 Carriage Assembly	54250
5	Drive Motor	54338
6	Drive Belt	54229
7	Stepper Motor	54348
8	Track Zero Sensor	10068

**PART NUMBER TO FIGURE REFERENCE
CROSS REFERENCE**

Part Number	Fig. Ref.
10011	10-10
10013	10-2
	10-17
10062	13-CR1
10065	10-5
10066	10-3
10068	10-14
10088	13-C7
10089	13-C29
10100	13-R43
10103	13-R87
10106	13-R56
10108	13-R58
10109	13-R101
10113	13-R3
10114	13-R64
10186	7-1
	7-12
10187	2-3
	2-6
	7-10
	8-2
	9-2
	10-1
	10-16
10804	5-4
10805	5-2
10813	8-5
	9-5
11305	7-5
11900	11-1
	11-4
	12-1
	12-4
11904	6-2
11942	6-4
12011	12-6
12039	10-11
12106	7-13
12501	2-5
12607	13-U13
12614	13-U18
12642	13-U11
12665	13-U15
12666	13-U6
12673	13-U1
12674	13-U14
12675	13-U16
12676	13-U10
12677	13-U7
15057	13-C3
15067	13-C4
15080	13-C1

Part Number	Fig. Ref.
15091	13-C19
15100	13-C26
15106	13-C2
15117	13-C15
15663	2-4
15900	13-CR18
	13-CR26
15902	13-CR25
15915	10-7
	11-3
	12-3
15924	13-CR27
15648	13-DS1
16207	13-U2
16232	13-U9
16260	13-U12
16265	13-U4
16270	13-U19
16273	13-U21
16274	13-U15
16278	13-U8
16313	13-L3
16314	13-L1
	13-L2
16706	13-R12
16709	13-R13
16721	13-R70
16722	13-R27
16727	13-R112
16738	13-R29
16739	13-R10
16744	13-R14
16754	13-R94
16756	13-R60
16766	13-R15
16768	13-R114
16770	13-R95
16770	13-R95
16773	13-R2
16777	13-R42
16779	13-R57
16785	13-R113
16786	13-R59
16787	13-R91
16795	13-R53
16796	13-R74
16829	13-R54
16832	13-R111
16837	13-U3
16838	13-R88
16889	13-R1
16897	13-R107
16907	13-R65

Part Number	Fig. Ref.
16916	13-R6
16917	13-R8
16925	13-R98
16929	13-R11
16931	13-R85
16932	13-R49
16933	13-R22
16964	13-R41
16966	13-R47
17212	10-9
17214	13-SW1
17619	13-Q2
17625	13-Q3
17742	6-6
17743	2-7
17744	10-12
19514	2-1
25219	13-Ref
50818	10-15
54023	10-4
54030	4-3
54039	7-3
54040	4-2
54057	7-4
54062	10-8
54077-2	11-2
54077-4	12-2
54131	7-8
54132	7-7
54138	5-3
54227	10-13
54229	3-1
54230	8-1
	9-1
54231	6-3
54232	5-1
54242	7-9
54243	8-3
	9-3
54250	8-4
54294	9-4
54328	5-5
54330	6-1
54334	7-2
54335	10-6
54338	2-2
54339	7-11
54342	8-6
54347	7-6
54348	6-5
54374	12-5
54516	4-1
54563	8-7

SECTION IX SCHEMATIC DIAGRAMS

The following schematic diagrams (figures 9-1 through 9-3) are furnished as an aid to malfunction analysis.

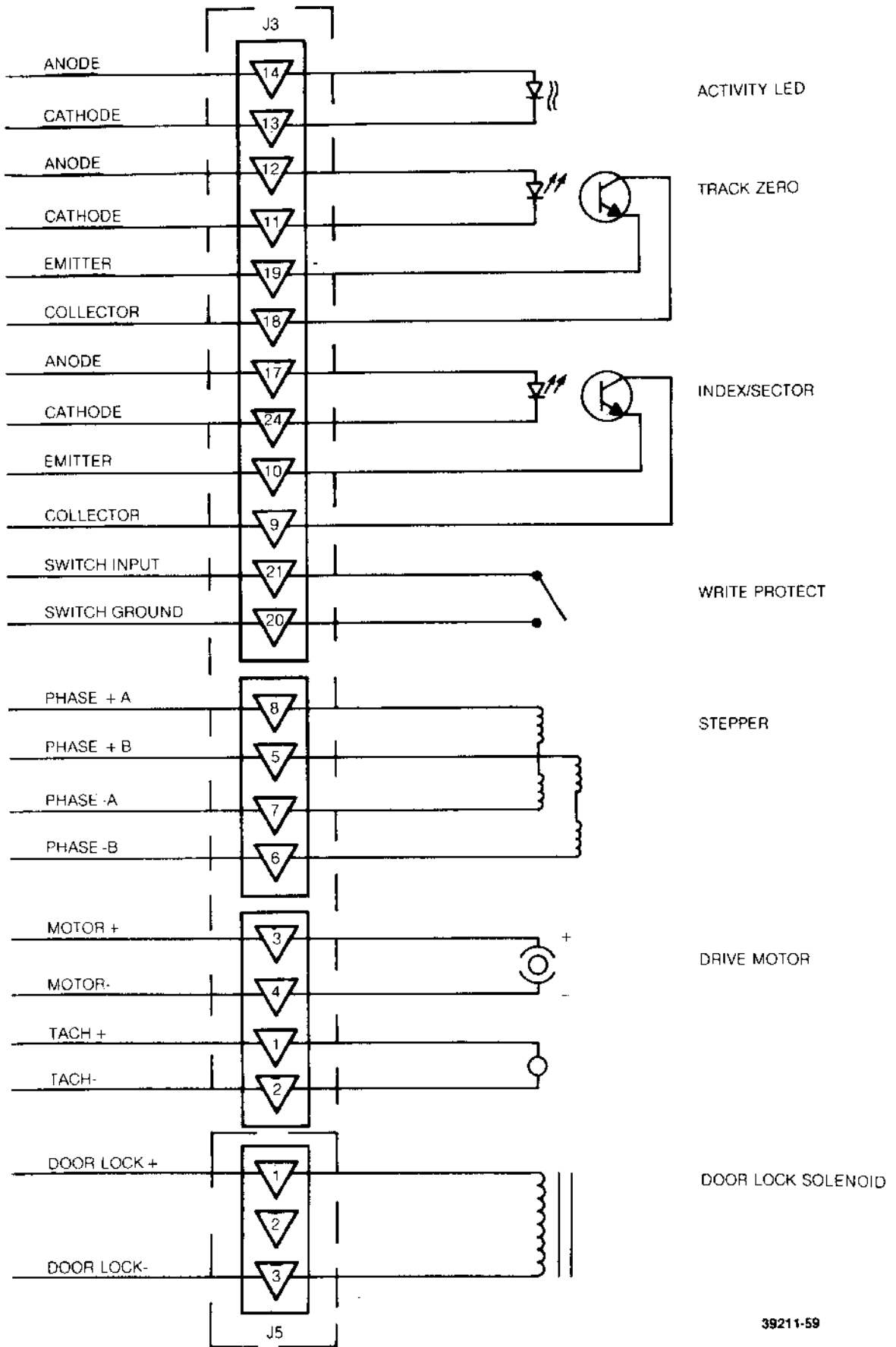

39211-59

FIGURE 9-1. MAIN HARNESS ASSEMBLY

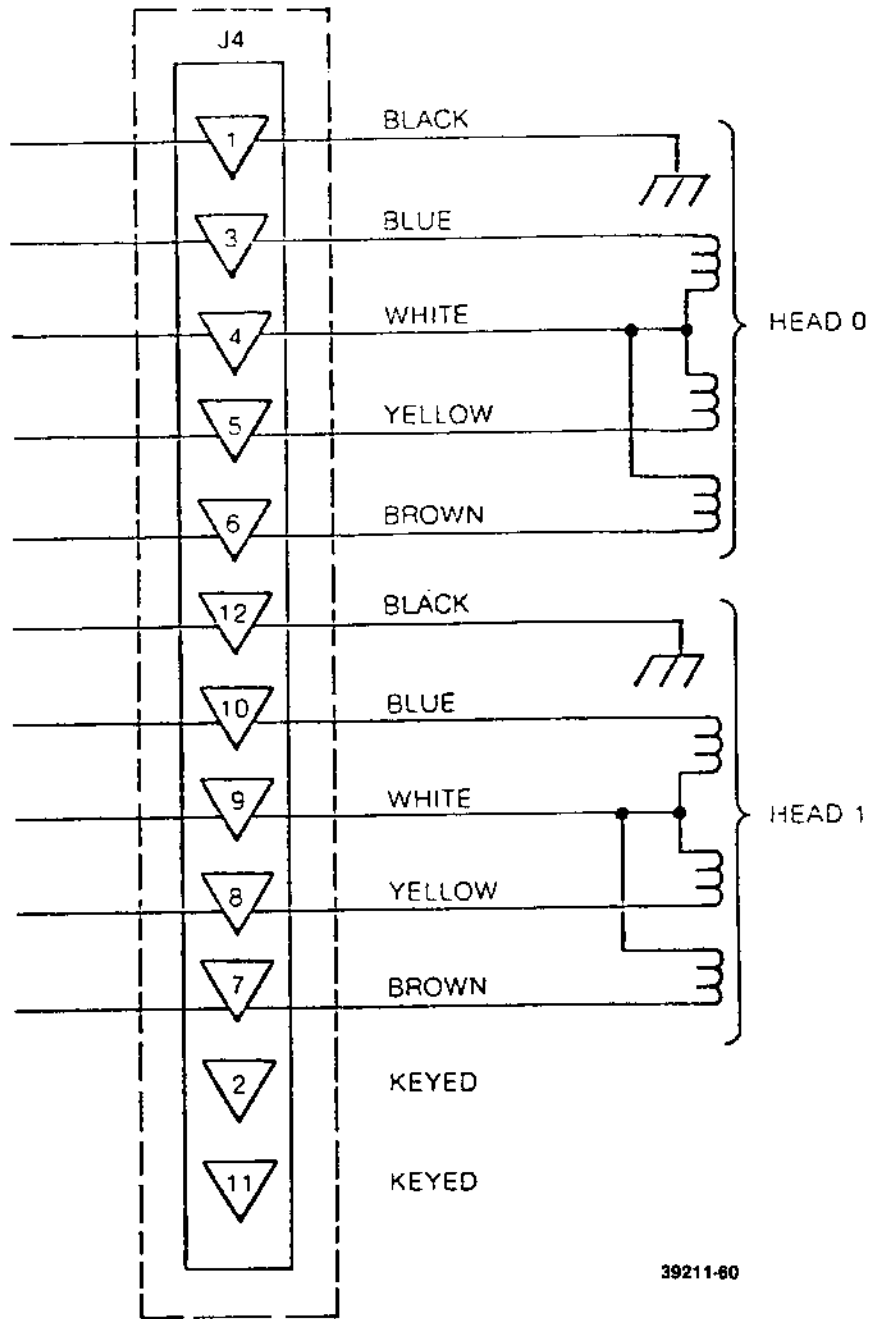
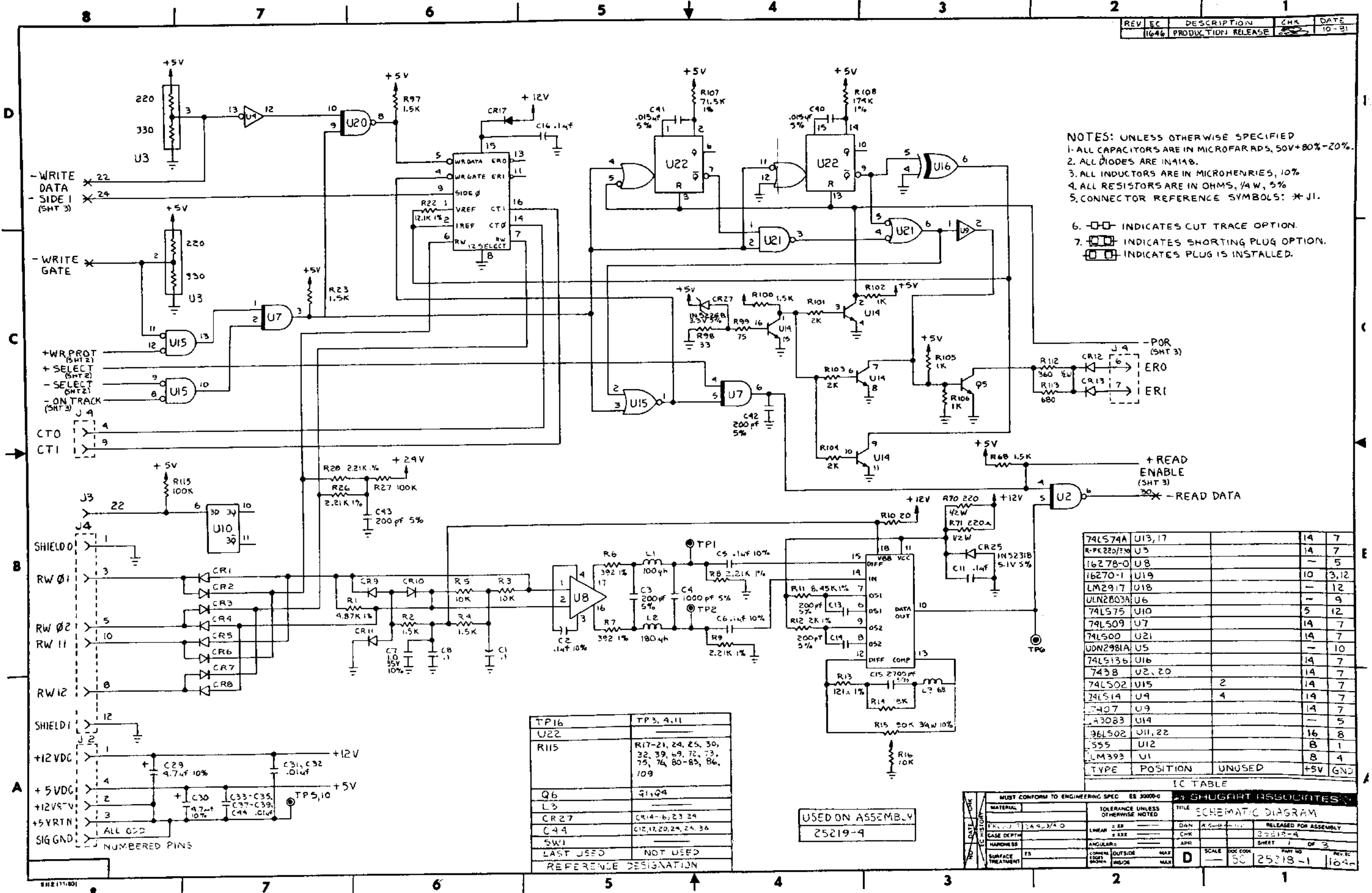

FIGURE 9-2. READ/WRITE HEAD CONNECTOR



- NOTES: UNLESS OTHERWISE SPECIFIED
1. ALL CAPACITORS ARE IN MICROFARADS, 50V+80%-20%.
 2. ALL DIODES ARE 1N4148.
 3. ALL INDUCTORS ARE IN MICROHENRIES, 10%
 4. ALL RESISTORS ARE IN OHMS, 1/4 W, 5%
 5. CONNECTOR REFERENCE SYMBOLS: * J1.
 6. INDICATES CUT TRACE OPTION.
 7. INDICATES SHORTING PLUG OPTION.
 - INDICATES PLUG IS INSTALLED.

IC	POSITION	UNUSED	+5V	GND
74LS74A	U13, 17		14	7
R-PK220/230	U3		14	7
16278-0	U8		-	5
16270-1	U19		10	3, 12
LM2917	U18		-	12
ULN2803A	U6		-	9
74LS75	U10		5	12
74LS09	U7		14	7
74LS00	U21		14	7
UDN2981A	U5		-	10
74LS136	U16		14	7
7438	U2, 20		14	7
74LS02	U15	2	14	7
74LS14	U9	4	14	7
7407	U9		14	7
43083	U14		-	5
36LS02	U11, 22		16	8
555	U12		8	1
LM393	U1		8	4
TYPE	POSITION	UNUSED	+5V	GND

REFERENCE DESIGNATION	LAST USED	NOT USED
TP16		TP3, 4, 11
U22		
R115		R17-21, 24, 25, 30, 32, 39, 69, 72, 73, 75, 76, 80-83, 86, 109
Q6		Q1, Q4
L3		
CR27		CR14-16, 23, 34
C44		C12, 17, 20, 24, 25, 36
SW1		
LAST USED		NOT USED
REFERENCE DESIGNATION		

USED ON ASSEMBLY
25219-4

MUST CONFORM TO ENGINEERING SPEC		EE 3000-0		SHUGART ASSOCIATES	
MATERIAL	TOLERANCE UNLESS OTHERWISE NOTED	TITLE	SCHEMATIC DIAGRAM		
FINISH	LINEAR	DWG	RELEASED FOR ASSEMBLY		
CASE DEPTH	2 X R	CHK	25218-4		
HARDNESS	ANGULAR	APR	SHEET 1 OF 3		
SURFACE TREATMENT	CONFORM TO SPEC	SCALE	25218-1		
	OUTSIDE	DATE	REV EC		
	INSIDE	10-81	1646		

FIGURE 9-3. SCHEMATIC DIAGRAM (SHEET 1 OF 3)
9-5/9-6 (blank)

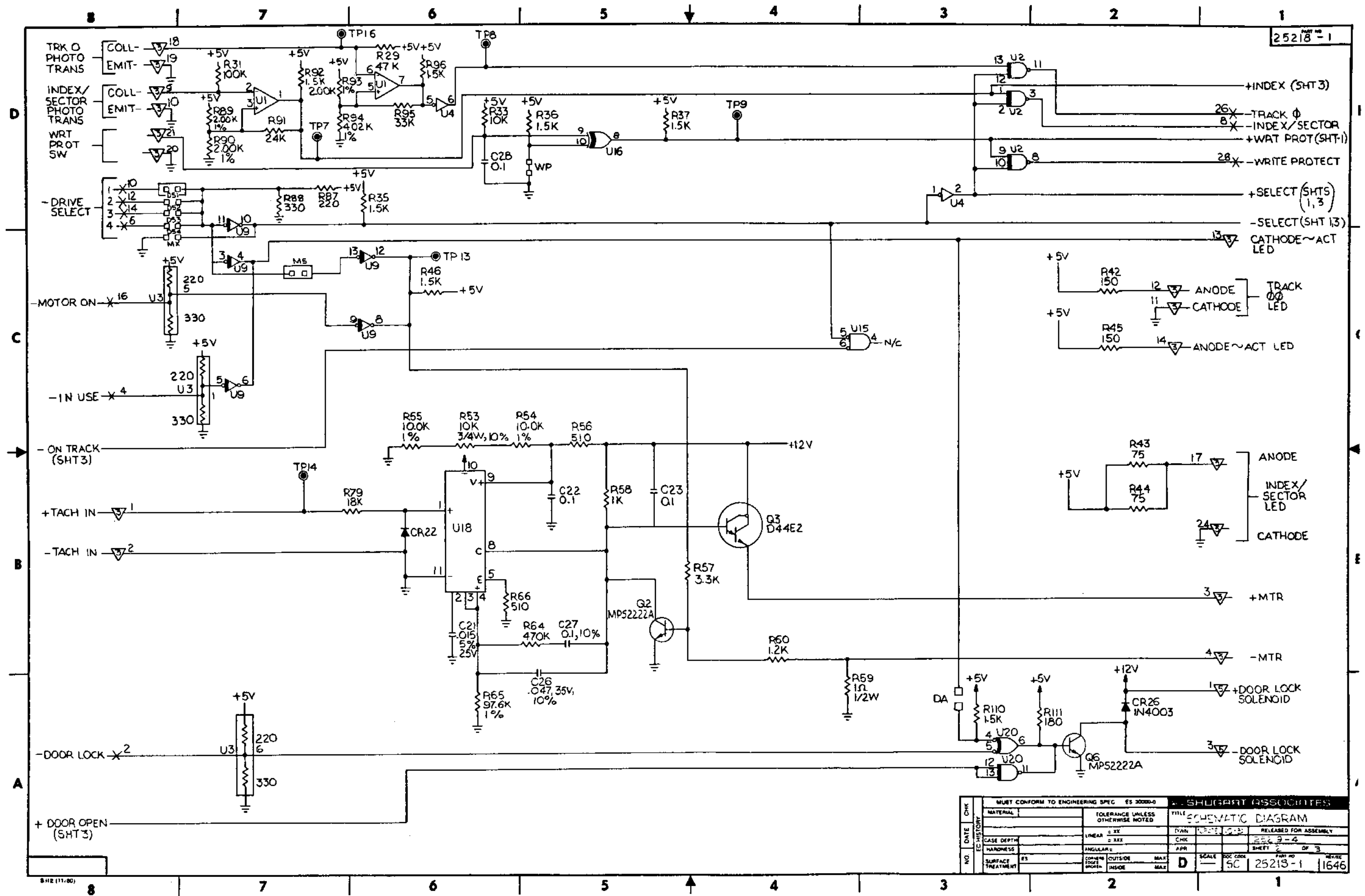

MUST CONFORM TO ENGINEERING SPEC ES 30000-0		SHUGART ASSOCIATES	
MATERIAL		TOLERANCE UNLESS OTHERWISE NOTED	
CASE DEPTH		TITLE SCHEMATIC DIAGRAM	
HARDNESS		DRAWN (DATE) (BY)	
SURFACE TREATMENT		CHECKED (DATE) (BY)	
		RELEASED FOR ASSEMBLY	
		SHEET 2 OF 3	
		SCALE 5C	
		PART NO 25213-1	
		REVISE 1646	

FIGURE 9-3. SCHEMATIC DIAGRAM (SHEET 2 OF 3)
9-7/9-8 (blank)

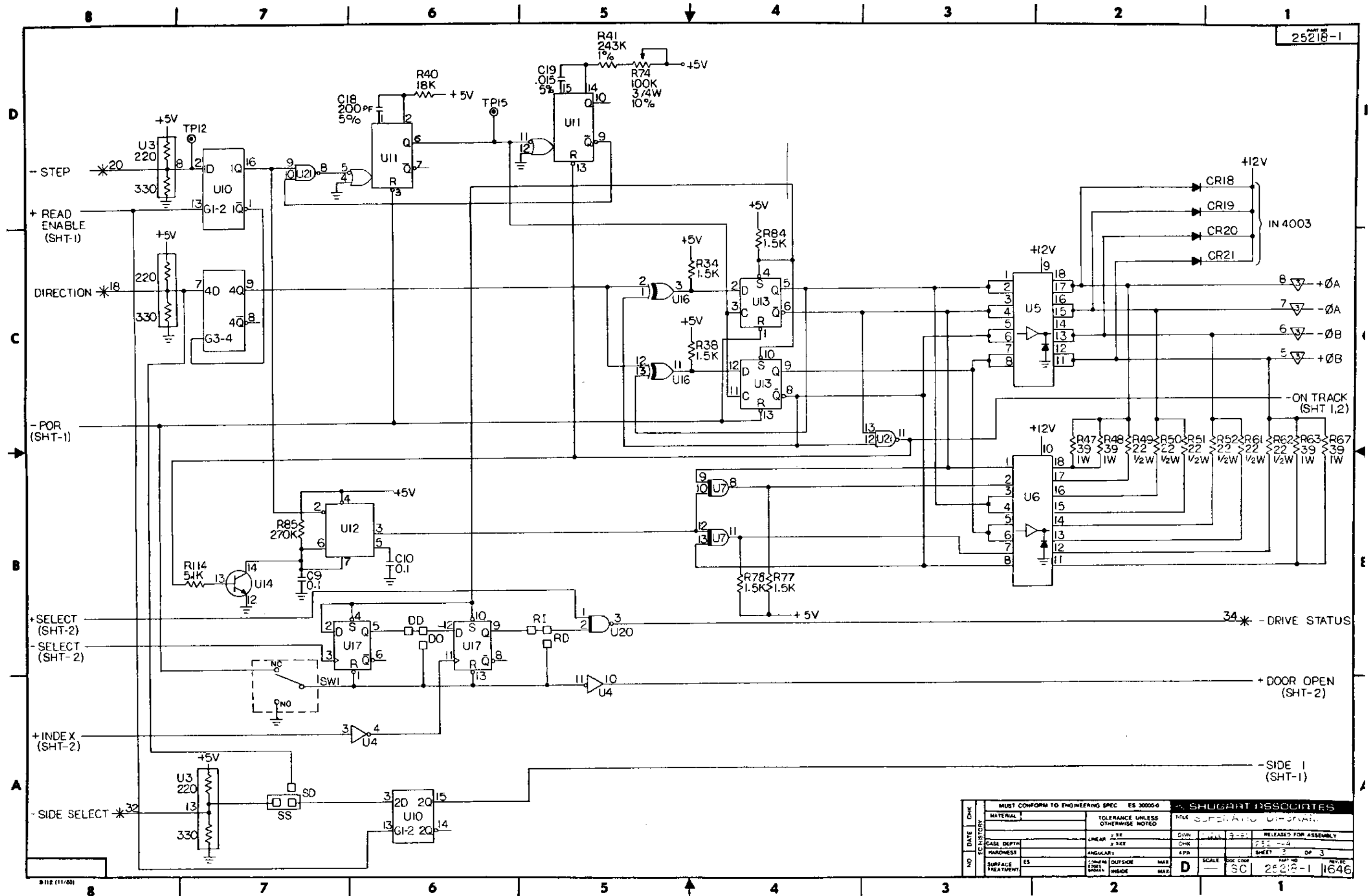

FIGURE 9-3. SCHEMATIC DIAGRAM (SHEET 3 OF 3)
9-9/9-10 (blank)

PUBLICATION CHANGE NOTICE

PN: 39211-0 **Product:** 410/460 **Date:** April 8, 1982 **Errata:** # A
Pub. Date: 11/81 **Pub. Type:** Service Manual

Make the following changes:

1. Page 1-2, paragraph 1.2.3, Maximum Wet Bulb - Operating:
Change 25.6° C to 29.4° C.
2. Page 6-6. After paragraph 6.8 add paragraph 6.9 as follows:

6.9 TEST POINTS ON DRIVE PCB

Test points for the drive PCB are as follows:

1. Read Data	7 Index	12 Step Pulse
2 Read Data	8 Trk 00	13 Motor On
5 Signal Ground	9 Write Protect	14 Tech In
6 Asymmetry	10 Ground	15 Inner Step

3. Page 8-9, Reference Designator 7-9:
Change P/N 54242 to 51331.
4. Page 8-20, third column, under "Part Number":
Change P/N 54242 to 51331.

After making the above changes, post this notice in front of the manual.

Shugart

Copyright Shugart

475 Oakmead Parkway Sunnyvale, California 94086

Telephone: (408) 733-0100 TWX: 910 339 9355 SHUGART SUVL