

SHUGART ASSOCIATES

ENGINEERING SPECIFICATION

CODE	PART NO.	REVEC
ES	30172-0	1667

SHEET	1	OF	15
-------	---	----	----

TITLE HEAD PERFORMANCE SPEC.

PRODUCT 390/400/400L

--	--	--	--

HEAD PERFORMANCE SPECIFICATION

FEB 25 1980

ORIGINATOR	R. STROMSTA 9/19/80				APPROVAL	<i>D. Santucci</i> 9-22-80			
EC NO	1426	1667							
DATE	11/80	8-81							

TITLE HEAD PERFORMANCE SPEC.

TABLE OF CONTENTS

	PAGE
COVER SHEET	1
TABLE OF CONTENTS	2
SPECIFICATION SUMMARY	3
1.0 SCOPE	4
2.0 USAGE	4
3.0 RELATED DOCUMENTS	4
4.0 CONDITIONS OF USE	5
4.1 GENERAL CONDITIONS	5
4.2 ENVIRONMENTAL CONDITIONS AND LIMITS	5
4.3 PHYSICAL CHARACTERISTICS	5
5.0 MECHANICAL PROPERTIES	5
5.1 SIDE 0 PENETRATION	5
5.2 PRESSURE PAD LOAD	7
5.3 CONFIGURATION	7
6.0 STATIC ELECTRICAL PROPERTIES	7
6.1 WIRING DIAGRAMS	7
6.2 POLARITY	7
6.3 ELECTRICAL PARAMETERS	7
7.0 DYNAMIC ELECTRICAL PROPERTIES	8
7.1 TEST CONDITIONS	8
7.2 WRITE CONDITIONS	8
7.3 READBACK REQUIREMENTS	9
8.0 ERASE REQUIREMENTS	12
8.1 TRIM ERASE REDUCTION	12
8.2 ERASE EFFICIENCY	12
8.3 DEMAGNETIZATION	13
9.0 ALIGNMENT REQUIREMENTS	13
9.1 SINGLE HEAD TEST LEVEL	13
9.2 HEAD/CARRIAGE ASSEMBLY	13
9.3 MACHINE	14
10.0 WEAR PERFORMANCE	15
10.1 DISK LIFE	15
10.2 HEAD LIFE	15
11.0 PACKAGING	15
12.0 APPROVED SOURCES	15

TITLE HEAD PERFORMANCE SPEC.

SPECIFICATION SUMMARY

- Density: 5536 BPI, 48 TPI, 5½" single sided flexible diskettes.
40 tracks on side 0.
- Conditions: 300 + 9 RPM, 2F = 250K flux reversals/second.
+ 0.010 ± 0.002 in. side 0 head penetration.
13 + 2 gram pressure pad load measured vertically.
4 to 50°C operating temperature.
- Static Electrical: Full coil; 30Ω + 3Ω, 3.10 + 0.60 mH, $f_R = 500$ KHZ minimum
Half coil; 17.5Ω + 2Ω, 0.89 + 0.15 mH top coil,
0.76 ± 0.15 mH bottom coil,
17 + 2% unbalance.
Erase coil; 13Ω + 2Ω, 0.60 ± 0.06 mH
- Current: $I_w = 6.0 ± 0.2$ mApp, 1.3 μs max. risetime,
0.1 mA overshoot nominal
38 + 4 mA erase current
- Readback Requierments: Single head & head/carriage assembly
Ambient temperature = 23 + 4°C
4.5 mVpp min. output, 2F @ Track 39
0.65 minimum resolution at Track 39
Writeover = 1.4% max. remnant 1F (-37dB).
Peak shift = 8% max.
Asymmetry = 400 ns max.
Dipulse spread = 4.1 μs maximum.
- Erase Requirements: Trim erase: 10% loss max.
Erase efficiency = 3.2% max. remnant 1F (-30dB).
Demagnetization = 10% loss max. after 10 seconds
- Alignments: Head/Carriage level
Radial: Does not apply.
Gap scatter (Index Burst): Does not apply.
Azimuth: 0° ± 10' maximum side 0
Drive level
See ES 30043, 30082, 30139
- Wear: Disk life 3 million revolutions
Head life 100 million revolutions

TITLE HEAD PERFORMANCE SPEC.

1.0 SCOPE

This specification defines the general, mechanical, electrical, and magnetic performance requirements for 5536 BPI, 48 TPI read/write head and cable assemblies intended for use in the SA390/400/400L flexible disk drives. The head/carriage assembly consists of a ceramic/ferrite slider rigidly bonded into a plastic button mounted in a plastic carriage on side 0, and a pressure pad/pivoting arm member mounted on side 1. The side 0 head is identical to the head used on the SA800 flexible disk drive. Each separate head assembly consists of a head, carriage, cable, and connector.

2.0 USAGE

The head assemblies are designed for installation in SA390/400/400L single sided 5½ inch flexible disk drives intended for full life interchange with drives of the same type. The heads record a track which is 0.0125 inches wide at a radial density of 48 TPI. Two 0.007 inch wide tunnel erase cores provide DC erased guard bands which lie on either side of the data track. These data free bands allow reliability in media interchange. The intended use is at a rotational speed of 300 RPM with packing densities up to 5536 flux reversals/inch at a maximum data rate of 250K flux reversals/second written on a single sided 0.003 inch thick 5.125 inch diameter flexible diskette.

In normal operation the rigidly mounted side 0 button head is penetrated 0.010 inches into the plane of the media, and is lightly loaded with a felt pad which is mounted on the opposite side of the disk.

The head air bearing surface has been designed to provide good data recovery, media life, and head life.

3.0 RELATED DOCUMENTS

- ES 30082 SA390 Drive Specification Summary
- ES 30044 Media Specification, Single Sided Minidiskette (SA10X)
- ES 30045 SA124 Alignment Minidiskette
- ES 30119 SA450 Amplitude Standard Minidiskette
- ES 30139 SA400L Functional Specification
- ES 30121 Media Specification, Double Sided Minidiskette (SA15X)
- ES 30043 SA400 Drive Specification Summary
- MF 00400 SA390/400/400L Machine Features

TITLE HEAD PERFORMANCE SPEC.

4.0 CONDITIONS OF USE

The head assemblies shall meet this specification when used with Shugart approved media under the following conditions.

4.1 General Conditions

4.1.1 Disk rotational speed = 300 ± 9 RPM

4.1.2 Side 0 track radii = 1.4375 to 2.2500

These are tracks 39 to 00, respectively.

4.1.3 The head shall meet all requirements of this specification at the single head level and head/carriage assembly level with the exception of some restrictions in environmental conditions at the drive level.

4.2 Environmental Conditions & Limits

	<u>Operating</u>	<u>Non-Operating</u>	<u>Shipping & Storage</u>
4.2.1 Dry bulb temperature, °C	4 to 50	-40 to 64	-40 to 65
4.2.2 Wet bulb temperature, °C	30 Max.	No Condensation	No Condensation
4.2.3 Relative humidity, %	8 to 95	1 to 95	95 Max.
4.2.4 Altitude, feet	0 to 10000	0 to 10000	40000 Max.
4.2.5 Temperature shock, °C/minute	3 Max.	-	50 Max.

4.2.6 Vibration and shock: Packaging shall be provided as required to protect the head assembly from damage during handling and shipment

4.3 Physical Characteristics

The construction, basic dimensions, and surface characteristics of the head/carriage assembly, as well as all core and air bearing dimensions are completely defined in the documents listed in sections 3.0. A sketch of the head assembly is shown in Figure 1.

5.0 MECHANICAL PROPERTIES

5.1 Head Penetration: The air bearing surface shall be:

5.1.1 0.010 ± 0.002 inches into the nominal plane of the media. This plane is defined as being coplanar with the face of the spindle.

5.1.2 0.030 ± 0.005 inches from the disk platen.

TITLE HEAD PERFORMANCE SPEC.

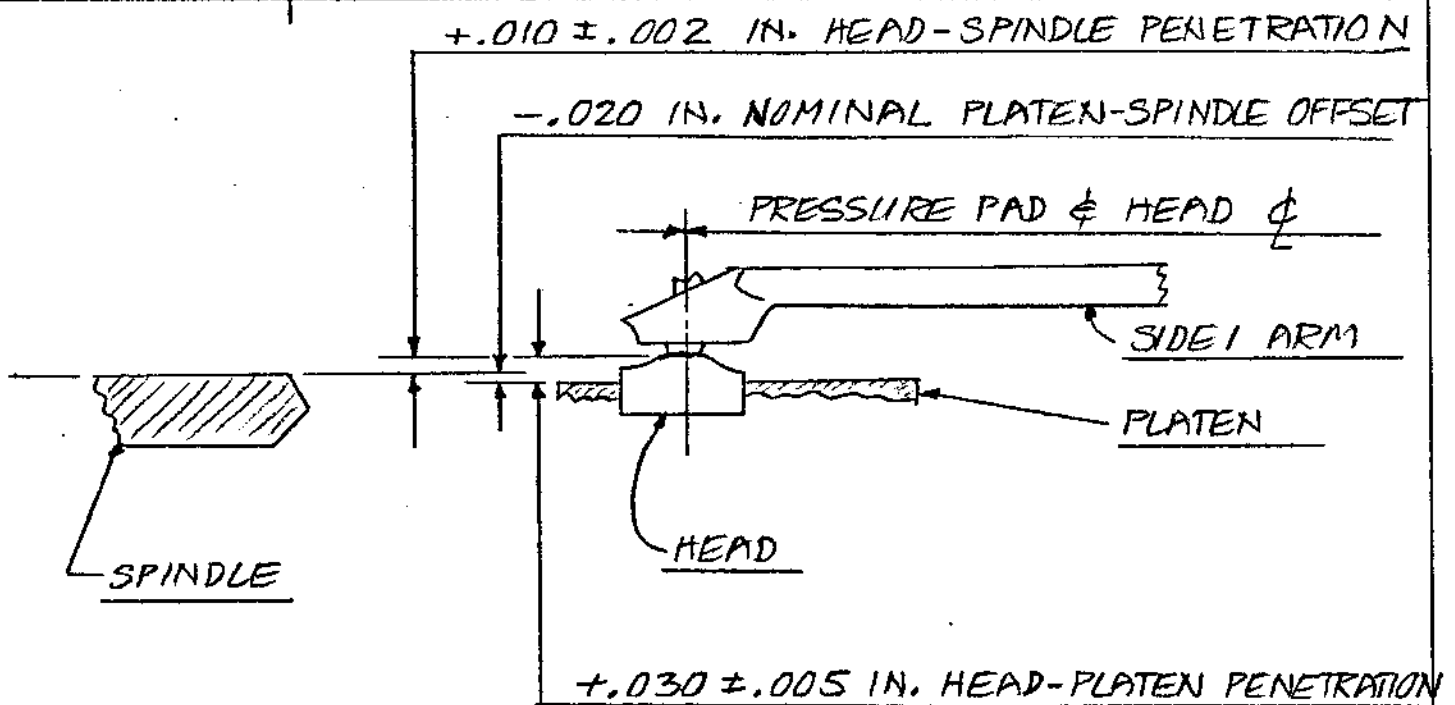
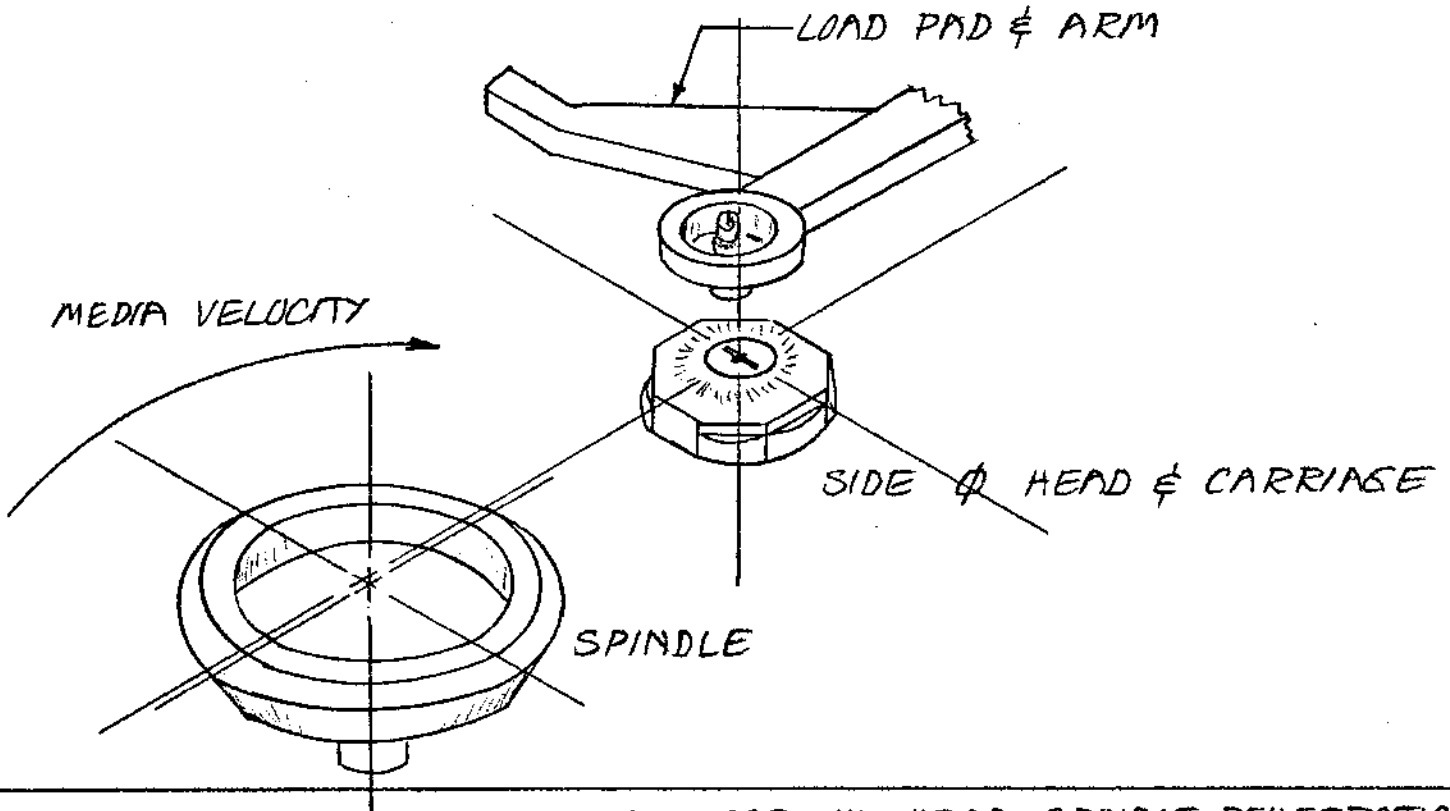

FIGURE 1

TITLE HEAD PERFORMANCE SPEC.

5.2 Load Pad

5.2.1 The force applied via the load pad shall be 13 ± 2 grams measured vertically. (The pressure pad arm swings in a horizontal Plane.)

5.3 Configuration

The nominal mounting configuration of the head in a drive is shown in Figure 1. The gap is nominally colinear with a disk radial line.

6.0 STATIC ELECTRICAL PROPERTIES

6.1 Wiring Diagram

The head has a 4 pin connector as shown in Figure 2.

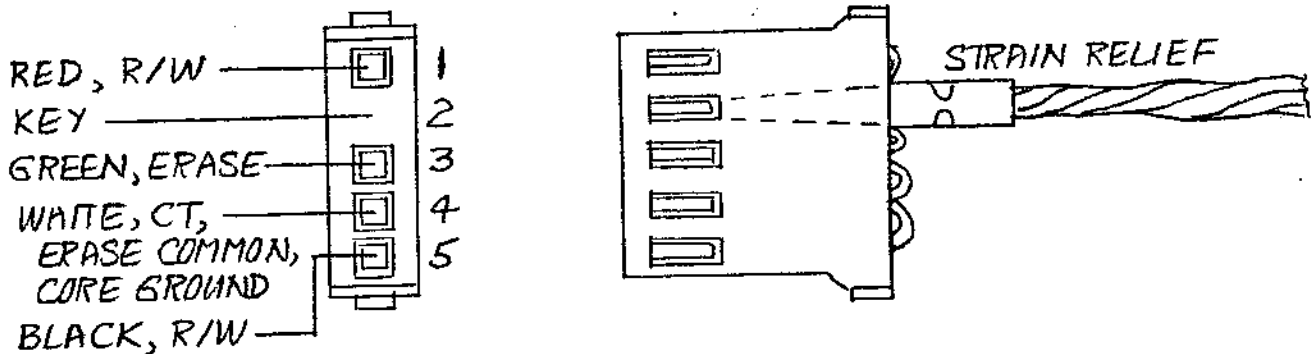

Figure 2: Head Connector Wiring Diagram

6.2 Polarity

Application of conventional current into the red R/W terminals, pin 1, shall cause magnetic flux to cross the R/W gap in a fore-aft direction; i.e., flux shall travel from the leading core element across the R/W gap to the trailing core element.

6.3 Electrical Parameters

The electrical parameters are shown in Figure 3. Measurements shall be made at the connector pins including the head and cable.

TITLE HEAD PERFORMANCE SPEC.

<u>Parameter</u>	<u>R/W, full coil</u>	<u>R/W, half coil</u>	<u>Erase</u>
Pins	1-5	1-4, 4-5	3-4
DC Resistance	$30 \pm 3\Omega$	$17.5 \pm 2\Omega$	$13 \pm 2\Omega$
Inductance (1)	3.10 ± 0.60 mH	0.89 \pm 0.15 mH top 0.76 \pm 0.15 mH bottom	0.60 ± 0.06
Coil Unbalance	-	$17\% \pm 2\%$	-
Resonant Freq. (2)	500 KHZ min.	-	-

None: (1) Inductance measured in air with an HP4262A LRC meter or equivalent at 10 KHZ frequency. 10 mH scale.

(2) Measured in air with an HP4815A or HP4800 Vector Impedance meter, or equivalent. The connector terminals are not terminated with any external load.

Figure 3: Static Electrical Parameters

7.0 DYNAMIC ELECTRICAL PROPERTIES

7.1 Test Conditions

7.1.1 Media: Shugart diskette conforming to specification ES 30119.

7.1.2 Rotational speed 300 ± 9 RPM

7.1.3 External read load 18K ohm //3-8 PF. (Head has 15K Ω internal between pins 1-5).

7.1.4 Track centerline locations.

	<u>Inner Radius</u>	<u>Outer Radius</u>
Side 0 core	1.4375 in.	2.2500 in.

7.1.5 Ambient Temperature $23 \pm 4^{\circ}\text{C}$

7.2 Write Conditions

7.2.1 Frequency

2F = 250K flux reversals/second (125KHZ)

(1T bit cell = 4 μs)

1F = 125K flux reversala/second (62.5KHZ)

(2T bit cell = 8 μs)

TITLE PERFORMANCE SPEC.

7.2.2 Read/Write Current

The operating current, I_w , shall be 6.0 ± 0.2 mApp thru the read/write coil as shown in Figure 4. This produces a nominal coil magnetomotive force of 0.60 ampere-turns zero-peak. The same current shall apply to all tracks. Rise and fall times, t_r & t_f , shall be $\leq 1.3 \mu s$, and shall be equal to within 100 ns. Overshoot, I_o , shall be 0.1 mA, nominal.

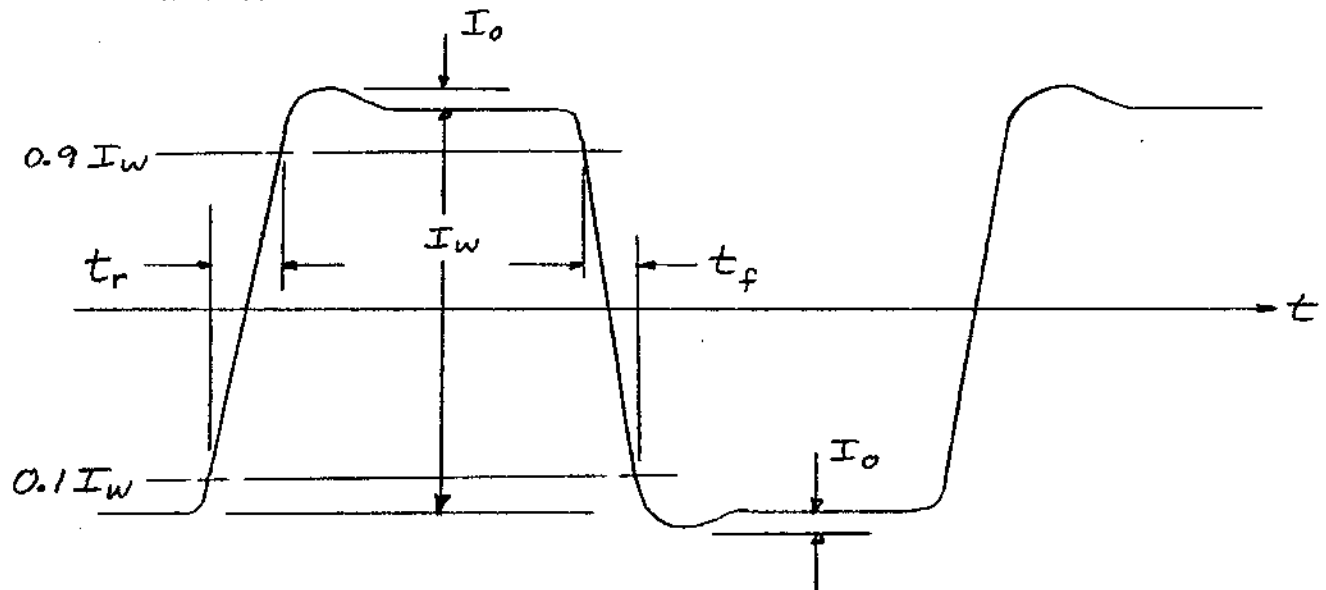

Figure 4: Write Current

7.2.3 Erase Current

The erase current shall be 38 ± 4 mA.

7.2.4 Degaussing

The R/W coil shall be degaussed prior to testing by applying a decaying 10 KHZ - 50 KHZ sinusoidal current of initial value 20 mApp across the full soil terminals. The current shall be permitted to decay to zero during degaussing.

7.3 Readback Requirements

7.3.1 Amplitudes

Amplitudes shall be differential peak-peak values referred to the full coil head connector terminals, and shall be averaged over one disk revolution. Amplifier gains at 1F and 2F shall be known, and shall be used to compute head outputs from amplifier outputs.

TITLE HEAD PERFORMANCE SPEC

The average 1F and 2F signal amplitudes shall be:

	<u>Track 39</u>	<u>Track 00</u>
1F	-	18.0 mVpp, max.
2F	4.5 mVpp, min.	-

The drive specifications may allow reduced 2F outputs at track 39 to accommodate media with property variations larger than those specified in ES 30119. Single head tests and head/carriage tests at Shugart shall adhere to the 4.5 mVpp minimum using ES 30119 media.

7.3.2 Resolution

$$\text{Resolution} = \frac{2F \text{ output}}{1F \text{ output}}$$

Resolution shall be 0.65 minimum at track 39.

7.3.3 Writeover

A 1F pattern is written continuously on the disk for several revolutions and a reference 1F signal amplitude noted, A 2F pattern is subsequently overwritten on the same area of the disk for one revolution. The amount of 1F remnant signal relative to the reference signal shall be less than 1.4% (-37 db) at track 39.

$$\% \text{ Writeover} = \frac{V_{1F}(\text{remnant})}{V_{1F}(\text{reference})} \times 100$$

$$\text{dB writeover} = 20 \log_{10} \left(\frac{V_{1F}(\text{remnant})}{V_{1F}(\text{reference})} \right)$$

The preferred measurement instrument is a spectrum analyzer.

7.3.4 Peak Shift

Peak shift is measured at track 39 using both polarities of the worst case uncompensated FM, MFM 1T2T (DB6) data pattern. Refer to Figure 5. Peak shift is defined relative to the 4 μ s (2F) bit cell time as the one-way movement of the peak of the readback pulse away from its ideal position in time.

Peak shift shall be 8% maximum, -4% minimum for either polarity.

$$-160 \text{ ns} \leq \Delta t \leq 320 \text{ ns}$$

$$3.68 \mu\text{s} \leq (2\Delta t + 1T) \leq 4.64 \mu\text{s}$$

Peak shift is typically positive. Negative peak shifts can occur, however, due to R/W core remnant magnetization, inadequate overwrite, coil unbalance, and other effects.

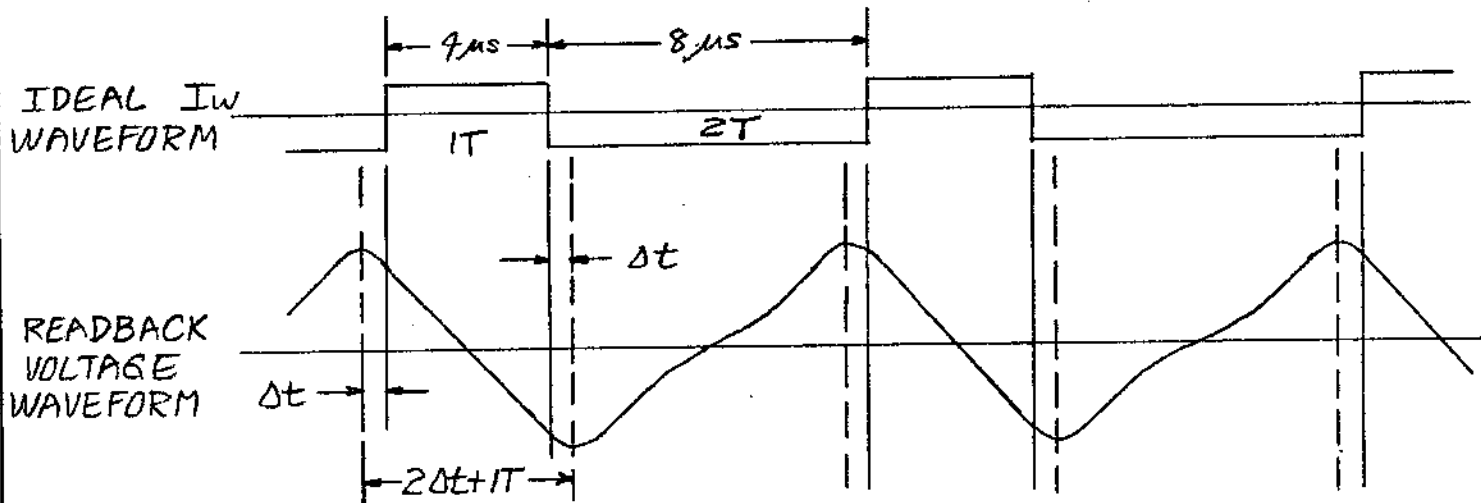

Figure 5: Peak Shift Test

7.3.5 Asymmetry may be measured at any track 00 thru 39 using a continuous 1F waveform.

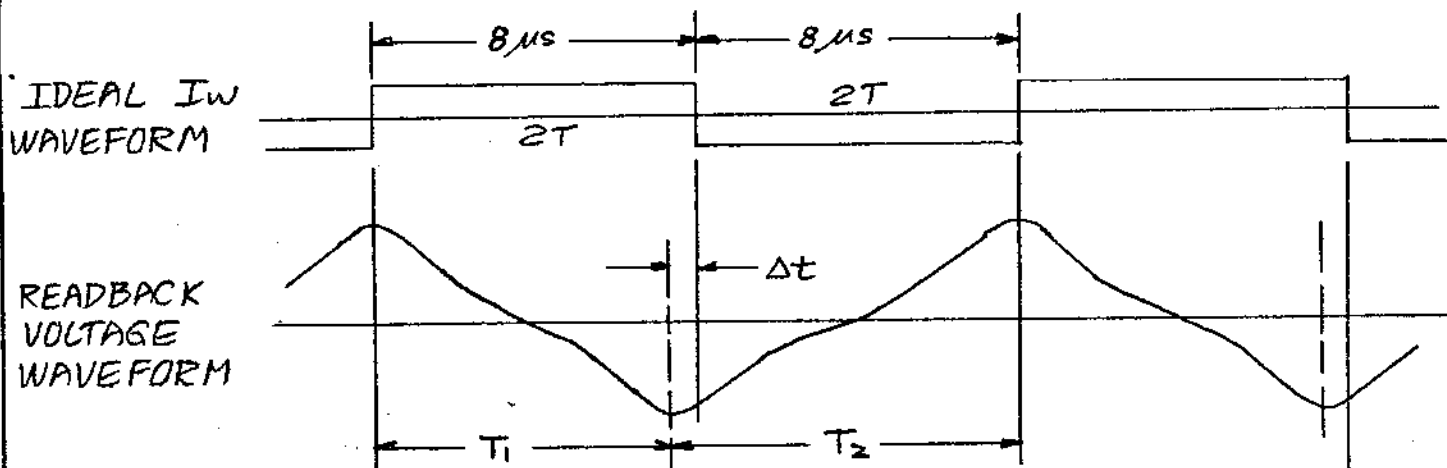

Figure 6: Asymmetry Test

$$\% \text{ Asymmetry} = \frac{|T_1 - T_2|}{T_1 + T_2} \times 100$$

The asymmetry shall be less than 2.18%.

$$T_1 + T_2 = 16 \mu s,$$

Therefore, $|T_1 - T_2| \leq 350 \text{ ns}$

$$|\Delta t| \leq 175 \text{ ns}$$

7.3.6 Dipulse Spread

Dipulse spread is measured at track 39 using both polarities of the dipulse transition pairs written continuously around the disk. The period between dipulses shall nominally be $\geq 16 \mu s$; $28 \mu s$ is recommended.

TITLE HEAD PERFORMANCE SPEC.

Figure 7: Dipulse Test

The maximum readback dipulse timing, t_d , is 4.10 μs maximum

8.0 ERASE REQUIREMENTS

The erase test requires a 1F continuous signal, $I_w = 6.0 \pm 0.2$ mApp, 38 mA erase current, and may be performed at any track 00 thru 39.

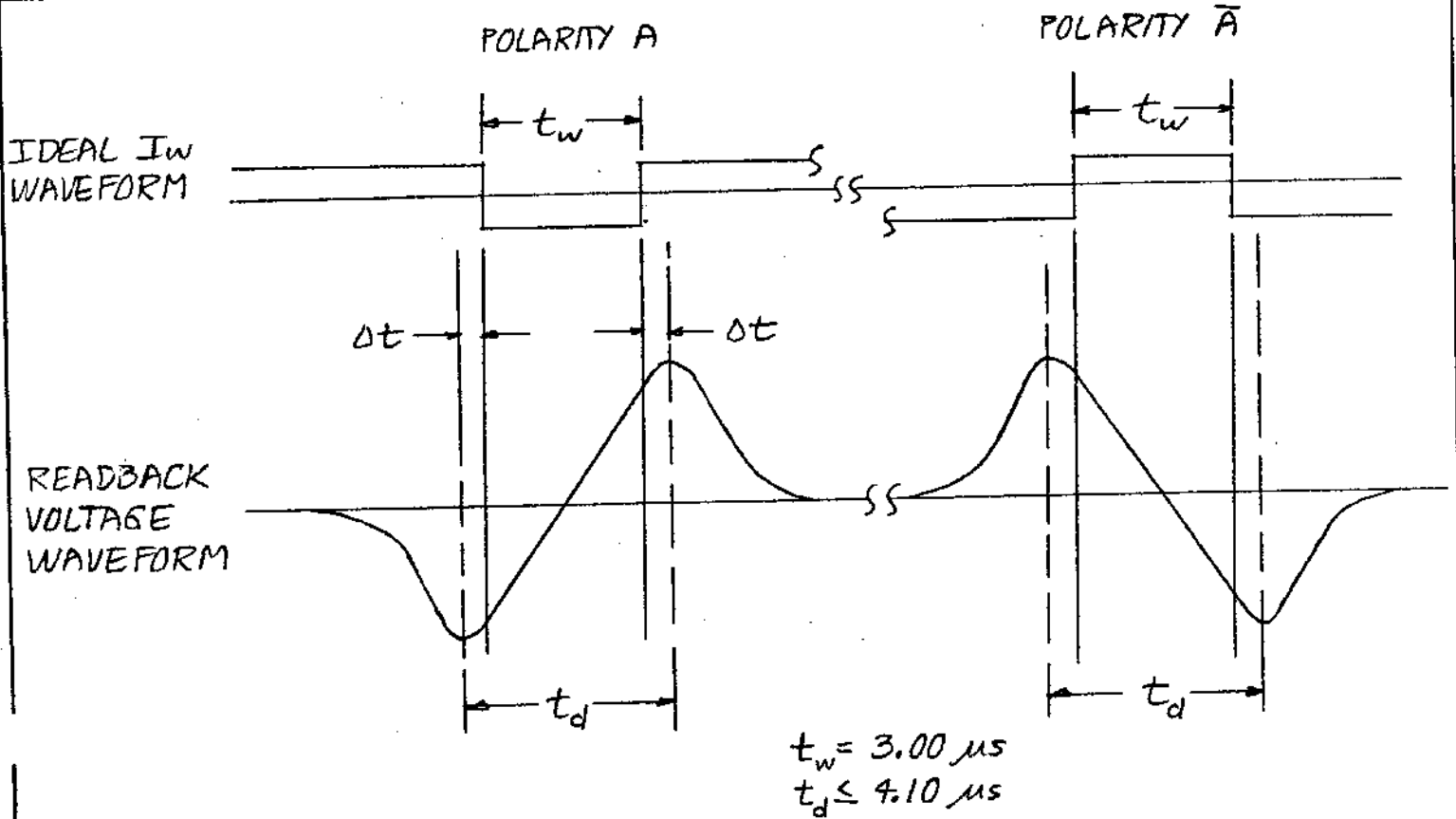
8.1 Trim Erase Reduction

The ratio of readback amplitude of a track written with the erase core energized to that of the same track written without the erase core energized shall be 0.90 or greater.

$$\frac{V_{1F} \text{ (erase on)}}{V_{1F} \text{ (erase off)}} \geq 0.90$$

8.2 Erase Efficiency

Write a normal continuous 1F signal. Move off track 0.005 inches and DC premag the R/W coil with normal I_w for 1 revolution with erase on. Return to track center and read the remnant 1F. The remnant signal shall not exceed 3.2%.

TITLE HEAD PERFORMANCE SPEC

(-30 dB) of the original 1F. Repeat for the opposite off track direction.

$$\frac{V_{1F \text{ (remnant)}}}{V_{1F \text{ (reference)}}} \leq 0.032 \text{ (-30 dB)}$$

8.3 Demagnetization

A reference 1F signal shall not be reduced in amplitude more than 10% after sweeping the de-energized head back and forth over the recorded track for a period of 10 seconds. The head shall meet all of the requirements of this specification for any number of passes. The head shall meet this requirement in the presence of external magnetic fields of up to 5 Gauss.

9.0 ALIGNMENT

Alignments are specified to control the absolute location of the side 0 read/write gap in terms of radial and circumferential displacements, and rotation angle (azimuth).

9.1 Head/Carriage Assembly Level

9.1.1 Radial Position.

Does not apply

9.1.2 Circumferential Position (Gap scatter, Index Burst).

Does not apply

9.1.3 Azimuth

Side 0 in arm/carriage assembly $0^{\circ} \pm 10'$ maximum.

SHUGART ASSOCIATES

ENGINEERING SPECIFICATION

CODE

PART NO.

REV EC

ES

30172-0

1667

SHEET

14

OF

TITLE HEAD PERFORMANCE SPEC

9.3 Machine

9.3.1 Radial Position

See MF 00400

9.3.2 Circumferential Position

See MF 00400

9.3.3 Azimuth

See MF 00400

TITLE HEAD PERFORMANCE SPEC

10.0 WEAR PERFORMANCE

10.1 Disk Life

The head or pressure pad shall not cause physical damage to approved diskettes for a minimum of 3.0×10^6 revolutions on one track. This applies to any Track 00 thru 39.

10.2 Head Life

The heads shall be capable of meeting this specification after running for 100×10^6 wear revolutions minimum. A wear revolution is defined as one revolution of the disk with the heads fully loaded.

It shall be shown by experiment prior to qualifying new head sources that after 0.36×10^6 wear revolutions, sample heads shall be capable of meeting this specification. These wear revolutions shall be accumulated by using 20 new diskettes, and accessing the heads over all tracks for a total of 1 hour per diskette for a total run time of 20 hours (0.36 M revs.). All voltage measurements and data checks described in sections 7.0 and 8.0 shall be made on a reference diskette which is not used to accumulate the wear revolutions.

11.0 PACKAGING

The head assembly shall be packaged to provide complete protection in handling and shipment using best commercial practices. Each assembly must be protected in the air bearing, flexure, and flex circuit areas at all times when not in actual use, to avoid damage to critical surfaces.

12.0 APPROVED SOURCES

12.1 Shugart Associates

Sunnyvale Manufacturing Facility
545 Oakmead Parkway
Sunnyvale, CA 94086

12.2 Shugart de Nogales

Terranzas De! Cid
Kilometro 7 Carretera International
Nogales, Sonora, Mexico