

Qume
A Subsidiary of ITT

MAINTENANCE

**QumeTrak 842
Maintenance**

December 1982

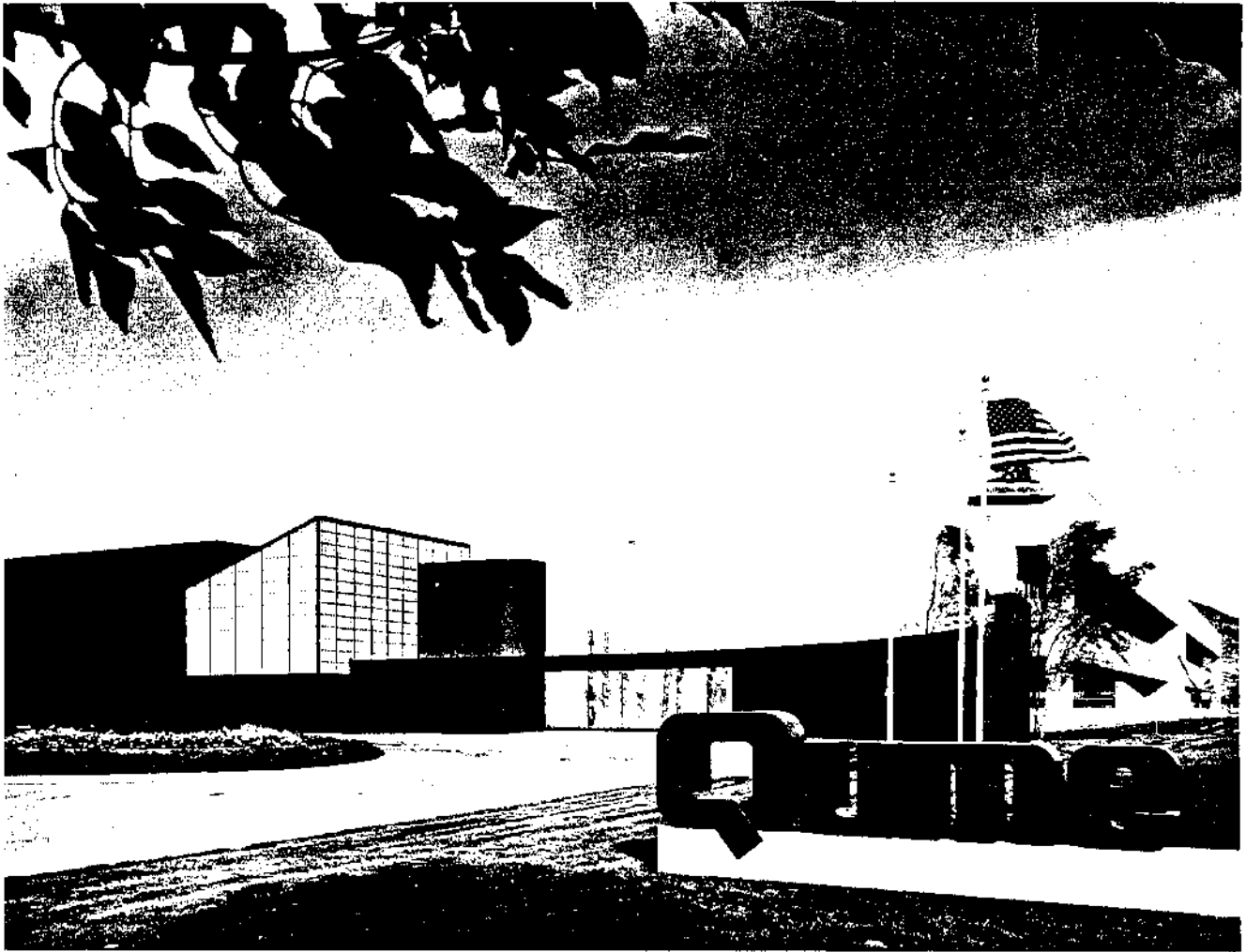

FOREWORD

This manual is one of the many publications which describe the QumeTrak 842 Flexible Disk Drive. Each manual covers the disk drive in its entirety, but from different aspects. Some subjects will be overlapping in some publications. This is because the Technical format and Standard of the Text has been maintained directly proportional to the Technical level of the potential user.

Title	Publication Number
QumeTrak 842 Maintenance Manual	36027
QumeTrak 842 Product Specifications Manual	36023
Memory Products Service & Spares Catalog	37032

TABLE OF CONTENTS

	PAGE
INTRODUCTION	1
SCOPE	1
DESCRIPTION	1
General	1
Specifications and Reliability	2
WARRANTY, SERVICE, AND TRAINING	2
Warranty and Service	2
Training	2
INTERFACE	3
ELECTRICAL INTERFACE	3
General	3
I/O Signal Interface	3
Input Lines	3
Output Lines	5
Alternate I/O Pins	6
PHYSICAL INTERFACE	8
Connectors and Cables	8
I/O Signals	8
DC Power	9
AC Power	9
Terminators	9
INSTALLATION	11
RECEIVING AND INSPECTION	11
MOUNTING	11
Mechanical Dimensions	11
Recommendations	12
INSTALLATION REQUIREMENTS	12
CUSTOMER STRAPPABLE OPTIONS	13
GENERAL	13
INCORPORATION OF OPTIONS	15
Programmable Shunt	15
Drive Select Options	15
Head Load Options	16
Side Select Options	16
Radial Ready Option	17
Radial Index Option	17
In Use Options	17
Door Lock Latch Option	18
Write Protect Option	18
Disk Change	18
2-Sided (Alternate Output)	18
MAINTENANCE	19
PREVENTIVE MAINTENANCE	19
PERIODIC CLEANING	19
MAINTENANCE TOOLS & EQUIPMENT	19
INTERNAL CONNECTIONS	20
TEST POINTS	20

Table of Contents (Continued)

	PAGE
SERVICE CHECKS	21
Index Lamp Assembly Service Check	21
Index Sensor Assembly Service Check	21
Index Lamp and Sensor Alignment Check	21
Track \emptyset Sensor Assembly Service Check	22
Write Protect Sensor Assembly Service Check	22
In Use LED Service Check	22
Head Load Solenoid Assembly Adjustment Check	23
Head Load Time Check	24
R/W Head Read Amplitude Check	25
R/W Head Azimuth Check	25
REMOVAL AND REPLACEMENT PROCEDURES	28
Printed Circuit Board (PCB)	28
Spindle Drive Belt and Drive Pulley	28
Bail Assembly	28
Bail Base	30
Drive Motor Assembly	30
In Use LED	31
Write Protect Sensor	32
Track \emptyset Sensor	32
Index Sensor Assembly	33
Index Lamp Assembly	33
Carrier Assembly	33
Pop-up Assembly	35
Door Lock Solenoid	35
Front Bezel Assembly	36
Head Load Solenoid	37
Dust Cover and Wiper	38
Steel Belt	39
Idler Assembly	41
Stepper Motor Assembly	41
Head/Carriage Assembly	42
ADJUSTMENTS	44
Drive Motor Pulley Positioning	44
Drive Door and Carrier Assembly Alignment	44
Pop-up Assembly Adjustment	45
Head Load Solenoid Assembly Adjustment	45
Bail gap adjustment	45
R/W head gap adjustment	46
Index Lamp Alignment	47
Stepper Motor Dust Cover/Wiper Adjustment	48
Head/Carriage Assembly Radial Alignment	48
TROUBLESHOOTING	51
General	51
Definition of Malfunction Terms	51
Prerequisite Checks	51
Troubleshooting Preconditions	51
Power Test	52
Troubleshooting Flow Charts	52
RECOMMENDED SPARE PARTS	67
DIAGRAMS	69
APPENDIX	83
QUMETRAK 842DC UNIQUE DATA	83

LIST OF ILLUSTRATIONS

FIG.	TITLE	PAGE
1	Recommended Controller Interface Circuits	3
2	Track Access Timing	4
3	Read Timing	4
4	Write Timing	5
5	Step Timing	5
6	Write Data Timing for Frequency Modulation (FM)	5
7	Write Data Timing for Modified Frequency Modulation (MFM)	5
8	Index Timing	5
9	Read Data Timing for Frequency Modulation (FM)	6
10	Interface Connection	7
11	Interface Connection	8
12	J1 Connector Dimensions (component side)	8
13	Unpacking the Disk Drive	10
14	QumeTrak 842, Top View	11
15	QumeTrak 842, Side View	11
16	Disk Drive Mounting	12
17	PCB Jumper Locations, Test Points & Connector Pin Assignments ...	14
18	Disk Change Timing	18
19	Bail Gap Check	23
20	Head Load Time Check	24
21	Azimuth Check	27
22	Drive Pulley Installation	28
23	Bail Assembly Removal and Replacement	29
24	Bail Assembly Re-Installation	30
25	Drive Motor Assembly Removal and Replacement	30
26	Connector Lead Removal (typical)	30
27	In Use LED Removal and Replacement	30
28	Index Sensor Assembly Replacement	33
29	Carrier Assembly Removal and Replacement	34
30	Door Lock Solenoid Removal and Replacement	36
31	Head Load Solenoid Removal and Replacement	38
32	Dust Cover Removal and Replacement	38
33	Head/Carriage Assembly Belt Clamp Access	39
34	Steel Belt End Clamp Access	39
35	Steel Belt/Stepper Mechanism	40
36	Steel Belt and Head/Carriage Alignment	41
37	Carrier-Collet Assembly Adjustment	44
38	Pop-Up Adjustment	45
39	Bail Gap Adjustment	46
40	R/W Head Gap Adjustment	47
41	Index Lamp Assembly Positioning	47
42	Stepper Motor Pulley Track 40 Alignment	48
43	R/W Head Radial Alignment	49
44	Power Failure Troubleshooting Flow Chart	53
45	Not Ready Troubleshooting Flow Chart	54
46	Seek Error Troubleshooting Flow Chart	56
47	Read Error Troubleshooting Flow Chart	59
48	Write Error Troubleshooting Flow Chart	62
49	No Head Loads Troubleshooting Flow Chart	65
50	Illustrated Parts Locations, sheets a-f	70
51	QumeTrak 842 Block Diagram	76
52	Typical Schematic Diagram, QumeTrak 842, sheets a-f	77

LIST OF TABLES

TABLE		PAGE
1	Performance Specifications	1
2	Reliability and Maintenance	2
3	Drive Selection	3
4	I/O Signal Connector P1/J1 Pin Assignments	8
5	I/O Signal Connector P1 Requirements for Flat Cable	9
6	I/O Signal Connector P1 Requirements for Twisted Wire Pairs	9
7	DC Connector P5/J5 Pin Assignments	9
8	DC Connector P5/J5 Requirements	9
9	AC Connector P0/J0 Pin Assignments	9
10	AC Connector P0/J0 Requirements	9
11	Installation Requirements	12
12	Factory Configuration of the Option Traces	13
13	Programmable Shunt Trace Functions	15
14	Multiplexed Drive Select Options	16
15	Side Select Options	17
16	Maintenance Tools	19
17	Transducer Connector P2/J2 Pin Assignments	20
18	Head Connector P3/J3 Pin Assignments	20
19	Test Points	20
20	Recommended Spare Parts, Field Level	67
21	Recommended Spare Parts, Depot Level	68

INTRODUCTION

SCOPE

This manual contains information describing the operation and maintenance of the QumeTrak 842 family of Flexible Disk Drives. This first section of the manual describes the design features and specifications. The INTERFACE section lists the physical interface connections of the QumeTrak 842's and describes the electrical interface lines. INSTALLATION provides inspection, unpacking, mounting, and warranty and servicing information. CUSTOMER STRAPPABLE OPTIONS describes the available customer strappable options and possible configuration modifications. MAINTENANCE provides preventive maintenance information, removal and replacement procedures, adjustment instructions, and troubleshooting procedures.

DESCRIPTION

General

The QumeTrak 842's are low cost direct access data storage devices that utilize a standard removable eight-inch flexible IBM diskette or equivalent as storage medium.

They are capable of supporting either IBM 3740 single density format (FM), or IBM System 34 double density format (MFM), including double sided recording. The functional electrical and mechanical requirements of the interface conform to ANSI (American National Standards Institute) standard. They also provide both electrical and physical interface compatibility with the Shugart SA850 Disk Drive.

QumeTrak 842's have a two-sided head/carriage assembly containing two proven, ceramic read/write (R/W) heads, and a flexured mounting arrangement that results in extremely high reliability. Fast access time (3ms track to track) is

NOTE

In this manual the media will be referred to as a "disk".

Table 1
Performance Specifications

	SINGLE DENSITY	DOUBLE DENSITY
CAPACITY PER DISK UNFORMATTED IBM FORMAT	0.8M bytes 0.6M bytes	1.6M bytes 1.2M bytes
RECORDING DENSITY (TRACK NO. 76)	3408 BPI	6816 BPI
TRACK DENSITY	48 TPI	48 TPI
NUMBER OF CYLINDERS	77	77
NUMBER OF TRACKS	154	154
RECORDING METHOD	FM	MFM
ROTATIONAL SPEED	360 RPM	360 RPM
TRANSFER RATE	250K bits/sec	500K bits/sec
LATENCY (AVERAGE)	83 ms	83 ms
ACCESS TIME		
AVERAGE	91 ms	91 ms
TRACK-TO-TRACK	3 ms	3 ms
SETTLING	15 ms	15 ms
HEAD LOAD TIME	35 ms	35 ms
MOTOR START TIME	2 sec	2 sec

INTRODUCTION

accomplished by a simple, precise steel belt drive with low power dissipation and minimal wear.

The QumeTrak 842's weigh only 13 pounds (six kg) and two drives can be mounted horizontally, or three drives vertically in a standard 19-inch rack or panel unit. Refer to the section on INSTALLATION for additional installation requirements.

Standard features on the QumeTrak 842 include:

- Negative DC power supply not required
- Daisy chain capability for up to four disk drives
- ISO write protect circuitry
- Program-controlled door lock that prevents removal of the disk when the R/W heads are loaded or in use
- In Use LED activity indicator on the front panel

SPECIFICATIONS AND RELIABILITY

This disk drive provides a storage capacity of 0.6M bytes on a two-sided single density flexible disk (IBM DISKETTE 2 or equivalent), and 1.2M bytes on the two-sided double density flexible disk (IBM DISKETTE 2D or equivalent). Refer to the table above for additional performance specifications. The next table lists the reliability specifications.

WARRANTY, SERVICE AND TRAINING

WARRANTY AND SERVICE

The basic Qume service policy, terms, conditions and prices for repairs are specifically described in Memory Products Service and Spares Catalog, publication number 37032. For specific warranty details refer to your QumeTrak 842 purchase contract.

TRAINING

Qume offers two types of customer training on the QumeTrak 842 Disk Drives; regularly scheduled classes held at Qume facilities and custom on-site training held at the customer's facility. All classes cover mechanical and electronic theory of operation; field and depot service level troubleshooting; subassembly removal and replacement procedures; mechanical and electronic adjustments; service checks; and preventive maintenance. Detailed information on customer training classes is contained in Memory Products Service and Spares Catalog publication number 37032.

Table 2
Reliability and Maintenance

ERROR RATE	
RECOVERABLE READ ERROR RATE	ONE ERROR PER 10^9 BITS READ
NON-RECOVERABLE READ ERROR RATE	ONE ERROR PER 10^{12} BITS READ
SEEK ERROR RATE	ONE ERROR PER 10^6 SEEKS
MTBF	8500 HOURS AT 100% DUTY CYCLE 13000 HOURS AT 50% DUTY CYCLE
MTTR	30 MINUTES
PREVENTIVE MAINTENANCE	6,000 POWER ON HOURS OR 2 YEARS
DESIGN LIFE	15,000 POWER ON HOURS OR 5 YEARS
*MEDIA LIFE	3.5×10^6 PASSES/TRACK
*USEFUL MEDIA LIFE IS EXCEEDED WHEN "HEAD OUTPUT" DROPS TO BELOW 80% OF INITIAL VALUE, AS MEASURED BY USING IBM DISKETTE (IBM P/N 1766872).	

INTERFACE

ELECTRICAL INTERFACE

GENERAL

The QumeTrak 842 has three interface connectors. Connector P1/J1 interfaces digital I/O signals. Connector P5/J5 interfaces the +5V and +24V DC power sources. The third connector (PO/JO) interfaces the AC power source. The pin assignments for these connectors are identified in the Interface Connections illustration below.

I/O SIGNAL INTERFACE

All the I/O signal interface lines are TTL compatible and are active (true) when low. The disk drive uses 7438 NAND buffers (open collector) as line drivers, and 7414 Schmitt trigger inverters as line receivers. The input of each receiver in a single drive or in the last drive of a daisy chain must be terminated in 150 ohms pulled up to +5 volts. The illustration below shows the recommended controller interface circuit.

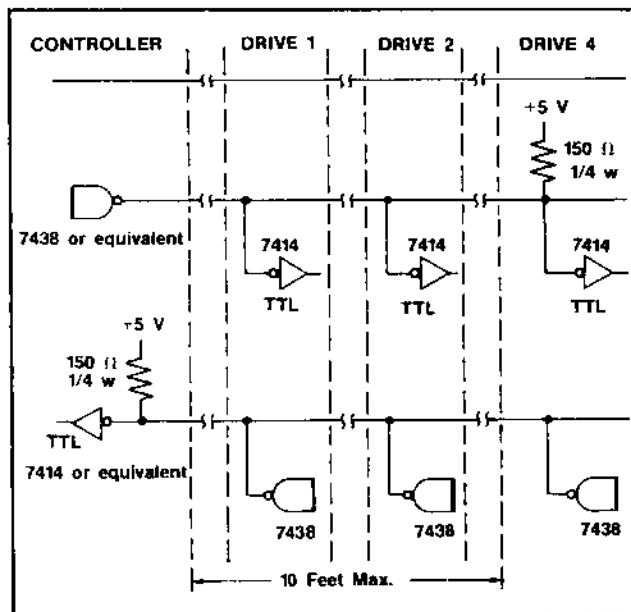

Figure 1. Recommended Controller Interface Circuits

INPUT LINES

There are twelve low active TTL input lines. Ten of the signal lines are factory standard and two are user installable options. The low (true) voltage level for the lines is 0 to 0.4 volts. The high (false) voltage level is 2.4 to 5.25 volts. The characteristics of the individual input lines are described below.

Drive Select 1-4. A low active level on the appropriate line (pin 26, 28, 30, or 32) enables communication between the individual drive and the controller. When two or more (up to four) drives are daisy chained, each drive must have a unique DRIVE SELECT address. The DRIVE SELECT address is controlled by jumpers DS1 through DS4. When the two pins of jumper DS1 are connected, the drive will be activated by an active low signal on the DRIVE SELECT 1 line. If the two pins of jumper DS2 are connected, the drive will be active when DRIVE SELECT 2 line is low active. The same system applies to jumpers DS3 and DS4. Refer to the table below.

Table 3
Drive Selection

Drive Number	Drive Select Input				Traces			
	1	2	3	4	DS1	DS2	DS3	DS4
1	L	H	H	H	S	O	O	O
2	H	L	H	H	O	S	O	O
3	H	H	L	H	O	O	S	O
4	H	H	H	L	O	O	O	S

L = low level, H = high level, S = short, O = open

NOTE

Only one jumper can be connected within a single drive. Each drive within a daisy chain must have a unique DRIVE SELECT number.

Direction. This line (pin 34) defines the direction of R/W head movement when the STEP line is pulsed. A low level on this line causes the head positioning mechanism to move the R/W head toward the center of the disk. With the Direction line at a high level, a pulse on the STEP line causes the head positioning mechanism to move the R/W head away from the center of the disk. The logic state of DIRECTION can be changed at any time after the trailing (positive going) edge of the STEP pulse, and to within one microsecond before the trailing edge of a following STEP pulse. The logic state of DIRECTION cannot be changed during the positive going transition of STEP, or within the one microsecond preceding the positive going transition of STEP.

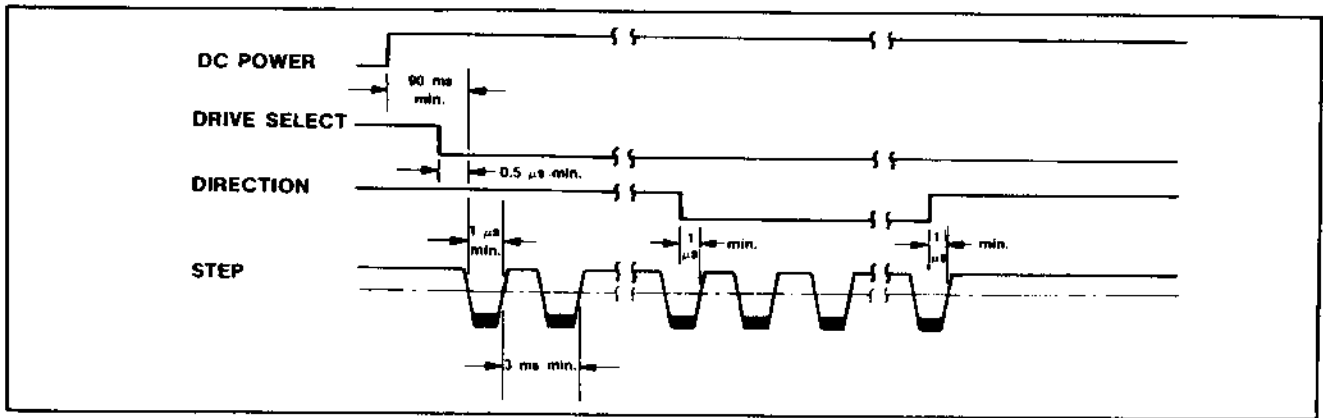

Figure 2. Track Access Timing

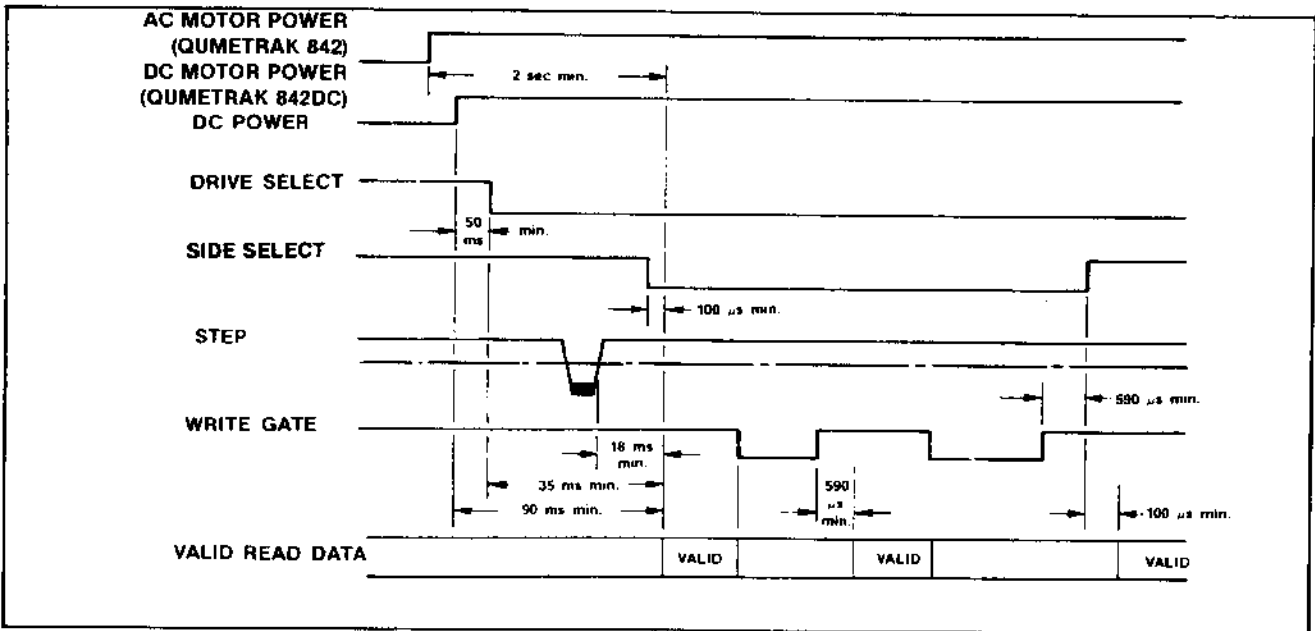

Figure 3. Read Timing

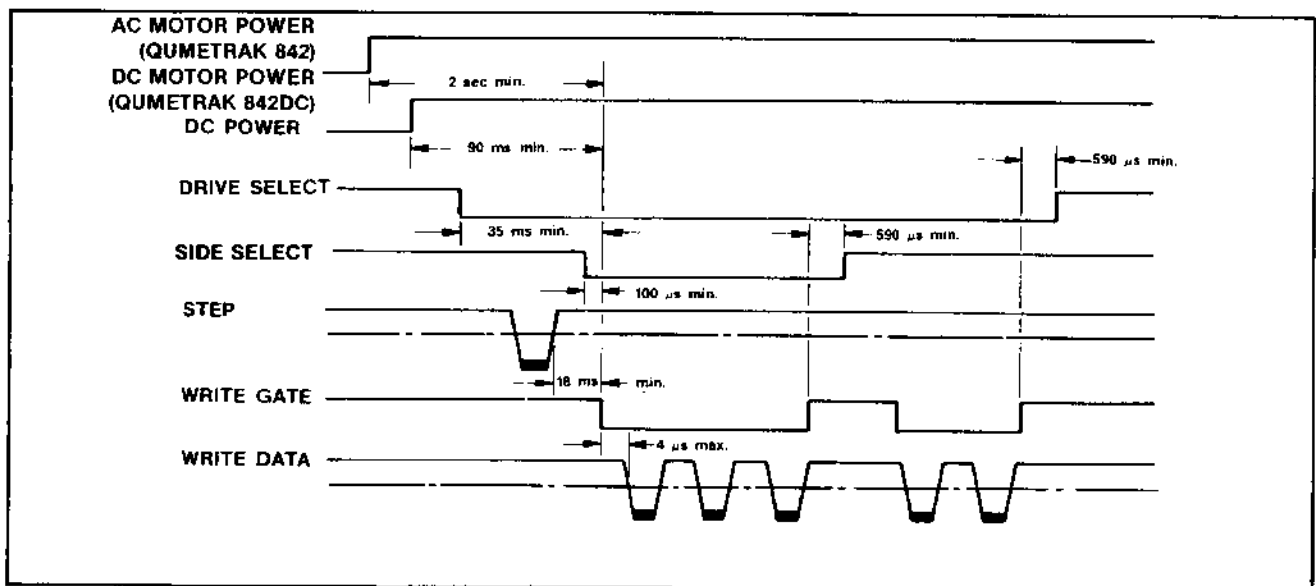
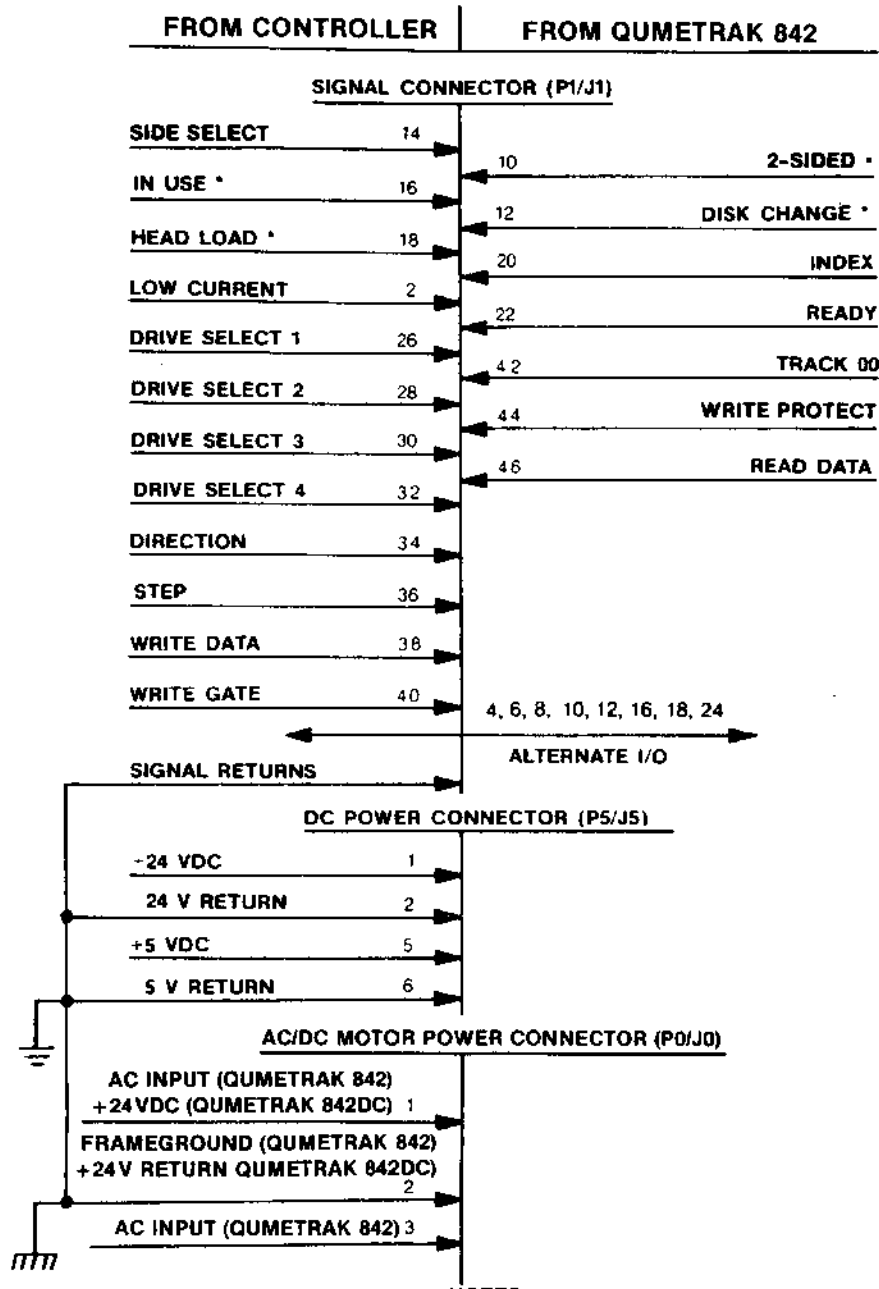

Figure 4. Write Timing



NOTES:

1. *Optional.
2. Signal returns (all odd numbered pins on P1/J1). +24 V return, +5 V return, and frame ground must be connected together at the controller.
3. Pins 48 and 50 on P1/J1 and Pins 3 and 4 on P5/J5 are reserved.
4. Signal names "SIDE SELECT" and "2-SIDED" have been changed (from "HEAD SELECT" and "DISK 2 SENSE", resp.) to comply with ANSI specifications.

Figure 10. Interface Connections

PHYSICAL INTERFACE

CONNECTORS AND CABLES

The physical interface between the QumeTrak 842 and the host system is made through three connectors, digital I/O signals (P1/J1), DC power (P5/J5), and AC power (P0/J0). The illustration below shows how four disk drives would be connected to the host system (drives #2 and #3 have been deleted for clarity). Refer to ELECTRICAL INTERFACE for specific I/O signal discussion.

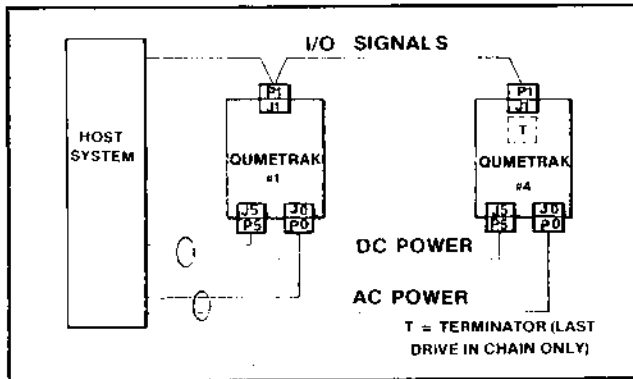

Figure 11. Interface Connection

I/O SIGNALS

I/O signal interfacing occurs through connection P1/J1 in the form of a 50-pin PCB edge connector. The dimensions for this connector are shown in the illustration below.

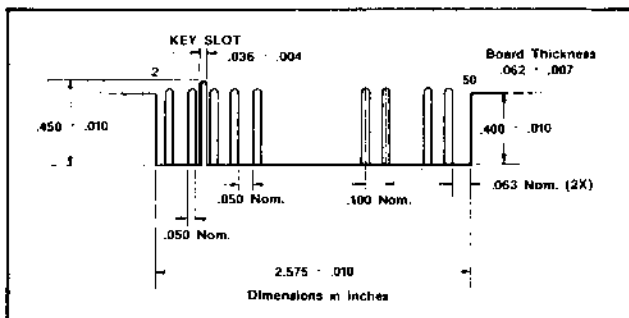

Figure 12. J1 Connector Dimensions (Component Side)

The table below lists the I/O signal connector pin assignments.

Table 4
I/O Signal Connector P1/J1 Pin Assignments

SIGNAL RETURN	SIGNAL	SIGNAL NAME			
		PIN NO.	PIN NO.	STANDARD	OPTION
3,5,7	4,6,8			ALTERNATE I/O	
1	2			LOW CURRENT	
9	10			ALTERNATE I/O	TWO-SIDED
11	12			ALTERNATE I/O	DISK CHANGE
13	14			SIDE SELECT I/O	ALTERNATE I/O
15	16			ALTERNATE I/O	IN USE
17	18			ALTERNATE I/O	HEAD LOAD
19	20			INDEX	
21	22			READY	
23	24			ALTERNATE I/O	
25	26			DRIVE SELECT 1	
27	28			DRIVE SELECT 2	
29	30			DRIVE SELECT 3	
31	32			DRIVE SELECT 4	
33	34			DIRECTION	
35	36			STEP	
37	38			WRITE DATA	
39	40			WRITE GATE	
41	42			TRACK 00	
43	44			WRITE PROTECT	
45	46			READ DATA	
47	48			RESERVED	
49	50			RESERVED	

NOTE
Also check Factory Configuration of Option Traces and Program Shunt Trace Functions table when interfacing.

Connector P1 can be for flat cable or twisted wire pairs. The two tables below list the respective requirements.

Table 5
I/O Signal Connector P1 Requirements
for Flat Cable

PARTS	3M P/N
CONNECTOR	3415-0001
POLARIZING KEY	3439-0000
CRIMP TOOL	
PRESS	3440
LOCATOR PLATE	3443-11
PLATEN	3442-1
FLAT CABLE (10 FEET MAX.)	3365-50

Table 6
I/O Signal Connector P1 Requirements
for Twisted Wire Pairs

PARTS	CRIMP TYPE	SOLDER TYPE	
	AMP P/N	AMP P/N	VIKING P/N
HOUSING	1-583717-1	1-583717-1	3VH25/1JN-5
CONTACT	583616-5	583854-3	—
POLARIZING KEY	583274-1	583274-1	091-0071-000
CRIMP TOOL	90268-1	—	—
EXTRACTOR TOOL	91073-1	91073-1	—
TWISTED PAIRS (20 FEET MAX.)	AWG 26	AWG 26	AWG 26

DC POWER

DC power is interfaced through connector P5/J5. The two tables below list the connector pin assignments and the cable requirements.

Table 7
DC Connector P5/J5 Pin Assignments

PIN NO.	SIGNAL NAME
1	+ 24 VDC
2	+ 24 V RETURN (GND)
3	NOT USED (GND)
4	NOT USED
5	+ 5 VDC
6	+ 5 V RETURN (GND)

Table 8
DC Connector P5/J5 Requirements

	P5 (CABLE SIDE)	J5 (DRIVE SIDE)
PARTS	AMP P/N	AMP P/N
HOUSING	1-480270-0	1-380999-0
CONTACT (6 PINS)	60619-1	—
CRIMP TOOL	90124-2	—
EXTRACTOR TOOL	1-305183-2	—
CABLE (10 FEET MAX.)	AWG 18 OR 16	—

AC POWER

AC power is interfaced through connector P0/J0. The two tables below list the connector pin assignments and the cable requirements.

Table 9
AC Connector P0/J0 Pin Assignments

PIN NO.	SIGNAL NAME
1	AC INPUT
2	FRAME GROUND
3	AC INPUT (NEUTRAL)

Table 10
AC Connector P0/J0 Requirements

	P0 (CABLE SIDE)	J0 (DRIVE SIDE)
PARTS	AMP P/N	AMP P/N
HOUSING	1-480700-0	1-480701-0
CONTACT (3 PINS)	350550-1	350705-1 AND 350669-1
CRIMP TOOL	90296-1	90296-1
EXTRACTOR TOOL	458994-1	458994-1
CABLE (20 FEET MAX.)	AWG 18 OR 16	AWG 18 OR 16

TERMINATORS

Input line terminators in the form of two DIP resistor modules must be plugged into DIP sockets on the PCB of a single drive or of the last drive only in a daisy chain.

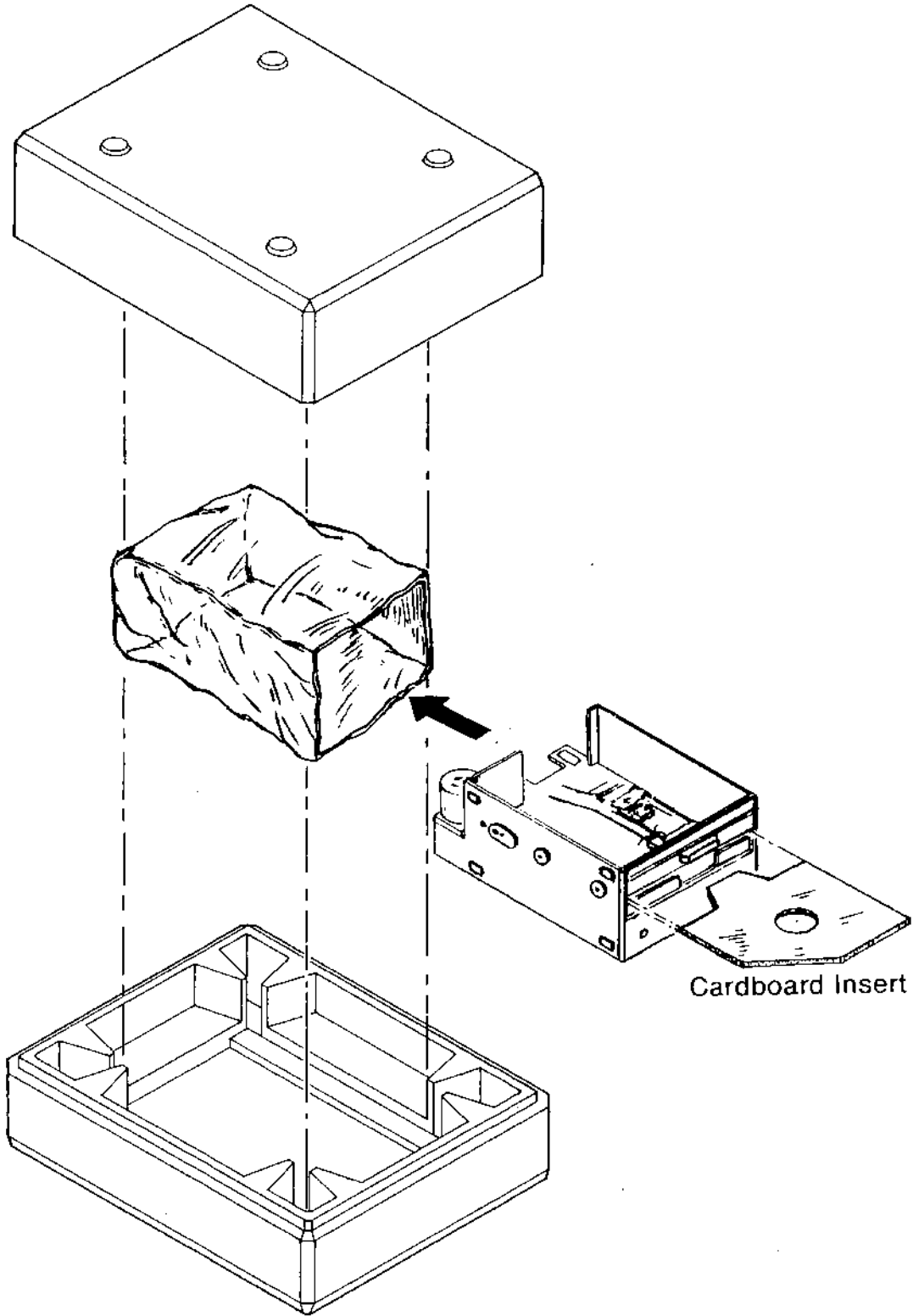

Cardboard Insert

381-A-02

Figure 13. Unpacking the Disk Drive

INSTALLATION

RECEIVING AND INSPECTION

Each disk drive is shipped in an individual container protected by a layer of foam packaging.

Unpack and inspect the disk drive as follows (refer to the illustration on the preceding page):

1. Inspect the container for external signs of damage. If any damage is observed, have the delivery agent note the damage on the shipping document. Some shippers may wish to be present when the container is opened if external damage is apparent.
2. Open the container and remove the disk drive.
3. Remove the plastic bag surrounding the disk drive.
4. Remove the cardboard square inserted in the front panel.
5. Remove cardboard shim from Door lock Solenoid.
6. Inspect the disk drive for scratches, dents, loose or damaged parts, or other signs of damage. Note any evidence of such damage on the invoice, and file a claim with the carrier immediately, if the condition of the unit so warrants.
7. Inspect the interior of the entire unit. Look for loose or broken parts, evidence of electrical damage, or other signs of damage.
8. If the drive will not be used for some time, it is advisable to place the cardboard insert back into the drive after completing inspection.
9. If damage that might impair drive operation is detected, do not attempt to operate the disk drive. Contact Qume for advice and instructions.

When repacking the disk drive for shipping or storage, use original packing material only and follow the above instructions in reverse order.

MOUNTING

MECHANICAL DIMENSIONS

Shown below are the top and side views of the disk drive. The mounting and clearance dimensions should be reviewed before installation.

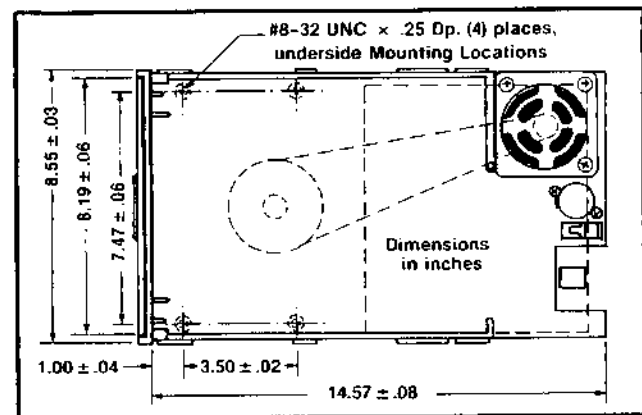

Figure 14. QumeTrak 842, Top View

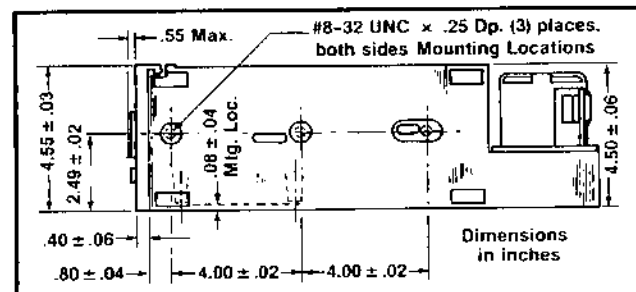

Figure 15. QumeTrak 842, Side View

RECOMMENDATIONS

The QumeTrak 842 can be mounted in any plane; horizontally for front loading, vertically for front

loading, or vertically for top loading. However, when the disk drive is mounted in a horizontal front-loading position it must be oriented such that the In Use LED indicator on the front bezel is below the front door as shown in the illustration.

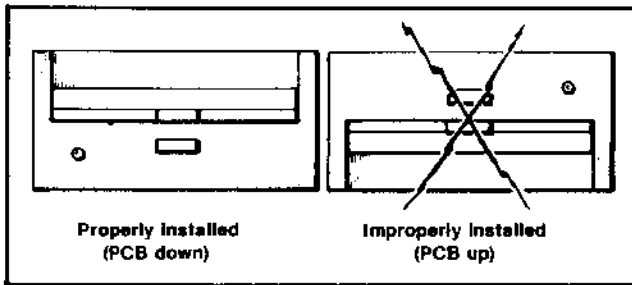

Figure 16. Disk Drive Mounting

INSTALLATION REQUIREMENTS

The QumeTrak 842 has certain power, environmental, and mechanical requirements. Review the table below before installing the disk drive.

Table 11
Installation Requirements

AC POWER REQUIREMENTS*	100/115 VAC INSTALLATIONS		VOLTS		CURRENT			
			100/115 VAC ± 10% 50/60 HZ ± 1%		0.8 A MAX. (START UP) 0.4 A MAX. (RUNNING)			
	200/230 VAC INSTALLATIONS		200/230 VAC ± 10% 50/60 HZ ± 1%		0.6 A MAX. (START UP) 0.3 A MAX. (RUNNING)			
DC POWER REQUIREMENTS**	VOLTAGE	MAX. RIPPLE	CURRENT (AMPS)					
				1 DRIVE	2 DRIVES	3 DRIVES	4 DRIVES	
	+ 24 V ± 10%	0.1 V (P-P)	TYP. MAX.	0.7 1.0	0.8 1.2	0.9 1.4	1.0 1.6	
+ 5 V ± 5%	0.05 V (P-P)	TYP. MAX.	0.9 1.3	1.6 2.2	2.3 3.1	3.0 4.0		
POWER DISSIPATION	55 W (190 BTU/HR) MAX.							
ENVIRONMENTAL	TEMPERATURE		OPERATING		STORAGE			
			+ 5°C TO + 43°C (41°F TO 110°F)		-10°C TO + 45°C (14°F TO 113°F)			
	RELATIVE HUMIDITY		20 TO 80%		8 TO 80%			
MAX. WET BULB		+ 29°C (84°F)		NO CONDENSATION				

MECHANICAL REFER TO PARAGRAPH ON MOUNTING

NOTES:

1. *Not applicable to the QumeTrak 842DC disk drive.
2. **Refer to the APPENDIX for QumeTrak 842DC disk drive power requirements.
3. DC power voltage as specified is at the DC power connector (J5) on the PCB.
4. DC supply current is for drives that are normally installed without customer options.
5. If the stepper motor and door solenoid are energized on all drives continuously, the maximum current requirement for the +24V supply is 1.0 A times the number of drives on the daisy chain.

CUSTOMER STRAPPABLE OPTIONS

GENERAL

The QumeTrak 842 may be modified to alter the functions that were described in the Interface section. These modifications are made by adding or deleting traces, installing pluggable jumpers, and by using the Alternate I/O pins. The table below shows the configuration of the option traces when the disk drive is shipped from the factory. The illustration on the next page shows the

location of the jumpers, traces, and Alternate I/O pads on the PCB.

CAUTION

Modifying a drive by cutting or soldering PCB traces may void the warranty. Consult your Qume representative.

Table 12
Factory Configuration of the Option Traces

DESIGNATOR	DESCRIPTION	FROM FACTORY	
		OPEN	SHORT
DS1 - DS4	DRIVE SELECT ADDRESS PINS (UP TO 4 DRIVES)	DS2, DS3 DS4	DS1
A,B,X	RADIAL HEAD LOAD		X
Z	IN USE FROM DRIVE SELECT		X
HL	STEPPER POWER FROM HEAD LOAD		X
R	ALTERNATE OUTPUT READY PAD		X
I	ALTERNATE OUTPUT INDEX PAD		X
C	ALTERNATE INPUT HEAD LOAD	X	
D	ALTERNATE INPUT IN USE	X	
DC	ALTERNATE OUTPUT DISK CHANGE	X	
2S	ALTERNATE OUTPUT 2-SIDED DISK	X	
DS	STEPPER POWER FROM DRIVE SELECT	X	
Y	IN USE FROM HEAD LOAD	X	
DL	DOOR LOCK LATCH	X	
RR	RADIAL READY		X
RI	RADIAL INDEX		X
WP	INHIBIT WRITE WHEN WRITE PROTECT		X
NP	ALLOW WRITE WHEN WRITE PROTECT	X	
D1,D2,D4,DDS	DRIVE ADDRESS SELECT (UP TO 8 DRIVES)	X	
B1 - B4	TWO-SIDED DRIVE SELECT	X	
S1 - S3	HEAD SELECT OPTION	S1,S3	S2
T40	TEST TRACK 40	X	
HA	TEST ACTUATE HEAD LOAD	X	
4,6,8,10, 12,16,18,24	ALTERNATE I/O PINS	X	

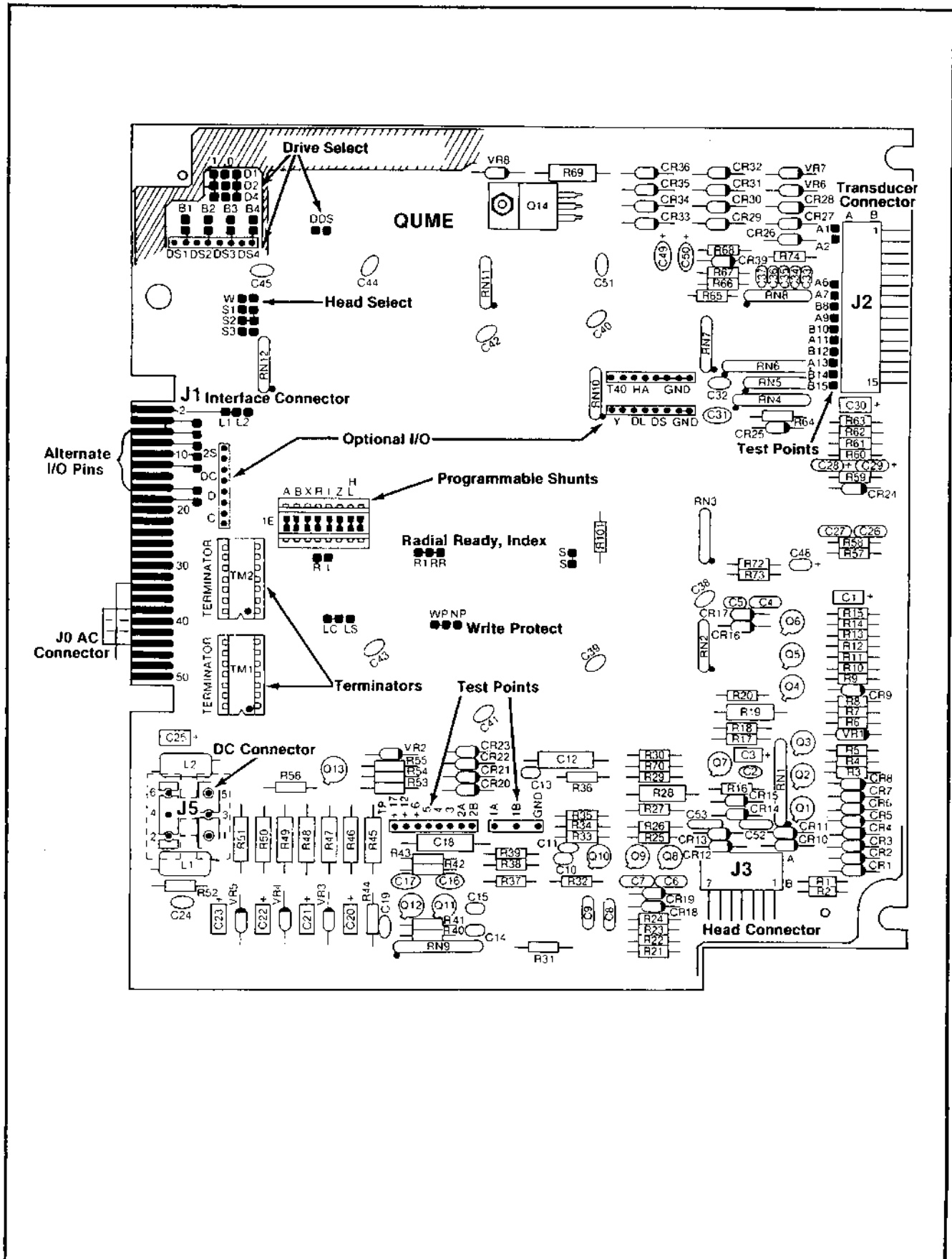

Figure 17. PCB Jumper Locations, Test Points & Connector Pin Assignments

INCORPORATION OF OPTIONS

PROGRAMMABLE SHUNT

A 16-pin programmable shunt with seven jumpers (shorts) in place for commonly used trace cut options is factory installed on the drive P.C. board.

Designations and functions of these jumpers (shorted vs. open) are listed below.

Table 13
Programmable Shunt Trace Functions

TRACE	FUNCTION - SHORTED (STD.)	FUNCTION - OPEN (OPTION)
A	DRIVE SELECT ACTIVE	DRIVE SELECT ACTIVE, HEAD LOAD ACTIVE FROM DRIVE SELECT
B	DRIVE SELECT ACTIVE	DRIVE SELECT ACTIVE HEAD LOAD ACTIVE
X	HEAD LOAD ACTIVE FROM DRIVE SELECT	HEAD LOAD ACTIVE FROM DRIVE SELECT OR IN USE
Z	IN USE ACTIVE FROM DRIVE SELECT	IN USE ACTIVE FROM HEAD LOAD OR OPTIONAL IN USE I/O
HL	STEPPER MOTOR POWER ACTIVE FROM HEAD LOAD	STEPPER MOTOR POWER IS ALWAYS ACTIVE
R	READY IN MULTIPLEX MODE (REFER TO NOTE 1)	READY IN RADIAL MODE (REFER TO NOTE 2)
I	INDEX IN MULTIPLEX MODE (REFER TO NOTE 1)	INDEX IN RADIAL MODE (REFER TO NOTE 2)

NOTES:

1. Multiplex mode requires DRIVE SELECT to check that the READY and/or INDEX lines are active on any drive.

2. Radial mode allows the controller to check that the READY and/or INDEX lines are active on any drive without DRIVE SELECT.

DRIVE SELECT OPTIONS

Factory configuration of the Drive Select circuit allows for up to four drives to be addressed in a daisy chain arrangement. Normally, a jumper is factory installed in location DS1, designating the drive as number one. Moving this jumper to any one of the three remaining locations (DS2-4), designates the drive for the corresponding position number. Two other options are available

Option 1

This option allows direct selection of the disk sides of up to two daisy chained double sided drives. The four disk sides are addressed as if they were separate drives on the existing four DRIVE SELECT input lines. Detailed instructions

on input configuration and jumper status are presented below under Side Select Options.

Option 2

This option allows up to eight drives to be multiplexed together. The four DRIVE SELECT lines are to be used for addressing the drive. DRIVE SELECT 1 is used to enable the DRIVE SELECT 2 (binary 1), DRIVE SELECT 3 (binary 2) and DRIVE SELECT 4 (binary 4) address lines. The logical drive assignment is accomplished by properly jumpering traces D1, D2, and D4, where D1 = (binary 1), D2 = (binary 2) and D4 = (binary 4). The jumper pads are arranged to appear as a 3X3 matrix. Within each column, the center pad must be jumpered to an adjacent Logical 1 or Logical 0 pad. The proper jumpers for each drive select number are shown in the table below.

CUSTOMER STRAPPABLE OPTIONS

Installation (refer to the PCB Jumper Locations, Test Points and Connector Pin Assignments illustration):

1. Add a 74L85, 4-bit comparator IC in PCB location 1K.
2. Jumper trace DDS.
3. Unplug trace DS1-DS4.
4. Properly jumper traces D1, D2, and D4.

Table 14
Multiplexed Drive Select Options

DRIVE NUMBER	DRIVE SELECT INPUT				JUMPER CENTER PAD TO:		
	1	2	3	4	D1	D2	D4
0	L	H	H	H	0	0	0
1	L	L	H	H	1	0	0
2	L	H	L	H	0	1	0
3	L	L	L	H	1	1	0
4	L	H	H	L	0	0	1
5	L	L	H	L	1	0	1
6	L	H	L	L	0	1	1
7	L	L	L	L	1	1	1

L = LOW LEVEL, H = HIGH LEVEL

HEAD LOAD OPTIONS

When a factory configured drive is selected, its heads are loaded and the stepper motor is energized. Three other options are available.

Option 1

This option allows a drive to be selected without loading the heads or enabling the stepper motor. The advantage is that the output status signals can be monitored while the head is unloaded, thereby extending the media life.

Installation (refer to the PCB Jumper Locations illustration):

1. Open trace X on the programmable shunt with a small screwdriver.
2. Plug trace C on the optional I/O pins near connector J1.

Option 2

This option allows a drive to be selected and the stepper motor to be enabled without loading the heads. As an example of this option, initial reset to Track 00 at power-on can be performed without the READY condition.

Installation (refer to the PCB Jumper Locations illustration):

1. Open traces B and HL on the programmable shunt with a small screwdriver.
2. Plug trace C on the optional I/O pins near connector J1.
3. Plug trace DS on the optional I/O pins near connector J2.

Option 3

This option (RADIAL READY) allows a drive to load the heads without selecting the drive or enabling the stepper motor. The advantage is that the heads can be kept loaded on all the drives, thereby eliminating the head load time when the drive is performing a disk copy operation.

Installation (refer to the PCB Jumper Locations illustration):

1. Open traces A and HL on the programmable shunt with a small screwdriver.
2. Plug trace C on the optional I/O pins near connector J1.
3. Plug trace DS on the optional I/O pins near connector J2.

SIDE SELECT OPTIONS

Normally, a R/W head is selected by the SIDE SELECT interface line in a daisy chain system of up to four drives. Two options are available:

Side Select From Direction Line

This option allows both SIDE SELECT and DIRECTION to be multiplexed on the same DIRECTION line. By cutting trace S2 and jumpering trace S1 near connector J1 (refer to the PCB Jumper Locations illustration), head selection is controlled by the DIRECTION line. DIRECTION can be used in this way because it is not being used during reading or writing (STEP must accompany DIRECTION to initiate head movement).

Side Select From Drive Select Lines

This option uses the existing DRIVE SELECT lines to address up to two double sided drives. It selects up to four sides as if the sides were separate drives.

Installation (refer to the PCB Jumper Locations illustration):

Cut trace S2 and jumper trace S3. The disk sides are then selected according to the table below.

**Table 15
Side Select Options**

DRIVE NUMBER	HEAD SELECT	DRIVE SELECT INPUT				TRACES
		1	2	3	4	
1	0	L	H	H	H	PLUG DS1 JUMPER B2 PLUG DS3 JUMPER B4
1	1	H	L	H	H	
2	0	H	H	L	H	
2	1	H	H	H	L	

L = LOW LEVEL, H = HIGH LEVEL

RADIAL READY OPTION

The READY line from a factory configured drive is only available to the interface when the drive is selected.

This option enables the user to monitor the READY line of each drive on the interface continuously.

Installation (refer to the PCB Jumper Locations illustration):

1. Cut trace RR (near the center of PCB).
2. Open trace R on the programmable shunt with a small screwdriver.
3. Jumper pad R (directly below the programmable shunt) to one of the available Alternate I/O pins (4,6,8, or 24). READY will then appear on the chosen Alternate I/O pin.

RADIAL INDEX OPTION

The INDEX line from a factory configured drive is only available to the interface when the drive is selected.

This option enables the user to monitor the INDEX line of each drive on the interface continuously.

Installation (refer to the PCB Jumper Locations illustration):

1. Cut trace R1 (near the center of the PCB).

2. Open trace I on the programmable shunt with a small screwdriver.

3. Jumper pad I (directly below the programmable shunt) to one of the available Alternate I/O pins (4,6,8, or 24). INDEX will then appear on the chosen Alternate I/O pin.

IN USE OPTIONS

Normally, the In Use LED indicator will be energized while DRIVE SELECT is active. The door solenoid will be activated when DRIVE SELECT and READY are active. The three options listed below will energize the In Use LED when activated to a low level.

Option 1

This option will turn on the In Use LED when the DRIVE SELECT or IN USE line is active.

Installation (refer to the PCB Jumper Locations illustration):

Plug trace D on the optional I/O pins near connector J1.

Option 2

This option will energize the In Use LED when the HEAD LOAD or IN USE line is active.

Installation (refer to the PCB Jumper Locations illustration):

1. Open trace Z on the programmable shunt with a small screwdriver.
2. Plug trace D on the optional I/O pins near connector J1.
3. Plug trace Y on the optional I/O pins near connector J2.

Option 3

This option will energize the In Use LED only when the IN USE line is active.

Installation (refer to the PCB Jumper Locations illustration):

1. Open trace Z on the programmable shunt with a small screwdriver.
2. Plug trace D on the optional I/O pins near connector J1.

DOOR LOCK LATCH OPTION

With this option, the door lock actuator can be latched without maintaining the IN USE signal throughout the door lock interval. IN USE may be activated by DRIVE SELECT.

Installation (refer to the PCB Jumper Locations illustration):

1. Plug trace D on the optional I/O pins near connector J1.
2. Plug trace DL on the optional I/O pins near connector J2.

WRITE PROTECT OPTION

With this option installed, a Write Protected disk will not inhibit writing but it will be reported to the controller.

Installation (refer to the PCB Jumper Locations illustration):

Cut trace WP and jumper trace NP (located near the center of the PCB).

DISK CHANGE (Alternate Output)

A low active level on this option line indicates that the disk drive door has been opened manually, the disk removed after the DRIVE SELECT signal has gone false, and then true again after a (different) disk has been installed.

Installation (refer to the PCB Jumper Locations illustration):

Plug trace DC on the optional I/O pins near connector J1.

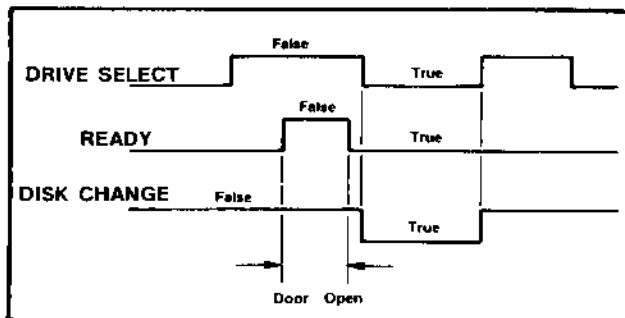

Figure 18. Disk Change Timing

2-SIDED (Alternate Output)

A low level on this line indicates that a two-sided disk is in use; a high level indicates a single-sided disk being used.

Installation (refer to the PCB Jumper Locations illustration):

Plug trace 2S on the optional I/O pins near connector J1.

MAINTENANCE

PREVENTIVE MAINTENANCE

The QumeTrak 842 drive should be cleaned every six months as outlined below. This interval assumes a reasonably dust-free environment. In use, keep the disk drive as free from dirt as possible. Place the unit in a clean plastic bag or sealable box when not in use for prolonged periods.

A general service check should be performed on the QumeTrak 842 every 6000 power-on hours. Include in this check inspecting for loose components and connectors. Re-tighten loose screws but be careful not to change the setting of adjustment screws, especially in the Head/Carriage Assembly and the Carrier Assembly areas. Inspect the Spindle Drive Belt (Qume P.N. 50025-01) and replace it if any evidence is found of fraying, cracking, or otherwise weakened areas. Perform the checks outlined under Service Checks in this part of the manual. Periodic adjustments are not required under normal operating conditions.

CAUTION

The head/carriage assembly is factory adjusted and tested and is not field serviceable. Do not, for any reason, attempt to repair this internal component. This can cause severe damage to the head surfaces or head support springs.

PERIODIC CLEANING

Cleanness is extremely important for the proper care of the disk drive. Perform this routine every six months or as required.

1. Eject the disk, if installed, and detach AC (J0) and DC (J5) connectors from the unit. Refer to the PCB Jumper Locations, Test Points & Connector Pin Assignments illustration.
2. Gain access to the disk drive's interior.
3. With a soft brush and lint free cloth remove all

dust deposits from the spindle drive motor and the surrounding area.

4. Check the entire drive unit and very cautiously eliminate any dirt or corrosion. Replace parts which may show evidence of wear or binding; refer to Removal and Replacement Procedures as required. Be sure to leave the drive free from lint.

5. Periodic cleaning of the R/W heads is recommended by using a quality head cleaning disk according to manufacturer instructions.

MAINTENANCE TOOLS AND EQUIPMENT

The tools and equipment listed in the table below are required for general maintenance of the QumeTrak 842. The hand tools are available at most hardware stores; the test instruments are standard electronic maintenance equipment.

Table 16
Maintenance Tools

TOOL	SIZE DESCRIPTION
PHILLIPS SCREW-DRIVER (2)	#1 HEAD, 4-INCH SHANK;
TWEEZERS	#2 HEAD, 4-INCH SHANK 4 TO 6 INCHES (NEEDLEPOINT)
ALLEN WRENCH (3)	1.5mm; 2.0mm; 2.5mm
METRIC FEELER GAUGE SET	TO 4mm (COMBINED)
DIAGONAL CUTTERS	4-INCH
NEEDLE NOSE PLIERS	4-INCH
SPRING HOOK (2)	8-INCH; 12-INCH
SOFT BRUSH	.5 TO 1.0 INCH
CLOTH OR PAPER	LINT FREE
THREADLOCKING COMPOUND	LOCTITE #222 OR EQUIV.
CERTIFIED R/W DISK	QUME P.N. 50151-02
CE ALIGNMENT DISK	QUME P.N. 50235-02 OR 50236-01
DISKETTE	SYSTEM COMPATIBLE WITH KNOWN GOOD RECORDING OF DATA
MULTIMETER	20 k Ω /V OR BETTER (TRIPLETT MODEL 310 OR EQUIV.)
OSCILLOSCOPE	DUAL TRACE (TEKTRONIX MODEL 465 OR EQUIV.)

INTERNAL CONNECTIONS

The drive internal connections between the PCB, various transducers (sensors, stepper motor, solenoids, indicator), and the R/W heads are established by way of two connectors: transducer connector (P2/J2) and head connector (P3/J3). The

two tables below correlate pin assignments, signal names, and wire colors.

Refer to the INTERFACE section for external drive connections information.

Table 17

Transducer Connector P2/J2 Pin Assignments

PIN NO.	SIGNAL NAME	COLOR	PIN NO.	SIGNAL NAME	COLOR
A15	IN USE LED RETURN	BLACK	B8	+ INDEX LED	RED
B15	+ IN USE LED	RED	A7	INDEX (1) SENSOR RETURN	BLACK
A14	WP LED RETURN	BLUE	B7	+ INDEX (1) SENSOR	RED
B14	+ WP LED	ORANGE	A6	INDEX (2) SENSOR RETURN (2-SIDED)	BLUE
A13	WP SENSOR RETURN	BLACK	B6	+ INDEX (2) SENSOR (2-SIDED)	ORANGE
B13	+ WP SENSOR	RED	A5	STEPPER Φ1	BLUE
A12	TRK 00 LED RETURN	BLUE	B5	KEY	
B12	+ TRK 00 LED	ORANGE	A4	STEPPER Φ3	RED
A11	TRK 00 SENSOR RETURN	BLACK	B4	STEPPER Φ2	YELLOW
B11	+ TRK 00 SENSOR	RED	A3	STEPPER Φ4	GREEN
A10	NOT USED		B3	STEPPER ΦC	WHITE
B10	NOT USED		A2	DOOR LOCK RETURN	BLACK
A9	NOT USED		B2	DOOR LOCK + 24V DC	RED
B9	NOT USED		A1	HEAD LOAD RETURN	BLACK
A8	INDEX LED RETURN	BLACK	B1	HEAD LOAD + 24V DC	RED

Table 18

Connector P3/J3 Pin Assignments

PIN NO	SIGNAL NAME	COLOR	PIN NO	SIGNAL NAME	COLOR
A7	R/W (HEAD 0)	WHITE	B4	ERASE RETURN (HEAD 1)	RED
B7	R/W (HEAD 1)	WHITE	A3	ERASE (HEAD 0)	YELLOW
A6	R/W RETURN (HEAD 0)	BLUE	B3	ERASE (HEAD 1)	YELLOW
B6	R/W RETURN (HEAD 1)	BLUE	A2	NOT USED	
A5	R/W (HEAD 0)	BLACK	B2	KEY	
B5	R/W (HEAD 1)	BLACK	A1	SHIELD (HEAD 0)	
A4	ERASE RETURN (HEAD 0)	RED	B1	SHIELD (HEAD 1)	

Table 19
Test Points

PIN NO.	SIGNAL NAME
GND	GND
1B	PREAMP 1B
1A	PREAMP 1A
2B	PREAMP 2B
2A	PREAMP 2A
3	INDEX
4	ERASE
5	READ DATA
+6	+6 VDC
+12	+12 VDC
+17	+17 VDC

TEST POINTS

Available on the PCB are a number of test points in the form of wire wrap pins for easy attachment of test equipment. Test point designators and signal names are identified in the table below as they are silkscreened on the PCB and called out in the schematic diagrams.

SERVICE CHECKS

For the service checks in this section, the disk drive interior mechanisms and the PCB must be accessible. At least AC and DC power must be applied to the unit as specified in the Interface Connections table for minimum drive operability.

Refer to the Illustrated Parts Locations drawings for identification of sub-assemblies.

Refer to the PCB Jumper Locations, Test Points & Connector Pin Assignments illustration for identification of PCB locations.

INDEX LAMP ASSEMBLY SERVICE CHECK

1. Power up the disk drive.
2. Check for +2.0 to +3.4V between PCB test points B8 and GND.
3. If the voltage measured is above +3.4V, replace the index lamp assembly as outlined under Index Lamp Removal and Replacement.
4. If the voltage measured is below +2.0V, perform Power Failure Troubleshooting Routine as outlined in the Troubleshooting section.

INDEX SENSOR ASSEMBLY SERVICE CHECK

1. Power up the disk drive.
2. Between PCB connector J2 pin B7 and GND, and J2 pin B6 and GND, check for $+5V \pm 5\%$.
3. Between PCB test points A7 and GND check for +4.0 to +5.25V without a disk installed and the drive door closed; and for 0 to +0.3V with a disk installed (upside down, so that the index hole cannot line up with the index lamp and sensor) and the door closed.
4. Check between PCB test points A6 and GND for the same voltages and under the same conditions described in step 3 above.
5. Remove the disk.
6. If any of the voltages measured in steps 2, 3, and 4 are outside the stated limits, replace the index sensor assembly as per Index Sensor Removal and Replacement instructions.

INDEX LAMP & SENSOR ALIGNMENT CHECK

After an index sensor or an index lamp assembly has been replaced, or if disk drive-to-drive compatibility (disk exchangeability) problems arise, check the index lamp and sensor alignment as outlined.

1. Verify that the pointer on the front of the index lamp assembly and the timing line on the index sensor assembly line up exactly when the drive door is closed.
2. Power up the drive.
3. Insert a CE disk (QUME P.N. 50235-02 or 50236-01).
4. Load the R/W heads against the disk and step to track 01.
5. Set up a dual trace oscilloscope (Tektronix 465 or equivalent):
 - Connect channel 1 to PCB test point 1A;
 - connect channel 2 to PCB test point 1B;
 - connect scope ground to PCB test point GND;
 - set vertical deflection for both channels to 50mV/division;
 - set both inputs to AC;
 - add channels 1 and 2;
 - connect the external scope trigger probe to PCB test point 3 (INDEX);
 - set trigger source to external;
 - select normal trigger mode;
 - select AC trigger coupling;
 - set horizontal sweep to 100 μ sec/division;
 - trigger on the leading edge (+) of the index pulse.
6. Observe the timing between the start of a sweep and the first peak of the index burst (125 ± 5 transitions of 1F data). It should be 500μ sec \pm 500μ sec for CE disk (QUME P.N. 50235-02) or 250μ sec \pm 100μ sec for CE disk (QUME P.N. 50236-01).
7. Step to track 76 and verify the same timing as observed above between the start of a sweep and the first peak of the index burst.
8. Select the other disk side and repeat steps 6 and 7 above.
9. Unload the R/W heads and remove the CE disk.

MAINTENANCE

Only if the index timing is outside the above tolerance, slightly loosen the screw that secures the index sensor assembly to the mainframe and adjust the index sensor position to obtain the specified timing; tighten the index sensor assembly mounting screw.

TRACK $\emptyset\emptyset$ SENSOR ASSEMBLY SERVICE CHECK

1. Move the head/carriage assembly by hand all the way against the stop at the rear of the drive (away from spindle). This positions the heads at track $\emptyset\emptyset$.

2. Power up the disk drive.

3. Between PCB connector J2 pin B11 and GND check for $+5V \pm 5\%$.

If this voltage is outside the stated tolerance, replace the PCB as outlined under Printed Circuit Board Removal and Replacement.

4. Check for $+1.0$ to $+1.7V$ between PCB test points B12 and GND.

5. Check for 0 to $+0.3V$ between PCB test points A11 and GND.

6. Power down the disk drive.

7. Move the head/carriage assembly by hand all the way toward the disk spindle.

8. Power up the disk drive.

9. Check for $+4.0$ to $+5.25V$ between PCB test points A11 and GND.

10. If any of the voltages measured in steps 4, 5, & 9 of the above procedures are outside the stated limits, replace the track $\emptyset\emptyset$ sensor assembly as per Track $\emptyset\emptyset$ Sensor Assembly Replacement instructions.

WRITE PROTECT SENSOR ASSEMBLY SERVICE CHECK

1. Power up the disk drive.

2. Between PCB connector J2 pin B13 and GND check for $+5V \pm 5\%$.

If this voltage is outside the stated tolerance, replace the PCB as outlined under Printed Circuit Board Removal and Replacement.

3. Check for $+1.0$ to $+1.7$ between PCB test points B14 and GND.

4. Check between PCB test points A13 and GND for $+4.0$ to $+5.25V$ without a disk and the drive door closed, and for 0 to $0.3V$ with an unprotected disk (no write protect notch) installed and the door closed.

5. Remove the disk.

6. If any of the voltages measured in steps 3 & 4 are outside stated limits, replace the write protect sensor assembly as per Write Protect Sensor Assembly Replacement instructions.

IN USE LED SERVICE CHECK

1. Power up the the disk drive.

2. Check for $+5V \pm 5\%$ between PCB test points B15 and GND.

If this voltage is not present, replace the PCB as outlined under Printed Circuit Board Removal and Replacement.

3. Temporarily connect a jumper from PCB connector J2 pin A15 to GND. The In Use LED should light up. Remove the jumper.

If the LED fails to light, replace it as per In Use LED Removal and Replacement instructions.

4. If the LED checks out OK in step 3 above, but fails to light during normal drive use with a disk installed and the drive door closed, refer to tables Factory Configuration of Options Traces, and Programmable Shunt Trace Functions and determine PCB jumper status with respect to In Use LED function.

5. Replace the PCB as outlined under Printed Circuit Board Removal and Replacement if a functional In Use LED fails to light as required with appropriate jumper and drive operating status.

HEAD LOAD SOLENOID ASSEMBLY ADJUSTMENT CHECK

This adjustment check is to be performed after maintenance involving any one of the following assemblies: carrier, bail, head load solenoid, or head/carriage. Also, if Read, Write, or Head Load difficulties arise, these may be caused by a loss of proper bail gap or head gap spacings.

1. Position the disk drive on a stable flat surface, interior mechanism exposed, with drive motor side up (PCB down). Orient it as shown in the illustration below.

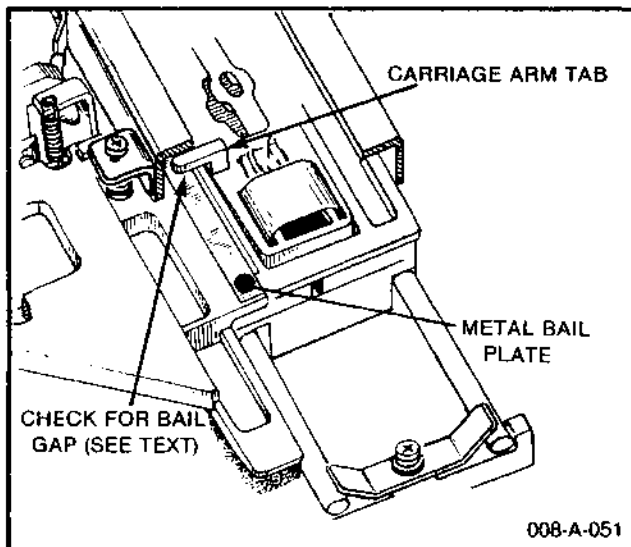

Figure 19. Bail Gap Check

2. Slide the head/carriage assembly by hand to the end of its range of travel all the way toward the rear of the disk drive (track 00 position).

3. Install a disk in the drive and close the drive door.

4. Power up the disk drive.

5. Load the heads against the disk (this may be done by a temporary jumper installed across test points HA and GND on the PCB).

6. Check the gap between the metal bail plate on the bail assembly and the plastic carriage arm tab on the head/carriage assembly. The gap should be within 0.020 and 0.400 inch (0.5 to 1.0 mm).

7. Unload the heads from the disk.

8. Slide the head/carriage assembly by hand all the way to the other end of its range of travel (track 76 position) toward the disk spindle.

9. Repeat steps 5 and 6 above.

10. Unload the heads and remove the disk from the drive.

11. If the bail gap is within the stated tolerance throughout the head/carriage assembly range of travel, proceed to check the head gap as outlined below.

If the bail gap is outside the stated tolerance, perform the bail gap adjustment as outlined under Head Load Solenoid Assembly Adjustment.

12. Rotate the disk drive so that the right-hand rear corner of the main frame casting with the blue Qume type label is at the near edge of the supporting surface (facing the operator).

13. Upright into the left-hand front corner of the disk drive (the one farthest away), place a piece of plain white paper.

14. Slide the head/carriage assembly by hand to approximately track 40 position in the middle of its range of travel (see Head/Carriage Assembly Belt Clamp Access illustration under Steel Belt Removal procedure).

15. Close the drive door.

16. Load and unload the heads one time (see step 5 above).

17. Look at the gap between the unloaded R/W heads by looking, from the right-hand rear corner of the disk drive (over the idler assembly), through the head/carriage assembly at the white paper surface in the left-hand front corner.

The gap should be between 0.004 to 0.010 inch (0.1 to 0.25mm; the nominal thickness of one ANSI standard disk is 0.003 inch/0.076mm).

CAUTION

The R/W head surfaces should not be brought in contact with each other; avoid this whenever possible, as it may cause head damage.

Do NOT place any objects between the heads to measure the head gap.

MAINTENANCE

If there is no gap between the heads, or if the gap appears too wide, perform the head gap adjustment as outlined under Head Load Solenoid Adjustment.

18. Power down the disk drive and remove the paper from the left-hand front corner; remove the temporary jumper from across test points HA and GND, if present.

HEAD LOAD TIME CHECK

The head loading time should be checked after maintenance involving the bail, bail base, head load solenoid, or head/carriage assemblies. This check verifies the free and proper movement and interaction of head load solenoid plunger, bail and R/W head lifting mechanism.

1. Power up the disk drive.
2. Insert a prerecorded disk and close the drive door.
3. Use a dual trace oscilloscope (Tektronix 465 or equivalent) and:

- Connect channel 1 to test point 1A and channel 2 to test point 1B on the disk drive PCB;
- attach the probe ground clips to the ground (GND) test point on the PCB;
- set the vertical deflection for both channels to 50mV/div;
- set both inputs to AC;
- invert channel 2;
- add channel 1 to channel 2;
- set horizontal sweep to 10ms/div;
- attach the external trigger probe to programmable shunt jumper HL (head load) on the disk drive PCB;
- select external trigger source;
- set the trigger coupling to AC and the trigger mode to normal;
- preset the trigger for a positive slope.

4. Load the drive heads against the disk.

This may be done by controller signal DRIVE SELECT in a factory configured drive, or by HEAD LOAD controller signal with jumper B removed and jumper C installed, or by disconnecting interface connector P1/J1 and closing a remote single pole switch temporarily connected between jumper pins HA and GND on the drive PCB.

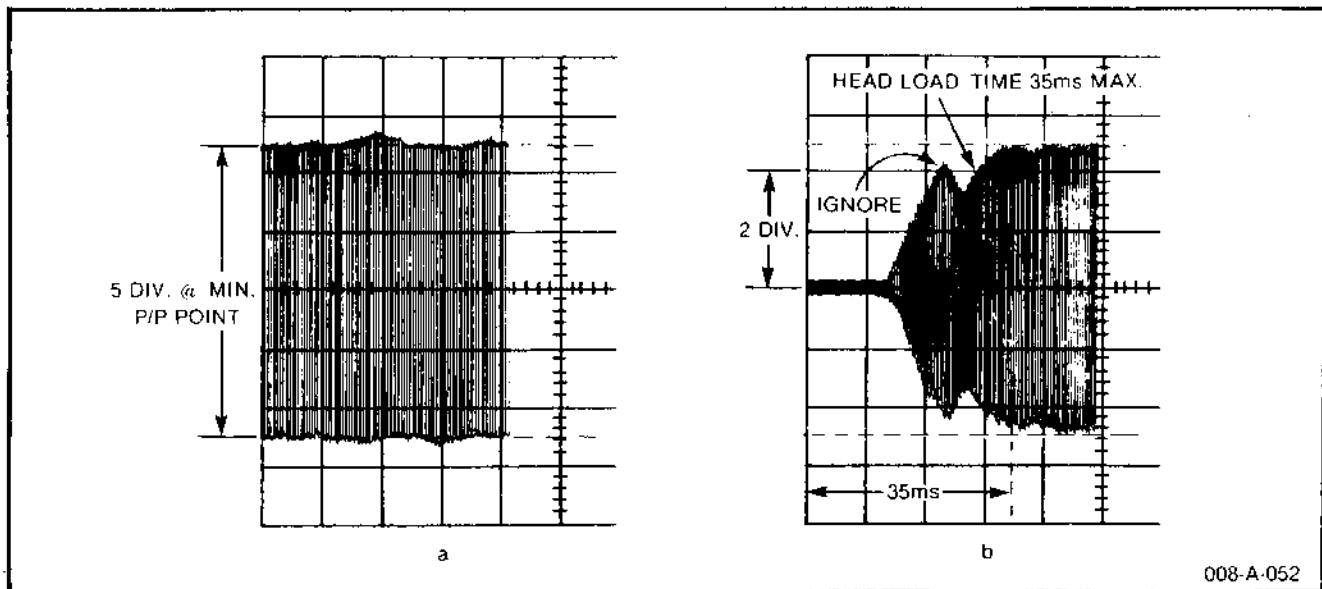

Figure 20. Head Load Time Check

5. Select a disk side and track with 1F data pattern.
6. Observe the read signal waveform on the scope and adjust the scope vertical gain for an amplitude of 5 divisions (100%) at the lowest peak-to-peak point of the displayed envelope. (see illustration a above).

7. Repeatedly load and unload the heads and adjust the scope's trigger slope control so that the scope display trace will be triggered by the head load command.

8. Read on the scope screen the time it takes for the signal envelope to reach and remain above the 80% amplitude point (2 divisions above center

line) from the beginning (trigger point) of the display trace. This head loading time must be less than or equal to 35 ms as shown in illustration b above.

9. Select a track with 1F data pattern on the second disk side and repeat steps 7 and 8 above.

10. Disconnect the oscilloscope from the disk drive; remove the prerecorded disk; restore the PCB jumper status as required for system operation.

If the head load time of 35 ms is exceeded on either disk side, check for a binding solenoid plunger, binding bail hinge, or improperly adjusted bail gap or head gap; if none of these are the cause, the head/carriage assembly may need to be replaced.

R/W HEAD READ AMPLITUDE CHECK

1. Power up the disk drive.
2. Verify good track alignment (refer to R/W Head Track Alignment).
3. Insert a good quality Qume Certified R/W Disk (P.N. 50151-01).
4. Select a disk side and load the R/W heads onto the disk.
5. Step to track 76 and write a 2F data signal (all "1").
6. Read the just recorded 2F signal.
7. Connect an oscilloscope (e.g. Tektronix model 465 or equivalent):
 - Vertical input probe (channel 1) to test point 1A;
 - the probe ground to the ground (GND) test point on the PCB;
 - set vertical deflection to 50 mV/division;
 - select AC input;
 - set the trigger source to internal;
 - set the trigger mode to normal;
 - select DC trigger coupling;
 - set the horizontal sweep to 0.5 msec./division;
 - trigger on the (channel 1) input signal.
8. Note the amplitude of the displayed read signal; it should be at least 100 mV pp if the R/W disk is good.

9. Write 1F data (all "0") on track 76.

10. Read the just recorded 1F signal and note the display amplitude on the scope.

11. Divide the 2F read amplitude by the 1F read amplitude. Minimum acceptable ratio is 0.4 (or 40%).

12. Select the other disk side (second R/W head) and repeat steps 5, 6, and 8 through 11 above.

13. Move the scope probe from test point 1A to test point 1B and repeat the above procedure for **both** disk sides (both R/W heads).

14. Unload the R/W heads from the disk.

15. Remove the R/W disk from the drive.

16. Disconnect the oscilloscope from the disk drive.

If any one of the four above ratios falls below 40%, the head/carriage assembly needs to be replaced, provided this is not caused by an increased head gap, faulty head azimuth, the head lifting off the disk surface, or by poor track alignment or worn media (disk surface). Perform R/W Head Azimuth Check, Head/Carriage Assembly Radial Alignment check, and use an alternate Certified R/W Disk before replacing the head/carriage assembly as outlined under Removal and Replacement Procedures. Do NOT omit the checks and adjustments listed at the end of the replacement procedure.

NOTE

The head/carriage assembly is factory adjusted and tested. In the field there must be no adjustment or repair attempted on the entire head/carriage assembly.

READ/WRITE (R/W) HEAD AZIMUTH CHECK

The R/W head azimuth significantly influences the signal amplitude of recorded and of read data. A head azimuth within ± 12 min. of zero is typical, while the head/carriage assembly needs to be replaced if the azimuth exceeds ± 18 min. Head azimuth cannot be adjusted.

1. Power up the disk drive.
2. Insert a CE alignment disk (QUME P.N. 50235-02 or 50236-01) in the drive and close the drive door.

MAINTENANCE

3. Load the R/W heads onto the CE disk.
4. Select a disk side.
5. Step the head/carriage assembly to track 76.
6. Use a dual trace oscilloscope (Tektronix 465 or equivalent) and:
 - Connect channel 1 to test point 1A and channel 2 to test point 1B on the disk drive PCB;
 - attach the probe ground clips to the ground (GND) test point on the PCB;
 - set the vertical deflection for both channels to 50mV/div;
 - set both inputs to AC;
 - invert channel 2;
 - add channel 1 to channel 2;
 - set the horizontal sweep to 0.5ms/div;
 - attach an external trigger to test point 3 (index timing) on the PCB and set the trigger source to external;
 - set the trigger coupling to AC and the trigger mode to external;
 - trigger on the leading edge of the index pulse.
7. Compare the wave form displayed to the Azimuth Check illustration below. If the displayed wave form is not within ± 18 minutes, the head/carriage assembly needs to be replaced.
8. Select the other disk side to test the second head and repeat step 7.
9. Unload the R/W heads.
10. Remove the CE disk from the drive.
11. Disconnect the oscilloscope from the disk drive.

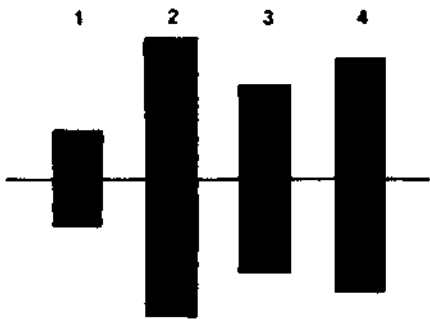

MAXIMUM ALLOWABLE AZIMUTH ERROR OF + 18 MINUTES. BURST #4 IS 25% LARGER IN AMPLITUDE THAN BURST #3.

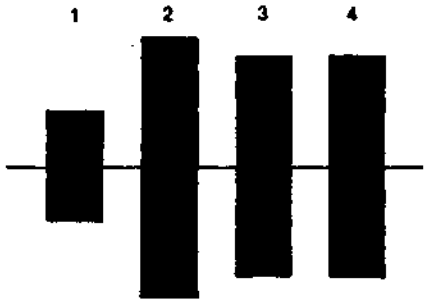

TYPICAL AZIMUTH ERROR OF + 12 MINUTES. BURSTS #3 AND #4 ARE EQUAL IN AMPLITUDE.

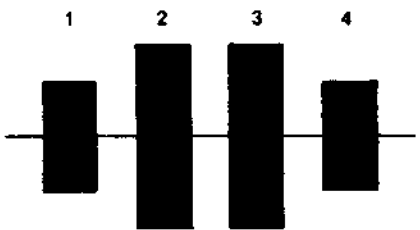

AN OPTIMUM ALIGNMENT OF ZERO MINUTES AZIMUTH ERROR. BURSTS #1 AND #4 ARE EQUAL IN AMPLITUDE, AS ARE BURSTS #2 AND #3.

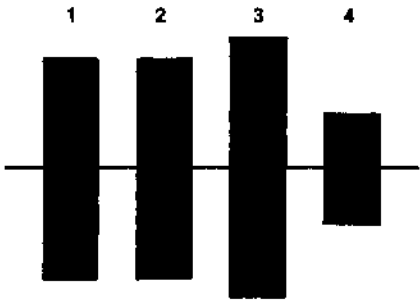

TYPICAL AZIMUTH ERROR OF - 12 MINUTES. BURSTS #1 AND #2 ARE EQUAL IN AMPLITUDE.

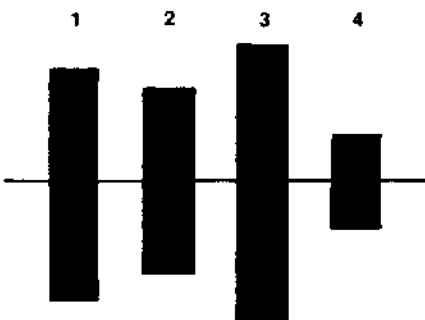

MAXIMUM ALLOWABLE AZIMUTH ERROR OF - 18 MINUTES. BURST #1 IS 25% LARGER IN AMPLITUDE THAN BURST #2.

USING A QUME CERTIFIED 12 MINUTE CE DISK (QUME P.N. 50235-02 OR 50236-01) THE AZIMUTH SHALL BE ACCEPTABLE IF A DRIVE SHOWS LESS THAN THE MAXIMUM ALLOWABLE 18 MINUTE AZIMUTH. THE MAXIMUM ALLOWABLE AZIMUTH IS CONSIDERED TO BE ATTAINED WHEN BURST #1 IS 25% LARGER THAN BURST #2, OR IF BURST #4 IS 25% LARGER THAN BURST #3.

003-A-009

Figure 21. Azimuth Check

REMOVAL AND REPLACEMENT PROCEDURES

For the procedures outlined in this section, top and bottom interior mechanisms of the disk drive must be accessible. Supply cables for AC and DC power to the drive unit are to be disconnected from their respective connectors (J0 and J5) in the drive. A disk must not be installed in the drive unless specifically instructed otherwise.

Reference is made to the Illustrated Parts Locations drawings which identify parts and assembly names and locations, and to numerous detail illustrations in this section.

CAUTION

Whenever performing any work on the disk drive with the disk removed, a clean piece of paper is to be inserted in place of the disk between the R/W heads to prevent their surfaces from contacting each other.

PRINTED CIRCUIT BOARD (PCB)

Removal

Refer to sheet a of the Illustrated Parts Locations drawings for identification of items and locations mentioned below.

1. Disconnect the interface cable, transducer cable, and R/W head cable from their respective PCB connectors (J1, J2, J3).

2. Remove the two screws which secure the PCB to the main frame casting along the edge of the interface connector (J1), and loosen the remaining two screws.

3. Slide the PCB edge out from under the two loosened screws and lift the PCB out of the drive.

Replacement

1. Reverse the above procedure for re-installation of the PCB.

SPINDLE DRIVE BELT AND DRIVE PULLEY

Removal

1. Remove the PCB as outlined under PCB Removal.

2. While turning the belt drive pulley by hand, guide the drive belt so that it will rise up and over the edge of the drive pulley.

3. Loosen the allen head setscrew in the drive pulley and slide the pulley from the motor shaft.

Replacement

Refer to the illustration below.

1. Slide the drive pulley onto the motor shaft and align the pulley setscrew with the flat surface on the shaft. Bring the top face of the drive pulley flush with the top of the motor shaft and tighten the setscrew.

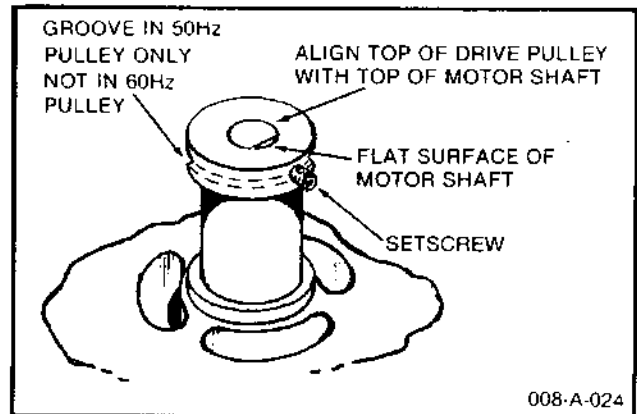

Figure 22. Drive Pulley Installation

2. Replace the drive belt, then rotate the spindle pulley counterclockwise by hand to verify that the belt is riding centered on the spindle pulley and drive pulley surfaces.

3. Install the PCB as outlined under PCB Removal and Installation and restore all connections.

BAIL ASSEMBLY

Removal

Refer to the illustrations below.

1. Manually slide the head/carriage assembly all the way towards the rear of the drive (track $\emptyset\emptyset$ position).

2. Cut a strip of clean paper (approximately 2 X 8 in.) and fold it end-to-end to half length.

Through the open front door of the drive, carefully insert the paper, fold first, into the disk slot of the head/carriage assembly (paper doubled over as described tends to stay in place in the slot more securely when the unit needs to be set on its side, than a single straight strip of paper; providing more reliable R/W head protection). Leave the drive door open.

3. Unhook the bail spring from the spring support arm on the head load solenoid.

4. Remove the screw with two washers that secures the bail assembly to the disk guide rail.

5. Tilt the bail assembly up from the bail base, slide it towards the side wall of the main frame casting and remove it from the drive after the metal bail plate clears the plastic carriage arm tab.

CAUTION

The R/W head surfaces must not be permitted to contact each other. Be sure that the paper remains between the heads in the head/carriage assembly disk slot throughout this procedure.

NOTE

Do not remove the head load solenoid plunger. Solenoid, solenoid plunger and shims are factory selected and matched. They should not be separated and must be replaced as a complete assembly only.

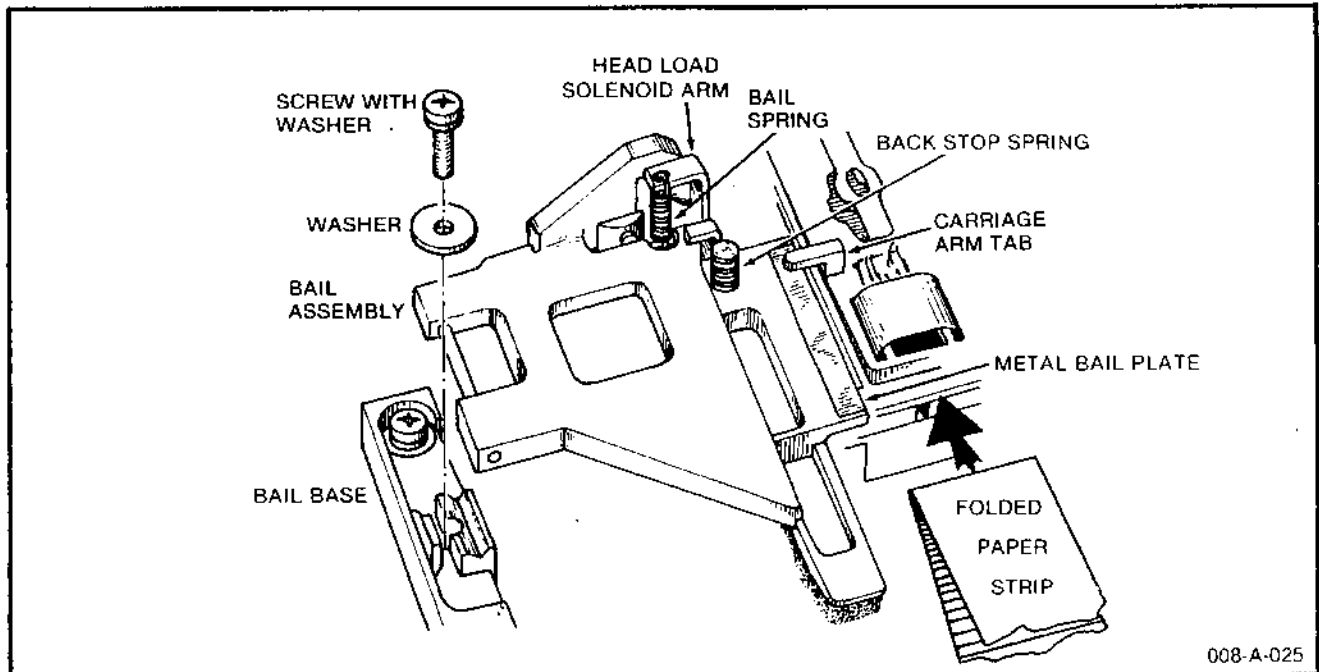

Figure 23. Bail Assembly Removal and Replacement

Replacement

Refer to the illustrations above and below.

1. Manually place the head/carriage assembly in track $\theta\theta$ position (all the way towards the rear of the drive).

2. Close the drive door.

3. Lift the solenoid plunger by about 1/2 inch and hold it there.

4. Insert the bail assembly from the side of the drive at a tilt so that the bail hook engages the plunger cross-pin, the back stop spring is under the bail adjustment screw, and the shelf with the metal bail plate rests **under** the carriage arm tab (but on top of the head/carriage assembly).

5. Secure the bail assembly to the bail base with a screw with two washers.

Verify that the solenoid plunger is not binding in any way; verify that the bail assembly is moving freely and has slight sideways play.

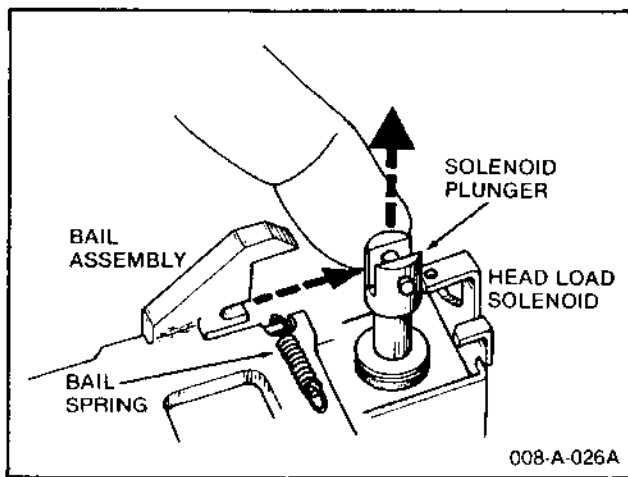

Figure 24. Bail Assembly Re-Installation

6. Hook the bail spring to the spring support arm on the head load solenoid.

7. Open the drive door and again verify freedom of movement of the solenoid plunger and of the bail assembly. Refer to the Head Load Solenoid Adjustment procedure if the solenoid plunger should be binding.

8. Remove the paper strip from between the R/W heads.

9. Perform Head Load Solenoid Adjustment Check and Head Load Time Check as outlined under Service Checks.

BAIL BASE

Removal

Refer to sheet e of the Illustrated Parts Locations drawings for identification of items and locations mentioned below.

1. Proceed through Bail Assembly Removal as outlined above.

2. Remove the screw with captive washers that secures the bail base to the main frame casting.

3. Lift out the bail base.

Replacement

1. Install the bail base in the drive, inserting the bail base tip into the horizontal guides on the inside of the front bezel.

2. Secure the bail base with a screw with captive washers.

3. Proceed through the Bail Assembly Replacement as outlined above.

DRIVE MOTOR ASSEMBLY

Removal

Refer to the illustration below.

1. Proceed through PCB Removal and Spindle Drive Belt and Drive Pulley Removal as outlined above.

2. Remove the screw and two washers securing the blue AC connector ground lead to the main frame casting.

3. Remove the AC connector from the connector bracket by compressing from the front the two clips which hold the connector in its bracket. Use pliers.

4. Remove the two screws with captive washers securing the capacitor and clamp to the main frame.

5. Remove the three screws and washers securing the drive motor to the main frame and lift out the drive motor assembly.

Replacement

Refer to the illustration below.

1. Install the drive motor on the main frame by pushing the motor against the main frame stops and securing it with three screws with captive washers.

2. Mount the capacitor and clamp to the main frame with two screws with captive washers.

3. Install the AC connector by pushing it into the AC connector bracket. The clips on either side of the connector will secure it.

4. Secure the blue AC connector ground lead to the main frame with a screw (nickel plated), washer, and star washer.

5. Proceed through Spindle Drive Belt and Drive Pulley Replacement and re-install the PCB as outlined above.

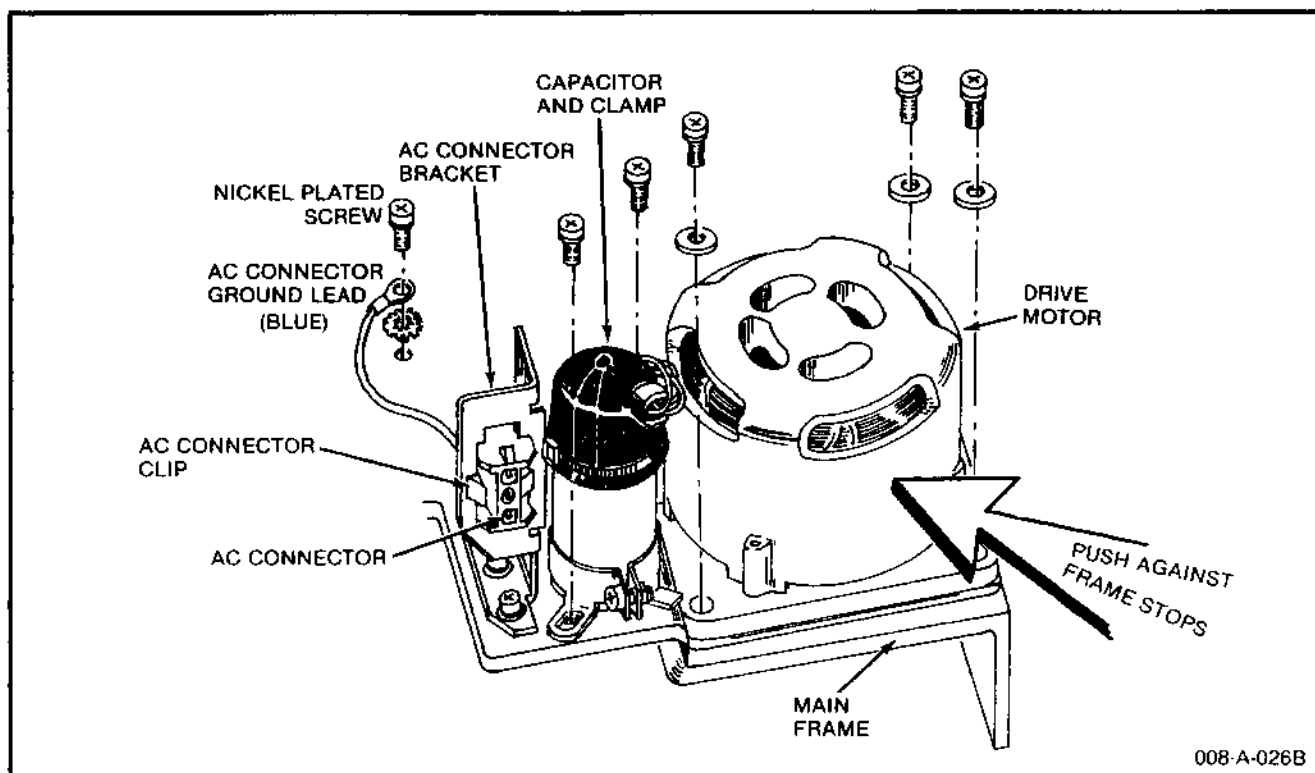

Figure 25. Drive Motor Assembly Removal and Replacement

IN USE LED

Removal

1. Disconnect the transducer cable connector (J2) from the PCB.
2. Remove the two In Use LED leads from the J2 connector by pushing down on the LED lead tabs in the connector with tweezers: black to J2-A15, red to J2-B15 (see Connector Lead Removal illustration below).
3. Separate the two In Use LED leads from the transducer cable.
4. Unplug 2 Pin socket cover from LED leads.
5. Pull the cover off the LED holder, then pull the holder off the LED (refer to the illustration below).

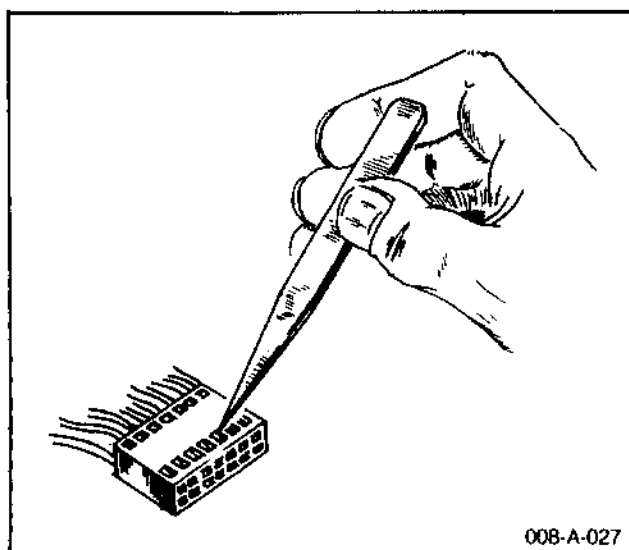

Figure 26. Connector Lead Removal (typical)

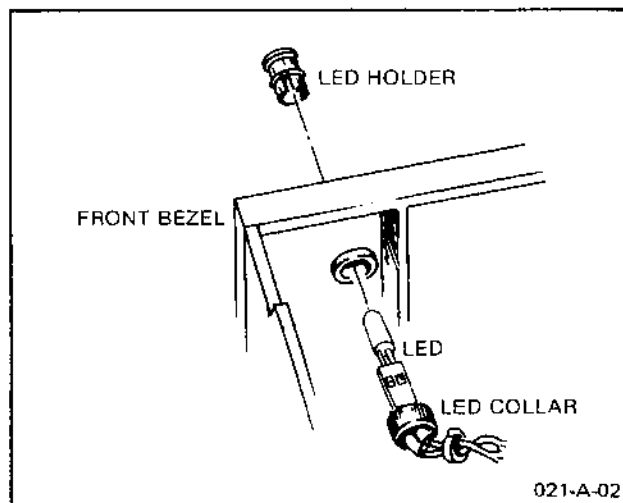

Figure 27. In Use Led Removal and Replacement

Replacement

1. Insert the LED holder from the front into the LED hole in the front bezel. Slide the collar over the In Use LED and onto the wires. With the holder in the front bezel hole, push the LED into the holder from behind, until it snaps into place.

Secure the LED holder by pushing the collar over the holder (refer to the In Use LED Removal and Replacement illustration above).

2. Route the two In Use LED leads along the transducer cable to the J2 connector.

3. Install the two leads in their proper locations in the J2 connector (refer to step 2, Removal). Make sure that the locking tabs on the leads engage in the connector slot. This will prevent the leads from pushing out when the connector is plugged in.

4. Plug the J2 connector into the PCB.

WRITE PROTECT SENSOR

Removal

1. Remove the bail assembly as outlined under Bail Assembly Removal.

2. Disconnect the transducer cable connector (J2) from the PCB.

3. Remove the four write protect sensor leads from the J2 connector by pushing down on the sensor lead tabs in the connector with tweezers: blue to J2-A14, orange to J2-B14, black to J2-A13, red to J2-B13 (refer to the Connector Lead Removal illustration).

4. Separate the four write protect sensor leads from the transducer cable. Note the routing of the leads from the cable to the sensor.

5. Remove the screw with captive washers which secures the write protect sensor assembly to the main frame casting. Remove the assembly.

Replacement

1. Install the write protect sensor assembly on the main frame, making sure the peg on the bottom of the assembly is in the main frame hole. Secure the assembly with a screw with captive washers.

2. Route the four sensor leads along the transducer cable to the J2 connector.

3. Install the leads in their proper locations in the J2 connector (refer to step 3, Removal). Make sure that the locking tabs on the leads engage in the connector slot. This will prevent the leads from pushing out when the connector is plugged in.

4. Plug the J2 connector into the PCB.

5. Install the bail assembly as outlined under Bail Assembly Replacement.

TRACK $\emptyset\emptyset$ SENSOR

Removal

1. Disconnect the transducer cable connector (J2) from the PCB.

2. Remove the four track $\emptyset\emptyset$ sensor leads from the J2 connector by pushing down on the sensor lead tabs in the connector with tweezers: blue to J2-A12, orange to J2-B12, black to J2-A11, red to J2-B11 (see the Connector Lead Removal Illustration).

3. Separate the four track $\emptyset\emptyset$ sensor leads from the transducer cable.

4. Remove the screw with captive washers which secures the track $\emptyset\emptyset$ sensor assembly to the main frame casting. Remove the assembly.

Replacement

1. Install the track $\emptyset\emptyset$ sensor assembly on the main frame, making sure the two pegs on the bottom of the assembly are in the main frame holes. Secure the assembly with a screw with captive washers.

2. Route the four sensor leads along the transducer cable to the J2 connector.

3. Install the four leads in their proper locations in the J2 connector (refer to step 2, Removal). Make sure that the locking tabs on the leads engage in the connector slot. This will prevent the leads from pushing out when the connector is plugged in.

4. Plug the J2 connector into the PCB.

INDEX SENSOR ASSEMBLY

Removal

1. Disconnect the transducer cable connector (J2) from the PCB.

2. Remove the four index sensor leads from the J2 connector by pushing down on the sensor lead tabs in the connector with tweezers: black to J2-A7, red to J2-B7, blue to J2-A6, orange to J2-B6 (see Connector Lead Removal illustration).

3. Separate the four index sensor leads from the transducer cable.

4. Remove the screw and large washer which secure the sensor to the mainframe. Remove the sensor.

Replacement

1. Install the index sensor assembly in the cut-out on the mainframe, positioning the sensor to the right against the mainframe (refer to the illustration below). Secure the sensor with a large washer and screw.

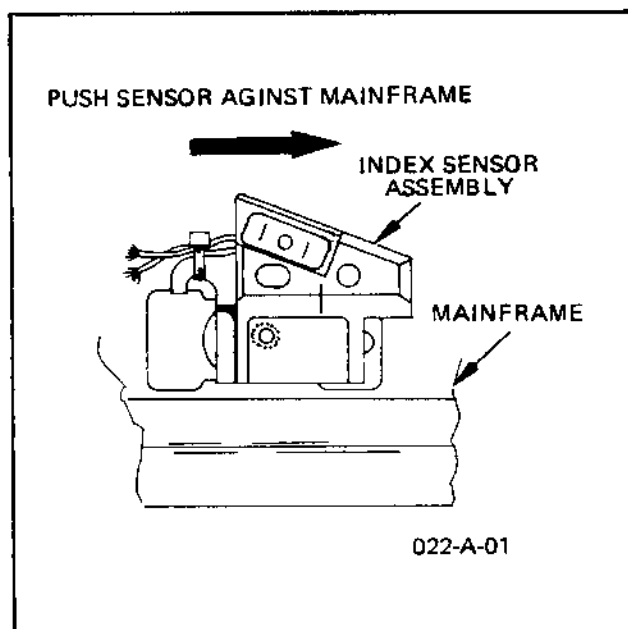

Figure 28. Index Sensor Assembly Replacement

2. Route the four index sensor leads along the transducer cable to the J2 connector.

3. Install the four leads in the J2 connector (refer to step 2, Removal). Make sure that the locking tabs on the leads engage in the connector slot. This will prevent the leads from pushing out when the connector is plugged in.

4. Plug the J2 connector into the PCB.

5. Perform Index Lamp & Sensor Alignment Check as outlined under Service Checks.

INDEX LAMP ASSEMBLY

Removal

1. Disconnect the transducer cable connector (J2) from the PCB.

2. Remove the two index lamp leads from the J2 connector by pushing down on the lamp lead tabs in the connector with tweezers: black to J2-A8, red to J2-B8 (refer to the Connector Lead Removal illustration).

3. Separate the two index lamp leads from the transducer cable. Note the routing of the leads from the cable, along the carrier assembly, to the index lamp.

4. Remove the two screws with captive washers which secure the index lamp assembly to the carrier assembly. Remove the assembly.

Replacement

1. Install the index lamp assembly on the carrier by tightening the two screws with captive washers finger tight only.

2. Route the two lamp leads along the carrier to the transducer cable and to the J2 connector.

3. Install the two leads in their proper locations in the J2 connector (refer to step 2, Removal). Make sure that the locking tabs on the leads engage in the connector slot. This will prevent the leads from pushing out when the connector is plugged in.

4. Plug the J2 connector into the PCB.

5. Perform Index Lamp Alignment as outlined under Adjustments.

CARRIER ASSEMBLY

Removal

Refer to the Illustrated Parts Locations drawings, sheet b, and to the illustration below.

MAINTENANCE

1. Cut a strip of clean paper (approximately 2 X 8 in.) and fold it end-to-end to half length.

While the drive front door is open, carefully insert the paper, folded end first, into the disk slot of the head/carriage assembly from the front.

Leave the drive door open.

CAUTION

The R/W head surfaces must not be permitted to contact each other. Be sure the paper remains between the heads in the head/carriage assembly disk slot throughout this procedure.

2. Depending on whether the index lamp is to remain in the disk drive while the carrier assembly is removed, or whether it is to be removed with the carrier:

- either release the index lamp assembly from the carrier assembly by removing both lamp mounting screws and pulling the index lamp leads from their supports on the carrier underside,
- or release the index lamp leads from the J2 connector by pushing down on the lead tabs in the connector with tweezers: black to J2-A8, red to J2-B8; separate the index lamp leads from the transducer cable.

CAUTION

The carrier assembly is spring loaded and will swing upward when the screws securing the carrier to the door latch plate are removed.

Do NOT permit the carrier front to swing up beyond the top edge of the front bezel as this may cause serious damage to the R/W head support springs in the head/carriage assembly. The head springs are precision preloaded and must not be flexed beyond their normal operating range.

3. While holding the front of the carrier assembly down against the spring tension, remove the two front screws and washers which secure the carrier to the door latch plate.

4. Squeeze the ready off lever (which is located towards the rear on the bail side of the carrier and

lifts the bail assembly) by hand towards the side of the carrier assembly until it clears the hook of the bail assembly.

Let the front of the bail assembly swing up, disengaging ready off lever and bail hook.

5. While holding down the front of the bail assembly slightly to gain access to the rear carrier screws, remove both screws, alternately a few turns at a time. Lift the carrier assembly from the drive unit.

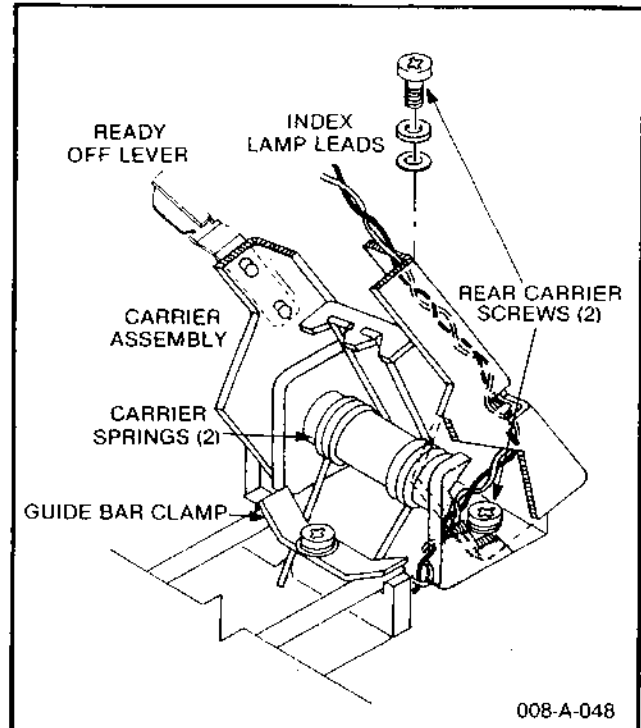

Figure 29. Carrier Assembly Removal and Replacement

Replacement

Refer to the illustration above.

1. Verify that the paper strip is present between the R/W heads as instructed under Removal above.

2. Insert both rear carrier screws with washers into their holes in the carrier assembly.

3. Properly place the angled (top) ends of both carrier springs into the notched-out recesses on the carrier and hold them in that position.

4. While holding the spring top ends in their carrier recesses, lift the carrier into position on the main frame casting, sliding the straight (lower)

spring ends into position in the two main frame casting recesses under the rear guide bar clamp.

5. Counteract the upward spring tension slightly and first engage both rear carrier screws only a few turns in their threads in the casting, then screw them in all the way but do not tighten at this time.

6. Squeeze the ready off lever by hand towards the side of the carrier assembly until it clears the hook of the bail assembly when the carrier front is lowered.

Release the ready off lever under the bail assembly hook, but do NOT release the front of the carrier assembly until the front screws are installed.

7. While holding the front of the carrier assembly down against the spring tension, install the two front screws and washers which secure the carrier to the door latch plate. Do not tighten these screws at this time.

Release the carrier front.

CAUTION

The carrier assembly is spring loaded and will swing up while the front screws are removed. Do NOT permit the carrier front to swing up beyond the top edge of the front bezel. The R/W head springs are precision preloaded and must not be flexed beyond their normal operating range as this may seriously damage them.

8. As applicable, install or connect the index lamp assembly; refer to step 2 of the Removal procedures above.

9. Push the carrier assembly towards the back of the drive and tighten the rear carrier screws. Verify that the plastic ends on the door latch plate do not bind against the guide tabs on the inside of the front bezel when the door is opened and closed.

10. Proceed through Drive Door and Carrier Assembly Alignment as outlined under Adjustments.

11. Proceed through Pop-Up Assembly Adjustment as outlined under Adjustments.

12. Perform R/W Head Gap Adjustment as outlined under Adjustments.

13. Perform Index Lamp Alignment as outlined under Adjustments.

POP-UP ASSEMBLY

Removal

Refer to sheets b and c of the Illustrated Parts Locations drawings for identification of items and locations mentioned below.

1. With the drive door open, remove the two screws with captive washers which secure the pop-up assembly to the main frame casting.

2. Lift the pop-up assembly up until the peg on its underside (between the screw holes) clears the main frame casting. Remove the assembly from the drive unit.

Replacement

1. Install the pop-up assembly by following the Removal procedure in reverse order.

Make sure that the pop-up assembly tip is inserted into the horizontal guides on the inside of the front bezel.

Hold the pop-up assembly pushed against the side of the main frame casting while tightening the screws.

2. Proceed through Pop-Up Assembly Adjustment as outlined under Adjustments.

DOOR LOCK SOLENOID

Removal

1. Disconnect the transducer cable connector (J2) from the PCB.

2. Remove the two door lock solenoid leads from the J2 connector by pushing down on the tabs with tweezers: black to J2-A2, red to J2-B2, (see Connector Lead Removal illustration).

3. Separate the two door lock solenoid leads from the transducer cable.

4. Remove the two screws and washers securing the solenoid/hook assembly to the front bezel. Remove the assembly and three springs (refer to the illustration below).

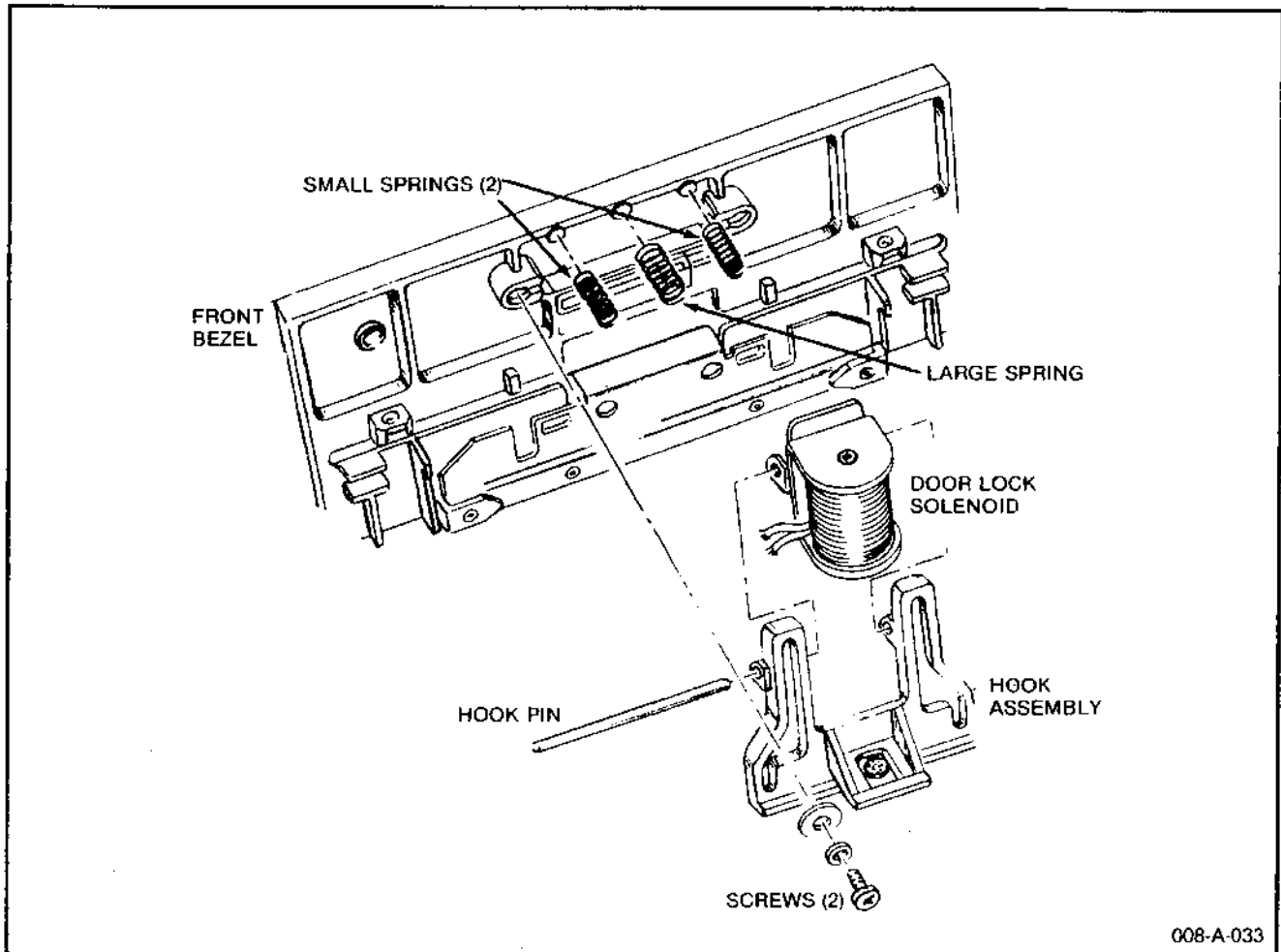

Figure 30. Door Lock Solenoid Removal and Replacement

008-A-033

5. To separate the hook assembly from the solenoid, pull out the hook pin. Be careful not to let the plunger with spring and padded washer drop out of the solenoid coil.

Replacement

1. Verify presence of the plunger in the solenoid coil (note arrangement of plunger hardware in that order: E-washer, spring, padded washer with cushion facing spring).

2. Assemble hook assembly and solenoid by inserting hook pin (refer to the Door Lock Solenoid illustration).

3. With the three springs in place (large spring in the center), install the solenoid/hook assembly on the front bezel. Secure the assembly with two screws with washers.

4. Route the two door lock solenoid leads along the transducer cable to the J2 connector.

5. Install the two leads in the J2 connector (refer to step 2, Removal). Make sure that the locking tabs on the leads engage in the connector slot. This will prevent the leads from pushing out when the connector is plugged in.

6. Plug the J2 connector into the PCB.

FRONT BEZEL ASSEMBLY

Removal

Refer to sheet b of the Illustrated Parts Locations drawings for identification of items and locations mentioned below.

1. Release the door lock solenoid assembly from the front bezel by removing two screws with washers. Be careful not to lose any of the three springs (see Door Lock Solenoid illustration).

2. Release the In Use LED from the front bezel

assembly: pull the collar off the LED holder, then pull the holder off the LED (refer to the In Use LED illustration).

3. Tie down the front of the carrier assembly towards the main frame casting using some wire or string, so that the drive door is in approximately half open position.

CAUTION

The carrier assembly is spring loaded and will swing up while the front screws are removed. Do NOT permit the carrier front to swing up beyond the top edge of the front bezel. The R/W head springs are precision preloaded and must not be flexed beyond their normal operating range as this may seriously damage them.

4. Remove the two screws and washers holding the carrier assembly to the door latch plate of the front bezel.

5. Remove the two screws with captive washers which secure the front bezel to the main frame casting. Lift the front bezel from the drive unit.

Replacement

1. Install the front bezel assembly on the main frame by securing it with two screws with captive washers.

2. Mount the front of the carrier assembly against the door latch plate, using two screws with washers. Do not tighten the screws at this time.

3. Install the In Use LED in the front bezel assembly: insert the LED holder from the front into the LED hole in the front bezel; slide the collar over the LED and onto the wires; with the holder in the front bezel hole, push the LED into the holder from behind until it snaps into place; secure the LED holder by pushing the collar over the holder (refer to the In Use LED Removal and Replacement illustration).

4. Install the door lock solenoid on the front bezel as outlined under Door Lock Solenoid Replacement above.

5. Proceed through Drive Door and Carrier Assembly Alignment as outlined under Adjustments.

HEAD LOAD SOLENOID

Removal

Refer to the illustration below.

NOTE

The position of the head load solenoid is relatively critical and influences the proper mechanical functioning of numerous components. Loosen the solenoid only if absolutely necessary.

1. Remove from the disk drive unit the PCB, spindle drive belt, and the bail assembly as instructed in the respective removal procedures.

2. Remove the two head load solenoid leads from the J2 connector by pushing down on the solenoid lead tabs in the connector with tweezers: black to J2-A1, red to J2-B1 (see Connector Lead Removal illustration).

3. Separate the two head load solenoid leads from the transducer cable.

4. Move the head/carriage assembly by hand all the way toward the spindle (forward).

5. Remove the two screws with captive washers which secure the head load solenoid to the solenoid bracket. Access to these screws is through two holes in the side of the main frame casting.

6. Remove the solenoid adjusting screw (between the two screws which secure the solenoid bracket to the main frame casting).

NOTE

Do not let the plunger fall out of the head load solenoid.

Plunger and shims are factory selected and matched to the solenoid and are not exchangeable or replaceable by themselves. Always replace the solenoid as a complete assembly only.

7. Remove the solenoid from the drive by dropping it down through the cutout in the casting.

8. Release the solenoid bracket from the main frame casting by removing the two screws with washers.

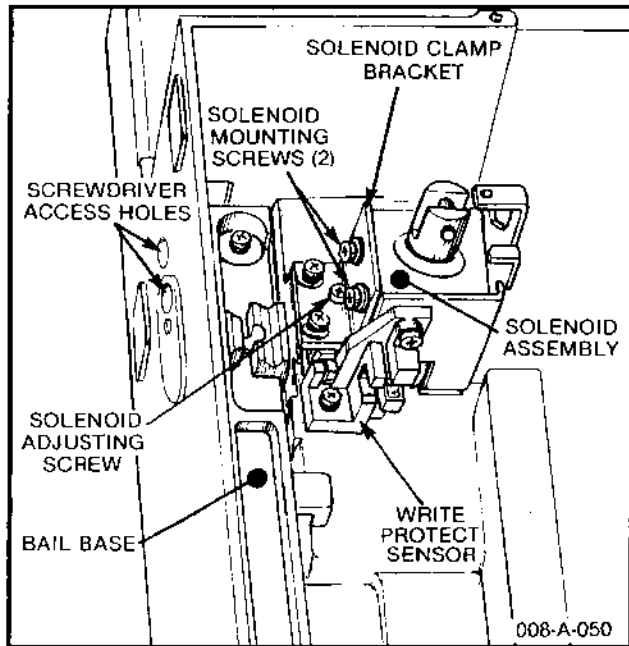

Figure 31. Head Load Solenoid Removal and Replacement

Replacement

1. Remove three screws and release the mounting bracket from the replacement solenoid assembly.

CAUTION

Do not exchange solenoid mounting brackets or plungers by themselves as this may cause solenoid performance problems. Always replace the complete solenoid with mounting bracket.

2. Mount the solenoid bracket to the main frame casting with two screws and washers, pushing the bracket toward the center of the drive while tightening the screws.

3. Install the solenoid by inserting it from below through the main frame casting and mounting it to the solenoid bracket with two screws with washers. Do not tighten these screws at this time.

4. Loosely engage the solenoid adjusting screw (see illustration above) but do not tighten.

5. Route the two head load solenoid leads along the transducer cable to the J2 connector.

6. Install the two leads in the J2 connector (refer to step 2, Removal). Make sure that the locking tabs on the leads engage in the connector slot. This will prevent the leads from pushing out when the connector is plugged in.

7. Re-install the spindle drive belt and the PCB as outlined in the applicable instructions.

8. Re-install the bail assembly as outlined under Bail Assembly Replacement; perform Head Load Solenoid Assembly Adjustment as outlined under Adjustments.

DUST COVER AND WIPER

Removal

1. Proceed through Pop-Up Assembly Removal as outlined above.

2. Remove the two screws with captive washers which secure the dust cover to the stepper motor flange. Lift off the cover.

3. If only the wiper is to be replaced, remove it from the dust cover.

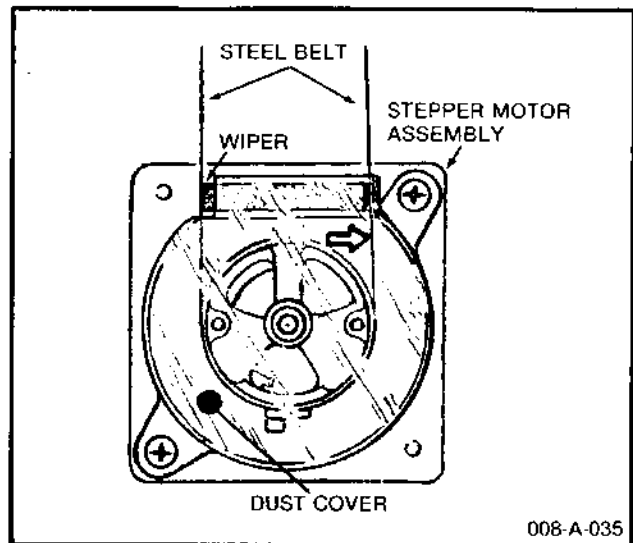

Figure 32. Dust Cover Removal and Replacement

Replacement

Refer to the illustration above.

1. If the wiper is being replaced, install the new wiper in the dust cover by pushing it against the

cover stop in the direction of the arrow on the cover.

2. Install the dust cover loosely with the two screws with captive washers on the stepper motor flange.

3. Align the dust cover so that the exposed wiper end lightly touches the steel belt. Secure the cover in this position by tightening the two screws.

4. Follow the Pop-Up Assembly Replacement instructions to install the pop-up assembly; proceed through Pop-Up Assembly Adjustment.

STEEL BELT

Removal

Refer to the illustrations below.

1. Remove the pop-up assembly as outlined under Pop-Up Assembly Removal.

CAUTION

Be careful not to kink the steel belt while working with it.

2. Remove the dust cover from over the stepper motor pulley after removing the two screws with captive washers.

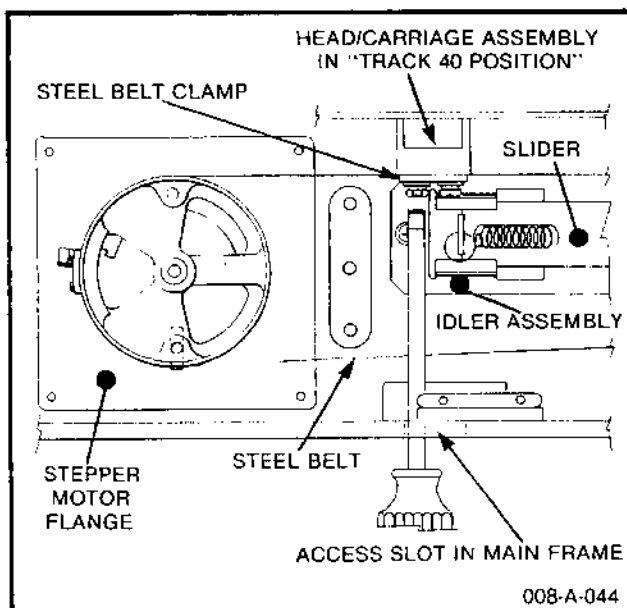

Figure 33. Head/Carriage Assembly Belt Clamp Access

3. Move the head/carriage assembly by hand so that the steel belt/carriage clamp screws line up with the access slot in the side of the main frame casting (this is approximate "Track 40 Position").

4. Using the access slot in the side of the main frame casting, remove the two screws with captive washers and the clamp plate which secure the steel belt. Note orientation of the clamp plate (properly oriented the rounded clamp plate edges must face the steel belt).

5. Push the slider on the idler assembly forward against the tension spring. Insert a short Phillips screwdriver into the now exposed hole in the main frame casting. This maintains the slider in forward position with the tension released from the steel belt.

CAUTION

Do not let the tip of the screwdriver contact the printed circuit board directly below.

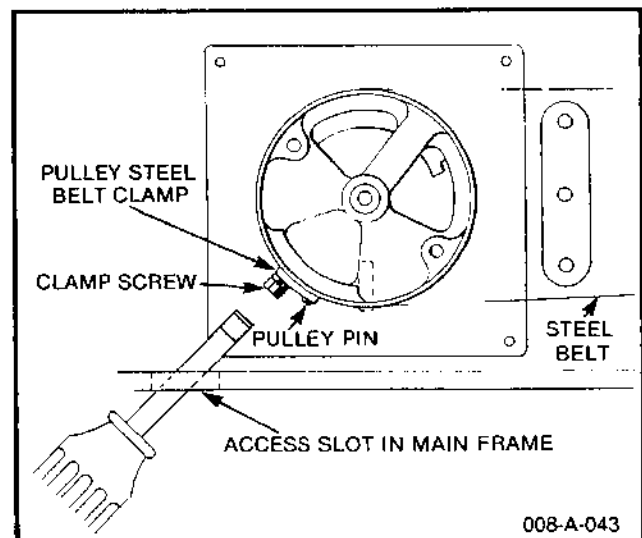

Figure 34. Steel Belt End Clamp Access

6. Rotate the stepper motor pulley counterclockwise until the screw which secures steel belt ends and clamp to the pulley is accessible with a screwdriver through the slot in the right side of the main frame casting.

7. Remove the screw and clamp plate which secure the steel belt ends to the stepper motor pulley.

8. Lift the steel belt ends from the stepper motor pulley pin and remove the belt.

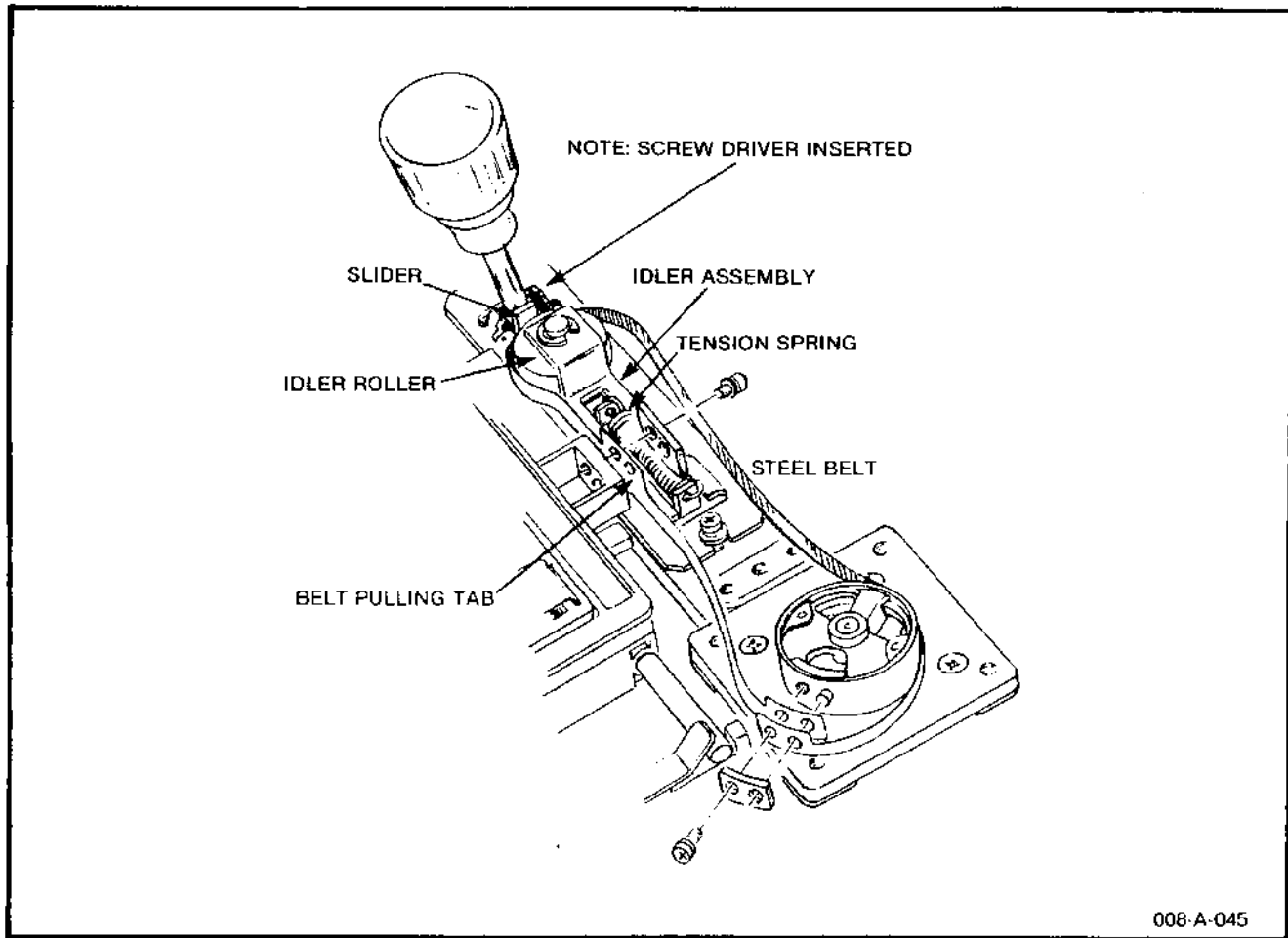

Figure 35. Steel Belt/Stepper Mechanism

Note the belt ends arrangement on the pulley (the "short" belt end from the head/carriage assembly should be at the bottom, next to the pulley).

Replacement

Refer to the illustrations above and below.

1. With the head/carriage assembly pulling tab on the steel belt pointing up, install the steel belt ends on the stepper motor pulley pin; "short" end from the head/carriage side first. Loosely secure the belt with the clamp and screw. Do not tighten the screw at this time.
2. Push the slider on the idler assembly forward against the tension spring and place the steel belt over the idler roller (see Steel Belt/Stepper Mechanism illustration above). Release the slider.
3. By turning the stepper motor pulley back and forth, check that the steel belt runs centered on

the idler roller throughout the belt's travel. Repeat this step several times to be certain.

4. Turn the stepper motor pulley so that the screw which secures the steel belt ends to the pulley is accessible through the slot in the right side of the main frame casting. Tighten the clamp screw.
5. Position the head/carriage assembly so that the belt clamp screw holes line up with the access slot in the side of the main frame casting (approximate "Track 40 Position").
6. By turning the stepper motor pulley, carefully align the holes in the steel belt tab to be centered over the threaded holes in the head/carriage assembly.
7. Secure the steel belt to the head/carriage assembly with the clamp plate and two screws with captive washers.

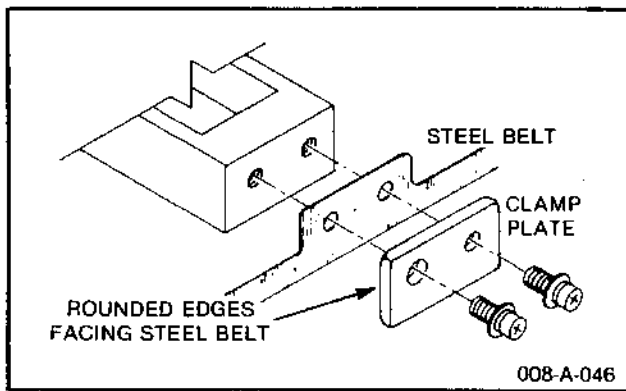

Figure 36. Steel Belt and Head/Carriage Alignment

NOTE

Be sure to have the side of the clamp plate with the rounded edges come to lie against the steel belt. This avoids stressing or warping the belt which might be caused if the clamp plate's cutting burr is pressed against the belt.

8. Perform Head/Carriage Assembly Radial Alignment as outlined under Adjustments.

9. Install the dust cover over the stepper motor pulley as outlined under Dust Cover and Wiper Replacement.

10. Install the pop-up assembly as outlined under Pop-Up Assembly Replacement; perform Pop-Up Assembly Adjustment check.

IDLER ASSEMBLY

Removal

1. Move the head/carriage by hand all the way forward towards the drive door (track 76 position).

2. Push the slider on the idler assembly forward against the tension spring and lift the steel belt from the idler roller (see Steel Belt/Stepper Mechanism illustration above).

3. Remove the two screws with captive washers which secure the idler assembly to the main frame casting.

Remove the assembly.

Replacement

1. Move the head/carriage assembly by hand to track 76 position (all the way towards the drive front).

2. Set the idler assembly in place on the main frame casting and loosely secure it with two screws with captive washers.

3. Push the idler assembly forward (toward the stepper motor) and tighten the two screws.

4. Push the slider on the idler assembly forward against the tension spring, and place the steel belt over the idler roller.

5. Pull the steel belt back and forth to check that it is running centered on the idler roller throughout the belt's travel. Repeat this step several times to be certain.

STEPPER MOTOR ASSEMBLY

Removal

Refer to sheets c and d of the Illustrated Parts Locations drawings for identification of items and locations mentioned below.

1. Disconnect the transducer cable connector (J2) from the PCB.

2. Remove the five stepper motor leads from the J2 connector by pushing down on the lead tabs in the connector with tweezers: blue to J2-A5, red to J2-A4, yellow to J2-B4, green to J2-A3, white to J2-B3 (see Connector Lead Removal illustration).

3. Separate the five stepper motor leads from the transducer cable and release them from the main frame (two places).

4. Remove the pop-up assembly as outlined under Pop-Up Assembly Removal.

5. Remove the dust cover from over the stepper motor pulley after removing the two screws with captive washers.

CAUTION

Be careful not to kink the steel belt while working with it.

MAINTENANCE

6. Proceed through Steel Belt Removal as outlined above.

7. Remove from the underside of the main frame casting the two screws with captive washers which secure the stepper motor.

Lift the motor out through the top of the drive.

Replacement

1. Install the stepper motor assembly on the main frame and loosely secure it with two screws with captive washers.

Do not tighten the screws at this time.

2. Secure the stepper motor leads to the main frame (two places) and route them along the transducer cable to the J2 connector.

3. Install the five leads in the J2 connector (refer to step 2, Removal). Make sure that the locking tabs on the leads engage in the connector slot. This will prevent the leads from pushing out when the connector is plugged in.

4. Plug the J2 connector into the PCB.

5. Install the steel belt as instructed under Steel Belt Replacement (perform Head/Carriage Assembly Radial Alignment as outlined under Adjustments at the end of the steel belt installation).

HEAD/CARRIAGE ASSEMBLY

Removal

1. Cut a strip of clean paper (approximately 1.5 X 6 in.) and fold it end-to-end to half length.

2. Through the open drive door insert the paper, fold first, from the front into the disk slot of the head/carriage assembly (see Bail Assembly Removal and Replacement illustration).

CAUTION

The R/W head surfaces must not be permitted to contact each other. Be sure that the paper remains between the R/W heads in the head/carriage assembly disk slot throughout this procedure.

3. Close the disk drive door.

4. Proceed through Printed Circuit Board Removal as outlined above.

5. Remove the spindle drive belt as instructed above.

6. Release the head/carriage cable from the main frame casting (one place).

7. Move the head/carriage assembly by hand so that the steel belt/head carriage clamp screws line up with the access slot in the side of the main frame casting (approximate "Track 40 Position", see Head/Carriage Assembly Belt Clamp Access illustration).

8. Through the access slot in the main frame casting remove the two screws with captive washers and the clamp plate, to release the head/carriage assembly from the steel belt.

9. Turn the idler roller by hand clockwise to position the pulling tab on the steel belt toward the rear of the drive to the end of its range of travel ("Track 00 position").

10. Slide the head/carriage assembly by hand toward the front of the drive to the end of its range of travel.

NOTE

Always handle the head/carriage assembly gently.

11. Release the two guide bar clamps (one on each end of the two head/carriage guide rails) by loosening their screws. Swing the guide bar clamps off the head/carriage guide rails.

12. Push both head/carriage guide rails toward the back of the drive until their front ends drop down through the cut-out in the main frame casting.

13. CAREFULLY drop the head/carriage assembly with guide rails through the cut-out in the main frame casting. Be careful not to let any of the head/carriage assembly tabs or protrusions hang up anywhere; do NOT force the head/carriage assembly down.

Replacement

1. Verify that the drive door is closed and that the pulling tab of the steel belt is positioned toward the rear of the drive at the end of its range of travel.

CAUTION

Be sure that a clean paper strip is present between the R/W head surfaces of the replacement head/carriage assembly as instructed under Removal procedures above.

2. Place the two guide rails in position on the replacement head/carriage assembly with only about 1/2 in. of the guide rails protruding from the front of the head/carriage assembly.

3. With the drive resting on its side, insert head/carriage assembly and rails from below through the cut-out in the main frame casting, long protruding (rear) ends of the rails first.

Be sure that the plastic carriage arm tab comes to rest **ON TOP** of the metal bail plate (see the Bail Assembly Removal and Replacement illustration).

4. Place the ends of both guide rails into position on their blocks on the main frame casting.

5. Swing the guide bar clamps (2) into position atop the guide rail ends and tighten their screws

while making sure that the head/carriage assembly slides freely on the guide rails.

CAUTION

Do not kink or bend the steel belt by bumping into the pull tab while sliding the head/carriage assembly back and forth.

6. Re-install the spindle drive belt and the PCB as outlined in the applicable instructions.

7. Proceed through all applicable steps outlined under Steel Belt Replacement to properly secure the steel belt to the head/carriage assembly.

CAUTION

To avoid damage to the drive, closely adhere to the detailed steel belt installation instructions.

8. Perform Head Load Solenoid Adjustment Check outlined under Service Checks **before** proceeding through the Head/Carriage Assembly Radial Alignment as instructed at the end of the steel belt installation.

9. Perform Head/Carriage Assembly Radial Alignment as outlined under Adjustments.

10. Perform R/W Head Read Amplitude Check and R/W Head Azimuth Check as outlined under Service Checks.

ADJUSTMENTS

The adjustments outlined in this section typically apply after replacement of subassemblies and restore the disk drive to performance within specifications. Periodic adjustments are not required under normal operating conditions.

For the adjustments the disk drive interior mechanisms must be accessible. When specified during some adjustments, AC and DC power are to be applied to the drive as per the Interface Connections table for minimum drive operability.

Reference is made to the Illustrated Parts Locations drawings which identify parts and assembly names and locations, and to other detail illustrations throughout the Maintenance section.

CAUTION

Whenever performing any work on the disk drive with the disk removed, a clean piece of paper is to be inserted in place of the disk between the R/W heads to prevent their surfaces from contacting each other.

DRIVE MOTOR PULLEY POSITIONING

Proper positioning of the drive pulley on the disk drive motor shaft is described under Spindle Drive Belt and Drive Pulley Replacement.

DRIVE DOOR AND CARRIER ASSEMBLY ALIGNMENT

For this procedure the two screws which mount the rear of the carrier assembly to the main frame casting, and the two screws which mount the front of the carrier assembly to the door latch plate should be only finger tight.

1. Power down the disk drive.
2. Open the disk drive front door.
3. While pushing the carrier assembly towards the rear of the disk drive, align the carrier so that the distances between the door latch plate and the front bezel are equal at the two carrier front screw points.

Tighten the two rear carrier screws.

4. Verify that the plastic ends on the door latch

plate do not bind against the guide tabs on the inside of the front bezel when the door is opened and closed. Repeat step 3 as may be required.

5. Close the disk drive front door.

6. Push down on the carrier assembly near the front carrier screws to obtain a gap between the carrier cross member and the E-ring of the collet assembly shaft.

Insert a feeler gauge in the gap and establish a gap size of 0.020 to 0.060 inch (0.5 to 1.5mm) as illustrated below.

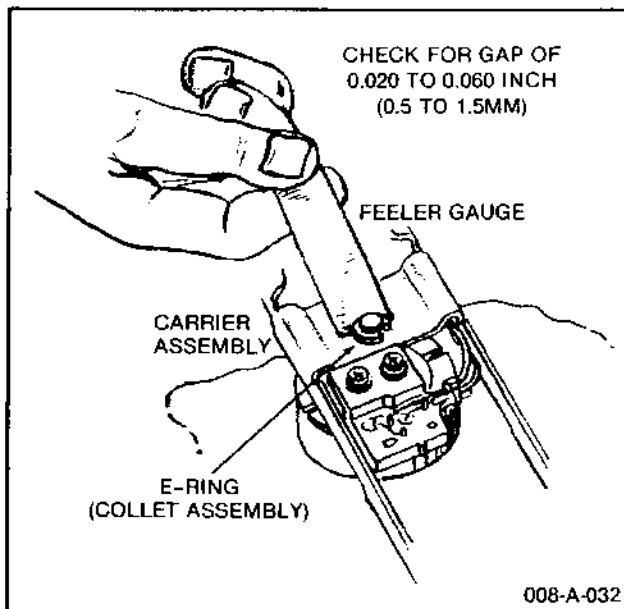

Figure 37. Carrier-Collet Assembly Adjustment

7. Align the drive front door so that it is parallel with the recess of the front bezel and tighten the two carrier front screws.

8. Open and close the drive door. Verify that the gap size between collet E-ring and carrier assembly is as specified above, and that the front door is parallel with the front bezel.

Repeat steps 6 and 7 as may be necessary.

9. Proceed through R/W Head Gap Adjustment as outlined under Head Load Solenoid Adjustment.

10. Proceed through Pop-Up Assembly Adjustment as outlined below.

POP-UP ASSEMBLY ADJUSTMENT

1. Power down the disk drive.
2. Rotate the pop-up adjustment screw on the carrier assembly clockwise as much as possible.
3. Close the drive door and latch the pop-up slider by sliding it toward the rear of the drive (away from the front door) until it engages under the pawls of the pop-up lever.
4. Open the drive door to within approximately 1/4 inch of being fully opened; hold it there.
5. Rotate the pop-up adjustment screw counterclockwise until the pop-up slider is just unlatched.
6. Repeat steps 3 and 4 to verify reliable pop-up unlatching when the door is within 1/4 inch of fully open.
7. Secure the pop-up setscrew with threadlocking compound (e.g. Loctite #222).

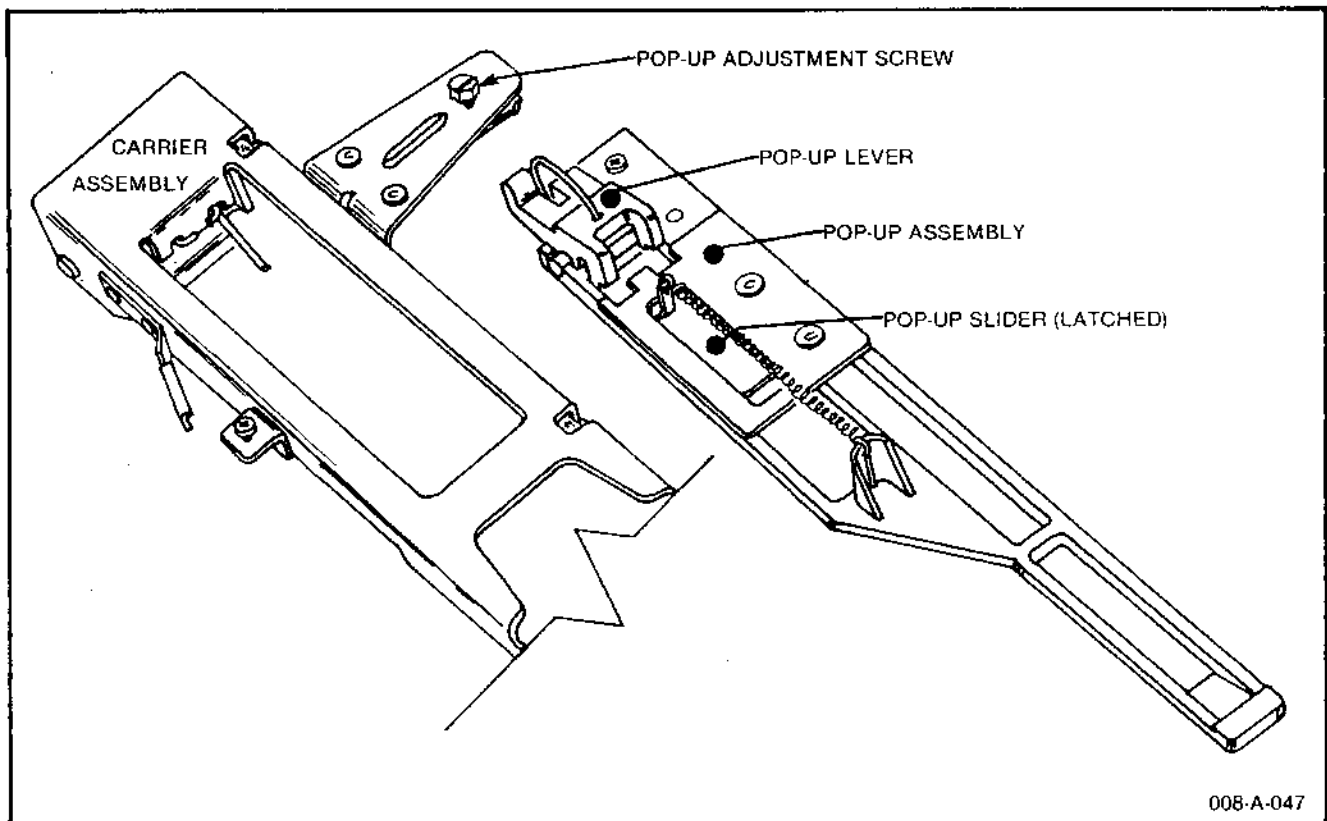
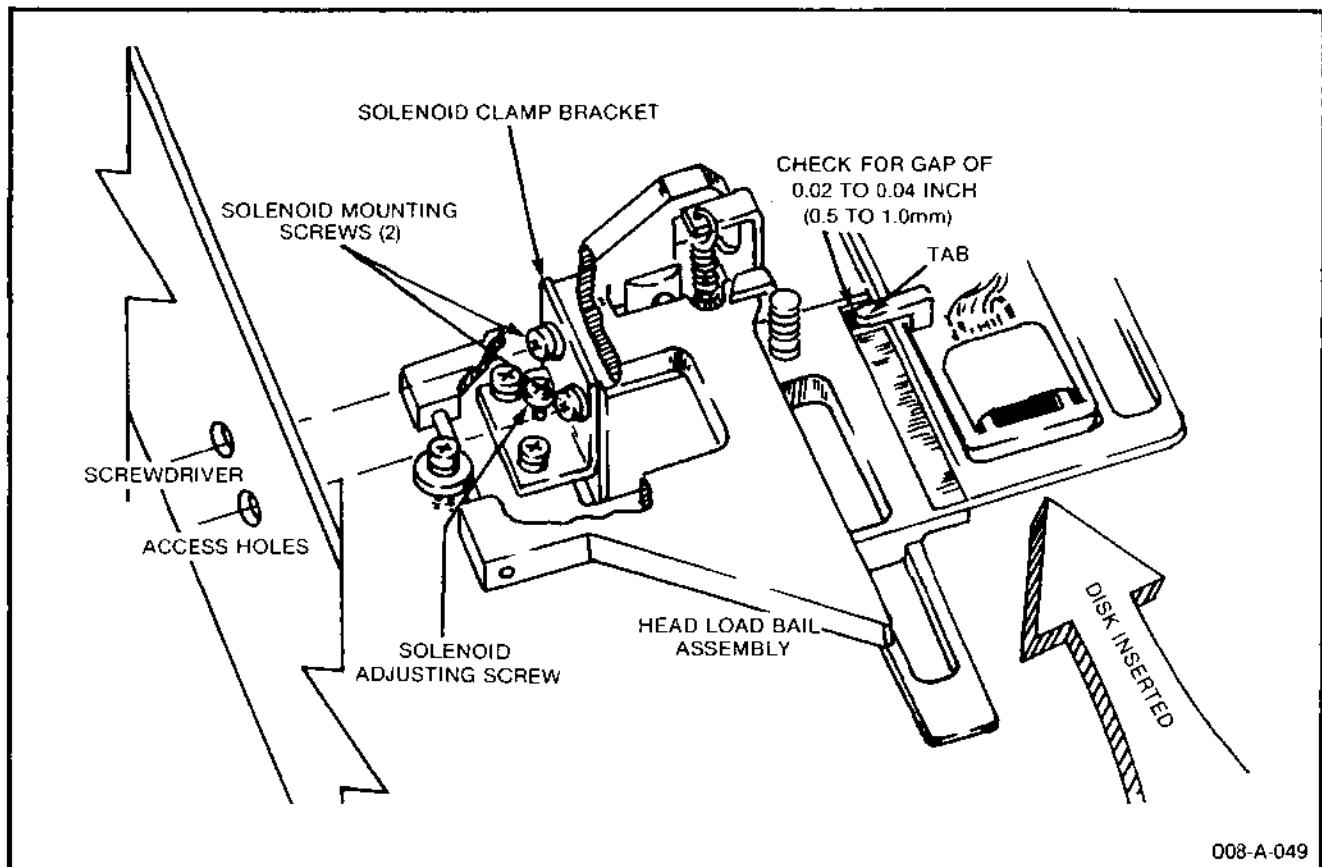

Figure 38. Pop-Up Adjustment

HEAD LOAD SOLENOID ASSEMBLY ADJUSTMENT

1. Position the disk drive on a stable flat surface, interior mechanism exposed, with drive motor side up (PCB down).
2. Install a disk in the drive and close the drive door.
3. If disconnected, restore power connections and power up the disk drive.
4. Perform bail gap adjustment as outlined:
 - Slightly (1 turn) loosen the two head load solenoid mounting screws. Access to these screws is through holes in the side of the main frame casting (see illustration below).
 - Slide the head/carriage assembly by hand to the end of its range of travel all the way toward the rear of the disk drive (track \emptyset position).
 - Load the heads against the disk (this may be done by a temporary jumper installed across test points HA and GND on the PCB).
 - Turn the solenoid adjusting screw in the



008-A-049

Figure 39. Bail Gap Adjustment

solenoid clamp bracket to adjust the gap between the metal bail plate on the bail assembly and the plastic carriage arm tab on the head/carriage assembly. The gap must be between 0.020 and 0.040 inch (0.5 to 1.0 mm). Turning the screw clockwise decreases the gap.

- Tighten the head load solenoid mounting screws.
- Re-check the bail gap size.
- Verify that the solenoid is mounted perpendicular to the main frame casting (head load solenoid arm straight up-and-down) and that the solenoid plunger is moving freely.
- Unload the heads from the disk.
- Slide the head/carriage assembly by hand all the way to the other end of its range of travel (track 76 position) toward the disk spindle.
- Again load the heads and verify that the bail gap is within the above stated tolerance. If necessary, repeat the adjustment.

- Unload the heads and remove the disk from the drive.

5. Perform R/W head gap adjustment as outlined:

- Rotate the disk drive so that the right-hand rear corner of the main frame casting with the blue Qume type label is at the near edge of the supporting surface (facing the operator).
- Upright in the left-hand front corner of the disk drive (the one farthest away), place a piece of plain white paper.
- Slide the head/carriage assembly by hand to approximately track 40 position in the middle of its range of travel (see Head/Carriage Assembly Belt Clamp Access illustration under Steel Belt Removal procedure).
- Close the drive door.
- Load and unload the heads one time (either by controller command, or by temporarily installing a jumper across test points HA and GND on the PCB).

- Look at the gap between the unloaded R/W heads by sighting, from the right-hand rear corner of the disk drive (over the idler assembly), through the disk slot in the head/carriage assembly at the white paper surface in the left-hand front corner. If the head surfaces are in contact with each other and there is no gap visible between them, load and unload the heads one more time, since the heads "stick" sometimes.

- If there still is no visible gap between the R/W heads, do NOT repeat loading and unloading, but back out the backstop screw in the carriage assembly (see illustration below) counter-clockwise about two turns. Open and close the drive door, then load and unload the heads; there should now be a visible head gap.

CAUTION

The R/W head surfaces should not be brought in contact with each other; avoid this whenever possible, as it may cause head damage.

Do NOT place any objects between the heads to measure the head gap.

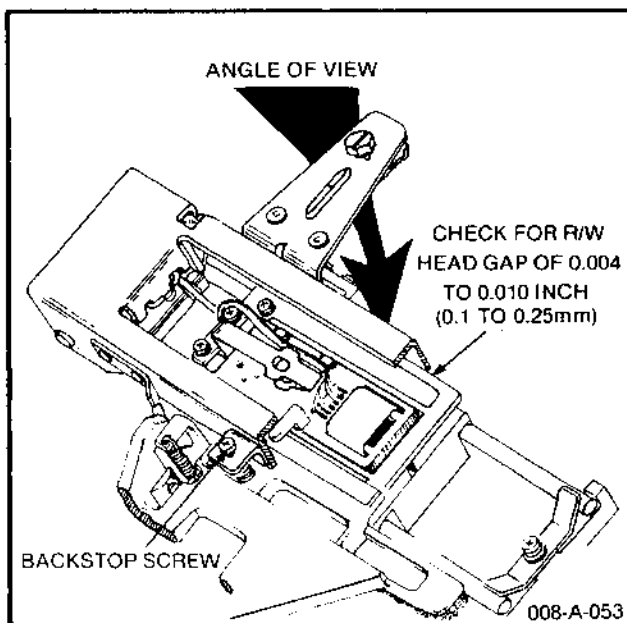

Figure 40. R/W Head Gap Adjustment

- Turn the backstop screw in the carrier assembly (see illustration below) to adjust the gap between the unloaded R/W heads. The gap must be between 0.004 to 0.010 inch (0.1 to 0.25mm; the nominal thickness of one ANSI stan-

ard disk is 0.003 inch/0.076mm); it cannot be measured and must be estimated. Carefully turning the backstop screw clockwise will bring the R/W heads closer together.

- Open and close the drive door, then load and unload the R/W heads again and verify proper head gap spacing by sighting through the disk slot in the head/carriage assembly as instructed above. If necessary, repeat the adjusting procedure.

- Power down the disk drive and remove the paper from the left-hand front corner; remove the temporary jumper from test points HA and GND, if present.

- Secure the backstop screw with threadlocking compound (e.g. Loctite #222).

6. Perform Head Load Time Check as outlined under Service Checks to ascertain that head load solenoid plunger or bail hinge are not binding.

INDEX LAMP ALIGNMENT

1. Close the disk drive front door.
2. Slightly loosen the two screws which mount the index lamp assembly to the carrier assembly.

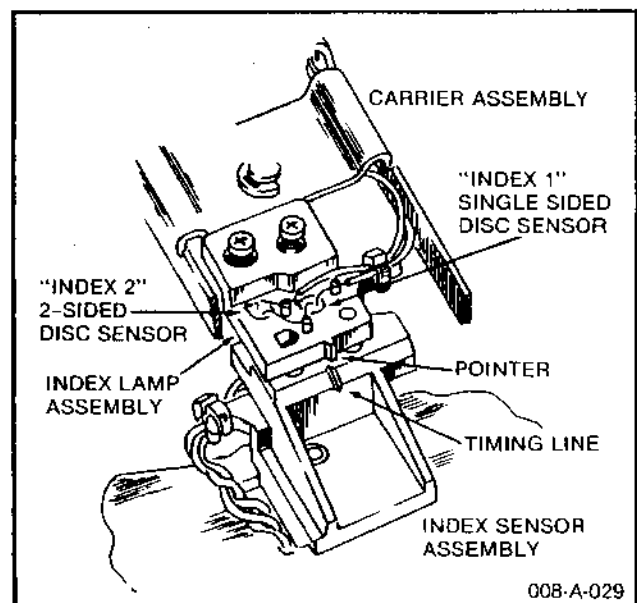

Figure 41. Index Lamp Assembly Positioning

3. Align the pointer on the front of the index lamp assembly exactly with the timing line on the index sensor assembly installed directly below on the main frame.

MAINTENANCE

Tighten the two mounting screws while holding the lamp assembly firmly against the carrier to maintain the alignment.

4. Proceed through Index Lamp and Sensor Alignment Check as outlined under Service Checks.

NOTE

Do NOT change the position of the index sensor assembly; it must remain firmly against the stop on the main frame casting.

STEPPER MOTOR DUST COVER/WIPER ADJUSTMENT

Access to and proper positioning of the stepper motor dust cover and the steel belt wiper are described under Dust Cover and Wiper Removal and Replacement.

HEAD/CARRIAGE ASSEMBLY RADIAL ALIGNMENT

This procedure establishes precise on-track positioning of the R/W heads. It is to be done on track 38 or 40, using a Qume certified two-sided CE alignment disk (QUME P.N. 50236-01 or 50235-02 respectively). The following procedure references track 40.

CAUTION

The head/carriage assembly is factory adjusted and tested and is not field serviceable. Do not, for any reason, attempt to make repairs or internal adjustments on this assembly, or clean the R/W heads. This can cause severe damage to the head surfaces or to the recording media.

1. Remove the pop-up assembly as outlined under Pop-Up Assembly Removal.

2. Place the disk drive on its side to orient it with the screwdriver access slot in the side of the main frame pointing up as shown in the Stepper Motor Pulley Track 40 Alignment illustration below.

3. Move the head/carriage assembly by hand so that the timing hole in the stepper motor pulley lines up precisely above the timing slot in the stepper motor flange. This is "Track 40 Position" and is illustrated below.

In this position the steel belt/carriage clamp screws also will be lined up with the access slot

in the side of the main frame casting.

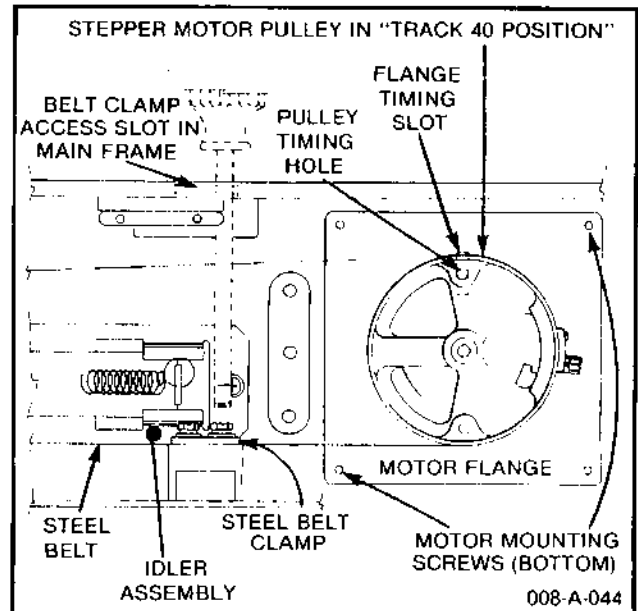

Figure 42. Stepper Motor Pulley Track 40 Alignment

4. If disconnected, restore power connections and power up the disk drive.

5. Connect a temporary jumper across test point pins T40 on the PCB. Verify that the stepper motor pulley remained in "track 40 Position", repeat step 3 above if necessary.

6. Use a dual trace oscilloscope (Tektronix 465 or equivalent) and:

- Connect channel 1 to test point 1A and channel 2 to test point 1B on the disk drive PCB;
- attach the probe ground clips to the ground (GND) test point on the PCB;
- set the vertical deflection for both channels to 50mV/div;
- set both inputs to AC;
- invert channel 2;
- add channel 1 to channel 2;
- set the horizontal sweep to 20ms/div;
- attach an external trigger to test point 3 (INDEX) on the PCB and set the trigger source to external;
- set the trigger coupling to AC and the trigger mode to external.

NOTE

Before using the CE disk, allow a minimum of 30 minutes for the disk to adapt to the ambient temperature in which it is to be used.

"CAT EYES" LOBE PATTERN ON TRACK 40 USING QUME CE DISK

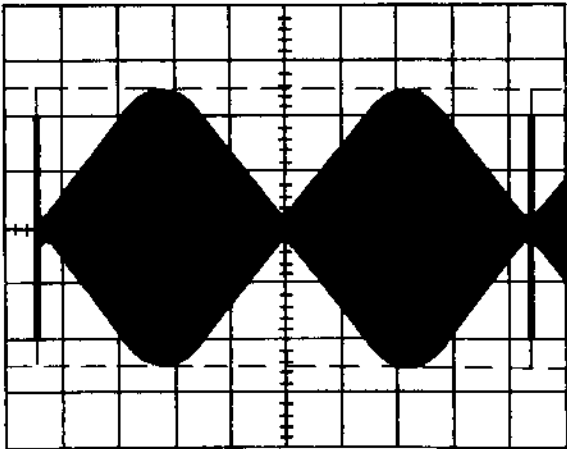

EQUAL AMPLITUDE (EXACTLY ON TRACK 40)

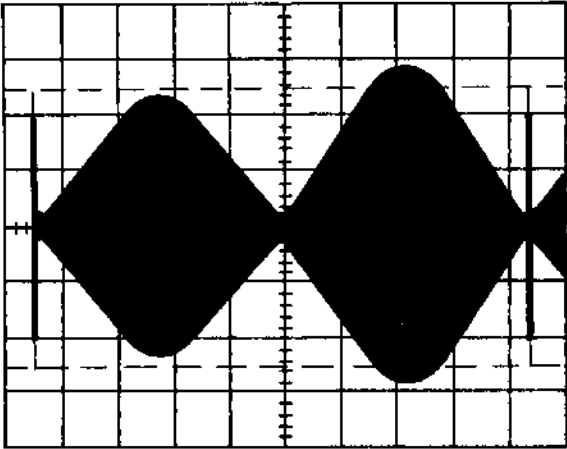

LEFT LOBE IS 80% OF RIGHT LOBE

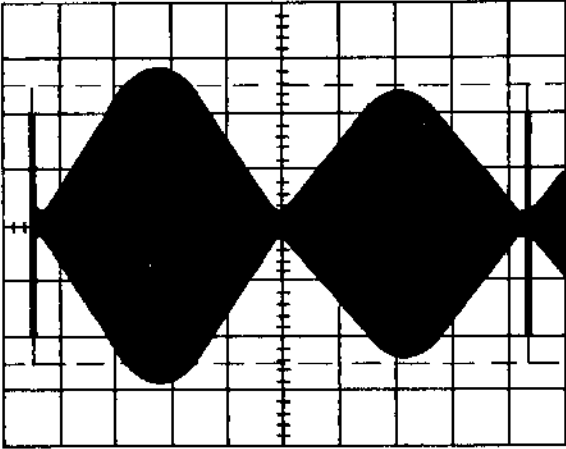

RIGHT LOBE IS 80% OF LEFT LOBE

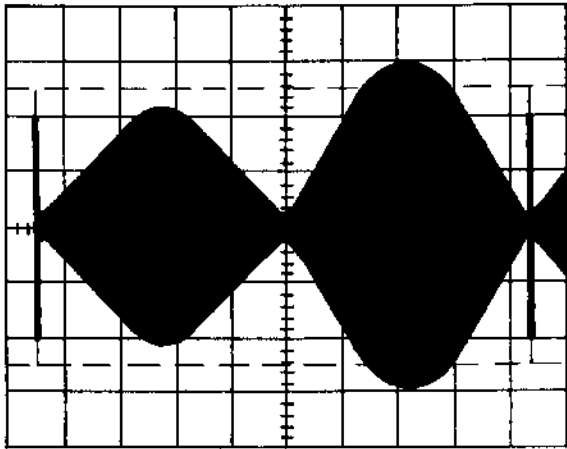

LEFT LOBE IS ABOUT 60% OF RIGHT LOBE

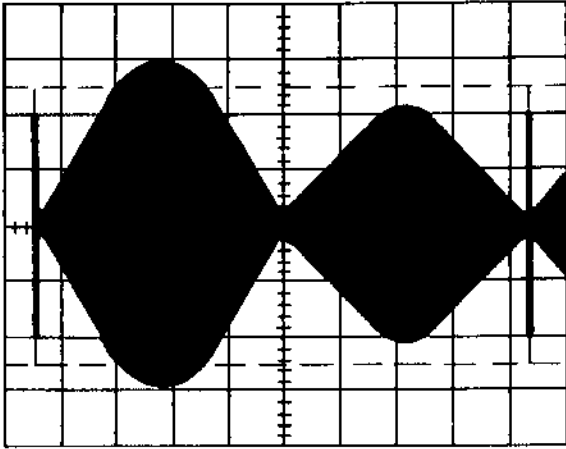

RIGHT LOBE IS ABOUT 60% OF LEFT LOBE

008-A-054

Figure 43. R/W Head Radial Alignment

MAINTENANCE

7. Insert a Qume certified CE alignment disk in the drive and close the drive door.
8. Load the R/W heads onto the CE disk and select a disk side.

CAUTION

Do not record on the CE disk. Recording on the CE disk will render it useless for alignment checks. A write protect notch has been placed in the disk jacket to reduce the possibility of accidental recording.

9. Using the trigger slope level control, synchronize the scope to obtain (from the R/W head of the selected side) the "cat eyes" display shown in the R/W Head Alignment illustration.

The oscilloscope will display two amplitude lobes. The R/W head is correctly aligned when the lobes are equal in amplitude, or at least within 80 percent of each other (refer to the R/W Head Radial Alignment illustration).

10. If the lobes are not within 80 percent of each other, loosen the two screws on the PCB side of the main frame which secure the stepper motor and slowly rotate the stepper motor assembly until the lobes are of equal amplitude.

11. Select the second disk side and note the "cat eyes" amplitude relationship.

12a. By turning the stepper motor assembly and alternately selecting disk sides 0 and 1, balance the radial alignment of the two R/W heads with each other as much as possible **while still remaining within the 80 percent alignment specification for each R/W head.** Balance the left lobe of R/W head 0 with the right lobe of R/W head 1.

12b. If a balanced condition (within the 80 percent specification) between both R/W heads cannot be obtained with the available rotational range of the stepper motor (and **only** under this circumstance), proceed as follows:

- Set the stepper motor to the approximate

center of its rotational adjustment range and tighten the two mounting screws.

- Through the access slot in the side of the main frame casting, slightly loosen the two screws with captive washers which secure clamp plate and steel belt to the head/carriage assembly.

- Very carefully move the head/carriage assembly to balance the radial alignment position of the two R/W heads with each other as well as possible, while still maintaining the 80 percent alignment specification for each R/W head.

- Carefully tighten the two steel belt clamp screws.

- If necessary, again loosen the two stepper motor mounting screws and repeat step 12a above to fine-tune the alignment, before continuing with the steps below.

13. Alternately tighten the two screws securing the stepper motor assembly to the main frame a little at a time to maintain the R/W head alignment.

14. Remove the temporary jumper from across test point pins T40 on the PCB.

15. To check the accuracy of the alignment, step to track 39 and back to track 40, and then step to track 41 and back to track 40.

Note the difference in "cat eyes" amplitudes which may result when approaching track 40 from either direction.

If the 80 percent specification is exceeded by either R/W head in either direction, loosen the stepper motor mounting screws again and optimize the offset. In this case steps 12 and 13 above, followed by step 15, must be repeated.

16. Unload the R/W heads from the disk.

17. Remove the CE disk from the drive.

18. Disconnect the oscilloscope from the disk drive.

19. Install the pop-up assembly as outlined under Pop-Up Assembly Replacement; perform Pop-Up Assembly Adjustment check.

TROUBLESHOOTING

GENERAL

This section presents troubleshooting procedures for the QumeTrak 842 Disk Drive. Aside from some application related preconditions and a few functional prerequisites, troubleshooting a QumeTrak 842 is limited to tracking down the cause of one of the following basic malfunctions. Not Ready, Seek Error, Read Error, Write Error, No Head Load. Troubleshooting of these malfunctions is presented in flowchart format. Reference by title is made in the flowcharts wherever one of the Service Checks or Adjustments sub-routines applies.

DEFINITION OF MALFUNCTION TERMS

1. **NOT READY** – the controller does not receive an expected READY signal from the disk drive.
2. **SEEK ERROR** – the disk drive is unable to access a designated disk side or track, or to confirm Track 00 access to the controller.
3. **READ ERROR** – the disk drive unit is unable to recover properly data previously stored on a disk.
4. **WRITE ERROR** – the disk drive unit is unable to record properly a data sequence on the disk.
5. **NO HEAD LOAD** – the R/W heads are not loaded against the disk surface when required.

PREREQUISITE CHECKS

1. Eliminate the possibility of the disk being the cause of malfunction:
 - Verify that the malfunction at hand is not caused by a disk incompatible with the overall system;
 - verify that the disk is inserted into the drive facing the right way, i.e. with the label on the disk jacket facing toward the front door (facing away from the In Use LED on the front panel);
 - use another disk known to have good data recorded on it to determine whether a “soft” or a “hard” error has occurred:

“Soft” disk errors are temporary (or recoverable) reading errors. They are typically caused by contamination of the disk surface picked up in use and handling. Repeated scanning of the disk surface with R/W heads loaded to it might cure the

situation but may also be detrimental to head performance.

“Hard” disk errors are permanent (or non-recoverable) in nature. They are typically caused by particles in excess of head gap size, or by microscopic voids or pits in the disk surface, resulting in error pulses or glitches in the recorded data. A soft error, when occurring during a write cycle will cause a recorded hard error.

2. The most efficient way to find out whether a malfunction is caused by a defective drive is to exchange a suspect unit with one known to be in good working order. If a compatible exchange QumeTrak 842 Disk Drive is available, its internal jumper status should be checked for proper system configuration. To verify and establish jumper compatibility, compare exchange and suspect drive PCB's and refer to tables: Factory Configuration of Option Traces, Programmable Shunt Trace Functions, Drive Select Options, and Head Select Options, in this manual.

3. Verify that external connectors J1/P1 and J5/P5, as well as associated cables are drive compatible, in good working order, and firmly attached at both ends.

4. Perform AC and DC power measurements as outlined under Power Test below.

TROUBLESHOOTING PRECONDITIONS

All information and particularly the QumeTrak 842 flow charts presented in this Troubleshooting Section are based on “Factory Configuration” of the QumeTrak 842 unit as listed under Customer Strappable Options in this manual, unless specifically stated otherwise.

When troubleshooting, identify the programmable functions status of the defective drive unit by comparing the drive's PCB jumpers to jumper tables: Factory Configuration of Option Traces, Programmable Shunt Trace Functions, Drive Select Options, and Head Select Options. Also, refer to the illustration PCB Jumper Locations, Test Point & Connector Pin Assignments for rapid identification of PCB locations. Deviation from “Factory Configuration” may in some cases result in drive performance significantly different from that stated in the troubleshooting flow diagrams.

MAINTENANCE

For troubleshooting the disk drive unit must be fully energized, with its PCB and drive mechanisms accessible. A pre-recorded disk with known good system data and/or a Qume CE alignment disk (QUME P.N. 50235-02 or 50236-01) is required.

POWER TEST

1. Check for presence of AC power at connector J0, across pins 1 and 3. AC potentials and tolerances are stated in table Installation Requirements in the Installation section. Refer to illustration PCB Jumper Locations, Test Points and Connector Pin Assignments.

2. Check DC potentials as listed below (use

multimeter and scope as required). To locate measurement points, refer to illustration PCB Jumper Locations, Test Points and Connector Pin Assignments.

J5, pin 1 to GND on the PCB : +24V \pm 10%; max. ripple 0.1V P/P;

J5, pin 5 to GND on the PCB : +5V \pm 5%; max. ripple 0.05V P/P;

TP + 17 to GND on the PCB : + 16.40V to + 17.60V;

TP + 12 to GND on the PCB : + 11.4V to + 12.6V;

TP + 6 to GND on the PCB : + 5.48V to 5.82V.

TROUBLESHOOTING FLOW CHARTS

These Troubleshooting Flow Charts begin on the Following pages:

Fig. 44 Power Failure page 53

Fig. 47 Read Error page 59

Fig. 45 Not Ready page 54

Fig. 48 Write Error page 62

Fig. 46 Seek Error page 56

Fig. 49 No Head Load page 65

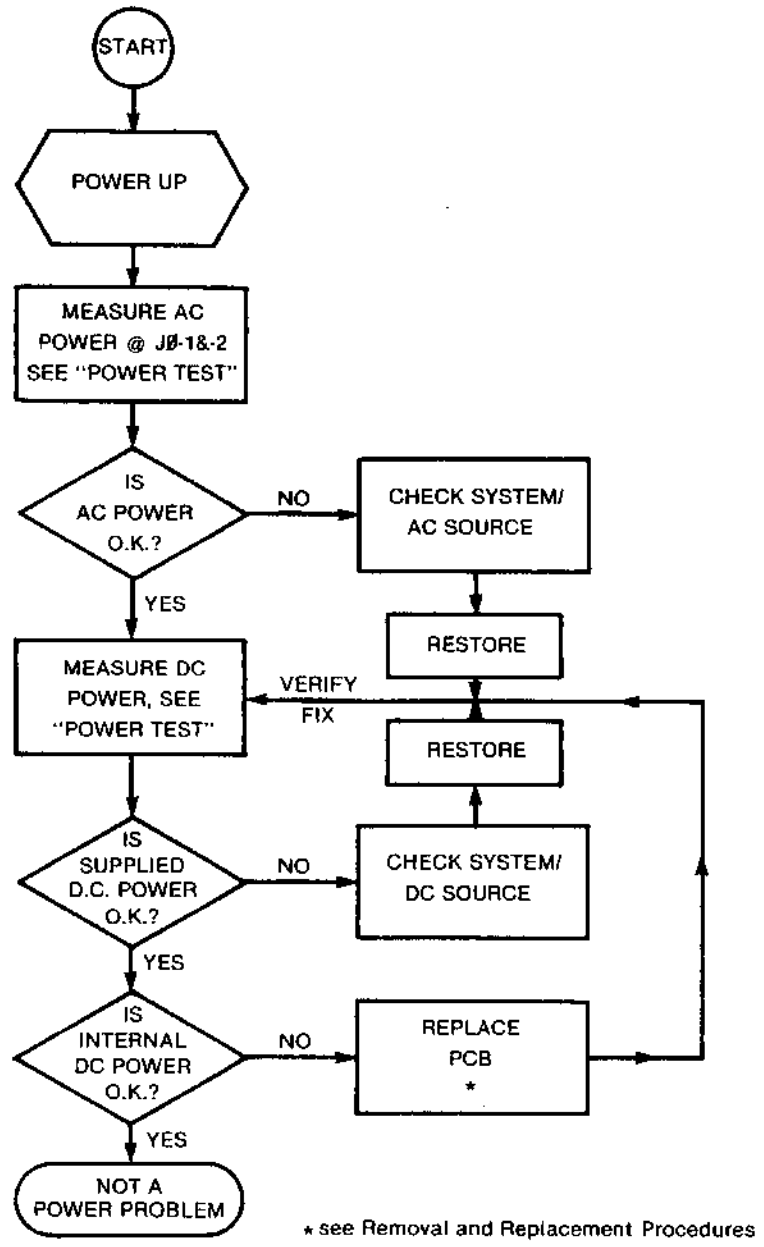
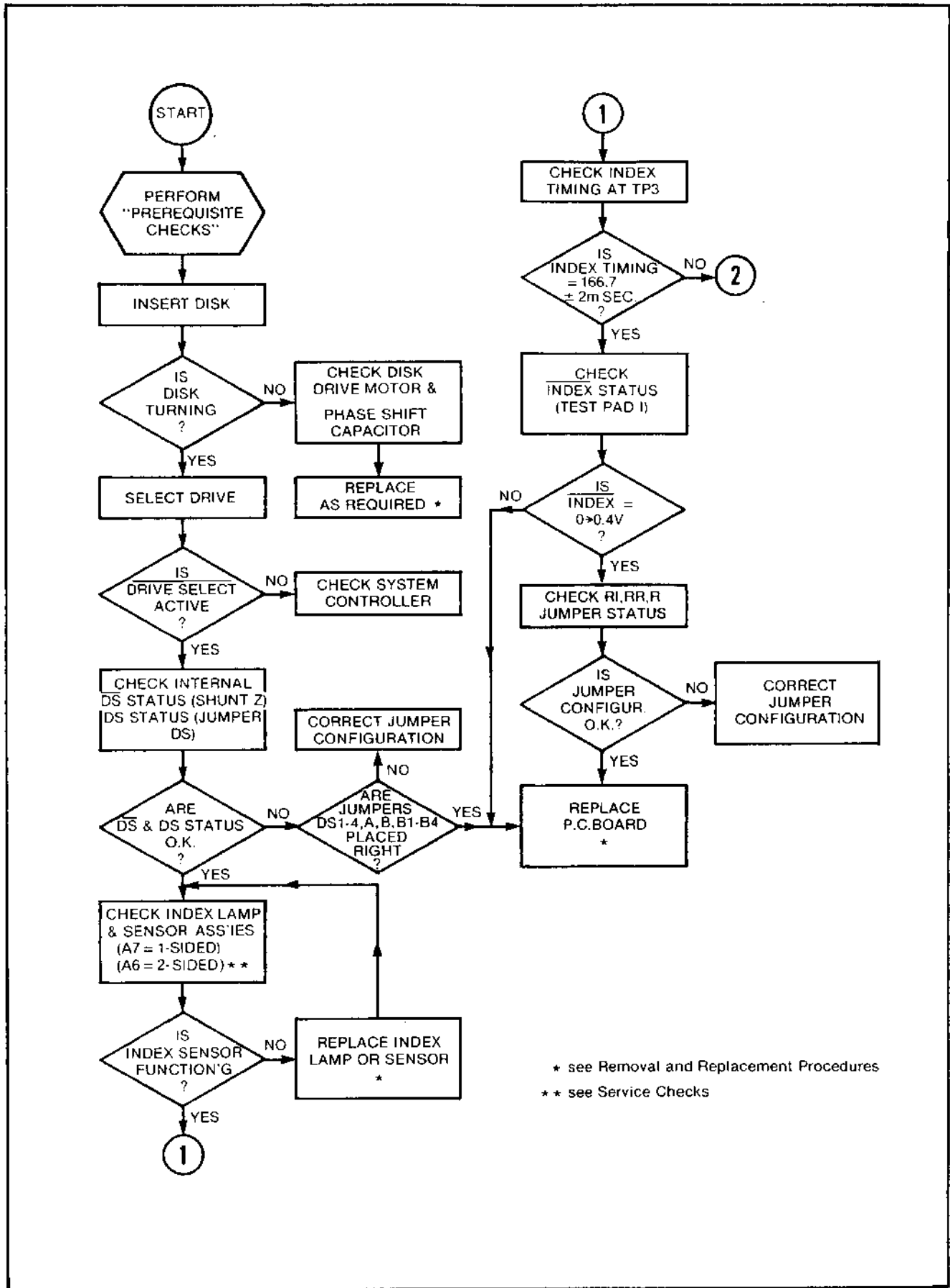

Figure 44. Power Failure Troubleshooting Routine



* see Removal and Replacement Procedures
 ** see Service Checks

Figure 45. Not Ready Troubleshooting Routine

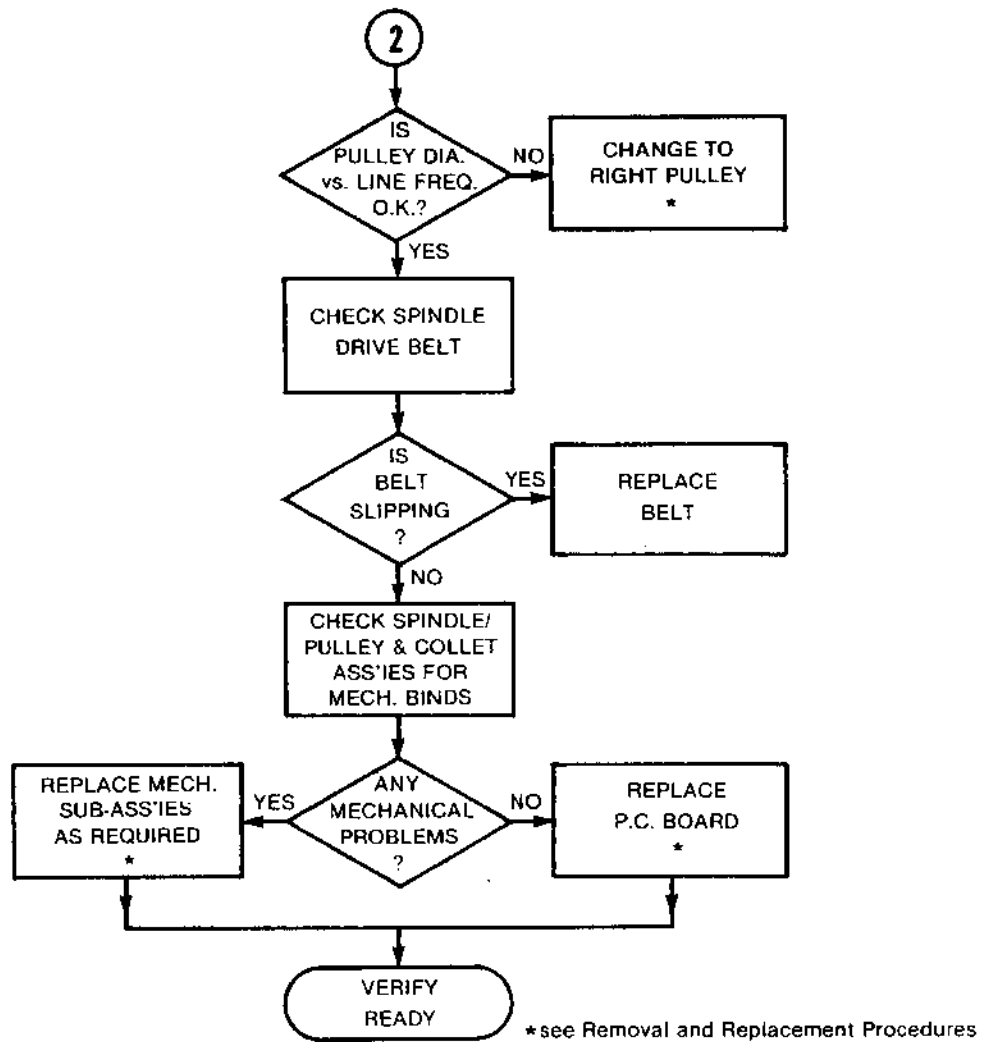

Figure 45. (continued)

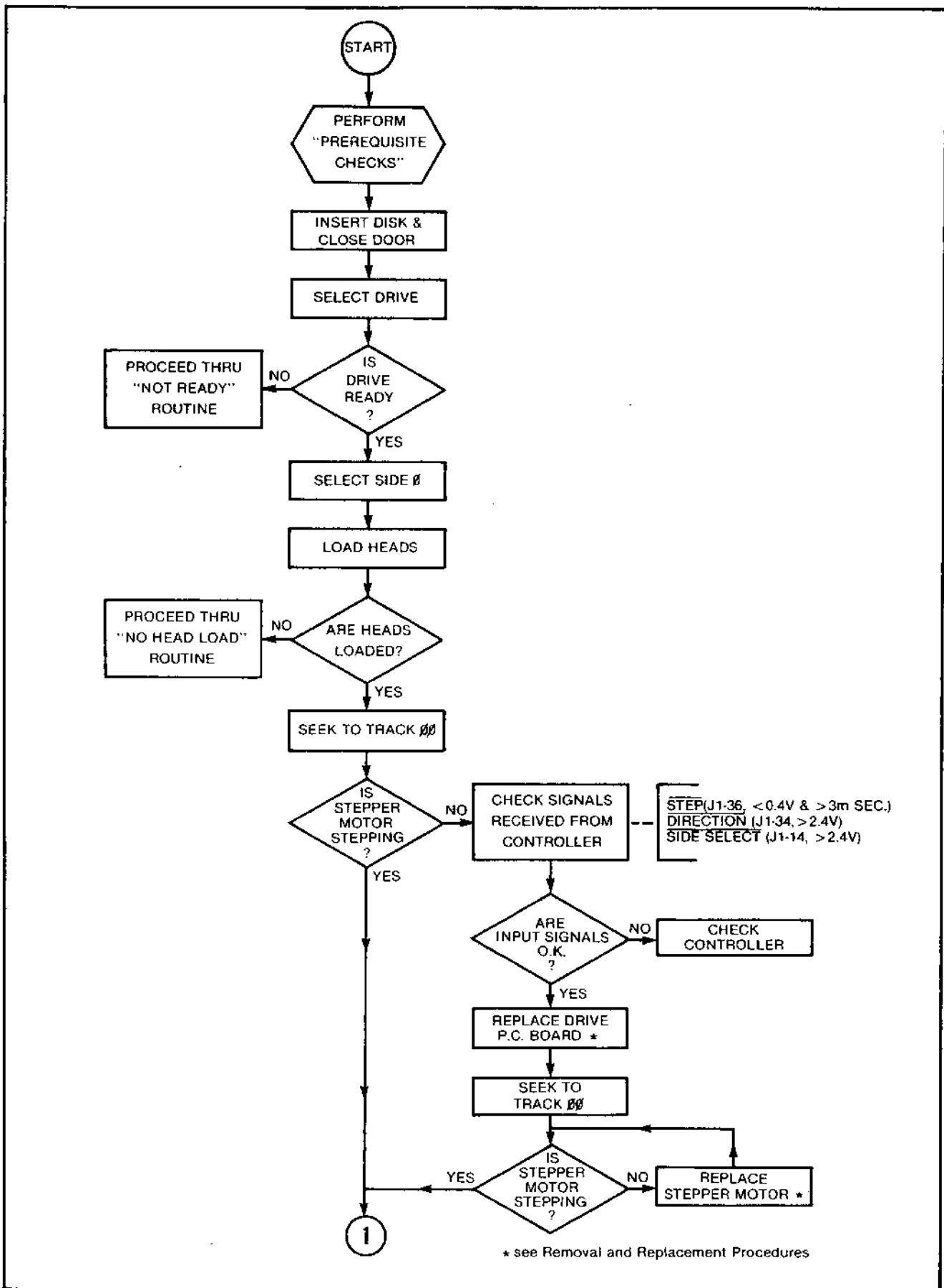

Figure 46. Seek Error Troubleshooting Routine

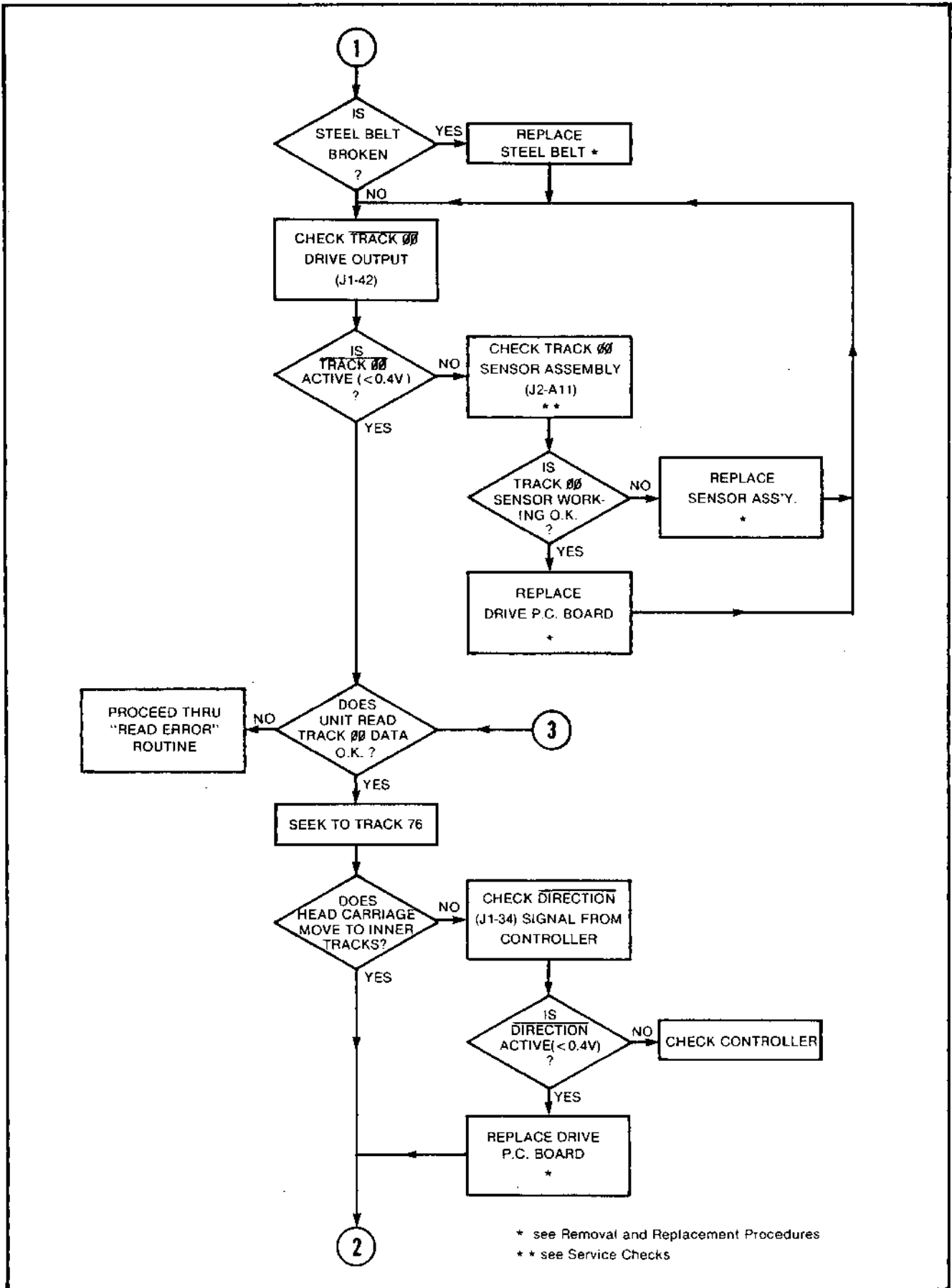
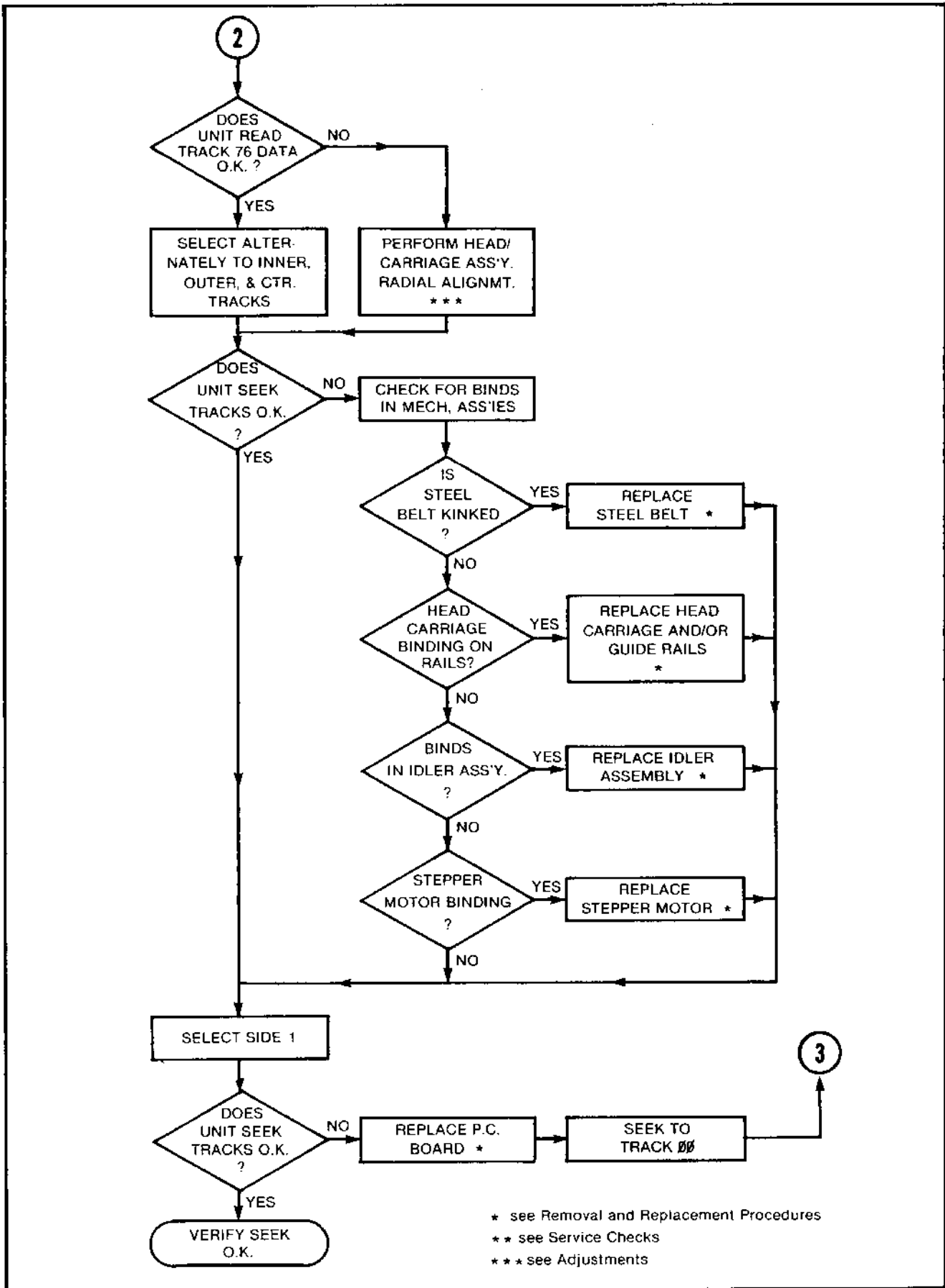
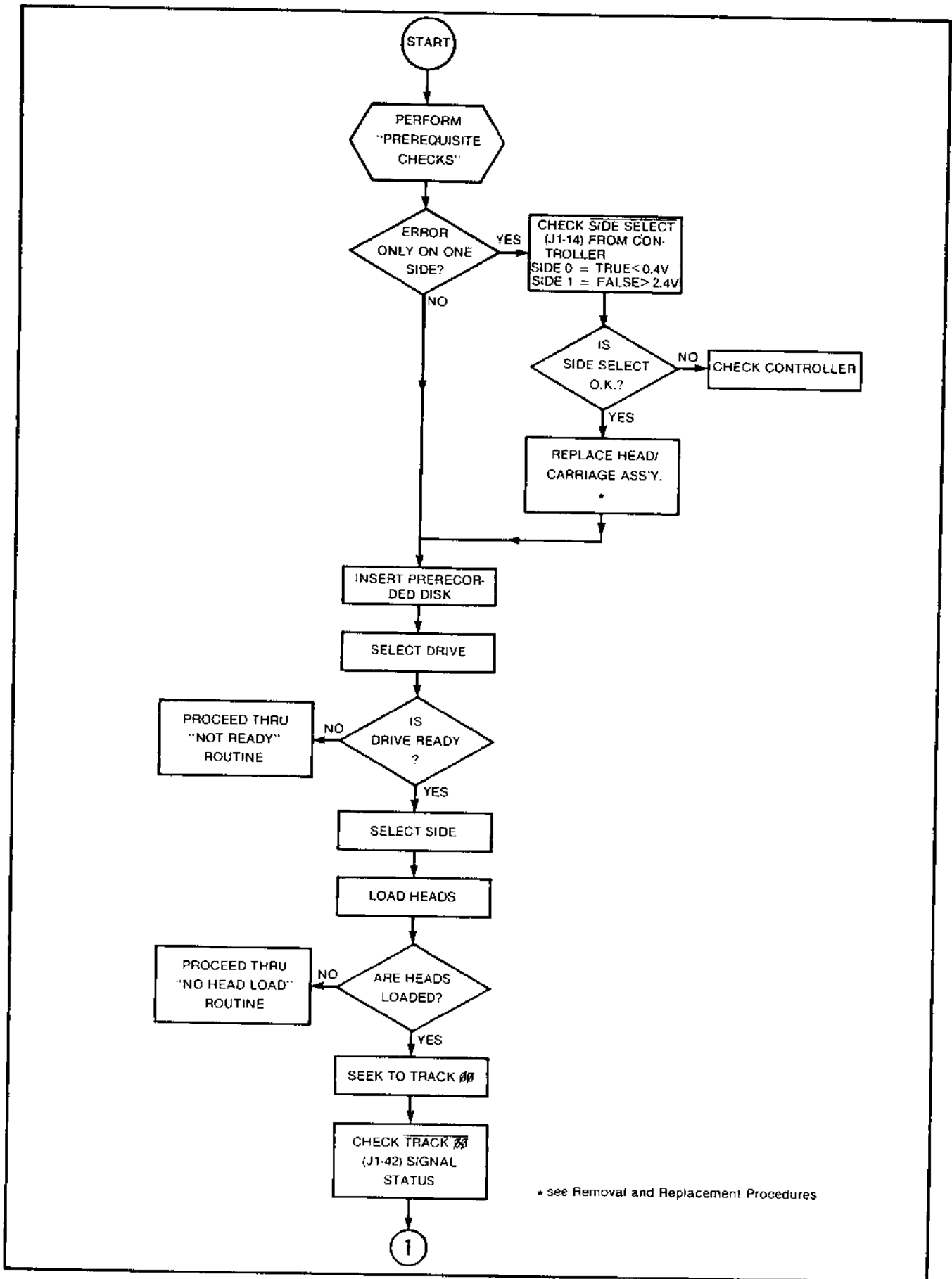

Figure 46. (continued)



* see Removal and Replacement Procedures
 ** see Service Checks
 *** see Adjustments

Figure 46. (continued)



* see Removal and Replacement Procedures

Figure 47. Read Error Troubleshooting Routine

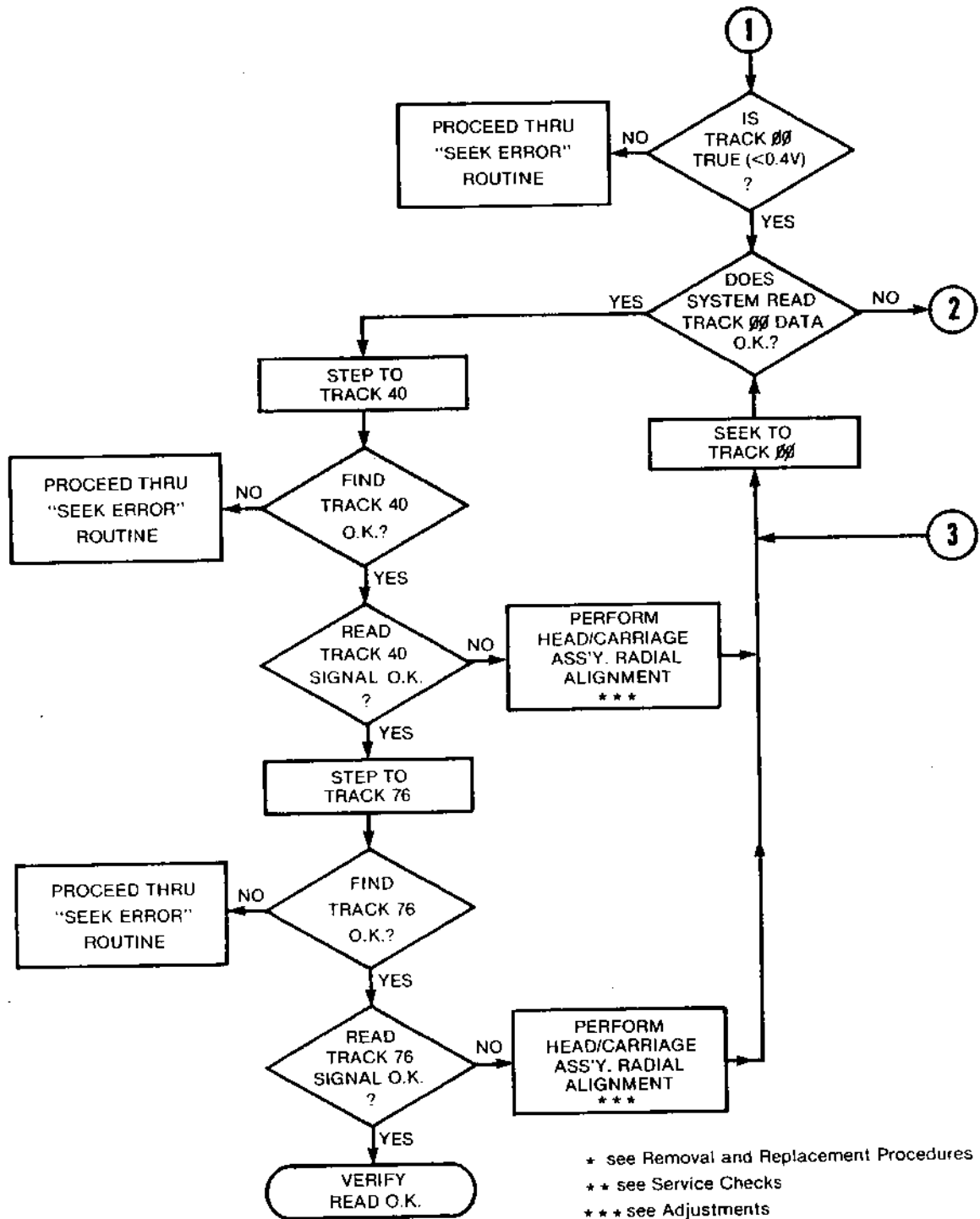
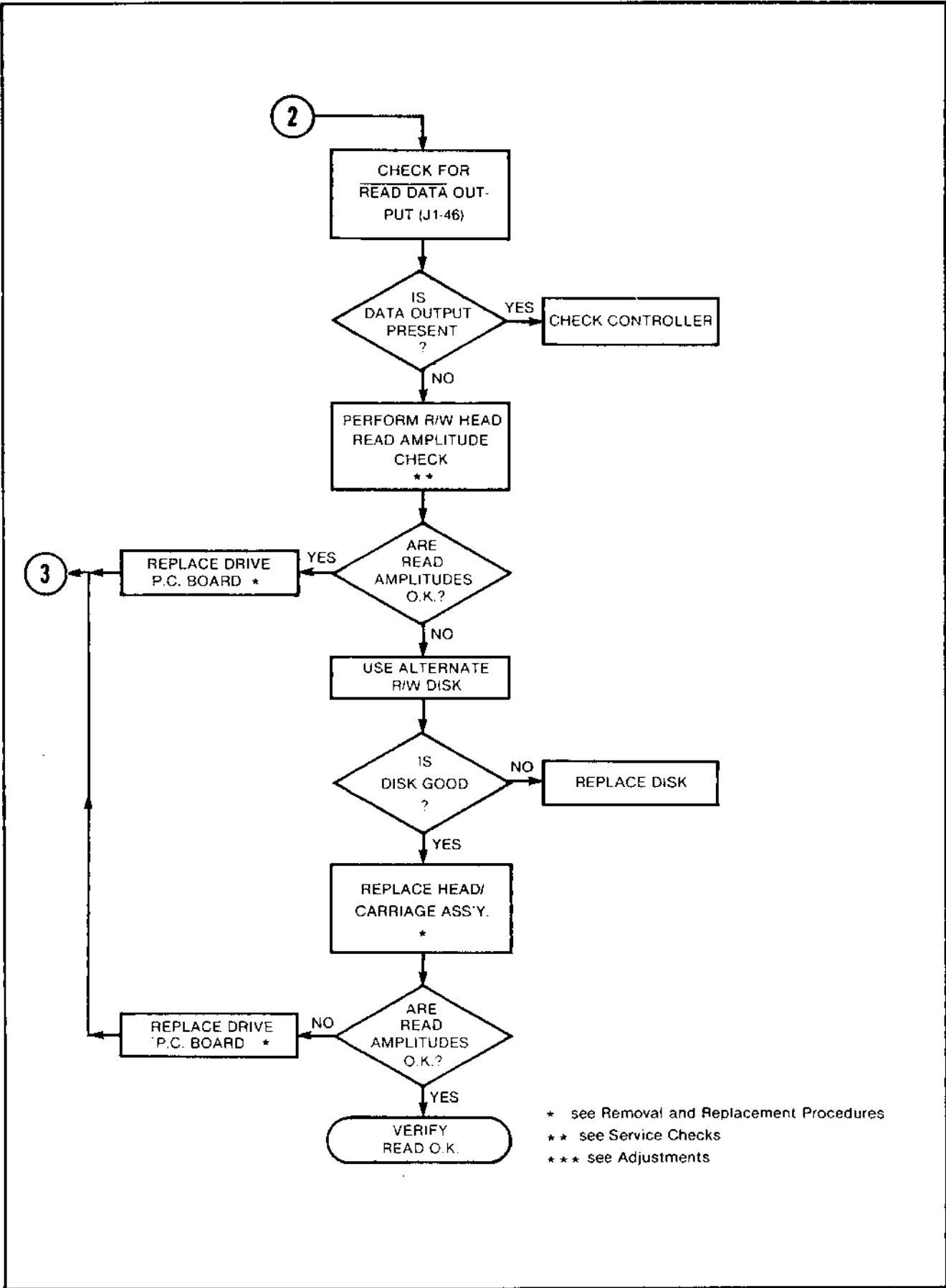

Figure 47. (continued)



* see Removal and Replacement Procedures
** see Service Checks
*** see Adjustments

Figure 47. (continued)

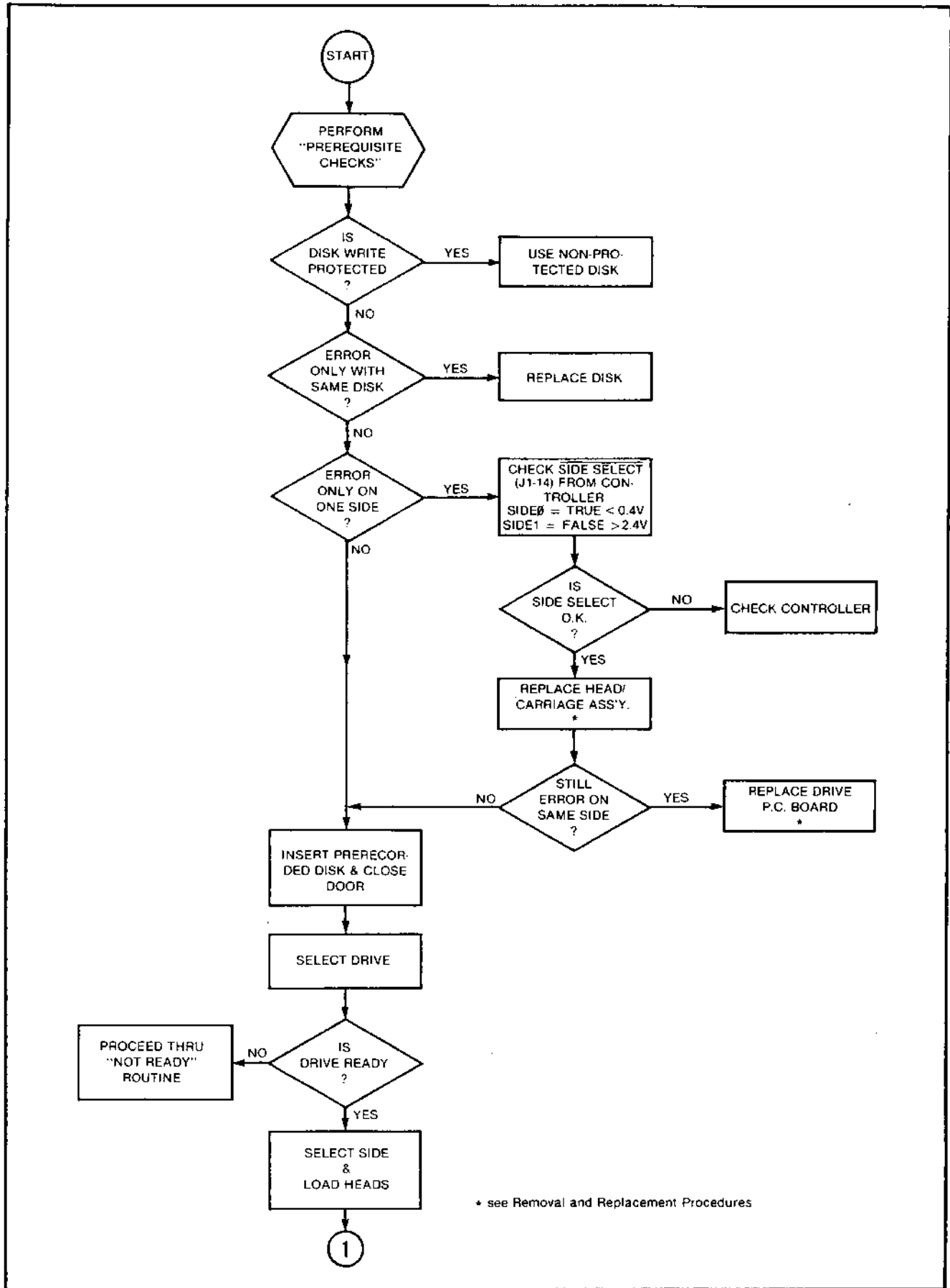

Figure 48. Write Error Troubleshooting Routine

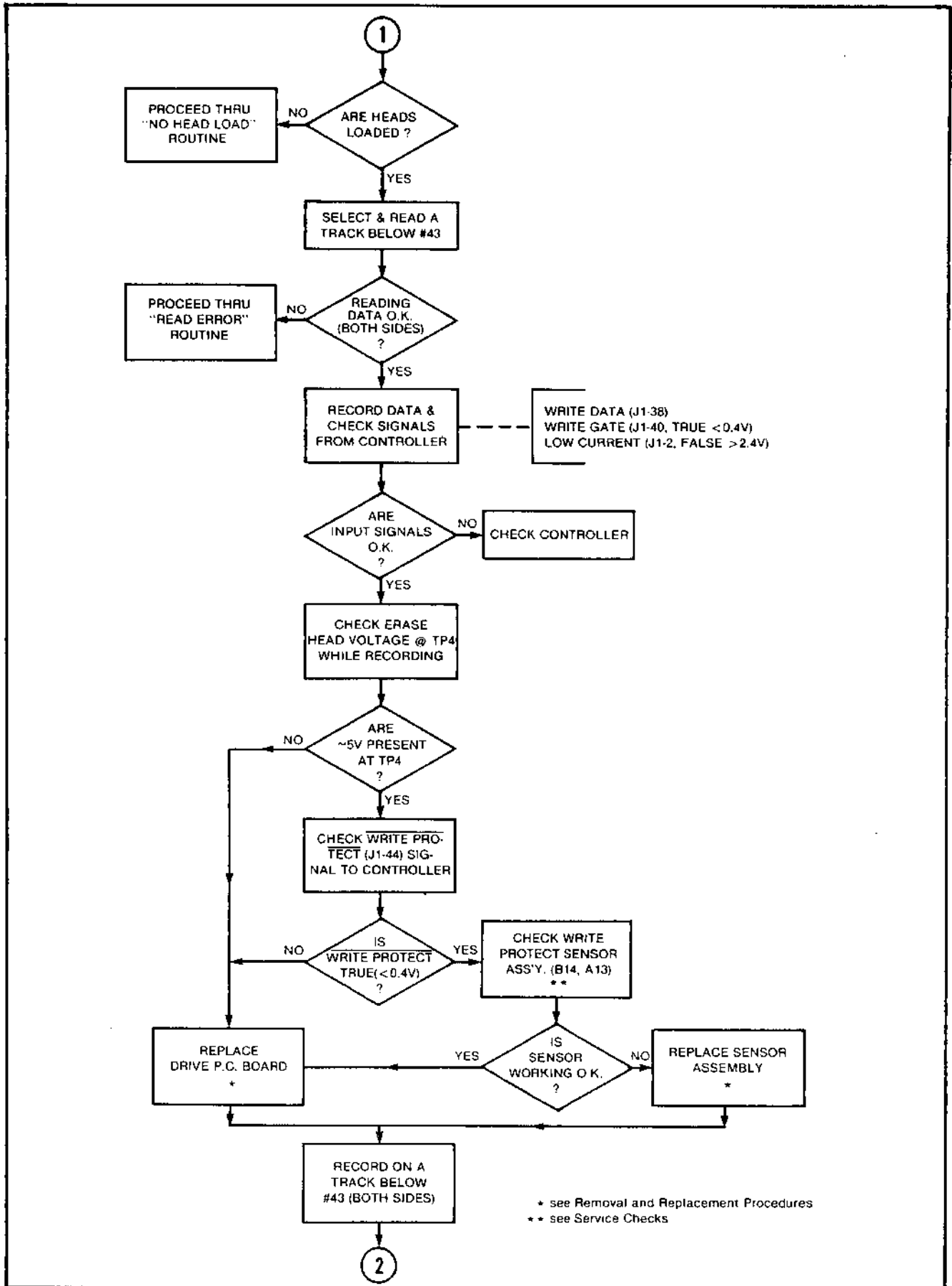

Figure 48. (continued)

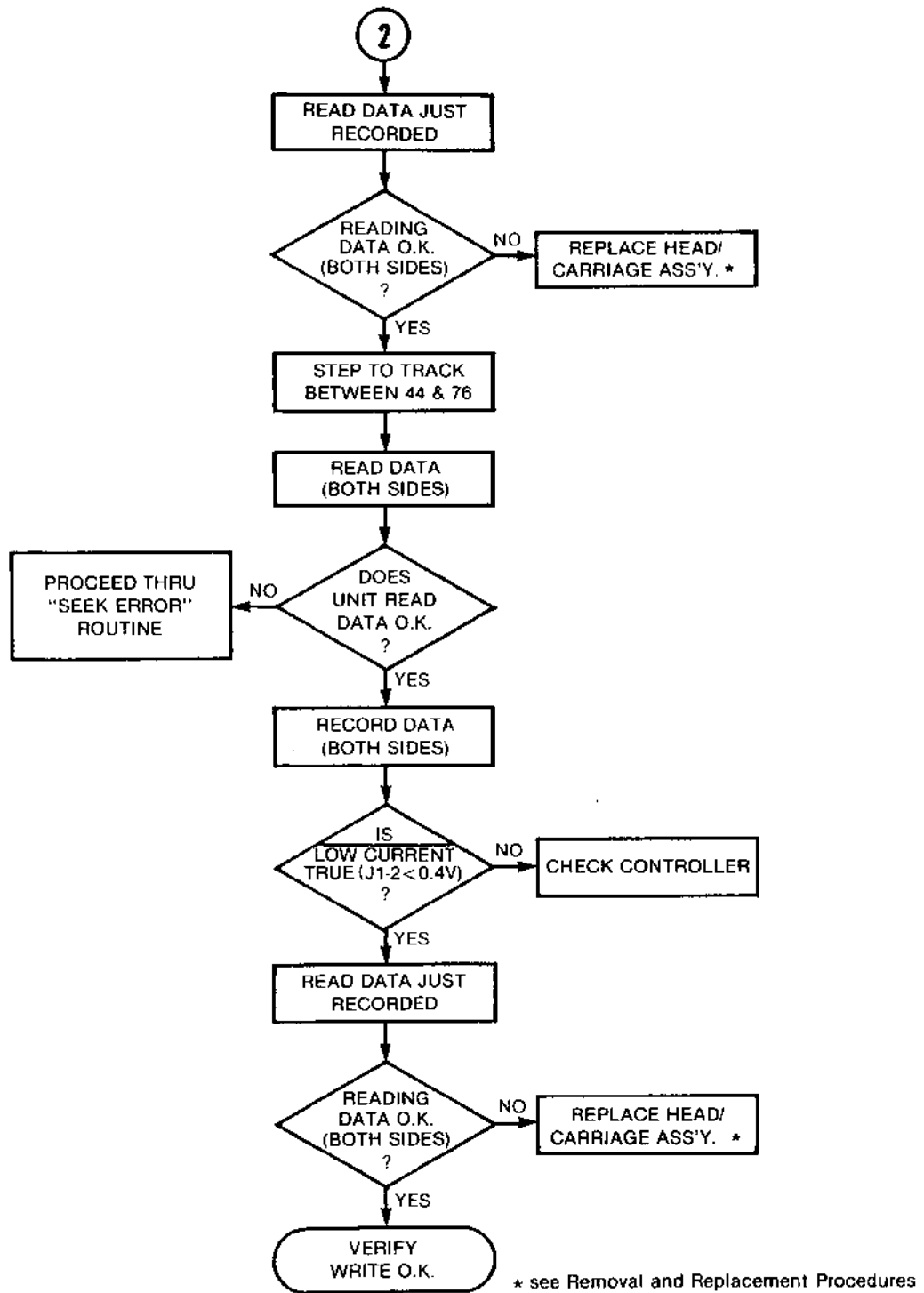

Figure 48. (continued)

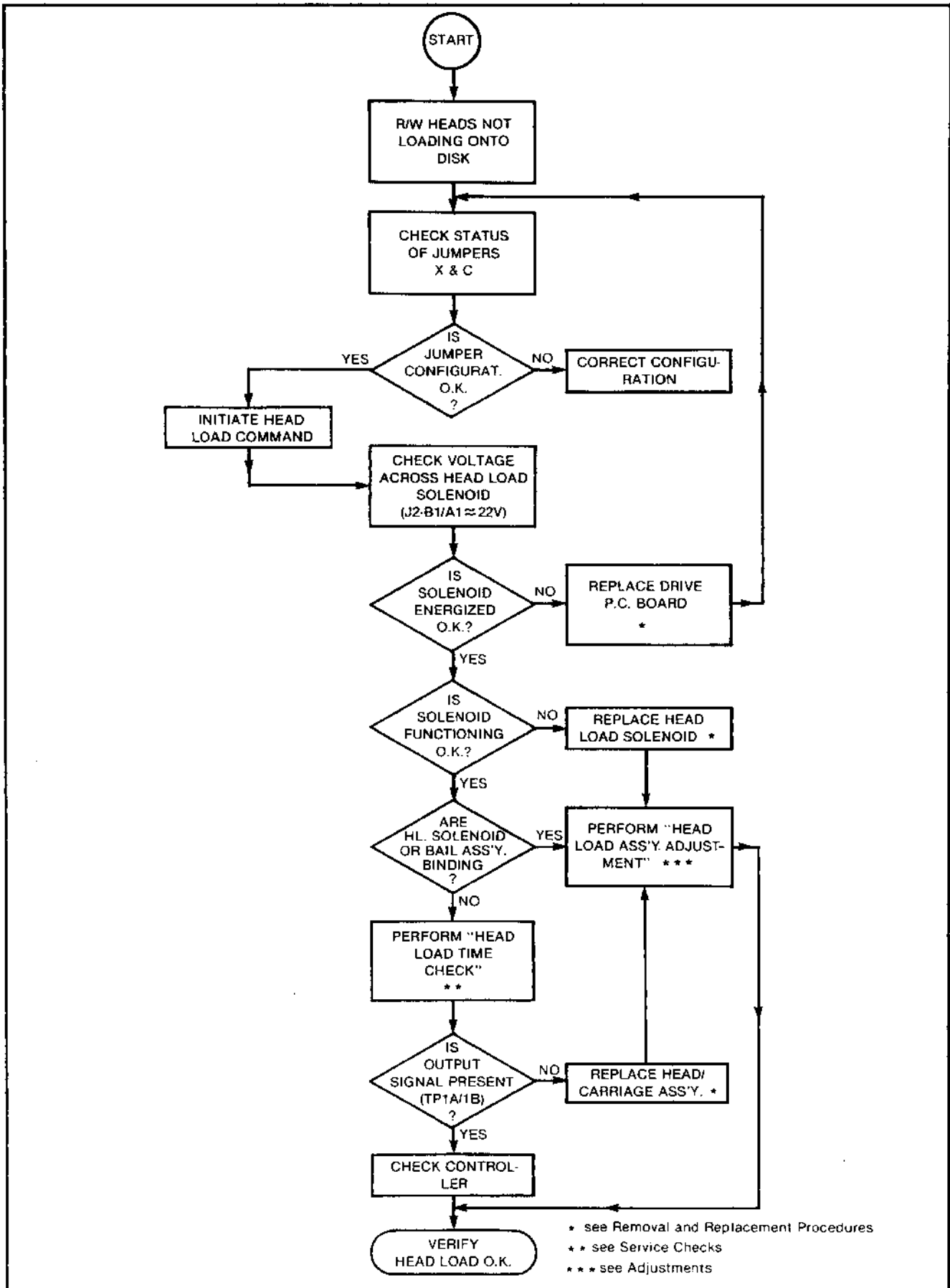

Figure 49. No Head Load Troubleshooting Routine

RECOMMENDED SPARE PARTS

Listed in the tables below are parts and subassemblies of the QumeTrak 842 disk drive. All items are identified by Qume part numbers and the quantities shown are recommended to support a given quantity of disk drives. Description and locations of all listed items may be found on the illustrated Parts Locations drawings (6 sheets)

in the Diagrams section.

The Qume Memory Products Service and Spares Catalog, publication number 37032, contains a complete list of all replaceable QumeTrak 842 parts as well as prices and terms for parts and repairs. It also states basic Qume service policy.

Table 20
Recommended Spare Parts - Field Level

DESCRIPTION	P/N	NUMBER OF DISK DRIVES				
		50	100	250	500	1000
		NUMBER OF SPARE PARTS				
IN USE LED	50096-01	1	2	3	5	8
WRITE PROTECT SENSOR	50007-01	1	2	3	5	8
TRACK 00 SENSOR	50006-01	1	2	3	5	8
INDEX SENSOR	50008-01	1	2	3	5	8
INDEX LAMP	50061-01	1	2	3	5	8
DRIVE BELT	50025-01	1	1	3	4	6
WIPER	50036-01	1	2	2	5	8
PCB ASSEMBLY	50147-01	1	1	3	5	8
HEAD/CARRIAGE ASSEMBLY	50011-02	1	2	2	4	8
STEEL BELT	50028-01	0	0	1	3	6
STEPPER MOTOR	50009-01	1	2	2	3	4

Table 21
Recommended Spare Parts - Depot Level

DESCRIPTION	P/N	NUMBER OF DISK DRIVES				
		50	100	250	500	1000
		NUMBER OF SPARE PARTS				
IN USE LED	50096-01	1	2	3	5	8
WRITE PROTECT SENSOR	50007-01	0	0	1	2	2
TRACK 00 SENSOR	50006-01	0	0	4	6	8
INDEX SENSOR	50008-01	0	0	2	3	4
INDEX LAMP	50061-01	1	2	3	5	8
DRIVE BELT	50025-01	0	0	1	2	2
PCB ASSEMBLY	50147-01	0	0	5	8	12
HEAD/CARRIAGE ASSEMBLY	50011-02	0	0	4	8	12
STEEL BELT	50028-01	0	0	3	5	7
STEPPER MOTOR	50009-01	0	0	2	4	6
POP-UP ASSEMBLY	50018-01	0	0	0	1	2
BAIL ASSEMBLY	50014-02	0	0	0	1	2
HEAD LOAD SOLENOID ASSEMBLY	50012-03	0	0	0	1	2
HOOK ASSEMBLY	50094-01	0	0	0	1	2
DOOR LOCK SOLENOID	50091-01	0	0	0	1	2
MOTOR PULLEY-50 HZ (ID GROOVE)	50020-01	0	0	0	1	2
MOTOR PULLEY-60 HZ (NO GROOVE)	50020-02	0	0	0	1	2
DRIVE MOTOR (AC) 115 V	50004-01	0	0	0	1	2
DRIVE MOTOR (AC) 230 V	50004-03	0	0	0	1	2
FRONT PANEL ASSEMBLY (WHITE)	50019-01	0	0	0	1	2
FRONT PANEL ASSEMBLY (BLACK)	50019-02	0	0	0	1	2
COLLET ASSEMBLY	50060-01	0	0	0	1	2
IDLER ASSEMBLY	50010-01	0	0	1	2	4
CARRIER ASSEMBLY	50013-02	0	0	1	1	1
PROGRAMMABLE SHUNT	55089-08	0	1	3	5	10

DIAGRAMS

The Illustrated Parts Locations drawings in this subsection show name and location of each disk drive subassembly as mentioned throughout this manual.

The Block Diagram illustrates the major circuit

functions and their interaction within the disk drive unit for quick maintenance reference.

A complete set of Typical Schematic Diagrams of the disk drive's electronic circuitry concludes this manual.

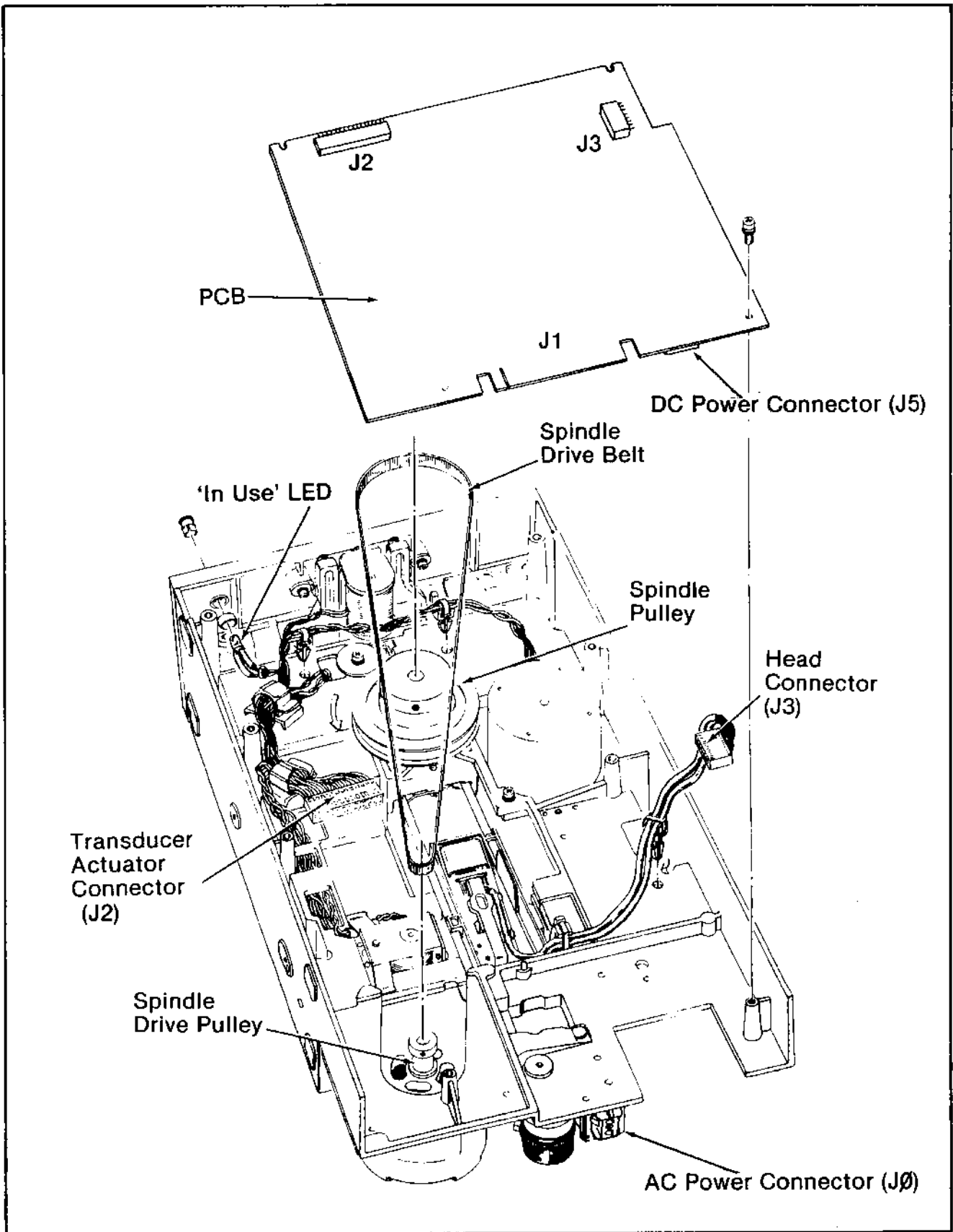

Figure 50a. Illustrated Parts Locations

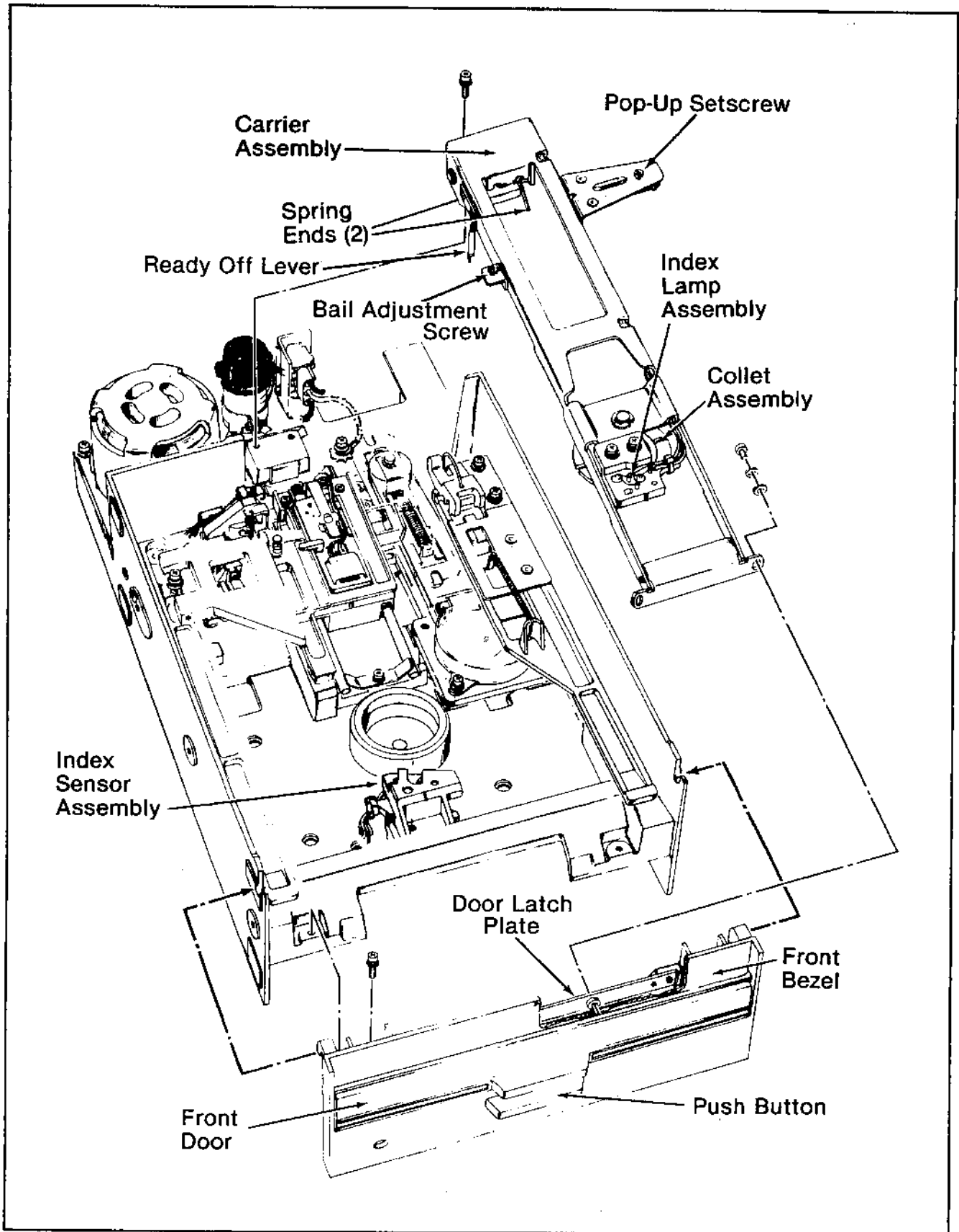

Figure 50b. Illustrated Parts Locations

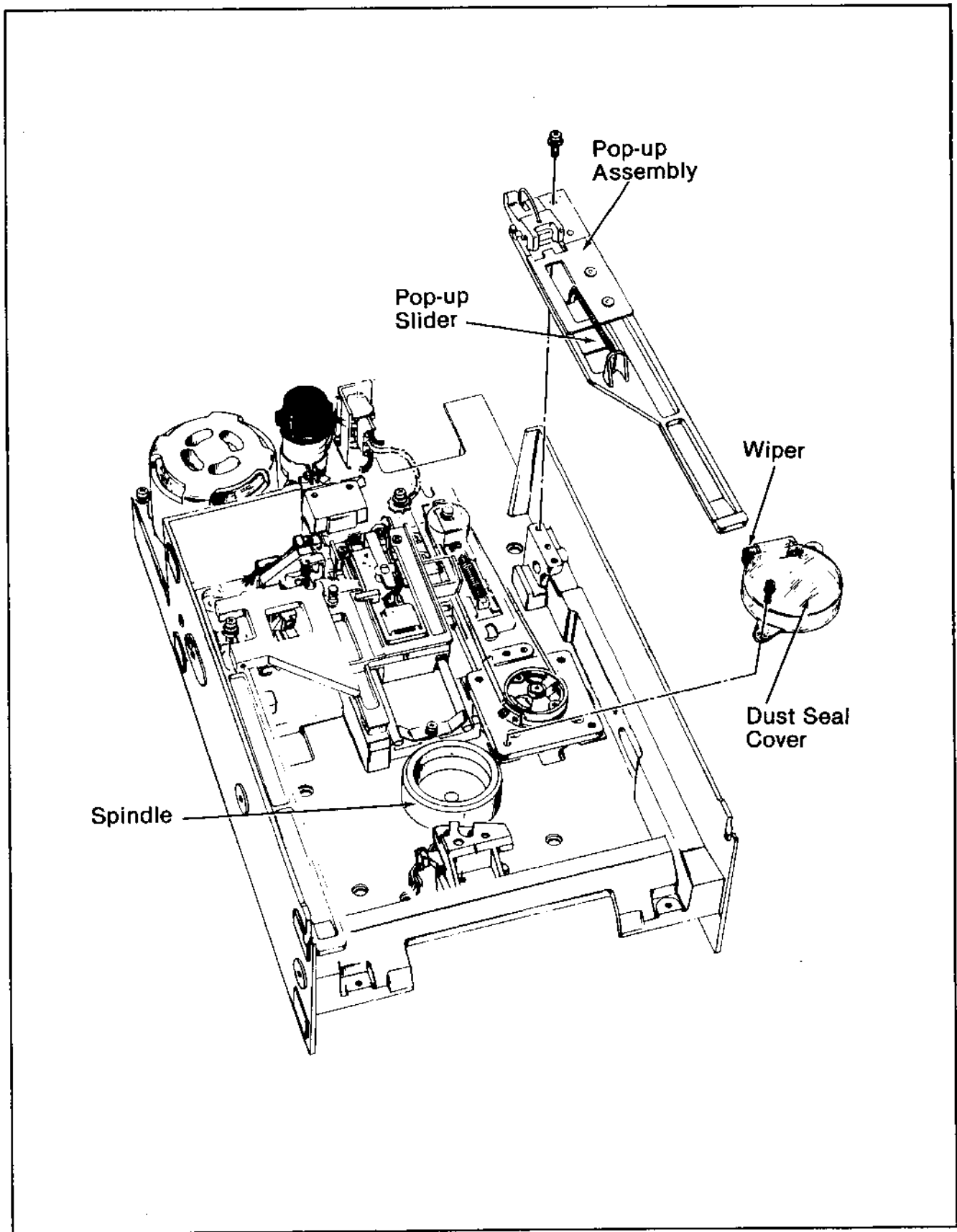

Figure 50c. Illustrated Parts Locations

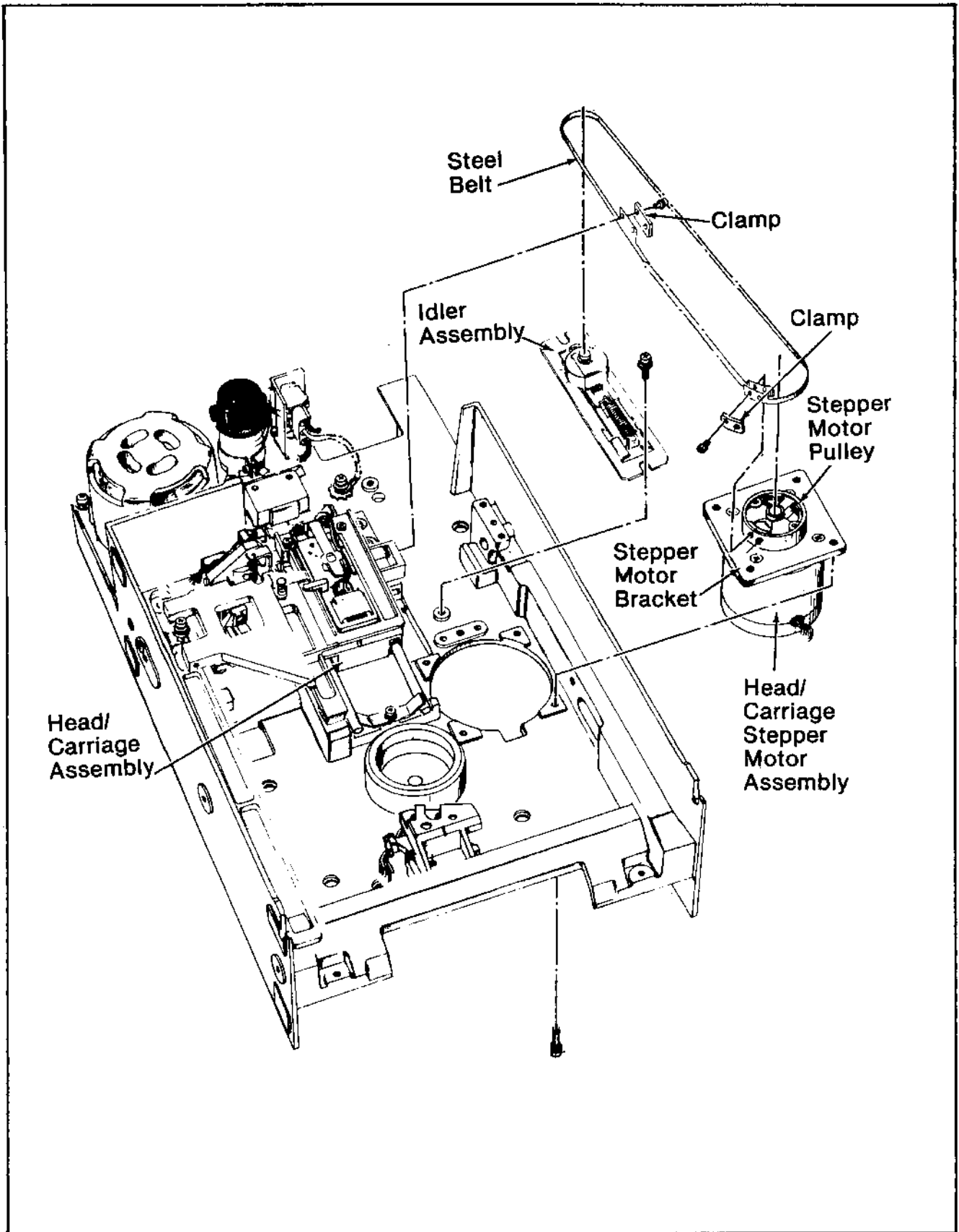

Figure 50d. Illustrated Parts Locations

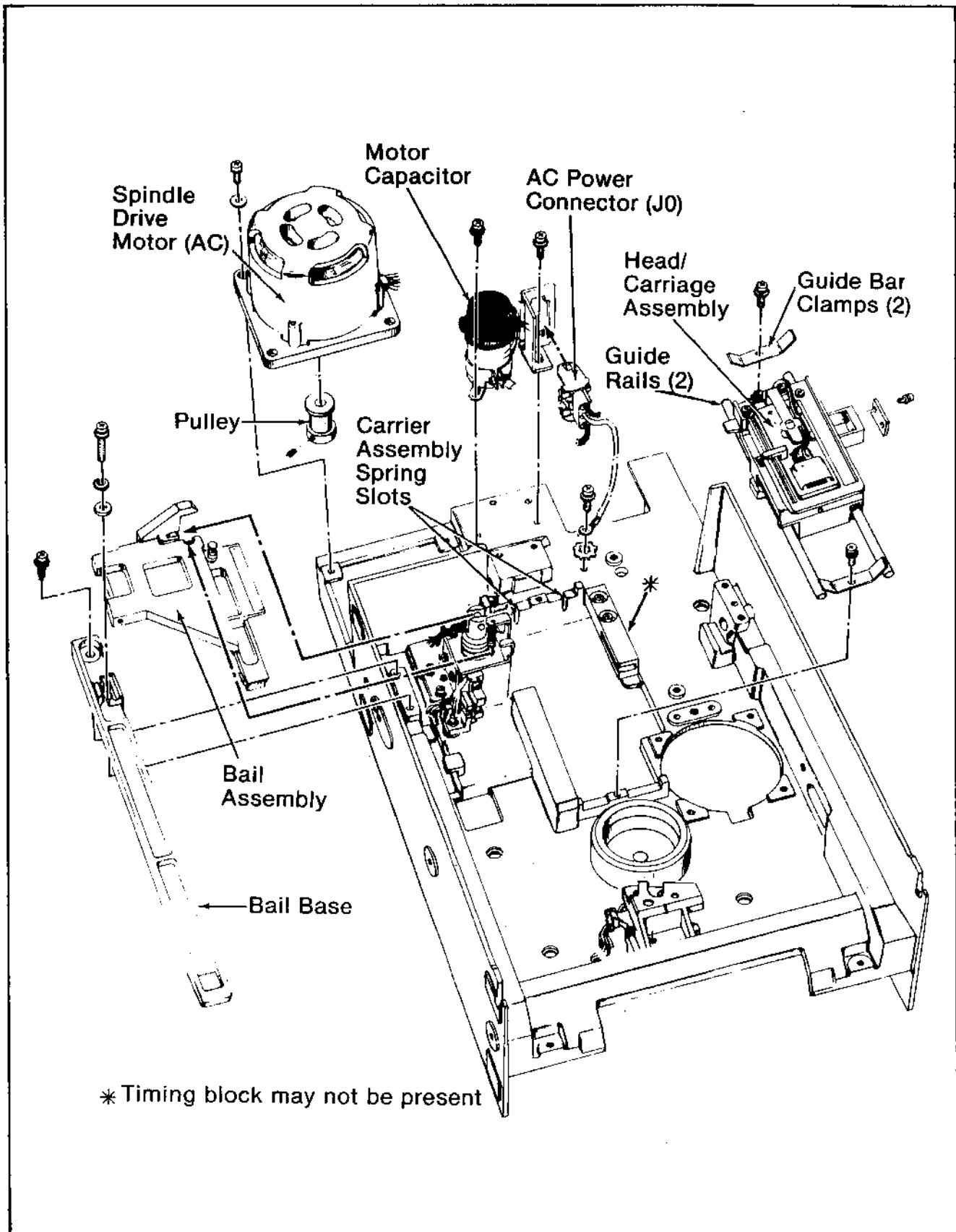

Figure 50e. Illustrated Parts Locations

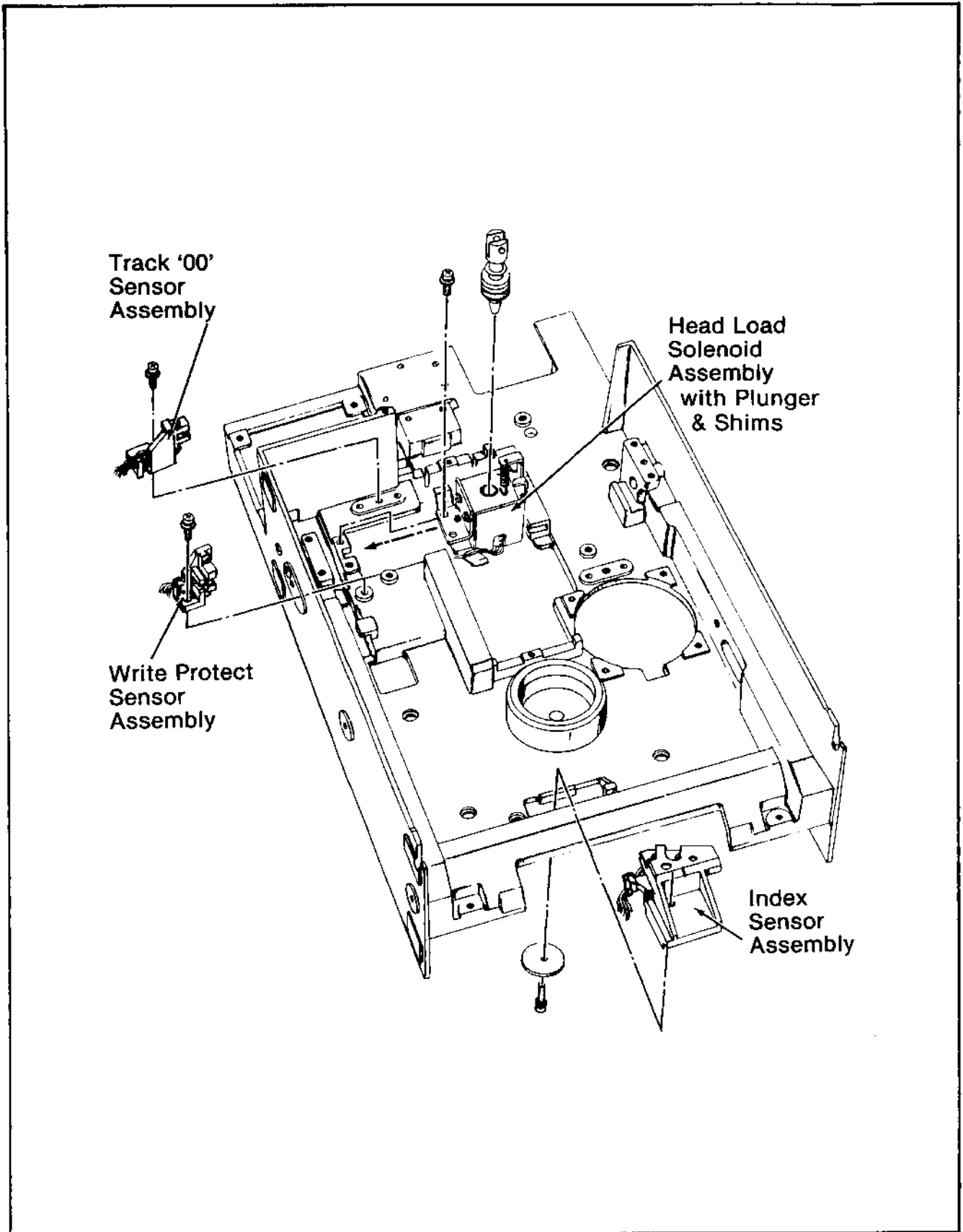

Figure 50f. Illustrated Parts Locations

Figure 51. QumeTrak 842 Block Diagram

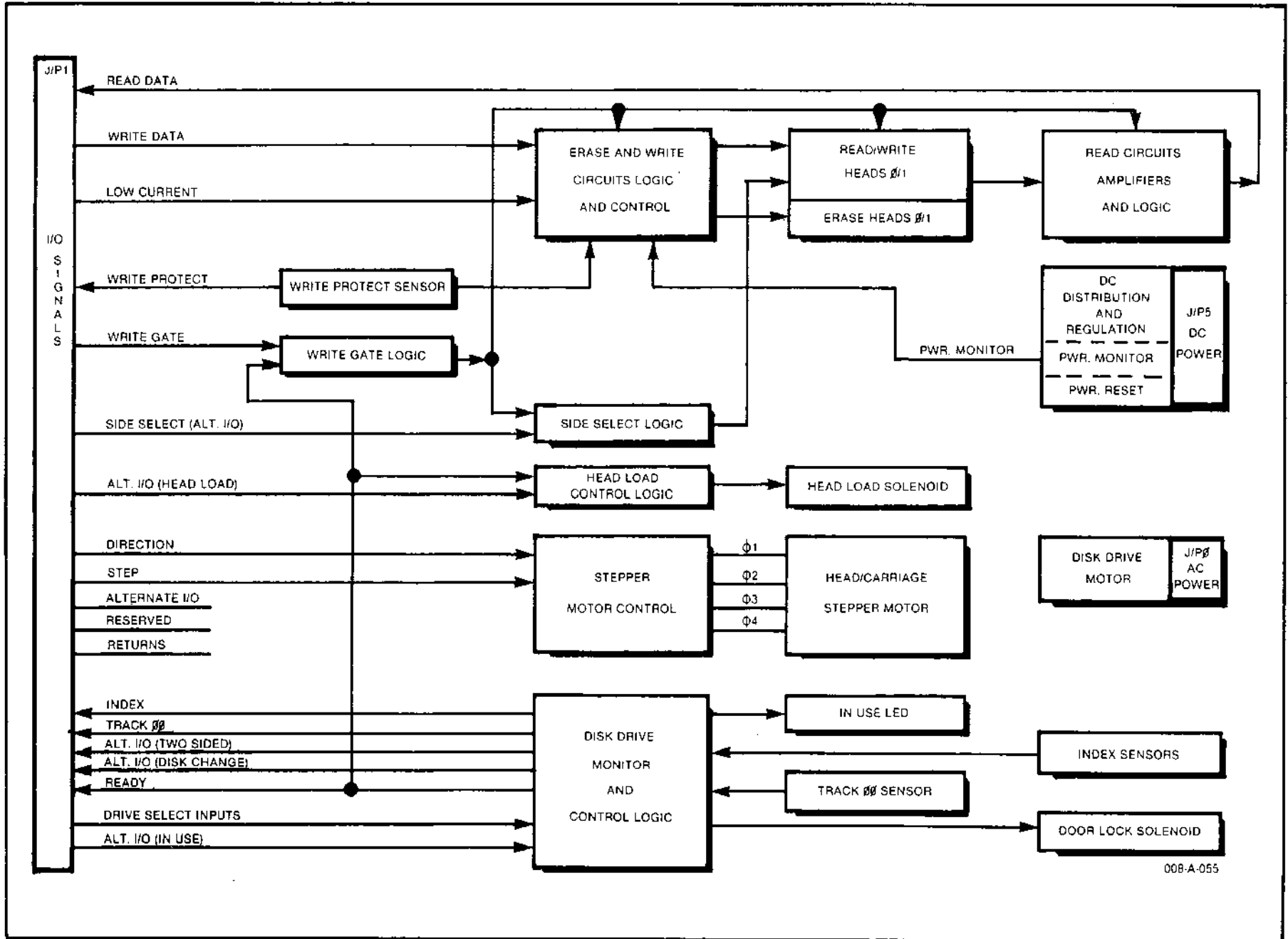

Figure 52a. Typical Schematic Diagram, QumeTrak 842

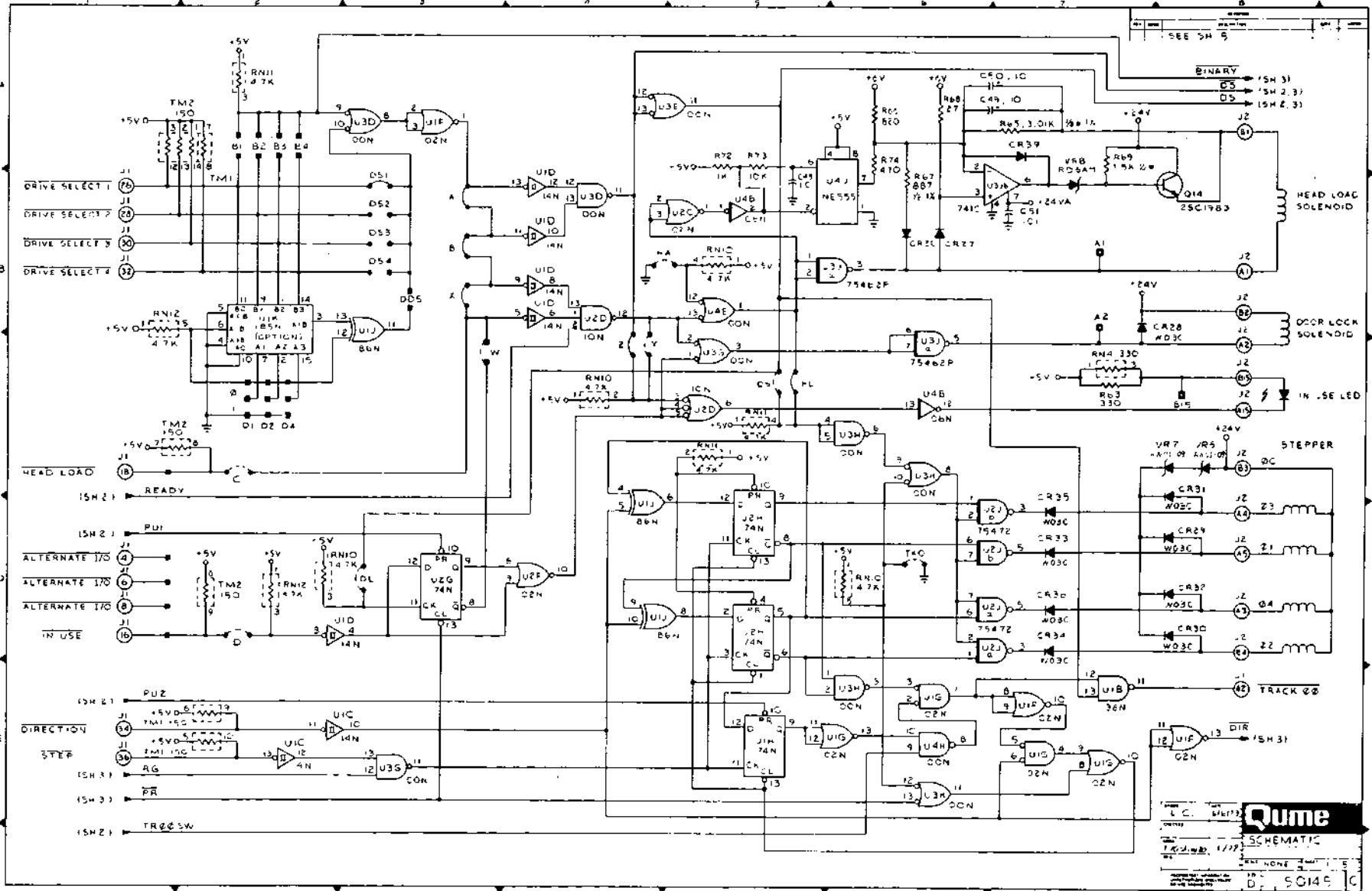

Figure 52b. Typical Schematic Diagram, QumeTrak 842

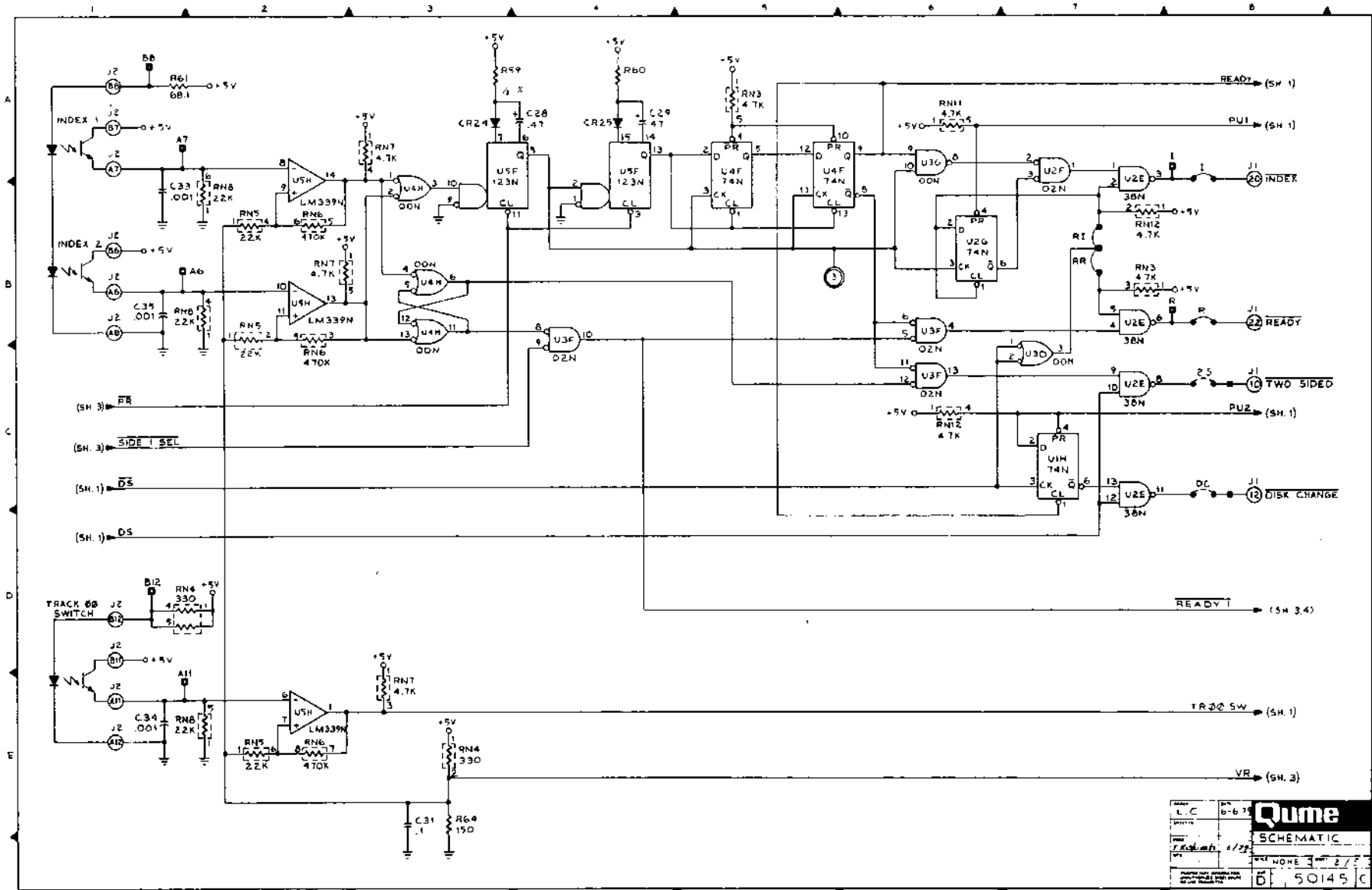

Figure 52c. Typical Schematic Diagram, QumeTrak 842

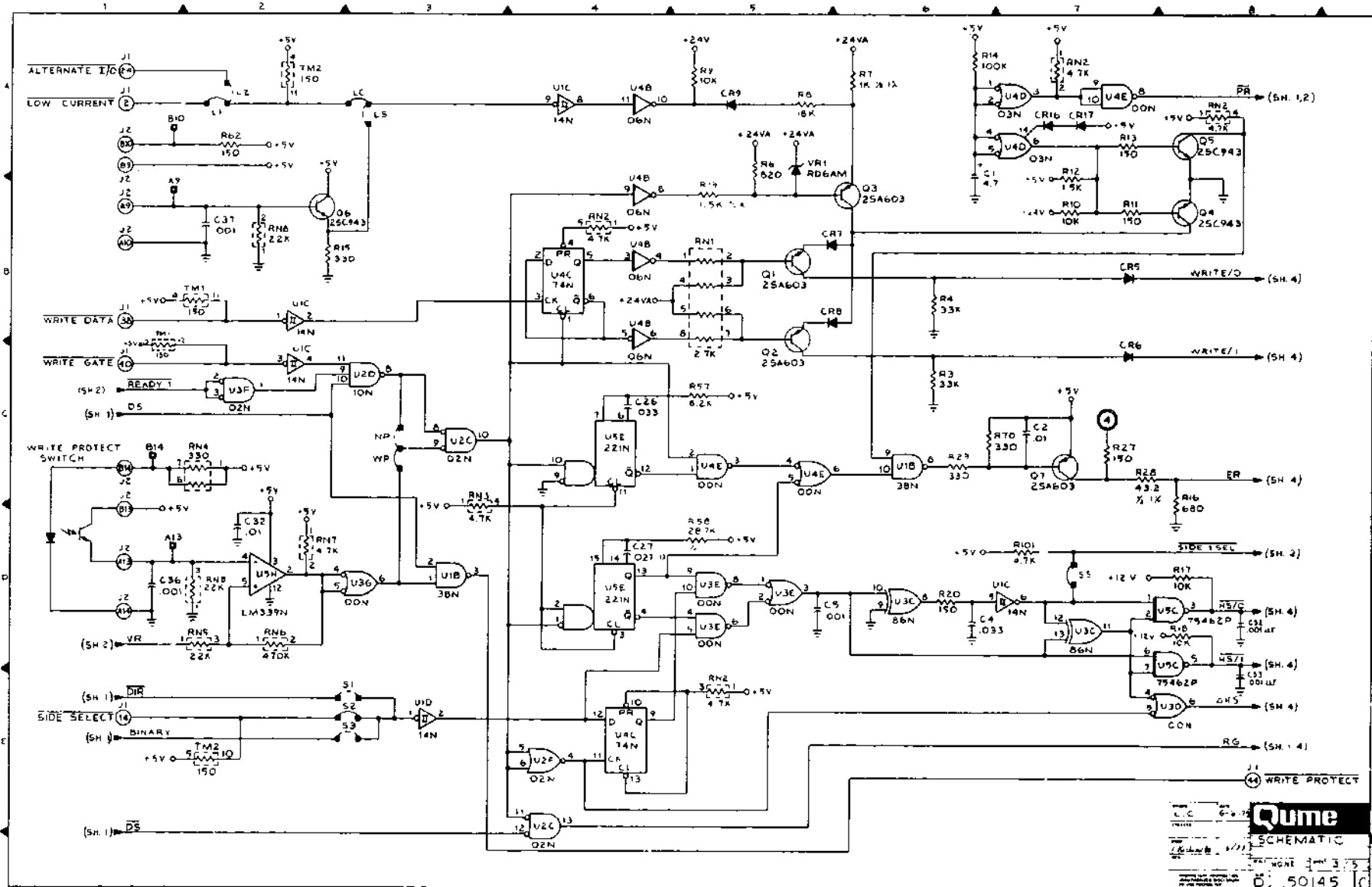
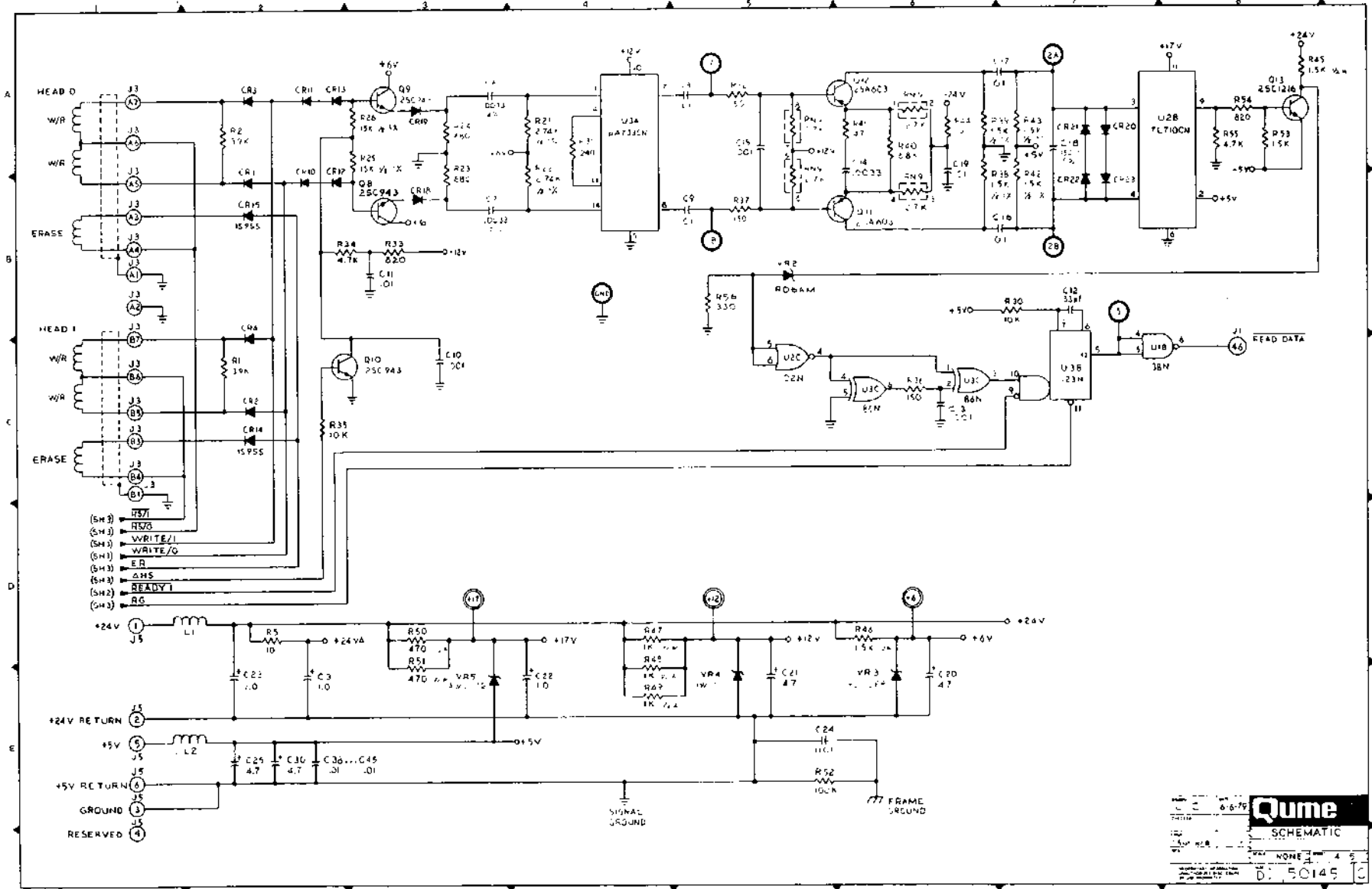

Figure 52d. Typical Schematic Diagram, QumeTrak 842



Qume
SCHEMATIC
D: 50145

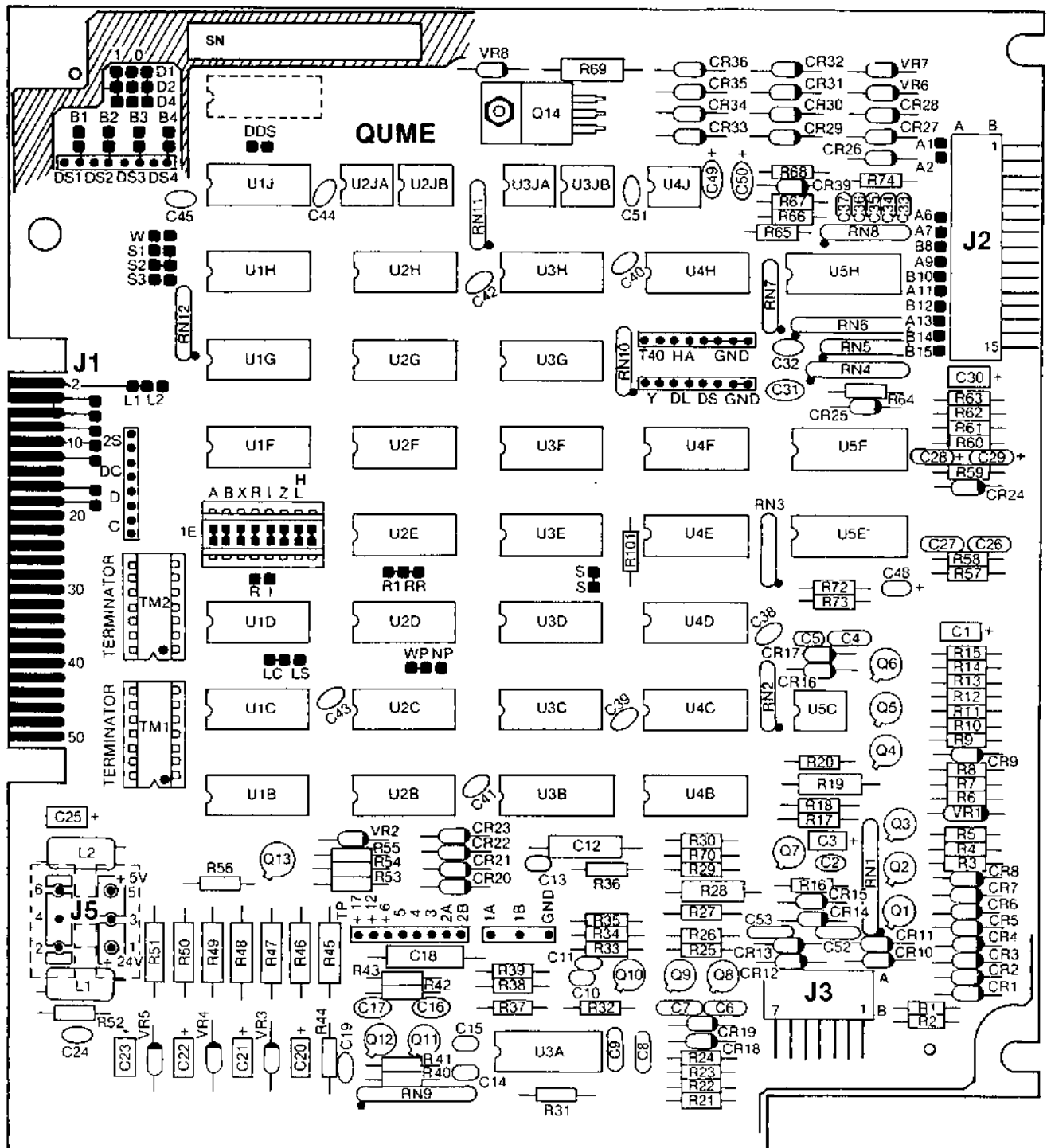
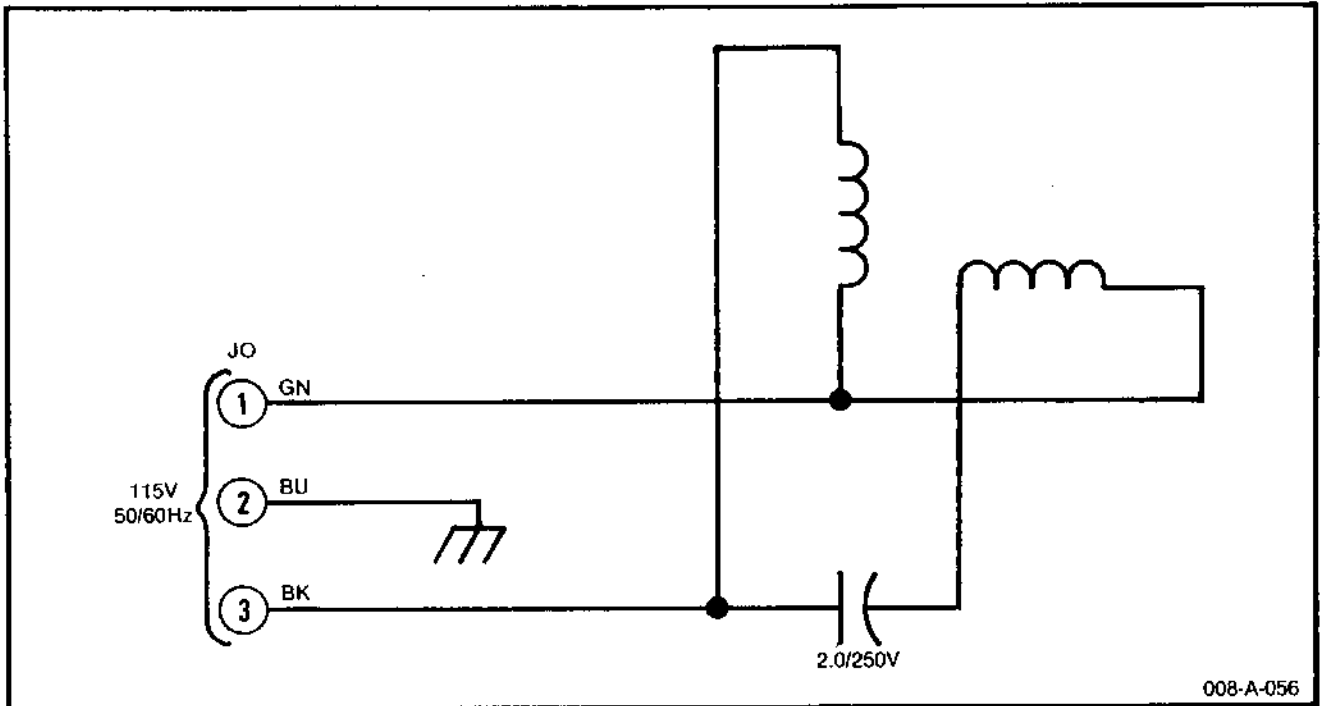

Figure 52e. Typical PCB Parts Location Diagram, QumeTrak 842



008-A-056

Figure 52f. Schematic Diagram, Disk Drive Motor Circuit, QumeTrak 842

APPENDIX

QUMETRAK 842DC UNIQUE DATA

The following product specifications data is applicable to the QumeTrak 842DC disk drive only. This drive incorporates a DC drive motor, eliminating the need for AC power at the unit.

Installation Requirements

DC POWER REQUIREMENTS	VOLTAGE	MAX. RIPPLE	CURRENT (AMPS)				
	+ 24 V ± 10%	0.1 V (P-P)		1 DRIVE	2 DRIVES	3 DRIVES	4 DRIVES
			TYP. MAX.	1.45 2.2	2.3 3.4	3.2 4.6	4.0 5.8
+ 5 V ± 5%	0.05 V (P-P)	TYP. MAX.	0.9 1.3	1.6 2.2	2.3 3.1	3.0 4.0	

DC Connector P0/J0 Pin Assignments

PIN NO.	SIGNAL NAME
1	+24VDC
2	+24V RETURN

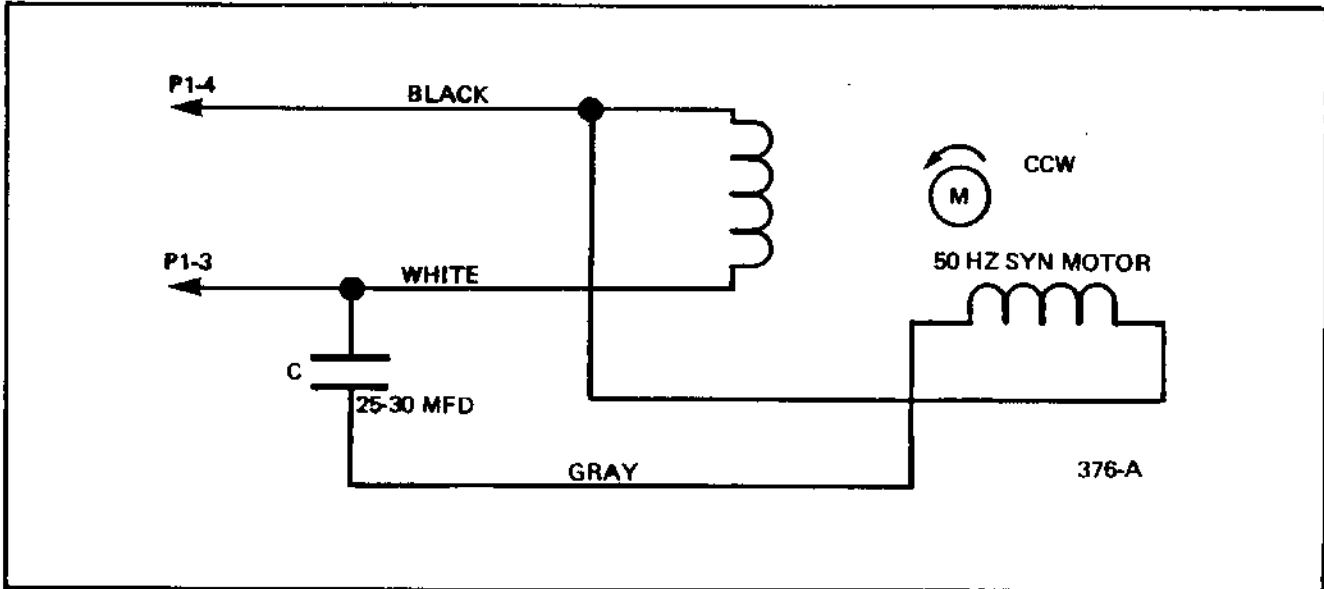

**QumeTrak 842DC Disk Drive
Motor Circuit**

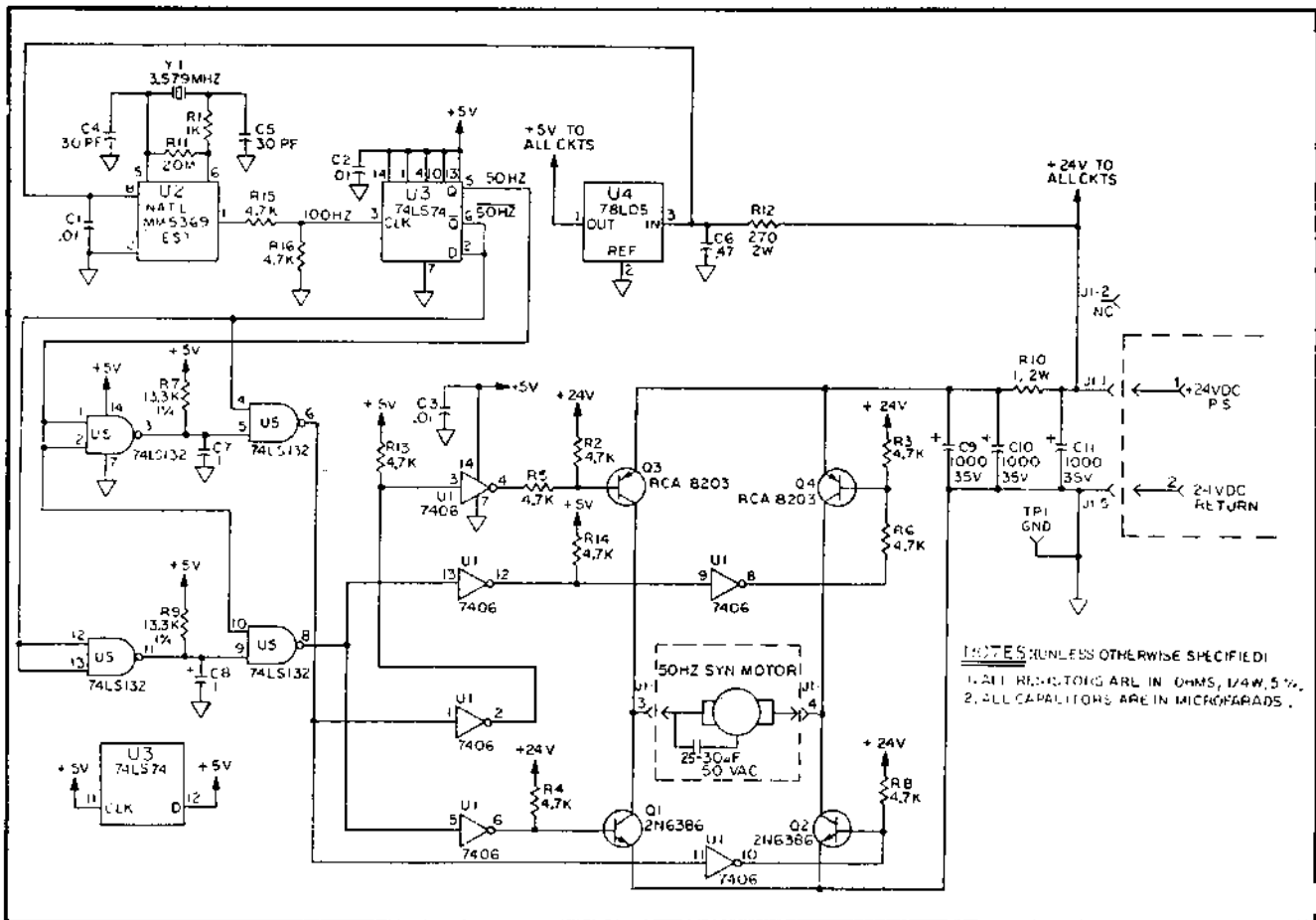

**QumeTrak 842DC Synchronous
Motor PCB**