



A Subsidiary of ITT

MAINTENANCE

**QumeTrak 542  
Maintenance**

June 1988

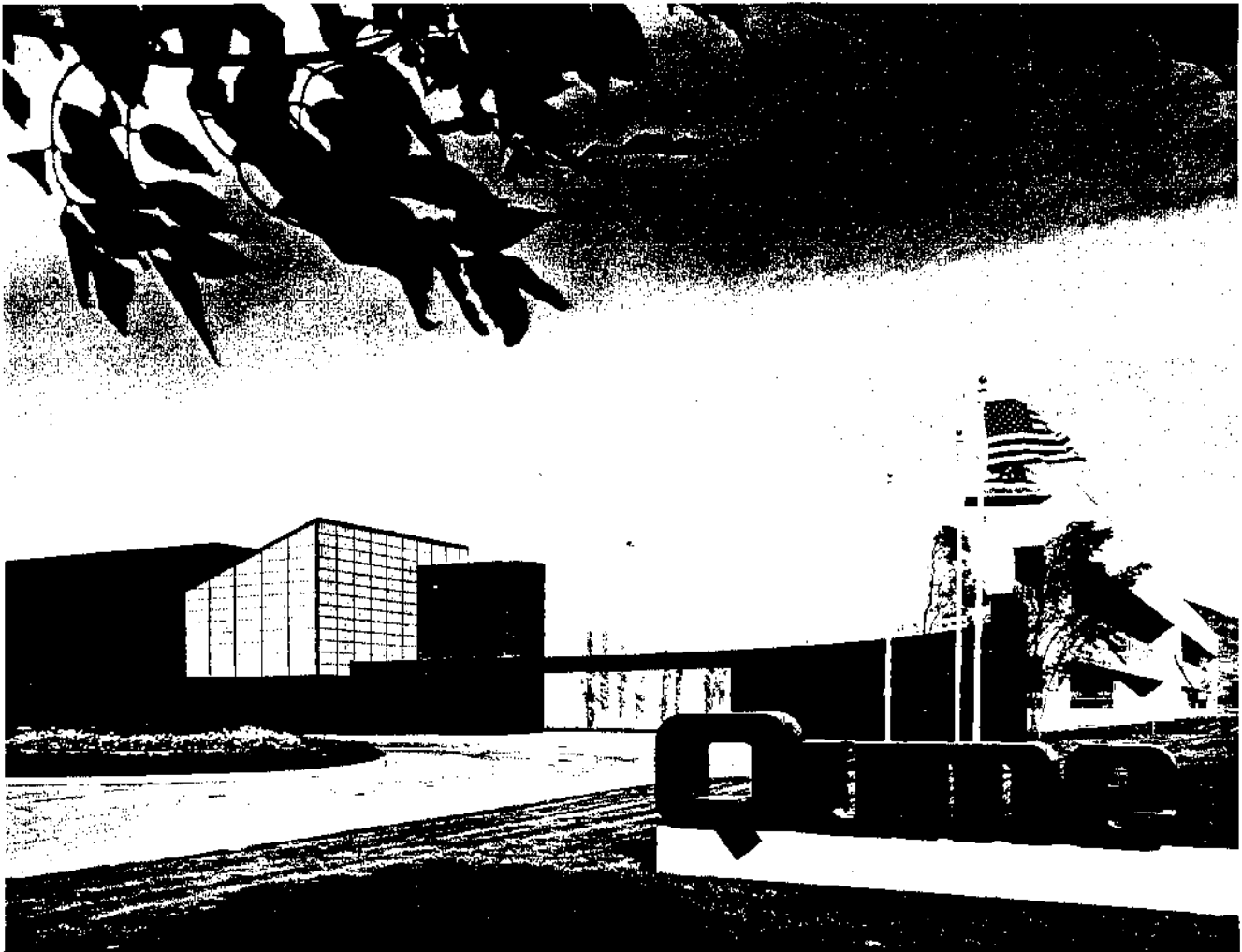

## FOREWORD

This manual is one of several publications which describe the QumeTrak 542 Flexible Disk Drive. Each manual covers the disk drive in its entirety, but from different aspects. Some subjects will be overlapping in some publications. This is because the technical format and standard of the text has been maintained directly proportional to the technical level of the potential user.

<b>Title</b>	<b>Publication Number</b>
QumeTrak 542 Product Description Manual	36013
Memory Products Service and Spares Catalog	37052

# TABLE OF CONTENTS

	PAGE
<b>INTRODUCTION</b> .....	1
SCOPE .....	1
DESCRIPTION .....	1
General .....	1
Performance Specifications .....	1
<b>INTERFACE</b> .....	3
<b>ELECTRICAL INTERFACE</b> .....	3
General .....	3
I/O Signal Interface .....	3
<b>INPUT LINES</b> .....	3
Head Load .....	3
Drive Select 0-3 .....	3
Motor On .....	5
Direction Select .....	5
Step .....	5
Write Data .....	5
Write Gate .....	5
Side Select .....	5
<b>OUTPUT LINES</b> .....	5
Index .....	6
Track 00 .....	7
Write Protect .....	7
Read Data .....	7
Ready .....	7
<b>PHYSICAL INTERFACE</b> .....	7
Connectors and Cables .....	7
I/O Signal Interface .....	7
DC Power .....	8
Terminator .....	8
Frame Ground .....	8
<b>INSTALLATION</b> .....	9
RECEIVING AND INSPECTION .....	9
INSTALLATION REQUIREMENTS .....	10
MOUNTING .....	11
Mechanical Dimensions .....	11
Recommendations .....	11
PROPER DISKETTE USE .....	12
WARRANTY, SERVICE AND TRAINING .....	12
Warranty and Service .....	12
Training .....	12
<b>CUSTOMER STRAPPABLE OPTIONS</b> .....	13
GENERAL .....	13
<b>INCORPORATION OF OPTIONS</b> .....	15
Programmable Shunt .....	15
Drive Select Options .....	15
Head Load Options .....	15
Stepper Motor Power Options .....	15
Side Select Options .....	16

## TABLE OF CONTENTS - CONTINUED

	<b>PAGE</b>
<b>MAINTENANCE</b> .....	17
<b>PREVENTIVE MAINTENANCE</b> .....	17
<b>MAINTENANCE TOOLS</b> .....	17
<b>REMOVAL AND REPLACEMENT PROCEDURES</b> .....	18
Printed Circuit Board .....	18
Front Door Assembly .....	18
Front Bezel Assembly .....	18
In Use LED .....	19
Media Guides .....	19
Write Protect Sensor and Lamp Assembly .....	20
Carrier Assembly .....	20
Collet Assembly .....	22
Spindle Components .....	22
Index Sensor and Lamp Assemblies .....	23
Head Load Solenoid Assembly .....	24
Motor Control Board .....	24
Drive Motor .....	25
Track 00 Switch Assembly .....	25
Head Carriage Assembly .....	26
Stepper Motor .....	27
<b>ADJUSTMENTS AND CHECKS</b> .....	29
GENERAL .....	29
DRIVE MOTOR ADJUSTMENT .....	29
HEAD ALIGNMENT ADJUSTMENT .....	29
TRACK 00 SWITCH ADJUSTMENT .....	30
TRACK 00 STOP ADJUSTMENT .....	30
INDEX SENSOR ADJUSTMENT .....	31
AZIMUTH ALIGNMENT CHECK .....	31
<b>TROUBLESHOOTING</b> .....	35
GENERAL .....	35
<b>DEFINITION OF QUMETRAK 542 FUNCTIONAL ERRORS</b> .....	35
Not Ready .....	35
Seek Error .....	35
Read Error .....	35
Write Error .....	35
No Head Load .....	35
<b>TROUBLESHOOTING TECHNIQUE</b> .....	35
<b>TROUBLESHOOTING FLOWCHARTS</b> .....	35
<b>RECOMMENDED SPARE PARTS</b> .....	41
<b>ILLUSTRATED PARTS</b> .....	43

## LIST OF ILLUSTRATIONS

FIGURE	TITLE	PAGE
1	Recommended Controller Interface Circuit	3
2	Interface Connections	4
3	Step Timing	5
4	Write Data Timing for Frequency Modulation (FM)	5
5	Control and Data Timing Requirements	6
6	Index Timing	6
7	Read Data Timing	7
8	Interface Connection	7
9	Connector J1 Dimensions (component side)	7
10	Connector J2	8
11	Unpacking the Disk Drive	9
12	QumeTrak 542 - Top View	11
13	QumeTrak 542 - Side View	11
14	QumeTrak 542 - Bottom View	11
15	Disk Drive Mounting	11
16	40 Track Diskette	12
17	PCB Trace/Jumper Locations	14
18	Stepper Motor Power Option Connections	16
19	Front Door Installation	18
20	In Use LED Removal	18
21	In Use LED Installation	19
22	Connector Lead Removal (Typical)	19
23	Carrier Assembly Removal and Replacement	21
24	Collet Assembly Removal and Replacement	22
25	Spindle Components Removal and Replacement	23
26	Index Sensor Installation	23
27	Motor Control Board - Drive Motor Leads	24
28	Stepper Motor and Head Carriage Removal and Installation	26
29	"Cats-eye" Pattern	30
30	Track 00 Stop Adjustment	31
31	Index Burst Pattern	31
32	Azimuth Check	33
33	Not Ready Troubleshooting Flowchart	36
34	Seek Error Troubleshooting Flowchart	37
35	Read Error Troubleshooting Flowchart	38
36	Write Error Troubleshooting Flowchart	39
37	No Head Load Troubleshooting Flowchart	40

# LIST OF TABLES

TABLE	TITLE	PAGE
1	Performance Specifications .....	2
2	Drive Select .....	3
3	Connector P1 Requirements for a Flat Cable .....	7
4	Connector P1 Requirements for Twisted Pairs .....	8
5	I/O Signal Connector P1/J1 Pin Assignments .....	8
6	Connector P2/J2 Requirements .....	8
7	Power Connector Pin Assignments .....	8
8	Installation Requirements .....	10
9	Factory Configuration of the Option Traces and Jumpers .....	13
10	Programmable Shunt Trace Functions .....	15
11	Maintenance Tools .....	17
12	Test Equipment and Tools Required .....	29
13	Recommended Spare Parts .....	41

# INTRODUCTION

## SCOPE

This manual contains information describing the operation and maintenance of the QumeTrak 542 Flexible Disk Drive. The first section of the manual describes the design features and the configuration specifications. The INTERFACE section lists the physical connections of the QumeTrak 542 and describes the electrical interface lines. The INSTALLATION section provides inspection, unpacking, and mounting information. The CUSTOMER STRAPPABLE OPTIONS section describes the available strappable options and possible configuration modifications. The MAINTENANCE section provides preventive maintenance information, removal and replacement procedures, adjustment instructions, diagnostics and troubleshooting procedures.

## DESCRIPTION

### GENERAL

The QumeTrak 542 Flexible Disk Drive is a low cost direct access data storage device for 5.25 inch, two-sided flexible (floppy) diskettes. It is an advanced and sophisticated design that is based on Qume's years of manufacturing experience with the larger QumeTrak 842 eight-inch version. The QumeTrak 542 employs a two-sided head carriage assembly with a ceramic Read/Write (R/W) head for long media life. It also uses a field-proven, lead screw system for highly accurate and reliable head positioning. The media drive is a DC spindle drive

motor. This eliminates the need for AC power to the unit. The QumeTrak 542 is also equipped with a door interlock which ensures that the door does not close unless the diskette is properly inserted.

The QumeTrak 542 weighs only three pounds (1.4 kg) and can be mounted three drives horizontally, or four drives vertically in a standard 19-inch rack and panel unit. Refer to the INSTALLATION section for additional information.

Standard Features on the QumeTrak 542 include:

- . Low heat dissipation
- . Four drive daisy chain capability
- . Internal write protect circuitry
- . In Use LED activity indicator on the front panel

The QumeTrak 542 has interface compatibility with the Shugart SA450 disk drive, and complies with the American National Standards Institute (ANSI) interface specifications for 5.25 inch flexible disk drives.

### PERFORMANCE SPECIFICATIONS

The QumeTrak 542 provides a formatted storage capacity of 143.4K bytes on a two-sided single density flexible diskette, and 286.7K bytes on a two-sided double density flexible diskette. Refer to the table below for additional performance specifications:

**Table 1**  
**Performance Specifications**

	<b>SINGLE DENSITY</b>	<b>DOUBLE DENSITY</b>
<b>CAPACITY PER DISK UNFORMATTED FORMATTED (16 SECTORS/TRACK)</b>	250K bytes 163.8K bytes	500K bytes 327.7K bytes
<b>RECORDING DENSITY (TRACK NO. 39)</b>	2938 BPI	5876 BPI
<b>TRACK DENSITY</b>	48 TPI	48 TPI
<b>NUMBER OF CYLINDERS</b>	40	40
<b>NUMBER OF TRACKS</b>	80	80
<b>RECORDING METHOD</b>	FM	MFM
<b>ROTATIONAL SPEED</b>	300 RPM	300 RPM
<b>TRANSFER RATE</b>	125K bits/sec	250K bits/sec
<b>LATENCY (AVERAGE)</b>	100 ms	100 ms
<b>ACCESS TIME</b>		
<b>AVERAGE</b>	175 ms	175 ms
<b>TRACK-TO-TRACK</b>	12 ms	12 ms
<b>SETTLING</b>	15 ms	15 ms
<b>HEAD LOAD TIME</b>	50 ms	50 ms
<b>MOTOR START TIME</b>	1 sec	1 sec



# INTERFACE

## ELECTRICAL INTERFACE

### GENERAL

The QumeTrak 542 has two interface connectors. Connector P1/J1 interfaces data signals, and connector P2/J2 interfaces the +5V and +12V DC power sources. The interface connections are shown in the illustration on the following page.

### I/O SIGNAL INTERFACE

All the I/O signal interface lines are TTL compatible and are active (true) when low. The disk drive uses 7438 NAND buffers (open collector) as output line drivers, and TTL logic level receivers on the input lines. The input of all receiver lines in a single drive, and those in the last drive of a daisy chain, must be terminated in 150 ohms pulled up to +5 volts (refer to the Terminator paragraph). The illustration below shows the recommended controller interface circuit.

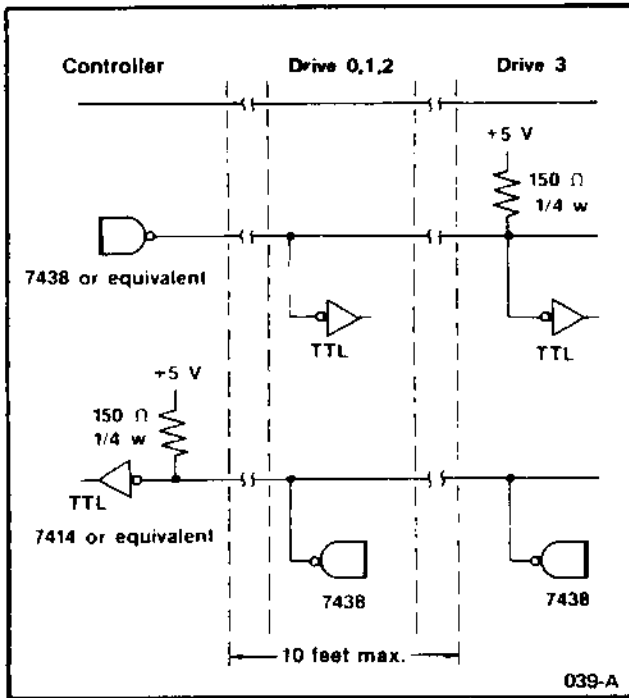

Figure 1. Recommended Controller Interface Circuit

### INPUT LINES

There are eleven active low TTL input lines. The low (true) voltage level for the lines is 0 to 0.4 volts. The high (false) voltage level is 2.4 to 5.25 volts. The characteristics of the individual input lines are described below:

### Head Load

An active low level on this line (pin 4) loads the R/W head against the diskette. In some applications HEAD LOAD is a Customer Strappable Option.

### DRIVE SELECT 0-3

An active low level on this line (pin 6, 10, 12, or 14) enables communication between an individual drive and the controller.

The QumeTrak 542 is shipped from the factory as shown in the Factory Configuration table. This allows the user to configure the drive to operate in a single or multiple drive system. Four separate input lines are provided for the using system to select the right drive on the interface. When two, three, or four drives are daisy chained, each drive must have a unique DRIVE SELECT address. The DRIVE SELECT address is controlled by a programmable shunt. When trace DS0 (on the programmable shunt) is shorted, the drive will be activated by an active low signal on the DRIVE SELECT 0 line. If trace DS1 is shorted, the drive will be activated when the DRIVE SELECT 1 line is active low. The same system applies to traces DS2 and DS3. Refer to the Drive Select table below:

#### NOTE

Only one trace can be shorted within a single drive. Each drive within a daisy chain must have a unique DRIVE SELECT number.

Table 2 Drive Select

Drive Number	Drive Select Input				Programmable Shunt			
	0	1	2	3	DS0	DS1	DS2	DS3
One Drive*	X	X	X	X	O	O	O	O
0	L	H	H	H	S	O	O	O
1	H	L	H	H	O	S	O	O
2	H	H	L	H	O	O	S	O
3	H	H	H	L	O	O	O	S

L = low level, H = high level, S = short, O = open  
X = don't care, \* = MX shorted

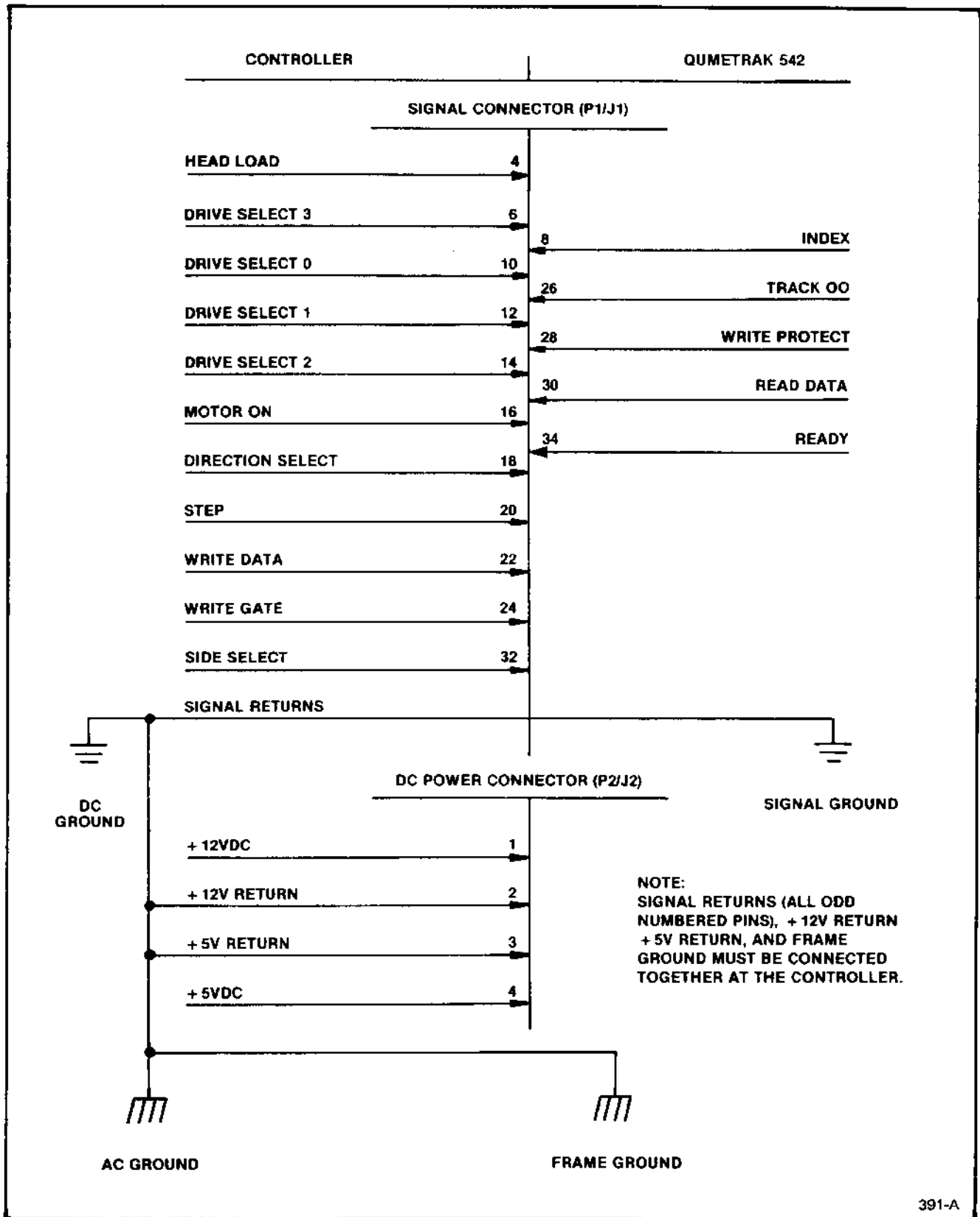

Figure 2. Interface Connections

**NOTE**

When DS0-DS3 are not desired, an Optional Drive Select can be used by shorting the MX trace on the programmable shunt. The HM trace must then also be shorted to activate the head load solenoid when the MOTOR ON signal is true.

**Motor On**

An active low level on this line (pin 16) enables the drive motor. The spindle takes one second after MOTOR ON is activated to come up to speed before reading or writing on the diskette. If no commands are to be issued to the drive within two seconds (10 media revolutions) of completion of a previous command, this line should be deactivated to ensure maximum motor life.

**Direction Select**

DIRECTION SELECT (pin 18) defines the direction of R/W head movement when the STEP line is pulsed. A low level on this line causes the head positioning mechanism to move the R/W head towards the center of the diskette. With the DIRECTION SELECT line at a high level, a pulse on the STEP line causes the head positioning mechanism to move the R/W head away from the center of the diskette. The logic state of DIRECTION SELECT can be changed at any time after the trailing (positive going) edge of the STEP pulse, and to within one microsecond before the trailing edge of a following STEP pulse. The logic state of DIRECTION SELECT cannot be changed during the positive going transition of STEP, or within the one microsecond preceding the positive going transition of STEP.

**Step**

An active low pulse on this line (pin 20) will cause the R/W head to be moved one track. The direction of movement is controlled by the DIRECTION SELECT line. Pulses applied to the STEP line have the timing characteristics shown below:

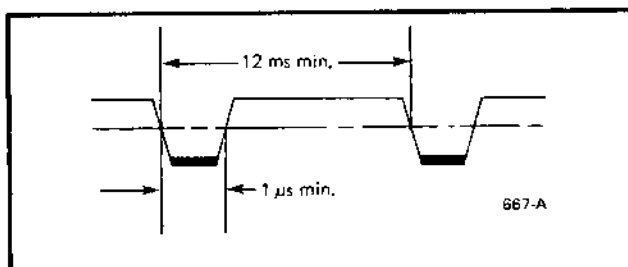

Figure 3. Step Timing

**Write Data**

This interface line (pin 22) provides the data to be written on the diskette. Each transition from a high level to an active low level causes the write current polarity through the head to be reversed. The timing characteristics for the WRITE DATA Frequency Modulation (FM) format are shown below:

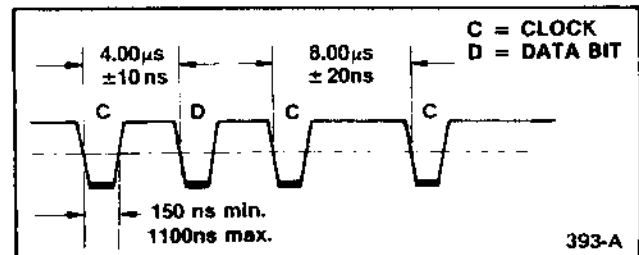

Figure 4. Write Data Timing for Frequency Modulation (FM)

**Write Gate**

An active low level on this line (pin 24) enables the write current source and disables the stepping (head positioning) circuitry. A high level on this line enables the read circuitry. Deactivation of DRIVE SELECT, and/or changing SIDE SELECT must be delayed at least one millisecond following a write operation to assure that the track is fully tunnel erased.

Refer to the Control and Data Timing Requirements illustration for the timing relationships.

**Side Select**

SIDE SELECT defines which surface of a two-sided diskette is to be accessed for data recording or retrieval. An active low level on this line (pin 32) selects the R/W head for side 1 of the diskette (the diskette surface that faces the PCB); a high level selects the R/W head for side 0 of the diskette (the diskette surface that faces the main frame). When switching from side to side a 100 microsecond delay is required before any read or write operation can be initiated.

**OUTPUT LINES**

There are five active low TTL output lines. The low (true) voltage level is 0 to 0.4 volt, with a maximum sink of 48 milliamps when the 7438 NAND buffers draw current. The high (false) voltage level is 2.4 to 5.25 volts, with a maximum leakage current of 250 microamps when the 7438 NAND buffers are at cutoff. The characteristics of the individual output lines are described below.

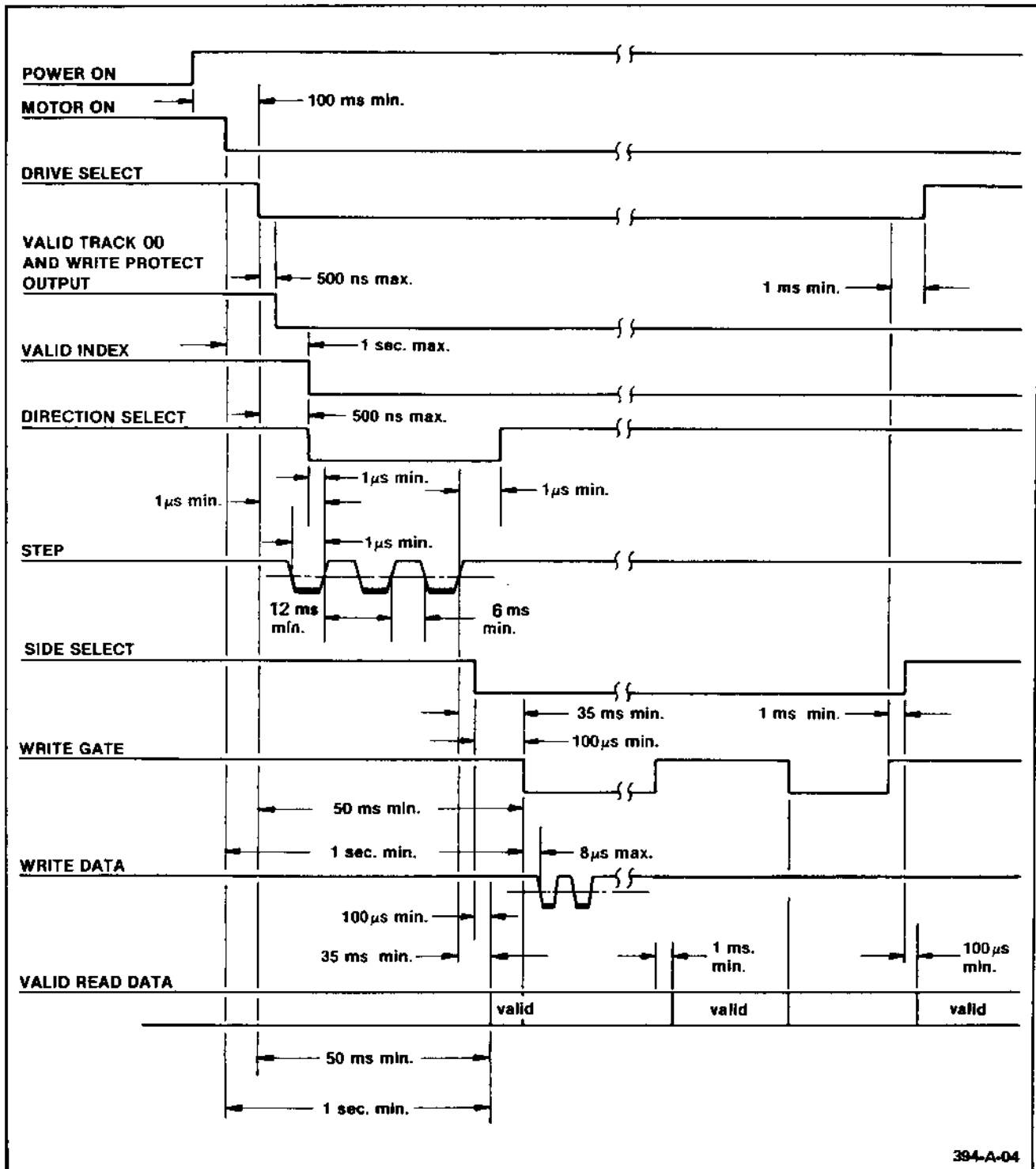

Figure 5. Control and Data Timing Requirements

**INDEX**

This interface signal (pin 8) is provided by the drive once each revolution. The leading (negative going) edge of the INDEX pulse indicates to the controller the beginning of the next track. See the timing characteristics for INDEX in the adjacent illustration.

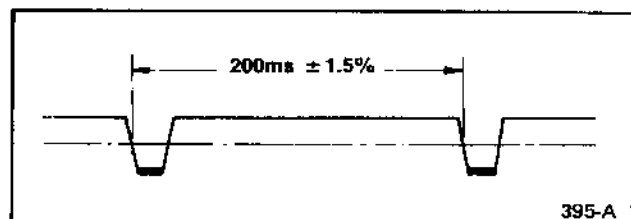

Figure 6. Index Timing

**Track 00**

An active low level on this line (pin 26) indicates that the R/W head is positioned at Track 00.

**Write Protect**

An active low level on this line (pin 28) indicates that a diskette with a disable tab covering the write enable notch is installed. Under normal operation, the drive will inhibit writing when a protected diskette is installed.

**Read Data**

Data from the diskette is output to the host system in the same form as it was received on the WRITE DATA line. Each flux reversal that is sensed on the diskette produces an active low pulse on the READ DATA line (pin 30), and a return to high level one microsecond later. The timing characteristics for READ DATA are shown below.

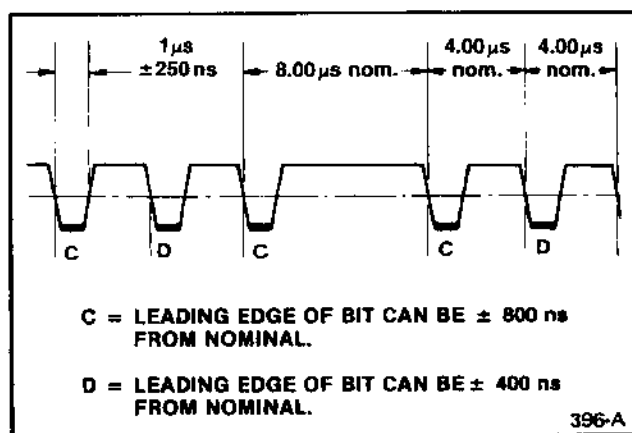

Figure 7. Read Data Timing

**Ready**

An active low level on this line (pin 34) indicates that the drive is ready to read or write data.

**PHYSICAL INTERFACE**

**CONNECTORS AND CABLES**

The physical interface between the QumeTrak 542 and the host system is made through two connectors: digital I/O signals on P1/J1, and DC power on P2/J2; a fast-on terminal tab provides for frame ground interconnection. The illustration below shows how four disk drives would be connected to the host system (drives #1 and #2 have been deleted for clarity). Refer to the ELECTRICAL INTERFACE section for specific pin connections.

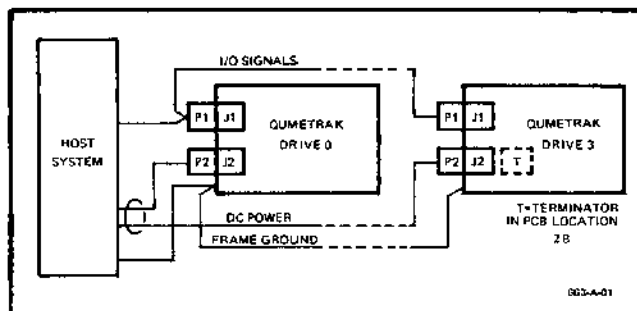

Figure 8. Interface Connection

**I/O SIGNAL INTERFACE**

All I/O signals are interfaced through connector P1/J1. Connection to J1 is through a 34-pin PCB edge card connector. The dimensions for this connector are shown in the illustration below.

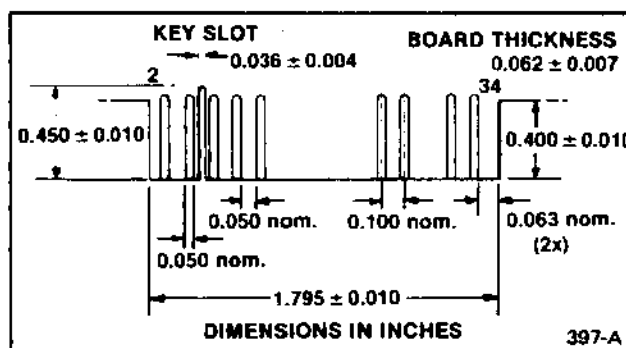

Figure 9. Connector J1 Dimensions (component side)

Connector P1 can be for a flat cable or a twisted pair. The two tables below list the respective requirements.

Table 3  
 Connector P1 Requirements for a Flat Cable

PARTS		3M P/N
CONNECTOR		3463-0001
POLARIZING KEY		3439-0000
CRIMP TOOL	PRESS	3440
	LOCATOR PLATE	3443-11
	PLATEN	3442-1
FLAT CABLE (10 FEET MAX.)		3365-34

**Table 4**  
Connector P1 Requirements for Twisted Pairs

PARTS	CRIMP TYPE	SOLDER TYPE
	AMP P/N	AMP P/N
HOUSING	583717-5	583717-5
CONTACT	1-583616-1	583854-3
POLARIZING KEY	583274-1	583274-1
CRIMP TOOL	90268-1	-
EXTRACTOR TOOL	91073-1	91073-1
TWISTED PAIR (10 FEET MAX.)	AWG 26	AWG 26

The table below lists the I/O signal connector pin assignments.

**Table 5**  
I/O Signal Connector P1/J1 Pin Assignments

SIGNAL RETURN	SIGNAL	SIGNAL NAME
PIN NO.	PIN NO.	STANDARD
1	2	RESERVED
3	4	HEAD LOAD
5	6	DRIVE SELECT 3
7	8	INDEX
9	10	DRIVE SELECT 0
11	12	DRIVE SELECT 1
13	14	DRIVE SELECT 2
15	16	MOTOR ON
17	18	DIRECTION SELECT
19	20	STEP
21	22	WRITE DATA
23	24	WRITE GATE
25	26	TRACK 00
27	28	WRITE PROTECT
29	30	READ DATA
31	32	SIDE SELECT
33	34	READY

**DC POWER**

DC Power is supplied through connector P2/J2. The two tables below list the cable requirements and connector pin assignments.

**Table 6**  
Connector P2/J2 Requirements

PARTS	P2	J2
	CABLE SIDE	DRIVE SIDE
	AMP P/N	AMP P/N
HOUSING	1-480424-0	1-480426-0
CONTACT (4 PINS)	60619-1	-
CRIMP TOOL	90124-2	-
EXTRACTOR TOOL	1-305183-2	-
CABLE (10 FEET MAX.)	AWG 18	-

**Table 7**  
Power Connector Pin Assignments

PIN NO.	SIGNAL NAME
1	+ 12VDC
2	+ 12V RETURN
3	+ 5 RETURN
4	+ 5VDC

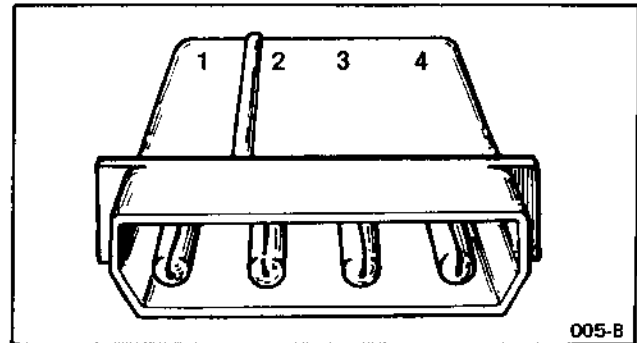

Figure 10. Connector J2

**TERMINATOR**

The terminator is a DIP resistor module which must be plugged into the DIP socket, location 2B, on the PCB of a single drive, or into the last drive of a daisy chain. No other drives in a daisy chain should have terminator resistors installed.

**FRAME GROUND**

The QumeTrak 542 must be grounded to the controller to insure proper operation and low noise susceptibility. The system frame ground wire should be connected to the disk drive frame. A fast-on tab is provided on the drive for this purpose.

FAST-ON TAB	MATING CONNECTOR
AMP P/N 61664-1	AMP P/N 60972-1

# INSTALLATION

## RECEIVING AND INSPECTION

The drive is wrapped in a plastic bag to prevent dust contamination of the R/W heads.

Unpack and inspect the disk drive as follows: (refer to figure 11).

1. Inspect the container for external signs of damage. If any damage is observed, have the delivery agent note the damage on the shipping document. Some shippers may wish to be present when the container is opened if external damage is apparent.

2. Open the container and remove the drive from its cradled position. Lift the drive from the bottom, up and out of the container.

3. Remove the drive from the plastic bag.

4. Open the drive door and remove the cardboard shipping insert.

**CAUTION**

The R/W heads must not be allowed to come together without a diskette, a clean piece of paper, or the cardboard shipping insert installed between the head surfaces.

5. Retain all packing materials for possible reshipment. Always install the cardboard insert between the heads should reshipment be necessary.

6. Inspect the drive for scratches, dents, loose components, and other obvious damage. Note any evidence of such damage on the invoice and file a claim with the carrier immediately, if the condition of the unit so warrants.

7. If damage that might impair drive operation is detected, do not attempt to operate the disk drive. Contact Qume for advice and instructions.

8. Refer to these instructions when repacking the drive.

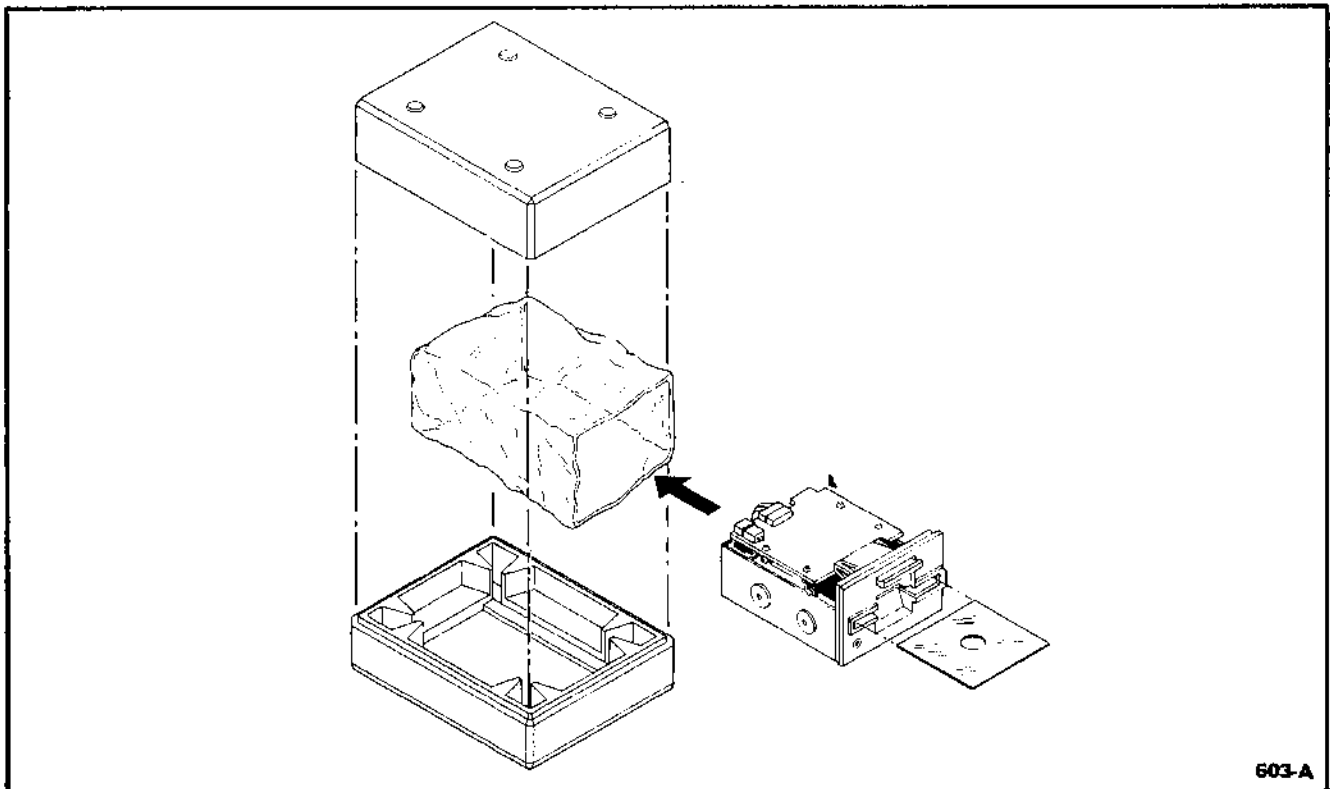

Figure 11. Unpacking the Disk Drive

### INSTALLATION REQUIREMENTS

The QumeTrak 542 has certain power, environmental, and mechanical requirements. Review the table below before installing the disk drive.

**Table 8  
Installation Requirements**

<b>DC POWER REQUIREMENTS (AT THE DC POWER CONNECTOR J2)</b>	<b>VOLTAGE</b>	<b>MAX. RIPPLE</b>	<b>CURRENT</b>
	+ 12 VDC ± 5%	0.1 V (P-P)	1.35A MAXIMUM / .8A TYPICAL
	+ 5 VDC ± 5%	0.05 V (P-P)	1.0A MAXIMUM / .7A TYPICAL
<b>POWER DISSIPATION</b>	CONTINUOUS: 18.7 W TYPICAL (64 BTU/HR) STAND BY: 7.5 W TYPICAL (25 BTU/HR)		
<b>ENVIRONMENT</b>	<b>TEMPERATURE</b>	<b>OPERATING</b>	<b>STORAGE</b>
		5°C TO 43°C (41°F TO 110°F)	- 10°C TO 45°C (14°F TO 113°F)
	<b>RELATIVE HUMIDITY</b>	20 TO 80% RH	8 TO 80% RH
	<b>MAX. WET BULB</b>	29°C (84°F)	NO CONDENSATION
<b>MECHANICAL</b>	<b>WIDTH</b>	146 mm (5.75 in.)	
	<b>HEIGHT</b>	82.6 mm (3.25 in.)	
	<b>DEPTH</b>	189.7mm (7.47in)	
	<b>WEIGHT</b>	1.4 Kg (3 lb)	
<b>MOUNTING POSITIONS</b>	HORIZONTAL FRONT LOAD (PCB SIDE UP ONLY) VERTICAL FRONT LOAD VERTICAL TOP LOAD		

561-A



## MOUNTING

### MECHANICAL DIMENSIONS

Shown below are the top, bottom, and side views of the QumeTrak 542. The mounting and clearance dimensions (shown in inches) should be reviewed before installation.

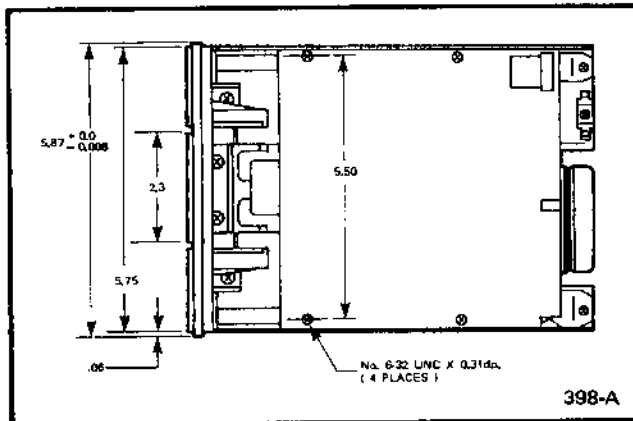

Figure 12. QumeTrak 542 — Top View

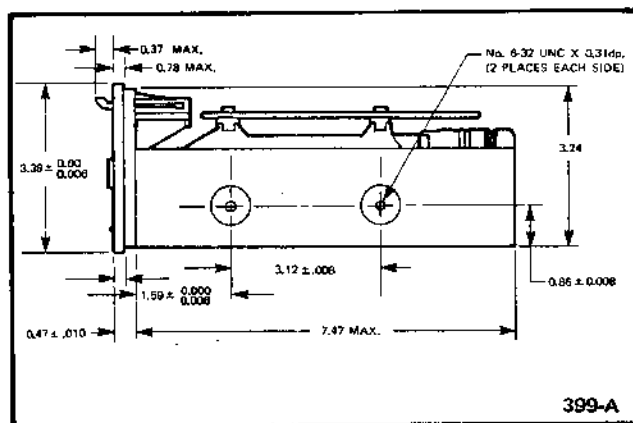

Figure 13. QumeTrak 542 — Side View

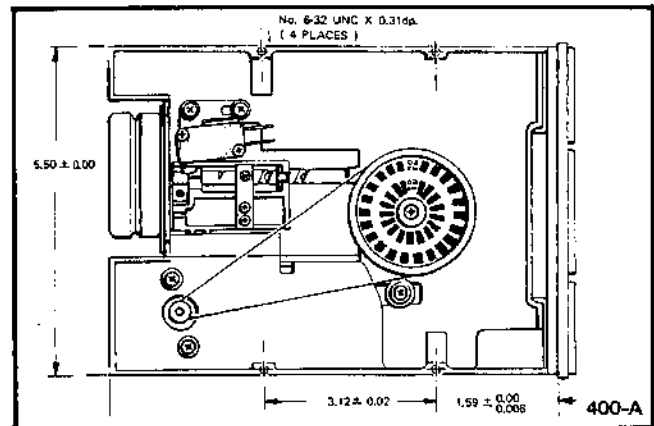

Figure 14. QumeTrak 542 — Bottom View

### RECOMMENDATIONS

The QumeTrak 542 can be mounted in any plane: horizontal for front loading and vertical for front or top loading. When the disk drive is mounted in a horizontal front loading position, it must be so placed that the door opens upward and the In Use LED on the front bezel is below the door (refer to the illustration below).

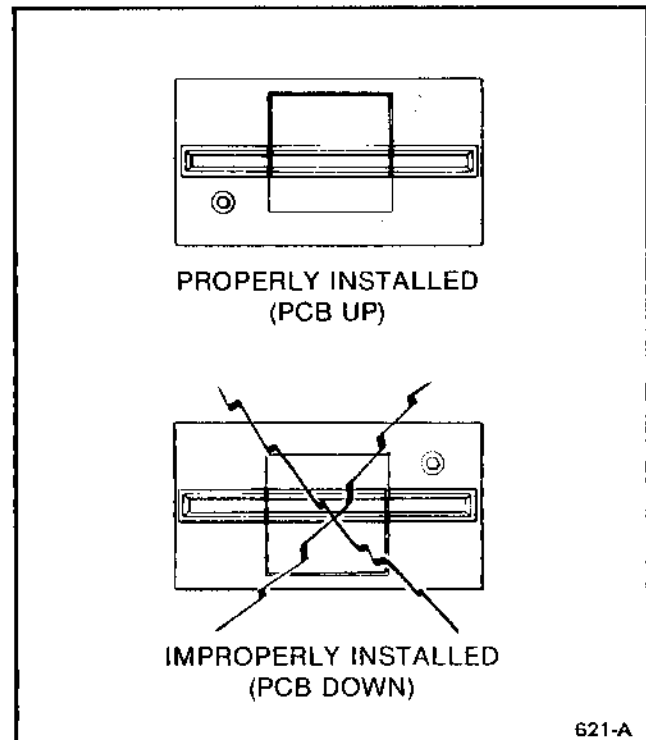
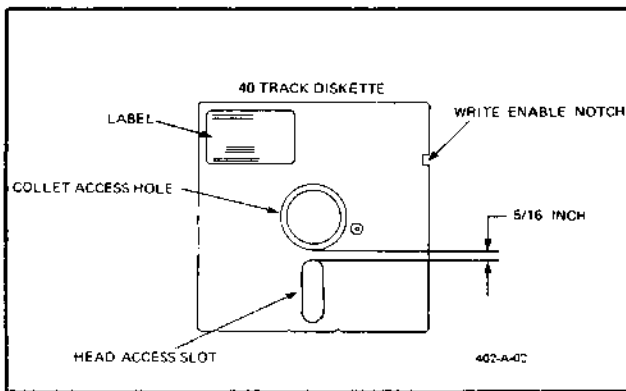

Figure 15. Disk Drive Mounting

## PROPER DISKETTE USE

It is paramount that a proper 5.25 inch diameter diskette is used in the QumeTrak 542. Ensure that only soft sectored 40 track capacity diskettes meant for drives of 40 track capability are being used in the drive. Attempting to use any other track capacity diskette in the drive may result in serious R/W head damage.

The 40 track diskette to be used in the QumeTrak 542, can be easily identified by noting the measurement between the collet access hole and the head access slot in the diskette sleeve (refer to the illustration below). For 40 track diskettes, this distance is 5/16 inch. It is advisable that double sided R/W certified diskettes are used; single sided diskettes, however may be used.



**Figure 16 40 Track Diskette**

Insert the diskette into the drive, head access slot first and with the diskette label facing towards the open door; close the drive door.

### CAUTION

Do not open the drive door while the In Use LED on the drive front is illuminated.

Handle diskettes with care. Never bring a diskette near a magnetic field or touch the diskette surface exposed by the head access slot. Protect the diskette from dust, dirt, direct sunlight and temperatures outside the manufacturer recommended safe range. Avoid bending, creasing, or writing on the diskette sleeve with pencil or ball-point pen.

## WARRANTY, SERVICE AND TRAINING

### WARRANTY AND SERVICE

The basic Qume service policy, terms, conditions and prices for repairs are specifically described in related to the Memory Products Service and Spares Catalog, publication number 37052. For specific warranty details refer to your QumeTrak 542 purchase contract.

### TRAINING

Qume offers depot service training on the QumeTrak 542 Disk Drive. These regularly scheduled classes, held at Qume's Hayward, California facility, cover mechanical and electronic theory of operation, field and service depot level troubleshooting, subassembly removal and replacement procedures, mechanical and electronic adjustments and service checks, and preventive maintenance. Detailed information on customer training classes is contained in the Memory Products Service and Spares Catalog, publication number 37052.

# CUSTOMER STRAPPABLE OPTIONS

## GENERAL

A user can modify the QumeTrak 542 by altering some of the functions described in the INTERFACE section. These modifications are made by adding or deleting jumpers on the programmable shunt, side select trace pads, and/or

stepper power pins. The following table shows the configuration of the option traces and jumpers when shipped from the factory. The illustration on the next page depicts their location on the disk drive PCB.

**Table 9**  
**Factory Configuration of the Option Traces and Jumpers**

TRACE/JUMPER DESIGNATOR	DESCRIPTION	FROM FACTORY	
		OPEN	SHORT
DS0	DRIVE SELECT ADDRESS (PIN 10)		X
DS1	DRIVE SELECT ADDRESS (PIN 12)		X
DS2	DRIVE SELECT ADDRESS (PIN 14)		X
DS3	DRIVE SELECT ADDRESS (PIN 6)		X
HS	HEAD LOAD FROM DRIVE SELECT SIGNAL		X
MX	OPTIONAL DRIVE SELECT		X
HM	HEAD LOAD FROM MOTOR ON SIGNAL	X	
P-M	STEPPER MOTOR POWER FROM MOTOR ON SIGNAL		X
P-S	STEPPER MOTOR POWER FROM DRIVE SELECT SIGNAL	X	
A,B1,B3	SIDE SELECT FOR DOUBLE-SIDED DRIVES FROM DRIVE SELECT SIGNAL	X	
HL	HEAD LOAD		X

**NOTE**

When shipped from the factory, pin P is normally jumpered to pin M in order to supply DC power to the stepper motor.

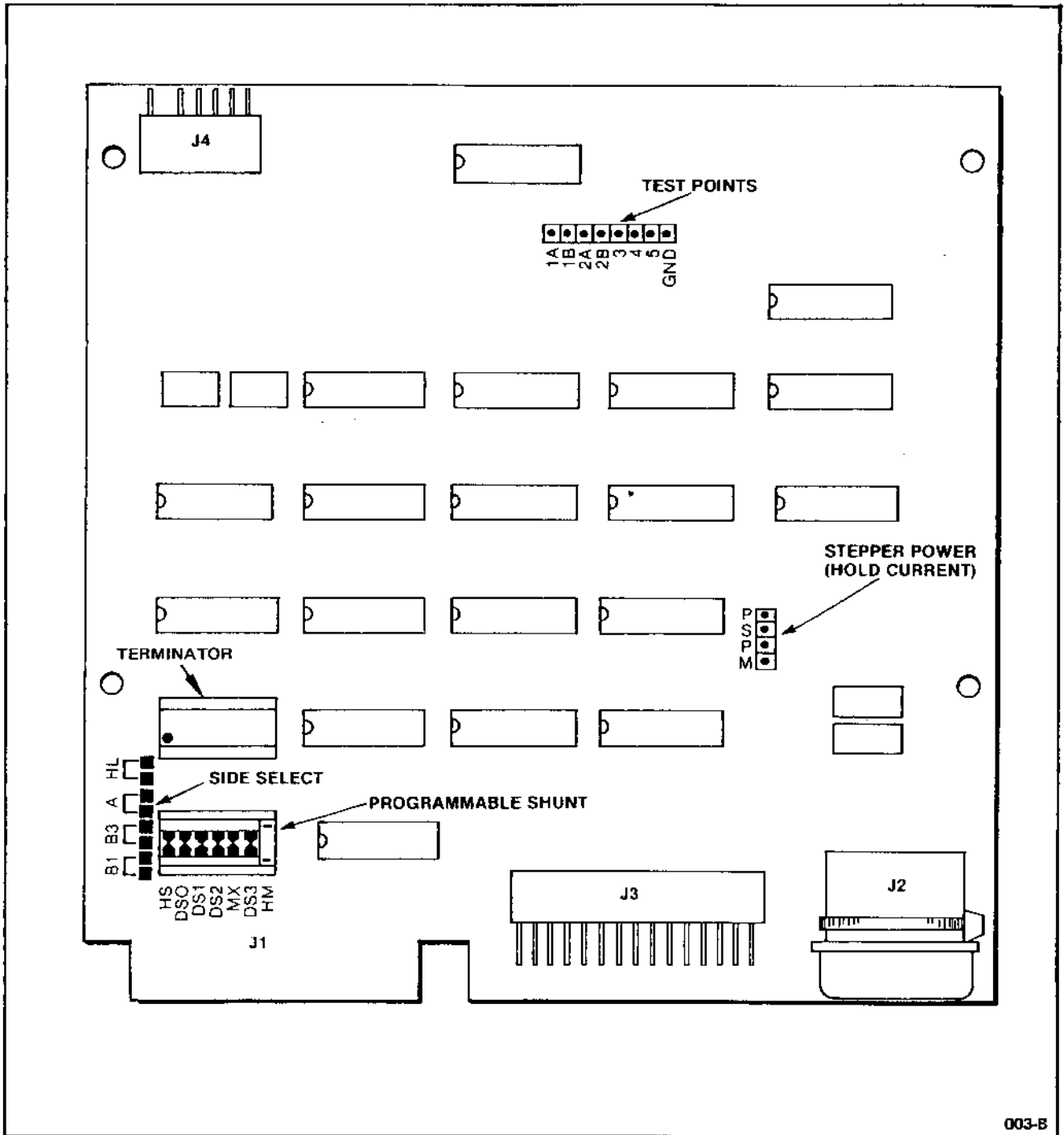

Figure 17. PCB Trace/Jumper Locations

003-B

## INCORPORATION OF OPTIONS

### PROGRAMMABLE SHUNT

A 14-pin programmable shunt is provided for the seven commonly used trace-cut options. All these traces, except trace HM, are normally

shorted before being shipped from the factory. The shorted and open functions of the pluggable options are tabulated below:

**Table 10 Programmable Shunt Trace Functions**

TRACE	FUNCTION - NORMALLY SHORTED	FUNCTION - OPEN
HS	HEAD LOAD FROM DRIVE SELECT	HEAD LOAD NOT CONTROLLED BY DRIVE SELECT
DS0	DRIVE SELECTED WHEN PIN 10 IS ACTIVE	DRIVE NOT SELECTED WHEN PIN 10 IS ACTIVE
DS1	DRIVE SELECTED WHEN PIN 12 IS ACTIVE	DRIVE NOT SELECTED WHEN PIN 12 IS ACTIVE
DS2	DRIVE SELECTED WHEN PIN 14 IS ACTIVE	DRIVE NOT SELECTED WHEN PIN 14 IS ACTIVE
MX	DRIVE WILL BE SELECTED INDEPENDENT OF DS0-DS3	DRIVE SELECT WILL BE ALLOWED FROM DS0-DS3
DS3	DRIVE SELECTED WHEN PIN 6 IS ACTIVE	DRIVE NOT SELECTED WHEN PIN 6 IS ACTIVE
HM*	HEAD LOAD FROM MOTOR ON SIGNAL	HEAD LOAD NOT CONTROLLED BY MOTOR ON SIGNAL
*NORMALLY OPEN WHEN SHIPPED FROM THE FACTORY.		

#### Drive Select Options

Traces DS0 through DS3 of the programmable shunt allow for up to four drives to be addressed in a daisy chain arrangement. If DS1 through DS3 are opened while DS0 remains shorted in a drive, it designates this drive as number zero (the first drive in the chain). Moving the short to any one of the three remaining locations (DS1-3), while all other DS locations are opened, designates the drive for the corresponding position number. One other option is available.

#### Option

Trace MX shorted. This option may be used in a one-drive system and causes the drive to be selected whenever power is applied, regardless of DS status. When this option is used, a HEAD LOAD signal is required to load the R/W head against the diskette, or trace HM may be shorted to allow the MOTOR ON signal to load the R/W head.

#### Head Load Options

When shipped from the factory, trace HS is shorted on the programmable shunt. This allows the R/W head to be loaded against the diskette when any jumpered DRIVE SELECT signal line (DS0-DS3) is activated. There is one other option available.

#### Option

Trace HM shorted; trace HS open. This allows the R/W head to be loaded against the diskette when the MOTOR ON signal is activated.

#### Stepper Motor Power Options (refer to the illustration below)

When shipped from the factory, jumper PM is installed. This arrangement supplies DC power to the stepper motor when the MOTOR ON signal is activated. Two other options are available.

#### Option 1

Jumper PS installed; jumper PM removed. This arrangement supplies power to the stepper motor whenever the drive is selected.

#### Option 2

No jumpers installed. This arrangement supplies power to the stepper motor whenever the drive is powered-up.

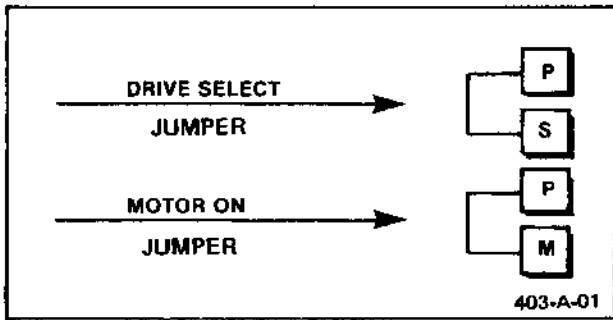

**Figure 18. Stepper Motor Power Option Connections**

**Side Select Options**

A high SIDE SELECT signal level determines that the diskette side 0 is accessed when a drive is selected via a DS0-3 shorted trace address line, or via shorted MX trace. Under these drive select conditions, side 1 is selected by an active low SIDE SELECT signal. This is applicable for single-drive systems, as well as up to four daisy chained drives. For a single drive system and for a two-drive daisy chain, one other option of side selection is available.

**Option**

When configuring a drive, refer to the PCB Trace/Jumper Locations illustration and to the Programmable Shunt Trace Functions table.

**For one drive:**

Short trace DS0 and open traces DS1-3 of the programmable shunt. Solder one wire jumper across pads B1, and a second jumper across pads A. This configuration allows the double sided drive to be addressed as two single sided drives (drive 0 and 1), where DS0 selects the drive and diskette side 0, and DS1 selects the drive and diskette side 1.

**For two daisy chained drives:**

Configure the first drive in the chain as described above under For One Drive.

Configure the second drive in the chain as follows: Short trace DS2 and open traces DS0, DS1, and DS3. Solder one wire jumper across pads B3, and a second jumper across pads A. This configuration allows the second drive to be addressed as two single sided drives (drive 2 and 3), where DS2 selects the drive and diskette side 0, and DS3 selects the drive and diskette side 1. To assure reliable side selection between side 1 of the first and second drive, pin 32 of the I/O Signal Connector, J1, on the second drive must remain disconnected.

**NOTE**

In any multi drive daisy chain configuration, the terminator resistor pack must be removed from the socket in PCB location 2B on all but the last drive of the chain.

# MAINTENANCE

## PREVENTIVE MAINTENANCE

Under normal conditions, the QumeTrak 542 does not require periodic adjustment. However, cleanliness is extremely important for the proper maintenance of the disk drive. Always look for dirt and corrosion, as well as wear, tear, binds, and loose connections.

### CAUTION

The head/carriage is a factory adjusted and tested assembly. Do not try to repair this internal component.

Keep the disk drive as dirt free as possible. Place the unit in a clean plastic bag or a sealable box for storage. Occasionally, dirt may build up on the shafts of the stepper motor assembly. Remove the dirt with a clean, lint-free cloth. The entire drive should be checked for the need of cleaning every six months. Always use a clean, lint-free cloth for cleaning any part of the drive. At this time relubricate the stepper motor shaft/carriage assembly tracking mechanism by placing one drop of light lubricating oil (Q.P.N. 55279-01) through the hole in the ball bearing retainer onto the felt pad that maintains the steel ball lubricated. The retainer is below the carriage assembly and is accessible from the underside of the drive (refer to the Stepper Motor and Head Carriage Removal and Installation illustration).

A general service check should be made on the QumeTrak 542 once every 3000 power-on hours or 12 months. The servicing of each assembly is described in the following section. During the service check, inspect the main frame for loose connectors, switches, and other components. Secure all loose parts properly. Inspect the drive belt for frayed or weakened areas. Replace the belt if it is worn or otherwise damaged.

## MAINTENANCE TOOLS

The tools tabulated below are required for general maintenance of the QumeTrak 542. These tools are available at most hardware stores.

Table 11  
Maintenance Tools

TOOL	SIZE (LENGTH)
PHILLIPS SCREWDRIVER (2)	#1 HEAD, 4 INCH SHANK; #2 HEAD, 4 INCH SHANK
TWEEZERS	4 TO 6 INCHES (NEEDLE POINT)
ALLEN WRENCH	1.5mm
FLAT HEAD SCREWDRIVER	4 INCH SHANK
SOLDERING EQUIPMENT	
CE DISKETTE	Q.P.N. 51201-01
LIGHT OIL	Q.P.N. 55279-01

706-A-01

## ILLUSTRATED ASSEMBLIES AND PARTS LOCATIONS

It is recommended that the technician refers to the Illustrated Parts Section to become familiar with the individual components and their exact locations before proceeding further with the MAINTENANCE section.

## REMOVAL AND REPLACEMENT PROCEDURES

### PRINTED CIRCUIT BOARD

1. Disconnect the DC power cable connector J2, the data cable connector J1, the transducer cable connector J3, and the R/W head cable connector J4 from the PCB.

2. Remove the four screws securing the PCB to the drive. Remove the PCB.

3. Reverse the procedure for installation.

### FRONT DOOR ASSEMBLY

#### Removal (refer to the illustration below)

1. Remove the diskette if installed, and the PCB (refer to the Printed Circuit Board paragraph).

2. Remove the two screws securing the front door to the carrier assembly.

3. Slide the front door out of the front bezel assembly.

#### Installation (refer to the illustration below)

1. While holding the carrier assembly down, slide the front door into the front bezel assembly.

2. When the front door is in place, the door hinge should rest on the top front edge of the carrier. Secure the front door to the carrier with two screws.

3. Install the PCB (refer to the Printed Circuit Board paragraph).

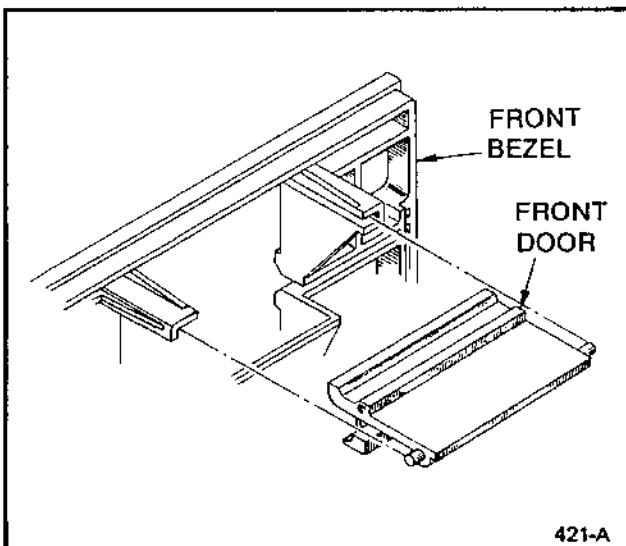

Figure 19. Front Door Installation

### FRONT BEZEL ASSEMBLY

#### Removal

1. Remove the diskette if installed, the PCB, and front door assembly (refer to the Printed Circuit Board and Front Door assembly paragraphs).

2. Remove the two screws securing the front bezel to the main frame.

3. Carefully remove the front bezel from the main frame keeping in mind that the In Use LED is still secured to the front bezel.

4. With a small screw driver, carefully lift one edge of the LED collar from the LED holder (refer to the illustration below).

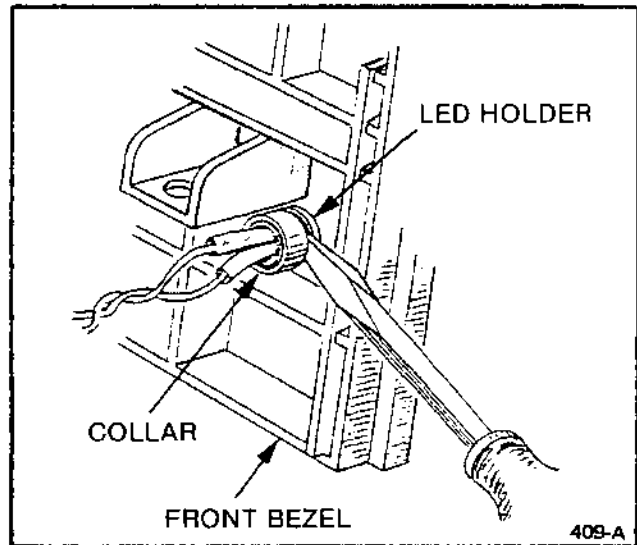

Figure 20. In Use LED Removal

5. Push the In Use LED through the front bezel to break the LED holder loose from the LED collar.

6. Remove the LED holder from the LED. Push the LED back through the front bezel.

#### Replacement

1. Push the In Use LED through the front bezel.

2. Press the LED holder onto the LED.

3. Push the LED and LED holder into the front bezel. Secure the In Use LED to the front bezel by slipping the LED collar over the LED holder. Ensure that the In Use LED is properly secured in the front bezel (refer to the illustration below).

4. Place the front bezel on the main frame and secure with two screws.



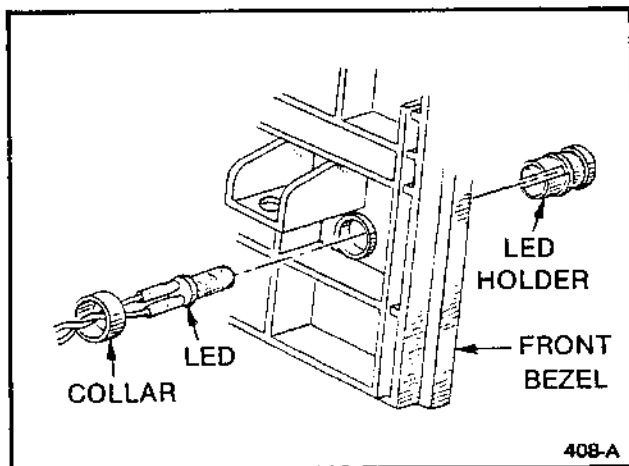

Figure 21. In Use LED Installation

5. Install the front door assembly and the PCB (refer to the Front Door Assembly and the Printed Circuit Board paragraphs).

#### IN USE LED

##### Removal

1. Remove the diskette if installed, and PCB and front bezel assemblies (refer to the Printed Circuit Board and the Front Bezel Assembly paragraphs).

2. Cut the tie wrap securing the wires near the base of the transducer cable connector J3.

3. Remove the two In Use LED leads from connector J3 by pushing down on the LED lead tabs in the connector with tweezers: black to A10, red to B10 (refer to the illustration below):

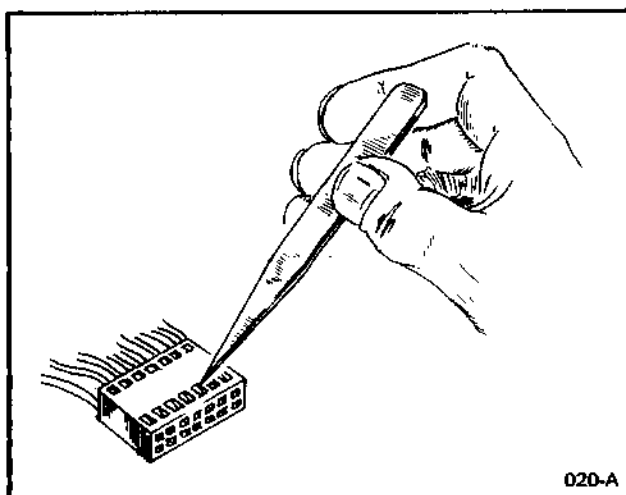

Figure 22. Connector Lead Removal (typical)

4. Separate the two In Use LED leads from the transducer cable, and remove the LED as described in the front bezel assembly removal para-

graph. Note the routing of the leads along the cable for later replacement.

##### Replacement

1. Install the two In Use LED leads in connector J3 (refer to step 3, Removal). Ensure that the locking tabs on the leads are properly engaged in the connector slots. This will prevent the leads from being pushed out when the connector is plugged into the PCB.

2. Secure the two leads to the transducer cable with a tie wrap near the base of connector J3.

3. Route the In Use LED leads along the transducer cable.

4. Install the In Use LED in the front bezel, (refer to the Front Bezel Assembly Replacement paragraph). Install the front bezel on the main frame.

5. Install the PCB (refer to the Printed Circuit Board paragraph).

#### MEDIA GUIDES

##### Removal

1. Remove the diskette if installed, and the PCB (refer to the Printed Circuit Board paragraph).

2. Remove the two R/W head cables (connector J4) from the right media guide (as viewed from the front of the disk drive). Note how the cables are attached to the guide for later replacement.

3. Remove the two screws securing the right media guide to the main frame and remove the guide.

4. Remove the two screws securing the left media guide to the main frame.

5. Carefully remove the left media guide from the main frame, being aware that the write protect sensor and lamp are still secured to the guide. Note the way the write protect lamp leads are routed between the guide and the main frame for later replacement.

6. Remove the write protect sensor and lamp from the media guide.

##### Replacement

1. Install the write protect sensor and lamp in the left media guide. The lamp (yellow and black leads) is installed from the top, and the sensor (orange and black leads) from the bottom.

2. Install the left media guide in the main frame. Ensure that the write protect lamp leads are routed between the guide and the main frame through the indentation on the guide.

3. Secure the media guide to the main frame with two screws.

4. Install the right media guide on the main frame and secure with two screws.

5. Attach the two R/W head cables to the right media guide. The cable to side A of connector J4 should be **above** the cable to side B of the connector.

6. Install the PCB (refer to the Printed Circuit Board paragraph).

## **WRITE PROTECT SENSOR AND LAMP ASSEMBLY**

### **Removal**

1. Remove the diskette if installed, and the PCB (refer to the Printed Circuit Board paragraph).

2. Remove the two screws securing the left media guide to the main frame.

3. Carefully remove the left media guide from the main frame, keeping in mind that the write protect sensor and lamp leads are routed between the guide and the main frame.

4. Remove the write protect sensor and lamp from the media guide.

5. Cut the tie wrap securing the wires near the base of transducer cable connector J3.

6. Remove the four write protect sensor and lamp leads from connector J3 by pushing down on the sensor and lamp lead tabs in the connector with tweezers: (sensor) black to A14, orange to B14, (lamp) black to A13, yellow to B13.

7. Separate the four write protect sensor and lamp leads from the transducer cable, and remove the sensor and lamp. Note the routing of the leads along the cable for later replacement.

### **Replacement**

1. Install the four write protect sensor and lamp leads in connector J3 (refer to step 6 above, regarding Removal). Ensure that the locking tabs on the leads engage in the connector slots. This will prevent the leads from being pushed out when the connector is plugged into the PCB.

2. Secure the four leads to the transducer cable with a tie wrap near the base of connector J3.

3. Route the write protect sensor and lamp leads along the transducer cable.

4. Install the write protect sensor and lamp in the left media guide. The lamp (yellow and black leads) is installed from the top, and the sensor (orange and black leads) is installed from the bottom.

5. Install the left media guide on the main frame. Ensure that the write protect lamp leads are routed between the guide and the main frame through the indentation on the guide.

6. Secure the media guide to the main frame with two screws.

7. Install the PCB (refer to the Printed Circuit Board paragraph).

## **CARRIER ASSEMBLY**

### **Removal (refer to the illustration below)**

1. Remove the diskette if installed, the PCB, and the front door assembly (refer to the Printed Circuit Board and Front Door Assembly paragraphs).

2. Push the index lamp out of the carrier assembly.

3. Remove the index lamp lead from the carrier assembly. Note how the lead is routed along the carrier for later replacement.

4. Remove the two screws securing the carrier to the main frame.

5. Carefully slide the carrier out from under the head carriage arm and remove the carrier assembly.

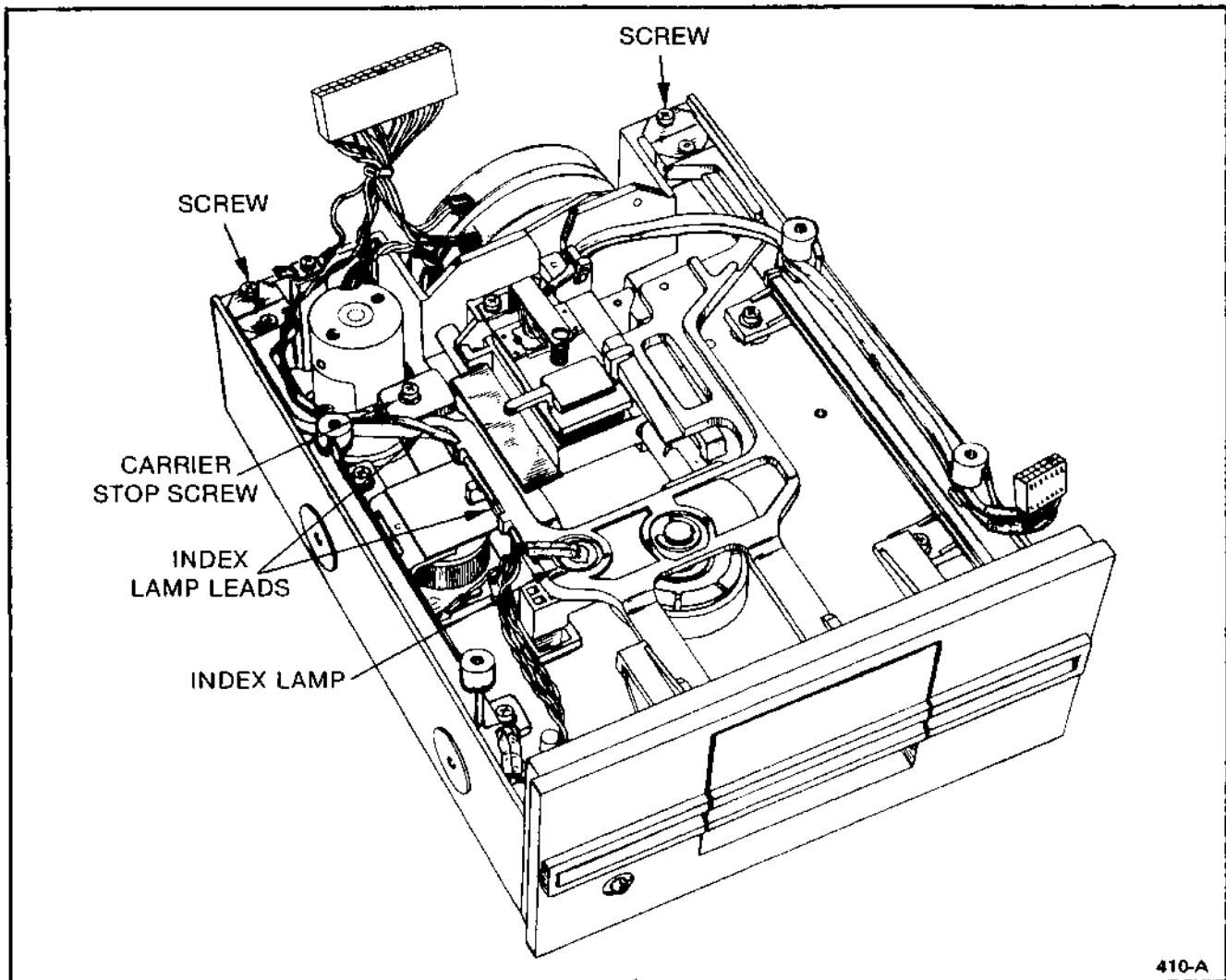

Figure 23. Carrier Assembly Removal and Replacement

**Replacement (refer to the illustration above)**

1. Carefully install the carrier assembly under the head carriage arm and into position on the main frame. Secure the carrier with two screws.

2. Route the index lamp lead along the carrier as shown, and install the lamp on the carrier.

3. Install the front door assembly (refer to the Front Door Assembly paragraph).

4. Adjust the carrier stop screw for a R/W head gap of 0.004 to 0.01 inch (0.1 to 0.25 mm). Cut two strips of 20 pound bond typing paper to approximately 1 X 3 inches. Place the two paper strips between the R/W head surfaces and close the drive door. Since the combined thickness of the paper strips is about 0.008 inch, a slight tug will

be noticed as the paper is moved between the heads. Adjust the carrier stop screw as required. Turning the stop screw clockwise will bring the heads closer together.

**CAUTION**

Do not allow the R/W heads to come together without a clean piece of paper or a diskette inserted between the head surfaces.

5. Install the PCB (refer to the Printed Circuit Board paragraph).

6. Adjust the index sensor (refer to the ADJUSTMENTS section).

**COLLET ASSEMBLY**

**Removal (refer to the Collet Assembly Removal and Installation illustration)**

1. Remove the diskette if installed, the PCB, front door assembly, and carrier assembly (refer to the Printed Circuit Board, Front Door Assembly, and Carrier Assembly paragraphs).
2. Remove the E-ring securing the collet assembly to the carrier and remove the carrier.
3. Remove the E-ring at other end of the collet shaft to remove the collet assembly.

**Replacement (refer to the Collet Assembly Removal and Installation)**

1. Install the collet assembly parts on the shaft as shown in the Collet Assembly illustration.

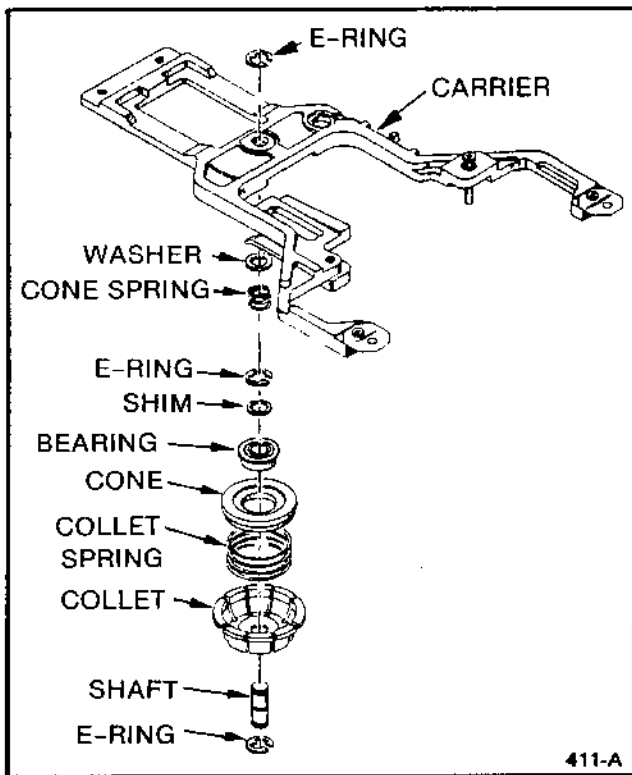

**Figure 24. Collet Assembly Removal and Replacement**

2. Install the carrier on the collet assembly and secure with an E-ring.

3. Install the carrier assembly, front door assembly, and PCB on the disk drive (refer to the Carrier Assembly, Front Door Assembly, and Printed Circuit Board paragraphs).

**SPINDLE COMPONENTS**

**Removal (refer to the Spindle Components Removal and Replacement illustration)**

1. Remove the diskette if installed. Remove the PCB, front door assembly, and carrier assembly (refer to the Printed Circuit Board, Front Door Assembly, and Carrier Assembly paragraphs) **only** if the spindle hub, bearing, and collar are removed.
2. Remove the drive belt from the spindle pulley.
3. While firmly holding the spindle pulley, remove the screw and washer that secures the spindle components to the spindle hub.
4. Remove the desired spindle components.

**Replacement (refer to the Spindle Components Removal and Replacement illustration)**

1. Install the spindle hub, bearing, and collar, if removed.
2. Install the wave and spindle washers, the bearing, and the spindle pulley, as shown. Secure with a screw and a washer.
3. Install the drive belt on the spindle pulley.
4. If the spindle hub, bearing, and collar were removed, install the carrier assembly, front door assembly, and PCB (refer to the Carrier Assembly, Front Door Assembly, and Printed Circuit Board paragraphs).

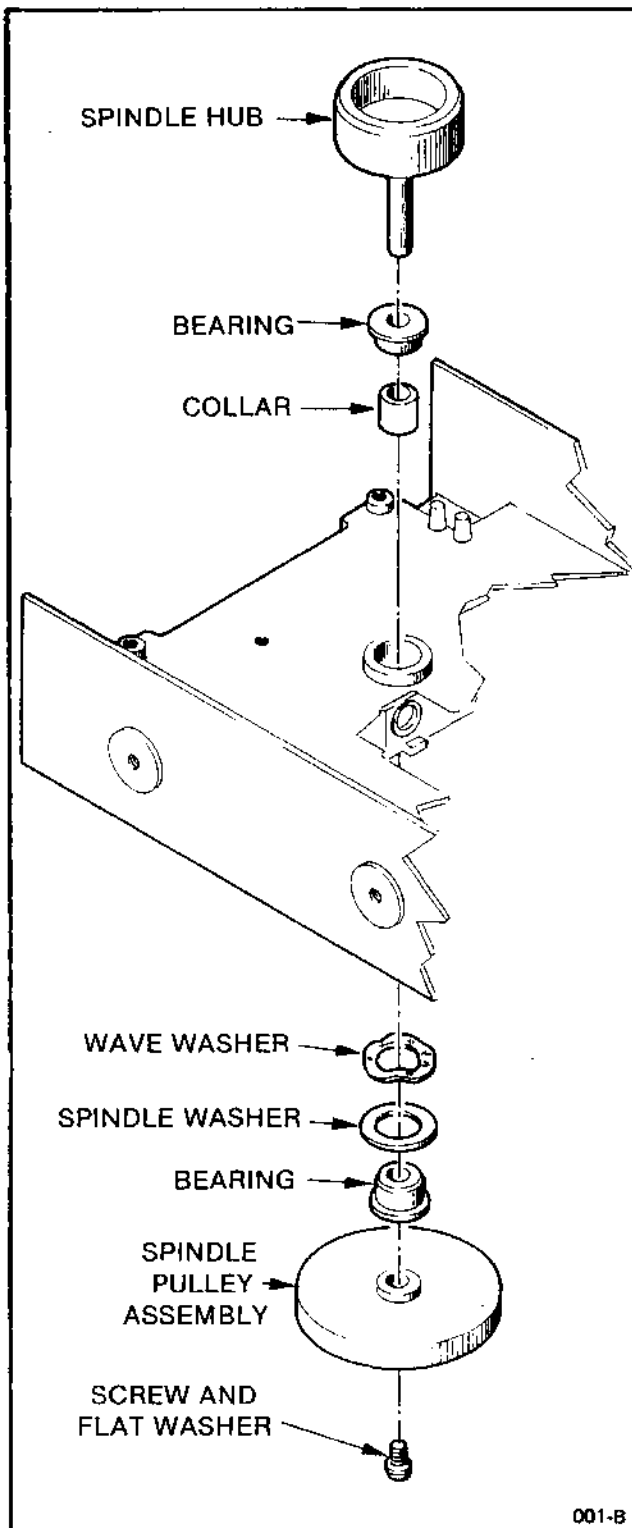

Figure 25. Spindle Components Removal and Replacement

**INDEX SENSOR AND LAMP ASSEMBLIES**

**Removal**

1. Remove the diskette if installed, the PCB, front door assembly, and carrier assembly (refer to the Printed Circuit Board, Front Door Assembly, and

Carrier Assembly paragraphs). When removing the carrier assembly, note how the two index lamp leads are routed along the carrier.

2. Remove the screw and washer securing the index sensor to the main frame. Remove the sensor. Note how the two sensor leads are routed along the main frame to the transducer cable connector J3.

3. Cut the tie wrap securing the wires near the base of connector J3.

4. Remove the four index sensor and lamp leads from connector J3 by pushing down on the sensor and lamp lead tabs in the connector with tweezers: (sensor) block to A12, blue to B12, (lamp) black to A11, white to B11.

5. Separate the four index sensor and lamp leads from the transducer cable, and remove the sensor and lamp.

**Replacement**

1. Install the four index sensor and lamp leads in connector J3 (refer to step 4 above, Removal). Be sure the locking tabs on the leads engage in the connector slots. This will prevent the leads from being pushed out when the connector is plugged into the PCB.

2. Secure the four leads to the transducer cable with a tie wrap near the base of connector J3.

3. Install the index sensor in the main frame, as shown in the illustration below. Secure the sensor with a screw and a washer.

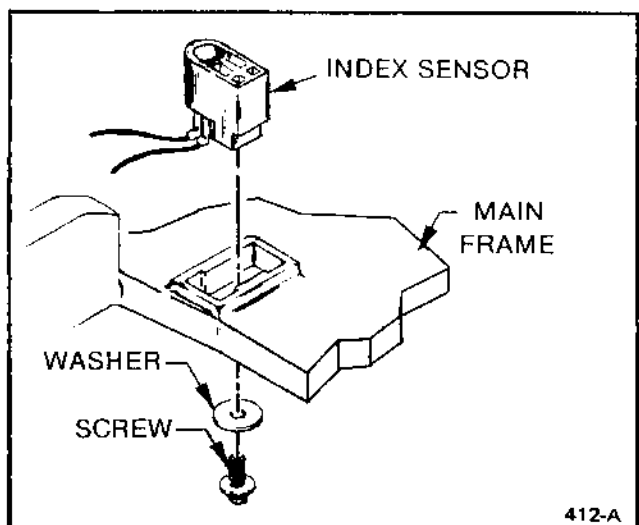

Figure 26. Index Sensor Installation

4. Install the carrier assembly and index lamp (refer to the Carrier Assembly paragraph).

5. Install the front door assembly and PCB (refer to the Front Door Assembly and Printed Circuit Board paragraphs).

6. Adjust the index sensor with the index lamp (refer to the ADJUSTMENTS section).

### HEAD LOAD SOLENOID ASSEMBLY

#### Removal

1. Remove the diskette if installed, the PCB, front door assembly, carrier assembly, and left media guide as viewed from the front of the disk drive (refer to the Printed Circuit Board, Front Door Assembly, Carrier Assembly, and Media Guide paragraphs).

2. Remove the screw securing the head load solenoid to the main frame. Note how the two solenoid leads are routed along the main frame to the transducer cable connector J3.

3. Cut the tie wrap securing the wires near the base of connector J3.

4. Remove the two head load solenoid leads from connector J3 by pushing down on the solenoid lead tabs in the connector with tweezers: green to A4, white to B4.

5. Separate the two head load solenoid leads from the transducer cable, and remove the solenoid.

#### Replacement

1. Install the two head load solenoid leads in connector J3 (refer to step 4 above, regarding Removal). Ensure that the locking tabs on the leads engage in the connector slots. This will prevent the leads from being pushed out when the connector is plugged into the PCB.

2. Secure the two leads to the transducer cable with a tie wrap near the base of connector J3.

3. Route the two head load solenoid leads along the main frame and install the solenoid. Slide the metal solenoid arm under the head carriage arm. Ensure that the key at the bottom of the solenoid is in the main frame slot.

4. Secure the head load solenoid with a screw.

5. Install the left media guide, the carrier assembly, front door assembly, and PCB (refer to the Media Guides, Carrier Assembly, Front Door Assembly, and Printed Circuit Board paragraphs).

### MOTOR CONTROL BOARD

#### Removal

1. Remove the diskette if installed, the DC power cable connector J2, and transducer cable connector J3 from the PCB.

2. Cut the tie wrap securing the wires near the base of connector J3.

3. Remove the three motor control board leads from connector J3 by pushing down on the control board lead tabs in the connector with tweezers: blue to A1, red to B1, and black to B2.

4. Separate the three motor control board leads from the transducer cable by cutting the two tie wraps attached to the main frame under the stepper motor.

5. Remove the three screws securing the motor control board and the heat sink to the main frame. Make sure that a nylon screw is used for the heat sink.

6. With soldering equipment, remove the four drive motor leads from the motor control board: 1–yellow, 2–red, 3–green and 4–blue. Numeric references are indicated on the component side of the board (refer to the illustration below).

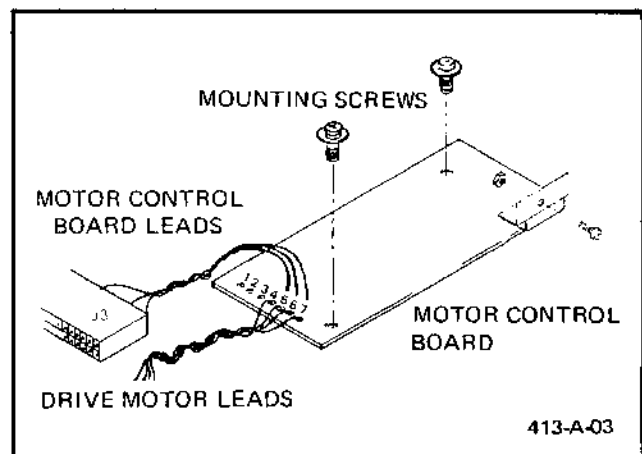

Figure 27. Motor Control Board — Drive Motor Leads

7. Remove the motor control board.

## Replacement

1. With soldering equipment, secure the four drive motor leads to the motor control board (refer to step 6, Removal).

2. Install the motor control board on the main frame, and secure with three screws. Ensure that a nylon screw is used for the heat sink.

3. Secure the three motor control board leads, four drive motor leads, and two track 00 switch leads along the main frame with two tie wraps. Attach the tie wraps to the main frame at the two holes under the stepper motor.

4. Install the three motor control board leads in connector J3 (refer to step 3, regarding Removal). Ensure that the locking tabs on the leads engage in the connector slots. This will prevent the leads from being pushed out when the connector is plugged into the PCB.

5. Secure the leads to the transducer cable with a tie wrap near the base of connector J3.

6. Install connectors J2 and J3 on the PCB.

7. Adjust the drive motor (refer to the ADJUSTMENTS section).

## DRIVE MOTOR

### Removal

1. Remove the diskette if installed, the DC power cable connector J2, and transducer cable connector J3 from the PCB.

2. Separate the four drive motor leads from the transducer cable by cutting the two tie wraps attached to the main frame under the stepper motor.

3. Remove the two screws securing the motor control board to the main frame.

4. With soldering equipment, remove the four drive motor leads from the motor control board: 1-yellow, 2-red, 3-green, and 4-blue. Numeric references are indicated on the component side of the board (refer to the illustration above).

5. Remove the drive belt.

6. Remove the two screws securing the drive motor to the main frame. Remove the drive motor.

### Replacement

1. Install the drive motor on the main frame and secure with two screws.

2. Install the drive belt.

3. With soldering equipment, secure the four drive motor leads to the motor control board (refer to step 4 above, regarding Removal).

4. Install the motor control board on the main frame and secure with two screws.

5. Secure four drive motor leads, three motor control leads, and two track 00 switch leads along the main frame with two tie wraps. Attach the tie wraps to the main frame at the two holes under the stepper motor.

6. Install connectors J2 and J3 on the PCB.

7. Adjust the drive motor (refer to the ADJUSTMENTS section).

## TRACK 00 SWITCH ASSEMBLY

### Removal

1. Remove the diskette if installed, the DC power cable connector J2, and transducer cable connector J3 from the PCB.

2. Cut the tie wrap securing the wires near the base of connector J3.

3. Remove the three track 00 switch leads from connector J3 by pushing down on the switch lead tabs in the connector with tweezers: yellow to A8, green to A9, and white to B9.

4. Separate the three track 00 switch leads from the transducer cable by cutting the two tie wraps attached to the main frame under the stepper motor.

5. Remove the two screws securing the track 00 switch and base to the main frame.

6. Remove the two screws securing the track 00 switch to the switch base.

### Replacement

1. Secure the track 00 switch to the switch base with two screws.

2. Install the track 00 switch and base on the main frame, and secure with two screws.

3. Secure the three track 00 switch leads, three motor control board leads, and four drive motor leads along the main frame with two tie wraps. Attach the tie wraps to the main frame at the two holes under the stepper motor.

4. Install the three track 00 switch leads in connector J3 (refer to step 3, regarding Removal). Ensure that the locking tabs on the leads engage in the connector slots. This will prevent the leads from being pushed out when the connector is plugged into the PCB.

5. Secure the leads to the transducer cable with a tie wrap near the base of connector J3.

6. Install connectors J2 and J3 on the PCB.

7. Adjust the track 00 switch (refer to the ADJUSTMENTS section).

**HEAD CARRIAGE ASSEMBLY**

**Removal (refer to the illustration below)**

1. Remove the diskette if installed, the PCB, and the door carrier assembly (refer to the Printed Circuit Board and Carrier Assembly paragraphs).

**CAUTION**

The R/W heads must not be allowed to come together. Insert a clean piece of paper between the head surfaces.

2. Remove the two R/W head cables (connector J4) from the right media guide (as viewed from the front of the disk drive). Note the way the cables are attached to the guide for later replacement.

3. Cut the tie wrap securing the wires near the base of connector J3.

4. Remove the six stepper motor leads from connector J3 by pushing down on the motor lead tabs in the connector with tweezers: black to A5, yellow to A6, brown to A7, red to B5, red to B6, and orange to B7.

5. From the underside of the carriage assembly, remove the two Phillips head screws and washers that secure the retainer, plate spring, steel ball and carriage to the shaft of the stepper motor.

6. Remove the two Phillips head screws, lock washers, and flat washers that secure the stepper motor to the main frame. Lift the stepper motor and carriage free.

7. Slide the carriage from the shaft of the stepper motor and remove.

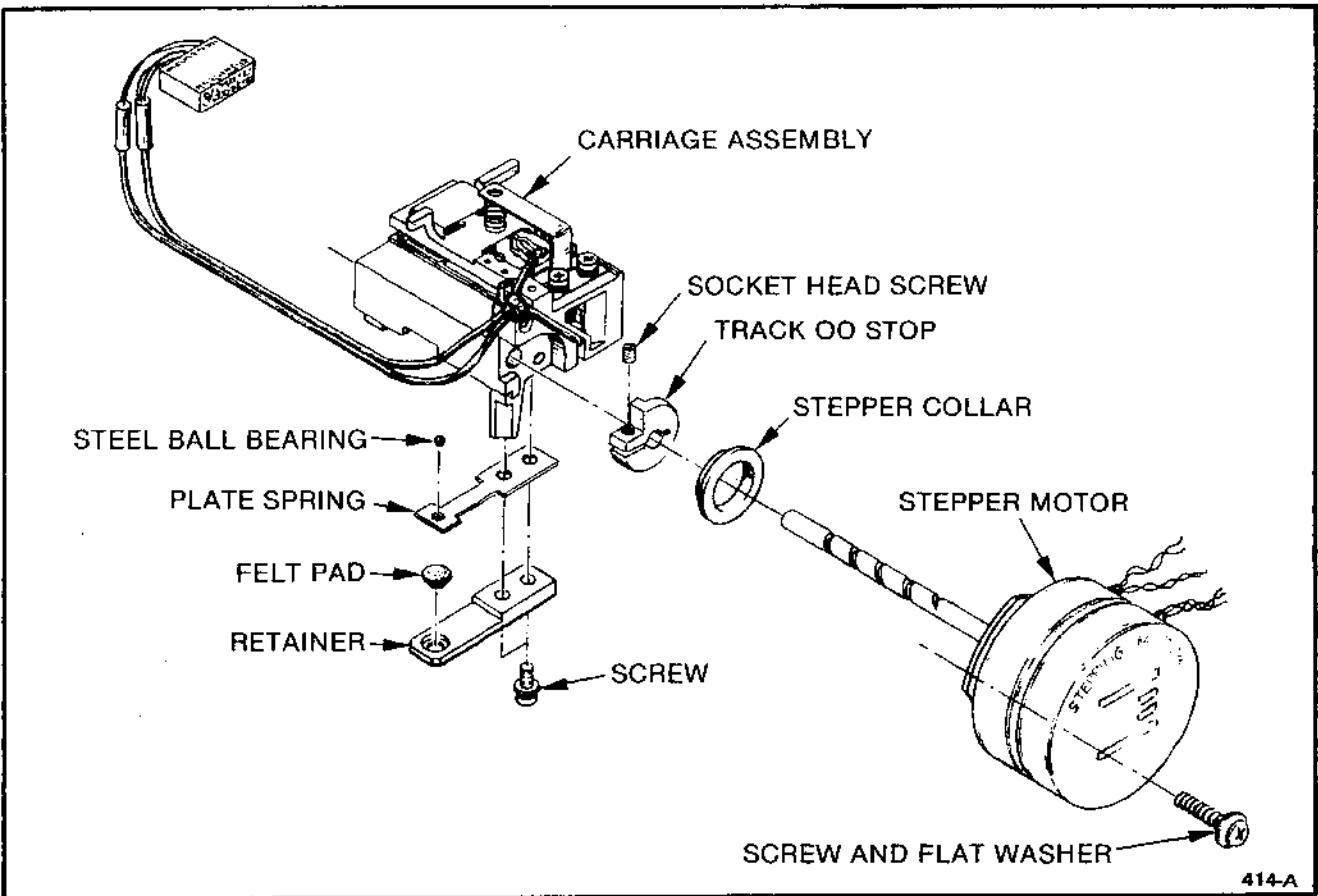

**Figure 28. Stepper Motor and Head Carriage Removal and Installation**



**REPLACEMENT (refer to the illustration above)**

1. Slide the carriage assembly into the stepper motor shaft and install as a unit in the main frame. Loosely tighten the two stepper motor mounting screws to hold the motor in place.

2. Slide the carriage to its forward limit and position the stepper motor shaft so as to locate a point in the spiral groove that is in alignment with the screw holes used to mount the plate spring and retainer.

3. Apply a small dab of grease in the hole of the plate spring. Place the steel ball in the greased hole and install the plate spring in the carriage. When properly aligned, the steel ball should ride in the spiral groove with the plate spring perpendicular to the stepper motor shaft.

4. Apply a drop of light lubricating oil (Q.P.N. 55279-01) to the fur felt in the retainer. Install the retainer with the fur felt against the steel ball in the plate spring and secure all in place on the carriage with two Phillips head screws and washers.

5. Install the six stepper motor leads in connector J3 by inserting the lead tabs into the connector slots as follows: black to A5, yellow to A6, brown to A7, red to B5, red to B6, and orange to B7.

6. Secure all leads terminating in connector J3 with a tie wrap near the base of the connector.

7. Secure the two R/W head cables on the right media guide.

8. Install the door carrier assembly and the PCB (refer to the Carrier Assembly and Printed Circuit Board paragraphs).

9. Adjust the track 00 switch, track 00 stop and the stepper motor as necessary (refer to the Adjustments section).

**STEPPER MOTOR****Removal (refer to the Stepper Motor and Head Carriage Removal and Installation illustration).**

1. Remove the diskette if installed, and the PCB (refer to the Printed Circuit Board paragraph)

**CAUTION**

The R/W heads must not be allowed to come together. Insert a clean piece of paper between the head surfaces.

2. Cut the tie wrap securing the wires near the base of connector J3.

3. Remove the six stepper motor leads from connector J3 by pushing down on the motor lead tabs in the connector with tweezers: black to A5, yellow to A6, brown to A7, red to B5, red to B6, and orange to B7.

4. From the underside of the carriage assembly, remove the two Phillips head screws and washers that secure the retainer, plate spring, steel ball and carriage to the shaft of the stepper motor.

5. Remove the two Phillips head screws, lock washers, and flat washers that secure the stepper motor to the main frame. Slide the stepper motor shaft out of the head carriage and remove the motor from the main frame.

6. Remove the track 00 stop and stepper collar from the motor shaft.

**Replacement (refer to the Stepper Motor and Head Carriage Removal and Installation illustration)**

1. Install the stepper collar on the stepper motor shaft with the flange side against the motor. Next install the track 00 stop on the stepper motor shaft with the flat side toward the stepper collar. Do not tighten the socket head screw as adjustment will be required later.

2. Insert the shaft of the stepper motor into the head carriage assembly and install the motor in the main frame. Loosely tighten the stepper motor mounting screws to hold the motor in place.

3. Slide the carriage to its forward limit and position the stepper motor shaft so as to locate a point in the spiral groove that is in line with the screw holes used to mount the plate spring and retainer.

4. Apply a small dab of grease in the hole of the plate spring. Place the steel ball in the greased

hole and install the plate spring in the carriage. When properly aligned, the steel ball should ride in the spiral groove with the plate spring perpendicular to the stepper motor shaft.

5. Apply a drop of light lubricating oil (Q.P.N. 55279-01) to the fur felt in the retainer. Install the retainer with the fur felt against the steel ball in the plate spring and secure all in place on the carriage with two Phillips head screws and washers.

6. Install the six stepper motor leads in connector J3 by inserting the lead tabs into the connector

slots as follows: black to A5, yellow to A6, brown to A7, red to B5, red to B6, and orange to B7.

7. Secure all leads terminating in connector J3 with a tie wrap near the base of the connector.

8. Install the PCB (refer to the Printed Circuit Board paragraph).

9. Adjust the track 00 switch, track 00 stop and the stepper motor as necessary (refer to the Adjustments section).

## ADJUSTMENTS AND CHECKS

### GENERAL

The test equipment and tools required for adjustment of the QumeTrak 542 are tabulated below:

**Table 12**  
**Test Equipment and Tools Required**

OSCILLOSCOPE	● TEKTRONICS 465 OR EQUIVALENT
EXERCISER	● SYSTEM CONTROLLER OR DRIVE EXERCISER/TESTER
CE DISKETTE	● Q.P.N. 51201-01
ALLEN DRIVER	● 1.5 mm
FEELER GAUGE	● 0.027 INCH (0.7 mm)
PHILLIPS SCREW-DRIVER (2)	● #1 HEAD, 4 INCH SHANK; ● #2 HEAD, 4 INCH SHANK
FLAT HEAD SCREWDRIVER	● 4 INCH SHANK

### CAUTION

The R/W heads must not be allowed to come together without a diskette or clean piece of paper inserted between the head surfaces.

### DRIVE MOTOR ADJUSTMENT

The QumeTrak 542 drive motor speed can be visually verified by referencing the "strobing effect" produced by the decal on the spindle pulley. The decal has two scales: a 50 Hz and a 60 Hz scale for use under artificial light produced by 50 Hz or by 60 Hz voltage. To check and/or adjust the drive motor speed proceed as follows:

1. Position the drive on its side in a well lighted area. Good lighting is important to ensure that the "strobing effect" produced by the decal is easily recognized. Ensure that only fluorescent or neon lighting is used as incandescent lighting will not be effective.

2. Install a diskette of known integrity in the disk drive.

3. Power up the disk drive so that the drive motor is turning the spindle pulley.

4. Observe the appropriate scale (50 Hz or 60 Hz) on the spindle pulley. Motor speed is properly

adjusted when the white/black pattern on the decal ring appears to be standing still and pulsate or flash. If the pattern rotates, slowly adjust VR1 on the motor control board until it stands still.

### HEAD ALIGNMENT ADJUSTMENT

#### NOTE

1. For a more precise adjustment the disk drive should be oriented in its (vertical or horizontal) "in-service" position while on the test bench.

2. Qume's CE diskettes are certified at  $70 \pm 5^\circ\text{F}$  and  $45 \pm 5\%$  relative humidity.

1. Set the oscilloscope controls as follows:

VOLTS/DIV (CH1 & CH2)	50 mv
VAR KNOB (CH1 & CH2)	CAL
CH2	INVERT
VERT MODE	ADD
AC/GND/DC (CH1 & CH2)	AC
HORZ DISPLAY	A
TRIG MODE	NORM
TRIG COUPLING	AC
A/B TIME/DIV	20 ms
SLOPE	+
SOURCE	EXTERNAL

2. Power up the disk drive.

3. Install a Qume CE diskette, P.N. 51201-01.

4. Connect oscilloscope channel probes 1 and 2 to TP1A and TP1B (R/W head signals) respectively, and the trigger probe to TP3 (Index) on the PCB. Connect the probe ground leads to the GND test point.

5. Starting from TRACK 00, step the head carriage "IN" on the diskette until a "cats-eye" pattern is observed on the oscilloscope as shown below. The pattern should appear on TRACK 16 (otherwise, set the head carriage on the closest even numbered track that affords an approximate "cats-eye" pattern). Note the relationship in amplitude between LOBES A and B.

6. Go to TRACK 40, then step "OUT" to the track where the "cats-eye" pattern is observed. Note the LOBE A vs. LOBE B relationship.

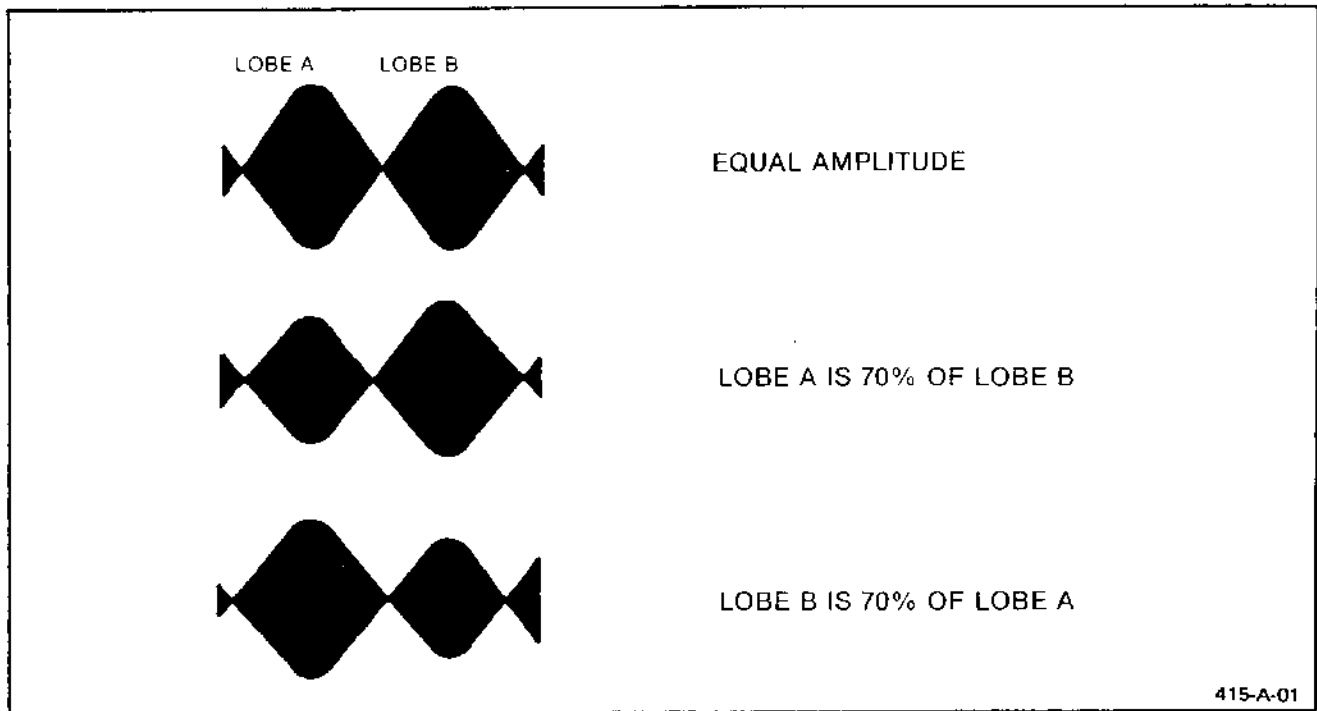

Figure 29. "Cats-eye" Pattern

7. For optimum performance LOBE A should equal LOBE B. If in either direction the amplitude of the smaller lobe is less than 70% of the taller one, the head alignment needs to be adjusted. If adjustment is necessary, average the two noted readings. Loosen the two stepper motor mounting screws and while observing the oscilloscope, slowly rotate the stepper motor into a position where the relationship of LOBE A vs. LOBE B is corrected by the computed average. This procedure compensates for any mechanical tolerance in head/track alignment between stepping "IN" and "OUT." Secure the mounting screws.

8. Repeat steps 5, 6, and 7 above.

9. Disconnect the oscilloscope probes from the PCB and remove the diskette from the drive. Power down the disk drive.

#### TRACK 00 SWITCH ADJUSTMENT

1. Verify head alignment (refer to the HEAD ALIGNMENT ADJUSTMENT paragraph, steps 1 through 8).

2. Single step the head carriage "OUT" to locate the head on TRACK 00.

3. Remove the oscilloscope probes from the PCB.

4. Set the oscilloscope controls as follows:

VOLTS/DIV (CH1)	2
VAR KNOB (CH1)	CAL
VERT MODE	CH1
AC/GND/DC	DC
TRIG MODE	AUTO

5. Connect the oscilloscope channel 1 probe to TP5 (Track 00) on the PCB. Connect the probe ground to the GND test point.

6. Observe on the oscilloscope a high (4V) level. If necessary to adjust, loosen the TRACK 00 switch mounting screws, and reposition the switch to obtain the desired 4V level. Secure the switch mounting screws.

7. Alternate the head carriage between TRACK 00 and TRACK 01 several times. Observe that on TRACK 00 a high (4V) is indicated on the oscilloscope, and on TRACK 01 a low (0V) level. Repeat step 6 as necessary to obtain the proper levels.

8. Disconnect the oscilloscope probes from the PCB and remove the diskette from the drive. Power down the disk drive.

#### TRACK 00 STOP ADJUSTMENT

1. Verify that the TRACK 00 switch is properly adjusted and that the head carriage is located at

TRACK 00 (refer to the TRACK 00 SWITCH ADJUSTMENT paragraph).

2. With a feeler gauge, check the gap between the head carriage and the TRACK 00 stop as shown below. The correct tolerance is 0.027 inch (0.7 mm  $\pm$  0.05 mm).

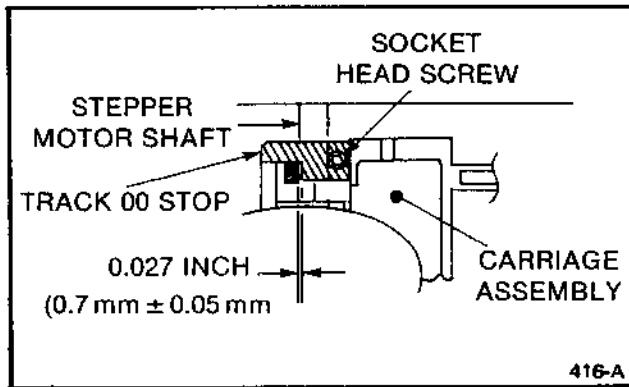

Figure 30. Track 00 Stop Adjustment

3. If adjustment is necessary, loosen the screw that secures the stop on the stepper motor shaft with a 1.5 mm allen driver. Move the stop until it affords the proper gap, and secure in place.

#### INDEX SENSOR ADJUSTMENT

1. Set the oscilloscope controls as follows:

VOLTS/DIV (CH1 & CH2)	50 MV
VAR KNOB (CH1 & CH2)	CAL
CH2	INVERT
VERT MODE	ADD
AC/GND/DC (CH1 & CH2)	AC
HORZ DISPLAY	A
TRIG MODE	NORM
TRIG COUPLING	AC
A/B TIME/DIV	0.2 ms
SLOPE	+
SOURCE	EXTERNAL

2. Power up the disk drive.

3. Install a CE diskette, Q.P.N. 51201-01, in the disk drive.

4. Connect the oscilloscope channel probes 1 and 2 to TP1A and TP1B (R/W head signals) respectively, and the trigger probe to TP3 (Index) on the PCB. Connect the probe ground leads to the GND test point.

5. Step the head carriage "IN" to TRACK 01.

6. Observe the following index burst pattern on the oscilloscope.

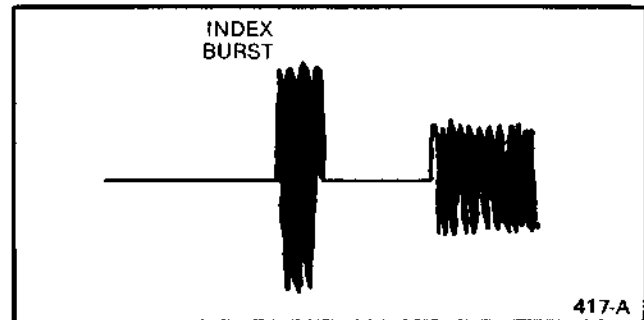

Figure 31. Index Burst Pattern

7. If the index burst occurs  $400 \mu\text{s} \pm 200 \mu\text{s}$  after the start of the index pulse, no adjustment is necessary. Otherwise, loosen the index sensor mounting screw. Place the blade of a screwdriver between the sensor and the main frame and gently move the sensor into proper adjustment ( $400 \mu\text{s} \pm 200 \mu\text{s}$ ) while monitoring the oscilloscope. Tighten the mounting screw.

8. Disconnect the oscilloscope probes from the PCB and remove the diskette from the drive. Power down the disk drive.

#### AZIMUTH ALIGNMENT CHECK

The AZIMUTH ALIGNMENT CHECK procedure is presented as a guideline for determining the degree of R/W head alignment integrity. The entire head/carriage assembly is factory adjusted and tested; there is no field adjustment. Replace the entire assembly if defective.

1. Set the oscilloscope as follows:

VOLTS/DIV (CH1 & CH2)	50 mv
VAR KNOB (CH1 & CH2)	CAL
CH2	INVERT
VERT MODE	ADD
AC/GND/DC (CH1 & CH2)	AC
HORZ DISPLAY	A
TRIG MODE	NORM
TRIG COUPLING	AC
A/B TIME/DIV	0.5 ms
SLOPE	+
SOURCE	EXTERNAL

2. Power up the disk drive.

3. Install a CE diskette, Q.P.N. 51201-01, in the

## ADJUSTMENTS AND CHECKS

disk drive and step the head carriage "IN" to TRACK 34. Activate SIDE SELECT 0.

4. Connect the oscilloscope channel probes 1 and 2 to TP1A and TP1B (R/W head signals) respectively, and the trigger probe to TP3 (Index) on the PCB. Connect the probe ground leads to the GND test point.

5. Observe the oscilloscope for a pattern similar to that shown in the Azimuth Check illustration.

6. Activate SIDE SELECT 1 and repeat step 5.

7. Disconnect the oscilloscope probes from the PCB and remove the diskette from the drive. Power down the disk drive.

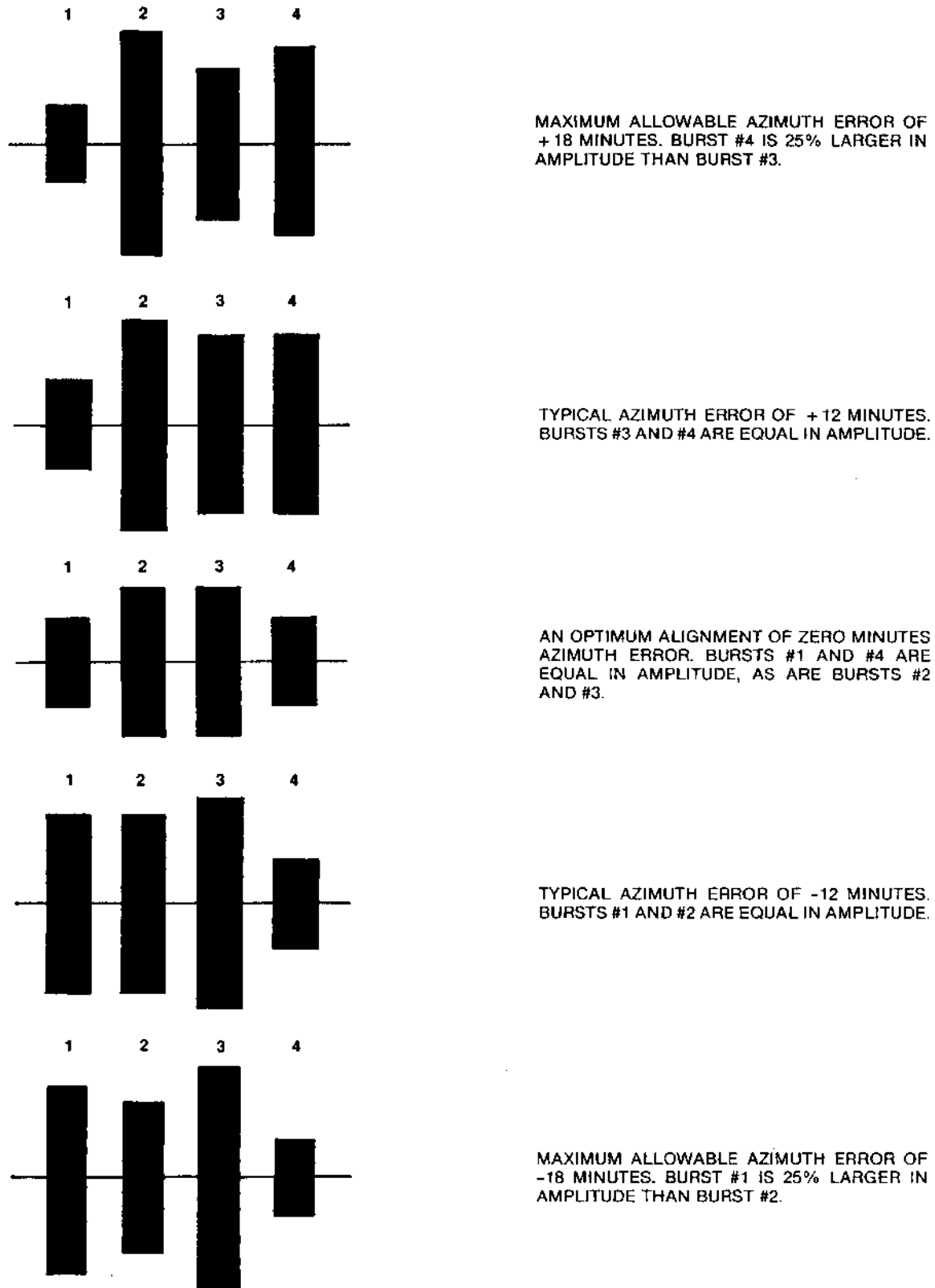

USING A QUME CERTIFIED 12 MINUTE CE DISK (QUME P.N. 51201-01) THE AZIMUTH SHALL BE ACCEPTABLE IF A DRIVE SHOWS LESS THAN THE MAXIMUM ALLOWABLE 18 MINUTE AZIMUTH. THE MAXIMUM ALLOWABLE AZIMUTH IS CONSIDERED TO BE ATTAINED WHEN BURST #1 IS 25% LARGER THAN BURST #2, OR IF BURST #4 IS 25% LARGER THAN BURST #3.

419-A

Figure 32. Azimuth Check

# TROUBLESHOOTING

## GENERAL

This section presents troubleshooting information dealing with the most common QumeTrak 542 functional errors; namely, Not Ready, Seek Error, Read Error, Write Errors, and No Head Load. The troubleshooting of these errors is accomplished in flowchart format.

## DEFINITION OF QUMETRAK 542 FUNCTIONAL ERRORS

### Not Ready

A condition in which the controller fails to receive a READY signal from the disk drive when it expects to receive one.

### Seek Error

A condition in which the drive is unable to access a particular diskette side or track, or to confirm track 00 access to the controller.

### Read Error

A condition in which the drive is unable to recover data previously written onto the diskette.

### Write Error

A condition in which the drive is unable to write data onto a diskette.

### No Head Load

A condition in which the R/W head fails to load onto the diskette. This condition may be associated with any of the above errors.

## TROUBLESHOOTING TECHNIQUE

Effective troubleshooting should always begin with a visual inspection. Look for such things as faulty wiring, damaged or misaligned components, and the presence of any foreign matter such as dust. Inspect for anything that can obviously alter performance of the drive.

Next, proceed to isolate the problem to the diskette, drive, or controller. Malfunctions that are diskette related can be easily detected by comparing the performance of the suspect diskette to one known to be in good condition. Most diskette problems can be attributed to either soft or hard errors. Soft errors resulting from contamination by dust and/or body oil on the diskette surface are usually caused by careless handling. Soft errors diminish the accurate read/write capability of the diskette, but do not necessarily render the diskette unusable. Conversely, hard errors caused by such things as scratches and abrasions permanently damage the medium.

Likewise, the drive unit can be determined defective or not by exchanging the original unit with one that is known to be operable. Verify that the drive is installed correctly. Specifically, check to see that the voltage requirements are supplied and that the strappable options are correctly placed. Proceed to the troubleshooting flowcharts for further isolation of a drive unit fault.

Once the drive unit is found to be functional, verify that the interface and controller programming are viable.

## TROUBLESHOOTING FLOWCHARTS

In order to use the troubleshooting flowcharts with optimum efficiency it is necessary to have the following equipment:

- A diskette of known integrity; CE diskette, Q.P.N. 51201-01, may be helpful.
- Multimeter, 20,000 ohms/volt.
- Oscilloscope, dual trace.



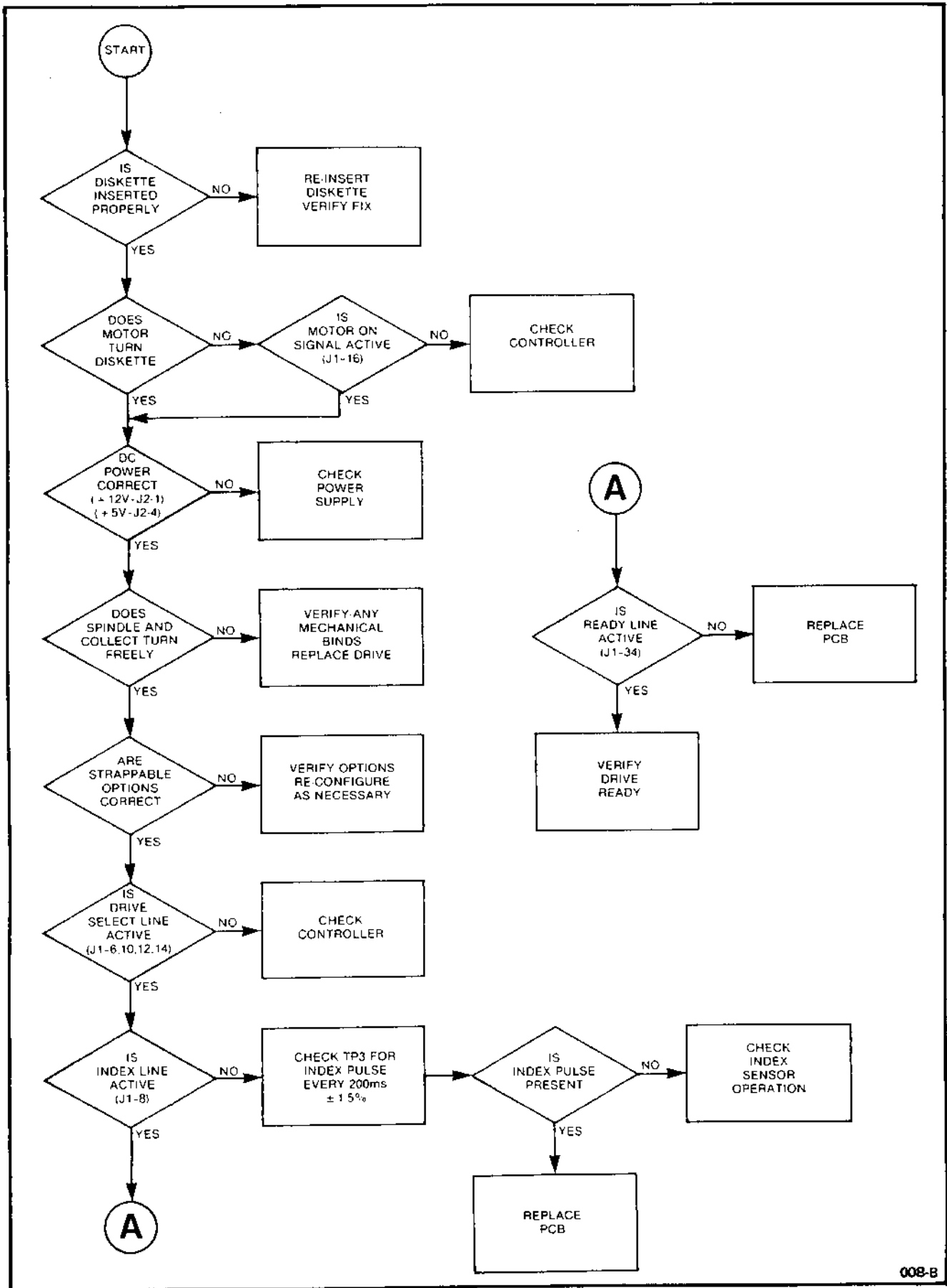

008-B

Figure 33. Not Ready Troubleshooting Flowchart

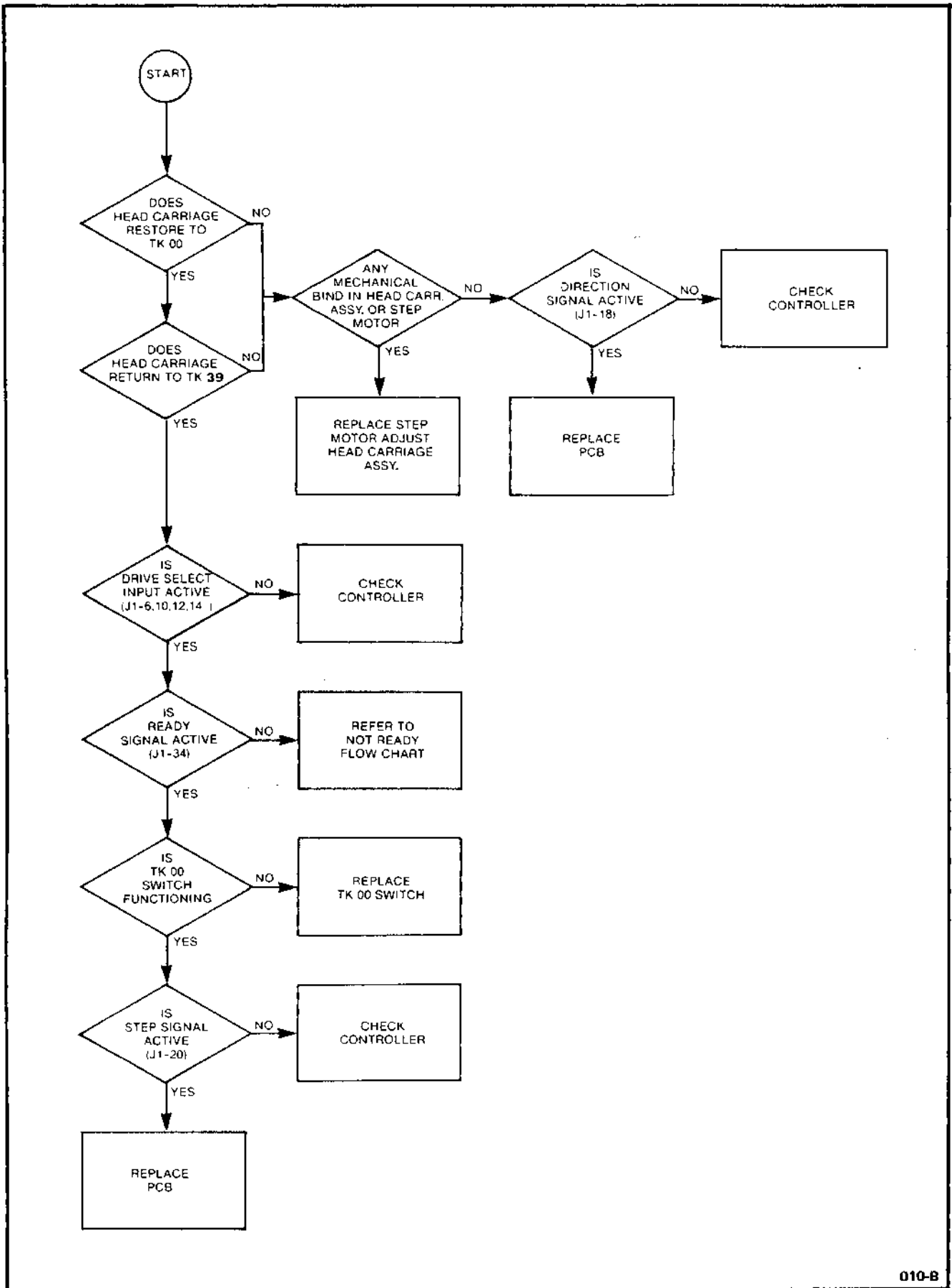

010-B

Figure 34. Seek Error Troubleshooting Flowchart

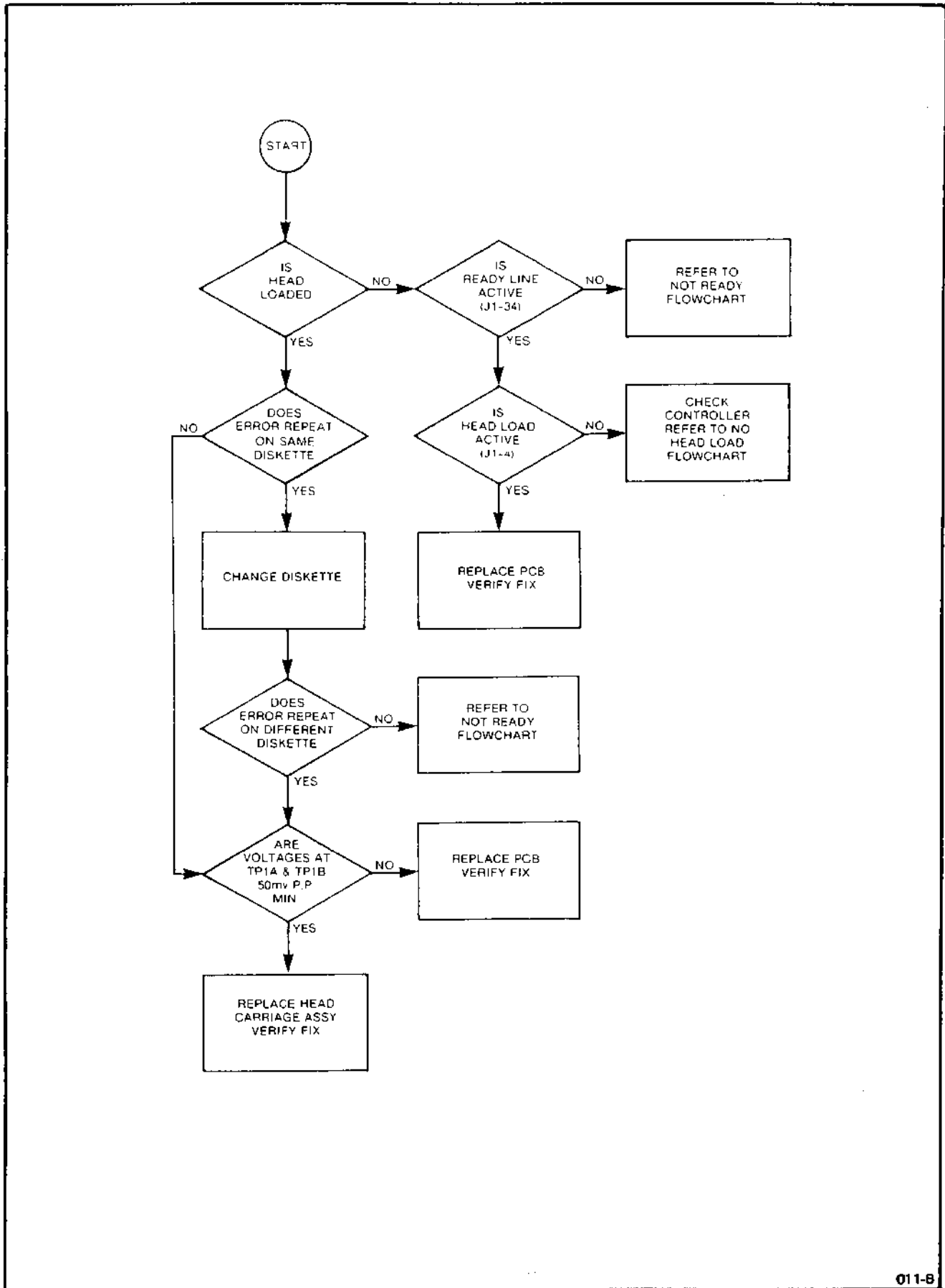

011-B

Figure 35. Read Error Troubleshooting Flowchart

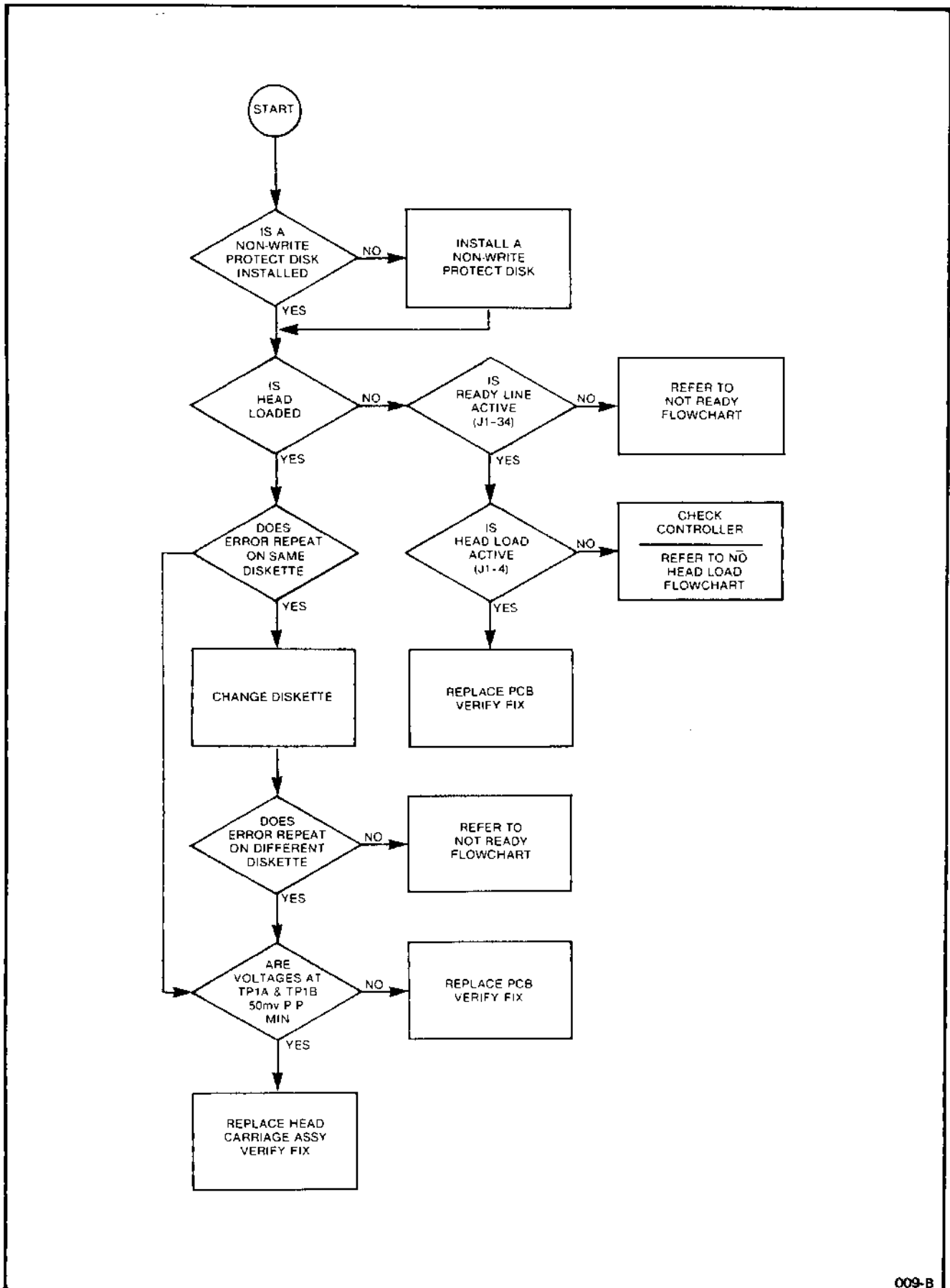

009-B

Figure 36 Write Error Troubleshooting Flowchart

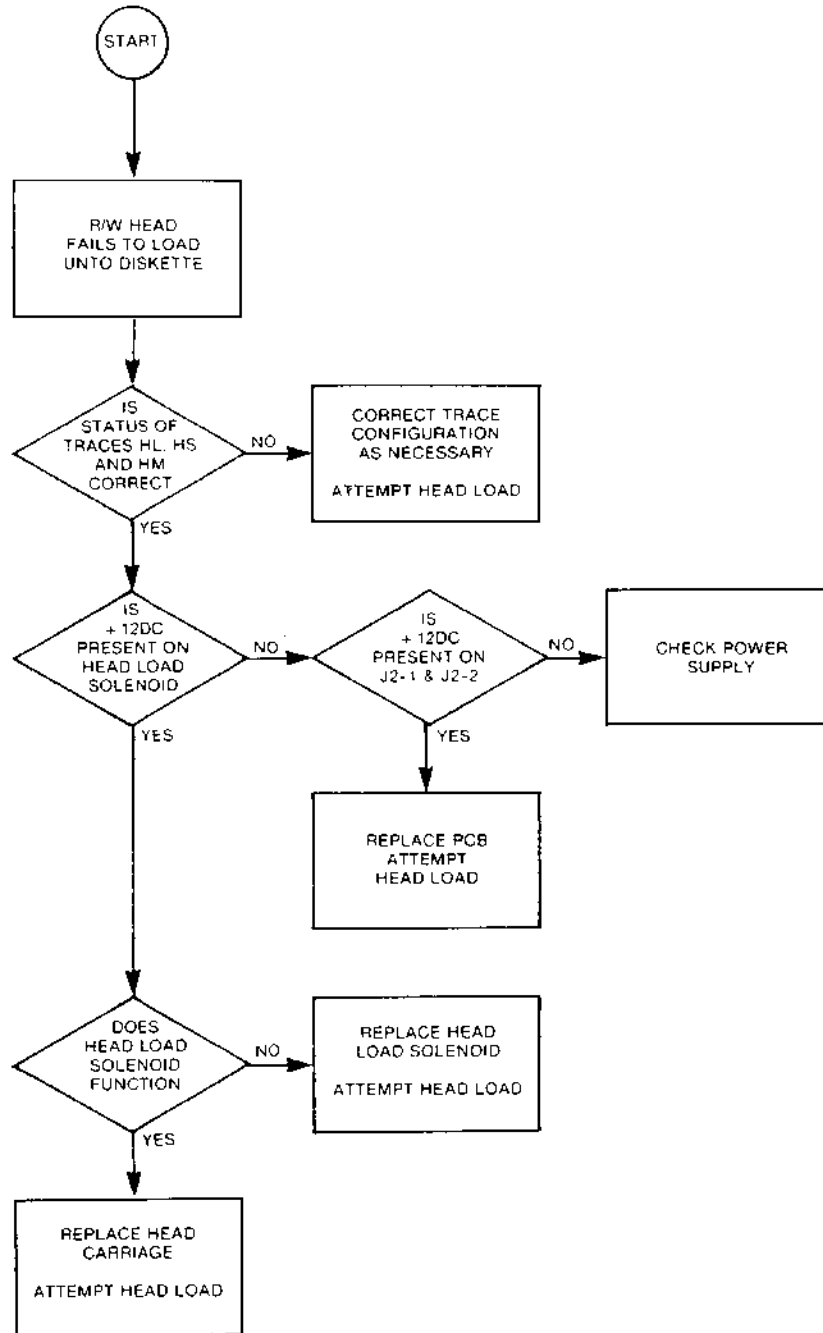

007-B

Figure 37. No Head Load Troubleshooting Flowchart

## RECOMMENDED SPARE PARTS

Tabulated below are the recommended spare parts according to description, part number, and quantity for supporting the QumeTrak 542 disk drive. Refer to the Illustrated Assemblies and Parts Locations paragraph for identification of parts.

The Qume Memory Products Service and Spares Catalog, publication number 37052, offers a comprehensive list of all QumeTrak 542 replaceable parts and lays down basic service policy.

**Table 13  
Recommended Spare Parts**

DESCRIPTION	P/N	NUMBER OF DISK DRIVES			
		50	100	250	500
		NUMBER OF SPARE PARTS			
STEPPER MOTOR ASSEMBLY	51126-01	—	1	1	2
DRIVE MOTOR	51079-02	1	1	2	3
MOTOR CONTROL BOARD ASSEMBLY	51082-02	1	1	2	3
PRINTED CIRCUIT BOARD	51004-01	—	1	1	2
HEAD CARRIAGE ASSEMBLY	51017-01	1	1	2	3
STEEL BALL	51009-01	1	1	2	3
SPRING PLATE	51012-01	1	1	2	3
FUR FELT	51014-01	1	1	2	3
RETAINER	51013-01	1	1	2	3
HEAD LOAD SOLENOID ASSEMBLY	51087-01	—	1	1	2
SPINDLE DRIVE BELT	51086-01	1	1	2	3
COLLET ASSEMBLY	51068-06	1	1	2	3
INDEX SENSOR ASSEMBLY	51083-01	1	1	2	3
WRITE PROTECT SENSOR ASSEMBLY	51185-01	1	1	2	3
TRACK 00 SWITCH	51109-01	1	1	2	3

## ILLUSTRATED PARTS

The following pages contain illustrated assemblies and corresponding parts lists for the QumeTrak 542 Flexible Disk Drive. Illustrations in each section provide an assembly guide and may be used for identification of missing or broken parts when repairing a disk drive. Some parts may be illustrated for clarity only. Parts not shown or listed are not available.

For information on service and repair policies, training policies, and spare parts pricing for the QumeTrak 542 Flexible Disk Drive, refer to the "Memory Products Service and Spares Catalog," publication number 37052.

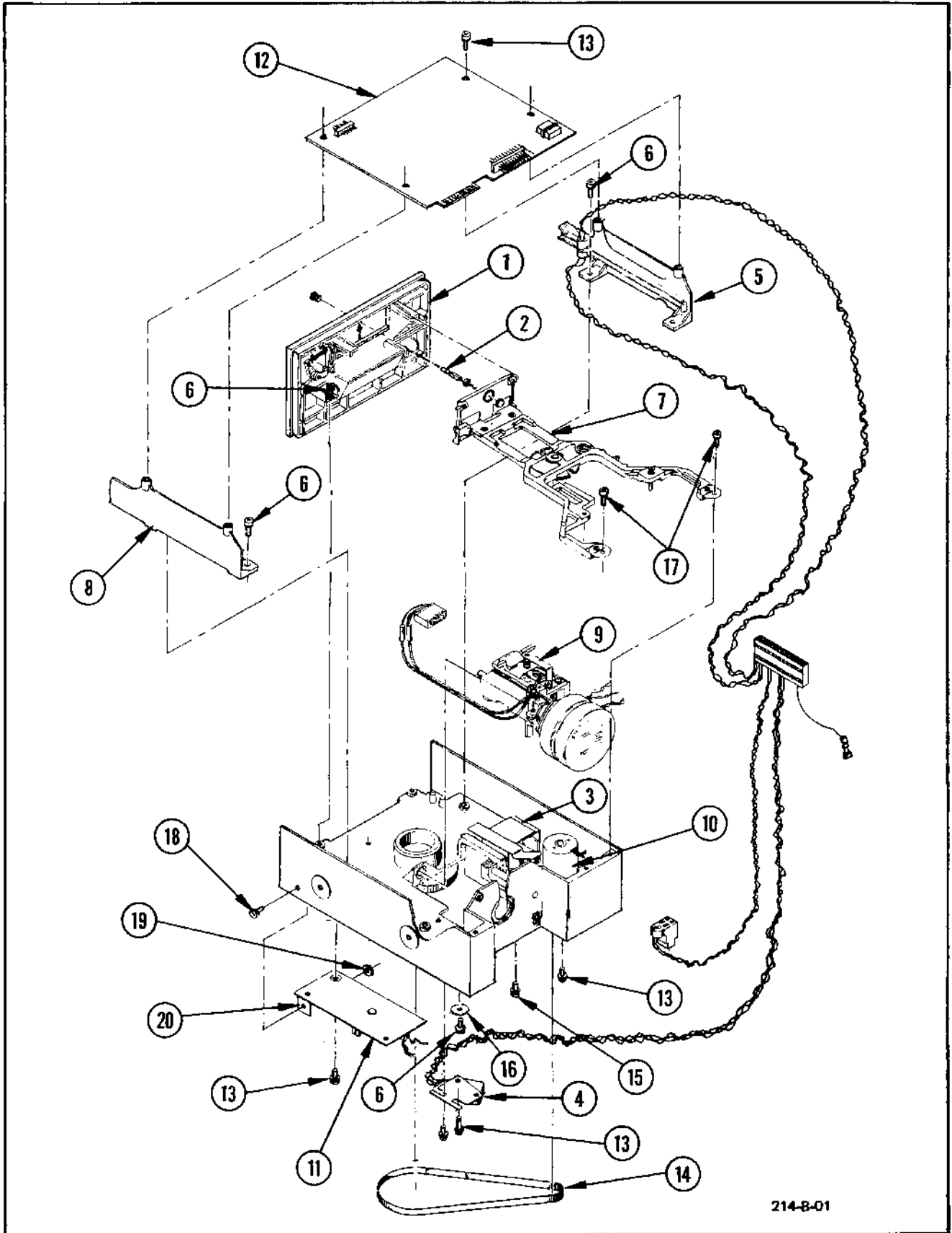

214-B-01

FINAL ASSEMBLY



**FINAL ASSEMBLY**

Item	Part No.	Description
1.	51115-02	Front Bezel Assembly
2.	51116-01	In-Use Lamp Assembly (Note 1)
3.	51087-01	Head Load Solenoid
4.	51109-01	Track 00 Sensor Assembly (Note 2)
5.	51150-02	Harness/Left Media Guide Assembly
6.	55173-08	Screw, PH, w Lk/Fltwsr 3 mm
7.	51149-02	Door Carrier Assembly (Note 3)
8.	52006-01	Media Guide Assembly, RH Carriage Stepper
9.	-----	Carriage Stepper Assembly (Note 4)
10.	51079-02	Drive Motor (Note 5)
11.	51082-02	Motor Control Board Assembly (Note 5)
12.	51004-01	PCB Assembly
13.	55173-06	Screw, w Lk/Fltwsr 4 × 8 mm
14.	51086-01	Drive Belt
15.	55173-12	Screw, PH, w Lk/Fltwsr
16.	55210-04	Washer
17.	55163-06	Screw, w Lk/Fltwsr 3 × 6 mm
18.	85355-06	Screw, M 3 × 0.5 × 6 mm Nylon FH
19.	55260-03	Nut, Plain Hex Metric
20.	94345-01	Transistor Insulator

**Notes:**

- (1) Part of item 1 (also available separately).
- (2) Part of item 5 (also available separately).
- (3) For illustrated parts breakdown, see next section.
- (4) Not available as an assembly. See Carriage Stepper Assembly section for illustrated parts breakdown.
- (5) Items 10 and 11 available as an assy: 51078-02 Drive Motor Assembly.

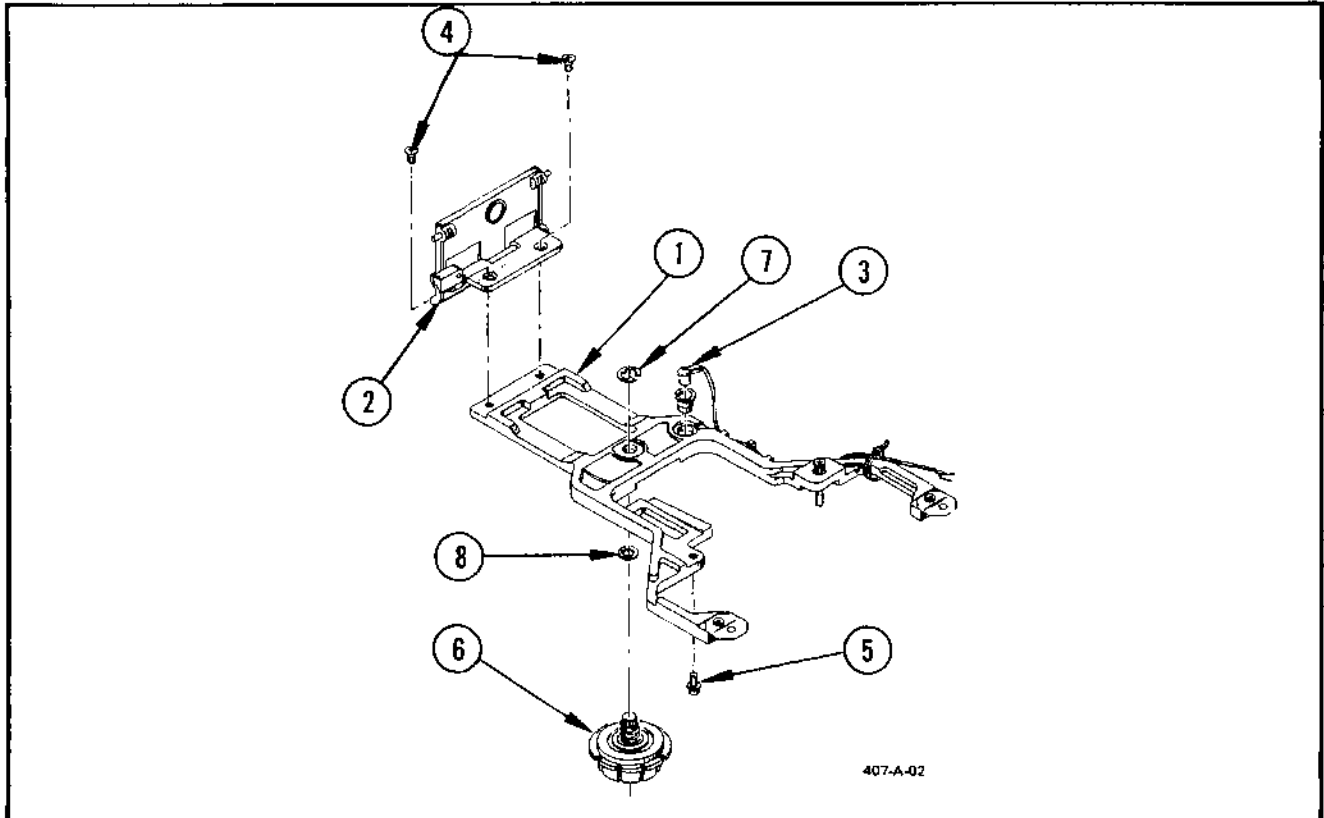

**DOOR CARRIER ASSEMBLY**

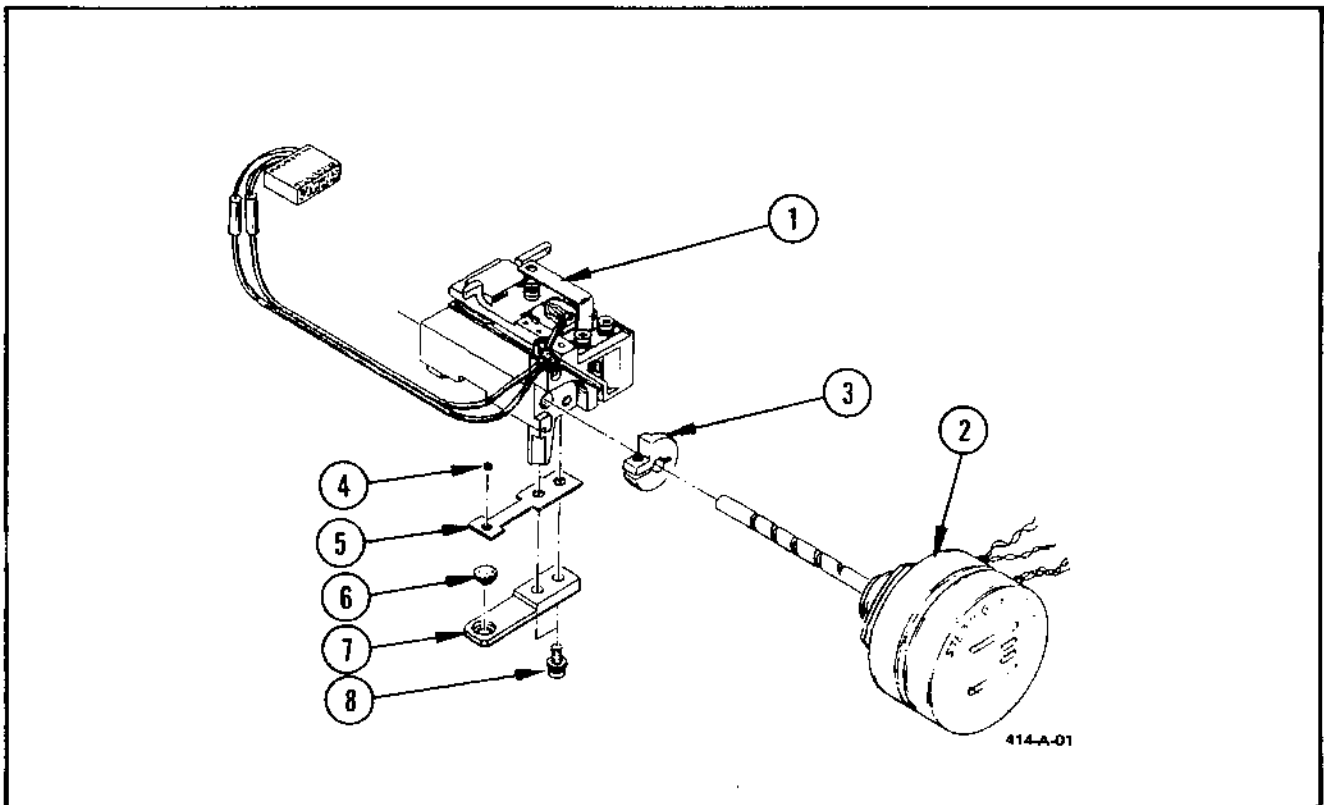

**CARRIAGE STEPPER ASSEMBLY**

**DOOR CARRIER ASSEMBLY**

<b>Item</b>	<b>Part No.</b>	<b>Description</b>
1.	-----	Carrier Subassembly (Note 1)
2.	51104-02	Front Door Assembly
3.	51062-01	Index Lamp Assembly
4.	51103-06	Flat Head Screw
5.	55163-06	Screw, w Lk/Fltwshr 3 x 6 mm
6.	51068-01	Collet Assembly
7.	51077-01	E-Ring
8.	51075-01	Washer
9.	55193-22	Screw, PH, 3 x 6 mm

**Notes:**

- (1) Not available separately. Order complete Door Carrier Assembly: 51149-02.

**CARRIAGE STEPPER ASSEMBLY**

<b>Item</b>	<b>Part No.</b>	<b>Description</b>
1.	51017-01	Carriage Assembly
2.	51126-01	Stepper Motor Assembly
3.	51007-01	Track 00 Stop
4.	51009-01	Steel Ball
5.	51012-01	Plate Spring
6.	51014-01	Felt Pad
7.	51013-01	Retainer
8.	55163-08	Screw, PH, w Lk/Fltwshr 3 x 6 mm

# DIAGRAMS

This section presents reference schematic and interconnection diagrams for a typical QumeTrak 542 disk drive.

Typical Schematic Diagram

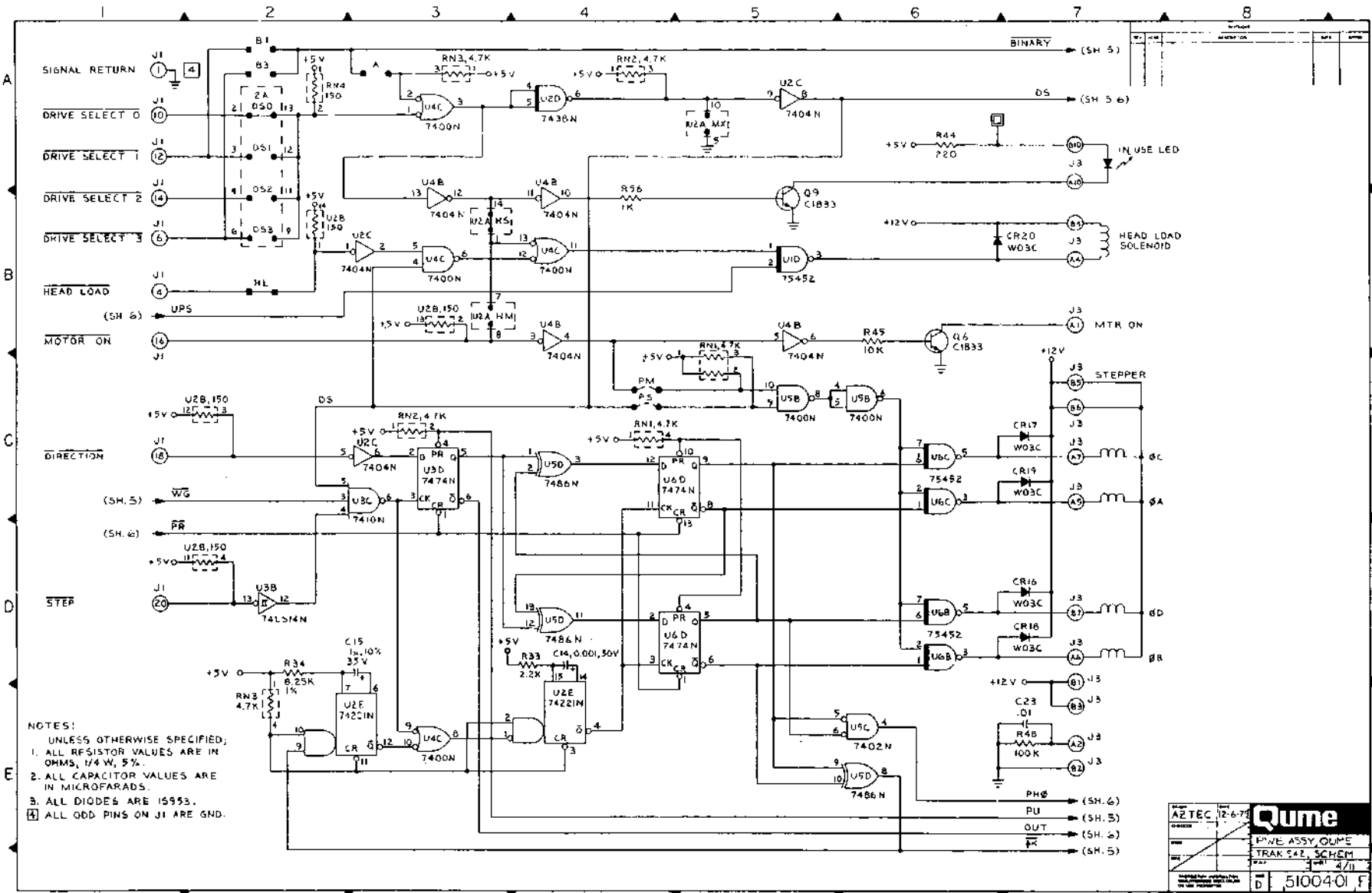

AZTEC	12-6-78	<b>Qume</b>
MPWE ASSY, OUMPE		
TRAK 242, SCHEM		
REV: 4/11		
5100401		

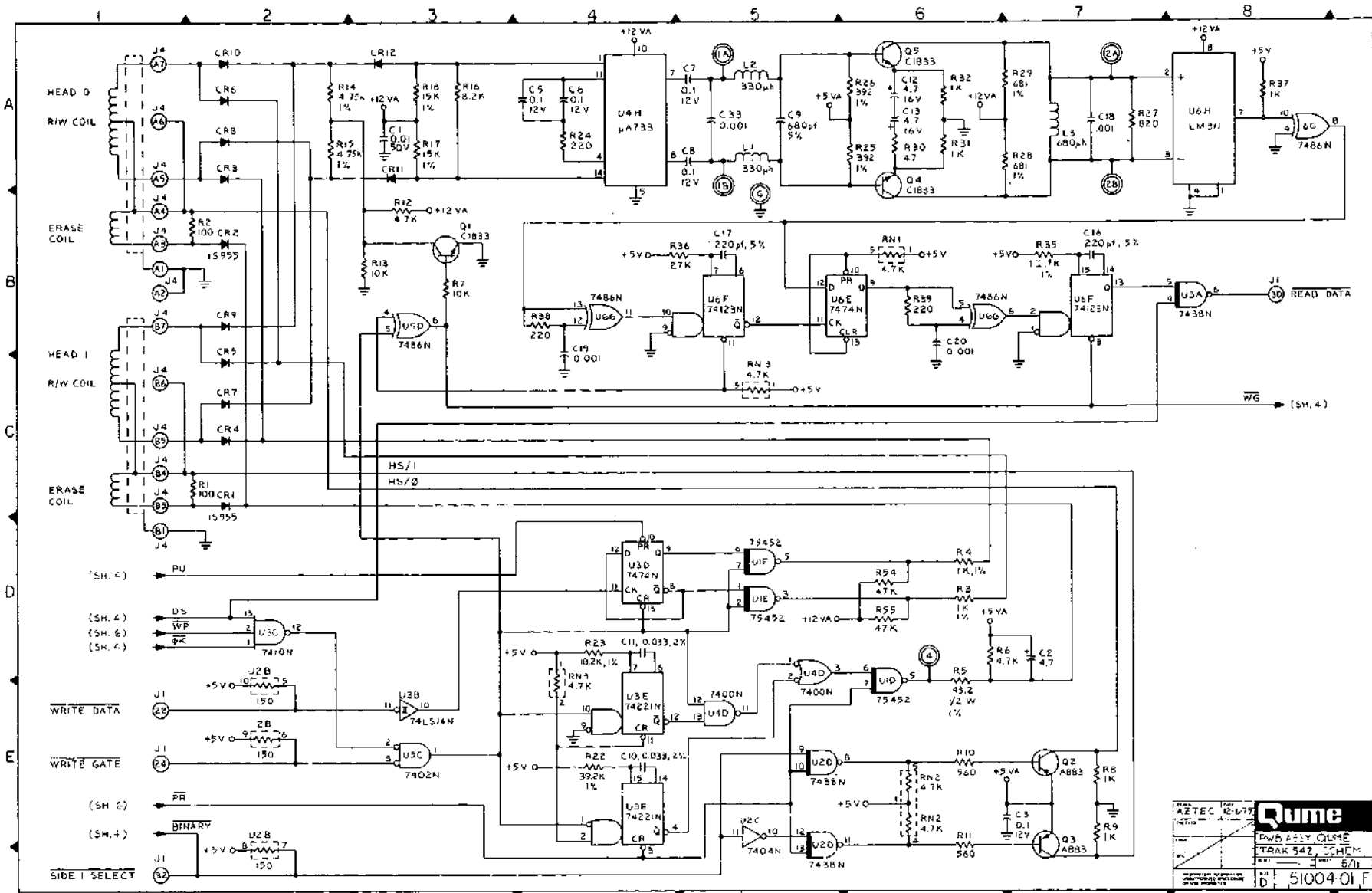

AZTEC 12-679	<b>Qume</b>
12-679	DWS 255 OLME
	TRAK 54Z CHEM
	5/11
10: 51004 01 F	

Typical Schematic Diagram

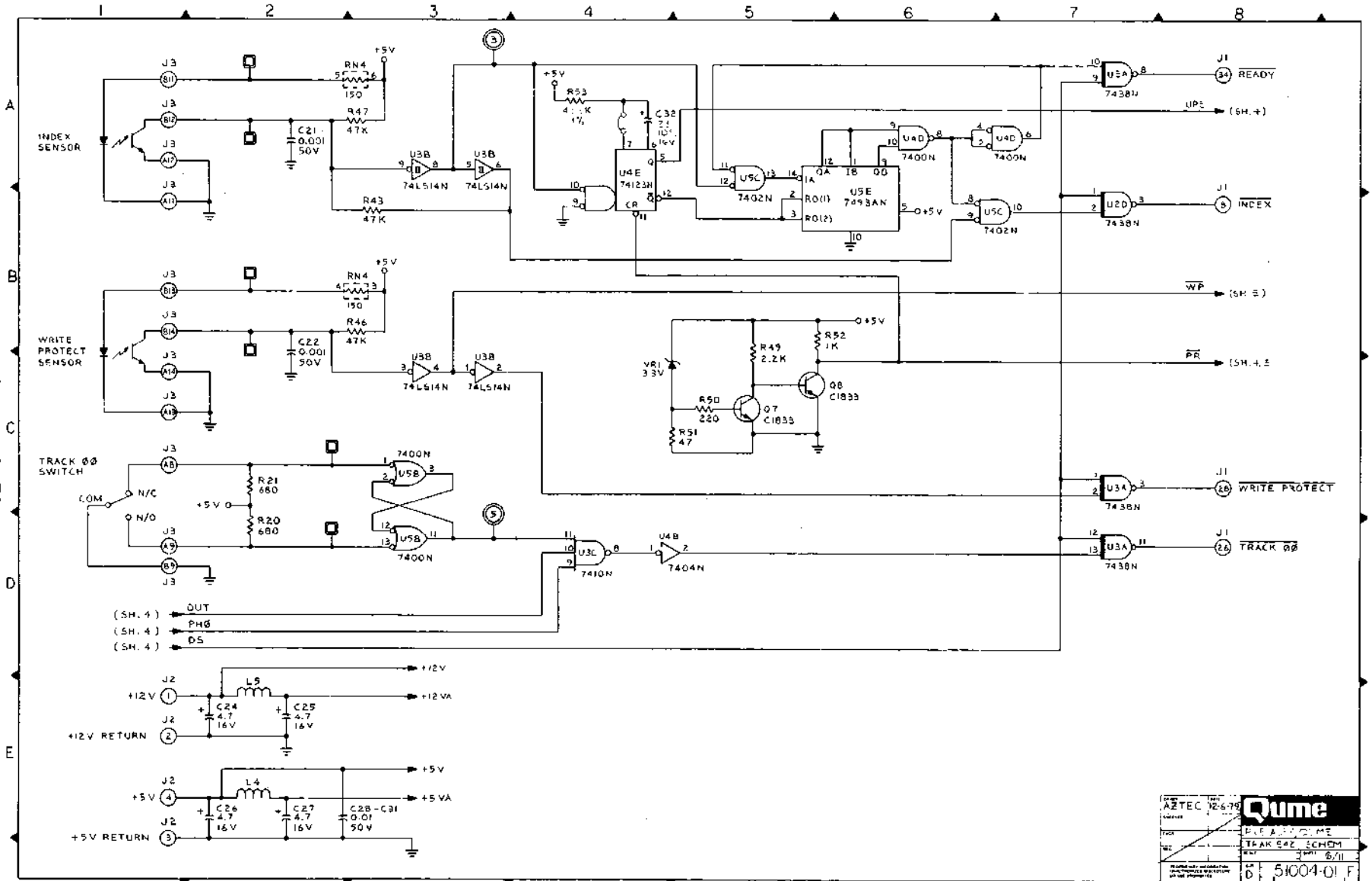

DATE	REV	BY	CHK
12-6-79	1	BUE	...
AZTEC		<b>Qume</b>	
TRACK 00		TRACK 00	
51004-01 F		...	

SEE MOUNTING DETAILS

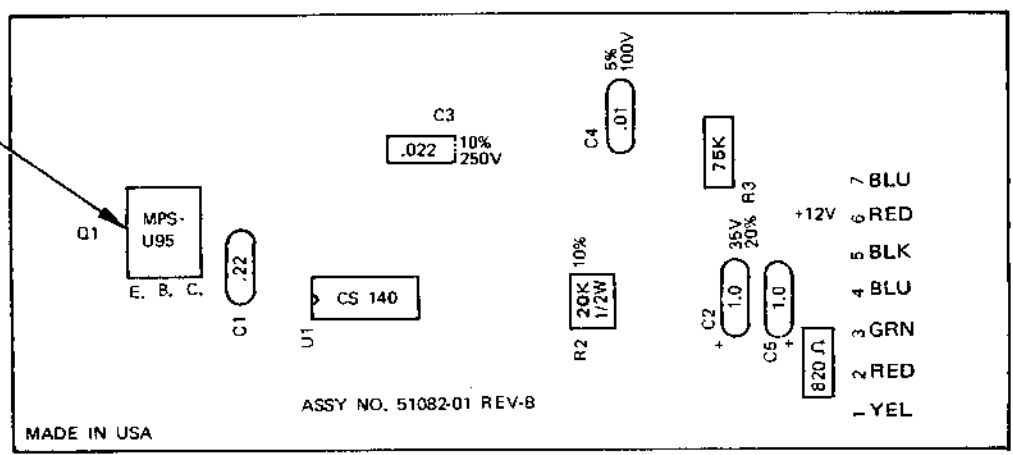

COMPONENT SIDE

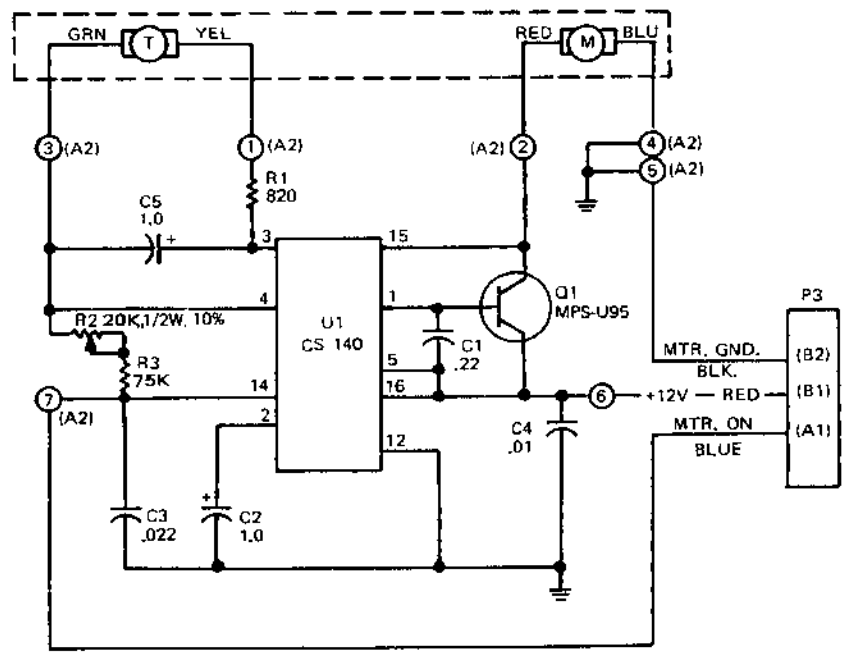
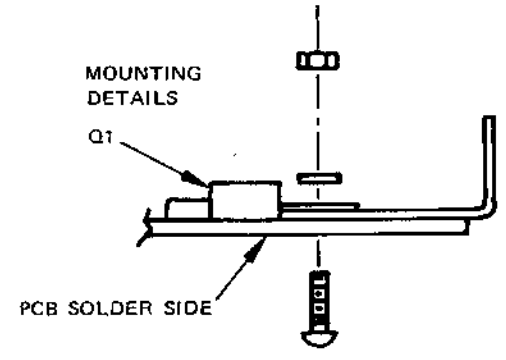

**Qume**

QUME MOTOR CONTROL BOARD

REV. 8

DATE: 7-2-XX C

Motor Control Board

628-A-02



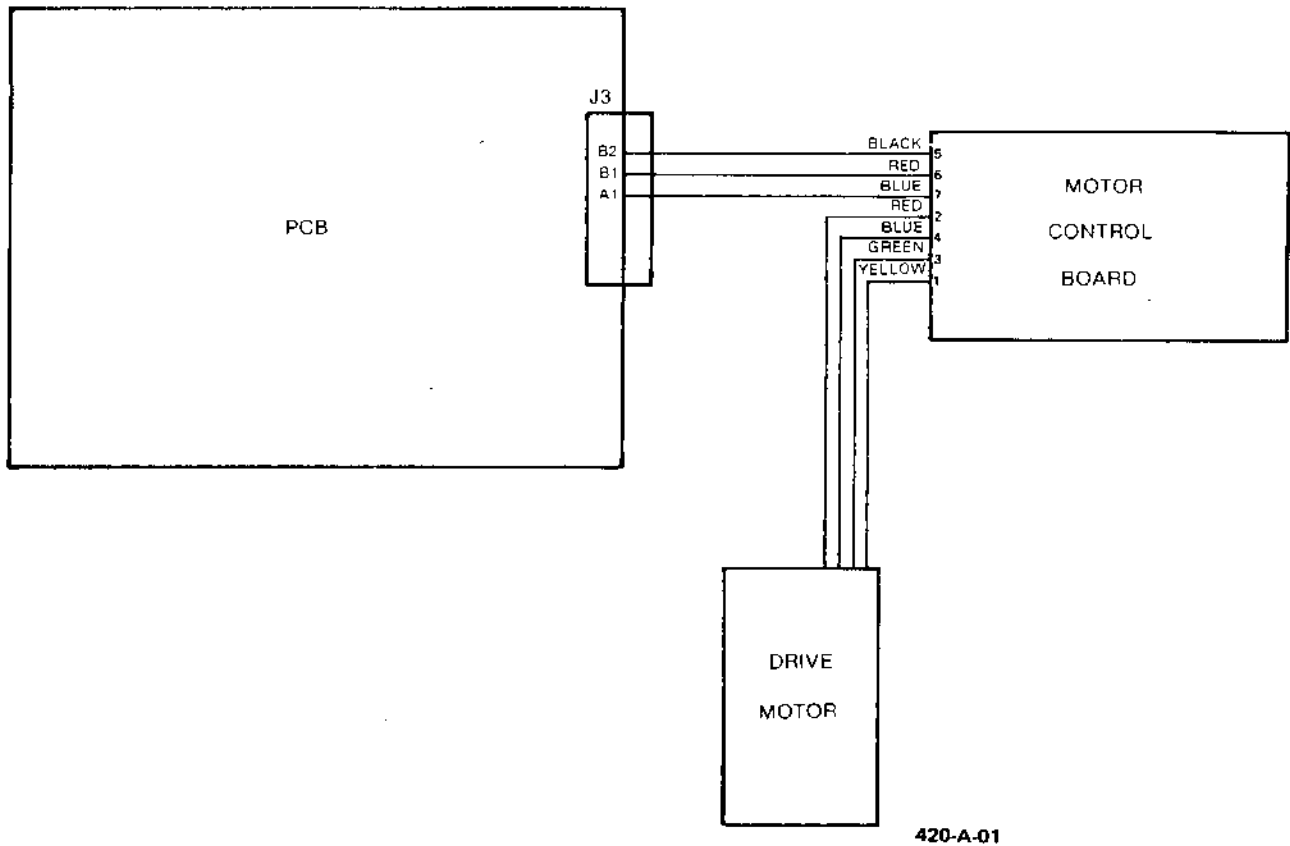

420-A-01

Typical Interconnection Diagram

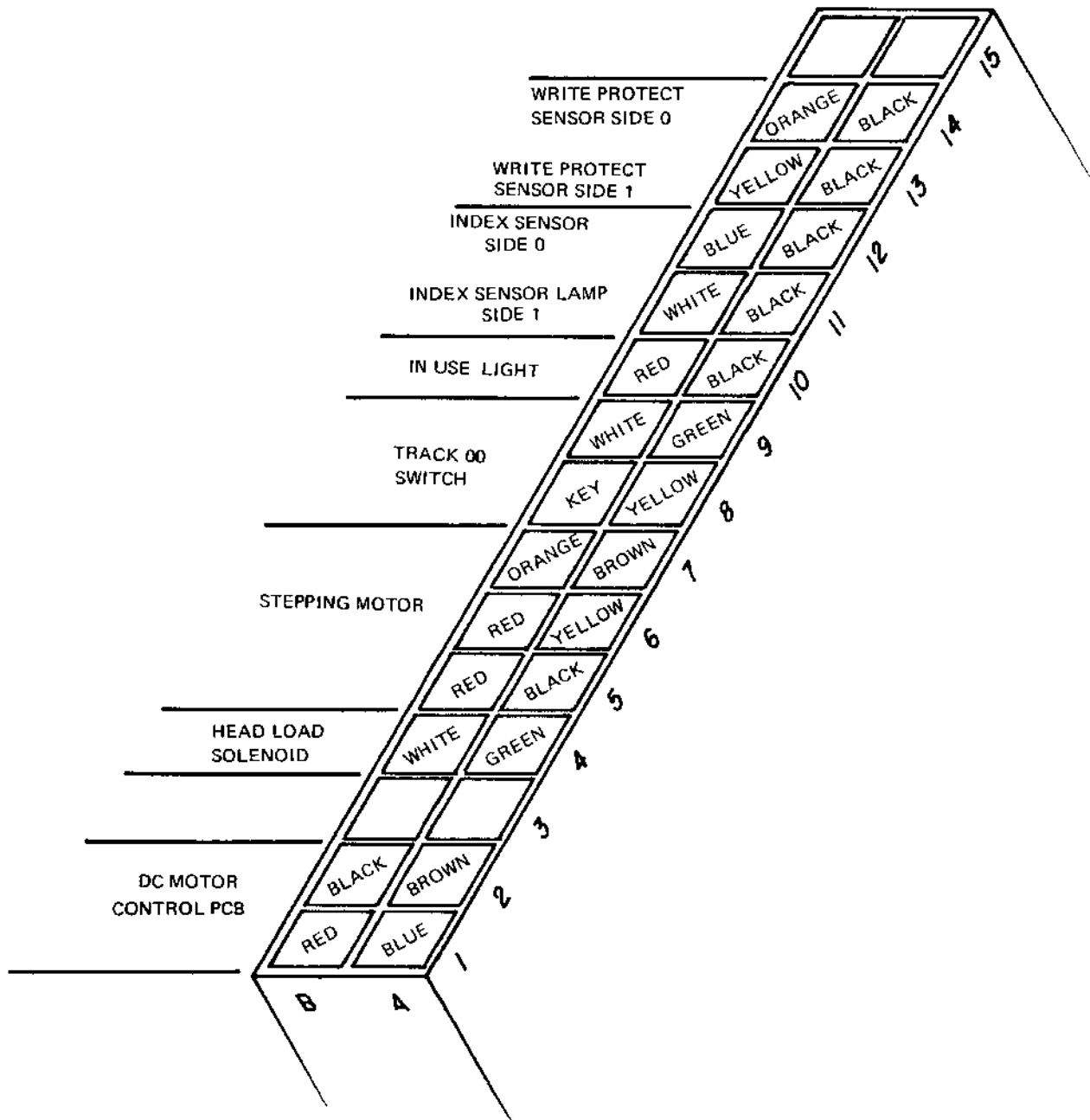

**J3 CONNECTOR**