

POSITIONER CONTROL

SIZE	CODE	REV. NO.	DWG. NO.	REV.
E	100E	600280	F	1
SCALE	100%	DO NOT SCALE DWG.	DATE	2/88

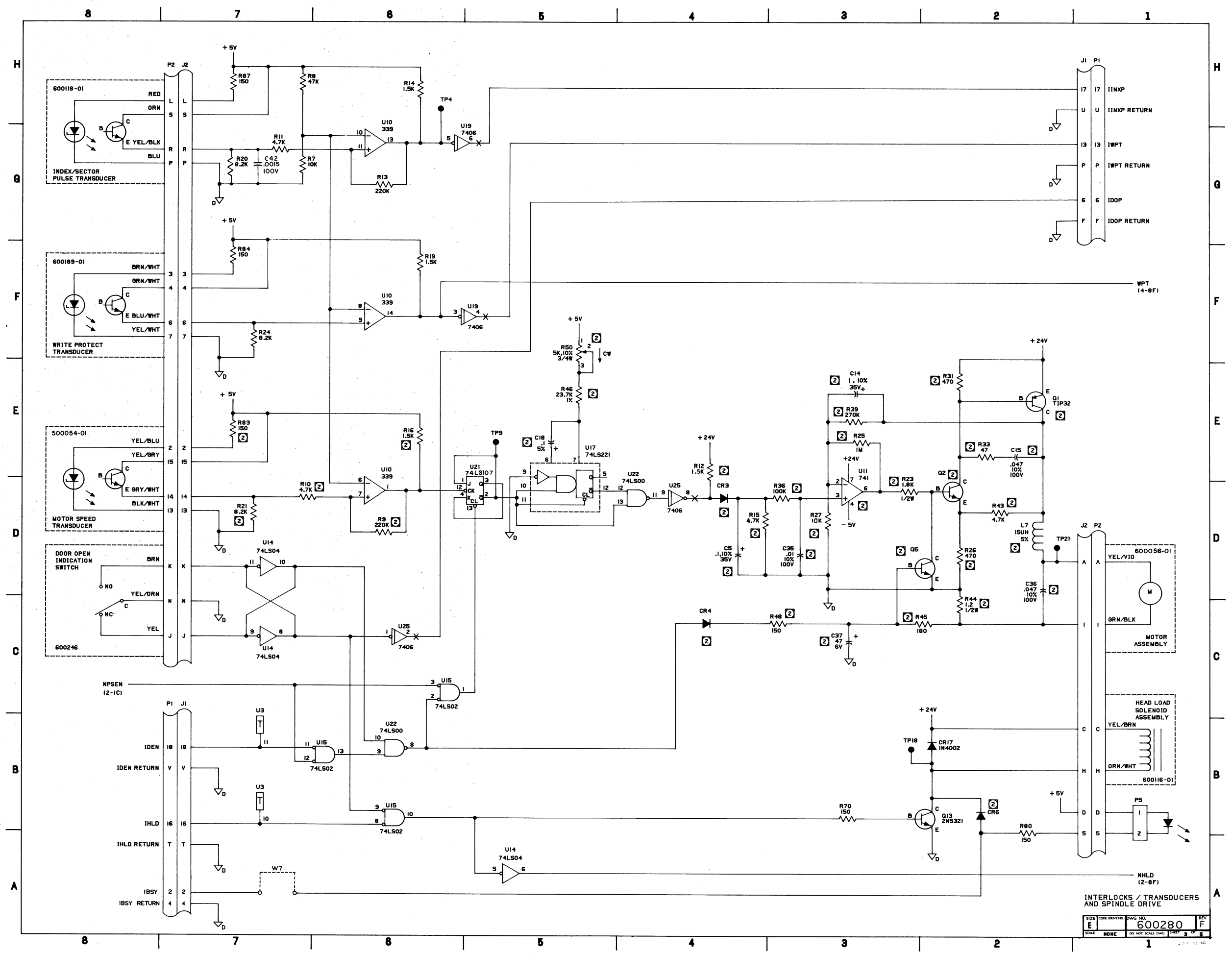

INTERLOCKS / TRANSDUCERS AND SPINDLE DRIVE

SIZE	CODE	REV
E	600280	F
SCALE	NONE	DATE

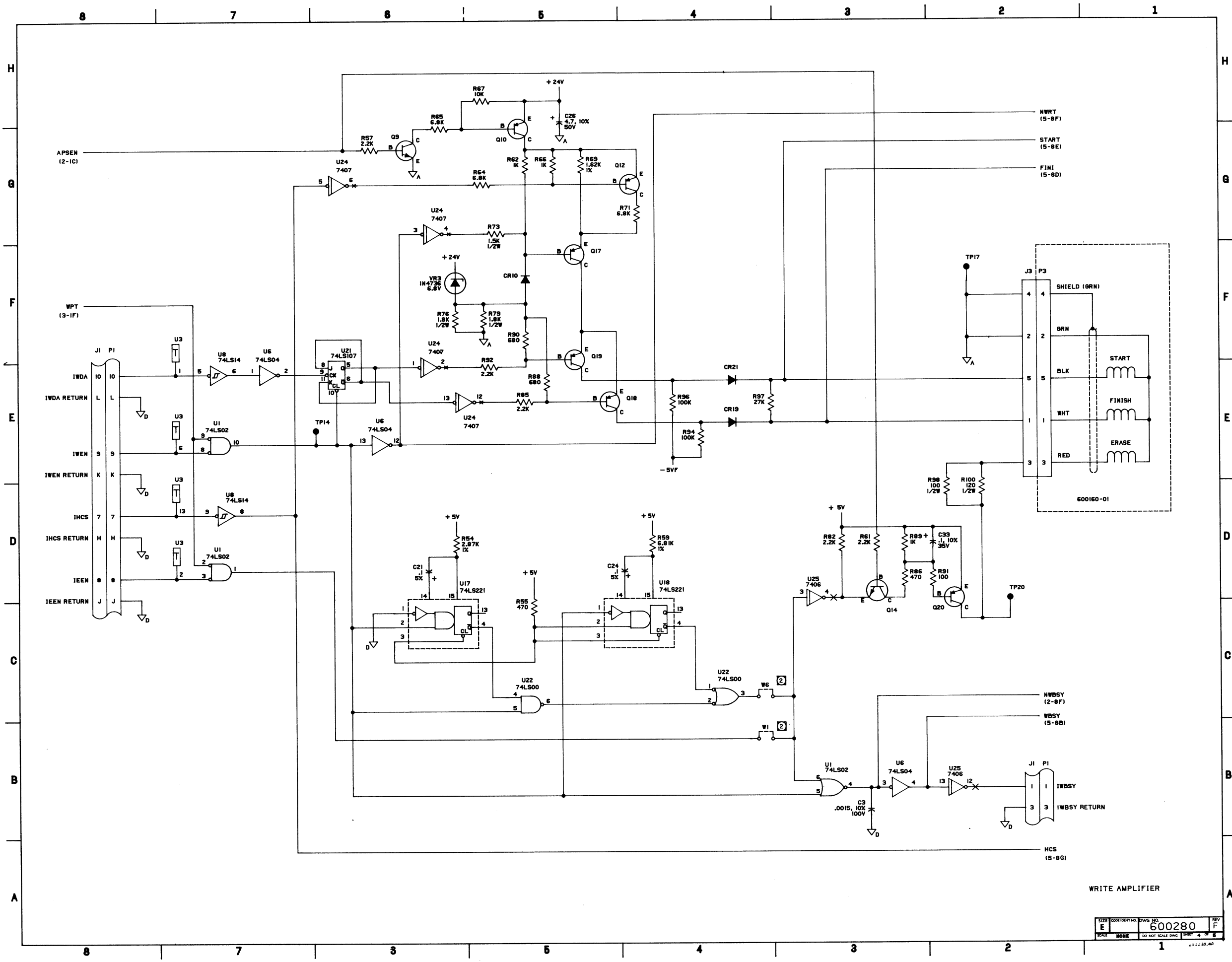

WRITE AMPLIFIER

SIZE	CODE IDENT NO	DWG NO	REV
E		600280	F
SCALE NONE		DO NOT SCALE DWG	SHEET 4 OF 8

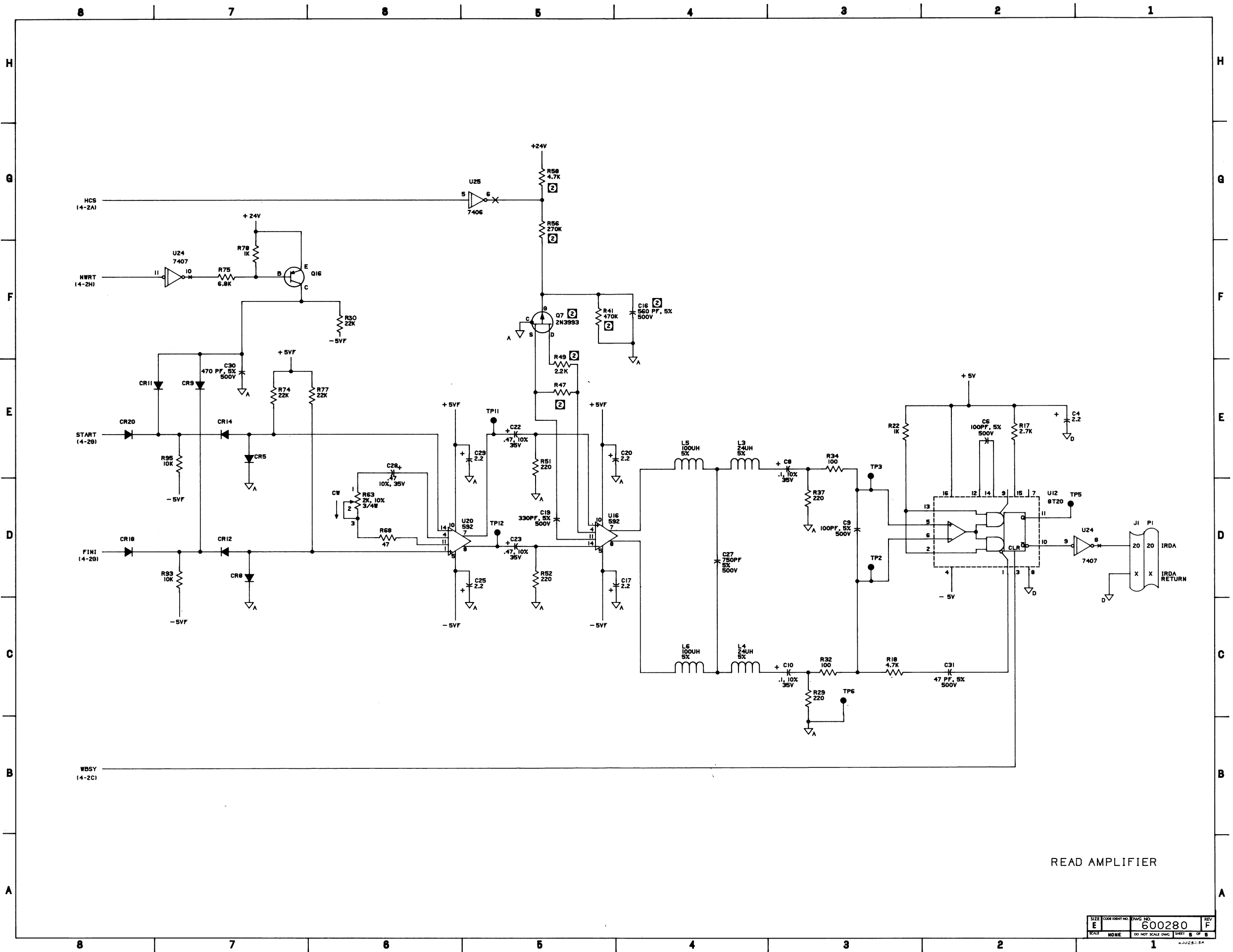

READ AMPLIFIER