

TITLE Carriage Retainer, D3000			PIB NO. DK 3075		
PRODUCT LINE:	TAPE <input type="checkbox"/> DISK <input checked="" type="checkbox"/> FORMATTER <input type="checkbox"/>	EQUIPMENT CHANGED N/A	MODEL SERIES AFFECTED D3000	EFFECTIVE DATE 3-3-78	

CLASS OF BULLETIN: <input type="checkbox"/> IMPROVEMENT <input type="checkbox"/> RETROFIT ON FAILURE <input type="checkbox"/> RETROFIT RECOMMENDED <input checked="" type="checkbox"/> SERVICE INFORMATION ONLY	ECN NO. 10739	EFFECTIVITY N/A
	PARTS KIT NO. N/A	
	TIME REQ. N/A	

The balance counterweight for the head carriage assembly has been redesigned to serve as a carriage retainer to prevent damage to the head carriage assembly during shipment. This part must be moved from its shipping position to its operating position, before attempting to operate the machine. The illustration shows both positions of the counterweight.

For proper operation of the machine, the weight must be installed on the head carriage, as shown by the dotted outline in the illustration. When the machine is to be transported the weight must be placed back in the shipping position. Both mounting screws should be kept in the carriage assembly to prevent their loss.

NOTE

Tie wrap straps, or a similar means, should be used to secure the head carriage assemblies for shipment on those machines which do not have the new style carriage retainers.

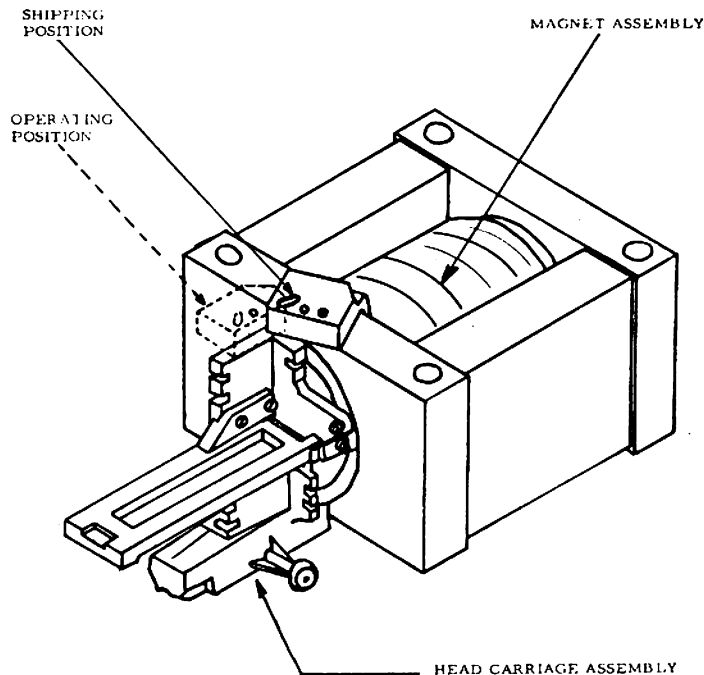

Should Additional Information Be Required - Contact

Distribution Code: 6318