

MODEL 270-277

Reason for Change: Design Improvement.

In an effort to improve even more on the reliability and performance of our models 270-277, we have changed the positioner lamp assembly (PerSci part # 200247) from a grain-of-wheat incandescent lamp to an infrared LED. The part number will remain the same as before (200247). This field change should be accomplished upon depletion of your present stock of lamps. If the following steps are followed, this change can be accomplished in the field by persons with electronic training.

Note: It will take less time to readjust if you don't remove Positioner Assy. Change Lamp and R15 from bottom ie start at step 3

1. Remove the positioner assy from the drive by removing the three mounting screws (see Installation and Maintenance Manual, page 2-21 Figure 2-9) on the positioner assy, and the two screws holding the magnet support clamp in place (be sure that you have unplugged P-8 and P-5 on the positioner servo PCB assy 200137, and P-15 and P-16 on the Data & Interface PCB assy 200236 first).
2. Slide the complete assy to the rear of the drive to disengage the heads from the head-load relays, and carefully swing the front of the assy out of the drive and extract the complete unit from the drive. (Note: There are small cable clamps holding the various cables attached to the assy, these must also be removed.)
3. Remove the four screws holding the lamp assy in place on the lamp amplifier assy.
4. Using a pair of wire cutters, clip the leads of the lamp assy as close to the lamp as possible
5. Using a pair of wire cutters, clip the leads on both sides of R15 and R21 as close as possible to the body of the resistor.
6. Using a low wattage soldering iron (700° or less) and a desoldering aid such as solder-wick or a solder sucker, remove the cut leads from the lamp and the resistors and clear the holes of solder obstructions.
7. Carefully install a 62 ohm ¼ watt resistor in place of R15, and leave R21 blank.
8. Mount the new LED lamp assy in place using the four screws that were removed from the lamp assy.

Note: Some newer Version boards don't have R21

*Note IRLED IS much brighter than ^{the} lamp it replaces, it will be necessary to reduce the gain of the op-amps substantially.
See schematic*

8A. It may be desirable to cut trace to TP7 and jumper a Wire from (TP7) to (R15 & Collector of transistor)

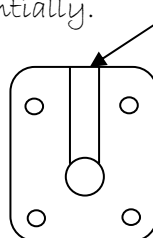

This groove points up toward the lamp amplifier PCB.

Fig. 1

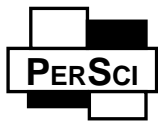

- 9. Being sure that you have mounted the assy with the groove on the inner face pointing toward the lamp amplifier PCB, bend the leads and solder them as shown in Fig. 2 below.

 * WARNING: THIS IS AN *
 * INFRARED DEVICE, NO *
 * LIGHT WILL BE VISIBLE *
 * DURING OPERATION. *

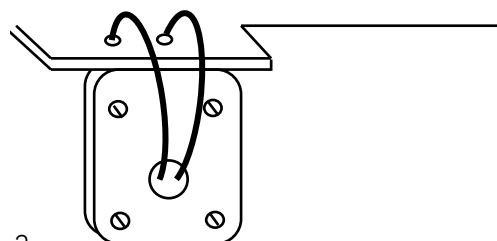

Fig. 2

- 10. Reassemble positioner assy into the drive (reverse steps 1 & 2), using care to position the pressure arms of side 0 and side 1 on the correct side of their respective head load relays and carrier plate assys.
- 11. After reassembly of the drive, and BEFORE INSERTING A DISK, manually load and unload the carriers and head load relays to be sure that you have reassembled it correctly.
- 12. Adjust the lamp voltage to 2 volts at the junction of R15 and Q1 (the end of R15 nearest to the lamp) using R3.

If you have any problems, assistance can be obtained by calling our Technical Assistance Hot Line: (213) 820-7613 Ext. 217

Mike Cree
Product Support Mgr.

NOTICE:

When installing this lamp or lamp amplifier assembly in your drive, you must make the following changes in your documentation:

INSTALLATION AND MAINTAINANCE MANUAL MODELS 270/272/277

Remove page 2-19 and replace it with the corrected page enclosed.

PCB ASSEMBLIES LOGIC AND SCHEMATIC DIAGRAM MODELS 270/272/277

Delete R21 from the line drawing and from the Material List (ITEM NO. 15) and change the description in ITEM NO. 15 to read: RESISTOR ¼ W 5% 62 (DRAWING #) 150000-620 (QTY) 1 (REMARKS) R15.
Drawing number 200096, Delete R21, change the value of R15 to 62, change the lamp to an LED as shown below:

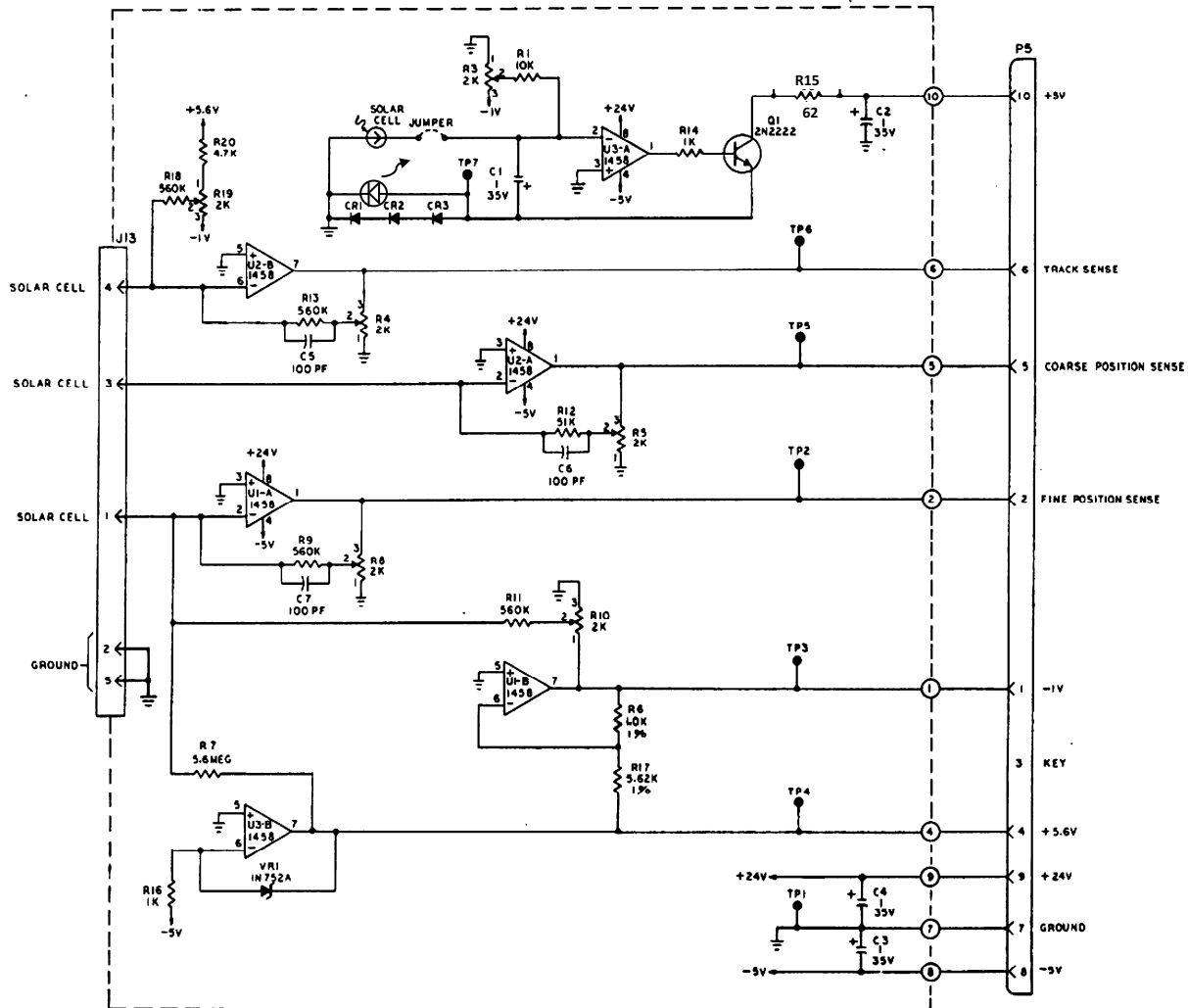

Table 2-2. Positioner Servo Adjustments

FUNCTION	CONTROL	TEST POINT	ADJUSTMENT
Lamp Voltage	R3	R15	SEE NOTE BELOW
Track Sense Balance	R19	TP6	+0.25V to +0.5V at Track 20 (Move carriage by hand to approximate locations.)
Track Sense	R4	TP6	-1.25V to -1.5V at track 76 (Move carriage by hand to approximate locations.)
Speed	R5	TP5	Negative level, changing approximately 1.5V as positioner moved from inner to outer limit.
Position Amplitude	R8	TP2	Adjust for 3.5V p-p minimum amplitude balance about ground as positioner moved back and forth by hand.
Position Balance	R10	TP2	
Oscilloscope Ground		TP1	(Oscilloscope should be floating to avoid ground loops.)

NOTE: The lamp (Infra-red LED) is factory set at 2 volts on the junction of Q1 and R15. When changing the lamp, connect the probe of your oscilloscope to the transistor side of R15 (the end closest to the lamp), adjust R3 for a reading of 2V.

Replace the lamp assembly with PerSci #200247 and set the lamp voltage at R15, using R3, to 2.0 volts. Perform other checks/adjustments on TP6, TP5, and TP2, as called for in table 2-2.

Final Adjustments

The adjustments of the preceeding sections should be sufficient for operation, but for attaining specified performance levels track sense and speed should be adjusted dynamically. Also, forward and reverse speed is balanced by adjusting R33 on the positioner servo PCB.

Plug P8 from the voice coil motor into J8 on the positioner servo PCB. Restore the positioner with the exerciser.

Move the oscilloscope probe to the end of C1 nearest R33, and oscilloscope ground to the end of R77 or R73 furthest from the heatsink on the positioner servo board. Alternately seek from track 60 to track 1. Synchronize the oscilloscope to the negative edge of the "seek complete" signal found at a

test point on the positioner or at P1-10 on the data and interface PCB. Adjust R33 for test symmetry between forward and reverse seeks. Alternate seeks between Track 00 and Track 76, keeping oscilloscope functions as they were, except for time. Adjust R5 on the lamp amplifier PCB such that the time for the longer seek (forward or reverse) to settle within 0.25V of ground is 110 ms. This completes the adjustment of the positioner servo.

Positioner Head Azimuth and Track Alignment, Side 0

- a. Set drive power off.
- b. Insert DYMEK SC1-4 alignment diskette into Side 0.
- c. Access Track 76 and load head Side 0.
- d. Monitor TP5 on the D & I board with scope set as follows:

MODE:	CH 1 MINUS CH 2
VOLTS/DIV:	BOTH CH .1 (X10 PROBES)
TIME BASE:	.5 mSEC/DIV
TRIGGER SOURCE:	PIN 8 of P1 on D & I BOARD

- e. To adjust the head azimuth, slacken the two positioner fastening screws shown in Figure 2-9. Refer to Figure 2-7a. Apply pressure, upward or downward, on the magnet as required to obtain the waveform shown.
- f. If the drive is used in a hard sectored system check machine azimuth by measuring index timing at Track 1 and Track 73. (See Page 2-10.) The difference in delay must be less than 110 usec. If not re-adjust head azimuth within its allowed limits to achieve the required difference in time delay.
- g. Carefully re-tighten screws.
- h. Access Track 38 and observe "cat's eyes" pattern (Figure 2-7b.)
- i. Slacken transducer adjustment screws (Figure 2-9.)
- j. Gently tap the lamp amplifier PCB to effect a small displacement in this assembly and observe "cat's eyes" pattern.
- k. When the amplitudes are the same, carefully tighten the transducer screws making any necessary adjustments in position to maintain equal amplitudes (within 5%).
- l. Re-check head azimuth. These adjustments are interactive.
- m. The above re-adjustments will require that index timing be reset. See Page 2-11.