

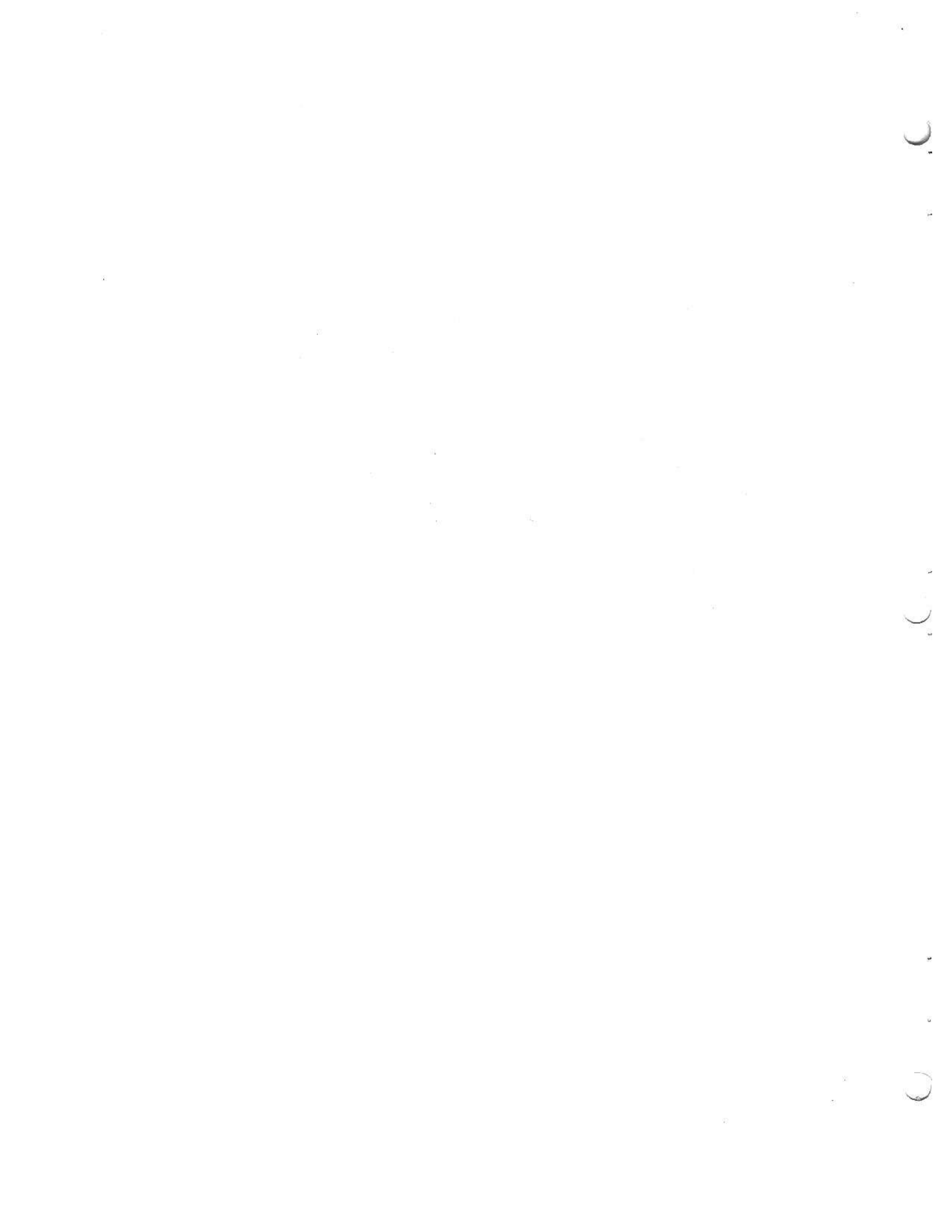

**Product Specifications**  
**Diskette Drive**  
**Model 277**



**This Document was scanned and  
contributed by:**

**Barry A. Watzman**



PRODUCT SPECIFICATION

MODEL 277 DISKETTE DRIVE

PerSci, Inc.



## TABLE OF CONTENTS

- 1.0 SCOPE
- 2.0 RELATED DOCUMENTS
- 3.0 GENERAL DESCRIPTION
  - 3.1 Diskette Drive
  - 3.2 Diskette Access
  - 3.3 Packaging
  - 3.4 Electronics
  - 3.5 Diskette
  - 3.6 Diskette System Configuration
  - 3.7 Interchangeability
- 4.0 OPTIONS
  - 4.1 Interface Options
- 5.0 DETAILED DESCRIPTION
  - 5.1 Physical Requirements
  - 5.2 Environmental Requirements
  - 5.3 Electrical Power Requirements
  - 5.4 Functional Requirements
  - 5.5 Safety Requirements
- 6.0 INTERFACE
  - 6.1 Diskette System Interconnections
  - 6.2 Signal Interface
  - 6.3 Power and Interface Pin Connections
  - 6.4 Power and Interface Signal Definitions
  - 6.5 Interface Requirements
- 7.0 MAINTENANCE
  - 7.1 Reliability Requirements
  - 7.2 Preventive Maintenance
  - 7.3 Corrective Maintenance





## 1.0 SCOPE

- 1.1 This document defines the Model 277 Diskette Drive. It formulates the Diskette Drive's general characteristics and parameters, its operating criteria, installation and maintenance requirements, and the logical and physical aspects of the interfacing cabling system connecting the Diskette Drive to a Controller. As used throughout this document, the term Diskette Drive refers to the Model 277 Diskette Drive, unless explicitly stated otherwise.

## 2.0 RELATED DOCUMENTS

- 2.1 The following related documents may be referenced for additional information:
- 2.1.1 IBM Diskette Original Equipment Manufacturer's Information, GA 21-9182-0, File No. GENL-19.
- 2.1.2 The IBM Diskette for Standard Data Interchange, GA 21-9182-0, File No. GENL 03/80.

## 3.0 GENERAL DESCRIPTION

### 3.1 Diskette Drive

- 3.1.1 The Model 277 Diskette Drive is designed to provide a means of low-cost, random-access data storage. This is accomplished through the recording of data on, and the retrieval of data from two separate rotating magnetic surfaces, as represented by two separate Diskette Cartridge Assemblies. These magnetic Diskette Cartridge Assemblies, as described under Paragraph 3.5, are referred to as the "Diskette" throughout the document.
- 3.1.2 Means for easy acceptance, rotation, and quick independent removal of each Diskette is provided by spindles which are linked to and derive their rotational motion from an electrical drive motor.

### 3.2 Diskette Access

- 3.2.1 Data is transferred to or from each Diskette through its separate read/write/erase head.
- 3.2.2 Each read/write/erase head is assembled on a carriage which is located on the common head positioning actuator. The read/write/erase head is in direct contact with the Diskette media surface. The head employs a single read/write gap followed by tunnel erase elements to provide erased areas between data tracks. Thus, normal track position tolerances between media and drives will not degrade the signal-to-noise ratio, and the Diskette interchangeability is enhanced.

3.2.3 The head carriage is actuated by electro-magnetic means, utilizing a servo-driven coil moving within a permanent stator. Positioning of the head with respect to the Diskette is determined by the magnitude and direction of the current introduced into the coil windings.

### 3.3 Packaging

3.3.1 The Model 277 Diskette Drive consists of: selectable read/write/erase electronics; common positioning control electronics; a common head positioning actuator; a common Track 00 sensor; a common spindle drive mechanism; two read/write/erase heads; two head loading actuators; two separate index sensors.

3.3.2 Rack or slide mounting is available. Maintenance access is through the sides. Diskette access is through the front panel. Interface connectors and cabling are accessible from the back side of the Diskette Drive.

3.3.3 The Diskette Drive operates in either of two positions: (1) Positioner and Diskette horizontal with the Diskette label facing up (horizontal rack mounting or desk top mounting, with front-loading access); (2) Positioner horizontal, Diskette vertical, with the Diskette label in the upper corner (horizontal rack mounting with front-loading access).

### 3.4 Electronics

3.4.1 Sufficient control electronics are employed to provide minimal data access time at optimal data transfer rates within compatibility requirements.

3.4.2 The electronics perform the following functions:

- interpret and generate control signals,
- move the read/write/erase heads to the selected track,
- load the heads and read or write data,
- drive the spindle motor,
- separate data pulses from clock pulses.

3.4.3 The Electronics are packaged on printed circuit boards containing the following circuits:

- head positioning actuator driver
- head load actuator drivers
- read/write/erase amplifier and transition detector
- index detection
- track position and data safety sensing
- spindle motor driver
- data separator.

3.4.4 Signal and power connectors are such as to provide the Model 277 Diskette Drive with plug-to-plug compatibility with desired electrical interfaces. Options are described in Section 4.0.

### 3.5 Diskette

- 3.5.1 The Diskette used in the Model 277 Diskette Drive shall be an IBM Diskette, IBM Part Number 2305830, or an approved equivalent.
- 3.5.2 The Diskette is a cartridge that consists of a flexible magnetic disk enclosed in a plastic jacket. The disk is free to rotate within the jacket. Access and index holes for the read/write/erase head and for data timing are provided. Data is recorded only on one side of the Diskette at the present time. The Model 277 has provisions for the addition of another Index photosense assembly to accommodate recording on both sides of the Diskette. Reading and writing are done with the head in contact with the disk.
- 3.5.3 The IBM Diskette is provided with an envelope and container to protect the Diskette when not in use. Detailed performance and handling specifications are described in the document referenced in Paragraphs 2.1.1 and 2.1.2.

### 3.6 Diskette System Configuration

- 3.6.1 A typical Model 277 Diskette Drive Storage System consists of one to four Model 277 Diskette Drives, one user-supplied controller, and one user-supplied Diskette Drive Power Supply.

### 3.7 Interchangeability

- 3.7.1 Each Diskette Drive in conjunction with the Controller transfers data to and from the Diskette in such fashion that Diskettes are fully "write/read" interchangeable within any other Model 277 Diskette Drive System.
- 3.7.2 The Model 277 Diskette Drive in connection with its Controller transfers data to and from the Diskette in such fashion that Diskettes are fully "write/read" interchangeable with the IBM 3741 Model 1, as configured by IBM in July, 1974.

## 4.0 OPTIONS

### 4.1 Interface Options

#### 4.1.1 Standard Option

The Standard Option is one dual-drive system containing dual-drive system features and interface as defined further in this document.

#### 4.1.2 Multiple-Drive Option

The Multiple-Drive Option provides for the operation from one Controller and one Power Supply of up to two Model 277 Diskette Drives (4 drive units) in close physical proximity to each other. All Diskette Drives in this system configuration use the Standard Option electronics printed circuit board. However, the line-terminating resistor modules on the Diskette Drive electronics PCB (Data and Interface PCB) are removed from all but the Drive farthest from the Controller, and the proper Drive Select Module is inserted in each Drive.

## 5.0 DETAILED DESCRIPTION

### 5.1 Physical Requirements

#### 5.1.1 Dimensions

Height	-	8.6"
Width	-	4.4"
Depth	-	15.0" from mounting surface; overall.
Weight (shipping)	-	22 pounds, maximum
Weight (installed)	-	20 pounds, maximum

#### 5.1.2 Mounting Provisions

The Model 277 Diskette Drive is mounting compatible with most existing drives. Outline dimensions and mounting provisions are shown on Figure 1.

The Drive has provisions for slide mounting (reference Figure 2).

The standard drive front panel dimensions are shown on Figure 1. Other front panel sizes are available as options.

## 5.2 Environmental Requirements

### 5.2.1 General

The Diskette Drive and Diskette shall be in the same environment and subject to the same environmental conditions for at least one hour prior to operation, as normal recommended operating procedure.

The Diskette Drive shall perform satisfactorily when exposed to the operating and non-operating conditions specified in Paragraphs 5.2.2, 5.2.3, and 5.2.4.

### 5.2.2 Temperature, Relative Humidity, Maximum Wet Bulb, Magnetic Fields Equipment Operational

50 to 100°F., with a maximum gradient of 20°F per hour, at a relative humidity of 8 to 80%. The wet bulb reading shall not exceed 78°F. The ambient stray magnetic field in the region of the head shall not exceed 5 Gauss.

#### Equipment Non-Operational

-20 to 120°F, at a relative humidity of 8 to 80% with a maximum wet bulb reading of 85°F. The ambient stray magnetic field in the region of the Diskette shall not exceed 50 oersteds.

### 5.2.3 Altitude

#### Equipment Operational

Sea level to 10,000 feet.

#### Equipment Non-Operational

Sea level to 35,000 feet.

#### 5.2.4 Shock and Vibration

The equipment shall not suffer damage nor fail to perform as specified after having been subjected to the following shock and vibration under non-operational conditions:

##### Shock

Internal bracing is allowed if needed to meet this requirement. Eighteen (18) impact shocks of 5 g's (+ 10%) consisting of three shocks in opposite directions along each of three mutually perpendicular axes. Each shock impulse shall be a half sine wave with a time duration of 11 (+ 1) milliseconds.

##### Vibration

Internal bracing is allowed, if needed, to meet this requirement. 1.5 g's (+ 10%) for the 5 to 55 Hertz range for four hours on each axis with a 20-minute frequency scan.

#### 5.2.5 Diskette Cartridge Storage and Handling

Operating procedures recommended by IBM in the reference of Paragraph 2.1.2 should be followed to protect the Diskette and increase its operating life.

#### 5.2.6 Cleanliness

The Model 277 Diskette Drive System is designed for use in commercial and industrial environments. However, no air filters or forced-air systems are provided within the Diskette Drive; hence, optimum performance can be expected when used in a computer room environment with the resultant air cleanliness found in such a location. Dust and other airborne contaminants are a major threat to the operating life of the media and drive recording and positioning systems. In applications where the Diskette Drive is operated within another cabinet or enclosure, installation of a filtered, positive pressure air circulation system is recommended to improve Diskette Drive System reliability.

#### 5.3 Electrical Power Requirements

##### 5.3.1 D.C. Power

The following D.C. Power is required per Dual Diskette Drive:

+5V DC $\pm$ 5%	1.7 Amps nominal running 2.2 Amps maximum running
Spindle Power (Limits: 7.0 - 10.0V)	1.2 Amps nominal running 2.0 Amps maximum running 10 Amps maximum 50 MS maximum surge 1% Duty Cycle Max (Starting Spindle Motor)

-5V DC $\pm$ 10%	0.15 Amps nominal 0.20 Amps maximum
+24V DC $\pm$ 10%	1.0 Amp nominal when seeking 0.2 Amp nominal when not seeking 1.2 Amp maximum seeking with 3.0 Amp maximum peak surges for up to 10 milliseconds at start of seek.

## 5.4 Functional Requirements

### 5.4.1 Operator Controls

#### Operator Switches and Indicators

No indicators are provided. Diskette eject switches are provided on the front panel, one for each drive.

#### Diskette Loading Controls

Diskette loading and unloading is under manual operator control. Loading and unloading mechanisms within the drive provide the following features:

- positive Diskette registration when loaded,
- visible, partial ejection of the Diskette when unloading,
- minimum possibility of Diskette damage due to loading/unloading,
- easy Diskette loading and unloading,
- unloading initiated manually or by remote control line, and  
(remote on designated options only)
- means for Diskette removal in the absence of Drive power.

### 5.4.2 Data Recording

#### Recording Mode

Data is represented on the Diskette by 8-bit bytes when using the IBM-compatible format. A double frequency encoding scheme is used whereby each data bit is preceded by a clock bit. Each byte is written starting with the high order clock bit, then the high order data bit, and so on until the low order data bit is finally written. The presence of a magnetic flux transition represents a binary one. Clock bits are binary ones unless otherwise noted. A byte with a value of binary zero comprises eight clock transitions and no data transitions.

#### Recording Format

The format according to which the Diskette Drive records data is determined by the programming of the Controller and is specified as the IBM 3740 Diskette Format. IBM 3740 Diskettes, or equivalent, are specified for use with the Model 277 Diskette Drive. These Diskettes are initialized by IBM prior to shipment by recording standard data address and data index areas in the proper locations on the Diskette. Figures 3 and 4 describe the IBM 3740 Diskette Format. Additional information on the IBM 3740 Diskette Format is presented in the references of Paragraphs 2.1.1 and 2.1.2.

### Recording Density

Data is recorded at a nominal density of 6536 (+ 4%) flux changes per inch for an all 1's pattern on the innermost track, and 3672 (+ 4%) flux changes per inch for an all 1's pattern on the outermost track.

### Recording Capacity

Unformatted data capacity is 3.1 megabits per Diskette and 41 kilobits per track, single-side recording. With the IBM 3740 Diskette format, data capacity is 1.9 megabits per Diskette and 26.6 kilobits per track, existing single-side recording. Seventy-seven (77) tracks are available.

### Write Data Transfer Rate

The Write Data Bit rate is determined by the Controller. The nominal bit rate is 250 kilobits per second. To insure that the recording density and the read data bit rate are held within the specified limits, the Write Data Bit rate shall not vary more than +0.3% from nominal.

### Read Data Transfer Rate

The Read Data Bit rate is determined by the recording density and the rotational speed of the Diskette being read. The nominal bit rate is 250 kilobits per second. Due to variations between Diskette Drives and Controllers, this bit rate may vary as much as +17% on an instantaneous basis (including pulse crowding effects).

### Recoverable Read Error Rate

A Recoverable Read Error is defined to be a read error corrected by no more than three attempts to read the record in error. The Recoverable Read Error Rate is less than one error per  $10^9$  bits read. All error rates are quoted for reading and writing on the same machine without removal and re-insertion of the Diskette. All error rate tests are to be performed with a new (unused) Diskette.

### Non-Recoverable Read Error Rate

A Non-Recoverable Read Error is defined to be a read error which cannot be corrected after three attempts to read the record in error. The Non-Recoverable Read Error Rate is less than one error per  $10^{12}$  bits read. Errors caused by the Diskette (i.e., due to surface flaws, etc.) shall not be included in the computation of the Non-Recoverable Read Error Rate.

## 5.4.3 Data Addressing

### Track Locations

The Diskette Drive is designed to locate data at the 77 defined tracks on the initialized surface of an IBM 3740 Diskette. Recorded tracks after tunnel erasure are 0.012" on 0.021" centers. The 77 tracks are numbered from 00 for the outermost track to 76 for the innermost track.

Track centerline is defined by the formula:

$$\text{centerline radius} = 2.029" + (76-N)/48" \\ + (\text{tolerance})"$$

where N is the physical track number.

#### 5.4.4 Head Positioning

##### General

One read/write/erase head is mounted on a movable head carriage. An electromagnetic positioner moves the carriage to position the head at any of 77 positions. It is possible for the positioner to move the head directly from one position to another without returning to a reference point.

##### Actuator

A servo-controlled voice coil motor is employed for head positioning.

##### Controller Seek Monitoring

The Controller shall monitor the seek time and, if the desired track has not been located within the allocated time, the Controller shall initiate a recalibration of the positioning system, causing the head to be repositioned to Track 00.

##### Head Positioning Times

Head Positioning times are:

track-to-track, including settling time:  
- 10 msec maximum

inside-to-outside track, including settling:  
- 100 msec maximum

##### Rotational Latency

Average rotational latency is 83.3 milliseconds.

##### Head Positioning Error Rate

The Head Positioning Error Rate is less than one positioning error per  $10^6$  seek executions.

#### 5.4.5 Diskette Rotational Speed Control

##### Spindle Drive System

A direct-coupled DC spindle motor servoed to follow a reference frequency comprises the Diskette Spindle Drive System. Spindle power is applied by inserting one or both Diskettes into the Diskette Drive.



### Motor Speed Regulation

Direct-Coupled DC Spindle Motor:

Average Diskette Rotational Speed:

- 360  $\pm$  7 rpm

Instantaneous Speed Variation:

-  $\pm$  5 rpm

### Motor Start Time

The Diskette Drive comes up to speed and attains operational status within 1 second after the application of Drive DC or Diskette insertion.

## 5.4.6 Head Loading

### Actuator

Each Diskette is moved into contact with its read/write/erase head by a solenoid-controlled head actuator. An interface signal separately activates each head load actuator and allows a pressure pad to bring the selected Diskette into contact with the read/write/erase head with the proper contact pressure.

### Head Engage Time

The Head Engage Time is less than 40 milliseconds.

### Head Contact Force

The head-to-disk contact force is 17 grams nominal, as established by testing and vendor recommendations.

## 5.5 Safety Requirements

### 5.5.1 Interlocks

An interlock indicating that a Diskette has been properly mounted in the Diskette Drive is provided for each individual unit within the dual drive. This interlock inhibits operation of the spindle motor and generation of the Ready interface signal when Diskettes are not properly mounted in the Diskette Drive.

### 5.5.2 Heat Dissipation

Nominal heat dissipation for the all-DC power Diskette Drive is 150 BTU per hour. Average operating power is 44 watts.

## 6.0 INTERFACE

### 6.1 Diskette System Interconnections

Within the configuration of a Diskette System, all Diskette Drives are connected to the Controller through a Signal Connector, either directly or by cabling routed in parallel to other Diskette Drives. Power is supplied to each Diskette Drive through a separate Power Connector. All Signal Lines shall have a maximum length of 20 feet, and shall use a wire diameter equivalent to AWG #30 or larger.

### 6.2 Signal Interface

The Signal Connector of the first Diskette Drive in a Diskette system is connected directly to the Controller through a 50-conductor flat cable, or through a cable consisting of twenty-five twisted wire pairs. The Signal Connectors of subsequent Diskette Drives are connected in parallel with the Signal Connector of the first Diskette Drive through similar cables.

### 6.3 Power and Interface Pin Connections

See Figure 7.

### 6.4 Power and Interface Signal Definitions

#### 6.4.1 Logic Levels

Interface line logic levels are as follows:

Negative level = 0.0V to +0.5V  
Positive level = +2.5 to +5.25V or open circuit  
I/O signals are negative when selected (True).

#### 6.4.2 Signal Connector

##### Ready 0

A negative level on this line indicates that a Diskette is loaded in Side 0 and is within 90% of operating speed. This line is logically Or'd internally with Ready 1. This signal is gated by the Drive Select Left line. If the spindle motor is gated off with the spindle motor enable, while a disk is in Side 0, this line will remain true.

##### Index 0

This line is normally at the positive level. A one millisecond pulse to the negative level is transmitted on this line once for each revolution of the Diskette in Side 0 as the Diskette index hole passes the index hole sensor. This line is logically Or'd internally with Index 1. This signal is gated by Drive Select Left line.

### Seek Complete

A negative level on this line indicates that a seek or restore operation has been completed. A positive level on this line indicates that a seek operation is in process. This signal is gated by either Drive Select line.

### Restore

A negative level on this line causes a low-speed repositioning of the heads to Track 00. This line takes priority over the Track Address Difference Register lines within the drive. This signal is gated by either Drive Select line.

### Spindle Motor Enable

A negative level on this line energizes the spindle motor. The Spindle Motor attains operating speed within 1 sec. after application of the negative level to this line. This signal is gated by either Drive Select line.

### Remote Eject 0

A negative level on this line energizes a relay that ejects the Diskette in Side 0. This line shall be held at the negative level for 1 second to allow operation of the eject mechanism. This signal is gated by either Drive Select line.

### Index 1

This line is normally at the positive level. A one millisecond pulse to the negative level is transmitted on this line once for each revolution of the Diskette in Side 1 (left side when viewed from front panel looking toward rear of drive) as the Diskette index hole passes the index hole sensor. This line is logically Or'd internally with Index 0. This signal is gated by the Drive Select Right line.

### Ready 1

A negative level on this line indicates that a Diskette is loaded in Side 1 and is within 90% of operating speed. This line is logically Or'd internally with Ready 0. This signal is gated by the Drive Select Right line. If the spindle is turned off by spindle enable and a disk is left in Side 1, this line will remain true.

### Remote Eject 1

A negative level on this line energizes a relay that ejects the Diskette in Side 1. This line shall be held at the negative level for 1 second to allow operation of the eject mechanism. This signal is gated by either Drive Select line.

### Drive Select 1 Left

A negative level on this line loads and selects Head 0 (the left-side head) of Diskette Drive 1 for connection to the Controller Interface Signals at the Signal Connector. Within Diskette Drive 1, all interface signals are controlled by this line and Drive Select 1 Right. Insertion of the Drive Select 1 Module on the Data and Interface PCB enables the Drive interface gating to respond to control levels on the Drive Select 1 Left line.

### Drive Select 1 Right

A negative level on this line loads and selects Head 1 (the right-side head) of Diskette Drive 1 for connection to the Controller Interface signals at the Signal Connector. Within Diskette Drive 1 all interface signals are controlled by this line and Drive Select 2 Left. Insertion of the Drive Select 1 Module on the Data and Interface PCB enables the Drive Interface gating to respond to control levels on the Drive Select 1 Right line.

### Drive Select 2 Left

A negative level on this line loads and selects Head 0 (the left-side head) of Diskette Drive 2 for connection to the Controller Interface Signals at the Signal Connector. Within Diskette Drive 2, all interface signals are controlled by this line and Drive Select 2 Right. Insertion of the Drive Select 2 Module in the Data and Interface PCB enables the Drive interface gating to respond to control levels on the Drive Select 2 Left line.

### Drive Select 2 Right

A negative level on this line loads and selects Head 1 (the right-side head) of Diskette Drive 2 for connection to the Controller Interface signals at the Signal Connector. Within Diskette Drive 2 all interface signals are controlled by this line and Drive Select 2 Left. Insertion of the Drive Select 2 Module on the Data and Interface PCB enables the Drive interface gating to respond to control levels on the Drive Select 2 Right line.

### Write Protect 0

A negative level on this line indicates that the Diskette in Side 0, the left-side head, is Write Protected and that the drive write circuitry is prevented from writing on this Diskette. This signal is Or'd internally with Write Protect 1 and is selected with Drive Select Left.

### Write Protect 1

A negative level on this line indicates that the Diskette in Side 1, the right-side head, is Write Protected and that the drive Write circuitry is prevented from writing on this Diskette. This signal is Or'd internally with Write Protect 0 and is selected with Drive Select Right.

### Direction Select

The level on this line defines the direction of motion of the head positioner when the Step line is pulsed. A negative level defines the direction as inward (higher track number) and a positive level as outward (lower track number and away from the center).

### Step

A 200 nanosecond to 5 millisecond pulse (consistent with input pulse recurrent frequency) to the negative level is presented on this line for each track to be crossed by the head during a seek to a new address. The Direction Select level shall be stable for 100 nanoseconds prior to the leading edge of this Step pulse. Pulse trains representative of up to 76 tracks of address change may be transmitted at pulse recurrent frequencies up to 500 kilohertz.

### Write Data

Write current changes polarity for each positive to negative transition on this line. This line shall remain stable for at least 180 nanoseconds before and after such a transition. This signal is gated by the Drive Select line.

### Write Gate

Write current is turned on for the duration of time that this line is held at a negative level. The selection of one head for writing automatically selects the other head for reading. This signal is gated by the Drive Select line. Erase current is also controlled by this line.

### Track 00

This line is normally at the positive level. A negative level is presented on this line when the heads are positioned over Track 00. This signal is gated by the Drive Select line.

### Read Data

This line transmits the output of the selected head at all times except when the Write Gate is enabled, at which time it transmits the output of the other drive head. Each flux transition on the Diskette is represented by a 200 nanosecond  $\pm 20\%$  pulse to the negative level on this line. This signal is gated by the Drive Select line.

### Separated Data

A phase locked loop data separator separates read data into data pulses and clock pulses, removing jitter due to peak shift effects. A data pulse occurs on the separated data line for each data pulse of read data, except during a dropped clock address mark. After the first dropped clock, data pulses are transferred to the separated clock line and clock pulses are transferred to the separated data line until the first missing data pulse, at which time normal operation is restored. Each data pulse is represented by a 200 nanosecond +20% pulse to the negative level on this line. This signal is gated by either Drive Select line.

### Separated Clock

The other output generated by the data separator is Separated Clock. A pulse occurs on this line for every clock pulse of the read data, except during a dropped clock address mark. During an address mark, data pulses are transferred to the separated clock line and clock pulses to the separated data line, until the first missing data pulse restores normal operation. Each clock pulse is represented by a 200 nanosecond +20% pulse to the negative level on this line. This signal is gated by either Drive Select line.

### Direct Head Load

A negative level on this line loads Side 0 and Side 1 head, overriding Drive Select. This feature allows copy routines which do not contain delays for head load time.

#### 6.4.3 D.C. Power to Diskette Drives

All DC Power lines shall have lengths and wire diameters consistent with meeting the power regulation requirements of the Diskette Drive, as specified in Paragraph 5.3.1.

Eight lines are used to transmit DC power through the Power Connector from the Power Supply into a Diskette Drive. One line pair (high and ground) is used for +5.0V DC, one for +5 Unregulated, one for +24.0V DC, and one for -5.0V DC. In addition, a separate single line is available to connect Drive and Power Supply chassis grounds.

Five-foot lengths of #18 AWG wire are normally acceptable for use as DC power lines between the Drive and typical power sources.

#### 6.5 Interface Requirements

##### 6.5.1 Power On Sequence

DC Power levels may be applied in any sequence to the Diskette Drive without causing damage to the Drive unit or writing on the Diskette due to drive electronics during the power-on transient interval.

A recommended conservative power-on sequence, which guards against marking a disk due to controller electronics, shall be as follows:

- Apply +5 Unregulated, +5.0V DC, and -5.0V DC to the Controller and to the Drives in any sequence.
- Set the Write Gate inputs to the Diskette Drives to their positive levels.
- Apply +24.0V DC to the Diskette Drives.
- Select the desired Diskette Drive by application of a negative level to the desired Drive Select line.
- Set the Restore interface line to the negative level.
- Upon receipt of a negative level on the Track 00 line, set Restore to the positive level.
- Upon receipt of a Seek Complete, proceed as desired.

#### 6.5.2 Power Off Sequence

Power levels may be removed in any sequence from the Diskette Drive without causing damage to the Drive or writing on the Diskette during the power-off transient interval. A recommended conservative power-off sequence shall be as follows:

- Set the Write Gate inputs to the Diskette Drives to their positive levels. Restore all drives to Track 00.
- Remove +24.0V DC from the Diskette Drives.
- Remove +5 Unregulated, +5.0V DC, and -5.0V DC from the Controller and Diskette Drives in any sequence.

#### 6.5.3 Data Access and Transfer

The timing inter-relationships during head positioning, head selection, and data transfer shall satisfy the following criteria and remain within the tolerances specified below:

- Diskette spindle speed: 360  $\pm$ 12 rpm.
- Maximum head positioning time for an adjacent track seek: 10 milliseconds.
- Maximum head positioning time for a 76-track seek: 110 milliseconds.
- Average rotational latency: 83.3 milliseconds.
- Maximum motor start time: 1 second.
- Radial dimensions of recording tracks: 3.612" for Track 00, 2.029" for Track 76.

- Separation between the Read/Write gap and the trailing Erase gap:  $0.036 \pm 0.003$ ".
- Index pulse interval time:  $166.7 \pm 3.3$  milliseconds.
- Read data cell time:  $4.0$  microseconds  $\pm 4\%$ .
- Write clock pulse to write data pulse:  $2.0$  microseconds  $\pm 0.3\%$ .
- Width of Read, Separated Data, and Separated Clock pulses:  $200$  nanoseconds  $\pm 20\%$ .
- Write data frequency:  $249.7$  Kilohertz  $\pm 0.3\%$ .
- Head load time:  $40$  milliseconds maximum.
- Erase gate turn-on:  $200 \pm 20$  microseconds after leading edge of Write Gate (internal drive timing).
- Erase gate turn-off:  $540 + 60$  microseconds after trailing edge of Write Gate (internal drive timing).
- Maximum rise and fall time of interface pulses:  $25$  nanoseconds.
- Phase-locked oscillator acquisition (lock-up) requirement is  $4$  bytes of all zeroes data.
- Data bits occur on the separated clock time after the first dropped clock of an address mark, and continue until the first data bit is dropped after an address mark.
- Write current amplitude automatically switched by internal drive logic between Tracks  $43$  and  $44$ .
- Restore is a low-speed head positioning operation to Track  $00$ . Completion of the Restore command is indicated by a negative level on the Seek Complete interface line.
- Track position incrementing of the Track Difference Buffer Register in the Drive is initiated by the positive-going (trailing) edge of the internal track detent pulse.
- The Direction Select line shall be stable for a minimum of  $100$  nanoseconds prior to the leading edge of the Step pulse(s).
- The entire pulse train on the Step line representative of a multi-track address change (one pulse per track) must be transmitted in less than  $2.0$  milliseconds, at pulse recurrent frequencies of up to  $500$  kilohertz.



## 7.0 MAINTENANCE

### 7.1 Reliability Requirements

The Model 277 Diskette Drive is designed and constructed to provide a useful life of five years or 15,000 hours, whichever occurs first, before a factory overhaul or replacement is required. Repair or replacement of parts is permitted during the lifetime of the unit.

#### 7.1.1 Mean Time Between Failures (MTBF)

Following an initial period of 200 hours, MTBF shall exceed 4,000 hours provided the proper preventive maintenance procedures are followed. The following expression defines MTBF:

$$\text{MTBF} = \frac{\text{Operating Hours}}{\text{No. of Equipment Failures}}$$

Operating hours mean total "power on" hours less any maintenance time. Equipment failures mean any stoppage or substandard performance of the equipment because of equipment malfunction. Equipment failure shall exclude down-time or substandard performance caused by operator error, adverse environment, power failure, controller failure, cable failure, use of a defective disk, or other failure not caused by the Diskette Drive. To establish a meaningful MTBF, operating hours must be greater than 2,500 hours and shall include all sites where the Diskette Drives are used. For the purpose of this specification, equipment failures are defined as those failures requiring repairs, adjustments, or replacements on an unscheduled basis, i.e., emergency maintenance is required because of hardware failure or substandard performance.

#### 7.1.2 Mean Time to Repair (MTTR)

Mean Time to Repair shall be less than 20 minutes and is defined as the time for an adequately trained and competent serviceman with a full contingent of spare parts to diagnose and correct a malfunction.

### 7.2 Preventive Maintenance

Head cleaning by the operator is not recommended. Routine scheduled Preventive Maintenance based on recommended procedures should be performed by suitable, trained, and competent maintenance personnel after every 1,000-hour operating interval or every six months, whichever is the shorter interval. In particular, read/write/erase heads shall be cleaned with 91% isopropyl alcohol, using lintless gauze wrapped around a spatula. After cleaning with alcohol-wetted gauze, the head should be cleaned with a dry gauze in the same manner to pick up any residue left when the alcohol evaporates. No residue of lint or alcohol shall be allowed to remain on the head. The Diskette shall not be cleaned.

### 7.3 Corrective Maintenance

- 7.3.1 A portable Exerciser provides a means for operation of the Diskette Drive off-line for diagnostic.
- 7.3.2 The portable Exerciser is connected to the Diskette Drive by cables and connectors which will plug into the Diskette Drive PCB as a substitution for the cables and connectors to the Controller and Power Supply.
- 7.3.3 The Exerciser provides power for itself and for a Diskette Drive.
- 7.3.4 With the Exerciser connected to the Diskette Drive, it is possible to operate the Diskette Drive and test the following functions of the head positioning system:
- Alternations between two selectable head positions (manual or automatic)
  - Step forward and reverse (manual and automatic)
  - Alternations between Track 00 and a head position that steps from Track 01 to Track 76 and back (manual and automatic).
- 7.3.5 With the Exerciser connected to the Diskette Drive, it is possible to test the read and write functions of the Diskette Drive with the following data patterns on any selected track:
- All 1's
  - All 0's
  - Alternating bytes of 1's and 0's
  - Full track erase.
- 7.3.6 With the Exerciser connected to the Diskette Drive, it is possible to test additional functions and circuitry, including the following:
- Index
  - Track 00
  - Head Load
  - Spindle Motor Drive.

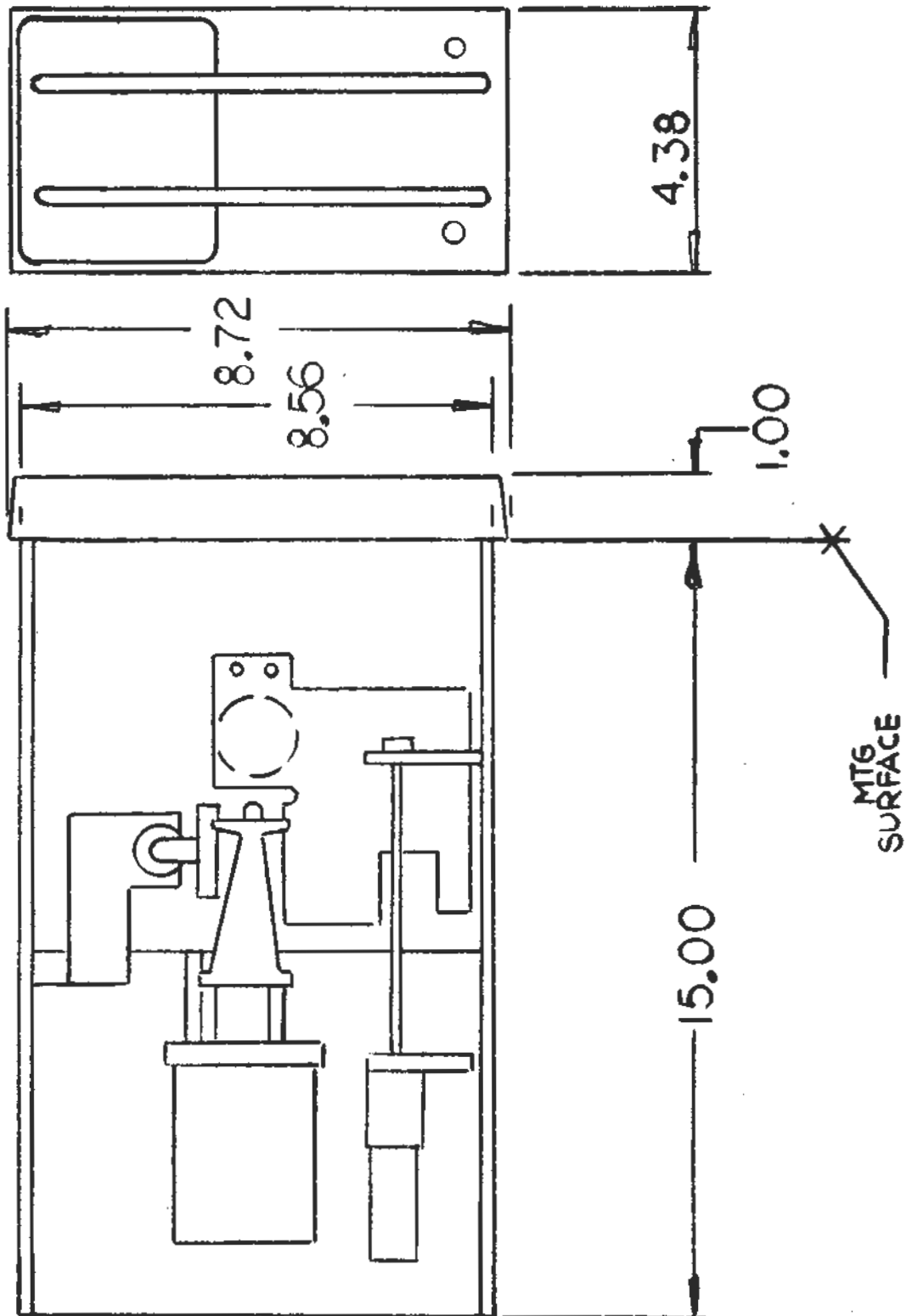

FIGURE 1. MODEL 277 OUTLINE DIMENSIONS

FIGURE 2  
 MODEL 277 SLIDE MOUNTING DIMENSIONS

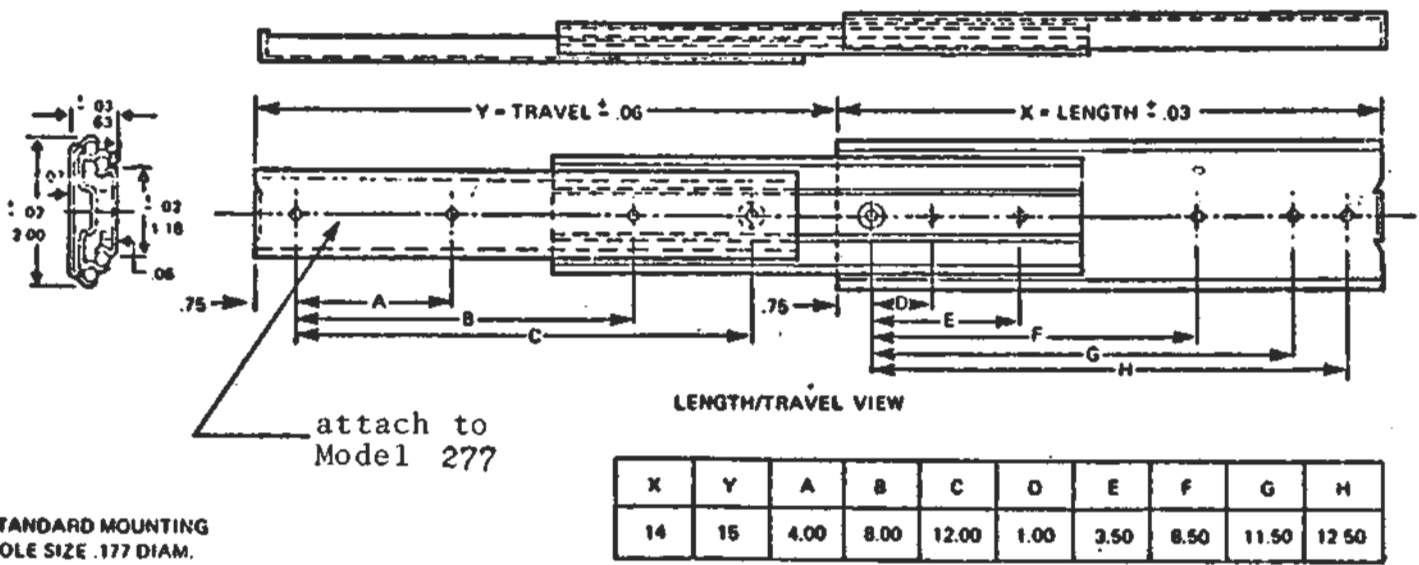
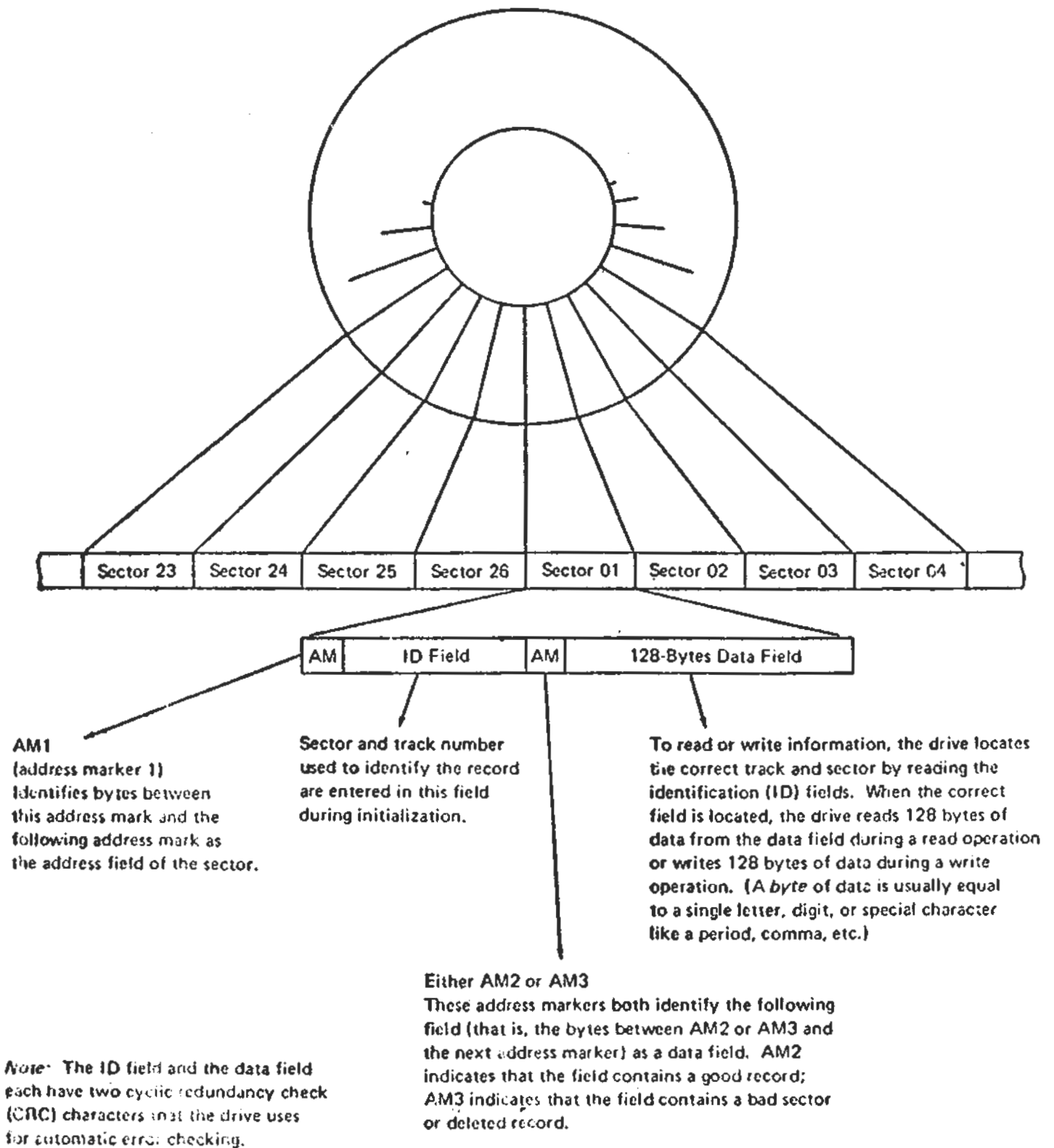

FIGURE 3  
IBM FORMAT



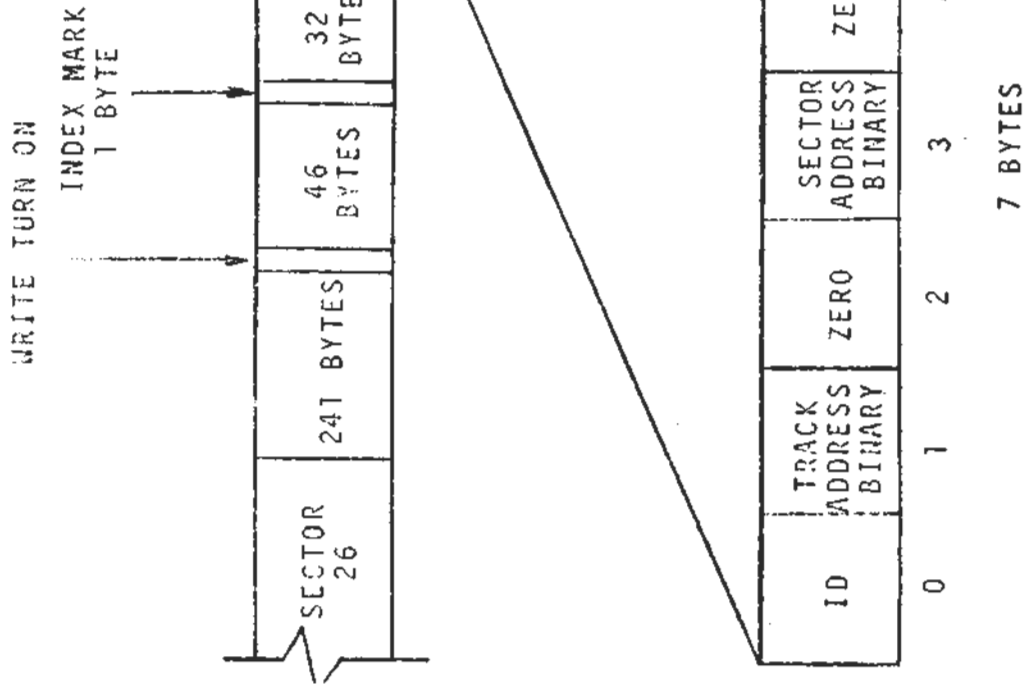

FIGURE 4. IBM DATA FORMAT

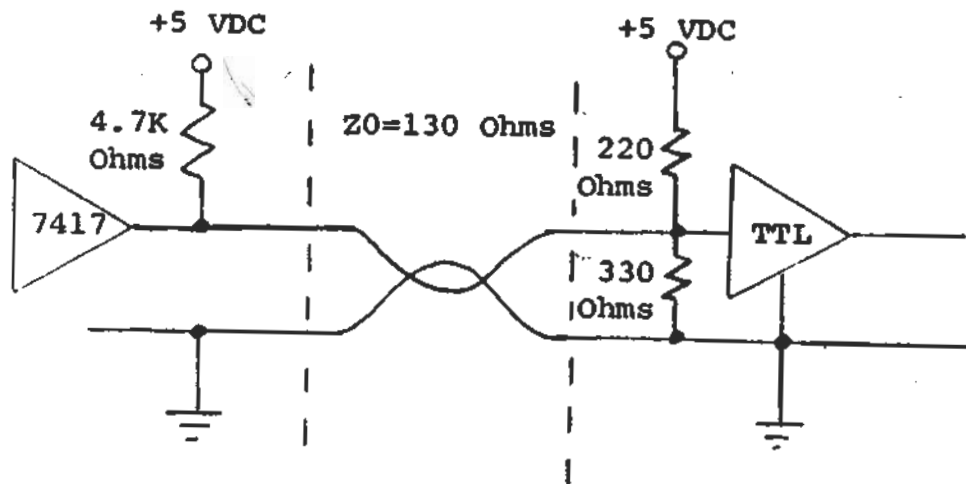

FIGURE 5  
LINE DRIVERS AND RECEIVERS

FIGURE 7 - POWER AND INTERFACE PIN CONNECTIONS - MODEL 277P1 - SIGNAL CONNECTOR

(50 Pin PCB Edge Connector-0.1" Centers)

Pin Numbers	Signal	*Side 0 (Left) and Side 1 (Right) Signals Internally Wire-Or'd.
1	2	Unassigned
3	4	Drive Select 2 Right
5	6	*Ready 1
7	8	*Index 1
9	10	Seek Complete
11	12	Restore
13	14	Remote Eject 0
15	16	Direct Headload
17	18	Drive Select 2 Left
19	20	*Index 0
21	22	*Ready 0
23	24	Spindle Motor Enable
25	26	Drive Select 1 Left
27	28	Drive Select 1 Right
29	30	*Write Protect 1
31	32	Remote Eject 1
33	34	Direction Select
35	36	Step
37	38	Write Data
39	40	Write Gate
41	42	Track 00
43	44	*Write Protect 0
45	46	Read Data
47	48	Separated Data
49	50	Separated Clock

P3 - POWER CONNECTOR

(10 Pin Molex-0.156" Centers)

Pin No.	Signal
1	Chassis Gnd
2	+5V DC
3	Spindle Power
4	Key
5	+24V DC
6	Gnd
7	Gnd
8	Gnd
9	Gnd
10	-5V DC

## Mating Connector

Connector-Molex 09-50-7101

Terminal - 08-50-0106

Polarizing Key - 15-04-0219

## Mating Connectors

## Flat Cable

Scotchflex 3415-000

or

T&amp;B Ansley 609-5005

## Solder Connector

Viking Connector 3VH25/1JN-5

or

TI Connector H312125



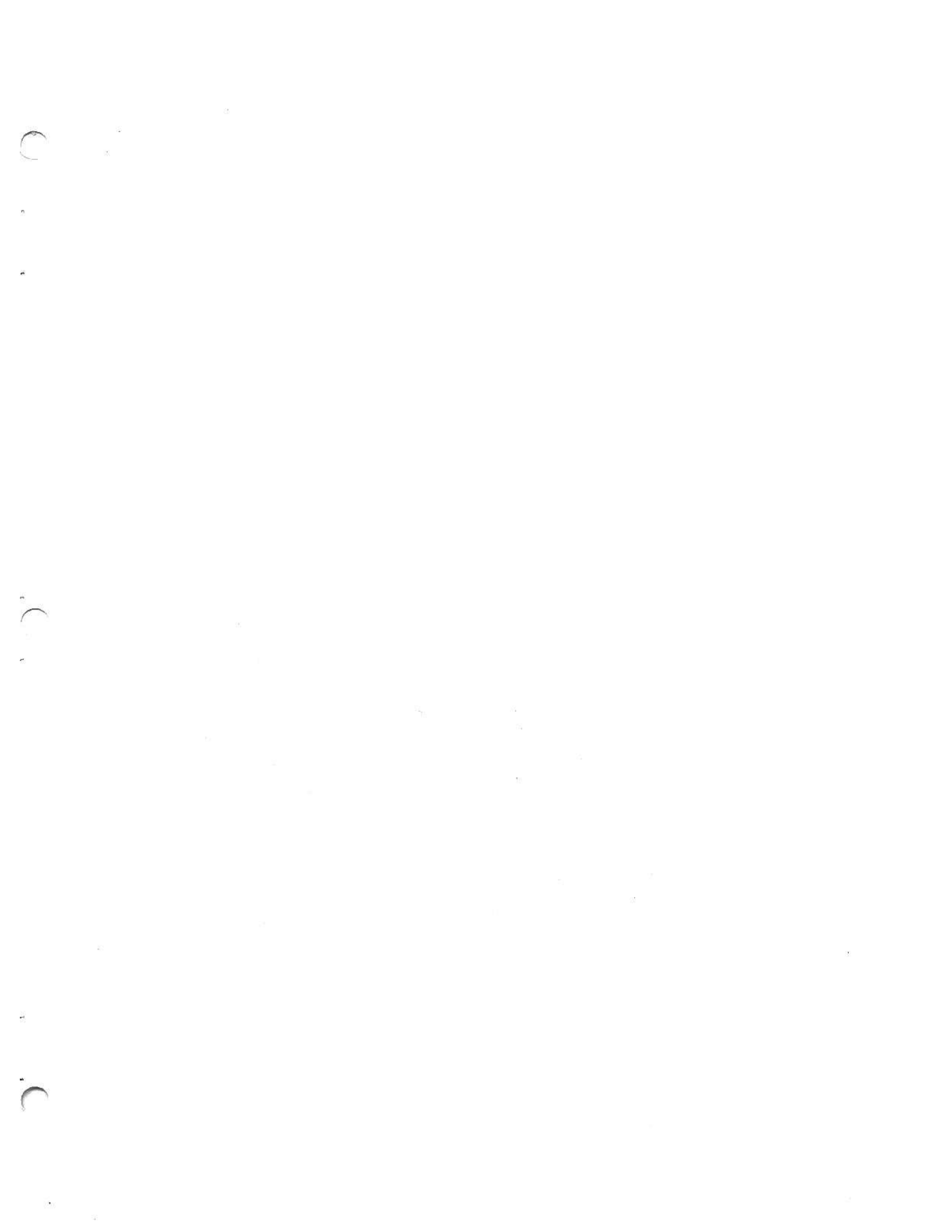

# **PERSCI, INC.**

**12210 Nebraska Ave  
W Los Angeles  
CA 90025**

**January, 1978**