

REV		REVISIONS DESCRIPTION	CHK	DATE	APPR
A	ENGIN REL				
B	R19 FROM P87 TO JUMPER POINT A & B P87 TO VSS BUS. ADD NOTE 5.				

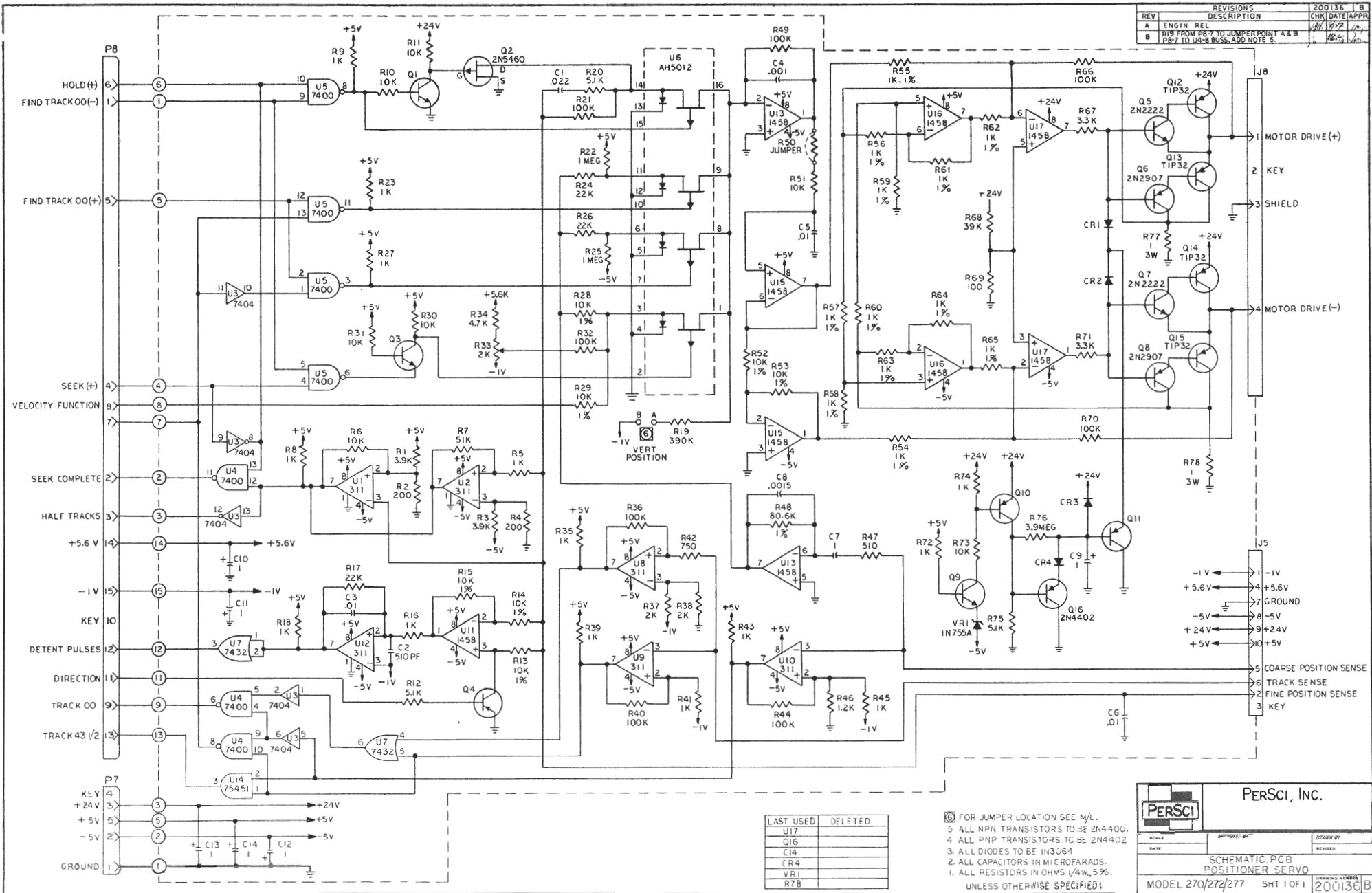

LAST USED	DELETED
U17	
Q16	
C14	
CR4	
VR1	
R78	

- Ⓢ FOR JUMPER LOCATION SEE M/L.
- ALL NPN TRANSISTORS TO BE 2N4400.
 - ALL PNP TRANSISTORS TO BE 2N4402.
 - ALL DIODES TO BE IN3064.
 - ALL CAPACITORS IN MICROFARADS.
 - ALL RESISTORS IN OHMS 1/4W, 5%.
- UNLESS OTHERWISE SPECIFIED

PERSCI, INC.

PERSCI

SCALE	DATE	DESIGNED BY	REVISIONS

SCHEMATIC PCB POSITIONER SERVO

MODEL 270/272/277 SHT 1 OF 1 DRAWING NUMBER 200136