

Preliminary

FD1036A

3.5" FLOPPY DISK DRIVE

PRODUCT DESCRIPTION

806-520236-0

REV. -0

NEC Corporation

PROPRIETARY NOTICE

The information and design disclosed herein were originated by and are the property of NEC Corporation. NEC reserves all patent, proprietary design, manufacturing, reproduction use, and sales rights thereto, and to any article disclosed therein, except to the extent rights are expressly granted to others. The foregoing does not apply to vendor proprietary parts.

Specifications remain subject to change to allow the introduction of design improvements.

Copyright 1985 ©
NEC Corporation
Printed in Japan

Edition	Description
1	Prepared in August 1985

CONTENTS

PROPRIETARY NOTICE	i
CONTENTS	iii
1. GENERAL	1
2. GENERAL SPECIFICATION	2
2.1 Drive Specifications	2
2.2 Drive Structure	5
2.3 Drive Operation	7
2.4 Disk Specifications	8
2.5 Disk Structure	9
3. INTERFACE	11
3.1 General Description	11
3.2 Physical Specifications	13
3.2.1 Signal Types and Pin Configuration	15
3.2.2 Power Connector and Pin Configuration	16
3.2.3 Connector Type	17
3.3 Electrical Specifications	18
3.3.1 Signal Level	18
3.3.2 Driver/Receiver	18
3.4 Input Signals	20
3.4.1 DRIVE SELECT 0 to 3 (DS0 to 3)	20

3.4.2	STEP (STP)	20
3.4.3	DIRECTION SELECT (DIR)	21
3.4.4	SIDE SELECT (SSL)	21
3.4.5	WRITE GATE (WGT)	22
3.4.6	WRITE DATA (WDT)	22
3.4.7	MOTOR ON (MON)	23
3.5	Output Signals	24
3.5.1	INDEX (IDX)	24
3.5.2	TRACK 00 (TK0)	24
3.5.3	READY (RDY)	25
3.5.4	READ DATA (RDT)	25
3.5.5	WRITE PROTECT (PRT)	26
3.6	Interface Signal Timing	27
3.6.1	Step and Track 00	27
3.6.2	Access Timing	27
3.6.3	Write Timing	28
3.6.4	Read Timing	28
3.6.5	Write Data Timing	29
3.6.6	DRIVE SELECT and Output Signal Timing	29
3.6.7	Autochucking Timing	29
3.7	Power Interface	30
3.7.1	Input Power Specifications	30
4.	OPERATING PROCEDURES	31
4.1	Setting a Floppy Disk	31
4.2	Removing the Floppy Disk	31

4.3	Display Lamp	31
5.	EXTERNAL SHAPE AND INSTALLATION	32
5.1	External Shape and Fitting Hole Positions	32
5.2	Installation	33
5.3	Recommended Air Flow	34
6.	PACKING AND TRANSPORTATION	35

1. GENERAL

The FD1036 micro-floppy disk drive is a double-sided micro-floppy disk drive with 135 tracks per inch (TPI).

The Micro-floppy disk (abbreviated as disk in this manual) used for the FD1036 is contained in a hard jacket with auto shutter.

The FD1036 micro-floppy disk drive has a total volume one fourth that of conventional 5-1/4" minifloppy disk drives and weights only approximately 560 g, yet has a comparable storage capacity.

The previous FD 1035 series is the short model with short depth (130 mm). The FD 1036 series is the slim model with thin thickness (30 mm).

The drive uses a direct-driven spindle with a brushless DC motor, and by due the low power design it consumes only 2.1 watts of power (Typ).

The low noise design assures silent operations.

In this manual the FD1036 micro-floppy disk drive is abbreviated as FDD.

2. GENERAL SPECIFICATIONS

2.1 Drive specifications

No.	Item		Specification		Unit
1	Recording mode		MFM	FM	
2	Capacity	Unformatted	1	0.5	MB
		Formatted (NOTE 1)	640	320	kB
3	Data transfer rate		250	125	k-bit/sec.
4	Maximum bit density		8717	4359	BPI
5	Tracks		160		
6	Average rotational speed		300		rpm
7	Seek time (Track-to-track)		3		ms
8	Seek settling time		15		ms
9	Track density		135		TPI
10	Start time (NOTE 2)		800		ms
11	Standard external dimensions (NOTE 3)	Width	30 (1.2)		mm (in)
		Height	101.6 (4)		mm (in)
		Depth	146 MAX (5.75)		mm (in)
12	Weight		56		gr
13	Operating environment conditions	Temperature	5 ~ 45		°C
		Relative humidity	20 ~ 80		%RH
		Maximum wet-bulb temperature	29.0 (woncondensing)		°C

No.	Item		Specification		Unit
14	Power supply requirement	Voltage (V)	Startup current (NOTE 4)	Steady-state current (NOTE 5)	
		+12	Less than 0.1	90	mA
		+5	60	200	mA
15	Power dissipation		0.3	2.1	W
16	Heat output		0.26	1.8	kcal/h
17	Reliability	MTBF (NOTE 6)	12000 (Under standard use condition)		POH
		MTTR	0.5		h
		Device life	15000 POH or 5 years (Design life)		
		Soft errors	10^{-9} (Not including 2 or less retry attempts)		Times/bit
		Hard errors	10^{-12}		Times/bit
		Seek error ratio	10^{-6}		Times/seek
18	Disk life		3.0×10^6		Pass count/track
19	Disk		Double sided 3.5" diskette specified by NEC		
20	Drive environment	Operating	Non-operating (Storage)	Transporting (Packing)	Unit
	Temperature	4 ~ 46 (39 ~ 115)	-20 ~ 50 (-4 ~ 122)	-40 ~ 60 (-40 ~ 140)	°C (°F)
	Relative humidity	20 ~ 80	10 ~ 90	5 ~ 95	%RH
	Maximum wet-bulb temperature	29 (84)	40 (104)	45 (113)	°C (°F)
	Largest temperature	20 (59)	30 (86)	30 (86)	°C/h (°F/h)

No	Item	Specification			Unit
	Allowable vibration (Except at resonance point) (NOTE 7)	0.5 (Less than 100 Hz)	2 (Less than 100 Hz)	2 (Less than 100 Hz)	G
	Allowable shock (Less than 10 ms)	5	15	40	G

NOTE1: 16 sectors/track , 256 bytes/sector time

2: Time until READY after MOTOR ON

3: Dimensions not including that of the front bezel.

4: If the disk is not inserted or the MOTOR ON signal is invalid.

5: When FDD is in READY status.

6: Under standard use conditions

(1) Drive service : 8 h/day
time (POH)

(2) Actual head load : 0.5 h/day
time (R/W time)

(3) Disk insertion/ : 25 times/day
ejection

(4) Motor ON/OFF : 300 times/day

(5) Average use time : 2 h/day
per disk (4 disks/day.drive)

7: Excitation in three directions one R/W test by our FDD tester for 0 to 79 track

8: Between SG and FG: 90K Ω (DC)

2.2

DRIVE STRUCTURE

The major component of FDD have the following functions:

(1) Base

Constructs the frame.

(2) Spindle motor assembly

Rotate the disk directly by using the DC spindle motor. The disk is set to the spindle with a magnet and is driven by a driving pin.

(3) Head carriage assembly

Contains a pair of magnetic heads facing across the disk. The R/W gap of the head on side one is dislocated 8 tracks inner than that of the head on side zero.

(4) Step motor

Move the carriage Assy by using the steel belt for head position.

- (5) Index sensor
Detect the drive position of the spindle motor.
- (6) Track 00 sensor
Detect whether the magnetic head is in the 00 track.
- (7) Write protect sensor
Detect the open/close of the write prohibition hole.
- (8) Eject mechanism
Used for manual insertion and removal of a disk and for automatic shutter control.
- (9) P.W.B.
Mounts the electric circuits that controls positioning of magnetic head, read/write operations, etc.
- (10) Display lamp
This is a lamp that displays a FDD status.
- (11) Front panel
Dress panel installed on the Drive front.

When a diskette is inserted into the FDD, the spindle motor rotates automatically until the chucking of the disk is finished. Then the FDD becomes a standby status. After the MOTOR ON signal is true, the FDD becomes ready when the spindle motor reaches the specified rotation speed.

When the drive is selected, it transfers the READY signal to the controller.

The magnetic head moves to a target track according to the STEP pulse and DIRECTION SELECT signals.

The desired magnetic head is selected by the SIDE SELECT signal from the controller. Now FDD is ready for read/write operations.

For a write operation, the WRITE DATA signal which is the serial data sent from the controller converted into magnetized pattern and is recorded on the disk.

For a read operation, the magnetized pattern recorded on the disk is detected by the head and is converted into serial data, and is sent to the controller as a READ DATA signal.

2.4

DISK SPECIFICATIONS

No.	Item	Specification	
1	Media type	3.5" double sided medium specified by NEC	
2	Product name	NEC micro floppy disk	
3	Number of disks	1	
4	Recording surfaces	2	
5	Number of total tracks per disk	160	
6	Disk cartridge size	90 x 94 mm	
7	Operating environment conditions	Temperature	10 ~ 60°C (50 ~ 140°F)
		Relative humidity	8 ~ 80% RH
		Wet-bulb temperature	29°C Maximum (84°F)
		Temperature gradient	20°C/h Maximum (36°F/h)
		External Magnetic field	4000 A/m (50 oersted) or less
		Note	Leave the disk at least 30 minutes in the drive operating environment before use.

2.5

DISK STRUCTURE

The floppy disk is contained in a hard jacket withinside of which liner sheets are provided for disk surface protection. The disk uses a polyethylene terephthalate base coated with magnetic layers. The liner consists of unwoven cloth and protects the disk surfaces from scratch or dust. The hard jacket is made of ABS resin.

The disk has a metal hub wihch is used to secure itself to the spindle. The hard jacket has a write-protect hole and automatic shutter.

The disk construction is shown in Figure 2.1.

Figure 2.1 shows the disk structure.

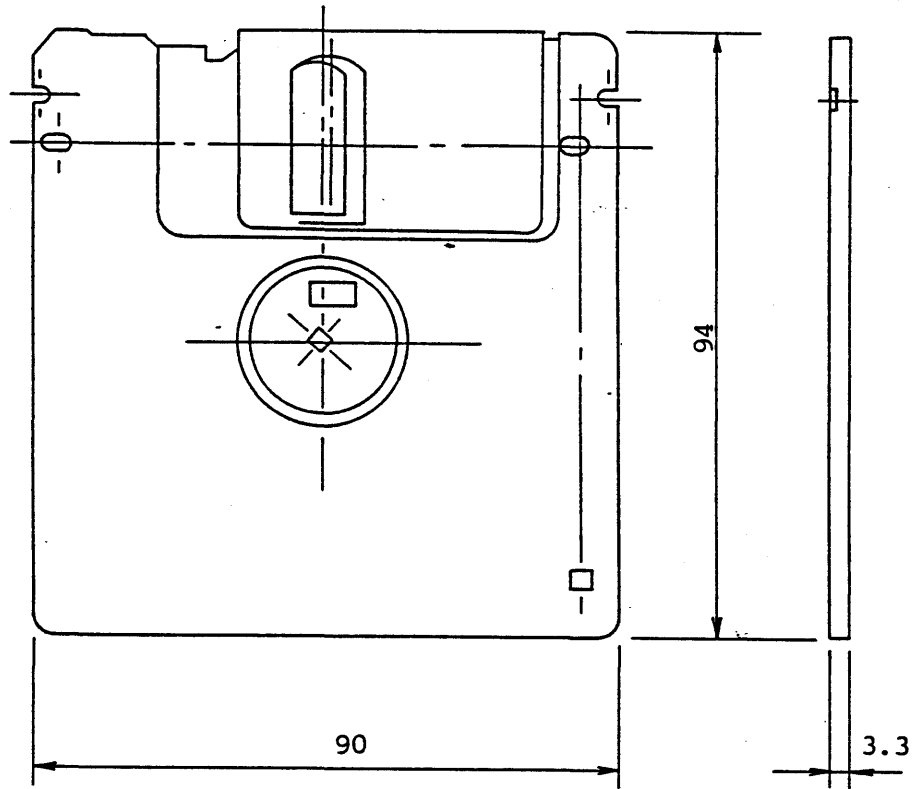

Fig. 2.1 Disk Structure

3. INTERFACE

3.1 GENERAL DESCRIPTION

FDD's may be connected to its controller in either parallel or daisy-chain configuration. The number of FDD's which can be connected to one controller depends on individual system and controller. For daisy-chain connection, each controller can control up to 4 FDD's.

Signal line termination resistors are provided on each FDD. The basic FDD connection to the controller is shown in Figure 3.1.

(a) Parallel connection

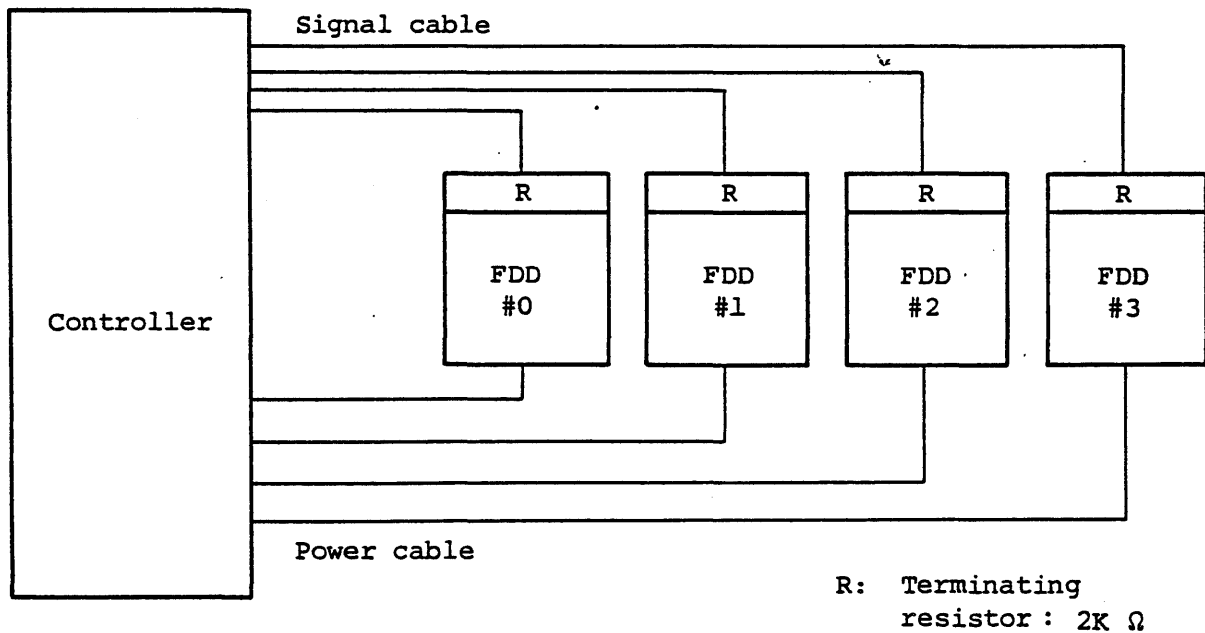

Signal cable maximum length 1 m

(b) Daisy Chain connection

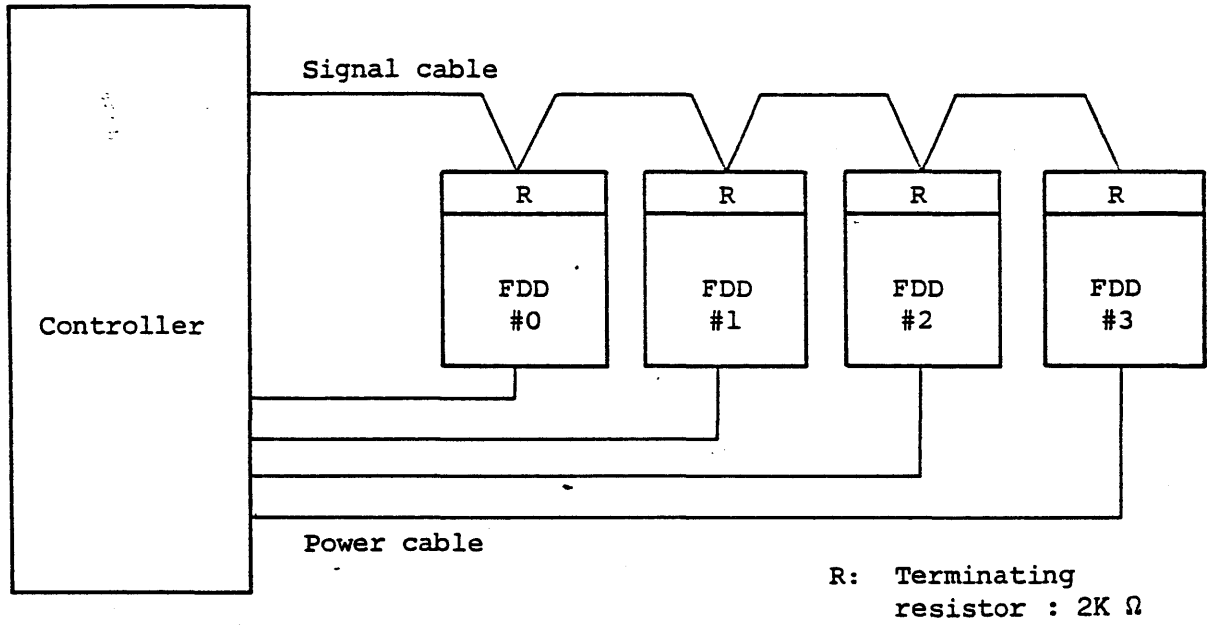

Signal cable total length maximum length 1 m

Fig. 3.1 Basic Connection Modes

3.2

PHYSICAL SPECIFICATIONS

The FDD is connected to its controller through a signal connector and a power connector. A faston terminal is provided for frame ground. The connector locations are shown in Figure 3.2.

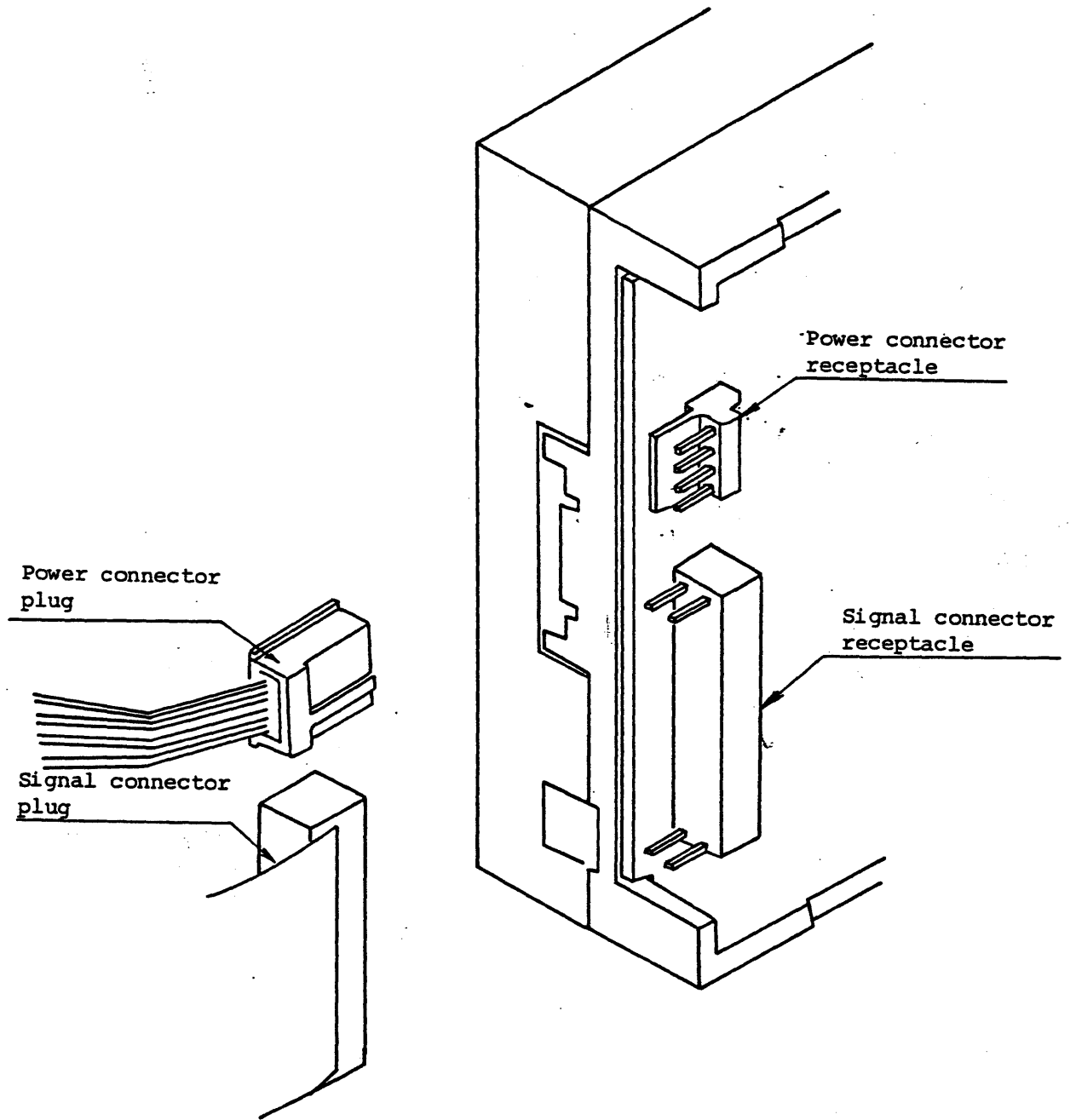
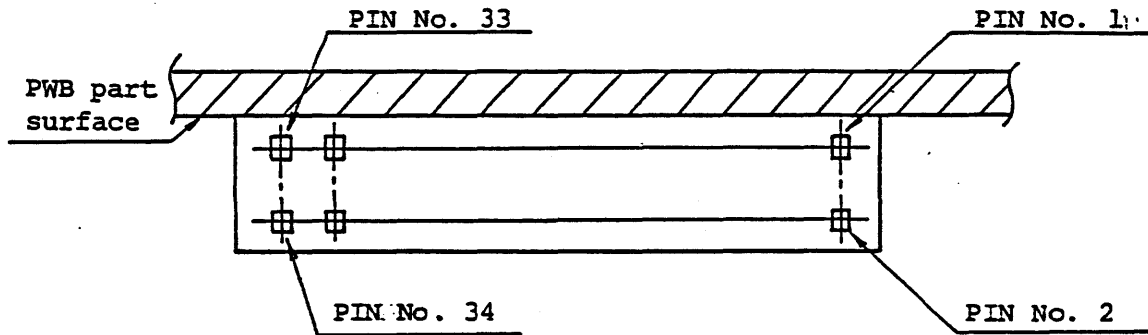

Fig. 3.2 Connector Locations

3.2.1 Signal Types and Pin Configuration

The following shows the signal connector pin configuration on the FD 1036:



Signal name	I/O Signal	Pin Number	Pin Number	Signal Name
MOTOR ON 1	Input signal	2	1	GND
IN USE	Input signal	4	3	GND
DRIVE SELECT 3	Input signal	6	5	GND
INDEX	Output signal	8	7	GND
DRIVE SELECT 0	Input signal	10	9	GND
DRIVE SELECT 1	Input signal	12	11	GND
DRIVE SELECT 2/ (MOTOR ON 1)	Input signal	14	13	GND
MOTOR ON	Input signal	16	15	GND
DIRECTION SELECT	Input signal	18	17	GND
STEP	Input signal	20	19	GND
WRITE DATA	Input signal	22	21	GND
WRITE GATE	Input signal	24	23	GND
TRACK 00	Output signal	26	25	GND
WRITE PROTECT	Output signal	28	27	GND
READ DATA	Output signal	30	29	GND
SIDE SELECT	Input signal	32	31	GND
READY	Output signal	34	33	GND

FG and SG processing as follows:

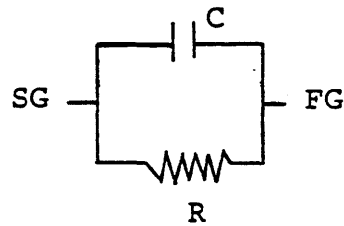

Impedance Terminator

$$R = 100 \text{ k}\Omega \text{ (}\pm 10\%), C = 0.1 \mu\text{F} \begin{pmatrix} + 80\% \\ - 40\% \end{pmatrix}$$

3.2.2 POWER CONNECTOR AND PIN CONFIGURATION

The following shows the power connector pin configuration:

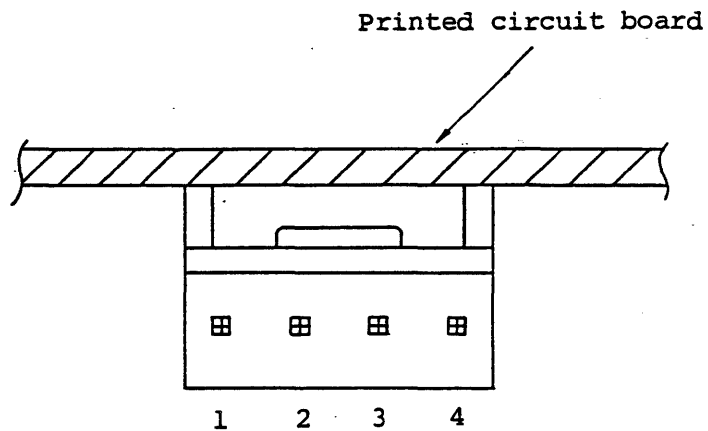

Fig. 3.3 Power Connector in Configuration

Table 3.1 Power Connector Pin Assignments

Pin number	Supply voltage
1	+5 V DC
2	GND
3	GND
4	+12 V DC

3.2.3 CONNECTOR TYPE

The following connector type are recommended for the signal and power connections for the FDD; equivalent connector types may also be used.

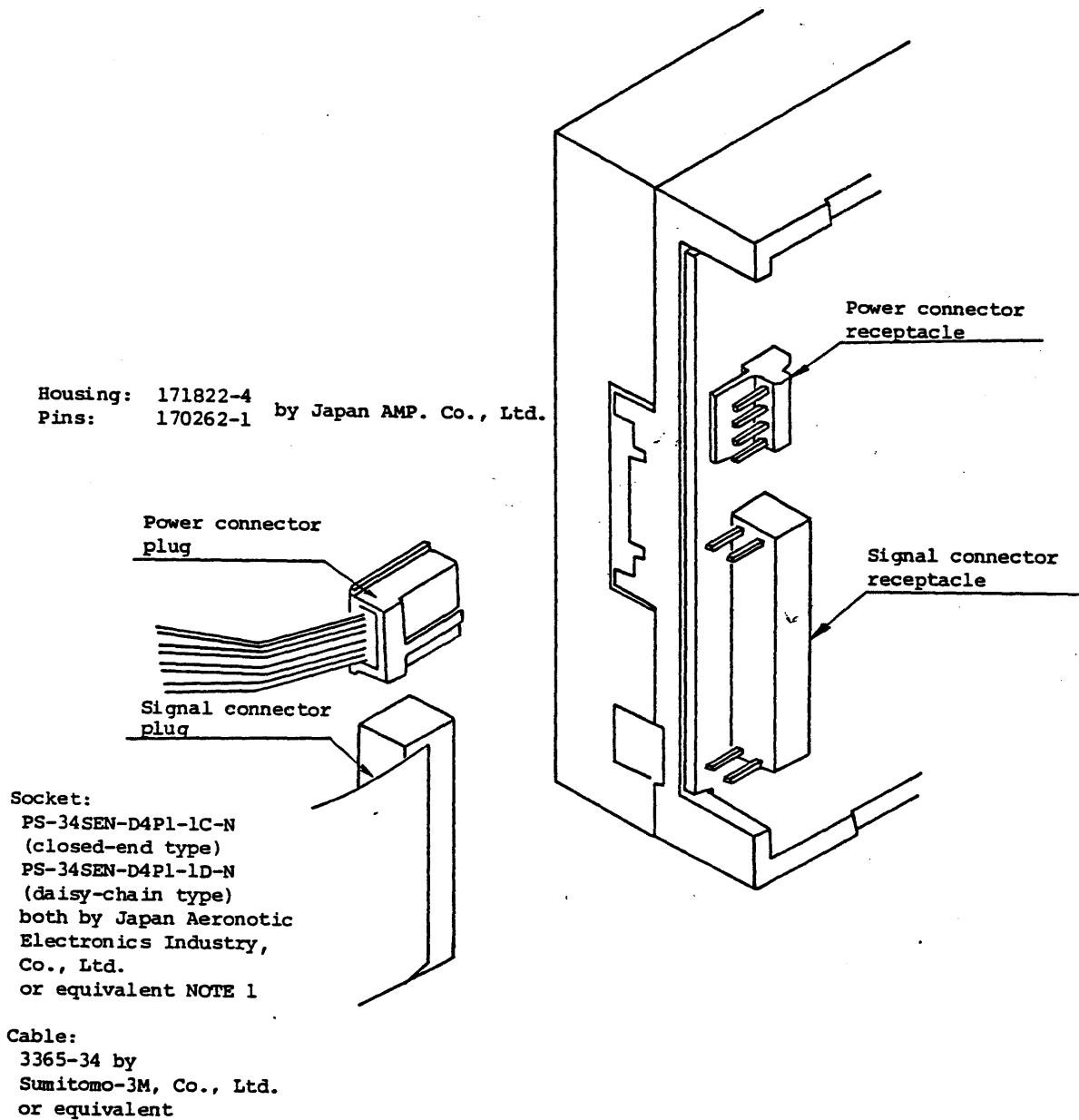

Fig. 3.4 Connector Locations and Recommended Models

3.3 ELECTRICAL SPECIFICATIONS

3.3.1 SIGNAL LEVEL

All the input/output signals are at TTL level with the following electrical specifications:

TRUE = Logical "0" (LOW level) 0, to +0.4 V

FALSE = Logical "1" (HIGH level) +2.5 to +5.25 V



3.3.2 DRIVER/RECEIVER

The driver which outputs signals from FDD to the controller is an open collector output circuit capable of obtaining sink current of maximum 40 mA at LOW level. The receiver which receives signals from the controller to FDD is a Schmitt trigger gate terminating with 2k Ohm.

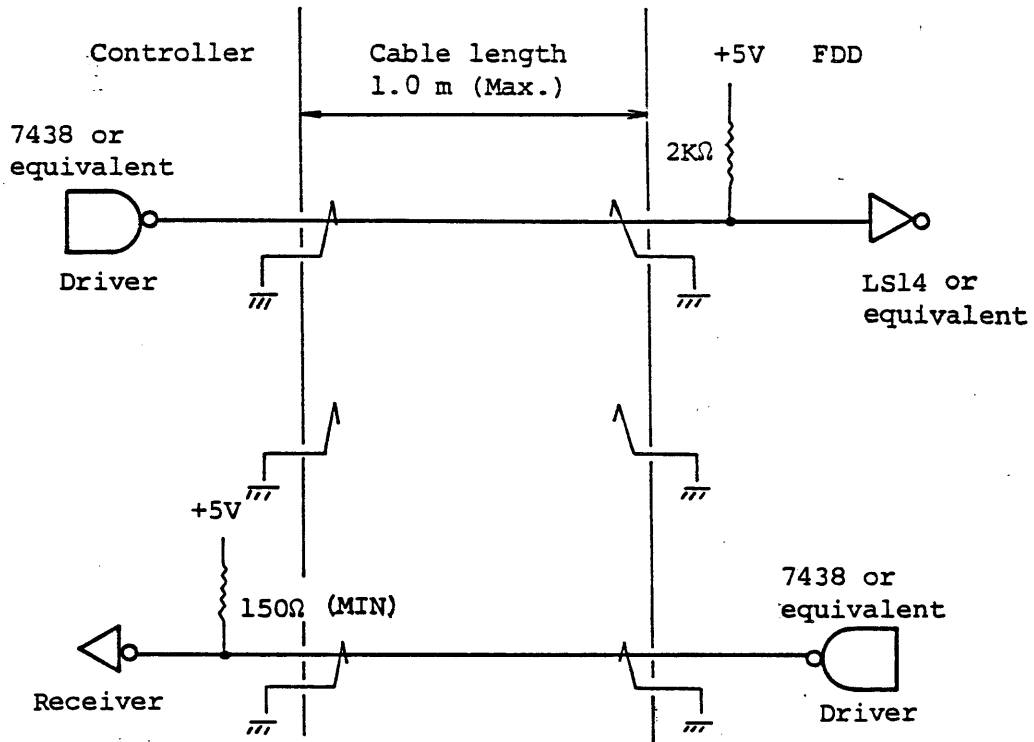

Fig. 3.5 Driver/Receiver Circuit Example

3.4 Input Signals

3.4.1 DRIVE SELECT 0 to 3 (DS0 to 3)

DRIVE SELECT 0 to 3 are signals for selecting a specified FDD. Setting one of DS0 to DS3 to LOW level selects the corresponding FDD, which makes effective the input/output lines.

FDD is specified by shorting one of the DX selection plugs 0 to 3 on the PWB.

3.4.2 STEP (STP)

Pulse signal which moves the magnetic head in the direction specified by the direction select signal. The head begins moving at the rising from LOW to HIGH level of this signal. The magnetic head moves over as many cylinders as the number of input pulses. Figure 3.6 shows the pulse timing conditions.

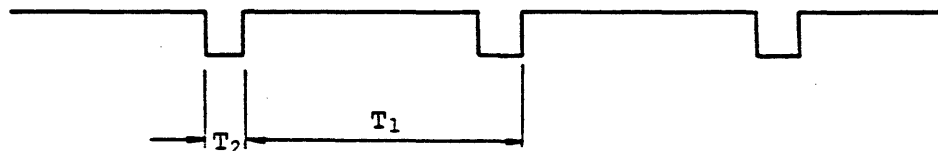

T_1 : 3 ms min.

T_2 : 0.8 μ s ~ 2 ms

Fig. 3.6 STEP Pulse Specification

3.4.3 DIRECTION SELECT (DIR)

Signal instructing the direction of magnetic head movement. The HIGH level indicates the direction toward the outer tracks and the LOW level indicates toward the inner tracks.

This signal must be switched definitely 0.8 μ s before the trailing edge (positive going) of the STEP signal.

3.4.4 SIDE SELECT (SSL)

Signal selecting one of the heads used for write or read. The HIGH level selects the magnetic head on the side "0" of the disk and the LOW level selects the side "1".

This signal must be switched 100 μ s before start of the read/write operation.

3.4.5 WRITE GATE (WGT)

This signal writes data when at LOW level and reads data when at HIGH level. Do not turn off the HEAD LOAD signal, switch the SIDE SELECT signal, or start positioning, for 1 ms after this signal has gone to HIGH level.

3.4.6 WRITE DATA (WDT)

Pulse signal that supplies data to be written to the disk. Every time the signal changes from HIGH to LOW level, the write current in the magnetic head changes direction, which changes the direction of magnetization on the disk.

Figure 3.7 shows the WRITE DATA specification.

3.5 Output Signals

3.5.1 INDEX (IDX)

Signal for indicating the origin on the disk. This is output once every revolution. Figure 3.8 shows the output pulse specification.

The reading edge of the pulse is used as a reference.

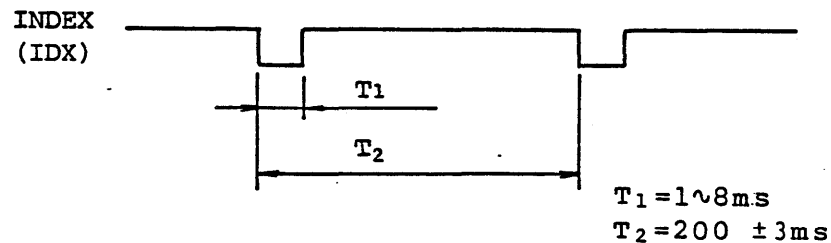

Fig. 3.8 INDEX Pulse Specification

3.5.2 TRACK 00 (TK0)

When at LOW level, this signal indicates that the heads are on track "00".

This signal is generated by the signal from the track 00 sensor and the (excitation) phase of the step motor.

3.5.3 READY (RDY)

Signal indicating that FDD is ready to operate.

This signal goes to LOW level, when the FDD is selected, if the following conditions are satisfied:

- (i) DC power is supplied. (5V, 12V)
- (ii) A disk is mounted.
- (iii) The rotational speed of the floppy disk has reached 90% of the specification.

(NOTE) When the spindle motor is rotating by the MOTOR ON signal

3.5.4 READ DATA (RDT)

Data read from a disk which is shaped into a pulse string.

Figure 3.9 shows the READ DATA signal obtained when normally recorded data is read.

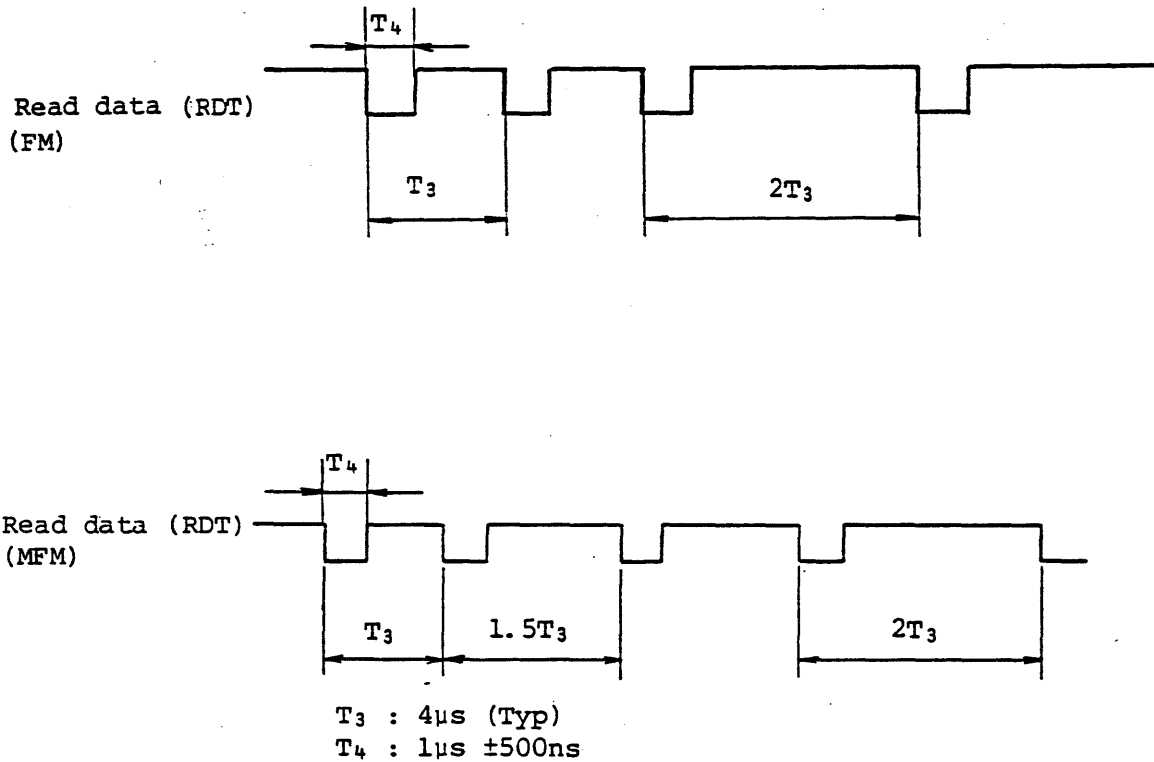

Fig. 3.9 READ DATA Signal Specification

3.5.5 WRITE PROTECT (PRT)

If a disk with its WRITE PROTECT hole uncovered is inserted into the drive, the PRT line goes low, which places the FDD in the WRITE PROTECT state.

3.6 Interface Signal Timing

3.6.1 Step and Track 00

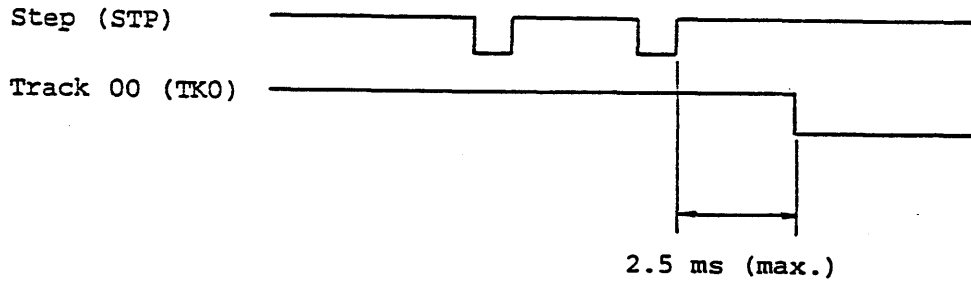

3.6.2 Access timing

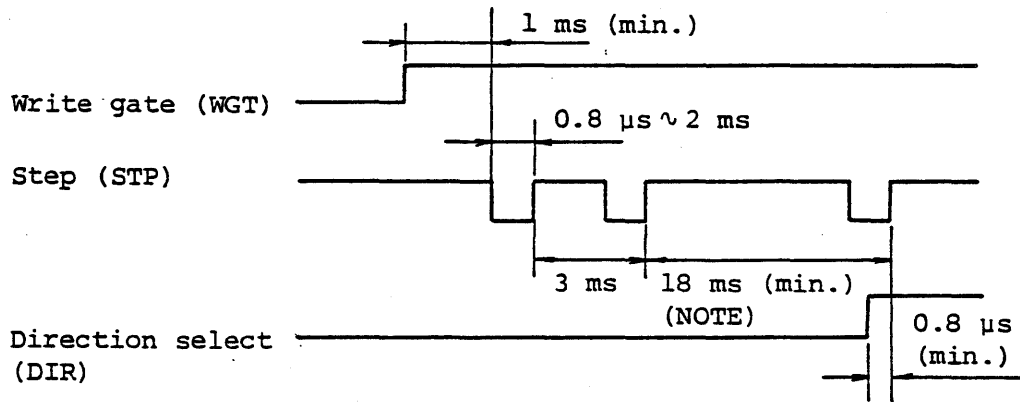

(NOTE) An interval of at least 18 ms is required between step pulses when the direction changes.

3.6.3 Write Timing

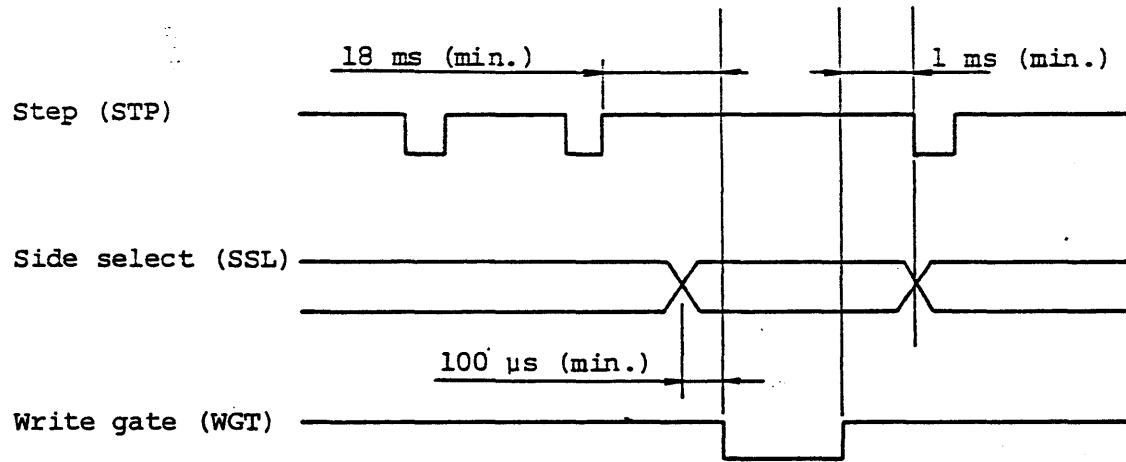

3.6.4 Read Timing

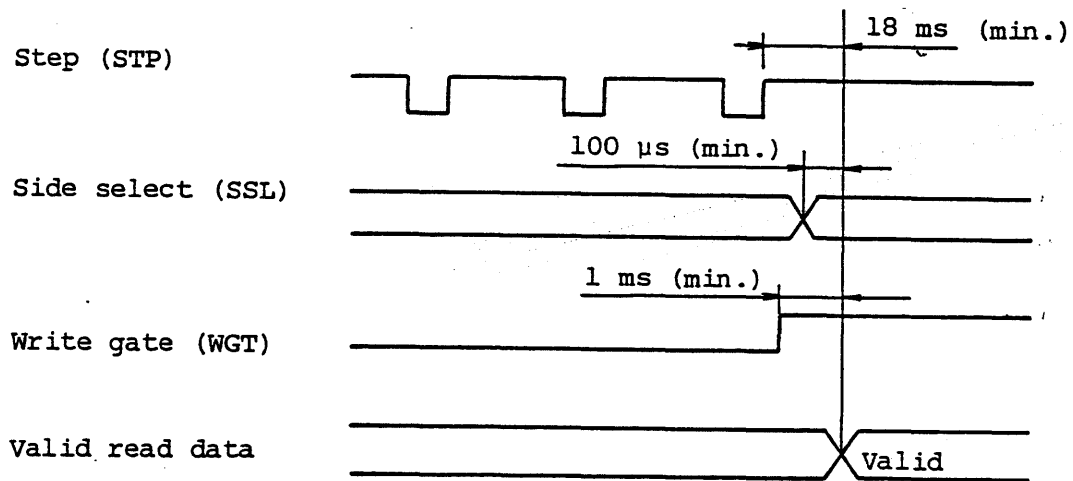

3.6.5 Write Data Timing

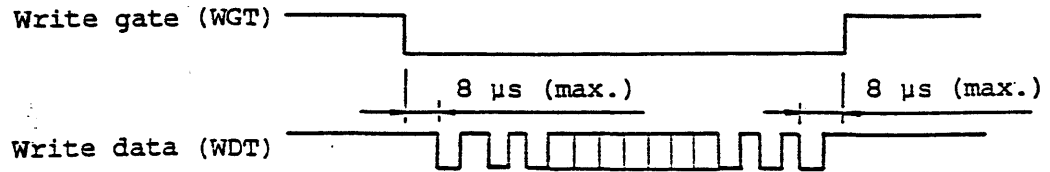

3.6.6 DRIVE SELECT and Output Signal Timing

The drive control and status signals are become valid 500 ns after that the DRIVE SELECT line is active.

3.6.7 Autochucking Timing

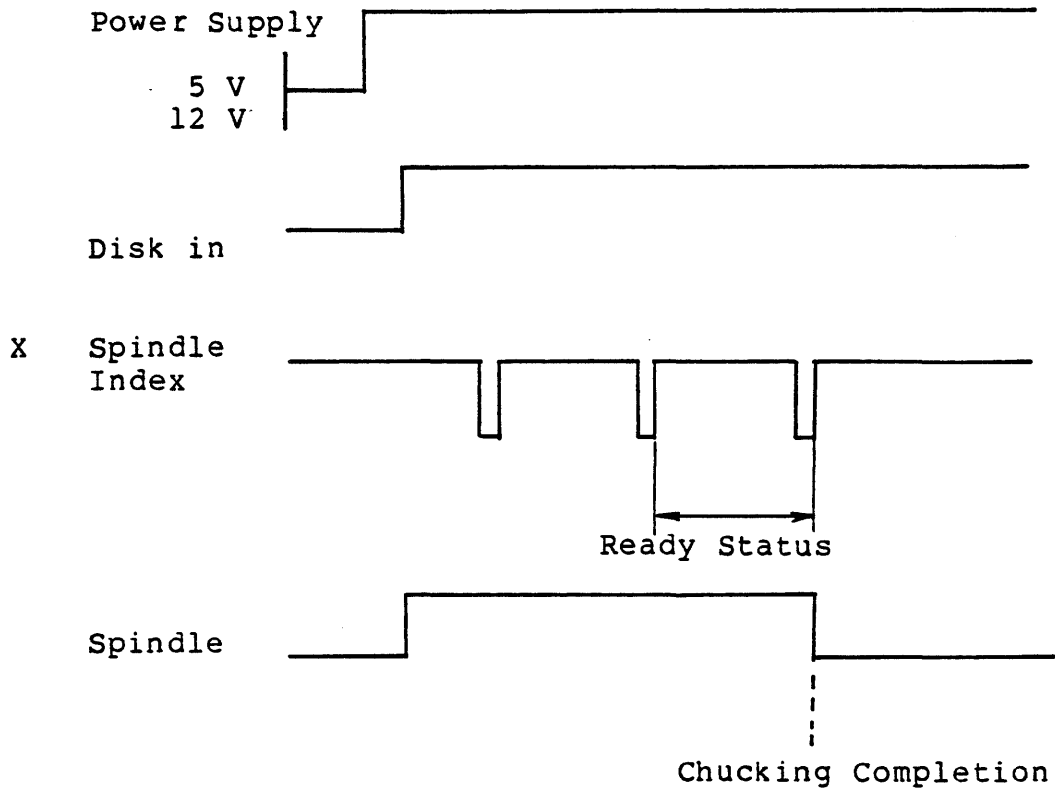

X is internal signal of the FDD.

3.7 POWER INTERFACE

3.7.1 INPUT POWER SPECIFICATIONS

Table 3.2 shows the DC power specifications for FDD.

A sequence for each DC power is not needed.

Table 3.2 Input Power Specifications

Item		+12V power	+5V power
Voltage (NOTE 6)		+12V \pm 5%	+5V \pm 5%
Current (NOTE 1)	Activating time	350 mA	140 mA
	Average when seek	140 mA	160 mA
	Average when read/write	90 mA	200 mA
	Average when standby	Less than 0.1 mA	60 mA
Ripple voltage (NOTE 2)		200mVp-p or less	100mVp-p or less

NOTE 1: This is FDD average consuming current.

2: This includes the spike voltage.

3: Data is protected in spite of DC power supply ON/OFF when FDD is not in Write operation.

4: If power supply is charged after moving the carriage to the outer or inner side for 1 track, the carriage is returned to track 0 immediately.

5: Do not turn on and off the power supply by the relay, etc.

6: Including ripple voltage.

4. OPERATING PROCEDURES

The basic operating procedures for FDD include the power on/off, disk setting and removal.

4.1 Setting A Floppy Disk

- (1) Insert the diskette slowly into the slot until the Eject button pops out.

4.2 Removing the Floppy disk

- (1) Make sure the write/read operation of FDD has finished.
- (2) To eject the diskette from the drive, just press the Eject button.

4.3 Display Lamp

The Display lamp indicates the FDD status.

It comes on while the FDD is selected.

5. EXTERNAL SHAPE AND INSTALLATION

5.1 External Shape and Fitting Hole Positions

Figure 5.1 shows the external shape and fitting hole positions.

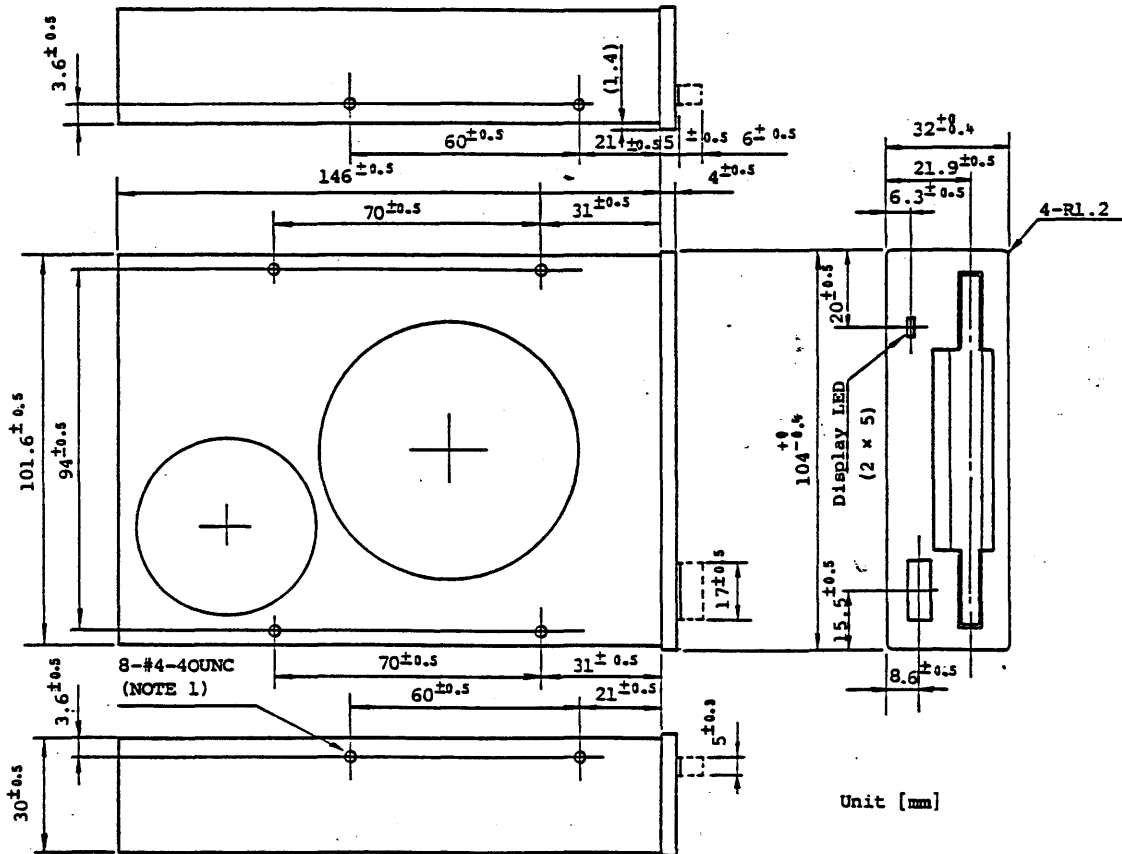

NOTE 1: The metric screw type is also available.

Fig. 5.1 External Shape and Fitting Hole Positions

5.2 Installation

(1) FDD may be installed in the following manners:

(a) Vertical

(b) Vertical

(c) Horizontal

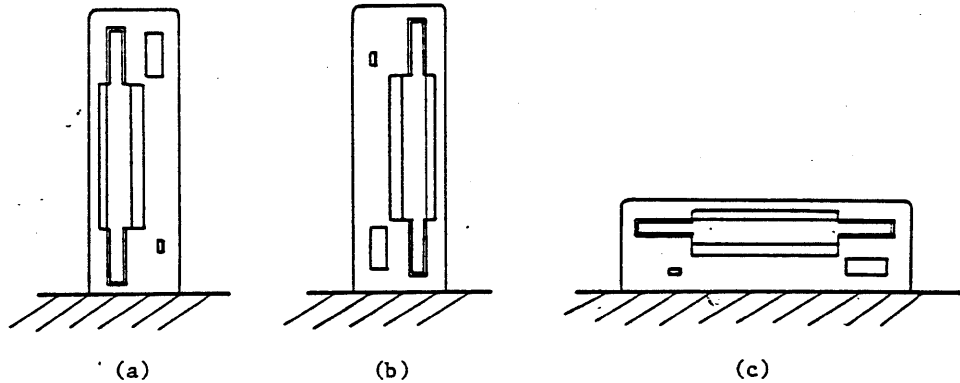

Consider the location of FDD in the system, so that it may be protected against the noise from CRT, power supply, etc., especially when installing it inside CRT.

5.3 Recommended Air Flow

(1) Installing one FDD

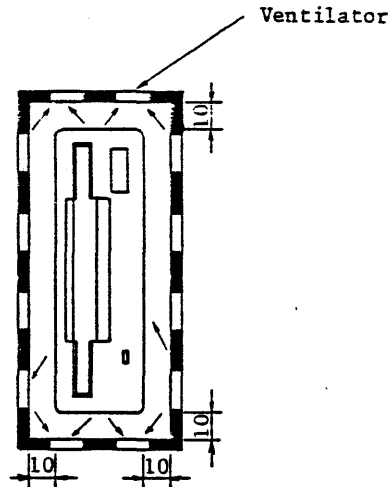

(2) Installing two FDDs

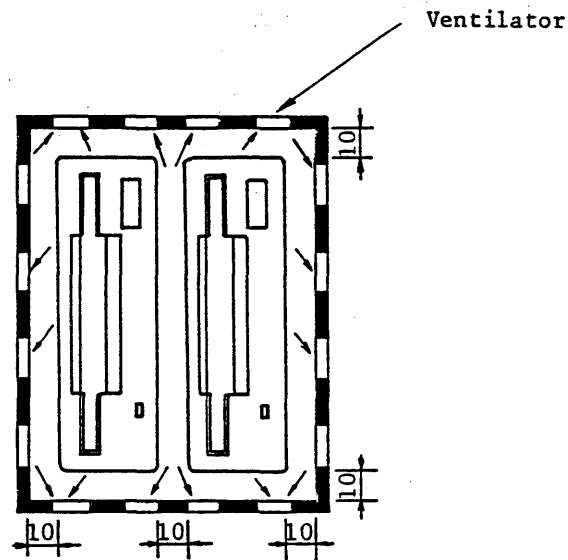

NOTE: Appropriate cooling is required if the ambient temperature around FDD rises considerably.

6. PACKING AND TRANSPORTATION

- (1) For external packing, either use the packing material used in the carrying in of FDD of make sure no direct shock will be transmitted to FDD.

- (2) Make sure that FDD will sustain no excessive shock during transportation.