

CalComp Model 140 & Model 142
Floppy Disk Drives
Technical Manual

technical
manual

Part No. 10150-901-003-2

**MODEL 140 AND MODEL 142
FLOPPY DISK DRIVES
TECHNICAL MANUAL**

April 1977 .



California Computer Products, Inc.
2411 W. La Palma, Anaheim, CA 92801

CONTENTS

Section		Page
1	INTRODUCTION	
	Description	1-1
	Physical and Electrical Characteristics	1-1
	Special Tools and Test Equipment	1-3
2	INSTALLATION AND OPERATION	
	Unpacking	2-1
	Installation	2-1
	Ac Power Cable	2-1
	Dc and Signal Cabling	2-1
	Data Output Selection	2-6
	Checkout	2-6
	Operation	2-6
	Floppy Disk Storage and Handling	2-6
	Write-Protect Option	2-7
	Floppy Disk Loading and Unloading	2-7
3	THEORY OF OPERATION	
	Principles of Operation	3-1
	Recording Medium	3-1
	Data Recording Method	3-2
	Peak Shift Precompensation	3-3
	Track Accessing	3-3
	Read Data Timing	3-3
	Write Data Timing	3-3
	Power-On to Data Transfer	3-6
	Functional Areas	3-6
	Control System	3-6
	Positioning System	3-8
	Read/Write System	3-9
	Mechanical System	3-9
	Drive Mechanism	3-9
	Disk Centering Mechanism	3-10
	Head Load Mechanism	3-10
	Positioning Mechanism	3-10
	Logic Symbology and Definitions	3-11
	Detailed Logic Description	3-11
	Control Logic	3-11
	Read/Write Head Positioning Logic	3-16
	Read/Write Logic	3-19
	+17 vdc Regulator Description	3-24
	Read Decoder with PLO Assembly	3-25
	Normal PLO Operation	3-26
	Missing-Pulse PLO Operation	3-27
	Sync-Up PLO Operation	3-27
	Data Decoder	3-27
	Read Sync	3-29

CONTENTS (Continued)

Section		Page
4	MAINTENANCE	
	Preventive Maintenance	4-1
	Monthly (covers on)	4-1
	Semiannually (covers removed)	4-1
	Disk Drive Exerciser	4-1
	Controls, Indicators, and Test Points	4-1
	Preparation for Offline Checkout	4-1
	Disconnecting the Exerciser	4-3
	Maintenance Procedures	4-3
	Tools and Test Equipment	4-3
	Plugs and Jacks	4-3
	PWB Assembly, Data and Control	4-4
	PWB Replacement	4-4
	Power	4-4
	Drive System	4-5
	Spindle System	4-9
	Position System	4-10
	Read/Write System	4-12
	Data Decoder with PLO Board Adjustments	4-13
5	ILLUSTRATED PARTS BREAKDOWN	
	Group Assembly Parts List	5-1
	Figure and Item Number	5-1
	Part Number	5-1
	Description	5-1
	Quantity Per Assembly	5-1
	Usage Code	5-1
	Purchased Parts	5-2
	Accessories	5-2

ILLUSTRATIONS

Figure		Page
1-1	Floppy Disk Drive	1-1
2-1	Disk Drive Shipping Configuration	2-1
2-2	Ac Power Cabling Wiring	2-2
2-3	Twisted Pair Interface Connector Board, Schematic Diagram	2-2
2-4	Ribbon Cable Interface Connector Board, Schematic Diagram	2-3
2-5	Termination for Disk Drive Output Signals	2-4
2-6	Termination for Disk Drive Input Signals	2-4
2-7	Floppy Disk Loading	2-7
3-1	Flexible Disk Construction	3-1
3-2	Code Format Comparisons and MFM Characteristics	3-2
3-3	Peak Shifting and Precompensation Conditions	3-4
3-4	Track Accessing Timing	3-5
3-5	Double Frequency Raw Data Timing	3-5

ILLUSTRATIONS (Continued)

Section		Page
3-6	MFM Raw Data Timing	3-5
3-7	Double Frequency Write Data Timing	3-6
3-8	MFM Write Data Timing	3-6
3-9	Power-On to Write Timing	3-7
3-10	Power-On to Read Timing	3-7
3-11	Disk Drive General Block Diagram	3-7
3-12	Disk Drive Mechanical System Pictorial View	3-9
3-13	Drive Mechanism	3-10
3-14	Disk Centering and Head Load Mechanism	3-10
3-15	Positioning Mechanism	3-11
3-16	Logic Symbology (Sheet 1 of 2)	3-12
3-16	Logic Symbology (Sheet 2 of 2)	3-13
3-17	Detailed Block Diagram	3-14
3-18	Index Pulse Detection on Speed Monitor, Simplified Logic Diagram	3-15
3-19	Index Detector	3-15
3-20	Ramp Generator	3-16
3-21	Power-On to Ready Transition Period Waveforms	3-16
3-22	Head Load Relay Driver	3-16
3-23	Single-Track Positioning Time Waveforms	3-17
3-24	Multiple-Track Positioning Time Waveforms	3-17
3-25	Stepper Motor Position Control Simplified Logic Diagram	3-17
3-26	Stepper Motor Direction Sequencing	3-18
3-27	Decode and Current Drivers for 00 Code	3-18
3-28	Track 00 Detector Circuit	3-19
3-29	Write Channel, Simplified Logic Diagram	3-20
3-30	Double-Frequency Write Control and Write Coils Current Flow	3-21
3-31	MFM Write Control and Write Coil Current Flow	3-21
3-32	Read/Write Matrix Gate for Read	3-23
3-33	Differentiator Input/Output Waveforms	3-23
3-34	Raw Data Output Gating	3-23
3-35	MFM Raw Read Data Waveforms	3-24
3-36	One-Shot Data Decoders	3-24
3-37	RAW and NRZ Read Data Decoder Waveforms	3-25
3-38	Read Decoder with PLO Block Diagram	3-25
3-39	PLO, Simplified Logic Diagram	3-26
3-40	PLO Locked On and Missing Pulse Operation	3-26
3-41	PLO Sync-Up	3-28
3-42	Read/Write Coding Waveforms	3-28
3-43	Data Decoder, Simplified Logic Diagram	3-29
3-44	Data Decoder Waveforms	3-30
3-45	Read Data Decoder Sync, Simplified Logic Diagram	3-30
3-46	Composite MFM Data Decoder Waveforms	3-31
3-47	Composite Double Frequency Data Decoder Waveforms	3-32
4-1	Model 2140 Disk Drive Exerciser	4-1
4-2	Exerciser and Disk Drive Setup	4-3
4-3	Disk Drive Interconnecting Cabling Diagram	4-3
4-4	Drive System Component Identification	4-5
4-5	Drive Belt Checks and Adjustments	4-5
4-6	Head Alignment Waveform	4-7
4-7	Index Pulse Timing Waveform	4-7
4-8	Index Pulse with Hard-Sector Option Timing Waveform	4-8

ILLUSTRATIONS (Continued)

Figure		Page
4-9	Spindle System Component Identification	4-9
4-10	Positioning System Component Identification	4-10
4-11	Track 00 Alignment Waveform	4-11
4-12	Head Load Check and Adjustment	4-12
4-13	Data Separator One-Shot Alignment Waveform	4-13
5-1	Model 140 Series and 142 Disk Drive Unit (Sheet 1 of 2)	5-4
5-1	Model 140 and 142 Disk Drive Unit (Sheet 2 of 2)	5-6
5-2	Cone Lift Cover Assembly	5-9
5-3	Drive Motor Assembly	5-11
5-4	Data and Control Board Assembly, VR49	5-13
5-4A	Data and Control Board Assembly, VR56	5-17
5-4B	Data and Control Board Assembly, VR57	5-21
5-4C	Data and Control Board Assembly, VR58	5-25
5-4D	Data and Control Board Assembly, VR60	5-29
5-4E	Data and Control Board Assembly, VR82	5-33
5-4F	Data and Control Board Assembly, VR83	5-37
5-5	Data Decoder with PLO Board Assembly, VR71	5-41
5-6	Data Decoder with PLO Board Assembly, VR81	5-43

TABLES

Table		Page
1-1	Physical and Electrical Characteristics	1-2
1-2	Tools and Test Equipment	1-3
2-1	Ac Power Cable	2-2
2-2	Twisted-Pair Interface Signal Cable Connections	2-5
3-1	Binary Code for In-Out Read/Write Head Positioning	3-18
4-1	Exerciser Switch, Indicator, and Test Point Functions	4-2
4-2	Initial Exerciser Control Settings	4-3
4-3	Jack and Plug Description	4-4
4-4	Power Requirements	4-4
5-1	Unit Options	5-3

SECTION 1

INTRODUCTION

This manual contains installation and operating instructions, theory of operation, maintenance procedures, and illustrated parts breakdown for the Model 140 and Model 142 Floppy Disk Drives (Figure 1-1). The Model 140 and 142 are compact, high-speed, random-access data storage units that use a flexible disk cartridge as the storage medium. Wherever differences between models exist, they are identified.

Before performing preventive or corrective maintenance on the disk drives, maintenance personnel should become familiar with the electrical characteristics and principles of operation of the disk drives.

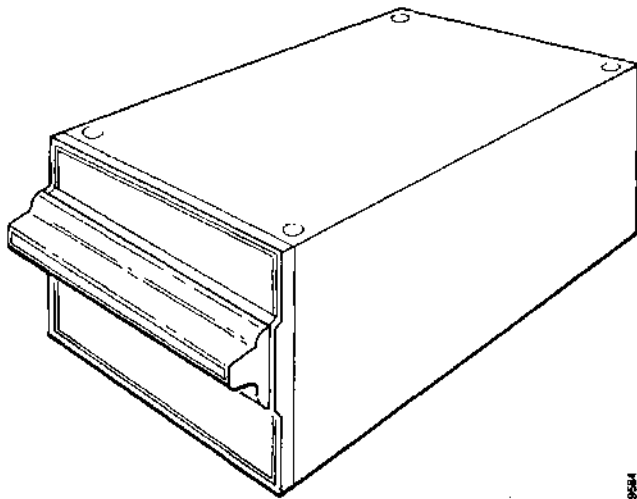

Figure 1-1. Floppy Disk Drive

This manual is intended as a technical guide for field engineers and other technical personnel who are involved in maintaining the disk drives. The information in this manual — other than that contained in this section — is divided into four basic sections.

- Installation and Operation

- Uncrating
- Installation
- Operation

- Theory of Operation

- Principles of Operation
- Functional Theory

- Maintenance

- Preventive Maintenance
- Maintenance Procedures

- Illustrated Parts Breakdown

DESCRIPTION

The Floppy Disk Drive is a high-speed, random-access memory device that is used for data storage in data processing systems. The disk drive is compact and except for power supplies is self contained. The disk drive can be rack mounted or used as a table top unit.

The disk drive uses a removable, flexible disk cartridge that is easily installed or removed through an access slot on the front of the disk drive. Removable covers allow access to the interior of the disk drive for maintenance purposes.

PHYSICAL AND ELECTRICAL CHARACTERISTICS

Physical and electrical characteristics for the disk drives are listed in Table 1-1.

TABLE 1-1. PHYSICAL AND ELECTRICAL CHARACTERISTICS

Physical Characteristics	
Height	4.90 inches
Width	8.40 inches
Depth	15.00 inches (add 3 inches for connector clearance)
Weight	16 pounds; 18 pounds shipping
Power Requirements	
Ac Power	100 to 240 vac, +10%, -20%, 50 ±0.5 Hz or 60 ±0.5 Hz, single phase
Ac Starting Current	1.7 amperes maximum, 60 Hz; 1.7 amperes maximum, 50 Hz
Ac Operating Current	1.2 amperes maximum, 60 Hz 1.1 amperes maximum, 50 Hz
Dc Power	+24v ±5% at 1.5 amperes maximum, 100 millivolts peak-to-peak ripple +5v ±5% at 1.0 ampere maximum, 50 millivolts peak-to-peak ripple
Operating Environment	
Temperature	60°F to 100°F (20°F maximum rate of change per hour)
Relative Humidity	20% to 80% (no condensation)
Heat Dissipation	275 Btu per hour
Specifications	
Disk Cartridge Capacity	
Double Density (Unformatted*)	
Per Disk	6,416,256 bits/802,032 bytes
Per Track	83,328 bits/10,416 bytes
Double Density (Hard Sector*)	
Per Disk	6,179,712 bits/772,464 bytes
Per Track	80,256 bits/10,032 bytes
Per Sector	2,508 bits
Single Density (Unformatted)	
Per Disk	3,208,128 bits/401,016 bytes
Per Track	41,664 bits/5,208 bytes
Single Density (Hard Sector)	
Per Disk	3,089,856 bits/386,232 bytes
Per Track	40,128 bits/5,016 bytes
Single Density (IBM 3740 Format)	
Per Disk	1,943,552 bits/292,944 bytes
Per Track	26,644 bits/3,328 bytes
Per Sector	1,024 bits/128 bytes
Carriage Positioning Time	160 milliseconds (average) 6 milliseconds track-to-track slew (minimum)

*Used only with the Model 142

TABLE 1-1. PHYSICAL AND ELECTRICAL CHARACTERISTICS (Continued)

Specifications (continued)	
Head Settling Time	10 milliseconds (maximum)
Head Load Time	30 milliseconds (maximum)
Recording Format	Fixed or variable length
Recording Format	Fixed or variable length
Recording Method	140 or 142: Double frequency, frequency modulated (FM) 142 only: Double frequency (FM) double density, modified frequency modulation (MFM)
Data Transfer Rate	FM: 250,000 bits per second MFM: 500,000 bits per second
Data Bit Cell Time	2 microseconds
Rotational Speed	360 rpm \pm 2.5%
Rotational Latency	
Average	83.3 milliseconds
Maximum	167 milliseconds
Recording Tracks	77
Track Spacing	0.0208 inch (nominal)
Bit Density	FM: 3268 bits per inch (inside track) MFM: 6536 bits per inch (inside track)
Track Density	48 tracks per inch
Recorded Track Width	0.013 inch (nominal)
Start Time	2.5 seconds (drive ready)

SPECIAL TOOLS AND TEST EQUIPMENT

Tools and test equipment recommended for use in maintaining the floppy disk drives are listed in Table 1-2.

TABLE 1-2. TOOLS AND TEST EQUIPMENT

Tools
Common Hand Tools Flashlight
Test Equipment
VOM Oscilloscope Model 2140 Exerciser Head Alignment Disk Cartridge
Cleaning Materials
Alcohol (91% solution) Lint-free cloth

SECTION 2

INSTALLATION AND OPERATION

This section contains procedures and descriptive material to aid trained personnel in unpacking, installing, and preparing disk drives for online operation. This section is divided into three basic parts relating to task-oriented objectives.

- Unpacking

- Unwrapping
 - Inspection

- Installation

- Cable fabrication, connection, and checkout
 - Preoperational checks
 - Operational checks

- Operation

The disk drive is packaged to ensure adequate protection for local, long distance, or overseas shipping and handling. Unpack and remove the unit from the shipping container as soon as it is received (see Figure 2-1).

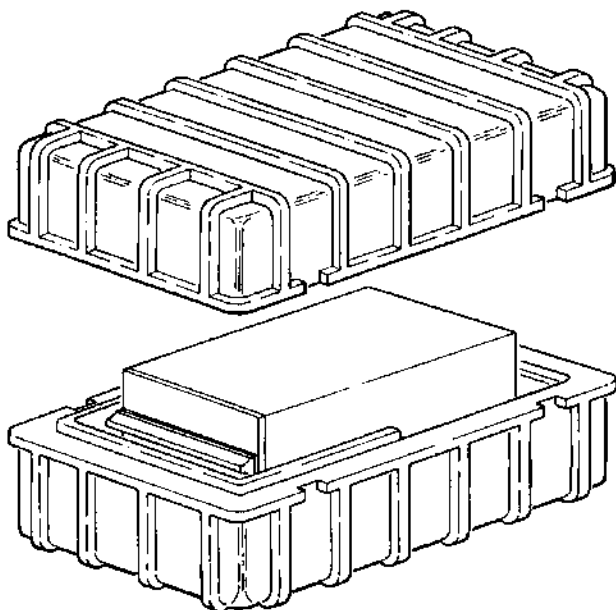

Figure 2-1. Disk Drive Shipping Configuration

UNPACKING

The following procedure is based on current packing methods and may be subject to minor deviations. After inspecting the container for obvious shipping damage, proceed as follows:

1. Cut and discard the fiberglass straps that secure the shipping container.

Note

Do not lift the disk drive by the floppy disk loading handle, as the handle can be damaged.

2. Remove all parts from the shipping container. Remove the inner packing material.
3. Check each part against the packing list.
4. Inspect all items visually for physical damage.

INSTALLATION

Most new installations will normally require that a power cable and a dc and signal cable be fabricated on site.

Ac Power Cable

The length of the ac power cable is determined at the installation site. Cable connectors are supplied with the disk drive.

CAUTION

Ensure that the power to be applied to the disk drive corresponds to the requirements specified on the nameplate of the disk drive.

Fabricate the ac power cable in a phase-to-neutral or in a phase-to-phase configuration in accordance with Table 2-1 and Figure 2-2.

Dc and Signal Cabling

Dc and signal cable connections between the controller and disk drives may be in either a radial or a daisy-chain arrangement. Two types of interface connector boards are

available to accommodate both applications. There are two versions of each connector board – terminated and unterminated.

TABLE 2-1. AC POWER CABLE

Connector 90606-003		
Pin	Phase-to-Neutral	Phase-to-Phase
1	115/208 vac	208 vac
2	Chassis Gnd	Chassis Gnd
3	115/208 vac	208 vac

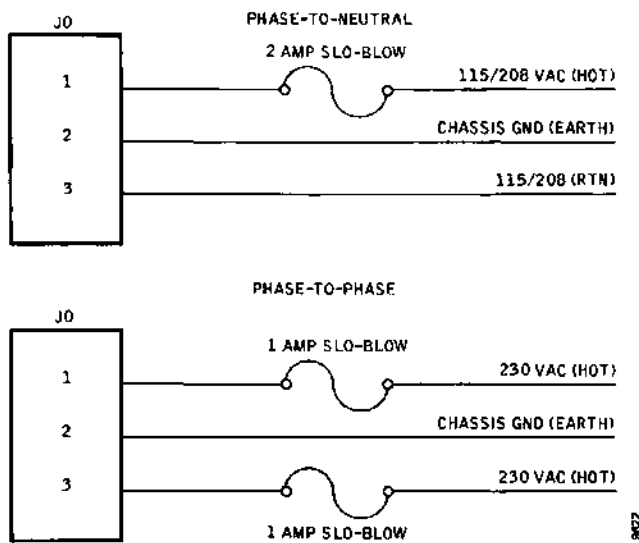
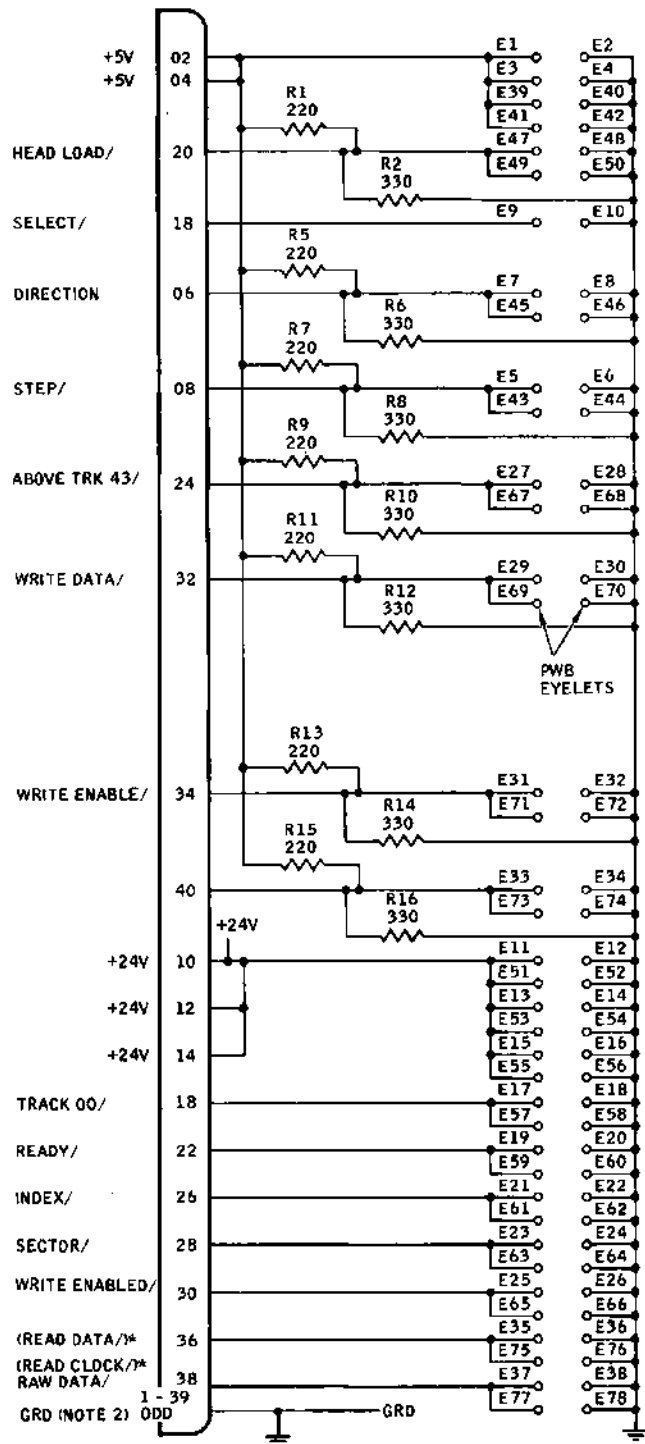

Figure 2-2. Ac Power Cable Wiring

One type of interface connector board is designed for twisted-pair wiring, which must be soldered to the board. The part number for this board is 12084-001 with terminating resistors and 12084-002 without terminating resistors (see Figure 2-3).

The other type of interface connector board is designed for ribbon cable, which has press-on connectors that plug into the interface connector board. The part number for both the terminated and unterminated boards is 16292-001; however, the terminated board must have terminating network 16557-001 plugged into IC socket XA2 (see Figure 2-4).

Fabricated dc and signal cables may be ordered from the factory or the cables can be fabricated on site.



(*) *USED WITH SINGLE DENSITY RECORDING (FM)

NOTES:

- PART NO. 12084-001 SHOWN; PART NO. 12084-002 DOES NOT HAVE TERMINATING RESISTORS
- ALL ODD-NUMBERED PINS ON P1 ARE GROUNDED

Figure 2-3. Twisted Pair Interface Connector Board, Schematic Diagram

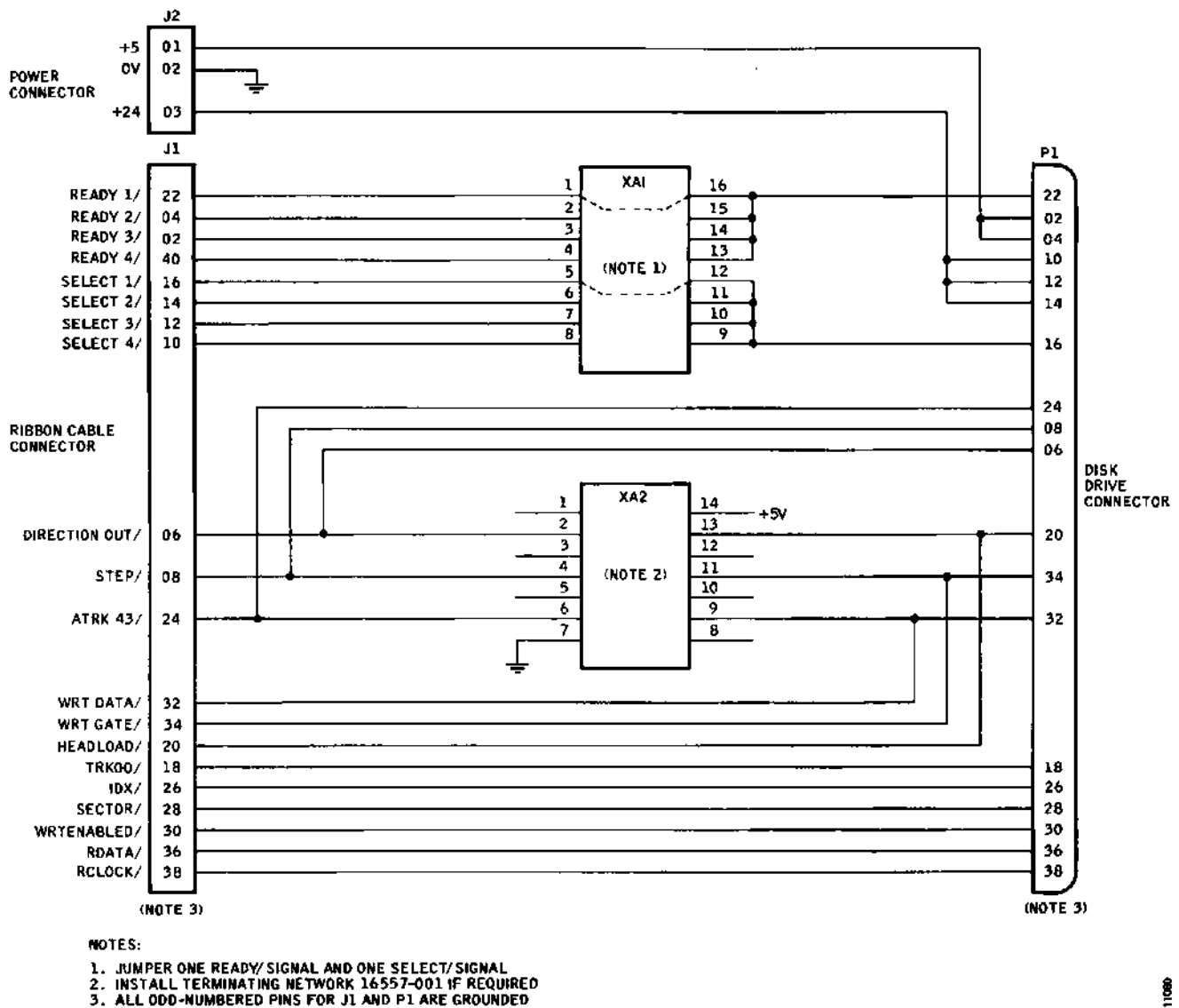

Figure 2-4. Ribbon Cable Interface Connector Board, Schematic Diagram

• **Daisy-Chained Application**

Daisy-chaining of multiple disk drives requires the use of both terminated and unterminated interface connector boards. The common I/O signals are daisy-chained from drive to drive; the interface connector board for the last disk drive in the chain is a terminated board (see Figures 2-5 and 2-6) that provides line terminations for all incoming signals to the disk drive.

The twisted-pair connector board has feedthrough solder lands with two eyelets in each land. System cabling can be accomplished by connecting signal and associated ground leads to one eyelet of the respective lands. The remaining eyelet of each land can be used to cable signal and associated ground leads to the next disk drive interface connector board. This technique can be used to interconnect the remaining disk drives.

The ribbon-cable interface connector board allows interconnection of disk drives and a controller through a ribbon cable. The ribbon cable has press-on connectors at various intervals that plug into ribbon cable interface connector boards at the disk drives. Up to four disk drives can be connected to the controller through one ribbon cable.

Note

The SELECT/ signal and its associated ground and the READY/ signal and its associated ground should not be daisy-chained in multiple disk drive applications. They should be connected to the controller separately. (When using the ribbon-cable interface connector board, SELECT/ and READY/ must be jumped for the appropriate disk drive.)

11080

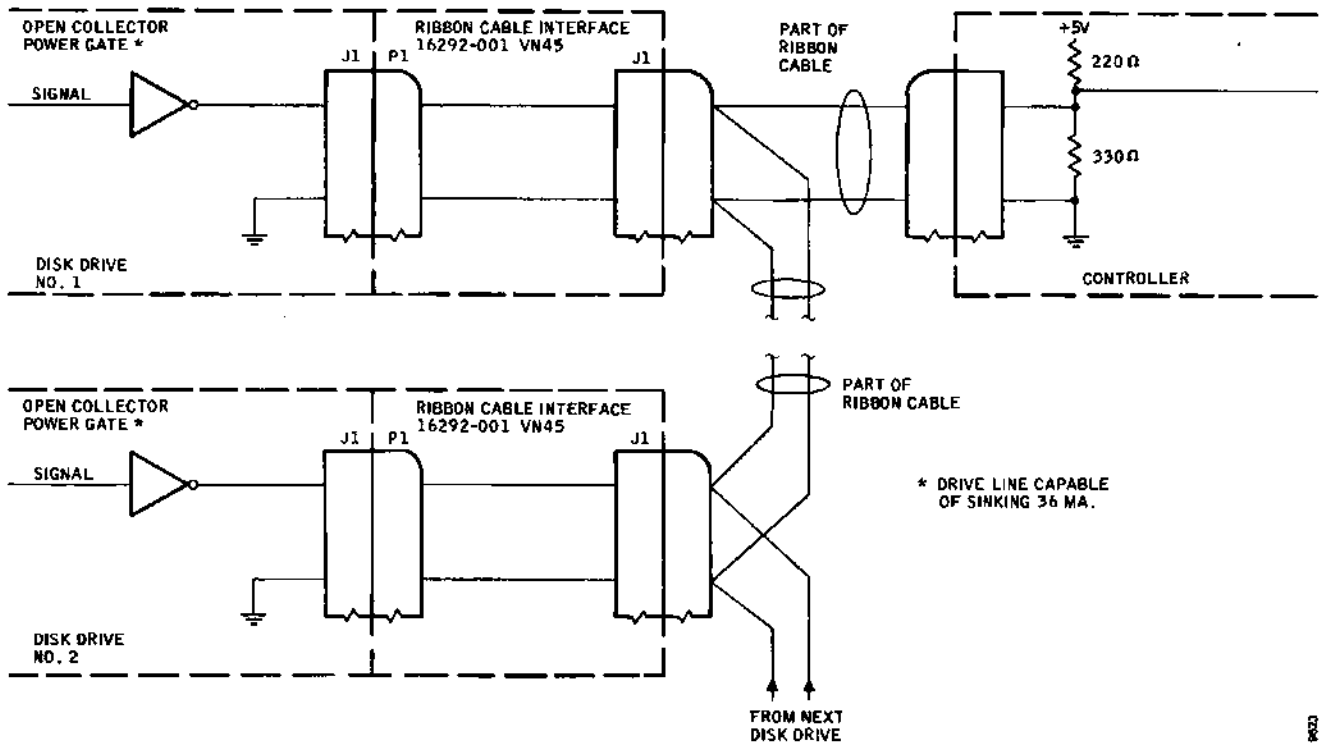

Figure 2-5. Termination for Disk Drive Output Signals

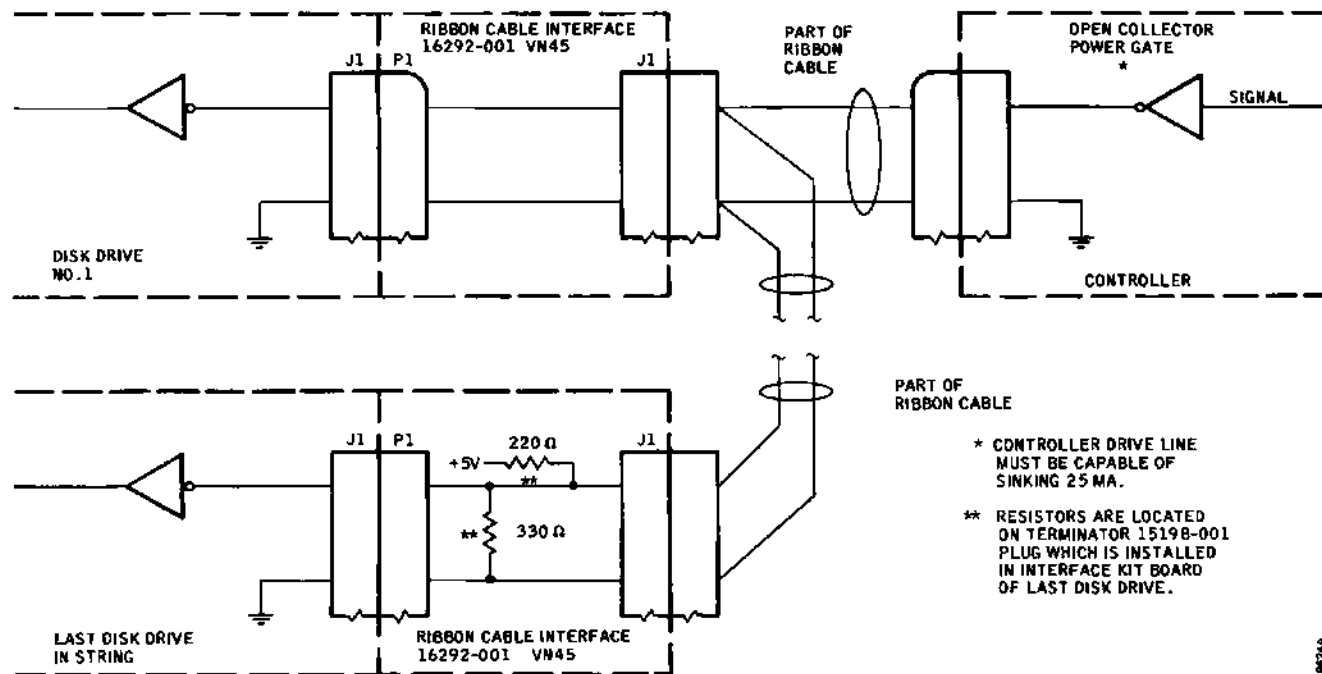

Figure 2-6. Termination for Disk Drive Input Signals

• **Radial Application**

When disk drives are connected radially to a controller, separate dc and signal cables radiate from the controller to each disk drive. A terminated interface connector board must be used for each disk drive.

• **Twisted-Pair Dc and Signal Cable Fabrication**

The twisted-pair dc and signal cable should consist of twisted pairs (approximately 30 twists per foot) whose wire size is either No. 24 or No. 26 AWG and not exceeding 25 feet in length.

1. Fabricate the twisted-pair dc and signal cable in accordance with Table 2-2. Use Cable Terminator

Assembly 12084-001 if terminations are required; use Cable Terminator Assembly 12084-002 if terminations are not required.

2. Use a VOM to check each cable for pin-to-pin shorts.
3. Use a VOM to check for continuity between corresponding pins at opposite ends of each cable.
4. Connect the dc and signal cable to the controller.
5. Apply power to the controller, and check each interface connector board to verify proper pin assignments. Refer to Table 2-2.
6. Turn power off at the controller, and connect the cables to the disk drives.

TABLE 2-2. TWISTED-PAIR INTERFACE SIGNAL CABLE CONNECTIONS

Signal	Signal Pin			Ground Pin		
	Number	Eyelet Connection From Controller or Preceding Drive	Eyelet Connection To Next Drive	Number	Eyelet Connection From Controller or Preceding Drive	Eyelet Connection To Next Drive
READ CLOCK** or RAW DATA	38	E37	E77	37	E38	E78
READ DATA**	36	E35	E75	35	E36	E76
PLO SYNC/*	40	E33	E73	39	E34	E74
WRITE DATA/	34	E31	E71	33	E32	E72
WRITE ENABLE/	32	E29	E69	31	E30	E70
ABOVE TRACK 43/	24	E27	E67	23	E28	E68
WRITE ENABLED/	30	E25	E65	29	E26	E66
SECTOR/	28	E23	E63	27	E24	E64
INDEX/	26	E21	E61	25	E22	E62
READY/	22	E19	—	21	E20	—
HEAD LOAD/	20	E47	E49	19	E48	E50
TRACK 00/	18	E17	E57	17	E18	E58
+24V	14	E15	E55	13	E16	E56
+24V	12	E13	E53	11	E14	E54
+24V	10	E11	E51	9	E12	E52
SELECT/	16	E9	—	15	E10	—
DIRECTION	6	E7	E45	5	E8	E46
STEP/	8	E5	E43	7	E6	E44
+5V	4	E3	E41	3	E4	E42
+5V	2	E1	E39	1	E2	E40

*Not Used

**When unseparated data is the output of the disk drive, pin 38 supplies the unseparated data (raw data) and read data output (pin 36) is not used.

● Ribbon Signal Cable Fabrication

The ribbon signal cable should consist of a 40-conductor ribbon signal cable (3M part number 3365/40 or equivalent) and one or more 40-pin connector (3M part number 3417-0000, 3417-3000, or equivalent) depending on the number of disk drives to be connected to the controller through the same cable.

1. With the use of a small arbor press, press the 40-pin connectors onto the ribbon cable at a predetermined interval.
2. Use a VOM to check each connector for pin-to-pin shorts.
3. Use a VOM to check for continuity between corresponding pins at each connector.
4. Connect the cable to the disk drives and to the controller.

● Dc Power Cable Fabrication

When a ribbon cable is used to connect the controller to the disk drives, a separate, 3-wire, dc power cable must be fabricated for each disk drive.

1. Crimp contacts (CalComp part number 90441-002) on one end of each wire.
2. Insert contacts into the plug housing (CalComp part number 90605-003). Verify that the contacts are inserted into the proper position in the plug (see J2 of Figure 2-4).
3. Connect a dc power cable to each disk drive.

Data Output Selection

The disk drive can be adapted to either of two decode outputs: separated data or unseparated data (raw data). If separated data is desired, make certain that Floppy Disk Plug Assembly 14519-001 is installed in IC socket A6. Assembly 14519-001 has jumpers between pins 4 and 11, pins 5 and 10, and pins 3 and 12. If unseparated data is desired, make certain that Floppy Disk Plug Assembly 14519-002 is installed in IC socket A6. Assembly 14519-002 has a jumper between pins 4 and 5.

Checkout

The disk drive can be checked out operationally by running the disk drive either offline with the exerciser or online with the system.

OPERATION

Floppy disk storage and handling as well as correct operating procedures are important for error-free operation.

Floppy Disk Storage and Handling

Since the recorded disk contains vital information, reasonable care should be exercised in its handling. Longer disk life and trouble-free operation will result if the following recommendations are followed.

- Floppy disk ID information should be written on an adhesive-type tape or label; then the label should be affixed to the disk cartridge covering. Writing directly on the floppy disk covering would damage the surface of the disk.
- Do not fasten paper clips to the edges of the disk jacket.
- Do not touch the surface of the disk exposed by the jacket slot.
- Do not clean the disk in any manner.
- Keep the disk away from magnetic fields and away from ferromagnetic materials that may be magnetized.
- Return the disk to its protective envelope when removed from the disk drive.
- Protect each disk from liquids, dust, and metallic substances at all times.
- Do not exceed the following environmental storage conditions:
 - Temperature: 50°F to 120°F (10°C to 48.9°C)
 - Relative Humidity: 8% to 80%
 - Maximum Wet Bulb: 80°F (26.7°C)
- Disks should be stored when not in use.

Before using a floppy disk on a disk drive after long-term storage, the floppy disk should be allowed to stabilize in the disk drive environment one hour for each hour out of the disk drive environment (up to 24 hours).

For short-term storage, the floppy disk(s) should be placed temporarily in the same area as the disk drive. No more than ten floppy disks should be stacked in a flat file.

Write-Protect Option

The data recorded on a floppy disk can be stored permanently by using the write-protect option. If the floppy disk is intended to be used only for reading, verify that an opaque tab is not affixed over the write-protect hole (see Figure 3-1) in the floppy disk jacket. To enable data recording, the tab must be installed.

Floppy Disk Loading and Unloading

Proper loading of the floppy disk is vital to the operation of the disk drive. Figure 2-7 shows the location of the floppy disk opening for loading.

The procedure for loading/unloading the floppy disk is as follows:

1. Move the handle to the open position.
2. Insert the floppy disk in the load aperture as shown in Figure 2-7. (Ensure that the head aperture is to the rear and that the label faces the handle).
3. Move the handle to the disk load position; verify that the cover latches securely in place.
4. To unload the floppy disk, press the release button on the handle. The load mechanism disengages the floppy disk from the drive mechanism.
5. Remove the floppy disk, and close the cover.

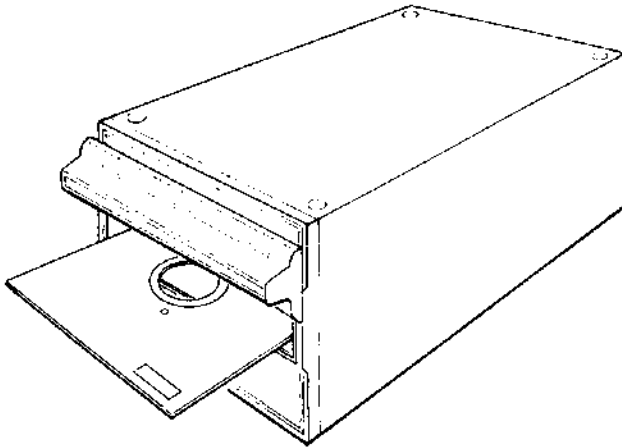

A. FLOPPY DISK IN LOAD POSITION

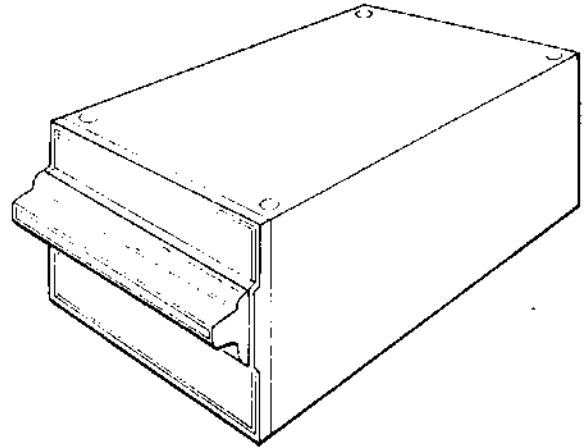

B. FLOPPY DISK LOADED

9685A

Figure 2-7. Floppy Disk Loading

SECTION 3

THEORY OF OPERATION

This section contains descriptions of the characteristics and the basic principles of operation of the Model 140 and the Model 142 Floppy Disk Drives. It also contains functional descriptions of various operating systems and the digital logic and analog circuits employed in this device.

PRINCIPLES OF OPERATION

Certain hardware and operational characteristics of the disk drive must be understood as a basis for more detailed study of functional systems and circuits. The following principles of operation provide this necessary background information.

Recording Medium

The disk drives use a removable, flexible disk as the storage medium. Figure 3-1 shows the construction and dimensions of a typical flexible disk and associated jacket. Only one side is used for recording.

The recording medium specified for use with the Model 140 and the Model 142 is a single-side oxide-coated, flexible disk enclosed within a protective plastic jacket. (Figure 3-1B). The protective jacket contains apertures for spindle loading, head contact, sector/index detection, and write-protect detection.

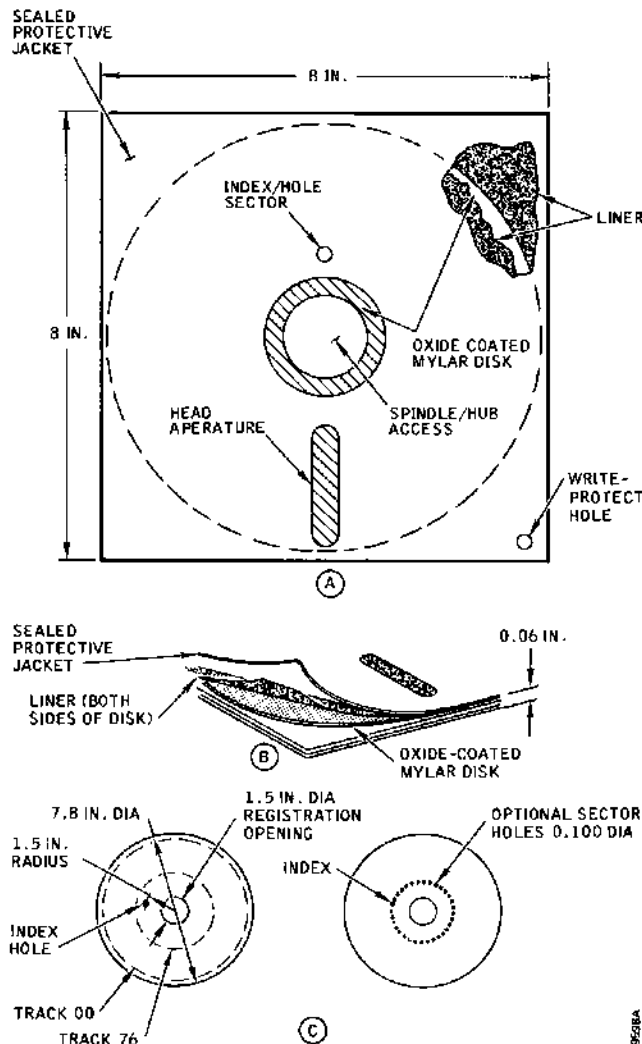

Figure 3-1. Flexible Disk Construction

The circular opening in the center of the jacket exposes the registration opening in the disk. The centering cone enters this opening to center and to clutch the disk against the rotating spindle and causes the disk to rotate within the jacket (cartridge).

When the cartridge is loaded, the read/write head is positioned in contact with the disk exposed by the elongated opening (bottom center of Figure 3-1A). The small circular opening in the jacket, above the large center circular openings, (Figure 3-1A) exposes 0.1-inch diameter holes in the disk (Figure 3-1C) that are detected as index and sector. The index pulse developed from the index hole is used to indicate the rotational speed of the disk and marks the beginning of the recording tracks. Sector pulses (32 per track) are developed from the evenly spaced sector holes in the disk and are used to divide each track into equal areas for recording format purposes.

Data is recorded by magnetizing digital bit patterns in concentric circles (tracks) on the recording surface of the magnetic-oxide coating. As shown in Figure 3-1C, the recording surface contains 77 tracks spaced at 0.020-inch intervals. The tracks are numbered 00 thru 76, beginning with the track nearest the outer edge of the disk.

Data Recording Method

Modified Frequency Modulation (MFM) is the recording method recommended for use in the Model 142 Disk Drive. Figure 3-2 provides a comparison between NRZ (non-return-to-zero), Manchester Code (used in the Model 140), and MFM. MFM flux reversals on the recording media occur at three frequencies: at one-, and one and one-half-, and two-bit cell intervals. This method of recording has three major advantages.

- Fewer flux reversals (lower recording frequency) for a given amount of data, which permit a higher packing density.
- Contains data bit and data clock information, both of which are recoverable.
- Flux change polarity has no relationship to bit value, which simplifies data recovery circuit design.

Data cell time for the 6536 bit-per-inch packing density (MFM) of the Model 142 is 2 microseconds at speed, making the maximum recording frequency 500 kilohertz (all-zeros or all-ones bit pattern). The minimum recording frequency would be half that — 250 kilohertz — for an alternate zero and one bit pattern.

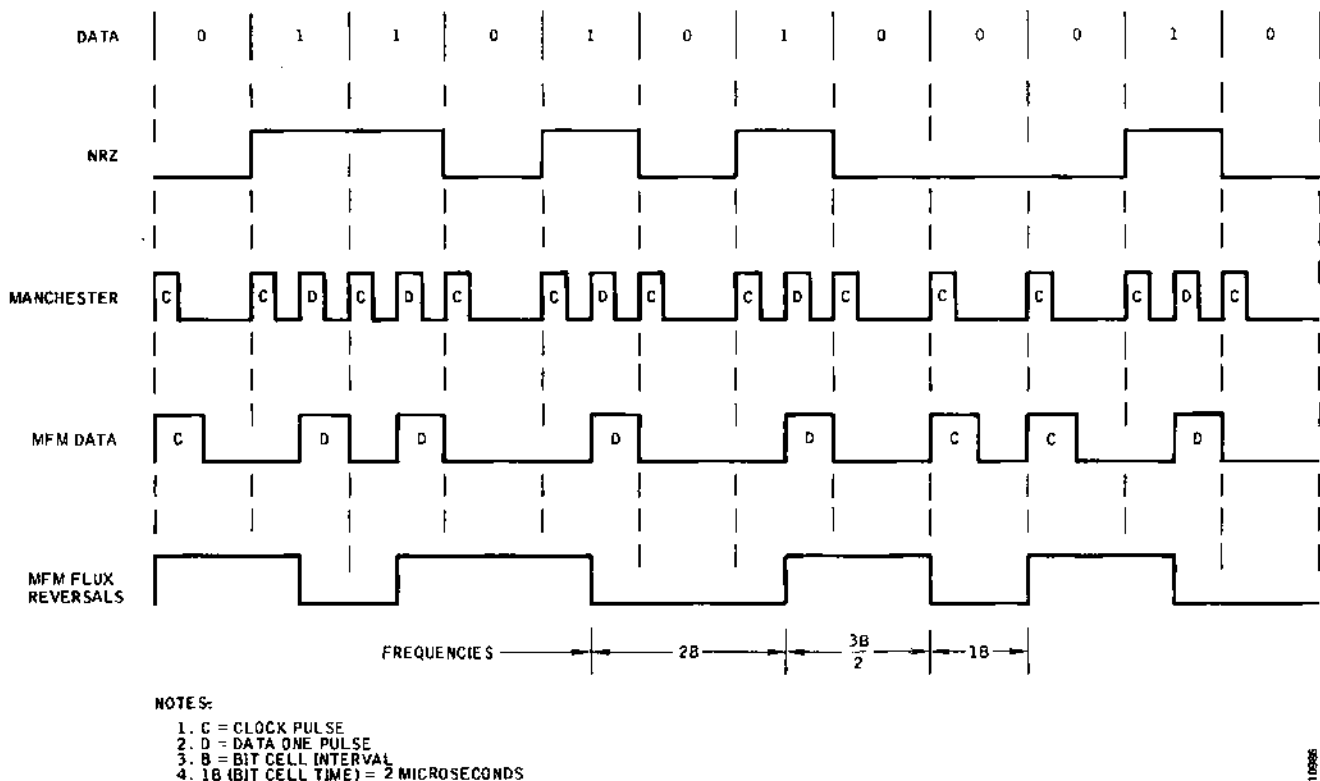

Figure 3-2. Code Format Comparisons and MFM Characteristics

MFM coding can be simplified to the following three rules:

- A flux change occurring at the midpoint of a data cell is *one* data bit, regardless of polarity.
- A flux change occurring at a data cell boundary is a data clock, regardless of polarity.
- A data clock flux reversal can only (and will always) occur between two *zero* bit data cells.

MFM data and clock information is recovered during reading by establishing bit cell time-related detection windows.

Peak Shift Precompensation

To enhance the readback capability, data to be written on the floppy disk may be precompensated in the controller for peak shift migration.

High-density, multifrequency recorded signals suffer from a magnetic effect known as peak shifting. Peak shifting is the tendency of closely spaced flux reversal domains to migrate away from each other into areas of lower density. In effect, unevenly spaced flux reversals stress themselves in an attempt to even out the spacing between them. See Figure 3-3A.

This magnetic interference effect, if not compensated for, could cause data and clock recovery problems during reading if detection window timing is marginal. To minimize the effect, the data is written in a prestressed condition. That is, flux reversals that would tend to be shifted late due to magnetic interference are written early, and vice versa.

Prestress direction is determined by looking at the intermediate stream of data and clock pulses and making logical decisions to write the flux reversal early, on time, or late. These decisions are based upon the transition intervals immediately before (T1) and immediately after (T2) the current transition (pulse B). See Figure 3-3B. The rules are as follows:

- If nominal T1 is greater than nominal T2, write pulse B late.
- If nominal T1 is less than nominal T2, write pulse B early.
- If nominal T1 and T2 are both 310 nanoseconds (low frequency) or 232 nanoseconds (medium frequency), write pulse B early.

- If nominal T1 and T2 are both 155 nanoseconds (high frequency), write pulse B on time.

Figure 3-3C defines the early, on-time, and late timing conditions relative to the bit cell interval. The amount of write precompensation is normally 10 percent of the information bit cell (about 200 nanoseconds).

Track Accessing

Track accessing is accomplished by using DIRECTION and STEP/ interface lines. The DIRECTION line must be set to the proper level and be stable for 100 nanoseconds, minimum, before the leading edge of STEP/. Figure 3-4 depicts track accessing timing requirements.

Head positioning is accomplished by pulsing the STEP/ line at 167 pulses per second with one head position change per pulse. If stepping occurs without unloading the head, 10 milliseconds of head settling time must be allowed after the last step before proceeding with data transfer.

Note

The disk drives are designed to operate at a step pulse rate of 167 pulses per second. Operation at lower step pulse rates may result in slightly noisy operation.

Should an access position error occur, a reference may be established either by reading the track header or by stepping the head out until the TRACK 00/ line becomes active.

Read Data Timing

Read data is transferred from the disk drive to the control unit in a serial fashion. Figure 3-5 illustrates the various timing parameters of the double frequency raw data signal; Figure 3-6 illustrates the various timing parameters of the MFM raw data signal.

Write Data Timing

Write data is transferred between the control unit and the disk drive in a serial fashion. The interface line WRITE ENABLE/ signal controls both the write-current generators and the straddle-erase circuits. WRITE ENABLE/ goes low to write data. Figure 3-7 illustrates the various write timing parameters of the double frequency recording; Figure 3-8 illustrates the various write timing parameters of the MFM recording.

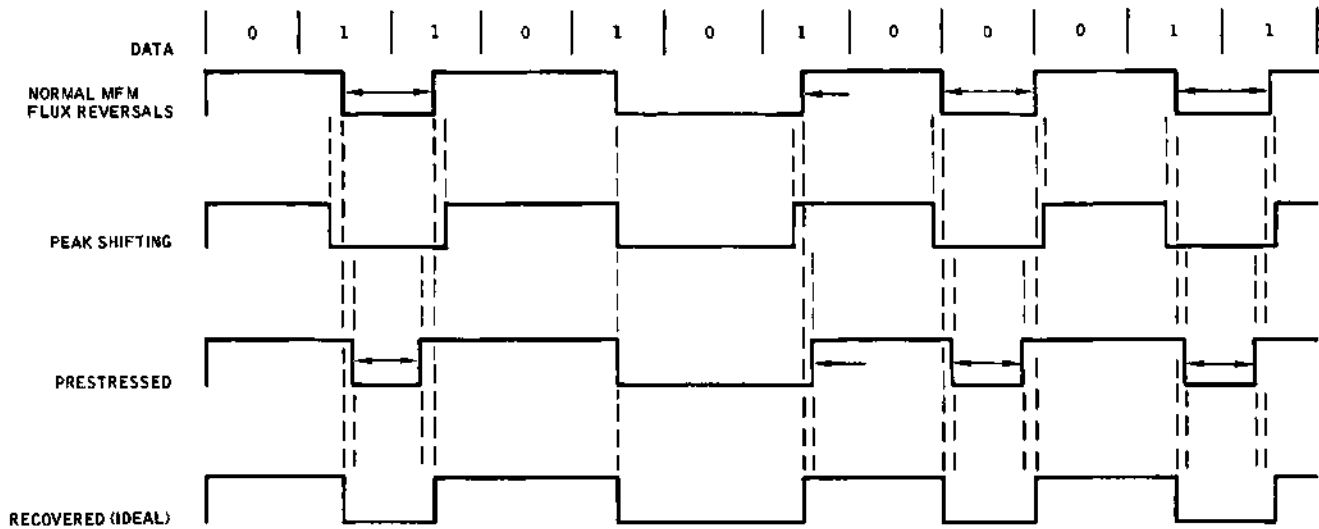

A. EFFECTS OF PEAK SHIFTING AND PRESTRESSING

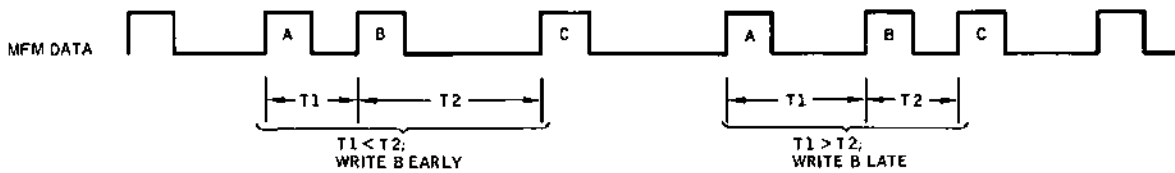

B. EXAMPLES OF PRESTRESS DETERMINATION

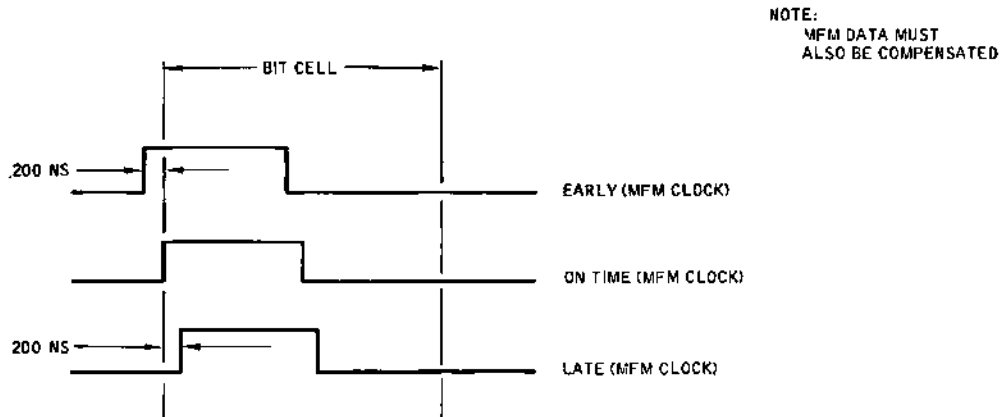

C. EARLY, ON-TIME, AND LATE TIMING

10687

Figure 3-3. Peak Shifting and Precompensation Conditions

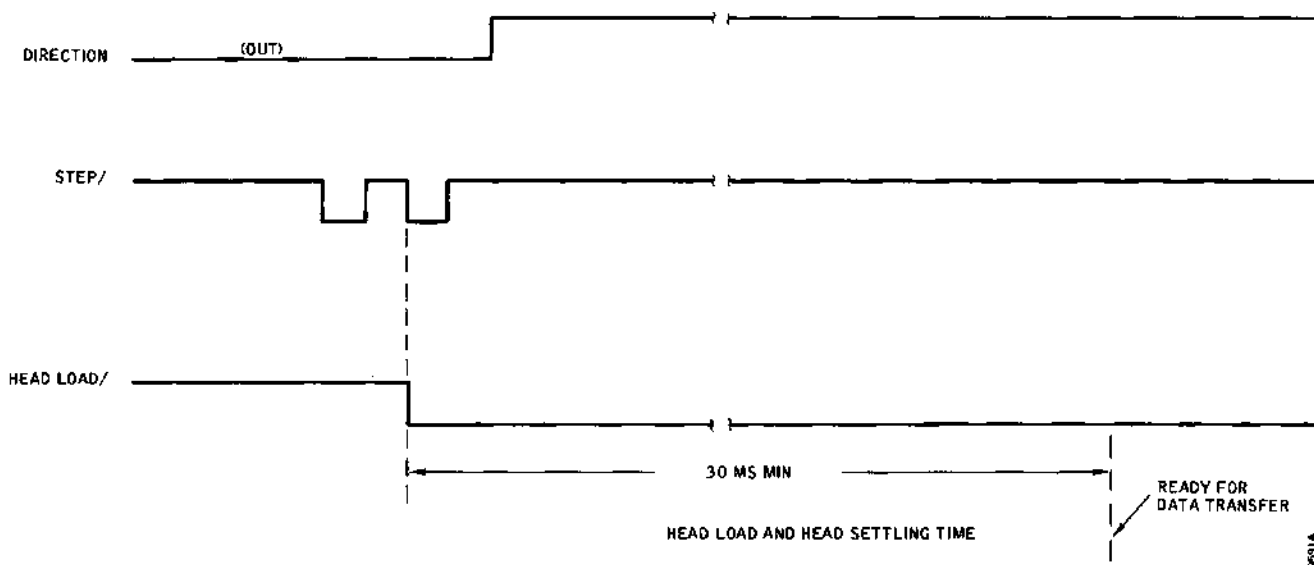
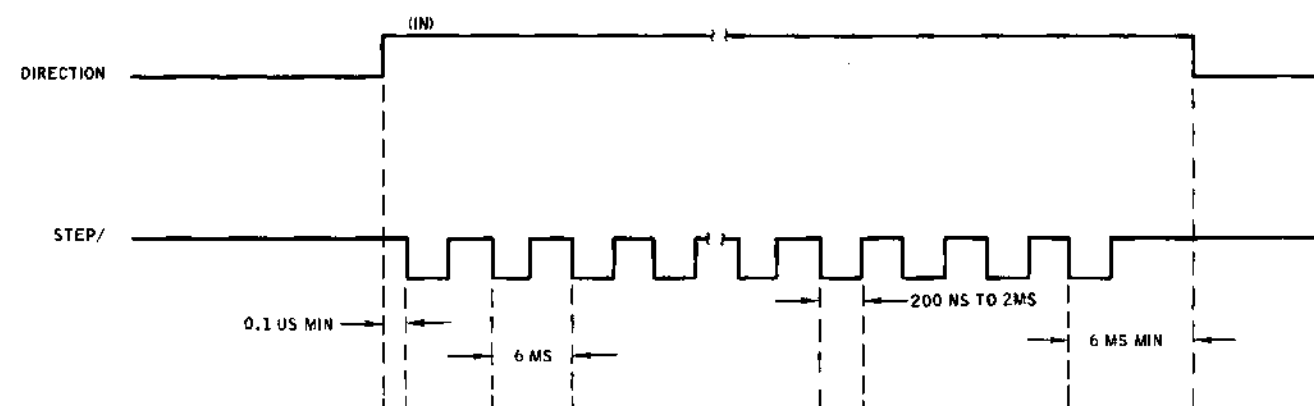

Figure 3-4. Track Accessing Timing

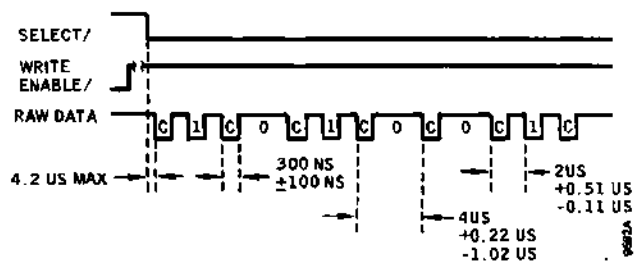

Figure 3-5. Double Frequency Raw Data Timing

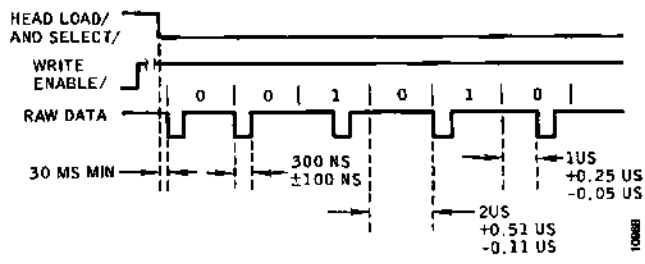

Figure 3-6. MFM Raw Data Timing

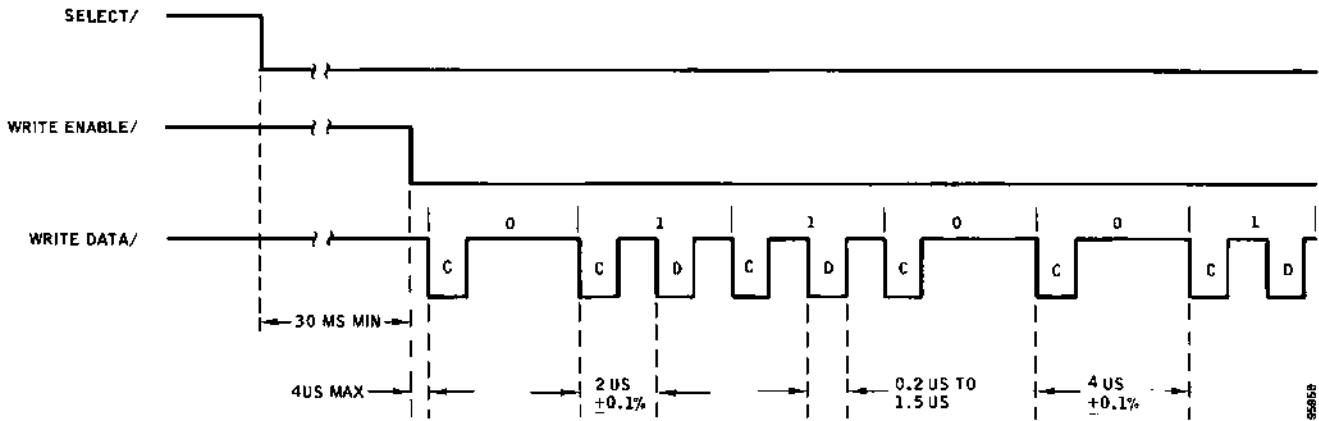

Figure 3-7. Double Frequency Write Data Timing

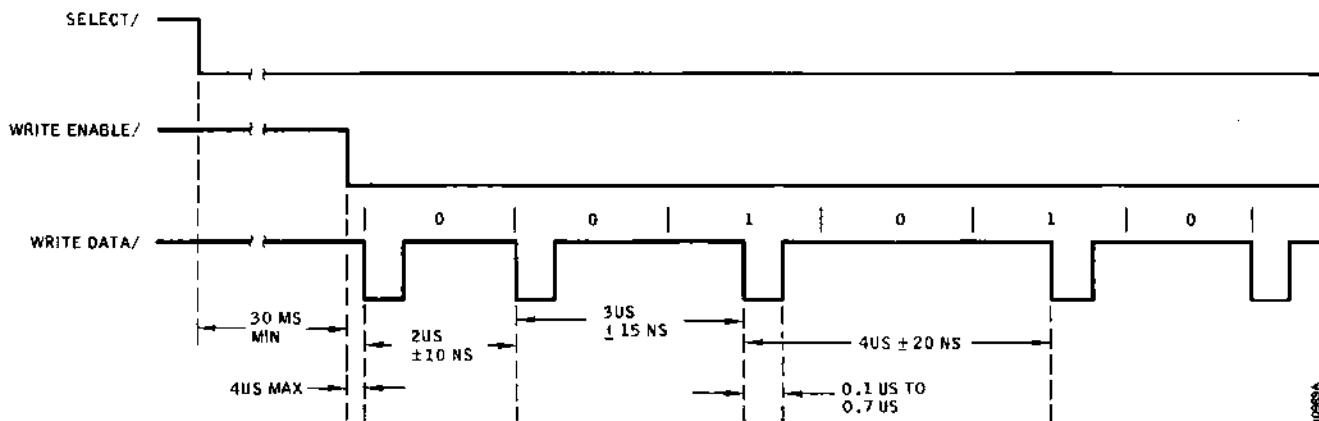

Figure 3-8. MFM Write Data Timing

Power-On to Data Transfer

Figures 3-9 and 3-10 are provided as references for power-on to data transfer. Power-on to write timing is depicted by Figure 3-9, and power-on to read timing is depicted by Figure 3-10.

In both cases, it is assumed that the controller will step the head to track 00 for a reference before stepping to a specified track. It is not necessary to have a cartridge loaded to step the read/write head. For explanatory purposes, it is assumed that a cartridge is loaded and that the controller will wait for the **READY/** interrupt before causing head stepping.

FUNCTIONAL AREAS

The floppy disk drives contain three main functional areas (see Figure 3-11):

- Control System
- Positioning System
- Read/Write System

Control System

The control system provides the interface circuitry between the controller and the disk drive. The system continuously monitors the operating status of the disk drive. Status conditions are summarized in a single **READY/** signal that can be checked by the controller at any time.

The controller addresses a disk drive for online operation by activating a unique select line. Commands are then received and executed by the selected disk drive. This technique allows multiple disk drive units to share common interface lines while remaining individually selectable.

● Command Execution

Commands are received by the disk drive in the form of one or more interface signals that designate one of the following operations:

- **SELECT** – Places the disk drive online with the controller

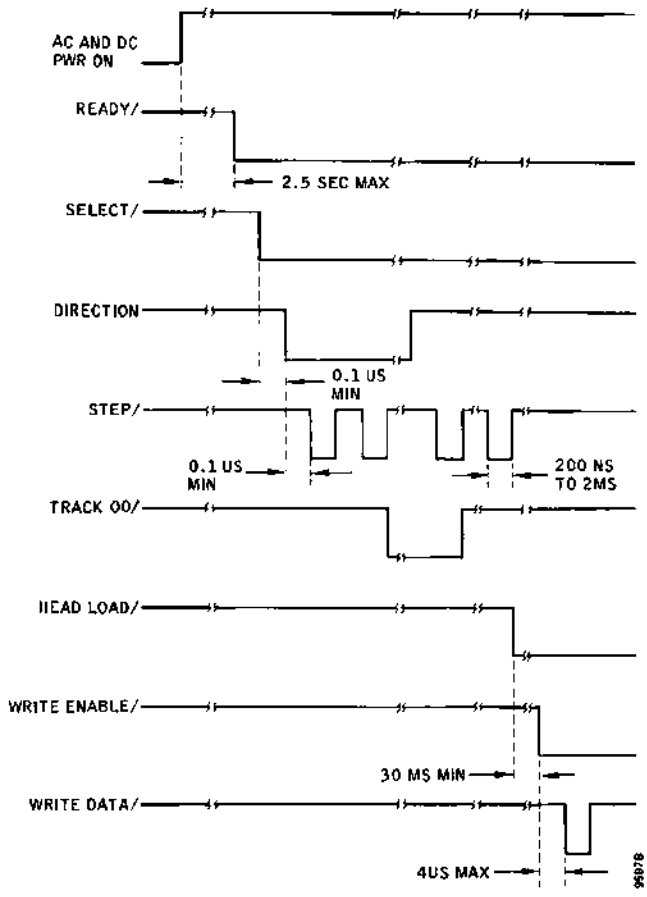

Figure 3-9. Power-On to Write Timing

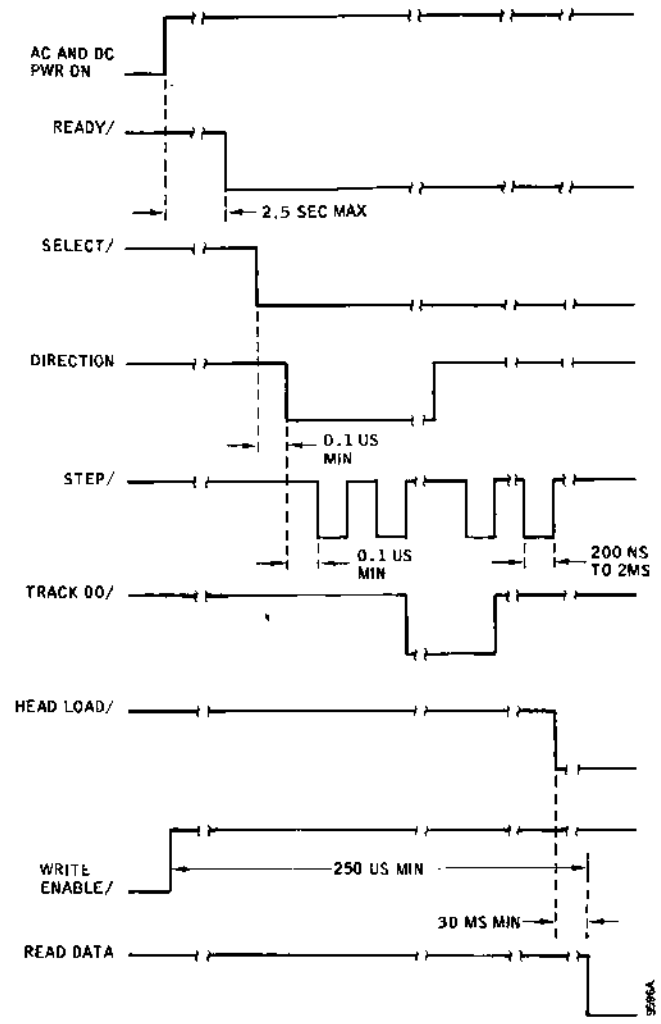

Figure 3-10. Power-On to Read Timing

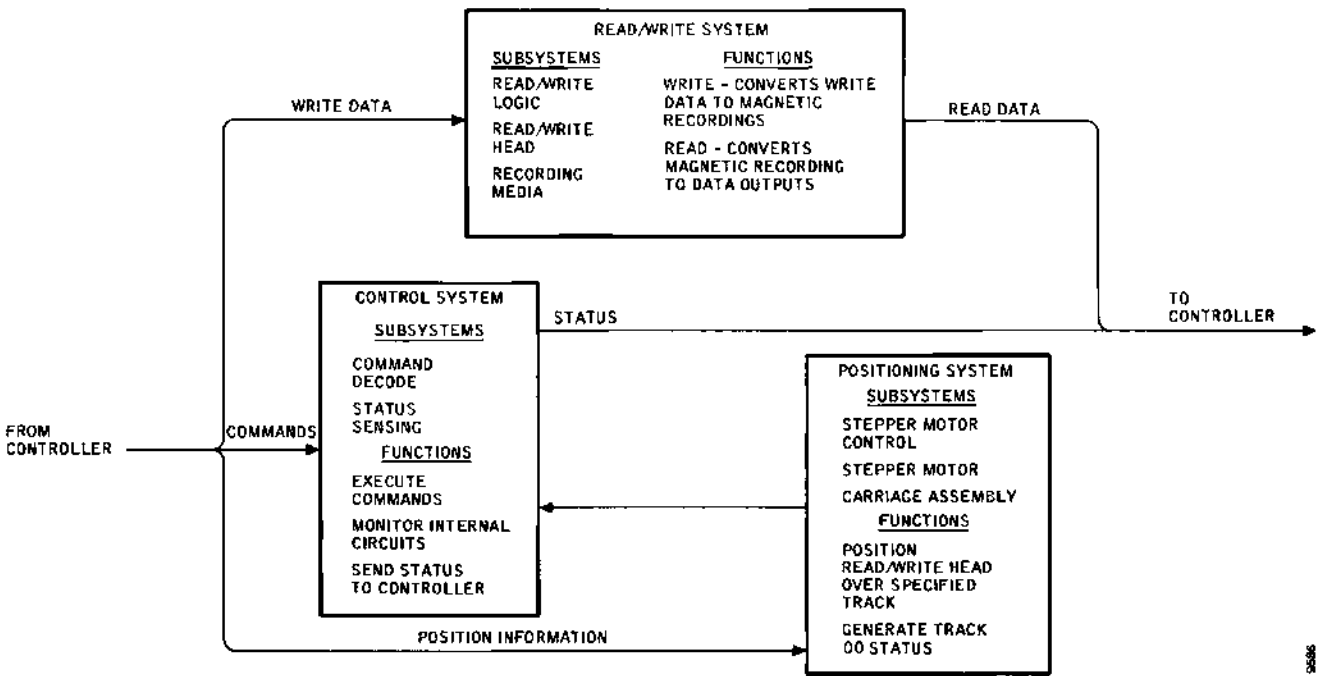

Figure 3-11. Disk Drive General Block Diagram

- **STEP** – Moves the read/write head in or out from track to track depending on the logic state of **DIRECTION**.
- **DIRECTION** – Determines the direction of read/write head movement when the **STEP** pulse is received. Head moves in when **DIRECTION** is high, out when **DIRECTION** is low.
- **HEAD LOAD** – Places the recording surface of the disk in close contact with the read/write head
- **WRITE** – Enables the write circuit and inhibits the read output
- **READ** – Enables the read outputs and inhibits writing

SELECT and **HEAD LOAD** instructions must precede a read or write operation.

SELECT enables input/output gates, while **HEAD LOAD** permits writing or reading on the floppy disk.

STEP and **DIRECTION** move the read/write head to either a higher or lower track position. Stepping may occur at a 6-millisecond per track rate or slower. Since relative track positioning is employed, the controller maintains current track position and generates the number of pulses necessary to reach a new track position. Once positioned, the controller designates a read operation or a write operation.

In a write operation, the disk drive records the data presented by the controller. In a read operation, data is decoded by the disk drive and routed to the controller.

● **Status Sensing**

Five disk drive status signals are gated immediately to the I/O lines when the controller selects a disk drive.

- **WRITE PROTECTED (Optional)** – A hardware write-protect condition exists.
- **TRACK 00** – Read/write head is positioned at track 00.
- **INDEX** – Start of a track
- **READY** – Not gated with **SELECT** and signifies that the disk drive is operational
- **SECTOR (Optional)** – Start of a sector

READY and **WRITE PROTECTED** are steady levels. **READY** status indicates that the disk is up to speed, dc power is within limits, and a floppy disk is loaded. **WRITE PROTECT** signifies that write data cannot be recorded on the floppy disk.

An **INDEX** pulse occurs once per disk revolution.

TRACK 00 status is available for initializing the controller track address register. This signal is developed from a photo-transducer when the carriage is aligned mechanically with track 00.

When the hard-sector option is installed, 32 sector pulses are transmitted to the controller for each revolution of the floppy disk.

Positioning System

The positioning system responds to stepping pulses (**STEP** command) received from the controller by moving the read/write head one track position per pulse. One major circuit and two mechanisms accomplish this operation.

● **Stepper Motor Control**

The stepper motor control converts each serial step pulse to a 2-bit count-up or count-down sequence. Each decode energizes one quadrature winding of the stepper motor and causes two 15-degree rotations of the motor shaft. One track position corresponds to 30 degrees of rotation.

● **Stepper Motor**

The variable-reluctance stepper motor positions the read/write head precisely. The stepper motor is energized by +24 vdc and operates in detent mode.

An internally generated magnetic field holds the rotor in a fixed position. To move from detent, one of four control lines is grounded. The rotor subsequently moves to the next detent. Sequential grounding of the control windings causes the rotor to rotate through detent positions at the maximum rate of 167 tracks per second.

A helical groove on the exposed rotor shaft converts rotary movement to linear movement to drive the carriage assembly.

● **Carriage Assembly**

The carriage assembly rides between a stationary guide rod and a helical drive shaft. The guide rod serves as a guide, while the helical drive shaft performs the positioning.

The read/write head, attached to the underside of the carriage assembly, penetrates the plane of the recording surface when a floppy disk is loaded. This **HEAD LOAD** command releases a spring-loaded head load arm that moves the floppy disk into contact with the read/write head to allow read/write operations.

Read/Write System

The read/write system records encoded data during a write operation and retrieves data during a read operation. The **WRITE ENABLE** signal from the controller designates a read operation when high or a write operation when low.

• Read/Write Operation

The read/write head is essentially an electromagnet that can concentrate a strong magnetizing force over a very small area of the adjacent recording surface. When recording, the flux field is alternated to magnetize the disk with the desired bit pattern.

The read/write head also contains a tunnel-erase electromagnet, the function of which is to erase the edges of the recorded track as data is being written. The width of the track is narrowed to approximately 0.012 inch by this technique to minimize interference and crosstalk between tracks.

When reading, the read/write electromagnet operates as a sensor. A flux reversal in the recorded track induces a voltage across the coils of the electromagnet. This voltage is amplified and conditioned to recover the recorded information.

MECHANICAL SYSTEM

The disk drive comprises the following mechanisms (see Figure 3-12):

- Drive Mechanism
- Disk Centering Mechanism
- Head Load Mechanism
- Positioning Mechanism

Drive Mechanism

The drive system (Figure 3-13) rotates the disk by using a single-phase motor that is selected to match the primary power of the controller system. Various drive motors are available to accommodate primary power ranging between 100 and 240 vac at 50 or 60 Hz. The disk drive attains ready status within 2.5 seconds of primary power application.

Rotation of the disk is through a belt and pulley connected to the other end of the motor shaft. The drive pulley and drive belt are selected for either 50 or 60 Hz input power. Rotational speed of the floppy disk is 360 rpm. The disk is engaged with the drive by the centering cone of the disk centering mechanism.

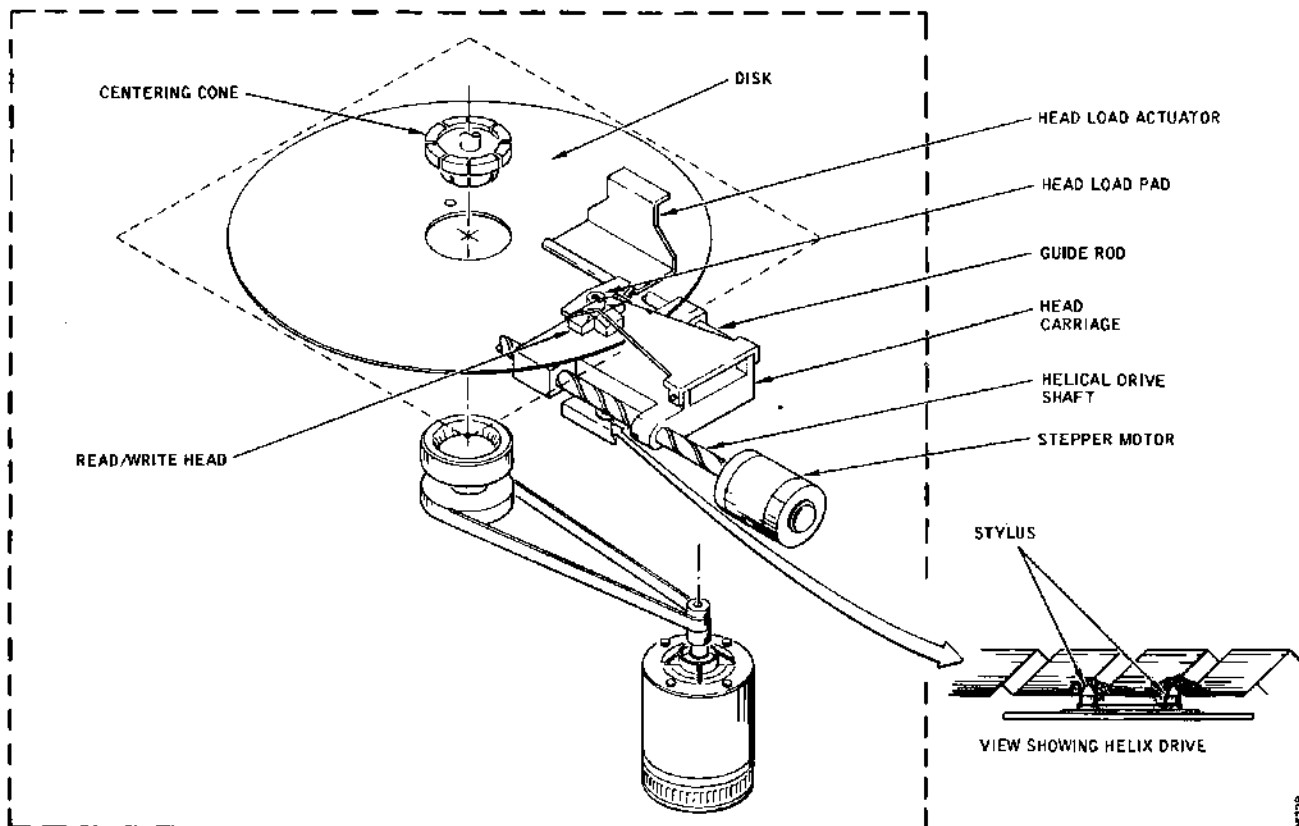

Figure 3-12. Disk Drive Mechanical System Pictorial View

98328

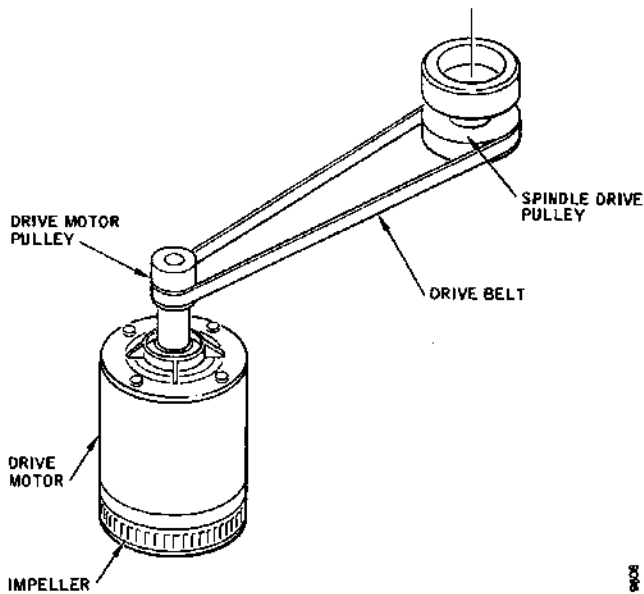

Figure 3-13. Drive Mechanism

Disk Centering Mechanism

The disk centering mechanism consists of a centering cone and a hollow drive hub. In the unload position, the centering cone is moved upward to create an opening through which the floppy disk is inserted. In this position, the centering cone is disengaged from the disk and from the drive hub.

To load a disk, the operator inserts the floppy disk, then presses down and latches the load handle. This causes the centering cone to enter the hollow drive hub and to expand the centering cone, which centers the disk in the correct track alignment. Spring pressure is applied the centering cone and drive hub to clamp the disk and to provide rotary motion.

Head Load Mechanism

The head load mechanism (Figure 3-14) consists of the head load arm, the read/write head, and the head load solenoid (not shown). Head loading is controlled by a head load command originating at the controller. This command actuates the head load solenoid, which causes the head load pad to press the disk against the read/write head so that the read/write head is in constant contact with the recording surface of the disk during a read or write operation.

When the head is loaded, a pad on the arm of the solenoid applies pressure to the cartridge, which is between the pad and a raised portion of the frame casting, to align the disk in the proper plane before it passes over the read/write head.

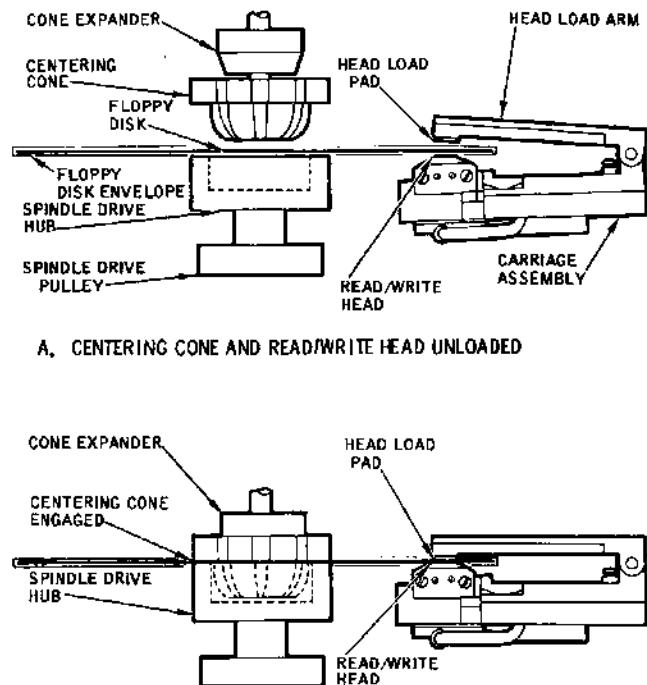

A, CENTERING CONE AND READ/WRITE HEAD UNLOADED

B, CENTERING CONE AND READ/WRITE HEAD LOADED

Figure 3-14. Disk Centering and Head Load Mechanism

Positioning Mechanism

The positioning mechanism (Figure 3-15) comprises a carriage assembly and a bidirectional stepper motor. The rotational movements of the stepper motor are converted to linear motion by the helical drive shaft.

The read/write head carriage is driven by the helical drive shaft. The carriage movement is guided toward and away from the center of the disk by a guide rod. When the stepper motor is pulsed, the helical drive shaft rotates clockwise or counterclockwise to move the carriage assembly in or out.

The stepper motor includes four (quadrature) windings. In detent, current flows in one winding and maintains the rotor in electromagnetic detent. For positioning, one or more pulses are applied sequentially to the quadrature windings and cause an imbalance in the electromagnetic field. The rotor of the stepper motor, consequently, revolves through detent positions until the step pulses are halted. The rotor then locks in that position. The sequence in which the quadrature windings of the stepper motor are pulsed dictates rotational direction and, subsequently, higher or lower track addressing from a relative position.

Track 00 (home) position is the disk drive reference track. This position is sensed by a phototransducer that generates

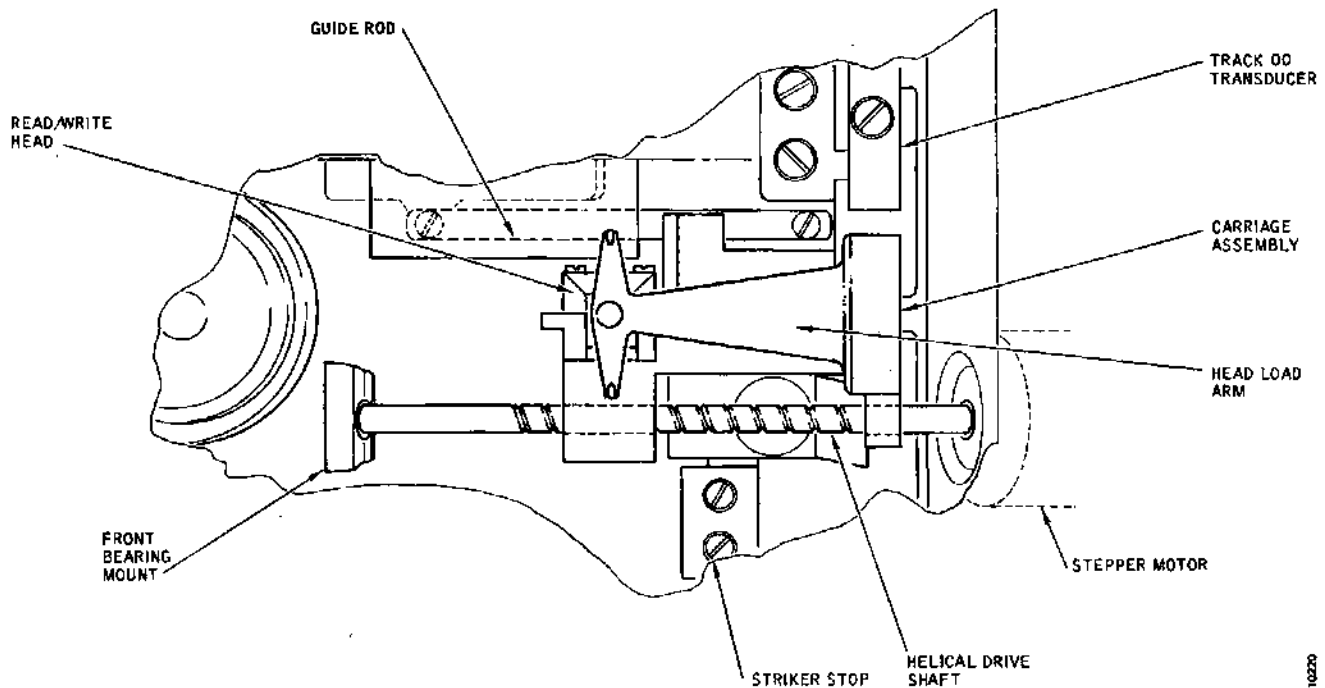

Figure 3-15. Positioning Mechanism

TRACK 00 status. This status is sent to the controller for initial track positioning. All track addressing is relative. The controller generates step pulses to position the carriage from the current track to a new track.

LOGIC SYMBOLY AND DEFINITIONS

The disk drives use 5-volt TTL logic, where a voltage more positive than +2.2 volts (turn-on threshold) is considered a logical high, and a voltage more negative than +0.4 volt (turn-off threshold) is considered a logical low.

Figure 3-16 shows the logic symbology and contains a definition for each element shown.

DETAILED LOGIC DESCRIPTION

Detailed logic descriptions of the disk drives are divided into three major functions:

- Control Logic
- Read/Write Positioning Logic
- Read/Write Logic

The significant interface signals between the major circuits are shown in Figure 3-17.

Control Logic

The control logic contained in the disk drives perform three functions:

- Generates and detects index and sector pulses
- Monitors disk speed for disk drive ready
- Actuates the head load/unload solenoid

The first two operations (Figure 3-18) utilize the index hole that is perforated in the disk. The time at which index occurs is directly proportional to disk speed. Thus, by comparing index timing against a known time base, the percentage of full disk rotational speed can be determined.

Also, INDEX is routed to the controller to signify start of track. Head load/unload operation is initiated by an input control signal that is enabled after disk operational speed is reached.

• Index Pulse Transducer

A light-emitting diode (LED) and phototransistor are physically positioned in the disk drive to monitor the index hole. As the index hole passes between the two devices, light passing from the LED to the phototransistor (Figure 3-19) results in a 2-millisecond, positive 4.0-volt pulse. The

10220

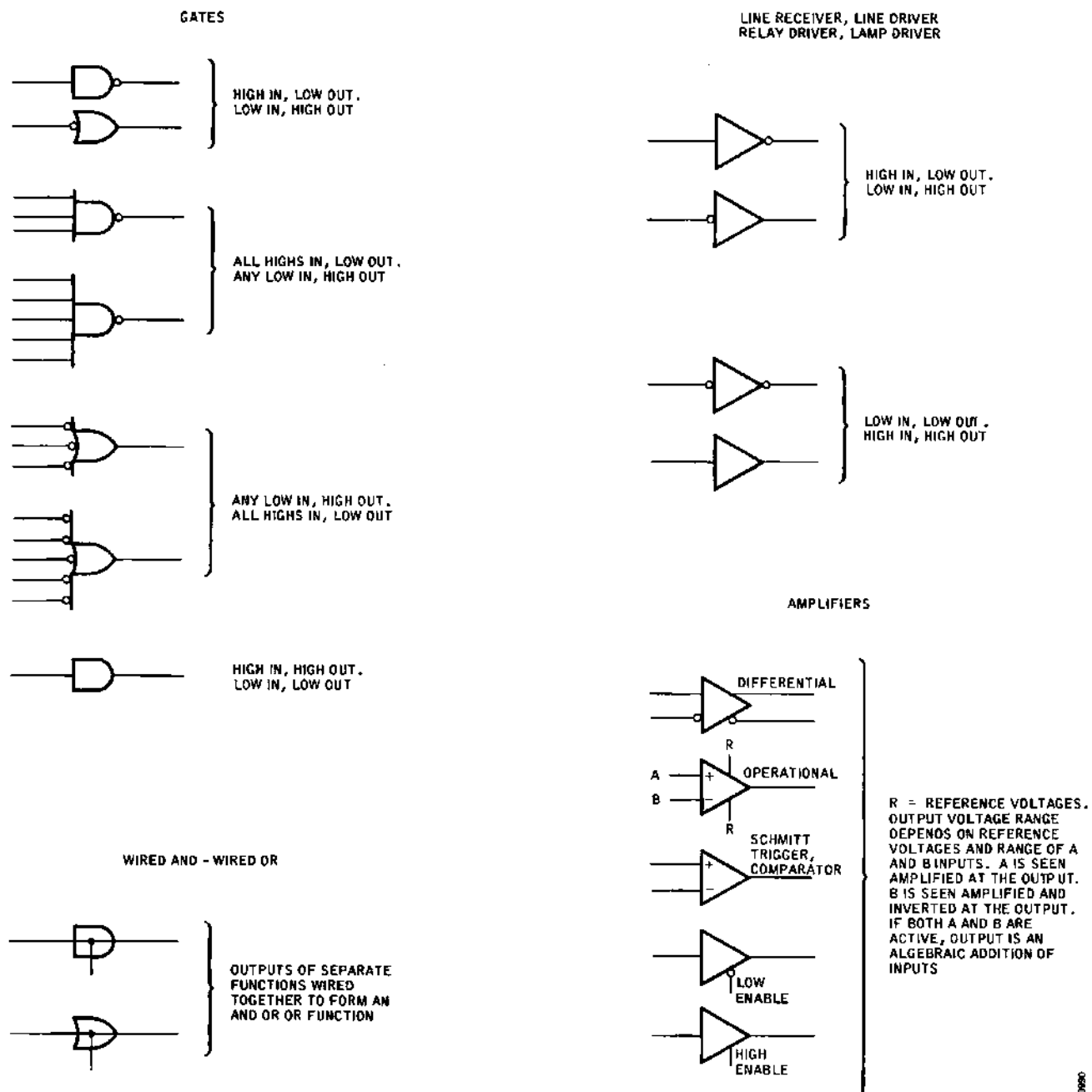

Figure 3-16. Logic Symboly (Sheet 1 of 2)

change at the input to differential amplifier A26 signifies index time. The output of the amplifier swings approximately +4.0 volts and is differentiated by C7 and R37. The negative transition triggers a 600-microsecond one-shot. The index transducer also detects sector marks when the hard-sector option is installed.

● Ramp Generator

The output of the 600-microsecond one-shot is the input to the ramp generator consisting of Q6, C10, and R44 (see Figure 3-20).

During index time, forward-biased Q6 provides a discharge path for C10. The time constant of C10 and R43 is approximately 70 microseconds, which is considerably shorter than the 600-microsecond pulse on the base of Q6. Capacitor C10 is completely discharged during this period.

After index time, Q6 is reverse biased, and C10 starts to charge through R44 towards +24 volts. This time constant (approximately 198 milliseconds or approximately 5.5 milliseconds with hard-sector option) corresponds to 60 percent of full speed. The resultant ramp is applied to high- and low-level detectors A25 that are biased at 18 and 11 volts,

IC ONE-SHOTS

COUNTER

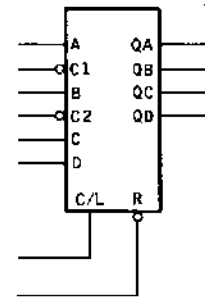
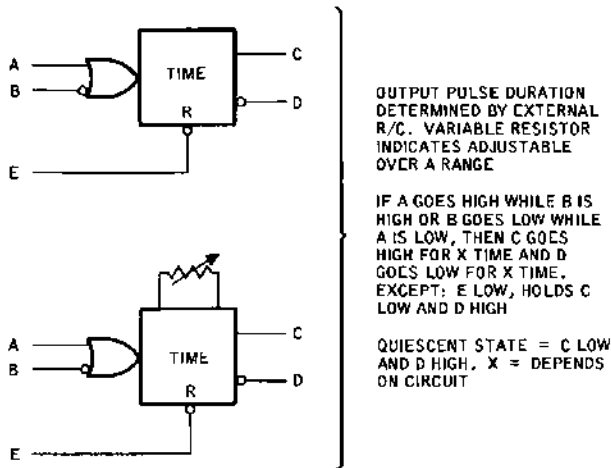

COUNT/LOAD (C/L) LOW = VALUES ON A, B, C, AND D ARE SET INTO INTERNAL FLIP-FLOPS (OUTPUTS ARE QA, QB, QC, AND QD RESPECTIVELY). C/L HIGH, NEGATIVE TRANSITION ON C1 = QA CHANGE STATE. C/L HIGH, QB NEGATIVE TRANSITION CHANGES STATE OF QC. C/L HIGH, QC NEGATIVE TRANSITION CHANGES STATE OF QD. IF QA IS WIRED TO C2, CHIP BECOMES A FOUR BIT UP-COUNTER AND CLOCK INPUT BECOMES C1. EXCEPT R LOW, RESETS ALL FLIP-FLOPS

D FLIP-FLOP

LIGHT-EMITTING DIODE

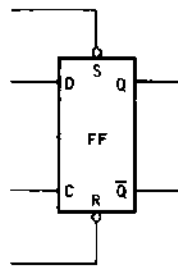

D HIGH AND C POSITIVE TRANSITION = Q HIGH; D LOW AND C POSITIVE TRANSITION = Q LOW. EXCEPT: S LOW HOLDS Q HIGH; R LOW HOLDS Q HIGH. Q IS ALWAYS THE INVERSE OF Q, EXCEPT WHEN S AND R ARE BOTH LOW AT THE SAME TIME (Q AND Q WILL BOTH BE HIGH)



IF A IS MORE POSITIVE THAN B, LIGHT IS EMITTED. IF B IS MORE POSITIVE THAN A, NO LIGHT IS EMITTED

Figure 3-16. Logic Symbology (Sheet 2 of 2)

respectively (see Figure 3-18). The high-level detector is used for disk speed monitoring, while the low-level detector is used to generate index count pulses. Both outputs are inhibited during power-up time, since the ramp period is greater than 198 milliseconds or 5.5 milliseconds (see Figure 3-21).

• Disk Speed Monitor

When power is applied to the disk drive and electronics, the speed of disk rotation increases, which, in turn, reduces the interval between ramp signal discharge times. As the ramp discharge time decreases, the peak level of the signal is lowered. When this level decreases to 18 volts, the threshold level of the high-level detector is exceeded, and Q7 is forward biased by differential amplifier A25 (see Figure 3-18). The inverted output of Q7 then applies a high to the C/L input of 4-bit counter A7, allowing the count of 4-bit counter A7 to be advanced.

As speed increases, the peak value of the ramp does not attain the level of 11 volts, which produces a negative shift in the output of low-level detector A25. This level forward-biases Q20, enabling index pulses to be applied to the CLK input of 4-bit counter A7. The count is then advanced by INDEX.

At a 12-count, gate A9 (count 12 detector) is enabled and inhibits further counting. The output of this gate is also applied to the controller as READY/. This signal indicates that disk speed and the +24 vdc voltage are normal and that the controller can initiate a head load command.

• Head Load Driver

After READY is true, the read/write head can be loaded by issuing a head load command (HEAD LOAD/ low) (see Figure 3-22). AND gate A5 applies a low output to Q2. Forward biased, Q2 then turns on power transistor Q3.

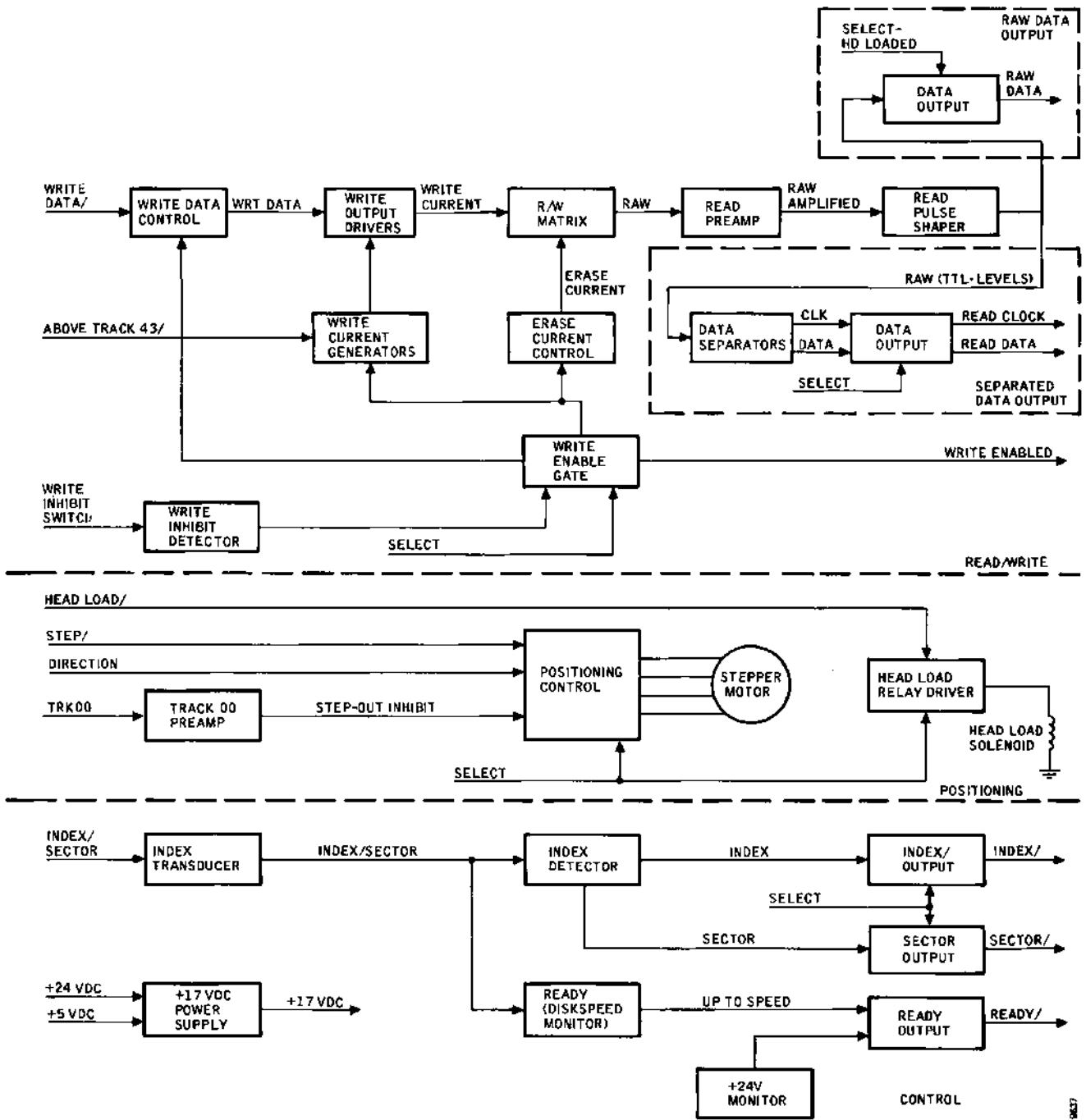

Figure 3-17. Detailed Block Diagram

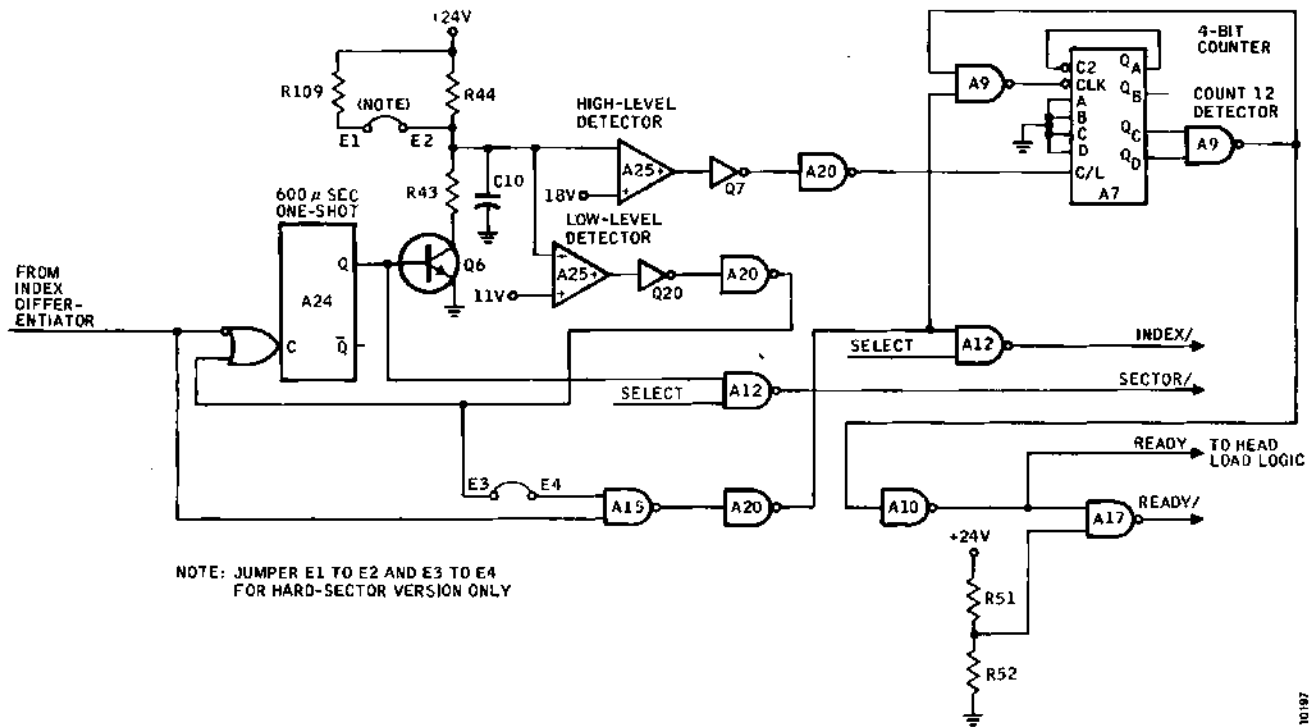

Figure 3-18. Index Pulse Detection on Speed Monitor, Simplified Logic Diagram

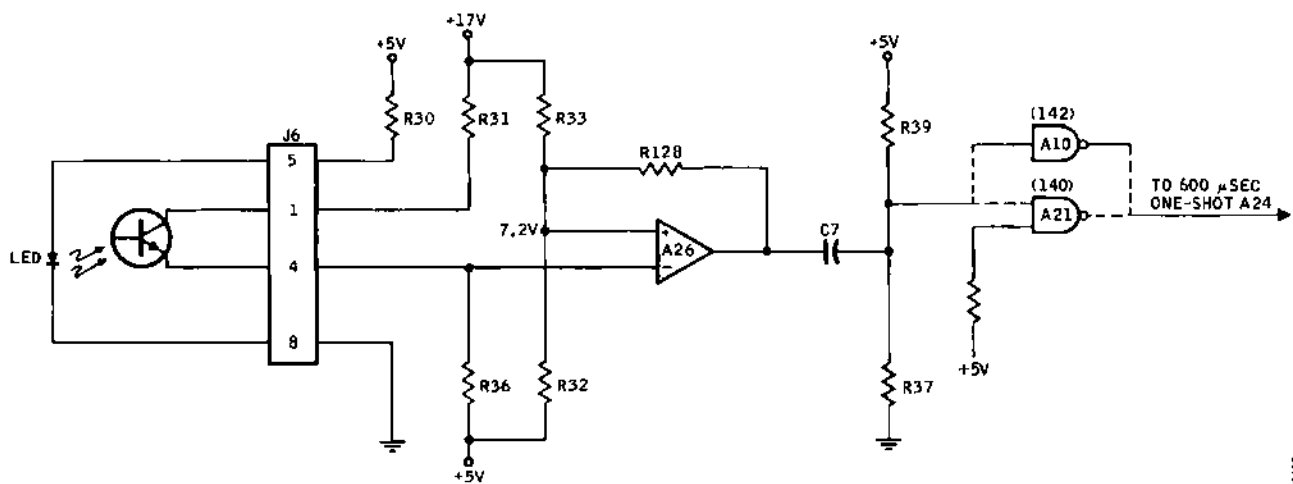

Figure 3-19. Index Detector

10/97

10/98

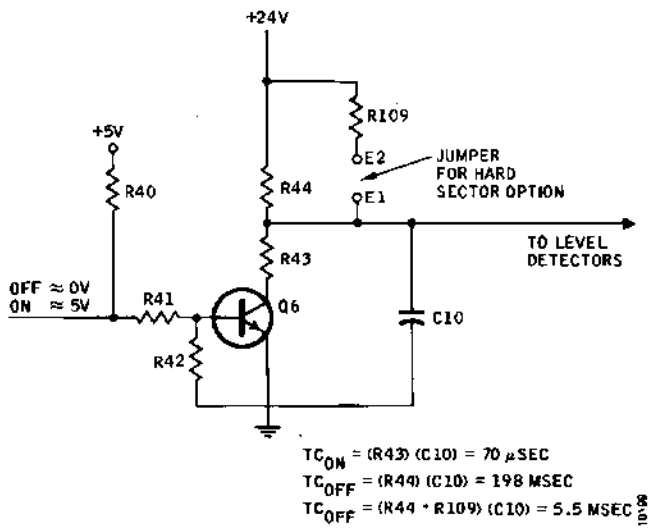

Figure 3-20. Ramp Generator

Current flow is subsequently routed through the coil of the head load solenoid and through Q3 to ground. The solenoid releases the arm that forces the read/write head against the disk.

Head load and positioning can be accomplished at the same time.

Read/Write Head Positioning Logic

The read/write head positioning logic moves the read/write head to a track in response to the controller issuing three signals:

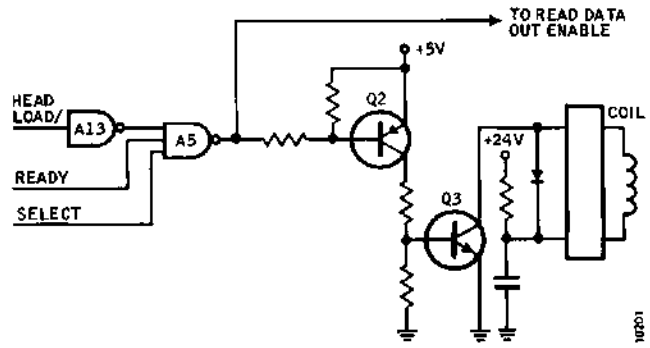

Figure 3-22. Head Load Relay Driver

- DIRECTION gives direction of movement relative to the current track position.
- STEP/ pulses determine, by the number received, the number of tracks.
- SELECT/ places the disk drive online with the controller.

The stepping rate is 167 pps (6 milliseconds per track). An additional 30 milliseconds must be allowed after the last step for positioning system stabilization. Thus, access time is expressed as 6 milliseconds times the number of tracks, plus 30 milliseconds.

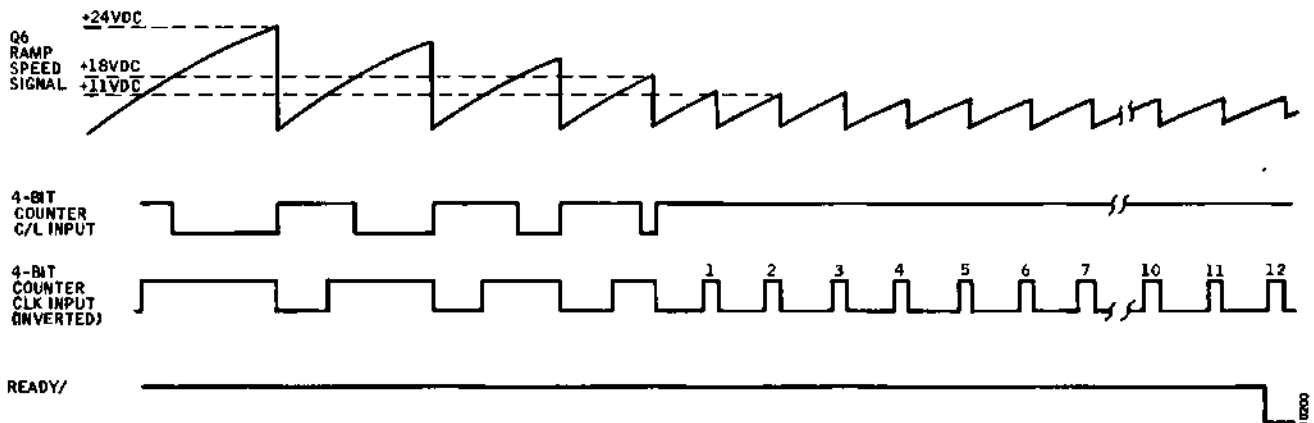

Figure 3-21. Power-On to Ready Transition Period Waveforms

The STEP pulse must have a 200-nanosecond minimum pulse width (2 milliseconds maximum), while DIRECTION must be stable for at least 100 nanoseconds prior to receipt of the first STEP pulse. Figures 3-23 and 3-24 show the timing of the two signals for single- and multiple-track positioning, respectively.

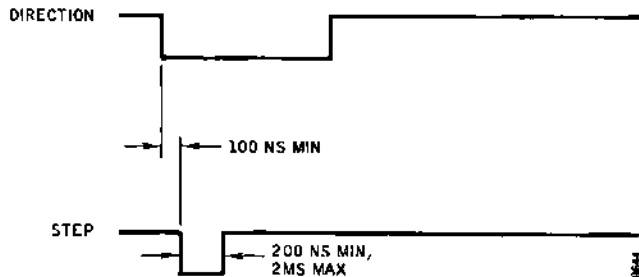

Figure 3-23. Single-Track Positioning Time Waveforms

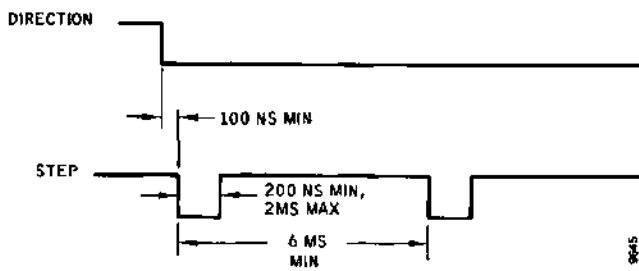

Figure 3-24. Multiple-Track Positioning Time Waveforms

• Direction Control Logic

The state of direction control flip-flop A8 is determined by DIRECTION. When DIRECTION is high, a zero is clocked into the D-input of direction control flip-flop A8 by the first STEP/ pulse. This level enables ingate A9 and disables outgate A15 (DIRECTION/ low) (see Figure 3-25).

To reverse read/write head positioning, the controller sets DIRECTION low. As a result, outgate A15 is enabled, and ingate A9 is disabled.

Rotation direction is determined by decoding the sequence of a 2-bit binary code produced by high-order stage A8 and low-order stage A24.

If the decided sequence starts at 00 and goes up, the read/write head is moved toward the hub. The direction is reversed if the decoded sequence goes down from a count of 11. The two sequences are shown in Figure 3-26.

Low-order one-shot A24 also provides the second step pulse that is required for 30-degree rotation.

• Secondary Step Pulse Generator

The controller STEP/ signal (first step) triggers low-order one-shot A24, which then sets. Assuming high-order flip-flop A8 to be reset, the count presented to the decode network would be 01, and A24 would be set. At the conclusion of the 3-millisecond delay, A24 is reset.

The negative transition of A24-Q is delayed for 33 microseconds, then it enables ingate A9. The inverted output of A9 subsequently clocks high order flip-flop A8 to advance the count to 10.

The two, step pulses – decoded as 01 and 10 – move the stepper motor through two, 15-degree, angular positions shown as pulses J4-05 and J4-03 in Figure 3-26.

The first step occurs during the first 3-millisecond stepping period, and the second step is active during the latter 3-millisecond period. For single-track positioning, the operation, which requires 6 milliseconds, is terminated after issuing a single STEP/ pulse.

Multiple-track positioning is initiated by the controller issuing a series of STEP/ pulses at 6-millisecond intervals. The 2-bit binary code is summarized in Table 3-1 for both in and out positioning.

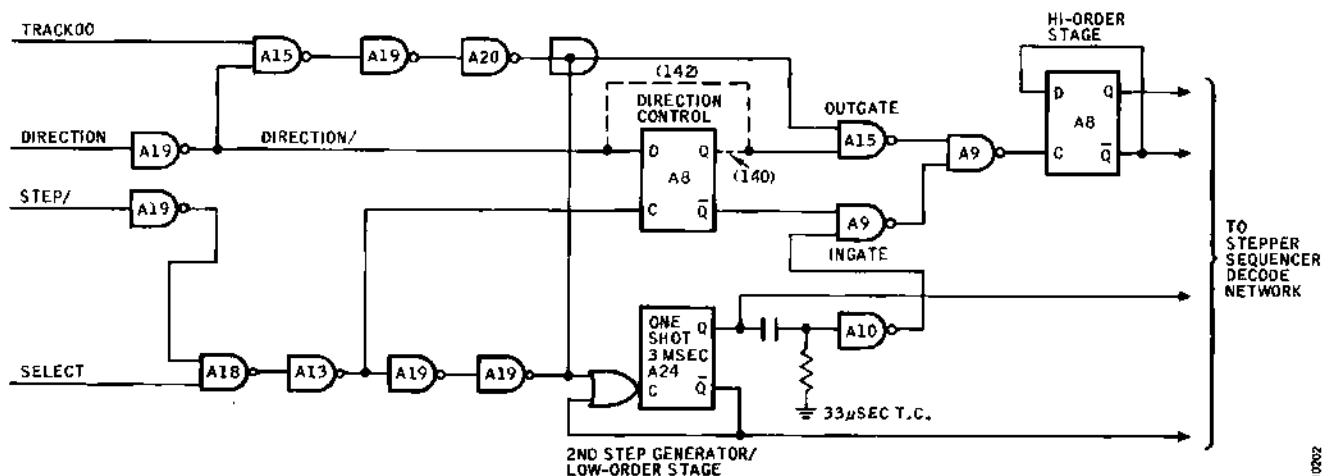

Figure 3-25. Stepper Motor Position Control Simplified Logic Diagram

10202

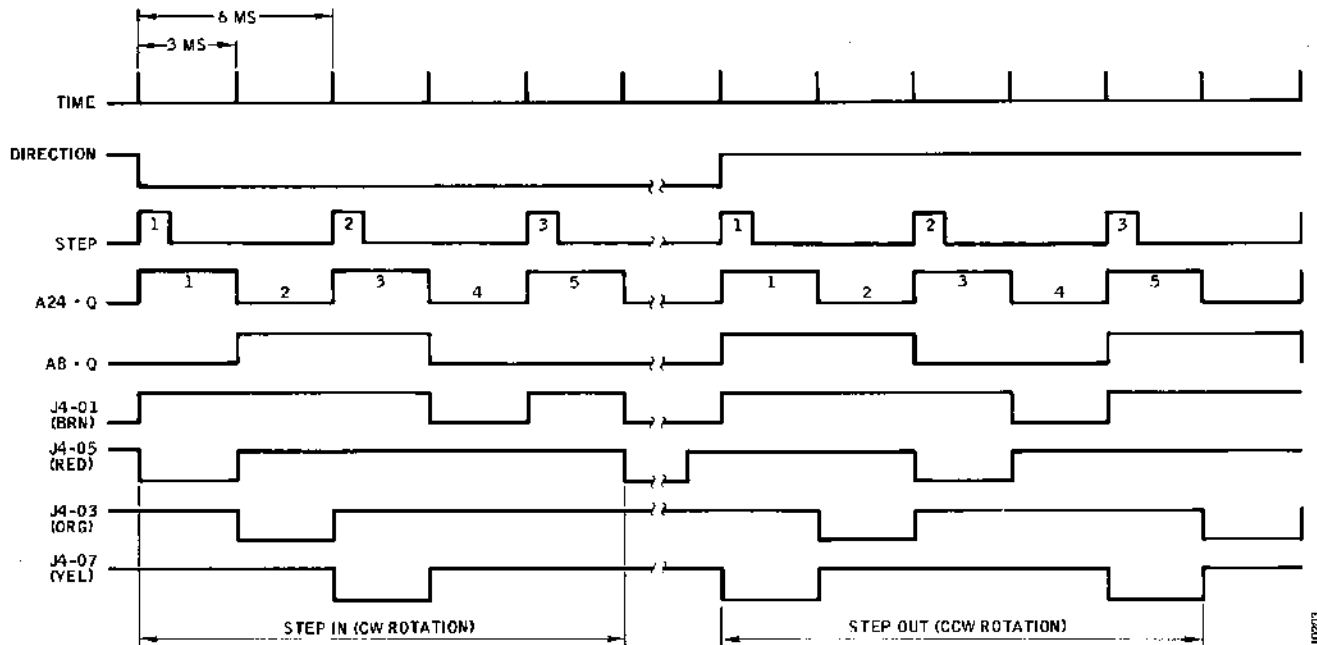

Figure 3-26. Stepper Motor Direction Sequencing

TABLE 3-1. BINARY CODE FOR IN-OUT READ/WRITE HEAD POSITIONING

Binary Code		Direction	Stepper Motor					
			Rotation	Angular Position (Degrees)				
A8	A24							
0	0	In	CW	0	60	120	240	300
0	1	In	CW	15	75	135	255	315
1	0	In	CW	30	90	150	270	330
1	1	In	CW	45	105	165	285	345
1	1	Out	CCW	0	-60	-120	-240	-300
1	0	Out	CCW	-15	-75	-135	-255	-315
0	1	Out	CCW	-30	-90	-150	-270	-330
0	0	Out	CCW	-45	-105	-165	-285	-345

When stepping is terminated, the stepper motor is maintained in the last position by the binary decode holding a ground on one of the quadrature windings as an electrical detent.

• Stepping Sequence Decode

Each of the four (quadrature) stepper motor windings is connected to a Darlington type driver that is controlled by a 2-bit decoder (see Figure 3-27).

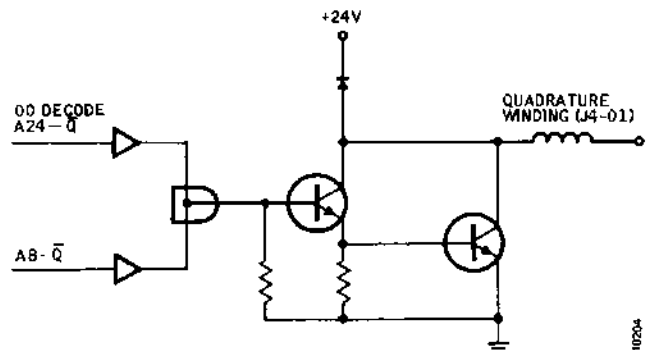

Figure 3-27. Decode and Current Drivers for 00 Code

The stepper motor is rotated by applying a ground sequentially to each of the four quadrature windings. This is accomplished by turning on the associated current driver. As shown in Figure 3-27, a high will be reflected at the base of the current driver when both high-order flip-flop A8 and low-order one-shot A24 are reset. If either is set, the wired-AND gate will be set low, cutting off the current driver.

Three similar decoders decode the other three states of the 2-bit code; this results in a ground being applied to one of the stepper motor windings.

• **Stepper Motor**

The stepper motor changes its angular position by 30° with each STEP/ pulse. The common tap of the quadrature windings is connected to +24 vdc. At each position, the rotor is maintained in an accurate, dynamic, magnetic balance.

The bidirectional rotation of the motor is dependent on the 2-bit code applied to the quadrature windings. Thus, the motor can be stepped clockwise or counterclockwise in accordance with the 2-bit code sequence. The helical drive shaft then positions the read/write head over one of 77 tracks. The initial position (home) is indicated by the track 00 transducer.

• **Track 00 Transducer**

The controller performs a restore cycle (seek home) during initialization and when the relative position is not known. The operation involves setting the DIRECTION line high and sending STEP/ pulses. The read/write positioning system responds by stepping to track 00 and then halting. The track 00 transducer detects this position and inhibits

further step-out positioning and, simultaneously, flags the controller by activating the TRACK00 status line.

The track 00 transducer circuit comprises a phototransistor, a light-emitting diode (LED), a differential amplifier, and pulse-shaping logic (see Figure 3-28).

Normally, the positive input of the differential amplifier is set to +7.2v, while the inverting input is biased at +5v. The differential output voltage is approximately +2.2 vdc under these conditions.

When track 00 is detected, light from the LED is blocked from the phototransistor, which increases the voltage at the inverting (-) input of A26 to approximately +9 vdc. The resultant output of the differential amplifier swings more negative and turns on Q1. The resultant high output of inverter A19 is ANDed with the inverted output of the high-order stage stepper control flip-flop (A8-Q) to qualify the TRACK00 signal as being in phase with the stepper control. The high level is gated by SELECT to signify TRACK00 status.

When the read/write head is at track 00, the high from inverter A19 is applied to the step-out positioning logic and inhibits step-out logic through gate A15 (refer to Figure 3-25).

Read/Write Logic

The read/write logic converts encoded serial data from the controller to flux patterns that are recorded on the surface of the disk. The recorded data is sensed and decoded into read data during a read operation. Both operations share a head that is switched to either read or write by WRITE ENABLE/. This signal enables the read/write matrix either to receive data from the write channel or to route analog data to the read channel.

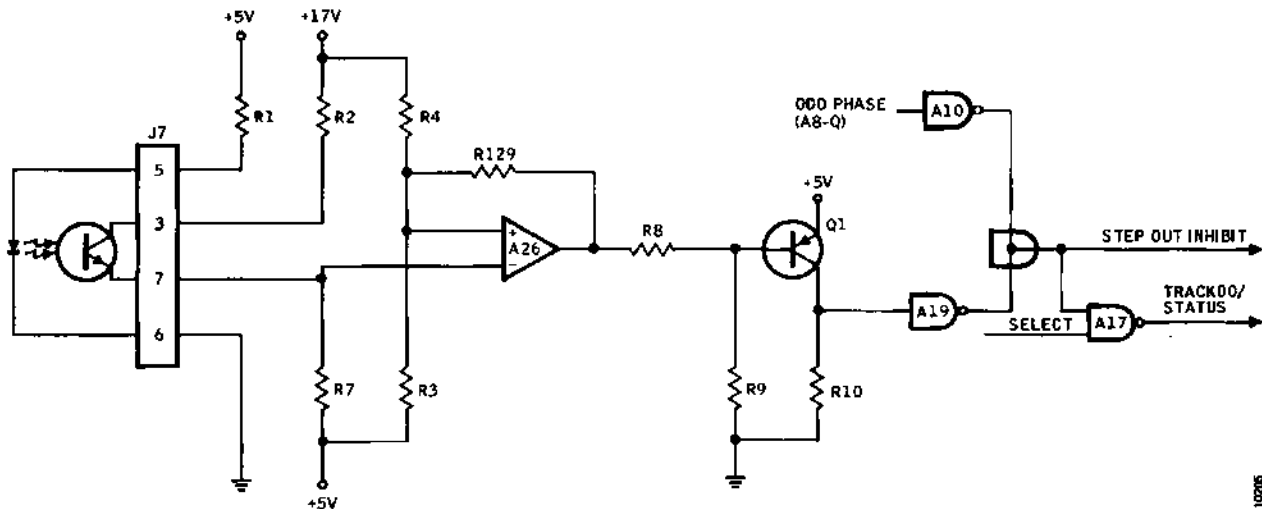

Figure 3-28. Track 00 Detector Circuit

10206

The read/write logic is separated into two major circuits:

- Write Channel
- Read Channel

• **Write Channel Operation**

The write channel converts encoded serial data from the controller to flux patterns that are recorded on the disk. The controller presents the data with a 4-microsecond bit cell period (2 microseconds for MFM). The write channel subsequently produces a flux change for each transition.

A write operation is initiated by the controller activating the WRITE ENABLE/ line (see Figure 3-29). This line remains active for the duration of the write operation and enables write current and tunnel-erase current circuits. The write current circuit records the data, while the tunnel-erase circuit confines track width to approximately 0.013 inch.

• **Read/Write Matrix -- Write Mode**

The read/write matrix is switched to write mode by inhibiting read channel output. The read inhibit, derived from the

low-level output of A18, is applied to the read side of the read/write matrix to prevent any current flow through this channel.

- **Write Current Control** – When the write current control circuit is not in the write mode, current flow is inhibited by the low-level output of A13. This low-level output causes the output of the write current generator to be shunted through diode CR21. Additionally, the low output of A13 and the direct set and reset inputs of the write data control flip-flop causes both the Q and Q/ outputs to be held at a high level. These high levels back-bias write current gates Q10 and Q11.

When the controller issues a write command (WRITE ENABLE/low), the direct set and reset inputs go high, thus enabling write data control flip-flop A16 to toggle on each positive-going transition of WRITE DATA (see Figures 3-30 and 3-31). Consequently, write current is turned on by alternately enabling write current gates Q10 and Q11. The current flows from ground through either Q10 and Q11 and its write coil to the current source.

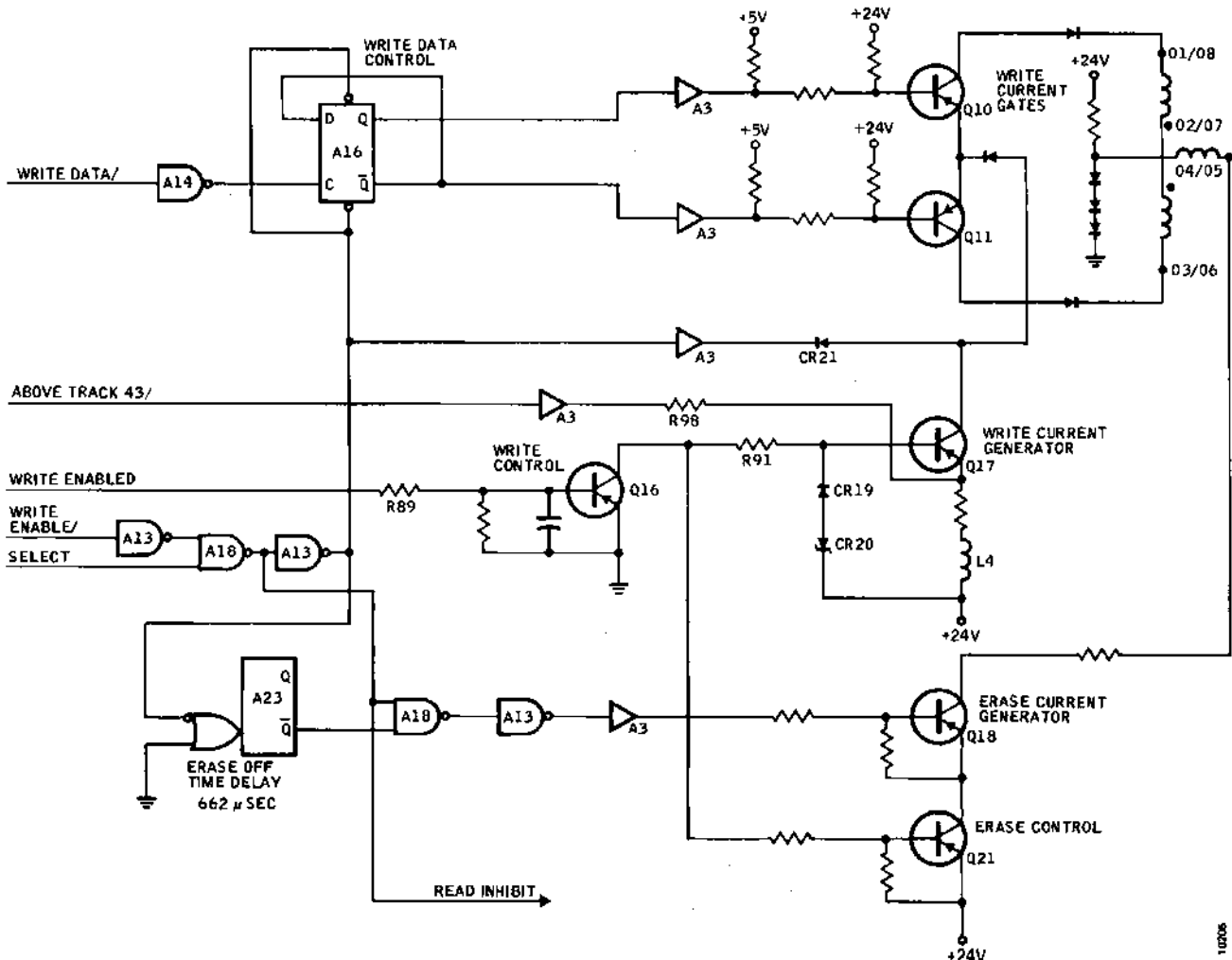

Figure 3-29. Write Channel, Simplified Logic Diagram

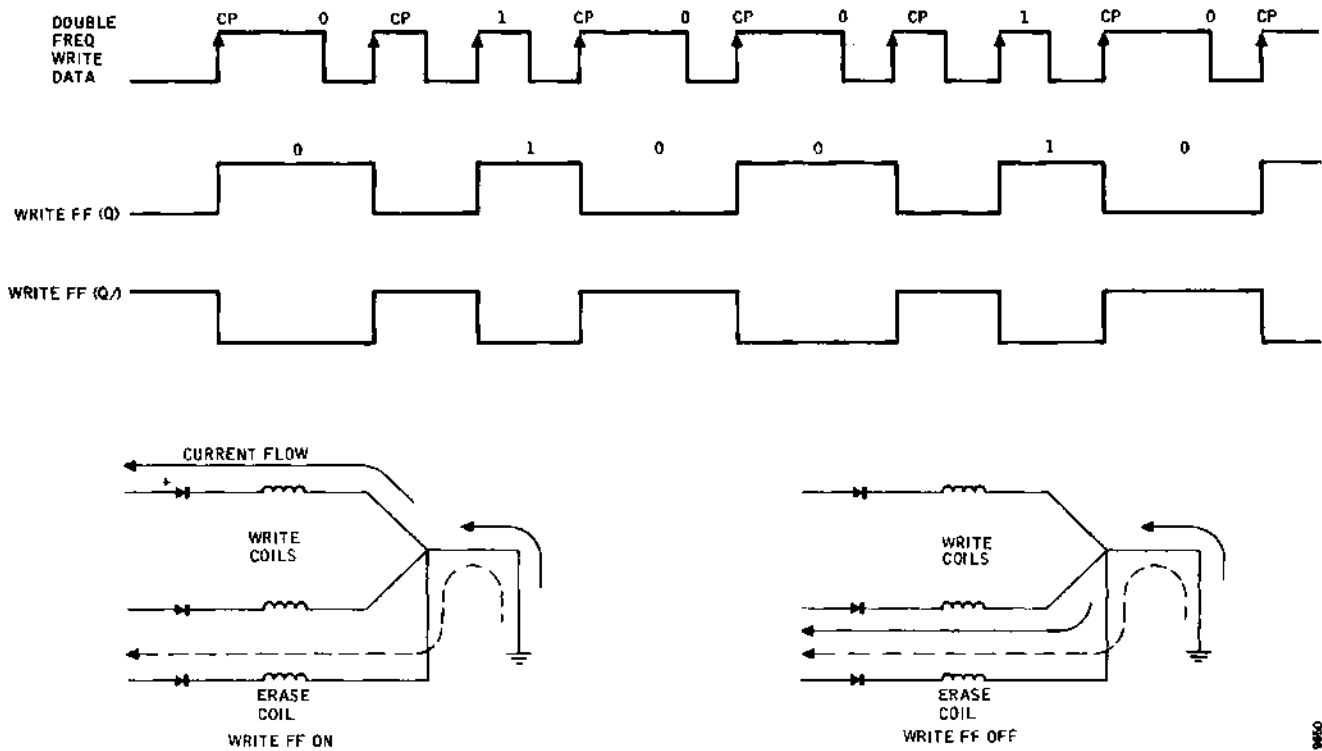

Figure 3-30. Double-Frequency Write Control and Write Coils Current Flow

0960

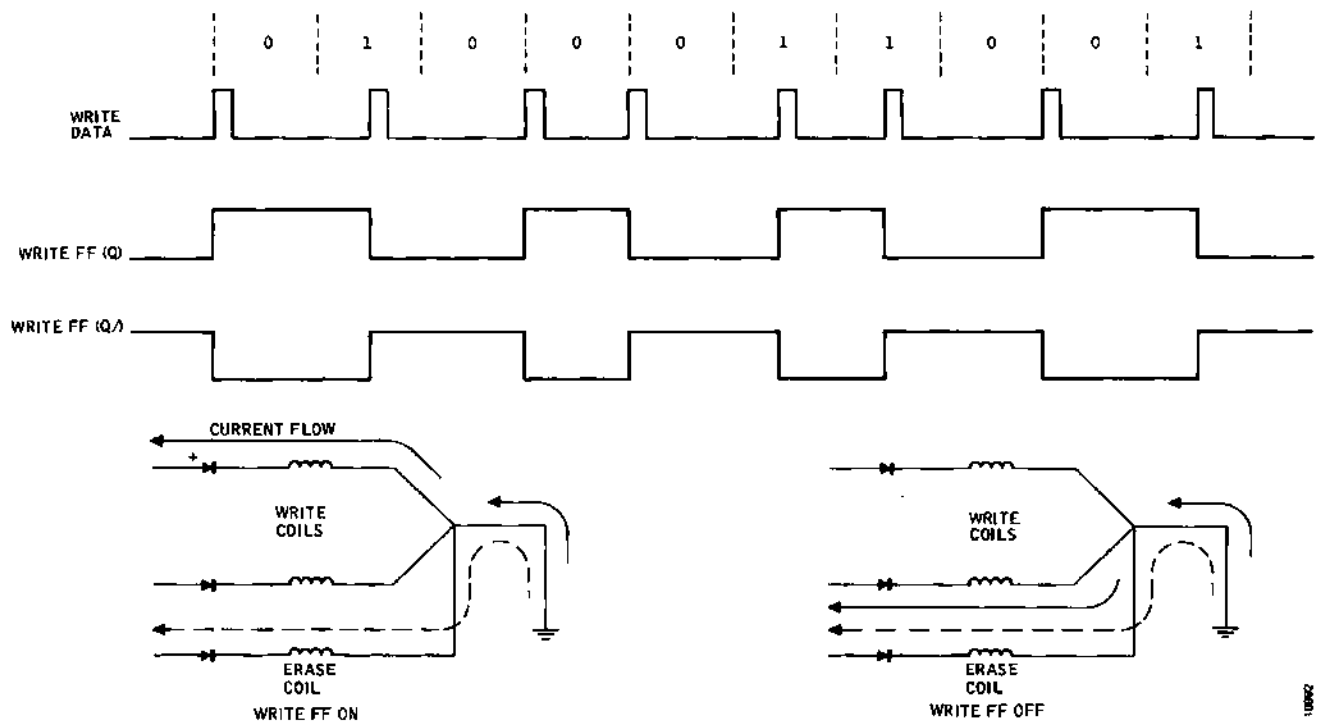

Figure 3-31. MFM Write Control and Write Coil Current Flow

10962

Transistors Q10 and Q11 are biased such that a high-level input from the respective write data control flip-flop will cause the transistor to cut off. With a low input from the respective flip-flop, the transistor will be forward biased and allow current to flow through the respective write coil.

- **Write Current Generator** – If not in write protect, the write current generator produces write current at all times which flows constantly through write current generator Q17. In read or idle mode, clamp diode CR21 diverts write current from the read/write head to noninverting gate A3.

When WRITE ENABLE/ is issued, diode CR21 is back biased, which allows write current to be present at the emitters of write current gates Q10 and Q11. Dependent upon write control flip-flop A16, one of the two gates is enabled. The resultant current flow is directed to one of the two write windings.

Write current generator Q17 is a constant-current source that is forward biased by write control transistor Q16. With write protect inhibited (WRITE ENABLED high), Q16 is forward biased. This applies a ground to resistor R91. The resultant 6.2 vdc through zener diode CR20 and diode CR19 forward-biases Q17 to supply the necessary write current to write current gates Q10 and Q11. Since write current is on constantly, leading edge current is extremely sharp. The trailing edge of write current is improved linearly by coil L4.

Additional circuitry is included to compensate for shorter bit cell spacing as track diameter decreases. When the addressed track number exceeds 43, the controller issues an ABOVE TRACK 43/ command that inserts resistor R98 in parallel with the Q17 bias network. The resultant lower bias level causes transistor Q17 to decrease its conduction, providing a lower current drive to the read/write head.

While data are being written, tunnel erase follows. The erase coil is physically offset to follow the write coils. Erase current is turned on at the same time that write current is turned on and remains on for 685 ± 180 microseconds after write current is terminated. Tunnel-erase current straddles the write track, thereby reducing track fringing and improving interchangeability.

- **Erase Current Generator** – Erase current generator Q18 is also a constant-current source and is directly controlled by WRITE ENABLE/. When enabled by the low-level output of inverter A13 through driver A3, erase current is turned on at the same time that WRITE ENABLE/ is activated and remains on for 662 microseconds after WRITE ENABLE/ is turned off.

One-Shot A23 senses the falling edge of WRITE ENABLE/ and generates a 662-microsecond, negative, holdover pulse.

This signal keeps the erase current generator on for an additional 685 microseconds. After this delay, an additional delay of 900 microseconds must be allowed for read amplifier recovery before a read operation can be initiated.

- **Read Channel Operation**

The read channel recovers data written on a prerecorded floppy disk or during a write cycle. A read operation is enabled by WRITE ENABLE/ being set high. This level enables read data and clock output gates and switches the read/write matrix for read operation.

The controller initiates a read cycle when:

- WRITE ENABLE/ is high
- SELECT is high
- HEAD LOAD/ is low

The read channel comprises the following logic circuits:

- Read/write matrix (switched to read)
- Preamplifier and differentiator
- Crossover detector-amplifier
- Logic level restorer
- Output gating
- **Read/Write Matrix – Read Mode** – The read/write matrix is conditioned for a read operation when the junction of R64 and R65 is at +21 volts (see Figure 3-32). This potential forward-biases diodes CR7 and CR8 and allows current to flow through either the upper or lower branch circuit.

When a flux change is detected by the read/write head, a signal is developed across R66 and R67. The low-level analog signal is capacitively coupled to amplifier A1.

- **Preamplifier and Differentiator** – Preamplifier A1 is a high-gain (approximately 90), linear amplifier that increases signal amplitude to approximately 1 volt peak to peak. Noise filters L1 and L2 limit high frequencies while passing the analog signal. The output of A1, measured differentially, appears as that shown in Figure 3-33A. The pattern represents one flux change for every bit cell time.

The signal is coupled to a high-pass differentiator that introduces a 90-degree delay and shapes the signal into a distorted square wave (see Figure 3-33B). The analog signal is subsequently converted to a square wave by the crossover detector-amplifier.

- **Crossover Detector-Amplifier** – The crossover detector comprises a pair of diodes connected opposite in polarity across the input to a linear amplifier. The linear amplifier

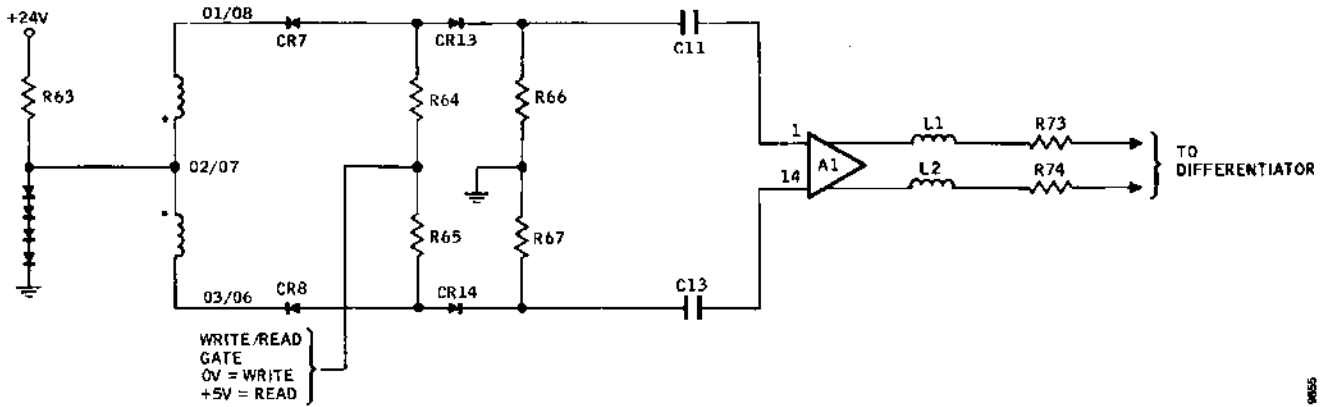

Figure 3-32. Read/Write Matrix Gate for Read

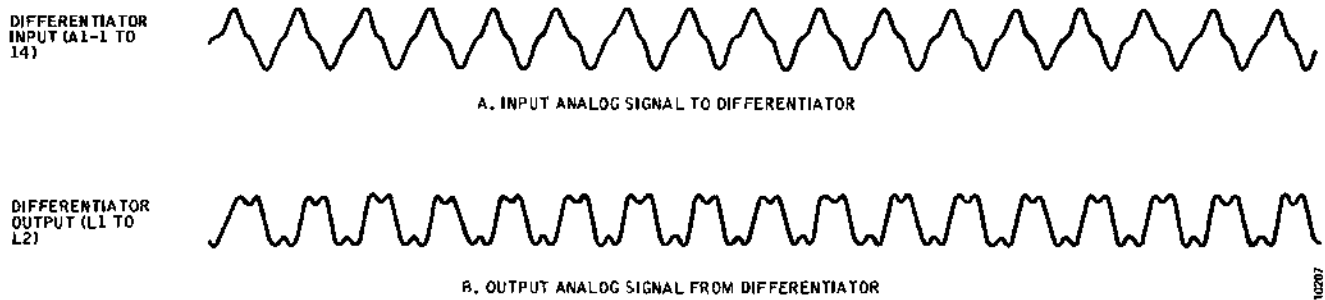

Figure 3-33. Differentiator Input/Output Waveforms

sharpens the rise and fall times. At this time, the analog signal is shaped into a digital signal; each transition represents a flux change sensed by the read/write head. The pattern is then restored to TTL logic levels.

- **Logic Level Restorer** – The logic level restorer is a two-stage circuit that establishes a zero base line and limits the amplitude to +5 volts. The first stage operates as a dc restorer, while the second stage operates as a limiter.

The pulse pattern now exhibits a transition between 0 volt and 5 volts for every flux change recorded on the disk track.

- **Raw Data Output Gating** – The raw data output gating network (Figure 3-34) consists of two differentiating networks and two inverters. The input data from the logic level restorer (A, Figure 3-35) is applied simultaneously to

both networks; however, the input to one network is the complement of the other. As a result, two identical differentiated waveforms of opposite polarity (B and C, Figure 3-35) are applied to OR gate A21. When either input (pin 12 or pin 13) of A21 goes below 2.2 volts, output pin 11 goes high (D, Figure 3-35). The time constant of the RC network is approximately 2 microseconds; therefore, the threshold level of OR gate A21 is held low for approximately 300 nanoseconds.

- **One-Shot Data Separator**

RAW data is converted to NRZ by a one-shot and two D-type flip-flops (see Figure 3-36).

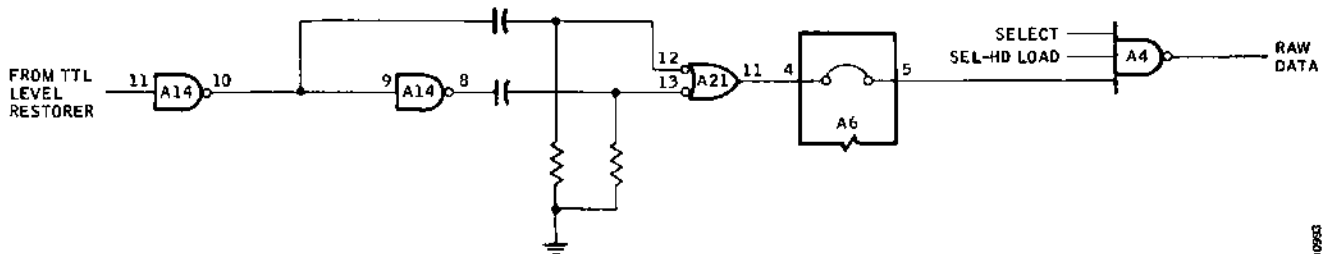

Figure 3-34. Raw Data Output Gating

9885

10207

10953

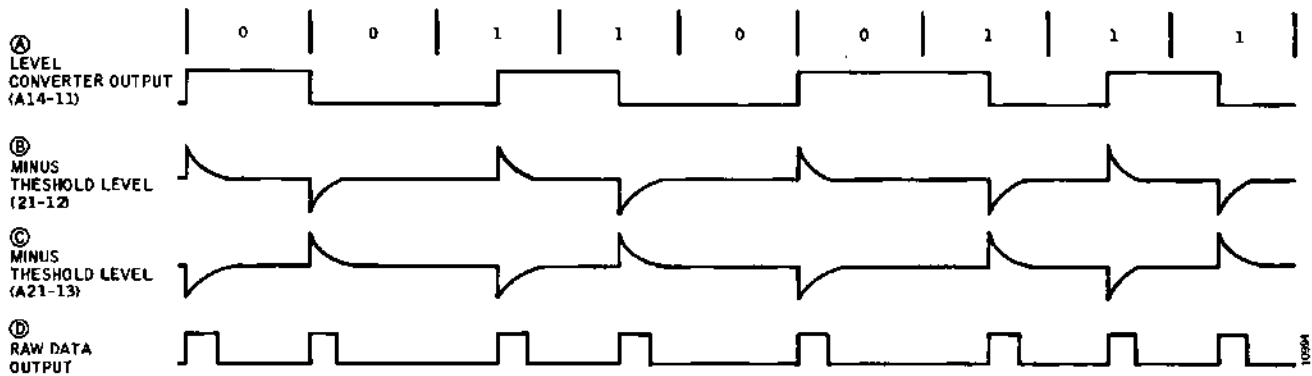

Figure 3-35. MFM Raw Read Data Waveforms

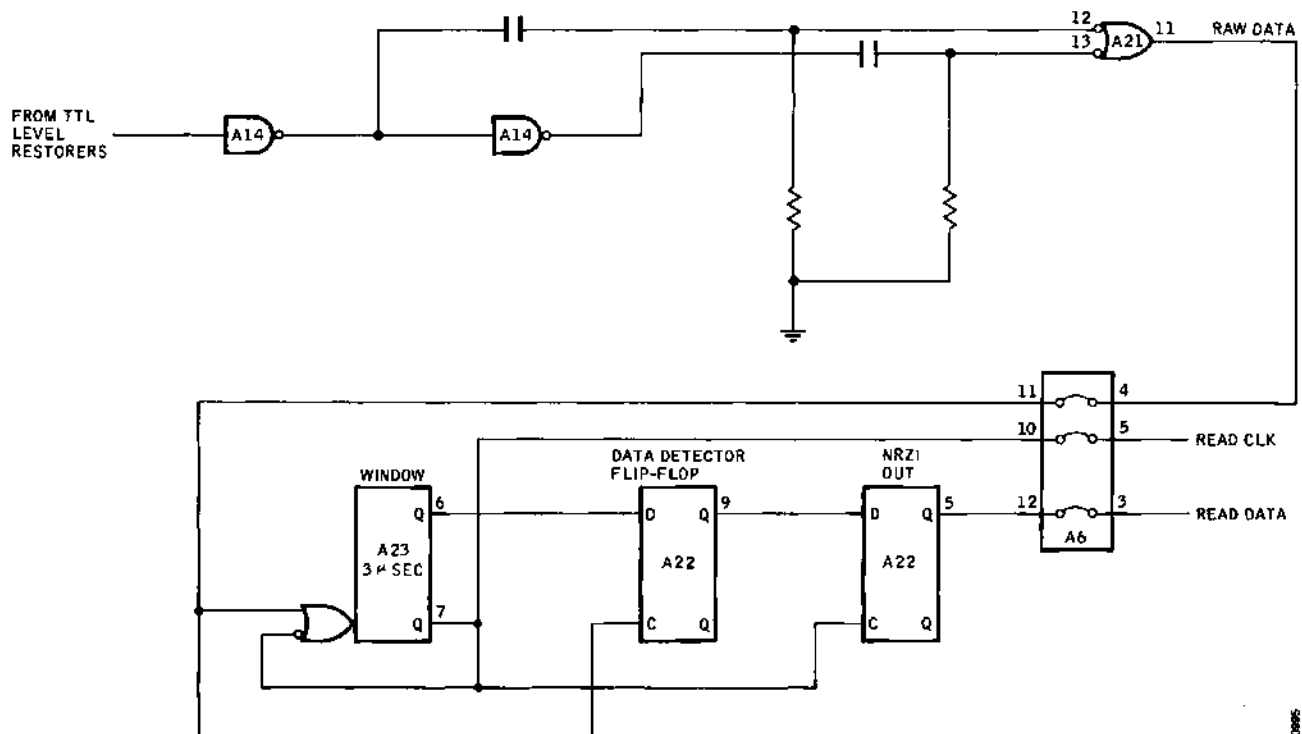

Figure 3-36. One-Shot Data Decoders

RAW data is applied to 3-microsecond one-shot A23, which provides the data window (refer to Figure 3-37, E and F).

The clock pulse that occurs at start of bit cell time triggers the one-shot. The inverted output of the one-shot is applied through a jumper connection to the read clock line. This level is maintained for 3 microseconds.

The one-shot sets data detector flip-flop A22 to store a 1 bit when a data pulse is detected between clocks (refer to Figure 3-37, G). Flip-flop A22 is set by the leading edge of a data pulse and is reset by the leading edge of the next clock in the raw data serial bit stream. Thus, a 1 bit is stored temporarily. This condition is conveyed to the controller by NRZ output flip-flop A22 (refer to Figure 3-37, H).

NRZ output flip-flop A22 is set and reset by clocks, only when the data detector flip-flop is set. The next clock or the start of the following bit cell period sets the NRZ flip-flop which remains set while data bits are present in the serial data stream. When a zero appears, the NRZ flip-flop is reset.

The controller can strobe the NRZ output line coincident with the trailing edge of the read clock. Thus, if a data pulse had occurred, NRZ flip-flop A22 would be set, producing a low (data) on the READ DATA output line.

+17 vdc Regulator Description

The disk drive receives +24 vdc and +5 vdc from the controller and derives regulated +17 vdc from the two voltage

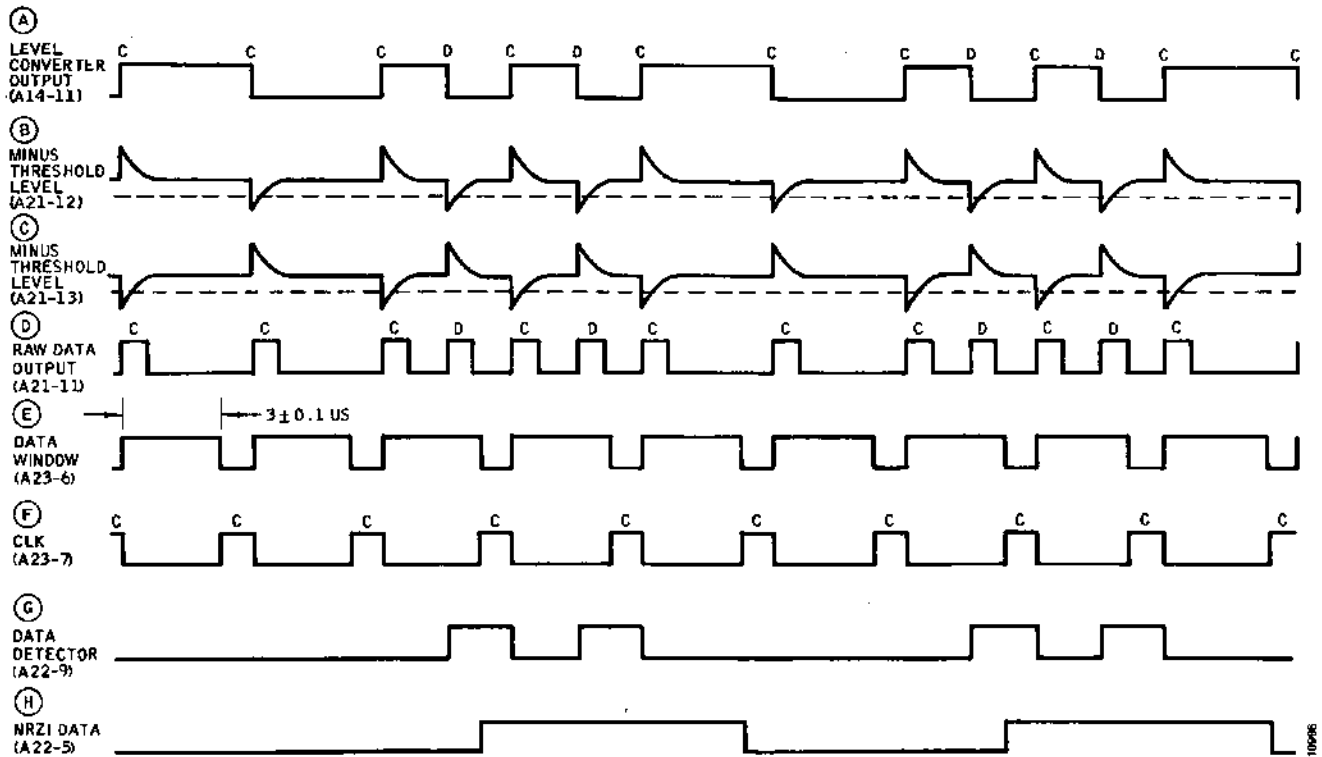

Figure 3-37. RAW and NRZ Read Data Decoder Waveforms

levels. Regulation is accomplished by using a shunt regulator and a zener diode, constant-voltage source.

The zener diode reference voltage is applied to the emitter of a control transistor whose base voltage is connected across a load resistor. As the load voltage varies, the condition of the control transistor changes accordingly. The shift in level, in turn, varies bias on the power transistor, thereby, increasing or reducing load current.

READ DECODER WITH PLO ASSEMBLY

The Read Decoder with PLO Assembly (read decoder assembly) contains the circuitry necessary to track and separate the raw data received from the disk drive into data and clock information.

The read decoder assembly is not part of the disk drive but may be installed in the host controller to decode the raw data output of the disk drive.

The part number of this Read Decoder with PLO used with Model 140 is 15967-001; Part Number 17032-001 is used with Model 142.

The read decoder assembly contains three functional circuits (see Figure 3-38):

- Phase-Locked Oscillator (PLO)
- Data Decoder
- Read Sync

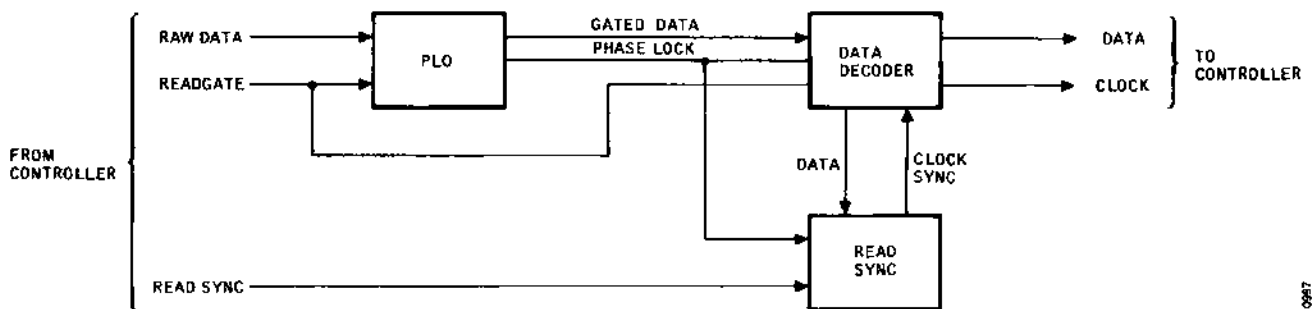

Figure 3-38. Read Decoder with PLO Block Diagram

Normal PLO Operation

The PLO portion of the assembly is depicted functionally in Figure 3-39. When no read operation is taking place (RDGT low), the WRTCLK signal (a 500 kHz square wave from the controller) is routed to OR gate D where it is inverted and

fed into one-shot E. This results in a short pulse from one-shot E each time the WRTCLK signal goes high. When RDGT goes high, gate B is inhibited, and gate C is enabled to pass DATA IN through to gate D (see Figure 3-40). The leading edge of a DATA IN pulse will generate the same pulse from one-shot E as did the WRTCLK square wave.

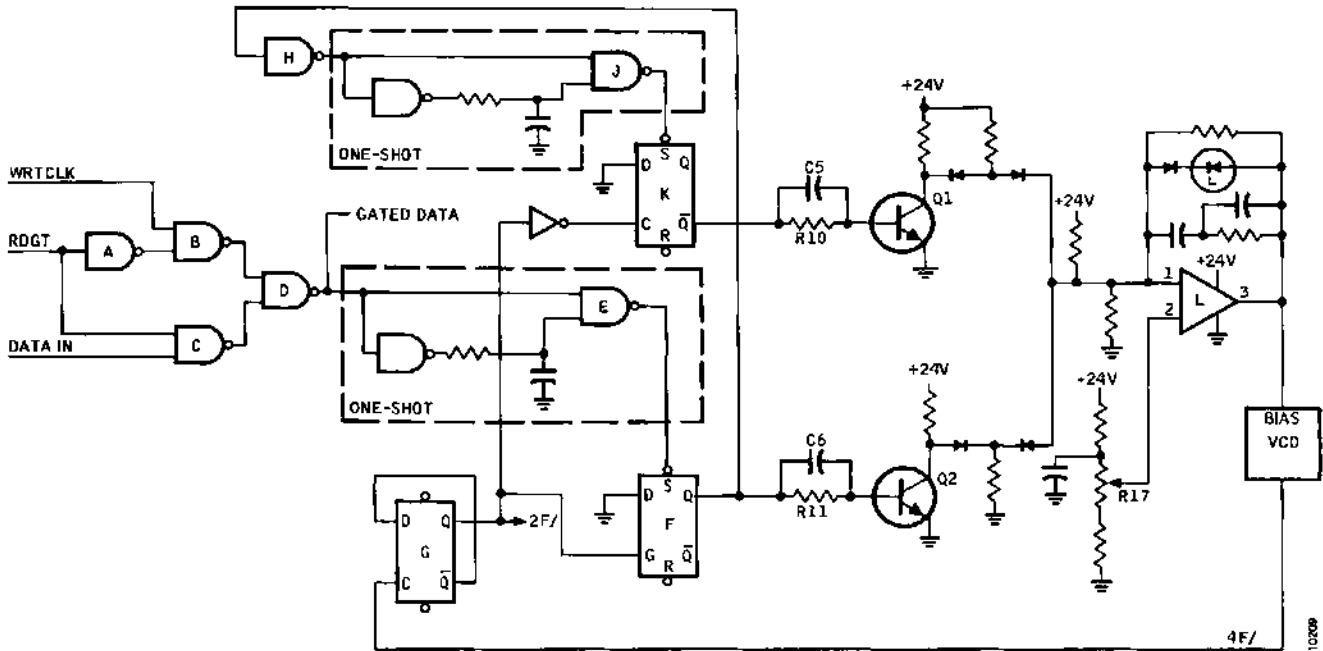

Figure 3-39. PLO, Simplified Logic Diagram

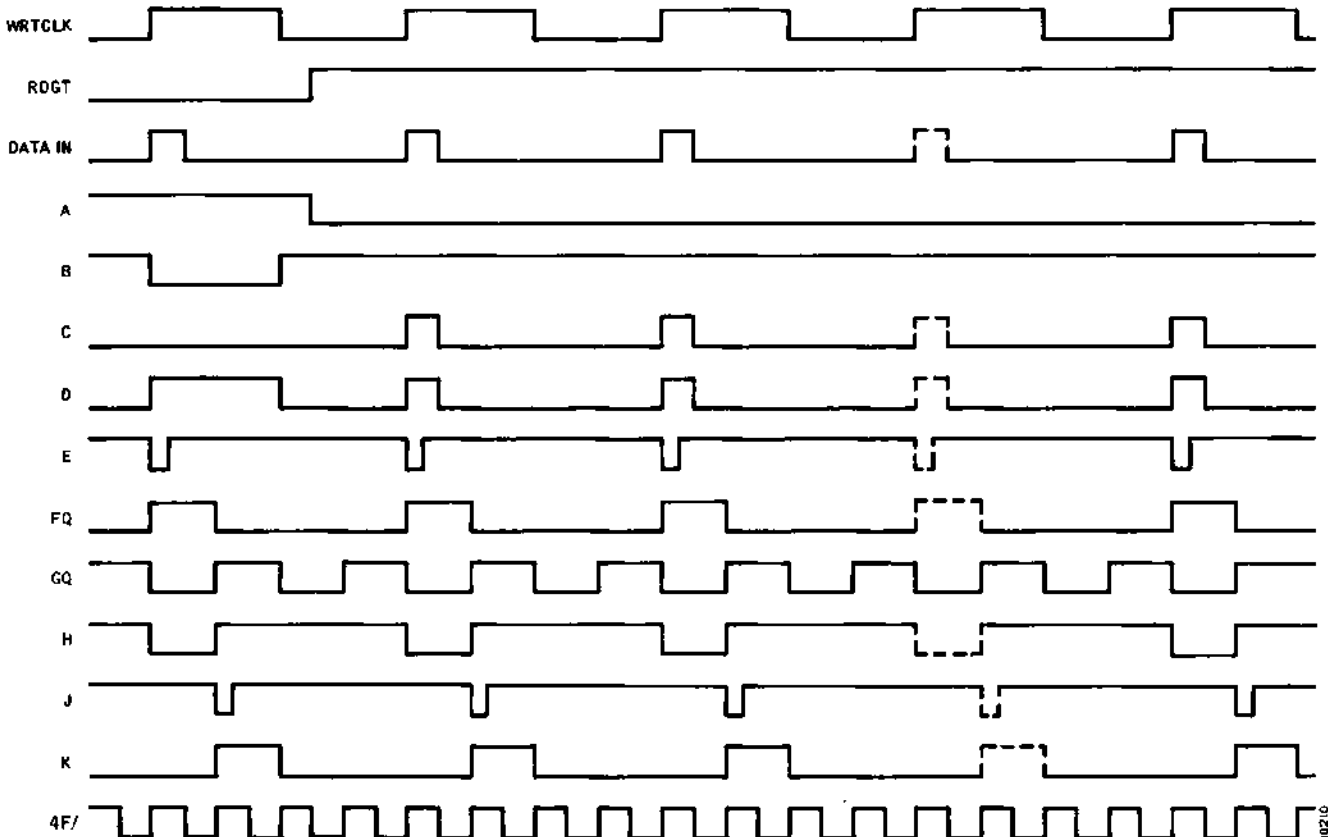

Figure 3-40. PLO Locked On and Missing Pulse Operation

Flip-flops K and F and transistors Q1 and Q2 develop a voltage level at the input (pin 1) of operational amplifier L that represents the amount of change in the VCO required to match the frequency of the data stream with signal 4F (four times the base or bit cell frequency). This lock-on should occur if ones or zeros are incoming as the DATA IN, since a one data pulse is separated from a zero data pulse by two 4F transitions or 2F. The PLO is required only to lock the data pulse onto the proper phase of 4F, and the data separator makes the determination of which data pulse is a one and which is a zero.

The output of flip-flop G is 2F/. This signal is used to clock zero flip-flop F two 4F/ transitions after the short pulse from one-shot E direct-sets flip-flop F. Flip-flop F remains in the reset state until the next data pulse is detected. Under normal or *in sync* operation, this cycle will continue as long as the data pulse is in sync with the active low portion of the 2F/ signal. This cycle has flip-flop F in the one state for two 4F/ transitions or 25 percent of a bit cell and in the zero state for six 4F/ transitions or 75 percent of a bit cell. By examining Figures 3-39 and 3-40 it can be seen that the operation of flip-flop K via gates H and J will be the same as flip-flop F only delayed by two 4F cycles and that it consists of a one period of 75 percent and a zero period of 25 percent.

The output of flip-flop F goes to the base of Q2 via RC network C6 and R11. The time constant of this RC network is very long relative to the incoming signal frequency. Over a period of time, this RC network will average the on time of the flip-flop F signal and place on the base of linear amplifier Q2 a level that represents the percentage of on time (i.e. 0.25v = 25 percent; 0.5v = 50 percent; 0.75v = 75 percent). An identical RC network is used at the input of Q1. The two signals from Q1 and Q2, one representing 75 percent on time and the other representing 25 percent on time, are wired-ORed via a decode network to the input of operational amplifier L. The level on pin 1 is compared with the level on pin 2 to yield a signal on pin 3 that biases the VCO network. By adjusting R17 (PLO center frequency), the level on pin 2 will change, causing a steady change in the bias of the VCO and altering the frequency of 4F. Any variations on pin 1 will also cause the bias to change.

Missing-Pulse PLO Operation

If a data pulse is dropped, it is not desirable to change the frequency of the VCO (see Figure 3-40). When a pulse is dropped, the cycle or on times of flip-flops K and F are changed from 75 percent and 25 percent to 93 percent and 7 percent respectively. Since the outputs are effectively added, this causes no change on pin 1 of operational amplifier L and consequently no change in the VCO.

Sync-Up PLO Operation

When the PLO input is switched from WRTCLK to DATA IN, the frequency will usually be different; this requires the PLO to *sync up*. The DATA IN pulses start out about half of a 4F cycle early in this example (see Figure 3-41). This causes the turn-on time of both FQ and KQ to increase. This increase is reflected in an increase in the level at pin 1 of operational amplifier L and, consequently in the bias of the VCO. Changing this bias causes the frequency of 4F to increase in an attempt to catch the data pulse. As the frequency of 4F increases, the on time of flip-flops F and K decrease via the accelerated clock input from flip-flop G. When the on time is decreased to 75 percent and 25 percent, the VCO stops changing, and the data and PLO are in sync.

Figure 3-41 shows the PLO sync-up at an exaggerated rate. The actual sync-up time would be between 60 and 70 bit times. This slow sync-up rate reduces the sensitivity of the PLO to high-frequency bit shifting or other system noise and increases the reliability of data recovery.

DATA DECODER

The data decoder converts MFM read data from the disk drive to conventional NRZ form for use by the controller. Figure 3-42 shows the different coding waveforms used in the disk drive read/write system.

The 2F/ signal at the input to gate A (Figure 3-43) is the in-sync, 1 megahertz square wave from the PLO. Signal 2F/ is routed to divide-by-two flip-flop B. The output of flip-flop B is a square wave whose cycle time is equal to one bit cell time or a frequency of 1F (see Figure 3-44). The appearance of a data bit during the first half of the cycle is decoded as a zero, and a data bit appearing during the last half of the cycle is decoded as a one. This decoding is accomplished by flip-flop F having BQ as its input and clocked by the READ DATA output of one-shot D. If a data bit occurs during the first half of the bit cell, it will clock a low into flip-flop F; if the data bit appears during the latter half of the bit cell, a high will be clocked into flip-flop F. With the MFM coding technique, it is also possible to have no data pulse during a bit cell (when a zero bit follows a one bit). This situation is decoded by the use of gate G, which resets flip-flop F at the end of a one bit time; thus the Q output of flip-flop F is a low (or zero, unless set by a one bit). This will then be a default zero bit if no data bits are detected; in effect, only one bits are decoded, and, if a one is not present during a bit cell, the data must be a zero; The one-bit-detected window is established by the high-active time of the 1F/ signal that clocks flip-flop H.

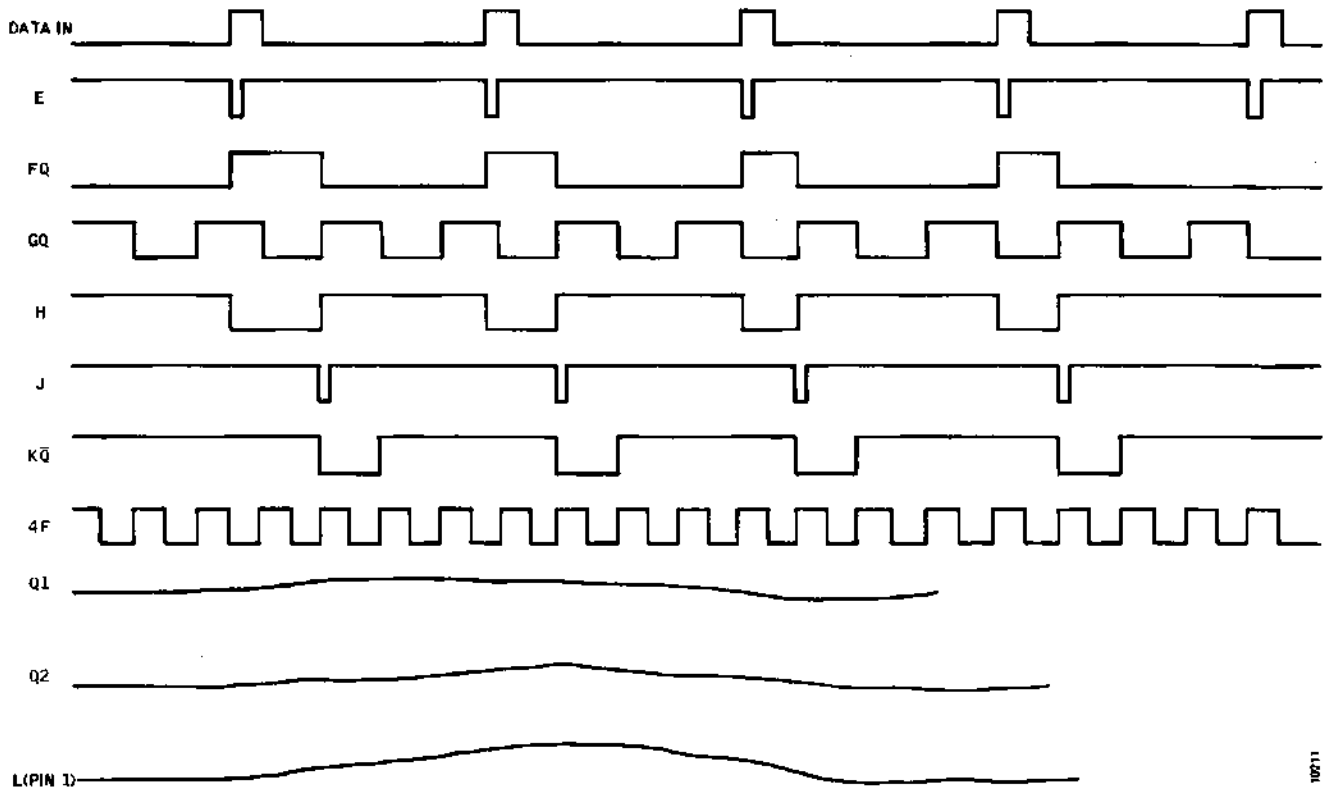

Figure 3-41. PLO Sync-Up

1021

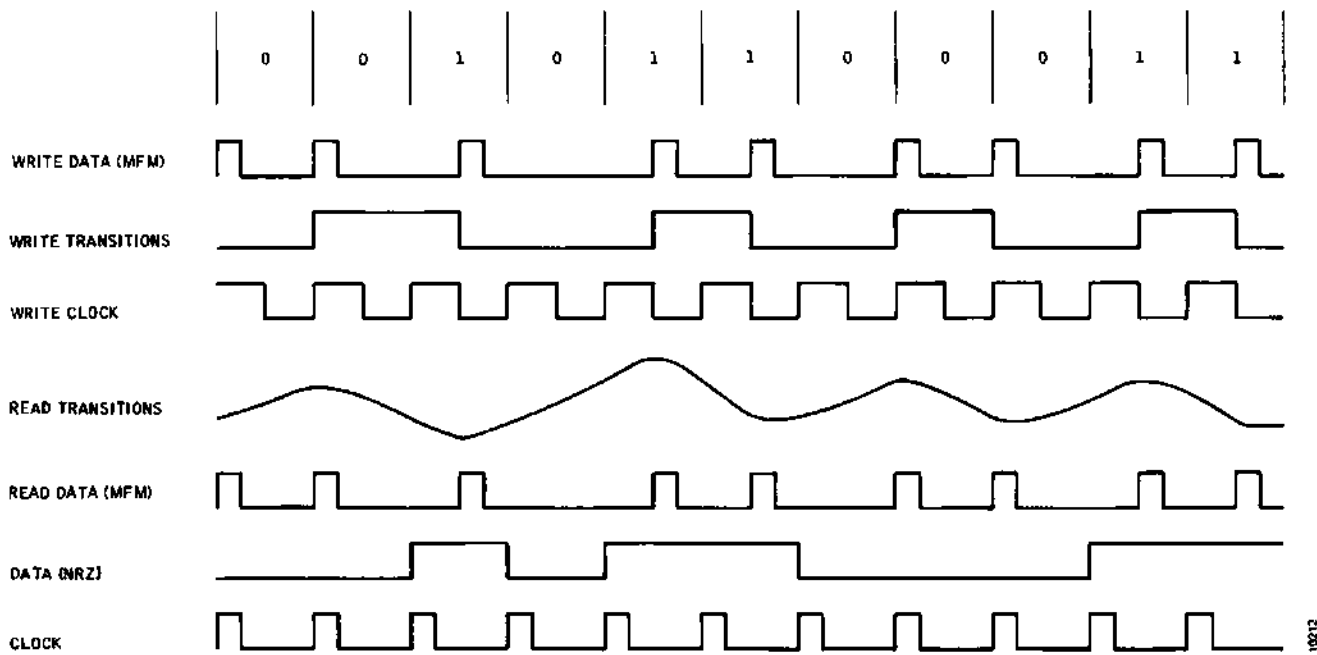

Figure 3-42. Read/Write Coding Waveforms

1022

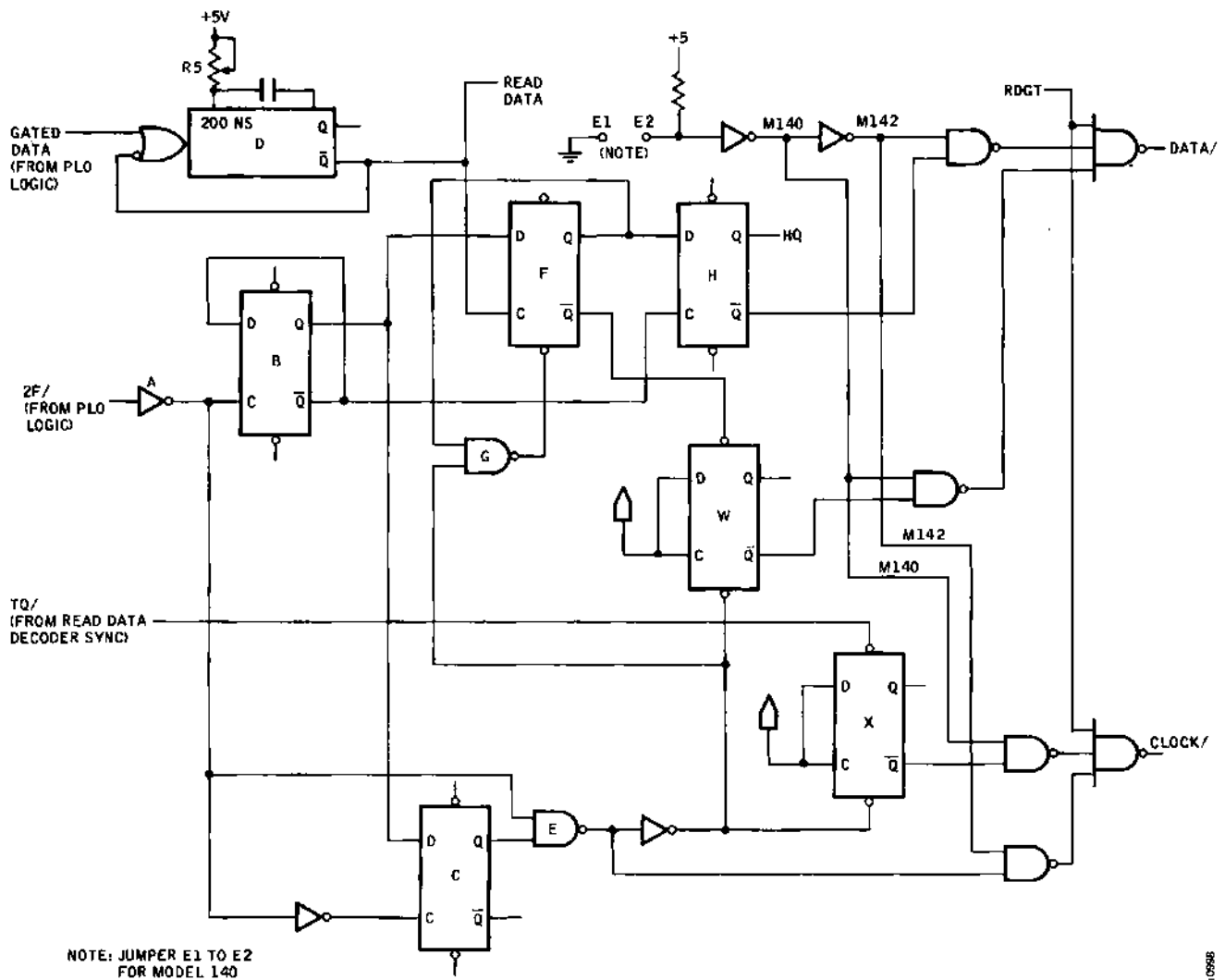

Figure 3-43. Data Decoder, Simplified Logic Diagram

The CLOCK/ output to the controller is developed at gate E by ANDing the Q output of flip-flop C (which is 1F/ shifted 500 nanoseconds late) with 2F to create a 500-nanosecond-long pulse whose leading edge is coincident with the beginning of each bit cell time (see Figure 3-44).

READ SYNC

The Read Data Decoder Sync Logic (Figure 3-45) positions the read clock pulse so that it is in sync with the proper portion of the bit cell, thus enabling the controller to interpret the NRZ read data correctly. In the MFM recording scheme, the clock bit occurs during the first half of the bit cell, and a data bit occurs during the last half of the bit cell (see Figure 3-46). By convention, the incoming data are

zero bits (during the 256-bit preamble) when the READ SYNC signal is activated by the controller. If 1F flip-flop B is synchronized such that the data out are being decoded as ones (during the preamble), it is necessary to shift the cycling of flip-flop B by one-half of a bit cell. When flip-flop B is shifted, the clock is moved (refer to the discussion of flip-flop C clock generation above), and the data is decoded as zeros. If the preamble is being decoded as zeros when the READ SYNC signal is activated, gate V inhibits gate P from direct-setting 1F flip-flop B and CLOCK SYNC flip-flop T.

Figure 3-46 depicts composite data decoder waveforms for MFM coding. Figure 3-47 depicts composite data decoder waveforms for double frequency coding.

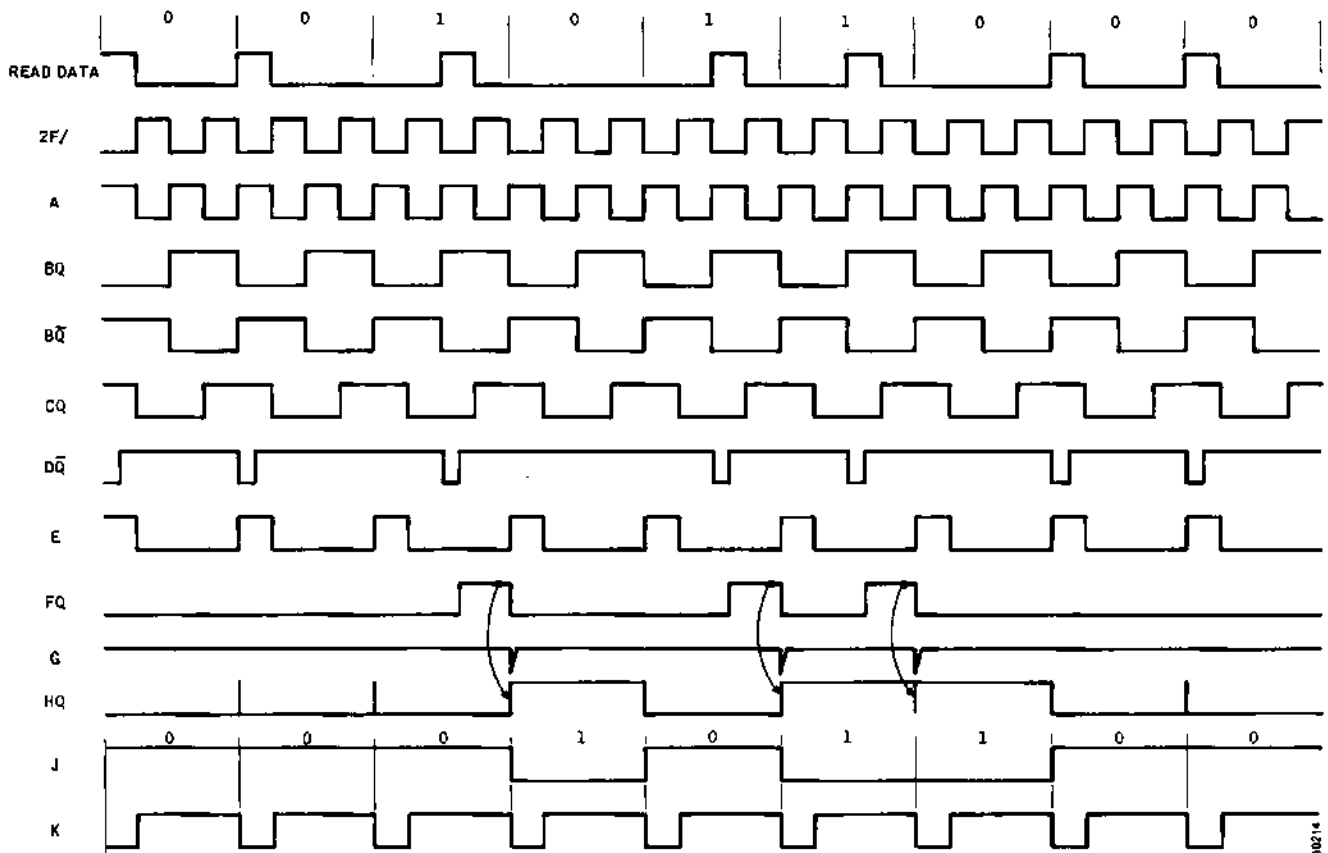

Figure 3-44. Data Decoder Waveforms

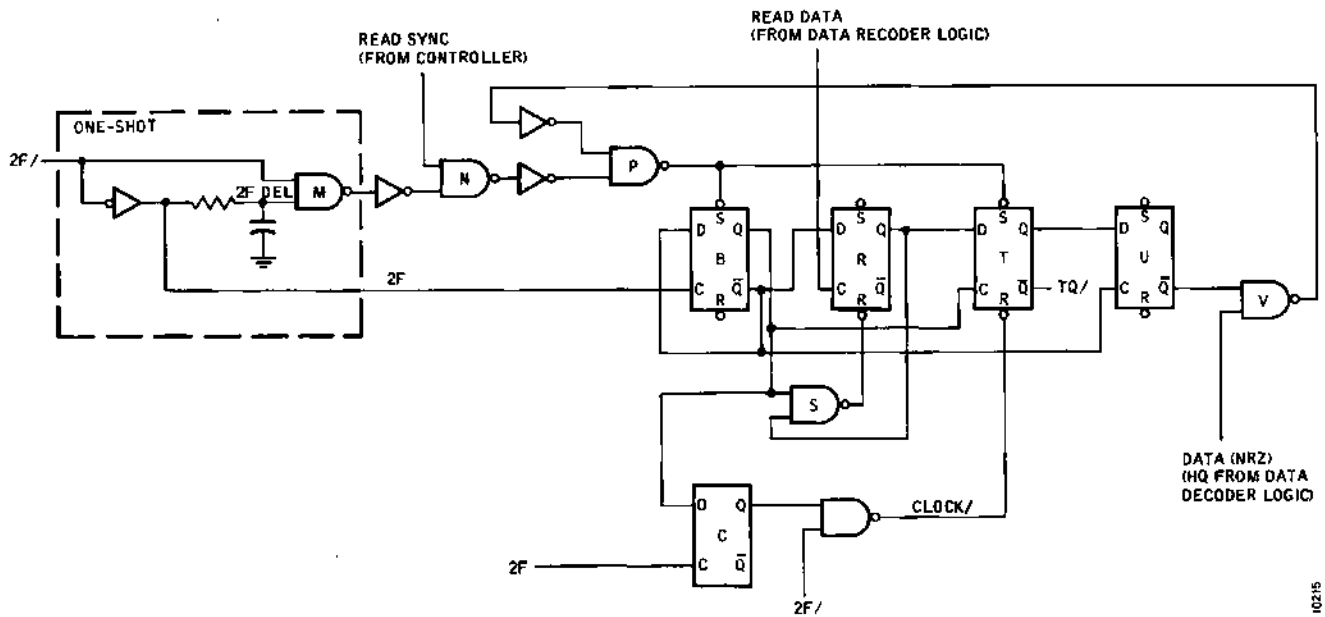

Figure 3-45. Read Data Decoder Sync, Simplified Logic Diagram

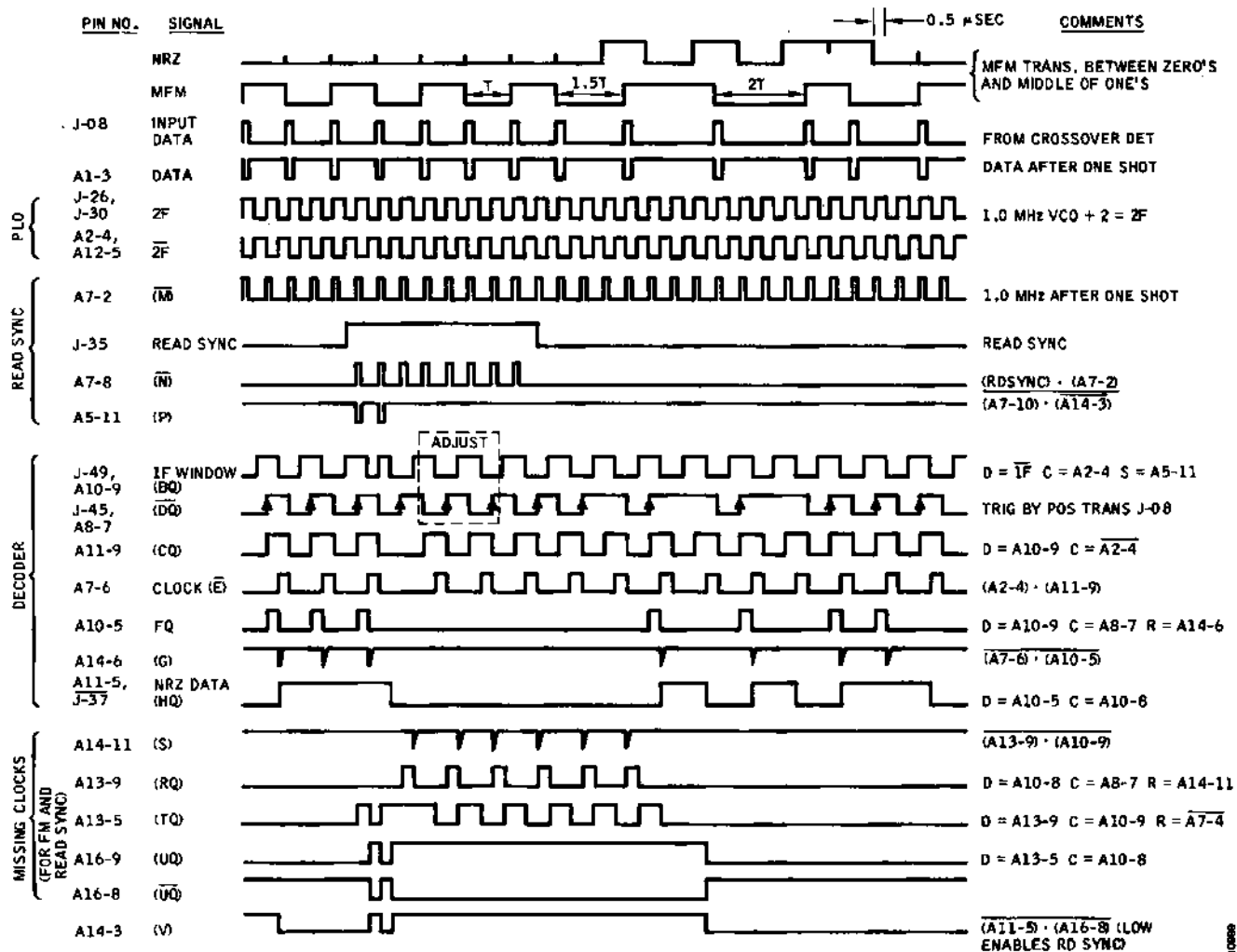

Figure 3-46. Composite MFM Data Decoder Waveforms

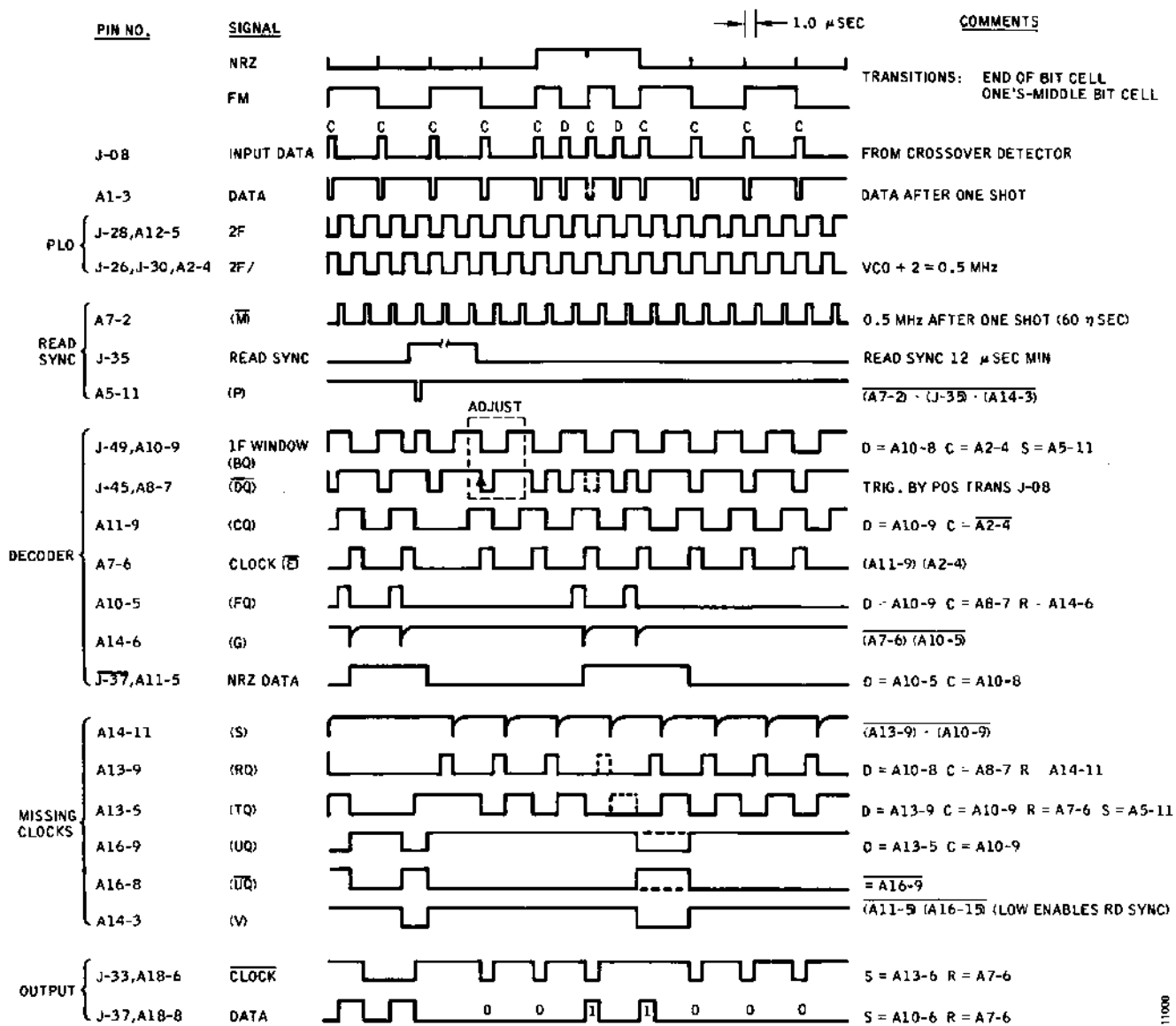

Figure 3-47. Composite Double Frequency Data Decoder Waveforms

11000

SECTION 4 MAINTENANCE

This section contains preventive maintenance, checks, adjustments, and removal and replacement procedures. Maintenance personnel should become familiar with the electrical characteristics and the principles of operation before performing preventive or corrective maintenance on the disk drives.

PREVENTIVE MAINTENANCE

The following preventive maintenance schedule is recommended.

Monthly (covers on)

1. Clean the exterior surfaces with a cloth dampened with a nonabrasive cleaning solution.
2. Examine the air filter, and clean the element as necessary.

Semiannually (covers removed)

1. Clean the interior surfaces, drive belt, drive pulley, and carriage assembly with alcohol and lint-free cloths.
2. Make read/write system checks.
 - Head load settling time (20 ms max, Model 140; 30 ms max, Model 142)
 - Visual examination of the read/write head for scratches, wear, and oxide deposits
 - If the head is dirty, clean it with 95% alcohol and a lint-free cloth. Do not touch the surface of the head with your fingers or blow your breath on it.
 - If the head has a defective surface, replace the head.
3. Make a drive system test; run available diagnostic tests to verify proper operation of each disk drive.

DISK DRIVE EXERCISER

Maintenance checks and adjustment procedures can be performed online by using the controller or offline by using the Model 2140 Disk Drive Exerciser (see Figure 4-1).

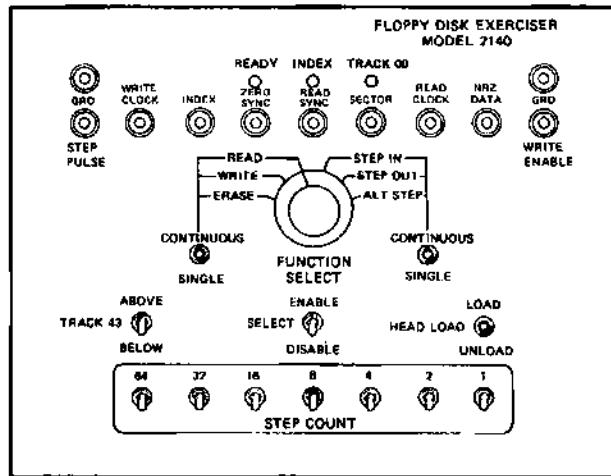

Figure 4-1. Model 2140 Disk Drive Exerciser

Controls, Indicators, and Test Points

The controls, indicators, and test points on the exerciser are described in Table 4-1.

Preparation for Offline Checkout

To set up the disk drive for checkout, proceed as follows:

1. Actuate the disk drive open control to disconnect the disk drive from the host controller.
2. Remove the interface paddle board from the rear edge connector of the disk drive.
3. Connect the exerciser to the disk drive with I/O cable 97420-026 that is supplied with the exerciser.
4. Verify that the exerciser is connected to the dc source (see Figure 4-2).
5. Verify that ac power is applied to the disk drive.
6. Set the controls on the exerciser to the positions indicated in Table 4-2.
7. Verify that power is applied to the exerciser.

TABLE 4-1. EXERCISER SWITCH, INDICATOR, AND TEST POINT FUNCTIONS

Switch, Indicator, or Test Point	Function
SWITCHES:	
FUNCTION SELECT	Rotary Switch: Selects operating mode.
CONTINUOUS/SINGLE (Right side)	Three-position Switch: In CONTINUOUS position, generates step in, step out, or alternate pulse train. In SINGLE position, produces single step pulse. In middle position, inactive.
CONTINUOUS/SINGLE (Left side)	Three-Position Switch: In CONTINUOUS position, writes encoded data on the disk from index or erases track of data, or reads data from disk sync with index. In SINGLE position, performs one-track read, write, or erase. In middle position, inactive.
SELECT	Two-Position Switch: In ENABLE position, selects disk drive, enabling I/O gates. In DISABLE position, deselects disk drive.
HEAD LOAD	Two-Position Switch: In LOAD position, causes disk to contact head. In UNLOAD position, retracts disk from head.
TRACK 43	Two-Position Switch: Causes lower write current to be produced in ABOVE (track 43) position.
STEP COUNT 1, 2, 4, 8, 16, 32, and 64	Two-position switches that specify the number of tracks to be traversed for a positioning operation.
INDICATORS:	
READY	When lighted, signifies: <ol style="list-style-type: none"> 1. Disk operational speed 2. Disk drive is selected 3. Voltages are normal 4. Floppy disk is loaded
INDEX	When lighted, indicates INDEX pulses are occurring.
TRACK 00	When lighted, indicates head is located over track 00.
TEST POINTS:	
STEP PULSE	Monitor for internally generated step pulses.
WRITE CLOCK	Monitor for write data output of exerciser
INDEX	Monitor for INDEX pulses produced by disk drive.
ZERO SYNC	Sync point for read-zero data
READ SYNC	Sync point to monitor read data
SECTOR	Monitor for sector pulses generated by disk drive
READ CLOCK	Monitor to observe read clock output of disk drive
NRZ DATA	Monitor to observe NRZ DATA output of disk drive
WRITE ENABLE	Monitor to observe write-protected signal

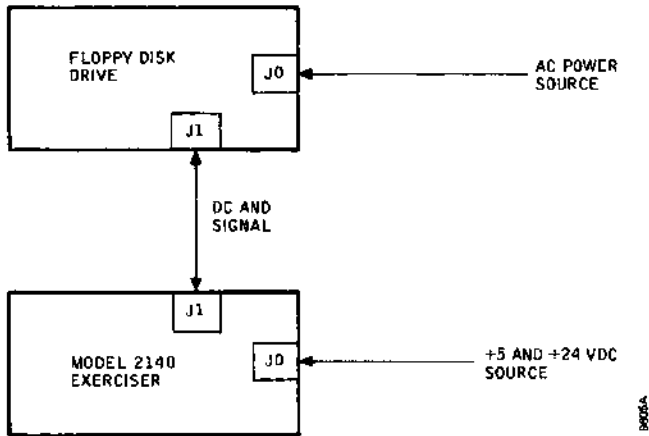

Figure 4-2. Exerciser and Disk Drive Setup

TABLE 4-2. INITIAL EXERCISER CONTROL SETTINGS

Control	Setting
HEAD LOAD switch	UNLOAD
SELECT switch	DISABLE
TRACK 43 switch	BELOW
FUNCTION SELECT switch	STEP IN
CONTINUOUS/SINGLE switches	Middle (neutral)

Disconnecting the Exerciser

To disconnect the exerciser, proceed as follows:

1. Set the controls on the exerciser to the positions indicated in Table 4-2.
2. Turn off power to both the exerciser and the disk drive.
3. Disconnect the exerciser I/O paddle board from the disk drive.
4. Store the exerciser, and return the disk drive to the online mode.
5. Connect the interface paddle board to the rear edge connector of the disk drive, if required.

MAINTENANCE PROCEDURES

The maintenance procedures are divided as follows:

- Check
- Adjustment
- Replacement

Note

The cognizant maintenance personnel should read the entire check, adjustment, or replacement procedure prior to performing the routine.

Tools and Test Equipment

The following materiel is required to perform the maintenance procedures:

- Common hand tools
- Flashlight
- Inspection mirror
- Cotton-tipped swabs (Q-tips)
- 95% isopropyl alcohol
- Freon TP
- Spring Gauge
- Gauze
- Alignment Diskette (CalComp P/N 17037-XXX)
- Voltohmmeter (VOM)
- Oscilloscope
- Disk Drive Exerciser, Model 2140

Plugs and Jacks

The interconnecting plugs and jacks are listed in Table 4-3 and identified in Figure 4-3. The connector pins should be checked for cleanliness and for total contact.

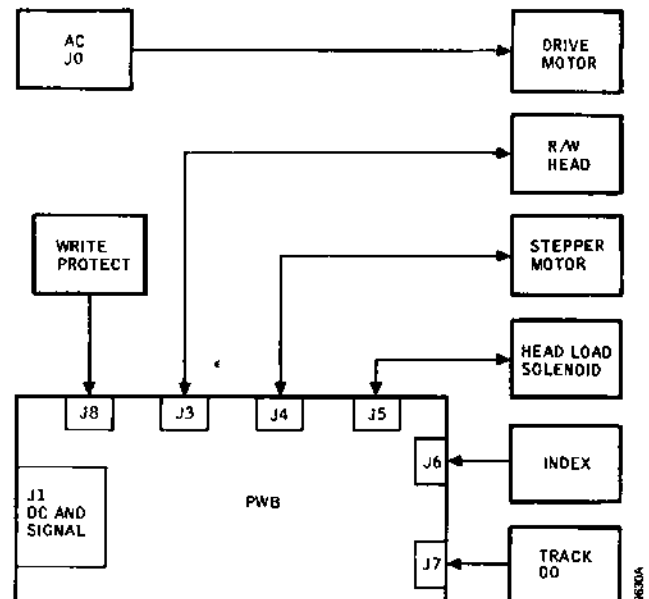

Figure 4-3. Disk Drive Interconnecting Cabling Diagram

TABLE 4-3. JACK AND PLUG DESCRIPTION

Connector	Function
J0	Ac power
J1	Dc power and signal
J3	Read/Write head
J4	Stepper motor
J5	Head load solenoid
J6	Index transducer
J7	Track 00 transducer
J8	Write-protect transducer

PWB Assembly, Data and Control

The disk drive electronics is contained on a single pwb assembly located on the underside of the chassis. All test points identified on the schematic are arranged along one side of the pwb as parallel solder lands. Even-numbered test points are located on the component side, while odd-numbered test points are located on the opposite side.

I/O connector J1 is used for controller or exerciser inter-connection through the paddle board connector. Dc voltage is supplied through pins of this connector by the interface unit.

PWB Replacement

To replace the pwb, proceed as follows:

1. Verify that dc and ac power to the disk drive are turned off.
2. Disconnect the I/O connector from the disk drive.
3. Remove the cover from the disk drive.
4. Remove the drive belt by using the procedure given under Drive Belt Replacement.
5. Mark and remove all connectors from the pwb.
6. Remove the screws that secure the pwb to the chassis.
7. Remove the pwb from the chassis by lifting it up; make sure that the pulley cutout clears the drive pulley.
8. Install the replacement pwb by reversing the procedural steps given above.

Power

Two dc voltages (+5v and +24v) and one ac drive voltage are applied to the disk drive from the controller. An internal shunt regulator develops a third dc level, +17 volts.

• Voltage Checks

WARNING

Exercise extreme care when the cover is removed and power is applied. The ac drive motor has voltages hazardous to personnel.

To check dc voltages, proceed as follows:

1. Remove the cover from the disk drive.
2. Using the oscilloscope, check the dc voltage levels at the following points:

Dc Voltage	Test Point
+24 vdc $\pm 7\%$	I/O connector J1-10
+5 vdc $\pm 2\%$	I/O connector J1-2
+17 vdc $\pm 5\%$	Test point 115

To check the ac voltage, proceed as follows:

1. Using a voltohmmeter, verify that the ac voltage between pins J0-1 and J0-3 (for phase-to-neutral) or between pins J0-1 and J0-2 and between J0-1 and J0-3 (for phase-to-phase) are within the limits specified in Table 4-4.

TABLE 4-4. POWER REQUIREMENTS

Ac Power	50 Hz ± 0.5 Hz 100 vac $\pm 10\%$, single phase 208 vac $\pm 10\%$, single phase 220 vac $\pm 10\%$, single phase 240 vac $\pm 10\%$, single phase
	60 Hz ± 0.5 Hz 100 vac $\pm 10\%$, single phase 115 vac $\pm 10\%$, single phase 208 vac $\pm 10\%$, single phase 230 vac $\pm 10\%$, single phase
Dc Power	+5 vdc $\pm 2\%$ at 0.5 ampere +24 vdc $\pm 7\%$ at 1.0 ampere

2. Using an oscilloscope, verify that the frequency is either 50 Hz ± 0.5 Hz or 60 Hz ± 0.5 Hz.

• Voltage Adjustment

No adjustments are provided for voltage levels.

If either the +24 vdc or the +5 vdc level is out of tolerance, check for internal loading by disconnecting the disk drive and checking the levels at the controller. If the levels are correct, check out the cable or isolate the trouble to a defective component on the pwb. If necessary, replace the pwb.

Drive System

The drive system comprises a drive motor and belt, an index transducer, and associated electronics (see Figure 4-4).

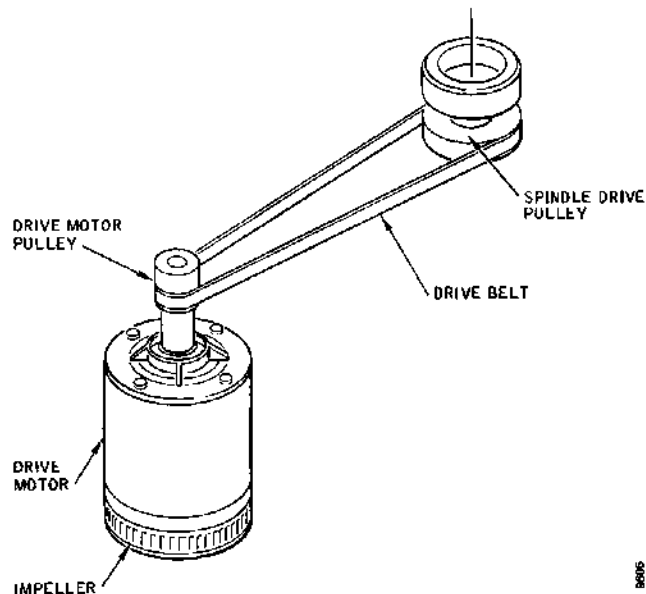

Figure 4-4. Drive System Component Identification

● Drive Motor and Belt Checks

To check the drive motor and belt, proceed as follows:

1. Turn ac and dc power off.
2. Remove the cover from the disk drive.
3. Inspect the drive belt for wear, particularly for fraying around its edges. If the belt is worn or frayed, replace it.
4. Rotate the drive motor manually. If binding is evident, replace the motor.
5. Verify that belt tension is 2.5 to 3.0 pounds (Figure 4-5). If tension is not as specified, perform the Drive Belt Tension Adjustment.
6. Turn ac power on.
7. Verify that the drive belt tracks in the center of both the drive motor and the spindle drive pulleys. If not as specified, perform the Drive Belt Tracking Adjustment.

● Drive Belt Tension Adjustment

To adjust drive belt tension, proceed as follows:

1. Turn ac power off.
2. Loosen the four drive motor mounting nuts (see Figure 4-5).

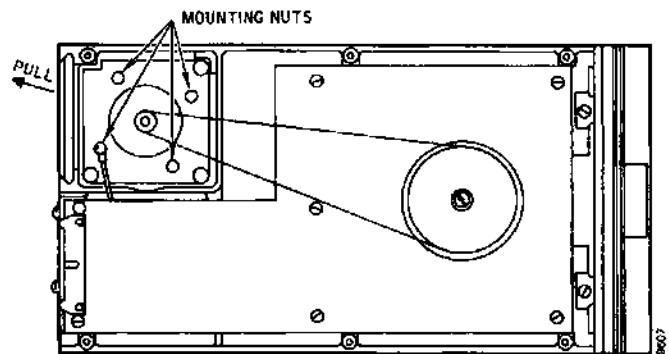

Figure 4-5. Drive Belt Checks and Adjustments

3. Using a spring gauge, move the motor until belt tension is 2.5 to 3.0 pounds.
4. Tighten the four drive motor mounting nuts to maintain the tension of step 3.

● Drive Belt Tracking Adjustment

To adjust drive belt tracking, proceed as follows:

1. Turn ac power on.
2. Observe whether the drive belt tracks high or low.
3. Turn ac power off.
4. Loosen the setscrew on the drive motor pulley.
5. If the belt tracks high, raise the pulley on the shaft.
6. If the belt tracks low, lower the pulley on the shaft.
7. Tighten the setscrew on the drive motor pulley.
8. Repeat these steps until the belt tracks in the center of both pulleys.

● Drive Belt Replacement

To replace the drive belt, proceed as follows:

1. Turn ac power off.
2. Slide the drive belt from the drive motor pulley.
3. Clean the surfaces of the motor and spindle drive pulleys by wiping them sparingly with alcohol.

4. Loosen the four drive motor mounting nuts (see Figure 4-5).
5. Install the replacement belt.
6. Using a spring gauge, move the motor until belt tension is 4.0 to 5.0 pounds.
7. Tighten the four drive motor mounting nuts.
8. Perform the belt tension and tracking adjustments after the new belt has run for several hours.

● **Drive Motor Replacement**

To replace the drive motor, proceed as follows:

1. Turn ac power off.
2. Remove the drive belt from the drive motor pulley.
3. Loosen the impeller setscrew, then remove the impeller.
4. Remove J0 and the J0 ground strap from the chassis.
5. Remove the four drive motor mounting nuts (see Figure 4-5).
6. Remove the drive motor.
7. Loosen the drive motor pulley setscrew, then remove the pulley.
8. Verify that the replacement motor and the defective motor have identical part numbers.
9. Mount the replacement motor on the motor mounting plate.
10. Install J0 and the J0 ground strap.
11. Install the impeller and adjust it for 0.04 (+0.03, -0.00) inch clearance between the impeller and disk drive casting.
12. Install the drive motor pulley.
13. Install the drive belt.
14. Perform the drive belt tension and tracking adjustments.

● **Head Alignment**

To align the head, proceed as follows:

1. Connect the exerciser to the disk drive and apply power.
2. Set the following switches on the exerciser to the positions indicated:
 - STEP COUNT – All switches down
 - HEAD LOAD to UNLOAD
 - SELECT to DISABLE
 - TRACK 43 to BELOW
 - CONTINUOUS/SINGLE to center position
 - FUNCTION SELECT to READ
3. Insert the head alignment diskette (label facing the handle).
4. Close the handle, and verify that the READY indicator lights.
5. Set the SELECT switch on the exerciser to ENABLE and verify that the INDEX indicator lights.
6. Set the STEP COUNT switches for a count of 38 (switches 32, 4, and 2 up).
7. Set the FUNCTION SELECT switch to STEP OUT.
8. Set the CONTINUOUS/SINGLE switch on the right of the exerciser to CONTINUOUS until the TRACK 00 indicator lights, then place the switch in its center position.
9. Set the FUNCTION SELECT switch to STEP IN and depress the CONTINUOUS/SINGLE switch (right side) to SINGLE momentarily.
10. Set the HEAD LOAD switch to LOAD.
11. Monitor the *cat-eyes* alignment waveform on track 38 (see Figure 4-6). The amplitude of the two lobes displayed should be within 80% of each other.
12. If the amplitudes of the two lobes are not within 80% of each other, loosen the three stepper motor mounting screws.
13. Rotate the stepper motor radially in order to move the head in or out. If the left lobe is less than 80% of the right lobe, rotate the stepper motor clockwise. If the right lobe is less than 80% of the left lobe, rotate the stepper motor counterclockwise.

SYNC: INT NEG 10 ms (uncal)
 CHAN 1: AC 0.05v TP99 L1
 CHAN 2: AC 0.05v TP101 L2
 MODE: Algebraic add and inverted

NOTE: Use the sweep time base and horizontal positioning to place the crossover on the left and right graticules.

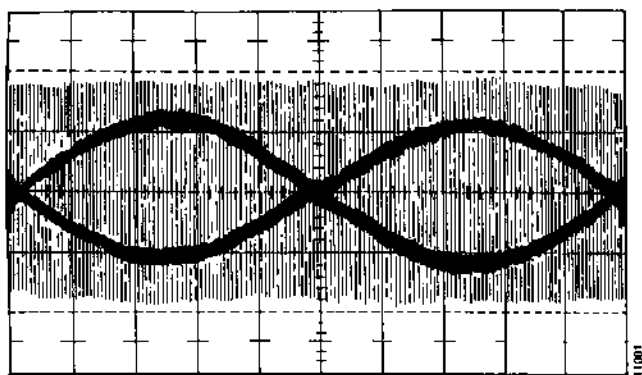

Figure 4-6. Head Alignment Waveform

14. When the lobes are equal, tighten the stepper motor mounting screws.
15. Set the HEAD LOAD switch to UNLOAD.
16. Set the FUNCTION SELECT switch to STEP OUT and depress the CONTINUOUS/SINGLE switch on the right side of the exerciser to SINGLE momentarily.
17. Set the FUNCTION SELECT switch to STEP IN and depress the CONTINUOUS/SINGLE switch on the right side of the exerciser to SINGLE momentarily.
18. Set the HEAD LOAD switch to LOAD, and verify that the lobes of the *cat-eyes* waveform are within at least 80% of each other. If not, repeat steps 12 thru 18 until they are.
19. Step in to track 76, then step out to track 38. The signal lobes should be within 80% of each other. If not, adjust the stepper motor so that the lobes are within 80% of each other after stepping both in and out to track 38.

Note

Whenever the head alignment procedure is performed, the Track 00 adjustment must be checked.

• **Index Transducer Alignment**

To align the index transducer, proceed as follows:

1. Connect channel 1 of the oscilloscope to J6-4.
2. Adjust the index LED (located in the cone lift cover) for maximum pulse amplitude.
3. Turn power off.

Note

The following step is not required for the Model 142, since it has an access hole through which this alignment can be performed.

4. Remove the pwb from the chasis while maintaining all electrical connections and ensuring that no shorting will occur.
5. Connect the exerciser to the disk drive and apply power.
6. Insert the head alignment diskette, close the handle, and verify that the READY indicator on the exerciser lights.
7. Set the exerciser to step the disk drive to track 1.
8. On the exerciser, set the FUNCTION SELECT switch to READ, the SELECT switch to ENABLE, the HEAD LOAD switch to LOAD, and the CONTINUOUS/SINGLE switch (left side) to CONTINUOUS.
9. Verify that the signal burst (on the alignment diskette) occurs 200 ± 100 microseconds after the start of sweep (index pulse). See Figure 4-7.

SYNC: EXT NEG 50 μ sec 10A6 (amplified index pulse)

CHAN 1: AC 200 mv TP99 L1

CHAN 2: AC 200 mv TP101 L2

MODE: Algebraic add and inverted

NOTE: Leading edge of the signal burst is $200 \pm 100 \mu$ s from start of sweep for Model 140 or 200 $\pm 50 \mu$ s for Model 142.

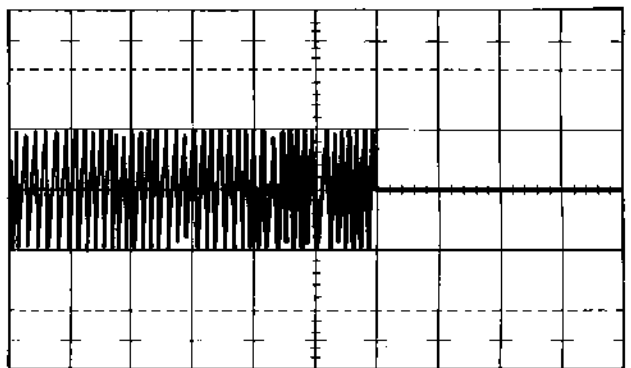

Figure 4-7. Index Pulse Timing Waveform

10. If the signal burst does not occur within the proper time frame, adjust the index transducer assembly to obtain the proper indication.

Note

Ensure that the transducer assembly is seated properly against the registration surface on the base casting.

11. Repeat steps 6 thru 9 until the proper timing is obtained.
12. Set the exerciser to step the disk drive to track 76, and verify the timing (same as in step 9).
13. If the index transducer assembly had to be adjusted to obtain proper timing, repeat steps 1 thru 3.
14. Jiggle the load handle on the disk drive. If the **READY** indicator goes out, the index transducer is not aligned properly. Repeat the alignment procedure.
15. Reinstall the pwb if it was removed in Step 4.

• **Index Transducer Alignment with Hard-Sector Option**

To align the index transducer in disk drives having the hard-sector option, proceed as follows:

1. Connect channel 1 of the oscilloscope to J6-4.
2. Adjust the index LED (located in the cone lift cover) for maximum pulse amplitude.
3. Turn power off.

Note

The following step is not required for the Model 142, since it has an access hole through which this alignment can be performed.

4. Remove the pwb from the chassis while maintaining all electrical connections and ensuring that no shorting will occur.
5. Connect the exerciser to the disk drive and apply power.
6. Insert the hard-sector alignment diskette and close the handle.
7. Set the exerciser to step the disk drive to track 1.

8. On the exerciser, set the **FUNCTION SELECT** switch to **READ**, the **SELECT** switch to **ENABLE**, the **HEAD LOAD** switch to **LOAD**, and the **CONTINUOUS/SINGLE** switch (left side) to **CONTINUOUS**.
9. Verify that the signal burst (on the alignment diskette) occurs 200 ± 50 microseconds after the start of sweep (index pulse). See Figure 4-8.

SYNC: EXT NEG 50 μ s 12A6 (INDEX/ signal)
CHAN 1: AC 200 mv TP99 L1
CHAN 2: AC 200 mv TP101 L2
MODE: Algebraic add and inverted
NOTE: Leading edge of the signal burst is 200 ± 50 microseconds from start of sweep.

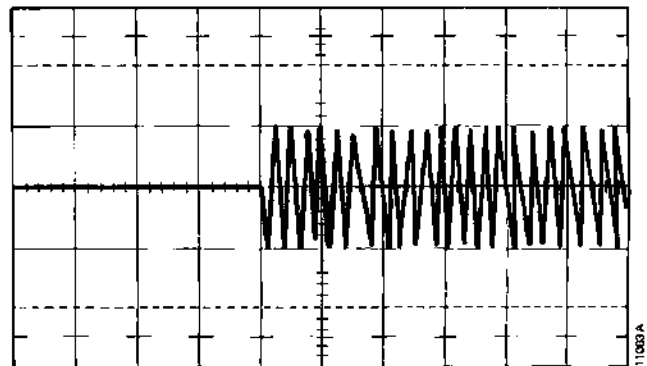

Figure 4-8. Index Pulse with Hard-Sector Option Timing Waveform

11. If the signal burst does not occur within the proper time frame, adjust the index transducer assembly to obtain the proper indication.

Note

Ensure that the transducer assembly is seated properly against the registration surface on the base casting.

12. Repeat steps 6 thru 11 until the proper timing is obtained.
13. Set the exerciser to step the disk drive to track 76.
14. Verify the timing (same as in step 10).

1. Remove the cover from the disk drive.
2. Remove the cone lift cover handle; allow the cone lift cover to pivot to a 45-degree angle.
3. Remove the retaining ring that secures the centering cone to the cone lift cover.
4. Install and secure the replacement centering cone.
5. Replace the cone lift cover.

● **Drive Hub Assembly Replacement**

To replace the drive hub assembly, proceed as follows:

1. Remove the cone lift cover by using the procedure given under Cone Lift Cover Replacement.
2. Remove the single screw that secures the drive pulley and drive hub to the drive hub bearing assembly.
3. Remove the three screws that secure the bearing hold-down plate to the disk drive casting.
4. Remove the upper and lower bearings by using hand pressure.
5. Remove the inner and outer bearing spacer and spring washer.

6. Inspect all parts for wear, and replace any defective part.
7. Clean the drive hub parts and bore thoroughly with alcohol.
8. Reassemble the drive hub assembly by reversing the steps above.

Position System

The positioning system comprises a stepper motor, head carriage assembly, and track 00 transducer (see Figure 4-10).

● **Stepper Motor Alignment**

To align the stepper motor, proceed as follows:

1. Turn off ac and dc power.
2. Remove the cover from the disk drive.
3. Perform the Head Alignment procedure.

● **Stepper Motor Replacement**

To replace the stepper motor, proceed as follows:

1. Remove the cone lift cover by using the Cone Lift Cover Replacement procedure.

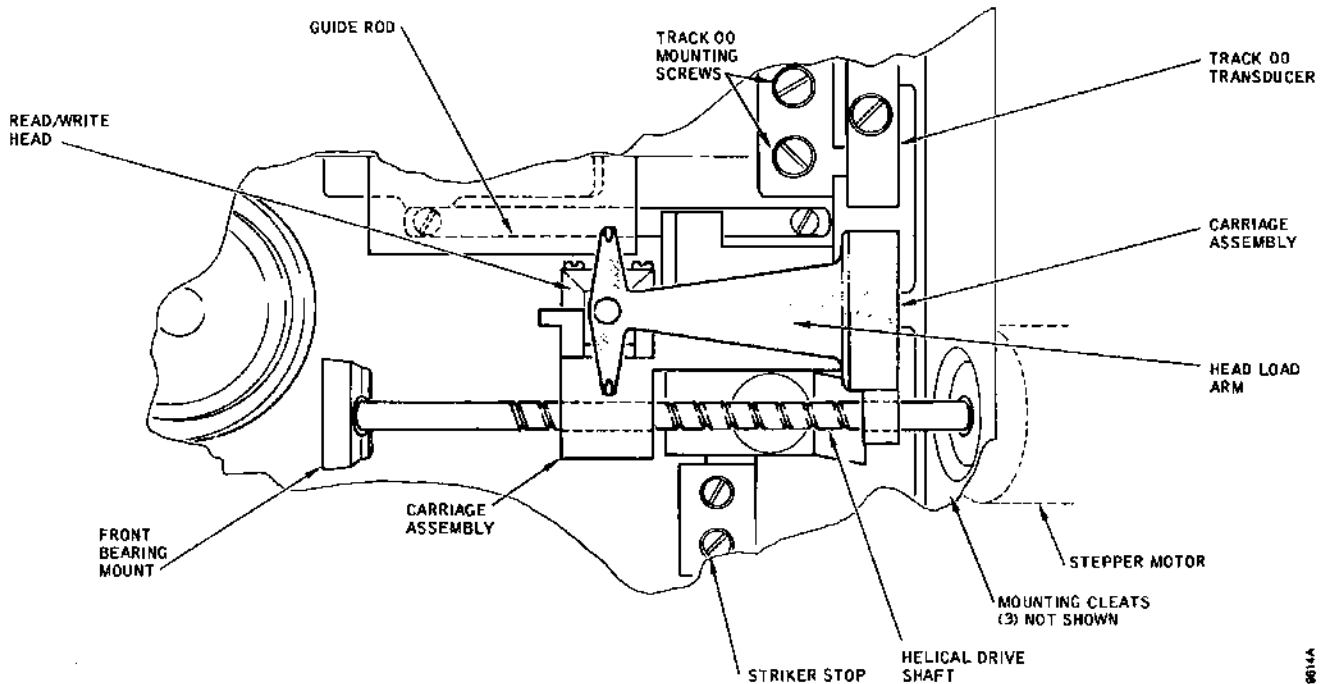

Figure 4-10. Positioning System Component Identification

15. If the index transducer assembly had to be adjusted to obtain proper timing, repeat steps 1 thru 3.
16. Reinstall the pwb if it was removed in step 4.

● Index Transducer Replacement

To replace the index transducer, proceed as follows:

1. Turn ac and dc power off.
2. Unplug the index transducer cable from the pwb (J6).
3. Remove the index transducer mounting screw, and lift the index transducer out.
4. To install the replacement index transducer, reverse this procedure.
5. Perform the Index Transducer Alignment.

Spindle System

The spindle system engages the floppy disk with the disk drive. The spindle comprises the cone lift assembly and drive hub assembly (see Figure 4-9).

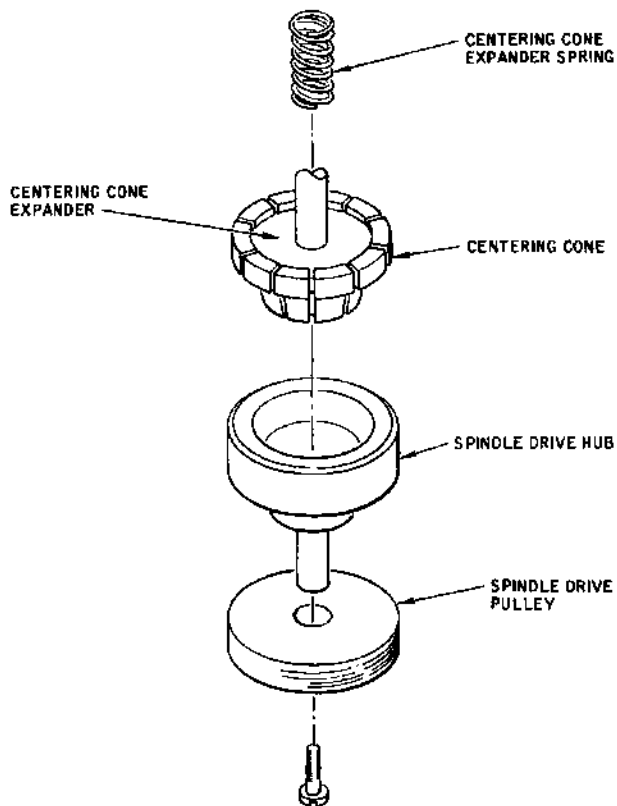

Figure 4-9. Spindle System Component Identification

● Cone Lift Cover Replacement

To replace the cone lift cover, proceed as follows:

1. Remove the top cover from the disk drive.
2. Remove the two screws that secure the handle to the cone lift cover.
3. Disconnect jacks P5 and P6 from the pwb assembly.

Note

The cone lift cover is connected to the disk drive by a shoulder screw on either side that is inserted through coil springs. When the shoulder screws are released, the coil springs will fly out unless the cover is held in place.

4. Hold the cone lift cover in place while removing one shoulder screw from each side.
5. Carefully slide the cone lift cover from the disk drive; allow the tangs of the coil springs to become free of casting grooves.
6. Remove the two nuts that secure the head load relay assembly to the cone lift cover. Disengage the head load wires from the clips at the rear of the cone lift cover.
7. Remove the two screws that secure the index transducer LED to the cone lift cover. Disengage the index transducer LED wires from the clips at the rear of the cone lift cover.
8. Remove one retaining ring that holds the centering cone to the cone lift cover.
9. Reinstall the components removed in steps 6 thru 8 on the replacement cone lift cover.
10. Insert the coil springs into the cone lift cover and preload them one-half turn.
11. Guide the tangs of the coil springs into the casting grooves while sliding the cone lift cover into place.
12. Install the two shoulder screws.
13. Reinstall the handle assembly.
14. Reinstall the cover.

● Centering Cone Replacement

To replace the centering cone, proceed as follows:

● Carriage Assembly Replacement

To replace the carriage assembly, proceed as follows:

1. Verify that ac and dc power to the disk drive are turned off.
2. Remove the cover from the disk drive.
3. Remove the stepper motor by using the Stepper Motor Replacement procedure.
4. Remove the carriage assembly.
5. Install the replacement carriage assembly by reversing the above steps.
6. At the completion of installation, perform the Head Alignment and Head Load Check and Adjustment procedures and Track 00 Transducer Adjustment procedure.

Read/Write System

The read/write head is mounted on the carriage assembly and is not replaceable as a unit. The complete carriage assembly must be replaced if it is determined to be defective.

The head load assembly operates in conjunction with the read/write head by allowing the spring-loaded read/write head to contact the recording surface of the disk.

● Head Load Check and Adjustment

To check and adjust head loading, proceed as follows:

1. Turn off ac and dc power.
2. Remove the cover from the disk drive.
3. Insert a 0.015-inch, plastic shim between the head and load arm (see Figure 4-12).

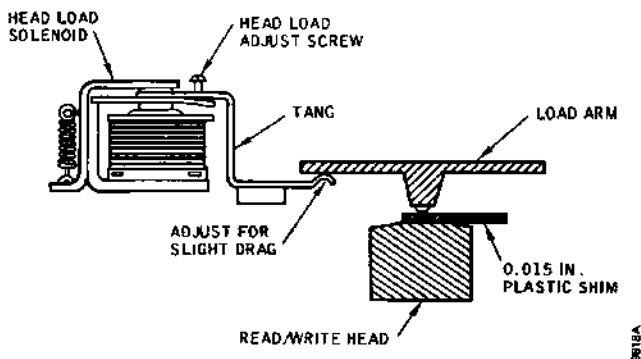

Figure 4-12. Head Load Check and Adjustment

4. Verify that the tang of the head load solenoid just contacts the load arm.
5. If it is adjusted incorrectly, set the Head Load Adjust screw (Figure 4-12) for a slight drag between the tang on the solenoid and the load arm.
6. Tighten the locknut on head load adjustment.
7. Install the exerciser.
8. Turn on ac and dc power; install a floppy disk.
9. Toggle the HEAD LOAD switch; observe that the head load solenoid is energized and deenergized.

● Head Load Solenoid Replacement

To replace the head load solenoid, proceed as follows:

1. Turn off ac and dc power.
2. Remove the cone lift cover by using the Cone Lift Cover Replacement procedure.
3. Disconnect the head load solenoid wires from the pwb (J5).
4. Remove the two nuts that hold the head load solenoid to the cone lift cover.
5. Install the replacement solenoid by reversing the procedure.
6. Perform the Head Load Check and Adjustment procedure.

● Data Separator Check and Adjustment

To check and adjust the data separator, proceed as follows:

1. Turn off ac and dc power to the disk drive.
2. Install the exerciser.
3. Load a scratch floppy disk.
4. Remove the cover from the disk drive.
5. Turn on ac and dc power to the disk drive and exerciser.
6. Set the exerciser switches as follows:
 - SELECT to ENABLE
 - FUNCTION SELECT to STEP OUT
 - CONTINUOUS/SINGLE (right) to CONTINUOUS

2. Remove the bottom cover from the disk drive assembly.
3. Remove the screw near the front bearing from the helix shaft (see Figure 4-10).
4. Remove the three screws, washers, and cleats that secure the stepper motor to the disk drive assembly.
5. Rotate the helix shaft to disengage the stepper motor from the read/write carriage assembly.
6. Disconnect plug J4 from the pwb assembly, then remove the stepper motor.
7. Reverse the procedure above to install the replacement stepper motor; however, observe the following:
 - Apply lubricant grease P/N 91447-001 sparingly to the helix shaft.
 - Thread the helix shaft through the stylus guide while holding the guide in place with the read/write carriage assembly.
 - Tighten the stepper motor mounting cleats.
8. At the completion of the installation, perform the Stepper Motor Alignment procedure.

• Track 00 Transducer Adjustment

To adjust the track 00 transducer, proceed as follows:

1. Remove the cone lift cover using the procedure given under Cone Lift Cover Replacement.
2. Connect the exerciser to the disk drive, and apply power.
3. Set the following switches on the exerciser to the positions indicated below:
 - HEAD LOAD to UNLOAD
 - SELECT to ENABLE
 - FUNCTION SELECT to ALT STEP
 - STEP COUNT to 1 (switch 1 up, all others down)
 - CONTINUOUS/SINGLE (right side) to CONTINUOUS
4. Verify visually that the TRACK 00 indicator on the exerciser is going on and off.
5. Install an IC tester clip on IC 15A and one on IC 19A.

6. Verify that the track 00 pulse (channel 2) goes high between four and five divisions (4 to 5 milliseconds) after the step out (channel 1). See Figure 4-11.

SYNC: INT NEG 1 ms Chan 1 only
 CHAN 1: DC 2v/div 15A3 Step out pulse -- negative
 CHAN 2: DC 2v/div 19A11 Track 00 output -- positive
 MODE: Chopped

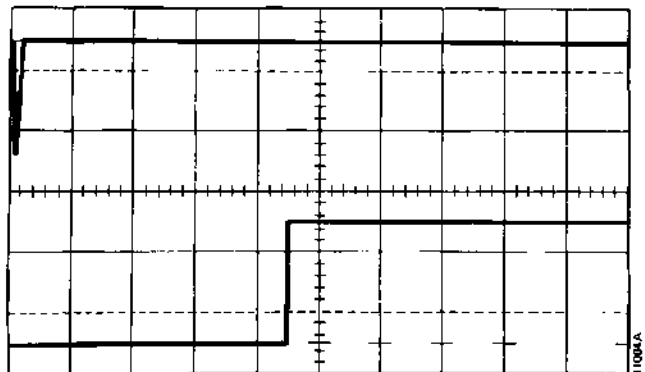

Figure 4-11. Track 00 Alignment Waveform

7. If the proper waveform cannot be obtained, set the head to track 00.
 8. Turn power off, and adjust the track 00 transducer as necessary.
- CAUTION**
- Only slight movement is required to adjust the transducer.*
9. Perform steps 3 thru 8 until the proper waveform is obtained.
 10. If adjustment was necessary, verify head alignment at track 38.

• Track 00 Transducer Replacement

To replace the track 00 transducer, proceed as follows:

1. Remove the cone lift cover by using the Cone Lift Cover Replacement procedure.
2. Remove the pwb.
3. Remove the two screws that hold the track 00 transducer to the disk drive assembly.
4. Replace the track 00 transducer by reversing the above step.

When the TRACK 00 indicator lights, set the switches as follows:

- CONTINUOUS/SINGLE (right) to center position
- CONTINUOUS/SINGLE (left) to CONTINUOUS
- HEAD LOAD to LOAD
- FUNCTION SELECT to WRITE

The exerciser will write 70 milliseconds of zeros followed by 70 milliseconds of ones. Then set FUNCTION SELECT to READ.

7. Monitor the data separator one-shot (see Figure 4-13).

PROG: Data Separator One-Shot
 SYNC: INT POS 1.0 μ s
 CHAN 1: 1 Dc 2.0v A23-6 One-Shot Output
 MODE: CHAN 1 only
 NOTE: Pulse width is $2.7 \pm 0.1 \mu$ s for Model 142,
 $3.0 \pm 0.1 \mu$ s for Model 140

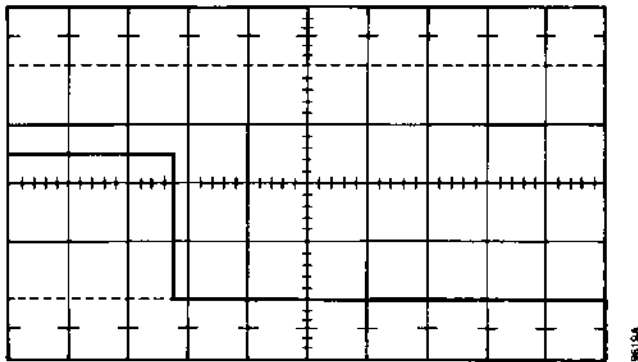

Figure 4-13. Data Separator One-Shot Alignment Waveform

8. If the output of the data separator one-shot is incorrect, adjust potentiometer R103.

Data Decoder with PLO Board Adjustments

The Data Decoder with PLO (phase-locked oscillator) board may be used with the Model 140 and the Model 142 at the option of the customer. The part number of the Data Decoder with PLO Board used with the Model 140 is

15967-001; part number 17032-001 is used with the Model 142. The Data Decoder with PLO Board is normally installed in the controller.

To adjust the Data Decoder with PLO Board, proceed as follows:

1. If not already connected together in its normal environment, connect pin 28 to pin 30 (pin 26 to pin 30 for Model 142).
2. Apply power.
3. Adjust frequency.
 - Monitor pin 28 (pin 26 for Model 142) with a frequency counter.
 - Adjust potentiometer R17 (FREQ) for 500 ± 4 kHz ($1.0 \text{ MHz} \pm 8$ kHz for Model 142).
 - Check the voltage at A15-6 to ensure that it is $+15 \pm 2.0$ volts.
4. Adjust the data decoder.
 - If not present, inject a 250 ± 5 kHz (500 ± 10 kHz for Model 142) logic level (low = 0.0v to 0.8v; high = 2.0v to 5.5v) square wave at pin 08 (DATA IN).
 - Adjust potentiometer R5 (WN) such that the rising edges of the signal at pin 45 (DATA) occur at the middle of the low state of the signal at pin 49 (WINDOW). Refer to Figure 3-47 for Model 140 and to 3-46 for Model 142.
 - Short pin 35 (READ SYNC) to ground (pin 57).
 - Observe pin 37 (DATA/); the signal should be high.
 - Observe pin 33 (CLOCK/); the frequency should be 250 ± 5 kHz (500 ± 10 kHz for Model 142) and in sync with the input signal (pin 08).

<u>Model</u>	<u>Usage Code</u>
140B, 100 vac, 50 Hz	D
140B, 208/220 vac, 50 Hz	E
140B, 240 vac, 50 Hz	F
140C, 115 vac, 60 Hz	G
140C, 230 vac, 60 Hz	H
140C, 220 vac, 50 Hz	J
140C, 240 vac, 50 Hz	K
140C, 100 vac, 60 Hz	L
140C, 208 vac, 60 Hz	M
140C, 100 vac, 50 Hz	N
140C, 208 vac, 50 Hz	O
140D, 115 vac, 60 Hz	P
140D, 230 vac, 60 Hz	Q
140D, 220 vac, 50 Hz	R
140D, 240 vac, 50 Hz	S
140D, 100 vac, 60 Hz	T
140D, 208 vac, 60 Hz	U
140D, 100 vac, 50 Hz	V
140D, 208 vac, 50 Hz	W
142, 115 vac, 60 Hz	X
142, 230 vac, 60 Hz	Y
142, 220 vac, 50 Hz	Z
142, 240 vac, 50 Hz	AA
142, 100 vac, 60 Hz	AB
142, 208 vac, 60 Hz	AC
142, 100 vac, 50 Hz	AD
142, 208 vac, 50 Hz	AE

PURCHASED PARTS

Many parts used in the disk drives may be obtained directly from a vendor.

Purchased parts will also be supplied by CalComp on receipt of an order specifying the part number as shown in this section. The inclusion of the model designation (such as Model 140) and the figure and item number for each part ordered will ensure positive identification of parts.

ACCESSORIES

The following accessories are available for use with the Disk Drives.

14066-001	Package, Exerciser
12067-001	Exerciser Assy, Model 2140
12891-001	Cover, Impeller
18059-001	Kit, Write Protect
18514-001	Kit, Mounting Hardware
18515-001	Kit, Connector Interface
14028-001	Field Data Package
14028-002	Field Data Package

Note

Before using this section, check the unit part number carefully to determine which options are incorporated in the unit. (See Table 5-1).

SECTION 5

ILLUSTRATED PARTS BREAKDOWN

This section contains an illustrated parts breakdown that describes and illustrates all replaceable parts for Model 140, 140B, 140C, 140D and 142 Disk Drives. The illustrated parts breakdown consists of a Group Assembly Parts List and Figures 5-1 thru 5-7 that illustrate the component parts of disk drives and their physical relationships. The component parts are listed in disassembly order with each having an assigned item number. The item number is shown on the accompanying illustration, which portrays its physical location within the assembly.

This section also contains an illustrated parts breakdown for Data Decoder with PLO Board Assemblies, VR71 and VR81. These two assemblies are normally used with Model 140 and 142 Disk Drives, respectively. However they are not part of the disk drives.

This section contains a listing of all items necessary to support the maintenance and overhaul effort for Model 140, 140B, 140C, 140D, and 142 Disk Drives. This illustrated parts breakdown is intended for use in requisitioning, storing, issuing, and identifying replacement parts. This section also illustrates assembly and disassembly relationships.

GROUP ASSEMBLY PARTS LIST

The Group Assembly Parts List consists of a complete breakdown of a disk drive into subassemblies and detailed parts. Each assembly is listed in its order of disassembly and is followed immediately by its component parts properly indented to show their relationships to the assembly. The Group Assembly Parts List is divided into five columns of information as follows:

- Figure and Item Number
- Part Number
- Description
- Quantity Per Assembly
- Usage Code

FIGURE AND ITEM NUMBER

The figure number relates the parts list to its associated illustration. The item number assigned to each part is shown on the illustration to show physical location.

PART NUMBER

The Part Number column lists part numbers of all parts that are replaceable in the unit. Items without a part number are listed as No Number. The notation xxx, when used with a part number, indicates various part parameters, such as cable lengths.

DESCRIPTION

Description includes designated and descriptive information necessary to adequately define the items. Entries are indented to indicate their relationship to the next higher assembly. The subheading Attaching Parts within this column lists those parts used for attaching the immediately preceding item, unless otherwise indicated.

The symbol - - * - - signifies the end of the attaching parts for the preceding item(s). The symbol NHA refers to the Next Higher Assembly, U/O indicates Used on, NFS indicates Not Furnished Separately, and N/I indicates that the item is Not Illustrated.

QUANTITY PER ASSEMBLY

The Quantity Per Assembly column contains the number of parts required for each assembly or subassembly. The letters A/R denote that the selection of a part, or parts, should be made As Required. REF refers to an assembly or item that is shown completely assembled in a preceding illustration or the item is listed for reference only.

USAGE CODE

The Usage Code column lists part variations within different models, assemblies, or subassemblies of the same equipment. In cases where the column is blank, the listed part will apply to all models, assemblies, or subassemblies listed in this publication.

Items designed for more than one configuration are coded for usability. Codes used in this publication are as follows:

<u>Model</u>	<u>Usage Code</u>
140, 115 vac, 60 Hz	A
140, 208/230 vac, 60 Hz	B
140, 100 vac, 60 Hz	C

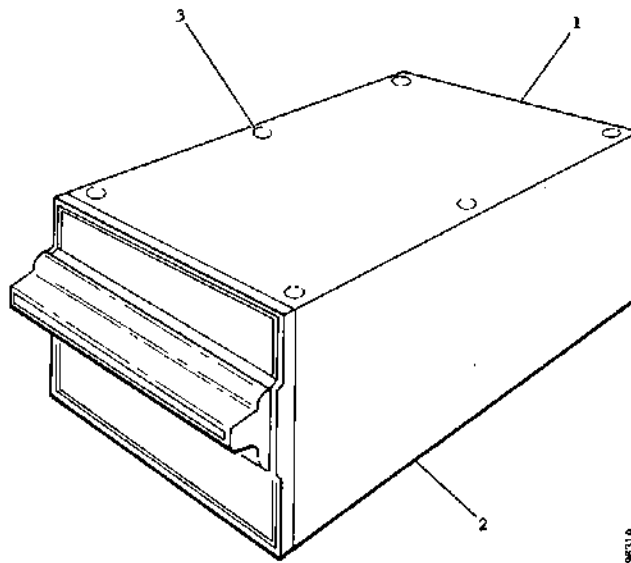
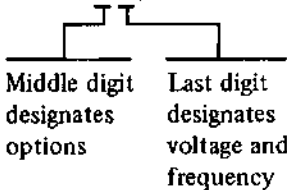

Figure 5-1. Model 140 Series and 142 Disk Drive Unit (Sheet 1 of 2)

FIGURE ITEM NO.	PART NUMBER	DESCRIPTION	QTY PER ASSY	USAGE CODE
1-	11700-0X1	Disk Drive Unit, Model 140, 115 fac, 60 Hz	REF	A
	11700-0X2	Disk Drive Unit, Model 140, 208/230 vac, 60 Hz	REF	B
	11700-0X5	Disk Drive Unit, Model 140, 100 vac, 60 Hz	REF	C
	18778-0X4	Disk Drive Unit, Model 140B, 100 vac, 50 Hz	REF	D
	18778-0X5	Disk Drive Unit, Model 140B, 208/220 vac, 50 Hz	REF	E
	18778-0X6	Disk Drive Unit, Model 140B, 240 vac, 50 Hz	REF	F
	14700-001	Disk Drive Unit, Model 140C, 115 vac, 60 Hz	REF	G
	14700-002	Disk Drive Unit, Model 140C, 230 vac, 60 Hz	REF	H
	14700-003	Disk Drive Unit, Model 140C, 220 vac, 50 Hz	REF	J
	14700-004	Disk Drive Unit, Model 140C, 240 vac, 50 Hz	REF	K
	14700-005	Disk Drive Unit, Model 140C, 100 vac, 60 Hz	REF	L
	14700-006	Disk Drive Unit, Model 140C, 208 vac, 50 Hz	REF	M
	14700-007	Disk Drive Unit, Model 140C, 100 vac, 50 Hz	REF	N
	14700-008	Disk Drive Unit, Model 140C, 208 vac, 50 Hz	REF	O
	14300-001	Disk Drive Unit, Model 140D, 115 vac, 60 Hz	REF	P
	14300-002	Disk Drive Unit, Model 140D, 230 vac, 60 Hz	REF	Q
	14300-003	Disk Drive Unit, Model 140D, 220 vac, 50 Hz	REF	R
	14300-004	Disk Drive Unit, Model 140D, 240 vac, 50 Hz	REF	S
	14300-005	Disk Drive Unit, Model 140D, 100 vac, 60 Hz	REF	T
	14300-006	Disk Drive Unit, Model 140D, 208 vac, 60 Hz	REF	U
	14300-007	Disk Drive Unit, Model 140D, 100 vac, 50 Hz	REF	V
	14300-008	Disk Drive Unit, Model 140D, 208 vac, 50 Hz	REF	W
	18411-0X1	Disk Drive Unit, Model 142, 115 vac, 60 Hz	REF	X
	18411-0X2	Disk Drive Unit, Model 142, 230 vac, 60 Hz	REF	Y

TABLE 5-1. UNIT OPTIONS

Unit Part Number/Model	Dash No.	Voltage/Frequency	Models
11700-0XX /140	-0X1 -0X2 -0X5	115 vac, 60 Hz 208/230 vac, 60 Hz 100 vac, 60 Hz	Model 140
18778-0XX /140B	-0X4 -0X5 -0X6	100 vac, 50 Hz 208/220 vac, 50 Hz 240 vac, 50 Hz	Model 140B
14700-00X /140C 14300-00X /140D	-001 -002 -003 -004 -005 -006 -007 -008	115 vac, 60 Hz 230 vac, 60 Hz 220 vac, 50 Hz 240 vac, 50 Hz 100 vac, 60 Hz 208 vac, 60 Hz 100 vac, 50 Hz 208 vac, 50 Hz	Models 140C & 140D
18411-0XX /142 	-0X1 -0X2 -0X3 -0X4 -0X5 -0X6 -0X7 -0X8	115 vac, 60 Hz 230 vac, 60 Hz 220 vac, 50 Hz 240 vac, 50 Hz 100 vac, 60 Hz 208 vac, 60 Hz 100 vac, 50 Hz 208 vac, 50 Hz	Model 142
	Dash No.	Options	
-00X	None		
-01X	Hard Sector		
-02X	Write Protect		
-03X	Hard Sector and Write Protect		
-04X	Basic Drive index aligned to hard sector spec no. 12994		
-05X	Write Protect with index aligned to hard sector spec no. 12994		
-06X	Basic Drive with index aligned to hard sector spec no. 12994 and one-shot data separator.		

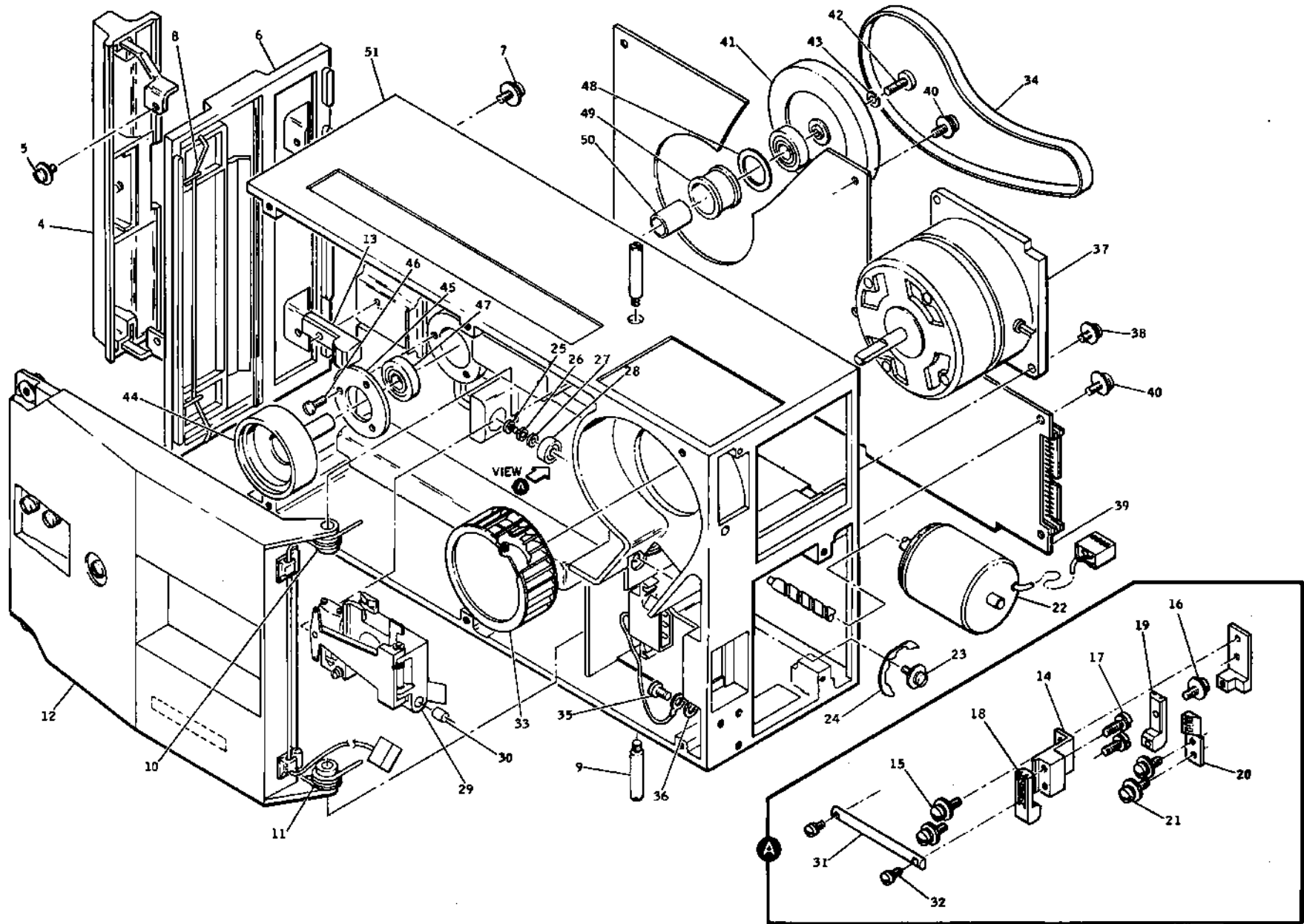

Figure 5-1. Model 140 and 142 Disk Drive Unit (Sheet 2 of 2)

FIGURE ITEM NO.	PART NUMBER	DESCRIPTION	QTY PER ASSY	USAGE CODE
1-	18411-0X3	Disk Drive Unit, Model 142, 220 vac, 50 Hz	REF	Z
	18411-0X4	Disk Drive Unit, Model 142, 240 vac, 50 Hz	REF	AA
	18411-0X5	Disk Drive Unit, Model 142, 100 vac, 60 Hz	REF	AB
	18411-0X6	Disk Drive Unit, Model 142, 208 vac, 60 Hz	REF	AC
	18411-0X7	Disk Drive Unit, Model 142, 100 vac, 50 Hz	REF	AD
	18411-0X8	Disk Drive Unit, Model 142, 208 vac, 50 Hz	REF	AE
-1	13810-001	. Cover, Disk Drive	1	
-2	13810-002	. Cover, Disk Drive	1	A-C, G-O X-AE
	17137-001	. Cover, Disk Drive Attaching Parts	1	D-F
-3	18865-604	. Screw, Machine, Flat, 82 CSK, 6-32 x 1/4 Lg (12 U/O Model 140, 140C, 142, 8 U/O Model 140B, 6 U/O Model 140D)* ---*---	*	
	11691-001	. Element, Filter, N/I	1	
	18662-001	. Screen, Filter, N/I	1	
-4	11699-001	. Handle Assy, Chassis, Disk Drive Attaching Parts	1	
-5	16922-307	. Screw, Pan Hd, 6-32 x 7/16 Lg ---*---	2	
	99357-004	. Pin, Dowel, N/I, NFS	2	
	91446-019	. Spring, Compression, N/I, NFS	1	
	11706-001	. Button, Handle, N/I, NFS	1	
	11703-001	. Handle, Molded, N/I, NFS	1	
-6	13580-001	. Panel Assy, Front, Molded Attaching Parts	1	
-7	16922-307	. Screw, Pan Hd, 6-32 x 7/16 Lg ---*---	2	
-8	17150-001	. Retaining Spring, Front Cover	1	A-F
-9	11723-001	. Screw, Shoulder	2	
-10	96982-013	. Spring, Torsion	1	
-11	96982-014	. Spring, Torsion	1	
-12	11698-001	. Cover Assy, Cone Lift (refer to Figure 5-2 for components)	1	
-13	13740-003	. Transducer Assy, Detector Attaching Parts	1	
	16922-310	. Screw, Pan Hd, 6-32 x 5/8 Lg, N/I ---*---	1	
-14	12877-001	. Block, Transducer Mtg Attaching Parts	1	
-15	16922-307	. Screw, Pan Hd, 6-32 x 7/16 Lg ---*---	2	
-16	16922-310	. Screw, Pan Hd, 6-32 x 5/8 Lg	1	
-17	16922-210	. Screw, Pan Hd, 6-32 x 5/8 Lg	2	
-18	11714-002	. Transducer Assy, Emitter	1	
-19	13740-002	. Transducer Assy, Detector	1	
-20	11729-001	. Stop, Stylus, Molded Attaching Parts	1	
-21	16922-307	. Screw, Pan Hd, 6-32 x 7/16 Lg ---*---	2	

FIGURE ITEM NO.	PART NUMBER	DESCRIPTION	QTY PER ASSY	USAGE CODE
1-	14618-001	. Board Assy, Data & Control, VR56 (U/W Model 140 & 140B, Option 01X) (refer to Figure 5-4A for components)	1	A-F
	14619-001	. Board Assy, Data & Control, VR57 (U/W Model 140 & 140B, Options 02X & 05X) (refer to Figure 5-4B for components)	1	A-F
	14620-001	. Board Assy, Data & Control, VR58 (U/W Model 140 & 140B, Option 03X) (refer to Figure 5-4C for components)	1	A-F
	14701-001	. Board Assy, Data & Control, VR60 (U/W Model 140C) (refer to Figure 5-4D for components)	1	G-O
	17284-001	. Board Assy, Data & Control, VR82 (U/W Model 142, Options 01X, & 03X) (refer to Figure 5-4E for components)	1	X-AE
	17287-001	. Board Assy, Data & Control, VR83 (U/W Model 142, Options 00X, 02X, 04X, & 05X) (refer to Figure 5-4F for components)	1	X-AE
		Attaching Parts		
-40	16922-307	. Screw, Pan Hd, 6-32 x 7/16 Lg ... * ...	7	
-41	11656-001	. Pulley, Drive Attaching Parts	1	
-42	90448-044	. Screw, Machine, Pan Hd, 10-32 x 1/2 Lg	1	
-43	90489-005	. Lockwasher, Split, No. 10 ... * ...	1	
	90482-046	. Setscrew, Cup Point, N/I	1	
-44	11652-001	. Hub, Drive	1	
-45	11655-001	. Retainer, Bearing Attaching Parts	1	
-46	90448-019	. Screw, Machine, Pan Hd, 6-32 x 7/16 Lg ... * ...	3	
-47	90047-012	. Bearing, Ball	2	
-48	95097-005	. Washer, Spring Wave	1	
-49	11653-001	. Spacer, Bearing (outer)	1	
-50	11654-001	. Spacer, Bearing (inner)	1	D-F, X-AE
	11858-001	. Spacer, Bearing, (inner), N/I	1	A-C, G-W
	95657-001	. Plate, Identification, N/I	1	
-51	16578-001	. Chassis, Disk Drive	1	D-F
	13700-001	. Chassis, Disk Drive	1	A-C, G-AE

FIGURE ITEM NO.	PART NUMBER	DESCRIPTION	QTY PER ASSY	USAGE CODE
1-	14762-001	. Transducer Assy, Write Protect, N/I, (U/W Model 140, 140B, & 142, Options 02X, 03X, & 05X)	1	A-F, X-AE
	16922-307	. Screw, Pan Hd, 6-32 x 7/16 Lg, N/I ----*----	1	
-22	11716-001	. Motor, Stepper Attaching Parts	1	
-23	16922-207	. Screw, Pan Hd, 6-32 x 7/16 Lg	3	
-24	17009-001	. Clamp, Motor Mtg ----*----		
-25	90448-074	. Screw, Pan Hd, 4-40 x 3/16 Lg	1	
-26	90489-002	. Lockwasher, Split	1	
-27	90488-003	. Washer, Flat	1	
-28	90047-014	. Bearing, Ball	1	
-29	15229-001	. Carriage Assy, Head	1	
-30	16299-001	. Spacer, Slip-on Track	1	
-31	15151-001	. Shaft, Guide	1	
-32	90448-019	. Screw, Pan Hd, 6-32 x 7/16 Lg	2	
-33	11713-001	. Impeller, Blower	1	
-34	11719-001	. Belt, Drive	1	A-C, G, H, L, M, P, Q, T, U, X, Y, AB, AC
	11719-002	. Belt, Drive	1	D-F, J, K, N, O, R, S, V, W, Z, AA, AD, AE
-35	90448-027	. Screw, Machine, Pan Hd, 8-32 x 1/4 Lg	1	
-36	90490-004	. Lockwasher, Internal Tooth	1	
-37	11694-001	. Motor Assy, AC, Drive, 115v, 60 Hz (refer to Figure 5-3 for components)	1	A, G, P, X
	11694-002	. Motor Assy, AC, Drive, 230v, 60 Hz (refer to Figure 5-3 for components)	1	B, H, Q, Y
	11694-003	. Motor Assy, AC, Drive, 220v, 50 Hz (refer to Figure 5-3 for components)	1	J, R, Z
	11694-004	. Motor Assy, AC, Drive, 240v, 50 Hz (refer to Figure 5-3 for components)	1	K, S, AA
	11694-005	. Motor Assy, AC, Drive, 100v, 60 Hz (refer to Figure 5-3 for components)	1	C, L, T, AB,
	11694-006	. Motor Assy, AC Drive, 208v, 60 Hz (refer to Figure 5-3 for components)	1	M, U, AC
	11694-007	. Motor Assy, AC, Drive, 100v, 50 Hz (refer to Figure 5-3 for components)	1	N, V, AD
	11694-008	. Motor Assy, AC, Drive, 208v, 50 Hz (refer to Figure 5-3 for components)	1	O, W, AE
	18779-001	. Motor Assy, AC, Drive (refer to Figure 5-3 for components)	1	D
	18779-002	. Motor Assy, AC, Drive (refer to Figure 5-3 for components)	1	E
	18779-003	. Motor Assy, AC, Drive (refer to Figure 5-3 for components) Attaching Parts	1	F
-38	16922-307	. Screw, Pan Hd, 6-32 x 7/16 Lg ----*----	5	
-39	13921-001	. Board Assy, Data & Control, VR49 (U/W Model 140 & 140B, Options 00X, 04X, & 06X) (refer to Figure 5-4 for components)	1	A-F

FIGURE ITEM NO.	PART NUMBER	DESCRIPTION	QTY PER ASSY	USAGE CODE
2-	11698-001	Cover Assy, Cone Lift (see Figure 5-1 for NHA)	REF	
-1	11730-001	. Shield, Magnetic	1	
		. Attaching Parts	2	
-2	90487-003	. Nut, Plain Hex	2	
-3	90489-002	. Lockwasher, Split	2	
-4	90488-003	. Washer, Flat	2	
		---*---		
-5	17620-001	. Solenoid Kit, Cover, Cone Lift	1	
		. Attaching Parts		
-6	90448-018	. Screw, Machine, Pan Hd, 4-40 x 5/16 Lg	2	
-7	90489-003	. Lockwasher, Split, No. 4	2	
		---*---		
-8	10838-001	. Clip, Cable	4	
-9	11714-001	. Transducer, Optical Emitter	1	
		. Attaching Parts		
-10	90448-020	. Screw, Machine, Pan Hd, 6-32 x 3/8 Lg	2	
-11	90489-003	. Lockwasher, Split, No. 6	2	
-12	90488-004	. Washer, Flat	2	
		---*---		
-13	93719-003	. Ring, Retaining, External	1	
-14	90488-008	. Washer, Flat	1	
-15	11664-001	. Washer, Spring (nylon)	1	
-16	91446-017	. Spring, Compression	1	
-17	93719-003	. Ring, Retaining	2	
-18	11665-001	. Washer, Bearing (Brass)	1	
-19	11666-001	. Spring, Compression	1	
-20	11658-001	. Disc, Cone Expanding	1	
-21	11657-001	. Cone, Centering	1	
-22	11660-001	. Shaft, Cone	1	
	11724-001	. Decal, Track Scale, N/I	1	
	11724-001	. Decal, Track Scale, N/I	1	
-23	11688-001	. Cover, Cone Lift (molded)	1	

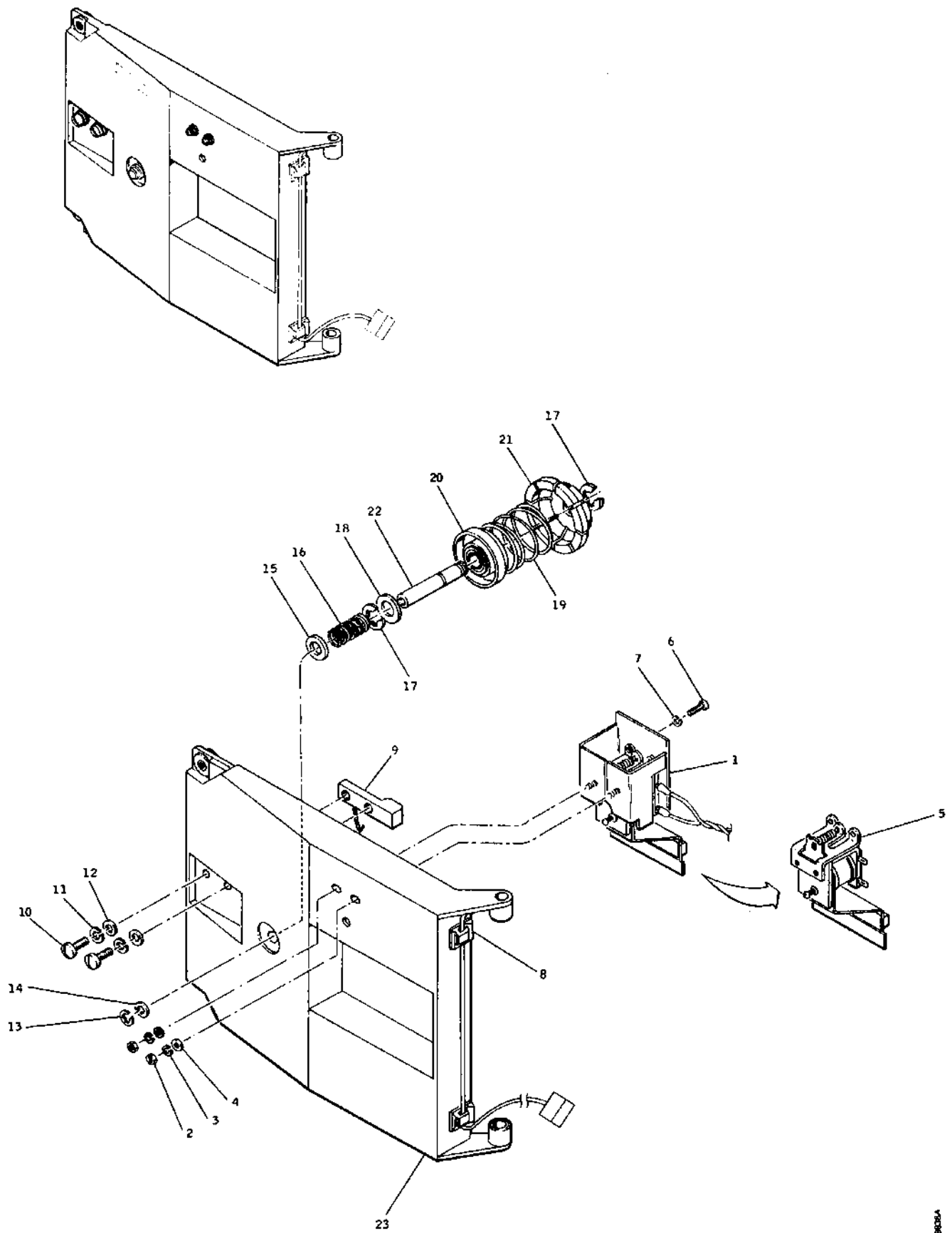

Figure 5-2. Cone Lift Cover Assembly

80354

FIGURE ITEM NO.	PART NUMBER	DESCRIPTION	QTY PER ASSY	USAGE CODE
3-2	11683-003	. Pulley, Drive Motor, 50 Hz	1	D, F, J, R, Z, K, S, AA, N, V, AD, O, W, AE
	11683-004	. Pulley, Drive Motor, 60 Hz	1	A, G, P, X, B, H, Q, Y, C, L, T, AB, M, U, AC
-3	11685-001	. Plate, Motor Mtg. Attaching Parts	1	
-4	90487-006	. Nut, Hexagon	4	
-5	90489-005	. Lockwasher, Split	4	
-6	90488-006	. Washer, Flat -----*	4	
-7	90603-003	. Terminal, Ring Torque	1	
-8	90605-003	. Connector, Molex, 3 Pin, J01	1	
-9	90440-002	. Pin, Connector	3	
-10	11648-001	. Motor, Ac, 100/115v, 50/60 Hz	1	
	11648-002	. Motor, Ac, 208/230v, 50/60 Hz	1	
	11648-003	. Motor, Ac, 220v, 50 Hz	1	J, R, Z, K, S AA, N, V, AD, O, W, AE
	18780-001	. Motor, Ac, 90-110v, 50 Hz	1	D
	18780-002	. Motor, Ac, 187-242v, 50 Hz	1	E
	18780-003	. Motor, Ac, 216-264v, 50 Hz	1	F

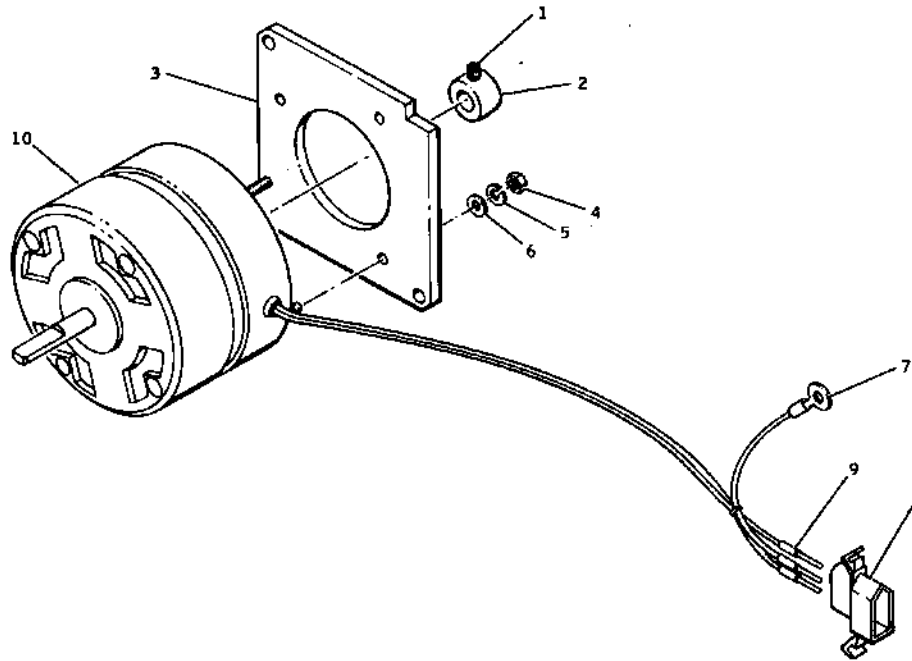

Figure 5-3. Drive Motor Assembly

FIGURE ITEM NO.	PART NUMBER	DESCRIPTION	QTY PER ASSY	USAGE CODE
3-	11694-001	Motor Assy, Ac, Drive, 115v, 60 Hz (see Figure 5-1 for NHA)	REF	A, G, P, X
	11694-002	Motor Assy, Ac, Drive, 230v, 60 Hz (see Figure 5-1 for NHA)	REF	B, H, Q, Y
	11694-003	Motor Assy, Ac, Drive, 220v, 50 Hz (see Figure 5-1 for NHA)	REF	J, R, Z
	11694-004	Motor Assy, Ac, Drive, 240v, 50 Hz (see Figure 5-1 for NHA)	REF	K, S, AA
	11694-005	Motor Assy, Ac, Drive, 100v, 60 Hz (see Figure 5-1 for NHA)	REF	C, L, T, AB
	11694-006	Motor Assy, Ac, Drive, 208v, 60 Hz (see Figure 5-1 for NHA)	REF	M, U, AC
	11694-007	Motor Assy, Ac, Drive, 100v, 50 Hz (see Figure 5-1 for NHA)	REF	N, V, AD
	11694-008	Motor Assy, Ac, Drive, 208v, 50 Hz (see Figure 5-1 for NHA)	REF	O, W, AE
	18779-001	Motor Assy, Ac, Drive (see Figure 5-1 for NHA)	REF	D
	18779-002	Motor Assy, Ac, Drive (see Figure 5-1 for NHA)	REF	E
	18779-003	Motor Assy, Ac, Drive (see Figure 5-1 for NHA)	REF	F
-1	12637-602	Setscrew, Cup Point, 6-32 x 1/8 Lg, N/I	1	

FIGURE ITEM NO.	PART NUMBER	DESCRIPTION	QTY PER ASSY	USAGE CODE
4	13921-001	Board Assy, Data & Control, VR49 (see Figure 5-1 for NHA) (U/W Model 140, & 140B, Options -00X, -04X, & -06X)	REF	A-F
-1	90328-001	. Transistor, Switching, NPN, Q14	1	
-2	90340-001	. Transistor, Switching, High-Speed, NPN, Q15	1	
-3	96385-001	. Transistor, Switching, NPN, Q3, 8	2	
-4	90327-001	. Transistor, Low-Level, PNP, Q1, 2, 7, 12, 13, 18, 19 20, 21	9	
-5	10726-001	. Amplifier, Linear, Operational, Dual, A25	1	
-6	90326-001	. Transistor, Low-Level, NPN, Q6, 9, 16	3	
-7	10208-001	. Transistor, Darlington, Dual, NPN, Q4, 5	2	
-8	92244-320	. Resistor, Variable, 10K, 20%, 3/4W, R103	1	
-9	94526-001	. Multivibrator, Dual, One-Shot, TTL, A23, A24	2	
-10	19148-001	. Gate, NAND, Quad, 2-Input, TTL, A21	1	
-11	92136-001	. Flip-Flop, Dual D, TTL, A16, 22	2	
-12	92127-001	. Gate, NAND, Hex, 1-Input, TTL, A14	1	
-13	95359-040	. Connector, J1	1	
-14	90313-001	. Gate, NAND, Dual, 4-Input, DTL, A4, A5, A12, A17	4	
-15	97272-001	. Socket, IC, 14-Pin, A6	1	
-16	95549-001	. Counter, Binary, Preset, TTL, A7	1	
-17	96389-001	. Flip-Flop, Dual D, SBD, TTL, A8	1	
-18	92128-001	. Gate, NAND, Quad, 2-Input, TTL, A9, A15, A18	3	
-19	90314-001	. Gate, NAND, Hex, 1-Input, DTL, A10, A13, A19, A20	4	
-20	90330-001	. Transistor, General-Purpose, PNP, Q10, 11, 17	3	
-21	97607-001	. Gate, Non-Invert, Hex, 1-Input, TTL A3, A11	2	
-22	10207-001	. Amplifier, Linear, Diff, A1	1	
-23	96758-001	. Amplifier, Linear, Diff Comp, A2, 26	2	
	90355-332	. Capacitor, .0033 uF, 10%, 100v, C7	1	
	18452-347	. Capacitor, Metal, Poly, .047 uF, 5%, C11, 13, 27	3	
	90355-222	. Capacitor, Mylar, .0022 uF, 100v, C3, 16, 26	3	
	90355-682	. Capacitor, Mylar, .0068 uF, 100v, C41, 45	2	
	90356-102	. Capacitor, Tantalum, 4.7 uF, 10v, C5, 25, 32	3	
	90356-204	. Capacitor, Tantalum, 2.2 uF, 20v, C15, 46, 50	3	
	90356-355	. Capacitor, Tantalum, 33 uF, 35v, C51	1	
	90356-521	. Capacitor, Tantalum, 4.7 uF, 50v, C31	1	
	90356-513	. Capacitor, Tantalum, 1.0 uF, 50v, C53	1	
	90360-004	. Capacitor, Polyester, .047 uF, 100v, C8	1	
	90360-047	. Capacitor, Polyester, .47 uF, 50v, C10, 14, 17, 19	4	
	90360-200	. Capacitor, Polyester, .22 uF, 50v, C2	1	
	95379-347	. Capacitor, Ceramic, .047 uF, 50v, C1, 6, 20, 24, 33-37 C42, 44, 49	12	
	98175-010	. Capacitor, Ceramic, 10 pF, 200v, C21	1	
	98175-118	. Capacitor, Ceramic, 180 pF, 200v, C23	1	
	98175-133	. Capacitor, Ceramic, 330 pF, 200v, C30	1	
	98175-156	. Capacitor, Ceramic, 560 pF, 200v, C18, 28, 29	3	
	98175-347	. Capacitor, Ceramic, .047 uF, 50v, C52, 54, 55	3	
	90364-100	. Resistor, 10 ohm, 5%, 1/4W, R6, 35, 53, 79, 82	5	
	90364-101	. Resistor, 100 ohm, 5%, 1/4W, R77, 130	2	
	90364-102	. Resistor, 1K, 5%, 1/4W, R12, 13, 76, 81, 83, 85, 108, 112 R119, 121-124	13	
	90364-103	. Resistor, 10K, 5%, 1/4W, R66, 67	2	
	90364-122	. Resistor, 1.2K, 5%, 1/4W, R101, 102	2	
	90364-123	. Resistor, 12K, 5%, 1/4W, R47, 100	2	
	90364-131	. Resistor, 130 ohm, 5%, 1/4W, R73, 74	2	

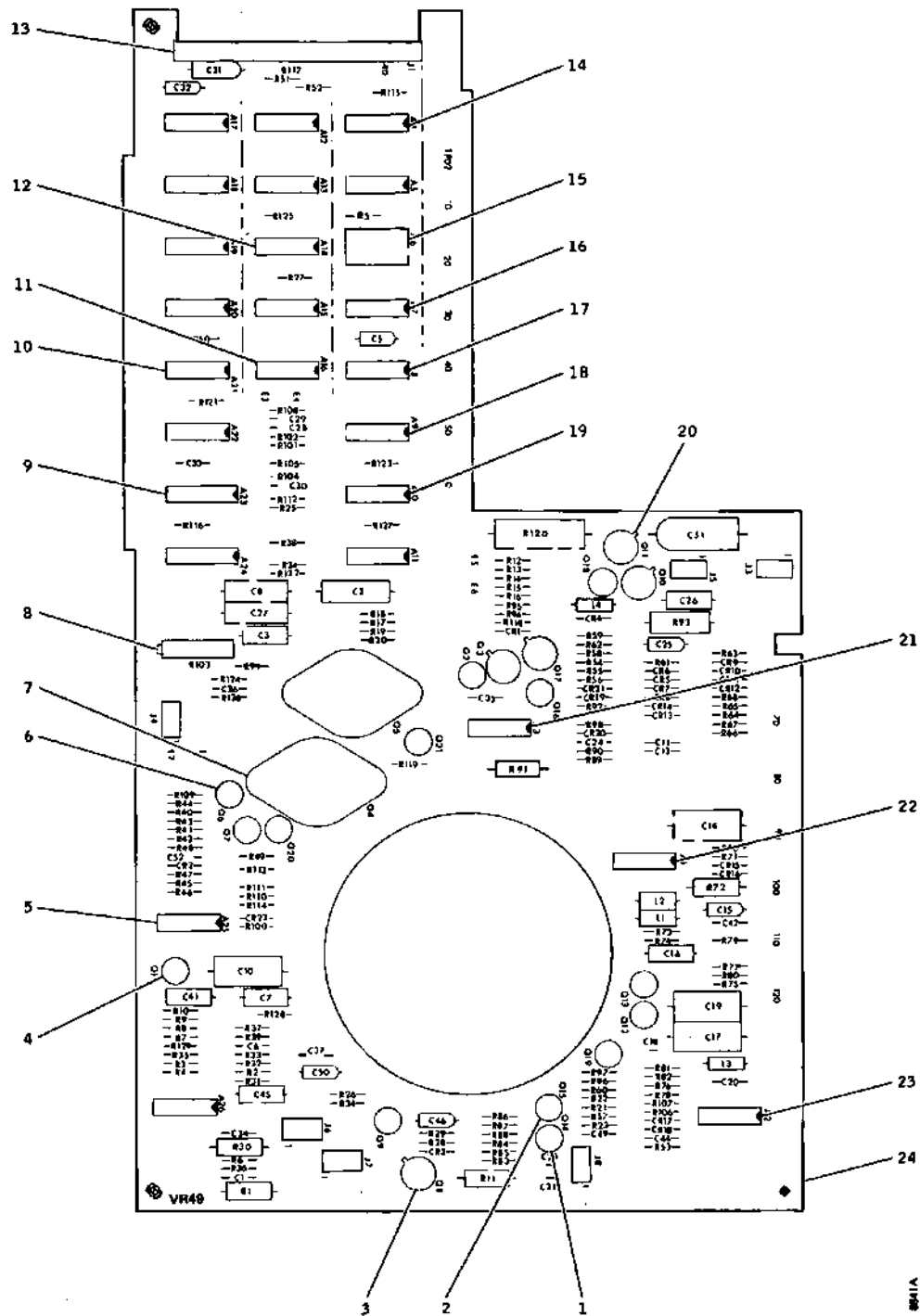

Figure 5-4. Data and Control Board Assembly, VR49

FIGURE ITEM NO.	PART NUMBER	DESCRIPTION	QTY PER ASSY	USAGE CODE
4-	90371-110	. Resistor, 100 ohm, 5%, 5W, R120	1	
	90376-130	. Inductor, Molded, 130 uH, L4	1	
	90376-240	. Inductor, Molded, 240 uH, L3	1	
	90965-330	. Inductor, Molded, 33 uH, L1, 2	2	
	90343-001	. Diode, Low-Capacitance, CR4-14, 17-19, 21	15	
	90344-001	. Diode, Rectifier, 1 Amp, 50v, CR1	1	
	90346-062	. Diode, Zener, 6.2v, 400 mW, CR2, 15, 16, 20, 22	5	
	90346-120	. Diode, Zener, 12v, 400 mW, CR3	1	
-24	13922-001	. Board, Data & Control	1	

FIGURE ITEM NO.	PART NUMBER	DESCRIPTION	QTY PER ASSY	USAGE CODE
4-	90364-151	. Resistor, 150 ohm, 5%, 1/4W, R43	1	
	90364-152	. Resistor, 1.5K, 5%, 1/4W, R25, 49, 51, 54, 58, 85, 84, 87, R105, 113, 115	11	
	90364-153	. Resistor, 15K, 5%, 1/4W, R27	1	
	90364-182	. Resistor, 1.8K, 5%, 1/4W, R9, 39, 96	3	
	90364-201	. Resistor, 200 ohm, 5%, 1/4W, R88	1	
	90364-202	. Resistor, 2K, 5%, 1/4W, R68, 127	2	
	90364-203	. Resistor, 20K, 5%, 1/4W, R21, 70, 71, 104	4	
	90364-221	. Resistor, 220 ohm, 5%, 1/4W, R5	1	
	90364-241	. Resistor, 240 ohm, 5%, 1/4W, R10, 14, 15, 50, 52, 97, 114	7	
	90364-272	. Resistor, 2.7K, 5%, 1/4W, R75, 80	2	
	90364-302	. Resistor, 3K, 5%, 1/4W, R56, 62, 86, 116	4	
	90364-303	. Resistor, 30K, 5%, 1/4W, R64, 65	2	
	90364-330	. Resistor, 33 ohm, 5%, 1/4W, R28	1	
	90364-331	. Resistor, 330 ohm, 5%, 1/4W, R117	1	
	90364-332	. Resistor, 3.3K, 5%, 1/4W, R16, 42, 48, 111	4	
	90364-362	. Resistor, 3.6K, 5%, 1/4W, R94	1	
	90364-392	. Resistor, 3.9K, 5%, 1/4W, R55, 59, 63, 106, 107	5	
	90364-393	. Resistor, 39K, 5%, 1/4W, R38	1	
	90364-511	. Resistor, 510 ohm, 5%, 1/4W, R60, 90	2	
	90364-561	. Resistor, 560 ohm, 5%, 1/4W, R17-20, 78	5	
	90364-621	. Resistor, 620 ohm, 5%, 1/4W, R40, 41	2	
	90364-682	. Resistor, 6.8K, 5%, 1/4W, R39, 118	2	
	90364-751	. Resistor, 750 ohm, 5%, 1/4W, R8, 26, 34	3	
	90364-752	. Resistor, 7.5K, 5%, 1/4W, R29	1	
	90364-911	. Resistor, 910 ohm, 5%, 1/4W, R125, 126	2	
	90364-912	. Resistor, 9.1K, 5%, 1/4W, R37	1	
	90365-201	. Resistor, 200 ohm, 5%, 1W, R72	1	
	90365-680	. Resistor, 68 ohm, 5%, 1W, R1, 30	2	
	90365-821	. Resistor, 820 ohm, 5%, 1W, R91	1	
	90365-101	. Resistor, 100 ohm, 5%, 1W, R11	1	
	90366-249	. Resistor, 270 ohm, 5%, 3W, R93	1	
	90367-104	. Resistor, 10K, 1%, 1/8W, R7, 57	2	
	90367-118	. Resistor, 11K, 1%, 1/8W, R22	1	
	90367-131	. Resistor, 1.21K, 1%, 1/8W, R92	1	
	90367-132	. Resistor, 12.1K, 1%, 1/8W, R98, 109	2	
	90367-140	. Resistor, 127K, 1%, 1/8W, R23	1	
	90367-160	. Resistor, 14.7K, 1%, 1/8W, R3, 32	2	
	90367-202	. Resistor, 19.6K, 1%, 1/8W, R2	1	
	90367-264	. Resistor, 3.01K, 1%, 1/8W, R46	1	
	90367-314	. Resistor, 42.2K, 1%, 1/8W, R24, 99	2	
	90367-315	. Resistor, 422K, 1%, 1/8W, R44	1	
	90367-341	. Resistor, 5.11K, 1%, 1/8W, R45	1	
	90367-369	. Resistor, 6.19K, 1%, 1/8W, R61	1	
	90367-377	. Resistor, 64.9K, 1%, 1/8W, R4, 33, 128, 129	4	
	90367-383	. Resistor, 6.81K, 1%, 1/8W, R110	1	
	90367-327	. Resistor, 4.64K, 1%, 1/8W, R36	1	
	90367-390	. Resistor, 7.15K, 1%, 1/8W, R31	1	

FIGURE ITEM NO.	PART NUMBER	DESCRIPTION	QTY PER ASSY	USAGE CODE
4A-	14618-001	Board Assy, Data & Control, VR56 (see Figure 5-1 for NHA) (U/W Model 140, & 140B, Options -01X)	REF	A-F
-1	90328-001	. Transistor, Switching, NPN, Q14	1	
-2	90340-001	. Transistor, Switching, High-Speed, NPN, Q15	1	
-3	96385-001	. Transistor, Switching, NPN, Q3, 8	2	
-4	90327-001	. Transistor, Low-Level, PNP, Q1, 2, 7, 12, 13, 18, 19 20, 21	9	
-5	10726-001	. Amplifier, Linear, Operational, Dual, A25	1	
-6	90326-001	. Transistor, Low-Level, NPN, Q6, 9, 16	3	
-7	10208-001	. Transistor, Darlington, Dual, NPN, Q4, 5	2	
-8	92244-320	. Resistor, Variable, 10K, 20%, 3/4W, R103	1	
-9	94526-001	. Multivibrator, Dual, One-Shot, TTL, A23, A24	2	
-10	19148-001	. Gate, NAND, Quad, 2-Input, TTL, A21	1	
-11	92136-001	. Flip-Flop, Dual D, TTL, A16, 22	2	
-12	92127-001	. Gate, NAND, Hex, 1-Input, TTL, A14	1	
-13	95359-040	. Connector, J1	1	
-14	90313-001	. Gate, NAND, Dual, 4-Input, DTL, A4, A5, A12, A17	4	
-15	97272-001	. Socket, IC, 14-Pin, A6	1	
-16	95549-001	. Counter, Binary, Preset, TTL, A7	1	
-17	96389-001	. Flip-Flop, Dual D, SBD, TTL, A8	1	
-18	92128-001	. Gate, NAND, Quad, 2-Input, TTL, A9, A15, A18	3	
-19	90314-001	. Gate, NAND, Hex, 1-Input, DTL, A10, A13, A19, A20	4	
-20	90330-001	. Transistor, General-Purpose, PNP, Q10, 11, 17	3	
-21	97607-001	. Gate, Non-Invert, Hex, 1-Input, TTL A3, A11	2	
-22	10207-001	. Amplifier, Linear, Diff, A1	1	
-23	96758-001	. Amplifier, Linear, Diff Comp, A2, 26	2	
	90355-332	. Capacitor, .0033 uF, 10%, 100v, C7	1	
	18452-347	. Capacitor, Metal, Poly, .047 uF, 5%, C11, 13, 27	3	
	90355-222	. Capacitor, Mylar, .0022 uF, 100v, C3, 16, 26	3	
	90355-682	. Capacitor, Mylar, .0068 uF, 100v, C41, 45	2	
	90356-102	. Capacitor, Tantalum, 4.7 uF, 10v, C5, 25, 32	3	
	90356-204	. Capacitor, Tantalum, 2.2 uF, 20v, C15, 46, 50	3	
	90356-355	. Capacitor, Tantalum, 33 uF, 35v, C51	1	
	90356-521	. Capacitor, Tantalum, 4.7 uF, 50v, C31	1	
	90356-513	. Capacitor, Tantalum, 1.0 uF, 50v, C53	1	
	90360-004	. Capacitor, Polyester, .047 uF, 100v, C8	1	
	90360-047	. Capacitor, Polyester, .47 uF, 50v, C10, 14, 17, 19	4	
	90360-200	. Capacitor, Polyester, .22 uF, 50v, C2	1	
	95379-347	. Capacitor, Ceramic, .047 uF, 50v, C1, 6, 20, 24, 33-37 C42, 44, 49	12	
	98175-010	. Capacitor, Ceramic, 10 pF, 200v, C21	1	
	98175-118	. Capacitor, Ceramic, 180 pF, 200v, C23	1	
	98175-133	. Capacitor, Ceramic, 330 pF, 200v, C30	1	
	98175-156	. Capacitor, Ceramic, 560 pF, 200v, C18, 28, 29	3	
	98175-347	. Capacitor, Ceramic, .047 uF, 50v, C52, 54, 55	3	
	90364-100	. Resistor, 10 ohm, 5%, 1/4W, R6, 35, 53, 79, 82	5	
	90364-101	. Resistor, 100 ohm, 5%, 1/4W, R77, 130	2	
	90364-102	. Resistor, 1K, 5%, 1/4W, R12, 13, 76, 81, 83, 85, 108, 112 R119, 121-124	13	
	90364-103	. Resistor, 10K, 5%, 1/4W, R66, 67	2	
	90364-122	. Resistor, 1.2K, 5%, 1/4W, R101, 102	2	
	90364-123	. Resistor, 12K, 5%, 1/4W, R47, 100	2	
	90364-131	. Resistor, 130 ohm, 5%, 1/4W, R73, 74	2	

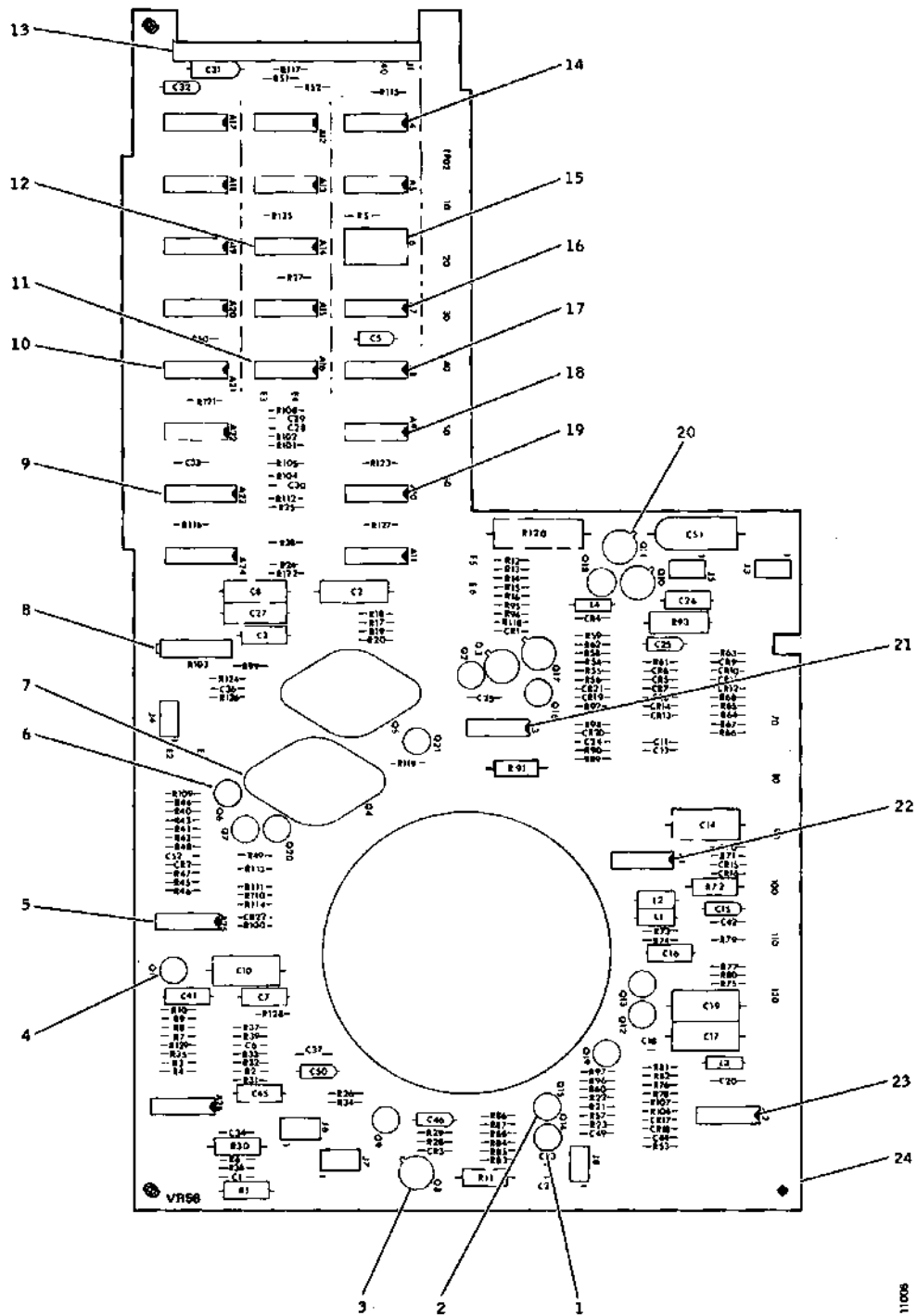

Figure 5-4A. Data and Control Board Assembly, VR56

FIGURE ITEM NO.	PART NUMBER	DESCRIPTION	QTY PER ASSY	USAGE CODE
4A-	90371-110	. Resistor, 100 ohm, 5%, 5W, R120	1	
	90376-130	. Inductor, Molded, 130 uH, L4	1	
	90376-240	. Inductor, Molded, 240 uH, L3	1	
	90965-330	. Inductor, Molded, 33 uH, L1, 2	2	
	90343-001	. Diode, Low-Capacitance, CR4-14, 17-19, 21	15	
	90344-001	. Diode, Rectifier, 1 Amp, 50v, CR1	1	
	90346-062	. Diode, Zener, 6.2v, 400 mW, CR2, 15, 16, 20, 22	5	
	90346-120	. Diode, Zener, 12v, 400 mW, CR3	1	
-24	13922-001	. Board, Data & Control	1	

FIGURE ITEM NO.	PART NUMBER	DESCRIPTION	QTY PER ASSY	USAGE CODE
4A-	90364-151	. Resistor, 150 ohm, 5%, 1/4W, R43	1	
	90364-152	. Resistor, 1.5K, 5%, 1/4W, R25, 49, 51, 54, 58, 85, 84, 87, R105, 113, 115	11	
	90364-153	. Resistor, 15K, 5%, 1/4W, R27	1	
	90364-182	. Resistor, 1.8K, 5%, 1/4W, R9, 39, 96	3	
	90364-201	. Resistor, 200 ohm, 5%, 1/4W, R88	1	
	90364-202	. Resistor, 2K, 5%, 1/4W, R68, 127	2	
	90364-203	. Resistor, 20K, 5%, 1/4W, R21, 70, 71, 104	4	
	90364-221	. Resistor, 220 ohm, 5%, 1/4W, R5	1	
	90364-241	. Resistor, 240 ohm, 5%, 1/4W, R10, 14, 15, 50, 52, 97, 114	7	
	90364-272	. Resistor, 2.7K, 5%, 1/4W, R75, 80	2	
	90364-302	. Resistor, 3K, 5%, 1/4W, R56, 62, 86, 116	4	
	90364-303	. Resistor, 30K, 5%, 1/4W, R64, 65	2	
	90364-330	. Resistor, 33 ohm, 5%, 1/4W, R28	1	
	90364-331	. Resistor, 330 ohm, 5%, 1/4W, R117	1	
	90364-332	. Resistor, 3.3K, 5%, 1/4W, R16, 42, 48, 111	4	
	90364-362	. Resistor, 3.6K, 5%, 1/4W, R94	1	
	90364-392	. Resistor, 3.9K, 5%, 1/4W, R55, 59, 63, 106, 107	5	
	90364-393	. Resistor, 39K, 5%, 1/4W, R38	1	
	90364-511	. Resistor, 510 ohm, 5%, 1/4W, R60, 90	2	
	90364-561	. Resistor, 560 ohm, 5%, 1/4W, R17-20, 78	5	
	90364-621	. Resistor, 620 ohm, 5%, 1/4W, R40, 41	2	
	90364-682	. Resistor, 6.8K, 5%, 1/4W, R39, 118	2	
	90364-751	. Resistor, 750 ohm, 5%, 1/4W, R8, 26, 34	3	
	90364-752	. Resistor, 7.5K, 5%, 1/4W, R29	1	
	90364-911	. Resistor, 910 ohm, 5%, 1/4W, R125, 126	2	
	90364-912	. Resistor, 9.1K, 5%, 1/4W, R37	1	
	90365-201	. Resistor, 200 ohm, 5%, 1W, R72	1	
	90365-680	. Resistor, 68 ohm, 5%, 1W, R1, 30	2	
	90365-821	. Resistor, 820 ohm, 5%, 1W, R91	1	
	90365-101	. Resistor, 100 ohm, 5%, 1W, R11	1	
	90366-249	. Resistor, 270 ohm, 5%, 3W, R93	1	
	90367-104	. Resistor, 10K, 1%, 1/8W, R7, 57	2	
	90367-118	. Resistor, 11K, 1%, 1/8W, R22	1	
	90367-131	. Resistor, 1.21K, 1%, 1/8W, R92	1	
	90367-132	. Resistor, 12.1K, 1%, 1/8W, R98, 109	2	
	90367-140	. Resistor, 127K, 1%, 1/8W, R23	1	
	90367-160	. Resistor, 14.7K, 1%, 1/8W, R3, 32	2	
	90367-202	. Resistor, 19.6K, 1%, 1/8W, R2	1	
	90367-264	. Resistor, 3.01K, 1%, 1/8W, R46	1	
	90367-314	. Resistor, 42.2K, 1%, 1/8W, R24, 99	2	
	90367-315	. Resistor, 422K, 1%, 1/8W, R44	1	
	90367-341	. Resistor, 5.11K, 1%, 1/8W, R45	1	
	90367-369	. Resistor, 6.19K, 1%, 1/8W, R61	1	
	90367-377	. Resistor, 64.9K, 1%, 1/8W, R4, 33, 128, 129	4	
	90367-383	. Resistor, 6.81K, 1%, 1/8W, R110	1	
	90367-327	. Resistor, 4.64K, 1%, 1/8W, R36	1	
	90367-390	. Resistor, 7.15K, 1%, 1/8W, R31	1	

FIGURE ITEM NO.	PART NUMBER	DESCRIPTION	QTY PER ASSY	USAGE CODE
4B-	14619-001	Board Assy, Data & Control, VR57 (see Figure 5-1 for NHA) (U/W Model 140, & 140B, Options -02X & -05X)	REF	A-F
-1	90328-001	. Transistor, Switching, NPN, Q14	1	
-2	90340-001	. Transistor, Switching, High-Speed, NPN, Q15	1	
-3	96385-001	. Transistor, Switching, NPN, Q3, 8	2	
-4	90327-001	. Transistor, Low-Level, PNP, Q1, 2, 7, 12, 13, 18, 19 20, 21	9	
-5	10726-001	. Amplifier, Linear, Operational, Dual, A25	1	
-6	90326-001	. Transistor, Low-Level, NPN, Q6, 9, 16	3	
-7	10208-001	. Transistor, Darlington, Dual, NPN, Q4, 5	2	
-8	92244-320	. Resistor, Variable, 10K, 20%, 3/4W, R103	1	
-9	94526-001	. Multivibrator, Dual, One-Shot, TTL, A23, A24	2	
-10	19148-001	. Gate, NAND, Quad, 2-Input, TTL, A21	1	
-11	92136-001	. Flip-Flop, Dual D, TTL, A16, 22	2	
-12	92127-001	. Gate, NAND, Hex, 1-Input, TTL, A14	1	
-13	95359-040	. Connector, J1	1	
-14	90313-001	. Gate, NAND, Dual, 4-Input, DTL, A4, A5, A12, A17	4	
-15	97272-001	. Socket, IC, 14-Pin, A6	1	
-16	95549-001	. Counter, Binary, Preset, TTL, A7	1	
-17	96389-001	. Flip-Flop, Dual D, SBD, TTL, A8	1	
-18	92128-001	. Gate, NAND, Quad, 2-Input, TTL, A9, A15, A18	3	
-19	90314-001	. Gate, NAND, Hex, 1-Input, DTL, A10, A13, A19, A20	4	
-20	90330-001	. Transistor, General-Purpose, PNP, Q10, 11, 17	3	
-21	97607-001	. Gate, Non-Invert, Hex, 1-Input, TTL A3, A11	2	
-22	10207-001	. Amplifier, Linear, Diff, A1	1	
-23	96758-001	. Amplifier, Linear, Diff Comp, A2, 26	2	
	90355-332	. Capacitor, .0033 uF, 10%, 100v, C7	1	
	18452-347	. Capacitor, Metal, Poly, .047 uF, 5%, C11, 13, 27	3	
	90355-222	. Capacitor, Mylar, .0022 uF, 100v, C3, 16, 26	3	
	90355-682	. Capacitor, Mylar, .0068 uF, 100v, C41, 45	2	
	90356-102	. Capacitor, Tantalum, 4.7 uF, 10v, C5, 25, 32	3	
	90356-204	. Capacitor, Tantalum, 2.2 uF, 20v, C15, 46, 50	3	
	90356-355	. Capacitor, Tantalum, 33 uF, 35v, C51	1	
	90356-521	. Capacitor, Tantalum, 4.7 uF, 50v, C31	1	
	90356-513	. Capacitor, Tantalum, 1.0 uF, 50v, C53	1	
	90360-004	. Capacitor, Polyester, .047 uF, 100v, C8	1	
	90360-047	. Capacitor, Polyester, .47 uF, 50v, C10, 14, 17, 19	4	
	90360-200	. Capacitor, Polyester, .22 uF, 50v, C2	1	
	95379-347	. Capacitor, Ceramic, .047 uF, 50v, C1, 6, 20, 24, 33-37 C42, 44, 49	12	
	98175-010	. Capacitor, Ceramic, 10 pF, 200v, C21	1	
	98175-118	. Capacitor, Ceramic, 180 pF, 200v, C23	1	
	98175-133	. Capacitor, Ceramic, 330 pF, 200v, C30	1	
	98175-156	. Capacitor, Ceramic, 560 pF, 200v, C18, 28, 29	3	
	98175-347	. Capacitor, Ceramic, .047 uF, 50v, C52, 54, 55	3	
	90364-100	. Resistor, 10 ohm, 5%, 1/4W, R6, 35, 53, 79, 82	5	
	90364-101	. Resistor, 100 ohm, 5%, 1/4W, R77, 130	2	
	90364-102	. Resistor, 1K, 5%, 1/4W, R12, 13, 76, 81, 83, 85, 108, 112 R119, 121-124	13	
	90364-103	. Resistor, 10K, 5%, 1/4W, R66, 67	2	
	90364-122	. Resistor, 1.2K, 5%, 1/4W, R101, 102	2	
	90364-123	. Resistor, 12K, 5%, 1/4W, R47, 100	2	
	90364-131	. Resistor, 130 ohm, 5%, 1/4W, R73, 74	2	

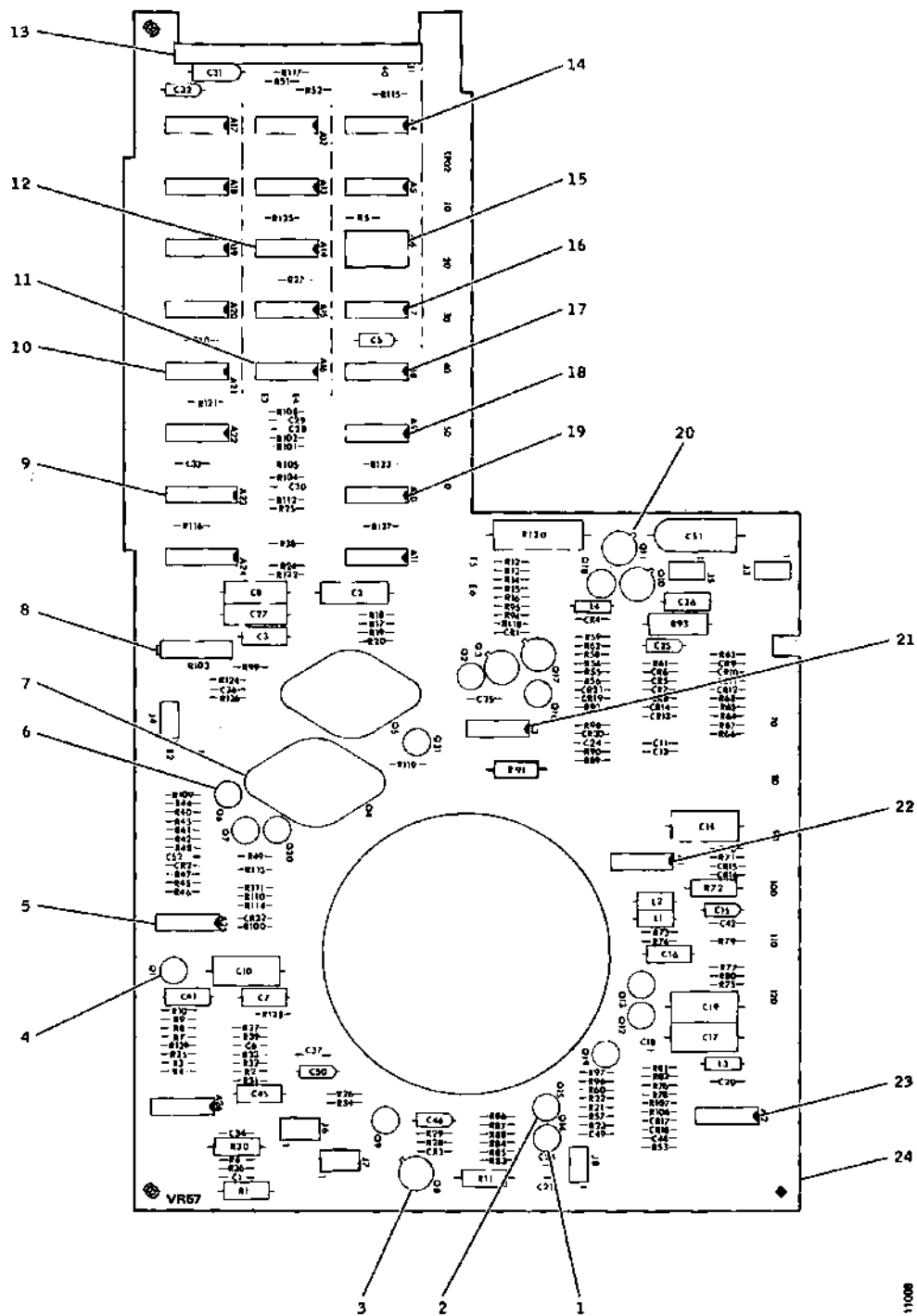

Figure 5-4B. Data and Control Board Assembly, VR57

FIGURE ITEM NO.	PART NUMBER	DESCRIPTION	QTY PER ASSY	USAGE CODE
4B-	90371-110	. Resistor, 100 ohm, 5%, 5W, R120	1	
	90376-130	. Inductor, Molded, 130 uH, L4	1	
	90376-240	. Inductor, Molded, 240 uH, L3	1	
	90965-330	. Inductor, Molded, 33 uH, L1, 2	2	
	90343-001	. Diode, Low-Capacitance, CR4-14, 17-19, 21	15	
	90344-001	. Diode, Rectifier, 1 Amp, 50v, CR1	1	
	90346-062	. Diode, Zener, 6.2v, 400 mW, CR2, 15, 16, 20, 22	5	
	90346-120	. Diode, Zener, 12v, 400 mW, CR3	1	
-24	13922-001	. Board, Data & Control	1	

FIGURE ITEM NO.	PART NUMBER	DESCRIPTION	QTY PER ASSY	USAGE CODE
4B-	90364-151	. Resistor, 150 ohm, 5%, 1/4W, R43	1	
	90364-152	. Resistor, 1.5K, 5%, 1/4W, R25, 49, 51, 54, 58, 85, 84, 87, R105, 113, 115	11	
	90364-153	. Resistor, 15K, 5%, 1/4W, R27	1	
	90364-182	. Resistor, 1.8K, 5%, 1/4W, R9, 39, 96	3	
	90364-201	. Resistor, 200 ohm, 5%, 1/4W, R88	1	
	90364-202	. Resistor, 2K, 5%, 1/4W, R68, 127	2	
	90364-203	. Resistor, 20K, 5%, 1/4W, R21, 70, 71, 104	4	
	90364-221	. Resistor, 220 ohm, 5%, 1/4W, R5	1	
	90364-241	. Resistor, 240 ohm, 5%, 1/4W, R10, 14, 15, 50, 52, 97, 114	7	
	90364-272	. Resistor, 2.7K, 5%, 1/4W, R75, 80	2	
	90364-302	. Resistor, 3K, 5%, 1/4W, R56, 62, 86, 116	4	
	90364-303	. Resistor, 30K, 5%, 1/4W, R64, 65	2	
	90364-330	. Resistor, 33 ohm, 5%, 1/4W, R28	1	
	90364-331	. Resistor, 330 ohm, 5%, 1/4W, R117	1	
	90364-332	. Resistor, 3.3K, 5%, 1/4W, R16, 42, 48, 111	4	
	90364-362	. Resistor, 3.6K, 5%, 1/4W, R94	1	
	90364-392	. Resistor, 3.9K, 5%, 1/4W, R55, 59, 63, 106, 107	5	
	90364-393	. Resistor, 39K, 5%, 1/4W, R38	1	
	90364-511	. Resistor, 510 ohm, 5%, 1/4W, R60, 90	2	
	90364-561	. Resistor, 560 ohm, 5%, 1/4W, R17-20, 78	5	
	90364-621	. Resistor, 620 ohm, 5%, 1/4W, R40, 41	2	
	90364-682	. Resistor, 6.8K, 5%, 1/4W, R39, 118	2	
	90364-751	. Resistor, 750 ohm, 5%, 1/4W, R8, 26, 34	3	
	90364-752	. Resistor, 7.5K, 5%, 1/4W, R29	1	
	90364-911	. Resistor, 910 ohm, 5%, 1/4W, R125, 126	2	
	90364-912	. Resistor, 9.1K, 5%, 1/4W, R37	1	
	90365-201	. Resistor, 200 ohm, 5%, 1W, R72	1	
	90365-680	. Resistor, 68 ohm, 5%, 1W, R1, 30	2	
	90365-821	. Resistor, 820 ohm, 5%, 1W, R91	1	
	90365-101	. Resistor, 100 ohm, 5%, 1W, R11	1	
	90366-249	. Resistor, 270 ohm, 5%, 3W, R93	1	
	90367-104	. Resistor, 10K, 1%, 1/8W, R7, 57	2	
	90367-118	. Resistor, 11K, 1%, 1/8W, R22	1	
	90367-131	. Resistor, 1.21K, 1%, 1/8W, R92	1	
	90367-132	. Resistor, 12.1K, 1%, 1/8W, R98, 109	2	
	90367-140	. Resistor, 127K, 1%, 1/8W, R23	1	
	90367-160	. Resistor, 14.7K, 1%, 1/8W, R3, 32	2	
	90367-202	. Resistor, 19.6K, 1%, 1/8W, R2	1	
	90367-264	. Resistor, 3.01K, 1%, 1/8W, R46	1	
	90367-314	. Resistor, 42.2K, 1%, 1/8W, R24, 99	2	
	90367-315	. Resistor, 422K, 1%, 1/8W, R44	1	
	90367-341	. Resistor, 5.11K, 1%, 1/8W, R45	1	
	90367-369	. Resistor, 6.19K, 1%, 1/8W, R61	1	
	90367-377	. Resistor, 64.9K, 1%, 1/8W, R4, 33, 128, 129	4	
	90367-383	. Resistor, 6.81K, 1%, 1/8W, R110	1	
	90367-327	. Resistor, 4.64K, 1%, 1/8W, R36	1	
	90367-390	. Resistor, 7.15K, 1%, 1/8W, R31	1	

FIGURE ITEM NO.	PART NUMBER	DESCRIPTION	QTY PER ASSY	USAGE CODE
4C-	14620-001	Board Assy, Data & Control, VR58 (see Figure 5-1 for NHA) (U/W Model 140, & 140B, Option -03X)	REF	A-F
-1	90328-001	. Transistor, Switching, NPN, Q14	1	
-2	90340-001	. Transistor, Switching, High-Speed, NPN, Q15	1	
-3	96385-001	. Transistor, Switching, NPN, Q3, 8	2	
-4	90327-001	. Transistor, Low-Level, PNP, Q1, 2, 7, 12, 13, 18, 19 20, 21	9	
-5	10726-001	. Amplifier, Linear, Operational, Dual, A25	1	
-6	90326-001	. Transistor, Low-Level, NPN, Q6, 9, 16	3	
-7	10208-001	. Transistor, Darlington, Dual, NPN, Q4, 5	2	
-8	92244-320	. Resistor, Variable, 10K, 20%, 3/4W, R103	1	
-9	94526-001	. Multivibrator, Dual, One-Shot, TTL, A23, A24	2	
-10	19148-001	. Gate, NAND, Quad, 2-Input, TTL, A21	1	
-11	92136-001	. Flip-Flop, Dual D, TTL, A16, 22	2	
-12	92127-001	. Gate, NAND, Hex, 1-Input, TTL, A14	1	
-13	95359-040	. Connector, J1	1	
-14	90313-001	. Gate, NAND, Dual, 4-Input, DTL, A4, A5, A12, A17	4	
-15	97272-001	. Socket, IC, 14-Pin, A6	1	
-16	95549-001	. Counter, Binary, Preset, TTL, A7	1	
-17	96389-001	. Flip-Flop, Dual D, SBD, TTL, A8	1	
-18	92128-001	. Gate, NAND, Quad, 2-Input, TTL, A9, A15, A18	3	
-19	90314-001	. Gate, NAND, Hex, 1-Input, DTL, A10, A13, A19, A20	4	
-20	90330-001	. Transistor, General-Purpose, PNP, Q10, 11, 17	3	
-21	97607-001	. Gate, Non-Invert, Hex, 1-Input, TTL A3, A11	2	
-22	10207-001	. Amplifier, Linear, Diff, A1	1	
-23	96758-001	. Amplifier, Linear, Diff Comp, A2, 26	2	
	90355-332	. Capacitor, .0033 uF, 10%, 100v, C7	1	
	18452-347	. Capacitor, Metal, Poly, .047 uF, 5%, C11, 13, 27	3	
	90355-222	. Capacitor, Mylar, .0022 uF, 100v, C3, 16, 26	3	
	90355-682	. Capacitor, Mylar, .0068 uF, 100v, C41, 45	2	
	90356-102	. Capacitor, Tantalum, 4.7 uF, 10v, C5, 25, 32	3	
	90356-204	. Capacitor, Tantalum, 2.2 uF, 20v, C15, 46, 50	3	
	90356-355	. Capacitor, Tantalum, 33 uF, 35v, C51	1	
	90356-521	. Capacitor, Tantalum, 4.7 uF, 50v, C31	1	
	90356-513	. Capacitor, Tantalum, 1.0 uF, 50v, C53	1	
	90360-004	. Capacitor, Polyester, .047 uF, 100v, C8	1	
	90360-047	. Capacitor, Polyester, .47 uF, 50v, C10, 14, 17, 19	4	
	90360-200	. Capacitor, Polyester, .22 uF, 50v, C2	1	
	95379-347	. Capacitor, Ceramic, .047 uF, 50v, C1, 6, 20, 24, 33-37 C42, 44, 49	12	
	98175-010	. Capacitor, Ceramic, 10 pF, 200v, C21	1	
	98175-118	. Capacitor, Ceramic, 180 pF, 200v, C23	1	
	98175-133	. Capacitor, Ceramic, 330 pF, 200v, C30	1	
	98175-156	. Capacitor, Ceramic, 560 pF, 200v, C18, 28, 29	3	
	98175-347	. Capacitor, Ceramic, .047 uF, 50v, C52, 54, 55	3	
	90364-100	. Resistor, 10 ohm, 5%, 1/4W, R6, 35, 53, 79, 82	5	
	90364-101	. Resistor, 100 ohm, 5%, 1/4W, R77, 130	2	
	90364-102	. Resistor, 1K, 5%, 1/4W, R12, 13, 76, 81, 83, 85, 108, 112 R119, 121-124	13	
	90364-103	. Resistor, 10K, 5%, 1/4W, R66, 67	2	
	90364-122	. Resistor, 1.2K, 5%, 1/4W, R101, 102	2	
	90364-123	. Resistor, 12K, 5%, 1/4W, R47, 100	2	
	90364-131	. Resistor, 130 ohm, 5%, 1/4W, R73, 74	2	

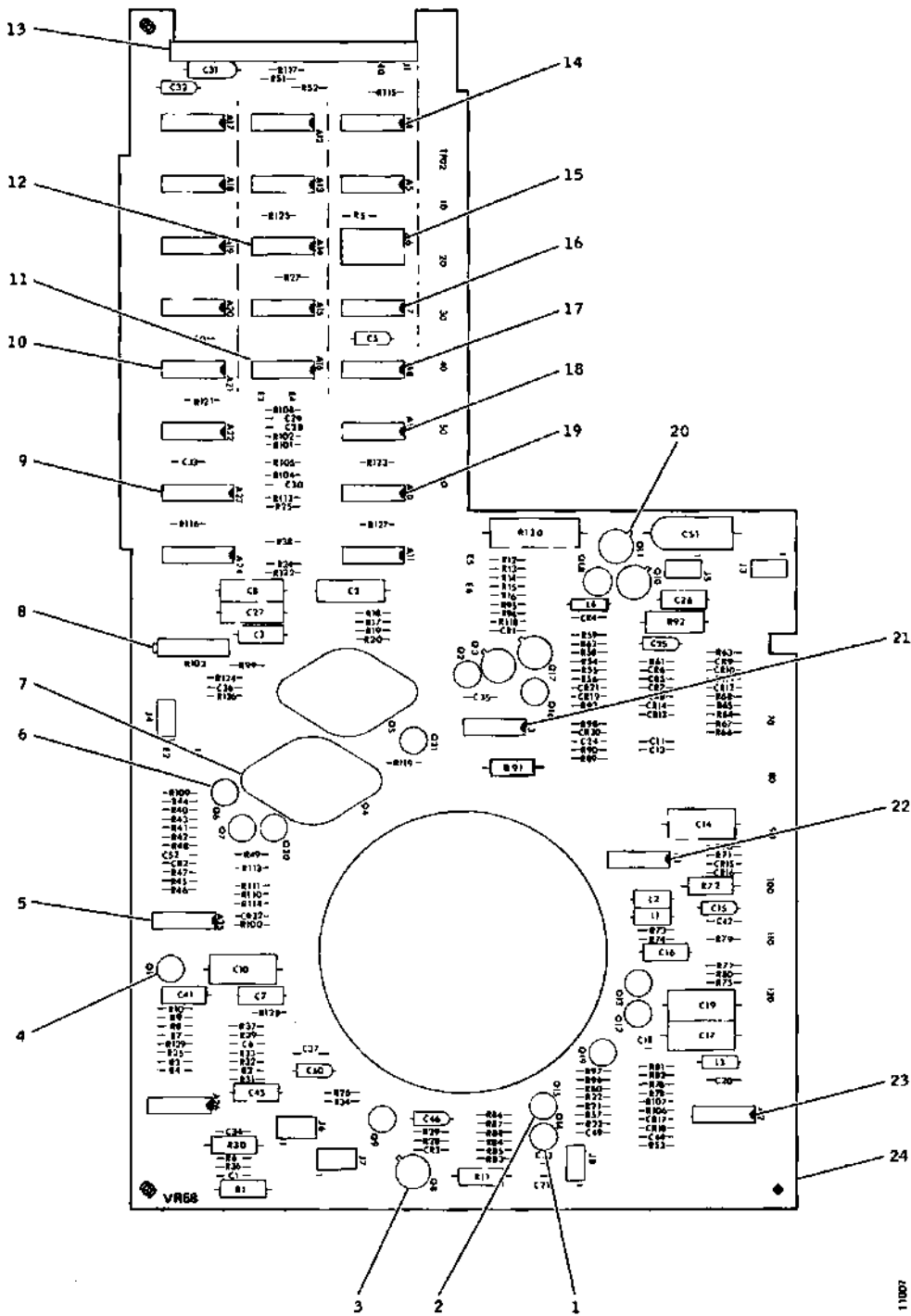

Figure S-4C. Data and Control Board Assembly, VR58

11007

FIGURE ITEM NO.	PART NUMBER	DESCRIPTION	QTY PER ASSY	USAGE CODE
4C-	90371-110	. Resistor, 100 ohm, 5%, 5W, R120	1	
	90376-130	. Inductor, Molded, 130 uH, L4	1	
	90376-240	. Inductor, Molded, 240 uH, L3	1	
	90965-330	. Inductor, Molded, 33 uH, L1, 2	2	
	90343-001	. Diode, Low-Capacitance, CR4-14, 17-19, 21	15	
	90344-001	. Diode, Rectifier, 1 Amp, 50v, CR1	1	
	90346-062	. Diode, Zener, 6.2v, 400 mW, CR2, 15, 16, 20, 22	5	
	90346-120	. Diode, Zener, 12v, 400 mW, CR3	1	
-24	13922-001	. Board, Data & Control	1	

FIGURE ITEM NO.	PART NUMBER	DESCRIPTION	QTY PER ASSY	USAGE CODE
4C-	90364-151	. Resistor, 150 ohm, 5%, 1/4W, R43	1	
	90364-152	. Resistor, 1.5K, 5%, 1/4W, R25, 49, 51, 54, 58, 85, 84, 87, R105, 113, 115	11	
	90364-153	. Resistor, 15K, 5%, 1/4W, R27	1	
	90364-182	. Resistor, 1.8K, 5%, 1/4W, R9, 39, 96	3	
	90364-201	. Resistor, 200 ohm, 5%, 1/4W, R88	1	
	90364-202	. Resistor, 2K, 5%, 1/4W, R68, 127	2	
	90364-203	. Resistor, 20K, 5%, 1/4W, R21, 70, 71, 104	4	
	90364-221	. Resistor, 220 ohm, 5%, 1/4W, R5	1	
	90364-241	. Resistor, 240 ohm, 5%, 1/4W, R10, 14, 15, 50, 52, 97, 114	7	
	90364-272	. Resistor, 2.7K, 5%, 1/4W, R75, 80	2	
	90364-302	. Resistor, 3K, 5%, 1/4W, R56, 62, 86, 116	4	
	90364-303	. Resistor, 30K, 5%, 1/4W, R64, 65	2	
	90364-330	. Resistor, 33 ohm, 5%, 1/4W, R28	1	
	90364-331	. Resistor, 330 ohm, 5%, 1/4W, R117	1	
	90364-332	. Resistor, 3.3K, 5%, 1/4W, R16, 42, 48, 111	4	
	90364-362	. Resistor, 3.6K, 5%, 1/4W, R94	1	
	90364-392	. Resistor, 3.9K, 5%, 1/4W, R55, 59, 63, 106, 107	5	
	90364-393	. Resistor, 39K, 5%, 1/4W, R38	1	
	90364-511	. Resistor, 510 ohm, 5%, 1/4W, R60, 90	2	
	90364-561	. Resistor, 560 ohm, 5%, 1/4W, R17-20, 78	5	
	90364-621	. Resistor, 620 ohm, 5%, 1/4W, R40, 41	2	
	90364-682	. Resistor, 6.8K, 5%, 1/4W, R39, 118	2	
	90364-751	. Resistor, 750 ohm, 5%, 1/4W, R8, 26, 34	3	
	90364-752	. Resistor, 7.5K, 5%, 1/4W, R29	1	
	90364-911	. Resistor, 910 ohm, 5%, 1/4W, R125, 126	2	
	90364-912	. Resistor, 9.1K, 5%, 1/4W, R37	1	
	90365-201	. Resistor, 200 ohm, 5%, 1W, R72	1	
	90365-680	. Resistor, 68 ohm, 5%, 1W, R1, 30	2	
	90365-821	. Resistor, 820 ohm, 5%, 1W, R91	1	
	90365-101	. Resistor, 100 ohm, 5%, 1W, R11	1	
	90366-249	. Resistor, 270 ohm, 5%, 3W, R93	1	
	90367-104	. Resistor, 10K, 1%, 1/8W, R7, 57	2	
	90367-118	. Resistor, 11K, 1%, 1/8W, R22	1	
	90367-131	. Resistor, 1.21K, 1%, 1/8W, R92	1	
	90367-132	. Resistor, 12.1K, 1%, 1/8W, R98, 109	2	
	90367-140	. Resistor, 127K, 1%, 1/8W, R23	1	
	90367-160	. Resistor, 14.7K, 1%, 1/8W, R3, 32	2	
	90367-202	. Resistor, 19.6K, 1%, 1/8W, R2	1	
	90367-264	. Resistor, 3.01K, 1%, 1/8W, R46	1	
	90367-314	. Resistor, 42.2K, 1%, 1/8W, R24, 99	2	
	90367-315	. Resistor, 422K, 1%, 1/8W, R44	1	
	90367-341	. Resistor, 5.11K, 1%, 1/8W, R45	1	
	90367-369	. Resistor, 6.19K, 1%, 1/8W, R61	1	
	90367-377	. Resistor, 64.9K, 1%, 1/8W, R4, 33, 128, 129	4	
	90367-383	. Resistor, 6.81K, 1%, 1/8W, R110	1	
	90367-327	. Resistor, 4.64K, 1%, 1/8W, R36	1	
	90367-390	. Resistor, 7.15K, 1%, 1/8W, R31	1	

FIGURE ITEM NO.	PART NUMBER	DESCRIPTION	QTY PER ASSY	USAGE CODE
4D-	14701-001	Board Assy, Data & Control, VR60 (see Figure 5-1 for NHA) (U/W Model 140C)	REF	G-O
-1	90328-001	. Transistor, Switching, NPN, Q14	1	
-2	90340-001	. Transistor, Switching, High-Speed, NPN, Q15	1	
-3	96385-001	. Transistor, Switching, NPN, Q3, 8	2	
-4	90327-001	. Transistor, Low-Level, PNP, Q1, 2, 7, 12, 13, 18, 19 20, 21	9	
-5	10726-001	. Amplifier, Linear, Operational, Dual, A25	1	
-6	90326-001	. Transistor, Low-Level, NPN, Q6, 9, 16	3	
-7	10208-001	. Transistor, Darlington, Dual, NPN, Q4, 5	2	
-8	92244-320	. Resistor, Variable, 10K, 20%, 3/4W, R103	1	
-9	94526-001	. Multivibrator, Dual, One-Shot, TTL, A23, A24	2	
-10	19148-001	. Gate, NAND, Quad, 2-Input, TTL, A21	1	
-11	92136-001	. Flip-Flop, Dual D, TTL, A16, 22	2	
-12	92127-001	. Gate, NAND, Hex, 1-Input, TTL, A14	1	
-13	95359-040	. Connector, J1	1	
-14	90313-001	. Gate, NAND, Dual, 4-Input, DTL, A4, A5, A12, A17	4	
-15	97272-001	. Socket, IC, 14-Pin, A6	1	
-16	95549-001	. Counter, Binary, Preset, TTL, A7	1	
-17	96389-001	. Flip-Flop, Dual D, SBD, TTL, A8	1	
-18	92128-001	. Gate, NAND, Quad, 2-Input, TTL, A9, A15, A18	3	
-19	90314-001	. Gate, NAND, Hex, 1-Input, DTL, A10, A13, A19, A20	4	
-20	90330-001	. Transistor, General-Purpose, PNP, Q10, 11, 17	3	
-21	97607-001	. Gate, Non-Invert, Hex, 1-Input, TTL A3, A11	2	
-22	10207-001	. Amplifier, Linear, Diff, A1	1	
-23	96758-001	. Amplifier, Linear, Diff Comp, A2, 26	2	
	90355-332	. Capacitor, .0033 uF, 10%, 100v, C7	1	
	18452-347	. Capacitor, Metal, Poly, .047 uF, 5%, C11, 13, 27	3	
	90355-222	. Capacitor, Mylar, .0022 uF, 100v, C3, 16, 26	3	
	90355-682	. Capacitor, Mylar, .0068 uF, 100v, C41, 45	2	
	90356-102	. Capacitor, Tantalum, 4.7 uF, 10v, C5, 25, 32	3	
	90356-204	. Capacitor, Tantalum, 2.2 uF, 20v, C15, 46, 50	3	
	90356-355	. Capacitor, Tantalum, 33 uF, 35v, C51	1	
	90356-521	. Capacitor, Tantalum, 4.7 uF, 50v, C31	1	
	90356-513	. Capacitor, Tantalum, 1.0 uF, 50v, C53	1	
	90360-004	. Capacitor, Polyester, .047 uF, 100v, C8	1	
	90360-047	. Capacitor, Polyester, .47 uF, 50v, C10, 14, 17, 19	4	
	90360-200	. Capacitor, Polyester, .22 uF, 50v, C2	1	
	95379-347	. Capacitor, Ceramic, .047 uF, 50v, C1, 6, 20, 24, 33-37 C42, 44, 49	12	
	98175-010	. Capacitor, Ceramic, 10 pF, 200v, C21	1	
	98175-118	. Capacitor, Ceramic, 180 pF, 200v, C23	1	
	98175-133	. Capacitor, Ceramic, 330 pF, 200v, C30	1	
	98175-156	. Capacitor, Ceramic, 560 pF, 200v, C18, 28, 29	3	
	98175-347	. Capacitor, Ceramic, .047 uF, 50v, C52, 54, 55	3	
	90364-100	. Resistor, 10 ohm, 5%, 1/4W, R6, 35, 53, 79, 82	5	
	90364-101	. Resistor, 100 ohm, 5%, 1/4W, R77, 130	2	
	90364-102	. Resistor, 1K, 5%, 1/4W, R12, 13, 76, 81, 83, 85, 108, 112 R119, 121-124	13	
	90364-103	. Resistor, 10K, 5%, 1/4W, R66, 67	2	
	90364-122	. Resistor, 1.2K, 5%, 1/4W, R101, 102	2	
	90364-123	. Resistor, 12K, 5%, 1/4W, R47, 100	2	
	90364-131	. Resistor, 130 ohm, 5%, 1/4W, R73, 74	2	

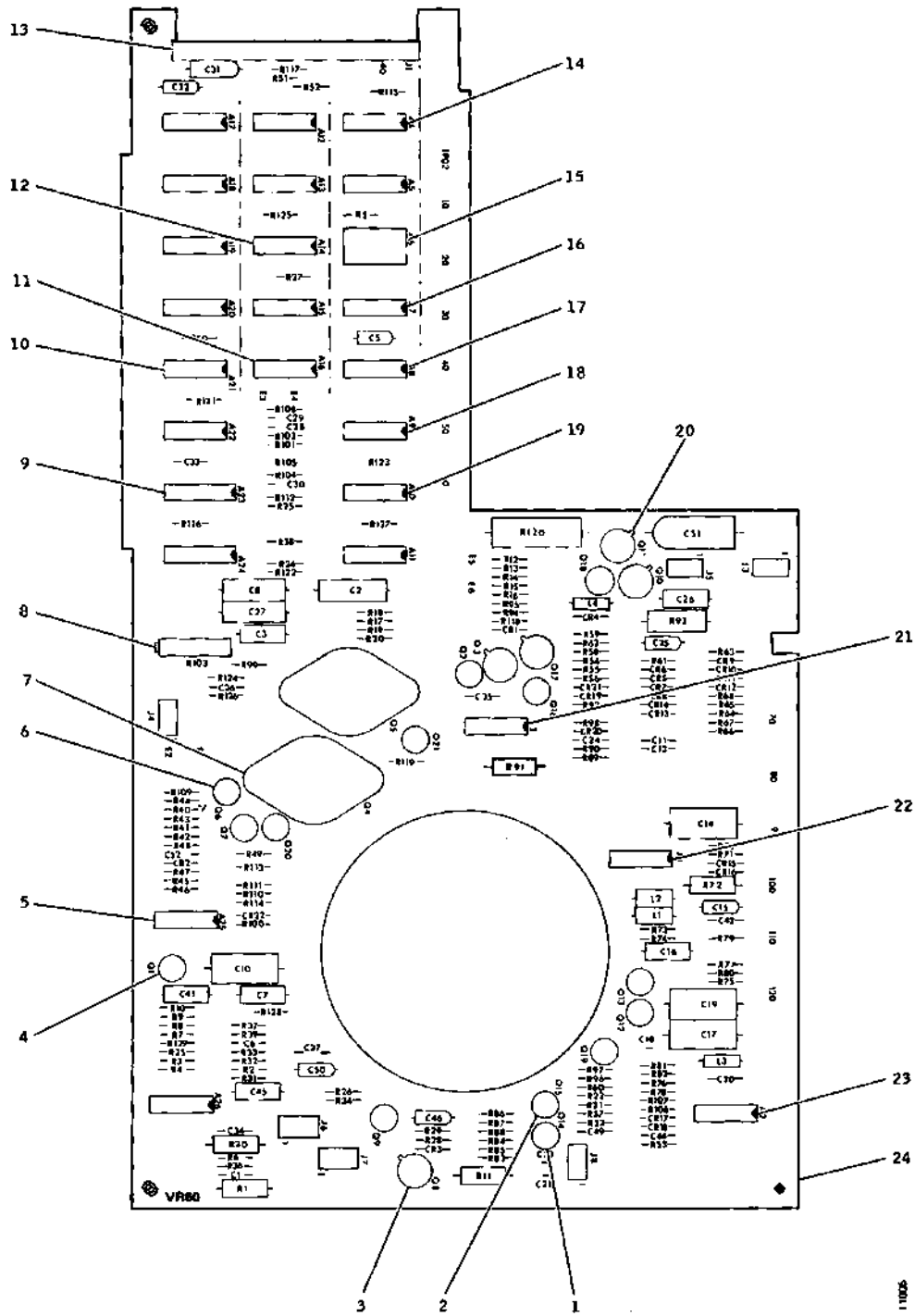

Figure 5-4D. Data and Control Board Assembly, VR60

FIGURE ITEM NO.	PART NUMBER	DESCRIPTION	QTY PER ASSY	USAGE CODE
4D-	90371-110	. Resistor, 100 ohm, 5%, 5W, R120	1	
	90376-130	. Inductor, Molded, 130 uH, L4	1	
	90376-240	. Inductor, Molded, 240 uH, L3	1	
	90965-330	. Inductor, Molded, 33 uH, L1, 2	2	
	90343-001	. Diode, Low-Capacitance, CR4-14, 17-19, 21	15	
	90344-001	. Diode, Rectifier, 1 Amp, 50v, CR1	1	
	90346-062	. Diode, Zener, 6.2v, 400 mW, CR2, 15, 16, 20, 22	5	
	90346-120	. Diode, Zener, 12v, 400 mW, CR3	1	
	-24	13922-001	. Board, Data & Control	1

FIGURE ITEM NO.	PART NUMBER	DESCRIPTION	QTY PER ASSY	USAGE CODE
4D-	90364-151	. Resistor, 150 ohm, 5%, 1/4W, R43	1	
	90364-152	. Resistor, 1.5K, 5%, 1/4W, R25, 49, 51, 54, 58, 85, 84, 87, R105, 113, 115	11	
	90364-153	. Resistor, 15K, 5%, 1/4W, R27	1	
	90364-182	. Resistor, 1.8K, 5%, 1/4W, R9, 39, 96	3	
	90364-201	. Resistor, 200 ohm, 5%, 1/4W, R88	1	
	90364-202	. Resistor, 2K, 5%, 1/4W, R68, 127	2	
	90364-203	. Resistor, 20K, 5%, 1/4W, R21, 70, 71, 104	4	
	90364-221	. Resistor, 220 ohm, 5%, 1/4W, R5	1	
	90364-241	. Resistor, 240 ohm, 5%, 1/4W, R10, 14, 15, 50, 52, 97, 114	7	
	90364-272	. Resistor, 2.7K, 5%, 1/4W, R75, 80	2	
	90364-302	. Resistor, 3K, 5%, 1/4W, R56, 62, 86, 116	4	
	90364-303	. Resistor, 30K, 5%, 1/4W, R64, 65	2	
	90364-330	. Resistor, 33 ohm, 5%, 1/4W, R28	1	
	90364-331	. Resistor, 330 ohm, 5%, 1/4W, R117	1	
	90364-332	. Resistor, 3.3K, 5%, 1/4W, R16, 42, 48, 111	4	
	90364-362	. Resistor, 3.6K, 5%, 1/4W, R94	1	
	90364-392	. Resistor, 3.9K, 5%, 1/4W, R55, 59, 63, 106, 107	5	
	90364-393	. Resistor, 39K, 5%, 1/4W, R38	1	
	90364-511	. Resistor, 510 ohm, 5%, 1/4W, R60, 90	2	
	90364-561	. Resistor, 560 ohm, 5%, 1/4W, R17-20, 78	5	
	90364-621	. Resistor, 620 ohm, 5%, 1/4W, R40, 41	2	
	90364-682	. Resistor, 6.8K, 5%, 1/4W, R39, 118	2	
	90364-751	. Resistor, 750 ohm, 5%, 1/4W, R8, 26, 34	3	
	90364-752	. Resistor, 7.5K, 5%, 1/4W, R29	1	
	90364-911	. Resistor, 910 ohm, 5%, 1/4W, R125, 126	2	
	90364-912	. Resistor, 9.1K, 5%, 1/4W, R37	1	
	90365-201	. Resistor, 200 ohm, 5%, 1W, R72	1	
	90365-680	. Resistor, 68 ohm, 5%, 1W, R1, 30	2	
	90365-821	. Resistor, 820 ohm, 5%, 1W, R91	1	
	90365-101	. Resistor, 100 ohm, 5%, 1W, R11	1	
	90366-249	. Resistor, 270 ohm, 5%, 3W, R93	1	
	90367-104	. Resistor, 10K, 1%, 1/8W, R7, 57	2	
	90367-118	. Resistor, 11K, 1%, 1/8W, R22	1	
	90367-131	. Resistor, 1.21K, 1%, 1/8W, R92	1	
	90367-132	. Resistor, 12.1K, 1%, 1/8W, R98, 109	2	
	90367-140	. Resistor, 127K, 1%, 1/8W, R23	1	
	90367-160	. Resistor, 14.7K, 1%, 1/8W, R3, 32	2	
	90367-202	. Resistor, 19.6K, 1%, 1/8W, R2	1	
	90367-264	. Resistor, 3.01K, 1%, 1/8W, R46	1	
	90367-314	. Resistor, 42.2K, 1%, 1/8W, R24, 99	2	
	90367-315	. Resistor, 422K, 1%, 1/8W, R44	1	
	90367-341	. Resistor, 5.11K, 1%, 1/8W, R45	1	
	90367-369	. Resistor, 6.19K, 1%, 1/8W, R61	1	
	90367-377	. Resistor, 64.9K, 1%, 1/8W, R4, 33, 128, 129	4	
	90367-383	. Resistor, 6.81K, 1%, 1/8W, R110	1	
	90367-327	. Resistor, 4.64K, 1%, 1/8W, R36	1	
	90367-390	. Resistor, 7.15K, 1%, 1/8W, R31	1	

FIGURE ITEM NO.	PART NUMBER	DESCRIPTION	QTY PER ASSY	USAGE CODE
4E.	17284-001	Board Assy, Data & Control, VR82 (see Figure 5-1 for NHA) (U/W Model 142 options -01X, -03X)	REF	X-AE
-1	90328-001	. Transistor, Switching, NPN, Q14	1	
-2	10726-001	. Amplifier, Linear, Operational, Dual, A25	1	
-3	90327-001	. Transistor, Low-Level, PNP, Q1, 2, 7, 12, 15 13, 18, 19, Q20, 21	10	
-4	90327-001	. Transistor, Low-Level, NPN, Q6, 9, 16	3	
-5	19094-001	. Transistor, Darlington, NPN, Q4, 5, 22, 23	4	
-6	92244-320	. Resistor, Variable, 10K, 20%, 3/4W, R103	1	
-7	94526-001	. Multivibrator, Dual, One-Shot, TTL, A23, A24	2	
-8	19148-001	. Gate, NAND, Quad, 2-Input, TTL, A21	1	
-9	92136-001	. Flip-Flop, Dual D, TTL, A16, 22	2	
-10	92127-001	. Gate, NAND, Hex, 1-Input, TTL, A14	1	
-11	95359-040	. Connector, J1	1	
-12	90313-001	. Gate, NAND, Dual, 4-Input, DTL, A4, A5, A12, A17	4	
-13	97272-001	. Socket, IC, 14-Pin, A6	1	
-14	95549-001	. Counter, Binary, Preset, TTL, A7	1	
-15	96389-001	. Flip-Flop, Dual D, SBD, TTL, A8	1	
-16	92128-001	. Gate, NAND, Quad, 2-Input, TTL, A9, A15, A18	3	
-17	90314-001	. Gate, NAND, Hex, 1-Input, DTL, A10, A13, A19, A20	4	
-18	96385-001	. Transistor, Switching, NPN, Q3, 8	2	
-19	90330-001	. Transistor, General-Purpose, PNP, Q10, 11, 17	3	
-20	97607-001	. Gate, Non-Invert, Hex, 1-Input, TTL A3, A11	2	
-21	10207-001	. Amplifier, Linear, Diff, A1	1	
-22	96758-001	. Amplifier, Linear, Diff Comp, A2, 26	2	
	90355-332	. Capacitor, .0033 uF, 10%, 100v, C7	1	
	18452-347	. Capacitor, Metal, Poly, .047 uF, 5%, C11, 13, 27	3	
	90355-222	. Capacitor, Mylar, .0022 uF, 100v, C3, 26	2	
	90355-682	. Capacitor, Mylar, .0068 uF, 100v, C41, 45	2	
	90356-102	. Capacitor, Tantalum, 4.7 uF, 10v, C5, 32	2	
	90356-204	. Capacitor, Tantalum, 2.2 uF, 20v, C15, 46, 50	3	
	90356-355	. Capacitor, Tantalum, 33 uF, 35v, C51	1	
	90356-521	. Capacitor, Tantalum, 4.7 uF, 50v, C31	1	
	90356-513	. Capacitor, Tantalum, 1.0 uF, 50v, C53	1	
	90360-004	. Capacitor, Polyester, .047 uF, 100v, C8	1	
	90360-047	. Capacitor, Polyester, .47 uF, 50v, C10, 14, 25	3	
	90360-120	. Capacitor, Polyester, .2 uF, 50v, C17	1	
	90360-200	. Capacitor, Polyester, .22 uF, 50v, C2	1	
	95379-347	. Capacitor, Ceramic, .047 uF, 50v, C1, 4, 16, 9, 20, 12, 24 C33-37, 44, 49, 19	15	
	90354-821	. Capacitor, Mica, 820 pF, 100v, C16, 18	2	
	98175-133	. Capacitor, 330 pF, 200v, C30	1	
	98175-156	. Capacitor, 560 pF, 200v, C28, 29	2	
	98175-347	. Capacitor, Ceramic, .047 uF, 50v, C52	1	
	90364-100	. Resistor, 10 ohm, 5%, 1/4W, R6, 35, 53, 106	4	
	90364-101	. Resistor, 100 ohm, 5%, 1/4W, R77, 87	2	
	90364-102	. Resistor, 1K, 5%, 1/4W, R12, 13, 95, 108, 112, 119, 121-124	10	
	90364-122	. Resistor, 1.2K, 5%, 1/4W, R101, 102	2	
	90364-151	. Resistor, 150 ohm, 5%, 1/4W, R43	1	
	90364-152	. Resistor, 1.5K, 5%, 1/4W, R25, 49, 51, 54, 58, 105, 113, 115	8	

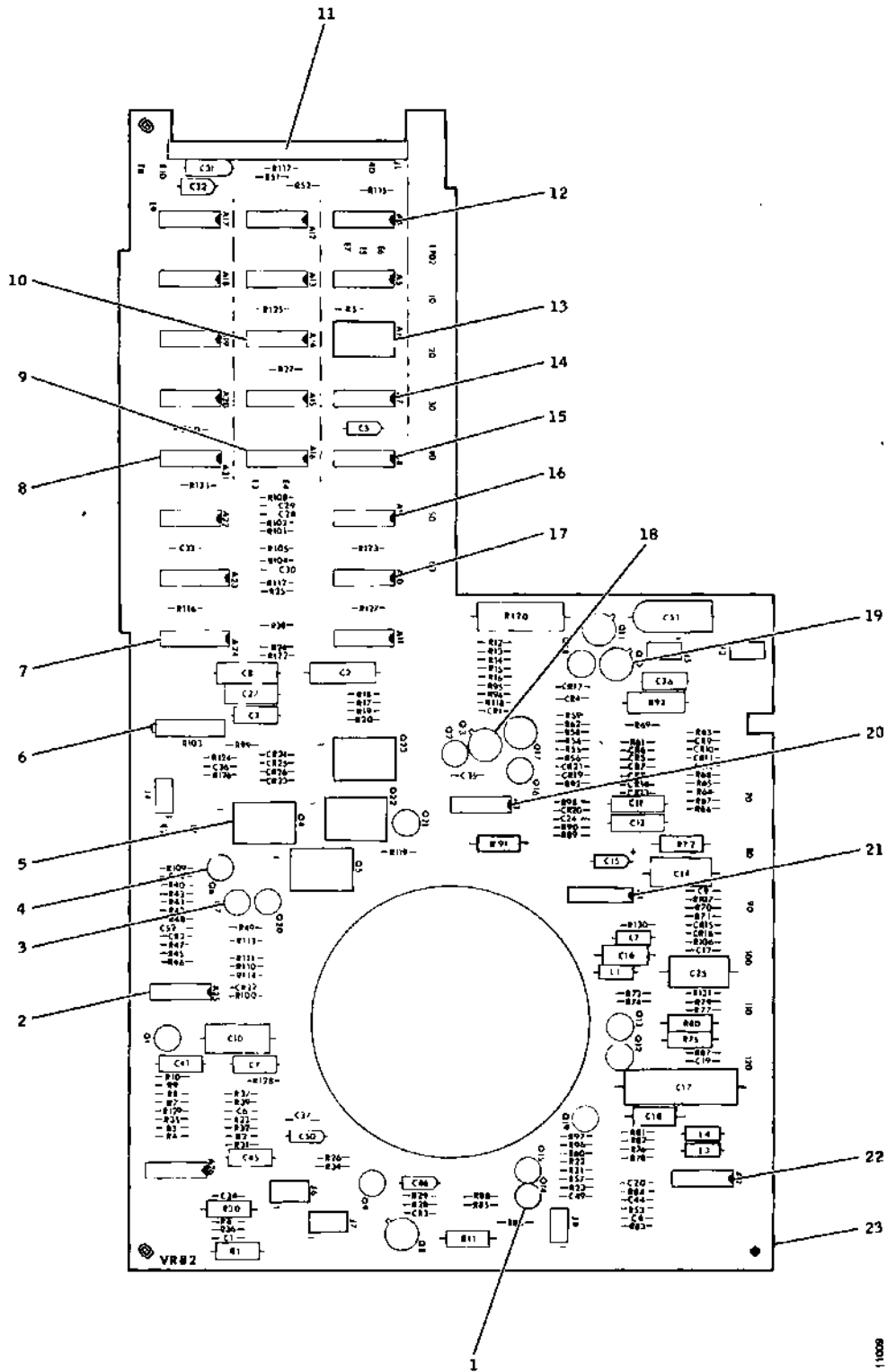

Figure 5-4E. Data and Control Board Assembly, VR82

FIGURE ITEM NO.	PART NUMBER	DESCRIPTION	QTY PER ASSY	USAGE CODE
4E-	90367-200	. Resistor, 196 ohm, 1%, 1/8W, R130, 131	2	
	90367-235	. Resistor, 249 ohm, 1%, 1/8W, R76, 81	2	
	90367-333	. Resistor, 4.87 ohm, 1%, 1/8W, R78	1	
	90367-292	. Resistor, 3.65K, 1%, 1/8W, R69	1	
	90367-109	. Resistor, 105 ohm, 1%, 1/8W, R73, 74	2	
	93952-026	. Resistor, 681 ohm, 1%, 1W, R75, 80	2	
	17172-001	. Diode, Switching, VHF/UHF, CR7, 8, 13, 14	4	
	17102-062	. Diode, Zener, 6.2v, 400 mv, CR20	1	
	90376-068	. Inductor, Molded, 68 uH, L1, 2, 3, 4	4	
	90343-001	. Diode, Low-Capacitance, CR4-8, 17-19, 21, 9-12, 23-26	14	
	90344-001	. Diode, Rectifier, 1 Amp, 50v, CR1	1	
	90346-062	. Diode, Zener, 6.2v, 400mv, CR2, 15, 16, 22	4	
	90346-120	. Diode, Zener, 12v, 400mv, CR3	1	
	-23	17285-001	. Board, Data & Control	1

FIGURE ITEM NO.	PART NUMBER	DESCRIPTION	QTY PER ASSY	USAGE CODE
4E-	90364-153	. Resistor, 15K, 5%, 1/4W, R27	1	
	90364-182	. Resistor, 1.8K, 5%, 1/4W, R9, 96	2	
	90364-222	. Resistor, 2.2K, 5%, 1/4W, R8	1	
	90364-202	. Resistor, 2K, 5%, 1/4W, R127	1	
	90364-203	. Resistor, 20K, 5%, 1/4W, R21, 104, 128, 129	4	
	90364-221	. Resistor, 220 ohm, 5%, 1/4W, R5	1	
	90364-241	. Resistor, 240 ohm, 5%, 1/4W, R10, 14, 15, 50 52, 97, 114	7	
	90364-470	. Resistor, 47 ohm, 5%, 1/4W, R83	1	
	90364-302	. Resistor, 3K, 5%, 1/4W, R56, 62, 116	3	
	90364-330	. Resistor, 33 ohm, 5%, 1/4W, R28, 82, 79	3	
	90364-331	. Resistor, 330 ohm, 5%, 1/4W, R117	1	
	90364-332	. Resistor, 3.3K, 5%, 1/4W, R16, 42, 48, 111, 107	5	
	90364-362	. Resistor, 3.6K, 5%, 1/4W, R94	1	
	90364-392	. Resistor, 3.9K, 5%, 1/4W, R55, 59, 63	3	
	90364-393	. Resistor, 39K, 5%, 1/4W, R38	1	
	90364-511	. Resistor, 510 ohm, 5%, 1/4W, R60, 90, 89	3	
	90364-561	. Resistor, 560 ohm, 5%, 1/4W, R17-20	4	
	90364-621	. Resistor, 620 ohm, 5%, 1/4W, R40, 41	2	
	90364-751	. Resistor, 750 ohm, 5%, 1/4W, R8, 26, 34	3	
	90364-752	. Resistor, 7.5K, 5%, 1/4W, R29	1	
	90364-911	. Resistor, 910 ohm, 5%, 1/4W, R125, 126	2	
	90364-912	. Resistor, 9.1K, 5%, 1/4W, R37	1	
	90365-201	. Resistor, 200 ohm, 5%, 1W, R72	1	
	90365-680	. Resistor, 68 ohm, 5%, 1W, R1, 30	2	
	90365-821	. Resistor, 820 ohm, 5%, 1W, R91	1	
	90365-101	. Resistor, 100 ohm, 5%, 1W, R11	1	
	90366-249	. Resistor, 270 ohm, 5%, 3W, R93	1	
	90367-104	. Resistor, 10K, 1%, 1/8W, R7, 57	2	
	90367-118	. Resistor, 11K, 1%, 1/8W, R22	1	
	90367-355	. Resistor, 562K, 1%, 1/8W, R70, 71	2	
	90367-132	. Resistor, 12.1K, 1%, 1/8W, R109	1	
	90367-140	. Resistor, 127K, 1%, 1/8W, R23	1	
	90367-160	. Resistor, 14.7K, 1%, 1/8W, R3, 32	2	
	90367-202	. Resistor, 19.6K, 1%, 1/8W, R2	1	
	90367-264	. Resistor, 3.01K, 1%, 1/8W, R46	1	
	90367-314	. Resistor, 42.0K, 1%, 1/8W, R24	1	
	90367-315	. Resistor, 422K, 1%, 1/8W, R44	1	
	90367-341	. Resistor, 5.11K, 1%, 1/8W, R45	1	
	90367-348	. Resistor, 5.36K, 1%, 1/8W, R66, 67	2	
	90367-377	. Resistor, 64.9K, 1%, 1/8W, R4, 33	2	
	90367-383	. Resistor, 6.81K, 1%, 1/8W, R110	1	
	90367-327	. Resistor, 4.64K, 1%, 1/8W, R36	1	
	90367-390	. Resistor, 4.15K, 1%, 1/8W, R31	1	
	90367-368	. Resistor, 61.9 ohm, 1%, 1/8W, R85	1	
	90371-110	. Resistor, 100 ohm, 5%, 5W, R120	1	
	90367-187	. Resistor, 1.78K, 1%, 1/8W, R92	1	
	90367-369	. Resistor, 6.19K, 1%, 1/8W, R61	1	
	90367-158	. Resistor, 147 ohm, 1%, 1/8W, R88	1	
	90367-174	. Resistor, 16.2K, 1%, 1/8W, R64, 65	2	
	90367-362	. Resistor, 5.90K, 1%, 1/8W, R98	1	
	90367-228	. Resistor, 237 ohm, 1%, 1/8W, R86	1	

FIGURE ITEM NO.	PART NUMBER	DESCRIPTION	QTY PER ASSY	USAGE CODE
4F-	17287-001	Board Assy, Data & Control, VR83 (see Figure 5-1 for NHA) (U/W Model 142 options -00X, -02X, -04X, & -05X)	REF	X-AE
-1	90328-002	. Transistor, Switching, NPN, Q14	1	
-2	90326-001	. Transistor, Low-Level, NPN, Q6, 9, 16	3	
-3	90327-001	. Transistor, Low-Level, PNP, Q1, 2, 7, 12, 13, 15, 18, 19, Q20, 21	10	
-4	10726-001	. Amplifier, Linear, Operational, Dual, A25	1	
-5	19094-001	. Transistor, Darlington, NPN, Q4, 5, 22, 23	4	
-6	92244-320	. Resistor, Variable, 10K, 20%, 3/4W, R103	1	
-7	94526-001	. Multivibrator, Dual, One-Shot, TTL, A23, A24	2	
-8	19148-001	. Gate, NAND, Quad, 2-Input, TTL, A21	1	
-9	92136-001	. Flip-Flop, Dual D, TTL, A16, 22	2	
-10	92127-001	. Gate, NAND, Hex, 1-Input, TTL, A14	1	
-11	95359-040	. Connector, J1	1	
-12	90313-001	. Gate, NAND, Dual, 4-Input, DTL, A10, A13, A12, A17	4	
-13	97272-001	. Socket, IC, 14-Pin, A6	1	
-14	95549-001	. Counter, Binary, Preset, TTL, A7	1	
-15	96389-001	. Flip-Flop, Dual D, SBD, TTL, A8	1	
-16	92128-001	. Gate, NAND, Quad, 2-Input, TTL, A9, A15, A18	3	
-17	90314-001	. Gate, NAND, Hex, 1-Input, DTL, A10, A13, A19, A20	4	
-18	96385-001	. Transistor, Switching, NPN, Q3, 8	2	
-19	90330-001	. Transistor, General-Purpose, PNP, Q10, 11, 17	3	
-20	97507-001	. Gate, Non-Invert, Hex, 1-Input, TTL A3, A11	2	
-21	10207-001	. Amplifier, Linear, Diff, A1	1	
-22	96758-001	. Amplifier, Linear, Diff Comp, A2, 26	2	
	90355-332	. Capacitor, .0033 uF, 10%, 100v, C7	1	
	18452-347	. Capacitor, Metal, Poly, .047 uF, 5%, C11, 13, 27	3	
	90355-222	. Capacitor, Mylar, .0022 uF, 100v, C3, 26	2	
	90355-682	. Capacitor, Mylar, .0068 uF, 100v, C41, 45	2	
	90356-102	. Capacitor, Tantalum, 4.7 uF, 10v, C5, 32	2	
	90356-204	. Capacitor, Tantalum, 2.2 uF, 20v, C15, 46, 50	3	
	90356-355	. Capacitor, Tantalum, 33 uF, 35v, C51	1	
	90356-521	. Capacitor, Tantalum, 4.7 uF, 50v, C31	1	
	90360-004	. Capacitor, Polyester, .047 uF, 100v, C8	1	
	90360-047	. Capacitor, Polyester, .47 uF, 50v, C10, 14, 25	3	
	90360-120	. Capacitor, Polyester, 2 uF, 50v, C17	1	
	90354-821	. Capacitor, Mica, 820 pF, 100v, C16, 18	2	
	90360-200	. Capacitor, Polyester, .22 uF, 50v, C2	1	
	95379-347	. Capacitor, Ceramic, .047 uF, 50v, C14, 16, 20, 9, 24, C33-37, 42, 44, 49, 12	15	
	98175-133	. Capacitor, Ceramic, 330 pF, 200v, C30	1	
	98175-156	. Capacitor, Ceramic, 560 pF, 200v, C28, 29	2	
	98175-347	. Capacitor, Ceramic, .047 uF, 50v, C52	1	
	90364-100	. Resistor, 10 ohm, 5%, 1/4W, R6, 35, 53, 106	4	
	90367-101	. Resistor, 10 ohm, 1%, 1/8W, R77, 87	2	
	90364-102	. Resistor, 1K, 5%, 1/4W, R12, 13, 108, 112, 119, 121-124, 95	10	
	90364-122	. Resistor, 1.2K, 5%, 1/4W, R101, 102	2	
	90364-123	. Resistor, 12K, 5%, 1/4W, R47, 100	2	
	90364-151	. Resistor, 150 ohm, 5%, 1/4W, R43	1	
	90364-152	. Resistor, 1.5K, 5%, 1/4W, R25, 49, 51, 54, 58, 105, 113, 115	8	

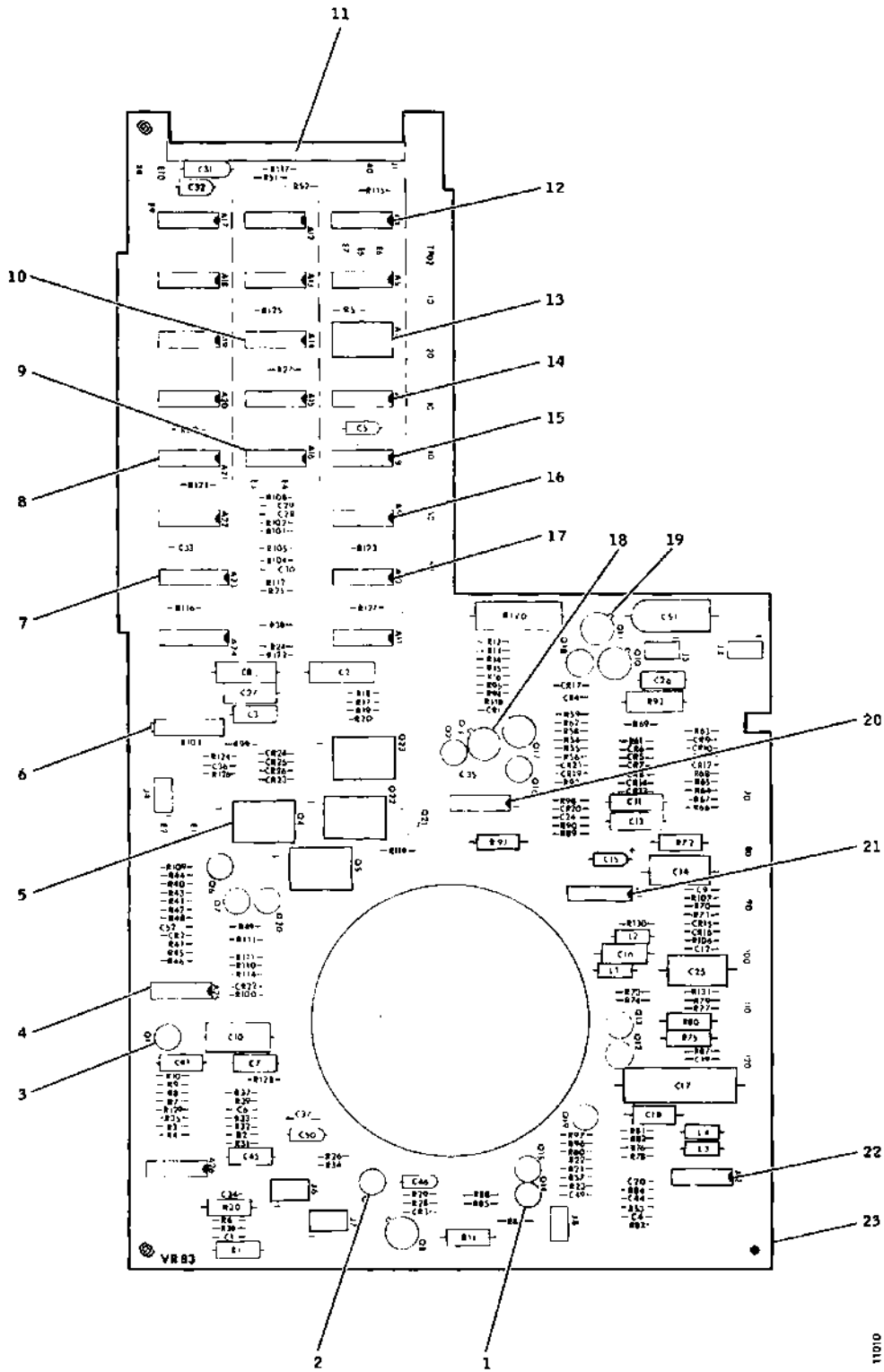

Figure S-4F. Data and Control Board Assembly, VR83

11010

FIGURE ITEM NO.	PART NUMBER	DESCRIPTION	QTY PER ASSY	USAGE CODE
4F-	90367-383	. Resistor, 6.81K, 1%, 1/8W, R110	1	
	90367-327	. Resistor, 4.64K, 1%, 1/8W, R36, 84	2	
	90367-390	. Resistor, 7.15K, 1%, 1/8W, R31	1	
	90367-355	. Resistor, 5.62K, 1%, 1/8W, R70, 71	2	
	90367-368	. Resistor, 619 ohm, 1%, 1/8W, R85	1	
	90367-200	. Resistor, 196 ohm, 1%, 1/8W, R130, 131	2	
	90367-228	. Resistor, 237 ohm, 1%, 1/8W, R86	1	
	90371-110	. Resistor, 100 ohm, 5%, 5W, R120	1	
	90376-068	. Inductor, Molded, 68 uH, L1, 2, 3, 4	4	
	90343-001	. Diode, Low-Capacitance, CR4-16, 17-19, 21, 23-26, 9-12	14	
	90344-001	. Diode, Rectifier, 1 Amp, 50v, CR1	1	
	90346-062	. Diode, Zener, 6.2v, 400mv, CR2, 15, 16, 22	4	
	90346-120	. Diode, Zener, 12v, 400mv, CR3	1	
	17172-001	. Diode, Switching, CR7, 8, 13, 14	4	
	17202-062	. Diode, Zener, 6.2v, CR20	1	
	-23	17288-001	. Board, Data & Control	1

FIGURE ITEM NO.	PART NUMBER	DESCRIPTION	QTY PER ASSY	USAGE CODE
4F-	90364-153	. Resistor, 15K, 5%, 1/4W, R27	1	
	90364-182	. Resistor, 1.8K, 5%, 1/4W, R9, 96	2	
	90364-202	. Resistor, 2K, 5%, 1/4W, R127	1	
	90364-203	. Resistor, 20K, 5%, 1/4W, R21, 104	2	
	90364-221	. Resistor, 220 ohm, 5%, 1/4W, R5	1	
	90364-241	. Resistor, 240 ohm, 5%, 1/4W, R10, 14, 15, 50, 52, 97, 114	7	
	90364-302	. Resistor, 3K, 5%, 1/4W, R56, 62, 116	3	
	90364-330	. Resistor, 33 ohm, 5%, 1/4W, R28, 79, 82	3	
	90364-331	. Resistor, 330 ohm, 5%, 1/4W, R117	1	
	90364-332	. Resistor, 3.3K, 5%, 1/4W, R16, 42, 48, 111, 107	5	
	90364-362	. Resistor, 3.6K, 5%, 1/4W, R94	1	
	90364-392	. Resistor, 3.9K, 5%, 1/4W, R55, 59, 63	3	
	90364-393	. Resistor, 39K, 5%, 1/4W, R38	1	
	90364-511	. Resistor, 510 ohm, 5%, 1/4W, R60, 90, 89	3	
	90364-561	. Resistor, 560 ohm, 5%, 1/4W, R17-20	4	
	90364-621	. Resistor, 620 ohm, 5%, 1/4W, R40, 41	2	
	90364-682	. Resistor, 6.8K, 5%, 1/4W, R39, 118	2	
	90364-751	. Resistor, 750 ohm, 5%, 1/4W, R8, 26, 34	3	
	95952-026	. Resistor, 681 ohm, 1%, 1W, R75, 80	2	
	90364-222	. Resistor, 2.2K, 5%, 1/4W, R68	1	
	90364-470	. Resistor, 47 ohm, 5%, 1/4W, R83	1	
	90364-752	. Resistor, 7.5K, 5%, 1/4W, R29	1	
	90364-911	. Resistor, 910 ohm, 5%, 1/4W, R125, 126	2	
	90364-912	. Resistor, 9.1K, 5%, 1/4W, R37	1	
	90365-201	. Resistor, 200 ohm, 5%, 1W, R72	1	
	90365-680	. Resistor, 68 ohm, 5%, 1W, R1, 30	2	
	90365-821	. Resistor, 820 ohm, 5%, 1W, R91	1	
	90365-101	. Resistor, 100 ohm, 5%, 1W, R11	1	
	90366-249	. Resistor, 270 ohm, 5%, 3W, R93	1	
	90367-104	. Resistor, 10K, 1%, 1/8W, R7, 57	2	
	90367-118	. Resistor, 11K, 1%, 1/8W, R22	1	
	90367-174	. Resistor, 16.2K, 1%, 1/8W, R64, 65	2	
	90367-187	. Resistor, 1.78K, 1%, 1/8W, R92	1	
	90367-348	. Resistor, 5.36K, 1%, 1/8W, R66, 67	2	
	90367-158	. Resistor, 5.36K, 1%, 1/8W, R66, 67	2	
	90367-109	. Resistor, 105 ohm, 1%, 1/8W, R73, 74	2	
	90367-362	. Resistor, 5.90K, 1%, 1/8W, R98	1	
	90367-132	. Resistor, 12.1K, 1%, 1/8W, R109	1	
	90367-140	. Resistor, 127K, 1%, 1/8W, R23	1	
	90367-160	. Resistor, 14.7K, 1%, 1/8W, R3, 32	2	
	90367-202	. Resistor, 19.6K, 1%, 1/8W, R2	1	
	90367-235	. Resistor, 249 ohm, 1%, 1/8W, R76, 81	2	
	90367-333	. Resistor, 487 ohm, 1%, 1/8W, R78	1	
	90367-292	. Resistor, 3.65K, 1%, 1/8W, R69	1	
	90367-264	. Resistor, 3.01K, 1%, 1/8W, R46	1	
	90367-314	. Resistor, 42.0K, 1%, 1/8W, R24, 99	2	
	90367-315	. Resistor, 422K, 1%, 1/8W, R44	1	
	90367-341	. Resistor, 5.11K, 1%, 1/8W, R45	1	
	90367-369	. Resistor, 6.19K, 1%, 1/8W, R61	1	
	90367-377	. Resistor, 64.9K, 1%, 1/8W, R4, 33, 128, 129	4	

FIGURE ITEM NO.	PART NUMBER	DESCRIPTION	QTY PER ASSY	USAGE CODE
5-	15967-001	Board Assy, Data Decoder with PLO, VR71	REF	
-1	96390-001	. Line Driver, Dual, 4-Input, SDB, TTL, A17		
-2	90364-431	. Resistor, 430 ohm, 5%, 1/8W, R3	1	
-3	90364-361	. Resistor, 360 ohm, 5%, 1/4W, R42	1	
-4	90364-471	. Resistor, 470 ohm, 5%, 1/4W, R4, 8, 9	3	
-5	98175-068	. Capacitor, Ceramic, 33 pF, 200v, C1, 3, 4	3	
-6	90364-152	. Resistor, 1.5K, 5%, 1/4W, R10, 11	2	
-7	90364-392	. Resistor, 3.9K, 5%, 1/4W, R13, 43	2	
-8	90328-001	. Transistor, Switching, NPN, Q1, 2, 3, 6	4	
-9	10357-001	. Diode, Low-Capacitance, CR1-4	4	
-10	98175-215	. Capacitor, Ceramic, 1500 pF, 100v, C9	1	
-11	12404-001	. Amplifier, Linear Operational, A15	1	
-12	90346-047	. Diode, Zener, 4.7v, VR1	1	
-13	90367-103	. Resistor, 1K, 1%, 1/8W, R22	1	
-14	90365-391	. Resistor, 390 ohm, 5%, 1W, R23	1	
-15	98175-410	. Capacitor, Ceramic, 0.1 uF, 50v, C35, 36	2	
-16	90365-821	. Resistor, 820 ohm, 5%, 1W, R24, 29	2	
-17	90367-362	. Resistor, 590K, 1%, 1/8W, R26, 33	2	
-18	90364-104	. Resistor, 100K, 5%, 1/4W, R27	1	
-19	90364-391	. Resistor, 390 ohm, 5%, 1/4W, R28, 30	2	
-20	90327-001	. Transistor, Low-Level, PNP, Q4, 5	2	
-21	90354-101	. Capacitor, Mica, 100 pF, 5%, 500v, C11, 14	2	
-22	90343-001	. Diode, Low-Capacitance Switch, CR5-7	3	
-23	90346-056	. Diode, Zener, 5.6v, VR5	1	
-24	90356-156	. Capacitor, Tantalum, 68 uF, 15v, C12	1	
-25	90356-355	. Capacitor, Tantalum, 33 uF, 10%, 500v, C33	1	
-26	98175-347	. Capacitor, Ceramic, 0.047 pF, 50v, C7, 8, 13, 15-20, 22-32, C34	22	
-27	92244-150	. Resistor, Variable, 500 ohm, R17	1	
-28	90367-337	. Resistor, 4.87K, 1%, 1/8W, R16, 18	2	
-29	92244-325	. Resistor, Variable, 25K, R5	1	
-30	90364-102	. Resistor, 1K, 5%, 1/4W, R1, 2, 6, 7, 25, 32, 34-38	11	
-31	94526-001	. Multivibrator, Dual, One-Shot, TTL, A8	1	
-32	98175-133	. Capacitor, Ceramic, 330 pF, 200v, C2	1	
-33	96389-001	. Flip-Flop, Dual D, SBD, TTL, A9-13, 16, 18	7	
-34	90364-122	. Resistor, 1.2K, 5%, 1/4W, R40, 41	2	
-35	98445-001	. Diode, Multijunction, CR8	1	
-36	10781-510	. Capacitor, Ceramic, 1 uF, 50v, C10	1	
-37	90364-511	. Resistor, 510 ohm, 5%, 1/4W, R31	1	
-38	90346-051	. Diode, Zener, 5.1v, VR2, 3, 4	3	
-39	90367-356	. Resistor, 56.2K, 1%, 1/8W, R20, 21	2	
-40	90367-341	. Resistor, 5.11K, 1%, 1/8W, R14, 15, 19, 39	4	
-41	96156-001	. Gate, NAND, Hex, 1-Input, SBD, TTL, A2, 7	2	
-42	90364-242	. Resistor, 2.4K, 5%, 1/4W, R12, 43	2	
-43	98175-033	. Capacitor, Ceramic, 33 pF, 200v, C5, 6	2	
-44	96155-001	. Gate, NAND, Quad, 2-Input, SBD, TTL, A1, 3-6 14, 19	7	
-45	15968-001	. Board, Read Decoder with PLO, PWB	1	

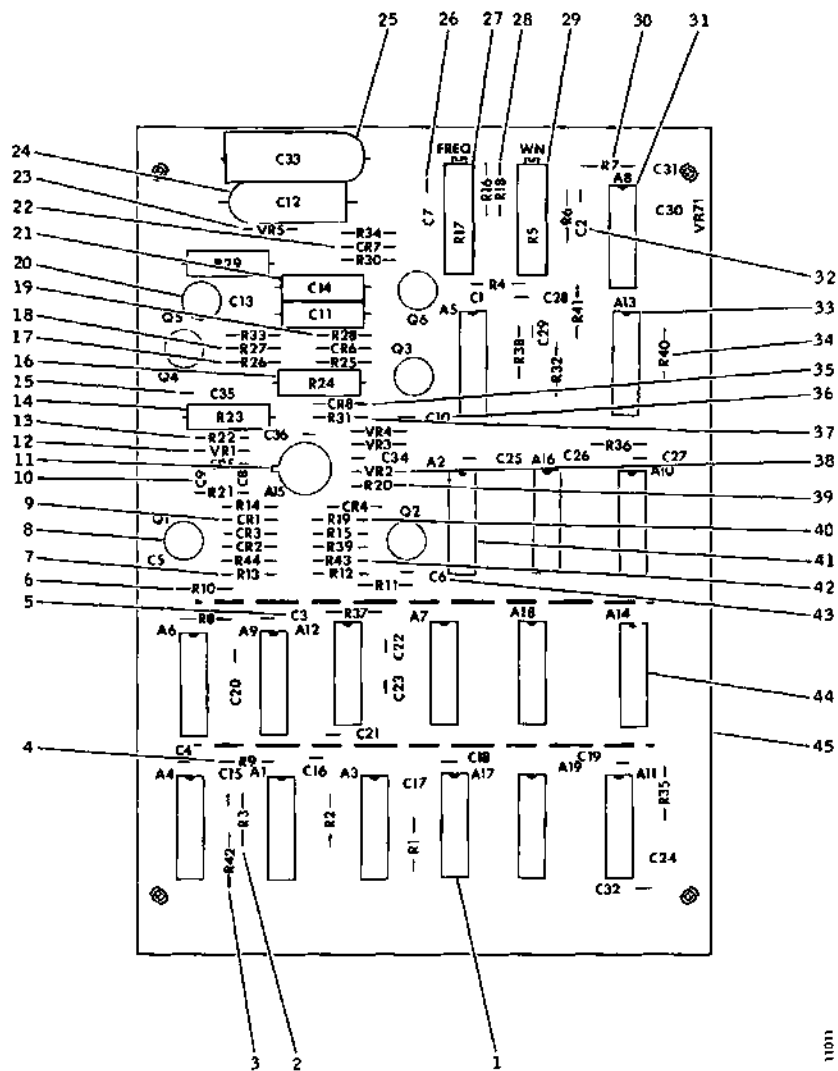

Figure 5-5. Data Decoder with PLO Board Assembly, VR71

FIGURE ITEM NO.	PART NUMBER	DESCRIPTION	QTY PER ASSY	USAGE CODE
6-	17032-001	Board Assy, Data Decoder with PLO, VR81	REF	
-1	96390-001	. Line Driver, Dual, 4-Input, SDB, TTL, A17	1	
-2	90364-431	. Resistor, 430 ohm, 5%, 1/8W, R3	1	
-3	90364-361	. Resistor, 360 ohm, 5%, 1/4W, R42	1	
-4	90364-471	. Resistor, 470 ohm, 5%, 1/4W, R4, 8, 9	3	
-5	98175-068	. Capacitor, Ceramic, 33 pF, 200v, C1, 3, 4	3	
-6	90364-152	. Resistor, 1.5K, 5%, 1/4W, R10, 11	2	
-7	90364-392	. Resistor, 3.9K, 5%, 1/4W, R13, 43	2	
-8	90328-001	. Transistor, Switching, NPN, Q1, 2, 3, 6	4	
-9	10357-001	. Diode, Low-Capacitance, CR1-4	4	
-10	98175-215	. Capacitor, Ceramic, 1500 pF, 100v, C9	1	
-11	12404-001	. Amplifier, Linear Operational, A15	1	
-12	90346-047	. Diode, Zener, 4.7v, VR1	1	
-13	90367-103	. Resistor, 1K, 1%, 1/8W, R22	1	
-14	90365-391	. Resistor, 390 ohm, 5%, 1W, R23	1	
-15	98175-410	. Capacitor, Ceramic, 0.1 uF, 50v, C35, 36	2	
-16	90365-821	. Resistor, 820 ohm, 5%, 1W, R24, 29	2	
-17	90367-362	. Resistor, 590K, 1%, 1/8W, R26, 33	2	
-18	90364-104	. Resistor, 100K, 5%, 1/4W, R27	1	
-19	90364-391	. Resistor, 390 ohm, 5%, 1/4W, R28, 30	2	
-20	90327-001	. Transistor, Low Level, PNP, Q4, 5	2	
-21	90354-101	. Capacitor, Mica, 100 pF, 5%, 500v, C11, 14	2	
-22	90343-001	. Diode, Low-Capacitance Switch, CR5-7	3	
-23	90346-056	. Diode, Zener, 5.6v, VR5	1	
-24	90356-156	. Capacitor, Tantalum, 68 uF, 15v, C12	1	
-25	90356-355	. Capacitor, Tantalum, 33 uF, 10%, 500v, C33	1	
-26	98175-347	. Capacitor, Ceramic, 0.047 pF, 50v, C7, 8, 13, 15-20, 22-32 C34	22	
-27	92244-150	. Resistor, Variable, 500 ohm, R17	1	
-28	90367-337	. Resistor, 4.87K, 1%, 1/8W, R16, 18	2	
-29	92244-325	. Resistor, Variable, 25K, R5	1	
-30	90364-102	. Resistor, 1K, 5%, 1/8W, R1, 2, 6, 7, 25, 32, 34-38	11	
-31	94526-001	. Multivibrator, Dual, One-Shot, TTL, A8	1	
-32	98175-133	. Capacitor, Ceramic, 330 pF, 200v, C2	1	
-33	96389-001	. Flip-Flop, Dual D, SBD, TTL, A9-13, 16, 18	7	
-34	90364-122	. Resistor, 1.2K, 5%, 1/4W, R40, 41	2	
-35	98445-001	. Diode, Multijunction, CR8	1	
-36	10781-510	. Capacitor, Ceramic, 1 uF, 50v, C10	1	
-37	90364-511	. Resistor, 510 ohm, 5%, 1/4W, R31	1	
-38	90346-051	. Diode, Zener, 5.1v, VR2, 3, 4	3	
-39	90367-356	. Resistor, 56.2K, 1%, 1/8W, R20, 21	2	
-40	90367-341	. Resistor, 5.11K, 1%, 1/8W, R14, 15, 19, 39	4	
-41	96156-001	. Gate, NAND, Hex, 1-Input, SBD, TTL, A2, 7	2	
-42	90364-242	. Resistor, 2.4K, 5%, 1/4W, R12, 43	2	
-43	98175-033	. Capacitor, Ceramic, 33 pF, 200v, C5, 6	2	
-44	96155-001	. Gate, NAND, Quad, 2-Input, SBD, TTL, A1, 3-6, 14, 19	7	
-45	17033-001	. Board, Read Decoder with PLO, PWB	1	

CALCOMP

California Computer Products, Inc.
2411 W. La Palma, Anaheim, CA 92801