



---

**CONTROL DATA®  
FLEXIBLE DISK DRIVE  
MODEL 9428**

GENERAL DESCRIPTION  
OPERATION  
INSTALLATION AND CHECKOUT  
THEORY OF OPERATION  
DIAGRAMS AND MAINTENANCE AIDS  
MAINTENANCE  
WIRE LISTS  
PARTS DATA

---

 **MAGNETIC PERIPHERALS, INC.**  
a Control Data Company

**HARDWARE MAINTENANCE MANUAL**



REVISION RECORD

REV	DATE	MANUAL/SECTION REVISION STATUS										CHANGE AUTHORITY
		1	2	3	4	5	6	7	8	9	10	
A	ISSUE 83 AUG 3 <i>lc</i>	A	A	A	A	A	A	A	A			W. J. Harrington 8/12/83
B	ii thru vi 83 OCT 3 <i>lc</i>	A	A	B	A	A	A	A	A			PL 61041
C	ii thru vi 84 MAR 14 <i>lc</i>	C	A	C	C	C	C	A	A			PL 61109
D	ii and iv 84 JUL 12 <i>lc</i>	C	A	C	C	C	C	A	A			PL61169
E	ii thru vi 84 SEP 14 <i>lc</i>	E	E	E	E	E	E	E	B			PL 61193
F	ii & iii 84 OCT 1 <i>lc</i>	E	E	E	E	E	E	E	B			PL 61217
G	ii 84 OCT 25 <i>lc</i>	E	E	E	E	E	G	E	B			PL 61222
H	ii 85 MAY 14 <i>lc</i>	H	E	E	E	E	G	E	B			PL 61303
J	ii thru vi 85 SEP 5 <i>lc</i>	J	J	J	J	J	J	J	C			PL 61317

REVISION I, O, Q, S, X and Z ARE NOT USED.

Address all comments concerning this publication to the distributor or use the enclosed user comment sheet located in the back of this publication.

# FDD CONFIGURATOR SHEET

 MAGNETIC PERIPHERALS, INC. a Control Data Company OKLAHOMA CITY, OK	①	
	②	
	③	
	④	
		 MADE IN USA 7777004B-A

- ① EQUIPMENT TYPE NUMBER
- ② HARDWARE PRODUCT CONFIGURATOR NUMBER (HPC)
- ③ SERIAL NUMBER INCLUDING SERIES CODE (BLOCK POINT).  
EXAMPLE: IN SERIAL NUMBER SN 01000234 THE FIRST TWO DIGITS "01" IS ALSO THE SERIES CODE (BLOCK POINT).
- ④ LOT NUMBER, MANUFACTURER LOCATION AND DATA CODE

H149a

## WARNING

" This product is an electromechanical device which could present hazards if improperly handled. The device should be maintained only by qualified personnel in accordance with instructions contained in this manual and sound safety practices. Careless disassembly or maintenance procedures may result in damage to the device or injury to personnel. Observe all CAUTIONS or WARNINGS attached to the device or contained in this manual.

These WARNINGS and or CAUTIONS are not exhaustive. The manufacturer cannot know in advance all possible maintenance procedures, or tools, which may be devised by persons who choose not to follow the instructions in this manual. Any deviation from the prescribed procedures may entail risks which have not been evaluated by the manufacturer.

Any persons who use a non-approved procedure or tool must satisfy themselves that no injury to personnel, no damage to the device, and no deterioration of device performance will result."

## PREFACE

This manual provides the information needed to install, operate and maintain the Model 9428 Flexible Disk Drive (FDD) (BR8B3A) and is intended to support customer engineers who require detailed information about the Flexible Disk Drive's operation.

The manual is composed of two publications, each having a unique publication number, contained in one volume. The Manual's Publication number (77715900) is that of the front matter, Sections 1 through 7. This number should be used when making reference to the 9428 Flexible Disk Drive Hardware Maintenance Manual. Section 8, Parts Data, is identified by a separate publication number.

### FCC NOTICE

This equipment generates and uses radio frequency energy. If not installed and used properly, that is, in strict accordance with the manufacturer's instructions, it may cause interference to radio and television reception.

It has been type tested and found to comply with the limits for a Class B computing device in accordance with the specifications in Subpart J of Part 15 of FCC Rules, when installed within the host cabinet of a certified Class B computer. The referenced FCC rules are designed to provide reasonable protection against such interference in a residential installation. However, there is no guarantee that interference will not occur in a particular installation.

If this equipment does cause interference to radio or television reception, which can be determined by turning the equipment OFF and ON, the user is encouraged to try to correct the interference by one or more of the following measures:

- Reorient the receiving antenna
- Relocate the equipment with respect to the receiver
- Move the equipment away from the receiver
- Plug the equipment into a different outlet so that equipment and receiver are on different branch circuits.

If necessary, you should consult the dealer or an experienced radio television technician for additional suggestions. You may find the following booklet prepared by the Federal Communications Commission helpful: How to Identify and Resolve Radio-TV Interference Problems.

This booklet is available from the US Government Printing Office, Washington DC 20402, Stock No. 004-0000-00345-4.

# TABLE OF CONTENTS

SECTION	PAGE
PREFACE.....	iv
GENERAL DESCRIPTION	
1.1 INTRODUCTION.....	1-1
1.2 PURPOSE AND USE OF EQUIPMENT.....	1-1
1.3 PRODUCT DESCRIPTION.....	1-1
1.3.1 Physical Description.....	1-1
1.3.2 Electrical Description.....	1-1
1.3.3 Environmental Considerations.....	1-3
1.3.4 Performance Characteristics.....	1-4
1.3.5 Flexible Diskette.....	1-4
OPERATION	
2.1 INTRODUCTION.....	2-1
2.2 OPERATING INSTRUCTIONS.....	2-1
2.2.1 Flexible Diskette Loading.....	2-1
2.2.2 Flexible Diskette Removal.....	2-1
2.3 ERROR RECOVERY.....	2-1
2.3.1 Seek Error.....	2-1
2.3.2 Write Error.....	2-2
2.3.3 Read Error.....	2-2
2.4 DISKETTE HANDLING RECOMMENDATIONS.....	2-2
INSTALLATION AND CHECKOUT	
3.1 INTRODUCTION.....	3-1
3.2 UNPACKING.....	3-1
3.3 INSTALLATION.....	3-1
3.4 CABLING AND CONNECTORS.....	3-1
3.5 INPUT/OUTPUT LINE TERMINATIONS.....	3-2
THEORY OF OPERATION	
4.1 INTRODUCTION.....	4-1
4.2 GENERAL DESCRIPTION.....	4-1
4.3 FUNCTIONAL DESCRIPTION.....	4-2
4.3.1 Control Logic.....	4-4
4.3.2 Write Logic.....	4-10
4.3.3 Read Logic.....	4-10
4.3.4 Disk Drive.....	4-10
4.3.5 Read/Write Heads.....	4-10
4.4 CONTROL AND DATA LINE CHARACTERISTICS.....	4-11
4.4.1 Logic Levels.....	4-11
4.4.2 Transmitter Characteristics.....	4-11
4.4.3 Line Receiver Characteristics.....	4-11
4.4.4 Control and Data Line Functions.....	4-12

## TABLE OF CONTENTS (CONTD.)

SECTION		PAGE
<b>DIAGRAMS AND MAINTENANCE AIDS</b>		
5.1	DIAGRAMS.....	5-1
5.2	MAINTENANCE AIDS.....	5-1
	5.2.1 Introduction.....	5-1
	5.2.2 Physical Description.....	5-1
	5.2.3 Logic Symbology.....	5-1
<b>MAINTENANCE</b>		
6.1	INTRODUCTION.....	6-1
6.2	MAINTENANCE TOOLS.....	6-1
6.3	TROUBLESHOOTING.....	6-1
	6.3.1 DC Voltage and Signal.....	6-1
6.4	ADJUSTMENT PROCEDURES.....	6-3
	6.4.1 Index to Burst Check and Adjustment.....	6-3
	6.4.2 Actuator Alignment.....	6-5
	6.4.3 Track '00' Switch Adjustment.....	6-7
	6.4.4 Spindle Speed Adjustment.....	6-8
6.5	REMOVAL AND REPLACEMENT PROCEDURES.....	6-8
	6.5.1 Printed Wire Assemblies.....	6-8
	6.5.2 Spindle Motor Assembly.....	6-10
7.0	DELETED.....	7-1
<b>PARTS DATA</b>		
8.0	ILLUSTRATED PARTS CATALOG.....	8-1

## 1.1 INTRODUCTION

The Model 9428 Flexible Disk Drive (FDD) is a compact, random access, data storage device that interfaces with a central processor through a control unit. Input/Output data and control signals are transmitted by means of an I/O cable. The FDD may be connected in star or daisychain configuration. In star configuration, each FDD is connected to a separate controller port. Up to four drives may be connected to a single port in daisychain configuration.

## 1.2 PURPOSE AND USE OF EQUIPMENT

Data, in the form of magnetic flux reversals, is written on, or read from the tracks of a rotating diskette. The FDD uses a single, 5.25-inch (133.4 mm) flexible, removable diskette (two recording surfaces) enclosed in a sealed jacket. The unit is capable of hard sector or soft sector format operation.

## 1.3 PRODUCT DESCRIPTION

The device contains a mechanism to mount and rotate the media, a track accessing positioner, writing, reading, and interface control circuitry. Interface signals, power, physical size, and mechanical mounting levels are compatible with standard industrial requirements. Media interchange is achieved with standard formats.

### 1.3.1 PHYSICAL DESCRIPTION

The physical dimensions for the equipment are given in Figure 1-1.

### 1.3.2 ELECTRICAL DESCRIPTION

The electrical specifications for the equipment are as follows:

#### DC POWER

+12 V $\pm 5\%$ 1.0 A typical	1.2 A max.*	Ripple 100 mV p-p
+ 5 V $\pm 5\%$ 0.5 A typical	0.5 A max.*	Ripple 100 mV p-p

#### AC POWER

None

\*NOTE: Specified current requirements are on a per drive basis. Current requirement increases by a factor equal to the number of drives per power supply. (i.e., Two drives per supply require +12 V at 2.4 A and +5 V at 1.0 A.)

CODE	PACKAGE DIMENSION	
	INCHES	MILLIMETRES
A	8.00 MAX	203.2
B	5.75 $\pm$ .00	146.0
C	0.19 $\pm$ .01	4.82
D	1.87 $\pm$ .02	47.5
E	3.12 $\pm$ .02	79.2
F	5.88 $\pm$ .01	149.4
G	1.625 $\pm$ .01	41.3
H	0.060 $\pm$ .01	1.5
I	5.50 $\pm$ .02	140.0
J	0.394 $\pm$ .02	10.0
K	0.030 $\pm$ .01	0.762
L	0.66 $\pm$ .01	16.7
M	0.580	14.7
N	0.86 $\pm$ .02	21.84

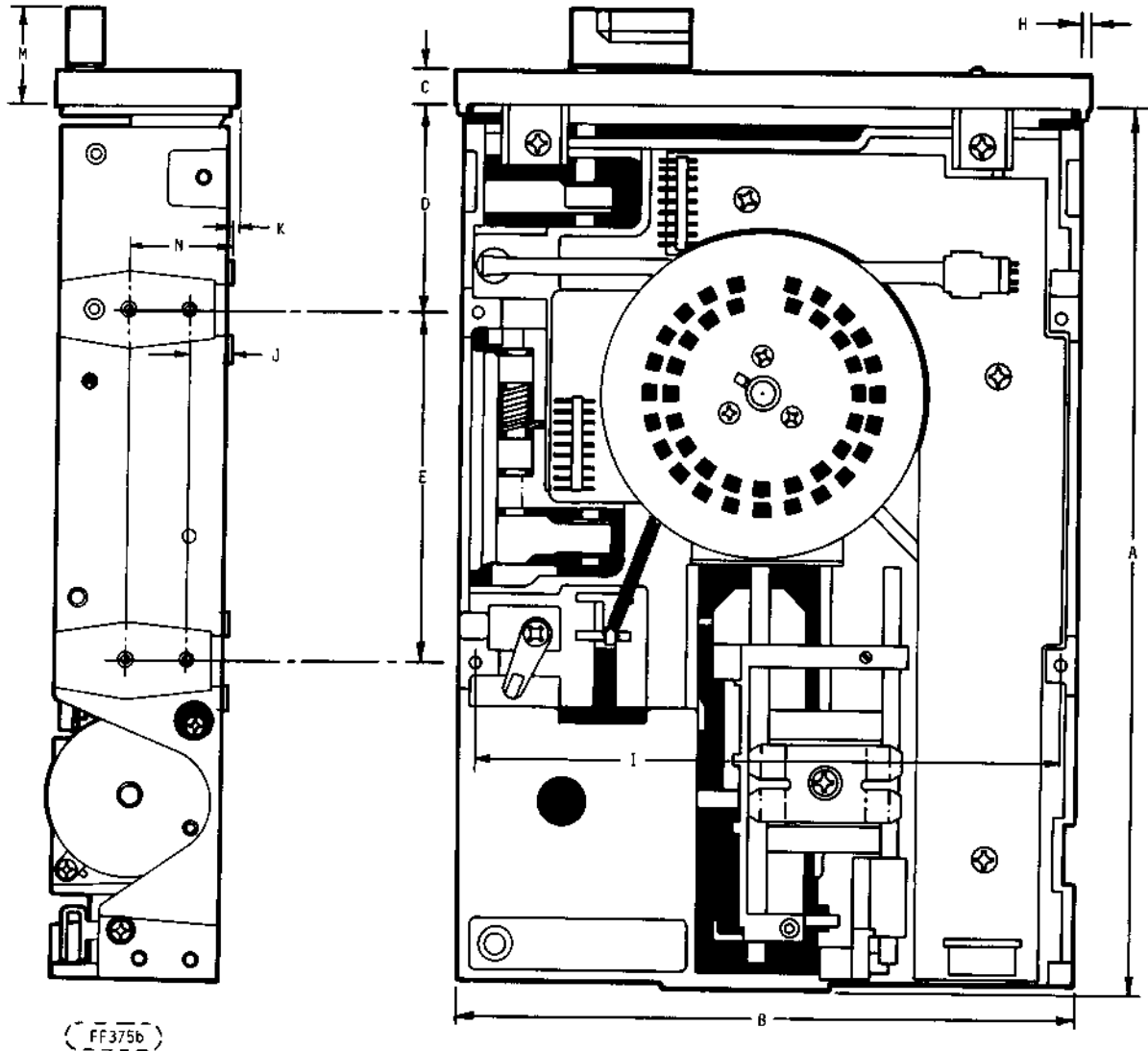

FIGURE 1-1. OVERALL AND MOUNTING DIMENSIONS OF 9428 FDD



**POWER DISSIPATION**

18.9 Watts (Maximum)  
 14.5 Watts (Nominal)

**INRUSH CURRENT**

Inrush current is dependent upon the power source as well as the FDD. Primary considerations are: 1. host power supply source impedance(s); 2. host to FDD power line resistance and inductance; and 3. FDD capacitance load presented by filter capacitors. Schematically, this may be represented as shown below:

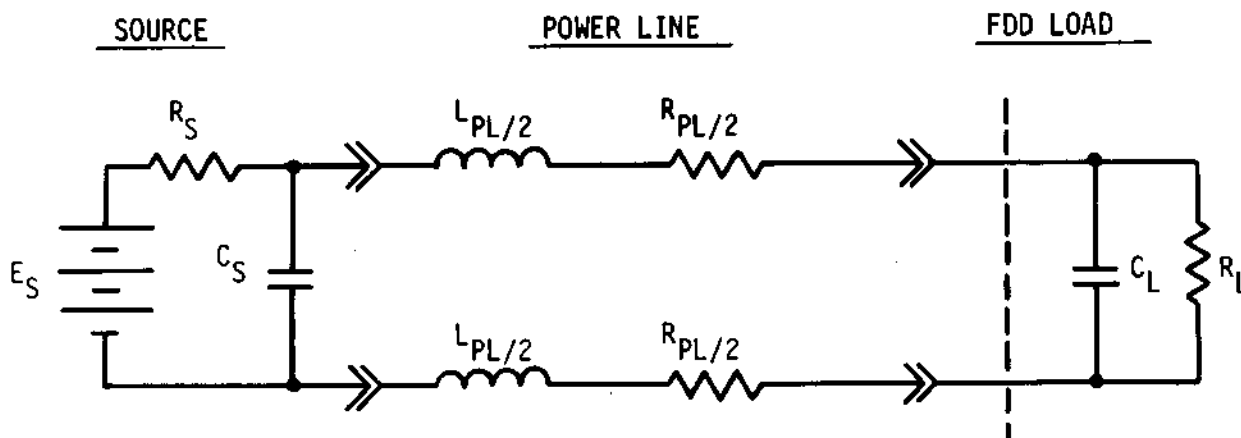

**INPUT IMPEDANCE**

The nominal equivalent loads for the 9428 are as follows:

	<u>+12 V</u>	<u>+5 V</u>
$C_L$	25 microfarads	50 microfarads
$R_L$	12 ohms	10 ohms

**1.3.3 ENVIRONMENTAL CONSIDERATIONS**

	<u>Operating *</u>	<u>Shipping and Storage</u>
Device Ambient Temperature	40° F to 115° F (4.4°C to 46.1°C)	-40° F to 144° F (-40°C to 62.2°C)
Relative Humidity	20% to 80%	0% to 95%
Maximum Wet Bulb	79° F (26.1°C)	No condensation

\*Actual operating temperature is limited by media environmental specifications and performance.

### 1.3.4 PERFORMANCE CHARACTERISTICS

The equipment specifications for the FDD are as follows:

	<u>Single Density</u>	<u>Double Density</u>
Capacity		
Unformatted		
Per disk	250 kbytes	500 kbytes
Per surface	125 kbytes	250 kbytes
Per track	3.1 kbytes	6.2 kbytes
Formatted (16 sectors, 128/256 bytes)		
Per disk	163.84 kbytes	327.68 kbytes
Per surface	81.92 kbytes	163.84 kbytes
Code	FM	MFM
Transfer Rate	125 kbits/s	250 kbits/s
Average latency	100 ms	100 ms
Seek Time		
Track to track	5 ms	5 ms
Average	80 ms	80 ms
Settling time	15 ms	15 ms
Side Select Time	200 $\mu$ s**	200 $\mu$ s**
Media	Hard/Soft Sector	Hard/Soft Sector
Rotational Speed	300 r/min $\pm$ 1.5%	
Track Density	48 TPI	
Flux Reversal Density (Track 39, Side 1)	5876 FRI	
Number of Tracks	40	
Inner recorded radius (Side 0)	1.437 in (36.53 mm)	
Outer recorded radius (Side 0)	2.250 in (57.2 mm)	
Inner recorded radius (Side 1)	1.354 in (34.16 mm)	
Outer recorded radius (Side 1)	2.167 in (55.0 mm)	

### 1.3.5 FLEXIBLE DISKETTE

CDC 445 or equivalent (Double Density)

CDC 444 or equivalent (Single Density)

---

\*\*Assumes motor on and drive selected.

## 2.1 INTRODUCTION

The FDD is under direct control of the input/output commands and power sources. No special start up procedure is required. Operation is fully automatic and normally requires no operator intervention.

## 2.2 OPERATING INSTRUCTIONS

Verify that power and I/O cables are securely attached before operation.

### 2.2.1 FLEXIBLE DISKETTE LOADING

- a. Apply DC power to drive.
- b. Turn diskette lever to open position.
- c. Remove diskette from storage envelope.
- d. Be sure the Write Protect slot in the jacket, as shown in Figure 2-1, is covered if the diskette is to be write protected.
- e. Carefully slide diskette into FDD, as shown in Figure 2-1, until jacket is solidly against stops.
- f. Turn diskette lever to closed position.
- g. Protect the empty envelope from liquids, dust and metallic materials.

### 2.2.2 FLEXIBLE DISKETTE REMOVAL

- a. Turn diskette lever to open position.
- b. Remove diskette from FDD and put it in its storage envelope.

## 2.3 ERROR RECOVERY

The following paragraphs supply information needed to recover from possible errors in equipment operation.

### 2.3.1 SEEK ERROR

Seek errors will rarely occur unless the stepping rate is significantly exceeded. If a seek error occurs, track location can be recalibrated by repetitive Step Out commands until Track 00 signal is received.

### 2.3.2 WRITE ERROR

To guard against degradation from imperfections in the media, no more than four attempts to write a record should be used when Read After Write errors are encountered. If a record cannot be successfully written in four attempts, the sector or track should be labeled defective and an alternate sector or track assigned. If more than two defective tracks are found the diskette should be replaced.

### 2.3.3 READ ERROR

If a Read error occurs, up to 10 attempts should be made to recover with rereads. If after 10 attempts the data has not been recovered, step the head several tracks away and then reposition to recover the data. Deenergizing the spindle motor when data transfers are not imminent will increase data reliability and extend the diskette life.

## 2.4 DISKETTE HANDLING RECOMMENDATIONS

The recorded diskette may contain vital information. Reasonable care should be exercised in its handling. Longer diskette life and trouble free operation will result if the following recommendations are followed.

- a. Do not use a writing device which deposits flakes, for example, lead or grease pencils, when writing on diskette jacket label.
- b. Do not fasten paper clips on diskette jacket edges.
- c. Do not touch diskette surface exposed by jacket slot.
- d. Do not clean diskette in any manner.
- e. Keep diskette away from magnetic fields and from ferromagnetic materials that may be magnetized.
- f. Return diskette to envelope when removed from FDD.
- g. Protect diskette from liquids, dust, and metallic substances at all times.
- h. Do not exceed the following storage environmental conditions:  

Temperature:	50° F to 125° F (10° C to 51.7° C)
Relative Humidity:	8% to 80%
Maximum Wet Bulb:	85° F (29.4° C)
- i. Store diskette in a box or cabinet when not in use.
- j. Remove diskette before applying or removing power to the FDD.

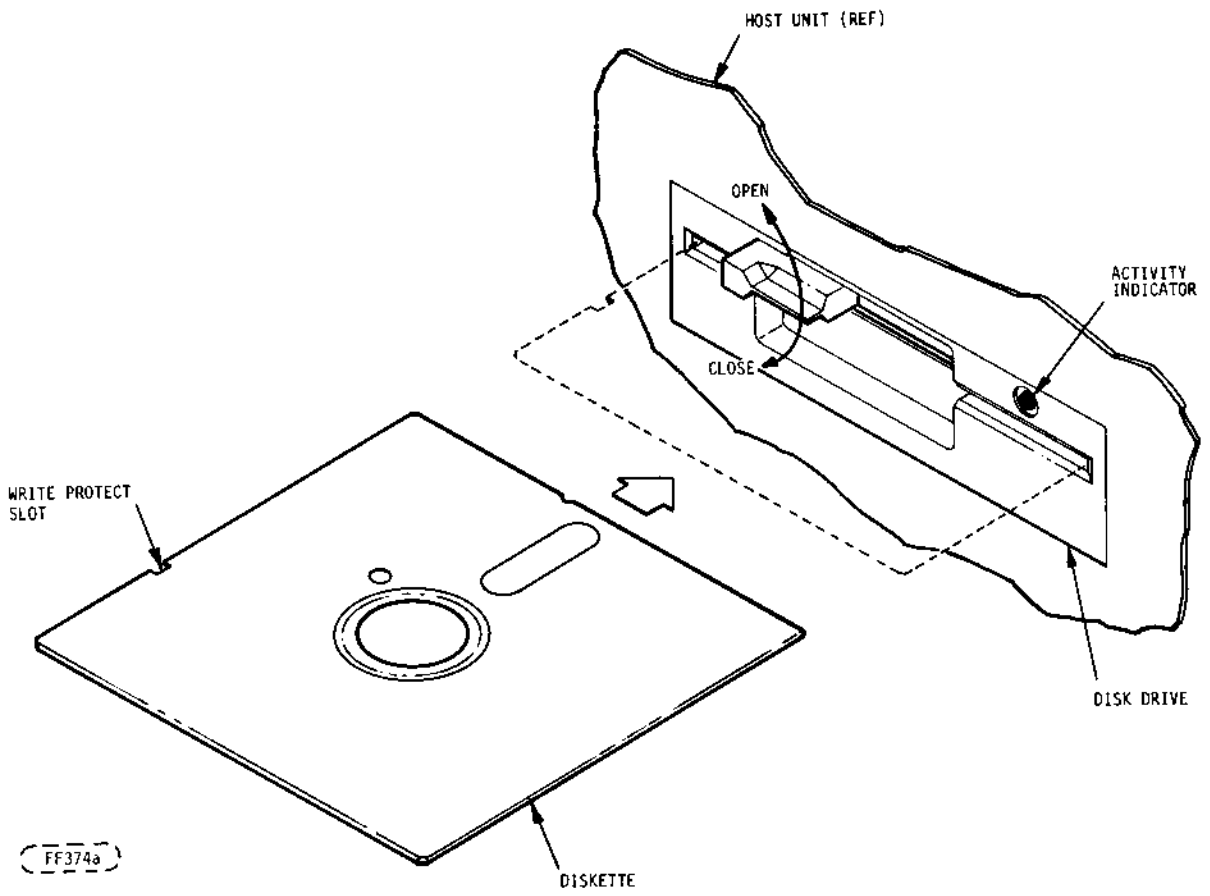

FF374a

FIGURE 2-1. DISKETTE INSTALLATION

### 3.1 INTRODUCTION

This section provides the information and procedures necessary to put an FDD into operation.

### 3.2 UNPACKING

Unpack FDD as follows:

- a. Cut banding and lift top half of styrofoam shell from unit.
- b. Lift unit from bottom half of styrofoam shell and remove unit.

During unpacking, care must be used so tools do not damage the unit. As a unit is unpacked, inspect it for possible shipping damage. All claims for this type of damage should be filed promptly with the carrier involved. If a claim is filed for damages, save the original packing materials.

### 3.3 INSTALLATION

Install the FDD in the designated location in the host equipment. Physical characteristics of the FDD are shown in Figure 1-1.

The 9428 has been designed as a component to high standards of design and construction. The product must depend on receiving adequate power and environment from its host equipment to obtain optimum operation, and to comply with applicable industry and governmental regulations. Special attention must be given by the host manufacturers in the areas of safety, power distribution, grounding, shielding, audible noise control, and temperature regulation of the device to insure specified performance and compliance with all applicable regulations.

To assure compliance with FCC Class B regulations, the FDD must be installed within an FCC Class B Certified host system (Personal Computer or other system) and the system installation instructions for the host system must be followed.

Typical Cabling, connectors, etc. are specified in paragraph 3.4 and illustrated in Figure 3-1.

### 3.4 CABLING AND CONNECTORS

Install the DC power cable on connector J2. The connector location and its pin assignments are shown in Figure 3-1. The recommended mating connector for J2 and type of wire are:

<u>MANUFACTURER</u>	<u>CONNECTOR P/N</u>	<u>CONTRACT P/N</u>	<u>TYPE OF WIRE</u>
AMP	1-480424-0	60617-1	18 AWG

Install the I/O cable on connector J1. The connector location and its pin assignments are shown in Figure 3-1. The I/O cable to connect the host controller to the FDD (or last FDD in a daisychain configuration) should be no longer than 10 feet, and contained within the host cabinet. The recommended mating connector for J1 and type of cable are:

<u>MANUFACTURER</u>	<u>CONNECTOR P/N</u>	<u>CONTRACT P/N</u>	<u>TYPE OF WIRE</u>
AMP	583717-5	1-583616-1	Twisted Pair 26 AWG
3M "Scotchflex"	3463-0001	NA	Flat Cable

The Input/Output electrical signal specifications are:

True = Logical One =  $V_{out} +0.0 \text{ V to } +0.4 \text{ V @ } I_{out} = 48 \text{ mA}$  (max) sinking  
False = Logical Zero =  $V_{out} +2.5 \text{ V to } +5.25 \text{ V}$  (open collector) @  $I_{out} = 250 \text{ } \mu\text{A}$  (max) sourcing

### 3.5 INPUT/OUTPUT LINE TERMINATIONS

The FDD provides the capability of terminating the following lines through a resistor pack installed in a DIP socket on the circuit board (see Figure 3-1):

- |                     |                               |
|---------------------|-------------------------------|
| 1. MOTOR ON         | 5. WRITE DATA                 |
| 2. DIRECTION SELECT | 6. WRITE GATE                 |
| 3. STEP             | 7. DRIVE SELECT (0 THROUGH 3) |
| 4. SIDE SELECT      | 8. IN USE                     |

The unit is shipped from the factory with the resistor pack installed. These lines must be terminated for proper operation.

In a multiple (daisychain) drive configuration, only the last FDD in the configuration is to be terminated. All other FDDs on the interface must have the resistor pack removed. In addition, the shunt "MX" (described in Section 4.3.1-h) must be open.

External termination may be used, in which case the host equipment may provide the termination beyond the last FDD. The lines must be terminated to +5 V through 1/4-watt resistors. Total line length must not exceed 10 feet (3.05 m).

NOTE: PWA COMPONENTS SHOWN SIMULATE A TYPICAL PWA ASSEMBLY AND DO NOT NECESSARILY REPRESENT ANY ACTUAL CONFIGURATION

USED FOR  
 8748/8048 MPU  
 PWA 77734904  
 PWA 77743720  
 PWA 77743940

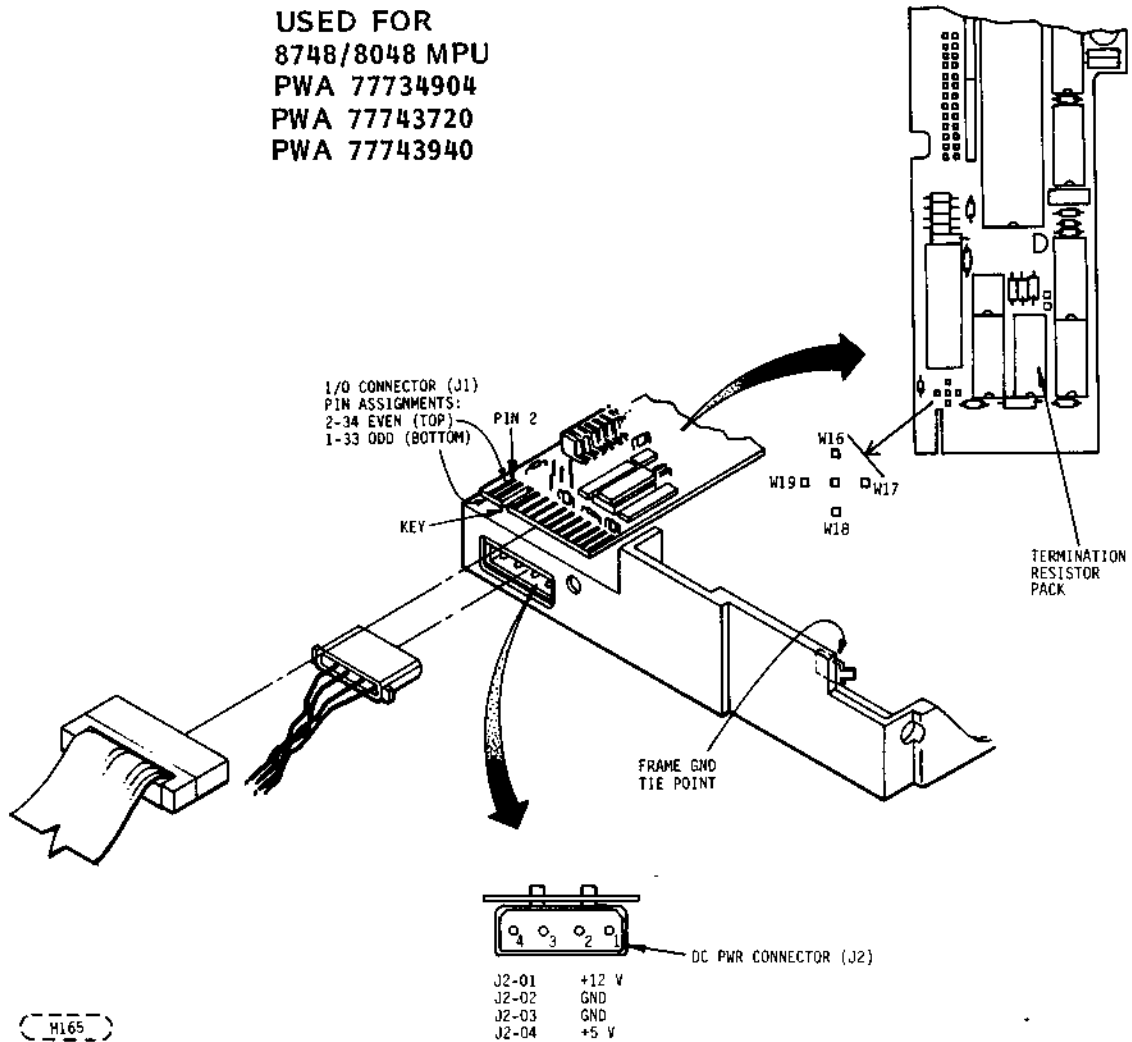

FIGURE 3-1. INPUT/OUTPUT (J1), DC POWER (J2), TERMINATOR, AND SHUNT LOCATION/DESCRIPTION (SHEET 1 OF 2)



USED FOR  
 TMS7020 MPU  
 PWA 77740650  
 PWA 77741910  
 PWA 77741940

NOTE: PWA COMPONENTS SHOWN SIMULATE  
 A TYPICAL PWA ASSEMBLY AND DO NOT  
 NECESSARILY REPRESENT ANY ACTUAL  
 CONFIGURATION

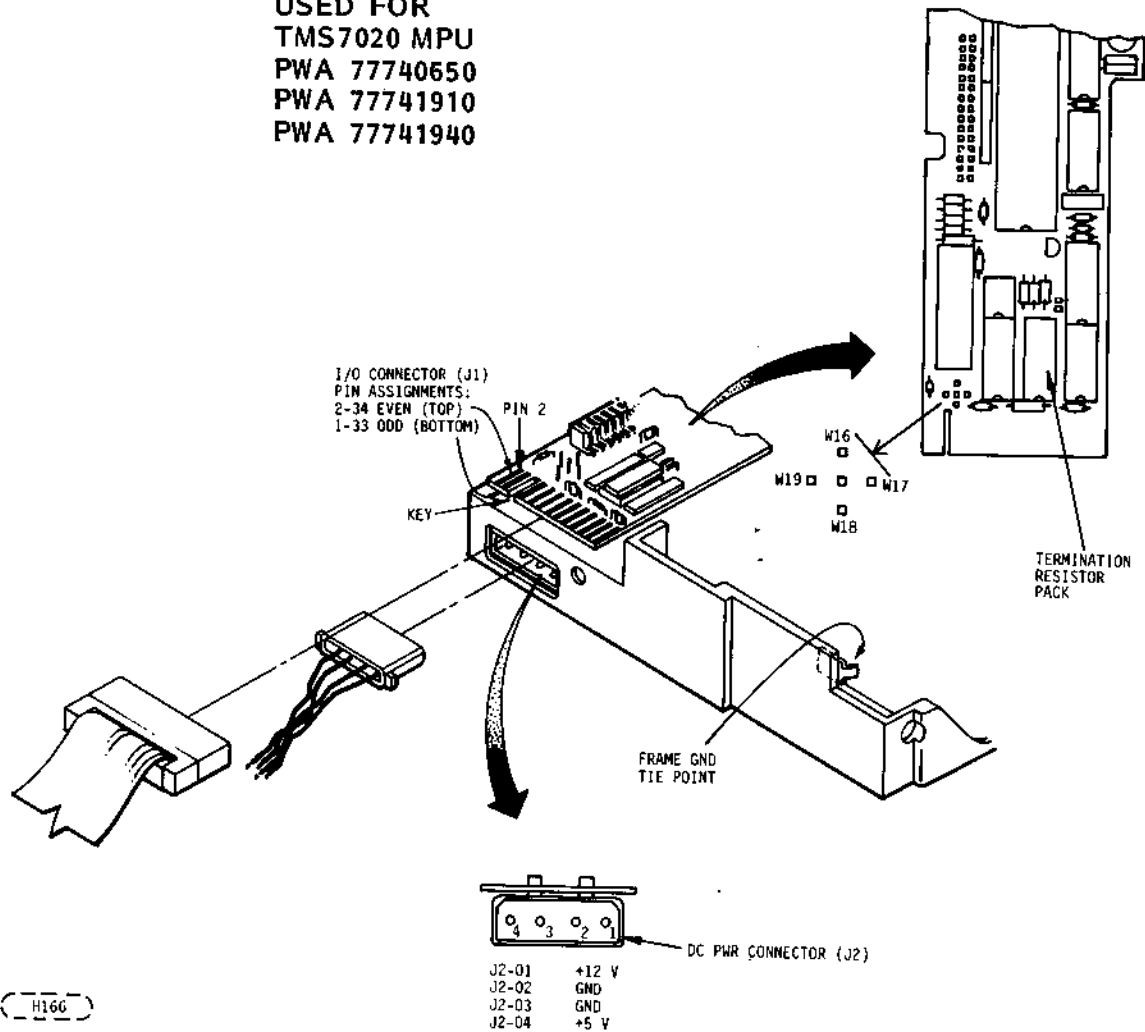

FIGURE 3-1. INPUT/OUTPUT (J1), DC POWER (J2), TERMINATOR, AND SHUNT LOCATION/DESCRIPTION (SHEET 2 OF 2)

## 4.1 INTRODUCTION

The theory of operation of the FDD is divided into two parts. The first part is a general theory of operation. The second part is a more detailed functional description of all major components, both electronic and mechanical, and describes all signals exchanged between the FDD and the controller.

## 4.2 GENERAL DESCRIPTION

The basic function of the FDD is to respond to the commands of the controller to: 1. Receive and generate control signals; 2. Position the Read/Write head to selected tracks; 3. Start/Stop and speed regulate spindle motor; and 4. Write or Read data on the desired surface of the diskette when selected.

Signals received and transmitted by the FDD are shown in Figure 4-1. All signals received by the FDD, except Motor On and In Use, are gated with Drive Select so no stepping, reading, or writing can be performed on an unselected FDD. Motor On is used to start and stop the spindle motor. All signals generated by the FDD are gated with Drive Select so no signals can be transmitted from an unselected FDD.

During the write operation, the selected FDD receives Side Select, Write Gate and Write Data. The Write Gate line remaining high implies a read operation on the surface determined by Side Select. Under these conditions, the FDD will transmit the Read Data signal to the controller. Controller Step commands are received initiating the Track Seek operation on a selected FDD. The FDD transmits Index/Sector pulses as long as it is selected. Also, the selected FDD transmits a Track 00 signal to the controller whenever the Read/Write heads are at Track 00.

Positioning of the carriage mounted Read/Write heads is accomplished by a metal band driven by a stepper motor. Each step command from the user system causes the stepper motor to move the Read/Write heads one track position.

A reading or writing operation begins by placing the Read/Write heads in contact with the diskette at the desired track. To write on the diskette, Write Gate is sent by the controller to condition the write logic. The write current in the head activated by Side Select, reverses polarity simultaneously with the high to low transitions of the Write Data pulses from the controller. The current reversals cause magnetic flux reversals, thus recording data and clock bits on the desired diskette track and surface. Erasure of previously recorded data is simultaneously accomplished during the writing operation. Tunnel erase ensures drive to drive diskette interchangeability.

To read from the diskette, magnetic flux reversals in the recorded data are sensed by the selected Read/Write head. This signal is amplified, digitized, and transmitted to the user system as composite clock and data information.

### 4.3 FUNCTIONAL DESCRIPTION

Refer to Figures 4-1, 5-1 and the Schematic Diagrams, Figure 5-3 for the following discussion.

The FDD is divided into the following major functional areas:

1. Control Logic
2. Write Logic
3. Read Logic
4. Disk Drive
5. Read/Write Head

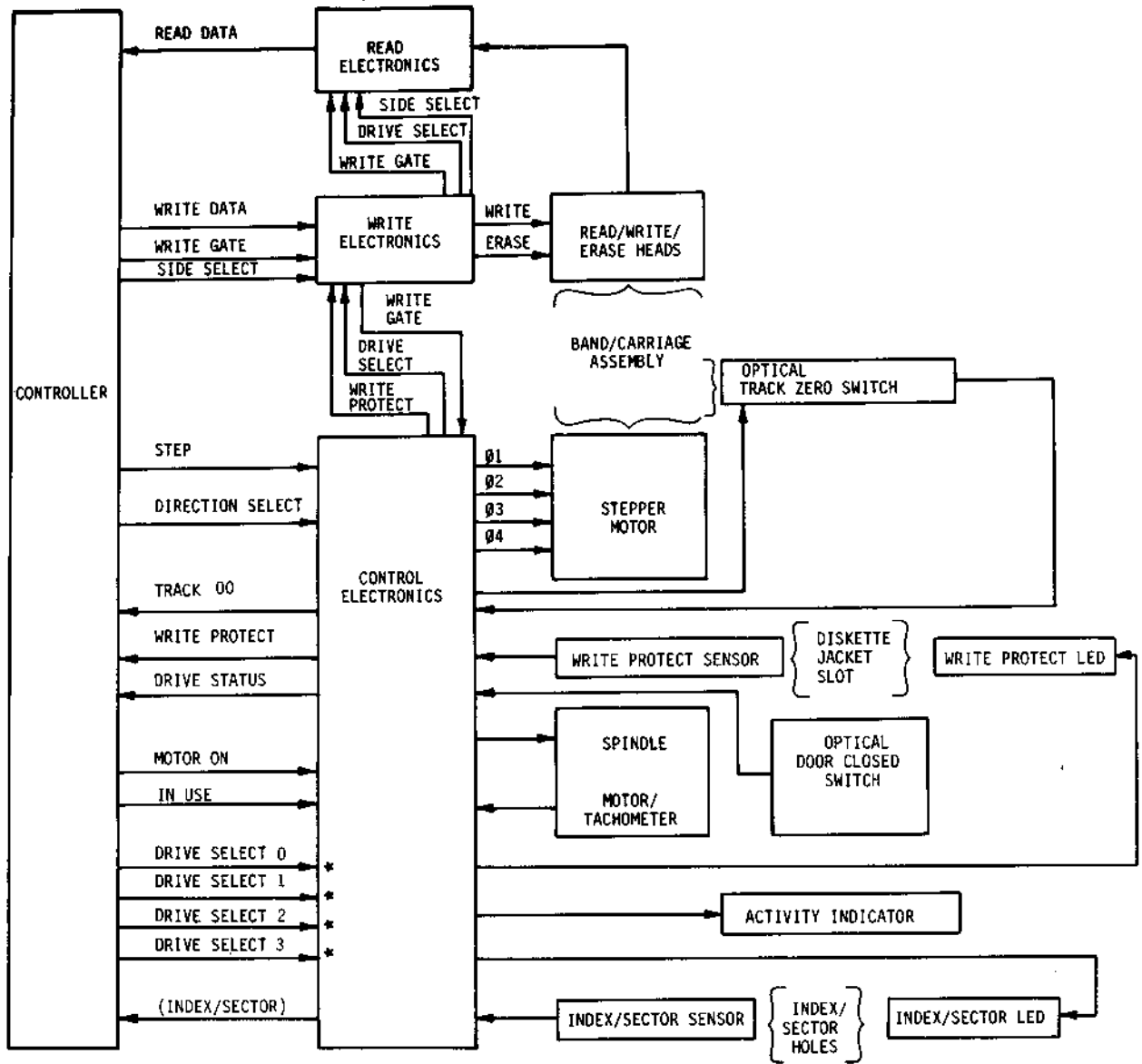

• SEE TEXT FOR ALTERNATE CUSTOMER SELECTABLE FUNCTIONALITY

FF314a

FIGURE 4-1. FUNCTIONAL BLOCK DIAGRAM

### 4.3.1 CONTROL LOGIC

The control logic generates signals that: 1. Activate the spindle motor and control its speed; 2. Step the Read/Write heads in or out upon selection and command of the controller; 3. Protect the diskette from writing if the write protect slot is covered; 4. Indicate when the Read/Write heads are at Track 00; 5. Generate Index/Sector pulses when the diskette is rotating and the FDD is selected; and 6. Provide drive selection of the FDD.

- a. The FDD is Ready when the Diskette reaches proper operating speed. The index pulses may be used by the host to determine operating speed. For hard sector diskettes, the controller must separate index pulses from sector pulses.
- b. At initial voltage application, phase group A of the stepper motor is energized. Each step command received sequentially energizes one of the four phase groups of the stepper motor.

Movement of the Read/Write heads is initiated by step commands (high to low transitions on the Step line) from the controller. The heads are stepped one track, toward the spindle (In) or away from the spindle (Out), with each command. A low level on the Direction line causes the Read/Write heads to step toward the spindle, and a high level causes the Read/Write heads to step away from the spindle.

The phase sequence through which the stepper motor is driven is controlled by the microprocessor. The step signal clocks the counter up or down depending on the status of the direction signal. To inhibit outward steps past Track Zero the counter is disabled at Track Zero when the Direction line is high. A counter in the microprocessor inhibits inward steps past Track 39.

- c. The Read/Write heads of a selected FDD will be loaded when the diskette is fully installed and the front panel lever is closed. Closing the front panel lever lowers the upper flexible head onto the diskette. The heads will not load when a diskette is not installed because an interposer prevents the heads from coming together and being damaged.
- d. The Write Protect function is selected by an optical switch. The switch is mounted so the absence of a write protect slot in the jacket of the diskette will be detected and gated with Drive Select from the interface. Write Protect inhibits writing on any diskette missing a write protect slot by blocking Write Gate.

- e. The Track Zero signal is generated when a flag on the carriage assembly interrupts the Track Zero optical switch and the stepper decode logic is in the phase group A state. When the FDD is selected, the active low Track Zero signal is transmitted to the interface.
- f. The Drive Status (READY) signal can indicate (optionally) that the door is closed, or that the door is closed and index has been detected. The door status is generated by a flag on the load arm that interrupts an optical switch on the upper PWA. Details are listed below:

Option A Indicates the door is closed and the drive is selected.

Option B Indicates the door is closed, the drive is selected, and one index pulse has been detected.

Option C Indicates the door is closed, the drive is selected, and two index pulses have been detected.

Note: A loss of index pulses alone after Drive Status is set does not reset Drive Status to a false logic level.

- g. The beginning of each diskette track is indicated by an index pulse. The diskette rotates between a light source (LED) and a sensor (photo transistor). When the index hole in the diskette passes over the light source, light is detected by the sensor. The sensor output is detected and transmitted to the controller as the index pulse when the FDD is selected.

The FDD may be used with hard sectored diskettes. The sector pulses are generated along with index pulses on the interface in one composite signal. The controller must separate index pulses from sector pulses for correct operation.

- h. The drive select function inhibits all command and status signals except In Use and Motor On. The position of the FDD in a daisychain configuration is determined by the orientation of the shunt in the DS0, DS1, DS2 or DS3 position on the PWA. The "MX" shunt must be removed for daisychain operation. Shunt "MX" may be left in place to cause the FDD always to be selected. This is useful for star configurations.
- i. For daisychain operation, as detailed in Step "h", shunt "MX" must be removed and the "DS" shunt oriented corresponding to the drive's position in the daisychain. The activity indicator will glow when the drive is selected. Also the activity indicator will glow any time a low level is applied to In Use. In daisychain operation, In Use will make the indicators of all FDD's glow simultaneously.

For star configured operation, as detailed in Step "h", shunt "MX" is left in place. The Drive Select signal(s) may then be used to make the activity indicator glow for any user defined activity by a low level on the Drive Select line(s) which has (have) the "DS" shunt in place.

TABLE 4-1. 9428 JUMPER OPTIONS (SHEET 1 OF 2)

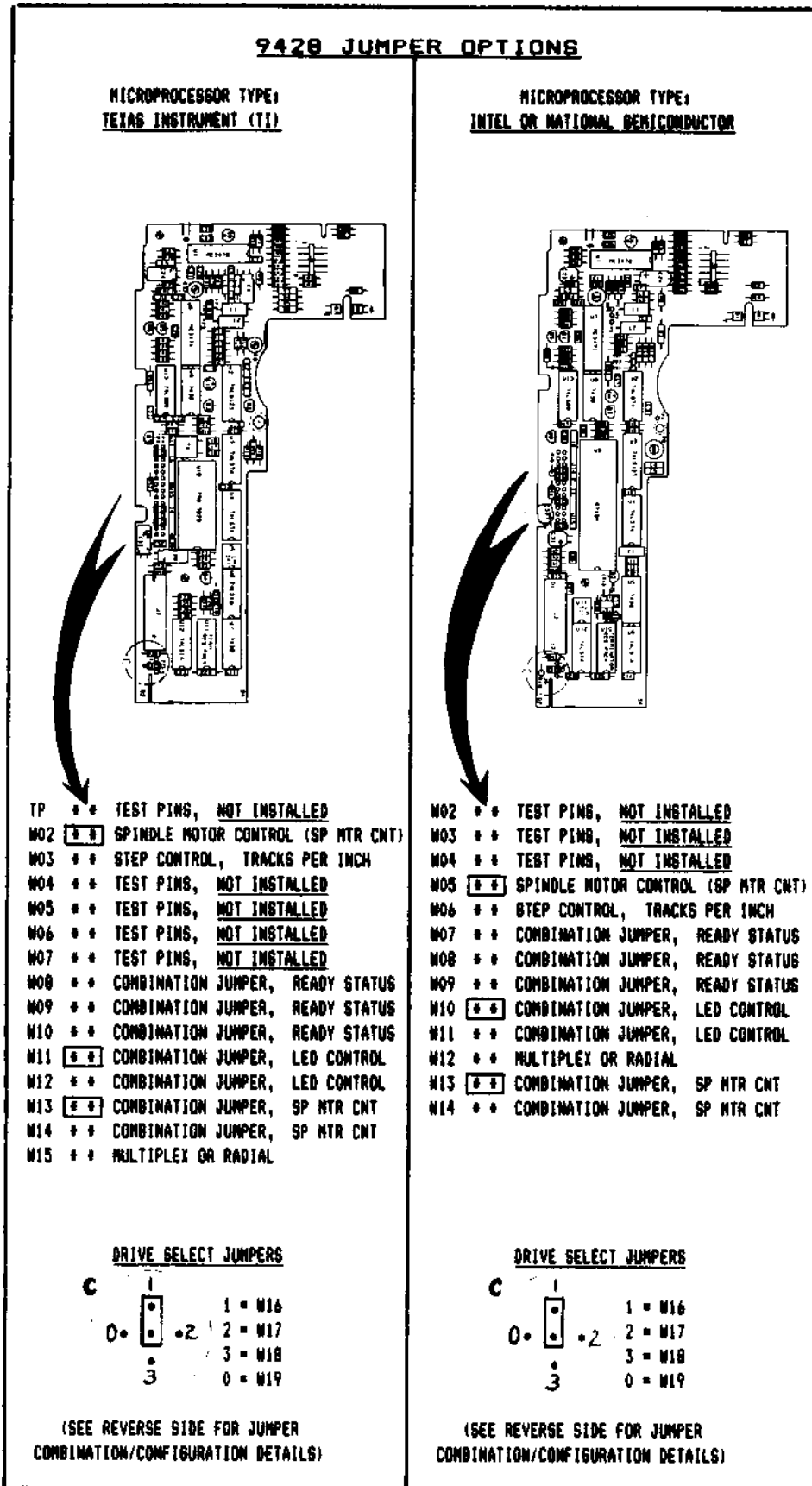



TABLE 4-1. 9428 JUMPER OPTIONS (SHEET 2 OF 2)

<b>9428</b>											
<b>'TI' MICROPROCESSOR</b>						<b>'INTEL' or 'NATIONAL' MICROPROCESSOR</b>					
STP = STEP			NO = MOTOR ON			POR = POWER ON RESET					
PLS = PULSE			DS = DRIVE SELECT			IDX = INDEX					
TPI = TRACKS PER INCH			DC = DOOR CLOSED			IN = JUMPER INSTALLED					
DBS = DRIVE DESELECT			IU = IN USE			OUT = JUMPER NOT INSTALLED					
SPINDLE MOTOR 'ON'			CONDITIONAL REQUIREMENTS AND CONTROL SIGNAL(S)			SPINDLE MOTOR 'ON'			CONDITIONAL REQUIREMENTS AND CONTROL SIGNAL(S)		
W14	W13	W02				W14	W13	W05			
OUT	IN	OUT	NO			OUT	IN	OUT	NO		
OUT	IN	IN	NO or DS			OUT	IN	IN	NO or DS		
IN	OUT	OUT	DC and NO			IN	OUT	OUT	DC and NO		
IN	OUT	IN	DC and (NO or DS)			IN	OUT	IN	DC and (NO or DS)		
"READY" STATUS			CONDITIONAL REQUIREMENTS AND CONTROL SIGNAL(S)			"READY" STATUS			CONDITIONAL REQUIREMENTS AND CONTROL SIGNAL(S)		
W10	W09	W08	DC			W09	W08	W07	DC		
OUT	OUT	OUT	*DC&(NO or DS)&1 IDX PLS			OUT	OUT	IN	*DC&(NO or DS)&1 IDX PLS		
OUT	IN	OUT	**DC&(NO or DS)&2 IDX PLS			OUT	IN	OUT	**DC&(NO or DS)&2 IDX PLS		
OUT	IN	IN	DC & DS & 1 IDX PLS			OUT	IN	IN	DC & DS & 1 IDX PLS		
<p>* IN THIS CONFIGURATION "READY" STAYS TRUE AFTER IT HAS BEEN GENERATED EVEN WHEN (NO or DS) GOES FALSE. "READY" IS RESET ONLY BY OPENING THE DOOR OR POR.</p> <p>** THIS IS THE HIGHEST (BEST) INTEGRITY "READY" CONFIGURATION. IT IS RESET BY OPENING THE DOOR OR (NO or DS) GOING FALSE. NOTE THAT LOSS OF INDEX PULSES ALONE AFTER "READY" IS SET DOES NOT RESET "READY" TO A FALSE STATUS.</p>											
ACTIVITY LED 'ON'		CONDITIONAL REQUIREMENTS AND CONTROL SIGNAL(S)			ACTIVITY LED 'ON'		CONDITIONAL REQUIREMENTS AND CONTROL SIGNAL(S)				
W12	W11				W11	W10					
OUT	IN	DS or IU			OUT	IN	DS or IU				
IN	OUT	DS and IU			IN	OUT	DS and IU				
TRACKS PER INCH		SET BY MANUFACTURER			TRACKS PER INCH		SET BY MANUFACTURER				
W03		9428 = W03 OUT			W06		9428 = W06 OUT				
OUT		40 TPI, 1 STP PLS=2 STPS			OUT		40 TPI, 1 STP PLS=2 STPS				
IN		96 TPI, 1 STP PLS=1 STP			IN		96 TPI, 1 STP PLS=1 STP				
MULTIPLEX OR RADIAL		CONDITIONAL REQUIREMENTS AND CONTROL SIGNAL(S)			MULTIPLEX OR RADIAL		CONDITIONAL REQUIREMENTS AND CONTROL SIGNAL(S)				
W15					W12						
OUT		DAISY CHAIN CONFIG.			OUT		DAISY CHAIN CONFIG.				
IN		RADIAL or STAR CONFIG.			IN		RADIAL or STAR CONFIG.				
<p>WRITE YOUR CONFIGURATION HERE</p> <p>EXAMPLE:     <b>INSTALLED</b>               = W2, W11, W13, W16</p> <p>* YOUR CONFIGURATION:</p> <p style="text-align: center;">W__ , W__ , W__ , W__</p>						<p>WRITE YOUR CONFIGURATION HERE</p> <p>EXAMPLE:     <b>INSTALLED</b>               = W5, W10, W13, W16</p> <p>* YOUR CONFIGURATION:</p> <p style="text-align: center;">W__ , W__ , W__ , W__</p>					

### 4.3.2 WRITE LOGIC

A write operation begins with Write Gate and Side Select commands from the controller when the FDD is selected. The commands simultaneously enable the write data bistable and turn on head center tap drivers, thus causing the center tap to go to approximately +12 V, block the input to the read circuit by reverse biasing diodes and after a delay energize the erase winding of the selected head. Data applied to the Write Data input alternately switches a constant write current through the write drivers to the selected head windings.

### 4.3.3 READ LOGIC

Read operation is enabled when the Read/Write heads are loaded on the diskette and Write Gate is inactive. With Write Gate inactive, the data blocking diodes are forward biased, and data sensed by the Read/Write head is amplified. The read signal from the diskette is in the form of a sinewave.

This analog signal is filtered by a passive constant phase filter, differentiated by an active differentiator and coupled to a comparator/logic circuit (a time domain filter) to detect zero crossings and reject noise in the differentiated read signal.

### 4.3.4 DISK DRIVE

Disk drive is accomplished by clamping the diskette between the cone assembly and a motorized spindle. The spindle is rotated at 300 r/min by the spindle motor. The motor is a brushless DC motor controlled by a servo amplifier. Motor speed is adjusted at the factory and should require no readjustment.

### 4.3.5 READ/WRITE HEADS

The Read/Write heads are in direct contact with the diskette during a read or write operation. Since the lower head is rigidly mounted on the carriage assembly, head load is achieved by allowing the upper flexible head, under tension, to force the diskette against the Read/Write heads. The head surfaces are designed for maximum signal transfer to and from the magnetic surfaces of the diskette with minimum head/diskette wear. The tunnel erase gaps DC erase the intertrack area to improve off track signal to noise ratio and permit diskette interchange between FDD units.

## 4.4 CONTROL AND DATA LINE CHARACTERISTICS

All signal lines must be terminated at the receiver. Terminator resistance used is typically 150 ohms. Transmission is by 26 AWG (min.), 120 ohm flat cable or twisted pair (one twist per inch) with a maximum line length of 10 feet. Figure 5-1 shows the timing of typical operations.

### 4.4.1 LOGIC LEVELS

The following definitions will be used throughout this manual:

low = Logic 1, Active State	Refers to the low voltage condition +0.4 V Max.
high = Logic 0, Inactive State	Refers to the high voltage condition +2.4 V Min.

### 4.4.2 TRANSMITTER CHARACTERISTICS

The FDD uses the equivalent of TTL 7438 (quad two input open collector drivers) to transmit all control and data signals. Each gate is capable of sinking a current of 48 mA with a maximum output voltage of 0.4 volt.

### 4.4.3 LINE RECEIVER CHARACTERISTICS

The FDD uses the equivalent of the 7414 family for line receivers. The input of each receiver is terminated in 150 ohms.

#### 4.4.4 CONTROL AND DATA LINE FUNCTIONS

The signals described in Table 4-2 are shown relative to a point of origin in Figure 4-1.

TABLE 4-2. INPUT/OUTPUT LINES (SHEET 1 OF 2)

SIGNAL	FUNCTION
<p><u>INPUT LINES</u> STEP</p>	<p>A one-microsecond minimum logic 1 level pulse on this line causes the heads to move one track as determined by the direction line. Twenty milliseconds maximum is required after a logic 0 to logic 1 transition (when the motion begins) before the carriage is stable.</p>
<p>DIRECTION SELECT</p>	<p>A logic 1 level on this line and step pulse causes the heads to move one track inward toward center of the diskette. A logic 0 level on this line and step pulse causes the heads to move one track outward from the center of the diskette. The level must be stable one microsecond before and one microsecond after the logic 0 to logic 1 transition of STEP.</p>
<p>MOTOR ON</p>	<p>A logic 1 level on this line starts the DC motor which rotates the diskette. The logic 1 level must be initiated 500 milliseconds before initiating a read or write operation to allow the spindle to come up to speed and stabilize.</p> <p>For increased head and media life, this signal should be at a logic 0 whenever a data transfer operation is not in process or pending.</p>
<p>WRITE GATE</p>	<p>To enable the FDD write driver, this line is held at a logic 1 level.</p> <p>To disable the FDD write drive and enable the FDD read circuitry, this line is held at logic 0. One millisecond maximum is required after a write operation before read data is stable.</p>

TABLE 4-2. INPUT/OUTPUT LINES (SHEET 2 OF 2)

SIGNAL	FUNCTION
<u>INPUT LINES</u>	
WRITE DATA	This line carries the composite write clock and coded data information to the FDD. The write clock and write data pulses must be 250 nanoseconds minimum to 2100 nanoseconds maximum in length and are true at the logic 1 level. Information to be recorded on the diskette is derived from the transition of each pulse from logic 0 to logic 1.
DRIVE SELECT	On this line a logic 1 level with shunt "DS0, DS1, DS2, or DS3" present enables the FDD interface.
SIDE SELECT	A logic 1 level on this line enables upper Head 1, a logic 0 level on this line enables lower Head 0, for read and/or write operations. A 200 microsecond delay is required after this level is changed before read data is valid or the Write Gate is switched to a logic 1.
IN USE	A logic 1 level will make the Activity Indicator glow.
<u>OUTPUT LINES</u>	
INDEX	A logic 1 pulse indicates detection of index and/or sector holes in the rotating diskette. The interval between index pulses is an indication of the rotating speed. Sector pulses indicate rotational position of the diskette.
TRK 00	A logic 1 level indicates the heads are positioned over Track 00.
WRT PROTECT	Logic 1 level indicates the write protect slot on the diskette is covered, and the diskette cannot be written on.
READ DATA	This line carries unseparated data and clock information. A logic 1 level pulse of one microsecond corresponds to a data or clock bit read from the diskette.
DRIVE STATUS	A logic 1 level indicates one of the conditions detailed in 4.3.1.f has occurred.

## 5.1 DIAGRAMS

This section contains the PWA documentation and related timing diagrams.

Figure 5-1 shows timing diagrams which illustrate signal time relationships during read, write, step in, and step out operations. Figure 5-2 lists J1 and J2 pin assignments. Figures 5-3A through 5-3D include the Data Control PWA schematic and assembly drawings for the types of PWAs used in this FDD. Be sure to identify the type before proceeding. Figures 5-4A through 5-4C include the Motor Control PWA schematics and assembly drawings.

## 5.2 MAINTENANCE AIDS

### 5.2.1 INTRODUCTION

This section contains detailed information on the logic circuits used in the FDD. The logic consists of two types of circuits: discrete component and integrated circuits (IC). Integrated circuits are contained within a single chip. Discrete component circuits are composed of individually identifiable resistors, capacitors, transistors, etc.

### 5.2.2 PHYSICAL DESCRIPTION (LOGIC)

All components are mounted on two PWAs. The PWAs contain both IC and discrete component circuits.

### 5.2.3 LOGIC SYMBOLOGY

Logic signals that are "active hi" have the suffix/+L attached to their names, and logic signals that are "active lo" have the suffix/-L attached. For example, the signal WRITE GATE/-L will be "hi" (logic 0) when the unit is not commanded to write. WRITE GATE/-L will go "active lo" (logic 1) when the unit is commanded to write data on the diskette. Signals that do not have/+L or /-L appended to their names are not logic signals.

Annotation used with logic storage devices is as follows:

S = Set input to bistable device  
R = Reset (Clear) input to bistable device  
G = Gate input has no direct action on circuit, but must be present before inputs (and/or outputs) are able to function. If more than one gate is used a numeric suffix is added (G1, G2, etc.)

- D = Identifies a signal which requires the presence of another signal to perform its function.
- C = Strobe pulse. Usually used to gate "D" inputs into a bistable device.
- T = Toggle input. Bistable device changes state each time "T" assumes its specified state.
- J = J outputs conditioned by leading edge of dynamic toggle (G).
- K = K output conditioned by leading edge of dynamic toggle (G).

Some of the logic symbols are illustrated and described in Table 5-1.

TABLE 5-1. LOGIC SYMBOLGY

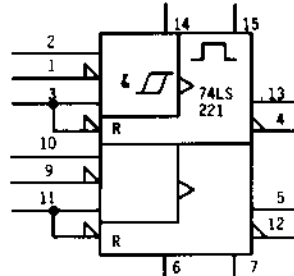

THE 74LS221 IS A DUAL MONOSTABLE MULTIVIBRATOR WITH SCHMITT TRIGGER INPUTS. THE TWO SECTIONS ARE INDEPENDENT EXCEPT FOR A COMMON POWER SOURCE. TRIGGERING OCCURS AT A PARTICULAR INPUT VOLTAGE LEVEL AND IS NOT DIRECTLY RELATED TO TRANSITION TIME OF THE INPUT SIGNAL. HYSTERESIS INPUT ALLOWS JITTER FREE TRIGGERING.

PIN 2 (10) GENERATES A TRIGGER ON ITS POSITIVE GOING SLOPE OR INHIBITS THE TRIGGER WHEN LOW. PIN 1 (9) GENERATES A TRIGGER ON ITS NEGATIVE GOING SLOPE OR INHIBITS THE TRIGGER WHEN HIGH. PIN 3 (11) ENABES THE TRIGGER WHEN HIGH OR INHIBITS THE TRIGGER AND RESETS THE MONOSTABLE WHEN LOW. PINS 13 (5) AND 4 (12) ARE RESPECTIVELY THE POSITIVE AND NEGATIVE GOING PULSE OUTPUTS. EXTERNAL R-C COMPONENTS CONNECTED TO PINS 14 AND 15 (6 AND 7) DETERMINE THE DURATION OF THE OUTPUT PULSE.

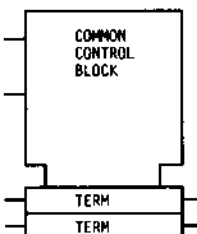

INPUTS TO THE COMMON CONTROL BLOCK AFFECT EVERY TERM IN THE ARRAY. INPUTS TO EACH TERM AFFECT ONLY THAT TERM.

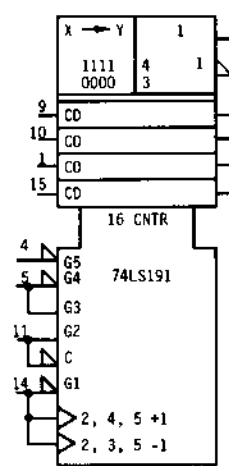

THE 74LS191 IS A SYNCHRONOUS UP/DOWN COUNTER. EACH STAGE HAS AN INPUT AND AN OUTPUT PIN AS FOLLOWS:

INPUT	STAGE	OUTPUT
9	D	7
10	C	6
1	B	2
15	A	3

PIN 4 WHEN LOW (G5) "SELECTS" THE IC AND ENABES IT TO RESPOND TO OTHER CONTROL SIGNALS.

PIN 11 WHEN LOW (C) ENABES PARALLEL INPUT. ALL FOUR STAGES ASSUME THE STATE OF THE INPUT PINS. WHEN PIN 11 IS HIGH (G2) DATA INPUTS ARE DISABLED AND THE COUNTER IS ENABED.

PIN 5 WHEN LOW (G4) PERMITS THE COUNTER TO INCREMENT. PIN 5 WHEN HIGH (G3) PERMITS THE COUNTER TO DECREMENT.

PIN 14 (G1) IS THE "CLOCK" INPUT. WHEN THE COUNTER IS ENABED, A LOW TO HIGH TRANSITION OF PIN 14 CAUSES THE COUNTER TO CHANGE STATE.

PIN 13 IS THE "RIPPLE CLOCK OUT" TO PERMIT COUNTERS TO BE CASCADED.

PIN 12 INDICATES MAX/MIN WHICH ANTICIPATES THE "RIPPLE CLOCK".

TP  
TEST POINT

LOGIC POLARITY INDICATOR- "LO" ACTIVE STATE.

IMPLIED SIGN INDICATOR- ABSENCE OF AN N SIGN INDICATOR IMPLIES A NON-INVERTING SIGNAL RELATIVE TO OTHER IMPLIED SIGN SIGNAL LINES. EFFECT IS THE SAME AS THE USE OF P SIGN INDICATOR INTERNALLY.

SIGN INDICATOR-USED TO INDICATE INVERSION RELATIVE TO IMPLIED SIGN SIGNAL LINES.

DYNAMIC INPUT ACTIVE DURING THE TRANSITION FROM LOW TO HIGH STATE

DYNAMIC INPUT ACTIVE DURING THE TRANSITION FROM HIGH TO LOW STATE

<p>X/Y    BINARY LEVEL CONVERTER</p> <p>I       "OR" GATE</p> <p>&amp;       "AND" GATE</p> <p>    SCHMITT TRIGGER - CIRCUIT WITH PULSE SHAPING CAPABILITIES</p> <p><math>\Sigma \infty</math>    SUMMING AMPLIFIER</p> <p>X → Y    CODER-INPUT CODE X CONVERTED TO OUTPUT CODE Y</p>	
---	--

FF235



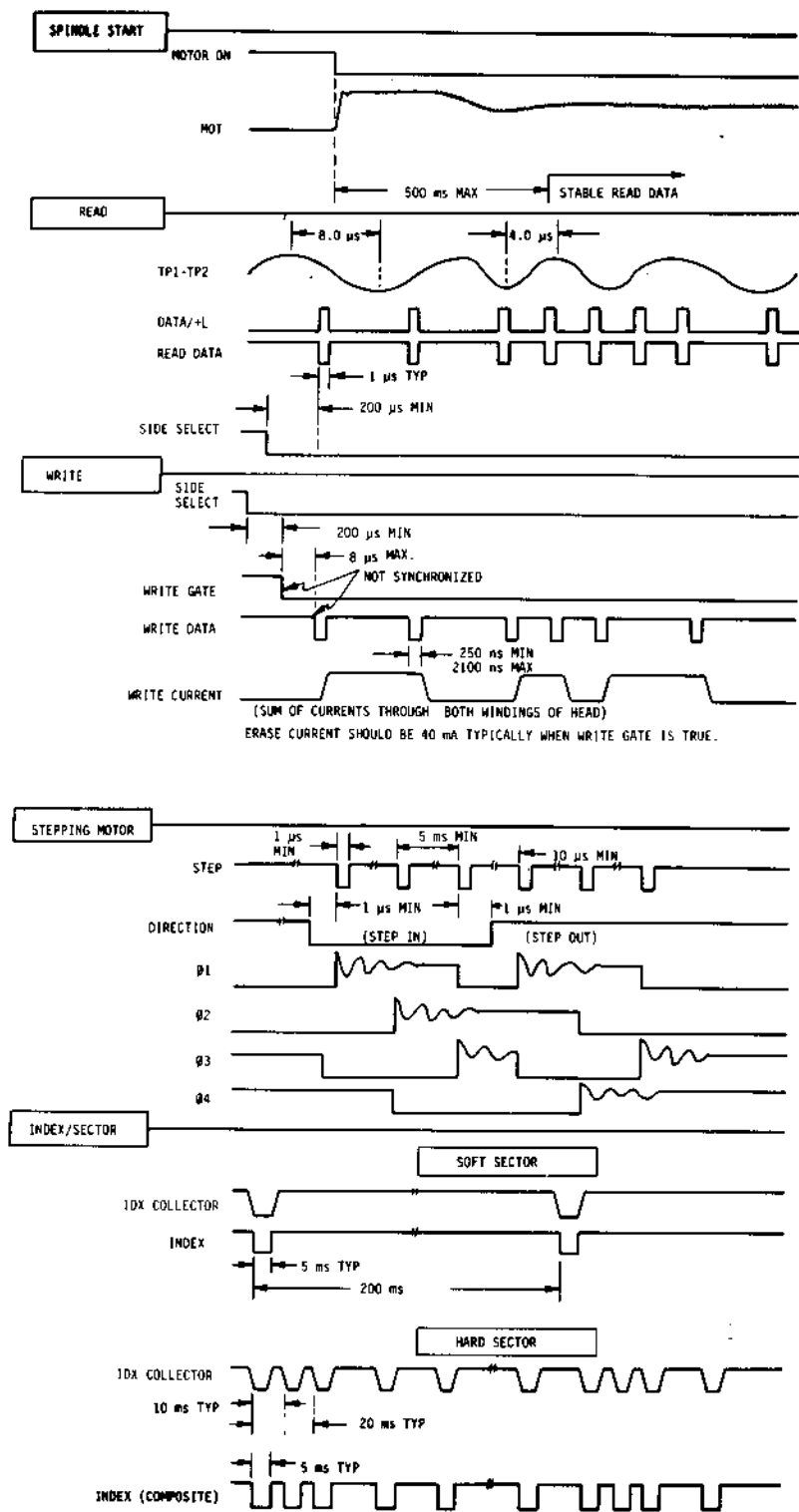

HD45

FIGURE 5-1. TIMING DIAGRAM

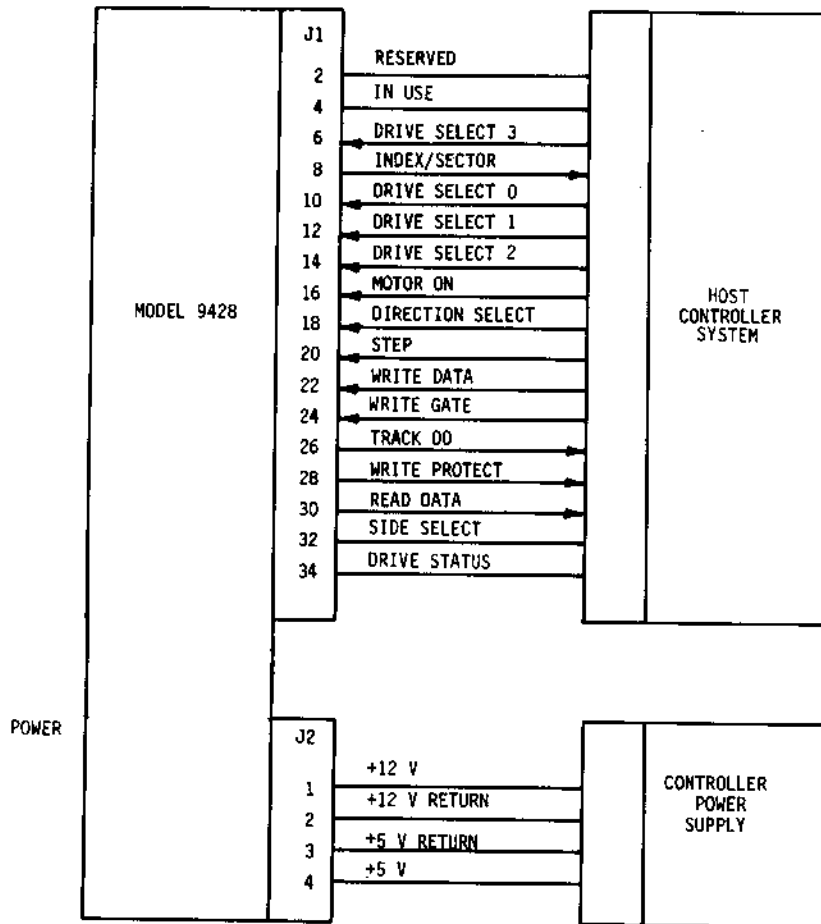

H214a

ALL J1 ODD NUMBER PINS DC GROUND.

FIGURE 5-2. J1 AND J2 PIN ASSIGNMENTS

TABLE 5-2. CONFIGURATION INDEX OF MAJOR ASSEMBLIES

<u>HPC #</u>	<u>DATA* PWA</u>	<u>MOTOR PWA</u>	<u>SPINDLE MOTOR</u>	<u>HEAD ASSEMBLY**</u>
77740000	A	77738651	77671895	77740444
77740001	A	77738651	77671895	77740444
77740002	NONE	NONE	77671895	77741420
77740003	A	77740185	77671895	77740444
77740004	A	77740185	77671895	77740444
77740005	A	77738651	77671895	77740444
77740006	A	77738651	77671895	77740444
77740007	A	77738651	77671895	77740444
77740008	B	77741571	77671896	77741420
77740009	B	77741571	77671896	77741420
77740010	C	77741571	77671896	77741420
77740011	A	77743656	77671895	77740444
77740012	A	77743661	77671895	77740444
77740013	A	77743661	77674895	77740444
77740014	B	77743670	77671896	77741420
77740015	77740650	77743656	77671895	77740444
77740016	C	77741571	77671896	77741420
77740017	C	77743785	77671896	77741420
77740018	C	77743785	77671896	77741420
77740054	77743720	77743661	77671895	77741420
77740055	77740650	77743661	77671895	77740444
77740056	77741940	77743661	77671895	77741420
77740057	C	77743661	77671895	77741420
77740058	77741940	77743656	77671895	77741420
77740059	C	77743656	77671895	77741420
77740060	C	77743661	77671895	77741420
77740061	C	77741571	77671896	77741420
77740062	B	77741571	77671896	77741420
77740076	C	77743661	77671895	77741420
77740077	C	77743661	77671895	77741420
77740078	C	77743656	77671895	77741420

\* A = 77740650 or 77734904  
 B = 77741910 or 77743940  
 C = 77741940 or 77743720

\*\* 77741420 may be substituted for 77740444

FIGURE 5-3A. DATA CONTROL PMA 77740650 (SHEET 1 OF 4)

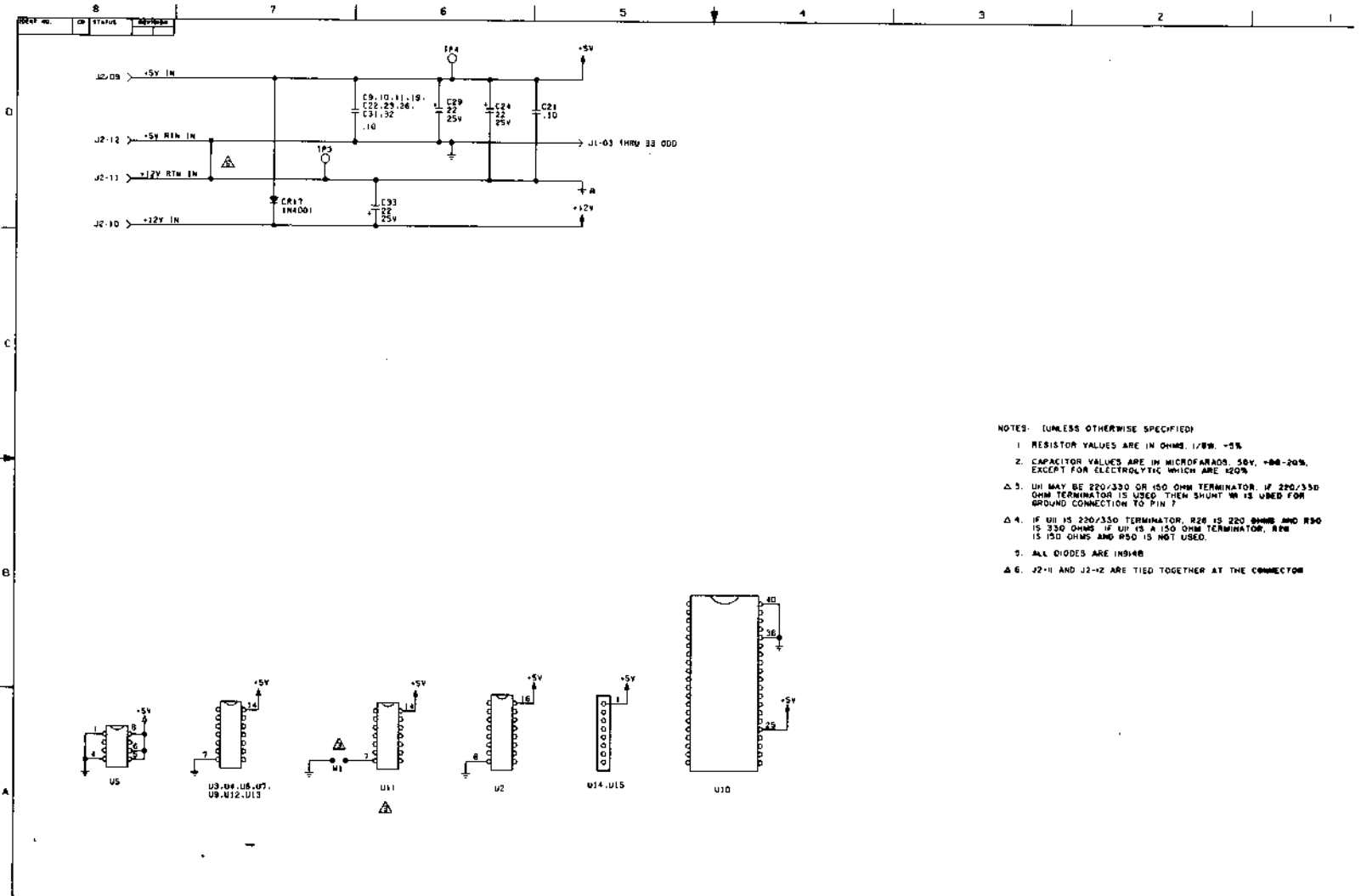

FIGURE 5-3A. DATA CONTROL PWA 77740650 (SHEET 2 OF 4)

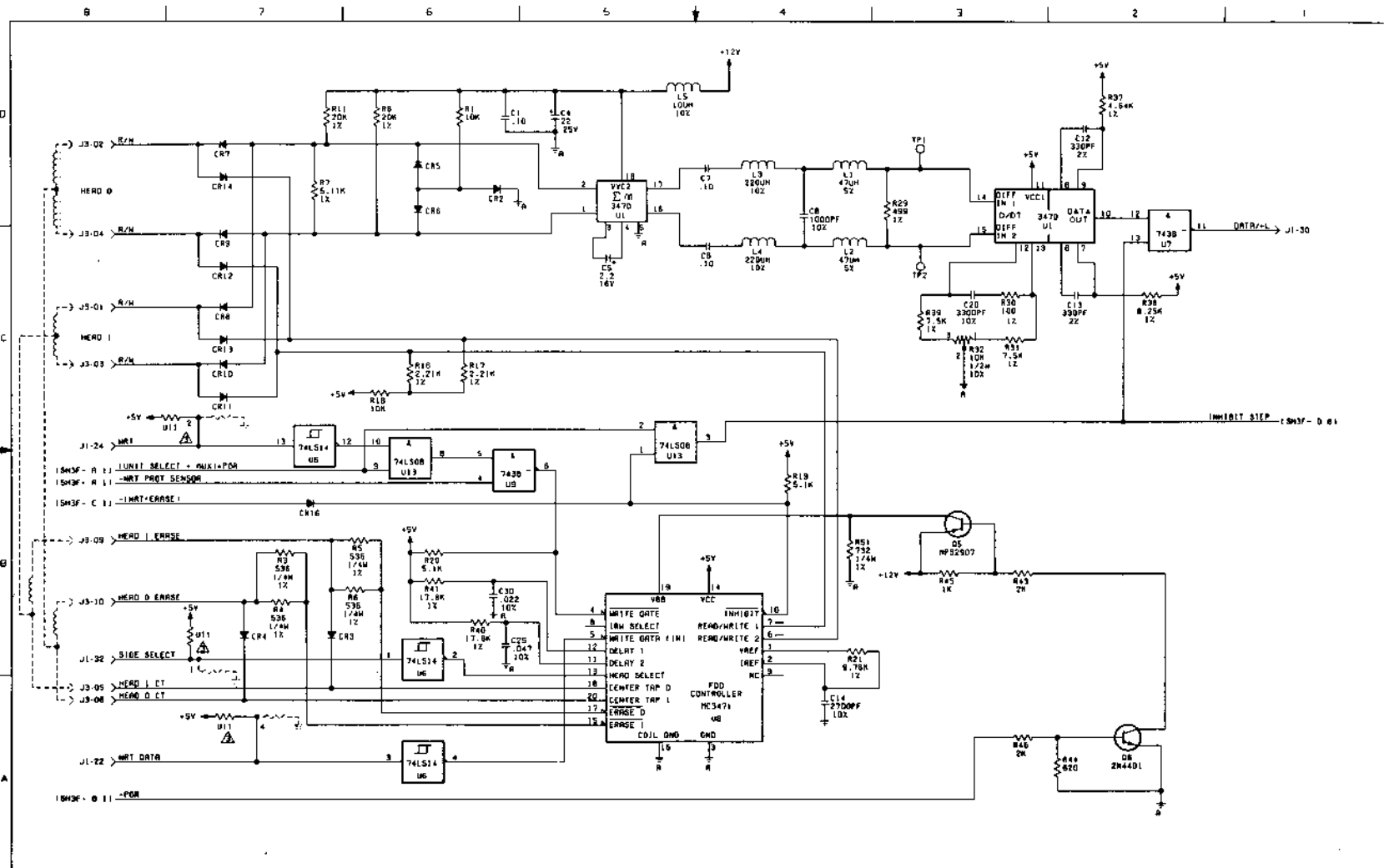
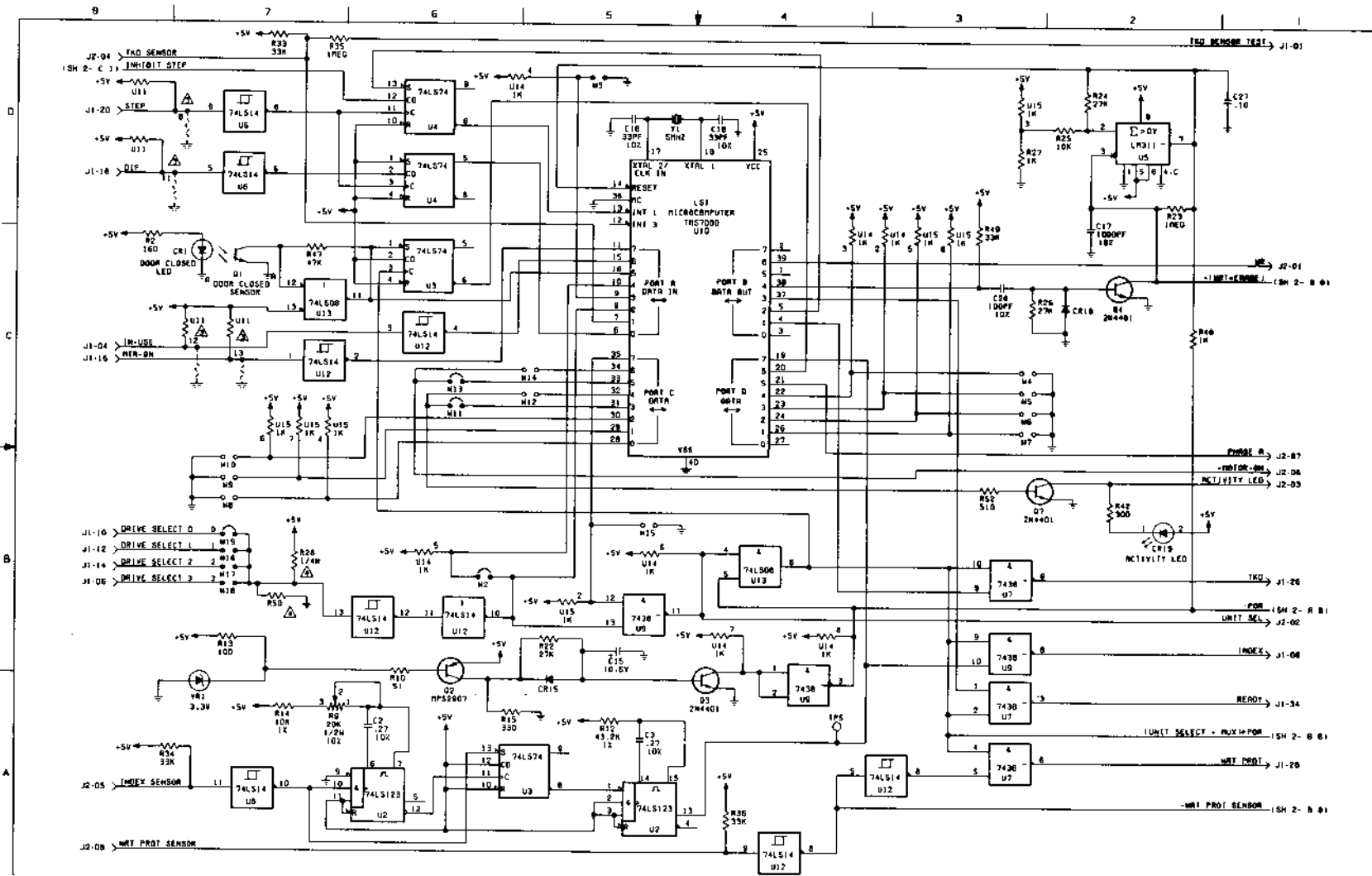
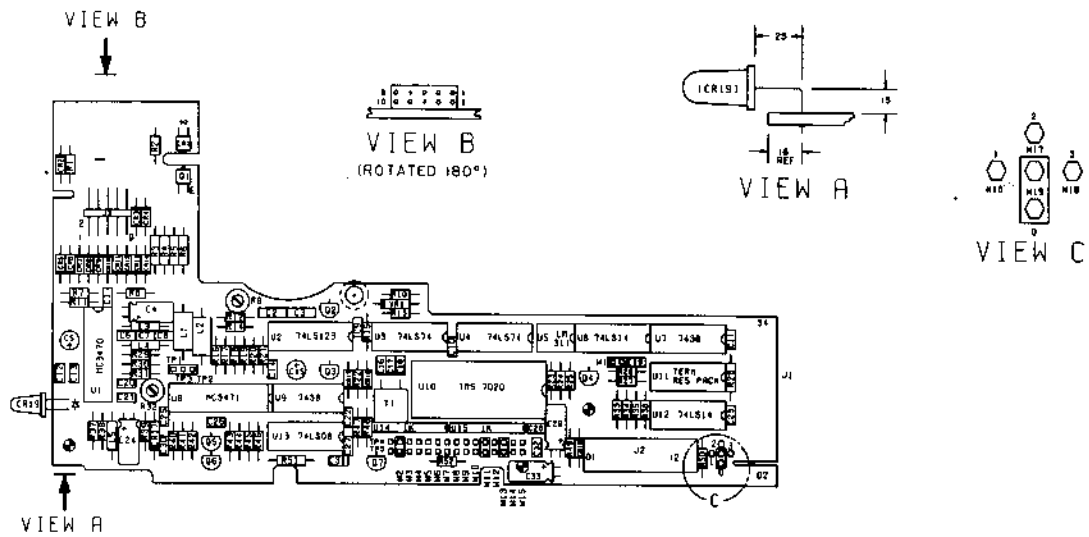

FIGURE 5-3A. DATA CONTROL PWA 77740650 (SHEET 3 OF 4)





CR1	=	SEP8507-2
CR2 - CR16, CR18	=	IN914B
CR17	=	IN4001
CR19	=	LED
VR1	=	3.3V 5%
Q1	=	SDP8407-1
Q2, Q5	=	MPS2907
Q3, Q4, Q6, Q7	=	2N4401

FIGURE 5-3A. DATA CONTROL PWA 77740650 (SHEET 4 OF 4)

FIGURE 5-3B. DATA CONTROL PWA 77734904 (SHEET 1 OF 4)

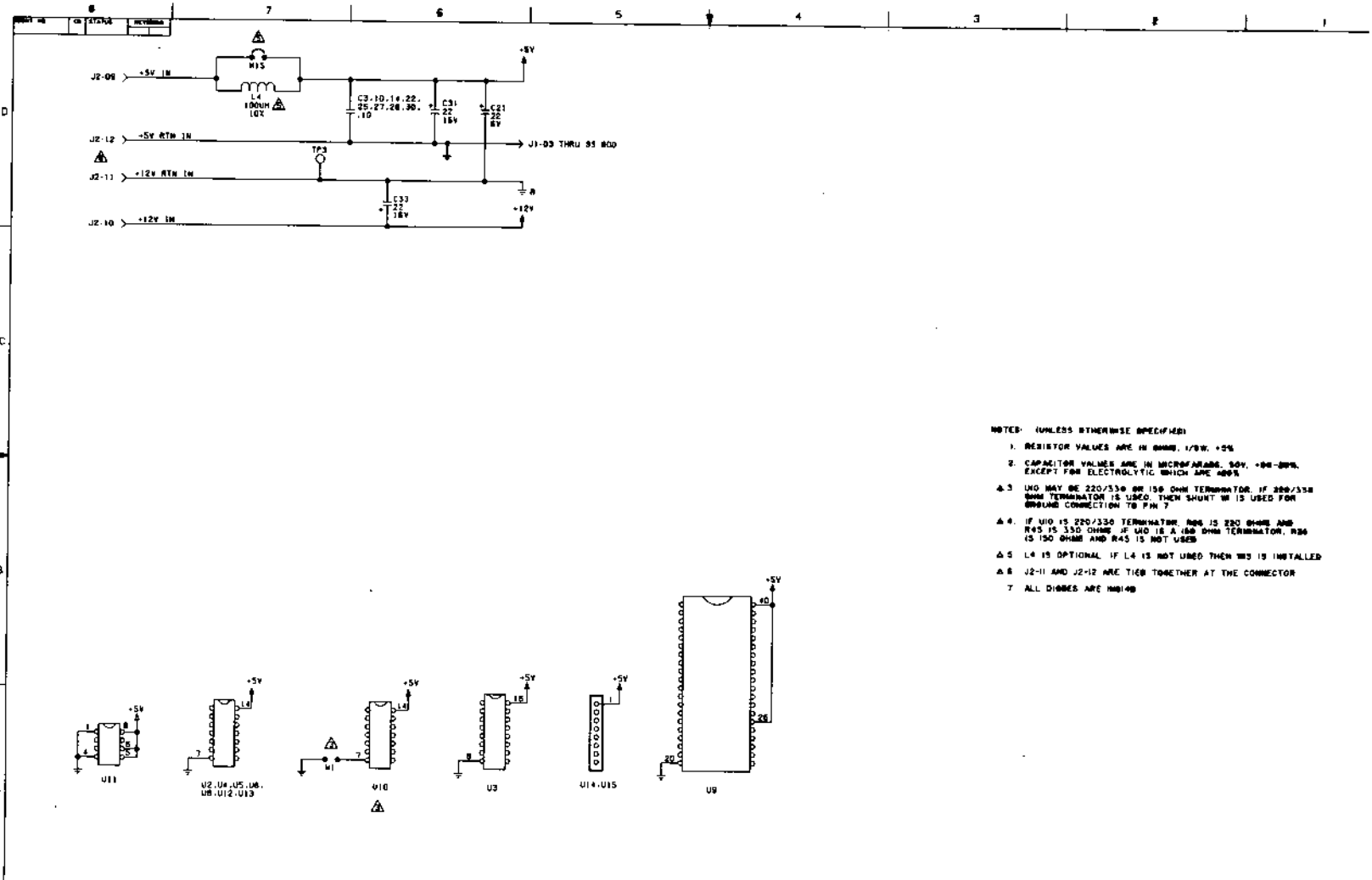

- NOTES: (UNLESS OTHERWISE SPECIFIED)
1. RESISTOR VALUES ARE IN OHMS, 1/8W, ±5%
  2. CAPACITOR VALUES ARE IN MICROFARADS, 50V, ±20-20%, EXCEPT FOR ELECTROLYTIC WHICH ARE 100%
  3. U10 MAY BE 220/330 OR 150 OHM TERMINATOR. IF 220/330 OHM TERMINATOR IS USED, THEN SHUNT W IS USED FOR GROUND CONNECTION TO PIN 7
  4. IF U10 IS 220/330 TERMINATOR, R46 IS 220 OHMS AND R45 IS 330 OHMS. IF U10 IS A 150 OHM TERMINATOR, R46 IS 150 OHMS AND R45 IS NOT USED
  5. L4 IS OPTIONAL. IF L4 IS NOT USED THEN W3 IS INSTALLED
  6. J2-11 AND J2-12 ARE TIED TOGETHER AT THE CONNECTOR
  7. ALL DIODES ARE 1N4001

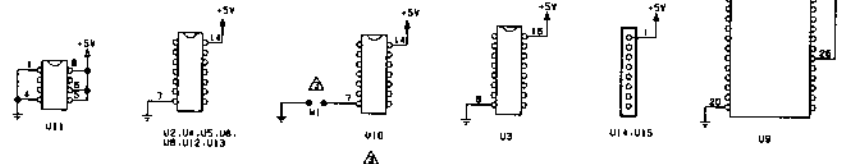



FIGURE 5-3B. DATA CONTROL PWA 77734904 (SHEET 2 OF 4)

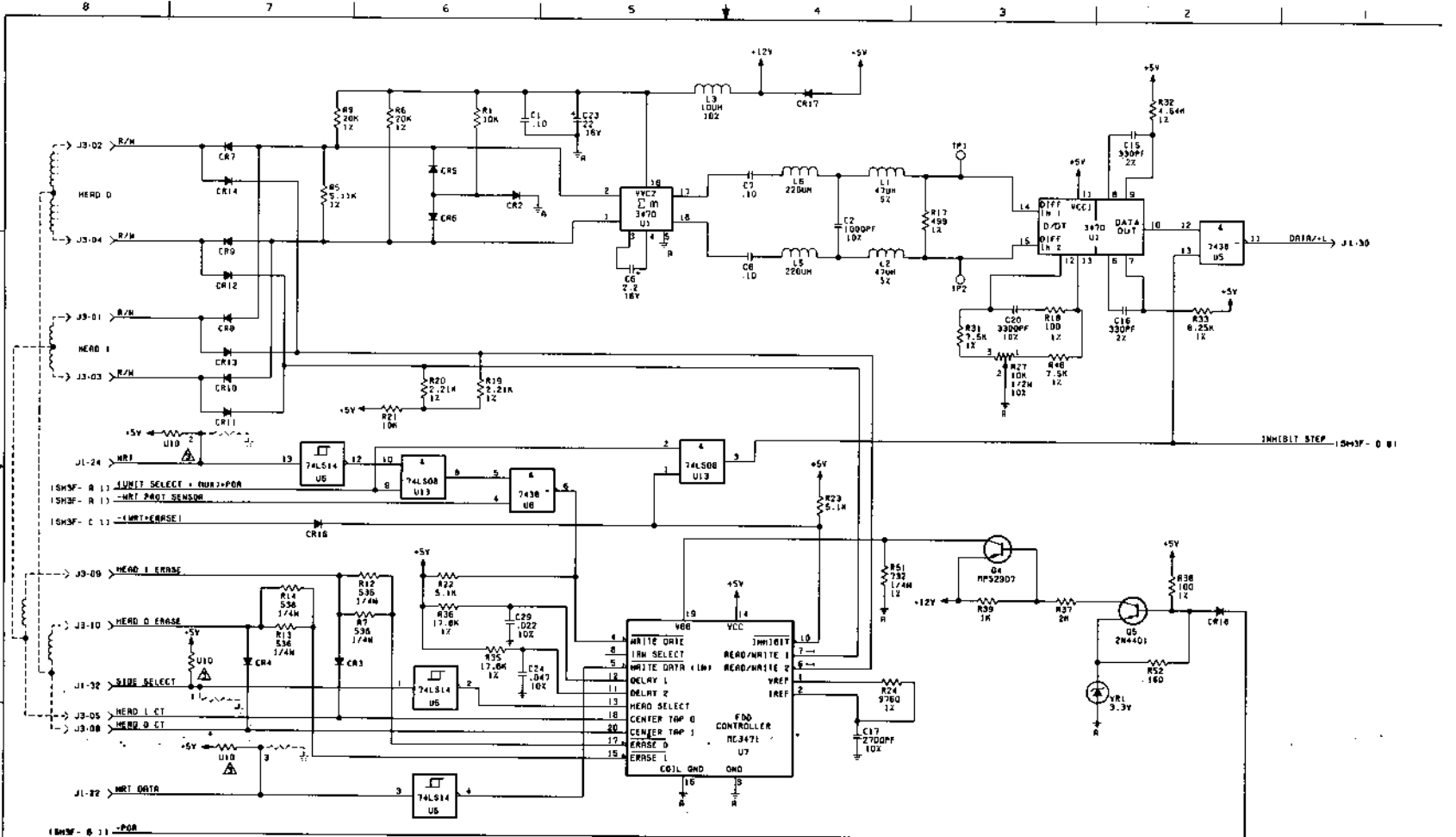
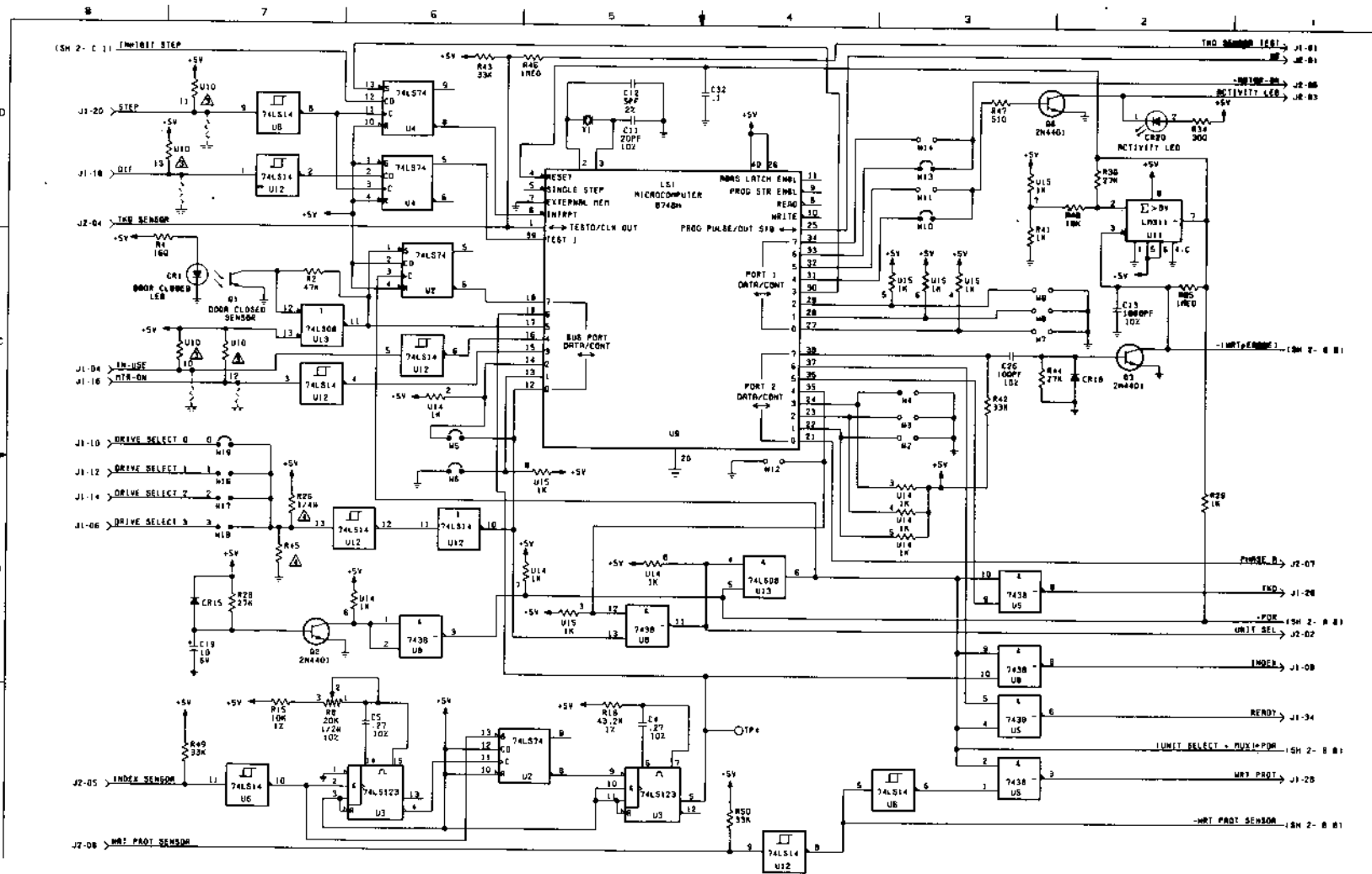
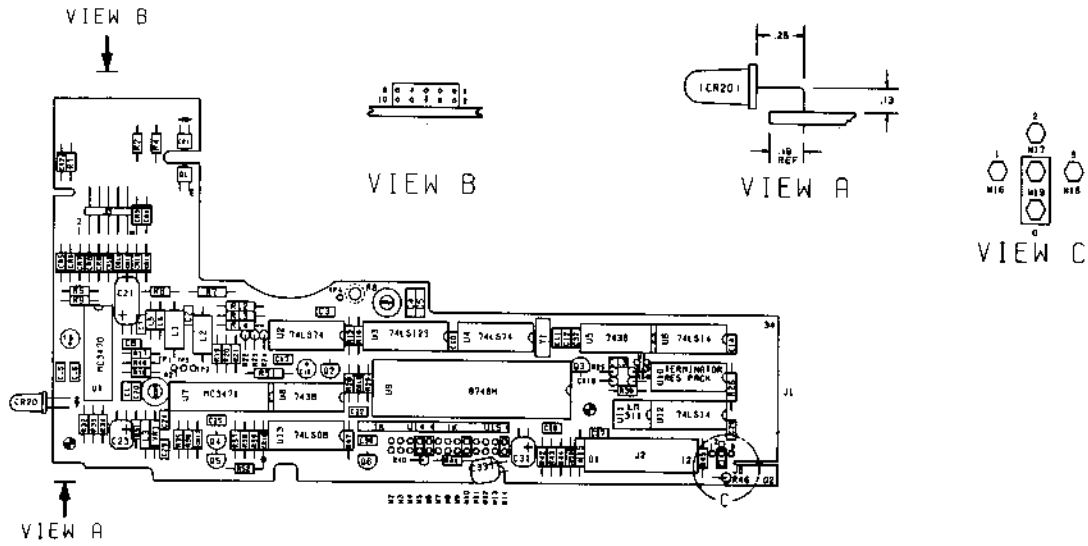

FIGURE 5-3B. DATA CONTROL PWA 77734904 (SHEET 3 OF 4)





CR1	=	SEP8507-2
CR2 - CR16, CR18, CR19	=	IN914B
CR17	=	IN4001
CR20	=	LED
VR1	=	3.3V 5%
Q1, Q4	=	MPS2907
Q2, Q3, Q5, Q6	=	2N4401

FIGURE 5-3B. DATA CONTROL PWA 77734904 (SHEET 4 OF 4)

FIGURE 5-3C. DATA CONTROL PMA'S 77741910 AND 77741940  
(SHEET 1 OF 5)

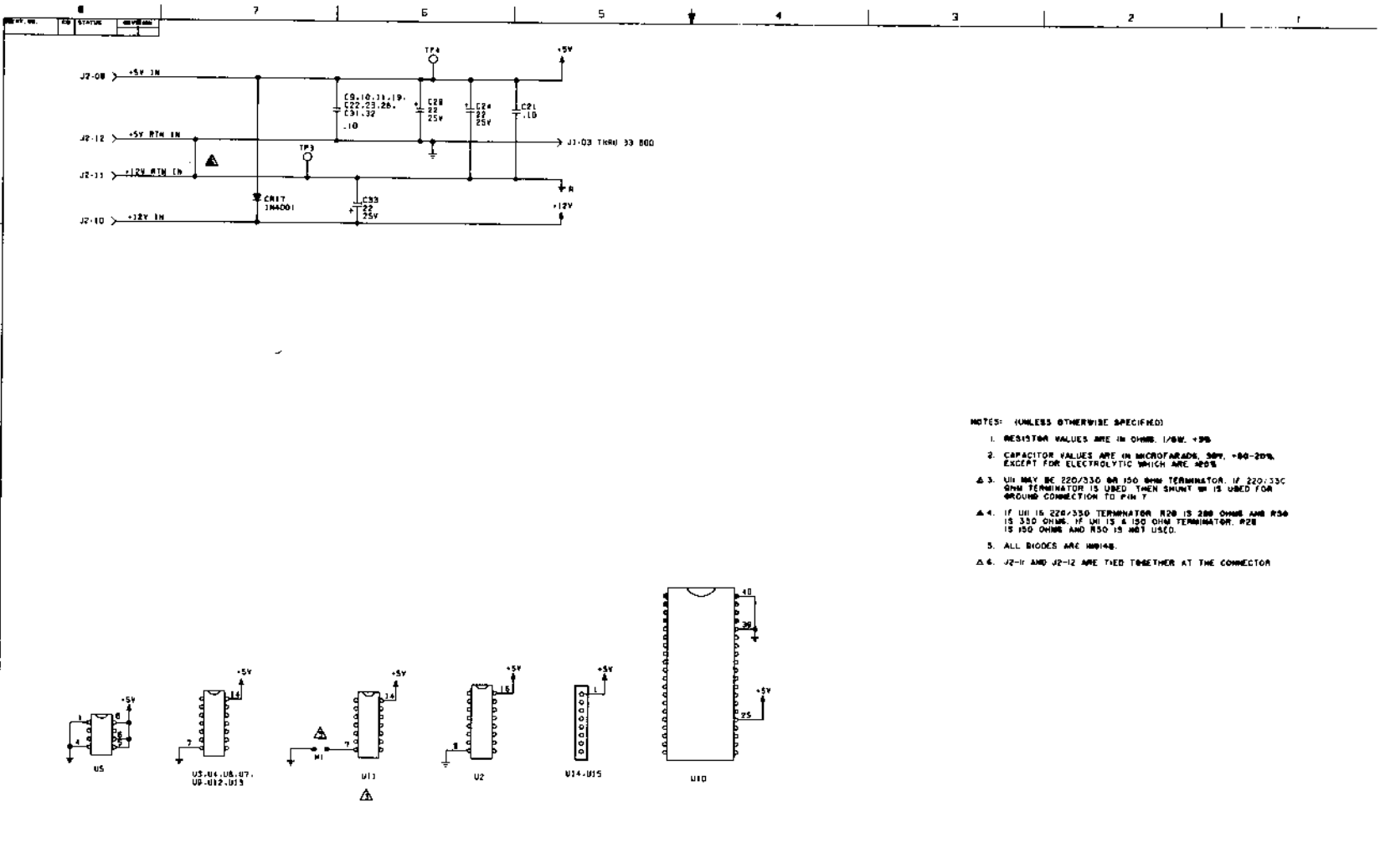

- NOTES: (UNLESS OTHERWISE SPECIFIED)
1. RESISTOR VALUES ARE IN OHMS, 1/5W, ±5%
  2. CAPACITOR VALUES ARE IN MICROFARADS, 50V, ±50-20%, EXCEPT FOR ELECTROLYTIC WHICH ARE 20V
  - △ 3. U11 MAY BE 220/330 OR 150 OHM TERMINATOR. IF 220/330 OHM TERMINATOR IS USED THEN SHUNT WR IS USED FOR GROUND CONNECTION TO PIN 7.
  - △ 4. IF U11 IS 220/330 TERMINATOR R20 IS 200 OHMS AND R30 IS 330 OHMS. IF U11 IS A 150 OHM TERMINATOR, R20 IS 150 OHMS AND R30 IS NOT USED.
  5. ALL BIDDIES ARE 1W/1/4W.
  - △ 6. J2-11 AND J2-12 ARE TIED TOGETHER AT THE CONNECTOR

FIGURE 5-3C. DATA CONTROL PWA'S 77741910 AND 77741940  
(SHEET 2 OF 5)

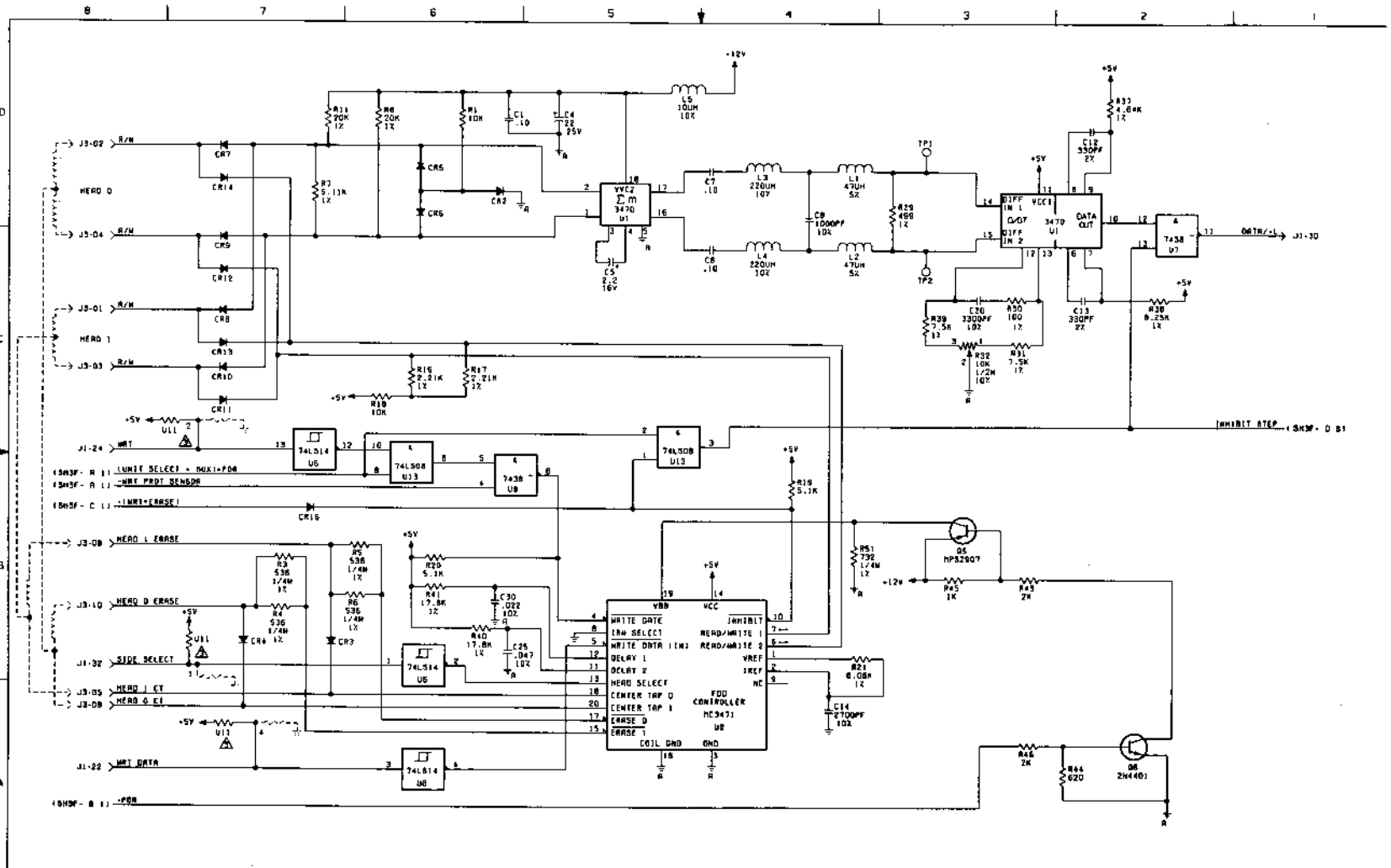
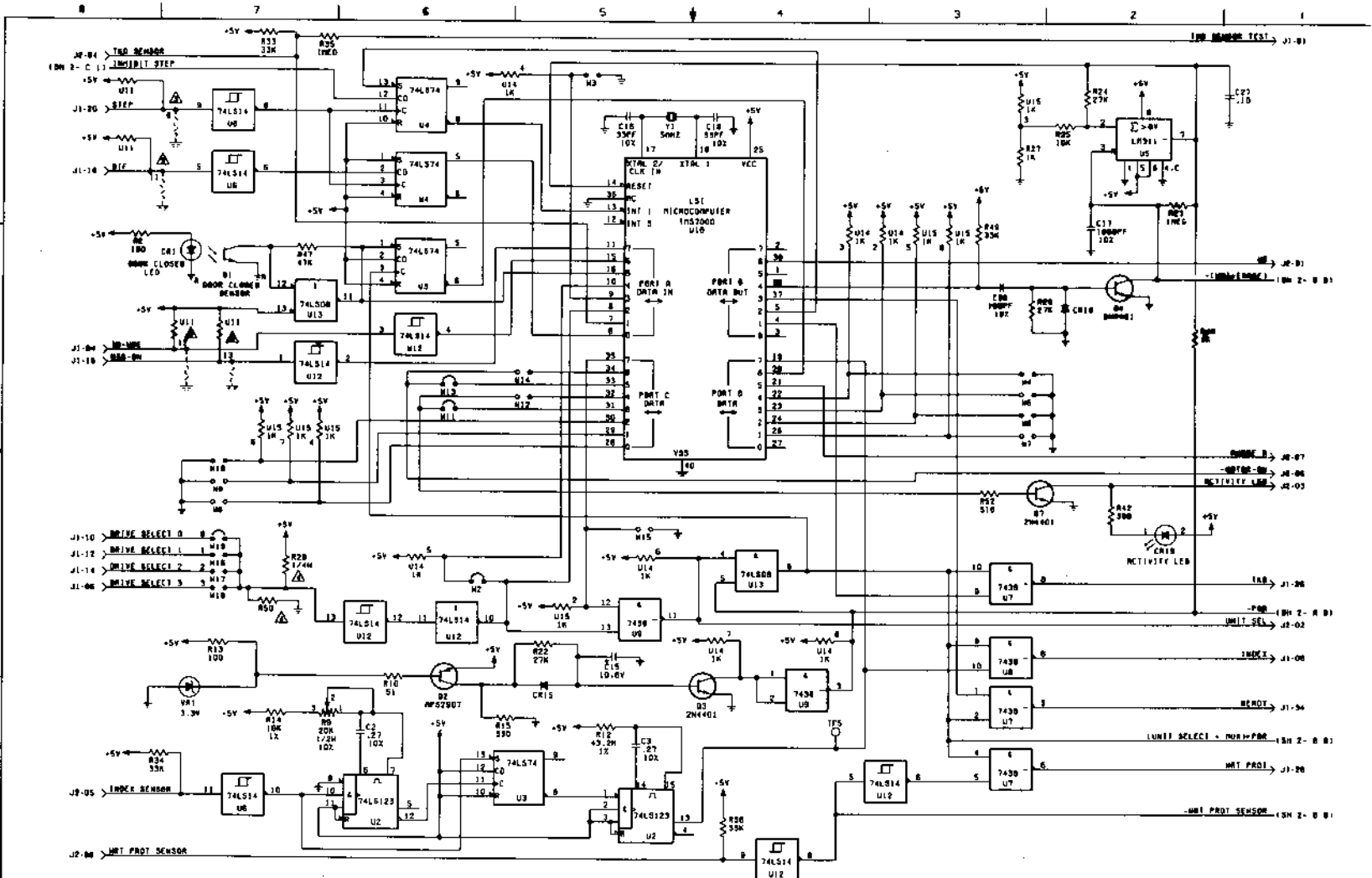
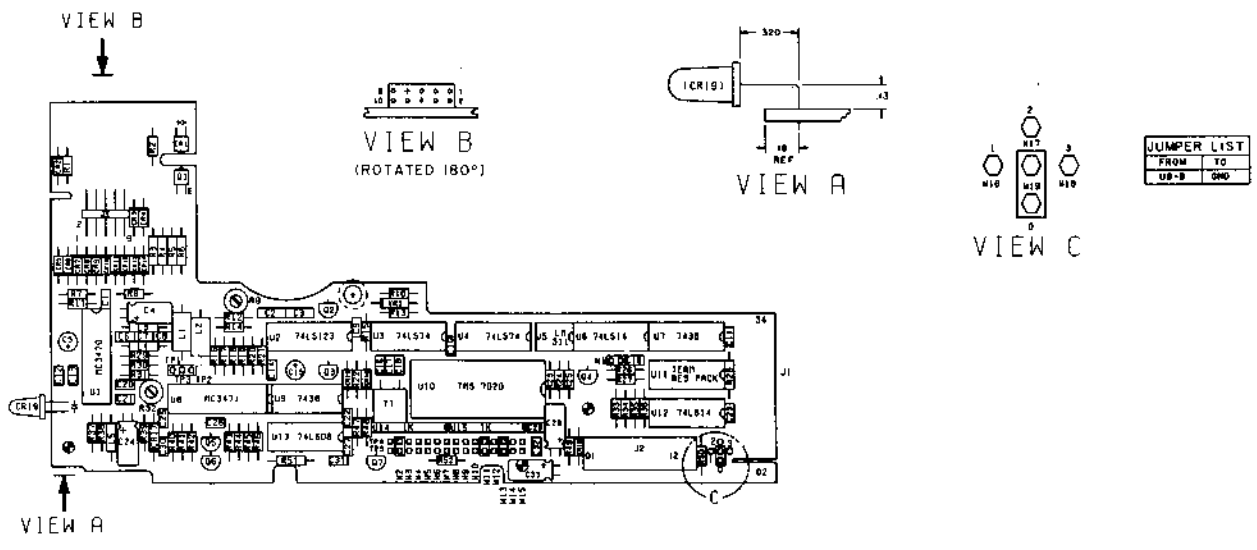

FIGURE 5-3C. DATA CONTROL PWA'S 77741910 AND 77741940  
(SHEET 3 OF 5)





- CR1 = SEP8507-2
- CR2 - CR16, CR18 = IN914B
- CR17 = IN4001
- CR19 = LED
- VR1 = 3.3V 5%
- Q1 = SDP8407-1
- Q2, Q5 = MPS2907
- Q3, Q4, Q6, Q7 = 2N4401

FIGURE 5-3C. DATA CONTROL PWA 77741910  
(SHEET 4 OF 5)

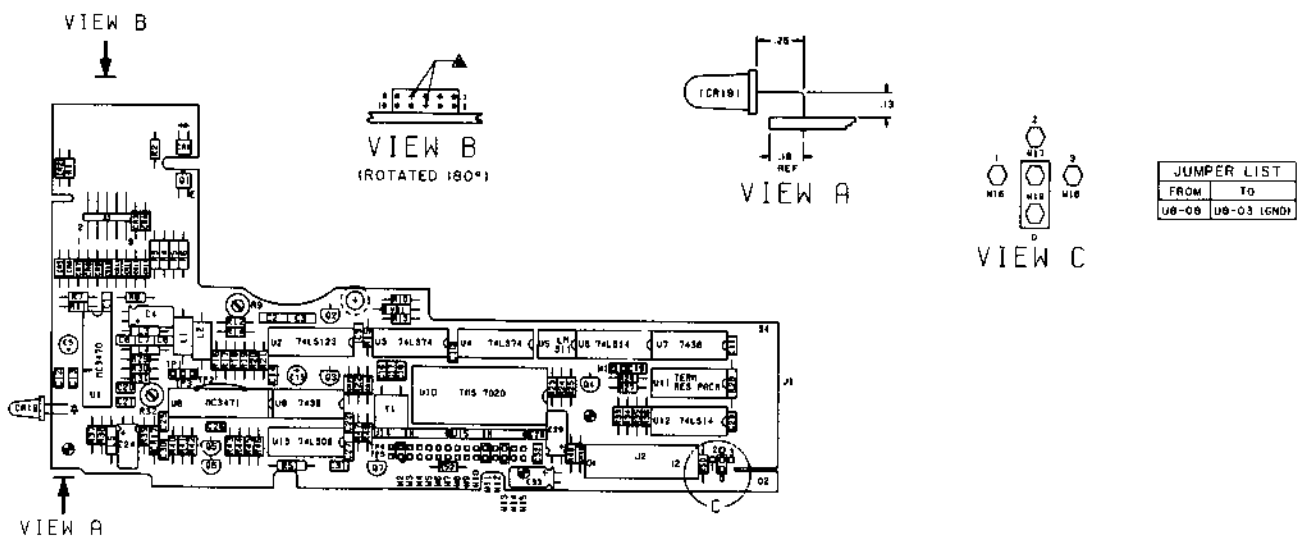

- CR1 = SEP8507-2
- CR2 - CR16, CR18 = IN914B
- CR17 = IN4001
- CR19 = LED
- VR1 = 3.3V 5%
- Q1 = SDP8407-1
- Q2, Q5 = MPS2907
- Q3, Q4, Q6, Q7 = 2N4401

FIGURE 5-3C. DATA CONTROL PWA 77741940  
(SHEET 5 OF 5)



FIGURE S-3D. DATA CONTROL PWA'S 77743720 AND 77743940  
(SHEET 1 OF 5)

77715900-J

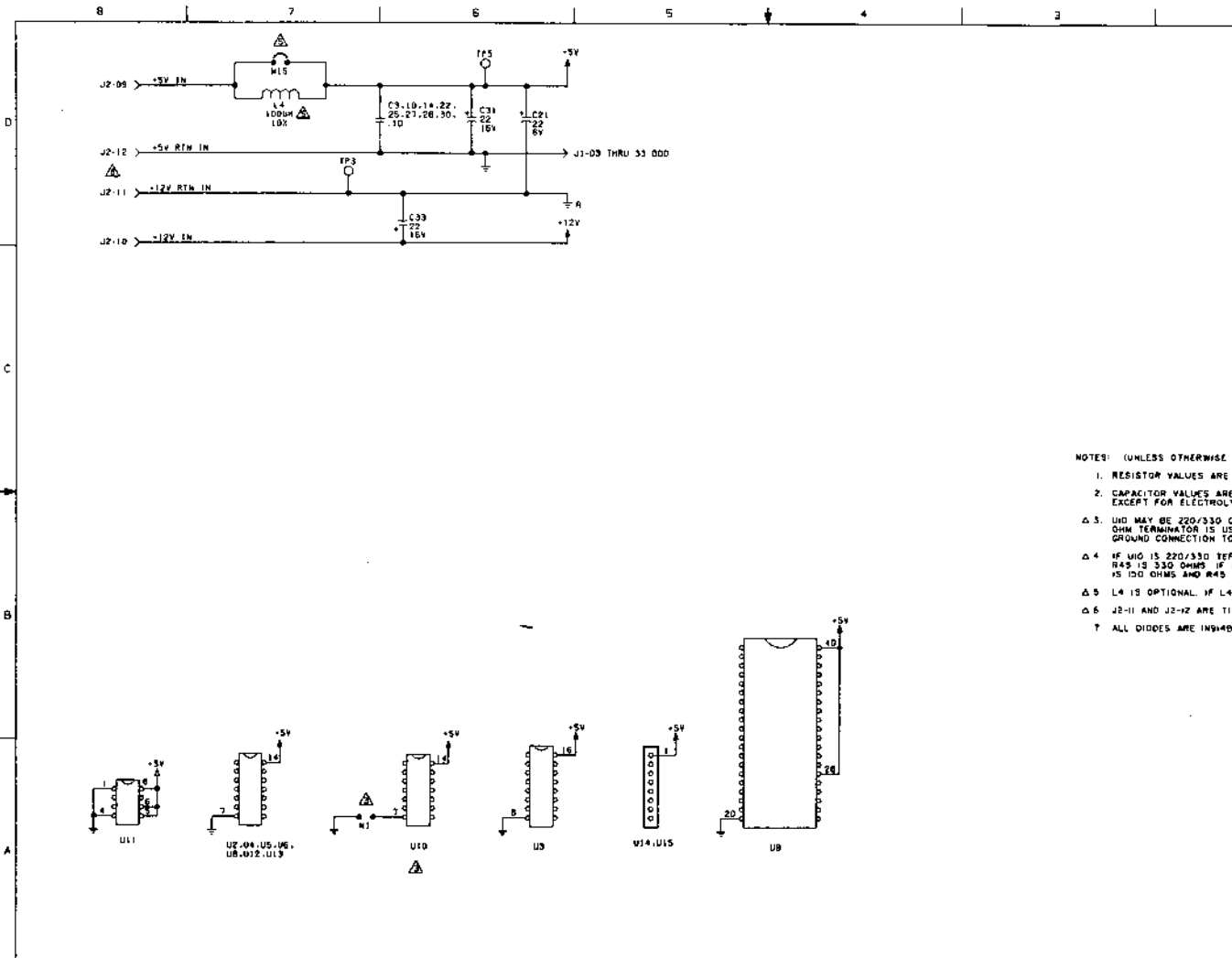

NOTES: (UNLESS OTHERWISE SPECIFIED)

1. RESISTOR VALUES ARE IN OHMS, 1/8W, ±5%
2. CAPACITOR VALUES ARE IN MICROFARADS, 50V, ±20-25%, EXCEPT FOR ELECTROLYTIC WHICH ARE 20%
3. U10 MAY BE 220/330 OR 150 OHM TERMINATOR. IF 220/330 OHM TERMINATOR IS USED, THEN SHUNT W IS USED FOR GROUND CONNECTION TO PIN 7
4. IF U10 IS 220/330 TERMINATOR, R26 IS 220 OHMS AND R45 IS 330 OHMS. IF U10 IS A 150 OHM TERMINATOR, R26 IS 150 OHMS AND R45 IS NOT USED
5. L4 IS OPTIONAL. IF L4 IS NOT USED THEN W3 IS INSTALLED
6. J2-11 AND J2-12 ARE TIED TOGETHER AT THE CONNECTOR
7. ALL DIODES ARE 1N914D

FIGURE 5-3D. DATA CONTROL PWA'S 77743720 AND 77743940  
(SHEET 2 OF 5)

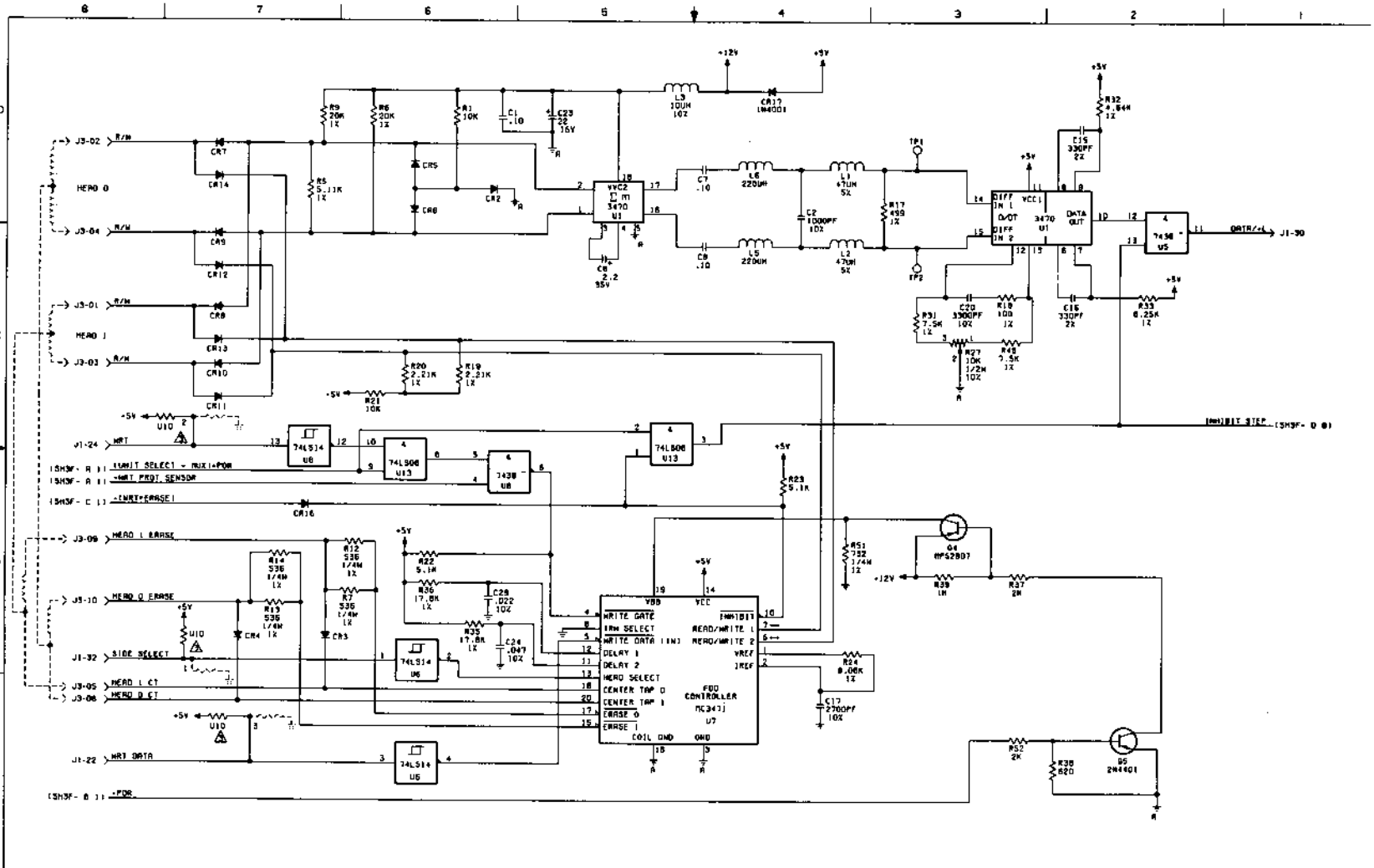
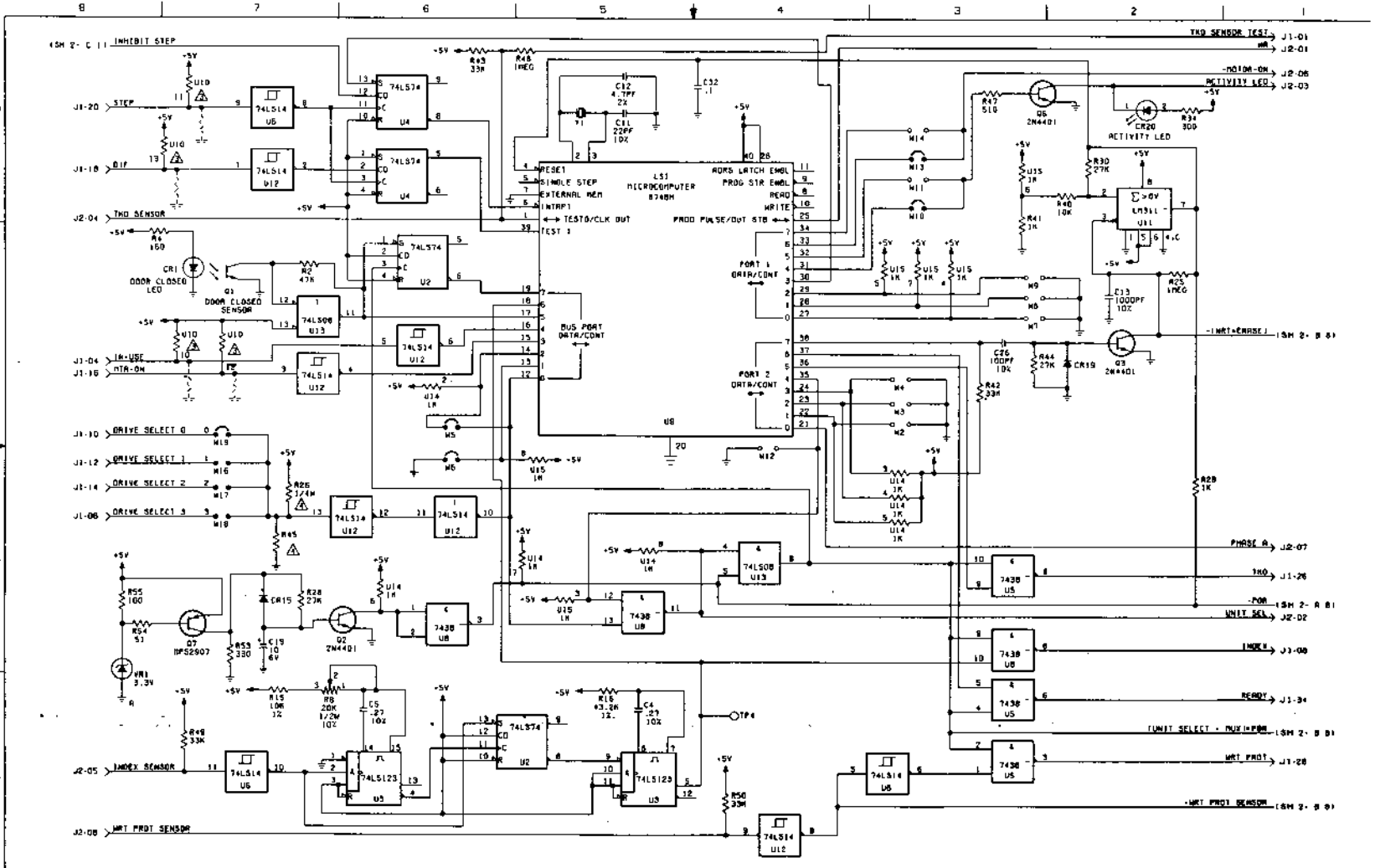
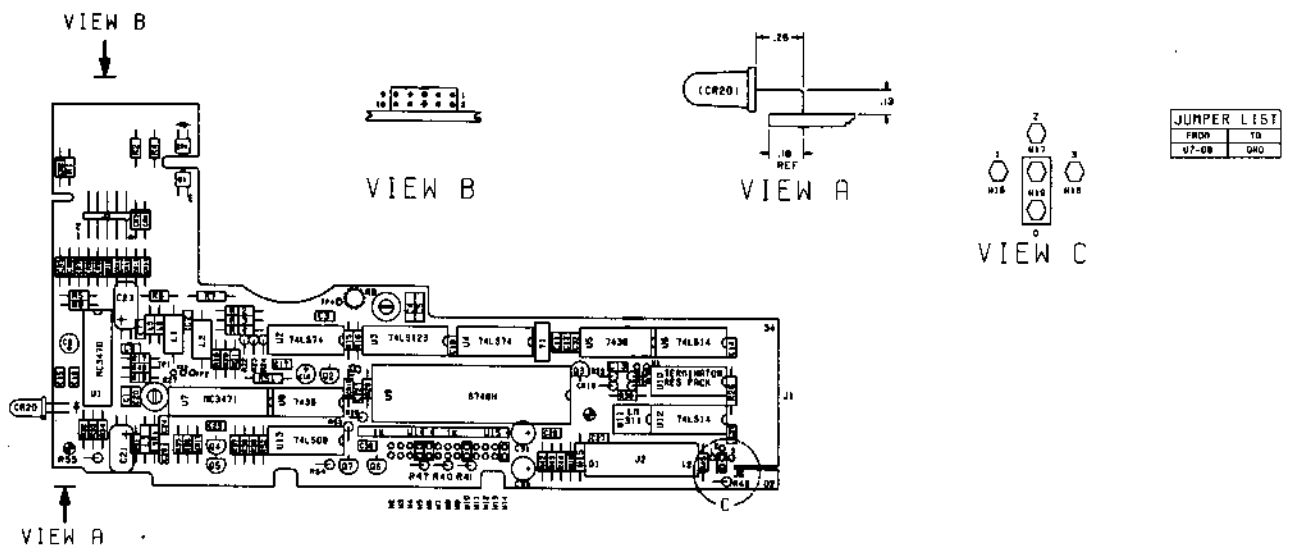

FIGURE 5-3D. DATA CONTROL PMA'S 77743720 AND 77743940  
(SHEET 3 OF 5)



8 7 6 5 4 3 2

J1-20 STEP J1-10 DIR J2-04 THD SENSOR J1-04 IN-USE J1-10 INTR-ON J1-10 DRIVE SELECT 0 J1-12 DRIVE SELECT 1 J1-14 DRIVE SELECT 2 J1-06 DRIVE SELECT 3 J2-05 INDEX SENSOR J2-08 UNIT PROTECT SENSOR J1-01 THD SENSOR TEST J2-01 MB J2-06 -MOTOR-ON J2-03 ACTIVITY LED J2-02 ACTIVITY LED J2-07 PHASE A J1-26 THD J2-D2 -FOR UNIT OK J3-00 INDEX J1-34 READY J2-B1 UNIT SELECT - MULTIPRO J1-28 UNIT PROTECT J2-B1 -UNIT PROTECT SENSOR



- CR1 = SEP8507-2
- CR2 - CR16, CR19 = IN914B
- CR17 = IN4001
- CR20 = LED
- VR1 = 3.3V 5%
- Q1 = SDP8407-1
- Q2, Q3, Q5, Q6 = 2N4401
- Q4, Q7 = MPS2907

FIGURE 5-3D. DATA CONTROL PWA 77743720  
(SHEET 4 OF 5)

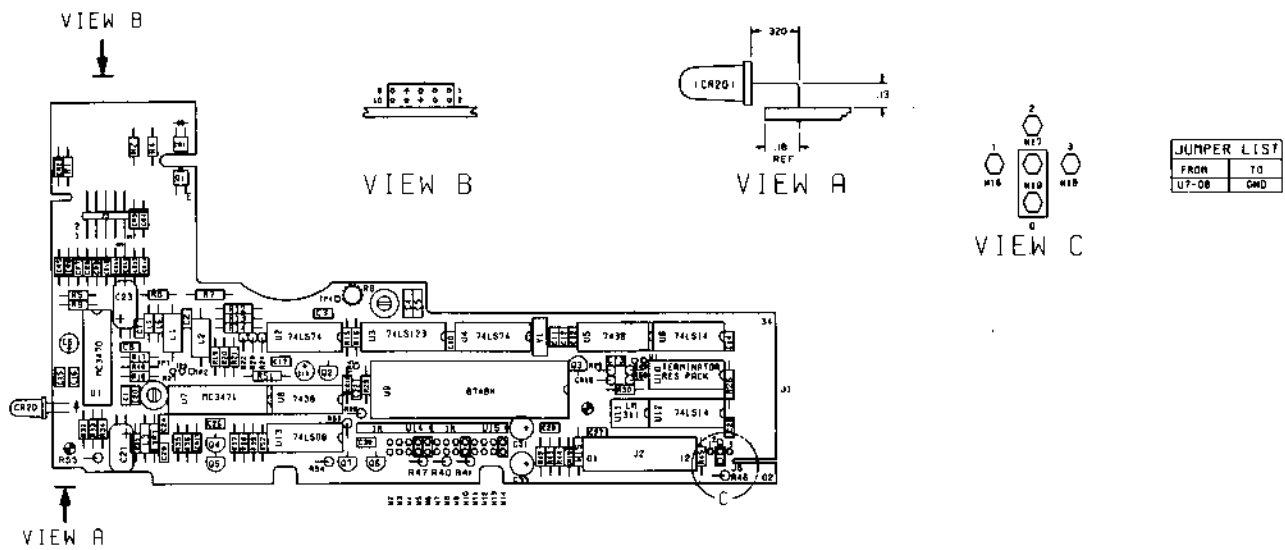

- CR1 = SEP8507-2
- CR2 - CR16, CR19 = IN914B
- CR17 = IN4001
- CR20 = LED
- VR1 = 3.3V 5%
- Q1 = SDP8407-1
- Q2, Q3, Q5, Q6 = 2N4401
- Q4, Q7 = MPS2907

FIGURE 5-3D. DATA CONTROL PWA 77743940  
(SHEET 5 OF 5)

FIGURE 5-4A. MOTOR CONTROL PWA'S 777386S1 AND 77740185  
(SHEET 1 OF 4)

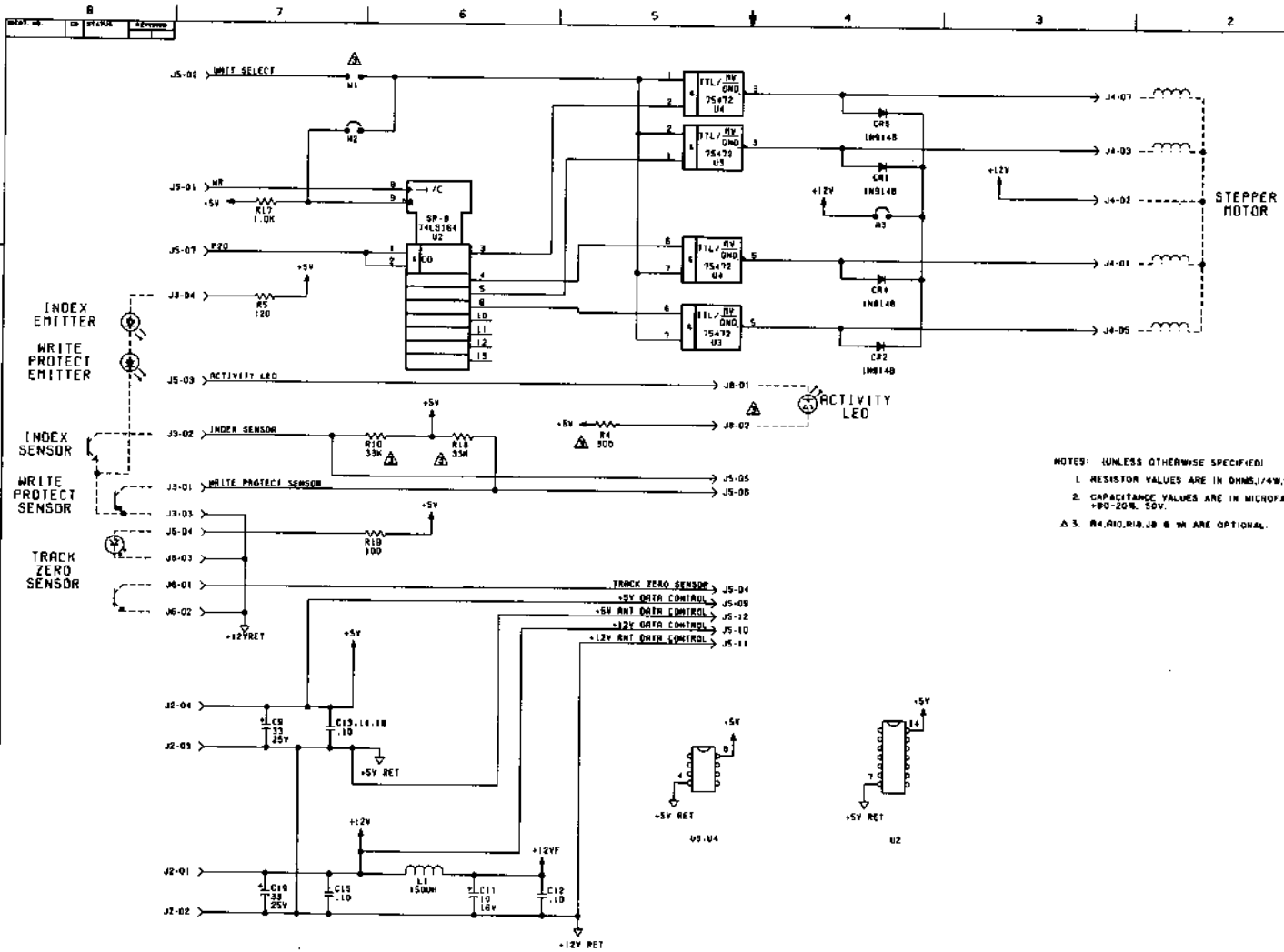

- NOTES: (UNLESS OTHERWISE SPECIFIED)
1. RESISTOR VALUES ARE IN OHMS, 1/4W, 5%
  2. CAPACITANCE VALUES ARE IN MICROFARADS, +80-20% 50V.
  - Δ 3. R4, R10, R10, J8 & W1 ARE OPTIONAL.

FIGURE 5-4A. MOTOR CONTROL PMA'S 77738551 AND 77740185  
(SHEET 2 OF 4)

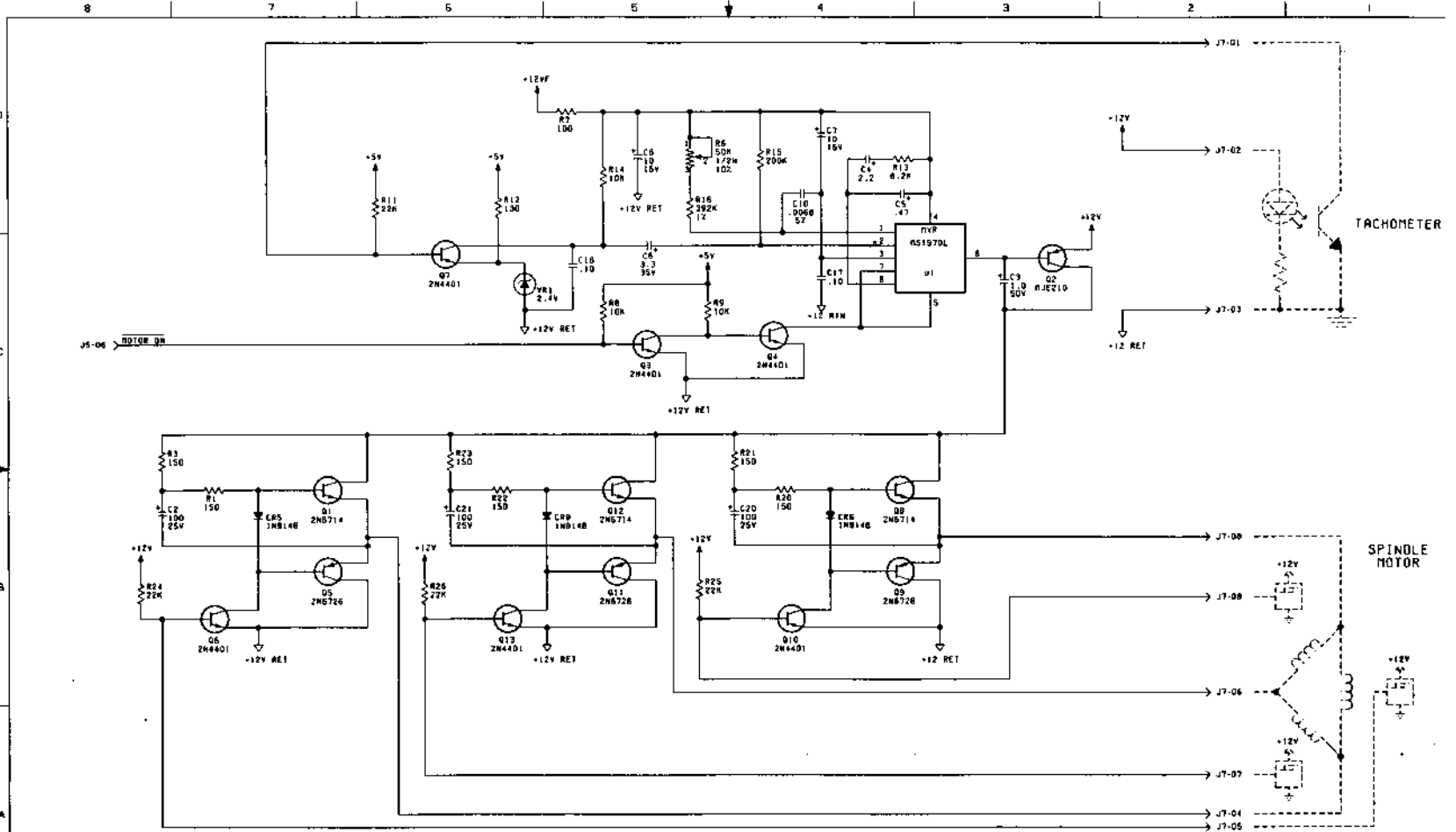

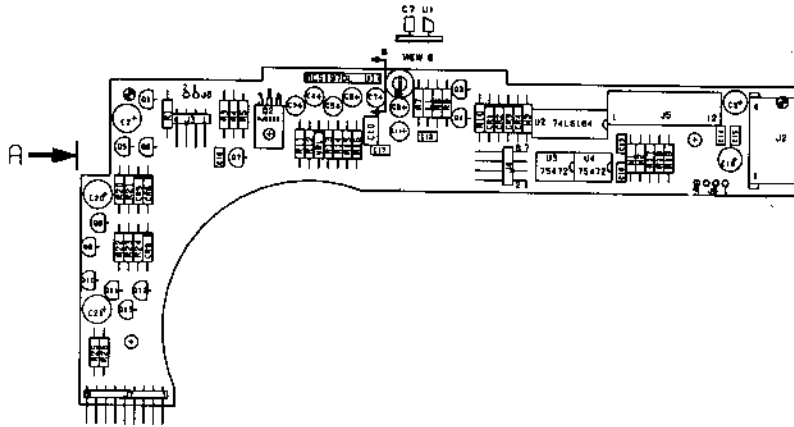

JUMPER LIST	
FROM	TO
C19-W	C14-S

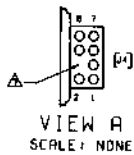

CR1 - CR6, CR9	= 1N914B
VR1	= 2.4V 5%
Q1, Q8, Q12	= 2N6714
Q2	= MJE210
Q3, Q4, Q6, Q7, Q10, Q13	= 2N4401
Q5, Q9, Q11	= 2N6726

FIGURE 5-4A. MOTOR CONTROL PWA 77738651  
(SHEET 3 OF 4)



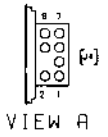
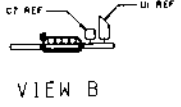
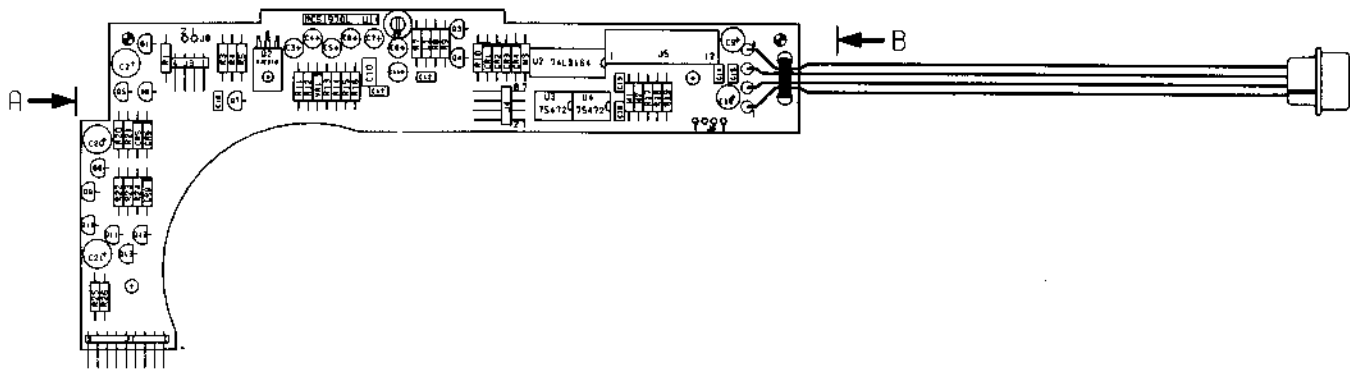

- |                          |           |
|--------------------------|-----------|
| CR1 - CR6, CR9           | = 1N914B  |
| VR1                      | = 2.4V 5% |
| Q1, Q8, Q12              | = 2N6714  |
| Q2                       | = MJE210  |
| Q3, Q4, Q6, Q7, Q10, Q13 | = 2N4401  |
| Q5, Q9, Q11              | = 2N6726  |

FIGURE 5-4A. MOTOR CONTROL PWA 77740185  
(SHEET 4 OF 4)

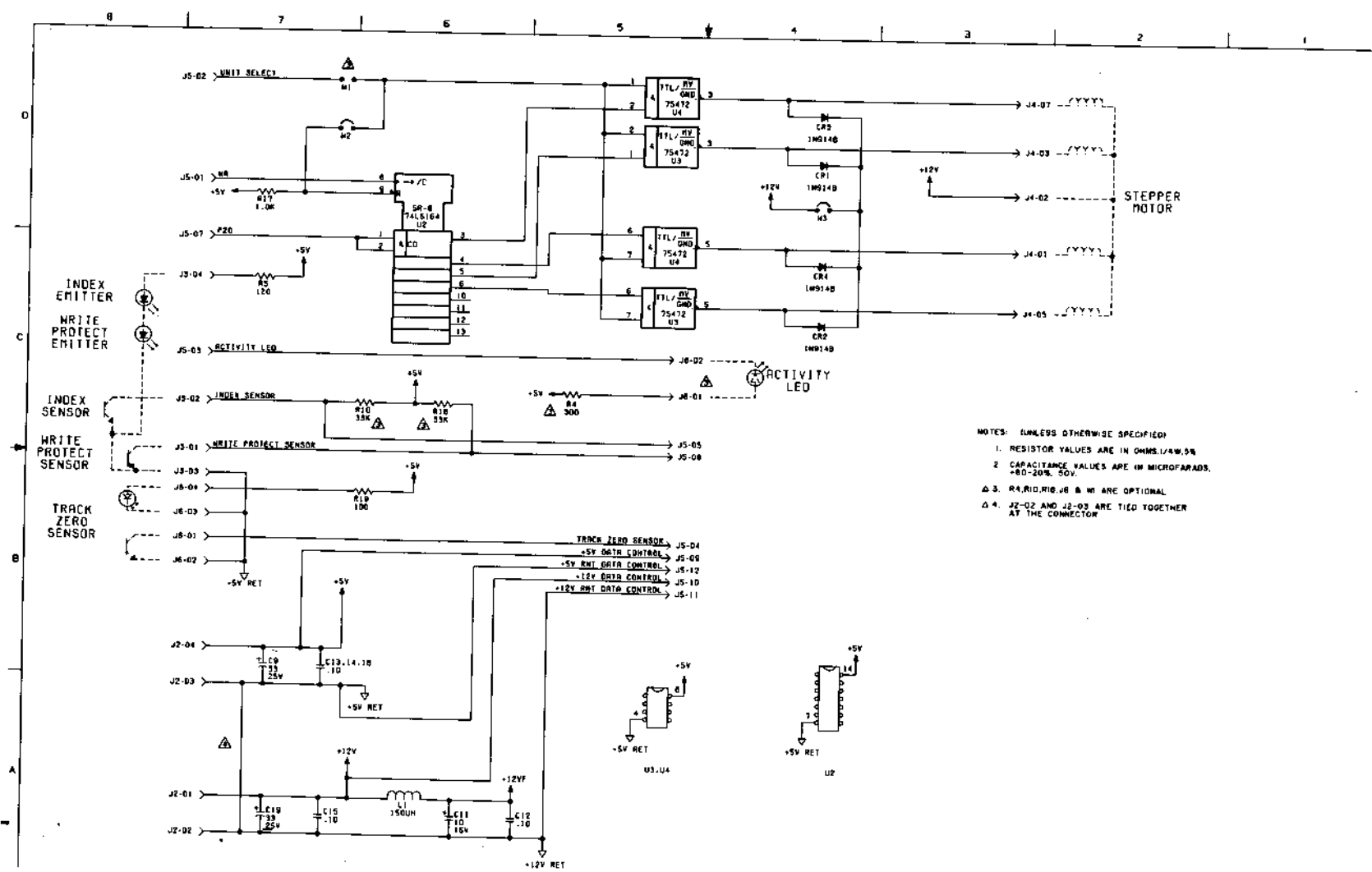

- NOTES: UNLESS OTHERWISE SPECIFIED
1. RESISTOR VALUES ARE IN OHMS./K/Ω/M
  2. CAPACITANCE VALUES ARE IN MICROFARADS. ±80-20% 50V.
  - Δ 3. R4, R10, R10, R8 & M1 ARE OPTIONAL
  - Δ 4. J2-02 AND J2-03 ARE TIED TOGETHER AT THE CONNECTOR

FIGURE 5-4B. MOTOR CONTROL PMA'S 77741571, 77743670 AND 77743785  
(SHEET 1 OF 4)

77715900-J

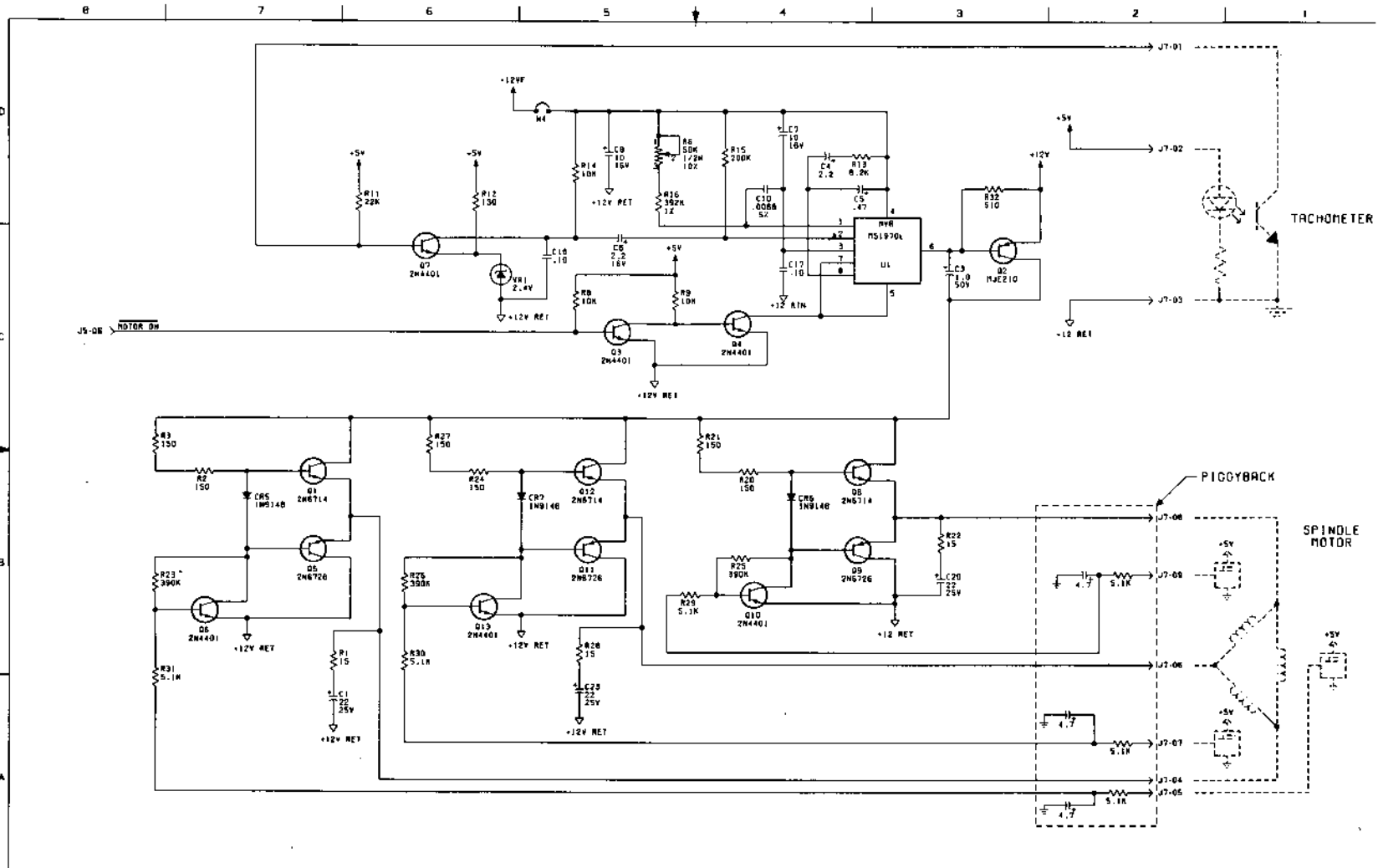
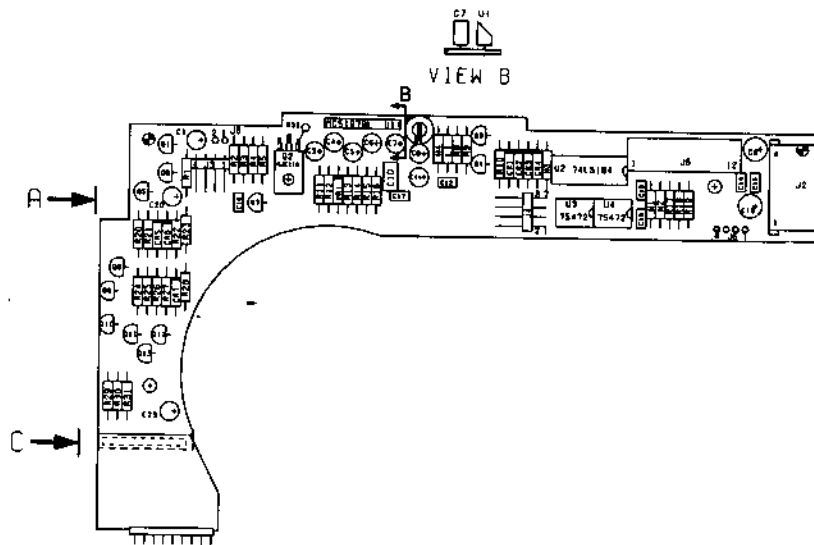
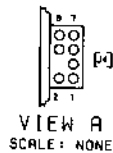
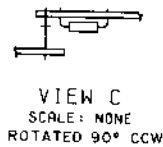

FIGURE 5-4B. MOTOR CONTROL PMA'S 77741571, 77743670 AND 77743785 (SHEET 2 OF 4)



VERIFY CONNECTIONS	
FROM	TO
R32-N	Q2-BASE (FEEDTHRU)
R32-S	Q2-E



- CR1 - CR7 = 1N914B
- VR1 = 2.4 5%
- Q1, Q8, Q12 = 2N6714
- Q2 = MJE210
- Q3, Q4, Q6, Q7, Q10, Q13 = 2N4401
- Q5, Q9, Q11 = 2N6726

FIGURE 5-4B. MOTOR CONTROL PWA 77741571  
(SHEET 3 OF 4)

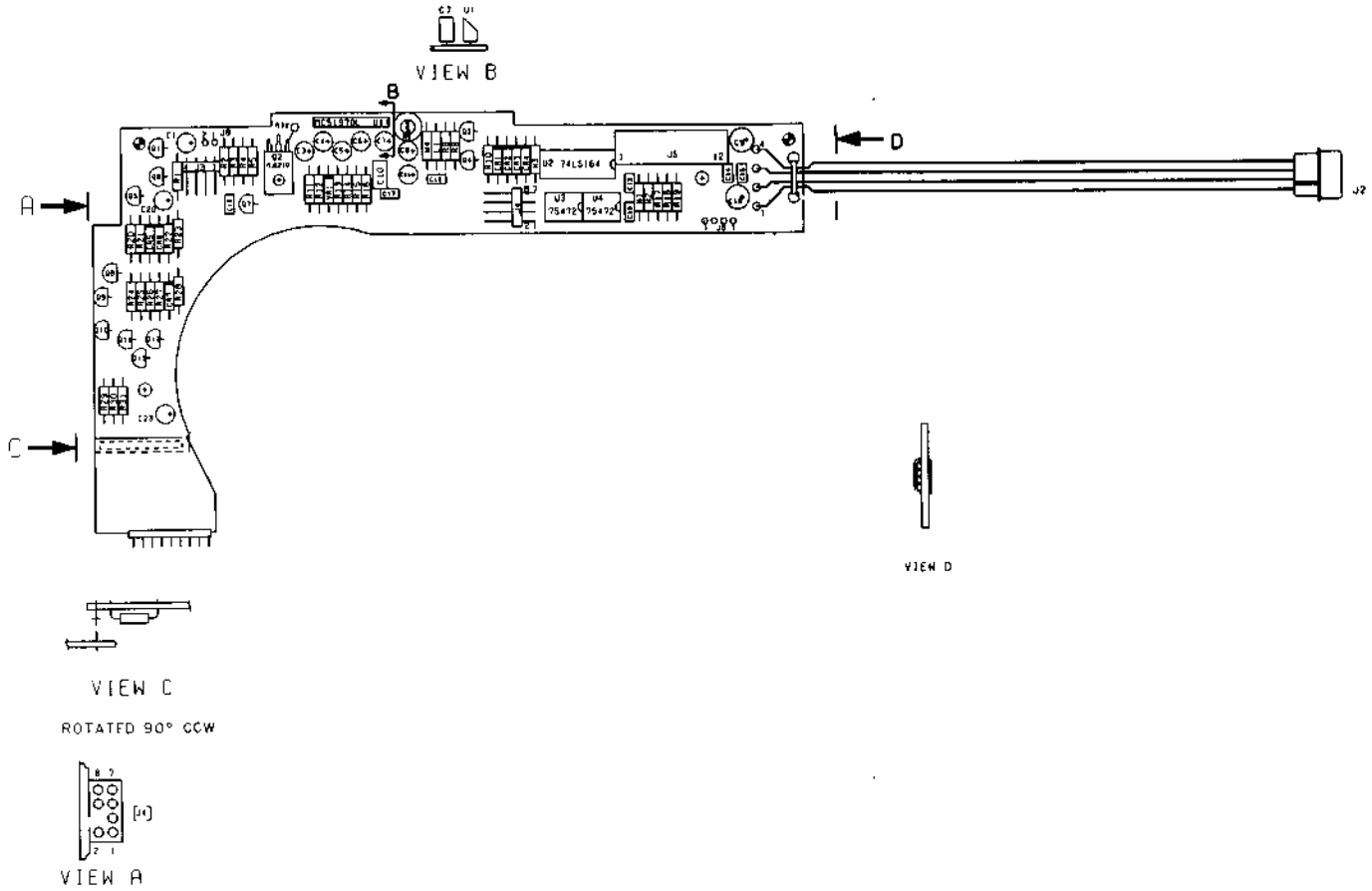

CR1 - CR7	= 1N914B
VR1	= 2.4 5%
Q1, Q8, Q12	= 2N6714
Q2	= MJE210
Q3, Q4, Q6, Q7, Q10, Q13	= 2N4401
Q5, Q9, Q11	= 2N6726

FIGURE 5-4B. MOTOR CONTROL PWA'S 77743670 AND 77743785  
(SHEET 4 OF 4)

FIGURE 5-4C. MOTOR CONTROL PWA'S 77743656 AND 77743661  
(SHEET 1 OF 4)

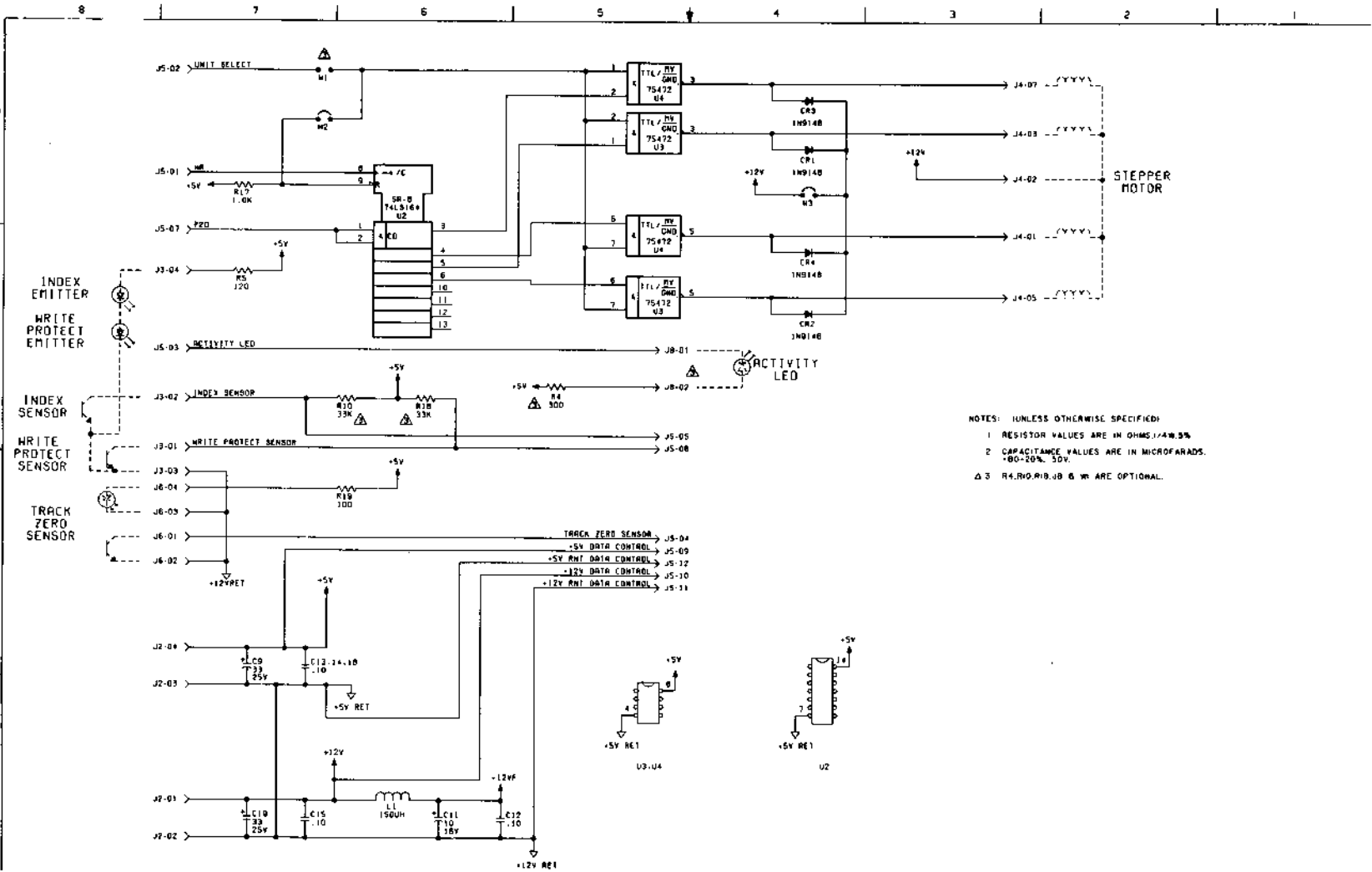

- NOTES: UNLESS OTHERWISE SPECIFIED:  
 1 RESISTOR VALUES ARE IN OHMS, 1/4W, 5%  
 2 CAPACITANCE VALUES ARE IN MICROFARADS,  
 +80%TOL, 50V.  
 3 R4, R9, R10, J8 & W1 ARE OPTIONAL.

FIGURE 5-4C. MOTOR CONTROL PWA'S 77743656 AND 77743661  
(SHEET 2 OF 4)

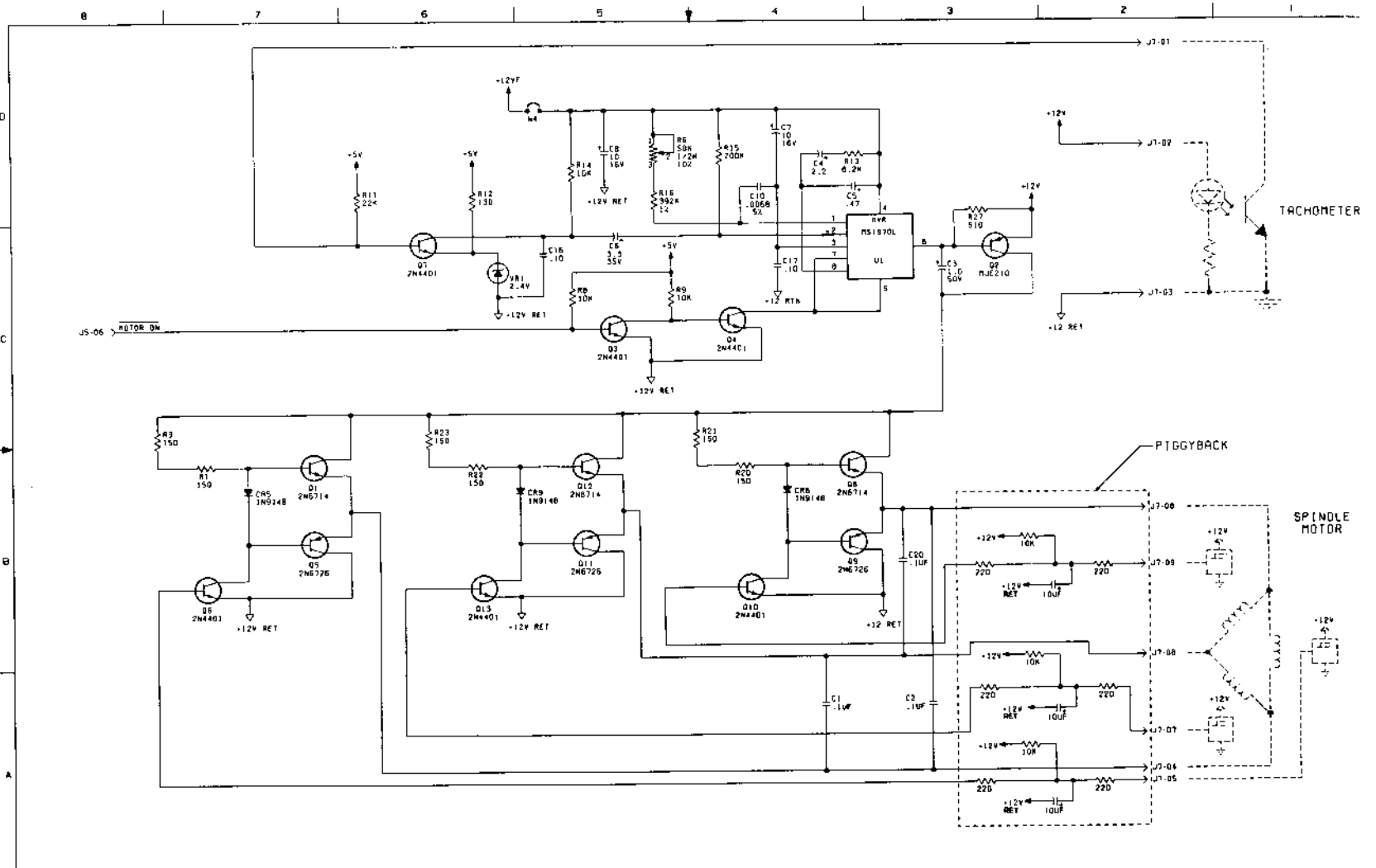

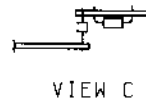
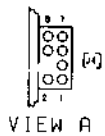
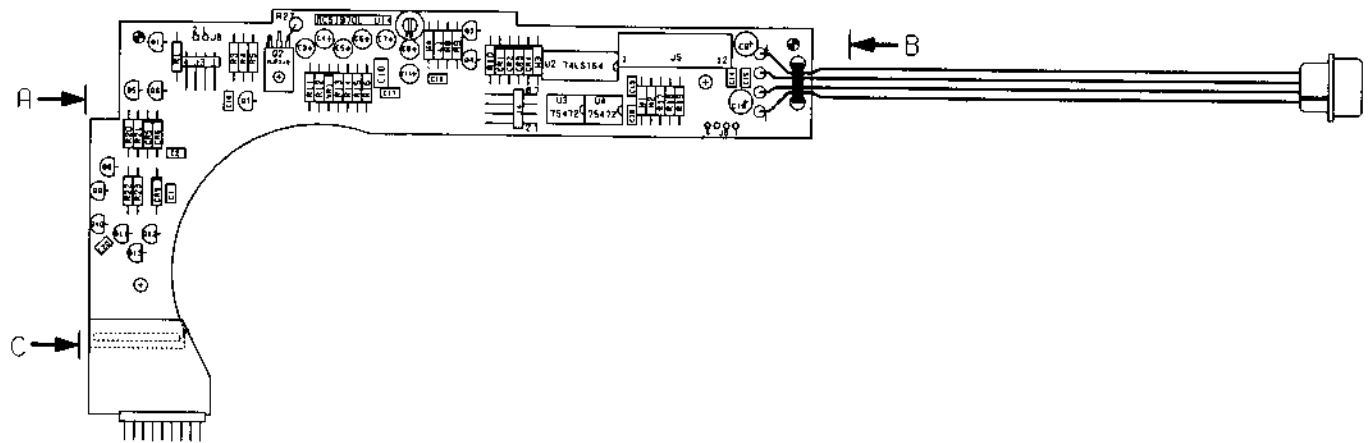

CR1 - CR6, CR9	= 1N914B
VR1	= 2.4V 5%
Q1, Q8, Q12	= 2N6714
Q2	= MJE210
Q3, Q4, Q6, Q7, Q10, Q13	= 2N4401
Q5, Q9, Q11	= 2N6726

FIGURE 5-4C. MOTOR CONTROL PWA 77743656  
(SHEET 3 OF 4)



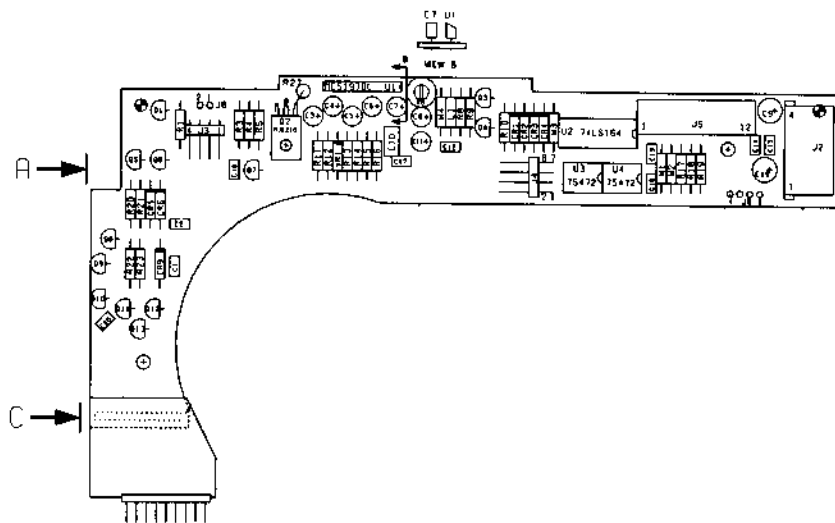

JUMPER LIST	
FROM	TO
C13-W	C14-S

VERIFY CONNECTIONS	
FROM	TO
R21-W	Q2-BASE
R21-S	Q2-E
C1-N	Q1-EMIT
C1-S	Q12-EMIT
C2-W	Q9-EMIT
C2-E	Q1-EMIT
C20-N	Q8-EMIT
C20-S	Q12-EMIT

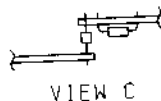
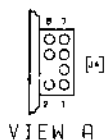

- CR1 - CR6, CR9 = 1N914B
- VR1 = 2.4V 5%
- Q1, Q8, Q12 = 2N6714
- Q2 = MJE210
- Q3, Q4, Q6, Q7, Q10, Q13 = 2N4401
- Q5, Q9, Q11 = 2N6726

FIGURE 5-4B. MOTOR CONTROL PWA 77743661  
(SHEET 4 OF 4)

## 6.1 INTRODUCTION

This section contains the instructions required to maintain the FDD.

## 6.2 MAINTENANCE TOOLS

Special tools (or equivalent) required to maintain an FDD are:

<u>DESCRIPTION</u>	<u>PART NUMBER</u>
Alignment Diskette	DYSAN 224/2A or 208-22

Standard tools required to maintain the FDD are:

- Screwdrivers  
Sizes: Phillips #1, Phillips #2
- Allen Wrenches  
Sizes: 0.050 inch (1.27 mm), 7/64 inch (2.78 mm)
- Oscilloscope, Tektronix 335, or equivalent.

## 6.3 TROUBLESHOOTING

An improperly adjusted FDD may exhibit symptoms of one that has a malfunction; therefore, the Adjustment Procedures (Section 6.4) should be performed before assuming the unit has failed. Refer to Figure 5-3 to locate test points to be used in troubleshooting. Before troubleshooting is started, check all DC supply voltages.

### 6.3.1 DC VOLTAGE AND SIGNAL

- a. Input power should be +5 V  $\pm 5\%$  and +12 V  $\pm 10\%$  measured at the input to the FDD (refer to Section 3.4).
- b. The signals should conform to the diagrams and waveforms shown in Figures 5-1, 6-1, 6-2 and 6-3.

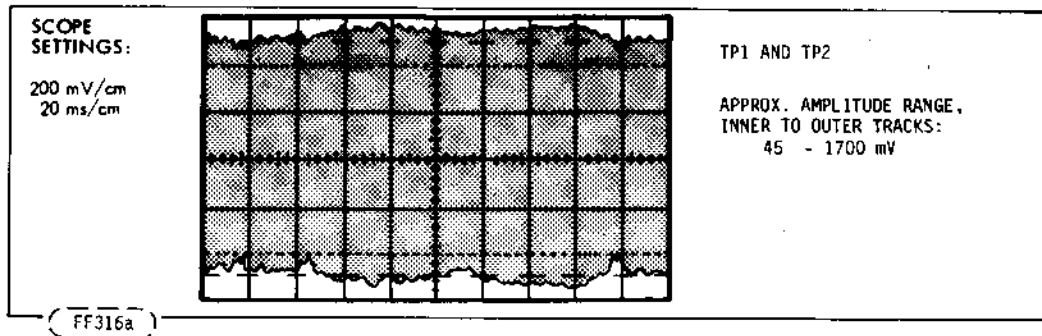

FIGURE 6-1. DIFFERENTIAL READ SIGNAL FOR ENTIRE TRACK

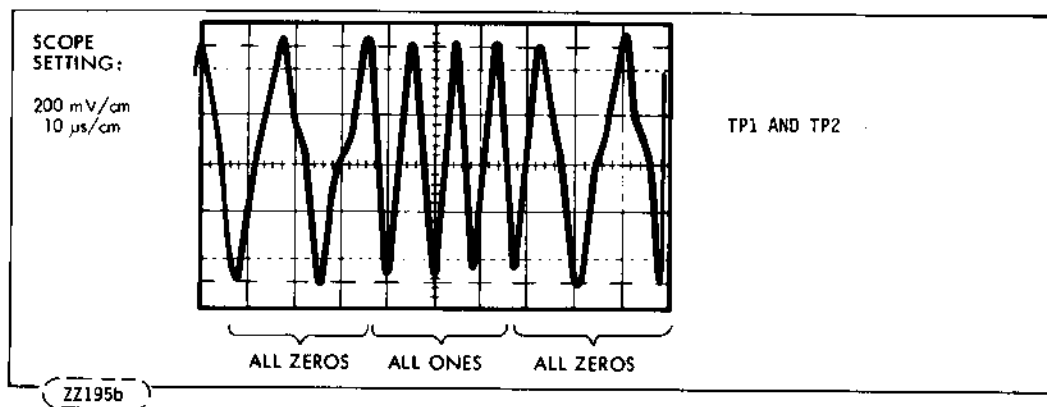

FIGURE 6-2. DIFFERENTIAL READ SIGNAL FOR PORTION OF OUTER TRACK

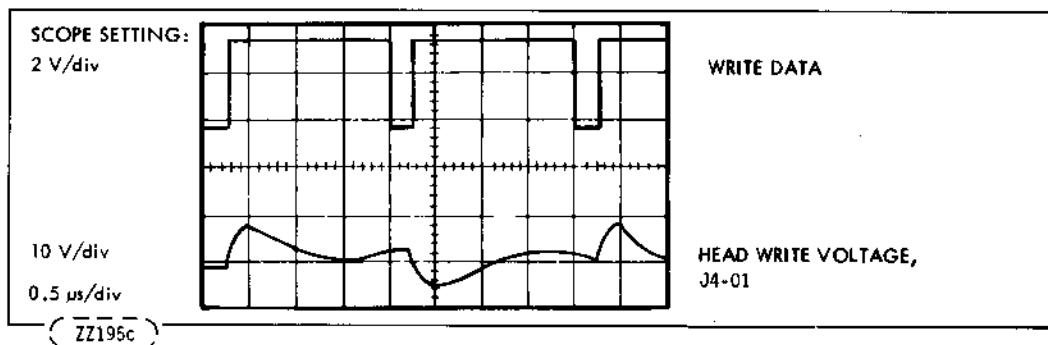

FIGURE 6-3. WRITE DATA AND HEAD WRITE VOLTAGE FOR OUTER TRACK

## 6.4 ADJUSTMENT PROCEDURES

### 6.4.1 INDEX TO BURST CHECK AND ADJUSTMENT

The Alignment Diskette is used to perform this procedure. Spindle speed must be correct before performing this adjustment. Refer to Section 6.4.4 and perform spindle speed adjustment if necessary.

- a. Precondition the Alignment Diskette (DYSAN 224/2A or 208-22) by allowing it one hour to reach room temperature.
- b. Alignments should not be attempted if the FDD and alignment media are not stabilized within the environmental limits of 65°-75° F (18.3°-23.8° C) and 40%-60% relative humidity.

#### CAUTION

The Alignment Diskette is for read only. Extreme caution should be used to be sure this diskette is not written on.

- c. Install the alignment diskette. Seek to Track 00, then seek to Track 34 and Read. (No data is recorded on Track 34.)
- d. Connect Channel 1 of scope to TP1 on the PWA. Channel 2 to J1-08 of the PWA. Set up the scope as follows:

Channel 1 Scale: 0.1 Volts/Div  
Channel 2 Scale: 2 Volts/Div

Channel 1 Coupling: AC  
Channel 2 Coupling: AC

Vertical Mode: ADD  
Trigger Mode: Normal  
Trigger Source: Channel 1  
Trigger Coupling: Low Frequency (High Frequency Reject)  
Trigger Slope: Negative  
Time Base: 50  $\mu$ s/Div

- e. To check a drive's index to burst time when the index optics or PWA have not been loosened, adjusted, or replaced:

Verify the time from the leading edge of the Index pulse to the burst pulse measures 200 +200 -150  $\mu$ s. If time is 200 +200 -150  $\mu$ s, it is acceptable and proceed to Step "g". (Refer to Figure 6-4B.)

If the index optics or PWA have been loosened, adjusted or replaced it is not sufficient to check index to burst timing. The index to burst adjustment procedure must be performed: proceed to Step "f".

- f. Adjust the time from the leading edge of the Index pulse to the midpoint between the burst pulses of Head 0 and Head 1 at Track 34 until it measures  $200 \pm 20$  us, (refer to Figure 6-4a). To adjust the index to burst time turn index potentiometer on the Data Control PWA.

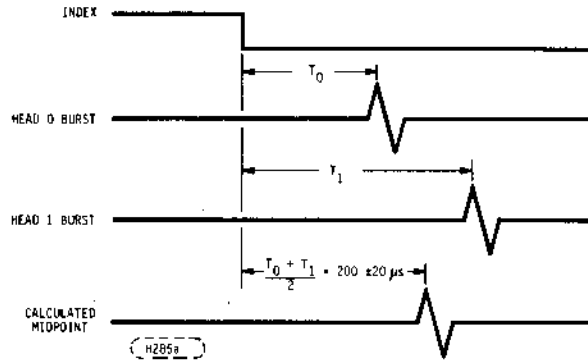

FIGURE 6-4A. INDEX TO BURST TIMING ADJUSTMENT

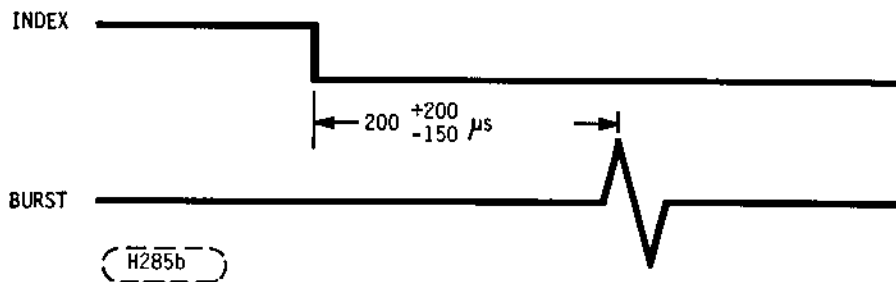

FIGURE 6-4B. INDEX TO BURST TIMING VERIFICATION

- g. All scope settings are to remain as defined in the original setup in Step "e", but it may be necessary to adjust the sync. Seek to Track 00 then seek to Track 01 and perform a read. While observing the signal on the scope, remove and reinsert the diskette three times.

Verify that the difference between the minimum and maximum index to burst time measured after each insertion is less than 100 us. In addition, each measurement must meet the index to burst check limits of  $200 \pm 200 -150$  us. If the change is greater than 100 us, the cone and spindle must be replaced and Steps "a" through "g" must be repeated.

## 6.4.2 ACTUATOR ALIGNMENT (DISKETTE)

The Alignment Diskette is used to perform this procedure.

- a. Precondition Alignment Diskette DYSAN 224/2A or 208-22 by allowing it one hour to reach room temperature.
- b. Adjustments should be attempted if the FDD and alignment media are not stabilized within the environmental limits of 65°-75°F (18.3°-23.8°C) and 40%-60% relative humidity.

### CAUTION

The Alignment Diskette is for read only. Extreme caution should be used to be sure this diskette is not written on.

- c. Seek to Track 16, select Head 0 and perform a read. (No data is recorded on Track 16. The tester or system requirements should be noted: refer to tester or system instructions for operation.)
- d. Connect Channel 1 of scope to TP1 on the PWA and Channel 2 to TP2 on the PWA.
- e. Connect the external sync probe to Index, J1-08.
- f. Set up scope as follows:

Channel 1 Scale:	0.1 Volts/Div
Channel 2 Scale:	0.1 Volts/Div - Inverted
Channel 1 Coupling:	AC
Channel 2 Coupling:	AC
Vertical Mode:	ADD
Trigger Mode:	Normal
Trigger Source:	External
Trigger Coupling:	Low Frequency (High Frequency Reject)
Trigger Slope:	Negative
Time Base:	20 ms/Div

### NOTE

Scope trace, after trigger level is adjusted for repetitive trace should display an envelope of data "caterpillars" consisting of two lobes (refer to Figure 6-5). If lobe pattern is observed, proceed to Step "g". If no such pattern can be displayed, proceed to Step "h".

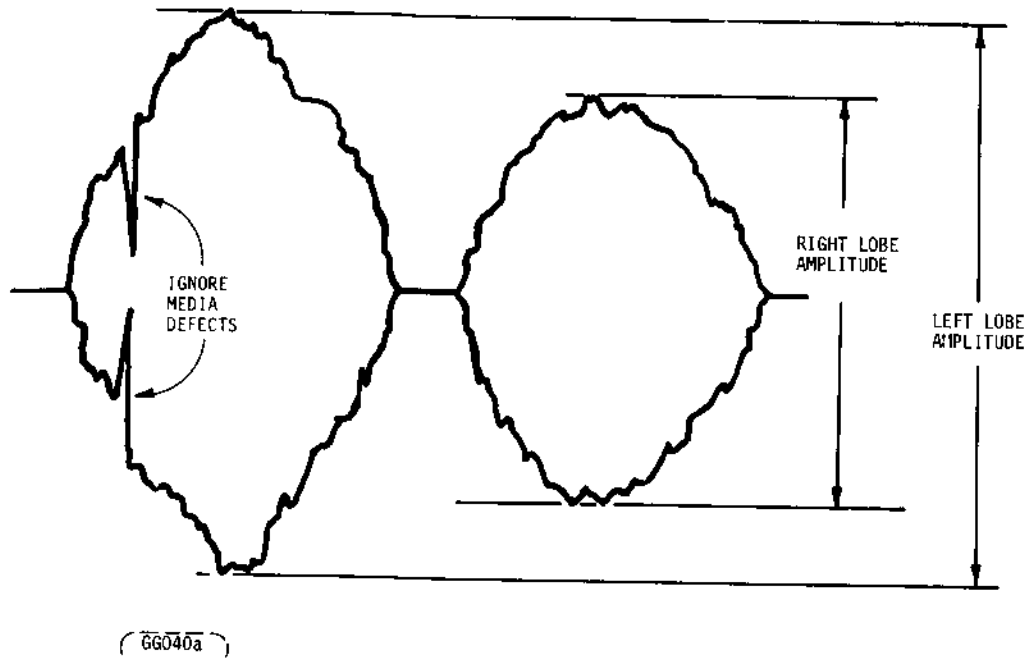

FIGURE 6-5. HEAD ALIGNMENT AMPLITUDE

- g. To check a drive's alignment when the stepper, band, or carriage has not been loosened, adjusted, or replaced:  
Verify the voltage ratio of the smaller lobe to the larger lobe is  $> 70\%$ . If  $> 70\%$ , alignment is acceptable and check is concluded. If  $< 70\%$ , proceed to Step "h".
- h. Change the scale of Channel 1 and Channel 2 to 0.02 volts/div. Move the trace on the scope (Position Knob) up until the bottom of the two lobes are setting approximately on the base line (refer to Figure 6-5). Loosen the stepper motor mounting screws (see Figure 6-8) and slowly rotate the stepper motor until the amplitude of both lobes is the same.
- i. Switch to Head 1 and repeat the measurement of the "cateye" pattern. Adjust the stepper to balance any offset that occurs between the two heads.
- j. Tighten the stepper motor screws. Return to Track 00 then seek Track 16. Verify the specification in Step "g" is still met. If the specification is not met, readjust the stepper motor, return to zero, and seek Track 16. Repeat the adjustment until the specification is met.
- k. Remove the Alignment Diskette.
- l. Perform the Track 00 Switch Adjustment, Section 6.4.3.

### 6.4.3 TRACK '00' SWITCH ADJUSTMENT

Perform the procedure given below whenever the optical Track 00 switch has been replaced, the device fails to give correct Track 00 indication, or the head has been realigned.

- Perform an alternate seek between Track 00 and Track 02. The "STEP IN" portion of the alternate seek cycle must be symmetrical with the "STEP OUT" portion, including any turn around delays at Track 00 and Track 02. The time between step pulses must be 5 ms with a minimum of 20ms and a maximum of 25 ms when reversing (see Figure 6-6). The Track 00 switch signal on J2-04 (Data PWA) should alternate between high and low logic levels at a 50% duty cycle measured at the +1.2 V level.
- To adjust, using an Allen wrench, turn the screw (Figure 6-7) that slides the switch bracket to achieve the correct duty cycle.
- After the Switch has been adjusted, step to Track 00 and verify J2-04 of the Data (upper) PWA is greater than +2 V. Verify J2-04 is less than +0.5 V when stopped on Track 02, approached from each direction.
- Using the Alignment Diskette, verify the Track 00 signal is present at TP1 and TP2 when the carriage is restored to Track 00.

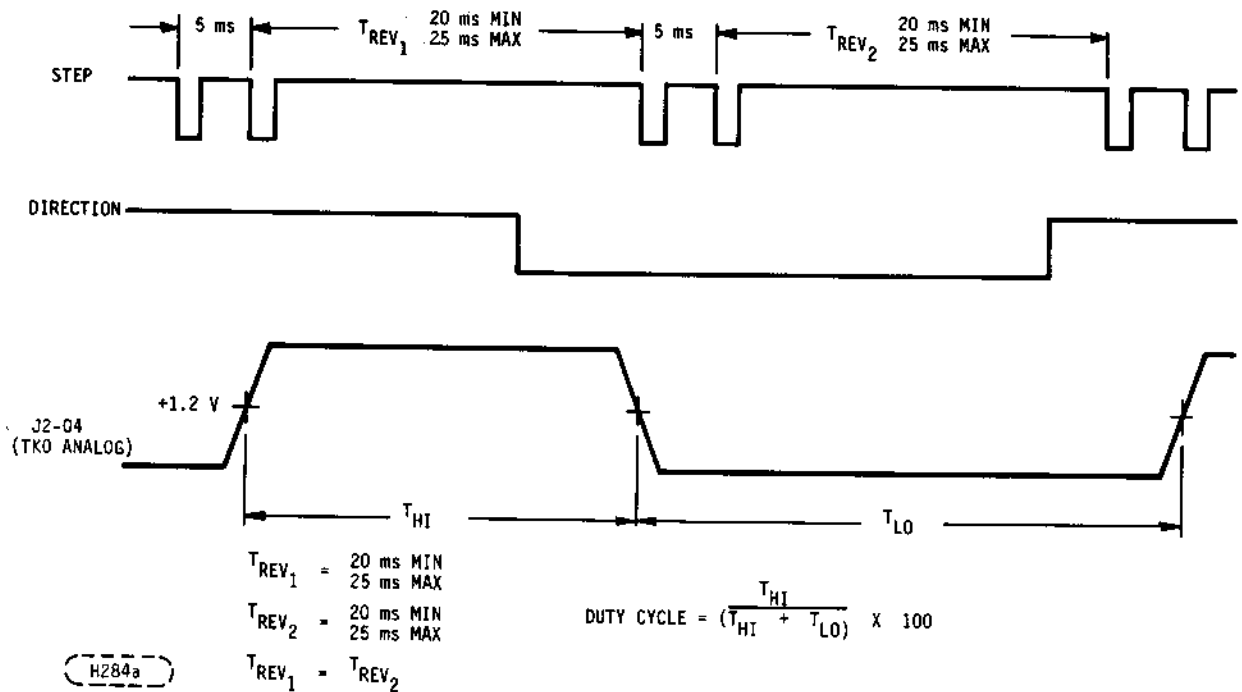

FIGURE 6-6. STEP PULSE TIMING DIAGRAM



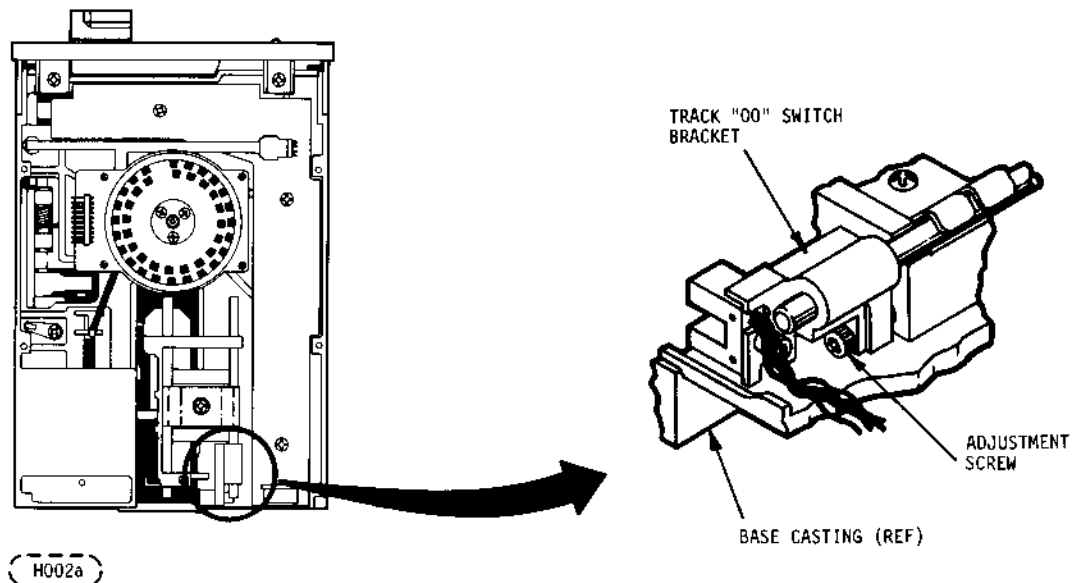

FIGURE 6-7. TRACK '00' ADJUSTMENT

#### 6.4.4 SPINDLE SPEED ADJUSTMENT

Adjust the potentiometer on the motor control PWA to set the spindle speed to  $300 \pm 3$  r/min. Adjust for a stable spindle strobe disk pattern for the appropriate frequency (50 or 60 Hz) or adjust for  $200 \pm 2$  ms between the leading edges of the index pulses. For this adjustment a diskette must be installed.

#### 6.5 REMOVAL AND REPLACEMENT PROCEDURES

The following procedures are arranged in the proper sequence for removal and replacement of major assemblies. To avoid damage to parts, the procedures must be performed in sequence.

Replacement of the stepper motor assembly and head assembly require special tools and procedures and should not be attempted except by factory trained personnel.

##### 6.5.1 PRINTED WIRE ASSEMBLIES (PWAS)

- a. Disconnect the I/O Cable from J1 and DC power from J2 (refer to Figure 3-1).
- b. Disconnect the harness and head connectors from the PWAs.
- c. Remove the retaining screws from the PWAs.
- d. Remove the PWAs by lifting them from their original positions.
- e. To replace the PWAs, reconnect the harness and head connectors.
- f. When reinstalling screws in the motor control PWA, tighten the screw through Q2 first.
- g. Program the option shunts if necessary and reconnect the I/O cable, and DC power.
- h. Perform the spindle speed adjustment (Section 6.4.4).
- i. Perform the index to burst adjustment (Section 6.4.1.).

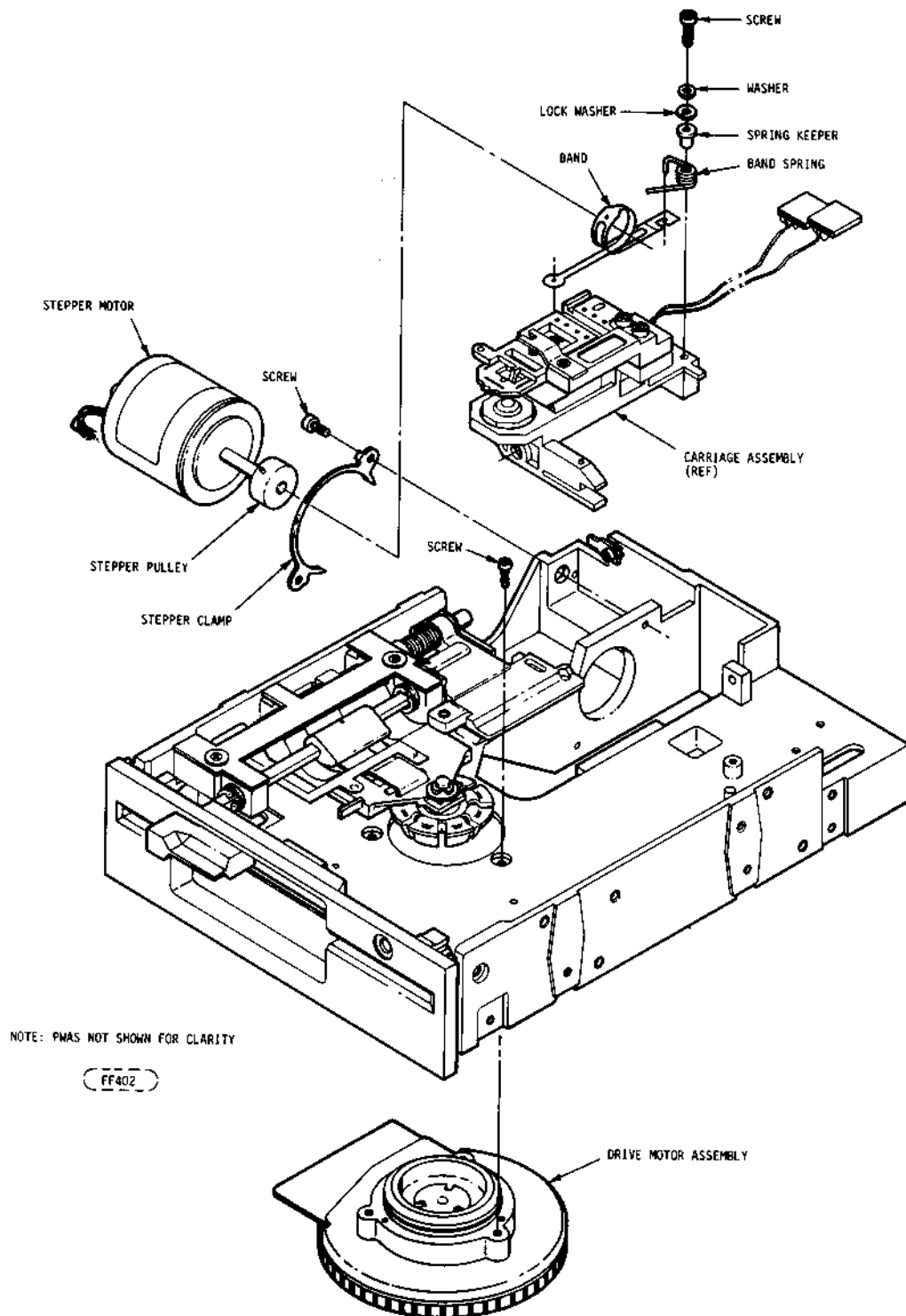

FIGURE 6-8. DRIVE MOTOR REMOVAL

## 6.5.2 SPINDLE MOTOR ASSEMBLY

- a. Perform the removal procedure for the Data (upper) PWA (Section 6.5.1).
- b. Remove three (3) screws securing the spindle motor (Figure 6-8).
- c. Disconnect the motor harness and remove the spindle motor assembly.
- d. To install the spindle motor assembly in the drive, reassemble the components of the removal operations (Steps "a" through "c") in reverse order.
- e. If a new spindle motor assembly is installed, perform the Spindle Speed Adjustment (Section 6.4.4).

SECTION

7

THIS SECTION HAS  
BEEN DELETED

77715900-J

7-1/7-2

## 8.1 INTRODUCTION

This

This section contains an illustrated parts breakdown that describes and illustrates the Model 9428/29 Flexible Disk Drive (FDD).

## 8.2 ILLUSTRATIONS

Item numbers within a circle (1) indicate an assembly (group of parts). Item numbers without a circle, 1, indicate a single part of a group of parts which is normally replaced as an assembly.

## 8.3 PARTS LIST

In addition

to the accompanying parts list of each illustration, two additional Parts Lists are available; the Numerical Parts List and the Cross Reference Index. Instruction for the use of all Parts Lists is given in paragraph 8.6.

## 8.4 REPLACEMENT PARTS

When ordering replacement parts for the FDD, the inclusion of the following information for each part ordered will ensure positive identification:

1. Publication Number at the bottom of this page.
2. Figure and Item Number
3. Product Identification Number (HPC) and Description

### NOTE

Before ordering parts however, refer to paragraph 8.5 Spare Parts.

## 8.5 SPARE PARTS

This Illustrated Parts Breakdown is complete to the extent that all parts and assemblies are depicted and identified. Replacement part availability depends on the materials and provisioning operation of the supplier.

## 8.6 PARTS LIST INSTRUCTIONS

### 8.6.1 ILLUSTRATION PARTS LISTS

The parts list for each illustration contains only those parts referenced by an item number on the illustration. Refer to paragraph 8.6.2 for explanation of parts list.

### 8.6.2 NUMERICAL PARTS LIST

- a. Lists all parts in Item Number sequence.
- b. Correlates Item Numbers with part identification numbers and the description of each.
- c. Identifies where each part is used (where used column) within the device by listing the Item Number(s) of the next higher assembly.
- d. Defines the location of each part by listing the sheet number(s) where depicted.

#### NOTE

The same part may be used in any number of assemblies or sheet locations.

### 8.6.3 CROSS REFERENCE INDEX

- Lists all parts in numeric sequence (by Identification Number), in conjunction with the referenced sheet number (third column).
- Defines the sheet number location of each item identified.

### 8.6.4 SHEET NUMBER REFERENCING

Sheet number references of Parts Lists and Illustrations refers to sheet locations in this section. Example: Sheet reference 3 represents sheet 8-3, sheet 4 represents sheet 8-4, etc.

## WHERE USED MATRIX (By Item Number)

I T E M	HPC	ITEM																								
		50	51	52	53	54	55	56	70	71	72	73	74	75	76	77	78	80	81	82	83	84	85	88	89	90
1	77740000	X						X									X									
2	77740001	X								X							X									
3	77740002						X	X									X									
4	77740003	X						X									X									
5	77740004	X							X								X								X	X
6	77740005	X						X									X									
7	77740006	X									X							X				X				
8	77740007	X												X				X				X				
9	77740008				X						X							X				X				
10	77740009				X									X				X				X				
11	77740010				X			X									X									
12	77740011		X					X									X									
13	77740012		X					X									X									
14	77740013		X							X							X									
15	77740014					X											X				X			X		
16	77740015		X							X							X									
17	77740016				X					X							X									
18	77740017				X			X									X									
19	77740018				X					X							X									
20	77740054			X				X									X									
21	77740055		X					X									X									
22	77740056			X				X									X									
23	77740057			X						X							X									
24	77740058			X				X									X									
25	77740059			X						X							X									
26	77740060			X				X									X									
27	77740061				X			X									X									
28	77740062				X									X					X					X		
29	77740076			X				X									X									
30	77740077			X						X							X									
31	77740078			X				X									X									

I T E M	HPC	ITEM																								
		50	51	52	53	54	55	56	70	71	72	73	74	75	76	77	78	80	81	82	83	84	85	88	89	90
35	77743000			X				X									X									
36	77743001			X						X							X									
37	77743002			X				X									X									
38	77743003			X				X									X									
39	77743004			X						X								X								
40	77743005			X						X								X								
41	77743006			X				X									X									
42	77743007			X											X								X			
43	77743008			X										X									X			
44	77743009			X						X								X								

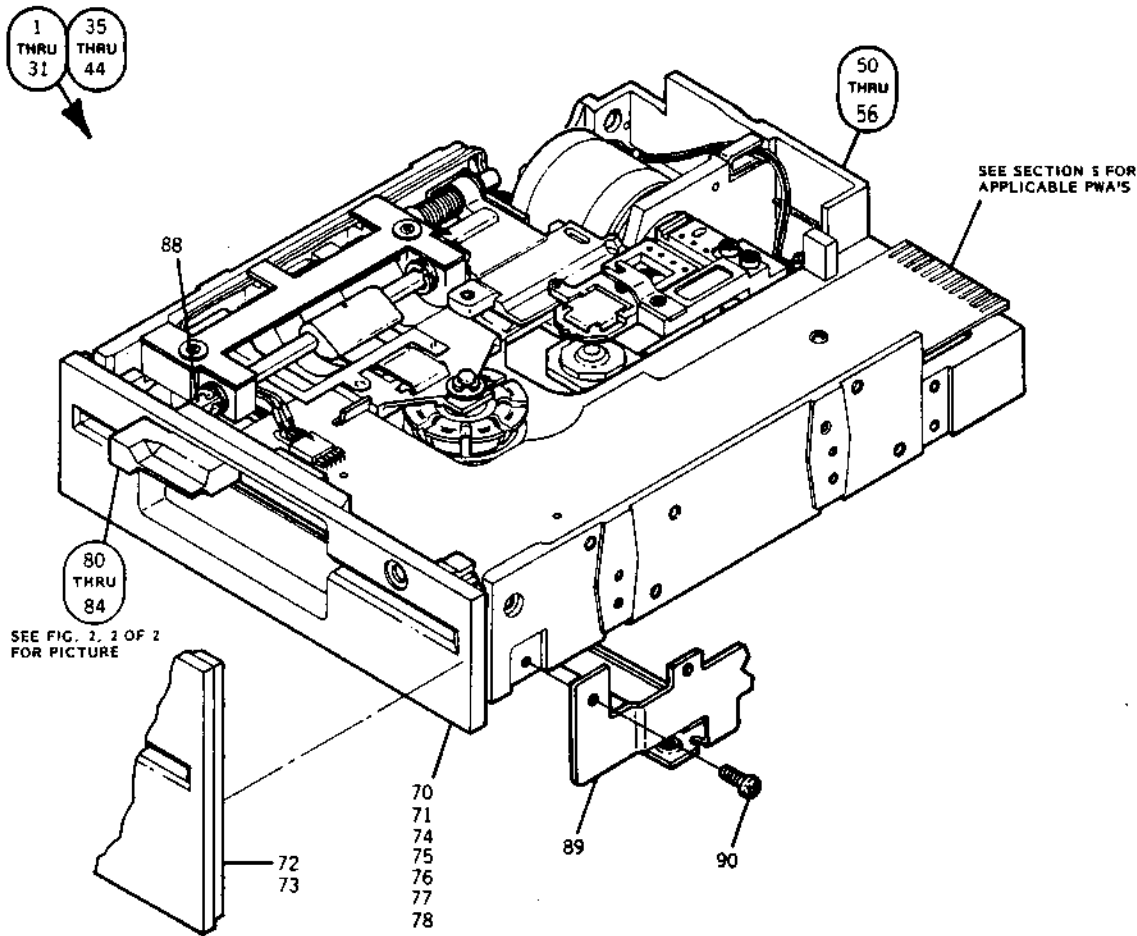

ITEM	IDENT NO	DESCRIPTION	WHERE USED	ITEM	IDENT NO	DESCRIPTION	WHERE USED
1	77740000	HPC	*	37	77743002	HPC	*
2	77740001	HPC	*	38	77743003	HPC	*
3	77740002	HPC	*	39	77743004	HPC	*
4	77740003	HPC	*	40	77743005	HPC	*
5	77740004	HPC	*	41	77743006	HPC	*
6	77740005	HPC	*	42	77743007	HPC	*
7	77740006	HPC	*	43	77743008	HPC	*
8	77740007	HPC	*	44	77743009	HPC	*
9	77740008	HPC	*	50	77690502	TOP MECH ASM	*
10	77740009	HPC	*	51	77690504	TOP MECH ASM	*
11	77740010	HPC	*	52	77690505	TOP MECH ASM	*
12	77740011	HPC	*	53	77690506	TOP MECH ASM	*
13	77740012	HPC	*	54	77690508	TOP MECH ASM	*
14	77740013	HPC	*	55	77690509	TOP MECH ASM	*
15	77740014	HPC	*	56	77734091	TOP MECH ASM	*
16	77740015	HPC	*	70	77735001	FRONT PANEL	*
17	77740016	HPC	*	71	77735002	FRONT PANEL	*
18	77740017	HPC	*	72	77738401	FRONT PANEL	*
19	77740018	HPC	*	73	77740901	FRONT PANEL	*
20	77740054	HPC	*	74	77741787	FRONT PANEL	*
21	77740055	HPC	*	75	77741851	FRONT PANEL	*
22	77740056	HPC	*	76	77743103	FRONT PANEL	*
23	77740057	HPC	*	77	77743550	FRONT PANEL	*
24	77740058	HPC	*	78	77743724	FRONT PANEL	*
25	77740059	HPC	*	80	77736901	CAMSHAFT LEVER ASM	*
26	77740060	HPC	*	81	77736902	CAMSHAFT LEVER ASM	*
27	77740061	HPC	*	82	77741275	CAMSHAFT LEVER ASM	*
28	77740062	HPC	*	83	77741276	CAMSHAFT LEVER ASM	*
29	77740076	HPC	*	84	77741762	CAMSHAFT LEVER ASM	*
30	77740077	HPC	*	88	77733896	MEDIA PUSHER	*
31	77740078	HPC	*	89	77734038	FRAME ASM	*
35	77743000	HPC	*	90	67184761	SCREW	*
36	77743001	HPC	*				

FIGURE 1. HPC



50  
THRU  
56

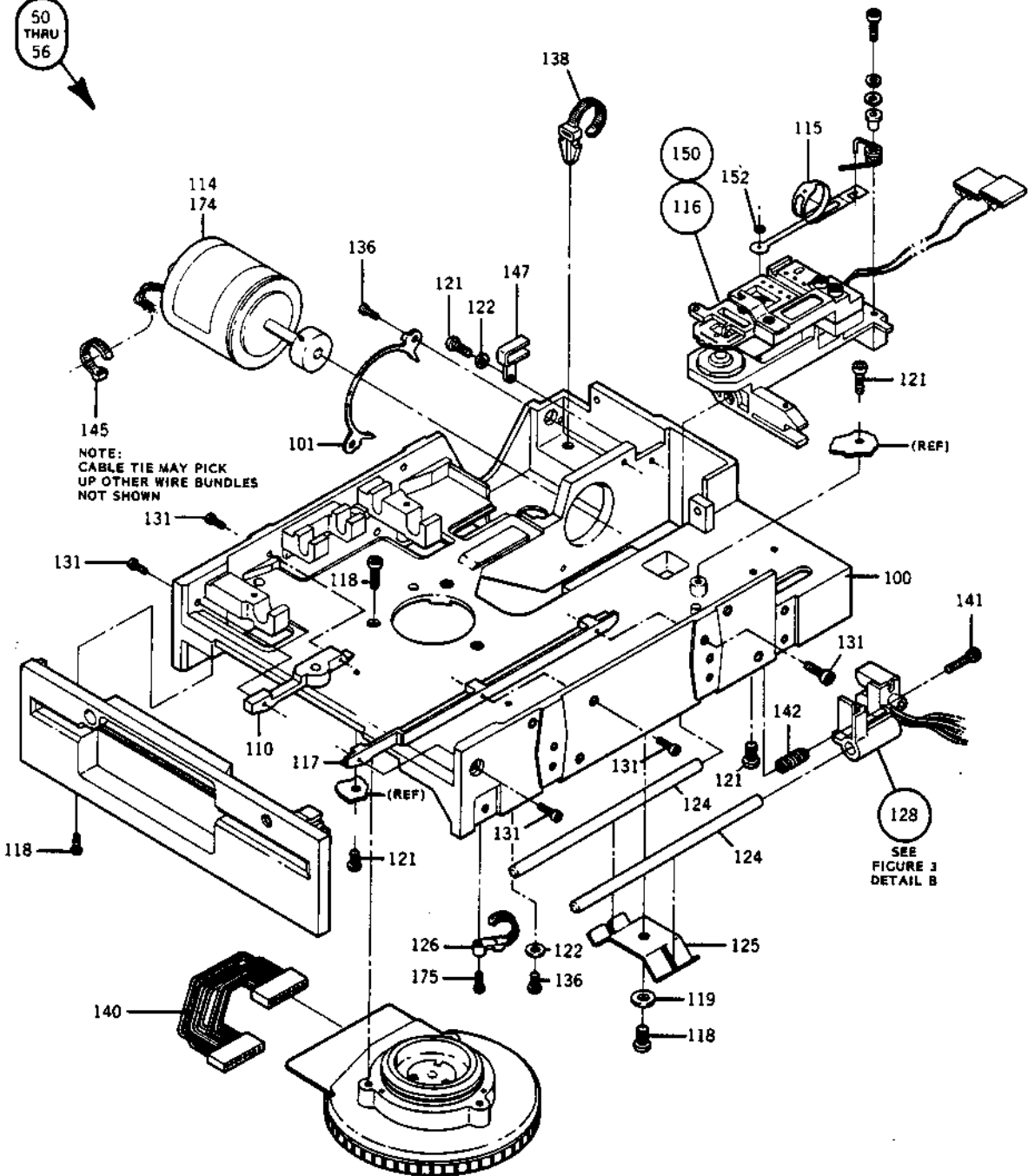

ITEM	IDENT NO	DESCRIPTION	WHERE USED	ITEM	IDENT NO	DESCRIPTION	WHERE USED
50	77490502	TOP MECH ASM	*	122	10125403	WASHER	50-56
51	77490504	TOP MECH ASM	*	123	77471895	MOTORIZED SPINDLE	50, 51
52	77490505	TOP MECH ASM	*	123	77471895	MOTORIZED SPINDLE	53, 56
53	77490506	TOP MECH ASM	*	124	77734017	GUIDE ROD	50-56
54	77490508	TOP MECH ASM	*	125	77733866	GUIDE ROD SPRING	50-56
55	77490509	TOP MECH ASM	*	126	94277421	CABLE TIE STRAP	50-56
56	77734031	TOP MECH ASM	*	128	77732773	TRACK "O" ASM	50-56
100	77733885	BASE MACHINING	50-56	131	95873210	SCREW	50-56
101	77732648	CLAMP	50-56	136	10127104	SCREW	50-56
110	77734016	LEFT GUIDERAIL	50-56	138	77412011	CABLE TIE	50-56
114	77740151	STEPPER MTR ASM	52	140	77731291	SPNDL MTR HARNESS	50-55
115	77738817	BAND ASM	50-56	141	10126220	SCREW	50-56
116	77741420	HEAD ASM	50, 51	142	94205369	SPRING	50-56
116	77741420	HEAD ASM	53-56	145	94277400	CABLE TIE STRAP	50-56
117	77734021	RIGHT GUIDERAIL	50-56	147	77731249	CABLE GUARD	50-56
118	10127111	SCREW	50-56	150	77741421	HEAD ASM	52
119	10125405	WASHER	50-56	151	77471896	MOTORIZED SPINDLE	52, 54, 55
121	10127102	SCREW	50-56	152	92074152	O-RING	50-56
				174	77472237	STEPPER MOTOR	50, 51
				174	77472237	STEPPER MOTOR	53-56
				175	10127113	SCREW	50-56

\*SEE WHERE USED MATRIX

FIGURE 2. TOP MECH ASSEMBLY (1 OF 2)

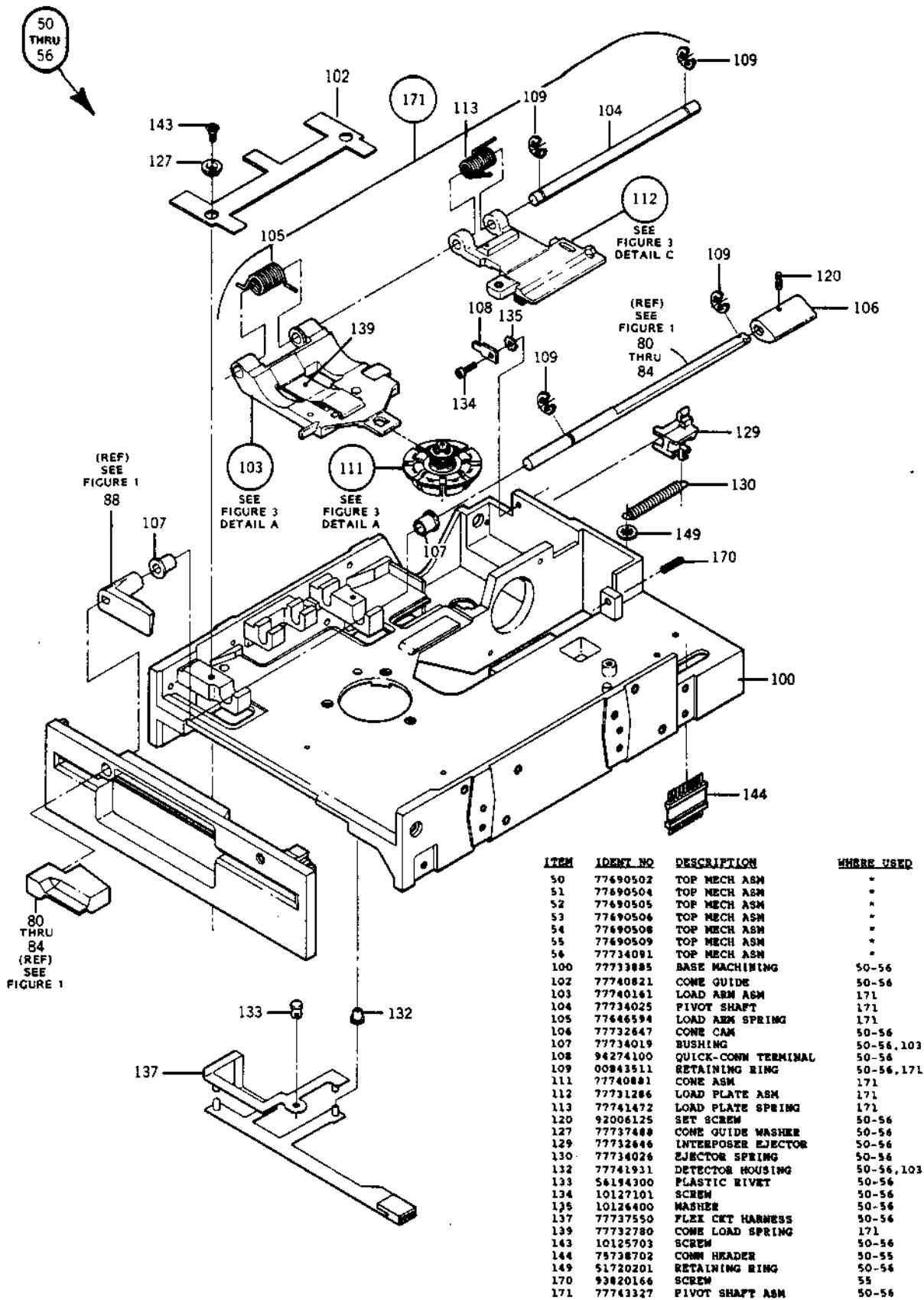

ITEM	IDENT NO	DESCRIPTION	WHERE USED
50	77490502	TOP MECH ASM	*
51	77490504	TOP MECH ASM	*
52	77490505	TOP MECH ASM	*
53	77490506	TOP MECH ASM	*
54	77490508	TOP MECH ASM	*
55	77490509	TOP MECH ASM	*
56	77734091	TOP MECH ASM	*
100	77733885	BASE MACHINING	50-56
102	77740821	CONE GUIDE	50-56
103	77740161	LOAD ARM ASM	171
104	77734025	PIVOT SHAFT	171
105	77446594	LOAD ARM SPRING	171
106	77732647	CONE CAM	50-56
107	77734019	BUSHING	50-56,103
108	94274100	QUICK-COMM TERMINAL	50-56
109	00843511	RETAINING RING	50-56,171
111	77740841	CONE ASM	171
112	77731266	LOAD PLATE ASM	171
113	77741472	LOAD PLATE SPRING	171
120	92006125	SET SCREW	50-56
127	77737489	CONE GUIDE WASHER	50-56
129	77732646	INTERPOSER EJECTOR	50-56
130	77734026	EJECTOR SPRING	50-56
132	77741931	DETECTOR HOUSING	50-56,103
133	56194300	PLASTIC RIVET	50-56
134	10127101	SCREW	50-56
135	10126400	WASHER	50-56
137	77737550	FLEX CKT HARNESS	50-56
139	77732780	CONE LOAD SPRING	171
143	10125703	SCREW	50-56
144	75738702	CONN HEADER	50-56
149	51720201	RETAINING RING	50-56
170	93820166	SCREW	55
171	77743327	PIVOT SHAFT ASM	50-56

\*SEE WHERE USED MATRIX

FIGURE 2. TOP MECH ASSEMBLY (2 OF 2)

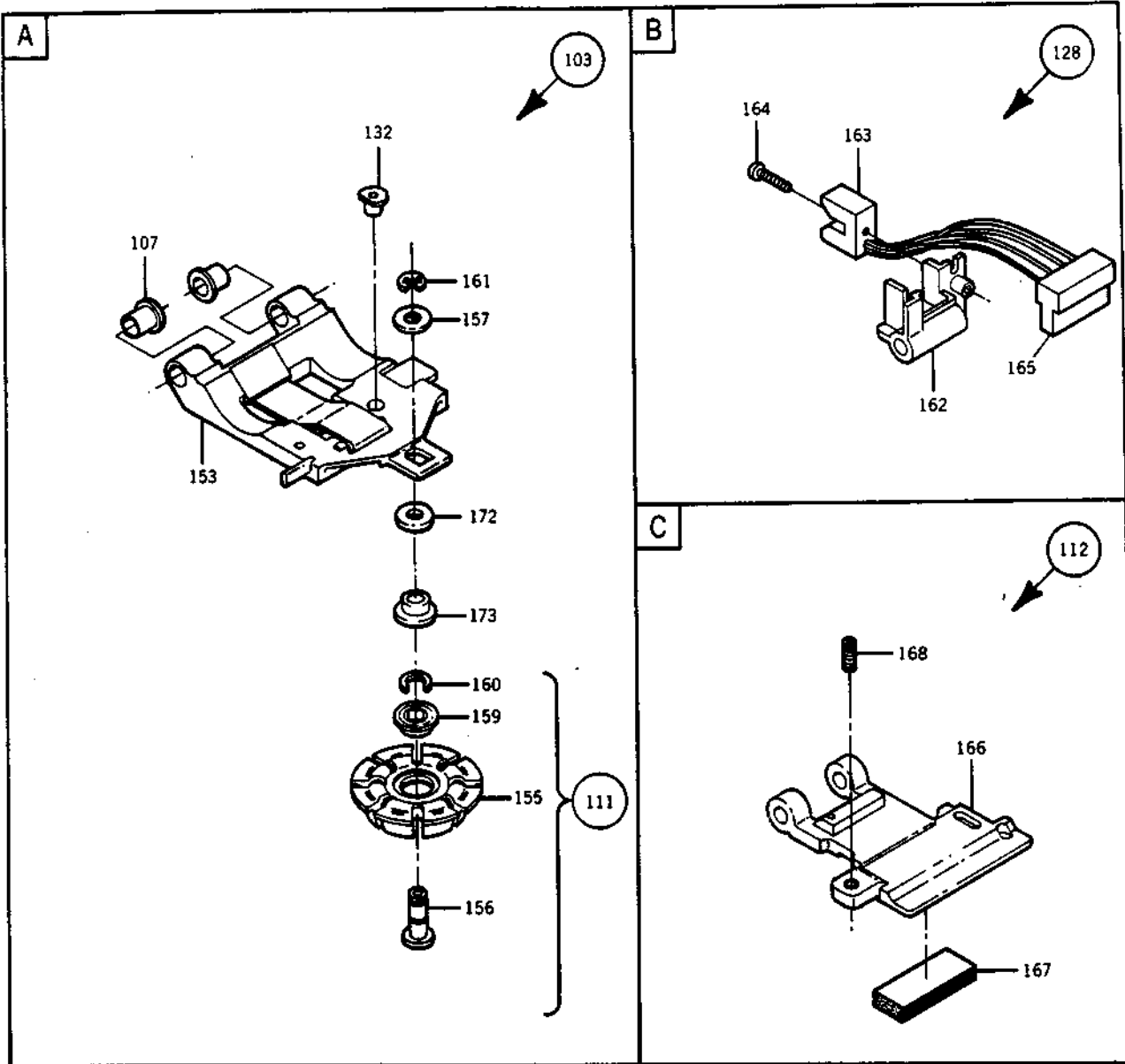

ITEM	IDENT NO	DESCRIPTION	WHERE USED
103	77740159	LOAD ARM ASM	171
107	77734019	BUSHING	50-56,103
111	77734028	CONE ASM	171
112	77731286	LOAD PLATE ASM	171
120	77732773	TRACK "O" ASM	50-56
132	77741931	DETECTOR HOUSING	50-56,103
153	77732791	CONE LOAD ARM	103
155	77734694	CONE	111
156	77740637	CONE SHAFT	111
157	77732788	WASHER	171
159	77613703	BALL BEARING	111
160	92033147	RETAINING RING	111
161	92033037	RETAINING RING	171
162	77731295	TRACK "O" BRACKET	128
163	77649008	OPTICAL SWITCH	128
164	94375803	SCREW	128
165	77613529	CONNECTOR	128
166	77730770	HEAD LOAD PLATE	112
167	77646144	FORM MEDIA CLAMP	112
168	93820165	SCREW	112
172	77741694	CAP	171
173	77741692	STOP	171

FIGURE 3. MISCELLANEOUS SUBASSEMBLIES

# NUMERICAL PARTS LIST

## (By Item Number)

ITEM	IDENT NO	DESCRIPTION	WHERE USED	SHEET	ITEM	IDENT NO	DESCRIPTION	WHERE USED	SHEET
1	77740000	HPC	*	54	107	77734019	BUSHING	50-56,103	56,7
2	77740001	HPC	*	54	108	94274100	QUICK-COMM TERMINAL	50-56	56
3	77740002	HPC	*	54	109	00843511	RETAINING RING	50-56,171	56
4	77740003	HPC	*	54	110	77734016	LEFT GUIDERAIL	50-56	55
5	77740004	HPC	*	54	111	77740881	CONE ASM	171	56,7
6	77740005	HPC	*	54	112	77731284	LOAD PLATE ASM	171	56,7
7	77740006	HPC	*	54	113	77741472	LOAD PLATE SPRING	171	56
8	77740007	HPC	*	54	114	77740251	STEPPER MTR ASM	52	55
9	77740008	HPC	*	54	115	77738817	BAND ASM	50-56	55
10	77740009	HPC	*	54	116	77741420	HEAD ASM	50,51	55
11	77740010	HPC	*	54	116	77741420	HEAD ASM	53-56	55
12	77740011	HPC	*	54	117	77734021	RIGHT GUIDERAIL	50-56	55
13	77740012	HPC	*	54	118	10127111	SCREW	50-56	55
14	77740013	HPC	*	54	119	10125605	WASHER	50-56	55
15	77740014	HPC	*	54	120	92006125	SET SCREW	50-56	56
16	77740015	HPC	*	54	121	10127102	SCREW	50-56	55
17	77740016	HPC	*	54	122	10125603	WASHER	50-56	55
18	77740017	HPC	*	54	123	77671895	MOTORIZED SPINDLE	50,51	55
19	77740018	HPC	*	54	123	77671895	MOTORIZED SPINDLE	53,56	55
20	77740054	HPC	*	54	124	77734017	GUIDE ROD	50-56	55
21	77740055	HPC	*	54	125	77733846	GUIDE ROD SPRING	50-56	55
22	77740054	HPC	*	54	126	94277421	CABLE TIE STRAP	50-56	55
23	77740057	HPC	*	54	127	77737488	CONE GUIDE WASHER	50-56	56
24	77740058	HPC	*	54	128	77732773	TRACK "O" ASM	50-56	55,7
25	77740059	HPC	*	54	129	77732646	INTERPOSER EJECTOR	50-56	56
26	77740060	HPC	*	54	130	77734026	EJECTOR SPRING	50-56	56
27	77740061	HPC	*	54	131	95873210	SCREW	50-56	55
28	77740062	HPC	*	54	132	77741931	DETECTOR HOUSING	50-56,103	56,7
29	77740076	HPC	*	54	133	54194300	PLASTIC RIVET	50-56	56
30	77740077	HPC	*	54	134	10127101	SCREW	50-56	56
31	77740078	HPC	*	54	135	10126400	WASHER	50-56	56
35	77743000	HPC	*	54	136	10127104	SCREW	50-56	55
36	77743001	HPC	*	54	137	77737550	FLEX CKT HARNESS	50-56	56
37	77743002	HPC	*	54	138	77612011	CABLE TIE	50-56	55
38	77743003	HPC	*	54	139	77732780	CONE LOAD SPRING	171	56
39	77743004	HPC	*	54	140	77731291	SPNDL MTR HARNESS	50-55	55
40	77743005	HPC	*	54	141	10126220	SCREW	50-56	55
41	77743006	HPC	*	54	142	94205369	SPRING "	50-56	55
42	77743007	HPC	*	54	143	10125703	SCREW	50-56	56
43	77743008	HPC	*	54	144	75738702	CONN HEADER	50-55	56
44	77743009	HPC	*	54	145	94277400	CABLE TIE STRAP	50-56	55
50	77690502	TOP MECH ASM	*	54,5,6	147	77731249	CABLE GUARD	50-56	55
51	77690504	TOP MECH ASM	*	54,5,6	149	51720201	RETAINING RING	50-56	56
52	77690505	TOP MECH ASM	*	54,5,6	150	77741421	HEAD ASM	52	55
53	77690506	TOP MECH ASM	*	54,5,6	151	77671894	MOTORIZED SPINDLE	52,54,55	55
54	77690508	TOP MECH ASM	*	54,5,6	152	92074152	O-RING	50-56	55
55	77690509	TOP MECH ASM	*	54,5,6	153	77732791	CONE LOAD ASM	103	57
56	77734091	TOP MECH ASM	*	54,5,6	155	77734694	CONE	111	57
70	77735001	FRONT PANEL	*	54	156	77740637	CONE SHAFT	111	57
71	77735002	FRONT PANEL	*	54	157	77732788	WASHER	171	57
72	77739401	FRONT PANEL	*	54	159	77613703	BALL BEARING	111	57
73	77740901	FRONT PANEL	*	54	160	92033147	RETAINING RING	111	57
74	77741787	FRONT PANEL	*	54	161	92033037	RETAINING RING	171	57
75	77741851	FRONT PANEL	*	54	162	77731295	TRACK "O" BRACKET	128	57
76	77743101	FRONT PANEL	*	54	163	77649008	OPTICAL SWITCH	128	57
77	77743550	FRONT PANEL	*	54	164	94275803	SCREW	128	57
78	77743726	FRONT PANEL	*	54	165	77413529	CONNECTOR	128	57
80	77736901	CAMSHAFT LEVER ASM	*	54,6	166	77730770	HEAD LOAD PLATE	112	57
81	77736902	CAMSHAFT LEVER ASM	*	54,6	167	77646144	FOAM MEDIA CLAMP	112	57
82	77741275	CAMSHAFT LEVER ASM	*	54,6	168	93820165	SCREW	112	57
83	77741276	CAMSHAFT LEVER ASM	*	54,6	170	93820166	SCREW	55	56
84	77741762	CAMSHAFT LEVER ASM	*	54,6	171	77743327	PIVOT SHAFT ASM	50-56	56
88	77733896	MEDIA PUSHER	*	54	172	77741694	CAP	171	57
89	77734038	FRAME ASM	*	54	173	77741692	STOP	171	57
90	67184741	SCREW	*	54	174	77672237	STEPPER MOTOR	50,51	55
100	77731885	BASE MACHINING	50-56	55,6	174	77672237	STEPPER MOTOR	53-56	55
101	77732648	CLAMP	50-56	55	175	10127113	SCREW	50-56	55
102	77740821	CONE GUIDE	50-56	56					
103	77740161	LOAD ARM ASM	171	56,7					
104	77734025	PIVOT SHAFT	171	56					
105	77646594	LOAD ARM SPRING	171	56					
106	77732647	CONE CAM	50-56	56					

\*SEE WHERE USED MATRIX

# CROSS REFERENCE INDEX

ITEM	IDENT NO	SHEET	ITEM	IDENT NO	SHEET	ITEM	IDENT NO	SHEET
109	00843511	S6	89	77733896	S4	156	77740637	S7
122	10125403	S5	110	77734016	S5	102	77740821	S6
119	10125405	S5	124	77734017	S5	111	77740881	S6,7
143	10125703	S6	107	77734019	S6,7	73	77740901	S4
141	10124220	S5	117	77734021	S5	82	77741275	S4,6
135	10124400	S4	104	77734025	S6	83	77741276	S4,6
134	10127101	S6	130	77734026	S4	116	77741420	S5
121	10127102	S5	89	77734038	S4	150	77741421	S5
136	10127104	S5	56	77734081	S4,5,6	113	77741472	S6
118	10127111	S5	155	77734694	S7	173	77741692	S7
175	10127113	S5	70	77735001	S4	172	77741694	S7
149	51720201	S6	71	77735002	S4	84	77741762	S4,6
133	56194300	S4	80	77736901	S4,6	74	77741787	S4
90	67184761	S4	81	77736902	S4,6	75	77741851	S4
144	75738702	S6	127	77737488	S6	132	77741931	S6,57
138	77612011	S5	137	77737550	S6	35	77743000	S4
145	77613529	S7	115	77738817	S5	36	77743001	S4
159	77613703	S7	72	77739401	S4	37	77743002	S4
147	77646144	S7	1	77740000	S4	38	77743003	S4
105	77646594	S6	2	77740001	S4	39	77743004	S4
163	77649008	S7	3	77740002	S4	40	77743005	S4
123	77671895	S5	4	77740003	S4	41	77743006	S4
151	77671896	S5	5	77740004	S4	42	77743007	S4
174	77672237	S5	6	77740005	S4	43	77743008	S4
50	77690502	S4,5,6	7	77740006	S4	44	77743009	S4
51	77690504	S4,5,6	8	77740007	S4	76	77743101	S4
52	77690505	S4,5,6	9	77740008	S4	171	77743327	S6
53	77690506	S4,5,6	10	77740009	S4	77	77743550	S4
54	77690508	S4,5,6	11	77740010	S8	78	77743726	S4
55	77690509	S4,5,6	12	77740011	S8	120	92006125	S6
146	77730770	S7	13	77740012	S4	161	92033037	S7
147	77731249	S5	14	77740013	S4	160	92033147	S7
112	77731286	S6,7	15	77740014	S4	152	92074152	S5
140	77731291	S5	16	77740015	S4	168	93820165	S7
142	77731295	S7	17	77740016	S4	170	93820166	S6
129	77732646	S6	18	77740017	S4	142	94205369	S5
106	77732647	S4	19	77740018	S4	108	94274100	S6
101	77732848	S5	20	77740054	S4	145	94277400	S5
128	77732773	S5,7	21	77740055	S4	126	94277421	S5
139	77732780	S6	22	77740056	S4	164	94375803	S7
157	77732788	S7	23	77740057	S4	131	95873210	S5
153	77732791	S7	24	77740058	S4			
125	77733866	S5	25	77740059	S4			
100	77733889	S5,6	26	77740060	S4			
			27	77740061	S4			
			28	77740062	S4			
			29	77740076	S4			
			30	77740077	S4			
			31	77740078	S4			
			114	77740151	S5			
			103	77740161	S6,7			

\*SEE WHERE USED MATRIX

# USER COMMENTS

## FILE REFERENCE

FROM: \_\_\_\_\_ Date \_\_\_\_\_  
 Name \_\_\_\_\_  
 Address \_\_\_\_\_  
 City \_\_\_\_\_  
 State \_\_\_\_\_ Zip Code \_\_\_\_\_  
 Area Code \_\_\_\_\_ Phone \_\_\_\_\_

### NOTE:

This form is not intended to be used as an order blank. Control Data Corporation welcomes your evaluation of this publication. Please indicate any errors, suggested additions or deletions, or general comments below.

Business-related questions are to be directed to your Local Sales Office.

Equipment Identification \_\_\_\_\_ Part Number \_\_\_\_\_ Serial No. \_\_\_\_\_

Document: (Title/Number/Revision) \_\_\_\_\_

### COMMENTS:

---

---

---

---

---

---

---

---

---

---

---

---

---

---

---

---

---

---

---

---

---

---

---

---

---

---

STAPLE

STAPLE

FOLD

FOLD



NO POSTAGE  
NECESSARY  
IF MAILED  
IN THE  
UNITED STATES

**BUSINESS REPLY MAIL**  
FIRST CLASS PERMIT NO. 1332 OKLAHOMA CITY, OKLA.

POSTAGE WILL BE PAID BY ADDRESSEE



CUT ALONG LINE

**MAGNETIC PERIPHERALS, INC.**

P.O. BOX 12313

OKLAHOMA CITY, OKLAHOMA 73157

*Attention Technical Publications, OKM250*

FOLD

FOLD