



# **Field Service Manual**

Revision 2.0

Part No. 2F00040-00

Copyright © 1983 Osborne Computer Corporation. All rights reserved worldwide. No part of this publication may be reproduced, transmitted, transcribed, stored in a retrieval system, or translated into any human or computer language, in any form or by any means without the express written permission of Osborne Computer Corporation, 26538 Danti Court, Hayward, CA 94545, USA.

Osborne Computer Corporation makes no representations or warranties regarding the contents hereof and specifically disclaims any implied warranty of merchantability or fitness for any particular purpose. Osborne Computer Corporation also reserves the right to revise this publication and to otherwise change the product described without obligation to notify any person or organization of such revision or change.

4.3.0	PARTS PRICE LIST	26–27	
4.4.0	PARTS ORDERING	28	
4.5.0	MINIMUM PARTS ORDER	28	
<b>5.0.0</b>	<b>THE OSBORNE ONE-YEAR EXTENDED WARRANTY</b>		<b>29</b>
5.1.0	INTRODUCTION	29	
5.2.0	EXTENDED WARRANTY COVERAGE	29	
5.3.0	WARRANTY ADDITIONS	30	
5.4.0	WARRANTY UPDATES	30	
5.5.0	WARRANTY RENEWAL	31	
5.6.0	USER RESPONSIBILITIES	31	
5.7.0	EXTENDED WARRANTY ADMINISTRATION	32	
5.8.0	WARRANTY FORM PROCEDURES	33	
5.9.0	EXTENDED WARRANTY PRICES	34	
5.10.0	EXTENDED WARRANTY REIMBURSEMENT	34	
5.11.0	EXTENDED WARRANTY CERTIFICATE	35	
5.12.0	WARRANTY REGISTRATION INSTRUCTIONS	36–37	
5.13.0	EXTENDED WARRANTY REGISTRATION FORM	38	
5.14.0	EXTENDED WARRANTY LABEL	38	
5.15.0	REQUEST TO END USER FOR ADDITIONAL INFORMATION	39	
5.16.0	REQUEST TO DEALER FOR ADDITIONAL INFORMATION		40
5.17.0	WARRANTY EXPIRATION NOTICE	41	

# OSBORNE 1/OSBORNE 1A Disassembly/Assembly and Alignments

6.0.0	REQUIRED TOOLS AND EQUIPMENT	43
6.0.1	Keyboard	43
6.0.2	Major Subassemblies Within Case	43
6.0.3	Disk Drive Alignments	43
6.0.4	Video Monitor	43
6.1.0	KEYBOARD DISASSEMBLY	44–45
6.1.1	BEZEL AND CHASSIS DISASSEMBLY	46–47
6.1.2	LOGIC BOARD DISASSEMBLY	48–49
6.1.3	VIDEO MONITOR DISASSEMBLY	50
6.1.4	POWER SUPPLY DISASSEMBLY	50–51
6.1.5	DISK DRIVE A DISASSEMBLY	52–53
6.1.6	DISK DRIVE B DISASSEMBLY	53–54
6.1.7	POWER PANEL DISASSEMBLY	54
6.2.0	POWER PANEL ASSEMBLY	55
6.2.1	DISK DRIVE B ASSEMBLY	55–58
6.2.2	DISK DRIVE A ASSEMBLY	58–60
6.2.3	POWER SUPPLY ASSEMBLY	60–61
6.2.4	VIDEO MONITOR ASSEMBLY	62
6.2.5	LOGIC BOARD ASSEMBLY	62–63
6.2.6	BEZEL AND CHASSIS ASSEMBLY	63–64
6.2.7	KEYBOARD ASSEMBLY	64–65

6.3.0	SIEMENS DISK DRIVE ALIGNMENTS	66
6.3.1	Drive Cable and Test Lead Hookup	66-67
6.3.2	Spindle Speed Adjustment	67-68
6.3.3	Track 00/39 Stop Adjustment	68-69
6.3.4	Track 00 Switch Adjustment	70-71
6.3.5	Index Sensor Timing Adjustment	72-73
6.3.6	Radial Head Alignment	74-75
6.4.0	MPI DISK DRIVE ALIGNMENTS	76
6.4.1	Drive Cable and Test Lead Hookup (MPI)	76-77
6.4.2	Spindle Speed Adjustment (MPI)	77-78
6.4.3	Track 00 Sensor Adjustment (MPI)	78-80
6.4.4	Index Sensor Adjustment (MPI)	81
6.4.5	Radial Track Alignment (MPI)	82-83
6.5.0	OSBORNE DISK DRIVE ALIGNMENT PROGRAM	84-88
6.6.0	VIDEO MONITOR ADJUSTMENTS	89
6.6.0.1	Precautions	89
6.6.1	Brightness/Contrast Adjustment	89
6.6.2	Vertical Size/Linearity Adjustment	90
6.6.3	Focus Adjustment	90
6.6.4	Raster Adjustment	90-91
6.7.0	OCC1A KEYBOARD DISASSEMBLY	92-93
6.7.1	OCC1A BEZEL AND CHASSIS DISASSEMBLY	94-95
6.7.2	OCC1A LOGIC BOARD DISASSEMBLY	96-97
6.7.3	OCC1A VIDEO MONITOR DISASSEMBLY	98
6.7.4	OCC1A POWER SUPPLY DISASSEMBLY	99
6.7.5	OCC1A DISK DRIVE A DISASSEMBLY	100
6.7.6	OCC1A DISK DRIVE B DISASSEMBLY	101-102
6.7.7	OCC1A AC POWER PANEL DISASSEMBLY	102-103
6.8.0	OCC1A AC POWER PANEL ASSEMBLY	104-107
6.8.1	OCC1A DISK DRIVE B ASSEMBLY	107-108
6.8.2	OCC1A DISK DRIVE A ASSEMBLY	108-109

6.8.3	OCC1A POWER SUPPLY ASSEMBLY	110–111
6.8.4	OCC1A VIDEO MONITOR ASSEMBLY	112–113
6.8.5	OCC1A LOGIC BOARD ASSEMBLY	114–115
6.8.6	OCC1A BEZEL AND CHASSIS ASSEMBLY	116–117
6.8.7	OCC1A KEYBOARD ASSEMBLY	118–119
6.9.0	OCC1 OPERATING VOLTAGE MODIFICATION	120
6.10.0	BATTERY PACK	121–122
6.11.0	OCC1/1A DOUBLE DENSITY INSTALLATION	123–127
6.11.1	Double-Density Installation Advisory	128
6.11.2	OCC Installations	128
6.11.3	Dealer Installations	129
6.12.0	OCC1/OCC1A SCREEN-PAC INSTALLATION	130–131
6.12.1	PC Board Assembly	132
6.12.2	Cable Installation	132–134
6.12.3	PC Board Installation	135–138
6.12.4	RCA External Video Connector	138
6.12.5	Screen-Pac Power Harness	139–140
6.12.6	Logic Board Installation	140–142
6.12.7	Osborne External Video Monitors	142

## **OSBORNE 1/OSBORNE 1A Troubleshooting and Preventive Maintenance**

7.0.0	TROUBLESHOOTING TECHNIQUE	143
7.0.1	Precautions	143
7.1.0	POWER PROBLEMS	144
7.1.1	System Doesn't Power Up	144–145
7.1.2	Reduced Screen Display/Slow-Running Disk	145
7.1.3	Disk Drive Errors During Applications	146

7.2.0	DISK DRIVE PROBLEMS	147
7.2.1	Boot Read Error	147-148
7.2.2	Drive Not Ready	148
7.2.3	BDOS Errors	149
7.3.0	CRT MALFUNCTIONS	150
7.3.1	Wavy Screen	150
7.3.2	Screen Not Centered	150
7.3.3	Blank Screen	150-151
7.3.4	Gaps in the Sign-On Message	151
7.3.5	Flashing Sign-On Message	151
7.4.0	KEYBOARD MALFUNCTIONS	152
7.4.1	Individual Key Malfunction	152
7.4.2	Complete Keyboard Failure	153
7.4.3	Displayed Character and Key Struck Don't Correspond	153
7.5.0	LOGIC BOARD PROBLEMS	154
7.5.1	Continuous Beep on Power Up	154
7.5.2	Scattered Video Display	154
7.5.3	Memory Error during Diagnostics Run	154
7.6.0	RS-232 AND IEEE-488 PORT PROBLEMS	155
7.6.1	No Output to Printer	155
7.6.2	Printer Drops Characters	155
7.6.3	Scrambled Printout	156
7.7.0	PREVENTIVE MAINTENANCE	156
7.8.0	DOUBLE DENSITY MALFUNCTIONS	157
7.8.1	System Doesn't Power Up	157
7.8.2	Reduced Screen Display	157
7.8.3	Drive Not Ready	158
7.8.4	Wavy or Blank Screen	158
7.8.5	Gaps in Sign-On Message	158
7.8.6	Continuous Beep on Power Up	158
7.8.7	Boot Errors	159
7.8.8	BDOS Errors	159
7.8.9	Drive Errors During Confidence Test	160
7.8.10	Single-Density Software Not Being Read	160

# OSBORNE EXECUTIVE Disassembly/Assembly and Alignments

8.0.0	REQUIRED TOOLS AND EQUIPMENT	165
8.1.0	KEYBOARD DISASSEMBLY	165-169
8.1.1	BEZEL AND CHASSIS DISASSEMBLY	169-171
8.1.2	LOGIC AND MEMORY BOARD DISASSEMBLY	172-176
8.1.3	VIDEO MONITOR AND POWER SUPPLY DISASSEMBLY	177-179
8.1.4	DISK DRIVE DISASSEMBLY	179-185
8.1.5	BULB REMOVAL AND POWER SWITCH DISASSEMBLY	185-187
8.1.6	AC POWER PANEL DISASSEMBLY	187-188
8.1.7	FAN DISASSEMBLY	188-189
8.1.8	FUSE REPLACEMENT	189-190
8.2.0	FAN ASSEMBLY	191-192
8.2.1	AC POWER PANEL ASSEMBLY	193-194
8.2.2	POWER SWITCH ASSEMBLY AND BULB REPLACEMENT	195-196
8.2.3	DISK DRIVE ASSEMBLY	196-202
8.2.4	VIDEO MONITOR AND POWER SUPPLY ASSEMBLY	202-205
8.2.5	LOGIC AND MEMORY BOARD ASSEMBLY	205-209
8.2.6	BEZEL AND CHASSIS ASSEMBLY	209-212
8.2.7	KEYBOARD ASSEMBLY	212-214
8.3.0	ALPS DISK-DRIVE ALIGNMENTS	215
8.3.1	Drive Cable Hookup	215-216
8.3.2	Spindle Speed Adjustment	217-218
8.3.3	Radial Head Alignment	218-219
8.3.4	Track 0 Limiter Adjustment	220
8.3.5	Track 0 Sensor Adjustment	220-222
8.3.6	Index Sensor Timing Adjustment	222-224
8.3.7	Amplitude Check	224-226



8.4.0	ZENITH 7" VIDEO MONITOR ADJUSTMENTS	227
8.4.1	Brightness/Contrast Adjustment	228
8.4.2	Focus Adjustment	228
8.4.3	Vertical Size Adjustment	229
8.4.4	Horizontal Width/Phase Adjustment	229

8.5.0	EXECUTIVE DEALER DIAGNOSTICS	000
8.5.1	EXECUTIVE DISK EXERCISOR PROGRAM	000

# OSBORNE EXECUTIVE Troubleshooting and Preventive Maintenance

9.0.0	TROUBLESHOOTING TECHNIQUE	233
9.0.1	Precautions	223
9.1.0	POWER PROBLEMS	233
9.1.1	System Doesn't Power Up	233
9.1.2	Reduced Screen Display/Slow-Running Disk	235
9.1.3	Disk Drive Errors During Applications	235
9.2.0	DISK DRIVE PROBLEMS	235
9.2.1	No Power at Drive Motor	236
9.2.2	Boot Read Error	236
9.2.3	Drive Not Ready	238
9.3.0	CRT MALFUNCTIONS	238
9.3.1	Wavy Screen	238
9.3.2	Screen Not Centered	238
9.3.3	Blank Screen	238
9.3.4	Gaps in the Sign-On Message	239
9.3.5	Flashing Sign-On Message	239
9.4.0	KEYBOARD MALFUNCTIONS	240
9.4.1	Individual Key Malfunction	240
9.4.2	Complete Keyboard Failure	240
9.4.3	Displayed Character and Key Struck Don't Correspond	241

9.5.0 LOGIC AND MEMORY BOARD PROBLEMS	241
9.5.1 Continuous Beep on Power Up	242
9.5.2 Scattered Video Display	242
9.5.3 Memory Error during Diagnostics Run	242
9.6.0 RS-232 AND IEEE-488 PORT PROBLEMS	242
9.6.1 No Output to Printer	243
9.6.2 Printer Drops Characters	243
9.6.3 Scrambled Printout	243
9.7.0 PREVENTIVE MAINTENANCE	244

## APPENDICES

APPENDIX 1. MOTOROLA 5" VIDEO MONITOR SERVICE	247
APPENDIX 2. ASTEC POWER SUPPLY SERVICE	263
APPENDIX 3. OSBORNE 1 SCHEMATICS	281
APPENDIX 4. ZENITH 7" VIDEO MONITOR SERVICE	291
APPENDIX 5. OSBORNE EXECUTIVE SCHEMATICS	319

Pages 1 - 42 missing from original document

## 6.0.0 Required Tools and Equipment

The following tools are required for Disassembly, Reassembly, Disk Drive Alignment and Video Monitor Adjustment.

### 6.0.1 Keyboard

- a) No. 2 Phillips Screw Driver, 9in. - 12in. length

### 6.0.2 Major Sub-Assemblies Within Main Case

- a) No. 2 Phillips Screw Driver, 9in. - 12in. length
- b) 1/20 inch Allen Wrench
- c) Needle-nose pliers

### 6.0.3 Disk Drive Alignments

- a) No. 2 Phillips Screw Driver, 9in. - 12in. length
- b) 1/20 inch Allen Wrench
- c) 6 inch Standard Screw Driver
- d) 3/32 inch Allen Wrench
- e) Oscilloscope
  - 1) Dual Channel
  - 2) External Trigger
  - 3) Minimum Frequency           50Mhz
  - 4) Sensitivity:                   200 Millivolts
  - 5) Sweep Speed:                200 Milliseconds
  - 6) Three 10 x 1 Probes with ground clips
- f) Alignment Diskette
  - 1) Dysan 224 or equivalent
- g) Osborne Alignment Program Diskette (P/N 2D 01003-00)
- h) Drive head cleaning kit

### 6.0.4 Video Monitor

- a) No. 2 Phillips Screw Driver, 9in. - 12in. length
- b) 1/20 inch Allen Wrench
- c) Broad-end, non-metallic adjustment tool
- d) Osborne Alignment Program Diskette (P/N 2D 01003-00)

## 6.1.0 KEYBOARD DISASSEMBLY

**CAUTION:** Identify connector orientations before detaching any cable.

- 6.1.0.1 Disconnect computer from power source.
- 6.1.0.2 Disconnect the Keyboard cable from the front Bezel by spreading the latches of the Keyboard connector.
- 6.1.0.3 Using a pad or soft material to protect the keyboard, turn the keyboard assembly over so the keys face down.
- 6.1.0.4 Remove the 6/32 Phillips screw located at each latch end of the keyboard case.
- 6.1.0.5 Lift the Keyboard case from the Keyboard and bezel assembly.
- 6.1.0.6 Carefully remove the Keyboard harness from the double back tape located on the Keyboard Bezel and Keyboard.
- 6.1.0.7 Carefully remove the Keyboard harness from the Keyboard connector.

---

### NOTE

*The Keyboard harness is aligned with Pin 1 of the Keyboard connector. Looking at the underside of the Keyboard with the numeric row of keys to the top, Pin 1 is the upper right Pin.*

---

- 6.1.0.8 Remove four 8/32 Phillips screws which secure the Keyboard to the bezel standoffs.
- 6.1.0.9 Remove the Keyswitch array from the Keyboard Bezel.

See Section 6.2.7 to reassemble the keyboard.



## 6.1.1 Bezel and Chassis Disassembly

- 6.1.1.1 Disconnect computer from power source.
- 6.1.1.2 Disconnect the Keyboard cable from the front Bezel by spreading the latches on the Keyboard connector.
- 6.1.1.3 Remove all external cables ( ie. RS-232, Modem, External Video, etc.).
- 6.1.1.4 Using a 1/20 inch Allen wrench, remove the video knobs.
- 6.1.1.5 Remove the 6/32 x 1/4 inch Phillips screws surrounding the Bezel.
- 6.1.1.6 Placing thumbs below CRT screen and fingers in the Disk storage pockets, apply a slight pressure inward with thumbs and pull Bezel straight forward.
- 6.1.1.7 With the Osborne resting flat on its rubber feet, turn it so the A/C Power Panel faces technician.
- 6.1.1.8 Remove two 6/32 x 1/4 inch Phillips screws from above and below the handle. Label these screws FOR HANDLE and set aside.

---

### NOTE

*Using an incorrect screw in reassembly may puncture the Disk harness running behind the handle.*

---

- 6.1.1.9 Remove six 6/32 Phillips screws securing the A/C Power Panel to the case. The two upper screws have washers. Label these screws FOR A/C POWER PANEL and set aside. Using incorrect screws in reassembly may puncture the drive harness!
- 6.1.1.10 With the Osborne resting flat on its rubber feet, turn it so the CRT screen faces technician.

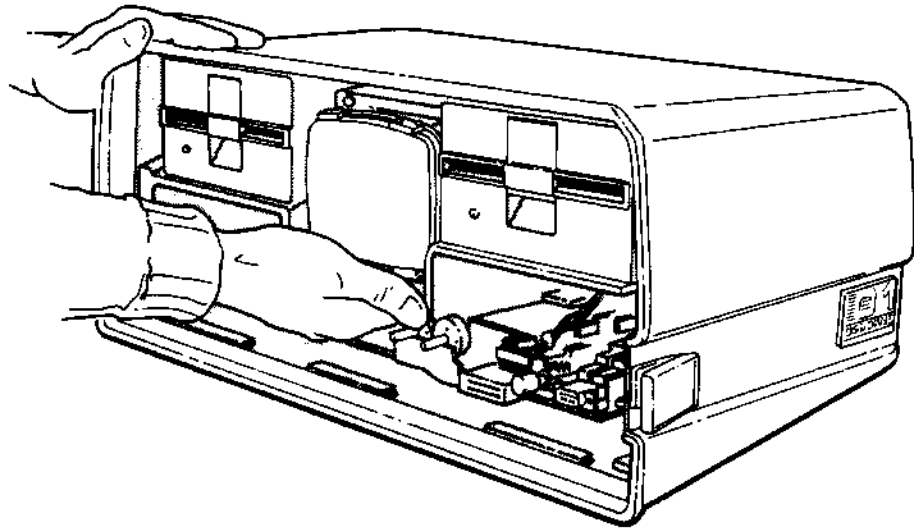

**FIGURE 6-3. CHASSIS REMOVAL**

- 6.1.1.11 Remove the 8/32 x 1/2 inch Phillips screws holding the chassis to the case. There are either two or four of these screws located on the left and right inside forward edges of the chassis.
- 6.1.1.12 Grasp the Chassis assembly between the CRT and the Logic Board. Lift the assembly slightly and pull it straight forward. Be careful when removing the chassis from the case. The A/C power panel will be dragging behind the chassis by wires only.
- 6.1.1.13 Pull remaining Power cord through case.

See Section 6.2.6 to reassemble the bezel and chassis.



## 6.1.2 Logic Board Disassembly

- 6.1.2.1 Disassemble the Osborne-1 following the instructions in Section 6.1.1.
- 6.1.2.2 Position the Chassis assembly with the Logic Board facing up and CRT screen facing Technician.
- 6.1.2.3 Remove the 6/32 Phillips screw at each corner of the Logic Board. The screw in the right front corner of some Logic Boards has a nylon insulation washer.
- 6.1.2.4 Lift the Logic Board by the front edge and hold it perpendicular to the chassis, video control shafts pointing straight up. Note all connector orientations while still attached.
- 6.1.2.5 Remove the DC harness connector located in the extreme left lower corner of the Logic Board.

---

### NOTE

*The DC harness connector is not keyed. The RED wire on the harness must go to the left.*

---

- 6.1.2.6 Remove the Disk harness connector located in the lower left corner of the logic board at the right of the DC harness connector. Grip the connector and CAREFULLY detach it, being sure not to bend any pins.

---

### NOTE

*The Disk Drive harness connector is not keyed. The RED stripe on the harness must go to the right.*

---

- 6.1.2.7 Remove the Video harness connector located in the upper left corner of the Logic Board to the right of the reset button.

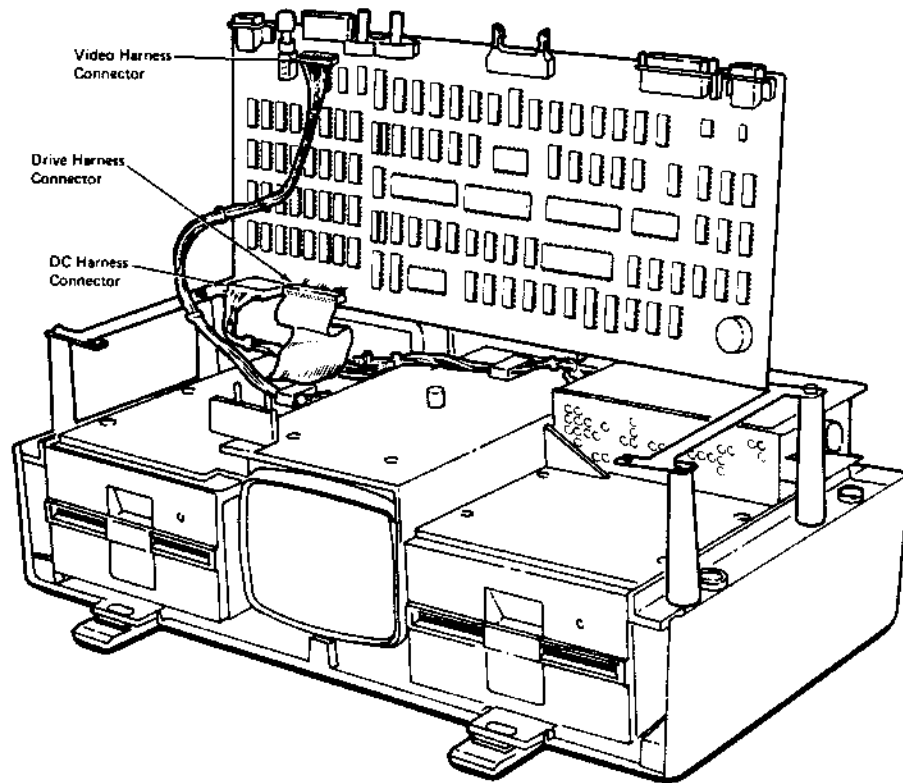

**FIGURE 6-4. LOGIC BOARD REMOVAL**

---

**NOTE**

*The Video harness connector is not keyed. The RED wire on the harness must go to the left.*

---

- 6.1.2.8 Remove External Video plug located on the front edge of the logic board between the reset button and video contrast shaft.
- 6.1.2.9 Remove the Logic Board.

See Section 6.2.5 to reassemble the logic board.

### 6.1.3 Video Monitor Disassembly

- 6.1.3.1 Disassemble the Osborne-1 following the instructions in Sections 6.1.1 and 6.1.2.
- 6.1.3.2 Position the chassis assembly Logic-Board-side-up and CRT screen facing Technician.
- 6.1.3.3 Remove four 6/32 Phillips screws securing the Monitor to the Chassis.
- 6.1.3.4 Grasp the left and right sides of the Chassis assembly and carefully lift it clear of the video monitor.
- 6.1.3.5 Remove the video harness connector located at the top rear of the video PC board. This is a keyed connector.
- 6.1.3.6 Remove the transparent face plate from the monitor screen.

See Section 6.2.4 to reassemble the video monitor.

### 6.1.4 Power Supply Disassembly

**CAUTION:** Working with Power Supplies is DANGEROUS. Power Supplies can hold an electrical charge for long periods of time. Be careful not to touch any components unnecessarily!

- 6.1.4.1 Disassemble the Osborne-1 following the instructions in Sections 6.1.1 and 6.1.2.
- 6.1.4.2 Position the Chassis assembly Logic-Board-side-up and CRT screen facing away from Technician.
- 6.1.4.3 Remove the 6/32 Phillips screw from each corner of the Power Supply unit.

---

**NOTE**

*Three of these screws have nylon washers. The screw in the upper right corner has a metal grounding washer.*

---

- 6.1.4.4 With the wires still attached, carefully lift the Power Supply out of the chassis.
- 6.1.4.5 Turn the Power Supply over left-to-right so the components face the Technician and the five large capacitors are in the lower left corner.
- 6.1.4.6 Remove the DC output connector from the Power Supply. This keyed connector is attached to one of the three identical male connections on the left side of the Power Supply.
- 6.1.4.7 Remove the ground wire connector from the Power Supply. This is a slip-on connector located in the upper left corner of the power supply.
- 6.1.4.8 Remove the AC input connector from the Power Supply. This is a keyed connector located left of the fuse on the upper side of the Power Supply.

See Section 6.2.3 to reassemble the power supply.

## 6.1.5 Disk Drive "A" Disassembly

---

### NOTE

*The A drive has an 8 pin 150 OHM Terminator resistor pack. B DRIVE DOES NOT.*

---

- 6.1.5.1 Disassemble the Osborne-1 following the instructions in Sections 6.1.1 and 6.1.2 .
- 6.1.5.2 Position the Chassis assembly Logic-Board-side-up and handle facing away from Technician.
- 6.1.5.3 Remove four 6/32 Phillips screws holding the "A" Drive to the Chassis assembly.

---

### NOTE

*Disk Drive A is the Drive closest to the Power Supply.*

---

- 6.1.5.4 With the wires still connected, pivot the shielded Drive horizontally to the right 90 degrees from its original position.
- 6.1.5.5 Remove two 6/32 Phillips screws which hold the shield to the Drive. These screws are located on the left and right sides of the Drive.
- 6.1.5.6 Hold the Drive shield down and lift the Drive enough to access the rear of the Drive.
- 6.1.5.7 Remove the disk harness connector and the ground connector from Drive. The disk harness connector is at the rear of the Drive PC board. The slip-on Ground connector is located at the rear of the Drive either on the Drive frame or shield.

---

**NOTE**

*The Disk Drive harness is not keyed. Facing the back of the Drive with strobe wheel side up, the harness is always connected RED STRIPE to the RIGHT*

---

- 6.1.5.8 Remove Drive from shield.
- 6.1.5.9 If the Drive is being replaced with another, remove the 8 pin Terminator from the Drive PC board and KEEP IT for installation on the new Drive (See Section 6.2.2) . The Terminator is located at position RN3 on the right rear corner of the PC board.

See Section 6.2.2 to reassemble the "A" drive.

## 6.1.6 Disk Drive "B" Disassembly

---

**NOTE**

*The A drive has an 8 pin 150 OHM Terminator resistor pack. "B" DRIVE DOES NOT.*

---

- 6.1.6.1 Disassemble the Osborne-1 following the instructions in Sections 6.1.1 and 6.1.2.
- 6.1.6.2 Position the Chassis assembly Logic-Board-side-up and handle facing away from Technician.
- 6.1.6.3 Remove four 6/32 Phillips screws securing the "B" Drive to the Chassis assembly.

---

**NOTE**

*Disk Drive B is the Drive furthest from the Power Supply.*

---

- 6.1.6.4 With the wires still connected, pivot the shielded Drive horizontally to the left 90 degrees from its original position.
- 6.1.6.5 Remove two 6/32 Phillips screws which hold the shield to the Drive. These screws are located on the left and right sides of the Drive.
- 6.1.6.6 Hold the Drive shield down and lift the Drive enough to access the rear of the Drive.
- 6.1.6.7 Remove the disk harness connector and the ground connector from drive. The disk harness connector is at the rear of the Drive PC board. The slip-on Ground connector is located at the rear of the Drive either on the Drive frame or shield.

---

**NOTE**

*The Disk Drive harness is not keyed. Facing the back of the Drive with strobe wheel side up, the harness is always connected RED STRIPE to the RIGHT.*

---

- 6.1.6.7 Remove Drive from shield.

See Section 6.2.1 to reassemble the "B" drive.

### **6.1.7 Power Panel Disassembly**

- 6.1.7.1 Disconnect computer from power source.
- 6.1.7.2 Disassemble the Osborne 1 following the instructions in Section 6.1.1.
- 6.1.7.3 Position the AC power panel with connections facing technician, circuit breaker assembly in lower left corner.
- 6.1.7.4 Disconnect the five-wire DC harness ground from the *upper* power panel connector to the right of the switch assembly.
- 6.1.7.5 Detach the power harness AC output connector from the *upper right* connection on the switch assembly.
- 6.1.7.6 Disconnect the power harness thermal cutout lead from the rightmost connection on the circuit breaker assembly.

See Section 6.2.0 to reassemble the power panel.

## 6.2.0 POWER PANEL ASSEMBLY

- 6.2.0.1 See Figures 6-5 and 6-6 to identify the various DC harness connectors.

---

### NOTE

*If the DC harness matches Figure 6-5, refer to Section 6.8.0 for power panel assembly.*

---

- 6.2.0.2 Position the AC power panel with connectors facing technician, circuit breaker assembly in lower left corner.
- 6.2.0.3 Connect the power harness thermal cutout lead to the rightmost connection on the circuit breaker assembly.
- 6.2.0.4 Connect the power harness AC output lead to the *upper right* connection on the switch assembly.
- 6.2.0.5 Connect the five-wire DC harness ground to the *upper* power panel connection at the right of the switch assembly.
- 6.2.0.6 Reassemble the Osborne 1 following the instructions in Section 6.2.6.

## 6.2.1 Disk Drive "B" Assembly

---

### NOTE

*The A drive has an 8 pin 150 OHM Terminator resistor pack. "B" DRIVE DOES NOT.*

---

- 6.2.1.1 Place Drive in shield with PC board facing down.
- 6.2.1.2 Position the Chassis assembly Logic-Board-side-up and handle facing away from Technician.



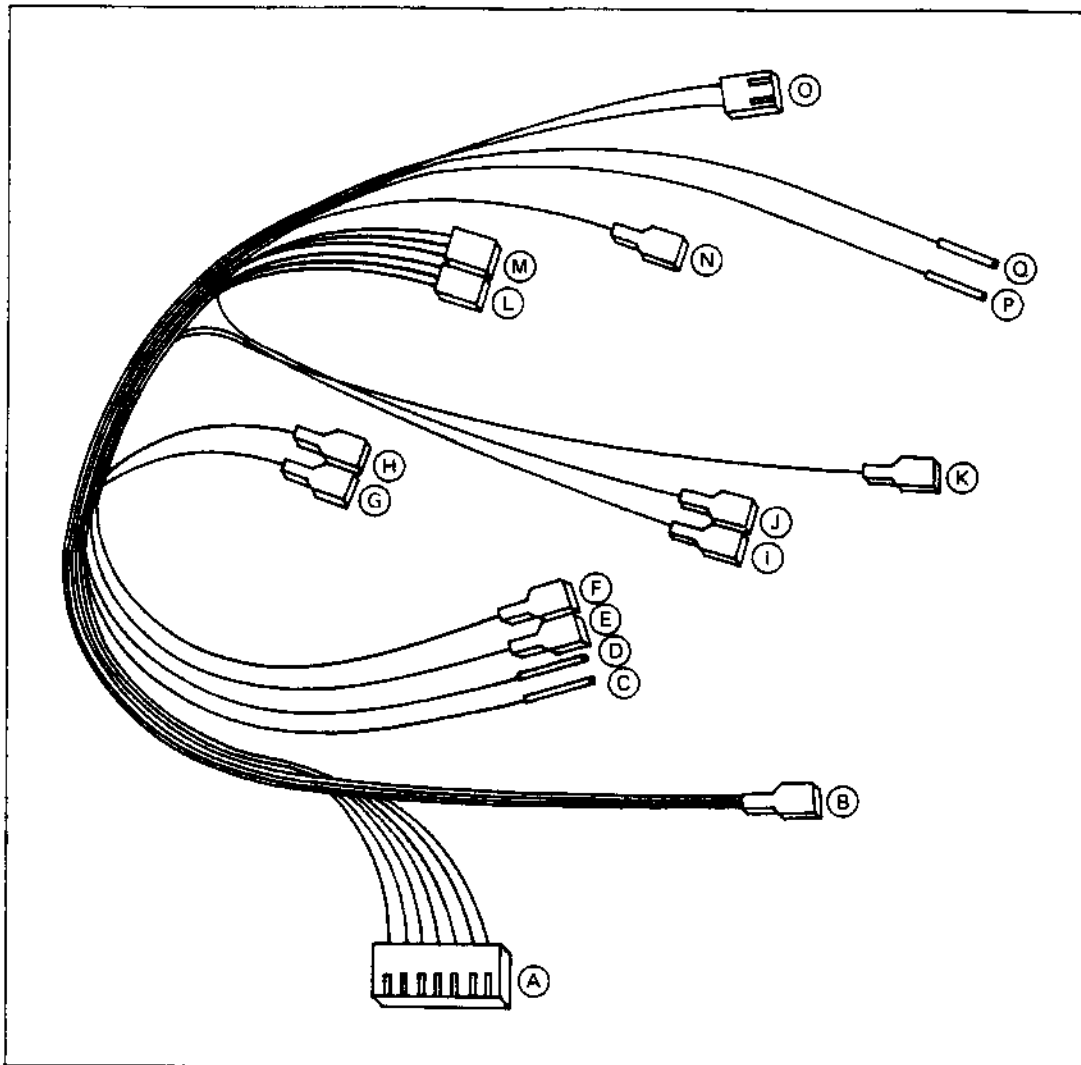

- |             |  |             |  |
|-------------|--|-------------|--|
| (A)         | Logic Board DC Input                                     | (K)         | "A" Drive Ground   |
| (B)         | AC Power Panel Ground (5 wire)                           | (L) and (M) | Interchangeable DC Output Connectors from Power Supply       |
| (C) and (D) | Interchangeable 115V and 230V Pin Connectors to AC Panel | (N)         | DC Power Supply Ground                                       |
| (E) and (F) | Power Panel AC Outputs                                   | (O)         | AC Input Connector   |
| (G)         | "B" Drive Ground   | (P) and (Q) | Interchangeable 115V and 230V Pin Connectors to Power Supply |
| (H)         | Video Monitor Ground                                     |             |  |
| (I) and (J) | Interchangeable Thermal Cutout Connectors                |             |  |

**FIGURE 6-5. DC POWER HARNESS**

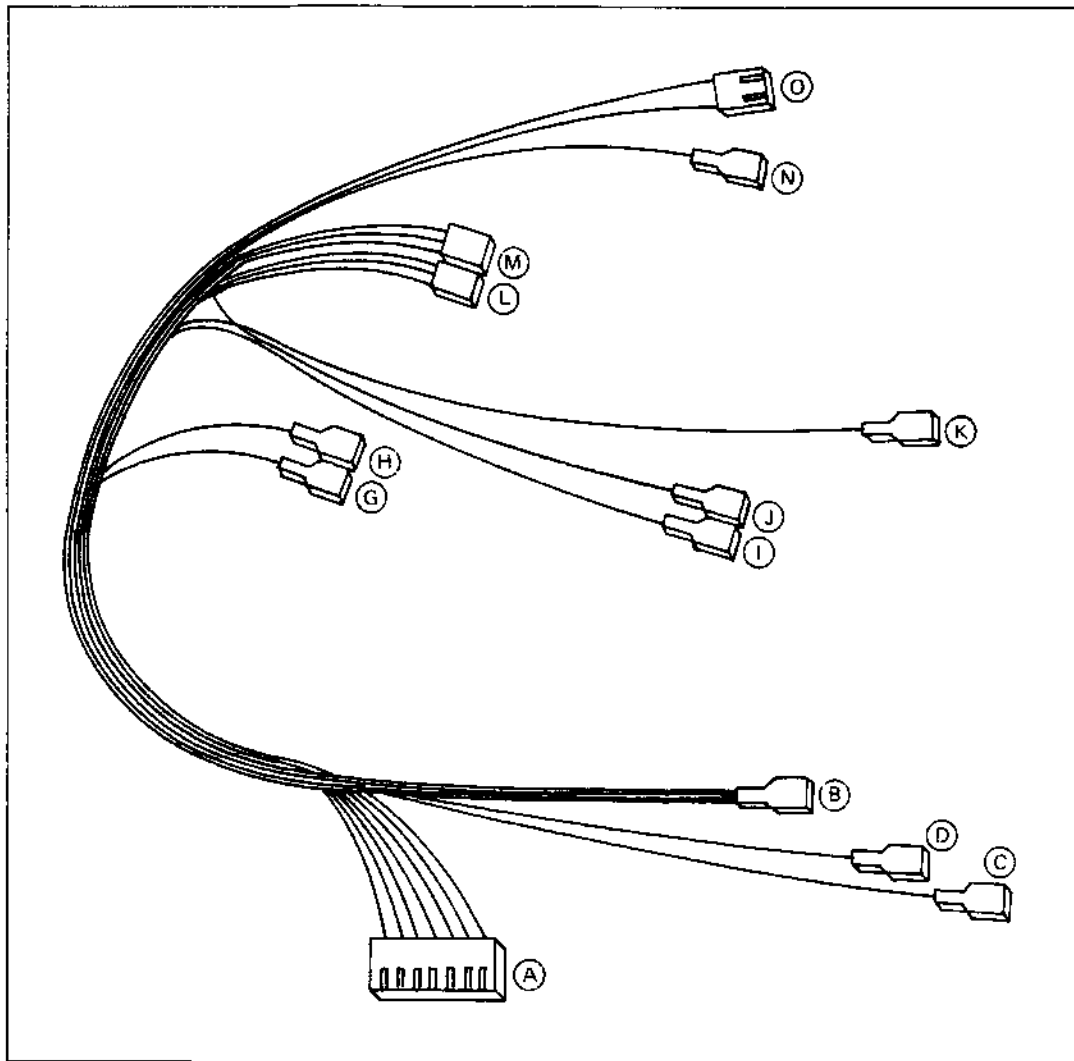

- |     |                                 |             |  |
|-----|---------------------------------|-------------|--|
| (A) | Logic Board DC Input            | (I) and (J) | Thermal Cutout Connectors                              |
| (B) | AC Power Panel Ground (5 Wires) | (L) and (M) | Interchangeable DC Output Connectors from Power Supply |
| (C) | Fuse Box Connector              | (K)         | "A" Drive Ground                                       |
| (D) | Switch Assembly AC Output       | (N)         | DC Power Supply Ground                                 |
| (G) | "B" Drive Ground                | (O)         | AC Input Connector                                     |
| (H) | Video Monitor Ground            |             |  |

**FIGURE 6-6. DC POWER HARNESS**

---

**NOTE**

*Disk Drive B is the Drive furthest from the Power Supply.*

---

- 6.2.1.3 Place shielded Drive to the left of Chassis assembly, strobe wheel facing up, Drive door facing away from Chassis.
- 6.2.1.4 Hold the Drive shield down and move the Drive enough to access the rear of the Drive.
- 6.2.1.5 Pull the narrow Logic Board connector on the end of the Drive harness up through the rectangular slot on the rear of the Drive shield. RED STRIPE on the harness edge is furthest away from Technician.
- 6.2.1.6 Connect the broad Drive connector located mid-way down Drive harness to the rear of the Drive PC board. RED STRIPE on the harness edge is furthest from Technician.
- 6.2.1.7 Connect the slip-on ground connector to the ground tab at the rear of the drive either on the drive frame or shield.
- 6.2.1.8 Align Drive with screw holes in the Drive shield. Install one 6/32 Phillips screw with star washer in each side of the Drive.
- 6.2.1.9 Slide Drive under Chassis assembly with Drive door facing Technician. Install four 6/32 Phillips screws to secure the "B" Drive to the Chassis.

## **6.2.2 Disk Drive "A" Assembly**

---

**NOTE**

*The "A" Drive has an 8 OHM Terminator resistor pack. "B" DRIVE DOES NOT. To locate the Terminator, position the Drive with the door facing Technician and PC board on top. The Terminator is at position RN3 in the right rear corner of the PC board. Pin 1 is the pin closest to Technician.*

---

- 6.2.2.1 Install Terminator resistor pack at position RN3 of PC board.
- 6.2.2.2 Place Drive in shield with PC board facing down.
- 6.2.2.3 Position the Chassis assembly Logic-Board-side-up and handle facing away from Technician.

---

**NOTE**

*Disk Drive A is the Drive closest to the Power Supply.*

---

- 6.2.2.4 Place shielded Drive to the right of Chassis assembly, strobe wheel facing up, Drive door facing away from Chassis.
- 6.2.2.5 Hold the Drive shield down and move the Drive enough to access the rear of the Drive.

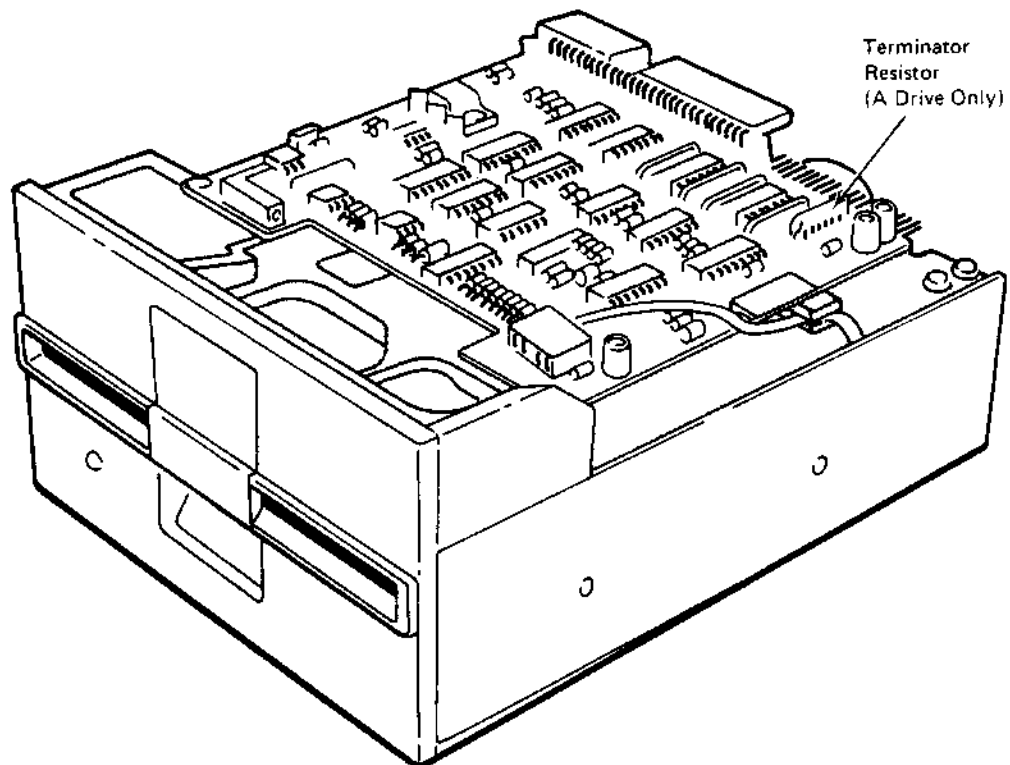

**FIGURE 6-7. DISK DRIVE A**

- 6.2.2.6 Insert the broad Drive connector on the end of the Drive harness through the rectangular slot at the rear of the Drive shield. Connect the Drive connector to the rear of the PC board, RED STRIPE on harness edge closest to Technician.
- 6.2.2.7 Connect the narrow slip-on ground connector to the ground tab at the rear of the drive either on the drive frame or shield.
- 6.2.2.8 Align Drive with screw holes in the Drive shield. Install one 6/32 Phillips screw with star washer in each side of the Drive.
- 6.2.2.9 Slide Drive under Chassis assembly with Drive door facing Technician. Install four 6/32 Phillips screws to secure the "A" Drive to the Chassis.

### 6.2.3 Power Supply Assembly

**CAUTION:** Working with Power Supplies is DANGEROUS. Power Supplies can hold an electrical charge for long periods of time. Be careful not to touch any components unnecessarily!

---

#### NOTE

*Power Supply procedures are with DC harness installed in Chassis.*

---

- 6.2.3.1 Position the Chassis assembly Logic-Board-side-up and handle facing Technician.
- 6.2.3.2 Turn the Power Supply so the components face Technician and five large capacitors are in the lower left corner.

---

#### NOTE

*If the DC harness matches Figure 6-5, refer to Section 6.8.3 for power supply assembly.*

---

- 6.2.3.3 Attach the AC input connector to the keyed connection left of the fuse on the Power Supply. (See Figures 6-5 and 6-6 for DC harness key.)
- 6.2.3.4 Attach the slip-on ground wire connector to the ground connection in the upper left corner of the power supply.
- 6.2.3.5 Attach the keyed DC output connector to one of the three identical male connections on the left side of the Power Supply.
- 6.2.3.6 With the wires attached, turn the Power Supply over right-to-left so the DC connector is to the right. Carefully insert the Power Supply into Chassis.
- 6.2.3.7 Align the screw holes on the Power Supply PC board with the Chassis assembly standoffs.
- 6.2.3.8 Install a 6/32 Phillips screw and washer in each corner of the Power Supply. Use a metal star washer in the upper right corner. Use nylon washers in the other three corners.

---

**NOTE**

*Be sure there is a 1 in. length of double-backed tape covering the "Y" pattern on the soldered-side of the Power Supply.*

---

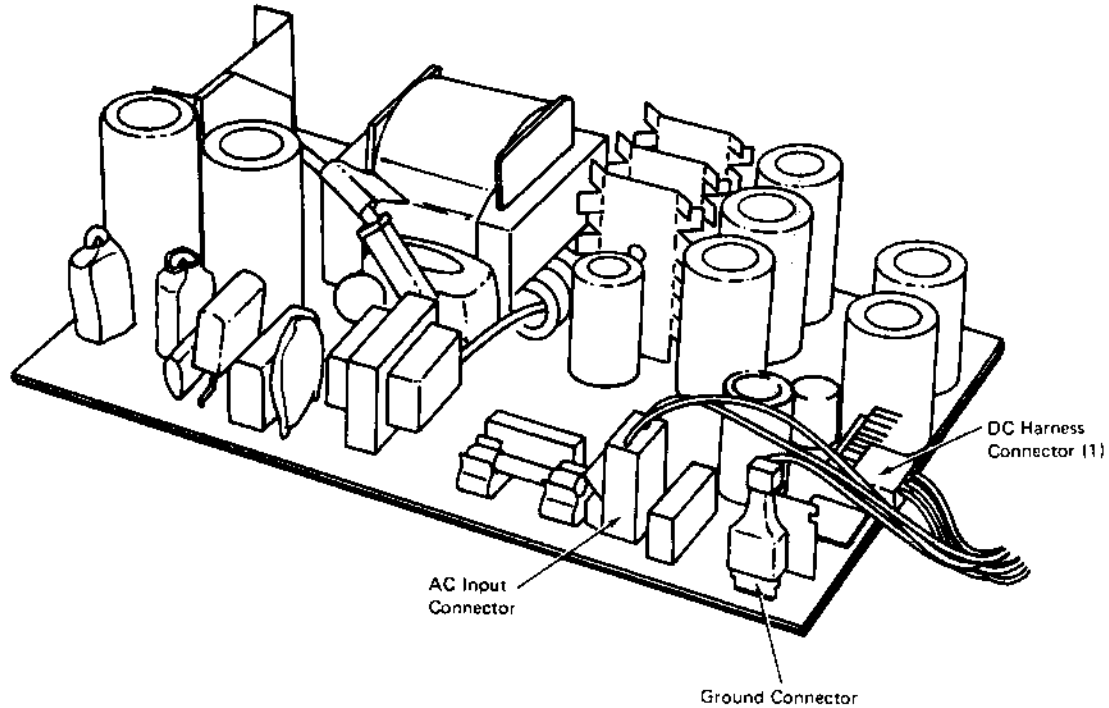

**FIGURE 6-8. POWER SUPPLY**

## **6.2.4 Video Monitor Assembly**

- 6.2.4.1 Position the Chassis assembly vertically with handle on work bench and Drive shields facing Technician.
- 6.2.4.2 If the Video harness has been removed, insert the small end-connector of the harness through the left rear slot of the Video shield from the inside.
- 6.2.4.3 Place the Video Monitor in front of Chassis assembly, CRT screen facing Technician and keyed PC board connection at top rear.
- 6.2.4.4 Connect the keyed large end-connector of the Video harness to the rear of the Monitor PC board.
- 6.2.4.5 Grasp the left and right sides of the Chassis assembly. Lift the Chassis and carefully lower it onto the Video Monitor.
- 6.2.4.6 Align the Monitor with the four screw holes in the Chassis. Install four 6/32 Phillips screws to secure the Monitor to the Chassis.

## **6.2.5 Logic Board Assembly**

- 6.2.5.1 Position the Chassis assembly Logic-Board-side-up and CRT screen facing Technician.
- 6.2.5.2 Hold the Logic Board perpendicular to the chassis, component-side facing Technician, video control shafts pointing straight up.
- 6.2.5.3 Connect the External Video plug to the connection on the edge of the Logic Board between the reset button and video contrast shaft.
- 6.2.5.4 With the Video harness running below the Logic Board, attach the Video harness connector to the 10 Pin connection on the Logic Board between reset button and contrast shaft, RED WIRE TO THE LEFT.
- 6.2.5.5 With the DC harness running below the Logic Board, attach the DC harness connector to the 7 Pin connection in the extreme left lower corner of the Logic Board, RED WIRE TO THE LEFT.

- 6.2.5.6 With the Disk harness running below the Logic Board, attach the Disk harness connector to the 34 Pin connection at the lower left of the Logic Board to the right of the DC harness, RED STRIPE TO THE RIGHT.
- 6.2.5.7 Lower the Logic Board onto its Chassis mounting blocks.
- 6.2.5.8 Install a 6/32 Phillips screw with star washer at each corner of the Logic Board. The screw in the right front corner of some older Logic Boards has a nylon insulation washer to protect the trace.

## 6.2.6 Bezel and Chassis Assembly

- 6.2.6.1 Position the Chassis assembly with Disk Drives on top, CRT screen facing Technician.
- 6.2.6.2 Place the case behind Chassis assembly, AC power panel recess to the rear right.
- 6.2.6.3 Pull Power cord through case until DC harness is taut or AC power panel is at case recess.
- 6.2.6.4 Grasp the Chassis assembly between the CRT and the Logic Board. Lift the assembly slightly and push it straight back into case. Be sure the AC Power panel is positioned correctly in its case recess.

---

### NOTE

*When installing Chassis into case be sure not to pinch, trap or rip harness assemblies.*

---

- 6.2.6.5 Install either two or four 8/32 x 1/2 inch Phillips screws on the left and right inside front edges of the Chassis to secure it to the case.
- 6.2.6.6 Keeping the Osborne flat on its rubber feet, turn it so the A/C Power Panel faces technician.
- 6.2.6.7 Install six 6/32 Phillips screws to secure the A/C Power Panel to the case.



---

**NOTE**

*The two upper screws MUST be 6/32 x 1/4 inch with washers. These were labelled FOR A/C POWER PANEL in Section 6.1.1.9. An incorrect upper screw may puncture the Drive harness.*

---

- 6.2.6.8 Install a 6/32 x 1/4 inch Phillips screw above and below the handle. These screws were labelled FOR HANDLE in Section 6.1.1.8. Using an incorrect screw may puncture the Disk harness behind the handle assembly.
- 6.2.6.9 Keeping the Osborne flat on its rubber feet, turn it so the CRT screen faces Technician.
- 6.2.6.10 Grasping Bezel with thumbs below CRT screen cutout and fingers in the Disk storage pockets, slide Bezel completely into case. Be sure keyboard connector latches are in closed position.
- 6.2.6.11 Install the 6/32 Phillips screws surrounding the Bezel to secure it to the case.
- 6.2.6.12 Using a 1/20 inch Allen wrench, install the brightness and contrast knobs onto their shafts.
- 6.2.6.13 With the Keyboard assembly in front of the Osborne, connect the Keyboard cable to the Keyboard connector below the CRT screen.

## **6.2.7 Keyboard Assembly**

- 6.2.7.1 Place the Keyboard Bezel onto a Pad or Soft material (to protect the Keyboard), standoffs facing up.
- 6.2.7.2 Align the Keyswitch array face down with cutouts on Keyboard Bezel.
- 6.2.7.3 Install four 8/32 Phillips screws to secure the keyboard to the bezel standoffs.

- 6.2.7.4 Locate the notch on the long edge of the Keyboard Bezel furthest from the "space" bar. There should be a 1 1/2-2 inch length of double-backed tape on the underside of the Bezel at this notch. Affix tape if necessary.
- 6.2.7.5 Check that there is also a 1 1/2 - 2 inch length of double-backed tape near the Keyboard connector on the underside of the Keyboard. Affix tape if necessary.
- 6.2.7.6 Connect Pin 1 (black stripe) on the Keyboard harness to Pin 1 of the Keyboard connector on the underside of the Keyboard.

---

**NOTE**

*To locate Pin 1 of the Keyboard connector, position the Keyboard with the numeric row of keys to the top. Facing the underside of the Keyboard, Pin 1 is in the upper right corner of the Keyboard connector. On the Keyboard Harness, Pin 1 is identified by a black stripe.*

---

- 6.2.7.7 Position the Keyboard harness in the notch on the long edge of the Keyboard Bezel and press it flat against both lengths of tape.
- 6.2.7.8 Lower the Keyboard case onto the Keyboard and Keyboard Bezel assembly so the Case and Bezel are flush.
- 6.2.7.9 Install a 6/32 Phillips screw at each latch end of the Keyboard case to secure it to the Keyboard assembly.
- 6.2.7.10 Turn Keyboard face up and connect the Keyboard cable to the Keyboard connector below the CRT screen.

## 6.3.0 SIEMENS DISK DRIVE ALIGNMENTS

---

### NOTE

*Before starting the alignment always make a visual inspection of the disk drive and PCB. Check for missing or broken connectors, faulty solder connections, and incorrect components.*

---

- 6.3.0.1 The Osborne Alignment Program diskette or similar device is needed to step the drive head between tracks during alignments. See Section 6.5.0.
- 6.3.0.2 Drive alignments are sensitive to temperature and humidity. Drives and testing media should be stabilized at room temperature before alignments are made.

### 6.3.1 Drive Cable and Test Lead Hookup

- 6.3.1.1 Position Drive unit with PC board on top and door facing Technician.
- 6.3.1.2 Check the P4-1, P4-2, and P4-3 connectors at the P2 connection on the rear of the PCB. The black wire on the P4-1 connector should be attached to the first pin on the right of P2. There should be FOUR PINS between the P4-1 and P4-2 connectors. The brown wire on the P4-2 connector should be second from the right. The yellow wire on the P4-3 connector should be to the right. (See Figure 6-9.)
- 6.3.1.3 Connect the drive cable to the P1 connection in the right rear corner of the PC board. The red stripe on the drive cable must be to technician's right. (See Figure 6-9.)

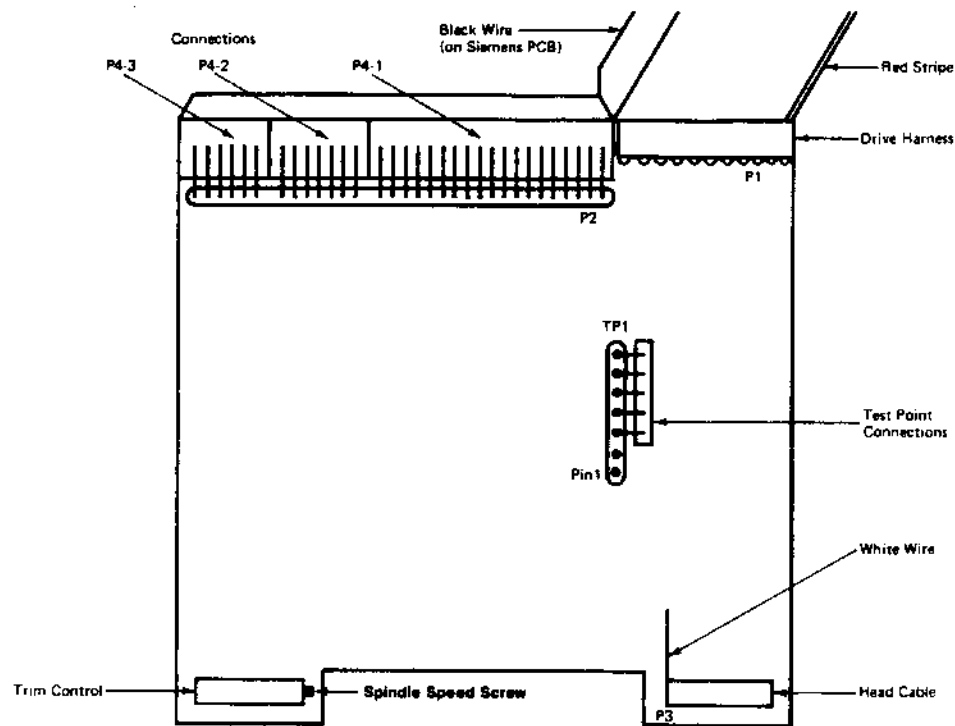

FIGURE 6-9. DISK DRIVE PCB

### 6.3.2 Spindle Speed Adjustment

Using the Drive Alignment Program:

- 6.3.2.1 Follow instructions 6.3.1.1 through 6.3.1.3 to connect the drive.
- 6.3.2.2 Insert an Alignment Program diskette into the drive.
- 6.3.2.3 Locate the trim control at position R23 on the drive PC board. (See Figure 6-9.) The small gold screw on the trim control is the spindle speed adjustment screw.
- 6.3.2.4 Boot the drive and select the DRIVE TIMER function on the Drive Alignment Program. (See Section 6.5.0.)
- 6.3.2.5 Note the time indicated in milliseconds by the DRIVE TIMER test. Correct time per revolution is 200 milliseconds  $\pm 5\%$ .
- 6.3.2.6 Slowly turn the spindle speed adjustment screw until timing is within tolerance.

To adjust spindle speed *without* the Drive Alignment Program:

- 6.3.2.7 Follow instructions 6.3.1.1 through 6.3.1.3 to connect the drive.
- 6.3.2.8 Insert a blank diskette into the drive.
- 6.3.2.9 Turn the drive unit so strobe wheel faces Technician. The strobe wheel has a black and white pattern as shown in Figure 6-12. The following adjustment must be made under fluorescent lighting. With 50 cycle lighting, use the inner strobe wheel pattern.
- 6.3.2.10 Power up the drive and step to track 16.
- 6.3.2.11 Locate the trim control at position R23 on the PC board. (See Figure 6-9.) The small gold screw on the trim control is the spindle speed adjustment screw.
- 6.3.2.12 Watch the strobe wheel and slowly turn the spindle speed screw until the strobe effect stops.
- 6.3.2.13 Watch the strobe wheel and turn the spindle speed screw in or out until any one strobe line rotates *clockwise* 90 degrees in a five-second interval.

### **6.3.3 Track 00/39 Stop Adjustment**

- 6.3.3.1 Follow instructions 6.3.1.1 through 6.3.1.3 to connect drive.
- 6.3.3.2 Remove the Head Cable Connector from position P-3 on the Drive PCB. (See Figure 6-9.) Leave all other connectors attached.
- 6.3.3.3 Remove four 4/40 × 0.25 Phillips screws holding drive PCB to drive frame.
- 6.3.3.4 Lift front of drive PCB enough to access the stop adjustment screws. (See Figure 6-10.)
- 6.3.3.5 Select the SEEK TRACK function on the Drive Alignment Program.
- 6.3.3.6 Adjust track 00 stop until clearance between track 00 stop and post on frame is  $0.010 \pm .005$  in.

- 6.3.3.7 Step to track 39 and verify the clearance between track 39 stop and post on frame.
- 6.3.3.8 Place drive PCB on frame.
- 6.3.3.9 Install four 4/40 × 0.25 Phillips screws to secure the PCB to the drive frame.
- 6.3.3.10 Attach the Head Cable Connector to position P-3 on PCB. (See Figure 6-9.)

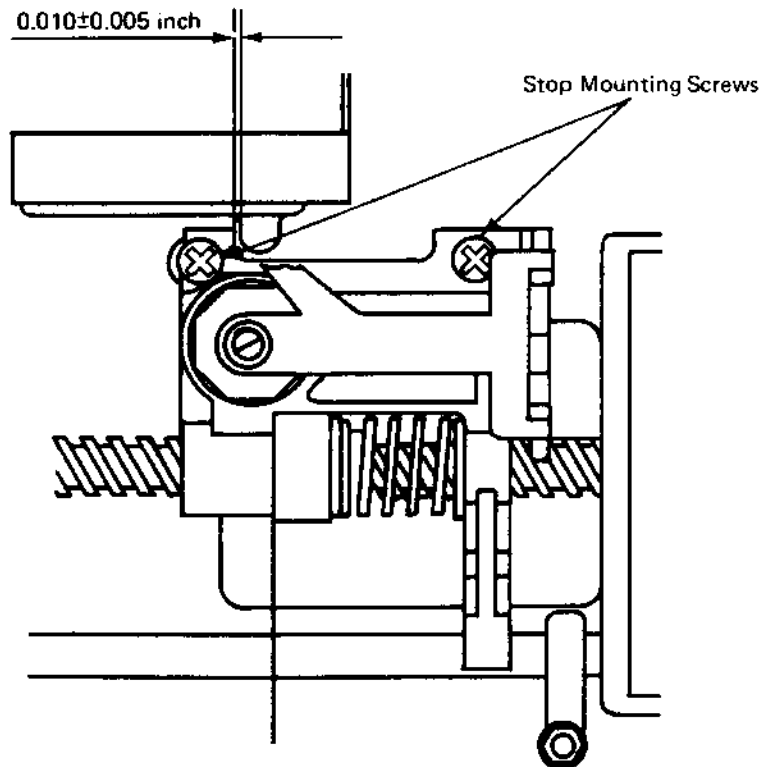

**FIGURE 6-10. TRACK 00/39 STOP ADJUSTMENT**

### 6.3.4 Track 00 Switch Adjustment

- 6.3.4.1 Check the P4-1, P4-2, and P4-3 connectors at the P2 connection on the rear of the drive PC board. See Figure 6-9 for connector order.
- 6.3.4.2 Connect the drive cable to the P1 connection in the right rear corner of the PC board. The red stripe on the drive cable must be to technician's right. (See Figure 6-9.)

**CAUTION:** Be careful not to short circuit the drive PC board when making the following connections and adjustments

- 6.3.4.3 Ground the oscilloscope test probe to pin 6 of the TP1 connection on the drive PC board. Pin 2 of this connection is missing.
- 6.3.4.4 Connect oscilloscope channel A to pin 4 and channel B to pin 8 of the TP1 connection.
- 6.3.4.5 Set the oscilloscope as follows:

Channel B - 1V/div (approximately 1V output)  
Channel A - 5V/div ( " 5V " )

Trigger A - internal source, positive slope, normal mode

Time base - 5 milliseconds/division

Chopped vertical mode, both channels displayed.

- 6.3.4.6 Insert and boot an Alignment Program diskette in the drive. (Type DISK after the A> on the screen, then press RETURN).
- 6.3.4.7 Select the ALT TRACK function on the Drive Alignment program.
- 6.3.4.8 Alternate the drive head between tracks 0 and 1.
- 6.3.4.9 Observe the square-wave signal on the oscilloscope for these tolerances:  
Channel A: positive portion:  $20 \pm 5$  milliseconds  
negative portion:  $30 \pm 5$  milliseconds
- 6.3.4.10 Switch oscilloscope to line trigger, then alternate the head between tracks 1 and 2. No signal should be displayed on the oscilloscope.

- 6.3.4.11 If the drive does not satisfy test conditions 6.3.4.9 and 6.3.4.10, loosen the track 00 switch mounting screws on the underside of the drive. (See Figure 6-11.)
- 6.3.4.12 Change to internal trigger. Alternate the head between tracks 0 and 1 and slide the track 00 switch until signal is within tolerance.
- 6.3.4.13 Switch oscilloscope to line trigger, then alternate between tracks 1 and 2 to confirm "no signal".
- 6.3.4.14 Change to internal trigger and alternate between tracks 0 and 1 to verify channel A signal.
- 6.3.4.15 Tighten mounting bracket screws on track 00 switch being careful not to move the switch.

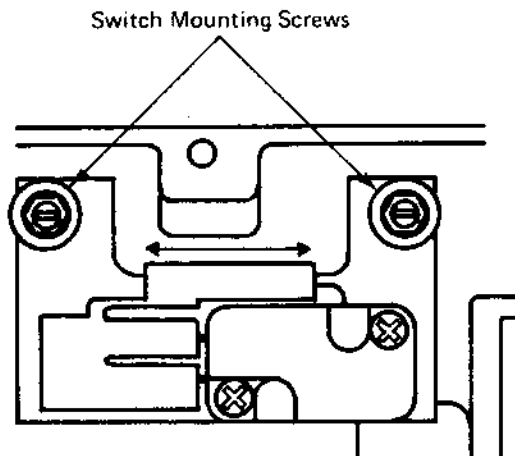

**FIGURE 6-11. TRACK 00 SWITCH ADJUSTMENT**



### **6.3.5 Index Sensor Timing Adjustment**

- 6.3.5.1 Follow steps 6.3.1.1 through 6.3.1.3 to connect disk drive.
- 6.3.5.2 Ground the oscilloscope to pin 6 of the TP1 connection on the drive PC board. Pin 2 of this connection is missing.
- 6.3.5.3 Connect oscilloscope channel A to pin 8 and channel B to pin 5 of the TP1 connection. Set channel B to internal trigger.
- 6.3.5.4 Insert an Alignment Program Diskette and power up the drive.
- 6.3.5.5 Set oscilloscope inputs to A/C, vertical deflection to 500 millivolts and timing base to 50 microseconds. (Settings may vary with oscilloscope.)
- 6.3.5.6 Select the SEEK TRACK function on the Drive Alignment Program and step to track 1.
- 6.3.5.7 Observe timing between start of sweep and first Data Pulse on Oscilloscope. (See Figure 6-13.) Timing should be  $200 \pm 50$  microseconds. If timing is not within tolerance, continue adjustment.
- 6.3.5.8 Loosen the mounting screw in the Index sensor mounting block on the underside of disk drive. (See Figure 6-12.)
- 6.3.5.9 Observe timing and adjust the index sensor until timing is  $200 \pm 50$  microseconds.
- 6.3.5.10 Open and close drive door. Then recheck timing. Repeat several times.
- 6.3.5.11 Slowly tighten mounting screw. Do Not Overtighten.
- 6.3.5.12 Recheck timing to ensure index sensor did not move when mounting screw was tightened.

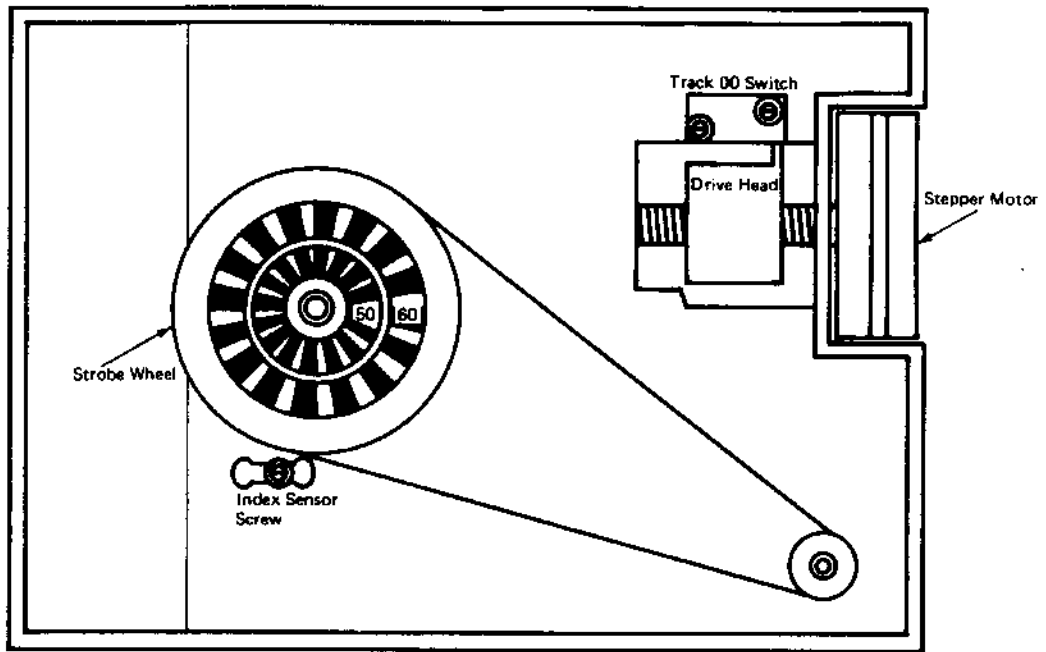

FIGURE 6-12. SIEMENS DISK DRIVE

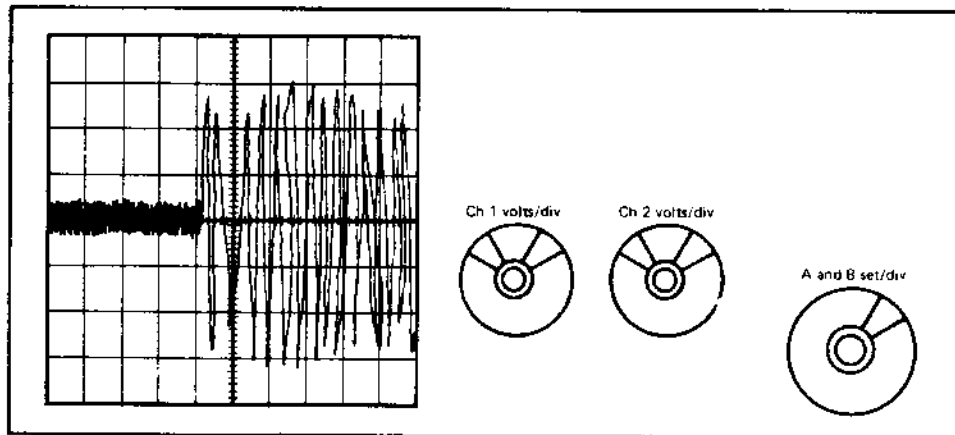
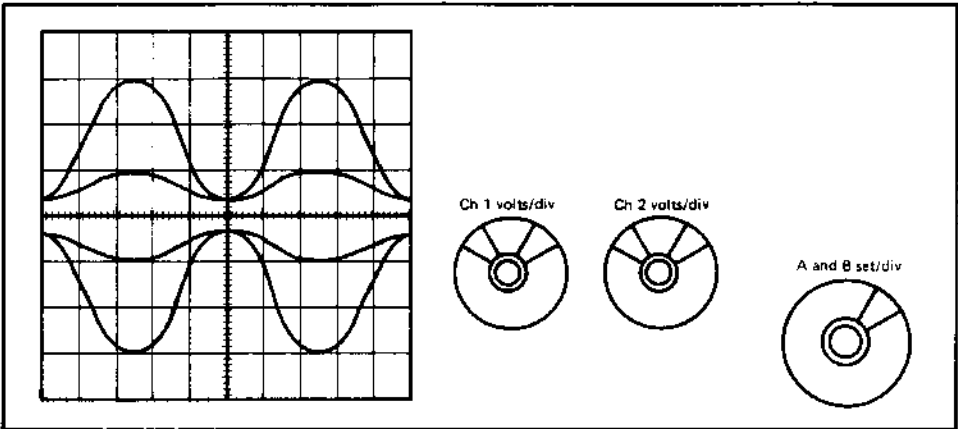

FIGURE 6-13. OSCILLOSCOPE PATTERN FOR INDEX SENSOR TIMING

### **6.3.6 Radial Head Alignment**

- 6.3.6.1 Follow steps 6.3.1.1 through 6.3.1.3 to connect Drive.
- 6.3.6.2 Ground the Oscilloscope to pin 6 of the TP1 connection on the drive PC board. Pin 2 of this connection is missing.
- 6.3.6.3 Connect Oscilloscope channel A to pin 8 and channel B to pin 5 of the TP1 connection. Set channel B to internal trigger.
- 6.3.6.4 Insert an Alignment Program Diskette and power up the drive.
- 6.3.6.5 Set Oscilloscope inputs to A/C, Vertical deflection to 100 millivolts, Time base to 20 milliseconds, channels A and B added.
- 6.3.6.6 Select the SEEK TRACK function on the Drive Alignment Program and step to track 16.
- 6.3.6.7 Loosen two 3/32 Allen screws holding Stepper Motor to rear of Drive frame.
- 6.3.6.8 Rotate Stepper Motor to move head radially in and out while observing Cat Eye pattern on Oscilloscope. (See Figure 6-14.) Adjust until Cat Eye Lobes are equal.
- 6.3.6.9 Tighten both stepper motor mounting screws being careful not to move motor.
- 6.3.6.10 Check adjustment by stepping off several tracks in each direction from track 16 and returning to it. Readjust if necessary until the Cat Eye lobes have the same shape and amplitude.
- 6.3.6.11 After completing radial head alignment, check the Track 00 switch and Track 00/39 stop. Readjust as necessary. (See Sections 6.3.3 and 6.3.4.)



**FIGURE 6-14. OSCILLOSCOPE CAT-EYE PATTERN FOR RADIAL HEAD ADJUSTMENT**

## 6.4.0 MPI DISK DRIVE ALIGNMENTS

---

### NOTE

*Before starting the alignment always make a visual inspection of the disk drive and PCB. Check for missing or broken connectors, faulty solder connections, and incorrect components.*

---

- 6.4.0.1 The Osborne Alignment Program diskette or similar device is needed to step the drive head between tracks during alignments. See Section 6.5.0.
- 6.4.0.2 Drive alignments are sensitive to temperature and humidity. Drives and testing media should be stabilized at room temperature before alignments are made.

### 6.4.1 Drive Cable and Test Lead Hookup (MPI)

- 6.4.1.1 Position Drive unit with PC board on top and door facing Technician.
- 6.4.1.2 Check the P4-1, P4-2, and P4-3 connectors at the P2 connection on the rear of the PCB. See Figure 6-15 for connector order.
- 6.4.1.3 Connect the drive cable to the P1 connection in the right rear corner of the PC board. The red stripe on the drive cable must be to technician's right. (See Figure 6-15.)

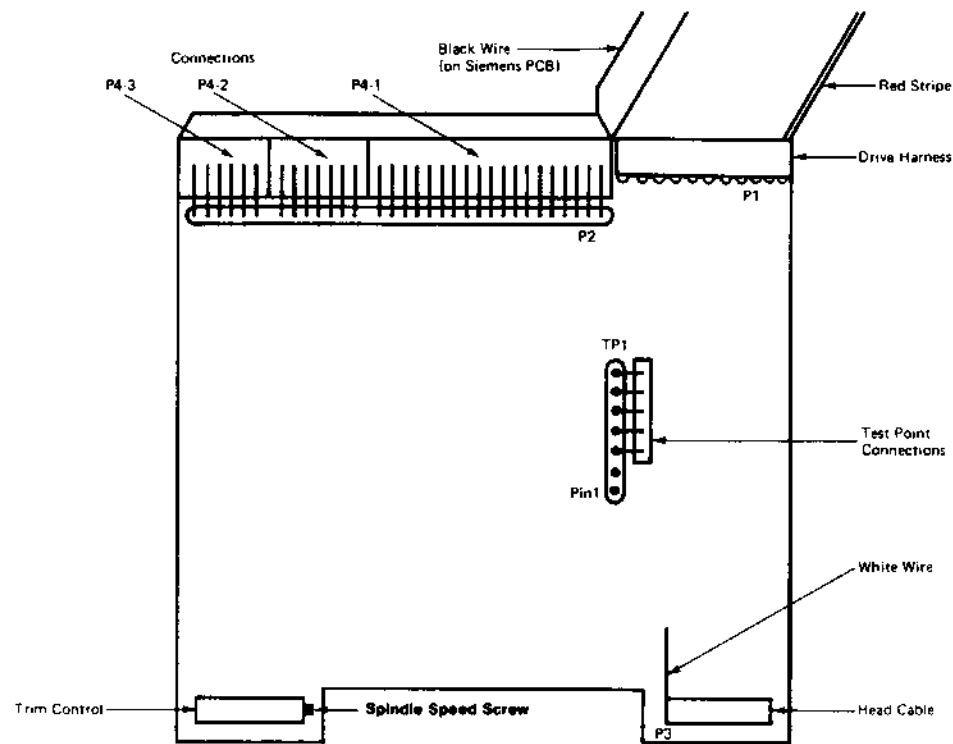

**FIGURE 6-15. DISK DRIVE PCB**

## 6.4.2 Spindle Speed Adjustment (MPI)

Using the Drive Alignment Program:

- 6.4.2.1 Follow instructions 6.4.1.1 through 6.4.1.3 to connect the drive.
- 6.4.2.2 Insert an Alignment Program diskette into the drive.
- 6.4.2.3 Locate the trim control at position R23 on the drive PC board. (See Figure 6-15.) The small gold screw on the trim control is the spindle speed adjustment screw.
- 6.4.2.4 Boot the drive and select the DRIVE TIMER function on the Drive Alignment Program. (See Section 6.5.0.)
- 6.4.2.5 Note the time indicated in milliseconds by the DRIVE TIMER test. Correct time per revolution is 200 milliseconds  $\pm$  5%.
- 6.4.2.6 Slowly turn the spindle speed adjustment screw until timing is within tolerance.

To adjust spindle speed *without* the Drive Alignment Program:

- 6.4.2.7 Follow instructions 6.4.1.1 through 6.4.1.3 to connect the drive.
- 6.4.2.8 Insert a blank diskette into the drive.
- 6.4.2.9 Turn the drive unit so strobe wheel faces Technician. The strobe wheel has a black and white pattern as shown in Figure 6-16. The following adjustment must be made under fluorescent lighting. With 50 cycle lighting, use the inner strobe wheel pattern.
- 6.4.2.10 Power up the drive and step to track 16.
- 6.4.2.11 Locate the trim control at position R23 on the PC board. (See Figure 6-15.) The small gold screw on the trim control is the spindle speed adjustment screw.
- 6.4.2.12 Watch the strobe wheel and slowly turn the spindle speed screw until the strobe effect stops.
- 6.4.2.13 Watch the strobe wheel and turn the spindle speed screw in or out until any one strobe line rotates *clockwise* 90 degrees in a five-second interval.

### **6.4.3 Radial Track Alignment (MPI)**

- 6.4.3.1 Follow instructions 6.4.1.1 through 6.4.1.3 to connect the drive.
- 6.4.3.2 Ground the oscilloscope to pin 6 of the TP1 connection on the drive PC board. Pin 2 of this connection is missing.
- 6.4.3.3 Connect oscilloscope channel A to pin 8 and channel B to pin 5 of the TP1 connection. Set channel B to internal trigger.
- 6.4.3.4 Insert an Alignment Program Diskette and power up the drive.
- 6.4.3.5 Set oscilloscope inputs to AC, vertical deflection to 100 millivolts, time base to 20 milliseconds, channels A and B added.
- 6.4.3.6 Select the SEEK TRACK function on the Drive Alignment Program and step to track 16.
- 6.4.3.7 With the drive on its side and strobe wheel facing Technician, loosen both stepper motor mounting screws on the underside of the drive. (See Figure 6-16.)
- 6.4.3.8 Rotate the stepper motor until the lobes of the cat-eye pattern on the oscilloscope are equal. (See Figure 6-17.)
- 6.4.3.9 Tighten both stepper motor mounting screws being careful not to move the motor.
- 6.4.3.10 Check alignment by stepping off several tracks in both directions from track 16 and then returning to it. Readjust if necessary.

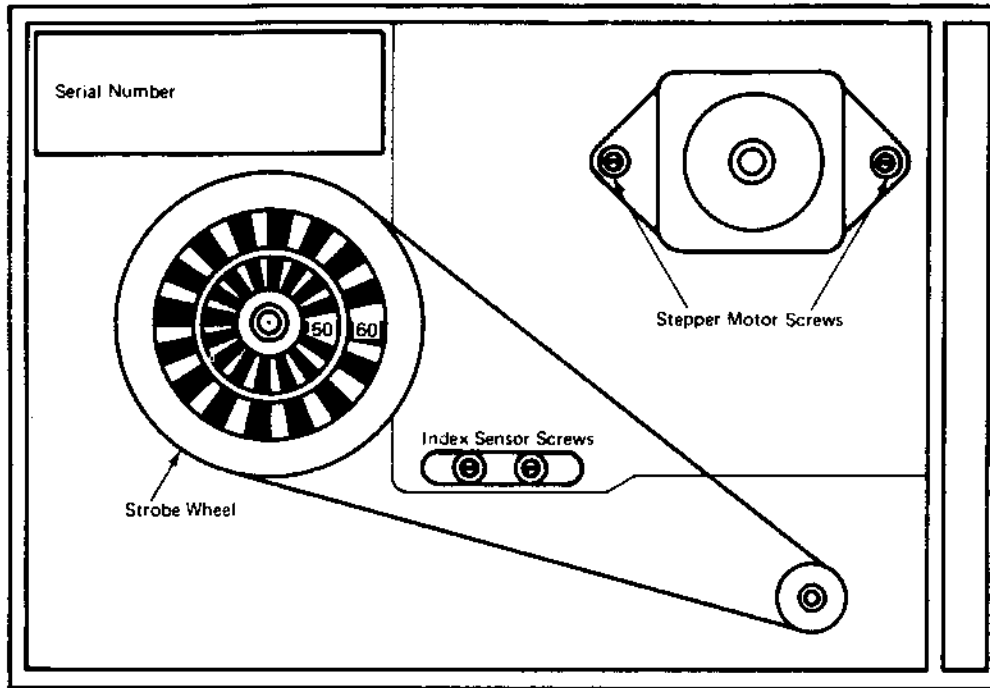

FIGURE 6-16. MPI DISK DRIVE

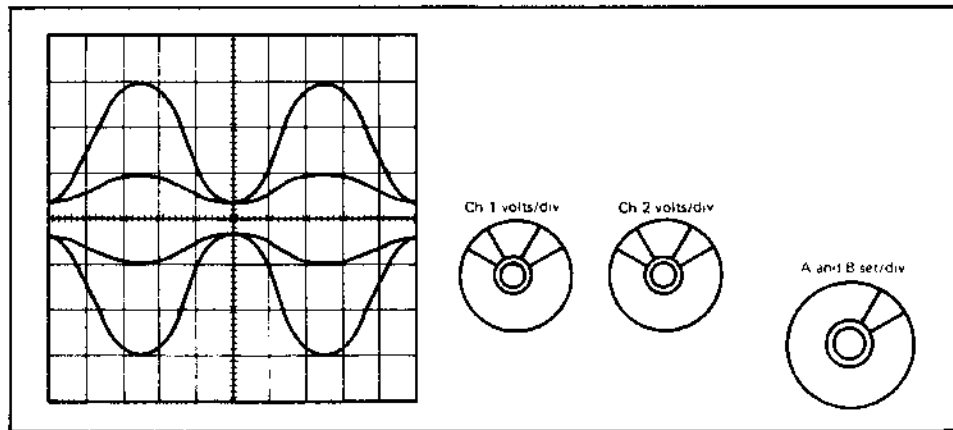

FIGURE 6-17. OSCILLOSCOPE CAT-EYE PATTERN FOR RADIAL HEAD ADJUSTMENT



## 6.4.4 Index Sensor Adjustment (MPI)

---

### NOTE

*Before making this adjustment be sure the Radial track alignment is correct. See Section 6.4.3.*

---

- 6.4.4.1 Follow instructions 6.4.1.1 through 6.4.1.3 to connect the Drive.
- 6.4.4.2 Ground the oscilloscope to pin 6 of the TP1 connection on the drive PC board. Pin 2 of this connection is missing.
- 6.4.4.3 Connect oscilloscope channel A to pin 8 and channel B to pin 5 of the TP1 connection. Set channel B to internal trigger.
- 6.4.4.4 Insert an Alignment Program Diskette and power up the drive.
- 6.4.4.5 Select the SEEK TRACK function on the Drive Alignment Program and step to track 1.
- 6.4.4.6 Set oscilloscope inputs to A/C, vertical deflection to 500 millivolts, time base to 50 microseconds. (Settings may vary with Oscilloscope.)
- 6.4.4.7 Observe timing between start of sweep and first data burst on oscilloscope. (See Figure 6-13.) Timing should be  $200 \pm 50$  microseconds. If timing is not within tolerance, continue adjustment.
- 6.4.4.8 Loosen two index sensor mounting screws located in the slot on the underside of the Disk Drive. (See Figure 6-16.)
- 6.4.4.9 Observe timing and adjust the index sensor until timing is  $200 \pm 50$  microseconds.
- 6.4.4.10 Open and close the Drive door. Then recheck timing. Repeat several times.
- 6.4.4.11 Slowly tighten the mounting screws, being careful not to move the index sensor. **DO NOT OVERTIGHTEN.**
- 6.4.4.12 Recheck timing to ensure index sensor did not move when mounting screws were tightened.

### 6.4.5 Track 00 Sensor Adjustment (MPI)

---

#### NOTE

*Before making this adjustment be sure the Radial track alignment is correct. See Section 6.4.3*

---

- 6.4.5.1 Check the P4-1, P4-2, and P4-3 connectors at the P2 connection on the rear of the drive PC board. See Figure 6-15 for connector order.
- 6.4.5.2 Connect the drive cable to the P1 connection in the right rear corner of the PC board. The red stripe on the drive cable must be to technician's right.

**CAUTION:** Be careful not to short circuit the drive PC board when making the following connections and adjustments.

- 6.4.5.3 Ground the oscilloscope test probe to pin 6 of the TP1 connection on the drive PC board. Pin 2 of this connection is missing.
- 6.4.5.4 Connect oscilloscope channel A to pin 4 and channel B to pin 8 of the TP1 connection.
- 6.4.5.5 Set the oscilloscope as follows:
  - Channel B - 1V/div (approximately 1V output)
  - Channel A - 5V/div ( " " 5V " )
  - Trigger A - internal source, positive slope, normal mode
  - Time base - 5 milliseconds/division
  - Chopped vertical mode, both channels displayed.
- 6.4.5.6 Insert and boot an Alignment Program diskette in the drive. (Type DISK after the A> on the screen, then press RETURN).
- 6.4.5.7 Select the ALT TRACK function on the Drive Alignment Program.
- 6.4.5.8 Alternate the drive head between tracks 0 and 1.

- 6.4.5.9 Observe the square-wave signal on the oscilloscope for these tolerances:  
Channel A: positive portion:  $20 \pm 5$  milliseconds  
negative portion:  $30 \pm 5$  milliseconds
- 6.4.5.10 Switch oscilloscope to line trigger, then alternate the head between tracks 1 and 2. No signal should be displayed on the oscilloscope.
- 6.4.5.11 If the drive does not satisfy test conditions 6.4.5.9 and 6.4.5.10, remove two 4/40 x 0.25 Phillips screws holding the drive PC board to the drive frame.
- 6.4.5.12 Lift the PC board enough to access the track 00 sensor mounting screws at the rear left of the drive. (See Figure 6-18.)

---

**NOTE**

*Be sure to reconnect the head cable to the PC board after detaching it to lift the board.*

---

- 6.4.5.13 Loosen both mounting screws.
- 6.4.5.14 Change to internal trigger. Alternate the head between tracks 0 and 1 and slide the sensor until signal is within tolerance.
- 6.4.5.15 Switch oscilloscope to line trigger, then alternate between tracks 1 and 2 to confirm "no signal".
- 6.4.5.16 Change to internal trigger and alternate between tracks 0 and 1 to verify channel A signal.
- 6.4.5.17 Tighten both track 00 sensor mounting screws being careful not to move the sensor.
- 6.4.5.18 Replace drive PC board onto drive frame and install two 4/40 x 0.25 Phillips screws to secure it. Be sure the head cable connector is attached to the PC board.

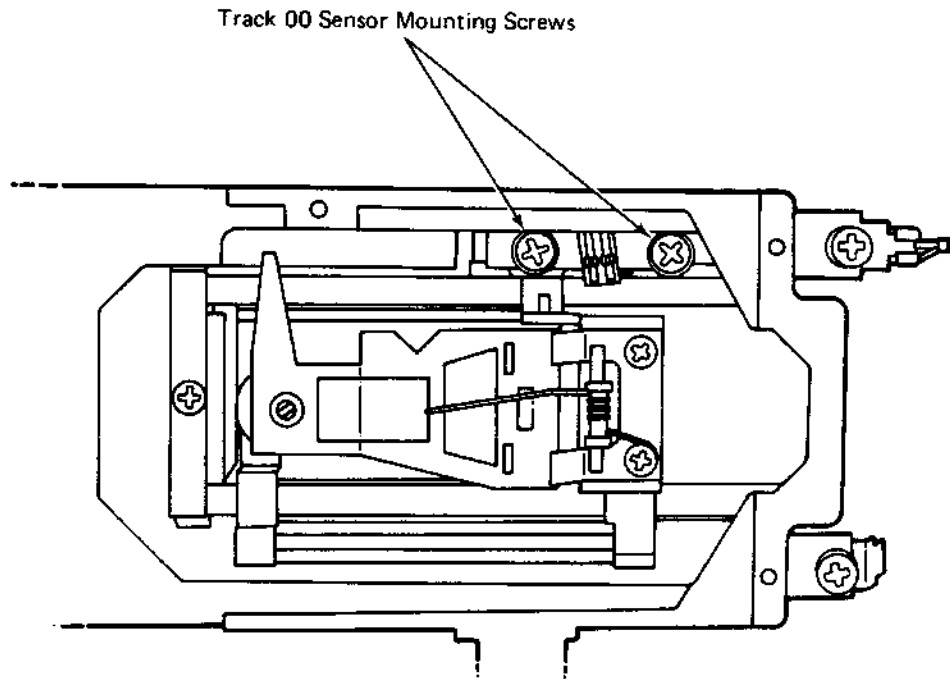

**FIGURE 6-18. TRACK 00 ASSEMBLY (MPI)**

## 6.5.0 OSBORNE DISK DRIVE ALIGNMENT PROGRAM

- 6.5.0.1 With this Program you can perform all drive head movements needed for disk alignments. Use the following instructions to become familiar with this program before making alignments.
- 6.5.0.2 Before proceeding, make a **copy** of the master diskette. Use the **copy** to make alignments. Store the master diskette in a safe place.
- 6.5.1 Insert "Osborne Alignment Program" Diskette in Drive A, press Reset button, then press RETURN to boot system.
- 6.5.2 Type DISK after the A> on the CRT screen, then press RETURN.
- 6.5.2.1 The CRT screen will now display:

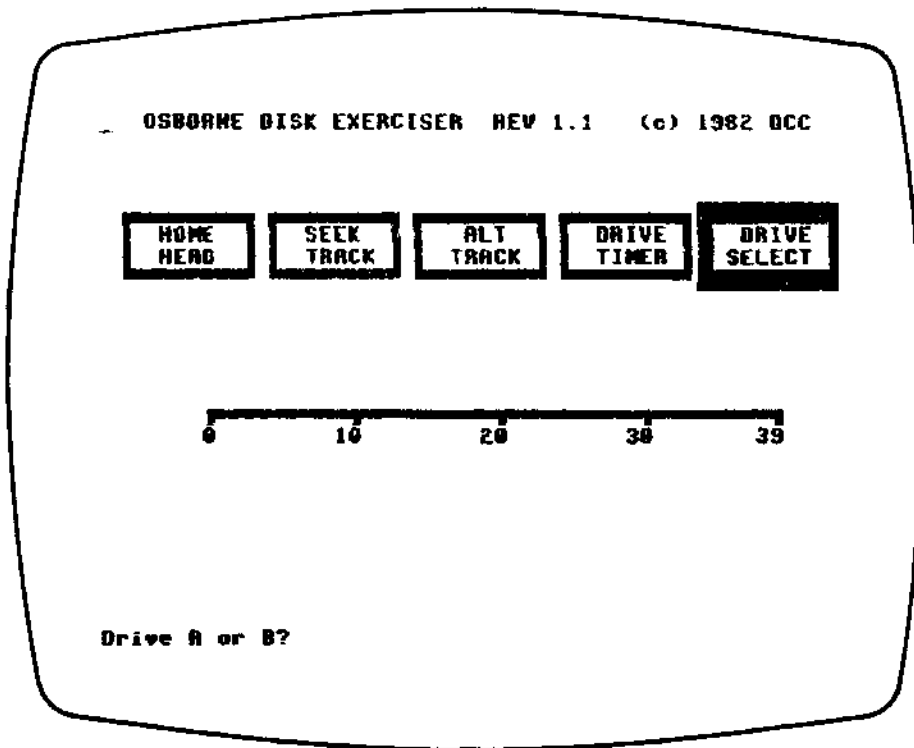
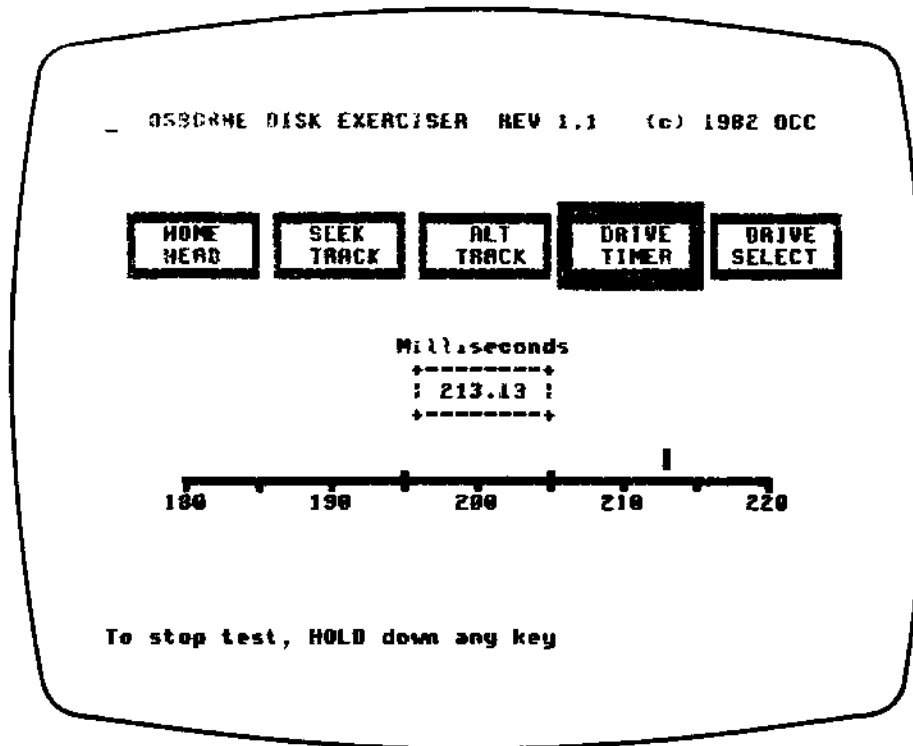

FIGURE 6-19. VIDEO MONITOR SCREEN

- 6.5.2.2 This display means that the Program is loaded in memory and waiting for your response. Each box on the screen indicates a test function which you can select. These tests are:
1. HOME HEAD
  2. SEEK TRACK
  3. ALT TRACK
  4. DRIVE TIMER
  5. DRIVE SELECT
- 6.5.2.3 Notice that the DRIVE SELECT box has a thicker border than the others. This is a moveable border which identifies the test function you select.
- 6.5.2.4 Below the function boxes is a line running from 0 to 39. This line identifies each of the 40 tracks at which the disk drive head may be positioned.
- 6.5.2.5 The message "Drive A or B?" appears at the lower left of the screen. This asks which Drive you wish to select as the test Drive.
- 6.5.3 Press A or B to select the Drive you wish to test first. If you also wish to test the other Drive, you must repeat the test procedure for it after completing testing on your first selection.
- 6.5.4 After you select the Drive to be tested, note these changes on the display:
1. An indicator block is now positioned over the 0 point on the line marked from 0 to 39. This indicates that the drive head is positioned over track 0.
  2. The selected Drive is identified directly below the 0 point on the display line.
  3. The track position is also identified directly below point 39 on the display line.
  4. The message at the bottom of the screen reads: For Menu Pick, Use Left/Right Arrows, Then Hit Return
- 6.5.5 Press the arrow key to select DRIVE TIMER.
- 6.5.6 Press RETURN to initiate action.
- 6.5.7 The menu has now changed to one of two displays depending on whether there was a diskette in the Drive selected. The displays are explained in steps 6.5.8 and 6.5.9.



- 6.5.8. If there was a diskette in the Drive selected (step 6.5.3), the display will appear as follows:
- 6.5.8.1 This display indicates that you are testing the Drive spindle speed. The speed is shown in two ways:
1. In the "Milliseconds" box on the screen;
  2. By an indicator positioned above the line marked from 180 to 220.
- 6.5.8.2 The correct time per revolution on either the Siemens or MPI Drives used in the Osborne is 200 milliseconds  $\pm$  5%.
- 6.5.9 If there was no diskette in the Drive selected in step 6.5.3 you will hear a "Beep" sound. The screen display will be the same as in step 6.5.8 *except* that:
1. The "Milliseconds" box will be blank;
  2. There will be no indicator positioned above the line marked from 180 to 220.
  3. The message at the bottom of the screen reads: Put Diskette in Drive, press any key to start timer.

- 6.5.9.1 If you wish to terminate this test, press CTRL. This will display the test function you had selected.
- 6.5.10 To terminate *any* test in progress, press any key and hold it down until the system responds.
- 6.5.10.1 If you terminate a test, the system responds by displaying the menu in step 6.5.2, which allows you to again select a test function.
- 6.5.11 Press the left arrow key to select the SEEK TRACK test function.
- 6.5.12 Press RETURN.
- 6.5.13 Select the track where you wish to position the drive head by entering any number from 0 to 39. For example, type 39.
- 6.5.14 Press RETURN. The drive head is now positioned over track 39 and the displayed indicator is over point 39 on the line marked from 0 to 39.
- 6.5.15 Press RETURN again to seek to another track in this test function. You can also select another test function by continuing as follows.
- 6.5.16 Press RETURN
- 6.5.17 Press the right arrow key to select ALT TRACKS, for example.
- 6.5.18 Press RETURN. Note that two messages are displayed: "This Test Will Recycle the Disk Head Between the Current Track and a New Track" and "Enter New Track Number (0-39)."
- 6.5.19 Type 0 and press RETURN. The drive head is now alternately seeking track 0 and track 39.
- 6.5.20 Press RETURN to terminate the test. Note that the drive head is now positioned over track 0 or the track number entered in step 6.5.19.
- 6.5.21 Press RETURN.
- 6.5.22 Type 1, then press RETURN. The drive head is now alternately seeking track 0 and track 1.
- 6.5.23 Press RETURN to terminate this test function.



## OSBORNE FIELD SERVICE MANUAL

- 6.5.24 Press the arrow key to select SEEK TRACK, then press RETURN.
- 6.5.25 Type 10, then press RETURN. The drive head is now positioned over track 10.
- 6.5.26 Press the arrow key to select HOME HEAD, then press RETURN. The drive head is now homed (positioned) over track 0.
- 6.5.27 Press CTRL C to exit from the program.

You have now performed all the functions of the Disk Drive Alignment Program.

## 6.6.0 VIDEO MONITOR ADJUSTMENTS

- 6.6.0.1 The Osborne Alignment Program diskette is needed for video monitor adjustments.

### PRECAUTIONS

Note the following precautions before making any adjustments to the Video Monitor.

1. Allow five minutes warm-up before starting any adjustments.
2. Use a NON-METALLIC tool to make adjustments.
3. Use EXTREME CARE when handling the Video Monitor. Rough handling may cause it to implode.
4. Some Video Monitor components carry high voltage (transformer etc.). USE EXTREME CAUTION.

---

### NOTE

*All Video Monitor alignments are made with Video assembly out of Chassis and connector attached. Before removing front bezel **lightly** trace its outline on the video screen shield with a felt-tip pen.*

---

### 6.6.1 Brightness/Contrast Adjustment

- 6.6.1.1 Power up the OCC-1.
- 6.6.1.2 Insert and boot Osborne Alignment Program diskette in either drive. (Type CRT after the A > on the screen, then press RETURN).
- 6.6.1.3 Rotate contrast control, R-48 on Logic Board, counterclockwise to minimum.
- 6.6.1.4 Rotate brightness control, R108 on monitor PC board, counterclockwise to minimum.
- 6.6.1.5 Rotate brightness control, R47 on Logic Board, clockwise to maximum.
- 6.6.1.6 Rotate R108 to raster threshold.
- 6.6.1.7 Rotate R48 control for desired video contrast.
- 6.6.1.8 Rotate R47 control for desired video brightness.

## 6.6.2 Vertical Size/Linearity Adjustment

- 6.6.2.1 Power up the OCC-1.
- 6.6.2.2 Insert and boot Osborne Alignment Program diskette in either drive.
- 6.6.2.3 Rotate vertical size control, R208 on Monitor PC Board, until desired display size is obtained.
- 6.6.2.4 See Figure 6-19. Adjust the vertical linearity control, R211 on Monitor PC board, until the extreme top and bottom characters ("A" and "B" in Figure 6-19) are the same height as the center characters ("C").
- 6.6.2.5 Readjust R208 until desired display size is obtained.

## 6.6.3 Focus Adjustment

- 6.6.3.1 Power up the OCC-1.
- 6.6.3.2 Insert and boot Osborne Alignment Program diskette in either drive.
- 6.6.3.3 Rotate focus control, R315 on Monitor PC board, to obtain best focus at a point near the center of the screen horizontally and 1/3 down from the top.

## 6.6.4 Raster Adjustment

---

### NOTE

*In adjustments 6.6.4.4 through 6.6.4.6 there is a danger of monitor implosion. These adjustments are not recommended and should be made in the field only in the most urgent cases. USE EXTREME CARE.*

---

- 6.6.4.1 Power up the OCC-1.

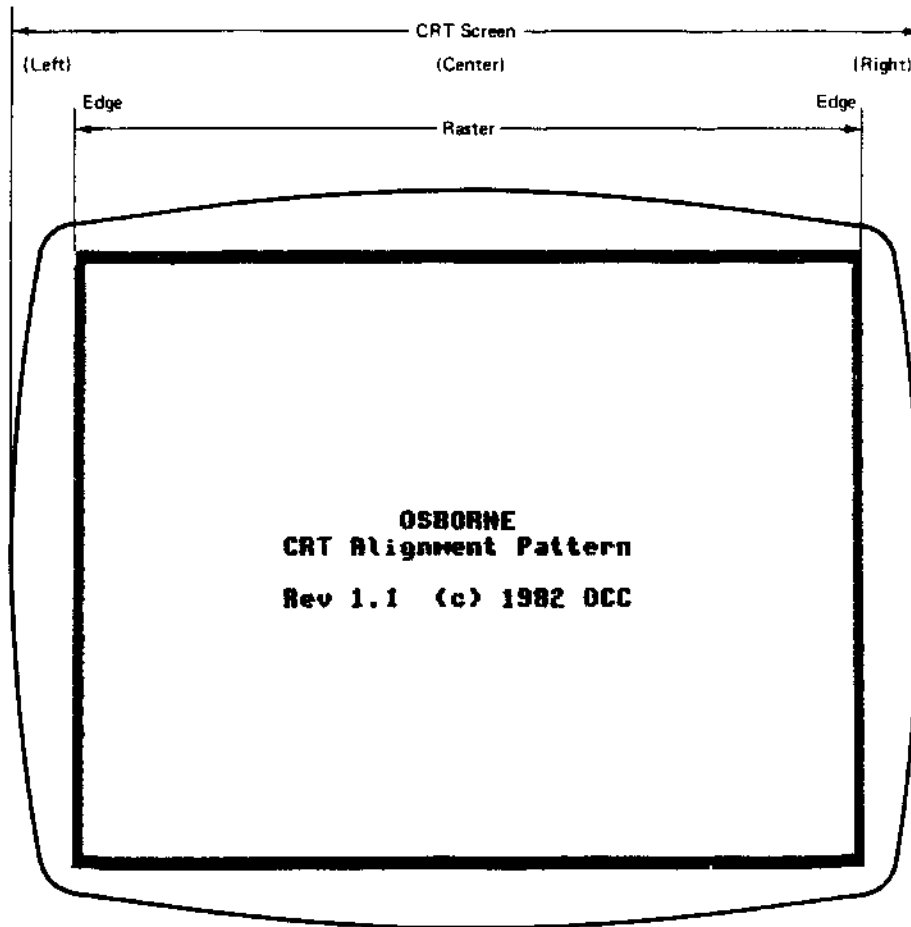

- 6.6.4.2 Insert and boot Osborne Alignment Program diskette in either drive. (Type CRT after the A > on the screen, then press RETURN).
- 6.6.4.3 If the screen display is tilted, read the NOTE above before proceeding. If the tilt adjustment is not being done, proceed to instruction 6.6.4.7.
- 6.6.4.4 Use a hot air gun to loosen the glue around the video monitor yoke.
- 6.6.4.5 Using a broad-end, NON-METALLIC tool, firmly push down on the yoke collar tabs (marked with red and blue dot) until the display is no longer tilted.
- 6.6.4.6 Reapply hot glue around Monitor yoke.
- 6.6.4.7 If the video raster is not centered on the screen (between felt-tip pen lines), move the two ring tabs at the rear of the monitor yoke in opposite directions until raster centers.

## 6.7.0 OSBORNE 1A KEYBOARD DISASSEMBLY

**CAUTION:** Identify connector orientations before detaching any cable.

- 6.7.0.1 Disconnect computer from power source.
- 6.7.0.2 Disconnect the keyboard cable from the front bezel by spreading the latches of the keyboard connector. Note that, facing the CRT screen, the keyboard cable is connected to the unit from the left.
- 6.7.0.3 Using a pad or soft material to protect the keyboard, turn the keyboard case over so the keys face down.
- 6.7.0.4 Remove four 6/32 Phillips screws located on the underside of the keyboard case.
- 6.7.0.5 Lift the keyboard case from the keyboard and keyboard bezel assembly.
- 6.7.0.6 Carefully remove the keyboard harness from the keyboard connector. The thickest wire in the harness is the grounding wire.

---

**NOTE**

*The keyboard harness is aligned with Pin 1 of the keyboard connector. Looking at the underside of the keyboard with the numeric row of keys to the top, Pin 1 is the upper right Pin. Pin 1 may also have an orange dot next to it.*

---

- 6.7.0.7 Remove four 8/32 Phillips screws which secure the keyboard to the bezel standoffs.
- 6.7.0.8 Lift the keyswitch array from the keyboard bezel.

See Section 6.8.7 to reassemble the keyboard.

### 6.7.1 OCC 1A Bezel and Chassis Disassembly

**CAUTION:** The interior of the case is coated with a special metallic paint. Avoid scratching this coating.

- 6.7.1.1 Disconnect computer from power source.
- 6.7.1.2 Disconnect the keyboard cable from the front bezel by spreading the latches on the keyboard connector.
- 6.7.1.3 Remove all external cables (RS-232, modem, external video, etc.).
- 6.7.1.4 Pull the video contrast and brightness knobs off their shafts.
- 6.7.1.5 Remove the 6/32 x 1/4 inch Phillips screws surrounding the bezel.
- 6.7.1.6 Placing thumbs below CRT screen and fingers in the disk storage pockets, apply a slight pressure inward with thumbs to loosen the bezel.
- 6.7.1.7 Grasp the bezel near the carrying-case latches and carefully pull it straight forward until it is free.
- 6.7.1.8 Remove the AC power cord from the power cord compartment.
- 6.7.1.9 Carefully turn the unit over so ventilation slots are on the bottom, video screen facing technician.
- 6.7.1.10 Remove five 6/32 x 3/4-inch Phillips screws holding the two halves of the carrying case together.
- 6.7.1.11 Hold down the carrying handle plate and the power cord compartment and lift the upper half of the case free of the unit.

---

#### NOTE

*The logic board and the power supply unit can be replaced at this point without further disassembly of the chassis. See Sections 6.7.2 and 6.7.4; 6.8.3 and 6.8.5.*

---

To further dismantle the unit, proceed as follows.

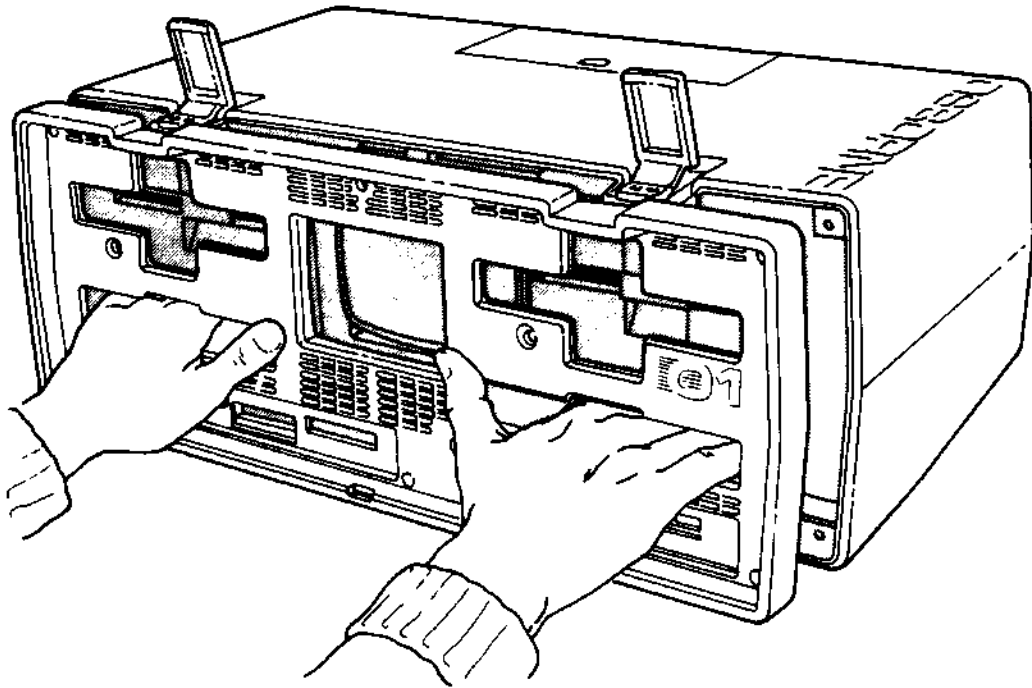

**FIGURE 6-20. BEZEL REMOVAL**

- 6.7.1.12 Slide the carrying handle plate out of the lower part of the case. Note that the broad area of the plate is *below* the handle at this point.
- 6.7.1.13 Lift the power cord compartment slightly and detach the door.
- 6.7.1.14 Place the power cord compartment face down on the logic board.
- 6.7.1.15 Place one hand under the front of the video monitor and the other at the back of the monitor and lift the chassis out of the case. Be sure the AC power cord compartment lifts freely with the chassis.

See Section 6.8.6 to reassemble the bezel and chassis.



## 6.7.2 OCC 1A Logic Board Disassembly

- 6.7.2.1 Disassemble the Osborne 1A following the instructions in Section 6.7.1.
- 6.7.2.2 Position the chassis assembly with logic board facing up and CRT screen facing technician.
- 6.7.2.3 Remove the 6/32 Phillips screw at each corner of the logic board. The screw in the right front corner of some logic boards has a nylon insulation washer.
- 6.7.2.4 Lift the logic board by the front edge and hold it perpendicular to the chassis, video control shafts pointing straight up. Note all connector orientations while still attached. Be sure no cables are snared as you lift the board.
- 6.7.2.5 Remove the DC harness connector and mylar insulator located in the extreme left lower corner of the logic board.
- 6.7.2.6 Remove the disk harness connector located in the lower left corner of the logic board at the right of the DC harness connector. Grip the connector and CAREFULLY detach it, being sure not to bend any pins.

---

### NOTE

*The disk drive harness connector is not keyed. The RED stripe on the harness must go to the right.*

---

- 6.7.2.7 Remove the video harness connector located in the upper left corner of the logic board to the right of the reset button.

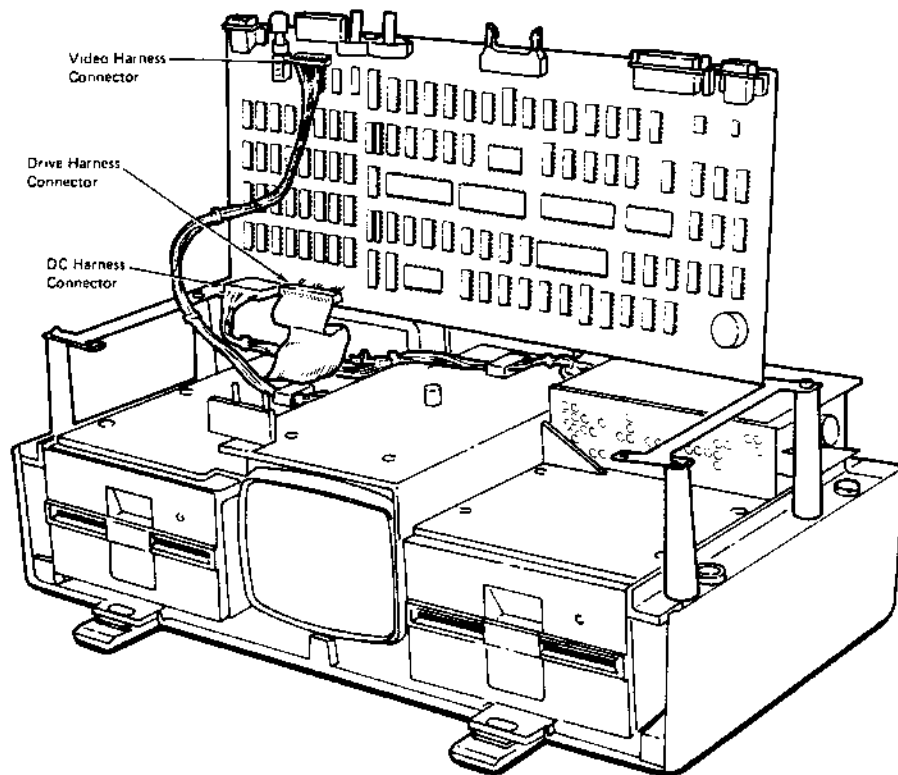

**FIGURE 6-21. LOGIC BOARD REMOVAL**

---

**NOTE**

*The video harness connector is not keyed. The RED wire on the harness must go to the left.*

---

- 6.7.2.8 Remove the external video plug located between the reset button and the contrast control on the front edge of the logic board.
- 6.7.2.9 Remove the logic board from the chassis.

See Section 6.8.5 to reassemble the logic board.

### **6.7.3 OCC 1A Video Monitor Disassembly**

- 6.7.3.1 Disassemble the Osborne 1A following the instructions in Sections 6.7.1 and 6.7.2.
- 6.7.3.2 Position the chassis assembly logic-board-side-up and CRT screen facing technician.
- 6.7.3.3 Slip the video harness cable from its tab on the chassis.
- 6.7.3.4 Disconnect the slip-on ground wire from its connection at the back of the video monitor shield.
- 6.7.3.5 Remove the disk drive harness from the four fasteners holding it to the back of the video shield.
- 6.7.3.6 Remove four 6/32 X 1/4 inch Phillips screws which secure the video monitor to the chassis. Label these screws FOR VIDEO MONITOR and set them aside.

---

#### **NOTE**

*Using an incorrect screw to reattach the video monitor to the chassis may short circuit the video PC board.*

---

- 6.7.3.7 Slide video monitor forward and out of chassis while guiding the monitor cable.
- 6.7.3.8 Remove video monitor from its shield.
- 6.7.3.9 Detach the video harness connector from the top rear of the video PC board. This is a keyed connector.
- 6.7.3.10 Remove the transparent face plate from the monitor screen.

See Section 6.8.4 to reassemble the video monitor.

## 6.7.4 OCC 1A Power Supply Disassembly

**CAUTION:** Working with power supplies is DANGEROUS! Power supply units can hold an electrical charge for long periods of time. Do not touch any components unnecessarily.

- 6.7.4.1 Disassemble the Osborne 1A following the instructions in Sections 6.7.1 and 6.7.2.
- 6.7.4.2 Position the chassis assembly logic-board-side-up and CRT screen facing away from technician.
- 6.7.4.3 Remove two 6/32 Phillips screws and the mylar insulator from the underside of the power supply.
- 6.7.4.4 Remove remaining two 6/32 Phillips screws securing the power supply to the chassis standoffs.

---

### NOTE

*All four power supply screws have metal star washers.*

---

- 6.7.4.5 With wires still attached and clear of their tab on the chassis, carefully lift the power supply out of the chassis.
- 6.7.4.6 Turn the power supply over left-to-right so the components face technician and five large capacitors are in the lower left corner.
- 6.7.4.7 Remove both DC output connectors from the left side of the power supply. These keyed connectors are attached to two of the three identical male connections on the left side of the power supply.
- 6.7.4.8 Remove the ground wire connector from the power supply. This is a slip-on connector located in the upper left corner of the power supply.
- 6.7.4.9 Remove the AC input connector from the power supply. This is a keyed connector located left of the fuse on the upper side of the power supply.
- 6.7.4.10 Remove both interchangeable pin connectors from the 115V and 230V pins on the power supply.

See Section 6.8.3 to reassemble the power supply.

## 6.7.5 OCC 1A Disk Drive "A" Disassembly

---

### NOTE

*The A drive has an 8 pin, 150 ohm, terminator resistor pack. B DRIVE DOES NOT.*

---

- 6.7.5.1 Disassemble the Osborne 1A following the instructions in Sections 6.7.1 and 6.7.2.
- 6.7.5.2 Position the chassis assembly logic-board-side-up and drive door facing technician.
- 6.7.5.3 Remove four 6/32 Phillips screws holding the "A" drive to the chassis assembly.

---

### NOTE

*Disk drive A is the drive closest to the power supply.*

---

- 6.7.5.4 Pivot the shielded drive horizontally to the right 90 degrees from its original position.
- 6.7.5.5 Detach the disk harness connector and the ground connector from the drive. The disk harness connector is at the rear of the drive PC board. The slip-on ground connector is located at the rear of the drive either on the drive frame or shield.
- 6.7.5.6 Remove four 6/32 Phillips screws which hold the shield to the drive. These screws are located on the left and right sides of the drive.
- 6.7.5.7 Remove the drive from its shield.
- 6.7.5.8 If the drive is being replaced with another, remove the 8 Pin terminator resistor from the drive PC board and KEEP IT for installation on the new drive. (See Section 6.8.2.) The terminator resistor is located at position RN3 on the right rear corner of the PC board.

See Section 6.8.2 to reassemble drive "A".

## 6.7.6 OCC 1A Disk Drive "B" Disassembly

---

### NOTE

*The A drive has an 8 pin, 150 ohm terminator resistor pack. B DRIVE DOES NOT.*

---

- 6.7.6.1 Disassemble the Osborne 1A following the instructions in Sections 6.7.1 and 6.7.2.
- 6.7.6.2 Position the chassis assembly logic-board-side-up and drive doors facing technician.
- 6.7.6.3 Remove four 6/32 Phillips screws securing the "B" drive to the chassis assembly.
- 6.7.6.4 Pivot the shielded drive horizontally to the left 90 degrees from its original position.
- 6.7.6.5 Detach the disk harness connector and the ground connector from drive. The disk harness connector is at the rear of the drive PC board. The slip-on ground connector is located at the rear of the drive either on the drive frame or shield.

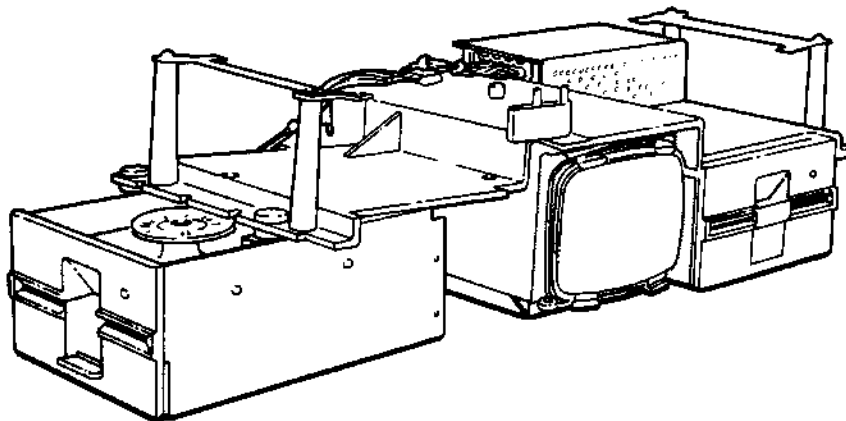

**FIGURE 6-22. "B" DRIVE DISASSEMBLY**

---

**NOTE**

*The disk drive harness is not keyed. Facing the back of the drive, strobe wheel side up, the harness connects RED STRIPE to the RIGHT.*

---

- 6.7.6.6 Remove four 6/32 Phillips screws which hold the shield to the drive. These screws are located on the left and right sides of the drive.
- 6.7.6.7 Remove the drive from its shield.

See Section 6.8.1 to reassemble the "B" drive.

### **6.7.7 OCC 1A Power Panel Disassembly**

- 6.7.7.1 Disassemble the Osborne 1A following the instructions in Sections 6.7.1 and 6.7.2.
- 6.7.7.2 Detach the ground wire to the video monitor shield.
- 6.7.7.3 Detach the ground wire from each disk drive shield.
- 6.7.7.4 Remove the thermal cutout from its clip on the chassis. The AC power panel should now be completely disconnected from the chassis.
- 6.7.7.5 Remove the mylar insulator sheet which covers the back of the power panel. The folded part of this insulator is closest to the power panel connections.
- 6.7.7.6 Remove four 6/32 x 1/4 inch Phillips screws which hold the AC power panel to the power panel compartment.
- 6.7.7.7 Position the AC power panel with connections facing the technician, switch assembly in lower left corner, ground wires in lower right corner.

- 6.7.7.8 Disconnect the five-wire slip-on ground connector from the lower right corner of the power panel.
- 6.7.7.9 Disconnect both interchangeable pin connectors from pins "C" and "D" of the power panel.
- 6.7.7.10 Disconnect both *lower* wires from the switch assembly in the lower left corner of the power panel. Do not disconnect the upper wires.
- 6.7.7.11 Detach the thermal cutout from the wire harness.

See Section 6.8.0 to reassemble the power panel.



## 6.8.0 OCC 1A POWER PANEL ASSEMBLY

- 6.8.0.1 Refer to Figure 6-23 to identify the various DC harness connectors as follows.
- |         |   |
|---------|---|
| A       | Logic board DC input  |
| B       | AC power panel ground (5 wire)  |
| C and D | Interchangeable 115V and 230V pin connectors to AC power panel                                  |
| E and F | Power panel AC outputs. E runs to the keyed AC input connector O. F runs to the thermal cutout. |
| G       | "B" drive ground. G runs to B.  |
| H       | Video monitor ground. H runs to B.  |
| I and J | Interchangeable thermal cutout connectors.  |
| K       | "A" drive ground  |
| L and M | Interchangeable DC output connectors from power supply.   |
| N       | DC power supply ground.   |
| O       | AC input connector.   |
| P and Q | Interchangeable 115V and 230V pin connectors to power supply.                                   |
- 6.8.0.2 Connect two slip-on connectors I and J to the thermal cutout.
- 6.8.0.3 Position the AC power panel with connectors facing technician, switch assembly in lower left corner, and ground wire connection at lower right (See Figure 6-24).
- 6.8.0.4 Connect the five-wire ground cable B to the connector in the lower right corner of the power panel.
- 6.8.0.5 Connect the AC output wires E and F to the lower connectors on the power panel switch assembly. Connect F, which runs to the thermal cutout, to the right of E
- 6.8.0.6 Connect two interchangeable pin connectors C and D to pins "C" and "D" of the power panel.
- 6.8.0.7 Align the power panel with the screw holes on the rear of the power panel compartment. Position the fuse box furthest from the door hinge cutouts on the power panel compartment.

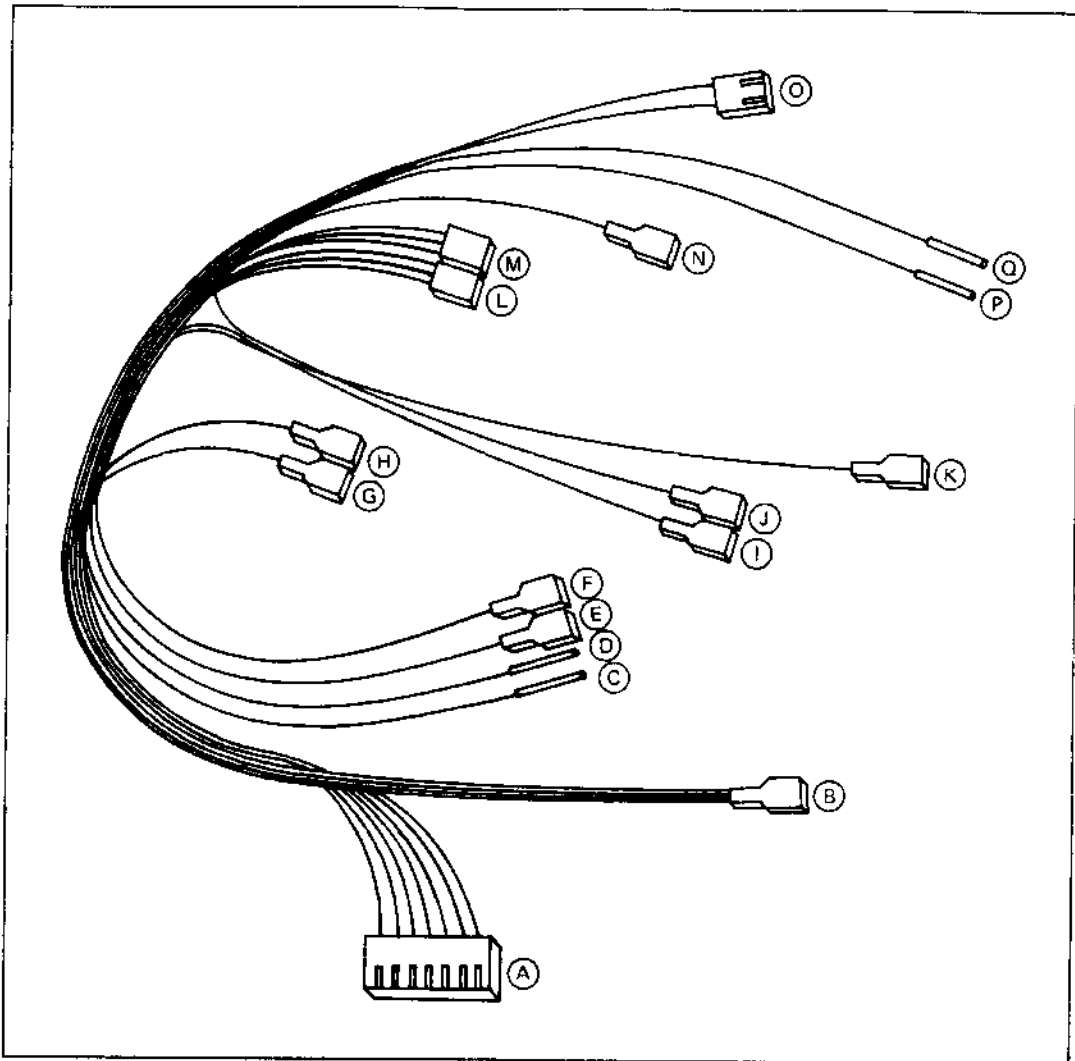

- |             |  |             |  |
|-------------|--|-------------|--|
| (A)         | Logic Board DC Input                                     | (K)         | "A" Drive Ground   |
| (B)         | AC Power Panel Ground (5 wire)                           | (L and M)   | Interchangeable DC Output Connectors from Power Supply       |
| (C) and (D) | Interchangeable 115V and 230V Pin Connectors to AC Panel | (N)         | DC Power Supply Ground                                       |
| (E) and (F) | Power Panel AC Outputs                                   | (O)         | AC Input Connector   |
| (G)         | "B" Drive Ground   | (P) and (Q) | Interchangeable 115V and 230V Pin Connectors to Power Supply |
| (H)         | Video Monitor Ground                                     |             |  |
| (I) and (J) | Interchangeable Thermal Cutout Connectors                |             |  |

**FIGURE 6-23. DC POWER HARNESS**

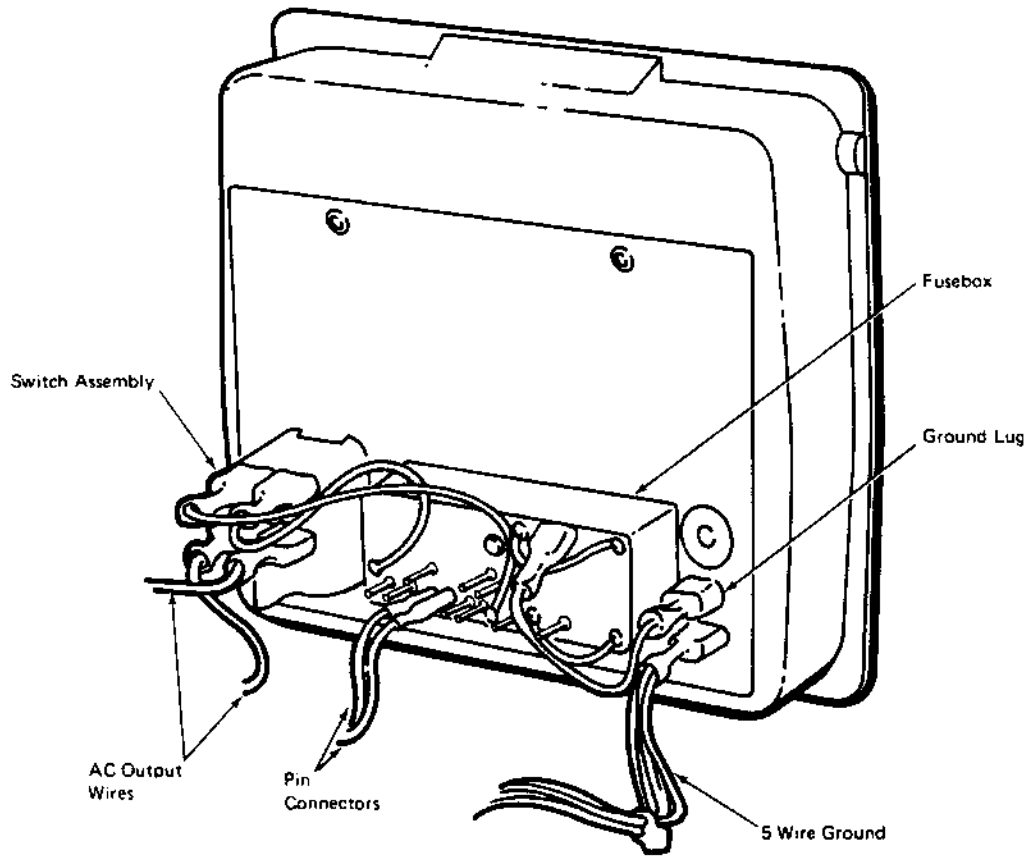

**FIGURE 6-24. AC POWER PANEL**

- 6.8.0.8 Install four 6/32 X 1/4 inch Phillips screws to secure the power panel to the back of the power panel compartment.
- 6.8.0.9 Place the mylar insulator sheet over the power panel connections. Position the folded part of this sheet closest to the connections and slip it onto the Phillips screws in each corner of the panel.
- 6.8.0.10 To secure the insulator in place, press a rubber cap onto the shaft of each Phillips screw holding the power panel to the panel compartment.
- 6.8.0.11 Fasten the thermal cutout to its chassis mounting clip beneath the power supply.
- 6.8.0.12 Place the thermal cutout wires I and J in their notch on the chassis. This prevents pinching of the wires between chassis and case.

### 6.8.1 OCC 1A Disk Drive "B" Assembly

---

#### NOTE

*The "A" drive has an 8 pin, 150 ohm terminator resistor pack (see Section 6.2.2). "B" DRIVE DOES NOT.*

---

- 6.8.1.1 Place drive in shield with PC board facing down.
- 6.8.1.2 Align drive with screw holes in the drive shield and install two 6/32 Phillips screws with star washers in each side of the drive.
- 6.8.1.3 Position the chassis assembly logic-board-side-up and power supply mounting closest to technician.

---

#### NOTE

*Drive B is the drive furthest from the power supply unit.*

---

- 6.8.1.4 Slide drive under chassis assembly with drive door facing away from technician.
- 6.8.1.5 Install four 6/32 Phillips screws which secure the "B" drive to the chassis.
- 6.8.1.6 Connect the slip-on ground connector located mid-way down the DC power harness to the ground tab at the rear of the drive shield.
- 6.8.1.7 Connect the broad drive connector located mid-way down the drive harness to the connection at the rear of the drive PC board. RED STRIPE on the harness edge is to the right.

## 6.8.2 OCC 1A Disk Drive "A" Assembly

---

### NOTE

*The "A" drive has an 8 ohm terminator resistor pack. "B" DRIVE DOES NOT. To locate the terminator, position the drive with door facing technician and PC board on top. The terminator is at position RN3 in the right rear corner of the PC board. Pin 1 is the pin closest to technician.*

---

- 6.8.2.1 Install terminator resistor pack at position RN3 of the drive PC board.
- 6.8.2.2 Place drive in shield with PC board facing down.
- 6.8.2.3 Align drive with screw holes in the drive shield and install two 6/32 Phillips screws with star washers in each side of the drive.
- 6.8.2.4 Position the chassis assembly logic-board-side-up and power supply mounting closest to technician.

---

### NOTE

*Disk drive A is the drive closest to the power supply.*

---

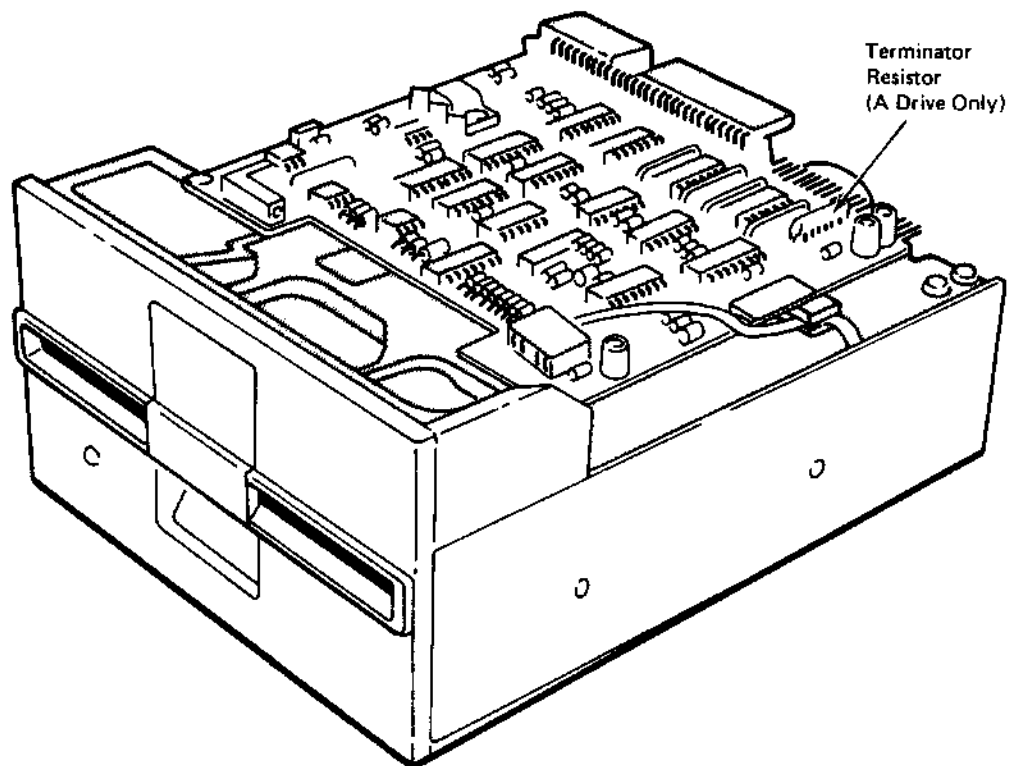

**FIGURE 6-25. DISK DRIVE A**

- 6.8.2.5 Place shielded drive to the left of chassis assembly, strobe wheel facing up, drive door facing away from chassis.
- 6.8.2.6 Connect the narrow slip-on ground connector to the ground tab at the rear of the drive shield.
- 6.8.2.7 Slide drive under chassis assembly with drive door facing away from technician.
- 6.8.2.8 Install four 6/32 Phillips screws to secure the "A" drive to the chassis.
- 6.8.2.9 Insert the broad drive connector on the end of the drive harness through the rectangular slot at the rear of the drive shield. Connect the drive connector to the rear of the PC board, RED STRIPE on harness edge to the right.
- 6.8.2.10 Attach the thermal cutout to its chassis mounting clip beneath the power supply.
- 6.8.2.11 Place the thermal cutout wires and the "A" drive ground wire in their notch on the chassis. This prevents pinching of the wires between chassis and case.

### 6.8.3 OCC 1A Power Supply Assembly

**CAUTION:** Working with power supplies is DANGEROUS!  
Power supply units can hold an electrical charge for long periods of time. Do not touch any components unnecessarily.

---

**NOTE**

*Power supply procedures are with DC harness installed in chassis.*

---

- 6.8.3.1 Position the chassis assembly logic-board-side-up and power supply mounting closest to technician.
- 6.8.3.2 Place power supply on the chassis so components face technician and the five large capacitors are in the lower left corner.

---

**NOTE**

*Refer to Figure 6-23 to identify the various DC harness connectors.*

---

- 6.8.3.3 Attach the AC input connector to the keyed connection left of the fuse on the power supply.
- 6.8.3.4 Attach the slip-on ground connector to the ground connection in the upper left corner of the power supply.
- 6.8.3.5 Attach the keyed DC output connectors to two of the three identical male connections on the left side of the power supply.
- 6.8.3.6 Connect two interchangeable pin connectors to the 115V and 230V pins on the power supply. *Be sure these are securely connected.*
- 6.8.3.7 With wires attached, turn the power supply over from right-to-left so the DC output connectors are to the right. Insert the power supply into the chassis *being careful not to snag any wires.*
- 6.8.3.8 Align the screw holes on the power supply PC board with the chassis standoffs.

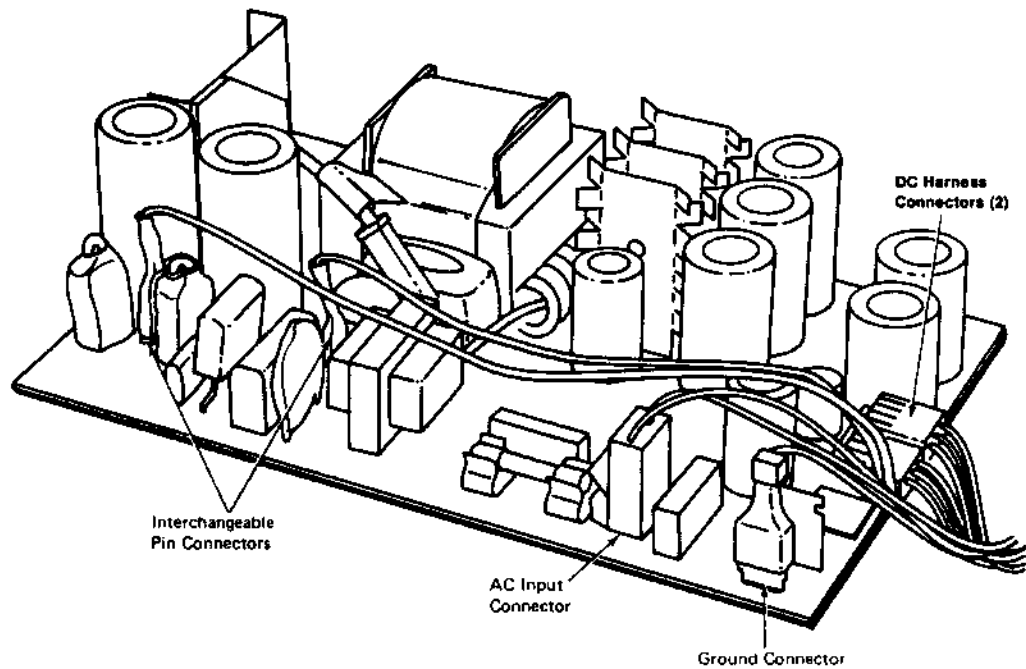

**FIGURE 6-26. POWER SUPPLY**

- 6.8.3.9 Install a 6/32 x 1/4-inch Phillips screw and star washer in the upper right and lower left corners of the power supply. Do not overtighten these screws!
- 6.8.3.10 Align the holes on the mylar insulator with the remaining two chassis standoffs.

---

**NOTE**

*The rectangular insulator **MUST BE** installed against the underside of the power supply. THIS IS A SAFETY REQUIREMENT!*

---

- 6.8.3.11 Install a 6/32 x 1/4-inch Phillips screw and star washer through each hole in the insulator and into the chassis standoffs. Do not overtighten these screws!
- 6.8.3.12 Slip the power supply harness into its tab on the chassis.



## 6.8.4 OCC 1A Video Monitor Assembly

- 6.8.4.1 Position the video monitor in front of the chassis assembly, CRT screen facing technician and keyed video PC board connection at top rear.
- 6.8.4.2 Lower the video monitor shield onto the monitor and align the monitor and monitor shield screw holes.
- 6.8.4.3 Connect the keyed large end-connector of the video harness to the rear of the monitor PC board.
- 6.8.4.4 Slide the video monitor into place in the chassis while guiding the video cable through its chassis access hole.
- 6.8.4.5 Align the monitor with the four screw holes in the chassis. Install four 6/32 X 1/4 inch Phillips screws to secure the monitor to the chassis. These are the screws labelled FOR VIDEO MONITOR in section 6.7.3.

---

### NOTE

*Using incorrect screws to reattach the video monitor to the chassis may short circuit the video PC board.*

---

- 6.8.4.6 Attach the slip-on ground connector to the connection at the rear of the video monitor shield.
- 6.8.4.7 Slip the disk drive harness into the four fasteners on the back of the video monitor shield.
- 6.8.4.8 Replace the transparent face plate onto the monitor screen.

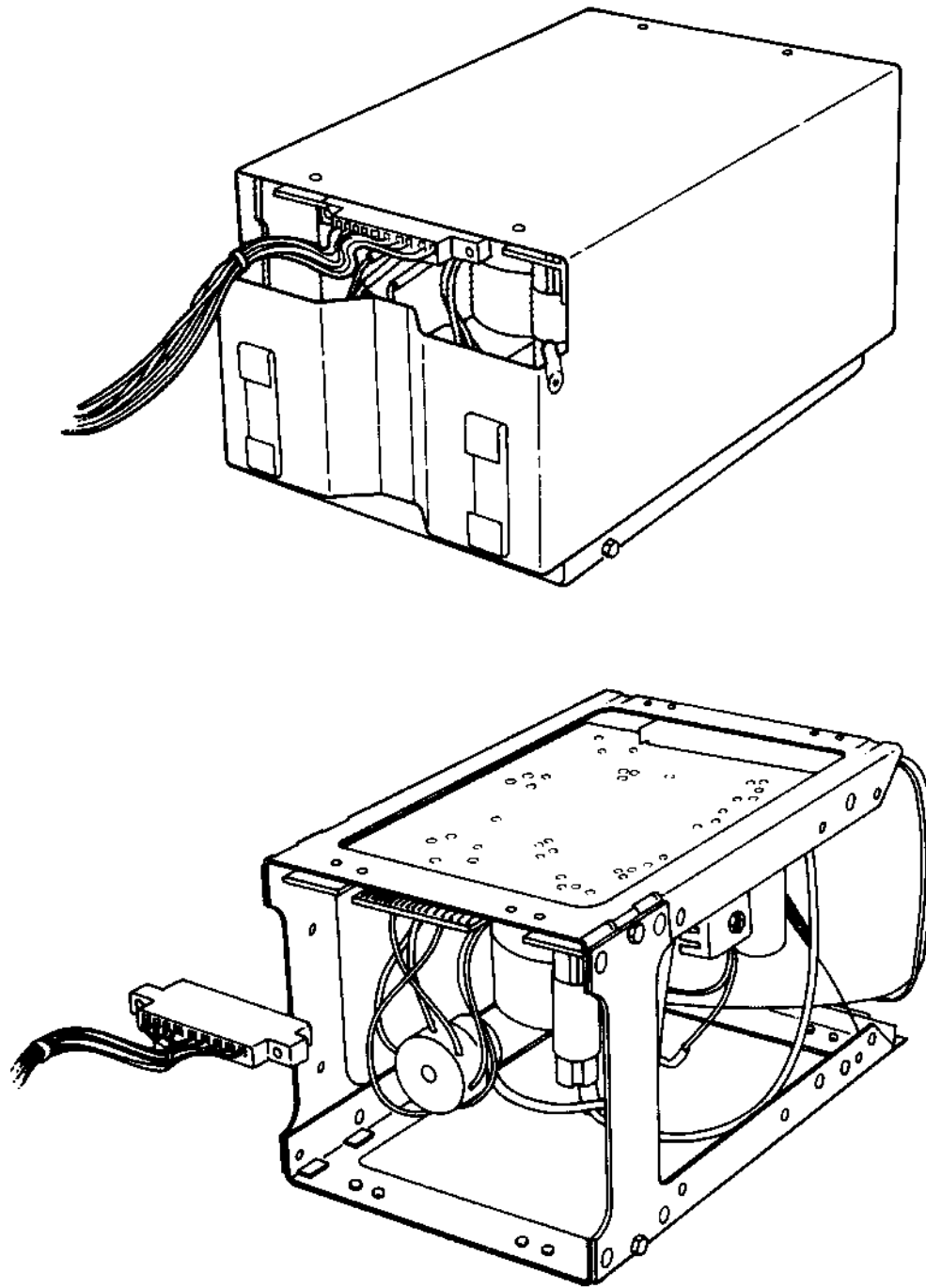

**FIGURE 6-27. VIDEO MONITOR ASSEMBLY**

## 6.8.5 OCC 1A Logic Board Assembly

- 6.8.5.1 Position the chassis assembly logic-board-side-up and CRT screen facing technician.
- 6.8.5.2 Hold the logic board perpendicular to the chassis, component side facing technician, video control shafts pointing straight up. (See Fig. 6-21.)
- 6.8.5.3 Connect the external video plug to the connection on the edge of the logic board between the reset button and video contrast shaft.
- 6.8.5.4 With video harness running below the logic board, attach the video harness connector to the 10 Pin connection on the logic board between the reset button and the contrast control, RED WIRE TO THE LEFT.
- 6.8.5.5 Insert the 7 hole mylar insulator onto the DC harness connection in the extreme left lower corner of the logic board. Fold the long part of the insulator flat against the underside of the logic board.

---

### NOTE

*The insulator **MUST BE** installed onto the DC harness connection to avoid burn hazard. THIS IS A SAFETY REQUIREMENT!*

---

- 6.8.5.6 With the DC harness running below the logic board, attach the DC harness connector to the 7 Pin connection in the extreme left lower corner of the logic board.
- 6.8.5.7 With the disk harness running below the logic board, attach the disk harness connector to the 34 Pin connection at the lower left of the logic board to the right of the DC harness, RED STRIPE TO THE RIGHT.

- 6.8.5.8 Lower the logic board onto its chassis mounting brackets.

---

**NOTE**

*The chassis mounting brackets are angled inward and slightly down. There should be two grommets on the inward side of each mounting bracket, facing downward away from the logic board.*

---

- 6.8.5.9 Install a 6/32 Phillips screw with star washer at each corner of the logic board. The screw in the right front corner of some logic boards has a nylon insulation washer to protect the trace. Do not overtighten these screws!

## 6.8.6 OCC 1A Bezel and Chassis Assembly

**CAUTION:** The interior of the case is coated with a special metallic paint. Avoid scratching this coating.

- 6.8.6.1 Position the chassis assembly logic-board-side-up, CRT screen facing technician.
- 6.8.6.2 Place the top half of the carrying case (the part with the ventilation slots) upside down on the work surface, latches closest to the technician.
- 6.8.6.3 Place power panel compartment face down on the logic board.
- 6.8.6.4 Place one hand under the front of the video monitor and the other at the back of the monitor and lift the chassis into the top half of the carrying case.

---

### NOTE

*When installing the chassis into the case, be careful not to pinch, trap, or rip harness assemblies.*

---

- 6.8.6.5 Align screw holes in the chassis with the five mounting standoffs in the case.
- 6.8.6.6 Position the power supply harness in the chassis tab over the video monitor.
- 6.8.6.7 Slide the power panel compartment into the case, fuse at the top and facing out.
- 6.8.6.8 Slide the carrying handle plate into the case. The broad area of the plate is *below* the handle at this point.
- 6.8.6.9 Place the lower half of the case onto the chassis assembly. Be sure that the AC power compartment, carrying handle plate, and upper/lower halves of the case align properly.
- 6.8.6.10 Slide the hinges of the power compartment door into their cutouts on the power panel compartment.

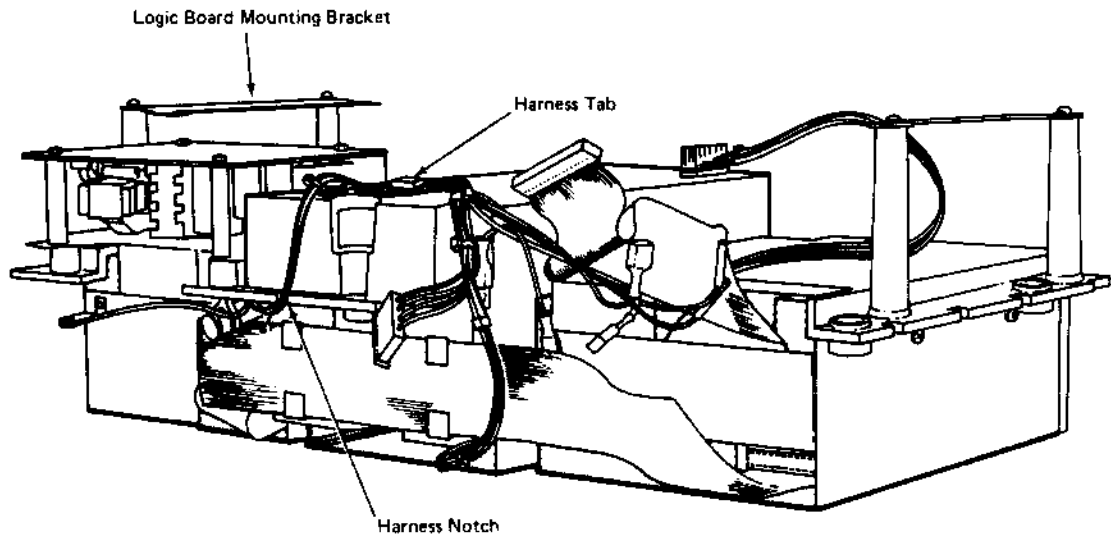

**FIGURE 6-28. CHASSIS ASSEMBLY—REAR VIEW**

- 6.8.6.11 Install five 6/32 x 3/4-inch Phillips screws which hold both halves of the case together. Tighten these screws until they are snug. **Do not overtighten!**
- 6.8.6.12 Turn the unit over so the ventilation slots are on top and CRT screen faces technician.
- 6.8.6.13 Placing thumbs below CRT screen cutout and fingers in the disk storage pockets, slide the bezel into the chassis. Be sure keyboard connector latches are in closed position.
- 6.8.6.14 Install the 6/32 Phillips screws which secure the bezel to the front of the chassis. **Do not overtighten these screws!**
- 6.8.6.15 Carefully push the video control knobs onto their shafts.
- 6.8.6.16 With the keyboard assembly in front of the unit, connect the keyboard cable to the keyboard connector below the CRT screen. Facing the screen, the cable connects from the left.

## 6.8.7 OCC 1A Keyboard Assembly

- 6.8.7.1 Place the keyboard bezel onto a pad or soft material (to protect the keyboard), standoffs facing up.
- 6.8.7.2 Align the keyswitch array face down with the cutouts on the keyboard bezel.
- 6.8.7.3 Install four 8/32 Phillips screws to secure the keyboard to the bezel stand-offs.
- 6.8.7.4 Connect Pin 1 (the thick ground wire) on the keyboard harness to Pin 1 of the keyboard connector on the underside of the keyboard.

---

### NOTE

*To locate Pin 1 of the keyboard connection, position the keyboard with the numeric row of keys to the top. Facing the underside of the keyboard, Pin 1 is in the upper right corner of the keyboard connection. Pin 1 may also have an orange dot next to it.*

---

- 6.8.7.5 Position the keyboard harness in the notch on the long edge of the keyboard bezel.
- 6.8.7.6 Lower the keyboard case onto the keyboard and keyboard bezel assembly so the case and bezel are flush.
- 6.8.7.7 Install four 6/32 x 1/4-inch Phillips screws to secure the keyboard case to the keyboard assembly.
- 6.8.7.8 Turn keyboard face up and connect the keyboard cable to the keyboard connection below the CRT screen. Facing the screen, the cable connects from the left.

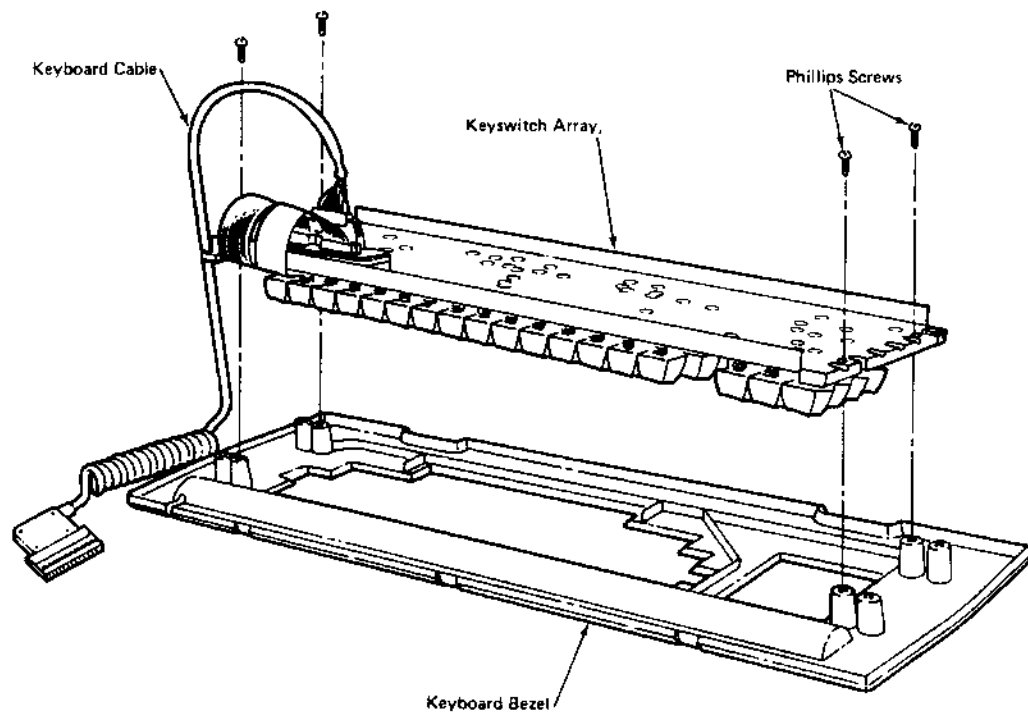

**FIGURE 6-29. KEYBOARD ASSEMBLY—OCC1A**



## **6.9.0 OCC 1A OPERATING VOLTAGE MODIFICATION**

- 6.9.0.1 The Osborne 1A can operate on either 120V or 220V. Adapting the system for one of these voltages requires that the correct fuse and fuse card be used.
- 6.9.0.2 Disconnect the AC power cord from the power panel.
- 6.9.0.3 Slide open the transparent fuse box door in the AC power panel. Flip the fuse pull to remove the fuse.
- 6.9.0.4 The fuse card is located underneath the fuse mounting. The current AC voltage setting of the system is visible as a number printed on the card (120 or 220).
- 6.9.0.5 To change the indicated voltage setting, pull the fuse card from the fuse box. Do this CAREFULLY so as not to damage the fuse card.
- 6.9.0.6 Turn the card and replace it in the fuse box so the desired voltage rating is the only number visible. Use the 120 rating for 110V operation and 220 rating for 220V.
- 6.9.0.7 Use a 1 amp, slow-blow, 250V fuse (3AG) for either 120V or 220V operation.
- 6.9.0.8 Replace the fuse and close the fuse box cover.
- 6.9.0.9 Reconnect the AC power cord to the power panel.

## 6.10.0 BATTERY PACK

- 6.10.1 An optional battery pack is available for powering the Osborne 1 and Osborne 1A computers. The pack includes:
1. A 12-volt battery enclosed in a carrying case with shoulder strap.
  2. A DC/DC inverter unit for connecting the computer and the battery.
  3. A battery charger which plugs into any standard 120V AC outlet. (U.S. models)
  4. A 6" connector cable for computers with non-detachable AC power cords.

### BATTERY OPERATION

Units with detachable power cord:

- 6.10.2 Turn power to the computer "OFF" and disconnect it from the power source.
- 6.10.3 Detach the power cord from the AC power panel on the back of the computer.
- 6.10.4 Connect the three-hole plug on one of the inverter cables to the power cord connection on the back of the computer.
- 6.10.5 Insert the *cigarette-type connector* on the other inverter cable into the hole on the side of the battery pack. Push the connector in until it fits snugly. (This connector also fits the standard automobile cigarette lighter socket.)

---

### NOTE

*The inverter unit has a switch built into its top surface. Switch position 0 is power "Off". Position 1 is power "On".*

---

- 6.10.6 Press the inverter switch to position 1 (On). The light on the inverter unit should go on.
- 6.10.7 Press the computer power switch "ON".
- Units without detachable power cord:
- 6.10.8 Turn power to the computer "OFF" and disconnect it from the power source.
- 6.10.9 Plug the AC power cord into the 6" connector cable.
- 6.10.10 Plug the 6" connector cable into the three-hole plug on one of the inverter cables.

- 6.10.11 Follow steps 6.10.5 through 6.10.7.
- 6.10.12 The battery will power the computer for approximately one hour of normal use. When battery power becomes too low for further operation, the inverter unit will "beep".
- 6.10.13 Before disconnecting the battery from the computer, press the power switch on the computer and the switch on the inverter "OFF" (position 0).

---

### BATTERY CHARGING

**WARNING:** *Never connect or disconnect the charger cord to the battery while the charger is plugged into an electrical outlet! Always disconnect the charger from the power source first.*

---

- 6.10.14 Insert the cigarette-type connector running from the battery charger into the hole on the side of the battery pack. Push the connector in until it fits snugly.
- 6.10.15 Plug the two-pronged battery charger into a 120V AC outlet.
- 6.10.16 Charge the battery at room temperature for a period of 12 to 48 hours. TO AVOID DANGER OF EXPLOSION, DO NOT OVERCHARGE THE BATTERY.
- 6.10.17 When disconnecting the battery charger, ALWAYS detach it from the AC power outlet BEFORE detaching the round connector from the battery.

---

### NOTE

*When operating an external video monitor with a battery-powered Osborne, all voltages must be compatible.*

---

## 6.11.0 OCC 1/1A DOUBLE-DENSITY INSTALLATION

---

### NOTE

*Before starting double-density installation, READ THE DOUBLE-DENSITY  
INSTALLATION ADVISORY, Section 6.11.1.*

---

6.11.0.1 These tools are needed for double-density installation.

Set of basic electronic hand tools  
Oscilloscope (60 Hz—Tektronix 2215 or equivalent)  
Two 10x1 scope probes  
Disk Alignment Program 1.1  
Dysan 224 Alignment diskette  
Double-Density Confidence Test

6.11.0.2 Double-density components include:

- (1) Double-density PC Board
- (1) 10-wire ribbon cable
- (1) 2732 monitor ROM chip, Rev 1.43
- (1) Double-density PC board stand-off

---

### NOTE

*The logic board for double-density installation must be Rev. G or higher. Return  
earlier boards to OCC for upgrading.*

*Disk drive PC boards for double-density installation must be Rev. J or higher.  
Return earlier boards to OCC for upgrading.*

---

## OSBORNE FIELD SERVICE MANUAL

- 6.11.0.3 Before installing double-density, INSPECT the unit being upgraded as follows:
1. Check the case, handle, and AC power panel for damage.
  2. Check that all keys are in place on the keyboard.
  3. Detach the keyboard from the unit. Check the keyboard cable and connector for damage.
  4. Check the keyboard connector on the front bezel for bent or broken pins.
  5. Check the video monitor and video contrast/brightness knobs for damage.
- 6.11.0.4 After completing visual inspection, turn the computer ON.
- 6.11.0.5 Insert an Alignment Program Diskette and check that each drive boots (see Section 6.5.0).
- 6.11.0.6 Check the video image for clarity and the video controls for correct function.
- IF THE UNIT PASSES FUNCTIONAL INSPECTION, proceed with double-density installation.
- 6.11.0.7 Disassemble the logic board (see Sections 6.1.2 or 6.7.2).
- 6.11.0.8 Disassemble both disk drives (Sections 6.1.5 and 6.1.6 or 6.7.5 and 6.7.6). Disk drive PC boards must be Rev. J or higher.
- Be certain both drives are correctly aligned (Sections 6.3.0–6.5.0). Spindle speed for double-density is 200 milliseconds  $\pm$  1 percent.
- 6.11.0.9 Reinstall the correctly aligned drives in the chassis (Sections 6.2.1 and 6.2.2, or 6.8.1 and 6.8.2).
- 6.11.0.10 Place the logic board flat on the work surface, component-side up and video shafts closest to technician.

- 6.11.0.11 If the monitor ROM (position D12 on the logic board) is not REV 1.43, remove it and install a REV 1.43 ROM in its place. The notch on the ROM aligns with the notch on the logic board socket.
- 6.11.0.12 Remove two jumpers from positions J4 and J5 on the logic board. Install one of these jumpers on position J3.
- 6.11.0.13 Hold the double-density PC board component-side up, 34-pin connector furthest from technician. Fit the sockets of this connector onto the logic board disk harness connector (P8).
- 6.11.0.14 Carefully press the double-density board into place on the disk harness connector.
- 6.11.0.15 The double-density PC board stand-off is notched on one edge and has double-backed tape on the opposite surface.
- The edge of the double-density PC board fits the notch in the stand-off. The taped surface rests flat on the main logic board.
- 6.11.0.16 Peel the covering off the tape and clean the surface of the logic board with 95% alcohol. Slip the left forward edge of the double-density PC board into the notch on the stand-off, then press the taped surface onto the logic board.
- 6.11.0.17 The 10-wire ribbon cable has a connector at each end. One socket (pin 10) in each connector is plugged.
- 6.11.0.18 Hold the cable with connector sockets down, red stripe furthest from technician. Press the connector on the left end of the cable onto logic board connectors J4 and J5. The plugged socket (pin 10) and the one next to it (pin 9) remain free.
- 6.11.0.19 Press the other connector on the 10-wire cable onto keyed connector P3 of the double-density PC board.

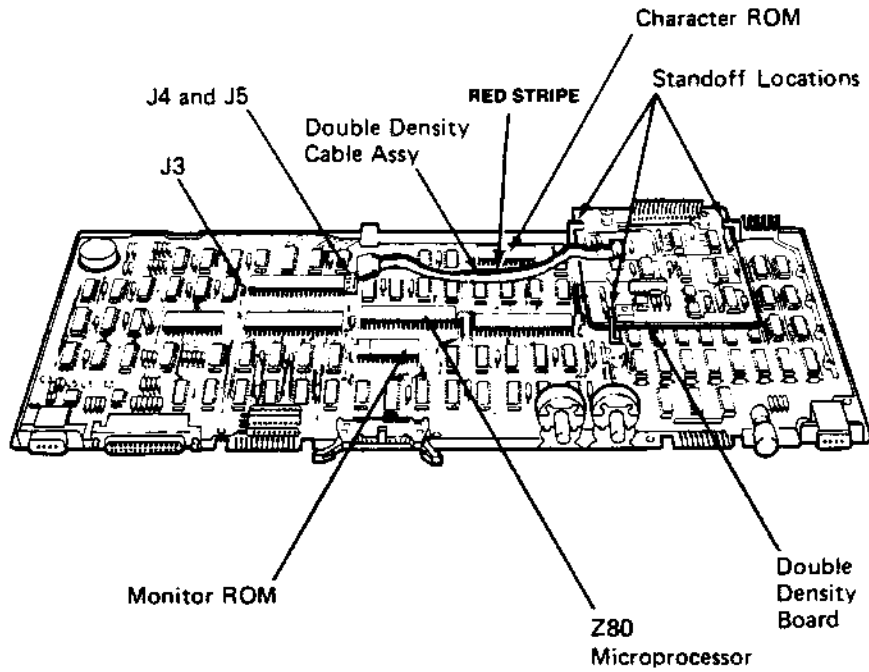

**Figure 6-30. DOUBLE-DENSITY ADAPTOR (INSTALLED)**

- 6.11.0.20 Reassemble the logic board (see Sections 6.2.5 or 6.8.5). The logic board *must be Rev. G or higher.*

The disk harness connects to the 34-pin connector on the double-density PC board, red stripe to the right.

- 6.11.0.21 Boot the system using the Double-Density Confidence Test. Remove this diskette and insert a double-density certified diskette in each drive. (If the system doesn't boot, see Section 7.8.0).

Press RETURN twice to start the test. Minimum testing time is 8 hours.

---

**NOTE**

*The RS 232 and IEEE 488 loopback connectors need not be in place for this test. In this case, errors will be displayed for these ports, but they will not affect the test results.*

---

- 6.11.0.22 If testing is passed (no errors), disconnect the unit from the power source and reassemble it (Sections 6.2.6 or 6.8.6).

If the unit fails, see Section 7.8.0.

- 6.11.0.23 Repeat step 6.11.0.21 *after the unit is reassembled.* If the unit fails, see Section 7.8.0.



### 6.11.1 Double-Density Installation Advisory

There's a small possibility that an upgraded double-density unit won't read its own single-density diskettes. This could be due to disk drive problems before the double-density upgrade:

1. Disk drive timing problems
2. Disk drive alignment problems
3. A combination of 1 and 2

Dealers **MUST** inform the end user of this possibility **BEFORE** the end user purchases a double-density upgrade.

Determine if there is such a problem by attempting to read several of the end user's single-density diskettes in a properly aligned double-density unit.

If the single-density diskettes are **NOT** readable, see Installation Options 1 and 2 below (Sections 6.11.3.1 and 6.11.3.2).

If the diskettes are readable, proceed with double-density installation.

---

#### NOTE

*Before installing double-density, advise the end user to copy all his diskettes.*

---

### 6.11.2 OCC Installations

OCC will return upgraded units to the Dealer after double-density has been installed. The end user then determines whether the unit reads his single-density software. If the unit reads **NONE** of the user's software, there may be a hardware problem. In this case, the end user returns the upgraded unit to the Dealer for inspection.

If the upgraded unit reads only **SOME** single-density diskettes, the end user sends the unreadable diskettes to OCC. Osborne will attempt to restore these diskettes to readable condition. However, OCC is not liable for accidental loss of data or diskettes. OCC will make all effort to restore diskettes to readable condition but cannot guarantee complete data integrity.

DWG. NO. 1B10011		REV. 1	REV. B	1
REV.	REV.	DESCRIPTION	DATE	APPROVED
RELEASED	A	PRE PRODUCTION RELEASE ECO # 0406	17 AUG 82	[Signature]
RELEASED	A	FIRST RELEASE ECO # 0437	11/11/82	[Signature]
RELEASED	B	ECO # 0465	G.S./MFR	11/11/82

FROM MAIN P.C. BOARD

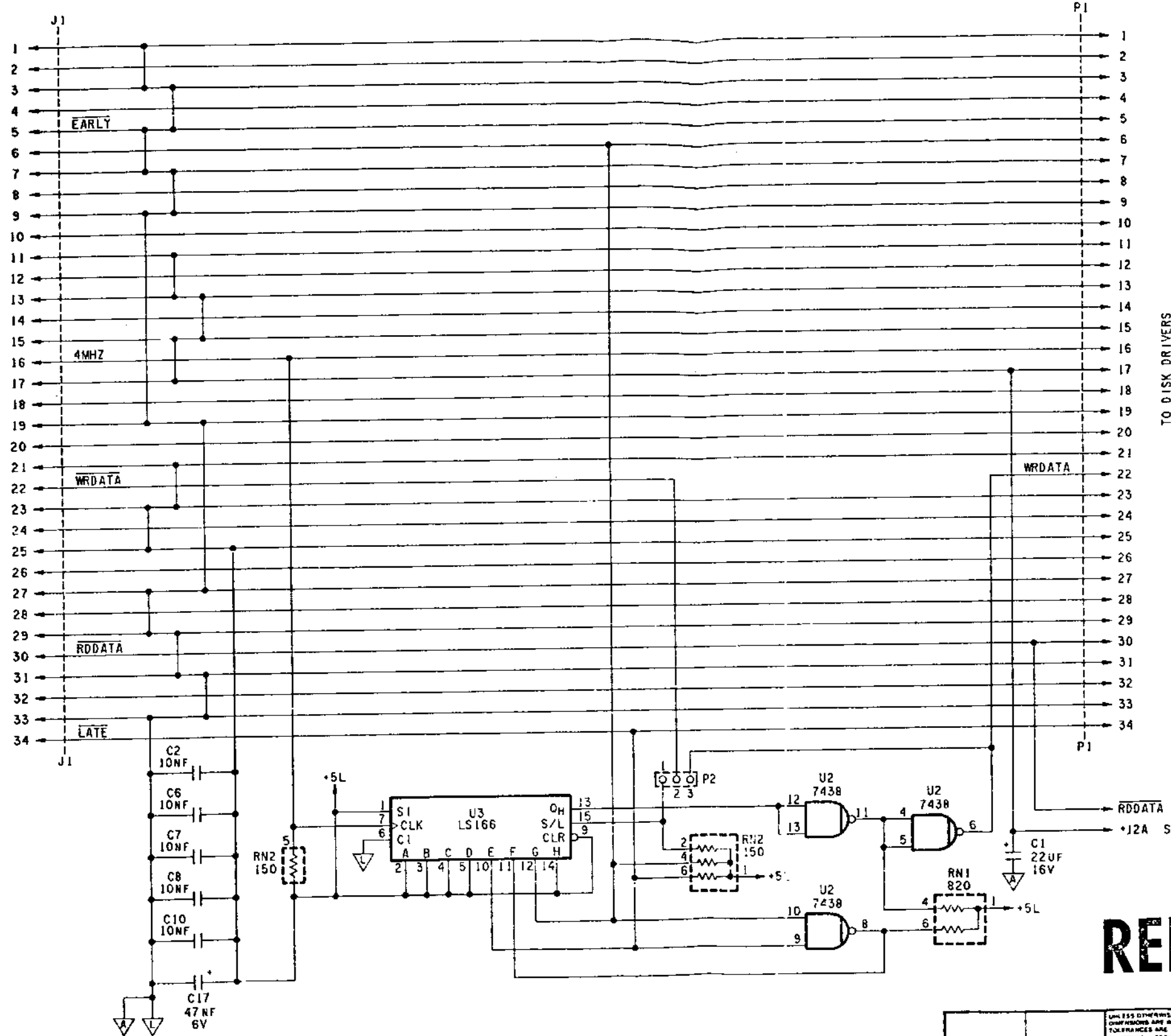

TO DISK DRIVERS

- NOTES: UNLESS OTHERWISE SPECIFIED
1. RESISTANCE VALUES ARE IN OHMS, 1/4W. ±5%
  2. CAPACITANCE VALUES ARE IN FARADS, 50V. ±20%
  3. VOLTAGE (REF) FOLLOWED BY 'A' REPRESENTS ANALOG. VOLTAGE (REF) FOLLOWED BY 'L' REPRESENTS LOGIC.

**RELEASED MFR** FEB 01 1983

UNLESS OTHERWISE SPECIFIED DIMENSIONS ARE IN INCHES FRACTIONS OF INCHES ANGLES IN DEGREES		<b>OSBORNE</b> 28500 Corporate Avenue Hayward, California 94545 415-887-8080	
MATERIAL	6B10011	APPROVALS	DATE
USED ON	DDA	DRAWN	JG 8/82
APPLICATION	DDA	CHECKED	[Signature] 5/2/83
DO NOT SCALE DRAWING		DATE	9/13/82
SCALE NONE		DWG. NO.	1B10011
		REV.	B
		SHEET	1 OF 2

2440622 SJS 080040

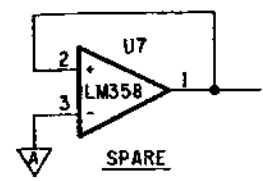
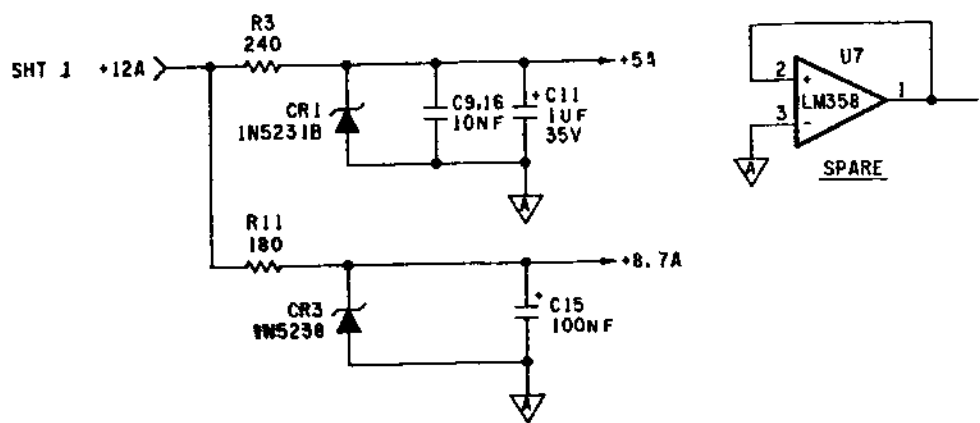
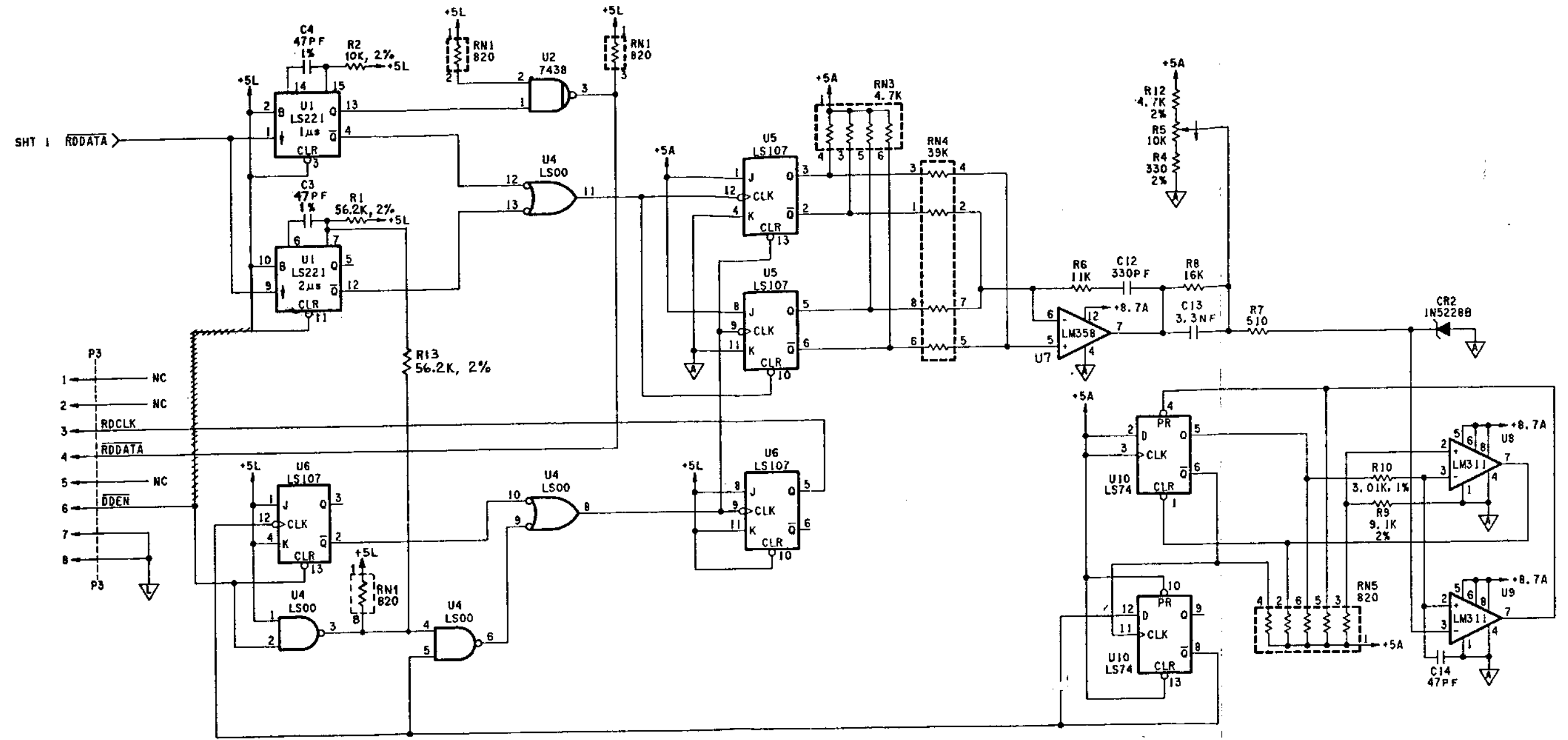

**RELEASED MFR** FEB 01 1983

UNLESS OTHERWISE SPECIFIED DIMENSIONS ARE IN INCHES TOLERANCES ARE FRACTIONS DECIMALS ANGLES FIFTH SIXTH		APPROVALS	DATE	<b>OSBORNE</b> 28600 Corporate Avenue Hayward, California 94545 415-887-8080 COMPUTER CORPORATION
MATERIAL	FINISH	DRN: IGL	8/82	
NEXT ASSY	USED ON	CHKD BY: M.L. KESSEY	8/12/72	DOUBLE DENSITY ADAPTER PCB SCHEMATIC
APPLICATION	DO NOT SCALE DRAWING	REV. NO.	DATE	1B10011 B

### 6.11.3 Dealer Installations

Before starting double density installation, test several of the end user's single-density diskettes on a properly aligned double-density unit. If the diskettes are readable, proceed with double-density upgrade.

If the single-density diskettes are NOT readable, proceed with Installation Option 1 OR Option 2.

#### 6.11.3.1 Installation Option 1

1. Align drive **B** of the unit being upgraded to specification (Field Service Manual sections 6.3.0–6.4.0).
2. Copy the single-density diskettes which were not readable from drive **A** to drive **B** of the unit being upgraded.
3. If the copies are readable in a properly aligned double-density unit, align drive **A** of the unit being upgraded to specification.
4. Proceed with double-density installation.

#### 6.11.3.2 Installation Option 2

1. Connect standard RS 232 modem cable between the unit being upgraded and a properly aligned double-density unit.
2. Use the BSTAM software package to transmit data from drive **A** of the unit being upgraded to the double-density unit.
3. Align drives **A** and **B** of the unit being upgraded to specification.
4. Proceed with double-density installation.

MAY 11, 1983

DEAR OSBORNE DEALER SERVICE DEPARTMENT,

These Screen-Pac installation instructions replace pages 130-142 of the Osborne Field Service Manual. There are significant changes in the way this kit is installed. Review these instructions thoroughly before attempting to repair or install Screen-Pac. This set of instructions is an interim measure to provide you with the proper literature before your kits arrive. There will a type set version included in the new printing of the Field Service Manual currently being revised.

## 80 COLUMN BULLETIN

The proper installation for the coax cable which goes from U1 on the 80 column board and terminates on B13 of the main logic board is as follows:

The inner conductor of the coax is pre-tinned and terminates on pin 6 of B13.

The shield of the coax is pre-tinned and terminates on pin 7 of B13.

To prevent the heat of the soldering iron from melting the shield of the inner conductor inside the coax housing place a heat sink on the shield behind the pre-tinned area and in front of the coax housing.

A heat sink is an alligator clip or a pair of surgical forceps. The reason for a heat sink is to draw the heat to that point and not let it pass to the inner conductor.

## 6.12.0 OCC 1/1A SCREEN-PAC INSTALLATION

## NOTE

1. If a unit is receiving both double-density and SCREEN-PAC upgrade, do the double-density installation first (see Section 6.11.0).
2. Single-layer main logic boards for SCREEN-PAC installation must be Revision G or higher. Return boards below Rev G to OCC for exchange.

SCREEN-PAC can be installed on any multi-layer main logic board. These boards have a 1/4 inch silver strip along their front edge.

3. Replace a sub-REV level, single-layer logic board with another single-layer board. Replace a multi-layer board with another multi-layer board.

6.12.0.1 These tools are needed for SCREEN-PAC installation:

<u>ITEM</u>	<u>PART NO.</u>
Set of basic electronic hand tools	
Soldering iron (35 watt or less)	
Extended Utility Diskette	3D10311-004
7/16 inch wrench	
Drill and 1/4-inch bit	

6.12.0.2 SCREEN-PAC components include:

<u>ITEM</u>	<u>PART NO.</u>
(1) SCREEN-PAC PC Board with (2) pin spacers	6N00001-01
(1) SCREEN-PAC IC harness	5N00002-01
(1) SCREEN-PAC power harness	5N00005-01
(1) Composite external video connector and cable	5N00006-01
(2) PC Board retainer clips	JN00008-01
(1) Template	3N00009-01
(1) 1.44 Monitor ROM	3A10082-00

- 6.12.0.3 INSPECT the unit being upgraded as follows and note any damage.
1. Check the case, handle, and AC power panel.
  2. Check that all keys are in place on the keyboard.
  3. Detach the keyboard from the unit. Check the keyboard cable and connector.
  4. Check the keyboard connector on the front bezel for bent or broken pins.
  5. Check the video monitor and video contrast/brightness knobs.

6.12.0.3 After completing visual inspection, turn the computer ON.

6.12.0.4 Check the video image for clarity and the video controls for correct function.

6.12.0.5 IF THE UNIT PASSES FUNCTIONAL INSPECTION, proceed with SCREEN-PAC installation.

IF THE UNIT DOES NOT PASS FUNCTIONAL INSPECTION, INFORM THE END USER OF ANY PROBLEMS BEFORE PROCEEDING with installation. Any non-functioning modules must be replaced at the end-user's expense.

#### 6.12.0.6 AMP SOCKETS BULLETIN

Before installing SCREEN-PAC, INSPECT the 40-pin Z80 socket and the 24-pin character generator socket on the main logic board.

If you see the manufacturer's name, AMP, on either socket, DO NOT PROCEED with 80-column installation.

The pins on the underside of the 80-column PC board do not fit AMP sockets correctly.

AMP sockets are a limited number of logic boards below Rev K.

If the logic board has AMP sockets, REPLACE IT with a board without AMP sockets before continuing.



**6.12.0.7 VIDEO MONITOR BULLETIN**

Before installing SCREEN-PAC, INSPECT the 5" internal monitor. Monitors with 2 PC boards will NOT function correctly with SCREEN-PAC installed.

These monitors cause uncontrollable vertical rolling of any external monitor connected to the computer.

If the internal monitor has TWO PC boards, REPLACE IT with a monitor having one PC board before continuing.

**6.12.0.8 SCREEN-PAC PCB BULLETIN**

If your Screen-Pac PC boards have a small capacitor soldered on the trace side on pins 8 and 15 of U1, remove it by snipping it's leads at the trace.

**6.12.0.9 B13 BULLETIN**

Locate IC B13 on the main logic board. If this IC is manufactured by FAIRCHILD or SG(Silicon General), the main logic board may not operate properly in the 80 column mode. This logic board must be replaced. See Section 6.12.8.11.

**6.12.1 PC Board Assembly**

6.12.1.1 Disassemble the unit down to the logic board (Sections 6.1.2 or 6.7.2).

6.12.1.2 Place the logic board flat on a soft work surface, component-side up and video shafts closest to technician.

6.12.1.3 Check that the monitor ROM (position D12 on the logic board) is REV level 1.44. Change the ROM if necessary.

6.12.1.4. There must be a jumper at logic board position J3. Install one if necessary.

6.12.1.5 Remove the Z-80 chip from the logic board. This chip is located in Row C of the logic board between columns 11 and 14.

6.12.1.6 Remove the REV A character generator chip from the logic board. This chip is located in Row A of the logic board between columns 15 and 17.

Remove the chip CAREFULLY so as not to damage it. Store the chip on anti-static foam material.

## 6.12.2 CABLE INSTALLATION

- 6.12.2.1 THE SCREEN-PAC IC harness has a 14-pin connector on one end. The other ends will be bare wire.
- IF THE HARNESS HAS CLIPS, CUT THEM OFF BEFORE CONTINUING.
- 6.12.2.2 The IC harness has 14 wires, numbered from 1 (yellow) to 14. Wires 3 (red) and 11 (yellow) on the 14 pin connector have been cut.
- 6.12.2.3 Strip each wire on the ribbon cable 1/16th inch from the end.

---

### CAUTION

Tin both the IC pin and the wire before soldering. DO NOT apply heat to the IC for more than two seconds when soldering. Cold solder joints must be avoided.

---

- 6.12.2.4 Tin and solder each wire to the IC chips on the main logic board as shown in Table 1.
- 6.12.2.5 A short length of coaxial cable is connected to IC U1 on the SCREEN-PAC board. If a clip is attached to this cable, CUT IT OFF, then solder the cable to IC B13 on the logic board (see Table 1).

TABLE 1. SOLDER CONNECTIONS

LOGIC BOARD		RIBBON CABLE COLOR CODE and WIRE NO.		SCREEN-PAC	
IC	PIN No.			IC	PIN No.
B11	12	Blue	9	-	
B16	1	Grey	7	-	
D14	5	Orange	12	-	
D16	4	Red	13	-	
D16	5	Brown	14	-	
D17	11	Brown	4	-	
D17	12	White	6	-	
D17	13	Purple	8	-	
D17	14	Green	10	-	
D16	14	Orange	2	-	
E13	1	Yellow	1	-	
E22	12	Black	5	-	
B13	6	Coax (center conductor)		U1	15
B13	7	Coax (ground shield)		U1	8

### 6.12.3 PC BOARD INSTALLATION

6.12.3.1 Hold the SCREEN-PAC PC board component-side-up and align it with the main logic board as follows:

SCREEN-PAC Board		PC Board
Video connector socket	aligns with	10-pin connector*
Z-80 pins	align with	40-pin socket
Character generator pins	align with	24-pin socket

\*This is the 10 pin connector located near the RESET button.

6.12.3.2 Each kit provides two wire wrap spacers. These should be positioned onto the wire wrap pins located on the trace side of the SCREEN-PAC board. These will help align the wire wrap pins during installation.

6.12.3.3 Press the SCREEN-PAC board in place on the main logic board. Be careful not to bend or break any pins.

6.12.3.4 Two retainer clips hold the SCREEN-PAC board to the main logic board.

6.12.3.5 Position one retainer clip on the edge of the SCREEN-PAK board between the character generator and column 13 on the rear of the logic board. The small tab on the clip should fit into the small hole on the main logic board. We suggest you use Tac-Pack (Loctite) adhesive to fasten this clip between columns 13 and 14 on the main logic board.

6.12.3.6 Position the second retainer clip on the opposite edge of the SCREEN-PAC board. We suggest you use TAC-PAK (Loctite) adhesive to fasten this clip on the main logic board between the SCREEN-PAC ribbon cable and the video brightness control.

6.12.3.7 Hold the main logic board component-side-up. Locate the 40-pin socket near the center of the SCREEN-PAC board and the 24-pin socket.

6.12.3.8 Carefully insert the Z-80 chip into the 40 pin socket on the SCREEN-PAC board. Align the notch on the Z-80 chip with the notch on the IC socket.

---

**NOTE**

---

Be very careful not to bend or break any of the wire-wrap pins under the SCREEN-PAC board.

---

- 6.12.3.8 Carefully press the REV A character generator chip onto the 24-pin socket near the edge of the SCREEN-PAC board. Align the notch on the character generator chip with the notch on the IC socket.

**6.12.4 RCA EXTERNAL VIDEO CONNECTOR**

- 6.12.4.1 The RCA external video connector requires a 1/4 inch hole through the front bezel next to the "BATTERY" cut-out. Use the template to position the hole properly.

The RCA connector includes a ground ring, washer and a 7/16 inch nut to secure it to the chassis bezel.

- 6.12.4.2 Press the template into place against the front surface of the bezel. Align the cut-outs on the template with the RESET and BATTERY cut-outs on the bezel.
- 6.12.4.3 Carefully drill a 1/4 inch hole through the front of the bezel at the point marked with the template.
- 6.12.4.4 The RCA video cable is a coaxial cable. The ground wire is attached to the ground ring. The center conductor carries the video signal.
- 6.12.4.5 Insert the RCA video connector through the 1/4 inch hole in the chassis bezel from the outside. The connector socket faces out.
- 6.12.4.6 Install the ground ring, the washer and the 7/16 inch nut on the RCA video connector shaft. Carefully tighten the nut until the connector is firmly in place.
- 6.12.4.7 Slide the signal connector on the RCA cable onto the center pin of the RCA video connector.

### 6.12.5 SCREEN-PAC POWER HARNESS

- 6.12.5.1 A 3-connector power harness runs from the power supply to the SCREEN-PAC PC board. The connector in the center of the harness is capped and not used.
- 6.12.5.2 Attach the uncapped 3-wire harness connector to the DC output connector on the power supply. This connector is keyed to fit only one way.
- 6.12.5.3 Attach the 2-wire harness connector to P1 (DC input) on the SCREEN-PAC PC board. The cable is keyed to connect only one way.

### 6.12.6 LOGIC BOARD INSTALLATION

- 6.12.6.1 Insert the 14-pin connector on the ribbon cable into socket P3 at the front of the SCREEN-PAC board.
- 6.12.6.2 Attach the drive and power connectors to the logic board (Section 6.2.5 or 6.8.5). Connect the internal video harness to position P2 on the SCREEN-PAC PC board.
- 6.12.6.3 Reassemble the logic board to the chassis. See Section 6.12.8 to test SCREEN-PAC functions.
- 6.12.6.4 If SCREEN-PAC functions correctly, reassemble the chassis and case except for the front bezel (Sections 6.2.6 or 6.8.6).
- 6.12.6.5 Position the bezel next to the case. Connect the RCA video cable to the 2-pin connector behind P2 on the SCREEN-PAC board. The RCA video cable is keyed to fit only one way.
- 6.12.6.6 Attach the bezel and keyboard to complete reassembly of the unit.

### 6.12.7 OSBORNE EXTERNAL VIDEO MONITORS

- 6.12.7.1 Osborne 12 inch video monitors need an adaptor assembly for connection to the RCA socket. OCC will provide this adaptor to end users with these monitors upon their request directly to OCC.

## 6.12.8 SCREEN-PAC TEST PROCEDURE

- 6.12.8.1 Use a write-protected copy of the EXTENDED UTILITY DISKETTE for this procedure.
- 6.12.8.2 Insert the Extended Utility Diskette in drive A.
- 6.12.8.3 Insert a WordStar copy in drive B.
- 6.12.8.4 See the SCREEN-PAC User's Guide to SYSGEN CP/M from the EXTENDED UTILITY DISKETTE to the WORDSTAR diskette.
- 6.12.8.5 See pages 7 - 10 of the SCREEN-PAC User's Guide to SETUP WordStar for 80 column format.
- 6.12.8.6 Insert the WordStar diskette in drive A and a formatted diskette in drive B.
- 6.12.8.7 Boot WordStar and log onto drive B. The characters on screen should appear smaller and shifted to the left.
- 6.12.8.8 Repeat steps 6.12.8.5 through 6.12.8.7 for 104 column format and verify correct operation at 104 columns.
- 6.12.8.9 If no difference is apparent between 52, 80, and 104 column screens, SCREEN-PAC is not installed correctly.  
  
Check all cable connections, then refer to the SCREEN-PAC troubleshooting chart if necessary.
- 6.12.8.10 If SCREEN-PAC problems cannot be solved, contact OCC Field Service.
- 6.12.8.11 Return sub-REV level main logic boards or video monitors removed for SCREEN-PAC. Specify DEALER UPGRADE below the Mechanical Adjustment entry on the MRA form.

### 6.12.9 SCREEN-PAC TROUBLESHOOTING

Symptoms: Scrambled screen display  
Flickering screen  
Missing letters/parts of words  
Non-functional in 52 or 80 column mode

#### 6.12.9.1 Scrambled Screen Display

1. Check IC harness connections
2. Check for power to the SCREEN-PAC board
3. Check input connector orientation at the the SCREEN-PAC board.
4. Check Z80 and REV A character generator chips for proper seating, and bent or broken pins.
5. Check that the logic board does not have AMP sockets.
6. Check that the 1.4" Monitor ROM is at D12 on the logic board.
7. Check pins 6 and 7 at B13 for correct coaxial connection.

#### 6.12.9.2 Flickering Screen

1. Check for cold solder joints.
2. Check that all IC clips have been removed, and their wires soldered in place.

#### 6.12.9.3 Missing Letters/Parts of Words

1. Check for bent or mis-connected wire-wrap pins.
2. Reseat the SCREEN-PAC board.

#### 6.12.9.4 Non-Functional in 52 or 80 Column Mode

1. Check for solder bridges.
2. Check IC harness connections.



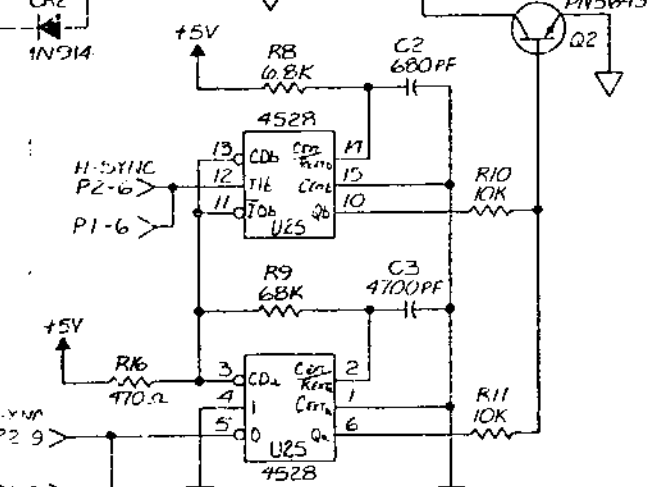
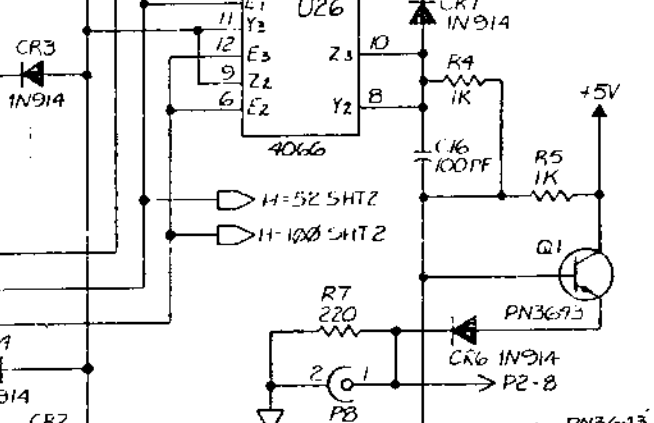
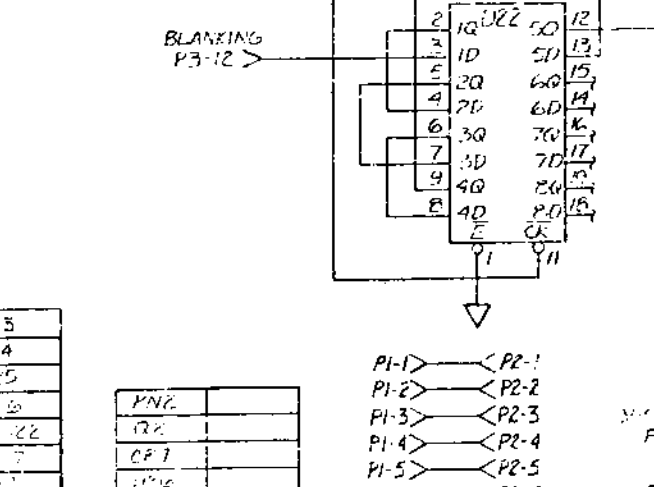
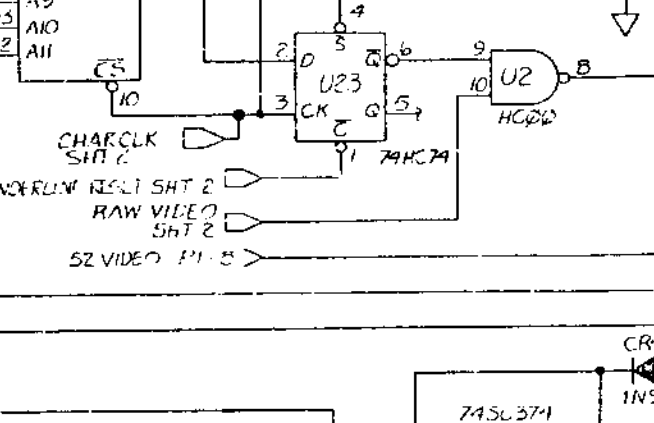
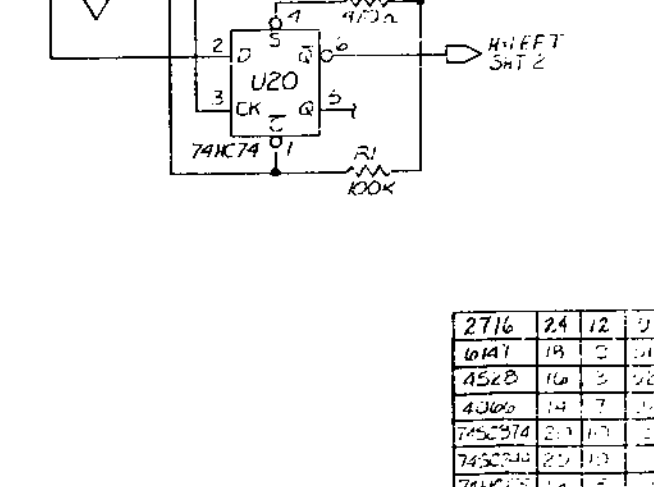
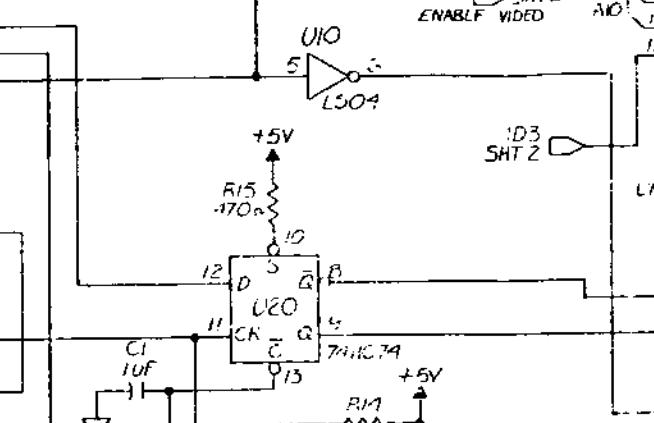
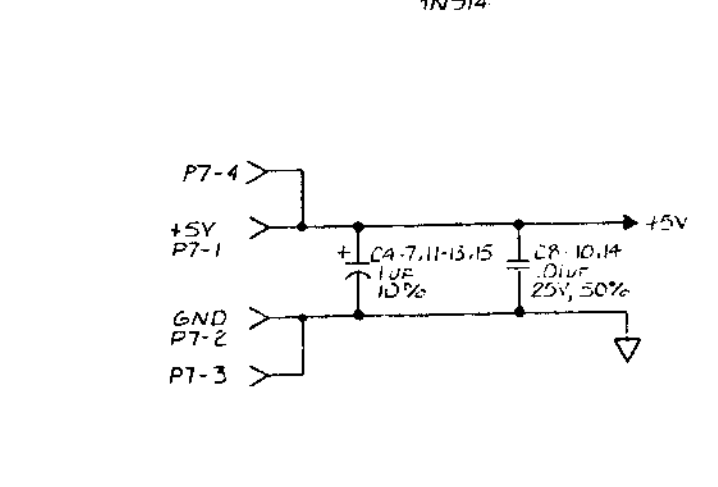
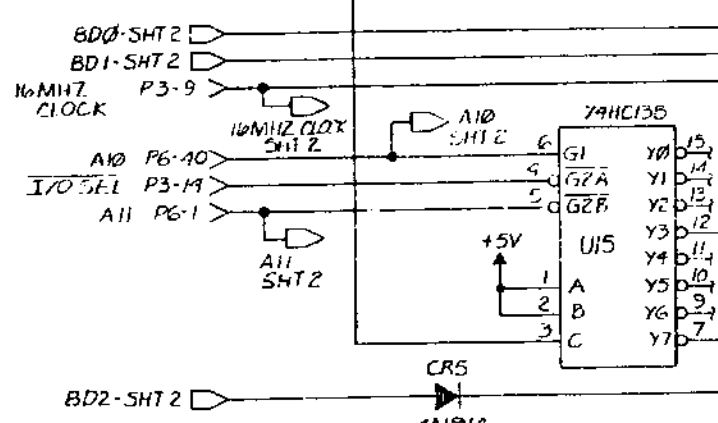
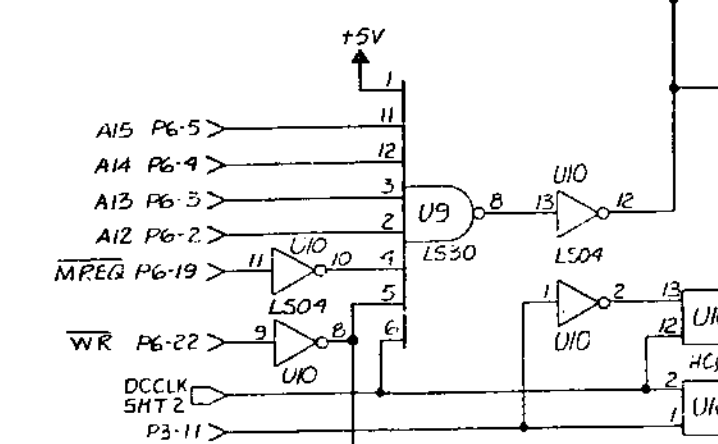
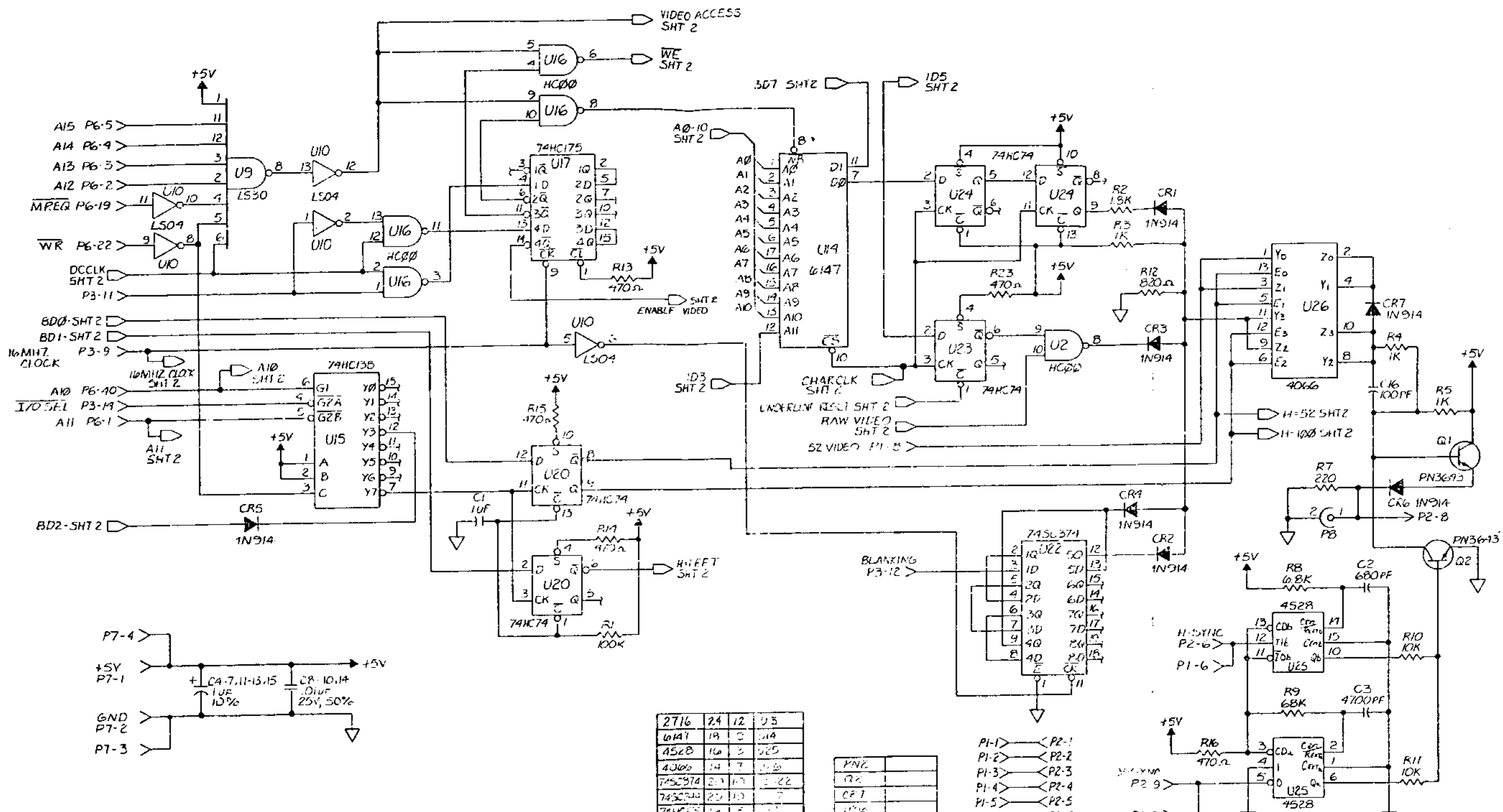

4. LOCATIONAL CODING, SIGNAL NAME & SHEET NO. EXAMPLE: ID3 SHT 2 INDICATES SHEET TO SHEET CONNECTION. ID2 INDICATES SAME SHEET CONNECTION.
  3. ALL CAPACITORS ARE IN MICROFARADS.
  2. P/N1 & P/N2 ARE Ω Ω OHMS.
  1. ALL RESISTORS ARE IN OHMS UNLESS OTHERWISE SPECIFIED.
- NOTES UNLESS OTHERWISE SPECIFIED

2716	24	12	U3
6147	18	5	U4
4528	16	3	U5
4066	14	7	U6
74LS374	20	17	U7
74LS147	20	10	U8
74HC74	16	7	U9
74LS100	16	5	U10
74HC175	16	15	U11
74HC135	16	15	U12
74LS104	14	7	U13
74LS10	14	7	U14
74LS104	14	7	U15
74LS10	14	7	U16
74LS10	14	7	U17
74LS10	14	7	U18
74LS10	14	7	U19
74LS10	14	7	U20
74LS10	14	7	U21
74LS10	14	7	U22
74LS10	14	7	U23
74LS10	14	7	U24
74LS10	14	7	U25
74LS10	14	7	U26
74LS10	14	7	U27
74LS10	14	7	U28
74LS10	14	7	U29
74LS10	14	7	U30
74LS10	14	7	U31
74LS10	14	7	U32
74LS10	14	7	U33
74LS10	14	7	U34
74LS10	14	7	U35
74LS10	14	7	U36
74LS10	14	7	U37
74LS10	14	7	U38
74LS10	14	7	U39
74LS10	14	7	U40

P/N1	
R2	
C7	
U6	
R22	
U2	
U23	
U24	
U25	
U26	
U27	
U28	
U29	
U30	
U31	
U32	
U33	
U34	
U35	
U36	
U37	
U38	
U39	
U40	

- P1-1 < P2-1
- P1-2 < P2-2
- P1-3 < P2-3
- P1-4 < P2-4
- P1-5 < P2-5
- P1-7 < P2-7
- P1-10 < P2-10

FEB 01 1983

**RELEASED MFR**

PART NUMBER: 1100001

**OSBORNE** COMPUTER CORPORATION  
26500 Corporate Avenue  
Hayward, California 94545  
415-887-8000

SCREEN PAC P/B SCHEMATIC

DATE	REV	DESCRIPTION	DATE	APPROVED
1/24/85	1	FIRST RELEASE ECO # 0479		EL

APPLICATION: SCREEN PAC P/B  
DO NOT SCALE DRAWING

SCALE: 1:1  
SHEET: 1 OF 1

REV. NO.	REV.	REV.	DATE	APPROVED
1	2	A		

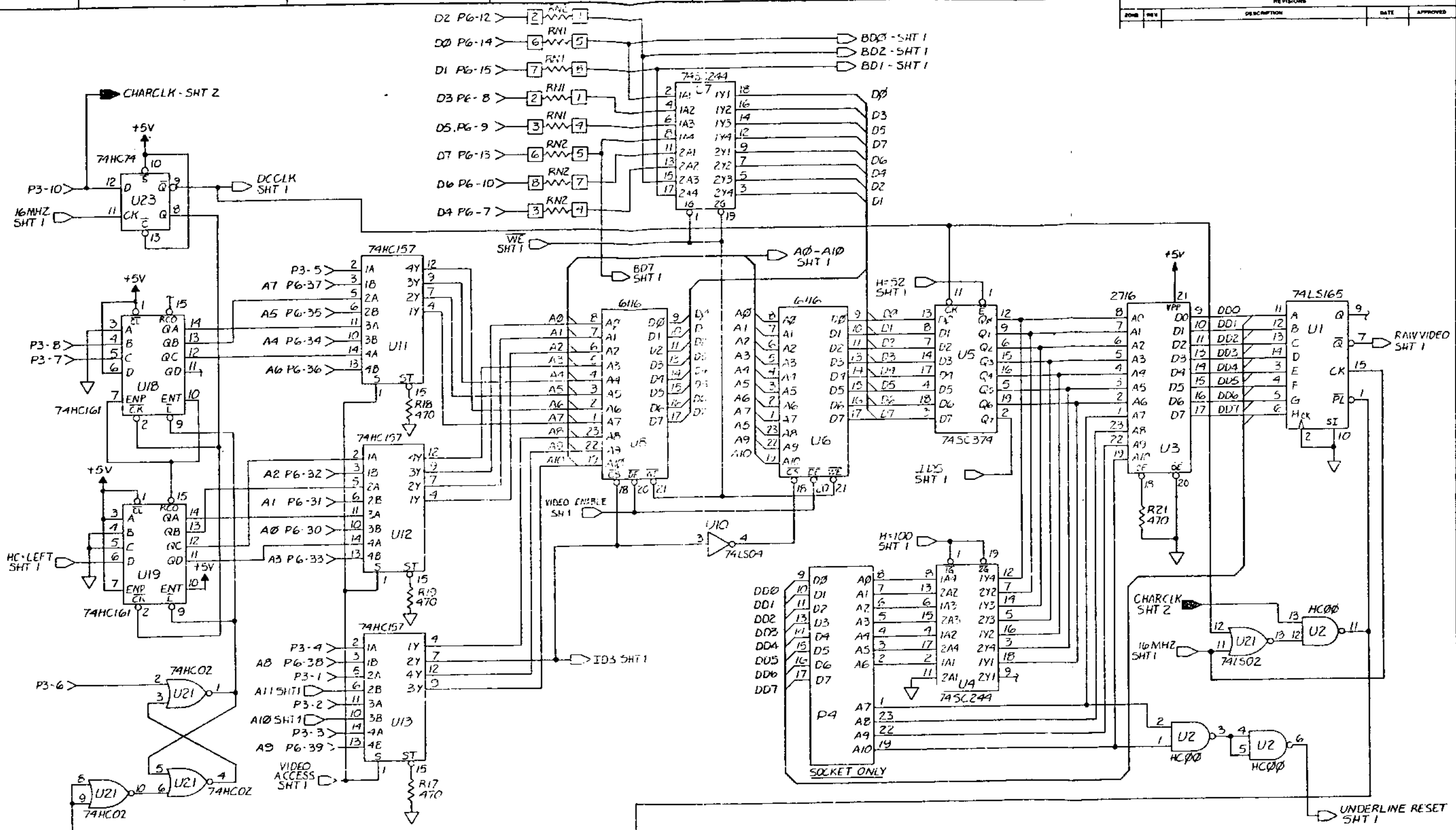

**RELEASED AFR**

FEB 01 1983

<b>OSBORNE</b> COMPUTER CORPORATION 26500 Corporate Avenue Hayward, California 94545 415-887-8000		APPROVALS: _____ DATE: _____ DRAWN: <i>JK</i> 12/16/82 CHECKED: _____ DESIGNED: <i>[Signature]</i> 11/16/82	
MATERIAL: _____ FABRIC: _____		DRAWING NO: <b>1N000P1</b> SHEET: <b>2 OF 2</b>	

## 6.12.0 OCC 1/1A SCREEN-PAC INSTALLATION

---

### NOTE

*If a unit is receiving both double-density and SCREEN-PAC upgrade, do the double-density installation first (see Section 6.11.0).*

---

#### 6.12.0.1 AMP SOCKETS BULLETIN

Before making the 80-column installation, **INSPECT** the 40-pin Z80 socket and the 24-pin character generator socket on the main logic board.

If you see the manufacturer's name, **AMP**, on either socket, **DO NOT PROCEED** with 80-column installation.

The pins on the underside of the 80-column PC board do not correctly fit **AMP** sockets.

**AMP** sockets are on some, but not all, logic boards lower than Rev K.

If you have a logic board with **AMP** sockets, contact OCC Field Service for replacement.

#### 6.12.0.2 VIDEO MONITOR BULLETIN

Before making the 80-column installation, **INSPECT** the 5" internal monitor. Black-and-white monitors with 2 PC boards will **NOT** function correctly with SCREEN-PAC installed.

These monitors cause uncontrollable vertical rolling of any external monitor connected to the computer.

If you have a black-and-white, 5" internal monitor with 2 PC boards, **DO NOT** proceed with SCREEN-PAC installation.

Contact OCC Field Service for replacement.

6.12.0.3 These tools are needed for SCREEN-PAC installation:

Set of basic electronic hand tools  
Extended Utility Diskette  
2.0 Diagnostics Diskette  
7/16-inch wrench  
Drill and 1/4-inch bit

6.12.0.4 SCREEN-PAC components include:

- (1) SCREEN-PAC PC Board with (2) pin spacers
- (1) SCREEN-PAC ribbon cable and clips
- (1) 2732 monitor ROM chip, Rev 1.43
- (1) SCREEN-PAC power harness
- (1) Composite external video connector and cable
- (1) Template
- (2) PC Board retainer clips

---

**NOTE**

*The main logic board must be Rev. G or higher. Return earlier boards to OCC for upgrading.*

---

6.12.0.5 INSPECT the unit being upgraded as follows and note any damage.

1. Check the case, handle, and AC power panel for damage.
2. Check that all keys are in place on the keyboard.
3. Detach the keyboard from the unit. Check the keyboard cable and connector for damage.
4. Check the keyboard connector on the front bezel for bent or broken pins.
5. Check the video monitor and video contrast/brightness knobs for damage.

- 6.12.0.6 After completing visual inspection, turn the computer ON.
- 6.12.0.7 Check the video image for clarity and the video controls for correct function.

IF THE UNIT PASSES FUNCTIONAL INSPECTION, proceed with SCREEN-PAC installation.

### **6.12.1 PC Board Assembly**

- 6.12.1.1 Disassemble the unit down to the logic board (Sections 6.1.2 or 6.7.2).
- 6.12.1.2 Place the logic board flat on a soft work surface, component-side up and video shafts closest to technician.
- 6.12.1.3 If the monitor ROM (position D12 on the logic board) is not REV 1.43, remove it. Install a REV 1.43 ROM in its place. The notch on the ROM aligns with the notch on the logic board socket.
- 6.12.1.4 There must be a jumper at logic board position J3. Install one if necessary.
- 6.12.1.5 Remove the Z-80 chip from the logic board. This chip is located in Row C of the logic board between columns 11 and 14 (Figure 6-31).
- 6.12.1.6 Remove the REV A character generator chip from the logic board. This chip is located in Row A of the logic board between columns 15 and 17.

### **6.12.2 Cable Installation**

- 6.12.2.1 The SCREEN-PAC ribbon cable has a 14-pin connector on one end. The other end splits into 8 segments, each attached to a clip. Each clip is labelled and fits onto one of the logic board IC chips (Figure 6-32).
- 6.12.2.2 Attach the clips on the ribbon cable to the logic board as follows. The notch (or dot) on each clip aligns with the notch on each IC chip.

Be sure the 14-pin ribbon cable connector faces UP as you attach these clips.

Clip		logic board chip
B11	attaches to	B11
B16	attaches to	B16
D14	attaches to	D14
D16	attaches to	D16
D17	attaches to	D17
D18	attaches to	D18
E13*	attaches to	E13
E22*	attaches to	E22

E13 and E22 are 14-pin chips. Install E13\* so pins 7 and 8 overhang chip E13. Install E22\* so pins 1 and 14 overhang chip E22 (Figure 6-32).

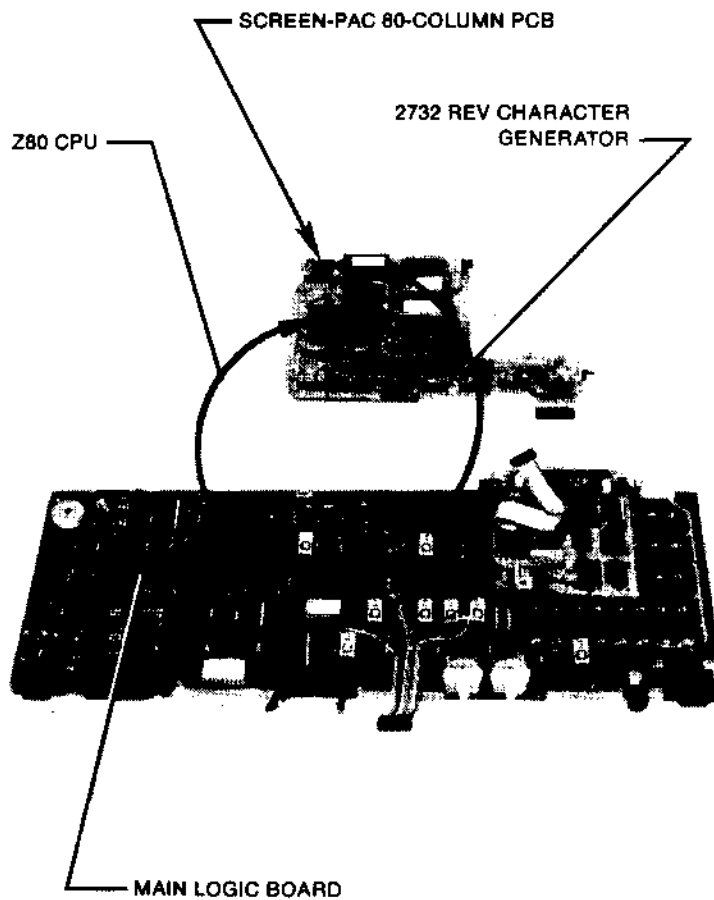

FIGURE 6-31. SCREEN-PAC 80-COLUMN PCB

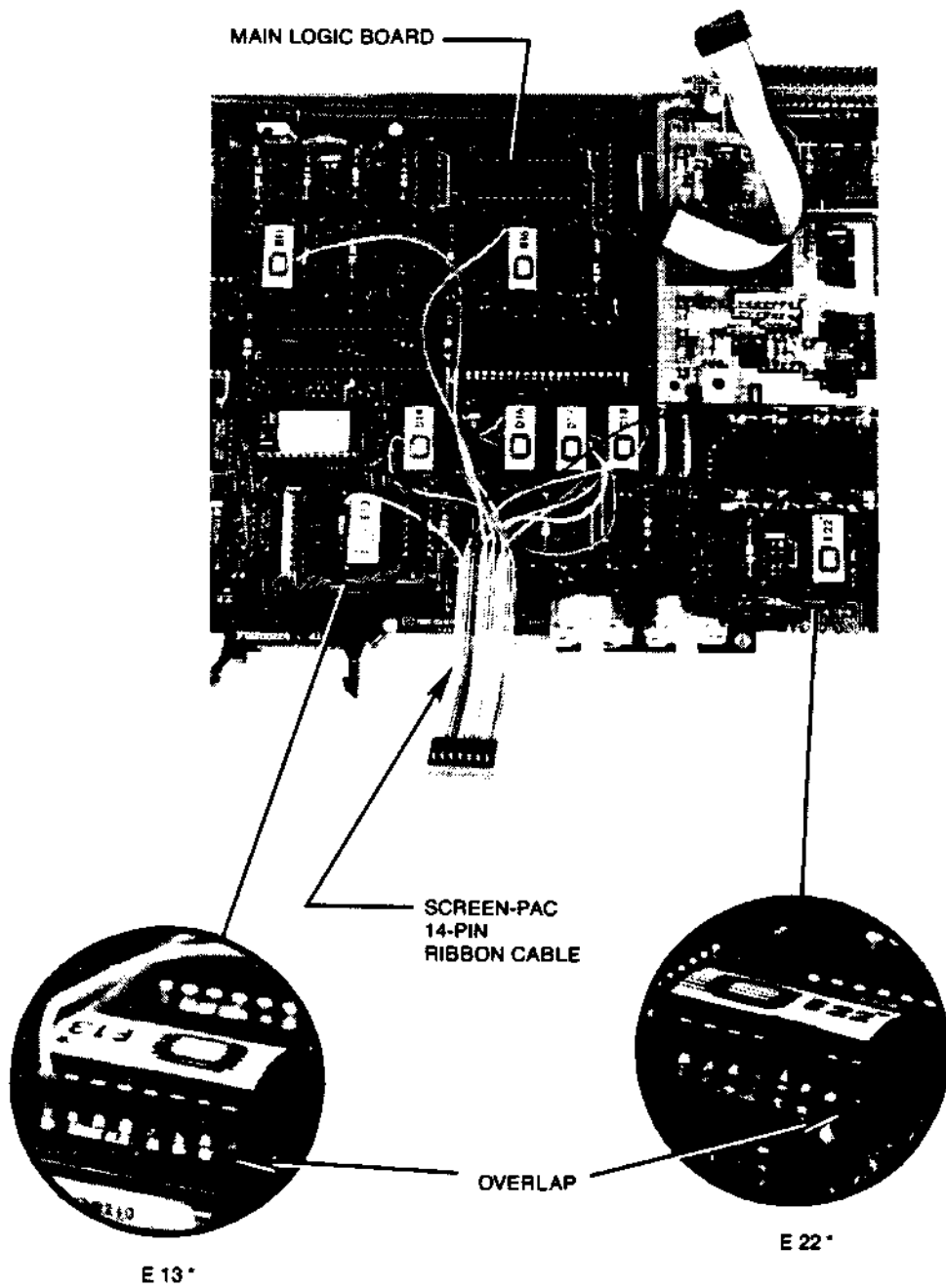
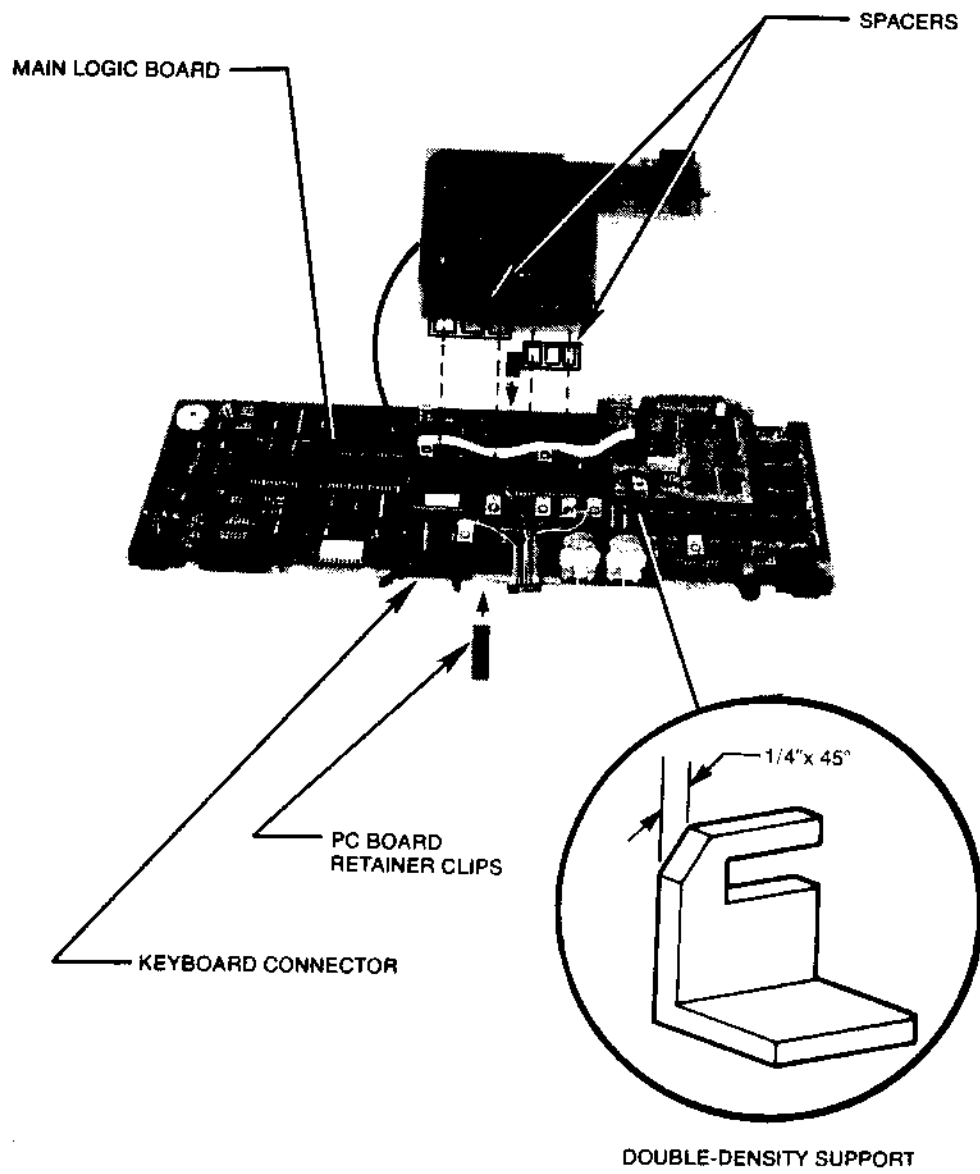

FIGURE 6-32. CHIP POSITIONINGS



**FIGURE 6-33. POSITIONING AND ALIGNMENT**



### 6.12.3 PC Board Installation

- 6.12.3.1 Hold the SCREEN-PAC PC board component-side up and align it with the main logic board as follows (Figure 6-33):

SCREEN-PAC Board		PC board
video connector pins	align with	10-pin socket
Z-80 pins	align with	40-pin socket
character generator pins	align with	24-pin socket

- 6.12.3.2 Press the SCREEN-PAC board into place on the main logic board. Be careful not to bend or break any pins. Use the pin spacer to help align the pins.

---

#### NOTE

*If a double-density PC board is already in place, make a diagonal cut in the stand-off between it and the SCREEN-PAC board. This allows the SCREEN-PAC board to fit next to the double-density board.*

---

- 6.12.3.3 Two retainer clips secure the SCREEN-PAC PC board to the main logic board (Figure 6-33).

Position one retainer clip on the edge of the SCREEN-PAC board between the character generator and connector P4/13. Fasten this clip to the small hole between rows 13 and 14 on the main logic board.

Position the second retainer clip on the opposite edge of the SCREEN-PAC board. Fasten this clip to the main logic board between the SCREEN-PAC ribbon cable and the video brightness control.

- 6.12.3.4 Hold the main logic board component-side up. Locate the 40-pin socket near the center of the SCREEN-PAC board and the 24-pin socket near one edge (Figure 6-31).
- 6.12.3.5 Carefully press the Z-80 chip onto the 40-pin socket of the SCREEN-PAC board. Align the notch on the Z-80 chip with the notch on the PC board trace.

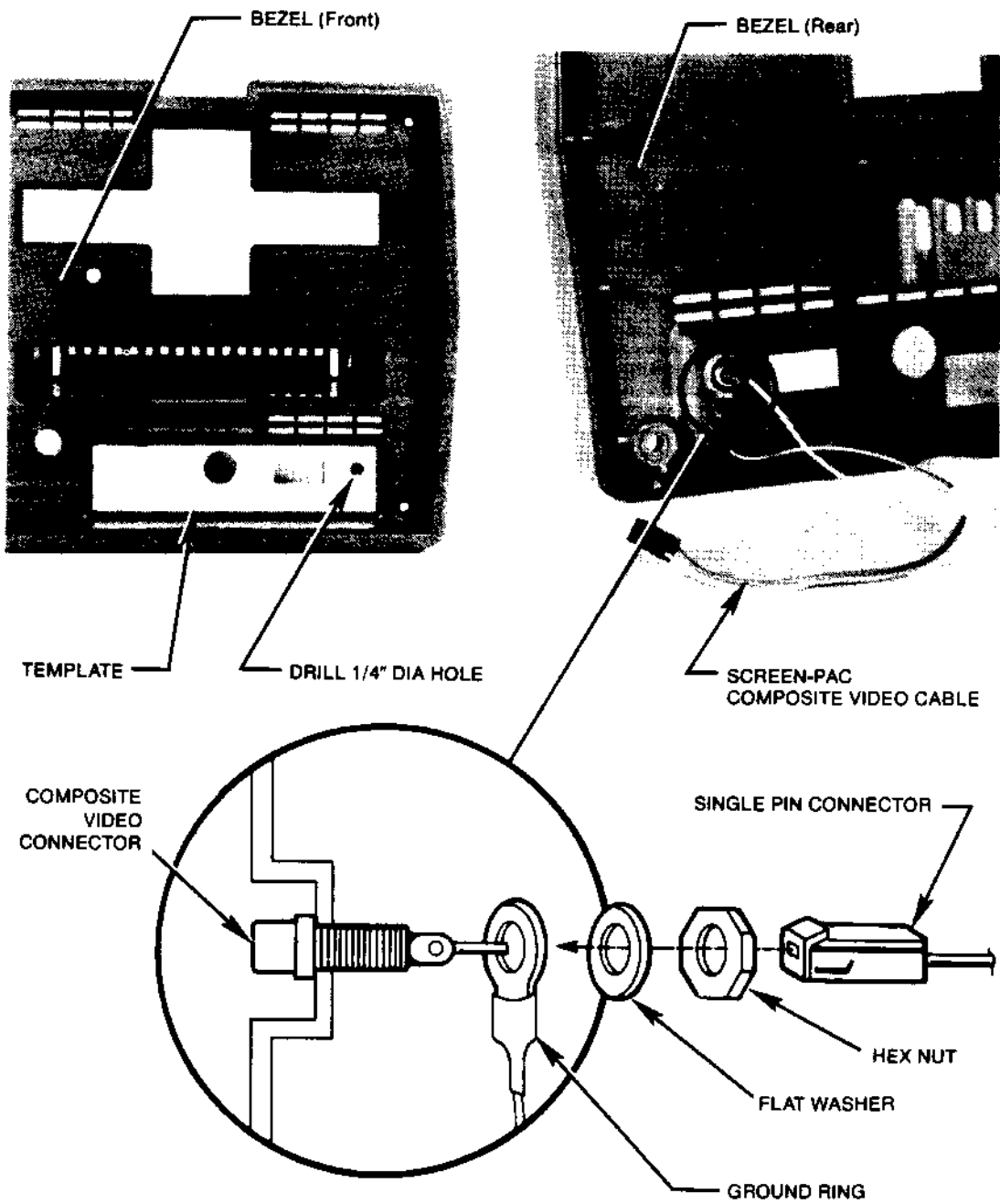

**FIGURE 6-34. RCA CONNECTOR INSTALLATION**

---

**NOTE**

*Be very careful not to bend/break any of the pins on the underside of the SCREEN-PAC PC board.*

---

- 6.12.3.6 Carefully press the character generator chip onto the 24-pin socket near the edge of the SCREEN-PAC PC board. Align the notch on the character generator chip with the notch on the PC board trace.

### **6.12.4 RCA External Video Connector**

- 6.12.4.1 The RCA external video connector requires a 1/4-inch hole through the front bezel next to the BATTERY cut-out. Use the template to position this hole correctly.

The RCA connector includes a ground ring, washer, and 7/16-inch nut to secure it to the chassis bezel (Figure 6-34).

- 6.12.4.2 Press the template into place against the *front surface* of the bezel. Align the cut-outs on the template with the RESET and BATTERY cut-outs on the bezel.
- 6.12.4.3 Carefully drill a 1/4-inch hole through the front of the bezel at the point marked by the template.
- 6.12.4.4 The RCA video cable has two wires. The green ground wire is attached to the ground ring. The blue wire is the video signal (Figure 6-34).
- 6.12.4.5 Insert the RCA video connector through the 1/4-inch hole in the chassis bezel from the outside in. The connector socket faces out.
- 6.12.4.6 Install the ground ring, the washer, and the 7/16-inch nut on the RCA video connector shaft. Carefully tighten the nut until the connector is securely in place (Figure 6-34).
- 6.12.4.7 Insert the blue video wire onto the pin of the RCA video connector.

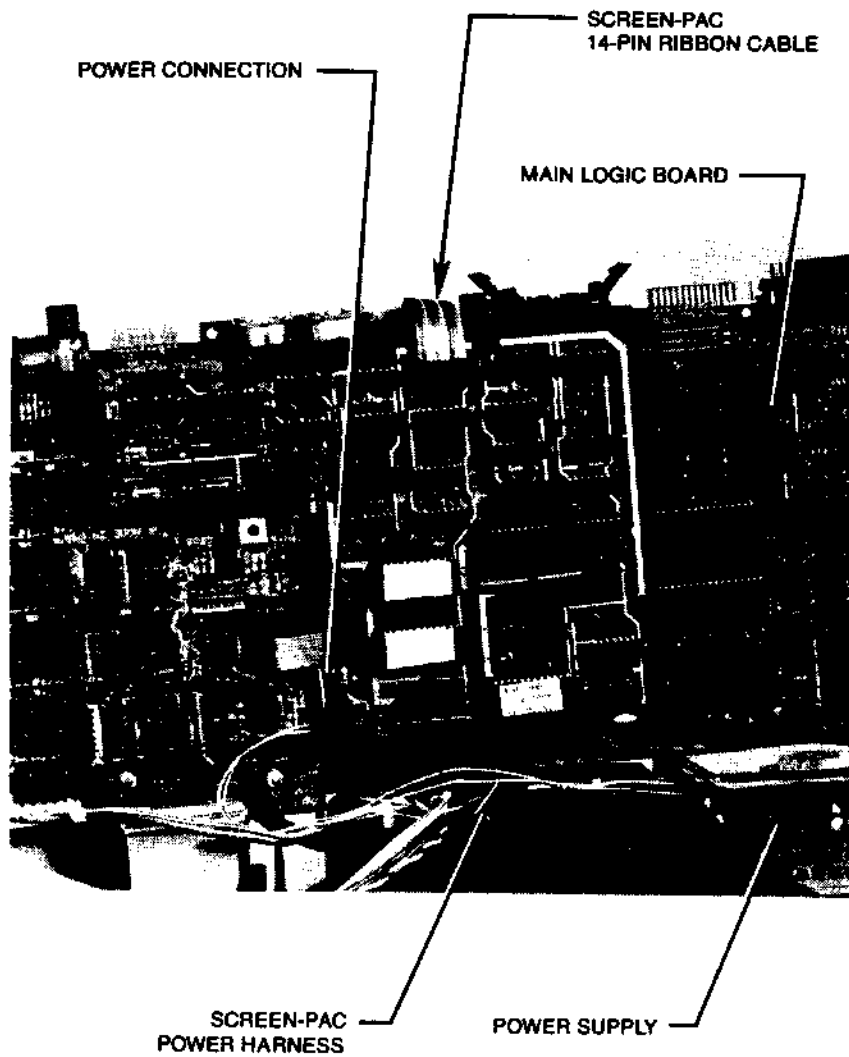

**FIGURE 6-35. POWER HARNESS**

### **6.12.5 SCREEN-PAC Power Harness**

- 6.12.5.1 Press the 14-pin connector on the ribbon cable onto the socket at the front of the SCREEN-PAC board (Figure 6-35).
- 6.12.5.2 A 2-wire power harness runs from the power supply to the SCREEN-PAC PC board.
- 6.12.5.3 Attach the connector on the power harness to the DC output connector on the power supply. The connector is keyed to fit only one way (Figure 6-35).
- 6.12.5.4 With the logic board held vertically, connect the 2-wire cable from the power supply to the ground connection on the SCREEN-PAC PC board. The cable is keyed to connect only one way (Figure 6-35).

### **6.12.6 Logic Board Installation**

- 6.12.6.1 Reassemble the logic board (see Section 6.2.5 or 6.8.5). Connect the internal video harness to position P2 on the SCREEN-PAC PC board (Figure 6-36).
- 6.12.6.2 Reassemble the logic board to the chassis. Using 52- or 80-column format, check video alignment and focus. Adjust if necessary (see Sections 6.6.2 and 6.6.3).
- 6.12.6.3 Reassemble the chassis and case except for the front bezel (Sections 6.2.6 or 6.8.6).
- 6.12.6.4 Connect the RCA video cable to the 2-pin connector behind position P2 on the SCREEN-PAC board. The RCA video cable is keyed to fit only one way (Figure 6-37).
- 6.12.6.5 Complete reassembling the unit.

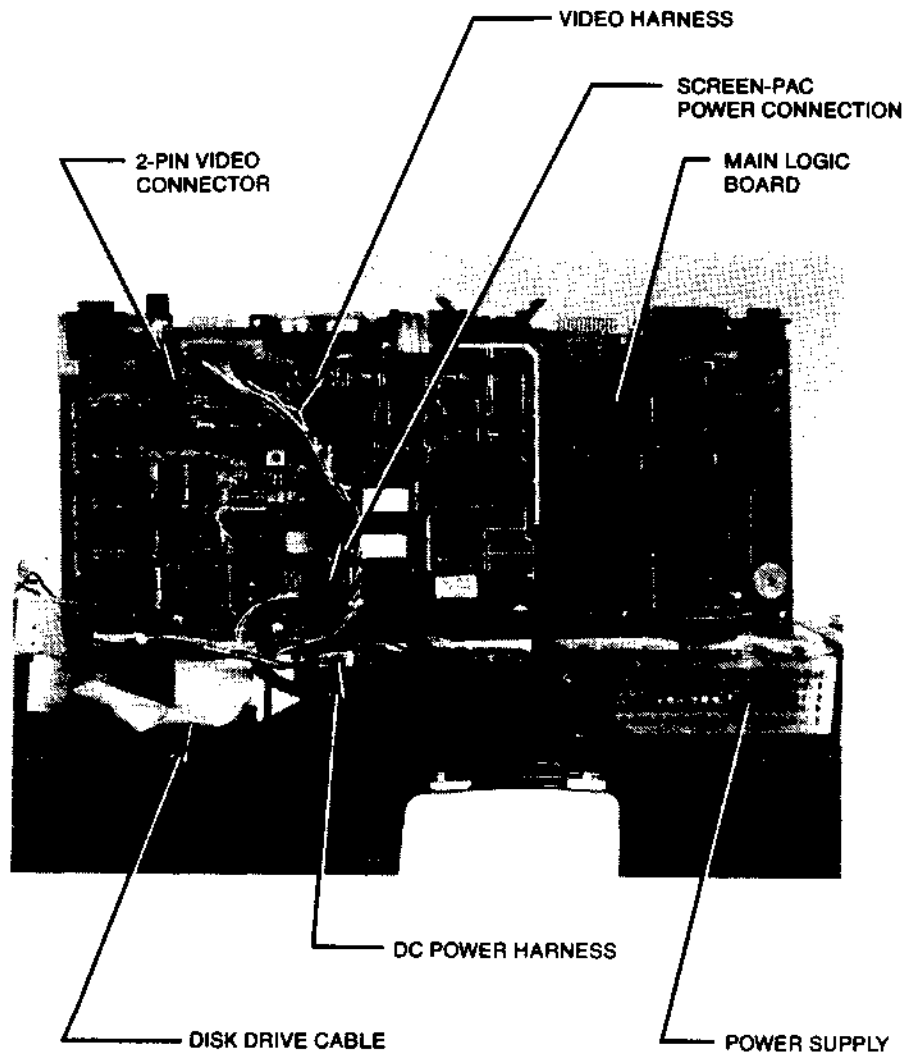

**FIGURE 6-36. HARNESS RECONNECTION**

### 6.12.7 Osborne External Video Monitors

Osborne 12-inch video monitors need an adaptor cable for connection to the RCA socket. OCC will provide this adaptor to end users with these monitors.

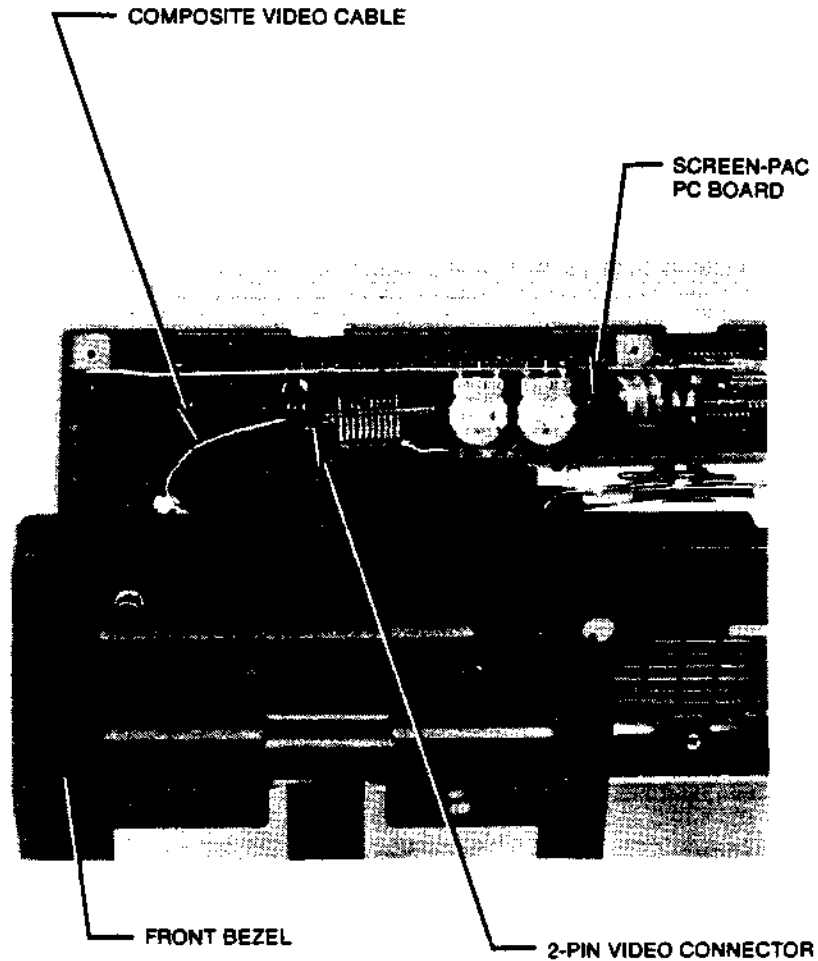

**FIGURE 6-37. VIDEO CABLE CONNECTION**

## SCREEN-PAC TROUBLESHOOTING GUIDE

PROBLEM	ACTION
Continuous beep when unit is switched ON	Switch OFF for 5 seconds. Then switch ON again.  Check Z80 chip, Z80 connector, and 40-pin socket for bent/broken pins.
Scrambled logo when unit is switched ON	Check SETUP program for 128 logical screen size.
Lines across screen in 52- and 80-column format	Check 24-pin character generator for secure fit and bent/broken pins.
No video display	Check power cable connections at PC board and power supply.
Only 52-column format functions correctly	<ol style="list-style-type: none"><li>1. Check power harness.</li><li>2. If problem continues, replace SCREEN-PAC PC board.</li></ol>



## DOUBLE-DENSITY TROUBLESHOOTING GUIDE

PROBLEM	ACTION
System doesn't power up	Check double-density installation Replace double-density PC board Replace ribbon cable
Reduced screen display	Check double-density installation Replace double-density PC board Replace ribbon cable
Drive not ready	Check double-density installation Replace double-density PC board Replace ribbon cable
Wavy or blank screen	Check double-density installation Replace double-density PC board Replace ribbon cable
Gaps in sign-on message	Replace Rev 1.43 monitor ROM See Section 7.3.4
Continuous beep on power-up	Replace Rev 1.43 monitor ROM See Section 7.5.1
Boot errors	Check double-density installation Check power supply voltages (Section 7.1.1) Check drive alignments (Sections 6.3.0-6.5.0) Replace double-density PC board Replace ribbon cable
BDOS errors	Check double-density installation Check power supply voltages (Section 7.1.1) Check drive alignments (Sections 6.3.0-6.5.0) Replace double-density PC board Replace ribbon cable
Drive errors during Confidence Test	Check power supply voltages Check drive alignments Check double-density op-amp (Section 7.8.9) Replace double-density PC board Replace ribbon cable
Single-density software not being read	See Double Density Installation Advisory

# **Troubleshooting and Preventive Maintenance**

## QUICK TROUBLESHOOTING GUIDE

<b>Problem</b>	<b>See</b>
System doesn't power up Reduced screen display/ Slow-running disk Drive errors during applications	Power Problems (7.1.0)
Boot read error Drive not ready BDOS errors	Drive Problems (7.2.0)
Wavy screen Screen not centered Blank screen Sign-on message gaps Flashing sign-on message	CRT Malfunctions (7.3.0)
Individual key malfunction Complete keyboard failure Displayed character/key struck do not correspond	Keyboard Malfunctions (7.4.0)
Continuous beep on power up Scattered video display Memory error during diagnostics	Logic Board Problems (7.5.0)
No output to printer Printer drops characters Scrambled printout	Port Problems (7.6.0)

---

## 7.0.0 Troubleshooting Technique

---

- 7.0.0.1 The first step in troubleshooting the Osborne system is to determine whether the problem is with an OCC component or external to the system. Disconnect such devices as printer, external monitor, modem, etc., and test the Osborne to see if the problem still occurs. If it does, use Osborne-supplied diagnostics and this troubleshooting guide to identify and correct the problem. See Chapter Six of the Field Service Manual for detailed instructions about module assembly, disassembly and replacement.
- 7.0.0.2 If there is no problem with external device(s) disconnected, test the external device(s) and the Osborne/external device interface (RS232 port, mondapt, etc.).
- 7.0.0.3 Make a thorough visual inspection of all modules suspected of malfunctioning.

### 7.0.1 Precautions

- 7.0.1.1 Unless otherwise indicated, DO NOT remove or install any component or connect/disconnect any plug or cable while power is "On".
- 7.0.1.2 Use extreme caution for any procedure which does require power to be "On".
- 7.0.1.3 Identify all cable orientations before making any disconnections.

## 7.1.0 POWER PROBLEMS

- Symptoms:
1. System does not power up
  2. Reduced screen display/slow-running disk
  3. Disk drive errors during applications

### 7.1.1 System Does Not Power Up

- 7.1.1.1 Be sure the power switch is turned "On". Switch it "Off" and then "On" again. If the unit "beeps", the drive activity lights flash, but the video screen remains blank, see Section 7.3.0.
- 7.1.1.2 Test the power source for correct voltages: 120V or 220V as applicable.
- 7.1.1.3 Switch power "Off". Test the AC power fuse or the circuit breaker as applicable. Replace the fuse or AC power panel if necessary. See Sections 6.1.7 and 6.2.0 or 6.7.7 and 6.8.0.
- 7.1.1.4 Check all cables for breaks, faulty connections, etc.
- 7.1.1.5 Check the AC thermal cutout with an ohm-meter. The meter should indicate a short circuit if the thermal cutout is functioning.

**WARNING: THE FOLLOWING TESTS NEED AC POWER "ON". USE EXTREME CAUTION!**

- 7.1.1.6 Check the DC connections at the power supply. Each connector is keyed to attach only one way.

- 7.1.1.7 Disconnect DC input connector from the logic board. Check the following connector wires for voltages indicated:

<u>Wire</u>	<u>Output</u>	<u>Min</u>	<u>Max</u>	<u>Ripple</u>
Pins 1 and 7 (Red)	+12V	+11.40	+12.60	150mV p-p
Pins 2 and 6 (Yellow)	+5V	+4.75	+5.25	50mV p-p
Pins 3 and 5 (Orange)	common			
Pin 4 (Green)	0 voltage			

Test Pins 1 and 7 to 3 and 5, and Pins 2 and 6 to 3 and 5.

1. If voltages are within above limits, the AC and DC power systems are operating correctly.
2. Both voltages are missing.  
REPLACE the AC power fuse.
3. One of the voltages is missing or out of tolerance.  
REPLACE the power supply (see Sections 6.1.4 and 6.2.3 or 6.7.4 and 6.8.3). Recheck power supply voltages.

## 7.1.2 Reduced Screen Display/Slow-Running Disk

- 7.1.2.1 Follow instruction 7.1.1.7 to check the DC voltages to the logic board.
1. Voltages are out of tolerance.  
REPLACE the power supply (see Sections 6.1.4 and 6.2.3 or 6.7.4 and 6.8.3). Recheck power supply voltages.
  2. Voltages are within tolerance.  
REPLACE the video monitor. See Sections 6.1.3 and 6.2.4 or 6.7.3 and 6.8.4.
  3. New monitor installed. Voltages within tolerance.  
REPLACE the logic board. See Sections 6.1.2 and 6.2.5 or 6.7.2 and 6.8.5.

### **7.1.3 Disk Drive Errors During Applications**

7.1.3.1 Follow instruction 7.1.1.7 to check DC voltages to the logic board.

1. Voltages are out of tolerance.  
REPLACE the power supply. See Sections 6.1.4 and 6.2.3 or 6.7.4 and 6.8.3.
2. Voltages are within tolerance.  
See Section 7.2.0 (Disk Drive Problems).

## 7.2.0 DISK DRIVE PROBLEMS

- Symptoms:
1. Boot read error
  2. Drive not ready
  3. BDOS errors

- 7.2.0.1 Run the Drive Alignment Program (DRIVE TIMER, ALT TRACK 0 and 1, and HOME HEAD) as the first step in troubleshooting disk drive problems.

### 7.2.1 Boot Read Error

- 7.2.1.1 Be sure system software and hardware are compatible, all connectors are correctly in place, and cables/harnesses are undamaged.

- 7.2.1.2 Clean the drive head involved. **BE CAREFUL NOT TO DISTURB DRIVE ALIGNMENT OR POSITION.** Use a head cleaning diskette, 97% isopropyl alcohol, or head cleaning fluid only.

- 7.2.1.3 If one drive doesn't boot the system, try the other drive. Then follow the sequence below.

1. Second drive boots correctly, both drive activity lights are on. **CHECK** that the terminator resistor is correctly installed on "A" drive only.
2. Second drive boots correctly. **DISCONNECT** internal video monitor and connect external one. Boot the drive. If drive boots, replace the internal monitor.
3. Internal monitor disconnected, drive does not boot. **SWITCH** position of the drives ("A" to "B" and "B" to "A"). Be sure terminator resistor is in "A" drive only.
4. Error switches with the drive. **REPLACE** or **ALIGN** drive with the boot error.
5. Boot read error doesn't switch. **REPLACE** the drive harness. If error continues, replace the logic board.



7.2.1.4 If neither drive boots, check keyboard and keyboard cable (see Section 7.4.2). Then follow the sequence below.

1. Neither drive boots.  
BOOT each drive with another diskette.
2. One drive boots.  
SEE Section 7.2.1.3.
3. Neither drive boots.  
DISCONNECT internal monitor and boot with an external one.
4. One drive boots with external monitor.  
REPLACE internal monitor and see Section 7.2.1.3.
5. Both drives boot.  
REPLACE internal monitor.
6. Neither drive boots with external monitor.  
REPLACE drive harness.
7. Neither drive boots.  
REPLACE logic board.
8. Neither drive boots.  
REPLACE or ALIGN both drives.

## 7.2.2 Drive Not Ready

7.2.2.1 Clean the drive head involved. BE CAREFUL NOT TO DISTURB DRIVE ALIGNMENT OR POSITION. Use a head cleaning diskette, 97% isopropyl alcohol, or head cleaning fluid only.

7.2.2.2 Be sure all connectors are correctly in place.

7.2.2.3 If one drive doesn't boot the system, try the other drive. Then follow the sequence below.

1. Second drive boots.  
SWITCH position of the drives.
2. Error doesn't switch with the drive.  
REPLACE drive harness.
3. Error switches with drive.  
REPLACE the logic board.

### 7.2.3 BDOS Errors

- 7.2.3.1 Be sure system software and hardware are compatible, all connectors are correctly in place, and cables/harnesses are undamaged.
- 7.2.3.2 Clean the drive head involved. BE CAREFUL NOT TO DISTURB DRIVE ALIGNMENT OR POSITION. Use a head cleaning diskette, 97% isopropyl alcohol, or head cleaning fluid only.
- 7.2.3.3 If one drive has BDOS error(s), try the other drive. Then follow this sequence.
1. Second drive has no BDOS errors.  
DISCONNECT internal video monitor and connect an external one. Boot the drive. If no BDOS errors, replace the internal monitor.
  2. BDOS error continues.  
SWITCH position of the drives and the terminator resistor. If error switches, replace or align drive with BDOS error.
  3. BDOS error doesn't switch with drive.  
REPLACE the disk harness. If error continues, replace the logic board.
- 7.2.3.4 If both drives have BDOS errors, try another diskette. Then follow this sequence.
1. BDOS errors continue.  
DISCONNECT internal monitor and boot with an external one. If one drive is error free, replace internal monitor and see Section 7.2.1.3.
  2. Both drives error free.  
REPLACE internal video monitor.
  3. Both drives have BDOS errors.  
REPLACE disk harness.
  4. Both drives have BDOS errors.  
REPLACE logic board.
  5. Both drives have BDOS errors.  
REPLACE or ALIGN both drives.

## 7.3.0 CRT MALFUNCTIONS

- Symptoms:
1. Wavy screen
  2. Screen not centered
  3. Blank screen
  4. Gaps in the sign-on message
  5. Flashing sign-on message

### 7.3.1 Wavy Screen

7.3.1.1 Follow instruction 7.1.1.7 to check power supply +12V.

1. Voltage is out of tolerance.  
REPLACE the power supply. See Sections 6.1.4 and 6.2.3 or 6.7.4 and 6.8.3.
2. Wavy video display during drive applications.  
REPLACE drive involved. See Chapter Six.
3. Voltage is within tolerance. Drives operate correctly.  
REPLACE the video monitor. See Sections 6.1.3 and 6.2.4 or 6.7.3 and 6.8.4.

### 7.3.2 Screen Not Centered

7.3.2.1 Adjust the video raster. See Section 6.6.4.

7.3.2.2 If the video display is tilted, replace the monitor. See Sections 6.1.3 and 6.2.4 or 6.7.3 and 6.8.4.

### 7.3.3 Blank Screen

7.3.3.1 Turn brightness and contrast controls completely clockwise.

7.3.3.2 Check video harness connectors at the monitor and logic board.

7.3.3.3 Turn power to the system "Off". Check that the external video plug is connected properly.

- 7.3.3.4 Turn power to the system "Off". With the logic board video connector attached, replace the video plug.
- 7.3.3.5 Follow instruction 7.1.1.7 to check power supply +12V. If out of tolerance, replace power supply. Then follow the sequence below.
1. Screen remains blank.  
REPLACE video harness.
  2. Screen remains blank.  
REPLACE video monitor.
  3. Screen remains blank.  
REPLACE logic board.

See Chapter Six for these replacement procedures.

### **7.3.4 Gaps in the Sign-On Message**

- 7.3.4.1 Follow instruction 7.1.1.7 to check power supply +12V. If out of tolerance, replace the power supply. See Sections 6.1.4 and 6.2.3 or 6.7.4 and 6.8.3.
- 7.3.4.2 If gap problem continues, replace the logic board. See Sections 6.2.5 and 6.8.5.

### **7.3.5 Flashing Sign-On Message**

---

**NOTE**

*Don't confuse a flashing sign-on message with a video vertical-hold malfunction.*

---

- 7.3.5.1 Check the keyboard for a stuck alphanumeric key and replace if necessary. See Sections 6.1.0 and 6.2.7 or 6.7.0 and 6.8.7.
- 7.3.5.2 Replace the keyboard cable. See Sections 6.1.0 and 6.2.7 or 6.7.0 and 6.8.7.
- 7.3.5.3 If flashing continues, replace the keyboard. See Sections 6.1.0 and 6.2.7 or 6.7.0 and 6.8.7.

## 7.4.0 KEYBOARD MALFUNCTIONS

- Symptoms:
1. Individual key malfunction
  2. Complete keyboard failure
  3. Displayed character and key struck do not correspond

### 7.4.1 Individual Key Malfunction

- 7.4.1.1 Run a keyboard test (Supersoft Diagnostics) to verify the problem.
- 7.4.1.2 Disconnect the keyboard cable from the unit, reconnect it and retest.
- 7.4.1.3 Check the keyboard connector on the logic board for bent or broken pins. Then follow this sequence.
  1. Malfunction continues.  
REPLACE keyboard cable.
  2. Malfunction continues.  
REPLACE keyboard.
  3. Malfunction continues.  
REPLACE the logic board.

See Chapter Six for these replacement procedures.

## **7.4.2 Complete Keyboard Failure**

### 7.4.2.1 Replace keyboard cable.

1. Failure continues.  
REPLACE keyboard.
2. Failure continues.  
REPLACE logic board.

See Chapter Six for these procedures.

## **7.4.3 Displayed Character and Key Struck Do Not Correspond**

### 7.4.3.1 Replace keyboard cable.

1. Malfunction continues.  
REPLACE keyboard.
2. Malfunction continues.  
REPLACE logic board.

See Chapter Six for these procedures.

## 7.5.0 LOGIC BOARD PROBLEMS

- Symptoms:
1. Continuous beep on power up
  2. Scattered video display
  3. Memory error during diagnostics run

### 7.5.1 Continuous Beep on Power Up

- 7.5.1.1 Disconnect keyboard. If beep continues, replace logic board. See Sections 6.2.5 and 6.8.5.
- 7.5.1.2 Disconnect keyboard. If beep stops, replace the keyboard cable.
1. New cable installed. Beep continues.  
REPLACE keyboard.

### 7.5.2 Scattered Video Display

- 7.5.2.1 Check power supply voltages. See Section 7.1.1.7.
1. Voltages within tolerance.  
REPLACE external video plug.
  2. Voltages within tolerance, problem continues.  
REPLACE the logic board. See Sections 6.2.5 and 6.8.5.

### 7.5.3 Memory Error During Diagnostics Run

- 7.5.3.1 Check power supply voltages. See Section 7.1.1.7.
1. Voltages within tolerance.  
REPLACE the logic board. See Sections 6.2.5 and 6.8.5.

## **7.6.0 RS-232 AND IEEE-488 PORT PROBLEMS**

- Symptoms:
1. No output to printer
  2. Printer drops characters
  3. Scrambled printout

### **7.6.1 No Output To Printer**

Follow this sequence.

1. Check Setup configuration of diskette.
2. Check Install (Wordstar only).
3. Check connectors and interface wiring.
4. Use known good software.
5. Use different printer.
6. Verify printer operates.
7. Replace logic board.

### **7.6.2 Printer Drops Characters**

Follow this sequence.

1. Check Setup configuration of diskette.
2. Check Install (Wordstar only).
3. Check connectors and interface wiring.
4. Replace logic board.



### 7.6.3 Scrambled Printout

Follow this sequence.

1. Check Setup configuration of diskette.
2. Check Install (Wordstar only).
3. Check connectors and interface wiring.
4. Use known good software.
5. Use different printer.
6. Verify printer operates.
7. Replace logic board.

## 7.7.0 PREVENTIVE MAINTENANCE

- 7.7.0.1 The Osborne 1 and 1A do not require scheduled preventive maintenance. OCC does recommend that disk drive heads be cleaned regularly. The conditions in which the system is used will determine the frequency of this service.

*Caution:* When cleaning disk drive heads be very careful not to disturb drive alignment or position. Use a head cleaning diskette, 97% isopropyl alcohol, or head cleaning fluid only.

- 7.7.0.2 Use a mild soap and water solution to clean the exterior of the Osborne case.

## 7.8.0 DOUBLE-DENSITY MALFUNCTIONS

- Symptoms:
1. System doesn't power up
  2. Reduced screen display
  3. Drive not ready
  4. Wavy or blank screen
  5. Gaps in sign-on message
  6. Continuous beep on power-up
  7. Boot errors
  8. BDOS errors
  9. Drive errors during Confidence Test
  10. Single-density software is not being read

---

### NOTE

*This section applies to units which functioned properly before double-density was installed.*

---

### 7.8.1 System Doesn't Power Up

- 7.8.1.1 Check that all double-density components are correctly installed (see Section 6.11.0).
- 7.8.1.2 Replace double-density PC board.
- 7.8.1.3 Replace double-density ribbon cable. If problem continues, see Section 7.1.1.

### 7.8.2 Reduced Screen Display

- 7.8.2.1 Check that all double-density components are correctly installed (see Section 6.11.0).
- 7.8.2.2 Replace double-density PC board.
- 7.8.2.3 Replace double-density ribbon cable. If problem continues, see Section 7.1.2.

### **7.8.3 Drive Not Ready**

- 7.8.3.1 Check that all double-density components are correctly installed (see Section 6.11.0).
- 7.8.3.2 Replace double-density PC board.
- 7.8.3.3 Replace double-density ribbon cable. If problem continues, see Section 7.2.2.

### **7.8.4 Wavy or Blank Screen**

- 7.8.4.1 Check that all double-density components are correctly installed (see Section 6.11.0).
- 7.8.4.2 Replace double-density PC board.
- 7.8.4.3 Replace double-density ribbon cable. If problem continues, see Sections 7.3.1 or 7.3.3.

### **7.8.5 Gaps in Sign-on Message**

- 7.8.5.1 Replace the Rev 1.43 monitor ROM.
- 7.8.5.2 If problem continues, see Section 7.3.4.

### **7.8.6 Continuous Beep on Power-up**

- 7.8.6.1 Replace the Rev 1.43 monitor ROM.
- 7.8.6.2 If problem continues, see Section 7.5.1.

### **7.8.7 Boot Errors**

- 7.8.7.1 Check that all double-density components are correctly installed (see Section 6.11.0).
- 7.8.7.2 Check power supply voltages (see Section 7.1.1.7).
- 7.8.7.3 Check drive alignments (see Sections 6.3.0–6.5.0). Spindle speed with double-density installed is 200 milliseconds  $\pm$  1 percent.
- 7.8.7.4 If boot errors continue:
  - 1. REPLACE double-density PC board.
  - 2. REPLACE double-density ribbon cable.

### **7.8.8 BDOS Errors**

- 7.8.8.1 Check that all double-density components are correctly installed (see Section 6.11.0).
- 7.8.8.2 Check power supply voltages (see Section 7.1.1.7).
- 7.8.8.3 Check drive alignments (see Sections 6.3.0–6.5.0). Spindle speed with double-density installed is 200 milliseconds  $\pm$  1 percent.
- 7.8.8.4 If boot errors continue:
  - 1. REPLACE double-density PC board.
  - 2. REPLACE double-density ribbon cable.

## **7.8.9 Drive Errors During Confidence Test**

- 7.8.9.1 Check power supply voltages (see Section 7.1.1.7).
- 7.8.9.2 Check drive alignments (see Sections 6.3.0–6.5.0). Spindle speed with double-density installed is 200 milliseconds  $\pm$  1 percent.
- 7.8.9.3 If drive errors continue, check the double-density op-amp as follows. Be very careful not to short-circuit the logic board against the chassis during this procedure.

1. Set oscilloscope channel 1 to auto trigger, time base to 10 ms, and DC output to 1 V/div.

Zero out the oscilloscope ground.

2. Connect channel 1 probe to position R8 output on the double-density PC board.
3. Connect oscilloscope ground to ground plane of position C9 on the double-density PC board.
4. Boot the system using Double-Density Confidence Test. When the menu appears, remove this diskette and insert a certified double-density diskette in each drive.
5. Press RETURN twice to start test.
6. During the SEEK/WRITE/READ/VERIFY portion of the test, adjust the potentiometer screw on the double-density PC board for a reading of 3.5 V  $\pm$  .5 V.

- 7.8.9.4 If drive errors continue:

1. REPLACE double-density PC board.
2. REPLACE double-density ribbon cable.

## **7.8.10 Single-Density Software Not Being Read**

- 7.8.10.1 See Double-Density Installation Advisory

# **OSBORNE EXECUTIVE**

**Disassembly/Assembly  
and Alignments**

**Troubleshooting and  
Preventive Maintenance**



**OSBORNE EXECUTIVE  
Disassembly/  
Assembly  
and  
Alignments**





## 8.0.0 REQUIRED TOOLS AND EQUIPMENT

The following tools are required for disassembly, assembly, and adjustment of the Osborne Executive computer.

- 1) No.2 Phillips screwdriver, 6 in.–9 in. length
- 1) 1/4-inch nut driver
- 1) Needle-nose pliers
- 1) 6-inch flat-tip screwdriver
- 1) Oscilloscope:
  - Dual channel
  - External trigger
  - Minimum frequency      50 Mhz
  - Sensitivity                200 Millivolts
  - Sweep speed                200 Milliseconds
  - Three 10 x 1 probes with ground clips
- 1) Alignment Diskette (Dysan 224-1A or equivalent)
- 1) Osborne Executive Diagnostic Diskette
- 1) Drive head-cleaning kit
- 1) Narrow-end, non-metallic video adjustment tool

## 8.1.0 KEYBOARD DISASSEMBLY

**CAUTION:** Identify connector orientations before detaching any cable.

- 8.1.0.1 Disconnect computer from the power source.
- 8.1.0.2 Disconnect the keyboard cable from the front bezel by spreading the latches of the keyboard connector.

**Note:** Facing the CRT screen, the keyboard cable connects from the left.

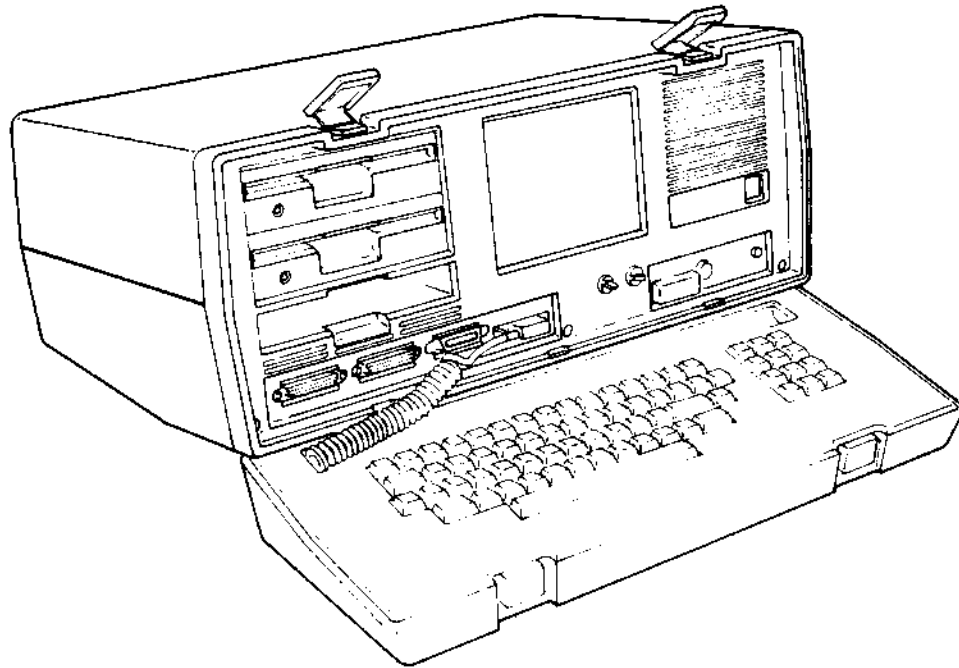
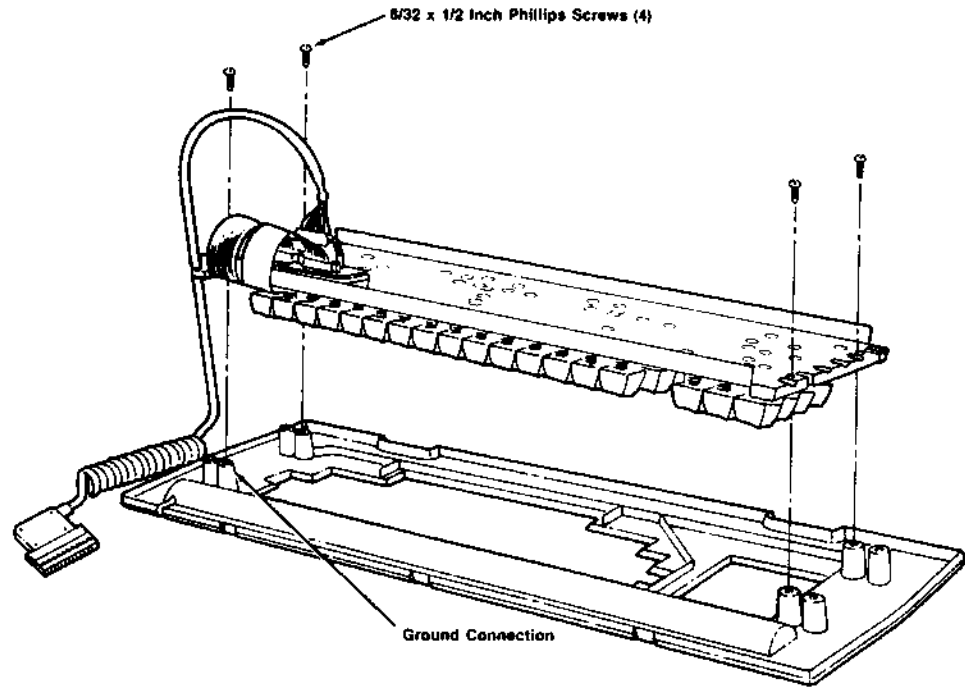

**FIGURE 8-1. OSBORNE EXECUTIVE**

- 8.1.0.3 Using a pad or soft material to protect the keyboard, turn the keyboard case over so the keys face down.
- 8.1.0.4 Remove four (4) 6/32 x 1/2 inch Phillips screws from the underside of the keyboard case.
- 8.1.0.5 Lift the keyboard case from the keyboard and keyboard bezel assembly.

8.1.0.6 *Type A keyboard:*

Remove one (1) 8/32 x 1/2 inch Phillips screw holding the ground wire to the keyboard bezel standoff.



**FIGURE 8-2. TYPE A KEYBOARD**

*Type B keyboard:*

Remove one (1) 6/32 hex nut and star washer holding the ground wire to the keyboard.

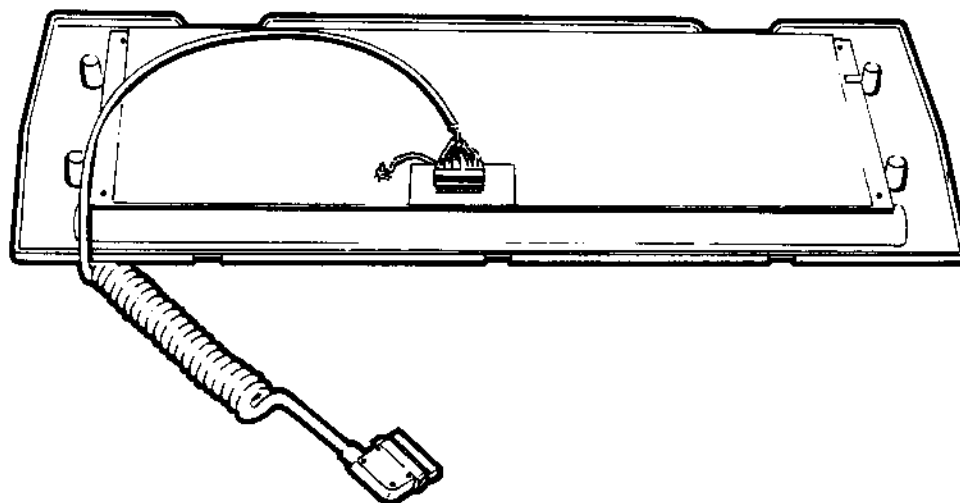

**FIGURE 8-3. TYPE B KEYBOARD**

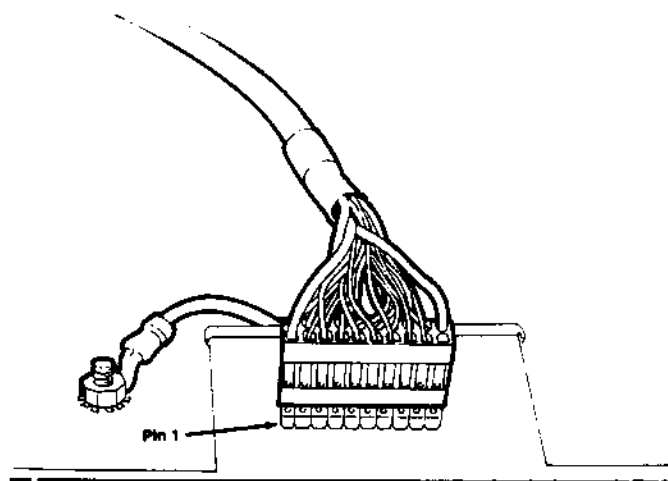

**FIGURE 8-4. TYPE B KEYBOARD GROUND NUT AND WASHER**

- 8.1.0.7 Note the orientation of the keyboard harness and keyboard connector. The keyboard harness connector is not keyed.

Carefully remove the keyboard harness from the keyboard connector.

---

#### NOTE

*The keyboard harness aligns with pin 1 of the keyboard connector. Looking at the underside of the keyboard with the row of numeric keys to the top, pin 1 is the UPPER RIGHT PIN. Pin 1 may also have an orange dot next to it.*

---

- 8.1.0.8 *Type A keyboard:*

Remove three (3) remaining 8/32 x 1/2 inch Phillips screws holding the keyboard to the bezel standoffs.

*Type B keyboard:*

Remove four (4) 8/32 x 1/2 inch Phillips screws holding the keyboard to the bezel standoffs.

- 8.1.0.9 Lift the keyswitch array from the keyboard bezel.

See Section 8.2.7 to reassemble the keyboard.

## 8.1.1 BEZEL AND CHASSIS DISASSEMBLY

**CAUTION:** The interior of the case is coated with a special metallic paint. Avoid scratching this coating.

- 8.1.1.1 Disconnect computer from power source and detach the power cord.
- 8.1.1.2 Disconnect the keyboard cable from the front bezel by spreading the latches on the keyboard connector.
- 8.1.1.3 Disconnect all external cables (RS-232, modem, external video, etc.).
- 8.1.1.4 Remove the video contrast and brightness knobs by carefully pulling them from their shafts.
- 8.1.1.5 Remove five (5) 6/32 x 1/4 inch Phillips screws surrounding the bezel.

- 8.1.1.6 Grasp the bezel near the carrying-case latches and pull it straight forward until it's free.

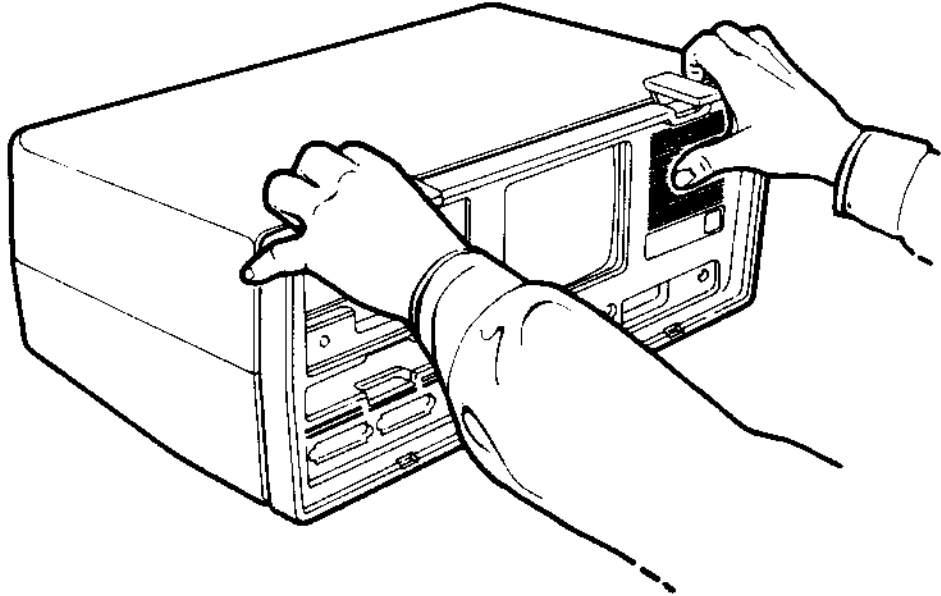

**FIGURE 8-5. BEZEL REMOVAL**

- 8.1.1.7 Position the unit with ventilation cover facing down and video screen facing technician.
- 8.1.1.8 Remove five (5) 6/32 x 3/4 inch Phillips screws holding both halves of the carrying case together.
- 8.1.1.9 Hold down the fan compartment and the power cord compartment and lift the upper half of the case free of the unit.
- 8.1.1.10 **NOTE ORIENTATION** of the keyed fan power harness at the rear of the drive housing.

Disconnect the fan power harness from the DC harness.

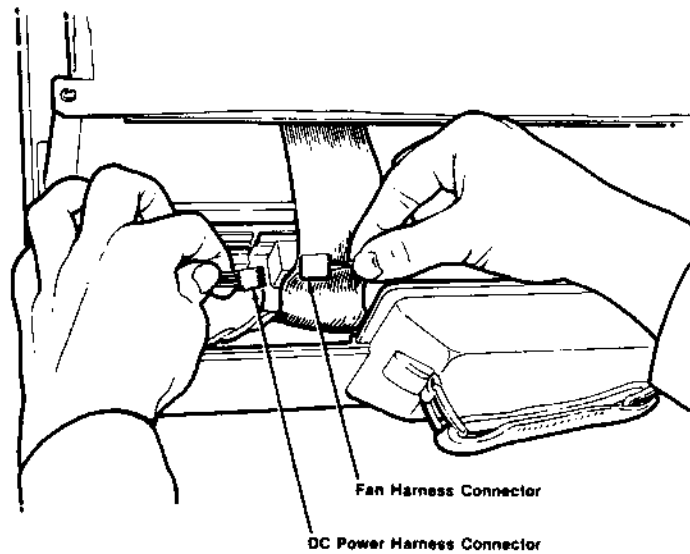
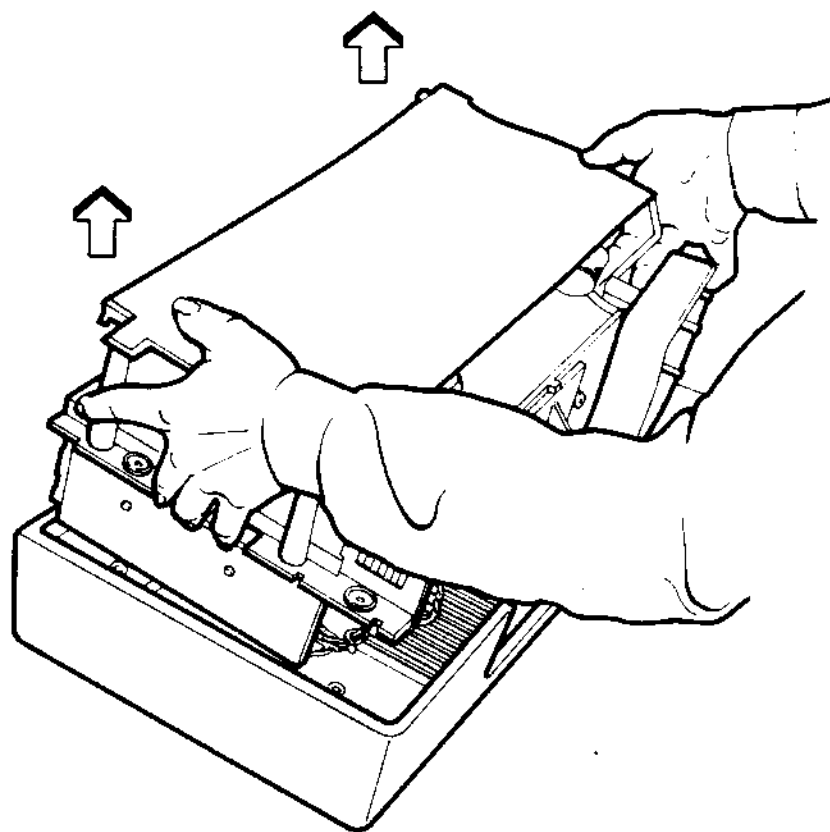

**FIGURE 8-6. FAN POWER HARNESS CONNECTOR**

- 8.1.1.11 Slide the fan assembly out of the lower half of the case. The area below the carrying handle is wider than the area above it.
- 8.1.1.12 Lift the power cord compartment slightly and detach the door.
- 8.1.1.13 Place one hand under the chassis at the power supply and the other hand under the chassis at the disk drive housing.

Carefully lift the chassis out of the case. Be sure the power cord compartment lifts freely with the chassis.



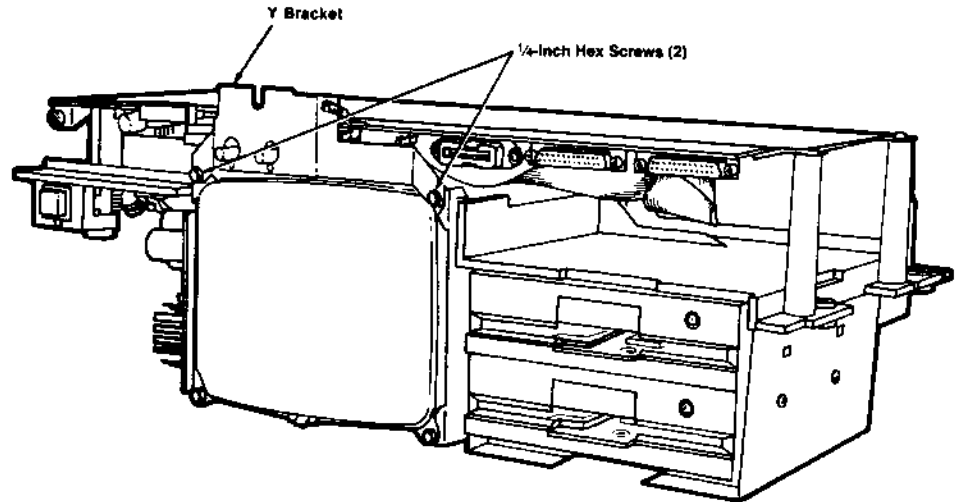

**FIGURE 8-7. CHASSIS REMOVAL**

See Section 8.2.6 to reassemble the chassis and bezel.

## **8.1.2 LOGIC AND MEMORY BOARD DISASSEMBLY**

- 8.1.2.1 Disassemble the Osborne Executive following the instructions in Section 8.1.1.
- 8.1.2.2 Position the chassis assembly with logic board facing up and CRT screen facing technician.
- 8.1.2.3 The Y bracket over the brightness and contrast controls is held to the monitor housing by two (2) 1/4-inch hex screws.



**FIGURE 8-8. Y BRACKET AND HEX SCREWS**

- 8.1.2.4 Remove both hex screws holding the Y bracket to the video monitor. Detach the Y bracket, then **REPLACE THE HEX SCREWS** into the monitor housing. These screws must be replaced to prevent monitor misalignment.
- 8.1.2.5 If you're NOT replacing the logic board with another one, remove four (4) 6/32 x 1/4 inch Phillips screws with star washers to detach the logic board AND mounting bracket from the chassis.

Note the ground wire in the left rear corner of the logic board.

**CAUTION:** The metal insulator shield IS NOT DETACHABLE from the logic board.

Be extremely careful not to puncture or tear the insulator shield.

- 8.1.2.6 If you ARE replacing the logic board with another one, remove two (2) 6/32 x 1/4 inch Phillips screws with star washers to detach it from the chassis AND two (2) 6/32 x 1/4 inch Phillips screws with nylon washers to detach it from the mounting bracket. Note the ground wire in the left rear corner of the logic board.

---

**NOTE**

*There are nylon washers ABOVE and BELOW the logic board where it fastens to the mounting bracket.*

---

Leave the mounting bracket attached to the chassis standoffs.

- 8.1.2.7 Lift the front edge of the logic board slightly and detach the video harness connector at the RIGHT of the Reset button.

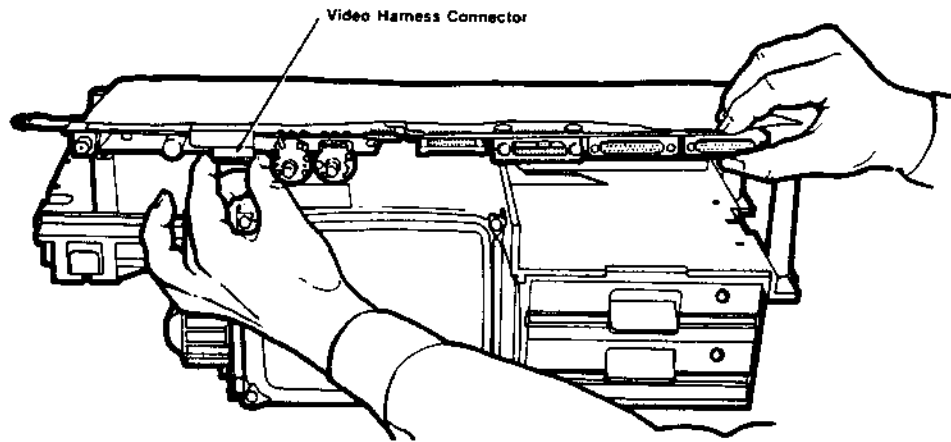

**FIGURE 8-9. VIDEO HARNESS CONNECTOR**

- 8.1.2.8 With the video harness detached, lift the logic board perpendicular to the chassis, video control shafts pointing straight up. Note all connector orientations.

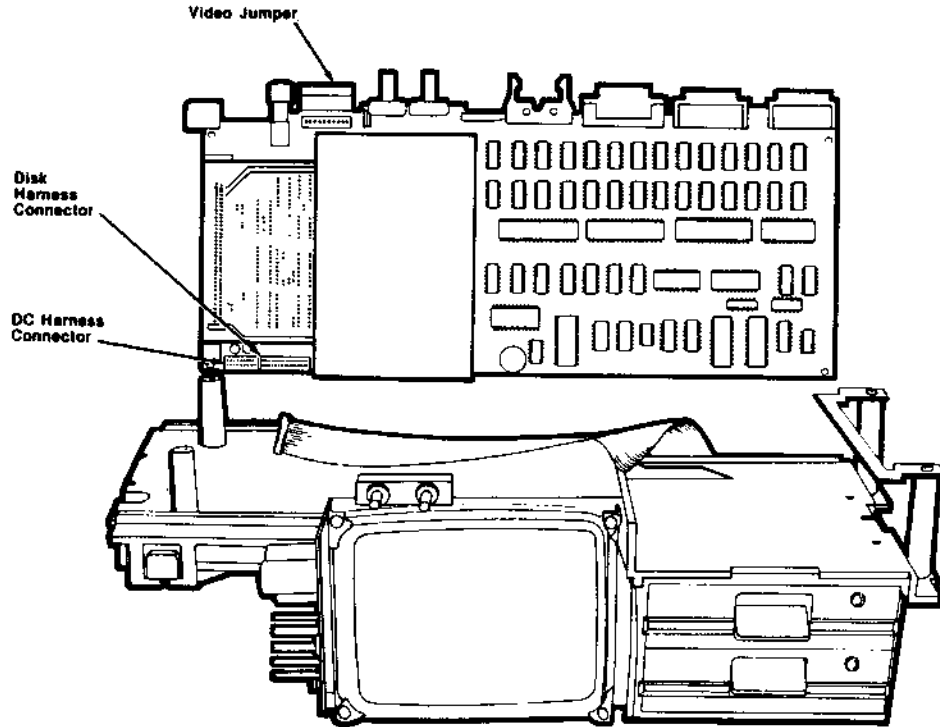

**FIGURE 8-10. LOGIC BOARD REMOVAL**

- 8.1.2.9 Remove the DC harness connector in the lower left corner of the logic board. This connector is not keyed.
- 8.1.2.10 Detach the disk harness connector in the lower left corner of the logic board to the right of the DC harness connector. Grip the connector and **CAREFULLY** detach it, being sure not to bend any pins.

---

**NOTE**

*The disk harness connector is NOT keyed. The red stripe on the harness must go to the RIGHT.*

---

- 8.1.2.11 Remove the external video plug located between the Reset button and the contrast control shaft.
- 8.1.2.12 Remove the logic board from the chassis.

- 8.1.2.13 The memory board is attached to the main logic board by four (4) stand-offs and a 72-pin connector.

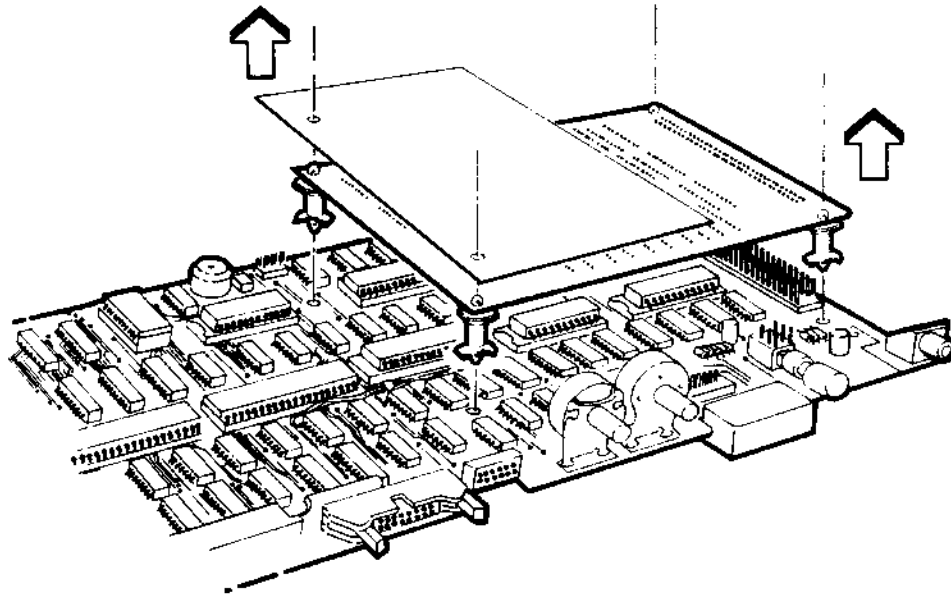

**FIGURE 8-11. MEMORY BOARD REMOVAL**

- 8.1.2.14 Remove the mylar shield which covers the memory board.
- 8.1.2.15 Grasp the memory board standoffs from under the main logic board and carefully push them out.

**CAUTION:** Do not force these standoffs.

- 8.1.2.16 Carefully lift the memory board off 72-pin connector **P11** on the main logic board.
- 8.1.2.17 Gently pull the memory board standoffs from the memory board.

See Section 8.2.5 to reassemble the logic and memory boards.

## 8.1.3 VIDEO MONITOR AND POWER SUPPLY DISASSEMBLY

- 8.1.3.1 Disassemble the Osborne Executive following the instructions in Section 8.1.2.
- 8.1.3.2 Position the chassis assembly with video monitor facing away from technician.
- 8.1.3.3 Remove the 8/32 x 1/4 inch Phillips screw and nylon washer holding the monitor shield to the drive-housing ground strap.

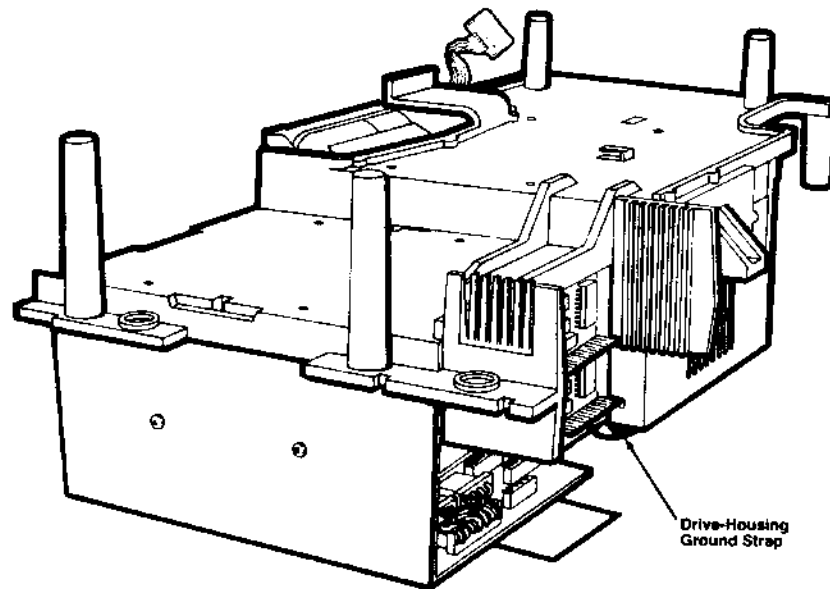

**FIGURE 8-12. DRIVE-HOUSING GROUND STRAP**

- 8.1.3.4 Disconnect two (2) keyed power-supply connectors from positions **TB1** and **TB2** on the power supply. **TB1** has 3 pins. **TB2** has 12 pins.
- 8.1.3.5 Disconnect the 4-socket voltage selector input from **TB3** on the power supply. The voltage selector input is located next to the four large capacitors on the power supply.
- 8.1.3.6 Remove four (4) 6/32 x 1/2 inch Phillips screws with star washers which hold the video monitor to the chassis. Label these screws **FOR VIDEO MONITOR** and set them aside.

---

**WARNING:** Using an incorrect screw to reassemble the video monitor to the chassis may short-circuit the video PC board.

---

- 8.1.3.7 Slide the video monitor out of the chassis while guiding the monitor cable through the chassis cutout.

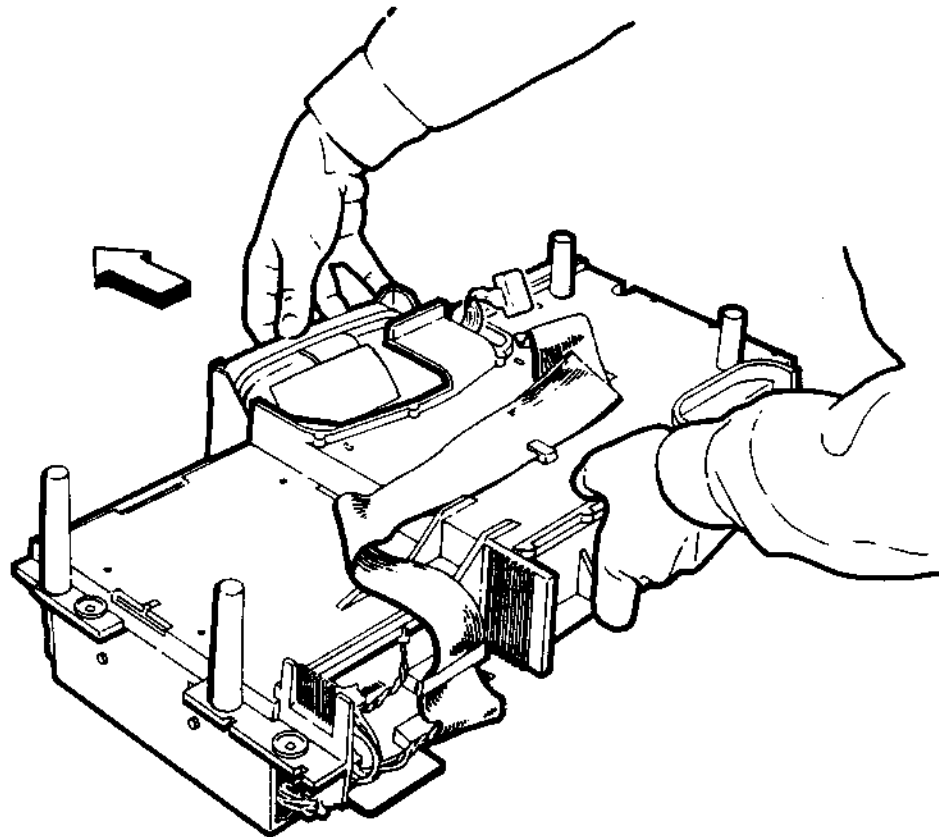

**FIGURE 8-13. MONITOR REMOVAL**

- 8.1.3.8 Locate one (1) 6/32 x 3/8 inch Phillips screw in the corner of the power supply next to the fuse. Remove this screw to disconnect the power-supply ground wire.

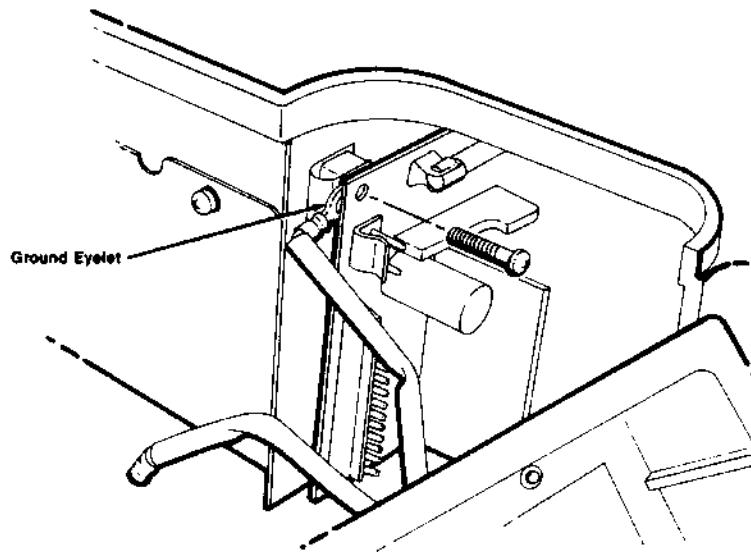

**FIGURE 8-14. POWER-SUPPLY GROUND SCREW AND EYELET**

- 8.1.3.9 Remove four (4) remaining 6/32 x 3/8 inch Phillips screws holding the power supply to the monitor chassis.

One of these screws is located in the center of the power supply.

See Section 8.2.4 to reassemble the video monitor and power supply.

## **8.1.4 DISK DRIVE DISASSEMBLY**

- 8.1.4.1 Disassemble the Osborne Executive following the instructions in Section 8.1.1.

- 8.1.4.2 Position the chassis logic-board-side-up and video monitor facing away from technician.



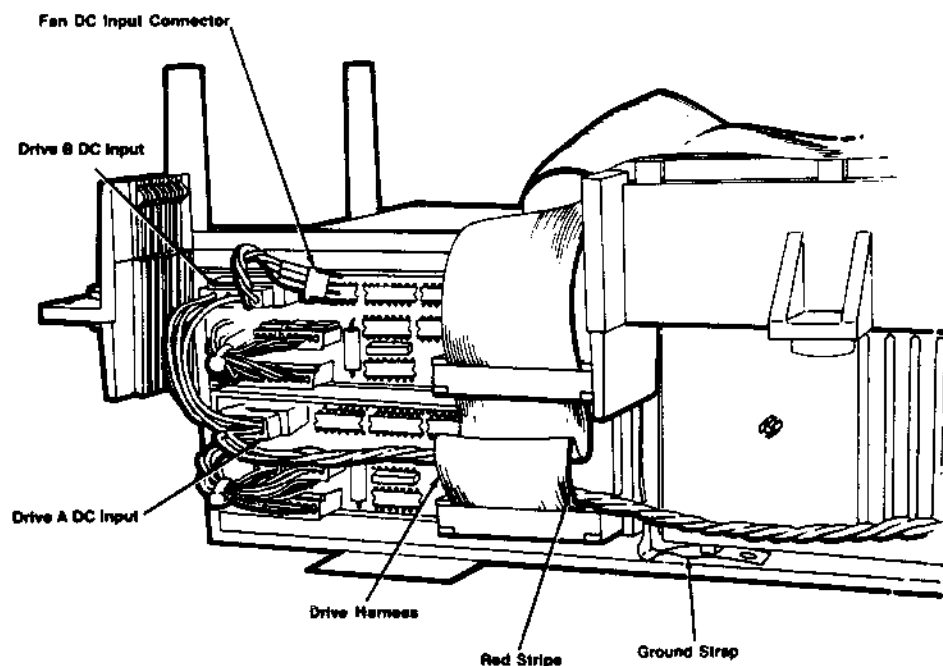

**FIGURE 8-15. DISK DRIVE CABLES**

8.1.4.3 Remove the 8/32 x 1/4 inch Phillips screw holding the drive-housing ground strap to the monitor shield.

8.1.4.4 Detach the keyed disk harness and the DC input harness from the back of each drive.

The disk harness is located on the RIGHT and the keyed DC harness on the LEFT of each drive.

---

**NOTE**

*The disk harness has a stripe on its RIGHT edge.*

---

8.1.4.5 Two latches lock the disk drive assembly to the chassis. Press the latch farthest from the monitor to unlock the drive assembly from the chassis.

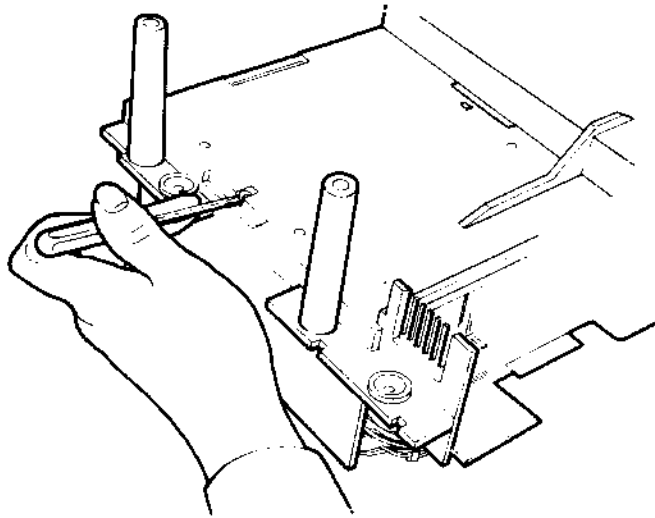

**FIGURE 8-16. DRIVE TO CHASSIS LATCH**

- 8.1.4.6 Carefully lift the chassis from left to right until it's clear of the drive assembly.

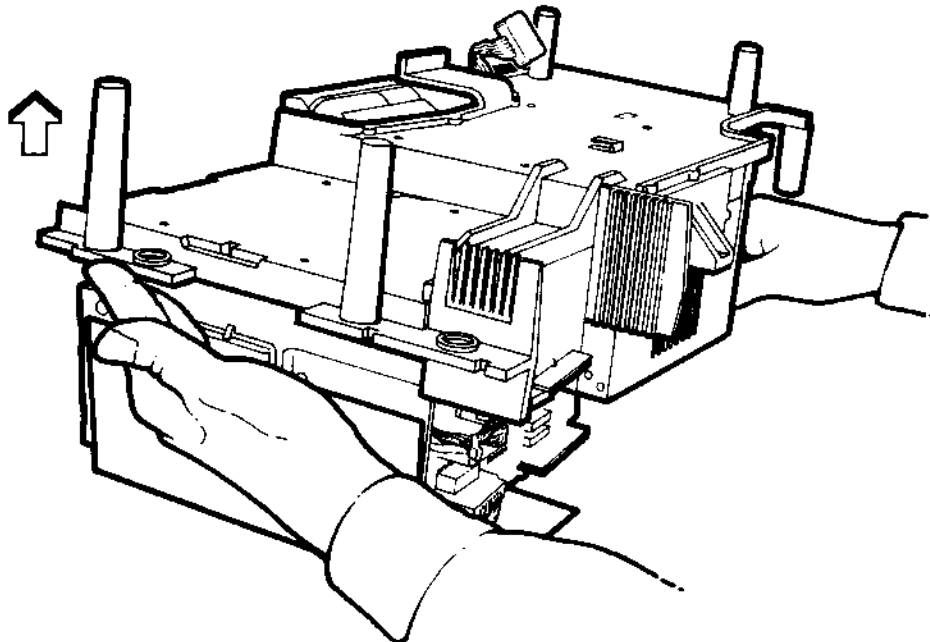

**FIGURE 8-17. DRIVE ASSEMBLY REMOVAL**

- 8.1.4.7 Position the drive assembly with ground strap at the bottom and drive doors facing away from technician. Drive B is the UPPER drive.

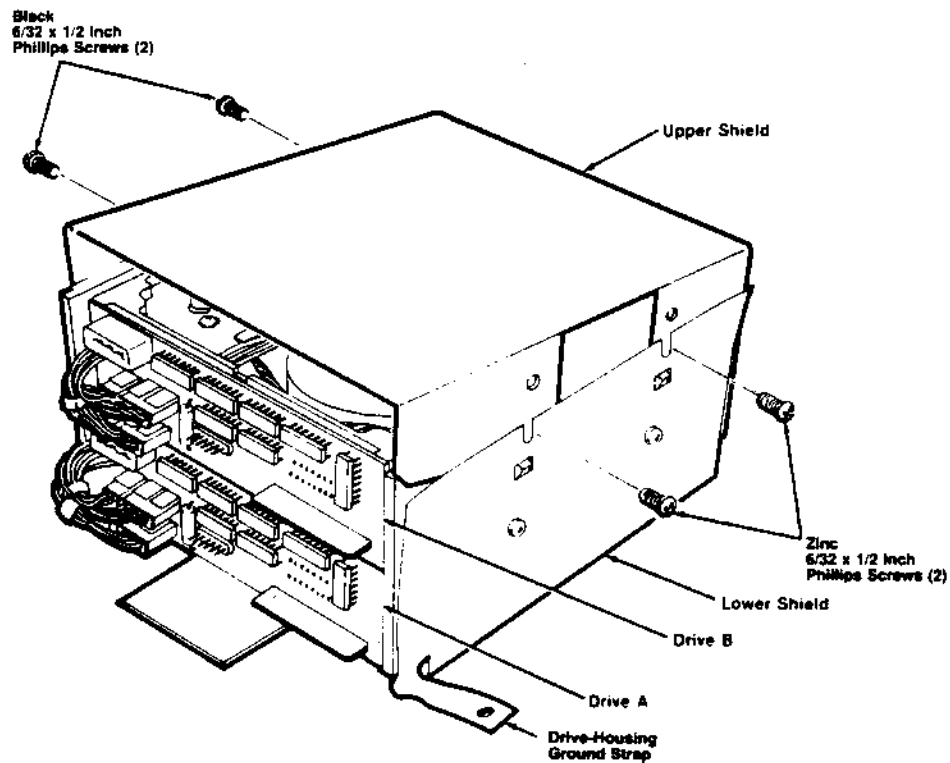

**FIGURE 8-18. DRIVE HOUSING AND SHIELDS**

- 8.1.4.8 Remove upper two (2) 6/32 x 1/2 inch Phillips screws from each side of the drive housing and detach the top shield.

---

**NOTE**

*The screws next to the video monitor are zinc-plated. The screws farthest from the monitor are black.*

---

- 8.1.4.9 Carefully lift drive B straight up and out of the drive housing.

---

**NOTE**

*Drive B has a jumper at positions HM and DS2 next to edge connector J1.*

---

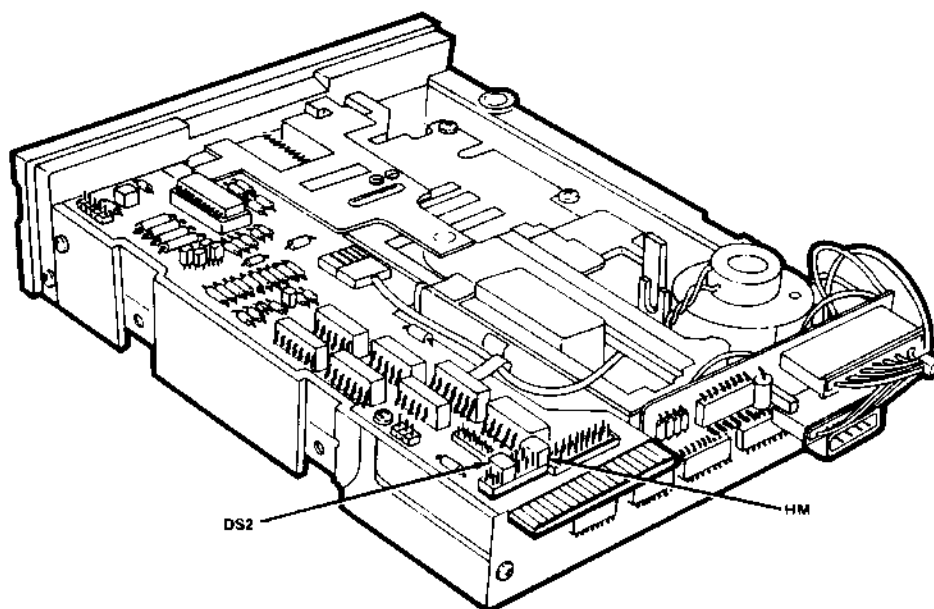

**FIGURE 8-19. DRIVE B JUMPERS**

- 8.1.4.10 Remove lower two (2) 6/32 x 1/2 inch Phillips screws with star washers from each side of the drive shield.
- 8.1.4.11 Carefully lift drive A straight up and out of the drive housing.

---

**NOTE**

*Drive A has a jumper at positions HM and DS1 next to edge connector J1.*

*Drive A also has a terminator resistor in socket R21.*

---

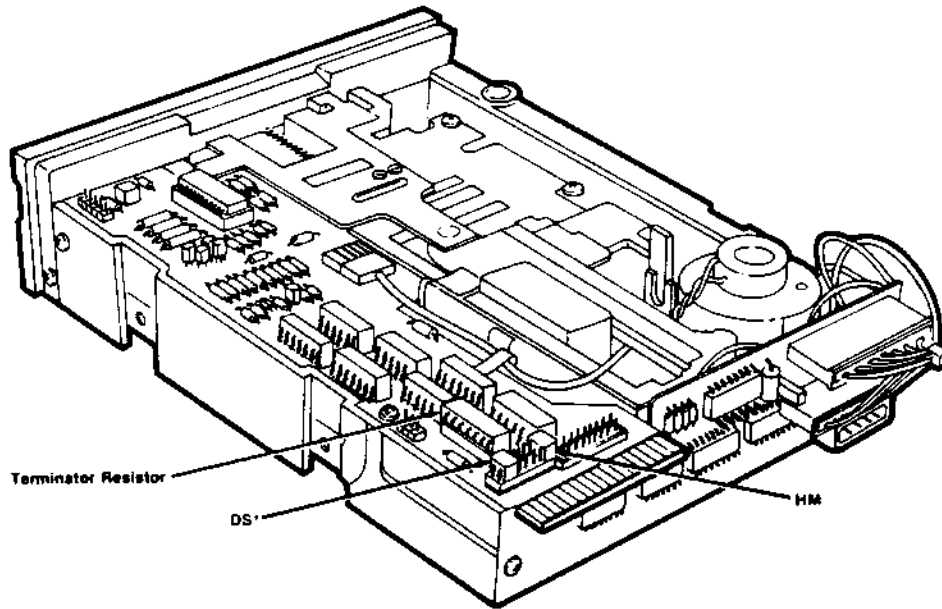

**FIGURE 8-20. DRIVE A JUMPERS**

8.1.4.12 Remove the drive housing from the lower shield.

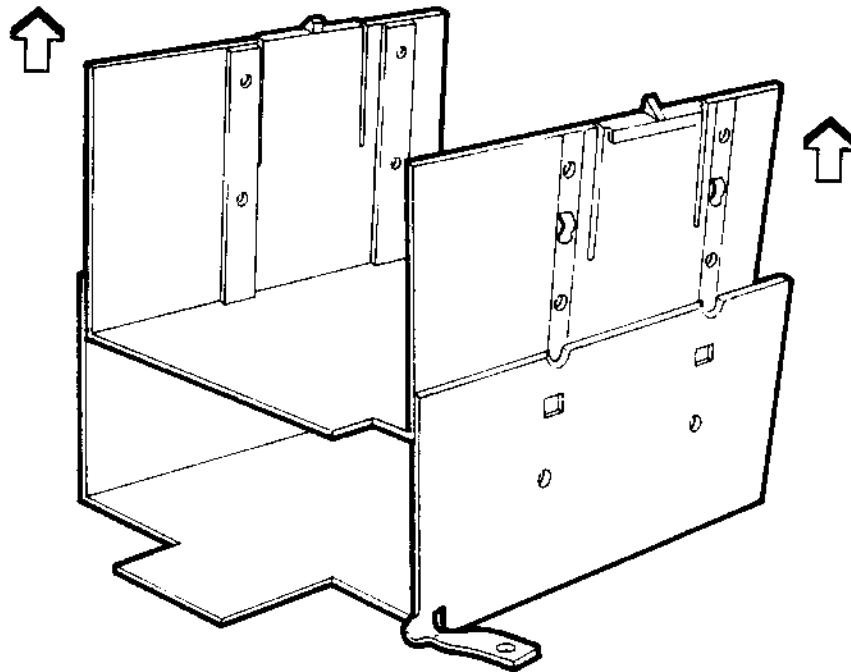

**FIGURE 8-21. DRIVE HOUSING AND LOWER SHIELD**

- 8.1.4.13 If you're replacing drive A, remove the 8-pin terminator from the drive PC board and KEEP IT for installation on the new drive. The terminator resistor is located at R21 in the rear corner of the drive A PC board.
- 8.1.4.14 Four (4) plastic guide brackets position the drives in the housing.
- 8.1.4.15 To remove a bracket, carefully press down on the latch holding it to the drive housing and pull the bracket free.

See Section 8.2.3 to reassemble the disk drives.

## 8.1.5 BULB REMOVAL AND POWER SWITCH DISASSEMBLY

---

### NOTE

*The bulb can be replaced without removing the switch.*

---

- 8.1.5.1 Follow instructions 8.1.1.1 through 8.1.1.6 to remove the front bezel.
- 8.1.5.2 The power switch and bulb are mounted in the front corner of the chassis near the power supply.

### BULB REMOVAL

- 8.1.5.3 Grasp the plastic push button at the front of the switch assembly and pull it forward.
- 8.1.5.4 Grasp the metal slide latch inside the switch housing and pull it forward to release the bulb.

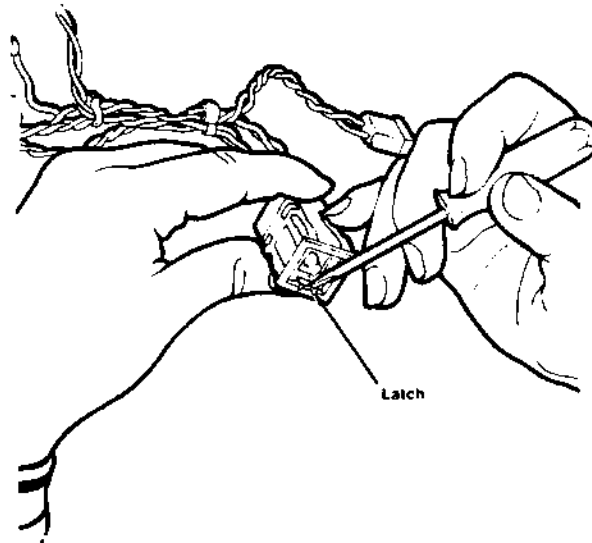

**FIGURE 8-22. BULB REMOVAL**

---

**NOTE**

*The power switch uses a 12V, No. 73 bulb.*

---

See Section 8.2.2 to replace the bulb.

**POWER SWITCH DISASSEMBLY**

- 8.1.5.5 Follow instructions 8.1.1.7 through 8.1.1.13 to remove chassis from case.
- 8.1.5.6 Push the switch assembly forward out of the chassis.
- 8.1.5.7 Guide the switch wires through the notch in the switch mounting to free them from the chassis.
- 8.1.5.8 **NOTE THE WIRE COLORS AND THEIR ORIENTATION** on the switch assembly.

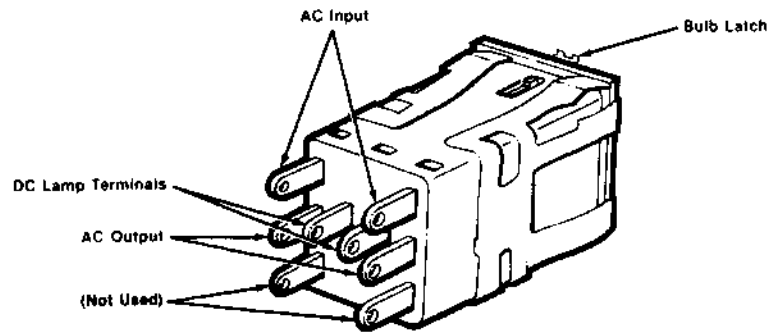

**FIGURE 8-23. POWER SWITCH CONNECTORS**

8.1.5.9 Disconnect the wire harness from the switch assembly.

See Section 8.2.2 to reassemble the power switch.

## 8.1.6 AC POWER-PANEL DISASSEMBLY

8.1.6.1 Disassemble the Osborne Executive following the instructions in Section 8.1.1.

8.1.6.2 NOTE THE WIRE COLORS AND THEIR ORIENTATION on the AC power panel.

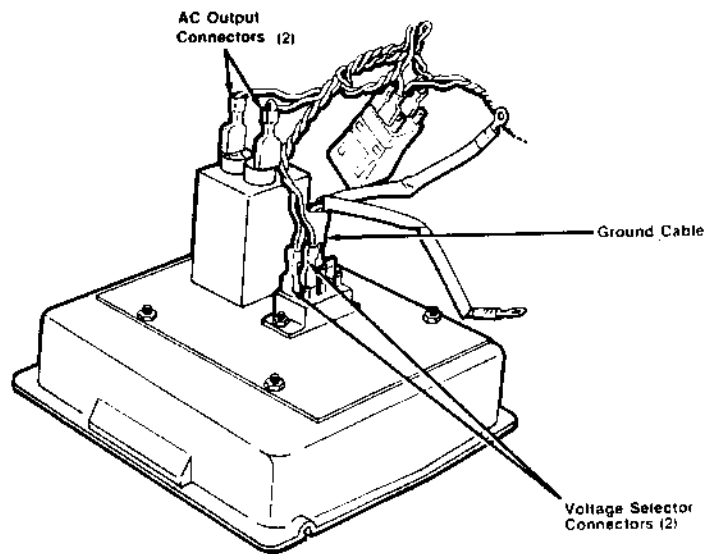

**FIGURE 8-24. AC POWER PANEL**



- 8.1.6.3 Disconnect the wire harness from the AC power panel.
- 8.1.6.4 Disconnect the slip-on ground wire connector from the power panel.
- 8.1.6.5 Remove four (4) 6/32 x 1/4 inch Phillips screws which hold the power cord compartment to the AC power panel.

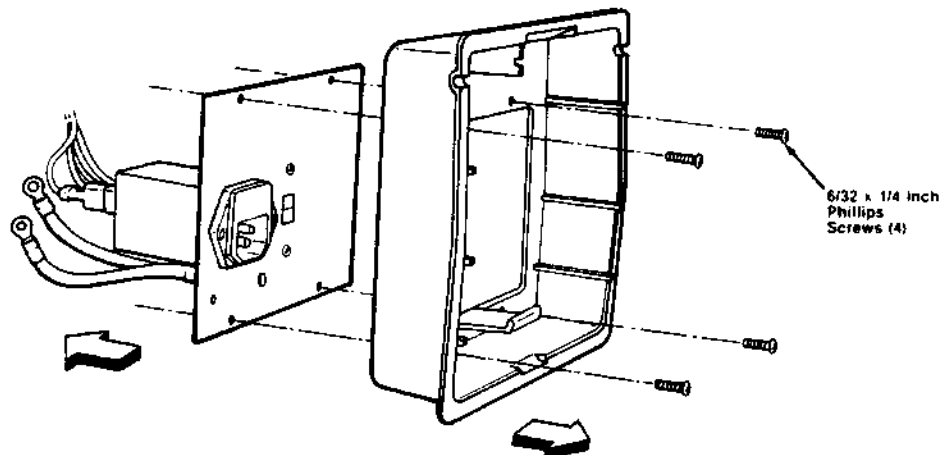
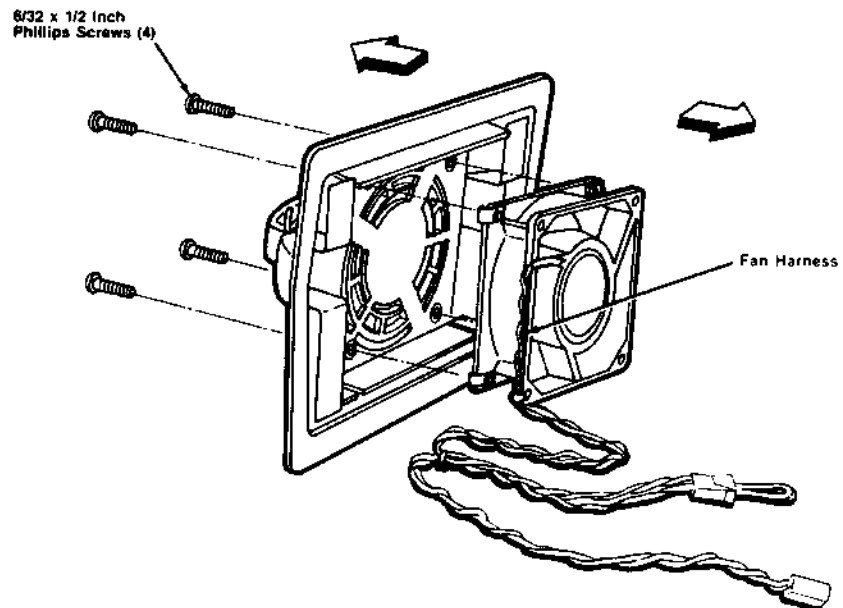

**FIGURE 8-25. POWER PANEL DISASSEMBLY**

See Section 8.2.1 to reassemble the AC power panel.

## **8.1.7 FAN DISASSEMBLY**

- 8.1.7.1 Disassemble the Osborne Executive following instructions 8.1.1.1 through 8.1.1.10.
- 8.1.7.2 Disconnect the fan power harness from the DC harness.
- 8.1.7.3 Slide the fan assembly out of the lower half of the case. The area below the carrying handle is **WIDER THAN** the area above it.
- 8.1.7.4 Slide open the fan compartment cover. Gently press the center of the cover and slide it free of the fan compartment.
- 8.1.7.5 Remove the filter from the fan compartment.
- 8.1.7.6 Remove four (4) 6/32 x 1/2 inch Phillips screws holding the fan to the fan compartment and lift it free.

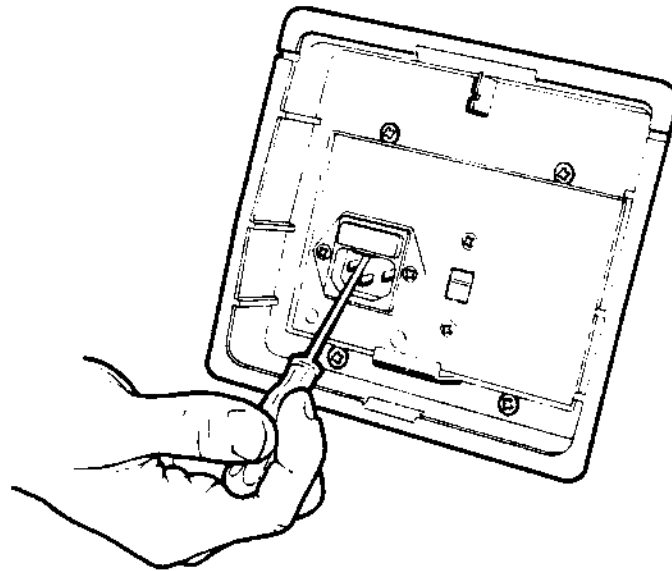

**FIGURE 8-26. FAN DISASSEMBLY**

See Section 8.2.0 to reassemble the fan.

## **8.1.8 FUSE REPLACEMENT**

- 8.1.8.1 The Osborne Executive can operate on 115V or 220V. Slide the voltage selector switch on the AC power panel to the appropriate setting.
- 8.1.8.2 Disconnect the AC power cord from the power panel.
- 8.1.8.3 The fuse compartment is housed in the AC power panel above the power cord connector.

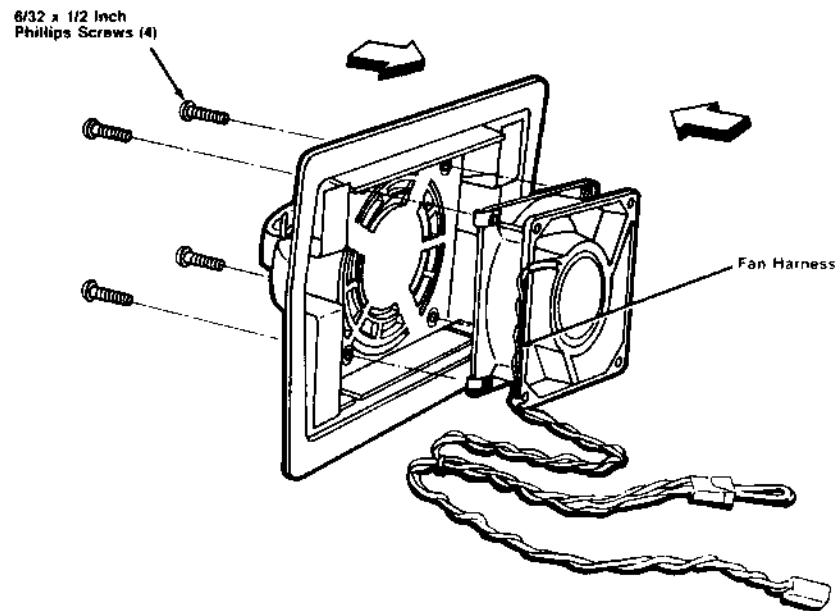

**FIGURE 8-27. FUSE REMOVAL**

- 8.1.8.4 Insert a flat-tip screwdriver under the fuse compartment notch and gently pry it from the power panel.
- 8.1.8.5 Slide the fuse from the fuse compartment.
- 8.1.8.6 Replace the fuse as follows:
  - 115V operation: 2 amp, 125V fast-blow fuse
  - 220V operation: 1 amp, 250V fast-blow fuse
- 8.1.8.7 Slide the fuse compartment into the AC power panel until it latches in place.

## 8.2.0 FAN ASSEMBLY

- 8.2.0.1 Position the fan compartment with the WIDE area below the carrying handle.
- 8.2.0.2 Align four (4) screw holes in fan housing with the holes in the fan compartment. Position the fan harness to the outside of the fan housing.



**FIGURE 8-28. FAN ASSEMBLY**

- 8.2.0.3 Install four (4) 6/32 x 1/2 inch Phillips screws from the front of the fan compartment into the fan housing.
- 8.2.0.4 Press the filter onto the four pointed fasteners in front of the fan.
- 8.2.0.5 Gently press the center of the fan cover and slide it onto the fan compartment.
- 8.2.0.6 See Section 8.2.6 to install the fan compartment into the case.

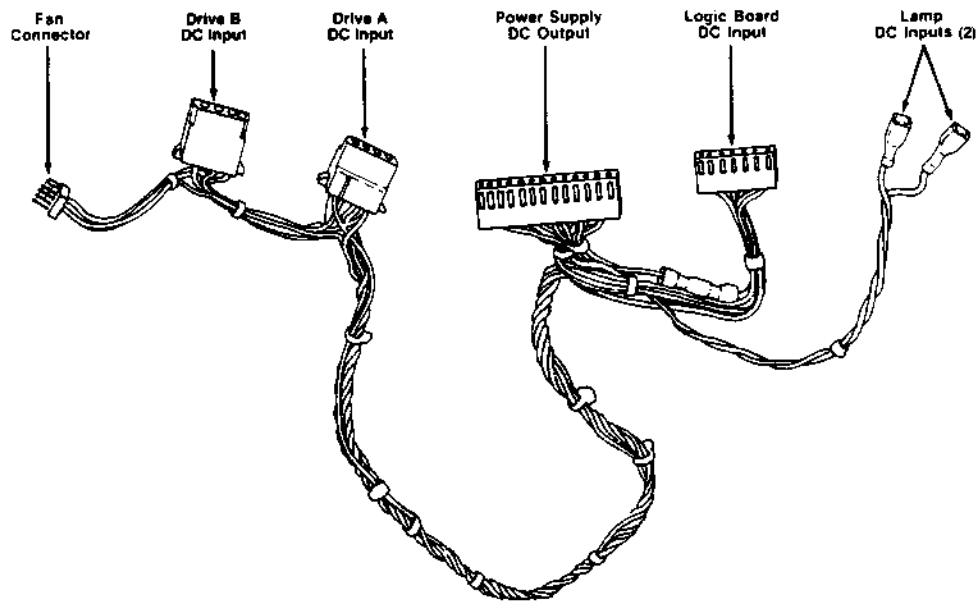

FIGURE 8-29. DC HARNESS

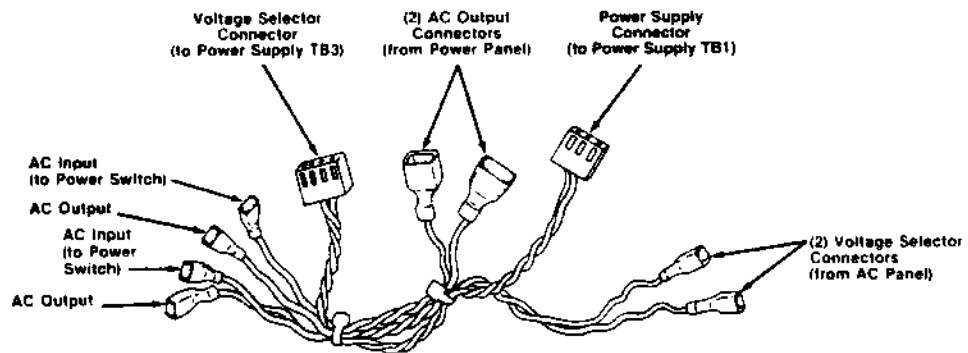

FIGURE 8-30. AC HARNESS

## 8.2.1 AC POWER-PANEL ASSEMBLY

- 8.2.1.1 Align the AC power panel with the screw holes on the back of the power panel compartment. The ground lug on the 3-prong electrical plug should be AWAY FROM the door hinge cutouts on the power panel compartment.

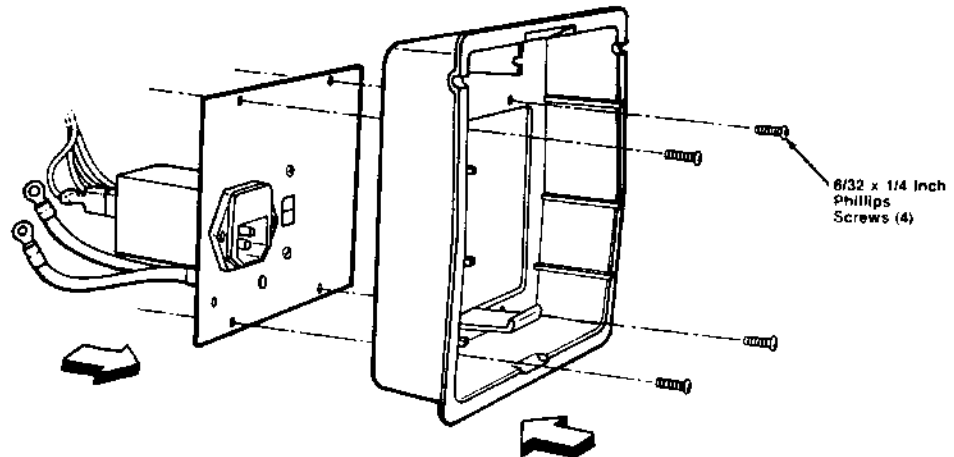
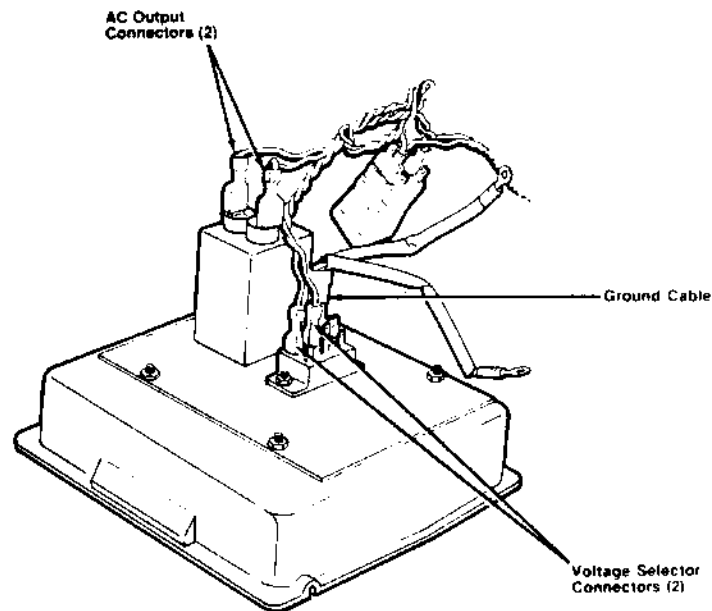

FIGURE 8-31. POWER PANEL ASSEMBLY

- 8.2.1.2 Install four (4) 6/32 x 1/4 inch Phillips screws through the front of the power panel compartment to secure it to the power panel.



**FIGURE 8-32. POWER PANEL CONNECTORS**

- 8.2.1.3 Identify two (2) power harness slip-on connectors running to the voltage selector input on the power supply.

Insert these connectors onto terminals 1 and 1A on the power-panel voltage selector.

---

**NOTE**

*These connectors are NOT interchangeable. If they're reversed, there'll be no power to the computer.*

---

- 8.2.1.4 Connect the slip-on ground cable to either ground terminal near the bottom of the AC power panel.

- 8.2.1.5 Identify two (2) slip-on AC output connectors running to the power switch.

Press these connectors onto the power cord terminals on the AC power panel. These connectors are interchangeable.

## 8.2.2 POWER SWITCH ASSEMBLY AND BULB REPLACEMENT

### POWER SWITCH ASSEMBLY

- 8.2.2.1 Position switch housing with bulb socket facing away from technician and bulb latch at the top. Note the switch terminals:

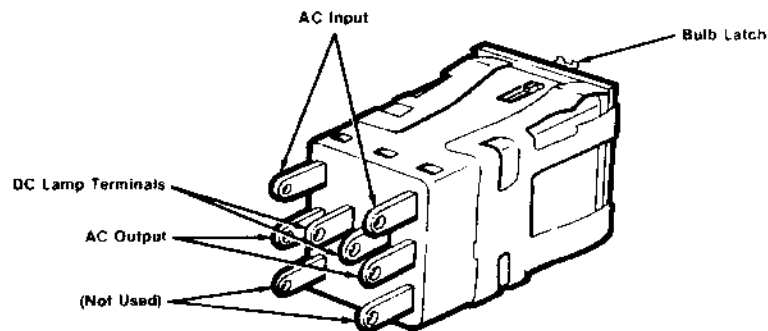

**FIGURE 8-33. POWER SWITCH TERMINALS**

- 8.2.2.2 Connect two (2) AC input wires from the power panel to the AC input terminals on the power switch.
- 8.2.2.3 Connect two (2) AC output wires from the power supply to the AC output terminals on the power switch.

---

#### NOTE

*Both wires on each side of the DC lamp terminals should be the same color.*

---

- 8.2.2.4 Connect two (2) DC input wires from TB3 on the power supply to the DC lamp terminals on the power switch. These wires are interchangeable.
- 8.2.2.5 The power switch assembly fits into the mounting bracket in the front corner of the chassis near the power supply.



- 8.2.2.6 Guide the power switch harness through the notch in the chassis mounting bracket.
- 8.2.2.7 Push the switch assembly into place on the chassis mounting bracket.

### BULB REPLACEMENT

---

**NOTE**

*The power switch uses a 12V, No. 73 bulb.*

---

- 8.2.2.8 Press new bulb into the socket in the power switch housing.
- 8.2.2.9 Press the plastic push button into the front of the power switch housing.

### 8.2.3 DISK DRIVE ASSEMBLY

- 8.2.3.1 Press four (4) plastic guide brackets into place on the drive housing.

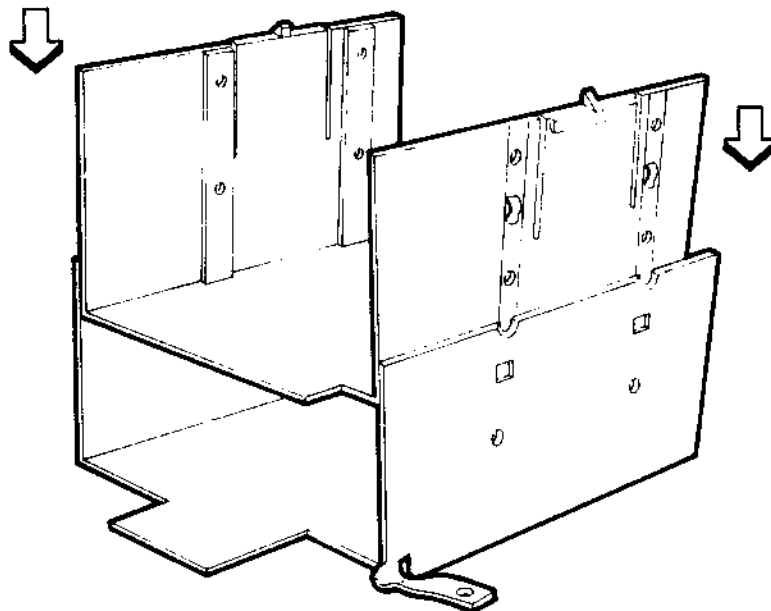

**FIGURE 8-34. DRIVE HOUSING AND LOWER SHIELD**

- 8.2.3.2 Align four (4) screw holes in the lower insulator shield with screw holes in the drive housing. The edge of the insulator shield should be flush with the edge of the housing.
- 8.2.3.3 With strobe wheel facing up, align notches on the sides of drive A with the guide brackets in the drive housing. The ground strap on the drive housing should be at the rear of the drive.
- 8.2.3.4 Insert drive A straight down into the drive housing.

---

**NOTE**

*Drive A has a jumper at positions **HM** and **DS1** next to edge connector J1.*

*Drive A also has a terminator resistor in socket R21.*

---

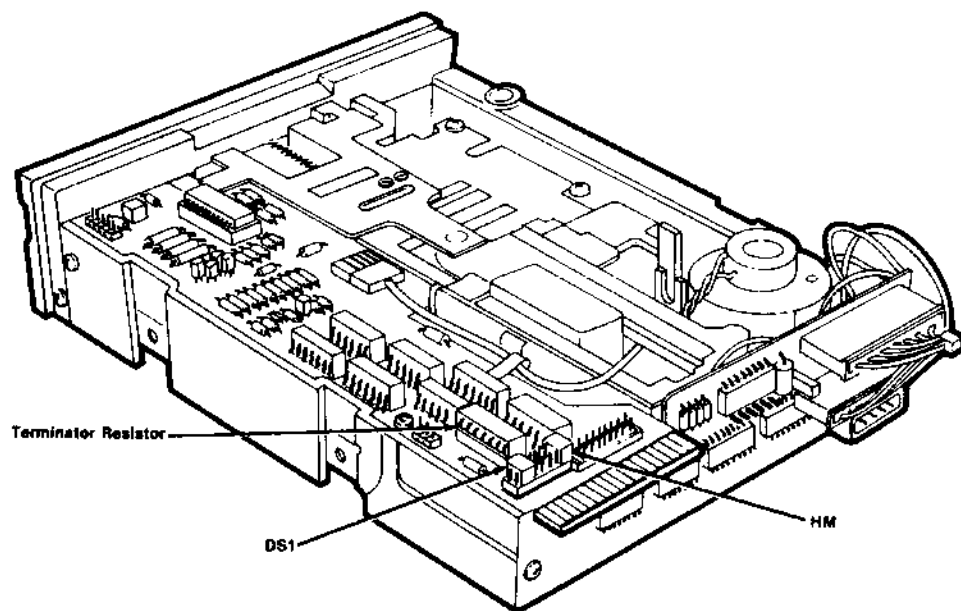

**FIGURE 8-35. DRIVE A JUMPERS**

- 8.2.3.5 Install lower two (2) 6/32 x 1/2 inch Phillips screws with star washers into EACH SIDE of the drive housing to secure drive A in place.

- 8.2.3.6 With strobe wheel facing up, align notches on the sides of drive **B** with guide brackets in the drive housing.
- 8.2.3.7 Insert drive **B** straight down into the drive housing.

---

**NOTE**

*Drive B has a jumper at positions **HM** and **DS2** next to edge connector J1.*

---

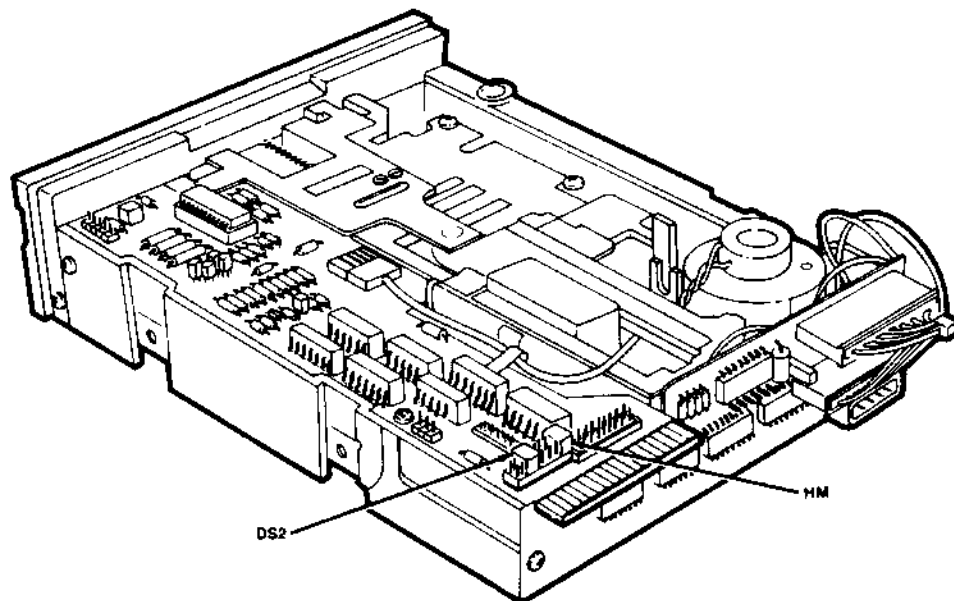

**FIGURE 8-36. DRIVE B JUMPERS**

- 8.2.3.8 Fit the upper drive shield onto the drive housing so the edges of the shield are between the housing and the lower shield.
- 8.2.3.9 Install upper two (2) ZINC-PLATED 6/32 x 1/2 inch Phillips screws into the side of the drive housing **NEXT TO** the video monitor.  
Install upper two (2) **BLACK** 6/32 x 1/2 inch Phillips screws into the side of the drive housing **FURTHEST FROM** the video monitor.

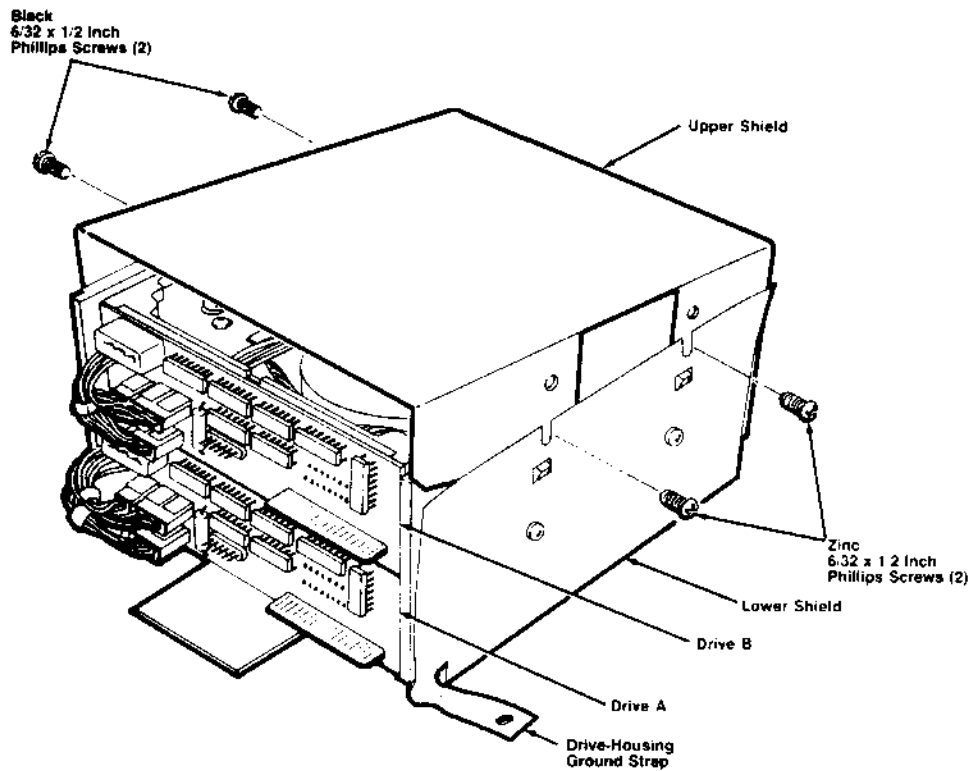

**FIGURE 8-37. DRIVE HOUSING AND SHIELDS**

- 8.2.3.10 Position chassis logic-board-side-up and video monitor facing technician.
- 8.2.3.11 With drive doors facing technician, slide the drive assembly under the chassis to the right of the video monitor.

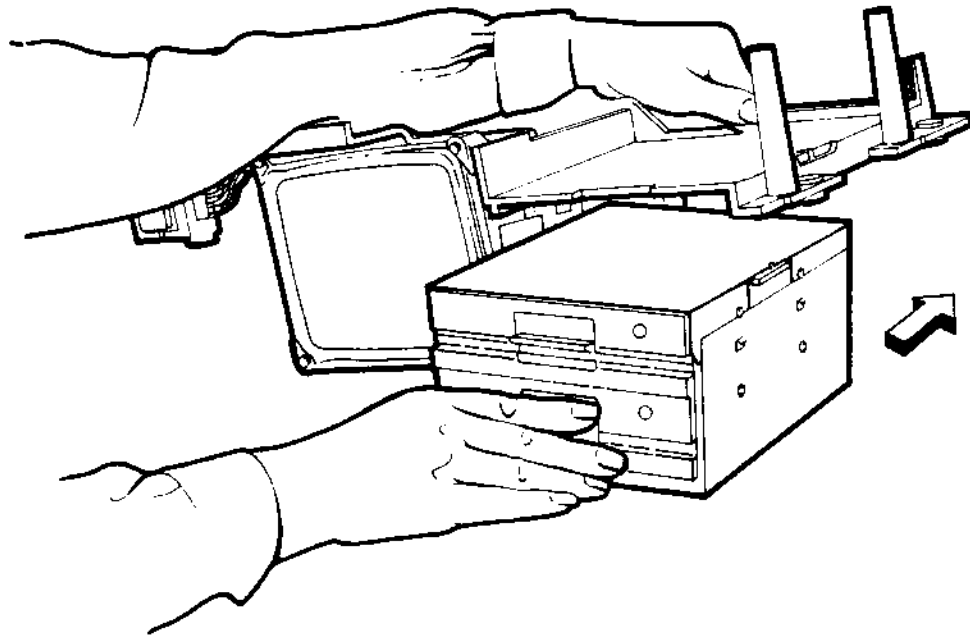

**FIGURE 8-38. DRIVE ASSEMBLY TO CHASSIS**

- 8.2.3.12 Two latches lock the drive assembly to the chassis. Carefully press the latches on the drive housing into the notches in the chassis.
- 8.2.3.13 Position chassis logic-board-side-up and video monitor facing away from technician.

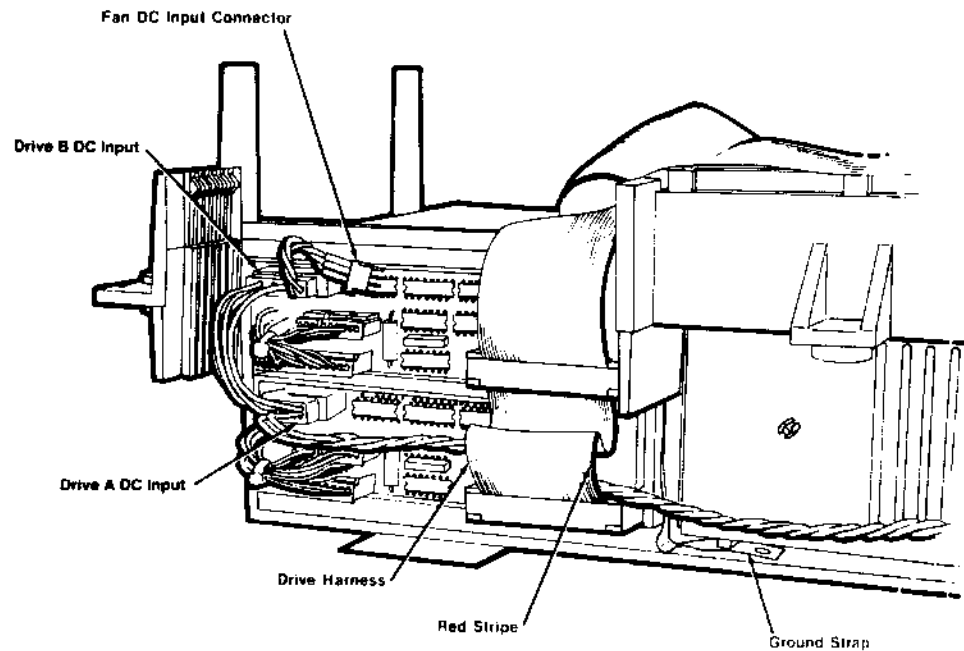

**FIGURE 8-39. DRIVE CABLES**

- 8.2.3.14 Insert the keyed DC input connector on the drive **B** input harness into the socket in the upper left corner of drive **B**.

---

**NOTE**

*The fan input connector is closest to the drive **B** connector.*

---

- 8.2.3.15 Insert the other keyed DC input connector into the socket in the upper left corner of drive **A**.
- 8.2.3.16 The drive **A** connector is at one end of the disk harness. The drive **B** connector is about 2 inches from it on the harness.
- 8.2.3.17 Insert the drive **A** disk harness connector into its socket on drive **A** (the lower drive). The red stripe on the harness must be to technician's **RIGHT**.
- 8.2.3.18 Hold the DC harness between the disk harness and the back of drive **A**. Plug the drive **B** disk harness connector into its socket on drive **B**.
- 8.2.3.19 Slide the disk harness under the chassis tab above the video monitor.

- 8.2.3.20 Install an 8/32 x 1-4 inch Phillips screw and nylon washer to attach the drive-housing ground strap to the monitor shield.

## 8.2.4 VIDEO MONITOR AND POWER SUPPLY ASSEMBLY

- 8.2.4.1 Position the video monitor with power supply standoffs facing up.
- 8.2.4.2 Align the power supply with five (5) screw holes in the monitor shield.
- 8.2.4.3 Install four (4) 6/32 x 3/8 inch Phillips screws to fasten the power supply to the monitor shield.

Install one of these screws in the center of the power supply. DO NOT INSTALL the screw nearest the power supply fuse.

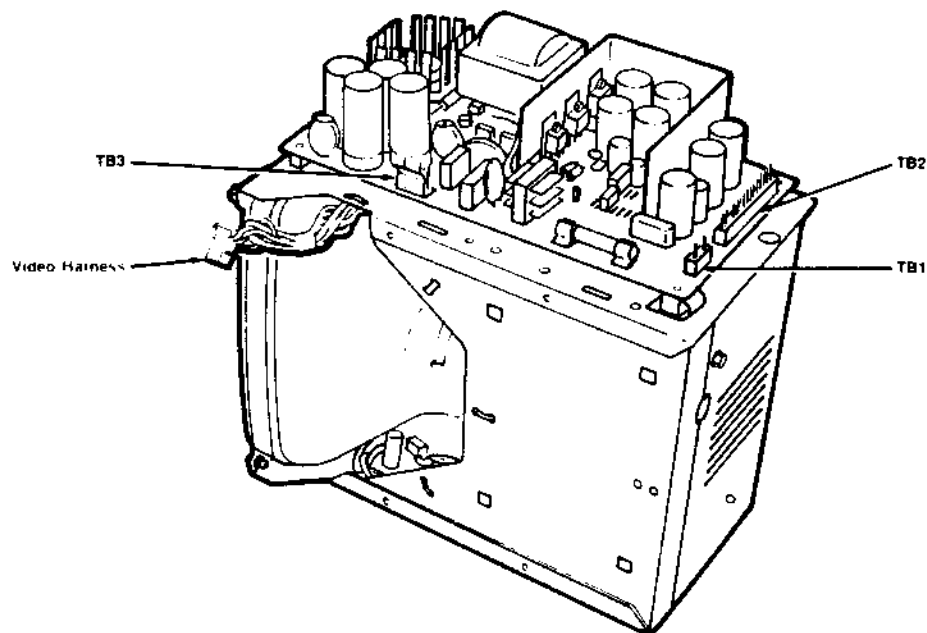

**FIGURE 8-40. POWER SUPPLY AND VIDEO MONITOR**

- 8.2.4.4 Slide the video monitor into position in the chassis while guiding the monitor cable through its chassis cutout.

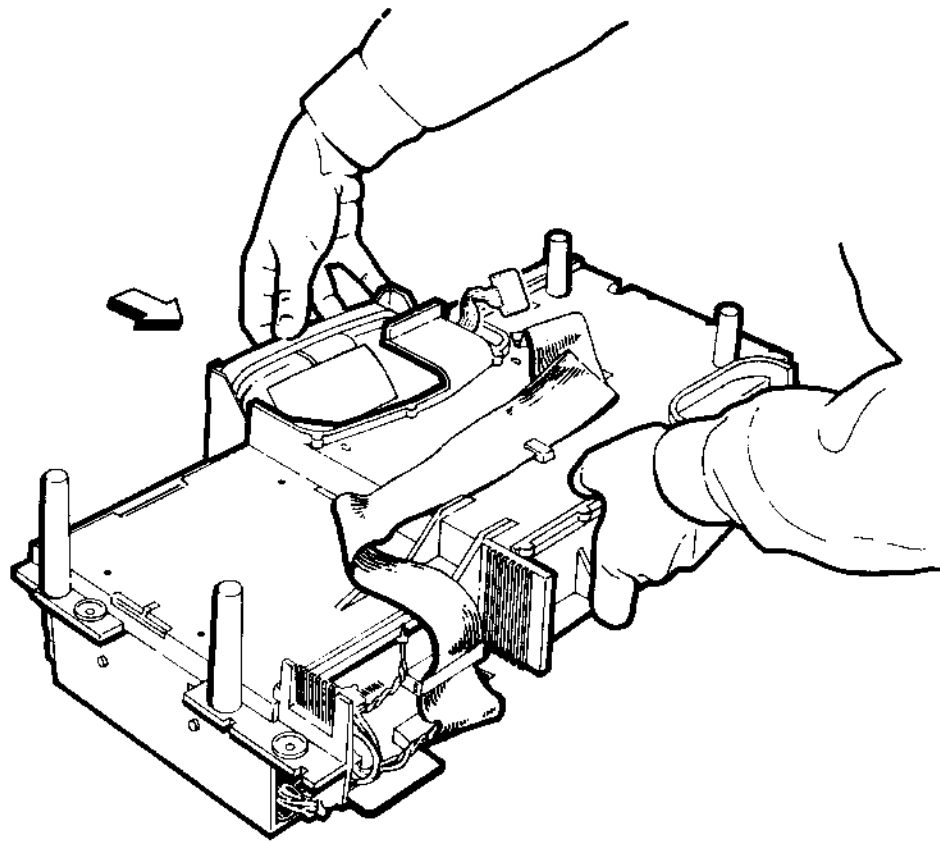

**FIGURE 8-41. VIDEO MONITOR TO CHASSIS**

- 8.2.4.5 Install four (4) 6/32 x 1/2 inch Phillips screws with star washers to secure the video monitor to the chassis. These screws were labeled **FOR VIDEO MONITOR** in Section 8.1.3.

---

**WARNING:** *Using an incorrect screw to assemble the video monitor to the chassis may short-circuit the video PC board.*

---

- 8.2.4.6 Install one (1) 6/32 x 3/8 inch Phillips screw next to the power supply fuse to connect the ground wire running from the AC power panel.
- The ground eyelet must be **BETWEEN** the power supply board and the standoff on the monitor shield.



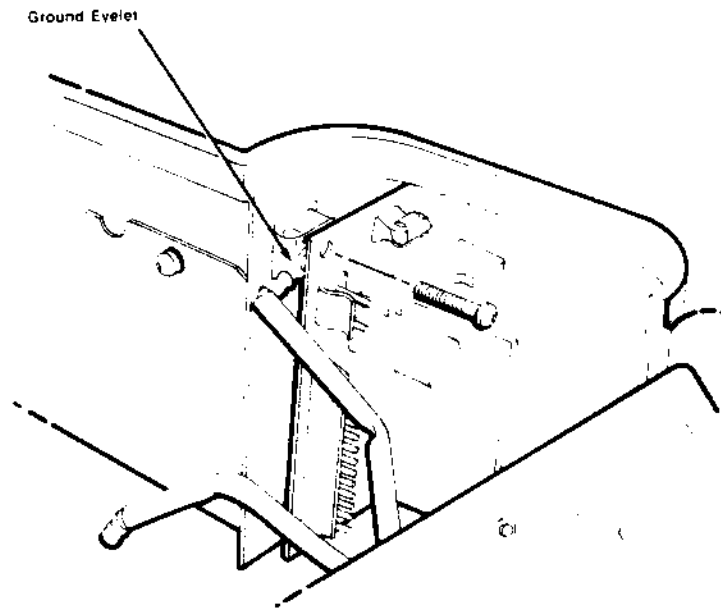

**FIGURE 8-42. POWER SUPPLY GROUND**

- 8.2.4.7 Connect two (2) keyed power-supply connectors to positions **TB1** and **TB2** on the power supply. **TB1** has 3 pins. **TB2** has 12 pins.
- 8.2.4.8 Insert the keyed 4-socket voltage selector onto **TB3** near the four large power-supply capacitors.
- 8.2.4.9 Position chassis logic-board-side-up and monitor screen facing away from technician.
- 8.2.4.10 Install one (1) 8/32 x 1/4 inch Phillips screw to attach the drive-housing ground strap to the monitor shield.

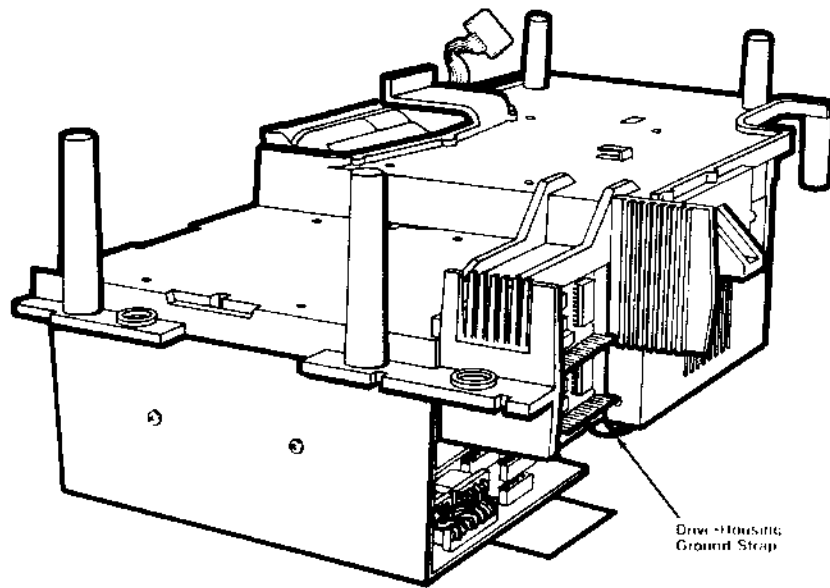

**FIGURE 8-43. DRIVE-HOUSING GROUND STRAP**

## **8.2.5 LOGIC AND MEMORY BOARD ASSEMBLY**

- 8.2.5.1 Hold memory board component-side down and 72-pin socket to the right.
- 8.2.5.2 Install four (4) standoffs into the memory board from the component side.

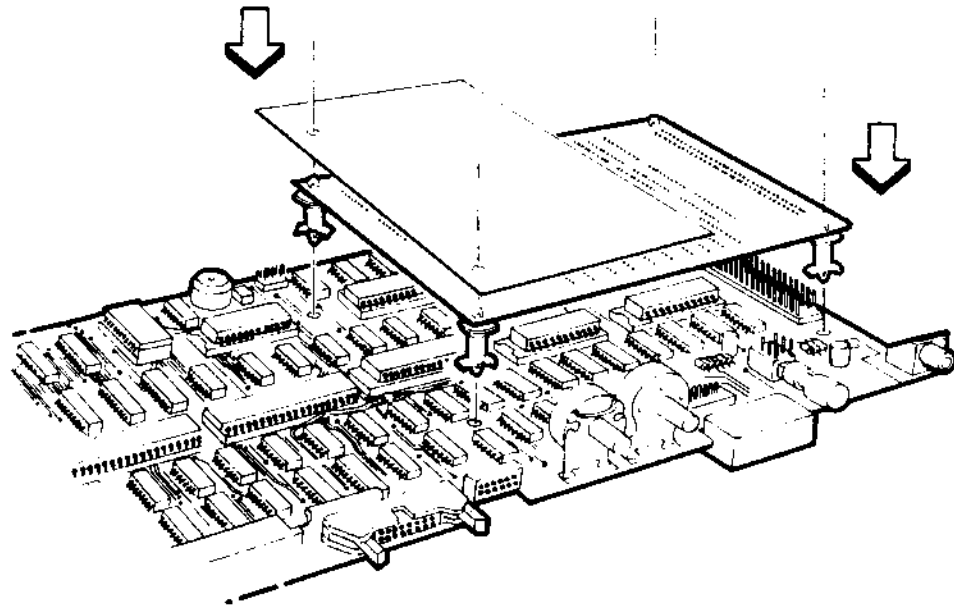

**FIGURE 8-44. MEMORY BOARD INSTALLATION**

- 8.2.5.3 Gently press the 72-pin socket on the memory board into place on the main logic board. Be careful to align the board correctly and not bend any pins.
- 8.2.5.4 Press four (4) memory board standoffs into the logic board mounting holes.  
Press the mylar shield into place over the memory board trace.
- 8.2.5.5 Position the chassis assembly logic-board-side-up and CRT screen facing technician.
- 8.2.5.6 Hold logic board perpendicular to the chassis, components facing technician and video control shafts pointing straight up.

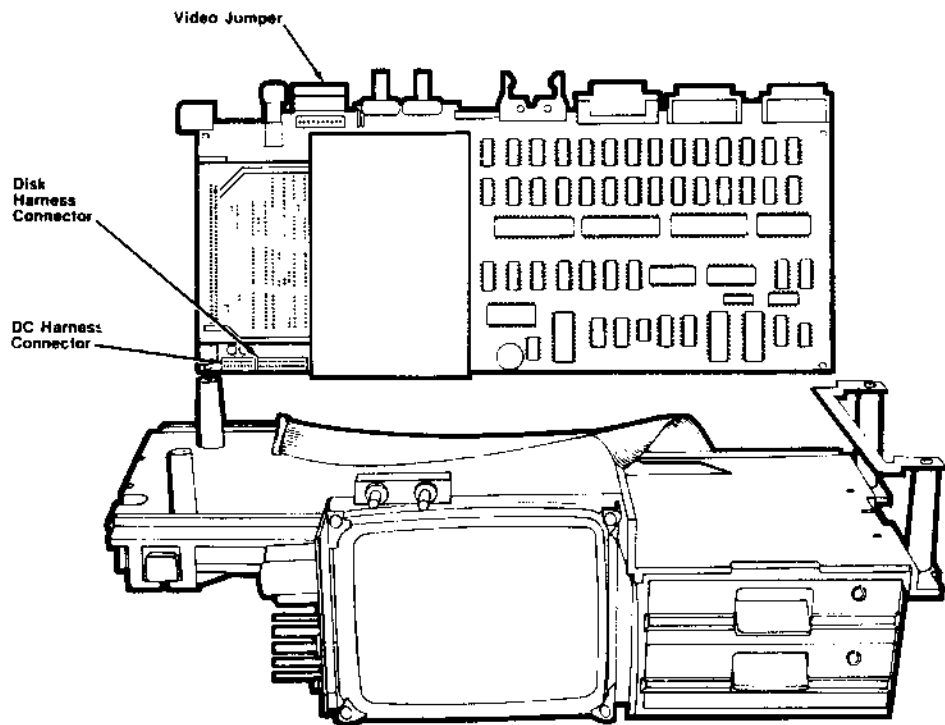

**FIGURE 8-45. LOGIC BOARD ASSEMBLY**

- 8.2.5.7 Attach the disk harness to the 34-pin connection on the logic board to the right of the DC harness connector. Be careful not to bend any pins when attaching the disk harness connector.

---

**NOTE**

*The disk harness connector is not keyed. The RED stripe on the harness must be to the RIGHT.*

---

- 8.2.5.8 Attach the DC harness connector to the 7-pin connection in the lower left corner of the logic board. This connector is not keyed.
- 8.2.5.9 Lower the logic board onto its chassis mountings.

- 8.2.5.10 Lift the front edge of the logic board slightly. Attach the video harness connector to the 10-pin connection at the right of the Reset button.  
The RED wire on the video harness must be to technician's LEFT.
- 8.2.5.11 If you're reinstalling the ORIGINAL logic board, install four (4) 6/32 x 1/4 inch Phillips screws with star washers to fasten the logic board AND mounting bracket to the chassis.  
Fasten the ground wire from the AC power panel to the left rear screw ABOVE the insulating shield.
- 8.2.5.12 If you're installing a NEW logic board, install two (2) 6/32 x 1/4 inch Phillips screws with nylon washers to secure the logic board and insulator to the chassis mounting bracket.

---

**NOTE**

*Use a nylon washer ABOVE and BELOW the logic board when fastening it to the mounting bracket.*

---

- Align the ground wire from the AC power panel with the left rear screw hole above the insulating shield.  
Install two (2) 6/32 x 1/2 inch Phillips screws with star washers on the left edge of the logic board.
- 8.2.5.13 Install the keyed, external video plug to the front edge of the logic board between the Reset button and the contrast control.
- 8.2.5.14 Remove two (2) 1/4-inch hex screws from the front edge of the video monitor nearest the logic board.
- 8.2.5.15 Position the Y bracket over the video control shafts and install both 1/4-inch hex screws to secure it to the chassis.

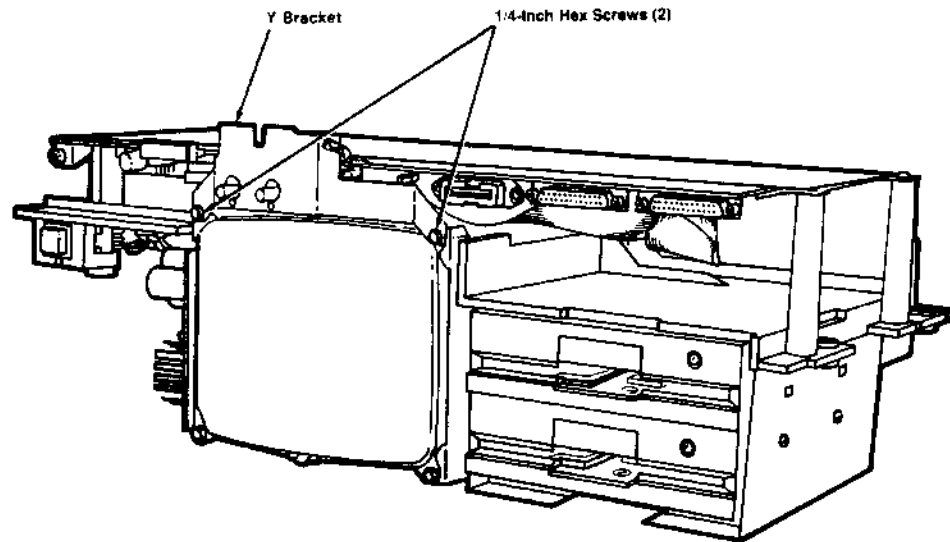

FIGURE 8-46. Y BRACKET

## 8.2.6 BEZEL AND CHASSIS ASSEMBLY

**CAUTION:** The interior of the case is coated with a special metallic paint. Avoid scratching this coating.

- 8.2.6.1 Position the chassis assembly logic-board-side-up, video monitor facing away from technician.
- 8.2.6.2 Place the top half of the carrying case (with the ventilation slots) upside down on the work surface, latches away from technician.
- 8.2.6.3 Place one hand under the chassis at the power supply and the other hand under the chassis at the disk drive housing.

Carefully lift the chassis into the top half of the carrying case.

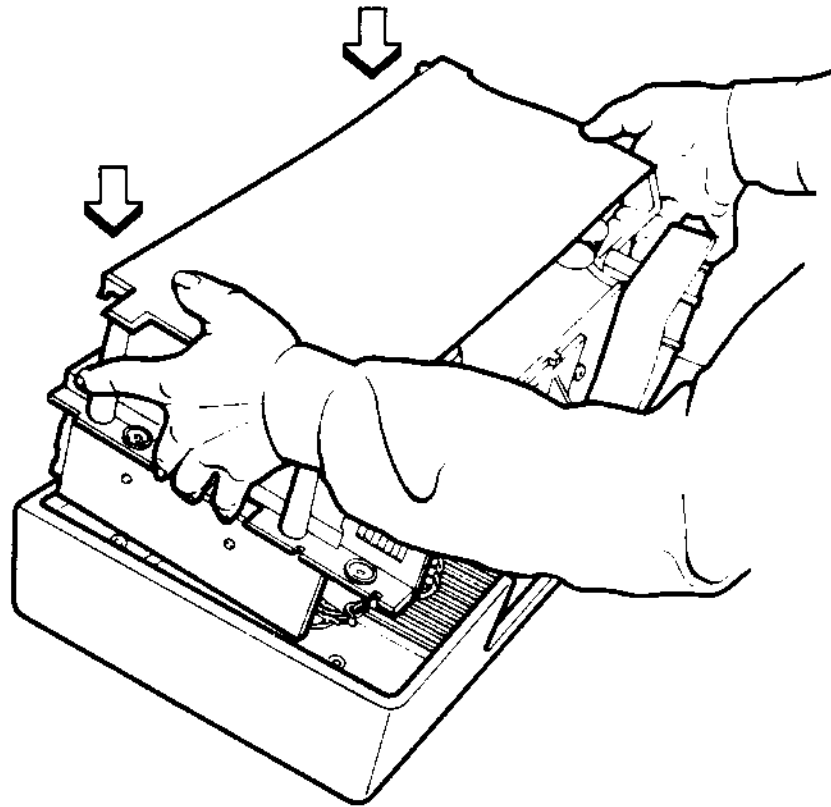

**FIGURE 8-47. CHASSIS TO CASE ASSEMBLY**

---

**NOTE**

*When installing the chassis into the case, be careful not to pinch, trap, or rip any wire harnesses.*

---

- 8.2.6.4 Align screw holes in the chassis with five (5) mounting standoffs in the case.
- 8.2.6.5 Slide the power panel compartment into the case, door hinge cutouts at the bottom.

- 8.2.6.6 Slide the carrying handle and fan compartment into the lower half of the case. The WIDE area of the fan assembly is BELOW the handle.
- 8.2.6.7 Connect the fan power harness to the DC harness.

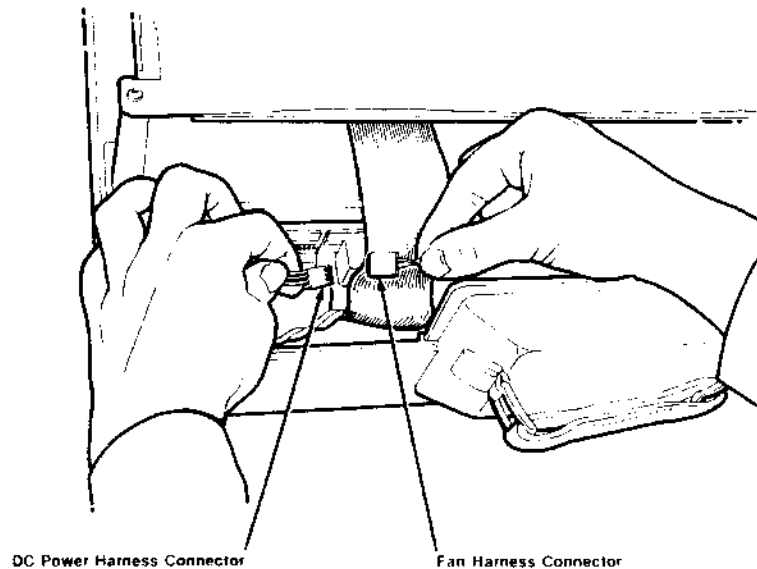

**FIGURE 8-48. FAN POWER HARNESS TO DC HARNESS**

- 8.2.6.8 Attach the power compartment door to the power compartment.
- 8.2.6.9 Place the lower half of the case onto the chassis assembly. Be sure the AC power compartment, fan compartment, and upper/lower halves of the case align properly.
- 8.2.6.10 Install five (5) 6/32 x 3/4 inch Phillips screws to fasten the case together. Tighten these screws until they're snug. **DO NOT OVERTIGHTEN.**
- 8.2.6.11 Turn the unit so ventilation cover is on top and video monitor faces technician.
- 8.2.6.12 Grasp the front bezel near the latch cutouts and carefully slide it into the chassis.  
Be sure the keyboard connector is in closed position and the braided logic-board ground cable is over the screw hole in the Y bracket.



- 8.2.6.13 Install five (5) 6/32 x 1/4 inch Phillips screws to fasten the bezel to the chassis. **DO NOT OVERTIGHTEN THESE SCREWS.**
- 8.2.6.14 Carefully push the video control knobs onto their shafts.
- 8.2.6.15 With the keyboard assembly in front of the unit, plug the keyboard cable into the keyboard connector below the CRT screen. Facing the screen, the cable connects from the **LEFT**.

## 8.2.7 KEYBOARD ASSEMBLY

- 8.2.7.1 Place the keyboard bezel onto a pad or soft material, standoffs facing up.
- 8.2.7.2 Align the keyswitch array face down with the cutouts on the keyboard bezel.

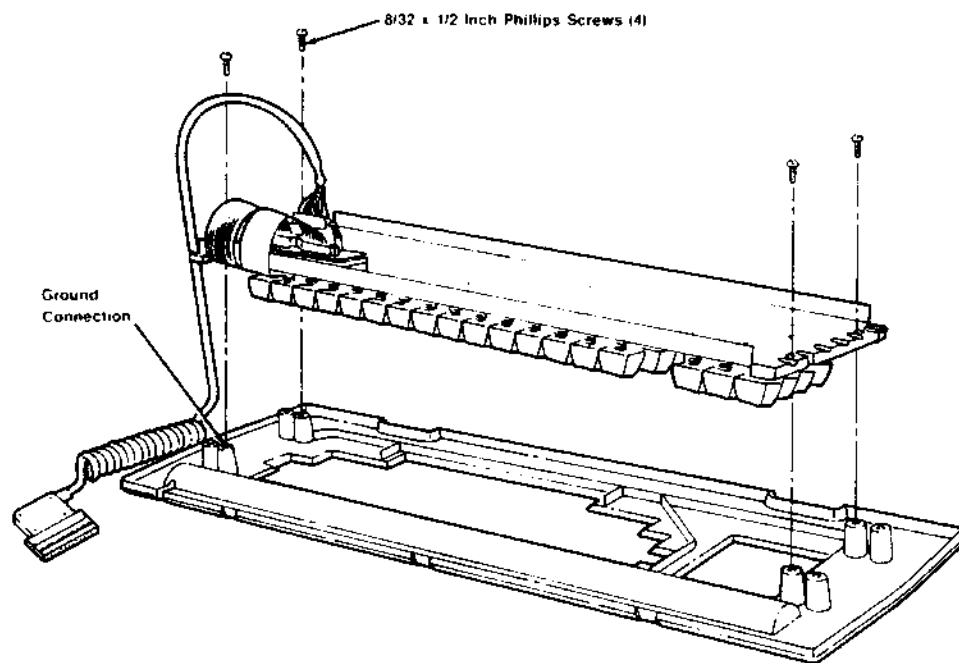

**FIGURE 8-49. TYPE A KEYBOARD**

- 8.2.7.3 *Type A keyboard:*  
Install three (3) 8/32 x 1/2 inch Phillips screws to secure the keyboard to the bezel standoffs. **DO NOT INSTALL** the screw nearest the keyboard harness connector.

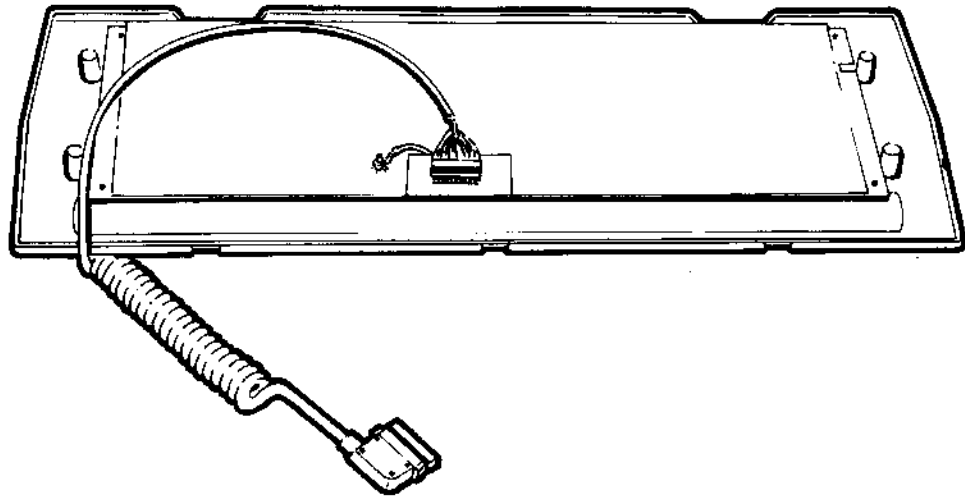

**FIGURE 8-50. TYPE B KEYBOARD**

*Type B keyboard:*

Install four (4) 8/32 x 1/2 inch Phillips screws to secure the keyboard to the bezel standoffs.

**CAUTION:** Be careful not to crimp or crease the keyboard cables.

- 8.2.7.4 Connect pin 1 on the keyboard harness to pin 1 of the keyboard connector. Be sure the keyboard harness orientation is correct.

---

**NOTE**

*To locate pin 1 of the keyboard connector, position keyboard with the numeric row of keys to the top.*

*Looking at the underside of the keyboard, pin 1 is in the UPPER RIGHT corner of the keyboard connector. Pin 1 may also have an orange dot next to it.*

---

- 8.2.7.5 *Type A keyboard:*

Install an 8/32 x 1/2 inch Phillips screw to fasten the ground wire to the remaining bezel standoff.

*Type B keyboard:*

Install a 6-32 hex nut and star washer to connect the ground wire to the lug next to the keyboard connector.

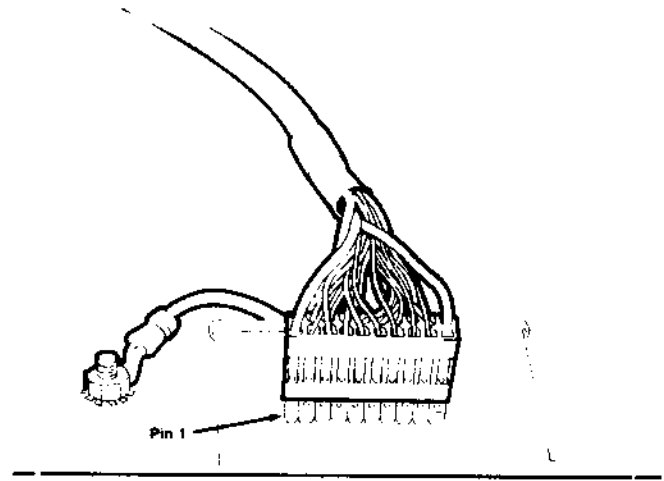

**FIGURE 8-51. TYPE B KEYBOARD GROUND NUT AND WASHER**

- 8.2.7.6 Position the keyboard harness in the notch on the long edge of the keyboard bezel.
- 8.2.7.7 Lower the keyboard case onto the keyboard and keyboard bezel assembly so the case and bezel are flush.
- 8.2.7.8 Install four (4) 6/32 x 1/4 inch Phillips screws to secure the keyboard case to the keyboard assembly.
- 8.2.7.9 Turn keyboard face up and plug the keyboard cable into the keyboard connector below the CRT screen. Facing the screen, the cable connects from the LEFT.

## 8.3.0 ALPS DISK-DRIVE ALIGNMENTS

- 8.3.0.1 The Osborne Disk Exercisor Program or similar device and a Dysan 224-1A or equivalent alignment diskette are needed for drive alignments.
- 8.3.0.2 Drive alignments are sensitive to temperature and humidity. Stabilize drives and media at room temperature before making alignments.
- 8.3.0.3 Insert the Osborne Disk Exercisor Program in the boot drive and the Dysan 224 or equivalent diskette in the drive being adjusted.

---

### NOTE

*Section 8.5.1 has user instructions for the Osborne Disk Exercisor Program.*

---

## 8.3.1 Drive Cable Hookup

- 8.3.1.1 Position drive with stepper motor on bottom and door facing away from technician.
- 8.3.1.2 Connect power cable to position J2 in the lower right corner of the rear PC board.
- 8.3.1.3 Connect drive cable to edge connector J1 on the top PC board. Pin 1—the colored edge of the cable—must be to technician's left.

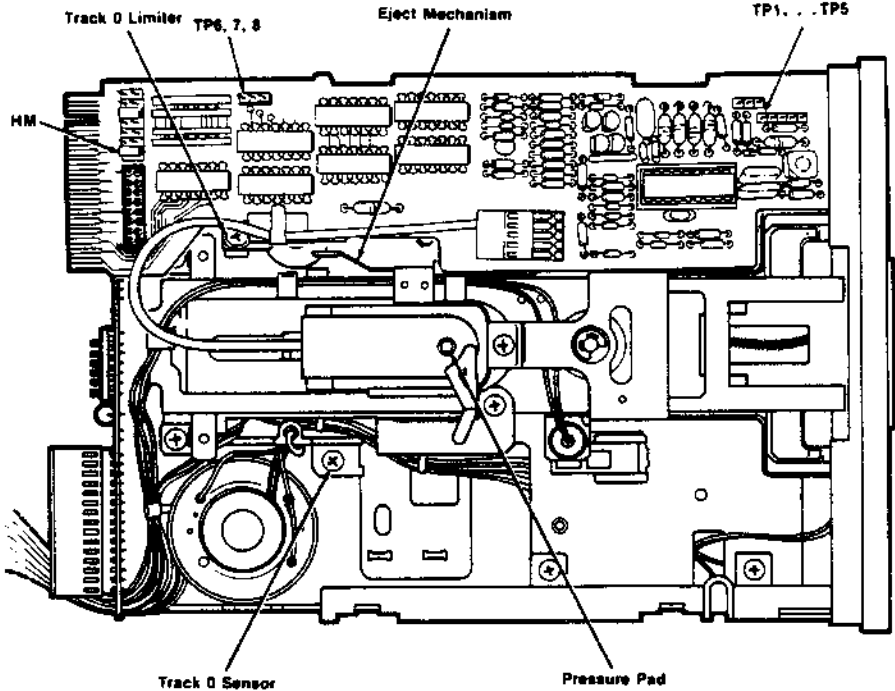

FIGURE 8-52. ALPS DRIVE TOP VIEW

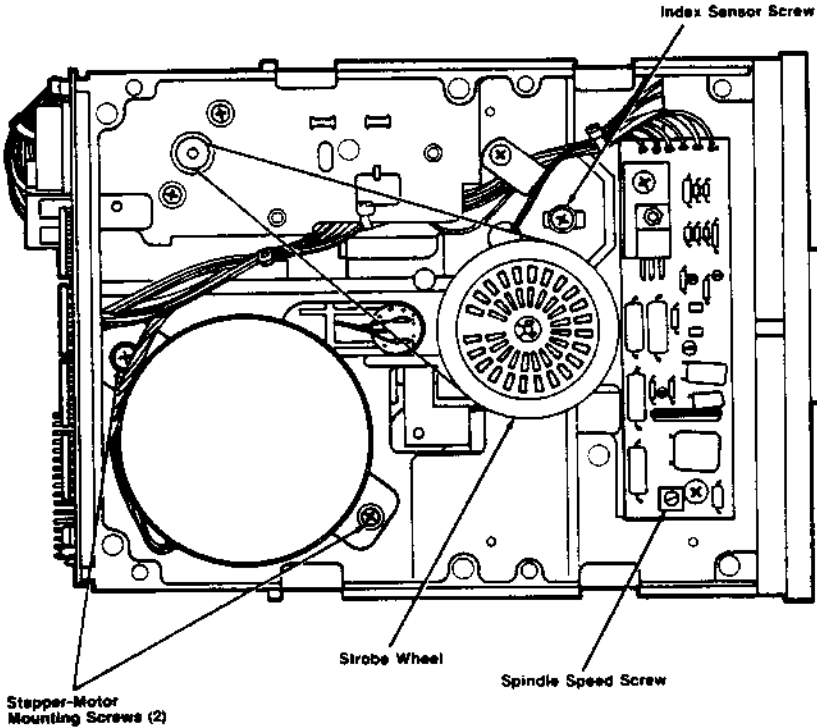
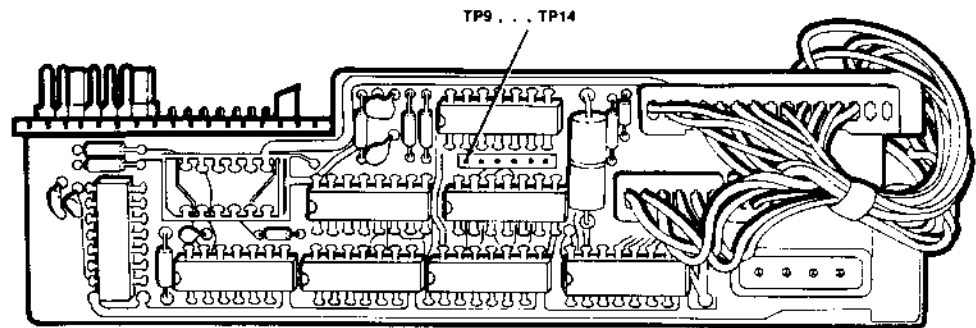

FIGURE 8-53. ALPS DRIVE BOTTOM VIEW



**FIGURE 8-54. TEST POINT CONNECTIONS (REAR PC BOARD)**

### 8.3.2 Spindle Speed Adjustment

Using the Osborne Disk Exercisor Program:

- 8.3.2.1 Follow instructions 8.3.1.1 through 8.3.1.3 to connect the drive.
- 8.3.2.2 Position drive so strobe wheel faces technician.
- 8.3.2.3 Insert an Executive Diagnostics diskette in the boot drive and select the DISK EXEC program.  
Insert a Dysan 224-1A or equivalent alignment diskette in the drive being adjusted.
- 8.3.2.4 Locate variable resistor **VR1** on the spindle-motor control board. The small screw on **VR1** is the spindle-speed adjustment screw (Figure 8-53).
- 8.3.2.5 Select the SEEK TRACK function on the Osborne Disk Exercisor Program, step to track 16, then select DRIVE TIMER function.
- 8.3.2.6 Note the time in milliseconds in the drive timer test. Correct time is  $200 \pm 1$  milliseconds.
- 8.3.2.7 Slowly turn the spindle-speed adjustment screw until timing is in tolerance.

To adjust spindle speed *without* the Disk Exercisor Program:

- 8.3.2.8 Follow instructions 8.3.1.1 through 8.3.1.3 to connect the drive.
- 8.3.2.9 Insert a blank diskette and boot the drive.

- 8.3.2.10 The strobe wheel on the bottom of the drive has a black-and-white pattern. Position the drive with strobe wheel facing technician (Figure 8-53).
- 8.3.2.11 Watch the strobe wheel pattern under fluorescent lighting. With 60-cycle lighting, use the outer strobe-wheel pattern.
- 8.3.2.12 Slowly turn the spindle-speed adjustment screw (Figure 8-53) until the strobe effect stops.

### 8.3.3 Radial Head Alignment

- 8.3.3.1 Follow instructions 8.3.1.1 through 8.3.1.3 to connect the drive.
- 8.3.3.2 Be sure the Disk Exercisor Program is in the boot drive and the Dysan 224 or equivalent diskette is in the drive being adjusted.
- 8.3.3.3 Select SEEK TRACK function on the Osborne Disk Exercisor Program and step to track 16.
- 8.3.3.4 Connect oscilloscope probes to the drive PC boards as follows:

<u>Ground</u>	<u>Channel 1</u>	<u>Channel 2</u>	<u>External Trigger</u>
TP5	TP1	TP2	TP12

- 8.3.3.5 Oscilloscope settings:

<u>Channel 1</u>	<u>Channel 2</u>
Vertical deflection 10 mV/div	Vertical deflection 10 mV/div
Vertical mode BOTH	Vertical mode ADD
AC coupling	AC coupling
Positive slope	Positive slope
	Inverted

Time base: 20 msec/div  
Trigger NORM, external source

- 8.3.3.6 Observe cat-eye pattern on oscilloscope. Shape and amplitude of cat-eyes should be within 80% of each other (Figure 8-55).

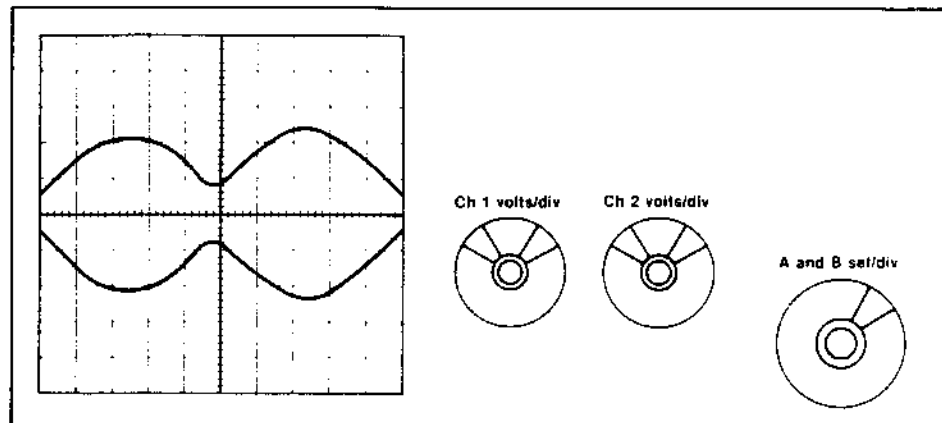

**FIGURE 8-55. CAT-EYE PATTERN**

---

**NOTE**

*If the cat-eye signal is flat or very weak, there may be an amplitude problem.*

*Follow the instructions in Section 8.3.7 to make an amplitude check.*

---

- 8.3.3.7 If cat-eye patterns are NOT within 80% of each other, loosen two (2) stepper motor mounting screws (Figure 8-53).
- 8.3.3.8 Rotate stepper motor until cat-eye patterns are within tolerance.
- 8.3.3.9 Tighten both stepper-motor mounting screws. Be careful not to move the motor.
- 8.3.3.10 While observing cat-eye pattern, step from track 16 to track 34 and back again. If pattern is not within tolerance, repeat steps 8.3.3.7 through 8.3.3.10.



### 8.3.4 Track 0 Limiter Adjustment

- 8.3.4.1 Position drive with PC boards facing up and door facing technician.
- 8.3.4.2 Locate the track 0 limiter to the right of the head assembly, directly under the head cable clip (Figure 8-52).
- 8.3.4.3 Select SEEK TRACK function on the Osborne Disk Exercisor Program and step the head to track 0.
- 8.3.4.4 Check track 0 limiter movement for a clearance of 0–0.25 mm.
- 8.3.4.5 If track 0 limiter is not within tolerance, loosen the Phillips screw on the track 0 limiter and adjust it to 0–0.25 mm clearance (Figure 8-52).
- 8.3.4.6 Tighten the Phillips screw, being careful not to disturb the adjustment.

### 8.3.5 Track 0 Sensor Adjustment

---

**NOTE**

*Before making this adjustment be sure the Radial Head alignment is correct. See Section 8.3.3.*

---

- 8.3.5.1 Follow instructions 8.3.1.1 through 8.3.1.3 to connect the drive.

**CAUTION:** Be careful not to short-circuit the drive PC board when making the following connections and adjustments.

8.3.5.2 Connect oscilloscope probes to the drive PC boards as follows:

<u>Ground</u>	<u>Channel 1</u>	<u>Channel 2</u>	<u>Internal Trigger</u>
TP5	TP6	TP10	

8.3.5.3 Oscilloscope settings:

<u>Channel 1</u>	<u>Channel 2</u>
Vertical deflection 0.5V/div	Vertical deflection 0.5V/div
Vertical mode BOTH	Vertical mode CHOP
AC coupling	AC coupling
Positive slope	Positive slope
	Signal NOT inverted

Time base: 10 msec/div

Trigger NORM, internal source

8.3.5.4 Insert Osborne Disk Exercisor Program in the boot drive and Dysan 224-1A or equivalent diskette in the drive being adjusted.

8.3.5.5 Select the ALT TRACK function on the Disk Exercisor Program.

8.3.5.6 Alternate drive head between tracks 0 and 2.

8.3.5.7 Observe the square-wave signal on the oscilloscope for these tolerances (Figure 8-56):

Channel 1—positive portion: less than 10 msec

—negative portion: less than 5 msec

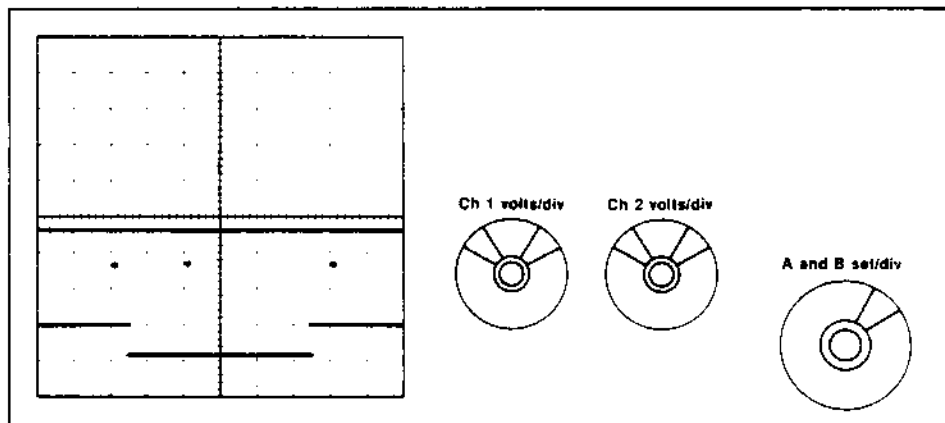

**FIGURE 8-56. TRACK 0 SENSOR SIGNAL**

- 8.3.5.8 Switch oscilloscope to line trigger, then alternate drive head between tracks 1 and 2. No signal should appear on the oscilloscope.
- 8.3.5.9 If the drive does NOT satisfy test conditions 8.3.5.7 and 8.3.5.8, loosen the 4/40 x 0.25 inch Phillips sensor mounting screw (Figure 8-52).
- 8.3.5.10 Alternate drive head between tracks 0 and 2. Slide the sensor until signal is within tolerance.
- 8.3.5.11 Tighten sensor mounting screw and check as follows:  
 Alternate between tracks 1 and 2 to confirm "no signal."  
 Alternate between tracks 0 and 2 to verify the square-wave signal.

### **8.3.6 Index-Sensor Timing Adjustment**

- 8.3.6.1 Follow instructions 8.3.1.1 through 8.3.1.3 to connect the drive.

8.3.6.2 Connect oscilloscope probes to the drive PC boards as follows:

<u>Ground</u>	<u>Channel 1</u>	<u>Channel 2</u>	<u>External Trigger</u>
TP5	TP1	TP2	TP12

8.3.6.3 Oscilloscope settings:

<u>Channel 1</u>	<u>Channel 2</u>
Vertical deflection 10 mV/div	Vertical deflection 10 mV/div
Vertical mode BOTH	Vertical mode ADD
AC coupling	AC coupling
Positive slope	Positive slope
	Inverted

Time base: 50 msec/div

Trigger NORM, external source

8.3.6.4 Be sure the Osborne Disk Exercisor Program is in the boot drive and the Dysan 224-1A or equivalent diskette is in the drive being adjusted.

8.3.6.5 Select SEEK TRACK function on the Osborne Disk Exercisor Program and step to track 1.

8.3.6.6 Observe timing between start of sweep and first data pulse on oscilloscope. Timing should be  $200 \pm 50$  microseconds (Figure 8-57).

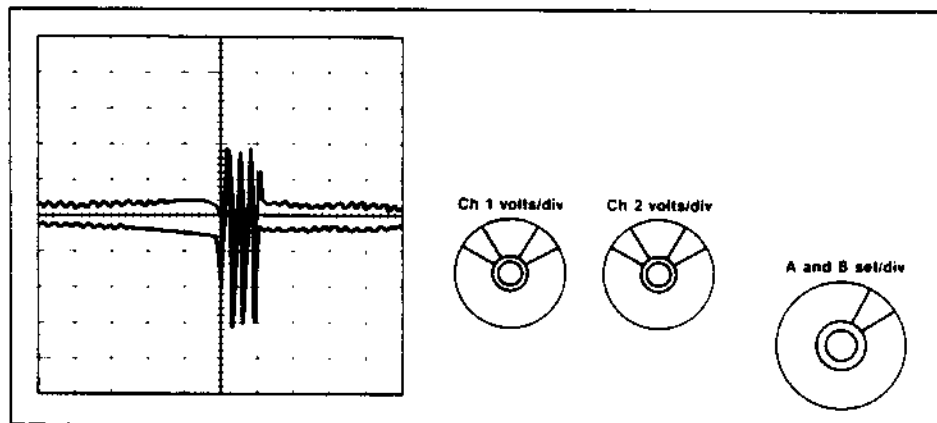

**FIGURE 8-57. INDEX SENSOR SIGNAL**

---

**NOTE**

*If there's no data pulse or it's very weak, there may be an amplitude problem.*

*Follow the instructions in Section 8.3.7 to make an amplitude check.*

---

- 8.3.6.7 If timing is NOT within tolerance, loosen the index sensor screw below the spindle pulley on the bottom of the drive (Figure 8-53).
- 8.3.6.8 Adjust the index sensor until timing is within tolerance. Tighten the index sensor screw being careful not to disturb the timing.
- 8.3.6.9 Open and close the drive door several times. Check timing and readjust if necessary.

**8.3.7 Amplitude Check**

---

**NOTE**

*Use the following as a **troubleshooting technique** if signals are weak/nonexistent during radial head and index sensor adjustments.*

---

8.3.7.1 Follow instructions 8.3.1.1 through 8.3.1.3 to connect the drive.

8.3.7.2 Connect oscilloscope probes to the drive PC boards as follows:

<u>Ground</u>	<u>Channel 1</u>	<u>Channel 2</u>	<u>External Trigger</u>
TP5	TP1	TP2	TP12

8.3.7.3 Oscilloscope settings:

<u>Channel 1</u>	<u>Channel 2</u>
Vertical deflection 10 mV/div	Vertical deflection 10 mV/div
Vertical mode BOTH	Vertical mode ADD
AC coupling	AC coupling
Positive slope	Positive slope
	Inverted

Time base: 0.5 msec/div

Trigger NORM, external source

8.3.7.4 Insert Osborne Disk Exercisor Program diskette in the boot drive and a Dysan 224-1A or equivalent diskette in the drive being adjusted.

8.3.7.5 Select SEEK TRACK function on the Osborne Disk Exercisor Program and step to track 0.

8.3.7.6 Amplitude pattern on the oscilloscope must be 0.27 volts or higher (Figure 8-58).

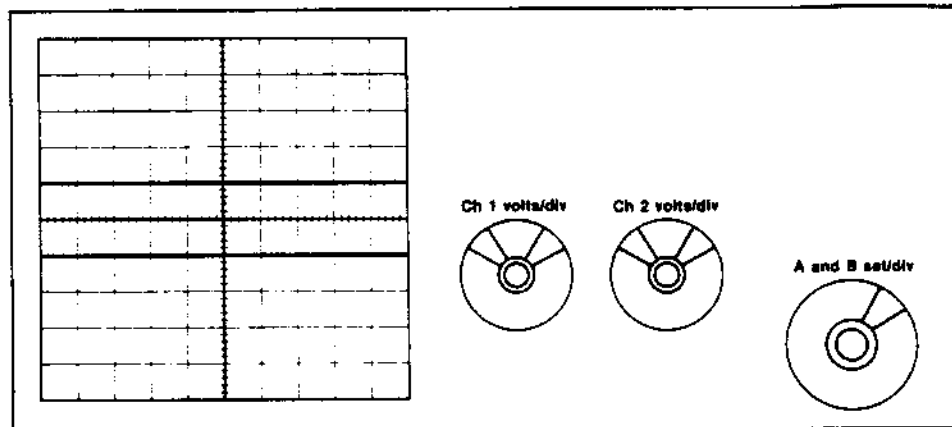

**FIGURE 8-58. AMPLITUDE SIGNAL**

- 8.3.7.7 If amplitude is less than 0.27 volts, remove alignment diskette.
  - 8.3.7.8 Locate the pressure pad arm above the Read/Write head (Figure 8-52).
  - 8.3.7.9 Insert a flat-tip screwdriver in the pressure-pad adjustment notch and rotate the pressure pad 180 degrees.
- CAUTION:** Don't move the drive head beyond its normal up/down travel.
- 8.3.7.10 Insert alignment diskette and check amplitude.
  - 8.3.7.11 If amplitude is below 0.27 volts, loosen two (2) stepper-motor mounting screws on the bottom of the drive (Figure 8-53).
  - 8.3.7.12 Rotate stepper motor in each direction while watching amplitude pattern on the oscilloscope.
  - 8.3.7.13 If amplitude increases to tolerance, tighten both stepper-motor mounting screws being careful not to disturb the adjustment.
  - 8.3.7.14 Check the radial head alignment and adjust if necessary (see Section 8.3.3).
  - 8.3.7.15 If amplitude DOES NOT increase, replace the disk drive.

## 8.4.0 ZENITH 7" VIDEO MONITOR ADJUSTMENTS

- 8.4.0.1 An Executive Diagnostics Diskette is needed for video monitor adjustments.
- 8.4.0.2 Adjustments can be made with disk drives removed and monitor attached to the chassis.

---

### NOTE

*Section 8.5.0 has user instructions for the Executive Diagnostics Diskette.*

---

### PRECAUTIONS

Follow these precautions before making any adjustments to the video monitor.

1. Allow five minutes' warm-up before starting any adjustments.
2. Use a NON-METALLIC tool to make adjustments.
3. Use EXTREME CARE when handling the Video Monitor. Rough handling may cause the CRT to implode.
4. Some Video Monitor components carry high voltage (transformer, etc.). USE EXTREME CAUTION.

---

### NOTE

*Before removing the front bezel from the chassis **lightly** trace its outline on the video screen with a felt-tip pen.*

---



## 8.4.1 Brightness/Contrast Adjustment

- 8.4.1.1 Turn ON the computer.
- 8.4.1.2 Insert and boot Executive Diagnostics Diskette in either drive. Select RUN QUICK Mode and Screen Pattern Test.
- 8.4.1.3 Rotate contrast control, R23 on logic board, for desired video contrast.
- 8.4.1.4 Rotate brightness control, R22 on logic board, for desired video brightness.

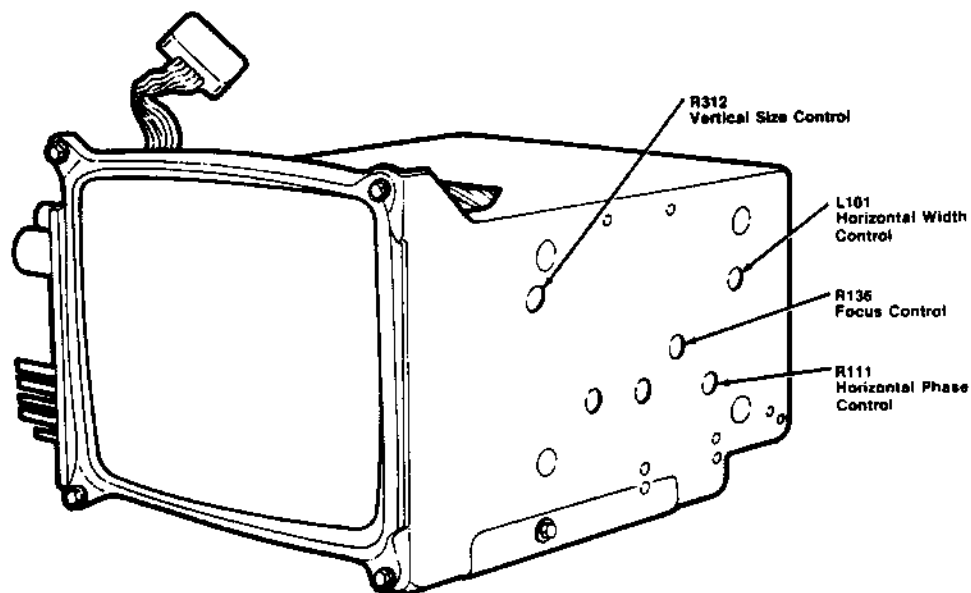

**FIGURE 8-59. VIDEO MONITOR ACCESS PORTS**

The following adjustments are made on the video monitor.

## 8.4.2 Focus Adjustment

- 8.4.2.1 Turn ON the computer.
- 8.4.2.2 Insert and boot Executive Diagnostics Diskette in either drive. Select RUN QUICK Mode and Screen Pattern Test.

- 8.4.2.3 Rotate focus control, R136 on monitor PC board, to obtain best focus at a point near the center of the screen horizontally and 1/3 down from the top (Figure 8-59).

### **8.4.3 Vertical Size Adjustment**

- 8.4.3.1 Turn ON the computer.
- 8.4.3.2 Insert and boot Executive Diagnostics Diskette in either drive. Select RUN QUICK Mode and Screen Pattern Test.
- 8.4.3.3 Rotate vertical size control, R312 on monitor PC board, to obtain desired display size (Figure 8-59).

### **8.4.4 Horizontal Width/Phase Adjustment**

- 8.4.4.1 Turn ON the computer.
- 8.4.4.2 Insert and boot Executive Diagnostics Diskette in either drive. Select RUN QUICK Mode and Screen Pattern Test.
- 8.4.4.3 Rotate horizontal width control, inductor L101 on the monitor PC board, for desired display size (Figure 8-59).
- 8.4.4.4 Rotate horizontal phase control, R111 on monitor PC board, for desired video border position (Figure 8-59).



**OSBORNE EXECUTIVE**  
**Troubleshooting**  
**and**  
**Preventive**  
**Maintenance**

## QUICK TROUBLESHOOTING GUIDE

Problem	Action
No power to computer	Check power panel & power supply fuses Check for loose/faulty connections: DC harness, AC power panel, power switch Check power supply voltages: AC input and DC output
No Sign-On message	Check P12 connector for shorted pins Check braided logic-board ground Check video harness connections Check copper/mylar insulator for shorting to logic board
Drives won't boot	Check keyboard connector pins Check disk-drive cable connections Check DC input connector and voltages to logic board Check for shorted IC pins/P12 wirewraps Check braided logic-board ground
Power switch reversed	Rewire switch
Warning Message on Power-Up	Check installation of copper/mylar shield on main logic board
Drive lights stay ON	Check drive cable connection at logic board and disk drives Replace drives Replace logic board

## 9.0.0 TROUBLESHOOTING TECHNIQUE

- 9.0.0.1 The first step in troubleshooting the Osborne Executive is to determine whether the problem is with an OCC component or external to the system.

Disconnect such devices as printer, external monitor, modem, etc. and test the computer to see if the problem still occurs. If it does, use Osborne-supplied diagnostics and this troubleshooting guide to identify and correct the problem.

See Chapter Eight of the *Field Service Manual* for detailed instructions about module assembly, disassembly and replacement.

- 9.0.0.2 If there's no problem with external device(s) disconnected, test the external device(s) and the Osborne/external device interface (RS-232 and IEEE-488 ports, etc.).
- 9.0.0.3 Make a thorough visual inspection of all modules suspected of malfunctioning.

### 9.0.1 Precautions

- 9.0.1.1 Unless otherwise instructed, *DO NOT* remove or install any component or connect/disconnect any plug or cable while power is ON.
- 9.0.1.2 Use extreme caution for any procedure which does require power to be ON.
- 9.0.1.3 Identify all cable orientations before making any disconnections.

## 9.1.0 POWER PROBLEMS

Symptoms:

1. System doesn't power up
2. Reduced screen display/slow-running disk
3. Disk drive errors during applications

### 9.1.1 System Doesn't Power Up

- 9.1.1.1 Be sure the power switch is turned ON. Switch it OFF, wait 15 seconds, then switch it ON again. If the unit beeps, the drive activity lights flash, but the video screen remains blank, see Section 9.3.0.

- 9.1.1.2 Test the power source for correct voltages: 115V or 220V as applicable.
- 9.1.1.3 Switch power OFF. Test the AC power fuse and circuit breaker as applicable. Replace the power panel fuse or AC power panel if necessary (Sections 8.1.6 and 8.1.8).
- 9.1.1.4 Check all cables for breaks, faulty connections, etc.
- 9.1.1.5 Check the DC connections at the power supply. Each connector is keyed to fit only one way.

---

**WARNING:** *The following tests need AC power on. Use extreme caution!*

---

- 9.1.1.6 Check the following connector wires for voltages indicated:

	<u>Output</u>	<u>Min</u>	<u>Max</u>	<u>Ripple</u>
Pins 1 and 7	+12V	+11.40	+12.60	150 mV p-p
Pins 2 and 6	+5V	+4.75	+5.25	50 mV p-p
Pins 3 and 5	common			
Pin 4	-12V	-11.40	-12.60	150 mV p-p

Test pins 1 and 7 to pins 3 and 5

Test pins 2 and 6 to pins 3 and 5

Test pin 4 to pins 3 and 5

1. If voltages are within above limits, the AC and DC power systems are operating correctly.
2. All voltages are missing.  
REPLACE the 1A, 250V power-supply fuse.
3. One of the voltages is missing or out of tolerance.  
REPLACE the power supply (see Sections 8.1.3 and 8.2.4).

- 9.1.1.7 Check the power supply voltages with and without a load applied. A large difference in potential may indicate a short-circuit in one of the modules.

## 9.1.2 Reduced Screen Display/Slow-Running Disk

9.1.2.1 Follow instruction 9.1.1.6 to check DC voltages to the logic board. Be sure all harnesses are connected properly.

1. Voltages are out of tolerance.  
REPLACE the power supply (Sections 8.1.3 and 8.2.4). Check power supply voltages.
2. Voltages are within tolerance.  
DISCONNECT internal monitor and CONNECT an external one.

If no problem with external monitor, REPLACE the internal monitor (Sections 8.1.3 and 8.2.4).

If problem continues with external monitor connected, REPLACE the logic board (Sections 8.1.2 and 8.2.5).

## 9.1.3 Disk Drive Errors during Applications

9.1.3.1 Follow instruction 9.1.1.6 to check DC voltages to the logic board.

1. Voltages are out of tolerance.  
REPLACE the power supply (see Sections 8.1.3 and 8.2.4).
2. Voltages are within tolerance.  
See Section 9.2.0 (Disk Drive Problems).

## 9.2.0 DISK DRIVE PROBLEMS

Symptoms: 1. No power at drive motor  
2. Boot read error  
3. Drive not ready

9.2.0.1 Run the Dealer Diagnostics Program as the first step in troubleshooting disk drive problems.



## 9.2.1 No Power at Drive Motor

9.2.1.1 Follow instruction 9.1.1.6 to check DC voltages.

1. Voltages are out of tolerance.  
CHECK power supply.
2. Power supply functions correctly.  
CHECK harness connector voltages.
3. Voltages are out of tolerance.  
REPLACE harness.

## 9.2.2 Boot Read Error

9.2.2.1 Be sure system software and hardware are compatible, all connectors are correctly in place, and cables/harnesses are undamaged.

9.2.2.2 Clean the drive head involved. **BE CAREFUL NOT TO DISTURB DRIVE ALIGNMENT OR POSITION.** Use a head cleaning diskette, 97% isopropyl alcohol or head cleaner **ONLY.**

A head cleaning diskette should be used for no more than 3 seconds.

9.2.2.3 If one drive doesn't boot the system, try the other drive. Then follow this sequence:

1. Second drive boots correctly, both drive lights are on.  
CHECK that jumpers are correctly in place and terminator resistor is installed on drive A only.

---

### NOTE

*ONLY drive A has a resistor in socket R21.*

*Jumper positions (Figures 8-35 and 8-36):*

<i>Drive A</i>	<i>Drive B</i>
<i>HM and DS1</i>	<i>HM and DS2</i>

---

2. Second drive boots correctly.  
DISCONNECT internal video monitor and connect external one.  
Boot the drive. If drive boots, replace the internal monitor.
3. Internal monitor disconnected, drive does not boot.  
SWITCH drive position (A to B and B to A).  
Be sure jumpers are correctly installed and terminator resistor is in drive A only.
4. Error switches with drive.  
ALIGN or REPLACE drive with the boot error.
5. Boot read error doesn't switch.  
REPLACE the drive harness. If error continues, replace the logic board.

9.2.2.4 If neither drive boots, check keyboard and keyboard cable (see Section 9.4.0). Then follow this sequence:

1. Neither drive boots.  
BOOT each drive with another diskette.
2. One drive boots.  
SEE Section 9.2.2.3.
3. Neither drive boots.  
DISCONNECT internal monitor and boot with an external one.
4. One drive boots with external monitor.  
REPLACE internal monitor and see section 9.2.2.3.
5. Both drives boot with external monitor.  
REPLACE internal monitor.
6. Neither drive boots with external monitor.  
REPLACE drive harness.
7. Neither drive boots with external monitor.  
REPLACE logic board.
8. Neither drive boots with external monitor.  
REPLACE or ALIGN both drives.

### **9.2.3 Drive Not Ready**

9.2.3.1 Check that all connectors are correctly in place.

9.2.3.2 If one drive doesn't boot the system, try the other drive.

1. Second drive boots.  
SWITCH drive position. Check that jumpers are installed correctly and terminator resistor is in drive **A** only.
2. Error does not switch with the drive.  
REPLACE drive harness.
3. Error switches with drive.  
REPLACE logic board.

## **9.3.0 CRT MALFUNCTIONS**

- Symptoms:
1. Wavy screen
  2. Screen not centered
  3. Blank screen
  4. Gaps in the sign-on message
  5. Flashing sign-on message

### **9.3.1 Wavy Screen**

9.3.1.1 Follow instruction 9.1.1.6 to check power supply voltages.

1. Voltage is out of tolerance.  
REPLACE the power supply (Sections 8.1.3 and 8.2.4).
2. Wavy video display during drive applications.  
REPLACE drive involved (Sections 8.1.4 and 8.2.3).
3. Voltage is within tolerance. Drives operate correctly.  
REPLACE the video monitor (Sections 8.1.3 and 8.2.4).

### **9.3.2 Screen Not Centered**

9.3.2.1 If the video raster is tilted, replace the monitor (Sections 8.1.3 and 8.2.4).

### 9.3.3 Blank Screen

- 9.3.3.1 Turn brightness and contrast controls completely clockwise.
- 9.3.3.2 Check video harness connectors at the monitor and logic board.
- 9.3.3.3 Turn power to the system OFF. Check that the external video jumper is connected properly.
- 9.3.3.4 Turn power to the system OFF. With the logic-board video connector attached, replace the video jumper.
- 9.3.3.5 Follow instruction 9.1.1.6 to check power supply voltages.

If out of tolerance, REPLACE power supply.

1. Screen remains blank.  
REPLACE video monitor (Sections 8.1.3 and 8.2.4).
2. Screen remains blank.  
REPLACE logic board (Sections 8.1.2 and 8.2.5).

### 9.3.4 Gaps in the Sign-On Message

- 9.3.4.1 Follow instruction 9.1.1.6 to check power supply voltages. If out of tolerance, replace the power supply. (Sections 8.1.3 and 8.2.4).
- 9.3.4.2 If gap problem continues, replace the logic board (Sections 8.1.2 and 8.2.5).

### 9.3.5 Flashing Sign-On Message

---

#### NOTE

*Don't confuse a flashing sign-on message with a vertical hold malfunction.*

---

- 9.3.5.1 Press RESET to reboot.
- 9.3.5.2 Disconnect keyboard cable.  
If flashing stops, REPLACE the keyboard cable (Sections 8.1.0 and 8.2.7).  
New cable installed, flashing continues.  
REPLACE the keyboard (Sections 8.1.0 and 8.2.7).

## 9.4.0 KEYBOARD MALFUNCTIONS

- Symptoms:
1. Individual key malfunction
  2. Complete keyboard failure
  3. Displayed character and key struck don't correspond

### 9.4.1 Individual Key Malfunction

- 9.4.1.1 Run keyboard diagnostics to verify the problem.
- 9.4.1.2 Disconnect the keyboard cable from the unit, reconnect it, and retest.
- 9.4.1.3 Check the keyboard connector on the logic board for bent or broken pins.
  1. Malfunction continues.  
REPLACE keyboard cable (Sections 8.1.0 and 8.2.7).
  2. Malfunction continues.  
REPLACE keyboard (Sections 8.1.0 and 8.2.7).
  3. Malfunction continues.  
REPLACE the logic board (Sections 8.1.2 and 8.2.5).

### 9.4.2 Complete Keyboard Failure

- 9.4.2.1 Replace keyboard cable.
  1. Failure continues.  
REPLACE keyboard (Sections 8.1.0 and 8.2.7).
  2. Failure continues.  
REPLACE logic board (Sections 8.1.2 and 8.2.5).

### 9.4.3 Displayed Character and Key Struck Don't Correspond

#### 9.4.3.1 Replace keyboard cable.

1. Malfunction continues.  
REPLACE keyboard (Sections 8.1.0 and 8.2.7)
2. Malfunction continues.  
REPLACE logic board (Sections 8.1.2 and 8.2.5).

## 9.5.0 LOGIC AND MEMORY BOARD PROBLEMS

- Symptoms:
1. Continuous beep on power up
  2. Scattered video display
  3. Memory error during diagnostics run

#### 9.5.0.1 Check all jumper positions on main logic board as follows:

### MAIN LOGIC BOARD JUMPER POSITIONS

<b>J1</b>	Pins 1 and 2 jumpered. Normal configuration Z80 jumper placement
<b>J2</b>	Pins 3 and 4 jumpered. Normal configuration Z80 jumper placement
<b>J3</b>	Pins 1 and 2 jumpered. Normal configuration Z80 jumper placement
<b>J4</b>	Pins 2 and 3 jumpered. Write enable input
<b>J5</b>	Pins 1 and 2 jumpered. Normal configuration Z80 jumper placement
<b>J6</b>	Unjumpered
<b>J8</b>	Unjumpered. Normal configuration Z80 jumper placement
<b>J9</b>	Unjumpered
<b>J10</b>	Unjumpered
<b>J11</b>	Pins 1 and 2 jumpered. SIO +12V Input
<b>J12</b>	Pins 1 and 2 jumpered. Modem ground
<b>J13</b>	Pins 1 and 2 jumpered. Serial ground. Pin 1 to Right

### **9.5.1 Continuous Beep on Power-Up**

9.5.1.1 Disconnect keyboard. If beep continues, replace memory board (Sections 8.1.2 and 8.2.5).

1. New memory board installed. Beep continues.  
REPLACE logic board (Sections 8.1.2 and 8.2.5)

9.5.1.2 Disconnect keyboard. If beep stops, replace the keyboard cable.

1. New cable installed. Beep continues.  
REPLACE keyboard (Sections 8.1.0 and 8.2.7)

### **9.5.2 Scattered Video Display**

9.5.2.1 Check power supply voltages. See instruction 9.1.1.6

1. Voltages within tolerance.  
REPLACE external video jumper.
2. Voltages within tolerance, problem continues.  
REPLACE memory board (Sections 8.1.2 and 8.2.5).
3. Voltages within tolerance, problem continues.  
REPLACE logic board (Sections 8.1.2 and 8.2.5).

### **9.5.3 Memory Error during Diagnostics Run**

9.5.3.1 Check power supply voltages. See instruction 9.1.1.6.

1. Voltages within tolerance.  
REPLACE memory board (Sections 8.1.2 and 8.2.5).

## **9.6.0 RS-232 AND IEEE-488 PORT PROBLEMS**

- Symptoms:
1. No output to printer
  2. Printer drops characters
  3. Scrambled printout

### **9.6.1 No Output to Printer**

Follow this sequence:

1. Check diskette Setup configuration.
2. Check Install (WordStar only).
3. Check connectors and interface wiring.
4. Use known good software.
5. Use different printer.
6. Verify printer operates.
7. Replace logic board.

### **9.6.2 Printer Drops Characters**

Follow this sequence:

1. Check diskette Setup configuration.
2. Check Install (WordStar only).
3. Check connectors and interface wiring.
4. Replace logic board.

### **9.6.3 Scrambled Printout**

Follow this sequence:

1. Check diskette Setup configuration.
2. Check Install (WordStar only).
3. Check connectors and interface wiring.
4. Use known good software.
5. Use different printer.
6. Verify printer operates.
7. Replace logic board.



## 9.7.0 PREVENTIVE MAINTENANCE

- 9.7.0.1 The Osborne Executive does not require scheduled preventive maintenance. OCC does recommend that drive heads be cleaned regularly. The conditions in which the system is used will determine the frequency of this service.

**CAUTION:** When cleaning drive heads be very careful not to disturb drive alignment or position. Use a head cleaning diskette, 97% isopropyl alcohol or head cleaner ONLY.

- 9.7.0.2 Use a mild soap and water solution to clean the exterior of the Osborne case.

# APPENDICES

**APPENDIX 1**  
**Motorola Video**  
**Monitor**  
**Service**



**MOTOROLA**

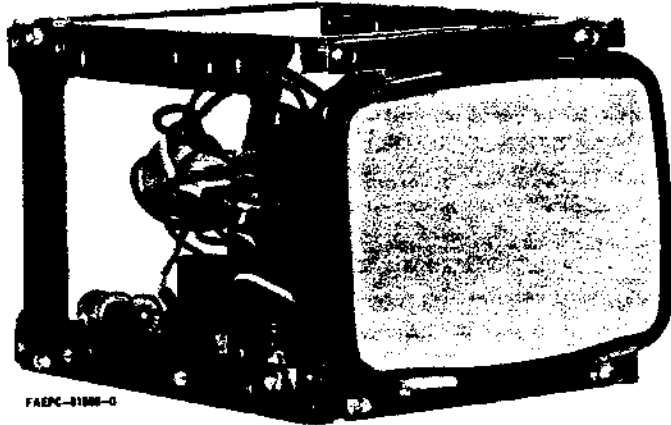

FA2PC-31000-0

*Model MD1000-190 CRT Display Monitor*

### GENERAL INFORMATION

The Motorola Model Series MD1000-190 CRT Display Monitors described in this Service Manual are fully transistorized (except for the CRT) applicable for displaying

# SERVICE MANUAL —VP40—

## MODEL MD1000-190

**CAUTION**  
NO WORK SHOULD BE ATTEMPTED ON ANY EXPOSED MONITOR CHASSIS BY ANYONE NOT FAMILIAR WITH SERVICING PROCEDURES AND PRECAUTIONS.

alphanumeric characters in direct drive applications. All input signals are developed externally to the monitor and are applied to individual video, horizontal, and vertical drive inputs. A single printed circuit card construction is used for the video and deflection circuits. Input and output connections to the printed circuit card are made through a 10-pin circuit card edge connector. A 5-in magnetic deflection type CRT with integral implosion protection is used. The power requirements are 12 VDC @ 800 mA (nominal) supplied from an external power source.

### TABLE OF CONTENTS

GENERAL INFORMATION .....	1	VERTICAL SIZE/LINEARITY ADJUSTMENT .....	6
SPECIFICATIONS .....	3	FOCUS ADJUSTMENT .....	6
SERVICE NOTES		RASTER CENTERING ADJUSTMENT .....	6
GENERAL SERVICING PRECAUTIONS .....	4	THEORY OF OPERATION	
GENERAL SUBSTITUTION OF PARTS .....	4	GENERAL .....	7
COMPONENT REMOVAL .....	4	VIDEO AMPLIFIER .....	7
CIRCUIT TRACING .....	4	HORIZONTAL AMPLIFIER & OSCILLATION .....	8
ROUTINE PERIODIC MAINTENANCE .....	4	HORIZONTAL OUTPUT .....	8
ROUTINE PERIODIC INSPECTION .....	4	HORIZONTAL OUTPUT TRANSFORMER .....	8
LOCALIZATION OF TROUBLES .....	4	FOCUS .....	9
CRT REPLACEMENT .....	5	VERTICAL DRIVE .....	9
OPERATIONAL CHECK/ADJUSTMENT PROCEDURES		SCHEMATIC DIAGRAM .....	11
GENERAL .....	5	CIRCUIT CARD DETAIL COMPONENT & SOLDER VIEW .....	11
EQUIPMENT REQUIRED .....	5	PARTS LIST .....	12
SERVICE ADJUSTMENTS			
BRIGHTNESS/CONTRAST ADJUSTMENT .....	6		



**MOTOROLA INC.**

*Display Systems*

1299 East Algonquin Road, Schaumburg, IL. (312) 397-8000

(VP40)  
12/81

68P25253A88-0  
© MOTOROLA INC. 1981

## SAFETY WARNING

**CAUTION: NO WORK SHOULD BE ATTEMPTED ON AN EXPOSED MONITOR CHASSIS BY ANYONE NOT FAMILIAR WITH SERVICING PROCEDURES AND PRECAUTIONS.**

1. **SAFETY PROCEDURES** should be developed by habit so that when the technician is rushed with repair work, he automatically takes precautions.

2. A **GOOD PRACTICE**, when working on any unit, is to first ground the chassis and to use only one hand when testing circuitry. This will avoid the possibility of carelessly putting one hand on chassis or ground and the other on an electrical connection which could cause a severe electrical shock.

3. Extreme care should be used in **HANDLING THE PICTURE TUBE** as rough handling may cause it to implode due to atmospheric pressure (14.7 lbs. per sq. in.). Do not nick or scratch glass or subject it to any undue pressure in removal or installation. When handling, safety goggles and heavy gloves should be worn for protection. Discharge picture tube by shorting the anode connection to chassis ground (not cabinet or other mounting parts). When discharging, go from ground to anode or use a well insulated piece of wire. When servicing or repairing the monitor, if the cathode ray tube is replaced by a type of tube other than that specified under the Motorola Part Number as original equipment in this Service Manual, then avoid prolonged exposure at close range to unshielded areas of the cathode ray tube. Possible danger of personal injury from unnecessary exposure to X-ray radiation may result.

4. An **ISOLATION TRANSFORMER** should always be used during the servicing of a unit whose chassis is connected to one side of the power line. Use a transformer of adequate power rating as this protects the serviceman from accidents resulting in personal injury from electrical shocks. It will also protect the chassis and its components from being damaged by accidental shorts of the circuitry that may be inadvertently introduced during the service operation.

5. Always **REPLACE PROTECTIVE DEVICES**, such as fishpaper, isolation resistors and capacitors and shields after working on the unit.

6. If the **HIGH VOLTAGE** is adjustable, it should always be **ADJUSTED** to the level recommended by the manufacturer. If the voltage is increased above the normal setting, exposure to unnecessary X-ray radiation could result. High voltage can accurately be measured with a high voltage meter connected from the anode lead to chassis.

7. **BEFORE RETURNING A SERVICED UNIT**, the service technician must thoroughly test the unit to be certain that it is completely safe to operate without danger of electrical shock. **DO NOT USE A LINE ISOLATION TRANSFORMER WHEN MAKING THIS TEST.**

In addition to practicing the basic and fundamental electrical safety rules, the following test, which is related to the minimum safety requirements of the Underwriters Laboratories should be performed by the service technician before any unit which has been serviced is returned.

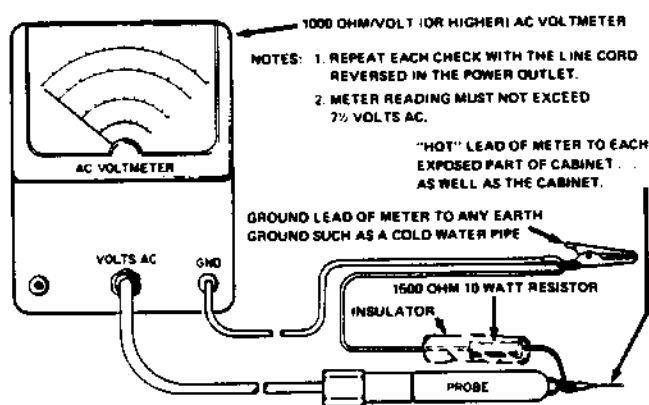

Voltmeter Hook-up for Safety Check

A 1000 ohm per volt AC voltmeter is prepared by shunting it with a 1500 ohm, 10 watt resistor. The safety test is made by contacting one meter probe to any portion of the unit exposed to the operator such as the cabinet trim, hardware, controls, knobs, etc., while the other probe is held in contact with a good "earth" ground such as a cold water pipe.

The AC voltage indicated by the meter may not exceed 7 1/2 volts. A reading exceeding 7 1/2 volts indicates that a potentially dangerous leakage path exists between the exposed portion of the unit and "earth" ground. Such a unit represents a potentially serious shock hazard to the operator.

The above test should be repeated with the power plug reversed, when applicable.

**NEVER RETURN A MONITOR** which does not pass the safety test until the fault has been located and corrected.

# Model MD1000-190 Specifications\*

## (PRELIMINARY)

<b>Cathode Ray Tube</b>	5-Inch Measured Diagonally (127 mm) Display Size: 3.80 in. X 2.54 in. Video Ampl. Voltage Gain: 10 min. with a 2.5V P-P min. Deflection Angle: 55°
<b>Video Performance</b>	Resolution: 850 lines, center; 500 lines, corner Bandwidth: Within 3dB, 10Hz to 12MHz
<b>Synchronization</b>	Horizontal: 15.75 kHz ( $\pm$ 500 Hz) Vertical: 50/60Hz Horizontal Blanking: 11 $\mu$ Sec min. (time includes retrace and delay) Vertical Blanking: 900 $\mu$ Sec min. (time includes retrace and video display)
<b>Input Signal</b>	Vertical Sync Drive: 50 $\mu$ Sec. to 1.4 mSec. input, TTL compatible, negative (positive optional) pulse; 4.0V P-P $\pm$ 1.0 Horizontal Sync Drive: 4 to 40 $\mu$ Sec input. TTL compatible, positive (negative optional) pulse 4.0V P-P $\pm$ 1.0 Video: positive white, input impedance greater than 1k ohm
<b>Power Requirement</b>	Operating Range: +12 VDC ( $\pm$ 0.5V)
<b>Controls</b>	Internal: brightness, vertical size, vertical linearity, horizontal size, raster centering, vertical hold, contrast, and focus. Optional: customer supplied brightness control for operator adjustment
<b>Linearity</b>	Character Size: 1. Height and width will not vary more than 10% from the average character size. 2. Adjacent characters will not vary more than 10%.
<b>Operating Environment</b>	Operating Temperature: 0°C to +55°C Storage Temperature: -40°C to +65°C Operating Altitude: 10,000 ft. max.

### NOTE

CRT's with bonded etched panels should not be subjected to storage or operating temperatures above 50°C

### PERFORMANCE STANDARD:

THIS EQUIPMENT IS DESIGNED TO COMPLY WITH DHHS X-RADIATION PERFORMANCE STANDARDS, U.L. AND C.S.A. SPECIFICATIONS PROVIDING B+ TO THE MONITOR DOES NOT EXCEED 14VDC.

\* IN A CONTINUAL EFFORT TO UPGRADE OUR STANDARD PRODUCT AS NEW TECHNOLOGICAL ADVANCES ARE MADE. SPECIFICATIONS ARE SUBJECT TO CHANGE WITHOUT NOTICE.

## SERVICE NOTES

### GENERAL SERVICING PRECAUTIONS

#### — CAUTION —

Before attempting to service the monitor, disconnect (or turn off) the external power supply; then, as an added precaution, discharge the CRT 2nd anode before handling any high voltage components. In addition, be sure to observe all safety warnings and service notes in the front of this manual.

When it is necessary to disconnect the deflection yoke, and/or CRT socket leads, pull their small female pins straight out without any back and forth rocking motion. This will prevent, or at least minimize deforming male pins and/or breaking their solder connections.

Use caution around the heat sink of the horizontal output transistor. The heat sink is at the same potential as the transistor collector. During normal operation with signal input present, the horizontal heat sink has 165 volt P-P pulses (with respect to system ground).

### GENERAL SUBSTITUTION OF PARTS

When components need be replaced, order Motorola replacement parts only. Avoid using other substitute semiconductor devices as these can cause system performance degradation. In the event of failure, and the need for emergency system restoration, generic substitution of semiconductor devices used are provided as an aid on the Schematic Diagram and Parts List.

### COMPONENT REMOVAL

Due to the nature of solid state devices such as integrated circuits (IC's), and etched printed circuit cards, special desoldering tools and IC removing techniques should be used. Care should be exercised not to damage the printed circuit card, break or lift the copper foil, and create cold solder connections.

Integrated circuits are very reliable components and should not be replaced until all checks have proven definitely that the IC is the defective component. Removal of the IC is time consuming and often careless or sloppy soldering techniques can cause additional problems.

### CIRCUIT TRACING

For ease in troubleshooting, circuit card components are mounted on one side, with foil circuitry on the reverse side of the circuit card. Schematic reference symbols and numbers are screened on both sides of the circuit card to help

locate and identify circuit components during troubleshooting.

Familiarize and study the attached Schematic Diagram and hints provided in this Service Manual before attempting to bypass logical troubleshooting sequence of measurements. The Schematic Diagram in this Service Manual contains voltage readings and oscilloscope test patterns at key points of the electrical circuit. These readings are typical for normal operating conditions and should be considered nominal varying slightly from unit to unit. Any considerable variations should be investigated as a possible defective circuit point.

### ROUTINE PERIODIC MAINTENANCE

Routine periodic maintenance service should be performed on the Display Monitors as well as all supporting system equipment to avoid equipment down-time, and make necessary level adjustments to compensate for slow degradation in quality of display due to component changes, which if left unattended could result in costly and extensive repairs.

### ROUTINE PERIODIC INSPECTION

Routine inspection schedules will depend upon the surrounding environment where the system is installed and should include

- Check all controls for proper mechanical and electrical operation.
- Dust and clean optical surfaces. High quality display requires clean viewing surfaces.
- Examine all components for outward signs of damage.
- Repair loose or worn out electrical connections burned or discolored insulation and parts.

### LOCALIZATION OF TROUBLES

Localization of trouble is most frequently accomplished by performing the adjustment procedure as outlined in this Service Manual and noting the results or indications for comparison with normal operating conditions. Refer to the text portion of this manual on alignment procedures and the respective schematic circuit for additional information.

- Visually check for obvious physical defects or broken leads, broken plating, broken or disconnected (unsoldered) components, or overheating parts. If any attempt is made to change a component, the circuit should be checked to insure that the problem causing the original failure has been identified and corrected, otherwise damage to the new part may occur.

- Check voltages for proper levels at the suspected component and proper voltages at the surrounding circuits. Certain defects or broken plating, broken leads, etc., may not be obvious to a visual inspection.
- The isolation of trouble to a defective component is most easily accomplished with the use of a multimeter and observing normal transistor and IC servicing techniques. During the process of isolation, continuous references must be made to the appropriate section of the schematic diagram to determine circuit configuration.

## CRT REPLACEMENT

Use extreme care in handling the CRT as rough handling may cause it to implode due to high vacuum pressure. Do not nick or scratch glass or subject it to any undue pressure in removal or installation. Use goggles and heavy gloves for protection. In addition, be sure to disconnect the monitor from all external voltage sources.

### — NOTE —

Discharge the CRT by shorting 2nd anode to the aquadag; then remove the CRT socket, deflection yoke and 2nd anode lead.

#### Procedure:

- Step 1. Remove the CRT socket, and the 2nd anode lead.
- Step 2. Remove push-in connectors (4) from both sides of the deflection yoke.
- Step 3. Remove (1) ¼-in hex head screw securing the printed circuit card to the chassis.
- Step 4. Gently slide the printed circuit card out towards the rear of the monitor. Do not use force as the printed circuit card is secured in place in nylon guiding rails. These guide rails are mounted to the sides of the chassis. When re-inserting the printed circuit card back into position, care should be exercised to first orient the card properly and making sure to align its sides into the nylon guide rails.
- Step 5. Loosen the screw on the deflection yoke and remove yoke.

### — NOTE —

The deflection yoke is secured to the neck of the CRT with hot melt adhesive. Carefully break the adhesive bond before sliding yoke from its position.

- Step 6. Remove the grounding spring clipped to the sides of the chassis.
- Step 7. Gently grasp the CRT from the rear and remove the (4) hex head screws securing the upper and lower CRT holding bracket. Slide the CRT out from the front.
- Step 8. Loosen the copper wire bracket holding screw and slide the bracket assembly off from the CRT.
- Step 9. Use Motorola Part No. 11-00131474 adhesive cloth tape to tape the sides of the replacement CRT before installing the CRT mounting brackets.

Step 10. Reverse the procedure/steps to install the new CRT.

## OPERATIONAL CHECK/ADJUSTMENT PROCEDURES

### GENERAL

The following procedures are provided to check the operation of the monitor and perform simple preinstallation adjustments (if required), or readjust after servicing and component replacement.

When reference is made to adjust to a specific size display (vertically and horizontally), refer to original model specifications for correct dimensions by the monitor model number. This also applies to minimum and maximum tolerances when adjusting for correct CRT geometry, linearity, focus, etc.

### — NOTE —

To assist in understanding more of the preceding terminology, refer to a separate Motorola Manual, "Incoming Inspection Guide" (Motorola part number 68P25253A71).

Perform the procedures in the sequence presented, and allow at least five (5) minutes warm-up before adjusting the monitor. In addition, when instructed to disconnect an input signal, do not ground the signal at the circuit card edge connector (P1). This action could damage the signal source generator. Instead, disconnect the signal at its source.

CCW = Counter Clockwise Rotation, CW = Clockwise Rotation. (As viewed from rear of circuit card.)

### EQUIPMENT REQUIRED

- Regulated 12VDC Power Supply
- Precision Digital Voltmeter
- Non-Metallic Alignment Tool



Test Signals (Bench test signals must be same amplitude, polarity, and frequency as final installed operating signal source. Refer to original specifications for values by monitor model number.)

The following Motorola gauges are required for performing complete and accurate CRT geometry and linearity alignment. Refer to original model specifications for correct gauges to use.

Linearity Gauge      Slot Gauge      Parallelogram Gauge

## SERVICE ADJUSTMENTS

Use a non-metallic tool when performing the following adjustments.

### BRIGHTNESS/CONTRAST ADJUSTMENT

#### Procedure:

Step 1. Disconnect the Video Drive signal, input at pin 8 of edge connector P1.

—or—

If unit is equipped with a customer supplied Contrast control, rotate for minimum signal.

Step 2. Rotate internal Brightness control, R108, to minimum.

Step 3. If unit is equipped with a customer supplied Remote Brightness control, rotate to full maximum position.

Step 4. Rotate R108 to the threshold of the raster.

Step 5. Reconnect Video Drive signal. Adjust customer supplied Contrast control for a desired video level.

Step 6. Adjust the Remote Brightness for the desired brightness level.

### VERTICAL SIZE/LINEARITY ADJUSTMENT

#### Procedure:

Step 1. Connect a test generator whose output is identical to the signal normally used.

Step 2. Rotate the Vert. Size control, R208, until optimum size display is obtained.

Step 3. (Refer to Figure 1.) Adjust the Vert. Linearity control, R211, until extreme top and bottom characters (designated "A" and "B") are equal in height to the center characters (designated "C").

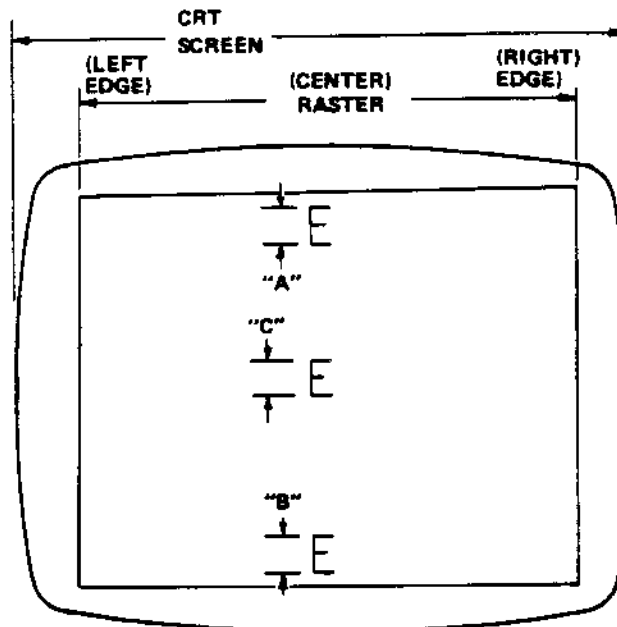

AEPC-01050-0

Figure 1. Partial CRT Display of Characters for Vertical Linearity Adjustment

Step 4. Readjust R208 until the desired height is obtained.

### FOCUS ADJUSTMENT

#### Procedure:

The optimum focus of the display is obtained by adjusting the focus control, R315, for best focus at a point that is near the center and approximately 1/3 down from the top of the display.

### RASTER CENTERING ADJUSTMENT

#### General

The deflection yoke of these direct drive monitors do not contain magnets; therefore, only raster centering is required whenever the CRT needs to be replaced.

#### Procedure:

Step 1. Adjust Vertical Size Control, R208, so that all edges of the raster are visible.

Step 2. Reposition the Yoke into the CRT for best raster centering.

Step 3. Readjust the Vertical Size Control, R208, to specified dimensions.

Step 4. Secure and bond the Yoke to the neck of the CRT using hot melt adhesive to prevent slippage.

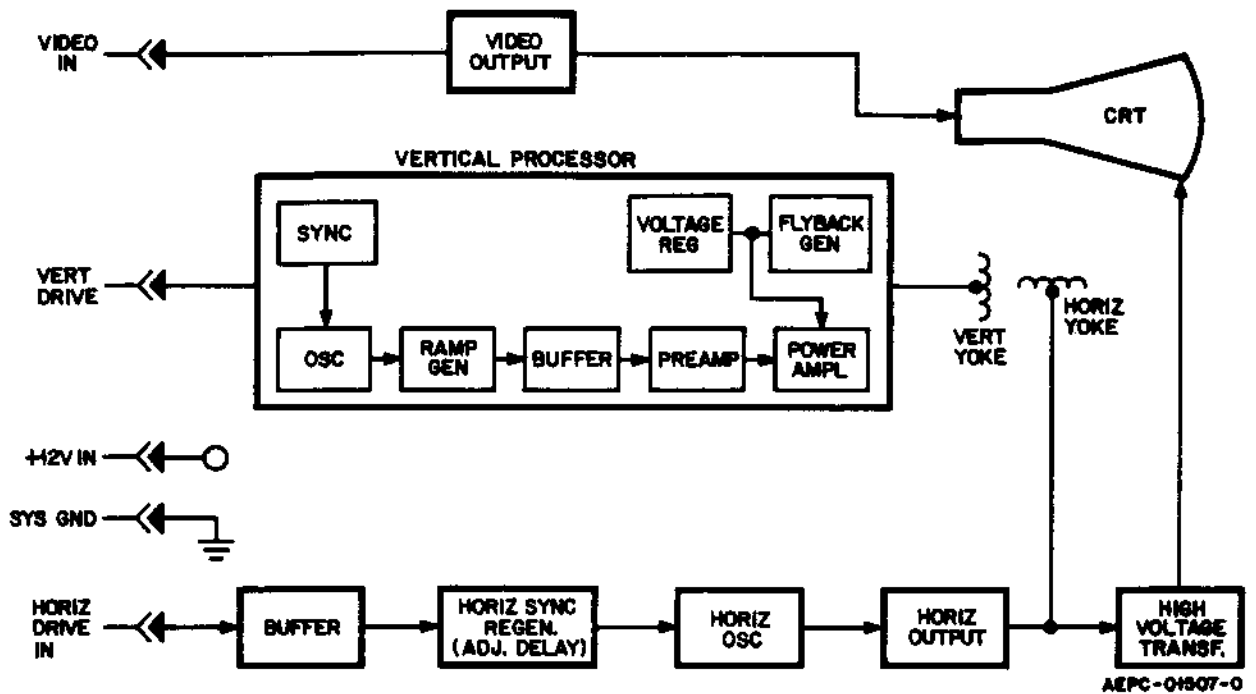

Figure 2. MD1000-190 Block Diagram

## THEORY OF OPERATION

### GENERAL

The Model MD1000-190 Series Monitors are direct drive units requiring separate video, horizontal drive and vertical drive inputs. All are TTL compatible. Power is supplied to the monitor from an external +12VDC source.

The monitor consists of a Video Amplifier, a Vertical Processing stage, and five stages of Horizontal Deflection.

### VIDEO AMPLIFIER (Refer to Figure 3)

The linear video amplifier consists of a one stage amplifier, Q101, capable of providing a minimum voltage gain of 10 with a 2.5V PP of signal input.

A TTL compatible non-composite video signal, is DC coupled to the base of Q101 via R103. Capacitor C102 and resistors R105, R106, maintain a flat frequency response whenever Q101 conducts.

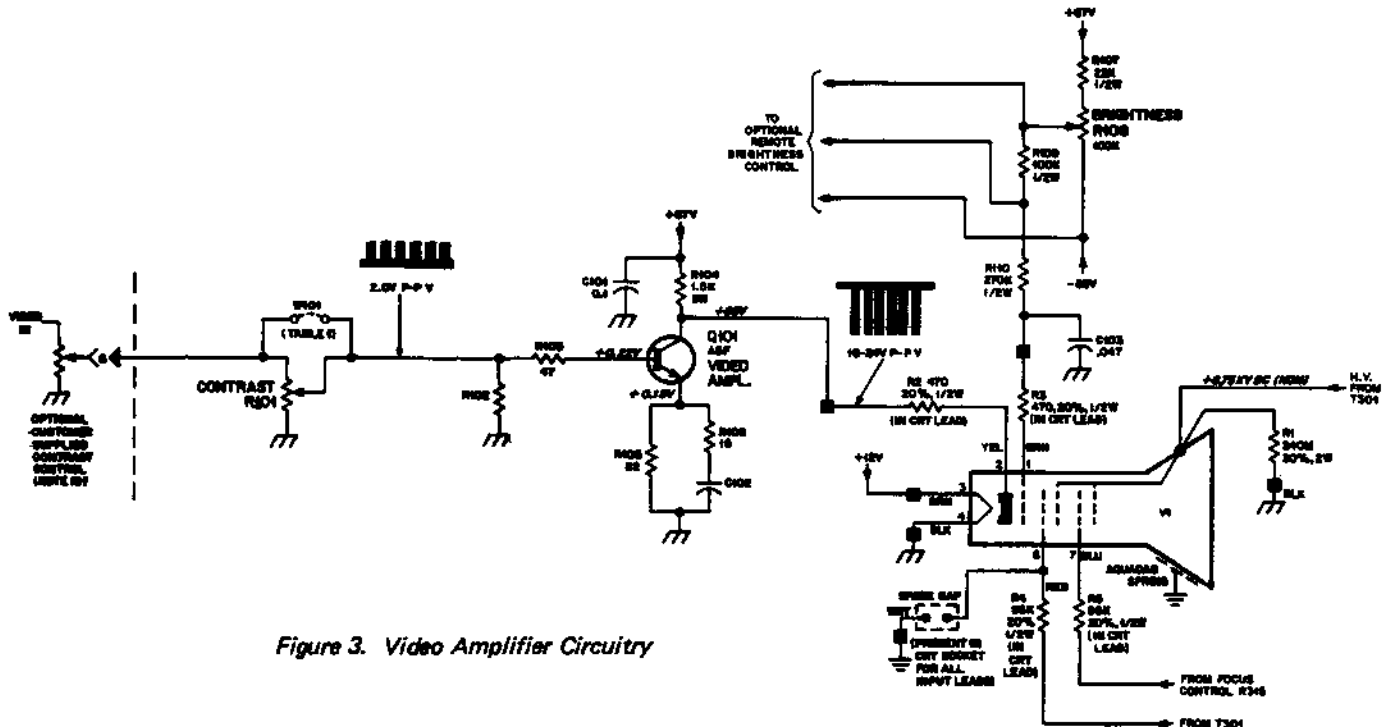

Figure 3. Video Amplifier Circuitry

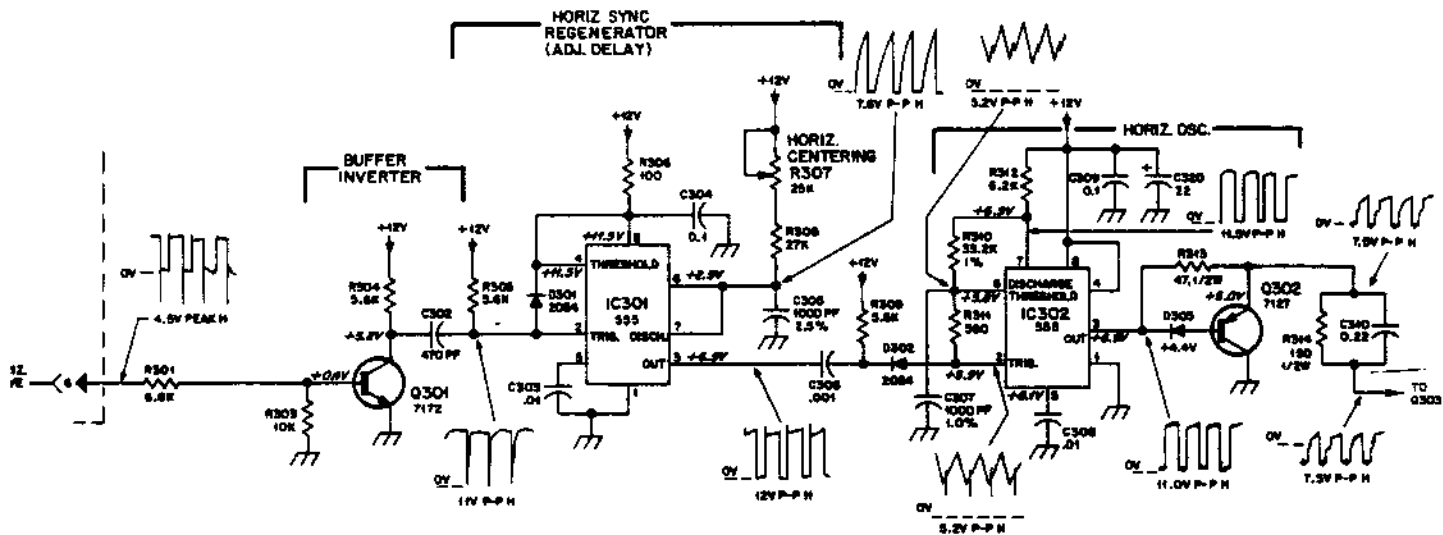

Figure 4. Horizontal Sync Regenerator and Oscillator

The resultant output of Q101 is developed across collector resistor R104 and is DC coupled to the CRT cathode via resistor R2. Q101 is protected from the CRT by a spark gap built into the CRT socket and R2 further isolates Q101 from transients.

#### HORIZONTAL AMPLIFIER AND OSCILLATOR (Refer to Figure 4)

Transistor Q301 is a single stage buffer/inverter which operates as a switch. During a no-signal condition, Q301 is biased at cut-off. The horizontal drive input is DC coupled to the base of Q301. Positive-going horizontal drive pulses of 2.5 volts P-P will turn Q301 on and cause it to saturate. The inverted output of Q301 is developed across resistor R304. These inverted pulses of approximately 11 volts P-P, pass through a differentiator circuit consisting of C302 and R305 which shapes the pulses into sharp spikes and are applied to the input (pin 2) of IC301.

Diode D301 clamps the input signal to +12 volts. IC301 is a timer IC used in a mono-stable multivibrator mode to delay the incoming drive pulse approximately one horizontal scan line. This delay is adjustable by R307 and is required to center the video information on the CRT. Components R307, R308 and C305 form an RC network which determine the amount of delay. This delay has a range of 1/2 to 1 1/2 horizontal scan lines. Capacitor C304 provides additional local filtering for IC301.

The 12 volt P-P non-symmetrical output of IC301 (pin 3) passes through a differentiator circuit consisting of C306 and R309. The differentiator produces positive and negative going spikes which are applied to diode D302 and only the negative-going spikes are allowed to pass to the input of IC302 (pin 2).

IC302 is used as a free-running oscillator operating above the horizontal synchronized input frequency. If a loss of a horizontal drive signal occurs, the oscillator will free-run at a higher frequency reducing the high voltage developed by the flyback transformer. This prevents any damage to components in the horizontal output circuitry. Components R310, R311, R312 and C307 determine the free-running frequency of the oscillator. The output of IC302 (pin 3) is an 11 volt P-P non-symmetrical square wave.

#### HORIZONTAL OUTPUT (Refer to Figure 5)

When the output of IC302 (pin 3) goes high, horizontal output transistor Q303 is forward biased via R313, R314 and C310 causing it to "turn-on." At this time transistor Q302 is reverse biased and is cut off. Diode D303 protects Q302 from reverse base-emitter voltage.

When the output of IC302 goes low, Q302 turns on; drawing current through R314 and C310 turning "off" Q303. RC network R314 and C310 is a speed-up network used to increase the collector switching time of Q303.

#### HORIZONTAL OUTPUT TRANSFORMER (Refer to Figure 5)

The horizontal output transistor, Q303, is simply a switch which is turned on and off at the horizontal scan rate by the driving signal applied to its base. A sawtooth current through the deflection coils is required to sweep the beam linearly across the CRT screen. The sweep begins at the center of the CRT and sweeps to the right. This happens when Q303 is turned on and its collector voltage drops to

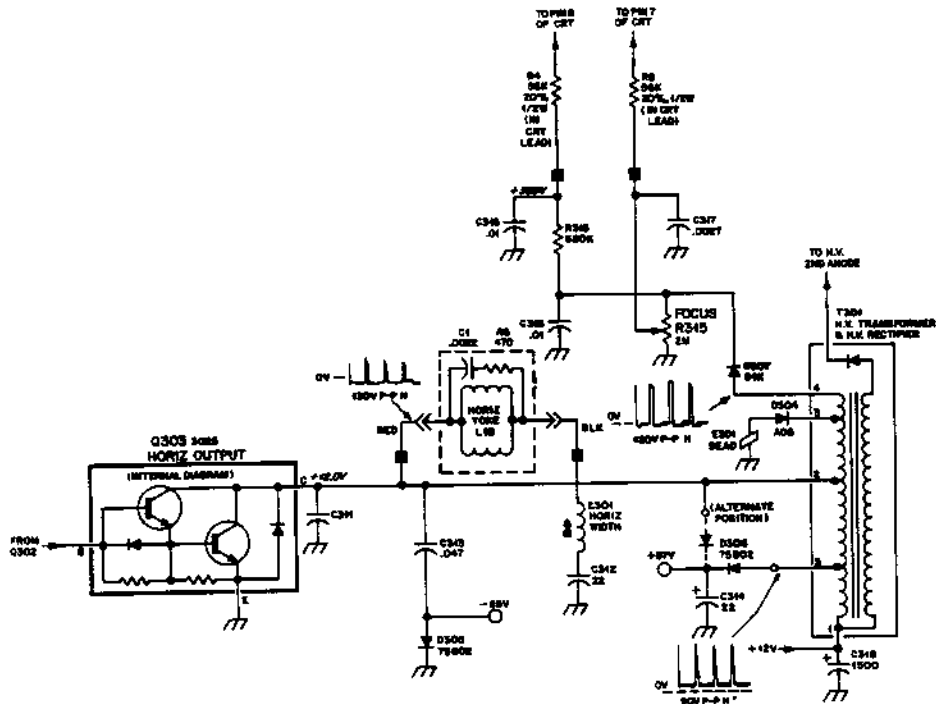

Figure 5. Horizontal Output Circuitry

near zero. C311 begins discharging through the deflection coils which deflect the beam to the right of the CRT. At this time, Q303 cuts off and C311 ceases to supply current to the deflection coils. However, an induced voltage appears across the deflection coil as the magnetic field collapses and oscillations then occurs between the deflection coils and C311.

During the first half cycle of this oscillation, the induced voltage is felt across the collector of now cut off Q303, C311, and the primary of T301 - the flyback transformer. This voltage is stepped up by T301 and rectified to produce the required high voltage applied to the 2nd anode of the CRT. The electron beam is also deflected to the left edge of the CRT due to the collapsing magnetic field of the deflection coils.

During the second half cycle of the oscillation, Q303 is still cut off. At this time, damper diode D304 becomes forward biased and begins conduction. The deflection coil current gradually decreases to zero during damper conduction allowing the beam to sweep linearly to the center of the screen.

#### FOCUS (Refer to Figure 5)

Focus voltage for the CRT is derived from the auto-transformer action of T301. D307 and C315 form a positive voltage source. This voltage is reduced by R316 and filtered by C316 to supply the second grid, G2, of the CRT. During auto-transformer action time, D305 conducts, charging C313 negative to positive. When the yoke field collapses, C313 discharges. This creates the -85 volt source for the brightness circuit.

#### VERTICAL DRIVE (Refer to Figure 6)

The vertical deflection circuit consists of one stage, IC201, which accomplishes all active vertical drive functions. Vertical input pulses are differentiated by C201 and R202. This allows IC201 to be edge sensitive. R201 provides proper input loading. Diode D201 couples only the negative-going spikes from the differentiator circuit to the sync input of IC201 (pin 8). R203 and R204 provide input current limiting. The sync input (pin 8) performs several functions. It strips away any random noise that may be present on the input line and conditions the vertical pulses for processing. It also converts the input voltage pulses to current to control the internal oscillator. The oscillator generates a non-symmetrical square wave with a short duty cycle approximately 60Hz. Components R205, R206 and C202 determine the frequency. This square wave signal is applied to a ramp generator whose slope and amplitude is determined by R207, R208, and C203. The ramp voltage signal is applied to a buffer stage which isolates the ramp generator from the output stages and reduces any loading effect on the previous stages. Components R209, R210, R211, C204, and C205 reshapes the ramp voltage to make it extremely linear.

The output signal from the buffer stage is applied to a preamp stage for amplification and then to a power amp stage which drives the vertical deflection coils directly via coupling capacitor C210. Components R216 and C209 provide damping to prevent any oscillations in the output circuit. R213, R314, R215, R217, R218, C206, C207 and C208 provide AC and DC feedback for the output stage to maintain proper gain and linearity.



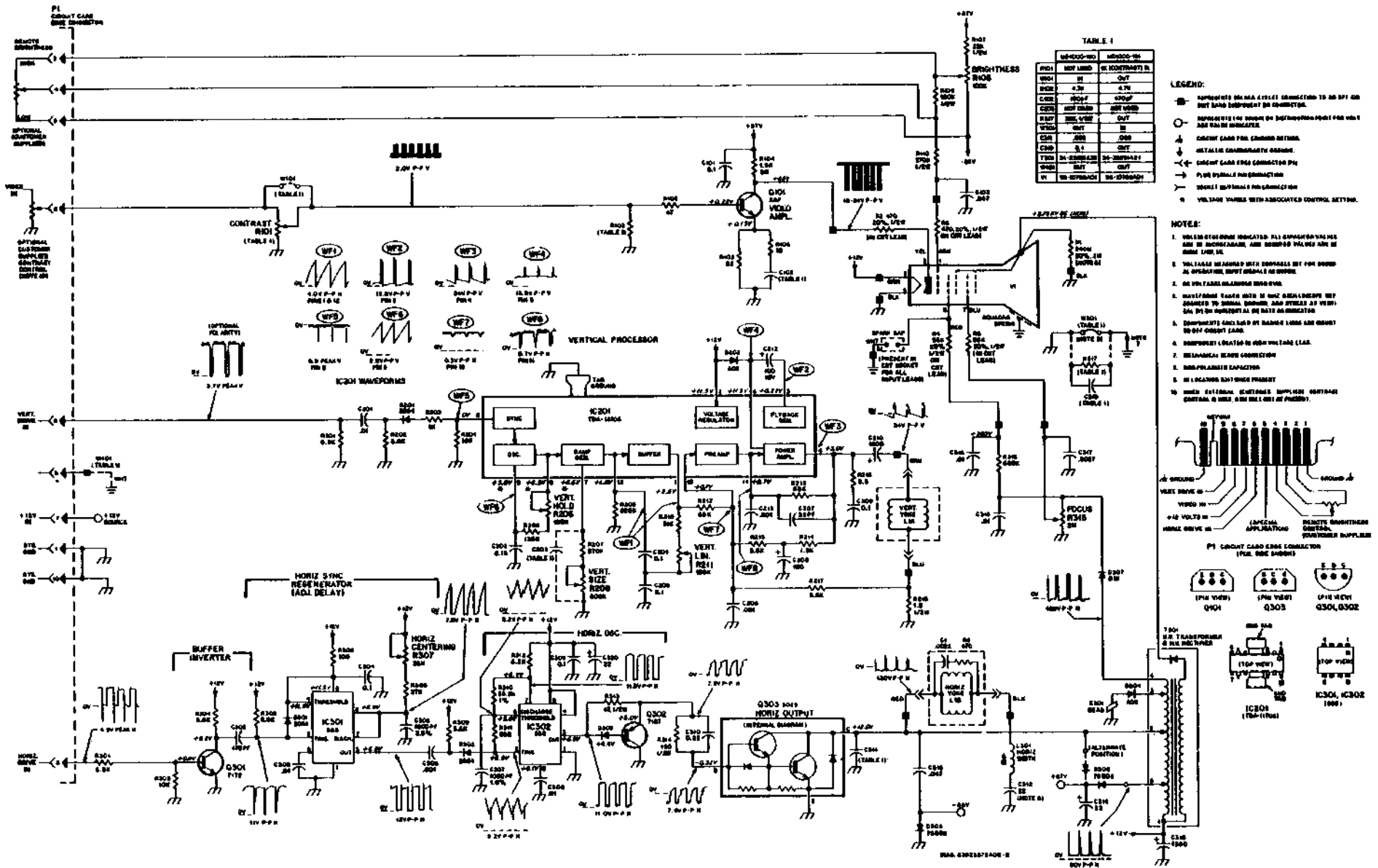

Schematic Diagram, Model MD1000-190 Series CRT Monitors

- COMPONENT SIDE SHOWN -

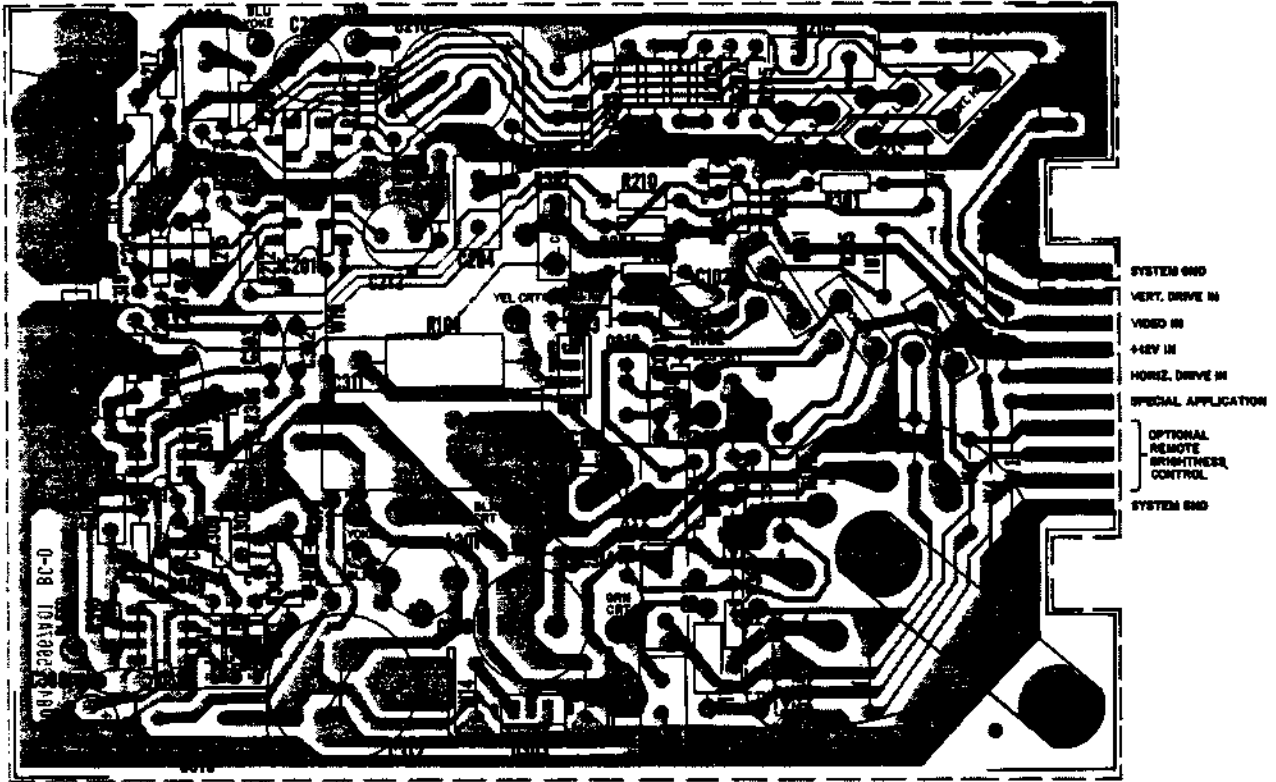

SOLDER ART CERC-04489-0  
OVERLAY CERC-04491-0

Monitor Circuit Card Detail, Component View

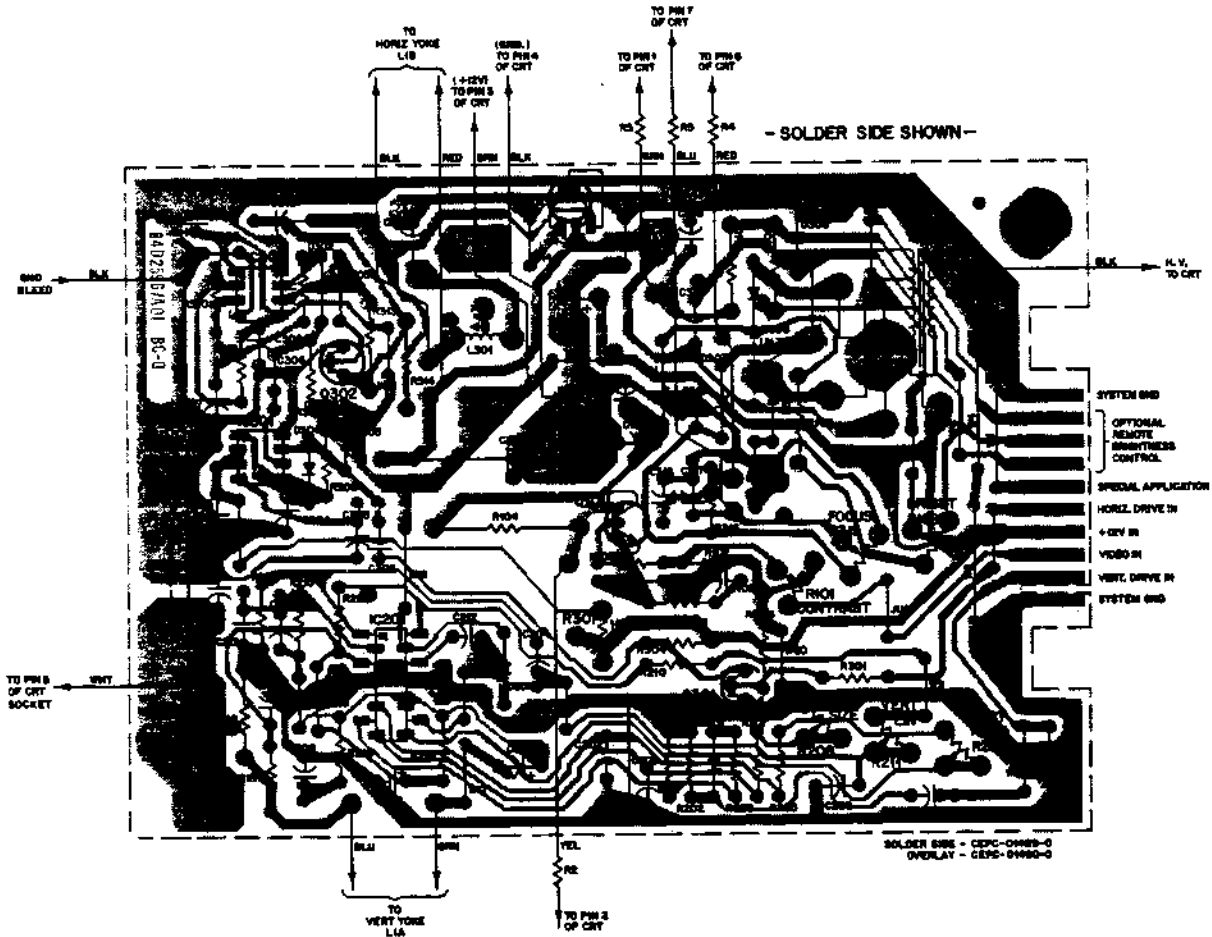

SOLDER SIDE - CERC-04489-0  
OVERLAY - CERC-04490-0

Monitor Circuit Card Detail, Solder View

## REPLACEMENT PARTS LIST

REF. NO.	PART NO.	DESCRIPTION	REF. NO.	PART NO.	DESCRIPTION
<b>CAPACITORS: (All Values are in Microfarads Unless Otherwise Noted.)</b>			<b>TRANSISTORS</b>		
C101	21R29964A05	0.5 +80-20 Z5U 100V Spcl.	Q101	48R137093	NPN TRANSISTOR A5F
C102	21S180E58	150PF 5% NPO 100V (MD1000-190)	Q301	48R137172	NPN TRANSISTOR 7172
	21-S180B53	470PF 10% Z5F 100V Disc. (MD1900-191)	Q302	48R137127	PNP TRANSISTOR 7127
C103	8R29959A65	0.047 10% 200V Plystr.	Q303	48-03025A00	DARL. TRANSISTOR 3025
C201	8R29959A41	0.01 10% 200V Plystr.		1V25576A60	includes heatwink and transistor 3025
C202	8R29967B92	0.15 10% 50V Plystr.	<b>RESISTORS/CONTROLS</b>		
C204,5	8R29967A11	0.1 10% 50V Plystr.	NOTE: Only power or special resistors are listed. Use the description when ordering standard values of fixed carbon resistors.		
C206	21S180B51	0.001 10% X5F 500V Disc.	R1	6R29978A01	RES. Fixed 240M
C207	21S180B94	33PF 10% NPO 500V Disc.	R101	18D25245A02	CONTROL, Contrast Var. 1K
C208	23R29914A40	100 16V PCM lytic	R108	18D25245A15	CONTROL, Brightness Var. 100K
C209	8R29959A76	0.1 10% 100V Plystr.	R206	18D25246A15	CONTROL, Var. Vert. Hold 100K
C210	23R29914A68	1500 25V PCM lytic	R208	18D25245A07	CONTROL, Var. Vert. Size 500K
C212	23R29914A40	100 16V PCM lytic	R211	18D25904A02	CONTROL, Var. Vert. Lin. 250K
C213	21S180B51	0.001 10V X5F 500V Disc	R307	18D25245A40	CONTROL, Var. Horiz. Centering 25K
C302	21S180B53	470PF 10% X5F 100V Disc	R315	18D25245A32	CONTROL, Var. Focus 2M
C303	21S180B90	0.01 20% Z5F 100V Disc	<b>COIL/CHOKES</b>		
C304	21R29964A05	0.1 +80-20 Z5U 100V Spcl	L1 A/B	24D25290A03	COIL, deflection
C305	8R29970A03	0.001 2.5% 100V polyprop.	L301	24D25603A03	COIL, width
C306	21S180B51	0.001 10% X5F 500V Disc	<b>INTEGRATED CIRCUITS (IC)</b>		
C307	8R29970A02	0.001 1% 100V Polyprop.	IC201	51R06015A00	IC, TDA1170S Vert. Proc.
C308	21S180B90	0.01 20% Z5U 100V Disc.	IC301, 302	51R06332A00	IC, 555 Timer
C309	21R29964A05	0.1 +80-20% Z5U 100V Spcl.	<b>TRANSFORMERS</b>		
C310	8R29959A88	0.22 10% 100V Plystr.	T301	24D25291A21	TRANSF., horiz. output (MD1000-191)
C311	8R29956A38	0.039 5% 200V Mylar (MD1000-190)	T301	24D25291A25	TRANSF., horiz. output (MD1000-190)
	8R29956A46	0.068 5% 200V Mylar	<b>MISCELLANEOUS</b>		
C312	23R29910A05	22 25V Lytic	V1	9610789A01	CRT, 5-in P4/H
C313	8R29959A65	0.047 10% 200V Plystr.		0725978A01	BRACKET, PC grounding
C314	23R29914B49	22 100V PCM Lytic		4125268A03	SPRING, deg.
C315, 316, 317	8R29959A42	0.01 10% 400V Plystr.		5925667A0X	NOTE: For Replacement of magnetic yokes, order replacement by specifying the Model No., description of the unit, and the unique CRT display characteristics.
	21S180C41	0.0027 20% Z5F 100V Disc.		1V25576A56	CRT socket and lugs
C318	23R29914A66	1500 25V Lytic		9D25241A11	SOCKET, CRT
C319	21R29964A05	0.1 +80-20% Z5U 100V Spcl (not used)		42D25298A04	ANODE connector
C320	23R29914A77	22 35V Lytic	E301	76A25809A02	Ferrite Bead,
<b>DIODES/RECTIFIERS</b>					
D201	48-02054A00	DIODE, 2054			
D202	48-00191A02	DIODE, A02			
D301,302, 303	48-02054A00	DIODE, 2054			
D304	48-00191A05	DIODE, A05			
D305,306	48-02075B02	DIODE, 75802			
D307	48R134978	DIODE, D1K			



**MANUAL: 68P25253A88-O FILE: VP40**

**MD1000-190 SERIES  
CRT DISPLAY MONITORS**

**APPENDIX 2**  
**Astec**  
**Power**  
**Supply/Service**

REPAIR MANUAL FOR ASTEC POWER SUPPLY AC8151



SECTION I: Test Set-up

A. Equipment Needed

1. Isolation Transformer (minimum of 500 VA rating)  
Dangerously high voltages are present in this power supply. So far the safety of the individual doing the testing please use an isolation transformer. The 500 VA rating is needed to keep the AC wave form from being clipped off at the peaks. These power supplies have peak charging capacitors and draw full power at the peak of the AC waveform.
2. 0-28V Variable Transformer (Variac)  
Used to vary input voltage. Recommend 10 Amp, 1.4 KVA rating, minimum.
3. Voltmeter - Needed to measure DC voltage to 50 VDC and AC voltages to 400 VAC. Recommend 2 Digital Multi Meters.
4. Oscilloscope - Need X10 and X100 probes.
5. Load Board with Connectors  
See table I for value of loads required. The entry on the table for safe load power is the minimum power ratings for the load resistors used.
6. Ohm Meter
7. Watt Meter

B. Set-up Procedure

Set-up as shown in Figure 1. You will want to monitor the input power and input voltage and the output voltage of the regulated buss, which is the +5 output with DVM's. Also, monitor the +5 output with the oscilloscope using 50mV/div sensitivity. The DVM monitoring the +5 output can also be used to check the other outputs. See text of Section III for test points within power supply.

SECTION II

A. Visual Inspection:

Check power supply for any broken, burned, or obviously damaged components. Visually check fuse, if any question check with

## B. Start-up

First note the position of the input voltage select wire. This wire can be found at the end of PCB opposite the input/output connectors. Make sure wire is in position corresponding to your test set-up 230V position if you are using 115V input. For the balance of this manual we will assume 230V operation. If you prefer 115V operation divide applicable values in half.

Load power supply with minimum load as specified in Table I. Bring power up slowly with Variable Transformer while monitoring +5V output with scope and DVM and input with DVM and Wattmeter. If the Wattmeter shows significant power with low AC power being applied shut down and refer to Section III. Supply should start with approx. 80-120VAC applied and should regulate when 190VAC is applied. If output has reached 5 volts, do a performance test as shown in Section IV. If there is no output refer to Section III.

## SECTION III: No Output

### A. Check fuse.

If fuse is blown replace but do not apply power until cause of failure is determined.

### B. Preliminary Check on Major Primary Components.

Check Thermister (R1), Diode Bridge (DB1), Power Transistor (Q2), Catch Diode (D3), Turn-off Transistor (Q1), Emitter Resistor (R11), and D1.

### C. Preliminary Check on Major Secondary Components.

Using ohm meter from output common to each output, with output loads disconnected, check for shorted rectifiers or capacitors. If +12V output is shorted also check crowbar SCR (SCR1) and Zener (Z1).

### D. Check for B+

Set-up power supply and attach X100 scope probe ground to end of R11 closest to input caps. Slowly turn up power and check for B+ on the plus (+) terminal of the Diode Bridge (DB1). With input at 190 VAC this point should be between 250-300 VDC. If this is not correct check fuse, thermister (R1), DB1, and if necessary R2, D3 and finally input capacitors C6, C7.

### E. Check Q1 Waveforms

Using X100 probe on case of T03 package of Q2 check collector waveform. Transistor should be switching, correct waveform is shown in Fig.3. If this is not present check for shorted junctions on Q2. If ok check base waveform. Base of Q2 is the uppermost of the two center leads on back of Q2 heatsink, Correct waveform is shown in Fig. 3. If this waveform is not present check L3, Q1, D1, and secondary components Q3, D11, D12, D5, and L4. If any of the semi conductors are found shorted or inductors open replace.

SECTION IV Performance test

Each of these test conditions should be set-up and noted to be within the limits specified in Table II.

TEST	INPUT	+5 LOAD	+12 LOAD	-12 LOAD
1	190 VAC	MAX	MAX	MAX
2	270 VAC	MAX	MAX	MAX
3	220 VAC	MAX	MIN	MIN
4	270 VAC	MIN	MIN	MIN
5	190 VAC	MIN	MIN	MIN

Table I: Load Board Values

Output	Min Load	Load R	Safe Load Power	Max Load	Load R	Safe Load Power
+5	0.45A	11.11 ohm	5 W	2.5A	2 ohm	25 W
+12	0.3A	.40 ohm	8 W	2.02A	24.24 ohm	50 W
-12	0	0	0	0.1A	120 ohm	2 W

Table II: Voltage and Ripple Spec:

Output	Min	Max	No Load	Ripple
+5	4.75V	5.25V	-	50mV-P-P
+12	11.40V	12.60V	-	150mV-P-P
-12	-11.00V	15.00V	-	150mV P-P

POWER SUPPLY

AC8151

THIS SPECIFICATION COVERS THE REQUIREMENTS FOR A SWITCHING POWER SUPPLY WITH DUAL LINE INPUT CAPABILITY.

+5V 2.5A / +12V 2.02A / -12V 0.1A

OPEN FRAME

**PROPRIETARY STATEMENT**

THIS DOCUMENT CONTAINS DATA AND INFORMATION PROPRIETARY TO ASTEC COMPONENTS LTD. THIS DATA AND INFORMATION SHALL NOT BE DISCLOSED, DISSEMINATION OR REPRODUCED IN WHOLE OR IN PART WITHOUT THE EXPRESS PRIOR WRITTEN AUTHORIZATION OF ASTEC COMPONENTS LTD.

A	8/12/80	D		TITLE	
B		E		INTERNAL PRODUCT SPECIFICATION	AC8151
C		F			
ASTEC COMPONENTS LTD. HONG KONG					Sheet 2 of 5 A-4

1. SCOPE

This document is a preliminary specification for power supply type AA11330.

2. APPLICABLE DOCUMENTS

- UL1012 - Power supplies
- VDE 0871B - EMI
- FCC 'B' - EMI

**PROPRIETARY STATEMENT**

THIS DOCUMENT CONTAINS DATA AND INFORMATION PROPRIETARY TO ASTEC COMPONENTS LTD. THIS DATA AND INFORMATION SHALL NOT BE DISCLOSED, DISSEMINATION OR REPRODUCED IN WHOLE OR IN PART WITHOUT THE EXPRESS PRIOR WRITTEN AUTHORIZATION OF ASTEC COMPONENTS LTD.

3. REQUIREMENTS

The supply is configured as an open frame printed circuit assembly.

3.1 ELECTRICAL

- 3.1.1 Input voltage 95/190 to 135/270 VAC 60Hz or 50Hz.
- 3.1.2 Input current maximum 0 85A Rms.
- 3.1.3 Efficiency 65% min at full load 115/230VAC in.
- 3.1.4 Outputs - Vo1 +5V, Vo2 +12V, Vo3 -12V.
- 3.1.5 Outputs current capacity.

Full Load

- Vo1 +5V at 2.5Amps
- Vo2 +12V at 2.02Amps
- Vo3 -12V at 0.1Amps

Individual output max rating

- Vo1 , 5 Amps if no load on +12V, 2.5Amps if +12V is 2.5Amps
- Vo2 , 2.5Amps if +5V is 2.5A or less.
- Vo3 , 0.5Amps

3.1.6 Max continous power output not to exceed 38Watts.

3.1.7 Initial set up voltage. The +5V output will be factory preset to 4.90 to 5.15Volts with all outputs at full load and 115VAC/230VAC in. Output voltage being measured at output terminals on the P.C.B.

A	8/11/80D		TITLE	
B		E	INTERNAL PRODUCT SPECIFICATIONS	AC8151
C		F		
 <b>ASTEC COMPONENTS LTD.</b>				HONG KONG
			Sheet 3 of 5	A-4



3.1.8 Output voltage tolerances under all conditions of rated line, load, temperature and drift after initial setting the output voltage shall remain within the following limits

Vo1 +5V , 4.75 to 5.25V  $\pm 5\%$  0.45 to 2.5A  
 Vo2 +12V , 11.4 to 12.6V  $\pm 5\%$  0.3 to 2.02A  
 Vo3 -12V, 11.0 to 15.0V  $\pm 25\%$  -8.3% 0 to 0.1A

3.1.9 Output ripple voltage over the rated line and load range, shall remain within the following limits.

Vo1 +5V 50mVp-p  
 Vo2 +12V 150mVp-p  
 Vo3 -12V 150mVp-p

3.1.10 Output short circuit - no damage to the supply will result when any output is short circuited via a 50mΩ or less.

3.1.11 Over voltage protection. Applied to the 5V circuit only. The crowbar trip range is 5.80 to 6.80V.

3.1.12 Operating temperature range 0°C to 50°C.

3.2 Figure 1 illustrate physical envelop, with mounting centres and input/ output connections.

3.2.2. Weight of power supply is 0.43Kg typical.

3.3. EMI requirement

The power supply shall meet the conduction limits of VDE 0871'B' rules for 230VAC in and Fcc 'B' rules for 115VAC in.

**PROPRIETARY STATEMENT**

THIS DOCUMENT CONTAINS DATA AND INFORMATION PROPRIETARY TO ASTEC-COMPONENTS LTD. THIS DATA AND INFORMATION SHALL NOT BE DISCLOSED, DISSEMINATION OR REPRODUCED IN WHOLE OR IN PART WITHOUT THE EXPRESS PRIOR WRITTEN AUTHORIZATION OF ASTEC COMPONENTS LTD. AC8131

A	8/11/80	D		TITLE
B		E		INTERNAL PRODUCT
C		F		

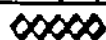

ASTEC COMPONENTS LTD:

HONG KONG

Sheet 4 of 5

A-4

Preliminary Data Sheet

AC8151

AC-DC SWITCHING POWER SUPPLY



FEATURES:

- \*High Efficiency
- \*Fully Protected - Voltage/Current
- \*Built-in EMI Filter - Meets VDE
- \*Low Output Ripple
- \*Vacuum Impregnated Transformers
- \*Dual Input Voltage Selection
- \*UL/CSA Approved
- \*100% Thermal Cycle and Burn-in

PERFORMANCE AND SPECIFICATION:

AC Input Voltage Input Frequency	95 VAC to 135 VAC or 190 VAC to 270 VAC 50 or 60 HZ, Jumper Selectable	
Output Characteristics	Voltage/Current	Tolerance (Note 1)
	+5V, 0.45A to 2.5A +12V, 0.30A to 2.02A -12V, 0 to 0.1A	±5% ±5% +25% - 8.3%
Maximum Individual Output Rating	+5V - 5.0A if no load on +12, 2.5A if 2.0A on +12V. +12V - 2.5A if +5V is 1.0A or less. -12V - 0.5A Max continuous power output not to exceed 38W.	
Efficiency Line Regulation Ripple and Spikes Over Voltage Protection Over Current Protection Operating Temperature Line Transient Response Power Line Disturbances Weight	70% minimum at Full Load ±0.5% High Line/Low Line at Full Load +5V/50mV p-p, +12V/150mV p-p, -12V/150mV p-p Crowbar on +5 set to trip from 5.8V to 6.8V Short Circuit protection on all outputs 0 - 50°C Meets IEEE Standards Supply will ride through a half cycle absence of input power at Full Load and 95VAC input 0.43 KG typical	

Note 1: Total output voltage tolerance, reference to nominal voltage and includes line, load, temperature, and set-up.

January, 1981

C1	MP. Cap 0.01uF ±20% 250VAC	068-10300010
C2	MP. Cap 0.1uF ±20% 250VAC	068-10400010
C3	Cer. Cap. 4700pF ±20% 400VAC	055-47220001
C4	Cer. Cap. 4700pF ±20% 400VAC	055-47220001
C5	MTL Poly Cap 0.22uF ±20% 250V	058-22400130
C6	Elect Cap. 100uF ±20% 250V	057-10120170
C7	Elect Cap. 100uF ±20% 250V	057-10120170
C8	Elect. Cap. 220uF +50-10% 10V	057-22120080
C9	Cer. Cap. 470pF ±10% 2KV 25P	055-47154426
C10	Cer. Cap. 0.01uF ±20% 1KV 25U	055-10368925
C11	Cer. Cap. 0.01uF ±20% 1KV 25U	055-10368925
C12	Poly Cap 0.22uF ±20% 100V	058-22400160
C13	Poly Cap 0.022uF ±20% 50V	058-22300090
C14	Poly Cap 0.22uF ±20% 100V	058-22400160
C15	Elect Cap 1000uF +50 -10% 25V	057-10220040
C16	Elect Cap 1000uF +50 -10% 25V	057-10220040
C17	Elect Cap 1000uF +50 -10% 25V	057-10220040
C18	Elect Cap 330uF +100 -20% 16V	057-33120120
C19	Elect Cap 330uF +100 -20% 16V	057-33120120
C20	Elect Cap 470uF +50 -10% 25V	057-47120110
C21	Elect Cap 2200uF +50 -10% 16V	057-22220020
C24	MTL Poly Cap 0.22uF ±20% 250V	058-22400130

**STATEMENT**

THIS DOCUMENT CONTAINS DATA AND INFORMATION  
 PROPERTY TO ASTEC COMPONENTS LTD. THIS  
 INFORMATION SHALL NOT BE DISCLOSED,  
 REPRODUCED OR REPRODUCED IN WHOLE OR IN PART  
 WITHOUT THE EXPRESS PRIOR WRITTEN AUTHORIZATION  
 OF ASTEC COMPONENTS LTD.

A	5/9/80	D		TITLE COMPONENT CODE LIST	AA11330
B		E			
C		F			
 <b>ASTEC COMPONENTS LTD.</b>					Sheet 1 of 4
<b>HONG KONG</b>					<b>A-4</b>

<u>CODE</u>	<u>DESCRIPTION</u>	<u>PART NUMBER</u>				
D3	Rectifier RGP10M	226-10400100				
D4	Rectifier 1N4001GP	226-10400080				
D5	Silicon Diode 1N4606	212-10700210				
D6	Rectifier Assembly	853-00200190				
D7	Rectifier Assembly	853-00200190				
D8	Rectifier Assembly	853-00200190				
D9	Rectifier RGP10B	226-10400070				
D11	Silicon diode 1N4606	212-10700210				
D12	Silicon diode 1N4606	212-10700210				
D13	Rectifier 1N4001GP	226-10400080				
DB1	Bridge rectifier KBP10	226-30500010				
IC1	Regulator TL431CLP	211-10800100				
L1	Filter Choke Coil Assembly	852-20100140				
L2	Filter Choke Coil Assembly	852-20100140				
L3	Base Choke	328-00100030				
L4	Choke 1.5mH	328-00100010				
L5	Filter Choke coil assembly	852-20100180				
L6	Filter choke coil assembly	852-20100180				
L7	Choke Coil	328-00100060				
Q1	NPN transistor SD467	209-11700460				
Q2	Power Transistor	853-00400050				
Q3	PNP transistor SB561	210-11700350				
A	5/g.'80	D	TITLE COMPONENT CODE LIST	AA11330		
B		E				
C		F				
 <b>ASTEC COMPONENTS LTD.</b>				HONG KONG	Sheet 2 of 4	A-4

<u>CODE</u>	<u>DESCRIPTION</u>	<u>PART NUMBER</u>
R1	Thermistor 4R ±10%	258-40970015
R2	Resistor carbon film 330K ±5% ¼W	240-33406033
R3	Resistor metal oxide film 220R ±5% 1W	248-22106052
R4	Resistor metal oxide film 33R ±5% 2W	248-33006063
R5	Resistor carbon film 1K ±5% ¼W	240-10206022
R6	Resistor carbon film 27R ±5% ¼W	240-27006022
R7	Resistor carbon film 68R ±5% ¼W	240-68006022
R8	Resistor metal oxide film 120R ±5% 1W	248-12106052
R9	Resistor carbon film 10R ±5% ¼W	240-10006022
R10	Resistor carbon film 10R ±5% ¼W	240-10006022
R11	Resistor metal film 0.75R ±5% 1W	247-07586054
R12	Resistor metal film 1R ±5% 1W	247-10086054
R13	Resistor carbon film 5.6R ±5% ¼W	240-56906022
R14	Resistor carbon film 68R ±5% ¼W	240-68006022
R15	Resistor carbon film 270R ±5% ¼W	240-27106033
R16	Resistor carbon film 270R ±5% ¼W	240-27106033
R17	Resistor carbon film 8.2R ±5% ¼W	240-82906022
R18	Resistor carbon film 560R ±5% ¼W	240-56106022
R19	Resistor carbon film 56R ±5% ¼W	240-56006022
R20	Resistor carbon film 56R ±5% ¼W	240-56006022
R21	Resistor carbon film 12K ±5% ¼W	240-12306022
R22	Resistor carbon film 470R ±5% ¼W	240-47106022
R23	Resistor metal film 4.7K ±2% ¼W	247-47015022
R24	Resistor carbon film 68K ±5% ¼W	240-68306022
R25	Resistor metal film 22K ±2% ¼W	247-22025022
R26	Resistor metal film 2.7K ±2% ¼W	247-27015022

A	5/9/80	D		TITLE COMPONENT CODE LIST	AA11330
B		E			
C		F			
 <b>ASTEC COMPONENTS LTD.</b>					Sheet 3 of 4
<b>HONG KONG</b>					<b>A-4</b>

<u>CODE</u>	<u>DESCRIPTION</u>	<u>PART NUMBER</u>
R27	Resistor carbon film 12R ±5% 1/4W	240-12006022
SCR1	SCR C122P	227-13000010
T1	Common mode transformer assembly	852-20200950
T2	Power transformer assembly	851-10200940
T3	Control transformer assembly	852-10200680
Z1	Zener diode 5.6V ±5% 1W	222-56086002

A	5/9/80	D		TITLE COMPONENT CODE LIST	AA11330		
B		E					
C		F					
 <b>ASTEC COMPONENTS LTD.</b>					HONG KONG	Sheet 4 of 4	A-4

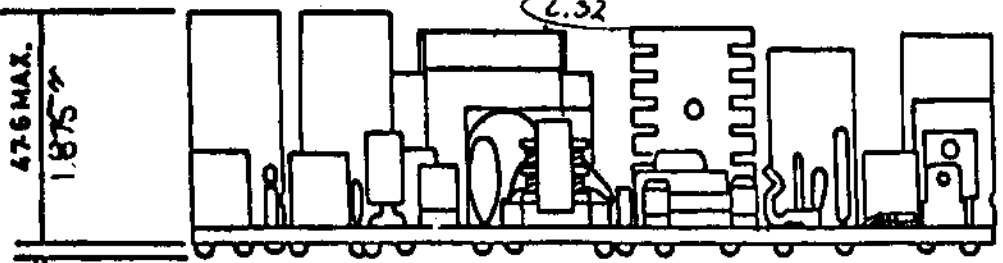
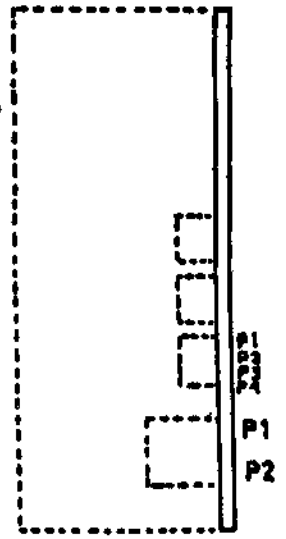
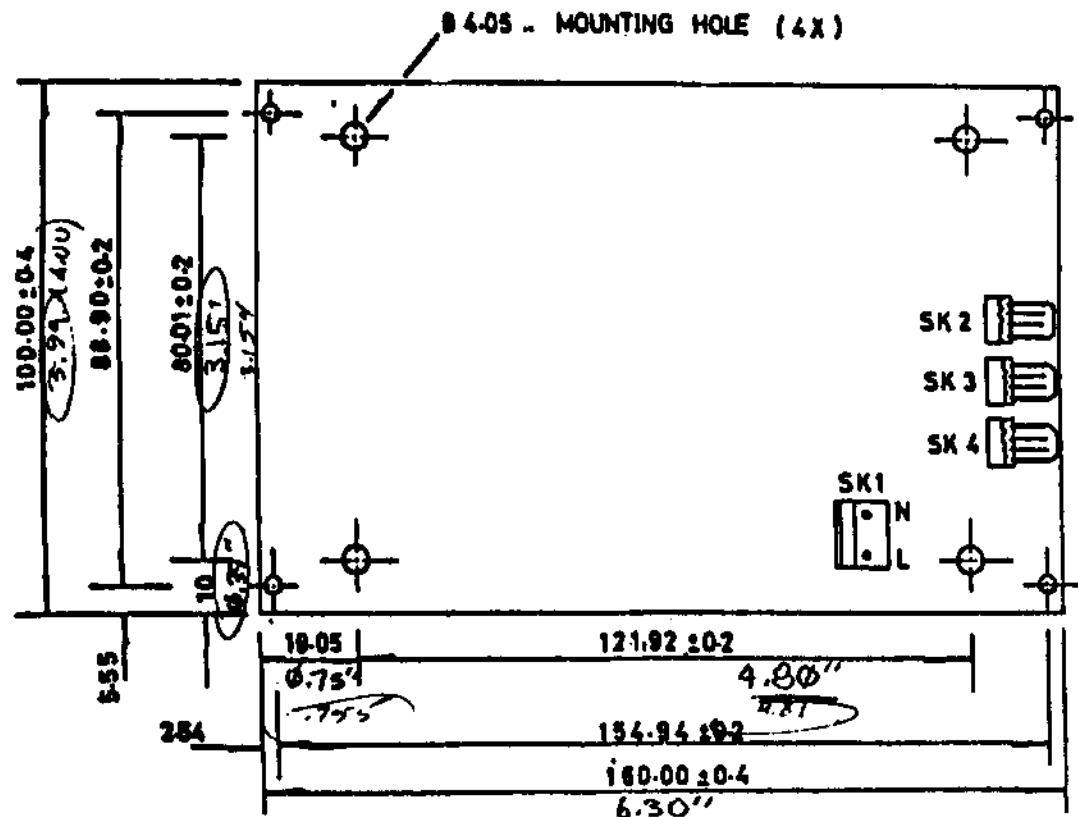

**PIN ASSIGNMENT :-**

- FOR SK1
  - P1 NEUTRAL
  - P2 LIVE
- FOR SK 2/3/4
  - P1 -12V
  - P2 +12V
  - P3 COMMON
  - P4 -5V

0.15" 3.81 MAX.  
2.07" DA

UNLESS OTHERWISE SPECIFIED ALL DIMENSIONS ARE IN MM	DO NOT SCALE DRAWING	TITLE
TOLERANCES:	DATE	AC8151 ASSEM
ANGLE	CHK	FIRST USED ON
DECIMAL	APPD	MATERIAL
00000	ASTEC COMPONENTS LTD.	HONG KONG

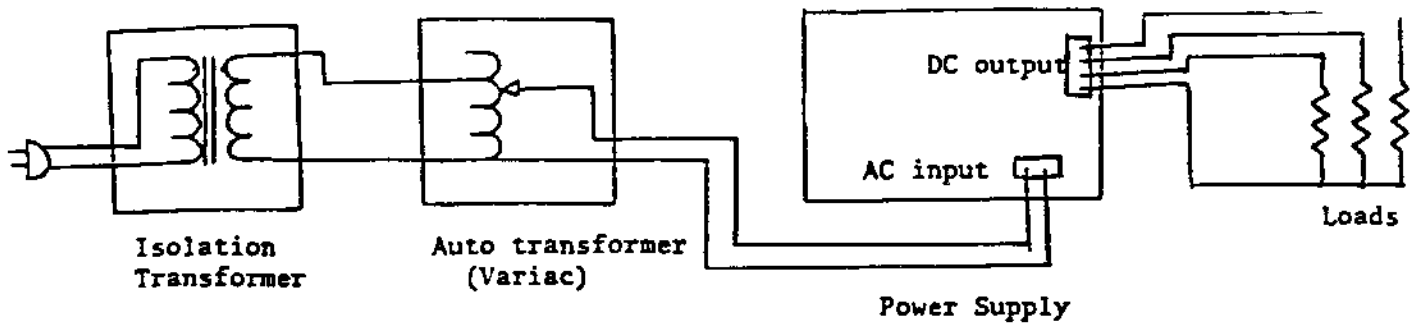
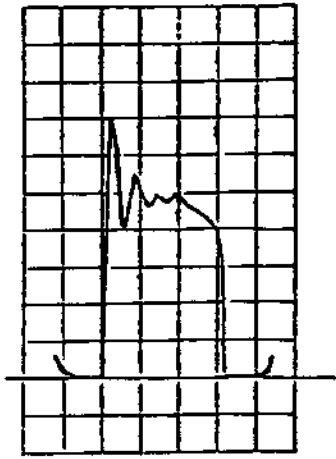
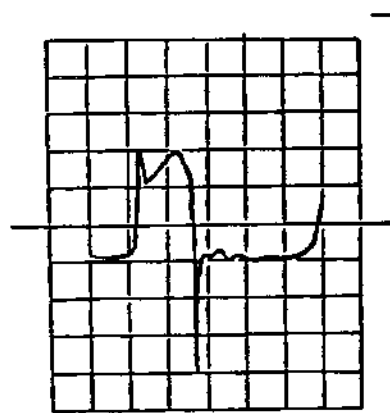

Fig. 2- Q2 Collector Waveform



100 V/Div  
5 uSec/Div  
Input- 240 VAC  
Loads- +5@2A  
+12@1A  
-12@0.1A

Fig. 3- Q2 Base Waveforms



1.0 V/Div  
5 uSec/Div  
Input and Loads  
same as Fig. 2

Fig. 4 Pin Assignment

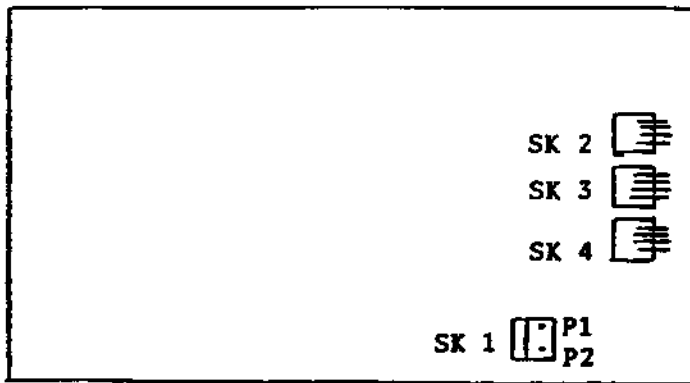

For SK 1  
P1- Neutral  
P2- Live

For Sk 2/3/4  
P1- -12 0.1A Max.  
P2- +12 2.02A Max.  
P3- Common  
P4- +5 2.5A Max.



R	R1	R4 R2 R5	R6-R13	R14-R18	R19-R27	R3
C	C1	C2,3,4	C24 C5 C6,7,8	C9 C10	C11 C12	C13-C23
L/T	T1	L2 L1	T3	T2	L5-L7	
Q/D		D1 D1 D2	Q2 D4 D3	D5-D9 D11-D13 Q3		
MISC	F1	DB1			IC1	Z1 SCR 1

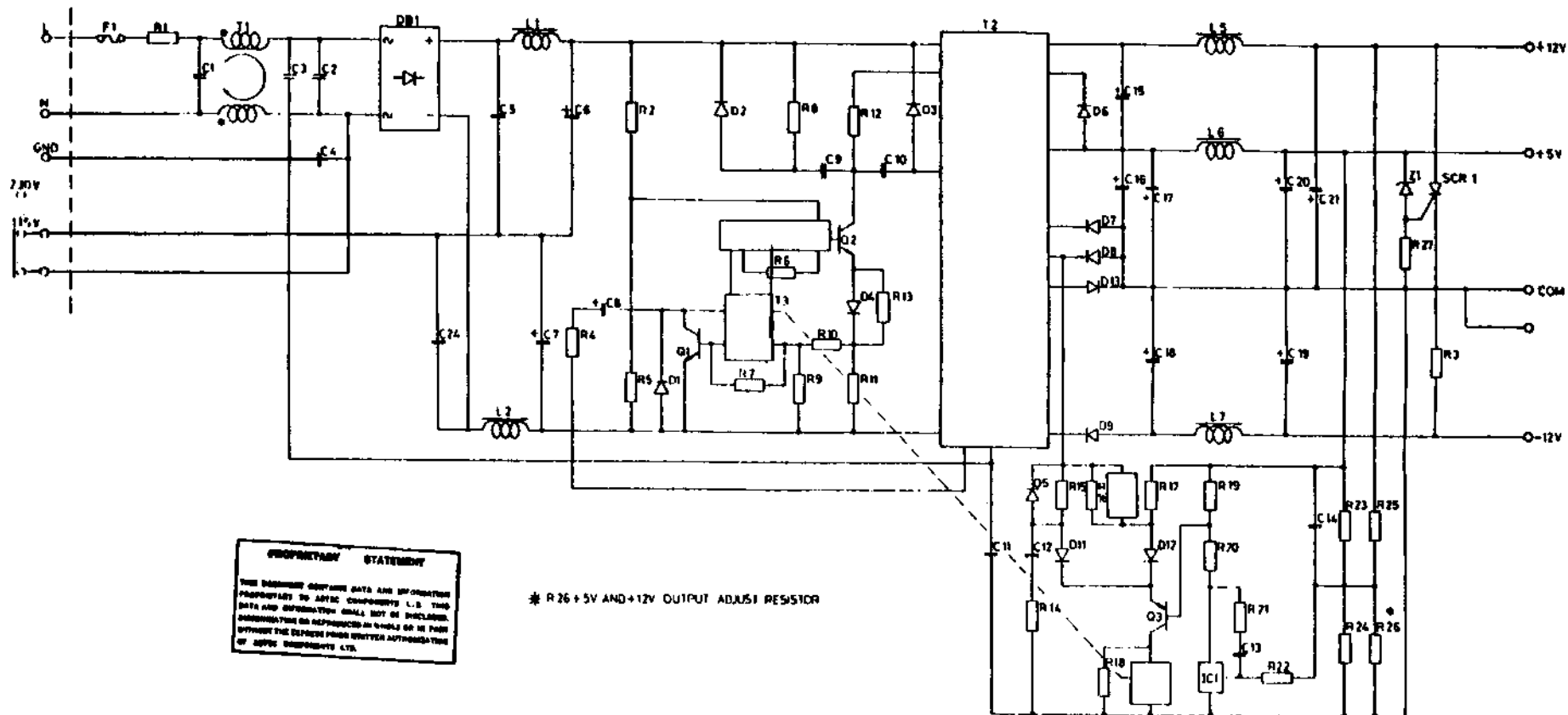

**PROPRIETARY STATEMENT**  
 THIS DOCUMENT CONTAINS DATA AND INFORMATION PROPRIETARY TO ASTEC COMPONENTS LTD. THIS DATA AND INFORMATION SHALL NOT BE DISCLOSED, REPRODUCED OR REPRODUCED IN WHOLE OR IN PART WITHOUT THE EXPRESS WRITTEN AUTHORIZATION OF ASTEC COMPONENTS LTD.

\* R 26 + 5V AND +12V OUTPUT ADJUST RESISTOR

**PROPRIETARY STATEMENT**  
 THIS DOCUMENT CONTAINS DATA AND INFORMATION PROPRIETARY TO ASTEC COMPONENTS LTD. THIS DATA AND INFORMATION SHALL NOT BE DISCLOSED, REPRODUCED OR REPRODUCED IN WHOLE OR IN PART WITHOUT THE EXPRESS WRITTEN AUTHORIZATION OF ASTEC COMPONENTS LTD.

UNLESS OTHERWISE SPECIFIED ALL DIMENSIONS ARE IN MM TOLERANCES:	DO NOT SCALE DRAWING	TITLE (REPAIR MANUAL) CIRCUIT DIAGRAM	
ANGLE NO ±	DATE 11 SEP 80	FIRST USED ON R4 B151	PART NO
DECIMAL ±	DATE 11 SEP 80	MATERIAL	FINISH
± ±	DATE 11 SEP 80		
± ±	DATE 11 SEP 80		
ASTEC COMPONENT LTD.		WORK BOOK	SH1 OF 1

1	RELEASE DRAW	USEFUL	DATE	DATE	DATE	DATE
DATE	REVISIONS	DATE	DATE	DATE	DATE	DATE

**APPENDIX 3**  
**Osborne**  
**Schematics**

DRAWING NO. IA10063		REV. 1	
DATE	DESCRIPTION	DATE	APPROVED
5/11/82	A FIRST RELEASE ECO # 0285	6/18/82	[Signature]
	B ECO # 0331A		

I.C. IDENTIFICATION TABLE				
REF. DESIGNATION	TYPE NO.	GND	+5V	+12V
UA12, UD1, UE10, UE22	LS00	7	14	
UB12, UD2	LS02	7	14	
UD7, UD8, UD9	LS03	7	14	
UE6, UE20	LS04	7	14	
UA11, UB3	S04	7	14	
UE13, UE14	LS05	7	14	
UA9, UA10, UD6, UE23	7406	7	14	
UA5, UB13, UB18, UC1	LS08	7	14	
UB5	LS11	7	14	
UA4, UE5, UE11, UC2	LS32	7	14	
UE7, UE8, UE9	7438	7	14	
UA6, UB4, UB6, UE21	LS74	7	14	
UB2	LS109	8	16	
UB1, UD10	LS139	8	16	
UE15, UE16, UE17, UE18	LS153	8	16	
UB17	LS155	8	16	
UB16	LS157	8	16	
UA7, UB11, UC3, UD3	LS161	8	16	
UD15, UD16, UD17, UD18	LS161	8	16	
UA14	74166	8	16	
UD14	LS175	8	16	
UA8, UA19	LS244	10	20	
UE19	5244	10	20	
UA18	LS273	10	20	
UB15	LS390	8	16	
UA13, UB14	LS393	7	14	
UC11	780-A	29	11	
UE1	555	1	8	
UE3	LM1458			
UB7	1793	20	21	40
UA15	2716	12	24	
UD4	LM3900	7	14	
UC7, UC15	6821	1	20	
UC4	6850	1	12	
UE12	81LS95	10	20	
UD11	2732	12	24	
UA20-UA27, UB20-UB27	4116	16	9	8
UC19-UC27, UD20, UD27				

REFERENCE DESIGNATION	
LA51	NOT USED
C85	C37, C60, C83
CR5	---
P9	P6, 7
Q2	---
R46	---
RN14	R9, 45
S1	---
X2	---

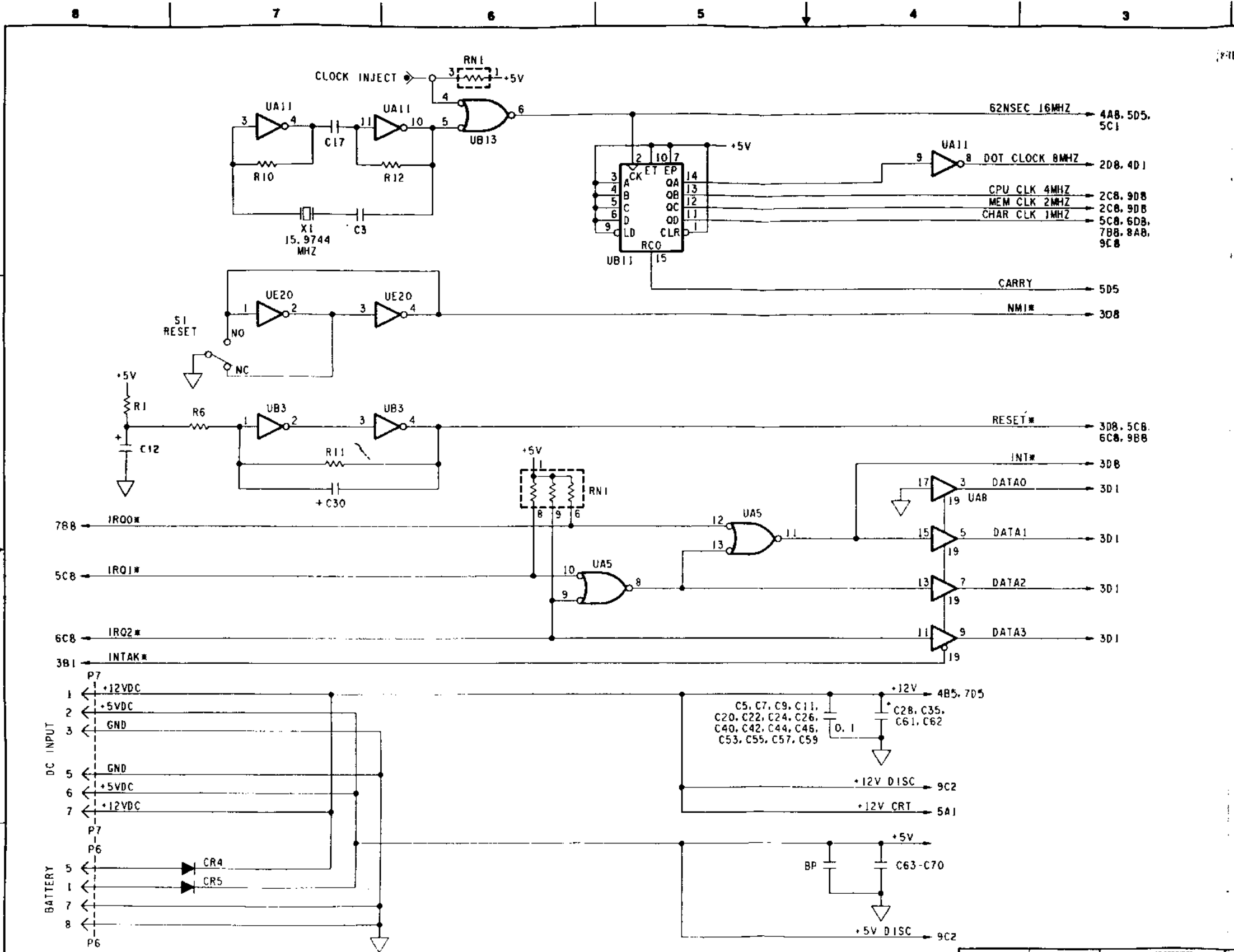

UNLESS OTHERWISE SPECIFIED DIMENSIONS ARE IN INCHES TOLERANCES ARE FRACTIONS DECIMALS ANGLES .XX1 .XX2 .XX3			
DATE: 28/2054	DESIGN: OCC1	APPROVALS: [Signature]	DATE: 5/82
NEXT ASBY: [Blank]	USED ON: [Blank]	DATE: 6-22-82	DATE: 6/18/82
APPLICATION: [Blank]		<b>MULTI LAYER MAIN LOGIC PCB SCHEMATIC</b>	
DO NOT SCALE DRAWING		SCALE: NONE	DWG. NO. IA10063

NS0144 BLODGETT 02JUN82

D  
C  
B  
A

D  
C  
B  
A

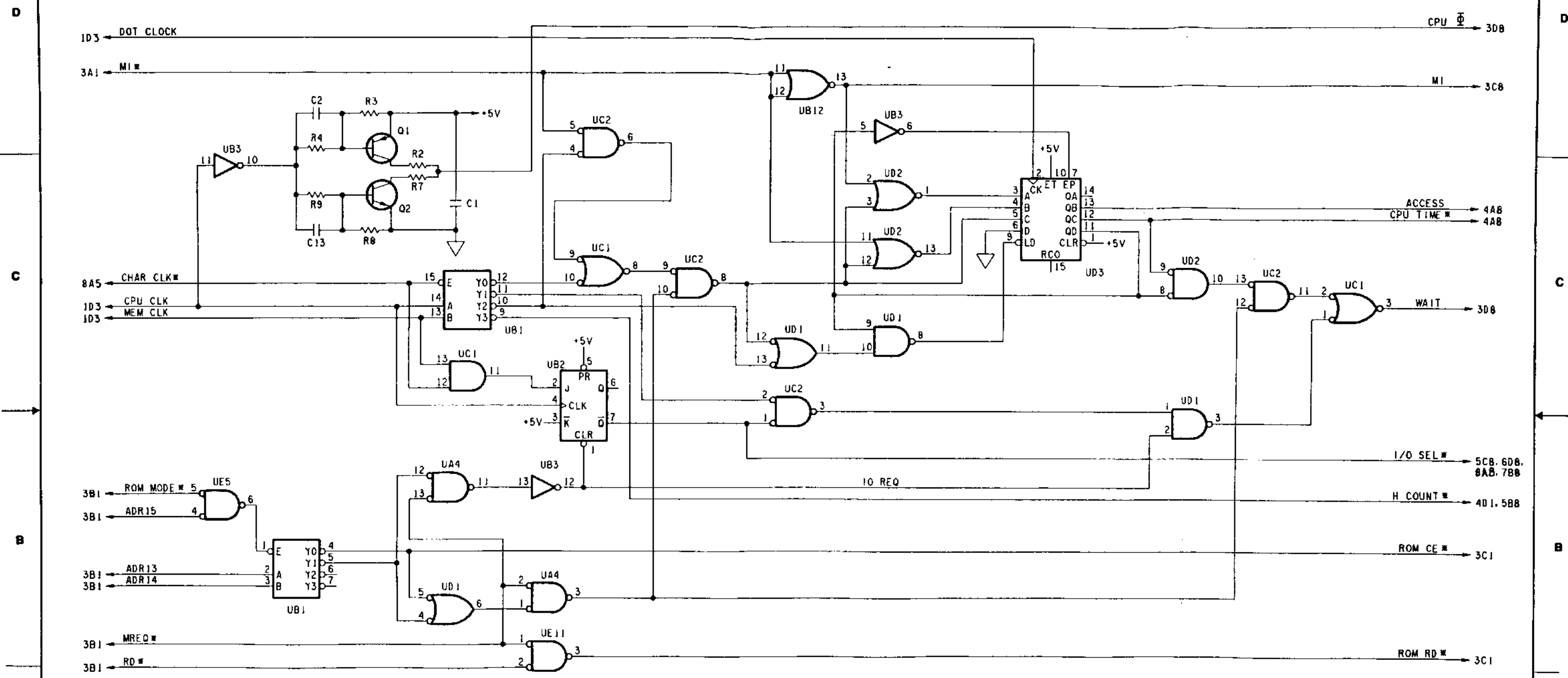

UNLESS OTHERWISE SPECIFIED DIMENSIONS ARE IN INCHES TOLERANCES ARE: FRACTIONS DECIMALS ANGLES XXX .XXX .		<b>OSBORNE</b> COMPUTER CORPORATION 3880 Corporate Avenue Hayward, California 94548 415-887-9008	
APPROVALS	DATE	MULTI LAYER MAIN LOGIC PCB SCHEMATIC	
CHECKED	5/82	PART NO. 1A10063 REV B	
ISSUED		SCALE NONE SHEET 2 OF 3	
APPLICATION	DO NOT SCALE DRAWING		

WG0145 BLODGETT 02JUN82

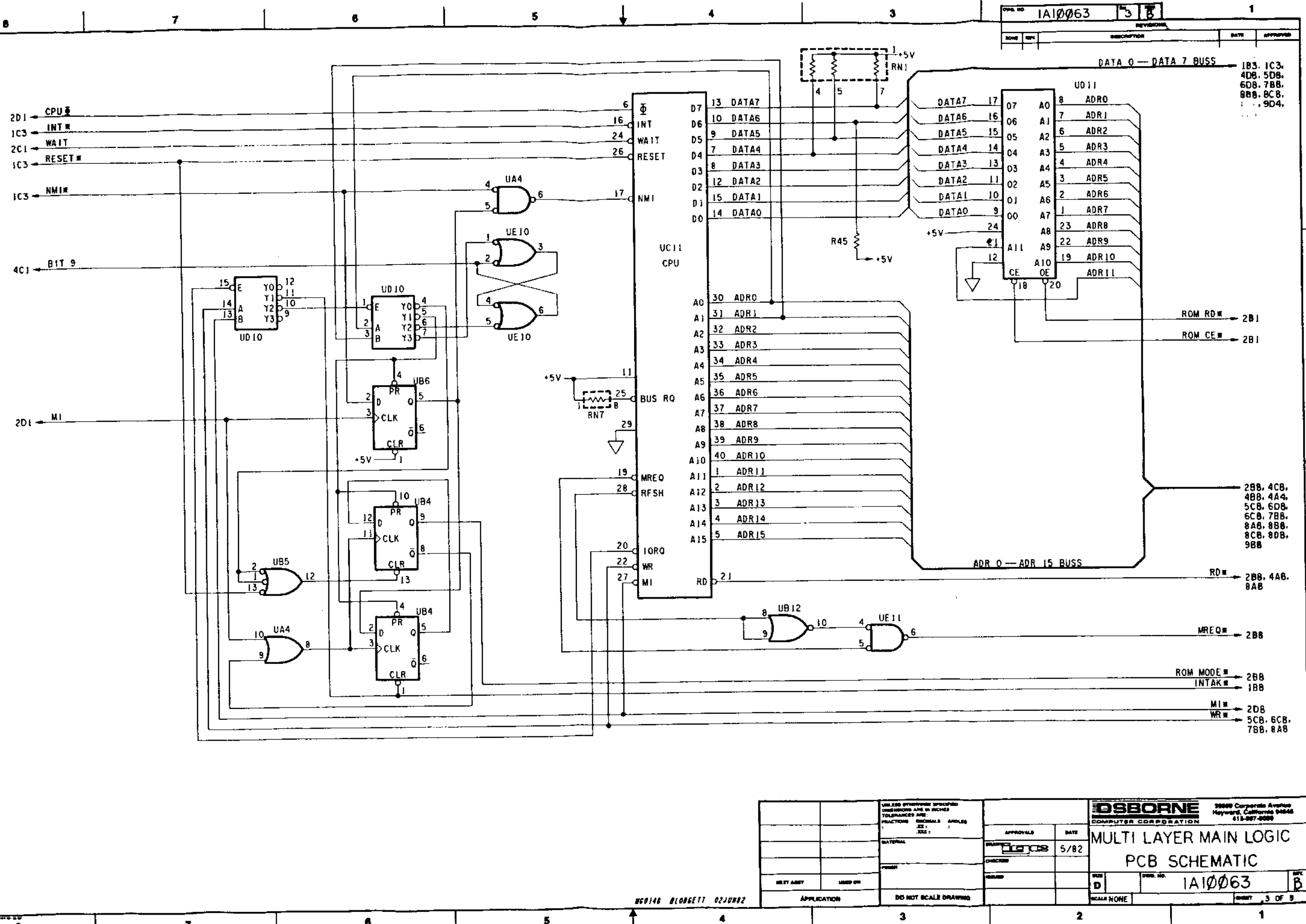

UNLESS OTHERWISE SPECIFIED DIMENSIONS ARE IN INCHES TOLERANCES ARE: FRACTIONS DECIMALS ANGLES XX.X .XX .XX		<b>OSBORNE</b> COMPUTER CORPORATION 20000 Corporate Avenue Hayward, California 94541 415-887-9000	
APPROVALS	DATE	MULTI LAYER MAIN LOGIC	
DESIGNED BY: [Signature]	5/82	PCB SCHEMATIC	
CHECKED BY:		DWG. NO.	1A10063
DATE:		REV.	B
SCALE: NONE		SHEET 3 OF 9	

NG0146 BLOGETT 02JUN82

APPLICATION DO NOT SCALE DRAWING

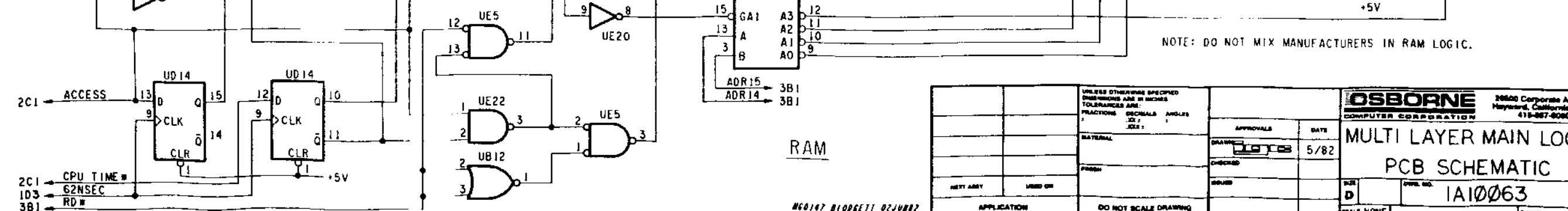
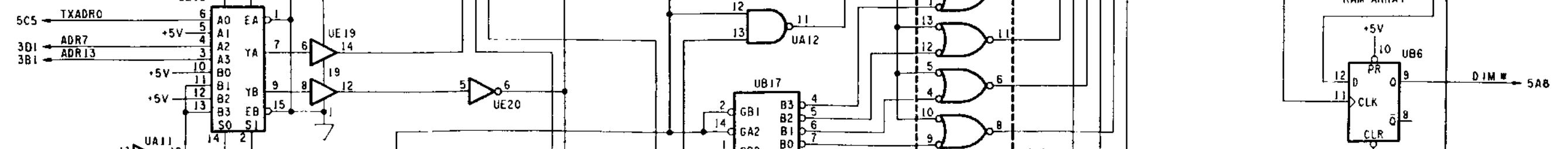
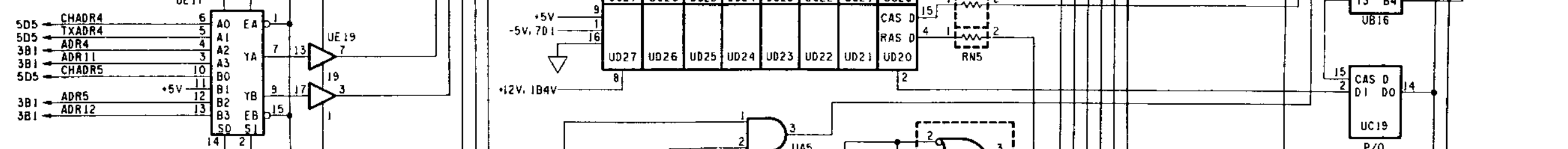
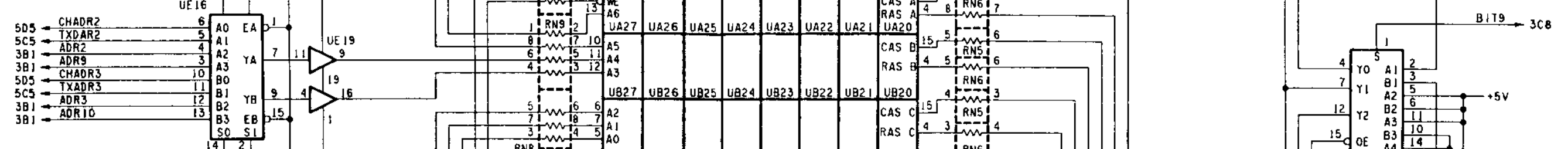
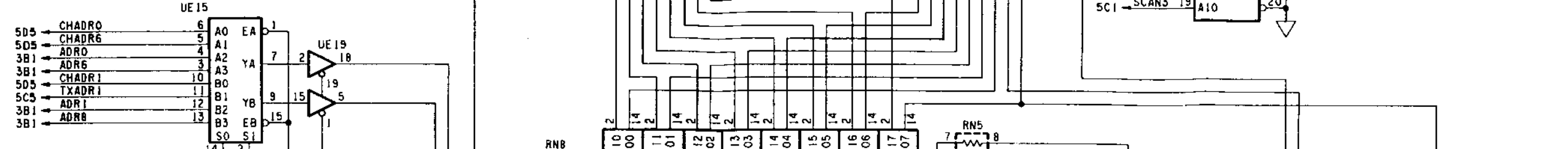
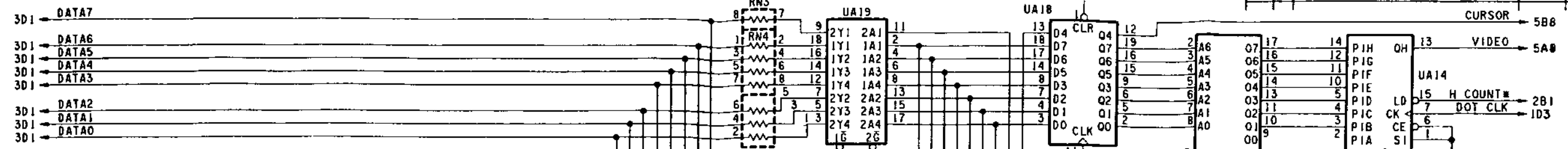

NOTE: DO NOT MIX MANUFACTURERS IN RAM LOGIC.

UNLESS OTHERWISE SPECIFIED DIMENSIONS ARE IN MICRONS TOLERANCES ARE: FRACTIONS DECIMALS ANGLES X.XX .01 .1		<b>OSBORNE</b> COMPUTER CORPORATION 2850 Corporate Avenue Hayward, California 94605 415-887-0080	
APPROVALS	DATE	<b>MULTI LAYER MAIN LOGIC</b> <b>PCB SCHEMATIC</b>	
DRAWN: <i>[Signature]</i>	5/82	REV. NO.	1A10063
CHECKED:		SCALE	NONE
APP.:		PRINT	4 OF 5

RAM

NG0147 BLODGETT 02JUN82



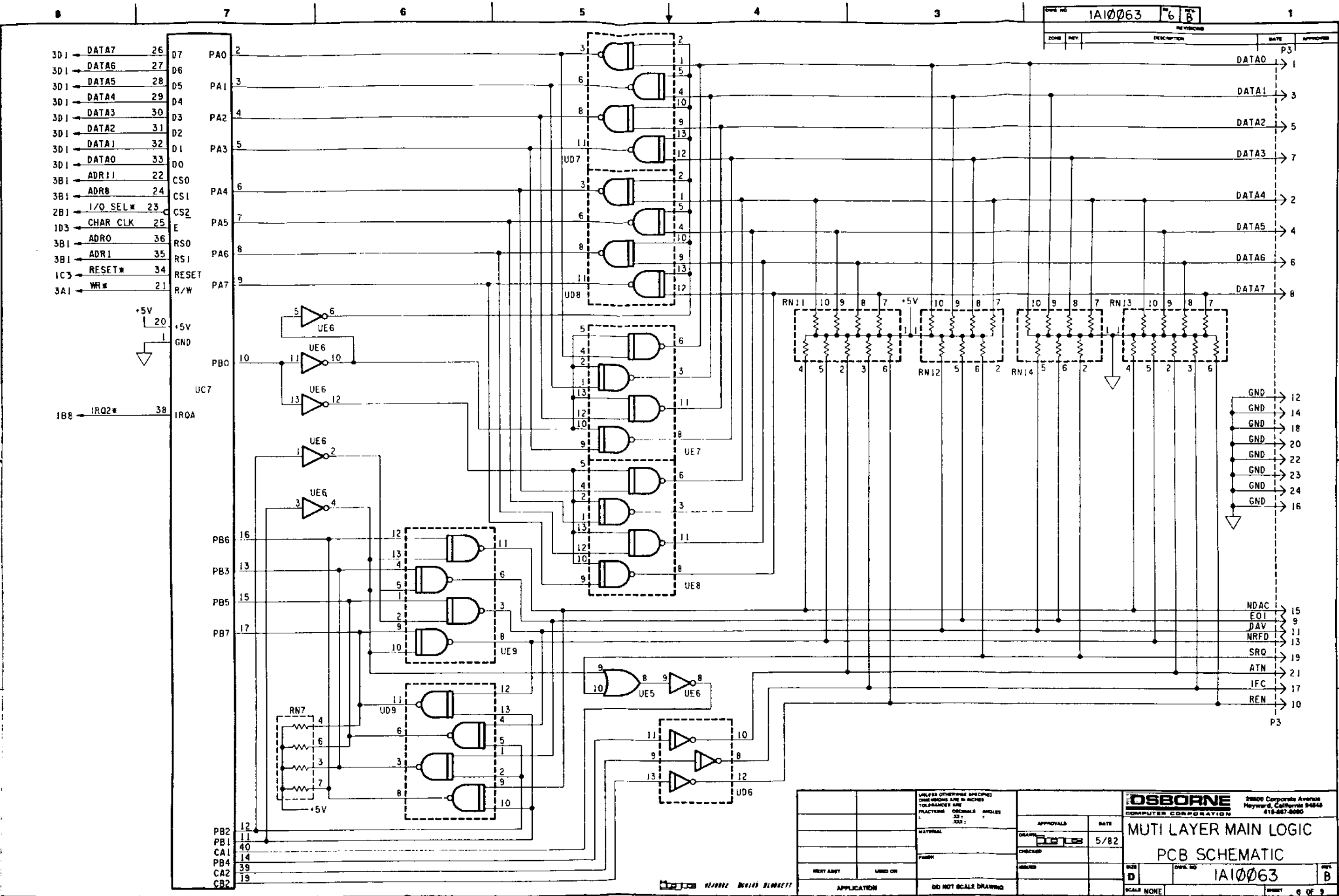

UNLESS OTHERWISE SPECIFIED DIMENSIONS ARE IN INCHES TOLERANCES ARE FRACTIONS DECIMALS ANGLES XX .XX .XX		<b>OSBORNE</b> COMPUTER CORPORATION 28600 Corporate Avenue Hayward, California 94545 415-887-0080	
APPROVALS	DATE	<b>MULTI LAYER MAIN LOGIC</b> <b>PCB SCHEMATIC</b>	
DRAWN: [Signature]	5/82	DWG. NO.	1A10063
CHECKED:		REV.	B
ISSUED:		SCALE	NONE
APPLICATION	DO NOT SCALE DRAWING	SHEET 6 OF 9	



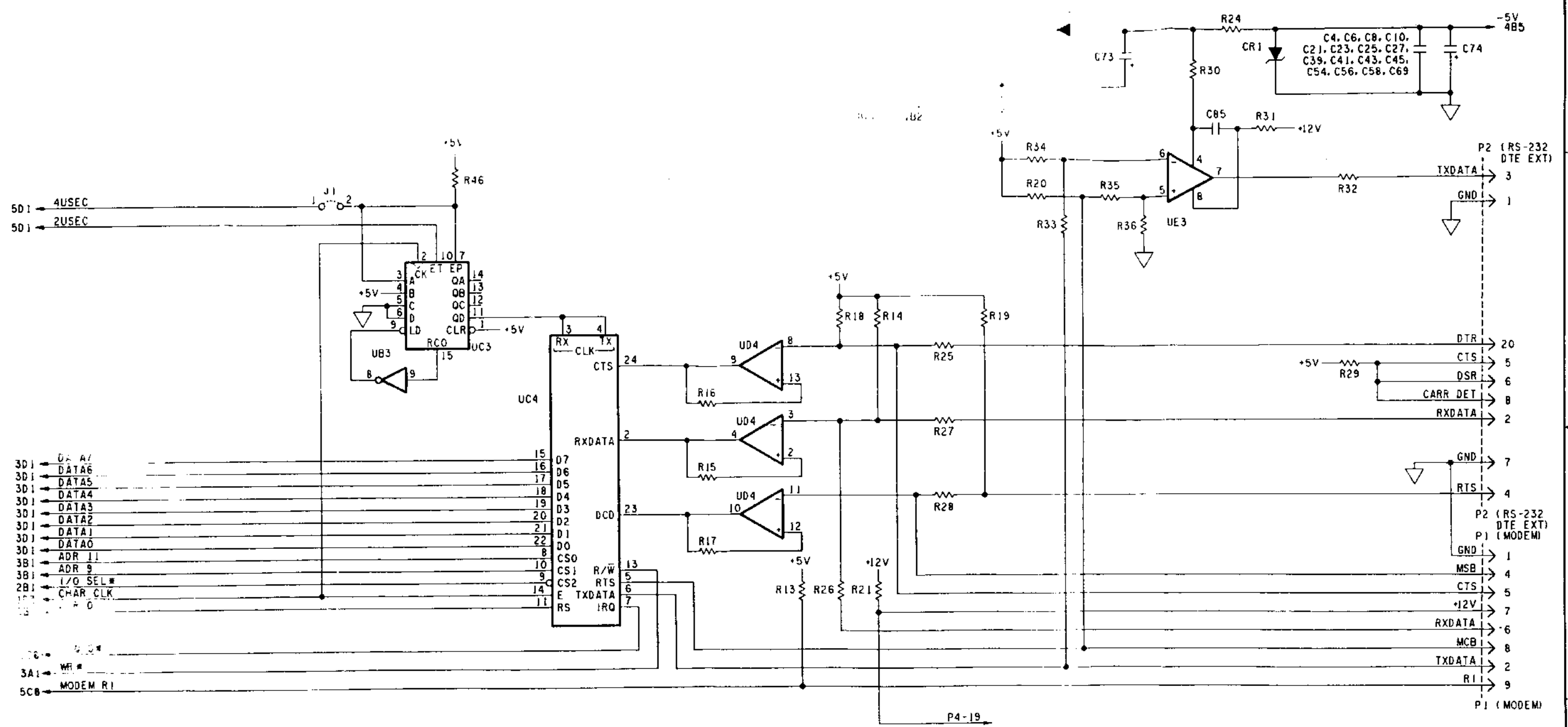

SERIAL I/O

UNLESS OTHERWISE SPECIFIED DIMENSIONS ARE IN INCHES TOLERANCES ARE: FRACTIONS DECIMALS ANGLES 30 0.005 0.005 0.005		APPROVALS		DATE
MATERIAL	DESIGNED	10/81		
FINISH	CHECKED			
NEXT ASSY	USED ON			
APPLICATION		DO NOT SCALE DRAWING		
OSBORNE		28500 Corporate Avenue Hayward, California 94545 415-887-8082		
MULTI LAYER MAIN LOGIC		PCB SCHEMATIC		
REV D	REV NO. 1A10063	REV B		
SCALE NONE	SHEET 7 OF 9			

NG0150 BLODGETT 02JUN82

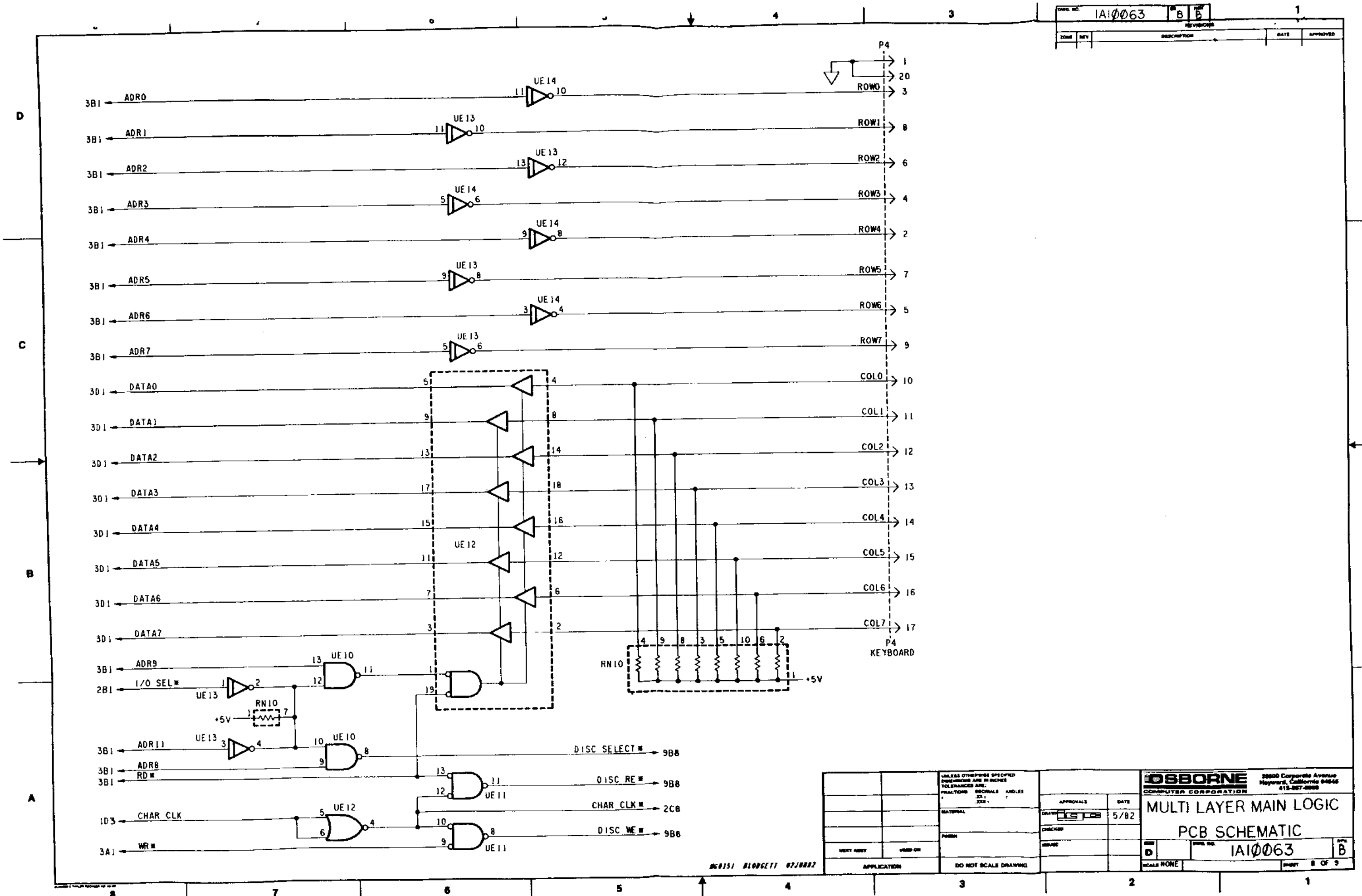

UNLESS OTHERWISE SPECIFIED DIMENSIONS ARE IN INCHES TOLERANCES ARE: FRACTIONS DECIMALS ANGLES ± .010 ± .005 ± .010		<b>OSBORNE</b> 28600 Corporate Avenue Hayward, California 94605 415-887-8888 <b>COMPUTER CORPORATION</b>	
APPROVALS	DATE	MULTI LAYER MAIN LOGIC	
DRAWN: [Signature]	5/82	PCB SCHEMATIC	
CHECKED:		DRAWING NO.	1A10063
DESIGNED:		REV.	B
VERT. ASST.	USED ON:	SCALE	NONE
APPLICATION:	DO NOT SCALE DRAWING	SHEET 8 OF 9	

80151 BLOGETT 07/0882

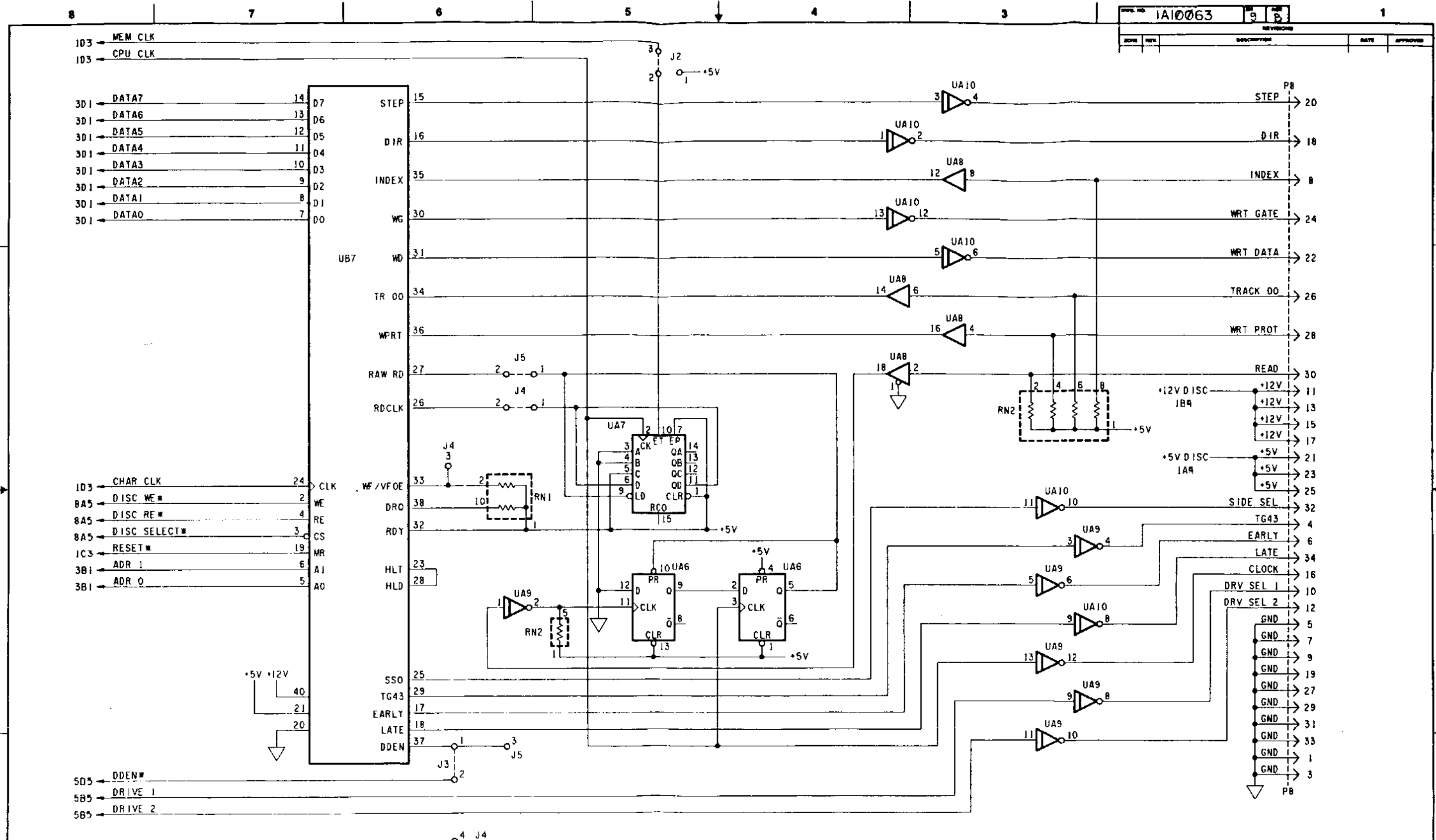

DISC CONTROLLER

860152 BLODGETT 03JUN82

UNLESS OTHERWISE SPECIFIED DIMENSIONS ARE IN INCHES FRACTIONS DECIMALS ANGLES DIP. DIA.		APPROVALS	DATE	<b>OSBORNE</b> 28800 Corporate Avenue Hayward, California 94648 415-887-8000
MATERIAL		DATE	5/82	
FINISH		CHECKED		<b>MULTI LAYER MAIN LOGIC</b> <b>PCB SCHEMATIC</b>
APPLICATION		SCALE		
DESIGN NO.	1A10063	REV.	B	SHEET 3 OF 3
SCALE				

**Appendix 4  
Zenith  
DT4  
7"  
Video  
Monitor  
Service**

# **Appendix 5**

## **Osborne**

### **Executive**

### **Schematics**

REV.	DESCRIPTION	DATE	BY
6	REVISED AND REDRAWN 4-21-83	4/21/83	[Signature]
7	ADDED REWORK	4/27/83	[Signature]
7	PKE PROD REL ECD # 532		
8	CHANGE REF. DESIG. ECD 581		
9	ADD CIRCUIT BETWEEN UE25 & UF25 ECD 587 B/0061543		
10	CHANGE RIB VALUE ECD#603		

**SPARE GATES**

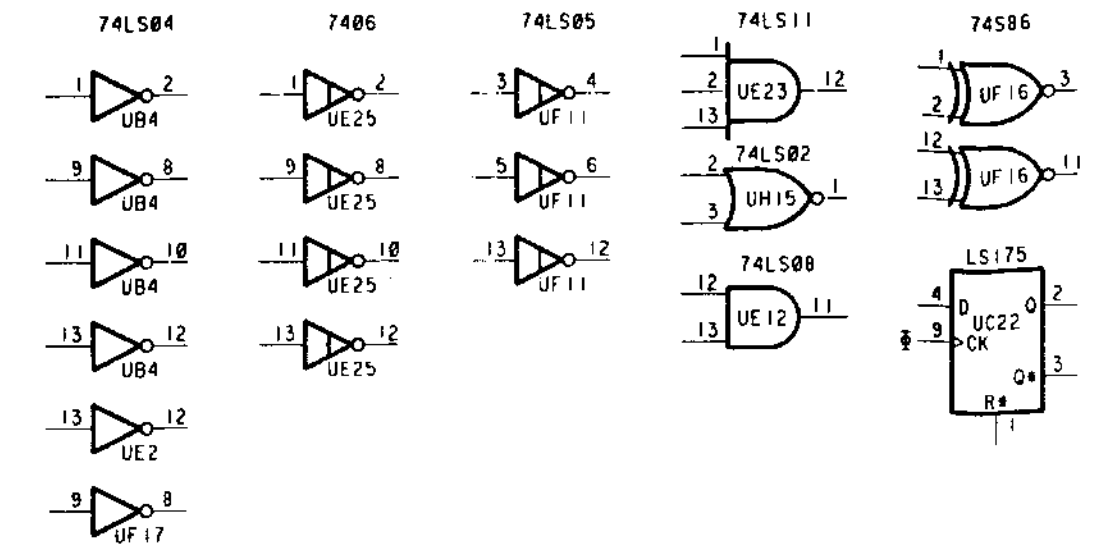

**POWER SUPPLY**

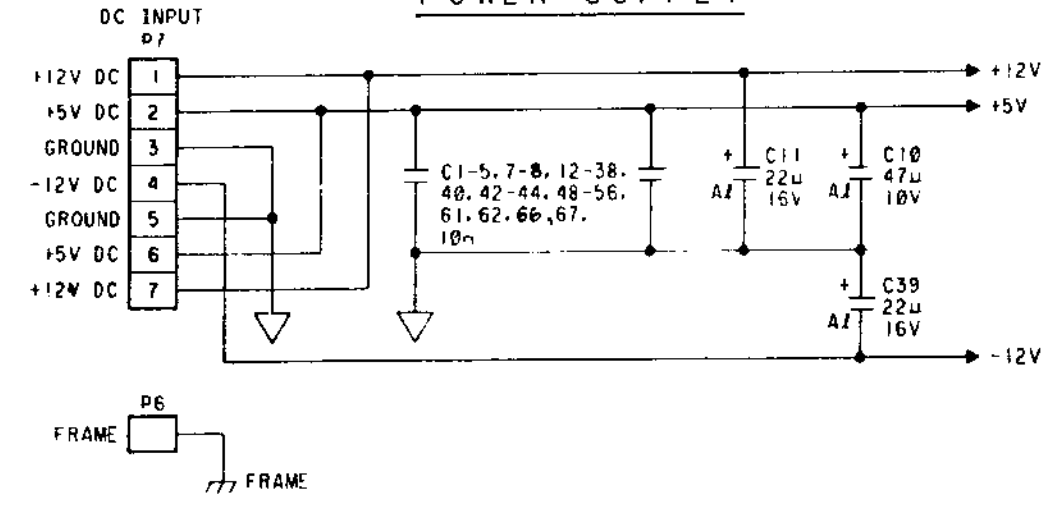

POWER AND GROUND TABLE									
REF. DESIGNATION	TYPE NO.	GND	+5V	+12V	REF. DESIGNATION	TYPE NO.	GND	+5V	+12V
UE13	74LS393	7	14		UC20, UE4, UE20, UE24	74LS00	7	14	
UB23	74S04	7	14		UC21, UE6, UH15	74LS02	7	14	
UB21, UE21, UF15	74S08	7	14		UF8, UF9, UF10	74LS03	7	14	
UC19	74S32	7	14		UB4, UE2, UE7	74LS04	7	14	
UB24, UE22, UE25	74S74	7	14		UE15, UF17, UF19	74LS05	7	14	
UF16	74S86	7	14		UF11, UF14	74LS05	7	14	
UC18, UC25	74S161	8	16		UE12	74LS08	7	14	
UB25	74S175	8	16		UB22, UE18, UF10	74LS10	7	14	
UA6	74S374	10	20		UE23	74LS11	7	14	
UA18, UE25, UF7, UF22	7406	7	14		UE5	74LS20	7	14	
UA19	7407	7	14		UC23, UC24, UE11	74LS74	7	14	
UE8, UE9, UE10	7438	7	14		UE16, UF20, UF21				
UF4, UF5	1488	7	14		UE3	74LS109	8	16	
UF1, UF2, UF6	1489A	7	14		UE14	74LS138	8	16	
UE1	4066	7	14		UA1, UB2, UF17	74LS139	8	16	
UD22	280A-CPU	29	11		UC13	74LS157	8	16	
UB8, UD12	6821	1	20		UC2, UC12, UC14, UC17	74LS161	8	16	
UB17	1793	20	21	40	UA13, UA17	74LS166	8	16	
UD4	280A-S10	31	9		UA8	74LS173	8	16	
UD10	2764	14	28		UC22, UE19	74LS175	8	16	
UD1	8253	12	24		UA7, UA10, UC10				
UA14	9216B	4	8		UC11, UF12, UF13	74LS244	10	20	
UA11, UB12, UD15	6116	14	28		UC1, UC15, UC16	74LS257	8	16	
UA3, UA4	6116	14	28		UA9, UC9	74LS374	10	20	
UC3, UC6	200NS	12	24						

- NOTES: UNLESS OTHERWISE SPECIFIED.
- ALL RESISTANCE VALUES ARE IN OHMS, 1/4W, 5%.
  - ALL RESISTORS 4.7K.
  - ALL CAPACITANCE VALUES IN FARADS.
  - RAMS MUST OPERATE WITH WRITE PULSE WIDTH OF 125 NS.
  - IF UA20 IS USED, OMIT UA14.
  - LOCATIONAL CODING FOR SHEET TO SHEET CONNECTIONS:

REFERENCE DESIGNATION	
LAST	NOT USED
C68	C9, C41
CN2	---
CR7	CR6
J13	J7
P15	P6
R26	R1, R3, R6-R9, R17
RN16	RN10
S1	---
X2	---

INDICATES SHEET NO. (BC6)

INDICATES ZONE ON THE SHEET.

THIS TRACE DOES NOT APPEAR ON BOARD. CONNECTION MUST BE COMPLETED USING JUMPER WIRE.

THIS TRACE MAY NOT BE ON SOME BOARDS, IF IT IS, CUT IT, OTHERWISE IGNORE THIS NOTE.

REV. 01	DATE 3/83	APP'D BY [Signature]	DATE 3/83	OSBORNE COMPUTER CORPORATION
PARTIAL		SCHEMATIC, OCC2 MAIN LOGIC PC BOARD		26530 DAVIS CT, HAYWARD, CALIFORNIA 94545
2K00073	OCC 2	DO NOT SCALE DRAWING	1K00035	10

# OSCILLATOR, CPU, MEMORY AND I/O TIMING

PART NO. 1K00035	REV. 10	DATE
DESCRIPTION SEE SHEET ONE		

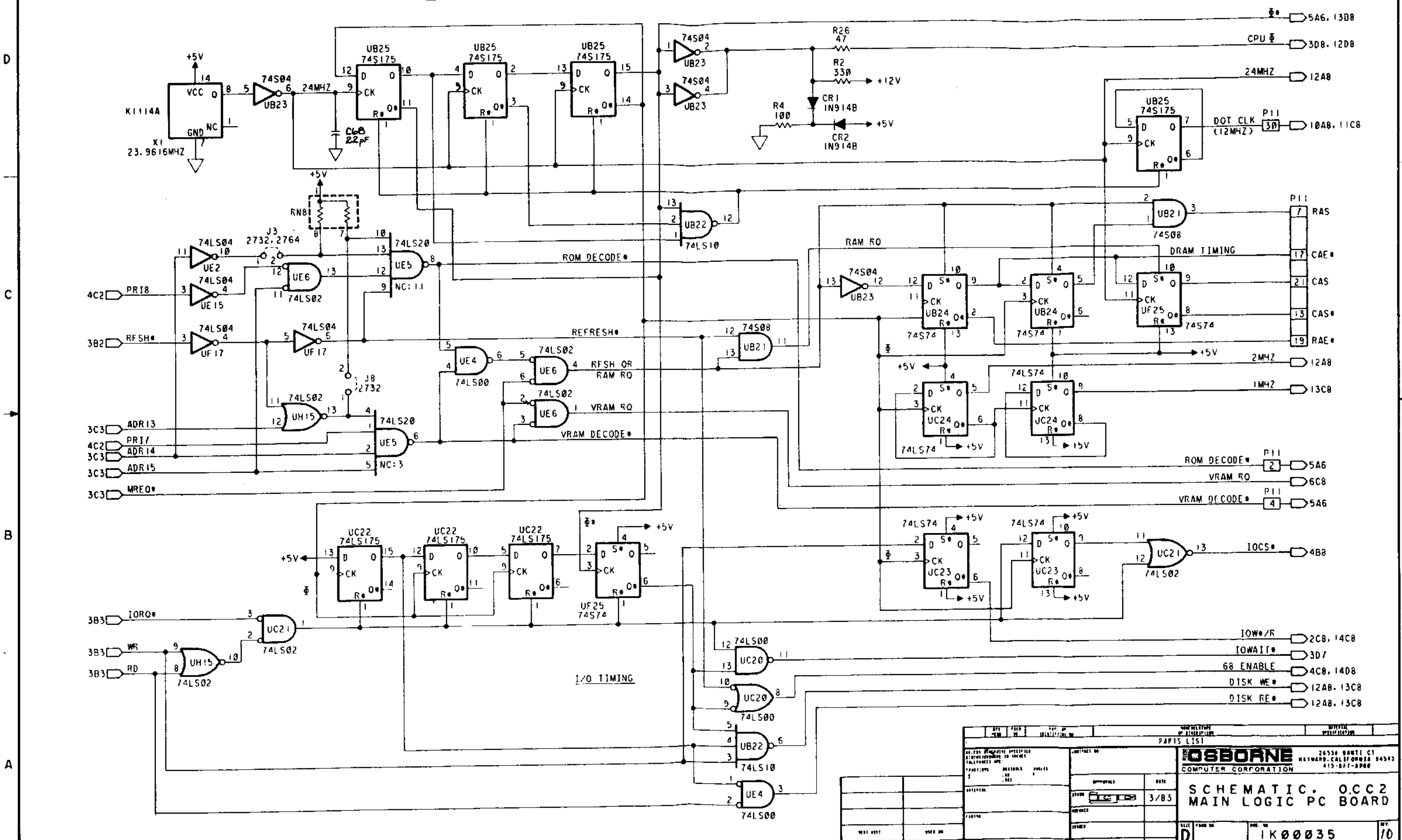

PARTS LIST		DATE: 3/83
<b>OSBORNE</b> COMPUTER CORPORATION		26330 BANTLE CT MILPITAS, CALIFORNIA 95035 415-971-8900
<b>SCHEMATIC, OCC2 MAIN LOGIC PC BOARD</b>		
DRAWN BY: [Signature]	CHECKED BY: [Signature]	DATE: 3/83
PART NO. 1K00035		REV. 10
PAGE 2 OF 15		

18M483 5/5 080128

REV	NO	DESCRIPTION	DATE	APPROVED
	3	SEE SHEET ONE		

# CPU, RESET

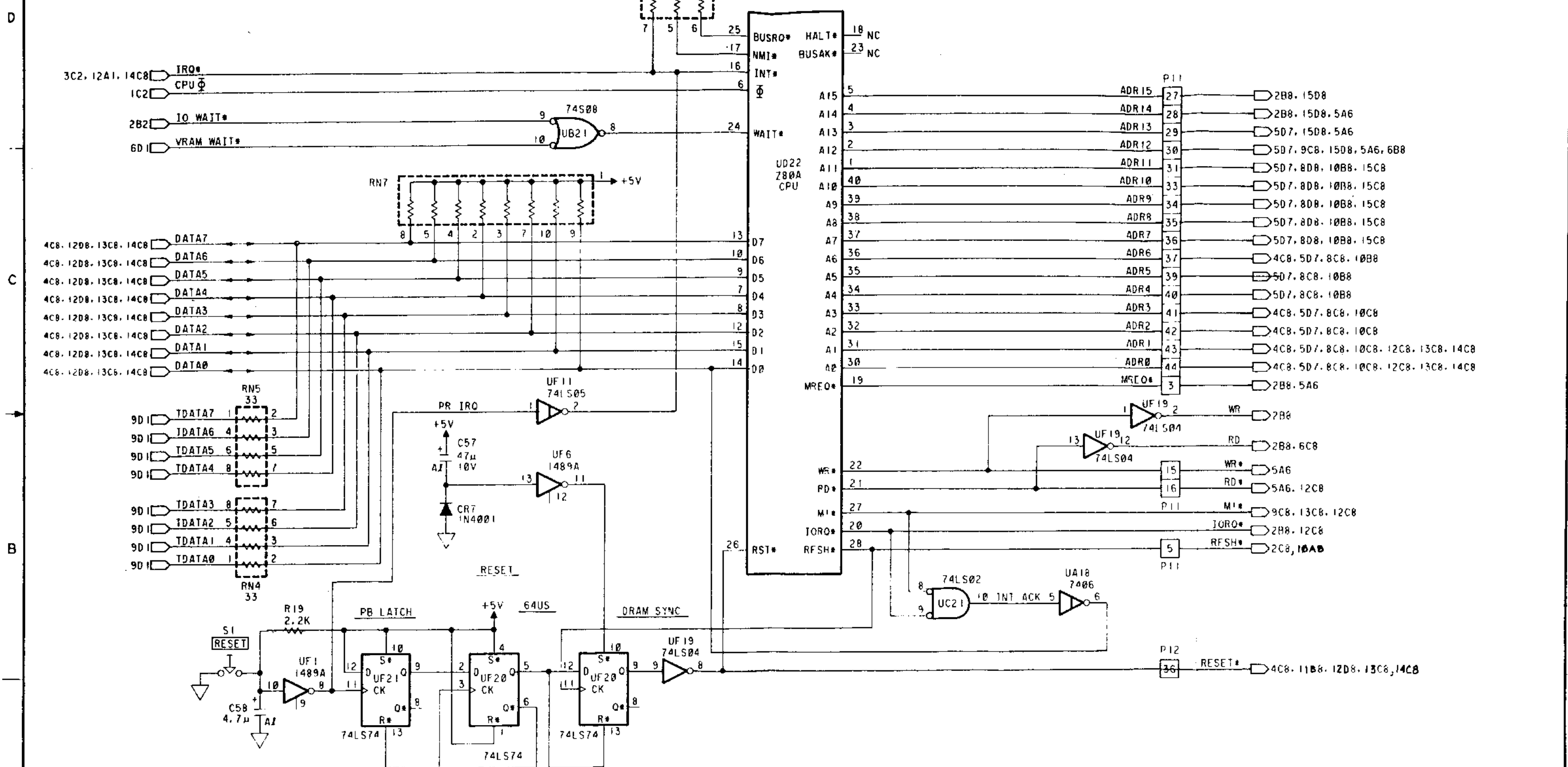

REV	NO	DESCRIPTION	DATE	APPROVED

PARTS LIST		OSBORNE COMPUTER CORPORATION		26530 BAWL CT MAYHURD, CALIFORNIA 94545 415-867-8800	
APPROVED		DATE		3/83	
DRAWN		CHECKED			
TITLE		PART NO		REV	
S1110		IK00035		10	
SCALE		NONE		SHEET 3 OF 15	









### VIDEO TIMING

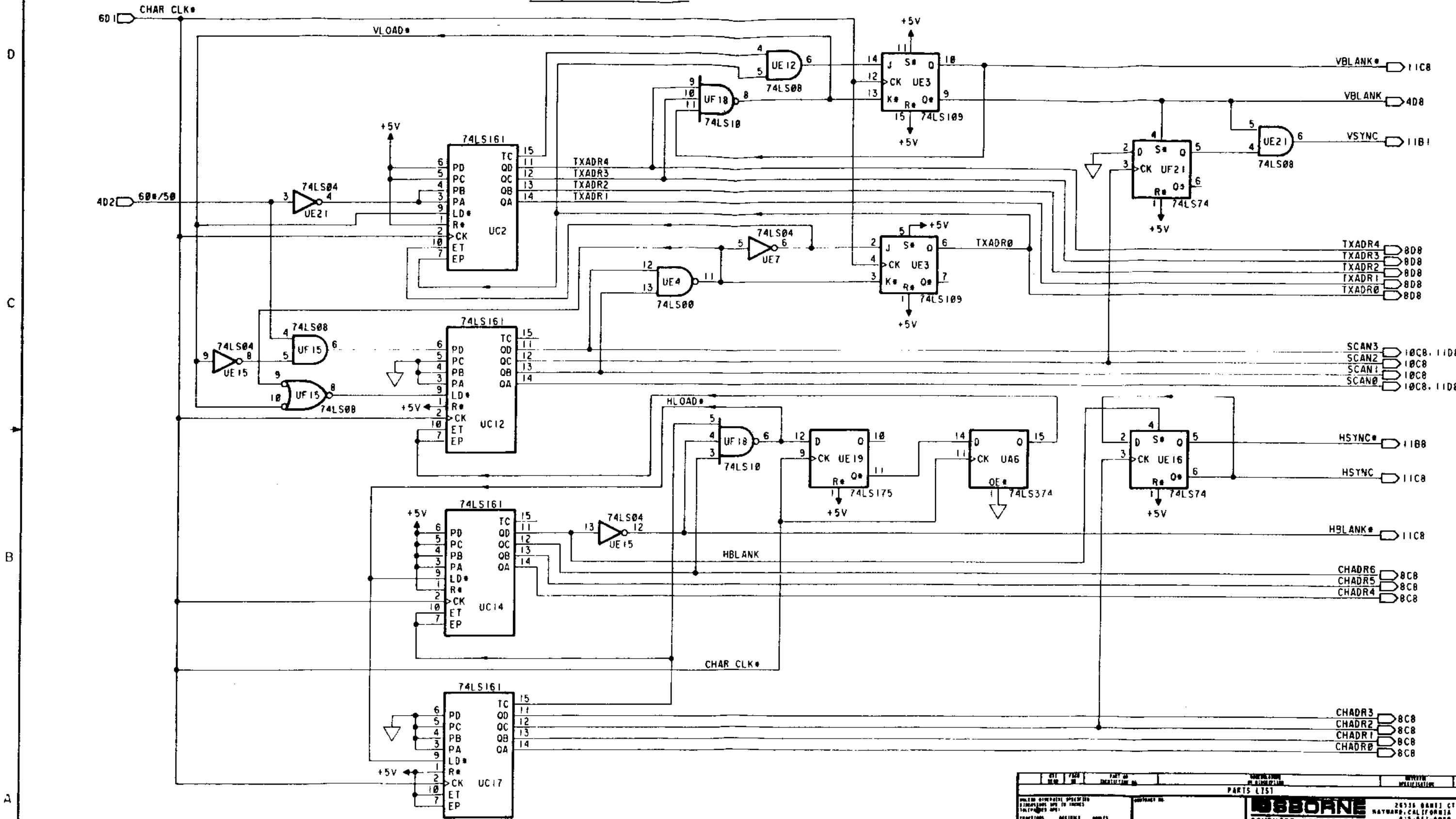

REV. 10		REV. 7		REV. 10	
PARTS LIST					
DATE	REV.	BY	CHKD.	DATE	APPROVED
SEE SHEET ONE					
<b>OSBORNE</b> COMPUTER CORPORATION 2633 BARRI CT HAYWARD, CALIFORNIA 94545 415-887-0900			DATE: 3/83 DRAWN: [Signature] CHECKED: [Signature] TITLE: SCHEMATIC, OCC2 MAIN LOGIC PC BOARD PART NO: 1K00035 REV: 10		
APPLICATION			DO NOT SCALE DRAWING		

### VIDEO ADDRESS MUX

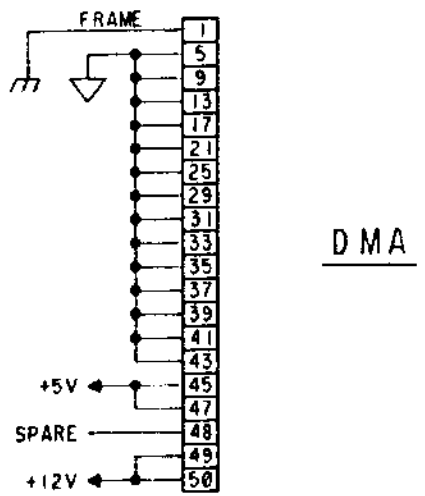
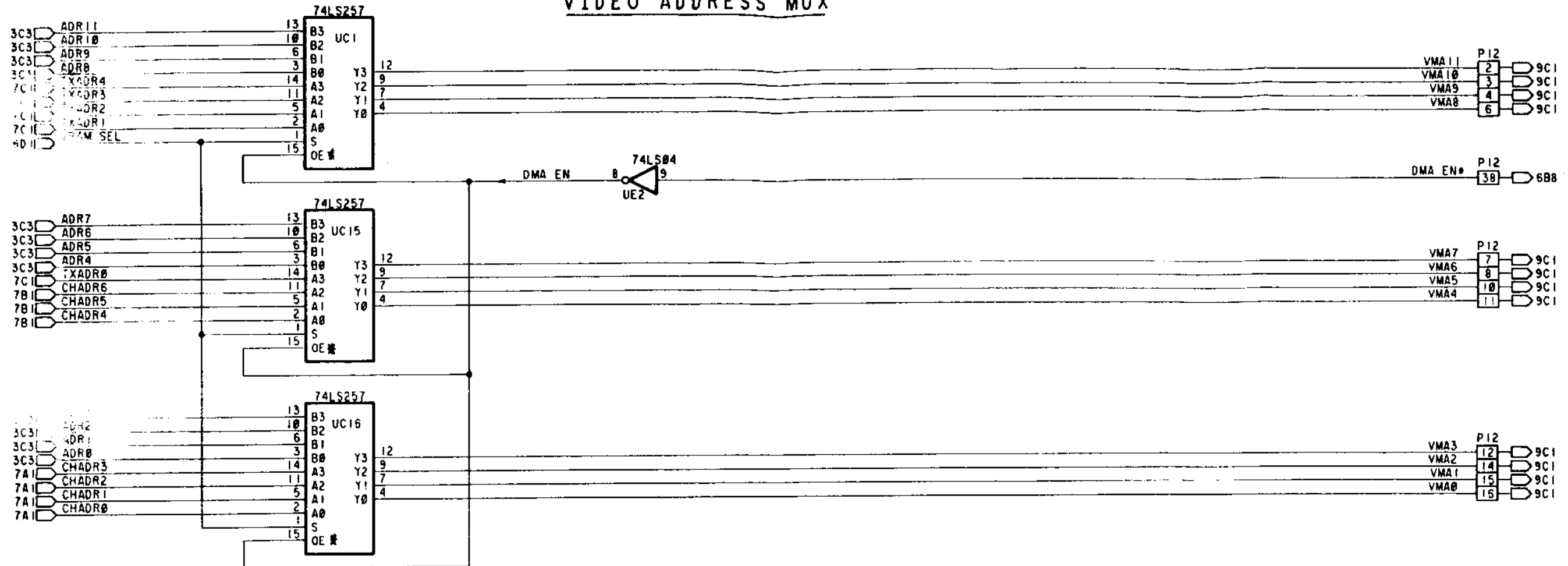

REV. NO. 1K00035		REV. 10		REV. 10	
DATE	REV.	DESCRIPTION	DATE	APPROVED	
		SEE SHEET ONE			
PARIS LIST					
MODEL NO. 1K00035 PART NO. 1K00035 PART NO. 1K00035		PART NO. 1K00035 PART NO. 1K00035		<b>OSBORNE</b> COMPUTER CORPORATION 26550 BARTI CT HAYWARD, CALIFORNIA 94543 415-887-0000	
DATE: 3/83 DRAWN: [Signature] CHECKED: [Signature]		DATE: 3/83 DRAWN: [Signature] CHECKED: [Signature]		SCHEMATIC, OCC2 MAIN LOGIC PC BOARD	
SIZE: D PART: NONE		PART: NONE PART: NONE		1K00035 8 OF 15	

# VIDEO RAM

REV. NO. 1K00035	REV. 3	REV. 10	
DATE		APPROVED	
SEE SHEET ONE			

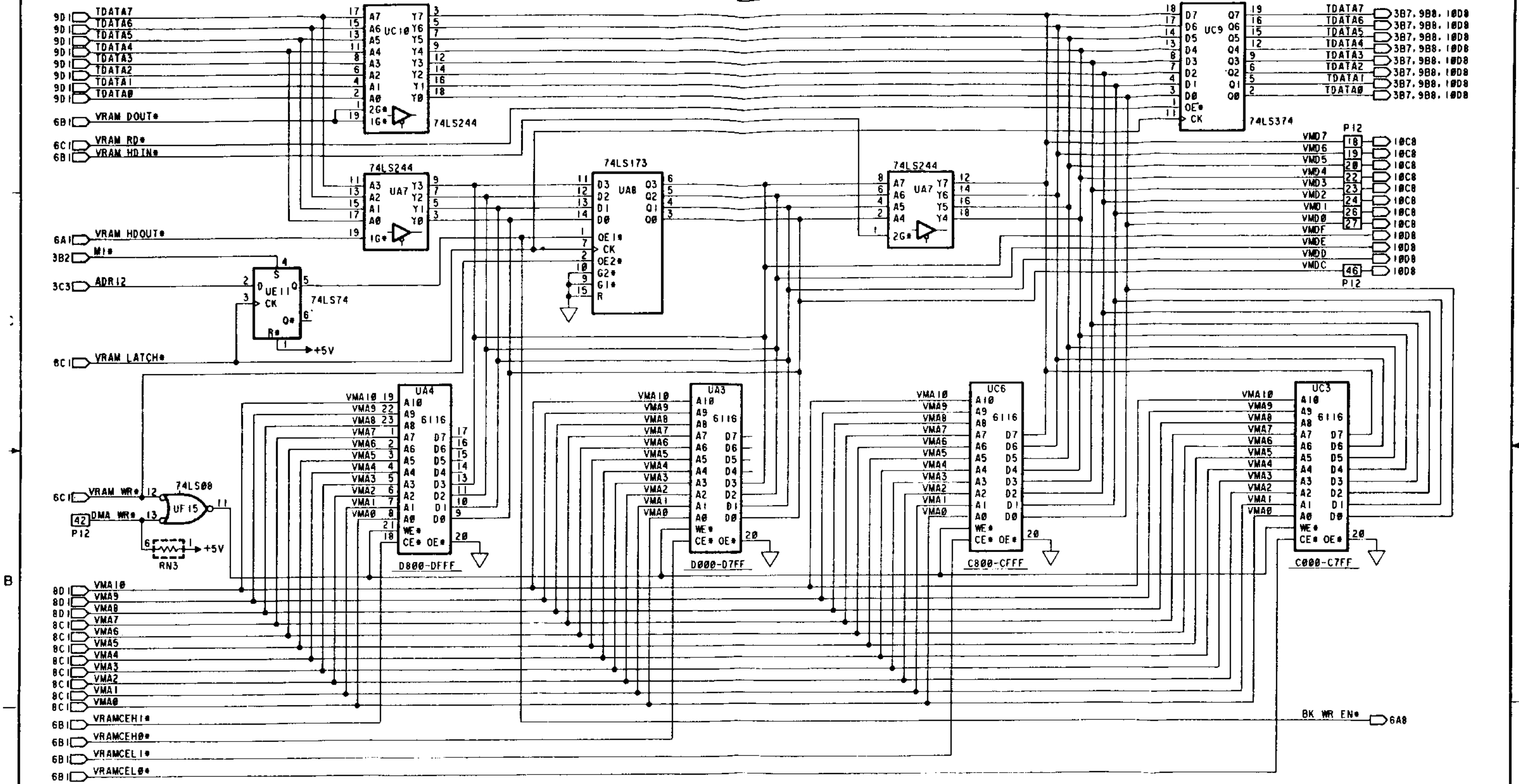

PARTS LIST																									
<table border="1" style="width: 100%; border-collapse: collapse;"> <tr> <th>QTY</th> <th>UOM</th> <th>PART NO.</th> <th>DESCRIPTION</th> <th>REVISION</th> </tr> <tr> <td> </td> <td> </td> <td> </td> <td> </td> <td> </td> </tr> </table>				QTY	UOM	PART NO.	DESCRIPTION	REVISION						<table border="1" style="width: 100%; border-collapse: collapse;"> <tr> <td colspan="2" style="text-align: center;"><b>OSBORNE</b></td> <td colspan="2" style="text-align: right;">26530 BARTLE CT MAYNARD, CALIFORNIA 94543 415-887-8800</td> </tr> <tr> <td colspan="4" style="text-align: center;">COMPUTER CORPORATION</td> </tr> </table>				<b>OSBORNE</b>		26530 BARTLE CT MAYNARD, CALIFORNIA 94543 415-887-8800		COMPUTER CORPORATION			
QTY	UOM	PART NO.	DESCRIPTION	REVISION																					
<b>OSBORNE</b>		26530 BARTLE CT MAYNARD, CALIFORNIA 94543 415-887-8800																							
COMPUTER CORPORATION																									
<table border="1" style="width: 100%; border-collapse: collapse;"> <tr> <td>APPROVED</td> <td>DATE</td> </tr> <tr> <td> </td> <td>3/83</td> </tr> </table>				APPROVED	DATE		3/83	<table border="1" style="width: 100%; border-collapse: collapse;"> <tr> <td colspan="2" style="text-align: center;">SCHEMATIC, OCC2</td> </tr> <tr> <td colspan="2" style="text-align: center;">MAIN LOGIC PC BOARD</td> </tr> </table>				SCHEMATIC, OCC2		MAIN LOGIC PC BOARD											
APPROVED	DATE																								
	3/83																								
SCHEMATIC, OCC2																									
MAIN LOGIC PC BOARD																									
<table border="1" style="width: 100%; border-collapse: collapse;"> <tr> <td>REV. NO.</td> <td>REV. NO.</td> <td>REV. NO.</td> <td>REV. NO.</td> </tr> <tr> <td> </td> <td> </td> <td> </td> <td> </td> </tr> </table>				REV. NO.	REV. NO.	REV. NO.	REV. NO.					<table border="1" style="width: 100%; border-collapse: collapse;"> <tr> <td>REV. NO.</td> <td>REV. NO.</td> <td>REV. NO.</td> <td>REV. NO.</td> </tr> <tr> <td> </td> <td> </td> <td> </td> <td> </td> </tr> </table>				REV. NO.	REV. NO.	REV. NO.	REV. NO.						
REV. NO.	REV. NO.	REV. NO.	REV. NO.																						
REV. NO.	REV. NO.	REV. NO.	REV. NO.																						
<table border="1" style="width: 100%; border-collapse: collapse;"> <tr> <td> </td> <td> </td> <td> </td> <td> </td> </tr> </table>								<table border="1" style="width: 100%; border-collapse: collapse;"> <tr> <td> </td> <td> </td> <td> </td> <td> </td> </tr> </table>																	
APPLICATION				DO NOT SCALE DRAWING																					
18MAR83 5:25 080135				1K00035																					

# FONT RAM

REV.	10	DATE	10/10
SEE SHEET ONE			

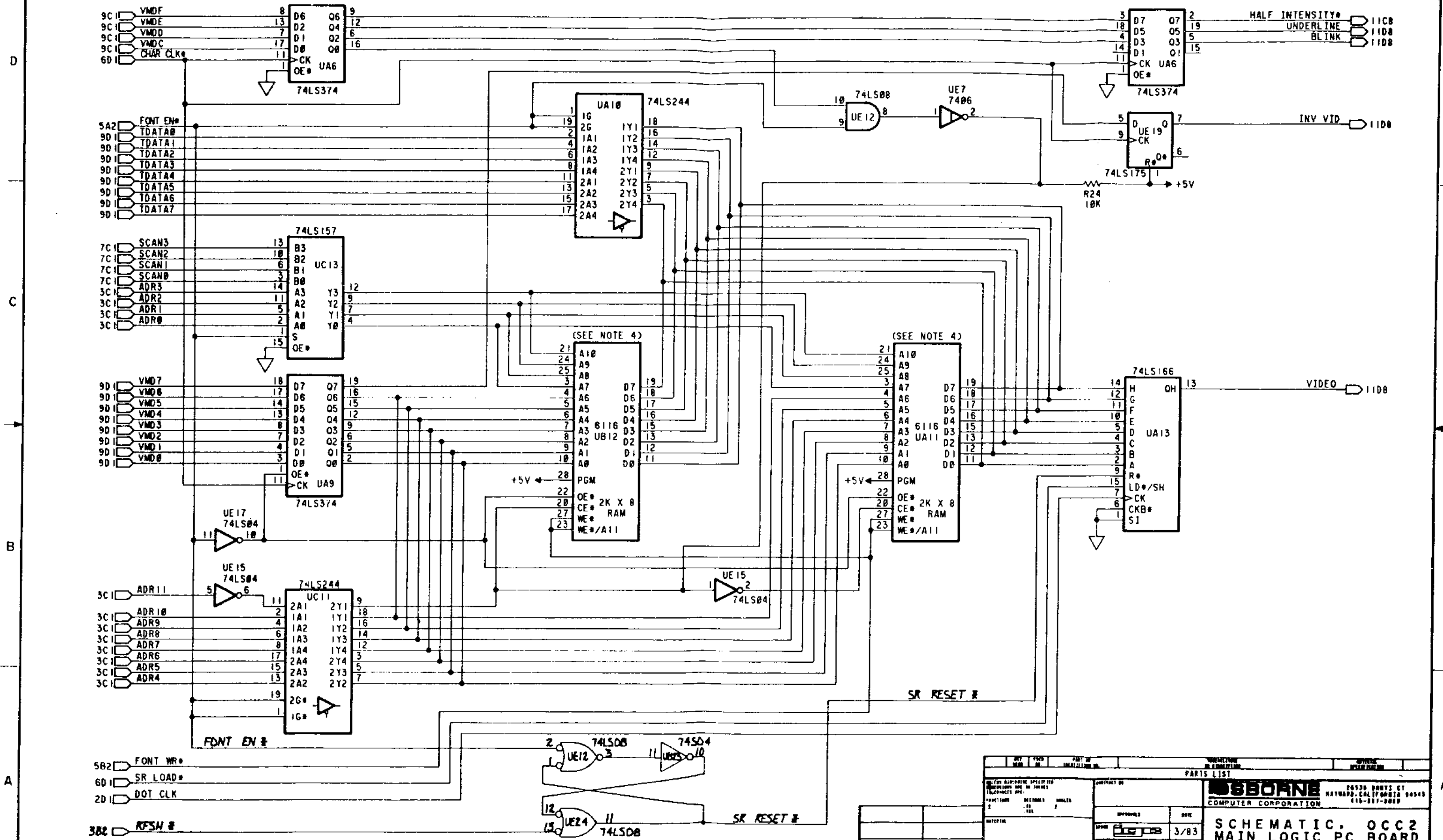

PARTS LIST		DATE	
QTY	DESCRIPTION	REV.	DATE
<b>OSBORNE</b> COMPUTER CORPORATION 26536 BERRY ST KATYUARD, CALIFORNIA 94543 415-897-9889		APPROVED: <b>OSBORNE</b> DATE: 3/83	
SCHEMATIC, OCC2 MAIN LOGIC PC BOARD		FILE NO: <b>1K00035</b> REV: <b>10</b>	





REV	DATE	DESCRIPTION	BY	APPROVED
1		SEE SHEET ONE		

### SERIAL I/O

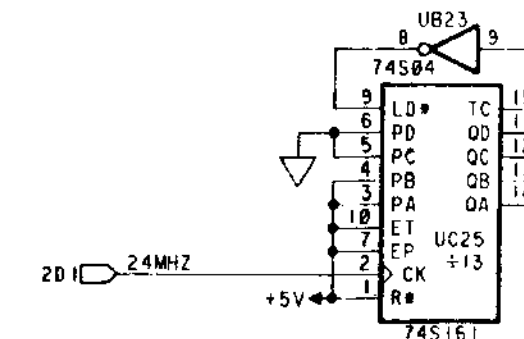
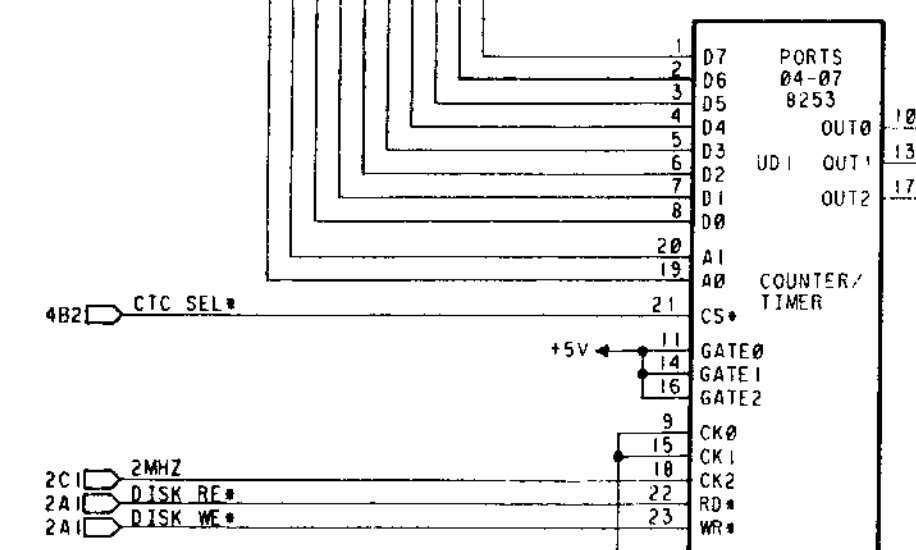
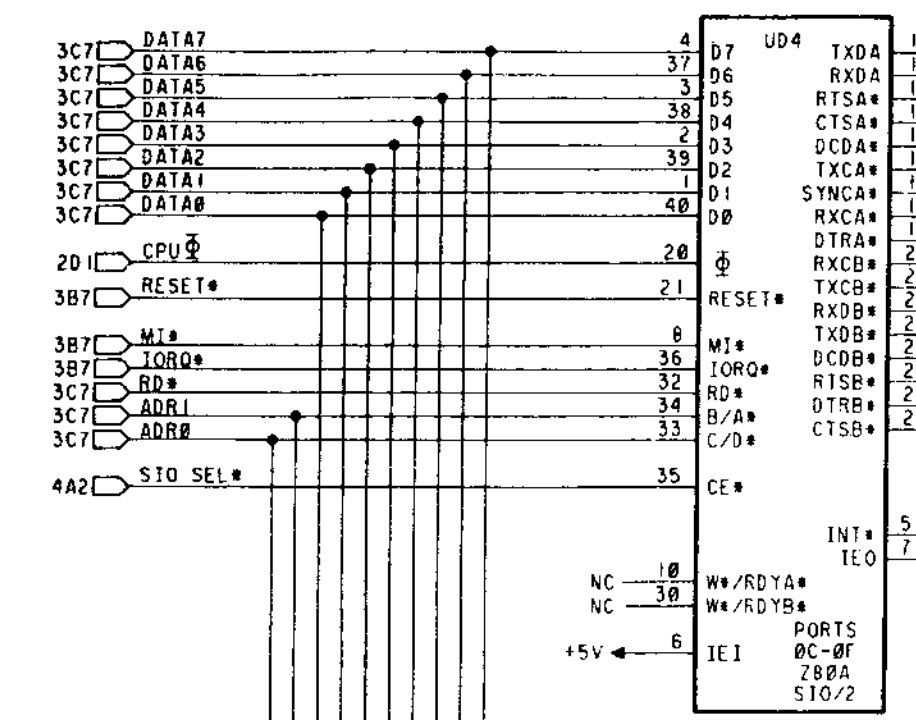
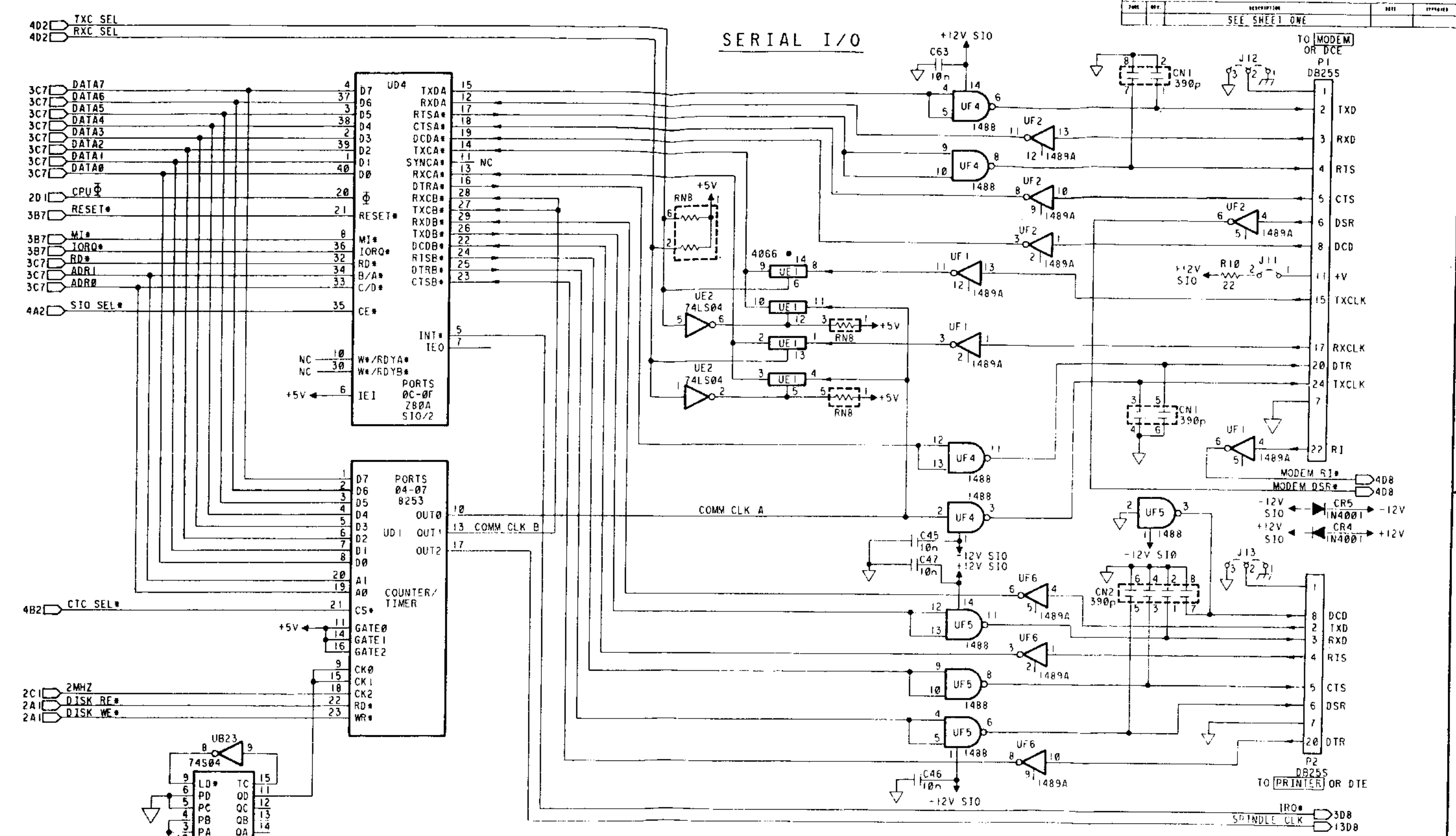

OSBORNE COMPUTER CORPORATION 2655A PARTS CT MAYNARD, CALIFORNIA 94543 415-877-8888		DATE: 3/83 SCALE: NONE SHEET: 12 OF 15
SCHEMATIC, OCC2 MAIN LOGIC PC BOARD		PARTS LIST 1K00035 10

18MAR83 SJS OBO138

### FDC INTERFACE

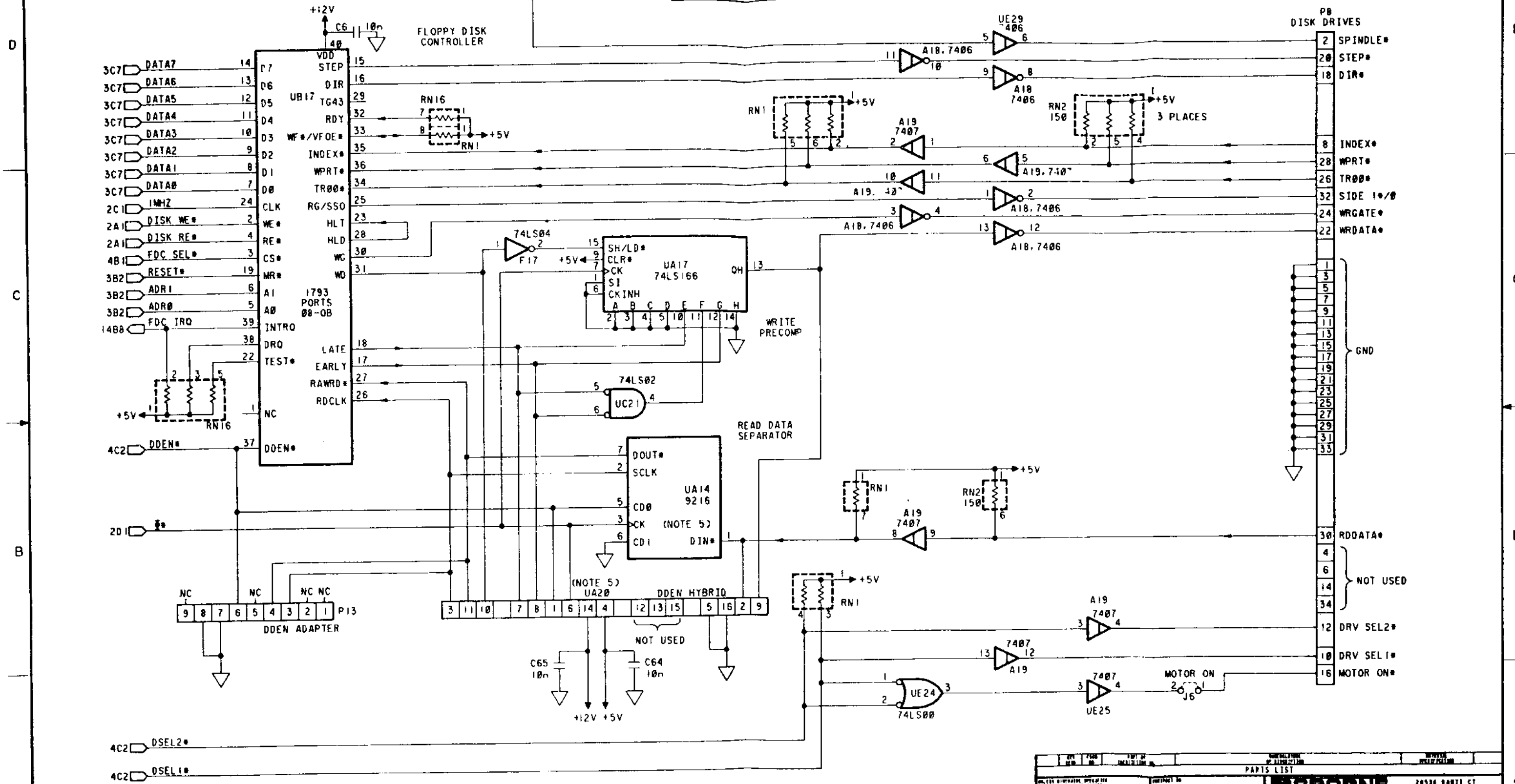

PARTS LIST		APPROVALS	
QTY	PART NO.	DATE	BY
<b>OSBORNE</b> COMPUTER CORPORATION 20520 BARTI CT HAYWARD, CALIFORNIA 94545 415-887-8888		DATE: 3/83 DRAWN: [Signature] CHECKED: [Signature]	
TITLE: SCHEMATIC, OCC2 MAIN LOGIC PC BOARD FILE NO: 1K00035 SHEET: 13 OF 15		DATE: 3/83 DRAWN: [Signature] CHECKED: [Signature]	

# 488 / PARALLEL INTERFACE

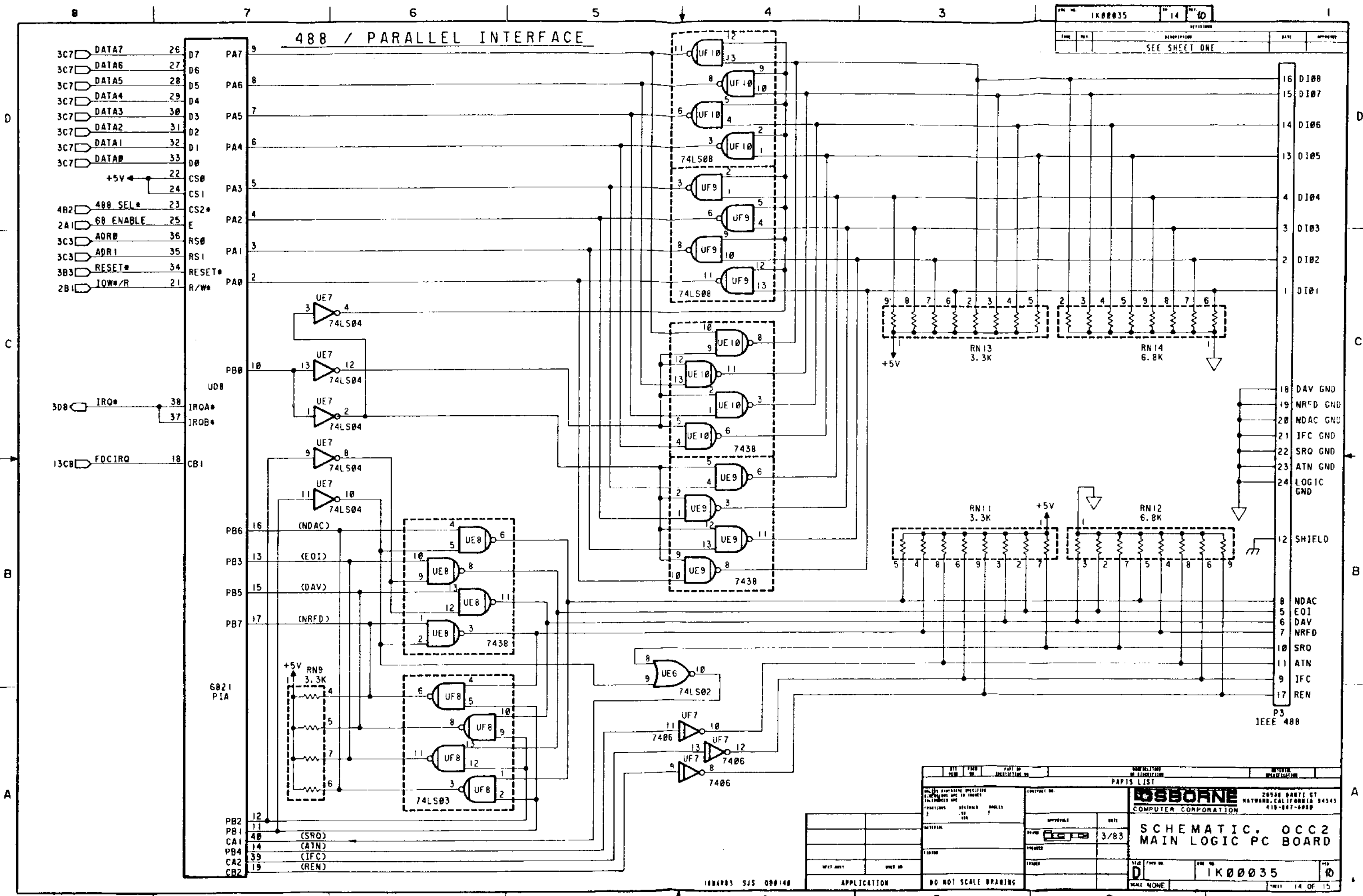

- 3C7 DATA7 26 D7 PA7 9
- 3C7 DATA6 27 D6 PA6 8
- 3C7 DATA5 28 D5 PA5 7
- 3C7 DATA4 29 D4 PA4 6
- 3C7 DATA3 30 D3 PA3 5
- 3C7 DATA2 31 D2 PA2 4
- 3C7 DATA1 32 D1 PA1 3
- 3C7 DATA0 33 D0 PA0 2
- +5V 22 CS0 PA3 5
- 24 CS1 PA3 5
- 4B2 488 SEL\* 23 CS2\* PA2 4
- 2A1 68 ENABLE 25 E PA2 4
- 3C3 ADR0 36 RS0 PA1 3
- 3C3 ADR1 35 RS1 PA1 3
- 3B3 RESET# 34 RESET# PA0 2
- 2B1 IQW#/R 21 R/W# PA0 2

- 3D8 IRQ# 38 IROA# U08 10
- 37 IROB# U08 10
- 13CB FDCIRQ 18 CB1 18

- PB6 16 (NDAC)
- PB3 13 (EOI)
- PB5 15 (DAV)
- PB7 17 (NRFD)

- PB2 12 (SRQ)
- PB1 11 (ATN)
- CA1 14 (IFC)
- PB4 39 (IFC)
- CA2 19 (REN)
- CB2 12

- 16 DIO8
- 15 DIO7
- 14 DIO6
- 13 DIO5
- 4 DIO4
- 3 DIO3
- 2 DIO2
- 1 DIO1
- 18 DAV GND
- 19 NRD GND
- 20 NDAC GND
- 21 IFC GND
- 22 SRQ GND
- 23 ATN GND
- 24 LOGIC GND
- 12 SHIELD
- 8 NDAC
- 5 EOI
- 6 DAV
- 7 NRFD
- 10 SRQ
- 11 ATN
- 9 IFC
- 17 REN

PAPER LIST OSBORNE COMPUTER CORPORATION		28556 DANTE CT HAYWARD, CALIFORNIA 94545 415-887-8888	
SCHEMATIC, OCC 2 MAIN LOGIC PC BOARD		DATE: 3/83 DRAWN: [Signature] CHECKED: [Signature]	
P1: [ ] P2: [ ] P3: [ ] P4: [ ] P5: [ ] P6: [ ] P7: [ ] P8: [ ] P9: [ ] P10: [ ] P11: [ ] P12: [ ] P13: [ ] P14: [ ] P15: [ ] P16: [ ] P17: [ ] P18: [ ] P19: [ ] P20: [ ] P21: [ ] P22: [ ] P23: [ ] P24: [ ] P25: [ ] P26: [ ] P27: [ ] P28: [ ] P29: [ ] P30: [ ] P31: [ ] P32: [ ] P33: [ ] P34: [ ] P35: [ ] P36: [ ] P37: [ ] P38: [ ] P39: [ ] P40: [ ] P41: [ ] P42: [ ] P43: [ ] P44: [ ] P45: [ ] P46: [ ] P47: [ ] P48: [ ] P49: [ ] P50: [ ]		1K00035 10 14 OF 15	

# KEYBOARD INTERFACE

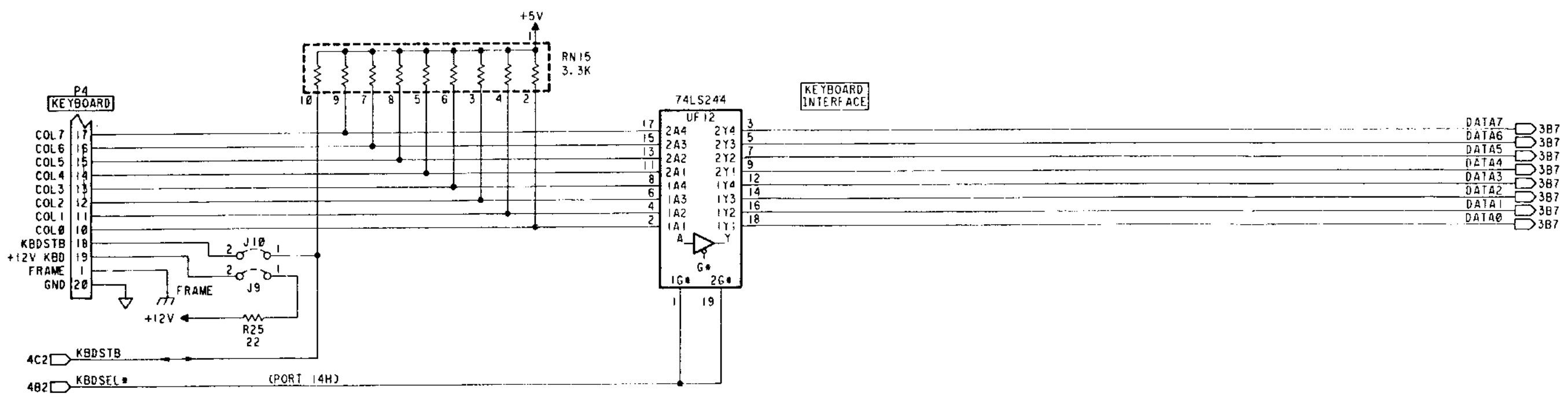
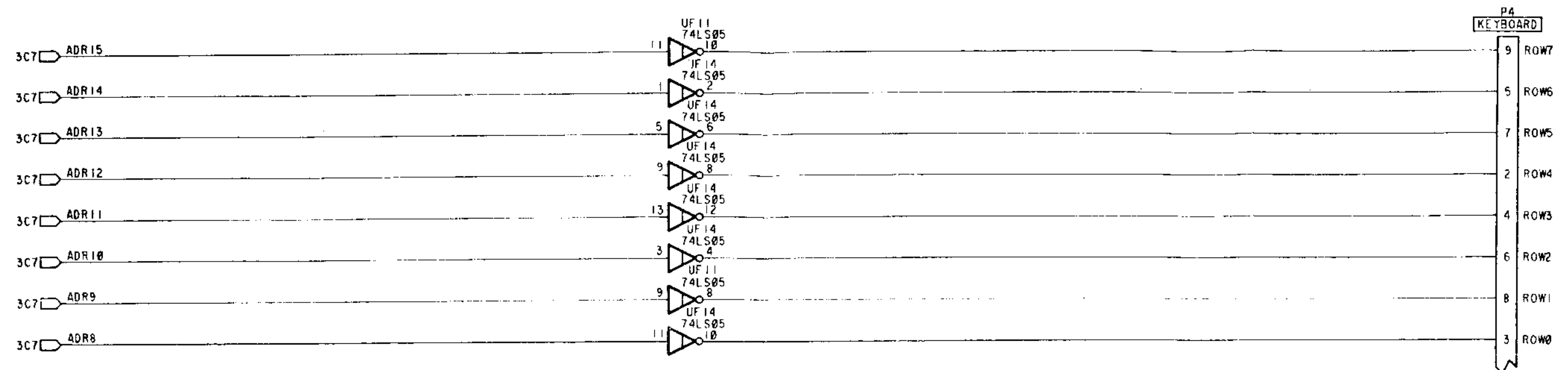

PART NO		REV		DATE		DESCRIPTION		BY		APPROVE					
1K00035		15		10		SEE SHEET ONE									
PARIS LIST															
OSBORNE COMPUTER CORPORATION 26538 BARTIS CT HAYWARD, CALIFORNIA 94545 415-887-1000						SCHEMATIC, OCC2 MAIN LOGIC PC BOARD									
DATE				3/83				REV				10			
PART NO				1K00035				REV				10			
REV				15 OF 15											