

HEATHKIT[®] MANUAL

for the

VIDEO TERMINAL

Model H9

ASSEMBLY

595-1996-05

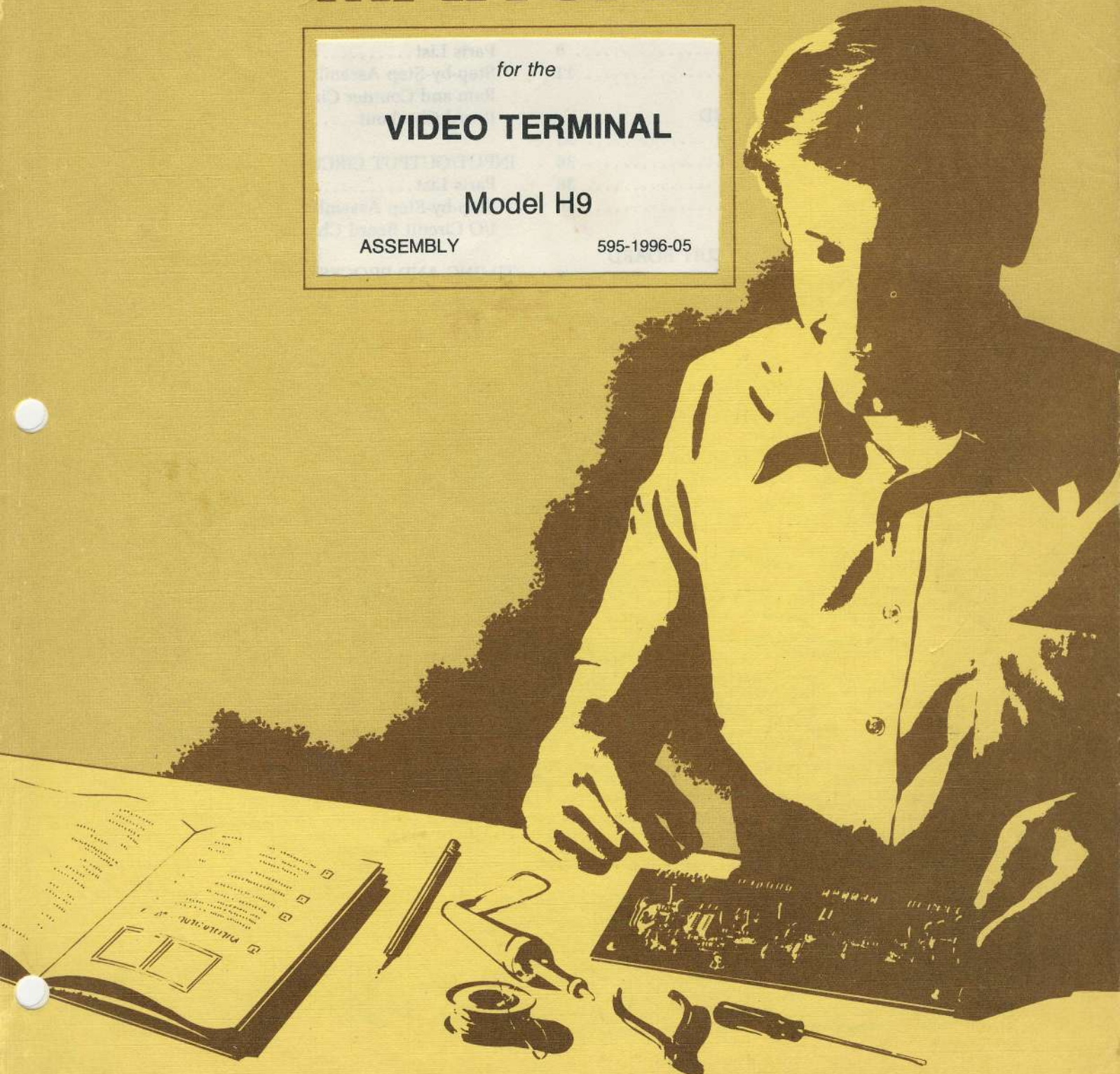

HEATH COMPANY • BENTON HARBOR, MICHIGAN

HEATH COMPANY PHONE DIRECTORY

The following telephone numbers are direct lines to the departments listed:

Kit orders and delivery information (616) 982-3411
Credit (616) 982-3561
Replacement Parts (616) 982-3571

Technical Assistance Phone Numbers

8:00 A.M. to 12 P.M. and 1:00 P.M. to 4:30 P.M., EST, Weekdays Only
R/C, Audio, and Electronic Organs (616) 982-3310
Amateur Radio (616) 982-3296
Test Equipment, Weather Instruments and
Home Clocks (616) 982-3315
Television (616) 982-3307
Aircraft, Marine, Security, Scanners, Automotive,
Appliances and General Products (616) 982-3496
Computers (616) 982-3309



YOUR HEATHKIT 90 DAY LIMITED WARRANTY

If you are not satisfied with our service - warranty or otherwise - or with our products, write directly to our Director of Customer Services, Heath Company, Benton Harbor, Michigan 49022. He will make certain your problems receive immediate, personal attention.

Our attorney, who happens to be quite a kitbuilder himself, insists that we describe our warranty using all the necessary legal phrases in order to comply with the new warranty regulations. Fine. Here they are:

For a period of ninety (90) days after purchase, Heath Company will replace or repair free of charge any parts that are defective either in materials or workmanship. You can obtain parts directly from Heath Company by writing us at the address below or by telephoning us at (616) 982-3571. And we'll pay shipping charges to get those parts to you — anywhere in the world.

We warrant that during the first ninety (90) days after purchase, our products, when correctly assembled, calibrated, adjusted and used in accordance with our printed instructions, will meet published specifications.

If a defective part or error in design has caused your Heathkit product to malfunction during the warranty period through no fault of yours, we will service it free upon proof of purchase and delivery at your expense to the Heath factory, any Heathkit Electronic Center (units of Schlumberger Products Corporation), or any of our authorized overseas distributors.

You will receive free consultation on any problem you might encounter in the assembly or use of your Heathkit product. Just drop us a line or give us a call. Sorry, we cannot accept collect calls.

Our warranty does not cover and we are not responsible for damage caused by the use of corrosive solder, defective tools, incorrect assembly, misuse, fire, or by unauthorized modifications to or uses of our products for purposes other than as advertised. Our warranty does not include reimbursement for customer assembly or set-up time.

This warranty covers only Heathkit products and is not extended to allied equipment or components used in conjunction with our products. **We are not responsible for incidental or consequential damages.** Some states do not allow the exclusion or limitation of incidental or consequential damages, so the above limitation or exclusion may not apply to you. This warranty gives you specific legal rights, and you may also have other rights which vary from state to state.

HEATH COMPANY
BENTON HARBOR, MI. 49022

Heathkit® Manual

for the

VIDEO TERMINAL

Model H9

ASSEMBLY

595-1996-05



HEATH COMPANY
BENTON HARBOR, MICHIGAN 49022

Copyright © 1977
Heath Company
All Rights Reserved
Printed in the United States of America



TABLE OF CONTENTS

<p>INTRODUCTION 3</p> <p>UNPACKING 4</p> <p>CHASSIS</p> <p style="padding-left: 20px;">Parts List 5</p> <p style="padding-left: 20px;">Assembly Notes 8</p> <p style="padding-left: 20px;">Step-by-Step Assembly 11</p> <p>POWER SUPPLY CIRCUIT BOARD</p> <p style="padding-left: 20px;">Parts List 33</p> <p style="padding-left: 20px;">Assembly Notes 36</p> <p style="padding-left: 20px;">Step-by-Step Assembly 38</p> <p style="padding-left: 20px;">Power Supply Checkout 46</p> <p>CHARACTER GENERATOR CIRCUIT BOARD</p> <p style="padding-left: 20px;">Parts List 52</p> <p style="padding-left: 20px;">Step-by-Step Assembly 54</p> <p style="padding-left: 20px;">Character Generator Circuit Board Checkout 61</p> <p>VIDEO CIRCUIT BOARD</p> <p style="padding-left: 20px;">Parts List 62</p> <p style="padding-left: 20px;">Step-by-Step Assembly 64</p> <p style="padding-left: 20px;">Video Circuit Board Checkout 73</p> <p>CRT Installation 75</p>	<p>KEYBOARD CIRCUIT BOARD</p> <p style="padding-left: 20px;">Parts List 85</p> <p style="padding-left: 20px;">Step-by-Step Assembly 87</p> <p style="padding-left: 20px;">Keyboard Circuit Board Checkout 99</p> <p>RAM AND COUNTER CIRCUIT BOARD</p> <p style="padding-left: 20px;">Parts List 103</p> <p style="padding-left: 20px;">Step-by-Step Assembly 105</p> <p style="padding-left: 20px;">Ram and Counter Circuit Board Checkout 112</p> <p>INPUT/OUTPUT CIRCUIT BOARD</p> <p style="padding-left: 20px;">Parts List 117</p> <p style="padding-left: 20px;">Step-by-Step Assembly 119</p> <p style="padding-left: 20px;">I/O Circuit Board Checkout 128</p> <p>TIMING AND PROCESSING UNIT CIRCUIT BOARD</p> <p style="padding-left: 20px;">Parts List 132</p> <p style="padding-left: 20px;">TPU Circuit Board Checkout 134</p> <p>ADJUSTMENTS 137</p> <p>FINAL ASSEMBLY 139</p> <p>WARRANTY Inside front cover</p> <p>CUSTOMER SERVICE Inside rear cover</p>
--	---



INTRODUCTION

The Heathkit Model H9 Video Terminal can display information coming from a computer or enter information into a computer. The information is displayed on a 12" (diagonal) cathode ray tube (CRT) which is capable of displaying 960 characters at one time in 12 rows with 80 characters per row.

A sixty-seven key ASCII keyboard permits you to compose and edit directly onto the CRT with a capability of 64 different characters and 24 different functions. This message or program can then be transmitted through the standard serial I/O interface (EIA, TTL, or 20 mA current loop) to a digital computer or through the parallel I/O interface to a paper tape punch.

The Video Terminal can be used with any digital computer in dedicated, stand-alone applications, or in time-sharing systems. It lets you communicate with a digital computer in higher-level languages, such as Basic, Assembler, etc., rather than in just machine language. The Video Terminal is also much faster (up to 9600 baud) than the standard electro-mechanical teleprinter systems. You can select any data rate between 110 and 9600 baud.

Other important features include:

- Automatic scrolling.
- Cursor controls.
- Erase to end of line.
- Erase page.
- Short form (four 12-line columns of 20 characters).
- Automatic line carryover.
- Plot mode.
- Built-in speaker (audible bell).

These features, along with the attractively-styled cabinet, make the Video Terminal a very versatile peripheral to your computer system.



UNPACKING

Inside the shipping carton there is a box stamped "PKS 1—6," and a number of loose parts. After you remove the box stamped PKS 1—6, all the remaining parts will be considered the "final pack." The cathode ray tube is separate in its own shipping carton.

Remove the box stamped PKS 1—6. Remove the cathode ray tube carton and set it aside until it is called for in a Parts List. **WARNING:** Do not open the cathode ray tube carton until you are instructed to do so in a step. Improper unpacking can result in personal injury or tube damage.

When you open the box stamped PKS 1—6, you will find a Pack Index Sheet in the top of the box. This

sheet shows how the box has been divided into different compartments which are referred to in the Manual as "packs." You will be directed to open each of these "packs" as it is needed. **CAUTION:** No parts should be removed from the boxes or their compartments until they are specifically called for by a Parts List in the Manual.

Each assembly section of the Manual contains its own "Parts List" and "Step-by-Step Assembly" instructions. At the beginning of each "Parts List," you will be instructed to open one of the packs. You will also be directed, in some Parts Lists, to remove certain parts from the final pack.



CHASSIS

PARTS LIST

Unpack the following parts from the final pack and check each part against the following Parts List. The key numbers correspond to the numbers on the Chassis Parts Pictorial (Illustration Booklet, Pages 1 and 2). Any part that is packaged in an individual envelope with a part number on it should be placed back in the envelope after it is identified until it is called for in a step.

NOTE: You should place the parts in a location other than your work area. Many of these parts will not be used until later in the assembly and will be in your way if placed on your work area.

Some parts are marked with a "171-" or "172-" packaging number. These numbers are used for packaging only and do not appear in the Manual Parts List. Save all packaging material until all parts have been located.

To order a replacement part, always include the **PART NUMBER**. Use the Parts Order Form furnished with this kit or at the rear of this Manual. If a Parts Order Form is not available, refer to "Replacement

Parts" inside the rear cover. Your Warranty is inside the front cover. For prices, refer to the separate "Heath Parts Price List."

Each circuit component in this kit has a Circuit Component Number (R2, C4, Q1, etc.). This is a specific number for only that one part in the kit. The purpose of these numbers, which are especially useful if a part ever has to be replaced, is to help you easily identify the same part in each section of the Manual. These numbers will appear:

- In the Parts List.
- At the beginning of each step where a component is installed.
- In some illustrations.
- In the Schematic.
- In the sections at the rear of the Manual.

IMPORTANT: The TPU circuit board assembly has been wired and tested at Heath Company. If it malfunctions during the 90-day period, return the complete circuit board assembly to Heath Company or a Heathkit Electronic Center. It will be promptly repaired and returned. **Individual replacement parts are not supplied under warranty. DO NOT** attempt to service this circuit board assembly yourself during the warranty period; to do so voids the warranty.



KEY No.	HEATH Part No.	QTY.	DESCRIPTION	CIRCUIT Comp. No.
---------	----------------	------	-------------	-------------------

CIRCUIT COMPONENTS

A1	6-470-12	1	47 Ω, 1/4-watt (yellow-violet-black) resistor	R1
A1	6-151	1	150 Ω, 1/2-watt (brown-green-brown) resistor	R2
A2	21-96	1	36 pF ceramic capacitor	C5
A2	21-17	1	270 pF ceramic capacitor	C4
A3	25-810	1	500 μF electrolytic capacitor	C3
A4	25-156	1	4000 μF electrolytic capacitor	C2
A5	25-822	1	12,000 μF electrolytic capacitor	C1
A6	51-194	1	Flyback transformer	T2
A7	54-943	1	Power transformer	T1
A8	58-8	1	Deflection yoke	L1
A9	56-26	1	1N191 diode (brown-white-brown)	D2
A9	56-56	1	1N4149 diode	D1
A10	60-2	2	Slide switch	SW1, SW2
A11	401-163	1	Speaker	SPKR1

WARNING: Do not remove the cathode ray tube from its carton until you are instructed to do so in a step.

A12	411-830	1	310GJB4 cathode ray tube	CRT1
-----	---------	---	--------------------------	------

NOTE: A transistor can be marked for identification in one of the following four ways:

1. Part number.
2. Type number.
3. Part number and type number.
4. Part number with a type number other than the one listed.

A13	417-894	1	BU180A transistor	Q1
A14	421-23	1	1-ampere, 3AG, slow-blow fuse	F1

INSULATORS

B1	73-92	1	3/4" × 5" foam tape
B2	73-132	1	Small rubber grommet
	73-23	1	Large rubber grommet
B3	75-30	1	Line cord strain relief
B4	75-52	1	Slide switch insulator
B5	75-728	12	Circuit board standoff
B6	75-734	4	Circuit board holder
	75-124	1	4-1/2" × 6" fish paper
B7	75-704	1	Transistor insulator

KEY No.	HEATH Part No.	QTY.	DESCRIPTION	CIRCUIT Comp. No.
---------	----------------	------	-------------	-------------------

CONNECTORS — SHELLS — PLUGS

C1	432-866	15	Small spring connector
C2	432-753	15	Large spring connector
C3	432-855	38	Female connector
C4	432-954	1	4-connector socket shell
C5	432-970	2	5-connector socket shell
C6	432-821	1	6-connector socket shell
C7	432-183	1	9-connector socket shell
C8	432-704	1	24-connector socket shell
C9	432-924	1	4-pin plug
C10	432-951	1	6-pin plug
C11	432-832	13	12-pin plug

HARDWARE

NOTE: The hardware may be packed in more than one packet. Open all the hardware packets (marked HDW) before you check the hardware against the Parts List.

#4 Hardware

D1	250-213	1	4-40 × 5/16" screw
D2	252-2	3	4-40 nut
D3	254-9	4	#4 lockwasher
D4	253-703	1	Plastic shoulder washer

#6 Hardware

D5	250-452	16	6-32 × 1/4" black screw
D6	250-381	8	6-32 × 3/8" black screw
D7	250-1264	10	6-32 × 3/8" hex head screw
D8	250-89	10	6-32 × 3/8" screw
D9	250-475	6	6-32 × 3/8" hex head self-tapping screw
D10	250-162	1	6-32 × 1/2" screw
D11	250-569	6	6-32 × 3/4" black screw
D12	250-13	4	6-32 × 1" screw
D13	252-3	16	6-32 nut
D14	252-22	4	#6 square push-on nut
D15	252-708	2	#6 round push-on nut
D16	252-195	16	6-32 self-retaining nut
D17	253-60	2	#6 flat washer
D18	254-1	16	#6 lockwasher
D19	259-1	12	#6 solder lug

#8 Hardware

D20	250-137	4	8-32 × 3/8" screw
D21	250-585	4	8-32 × 1/2" screw
D22	252-4	8	8-32 nut
D23	254-2	6	#8 internal tooth lockwasher
D24	254-28	6	#8 external/internal tooth lockwasher
D25	259-2	4	#8 solder lug



KEY HEATH QTY. DESCRIPTION
No. Part No.

CIRCUIT
Comp. No.

LINE CORD — HARNESSES — WIRE — CABLE — SLEEVING

89-54	1	Line cord
134-1001	1	Main harness
134-1002	1	Bus harness
134-1009	1	21-wire cable assembly
134-1016	1	8-wire cable assembly
340-8	10'	Bare wire
344-15	2'	Black wire
344-59	10'	White wire
344-94	30"	Yellow wire
347-1	8"	8-wire cable
346-1	12"	Sleeving

METAL PARTS

E1	204-2325	2	CRT brace
E2	204-135	2	Angle bracket
E3	206-1247	1	High voltage top shield
E4	206-1248	1	High voltage bottom shield
E5	203-1886-1	1	Rear panel
E6	204-2324	1	CRT bracket
E7	207-86	1	Capacitor clamp
E8	207-63	1	Capacitor strap
E9	200-1321	1	Chassis
E10	203-1887-1	1	Front panel
E11	203-1885-1	1	Bottom panel

MISCELLANEOUS

	74-6	1	Roll masking tape
F1	90-1210-1	1	Cabinet shell
	181-2679-2	1	Assembled timing and processing unit (TPU) circuit board

KEY HEATH QTY. DESCRIPTION
No. Part No.

CIRCUIT
Comp. No.

Miscellaneous (cont'd.)

F2	260-16	4	Alligator clip
	203-1894	1	Cabinet side panel set consisting of: Left side (#203-1889) Right side (#203-1890)
F3		1	Screwdriver blade
F4	205-778	1	Coil spring
F5	258-33	2	Tension spring
F6	258-79	6	Rubber foot
F7	261-21	4	Silicone grease
F8	352-13	1	Cable tie
F9	354-7	6	High voltage label
F10	390-147	1	Chassis plug label
	390-1382	2	Model label
F11	390-1387	1	Model label holder
F12	391-611	1	Fuse holder
F13	423-11	1	3-lug terminal strip
F14	431-604	1	5-lug terminal strip
F15	431-42	1	Cabinet window
	446-686	1	Magnifying glass
	406-664	1	Plastic nut starter
F16	490-5	1	De-solder wick (braid)
	490-185	1	Integrated circuit (IC) puller
F17	490-189	1	Wrench
F18	490-168	1	Blue and white label
	391-34	1	Parts Order Form
	597-260	1	Solder
		1	Manual (See Page 1 for part number.)
		1	Illustration Booklet
		1	Operation Manual (See Page 1 for part number.)



ASSEMBLY NOTES

TOOLS

You will need these tools to assemble your kit.

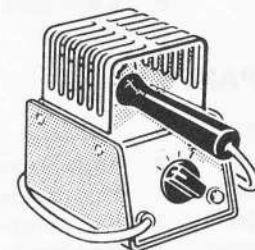
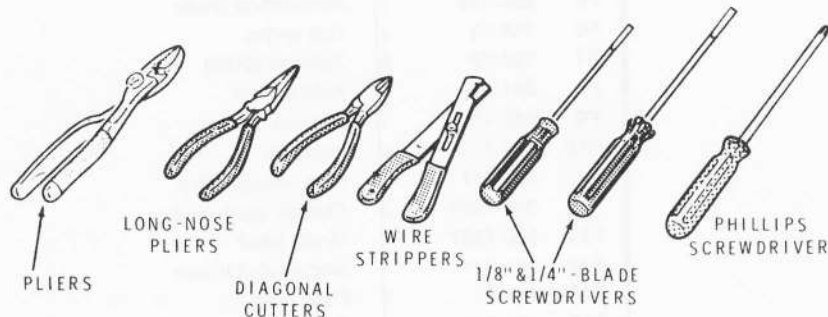

HEATHKIT
SOLDERING
IRON

OR

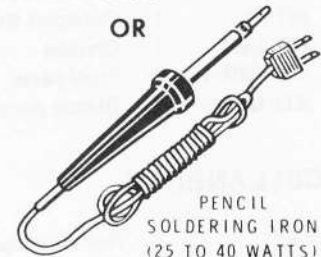

PENCIL
SOLDERING IRON
(25 TO 40 WATTS)

OTHER HELPFUL TOOLS

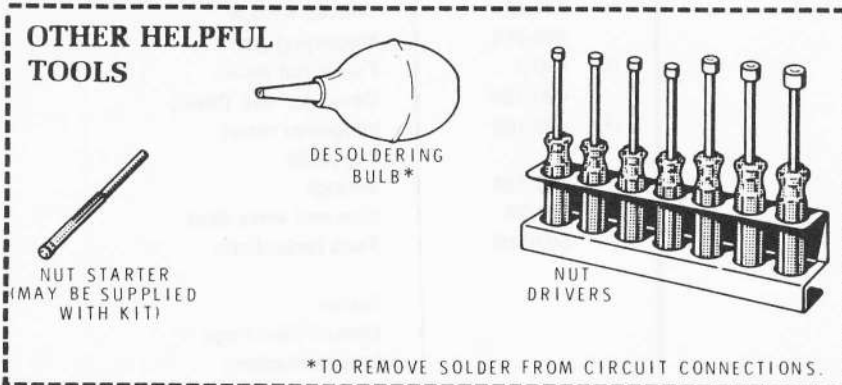

*TO REMOVE SOLDER FROM CIRCUIT CONNECTIONS.

ASSEMBLY

1. Follow the instructions carefully and read the entire step before you perform the operation.
2. The illustrations in the Manual are called Pictorials and Details. Pictorials show the overall operation for a group of assembly steps; Details generally illustrate a single step. When you are directed to refer to a certain Pictorial "for the following steps," continue using that Pictorial until you are referred to another Pictorial for another group of steps.
3. Most kits use a separate "Illustration Booklet" that contains illustrations (Pictorials, Details, etc.) that are too large for the Assembly Manual. Keep the "Illustration Booklet" with the Assembly Manual. The illustrations in it are arranged in Pictorial number sequence.
4. Position all parts as shown in the Pictorials.
5. Solder a part or a group of parts only when you are instructed to do so.



6. Each circuit part in an electronic kit has its own component number (R2, C4, etc.). Use these numbers when you want to identify the same part in the various sections of the Manual. These numbers, which are especially useful if a part has to be replaced, appear:
- In the Parts List,
 - At the beginning of each step where a component is installed,
 - In some illustrations,
 - In the Schematic,
 - In the section at the rear of the Manual.
7. When you are instructed to cut something to a particular length, use the scales (rulers) provided at the bottom of the Manual pages.

SAFETY WARNING: Avoid eye injury when you cut off excess lead lengths. Hold the leads so they cannot fly toward your eyes.

SOLDERING

Soldering is one of the most important operations you will perform while assembling your kit. A good solder connection will form an electrical connection between two parts, such as a component lead and a terminal strip lug. A bad solder connection could prevent an otherwise well-assembled kit from operating properly.

It is easy to make a good solder connection if you follow a few simple rules:

1. Use the right type of soldering iron. A 25 to 40-watt pencil soldering iron with a 1/8" or 3/16" chisel or pyramid tip works best.
2. Keep the soldering iron tip clean. Wipe it often on a wet sponge or cloth; then apply solder to the tip to give the entire tip a wet look. This process is called tinning, and it will protect the tip and enable you to make good connections. When solder tends to "ball" or does not stick to the tip, the tip needs to be cleaned and retinned.

Solder each connection as follows:

1. Push the soldering iron tip against the wire **and** the lug. Heat both the wire and the lug for two or three seconds.

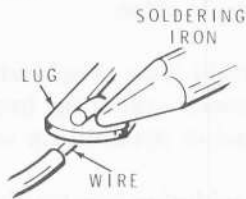

2. Apply solder to the wire and the lug, **not** to the soldering iron. **IMPORTANT:** Let the heat of the wire and lug melt the solder.

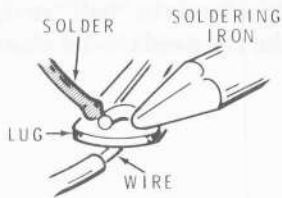

3. As the solder begins to melt, allow it to flow around the connection. Then remove the solder and the iron and let the connection cool.

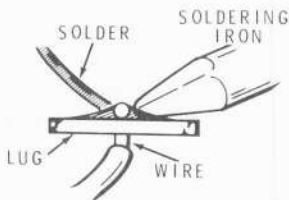

A GOOD SOLDER CONNECTION

SOLDER FLOWS OUTWARD AND GRADUALLY BLENDS WITH THE WIRE AND LUG.

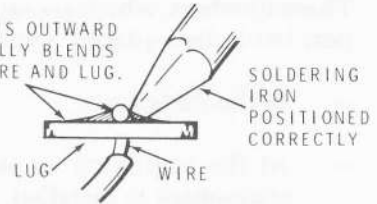

When both the wire and the lug are heated at the same time, the solder will flow onto the wire and the lug evenly. The solder will make a good electrical connection between the wire and the lug.

POOR SOLDER CONNECTIONS

SOLDER DOES NOT FLOW ONTO THE LUG AND WIRE. A DARK ROSIN BEAD SURROUNDS AND INSULATES THE WIRE FROM THE CONNECTION.

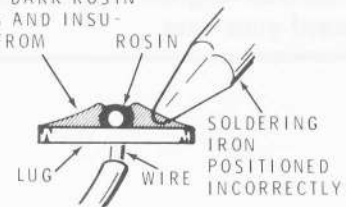

When the wire is not heated sufficiently, the solder will not flow onto the wire as shown above. To correct, reheat the connection and, if necessary, apply a small amount of additional solder to obtain a good connection.

SOLDER APPEARS TO FLOW INWARD AND SET ON TOP OF LUG.

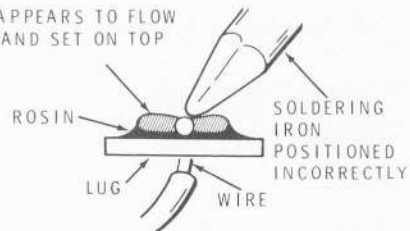

When the lug is not heated sufficiently, the solder will blob on the lug as shown above. To correct, reheat the connection and, if necessary, apply a small amount of additional solder to obtain a good connection.

STEP-BY-STEP ASSEMBLY

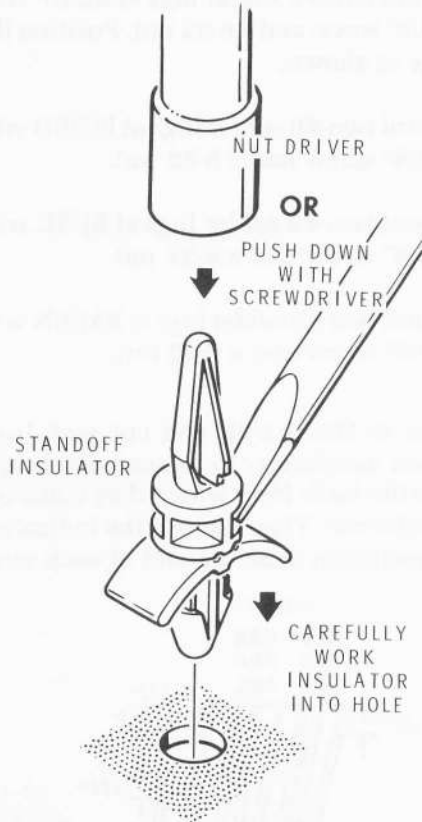

Detail 1-1A

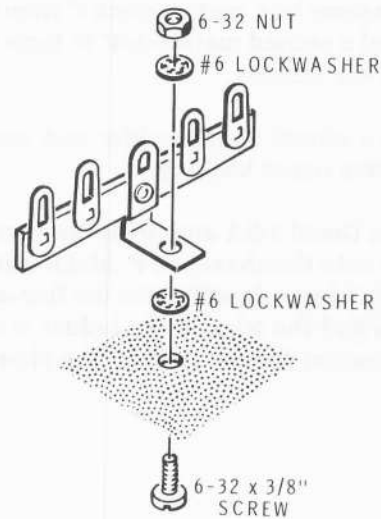

Detail 1-1B

Refer to Pictorial 1-1 (Illustration Booklet, Page 3) for the following steps.

- (✓) Position the chassis bottom-side up as shown.
- (✓) Install a small rubber grommet in the chassis at hole AA.
- (✓) Place all of the circuit board standoffs in warm water and soak them for 3 to 5 minutes.
- (✓) Refer to Detail 1-1A and install a circuit board standoff at AB in the chassis.
- (✓) Install circuit board standoffs in the chassis at AC, AD, AG, AH, AJ, AK, AM, AN, and AP.

NOTE: Use the nut starter furnished with the kit to pick up and start 4-40 and 6-32 nuts on screws. The wrench supplied can be used to tighten hex head screws and nuts in hard-to-reach places.

- (✓) Refer to Detail 1-1B and mount a 5-lug terminal strip at AR. Use a 6-32 × 3/8" screw, two #6 lockwashers, and a 6-32 nut. Be sure to position a lockwasher on each side of the mounting foot. **NOTE: Do not** use the black or hex head hardware unless it is specifically called for in a step.
- (✓) Mount a #6 solder lug at AT with a 6-32 × 3/8" screw, and a 6-32 nut. Position the solder lug as shown.

Refer to Pictorial 1-2 (Illustration Booklet, Page 4) for the following steps.

- (✓) Turn the chassis over and position it as shown.
- (✓) Make a line across the chassis 4-5/16" from the back lip as shown.
- (✓) On this line, make a mark 1" from the left side and a second mark 3-1/4" in from the left side of the chassis.
- (✓) On this same line, make a mark 1" from the right side and a second mark 3-1/4" in from the right side of the chassis.
- (✓) Locate a circuit board holder and remove the protective paper backing.
- (✓) Refer to Detail 1-2A and press the circuit board holder onto the chassis at P. Make sure the slot in the holder is directly over the line across the chassis and the edge of the holder is on the 1" mark nearest the left edge of the chassis.

- (✓) In the same manner, press circuit board holders to the chassis at Q, at R, and at S.
- (✓) Install circuit board standoffs at AE and AF **from the underside** of the chassis.
- (✓) Mount two #6 solder lugs at BE/BF with a 6-32 × 3/8" screw and a 6-32 nut. Position the solder lugs as shown.
- (✓) Mount two #6 solder lugs at BG/BH with a 6-32 × 3/8" screw and a 6-32 nut.
- (✓) Mount two #6 solder lugs at BJ/BK with a 6-32 × 3/8" screw and a 6-32 nut.
- (✓) Mount two #6 solder lugs at BM/BN with a 6-32 × 3/8" screw and a 6-32 nut.
- (✓) Refer to Detail 1-2B and cut each lead of the power transformer to its specified length. Measure the leads from where they come out of the transformer. Then remove the indicated length of insulation from the end of each wire.

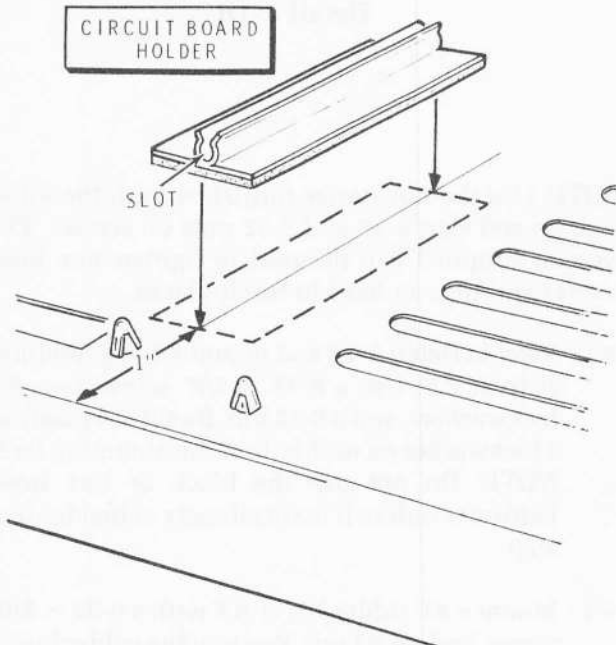

Detail 1-2A

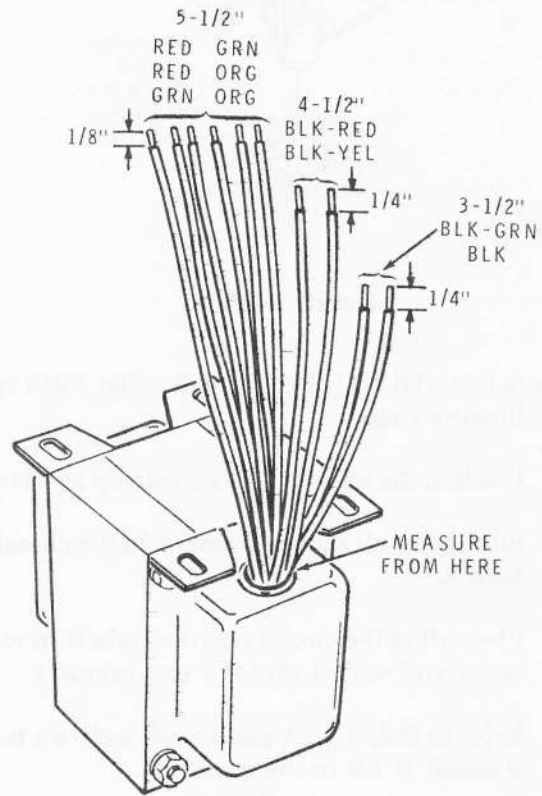

Detail 1-2B

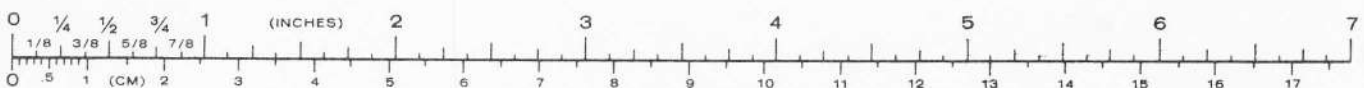

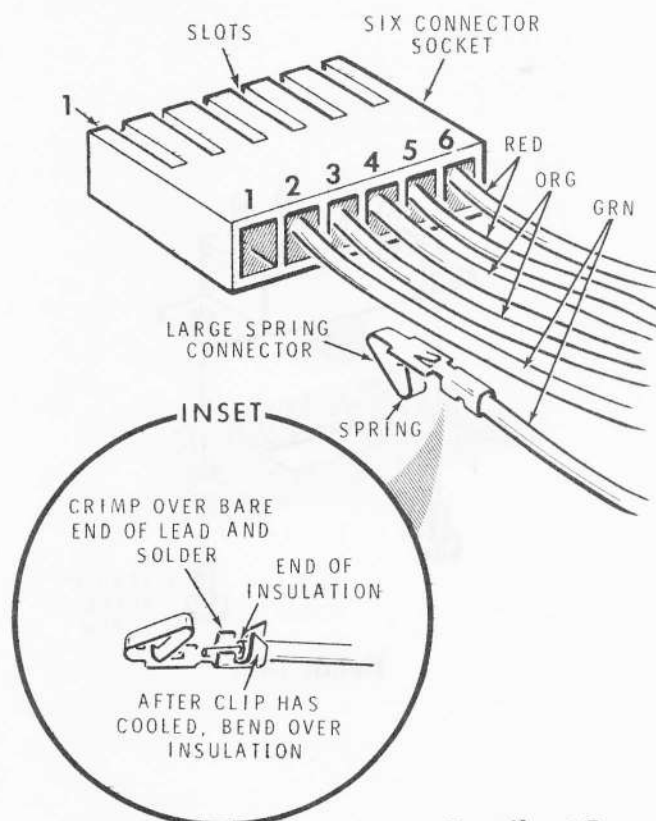

Detail 1-2C

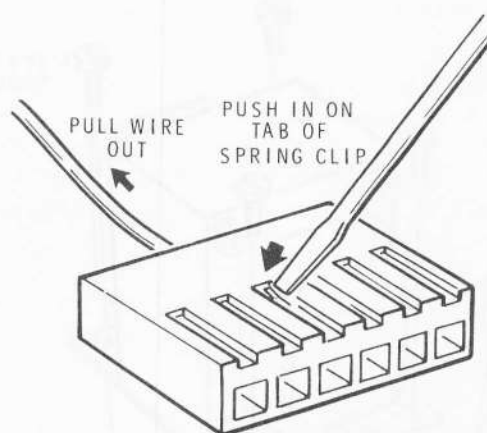

Detail 1-2D

NOTE: If it is ever necessary to remove a spring connector from the socket shell, use a small screwdriver and depress the tab on the spring connector through the slot in the connector shell while you pull the wire out. See Detail 1-2D.

- (✓) Refer to Detail 1-2C and crimp and solder a large spring connector onto one of the green power transformer leads. NOTE: Be sure that you do not solder the spring part of the connector so that it can not move.
- (✓) Check your solder connection to make sure that the connection is solid. The connection should have a smooth, shiny appearance. If the connection is dull or grainy, reheat the connection.
- (✓) Crimp and solder large spring connectors onto the other green, both orange, and both red transformer leads.
- (✓) Locate the 6-connector socket shell and note the numbers 1 and 6 stamped in the front of the shell. This indicates holes 1 and 6.

- (✓) Refer again to Detail 1-2C and insert the large spring connector on one of the green transformer leads into hole 1 on the socket shell. Be sure to position the spring part away from the slotted side of the socket shell. Push in until you hear the connector snap into the shell.

Install the other transformer leads into the socket shell in the same manner as follows:

- (✓) Other green lead into hole 2.
- (✓) Either orange lead into hole 3.
- (✓) Other orange lead into hole 4.
- (✓) Either red lead into hole 5.
- (✓) Other red lead into hole 6.

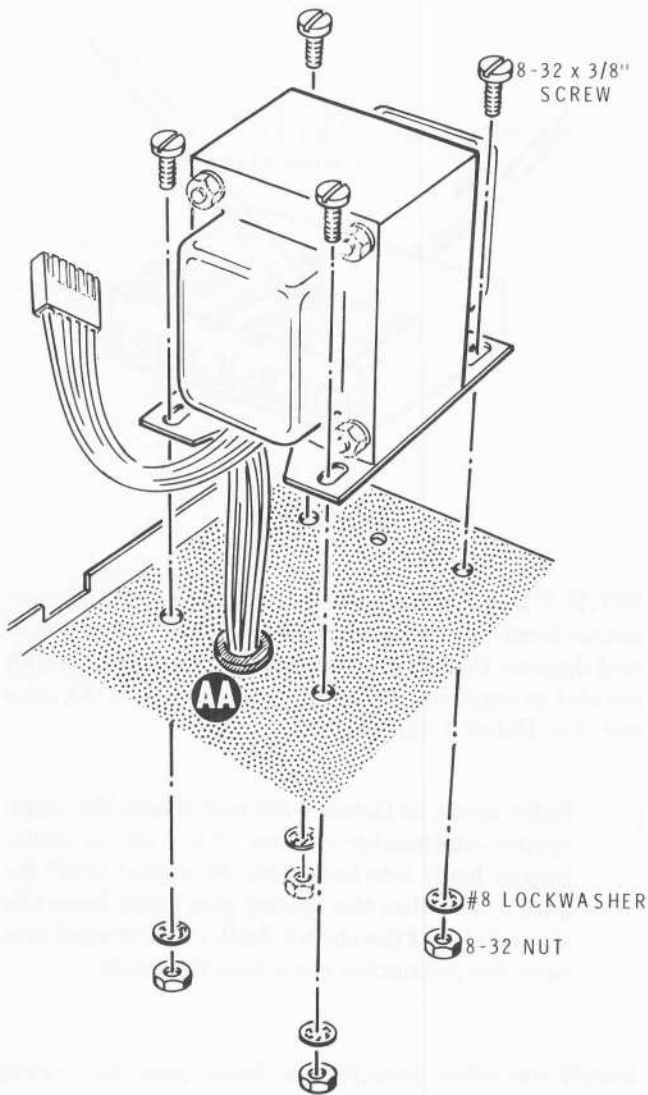

Detail 1-2E

(✓) T1: Refer to Detail 1-2E and insert the other four power transformer leads down through grommet AA. Then mount the power transformer to the chassis with four 8-32 × 3/8" screws, four #8 lockwashers, and four 8-32 nuts. Move the transformer away from the rear panel as far as the mounting holes will permit. Then tighten the hardware.

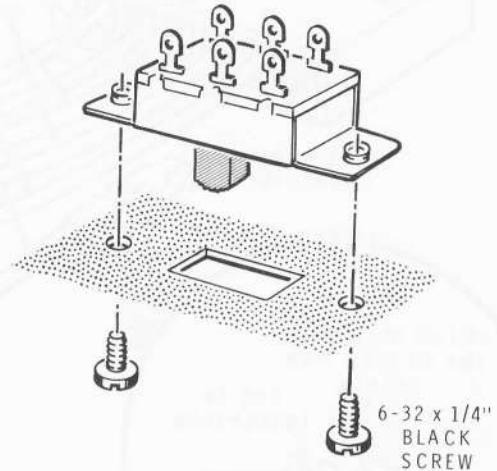

Detail 1-3A

Set the chassis aside temporarily.

Refer to Pictorial 1-3 (Illustration Booklet, Page 4) for the following steps.

- (✓) Locate the rear panel and position it as shown.
- (✓) SW2: Refer to Detail 1-3A and install a 6-lug slide switch SW2 with two 6-32 × 1/4" black screws.
- (✓) SW1: Install a 6-lug slide switch at SW1. Use only two 6-32 × 1/4" black screws.
- () F1: Refer to Detail 1-3B and install the fuseholder at F1. Use the hardware that is supplied with the fuseholder. Be sure to position the fuseholder lugs as shown. NOTE: Do not overtighten the hardware or the fuseholder may break.

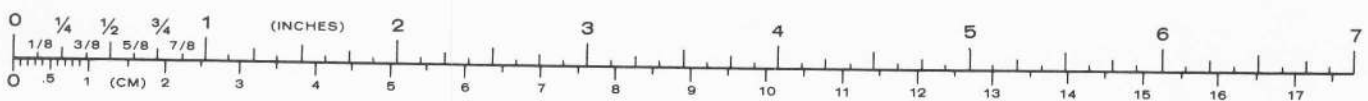

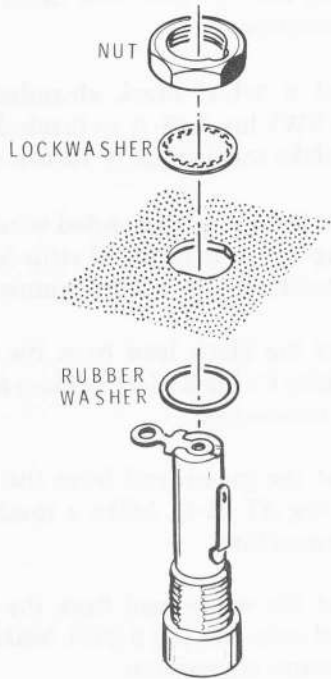

Detail 1-3B

(✓) Refer to Detail 1-3C and bend lug 1 of the fuseholder out slightly. Be careful that you do not apply pressure to the lug where it comes out of the fuseholder.

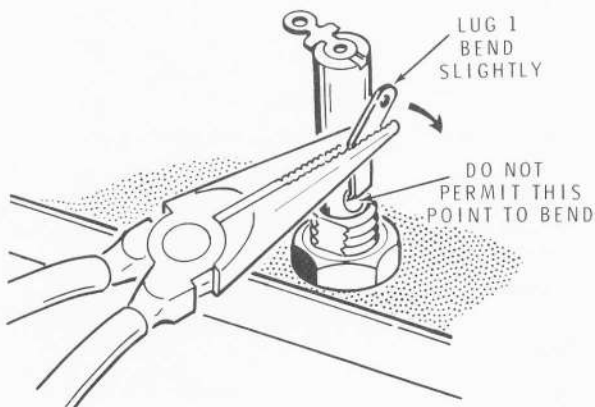

Detail 1-3C

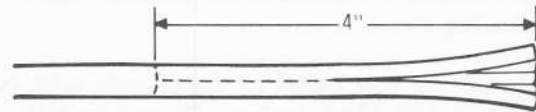

1. REMOVE 4" OF OUTER INSULATION. BE CAREFUL THAT YOU DO NOT CUT THE INSULATION OF THE INNER LEADS.

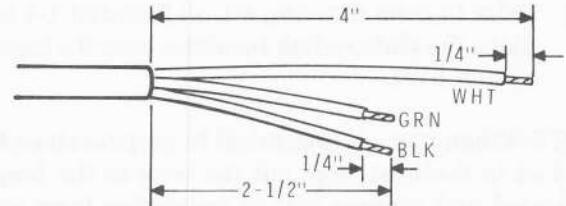

2. CUT THE LEADS TO THE INDICATED LENGTHS AND REMOVE 1/4" INSULATION FROM THE END OF EACH LEAD.



3. TWIST THE FINE WIRE STRANDS AT THE END OF EACH LEAD AND MELT A VERY SMALL AMOUNT OF SOLDER TO THE STRANDS TO HOLD THEM TOGETHER.

Detail 1-3D

(✓) Refer to Detail 1-3D and prepare the end of the line cord as shown.

(✓) Refer to Detail 1-3E and install the strain relief on the line cord where the outer insulation begins. Then install the strain relief into hole CB from the back of the rear panel.

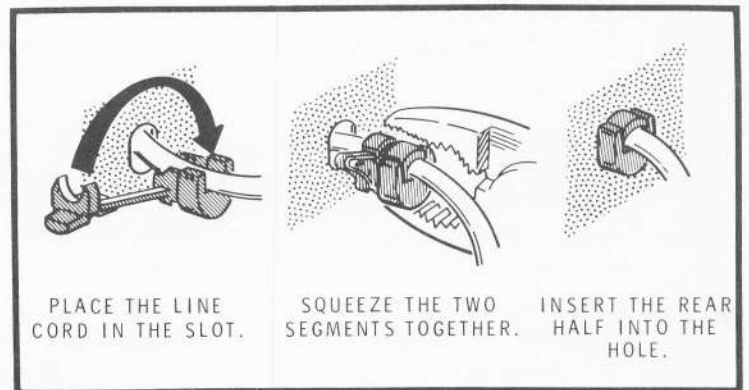

Detail 1-3E

Refer to Pictorial 1-4 (Illustration Booklet, Page 4) for the following steps.

- Mount the rear panel to the chassis with two 6-32 × 1/4" black screws. Do not install any screws in the two holes near the large cutout in the rear panel.
- Refer to inset drawing #1 on Pictorial 1-4 and place the slide switch insulator over the lugs of switch SW1.

NOTE: When you are instructed to prepare **stranded** wire as in the next step, cut the wire to the length indicated and remove 1/4" of insulation from each end. Then twist the fine wire strands at the ends of the wire and melt a small amount of solder to the strands to hold the strands together.

- Prepare the following black **stranded** wires.

2-1/4"
4"

NOTES:

1. When you are instructed to make a mechanically secure connection as in the next step, form a hook in the end of the wire and insert the wire through the lug. Then crimp the hook securely to the lug. See inset drawing #2 on Pictorial 1-4.
2. In the following steps, (NS) means not to solder the connection because other wires will be added later. (S-), with a number such as (S-3),

means to solder the connections. The number following the "S" tells how many wires are at the connection.

- Connect a 2-1/4" black **stranded** wire from switch SW1 lug 5 (S-1) to fuseholder F1 lug 1 (S-1). Make mechanically secure connections.
- Connect the 4" black **stranded** wire from switch SW1 lug 4 (S-1) to terminal strip AR lug 1 (NS). Make mechanically secure connections.
- Connect the black lead from the line cord to fuseholder F1 lug 2 (S-1). Make a mechanically secure connection.
- Connect the green lead from the line cord to solder lug AT (S-1). Make a mechanically secure connection.
- Connect the white lead from the line cord to terminal strip AR, lug 5 (NS). Make a mechanically secure connection.

Connect the power transformer leads to terminal strip AR in the following steps. Make mechanically secure connections.

- Black-red lead to lug 1 (NS).
- Black-yellow lead to lug 2 (NS).
- Black-green lead to lug 4 (NS).
- Black lead to lug 5 (NS).





NOTE: Two sets of line voltage wiring instructions follow; one for 120 VAC line voltage, and one for 240 VAC line voltage. In the U.S.A., 120 VAC is most often used, while in other countries 240 VAC is more commonly used. USE ONLY THE INSTRUCTIONS THAT AGREE WITH THE LINE VOLTAGE IN YOUR AREA.

120 VAC WIRING

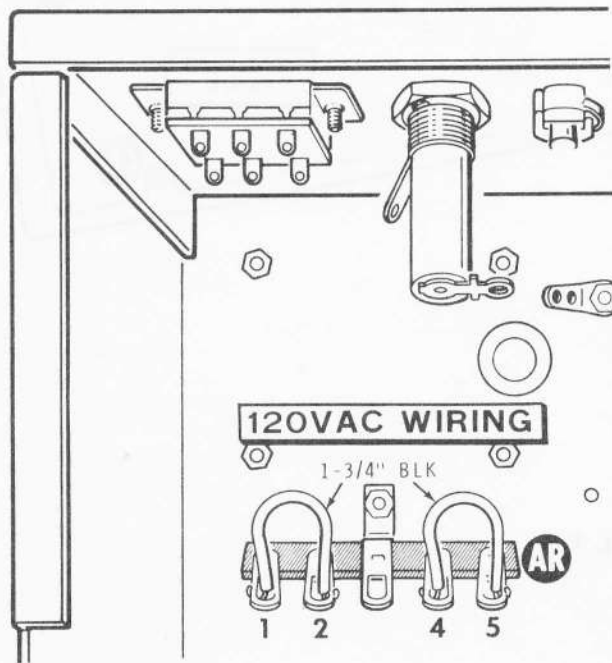

Detail 1-4A

Refer to Detail 1-4A for the following steps.

- (✓) Prepare two 1-3/4" black **stranded** wires.
- (✓) Connect a 1-3/4" black **stranded** wire to terminal strip AR between lugs 1 (S-3) and 2 (S-2). Make these connections mechanically secure.
- (✓) Connect a 1-3/4" black **stranded** wire to terminal strip AR between lugs 4 (S-2) and 5 (S-3). Make mechanically secure connections.
- (✓) Remove the red cap from the fuseholder and insert the 1-ampere slow-blow fuse. Then replace the cap into the fuseholder.

240 VAC WIRING

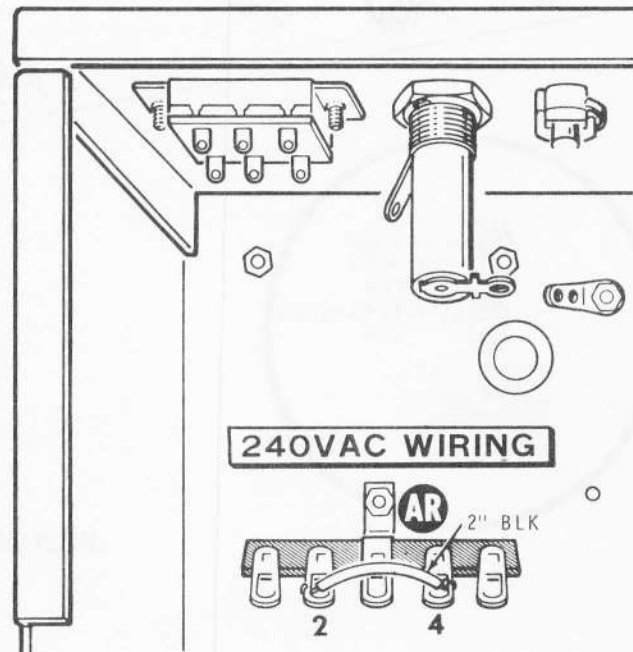

Detail 1-4B

Refer to Detail 1-4B for the following steps.

- () Prepare a 2" black **stranded** wire.
- () Connect this 2" black **stranded** wire to terminal strip AR between lugs 2 (S-2) and 4 (S-2). Make mechanically secure connections.
- () Solder lug 1 (S-2) and lug 5 (S-2) of terminal strip AR.
- () Remove the red cap from the fuseholder and insert the 1/2-ampere slow-blow fuse (not supplied). Then replace the cap into the fuseholder.

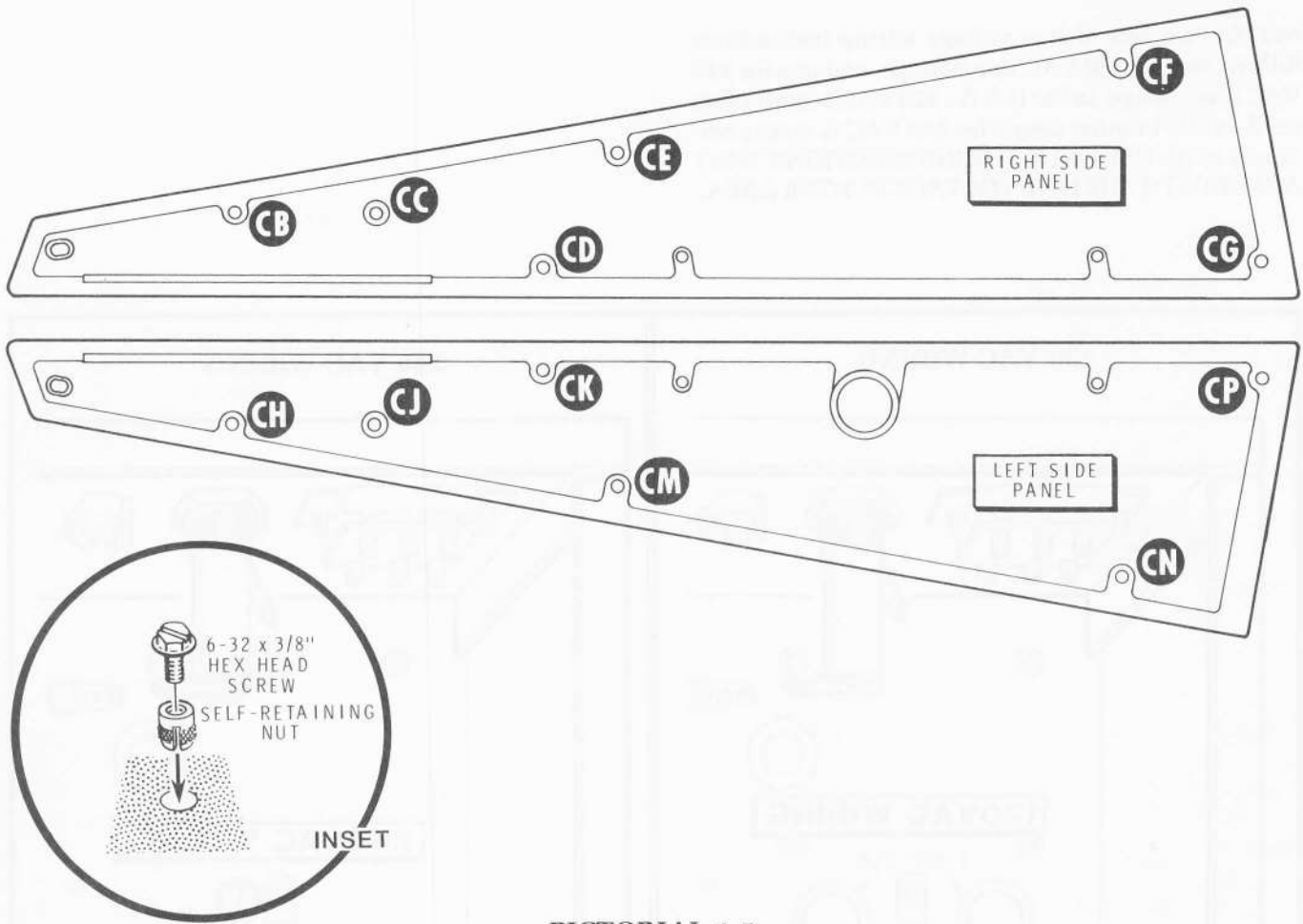

PICTORIAL 1-5

Refer to Pictorial 1-5 for the following steps.

- () Set the chassis aside temporarily.

NOTE: You may wish to place a soft cloth on your work area surface for the remainder of the kit assembly. This will keep the side panels from getting scratched.

- (✓) Locate both side panels and position them on a soft cloth.
- (✓) Refer to the inset drawing and insert a self-retaining nut into hole CB slotted end first.

Press or tap the nut into the side panel until it is flush with the surface.

- () Turn a 6-32 × 3/8" hex head screw into the self-retaining nut to spread the nut. Do not turn the screw all the way in. Then remove the screw.

In the same manner, install self-retaining nuts in the following holes.

- () CC () CF () CJ () CN
- () CD () CG () CK () CP
- () CE () CH () CM

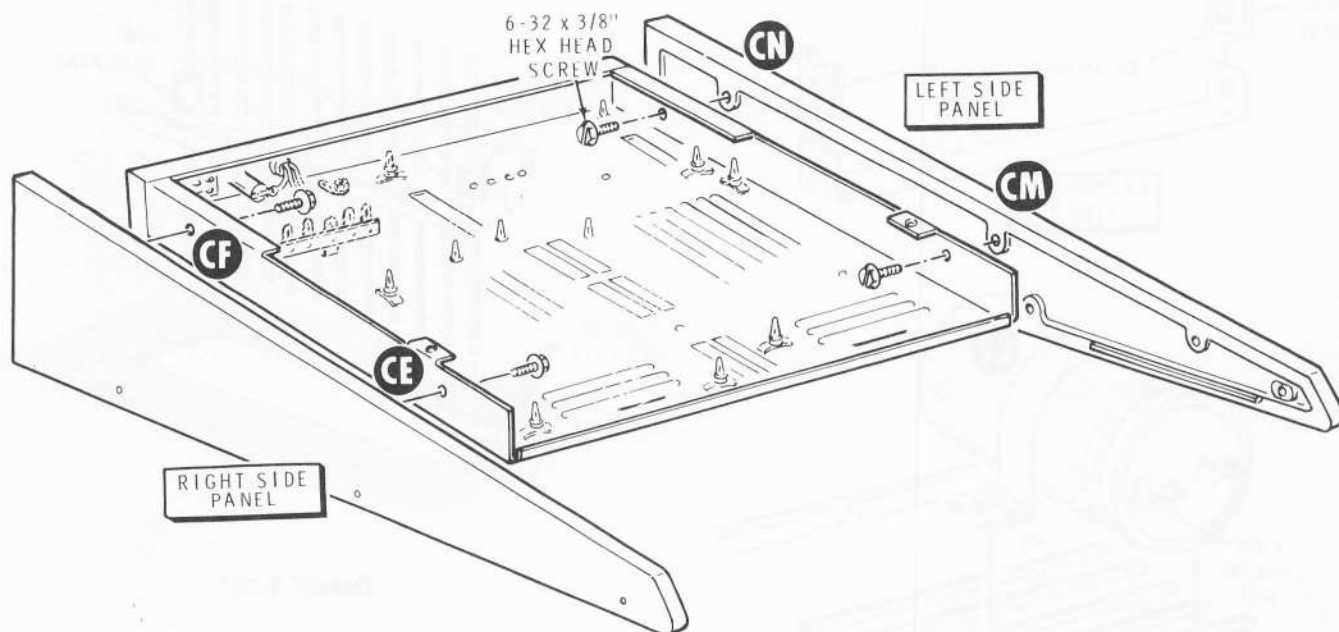

PICTORIAL 1-6

Refer to Pictorial 1-6 for the following steps.

- (✓) Position the chassis bottom-side up as shown.
- (✓) Mount the right side panel to the chassis with 6-32 × 3/8" hex head screws at CE and CF. Use the wrench supplied. Do not overtighten these screws.
- (✓) Mount the left side panel to the chassis with 6-32 × 3/8" hex head screws at CM and CN.

Refer to Pictorial 1-7 (Illustration Booklet, Page 5) for the following steps.

- (✓) Position the chassis topside up as shown.
- (✓) Mount the rear panel to the upper rear side panels with 6-32 × 3/8" hex head screws at locations CP and CG.
- (✓) Mount the CRT bracket to the top of the chassis with four 6-32 × 1/4" black screws.

- (✓) Refer to Detail 1-7A and install a 6-32 × 1/2" screw with a #6 lockwasher, and a 6-32 nut in the capacitor clamp. Do not tighten this screw at this time.
- (✓) Refer to Detail 1-7A and mount the capacitor clamp at C1 with two 6-32 × 3/8" screws, two #6 lockwashers, and two 6-32 nuts. Do not tighten this hardware at this time.

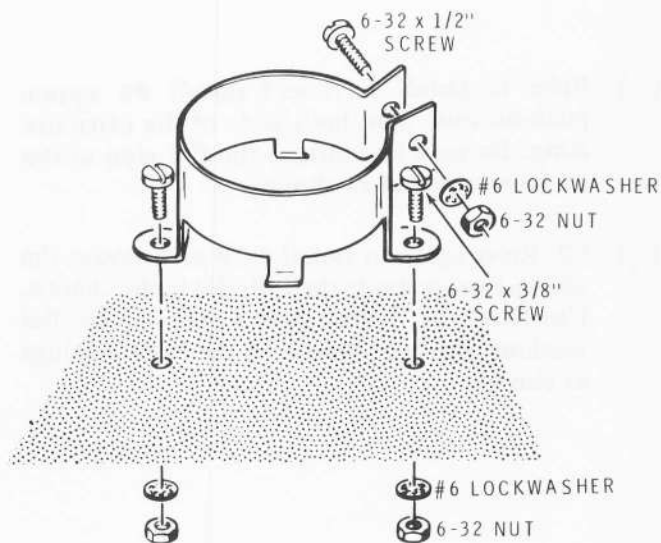

Detail 1-7A

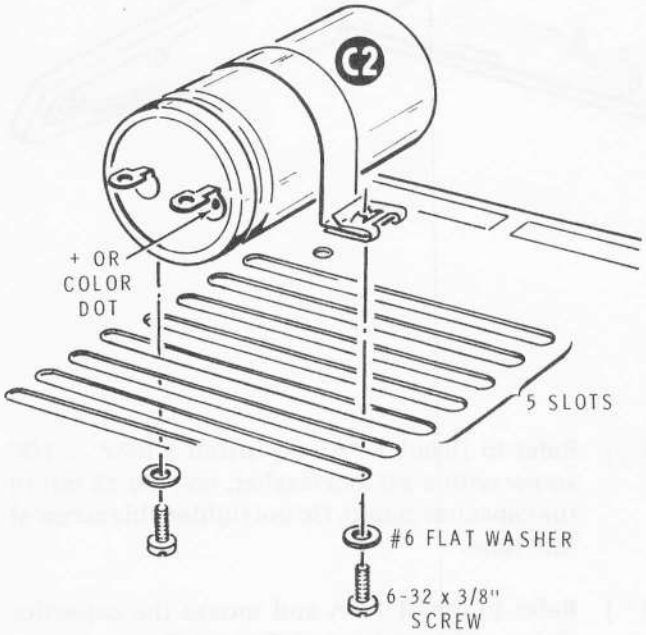
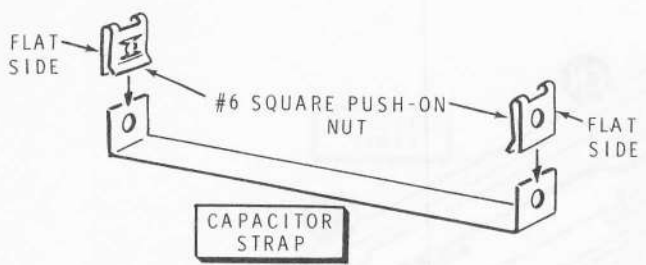

Detail 1-7B

- (✓) Refer to Detail 1-7B and install #6 square push-on nuts onto both ends of the capacitor strap. Be sure to position the flat side of the push-on nuts out as shown.
- (✓) C2: Refer again to Detail 1-7B and mount the 4000 μ F capacitor to the fifth slot in the chassis. Use two 6-32 \times 3/8" screws and two #6 flat washers. Be sure to position the capacitor lugs as shown.

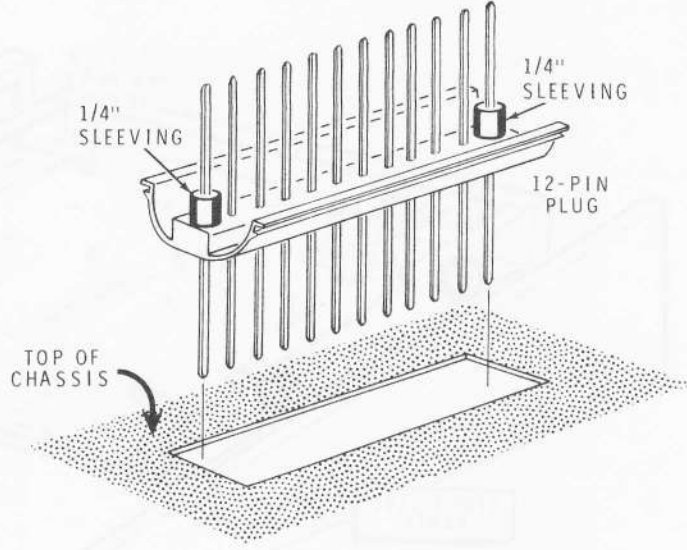

Detail 1-7C

- () Refer to Detail 1-7C and install a 12-pin plug at C from the top of the chassis.

In the same manner, install 12-pin plugs at the following location.

- | | | |
|-------|-------|-------|
| (✓) D | (✓) H | (✓) N |
| (✓) E | (✓) J | (✓) P |
| (✓) F | (✓) K | |
| (✓) G | (✓) M | |

- (✓) Install a 12-pin plug and a 6-pin plug (end to end) at A.
- (✓) Install a 12-pin plug and a 4-pin plug (end to end) at B.
- () Cut twenty-six, 1/4" lengths of sleeving.
- (✓) Refer to Detail 1-7C and place a piece of sleeving over the outer pins of each plug on the top side of the chassis. Where more than one plug is used to make up a plug as in plug A, place sleeving over the two outer-most pins. Be sure to position the sleeving down against the nylon plug body.

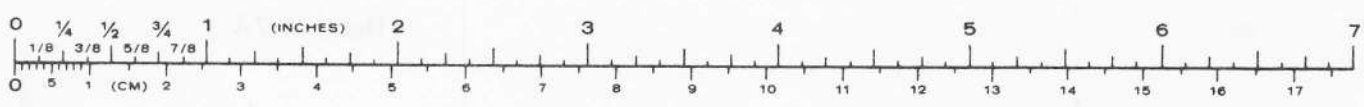

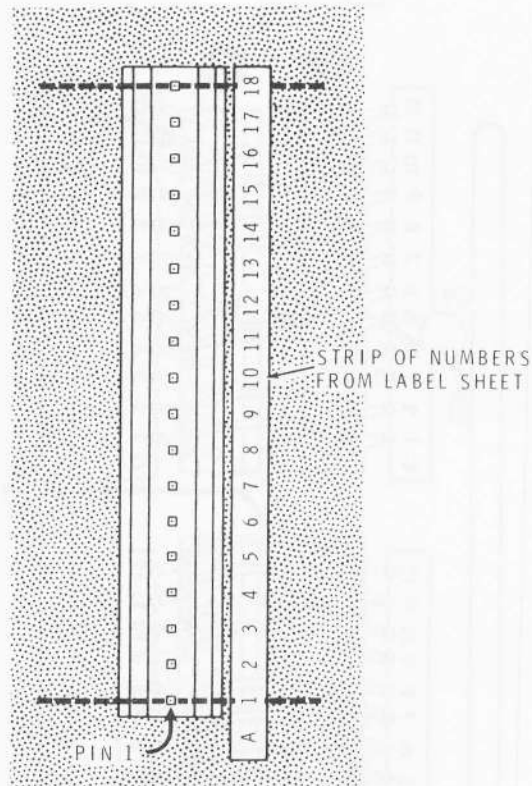

Detail 1-7D

NOTE: Locate one of the chassis plug labels and refer to Detail 1-7D. In the following steps, each strip of numbers will be removed from the label and pressed onto the chassis beside the appropriate plug. Refer to Pictorial 1-7 for the pin 1 location of each plug.

- () Remove number strip A from the label sheet and remove the protective paper backing. Then position the label so that number "1" is even with pin 1 of plug A and press the number strip onto the chassis.
- () Remove number strip B from the label sheet. Then cut numbers 17 and 18 from the label and discard them. Remove the protective paper backing and press the number strip alongside plug B.

- () The other plugs are 12-pin plugs; therefore, cut numbers 13 through 18 from the rest of the label sheet. Each remaining number strip should contain numbers 1 through 12.

Remove and install the correct label beside the following plugs. NOTE: Label "L" will not be used.

- | | | |
|---|---|---|
| (<input checked="" type="checkbox"/>) C | (<input checked="" type="checkbox"/>) G | (<input checked="" type="checkbox"/>) M |
| (<input checked="" type="checkbox"/>) D | (<input checked="" type="checkbox"/>) H | (<input checked="" type="checkbox"/>) N |
| (<input checked="" type="checkbox"/>) E | (<input checked="" type="checkbox"/>) J | (<input checked="" type="checkbox"/>) P |
| (<input checked="" type="checkbox"/>) F | (<input checked="" type="checkbox"/>) K | |

Save the remaining chassis plug label for use later.

TOP OF CHASSIS

2

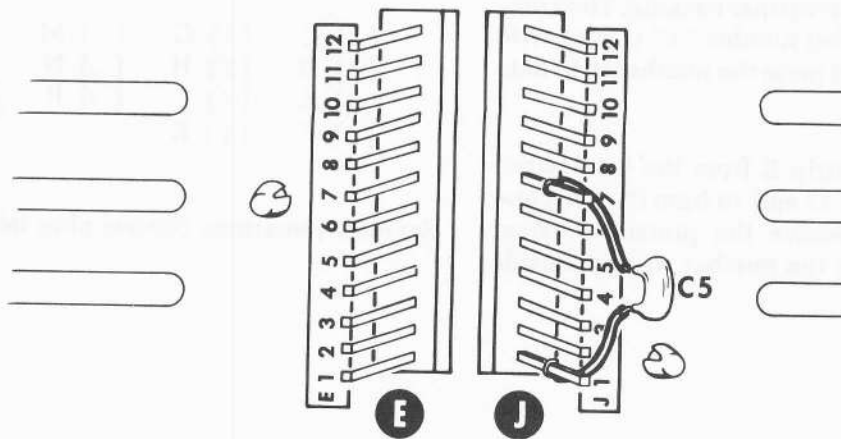
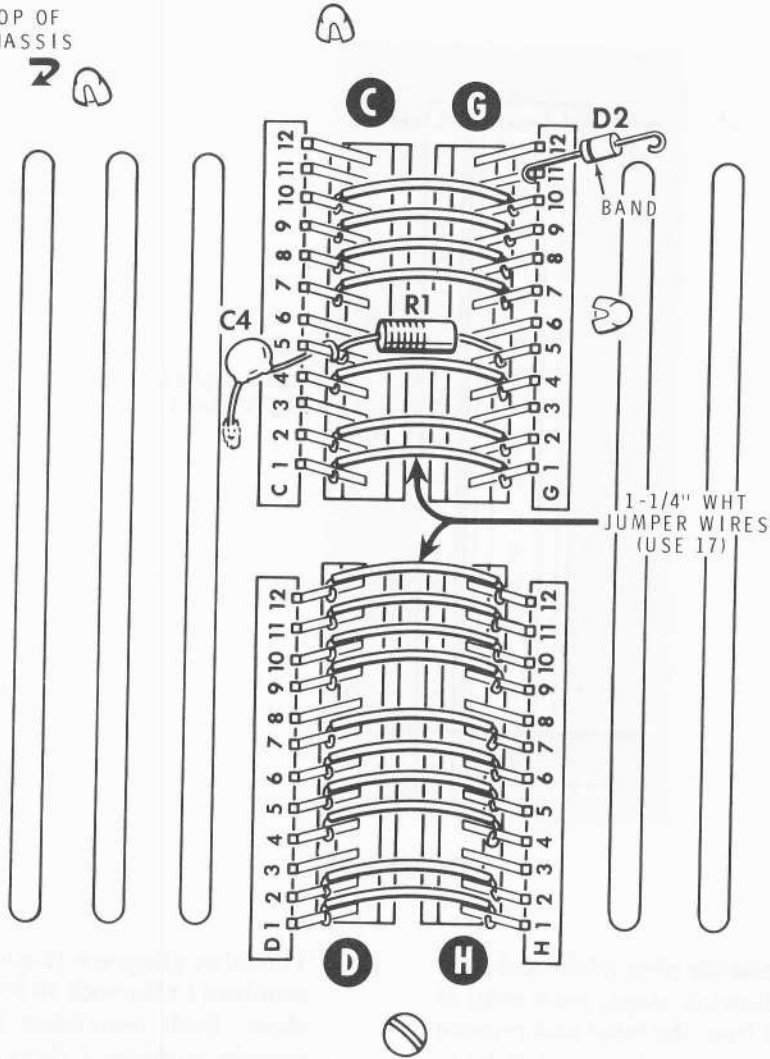

PICTORIAL 2-1

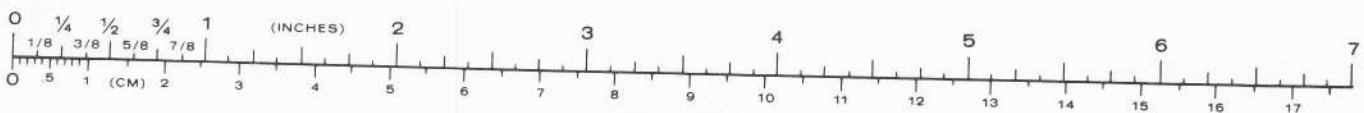

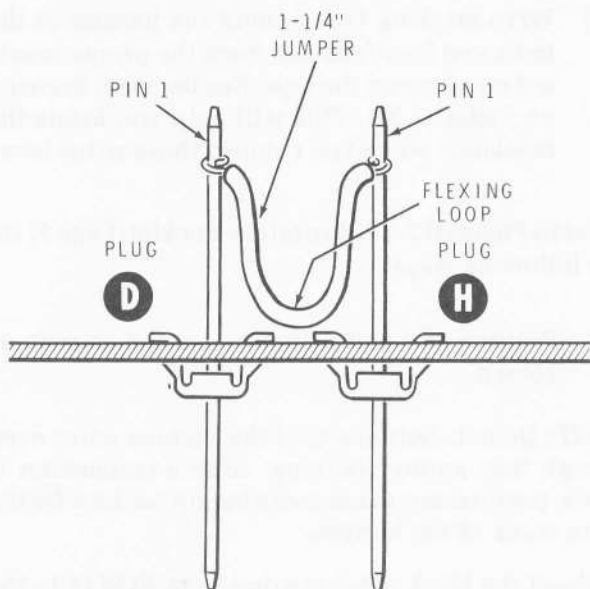

Detail 2-1A

CHASSIS WIRING

Refer to Pictorial 2-1 for the following steps.

NOTE: When you are instructed to prepare a white wire, cut the wire to the indicated length and remove 1/4" of insulation from both ends.

- Prepare seventeen 1-1/4" white wires to be used as jumper wires in the following steps.

NOTE: As you install the following jumper wires, it will be easier if you first form a loop in the ends of the wires. Then slide the wires down over the plug pins. Solder the jumper wires to the plug pins as each wire is installed. See Detail 2-1A.

Solder jumper wires between plug D and plug H as follows:

- Jumper wire between pins 1.
- Jumper wire between pins 2.
- Jumper wires between pins 4.
- Jumper wire between pins 5.
- Jumper wire between pins 6.
- Jumper wire between pins 7.
- Jumper wire between pins 9.

- Jumper wire between pins 10.
- Jumper wire between pins 11.
- Jumper wire between pins 12.
- CHECK:** There should not be a jumper wire connected between pins 3 or pins 8 of plugs D and H.

Solder jumper wires between plug C and plug G as follows:

- Jumper wire between pins 1.
- Jumper wire between pins 2.
- Jumper wire between pins 4.
- Jumper wire between pins 7.
- Jumper wire between pins 8.
- Jumper wire between pins 9.
- Jumper wire between pins 10.
- CHECK:** There should not be a jumper wire connected between pins 3, 5, 6, 11, or 12 of plugs C and G.
- R1: Cut both leads of a 47Ω, 1/4-watt (yellow-violet-black) resistor to 1/2". Connect this resistor from plug C pin 5 (NS) to plug G pin 5 (S-1). Leave enough room at the top of plug C pin 5 for two more connections.
- C4: Cut both leads of a 270 pF ceramic capacitor to 1/2". Connect one lead of this capacitor to plug C lug 5 (NS). Solder the other lead directly to the chassis as shown.
- C5: Cut both leads of a 36 pF ceramic capacitor to 3/4". Then place 1/2" of sleeving over each lead. Connect this capacitor to plug J between pins 1 (S-1) and 7 (S-1). Make these connections close to the chassis because a socket will go onto the plug pins later.
- D2: Cut both leads of a 1N191 (brown-white-brown) diode (#56-26) to 3/8". Then bend a small hook in the end of each lead. Connect the lead at the banded end of the diode to plug G pin 11 (S-1). The other lead of the diode will be connected later.



Refer to Pictorial 2-2 (Illustration Booklet, Page 6) for the following steps.

- () Locate the main harness (#134-1001) and straighten it out as shown. Position the individual wires at each breakout (BO) and each connector socket as shown. BE SURE each connector socket has its slots **up** or **down** just like Pictorial 2-2.
- (✓) Locate the remaining chassis plug label and remove the A strip from it. Cut the label between the numbers "9" and "10" so it will not be damaged. Then remove the protective paper backing.
- (✓) Press this label onto the double socket connectors at A on the harness. Be sure that the number "1" on the label is lined up with the hole having the large gray wire, (the letter A will be on the end of the connector) and the number "10" is lined up with the hole having the black wire.
- (✓) Remove number strip B from the label sheet. Then cut numbers 17 and 18 off this strip so you have a strip with the letter B followed by numbers 1 through 16. Next, cut this strip between the numbers 9 and 10. Save the part of this strip with numbers 10 through 16 for later use. Remove the paper backing from the B through 9 strip and press it onto connector socket B as shown.
- (✓) Cut numbers 13 through 18 from all of the remaining number strips on the sheet. Each remaining strip should have a letter followed by the numbers 1 through 12.

Remove and install the correct label on the proper harness connector sockets as follows. Be sure to position the labels exactly as shown in Pictorial 2-2.

(✓) E	(✓) M
(✓) J	(✓) N
(✓) K	(✓) P

- (✓) Save the F label for use later and discard the remaining labels, as they will not be used.
- (✓) Mark the remaining harness connector sockets with their "S" number and a number 1, 7, or 8 at the proper end as shown. Use a felt tip marker or ball point pen and the masking tape furnished with the kit.

- (✓) Wrap masking tape around the harness at the indicated locations and mark the proper breakout numbers on the tape. See the inset drawing on Pictorial 2-2. This will help you locate the breakouts when you connect these wires later.

Refer to Pictorial 2-3 (Illustration Booklet, Page 7) for the following steps.

- () Position the main harness on the chassis as shown.

NOTE: Do not shorten any of the harness wires even though they appear too long. After a connection is made, position any excess wire length back under the main trunk of the harness.

Connect the black wires coming from BO#14 to the indicated solder lugs in the following steps. Make mechanically secure connections. Connect the seven shorter wires to solder lugs BE, BG, BJ, and BM. Connect the eight longer wires to the other four solder lugs.

- () Black wire to the lower hole (hole closest to the chassis) in solder lug BE (S-1).

NOTE: Do not connect a wire in the upper hole of solder lug BE at this time.

- (✓) Black wire to the lower hole in solder lug BG (S-1).
- (✓) Black wire to the upper hole in solder lug BG (S-1).
- (✓) Black wire to the lower hole in solder lug BJ (S-1).
- (✓) Black wire to the upper hole in solder lug BJ (S-1).
- (✓) Black wire to the lower hole in solder lug BM (S-1).
- (✓) Black wire to the upper hole in solder lug BM (S-1).
- (✓) Black wire to the lower hole in solder lug BF (S-1).
- () Black wire to the upper hole in solder lug BF (S-1).



- (✓) Black wire to the lower hole in solder lug BH (S-1).
- (✓) Black wire to the upper hole in solder lug BH (S-1).
- (✓) Black wire to the lower hole in solder lug BK (S-1).
- (✓) Black wire to the upper hole in solder lug BK (S-1).
- (✓) Black wire to the lower hole in solder lug BN (S-1).
- (✓) Black wire to the upper hole in solder lug BN (S-1).
- (✓) CHECK: Solder lug BE should not have a wire connected to the upper hole.
- (✓) Prepare the ends of a 3" black **stranded** wire.
- () Refer to Detail 2-3A and crimp and solder a large spring connector to one end of this wire.

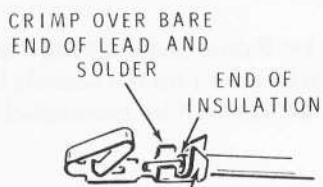

Detail 2-3A

AFTER CLIP HAS COOLED, BEND OVER INSULATION

- (✓) Solder the free end of this wire between the indicated chassis slots on the chassis near circuit board holder Q.
- (✓) Insert the connector end of this wire into slot 11 in socket S302 on the main harness.

Refer to Pictorial 2-4 (Illustration Booklet, Page 8) for the following steps.

- (✓) Locate the 21-wire cable assembly. Then refer to Detail 2-4A (Illustration Booklet, Page 8) and install the 24-connector plug into the rear panel at P602. Insert the plug so that pin 1 (white-brown wire) is at the top.
- (✓) In the same manner install the 9-connector plug on the 8-wire cable into the rear panel at P603. Insert this plug so that pin 1 (green wire) is at the top.

Connect the wires coming from BO#17 of the main harness to switch SW2 as follows:

- (✓) White-orange wire to lug 4 (S-1).
- (✓) Orange wire to lug 5 (S-1).
- (✓) Violet wire to lug 6 (NS).
- (✓) White-red wire to lug 6 (S-2).
- (✓) Green wire to lug 3 (S-1).
- (✓) White wire to lug 1 (S-1).

Connect the wires coming from BO#10 of the main harness to chassis plug C as follows:

- (✓) Both black wires to pin 12 (S-2). Make these connections lower on the pin. Be careful that the connection does not touch the chassis or another pin.
- (✓) Both red wires to pin 11 (S-2). Make these connections higher up on the pin so that there is no danger of these connections touching the connections on pins 10 or 12.
- (✓) Blue wire to pin 6 (S-1).
- (✓) Green wire to pin 5 (S-3). NOTE: There are components already connected to this pin.

Connect the wires coming from BO#9 as follows:

- (✓) Orange wire to plug D pin 8 (S-1).
- (✓) White-green wire to plug D pin 3 (S-1).
- (✓) Red wire to plug H pin 8 (S-1).
- (✓) Large yellow wire to plug H pin 3 (S-1).

Connect the wires coming from BO#19 to chassis plug G as follows:

- (✓) Small black wire to pin 12 (S-1).
- (✓) Push a 1-1/2" length of sleeving over the white-black wire. Form a hook in the end of the wire and connect it to the free lead of diode D2 coming from pin 11 (S-1). Then push the sleeving over the connection and diode.

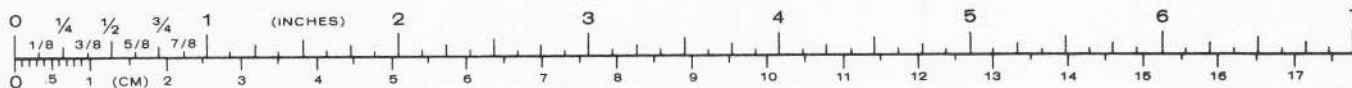

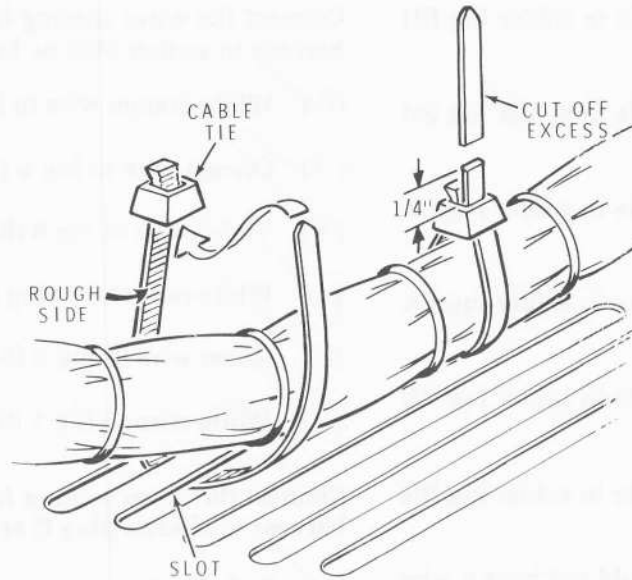

Detail 2-5A

- (✓) Gray wire to pin 6 (S-1).
- (✓) Brown and blue wires to pin 3 (S-2).
- (✓) Connect the large black wire coming from BO#19 to the unmarked lug of capacitor C2 (S-1).
- (✓) Connect the orange wire coming from BO#19 to the plus (+) or color marked lug of capacitor C2 (S-1).

Refer to Pictorial 2-5 (Illustration Booklet, Page 9) for the following steps.

NOTE: The pressure required to push a socket onto a chassis plug may cause the plug to push through the chassis. Therefore, support the chassis plugs from the other side as you install a socket. If a plug does push through the chassis, be sure to reinstall it from the same side as it was originally.

- (✓) Push both halves of socket A onto chassis plug A. Make sure the harness socket label numbers match the chassis plug label numbers.
- (✓) Push socket B onto chassis plug B so the 1 on its label matches the 1 on the chassis label. NOTE: Another socket will be connected to this plug later.
- (✓) Push socket E onto chassis plug E.
- (✓) Push socket J onto chassis plug J.
- (✓) Push socket K onto chassis plug K.
- (✓) Push socket P onto chassis plug P.
- (✓) Push socket N onto chassis plug N.
- (✓) Push socket M onto chassis plug M.

Refer to Detail 2-5A and install cable ties on the main harness at the following locations:

- (✓) BP (✓) BQ
- (✓) BS (✓) BR
- (✓) BT (✓) BU



Refer to Detail 2-6A (Illustration Booklet, Page 10) for the following six steps.

- (✓) 1. Locate the bus harness (#134-1002) and straighten it out as shown. Position each connector socket as shown. BE SURE each connector socket has its slots up or down just like Detail 2-6A.
- (✓) 2. Locate the F strip that was set aside from the label sheet earlier, and remove its protective paper backing.
- (✓) 3. Press this label onto socket connector F. Be sure the number "1" on the label is lined up with the hole having the two brown wires.
- (✓) 4. In the same manner, install the saved label having numbers 10 through 16 onto connector socket B.
- (✓) 5. Mark connector socket S402 as shown.
- (✓) 6. If you wish, label breakout #1 of the harness.

Refer to Pictorial 2-6 (Illustration Booklet, Page 10) for the following steps.

- (✓) 1. Position the bus harness on the chassis as shown.
- (✓) 2. Push socket B from the bus harness onto chassis plug B so that the label on the socket matches the label on the chassis.
- (✓) 3. Locate the eight wires coming from BO#1 on the bus harness. Then refer to Detail 2-6B and apply a small amount of solder to each spring clip where it is crimped to a wire. BE CAREFUL that you do not solder the spring part to the clip.

NOTE: When you install a spring clip into a connector, insert each clip so that the spring portion is away from the slotted side of the socket. Push the clip into the socket until it "clicks" into place. After you install each clip, pull on the wire to make sure it is locked in place.

Insert the spring clips on the wires coming from BO#1 on the bus harness into socket S601 on the main harness as follows:

- (✓) 1. Gray wire into hole 6.
- (✓) 2. Violet wire into hole 7.
- (✓) 3. Blue wire into hole 8.
- (✓) 4. Green wire into hole 9.
- (✓) 5. Yellow wire into hole 10.
- (✓) 6. Orange wire into hole 11.
- (✓) 7. Red wire into hole 12.
- (✓) 8. Brown wire into hole 13.

Insert the spring clips on the wires coming from BO#7 on the main harness into socket F on the bus harness as follows.

- (✓) 1. White wire into hole 7.
- (✓) 2. Large yellow wire into hole 8.
- (✓) 3. Push socket F onto chassis plug F so that the label on the socket matches the label on the chassis.

Set the chassis aside temporarily.

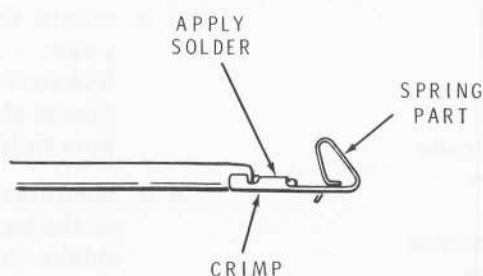

Detail 2-6B

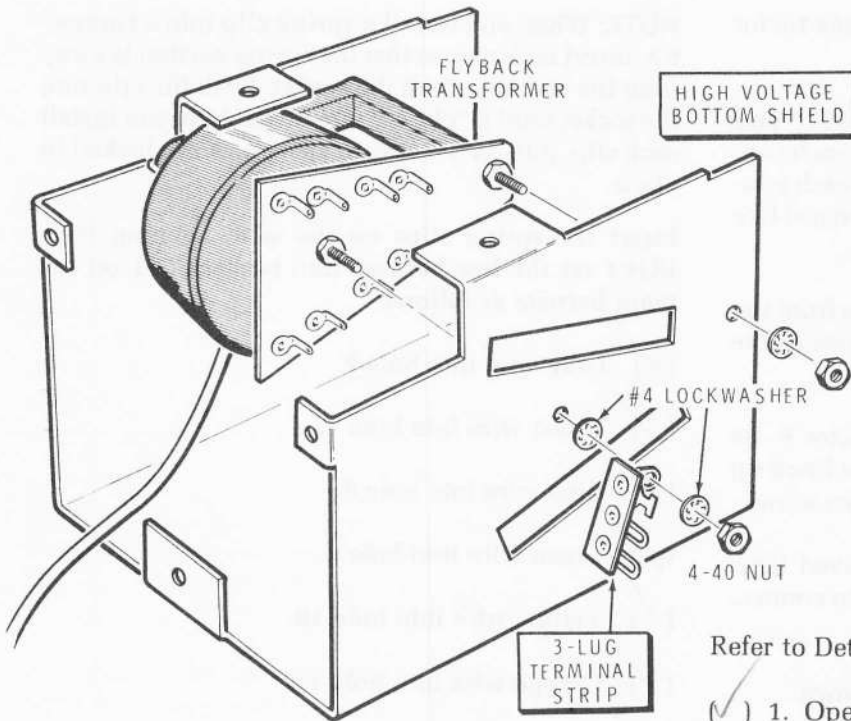

Detail 2-7A

HIGH VOLTAGE ASSEMBLY

Refer to Pictorial 2-7 (Illustration Booklet, Page 11) for the following steps.

- () T2: Refer to Detail 2-7A and mount the flyback transformer (#51-194) and a 3-lug terminal strip on the high voltage bottom shield. Use three #4 lockwashers, and two 4-40 nuts. NOTE: Two lockwashers should be installed with the terminal strip. Position the transformer and terminal strip as shown.
- () Locate the following parts. You will use these parts in the next five steps.

Quantity	Description
1	4-40 × 5/16" screw
1	#4 lockwasher
1	4-40 nut
1	Transistor insulator
1	Silicone grease
1	BU180A transistor (#417-894)
1	#4 plastic shoulder washer

Refer to Detail 2-7B for the next six steps.

- (✓) 1. Open the silicone grease container by making a small cut in one side.
- (✓) 2. Apply a thin coat of silicone grease on both sides of the transistor insulator. Save the remaining silicone grease, it will be used later.
- (✓) 3. Position the transistor insulator onto the metal side of the transistor so that the hole in the insulator and the hole in the transistor line up.
- (✓) 4. Q1: Insert the transistor leads into the **lower holes** in terminal strip DA (do not solder). Then position the transistor against the high voltage bottom shield so that the mounting holes line up. Reposition the terminal strip if necessary. Be sure the insulator is positioned so the metal side of the transistor can not touch the high voltage bottom shield.
- (✓) 5. Mount the transistor with a 4-40 × 5/16" screw, a #4 plastic shoulder washer, a #4 lockwasher, and a 4-40 nut. Make sure the plastic shoulder washer is inserted into the hole in the transistor.
- (✓) 6. Measure the resistance between the metal tab on the transistor and the high voltage bottom shield. You should obtain an infinity indication. If not, reverse your ohmmeter leads and check again. If you still do not get an infinity reading, recheck the transistor mountings to remove the short circuit.

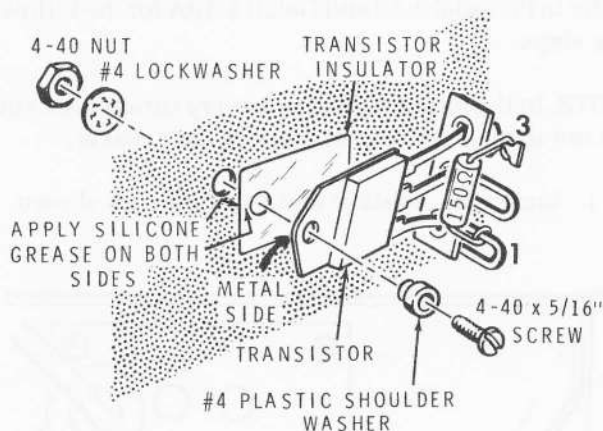

Detail 2-7B

- (✓) Solder the transistor leads to the lower holes in terminal strip DA.
- (✓) R2: Refer again to Detail 2-7B and connect a 150 Ω , 1/2-watt (brown-green-brown) resistor to terminal strip DA between lugs 1 (NS) and 3 (NS).
- (✓) Prepare the following wires.

1-1/2"	bare
2-3/4"	bare
1-1/2"	bare
4"	black stranded
1-1/2"	white

- (✓) Connect a 1-1/2" bare wire between transformer T2 lug 4 (S-1) and terminal strip DA lug 3 (NS). Position this wire away from the other lugs. This wire can touch the high voltage bottom shield.
- (✓) Connect a 2-3/4" bare wire between terminal strip DA lug 3 (S-3) and the shield lug at DB (NS). Position this wire away from the other lugs. This wire can touch the high voltage bottom shield.
- (✓) Connect a 1-1/2" bare wire between transformer T2 lug A (S-1) and the shield lug at DC (NS). This wire can touch the high voltage bottom shield.
- (✓) Connect one end of the 4" **black stranded** wire to the shield lug at DB (S-2). The other end of this wire will be connected later.

- (✓) Connect a 1-1/2" white wire between terminal strip DA lug 2 (NS) and transformer T2 lug 3 (S-1).
- () Cut the positive (+) marked lead of the 500 μF electrolytic capacitor to 1-3/4" and the other lead to 3/4". Then place 1" of sleeving over the positive (+) marked lead.

NOTE: When you install the positive (+) marked lead of this capacitor in the next step, insert the lead through the lug and then make a 1/4" loop in the lead. Solder the lead to the lug but do not get solder in the loop (see the inset drawing on Pictorial 2-7). Be sure this lead does not touch the high voltage bottom shield.

- (✓) C3: Connect the positive (+) marked lead of the 500 μF electrolytic capacitor to transformer T2 lug 1 (S-1) and the other lead to the shield lug at DC (S-2).
- (✓) Locate the large rubber grommet and make a cut in one side. Then position the grommet onto the high voltage lead coming from flyback transformer T2.
- (✓) Position the large rubber grommet into the cut-out in the high voltage top shield at DD so that the cut part is outward.
- (✓) Install the high voltage top shield to the bottom shield with three 6-32 \times 3/8" hex head self-tapping screws, with a #6 solder lug at hole DE. Position the solder lug as shown.

Refer to Pictorial 2-8 (Illustration Booklet, Page 11) for the following steps.

- (✓) Connect the black wire coming from the high voltage assembly lug DB to the upper hole in solder lug BE on the chassis (S-1). Be careful not to melt the insulation on any of the nearby wires.
- (✓) Mount the high voltage assembly to the chassis with a 6-32 \times 3/8" hex head self-tapping screw from under the chassis and two 6-32 \times 1/4" black screws through the rear panel. Be sure no wires are pinched between the high voltage assembly and the chassis.
- (✓) Remove the paper backing from the high voltage label and press the label on the high voltage top shield. Be sure you do not cover the ventilation holes.



Refer to Pictorial 2-9 (Illustration Booklet, Page 12) for the following steps.

Connect the wires coming from BO#13 of the main harness to the high voltage assembly as follows.
NOTE: Position the harness as shown.

- (✓) Large brown wire to transformer T2 lug 5 (S-1). Make sure the wire does not touch the bare wire connected to lug 4.
- (✓) Large violet wire to terminal strip DA lug 1 (S-2).
- (✓) Large yellow wire to terminal strip DA lug 2 (S-2).
- () Both medium red wires to transformer T2 lug 1 (S-2). Solder the wires to the loop made by the capacitor lead.

CHASSIS WIRING CONTINUED

- (✓) C1: Install the 12,000 μ F electrolytic capacitor in the capacitor mounting clamp at C1. Position the capacitor so that the positive (+ marked or color dot lug) is toward power transformer T1. Then tighten the clamp screw to hold the capacitor and the capacitor mounting clamp hardware in the chassis.

Connect the black and red wires coming from socket S102 of the main harness to capacitor C1 as follows:

- (✓) Medium red wire to the positive marked (+ or color dot) lug (S-1).
- () Medium black wire to the unmarked lug (NS).
- () Connect the medium black wire from BO#16 of the main harness to capacitor C1 unmarked lug (S-2).

Refer to Pictorial 2-10 and Detail 2-10A for the following steps.

NOTE: In the following steps, be very careful that you do not damage the paper cone of the speaker.

- () Locate the speaker and position it as shown.

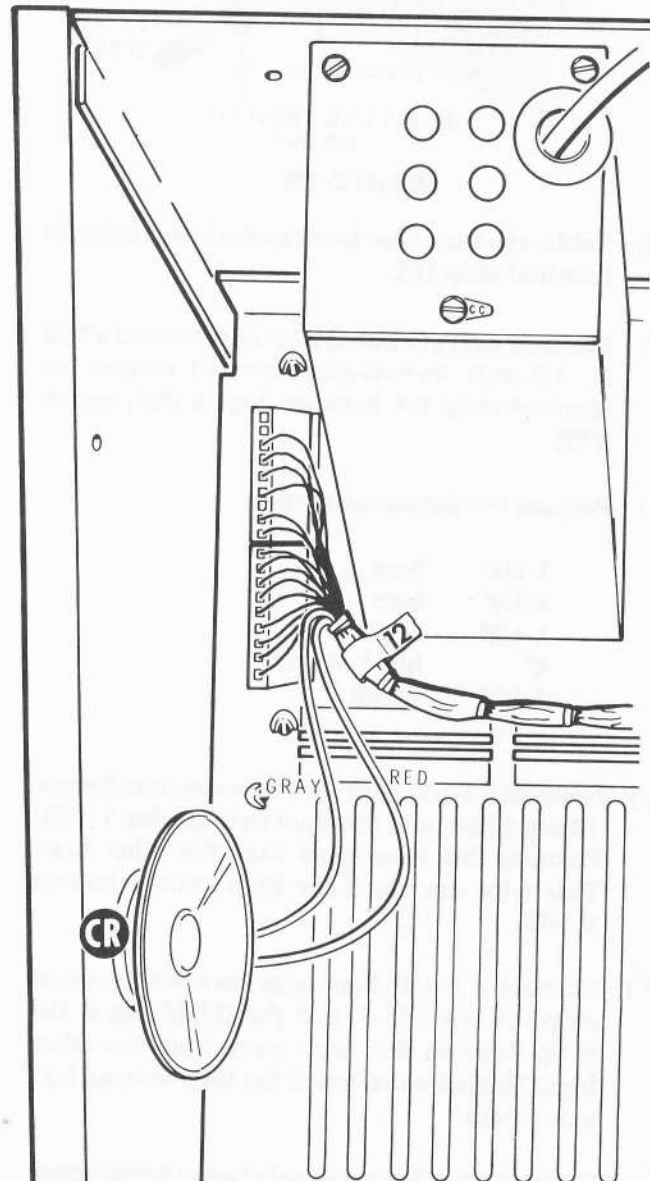

PICTORIAL 2-10

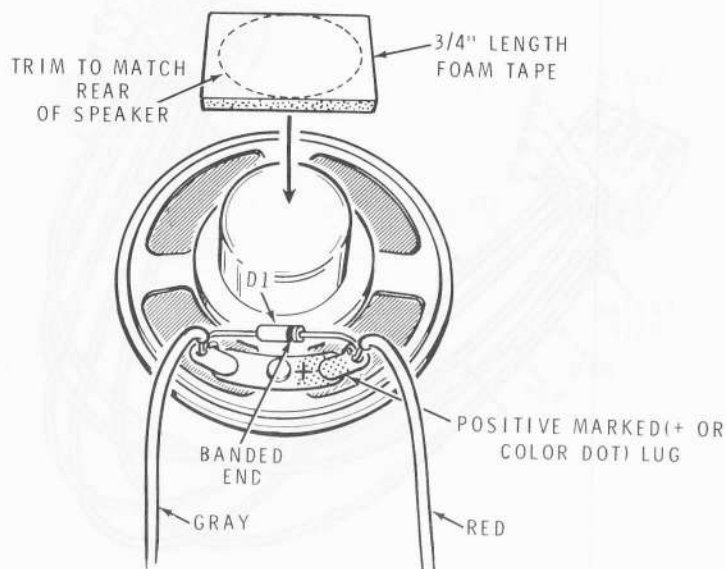

Detail 2-10A

- (✓) D1: Connect the lead from the banded end of a 1N4149 diode (#56-56) to the positive marked (+ or color dot) lug of the speaker (NS). Connect the other diode lead to the unmarked lug of the speaker (NS). Position the diode up 1/8" off the speaker.
- (✓) Connect the red wire coming from BO#12 to the positive marked (+ or color dot) lug of the speaker (S-2).
- (✓) Connect the gray wire coming from BO#12 to the unmarked speaker lug (S-2).
- (✓) Locate the thin foam tape and cut a 3/4" length. Then remove the protective paper backing from one side of the foam tape and press the tape to the back of the speaker. Then trim off the corners to match the back of the speaker.
- (✓) Remove the protective paper backing from the other side of the foam tape and press the speaker into recess CR provided in the left side panel.

Refer to Pictorial 2-11 for the following steps.

- (✓) Locate the yellow wire and cut it in half. Then prepare both ends of each wire.
- (✓) Crimp and solder an alligator clip to both ends of each yellow wire.

These yellow clip leads will be used later. Lay them aside.

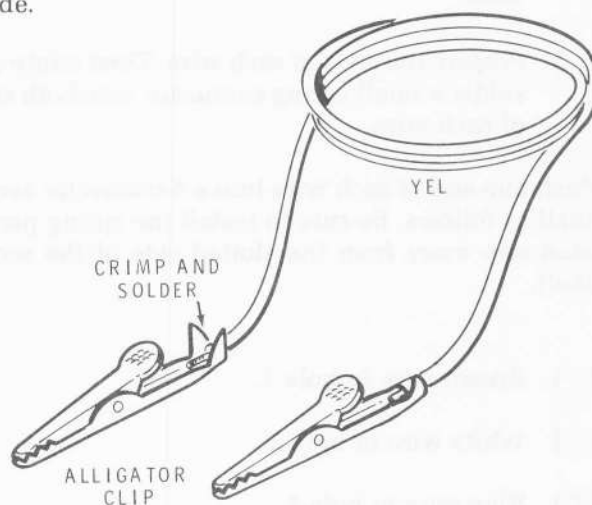

PICTORIAL 2-11



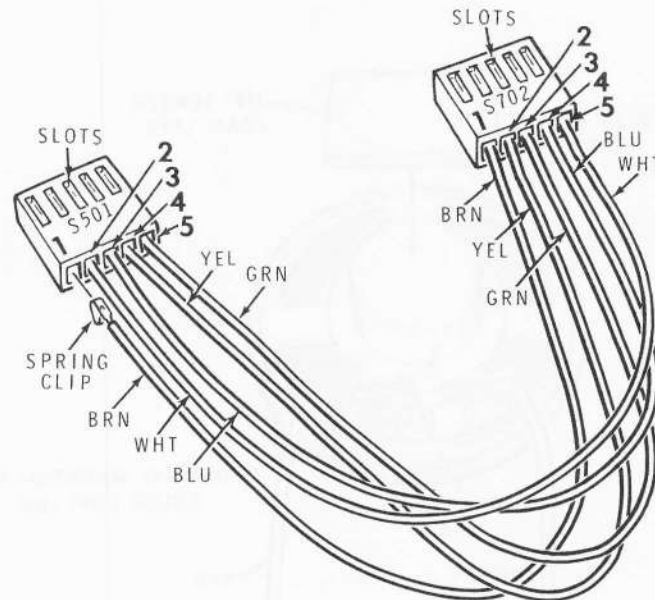

PICTORIAL 2-12

Refer to Pictorial 2-12 for the following steps.

- () Locate the 8-wire cable and cut a 4" length. Save the remaining length of this cable.
- () Carefully remove the outer insulation from the 4" cable. Save the brown, yellow, green, blue, and white wires for use in the following steps. Discard the remaining wires, as they will not be used.
- () Prepare the ends of each wire. Then crimp and solder a small spring connector onto both ends of each wire.

Push one end of each wire into a 5-connector socket shell as follows. Be sure to install the spring part of each clip away from the slotted side of the socket shell.

- () Brown wire in hole 1.
- () White wire in hole 2.
- () Blue wire in hole 3.
- () Yellow wire in hole 4.
- () Green wire in hole 5.

- () Mark this connector socket "S501" and mark a number "1" at the hole with the brown wire.

Install the other end of each wire into a 5-connector shell as follows. NOTE: The wires are not in the same order on this end of the cable.

- () Brown wire in hole 1.
- () Yellow wire in hole 2.
- () Green wire in hole 3.
- () Blue wire in hole 4.
- () White wire in hole 5.

- () Mark this connector socket "S702" and mark a number "1" at the hole with the brown wire. This cable will be used later; set it aside.

This completes the initial assembly and wiring of the chassis. Set the chassis aside and proceed to the "Power Supply Circuit Board." The parts that are left over at this time will be used later.

POWER SUPPLY CIRCUIT BOARD

PARTS LIST

Unpack the pack marked #1 and check each part against the following Parts List. The key numbers correspond to the numbers on the Power Supply Circuit Board Parts Pictorial (Illustration Booklet, Page 13). Any part that is packaged in an individual envelope with a part number on it should be placed back in the envelope after it is identified until it is called for in a step.

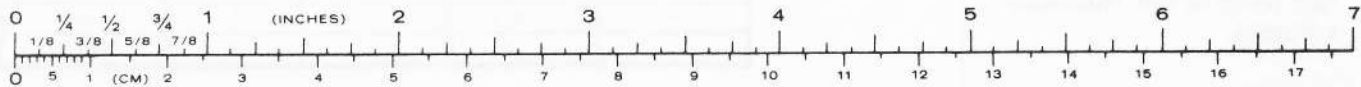

PARTS

Resistors will be called out by their resistance value in Ω (ohms), k Ω (kilohms), or M Ω (megohms). Certain types of resistors will have the value printed on the body, while others will be identified by a color code. The colors of the bands and the value will be given in the steps, therefore the following color code is given for information only.

EXAMPLES:

BROWN 1
GREEN 5
ORANGE 1,000
SILVER $\pm 10\%$

$15 \times 1,000 = 15,000 \Omega$ (15,000 OHMS),
or "15 k Ω "

ORANGE 3
BLACK 0
GREEN 100,000
GOLD $\pm 5\%$

$30 \times 100,000 = 3,000,000 \Omega$ (or 3 M Ω)
3 M $\Omega = 3$ MEGOHMS

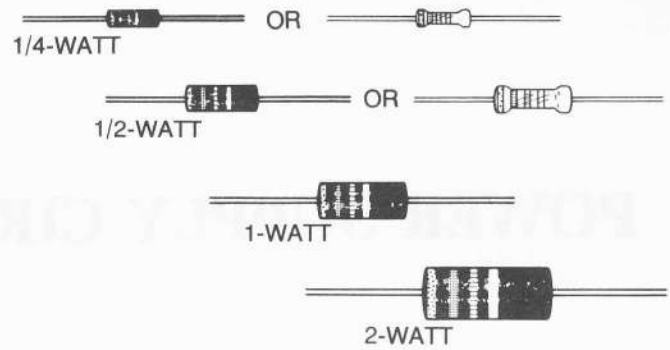

RESISTOR COLOR CODE

TOLERANCE
Gold 5%
Silver 10%

COLOR	1st DIGIT	2nd DIGIT	MULTIPLY BY
BLACK	0	0	1
BROWN	1	1	10
RED	2	2	100
ORANGE	3	3	1,000
YELLOW	4	4	10,000
GREEN	5	5	100,000
BLUE	6	6	1,000,000
VIOLET	7	7	10,000,000
GRAY	8	8	100,000,000
WHITE	9	9	1,000,000,000
GOLD			.1
SILVER			.01

Capacitors will be called out by their capacitance value in μF (microfarads) or pF (picofarads) and type: ceramic, Mylar*, electrolytic, etc. Some capacitors may have their value printed in the following manner:

EXAMPLES:

$151\text{K} = 15 \times 10 = 150 \text{ pF}$
 $759 = 75 \times 0.1 = 7.5 \text{ pF}$

NOTE: The letter "R" may be used at times to signify a decimal point; as in: 2R2 = 2.2 (pF or μF).

First digit of capacitor's value: 1

Second digit of capacitor's value: 5

Multiplier: Multiply the first & second digits by the proper value from the Multiplier Chart.

To find the tolerance of the capacitor, look up this letter in the Tolerance columns.

MULTIPLIER		TOLERANCE OF CAPACITOR		
FOR THE NUMBER:	MULTIPLY BY:	10pF OR LESS	LETTER	OVER 10pF
0	1	$\pm 0.1\text{pF}$	B	
1	10	$\pm 0.25\text{pF}$	C	
2	100	$\pm 0.5\text{pF}$	D	
3	1000	$\pm 1.0\text{pF}$	F	$\pm 1\%$
4	10,000	$\pm 2.0\text{pF}$	G	$\pm 2\%$
5	100,000		H	$\pm 3\%$
			J	$\pm 5\%$
8	0.01		K	$\pm 10\%$
9	0.1		M	$\pm 20\%$

*DuPont Registered Trademark

KEY No.	HEATH Part No.	QTY.	DESCRIPTION	CIRCUIT Comp. No.
---------	----------------	------	-------------	-------------------

RESISTORS

All resistors are 5% (fourth band gold) unless designated 10% (fourth band silver).

1/4-Watt

A1	6-470-12	1	47 Ω (yellow-violet-black)	R101
A1	6-621-12	1	620 Ω (blue-red-brown)	R104
A1	6-222-12	1	2200 Ω (red-red-red)	R106
A1	6-392-12	1	3900 Ω (orange-white-red)	R103
A1	6-103-12	1	10 k Ω (brown-black-orange)	R105

Other Resistors

A2	1-15-1	1	47 Ω , 10%, 1-watt (yellow-violet-black)	R107
A3	3-2-2	1	.33 Ω , 2-watt (orange-orange-silver)	R102

CAPACITORS

B1	25-200	1	.68 μ F tantalum	C104
31	25-221	3	2.2 μ F tantalum	C101, C102, C107
B2	25-180	2	2.2 μ F tantalum (tubular)	C103, C106
B3	25-818	1	500 μ F electrolytic	C105

DIODES

C1	56-56	1	1N4149	D113
C1	57-27	8	1N2071	D105, D106, D107, D108, D109, D110, D111, D112
C1	57-42	4	3A1	D101, D102, D103, D104

TRANSISTORS — INTEGRATED CIRCUITS (IC's)

NOTE: Transistors and integrated circuits are marked for identification in one of the following four ways:

1. Part number.

KEY No.	HEATH Part No.	QTY.	DESCRIPTION	CIRCUIT Comp. No.
---------	----------------	------	-------------	-------------------

Transistors — Integrated Circuits (cont'd.)

2. Type number. (On integrated circuits, this refers only to the numbers and letters listed. Any additional letters or numbers on an IC are not significant.)
3. Part number and type number.
4. Part number with a type number other than the one listed.

D1	417-819	1	MJE171 transistor	Q102
D2	417-899	1	MI2955 transistor	Q101
D3	442-609	1	78M20 IC	IC103
D4	442-644	1	78L12 IC	IC104
D5	442-54	2	7805 IC	IC101, IC102
D6	442-618	1	UA79MGT2C IC	IC105

HARDWARE

E1	250-381	2	6-32 \times 3/8" black screw
E2	250-26	2	6-32 \times 5/8" screw
E3	250-1173	2	6-32 \times 7/8" screw
E4	252-3	4	6-32 nut
E5	254-1	6	#6 lockwasher
E6	255-74	2	1/16" long spacer
E7	255-77	2	7/16" long spacer

SHELL — CONNECTOR — PLUGS — SOCKET

F1	432-865	2	3-connector socket shell	
F2	432-866	8	Small spring connector (2-extra)	
F3	432-943	1	2-pin plug	P103
F4	432-967	2	12-pin plug	P101, P102
F5	434-189	1	Transistor socket	

MISCELLANEOUS

G1	75-140	1	Transistor insulator
G2	75-88	1	Transistor cap

PARTS FROM FINAL PACK

	85-1957-2	1	Power supply circuit board
G3	215-621	1	Transistor heat sink

ASSEMBLY NOTES

ASSEMBLY

1. Position all parts as shown in the Pictorials.
2. Solder a part or a group of parts only when you are instructed to do so.

SOLDERING

1. Keep the soldering iron tip clean. Wipe it often on a wet sponge or cloth; then apply solder to the tip to give the entire tip a wet look. This process is called tinning, and it will protect the tip and enable you to make good connections. When solder tends to "ball" or does not stick to the tip, the tip needs to be cleaned and retinned.
2. Do not create solder bridges between adjacent circuit board foils. A solder bridge usually occurs when you use too much solder and then drag the soldering iron across the board when you remove it from the connection. Always use

just enough solder to make a good connection, and lift the soldering iron straight up from the circuit board. If a solder bridge should develop, turn the circuit board foil side down and heat the solder between connections. The excess solder will run onto the tip of the soldering iron, and this will remove the solder bridge. See the drawing below. You can also place the desoldering wick (braid) on a solder bridge. Then heat the wick with the soldering iron and the wick will soak up the excess solder. If you suspect a solder bridge exists, but are not sure, compare the foil side of the circuit board with the "X-Ray View" of that circuit board.

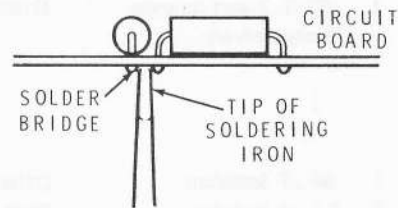

A GOOD SOLDER CONNECTION

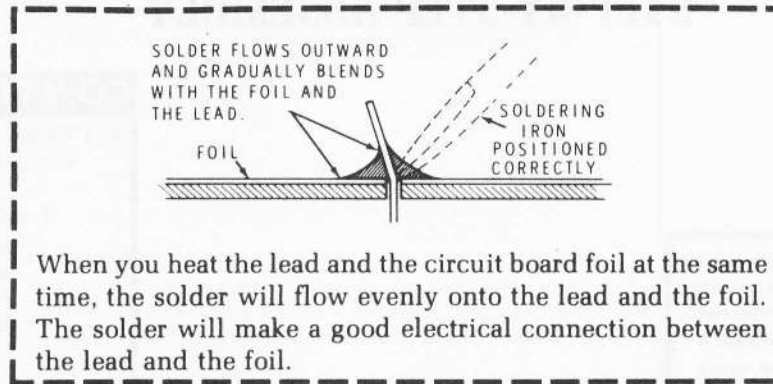

POOR SOLDER CONNECTIONS

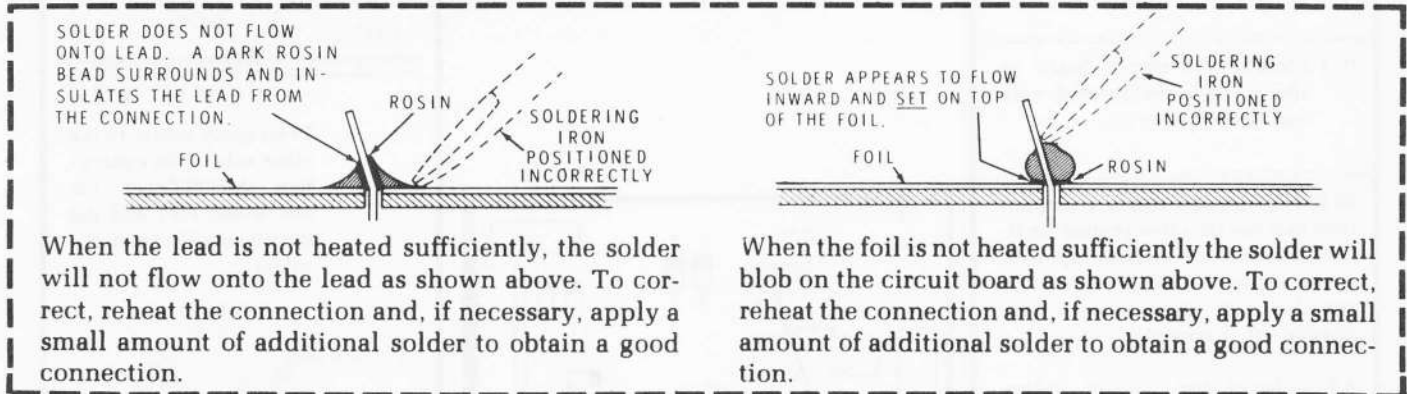

SOLDER BRIDGES

A solder bridge between two adjacent foils is shown in photograph A. Photograph B shows how the connection should appear. A solder bridge may occur if you accidentally touch an adjacent previously soldered connection, if you use too much solder, or if you "drag" the soldering iron across other foils as you remove it from the connection. A good rule to follow is: always take a good look at the foil area around each lead before you solder it. Then, when you solder the connection, make sure the solder remains in this area and does not bridge to another foil. This is especially important when the foils are small and close together. NOTE: It is all right for solder to bridge two connections on the same foil.

Use only enough solder to make a good connection, and lift the soldering iron straight up from the circuit board. If a solder bridge should develop, turn the circuit board foil-side-down and heat the solder between connections. The excess solder will run onto the tip of the soldering iron, and this will remove the solder bridge. NOTE: The foil side of most circuit boards has a coating on it called "solder resist." This is a protective insulation to help prevent solder bridges.

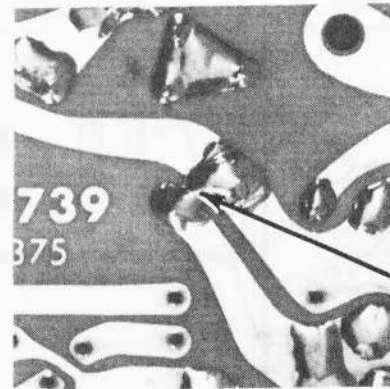

SOLDER BRIDGE



STEP-BY-STEP ASSEMBLY

START

In the following steps, you will be given detailed instructions on how to install and solder the first part on the circuit board. Read and perform each step carefully. Then use the same procedure whenever you install parts on a circuit board.

(✓) Position the circuit board as shown with the printed side (not the foil side) up.

NOTE: When you install a component that has its value printed on it, position the value marking up, so it can be easily read. Diodes should be mounted with their type or part number up, if possible.

All resistors are 1/4-watt unless specified otherwise in a step.

(✓) R106: Hold a 2200 Ω (red-red-red) resistor by the body as shown and bend the leads straight down.



(✓) Push the leads through the holes at the proper location on the circuit board. Resistors can be positioned either way.

(✓) Press the resistor against the circuit board. Then bend the leads outward slightly to hold the resistor in place.

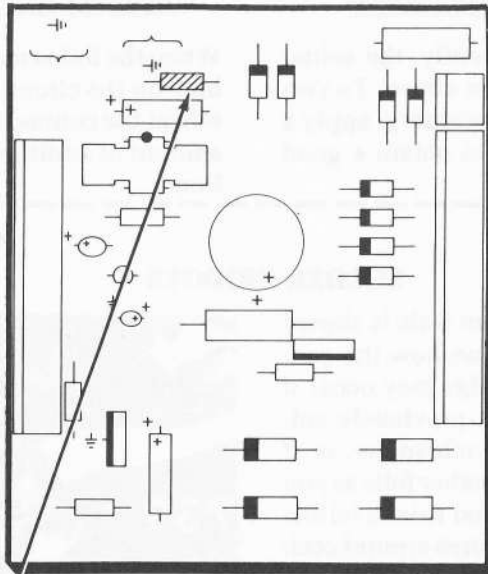
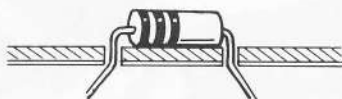

PICTORIAL 3-1

CONTINUE

() Solder the resistor leads to the circuit board as follows:

1. Push the soldering iron tip against both the lead and the circuit board foil. Heat **both** for two or three seconds.

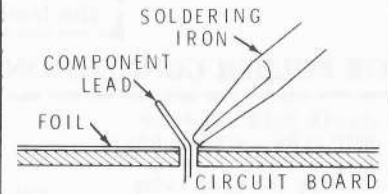

2. Then apply solder to the other side of the connection. **IMPORTANT:** Let the heated lead and the circuit board foil melt the solder.

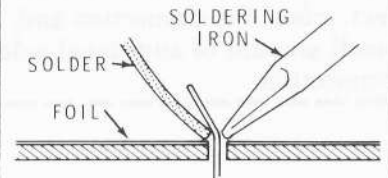

3. As the solder begins to melt, allow it to flow around the connection. Then remove the solder and the iron and let the connection cool.

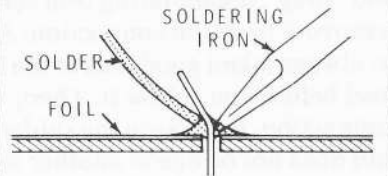

() Cut off the excess lead lengths close to the connection. **WARNING:** Clip the leads so the ends will not fly toward your eyes.

() Check each connection. Compare it to the illustrations on Page 37. After you have checked the solder connections, proceed with the assembly on Page 39. Use the same soldering procedure for each connection.

IMPORTANT: THE BANDED END OF DIODES CAN BE MARKED IN A NUMBER OF WAYS.

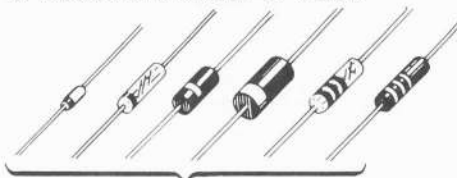

BANDED END

Detail 3-2A

CONTINUE ↘

NOTE: When you install a diode, always match the band on the diode with the band mark on the circuit board. See Detail 3-2A. THE CIRCUITRY WILL NOT WORK PROPERLY IF A DIODE IS INSTALLED BACKWARDS. Grip the diode leads between the body of the diode and the bend when you bend the leads to prevent diode damage.

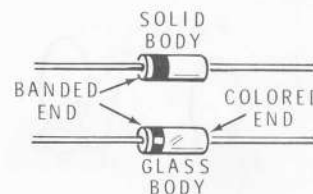
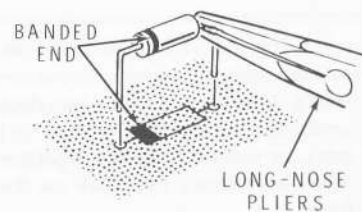

If your diode has a solid body, the band is clearly defined. If your diode has a glass body, do not mistake the colored end **inside** the diode for the banded end. Look for a band painted on the **outside** of the glass.

Install 1N2071 diodes (#57-27) at the following eight locations.

- (✓) D105 (✓) D109
- (✓) D106 (✓) D110
- (✓) D107 (✓) D111
- (✓) D108 (✓) D112

(✓) Solder the leads to the foil and cut off the excess lead lengths.

START ↘

NOTE: Make sure you have installed the first resistor in Pictorial 3-1.

(✓) R105: 10 k Ω (brown-black-orange).

(✓) R101: 47 Ω (yellow-violet-black).

(✓) R103: 3900 Ω (orange-white-red).

(✓) R104: 620 Ω (blue-red-brown).

(✓) Solder the leads to the foil and cut off the excess lead lengths.

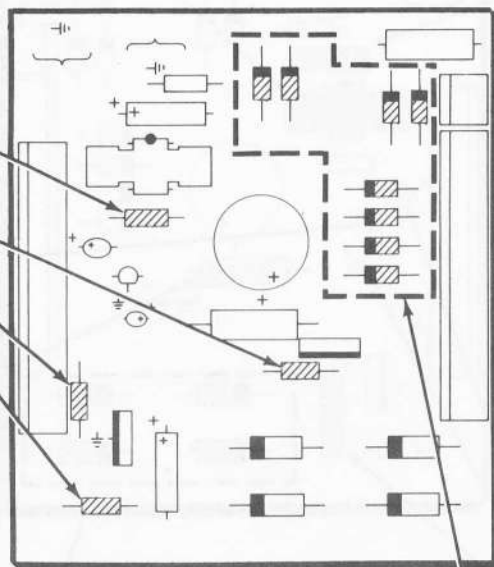

PICTORIAL 3-2

START ↘

NOTE: When you install a tubular tantalum capacitor, match the marked (+ or colored) end on the capacitor with the positive (+) mark on the circuit board.

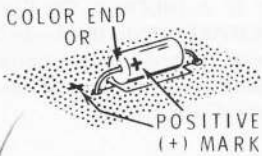

(✓) C106: 2.2 μ F tubular tantalum.

NOTE: When you install a tantalum capacitor, match the positive (+) mark, or color dot on the capacitor with the positive (+) mark on the board.

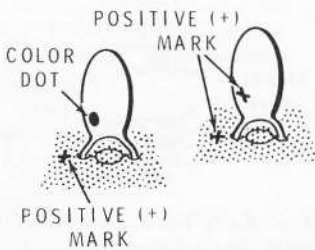

(✓) C107: 2.2 μ F tantalum.

(✓) C104: .68 μ F tantalum.

(✓) C103: 2.2 μ F tubular tantalum.

(✓) Solder the leads to the foil and cut off the excess lead lengths.

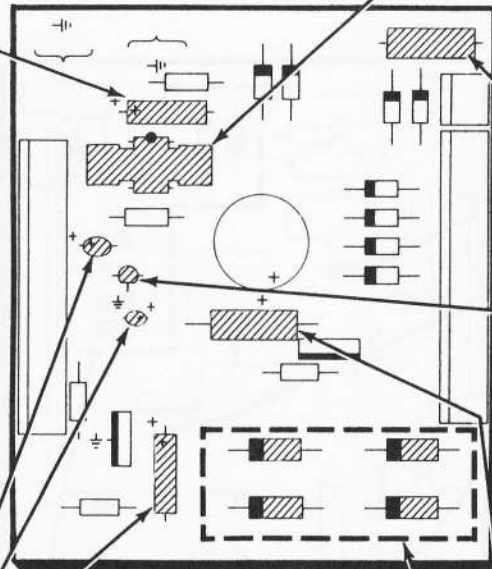

PICTORIAL 3-3

CONTINUE ↘

(✓) IC105: UA79MGT2C IC (#442-618). Match the index mark on the IC with the index mark on the circuit board. Push the IC pins into their holes in the board. Bend the pins slightly to hold the IC in place. Then solder the pins to the foil.

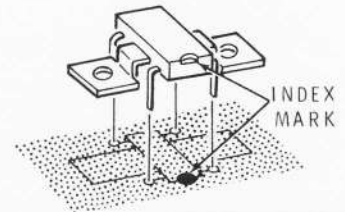

(✓) R107: 47 Ω , 1-watt (yellow-violet-black).

(✓) IC104: 78L12 IC (#442-644). Line up the flat on the IC with the flat on the circuit board outline. Insert the leads of the IC into their correct holes, which are indicated by OUT, ground (\oplus), and IN. Position the bottom of the IC 1/4" above the board. Then solder the leads to the foil and cut off the excess lead lengths.

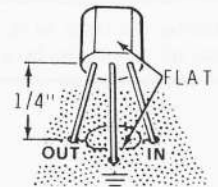

(✓) R102: .33 Ω , 2-watt (orange-orange-silver).

Install 3A1 diodes (#57-42) at the following four locations. Position the body of each diode 1/4" above the board.

- (✓) D101 (✓) D103
- (✓) D102 (✓) D104

(✓) Solder the leads to the foil and cut off the excess lead lengths.

START

NOTES:

1. Solder the pins or leads of each part as it is installed. Then cut off any excess lead lengths.
2. When you install a plug, position the lip of the plug over the narrow space in the plug outline on the circuit board. Insert the plug pins all the way into the holes and solder the pins to the foil.

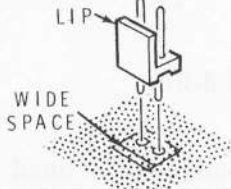

(✓) P103: 2-pin plug.

(✓) P102: 12-pin plug.

(✓) P101: 12-pin plug.

(✓) IC103: 78M20 IC (#442-609). Position the metal side of the IC as shown. Insert the OUT, ground (\pm), and IN leads in their correct holes in the circuit board. Position the IC 1/4" above the board.

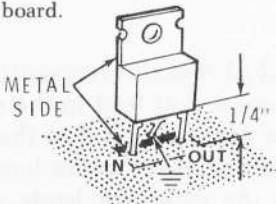

(✓) Q102: MJE171 transistor (#417-819). Position the metal side of the transistor as shown. Insert the B, C, and E leads into their correct holes in the circuit board. Position the bottom of the transistor 1/4" above the board.

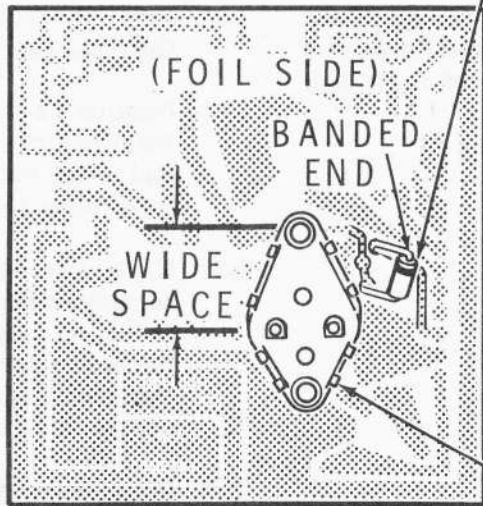
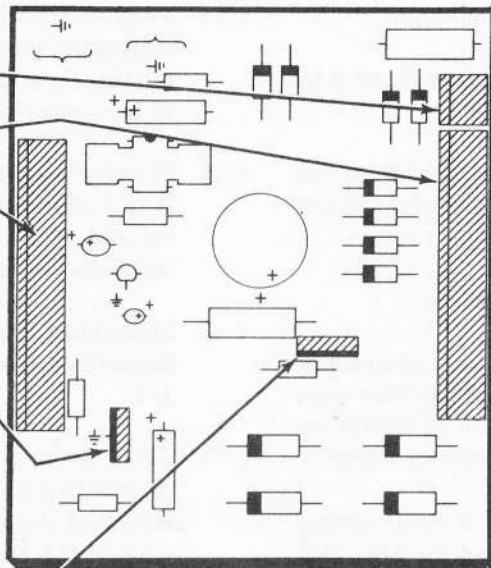
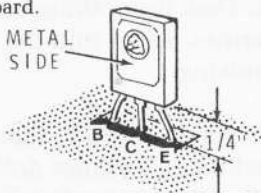

PICTORIAL 3-4

CONTINUE

(✓) Turn the circuit board over and position it foil side up as shown.

NOTE: In the next step, keep the diode leads as short as possible and make sure the leads do not touch any other foils or connections.

(✓) D113: 1N4149 diode (#56-56). Solder the leads to the two indicated foils. Be sure to position the banded end as shown. There are no holes in the circuit board for the leads. Solder the leads directly to the foil.

NOTE: When you install the following transistor socket, insert the pins into their holes in the circuit board and push the socket down as far as possible. Note the wide space between the socket holes. Keep the socket parallel to the circuit board.

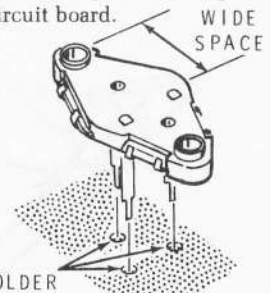

(✓) Transistor socket.

Set the circuit board aside temporarily.

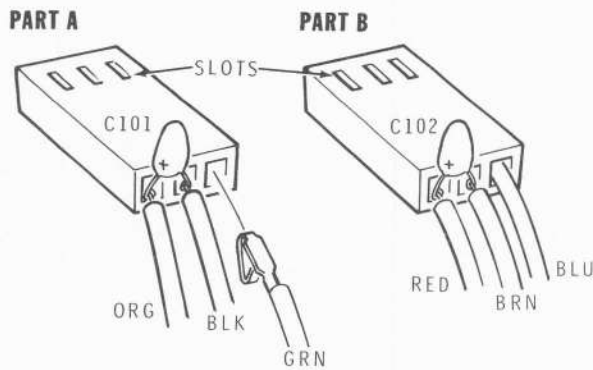

PICTORIAL 3-5

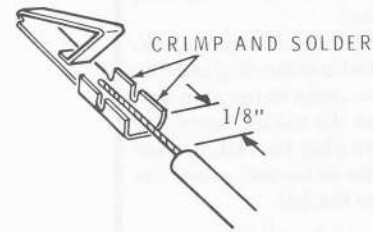

Detail 3-5B

Refer to Pictorial 3-5 for the following steps.

- (✓) Locate the remaining 8-wire cable and cut it to 3-1/2".
- (✓) Carefully remove the outer insulation from the 3-1/2" piece of 8-wire cable. Be careful not to cut the insulation on the wires.
- (✓) Discard the yellow and white wires.
- (✓) Remove 1/8" of insulation from **only** one end of the blue and green wires. Twist the fine wire strands and melt a small amount of solder on the exposed fine strands of these two wires.
- (✓) Refer to Detail 3-5A and install a small spring connector on the prepared end of the blue and green wires. Set these wires aside temporarily.
- (✓) Remove 3/8" of insulation from **only** one end of the brown, red, black, and orange wires. Twist the fine wire strands and melt a small amount of solder to the exposed strands of these four wires.

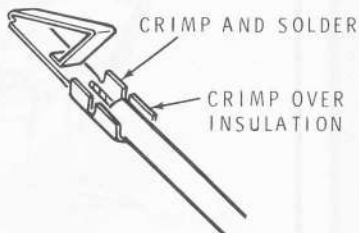

Detail 3-5A

- (✓) Refer to Detail 3-5B and install a small spring connector on the prepared end of the brown, red, black, and orange wires. NOTE: Leave 1/8" of bare wire behind the spring connector.
- (✓) Position a 3-connector socket shell as shown in Part A of Pictorial 3-5. Then insert the connector end of the orange and black wires into the indicated holes in the housing.
- (✓) Straighten the leads of two 2.2 μF tantalum capacitors. Cut the leads of both capacitors to 1/4".
- (✓) C101: Connect a 2.2 μF tantalum capacitor with its positive (+ or color dot) lead to the orange wire and the other capacitor lead to the black wire of the prepared socket. Solder both connections. Be sure the capacitor leads do not touch each other.
- (✓) Install the connector end of the green wire into the remaining hole in this connector housing.
- (✓) Position a 3-connector socket shell as shown in Part B of Pictorial 3-5. Then insert the connector end of the red and brown wires into the indicated holes in the housing.
- (✓) C102: Connect the other 2.2 μF tantalum capacitor with its positive (+ or color dot) lead to the red wire and the other capacitor lead to the brown wire of the prepared socket. Solder both connections. Be sure the capacitor leads do not touch each other.
- (✓) Install the connector end of the blue wire in the remaining hole in this connector housing.

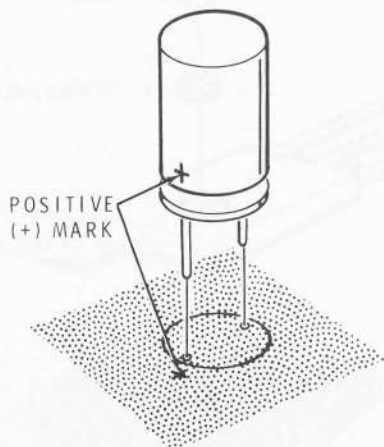

Detail 3-6A

Refer to Pictorial 3-6 (Illustration Booklet, Page 13) for the following steps.

- Twist together the wires of either connector. If necessary, cut the wire ends even with the shortest wire so all these wires are the same length. Remove 1/4" of insulation from each wire end. Twist the fine wires and melt a small amount of solder on the exposed end of each wire.
- In the same manner, prepare the wires of the remaining connector.

Install the wires of the connector with the green wire into the power supply circuit board holes at location IC101. Solder each wire as it is installed and cut off the excess lead lengths.

- Green wire to hole OUT.
- Black wire to hole \perp (ground).
- Orange wire to hole IN.

In the same manner, connect the wires of the socket with the blue wire into the holes at IC102 in the power supply board as follows:

- Blue wire to hole OUT.
- Brown wire to hole \perp (ground).
- Red wire to hole IN.

- C105: Refer to Detail 3-6A and install the 500 μ F electrolytic capacitor at location C105 on the power supply circuit board. Be sure to install the positive (+) lead into the positive (+) hole in the circuit board. Solder the leads to the foil and cut off the excess lead lengths.

CIRCUIT BOARD VISUAL CHECK

It is important that the following checkout procedure be done after the circuit board is completed.

Carefully inspect the foil side of the circuit board for the following most commonly made errors.

- Unsoldered connections.
- Poor solder connections.
- Solder bridges between foil patterns. NOTE: If you suspect a solder bridge, check the foil on the circuit board against the foil pattern shown in the X-Ray View section of the Operation Manual.
- Protruding leads which could touch together.

When you make the following visual checks, refer to the Pictorial where the part was installed and check it against the installation instructions.

- Check the diodes for proper installation.
- Check the transistors for proper installation.
- Check the integrated circuits for proper type and installation.
- Check the electrolytic and tantalum capacitors for the correct position of the positive (+) end.
- Check the plugs for proper installation.
- Set the circuit board aside temporarily.

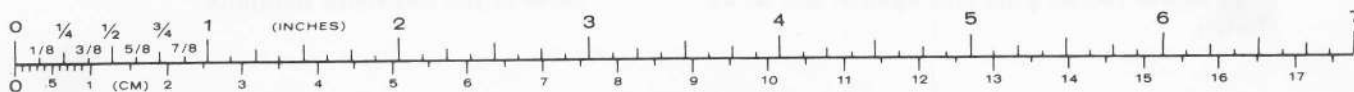

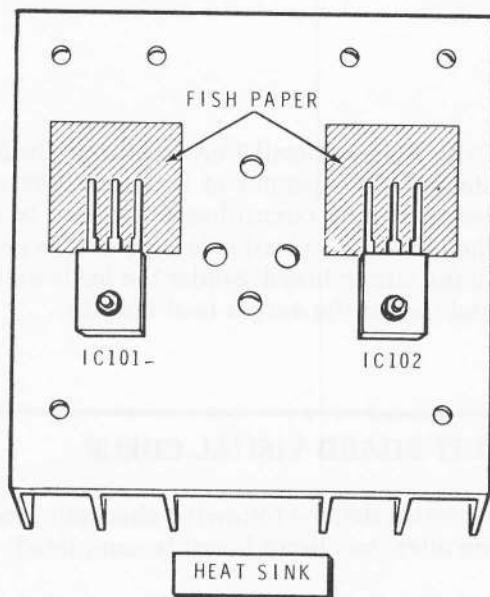

PICTORIAL 3-7

Refer to Pictorial 3-7 for the following steps.

- (✓) Locate the two 7805 integrated circuits (#442-54) and the remaining silicone grease. Apply a thin layer of silicone grease to the metal side of each of these IC's. Save the remaining silicone grease for use later.
- (✓) IC101: Refer to Detail 3-7A and mount one of these 7805 (#442-54) IC's metal side down at location IC101 on the transistor heat sink. Use a 6-32 x 3/8" black screw, #6 lockwasher, and a 6-32 nut.
- (✓) IC102: In the same manner, mount the other 7805 (#442-54) IC metal side down at location IC102 on the heat sink.
- (✓) Locate the 4-1/2" x 6" piece of fish paper and cut it to 4-1/2" x 5". Save this large piece for use later. The 1" x 4-1/2" piece will be used in the next step.
- (✓) Cut two 3/4" x 3/4" pieces from the 1" x 4-1/2" piece of fish paper. The remaining piece of this fish paper will not be used.
- (✓) Remove the paper backing from one piece of fish paper and press the fish paper in place on the heat sink next to IC101. Push the indicated edge under the IC pins and against the IC as shown.

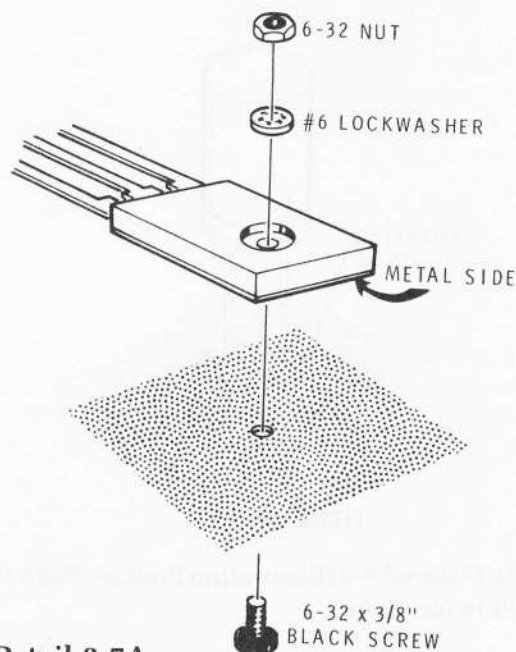

Detail 3-7A

- (✓) In the same manner, install the other piece of fish paper on the heat sink at IC102.

Refer to Pictorial 3-8 for the following steps.

- (✓) Plug the IC101 connector (with orange wire) coming from the power supply circuit board onto the pins of IC101 on the heat sink. Be sure the slots in the connector are up as shown.
- (✓) Bend the body of the capacitor on this connector down against the connector leads.
- (✓) In the same manner, install the IC102 connector onto the pins of IC102 and bend its capacitor down against the connector leads.

NOTE: When you mount the circuit board on the heat sink in the next step, the shoulders on transistor socket Q101 must fit into their holes in the heat sink. If necessary, twist the transistor socket as needed to get a proper fit into the heat sink.

- (✓) Mount the power supply circuit board on the heat sink with 6-32 x 7/8" screws, 7/16" long spacers, #6 lockwashers, and 6-32 nuts.
- () Apply a thin layer of silicone grease to both sides of the transistor insulator.

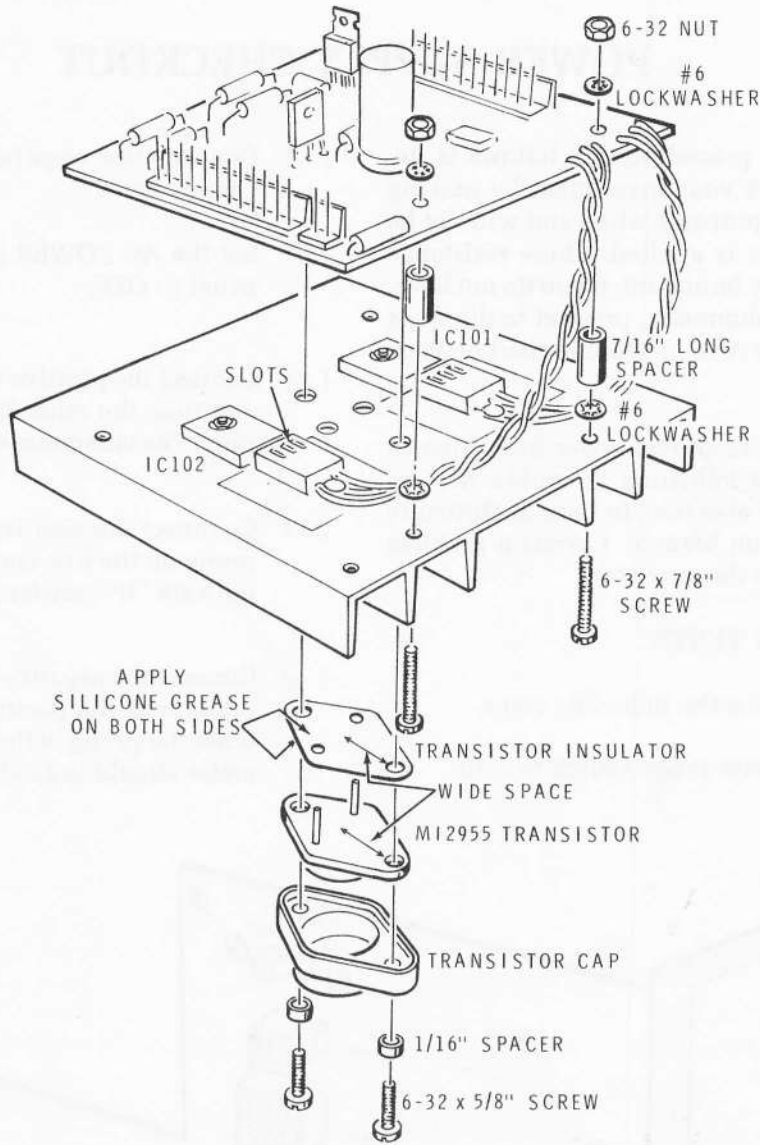

PICTORIAL 3-8

- (✓) Place the transistor insulator on the MI-2955 transistor (#417-899). Note the wide space between the insulator holes and the wide space between the transistor pins and one of its holes.
- (✓) Q101: Mount the MI-2955 transistor (#417-899) at location Q101 on the heat sink. Position the wide space of the transistor properly and push

the transistor pins into its socket on the power supply circuit board.

- (✓) Install the transistor cap on Q101 with 6-32 × 5/8" screws and 1/16" long spacers. Securely tighten the screws so the spacers are tight against the transistor. This is necessary for a good electrical contact.

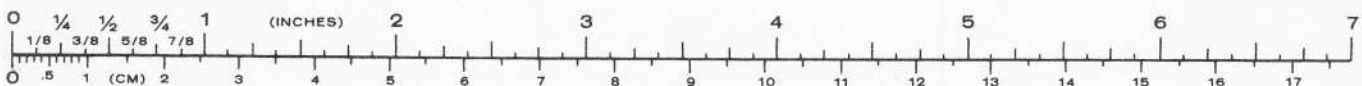

POWER SUPPLY CHECKOUT

NOTE: The checkout procedure that follows is designed to help protect your investment by making sure that your unit is properly wired and will not be damaged when power is applied. These resistance measurements are very important. If you do not have, or can not obtain an ohmmeter, proceed to the steps following the Possible Area of Trouble chart on Page 47.

If you do not obtain the correct meter indication in any step, refer to the following "Possible Area of Trouble" column and also the "In Case of Difficulty" section in the Operation Manual. Correct a problem before you proceed to the next step.

PRIMARY WIRING TESTS

Refer to Pictorial 3-9 for the following steps.

- (✓) Set your ohmmeter range switch to $\times 10$.

- (✓) Connect the negative ohmmeter lead to the chassis panel.
- (✓) Set the AC POWER (PWR) switch on the rear panel to OFF.
- (✓) Connect the positive ohmmeter lead to first one and then the other flat prong of the line cord plug. The ohmmeter should indicate INFINITE.
- (✓) Connect the positive meter lead to the round prong on the line cord plug. The meter should indicate "0" resistance.
- (✓) Connect the negative ohmmeter lead to one flat prong and the positive ohmmeter lead to the other flat prong of the line cord plug. The ohmmeter should indicate INFINITE.

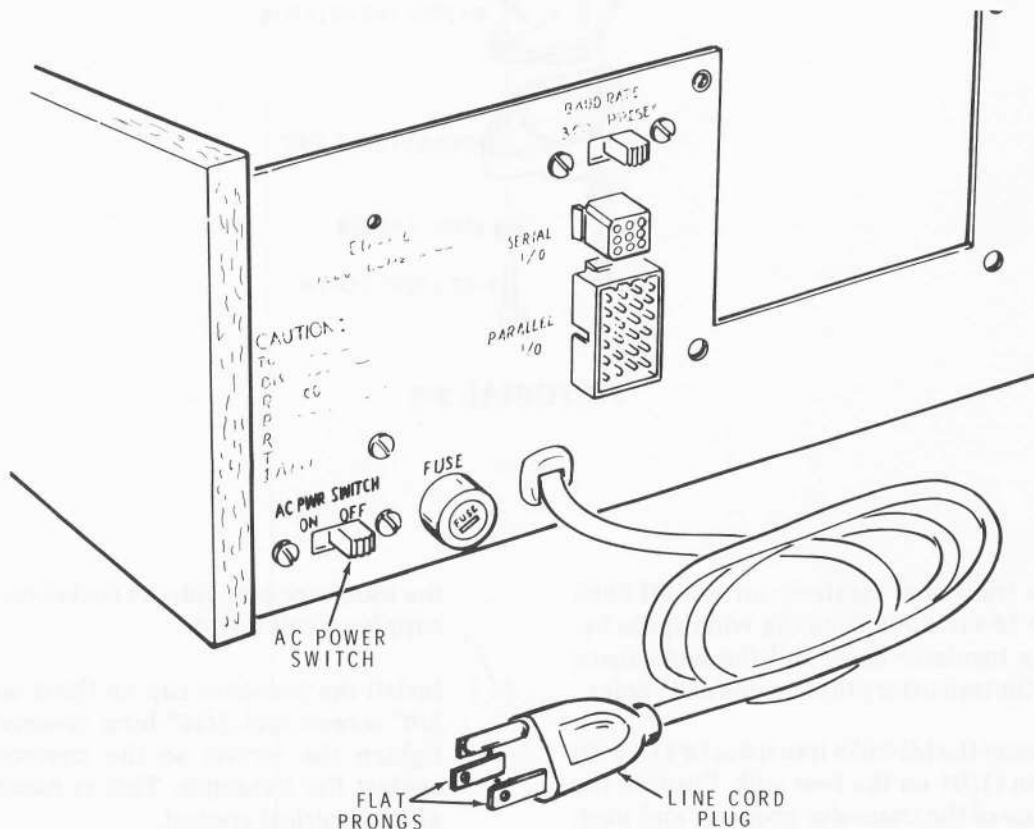

PICTORIAL 3-9



- () With the ohmmeter leads still connected to the line cord plug prongs, move the AC POWER switch on the rear panel to the ON position. The ohmmeter should indicate approximately six ohms.
- () Disconnect the ohmmeter leads and place the AC POWER switch in the OFF position.

POSSIBLE AREA OF TROUBLE

1. Fuseholder (fuse not installed).
2. Terminal strip AR (wiring error).
3. AC PWR switch (wires connected to wrong lugs).
4. Ohmmeter is connected to round prong in place of the flat prong on the line cord plug.

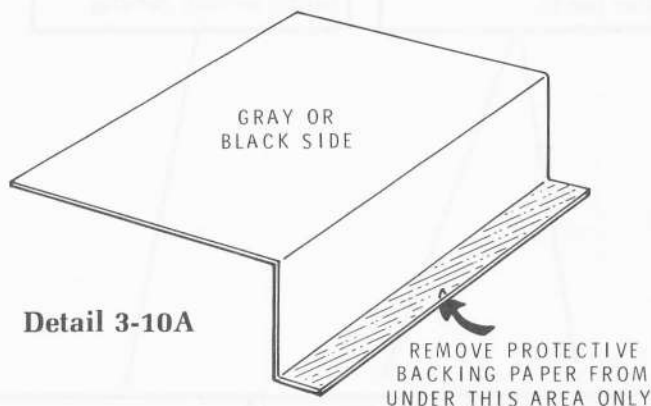
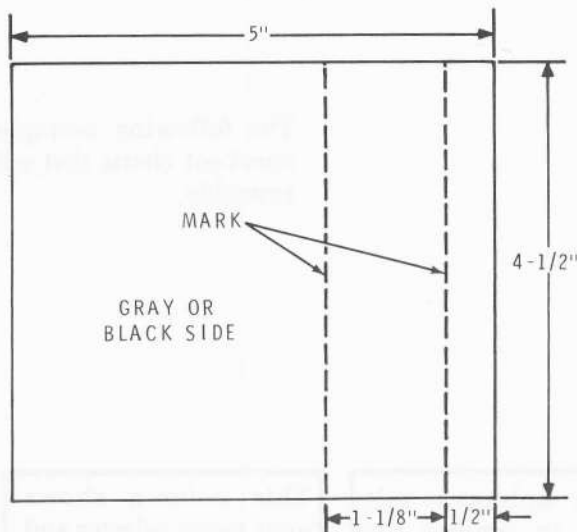

Detail 3-10A

Refer to Detail 3-10A for the next two steps.

1. () Locate the "saved 4 1/2" x 5" piece of fish paper.
2. () Score the gray or black side of the fish paper with a knife or pointed object. Be careful that you do not cut through the paper. Then fold the paper as shown and remove the protective backing paper from the narrow section.

Refer to Pictorial 3-10 for the following steps.

- () Place the fish paper into the chassis under the chassis flange as shown. Press the narrow tab against the chassis to hold it in place.
- () Set the chassis aside and locate the power supply circuit board.

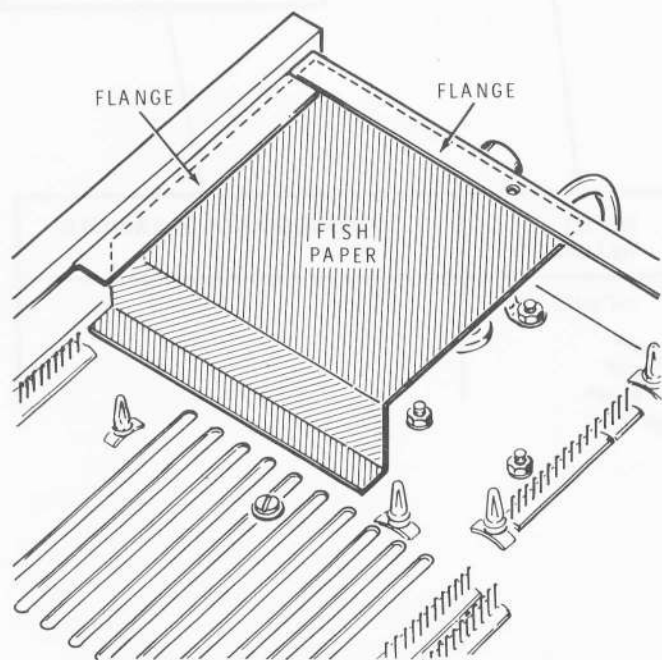

PICTORIAL 3-10

Refer to Pictorial 3-10 for the following steps.

- () Position the chassis bottom-side up.



The following example is an explanation of the checkout charts that will follow each circuit board assembly.

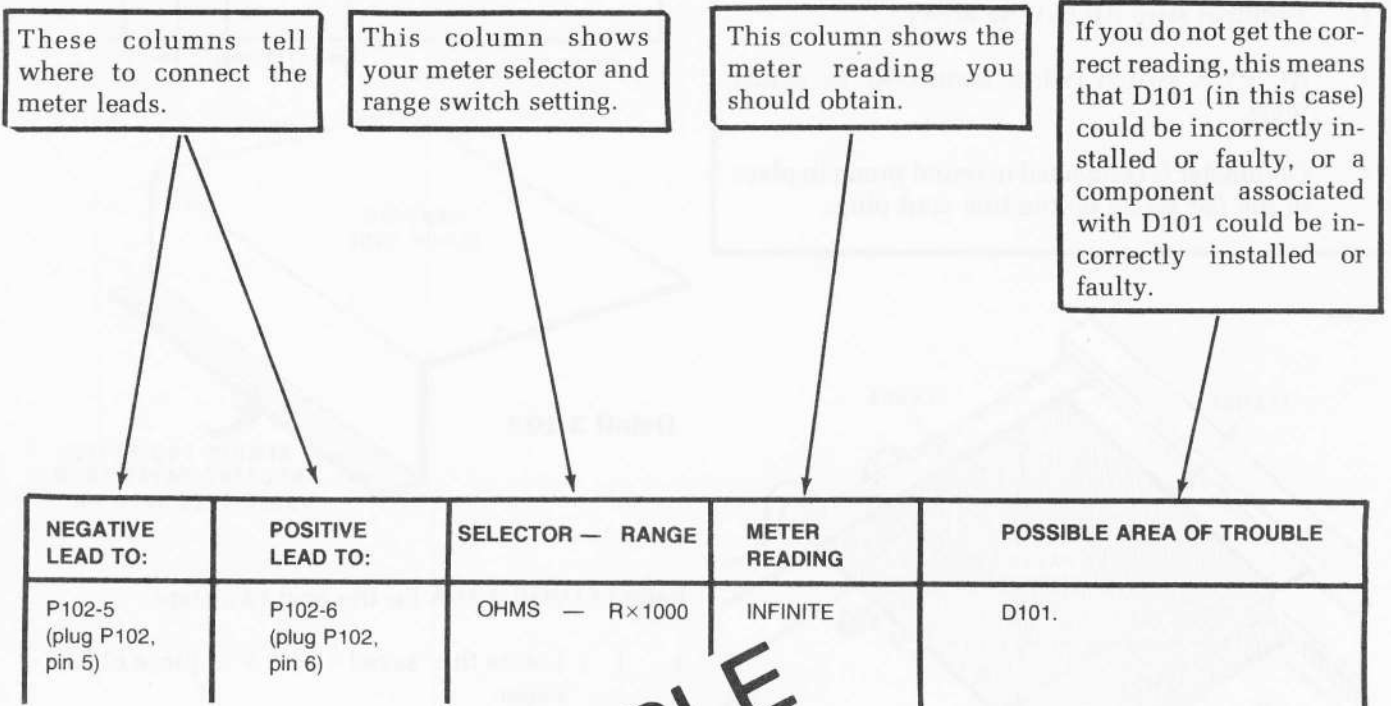

EXAMPLE



NOTE: The positive power source in your ohmmeter could be connected to either meter lead. Therefore, if you do not obtain the correct indication in any of the resistance measurements, reverse your meter leads and make the measurement again. If you obtain the correct meter indication this way, make the rest of the resistance measurements with your leads connected in this manner.

PICTORIAL 3-11

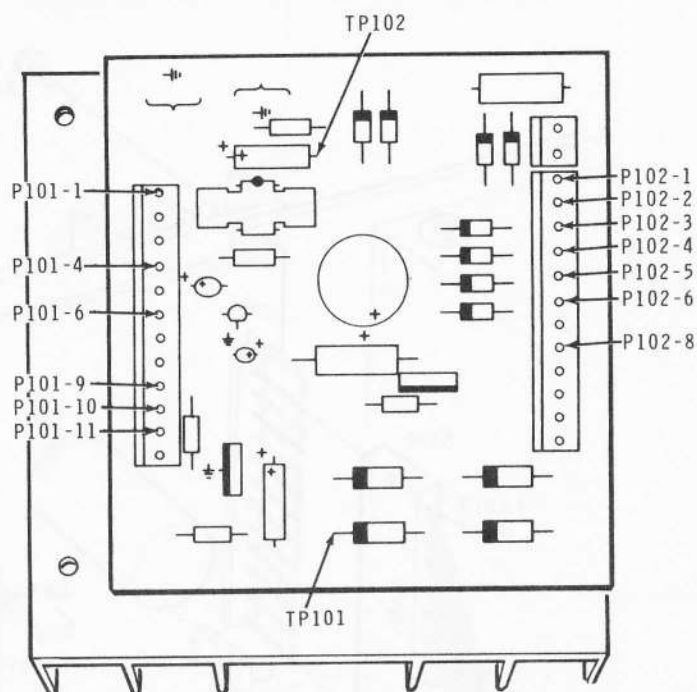

RESISTANCE MEASUREMENTS

Refer to Pictorial 3-11 for the following steps.

Make the following resistance measurements on the power supply circuit board. NOTE: The shaded boxes indicate plug P102 while the unshaded boxes indicate plug P101.

Allow the meter time to stop moving before you read it.

	NEGATIVE LEAD TO:	POSITIVE LEAD TO:	SELECTOR — RANGE	METER INDICATION	POSSIBLE AREA OF TROUBLE
()	P102-5	P102-6	OHMS — R×1000	INFINITE	D101, D102, D103, D104
()	P102-3	P102-4	OHMS — R×1000	INFINITE	D105, D106, D107, D108
()	P102-1	P102-2	OHMS — R×1000	GREATER THAN 100 kΩ	D109, D110, D111, D112
()	P101-6	P101-1	OHMS — R×1000	GREATER THAN 1000 Ω	IC101
()	P101-6	P101-4	OHMS — R×1000	GREATER THAN 1000 Ω	IC102
()	P101-6	P101-9	OHMS — R×1000	GREATER THAN 1000 Ω	IC105, C107
()	P101-6	P101-10	OHMS — R×1000	GREATER THAN 1000 Ω	IC104
()	P101-6	P101-11	OHMS — R×1000	GREATER THAN 1000 Ω	Q101, IC103, IC104, C104
()	P101-6	P102-8	OHMS — R×10k	GREATER THAN 100 kΩ	Q101, Q102, METER RANGE SWITCH NOT CORRECTLY SET.
()	P101-6	TP101	OHMS — R×1000	GREATER THAN 1000 Ω	IC101, IC102, C101, C102
()	P101-6	TP102	OHMS — R×100	GREATER THAN 500 Ω	IC105, C105, C106

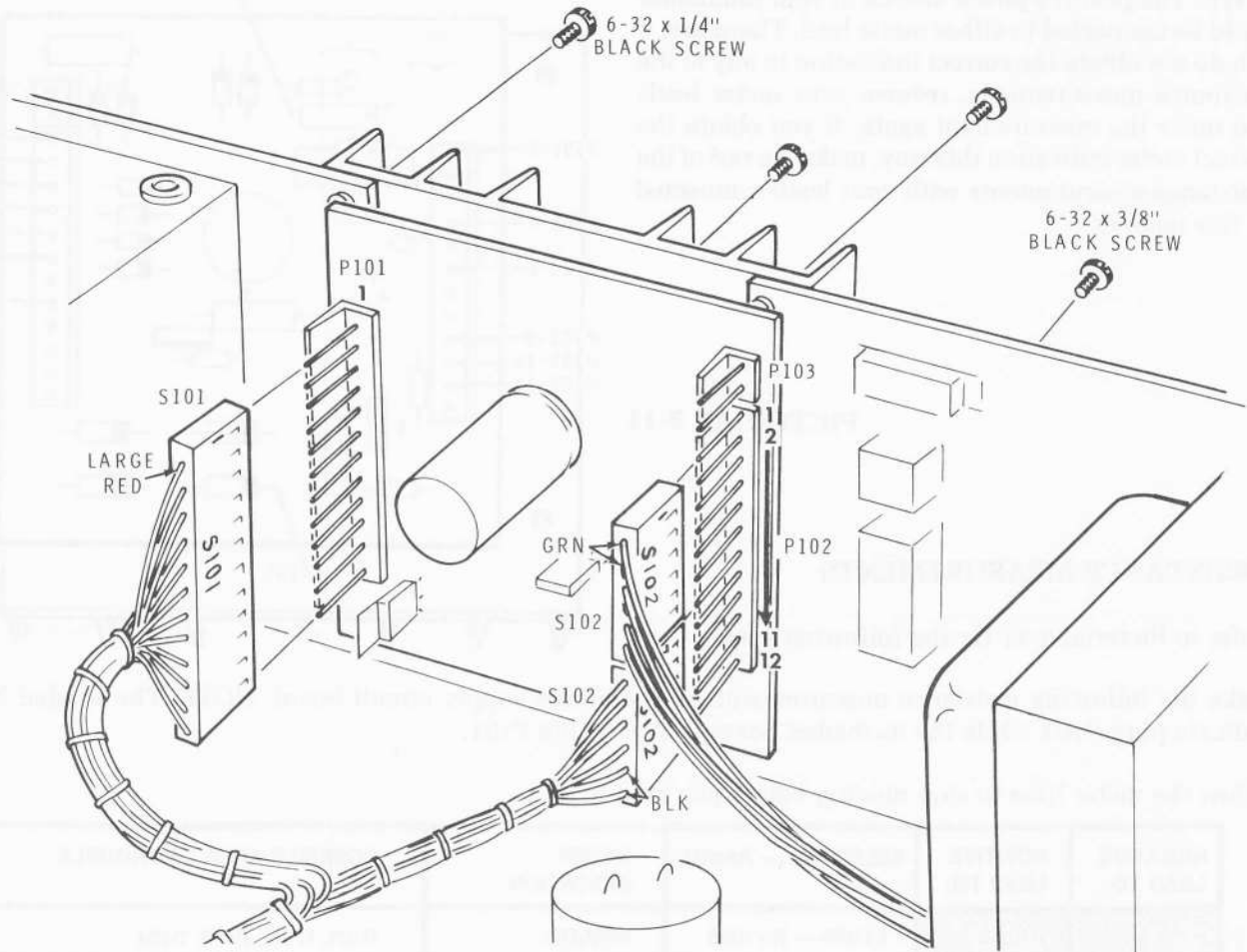

PICTORIAL 3-12

POWER SUPPLY CIRCUIT BOARD INSTALLATION

Refer to Pictorial 3-12 for the following steps.

- (✓) Slide the power supply circuit board and heat sink assembly down into the chassis as shown. Note that plug P101 is toward the left side panel.

NOTE: The following harness sockets can be incorrectly connected to the circuit board plugs one pin off (example: pin 1 in the socket can be connected to pin 2 on the plug). This situation can damage components on the circuit board when power is applied. Therefore, it is important to make sure each socket is properly installed.

- (✓) Push connector socket S101 (from the main harness) onto plug P101 on the power supply circuit board so number "1" on the socket (large red wire) matches pin 1 on the board.

- () Push connector socket S102 (from the main harness) onto plug P102 on the power supply circuit board so the number "7" on the socket (black wire) matches pin 7 on the circuit board.

- () Push connector socket S102 (coming from the power transformer) onto plug P102 on the power supply circuit board so the number "1" on the socket (the green transformer lead) matches pin 1 on the circuit board. **NOTE:** Pins 1 and 2 of plug P103 (directly above plug P102) on the power supply circuit board should not have anything connected to them.

- (✓) Secure the heat sink to the rear panel with 6-32 × 1/4" black screws in the two **top** holes and 6-32 × 3/8" black screws in the two **bottom** holes. Start all four screws before you tighten any of them.



- () Set the AC POWER switch on the rear panel to OFF.

WARNING: When the line cord is connected to an AC outlet, dangerous AC voltage is present in the area under the fish paper on the underside of the chassis (see Detail 3-12A in the Illustration Booklet). Do not make contact with this area while the line cord is connected to an AC outlet or you will receive a hazardous electrical shock.

- () Connect the line cord plug to an AC outlet.

NOTES:

1. When you are instructed to connect a meter lead to the chassis, connect the lead to the solder lug on top of the high voltage assembly.
2. When you are instructed to make a measurement on a circuit board plug pin, insert the meter probe into the back of the harness socket that is connected to that plug and make contact with the spring clip that corresponds to the plug pin indicated (see Detail 3-12B).

NOTE: Your voltage indications in the following steps will depend upon the accuracy of your meter. They should be close to the indication in the "Meter Reading" column ($\pm 10\%$).

- () Set the AC POWER switch to ON.

Make the following voltage measurements on the power supply circuit board.

	NEGATIVE LEAD TO:	POSITIVE LEAD TO:	SELECTOR — RANGE	METER INDICATION	POSSIBLE AREA OF TROUBLE
()	CHASSIS	P101-1	DC + 15V	5V	IC101, D101, D102, D103, D104, C101, T1.
()	CHASSIS	P101-4	DC + 15V	5V	IC102, C102
()	CHASSIS	P101-10	DC + 15V	12V	IC103, IC104, C104
()	CHASSIS	P101-11	DC + 50V	26V	Q101, Q102, IC103
()	CHASSIS	P102-8	DC + 50V	40V	D105, D106, D107, D108, T1
NOTE: If you do not have the DC- function on your meter, interchange the meter leads in the next measurement.					
()	CHASSIS	P101-9	DC- 15V	-12V	D109, D110, D111, D112, IC105, C105, C106, C107

- () Set the AC PWR switch to OFF and disconnect the line cord.

This completes the power supply checkout. Set the chassis aside and proceed to the "Character Generator Circuit board."

CHARACTER GENERATOR CIRCUIT BOARD

PARTS LIST

Unpack the pack marked #2 and check each part against the following Parts List. The key numbers correspond to the numbers on the Character Generator Circuit Board Parts Pictorial (Illustration Booklet, Page 15). Any part that is packaged in an individual envelope with a part number on it should be placed back in the envelope after it is identified until it is called for in a step.

KEY No.	HEATH Part No.	QTY.	DESCRIPTION	CIRCUIT Comp. No.	KEY No.	HEATH Part No.	QTY.	DESCRIPTION	CIRCUIT Comp. No.
RESISTORS					CAPACITORS				
All resistors are 5% (fourth band gold).									
1/4-Watt									
A1	6-271-12	1	270 Ω (red-violet-brown)	R203	B1	20-173	1	20 pF mica	C213
A1	6-122-12	1	1200 Ω (brown-red-red)	R205	B2	21-95	10	.1 μ F ceramic	C201, C202, C203, C204, C205, C206, C207, C208, C209, C211
A1	6-222-12	3	2200 Ω (red-red-red)	R207, R212, R213	B3	25-223	1	47 μ F tantalum	C212
A1	6-472-12	6	4700 Ω (yellow-violet-red)	R202, R206, R208, R209, R211, R214	SOCKETS				
A1	6-103-12	1	10 k Ω (brown-black-orange)	R201	C1	432-923	1	4-pin socket	S201
A1	6-105-12	1	1 M Ω (brown-black-green)	R204	C2	432-950	1	6-pin socket	S202
					C3	432-779	2	12-pin socket	S201, S202
						434-298	18	14-pin IC socket	
						434-299	3	16-pin IC socket	
					C4	434-307	1	24-pin IC socket	



KEY No.	HEATH Part No.	QTY.	DESCRIPTION	CIRCUIT Comp. No.
---------	----------------	------	-------------	-------------------

TRANSISTOR — INTEGRATED CIRCUITS (IC's)

NOTE: Transistors and integrated circuits are marked for identification in one of the following four ways:

1. Part number.
2. Type number. (On integrated circuits this refers only to the numbers and letters listed. Any additional letters or numbers on an IC are not significant.)
3. Part number and type number.
4. Part number with a type number other than the one listed.

IMPORTANT

Before you open any IC package, and if any components are missing from the sealed IC package, return the **unopened** package for replacement. Claims for missing IC's will not be honored.

If you locate damaged or defective IC's, order individual replacements. Be sure to follow the standard instructions on the "Part Order Form" and on the inside rear cover of the Manual. Save defective or damaged components for return instructions.

D1	417-881	1	MPSA 13 transistor	Q201
D2	443-26	1	74S00 IC	IC210
D2	443-728	1	74LS00 IC	IC218
D2	443-46	1	7402 IC	IC221

KEY No.	HEATH Part No.	QTY.	DESCRIPTION	CIRCUIT Comp. No.
---------	----------------	------	-------------	-------------------

Transistors — Integrated Circuits (cont'd.)

D2	443-745	1	74LS03 IC	IC201
D2	443-755	2	74LS04 IC	IC212, IC219
D2	443-780	1	74LS08 IC	IC217
D2	443-12	1	7410 IC	IC222
D2	443-730	3	74LS74 IC	IC207, IC208, IC211
D2	443-813	2	74LS90 IC	IC214, IC215,
D2	443-7	1	7490 IC	IC220
D2	443-838	1	74LS93 IC	IC216
D2	443-814	1	74LS95 IC	IC204
D3	443-752	2	74LS175 IC	IC202, IC203
D3	443-612	1	74193 IC	IC213
D2	443-719	2	74LS266 IC	IC206, IC209

CAUTION: The protected RO32513 (#443-812) IC can be damaged by static electricity. DO NOT remove it from the foam pad until you are instructed to do so in a step.

D4	443-812	1	RO32513 IC (protected)	IC205
----	---------	---	------------------------	-------

MISCELLANEOUS

E1	404-207	1	12.395 MHz crystal	Y201
----	---------	---	--------------------	------

PART FROM FINAL PACK

85-1956-2	1	Character generator circuit board
-----------	---	-----------------------------------

STEP-BY-STEP ASSEMBLY

START

This, and some other circuit boards have foil on both sides. DO NOT solder on the printed (component) side of the circuit board. The side of the circuit board opposite the printed side, will be referred to as the foil side. A completed circuit board will have a considerable number of unsoldered holes. This is normal. These "plated-through" holes connect together the foils on the two sides of the circuit board at the proper locations.

(✓) Position the circuit board as shown with the lettered side up.

(✓) R208: 4700 Ω (yellow-violet-red).

(✓) R206: 4700 Ω (yellow-violet-red).

(✓) R201: 10 kΩ (brown-black-orange).

(✓) R207: 2200 Ω (red-red-red).

(✓) R209: 4700 Ω (yellow-violet-red).

(✓) R204: 1 MΩ (brown-black-green).

(✓) R205: 1200 Ω (brown-red-red).

(✓) R203: 270 Ω (red-violet-brown).

(✓) R202: 4700 Ω (yellow-violet-red).

(✓) R214: 4700 Ω (yellow-violet-red).

(✓) R213: 2200 Ω (red-red-red).

(✓) R211: 4700 Ω (yellow-violet-red).

(✓) R212: 2200 Ω (red-red-red).

(✓) Solder the leads to the foil and cut off the excess lead lengths.

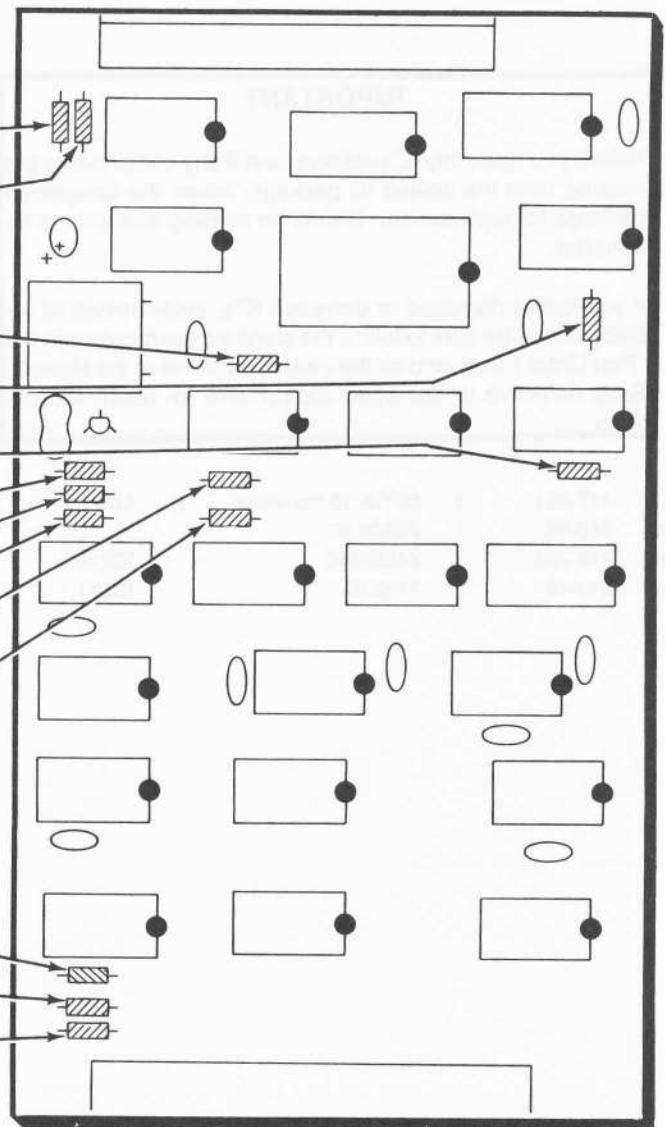

PICTORIAL 4-1

START →

NOTE: Be very careful when you install the IC sockets, as it is possible to place a 14-pin socket in a 16-pin socket location by mistake. Insert the socket pins into the holes. The index mark on the circuit board must still be visible after it is installed. Make sure all of the pins went into the circuit board holes. Then solder every pin of each socket to the foil.

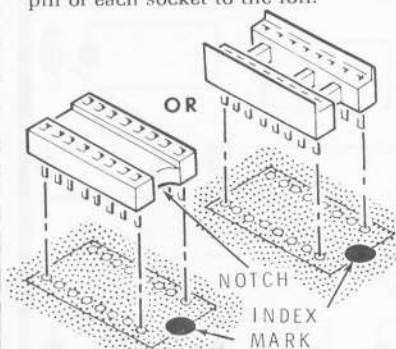

16-pin IC sockets at the three following locations.

- (✓) IC202 (✓) IC203 (✓) IC213

14-pin IC sockets at the eighteen following locations.

- () IC201 () IC210 () IC217
- () IC204 () IC211 () IC218
- () IC206 () IC212 () IC219
- () IC207 () IC214 () IC220
- () IC208 () IC215 () IC221
- () IC209 () IC216 () IC222

(✓) 24-pin IC socket at IC205.

Carefully check each socket for solder bridges between pins. If a solder bridge has occurred, hold the circuit board foil-side-down as shown, and hold the soldering iron tip between the two points that are bridged. The solder will flow down the soldering iron tip, or use the de-solder wick (braid) as explained in the Assembly Notes on Page 36.

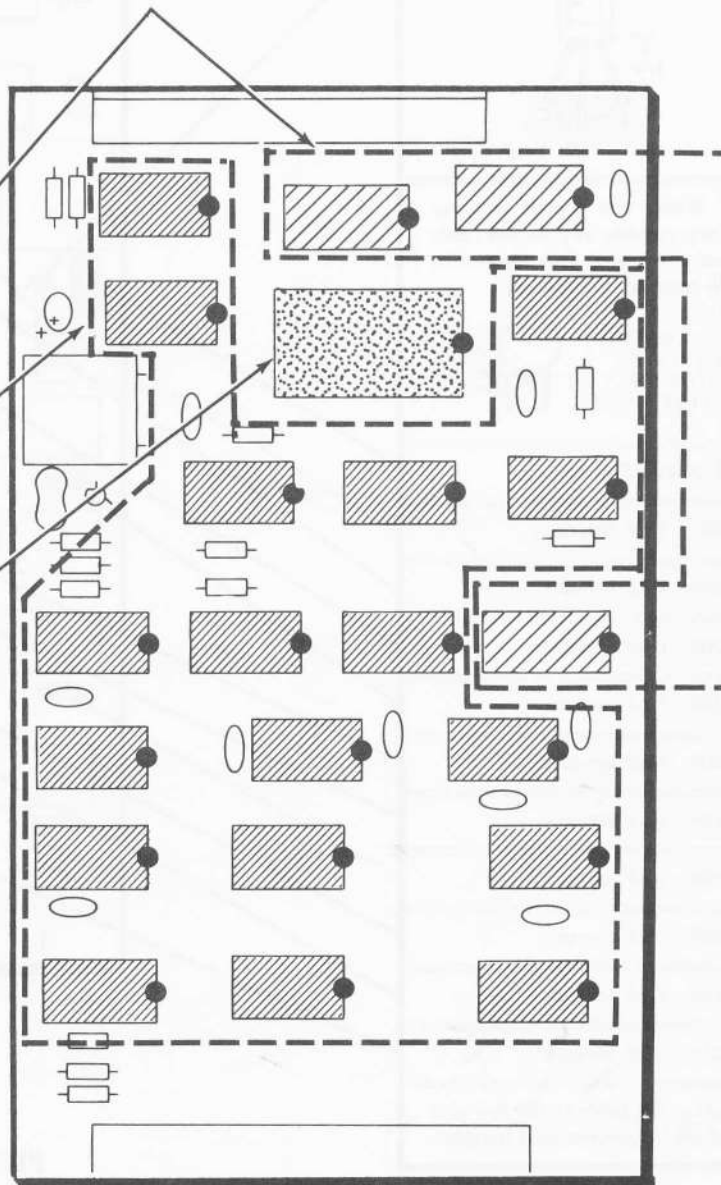
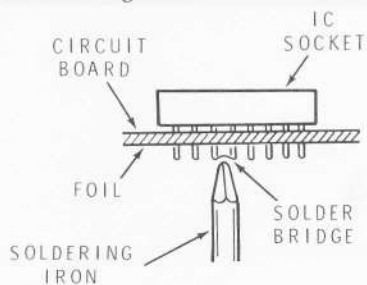

PICTORIAL 4-2

START

(✓) Q201: MPSA13 transistor (#417-881). Align the flat on the transistor with flat on the circuit board outline. Insert the E, B, and C leads into their corresponding holes in the board. Position the bottom of the transistor 1/4" above the board. Then solder the leads to the foil and cut off the excess lead lengths.

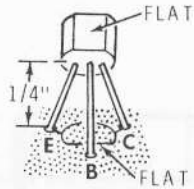

NOTE: When you install ceramic capacitors, remove any excess coating from the leads. Use long-nose pliers to remove this coating.

REMOVE COATING EVEN WITH BOTTOM OF CAPACITOR BODY



() C213: 20 pF mica.

(✓) C201: .1 μ F ceramic.

(✓) C206: .1 μ F ceramic.

(✓) C207: .1 μ F ceramic.

(✓) C202: .1 μ F ceramic.

(✓) C203: .1 μ F ceramic.

(✓) C204: .1 μ F ceramic.

(✓) C205: .1 μ F ceramic.

(✓) C208: .1 μ F ceramic.

(✓) C209: .1 μ F ceramic.

(✓) C211: .1 μ F ceramic.

(✓) Solder the leads to the foil and cut off the excess lead lengths.

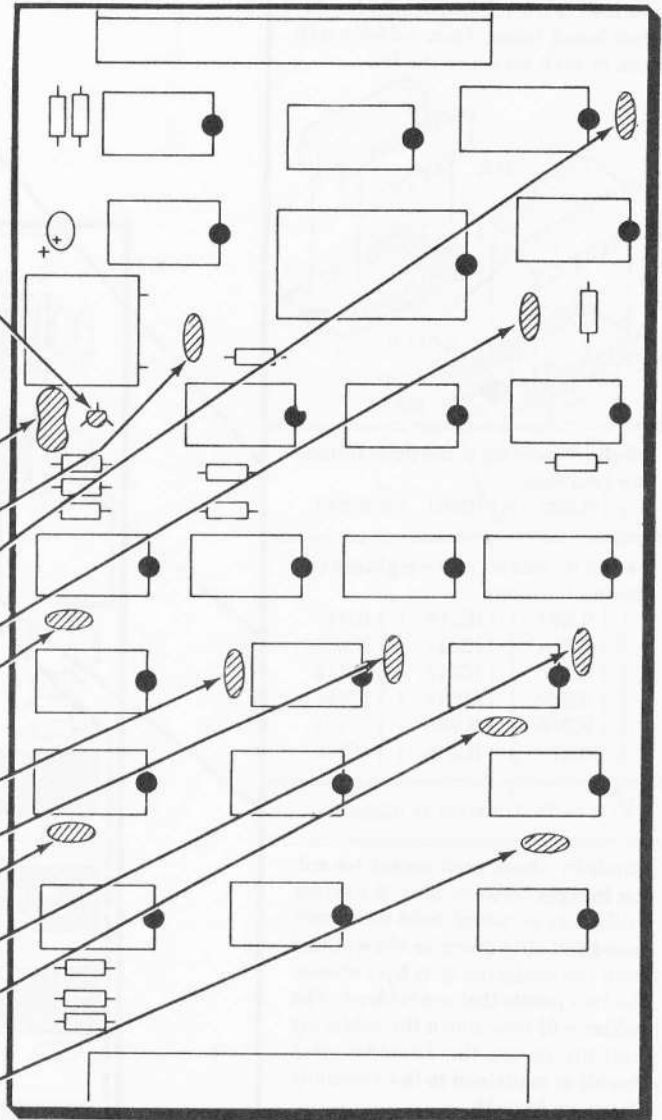

PICTORIAL 4-3



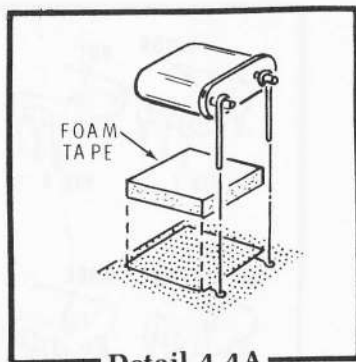

START

When you install a socket on a circuit board, insert the pins in the small holes. Then solder the pins to the foil.

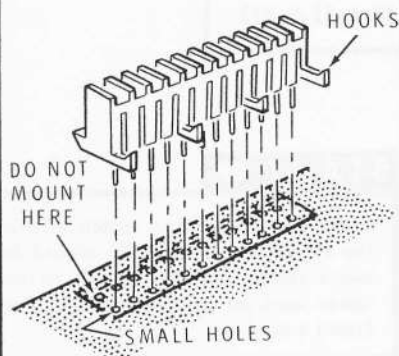

() 12-pin socket.

() 4-pin socket.

() C212: 47 μ F tantalum. Match the positive (+ or color dot) on the capacitor with the positive (+) mark on the board.

() Y201: 12.395 MHz crystal (#404-207). Refer to Detail 4-4A and remove the paper backing from one side of a 3/4" x 3/4" piece of the leftover foam tape and press it onto the crystal. Remove the remaining paper backing and press the crystal onto the circuit board. Form a hook in one end of two 1" bare wires. Hook the end of each bare wire on a crystal pin and the other end into its board hole. Be sure the wires do not touch the crystal case. Solder the wires to the crystal pins and the foil. Cut off the wire lengths.

() 12-pin socket.

() 6-pin socket.

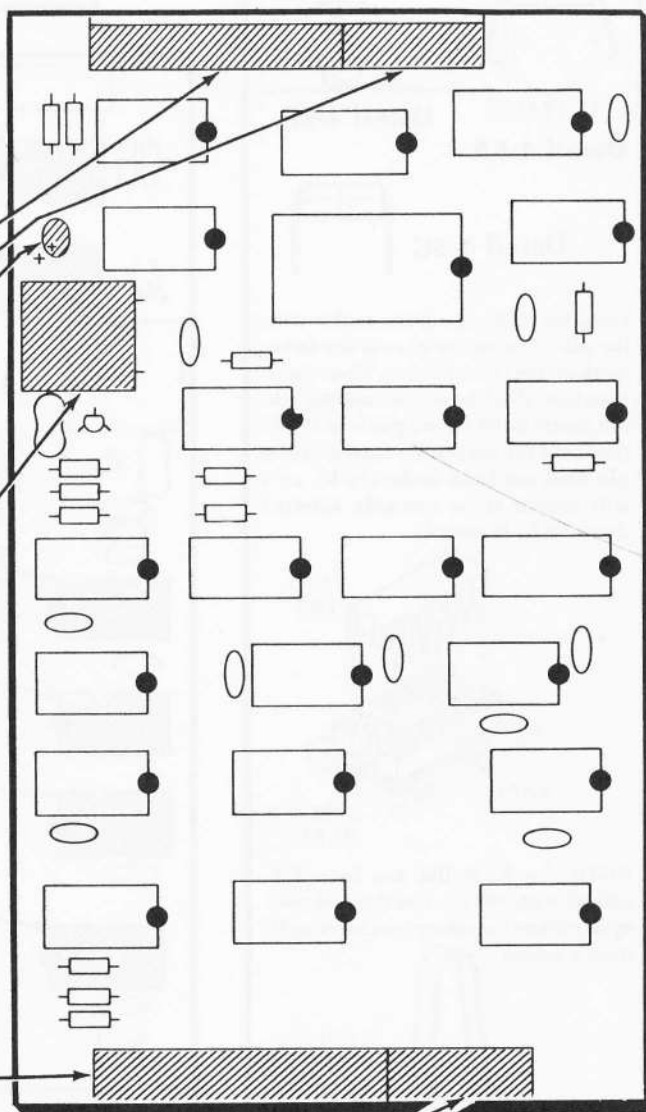

PICTORIAL 4-4

INTEGRATED CIRCUIT (IC) INSTALLATION.

The pins on the IC's supplied with this kit are bent out at an angle as shown in Detail 4-5A. DO NOT try to install them this way; it may damage the sockets, or cause intermittent connections that are very difficult to find later.

Before you install an IC, lay it down on its side as shown in Detail 4-5B and gently roll the IC over to bend the row of pins in slightly so they look like Detail 4-5C.

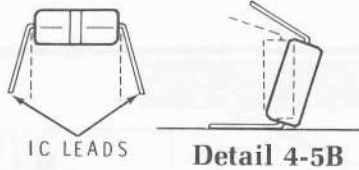

Detail 4-5A



Place the IC on top of the socket with the pin 1 end of the IC over the index mark on the circuit board. Then check to be sure all of the pins are started into the socket holes before you seat the IC pins into the socket. Be careful that a pin does not bend under the IC, as it will appear to be correctly inserted once the IC is seated.

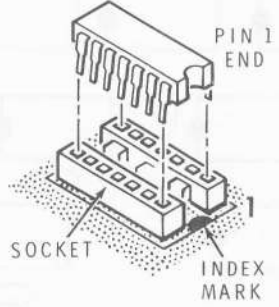

NOTE: An IC puller has been furnished with this kit. Use it if it should ever become necessary to remove an IC from a socket.

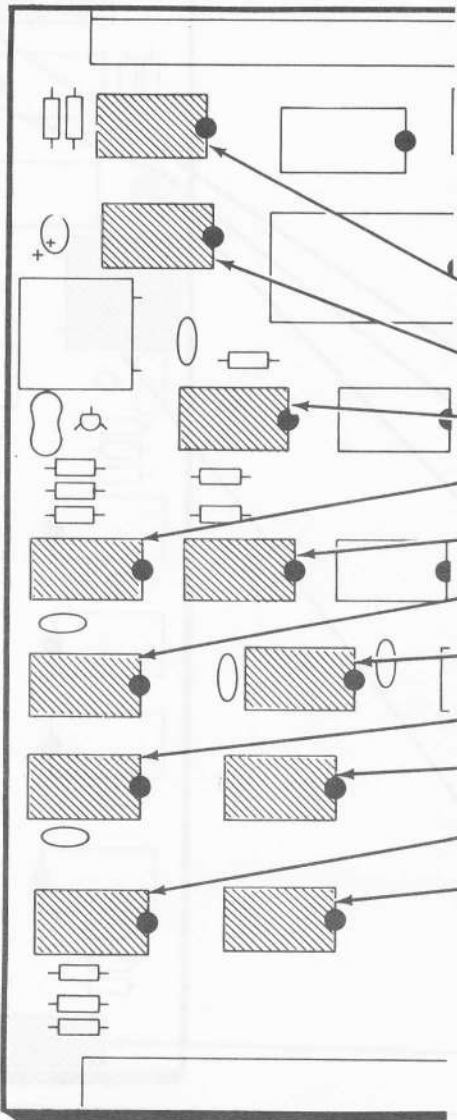
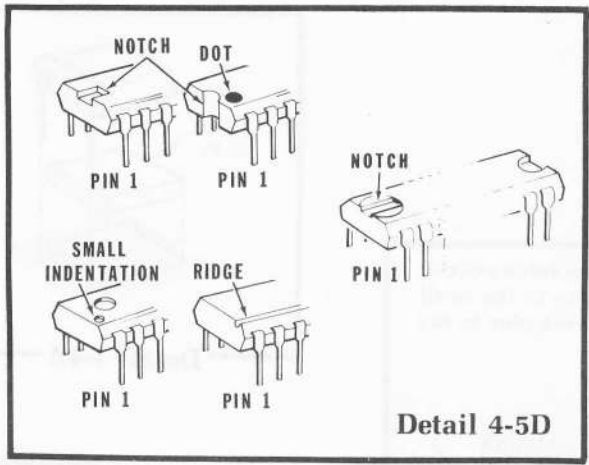
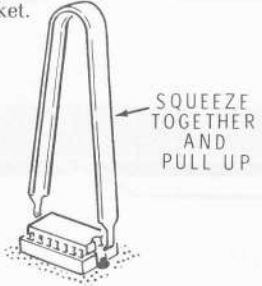

START

In the following steps, install IC's in the designated sockets. Be careful to match the pin 1 end of each IC to the index mark on the circuit board. See Detail 4-5D.

- IC201: 74LS03 IC (#443-745).
- IC204: 74LS95 IC (#443-814).
- IC207: 74LS74 IC (#443-730).
- IC210: 74S00 IC (#443-26).
- IC211: 74LS74 IC (#443-730).
- IC214: 74LS90 IC (#443-813).
- IC215: 74LS90 IC (#443-813).
- IC217: 74LS08 IC (#443-780).
- IC218: 74LS00 IC (#443-728).
- IC220: 7490 IC (#443-7).
- IC221: 7402 IC (#443-46).

PICTORIAL 4-5

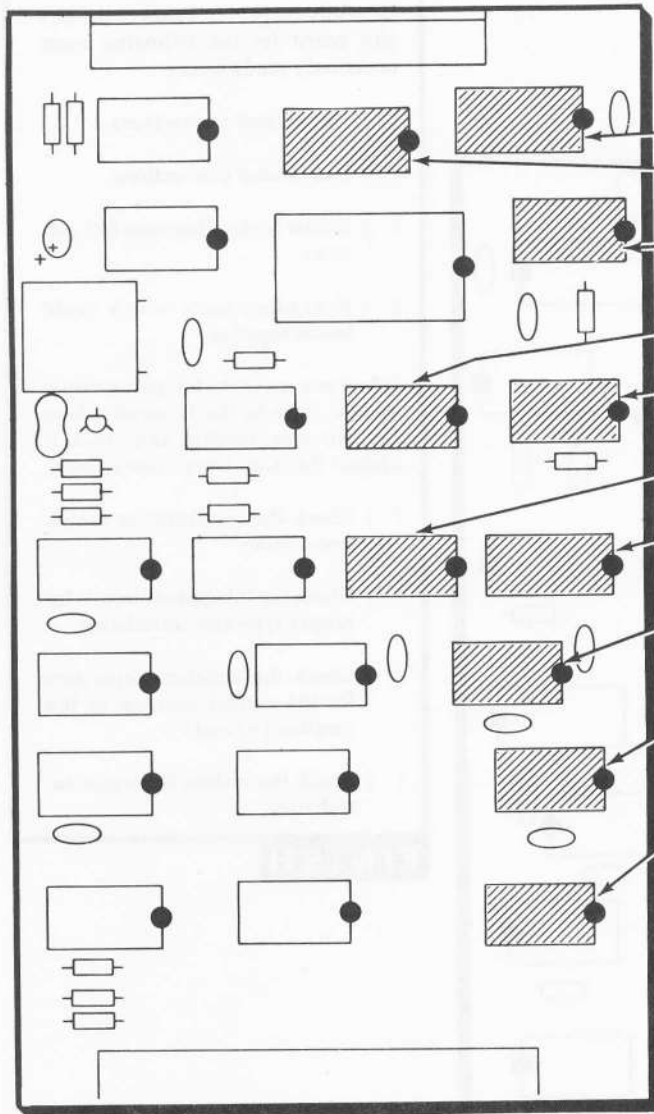

START ↓

- (✓) IC203: 74LS175 IC (#443-752).
- (✓) IC202: 74LS175 IC (#443-752).
- (✓) IC206: 74LS266 IC (#443-719).
- (✓) IC208: 74LS74 IC (#443-730).
- (✓) IC209: 74LS266 IC (#443-719).
- (✓) IC212: 74LS04 IC (#443-755).
- (✓) IC213: 74193 IC (#443-612).
- (✓) IC216: 74LS93 IC (#443-838).
- (✓) IC219: 74LS04 IC (#443-755).
- (✓) IC222: 7410 IC (#443-12).

PICTORIAL 4-6

START ↘

CAUTION: When you install a protected IC, be sure it does not get damaged by static electricity. Once you remove the foam pad from the IC. **DO NOT** let go of the IC. Install the IC as follows. Read the entire step before you pick up the IC.

1. Pick up the IC and touch the foam pad with both hands.
2. Hold the IC with one hand and remove the foam pad with the other hand.
3. Continue to hold the IC with one hand and straighten any bent pins with the other hand.
4. Pick up the circuit board in the other hand.
5. Align the pin 1 end of the IC with the index mark on the circuit board.
6. Then push the IC pins into the IC socket. Once in the socket, the IC is protected.

() IC205: R032513 protected IC (#443-812).

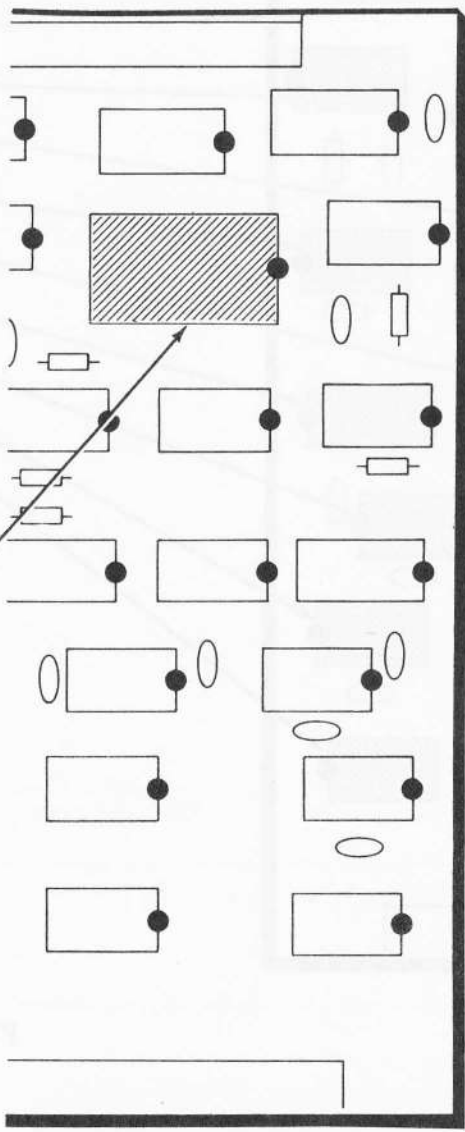

CONTINUE ↘

CIRCUIT BOARD CHECKOUT

Visual Inspection

Carefully inspect foil side of the circuit board for the following most commonly made errors.

- () Unsoldered connections.
- () Poor solder connections.
- () Solder bridges between foil patterns.
- () Protruding leads which could touch together.

When you make the following visual checks, refer to the Pictorial where the part was installed and check it against the installation instructions.

- () Check the transistor for proper installation.
- () Check the integrated circuits for proper type and installation.
- () Check the tantalum capacitors for the correct position of the positive (+) end.
- () Check the sockets for proper installation.

FINISH

PICTORIAL 4-7



CHARACTER GENERATOR CIRCUIT BOARD CHECKOUT

RESISTANCE MEASUREMENTS

Refer to Pictorial 4-8 (Illustration Booklet, Page 15) for the following steps.

Make the following resistance measurement on the character generator circuit board.

NEGATIVE LEAD TO:	POSITIVE LEAD TO:	SELECTOR — RANGE	METER INDICATION	POSSIBLE AREA OF TROUBLE
() S201-6	S201-3	OHMS — $R \times 100$	GREATER THAN THAN 400 Ω	An IC incorrectly installed or installed in the wrong location. Check carefully for solder bridges, especially between the IC socket pins.

CHARACTER GENERATOR CIRCUIT BOARD INSTALLATION

Refer to Pictorial 4-9 (Illustration Booklet, Page 15) for the following steps.

- () Position the chassis up on its right (power transformer) side.
- () Install the character generator circuit board onto plugs P201 and P202. Push the circuit board toward the chassis until it is fully seated on the plugs and circuit board standoffs.

VOLTAGE MEASUREMENTS

Refer again to Pictorial 4-8 for the following steps.

- () Connect the line cord to an AC outlet and set the AC POWER switch to ON.

Make the following voltage measurement on the character generator circuit board.

NEGATIVE LEAD TO:	POSITIVE LEAD TO:	SELECTOR — RANGE	METER INDICATION	POSSIBLE AREA OF TROUBLE
() CHASSIS	S201-3	DC + 15V	5V	AN IC incorrectly installed or installed in the wrong location. Check carefully for solder bridges, especially between the IC socket pins.

- () Set the AC POWER switch to OFF and disconnect the line cord.

This completes the character generator checkout. Set the chassis aside and proceed to "Video Circuit board."

VIDEO CIRCUIT BOARD

PARTS LIST

Unpack the pack marked #3 and check each part against the following Parts List. The key numbers correspond to the numbers on the Video Circuit Board Parts Pictorial (Illustration Booklet, Page 16). Any

part that is packaged in an individual envelope with a part number on it should be placed back in the envelope after it is identified until it is called for in a step.

KEY No.	HEATH Part No.	QTY.	DESCRIPTION	CIRCUIT Comp. No.
---------	----------------	------	-------------	-------------------

RESISTORS

All resistors are 5% (fourth band gold) unless designated otherwise.

NOTE: The resistors may be packed in more than one envelope. Open all resistor envelopes (marked R or RES) in this pack before you check the resistors against the Parts List.

1/2-Watt

A1	6-399	1	3.9 Ω (orange-white-gold)	R323
A1	6-100	3	10 Ω (brown-black-black)	R305, R319, R322
A1	6-560	1	56 Ω (green-blue-black)	R317
A1	6-104	1	100 Ω (brown-black-brown)	R345
A1	6-151	2	150 Ω (brown-green-brown)	R316, R324
A1	1-9	7	1000 Ω (brown-black-red)	R312, R318, R340, R344, R346, R347, R348
A1	6-182	3	1800 Ω , (brown-gray-red)	R329, R331, R343
A1	6-272	3	2700 Ω (red-violet-red)	R301, R302, R328

KEY No.	HEATH Part No.	QTY.	DESCRIPTION	CIRCUIT Comp. No.
---------	----------------	------	-------------	-------------------

Resistors (cont'd.)

A1	6-332	1	3300 Ω (orange-orange-red)	R306
A1	6-103	2	10 k Ω (brown-black-orange)	R311, R342
A1	6-223	2	22 k Ω (red-red-orange)	R304, R325
A1	6-104	2	100 k Ω (brown-black-yellow)	R315, R337
A1	6-184	2	180 k Ω (brown-gray-yellow)	R313, R314
A1	6-105	4	1 M Ω (brown-black-green)	R307, R308, R309, R339
A1	6-335	1	3.3 M Ω (orange-orange-green)	R341

Other Resistors

A2	1-2-1	1	1000 Ω , 1-watt (brown-black-red)	R327
A3	1-20-2	1	100 Ω , 2-watt (brown-black-brown)	R335
A4	5-9-2	1	390 Ω , 2-watt film	R332
A5	3-21-5	1	2.6 Ω , 5-watt	R321

KEY No.	HEATH Part No.	QTY.	DESCRIPTION	CIRCUIT Comp. No.
---------	----------------	------	-------------	-------------------

CAPACITORS

Ceramic

B1	21-170	1	.75 pF (spark gap)	C333
B2	21-56	2	470 pF	C310, C335
B2	21-140	1	1000 pF (.001 μ F)	C314
B2	21-16	4	.01 μ F	C301, C323, C331, C325
B3	21-733	2	.05 μ F	C326, C327

TANTALUM — ELECTROLYTIC

B4	25-221	2	2.2 μ F tantalum	C303, C317
B5	25-180	1	2.2 μ F tantalum (tubular)	C332
B6	25-94	1	10 μ F electrolytic (tubular)	C324
B7	25-804	1	100 μ F electrolytic	C328
B8	25-28	1	100 μ F electrolytic (tubular)	C305
B7	25-818	1	500 μ F electrolytic	C309

Mylar

B9	27-91	1	3300 pF (.0033 μ F)	C318
B9	27-115	1	5000 pF (.005 μ F)	C319
B9	27-108	1	.022 μ F	C321
B10	27-77	7	.1 μ F	C302, C304, C306, C307, C308, C311, C329
B11	27-180	1	3 μ F	C322

Film

B12	29-22	1	4700 pF film	C312
-----	-------	---	--------------	------

DIODES

C1	56-56	2	1N4149	D301, D302
C1	56-73	1	MZ2360	D303
C1	57-27	1	1N2071	D304
C1	57-64	3	DRS110	D305, D306, D307

KEY No.	HEATH Part No.	QTY.	DESCRIPTION	CIRCUIT Comp. No.
---------	----------------	------	-------------	-------------------

TRANSISTORS — INTEGRATED CIRCUIT (IC)

NOTE: Transistors and integrated circuits are marked for identification in one of the following four ways:

1. Part number.
2. Type number. (On an integrated circuit this refers only to the numbers and letters listed. Any additional letters or numbers on the IC are not significant.)
3. Part number and type number.
4. Part number with a type number other than the one listed.

D1	417-874	1	2N3906 transistor	Q309
D2	417-235	1	2N4121 transistor	Q302
D1	417-875	1	2N3904 transistor	Q308
D3	417-819	1	MJE171 transistor	Q306
D3	417-818	2	MJE181 transistor	Q305, Q307
D1	417-864	2	MPSA05 transistor	Q301, Q304
D1	417-881	1	MPSA13 transistor	Q303
D4	442-620	1	MC1391 IC	IC301

CONNECTORS — PLUGS — SHELL — SOCKETS

E1	432-134	3	Circuit board connector	
E2	432-753	2	Large spring connector	
E3	432-827	1	4-pin plug	P301
E4	432-967	1	12-pin plug	P302
E5	432-974	1	2-connector shell	
E6	434-163	1	CRT socket (with leads)	
E7	434-230	1	8-pin IC socket	

MISCELLANEOUS

F1	10-904	1	5000 Ω (5k) control	R303
F1	10-941	1	100 k Ω control	R338
F1	10-989	1	5 M Ω control	R336
F2	40-1721	1	39 μ H inductor	L301
F3	215-99	2	Heat sink	
F4	250-213	2	4-40 \times 5/16" screw	
F5	252-2	2	4-40 nut	
F6	254-9	2	#4 lockwasher	

PART FROM FINAL PACK

85-2082-1	1	Video circuit board	
-----------	---	---------------------	--

STEP-BY-STEP ASSEMBLY

START

(✓) Position the circuit board as shown with the printed side up.
NOTE: Only a portion of the circuit board is shown in some Pictorials. The small "Identification Drawing" at the top of a Pictorial shows the area of the circuit board to be assembled.

(✓) R302: 2700 Ω (red-violet-red).

(✓) R306: 3300 Ω (orange-orange-red).

(✓) R307: 1 MΩ (brown-black-green).

(✓) R309: 1 MΩ (brown-black-green).

(✓) R308: 1 MΩ (brown-black-green).

(✓) R312: 1000 Ω (brown-black-red).

(✓) R316: 150 Ω (brown-green-brown).

() Solder the leads to the foil and cut off the excess lead lengths.

(✓) R317: 56 Ω (green-blue-black).

(✓) R319: 10 Ω (brown-black-black).

(✓) R324: 150 Ω (brown-green-brown).

(✓) R325: 22 kΩ, (red-red-orange). May be marked "27 k" on the circuit board.

(✓) R328: 2700 Ω (red-violet-red).

(✓) R329: 1800 Ω (brown-gray-red).

() Solder the leads to the foil and cut off the excess lead lengths.

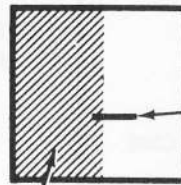

IDENTIFICATION DRAWING

PART NUMBER

The parts installed in this Pictorial are in this area of the circuit board.

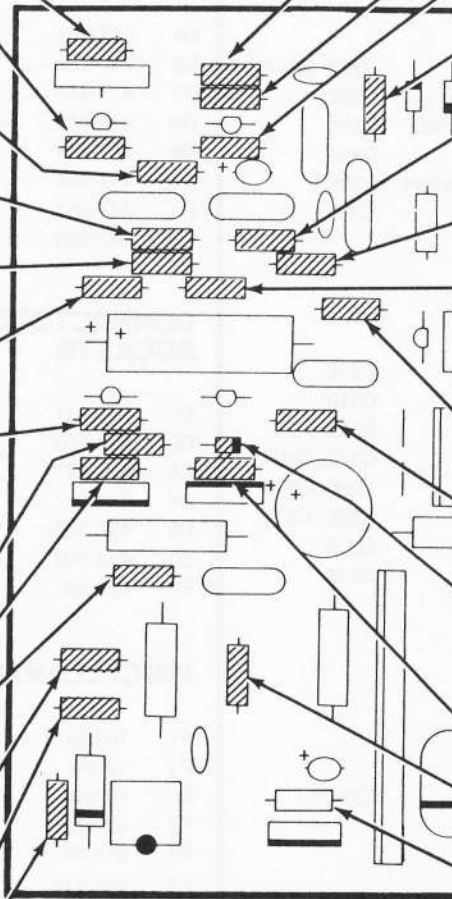

PICTORIAL 5-1

CONTINUE

(✓) R301: 2700 Ω (red-violet-red).

(✓) R304: 22 kΩ (red-red-orange).

(✓) R305: 10 Ω (brown-black-black).

(✓) R315: 100 kΩ (brown-black-yellow).

(✓) R313: 180 kΩ (brown-gray-yellow).

(✓) R314: 180 kΩ (brown-gray-yellow).

() R311: 10 kΩ (brown-black-orange).

() Solder the leads to the foil and cut off the excess lead lengths.

() R323: 3.9 Ω (orange-white-gold).

(✓) R318: 1000 Ω (brown-black-red).

(✓) D303: MZ2360 diode (#56-73). Always match the band on a diode with the band on the circuit board outline.

(✓) R322: 10 Ω (brown-black-black).

(✓) R331: 1800 Ω (brown-gray-red).

DO NOT install a part at this location.

() Solder the leads to the foil and cut off the excess lead lengths.

IDENTIFICATION
DRAWING

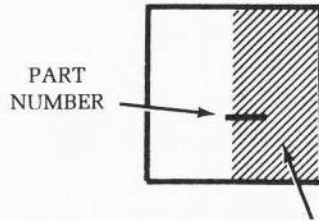

The parts installed in this Pictorial are in this area of the circuit board.

START ↘

- D301: 1N4149 diode (#56-56).
- D302: 1N4149 diode (#56-56).
- R343: 1800 Ω (brown-gray-red).
- R342: 10 k Ω (brown-black-orange).
- R345: 100 Ω (brown-black-brown).
- R344: 1000 Ω brown-black-red).
- When a bare wire is called for in a step, cut the specified length of wire from the bare wire furnished in the kit.
- 1" bare wire.
- 1" bare wire.
- Solder the leads to the foil and cut off the excess lead lengths.

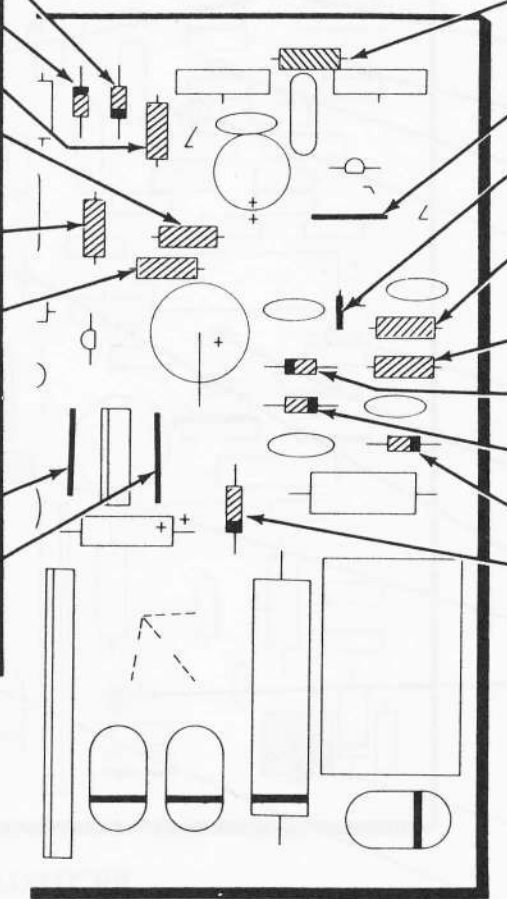

CONTINUE ↙

- R337: 100 k Ω (brown-black-yellow). NOTE: Be sure that you do not install this in the 100 k Ω control position by mistake.
- 1" bare wire.
- 1" bare wire.
- R341: 3.3 M Ω (orange-orange-green).
- R339: 1 M Ω (brown-black-green).
- D306: DRS110 diode (#57-64).
- D305: DRS110 diode (#57-64).
- D307: DRS110 diode (#57-64).
- D304: 1N2071 diode (#57-27).
- Solder the leads to the foil and cut off the excess lead lengths.

PICTORIAL 5-2



START

NOTE: When you install a transistor, always align its flat with the flat (or the transistor wide space opposite the flat) on the board. Insert the transistor leads in their correct holes in the board. Position the bottom of the transistor 1/4" above the board. Solder the leads to the foil and cut off the excess lead lengths as each transistor is installed.

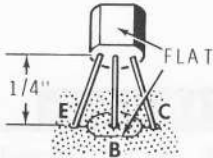

- (✓) Q308: 2N3904 transistor (#417-875).
- (✓) Q302: 2N4141 transistor (#417-235).
- (✓) Q301: MPSA05 transistor (#417-864).
- (✓) C303: 2.2 μ F tantalum. When you install a tantalum capacitor, always match its positive mark (+ or color dot) with the (+) mark on the board.
- (✓) Q304: MPSA05 transistor (#417-864).
- (✓) Q303: MPSA13 transistor (#417-881).
- (✓) Q309: 2N3906 transistor (#417-874).
- (✓) C332: 2.2 μ F tubular tantalum.
- (✓) C317: 2.2 μ F tantalum.
- (✓) Solder the leads to the foil and cut off the excess lead lengths.
- (✓) 8-pin IC socket at IC301.
- (✓) Three circuit board pins. Push each pin as far as possible into its hole. Then solder the pin to the foil. See Detail 5-3A.

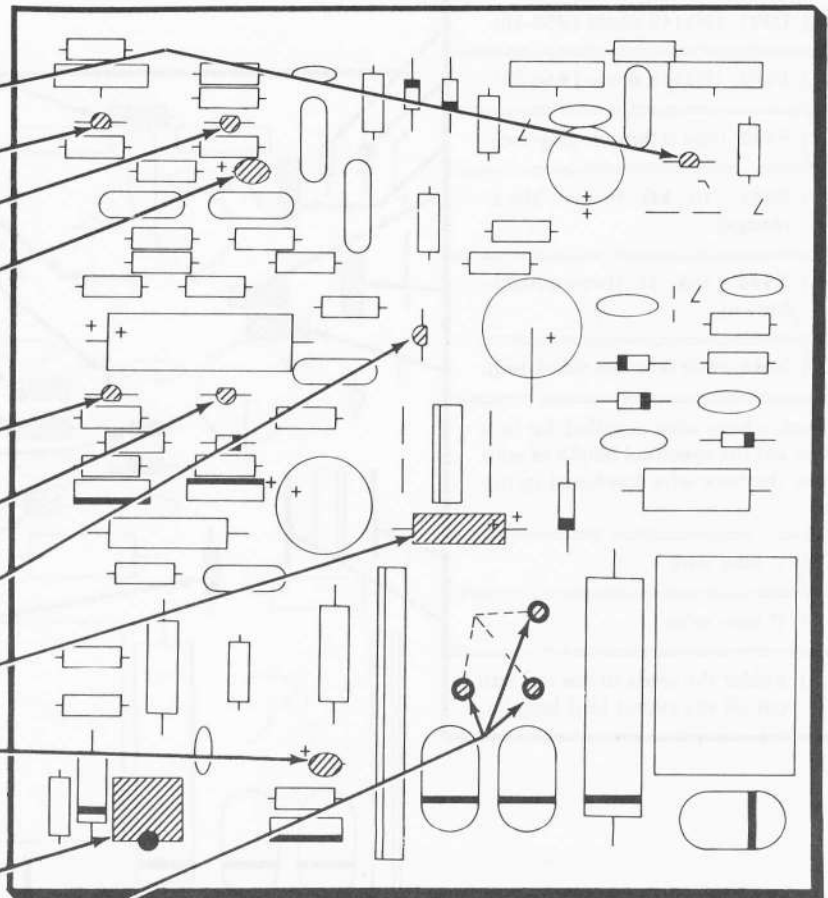

PICTORIAL 5-3

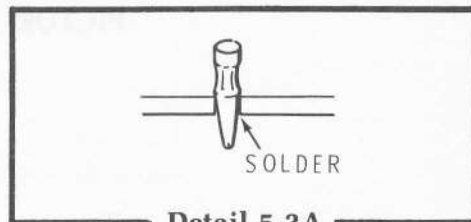

Detail 5-3A

START ↓

- (✓) R335: 100 Ω, 2-watt (brown-black-brown).
- (✓) C305: 100 μF electrolytic. Match its positive (+) mark with the plus (+) mark on the circuit board outline.
- (✓) R321: 2.6 Ω, 5-watt.
- (✓) R332: 390 Ω, 2-watt film.
- (✓) R327: 1000 Ω, 1-watt (brown-black-red).
- (✓) C312: 4700 pF film. Match its color end with the band on the circuit board outline.
- (✓) Solder the leads to the foil and cut off the excess lead lengths.
- (✓) Prepare the ends of a 1-1/4" white wire. Solder one end into the indicated hole. Push the free end of the wire into the indicated circuit board pin.

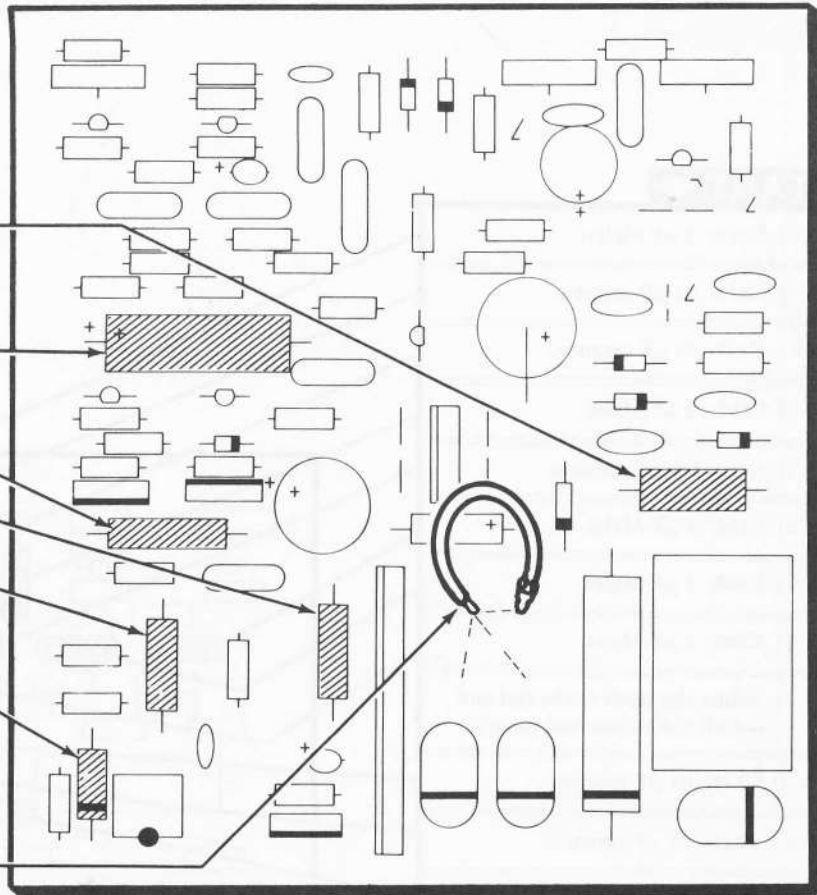

- (✓) Turn the circuit board over and position it foil side up as shown.

NOTE: In the next step, keep the capacitor leads as short as possible and make sure the leads do not touch any other foils or connections.

- (✓) C335: 470 pF ceramic capacitor. Solder the leads to the indicated foils. There are no holes in the circuit board for the leads. Solder the leads directly to the foil.
- (✓) Reposition the circuit board component side up as it was before.

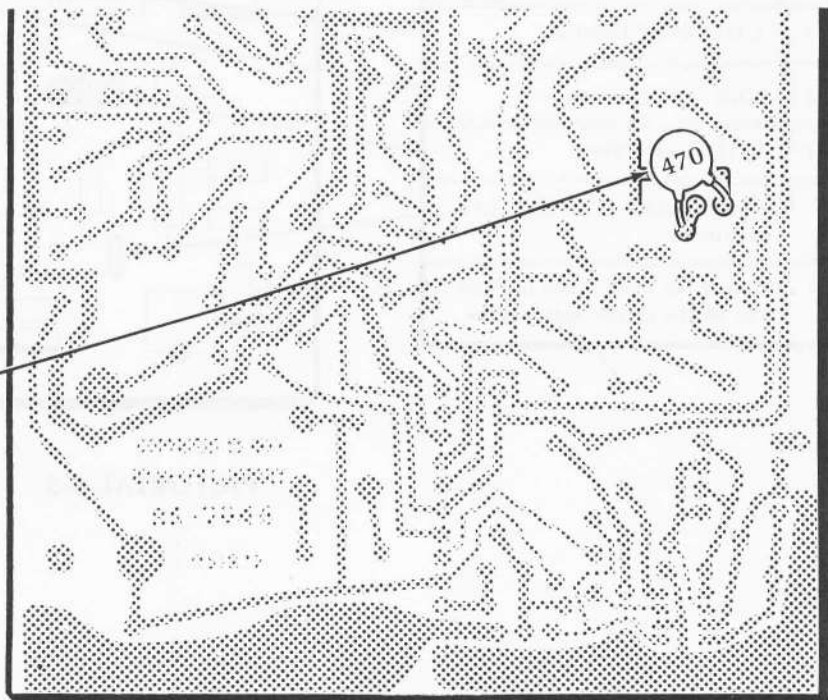

PICTORIAL 5-4

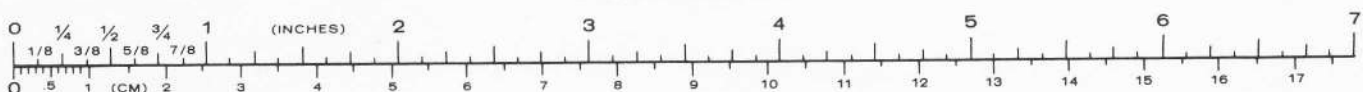

START →

- () C329: .1 μ F Mylar.
- () C331: .01 μ F ceramic.
- () C301: .01 μ F ceramic.
- () C302: .1 μ F Mylar.
- () C310: 470 pF ceramic.
- () C304: .1 μ F Mylar.
- () C306: .1 μ F Mylar.
- () C307: .1 μ F Mylar.
- () Solder the leads to the foil and cut off the excess lead lengths.
- () C325: .01 μ F ceramic.
- () C323: .01 μ F ceramic.
- () C308: .1 μ F Mylar.
- () C327: .05 μ F ceramic.
- () C326: .05 μ F ceramic.
- () C311: .1 μ F Mylar.
- () C314: 1000 pF (.001 μ F) ceramic.
- () Solder the leads to the foil and cut off the excess lead lengths.

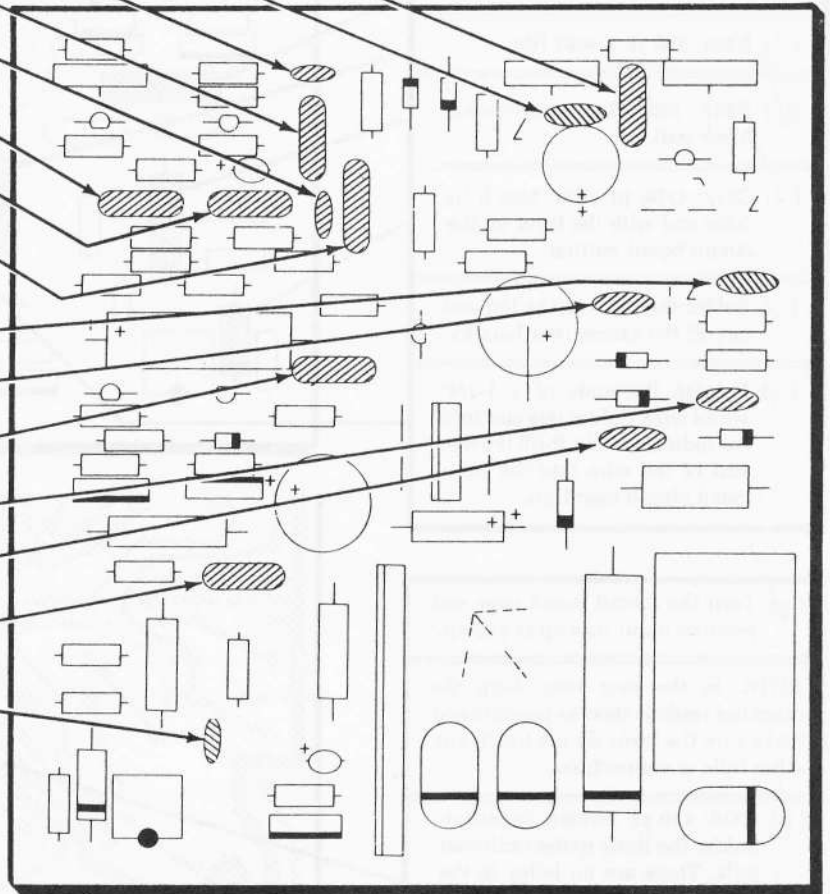

PICTORIAL 5-5

START →

NOTE: When you install a control, push the control down tight against the circuit board. Then solder the lugs to the foil.

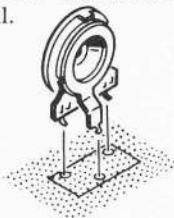

(✓) R336: 5 MΩ control (#10-989).

(✓) R338: 100k Ω control (#10-941).

(✓) R303: 5000 Ω (5k) control (#10-904).

(✓) C328: 100 μF electrolytic. Match the positive (+) lead on the capacitor with the plus (+) mark on the board.

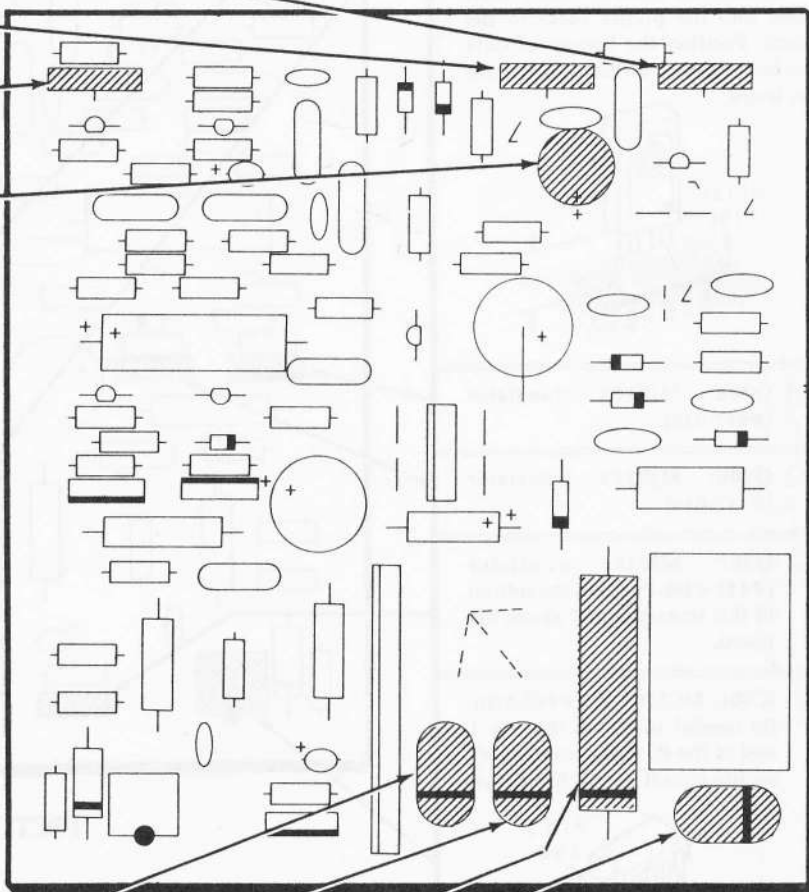

CONTINUE →

NOTE: Match the band on the following four capacitors with their band on the circuit board outline.

(✓) C319: 5000 pF (.005 μF) Mylar.

(✓) C318: 3300 pF (.0033 μF) Mylar.

(✓) C322: 3 μF Mylar.

(✓) C321: .022 μF Mylar.

(✓) Solder the leads to the foil and cut off the excess lead lengths.

PICTORIAL 5-6

START

NOTE: Solder the pins of each part as it is installed. Then cut off any excess pin lengths.

(✓) P301: 4-pin plug. Align the lip on the plug with the narrow space on the circuit board outline.

(✓) P302: 12-pin plug.

NOTE: When you install the following **three** transistors, position their metal side as shown. Insert their leads into the proper holes in the board. Position the bottom of only the next **two** transistors $7/16''$ above the board.

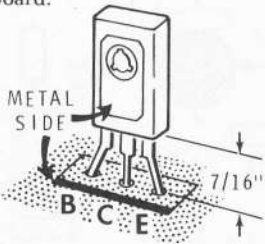

(✓) Q305: MJE181 transistor (#417-818).

(✓) Q306: MJE171 transistor (#417-819).

(✓) Q307: MJE181 transistor (#417-818). Position the bottom of this transistor $1/4''$ above the board.

(✓) IC301: MC1391 IC (#442-620). Be careful to match the pin 1 end of the IC to the index mark on the circuit board. See Detail 5-7A.

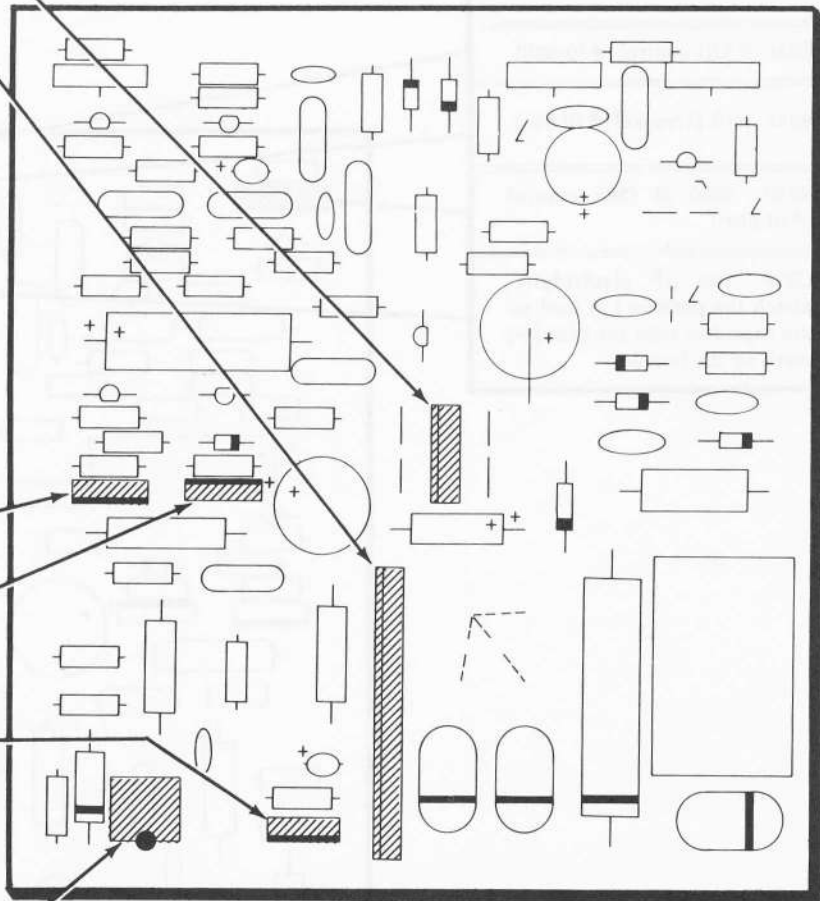
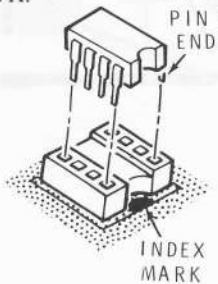

PICTORIAL 5-7

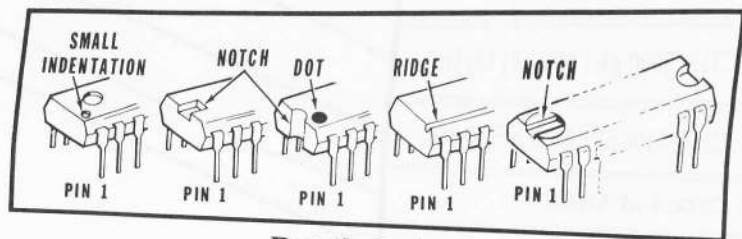

Detail 5-7A

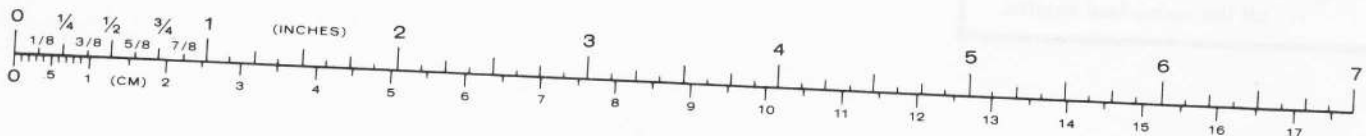

START

- () Locate four 1000 Ω (brown-black-red) resistors and cut **one** lead of each resistor to $3/8"$. Refer to Detail 5-8A and bend the short lead of each resistor into a hook.

NOTE: When you install these resistors in the following steps, only the long lead will be connected to the circuit board. See Detail 5-8A. Solder the lead to the foil and cut off the excess lead length as each resistor is installed.

- (✓) R346: 1000 Ω at G1.

- (✓) R340: 1000 Ω at the indicated end of the 1000 Ω resistor outline.

- (✓) R347: 1000 Ω at G2.

- (✓) Install a heat sink on transistor Q306. Be sure the heat sink is against the metal side of the transistor. Use a 4-40 \times 5/16" screw, a #4 lockwasher, and a 4-40 nut.

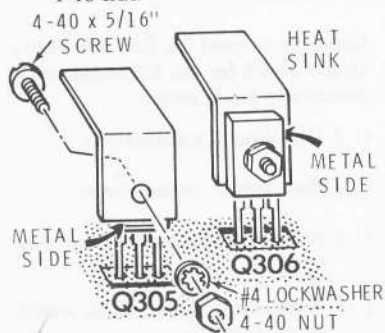

- (✓) In a similar manner, mount a heat sink on transistor Q305. Position the heat sink against the metal side of the transistor as shown.

- (✓) C309: 500 μ F electrolytic.

- (✓) C324: 10 μ F tubular electrolytic. The lead from the positive (+) end of the capacitor goes in the hole within the circle outline on the board.

- (✓) L301: 39 μ H inductor.

- (✓) Solder the leads to the foil and cut off any excess lead lengths.

Proceed to the top right step on this page.

CONTINUE

- (✓) R348: 1000 Ω at CATHODE. Install this resistor from the foil side of the board. Leave the resistor body $1/8"$ away from the foil to insure a good solder connection. Solder the lead to the foil.

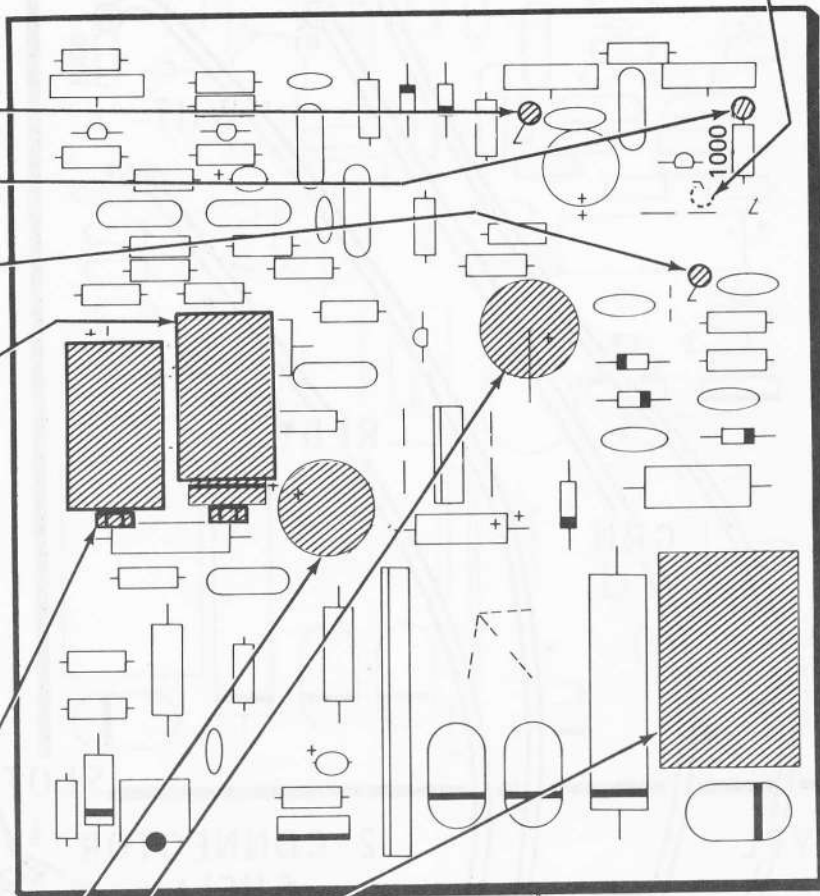
PICTORIAL 5-8

Detail 5-8A

START ↓

() Cut all but the yellow lead of the CRT socket to 6-1/2" in length. Measure from where the leads come out of the socket. Cut the yellow lead to 4-1/2" long. Then remove 1/4" of insulation from the end of each lead.

Bend a hook in the end of all but the brown and orange wires. Connect the following three wires to the hook in the wire of the resistors on the lettered side of the circuit board. Solder each wire as it is connected.

- () Green lead to G1.
- () White lead to the 1000 Ω (brown-black-red) resistor that is at the end of the 1000 marking on the circuit board.
- () Red lead to G2.

() Install large spring connectors on the end of the brown and orange leads. Insert the connector ends of these leads into the 2-connector shell as shown. Then label the socket "S103" with a number "1" at the brown lead.

NOTE: The yellow wire will be connected later.

CIRCUIT BOARD CHECKOUT

Visual Inspection

Carefully inspect the foil side of the circuit board for the following most commonly made errors.

- () Unsoldered connections.
- () Poor solder connections.
- () Solder bridges between foil patterns.
- () Protruding leads which could touch together.

When you make the following visual checks, refer to the Pictorial where the part was installed and check it against the installation instructions.

- () Check the transistors for proper type and installation.
- () Check the diodes for correct positioning of the banded end.
- () Check the integrated circuit for proper type and installation.
- () Check the electrolytic and tantalum capacitors for the correct position of the positive (+) end.
- () Check the plugs for proper installation.

FINISH

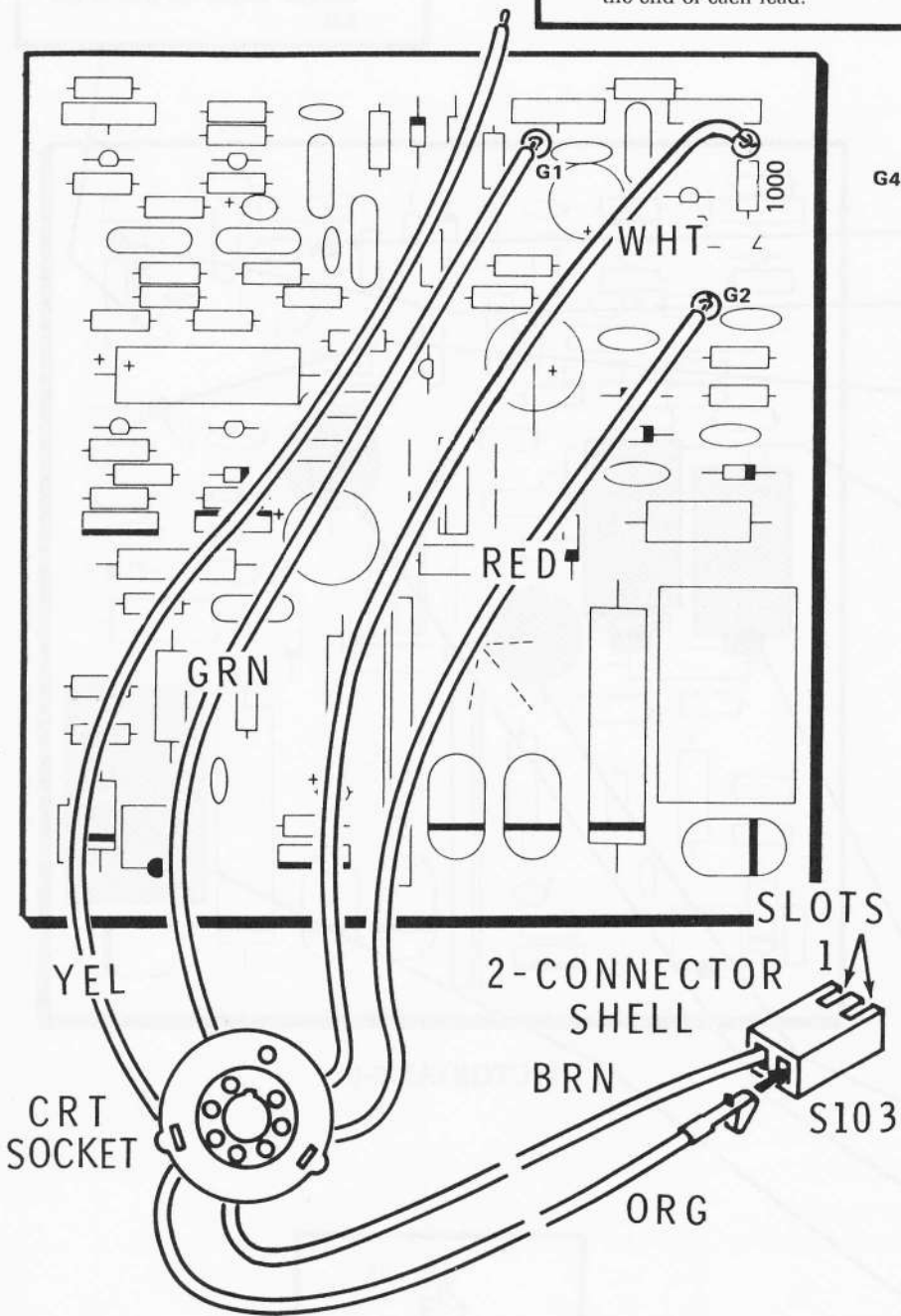

PICTORIAL 5-9

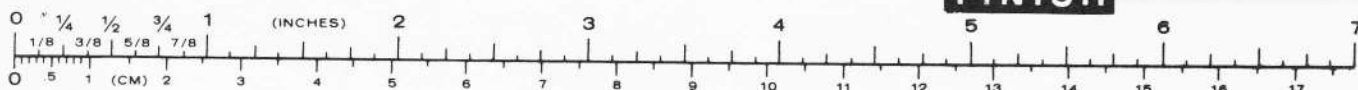

VIDEO CIRCUIT BOARD CHECKOUT

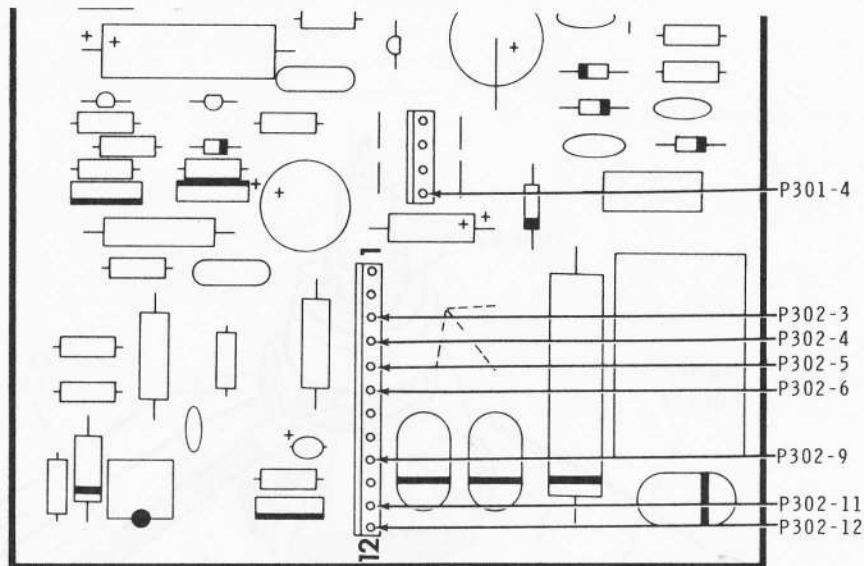

PICTORIAL 5-10

RESISTANCE MEASUREMENTS

Refer to Pictorial 5-10 for the following steps.

Make the following resistance measurements on the video circuit board.

NEGATIVE LEAD TO:	POSITIVE LEAD TO:	SELECTOR — RANGE	METER READING	POSSIBLE AREA OF TROUBLE
() P302-3	P302-6	OHMS — RX1000	GREATER THAN 1000 Ω	Q308, Q309
() P302-4	P301-4	OHMS — RX 1000	GREATER THAN 1000 Ω	Q306, C309
() P302-4	P302-6	OHMS — RX 1000	GREATER THAN 20 K Ω	Q301, Q302
() P302-4	P302-5	OHMS — RX 1000	GREATER THAN 10 K Ω	Q303, Q304, Q305, Q306
() P302-11	P302-9	OHMS — RX 1000	GREATER THAN 10 K Ω	C321, Check for solder bridges on the foil.
() P302-12	P302-6	OHMS — RX 1000	GREATER THAN 10 K Ω	Q307, Check for solder bridges on the foil.
() P302-12	P302-5	OHMS — RX 1000	GREATER THAN 1000 Ω	IC301

Set the video circuit board aside temporarily.

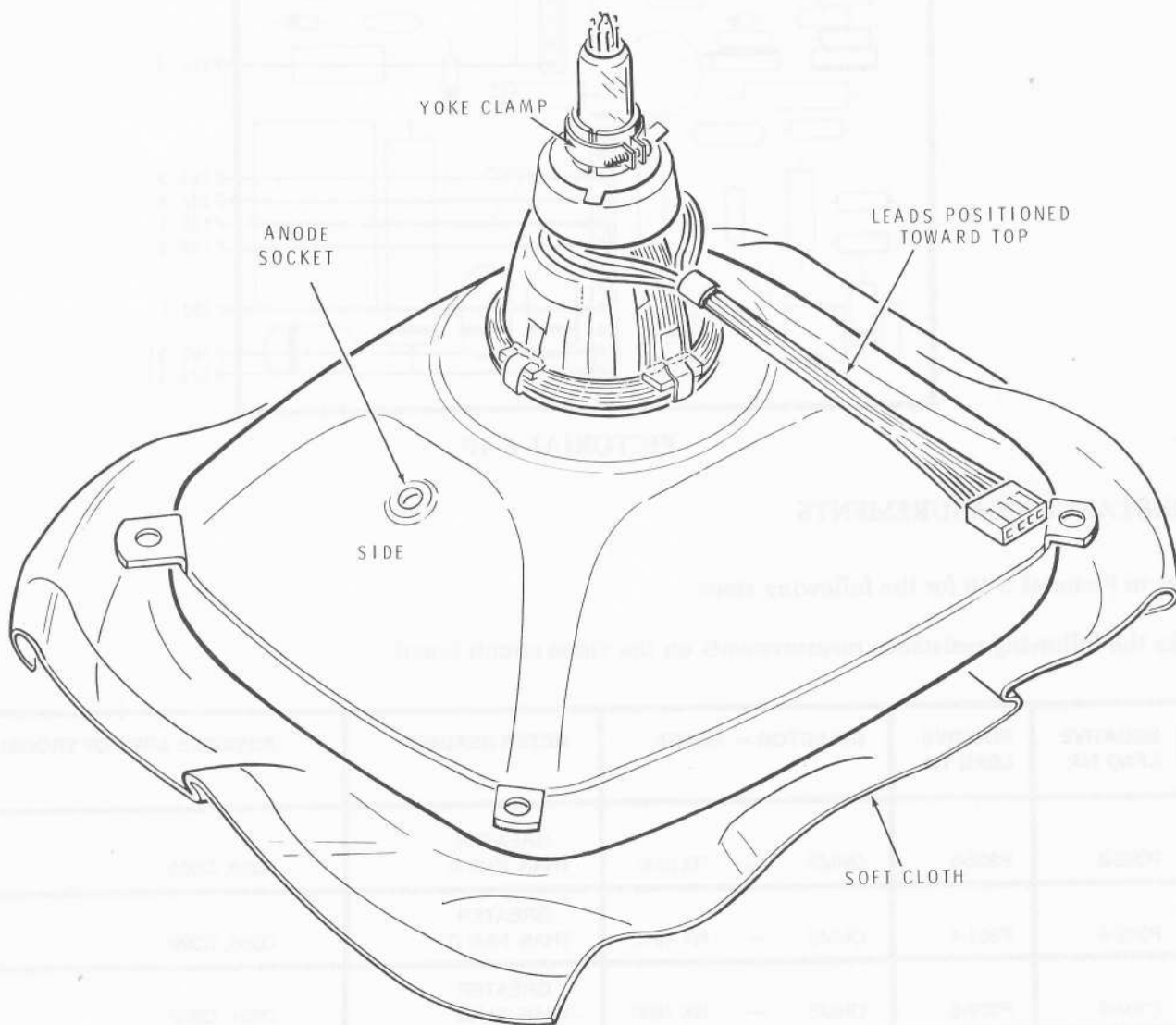

PICTORIAL 5-11



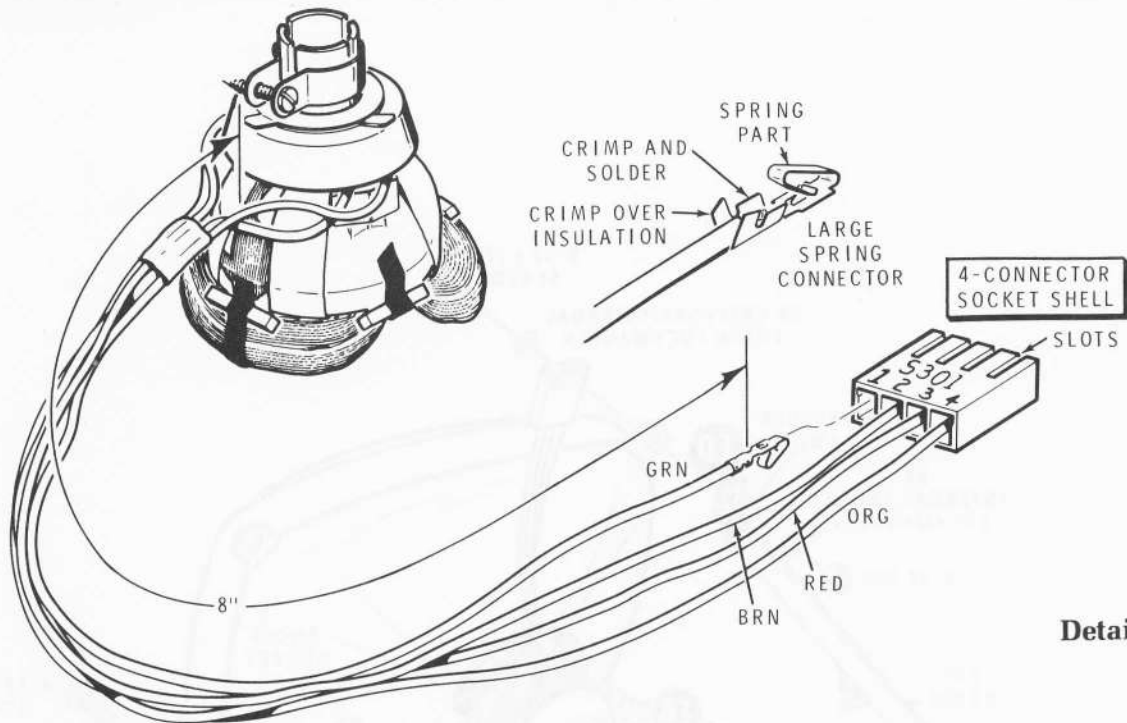

Detail 5-11A

CRT INSTALLATION

Refer to Pictorial 5-11 for the following steps.

- () Refer to Detail 5-11A and cut the deflection yoke leads to 8". Remove 3/16" of insulation from the end of each lead.
- () Refer again to Detail 5-11A and crimp and solder a large spring connector onto the end of each deflection yoke lead. BE CAREFUL that you do not solder the spring part to the connector so that it will not move.

Insert the spring connector on the ends of the deflection yoke leads into a 4-connector socket shell as follows. Insert the connector with the spring part away from the slotted side of the socket shell.

- () Green wire into hole 1.
- () Brown wire into hole 2.
- () Red wire into hole 3.
- () Orange wire into hole 4.
- () Label this connector socket "S301" with a number "1" near the hole with the green lead.

- () Cut the tape that holds the yoke clamp to the yoke and reposition the clamp as shown.

WARNING

Use extreme caution when you handle the CRT. Do not strike, scratch, or subject the picture tube to more than moderate pressure at any time. Due to its high vacuum and large glass surface, a fracture of the glass could result in an implosion of considerable violence.

NEVER LIFT THE CRT by its neck. Always lift it by the edges around the face of the tube. When you handle the CRT, do not touch the anode socket as you can receive an electrical shock, even though the CRT has not been used.

- () Carefully unpack the CRT and place it face down on a soft cloth as shown. Note the anode socket.
- () Slide the deflection yoke over the neck of the CRT with the leads coming from the yoke as shown. Push the yoke firmly against the flared part of the CRT. Do not tighten the yoke clamp screw. Position the leads towards the top of the CRT.

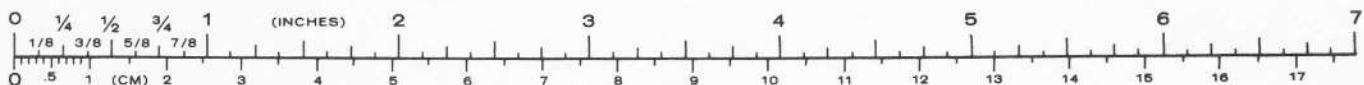

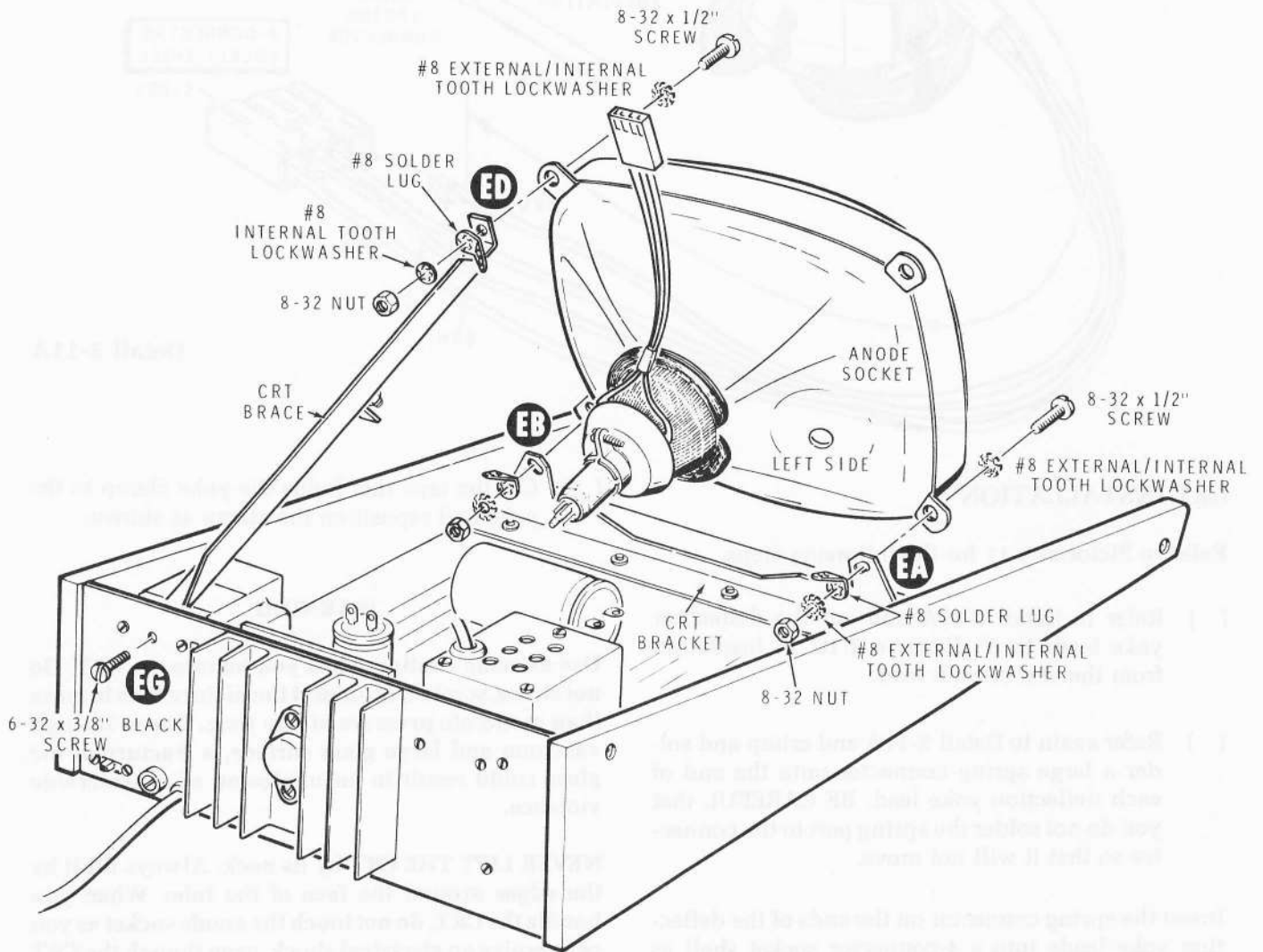

PICTORIAL 5-12

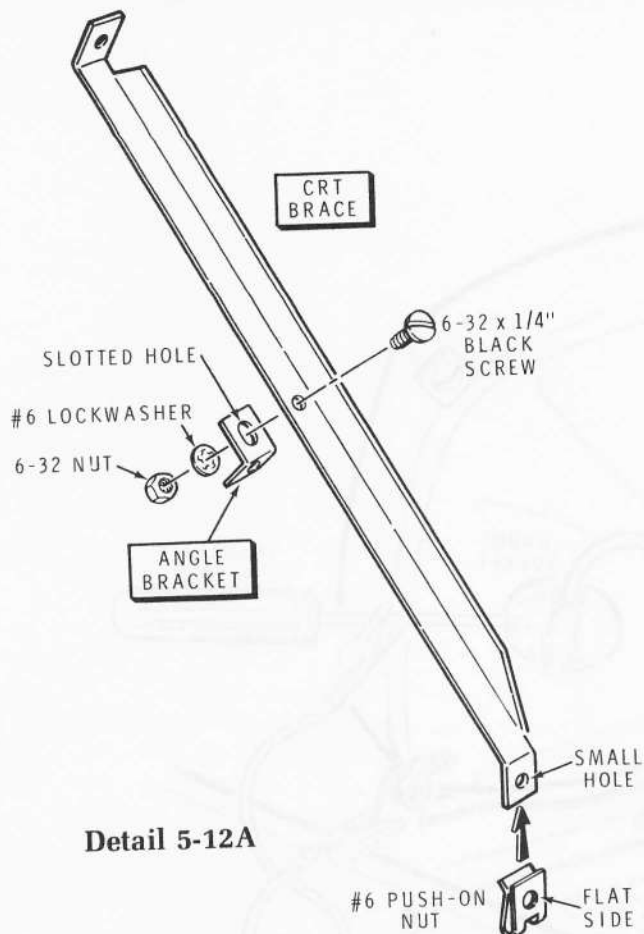

Detail 5-12A

Refer to Pictorial 5-12 for the following steps.

- (✓) Refer to Detail 5-12A and mount an angle bracket to a CRT brace. Use a 6-32 × 1/4" black screw, a # lockwasher, and a 6-32 nut. Position the angle bracket as shown. Do not tighten the hardware.
- (✓) Refer to Detail 5-12A and install a square push-on nut on the end of the CRT brace with the **small** hole. Be sure to install the push-on nut so the flat side is positioned as shown. Set this brace aside, it will be used later.
- (✓) In the same manner, mount an angle bracket and push-on nut to the other CRT brace. Use this brace in the next step.
- (✓) Mount the brace to the rear panel at EG with a 6-32 × 3/8" black screw. Do not tighten this screw.

- () Temporarily proceed to Pictorial 6-13 (Illustration Booklet, Page 23) and position sockets S401, both S402, S403, and S701 as shown before you install the CRT in the following steps.
- () Locate the following hardware. Use this in the next step.

QTY	DESCRIPTION
1	8-32 × 1/2" screw
1	#8 internal/external tooth lockwasher
1	#8 internal tooth lockwasher.
1	#8 solder lug
1	8-32 nut

NOTE: You may wish to have another person help you install the CRT in the next two steps. Be careful that you do not strike the neck of the CRT. Do not permit the CRT to rest on the neck.

- () Place the CRT into the chassis with the mounting tabs in front of the CRT mounting bracket. Make sure the anode socket is positioned as shown. Mount the CRT to the CRT bracket at ED with the hardware from the previous step. Do not tighten this hardware.
- () Mount the CRT to the CRT bracket at EA and EB. Use an 8-32 × 1/2" screw, two #8 external/internal tooth lockwashers, a #8 solder lug, and an 8-32 nut at each hole.

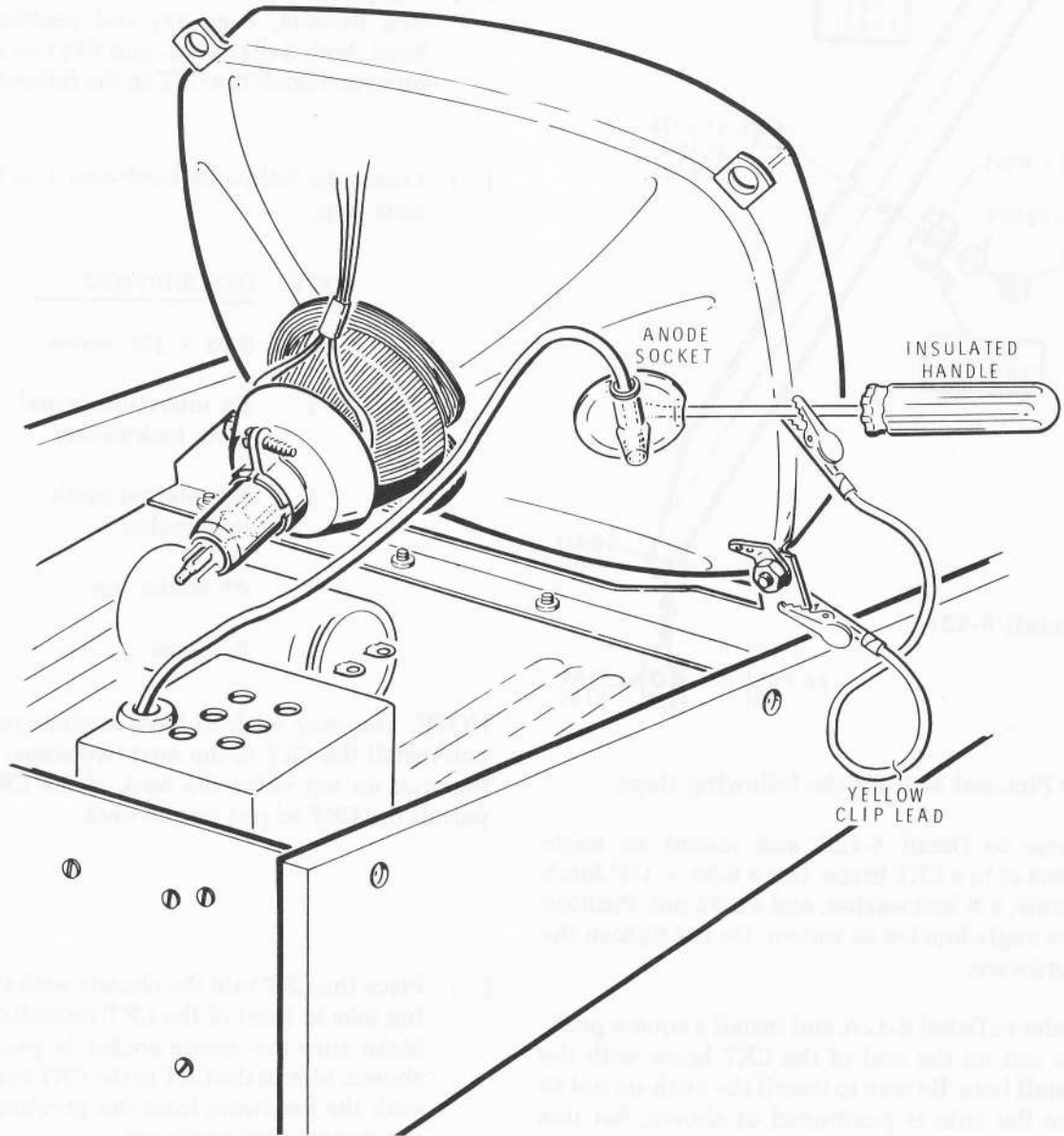

Detail 5-13A

Refer to Pictorial 5-13 (Illustration Booklet, Page 17) for the following steps.

- (✓) Connect one end of a yellow clip lead to the chassis. Then touch the other end of the clip lead to the anode socket on the CRT to discharge any stored-up charge. DO NOT hold the alligator clip in your fingers. Hold the yellow lead by its insulation and do not touch the chassis with your other hand.
- (✓) Refer to the inset drawing on Pictorial 5-13 and install the high voltage lead from the high voltage assembly. Fold the plastic boot on the end of the lead back out of the way as shown. Push the plastic boot against the CRT after the lead is connected. Position the plastic boot so that the high voltage lead comes out of the boot toward the top of the CRT.

NOTE: If it is ever necessary to remove the high voltage lead from the CRT, refer to Detail 5-13A and proceed as follows:

1. First discharge the CRT. This high voltage is dangerous, and discharging the CRT is important. Connect one end of the yellow clip lead to the chassis and the other end to a small-blade screwdriver with a plastic handle. Then slip the screwdriver under the boot to make contact with the anode socket. CAUTION: Do not touch anything with your other hand while you perform this step.
2. Fold the boot back and use a screwdriver to push one of the high voltage clips towards the other. This will permit you to remove the high voltage lead.

- (✓) Push the video circuit board down into the circuit board holders at Q and R. Position the circuit board so that the foil is toward the rear panel and the three controls are at the top.
- (✓) Mount a CRT brace to the CRT at EC with an 8-32 × 1/2" screw, a #8 internal/external tooth lockwasher, a #8 solder lug, a #8 internal tooth lockwasher, and an 8-32 nut. Do not tighten this hardware.
- (✓) Position the video circuit board behind the angle bracket on the CRT brace at EE. Do not tighten the hardware.
- (✓) Mount the other end of the brace to the rear panel with a 6-32 × 3/8" black screw.
- (✓) Position the #8 solder lug at EC inward and tighten the hardware. Bend the solder lug as shown.
- () Position the circuit board angle bracket at EE against the top edge of the video circuit board. Then slide the angle bracket toward the rear panel as far as it will go and tighten the hardware.
- () Cut a 32" length of bare wire. Use this wire in the following steps.



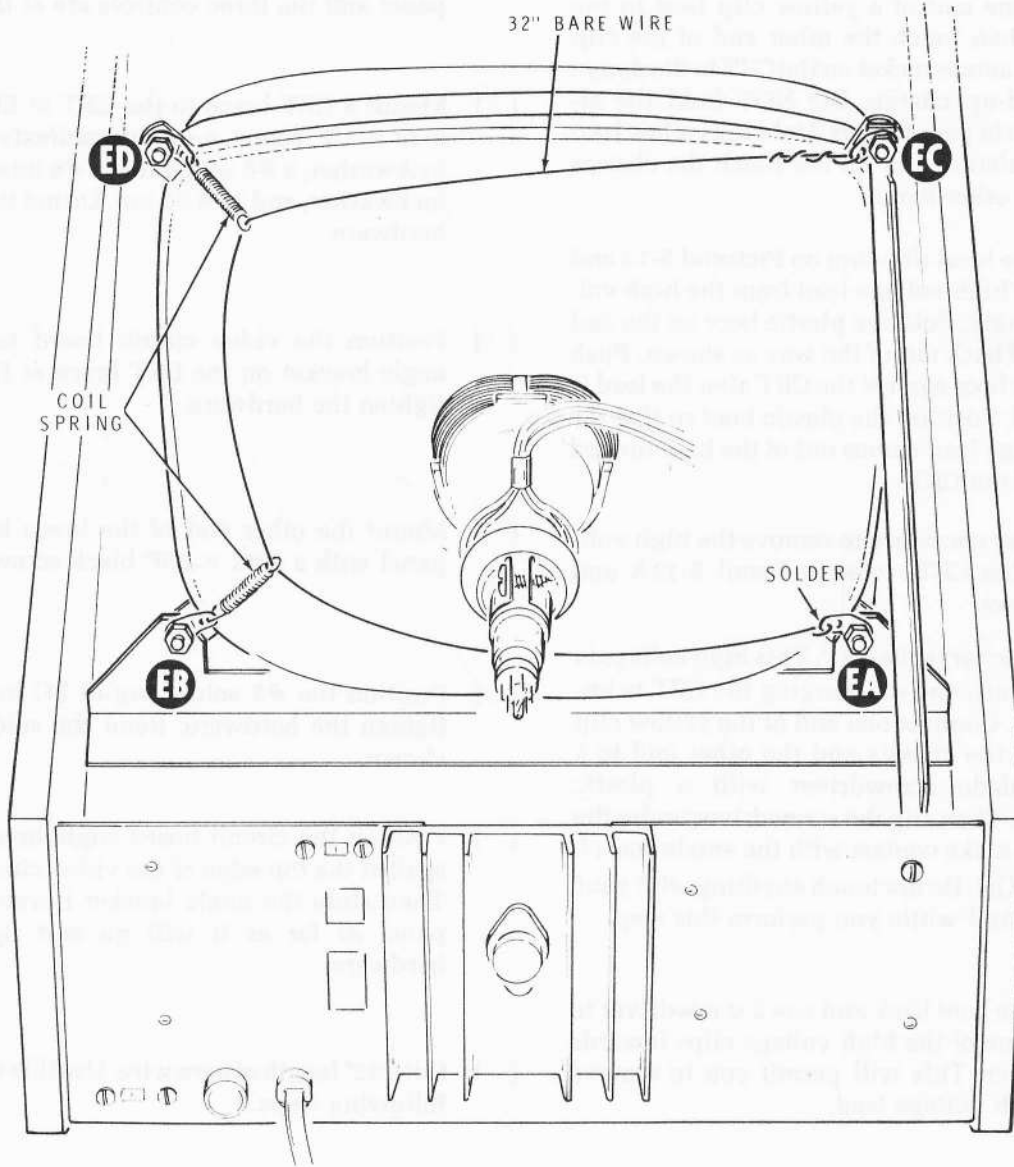

Detail 5-13B





Refer to Detail 5-13B for the next four steps.

WARNING: When you solder a connection as in the next step, make sure you do not touch the CRT with the soldering iron or drop hot solder on the CRT as this could cause the tube to implode.

1. () Solder one end of the bare wire to the solder lug at EA.
2. () Slide the loop end of a coil spring over this bare wire. Then hook the spring into the solder lug at EB.
3. () Slide the loop end of another coil spring onto the bare wire. Then hook this spring into the solder lug at ED.
4. () Route the bare wire to the inside of the CRT brace and connect it to the solder lug at EC. Pull on the bare wire until both tension springs are stretched slightly. Then wrap the bare wire back on itself. Do not solder this lug. Cut off any excess wire length.

(✓) Push socket S302 from the main harness onto plug P302 on the video circuit board so the number "1" on the socket (large gray wire) matches the number "1" on the board.

(✓) Push socket S301 coming from the deflection yoke onto plug P301 on the video circuit board so the number "1" on the socket (green lead) matches the number "1" on the board.

(✓) Push socket S103 coming from the CRT socket onto plug P103 on the power supply circuit board so the number "1" on the socket (brown lead) matches the number "1" on the board.

(✓) C333: Cut one lead of a .75 pF ceramic (spark gap) capacitor to 1/2". Bend a hook in this lead and connect it into the hook in the lead of the resistor that extends from the rear of the video circuit board (NS). Connect the other lead to solder lug DE on top of the high voltage assembly (S-1).

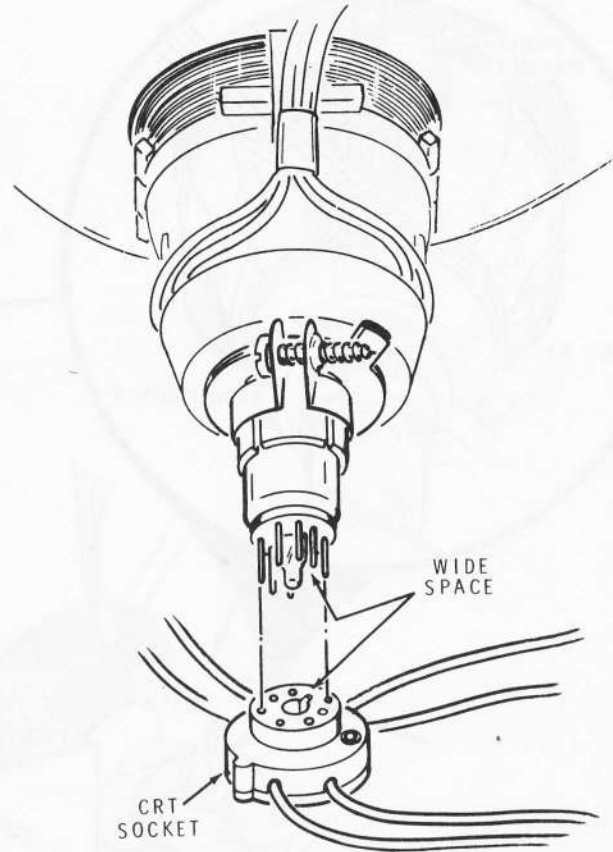

Detail 5-13C

(✓) Connect the yellow wire coming from the CRT socket to the lead of the resistor that extends from the rear of the video circuit board (S-3). Make sure that this connection does not touch the high voltage assembly cage.

Refer to Detail 5-13C for the next two steps.

(✓) Remove the plastic pin protector from the end of the neck if one is present.

(✓) Carefully push the CRT socket (coming from the video circuit board) onto the CRT pins. Note the wide space between the CRT pins and on the socket. Position the white, green, and red leads down as far as possible away from the yellow lead of the CRT socket.

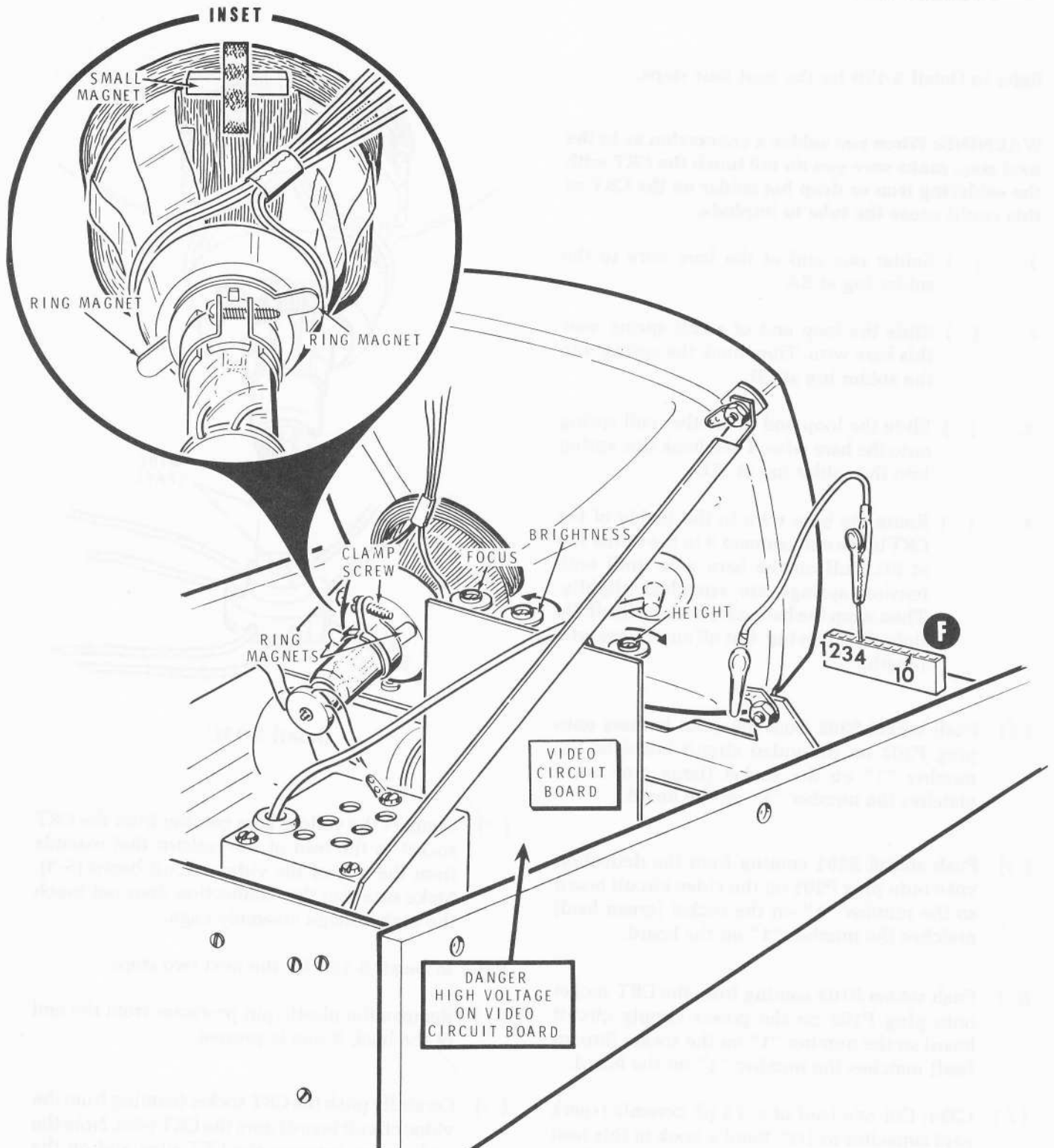

PICTORIAL 5-14

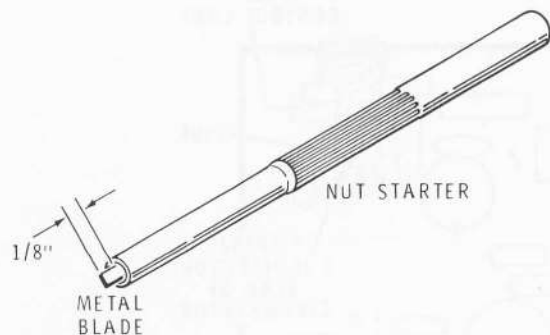

Detail 5-14A

VISUAL CHECKS

Refer to Pictorial 5-14 for the following steps.

- Locate the screwdriver blade (#205-778) and insert it into the small end of the nut starter (see Detail 5-14A). Use this as a screwdriver to make the following control adjustments.
- Set the HEIGHT control at the top of the video circuit board fully clockwise (as viewed from the top).
- Set the FOCUS control at the top of the video circuit board to its center of rotation.
- Set the BRIGHTNESS control at the top of the video circuit board fully counterclockwise (as viewed from the top).
- Remove the protective sheet (if there is one) from the face of the CRT.

NOTE: If you do not obtain the proper response in the next step, proceed to the "Voltage Measurements."

- Connect the line cord to an AC outlet and set the AC POWER switch to ON. After a few seconds, turn the BRIGHTNESS control on top of the video circuit board clockwise only as much as you need to see the display comfortably. The screen should display 12 rows of question marks with underlines. The display should be clear and stable, not jittery.

- Observe the top, bottom and sides of the display. If any one side appears to be bowed out objectionably, refer to the inset drawing on Pictorial 5-14 and remove the small magnet that is attached to the back of the yoke on the side that the display is bowed. Remove this magnet very carefully or the yoke could be damaged.

WARNING: There is high voltage at a number of locations on the video circuit board. Avoid touching this board when you perform the following steps.

- There are two ring magnets on the neck of the yoke (metal rings with tabs). Move these magnets around the neck of the yoke while you observe the CRT screen. Then position the ring magnets for the best centering of the display.
- Note the top row of question marks on the screen. If the display is not straight with respect to the CRT screen, rotate the deflection yoke slightly to straighten the display.
- CAREFULLY tighten the clamp screw in the deflection yoke **only** enough to keep the yoke from moving.
- Connect one end of a yellow clip lead to the chassis. Connect the other end of this lead to pin 4 on plug F. The pins extend beyond the bottom of the chassis for easy access. The screen should display rows of sevens with underlines.
- With this clip lead still connected to pin 4, connect a second clip lead between pins 1 and 4. The screen should display rows of sixes with underlines.
- Remove the second clip lead from pin 1 and connect it to pin 3. The screen should display rows of threes with underlines.
- Remove the second clip lead from pin 3 and connect it to pin 10. The screen should display rows of "W's" with underlines.
- Remove both clip leads.
- Set the AC POWER switch to OFF and disconnect the line cord.

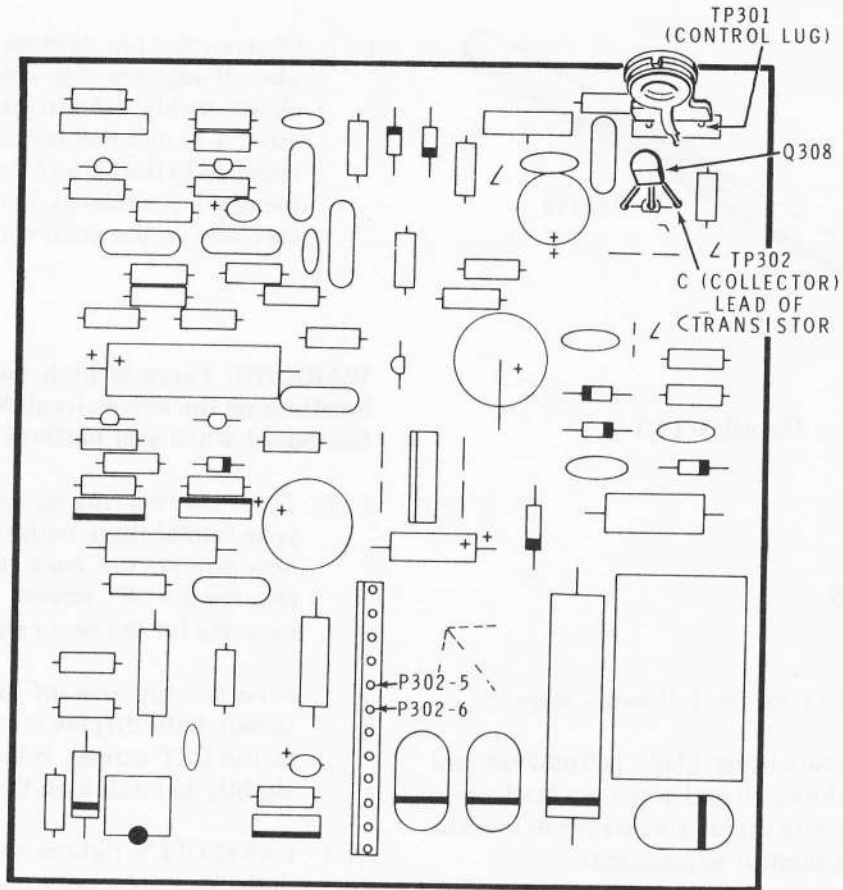

PICTORIAL 5-15

NOTE: If you obtained the proper response in the previous checks, proceed to the "Keyboard Circuit Board."

VOLTAGE MEASUREMENTS

Refer to Pictorial 5-15 for the following steps.

Make the following voltage measurements on the video circuit board.

	NEGATIVE LEAD TO:	POSITIVE LEAD TO:	SELECTOR — RANGE	METER INDICATION	POSSIBLE AREA OF TROUBLE
()	CHASSIS	P302-5	DC + 50V	36V	Q303, Q304, Q305, Q306
()	CHASSIS	P302-6	DC + 50V	26V	Q302, Q305, Q307, IC301, Q308, Q309, T2, Q1 (on high voltage assembly).
()	CHASSIS	TP301	DC + 500V	400V	D304, T2
()	CHASSIS	TP302	DC +50V	26V	C328, C329, C308, Q309.

Correct any problems and then perform the "Visual Checks" on Page 83.

KEYBOARD CIRCUIT BOARD

PARTS LIST

Unpack the pack marked #4 and check each part against the following Parts List. The key numbers correspond to the numbers on the Keyboard Circuit Board Parts Pictorial (Illustration Booklet, Page 18). Any part that is packaged in an individual envelope with a part number on it should be placed back in the envelope after it is identified until it is called for in a step.

KEY No.	HEATH Part No.	QTY.	DESCRIPTION	CIRCUIT Comp. No.
---------	----------------	------	-------------	-------------------

RESISTORS

All resistors are 5% (fourth band gold).

1/4-Watt

A1	6-101-12	2	100 Ω (brown-black-brown)	R404, R405
A1	6-222-12	1	2200 Ω (red-red-red)	R407
A1	6-472-12	14	4700 Ω (yellow-violet-red)	R402, R408, R409, R411, R412, R413, R414, R415, R416, R417, R418, R419, R421, R431
A1	6-103-12	1	10 k Ω (brown-black-orange)	R406
A1	6-223-12	1	22 k Ω (red-red-orange)	R403
A1	6-333-12	1	33 k Ω (orange-orange-orange)	R401
A1	6-154-12	4	150 k Ω (brown-green-yellow)	R422, R424, R426, R428

KEY No.	HEATH Part No.	QTY.	DESCRIPTION	CIRCUIT Comp. No.
---------	----------------	------	-------------	-------------------

Resistors (cont'd.)

1/2-WATT

A2	6-471	4	470 Ω (yellow-violet-brown)	R423, R425, R427, R429
----	-------	---	------------------------------------	------------------------

CAPACITORS

B1	21-46	1	.005 μ F ceramic	C405
B1	21-199	4	.1 μ F ceramic	C401, C402, C403, C404, C406, C407, C408, C409
B2	27-73	4	.047 μ F Mylar	

DIODES

C1	56-26	1	1N191 (brown-white-brown)	D401
C1	56-56	5	1N4149 diode	D402, D403, D404, D405, D406



KEY No.	HEATH Part No.	QTY.	DESCRIPTION	CIRCUIT Comp. No.
---------	----------------	------	-------------	-------------------

TRANSISTOR — INTEGRATED CIRCUITS (IC's)

NOTE: Transistors and integrated circuits are marked for identification in one of the following four ways:

1. Part number.
2. Type number. (On integrated circuits this refers only to the numbers and letters listed. Any additional letters or numbers on an IC are not significant.)
3. Part number and type number.
4. Part number with a type number other than the one listed.

D1	417-801	1	MPSA20 transistor	Q401
D2	443-728	2	74LS00 IC	IC407, IC408
D2	443-779	1	74LS02 IC	IC406
D2	443-838	1	74LS93 IC	IC401
D2	443-811	2	74LS125 IC	IC404, IC405
D3	443-754	1	74LS240 IC	IC403

CAUTION: The protected MM5740AAE/N (#443-767) IC can be damaged by static electricity. DO NOT remove it from the foam pad until you are instructed to do so in a step.

D4	443-767	1	MM5740AAE IC (protected)	IC402
----	---------	---	--------------------------	-------

CONNECTOR — PLUGS — SOCKETS

E1	432-134	5	Circuit board connector (1 extra)	
----	---------	---	-----------------------------------	--

KEY No.	HEATH Part No.	QTY.	DESCRIPTION	CIRCUIT Comp. No.
---------	----------------	------	-------------	-------------------

E2	432-867	1	6-pin edge plug	P401
E3	432-968	2	15-pin edge plug	P402, P403
E4	434-298	6	14-pin IC socket	
E5	434-311	1	20-pin IC socket	
E6	434-253	1	40-pin IC socket	

MISCELLANEOUS

F1	64-839	60	Pushbutton switch (momentary)	
F2	64-840	7	Pushbutton switch (latching)	
F3	250-323	6	4-40 × 5/8" screw	
F4	252-15	6	Small 4-40 nut	
F5	252-2	6	Large 4-40 nut	
F6	254-9	12	#4 lockwasher	
F7	255-1	6	1/8" long spacer	
F8	266-1016		Set of space bar parts consisting of:	
		2	Screw	
		2	Plastic guide	
		2	Metal slider	
		1	Torsion bar	
		1	"U" clip	
F9	462-1023	66	Key knob	
F10	462-1072	1	Space bar knob	

PARTS FROM FINAL PACK

	85-1960-1	2	Keyboard circuit board	
F11	204-2323	2	Keyboard bracket	
	390-1552	1	Key label set	

STEP-BY-STEP ASSEMBLY

The parts installed in this Pictorial are in this area of the circuit board.

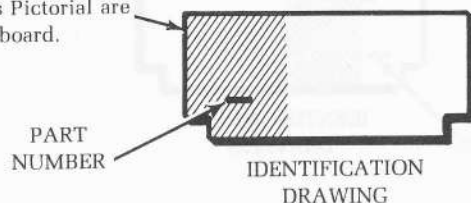

START

Position the circuit board as shown with the lettered side up.

(✓) R402: 4700 Ω (yellow-violet-red).

(✓) R403: 22 k Ω (red-red-orange).

(✓) R407: 2200 Ω (red-red-red).

(✓) D401: 1N191 diode (brown-white-brown, #56-26). Match the band on the diode with the band on the circuit board outline.

(✓) 1-1/2" bare wire.

(✓) R406: 10 k Ω (brown-black-orange).

(✓) 1-3/4" bare wire.

(✓) 1-7/8" bare wire.

(✓) R401: 33 k Ω (orange-orange-orange).

(✓) 1-3/8" bare wire.

(✓) R404: 100 Ω (brown-black-brown).

(✓) 1-5/8" bare wire.

() Solder the leads to the foil and cut off the excess lead lengths.

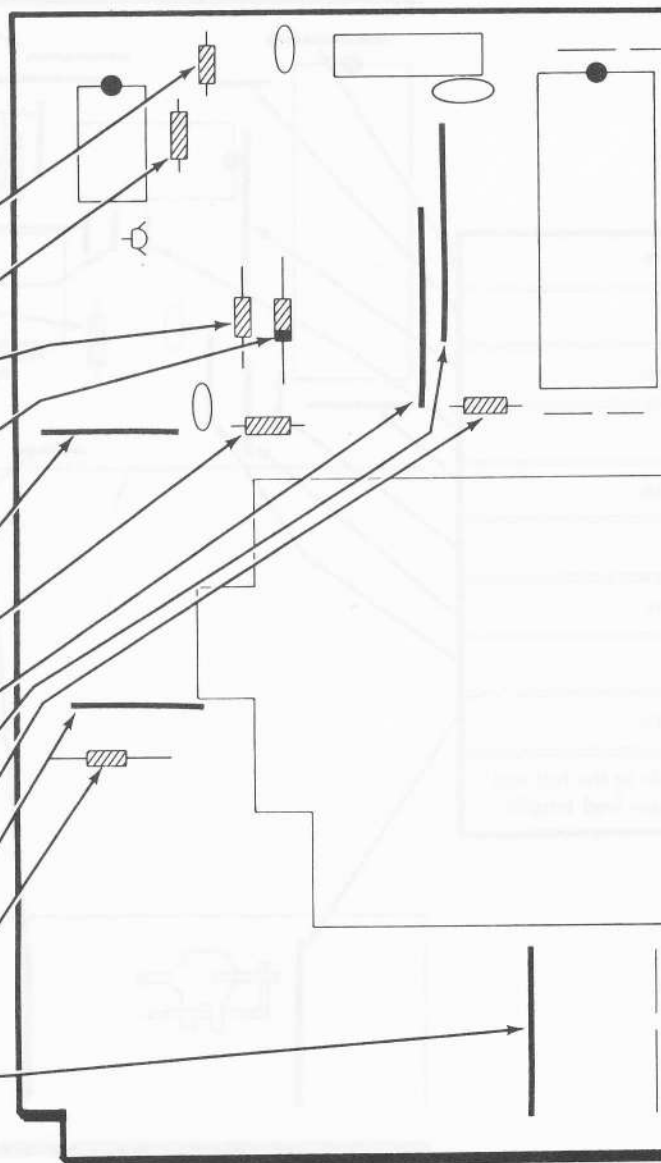

PICTORIAL 6-1

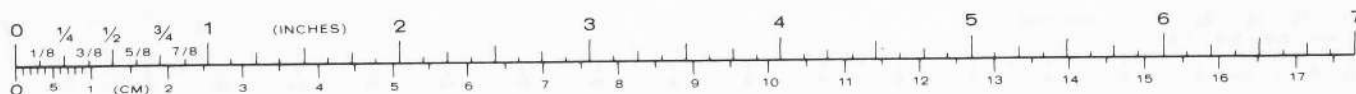

The steps performed in this Pictorial are in this area of the circuit board.

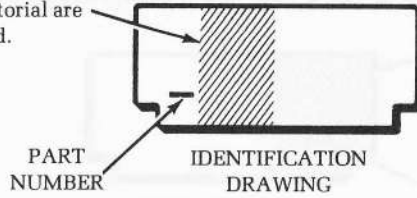

START ↘

- 1-1/4" bare wire.
- 1" bare wire.
- 1-1/2" bare wire.
- 1" bare wire.
- 1-1/4" bare wire.
- 1" bare wire.
- 1-1/4" bare wire.
- 1" bare wire.
- 1-1/2" bare wire.
- Solder the leads to the foil and cut off the excess lead lengths.

CONTINUE ↘

- 1-1/4" bare wire.
- 1-1/4" bare wire.
- 1" bare wire.
- 1" bare wire.
- 1" bare wire.
- 1" bare wire.
- R412: 4700 Ω (yellow-violet-red).
- R408: 4700 Ω (yellow-violet-red).
- 1" bare wire.
- 1-1/2" bare wire.
- Solder the leads to the foil and cut off the excess lead lengths.

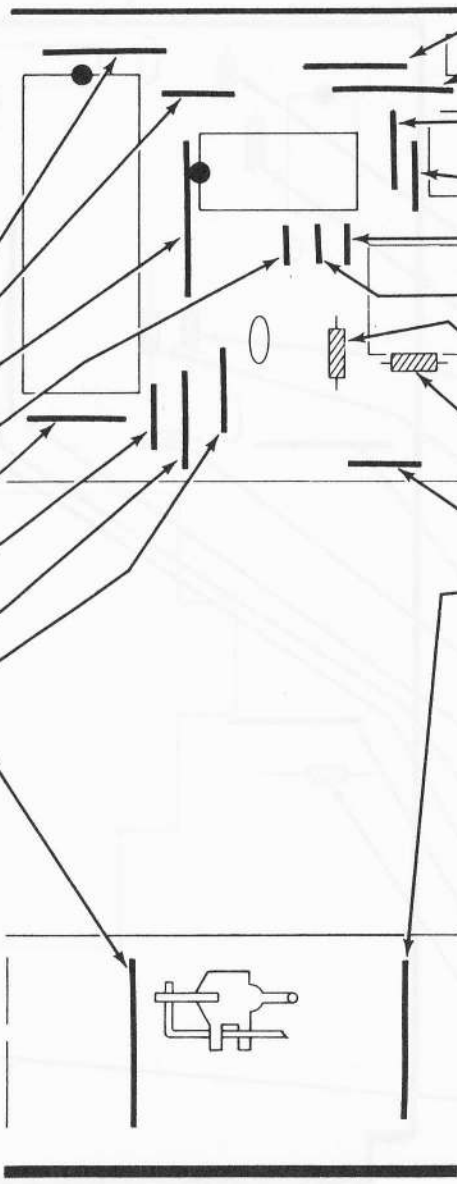

PICTORIAL 6-2



The parts installed in this Pictorial are in this area of the circuit board.

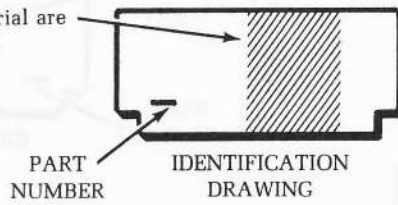

START →

- 1-3/4" bare wire.
- 1-5/8" bare wire.
- 1" bare wire.
- 1" bare wire.
- 1-1/8" bare wire.
- 1" bare wire.
- Solder the leads to the foil and cut off the excess lead lengths.
- 1-1/4" bare wire.
- 1-1/8" bare wire.
- R415: 4700 Ω (yellow-violet-red).
- R416: 4700 Ω (yellow-violet-red).
- R409: 4700 Ω (yellow-violet-red).
- 1" bare wire.
- 1-3/4" bare wire.
- 1-1/2" bare wire.
- 1" bare wire.
- 1-1/2" bare wire.
- Solder the leads to the foil and cut off the excess lead lengths.

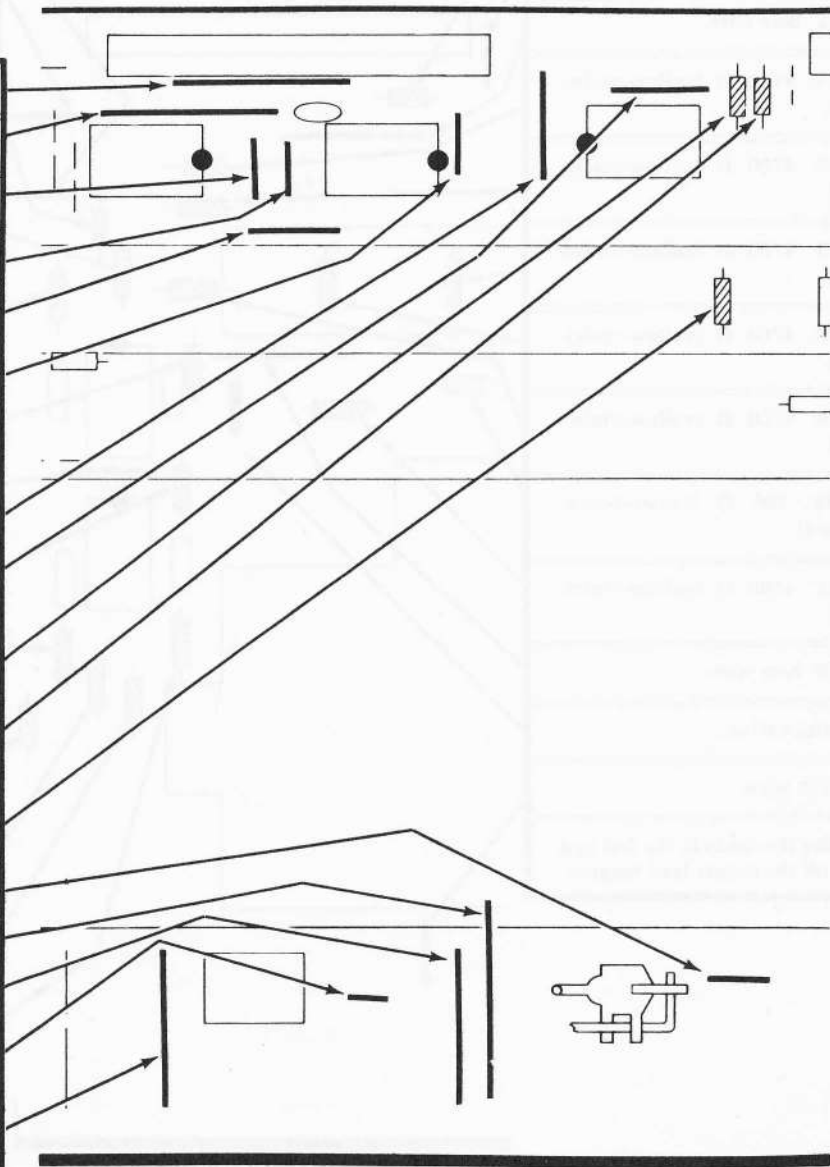

PICTORIAL 6-3

The parts installed in this Pictorial are in this area of the circuit board.

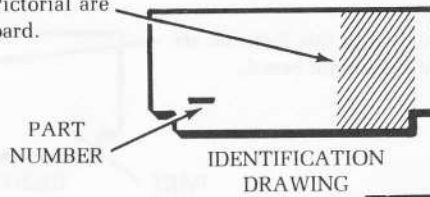

START →

- R411: 4700 Ω (yellow-violet-red).
- 1" bare wire.
- 1-1/2" bare wire.
- R414: 4700 Ω (yellow-violet-red).
- R418: 4700 Ω (yellow-violet-red).
- R413: 4700 Ω (yellow-violet-red).
- R417: 4700 Ω (yellow-violet-red).
- R419: 4700 Ω (yellow-violet-red).
- R405: 100 Ω (brown-black-brown).
- R421: 4700 Ω (yellow-violet-red).
- 1-3/8" bare wire.
- 1" white wire.
- 1" bare wire.
- Solder the leads to the foil and cut off the excess lead lengths.

CONTINUE →

- 1" bare wire.
- 1-1/8" bare wire.
- D402: 1N4149 diode (#56-56). Match the band on the diode with the band on the circuit board outline.
- R425: 470 Ω (yellow-violet-brown). NOTE: This location may be marked "4700."
- R427: 470 Ω (yellow-violet-brown). NOTE: This location may be marked "4700."
- R424: 150 kΩ (brown-green-yellow).
- 1" bare wire.
- R428: 150 kΩ (brown-green-yellow).
- R423: 470 Ω (yellow-violet-brown). NOTE: This location may be marked "4700."
- R431: 4700 Ω (yellow-violet-red).
- R422: 150 kΩ (brown-green-yellow).
- R426: 150 kΩ (brown-green-yellow).
- R429: 470 Ω (yellow-violet-brown). NOTE: This location may be marked "4700."
- Solder the leads to the foil and cut off the excess lead lengths.

PICTORIAL 6-4



The parts installed in this Pictorial are in this area of the circuit board.

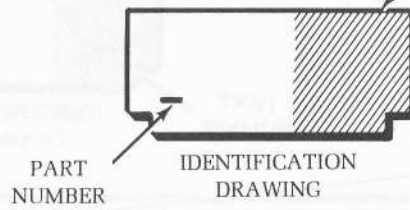

START →

NOTE: When you install an IC socket, make sure each socket pin is in its board hole and that the index mark (color dot) on the circuit board outline is still visible after the socket is installed. Then solder the pins to the foil as each socket is installed.

- (✓) 14-pin IC socket at IC405.
- (✓) 14-pin IC socket at IC406.
- (✓) 14-pin IC socket at IC407.
- (✓) 14-pin IC socket at IC408.

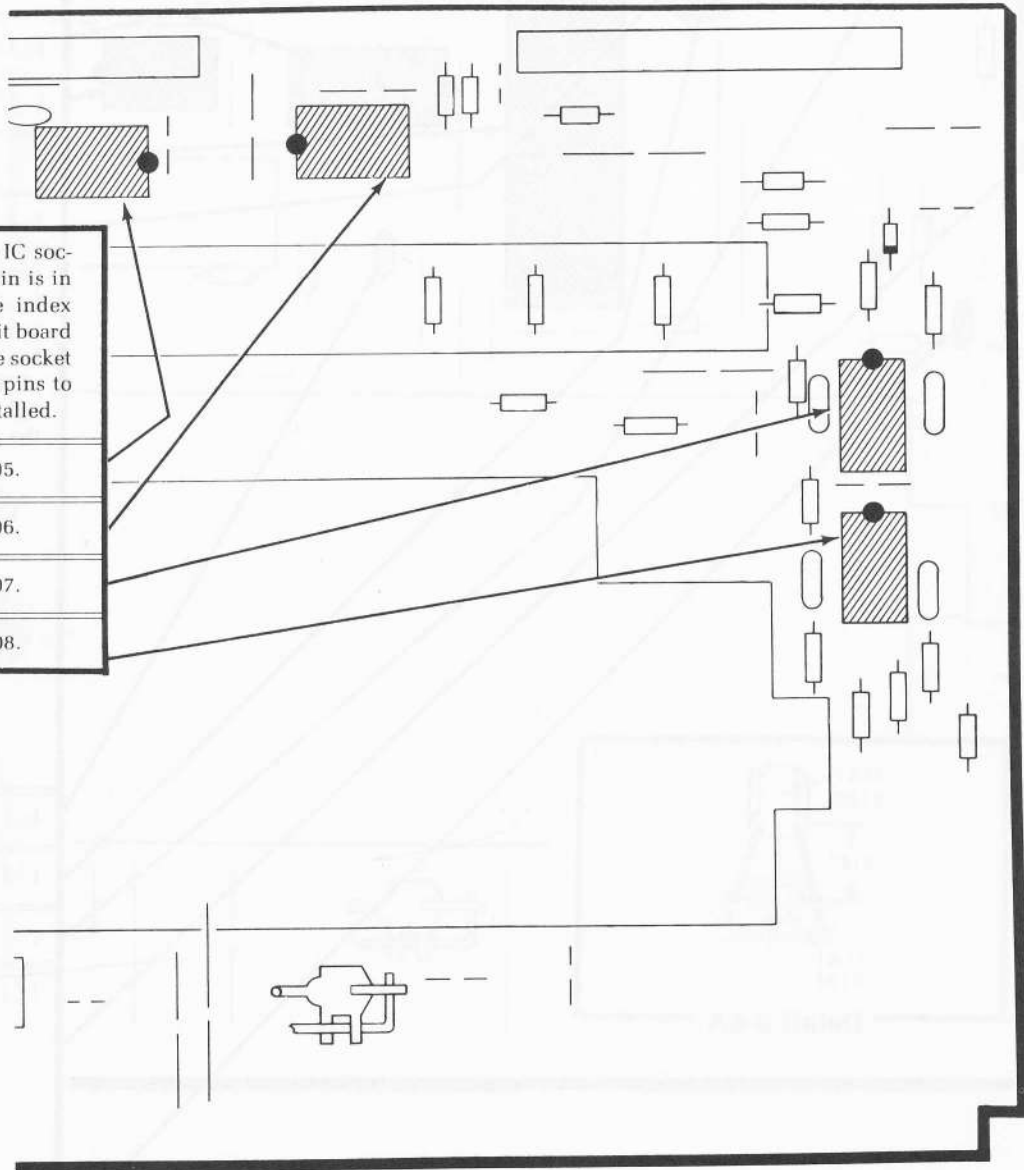

PICTORIAL 6-5

The parts installed in this Pictorial are in this area of the circuit board.

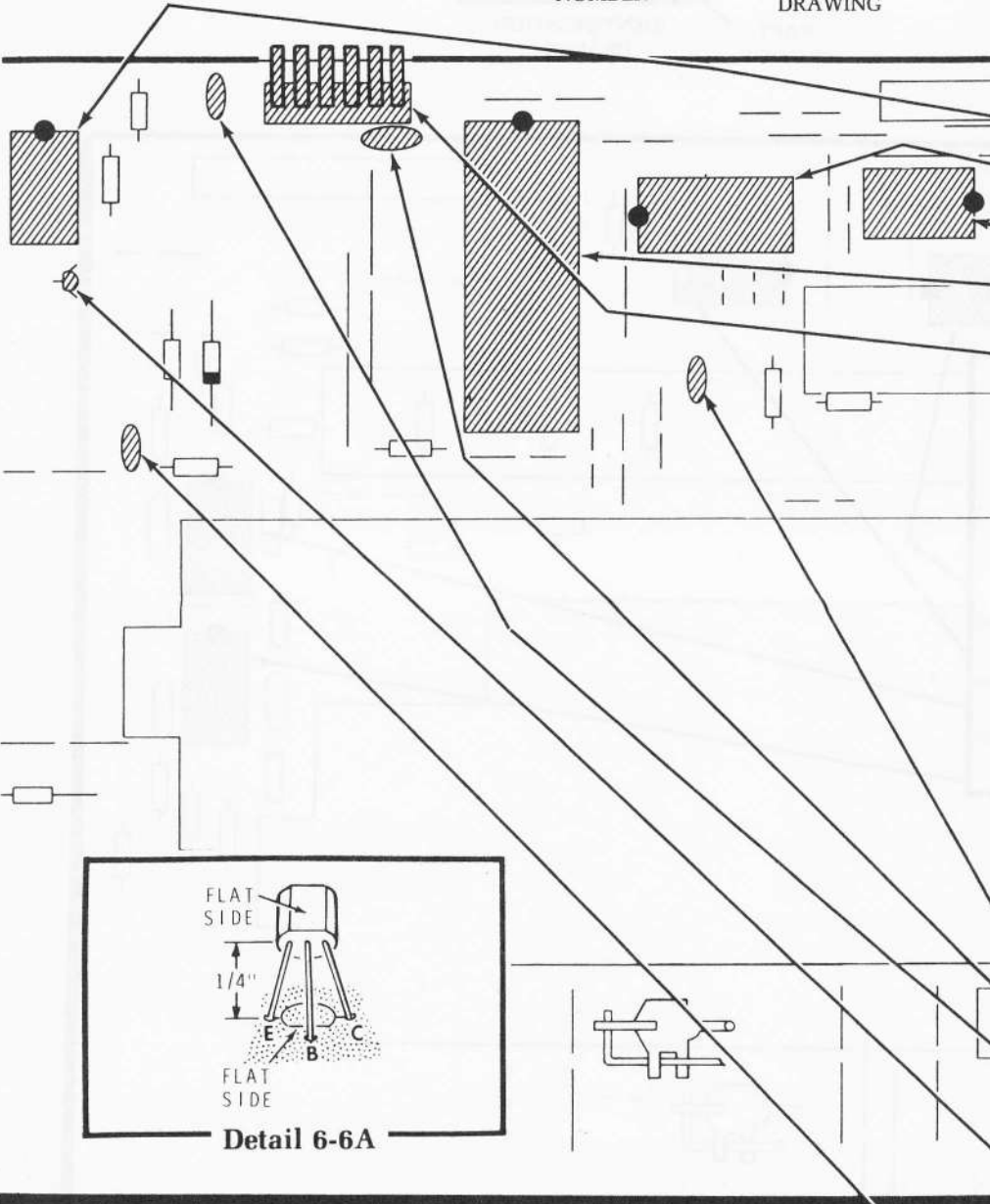
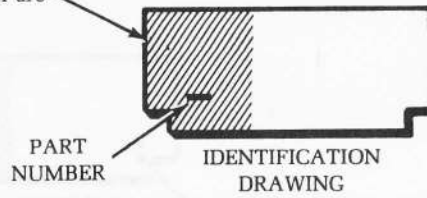

- START** →
- (✓) 14-pin IC socket at IC401.
 - (✓) 20-pin IC socket at IC403.
 - (✓) 14-pin IC socket at IC404.
 - (✓) 40-pin IC socket at IC402.
 - (✓) 6-pin edge plug at P401.
- NOTE:** When you install edge plugs, insert the straight pins of the plug into the circuit board holes with the bent pins pointing towards the edge of the circuit board. Push the plug tight against the board. Then solder the pins to the foil.
-
- (✓) C404: .1 μ F ceramic.
 - (✓) C401: .1 μ F ceramic.
 - (✓) C403: .1 μ F ceramic.
 - (✓) Q401: MPSA 20 transistor (#417-801). Align the flat on the transistor with the flat on the circuit board outline and insert the leads in the correct holes. Then solder the leads to the foil and cut off the excess lead lengths. See Detail 6-6A.
 - (✓) C405: .005 μ F ceramic.
 - (✓) Solder the leads to the foil and cut off the excess lead lengths.

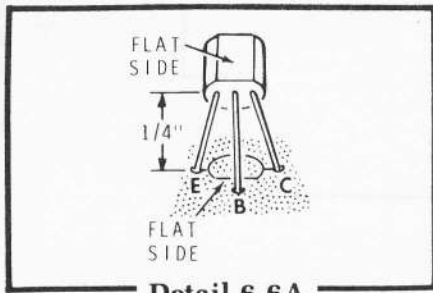

PICTORIAL 6-6

The parts installed in this Pictorial are in this area of the circuit board.

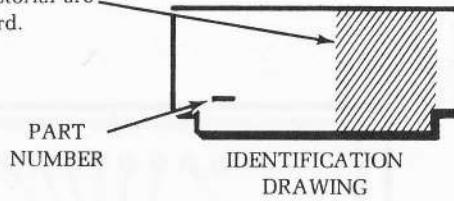

START ↓

- 15-pin edge plug at P403.
- 15-pin edge plug at P402.

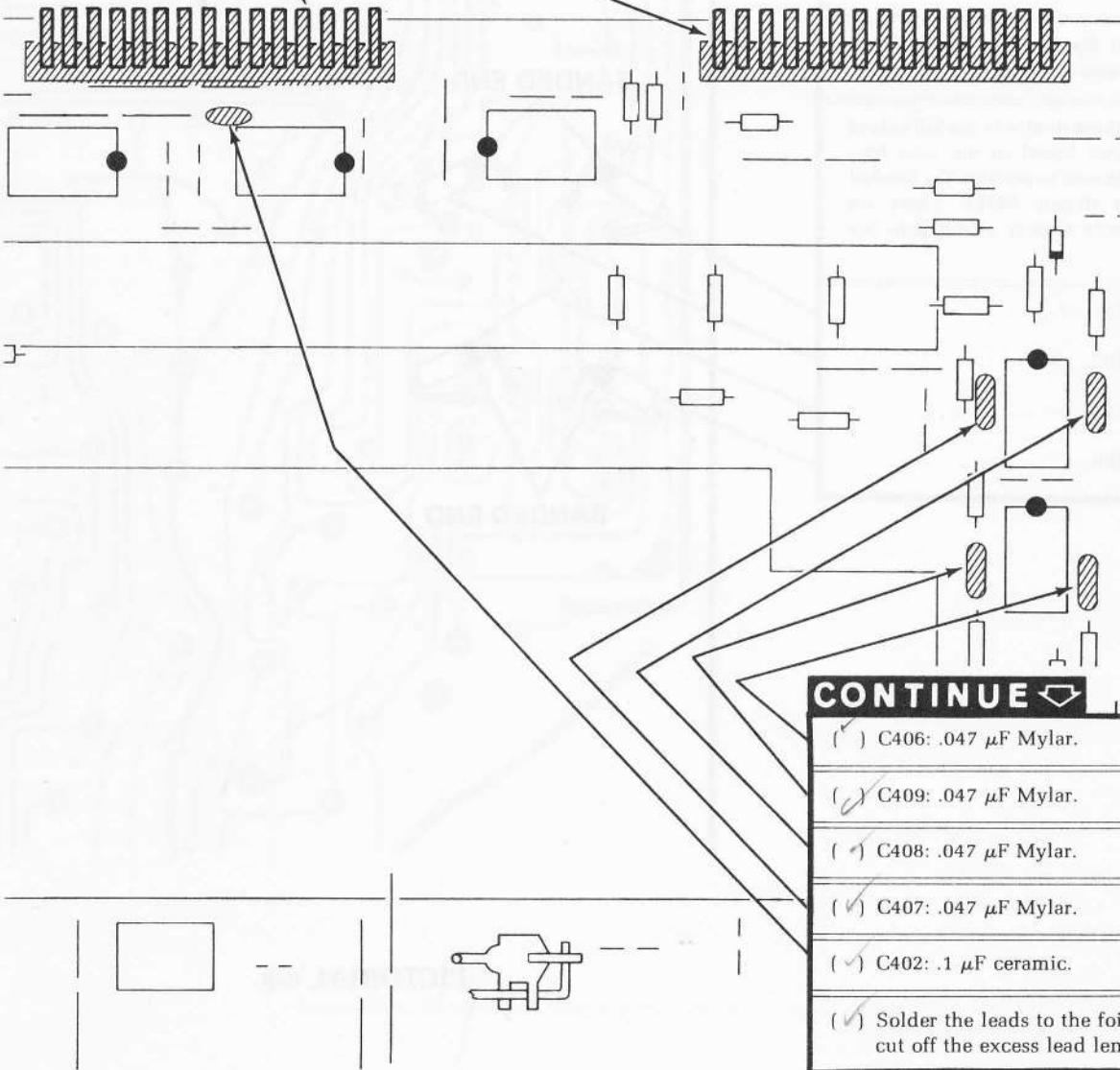

CONTINUE ↓

- C406: .047 μ F Mylar.
- C409: .047 μ F Mylar.
- C408: .047 μ F Mylar.
- C407: .047 μ F Mylar.
- C402: .1 μ F ceramic.
- Solder the leads to the foil and cut off the excess lead lengths.

PICTORIAL 6-7

START

() Position the keyboard foil side up as shown.

(✓) Cut the leads of four 1N4149 diodes (#56-56) to 1/4".

Solder these diodes to the foil side of the circuit board in the next four steps. Be sure to position the banded ends as shown. NOTE: There are other parts already soldered in the holes.

(✓) D404

(✓) D403

(✓) D405

(✓) D406

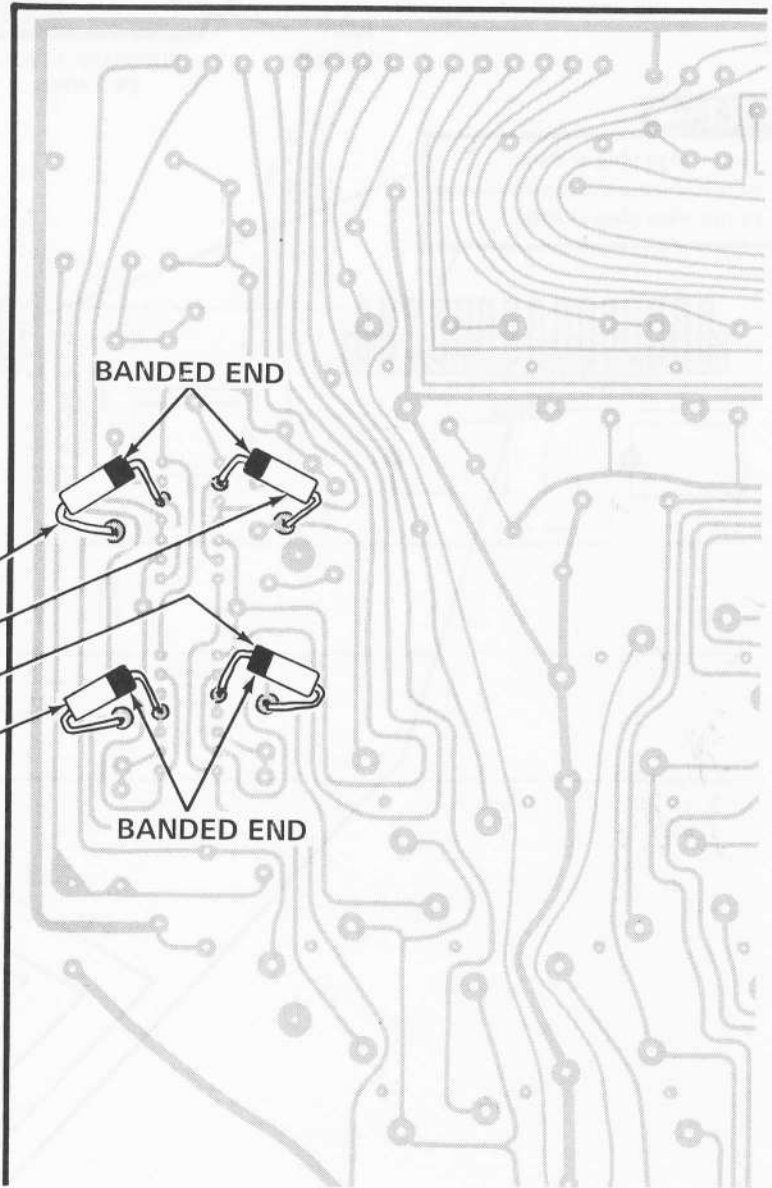

PICTORIAL 6-8

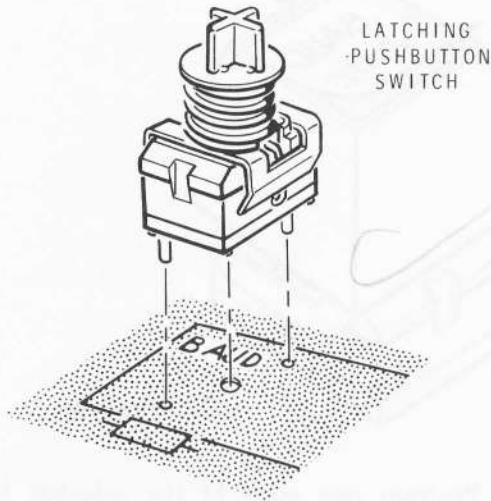

Detail 6-9A

Refer to Pictorial 6-9 (Illustration Booklet, Page 20) for the following steps.

- (✓) Before you install the pushbutton switches, make a continuity check on each switch using an ohmmeter. Set the ohmmeter to low range and connect one lead to each switch pin. With the switch plunger out (switch off) the ohmmeter should read "INFINITE." With the switch plunger in (switch on), the ohmmeter should read "0." Some of the switches are latching type (will stay in their last position until actuated again) and some are not.

When you install the pushbutton switches in the following steps, insert the three pins of each switch into their circuit board holes and push the switch tight against the circuit board. Carefully turn the circuit board over and solder the two metal pins to the foil. Then check to see that the switch is still tight against the circuit board. If it is not tight, reheat the connections while you push on the switch.

- (✓) Locate the seven latching pushbutton switches. Refer to Detail 6-9A and install one of these switches at the BAUD location on the circuit board. The switches can be installed either way.

In the same manner install the remaining six latching pushbutton switches at the following locations:

NOTE: Refer to Pictorial 6-9, not the circuit board screening when you install the Short Form switch. The circuit board may be screened in error.

- | | |
|----------------|----------------|
| () SHORT FORM | () PLOT |
| () DUPLEX | () AUTO CARRY |
| () OFF LINE | () SCROLL |

- (✓) In the same manner, install the 60 momentary pushbutton switches in the remaining pushbutton locations on the circuit board.
- () Refer to Detail 6-9B (Illustration Booklet, Page 21) and install a 4-40 × 5/8" screw, a #4 lockwasher, and a **small** 4-40 nut at each of the six indicated holes in the circuit board. Securely tighten this hardware.
- () Refer to Detail 6-9B and install the two keyboard brackets on the screws just installed. Use 1/8" long spacers, #4 lockwashers, and **large** 4-40 nuts. Be sure to position the brackets as shown. Make sure that the diode leads do not touch the keyboard brackets or any connections on the keyboard.

Refer to Detail 6-9C on Pictorial 6-9 (Illustration Booklet, Page 20) for the following steps.

- () Turn the circuit board foil side up as shown.
- () Install and solder circuit board connectors in holes 30, 3.7, 7.5, and 15 on the foil side of the board. Be sure you do not fill the pin with solder.
- () Prepare the ends of a 1-1/2" white wire.

NOTE: When you connect a wire to the foil side of a circuit board, as in the next step, keep the insulation 1/8" above the circuit board to be sure you obtain a good solder connection.

- () Solder one end of this 1-1/2" white wire in the indicated hole in the circuit board.
- () Push the free end of this wire into the 3.7 circuit board connector.
- () Turn the circuit board over.



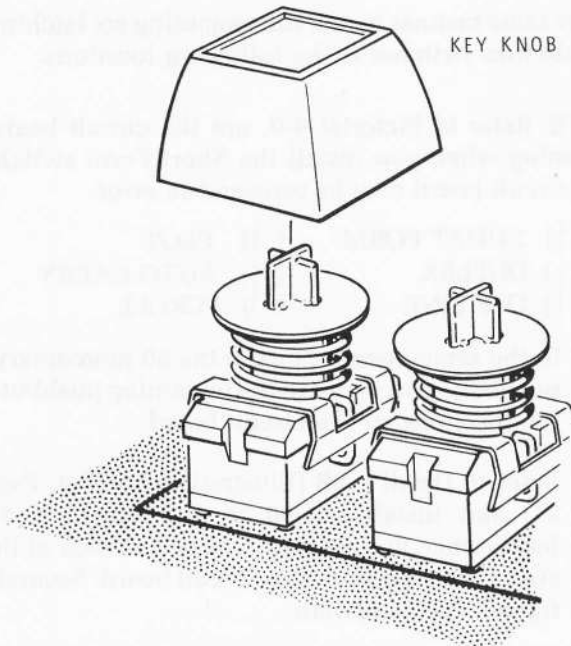

Detail 6-10A

Refer to Pictorial 6-10 (Illustration Booklet, Page 22) for the following steps.

CAUTION: When you push the knobs on the pushbutton switches, in the following step, be sure to support the circuit board from the foil side so the board does not get broken.

- () Refer to Detail 6-10A and push a key knob onto the BAUD RATE pushbutton switch. Press firmly on the knob to make sure it is all the way on the switch.
- () In the same manner, install key knobs on all the remaining pushbutton switches except for the bottom switch where the space bar knob will be installed later.

CAUTION: When you install the key labels in the following step, be sure you install the proper label on the proper key. Once a label is installed it is almost impossible to get it off without damage to the label. If you install a key label on the wrong key, remove the key from the switch; do not remove the label. The key can then be put in its right place according to the label.

- () Locate the key label set. Refer to Detail 6-10B and install each label as follows:

1. Carefully remove a label from the protective backing.

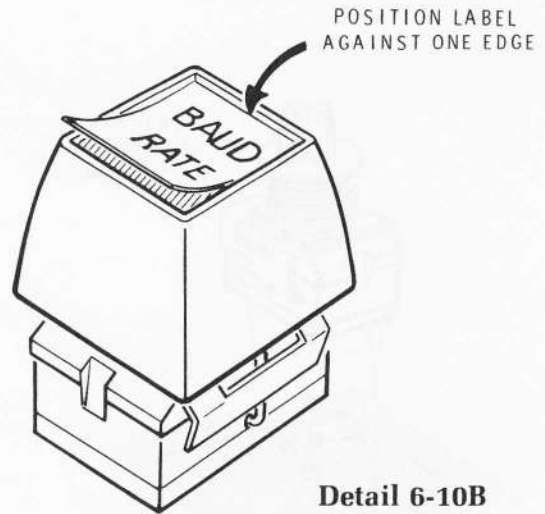

Detail 6-10B

2. Position one edge of the selected label against one edge of the recess of the proper key knob.
3. Lower the opposite edge of the label into the recess of the key knob. Then press the label into place.

- () Locate the set of space bar parts.
- () Refer to Detail 6-10C and install the plastic guides at their locations on the circuit board with the screws supplied. **CAUTION: DO NOT** overtighten these screws as the holes in the plastic guides can be stripped out easily.

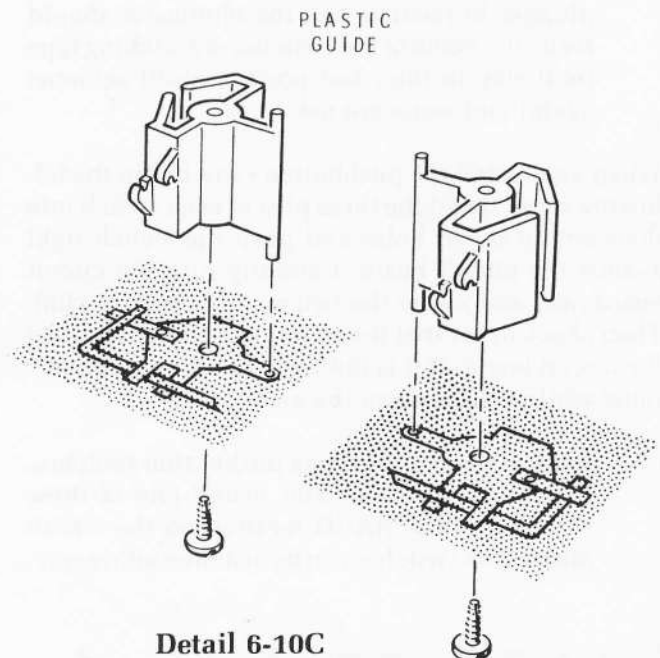

Detail 6-10C

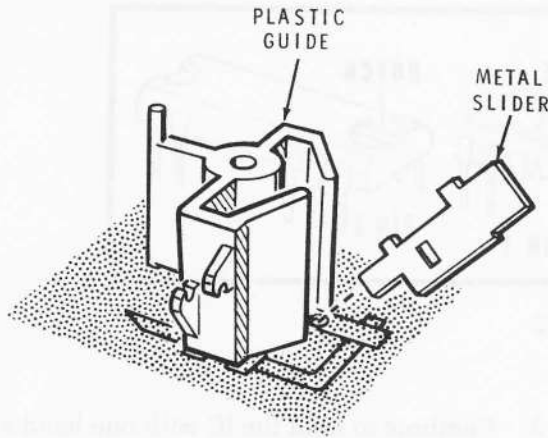

Detail 6-10D

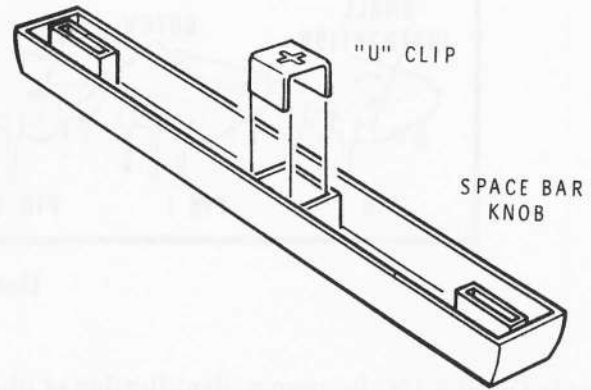

Detail 6-10E

- () Refer to Detail 6-10D and fit a metal slider into each plastic guide.
- () Refer to Detail 6-10E and push the "U" clip into the space bar knob. Be sure to center the clip in the knob.
- () Refer to Detail 6-10F and fit the space bar knob onto the pushbutton switch and the two metal sliders. Then slowly push the space bar knob down as far as possible on the switch and sliders. BE SURE the circuit board is supported from the foil side.

- () Refer to Detail 6-10F and fit each end of the torsion bar into the square hole in each metal slider. Then push the torsion bar into the retainer clip on each plastic guide.
- () Push the space bar several times to check operation. If the bar does not operate freely, loosen the screws in the plastic guides (on the foil side of the circuit board) and permit the guides to realign themselves to the space bar. Then re-tighten the screws.

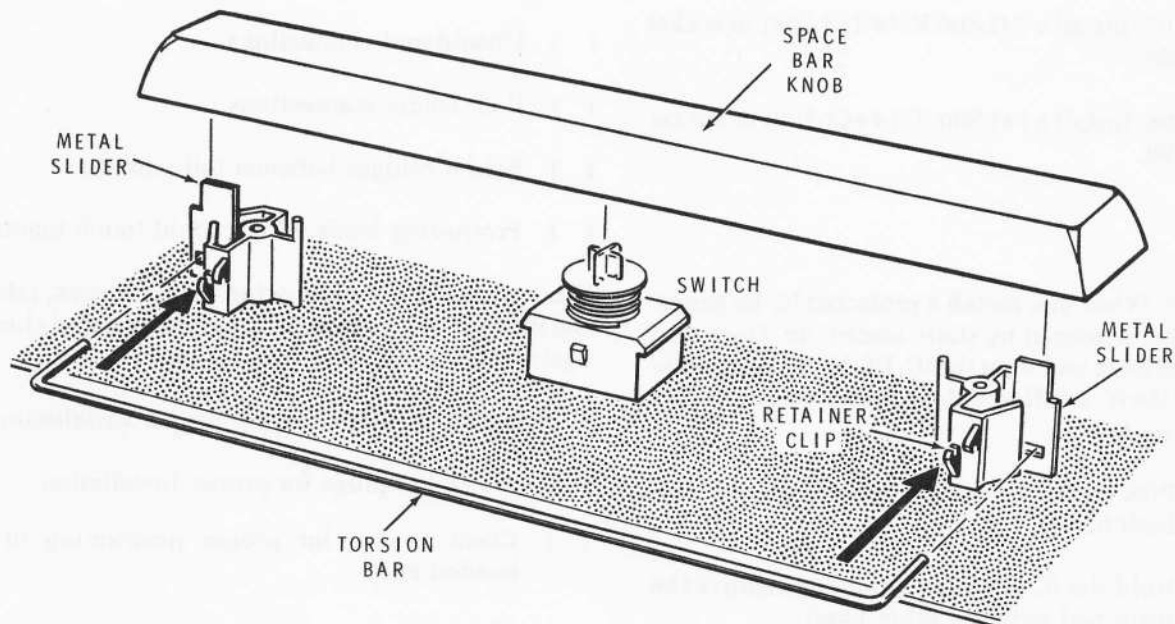

Detail 6-10F

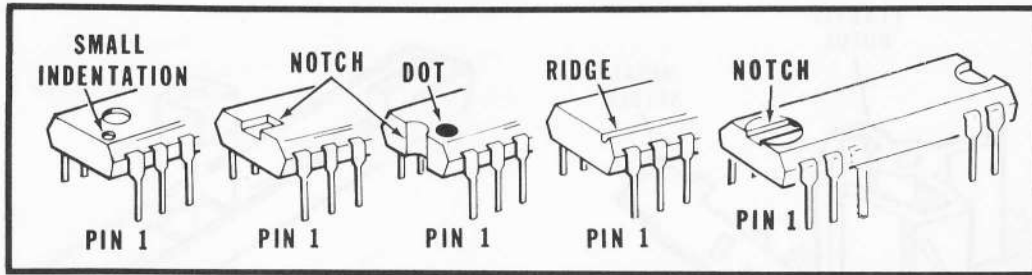

Detail 6-10G

Refer to Detail 6-10G for proper identification of pin #1 of the integrated circuits that will be installed on the keyboard circuit board in the following steps.

- () IC401: Install a 74LS93 IC (#443-838) in socket IC401.
 - () IC403: Install a 74LS240 IC (#443-754) in socket IC403.
 - () IC404: Install a 74LS125 IC (#443-811) in socket IC404.
 - () IC405: Install a 74LS125 IC (#443-811) in socket IC405.
 - () IC406: Install a 74LS02 IC (#443-779) in socket IC406.
 - () IC407: Install a 74LS00 IC (#443-728) in socket IC407.
 - () IC408: Install a 74LS00 IC (#443-728) in socket IC408.
3. Continue to hold the IC with one hand and straighten any bent pins with the other hand.
 4. Pick up the circuit board in the other hand.
 5. Align the pin 1 end of the IC with the index mark on the circuit board.
 6. Then push the IC pins into the IC socket. Once in the socket, the IC is protected.

- () IC402: Install an MM5740AAEIC (#443-767) in socket IC402.

CIRCUIT BOARD VISUAL CHECK

Carefully inspect foil side of the circuit board for the following most commonly made errors.

- () Unsoldered connections.
- () Poor solder connections.
- () Solder bridges between foil patterns.
- () Protruding leads which could touch together.

CAUTION: When you install a protected IC, be sure it does not get damaged by static electricity. Once you remove the foam pad from the IC, **DO NOT** let go of the IC. Install the IC as follows: Read the entire step before you pick up the IC.

1. Pick up the IC and touch the foam pad with both hands.
2. Hold the IC with one hand and remove the foam pad with the other hand.

When you make the following visual checks, refer to the Pictorial where the part was installed and check it against the installation instructions.

- () Check the transistor for proper installation.
- () Check the plugs for proper installation.
- () Check diodes for proper positioning of the banded end.
- () Check IC's for proper type and installation.

KEYBOARD CIRCUIT BOARD CHECKOUT

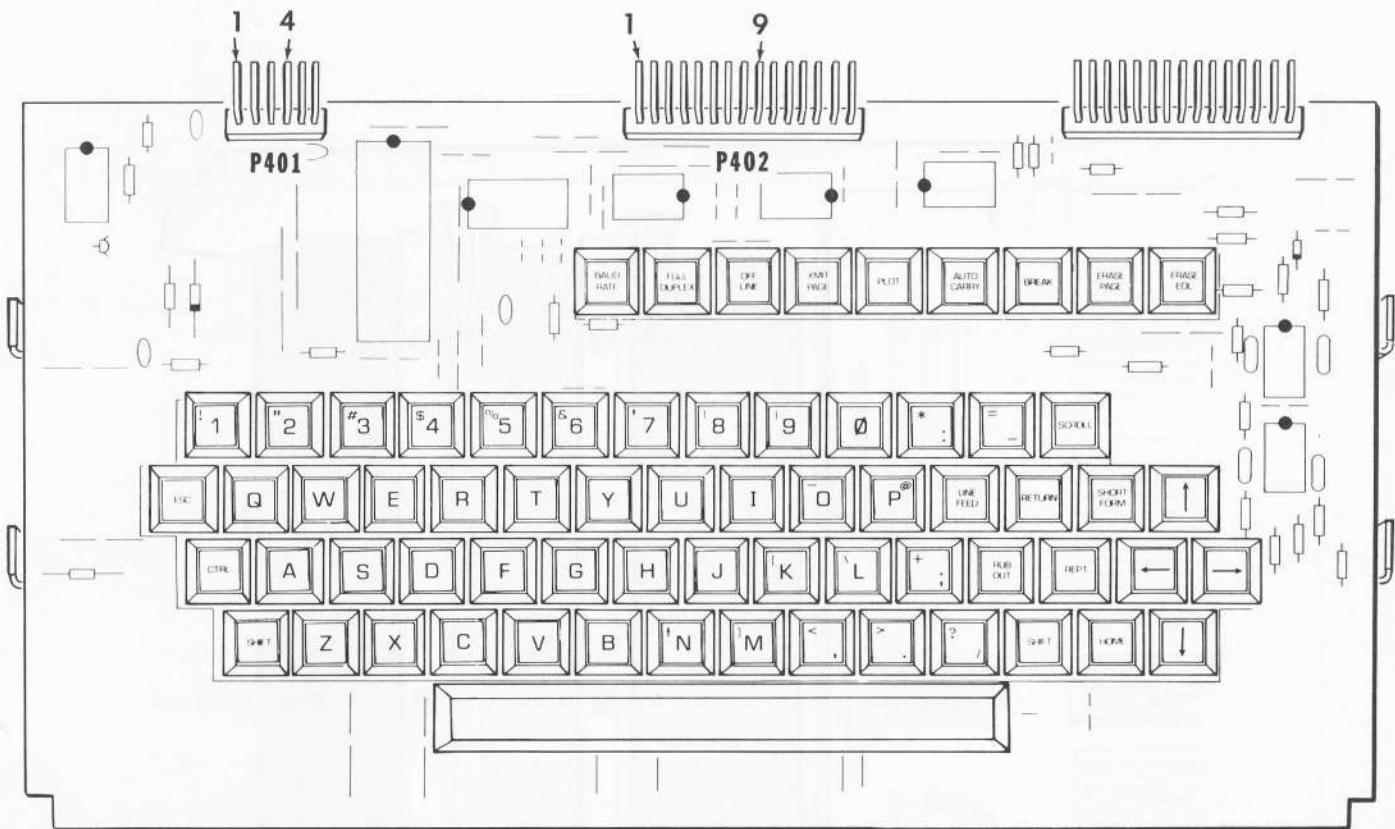

PICTORIAL 6-11

RESISTANCE MEASUREMENTS

Refer to Pictorial 6-11 for the following steps.

NOTE: Most of the keys (pushbutton switches) on the keyboard are spring loaded; however, seven keys (such as the BAUD RATE key) can be locked on (down). Make sure all keys are off (up).

Make the following resistance measurements on the keyboard.

NEGATIVE LEAD TO:	POSITIVE LEAD TO:	SELECTOR — RANGE	METER INDICATION	POSSIBLE AREA OF TROUBLE
() P401-1	P401-4	OHMS — R×1000	GREATER THAN 5 kΩ	IC402
() P401-1	P402-9	OHMS — R×100	GREATER THAN 500 Ω	IC401, IC403, IC404, IC405, IC406, IC407, IC408

- () With the negative meter lead still connected to plug P401 pin 1, touch the positive meter lead to the other plug pins. All of the other plug pins on the keyboard should read greater than 4000 Ω. If you obtain a reading of less than 4000 Ω, look for solder bridges on the foil.

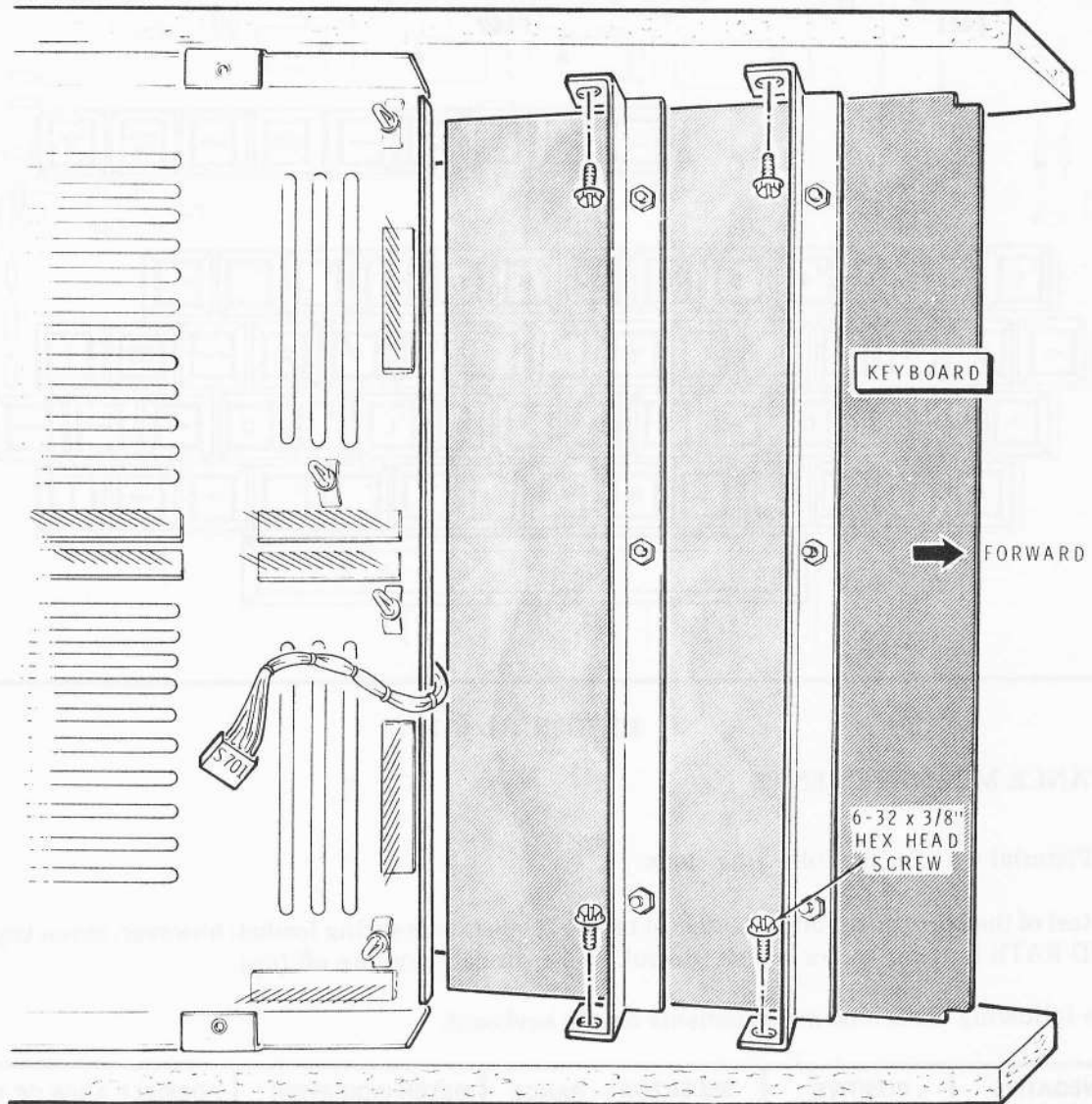

PICTORIAL 6-12

KEYBOARD INSTALLATION

Refer to Pictorial 6-12 for the following steps.

- () Carefully position the chassis on its right (power transformer) side and the top corner of the CRT.
- () Be sure 5-wire socket S701 (coming from the main harness) is under the chassis for connection later.

Refer to Pictorial 6-13 (Illustration Booklet, Page 23) for the following steps.

- () Push socket S401 from the main harness onto plug P401 so that the number "1" on the connector (medium black wire) matches the number "1" on the keyboard.
- () Push the other connector socket S402 onto plug P402 so that the number "1" on the socket (brown wire) matches the number "1" on the keyboard.
- () Push the other connector socket S402 onto plug P402 so that the number "8" on the socket (green wire) matches the number "8" on the keyboard.
- () Push socket S403 onto plug P403 so that the number "1" on the socket (two violet wires) matches the number "1" on the keyboard.
- () Refer again to Pictorial 6-12 and mount the keyboard to the side panels with four 6-32 × 3/8" hex head screws as shown. Do not tighten any of the screws.
- () Position the keyboard as far front (away from the CRT) as possible and tighten the four mounting screws.
- () Position the chassis topside up.

VISUAL CHECKS

Refer to Pictorial 6-13 (Illustration Booklet, Page 23) for the following steps.

NOTE: If you do not obtain the correct indication in the following checkout, proceed to the "Voltage Measurements."

- () Connect a clip lead between solder lug EA (at the lower left corner of the CRT) and plug P402, pin 8.
- () Connect another clip lead between solder lug EB (at the lower right corner of the CRT) and plug P402 pins 14 and 15. Clip the lead to both pins.
- () Connect the line cord to an AC outlet and set the AC POWER switch to ON.
- () Push keys 1 through 0 (top row). The screen should display (in rows) the number of the key that you push.
- () Push keys Q through P (second row). The screen should display (in rows) the letter of the key that you push.
- () Push keys A through L (third row). The screen should display (in rows) the letter of the key that you push.
- () Push keys Z through M (fourth row). The screen should display (in rows) the letter of the key that you push.
- () Set the AC POWER switch to OFF, remove the clip leads, and disconnect the line cord.

NOTE: If you obtained the proper response in the previous checks, proceed to the "Ram And Counter Circuit Board."



VOLTAGE MEASUREMENTS

Refer to Pictorial 6-13 for the following steps.

Make the following voltage measurements on the keyboard.

	NEGATIVE LEAD TO:	POSITIVE LEAD TO:	SELECTOR — RANGE	METER INDICATION	POSSIBLE AREA OF TROUBLE
()	CHASSIS	P401-4	DC — 15V	-11.5V	See the following "Possible Cause" checks.
()	CHASSIS	P402-9	DC + 15V	5V	

POSSIBLE CAUSE CHECKS

1. Disconnect the harness socket and make the same voltage measurements at the socket. If you do not have the correct voltage at the socket connector, the problem is in the harness.
2. If you do have the correct voltage at the harness socket, carefully check for solder bridges on the keyboard foil, especially around the IC sockets.
3. Remove the IC's one at a time (with the power off). Then with the power on, recheck for the correct voltage at the plug pins (with the harness sockets installed). If you obtain the correct voltage with an IC removed, the IC is possibly shorted.

Correct any problems and then perform "Visual Checks" on Page 101.

RAM AND COUNTER CIRCUIT BOARD

PARTS LIST

Unpack the pack marked #5 and check each part against the following Parts List. The key numbers correspond to the numbers on the Ram and Counter Circuit Board Parts Pictorial (Illustration Booklet,

Page 24). Any part that is packaged in an individual envelope with a part number on it should be placed back in the envelope after it is identified until it is called for in a step.

KEY No.	HEATH Part No.	QTY.	DESCRIPTION	CIRCUIT Comp. No.
---------	----------------	------	-------------	-------------------

RESISTORS

All resistors are 5% (fourth band gold).

1/4-Watt

A1	6-122-12	1	1200 Ω (brown-red-red)	R519
A1	6-222-12	9	2200 Ω (red-red-red)	R501, R502, R503, R506, R507, R508, R514, R517, R523
A1	6-472-12	11	4700 Ω (yellow-violet-red)	R504, R505, R509, R511, R512, R513, R515, R516, R518, R519, R521

KEY No.	HEATH Part No.	QTY.	DESCRIPTION	CIRCUIT Comp. No.
---------	----------------	------	-------------	-------------------

CAPACITORS

B1	21-22	1	220 pF ceramic	C527
B1	21-95	22	.1 μ F ceramic	C503, C504, C505, C506, C507, C508, C509, C511, C512, C513, C514, C515, C516, C517, C518, C519, C521, C522, C523, C524, C525, C526
B2	25-223	2	47 μ F tantalum	C501, C502

DIODE

C1	56-87	1	FH1100	D501
----	-------	---	--------	------

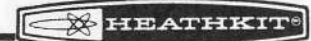

KEY No.	HEATH Part No.	QTY.	DESCRIPTION	CIRCUIT Comp. No.
---------	----------------	------	-------------	-------------------

INTEGRATED CIRCUITS (IC's)

NOTE: Integrated circuits are marked for identification in one of the following four ways:

1. Part number.
2. Type number. (This refers only to the numbers and letters listed. Any additional letters and numbers on an IC are not significant).
3. Part number and type number.
4. Part number with a type number other than the one listed.

IMPORTANT

Before you open any IC package, and if any components are missing from the sealed IC package, return the **unopened** package for replacement. Claims for missing IC's will not be honored.

If you locate damaged or defective IC's, order individual replacements. Be sure to follow the standard instructions on the "Parts Order Form" and on the inside rear cover of the Manual. Save defective or damaged components for return instructions.

D1	443-728	4	74LS00 IC	IC504, IC517, IC523, IC528
D1	443-779	2	74LS02 IC	IC512, IC527
D1	443-745	5	74LS03 IC	IC505, IC511, IC514, IC529, IC530
D1	443-780	1	74LS08 IC	IC526

KEY No.	HEATH Part No.	QTY.	DESCRIPTION	CIRCUIT Comp. No.
---------	----------------	------	-------------	-------------------

Integrated Circuits (cont'd.)

D1	443-816	1	74LS09 IC	IC515
D1	443-797	1	74LS10 IC	IC524
D1	443-798	1	74LS20 IC	IC525
D1	443-800	1	74LS27 IC	IC510
D2	443-781	3	74LS75 IC	IC501, IC518, IC521
D2	443-817	1	74LS192 IC	IC502
D2	443-815	2	74LS193 IC	IC513, IC519
D1	443-719	3	74LS266 IC	IC503, IC508, IC520
D1	443-733	1	74LS293 IC	IC522
D1	443-4	1	7472 IC	IC509
D1	443-5	1	7473 IC	IC506

CAUTION: The protected 2114 (443-764) IC's can be damaged by static electricity. DO NOT remove them from their foam pad until you are instructed to do so in a step.

D3	443-764	2	2114 (4045, 40L45, or 6614) IC (protected)	IC507, IC516
----	---------	---	--	--------------

SOCKETS — PLUG

E1	432-779	4	12-pin socket	S501, S502, S503, S504
E2	434-298	22	14-pin IC socket	
E3	434-299	6	16-pin IC socket	
E4	434-310	2	18-pin IC socket	
E5	432-969	1	5-pin plug	P501

PART FROM FINAL PACK

85-1958-1	1	Ram and counter circuit board
-----------	---	-------------------------------

STEP-BY-STEP ASSEMBLY

START →

- | |
|---|
| <input checked="" type="checkbox"/> Position the circuit board as shown with the printed side up. |
| <input checked="" type="checkbox"/> R504: 4700 Ω (yellow-violet-red). |
| <input checked="" type="checkbox"/> R509: 4700 Ω (yellow-violet-red). |
| <input checked="" type="checkbox"/> R513: 4700 Ω (yellow-violet-red). |
| <input type="checkbox"/> D501: FH1100 diode (#56-87). Match the band on the diode with the band on the circuit board outline. |
| <input checked="" type="checkbox"/> R518: 4700 Ω (yellow-violet-red). |
| <input type="checkbox"/> R521: 4700 Ω (yellow-violet-red). |
| <input checked="" type="checkbox"/> R519: 1200 Ω (brown-red-red). |
| <input type="checkbox"/> R512: 4700 Ω (yellow-violet-red). |
| <input checked="" type="checkbox"/> R511: 4700 Ω (yellow-violet-red). |
| <input checked="" type="checkbox"/> R515: 4700 Ω (yellow-violet-red). |
| <input type="checkbox"/> Solder the leads to the foil and cut off the excess lead lengths. |

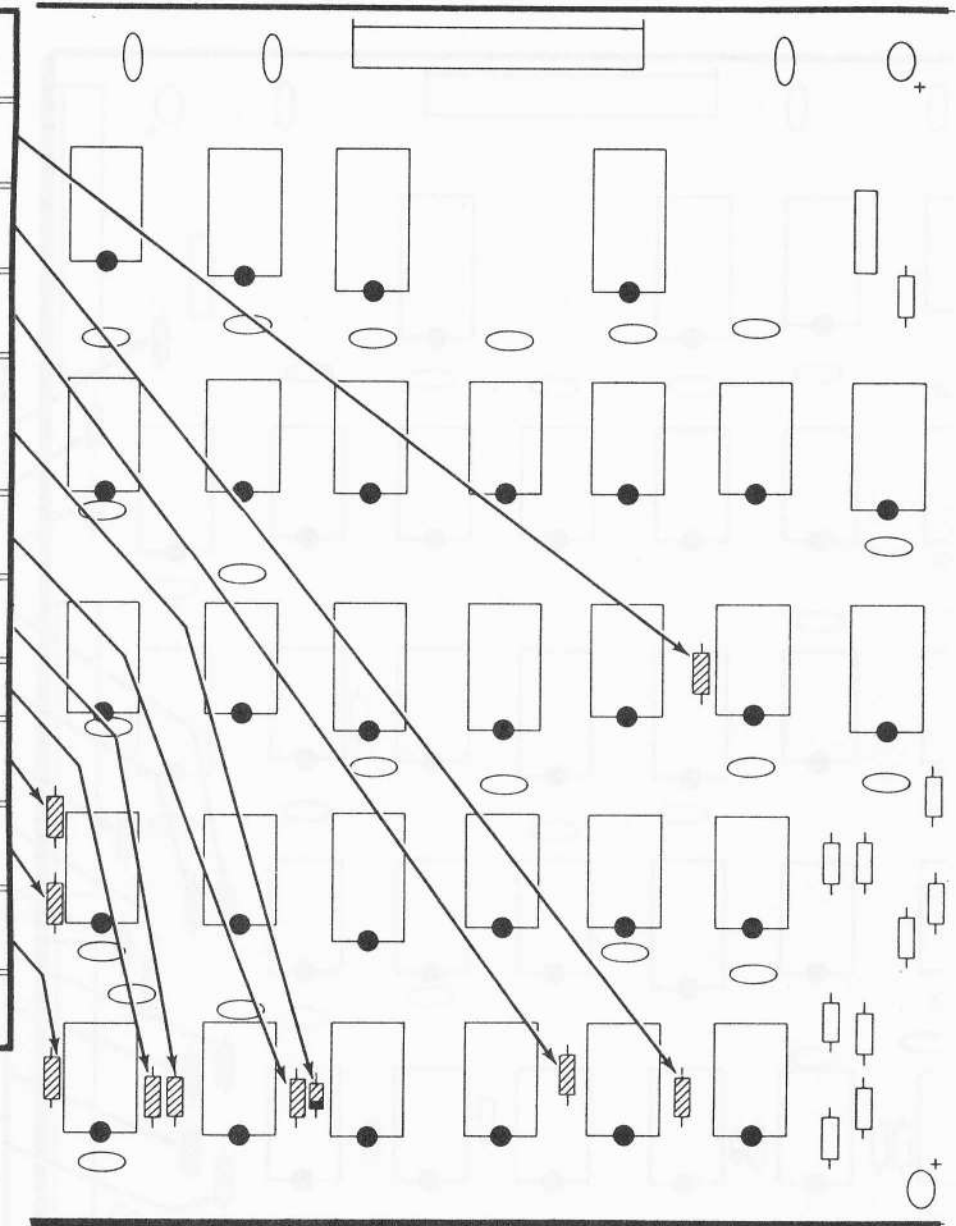

PICTORIAL 7-1

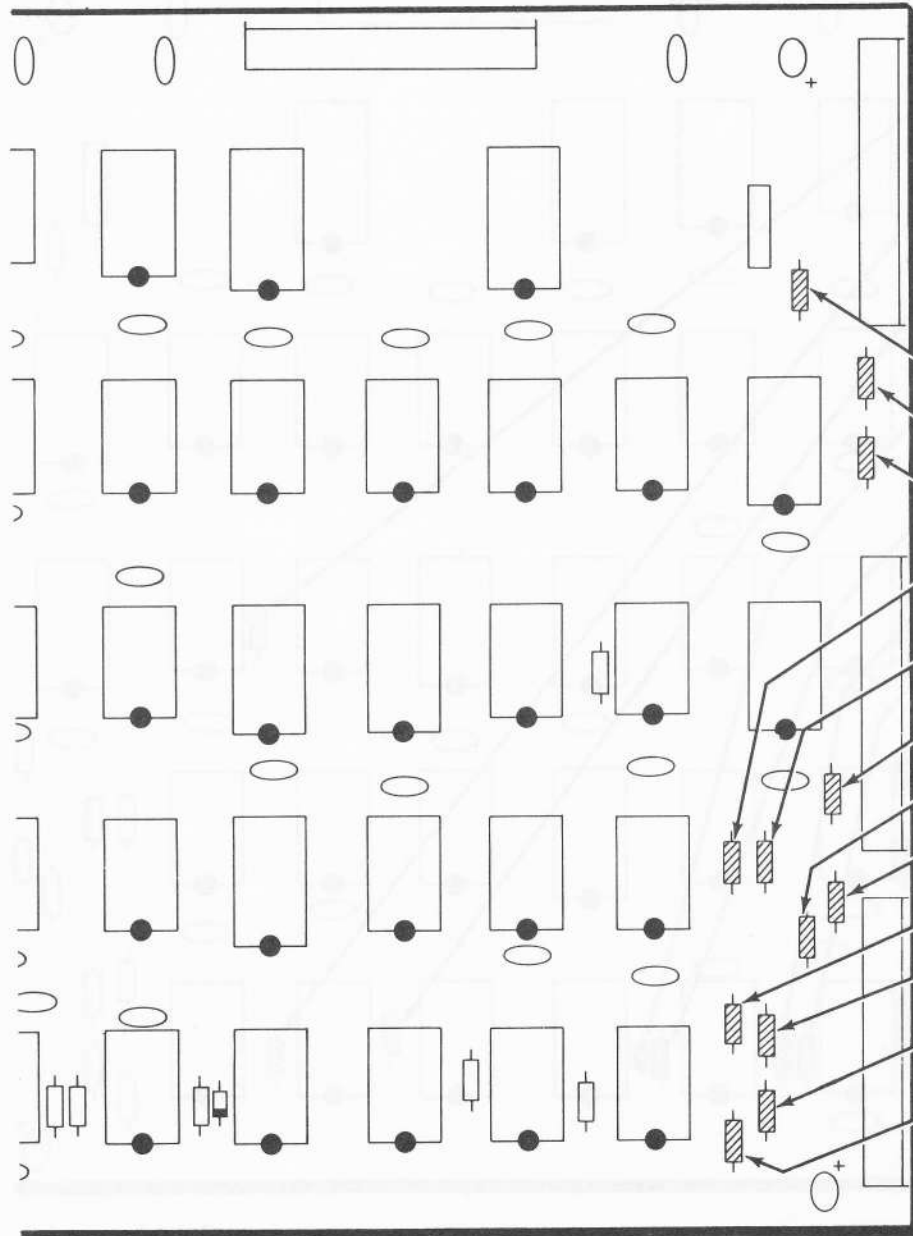

- START** ↓
- (✓) R514: 2200 Ω (red-red-red).
 - (✓) R503: 2200 Ω (red-red-red).
 - (✓) R501: 2200 Ω (red-red-red).
 - (✓) R506: 4700 Ω (yellow-violet-red).
 - (✓) R505: 4700 Ω (yellow-violet-red).
 - (✓) R502: 2200 Ω (red-red-red).
 - (✓) R516: 2200 Ω (red-red-red).
 - (✓) R517: 2200 Ω (red-red-red).
 - () R508: 2200 Ω (red-red-red).
 - () R523: 2200 Ω (red-red-red).
 - (✓) R522: 4700 Ω (yellow-violet-red).
 - (✓) R507: 2200 Ω (red-red-red).
 - (✓) Solder the leads to the foil and cut off the excess lead lengths.

PICTORIAL 7-2

START ▼

NOTE: When you install an IC socket, make sure the index mark (color dot) on the circuit board outline is still visible after the socket is installed. Solder the socket pins to the foil as each socket is installed. DO NOT install a 14-pin or 16-pin socket at an 18-pin socket location, or a 14-pin socket in a 16-pin socket location.

18-pin IC sockets at IC507 and IC516.

Install 16-pin IC sockets at the following six locations.

- IC501 IC518
- IC502 IC519
- IC513 IC521

Install 14-pin IC sockets at the following 22 (all remaining IC) locations.

- IC503 IC512 IC524
- IC504 IC514 IC525
- IC505 IC515 IC526
- IC506 IC517 IC527
- IC508 IC520 IC528
- IC509 IC522 IC529
- IC510 IC523 IC530
- IC511

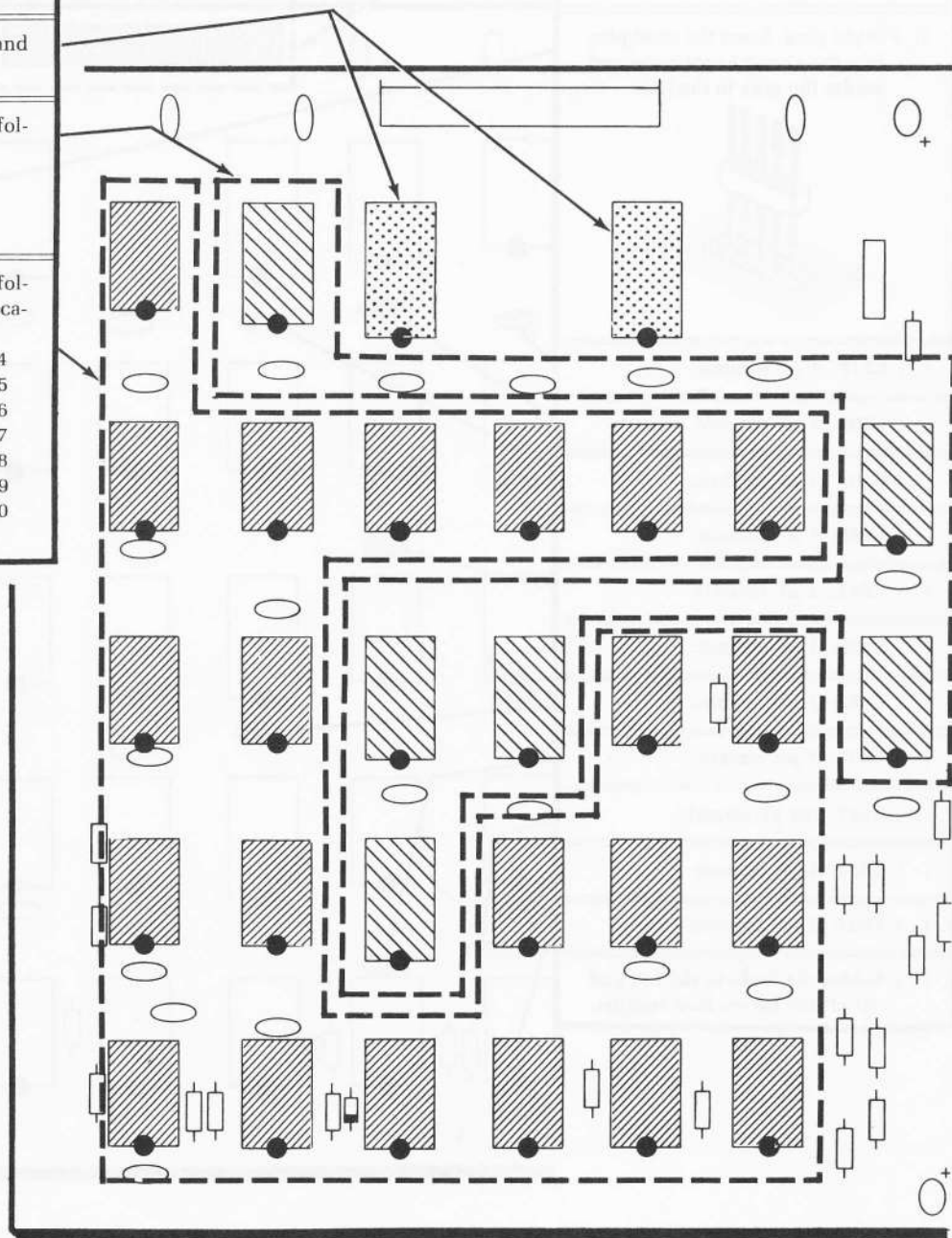

PICTORIAL 7-3

START →

Install 12-pin sockets at the following four locations. Solder the pins in the smallest diameter holes as each socket is installed.

- () S501 () S503
- () S502 () S504

() 5-pin plug. Insert the short pins into the circuit board holes and solder the pins to the foil.

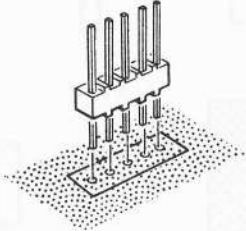

() C512: .1 μF ceramic.

() C509: .1 μF ceramic.

() C507: .1 μF ceramic.

() C515: .1 μF ceramic.

() C514: .1 μF ceramic.

() C526: .1 μF ceramic.

() C522: .1 μF ceramic.

() C523: .1 μF ceramic.

() C527: 220 pF ceramic.

() C525: .1 μF ceramic.

() C524: .1 μF ceramic.

() Solder the leads to the foil and cut off the excess lead lengths.

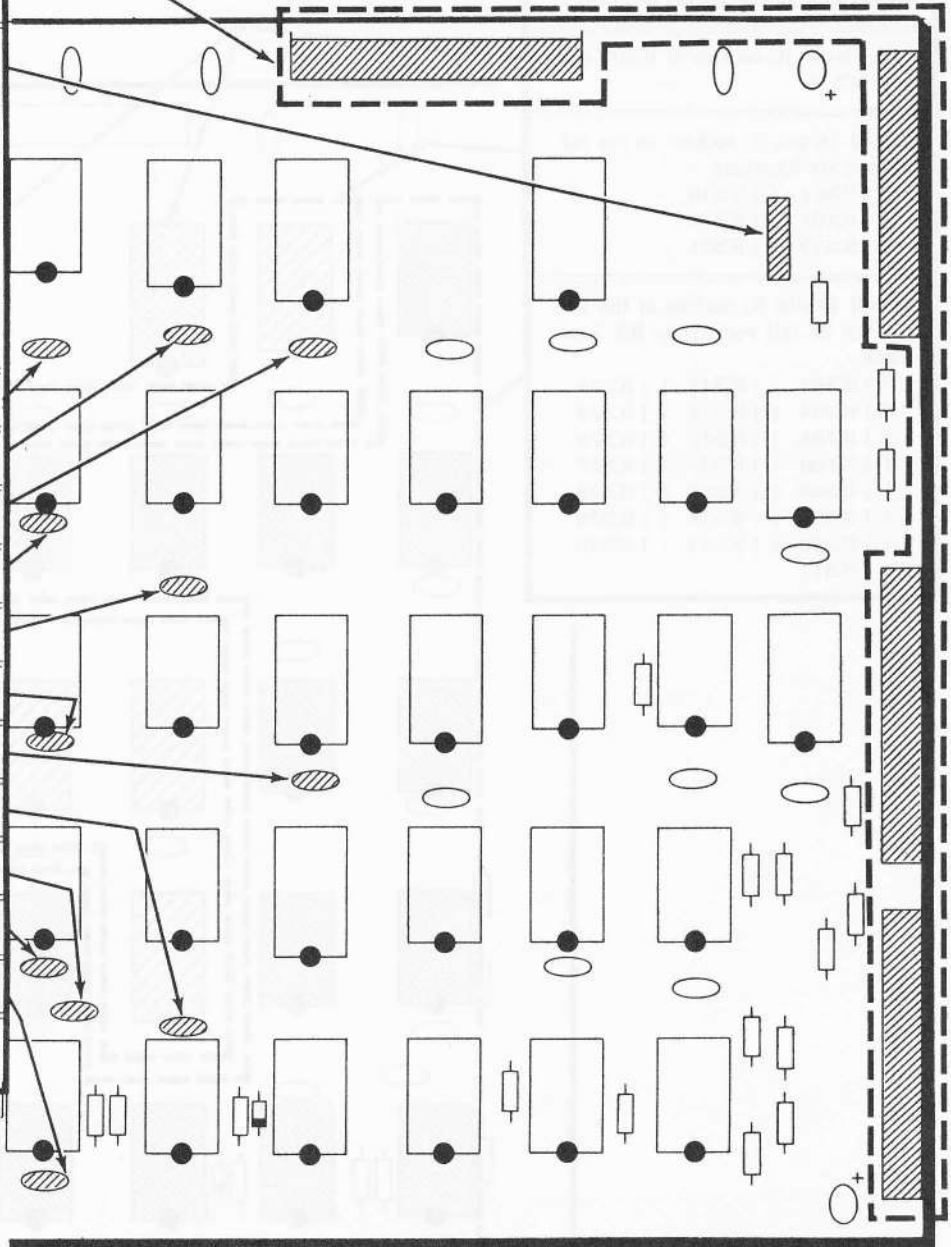

PICTORIAL 7-4

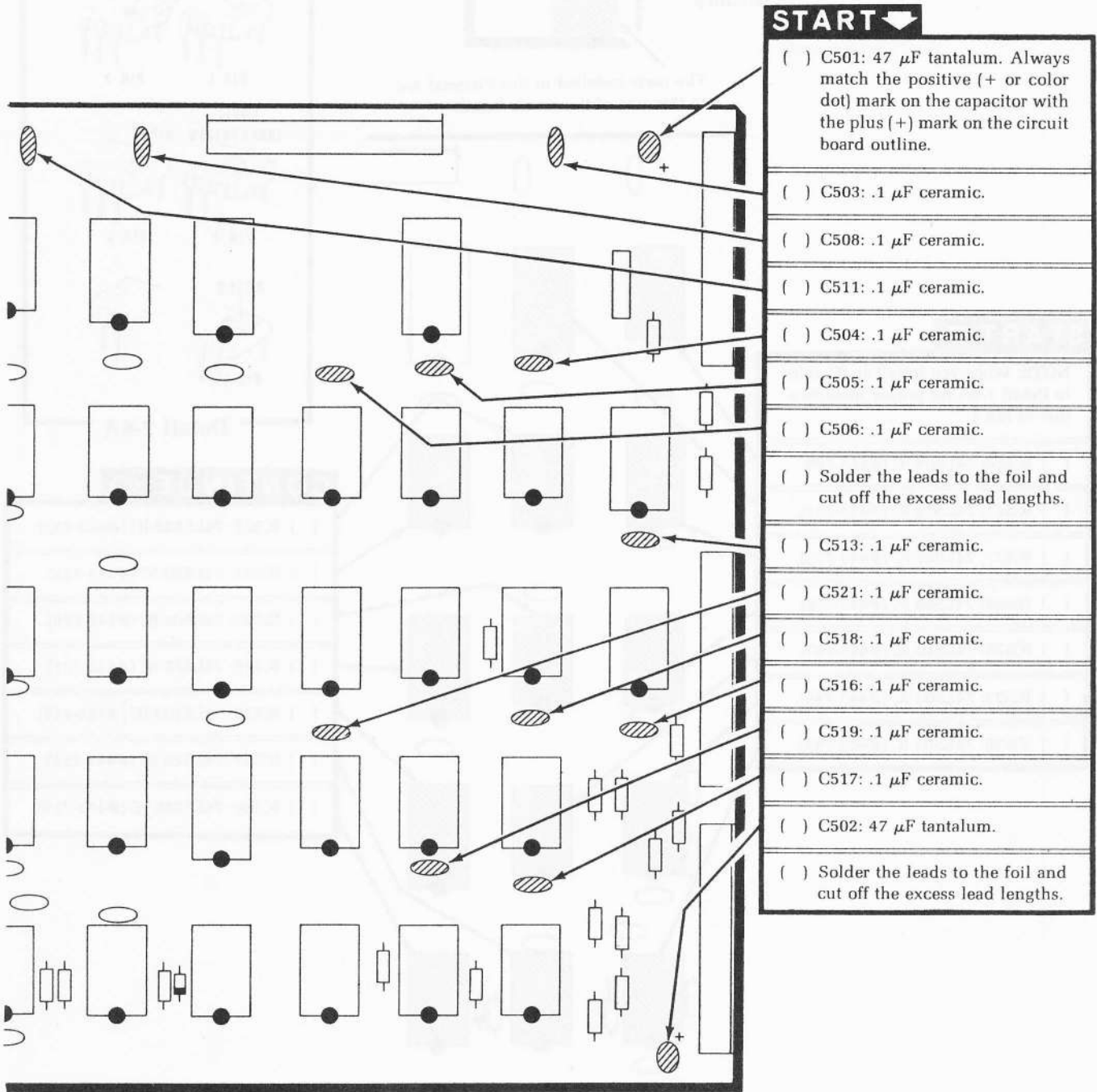

- START** ▼
- () C501: 47 μ F tantalum. Always match the positive (+ or color dot) mark on the capacitor with the plus (+) mark on the circuit board outline.
 - () C503: .1 μ F ceramic.
 - () C508: .1 μ F ceramic.
 - () C511: .1 μ F ceramic.
 - () C504: .1 μ F ceramic.
 - () C505: .1 μ F ceramic.
 - () C506: .1 μ F ceramic.
 - () Solder the leads to the foil and cut off the excess lead lengths.
 - () C513: .1 μ F ceramic.
 - () C521: .1 μ F ceramic.
 - () C518: .1 μ F ceramic.
 - () C516: .1 μ F ceramic.
 - () C519: .1 μ F ceramic.
 - () C517: .1 μ F ceramic.
 - () C502: 47 μ F tantalum.
 - () Solder the leads to the foil and cut off the excess lead lengths.

PICTORIAL 7-5

IDENTIFICATION
DRAWING

PART
NUMBER

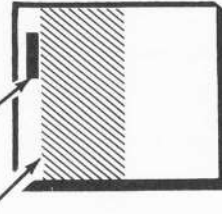

The parts installed in this Pictorial are
in this area of the circuit board.

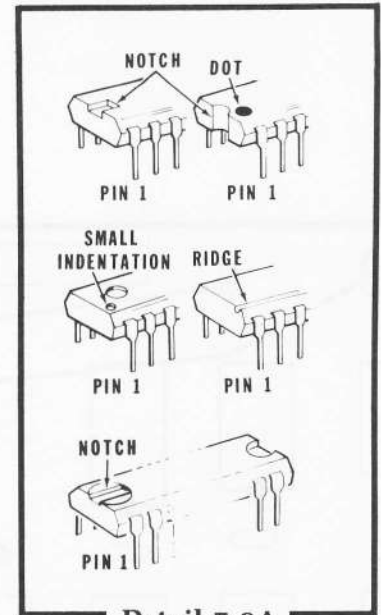

Detail 7-6A

START ↓

NOTE: When you install an IC, refer
to Detail 7-6A for proper identifica-
tion of pin 1.

- () IC526: 74LS08 IC (#443-780).
- () IC521: 74LS75 IC (#443-781).
- () IC527: 74LS02 IC (#443-779).
- () IC528: 74LS00 IC (#443-728).
- () IC524: 74LS10 IC (#443-797).
- () IC529: 74LS03 IC (#443-745).
- () IC530: 74LS03 IC (#443-745).

CONTINUE ↓

- () IC522: 74LS293 IC (#443-733).
- () IC517: 74LS00 IC (#443-728).
- () IC523: 74LS00 IC (#443-728).
- () IC518: 74LS75 IC (#443-781).
- () IC519: 74LS193 IC (#443-815).
- () IC525: 74LS20 IC (#443-798).
- () IC520: 74LS266 IC (#443-719).

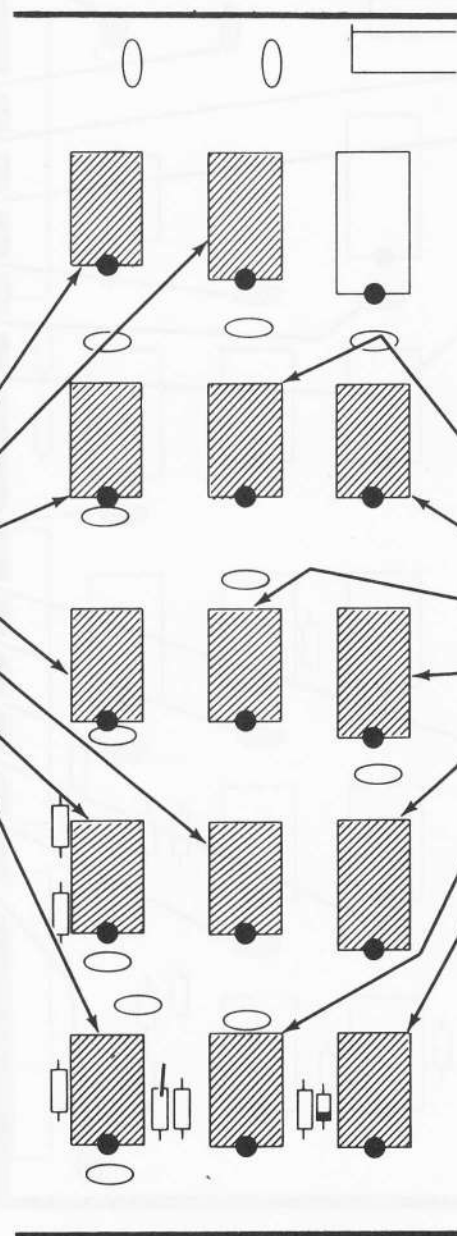

PICTORIAL 7-6

IDENTIFICATION
DRAWING

PART
NUMBER

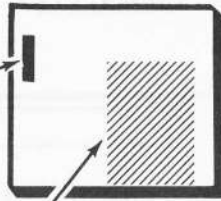

The parts installed in this Pictorial are
in this area of the circuit board.

START →

- () IC512: 74LS02 IC (#443-779).
- () IC513: 74LS193 IC (#443-815).
- () IC509: 7472 IC (#443-4).
- () IC514: 74LS03 IC (#443-745).
- () IC510: 74LS27 IC (#443-800).
- () IC505: 74LS03 IC (#443-745).
- () IC515: 74LS09 IC (#443-816).
- () IC511: 74LS03 IC (#443-745).
- () IC506: 7473 IC (#443-5).

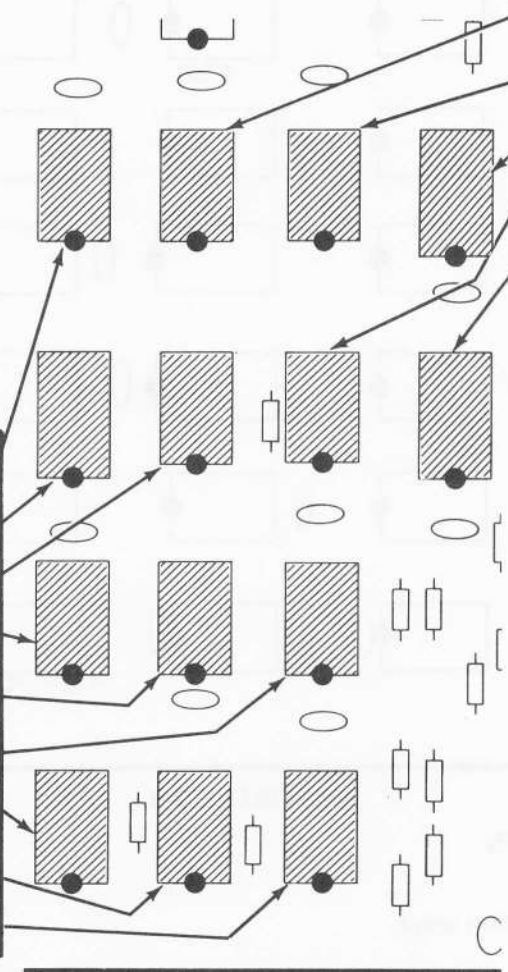

CONTINUE ↘

- () IC508: 74LS266 IC (#443-719).
- () IC503: 74LS266 IC (#443-719).
- () IC501: 74LS75 IC (#443-781).
- () IC504: 74LS00 IC (#443-728).
- () IC502: 74LS192 IC (#443-817).

NOTE: The two remaining IC's will
be installed later.

CIRCUIT BOARD CHECKOUT

Visual Inspection

Carefully inspect the foil side of the
circuit board for the following most
commonly made errors.

- () Unsoldered connections.
- () Poor solder connections.
- () Solder bridges between foil pat-
terns.
- () Protruding leads which could
touch together.

When you make the following visual
checks, refer to the Pictorial where
the part was installed and check it
against the installation instructions.

- () Check the integrated circuits for
proper type and installation.
- () Check the diode for proper type
and installation.
- () Check the plug and sockets for
proper installation.
- () Check the tantalum capacitors
for proper position of the posi-
tive (+ or color dot).

FINISH

PICTORIAL 7-7

RAM AND COUNTER CIRCUIT BOARD CHECKOUT

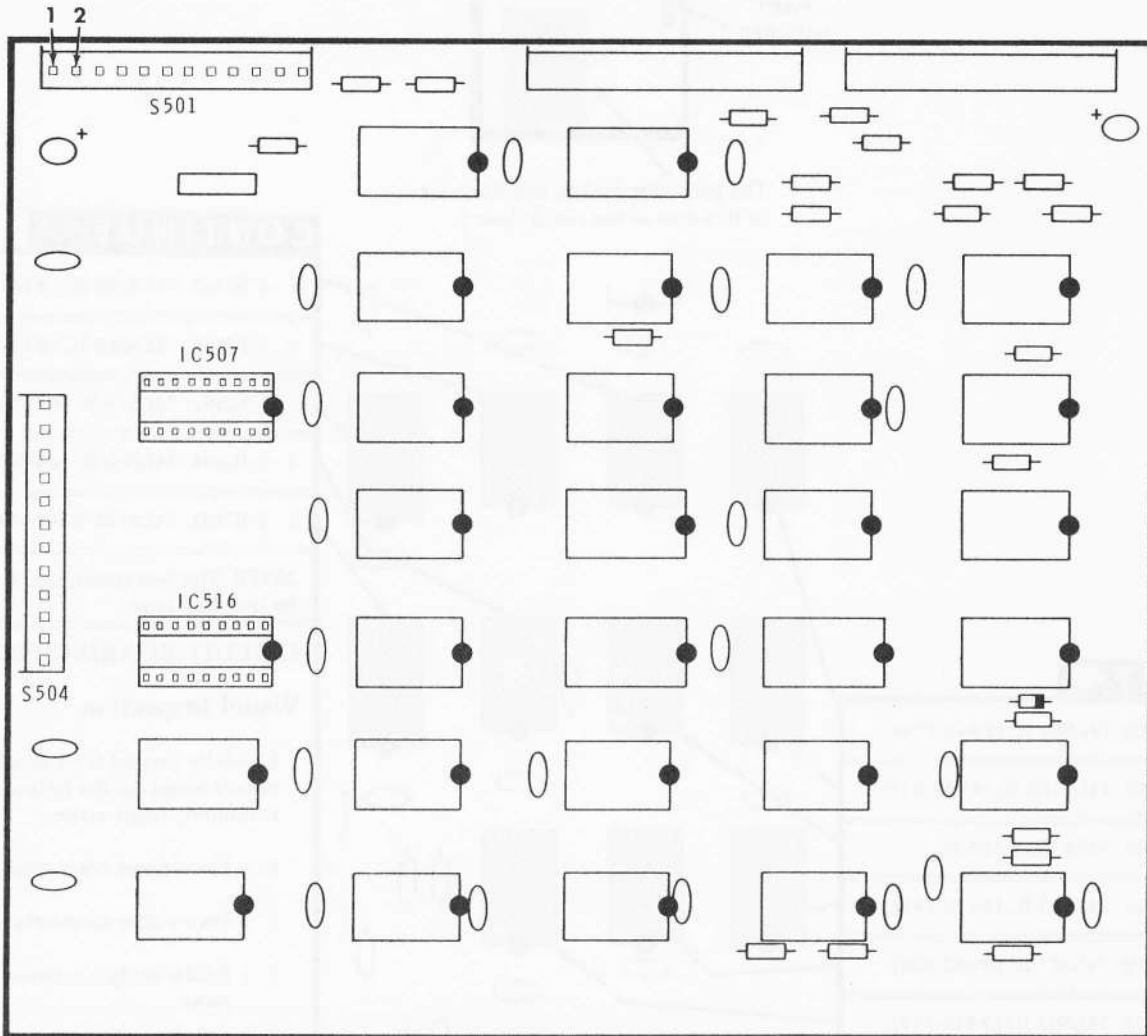

PICTORIAL 7-8

RESISTANCE MEASUREMENTS

Refer to Pictorial 7-8 for the following steps.

CAUTION: Be sure the 2114 protected IC's (#443-764) are not in their sockets at locations IC507 and IC516. They can be damaged by making the following resistance measurements.

Make the following resistance measurements on the ram and counter circuit board.

NEGATIVE LEAD TO:	POSITIVE LEAD TO:	SELECTOR — RANGE	METER INDICATION	POSSIBLE AREA OF TROUBLE
() S501-1	S501-2	OHMS — R × 1000	GREATER THAN 1000 Ω	Check for solder bridges on the foil, especially around the IC sockets.

- () With the negative meter lead still connected to socket S501 pin 1, touch the positive meter lead to each connector in socket S504. The meter should read INFINITE. If you obtain a reading less than INFINITE, look for solder bridges on the foil.

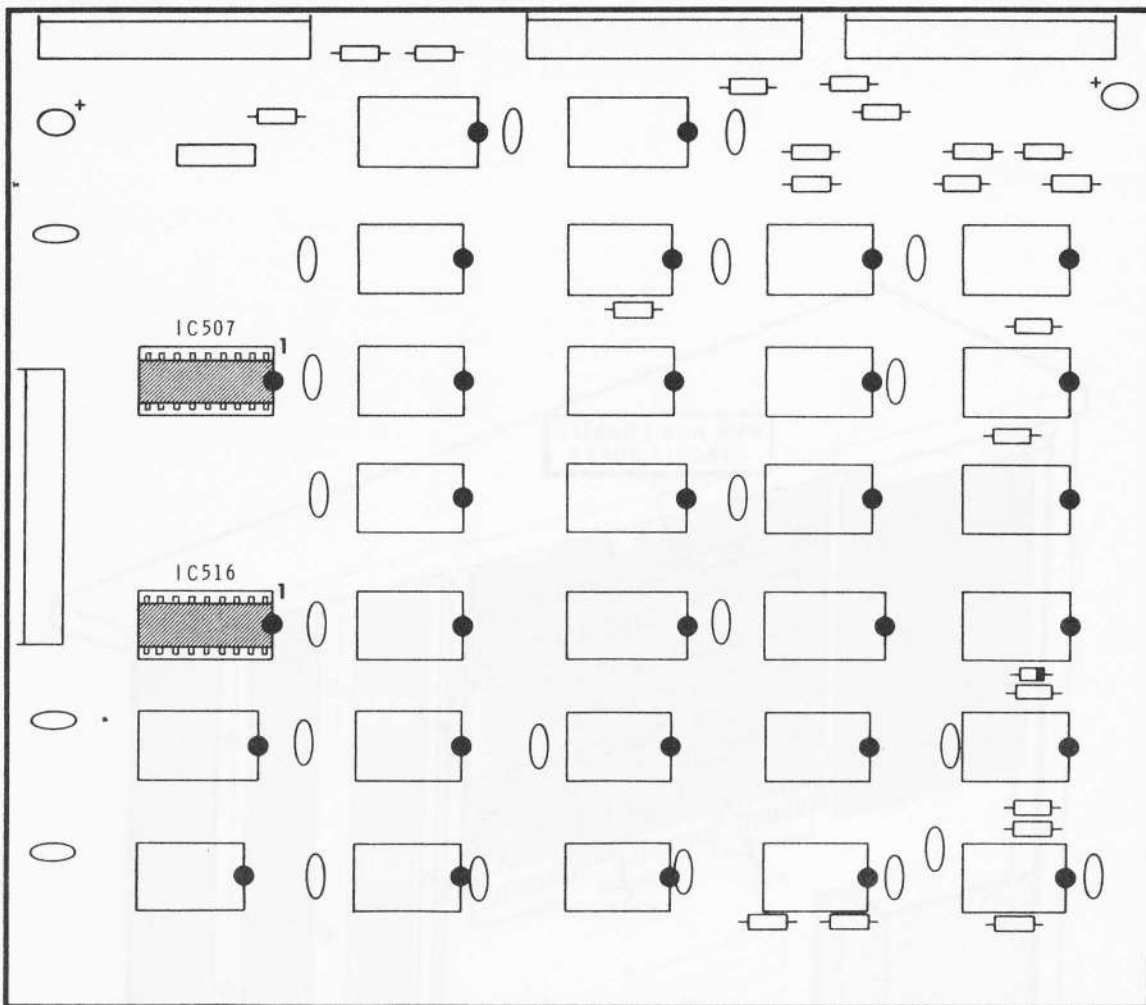

PICTORIAL 7-9

Refer to Pictorial 7-9 for the following steps.

CAUTION: When you install a protected IC, be sure it does not get damaged by static electricity. Once you remove the foam pad from the IC, **DO NOT** let go of the IC. Install the IC as follows. Read the entire step before you pick up the IC.

1. Pick up the IC and touch the foam pad with both hands.
2. Hold the IC with one hand and remove the foam pad with the other hand.
3. Continue to hold the IC with one hand and straighten any bent pins with the other hand.
4. Pick up the circuit board with the other hand.
5. Align the pin 1 end of this IC with the index mark on the circuit board.
6. Then push the IC pins into the IC socket. Once in the socket, the IC is protected.

() IC507: Install a 2114 (4045, 40L45, or 6614) IC (#443-764) in socket IC507.

() IC516: Install a 2114 (4045, 40L45, or 6614) IC (#443-764) in socket IC516.

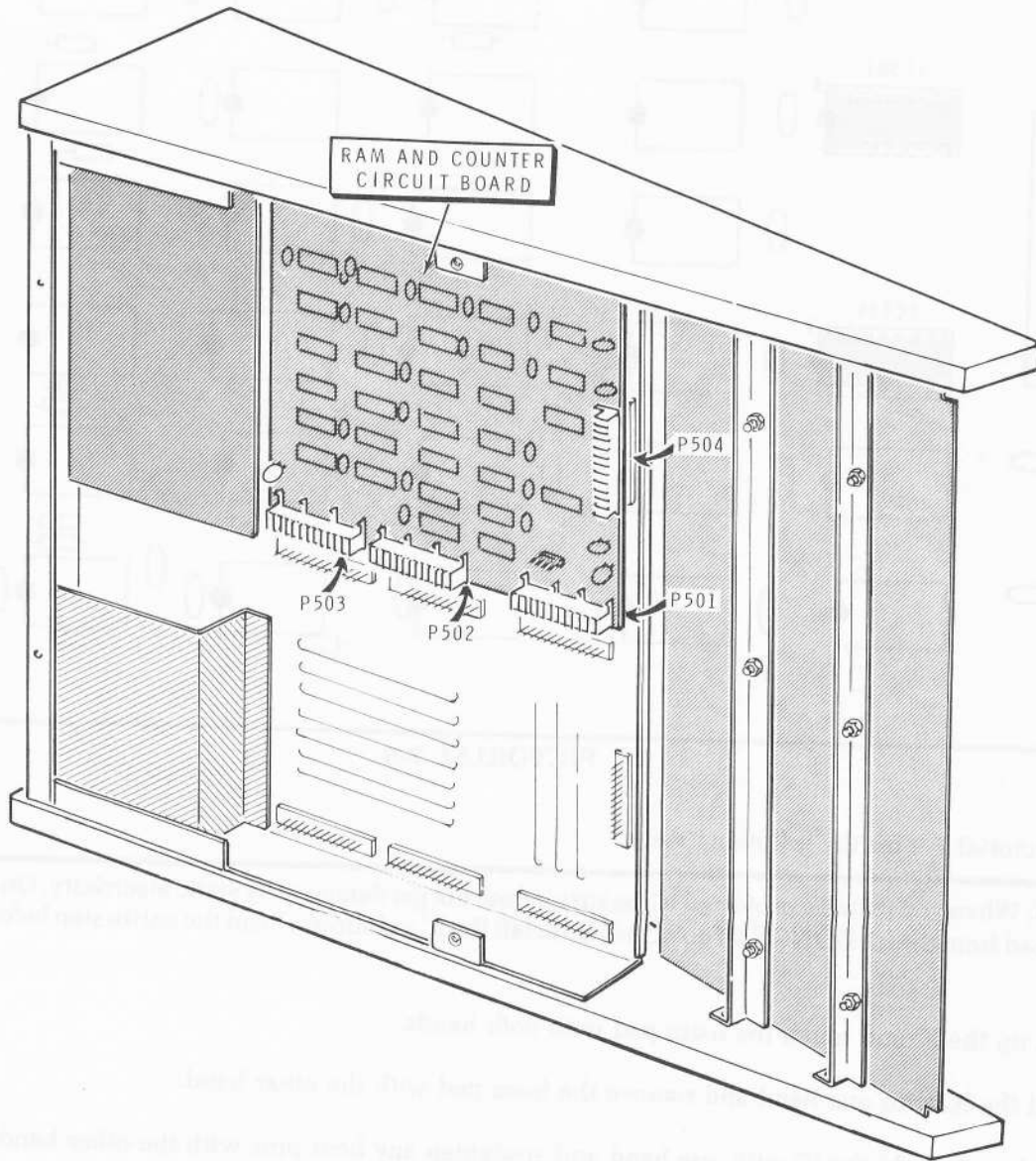

PICTORIAL 7-10

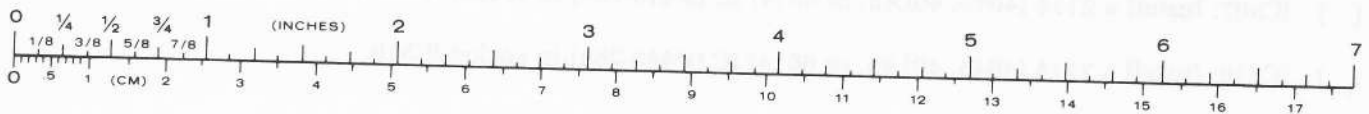

RAM AND COUNTER CIRCUIT BOARD INSTALLATION

Refer to Pictorial 7-10 for the following steps.

- () Position the chassis up on its right (power transformer) side.
- () Position the ram and counter circuit board onto plugs P501, P502, P503, and P504. Make sure all plug pins are started into the circuit board sockets. Then push the board down onto the circuit board standoffs and the plug pins **evenly all the way around the board**. Do not push one socket all the way onto a plug and then another socket, as this could damage the circuit board.

VOLTAGE MEASUREMENTS

Refer to Pictorial 7-11 (Illustration Booklet, Page 25) for the following steps.

NEGATIVE LEAD TO:	POSITIVE LEAD TO:	SELECTOR — RANGE	METER INDICATION	POSSIBLE AREA OF TROUBLE
() CHASSIS	S501-2	DC + 15V	5V	See the following "Possible Cause Checks."

POSSIBLE CAUSE CHECKS

1. Remove the circuit board and make the same voltage measurements at the chassis plug. If you do not have the correct voltage at the plug, the problem is in the harness.
2. If you do have the correct voltage at the chassis plug, carefully check for solder bridges on the bottom of the circuit board, especially around the IC sockets.
3. Reinstall the circuit board. Then remove the IC's one at a time (with the power off). Then with the power on, recheck for the correct voltage at the socket connector. If you obtain the correct voltage with an IC removed the IC is possibly shorted.



READ AND COINTEGRATE CIRCUIT BOARD
INSTALLATION

Refer to Figure 1-10 for the following steps:

1. Position the board in the rack and secure it with the screws.
2. Connect the board to the power supply and the other components of the system.

VOLTAGE MEASUREMENTS

Refer to Figure 1-11 illustrating typical voltages for the following table:

MEASURED VOLTAGE	MEASURED VOLTAGE	MEASURED VOLTAGE	MEASURED VOLTAGE	MEASURED VOLTAGE
5.0V	5.0V	5.0V	5.0V	5.0V

TRIGGER CAUSE CHECKS

1. Verify the correct board and make the correct voltage measurements at the correct pins. If you do not have the correct voltage at the pins, the problem is in the board.
2. If you do have the correct voltage at the correct pins, carefully check for solder bridges on the bottom of the board. Solder bridges can cause the IC to work.
3. Replace the circuit board. Then remove the IC and a trace with the power. Then with the power on, check for the correct voltage at the correct pins. If you obtain the correct voltage with the IC removed, the IC is possibly damaged.

INPUT/OUTPUT CIRCUIT BOARD

PARTS LIST

Unpack the pack marked #6 and check each part against the following Parts List. The key numbers correspond to the numbers on the Input/Output (I/O) Circuit Board Parts Pictorial (Illustration Booklet,

Page 24). Any part that is packaged in an individual envelope with a part number on it should be placed back in the envelope after it is identified until it is called for in a step.

KEY No.	HEATH Part No.	QTY.	DESCRIPTION	CIRCUIT Comp. No.
---------	----------------	------	-------------	-------------------

RESISTORS

All resistors are 5% (fourth band gold).

1/4-Watt

A1	6-221-12	1	220 Ω (red-red-brown)	R615
A1	6-271-12	3	270 Ω (red-violet-brown)	R622, R625, R627
A1	6-332-12	1	3300 Ω (orange-orange-red)	R631
A1	6-472-12	17	4700 Ω (yellow-violet-red)	R601, R602, R603, R604, R605, R606, R607, R608, R609, R611, R612, R613, R614, R616, R619, R623, R626
A1	6-103-12	1	10 k Ω (brown-black-orange)	R618
A1	6-393-12	1	39 k Ω (orange-white-orange)	R617
A1	6-104-12	3	100 k Ω (brown-black-yellow)	R621, R624, R628

KEY No.	HEATH Part No.	QTY.	DESCRIPTION	CIRCUIT Comp. No.
---------	----------------	------	-------------	-------------------

Other Resistors

A1	1-42	1	270 Ω , 1/2-watt (red-violet brown)	(optional use)
A2	1-2-1	2	1000 Ω , 1-watt (brown-black-red)	R629, R632

CAPACITORS

B1	21-95	5	.1 μ F ceramic	C602, C603, C604, C605, C606
B1	21-17	1	270 pF ceramic	C607
B2	25-220	1	10 μ F tantalum	C601

DIODES

C1	56-26	1	1N191 (brown-white-brown)	D602
C1	56-56	1	1N4149	D604
C1	57-65	3	1N4002	D601, D603, D605

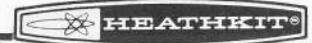

KEY No.	HEATH Part No.	QTY.	DESCRIPTION	CIRCUIT Comp. No.
---------	----------------	------	-------------	-------------------

TRANSISTORS — INTEGRATED CIRCUITS (IC's)

NOTE: Transistors and integrated circuits are marked for identification in one of the following four ways:

1. Part number.
2. Type number. (On integrated circuits this refers only to the numbers and letters listed. Any additional letters or numbers on an IC are not significant.)
3. Part number and type number.
4. Part number with a type number other than the one listed.

D1	417-801	2	MPSA20 transistor	Q603, Q604
D1	417-865	1	MPSA55 transistor	Q601
D1	417-897	1	Selected FET transistor	Q602

IMPORTANT

Before you open any IC package, and if any components are missing from the sealed IC package, return the **unopened** package for replacement. Claims for missing IC's will not be honored.

If you locate damaged or defective IC's, order individual replacements. Be sure to follow the standard instructions on the "Parts Order Form" and on the inside rear cover of the Manual. Save defective or damaged components for return instructions.

D2	443-808	3	4N26 IC	IC604, IC605, IC606
D2	443-1	1	7400 IC	IC609
D2	443-728	2	74LS00 IC	IC608, IC611
D2	443-779	3	74LS02 IC	IC610, IC617, IC624
D2	443-745	1	74LS03 IC	IC607

KEY No.	HEATH Part No.	QTY.	DESCRIPTION	CIRCUIT Comp. No.
---------	----------------	------	-------------	-------------------

Transistors — Integrated Circuits (cont'd.)

D2	443-780	1	74LS08 IC	IC615
D2	443-797	1	74LS10 IC	IC619
D2	443-732	1	74LS30 IC	IC613
D2	443-807	2	74LS42 IC	IC614, IC623
D2	443-730	1	74LS74 IC	IC618
D2	443-752	3	74LS175 IC	IC616, IC621, IC622
D2	443-791	2	74LS244 IC	IC603, IC620
D2	443-733	2	74LS293 IC	IC601, IC602

NOTE: The protected IM6402 (#443-761) IC can be damaged by static electricity. DO NOT remove it from the foam pad until you are instructed to do so in a step.

D3	443-859	1	TMS6011N (protected)	IC612
----	---------	---	----------------------	-------

CONNECTOR — PLUGS — SOCKETS

E1	432-134	6	Circuit board connector (1 extra)	
E2	432-903	1	10-pin plug	P603
E3	432-946	3	25-pin plug	P601, P602, P604
E4	434-315	3	6-pin IC socket	
	434-298	13	14-pin IC socket	
	434-299	5	16-pin IC socket	
	434-311	2	20-pin IC socket	
	434-253	1	40-pin IC socket	

PART FROM FINAL PACK

85-2136-1	1	Input/output circuit board
-----------	---	----------------------------

STEP-BY-STEP ASSEMBLY

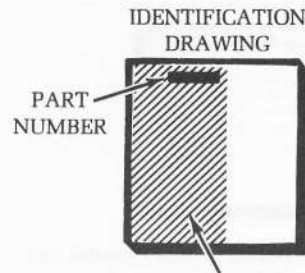

The parts installed in this Pictorial are in this area of the circuit board.

START

- () Position the circuit board as shown with its printed side up.
- () R613: 4700 Ω (yellow-violet-red).
- () R612: 4700 Ω (yellow-violet-red).
- () R615: 220 Ω (red-red-brown).
- () R614: 4700 Ω (yellow-violet-red).
- () R611: 4700 Ω (yellow-violet-red).
- () R602: 4700 Ω (yellow-violet-red).
- () R601: 4700 Ω (yellow-violet-red).
- () R609: 4700 Ω (yellow-violet-red).
- () Solder the leads to the foil and cut off the excess lead lengths.

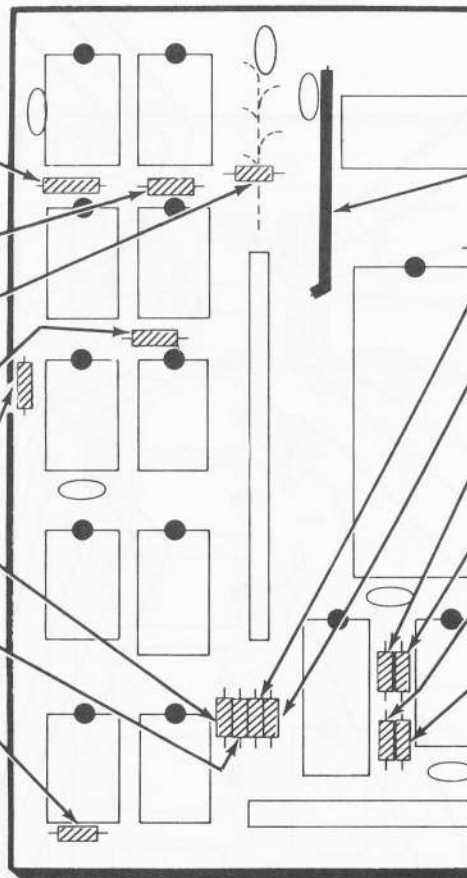

CONTINUE

- () 2" white wire.
- () R603: 4700 Ω (yellow-violet-red).
- () R604: 4700 Ω (yellow-violet-red).
- () R606: 4700 Ω (yellow-violet-red).
- () R607: 4700 Ω (yellow-violet-red).
- () R605: 4700 Ω (yellow-violet-red).
- () R608: 4700 Ω (yellow-violet-red).
- () Solder the leads to the foil and cut off the excess lead lengths.

PICTORIAL 8-1

IDENTIFICATION
DRAWING

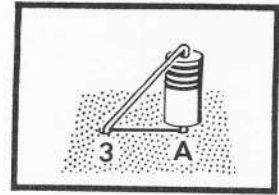
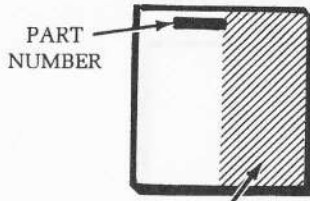

Detail 8-2A

The parts installed in this Pictorial are in this area of the circuit board.

START ↘

NOTE: When you install a diode, always match the band on the diode with the band on the circuit board outline.

- (✓) D601: 1N4002 diode (#57-65).
- (✓) R626: 4700 Ω (yellow-violet-red).
- (✓) R627: 270 Ω, 1/4-watt (red-violet-brown).
- (✓) R628: 100 kΩ (brown-black-yellow).
- (✓) R619: 4700 Ω (yellow-violet-red).
- (✓) R621: 100 kΩ (brown-black-yellow).
- (✓) R616: 4700 Ω (yellow-violet-red).
- (✓) D602: 1N191 diode (brown-white-brown, #56-26).

NOTE: The wires installed in some of the following steps select the EIA mode of operation which will be used for testing the VIDEO Terminal. The Terminal can be changed to another mode of operation later by following the instructions in the Operation Manual.

- (✓) 1" white wire between holes G and 15. Be sure this wire does not touch the circuit board foil that is under it.
- (✓) 1" bare wire between holes H and EIA.

() Solder the leads to the foil and cut off the excess lead lengths.

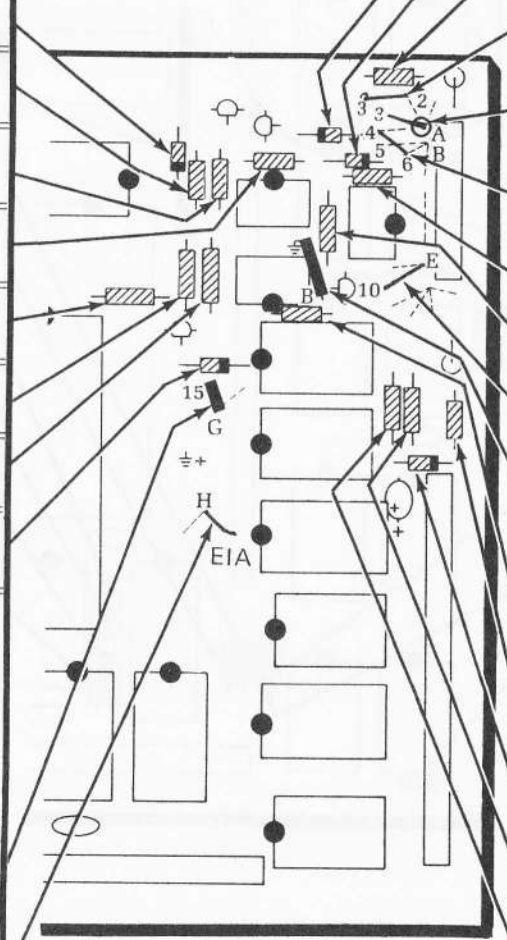

PICTORIAL 8-2

CONTINUE ↘

- () D605: 1N4002 diode (#57-65).
- (✓) D603: 1N4002 diode (#57-65).
- (✓) R631: 3300 Ω (orange-orange-red).
- (✓) 1" bare wire between hole 2 and indicated hole 3.
- (✓) 270 Ω, 1/2-watt (red-violet-brown) between hole A and other hole 3. See Detail 8-2A.
- (✓) 1" bare wire between holes 4 and 6. Be sure the wire does not touch hole 5.
- (✓) R625: 270 Ω (red-violet-brown).
- (✓) R622: 270 Ω (red-violet-brown).
- (✓) 1" white wire between holes E and 10.
- (✓) 1-1/4" white between holes B and ground (1/2). Be sure you do not install this wire in the B (base) hole of transistor Q604 by mistake.
- (✓) R623: 4700 Ω (yellow-violet-red).
- (✓) R617: 39 kΩ (orange-white-orange). The circuit board may be screened 10 k.
- (✓) D604: 1N4149 diode (#56-56).
- (✓) R618: 10 kΩ (brown-black-orange). The circuit board may be screened 4700.
- (✓) R624: 100 kΩ (brown-black-yellow).
- () Solder the leads to the foil and cut off the excess lead lengths.

START 

NOTE: When you install an IC socket, make sure the index mark (dot) on the circuit board outline is still visible after the socket is installed. Solder the pins to the foil as each socket is installed.

Install 6-pin IC sockets at the three following locations:

IC604 IC605 IC606

Install 20-pin IC sockets at the two following locations:

IC603 IC620

Install 16-pin IC sockets at the five following locations:

IC614 IC621 IC623
 IC616 IC622

Install 14-pin IC sockets at the thirteen following (all the remaining 14-pin socket) locations:

IC601 IC610 IC618
 IC602 IC611 IC619
 IC607 IC613 IC624
 IC608 IC615
 IC609 IC617

Install a 40-pin IC socket at location IC612.

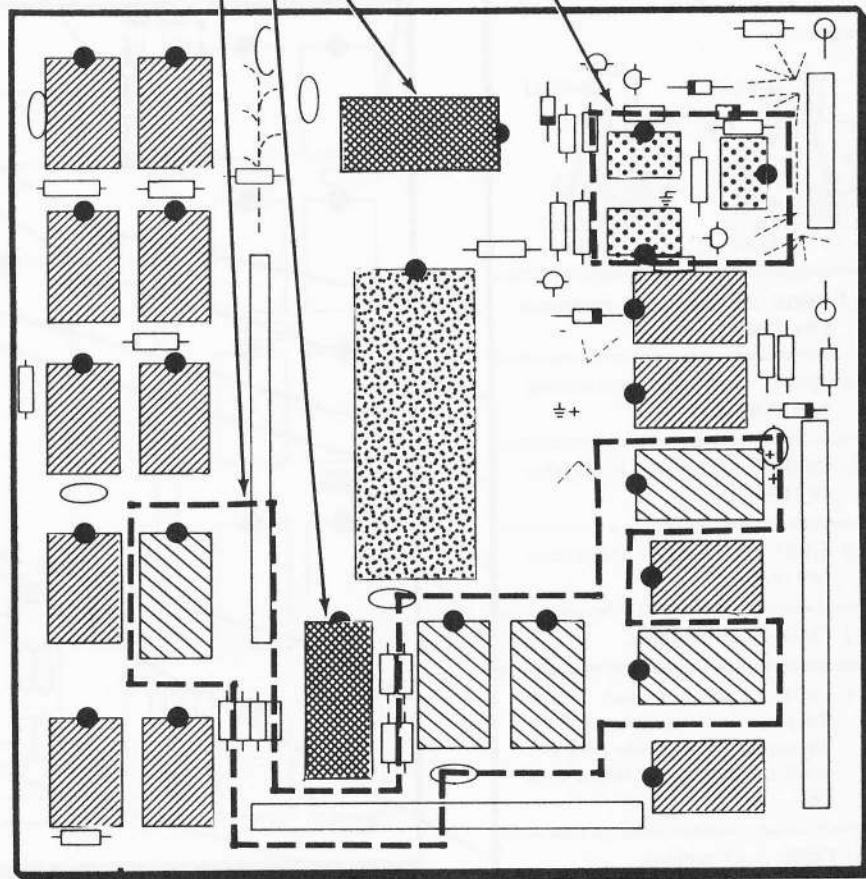

PICTORIAL 8-3

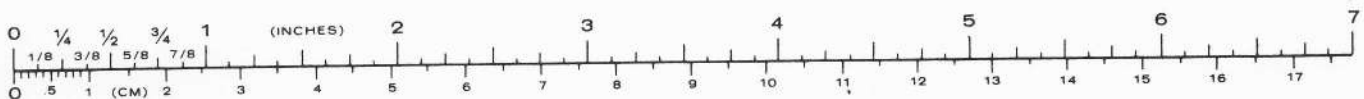

START 

() Five circuit board pins. Solder each pin to the foil as it is installed.

() C603: .1 μ F ceramic.

NOTE: When you install a transistor, match the flat on the transistor with the flat on the circuit board outline and insert the leads in the proper holes. Then solder the leads to the foil and cut off the excess lead lengths.

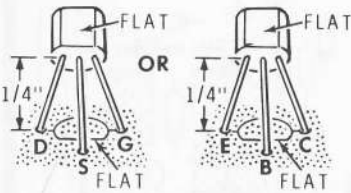

() Q602: Selected FET transistor (#417-897).

() Q601: MPSA55 transistor (#417-865).

() Q603: MPSA20 transistor (#417-801).

() Q604: MPSA20 transistor (#417-801).

() C604: .1 μ F ceramic.

() C601: 10 μ F tantalum. Match the positive (+ or color dot) on the capacitor with the plug (+) mark on the circuit board outline.

() C605: .1 μ F ceramic.

() C606: .1 μ F ceramic.

() Solder the leads to the foil and cut off the excess lead lengths.

DO NOT INSTALL THIS CAPACITOR AT THIS TIME.

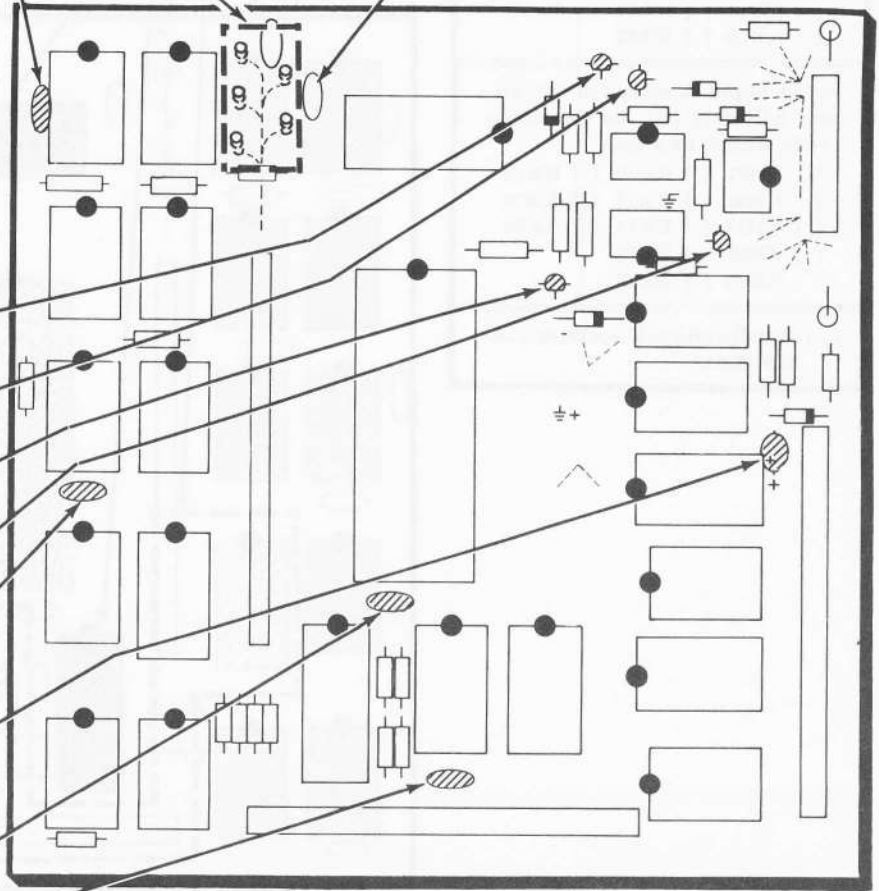

PICTORIAL 8-4

START 

(✓) Solder one end of a 2" white wire into the indicated circuit board hole and cut off the excess lead length. Insert the other end of the wire into circuit board connector "600". Then push the wire down against the board as shown.

NOTE: Install the next two plugs on the **lettered** side of the circuit board. Solder the short pins to the foil side of the board as each plug is installed.

() P601: 25-pin plug.

() P604: 25-pin plug.

() R632: 1000 Ω, 1-watt (brown-black-red). Upper right side of the circuit board.



() R629: 1000 Ω, 1-watt (brown-black-red). Upper right corner of the circuit board.

() Solder the leads to the foil and cut off the excess lead lengths.

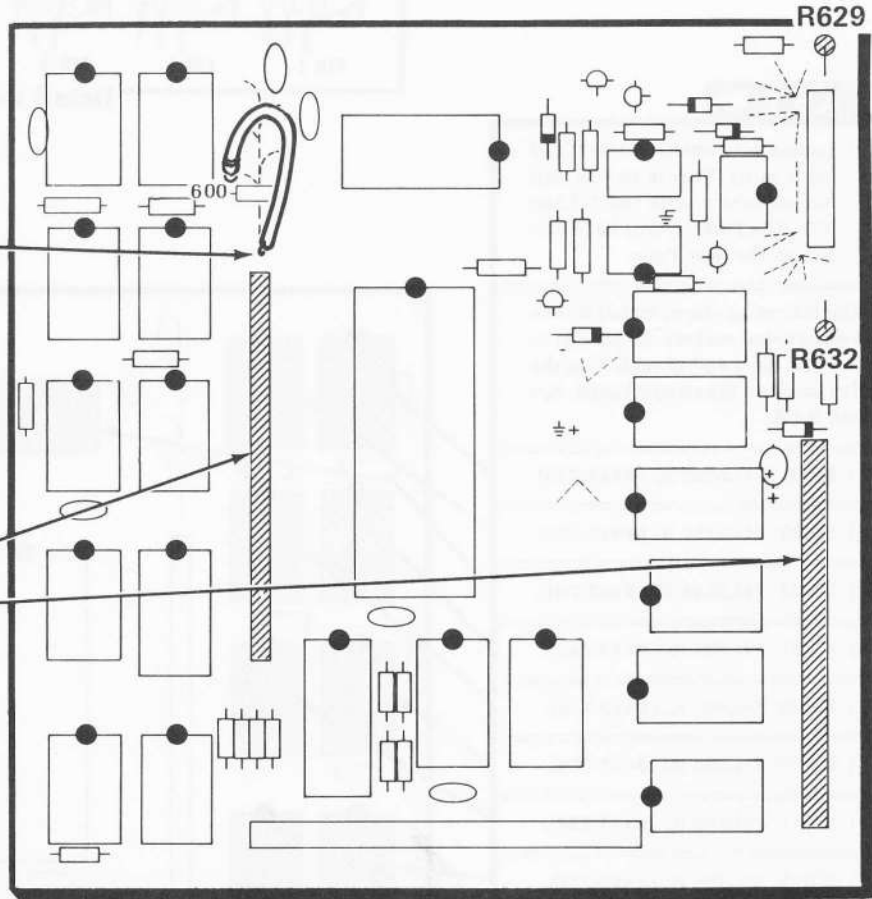

PICTORIAL 8-5



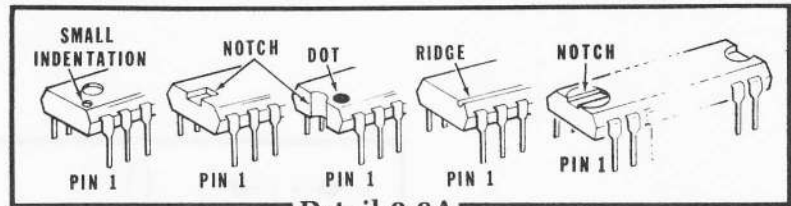

Detail 8-6A

START →

() Locate the 7400 IC (#443-1) and set it aside. This is so you will not confuse it with the 74LS00 IC's. The 7400 IC will be installed on the next Page.

In the following steps, install IC's in the designated sockets. Be careful to match the pin 1 end of each IC to the index mark on the circuit board. See Detail 8-6A.

- () IC601: 74LS293 IC (#443-733).
- () IC602: 74LS293 IC (#443-733).
- () IC603: 74LS244 IC (#443-791).
- () IC607: 74LS03 IC (#443-745).
- () IC608: 74LS00 IC (#443-728).
- () IC610: 74LS02 IC (#443-779).
- () IC611: 74LS00 IC (#443-728).
- () IC615: 74LS08 IC (#443-780).
- () IC616: 74LS175 IC (#443-752).
- () IC618: 74LS74 IC (#443-730).
- () IC619: 74LS10 IC (#443-797).
- () IC620: 74LS244 IC (#443-791).
- () IC621: 74LS175 IC (#443-752).
- () IC622: 74LS175 IC (#443-752).

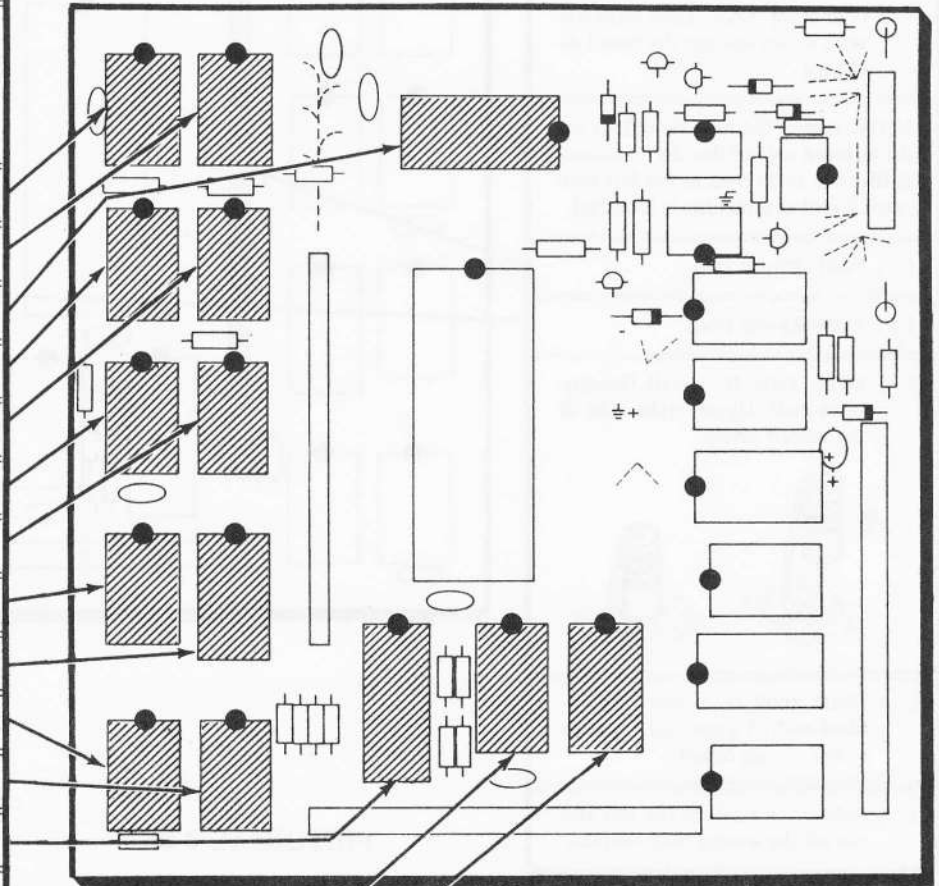

PICTORIAL 8-6

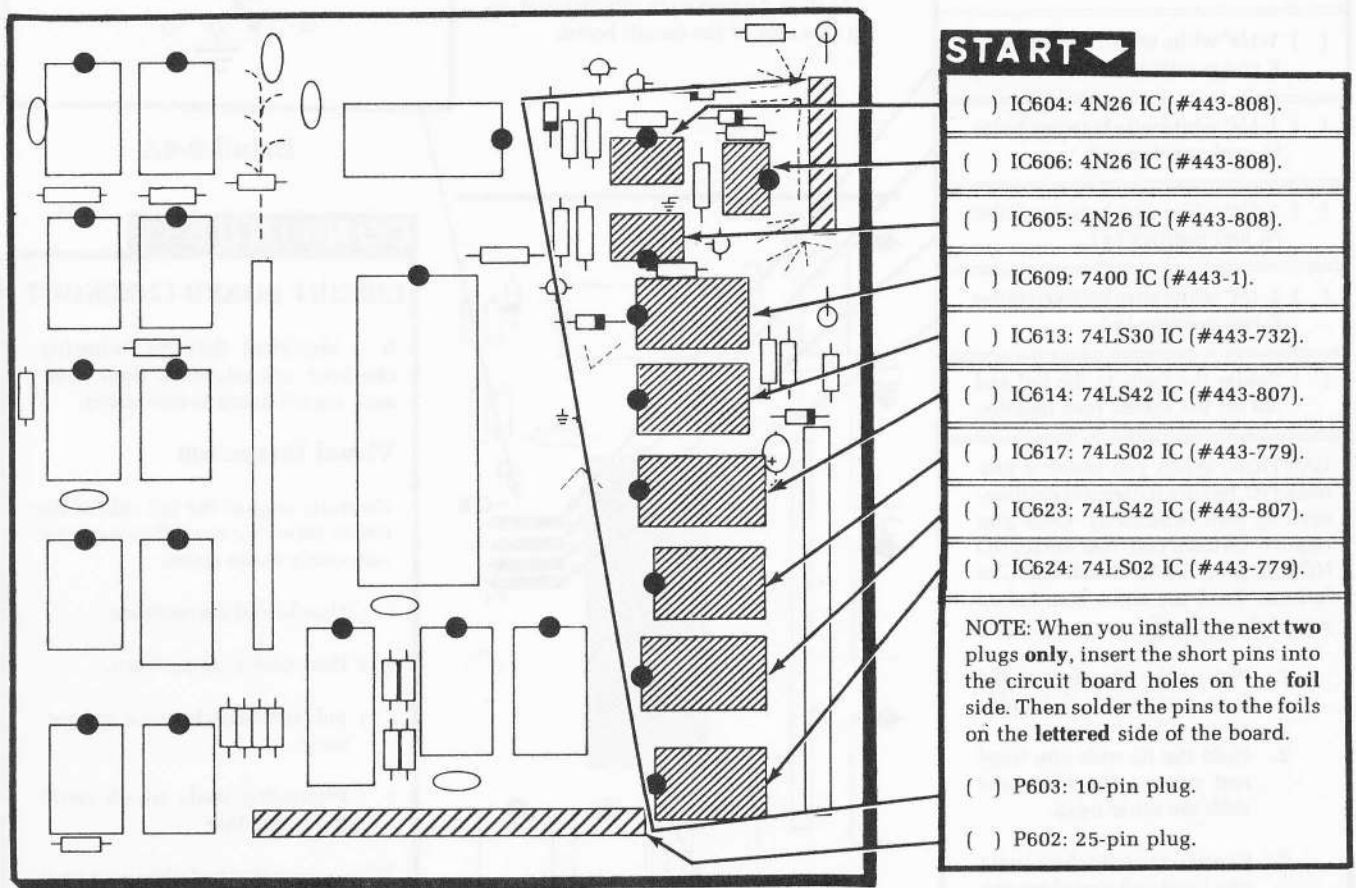

PICTORIAL 8-7

START

NOTE: In the next four steps, be sure you connect the wires between the lettered holes and the positive (+) holes and NOT between the ground (⊖) holes and positive (+) holes. See Detail 8-8A.

- () 1-1/4" white wire between holes E and positive (+).
- () 1-1/4" white wire between holes N₁ and positive (+).
- () 1-1/4" white wire between holes N₂ and positive (+).
- () 1-1/4" white wire between holes P and positive (+).
- () Solder the leads to the foil and cut off the excess lead lengths.

CAUTION: When you install a protected IC, be sure it does not get damaged by static electricity. Once you remove the foam pad from the IC, DO NOT let go of the IC. Install the IC as follows. Read the entire step before you pick up the IC.

1. Pick up the IC and touch the foam pad with both hands.
2. Hold the IC with one hand and remove the foam pad with the other hand.
3. Continue to hold the IC with one hand and straighten any bent pins with the other hand.
4. Pick up the circuit board in the other hand.
5. Align the pin 1 end of the IC with the index mark on the circuit board.
6. Then push the IC pins into the IC socket. Once in the socket, the IC is protected.

() IC612: TMS6011N protected IC (#443-859).

IDENTIFICATION DRAWING

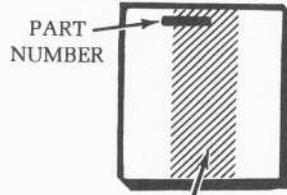

The steps performed in this Pictorial are in this area of the circuit board.

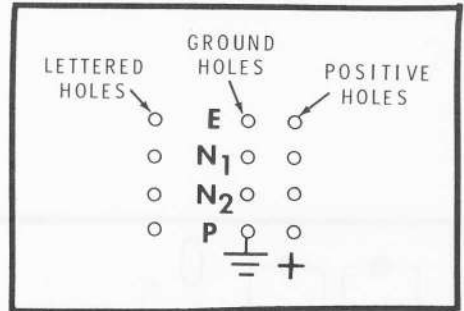

Detail 8-8A

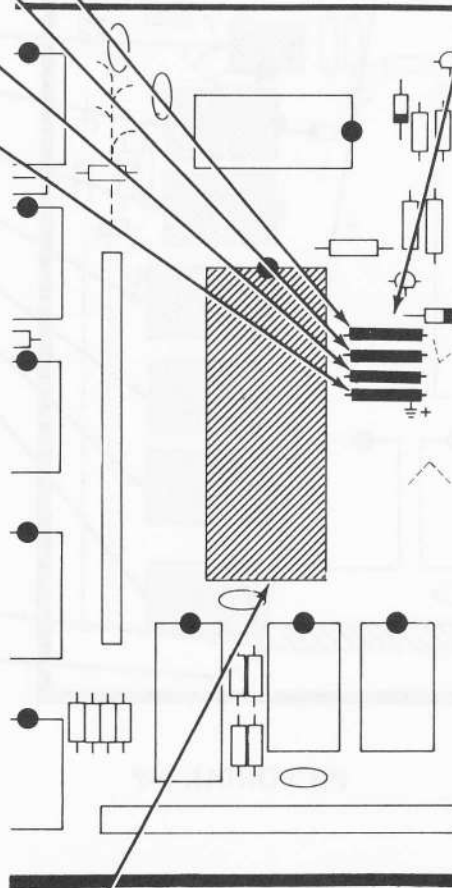

PICTORIAL 8-8

CONTINUE

CIRCUIT BOARD CHECKOUT

It is important that the following checkout procedure be done after each circuit board is completed.

Visual Inspection

Carefully inspect the foil side of the circuit board for the following most commonly made errors.

- () Unsoldered connections.
- () Poor solder connections.
- () Solder bridges between foil patterns.
- () Protruding leads which could touch together.

When you make the following visual checks, refer to the Pictorial where the part was installed and check it against the installation instructions.

- () Check the transistors for proper installation.
- () Check the integrated circuits for proper type and installation.
- () Check the tantalum capacitors for the correct position of the positive (+) end.
- () Check the diodes for proper type and installation.

FINISH

IN-CIRCUIT BOARD CHECKOUT

RESISTANCE MEASUREMENTS

Refer to Figure 8 for the following steps:

START

- () C607: 270 pF ceramic.
- () C602: .1 μ F ceramic.
- () Solder the leads to the foil side of the circuit board. Cut off the excess lead lengths.

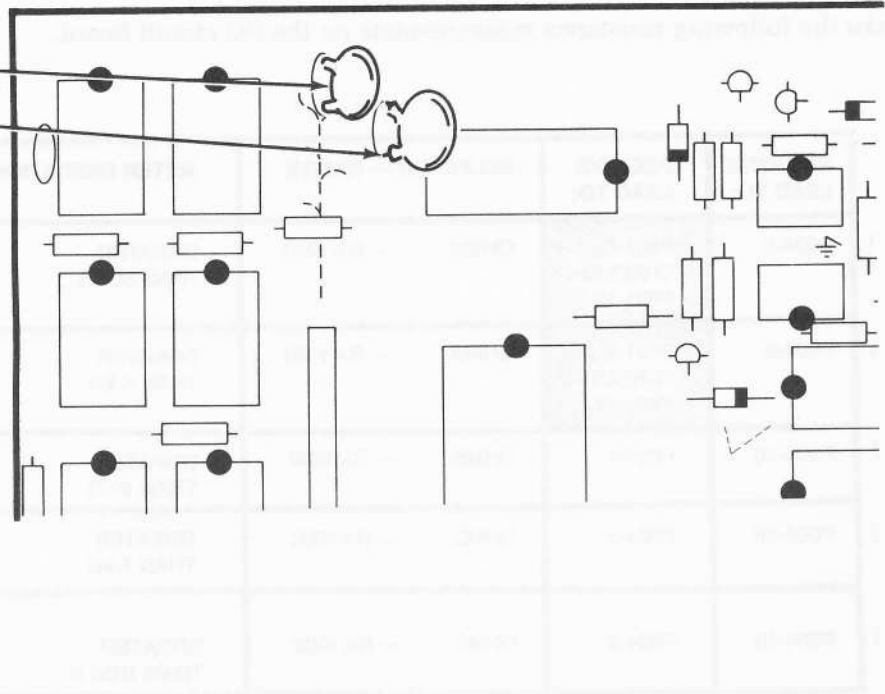

PICTORIAL 8-9

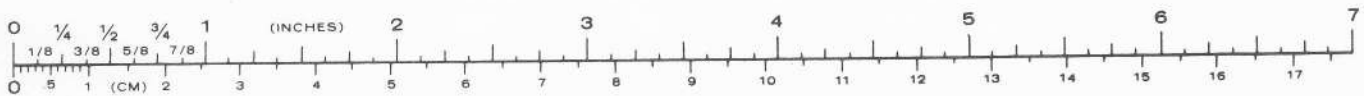

I/O CIRCUIT BOARD CHECKOUT

RESISTANCE MEASUREMENTS

Refer to Pictorial 8-10 for the following steps.

Make the following resistance measurements on the I/O circuit board.

	NEGATIVE LEAD TO:	POSITIVE LEAD TO:	SELECTOR — RANGE	METER INDICATION	POSSIBLE AREA OF TROUBLE
()	P604-5	P601-6 THROUGH P601-13	OHMS — R×1000	GREATER THAN 50 kΩ	Check for solder bridges on the foil, especially around the IC sockets.
()	P604-6	P601-6 THROUGH P601-13	OHMS — R×1000	GREATER THAN 5 kΩ	
()	P604-10	P604-1	OHMS — R×1000	GREATER THAN 5 kΩ	
()	P604-10	P604-5	OHMS — R×1000	GREATER THAN 5 kΩ	
()	P604-10	P604-6	OHMS — R×1000	GREATER THAN 1000 Ω	

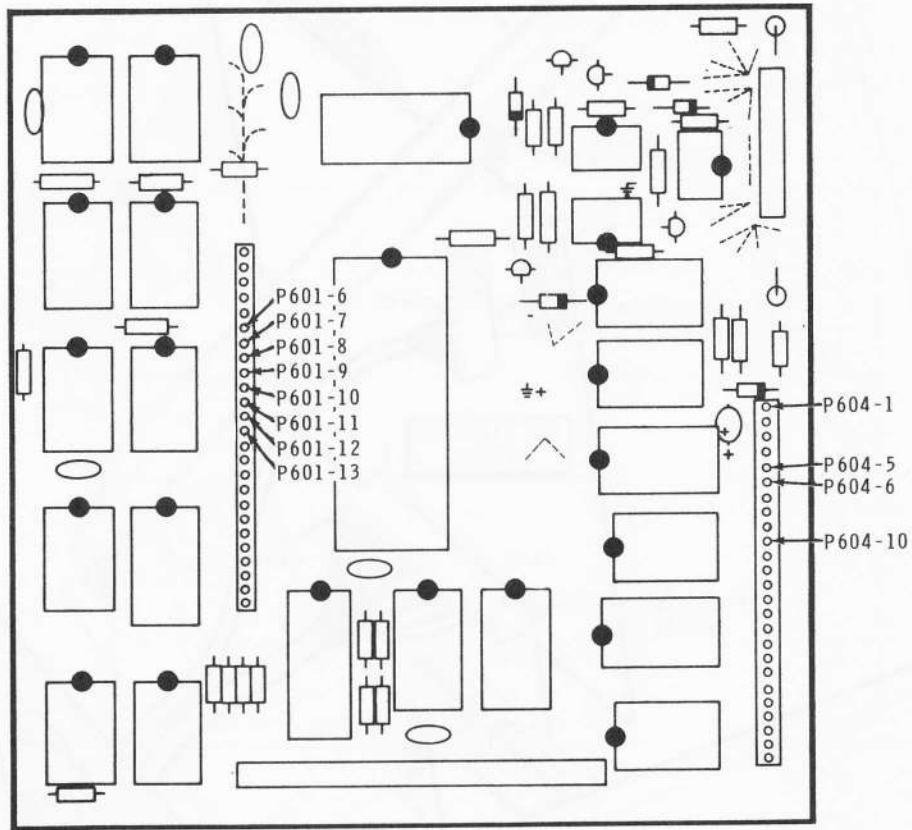

PICTORIAL 8-10

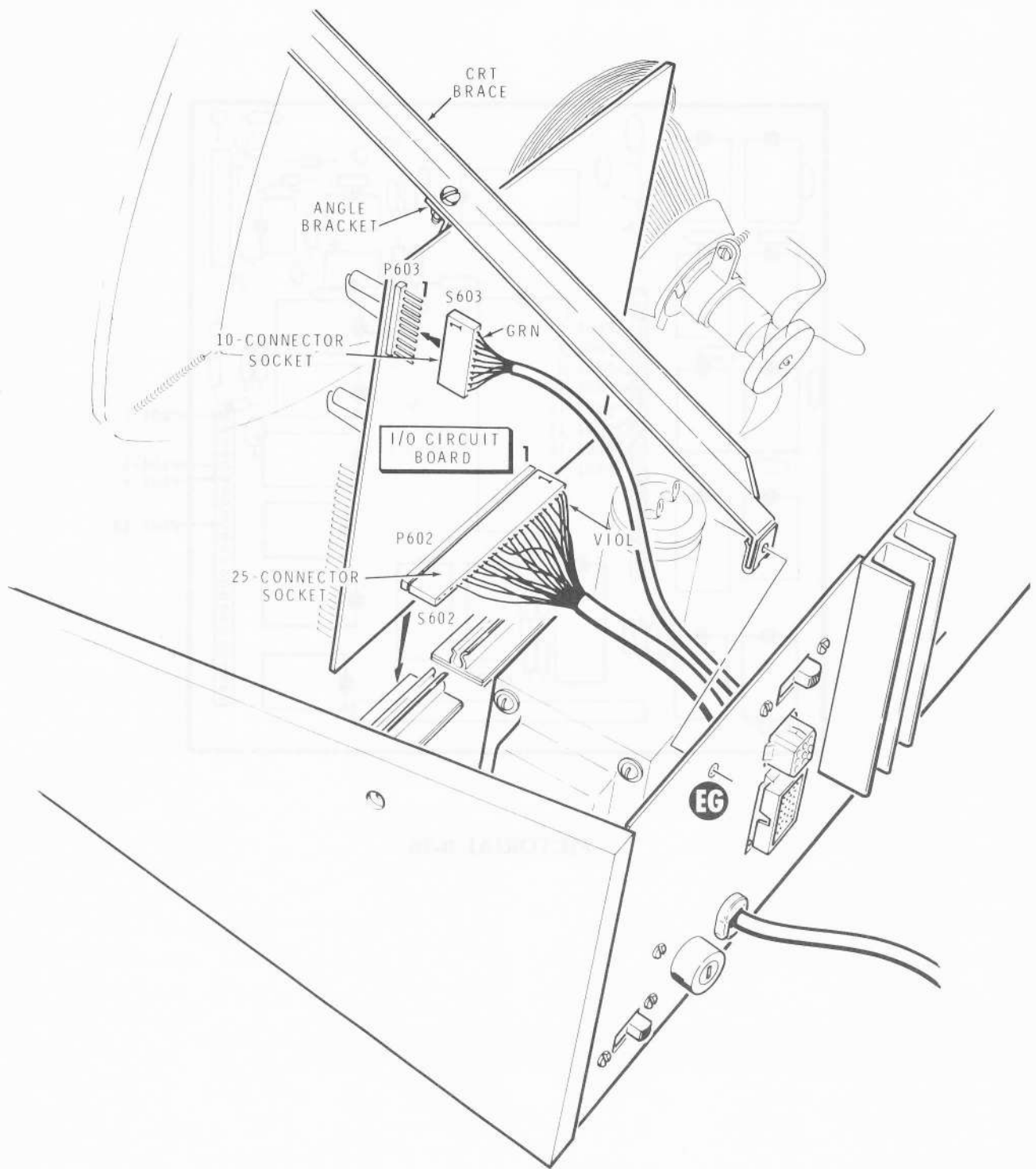

PICTORIAL 8-11

I/O CIRCUIT BOARD INSTALLATION

Refer to Pictorial 8-11 for the following steps.

- () Remove the 6-32 × 3/8" black screw from the CRT brace at EG. This will permit the brace to move up enough to allow installation of the I/O circuit board.
- () Position the I/O circuit board as shown. Then push the 25-connector socket coming from the rear panel onto plug P602 (on the foil side of the circuit board) so the number "1" on the connector socket (violet wire) is connected to pin 1 (see the lettered side on the board).
- () Push the I/O circuit board down into the circuit board holders on the chassis.
- () Push 10-connector socket coming from the rear panel onto plug P603 (on the foil side of the circuit board) so that connector number "1" (green wire) is connected to pin 1 (see the lettered side of the board).
- () Position the CRT brace down so the angle bracket is in **front** of the circuit board as shown.
- () Remount the brace to the rear panel at EG with the screw that was removed earlier. Tighten the hardware on both ends of this brace.
- () With a screwdriver tip, bend the bottom edge of the CRT brace angle bracket rearward until it is parallel with the surface of the board and holds the board securely in place. NOTE: If necessary, loosen the angle bracket mounting hardware to push the bracket tightly against the top edge of the board, then retighten this hardware.
- () Refer to Pictorial 8-12 (Illustration Booklet, Page 26) for the following steps.
- () Push socket S601 (coming from the main harness) onto plug P601 so that the number "1" (white-orange wire) matches pin "1" on the board.
- () Push socket S604 (coming from the main harness) onto plug P604 so that connector number "1" (medium brown wire) matches pin "1" on the board.

This completes the I/O circuit board installation. Proceed to the "TPU Circuit Board."

TIMING AND PROCESSING UNIT CIRCUIT BOARD

PARTS LIST

NOTE: This circuit board was factory assembled and checked. The following Parts List is included for parts replacement purposes. Parts Pictorial in Illustration Booklet, Page 7.

IMPORTANT: The TPU circuit board assembly has been wired and tested at Heath Company. If it malfunctions during the 90-day period, return the complete circuit board assembly to Heath Company or a Heathkit Electronic Center. It will be promptly repaired and returned. **Individual replacement parts are not supplied under warranty. DO NOT** attempt to service this circuit board assembly yourself during the warranty period; to do so voids the warranty.

For out-of-warranty circuit boards, you can have them repaired by Heath Company, (or a Heathkit Electronic Center), or you can purchase individual replacement parts to do your own service.

KEY No.	HEATH Part No.	QTY.	DESCRIPTION	CIRCUIT Comp. No.	KEY No.	HEATH Part No.	QTY.	DESCRIPTION	CIRCUIT Comp. No.
	181-2679-2	1	Assembled TPU circuit board consisting of the following:		Resistors (cont'd.)				
					A1	6-103-12	1	10 k Ω (brown-black-orange)	R726
					A1	6-223-12	2	22 k Ω (red-red-orange)	R717, R725
					A1	6-104-12	1	100 k Ω (brown-black-yellow)	R728
RESISTORS					CAPACITORS				
All resistors are 5% (fourth band gold).									
1/4-Watt									
A1	6-101-12	1	100 Ω (brown-black-brown)	R731	B1	20-131	1	360 pF mica	C718
A1	6-472-12	31	4700 Ω (yellow-violet-red)	R701, R702, R703, R704, R705, R706, R707, R708, R709, R710, R711, R712, R713, R714, R715, R716, R718, R719, R721, R722, R723, R724, R727, R729, R730, R732, R733, R734, R735, R736, R737	B2	21-140	1	.001 μ F ceramic	C721
					B2	21-95	14	.1 μ F ceramic	C701, C702, C703, C704, C705, C706, C707, C708, C709, C711, C712, C713, C714, C715
					B3	25-221	1	2.2 μ F tantalum	C717
					B3	25-220	1	10 μ F tantalum	C719
					B4	25-162	1	33 μ F tantalum	C716
					DIODE				
					C1	56-56	1	1N4149	D701



KEY	HEATH	QTY.	DESCRIPTION	CIRCUIT
No.	Part No.			Comp. No.

TRANSISTOR — INTEGRATED CIRCUITS (IC's)

NOTE: Transistors and integrated circuits are marked for identification in one of the following four ways:

1. Part number.
2. Type number. (On integrated circuits this refers only to the numbers and letters listed. Any additional letters or numbers on an IC are not significant.
3. Part number and type number.
4. Part number with a type number other than the one listed.

D1	417-801	1	MPSA20 transistor	Q701
----	---------	---	-------------------	------

IMPORTANT

Before you open any IC package, and if any components are missing from the sealed IC package, return the **unopened** package for replacement. Claims for missing IC's will not be honored.

If you locate damaged or defective IC's, order individual replacements. Be sure to follow the standard instructions on the "Parts Order Form" and on the inside rear cover of the Manual. Save defective or damaged components for return instructions.

D2	443-728	9	74LS00 IC	IC703, IC711, IC719, IC726, IC731, IC732, IC739, IC740, IC741
----	---------	---	-----------	---

KEY	HEATH	QTY.	DESCRIPTION	CIRCUIT
No.	Part No.			Comp. No.

Transistors — Integrated Circuits (cont'd.)

D2	443-779	4	74LS02 IC	IC705, IC708, IC735, IC737
D2	443-745	5	74LS03 IC	IC721, IC722, IC727, IC733, IC742
D2	443-818	1	74LS05 IC	IC717
D2	443-780	5	74LS08 IC	IC701, IC710, IC714, IC729, IC734
D2	443-816	1	74LS09 IC	IC715
D2	443-797	2	74LS10 IC	IC707, IC716
D2	443-800	2	74LS27 IC	IC713, IC718
D2	443-807	1	74LS42 IC	IC712
D2	443-730	6	74LS74 IC	IC704, IC706, IC709, IC723, IC725, IC738
D2	443-22	1	74121 IC	IC736
D2	443-752	1	74LS175 IC	IC720
D3	443-787	1	DM8575 IC	IC702

NOTE: The three following IC's **must** be identified by their Heath part number. Although these IC's have the same type number, they are not interchangeable.

D2	444-10	1	74S188 IC	IC728
D2	444-11	1	74S188 IC	IC730
D2	444-12	1	74S188 IC	IC724

TPU CIRCUIT BOARD CHECKOUT

TPU CIRCUIT BOARD INSTALLATION





Refer to Pictorial 9-1 (Illustration Booklet, Page 27) for the following steps.

- () Position the chassis on its left side (high voltage assembly side).
- () Locate the TPU circuit board and install it onto plugs P701, P702, P703, P704, P705, P706, and P707. Make sure all plug pins are started into the sockets. Then push the board down onto the plug pins evenly all the way around the board.
- () Push socket S701 (on the main harness) onto plug P701 on the TPU circuit board.
- () Locate the 5-wire cable that was prepared earlier. Note that the wire order is not the same on both ends of this cable. Be sure to connect the correct end of this cable in the next step.
- () Push socket S702 onto plug P702 (on the TPU circuit board) so that pin 1 (brown wire) matches the number "1" on the circuit board.
- () Push socket S501 onto plug P501 (on the ram and counter circuit board) so that pin 1 (brown wire) matches the number "1" on the circuit board.



VISUAL CHECKS

- () Position the chassis top side up.
- () Set all keys on the keyboard to their up positions.
- () Connect the line cord to an AC outlet and set the AC PWR switch to ON. After a few seconds of warmup, a cursor mark should appear in the upper left part of the screen.

NOTE: If you do not obtain the correct results in the following steps, first recheck the steps to make sure that you performed the operation correctly. If you still do not obtain the correct results, proceed to "Voltage Measurements" on Page 136.

- () Depress the long spacer bar several times. The cursor should move each time the bar is depressed.
- () Depress the cursor right key  (at the right side of the keyboard) several times. The cursor should move right each time the key is depressed. NOTE: When the cursor reaches the edge of the screen, it will automatically reset itself to the opposite side of the screen.
- () Depress the cursor left key  several times. The cursor should move left each time the key is depressed.
- () Depress the cursor down key  five times. The cursor should move down five spaces.
- () Depress the cursor up key  five times. The cursor should move up five spaces.
- () Push several character (lettered) keys. The cursor should move each time a key is depressed and the character should be displayed on the screen.
- () Depress the ERASE PAGE key at the top of the keyboard. The screen should be cleared and the cursor should reset back to the upper left part of the screen. Depress this key anytime you want to reset the cursor. You will not be instructed when to reset the cursor.
- () Depress the XMIT PAGE key. The cursor should continue to move across the screen.



- () Depress several character keys. A character should appear on the screen where the cursor was, at the time the key was depressed.
- () Depress the BREAK key. The cursor should stop moving.
- () Hold the CTRL key down and depress the "G" key. You should hear a "beep" from the speaker each time the "G" key is depressed.
- () Hold the CTRL key down and depress the "H" key. The cursor should backspace each time the key is pressed.
- () Depress the HOME key. The cursor should move back to the upper left part of the screen without clearing the screen.
- () Hold the "L" key down and depress the REPT key to obtain a complete line of characters.
- () Next, hold the left key  down and depress the REPT key until the cursor is positioned near the middle of the line.
- () Depress the ERASE EOL key. The characters to the right of the cursor should be erased.
- () Push the ERASE PAGE key and then the PLOT key. A line of dashes should appear across the screen half way down.
- () Next, push the alphabet keys in order. The line should progress upward as the letter appears in four rows across the lower half of the screen.
- () Set all the keys to their up position. Then set the SCROLL key to its depressed position.
- () Use the cursor down key  and position the cursor at the lower left of the screen.
- () Depress the "J" key several times. A row of J's should appear on the screen.
- () Hold the CTRL key down and depress the "J" key several times. The display should move up one space each time you depress the "J" key.

- () Set the following keys to their depressed positions:

SCROLL
SHORT FORM
AUTO CARRY
BAUD RATE

- () Hold the REPT key and any character key down. The screen should fill up with four columns of characters. Hold a different character key down for each column. As the last character in the right column is printed, the display should shift left one column.
- () Set all of the keys to their up positions.

Refer to Pictorial 9-2 for the following steps.

- () Locate two female connectors and a 3" white wire.
- () Solder the connectors to the ends of the white wire. Use this jumper wire in the next step.
- () Connect the jumper wire between pins 1 and 4 of the SERIAL I/O socket on the rear panel.
- () Set the FULL DUPLEX key to its depressed position.
- () Push any character keys. That character should appear on the screen. Without the jumper wire, the letter will not appear on the screen.
- () Remove the jumper wire.
- () Set the AC POWER switch to OFF and disconnect the line cord.

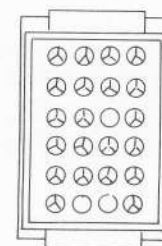
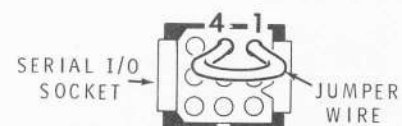

PICTORIAL 9-2



NOTE: If you obtained the correct results in the preceding checks, disregard the following "Voltage Measurements" and proceed to "Adjustments."

VOLTAGE MEASUREMENTS

Refer to Pictorial 8-11 (on Page 130) for the following steps.

	NEGATIVE LEAD TO:	POSITIVE LEAD TO:	SELECTOR — RANGE	METER INDICATION	POSSIBLE AREA OF TROUBLE
()	CHASSIS	P604-1	DC - 15V	-12V	See the following "Possible Cause Checks."
()	CHASSIS	P604-5	DC + 15V	+12V	
()	CHASSIS	P604-6	DC + 15V	+5V	

POSSIBLE CAUSE CHECKS

1. Remove socket S604 from the circuit board and make the same voltage measurements at the socket. If you do not have the correct voltage at the plug, the problem is in the harness.
2. If you do have the correct voltage at the chassis socket, carefully check for solder bridges on the bottom of the I/O circuit board especially around the IC sockets.
3. Check the transistors and IC's to make sure they are correctly positioned and into their correct location.
4. Check the diodes to make sure they are correctly positioned (banded end as shown on the circuit board).
5. Check the tantalum capacitor to make sure it is correctly positioned (plus mark as shown on the circuit board).

Correct any problems and then perform the "Visual Checks" on Page 134.

ADJUSTMENTS

Refer to Pictorial 10-1 (Illustration Booklet, Page 28) for the following steps.

- () Connect the line cord to an AC outlet and set the AC PWR switch to ON.
- () Depress the BAUD RATE and AUTO CARRY keys.
- () Hold the REPT key and any character key down until the screen is filled with characters.
- () Adjust the HEIGHT control (on the video circuit board) until the corners of the display are approximately $3/8$ " from the top and bottom of the screen.
- () Note the width of the display on the screen, especially the corners. If the display does not adequately fill the screen from side to side, remove the WIDTH jumper from its socket (on the video circuit board) and push it into the next socket clockwise. The socket that this wire is presently in is for the narrowest display.
- () Adjust the BRIGHTNESS control (on the video circuit board) to obtain a desirable brightness on the screen. Remember that a soft brightness is easier on your eyes for an extended period of time than a brilliant brightness.
- () Adjust the FOCUS control (on the video circuit board) to obtain the best focus. Look at the characters in the center of the screen as you make this adjustment. This control will probably be set at or near its full clockwise rotation (as viewed from the top).

BAUD RATE ADJUSTMENT

Refer to Pictorial 10-2 (Illustration Booklet, Page 28) for the following steps.

The baud rate is the rate at which the serial interface can handle data. The baud rate switch on the rear panel has a "300" and a "preset" position. When this switch is in the "preset" position, the baud rate is determined by the jumper wire setting on the I/O circuit board (600, 1200, 2400, 4800, and 9600).

If you do not know at this time what baud rate you want, do not make any change in this jumper wire. If you do want a different baud rate, move the jumper wire to the desired preset.

NOTE: If you preset the baud rate for 1200 or greater, you will have to move the green wire from lug 3 to lug 2 of switch SW2. See Pictorial 10-3.

This completes the adjustments. Proceed to "Final Assembly."

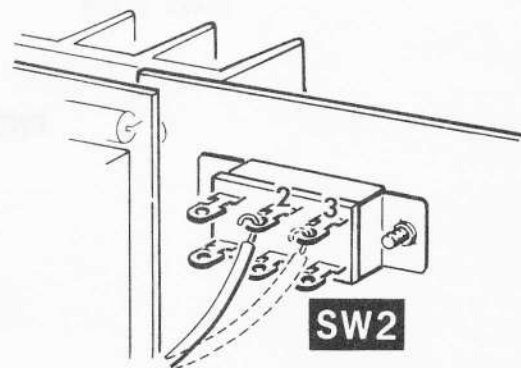

PICTORIAL 10-3

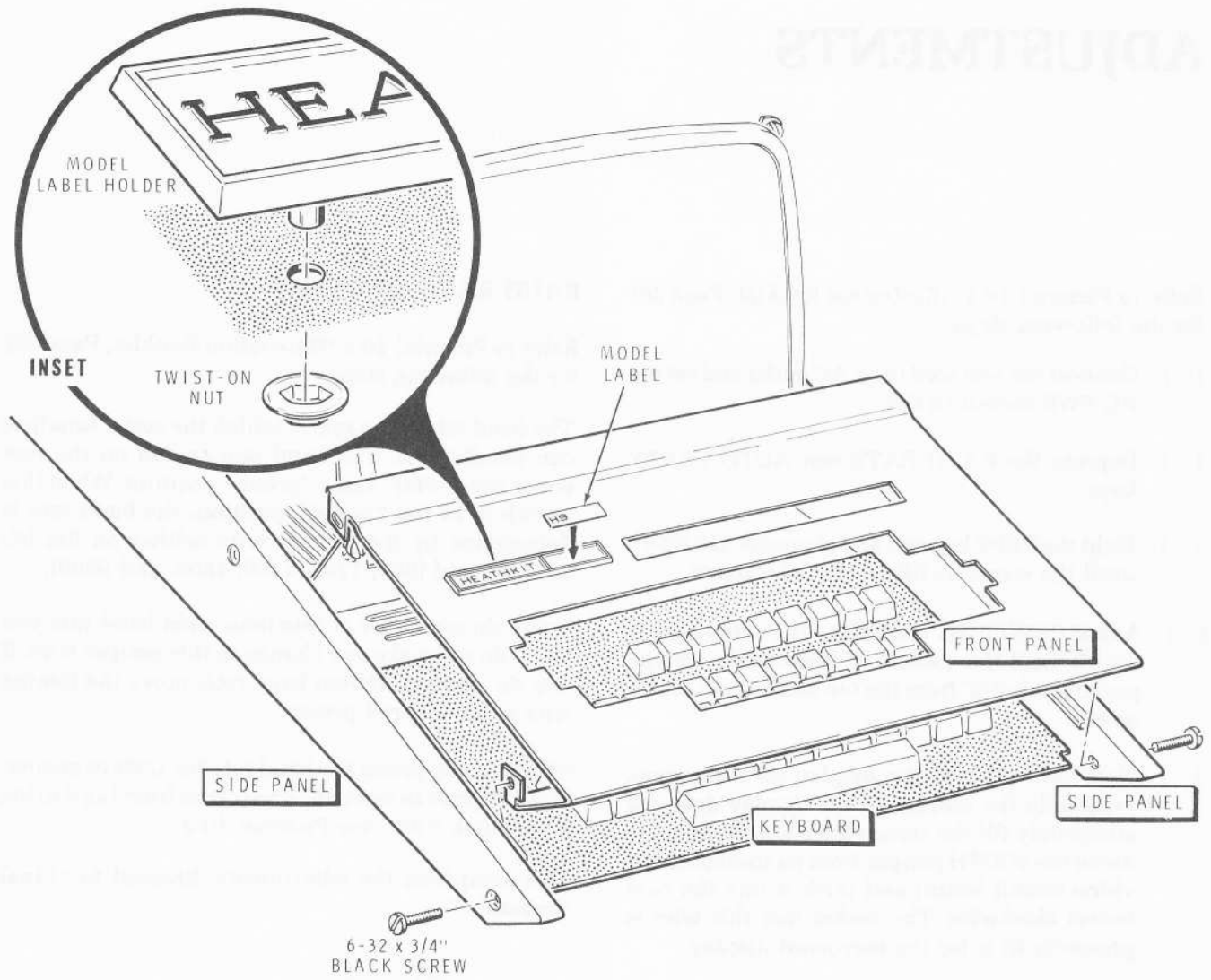

PICTORIAL 11-1



FINAL ASSEMBLY

Refer to Pictorial 11-1 for the following steps.

- () Locate the front panel and the model label holder.
 - () Refer to the inset drawing and insert the bosses on the model label holder through the front panel. Then install #6 round push-on nuts onto the bosses. Be sure to install the push-on nuts with their concave side toward the front panel.
 - () Locate the model label and remove the protective paper backing. Then press the label into place in the model label holder.
 - () Place the front panel over the keyboard so that it does not touch any of the keys. Then secure the front of the panel at each side with a 6-32 \times 3/4" black screw in the indicated holes in each side panel. Do not install any screws in the back tabs of the front panel.
- Check to see that the keys of the keyboard are centered in the two cutouts in the front panel. If they are not centered, the keyboard circuit board can be moved from side-to-side or front-to-back as follows:
1. () Side-to-side: Loosen the six nuts that hold the board to the two keyboard brackets. Reposition the keyboard sideways as needed and retighten the nuts.
 2. () Front-to-back: Loosen the four screws that hold the keyboard brackets to the side panels. Move the keyboard forward or backward as needed, and retighten the screws.

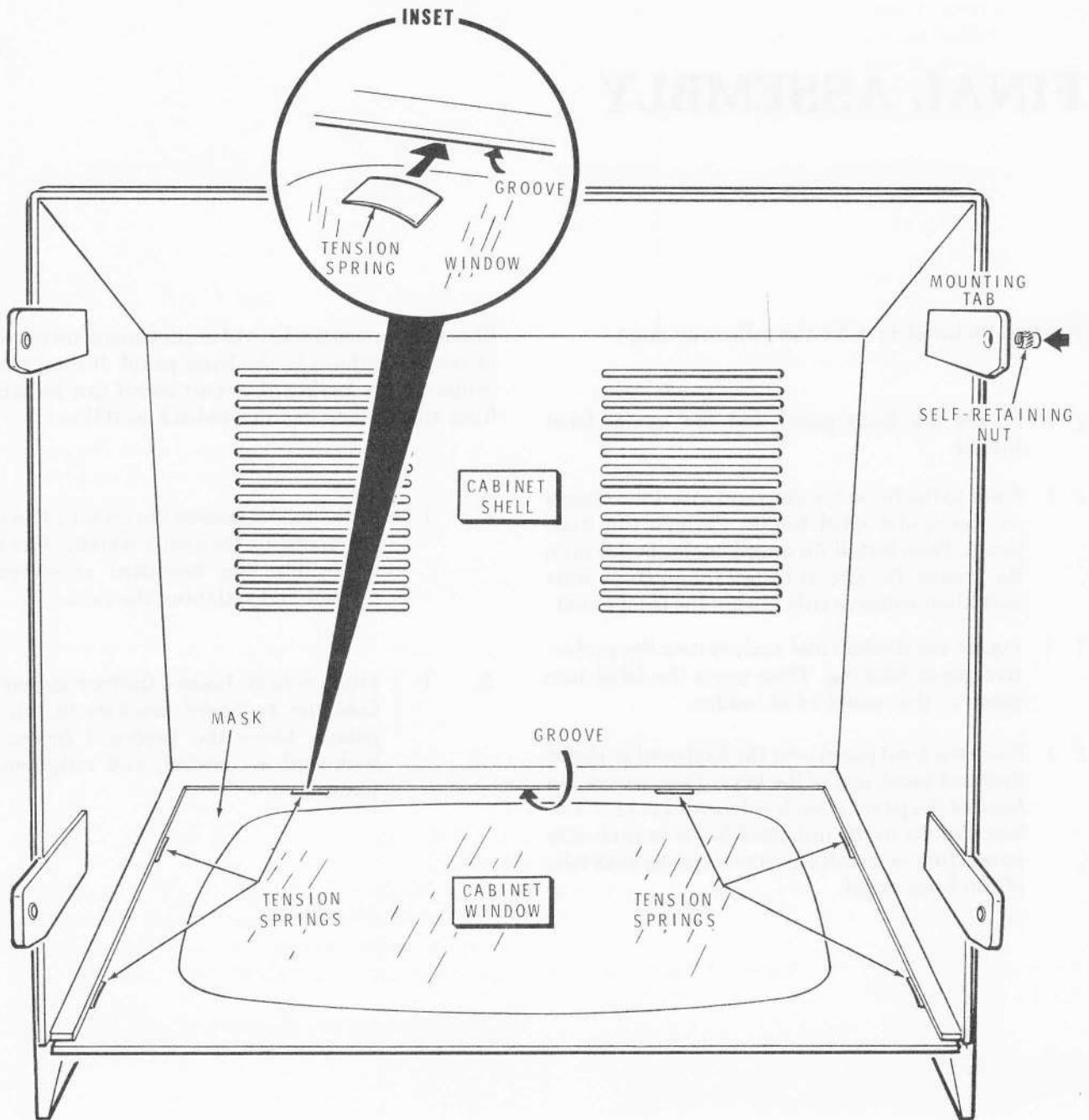

Detail 11-2A

Refer to Pictorial 11-2 (Illustration Booklet, Page 29) for the following steps.

- () Locate the blue and white identification label and remove the protective paper backing. Then press the label to the left front side of the chassis as shown. Refer to the numbers on this label in any correspondence you may have with the Heath Company concerning this kit.
- () Refer to Detail 11-2A and install self-retaining nuts in the holes in the four mounting tabs of the cabinet shell. Install the nuts from the outside and use a 6-32 \times 3/4" black screw to spread the nuts in their holes.
- () Locate the cabinet window and remove the protective sheet from both sides.
- () Refer to Detail 11-2A and install the window in the groove in the cabinet shell with the glossy side on the inside. Make sure the window is even with the bottom edges of the cabinet.
- () Refer to the inset drawing on Detail 11-2A and install six tension springs between the window and the cabinet on the inside of the window. Space these springs evenly.
- () Install the cabinet shell onto the chassis as follows: Position the cabinet over the CRT with the front of the cabinet tilted slightly downward. Position the window behind the front panel first, then lower the rear of the cabinet into place.
- () Secure the cabinet to the side panels with four 6-32 \times 3/4" black screws. Do not overtighten these screws.

Refer to Pictorial 11-3 (Illustration Booklet, Page 29) for the following steps.

- () Position the chassis up on its right side.

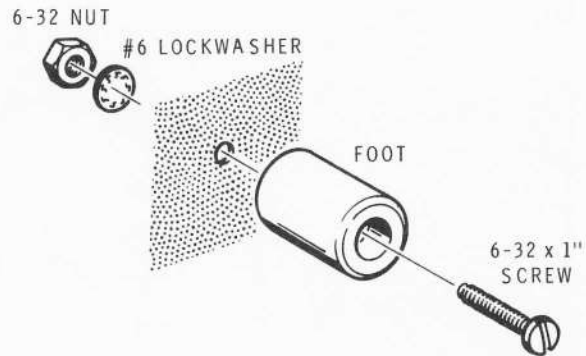

Detail 11-3A

- () Refer to Detail 11-3A and mount the feet to the painted side of the bottom plate as shown. Use four 6-32 \times 1" screws, four #6 lockwashers, and four 6-32 nuts. Do not overtighten this hardware.
- () Mount the bottom plate to the underside of the chassis with four 6-32 \times 3/8" black screws and two 6-32 \times 3/8" hex-head self-tapping screws. Be sure to position the slotted holes toward the rear panel. Insert the front of the bottom panel under the front panel.
- () Position the chassis topside up.

NOTE: You will have some connector shells and connectors left over at this time. These are to be used to construct a connecting cable so that you can use your H9 Video Terminal with other equipment.

This completes the assembly of your H9 Video Terminal. Proceed to the "Operation Manual."

FOR PARTS REQUESTS ONLY

- Be sure to follow instructions carefully.
- Use a separate letter for all correspondence.
- Please allow 10 - 14 days for mail delivery time.

DO NOT WRITE IN THIS SPACE

INSTRUCTIONS

- Please print all information requested.
- Be sure you list the correct **HEATH** part number exactly as it appears in the parts list.
- If you wish to prepay your order, mail this card and your payment in an envelope. Be sure to include 10% (25¢ minimum, \$3.50 maximum) for insurance, shipping and handling. Michigan residents add 4% tax.
Total enclosed \$_____
- If you prefer COD shipment, check the COD box and mail this form. COD

NAME _____
 ADDRESS _____
 CITY _____
 STATE _____ ZIP _____

The information requested in the next two lines is not required when purchasing nonwarranty replacement parts, but it can help us provide you with better products in the future.

Model # _____ Invoice # _____
 Date _____ Location _____
 Purchased _____ Purchased _____

LIST HEATH PART NUMBER	QTY.	PRICE EACH	TOTAL PRICE

TOTAL FOR PARTS	
HANDLING AND SHIPPING	
MICHIGAN RESIDENTS ADD 4% TAX	
TOTAL AMOUNT OF ORDER	

SEND TO: **HEATH COMPANY**
 BENTON HARBOR
 MICHIGAN 49022
ATTN: PARTS REPLACEMENT

Phone (Replacement parts only): 616 982-3571

THIS FORM IS FOR U.S. CUSTOMERS ONLY
 OVERSEAS CUSTOMERS SEE YOUR DISTRIBUTOR

FOR PARTS REQUESTS ONLY

- Be sure to follow instructions carefully.
- Use a separate letter for all correspondence.
- Please allow 10 - 14 days for mail delivery time.

DO NOT WRITE IN THIS SPACE

INSTRUCTIONS

- Please print all information requested.
- Be sure you list the correct **HEATH** part number exactly as it appears in the parts list.
- If you wish to prepay your order, mail this card and your payment in an envelope. Be sure to include 10% (25¢ minimum, \$3.50 maximum) for insurance, shipping and handling. Michigan residents add 4% tax.
Total enclosed \$_____
- If you prefer COD shipment, check the COD box and mail this form. COD

NAME _____
 ADDRESS _____
 CITY _____
 STATE _____ ZIP _____

The information requested in the next two lines is not required when purchasing nonwarranty replacement parts, but it can help us provide you with better products in the future.

Model # _____ Invoice # _____
 Date _____ Location _____
 Purchased _____ Purchased _____

LIST HEATH PART NUMBER	QTY.	PRICE EACH	TOTAL PRICE

TOTAL FOR PARTS	
HANDLING AND SHIPPING	
MICHIGAN RESIDENTS ADD 4% TAX	
TOTAL AMOUNT OF ORDER	

SEND TO: **HEATH COMPANY**
 BENTON HARBOR
 MICHIGAN 49022
ATTN: PARTS REPLACEMENT

Phone (Replacement parts only): 616 982-3571

THIS FORM IS FOR U.S. CUSTOMERS ONLY
 OVERSEAS CUSTOMERS SEE YOUR DISTRIBUTOR

CUT ALONG DOTTED LINE

CUSTOMER SERVICE

REPLACEMENT PARTS

Please provide complete information when you request replacements from either the factory or Heath Electronic Centers. Be certain to include the **HEATH** part number exactly as it appears in the parts list.

ORDERING FROM THE FACTORY

Print all of the information requested on the parts order form furnished with this product and mail it to Heath. For telephone orders (parts only) dial 616 982-3571. If you are unable to locate an order form, write us a letter or card including:

- Heath part number.
- Model number.
- Date of purchase.
- Location purchased or invoice number.
- Nature of the defect.
- Your payment or authorization for COD shipment of parts not covered by warranty.

Mail letters to: Heath Company
Benton Harbor
MI 49022
Attn: Parts Replacement

Retain original parts until you receive replacements. Parts that should be returned to the factory will be listed on your packing slip.

OBTAINING REPLACEMENTS FROM HEATH ELECTRONIC CENTERS

For your convenience, "over the counter" replacement parts are available from the Heath Electronic Centers listed in your catalog. Be sure to bring in the original part and purchase invoice when you request a warranty replacement from a Heath Electronic Center.

TECHNICAL CONSULTATION

Need help with your kit? — Self-Service? — Construction? — Operation? — Call or write for assistance. you'll find our Technical Consultants eager to help with just about any technical problem except "customizing" for unique applications.

The effectiveness of our consultation service depends on the information you furnish. Be sure to tell us:

- The Model number and Series number from the blue and white label.
- The date of purchase.
- An exact description of the difficulty.
- Everything you have done in attempting to correct the problem.

Also include switch positions, connections to other units, operating procedures, voltage readings, and any other information you think might be helpful.

Please do not send parts for testing, unless this is specifically requested by our Consultants.

Hints: Telephone traffic is lightest at midweek — please be sure your Manual and notes are on hand when you call.

Heathkit Electronic Center facilities are also available for telephone or "walk-in" personal assistance.

REPAIR SERVICE

Service facilities are available, if they are needed, to repair your completed kit. (Kits that have been modified, soldered with paste flux or acid core solder, cannot be accepted for repair.)

If it is convenient, personally deliver your kit to a Heathkit Electronic Center. For warranty parts replacement, supply a copy of the invoice or sales slip.

If you prefer to ship your kit to the factory, attach a letter containing the following information directly to the unit:

- Your name and address.
- Date of purchase and invoice number.
- Copies of all correspondence relevant to the service of the kit.
- A brief description of the difficulty.
- Authorization to return your kit COD for the service and shipping charges. (This will reduce the possibility of delay.)

Check the equipment to see that all screws and parts are secured. (Do not include any wooden cabinets or color television picture tubes, as these are easily damaged in shipment. Do not include the kit Manual.) Place the equipment in a strong carton with at least **THREE INCHES** of *resilient* packing material (shredded paper, excelsior, etc.) on all sides. Use additional packing material where there are protrusions (control sticks, large knobs, etc.). If the unit weighs over 15 lbs., place this carton in another one with 3/4" of packing material between the two.

Seal the carton with reinforced gummed tape, tie it with a strong cord, and mark it "Fragile" on at least two sides. Remember, the carrier will not accept liability for shipping damage if the unit is insufficiently packed. Ship by prepaid express, United Parcel Service, or insured Parcel Post to:

Heath Company
Service Department
Benton Harbor, Michigan 49022

HEATH

Schlumberger

HEATH COMPANY • BENTON HARBOR, MICHIGAN
THE WORLD'S FINEST ELECTRONIC EQUIPMENT IN KIT FORM

LITHO IN U.S.A.