

HEATHKIT[®] MANUAL

for the

PAPER TAPE READER/PUNCH

Model H10

ASSEMBLY

595-1970-01

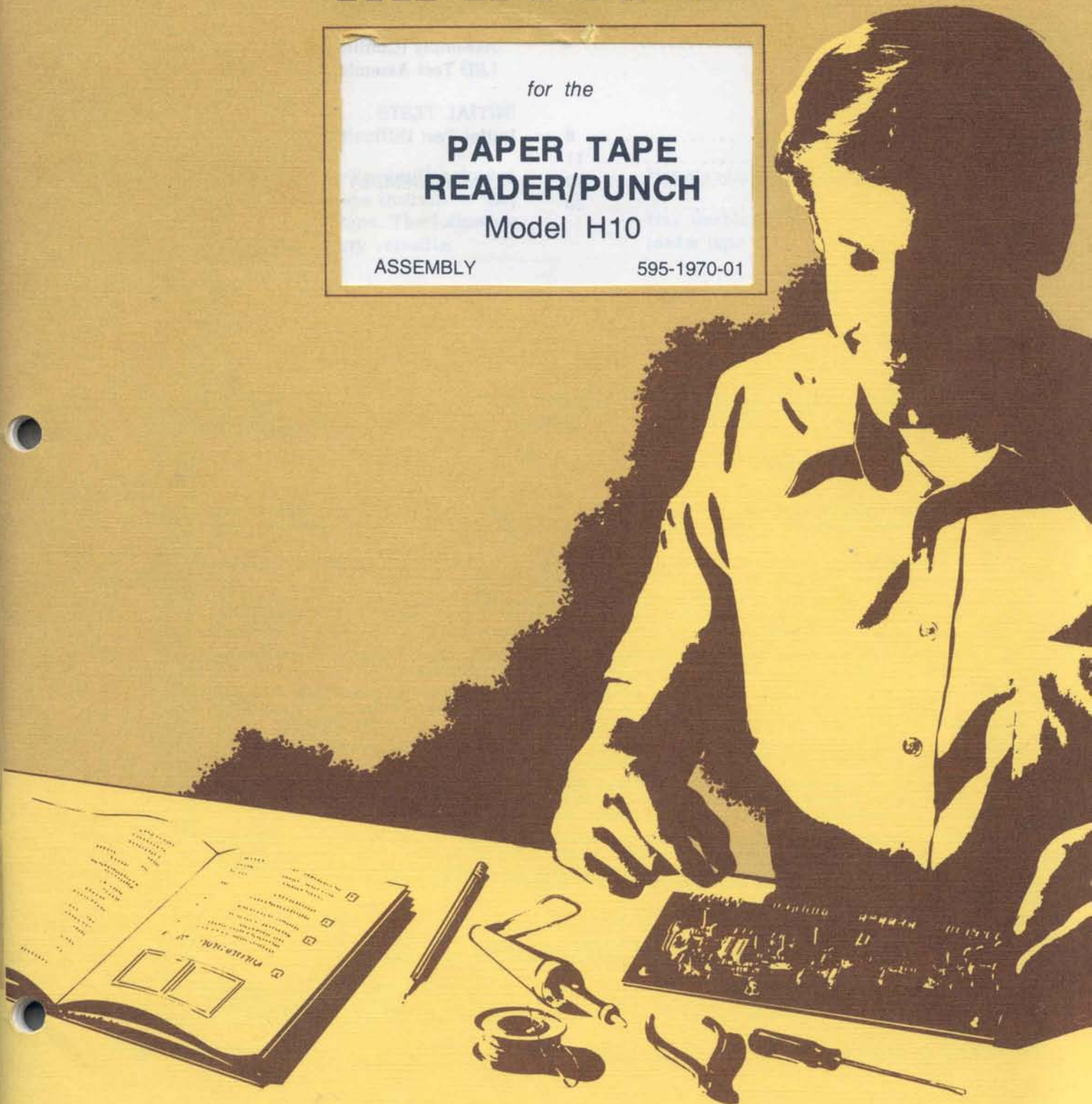

HEATH COMPANY • BENTON HARBOR, MICHIGAN

HEATH COMPANY PHONE DIRECTORY

The following telephone numbers are direct lines to the departments listed:

Kit orders and delivery information (616) 982-3411
Credit (616) 982-3561
Replacement Parts (616) 982-3571

Technical Assistance Phone Numbers

8:00 A.M. to 12 P.M. and 1:00 P.M. to 4:30 P.M., EST, Weekdays Only
R/C, Audio, and Electronic Organs (616) 982-3310
Amateur Radio (616) 982-3296
Test Equipment, Weather Instruments and
Home Clocks (616) 982-3315
Television (616) 982-3307
Aircraft, Marine, Security, Scanners, Automotive,
Appliances and General Products (616) 982-3496
Computers — Hardware (616) 982-3309
Computers — Software:
Operating Systems, Languages, Utilities (616) 982-3860
Application Programs (616) 982-3884
Heath Craft Wood Works (616) 982-3423



YOUR HEATHKIT 90-DAY LIMITED WARRANTY

Consumer Protection Plan for Heathkit Consumer Products

Welcome to the Heath family. We believe you will enjoy assembling your kit and will be pleased with its performance. Please read this Consumer Protection Plan carefully. It is a "LIMITED WARRANTY" as defined in the U.S. Consumer Product Warranty and Federal Trade Commission Improvement Act. This warranty gives you specific legal rights, and you may also have other rights which vary from state to state.

Heath's Responsibility

PARTS — Replacements for factory defective parts will be supplied free for 90 days from date of purchase. Replacement parts are warranted for the remaining portion of the original warranty period. You can obtain warranty parts direct from Heath Company by writing or telephoning us at (616) 982-3571. And we will pay shipping charges to get those parts to you . . . anywhere in the world.

SERVICE LABOR — For a period of 90 days from the date of purchase, any malfunction caused by defective parts or error in design will be corrected at no charge to you. You must deliver the unit at your expense to the Heath factory, any Heathkit Electronic Center (units of Veritechnology Electronics Corporation), or any of our authorized overseas distributors.

TECHNICAL CONSULTATION — You will receive free consultation on any problem you might encounter in the assembly or use of your Heathkit product. Just drop us a line or give us a call. Sorry, we cannot accept collect calls.

NOT COVERED — The correction of assembly errors, adjustments, calibration, and damage due to misuse, abuse, or negligence are not covered by the warranty. Use of corrosive solder and/or the unauthorized modification of the product or of any furnished component, will void this warranty in its entirety. This warranty does not include reimbursement for inconvenience, loss of use, customer assembly, set-up time, or unauthorized service.

This warranty covers only Heath products and is not extended to other equipment or components that a customer uses in conjunction with our products.

SUCH REPAIR AND REPLACEMENT SHALL BE THE SOLE REMEDY OF THE CUSTOMER AND THERE SHALL BE NO LIABILITY ON THE PART OF HEATH FOR ANY SPECIAL, INDIRECT, INCIDENTAL OR CONSEQUENTIAL DAMAGES, INCLUDING BUT NOT LIMITED TO ANY LOSS OF BUSINESS OR PROFITS, WHETHER OR NOT FORSEEABLE.

Some states do not allow the exclusion or limitation of incidental or consequential damages, so the above limitation or exclusion may not apply to you.

Owner's Responsibility

EFFECTIVE WARRANTY DATE — Warranty begins on the date of first consumer purchase. You must supply a copy of your proof of purchase when you request warranty service or parts.

ASSEMBLY — Before seeking warranty service, you should complete the assembly by carefully following the manual instructions. Heathkit service agencies cannot complete assembly and adjustments that are customer's responsibility.

ACCESSORY EQUIPMENT — Performance malfunctions involving other non-Heath accessory equipment, (antennas, audio components, computer peripherals and software, etc.) are not covered by this warranty and are the owner's responsibility.

SHIPPING UNITS — Follow the packing instructions published in the assembly manuals. Damage due to inadequate packing cannot be repaired under warranty.

If you are not satisfied with our service (warranty or otherwise) or our products, write directly to our Director of Customer Service, Heath Company, Benton Harbor MI 49022. He will make certain your problems receive immediate, personal attention.

Heathkit® Manual

for the

PAPER TAPE READER/PUNCH

Model H10

ASSEMBLY

595-1970-01

WARNING: TO PREVENT FIRE OR SHOCK
HAZARD, DO NOT EXPOSE THIS INSTRUMENT TO RAIN
OR MOISTURE.

HEATH COMPANY
BENTON HARBOR, MICHIGAN 49022

Copyright © 1977
Heath Company
All Rights Reserved
Printed in the United States of America



TABLE OF CONTENTS

INTRODUCTION	3	CHASSIS	
UNPACKING INSTRUCTIONS	4	Parts List	26
ASSEMBLY NOTES	5	Step-by-Step Assembly	29
		Resistance Tests	39
		Assembly (Continued)	40
		LED Test Assembly	64
CIRCUIT BOARDS		INITIAL TESTS	65
Parts List	8	Initial Test Difficulties	74
Step-by-Step Assembly	11	FINAL ASSEMBLY	75
Main Circuit Board	11		
Reader Circuit Board	23		



INTRODUCTION

The Heath Model H10 Paper Tape Reader/Punch is an accurate, versatile, and easy-to-use instrument that both reads and punches paper tape. The following features make this instrument very versatile:

- High speed reading (50 characters per second).
- Tapes are easily copied.
- Uses standard 1" paper tape (roll or fan-fold).
- Reader and punch may be operated simultaneously and yet controlled independently.
- Has standard TTL parallel interface.
- Has pushbutton feed switch to generate leader tape.
- Uses photo-electric tape reader for long life and trouble-free operation.
- The reader tape transport is driven by a stepper motor for dependable operation.

The modern, digital design assures excellent accuracy and reliability. The handsome styling complements the Heath Computer Series.

UNPACKING INSTRUCTIONS

DO NOT UNPACK ANY PARTS UNTIL YOU ARE INSTRUCTED TO DO SO.

The packaging consists of the main carton which contains a package marked Pack #1 and some other parts. These other parts will be considered the Final Pack, even though they may not be marked "Final Pack."

Return any part, or group of parts, that is packaged in a bag or envelope with a part number on it to its container after you identify it. Leave it there until you actually use it in a step. This will prevent intermixing of parts and help you identify parts.



ASSEMBLY NOTES

TOOLS

You will need these tools to assemble your kit.

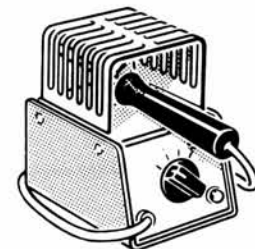
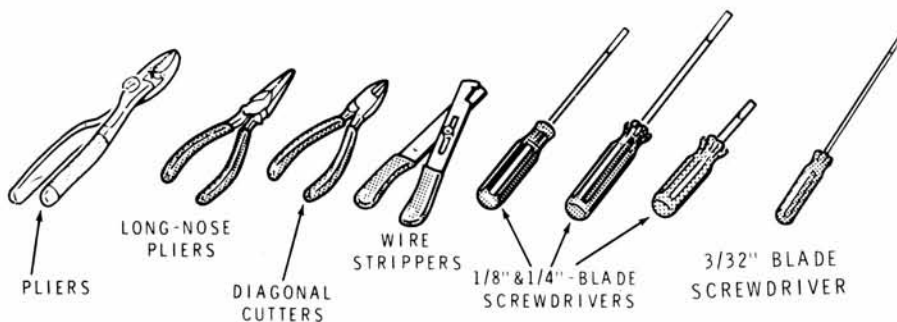

HEATHKIT
SOLDERING
IRON

OR

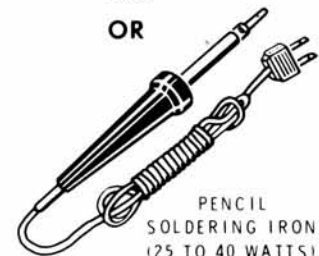

PENCIL
SOLDERING IRON
(25 TO 40 WATTS)

OTHER HELPFUL TOOLS

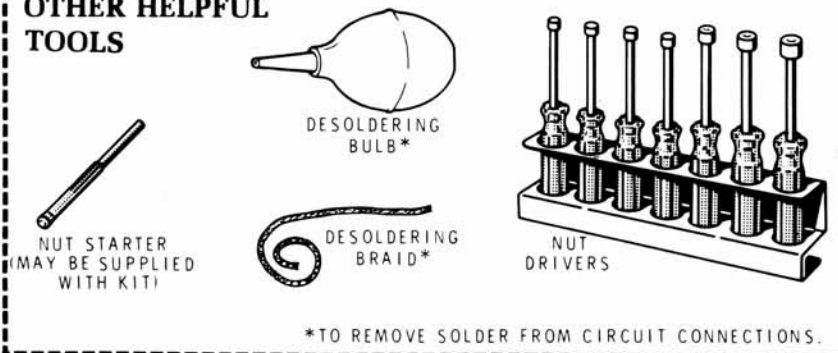

*TO REMOVE SOLDER FROM CIRCUIT CONNECTIONS.

ASSEMBLY

- Follow the instructions carefully and read the entire step before you perform the operation.
- The illustrations in the Manual are called Pictorials and Details. Pictorials show the overall operation for a group of assembly steps; Details generally illustrate a single step. When you are directed to refer to a certain Pictorial "for the following steps," continue using that Pictorial until you are referred to another Pictorial for another group of steps.
- Most kits use a separate "Illustration Booklet" that contains illustrations (Pictorials, Details, etc.) that are too large for the Assembly Manual. Keep the "Illustration Booklet" with the Assembly Manual. The illustrations in it are arranged in Pictorial number sequence.
- Position all parts as shown in the Pictorials.
- Solder a part or a group of parts only when you are instructed to do so.

6. Each circuit part in an electronic kit has its own component number (R2, C4, etc.). Use these numbers when you want to identify the same part in the various sections of the Manual. These numbers, which are especially useful if a part has to be replaced, appear:

- In the Parts List,
- At the beginning of each step where a component is installed,
- In some illustrations,
- In the Schematic,
- In the section at the rear of the Manual.

7. When you are instructed to cut something to a particular length, use the scales (rulers) provided at the bottom of the Manual pages.

SAFETY WARNING: Avoid eye injury when you cut off excess lead lengths. Hold the leads so they cannot fly toward your eyes.

SOLDERING

Soldering is one of the most important operations you will perform while assembling your kit. A good solder connection will form an electrical connection between two parts, such as a component lead and a circuit board foil. A bad solder connection could prevent an otherwise well-assembled kit from operating properly.

It is easy to make a good solder connection if you follow a few simple rules:

1. Use the right type of soldering iron. A 25 to 40-watt pencil soldering iron with a 1/8" or 3/16" chisel or pyramid tip works best.
2. Keep the soldering iron tip clean. Wipe it often on a wet sponge or cloth; then apply solder to the tip to give the entire tip a wet look. This process is called tinning, and it will protect the tip and enable you to make good connections. When solder tends to "ball" or does not stick to the tip, the tip needs to be cleaned and retinned.



PARTS

Resistors will be called out by their resistance value in Ω (ohms), $k\Omega$ (kilohms), or $M\Omega$ (megohms). Certain types of resistors will have the value printed on the body, while others will be identified by a color code. The colors of the bands and the value will be given in the steps, therefore the following color code is given for information only.

EXAMPLES:

BROWN 1
GREEN 5
ORANGE 1,000
SILVER $\pm 10\%$

$15 \times 1,000 = 15,000 \Omega$ (15,000 OHMS),
or "15 $k\Omega$ "

ORANGE 3
BLACK 0
GREEN 100,000
GOLD $\pm 5\%$

$30 \times 100,000 = 3,000,000 \Omega$ (or 3 $M\Omega$)
3 $M\Omega = 3$ MEGOHMS

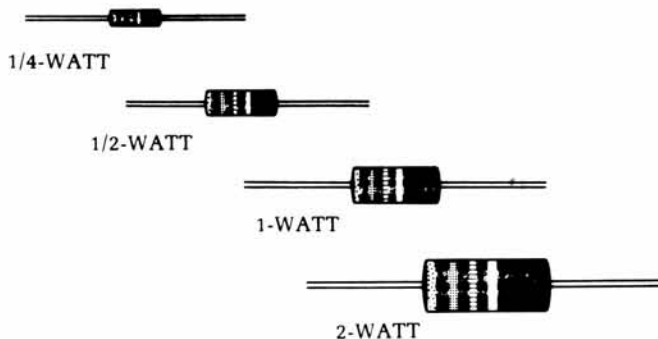

RESISTOR COLOR CODE

TOLERANCE
Gold 5%
Silver 10%
No Band 20%

COLOR	1st DIGIT	2nd DIGIT	MULTIPLY BY
BLACK	0	0	1
BROWN	1	1	10
RED	2	2	100
ORANGE	3	3	1,000
YELLOW	4	4	10,000
GREEN	5	5	100,000
BLUE	6	6	1,000,000
VIOLET	7	7	10,000,000
GRAY	8	8	100,000,000
WHITE	9	9	1,000,000,000
GOLD			.1
SILVER			.01

Capacitors will be called out by their capacitance value in μF (microfarads) or pF (picofarads) and type: ceramic, Mylar*, electrolytic, etc. Some capacitors may have their value printed in the following manner:

First digit of capacitor's value: 1

Second digit of capacitor's value: 5

Multiplier: Multiply the first & second digits by the proper value from the Multiplier Chart.

To find the tolerance of the capacitor, look up this letter in the Tolerance columns.

EXAMPLES:

$151K = 15 \times 10 = 150 pF$
 $759 = 75 \times 0.1 = 7.5 pF$

NOTE: The letter "R" may be used at times to signify a decimal point; as in: $2R2 = 2.2$ (pF or μF).

MULTIPLIER		TOLERANCE OF CAPACITOR		
FOR THE NUMBER:	MULTIPLY BY:	10pF OR LESS	LETTER	OVER 10pF
0	1	$\pm 0.1 pF$	B	
1	10	$\pm 0.25 pF$	C	
2	100	$\pm 0.5 pF$	D	
3	1000	$\pm 1.0 pF$	F	$\pm 1\%$
4	10,000	$\pm 2.0 pF$	G	$\pm 2\%$
5	100,000		H	$\pm 3\%$
			J	$\pm 5\%$
8	0.01		K	$\pm 10\%$
9	0.1		M	$\pm 20\%$

*DuPont Registered Trademark

CIRCUIT BOARDS

PARTS LIST

Unpack Pack #1 and check the parts against the following list. The key numbers correspond to the numbers on the Parts Pictorial on Page 1 of the Illustration Booklet.

To order a replacement part, use the Parts Order Form furnished with this kit. If a Parts Order Form is not available, refer to "Replacement Parts" inside the rear cover of the Manual. Your Warranty is located inside the front cover. For prices, refer to the separate "Heath Parts Price List."

KEY No.	HEATH Part No.	QTY.	DESCRIPTION	CIRCUIT Comp. No.
---------	----------------	------	-------------	-------------------

RESISTORS

NOTE: The resistors may be packed in more than one envelope. Open all the resistor envelopes in this pack before you check the resistors against the Parts List.

1/2-Watt, 10% (silver fourth band)

A1	1-66	2	150 Ω (brown-green-brown)	R43, R44
A1	1-6	12	470 Ω (yellow-violet-brown)	R9, R11, R15, R19, R24, R28, R33, R37, R42, R78, R85, R86
A1	1-9	21	1000 Ω (brown-black-red)	R48, R49, R51, R52, R53, R54, R55, R56, R66, R67, R68, R69, R71, R72, R73, R74, R81, R83, R84, R90, R94

KEY No.	HEATH Part No.	QTY.	DESCRIPTION	CIRCUIT Comp. No.
---------	----------------	------	-------------	-------------------

Resistors (cont'd.)

A1	1-10	14	1200 Ω (brown-red-red)	R57, R58, R59, R61, R62, R63, R64, R65, R79, R82, R89, R91, R92, R93
A1	1-46	8	3900 Ω (orange-white-red)	R14, R18, R23, R27, R32, R36, R41, R47
A1	1-19	8	6800 Ω (blue-gray-red)	R12, R16, R21, R25, R29, R34, R38, R45
A1	1-22	1	22 k Ω (red-red-orange)	R80
A1	1-34	8	680 k Ω (blue-gray-yellow)	R13, R17, R22, R26, R31, R35, R39, R46

1/4-Watt, 1%

A2	2-662-12	2	7500 Ω	R76, R77
A2	2-723-12	1	12.4 k Ω	R75
A2	2-43-12	1	50 k Ω	R88



KEY No.	HEATH Part No.	QTY.	DESCRIPTION	CIRCUIT Comp. No.
---------	----------------	------	-------------	-------------------

CONTROL

A3	10-390	8	20kΩ	R1, R2, R3, R4, R5, R6, R7, R8
----	--------	---	------	---

CAPACITORS

B1	21-95	6	.1 μF ceramic	C1, C7, C8, C12, C14, C15 C16
B2	27-2	1	1 μF Mylar	C9, C11, C13
B3	25-841	3	4.7 μF (yellow-violet-green) tantalum	C17
B4	25-804	1	100 μF electrolytic	

DIODES

C1	56-6	1	1N710 (6.8V) zener	D1
C1	56-56	4	1N4149	D21, D22, D23, D24
C1	56-605	3	1N4746A	D9, D10, D11
C1	57-42	2	3A1	D2, D7
C1	57-65	14	1N4002	D3, D4, D5, D6, D12, D13, D14, D15, D16, D17, D18, D19, D20, D25

TRANSISTORS — INTEGRATED CIRCUITS (IC's)

NOTE: Transistors and IC's are marked for identification in one of the following four ways:

1. Part number.
2. Type number (IC's may have additional letters or numbers).
3. Part number and type number.
4. Part number with a type number other than the one listed.

Transistors

D1	417-94	10	2N3416	Q3, Q5, Q7, Q9, Q11, Q13, Q15, Q17, Q19, Q21 Q23, Q24, Q25, Q26 Q1
D2	417-864	4	MPSA05	Q101, Q102, Q103, Q104, Q105, Q106, Q107, Q108
D2	417-801	1	MPSA20	
D3	417-859	8	MRD14B	

KEY No.	HEATH Part No.	QTY.	DESCRIPTION	CIRCUIT Comp. No.
---------	----------------	------	-------------	-------------------

Transistors — Integrated Circuits (cont'd.)

D4	417-818	11	MJE181	Q2, Q4, Q6, Q8, Q10, Q12, Q14, Q16, Q18, Q20, Q22
----	---------	----	--------	---

IMPORTANT:

If any components are missing from the sealed IC package, return the unopened package for replacement. Claims for missing IC's will not be honored.

If you locate damaged or defective IC's, order individual replacements. Be sure to follow the standard instructions on the "Parts Order Form" and on the inside rear cover of the manual. Save defective or damaged components for return instructions.

Integrated Circuits

E1	442-54	1	UA7805	IC17
E2	442-616	2	LM3302N, LM2901, or μA775 (selected)	IC1, IC2
E2	443-1	1	SN7400N	IC13
E2	443-4	1	SN7472N	IC15
E2	443-6	2	SN7474N	IC8, IC16
E2	443-22	3	SN74121N	IC9, IC11, IC12
E2	443-45	1	SN7408N	IC10
E2	443-72	3	SN7417N	IC3, IC4, IC7
E2	443-89	2	SN7409N	IC5, IC6
E2	443-806	1	9600	IC14

HARDWARE**#3 Hardware**

F1	250-172	3	3-48 × 3/8" screw
F2	252-1	3	3-48 nut
F3	254-7	3	#3 lockwasher

#4 & #5 Hardware

G1	250-1124	1	4-40 × 1/4" black screw
G2	252-15	1	4-40 nut
G3	254-9	1	#4 lockwasher
G4	253-43	2	#5 fiber washer

#6 Hardware

H1	250-56	2	6-32 × 1/4" screw
H2	252-3	2	6-32 nut
H3	254-1	2	#6 lockwasher



KEY No.	HEATH Part No.	QTY.	DESCRIPTION	CIRCUIT Comp. No.
---------	----------------	------	-------------	-------------------

MISCELLANEOUS

J1	64-841	1	Pushbutton switch	SW4
J2	75-139	1	Transistor insulator	
J3	204-2249	1	Heat sink	
J4	214-205	1	Transistor housing	
J5	352-13	1	Silicone grease	
J6	354-6	1	Cable tie	
J7	434-298	16	IC socket	
J8	490-5	1	Nut starter	
J9	432-134	1	Wire connector	
J10	85-1927-1	1	Reader circuit board	

PARTS FROM FINAL PACK

	85-1926-1	1	Main circuit board	
K1	134-1010	1	Wire harness with connector	
	489-1	1	Sandpaper	
			Solder	

Wire

344-2	48"	Black stranded
344-50	48"	Black solid
344-51	30"	Brown
344-52	72"	Red
344-53	72"	Orange

KEY No.	HEATH Part No.	QTY.	DESCRIPTION	CIRCUIT Comp. No.
---------	----------------	------	-------------	-------------------

Wire (Continued)

344-54	37"	Yellow
344-55	36"	Green
344-56	24"	Blue
344-57	16"	Violet
344-58	18"	Gray
344-59	13"	White
344-70	18"	White-black
344-71	9"	White-brown
344-72	9"	White-red
344-73	9"	White-orange
344-74	9"	White-yellow
344-75	10"	White-green
344-76	10"	White-blue
344-77	13"	White-violet
344-78	13"	White-gray

Printed Material

NOTE: Be sure you refer to the number on the blue and white label in any communications you may have with the Heath Company about this kit.

391-34	1	Blue and white label
597-260	1	Parts Order Form
	1	Manual (See Page 1 for part number).



STEP-BY-STEP ASSEMBLY

MAIN CIRCUIT BOARD

START

In the following steps, you will be given detailed instructions on how to install and solder the first part on the circuit board. Read and perform each step carefully. Then use the same procedure whenever you install parts on a circuit board.

- () Position the main circuit board as shown with the printed side up.

- () R44: Hold a 150 Ω (brown-green-brown) resistor by the body as shown. Then bend the leads down.



- () Push the leads through the holes at the indicated location on the circuit board. The end with color bands may be positioned either way.

- () Press the resistor against the circuit board. Then bend the leads outward slightly to hold the resistor in place.

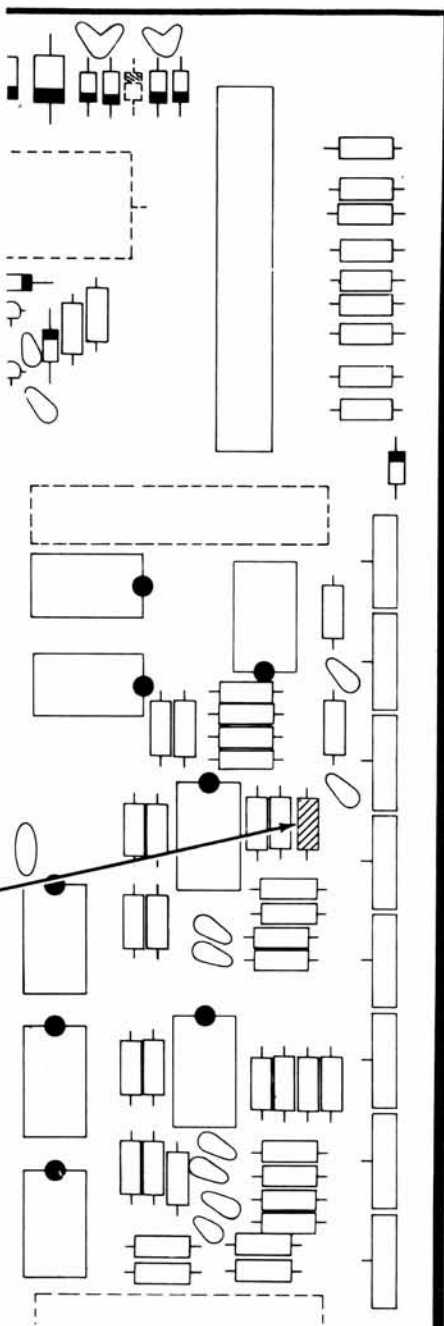

PICTORIAL 1-1

CONTINUE

- () Solder the resistor leads to the circuit board as follows:

1. Push the soldering iron tip against both the lead and the circuit board foil. Heat **both** for two or three seconds.

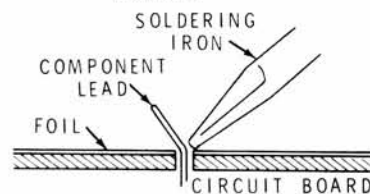

2. Then apply solder to the other side of the connection. **IMPORTANT:** Let the heated lead and the circuit board foil melt the solder.

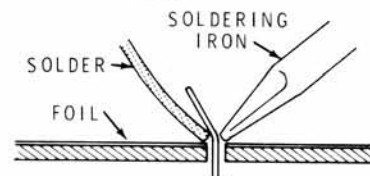

3. As the solder begins to melt, allow it to flow around the connection. Then remove the solder and the iron and let the connection cool.

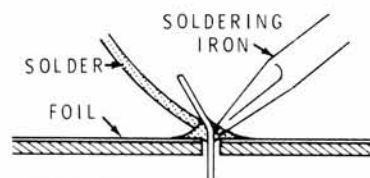

- () Cut off the excess lead lengths close to the connection. **WARNING:** Clip the leads so the ends will not fly toward your eyes.

- () Check the connection. Compare it to the illustrations on Page 12. After you have checked the solder connections, proceed with the assembly on Page 13. Use the same soldering procedure for each connection.

A GOOD SOLDER CONNECTION

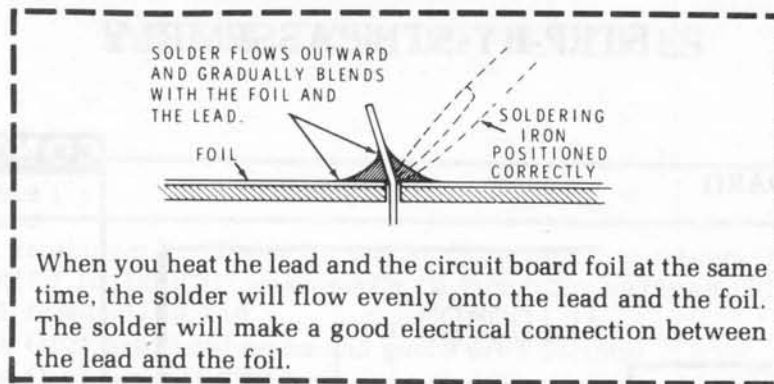

POOR SOLDER CONNECTIONS

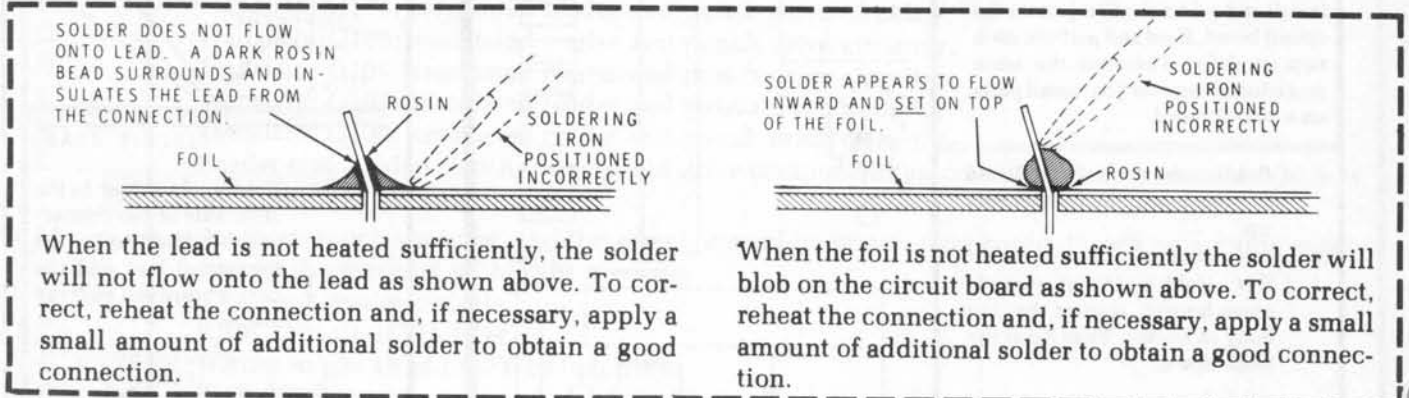

SOLDER BRIDGES

A solder bridge between two adjacent foils is shown in photograph A. Photograph B shows how the connection should appear. A solder bridge may occur if you accidentally touch an adjacent previously soldered connection, if you use too much solder, or if you "drag" the soldering iron across other foils as you remove it from the connection. A good rule to follow is; always take a good look at the foil area around each lead before you solder it. Then, when you solder the connection, make sure the solder remains in this area and does not bridge to another foil. This is especially important when the foils are small and close together. NOTE: It is alright for solder to bridge two connections on the same foil.

Use only enough solder to make a good connection, and lift the soldering iron straight up from the circuit board. If a solder bridge should develop, turn the circuit board foil-side-down and heat the solder between connections. The excess solder will run onto the tip of the soldering iron, and this will remove the solder bridge. NOTE: The foil side of each circuit board has a coating on it called "solder resist." This is a protective insulation to help prevent solder bridges.

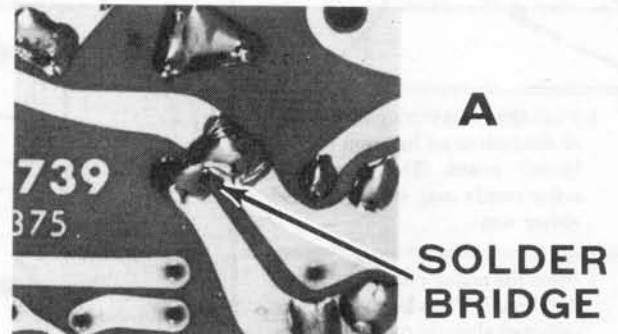

START ↘

Install fourteen 1200 Ω (brown-red-red) resistors.

- () R59
- () R63
- () R62
- () R65
- () R61
- () R64
- () R58
- () R57
- () R79
- () R92
- () R93
- () R89
- () R91
- () R82

() Solder the leads to the foil and cut off the excess lead lengths.

CONTINUE ↘

Install eleven 470 Ω (yellow-violet-brown) resistors.

- () R11.
- () R15.
- () R24.
- () R19.
- () R85.
- () R86.
- () R33.
- () R28.
- () R42.
- () R37.
- () R78.

() Solder the leads to the foil and cut off the excess lead lengths.

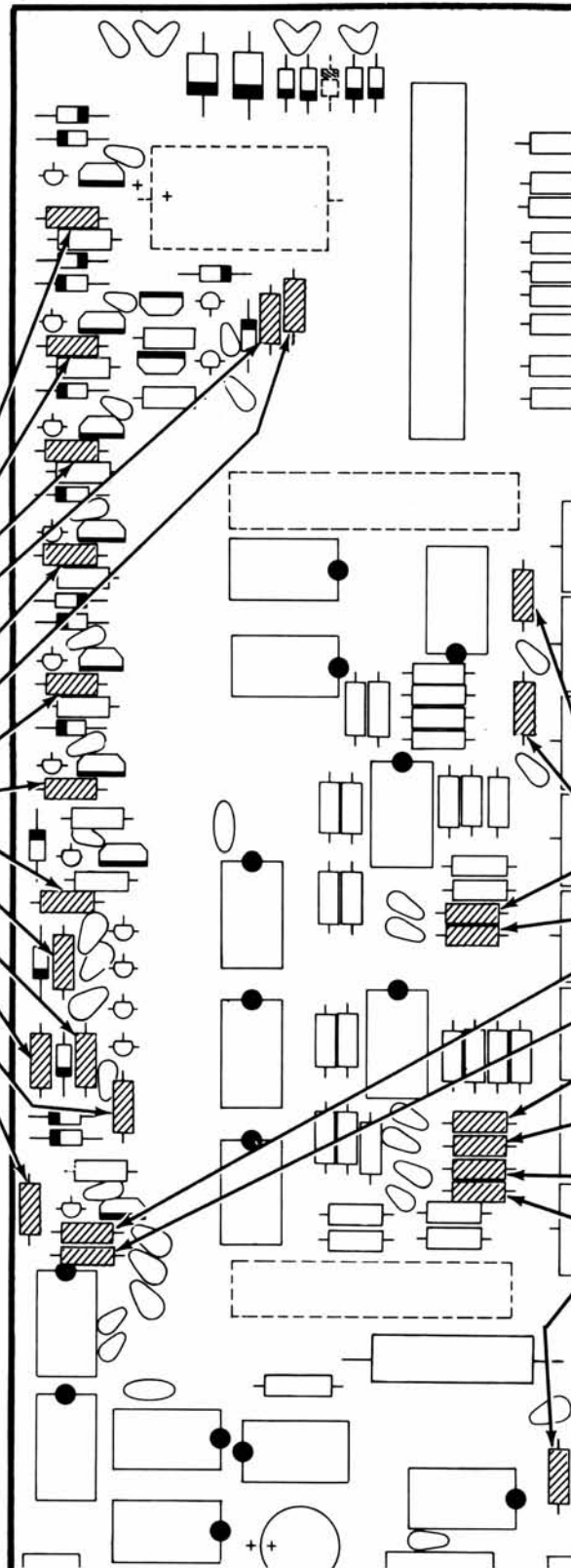

PICTORIAL 1-2

START ▾

Install twenty-one 1000 Ω (brown-black-red) resistors.

- () R68
- () R72
- () R73
- () R71
- () R74
- () R69
- () R67
- () R66
- () R81
- () R90
- () R84
- () R83

() Solder the leads to the foil and cut off the excess lead lengths.

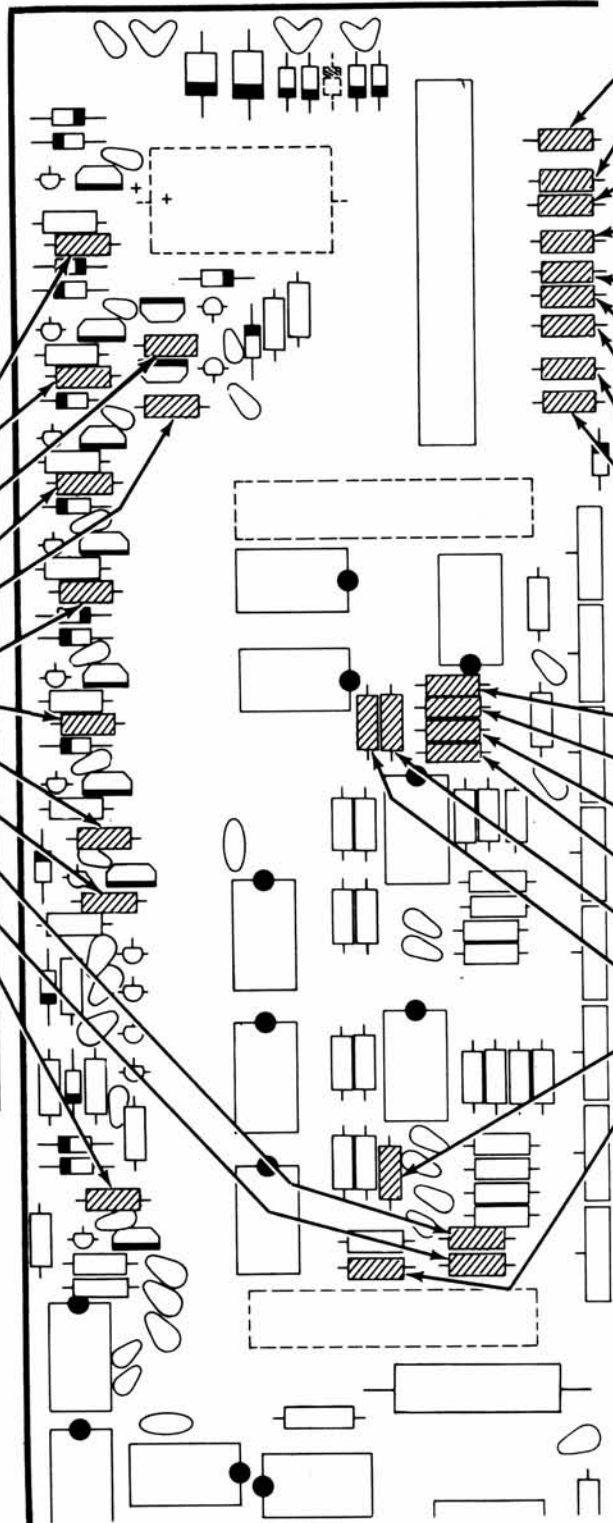

CONTINUE ▾

- () R48.
- () R94.
- () R49.
- () R55.
- () R52.
- () R56.
- () R53.
- () R51.
- () R54.

() Solder the leads to the foil and cut off the excess lead lengths.

Install eight 3900 Ω (orange-white-red) resistors.

- () R23.
- () R27.
- () R18.
- () R14.
- () R36.
- () R32.
- () R47.
- () R41.

() Solder the leads to the foil and cut off the excess lead lengths.

PICTORIAL 1-3

START ↘

- Install eight 680 kΩ (blue-gray-yellow) resistors.
- () R13
 - () R17
 - () R22
 - () R26
 - () R35
 - () R31
 - () R39
 - () R46
-
- () Solder the leads to the foil and cut off the excess lead lengths.
- () R43: 150 Ω (brown-green-brown).
 - () R88: 50 kΩ, 1/4-watt, 1%.
 - () R76: 7500 Ω, 1/4-watt, 1%.
 - () R77: 7500 Ω, 1/4-watt, 1%.
 - () R75: 12.4 kΩ, 1/4-watt, 1%.
 - () R80: 22 kΩ (red-red-orange).
 - () R9: 470 Ω (yellow-violet-brown).
- () Solder the leads to the foil and cut off the excess lead lengths.

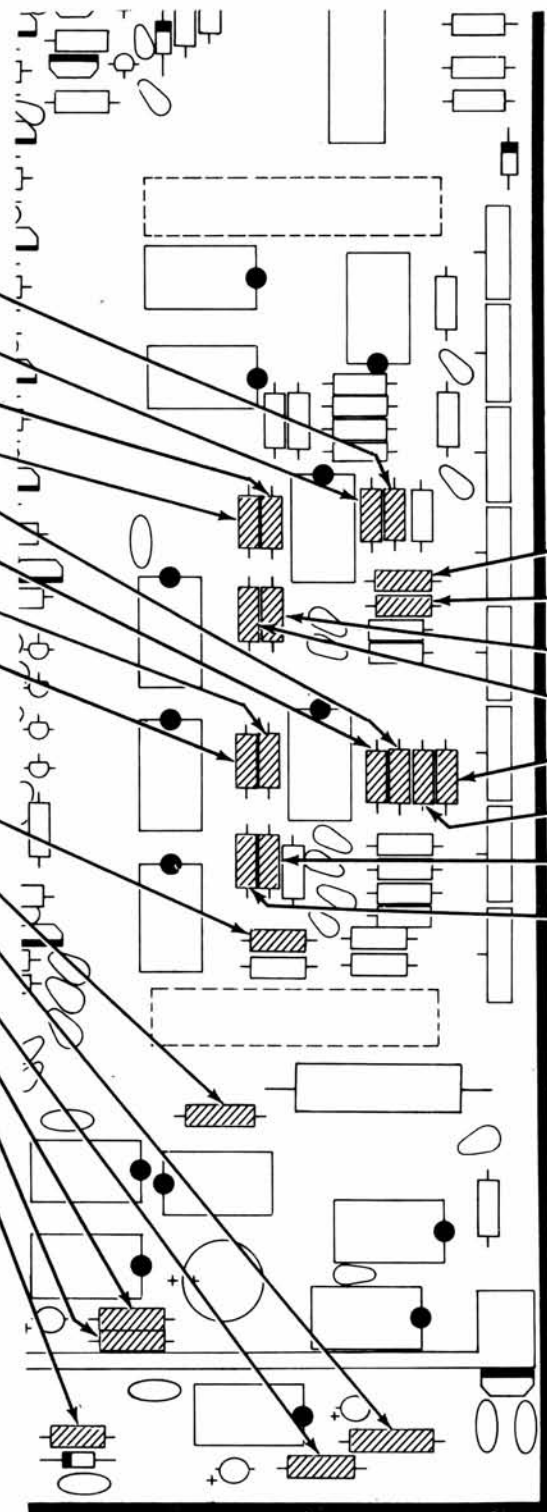

CONTINUE ↘

- Install eight 6800 Ω (blue-gray-red) resistors.
- () R16.
 - () R12.
 - () R21.
 - () R25.
 - () R29.
 - () R34.
 - () R38.
 - () R45.
-
- () Solder the leads to the foil and cut off the excess lead lengths.

PICTORIAL 1-4

START →

NOTE: When you install a diode, always match the band on the diode with the band mark on the circuit board. A DIODE WILL NOT WORK IF IT IS INSTALLED BACKWARDS. See Detail 1-5A at the bottom of the right hand column.

If your diode has a solid body, the band is clearly defined. If your diode has a glass body, do not mistake the colored end inside the diode for the banded end. Look for a band painted on the outside of the glass.

() D7: 3A1 diode (#57-42).

() D2: 3A1 diode (#57-42).

Install three 1N4746A diodes (#56-605).

() D10

() D11

() D9

Install four 1N4149 diodes (#56-56).

() D23

() D24

NOTE: Be sure the indicated leads of the next two diodes do not touch the nearby foil on top of the circuit board.

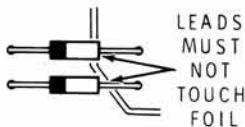

() D21

() D22

() Solder the leads to the foil and cut off the excess lead lengths.

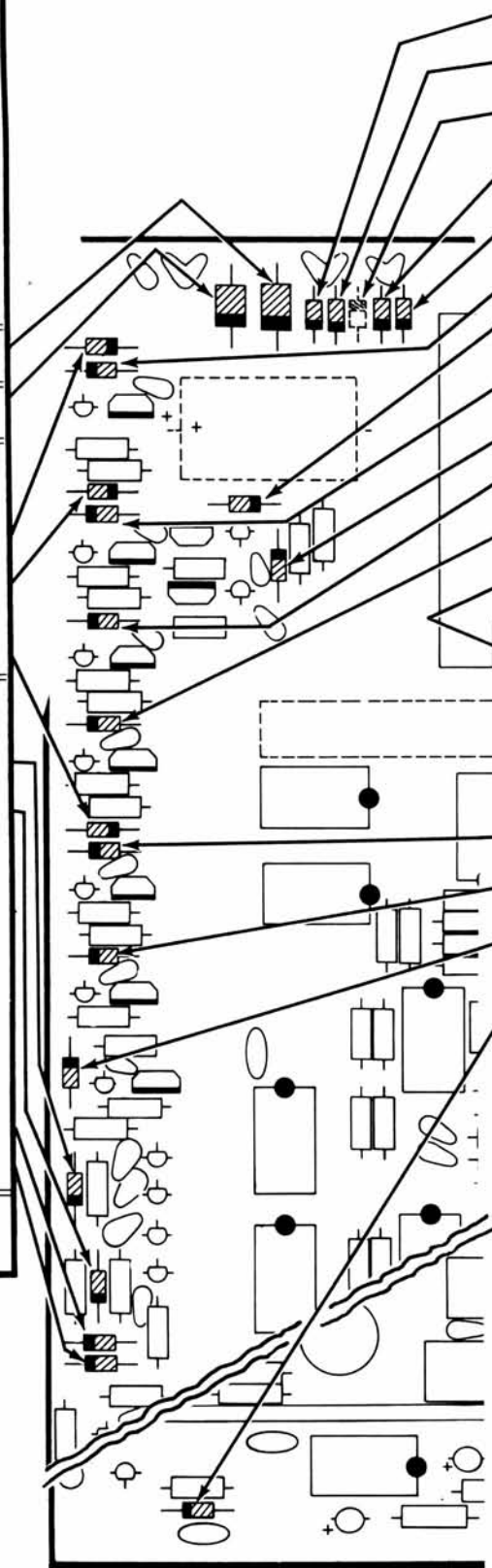

CONTINUE ⇐

Install fourteen 1N4002 diodes (#57-65).

() D3.

() D6.

D8: Do not install a diode here.

() D4.

() D5.

() D14.

() D18.

() D17.

() D19.

() D16.

() D15.

() D25.

() D13.

() D12.

() D20.

() D1: 1N710 zener diode (#56-6).

() Solder the leads to the foil and cut off the excess lead lengths.

IMPORTANT: THE BANDED END OF DIODES CAN BE MARKED IN A NUMBER OF WAYS.

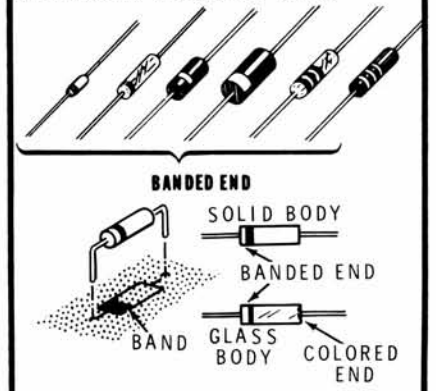

PICTORIAL 1-5

Detail 1-5A

START

- () Install sixteen IC sockets. As you install each socket, be sure the leads are straight, insert the leads into the holes, and solder the leads to the foil.

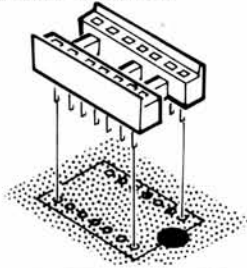

NOTE: To install an integrated circuit (IC), be sure the leads are straight. Refer to Detail 1-6A (at the bottom of the right-hand column) and identify the pin 1 end of the integrated circuit. Then position the pin 1 end toward the index mark on the circuit board and carefully install the integrated circuit. Make sure all the pins are in their respective holes.

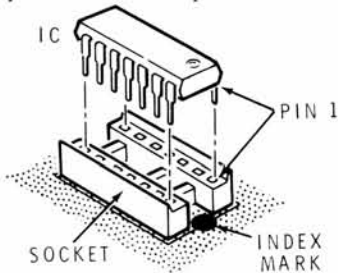

- () Install two SN7417N IC's (#443-72) at IC4 and IC7.
- () Install three SN74121N IC's (#443-22) at IC12, IC11, and IC9.

CONTINUE

- () IC3: SN7417N IC (#443-72).
- () Install two SN7409N IC's (#443-89) at IC6 and IC5.
- () IC15: SN7472N IC (#443-4).
- () Install two LM3302N, LM2901, or μ A775 IC's (#442-616) at IC1 and IC2.
- () IC16: SN7474N IC (#443-6).
- () IC13: SN7400N IC (#443-1).
- () IC8: SN7474N IC (#443-6).
- () IC14: 9600 IC (#443-806).
- () IC10: SN7408N IC (#443-45).

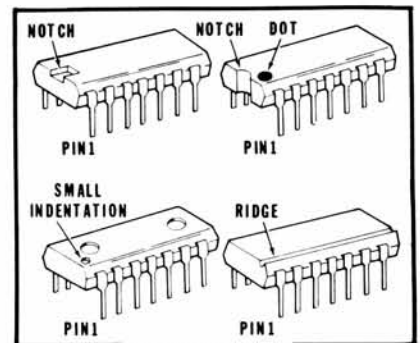
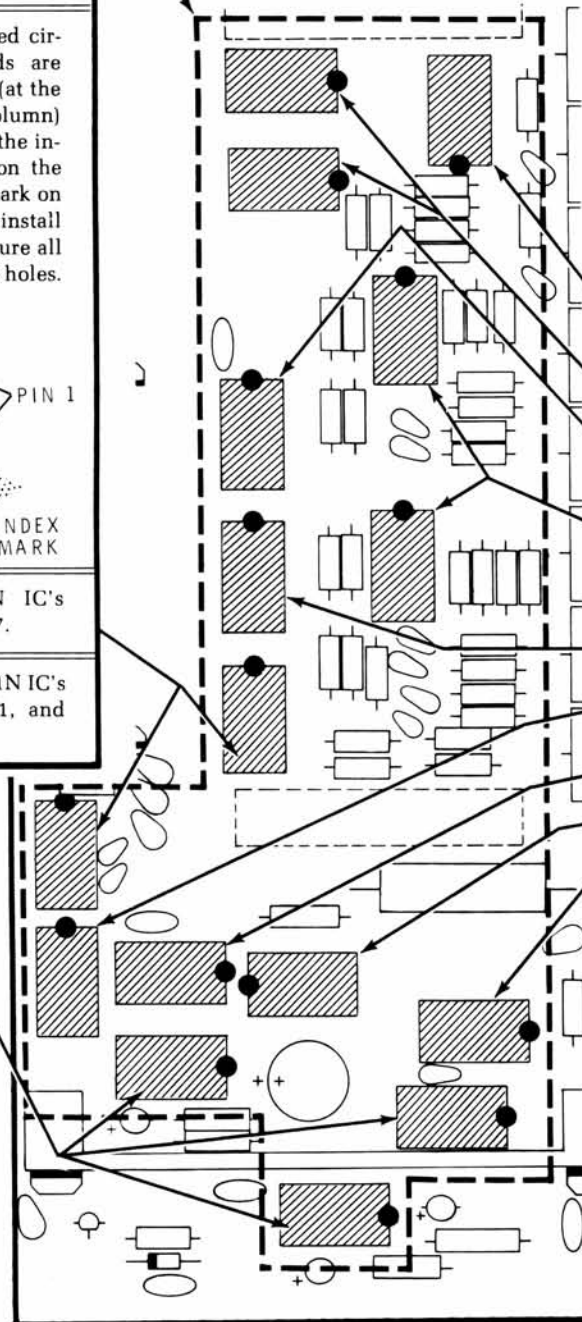

Detail 1-6A

PICTORIAL 1-6

START

- () SW4: Pushbutton switch.
- 1. Be sure the switch lugs are straight.
- 2. Position the switch as shown and insert the lugs into the circuit board holes. Then press the switch down as far as it will go.
- 3. Turn the circuit board over. Then at each end of the switch assembly, solder only two pins to the foil.
- 4. Check the switch assembly. If it is properly seated, solder the rest of the pins to the foil.

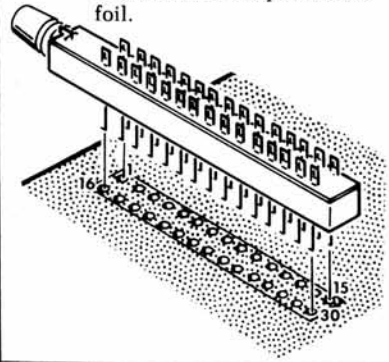

- () C15: .1 μ F ceramic.
- () C16: 1 μ F Mylar.
- () Solder the leads to the foil and cut off the excess lead lengths.

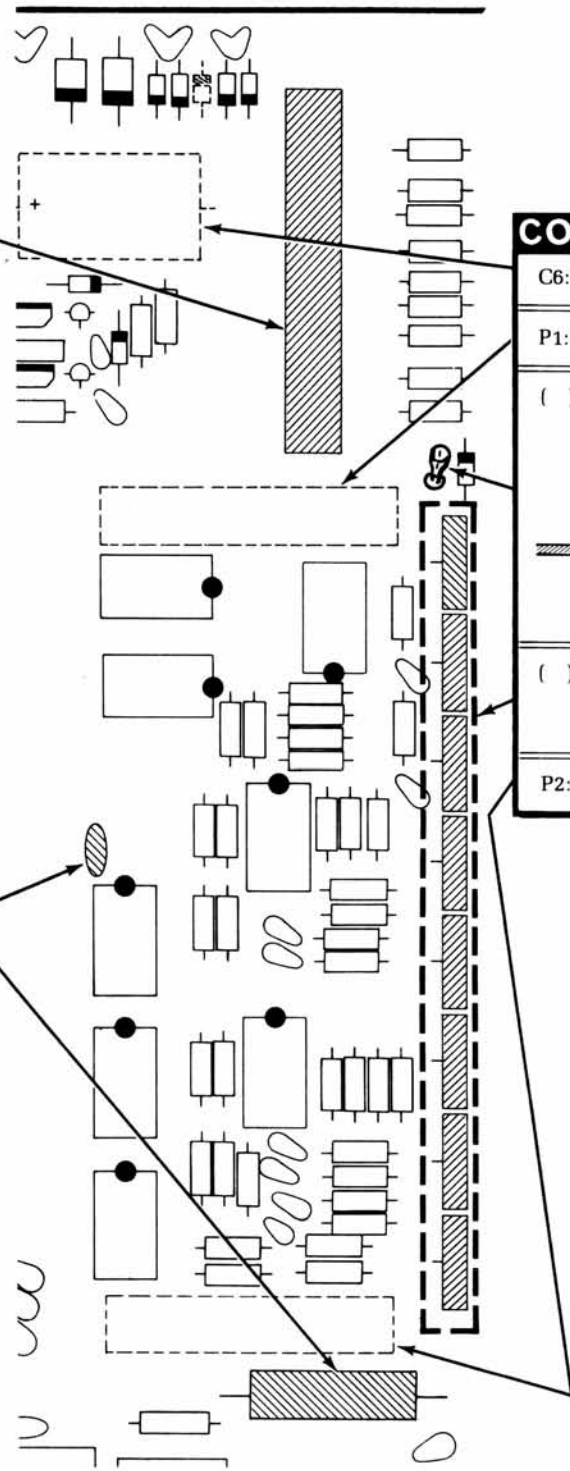

CONTINUE

- C6: Do not install a capacitor here.
 - P1: Do not install a part here.
 - () Wire connector at TP +5V. Solder it to the foil.
-
- () Install eight 20 k Ω controls at R1 through R8. Solder each control as you install it.
 - P2: Do not install a part here.

PICTORIAL 1-7

START ↘

Install ten 2N3416 transistors (#417-94).

() Q7: Line up the flat on the transistor with the flat on the circuit board and insert the transistor leads into the corresponding E, C, and B holes in the circuit board. Solder the transistor as it is installed and cut off the excess lead lengths.

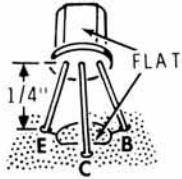

- () Q15
- () Q13
- () Q17
- () Q11
- () Q9
- () Q5
- () Q3
- () Q19
- () Q21

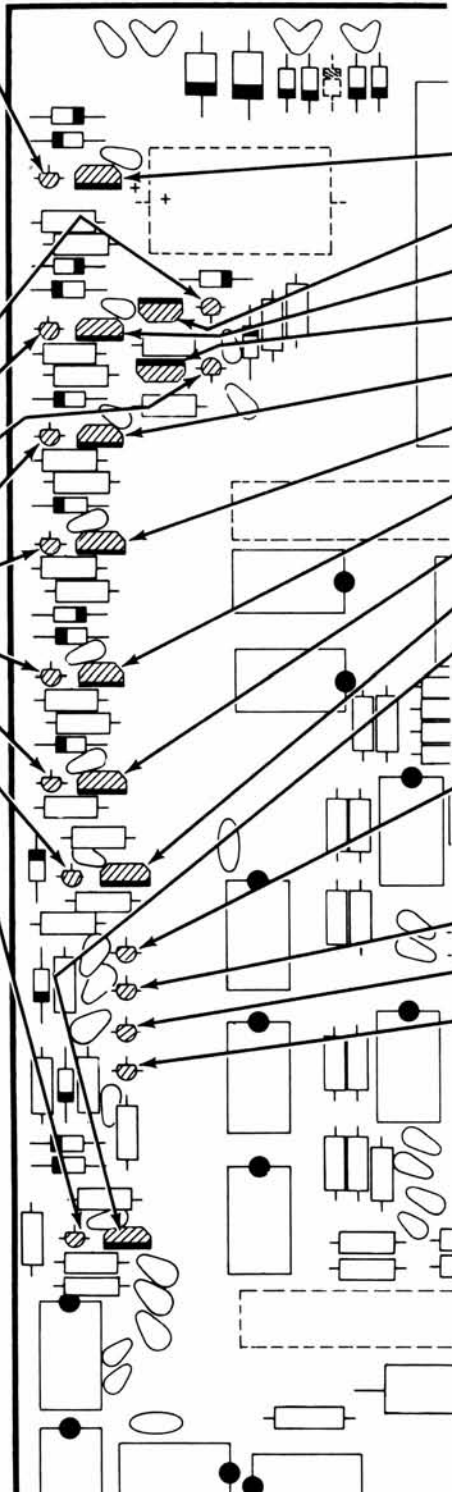

CONTINUE ↘

Install ten MJE181 transistors (#417-818).

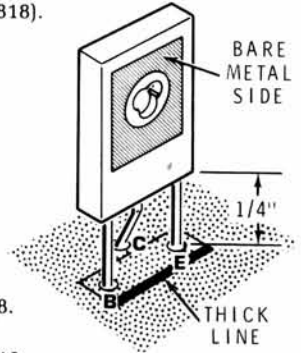

- () Q8.
- () Q16.
- () Q14.
- () Q18.
- () Q12.
- () Q10.
- () Q6.
- () Q4.
- () Q20.
- () Q22.

Install four MPSA05 transistors (#417-864).

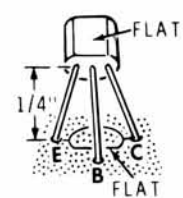

- () Q25.
- () Q26.
- () Q23.
- () Q24.

PICTORIAL 1-8

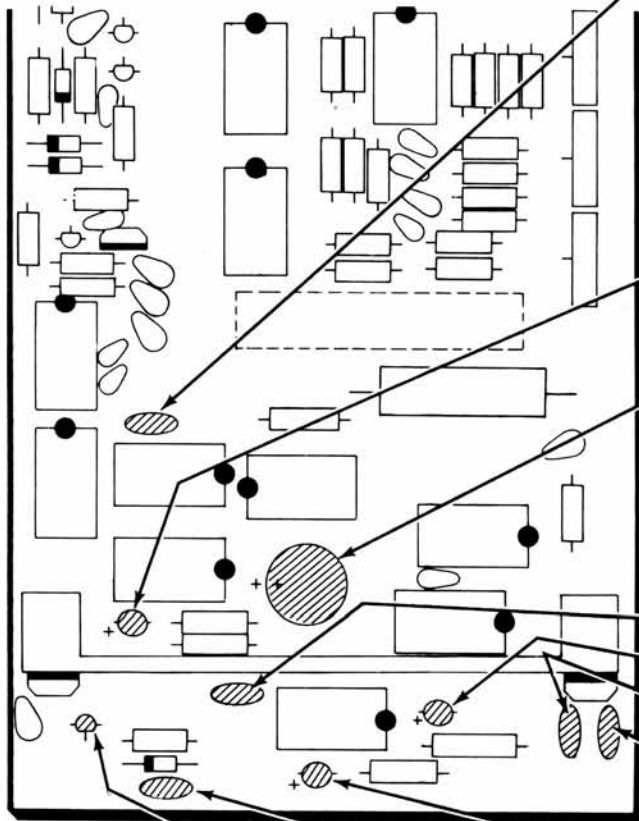

PICTORIAL 1-9

START

() C14: .1 μ F ceramic.

NOTE: When you install a tantalum capacitor, always match the plus (+) or dot marked side of the capacitor with the plus (+) mark on the circuit board.

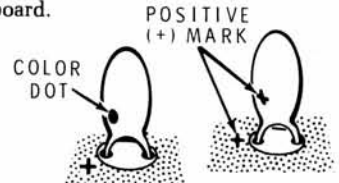

() C9: 4.7 μ F (yellow-violet-green) tantalum.

() C17: 100 μ F electrolytic. Match the plus (+) marked side of the capacitor with the plus (+) mark on the circuit board.

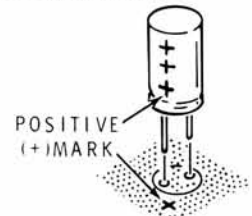

() C12: .1 μ F ceramic.

() C11: 4.7 μ F (yellow-violet-green) tantalum.

() C7: .1 μ F ceramic.

() C8: .1 μ F ceramic.

() C13: 4.7 μ F (yellow-violet-green) tantalum.

() C1: .1 μ F ceramic.

() Solder the leads to the foil and cut off the excess lead lengths.

() Q1: MPSA20 transistor (#417-801). Solder the leads to the foil and cut off the excess lead lengths.

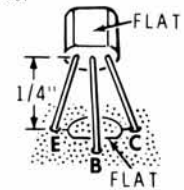

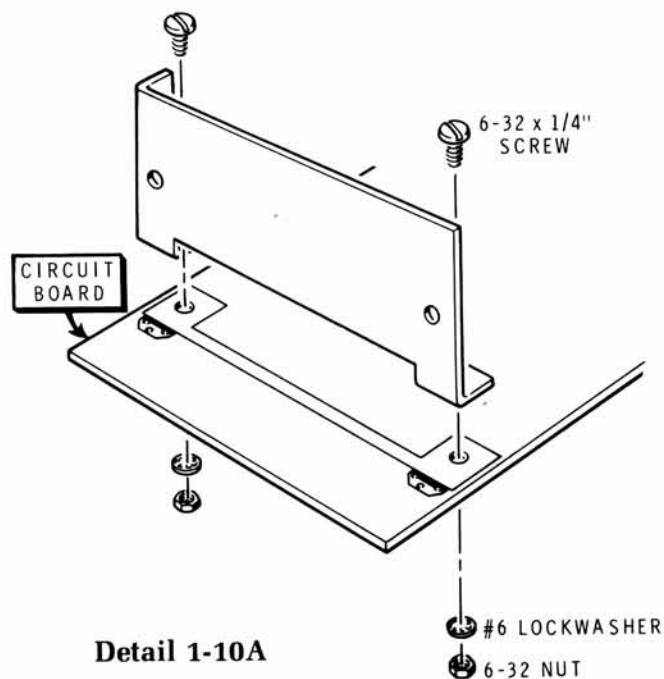

Detail 1-10A

Refer to Pictorial 1-10 (Illustration Booklet, Page 2) for the following steps.

NOTE: In the following steps, use the plastic nut starter supplied with this kit to hold and start 4-40 and 6-32 nuts on screws.

- () Refer to Detail 1-10A and mount the heat sink to the circuit board as shown. Use two 6-32 \times 1/4" screws, two #6 lockwashers, and two 6-32 nuts.
- () Refer to Detail 1-10B, open the container of silicone grease, and apply a thin layer of the grease to the bare metal side of a UA7805 IC (#442-54).
- () IC17: Again refer to Detail 1-10B and mount the prepared IC at IC17 as shown. Use a 4-40 \times 1/4" black screw, a #4 lockwasher, and a 4-40 nut. Solder the leads to the foil and cut off the excess lead lengths.
- () Refer to Detail 1-10C, apply a thin layer of silicone grease to both sides of a transistor insulator, and to the bare metal side of the remaining MJE-181 transistor (#417-818).
- () Q2: Again refer to Detail 1-10C and mount the prepared transistor and insulator at Q2 as shown. Use a 3-48 \times 3/8" screw, a #3 lockwasher, and a 3-48 nut. Solder the leads to the foil and cut off the excess lead lengths.

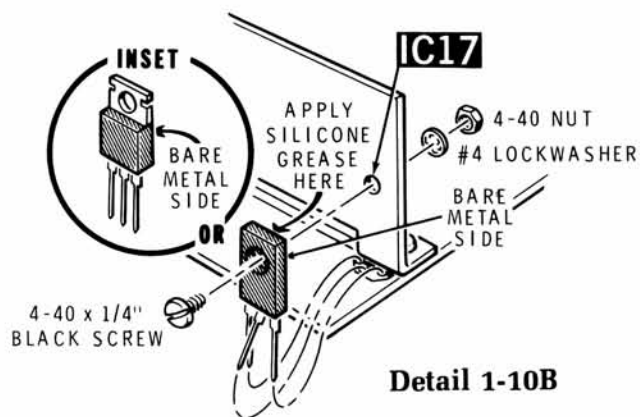

Detail 1-10B

Circuit Board Checkout

Carefully inspect the circuit board for the following conditions:

- () Unsoldered connections.
- () Poor solder connections.
- () Solder bridges between foil patterns.
- () Protruding leads which could touch together.
- () Transistors and integrated circuits for proper **type and installation**.
- () Tantalum and electrolytic capacitors for the correct position of the plus end.
- () Diodes for the correct position of the banded end.

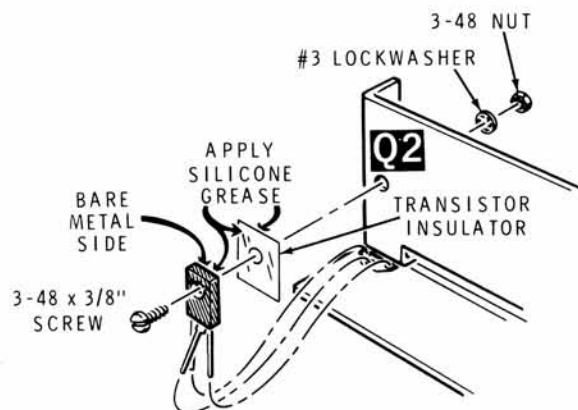

Detail 1-10C

Solenoid Wires

Refer to Pictorial 1-11 (Illustration Booklet, Page 2) for the following steps.

NOTE: When you prepare a wire, cut it to the indicated length and remove 1/4" of insulation from the ends. Be careful; do not nick the wire when you remove the insulation.

() Prepare the following wires.

COLOR	LENGTH
Blue	13"
Orange	15"
Red	15"
Brown	17"
Yellow	12"
Green	13-1/2"
Violet	12-1/2"
Gray	15"
White	12"
White/black	15-1/2"

Connect one end of each prepared wire to the main circuit board as follows. Solder each wire as you install it. The free ends will be connected later.

- () Blue to hole 6'.
- () Orange to hole 3'.
- () Red to hole 2'.
- () Brown to hole 1'.
- () Yellow to hole 4'.
- () Green to hole 5'.
- () Violet to hole 7'.
- () Gray to hole 8'.
- () White to hole 9'.
- () White-black to hole AF.
- () Position the ten wires together, twist them for 3" as shown, and then route the free wire ends as shown.

Wire Harness

Refer to Pictorial 1-12 (Illustration Booklet, Page 3) for the following steps.

() Position the wire harness with connector as shown.

In the following steps, you will connect the wire harness to switch SW4. Solder each wire as you connect it. NOTE: You will first connect wires to the left row of switch lugs and then to the right row of lugs.

- () White-brown coming from end of harness to lug 16.
- () Red to lug 22.
- () White-red to lug 24.
- () Brown to lug 25.
- () Other white-brown to lug 27.
- () Blue to lug 28.
- () White-blue to lug 30.
- () Gray to lug 1.
- () White-gray to lug 3.
- () Violet to lug 4.
- () White-violet to lug 6.
- () Green to lug 7.
- () White-green to lug 9.
- () Yellow to lug 10.
- () White-yellow to lug 12.
- () Orange to lug 13.
- () White-orange to lug 15.



READER CIRCUIT BOARD

- () Refer to Pictorial 2-1 and position the transistor housing and reader circuit board as shown. Then line up the four indicated holes and secure the two parts together with two 3-48 x 3/8" screws, two #5 fiber washers, two #3 lockwashers, and two 3-48 nuts as shown. Make sure the indicated edges line up as evenly as possible and that the transistor holes line up.

Refer to Pictorial 2-2 for the following steps.

- () Use the sandpaper and smooth the indicated edges of the reader assembly. Round off the foil edge of the reader circuit board slightly.
- () Blow into the circuit board transistor holes to clear the light channels of foreign material.
- () If you wish to protect the light channels from becoming clogged with foreign material, place transparent Mylar tape (Scotch Magic Tape* or equivalent; not supplied) over the light channels as shown.

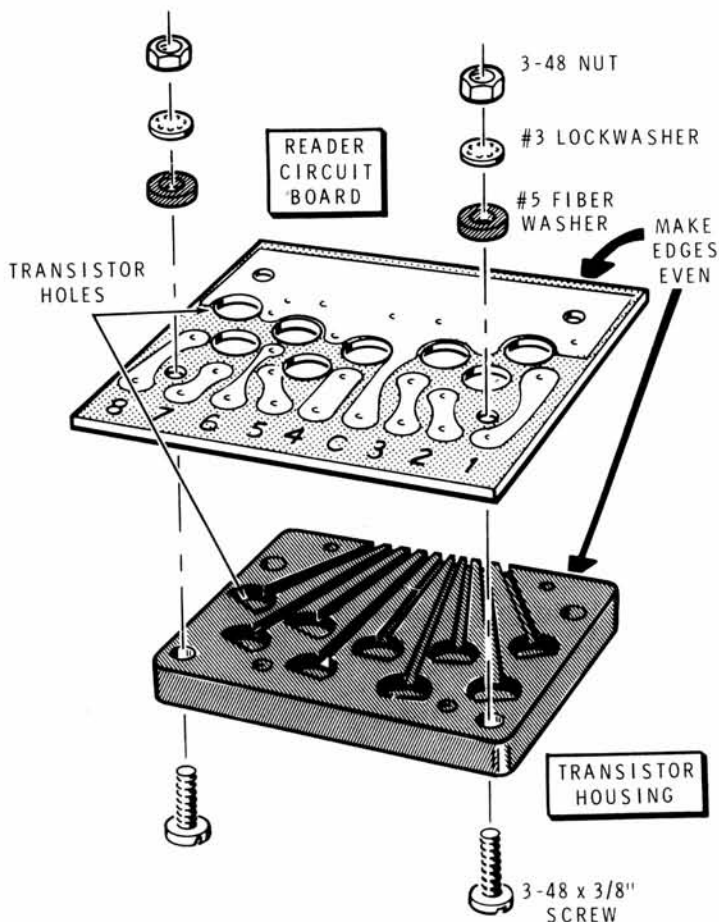

PICTORIAL 2-1

Connect the remaining harness wires to the main circuit board as follows.

Solder each wire as you connect it.

- () Green to hole AM.
- () White-yellow to hole L.
- () Yellow to hole H.
- () Black to indicated hole GND.
- () White-blue to hole AL.
- () Set the circuit board aside temporarily.

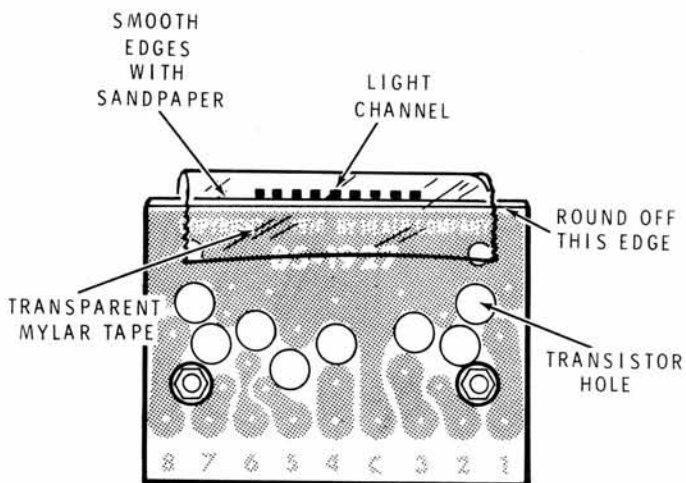

PICTORIAL 2-2

*Registered trademark, 3M Company.

Refer to Pictorial 2-3 for the following steps.

CAUTION: Perform the next two steps carefully as you cut off the proper transistor leads.

- () Refer to Detail 2-3A, position an MRD14B transistor (#417-859) with its flat as shown, and cut off the indicated lead.
- () In the same manner, prepare the other seven MRD14B transistors (#417-859).
- () Cut all the remaining transistor leads (if necessary) so the leads are not longer than 5/8".
- () Refer to Detail 2-3B, position a transistor as shown, and bend the transistor leads in the directions shown and to the dimensions shown. Bend both leads to the same dimensions.

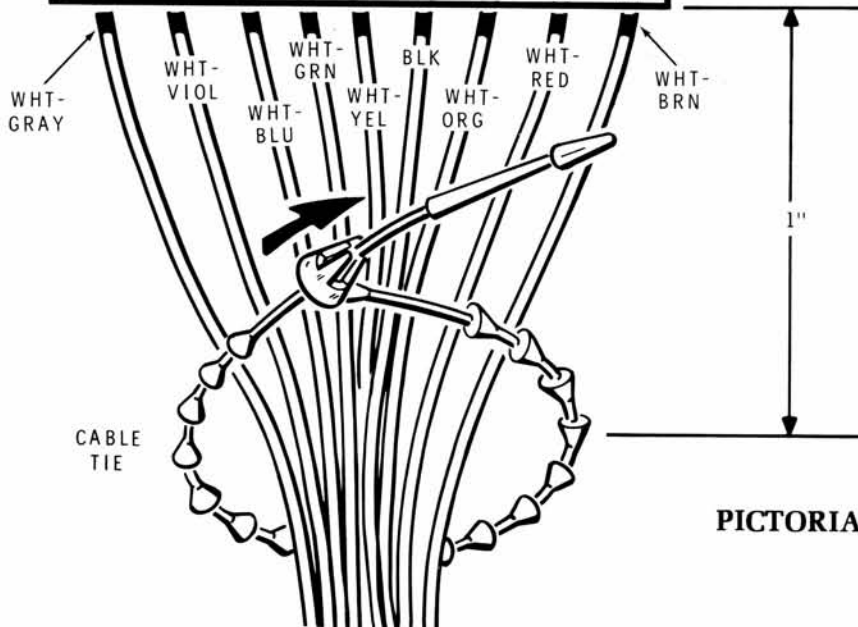
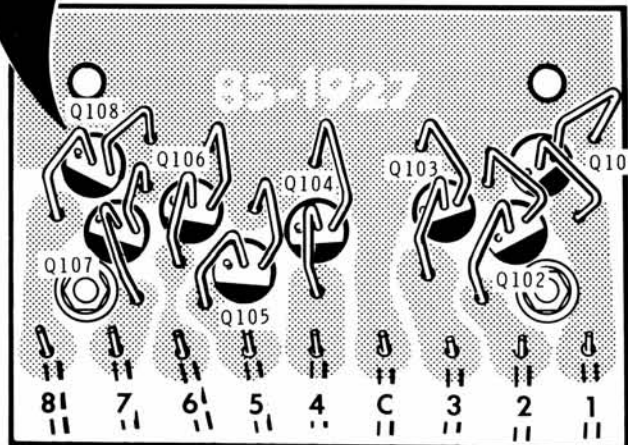

PICTORIAL 2-3

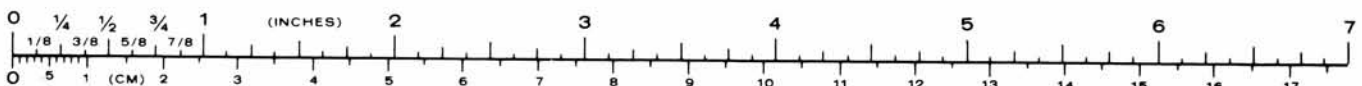

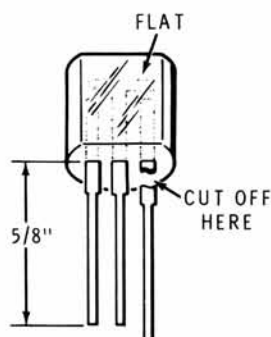

Detail 2-3A

() In the same manner, prepare the other seven transistors.

() Q108: Refer to the inset drawing and insert one of the prepared transistors as far as it will go into the reader assembly at Q108. (Because of the flat, it can go in only one way.) Bend the transistor leads as necessary, insert them into the proper holes as shown, and solder them to the foils. NOTE: Do not insert the leads any further than necessary into the circuit board holes. Some of the leads could block the light channels. Also, be sure none of the leads touch each other.

In the same manner, install the other seven transistors as follows:

- () Q107.
- () Q106.
- () Q105.
- () Q104.
- () Q103.
- () Q102.
- () Q101.

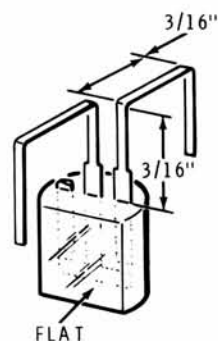

Detail 2-3B

() Prepare the following wires.

COLOR	LENGTH
White-gray	12"
White-violet	10-3/4"
White-blue	9"
White-green	9"
White-yellow	8"
Black solid	9-1/2"
White-orange	8"
White-red	8-1/2"
White-brown	8-3/4"

In the following steps, you will connect one end of each prepared wire to the indicated side of the reader circuit board. The free ends will be connected later. Solder each wire as you install it.

- () White-gray to hole 8.
- () White-violet to hole 7.
- () White-blue to hole 6.
- () White-green to hole 5.
- () White-yellow to hole 4.
- () Black solid to hole C.
- () White-orange to hole 3.
- () White-red to hole 2.
- () White-brown to hole 1.
- () Install a cable tie as shown. Cut off the excess length of cable tie.
- () Set the reader assembly aside temporarily.

CHASSIS

PARTS LIST

Check the remaining parts against the following list. See Pages 4, 5, and 6 in the Illustration Booklet for key number drawings.

To order a replacement part, always include the part number and use the Parts Order Form furnished with this kit. If a Parts Order Form is not available, refer to "Replacement Parts" inside the rear cover. Your Warranty is inside the front cover. For prices, refer to the separate "Heath Parts Price List."

KEY No.	HEATH Part No.	QTY.	DESCRIPTION	CIRCUIT Comp. No.
ELECTRICAL PARTS				
A1	1-10	2	1200 Ω (brown-red-red) resistor	R96, R98
A1	1-14	3	3300 Ω (orange-orange-red) resistor	R95, R97, R99
A1	1-48	1	390 Ω (orange-white-brown) resistor	Test Resistor
A2	21-43	1	.001 μ F ceramic capacitor	C18
A2	21-70	1	.01 μ F ceramic capacitor	C2
A2	21-143	1	.05 μ F ceramic capacitor	C19
A3	25-272	2	6000 μ F, 15V electrolytic capacitor	C4, C5
A4	25-217	1	6000 μ F, 40V electrolytic capacitor	C3
A5	56-605	1	1N4746A diode	D27
A5	57-56	1	1N4002 diode	D26
A6	417-201	1	X29A829 transistor	Q27
A6	417-801	1	MPSA20 transistor	Q28
A7	69-83	10	Solenoid	L1, L2, L3, L4, L5, L6, L7, L8, L9, L10
A8	412-616	1	LED	LED1
A9	412-81	1	#1141 lamp	LP1
A10	421-20	1	1/2-ampere, slow-blow fuse	F1
A10	421-23	1	1-ampere, slow-blow fuse	F1
A11	420-97	1	Stepper motor	M1
A12	54-939	1	Power transformer	T1

KEY No.	HEATH Part No.	QTY.	DESCRIPTION	CIRCUIT Comp. No.
SWITCHES				
B1	60-54	1	120/240	SW3
B2	60-608	1	NOR/LOW	SW2
B3	60-619	1	POWER	SW1
B4	64-839	1	Pushbutton switch (momentary contact)	SW6
B5	64-840	2	Pushbutton switch (latching)	SW5, SW7

SPACERS — SPRINGS

C1	255-1	2	1/8" spacer
C2	255-79	2	3/16" threaded spacer
C3	255-88	1	3/16" nylon spacer
C4	255-49	2	5/16" spacer
C5	255-730	1	1" spacer
C6	255-60	3	1-1/8" threaded spacer
C7	255-708	2	1-3/4" spacer
C8	258-1	1	Roller spring
C9	258-4	2	Reader guide spring
C10	258-33	1	Tape tension spring
C11	258-710	1	Dog spring
C12	266-922	1	Finger spring



KEY No.	HEATH Part No.	QTY.	DESCRIPTION	CIRCUIT Comp. No.
---------	----------------	------	-------------	-------------------

TERMINAL STRIPS — CONNECTORS

D1	431-1	2	Vertical post terminal strip	
D2	431-2	1	Small 2-lug terminal strip	
D3	431-41	1	Large 2-lug terminal strip	
D4	431-49	1	11-lug terminal strip	
D5	432-789	1	Female connector with wire	
D6	432-855	50	Female connector	

HARDWARE

Hardware packets are marked to show the size of the hardware they contain (HDW #4, or HDW #2 and #6, etc.). You may have to open more than one packet to locate all the hardware of any one (#6, for example) size.

#3 Hardware

E1	250-49	2	3-48 × 1/4" screw
E2	250-172	1	3-48 × 3/8" screw
E3	250-201	3	3-48 × 1/2" screw
E4	252-1	6	3-48 nut
E5	254-7	7	#3 lockwasher

#4 & #5 Hardware

F1	250-156	4	4-40 × 1/8" setscrew
F2	250-1124	7	4-40 × 1/4" black screw
F3	250-312	2	4-40 × 3/4" screw
F4	252-15	7	4-40 nut
F5	254-9	7	#4 lockwasher
F6	253-43	9	#5 fiber flat washer
F7	253-40	1	#5 flat washer

#6 Hardware

G1	250-33	4	6-32 × 1/8" setscrew
G2	250-56	22	6-32 × 1/4" screw
G3	250-116	26	6-32 × 1/4" black screw
G4	250-274	2	6-32 × 5/16" flat head screw
G5	250-365	3	#6 × 1/4" sheet metal screw
G6	250-1255	18	6-32 × 1/4" allen head screw
G7	250-587	8	6-32 × 5/16" screw
G8	250-381	3	6-32 × 3/8" black screw
G9	250-276	1	6-32 × 3/8" black flat head screw
G10	250-441	1	#6 × 3/8" flat head, sheet metal screw
G11	250-75	2	#6 × 1/2" wood screw
G12	250-40	2	6-32 × 1-1/2" screw
H1	252-3	28	6-32 nut

KEY No.	HEATH Part No.	QTY.	DESCRIPTION	CIRCUIT Comp. No.
---------	----------------	------	-------------	-------------------

Hardware (cont'd.)

H2	252-22	2	#6 square Speed Nut*
H3	252-127	2	#6 long Speed Nut
H4	252-195	8	6-32 brass insert nut
H5	253-21	2	#6 flat washer
H6	254-1	30	#6 lockwasher
H7	254-27	18	#6 large lockwasher
H8	259-1	3	#6 solder lug

#8 & #10 Hardware

J1	250-87	2	8-32 × 3/16" screw
J2	250-98	4	8-32 × 1/2" screw
J3	252-4	8	8-32 nut
J4	254-2	10	#8 lockwasher
J5	250-126	8	10-32 × 1/2" screw
J6	252-5	11	10-32 nut
J7	253-98	11	#10 small flat washer
J8	253-19	3	#10 large flat washer

Other Hardware

K1	251-1	2	Large hole spade bolt
K2	251-11	10	Small hole spade bolt
K3	252-193	2	Push-on nut
K4	253-59	2	Small spring washer
K5	253-36	1	Large spring washer
K6	253-50	2	Nylon shoulder washer

METAL PARTS

L1	208-43	1	Lamp clip
L2	262-44	1	1-1/2" shaft
L3	453-285	1	3-1/4" shaft
L4	451-603	1	Ratchet gear
L5	455-21	2	Brass collar
L6	455-94	2	Aluminum collar
L7	266-918-1	1	Reader tape guide
L8	266-919	1	Punch tape guide
L9	266-920	6	Long linkage
L10	266-948	6	Medium linkage
L11	266-921	4	Short linkage
L12	266-936	1	Roller

CAUTION: Do not open the box containing the following punch assembly until you are instructed to do so in the Manual.

L13	266-937	1	Punch assembly — Keep it in its box until needed. consists of:
		8	Large punch
		1	Small punch
		1	Die block

*Registered Trademark, Tinnerman Co.

KEY No.	HEATH Part No.	QTY.	DESCRIPTION	CIRCUIT Comp. No.
---------	----------------	------	-------------	-------------------

PANELS — BRACKETS

M1	203-1872-1	1	Front panel	
M2	203-1873-1	1	Top panel	
M3	203-1874-1	1	Punch ramp	
M4	203-1875-1	1	Reader chute	
M5	203-1876-1	1	Reader trough	
M6	203-1877-1	1	Right side panel	
M7	203-1878-1	1	Left side panel	
M8	204-1888	2	Angle bracket	
M9	204-2250	1	Solenoid bracket (F)	
M10	204-2251	2	Solenoid bracket	
N1	204-2271	1	Drive solenoid bracket	
N2	204-2253	1	Left reader bracket	
N3	204-2254-1	1	Right reader bracket	
N4	204-2255	1	Switch bracket	
N5	204-2272	1	Stop bracket	
N6	204-2273-1	1	Right tape bracket	
N7	204-2274-1	1	Left tape bracket	
N8	204-2278	1	Roller bracket	
N9	204-2298	1	Roller mounting bracket	

PLATES — CHASSIS

N10	205-1715	9	Actuator	
N11	205-1725	1	Dog plate	
N12	205-1726-1	2	Tensioner plate	
N13	205-1729	1	Guide plate	
N14	200-1291-1	1	Chassis	

KEY No.	HEATH Part No.	QTY.	DESCRIPTION	CIRCUIT Comp. No.
---------	----------------	------	-------------	-------------------

MISCELLANEOUS

P1	73-59	2	Small grommet	
P2	73-6	11	Large grommet	
P3	75-736	1	Line cord strain relief	
	89-54	1	Line cord	
P4	207-73	1	Capacitor strap	
P5	261-20	4	Round foot	
P6	261-41	5	Square foot	
P7	266-917	1	Plastic spool	
P8	266-924	1	Chad tray	
P9	266-928-1	1	Fan-fold tray	
P10	346-20	4"	Large sleeving	
P11	346-66	30"	Small sleeving	
P12	347-65	36"	Cable	
P13	352-13	1	Silicone grease	
P14	352-28	1	Thread-locking sealant	
P15	354-6	9	Cable tie	
P16	390-1255	1	Fuse label	
P17	390-1351	1	Model label	
P18	390-1352	1	Switch label	
P19	391-611	1	Nameplate	
P20	422-1	1	Fuse block	
P21	432-704	2	Connector shell	
	445-25	1	Paper tape	
Q1	451-602	2	Sprocket	
Q2	455-44	5	Nylon bearing	
Q3	462-1023	3	Knob	
Q4	490-85	1	Large allen wrench	
Q5	490-23	1	Small allen wrench	

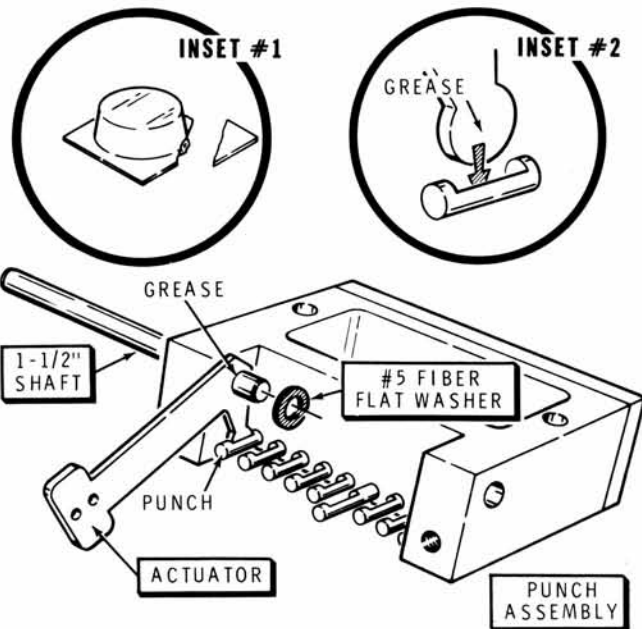

Detail 3-1A



STEP-BY-STEP ASSEMBLY

Refer to Pictorial 3-1 (Illustration Booklet, Page 6) for the following steps.

CAUTION: When you open the box containing the punch assembly and when you work with the punch assembly in the following steps, be extremely careful and do not let the punches fall out. The punches are **NOT** interchangeable.

- () Open the punch assembly box as follows:

Lay the box flat on your work surface. Then open both ends of the box and push the assembly out carefully.

- () Refer to Detail 3-1A, position the punch assembly as shown, and remove any tape or other material that is holding the punches in the die block. Do not allow the punches to come out.

Refer to Detail 3-1A for the next six steps.

- () 1. Reposition the punch assembly as shown; then rotate the punches in the die block so the notches are as shown.
- () 2. Refer to inset drawing #1 and cut open a container of silicone grease.
- () 3. Insert either end of the 1-1/2" shaft into the die block as shown.
- () 4. Apply silicone grease to the large hole and the round portion of an actuator (see inset drawing #2), slide the actuator onto the shaft, and fit the actuator into its notch in the proper punch. (Again, see inset drawing #2.)
- () 5. Slide a #5 fiber flat washer onto the 1-1/2" shaft.
- () 6. In a similar manner, install the remaining eight actuators and eight fiber washers onto the 1-1/2" shaft. The last part you put on the shaft should be a fiber washer.

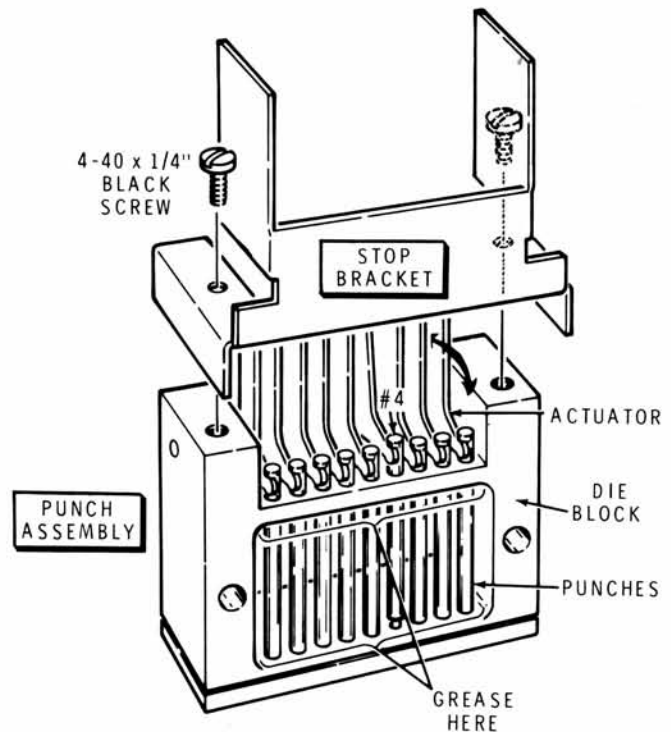

Detail 3-1B

- () Carefully reposition the punch assembly and mount the stop bracket to the die block with two 4-40 x 1/4" black screws as shown in Detail 3-1B. Do not allow the actuators to fall backwards until the stop bracket is mounted, or the ends of the punches will come out of the die block.
- () Move the actuators back and forth, and apply silicone grease to each punch where it touches the die block. Use a toothpick or similar item to apply the grease. **NOTE:** Punch #4 is different than the other punches and will not sit as far down in the die block as the others.
- () Refer to the Pictorial and loosely mount the punch assembly to the chassis with two 4-40 x 3/4" screws, two #4 lockwashers, and two 4-40 nuts.

Refer to Pictorial 3-2 (Illustration Booklet, Page 7) for the following steps.

- () Turn the chassis upside down as shown.
- () Cut a 12" length of paper tape from the supplied roll.
- () Refer to inset drawing #1 and position the punch assembly actuators to the right. Then slide approximately 2" of the paper tape through the punch assembly as shown.
- () Lay the remaining length of tape down onto the chassis between the three chassis buttons as shown.
- () Position the punch assembly sideways as necessary so the tape lays flat against the chassis.
- () From the rear of the chassis, sight down the chassis and position the punch assembly so the start of the bevel (see inset drawing #2) is flush with the chassis bottom. Then tighten the punch assembly screws. Remove the tape if necessary.
- () Recheck the previous two steps and readjust the punch assembly if necessary.

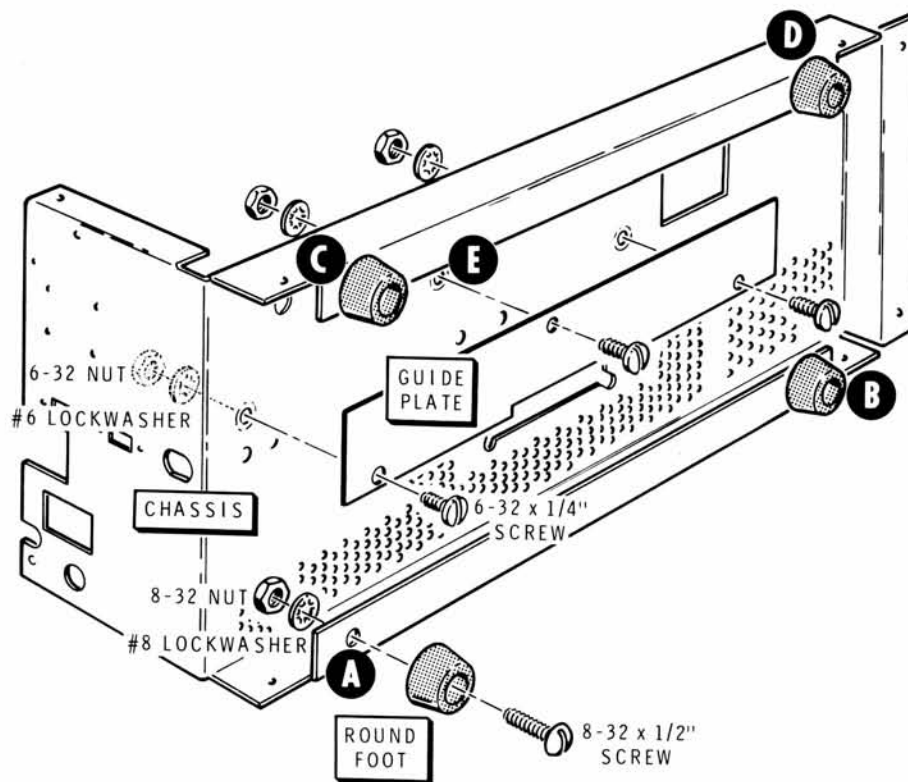

PICTORIAL 3-3

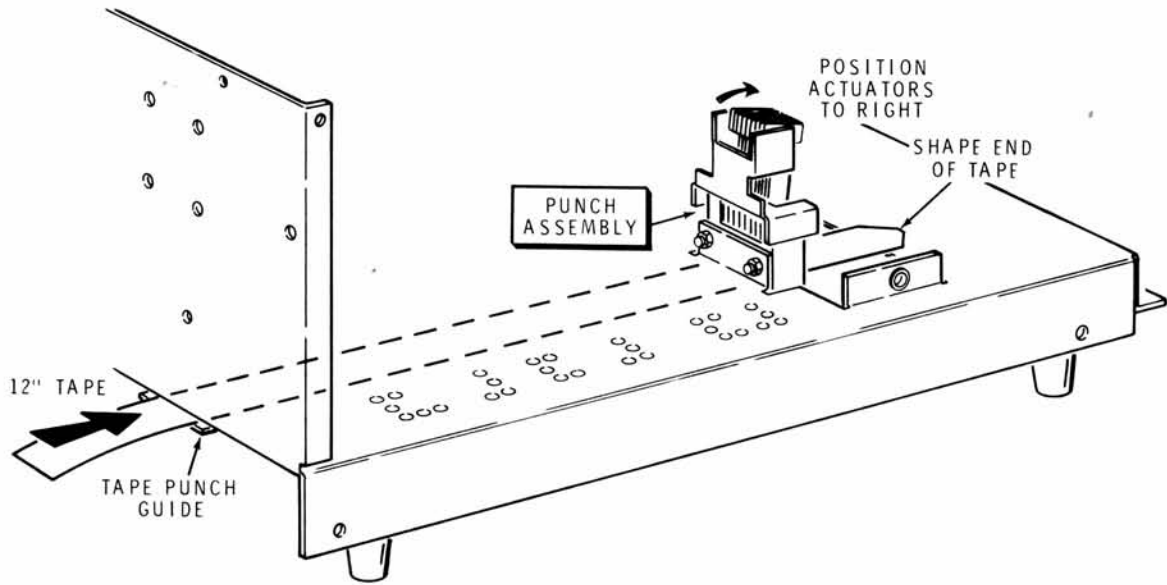

Detail 3-3A

Refer to Pictorial 3-3 for the following steps.

- () Position the chassis on its side as shown.
- () Mount a round foot at A with an 8-32 × 1/2" screw, a #8 lockwasher, and an 8-32 nut as shown.
- () In a similar manner, mount three rubber feet at B, C, and D.
- () Mount the guide plate at E with three 6-32 × 1/4" screws, three #6 lockwashers, and three 6-32 nuts.

Refer to Detail 3-3A for the following steps.

- () Set the chassis right side up.
- () With scissors, shape the end of the tape as shown in Detail 3-3A. Then insert the length of tape into the punch tape guide from the rear of the chassis. Push the tape in until it comes to the punch assembly.
- () Position the punch actuators to the right and then gently push the tape into and through the punch. The tape should slide through the punch easily. Readjust the punch if necessary.
- () Remove the tape and set it aside.

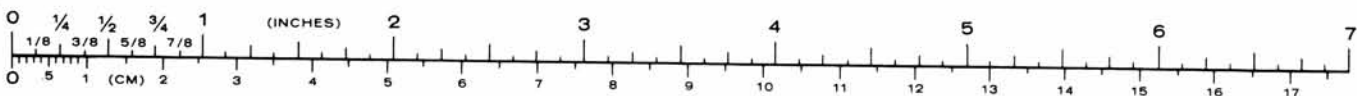

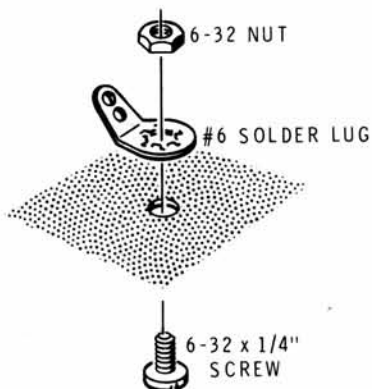

Detail 3-4A

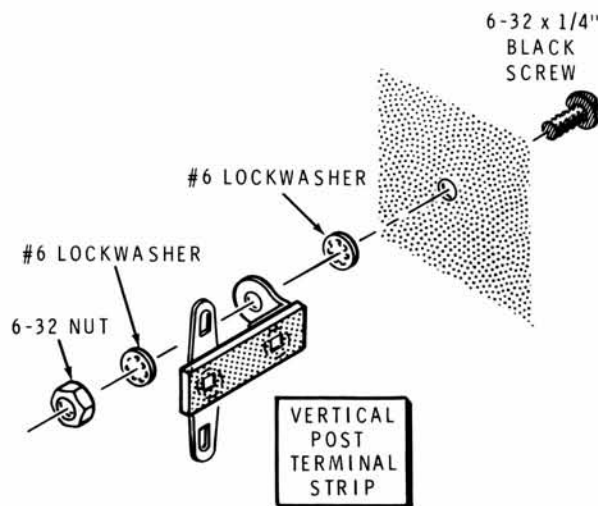

Detail 3-4C

Refer to Pictorial 3-4 (Illustration Booklet, Page 7) for the following steps.

- () Reposition the chassis as shown.
- () Refer to Detail 3-4A and mount a #6 solder lug at G. Use a 6-32 \times 1/4" screw and a 6-32 nut. Be sure to position the solder lug as shown in the Pictorial.
- () Refer to Detail 3-4B and mount the fuse block at F1 with a 6-32 \times 3/8" black screw, two #6 lockwashers, and a 6-32 nut.

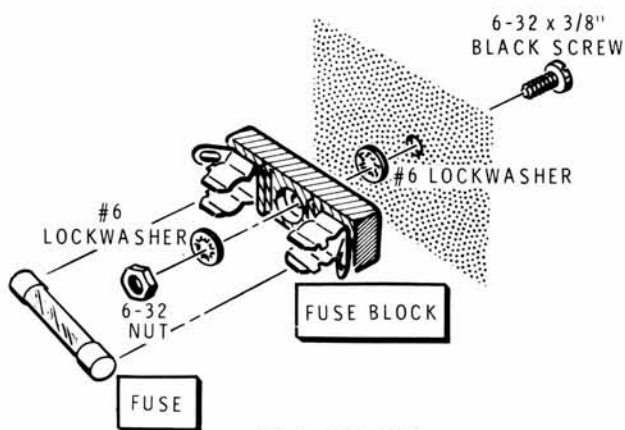

Detail 3-4B

NOTE: Two fuses are supplied with this kit, a 1-ampere for 120 VAC line voltage and a 1/2-ampere for 240 VAC line voltage. In the following step, use only the fuse that agrees with the line voltage in your area.

- () F1: Again, refer to Detail 3-4B and push the proper fuse into the fuse block.
- () Mark the fuse rating on the fuse label (1-ampere for 120-volt operation, or 1/2-ampere for 240-volt operation). Then remove the paper backing and press the label onto the chassis as shown in the Pictorial.
- () Refer to Detail 3-4C and mount a vertical post terminal strip at H. Use a 6-32 \times 1/4" black screw, two #6 lockwashers, and a 6-32 nut. Position the terminal strip as shown in the Pictorial.
- () In a similar manner, mount a **large** 2-lug terminal strip at J. Position it as shown in the Pictorial. (If necessary, see drawing D3 on Page 4 of the Illustration Booklet.)
- () In a similar manner, mount a **small** 2-lug terminal strip at K. Position it as shown in the Pictorial.

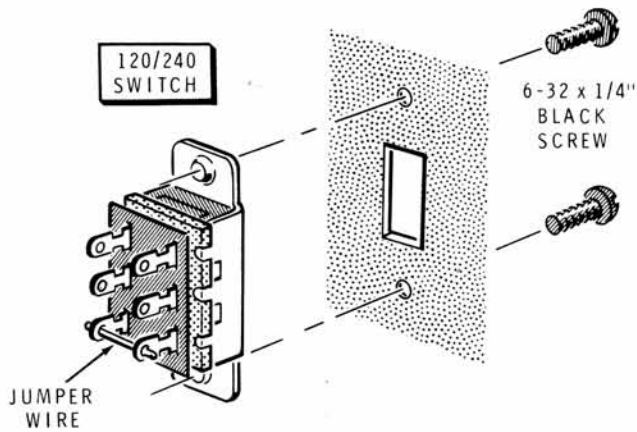

Detail 3-4D

- () SW3: Refer to Detail 3-4D and mount the 120/240 switch at SW3. Use two 6-32 × 1/4" black screws and be sure to position the switch lugs with the jumper wire as shown in the Pictorial.
- () SW2: In a similar manner, mount the NOR/LOW switch at SW2. Be sure the letters NOR and LOW are right side up.
- () Refer to Detail 3-4E and mount the shorter arm of an angle bracket at L as shown. Use a 4-40 × 1/4" black screw, a #4 lockwasher, and a 4-40 nut as shown.
- () In a similar manner, mount another angle bracket at M.
- () Refer to the inset drawing on Detail 3-4F, position a large hole spade bolt as shown, and mount the spade bolt onto one end of the capacitor strap as shown. Use a 6-32 × 1/4" screw, a #6 lockwasher, and a 6-32 nut.
- () In a similar manner, mount another large hole spade bolt onto the other end of the capacitor strap.

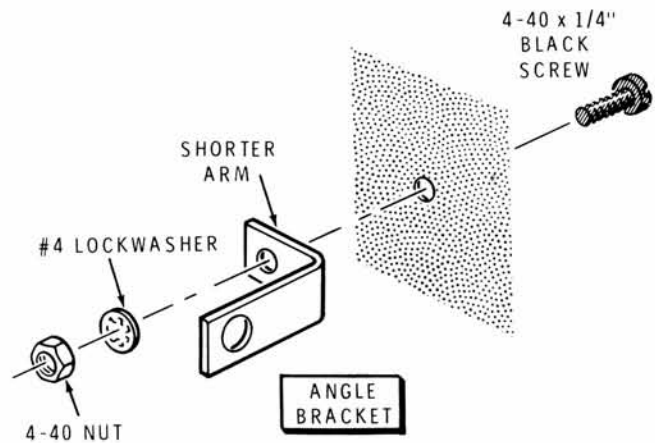

Detail 3-4E

- () C3: Position the 6000 μ F, 40-volt electrolytic capacitor onto the chassis at C3 with its positive (plus or red marked) lug positioned as shown. (NOTE: The lugs on your capacitor may look different than those shown.)
- () Bend the capacitor strap around the capacitor, and secure the spade bolts to the chassis with two #6 lockwashers and two 6-32 nuts as shown in the Pictorial.

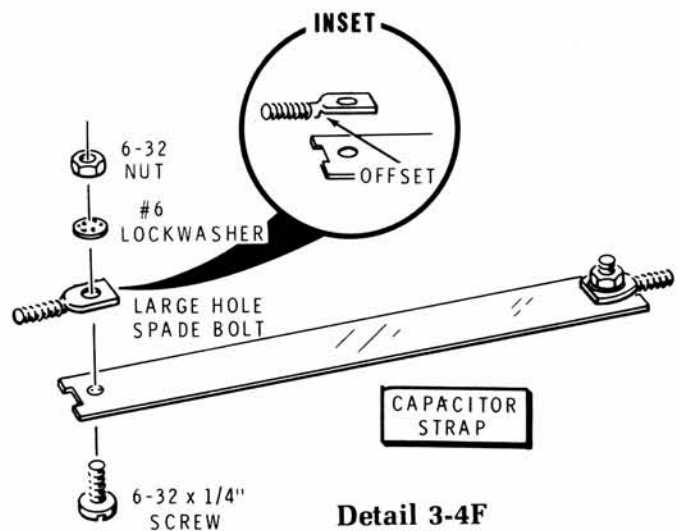

Detail 3-4F

Refer to Pictorial 3-5 (Illustration Booklet, Page 8) for the following steps.

- () Refer to Detail 3-5A and mount a vertical post terminal strip at N. Use a 6-32 x 1/4" screw, two #6 lockwashers, and a 6-32 nut as shown. Position the terminal strip as shown in the Pictorial.
- () Insert nylon bearings into holes P and Q as shown in the Pictorial. See the inset drawing.
- () Refer to Detail 3-5B and mount the left reader bracket to the chassis at R. Use two 6-32 x 1/4" screws, two #6 lockwashers, and two 6-32 nuts.
- () Refer to Detail 3-5C and loosely mount the reader assembly to the reader chute as shown. Use two 3-48 x 1/2" screws, two #3 lockwashers, and two 3-48 nuts as shown. Do not tighten the screws. You will tighten them later.

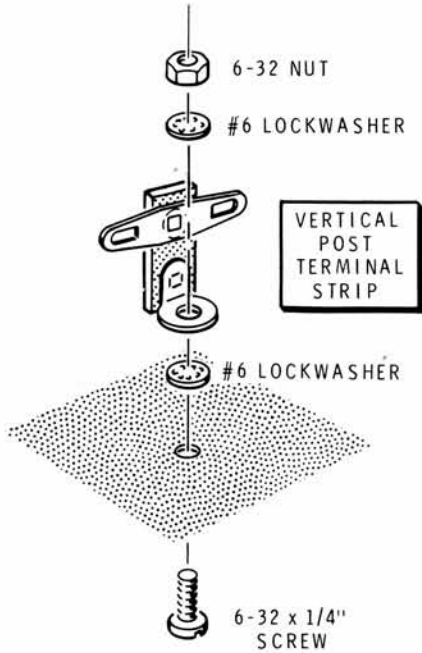

Detail 3-5A

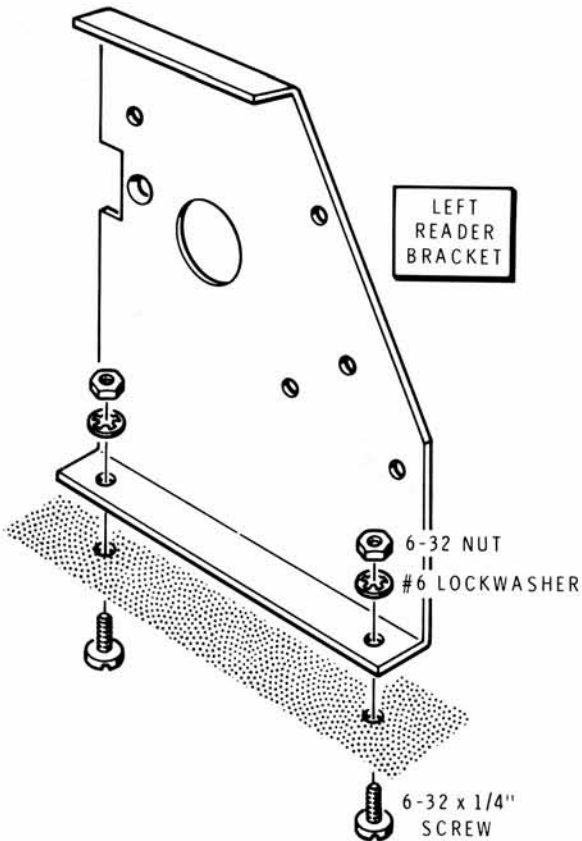

Detail 3-5B

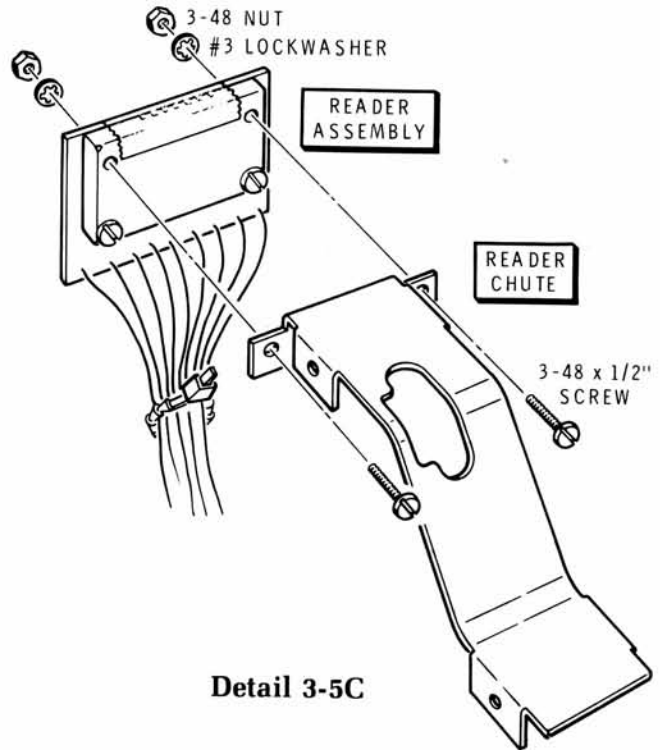

Detail 3-5C

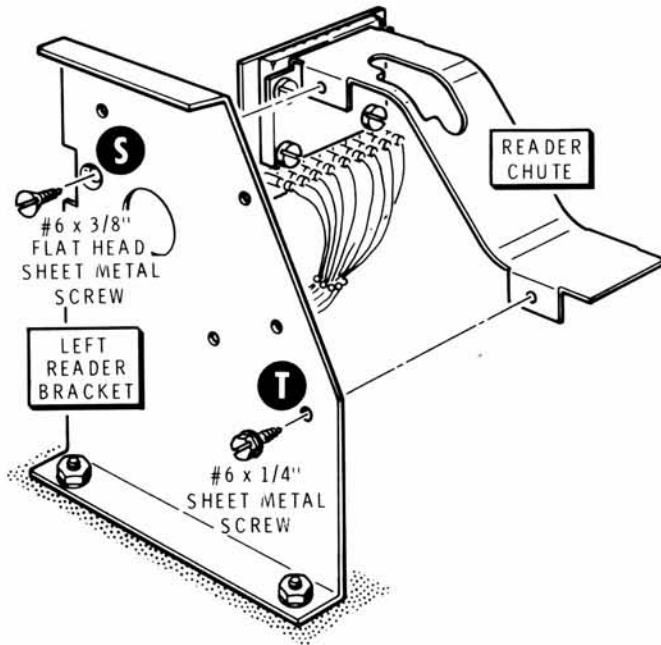

Detail 3-5D

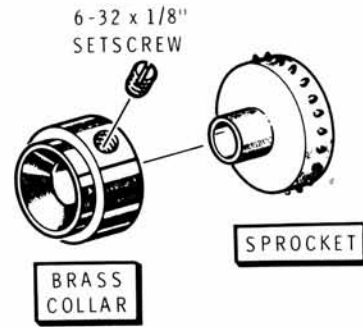

Detail 3-5E

- Loosely mount the motor with two 6-32 x 3/8" black screws, two #6 lockwashers, and two 6-32 nuts as shown.
- Position the motor so the surface of the sprocket that will touch the paper tape is flush with, or extends slightly up past, the surface of the reader chute. (See the inset drawing.) Then tighten the motor mounting screws.

- Refer to Detail 3-5D and mount the reader chute to the left reader bracket. Use a #6 x 3/8" flat head, sheet metal screw at S and a #6 x 1/4" sheet metal screw at T.
- Refer to Detail 3-5E and start a 6-32 x 1/8" setscrew into a brass collar. Then slide the collar onto a sprocket as shown but DO NOT tighten the setscrew.
- Refer to Detail 3-5F and position the stepper motor so the wires come out the bottom rear as shown.
- M1: Again refer to Detail 3-5F and mount the stepper motor as follows:
 - Insert the motor shaft through hole M1 in the left reader bracket.
 - Slide the sprocket onto the motor shaft as shown.

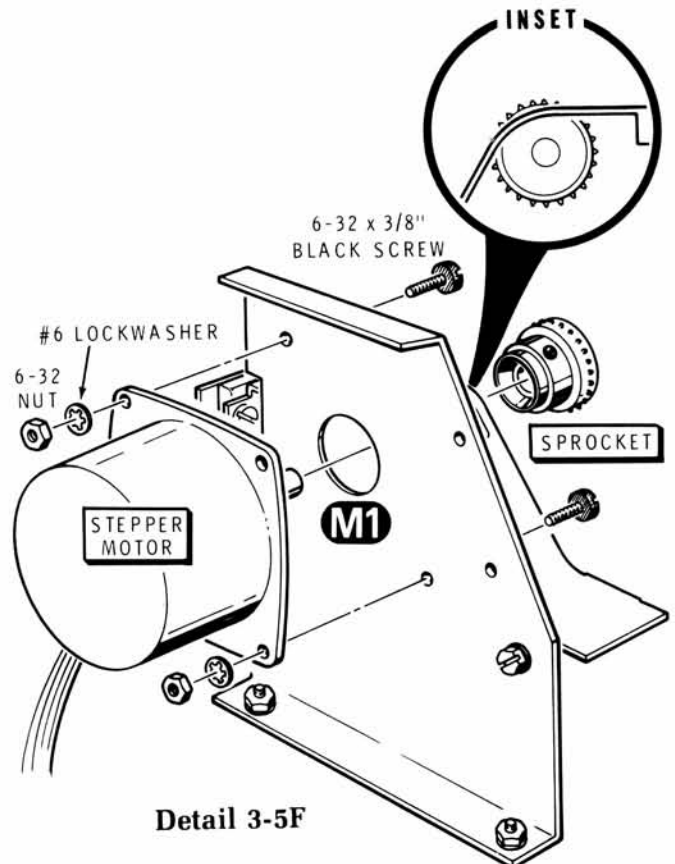

Detail 3-5F

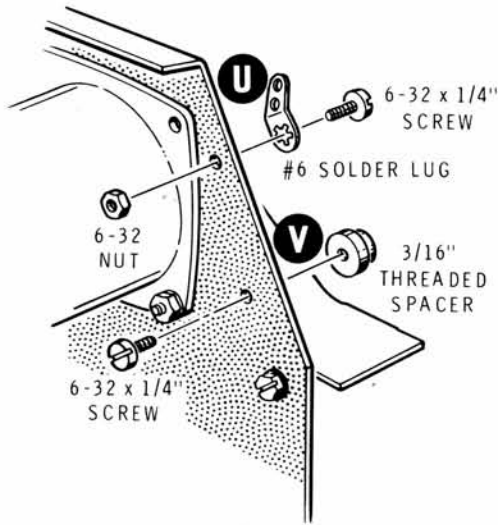

Detail 3-5G

- () Refer to Detail 3-5G and mount a #6 solder lug at U. Use a 6-32 x 1/4" screw and a 6-32 nut. Position the solder lug as shown.
- () Again refer to Detail 3-5G and mount a 3/16" threaded spacer at V as shown. Use a 6-32 x 1/4" screw.

- () Refer to Detail 3-5H, position the right reader bracket as shown, and mount a #6 solder lug at W as shown. Use a 6-32 x 1/4" screw and a 6-32 nut.
- () Again refer to Detail 3-5H and mount a 3/16" threaded spacer at X as shown. Use a 6-32 x 1/4" screw.
- () Refer to Detail 3-5J, position the reader tape guide onto spacers V and X, and then install the two #6 x 1/4" sheet metal screws as shown. Center the sprocket in the guide slot but do not tighten its screw yet.

- () Refer to Detail 3-5K and secure the bracket to the chassis with two 6-32 x 1/4" screws, two #6 lockwashers, and two 6-32 nuts as shown. Temporarily loosen any other mounting screws as necessary.
- () Again refer to Detail 3-5K and install the two reader guide springs. NOTE: Be sure neither solder lug protrudes past the front edge of the brackets. See the inset drawing. Also, be sure the reader tape guide moves freely and that the ends of the slot do not touch the sprocket teeth. Adjust screws V and X as necessary.

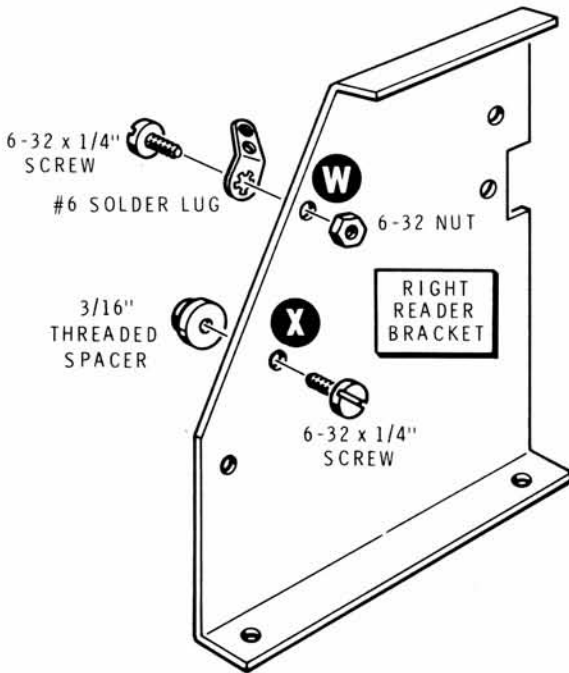

Detail 3-5H

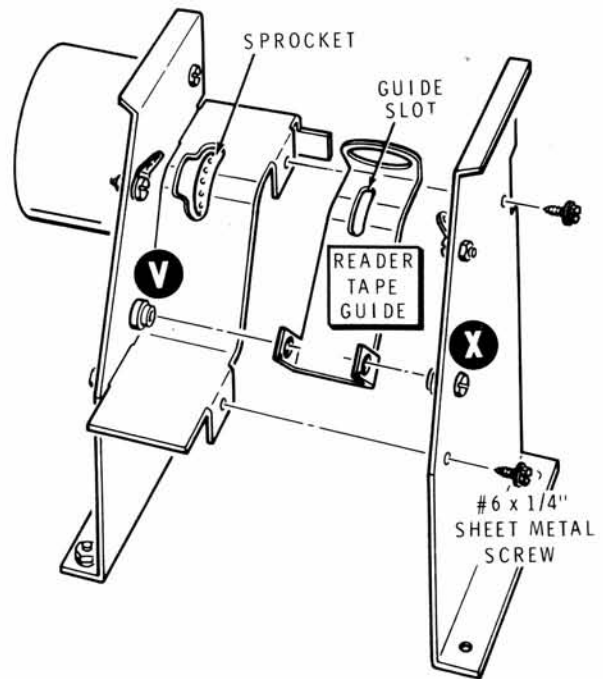

Detail 3-5J

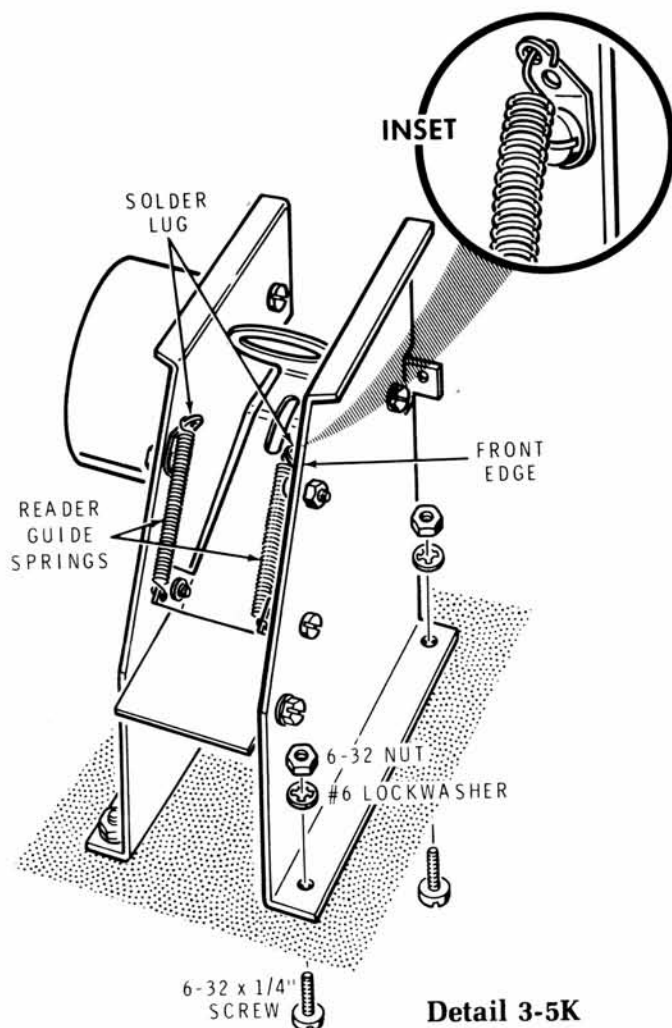

Detail 3-5K

Refer to Pictorial 3-6 (Illustration Booklet, Page 9) for the following steps.

- () Cut both leads of two 6000 μ F, 15-volt, electrolytic capacitors to $3/4$ ".

NOTE: In the following steps, (NS) means not to solder because other wires will be added later. "S-" with a number, such as (S-3) means to solder the connection. The number following the "S" tells how many wires are at the connection.

- () C5: Connect the lead at the plus (+) marked end of a prepared capacitor to terminal strip K lug 1 (NS). Connect the other lead to terminal strip H lug 1 (S-1). Position the capacitor $1/8$ " from the rear panel.

- () C4: Connect the lead at the plus (+) marked end of the other prepared capacitor to terminal strip K lug 2 (NS). Connect the other lead to terminal strip H lug 2 (NS). Position the capacitor $1/8$ " from the rear panel.

- () Cut each lead of the .01 μ F ceramic capacitor to $3/4$ ".

- () C2: Connect the prepared capacitor to terminal strip J between lugs 1 (NS) and 2 (NS).

- () Prepare the following wires.

WIRE	LENGTH
Solid black	12"
Solid black	6"
Green	14"
Orange	11"
Orange	8-1/2"
Orange	12"
Red	8"
Red	6"

- () Connect the 12" solid black wire from terminal strip H lug 2 (S-2) to capacitor C3 lug 2 (NS).

- () Connect the 6" solid black wire to capacitor C3 lug 2 (S-2). Route the free end of the wire as shown. It will be connected later.

- () Connect the 14" green wire to terminal strip K lug 1 (S-2). Route the free end of the wire as shown. It will be connected later.

- () Connect the 11" orange wire from terminal strip K lug 2 (NS) to terminal strip N lug 1 (NS).

- () Connect the 8-1/2" orange wire to terminal strip N lug 1 (S-2). Route the free end of the wire as shown. It will be connected later.

- () Connect the 12" orange wire to terminal strip K lug 2 (S-3). Route the free end of the wire as shown. It will be connected later.

- () Connect the 8" red wire to capacitor C3 lug 1 (NS). Route the free end of the wire as shown. It will be connected later.

- () Connect the 6" red wire to capacitor C3 lug 1 (S-2). Route the free end of the wire as shown. It will be connected later.



NOTE: When you prepare a **stranded** wire, twist the bare ends and melt solder on them to hold the fine wire strands together.

- () Cut the gray and yellow wires of motor M1 (total of four wires) to 4-1/2" and prepare the ends. Measure the wires from where they come out of the motor. See inset drawing #1.
- () Connect the four prepared motor wires to terminal strip N lug 2 (S-4). Route the other motor wires and reader assembly wires as shown.

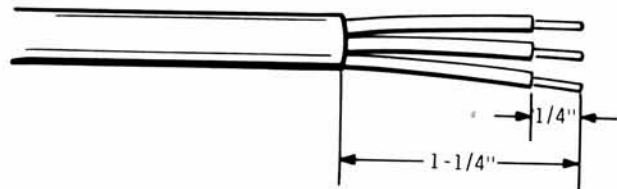

Detail 3-7A

- () Prepare four 2-1/2" black **stranded** wires.

In the following steps, wrap the leads around the lugs to make mechanically secure connections as shown in inset drawing #2.

- () Connect a 2-1/2" stranded wire from switch SW3 lug 2 (S-1) to switch SW2 lug 2 (S-1).
- () Connect a 2-1/2" stranded wire from switch SW3 lug 5 (S-1) to switch SW2 lug 5 (S-1).
- () Connect a 2-1/2" stranded wire from switch SW3 lug 1 (NS) to terminal strip J lug 2 (NS).
- () Connect a 2-1/2" stranded wire from switch SW3 lug 4 (NS) to terminal strip J lug 1 (NS).
- () Prepare both ends of the remaining length of black **stranded** wire.
- () Connect the prepared black stranded wire from fuse block F1 lug 1 (S-1) to terminal strip J lug 1 (S-3). Route the wire as shown.

Refer to Pictorial 3-7 (Illustration Booklet, Page 10) for the following steps.

- () Refer to Detail 3-7A and carefully prepare the end of the line cord as shown. Then, twist the wire strands together and melt a small amount of solder on the bare wire ends.
- () Pass the prepared end of the line cord through hole AA from the lettered side of the rear panel.

In the following steps, wrap the leads around the lugs to make mechanically secure connections.

Connect the line cord leads as follows:

- () Green lead to solder lug G (S-1).
- () Black lead to fuse block F1 lug 2 (S-1).
- () White lead to terminal strip J lug 2 (S-3).
- () Refer to Detail 3-7B and secure the line cord in rear panel hole AA with the strain relief.

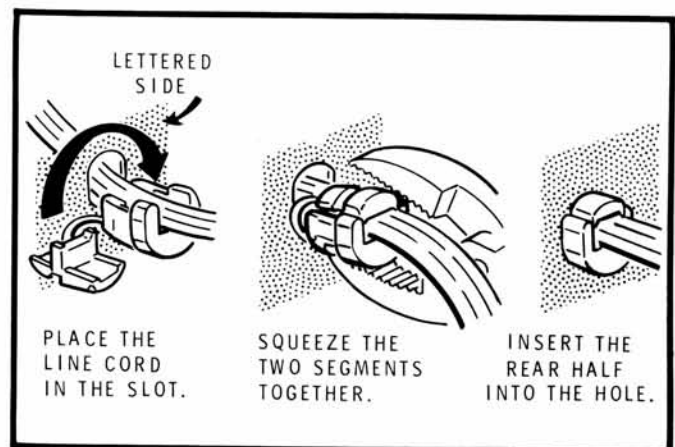

Detail 3-7B



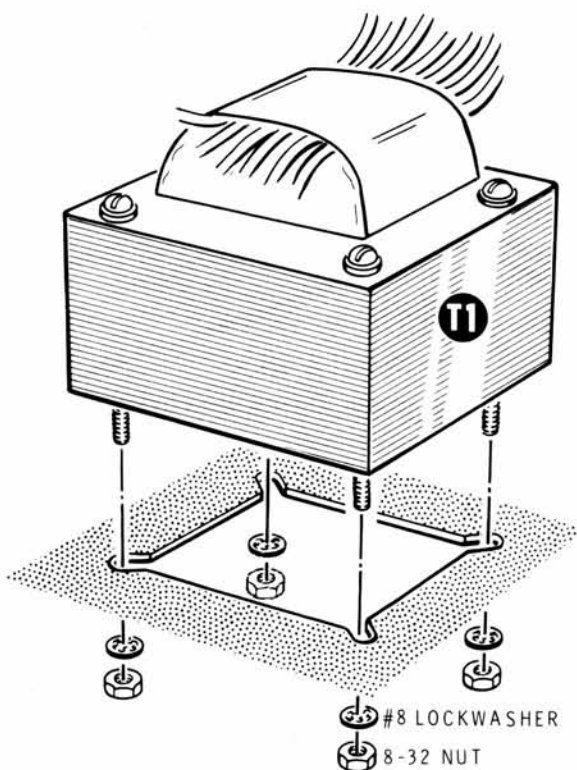

Detail 3-7C

- () T1: Refer to Detail 3-7C and mount the power transformer at T1 with four #8 lockwashers and four 8-32 nuts. Be sure the red, orange, green, and brown leads are positioned as shown in the Pictorial. Do NOT pinch any wires under the transformer.

Connect some of the transformer leads as follows. Position the leads as shown, and down against the chassis. Make mechanically secure connections.

- () Black-red to switch SW3 lug 4 (S-2).
- () Black to switch SW3 lug 1 (S-2).
- () Black-gray to switch SW2 lug 6 (S-1). Be sure you do not use the black-white lead here.
- () Black-white to switch SW2 lug 3 (S-1).
- () Black-yellow to switch SW2 lug 4 (S-1).
- () Black-green to switch SW2 lug 1 (S-1).

- () Bend the transformer leads toward the rear panel and install three cable ties on the transformer leads in the positions shown. See inset drawing #1.
- () Wrap the bare end of each remaining transformer lead with a length of tape (not supplied). Any kind of nonmetallized tape will do; cellophane, masking, electrical, adhesive, etc. See inset drawing #2.

If an ohmmeter is available, perform the following "Resistance Tests." If an ohmmeter is not available, carefully recheck the wiring and chassis for solder bridges, solder splashes, clipped leads, and pinched leads. Then proceed to "Assembly Continued."

RESISTANCE TESTS

- () Connect the ohmmeter common lead to the chassis as shown.
- () Set the ohmmeter to the $R \times 10$ position.
- () Connect the ohmmeter test lead to the three prongs of the line cord, one at a time. The center prong should produce a reading of zero ohms and the other two should read infinite. (If not, recheck the wiring.)
- () Disconnect the ohmmeter test leads.
- () Be sure switch SW3 is set to the proper position; 120 or 240.
- () Position switch SW2 to the LOW position.

NOTE: In the next step, you will momentarily plug the line cord into an AC outlet. Do NOT touch any of the locations marked HIGH VOLTAGE on the Pictorial or an electrical shock will result. The transformer may hum; this is normal. However, the fuse should not blow. If it does; recheck the wiring, remove the problem, and install another fuse. Then reperform the test.

- () Plug in the line cord for a few moments and then unplug it.
- () Position switch SW2 to the NOR position.
- () Again plug in the line cord for a few moments and then unplug it.

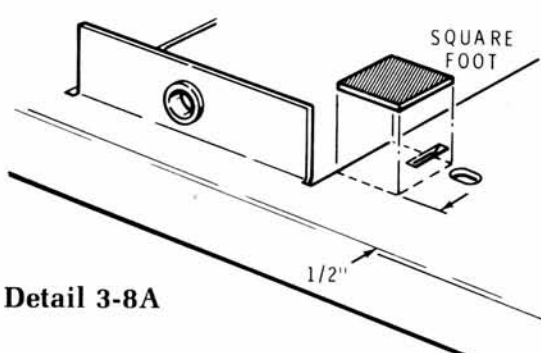

Detail 3-8A

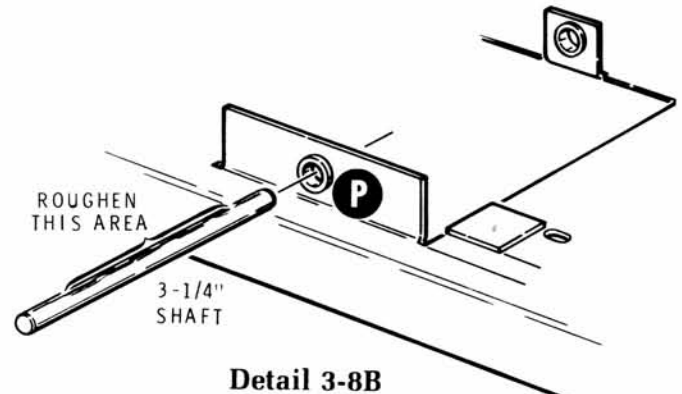

Detail 3-8B

ASSEMBLY CONTINUED

Refer to Pictorial 3-8 (Illustration Booklet, Page 11) for the following steps.

- () Refer to Detail 3-8A, remove the protective backing from a square foot, and press the foot onto the chassis at AA.
- () Refer to Detail 3-8B, use sandpaper, and lightly rough up the center two inches of the 3-1/4" shaft. Make your sanding strokes run lengthwise and not around the shaft.
- () Again refer to Detail 3-8B and slide the 3-1/4" shaft into nylon bearing P. Check to be sure the shaft runs freely in both bearings. If it does not, remove the shaft and reposition the bearings slightly as necessary.
- () Refer to Detail 3-8C and slide the following parts onto end Q of the 3-1/4" shaft in the order given below. Be sure to position each part as shown in the Detail.
- () Aluminum collar — loosely install two 4-40 x 1/8" setscrews in the collar. Use the small allen wrench.
- () 3/16" nylon spacer. Do not use a nylon shoulder washer here.
- () Dog plate and nylon bearing. (See inset drawing #1.) Install the nylon bearing into the dog plate before you slide them onto the shaft.
- () Ratchet gear — loosely install two 6-32 x 1/8" setscrews in the gear.
- () Sprocket and brass collar — loosely install a 6-32 x 1/8" setscrew in the collar.
- () Aluminum collar — install two 4-40 x 1/8" setscrews in the collar and secure the collar 1/4" from end Q of the shaft. See inset drawing #2.

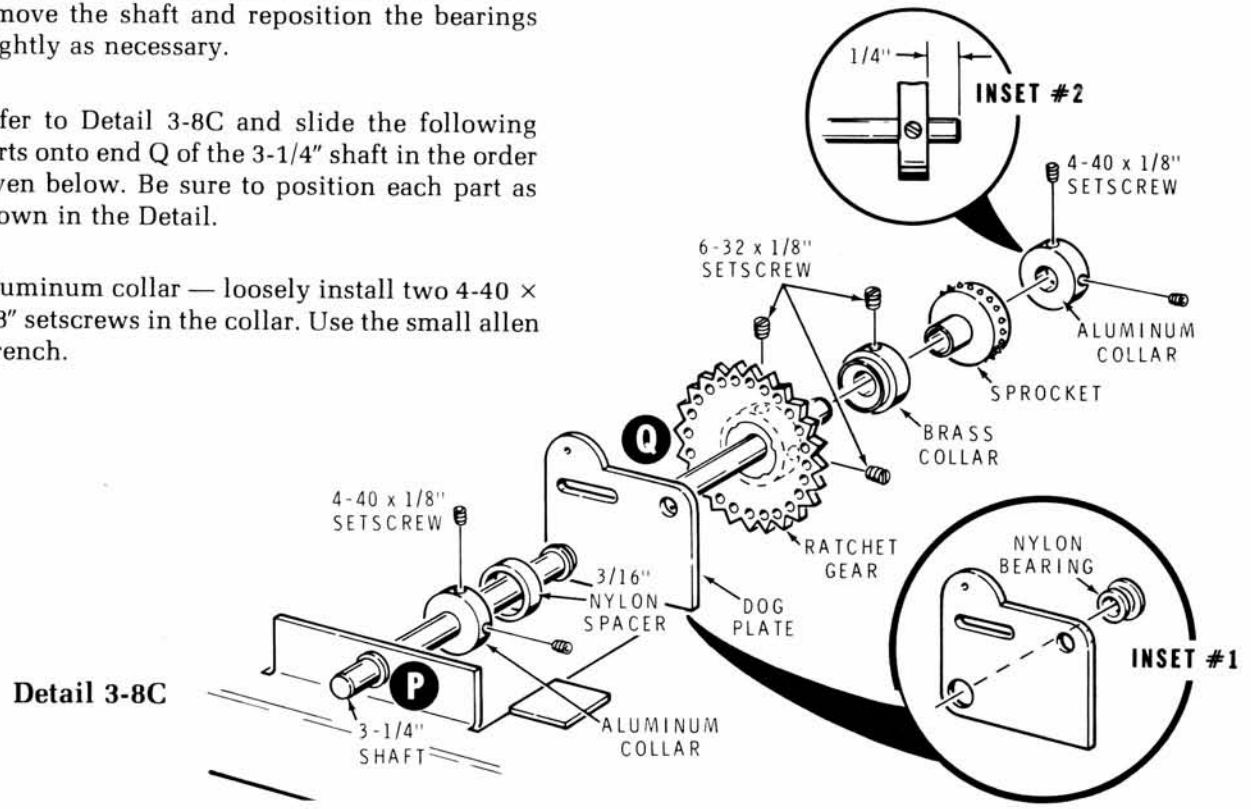

Detail 3-8C

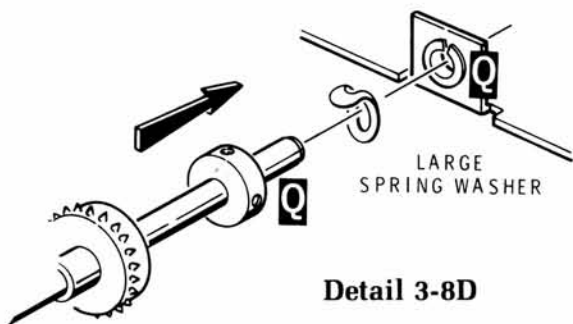

Detail 3-8D

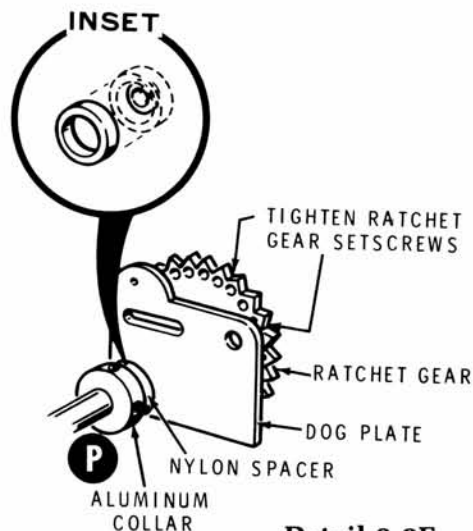

Detail 3-8E

- () Refer to Detail 3-8D, slide a large spring washer onto end Q of the shaft as shown, and insert the shaft end into nylon bearing Q until the spring washer is flat. This preconditions the spring washer. Be sure to position the washer so the curve is as shown.
- () Again, push on end P of the shaft until the spring washer is compressed very slightly. Then slide the loose aluminum collar up against the nylon bearing P as far as it will go and tighten the setscrews in the aluminum collar. When you let go of the shaft, the spring washer should still be compressed slightly. Reperform this adjustment if the spring washer is not compressed. Also, the shaft must be able to rotate freely.
- () Refer to Detail 3-8E and slide the 3/16" nylon spacer, dog plate, and the ratchet gear up against aluminum collar P until they touch and tighten the setscrews in the ratchet gear. Be sure the nylon spacer fits properly over the nylon bearing in the dog plate (see the inset drawing) and the parts are not pushed together too tightly.
- () Again insert the 12" length of paper tape into the punch tape guide (from the rear of the chassis) and position the tape so the leading edge of the tape is protruding slightly from the punch assembly.
- () Move all nine actuators to the left and then back to the right. This will punch nine holes in the paper tape. (One actuator will not move as far as the others.)

- () Refer to Detail 3-8F and push the paper tape farther through the punch assembly and slide the sprocket on its shaft until its teeth are in line with the sprocket hole in the tape. Then tighten the sprocket setscrew.
- () Remove the paper tape.

One of the nine holes you just punched is smaller than the other eight holes. This is the sprocket drive hole. You will use this hole in the next step.

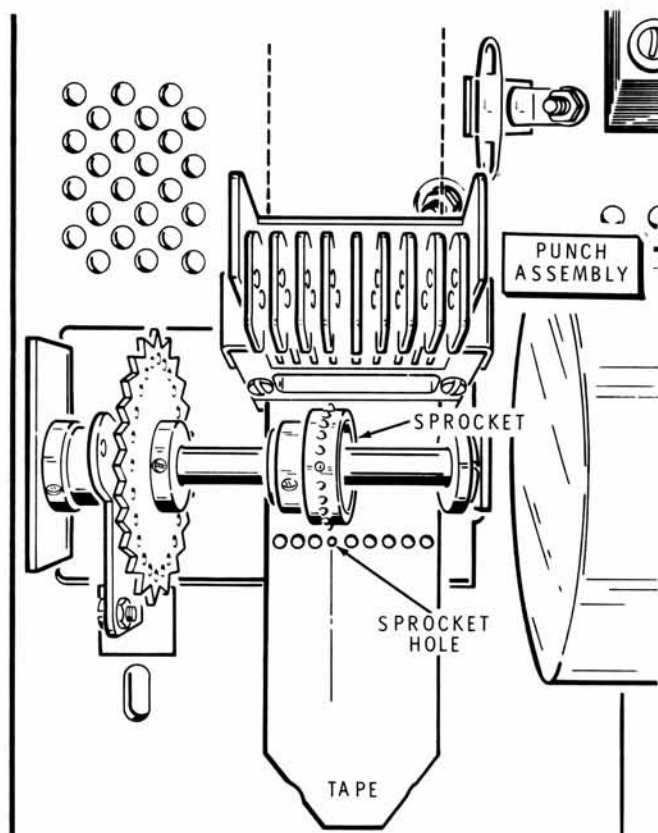

Detail 3-8F



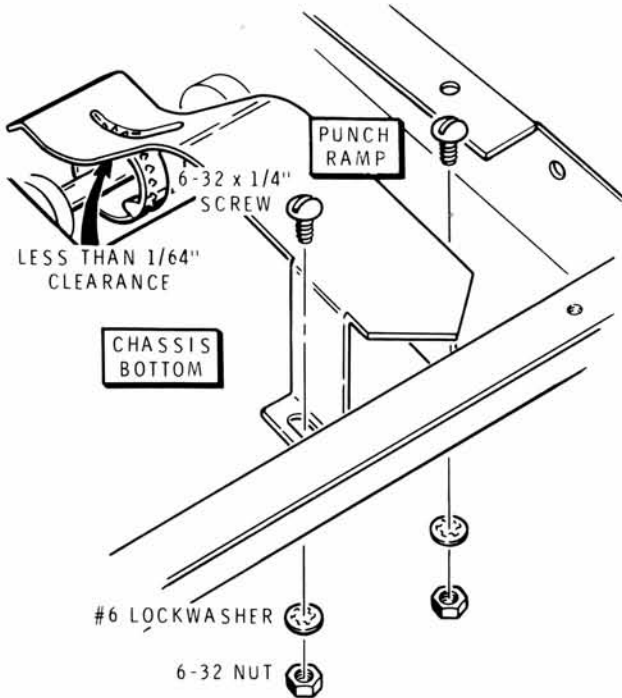

Detail 3-8G

- () Refer to Detail 3-8G, turn the chassis over, and temporarily mount the punch ramp to the chassis with two 6-32 × 1/4" screws, two #6 lockwashers, and two 6-32 nuts. Mount the ramp so the sprocket teeth are centered in the ramp slot.
- () Carefully bend the ramp until it clears the sprocket by less than 1/64".
- () Remove the punch ramp and turn the chassis over.
- () Refer to Detail 3-8H and mount the punch ramp with two 6-32 × 1/4" screws, two #6 lockwashers, and two 6-32 nuts. Mount the ramp so the sprocket teeth are centered in the ramp slot. The ramp should be **pressing** lightly against the sprocket as shown in the inset drawing.

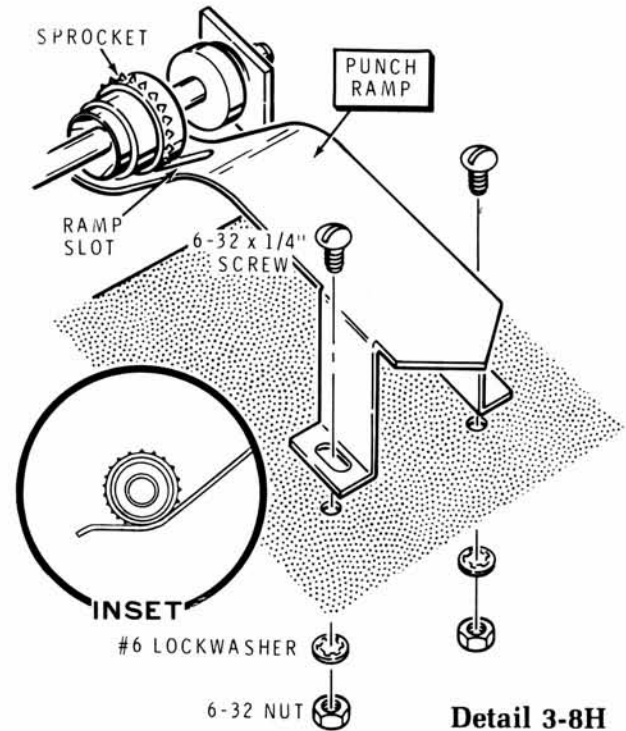

Detail 3-8H

- () Refer to Detail 3-8J and mount the punch tape guide to the punch ramp. Use a 6-32 × 1/4" screw, #6 lockwasher, and 6-32 nut as shown. Position the guide so it does not touch the ramp where the tape will be traveling. There should be approximately 1/32" clearance for the tape between the guide and the ramp. (More clearance may cause the tape to bunch up during humid weather.)

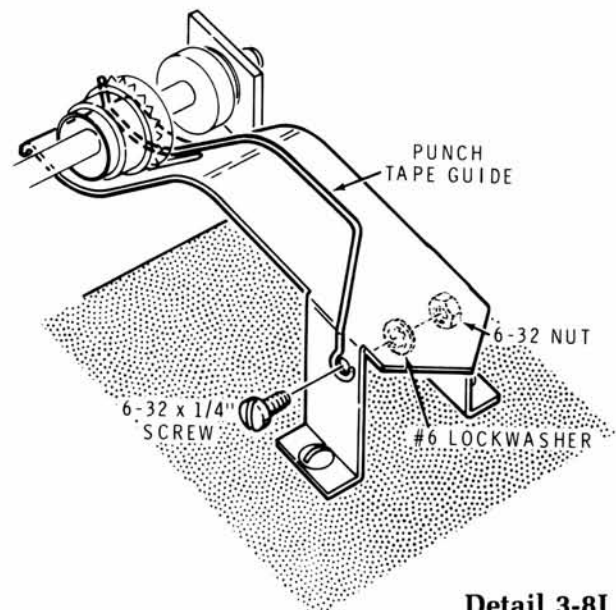

Detail 3-8J

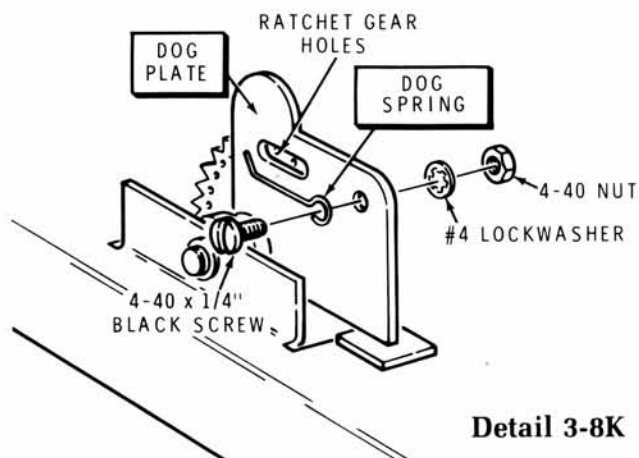

Detail 3-8K

- () Refer to Detail 3-8K and mount the dog spring to the dog plate as shown. Use 4-40 × 1/4" black screws, #4 lockwasher, and 4-40 nut. Be sure the spring contacts the ratchet gear holes and is vertically centered in the holes.
- () Apply silicone grease to the ratchet gear teeth and holes.

Refer to Pictorial 3-9 (Illustration Booklet, Page 11) for the following steps.

- () Position the chassis onto its right side.
- () Refer to Detail 3-9A and mount the roller mounting bracket at AB with a 6-32 × 1/4" screw, #6 lockwasher, and 6-32 nut as shown.
- () Refer to Detail 3-9B and mount two small grommets onto the roller bracket as shown.

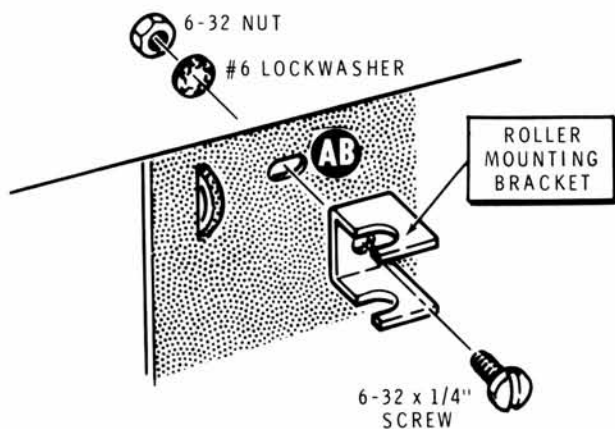

Detail 3-9A

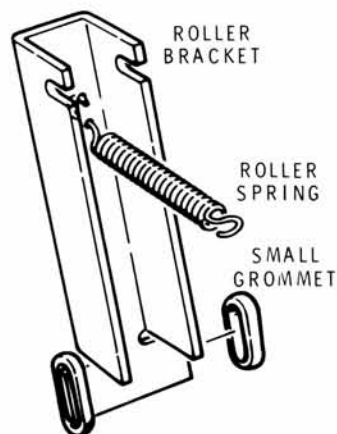

Detail 3-9B

- () Again refer to Detail 3-9B, position the roller bracket as shown, and install one end of the roller spring into the roller bracket as shown. Bend the end of the spring as necessary. Use long-nose pliers.
- () Refer to Detail 3-9C, position the roller bracket near the roller mounting bracket, and connect the free end of the spring to the chassis as shown.
- () Refer to part A of Detail 3-9D (Illustration Booklet, Page 11) and slide the roller into the roller bracket slots. Then refer to part B of the Detail and position the roller bracket into the roller mounting bracket notches. The roller should fit into the ratchet gear.
- () Apply silicone grease to the roller.
- () Set the chassis right side up again.

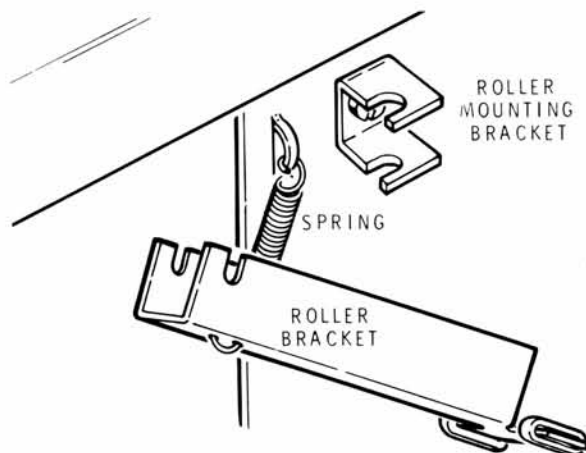

Detail 3-9C

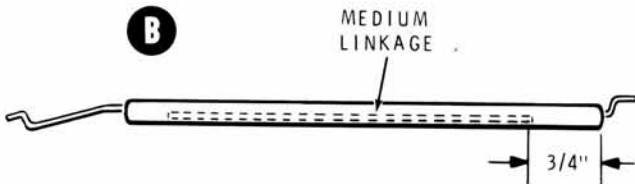
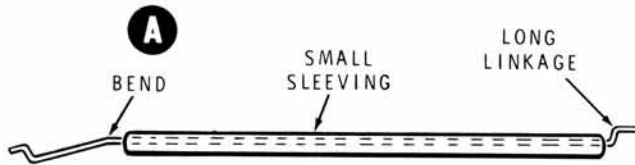

Detail 3-10A

Refer to Pictorial 3-10 (Illustration Booklet, Page 12) for the following steps.

In the following steps, you will shrink lengths of small sleeving onto linkages. The steps will tell you to preheat an oven and use its heat to do the shrinking. However, you may use a cigarette lighter, soldering iron, matches, or other heat source if you wish. However, be careful that you do not melt the sleeving if you use one of the other heat sources.

- () Preheat an oven to 250°F. NOTE: Do not use an RF (microwave) oven.
- () Cut six 5" lengths of small sleeving.
- () Refer to part A of Detail 3-10A, position a long linkage with its indicated bend as shown, and slide a length of small sleeving over the linkage as shown.
- () Refer to part B of Detail 3-10A and slide a medium linkage into the sleeving. Position the linkage 3/4" from one end of the sleeving as shown. Push it in with a length of wire.
- () In a similar manner, prepare the other five long and medium linkages.
- () Place the six prepared linkage combinations on a cookie sheet (or other similar item) and place them in the oven for five minutes. The sleeving should shrink down over the linkages and hold them together.

- () Turn off the oven and remove the linkages from the oven.

In the following steps, the linkage combinations will be called "long linkages."

- () Coat the exposed metal ends of the long linkages and the ends of the short linkages with silicone grease.

NOTES:

1. The long linkages have a bend near one end. Be sure you install this end in the following steps.
 2. The actuators have two holes. After you install a linkage in a hole of one actuator, be sure to use the opposite hole of the next actuator. This will stagger the linkages properly.
 3. Insert the following linkages from the proper side of the actuator as shown in Detail 3-10B. The steps will tell you when to install linkages from the other side.
 4. Position the linkages as shown in Pictorial 3-10. The linkages in this and other Pictorials are shown curved so you can more clearly see where they go.
- () Refer to Detail 3-10B and install the bent end of a long linkage in the bottom hole of actuator #9. Move the actuator as necessary and install the linkage from the side shown.
 - () Install the bent end of a long linkage in the top hole of actuator #8.
 - () Install the bent end of a long linkage in the bottom hole of actuator #7.

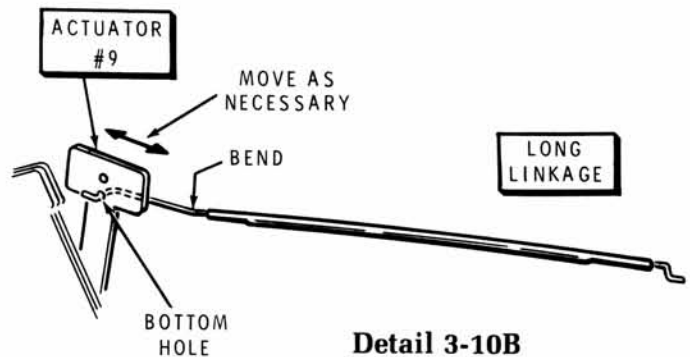

Detail 3-10B





NOTE: The short linkages have a 1/4" end and a 1/8" end. Be sure to use the 1/4" ends in the next three steps.

- () Install the 1/4" end of a small linkage in the top hole of actuator #6.
- () Install the 1/4" end of a small linkage in the bottom hole of actuator #5.
- () Install the 1/4" end of a small linkage in the top hole of actuator #4.

NOTE: Install the next three linkages from the opposite side of the actuators. See the inset drawing on Pictorial 3-10.

- () Install the bent end of a long linkage in the bottom hole of actuator #3.
- () Install the bent end of a long linkage in the top hole of actuator #2.
- () Install the bent end of a long linkage in the bottom hole of actuator #1.
- () Refer to Detail 3-10C and install three large grommets in solenoid bracket F. This bracket is marked with an "F."
- () In a similar manner, install large grommets in the other two solenoid brackets and set these brackets aside.
- () Locate the ten solenoids, the ten small-hole spade bolts, and the tube of thread-locking sealant.

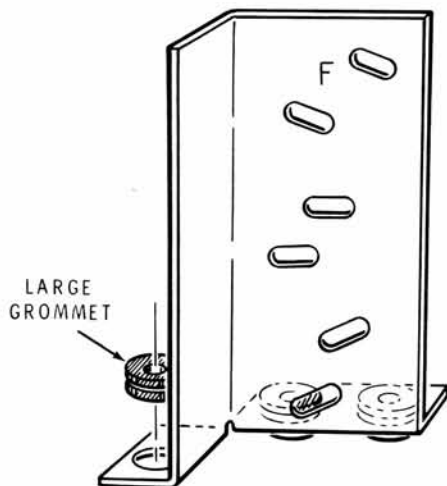

Detail 3-10C

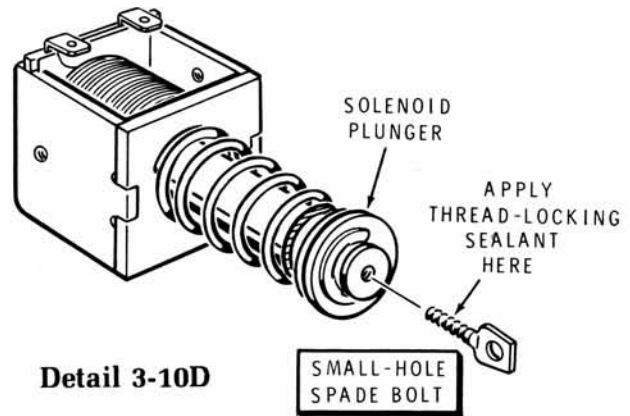

Detail 3-10D

- () Remove any restraining material from the solenoids so the plungers can operate.
- () Refer to Detail 3-10D, put a drop of thread-locking sealant on a spade bolt, and turn it all the way into a solenoid plunger.
- () In a similar manner, install the other nine spade bolts in the other nine solenoids.
- () L9: Refer to Detail 3-10E, and loosely mount a solenoid to solenoid bracket F at L9 with two 6-32 x 1/4" allen head screws and two #6 large lockwashers. Use the large allen wrench if necessary. Be sure the solenoid lugs are positioned as shown.

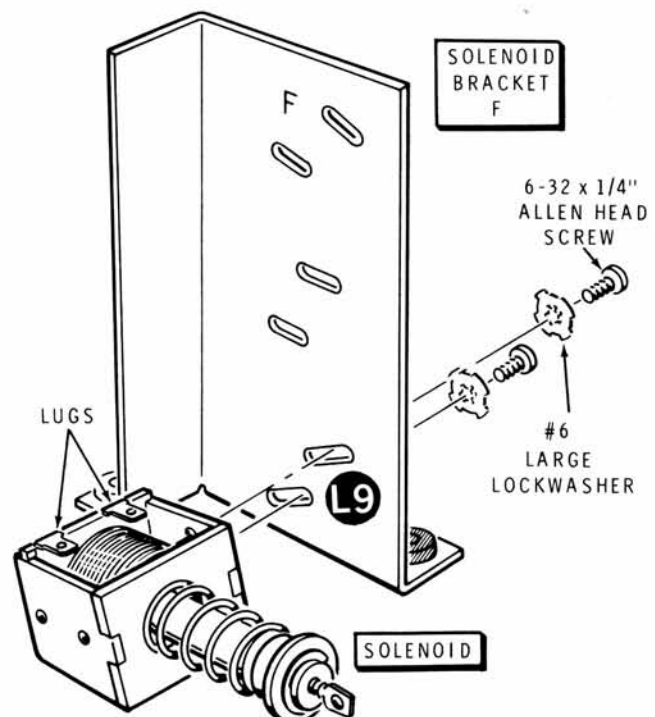

Detail 3-10E

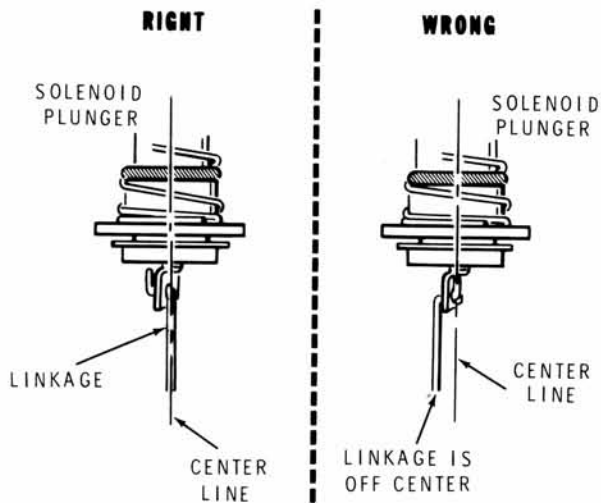

Detail 3-10F

NOTE: When you connect a linkage to a solenoid, make sure the center line of the linkage lines up with the center of the solenoid plunger. (See Detail 3-10F.)

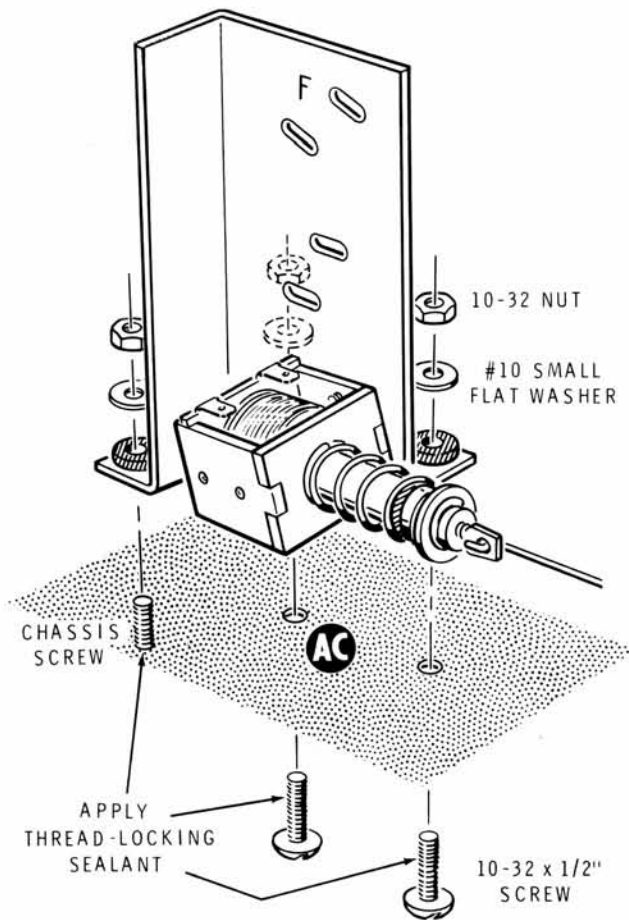

Detail 3-10G

- () Connect solenoid L9 to the short linkage coming from actuator #4.
- () Refer to Detail 3-10G and mount solenoid bracket F at AC with two 10-32 x 1/2" screws, three #10 small flat washers, and three 10-32 nuts. Apply thread-locking sealant to the two mounting screws and the chassis screw, and only tighten the nuts until the grommets compress slightly. Do not pinch any wires between the bracket and the chassis.
- () Refer to Detail 3-10H and push in the plunger of solenoid L9 as far as it will go. Then slide the solenoid in the bracket until the edge of the actuator is 1/4" from its resting position as shown. Tilt the solenoid so the plunger and linkage are in a straight line and then tighten the solenoid screws with the large allen wrench. Manually operate the solenoid to be sure it operates freely.

NOTE: When you connect wires to solenoids, route them so they are not pinched between parts and so they are away from moving parts. Also, be sure you make good connections. They will be very difficult to check later.

- () Refer to Pictorial 3-10, position the main circuit board near the chassis as shown, route the indicated circuit board wires as shown, and connect the white wire to solenoid L9 lug 1 (S-1). See Detail 3-10J.
- () Prepare two 4" red wires and a 7" red wire.

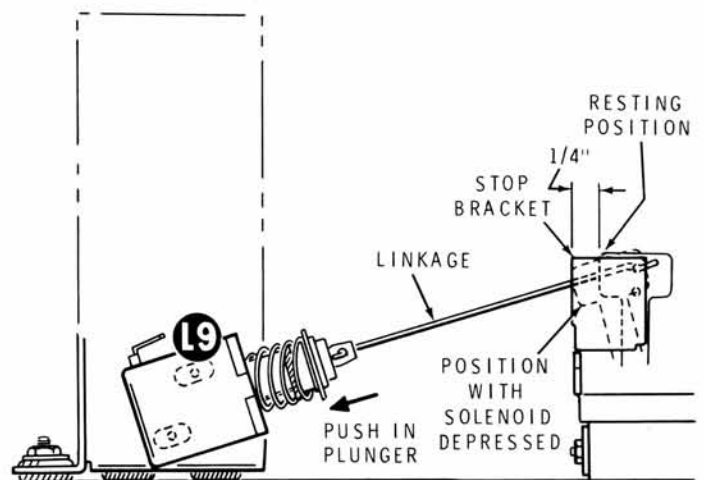

Detail 3-10H

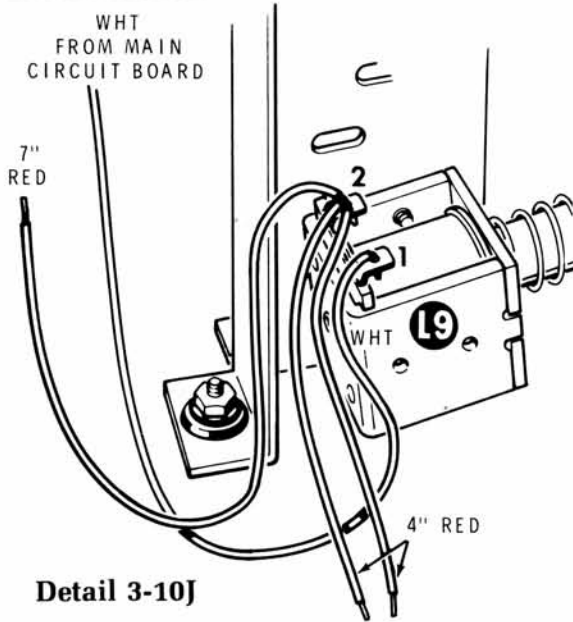

Detail 3-10J

() Again refer to Detail 3-10J and connect one end of each of the three prepared red wires to solenoid L9 lug 2 (S-3).

() L4: Refer to Detail 3-10K and, as before, connect solenoid L4 to the linkage coming from actuator #5. Then loosely mount the solenoid to the solenoid bracket with two 6-32 × 1/4" allen head screws and two #6 large lockwashers, and make the adjustment as shown in Detail 3-10H. Tilt the solenoid so the plunger and linkage are in a straight line and then tighten the screws. Manually operate the solenoid to be sure it operates freely.

() Again refer to Detail 3-10K and connect one of the shorter red wires coming from solenoid L9 lug 2 to solenoid L4 lug 2 (NS). (The other shorter red wire will be connected later.)

() Prepare a 4" red wire and connect one end to solenoid L4 lug 2 (S-2).

() Connect the main circuit board yellow wire to solenoid L4 lug 1 (S-1).

() L5: Refer to Detail 3-10L and, as before, connect a solenoid to the linkage coming from actuator #6. Then loosely mount the solenoid to the solenoid bracket at L5 with two #6 × 1/4" allen head screws and two #6 large lockwashers, make the adjustment as shown in Detail 3-10H, and tighten the screws. Manually operate the solenoid to be sure it operates freely.

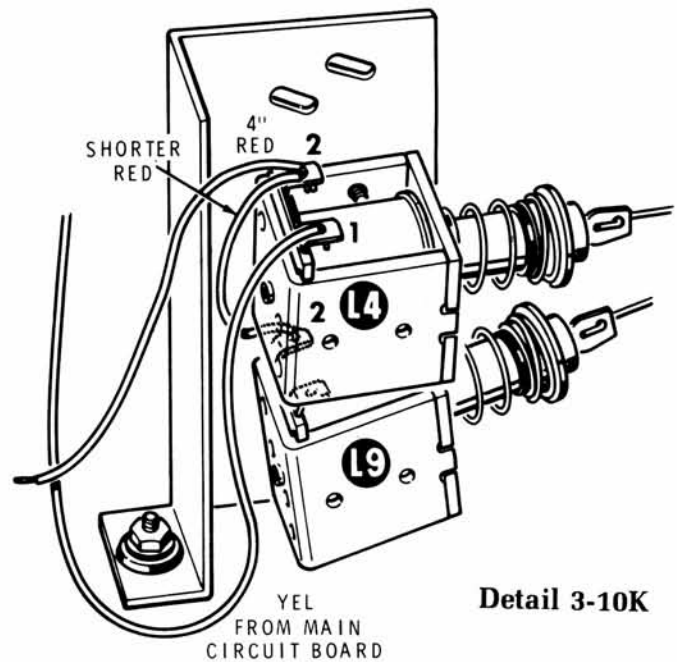

Detail 3-10K

() Again refer to Detail 3-10L and connect the free end of the red wire coming from solenoid L4 lug 2 to solenoid L5 lug 2 (S-1).

() Connect the green main circuit board wire to solenoid L5 lug 1 (S-1).

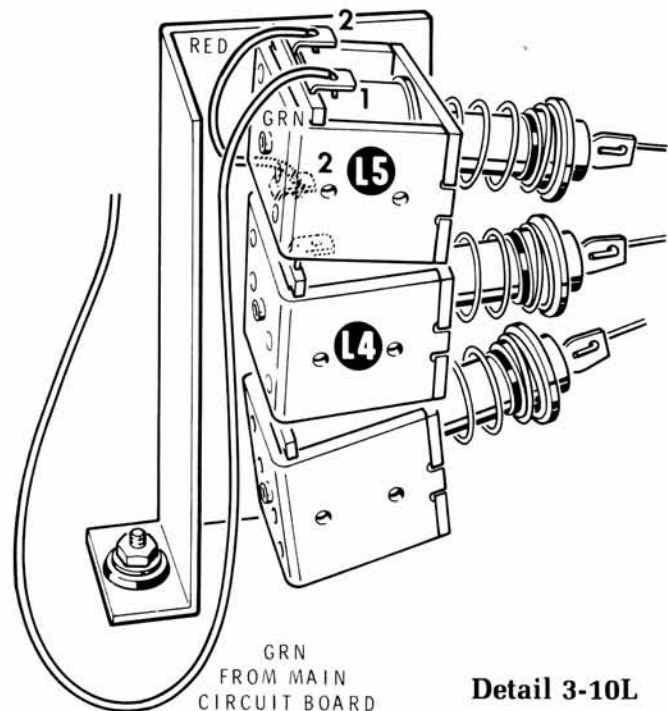

Detail 3-10L



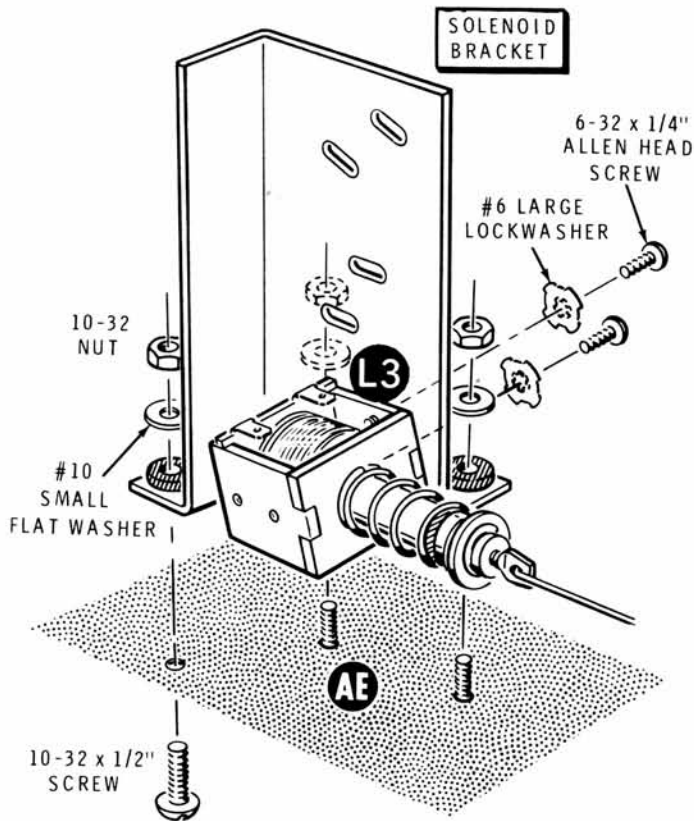

Detail 3-11A

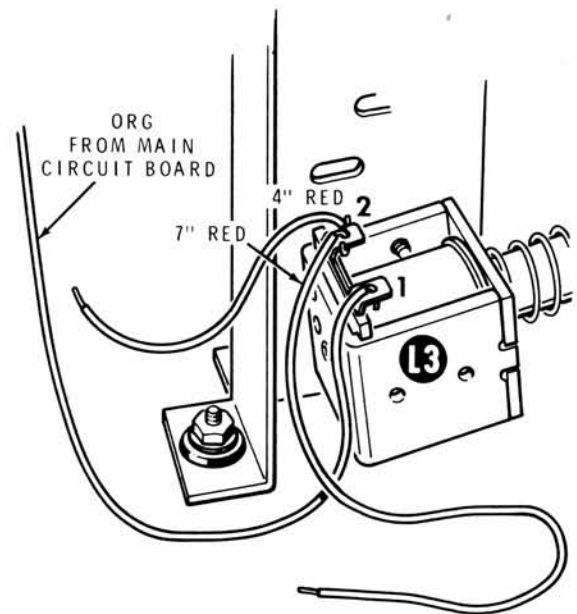

Detail 3-11B

Refer to Pictorial 3-11 (Illustration Booklet, Page 13) for the following steps.

- () L3: Refer to Detail 3-11A and, as before, loosely mount a solenoid to another solenoid bracket at L3 with two 6-32 \times 1/4" allen head screws and two #6 large lockwashers.
- () Connect solenoid L3 to the linkage coming from actuator #3. Insert it as shown in Detail 3-11A.
- () Again refer to Detail 3-11A and mount the solenoid bracket at AE with one 10-32 \times 1/2" screw, three #10 small flat washers, and three 10-32 nuts. Apply thread-locking sealant to the three mounting screws and only tighten the nuts until the grommets compress slightly.

- () As before, make the adjustment as shown in Detail 3-10H and tighten the screws. Manually operate the solenoid to be sure it operates freely.
- () Prepare a 4" red wire and a 7" red wire.

Refer to Detail 3-11B for the next two steps.

- () Connect one end of each of the two prepared red wires to solenoid L3 lug 2 (S-2).
- () Connect the main circuit board orange wire to solenoid L3 lug 1 (S-1).

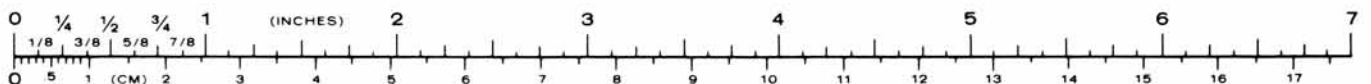

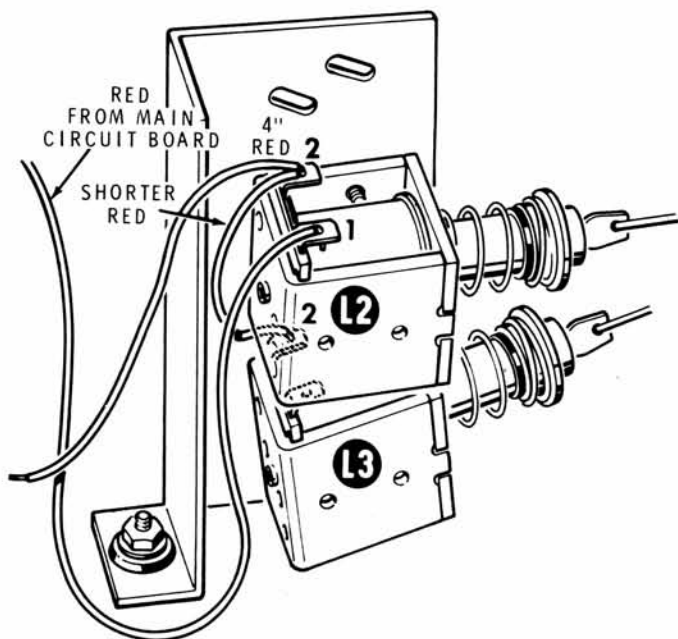

Detail 3-11C

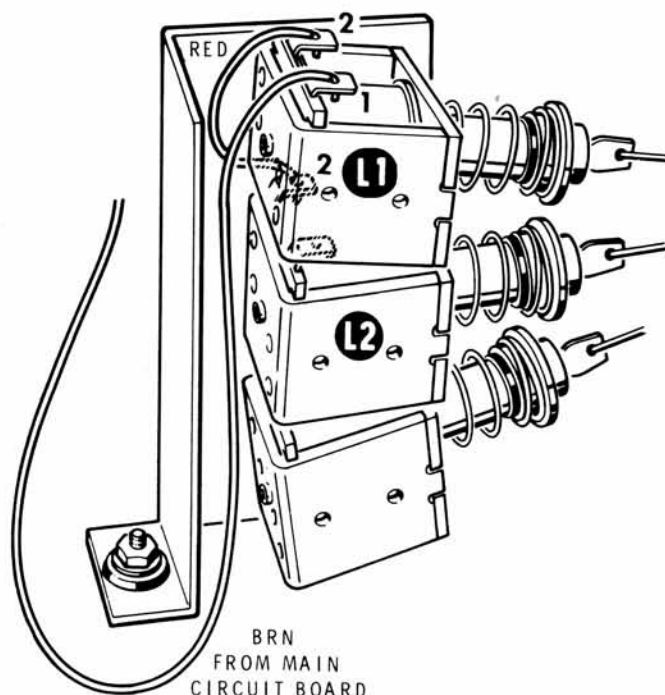

Detail 3-11D

- () L2: Refer to Detail 3-11C and, as before, connect a solenoid to the linkage coming from actuator #2. Then loosely mount the solenoid to the solenoid bracket at L2 with two #6 × 1/4" allen head screws and two #6 large lockwashers, make the adjustment shown in Detail 3-10H, and tighten the screws. Manually operate the solenoid to be sure it operates freely.
- () Again, refer to Detail 3-11C and connect the free end of the shorter red wire coming from solenoid L3 lug 2 to solenoid L2 lug 2 (NS).
- () Prepare a 4" red wire and connect one end to solenoid L2 lug 2 (S-2).
- () Connect the main circuit board red wire to solenoid L2 lug 1 (S-1). Disregard the red wire coming from capacitor C3.
- () L1: Refer to Detail 3-11D and, as before, connect a solenoid to the linkage coming from actuator #1. Then loosely mount the solenoid to the solenoid bracket at L1 with two 6-32 × 1/4" allen head screws and two #6 large lockwashers, make the adjustments shown in Detail 3-10H, and tighten the screws. Manually operate the solenoid to be sure it operates freely.
- () Again refer to Detail 3-11D and connect the free end of the red wire coming from solenoid L2 lug 2 to solenoid L1 lug 2 (S-1).
- () Connect the main circuit board brown wire to solenoid L1 lug 1 (S-1).

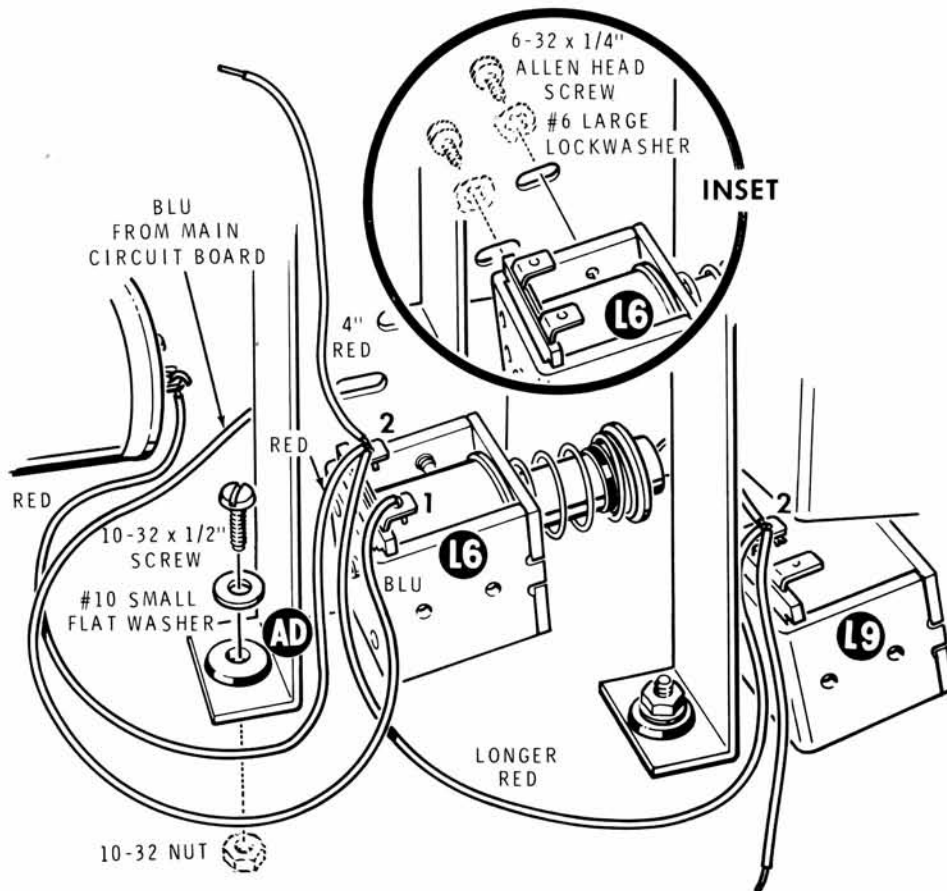

Detail 3-12A

Refer to Pictorial 3-12 (Illustration Booklet, Page 13) for the following steps.

- () L6: Refer to the inset drawing in Detail 3-12A and, as before, loosely mount a solenoid to another solenoid bracket at L6 with two 6-32 × 1/4" allen head screws and two #6 large lockwashers.

Refer to Detail 3-12A for the next five steps.

- () 1. Prepare a 4" red wire and connect one end to solenoid L6 lug 2 (NS).
- () 2. Set the solenoid and its bracket into the chassis and lay it back against capacitor C3.
- () 3. Connect the red wire coming from capacitor C3 to solenoid L6 lug 2 (NS).

- () 4. Connect the longer red wire coming from solenoid L9 lug 2 to solenoid L6 lug 2 (S-3).
- () 5. Connect the main circuit board blue wire to solenoid L6 lug 1 (S-1).
- () As shown in the Pictorial, connect solenoid L6 to the linkage coming from actuator #7.
- () Mount the solenoid bracket at AD with three 10-32 × 1/2" screws, three #10 small flat washers, and three 10-32 nuts. Apply thread-locking sealant to the three mounting screws and only tighten the nuts until the grommets compress slightly. Be careful; do not pinch any wires between the metal parts.
- () As before, make the adjustment shown in Detail 3-10H and tighten the screws. Manually operate the solenoid to be sure it operates freely.

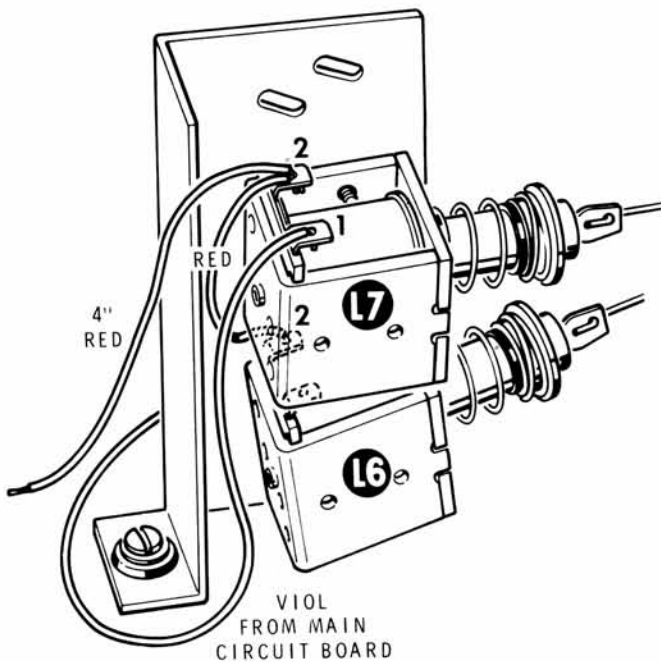

Detail 3-12B

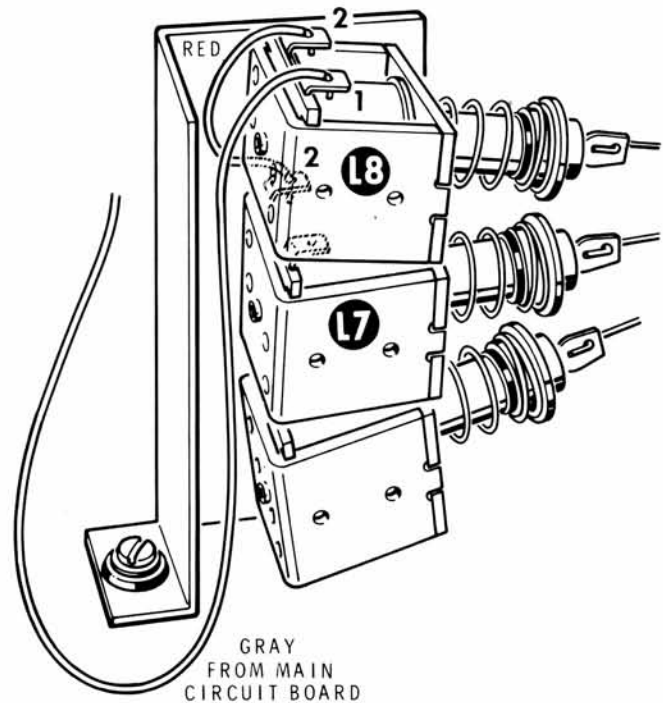

Detail 3-12C

Refer to Detail 3-12B for the next four steps.

- () 1. L7: As before, connect a solenoid to the linkage coming from actuator #8. Then loosely mount the solenoid to the solenoid bracket at L7 with two 6-32 \times 1/4" allen head screws and two #6 large lockwashers, make the adjustment shown in Detail 3-10H, and tighten the screws. Manually operate the solenoid to be sure it operates freely.
- () 2. Connect the free end of the red wire coming from solenoid L6 lug 2 to solenoid L7 lug 2 (NS).
- () 3. Prepare a 4" red wire and connect one end to solenoid L7 lug 2 (S-2).
- () 4. Connect the main circuit board violet wire to solenoid L7 lug 1 (S-1).

Refer to Detail 3-12C for the following steps.

- () L8: As before, connect a solenoid to the linkage coming from actuator #9. Then loosely mount the solenoid to the solenoid bracket at L8 with two 6-32 \times 1/4" allen head screws and two #6 large lockwashers, make the adjustment shown in Detail 3-10H, and tighten the screws. Manually operate the solenoid to be sure it operates freely.
- () Connect the free end of the red wire coming from solenoid L7 lug 2 to solenoid L8 lug 2 (S-1).
- () Connect the main circuit board gray wire to solenoid L8 lug 1 (S-1).



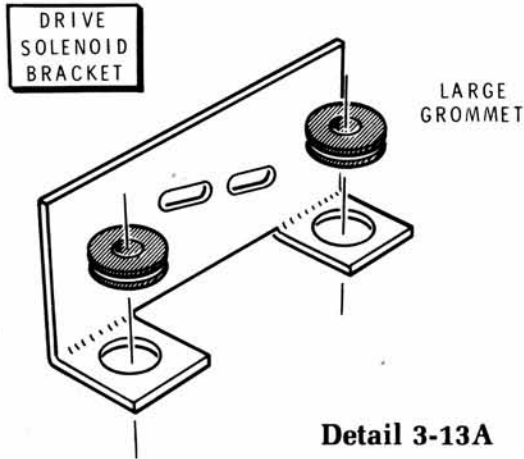

Detail 3-13A

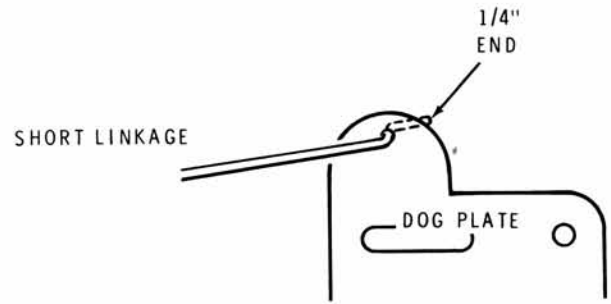

Detail 3-13C

Refer to Pictorial 3-13 (Illustration Booklet, Page 14) for the following steps.

- () Refer to Detail 3-13A and install two large grommets in the drive solenoid bracket.
- () L10: Refer to Detail 3-13B and loosely mount a solenoid to the bracket with two 8-32 x 3/16" screws and two #8 lockwashers as shown. Position it as far to the right in the bracket as possible.
- () Refer to Detail 3-13C and install the 1/4" end of a short linkage in the dog plate as shown.
- () As before, connect solenoid L10 to the free end of the short linkage.
- () Refer to Detail 3-13D and mount the drive solenoid bracket at AF with two 10-32 x 1/2" screws, two #10 small flat washers, and two 10-32 nuts. Apply thread-locking sealant to both screws.

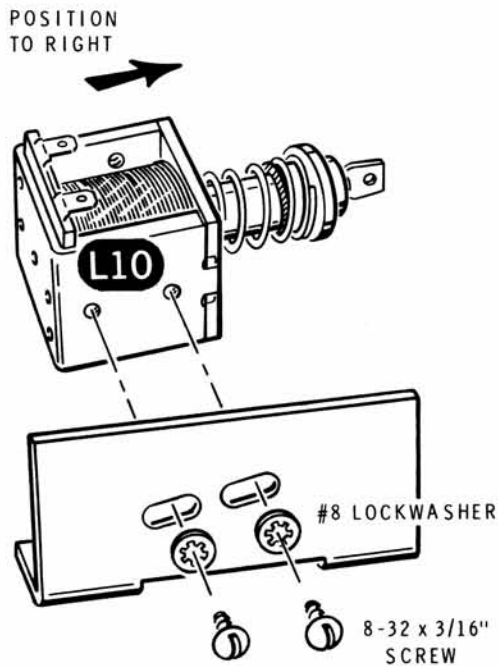

Detail 3-13B

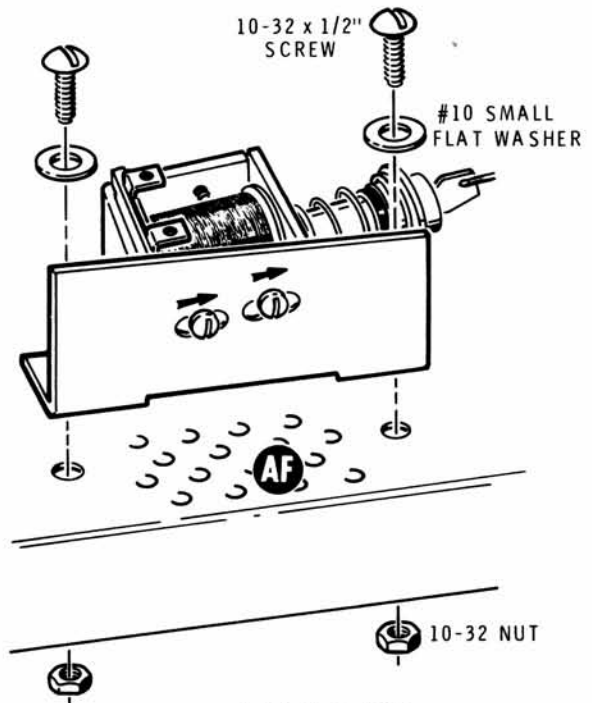

Detail 3-13D



- () Refer to Detail 3-13E, loosen screw AB, and adjust the roller mounting bracket for the 1/64" to 1/32" clearance as shown in the inset drawing. Then securely tighten the bracket screw. Firmly hold the bracket in place as you tighten the screw to prevent it from turning and "off centering" the detent roller on the detent. Be sure the dog spring is centered vertically in the ratchet gear hole as shown in the inset drawing.
- () Again, refer to Detail 3-13E and manually depress the solenoid plunger. The ratchet will advance one step. While you hold the plunger in, adjust the solenoid again for a 1/64" to 1/32" clearance in this new position. Then tighten the solenoid mounting screws.
- () Manually operate the solenoid several times. The plunger should freely return to its resting position. If it does not, loosen the ratchet gear setscrews, move the gear away from the dog plate slightly, and then retighten the setscrews.
- () Connect the free end of the red wire coming from solenoid L9 lug 2 to solenoid L10 lug 2 (NS).
- () Connect the free end of the red wire coming from solenoid L3 lug 2 to solenoid L10 lug 2 (NS).
- () Cut both leads of the 1N4746A diode (#56-605) to 1/2".
- () Cut both leads of the 1N4002 diode (#57-65) to 1/2".
- () D26: Connect the lead at the banded end of the 1N4002 diode (#57-65) to solenoid L10 lug 2 (S-3). Position the diode as shown in Pictorial 3-13.
- () Connect the main circuit board white-black wire to solenoid L10 lug 1 (NS).
- () D27: Connect the lead at the banded end of the 1N4746A diode (#56-605) to solenoid L10 lug 1 (S-2).
- () Connect together the free leads of the diodes and solder the connection.
- () Position all wires away from the solenoids and solenoid brackets so that vibration and solenoid action will not wear on the wire insulation.

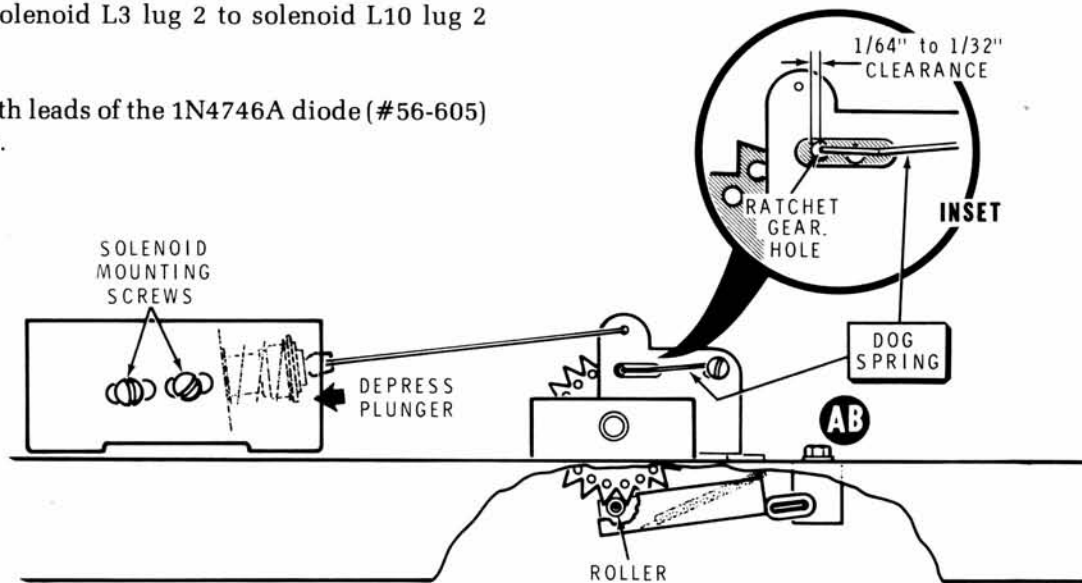

Detail 3-13E



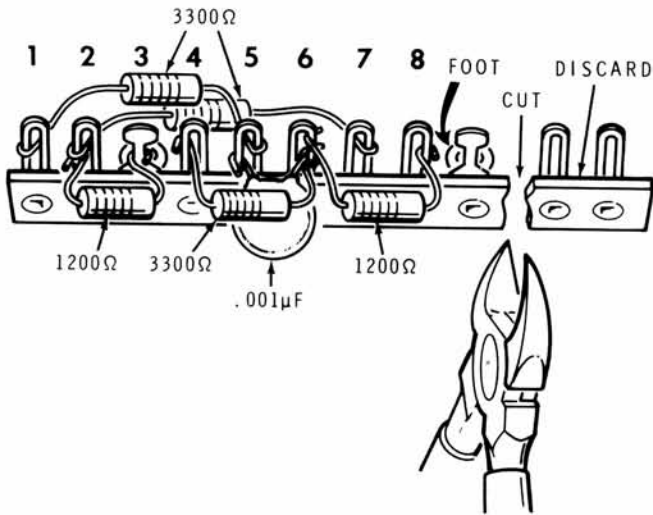

PICTORIAL 3-14

Refer to Pictorial 3-14 for the following steps.

- () Position the 11-lug terminal strip so its feet are as shown and cut off and discard the indicated 2-lug section of the terminal strip. Use diagonal cutters.

NOTE: In the following steps, you will connect parts to the terminal strip.

- () R98: Cut both leads of a 1200 Ω resistor (brown-red-red) to 1/2". Then connect the resistor between lugs 2 (NS) and 3 (NS).
- () R95: Cut both leads of a 3300 Ω resistor (orange-orange-red) to 1/2". Then connect the resistor between lugs 4 (NS) and 6 (NS).
- () R96: Cut both leads of a 1200 Ω resistor (brown-red-red) to 1/2". Then connect the resistor between lugs 6 (NS) and 8 (NS).
- () R97: Connect a 3300 Ω resistor (orange-orange-red) between lugs 2 (S-2) and 7 (S-1).
- () R99: Connect a 3300 Ω resistor (orange-orange-red) between lugs 1 (NS) and 5 (NS).
- () C18: Connect a .001 μF ceramic capacitor between lugs 5 (S-2) and 6 (S-3).

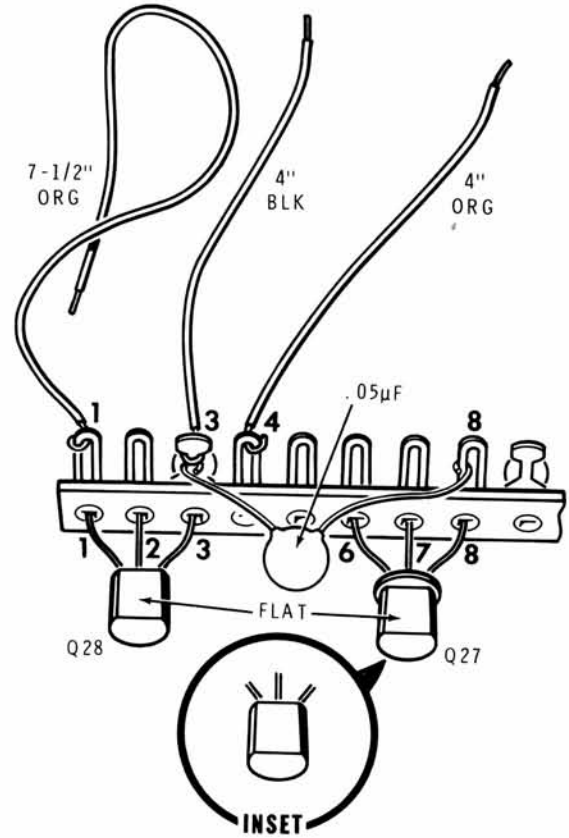

PICTORIAL 3-15

Refer to Pictorial 3-15 for the following steps.

- () C19: Connect a .05μF ceramic capacitor between lugs 3 (NS) and 8 (NS) of the terminal strip. Be sure its leads do not touch other component leads.

- () Prepare the following wires:

COLOR	LENGTH
Orange	7-1/2"
Black	4"
Orange	4"

In the following steps, you will connect one end of the prepared wires to the terminal strip. The free ends will be connected later.

- () 7-1/2" orange to lug 1 (S-2).
- () 4" black to lug 3 (S-3).
- () 4" orange to lug 4 (S-2).



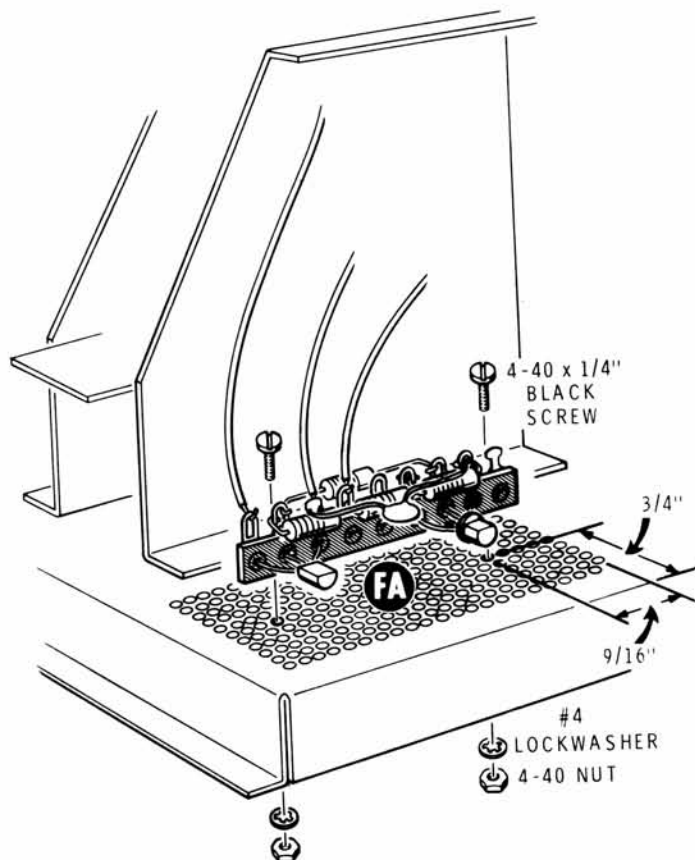

PICTORIAL 3-16

NOTE: In the following steps, use the eyelets and not the lugs. Insert the leads through the eyelets and solder the connections.

- () Q28: Position the MPSA20 transistor (#417-801) with its flat up as shown; insert the leads into eyelets 1, 2, and 3; and solder the connections.
- () Q27: In a similar manner, mount the X29A829 transistor (#417-201) in eyelets 6, 7, and 8. (NOTE: The transistor may also look like the one in the inset drawing.)
- () Cut off any excess lead lengths and be sure no bare leads are touching together or are touching adjacent lugs.
- () Refer to Pictorial 3-16 and mount the prepared terminal strip to the chassis at FA as shown; use the chassis holes shown. Also, use two 4-40 × 1/4" black screws, two #4 lockwashers, and two 4-40 nuts.

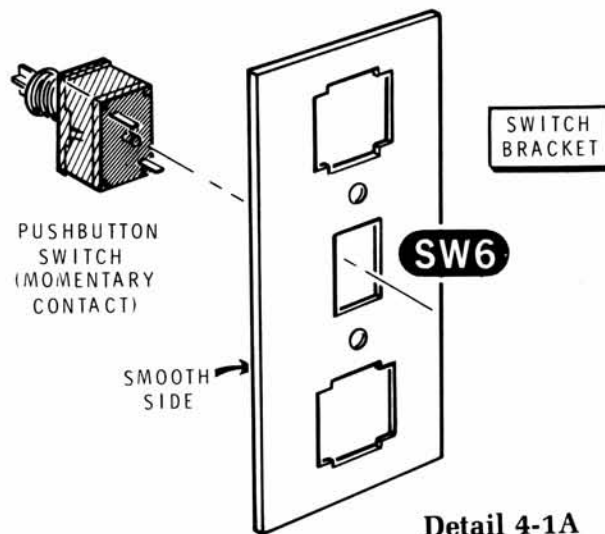

Detail 4-1A

Refer to Pictorial 4-1 (Illustration Booklet, Page 14) for the following steps.

- () SW6: Refer to Detail 4-1A and mount the momentary contact pushbutton switch in the switch bracket at SW6. The bracket is symmetrical. You can position it either way. However, the bracket is punched and has a rough side and a smooth side. Mount the switch from the smooth side.
- () SW7, SW5: As before, mount the latching pushbutton switches at SW7 and SW5. Be sure the indicated switch wires are positioned as shown in the Pictorial.
- () Prepare the following wires:

COLOR	LENGTH
Black	2"
Black	2"
Black	10-1/2"
Brown	7-1/4"
Blue	9-1/2"

In the following steps, you will connect the prepared wires to the switches. The free ends of wires will be connected later. Do not use too much heat. The switch cases melt easily.

- () 2" black from SW7 lug 2 (S-1) to SW6 lug 2 (NS).
- () 2" black from SW6 lug 2 (S-2) to SW5 lug 2 (NS).
- () 10-1/2" black to SW5 lug 2 (S-2).

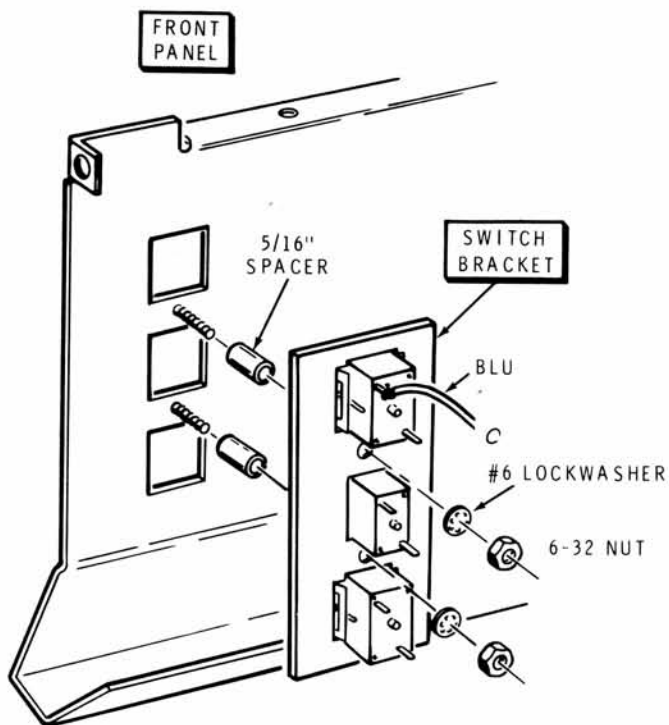

Detail 4-1B

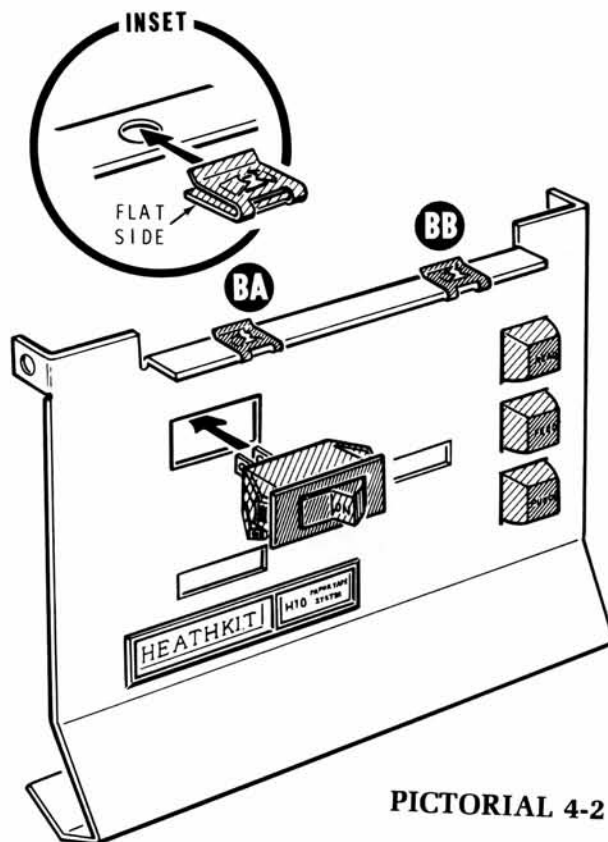

PICTORIAL 4-2

- () 7-1/4" brown to SW5 lug 1 (S-1).
- () 9-1/2" blue to SW7 lug 1 (S-1).
- () Install a cable tie around the wires 2" from the end of the blue wire as shown.
- () Refer to Detail 4-1B and mount the switch bracket to the front panel with two 5/16" spacers, two #6 lockwashers, and two 6-32 nuts. Be sure the blue wire is positioned as shown.
- () Push knobs onto the three switches.
- () Remove the READ label from the switch labels and apply it to the knob on switch SW7.
- () Apply the FEED label to the knob of switch SW6.
- () Apply the PUNCH label to the knob of switch SW5.

Refer to Pictorial 4-2 for the following steps.

- () Refer to Detail 4-2A and mount the nameplate to the front panel with two push-on nuts.

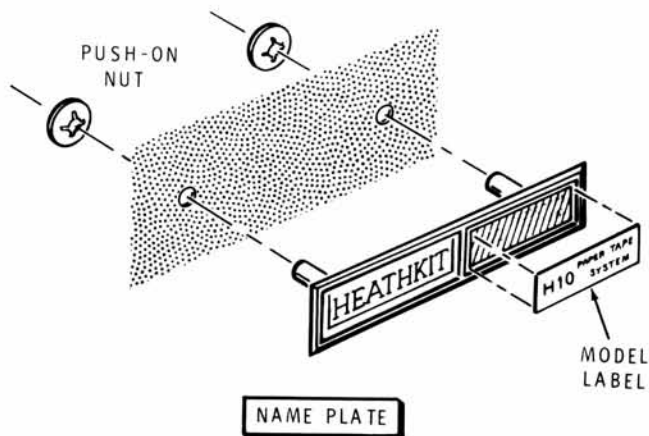

Detail 4-2A





- () Again refer to Detail 4-2A, remove the protective backing from the model label, and press the label onto the nameplate as shown.
- () SW1: Push the power switch into the front panel at SW1 as shown in the Pictorial.
- () Refer to inset drawing on the Pictorial and install two #6 square Speed Nuts at BA and BB. Position the flat side down as shown.
- () Set the front panel aside temporarily.

Refer to Pictorial 4-3 (Illustration Booklet, Page 15) for the following steps.

- () Be sure the black stranded wire is routed so it will not interfere with the operation of any solenoid.
- () Refer to Detail 4-3A and cut the black stranded wire 1" from the front of the chassis as shown and prepare the wire ends.
- () Cut two 1" lengths of large sleeving and slide a length over each of the black stranded wires.
- () Refer to Detail 4-3B (Illustration Booklet, Page 15) and mount the front panel to the chassis with two 6-32 \times 1/4" black screws. Be sure the ends of the punch ramp and reader chute protrude through the front panel. Also, do not pinch any wires between the metal parts, and check to be sure that no front panel switches are touching terminal strip FA or any parts mounted on it.
- () Connect the end of either black stranded wire to switch SW1 lug 2 (S-1). Be sure to make a mechanically secure connection.
- () Slide the length of sleeving over the switch lug and carefully shrink it. Use a match or hot soldering iron.
- () Connect the other black stranded wire to switch SW1 lug 1 (S-1). Be sure to make a mechanically secure connection.
- () Slide the length of sleeving over the switch lug and carefully shrink it.

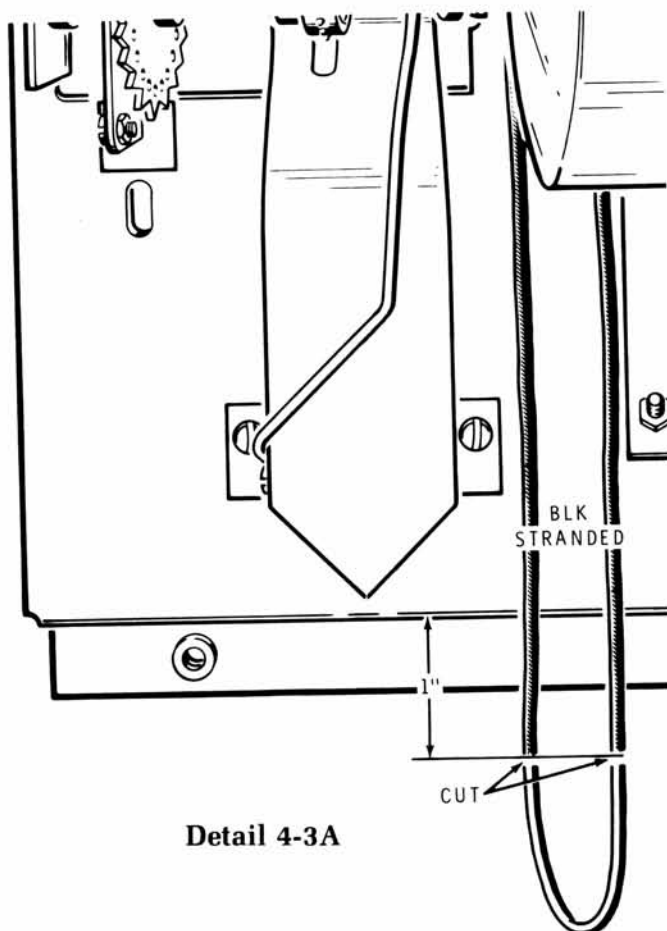

Detail 4-3A

Refer to Pictorial 4-4 (Illustration Booklet, Page 16) for the following steps.

- () Connect the free end of the orange wire coming from terminal strip N to terminal strip FA lug 8 (S-3).

In the following steps, you will connect wires to the main circuit board. Solder each connection and cut off the excess wire lengths. Also, route the wires and position them down on the circuit board as shown.

- () Connect the free end of the orange wire coming from terminal strip FA lug 1 to hole AJ (S-1).

Connect the wires coming from the front panel switches as follows:

- () Blue to hole AK.
- () Brown to hole AG.
- () Black to indicated hole GND.

Connect the wires coming from motor M1.

- Black from motor hole 1 to hole AA.
- Red from motor hole 1 to hole AB.
- Black from motor hole 2 to hole AC.
- Red from motor hole 2 to hole AD.

Connect the wires coming from the reader circuit board. Route them under the nearby wire harness.

- White-gray to hole 8.
- White-violet to hole 7.
- White-green to hole 5.
- White-blue to hole 6.
- White-orange to hole 3.
- White-yellow to hole 4.
- White-brown to hole 1.
- White-red to hole 2.
- Black to remaining hole GND.
- Place a cable tie around the reader circuit board wires.

Connect the free ends of the remaining black, red, orange, and green wires (connected to the rear panel parts and capacitor C3):

- Orange to hole +12V.
- Black to hole GND.
- Red to hole +25V.

- Green to hole +9V.

- Remove the tape from the ends of the transformer wires.

Connect the remaining wires coming from transformer T1 as follows:

- Brown to hole B.
- Either red wire to either hole R.
- Other red wire to other hole R.
- Either orange wire to either hole O.
- Other orange wire to other hole O.
- Either green wire to either hole G.
- Other green wire to other hole G.
- Place a cable tie around the transformer wires as shown, route the wires as shown, and position them down on the chassis.
- Place three more cable ties around all the wires near capacitor C3 as shown.
- Prepare an 11" yellow wire and connect it to hole AE. The free end will be connected later.

Refer to Detail 4-4A for the next two steps.

- Connect the free end of the black wire coming from terminal strip FA lug 3 to switch SW6 lug 2 (S-1). NOTE: Two wires were previously soldered to this lug.
- Connect the free end of the orange wire coming from terminal strip FA lug 4 to switch SW6 lug 1 (S-1).



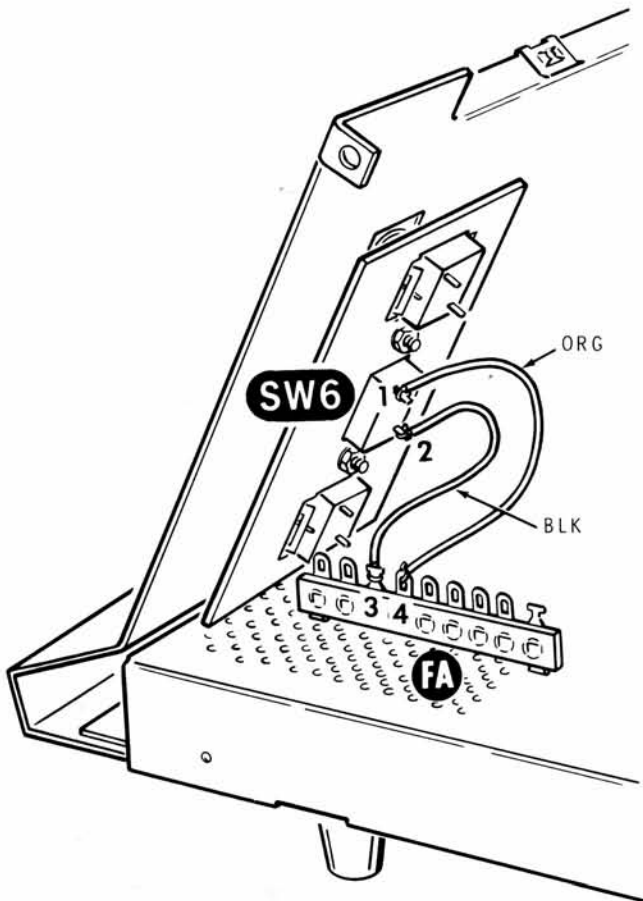

Detail 4-4A

Refer to Pictorial 4-5 (Illustration Booklet, Page 17) for the following steps.

- () Refer to Detail 4-5A and slide the following parts onto a 6-32 x 1-1/2" screw in the order listed: #6 flat washer, 1" spacer, #6 flat washer, small spring washer, #5 flat washer, and a small spring washer.

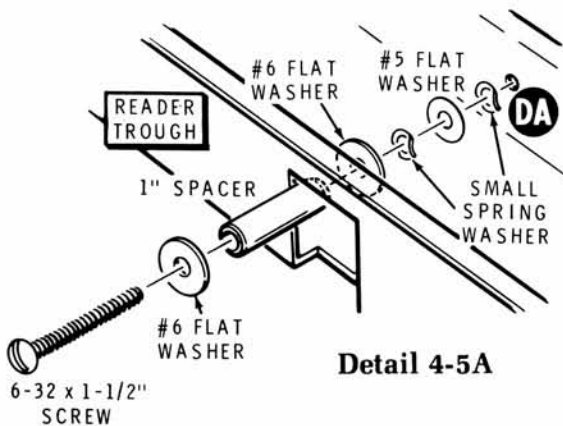

Detail 4-5A

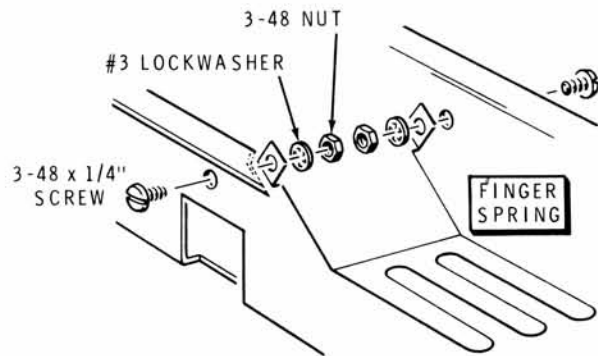

Detail 4-5B

- () Install the screw in the reader trough at DA. Tighten the screw until the spring washers just start to compress. (Be sure there is room for paper tape to slide under the spacer.)
- () Refer to Detail 4-5B and loosely mount the finger spring as shown. Use two 3-48 x 1/4" screws, two #3 lockwashers, and two 3-48 nuts. You will tighten the hardware later.

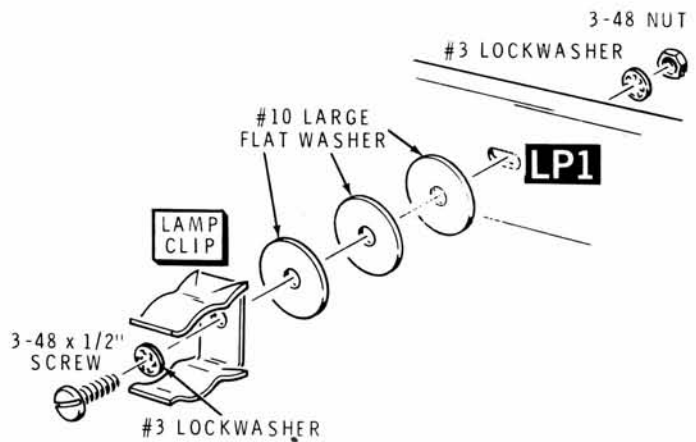

Detail 4-5C

- () Refer to Detail 4-5C and loosely mount the lamp clip at LP1. Use a 3-48 x 1/2" screw, a #3 lockwasher, three #10 large flat washers, a #3 lockwasher, and 3-48 nut.

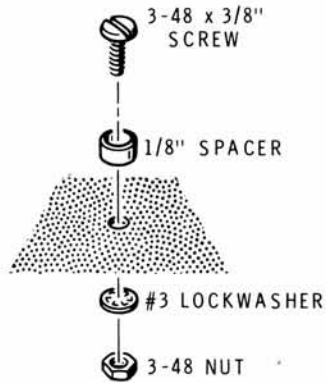

Detail 4-5D

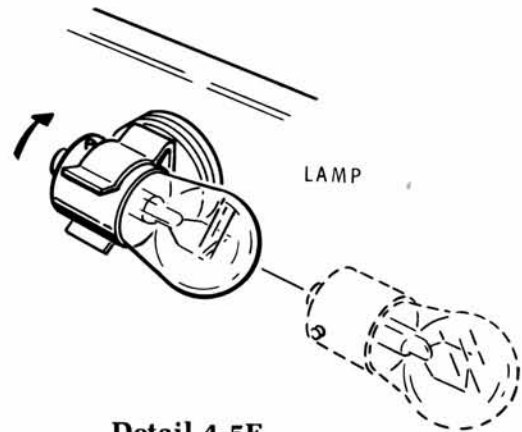

Detail 4-5E

- () Refer to Detail 4-5D and mount a 1/8" spacer at DB. Use a 3-48 \times 3/8" screw, a #3 lockwasher, and a 3-48 nut.
- () LP1: Refer to Detail 4-5E and slide the #1141 lamp into the lamp clip at LP1 as shown.
- () Refer to Detail 4-5F and remove the nuts and lockwashers from screws DC and DD. Then mount the reader trough as shown, replace the lockwashers and nuts you just removed, and secure the back of the trough to the rear panel with a 6-32 \times 1/4" black screw. Be sure the trough is flush with the top of the reader assembly before you tighten the hardware. Be careful; do not bend the transistor leads on the reader circuit board.
- () Refer to Detail 4-5G and rotate lamp LP1 so its filament is horizontal, and position the lamp so the filament is 5/8" above the reader assembly (see the inset drawing) and directly over the light channels in the reader assembly. Then tighten the nut at LP1.
- () Again refer to Detail 4-5G and adjust the finger spring so the ends of its fingers rest lightly on the circuit board of the reader assembly. Be sure the fingers do not cover the holes in the reader assembly. Then tighten the finger spring screws.

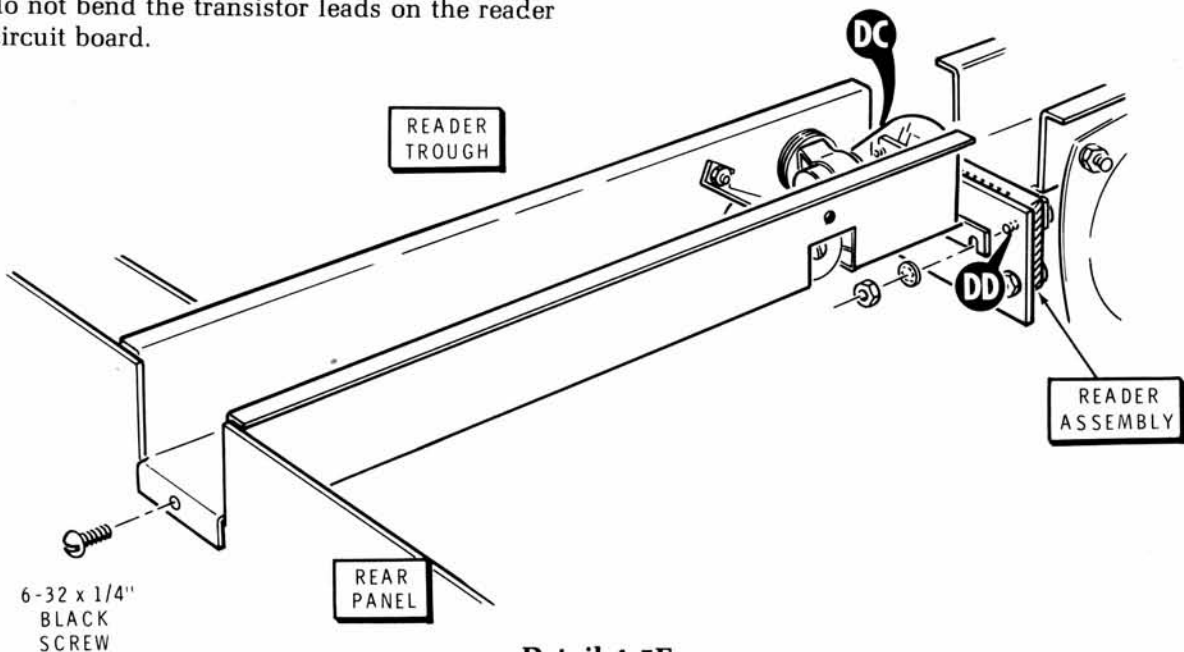

Detail 4-5F

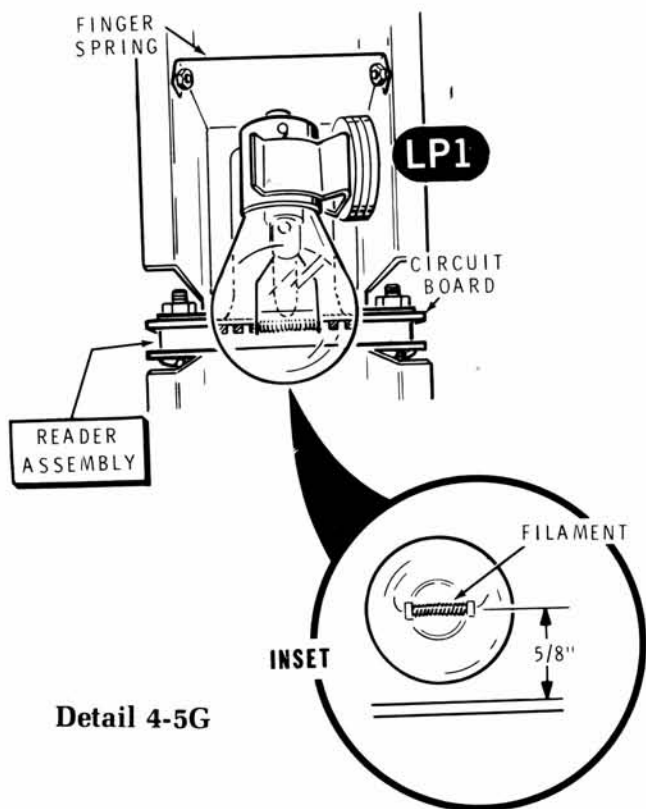

Detail 4-5G

Refer to Pictorial 4-6 (Illustration Booklet, Page 17) for the following steps.

- () Refer to Detail 4-6A and push a #6 long Speed Nut onto angle bracket L. Position the flat side of the nut as shown.
- () Refer to Detail 4-6B and push a #6 long Speed Nut onto the main circuit board at M. Position the flat side of the nut as shown.

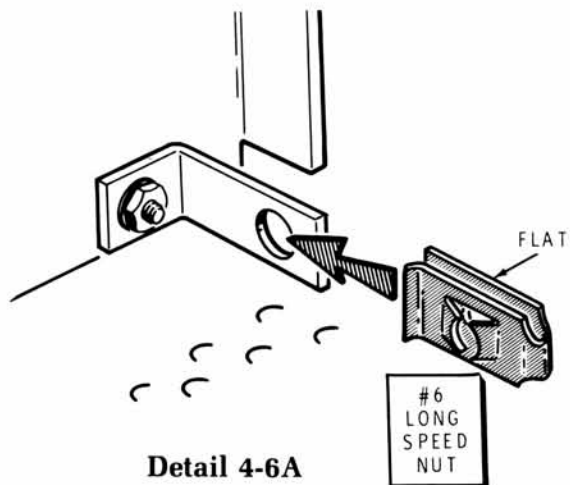

Detail 4-6A

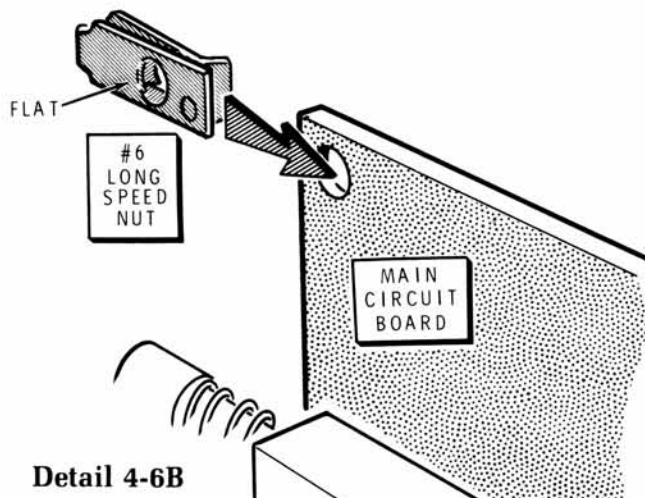

Detail 4-6B

- () Refer to Detail 4-6C, bend the two end tabs back, and insert plug P3 into the rear panel at P3. Be sure the ribs are positioned as shown.
- () Mount the main circuit board with three 6-32 \times 1/4" screws as shown. Do not pinch any wires between the chassis and the other parts, position the wires as necessary to keep the circuit board from bowing, and check to be sure that no wires will interfere with solenoid action.
- () Solder the free end of the yellow wire coming from main circuit board hole AE to the center connector of lamp LP1. Route this wire between the reader trough and the right reader bracket as shown.

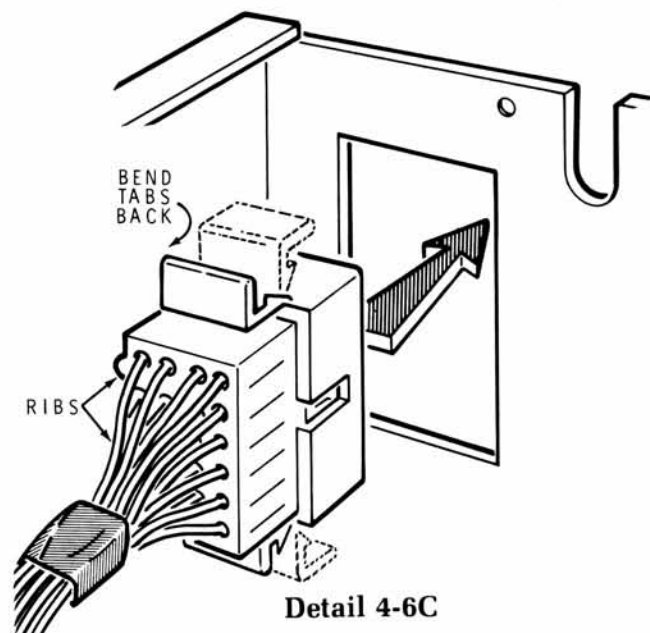

Detail 4-6C

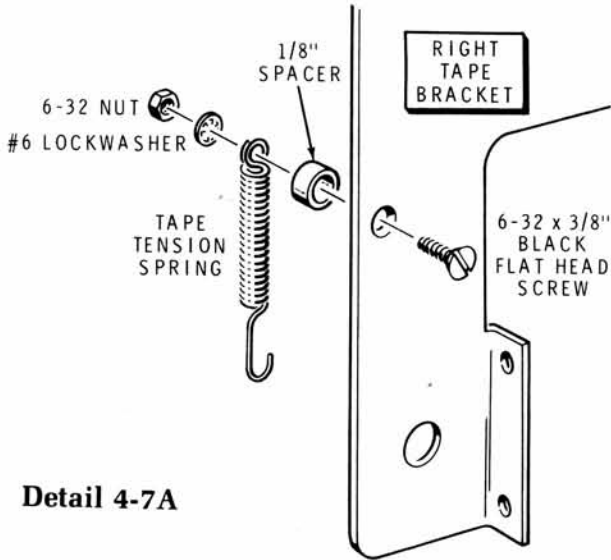

Detail 4-7A

Refer to Pictorial 4-7 (Illustration Booklet, Page 18) for the following steps.

- () Refer to Detail 4-7A and mount a 1/8" spacer and tape tension spring to the right tape bracket at EA with a 6-32 x 3/8" black flat head screw, #6 lockwasher, and 6-32 nut as shown.

Refer to Detail 4-7B for the next three steps.

- () Loosely mount three 1-1/8" threaded spacers on the right tape bracket as shown. Use three 1-1/8" threaded spacers and three 6-32 x 1/4" black screws.

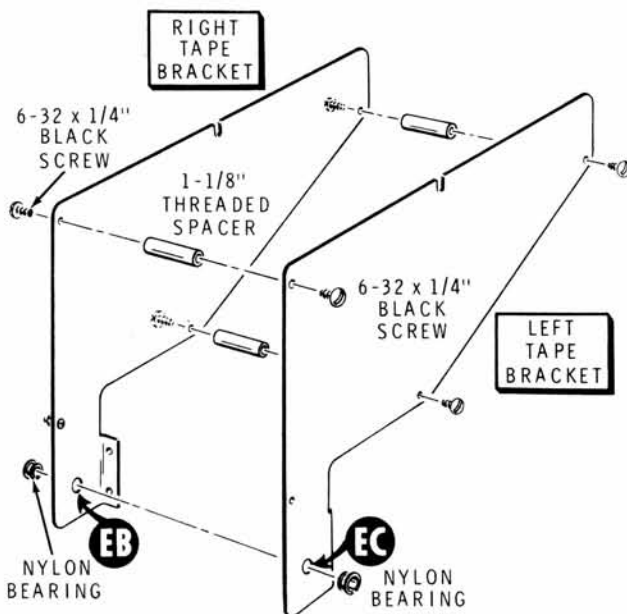

Detail 4-7B

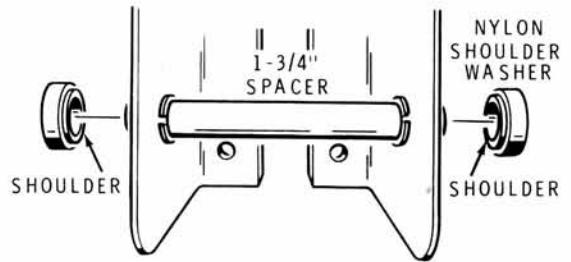

Detail 4-7C

- () Mount the left tape bracket to the three spacers with three 6-32 x 1/4" black screws. Tighten all six screws.
- () Install two nylon bearings at EB and EC.
- () Refer to Detail 4-7C and slide a 1-3/4" spacer into the nylon bearings as shown. Then push a nylon shoulder washer onto each end of the spacer. Position the shoulder of each washer as shown.
- () Refer to Detail 4-7D and secure a tensioner plate to each end of the 1-3/4" spacer as shown. Use two 6-32 x 1/4" black screws. Position the plates with the small holes as shown.
- () Connect tape tension spring EA to the small hole in the tensioner plate. See the inset drawing on Pictorial 4-7.

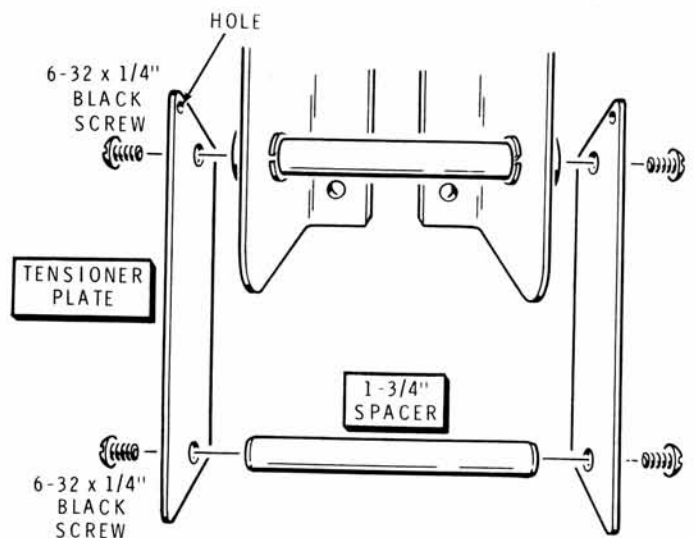

Detail 4-7D

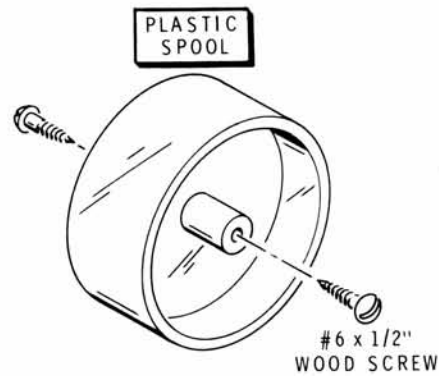
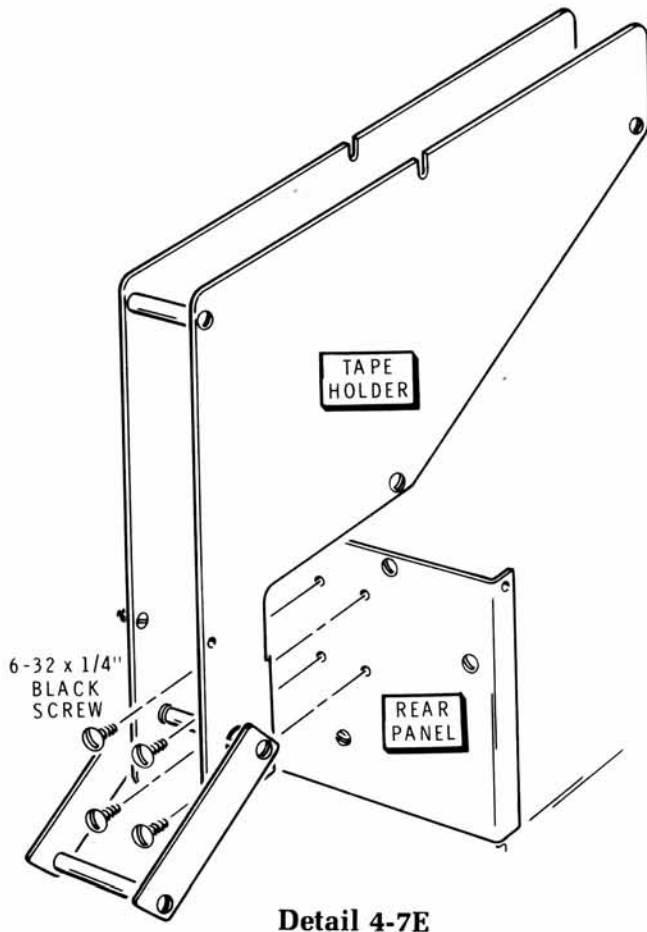

- () Again refer to Detail 4-7D and mount another 1-3/4" spacer to the tensioner plates. Use two 6-32 x 1/4" black screws.
- () Refer to Detail 4-7E and mount the tape holder to the rear panel with four 6-32 x 1/4" black screws.

- () Carefully peel away the backing paper from the blue and white identification label. Then press the label onto the rear panel. Be sure to refer to the numbers on this label in any communications you have with Heath Company about this kit.
- () Refer to Detail 4-7F and install the **threaded portions** of two #6 x 1/2" wood screws in the plastic spool as shown.
- () Insert the plastic spool into the center of the roll of paper tape and set the tape in the tape holder as shown in the Pictorial.

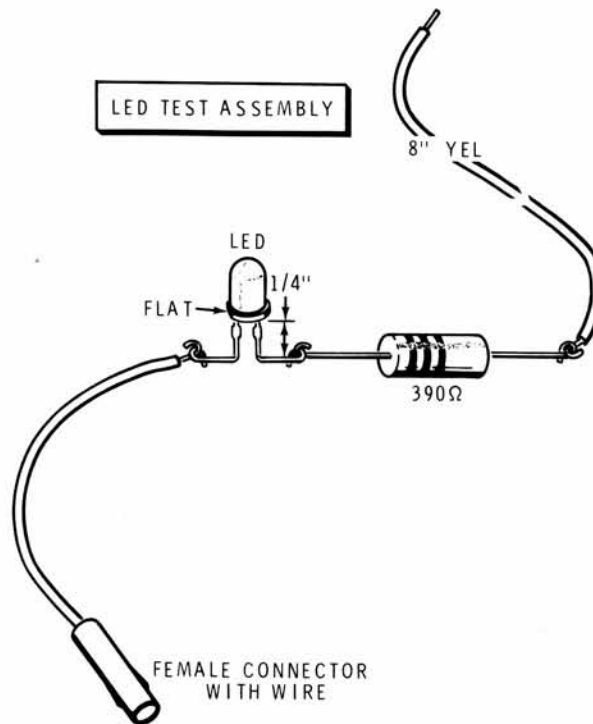

PICTORIAL 5-1

LED TEST ASSEMBLY

Refer to Pictorial 5-1 for the following steps.

- () Cut both leads of the 390 Ω resistor (orange-white-brown) to 1/2".
- () Prepare an 8" yellow wire.
- () Use long-nose pliers and bend both leads of the LED as shown.
- () LED1: Connect the lead nearest the flat of the LED to the female connector with wire (S-1).
- () R96: Connect the other lead of the LED to either lead of the 390 Ω resistor (orange-white-brown); (S-1).
- () Connect the free lead of the resistor to the 8" yellow wire (S-1).
- () Set the LED test assembly aside temporarily.

This completes the assembly of your Reader/Punch, except for the "Final Assembly." Proceed to "Initial Tests."



INITIAL TESTS

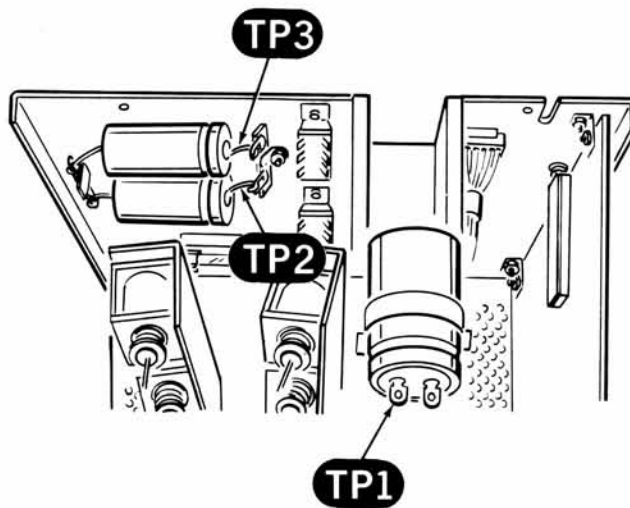

PICTORIAL 6-1

If an ohmmeter is available, perform the following "Resistance Tests."

If an ohmmeter is not available, carefully recheck the wiring and chassis for solder bridges, solder splashes, clipped leads, and pinched leads. Then proceed to "Power Tests."

RESISTANCE TESTS

Refer to Pictorial 6-1 for the following steps.

- () Connect the ohmmeter common lead to the chassis of the Reader/Punch.
- () Set the ohmmeter to the $R \times 10$ position.

In the following chart, connect the ohmmeter test lead to the indicated test points. If a reading is less than the value listed, recheck the wiring for solder bridges on the main circuit board, pinched leads on the chassis, and parts incorrectly installed. NOTE: Some meter readings may be much greater than those listed. This is all right.

TEST POINT	READING
() 1	1000 Ω or greater
() 2	15 Ω or greater
() 3	50 Ω or greater

- () Disconnect the ohmmeter test leads.

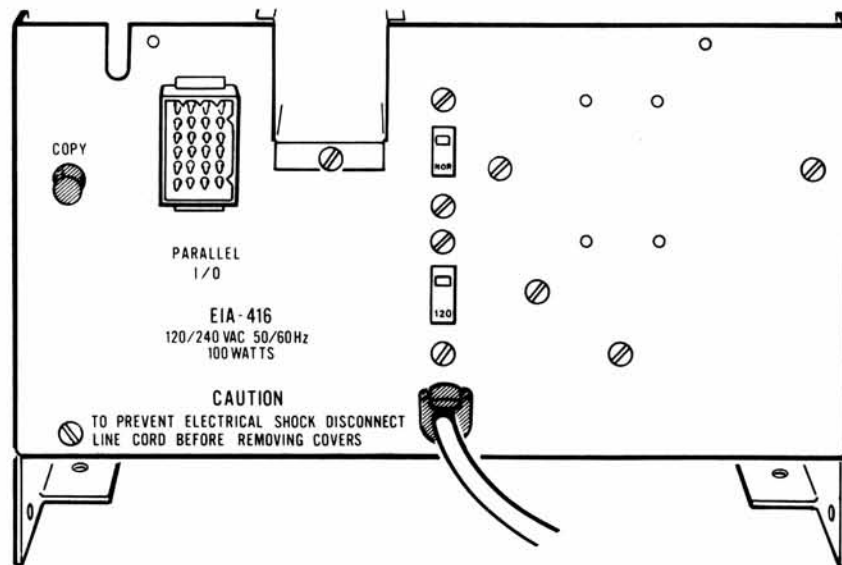
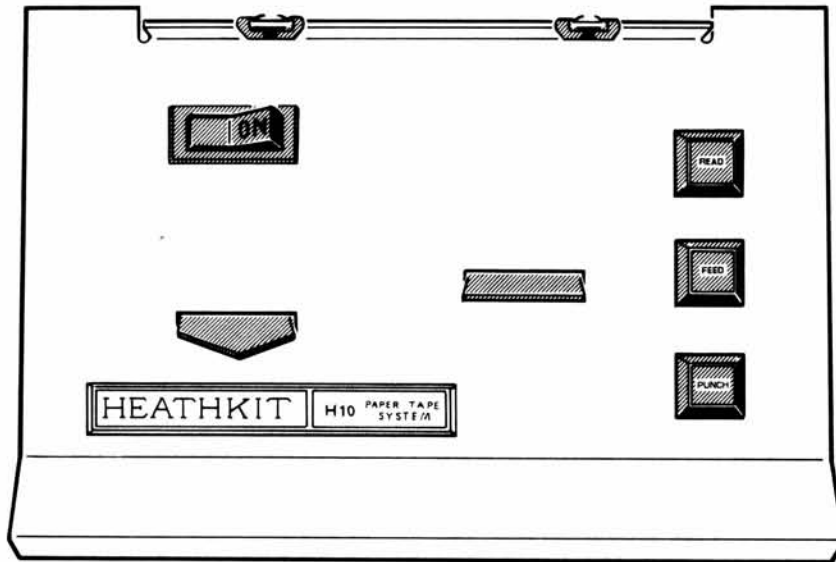

PICTORIAL 6-2



POWER TESTS

Refer to Pictorial 6-2 for the following.

Set the switches as follows:

Front Panel Switches

POWER switch — OFF.
 READ switch — OUT.
 PUNCH switch — OUT.

Rear Panel Switches

COPY — OUT.
 NOR/LOW — NOR.
 120/240 — To the position that matches the fuse
 you previously installed and the line
 voltage you intend to operate your
 Reader/Punch on.

NOTE: Each of the following tests is identified with a capital letter. If you do not obtain the proper results in any of these tests, unplug the line cord, and then proceed to the appropriate part of the "Initial Test Difficulties" on Page 74 ("Test A, B," etc.) to locate and correct the problem. If you cannot solve the problem, proceed to "In Case of Difficulty" in the Operation Manual. Do not proceed to another test until you obtain the proper results.

WARNING: When the line cord is connected to an AC outlet, line voltage is present at several places in your kit. Be sure you do not contact this voltage or an electrical shock will result. (See Pictorial 17 in the Operation Manual.)

NOTE: It is normal for the stepper motor (M1) to be quite warm while the unit is turned on.

In the following steps, you will plug in the line cord and turn the Reader/Punch on. The lamp should turn on, but no solenoids should remain energized. (It is all right for the solenoids to energize momentarily.) If one or more solenoids remains energized, immediately turn the power off and repair the problem before you proceed to another step. **CAUTION:** When you troubleshoot a continuously energized solenoid, do not leave the solenoid on for more than five minutes.

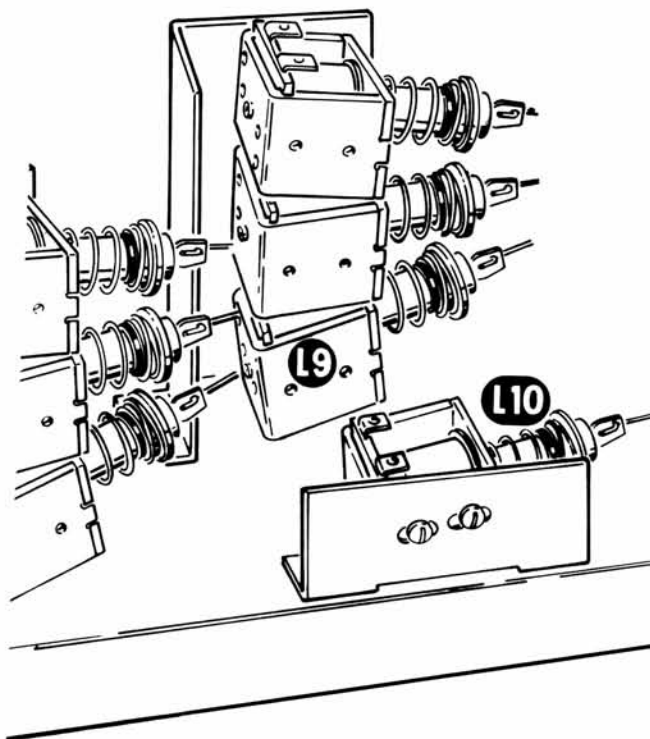

Detail 6-2A

Then let it stay off for at least 15 minutes. Otherwise, the solenoid may be damaged.

- () Plug in the line cord.
- A () Push the POWER switch to its on position. (The lamp should be at half brilliance. It is a 12-volt lamp being operated at approximately 5.5 volts.)
- B () Push and hold the FEED pushbutton in for a few moments. Only the sprocket hole punch solenoid (L9) and the paper advance solenoid (L10) should energize. They should alternately energize and de-energize at an approximate rate of ten times per second. See Detail 6-2A.

NOTES:

1. If you have trouble making the following adjustments, first recheck the position of reader lamp LP1. (See Detail 4-5G on Page 61.) Also check the lamp voltage to be sure it is operating at +5.1 volts to +6.1 volts DC.
2. If you applied Mylar tape over the light channels of the reader assembly and ever remove or replace the tape, be sure you reperform the following steps.
3. Do not have a bright light near the reader assembly as you perform the steps.

Refer to Pictorial 6-3 for the following steps.

- Turn the eight circuit board controls (R1 through R8) fully clockwise.
- Push the indicated wire end of the LED test assembly into the TP +5V connector on the main circuit board.
- Push the test assembly connector onto pin 1 of connector P3. (See inset drawing #1.)

NOTE: In the next step, adjust control R1.

- C 1. Adjust the control counterclockwise until the LED just lights. Then mark the position of the control. (See inset drawing #2.) NOTE: If the LED does not light, this is all right. Turn the control fully counterclockwise and mark its position.
2. Place a length of blank tape into the reader trough so it is between the lamp and the reader assembly.
3. Turn the control clockwise until the LED goes out or the control is fully clockwise. Mark the position of the control.
4. Center the control between the two marked positions. Then remove the tape from the reader.

Refer to the following chart and, one at a time, push the test assembly connector onto the indicated seven pins of connector P3. Repeat the above four steps for each pin connection and adjust the proper control.

	CONNECTOR P3, PIN:	ADJUST CONTROL
D ()	2	R2
E ()	3	R3
F ()	4	R4
G ()	5	R5
H ()	6	R6
J ()	7	R7
K ()	8	R8

- Place a length of blank tape into the reader trough so it is between the lamp and the reader assembly. Use the most transparent tape that you will be using in your Reader/Punch.
- C-K Reconnect the LED test assembly to pins 1 through 8 of connector P3. The LED must light at each position.
- Leave the LED test assembly connected to pin 8.
- Remove the blank tape.
- Push the rear panel COPY switch to the IN position.
- L Push the PUNCH switch to the IN position. All the solenoids should operate and the reader drive sprocket should step forward.
- Push the PUNCH switch to the OUT position.
- Refer to Page 7 of the Operation Manual and load a roll of tape into the punch.
- Push in the FEED switch and generate approximately 18" of leader tape.
- M Push the PUNCH switch to the IN position. Eight holes (larger than, and in addition to, the sprocket hole) should be clearly punched in the tape simultaneously. Make 18" of punched tape and then push the PUNCH switch to the OUT position.
- Tear off the punched tape.

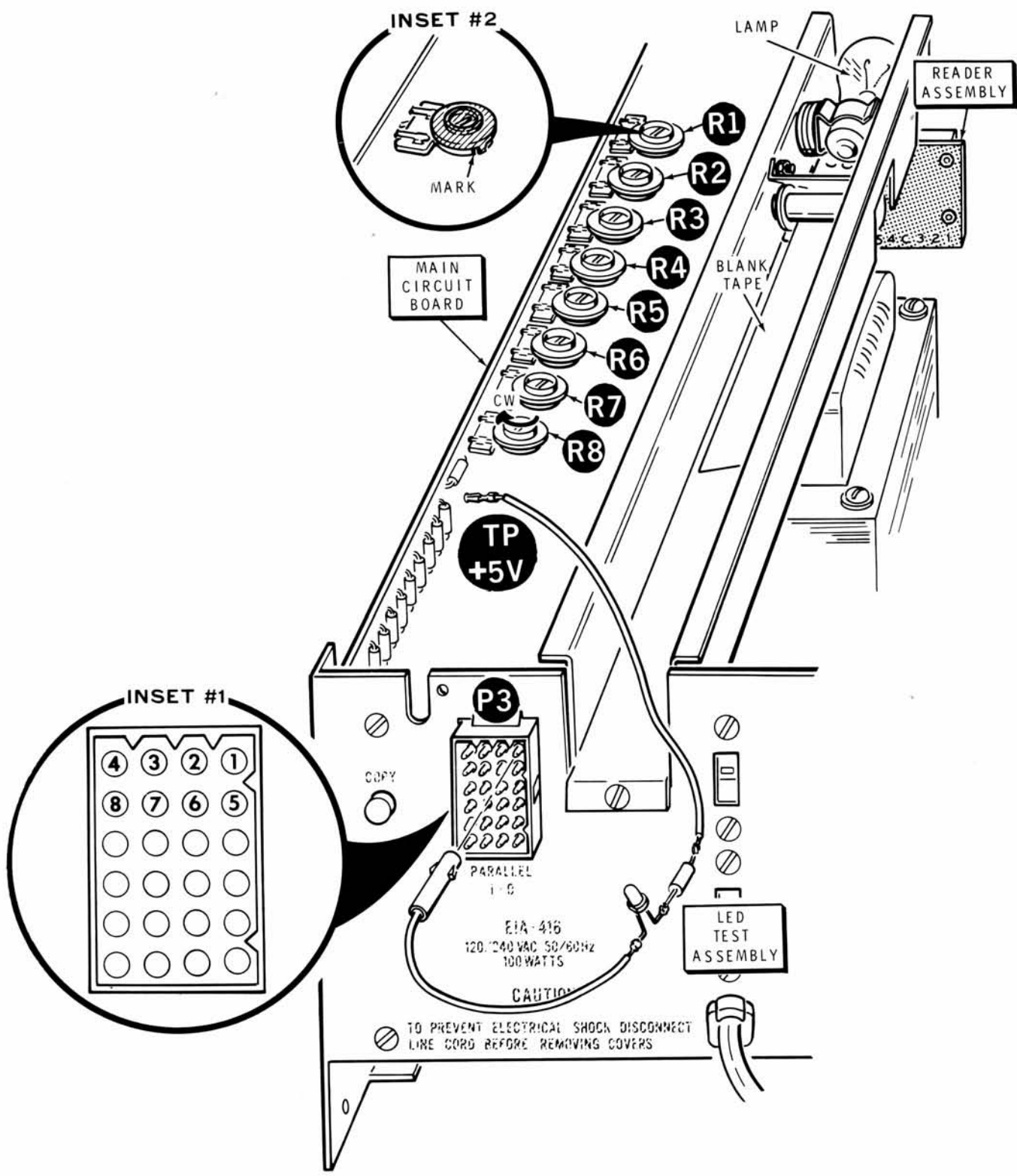

PICTORIAL 6-3

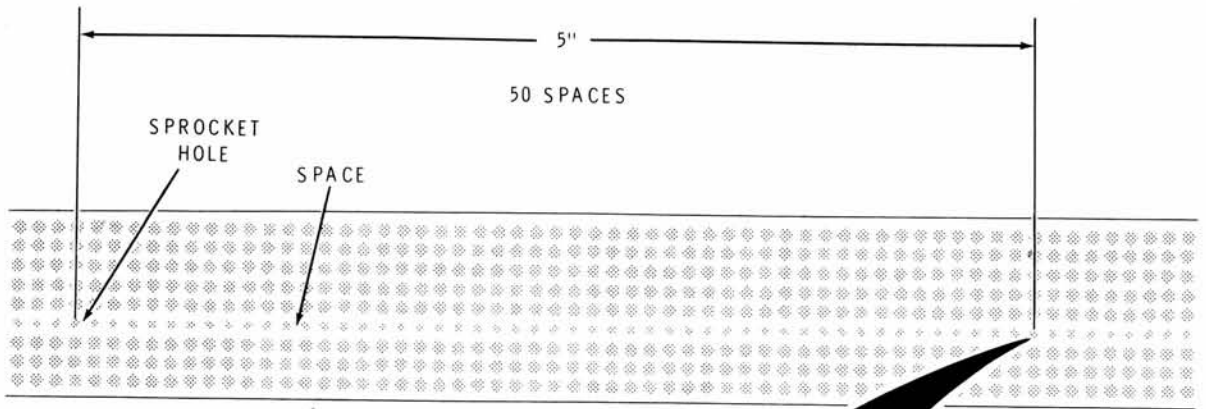

PICTORIAL 6-4

- M () Refer to Pictorial 6-4, use an accurate rule (steel preferred), and measure the last 5" of tape punched from the center of one of the sprocket holes as shown. 50 spaces must be within this 5 inches and the center of the last hole must not be off more than .025". Part A of the inset drawing shows the ideal measurements with acceptable error — .025" or approximately 1/2 a sprocket hole. If the error in the measurement is **not** acceptable, refer to Detail 6-4A and:

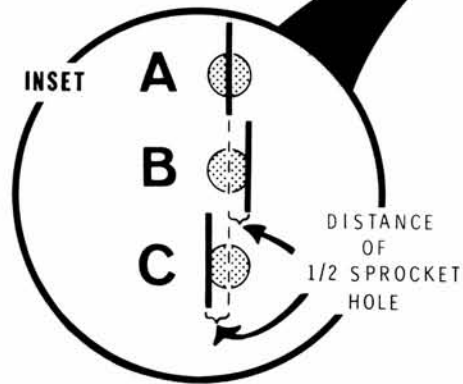

NOTE: The following is a trial-and-error adjustment and may need to be performed several times to get the accuracy required.

- Be sure the punch ramp is properly adjusted.
- Slightly loosen the punch drive sprocket screw.
- Turn the sprocket a few thousandths of an inch (1/4 the width of a drive tooth or less).
- Retighten the sprocket screw.
- Generate and measure another length of punched tape. If the measurement is now closer to being correct, make the next adjustment in the same direction. However, if the measurement is further from being correct, make the next adjustment in the opposite direction and make smaller adjustments.

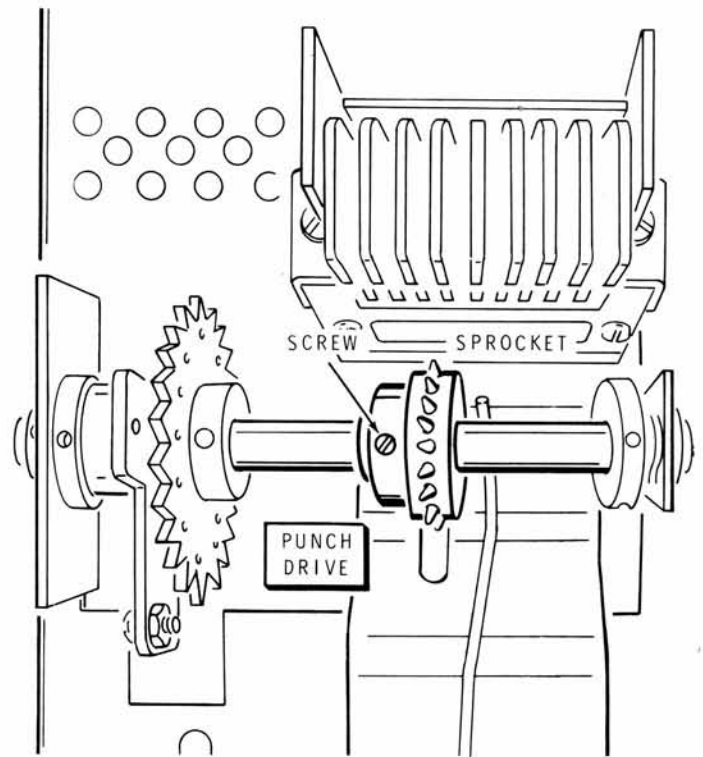

Detail 6-4A

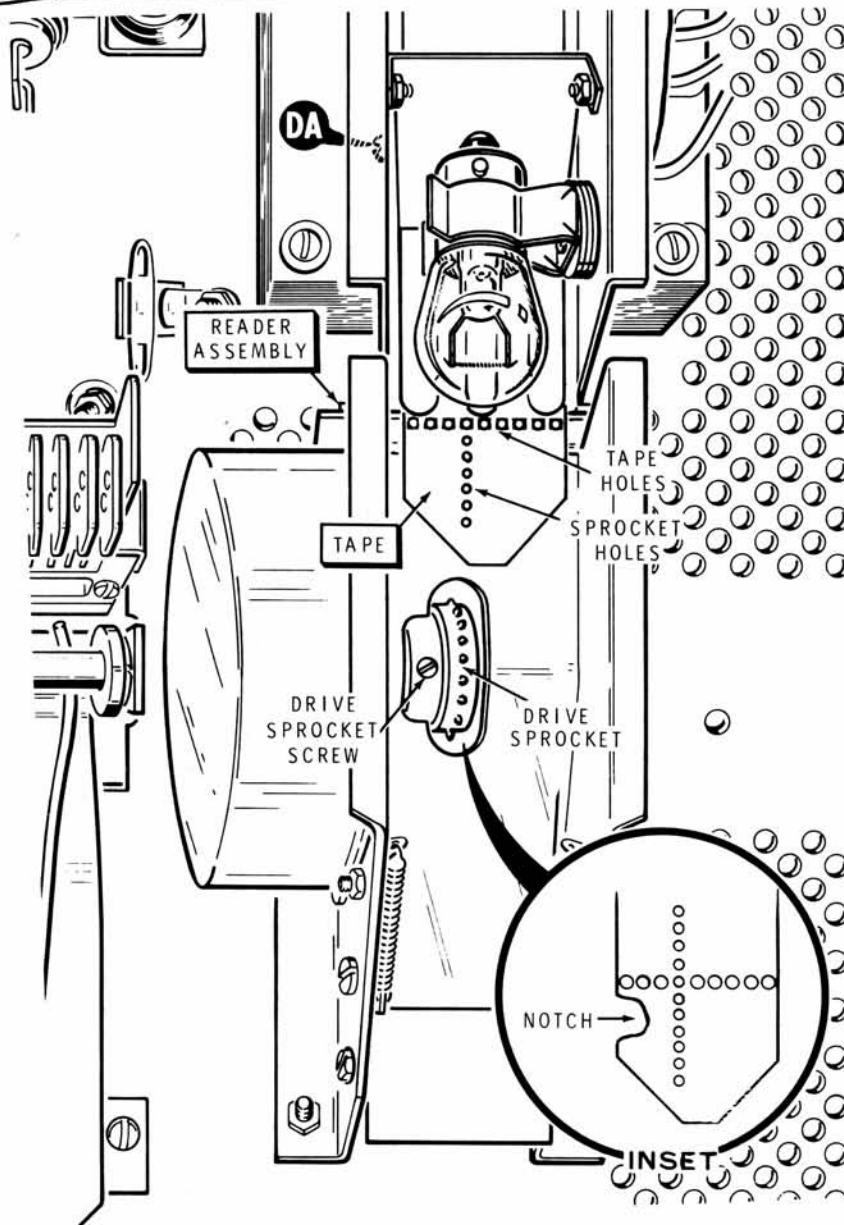

PICTORIAL 6-5

Refer to Pictorial 6-5 for the following steps.

- () Insert the length of properly punched tape into the reader trough until the leading edge of the tape is between the photo housing and the drive sprocket. Be sure the tape is positioned with the sprocket holes as shown.
 - () Line up the tape holes with the holes in the reader assembly. Then adjust screw DA until the tape is parallel to the reader trough and still aligned over the reader assembly holes.
 - () Loosen the drive sprocket screw and position the sprocket so it lines up with the drive holes in the tape.
- NOTE: Be sure the power is on for the next step.
- () Pull the tape over the drive sprocket and line up the tape holes with the holes in the reader assembly by rotating the drive sprocket on the motor shaft. Be sure the drive sprocket teeth are positioned properly in the drive holes of the tape. Then carefully tighten the drive sprocket screw and recheck the adjustment. If necessary, make a notch in the tape as shown in the inset drawing to make this step easier.
 - () Push the COPY switch (on the rear panel) to the OUT position.

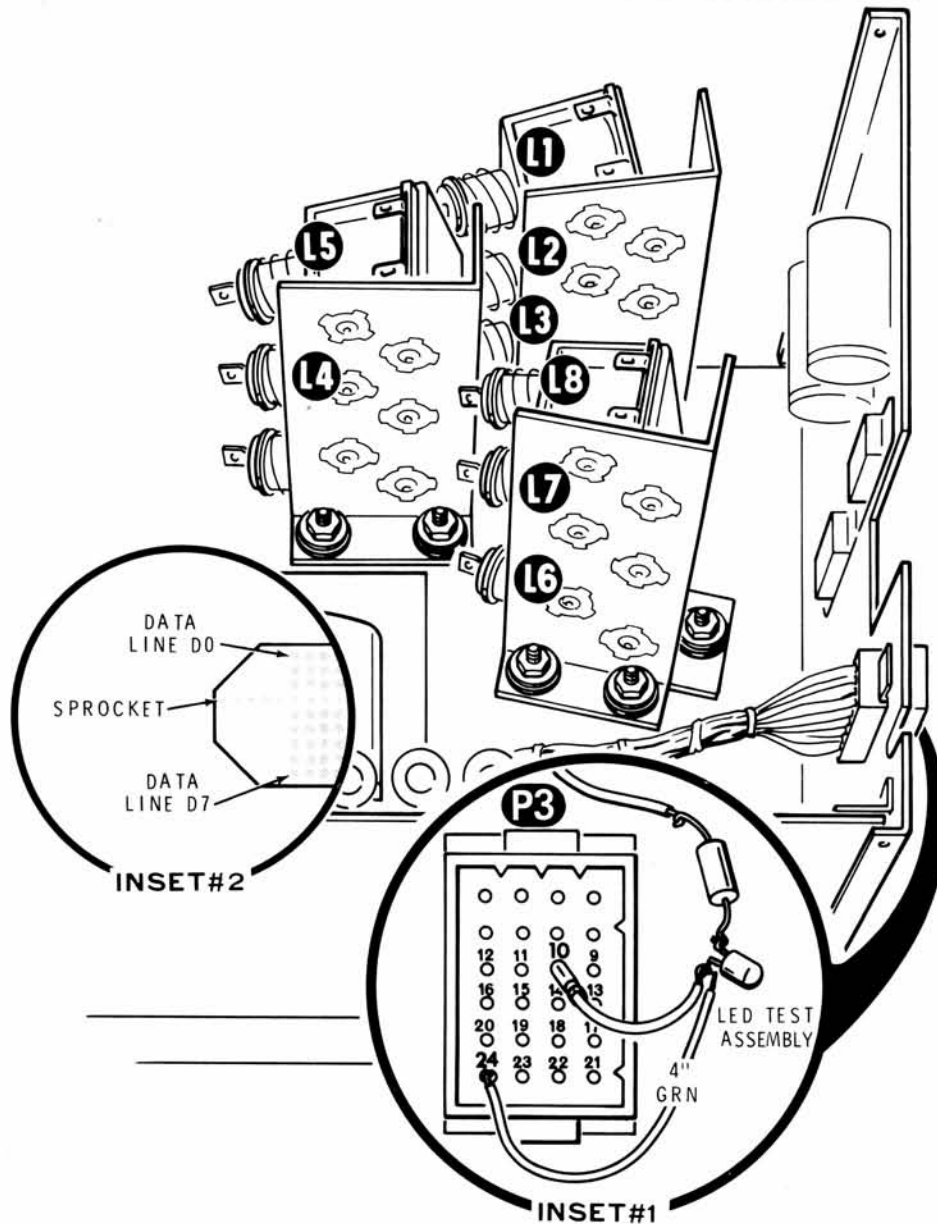

PICTORIAL 6-6

Refer to Pictorial 6-6 for the following steps.

- () Refer to the inset drawing and plug the LED test assembly into connector P3 pin 10.
- N () Push the READ switch to the IN position. The tape should not move.
- () Prepare a 4" green wire.
- N () Refer to inset drawing#1 and momentarily touch the green wire from connector P3 pin 24 to the indicated lead of the LED. The tape should move at least one step.
- P () Connect the LED test assembly to pin 9 of connector P3. The LED should light.
- P () Push the READ switch to the OUT position. The LED should go out.





- () Again push the READ switch to the IN position. The tape may or may not start moving through the reader.
- P () Again momentarily touch the green wire to pins 24 and 10 of connector P3. The LED should flicker. (Any tape still moving through the reader should advance jerkily.)
- Q () Push the PUNCH switch to the IN position. Nothing should happen.
- Q () Momentarily touch the prepared wire to pins 24 and 20 of connector P3. The punch should run at maximum speed and punch all holes.
- () Push the READ switch to the OUT position.
- R () Connect the LED test assembly to pin 21 of connector P3. The LED should light.
- R () Momentarily push in the FEED switch. The LED should go out and leader tape should be punched.
- S () Connect the LED test assembly to pin 19 of connector P3. The LED should be off.
- S () Momentarily push in the FEED switch. The LED should turn on and leader tape should be punched.
- () Push the PUNCH switch to the OUT position.
- () Refer to Detail 6-6A, prepare a 4" yellow wire, and connect and solder a female connector on each wire end as shown.
- () Connect this prepared wire to pins 20 and 24 of connector P3. Slide the connectors onto the pins.

In the following steps, push the PUNCH switch to the IN position, and touch the 4" green wire between pin 24 and the indicated pin of connector P3. The proper solenoid should stop operating and the other solenoids should continue to operate. It may still move slightly, but it will not punch.

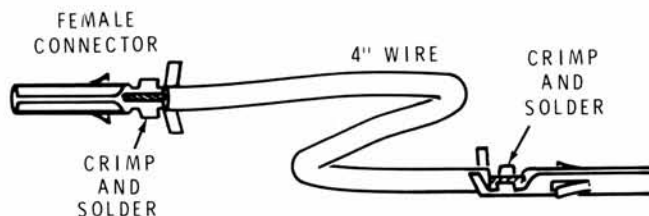

Detail 6-6A

- T () Pin 11. Solenoid L1 should stop and data line DO will not be punched (See inset drawing #2.)
- T () Pin 12. Solenoid L2 should stop and data line D1 will not be punched.
- T () Pin 13. Solenoid L3 should stop and data line D2 will not be punched.
- T () Pin 14. Solenoid L4 should stop and data line D3 will not be punched.
- T () Pin 15. Solenoid L5 should stop and data line D4 will not be punched.
- T () Pin 16. Solenoid L6 should stop and data line D5 will not be punched.
- T () Pin 17. Solenoid L7 should stop and data line D6 will not be punched.
- T () Pin 18. Solenoid L8 should stop and data line D7 will not be punched.
- () Push the COPY switch to the IN position.
- () Place the tape you generated in the previous steps into the reader.
- U () Push the PUNCH switch to the IN position if not already done. The tape being read should be copied exactly by the punch.
- () Turn off the POWER switch and unplug the line cord.
- () Remove the wires from connector P3 and the LED test assembly from the main circuit board.

This completes the "Initial Test." Proceed to "Final Assembly."

INITIAL TEST DIFFICULTIES

TEST	CHECK:
A	Fuse F1; transformer T1; Diodes D4, D5, D1; capacitor C5; transistors Q1, Q2; lamp LP1; IC17.
B	Diodes D2, D7, D3, D6; IC17; capacitors C3, C4; Punch Timing circuits; IC7F; transistors Q19, Q20, Q21, Q22; Solenoids L9, L10.
C	Transistor Q101; associated reader and punch drive circuitry.
D	Transistor Q102; associated reader and punch drive circuitry.
E	Transistor Q103; associated reader and punch drive circuitry.
F	Transistor Q104; associated reader and punch drive circuitry.
G	Transistor Q105; associated reader and punch drive circuitry.
H	Transistor Q106; associated reader and punch drive circuitry.
J	Transistor Q107; associated reader and punch drive circuitry.
K	Transistor Q108; associated reader and punch drive circuitry.
L	Reader motor drive circuits or solenoid drive components associated with the solenoid which is not operating properly.
M	Readjust punch sprocket slightly; punch assembly; punch tape guide. Punch tape guide must contact the sprocket with light pressure.
N	IC14; tape reader circuits.
P	IC13C, IC13D, IC7D, IC14.
Q	Wiring to pin 16 of COPY switch SW4.
R	IC7B, IC8B.
S	IC7E.
T	Wiring from connector P3 to COPY switch SW4; associated AND gate of IC5 or IC6.
U	Wiring from the reader circuit board to the main circuit board.

FINAL ASSEMBLY

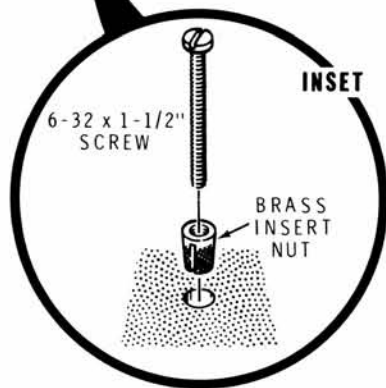
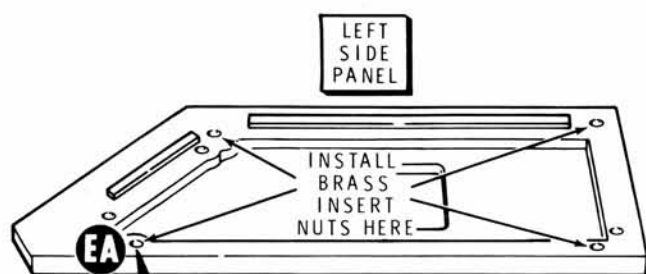

Detail 7-1A

Refer to Pictorial 7-1 (Illustration Booklet, Page 18) for the following steps.

NOTE: In the following steps, be sure to use only the indicated panel holes.

() Refer to the inset drawing on Detail 7-1A and install a 6-32 brass insert nut in hole EA of the left side panel as follows:

- Start a 6-32 × 1-1/2" screw two turns into a brass insert nut.
- Push the nut into the panel hole and tap it down into place until the top of the nut is flush with the panel.
- Turn the screw five turns into the nut.
- Remove the screw.

() Again refer to Detail 7-1A and install three other nuts in the other indicated panel holes.

() Refer to Detail 7-1B and install four 6-32 brass insert nuts in the indicated holes in the right side panel.

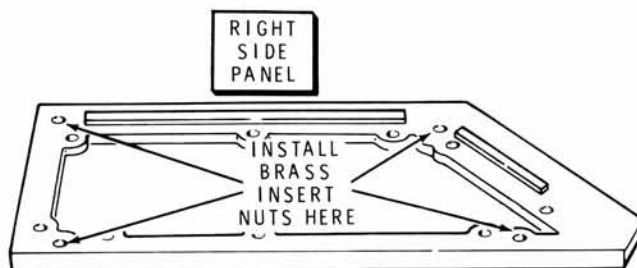

Detail 7-1B

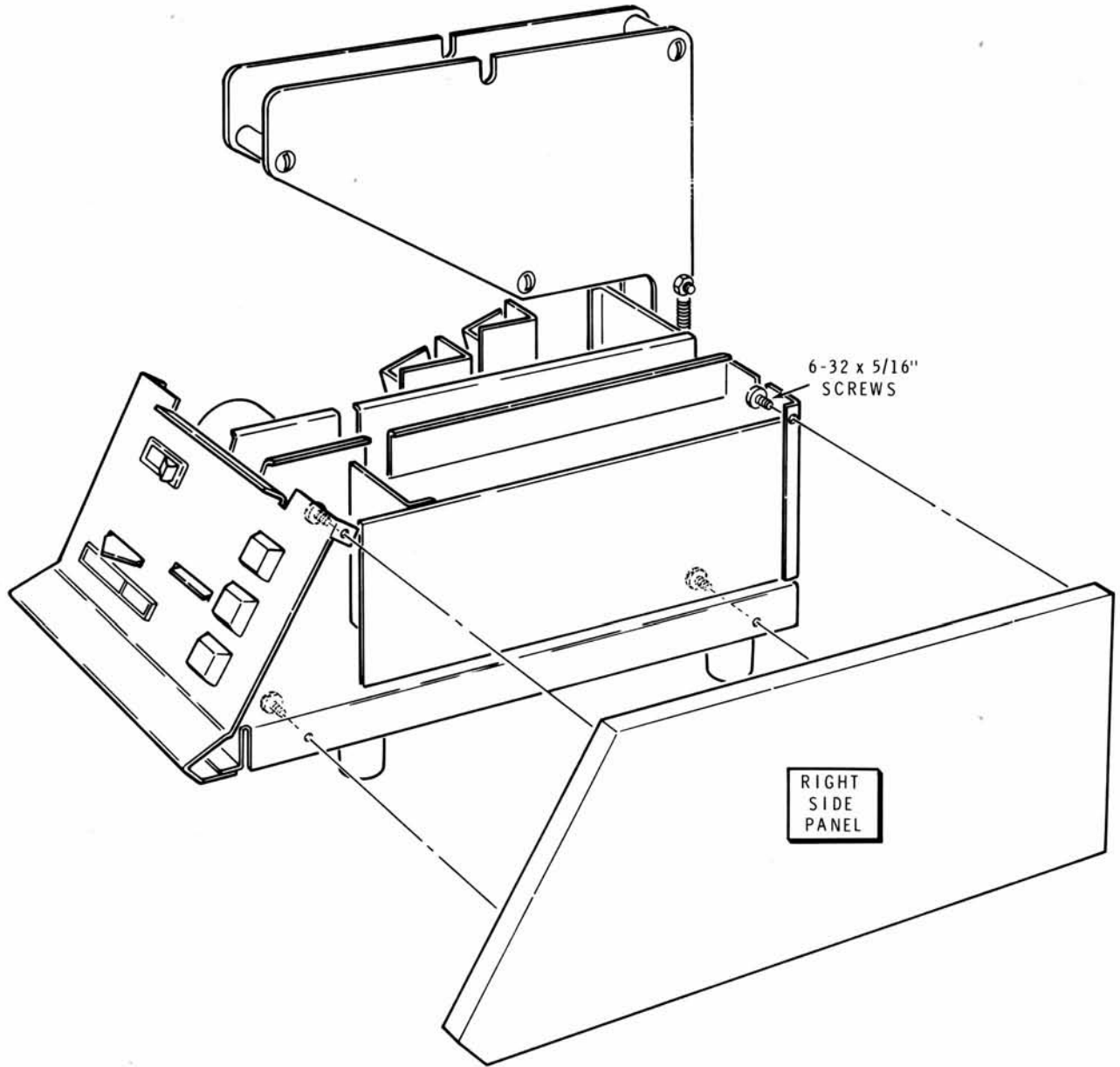

Detail 7-1C

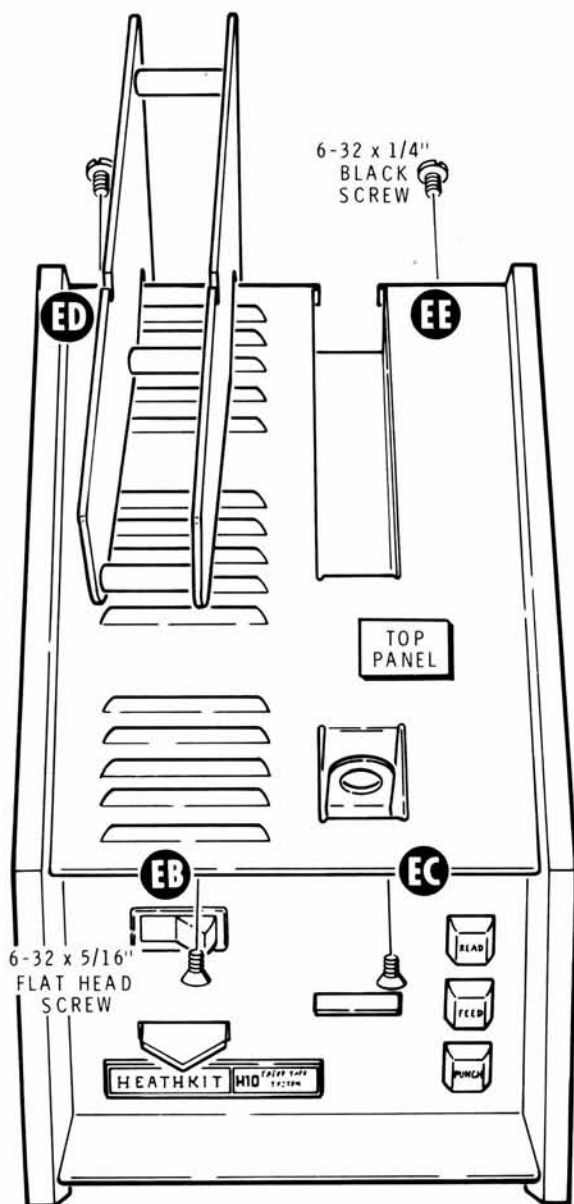

Detail 7-1D

- () Refer to Detail 7-1C and mount the right side panel to the chassis with four 6-32 \times 5/16" screws.
- () In a similar manner, mount the left side panel to the chassis with four 6-32 \times 5/16" screws.
- () Refer to Detail 7-1D and mount the top panel. Use two 6-32 \times 5/16" flat head screws at EB and EC, and two 6-32 \times 1/4" black screws at ED and EE.

Refer to Pictorial 7-2 (Illustration Booklet, Page 19) for the following steps.

NOTE: If you intend to connect the Paper Tape Reader/Punch to other Heath equipment (except the H8 Computer), prepare both ends A and B of the interconnect cable as follows.

If you do not intend to connect to Heath equipment, use only the instructions to prepare end A of the cable. Prepare the other end of the cable as necessary to fit your equipment.

CABLE END A

Refer to Detail 7-2A (Illustration Booklet, Page 19) and remove 1-1/2" of outer insulation from one end of the cable. Be careful you do not cut the insulation of the inner wires. Then remove 1/4" of insulation from the wire ends.

- () Refer to Detail 7-2B, twist together the ends of the black and brown wires, and install a female connector on them as shown. NOTE: Do not use the tan wire by mistake.
- () Refer to Detail 7-2C and install a female connector on the red wire.
- () Install female connectors on the remaining wires.
- () Position a connector shell with its ribs as shown.



NOTE: In the following steps, you will push the female connectors into the connector shell. Be sure you get the right connector in the right hole. The connectors are virtually impossible to remove (without a special tool) once they are installed. Push each connector in until it locks in place. Tug gently on its wire to be sure it will not come out. The holes are identified by small numbers molded into the connector shell.

CAUTION: Be sure to use Pictorial 7-2 and not 7-3 for the following steps.

- Black and brown combination to hole 24.
- White-yellow to hole 23.
- Orange to hole 22.
- White-green to hole 21.
- Tan to hole 20.
- Red-black to hole 19.
- Blue to hole 18.
- Pink to hole 17.
- White-red to hole 16.
- White-black to hole 15.
- Yellow to hole 14.
- Violet to hole 13.
- White-blue to hole 12.
- Red-green to hole 11.
- Gray to hole 10.
- White-orange to hole 9.
- Red-yellow to hole 8.
- White-violet to hole 7.
- Green to hole 6.
- White to hole 5.
- White-brown to hole 4.
- White-gray to hole 3.

White-black-red to hole 2.

Red to hole 1.

CABLE END B

- Again refer to Detail 7-2A and remove 1-1/2" of outer insulation from the other end of the cable. Be careful you do not cut the insulation of the inner wires. Then remove 1/4" of insulation from the wire ends.
- Again refer to Detail 7-2B, twist together the ends of the black and brown wires, and install a female connector on them as shown. NOTE: Do not use the tan wire by mistake.
- Again refer to Detail 7-2C and install female connectors on all the remaining wires.

Refer to Pictorial 7-3 for the following steps.

- Position a connector shell with its ribs as shown.

NOTE: In the following steps, you will push the female connectors into the connector shell. Be sure you get the right connector in the right hole. The connectors are virtually impossible to remove (without a special tool) once they are installed. Push each connector in until it locks in place. Tug gently on its wire to be sure it will not come out. The holes are identified by small numbers molded into the connector shell.

- Black and brown combination to hole 24.
- White-yellow to hole 23.
- Orange to hole 22.
- Gray to hole 21.
- White-orange to hole 20.
- Red-black to hole 19.
- Red-yellow to hole 18.
- White-violet to hole 17.
- Green to hole 16.
- White to hole 15.
- White-brown to hole 14.

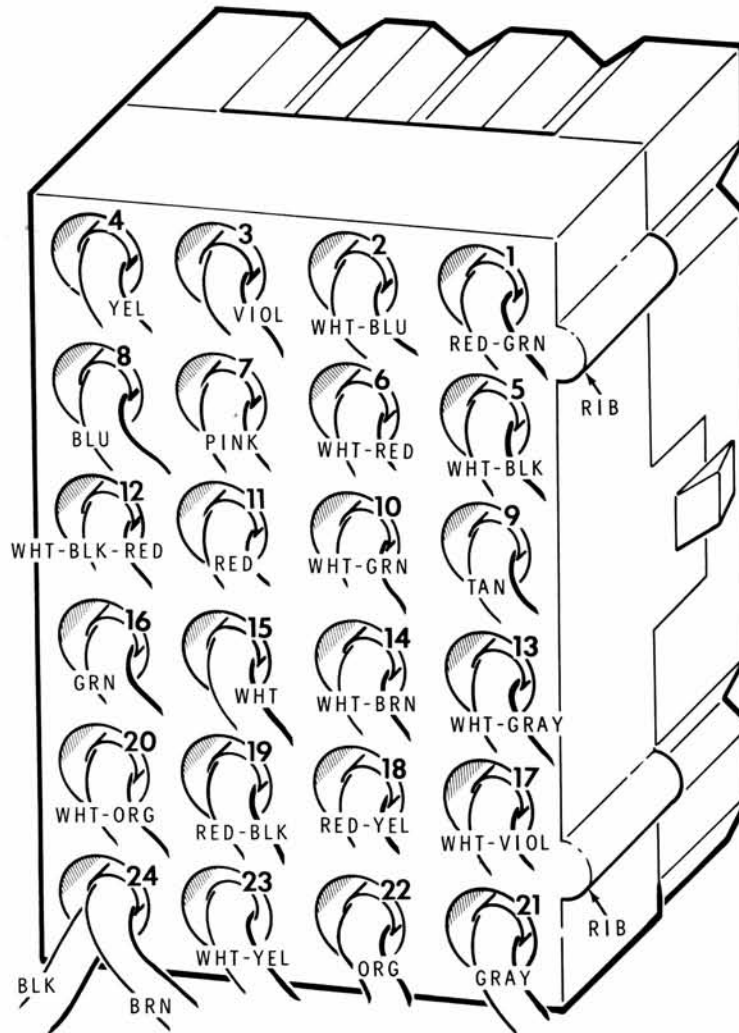

PICTORIAL 7-3

- | | |
|--|--|
| <input type="checkbox"/> White-gray to hole 13. | <input type="checkbox"/> White-blue to hole 2. |
| <input type="checkbox"/> White-black-red to hole 12. | <input type="checkbox"/> Red-green to hole 1. |
| <input type="checkbox"/> Red to hole 11. | |
| <input type="checkbox"/> White-green to hole 10. | |
| <input type="checkbox"/> Tan to hole 9. | |
| <input type="checkbox"/> Blue to hole 8. | |
| <input type="checkbox"/> Pink to hole 7. | |
| <input type="checkbox"/> White-red to hole 6. | |
| <input type="checkbox"/> White-black to hole 5. | |
| <input type="checkbox"/> Yellow to hole 4. | |
| <input type="checkbox"/> Violet to hole 3. | |

SQUARE FEET

NOTE: If during normal operation your Reader/Punch moves across the surface it is sitting on, perform the following:

- Use a cleaning agent and clean the bottoms of the feet of your Reader/Punch.
- Remove the protective backings and apply the square feet (supplied in your kit) to the bottom of the existing feet.

This completes the assembly of your kit. Proceed to the Operation Manual and read the information there.



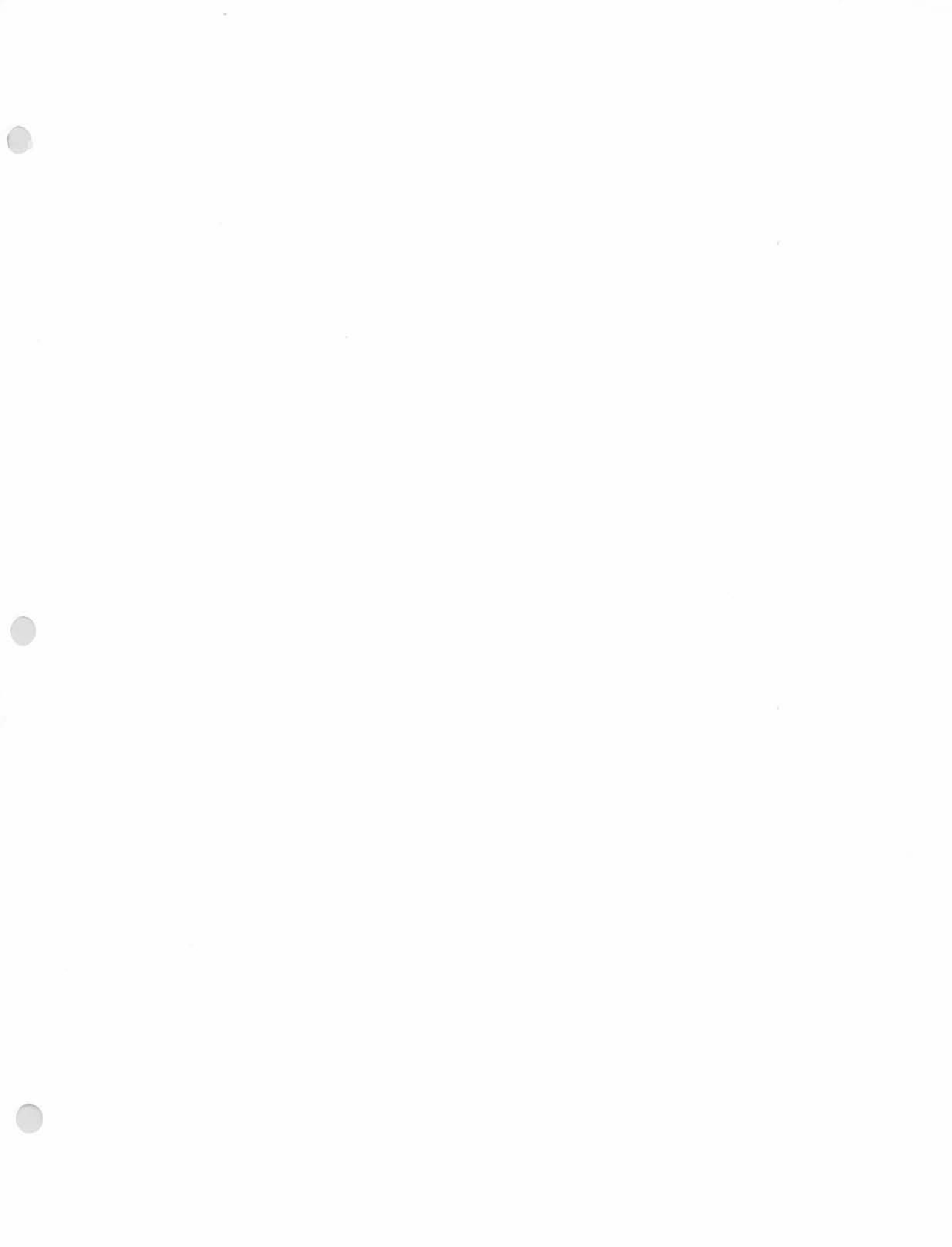



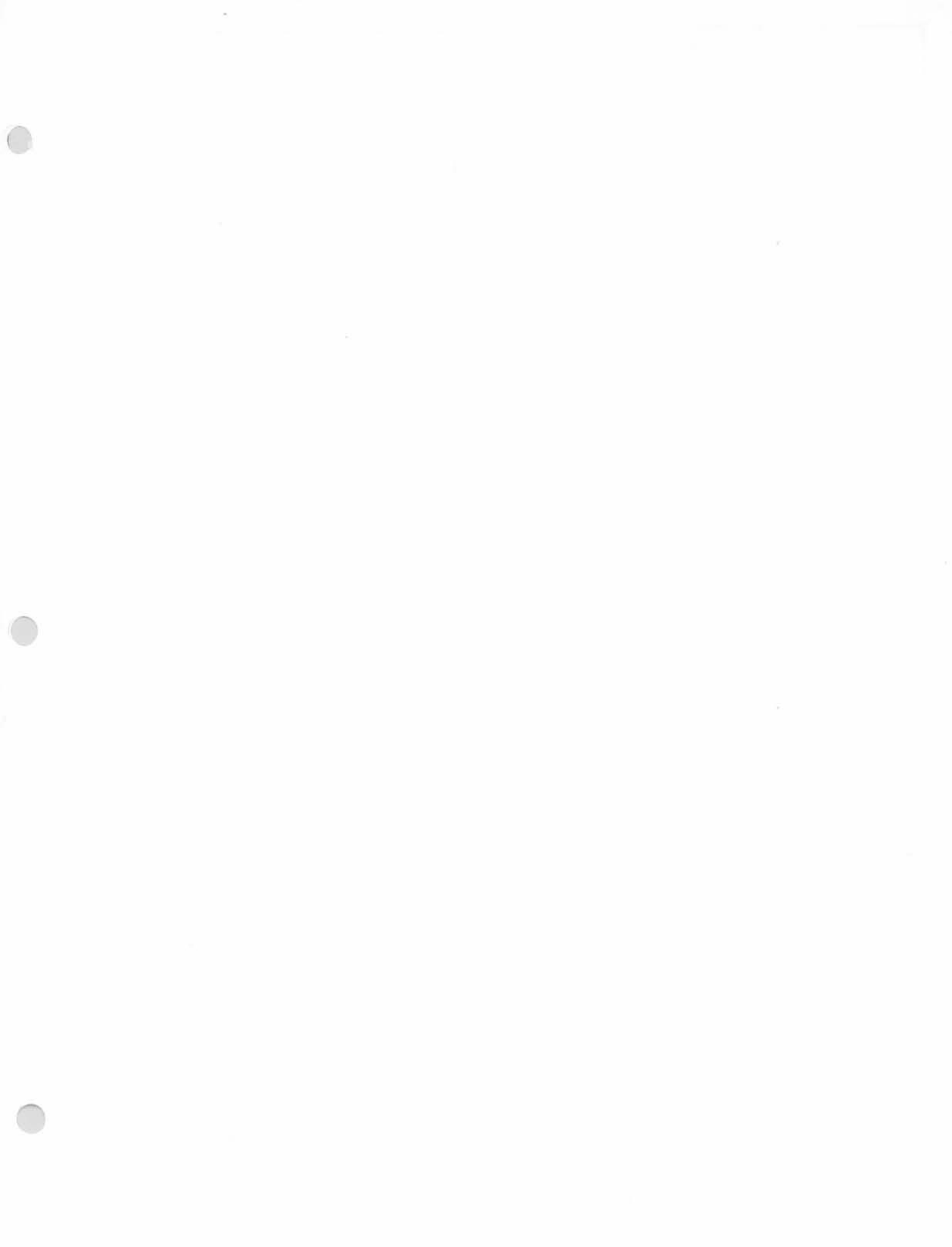

FOR PARTS REQUESTS ONLY

- Be sure to follow instructions carefully.
- Use a separate letter for all correspondence.
- Please allow 10 - 14 days for mail delivery time.

DO NOT WRITE IN THIS SPACE

INSTRUCTIONS

- Please print all information requested.
- Be sure you list the correct **HEATH** part number exactly as it appears in the parts list.
- If you wish to prepay your order, mail this card and your payment in an envelope. Be sure to include 10% (25¢ minimum, \$3.50 maximum) for insurance, shipping and handling. Michigan residents add 4% tax.
Total enclosed \$_____
- If you prefer COD shipment, check the COD box and mail this form. COD

NAME _____
 ADDRESS _____
 CITY _____
 STATE _____ ZIP _____

The information requested in the next two lines is not required when purchasing nonwarranty replacement parts, but it can help us provide you with better products in the future.

Model # _____ Invoice # _____
 Date Purchased _____ Location Purchased _____

LIST HEATH PART NUMBER	QTY.	PRICE EACH	TOTAL PRICE

TOTAL FOR PARTS _____
 HANDLING AND SHIPPING _____
 MICHIGAN RESIDENTS ADD 4% TAX _____
TOTAL AMOUNT OF ORDER _____

SEND TO: **HEATH COMPANY**
 BENTON HARBOR
 MICHIGAN 49022
ATTN: PARTS REPLACEMENT

Phone (Replacement parts only): 616 982-3571

THIS FORM IS FOR U.S. CUSTOMERS ONLY
 OVERSEAS CUSTOMERS SEE YOUR DISTRIBUTOR

FOR PARTS REQUESTS ONLY

- Be sure to follow instructions carefully.
- Use a separate letter for all correspondence.
- Please allow 10 - 14 days for mail delivery time.

DO NOT WRITE IN THIS SPACE

INSTRUCTIONS

- Please print all information requested.
- Be sure you list the correct **HEATH** part number exactly as it appears in the parts list.
- If you wish to prepay your order, mail this card and your payment in an envelope. Be sure to include 10% (25¢ minimum, \$3.50 maximum) for insurance, shipping and handling. Michigan residents add 4% tax.
Total enclosed \$_____
- If you prefer COD shipment, check the COD box and mail this form. COD

NAME _____
 ADDRESS _____
 CITY _____
 STATE _____ ZIP _____

The information requested in the next two lines is not required when purchasing nonwarranty replacement parts, but it can help us provide you with better products in the future.

Model # _____ Invoice # _____
 Date Purchased _____ Location Purchased _____

LIST HEATH PART NUMBER	QTY.	PRICE EACH	TOTAL PRICE

TOTAL FOR PARTS _____
 HANDLING AND SHIPPING _____
 MICHIGAN RESIDENTS ADD 4% TAX _____
TOTAL AMOUNT OF ORDER _____

SEND TO: **HEATH COMPANY**
 BENTON HARBOR
 MICHIGAN 49022
ATTN: PARTS REPLACEMENT

Phone (Replacement parts only): 616 982-3571

THIS FORM IS FOR U.S. CUSTOMERS ONLY
 OVERSEAS CUSTOMERS SEE YOUR DISTRIBUTOR

CUT ALONG DOTTED LINE

CUSTOMER SERVICE

REPLACEMENT PARTS

Please provide complete information when you request replacements from either the factory or Heath Electronic Centers. Be certain to include the **HEATH** part number exactly as it appears in the parts list.

ORDERING FROM THE FACTORY

Print all of the information requested on the parts order form furnished with this product and mail it to Heath. For telephone orders (parts only) dial 616 982-3571. If you are unable to locate an order form, write us a letter or card including:

- Heath part number.
- Model number.
- Date of purchase.
- Location purchased or invoice number.
- Nature of the defect.
- Your payment or authorization for COD shipment of parts not covered by warranty.

Mail letters to: Heath Company
Benton Harbor
MI 49022
Attn: Parts Replacement

Retain original parts until you receive replacements. Parts that should be returned to the factory will be listed on your packing slip.

OBTAINING REPLACEMENTS FROM HEATH ELECTRONIC CENTERS

For your convenience, "over the counter" replacement parts are available from the Heath Electronic Centers listed in your catalog. Be sure to bring in the original part and purchase invoice when you request a warranty replacement from a Heath Electronic Center.

TECHNICAL CONSULTATION

Need help with your kit? — Self-Service? — Construction? — Operation? — Call or write for assistance. you'll find our Technical Consultants eager to help with just about any technical problem except "customizing" for unique applications.

The effectiveness of our consultation service depends on the information you furnish. Be sure to tell us:

- The Model number and Series number from the blue and white label.
- The date of purchase.
- An exact description of the difficulty.
- Everything you have done in attempting to correct the problem.

Also include switch positions, connections to other units, operating procedures, voltage readings, and any other information you think might be helpful.

Please do not send parts for testing, unless this is specifically requested by our Consultants.

Hints: Telephone traffic is lightest at midweek — please be sure your Manual and notes are on hand when you call.

Heathkit Electronic Center facilities are also available for telephone or "walk-in" personal assistance.

REPAIR SERVICE

Service facilities are available, if they are needed, to repair your completed kit. (Kits that have been modified, soldered with paste flux or acid core solder, cannot be accepted for repair.)

If it is convenient, personally deliver your kit to a Heathkit Electronic Center. For warranty parts replacement, supply a copy of the invoice or sales slip.

If you prefer to ship your kit to the factory, attach a letter containing the following information directly to the unit:

- Your name and address.
- Date of purchase and invoice number.
- Copies of all correspondence relevant to the service of the kit.
- A brief description of the difficulty.
- Authorization to return your kit COD for the service and shipping charges. (This will reduce the possibility of delay.)

Check the equipment to see that all screws and parts are secured. (Do not include any wooden cabinets or color television picture tubes, as these are easily damaged in shipment. Do not include the kit Manual.) Place the equipment in a strong carton with at least **THREE INCHES** of *resilient* packing material (shredded paper, excelsior, etc.) on all sides. Use additional packing material where there are protrusions (control sticks, large knobs, etc.). If the unit weighs over 15 lbs., place this carton in another one with 3/4" of packing material between the two.

Seal the carton with reinforced gummed tape, tie it with a strong cord, and mark it "Fragile" on at least two sides. Remember, the carrier will not accept liability for shipping damage if the unit is insufficiently packed. Ship by prepaid express, United Parcel Service, or insured Parcel Post to:

Heath Company
Service Department
Benton Harbor, Michigan 49022



HEATH COMPANY • BENTON HARBOR, MICHIGAN
THE WORLD'S FINEST ELECTRONIC EQUIPMENT IN KIT FORM

LITHO IN U.S.A.