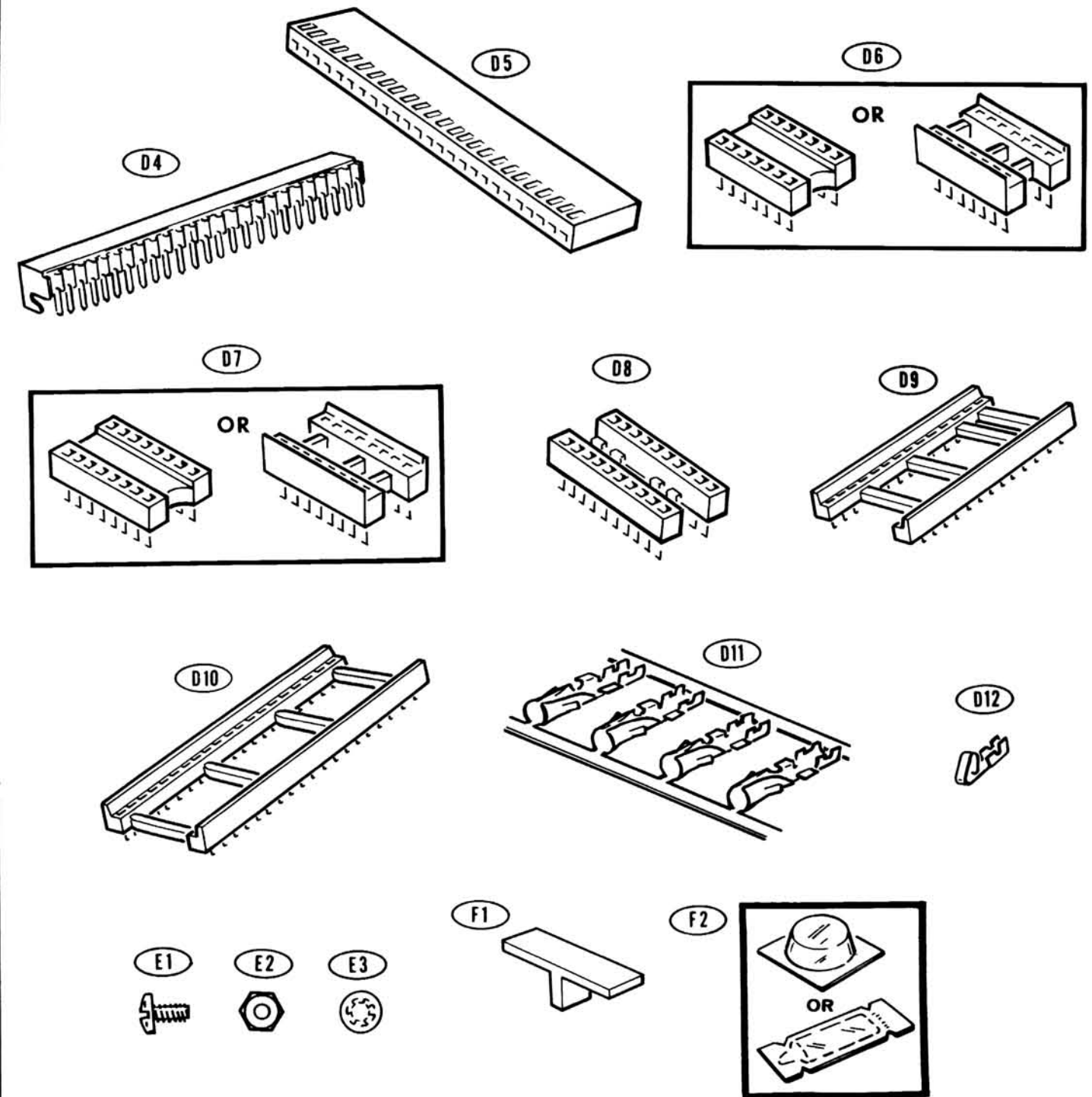
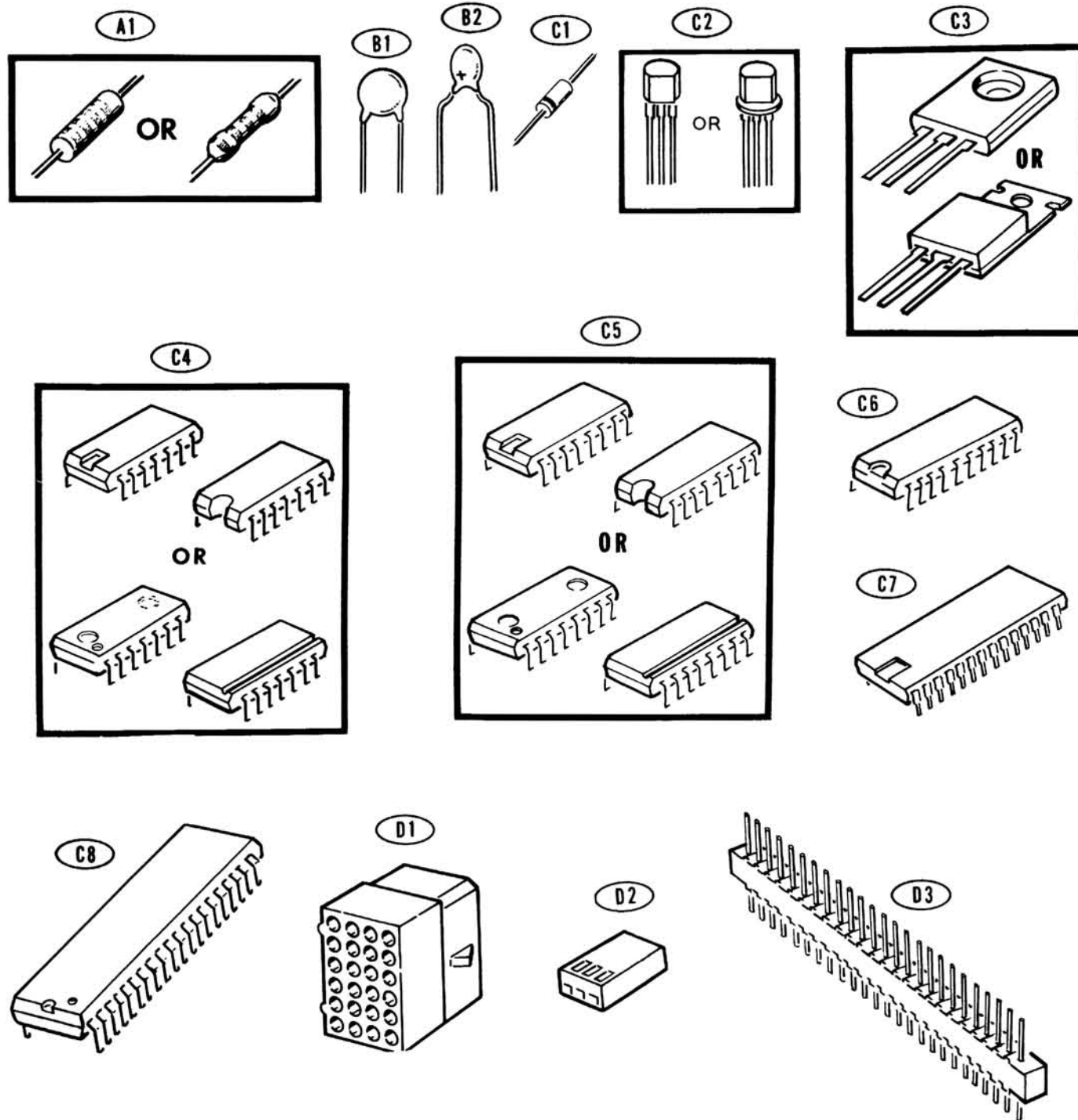
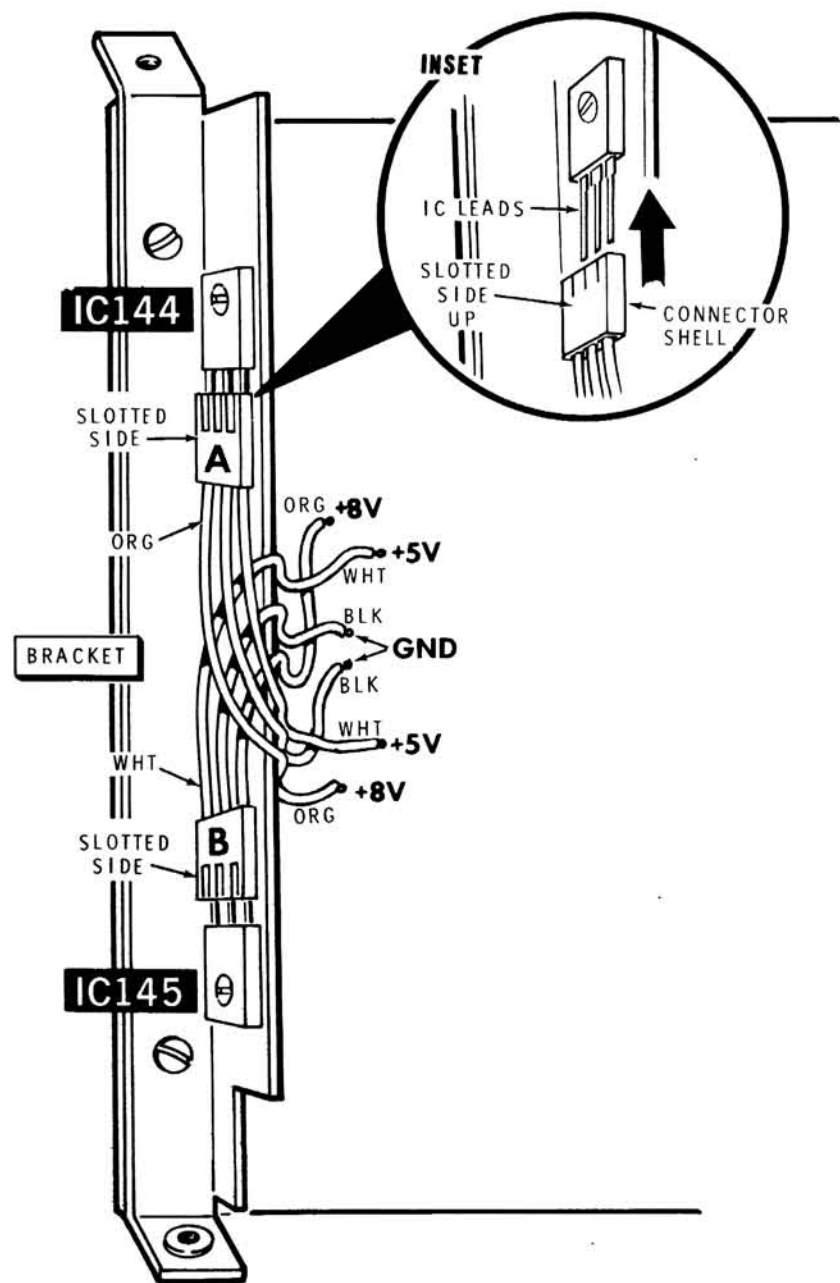

ILLUSTRATION BOOKLET

Part of 595-2033-02

PARTS PICTORIAL





PICTORIAL 1-13

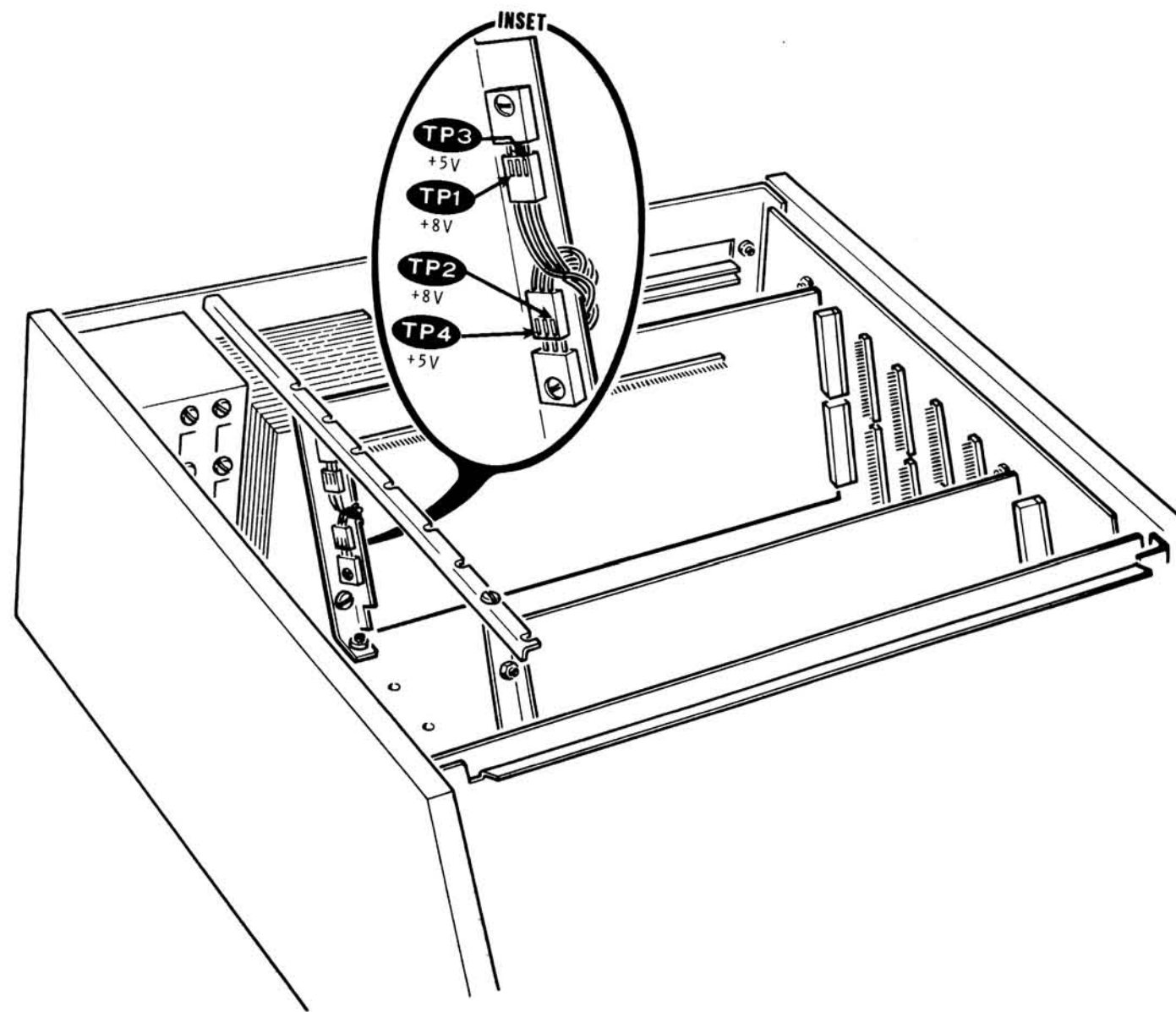

PICTORIAL 1-14

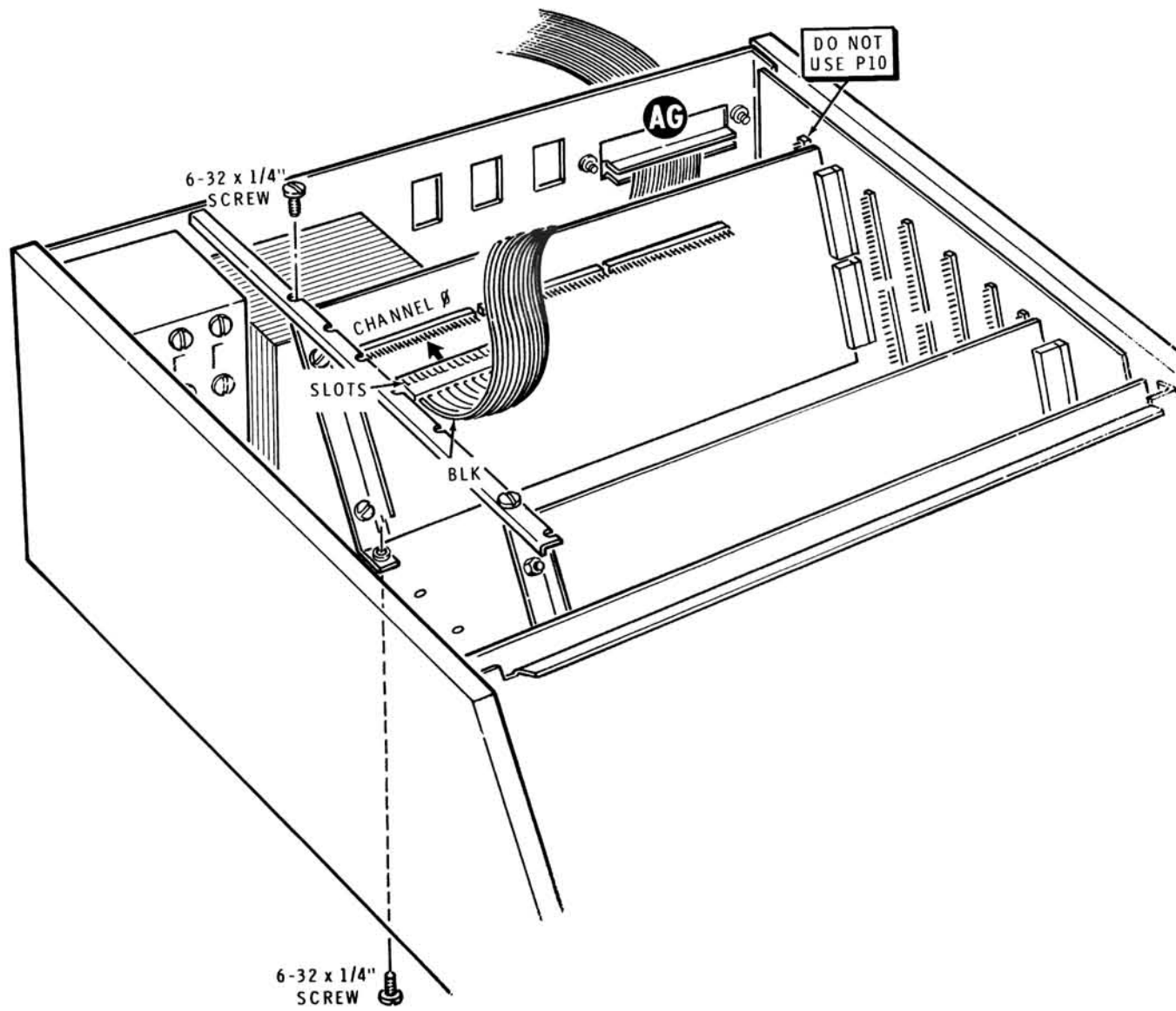

PICTORIAL 2-5

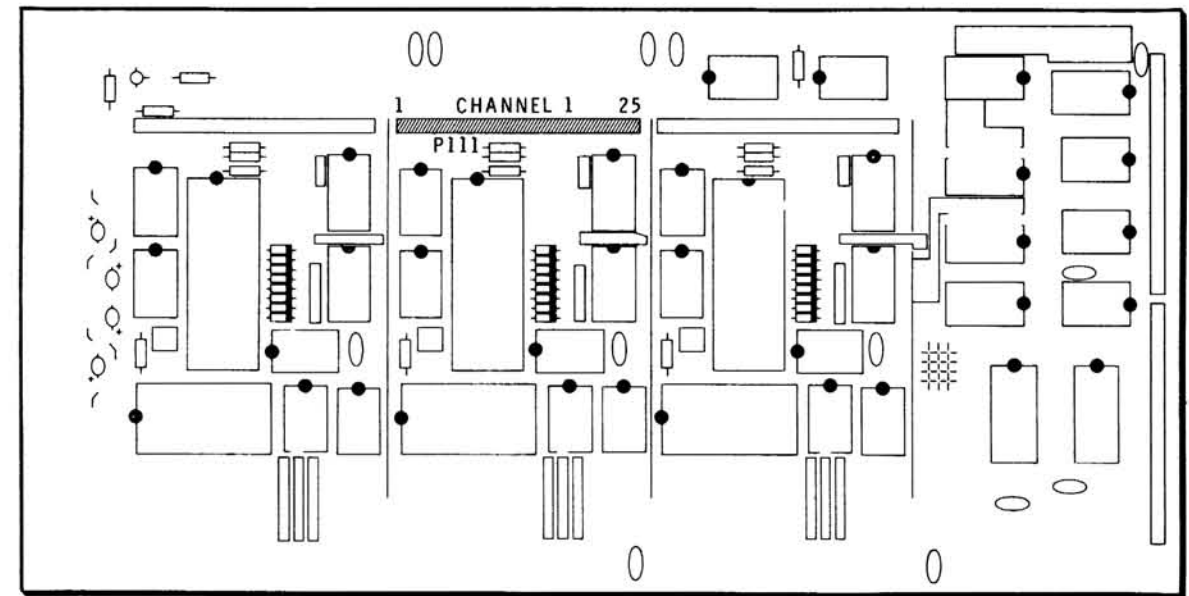

PICTORIAL 2-3

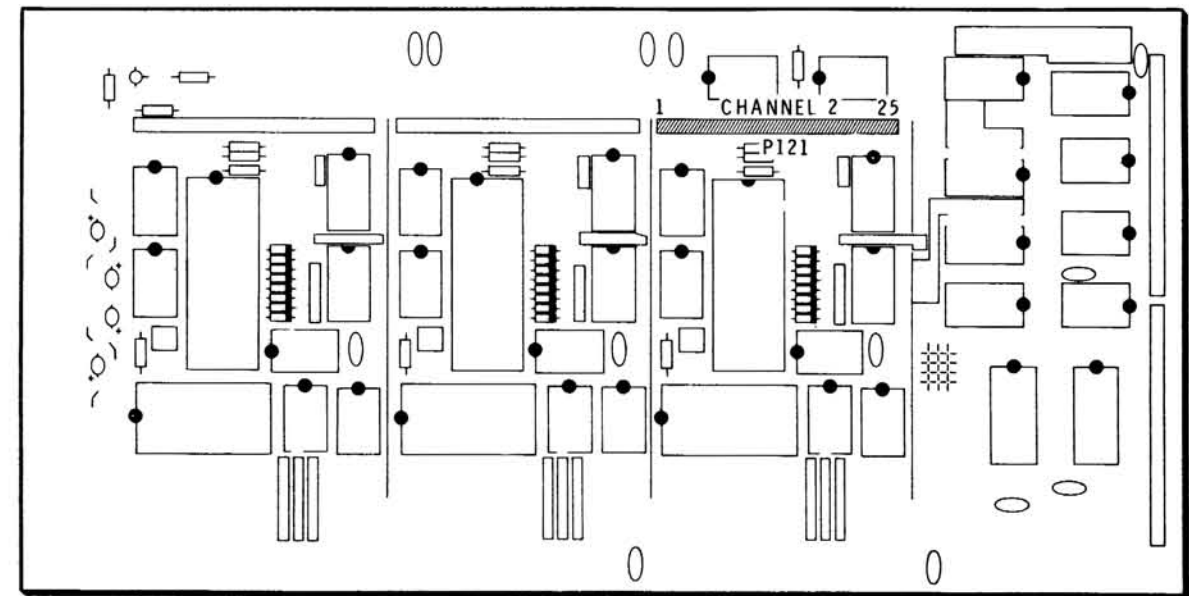

PICTORIAL 2-4

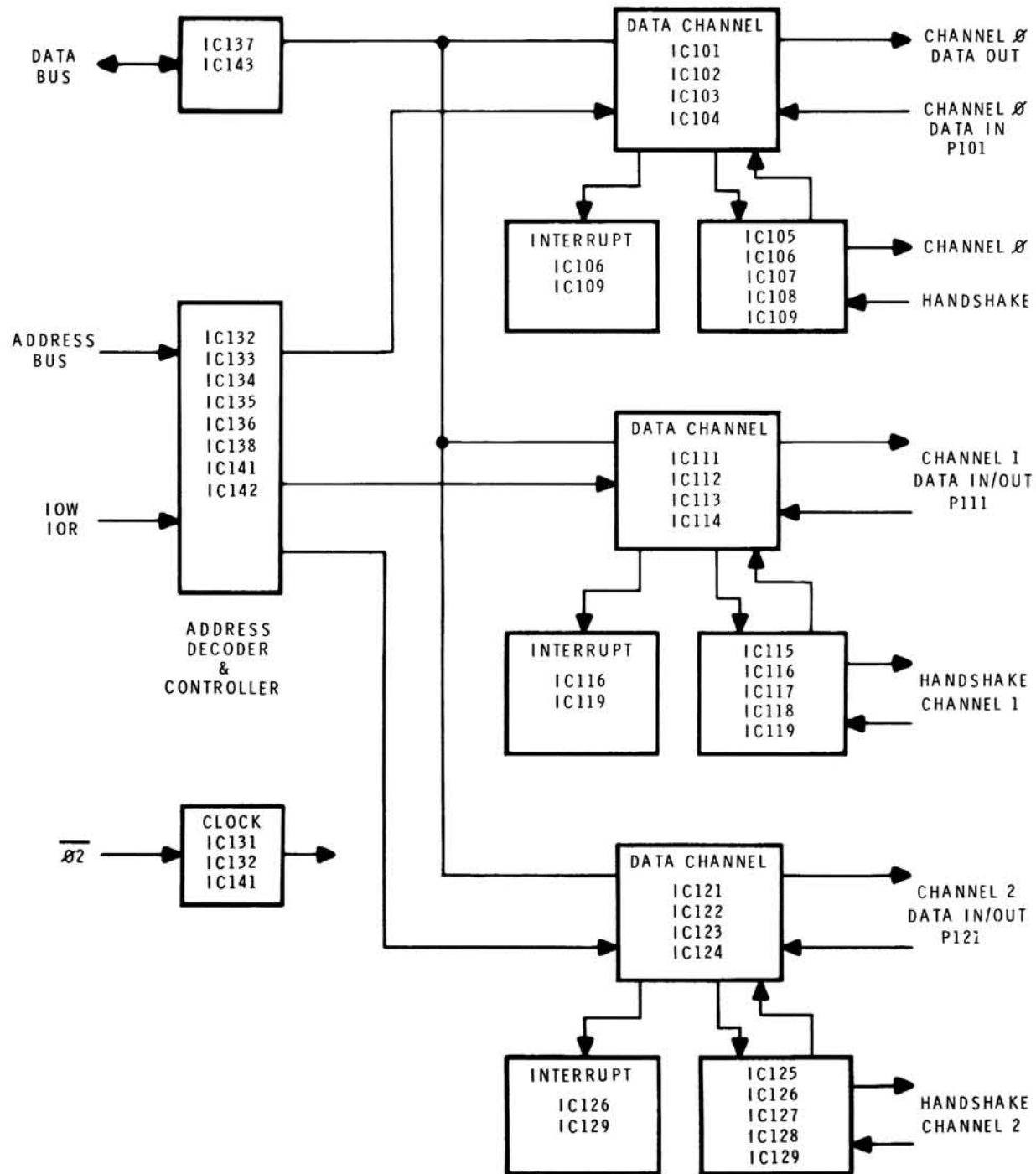

PICTORIAL 4-3

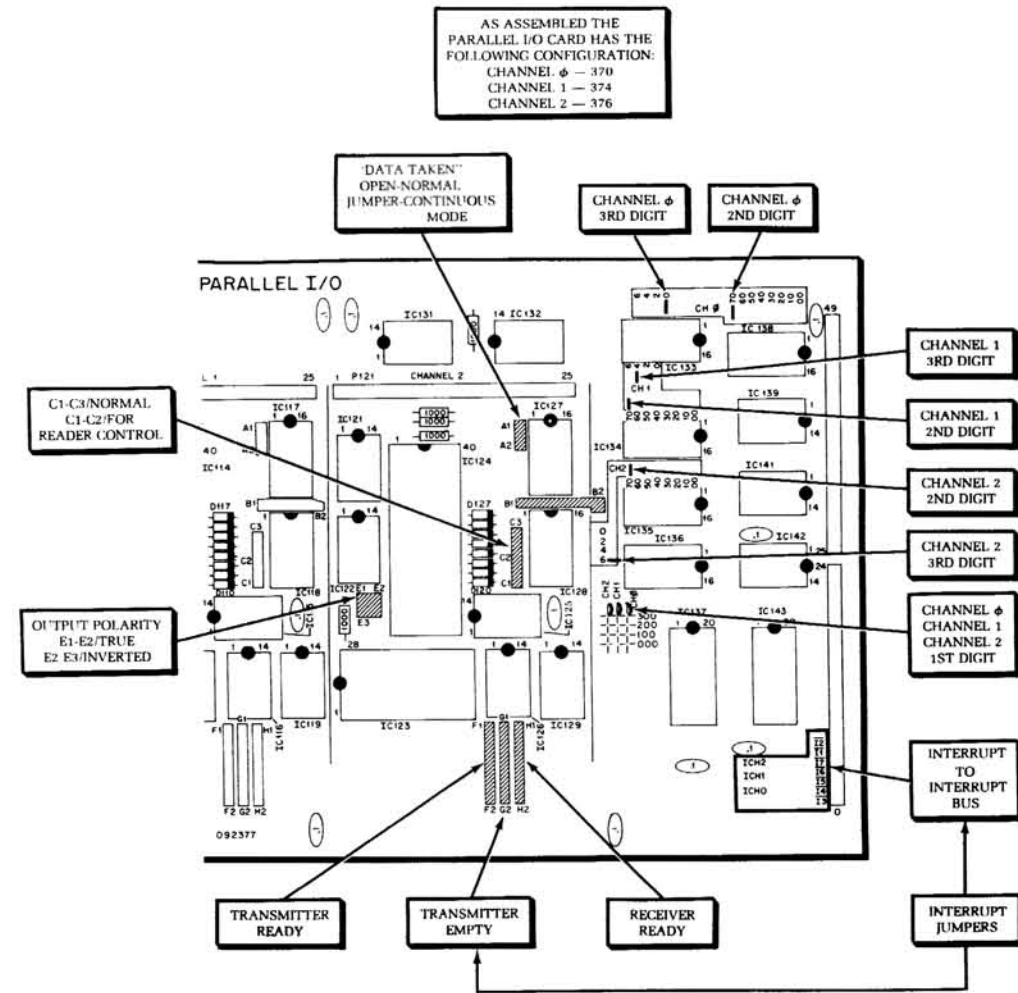

PICTORIAL 3-2

