

8E 7309

ILLUSTRATED PARTS BREAKDOWN

PC04 PAPER TAPE READER/PUNCH

HOW TO USE THE IPB

GENERAL

This IPB is compiled following the organization and nomenclature of the engineering drawing structure.

MAJOR ASSEMBLY LOCATOR

The Major Assembly Locator (first illustration) is an index that provides a description and a figure reference for all illustrations used in this manual.

INDENTED PARTS LIST

This manual identifies each assembly being broken down (figure reference callout), and all parts of that assembly. Further breakdown of an assembly is shown by an asterisk (*) preceding the item callouts in the Description Column. The number of asterisks preceding an item is used to denote the subordination of that item with respect to the Major Assembly. A single asterisk preceding an item description indicates that the item is part of the major assembly being illustrated. Items that are subordinate to single asterisks items, are denoted by two asterisks (**) and immediately follow the related single asterisk item. Additional asterisks are used, as required, to denote further subordination. This system of part identification, provides a means for the user to identify the next higher assembly item and make alternate selections for parts when the required replacement part or assembly is not immediately available.

COLUMN CALLOUT DESCRIPTION

Figure & Item — Indicates the figure number and item number of each part.

Description — Lists the name of the part and pertinent specifications (when required). Asterisks preceding the description denote the subordination of the part to the next higher assembly.

DEC Part No. — Lists the DEC part ordering number. A blank in this column indicates a DEC part number was not assigned at the time of publication.

ECO Cut-In — The notation at the top of this column indicates the ECO level of the system (option), at which the IPB was initially prepared. Subsequent ECO level designations, that modify existing parts or add new parts to the device, are inserted in the ECO Cut-In column next to the part that is added or modified. A bracket ([]) preceding the item description is used to indicate the parts affected by ECO's.

Vendor Code/Part No. — Indicates vendor parts that are not stocked by DEC. Refer to the Field Service Spares Catalog (vendor part number to DEC part number) for the vendor code cross-reference.

Used On Code — Letters in this column correspond to the variation codes assigned in Figure 1. Parts with an Alpha notation(s) are used only in those option variations. A blank indicates that the part is used on all option variations.

Ref Fig No. — A cross reference between illustrations. For each Major Assembly, the number in this column denotes the figure of the next higher assembly. For all subassemblies, the number in this column denotes the figure showing additional detailed breakdown.

SYMBOL USAGE

Hardware Designators — Alpha designators for screws (S), washers (W), nuts (N), and retaining rings (R) are inserted after the item number callouts on the illustration when stacked item numbers are used.

Attaching Hardware — The @ symbol is inserted before any part that is used as attaching hardware. Attaching hardware is denoted as those parts that are not an integral part of the referenced assembly.

(NFR) Not Field Repairable — The (NFR) symbol is inserted after any assembly that is not to be field dismantled.

Other Symbols — Any other symbols that are required for kits, accessories, etc., will be explained and appear as part of the item description.

REVISION HISTORY

PRINTING	ECO LEVEL	DATE	PAGES AFFECTED
1st Printing	PC04-00000-00056	5/30/73	N/A
1st Printing	5408310-00000-00005	5/30/73	N/A
1st Printing	5408935-00000-00001	5/30/73	N/A
1st Printing	5408385-00001-00001	5/30/73	N/A
1st Printing	7006520-00000-00000	5/30/73	N/A

Copyright © 1973, by Digital Equipment Corporation

DEC reserves the right, without notice, to make substitutions and modifications in the specifications of products documented in this manual and further reserves the right to withdraw any of these products from the market without notice.

DEC is not responsible for errors which may appear in the technical description (including illustrations and photographs) of the products covered by this manual.

None of the descriptions contained in this manual imply the granting of any license whatsoever to make, use or sell equipment constructed in accordance therewith.

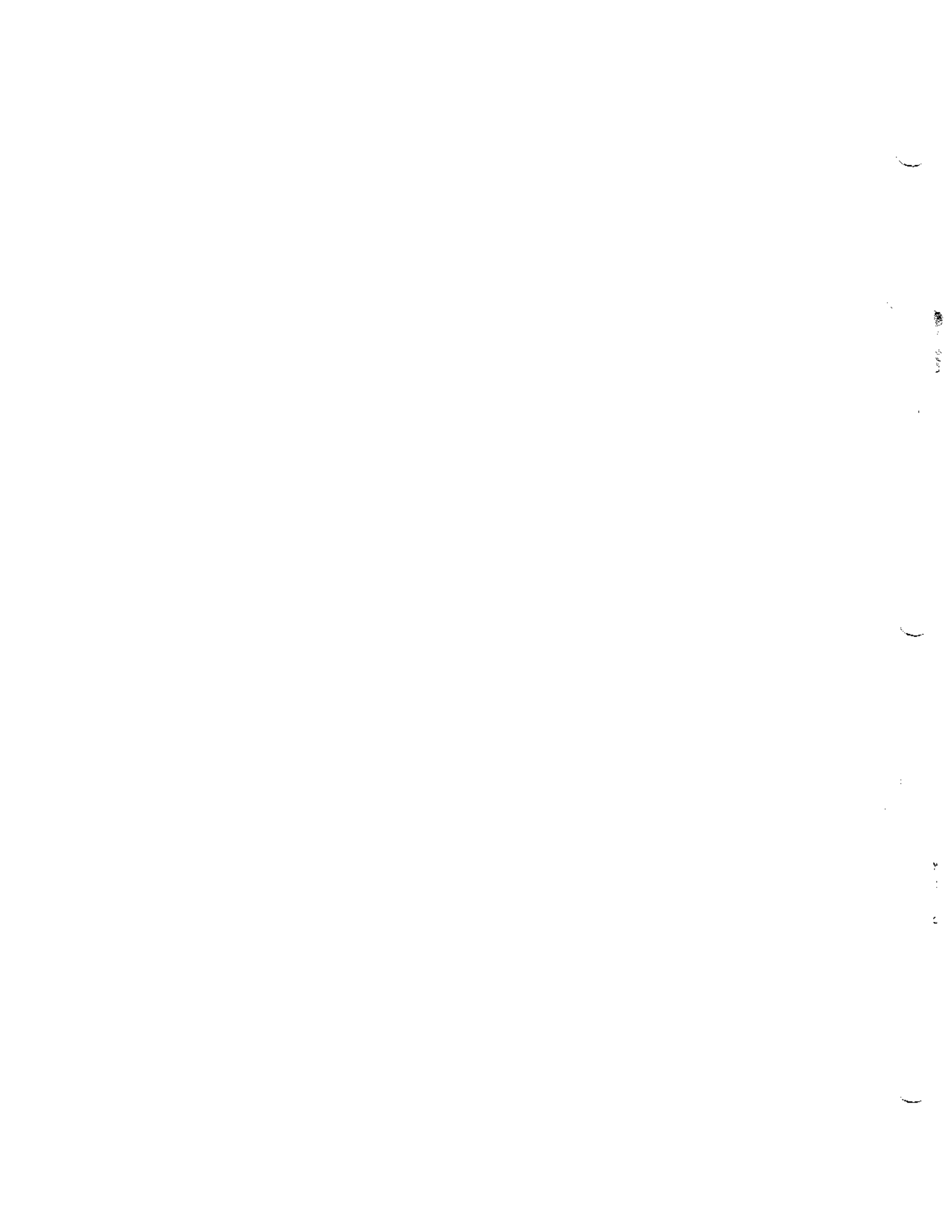

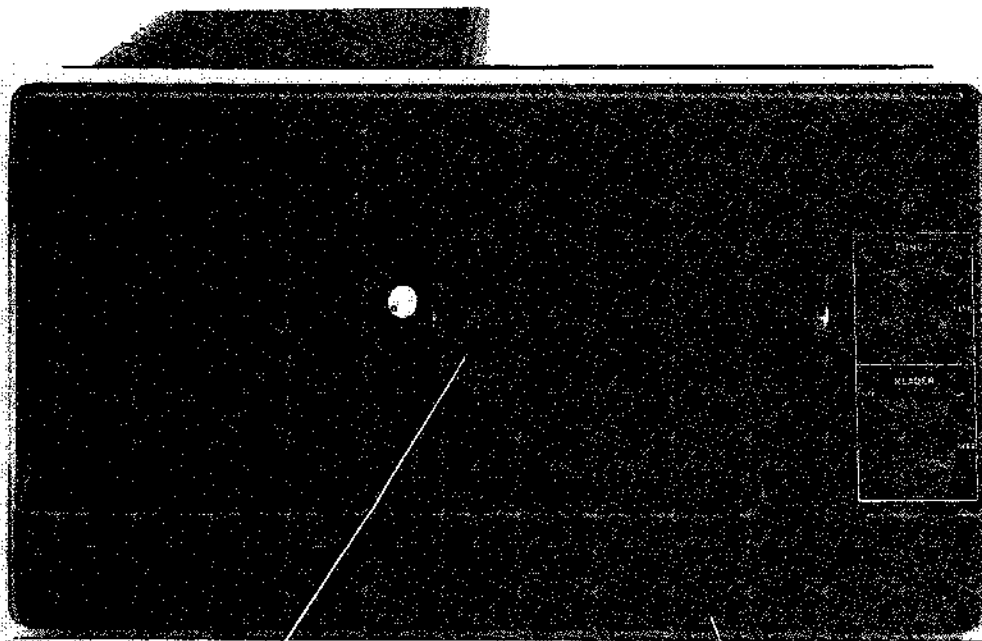

READER ASSEMBLY
Fig. 4

PAPER TAPE READER/PUNCH ASSEMBLY
Fig. 1

SWITCH ASSEMBLY
Fig. 5

PR SWITCH
BOARD ASSEMBLY
Fig. 6

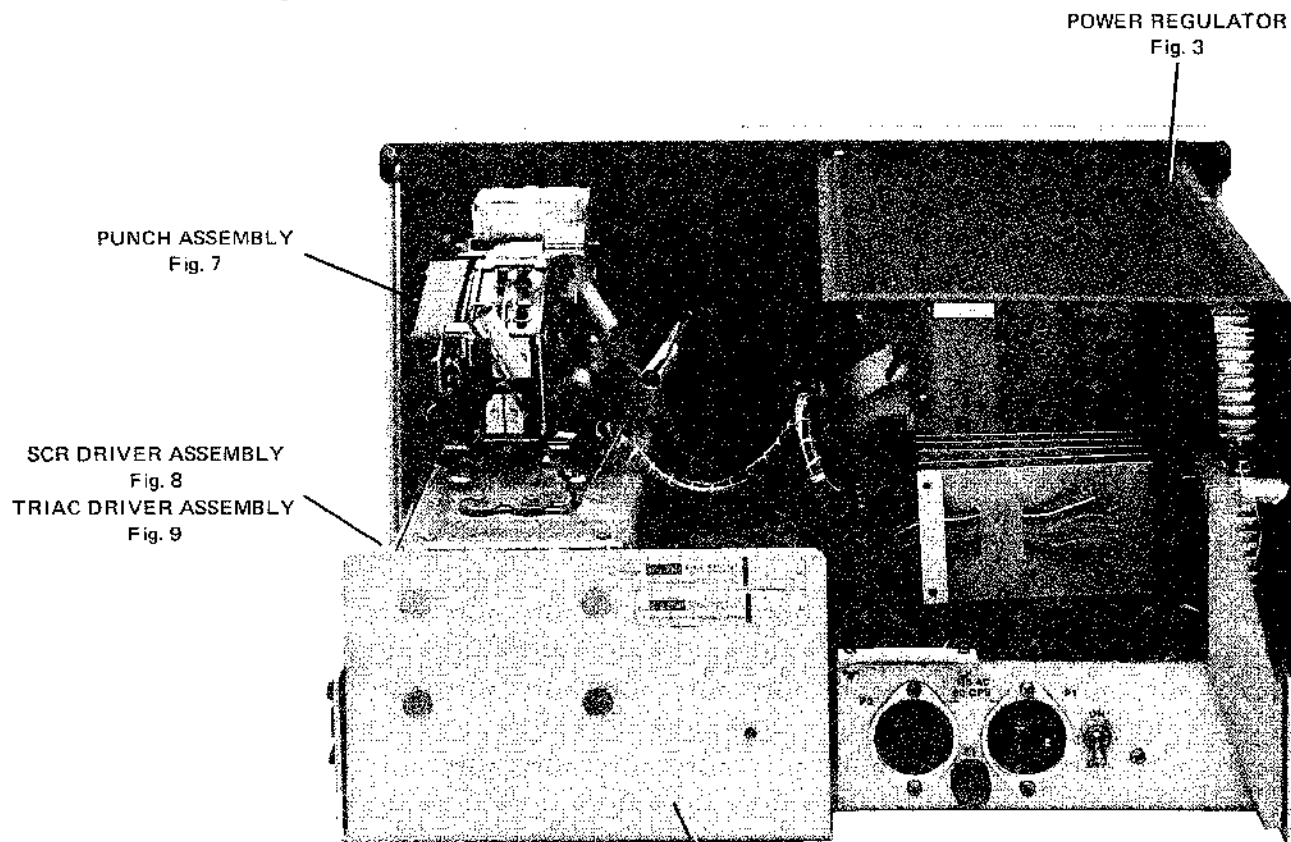

PUNCH ASSEMBLY
Fig. 7

SCR DRIVER ASSEMBLY
Fig. 8
TRIAC DRIVER ASSEMBLY
Fig. 9

POWER REGULATOR
Fig. 3

CHASSIS and POWER SUPPLY ASSEMBLY
Fig. 2

PC04-02

PC04 Major Assembly Locator

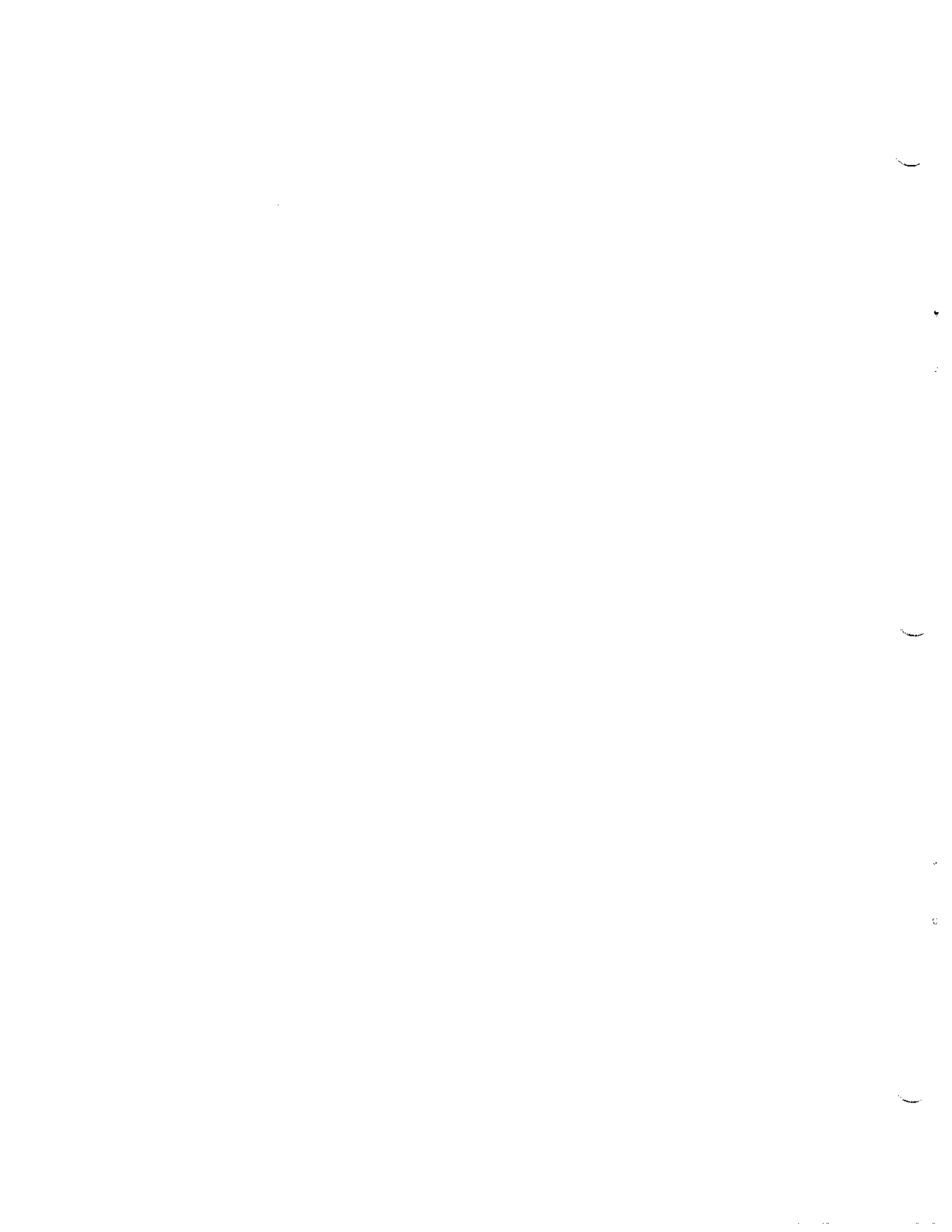

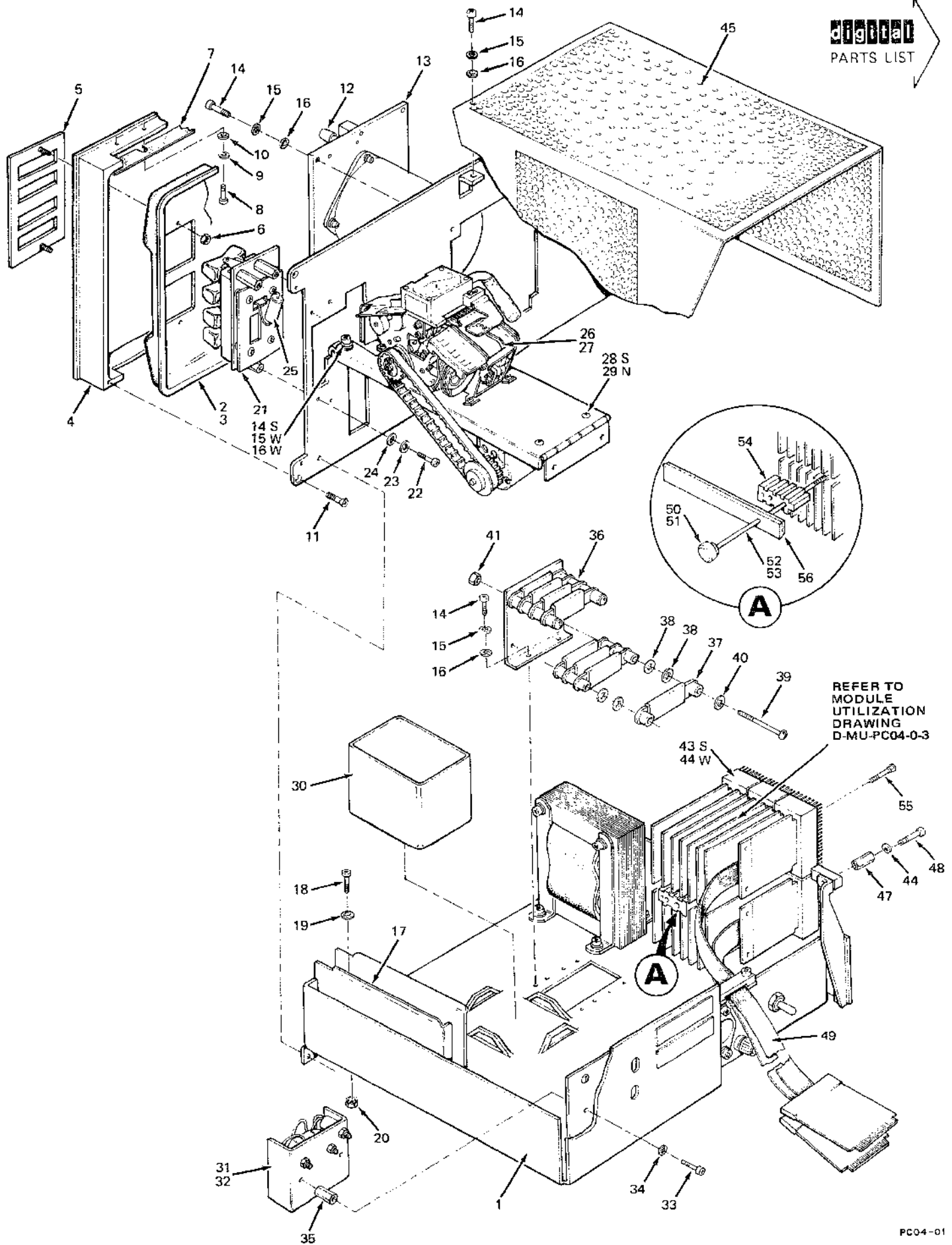
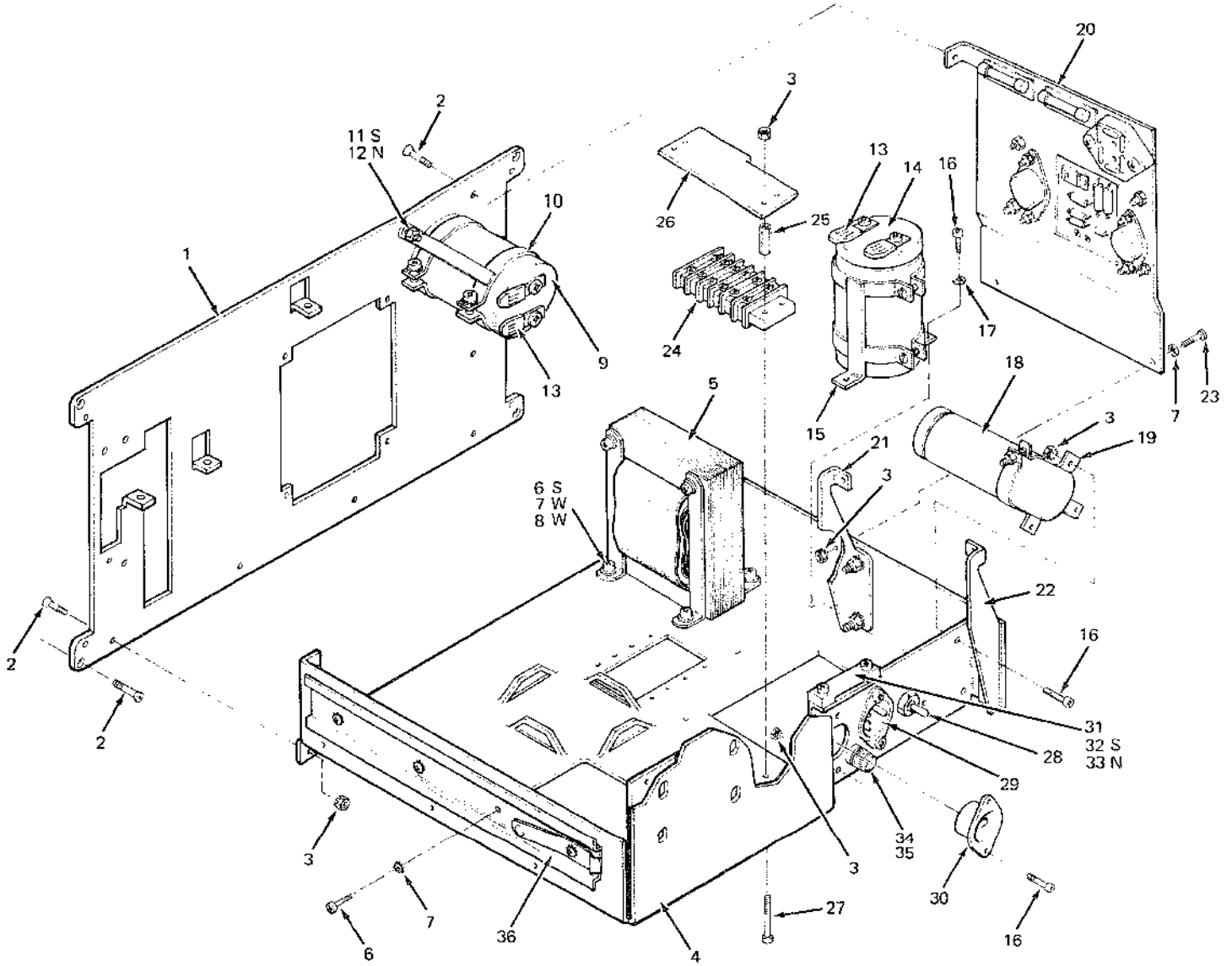

Figure 1. Paper Tape Reader/Punch Assembly

FIG & ITEM NO.	DESCRIPTION	DEC PART NO.	ECO CUT-IN PC04-00000	USED ON CODE	VENDOR		REF FIG NO.
					CODE	PART NO.	
1-	MODEL PC04 PAPER TAPE READER/PUNCH ASSEMBLY						
	Code "A" used on PC04-B (60 Hz, PT PU, RDR & PS)	PC04-B		A			
	Code "B" used on PC04-BA (50 Hz, PT PU, RDR & PS)	PC04-BA		B			
	Code "C" used on PC04-BB (PC04-B for PDP8/I, 60 Hz)	PC04-BB	00006	C			
	Code "D" used on PC04-BC (PC04-BA for PDP8/I, 50 Hz)	PC04-BC	00006	D			
	Code "E" used on PC04-BL (PC04-B for PDP8/L, 60 Hz)	PC04-BL		E			
	Code "F" used on PC04-BM (PC04-BA for PDP8/L, 50 Hz)	PC04-BM		F			
	Code "G" used on PC04-C (60 Hz, PT PU, RDR, PS & SCR)	PC04-C		G			
	Code "H" used on PC04-CA (50 Hz, PT PU, RDR, PS & SCR)	PC04-CA		H			
	Code "J" used on PC04-CL (Pos Log, 60 Hz, PT PU, RDR, PS & SCR)	PC04-CL	00053	J			
	Code "K" used on PC04-CM (Pos Log, 50 Hz, PT PU, RDR, RS & SCR)	PC04-CM	00053	K			
	Code "L" used on PC04-P (60 Hz, PT PU, & PS)	PC04-P		L			
	Code "M" used on PC04-PA (50 Hz, PT PU, & PS)	PC04-PA		M			
	Code "N" used on PC04-PL (PC04-P for PDP8/L)	PC04-PL		N			
	Code "P" used on PC04-PM (PC04-PA for PDP8/L)	PC04-PM		P			
	Code "R" used on PC04-R (RDR & PS 50/60 Hz)	PC04-R		R			
	Code "S" used on PC04-RB (PC04-R for PDP8/I and PDP8/L)	PC04-RB	00006	S			
1	*CHASSIS AND POWER SUPPLY ASSEMBLY	70-06246-00					2
2	*Cover Assy. (Punch/Reader)	70-06252-01		A,B,C,D,E,F			
	*Cover Assy. (Punch)	70-06252-02		L,M,N,P			
	*Cover Assy. (Reader)	70-06252-03		R,S			
	*Cover Assy. (Punch/Reader and SCR)	70-06252-04		G,H			
	*Cover Assy. (Punch/Reader and SCR)	70-06252-06	00053	J,K			
3	**Cover, PCO (Basic & Comb)	12-09396-02		A,B,C,D,E,F, G,H,J,K			
	**Cover, PCO (Punch)	12-09396-04		L,M,N,P			
	**Cover, PCO (Reader)	12-09396-06		J,K			
4	**Bezel, PCO	74-07099-00					
5	**Bezel, Switch	74-07134-01		A,B,C,D,E,F			
	**Bezel, Switch	74-07134-02		L,M,N,P			
	**Bezel, Switch	74-07134-03		R,S			
	**Bezel, Switch	74-07134-04		G,H			
	**Bezel, Switch	74-07134-05		L			
	**Bezel Switch	74-07134-06	00053	J,K			
6	**Nut, Hex No. 6-32	90-06558-00					
7	**Shim, Bezel	74-07849-00					
8	**Screw, Phi Hd Pan No. 6-32 x 1/2 Lg	90-06020-01					
9	**Washer, Flat No. 6	90-06656-00					
10	**Washer, Lock No. 6 Int Tooth	90-06633-00					
11	**Screw, Phi Hd Flat No. 6-32 x 5/16 Lg	90-06021-02					
12	@Knob Reader	12-04747-00					
13	*READER ASSEMBLY	70-06247-00		A,B,C,D,E,F, G,H,J,K,R,S			4
14	*Screw, Phi Hd Pan No. 6-32 x 1/2 Lg	90-06024-01					
15	*Washer, Flat No. 6	90-06653-00					
16	*Washer, Lock No. 6 Int Tooth	90-06033-00					
17	*TAPE CONTAINER	74-07131-00					
18	*Screw, Phi Hd Flat No. 4-40 x 3/8 Lg	90-06011-02					

FIG & ITEM NO.	DESCRIPTION	DEC PART NO.	ECO CUT-IN PC04- 00000	USED ON CODE	VENDOR		REF FIG NO.
					CODE	PART NO.	
1-							
19	*Washer, Int Tooth No. 4	90-06632-00					
20	*Nut, Hex No. 4-40	90-06556-00					
21	*SWITCH ASSEMBLY	54-08310-03		A, B, C, D, E, F			5
	*SWITCH ASSEMBLY	54-08935-00		L, M, N, P			6
	*SWITCH ASSEMBLY	54-08310-03		G, H			5
	*SWITCH ASSEMBLY	54-08310-05		J, K			5
22	*Screw, Phi Hd Pan No. 6-32 x 3/8 Lg	90-06022-01					
23	*Washer, Flat No. 6	90-06653-00					
24	*Washer, Lock No. 6 Int Tooth	90-06033-00					
25	*THYRECTOR	11-00106-00		A, B, C, D, E, F, L, M, N, P			
26	*PUNCH ASSEMBLY (60 Hz)	70-06248-01		A, C, E, G, J, L, N			7
27	*PUNCH ASSEMBLY (50 Hz)	70-06248-02		B, D, F, H, K, M, P			7
28	*Screw, Phi Hd Pan No. 6-32 x 5/16 Lg	90-06021-01					
29	*Nut, Keps No. 6-32	90-06560-00					
30	*CHAD BOX ASSEMBLY	74-05300-00					
	*CHAD BOX ASSEMBLY	12-10272-00					
31	*SCR DRIVER ASSEMBLY	54-08385-00		G, H			8
32	*TRIAC DRIVER ASSEMBLY	70-06520-00		J, K			9
33	*Screw, Phi Hd Pan No. 6-32 x 3/4 Lg	90-06026-01					
34	*Washer, Lock No. 6	90-06033-00					
35	*Spacer, Hex No. 1/4 AF x 3/8 Lg x No. 6 hole	90-06801-00					
36	*BRACKET RESISTORS	74-08091-00	00022	A, B, C, D, E, F, G, H, J, K, L, R, S			
37	*Resistor (R1 thru R8) 50 Ohm 20W 5%						
	*Resistor (R1 thru R8) 25 Ohm 40W 5%	13-09896-00	00022	A, B, C, D, E, F, G, H, J, K, L, R, S			
38	*Washer, Flat No. 10	90-06664-00					
39	*Screw, Phi Hd Pan No. 10-32 x 2 1/4 Lg	90-06083-01					
40	*Washer, Lock No. 10	90-06635-00					
41	*Nut, Keps No. 10-32	90-06565-00					
42	*WIRED ASSEMBLY	70-06247-00		A, B, C, D, G, H, L, M, R, S			
	*WIRED ASSEMBLY	70-06268-01		E, F, N, P			
	*WIRED ASSEMBLY	70-06268-02	00053	J, K			
43	*Screw, Phi Hd Pan No. 8-32 x 3/8 Lg	90-06037-01					
44	*Washer, Lock No. 8	90-06634-00					
45	*POWER SUPPLY COVER	74-07436-00					
46	*DEC NAME PLATE	90-08141-00					
47	*Spacer, Hex No. 3/8 x 3/4 Lg	90-06823-00					
48	*Screw, Phi Hd Pan 8-32 x 1 Lg	90-06043-01					
49	*I/O Cable, PC04 (W033 to W077)	70-06281-00		A, B, C, D, G, H, M, N, R, S			
	*Cable Connector (M926 to W033S)	74-07067-01		E, F			
	*Cable Connector (Punch) (M926 to W033S)	70-06145-01		N, P			
	*Cable Connector (M926 to W033S)	74-07067-03	00053	J, K			
60	*SCR, MODULE RETAINER	74-05642-00		A, B, C, D, E, F, G, H, J, K, L, P, R, S			
51	**Module Retainer	12-09377-02					
52	**Screw No. 10-32 x 4-15/16 Lg	74-05642-00					
53	**Screw No. 10-32 x 8-7/16 Lg	74-05642-01					
54	*Module Retainer, Universal	12-09850-00					
55	*Screw, Phi Fillister Hd No. 8-32 x 1 1/2 Lg	90-07799-06					
56	*Bar, Hold Down (6 in.)	74-08339-07					





PC04-03

Figure 2. Chassis and Power Supply Assembly

FIG & ITEM NO.	DESCRIPTION	DEC PART NO.	ECO CUT-IN PC04-00000	USED ON CODE	VENDOR CODE	VENDOR PART NO.	REF FIG NO.
2--	CHASSIS AND POWER SUPPLY ASSEMBLY	70-06246-00					1
1	*FRONT PANEL	74-07075-00					
2	*Screw, Phi Hd Flat No. 6-32 x 1/4 Lg	90-06020-02					
3	*Nut, Keps No. 6-32	90-06560-00					
4	*CHASSIS	74-07074-00					
5	*TRANSFORMER	16-09357-00					
6	*Screw, Phi Hd Pan No. 10-32 x 3/8 Lg	90-06071-01					
7	*Washer, Flat No. 10	90-06664-00					
8	*Washer, Lock No. 10	90-06635-00					
9	*CAPACITOR 80,000 MFD	10-09190-00					
10	*Bracket, Capacitor	12-01406-00					
11	*Screw, Phi Hd Flat No. 8-32 x 1/4 Lg	90-06035-02					
12	*Nut, Keps No. 8-32	90-06563-00					
13	*Tab, Connector	90-07619-00					
14	*CAPACITOR, 8600 MFD 50V	10-02811-00					
15	*Bracket, Capacitor	12-10249-00					
16	*Screw, Phi Hd Pan No. 6-32 x 5/16 Lg	90-06021-01					
17	*Washer, Lock No. 6	90-06633-00					
18	*CAPACITOR, 18000 MFD	10-09188-00					
19	*Bracket, Capacitor	12-09242-00					
20	*POWER REGULATOR ASSEMBLY	70-06512-00	00009				3
21	*BRACKET MOUNTING BAR (R.H.)	74-07065-01					
22	*BRACKET MOUNTING BAR (L.H.)	74-07065-02					
23	*Screw, Phi Hd Pan No. 6-32 x 3/8 Lg	90-06022-01					
24	*JONES STRIP	90-06910-00					
25	*Stand-off, Hex No. 6-32 x 5/16 Lg	90-06842-00					
26	*Cover, Jones Strip	53-03184-00					
	*Cover, Jones Strip	53-09641-00	00051				
27	*Screw, Phi Hd Pan No. 6-32 x 1-1/8 Lg	90-07853-01					
28	*Switch, Unit ON/OFF PWR	12-04722-00					
29	*Power Inlet, Amphenol	12-01252-00					
30	*Power Outlet, Hubbell	12-01251-00					
31	*Clamp, Cable	12-02704-00					
32	*Screw, Phi Hd Pan No. 4-40 x 3/8 Lg	90-06011-01					
33	*Nut, Keps No. 4-40	90-06557-00					
34	*Holder, Fuse	90-07242-00					
35	*Fuse, 3 Amp Slo Bio	90-07218-00					
36	*Chassis-Trak Set	12-09147-00					

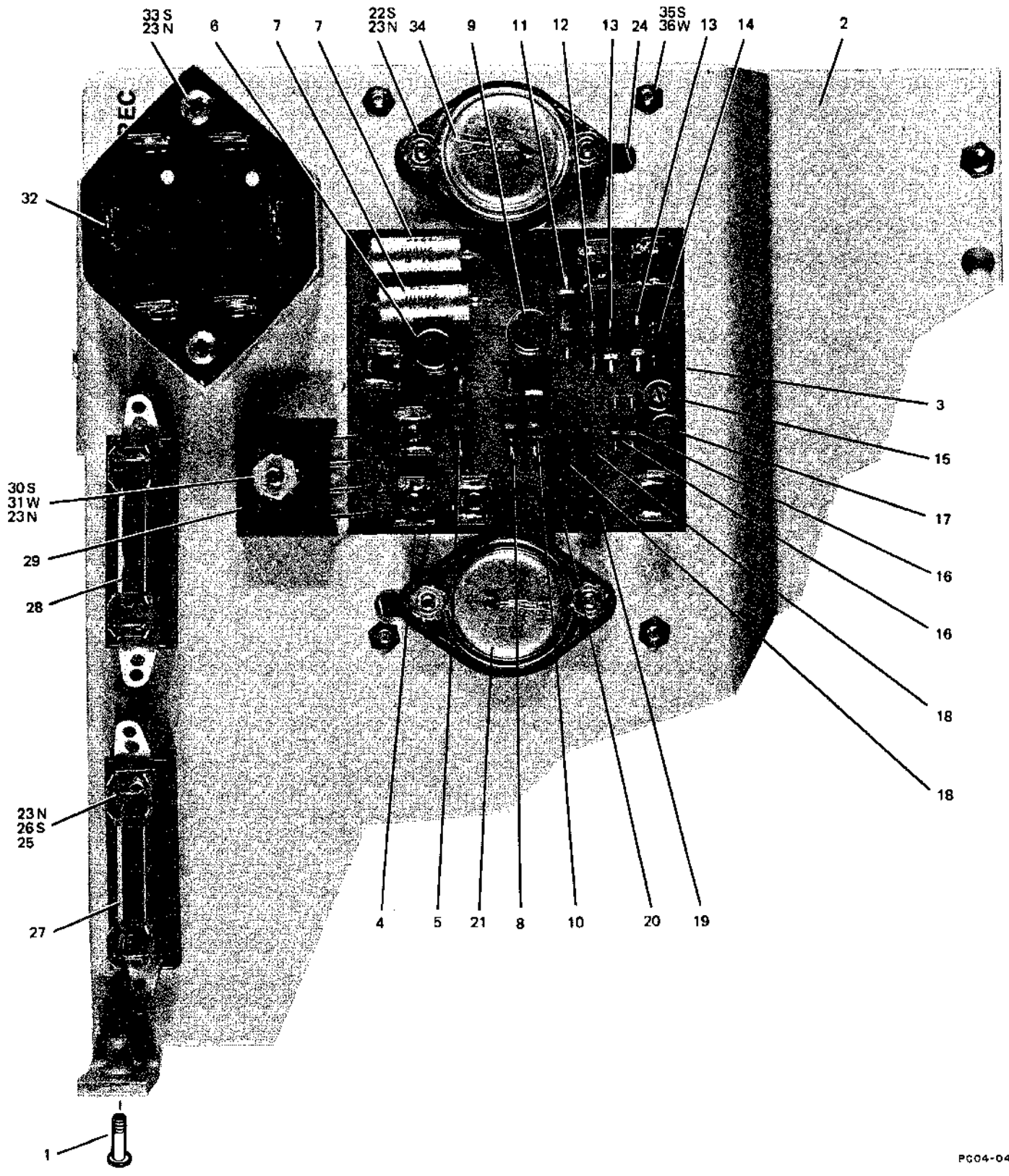

Figure 3. Power Regulator Assembly

PC04-04

FIG & ITEM NO.	DESCRIPTION	DEC PART NO.	ECO CUT-IN PC04-00000	USED ON CODE	VENDOR		REF FIG NO.
					CODE	PART NO.	
3-	[POWER REGULATOR ASSEMBLY	54-08407-00					2
1	POWER REGULATOR ASSEMBLY	70-06512-00	00009				
2	@Screw, Phi Hd Pan No. 6-32 x 3/8 Lg	90-06022-01					
3	*Heatsink, Power Regulator	74-07069-00					
4	[*POWER REGULATOR BOARD ASSEMBLY	54-08308-00					
5	*POWER REGULATOR BOARD ASSEMBLY	54-08918-00	00032				
6	**Tab, Faston	90-07113-00					
7	**Resistor, 180 Ohm 1/4W 5%	13-00260-00					
8	**Transistor, DEC No. 2219	15-01881-00					
9	**Capacitor, 47 MFD 20V 20%	10-00079-00					
10	**Resistor, 68 Ohm 1/4W 10%	13-00220-00					
11	**Transistor, No. 2N4234	15-04809-00					
12	**Resistor, 470 Ohm 1/4W 5%	13-00315-00					
13	**Resistor, 3K Ohm 1/4W 5%	13-00431-00					
14	**Diode, 3.9V 5% No. 1N748A	11-00122-00					
15	**Diode, No. 1N4001	11-02942-00					
16	**Diode, No. 1N964B	11-09988-00					
17	**Resistor, Potentiometer, 200 Ohm 1/4W 20%	13-09150-10					
18	**Resistor, 15 Ohm 1/4W 10%	13-01421-00					
19	**Resistor, Potentiometer, 50 Ohm 1/4W 20%	13-09150-11					
20	**Capacitor, 100 MFD 20V 20%	10-00016-00					
21	**Transistor, DEC No. 6534D	15-03409-00					
22	**Transistor, DEC No. 6531	15-09338-00					
23	*TRANSISTOR, No. 2N3790	15-03399-00					
24	*Screw, Phi Hd Pan No. 6-32 x 7/16 Lg	90-06023-01					
25	*Nut, Keps No. 6-32	90-06560-00	00032				
26	*Washer, Insulated	90-06721-00					
27	*FUSE HOLDER	90-06996-00					
28	*Screw, Phi Hd Pan No. 6-32 x 3/8 Lg	90-06022-01					
29	*Fuse, 1 Amp Fast-Blow	90-07211-00					
30	[*Fuse, 2 Amp Slow-Blow	90-07219-00	00023				
31	*Fuse, 4 Amp Fast-Blow	11-09366-00	00032				
32	*BRIDGE, RECTIFIER No. MDA 960-3	90-06025-01	00032				
33	*Screw, Phi Hd Pan No. 6-32 x 5/8 Lg	90-06656-00	00032				
34	*Washer, Flat No. 6	11-05397-00					
35	*BRIDGE, RECTIFIER DM2	90-06026-01					
36	*Screw, Phi Hd Pan No. 6-32 x 3/4 Lg	15-03068-00					
	*TRANSISTOR No. 2N3715	90-06009-01					
	*Screw, Phi Hd Pan No. 4-40 x 1/4 Lg	90-06632-00					
	*Washer, Lock No. 4 Int Tooth						

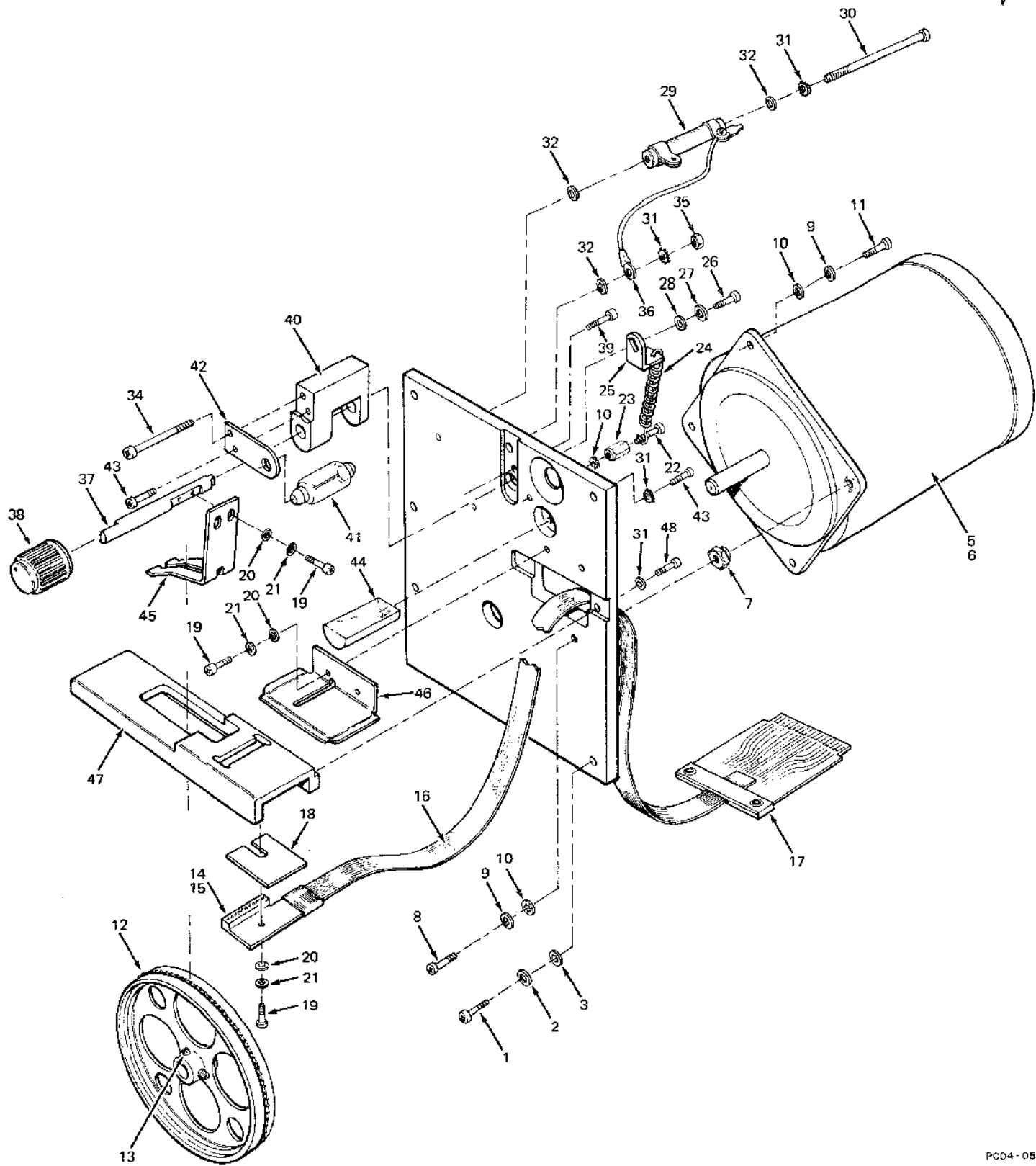

Figure 4. Reader Assembly

FIG & ITEM NO.	DESCRIPTION	DEC PART NO.	ECO CUT-IN PC04-00000	USED ON CODE	VENDOR CODE	VENDOR PART NO.	REF FIG NO.
4-	READER ASSEMBLY	70-06247-00					1
1	@Screw, Phi Hd Pan No. 6-32 x 1/2 Lg	90-08024-01					
2	@Washer, Lock No. 6 Int Tooth	90-06033-00					
3	@Washer, Flat No. 6	90-06653-00					
4	*Reader Plate	74-07085-00					
5	*SLO-SYN DRIVING MOTOR REWORK	74-07684-00					
6	**Slo-Syn Driving Motor	12-09369-00					
7	**Insert, Southco No. 6-32	90-09206-00					
8	*Screw, Phi Hd Truss No. 6-32 x 5/8 Lg	90-06025-03					
9	*Washer, Flat No. 6	90-06656-00					
10	*Washer, Lock No. 6 Int Tooth	90-06633-00					
11	*Screw, Phi Hd Pan No. 6-32 x 1/2 Lg	90-06024-01					
12	*TAPE SPROCKET	12-04899-00					
13	*Screw, Set Socket Hd No. 6-32 x 1/8 Lg	90-06290-00					
14	*PHOTO TRANSISTOR ASSEMBLY	70-06267-00					
15	***Photo Transistor Assembly (obsolete)	54-09306-00					
	**Photo Transistor Assembly	54-09227-00	00039				
16	**Flexprint (11 conductor)	91-05692-02					
17	**Cable Connector (WD77)	WD77					
18	*Shim, Photo Transistor Board (deleted)	74-07800-00					
19	*Screw, Phi Hd Pan No. 2-56 x 1/4 Lg	90-06001-01					
20	*Washer, Lock No. 2 Int Tooth	90-06631-00					
21	*Washer, Flat No. 2	90-06653-00					
22	*Screw, Phi Hd Pan No. 6-32 x 7/8 Lg	90-06027-01					
23	*Spacer, Hex No. 6-32 x 5/16 Lg	90-06842-00					
24	*Spring, over center (delete)	74-05247-00					
	*Spring, over center	12-09863-00	00019				
25	*Arm, Spring	74-07118-00					
26	*Screw, Phi Hd Pan No. 4-40 x 1/4 Lg	90-06009-01					
27	*Washer, Flat No. 4	90-06656-00					
28	*Washer, Lock No. 4 Int Tooth	90-06655-00					
29	*RESISTOR 2.0 Ohm 10W	13-09577-00					
30	*Screw, Phi Hd Pan No. 6-32 x 2 1/2 Lg	90-07851-00					
31	*Washer, Lock No. 6 Int Tooth	90-07649-00					
32	*Washer, No. 2153 H.H. SMITH No. 6	90-07632-00					
33	*Tab, Faston (Male)	90-07851-00					
34	*Screw, Phi Hd Pan No. 6-32 x 1 3/4 Lg	90-06031-01					
35	*Nut, Keps No. 6-32	90-06560-00					
36	*Solderless Connector	90-06780-00					
37	*Shaft, Reader Plate	74-07120-00					
38	*Knob, Reader	12-04747-00					
39	*Screw, Socket Hd Cap No. 6-32 x 3/4 Lg	90-06332-00					
40	*BLOCK, READER	74-07119-00					
41	*Bulb No. 6475 OSRAM	12-04734-00					
42	*Spring, Bulb	74-07116-00					
43	*Screw, Phi Hd Pan No. 6-32 x 1/4 Lg	90-06020-01					
44	*LENS (obsolete)						
	*LENS	74-04988-00	00019				
45	*DEPRESSOR, TAPE	74-07121-00					
46	*BRACKET, TAPE HOLD DOWN	74-07144-00					
47	*GUIDE, TAPE PATH	74-07076-00					
48	*Screw, Phi Hd Pan No. 6-32 x 3/8 Lg	90-06022-01					

FIG & ITEM NO.	DESCRIPTION	DEC PART NO.	ECO CUT-IN	USED ON CODE	VENDOR		REF FIG NO.
			54-08310-00001		CODE	PART NO.	
5-	SWITCH ASSEMBLY	54-08310-00					1
	Code "A" used on PC05-P and PA	54-08310-01		A			
	Code "B" used on PC04-C and CA	54-08310-03		B			
	Code "C" used on PC04-B, BA, BB, BC, BL, and BM	54-08310-04		C			
	Code "D" used on PC04-CL and CM	54-08310-05	00005	D			
	NOTE						
	54-08310-02 deleted and replaced by 54-08935 (Ref. Figure 6)						
	1 *Printed Circuit Board	50-08309-00					
	2 *Button, Rocker Switch	12-05941-00			BC		
	3 *Switch, Momentary	12-05375-00					
	4 *Switch, Rocker	12-05317-13					
	5 *Rubber, Sponge	18-09653-00					
	6 *Bar, Switch Board Spacer	74-07175-00					
	7 *Spacer, No. 1/4 AF x 1/2 Lg (added)	90-06803-00	00004				
	8 *Screw, Phi Hd Pan No. 6-32 x 1/4 Lg (delete)	90-06020-01					
9 *Screw, Phi Hd Pan No. 6-32 x 3/4 Lg	90-06026-01	00004					
10 *Washer, Lock No. 6 Int Tooth	90-06633-00						
11 *Spacer, Hex No. 1/4 AF x 3/4 Lg	90-07938-00						
12 *Screw, Phi Hd Pan No. 6-32 x 1/4 Lg	90-06020-01						
13 *Shield, Switch Assembly (added)	53-09640-00	00004					
14 *Transistor DEC 6531	15-09338-00	00001					
15 *Transistor DEC 6534D (wrong Part No.)	15-03409-01	00001					
16 *Transistor DEC 6534D	15-03409-03	00002					
17 *Resistor 470 Ohm 1/2W 5%	13-00316-00	00001					

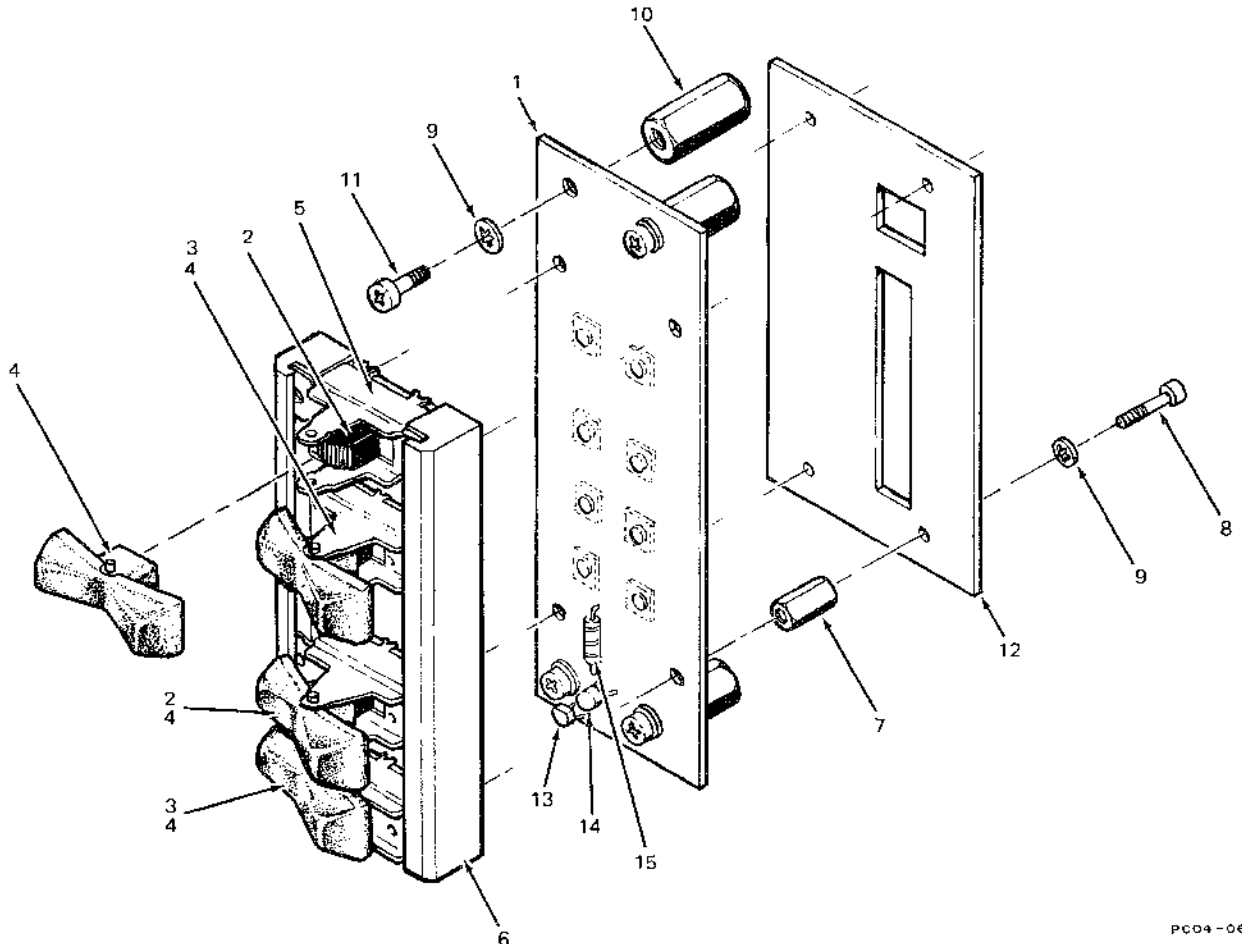
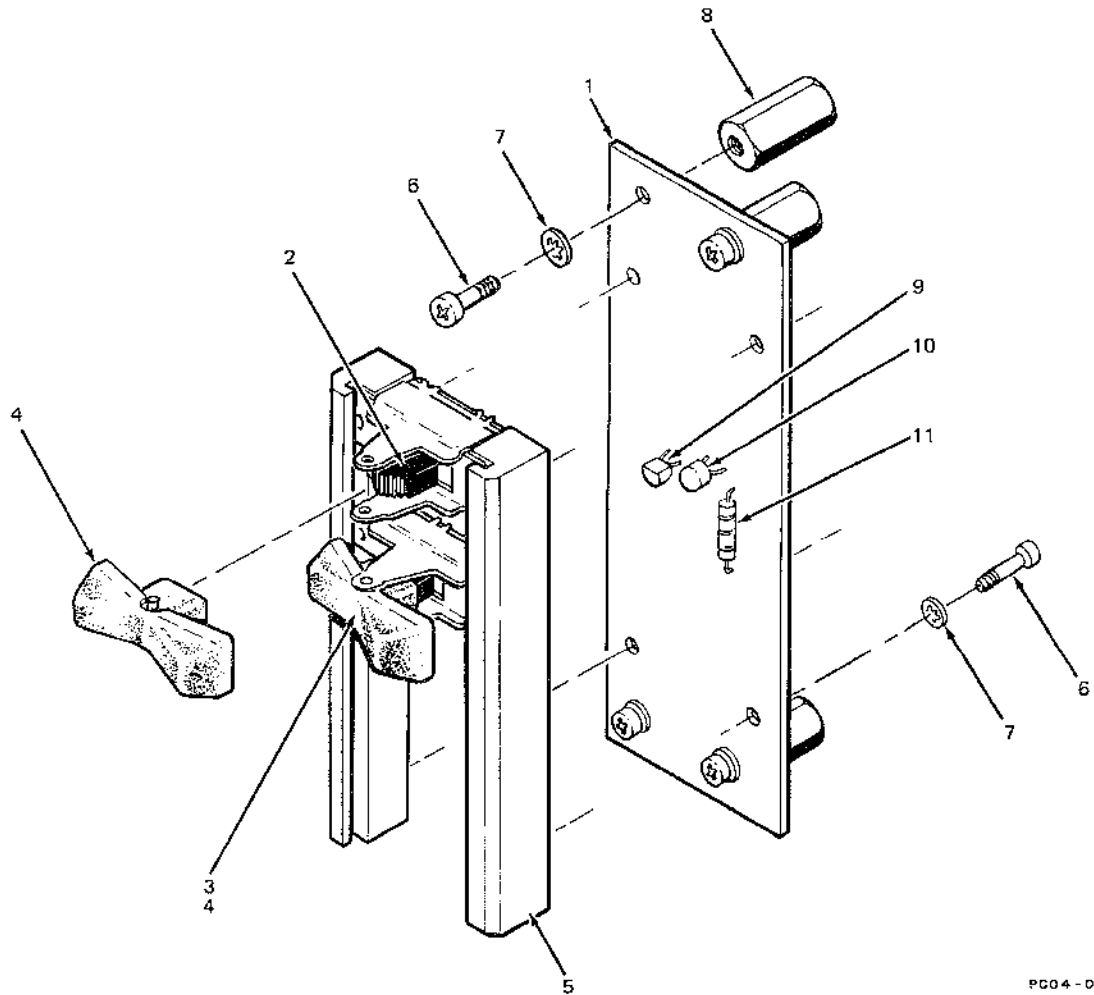

Figure 5. Switch Assembly

PC04-06



FIG & ITEM NO.	DESCRIPTION	DEC PART NO.	ECO CUT-IN	USED ON CODE	VENDOR		REF FIG NO.
			54-08935 00001		CODE	PART NO.	
6-	PR SWITCH BOARD (Replaces 54-08310-02)	54-08935-00	PC05-00018				1
1	*Board, Etched Circuit	50-08934-00					
2	*Switch, Rocker	12-05941-00					
3	*Switch, Rocker	12-05375-00					
4	*Button, Rocker Switch	12-05317-07					
5	*Bar, Spacer (Switch Board)	74-07175-00					
6	*Screw, Phi Hd Pan No. 6-32 x 1/4 Lg	90-06020-01					
7	*Washer, Lock No. 6 Int Tooth	90-06633-00					
8	*Spacer, No. 3/8 AF x 3/4 Lg	90-07938-00					
9	*Transistor, DEC 6531	15-09338-00					
10	*Transistor, DEC 6534D	15-03409-00					
11	*Resistor, 470 Ohm 1/4W 5%	13-00316-00					



PC04-07

Figure 6. PR Switch Assembly

)

.

.

)

.

.

)

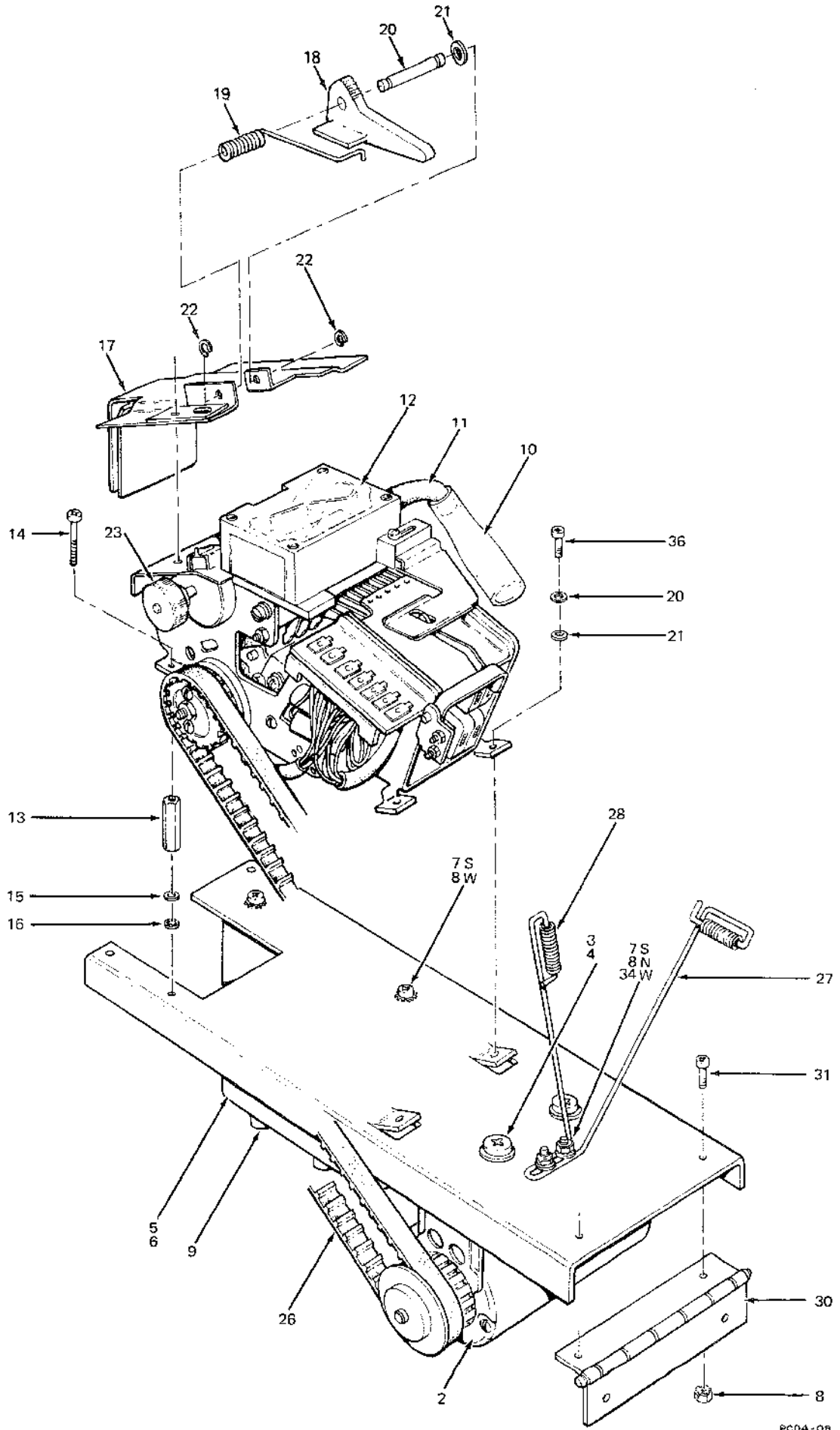
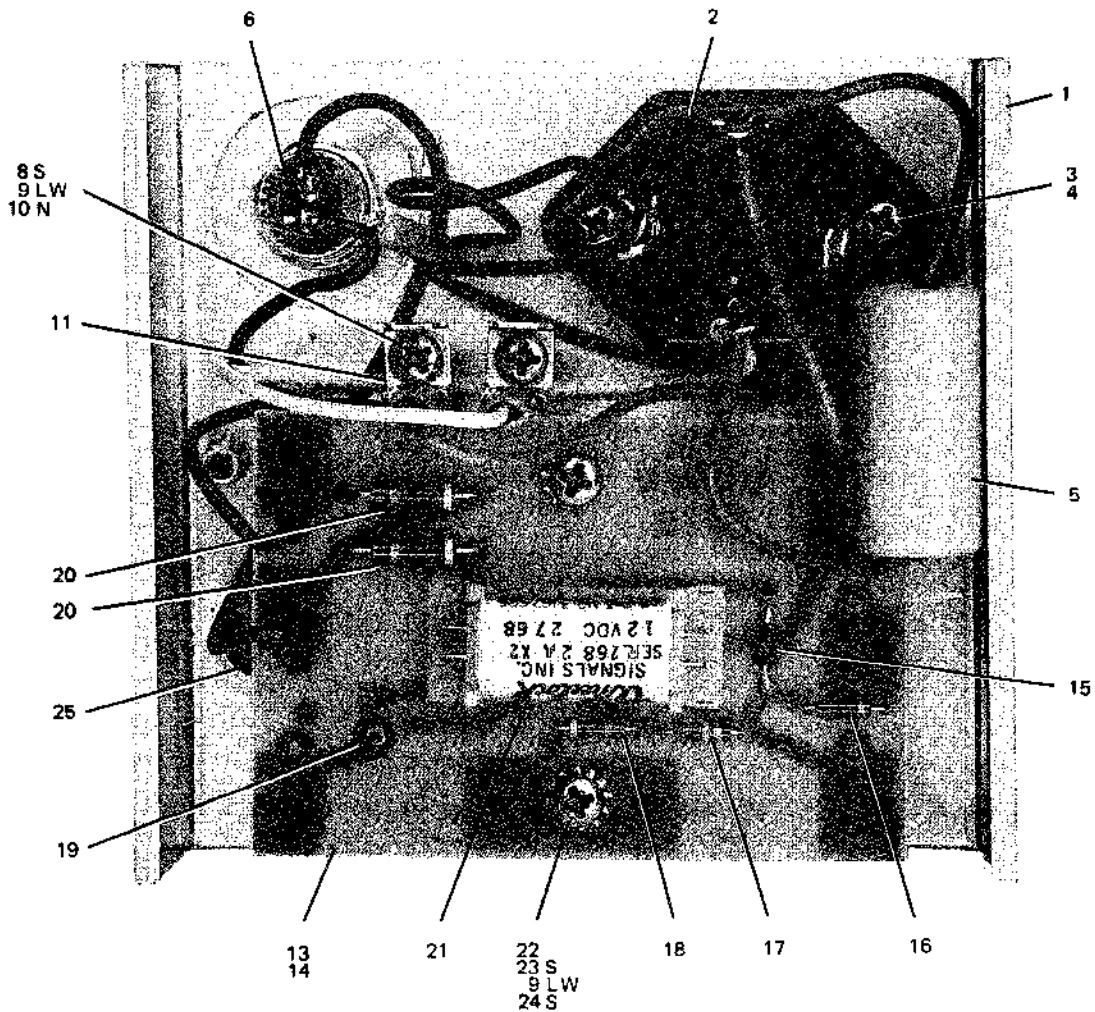
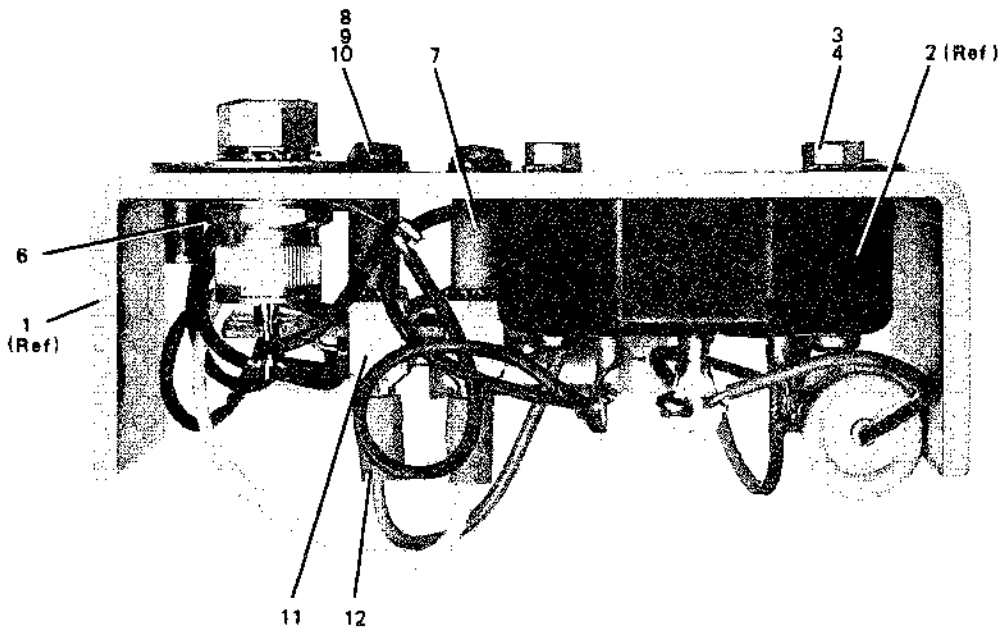

Figure 7. Punch Assembly

PC04-GB

FIG & ITEM NO.	DESCRIPTION	DEC PART NO.	ECO CUT-IN PC04-00000	USED ON CODE	VENDOR CODE	VENDOR PART NO.	REF FIG NO.
7-	PUNCH ASSEMBLY	70-06248-00					1
	Code "A" used on PUNCH ASSEMBLY 60 Hz	70-06248-01		A			
	Code "B" used on PUNCH ASSEMBLY 50 Hz	70-06248-02		B			
1	*Chassis, Punch	74-07071-00					
2	*Motor, GE	12-09365-00					
3	*Screw, Phi Hd Pan No. ¼-20 x ½ Lg	90-06056-01					
4	*Washer, Lock No. ¼ Int Tooth	90-06637-00					
5	*Capacitor 7 MFD	10-02038-00					
6	*Bracket, Capacitor Type B Footed	10-02028-00					
7	*Screw, Phi Hd Pan No. 6-32 x ½ Lg	90-06024-01					
8	*Nut, Keps No. 6-32	90-06560-00					
9	*Cap, Capacitor	90-08164-00					
10	*Tube, Chad Extension	91-07698-10					
11	*Tube, Chad	74-07386-00					
12	*PUNCH PAPER TAPE (ROYTON 500)	30-09356-00					
13	*Spacer, Hex No. 6-32 x ¼ x 1½ Lg	90-06811-00					
14	*Screw, Phi Hd Pan No. 6-32 x 1-3/4 Lg	90-06031-01					
15	*Washer, Flat No. 6	90-06656-00					
16	*Washer, Lock No. 6 Int Tooth	90-06633-00					
17	*Chute, Tape	74-08171-00					
18	*Depressor, Tape	12-09915-00					
19	*Spring, Torsion	12-09924-00					
20	*Pin	74-08172-00					
21	*Washer, Nylon	90-08993-00					
22	*"E" Ring, Truarc	90-09057-00					
23	*Knob, Punch	12-09904-00					
24	*Pulley (60 Hz)	74-06089-01		A			
25	*Pulley (50 Hz)	74-06089-02		B			
26	*Belt	12-04760-00					
27	*PUNCH FEED BRACKET	74-07084-00					
	*PUNCH FEED BRACKET	74-08088-00	00021				
28	*Spring	90-09045-00					
29	*"C" Washer	90-09047-00					
30	*Hinge	12-04760-00					
31	*Screw, Phi Hd Pan No. 6-32 x 3/8 Lg	90-06022-01					



PC04-09

Figure 8. SCR Driver Assembly

FIG & ITEM NO.	DESCRIPTION	DEC PART NO.	ECO CUT-IN 54-08385 00001	USED ON CODE	VENDOR		REF FIG NO.
					CODE	PART NO.	
8--	SCR DRIVER ASSEMBLY	54-08385-00					1
1	*Chassis	74-07070-00					
2	*Diode MDA 952-5	11-05280-00					
3	*Screw, Phi Hd Pan No. 6-32 x 7/8 Lg	90-06027-01					
4	*Nut, Kep No. 6-32	90-06560-00					
5	*Thyrector GRS20SP4B4	11-00106-00					
6	*Diode C20B	11-01820-00					
7	*Spacer, Phenolic No. 1/4 Dia x 7/16 Lg	90-06892-00					
8	*Screw, Nylon No. 6-32 x 3/4 Lg	90-07953-00					
9	*Washer, Lock No. 6 Int Tooth	90-06633-00					
10	*Nut, Nylon No. 6-32	90-07954-00					
11	*Tab	90-07113-00					
12	*Connector, Solderless	90-06979-00					
13	*TERMINAL BOARD ASSEMBLY	54-03770-00					
14	**Terminal Board	50-03717-00					
15	**Diode No. MR2064	11-03183-00					
16	**Resistor (R5) 1.5K Ohm 1/4W 5%	13-00391-00					
17	**Resistor (R4) 12K Ohm 1/4W 5%	13-00488-00					
18	**Resistor (R3) 3K Ohm 1/4W 5%	13-00432-00					
19	**Transistor DEC No. 2894-3B	15-03099-00					
20	**Resistor (R1, R2) 47 Ohms 1/4W 5%	13-01695-00					
21	**Relay No. 268-2A x2, 12 Vdc	12-02267-00					
22	*Spacer, Hex No. 1/4 x 5/16 Lg	90-06857-00					
23	*Screw, Phi Hd Pan No. 6-32 x 1/4 Lg.	90-06020-01					
24	*Screw, Phi Hd Pan No. 6-32 x 3/8 Lg	90-06022-01					
25	*Grommet	90-07015-00					

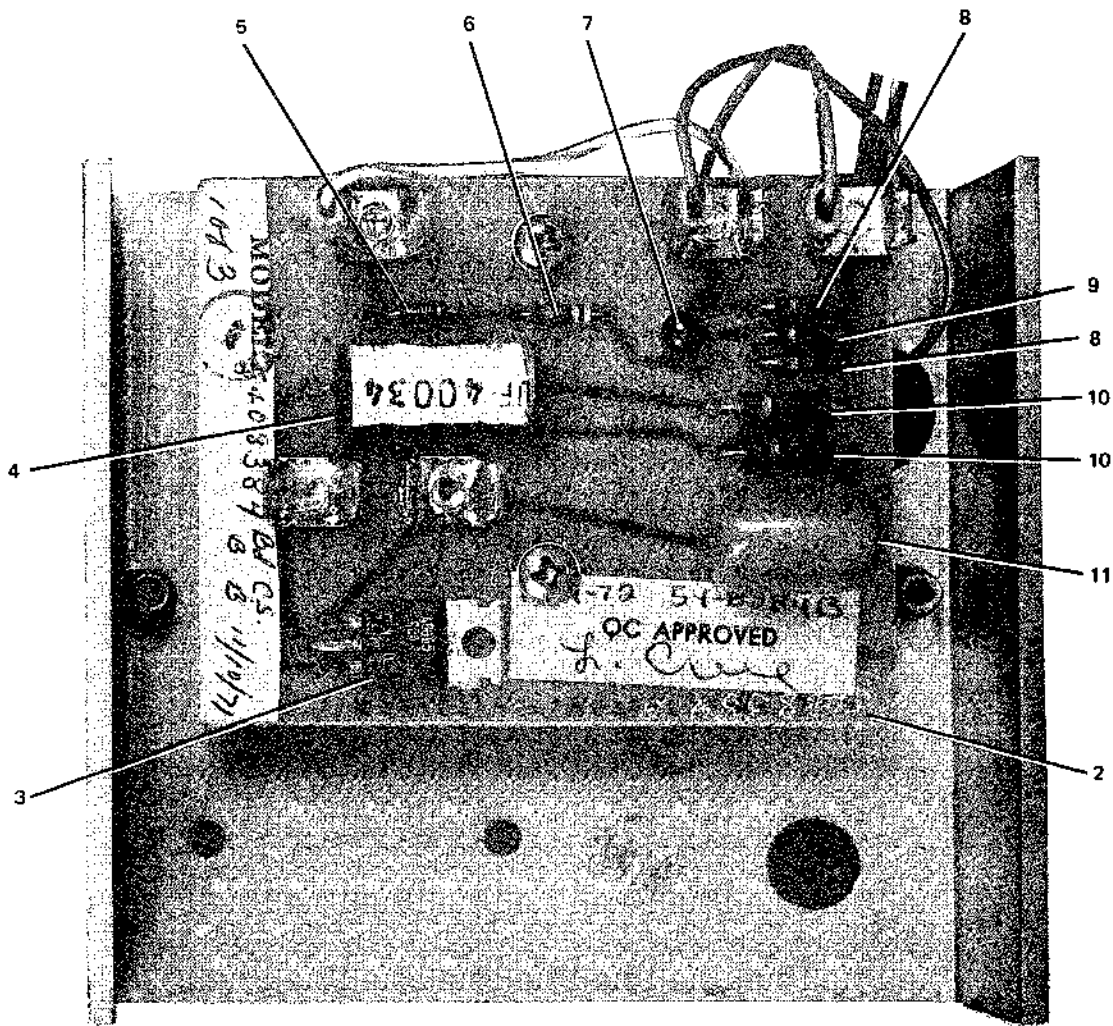
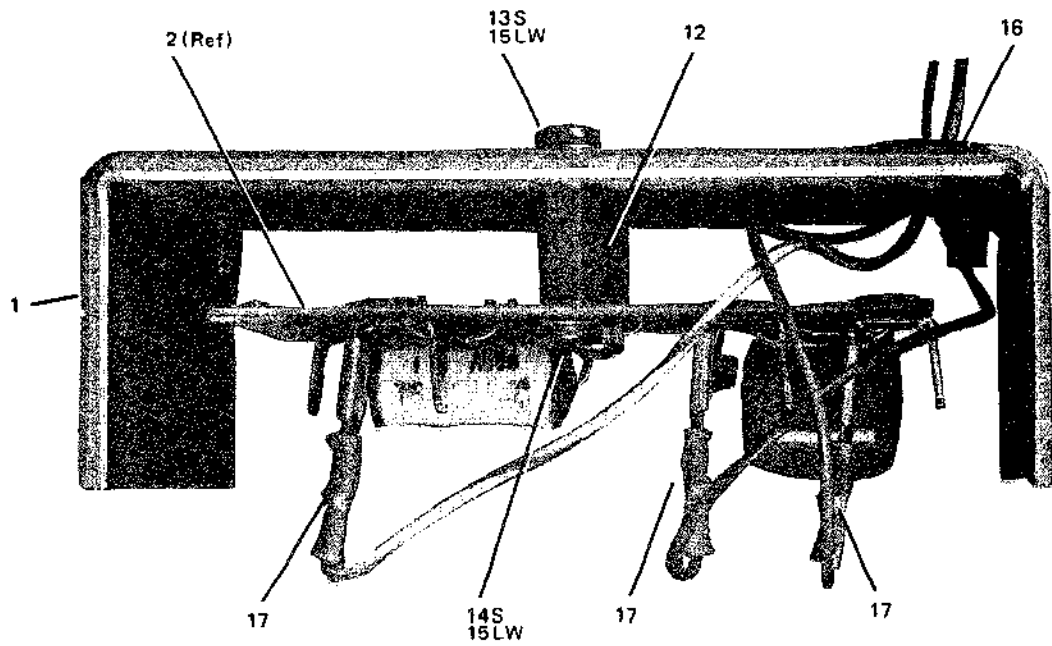

Figure 9. Triac Driver Assembly

PC04 - 10

FIG & ITEM NO.	DESCRIPTION	DEC PART NO.	ECO CUT-IN 70-06520-00000	USED ON CODE	VENDOR		REF FIG NO.
					CODE	PART NO.	
9-	TRIAC DRIVER ASSEMBLY	70-06520-00	PC05-00024				1
1	*Chassis	74-07070-00					
2	*TRIAC ASSEMBLY	54-08384-00					
3	**Triac 8 Amp 400V DEC No. 40669	15-10070-00					
4	**Relay, 12 Vdc DEC No. 40034	12-10101-00					
5	**Diode MR2064	11-03183-00					
6	**Resistor (R4) 330 Ohm ¼W 5%	13-00295-00					
7	**Transistor (Q1) DEC No. 6534D	15-03409-00					
8	**Resistor (R1, R3) 1K Ohm ¼W 5%	13-00365-00					
9	**Resistor (R2) 2K Ohm ¼W 5%	13-02388-00					
10	**Resistor (R5, R6) 100 Ohm ¼W 5%	13-00228-00					
11	**Capacitor 0.1 MFD 400V 20%	10-10075-00					
12	*Spacer, Hex No. ¼ AF x 3/8 Lg	90-06844-00					
13	*Screw, Phi Hd Pan No. 6-32 x 5/16 Lg	90-06021-01					
14	*Screw, Phi Hd Pan No. 6-32 x ¼ Lg	90-06020-01					
15	*Washer, Lock No. 6 Int Tooth	90-06633-00					
16	*Grommet	90-07015-00					
17	*Terminal, solderless	90-07917-00					

**ILLUSTRATED PARTS BREAKDOWN
COMMENT SHEET**

Any and all comments and suggestions for correcting errors and/or additional information to improve this manual will be reviewed and researched for possible use when this manual is revised and/or reprinted. Enter your comments and suggestions in the form provided below and return to Technical Documentation.

MODEL _____

PUBLICATION NO. _____

FIGURE NO. _____ ITEM NO. _____

FIGURE NO. _____ ITEM NO. _____

CHANGE FROM _____

CHANGE FROM _____

CHANGE TO _____

CHANGE TO _____

FIGURE NO. _____ ITEM NO. _____

FIGURE NO. _____ ITEM NO. _____

CHANGE FROM _____

CHANGE FROM _____

CHANGE TO _____

CHANGE TO _____

FIGURE NO. _____ ITEM NO. _____

FIGURE NO. _____ ITEM NO. _____

CHANGE FROM _____

CHANGE FROM _____

CHANGE TO _____

CHANGE TO _____

ADDITIONAL COMMENT(S)

Name _____

Cost Center _____

date: _____

Fold Here -----

Do Not Tear - Fold Here and Staple -----

**FIRST CLASS
PERMIT NO. 33
MAYNARD, MASS.**

**BUSINESS REPLY MAIL
NO POSTAGE STAMP NECESSARY IF MAILED IN THE UNITED STATES**

Postage will be paid by:

**Digital Equipment Corporation
Technical Documentation Department
146 Main Street
Maynard, Massachusetts 01754**

