

ILLUSTRATED PARTS BREAKDOWN

RK05J DISK DRIVE

HOW TO USE THE IPB

GENERAL

This IPB is compiled following the organization and nomenclature of the engineering drawing structure.

MAJOR ASSEMBLY LOCATOR

The Major Assembly Locator (first illustration) is an index that provides a description and a figure reference for all illustrations used in this manual.

INDENTED PARTS LIST

This manual identifies each assembly being broken down (figure reference callout), and all parts of that assembly. Further breakdown of an assembly is shown by an asterisk (*) preceding the item callouts in the Description Column. The number of asterisks preceding an item is used to denote the subordination of that item with respect to the Major Assembly. A single asterisk preceding an item description indicates that the item is part of the major assembly being illustrated. Items that are subordinate to single asterisks items, are denoted by two asterisks (**) and immediately follow the related single asterisk item. Additional asterisks are used, as required, to denote further subordination. This system of part identification, provides a means for the user to identify the next higher assembly item and make alternate selections for parts when the required replacement part or assembly is not immediately available.

COLUMN CALLOUT DESCRIPTION

Figure & Item - Indicates the figure number and item number of each part.

Description - Lists the name of the part and pertinent specifications (when required). Asterisks preceding the description denote the subordination of the part to the next higher assembly.

DEC Part No. - Lists the DEC part ordering number. A blank in this column indicates a DEC part number was not assigned at the time of publication.

ECO Cut-In - The notation at the top of this column indicates the ECO level of the system (option), at which the IPB was initially prepared. Subsequent ECO level designations, that modify existing parts or add new parts to the device, are inserted in the ECO Cut-In column next to the part that is added or modified. A bracket ([]) preceding the item description is used to indicate the parts affected by ECO's.

Vendor Code/Part No. - Indicates vendor parts that are not stocked by DEC. Refer to the Field Service Spares Catalog (vendor part number to DEC part number) for the vendor code cross-reference.

Used On Code - Letters in this column correspond to the variation codes assigned in Figure 1. Parts with an Alpha notation(s) are used only in those option variations. A blank indicates that the part is used on all option variations.

Ref Fig No. - A cross reference between illustrations. For each Major Assembly, the number in this column denotes the figure of the next higher assembly. For all subassemblies, the number in this column denotes the figure showing additional detailed breakdown.

SYMBOL USAGE

Hardware Designators - Alpha designators for screws (S), washers (W), nuts (N), and retaining rings (R) are inserted after the item number callouts on the illustration when stacked item numbers are used.

Attaching Hardware - The @ symbol is inserted before any part that is used as attaching hardware. Attaching hardware is denoted as those parts that are not an integral part of the referenced assembly.

(NFR) Not Field Repairable - The (NFR) symbol is inserted after any assembly that is not to be field dismantled.

Other Symbols - Any other symbols that are required for kits, accessories, etc., will be explained and appear as part of the item description.

REVISION HISTORY

OTHER IPB MANUALS REFERENCED WITHIN THIS MANUAL

PRINTING	ECO LEVEL	DATE	PAGES AFFECTED	
3rd Printing	RK05 00014-00069 RK05J 00000-00010 70-08702 00000-00007 H604 00002-00004 54-09574 00000-00003 54-09698 00002-0005A	12-7-77	N/A	EK-H743-IP
<p>NOTE: This 3rd Printing EK-RK05J-IP-003 SUPERSEDES 2nd Printing DEC-RK05-IPB-2 (NOTE THAT THE DOCUMENT NO. OF THIS IPB HAS CHANGED)</p>				

Copyright © 1977 by Digital Equipment Corporation

DEC reserves the right, without notice, to make substitutions and modifications in the specifications of products documented in this manual and further reserves the right to withdraw any of these products from the market without notice.

DEC is not responsible for errors which may appear in the technical description (including illustrations and photographs) of the products covered by this manual.

None of the descriptions contained in this manual imply the granting of any license whatsoever to make, use or sell equipment constructed in accordance therewith.

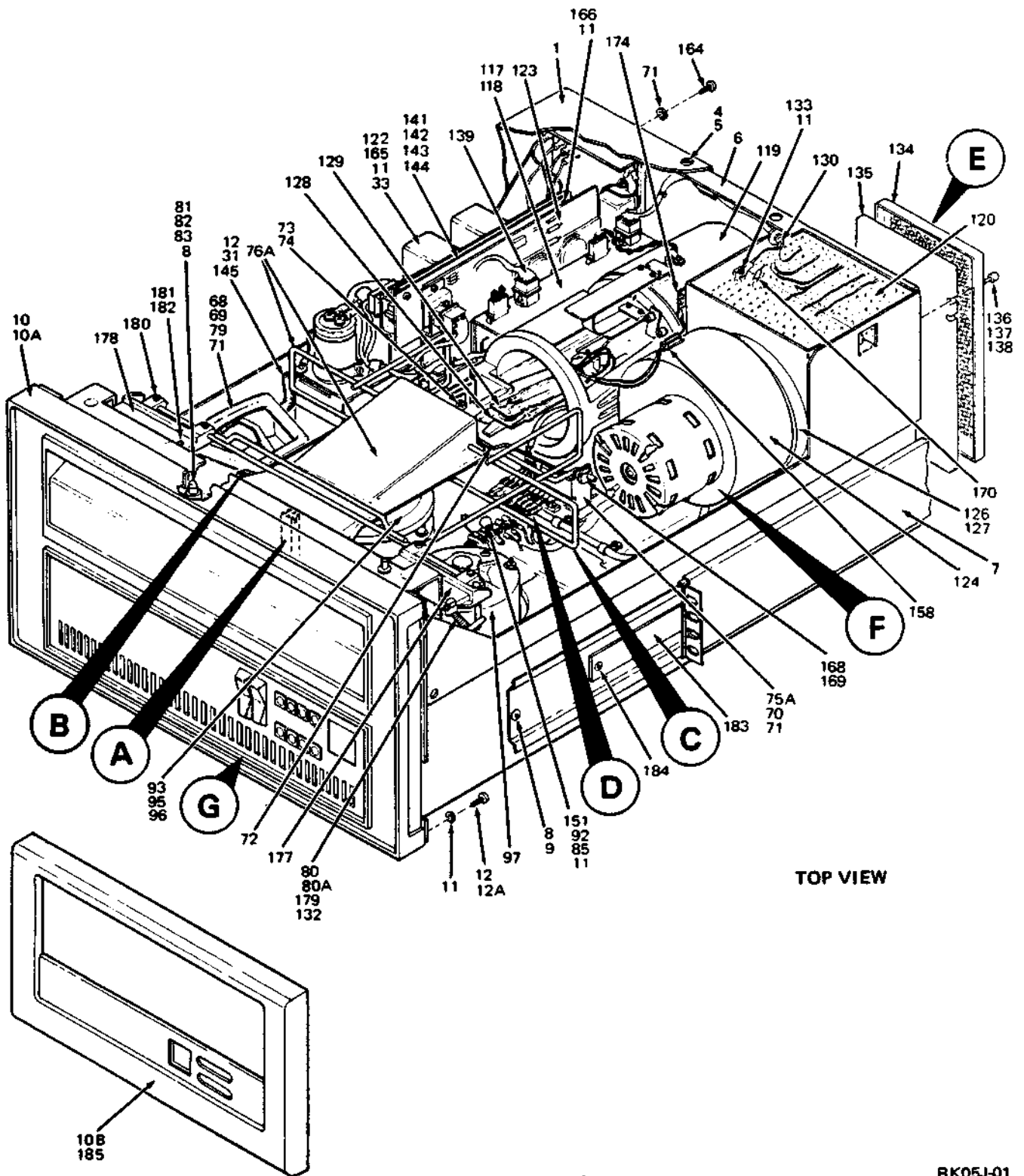
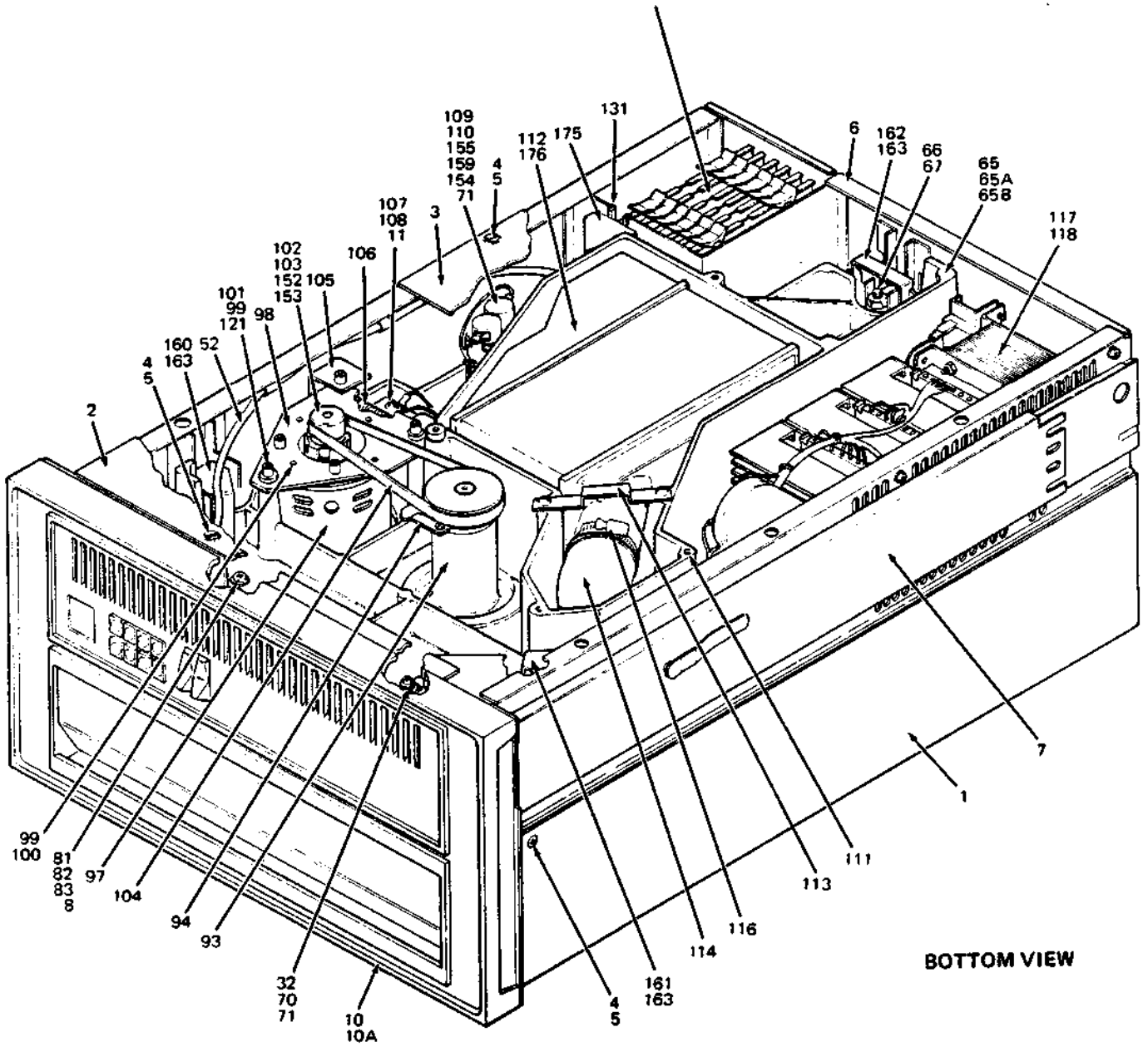

Figure 1. RK05J Disk Drive Assembly (Sheet 1 of 5)

RK05J-01

SEE MODULE UTILIZATION
DRAWING C-MU-RK05-0-2



BOTTOM VIEW

RK05J-01A

Figure 1. RK05J Disk Drive Assembly (Sheet 2 of 5)

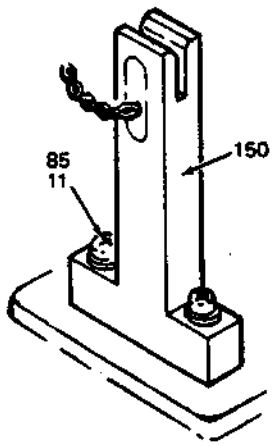

A

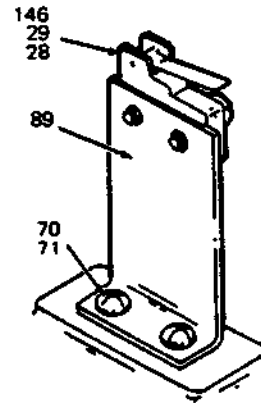
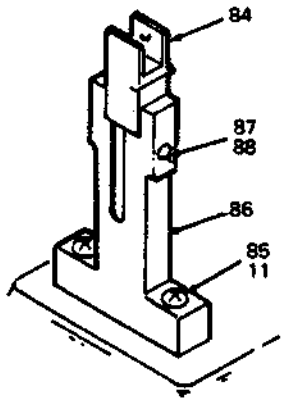

B

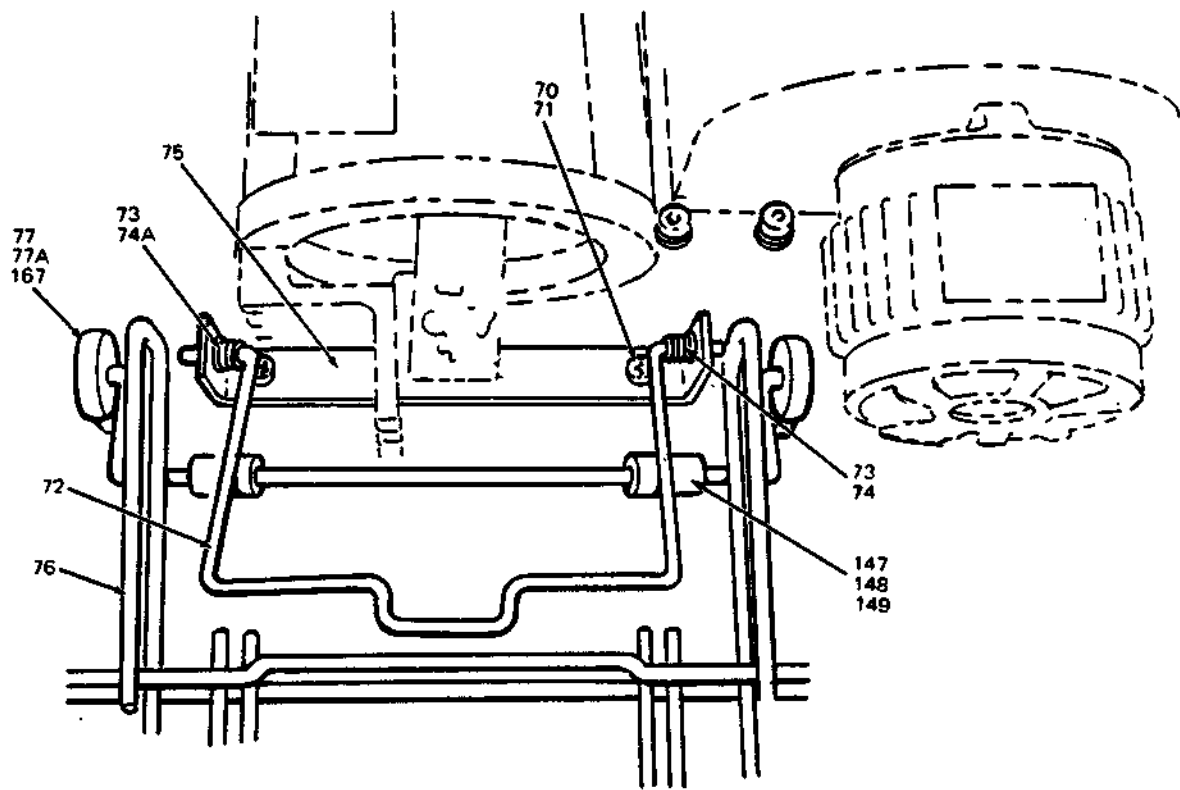

C

RK05J-01B

Figure 1. RK05J Disk Drive Assembly (Sheet 3 of 5)

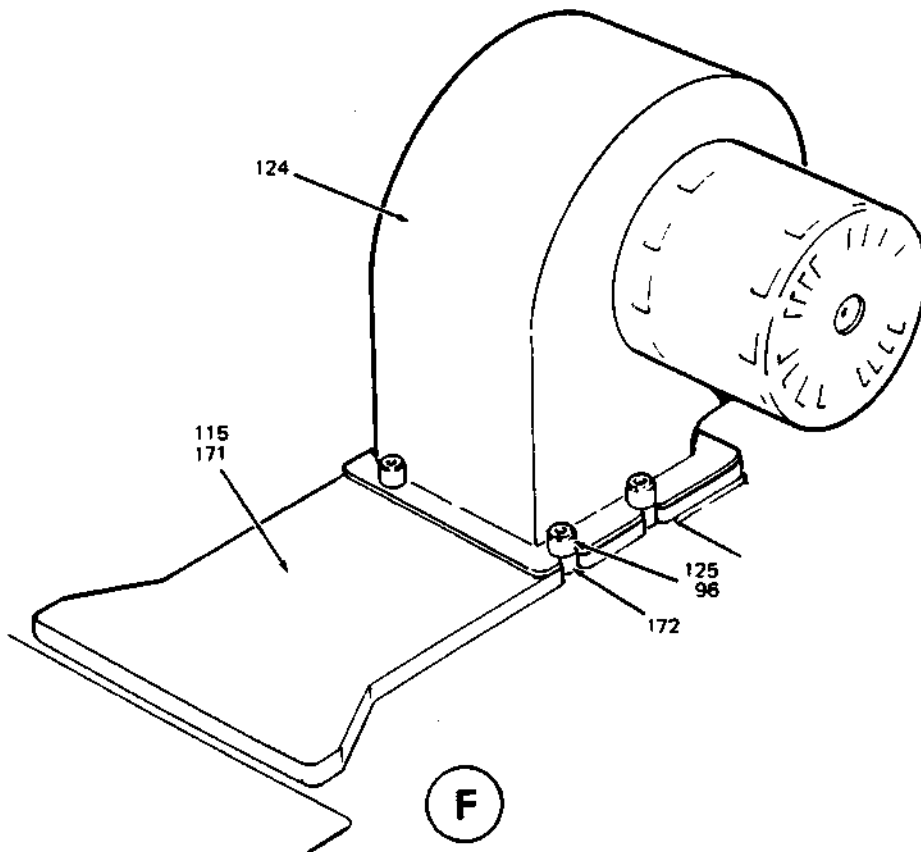
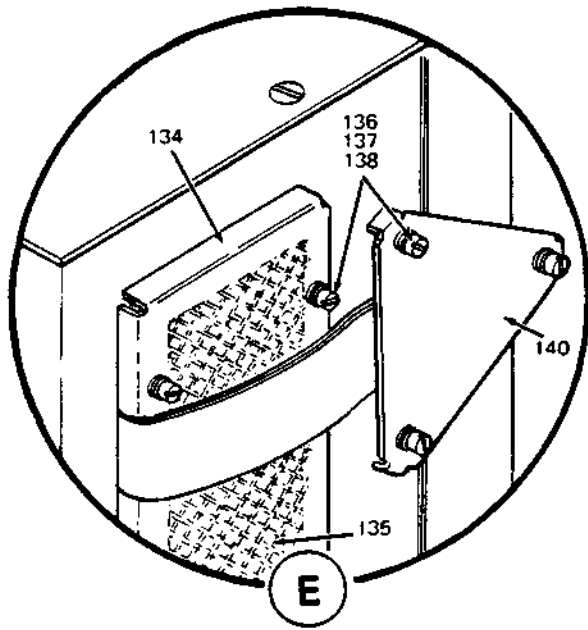
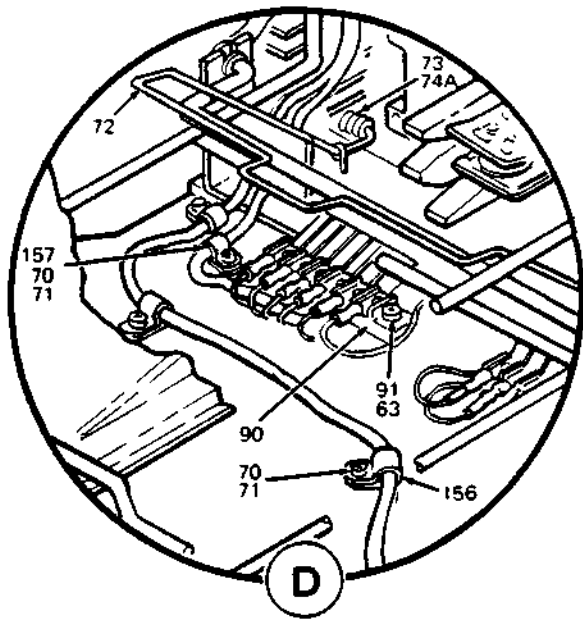

RK05J-01C

Figure 1. RK05J Disk Drive Assembly (Sheet 4 of 5)

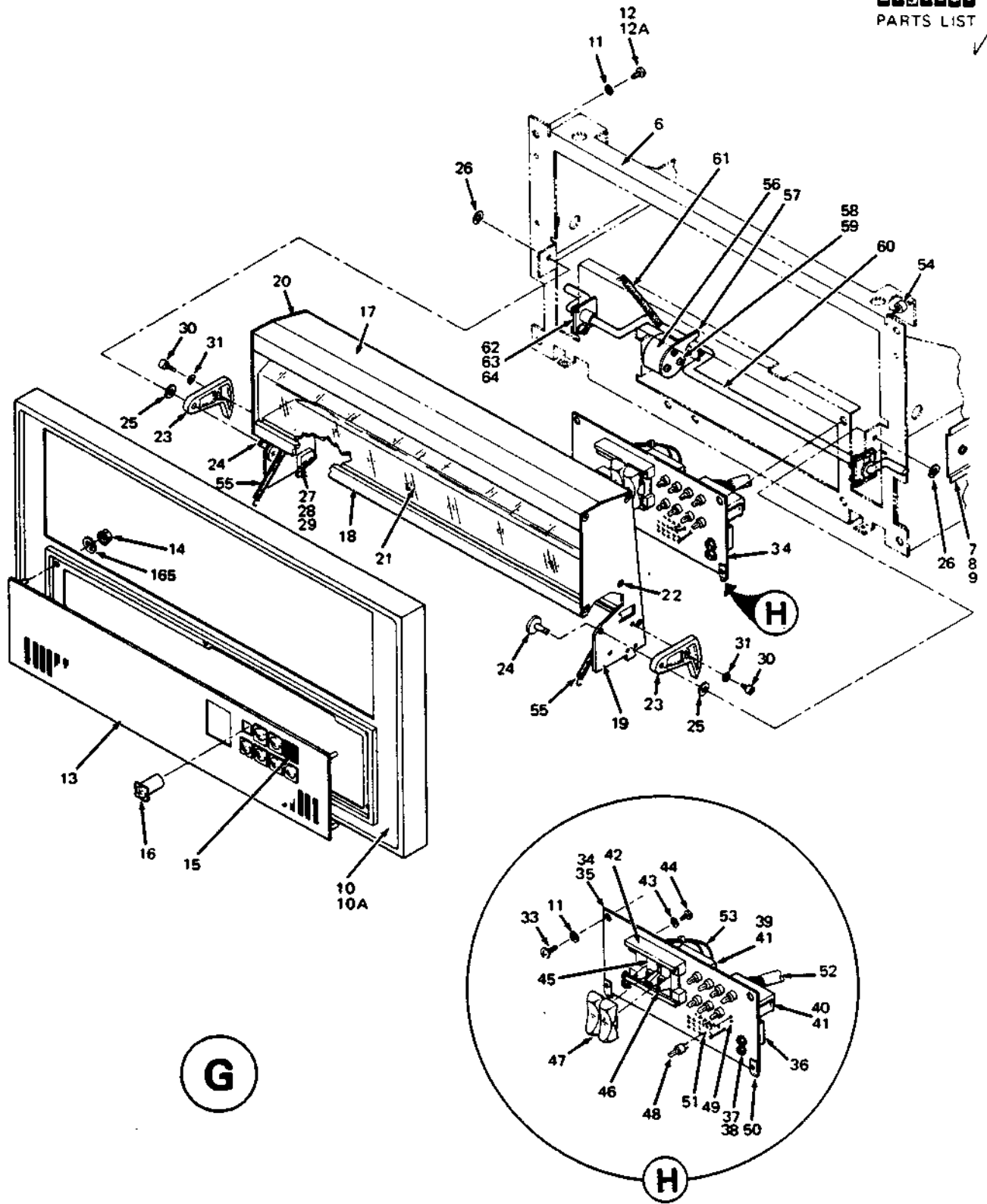

RK05J-01D

Figure 1. RK05J Disk Drive Assembly (Sheet 5 of 5)

FIG. & ITEM NO.	DESCRIPTION	DEC PART NO.	ECO CUT-IN RK05 00014	USED ON CODE	REF FIG NO.
1-	RK05J DISK DRIVE ASSEMBLY Code A - Used on Model RK05J-AA 60 Hz 115V Code B - Used on Model RK05J-AB 60 Hz 230V Code C - Used on Model RK05J-BA 50 Hz 115V Code D - Used on Model RK05J-BB 50 Hz 230V Code E - Used on Model RK05J-CA (RK05J-AA with Bezel for H9500 Cabinet) Code F - Used on Model RK05J-CB (RK05J-AB with Bezel for H9500 Cabinet) Code G - Used on Model RK05J-CC (RK05J-BA with Bezel for H9500 Cabinet) Code H - Used on Model RK05J-CD (RK05J-BB with Bezel for H9500 Cabinet)	RK05J-AA RK05J-AB RK05J-BA RK05J-BB RK05J-CA RK05J-CB RK05J-CC RK05J-CD		A B C D E F G H	
1	*Cover, Top	74-09249-00			
2	*Cover, Bottom (Front)	74-09247-00			
3	*Cover, Bottom (Rear)	74-09248-00			
4	*Screw, Flush Head (Southco)	90-09183-00			
5	*Washer, Retaining (Southco)	90-09180-00			
6	*Housing, Chassis	74-09238-00			
7	*Slide, Chassis (23" Travel)	12-09152-02			
8	*Washer, Int. Tooth Lock No. 10	90-06635-00			
9	*Screw, Phl. Truss Hd. No. 10-32 x 3/8	90-06071-03			
10	*Bezel (Sand Casting) (See Note 1)	74-09217-00		ABCD	
10A	*Bezel (Die Casting) (See Note 1)	12-11250-00		ABCD	
10B	*Bezel Assembly (For H9500 Series Cabinet)	70-12967-00		EFGH	
11	*Washer, Int. Tooth Lock No. 6	90-06633-00			
12	*Screw, Phl. Pan Hd. No. 6-32 x 1/2 (Note: Used with Bezels 74-09217 (Item 10) and 70-12967 Item 10B)	90-06024-01			
12A	*Screw, Phl. Pan Hd. No. 6-32 x 1/2 Self-Tapping (Note: Used with Bezel 12-11250-00 Item 10A)	90-09514-00			
13	*Panel, Front	74-09207-00			
14	*Nut, Kep No. 6-32	90-08185-00			
15	[*Light Cap (Red) (Old Style) (Deleted) *Light Cap (Red) (New Style with Locking Ears) (Added)	12-10798-02 12-11334-01	RK05 00046	ABCD	
16	[*Light Cap (White) (Old Style) (Deleted) *Light Cap (White) (New Style with Locking Ears) (Added)	12-10798-01 12-11334-00	RK05 00046	ABCD	
17	*Handle, Door	12-10667-00			
18	*Bottom, Door	12-10668-00			
19	*Side, Door RH	74-09135-01			
20	*Side, Door LH	74-09135-02			

FIG. & ITEM NO.	DESCRIPTION	DEC PART NO.	ECO CUT-IN RK05 00014	USED ON CODE	REF FIG NO.
1-					
21	*Panel, Door	74-09136-00			
22	*Screw, Phl. Flat Hd. No. 6-32 x 3/8 Self-Tapping	90-09099-00			
23	*Cam	74-09169-00			
24	*Pivot	74-09164-00			
25	*Washer	74-09165-00			
26	*Ring, Retaining	90-07784-00			
27	*Switch (SW2)	12-10839-00			
28	*Washer, Int. Tooth Lock No. 2	90-06631-00			
29	*Screw, Phl. Pan Hd. No. 2-56 x 3/8	90-06003-01			
30	*Screw, Soc Hd. Cap No. 6-32 x 3/8	90-08043-08			
31	*Washer, Ext. Tooth Lock No. 6	90-07649-00			
32	*Cable Clamp 1/8	90-07079-00			
33	*Screw, Phl. Pan Hd. No. 6-32 x 3/8	90-06022-01			
34	*CONTROL PANEL ASSEMBLY	54-09698-00			
35	**Board, Etched Circuit	50-09698-00			
36	**Bracket, Connector	55-09829-00			
37	**Screw, Phl. Pan Hd. No. 4-40 x 5/16	90-06010-01			
38	**Nut, Kep No. 4-40	90-06557-00			
39	**Connector (J2) Socket Housing, 4 Pin Mate-N-Lok	12-09350-04			
40	**Connector (J3) Socket Housing, 15 Pin Mate-N-Lok	12-09350-15			
41	**Terminal, Socket Contact	12-09456-00			
42	**Bar, Switch Mounting	55-09830-00			
43	**Washer, Int. Tooth Lock .280 OD x .146 ID x .018	90-06633-00			
44	**Screw, Phl. Pan Hd. No. 6-32 x 5/16	90-06021-01			
45	**Switch, Rocker (S2)	12-05941-00			
46	**Switch, Rocker (S3)	12-05375-00			
47	**Button, Switch	12-05317-07			
48	**Lamp	12-09169-00			
49	**Terminal, Solderless	90-07812-00			
50	**Nut, Clip No. 6-32 (Deleted)	90-08423-00	54-09698 00004		
51	**Eyelet, Feed Through	90-06731-00			
52	*HARNESS, Control Panel	70-08705-00			
53	*HARNESS, Control Panel (To Switches)	70-08819-00			
54	*Bumper, Screw	12-10801-00			
55	*Spring, Extension (Door) (Deleted)	90-09093-00			
	*Spring, Extension (Door) (Added)	90-09735-00	RK05 00066		
56	*Solenoid, Rotary (Used with Items 57, 58, 59)	12-10806-00			
	*Solenoid, Rotary (Solenoid and Arm Combined - Replaces Items 56, 57, 58, 59) (Added)	12-11435-00	RK05 00038		
57	*Arm, Solenoid	74-09140-00			

FIG. & ITEM NO.	DESCRIPTION	DEC PART NO.	ECO CUT-IN RK05 00014	USED ON CODE	REF FIG NO.
1-					
58	*Washer, Split Lock No. 5	90-06691-00			
59	*Screw, Phi. Pan Hd. No. 5-40 x 1/4	90-09096-01			
60	*Lock, Door	12-10815-00			
61	*Spring, Extension (Door Lock)	90-09094-00			
62	*Clamp, Door Lock	74-09546-00			
63	*Washer, Split Ring No. 4	90-06688-00			
64	*Screw, Soc. Hd. Cap No. 4-40 x 5/16	90-08936-08			
65	*Base Plate (See Notes 2 and 3)	74-09311-00			
65A	*Base Plate (See Notes 2 and 3) (Added)	74-13507-00	RK05 00059		
65B	*Base Plate (See Notes 2 and 3) (Added)	74-13073-00	RK05 00066		
66	*Shock Mount	12-10843-00			
67	*Nut, Kep	90-06568-00			
68	*Airduct	12-10681-00			
69	*Gasket, Airduct	74-09254-00			
70	*Screw, Phi. Pan Hd. No. 8-32 x 5/16	90-06036-01			
71	*Washer, Int. Tooth Lock No. 8	90-06634-00			
72	*Opener, Cartridge Door	12-10680-00			
73	*Ring, Retaining	90-09098-00			
74	*Spring, Cartridge Door Opener Torsion (RH)	12-11384-00			
74A	*Spring, Cartridge Door Opener Torsion (LH)	12-11384-01			
75	*Bracket, Cartridge Door (See Notes 2 and 3)	74-09233-00			
75A	*Bracket, Cartridge Receiver (See Notes 2 and 3) (Added)	74-13307-00	RK05 00066		
76	*Receiver, Cartridge (Deleted) (See Note 4)	12-10679-00			
76A	*Receiver, Cartridge (Added) (See Note 4)	12-12282-00	RK05 00066		
77	*Post, Pivot (Deleted) (See Note 4)	12-10804-00			
77A	*Pivot Post Assembly (Added) (Includes 5/16-18 Nylock Nut 90-08061-00) (Replaced by Item 75A - See Note 4)	74-13746-00	RK05 00066		
78	*Nut, Hex No. 5/16-18 (Deleted) (See Note 4)	90-09213-00	RK05 00066		
79	*Screw, Phi. Pan Hd. No. 8-32 x 3/8	90-06037-01			
80	*Spring, Extension (Cartridge Receiver) (Deleted)	90-09092-00			
80A	*Spring, Extension (Cartridge Receiver) (Added) (See Note 4)	90-09734-00	RK05 00066		
81	*Post, Cartridge Support	74-09134-00			
82	*Washer, .200 ID x .625 OD x .032	90-06668-00			
83	*Screw, Phi. Truss Hd. No. 10-32 x 5/8	90-06074-03			
84	*Transducer, Sector (See Note, Item 150)	30-10642-00			
85	*Screw, Phi. Pan Hd. No. 6-32 x 5/8	90-06025-01			

FIG. & ITEM NO.	DESCRIPTION	DEC PART NO.	ECO CUT-IN RK05 00014	USED ON CODE	REF FIG NO.
1-					
86	*Holder, Sector Transducer (See Note, Item 150)	74-09150-00			
87	*Screw, Soc. Hd Cap No. 6-32 x 5/8	90-06331-08			
88	*Washer, Lock No. 6 Split Ring	90-07801-00			
89	*Bracket, Switch	74-09258-00			
90	*Terminal Strip (TB1, TB2)	12-10685-00			
91	*Screw, Soc. Hd Cap No. 4-40 x 1/2	90-08042-08			
92	*Terminal Strip (TB4)	90-06905-00			
93	*DISK SPINDLE ASSEMBLY (NFR)	12-10616-00			
94	**Brush Assembly (Supplied with Item 93)	12-10985-00			
95	*Screw, Soc Hd. Cap No. 1/4-20 x 3/4 (For Attaching Disk Spindle to Base)	90-06372-08			
96	*Washer, Split Ring Lock 1/4 (For Attaching Disk Spindle to Base)	90-07797-00			
97	*Motor, Induction 50/60 Hz	12-10808-00			
98	*Plate, Motor Mounting	74-09143-00			
99	*Washer, Split Ring Lock No. 8	90-06690-00			
100	*Screw, Soc Hd. Cap No. 8-32 x 1/2 (For Attaching Motor to Plate)	90-06338-08			
101	*Screw, Soc Hd. Cap No. 8-32 x 3/4 (For Attaching Plate to Base)	90-06042-01			
102	*Pulley, Motor 60 Hz	74-09418-01		ABEF	
103	*Pulley, Motor 50 Hz	74-09418-02		CDGH	
104	*Belt, Woven	12-10812-00			
105	*Bracket, Spring	74-09508-00			
106	*Spring, Extension (Belt Tension)	90-09095-00			
107	*Relay, Motor Starting	12-10800-00			
108	*Screw, Phl. Pan Hd. No. 6-32 x 1/4	90-06020-01			
109	*Capacitor, 5 MFD 370V (with Clamp) (Deleted)	10-09397-00			
	*Capacitor, 5 MFD 370V (without Clamp) (Added)	10-09397-01	RK05 00055		
110	*Cover, Insulation (Cap)	90-08164-00			
111	*Receptacle, Press-In, 1/4 Turn Fastener (Note: Used with Base Plate 74-09311-00 Item 65 only)	90-09550-00			
112	*Filter, Absolute (Deleted)	12-10803-00			
	*Filter, High Efficiency Air (Added) (Note: This Filter replaces all previous Filters and Plenum Cover 74-09232-00. Ref. ECO RK05-00059.)	12-12175-01	RK05 00059		
113	*Bracket, Filter (Added)	74-13308-00	RK05 00059		
	*Bracket, Filter (Deleted)	74-13308-00	RK05J 00003		
114	*Outlet Port (Added)	12-12177-00	RK05 00059		

FIG. & ITEM NO.	DESCRIPTION	DEC PART NO.	ECO CUT-IN RK05 00014	USED ON CODE	REF FIG NO.
1-					
115	*Inlet Port (Added)	12-12178-00	RK05 00059		
116	*Clamp, Hose (Added)	12-12430-00	RK05 00059		
117	*H743 POWER SUPPLY 115V 60 Hz	H743-AA		ACEG BDFH	2
118	*H743 POWER SUPPLY 230V 60 Hz <small>See H743 IPB Manual</small>	H743-AB			
119	*LINEAR POSITIONER ASSEMBLY	70-08702-00			
120	*WIRED ASSEMBLY	70-08696-00			
	**Capacitor 1000 MMF 250V 20% (Added) (Pin B8F2 to B08C2)	10-00043-00	RK05 00026		
	**Capacitor, 1000 MMF 250V 20% (Added) (Pin A2C1 to A1T1)	10-00043-00	RK05 00045		
	**Terminal, AMP No. 8592	90-07655-00			
121	*Bushing, Motor Mount	74-09256-00			
122	*DECPACK MOTOR RELAY BOARD ASSY.	54-09574-00			4, 4A
123	*HEAD POSITION SERVO POWER AMPLIFIER BOARD ASSY.	H604-00			3, 3A
124	*BLOWER and MOTOR ASSEMBLY	12-10807-01			
125	*Screw, Soc Hd. Cap No. 1/4 -20 x 7/8	90-06371-08			
126	*Inlet Ring, Blower (Deleted)	12-11167-00	RK05 00059		
127	*Seal, Inlet Ring (Deleted)	74-10547-00			
	*Seal, Inlet Ring (Added) (Note: This seal is an integral part of the Blower Assembly Item 124)	74-13836-00	RK05 00059		
128	*Head, W/R "B" UP (Lower Head) 100 TPI <small>See Note 5</small>	30-10863-01			
129	*Head, W/R "B" DOWN (Upper Head) 100 TPI	30-10863-02			
130	*HARNESS, Logic	70-08703-00			
131	*Grommet 1/16"	90-07035-00			
132	*Bracket, Spring (Cartridge Receiver)	74-10622-00			
133	*Screw, Phl. Pan Hd. No. 6-32 x 3/4	90-06026-01			
134	*Cover, Pre-Filter	74-10512-00			
135	*Pad, Filter	74-09253-00			
136	*Screw, Captive	90-08372-01			
137	*"O" Ring 1/8 x 1/4	90-07835-00			
138	*Washer, Nylon No. 6 .156 x .312 x .032	90-06707-00			
139	*HARNESS, (Power Supply to Control Panel)	70-07806-00			
140	*Clamp, Cable Plate	74-10515-00			
141	*Shield, Shock (Relay Board)	74-09469-00			
142	*Screw, Phl Pan Hd No. 4-40 x 7/16	90-06012-01			
143	*Nut, Kep No. 4-40	90-06557-00			
144	*Spacer, 3/16 AF x 1/8 x No. 4 Hole	90-06791-00			
145	*Ground Strap	90-06990-00			

FIG. & ITEM NO.	DESCRIPTION	DEC PART NO.	ECO CUT-IN RK05 00014	USED ON CODE	REF FIG NO.
1-					
146	*Switch, Cartridge Seat (Added) (SW1)	74-13251-00	RK05 00056		
147	*Sleeve, Rubber (Added)	74-11271-00	RK05 00041		
	*Sleeve, Rubber (Deleted) Note: Used with Old Design Cartridge Receiver 12-10679-00 (Item 76) only.	74-11271-00	RK05 00066		
148	*Loctite, IS06 (Use to adhere Item 147 to 12-10679-00 Item 76)	49-01094-00			
149	*Accelerator (For Adhesive Item 148)	49-01106-00			
150	*Transducer, Sector Optical (Added) (Note: Replaces Items 84, 86, 87, 88 as a single interchangeable unit.	30-10642-01	RK05 00051		
151	*Varistor, VP 130A10 (D1) (TB4-3 to TB4-6)	11-10997-00			
152	*Screw, Soc. Set No. 8-32 x 3/16 (For Pulley Items 102, 103)	90-09654-10			
153	*Loctite, No. TL-242 (For Item 152)	49-01093-00			
154	*Screw, Phi. Pan Hd. No. 8-32 x 3/4	90-06041-01			
155	*Bracket, Capacitor	12-12149-00			
156	*Cable Clamp 3/16	90-07080-00			
157	*Cable Clamp 5/16	90-07083-00			
158	*Cable Clamp, Adhesive	90-08341-00			
159	*Cable Clamp, Adhesive	90-08340-00			
160	*Shipping Bracket (Base Plate Front RH)	74-10524-01			
161	*Shipping Bracket (Base Plate Front LH)	74-10524-02			
162	*Shipping Bracket (Base Plate Rear)	74-10523-00			
163	*Screw, Soc Hd. Cap No. 8-32 x 1/2	12-12428-00			
164	*Screw, Phi. Pan Hd. No. 8-32 x 1/2	90-06039-01			
165	*Washer, Flat .375 x .156 x .032	90-06653-00			
166	*Screw, Phi. Pan Hd. No. 6-32 x 5/16	90-06021-01			
167	*Washer, .343 ID x .687 OD x .062	90-06679-00			
168	*Nut, Tinnerman Push-On Speed	90-09738-00			
169	*Washer, Nylon Shoulder	90-09739-00			
170	*Capacitor 6.8 MFD 35V 10%	10-05306-00			
171	*Cooling Duct (Added)	12-12429-00			
172	*Standoff (Added)	74-13747-00			
173	*Cushion Card (Added) (Located on inside of Cover Item 3)	74-13735-00	RK05 00059		
174	*Seal, Head Connector (Added)	74-13734-00			
175	*Seal, Cable Slot (Added)	74-13733-00			
176	*Hook Strap (Added)	74-14108-00	RK05 00063		
177	*Clamp, Cartridge RH (Added) (See Note 4)	12-12281-01	RK05 00066		

FIG. & ITEM NO.	DESCRIPTION	DEC PART NO.	ECO CUT-IN RK05 00014	USED ON CODE	REF FIG NO.
1-					
178	*Clamp, Cartridge LH (Added) (See Note 4)	12-12281-02			
179	*Pin, Roll .094 x .50 (Added)	90-06526-00	RK05 00066		
180	*Screw, Self-Tapping No. 6-32 x 1/2 (Added)	90-09514-00			
181	*Screw, Soc. Hd. Set No. 10-32 x 3/4	90-06315-10			
182	*Nut, Relock Cap No. 10-32	90-06610-00			
183	*Slide Lock	74-18117-00			
184	*Screw, Flat Hd. No. 10-32 x 1/2	90-06073-02			
185	*Washer, .500 OD x .187 ID x .062 (Used with Item 10B)	90-06662-00		EFGH	
	*Decals, (RK05) (Not Shown)	74-09600-00			
	ACCESSORY LIST (Not Shown)				
	†BC11A Accessory Cable (Drive Interconnecting Cable or Unibus Cable for RK11C or RK11D)	BC11A-08			
	†Control Cable (RK8E or RKV11D Accessory Cable)	70-09026-00			
	†Disk Cartridge (12 Sector)	30-10350-00			
	†Disk Cartridge (16 Sector)	30-10350-02			
	†Head Cleaning Kit	22-00007-00			
	†Drive Identification Numbers (set of 8 numbers - 0-7)	36-11382-00			
	†Alignment Pack	RK05-AC			
	†Plastic Storage Bag for Disk Pack	12-11642-00			
	†Terminator Module	M930			
	†Shipping Bracket LH (when shipped in a rack)	74-09691-01			
	†Shipping Bracket RH (when shipped in a rack)	74-09691-02			
	†Mounting Hardware Kit	70-09276-00			
	Note 1: Bezels 74-09217-00 (Item 10) and 12-11250-00 (Item 10A) are interchangeable.				
	Note 2: Base Plates 74-09311-00, 74-13507-00, and 74-13073-00 (Items 65, 65A, 65B) are all interchangeable.				
	Note 3: If Base Plate 74-09311-00 (Item 65) or 74-13507-00 (Item 65A) is used, use Pivot Post 74-13746-00 (Item 77A), Cartridge Door Bracket 74-09233-00 (Item 75), Washer 90-06679-00 (Item 167), Nut 90-06568-00 (Item 67).				
	If Base Plate 74-13073-00 (Item 65B) is used, use Cartridge Receiver Bracket 74-13307-00 (Item 75A), Nut 90-09738-00 (Item 168) and Nylon Shoulder Washer 90-09739-00 (Item 169).				

FIG. & ITEM NO.	DESCRIPTION	DEC PART NO.	ECO CUT-IN RK05 00014	USED ON CODE	REF FIG NO.
1-	<p>Note 4: If new design Cartridge Receiver 12-12282-00 (Item 76A) is used with new Base Plate 74-13073-00 (Item 65B) - use Cartridge Receiver Bracket 74-13307-00 (Item 75A), Extension Spring 90-09734-00 (Item 80A), Cartridge Clamp R.H. 12-12281-01 (Item 177) and Cartridge Clamp L. H. 12-12281-02 (Item 178).</p> <p>If new design Cartridge Receiver 12-12282-00 (Item 76A) is used with old Base Plates 74-09311-00 (Item 65) or 74-13507-00 (Item 65A) - use Cartridge Door Bracket 74-09233-00 (Item 75), Pivot Post Assy. 74-13746-00 (Item 77A), Extension Spring 90-09734-00 (Item 80A), Cartridge Clamp R.H. 12-12281-01 (Item 177) and Cartridge Clamp L.H. 12-12281-02 (Item 178).</p> <p>If old design Cartridge Receiver 12-10679-00 (Item 76) is used with old Base Plates 74-09311-00 (Item 65) or 74-13507-00 (Item 65A) - use Pivot Post Assy. 74-13746-00 (Item 77A) and Extension Spring 90-09092-00 (Item 80).</p> <p>Note 5: Color Code Yellow or Orange on back of Ceramic Head denotes 100 TPI.</p>				

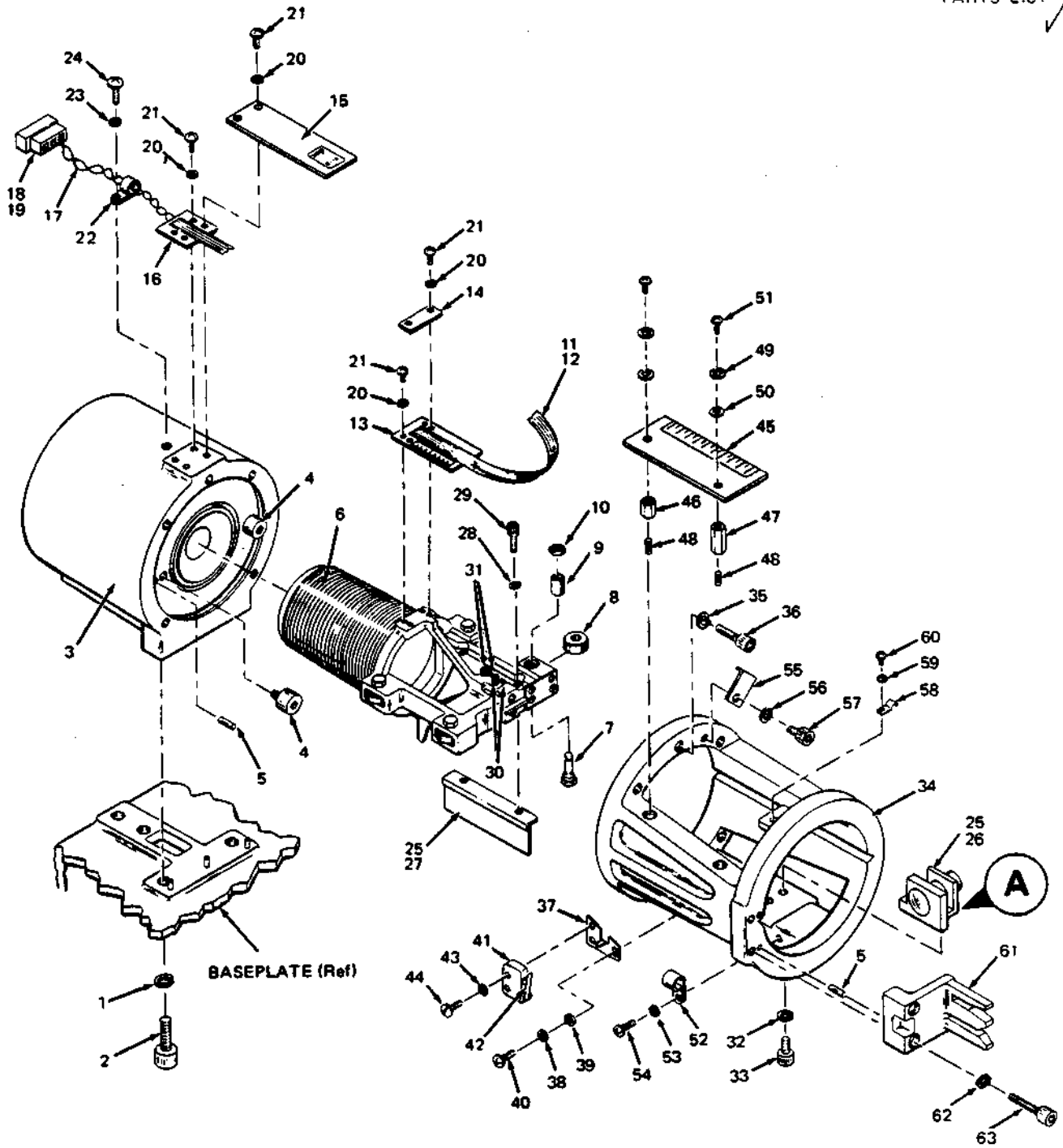

RK05J-02

Figure 2. Linear Positioner Assembly (Sheet 1 of 2)

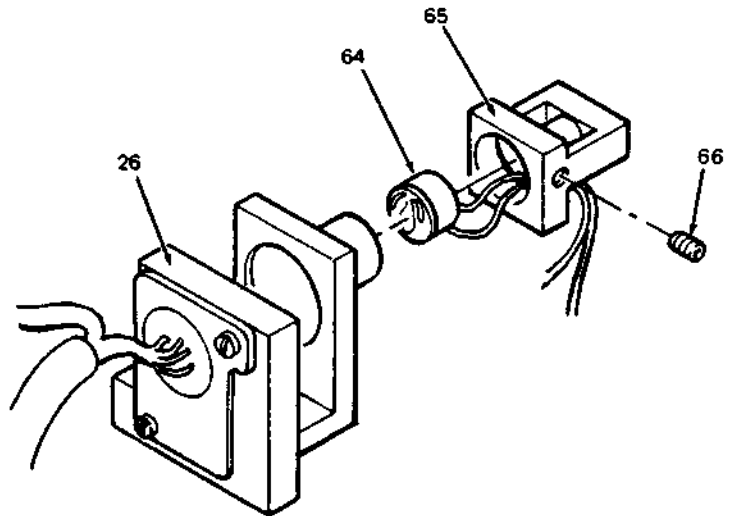
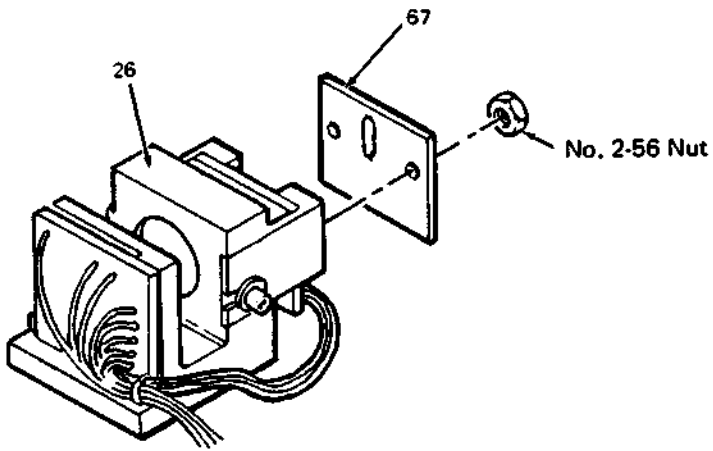

A

RK05J-02A

Figure 2. Linear Positioner Assembly (Sheet 2 of 2)

FIG. & ITEM NO.	DESCRIPTION	DEC PART NO.	ECO CUT-IN 70-08702 00000	USED ON CODE	REF FIG NO.
2-	LINEAR POSITIONER ASSY. (100 TPI)	70-08702-00			1
1	@Washer, Lock, 1/4 Split Ring	90-07797-00			
2	@Screw, Soc. Hd. Cap. 1/4-20 x 7/8	90-06371-08			
3	*MAGNET HOUSING ASSEMBLY (NFR)	74-10708-00			
4	*Screw, Bumper	12-10801-00			
5	*Pin, Dowel 1/8 Dia. x 1/2 Lg.	90-08106-00			
6	*CARRIAGE AND COIL ASSEMBLY (NFR)	74-10707-00			
7	*Shaft, Bearing	74-09142-00			
8	[*Bearing Assy. (Substitute Assy.) (See Note 1)	74-09386-00			
	[*Bearing Assy. (Preferred Assy.) (See Note 1)	12-11475-00	00001		
9	*Bushing, Bearing Holder	74-09239-00			
10	*Nut, Hex No. 6-32 S.S.	90-08957-00			
11	*FLEX STRIP CABLE ASSEMBLY	70-08707-00			
12	**Strip, Flex	17-00017-00			
13	**Support, Flex Strip	50-09940-02			
14	**Clamp, Flex Strip	74-09404-00			
15	**Support, Flex Strip	74-09366-00			
16	**Support, Flex Strip	50-09940-01			
17	**Wire, 18 AWG Blk/Red TWP	91-07330-02			
18	**Connector, Mate-N-Lok, 3 Pin	12-09351-03			
19	**Contact, Pin (Male)	12-09378-01			
20	**Washer, Lock, No. 2 Int. Tooth	90-06631-00			
21	**Screw, No. 2-56 x 1/4, Phl. Pan. Hd.	90-06001-01			
22	*Clamp, Cable, Nylon 1/8 Dia.	90-07079-00			
23	*Washer, Lock No. 8 Split Ring	90-06690-00			
24	*Screw, Phl. Pan Hd. No. 8-32 x 5/16	90-06036-01			
25	*LINEAR TRANSDUCER ASSY. (100 TPI)	30-10638-00			
26	**Block, Transducer (100 TPI)	30-10638-01			
27	**Scale, Transducer Glass (100 TPI)	30-10638-02			
28	*Washer, Lock No. 4, Split Ring	90-06688-00			
29	*Screw, Soc. Hd. Cap No. 4-40 x 1/2 SST	90-08042-03			
30	[*Screw, Brass Tipped, Soc. Hd. Set (deleted) 3/32	90-09761-00			
	[*Screw, Brass Tipped, Soc. Hd. Set (added) 3/32 See Note 4	12-13833-00	00006		
31	*Screw, Self-Locking Soc. Hd. Set (Head Adj. Screw)	12-11027-00			
32	*Washer, No. 6 Int. Tooth	90-06633-00			
33	*Screw, Soc. Hd. Cap No. 6-32 x 3/8 SST	90-08045-08			
34	*Slide	74-09208-00			
35	*Washer, Lock No. 10 Split Ring	90-07906-00			
36	*Screw, Soc. Hd. Cap No. 10-32 x 7/8 SST	90-06349-08			
37	*Bracket, Switch	74-09304-00			
38	*Washer, No. 2 Int. Tooth	90-06631-00			
39	*Washer, No. 4 Flat	90-08172-00			
40	*Screw, Phl. Pan Hd. No. 2-56 x 1/4 SST	90-06001-01			

FIG. & ITEM NO.	DESCRIPTION	DEC PART NO.	ECO CUT-IN 70-08702 00000	USED ON CODE	REF FIG NO.
2-					
41	*Switch	12-10838-01			
42	*Lever, Switch Actuator	12-10838-02			
43	*Washer, Int. Tooth No. 2	90-06631-00			
44	*Screw, Slotted Rd. Hd.	90-06005-01			
45	*Scale	50-09941-00			
46	*Spacer, 3/8 Lg.	90-06844-00			
47	*Spacer, 3/4 Lg.	90-06859-00			
48	*Screw, Soc. Set No. 6-32 x 3/8 Lg.	90-06293-10			
49	*Washer, No. 6 Int. Tooth	90-06633-00			
50	*Washer, Flat	90-06653-00			
51	*Screw, Phi. Pan Hd. No. 6-32 x 5/16	90-06021-01			
52	*Clamp, Cable	90-07080-00			
53	*Washer, No. 6 Int. Tooth	90-06633-00			
54	*Screw, Phi. Pan Hd. No. 6-32 x 5/16	90-06021-01			
55	*Strap, Carriage Shipping	74-09368-00			
56	*Washer, Lock No. 10 Split Ring SST	90-07906-00			
57	*Screw, Soc. Hd. Cap No. 10-32 x 3/8	90-06345-08			
58	*Clamp, Cable	74-09326-00			
59	*Washer, No. 2 Int. Tooth	90-06631-00			
60	*Screw, Phi. Pan Hd. No. 2-56 x 1/4	90-06001-00			
61	*DUCK BILL	12-10744-00			
62	*Washer, Lock No. 8 Split Ring	90-06690-00			
63	*Screw, Soc. Hd. Cap No. 8-32 x 3/4	90-06340-08			
64	*POTTED BULB ASSEMBLY (See Note 2)	30-10638-03			
65	*CLAMP ASSEMBLY (See Note 2)	70-12691-00			
66	**Screw, Knurled Point, Set	90-00044-01			
67	*BULB ASSEMBLY (See Note 3)	30-10638-04			
	<p>Note 1: All (4) Bearings must be replaced at the same time.</p> <p>Note 2: Items 64, 65, 66 are used with "Dynamics Research Corp." Type Transducer Assy. ONLY. See FCO 7008702-S0005 for Replacement Procedures.</p> <p>Note 3: Item 67 is used with "Teledyne-Gurley" type Transducer Assembly ONLY.</p> <p>Note 4: Old design Linear Positioner Assy. can be identified by checking the Head Clamping Screw (Item 30). This screw is a Self-Locking Socket Head Set Screw Part No. 12-10811-00 and uses a 3/64 Allen Wrench torqued at 45 in. oz.</p> <p>New design Linear Positioner Assy. can be identified in the same manner except that this screw is a Brass Tipped Socket Head Set Screw Part No. 12-13833-00 and uses a 3/32 Allen Wrench torqued at 125 in. oz.</p>				

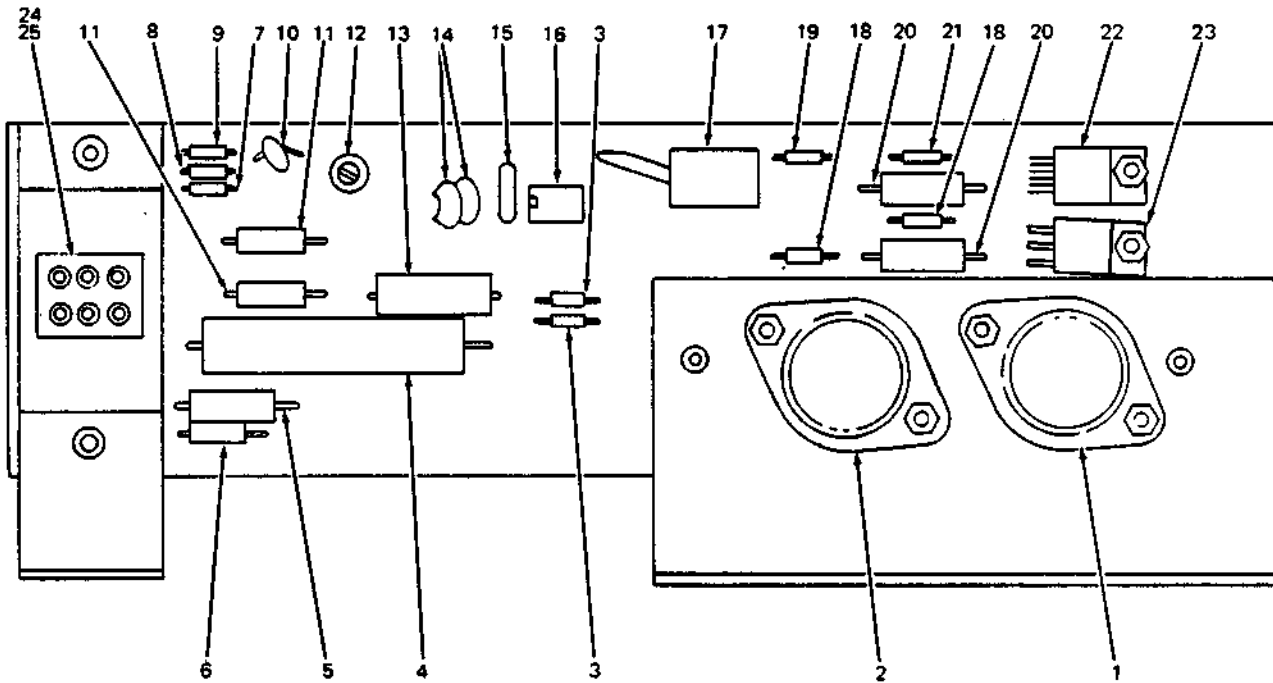

ETCH REV J

RK05J-03

Figure 3. Head Position Servo Power Amplifier Assembly (Etch Rev J)

FIG. & ITEM NO.	DESCRIPTION	DEC PART NO.	J ECO CUT-IN H604 00002	USED ON CODE	REF FIG NO.
3-	HEAD POSITION SERVO POWER AMPLIFIER ASSEMBLY (ETCH REV J)	H604-00			1
1	*Transistor (Q3) 2N3791	15-09581-00			
2	*Transistor (Q4) 2N3715	15-03068-00			
3	*Resistor (R3, R14) 22 Ohms 1/4W 10%	13-00188-00			
4	*Resistor (R13) .1 Ohms 10W 1%	13-09108-00			
5	*Resistor (R11) 200 Ohms 1W 5%	13-02382-00			
6	*Resistor (R12) 10 Ohms .5W 5%	13-00168-00			
7	*Resistor (R4) 1K Ohms 1/4W 5%	13-00365-00			
8	*Resistor (R2) 2K Ohms 1/4W 5%	13-02388-00			
9	*Resistor (R1) 470 Ohms 1/4W 5% (obsolete)	13-00316-00			
	*Resistor (R1) 1K Ohms 1/4W 5% (added)	13-00365-00	00003		
10	*Thermistor (R16) 1K 10% (obsolete) (Replaced with Jumper)	13-10071-00	00003		
11	*Capacitor (C3, C4) 15 UF 20V 10%	10-04812-00			
12	*Potentiometer (R15) 2K 1/2W 10%	13-09410-00			
13	*Capacitor (C5) .1 UF 100V 10%	10-02342-00			
14	*Capacitor (C1, C2) .01 UF 100V 20%	10-01610-00			
15	*Capacitor (C6) 33 PF 100V 5%	10-00009-00			
16	*IC (E1) Dec 301	19-10282-00			
17	*Switch, Toggle (S1) T-8001	12-10209-00			
18	*Resistor (R9, R10) 100 Ohms .25W 10%	13-00231-00			
19	*Resistor (R5) 220 Ohms .25W 10%	13-00275-00			
20	*Resistor (R7, R8) 3 Ohms .5W 5%	13-01643-00			
21	*Resistor (R6) 1.2 Ohms .25W 10%	13-00366-00			
22	*Transistor (Q1) D44C8 or TIP 31A	15-10421-00			
23	*Transistor (Q2) D45C6	15-10414-00			
24	*Housing, Socket, 6 pin (Mate-N-Lok)	12-09350-06			
25	*Pin, Housing (Mate-N-Lok)	12-09456-00			

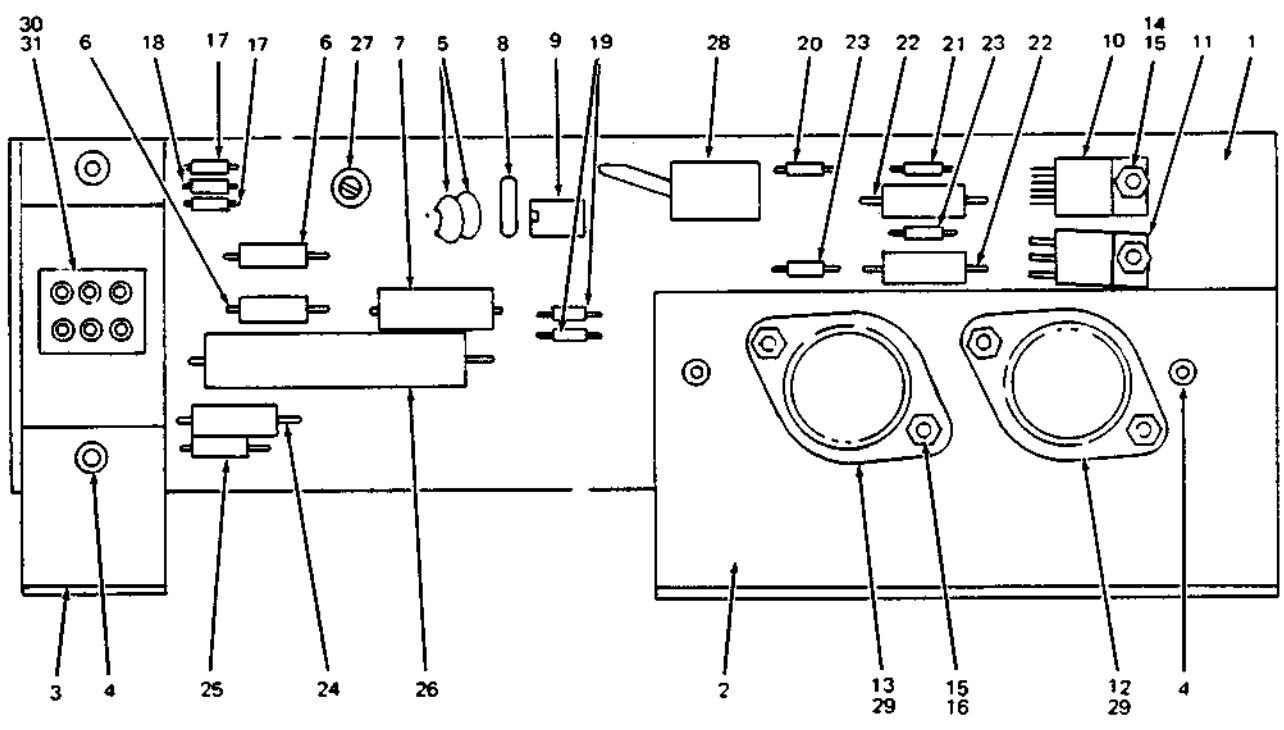

ETCH REV K

RK05J-03A

Figure 3A. Head Position Servo Power Amplifier Assembly (Etch Rev K)

FIG. & ITEM NO.	DESCRIPTION	DEC PART NO.	K ECO CUT-IN H604 00004	USED ON CODE	REF FIG NO.
3A-	HEAD POSITION SERVO POWER AMPLIFIER ASSEMBLY (ETCH REV. K)	H604-00			1
1	*Board, Etched Circuit (Etch Rev K)	50-09741-00			
2	*Bracket, Heat Sink	55-09810-00			
3	*Bracket, Servo Board	55-09812-00			
4	*Eyelet .121 OD x .219	90-06732-00			
5	*Capacitor (C1, C2) .01 MFD .50V 20%	10-01610-00			
6	*Capacitor (C3, C4) 15 MFD .20V 10%	10-04812-00			
7	*Capacitor (C5) .1 MFD 100V 10%	10-02342-00			
8	*Capacitor (C6) 33 PF 100V 5%	10-00009-00			
9	*IC (E1) LM301	19-10282-00			
10	*Transistor (Q1) DEC D44C8 or TIP 31A	15-10421-00			
11	*Transistor (Q2) DEC D45C8	15-10414-00			
12	*Transistor (Q3) 2N3791	15-09582-00			
13	*Transistor (Q4) 2N3715	15-03068-00			
14	*Screw, Binder Hd. Slotted No. 4-40 x 1/4	90-06009-04			
15	*Nut, Kep No. 4-40	90-06557-00			
16	*Screw, Binder Hd. Slotted No. 4-40 x .44	90-06012-04			
17	*Resistor (R1, R4) 1K Ohm .25V, 5%	13-00365-00			
18	*Resistor (R2) 2K Ohm 1/4W 5%	13-02388-00			
19	*Resistor (R3, R14) 22 Ohm 1/4W 5%	13-01969-00			
20	*Resistor (R5) 220 Ohm 1/4W 5%	13-00271-00			
21	*Resistor (R6) 1.2K Ohm 1/4W 5%	13-01320-00			
22	*Resistor (R7, R8) 3 Ohm 2W 5%	13-01643-00			
23	*Resistor (R9, R10) 100 Ohm 1/4W 5%	13-00229-00			
24	*Resistor (R11) 200 Ohm 1W 5%	13-02382-00			
25	*Resistor (R12) 10 Ohm 5W 5%	13-00168-00			
26	*Resistor (R13) .1 Ohm 10W 1%	13-09108-00			
27	*Potentiometer (R15) 2K Ohm 1/2W 10%	13-09150-07			
28	*Switch (S1) Toggle T-8001	12-10209-00			
29	*Washer, Insulator	90-06721-00			
30	*Connector, Socket Housing, 6 Pin Mate-N-Lok	12-09350-06			
31	*Terminal, Socket Contact	12-09456-01			

FIG. & ITEM NO.	DESCRIPTION	DEC PART NO.	E ECO CUT-IN 54-09574 00000	USED ON CODE	REF FIG NO.
4-	DECPACK MOTOR RELAY BOARD ASSEMBLY (ETCH REV E)	54-09574-00			1
1	*Relay (K1, K2) 3 Pole, 12V 10A	12-10683-00			
2	*Diode (D4, D5) D003	11-00100-00			
3	*Arc Suppressor (Thyrector) (D2, D3) 6RS20SP4B4	11-00106-00			
4	*Resistor (R1, R2) 27 Ohms 1W 5%	13-01516-00			
5	*Diode (D1) D672	11-05275-00			
6	*Resistor (R3) 1K Ohms 1/4W 5% (deleted)	13-00365-00			
	*Resistor (R3) 750 Ohms 1/4W 5% (added)	13-01401-00	00001		
7	*Housing, Socket (Mate-N-Lok) 15 pin	12-09350-15			
8	*Pin Housing (Mate-N-Lok)	12-09456-01			
9	@Shield, Shock	74-09469-00			
10	@Screw, Phl Pan Hd No. 4-40 x 3/8	90-06011-01			
11	@Nut, Kep No. 4-40	90-06557-00			
12	@Spacer, 3/16 AF x 1/8 Lg. x No. 4 Hole	90-06791-00			

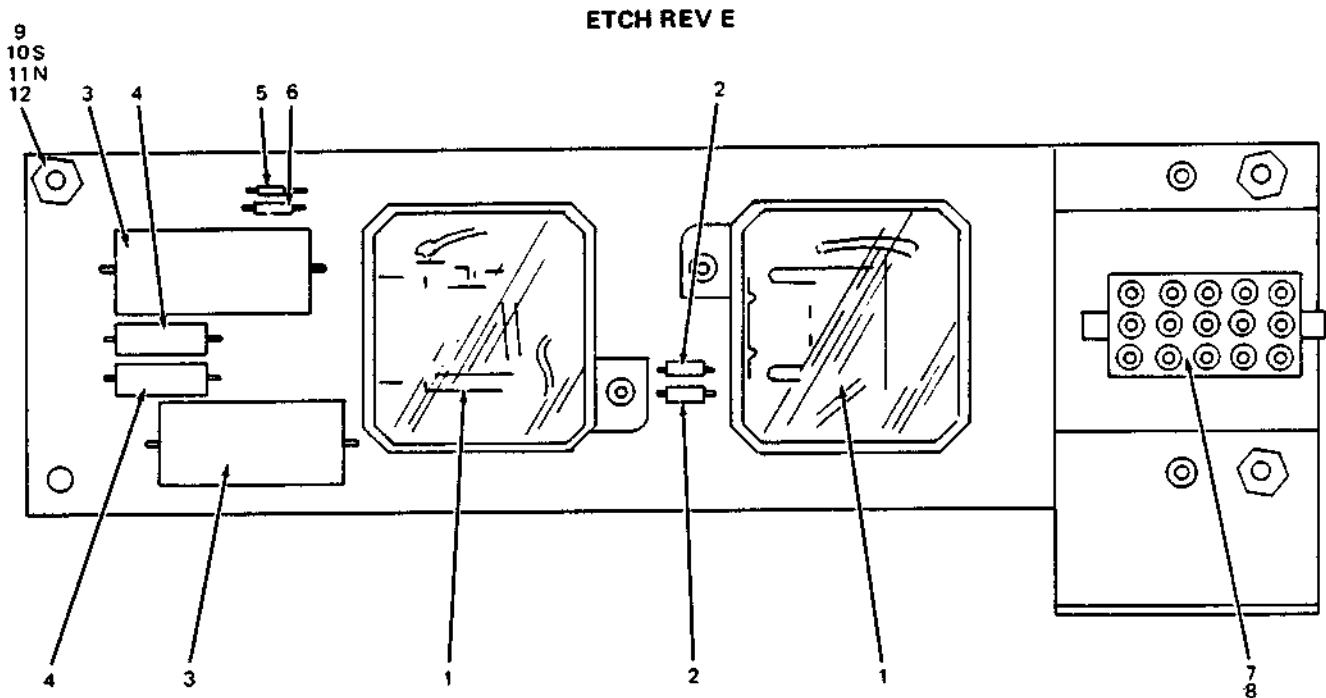

RK05J-04

Figure 4. DEC Pack Motor Relay Board Assembly (Etch Rev E)

FIG. & ITEM NO.	DESCRIPTION	DEC PART NO.	H ECO CUT-IN 54-09574 00002	USED ON CODE	REF FIG NO.
4A-	DECPACK MOTOR RELAY BOARD ASSEMBLY (ETCH REV F)	54-09574-00			1
1	*Relay (K1, K2) 3 Pole, 12V 10A	12-10683-00			
2	*Diode (D4, D5) D003	11-00100-00			
3	*Arc Suppressor (Thyrector) (D2, D3) 6RS20SP4B4	11-00106-00			
4	*Resistor (R1, R2) 27 Ohms 1W 5%	13-01516-00			
5	*Diode (D1) D672	11-05275-00			
6	*Diode (D6, D7) IN4004	11-05796-00			
7	*Resistor (R3) 750 Ohms 1/4W 5%	13-01401-00			
8	*Housing, Socket (Mate-N-Lok) 15 Pin	12-09350-15			
9	*Pin Housing (Mate-N-Lok)	12-09456-01			
10	@Shield, Shock	74-09469-00			
11	@Screw, Phi Pan Hd No. 4-40 x 3/8	90-06011-01			
12	@Nut, Kep No. 4-40	90-06557-00			
13	@Spacer, 3/16 AF x 1/8 Lg x No. 4 Hole	90-06791-00			
					DEC

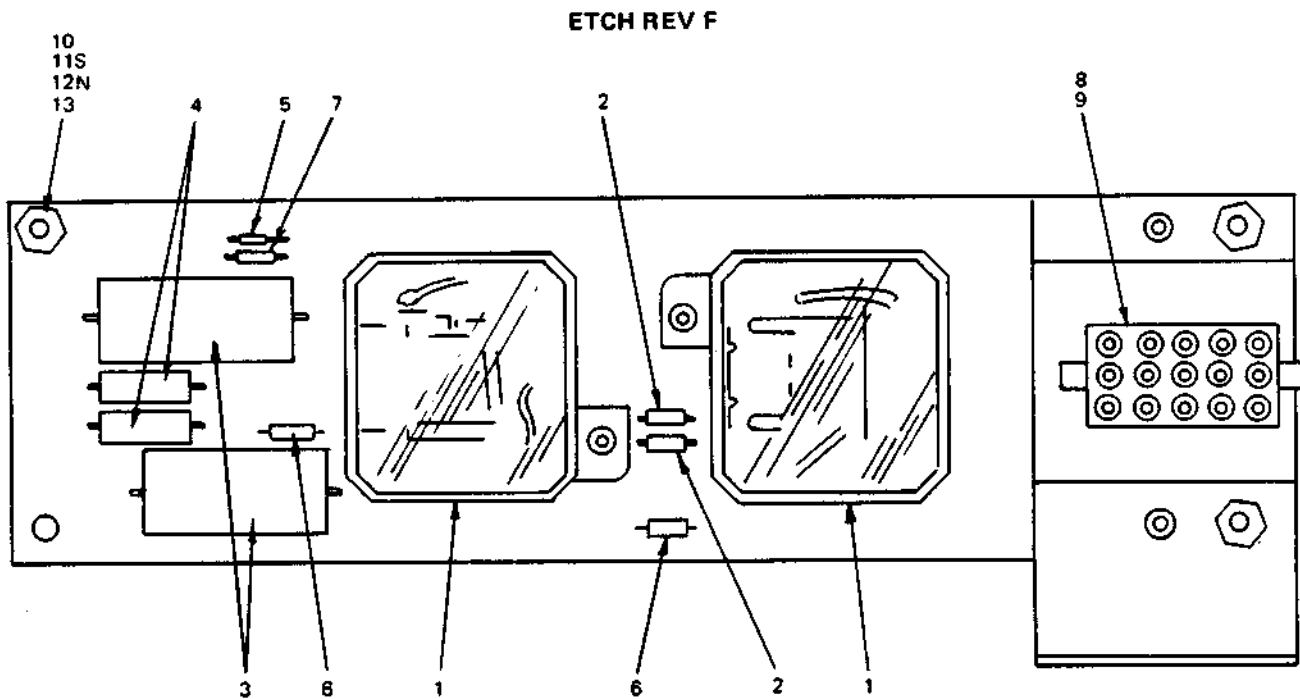

RK05J-04A

Figure 4A. DEC Pack Motor Relay Board Assembly (Etch Rev F)

**ILLUSTRATED PARTS BREAKDOWN
COMMENT SHEET**

Any and all comments and suggestions for correcting errors and/or additional information to improve this manual will be reviewed and researched for possible use when this manual is revised and/or reprinted. Enter your comments and suggestions in the form provided below and return to Technical Documentation.

MODEL RK05J DISK DRIVE

PUBLICATION NO. EK-RK05J-IP-003

FIGURE NO. _____ ITEM NO. _____
CHANGE FROM _____
CHANGE TO _____

FIGURE NO. _____ ITEM NO. _____
CHANGE FROM _____
CHANGE TO _____

FIGURE NO. _____ ITEM NO. _____
CHANGE FROM _____
CHANGE TO _____

FIGURE NO. _____ ITEM NO. _____
CHANGE FROM _____
CHANGE TO _____

FIGURE NO. _____ ITEM NO. _____
CHANGE FROM _____
CHANGE TO _____

FIGURE NO. _____ ITEM NO. _____
CHANGE FROM _____
CHANGE TO _____

ADDITIONAL COMMENT(S)

Please describe your position. _____

Name _____ Organization _____

Street _____ Department _____

City _____ State _____ Zip or Country _____

Fold Here

Do Not Tear - Fold Here and Staple

FIRST CLASS
PERMIT NO. 33
MAYNARD, MASS.

BUSINESS REPLY MAIL
NO POSTAGE STAMP NECESSARY IF MAILED IN THE UNITED STATES

Postage will be paid by:

Digital Equipment Corporation
Technical Documentation Department
146 Main Street
Maynard, Massachusetts 01754

