

ILLUSTRATED PARTS BREAKDOWN

PDP8E 12 BIT COMPUTER

HOW TO USE THE IPB

GENERAL

This IPB is compiled following the organization and nomenclature of the engineering drawing structure.

MAJOR ASSEMBLY LOCATOR

The Major Assembly Locator (first illustration) is an index that provides a description and a figure reference for all illustrations used in this manual.

INDENTED PARTS LIST

This manual identifies each assembly being broken down (figure reference callout), and all parts of that assembly. Further breakdown of an assembly is shown by an asterisk (*) preceding the item callouts in the Description Column. The number of asterisks preceding an item is used to denote the subordination of that item with respect to the Major Assembly. A single asterisk preceding an item description indicates that the item is part of the major assembly being illustrated. Items that are subordinate to single asterisk items, are denoted by two asterisks (**) and immediately follow the related single asterisk item. Additional asterisks are used, as required, to denote further subordination. This system of part identification, provides a means for the user to identify the next higher assembly item and make alternate selections for parts when the required replacement part or assembly is not immediately available.

COLUMN CALLOUT DESCRIPTION

Figure & Item — Indicates the figure number and item number of each part.

Description — Lists the name of the part and pertinent specifications (when required). Asterisks preceding the description denote the subordination of the part to the next higher assembly.

DEC Part No. — Lists the DEC part ordering number. A blank in this column indicates a DEC part number was not assigned at the time of publication.

ECO Cut-In — The notation at the top of this column indicates the ECO level of the system (option), at which the IPB was initially prepared. Subsequent ECO level designations, that modify existing parts or add new parts to the device, are inserted in the ECO Cut-In column next to the part that is added or modified. A bracket ([]) preceding the item description is used to indicate the parts affected by ECO's.

Vendor Code/Part No. — Indicates vendor parts that are not stocked by DEC. Refer to the Field Service Spares Catalog (vendor part number to DEC part number) for the vendor code cross-reference.

Used On Code — Letters in this column correspond to the variation codes assigned in Figure 1. Parts with an Alpha notation(s) are used only in those option variations. A blank indicates that the part is used on all option variations.

Ref Fig No. — A cross reference between illustrations. For each Major Assembly, the number in this column denotes the figure of the next higher assembly. For all subassemblies, the number in this column denotes the figure showing additional detailed breakdown.

SYMBOL USAGE

Hardware Designators — Alpha designators for screws (S), washers (W), nuts (N), and retaining rings (R) are inserted after the item number callouts on the illustration when stacked item numbers are used.

Attaching Hardware — The @ symbol is inserted before any part that is used as attaching hardware. Attaching hardware is denoted as those parts that are not an integral part of the referenced assembly.

(NFR) Not Field Repairable — The (NFR) symbol is inserted after any assembly that is not to be field dismantled.

Other Symbols — Any other symbols that are required for kits, accessories, etc., will be explained and appear as part of the item description.

REVISION HISTORY

PRINTING	ECO LEVEL	DATE	PAGES AFFECTED
1st Printing	PDP8E 00000-00064	2-8-74	N/A
"	H960 BC/BD 00000-00002		"
"	70-07074 00000-00002		"
"	H724/H724A 00000-00021		"
"	54-09264 00000-00005		"
"	54-09262 00000-00009		"
"	54-09248 00000-00001		"

Copyright © 1974, by Digital Equipment Corporation

DEC reserves the right, without notice, to make substitutions and modifications in the specifications of products documented in this manual and further reserves the right to withdraw any of these products from the market without notice.

DEC is not responsible for errors which may appear in the technical description (including illustrations and photographs) of the products covered by this manual.

None of the descriptions contained in this manual imply the granting of any license whatsoever to make, use or sell equipment constructed in accordance therewith.

H960 CABINET ASSEMBLY
Fig. 2

854 POWER CONTROL
(See Manual DEC-854/854B, C-IPB)

861 POWER CONTROL
(See Manual DEC-861A, B, C-IPB)

H724/H724A POWER SUPPLY ASSEMBLY
Fig. 4
A-1 CONTROL BOARD ASSEMBLY
Fig. 5
A-2 CONTROL BOARD ASSEMBLY
Fig. 6
HEAT SINK HOUSING ASSEMBLY
Fig. 7
TURRET BOARD ASSEMBLY
Fig. 8

PDP8E COMPUTER ASSEMBLY
Fig. 1

MODULES
Fig. 1 and Omnibus Assignment Dwg.
A-SP-PDP8E-0-4

CONSOLE ASSEMBLY (TURNKEY)
(See Manual DEC-KC8EA/EC-IPB)

CONSOLE ASSEMBLY (PROGRAMMER)
(See Manual DEC-KC8EA/EC-IPB)

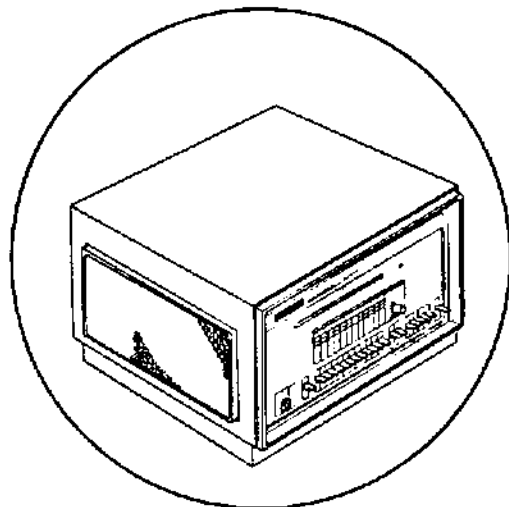

SUPER COVER ASSEMBLY
Fig. 3

PDP8E-06

Major Assembly Locator, PDP8E Computer

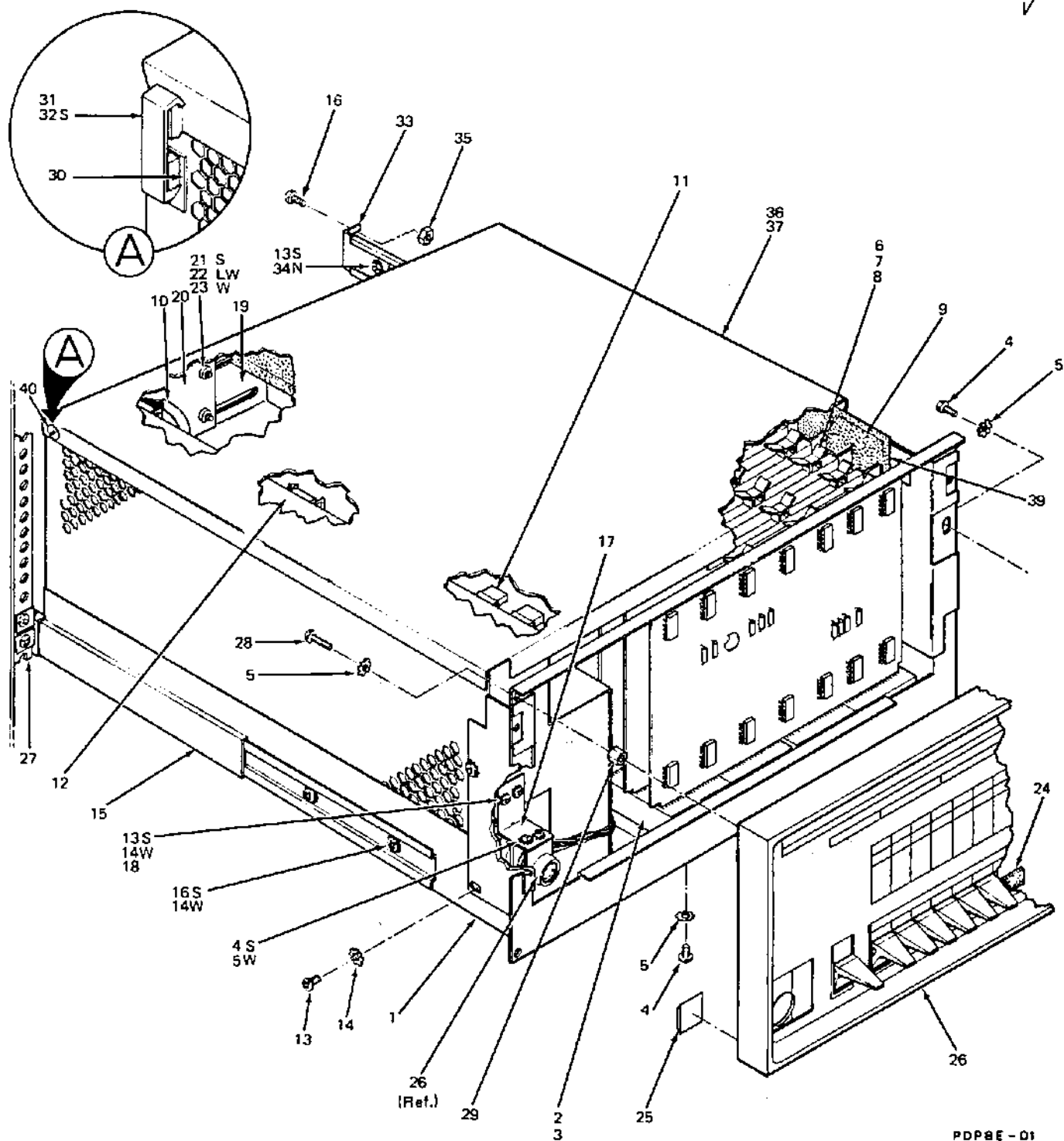

PDP8E - 01

Figure 1. Model PDP8E Computer Assembly (12 Bit)

FIG & ITEM NO.	DESCRIPTION	DEC PART NO.	ECO CUT-IN PDP8E 00064	USED ON CODE	VENDOR CODE	PART NO.	REF FIG NO.
1-	MODEL PDP8E COMPUTER ASSY (12 BIT)						
	Code A used on PDP8E-AA, 115V (Rack)	PDP8E-AA		A			
	Code B used on PDP8E-AB, 230V (Rack)	PDP8E-AB		B			
	Code C used on PDP8E-BA, 115V (Table)	PDP8E-BA		C			
	Code D used on PDP8E-BB, 230V (Table)	PDP8E-BB		D			
	Code E used on PDP8E-CA, 115V (Cab.)	PDP8E-CA		E			
	Code F used on PDP8E-CB, 230V (Cab.)	PDP8E-CB		F			
	Code G used on PDP8E-DA, 115V (Rack)	PDP8E-DA		G			
	Code H used on PDP8E-DB, 230V (Rack)	PDP8E-DB		H			
	Code J used on PDP8E-EA, 115V (Table)	PDP8E-EA		J			
	Code K used on PDP8E-EB, 230V (Table)	PDP8E-EB		K			
	Code L used on PDP8E-FA, 115V (Cab.)	PDP8E-FA		L			
	Code M used on PDP8E-FB, 230V (Cab.)	PDP8E-FB		M			
	Code N used on PDP8E-GA, 115V (Rack)	PDP8E-GA		N			
	Code P used on PDP8E-GB, 230V (Rack)	PDP8E-GB		P			
	Code Q used on PDP8E-HA, 115V (Rack)	PDP8E-HA		Q			
	Code R used on PDP8E-HB, 230V (Rack)	PDP8E-HB		R			
	Code S used on PDP8E-JA, 115V (Rack)	PDP8E-JA		S			
	Code T used on PDP8E-JB, 230V (Rack)	PDP8E-JB		T			
	Code U used on PDP8E-KA, 115V (Rack)	PDP8E-KA		U			
	Code V used on PDP8E-KB, 230V (Rack)	PDP8E-KB		V			
	Code W used on PDP8E-LA, 115V (Rack)	PDP8E-LA		W			
	Code X used on PDP8E-LB, 230V (Rack)	PDP8E-LB		X			
	Code Y used on PDP8E-MA, 115V (Rack)	PDP8E-MA		Y			
	Code Z used on PDP8E-MB, 230V (Rack)	PDP8E-MB		Z			
1	*Chassis	74-08233-00					
2	*OMNIBUS ASSEMBLY	H919-00					
3	*Pad, Foam	12-10302-00	00014				
4	*Screw, Phi Pan Hd No. 8-32 x .38	90-06037-01					
5	*Washer, Lock Ext Tooth No. 8	90-08072-00					
6	*CENTRAL PROCESSOR	KK8-E					
7	*CORE MEMORY, 4K	MMB-E		A thru M			
				STYZ			
8	*ASYNCH DATA CONTROL	KL8-E		A thru M			
9	*Filter, Side	74-08250-00		ABEFGH			
				L thru Z			
10	*HARNESS, Power Wiring	70-06993-00					
11	*Housing, Socket, Mate-N-Lok	12-09351-03					
12	*POWER SUPPLY ASSEMBLY, 115V	H724-00		ACEGJL			4
				NQSUWY			
	*POWER SUPPLY ASSEMBLY, 230V	H724A-00		BDFHKM			4
				PRTWXZ			
13	*Screw, Phi Pan Hd No. 10-32 x .38	90-06071-01					
14	*Washer, Lock Ext Tooth No. 10	90-07651-00					
15	*Slide, Chassis, 22 inch	74-08861-00		ABEFGH			
				L thru Z			
16	*Screw, Phi Truss Hd No. 10-32 x .38	90-06071-03		ABEFGH			
				L thru Z			
17	*Bracket, Support	74-08249-00					
18	*Spacer 1/4 x 1/8 (added)	90-06795-00	00014	N thru Z			
19	*Bracket, Strain Relief (added)	74-10739-00	00063				
20	*Strain Relief (deleted)	74-08247-00					
	*Strain Relief (added)	74-10738-00	00063				
21	*Screw, Phi Pan Hd No. 6-32 x .38	90-06622-01					
22	*Washer, Lock Int Tooth No. 6 (added)	90-06633-00	00014				
23	*Washer, Flat No. 6 (added)	90-06653-00	00014				
24	*Bumper, Rubber (added) (Used on early versions)	74-08611-01	00014	A thru M			
25	*Bumper, Rubber (added)	74-08611-02	00014	A thru M			
	*Bumper, Rubber (deleted)	74-08611-02	00035	A thru M			
	*Bumper, Rubber (added)	90-08525-00	00035	A thru M			

FIG & ITEM NO.	DESCRIPTION	DEC PART NO.	ECO CUT-IN PDP8E 00064	USED ON CODE	VENDOR		REF FIG NO.
					CODE	PART NO.	
1-							
26	*CONSOLE ASSEMBLY (PROGRAMMER)	KC8-EA		A thru M	See Manual	DEC-KC8EA/EC-IPB	
	*CONSOLE ASSEMBLY (TURNKEY)	KC8-EC		N thru Z	See Manual	DEC-KC8EA/EC-IPB	
27	*CABINET ASSEMBLY (115V)	H960-BC		EL			2
	*CABINET ASSEMBLY (230V)	H960-BD		FM			2
28	*Screw, Phi Fil Hd Self Tapping No. 8-32x5/8	90-06120-06		N thru Z			
29	*Spacer, 1/4 AF x 7/16 No. 8 (added) Used with TURNKEY panel only	90-07603-00	00014	N thru Z			
30	*Spacer, Latch, (Used on early versions)	74-08629-00		ABEFGH			
				L thru Z			
31	*Latch, Draw Catch Fastener (Used on early versions)	12-10264-02		ABEFGH			
				L thru Z			
32	*Screw, Flt Hd No. 6-32 x 1/2 (Used on early versions)	90-06024-02		ABEFGH			
				L thru Z			
33	*Bracket, Shipping (Remove at Installation)	74-08867-00		EFLM			
34	*Nut, Kaps No. 10-32	90-06565-00		EFLM			
35	*Nut, Captive No. 10-32	90-07786-00		EFLM			
36	*SUPER COVER ASSEMBLY (For Table Top Version)	70-07074-00		CDJK			3
37	*Cover Assembly	74-08235-00		ABEFGH			
				L thru Z			
38	**Foam, Adhesive back (deleted)	90-08749-00		ABEFGH			
				L thru Z			
	**Foam, Adhesive back (added)	90-08520-00	00017				
39	**Fastener, Velcro H65-8A-0140	90-08875-02		ABEFGH			
				L thru Z			
40	**Keeper, Southco 07-10-102-12	12-10264-01		ABEFGH			
				L thru Z			

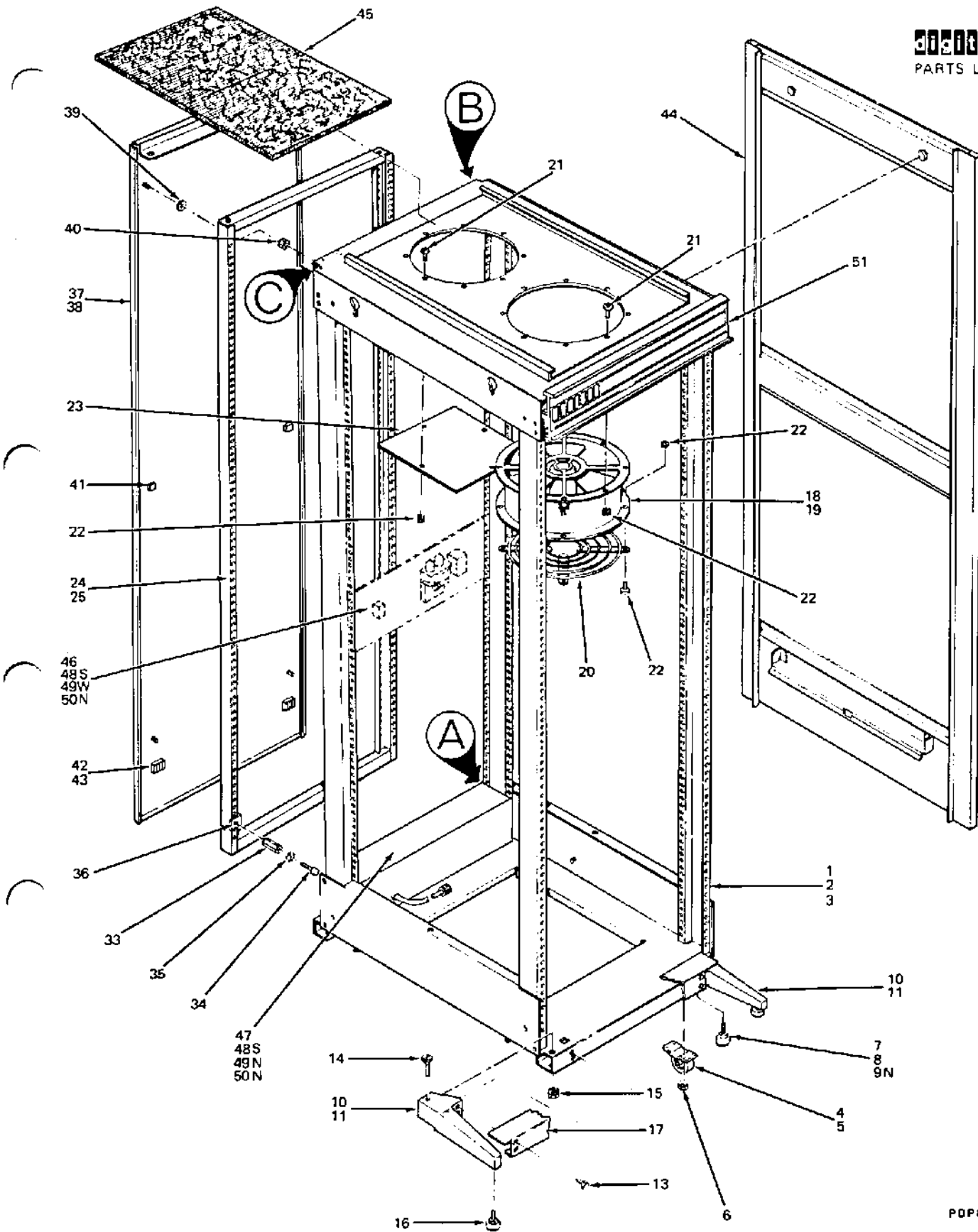

PDP8E-02

Figure 2. H960 Cabinet Assembly (Sheet 1 of 2)

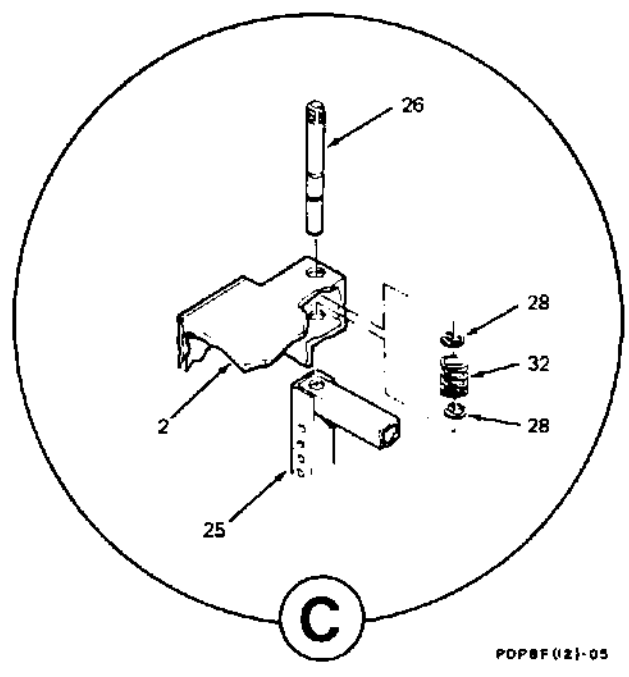
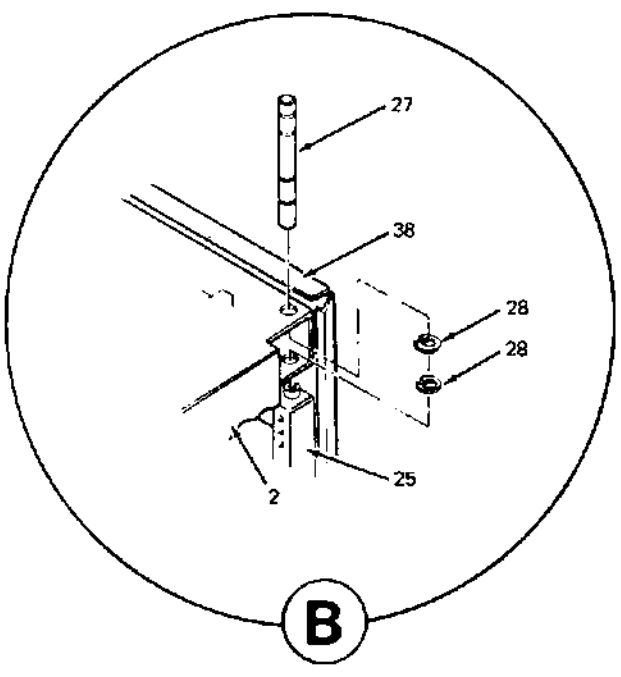
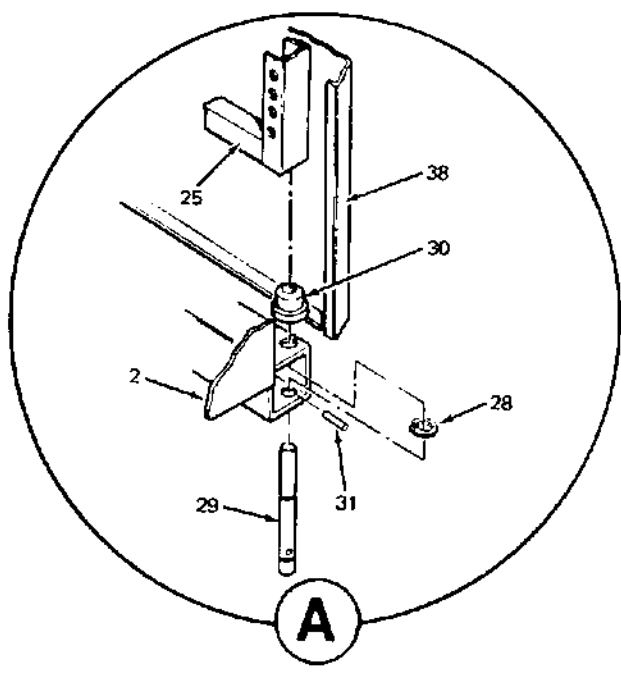

POP8F (12)-05

Figure 2. H960 Cabinet Assembly (Sheet 2 of 2)

FIG & ITEM NO.	DESCRIPTION	DEC PART NO.	ECO CUT-IN H960 00002	USED ON CODE	VENDOR		REF FIG NO.
					CODE	PART NO.	
2-	H960 CABINET ASSEMBLY						1
	Cabinet Assembly H960-BC (115V)	H960-BC		EL			
	Cabinet Assembly H960-BD (230V)	H960-BD		FM			
1	*BASIC CABINET ASSEMBLY, 19 inch	70-06501-00					
2	**CABINET ASSEMBLY, (19 Inch) with Casters & Levelers	70-06478-00					
3	***FRAME ASSEMBLY, 19 inch	H950-A					
4	***Caster Set	H952-E					
5	****Caster	90-05835-00					
6	****Nut, Keps No. 5/16-18	90-06568-00					
7	***Leveler Set	H952-F					
8	****Leveler	90-07600-00					
9	****Nut, Lock Hex No. 1/2-13	90-06595-00					
10	**STABILIZER FOOT ASSEMBLY	H952-B					
11	***Foot, Stabilizer (R.H.)	74-06699-01					
12	***Foot, Stabilizer (L.H.)	74-06699-02					
13	**Screw, Phi Truss Hd No. 10-32 x 3/4 (Passivate)	90-07630-00					
14	***Screw, Shoulder, Flat Hd No. 1/4-20 x 2-5/8	90-08370-00					
15	***Nut, Keps No. 1/4-20	90-08203-00					
16	***Leveler	90-07601-00					
17	**Kick Plate	74-06782-00					
18	**FAN ASSEMBLY	H952-C					
19	***Fan, Caravel (115V)	12-04826-00		EL			
	***Fan, Caravel (230V)	12-09798-00		FM			
20	***Guard, Finger	12-09175-00					
21	***Screw, Phi Pan Hd No. 6-32 x 1/2	90-06022-01					
22	***Nut, Keps No. 6-32	90-06560-00					
23	***Cover, Fan Hole	74-06706-00					
24	**MOUNTING PANEL, DOOR ASSEMBLY	H950-DA					
25	***Frame, Mounting Door Assembly, R.H.	74-06705-01					
26	***Pin, Door Retainer	74-06670-00					
27	***Pin, Door	74-06671-00					
28	***Ring, Retaining	90-07184-00					
29	***Pin, Door	74-06672-00					
30	***Bushing, Pivot	74-06702-00					
31	***Pin, Roll	90-06518-00					
32	***Spring, 5/16 ID x 11/32 OD x 1-1/8	90-07097-00					
33	***Spacer, 1/2 AF x 3/4 No. 10	90-06833-00					
34	***Screw, Truss Hd No. 10-32 x 1.0	90-06077-03					
35	***Washer, Lock Ext Tooth No. 10	90-07651-00					
36	***Nut, Tinnerman No. 10-32	90-07786-00					
37	**MOUNTING PANEL, DOOR ASSEMBLY, R.H.	H950-FA					
38	**Skin, Mounting Door	74-06722-00					
39	**Spacer, 1/2 AF x .196 ID x 3/16	90-06828-00					
40	**Nut, Keps No. 10-32	90-06565-00					
41	**Fastener	90-07833-00					
42	**Magnet	12-09165-00					
43	**Nut, Keps No. 6-32	90-06560-00					
44	*Panel, End	H952-A					
45	*Filter	H950-SA					
46	*POWER CONTROL ASSEMBLY (115V) (Used in early models)	854-0		EL		See Manual DEC-854/854B,C-IPB	
	*POWER CONTROL ASSEMBLY (230V) (Used in early models)	854-B		FM		See Manual DEC-854/854B,C-IPB	
47	*POWER CONTROL ASSEMBLY (115V)	861-C		EL		See Manual DEC-861A,B,C-IPB	
	*POWER CONTROL ASSEMBLY (230V)	861-B		FM		See Manual DEC-861A,B,C-IPB	
48	*Screw, Phi Truss Hd No. 10-32 x .38	90-06074-01					
49	*Washer, Lock Int Tooth No. 10	90-07654-00					
50	*Nut, Tinnerman No. 10-32	90-07786-00					
51	*Logo	74-07936-06					

FIG & ITEM NO.	DESCRIPTION	DEC PART NO.	ECO CUT-IN 70-07074 00000	USED ON CODE	VENDOR		REF FIG NO.
					CODE	PART NO.	
3-	SUPER COVER ASSEMBLY (PDP8E)	70-07074-00		CDJK			1
1	*Cover, Super	74-08343-00					
2	*Screw, Spring Captivated No. 10-32 x 1.0 Southco	90-08845-00	X				
3	**Foam	12-10004-00	X				
4	*Grommet 1/16 x 2.5 No. 122-37-1500	90-07035-00					
5	*Receptacle, Clip On No. 82-47-104-15 Southco	90-08196-00					
6	*Strain Relief	74-08419-00					
7	*Fastener, 1/4 Turn No. 82-11-120-16 Southco	90-08199-00					
8	*Ring, Retaining 1/4 Turn Fastener No. 82-32-101-17 Southco	90-08200-00					
9	*Washer, Flat No. 1/4	90-06676-00					
10	*Moulding, Latch	12-09224-00					
11	*Screw, Flat Head No. 10-32 x 3/8 SST	90-06071-02					
12	*Bezel (5-1/4 inch)	12-09226-00					
13	*Screen, Bezel	74-07863-00	X				
14	*Fastener, Push-nut	90-08839-00					
15	*Filter, Bezel	74-07866-00	7.00				
16	*Retainer, Filter	74-07869-00					

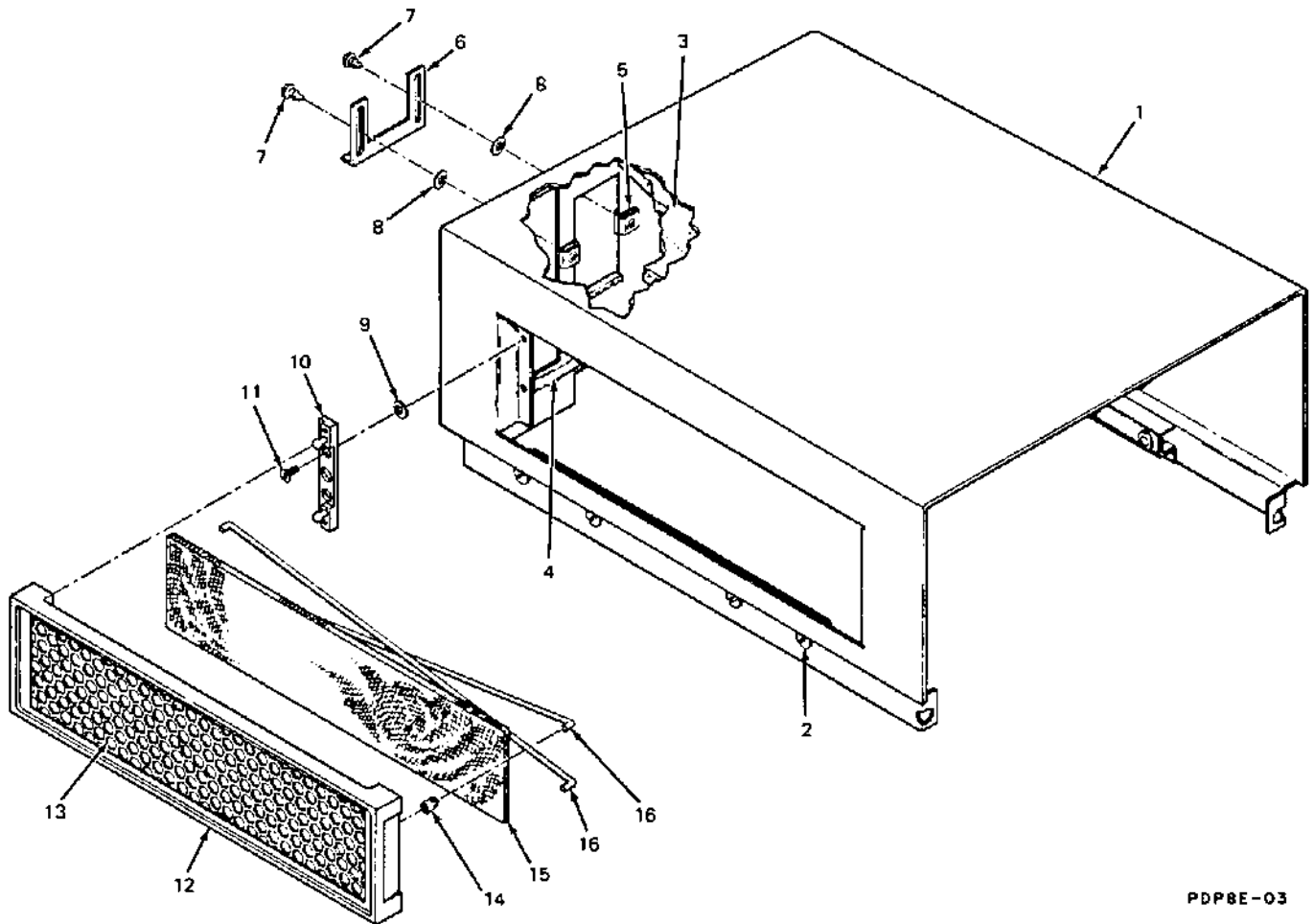

PDP8E-03

Figure 3. Super Cover Assembly

See Sheet 2 of 2 For
Additional Callouts

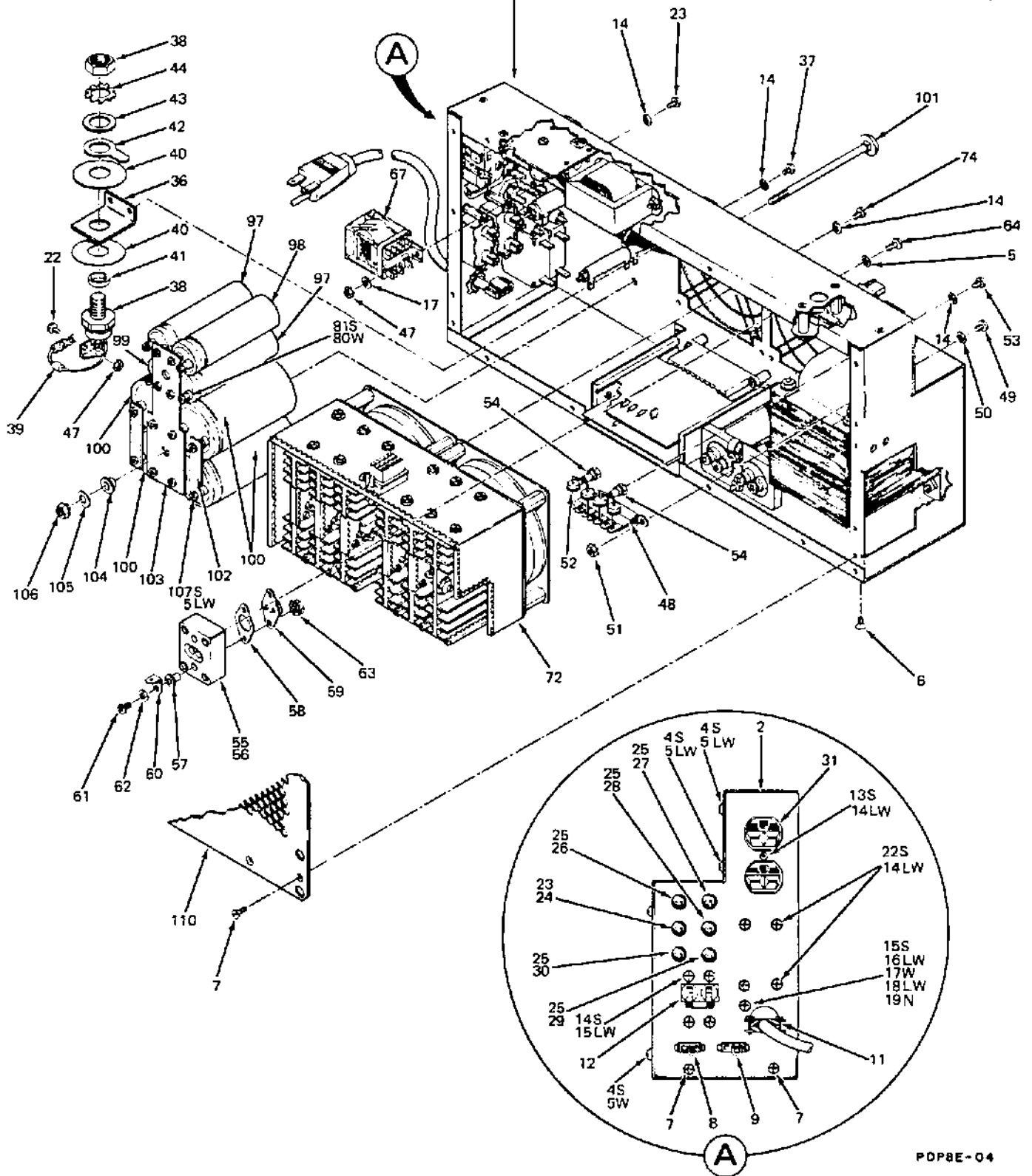
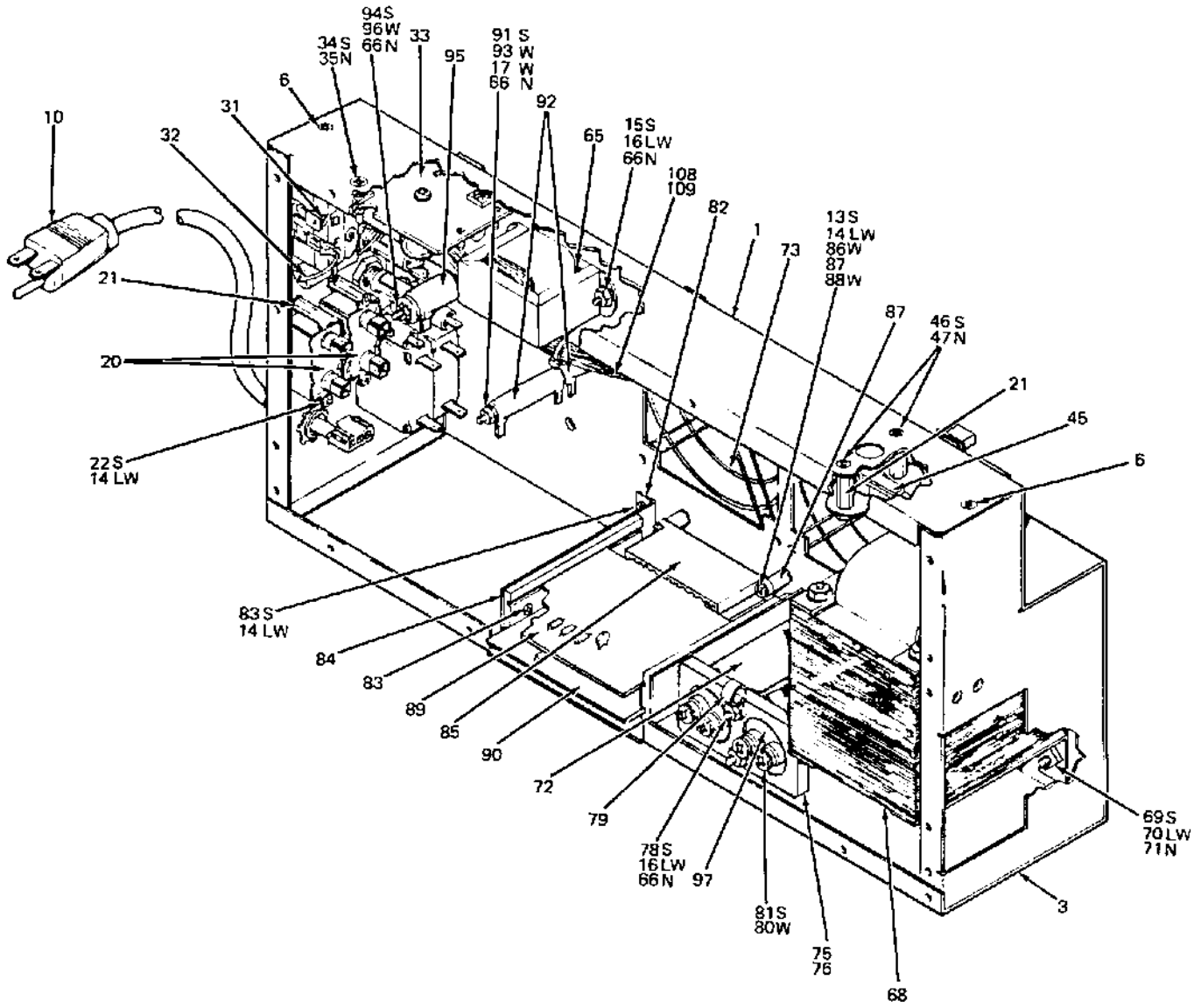

Figure 4. H724/H724A Power Supply Assembly (Sheet 1 of 2)



PDP8E-04

Figure 4. H724/H724A Power Supply Assembly (Sheet 2 of 2)

FIG & ITEM NO.	DESCRIPTION	DEC PART NO.	ECO CUT-IN H724/ H724-A 00000	USED ON CODE	VENDOR		R. F. FIG NO.
					CODE	PART NO.	
4-	H724/H724A POWER SUPPLY ASSY						1
	Power Supply Assembly 115V	H724-0		ACEGJL NQSUWY BDFHKM PRTVXZ			
	Power Supply Assembly 230V	H724-A					
1	*Chassis	53-09257-00					
2	*Panel, Rear	53-09252-00					
3	*Panel, Front	53-09260-00					
4	*Screw, Phi Pan Hd No. 10-32 x 7/16	90-06072-01					
5	*Washer, Lock Int Tooth No. 10	90-06635-00					
6	*Screw, Phi Flat Hd No. 6-32 x 5/16	90-06021-02					
7	*Screw, Phi Flat Hd No. 6-32 x 3/8	90-06022-02					
8	*Jumper (J1)	70-07006-01					
9	*Jumper (J2)	70-07006-02					
10	*Power Cord (115V)	17-00006-15		ACEGJL NQSUWY BDFHKM PRTVXZ			
	*Power Cord (230V) (deleted)	17-00005-15					
	*Power Cord (230V) (added)	17-00016-15	00019	BDFHKM PRTVXZ			
11	*Connector, EFCOR 3/8 dia.	90-08280-00					
12	*Circuit Breaker (CB1) 10A (115V)	12-10191-00		ACEGJL NQSUWY BDFHKM PRTVXZ			
	*Circuit Breaker (CB1) 5A (230V) (deleted)	12-10191-01					
	*Circuit Breaker (CB1) 5A (230V) (added)	12-10364-00	00002	BDFHKM PRTVXZ			
13	*Screw, Phi Pan Hd No. 6-32 x 5/16	90-06021-01					
14	*Washer, Lock Int Tooth No. 6	90-06633-00					
15	*Screw, Phi Pan Hd No. 8-32 x 1/2	90-06039-01					
16	*Washer, Lock Int Tooth No. 8	90-06634-00					
17	*Washer, Flat No. 8	90-06660-00					
18	*Washer, Lock Ext Tooth No. 8	90-08072-00					
19	*Nut, Hex No. 8-32	90-06561-00					
20	*Capacitor (C500, C501) .1 MFD 1000 Vdc (deleted)	10-10193-00					
	*Capacitor (C500, C501) .1 MFD 1000 Vdc (added)	10-02153-00	00002				
21	*Spacer, 1/4 AF x 7/8 No. 6-32	90-06861-00					
22	*Screw, Phi Pan Hd No. 6-32 x 3/8	90-06022-01					
23	*Fuseholder (F200) (deleted)	90-07242-00					
	*Fuseholder (F200) (added)	12-11348-00	00021				
24	*Fuse (F200) 25 AMP ABC 25 Busman	90-08385-00					
25	*Fuseholder (F100, F150, F300, F400, F500)	90-07242-00					
26	*Fuse (F100) 1.5 AMP AGC 1-1/2 Busman	90-08388-00					
27	*Fuse (F150) 2.5 AMP AGC 2-1/2 Busman	90-08387-00					
28	*Fuse (F300) 10 AMP ABC 10 Busman	90-08390-00					
29	*Fuse (F400) .125 AMP 3 AGC Fast-Blo (del)	90-08389-00					
	*Fuse (F400) .125 AMP 3 AGC Slo-Blo (add)	90-08527-00	00012				
30	*Fuse (F500) .5 AMP AGC 1/2 Busman	90-07208-00					
31	*Receptacle, Duplex 115V	12-05351-00		ACEGJL NQSUWY BDFHKM PRTVXZ			
	*Receptacle, Duplex 230V (deleted)	90-08856-00					
	*Receptacle, Duplex 230V (added)	12-11204-00	00018	BDFHKM PRTVXZ			
32	*Thyrector (CR500) 6RS20SP5B5 (115V)	11-10181-00		ACEGJL NQSUWY BDFHKM PRTVXZ			
	*Thyrector (CR500) 6RS20SP9B9 (230V)	11-02915-00					
33	*TURRET BOARD ASSEMBLY	54-09248-00					8

FIG & ITEM NO.	DESCRIPTION	DEC PART NO.	ECO CUT-IN H724/ H724-A 00000	USED ON CODE	VENDOR		REF FIG NO.
					CODE	PART NO.	
4-							
34	*Screw, Phi Flat Hd No. 8-18 x 1/2	90-08409-02					
35	*Nut, Toggle Tinnerman	90-08395-00					
36	*Bracket, SCR PRV Mounting	53-09199-00					
37	*Screw, Phi Pan Hd Thd Cutting No. 6-32 x 3/8	90-08407-01					
38	*Rectifier, Silicon Controlled (Q207) No. C-45A	11-10183-00					
39	*Capacitor (C204) 1_MFD 35 Vdc	10-01776-00					
40	*Washer, Mica (SCR)	90-08418-00					
41	*Bushing, Insulating (SCR)	90-08448-00					
42	*Lug, Ground No. 1/2 (SCR)	90-08439-00					
43	*Washer, Flat No. 1/2 (SCR)	90-08068-00					
44	*Washer, Lock Ext Tooth ID .618	90-08447-00					
45	*Switch, (S1) Thermostat	12-10199-00					
46	*Screw, Phi Flat Hd No. 6-32 x 1/4	90-06029-02					
47	*Nut, Keps No. 6-32	90-06560-00					
48	*Strip, Terminal 7 Position Jones No. 2007	90-08392-00					
49	*Screw, Phi Pan Hd No. 4-40 x 5/16	90-06010-01					
50	*Washer, Lock Int Tooth No. 4	90-06632-00					
51	*Nut, Keps No. 4-40	90-06557-00					
52	*Diode (CR100-CR101, CR150-CR151) IN4721	11-10182-00					
53	*Screw, Phi Pan Hd No. 6-32 x 3/16	90-07842-01					
54	*Lug, Turret No. 6-32	90-06966-00					
55	*HEAT SINK ASSEMBLY	70-07205-00					
56	**Casting, Heat Sink	12-10210-01					
57	**Bushing, Insulating	90-08421-00					
58	**Insulator, Plastic Film	90-08419-00					
59	**Transistor (Q100, Q200, Q300) 2N3055	15-00008-00					
60	**Lug, Ground No. 6	90-06761-00					
61	**Screw, Phi Pan Hd No. 6-32 x 11/16	90-07794-01					
62	**Washer, Flat No. 6	90-06653-00					
63	**Nut, Keps No. 6-32	90-06560-00					
64	*Screw, Phi Pan Hd No. 10-32 x 11/16	90-08915-01					
65	*Transformer (T2) No. 6012297	16-10177-00					
66	*Nut, Keps No. 8-32	90-06563-00					
67	*Relay (K1) 24V	12-10198-00					
68	*Transformer (T1) No. 6012296	16-10178-00					
69	*Screw, Phi Pan Hd No. 1/4-20 x 3/4	90-06058-03					
70	*Washer, Lock Int Tooth No. 1/4	90-06637-00					
71	*Nut, Tinnerman No. 1/4-20	90-06590-00					
72	*HEAT SINK HOUSING ASSEMBLY	70-07197-00					7
73	*Guard, Inlet Muffin Fan	12-10263-00					
74	*Screw, Phi Pan Hd No. 6-32 x 3/4	90-06026-01					
75	*Plate, Capacitor Top	53-09200-00					
76	*Plate, Capacitor Bottom	53-09201-00					
77	*Capacitor (C300-C301) 14,000 MFD 40 Vdc	10-10187-00					
78	*Screw, Slot Hd Round No. 8-32 x 4-5/8	90-08412-00					
79	*Clamp, Cable Holub	90-07081-00					
80	*Washer, Lock Split	90-07906-00					
81	*Screw, Phi Pan Hd No. 10-32 x 3/8	90-06071-01					
82	*Bracket, Card Guide	53-09197-00					
83	*Screw, Pan Hd Self Cutting No. 6-32 x 1/4	90-08408-01					
84	*Card Guide	53-09196-00					
85	*Block, Connector (18 Pin-Reworked)	55-09626-00					
86	*Washer, Flat No. 6	90-06653-00					
87	*Spacer, Connector Block	53-09198-00					
88	*Washer, Lock Ext Tooth No. 6	90-07649-00					
89	*CONTROL BOARD ASSEMBLY-A1	54-09264-00					5
90	*CONTROL BOARD ASSEMBLY-A2	54-09262-00					6
91	*Screw, Round Hd Slot No. 8-32 x 4-1/2	90-08411-05					
92	*Resistor (R100, R300) 300 Ohm 10W 5%	13-10188-00					
93	*Washer, Insulating	90-08416-00					

FIG & ITEM NO.	DESCRIPTION	DEC PART NO.	ECO CUT-IN H724/ H724-A 00000	USED ON CODE	VENDOR		REF FIG NO.
					CODE	PART NO.	
4-							
94	*Screw, Round Hd Slot No. 8-32 x 2-9/16	90-08410-05					
95	*Resistor (R200) 100 Ohm 25W 5%	13-02888-00					
96	*Center Washer	90-06674-00					
97	*Capacitor (C101, C302) 10,000 MFD 20 Vdc	10-10185-00					
98	*Capacitor (C205) 18,000 MFD 10 Vdc	10-10197-00					
99	*Capacitor (C100) 6,000 MFD 40 Vdc	10-10186-00					
100	*Capacitor (C200-C203) 30,000 MFD 25 Vdc	10-10184-00					
101	*Bolt, Carriage, No. 1/4-20 x 5	90-08401-00					
102	*Bar, Bus	53-09202-00					
103	*Plate, Bus	53-09251-00					
104	*Bushing, Flanged	90-08426-00					
105	*Washer, Flat No. 1/4	90-06676-00					
106	*Nut, 1/4-20 (deleted)	90-06586-00					
	*Nut, 1/4-20 (added)	90-08203-00	00013				
107	*Screw, Phi Fan Hd No. 10-32 x 1/2	90-06073-01					
108	*HARNESS, Main Chassis	70-07191-00					
109	*Connector, Harness	70-07192-00					
110	*Cover	53-09187-00					

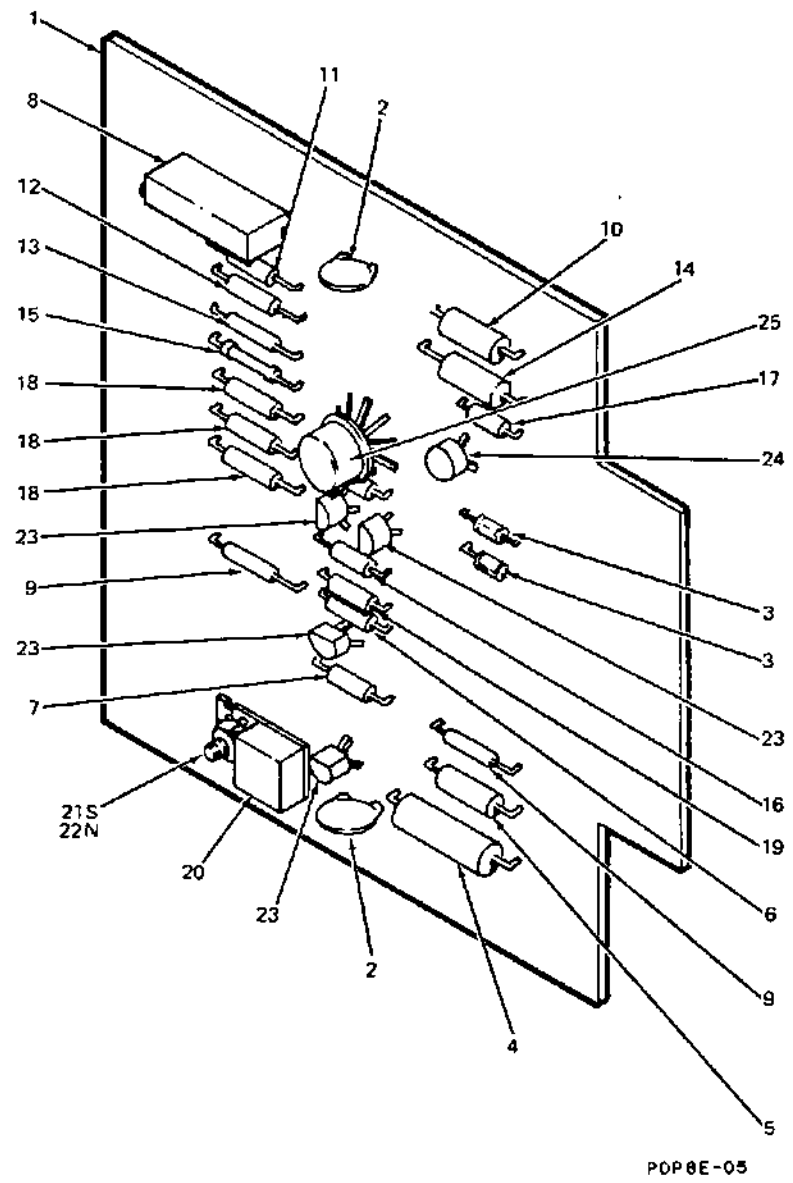

PDP8E-05

ETCH REV B

Figure 5. A-1 Control Board Assembly (Etch Rev B)

FIG & ITEM NO.	DESCRIPTION	DEC PART NO.	ECO CUT-IN 64-09264 00000	USED ON CODE	VENDOR		REF FIG NO.
					CODE	PART NO.	
5-	A1-CONTROL BOARD ASSEMBLY (ETCH REV. B)	54-09264-00					4
1	*Board, Etched Circuit (Etch Rev B)	50-09263-00					
2	*Capacitor (C1, C3) .01 MFD 100V 20% Disc	10-01610-00					
3	*Diode (CR1, CR2) D664	11-00114-00					
4	*Resistor (R1) 3.6K 1/4W 5%	13-10174-00					
5	*Resistor (R2) 1.3K 1/2W 5%	13-10175-00					
6	*Resistor (R3) 1.5K 1/4W 5%	13-00391-00					
7	*Resistor (R4) 3.3K 1/4W 5%	13-00439-00					
8	*Resistor (R5) Potentiometer 500 Ohms 3/4W 10%	13-09143-06					
9	*Resistor (R6, R7) 3.16K 1/8W 1%	13-03045-00					
10	*Resistor (R8) 6.8K 1/2W 5%	13-00461-00					
11	*Resistor (R9) 1.21K 1/8W 1%	13-02871-00					
12	*Resistor (R10) 5.76K 1/8W 1%	13-02859-00					
13	*Resistor (R11) 681 Ohms 1/8W 1%	13-02872-00					
14	*Resistor (R12) 10K 1/2W 5%	13-00478-00					
15	*Resistor (R13) 6.81K 1/8W 1%	13-04870-00					
16	*Resistor (R14, R33) 2.2K 1/4W 5%	13-00417-00					
17	*Resistor (R15) 1K 1/4W 5%	13-00365-00					
18	*Resistor (R16, R18, R19) 1K 1/8W 1%	13-03114-00					
19	*Resistor (R17) 15K 1/4W 5%	13-00496-00					
20	*Transistor (Q1) DEC44C3	15-10171-00					
21	*Screw, Phi Pan Hd No. 4-40 x .25	90-08301-01					
22	*Nut, Keps No. 4-40	90-06557-00					
23	*Transistor (Q2-Q5) DEC6631	15-09338-00					
24	*Transistor (Q6) DEC6534B	15-03409-01					
25	*IC (VR1) DEC723	19-09981-00					

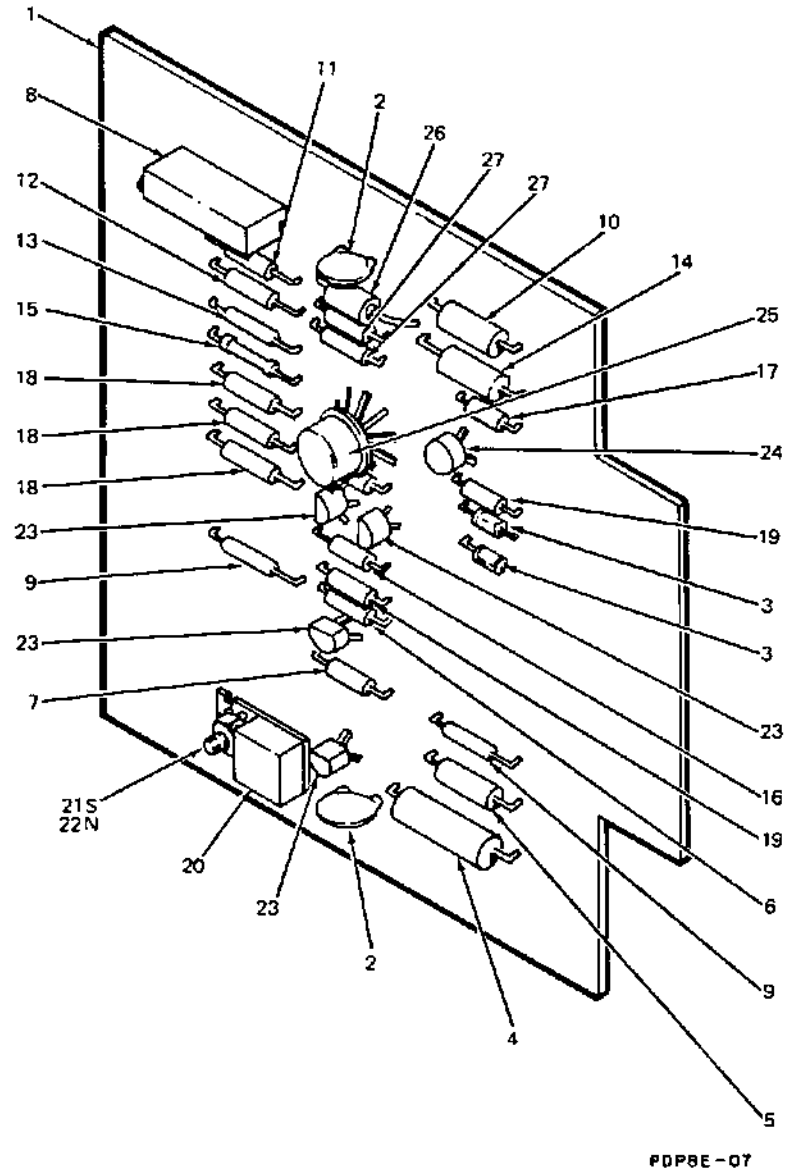

ETCH REV C

Figure 5A. A-1 Control Board Assembly (Etch Rev C)

FIG & ITEM NO.	DESCRIPTION	DEC PART NO.	ECO CUT-IN 54-09264 00001	USED ON CODE	VENDOR		REF FIG NO.
					CODE	PART NO.	
5A-	A1-CONTROL BOARD ASSEMBLY (ETCH REV. C)	54-09264-00					4
1	*Board, Etched Circuit (Etch Rev C)	50-09263-00					
2	*Capacitor (C1, C3) .01 MFD 100V 20% Disc	10-01610-00					
3	*Diode (CR1, CR2) D664	11-00114-00					
4	*Resistor (R1) 3.6K 1W 5%	13-10174-00					
5	*Resistor (R2) 1.3K 1/2W 5%	13-10175-00					
6	*Resistor (R3) 1.5K 1/4W 5%	13-00391-00					
7	*Resistor (R4) 3.3K 1/4W 5%	13-00439-00					
8	*Resistor (R5) Potentiometer 500 Ohms 3/4W 10%	13-09143-06					
9	*Resistor (R6, R7) 3.16K 1/8W 1%	13-03045-00					
10	*Resistor (R8) 6.8K 1/2W 5%	13-00461-00					
11	*Resistor (R9) 1.21K 1/8W 1%	13-02871-00					
12	*Resistor (R10) 5.76K 1/8W 1%	13-02859-00					
13	*Resistor (R11) 681 Ohms 1/8W 1%	13-02872-00					
14	*Resistor (R12) 10K 1/2W 5%	13-00478-00					
15	*Resistor (R13) 6.81K 1/8W 1%	13-04870-00					
16	*Resistor (R14, R33) 2.2K 1/4W 5%	13-00417-00					
17	*Resistor (R15) 1K 1/4W 5%	13-00365-00					
18	*Resistor (R16, R18, R19) 1K 1/8W 1%	13-03114-00					
19	*Resistor, (R17, R61) 10K 1/4W 5%	13-00479-00					
20	*Transistor (Q1) DEC44C3	15-10171-00					
21	*Screw, Phi Pan Hd No. 4-40 x .25	90-08301-01					
22	*Nut, Keps No. 4-40	90-06557-00					
23	*Transistor (Q2-Q5) DEC6531	15-09338-00					
24	*Transistor (Q8) DEC6534B	15-03409-01					
25	*IC (VR1) DEC723	19-09981-00					
26	*Capacitor (C2) 1.0 MFD 35 Vdc 10%	10-01776-00					
27	*Resistor (R59, R60) 470 Ohm 1/4W 5%	13-00316-00					

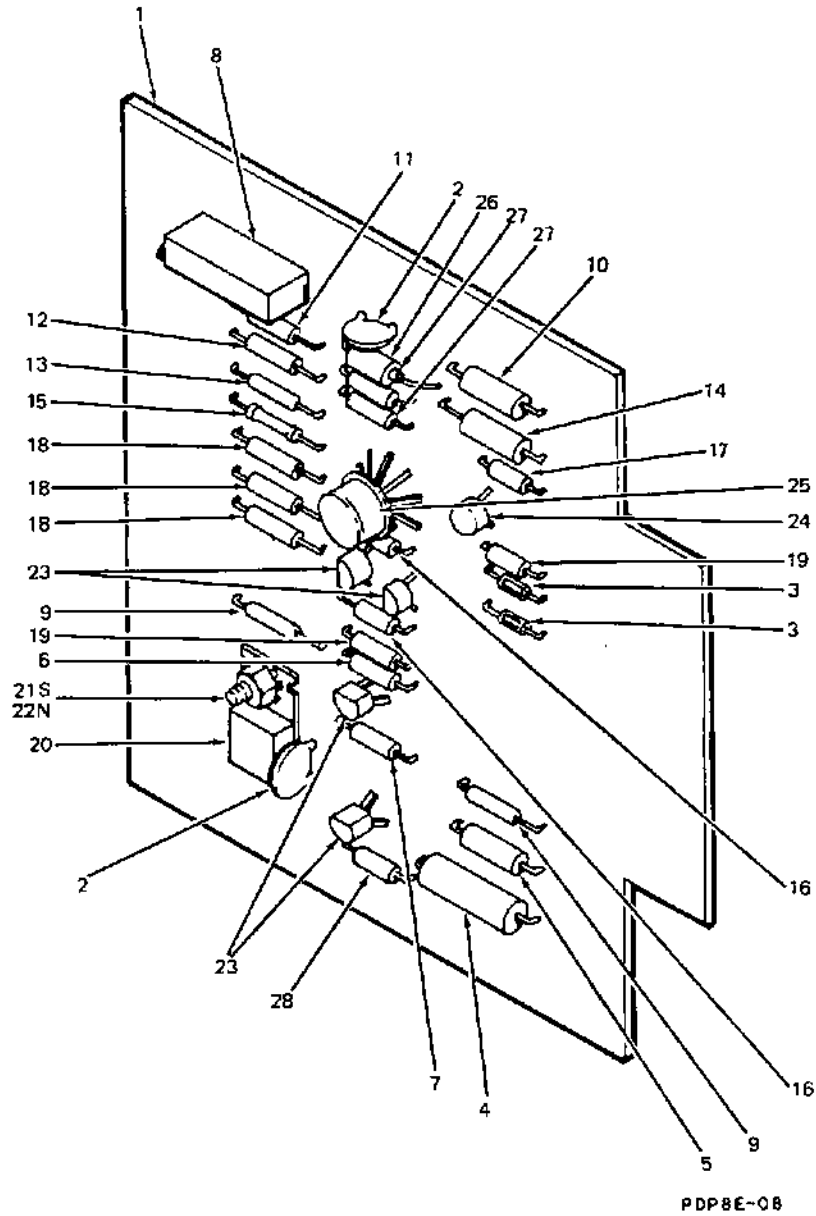

ETCH REV D

Figure 5B. A-1 Control Board Assembly (Etch Rev D)

FIG & ITEM NO.	DESCRIPTION	DEC PART NO.	ECO CUT-IN 54-09264 00003	USED ON CODE	VENDOR CODE	VENDOR PART NO.	REF FIG NO.
58-	A1-CONTROL BOARD ASSEMBLY (ETCH REV. D)	54-09264-00					4
1	*Board, Etched Circuit (Etch Rev D)	50-09263-00					
2	*Capacitor (C1, C3) .01 MFD 100V 20% Disc	10-01610-00					
3	*Diode (CR1, CR2) D664	11-00114-00					
4	*Resistor (R1) 3.6K 1W-5%	13-10174-00					
5	*Resistor (R2) 1.3K 1/2W 5%	13-10175-00					
6	*Resistor (R3) 1.5K 1/4W 5%	13-00391-00					
7	*Resistor (R4) 3.3K 1/4W 5%	13-00439-00					
8	*Resistor (R5) Potentiometer 500 Ohms 3/4W 10%	13-09143-06					
9	*Resistor (R6, R7) 3.16K 1/8W 1%	13-03045-00					
10	*Resistor (R8) 6.8K 1/2W 5%	13-00461-00					
11	*Resistor (R9) 1.21K 1/8W 1%	13-02871-00					
12	*Resistor (R10) 5.76K 1/8W 1%	13-02859-00					
13	*Resistor (R11) 681 Ohms 1/8W 1%	13-02872-00					
14	*Resistor (R12) 10K 1/2W 5%	13-00478-00					
15	*Resistor (R13) 6.81K 1/8W 1%	13-04870-00					
16	*Resistor (R14, R33) 2.2K 1/4W 5%	13-00417-00					
17	*Resistor (R15) 1K 1/4W 5%	13-00365-00					
18	*Resistor (R16, R18, R19) 1K 1/8W 1%	13-03114-00					
19	*Resistor (R17, R61) 10K 1/4W 5%	13-00479-00					
20	*Transistor (Q1) 2N5294	15-10377-00					
21	*Screw, Phl Pan Hd No. 4-40 x .25	90-08301-01					
22	*Nut, Keps No. 4-40	90-06557-00					
23	*Transistor (Q2-Q5) DEC6531	15-09338-00					
24	*Transistor (Q8) DEC6534B	15-03409-01					
25	*IC (VR1) DEC723	19-09981-00					
26	*Capacitor (C2) 1.0 MFD 35 Vdc 10%	10-01776-00					
27	*Resistor (R59, R60) 470 Ohm 1/4W 5%	13-00316-00					
28	*Resistor (R62) 220 Ohm 1/4W 5%	13-00271-00					

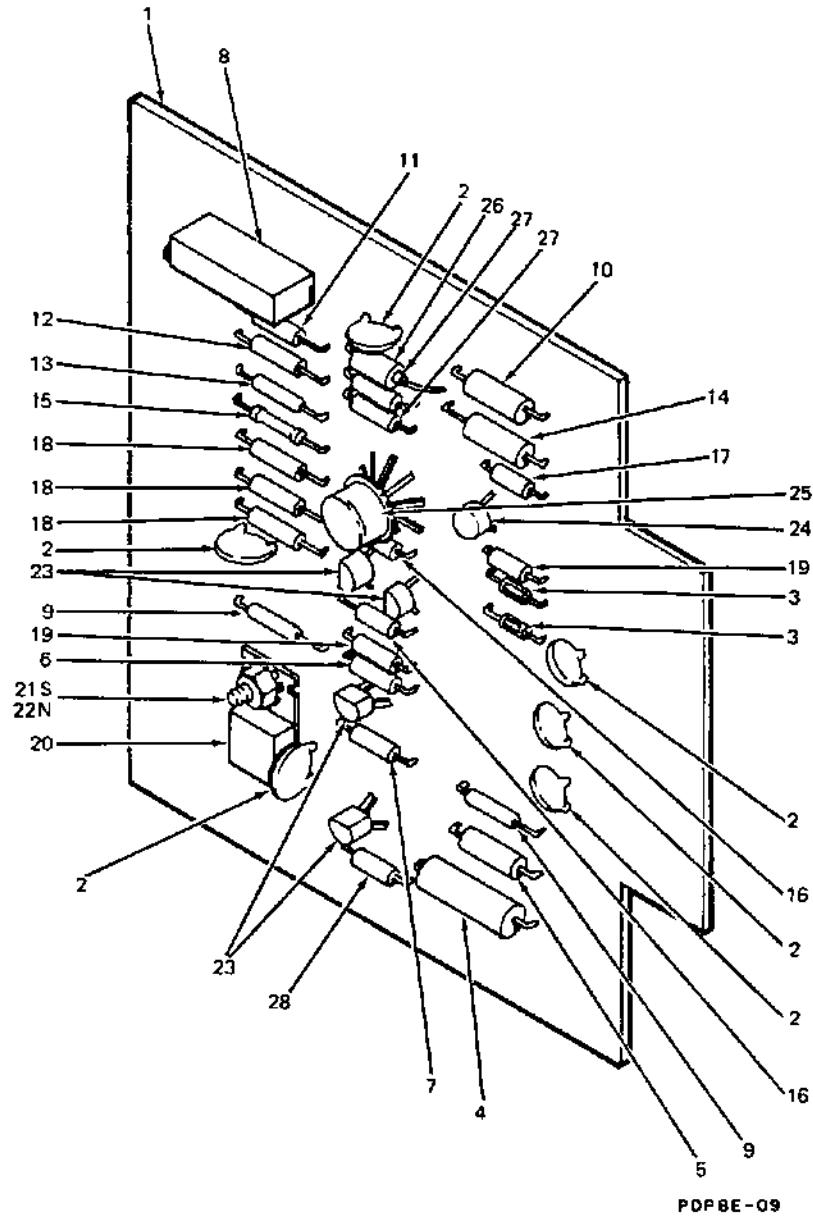

ETCH REV E

Figure 5C. A-1 Control Board Assembly (Etch Rev E)

FIG & ITEM NO.	DESCRIPTION	DEC PART NO.	ECO CUT-IN 54-09264 00005	USED ON CODE	VENDOR		REF FIG NO.
					CODE	PART NO.	
5C-	A1-CONTROL BOARD ASSEMBLY (ETCH REV. E)	54-09264-00					4
1	*Board, Etched Circuit (Etch Rev E)	50-09263-00					
2	*Capacitor (C1, C3, C17-C20) .01 MFD 100V 20% Disc	10-01610-00					
3	*Diode (CR1, CR2) D664	11-00114-00					
4	*Resistor (R1) 3.6K 1W 5%	13-10174-00					
5	*Resistor (R2) 1.3K 1/2W 5%	13-10175-00					
6	*Resistor (R3) 1.5K 1/4W 5%	13-00391-00					
7	*Resistor (R4) 3.3K 1/4W 5%	13-00439-00					
8	*Resistor (R5) Potentiometer 500 Ohms 3/4W 10%	13-09143-06					
9	*Resistor (R6, R7) 3.16K 1/8W 1%	13-03045-00					
10	*Resistor (R8) 6.8K 1/2W 5%	13-00461-00					
11	*Resistor (R9) 1.21K 1/8W 1%	13-02871-00					
12	*Resistor (R10) 5.76K 1/8W 1%	13-02859-00					
13	*Resistor (R11) 68 Ω Ohms 1/8W 1%	13-02872-00					
14	*Resistor (R12) 10K 1/2W 5%	13-00478-00					
15	*Resistor (R13) 6.81K 1/8W 1%	13-04870-00					
16	*Resistor (R14, R33) 2.2K 1/4W 5%	13-00417-00					
17	*Resistor (R15) 2K 1/4W 5%	13-02388-00					
18	*Resistor (R16, R18, R19) 1K 1/8W 1%	13-03114-00					
19	*Resistor (R17, R61) 10K 1/4W 5%	13-00479-00					
20	*Transistor (Q1) 2N5294	15-10377-00					
21	*Screw, Phi Pan Hd No. 4-40 x .25	90-08301-01					
22	*Nut, Keps No. 4-40	90-06557-00					
23	*Transistor (Q2-Q5) DEC6531	15-09338-00					
24	*Transistor (Q8) DEC6534B	15-03409-01					
25	*IC (VR1) DEC723	19-09981-00					
26	*Capacitor (C2) 1.0 MFD 35 Vdc 10%	10-00479-00					
27	*Resistor (R59, R60) 470 Ohm 1/4W 5%	13-00316-00					
28	*Resistor (R62) 220 Ohm 1/4W 5%	13-00271-00					

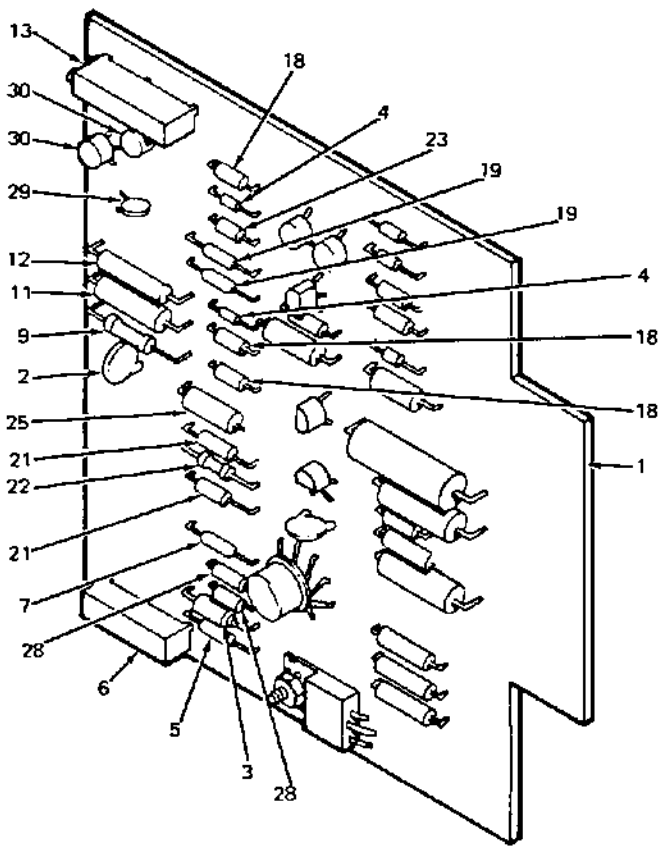
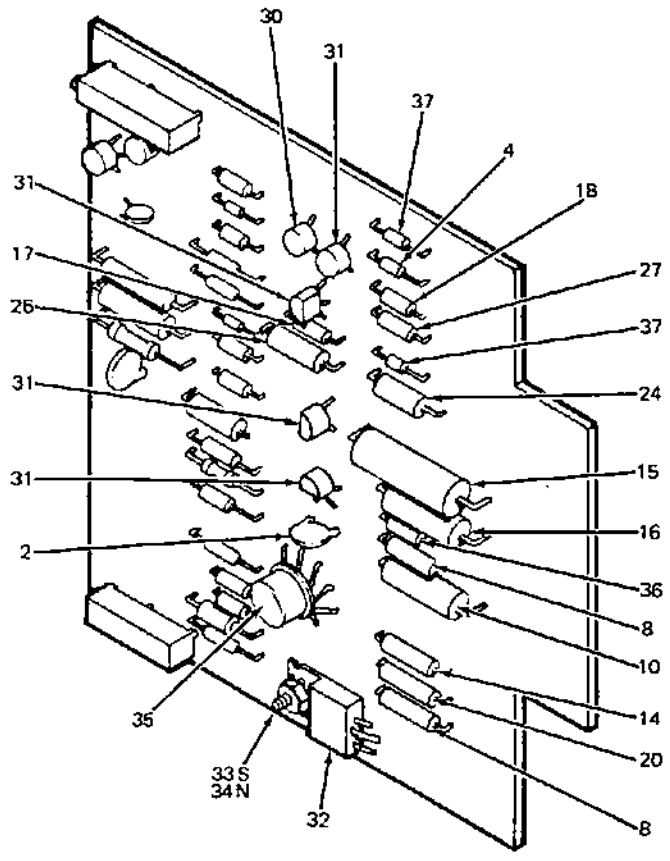

ETCH REV C

PDPBE-10

Figure 6. A-2 Control Board Assembly (Etch Rev C)

FIG & ITEM NO.	DESCRIPTION	DEC PART NO.	ECO CUT-IN 54-09262 00000	USED ON CODE	VENDOR		REF FIG NO.
					CODE	PART NO.	
6-	A2-CONTROL BOARD ASSEMBLY (ETCH REV. C)	54-09262-00					4
1	* Board, Etched Circuit (Etch Rev C)	50-09261-00					
2	* Capacitor (C10, C11) .01 MFD 100V 20%	10-01610-00					
3	* Capacitor (C12) 1.0 MFD 35V 10%	10-01776-00					
4	* Diode (CR3-CR5) IN914 or equiv. (D664)	11-00114-00					
5	* Resistor (R20) 1.21K Ohm 1/8W 1% MF	13-02871-00					
6	* Resistor (R21) Potentiometer, 3/4W 10% 76 PR	13-09143-06					
7	* Resistor (R22) 7.5K Ohm 1/8 W 1% MF	13-05322-00					
8	* Resistor (R23, R24) 1K Ohm 1/2 W 5%	13-00364-00					
9	* Resistor (R25) 221 Ohm 1/4W 1% MF	13-02222-00					
10	* Resistor (R26) 30 Ohm 1W 10%	13-02782-00					
11	* Resistor (R27) 422 Ohm 1/2W 1% MF	13-00313-00					
12	* Resistor (R28) 681 Ohm 1/2W 1% MF	13-02922-00					
13	* Resistor (R29) Potentiometer, 2K Ohm 3/4W 10% 76 PR	13-09143-08					
14	* Resistor (R30) 200 Ohm 1/2W 5%	13-02381-00					
15	* Resistor (R31) 82 Ohm 2W 10%	13-01654-00					
16	* Resistor (R32) 51 Ohm 1W 5%	13-10173-00					
17	* Resistor (R34) 3.3K Ohm 1/4W 5%	13-00439-00					
18	* Resistor (R36, R51-R53) 1K Ohm 1/4W 5%	13-00365-00					
19	* Resistor (R37, R42) 1K Ohm 1/8W 1% MF	13-03114-00					
20	* Resistor (R38) 2K Ohm 1/2W 5%	13-02387-00					
21	* Resistor (R39, R40) 3.16K Ohm 1/8W 1% MF	13-03045-00					
22	* Resistor (R41) 21.5K Ohm 1/8W 1% MF	13-03155-00					
23	* Resistor (R43) 10K Ohm 1/4W 5%	13-00479-00					
24	* Resistor (R44) 510 Ohm 1/2W 5%	13-02321-00					
25	* Resistor (R45) 1.5K Ohm 1/2W 5%	13-00394-00					
26	* Resistor (R50) 3.3K Ohm 1/2W 5%	13-00440-00					
27	* Resistor (R55) 2.2K Ohm 1/4W 5%	13-00417-00					
28	* Resistor (R57, R58) 470 Ohm 1/4W 5%	13-00316-00					
29	* Thermistor (RT1) 1000 ± 10%	13-10170-00					
30	* Transistor (Q6, Q7, Q13, Q14) MPS 6531	15-09338-00					
31	* Transistor (Q9, Q12, Q15) DEC6634-B	15-03409-01					
32	* Transistor (Q10) DEC44C3	15-10171-00					
33	* Screw, Phi Pan Hd No. 4-40 x .25	90-08301-01					
34	* Nut, Kap No. 4-40	90-06557-00					
35	* I.C. (VR6) DEC723	19-09981-00					
36	* Diode (VR7) IN749A Zener	11-09977-00					
37	* Diode (VR8, VR9) IN752A Zener	11-02808-00					

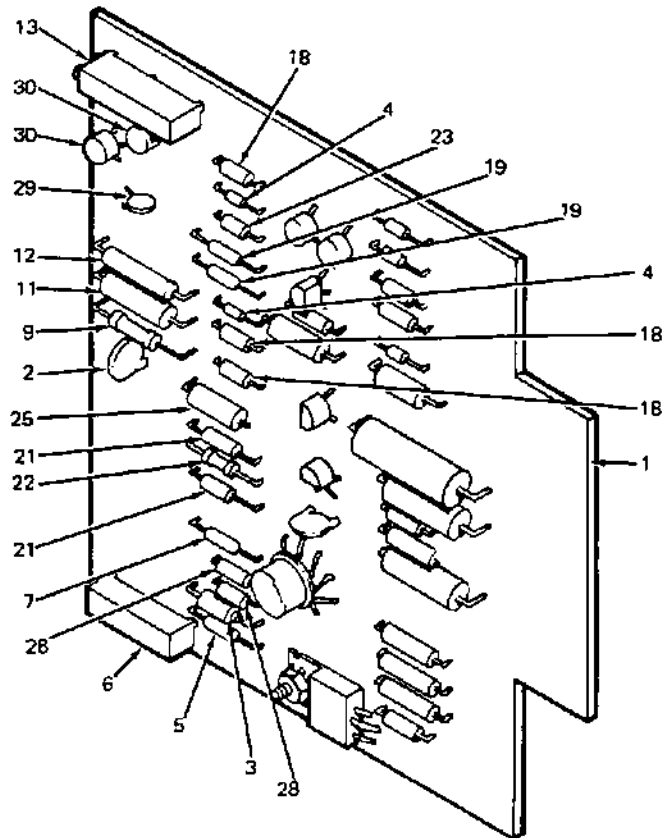
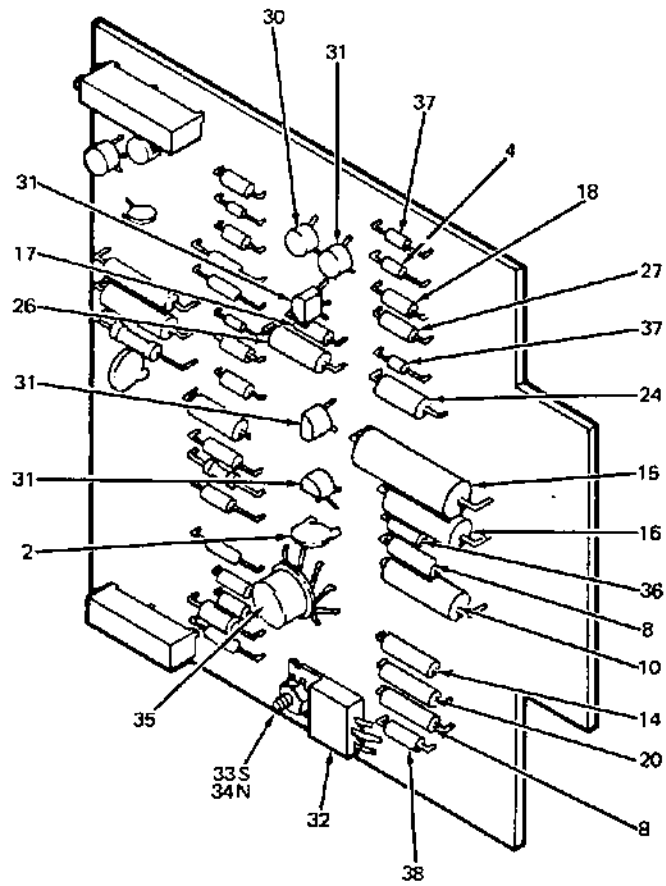

ETCH REV D

PDP8E-11

Figure 6A. A-2 Control Board Assembly (Etch Rev D)

FIG & ITEM NO.	DESCRIPTION	DEC PART NO.	ECO CUT-IN 54-09262 00003	USED ON CODE	VENDOR		REF FIG NO.
					CODE	PART NO.	
6A-	A2-CONTROL BOARD ASSEMBLY (ETCH REV. D)	54-09262-00					4
1	*Board, Etched Circuit (Etch Rev D)	50-09261-00					
2	*Capacitor (C10, C11) .01 MFD 100V 20%	10-01610-00					
3	*Capacitor (C12) 1.0 MFD 35V 10%	10-01776-00					
4	*Diode (CR3-CR5) IN914 or equiv. (D664)	11-00114-00					
5	*Resistor (R20) 1.21K Ohm 1/8W 1% MF	13-02871-00					
6	*Resistor (R21) Potentiometer, 3/4W 10% 76 PR	13-09143-06					
7	*Resistor (R22) 7.5K Ohm 1/8 W 1% MF	13-06322-00					
8	*Resistor (R23, R24) 1K Ohm 1/2 W 5%	13-00364-00					
9	*Resistor (R25) 221 Ohm 1/4W 1% MF	13-02222-00					
10	*Resistor (R26) 30 Ohm 1W 10%	13-02782-00					
11	*Resistor (R27) 422 Ohm 1/2W 1% MF	13-00313-00					
12	*Resistor (R28) 681 Ohm 1/2W 1% MF	13-02922-00					
13	*Resistor (R29) Potentiometer, 2K Ohm 3/4W 10% 76 PR	13-09143-08					
14	*Resistor (R30) 200 Ohm 1/2W 5%	13-02381-00					
15	*Resistor (R31) 82 Ohm 2W 10%	13-01554-00					
16	*Resistor (R32) 51 Ohm 1W 5%	13-10173-00					
17	*Resistor (R34) 3.3K Ohm 1/4W 5%	13-00439-00					
18	*Resistor (R36, R51-R53) 1K Ohm 1/4W 5%	13-00365-00					
19	*Resistor (R37, R42) 1K Ohm 1/8W 1% MF	13-03114-00					
20	*Resistor (R38) 2K Ohm 1/2W 5%	13-02387-00					
21	*Resistor (R39, R40) 3.16K Ohm 1/8W 1% MF	13-03045-00					
22	*Resistor (R41) 21.5K Ohm 1/8W 1% MF	13-03155-00					
23	*Resistor (R43) 10K Ohm 1/4W 5%	13-00479-00					
24	*Resistor (R44) 510 Ohm 1/2W 5%	13-02321-00					
25	*Resistor (R45) 1.5K Ohm 1/2W 5%	13-00394-00					
26	*Resistor (R50) 3.3K Ohm 1/2W 5%	13-00440-00					
27	*Resistor (R55) 2.2K Ohm 1/4W 5%	13-00417-00					
28	*Resistor (R57, R58) 470 Ohm 1/4W 5%	13-00316-00					
29	*Thermistor (RT1) 1000 ± 10%	13-10170-00					
30	*Transistor (Q6, Q7, Q13, Q14) MPS 6531	15-09338-00					
31	*Transistor (Q9, Q12, Q15) DEC6534-B	15-03409-01					
32	*Transistor (Q10) 2N5294	15-10377-00					
33	*Screw, Phi Pan Hd No. 4-40 x .25	90-08301-01					
34	*Nut, Kep No. 4-40	90-06557-00					
35	*I.C. (VR5) DEC723	19-09981-00					
36	*Diode (VR7) IN749A Zener	11-09977-00					
37	*Diode (VR8, VR9) IN752A Zener	11-02808-00					
38	*Resistor (R56) 220 Ohm 1/4W 5%	13-00271-00					

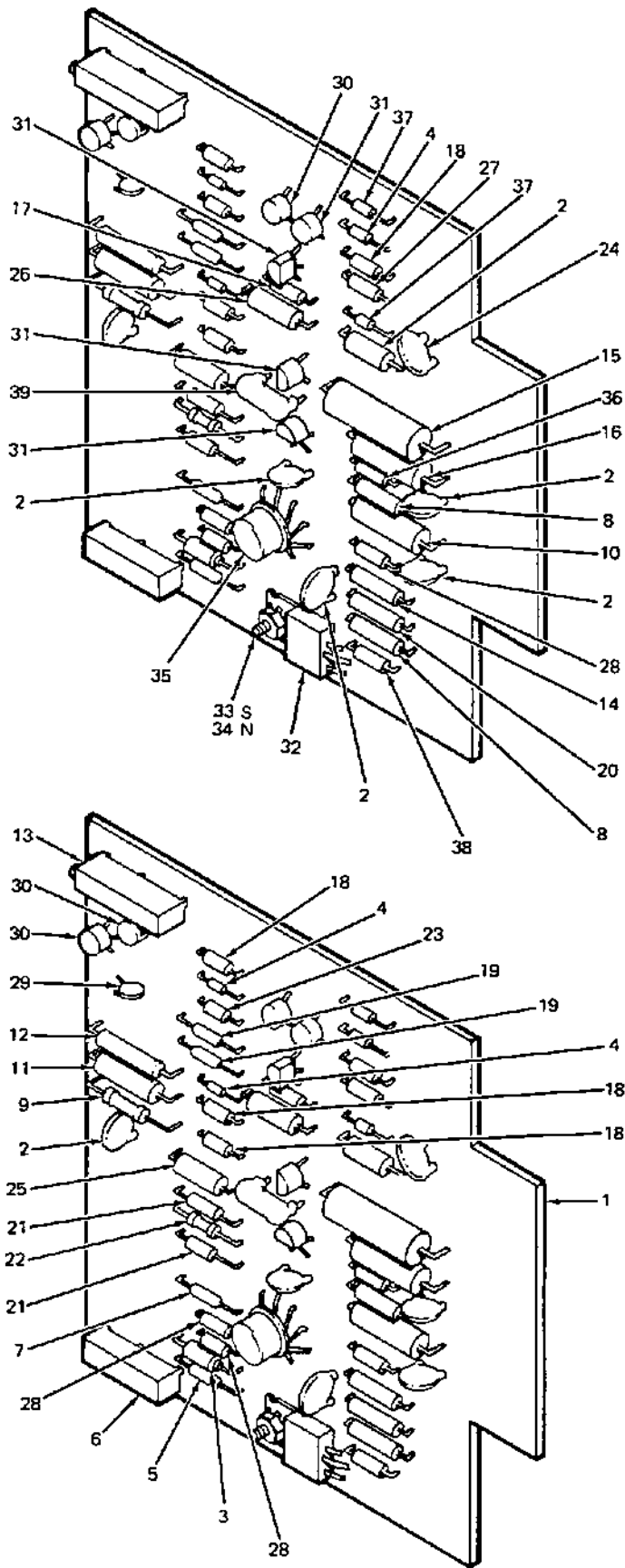

ETCH REV E

PDP8E-12

Figure 68. A-2 Control Board Assembly (Etch Rev E)

FIG & ITEM NO.	DESCRIPTION	DEC PART NO.	ECO CUT-IN 54-09262 00005	USED ON CODE	VENDOR		REF FIG NO.
					CODE	PART NO.	
68-	A2-CONTROL BOARD ASSEMBLY (ETCH REV. E)	54-09262-00					4
1	*Board, Etched Circuit (Etch Rev E)	50-09261-00					
2	*Capacitor (C10, C11, C13-C15) .01 MFD 100V 20%	10-01610-00					
3	*Capacitor (C12) 1.0 MFD 35V 10%	10-01776-00					
4	*Diode (CR3-CR5) IN914 or equiv. (D664)	11-00114-00					
5	*Resistor (R20) 1.21K Ohm 1/8W 1% MF	13-02871-00					
6	*Resistor (R21) Potentiometer, 3/4W 10% 76 PR	13-09143-06					
7	*Resistor (R22) 7.6K Ohm 1/8 W 1% MF	13-05322-00					
8	*Resistor (R23, R24) 1K Ohm 1/2 W 5%	13-00364-00					
9	*Resistor (R25) 221 Ohm 1/4W 1% MF	13-02222-00					
10	*Resistor (R26) 30 Ohm 1W 10%	13-02782-00					
11	*Resistor (R27) 422 Ohm 1/2W 1% MF	13-00313-00					
12	*Resistor (R28) 681 Ohm 1/2W 1% MF	13-02922-00					
13	*Resistor (R29) Potentiometer, 2K Ohm 3/4W 10% 76 PR	13-09143-08					
14	*Resistor (R30) 200 Ohm 1/2W 5%	13-02381-00					
15	*Resistor (R31) 82 Ohm 2W 10%	13-01654-00					
16	*Resistor (R32) 51 Ohm 1W 5%	13-10173-00					
17	*Resistor (R34) 3.3K Ohm 1/4W 5%	13-00439-00					
18	*Resistor (R36, R51-R53) 1K Ohm 1/4W 5%	13-00365-00					
19	*Resistor (R37, R42) 1K Ohm 1/8W 1% MF	13-03114-00					
20	*Resistor (R38) 2K Ohm 1/2W 5%	13-02387-00					
21	*Resistor (R39, R40) 3.16K Ohm 1/8W 1% MF	13-03045-00					
22	*Resistor (R41) 21.5K Ohm 1/8W 1% MF	13-03155-00					
23	*Resistor (R43) 10K Ohm 1/4W 5%	13-00479-00					
24	*Resistor (R44) 510 Ohm 1/2W 5%	13-02321-00					
25	*Resistor (R45) 1.5K Ohm 1/2W 5%	13-00394-00					
26	*Resistor (R50) 3.3K Ohm 1/2W 5%	13-00440-00					
27	*Resistor (R55) 2.2K Ohm 1/4W 5%	13-00417-00					
28	*Resistor (R57-R59) 470 Ohm 1/4W 5%	13-00316-00					
29	*Thermistor (RT1) 1000 ± 10%	13-10170-00					
30	*Transistor (Q6, Q7, Q13, Q14) MPS 6631	15-09338-00					
31	*Transistor (Q9, Q12, Q15) DEC6534-B	15-03409-01					
32	*Transistor (Q10) DEC44C3	15-10171-00					
33	*Screw, Phi Pan Hd No. 4-40 x .25	90-08301-01					
34	*Nut, Kep No. 4-40	90-06557-00					
35	*I.C. (VR6) DEC723	19-09981-00					
36	*Diode (VR7) IN749A Zener	11-09977-00					
37	*Diode (VR8, VR9) IN752A Zener	11-02808-00					
38	*Resistor (R56) 220 Ohm 1/4W 5%	13-00271-00					
39	*Capacitor (C21) 330 PF 100V 5%	10-00023-00					

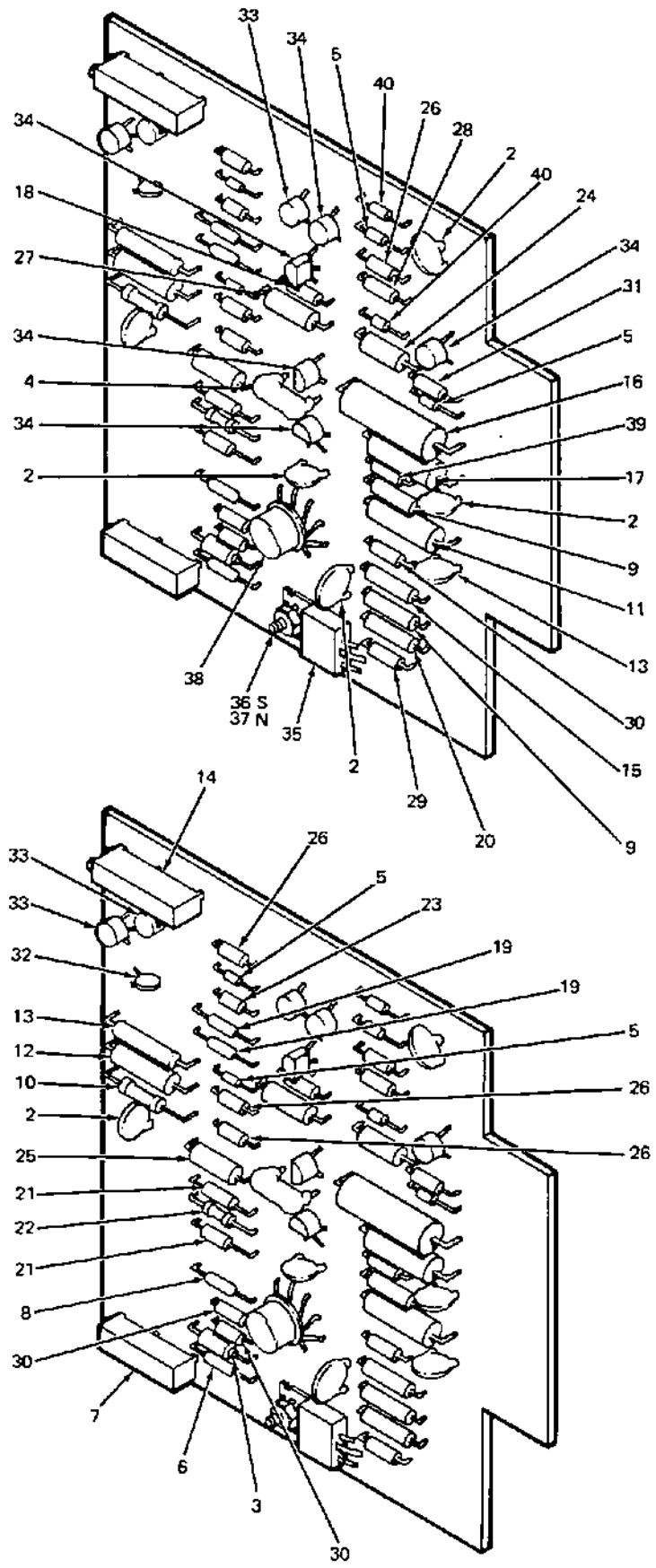

ETCH REV F

PDP8E-13

Figure 6C. A-2 Control Board Assembly (Etch Rev F)

FIG & ITEM NO.	DESCRIPTION	DEC PART NO.	ECO CUT-IN 54-09262 00006	USED ON CODE	VENDOR		REF FIG NO.
					CODE	PART NO.	
6C-	A2-CONTROL BOARD ASSEMBLY (ETCH REV F)	54-09262-00					4
1	*Board, Etched Circuit (Etch Rev F)	50-09261-00					
2	*Capacitor (C10, C11, C13-C16) .01 MFD 100V 20%	10-01610-00					
3	*Capacitor (C12) 1.0 MFD 35V 10%	10-01776-00					
4	*Capacitor (C21) 330 PF 100V 5%	10-00023-00					
5	*Diode (CR3-CR6) IN914 or equivalent (D664) (See Note 1.)	11-00114-00					
6	*Resistor (R20) 1.21K Ohm 1/8W 1% MF (del)	13-02871-00					
	*Resistor (R20) 825 Ohm 1/8W 1% MF (added)	13-05143-00	00009				
7	*Resistor (R21) Potentiometer 500 Ohm 3/4W 10% 76 PR (deleted)	13-09143-06					
	*Resistor (R21) Potentiometer 1K Ohm 3/4W 10% 76 PR (added)	13-09143-07	00009				
8	*Resistor (R22) 7.5K Ohm 1/8W 1% MF	13-05322-00					
9	*Resistor (R23, R24) 1K Ohm 1/2W 5%	13-00364-00					
10	*Resistor (R25) 221 Ohm 1/4W 1% MF	13-02222-00					
11	*Resistor (R26) 30 Ohm 1W 5%	13-02782-00					
12	*Resistor (R27) 422 Ohm 1/2W 1% MF	13-00313-00					
13	*Resistor (R28) 681 Ohm 1/2W 1% MF	13-02922-00					
14	*Resistor (R29) Potentiometer 2K Ohm 3/4W 10% 76 PR	13-09143-08					
15	*Resistor (R30) 200 Ohm 1/2W 5%	13-02381-00					
16	*Resistor (R31) 82 Ohm 2W 10%	13-01654-00					
17	*Resistor (R32) 51 Ohm 1W 5% (deleted) (See Note 2.)	13-10173-00					
	*Resistor (R32) 100 Ohm 1W 5% (added)	13-00232-00	00007				
18	*Resistor (R34) 3.3K Ohm 1/4W 5%	13-00439-00					
19	*Resistor (R37, R42) 1K Ohm 1/8W 1% MF	13-03114-00					
20	*Resistor (R38) 2K Ohm 1/2W 5%	13-02387-00					
21	*Resistor (R39-R40) 3.16K Ohm 1/8W 1% MF	13-03045-00					
22	*Resistor (R41) 21.5K Ohm 1/8W 1% MF	13-03155-00					
23	*Resistor (R43) 10K Ohm 1/4W 5%	13-00479-00					
24	*Resistor (R44) 510 Ohm 1/2W 5%	13-02321-00					
25	*Resistor (R45) 1.5K Ohm 1/2W 5%	13-00394-00					
26	*Resistor (R36, R51-R53) 1K Ohm 1/4W 5%	13-00365-00					
27	*Resistor (R50) 3.3K Ohm 1/2W 5%	13-00440-00					
28	*Resistor (R55) 2.2K Ohm 1/4W 5%	13-00417-00					
29	*Resistor (R56) 220 Ohm 1/4W 5%	13-00271-00					
30	*Resistor (R57-R59) 470 Ohm 1/4W 5%	13-00316-00					
31	*Resistor (R63) 10 Ohm 1/4W 5% (See Note 1.)	13-01317-00					
32	*Thermistor (RT1) 1K Ohm \pm 10%	13-10170-00					
33	*Transistor (Q6, Q7, Q13, Q14) MPS 6531	15-09338-00					
34	*Transistor (Q9, Q12, Q15, Q16) DEC6534-B (See Note 1.)	15-03409-01					
35	*Transistor (Q10) 2N5294	15-10377-00					
36	*Screw, Phi Pan Hd No. 4-40 x .25	90-08301-01					
37	*Nut, Kap No. 4-40	90-06567-00					
38	*I.C. (VR5) DEC723	19-09981-00					
39	*Diode (VR7) IN751A (del) (See Note 2.)	11-09977-00					
	*Diode (VR7) IN749A (added)	11-05873-00	00007				
40	*Diode (VR8, VR9) IN752A Zener	11-02808-00					
	<p>Note 1: CR6, R63 and Q16 (ECO-00006) must be installed in both the PDP8E and BA Power Supplies when BAB-BA Expander Box is used.</p> <p>Note 2: R32 and VR7 changed only on those boards with ECO-00006 installed as of 2-7-72.</p>						

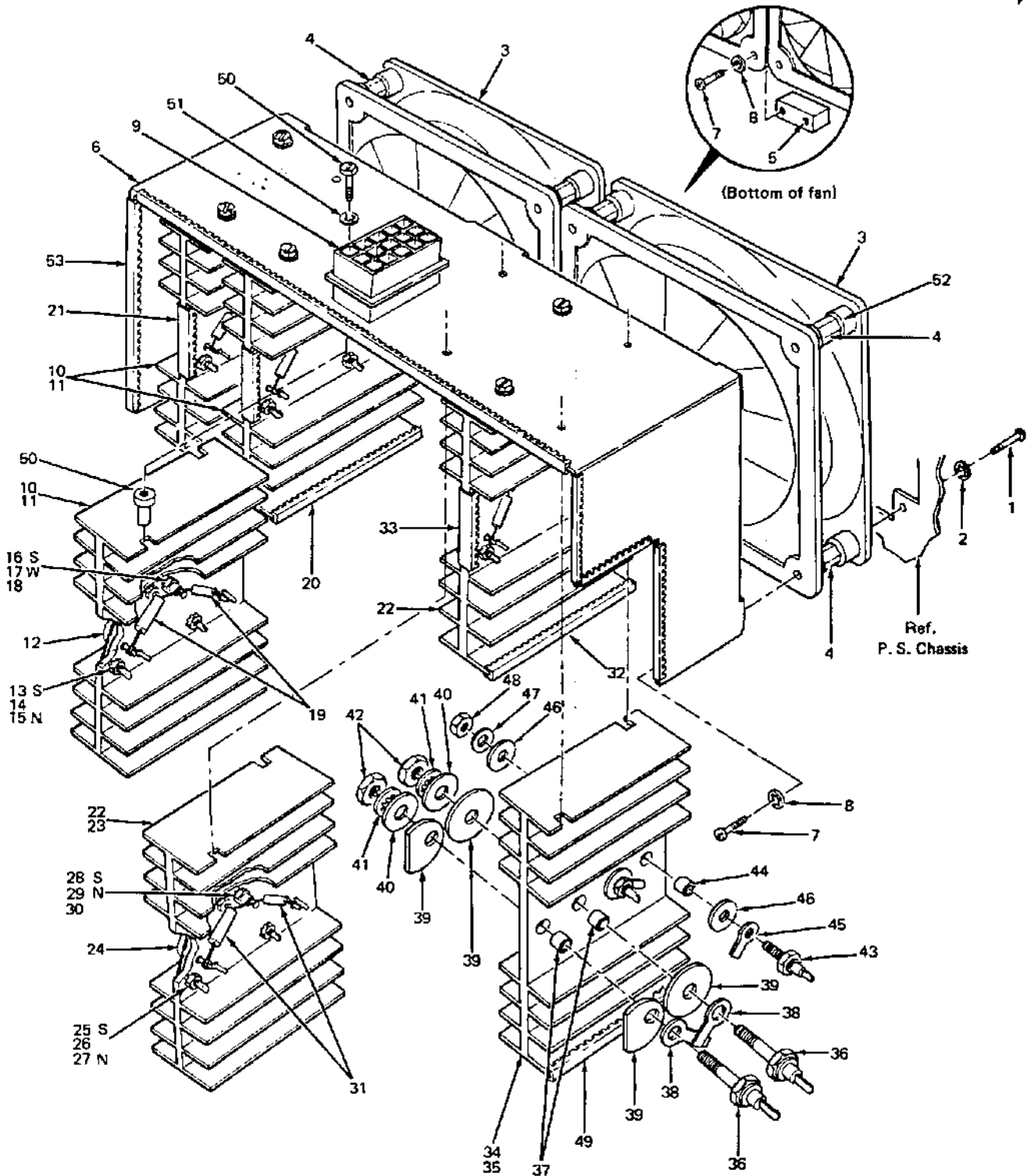

PDP8E-14

Figure 7. Heat Sink Housing Assembly

FIG & ITEM NO.	DESCRIPTION	DEC PART NO.	ECO CUT-IN H724 00000	USED ON CODE	VENDOR		REF FIG NO.
					CODE	PART NO.	
7-	HEAT SINK HOUSING ASSY	70-07197-00					4
1	*Screw, Phi Pan Hd No. 6-32 x 3/4	90-06026-01					
2	*Washer, Lock Int Tooth No. 6	90-06633-00					
3	*Fan, Super Boxer 50/60 Hz	12-09403-00					
4	*Spacer, 1/4 AF x 11/16 No. 6-32	90-06858-00					
5	*Standoff, Fan Support	53-09265-00					
6	*Housing, Heat Sink	53-09266-00					
7	*Screw, Phi Pan Hd No. 6-32 x 3/4	90-06026-01					
8	*Washer, Lock Int Tooth No. 6 (added)	90-06633-00	H724 00011				
9	*Housing, Cable	70-09286-00					
10	*TRANSISTOR HEAT SINK ASSY	70-07195-01					
11	**Heat Sink, Transistor	12-10211-01					
12	**Transistor (Q201, Q206) 2N3055	15-10008-00					
13	**Screw, Phi Pan Hd No. 6-32 x 7/16	90-06023-01					
14	**Lug, Ground Shakeproof No. 2104 No. 6	90-06761-00					
15	**Nut, Kep No. 6-32	90-06560-00					
16	**Screw, Phi Pan Hd No. 6-32 x 5/16	90-06021-01					
17	**Washer, Lock Int Tooth No. 6	90-06633-00					
18	**Lug, Turret No. 6-32	90-06966-00					
19	**Resistor, .14 Ohm 5W 1%	13-10189-00					
20	**Grommet, Caterpillar 1/16 thk	90-07035-00					
21	**Grommet, Caterpillar 1/8 thk (added)	90-07622-00	H724 00011				
22	*TRANSISTOR HEAT SINK ASSY	70-07195-02					
23	**Heat Sink, Transistor	12-10211-01					
24	**Transistor (Q301-Q304) 2N3055	15-10008-00					
25	**Screw, Phi Pan Hd No. 6-32 x 7/16	90-06023-01					
26	**Lug, Ground Shakeproof No. 2104 No. 6	90-06761-00					
27	**Nut, Kep No. 6-32	90-06560-00					
28	**Screw, Phi Pan Hd No. 6-32 x 5/16	90-06021-01					
29	**Washer, Lock Int Tooth No. 6	90-06633-00					
30	**Lug, Turret No. 6-32	90-06966-00					
31	**Resistor, .25 Ohm 3W 1%	13-10219-00					
32	**Grommet, Caterpillar 1/16 thk	90-07035-00					
33	**Grommet, Caterpillar 1/8 thk	90-07622-00					
34	*DIODE HEAT SINK ASSY	70-07196-00					
35	*Heat Sink, Diode	12-10212-01					
36	**Diode, 1N1185A	11-09979-00					
37	**Bushing, Insulated	90-08441-00					
38	**Lug, Solder Shakeproof	90-08506-00					
39	**Washer, Thermo Film .3021D x .8800D	90-08425-00					
40	**Washer, Flat No. 1/4 (added)	90-07792-00					
41	**Washer, Lock Int Tooth No. 1/4 (added)	90-06637-00					
42	**Nut, No. 1/4-28 (added)	90-08063-00	H724 00011				
43	**Diode 1N1201A	11-10006-00					
44	**Bushing, Insulated	90-08440-00					
45	**Lug, Solder Shakeproof	90-07815-00					
46	**Washer, Thermo Film .2031D x .5620D	90-08424-00					
47	**Washer, Flat No. 10 (added)	90-06562-00					
48	**Nut, Kep No. 10-32 (added)	90-06565-00					
49	**Grommet, Caterpillar 1/16 thk (added)	90-07035-00	H724 00011				
50	*Nut, Push Nylon	90-08396-00					
51	*Washer, Lock Int Tooth No. 6 (Replaces washer supplied with item No. 50)	90-06634-00					
52	*Washer, Flat No. 6 (added)	90-06656-00	H724 00011				
53	*Grommet, Caterpillar 1/16 thk (deleted)	90-07622-00					
	*Grommet, Caterpillar 1/16 thk (added)	90-07035-00	H724 00011				

FIG & ITEM NO.	DESCRIPTION	DEC PART NO.	ECO CUT-IN 64-09248 00000	USED ON		VENDOR PART NO.	REF FIG NO.
				CODE	CODE		
8-	TURRET BOARD ASSEMBLY	64-09248-00					4
1	*Board, Turret	53-09201-00					
2	*Capacitor, 250 MFD 50 Vdc	10-10192-00					
3	*Clamp, Nylon Holub (deleted)	90-07088-00					
	*Clamp, Nylon Holub (added)	90-07087-00	H724 00011				
4	*Screw, Phi Pan Hd No. 8-32 x 7/16	90-06038-01					
5	*Washer, Flat No. 8	90-06660-00					
6	*Nut, Kap No. 8-32	90-06563-00					
7	*Post, Terminal	90-08427-00					
8	*Capacitor, .01 MFD 100V Disc	10-01610-00					
9	*Resistor, 3.9K Ohm 1/2W 5%	13-00443-00					
10	*Diode, 1N4002	11-04861-00					

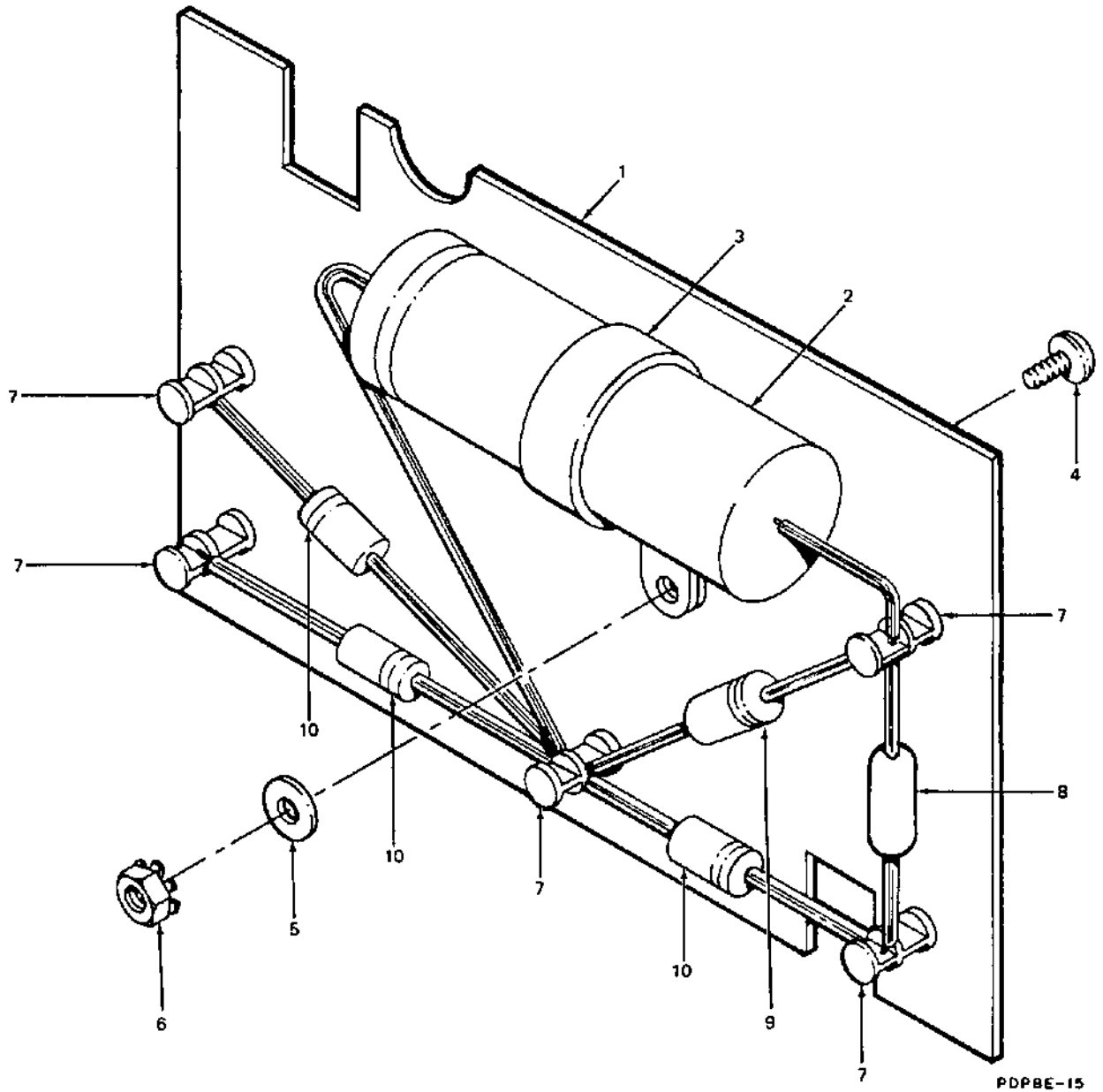

Figure 8. Turret Board Assembly

**ILLUSTRATED PARTS BREAKDOWN
COMMENT SHEET**

Any and all comments and suggestions for correcting errors and/or additional information to improve this manual will be reviewed and researched for possible use when this manual is revised and/or reprinted. Enter your comments and suggestions in the form provided below and return to Technical Documentation.

MODEL _____

PUBLICATION NO. _____

FIGURE NO. _____ ITEM NO. _____
CHANGE FROM _____
CHANGE TO _____

FIGURE NO. _____ ITEM NO. _____
CHANGE FROM _____
CHANGE TO _____

FIGURE NO. _____ ITEM NO. _____
CHANGE FROM _____
CHANGE TO _____

FIGURE NO. _____ ITEM NO. _____
CHANGE FROM _____
CHANGE TO _____

FIGURE NO. _____ ITEM NO. _____
CHANGE FROM _____
CHANGE TO _____

FIGURE NO. _____ ITEM NO. _____
CHANGE FROM _____
CHANGE TO _____

ADDITIONAL COMMENT(S)

Name _____

Cost Center _____

date: _____

Fold Here

Do Not Tear - Fold Here and Staple

FIRST CLASS
PERMIT NO. 33
MAYNARD, MASS.

BUSINESS REPLY MAIL
NO POSTAGE STAMP NECESSARY IF MAILED IN THE UNITED STATES

Postage will be paid by:

Digital Equipment Corporation
Technical Documentation Department
Digital Park, PK3-2
Maynard, Massachusetts 01754

