

digital

8A500

Engineering Drawings

Digital Equipment Corporation

The material herein is for information purposes only and is subject to change without notice. Digital Equipment Corporation assumes no responsibility for any errors which may appear herein.

These drawings and specifications herein are the property of Digital Equipment Corporation and shall not be reproduced or copied or used in whole or in part as the basis for the manufacture or sale of items without written permission.

Copyright © 1975, Digital Equipment Corporation

CUSTOMER PRINT SET INDEX

THIS IS PRINT SET

DRAWING DIRECTORY
FIELD INSTALL. & ACCEPT. PROCED.
SHIPPING LIST
SOFTWARE LIST
8A500 PARTS LIST
H9300 CHASSIS ASSEMBLY
MEMORY STACK
8A INTERNAL OPTION # 2
MEMORY EXT. & TIME SHARE CONTROL
8A INTERNAL OPTION # 1
PROGRAMMERS CONSOLE

SEQUENCE B-DD-8A500-0
A-SP-8A400-0-1
A-PL-8A500-0-2
A-PL-8A500-0-3
A-PL-8A500-0-0
B-DD-H9300-0
B-DD-MM8-0
B-DD-KM8-A
A-ML-KM8-E
B-DD-DKC8-A
B-DD-KC8-A

SEQUENCE

UNIT VARIATIONS		PRINT SET	
VAR	TITLE	MP-8A500	
8A500-BM	MM8-AA, KM8-AA, 115V, 60HZ	X	
8A500-BN	MM8-AA, KM8-AA, 230V, 50HZ	X	
8A500-BP	MM8-AB, KM8-AA, 115V, 60HZ	X	
8A500-ER	MM8-AB, KM8-AA, 230V, 50HZ	X	
8A500-CM	MM8-AA, KM8-AA, DKC8-AA, 115V, 60HZ	X	
8A500-CN	MM8-AA, KM8-AA, DKC8-AA, 230V, 50HZ	X	
8A500-CP	MM8-AB, KM8-AA, DKC8-AA, 115V, 60HZ	X	
8A500-CR	MM8-AB, KM8-AA, DKC8-AA, 230V, 50HZ	X	
8A500-EM	MM8-AA, KM8-E, 115V, 60HZ	X	
8A500-EN	MM8-AA, KM8-E, 230V, 50HZ	X	
8A500-EP	MM8-AB, KM8-E, 115V, 60HZ	X	
8A500-ER	MM8-AB, KM8-E, 230V, 50HZ	X	
8A500-HM	MM8-AA, KM8-E, DKC8-AA, KC8-AA, 115V, 60HZ	X	
8A500-HN	MM8-AA, KM8-E, DKC8-AA, KC8-AA, 230V, 50HZ	X	
8A500-HP	MM8-AB, KM8-E, DKC8-AA, KC8-AA, 115V, 60HZ	X	
8A500-HR	MM8-AB, KM8-E, DKC8-AA, KC8-AA, 230V, 50HZ	X	
8A500-LM	MM8-AA, KM8-AB, DKC8-AA, KC8-AA, 115V, 60HZ	X	
8A500-LN	MM8-AA, KM8-AB, DKC8-AA, KC8-AA, 230V, 50HZ	X	
8A500-LP	MM8-AB, KM8-AB, DKC8-AA, KC8-AA, 115V, 60HZ	X	
8A500-LR	MM8-AB, KM8-AB, DKC8-AA, KC8-AA, 230V, 50HZ	X	

DEC 16 1975 1062 1A-R972

REVISIONS	REV		USED ON OPTION/MODEL	DRN.	D. SULLIVAN	DATE	5-8-75	TITLE	8A500			
	CHG. NO.			CHK'D.		DATE	5/9/75					
	DATE			PROJ ENG.		DATE	5/9/75					
				PROD.		DATE	5/9/75					
				FIELD SERV.		DATE	5/9/75					
SHEET 1 OF 3				SIZE	B	CODE	DD	NUMBER	8A500-0		REV	
				DIST								

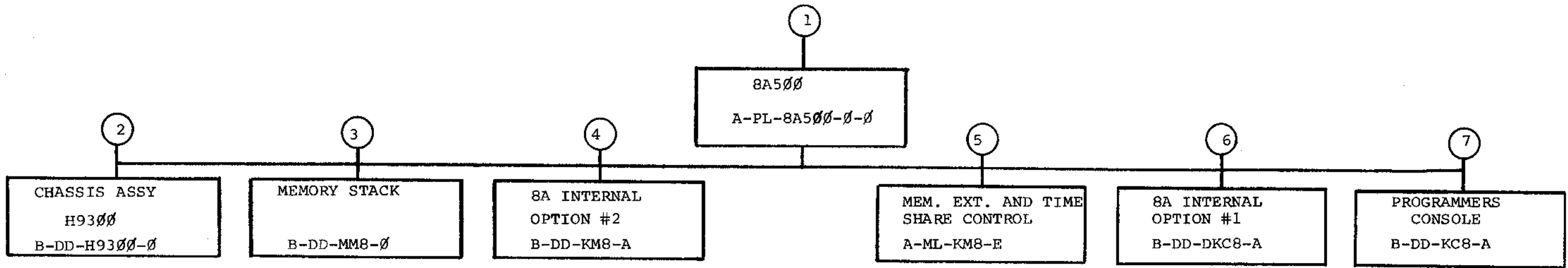

TITLE	SIZE	CODE	NUMBER	REV
8A500	B	DD	8A500-0	

CUSTOMER PRINT SET		ELECTRICAL					CUSTOMER PRINT SET		MECHANICAL						
	MP-8A500	FIND NO.	DRAWING NO.	REV	NO OF SHT	DESCRIPTION	OPTION NO./FILE DATE		MP-8A500	FIND NO.	DRAWING NO.	REV	NO OF SHT	DESCRIPTION	OPTION NO./FILE DATE
	C	3	B-DD-MM8-0	#	2	MEMORY STACK	MM8-A		X	1	A-PL-8A500-0-0	*	2	8A500 PARTS LIST	
									X		A-PL-8A500-0-2	*	1	SHIPPING LIST	
									X		A-PL-8A500-0-3	*	1	SOFTWARE LIST	
	C	4	B-DD-KM8-A	#	2	8A INTERNAL OPTION # 2	KM8-A		X		A-SP-8A400-0-1	#	5	FIELD INSTALL. & ACCEPT. PROCED.	8A400
											A-SP-3700170-0-0			PKG. INSTR. INNER CARTON	
											A-SP-3700172-0-0			PDP8A CUSHIONED CUST. SHIP. PKG.	
	C	5	A-ML-KM8-E	#	2	MEM. EXT. AND TIME SHARE CONTROL	KM8-E				C-PS-3612308-0-0		1	NAMEPLATE, 8A500	
	C	6	B-DD-DKC8-E	#	2	8A INTERNAL OPTION # 1	DKC8-A		X	2	B-DD-H9300-0	#	4	CHASSIS ASSEMBLY H9300	H9300
	C	7	B-DD-KC8-A	#	2	PROGRAMMERS CONSOLE	KC8-A								

CUSTOMER PRINT SET CODES
X = PRINT OF DOCUMENT INCLUDED IN PRINT SET
C = INCLUDES ALL PRINTS INDICATED ON DOCUMENT
S = CONFIDENTIAL AUTHORIZED SIGNATURE REQUIRED

TITLE: 8A500
SHEET 3 OF 3
SIZE CODE: B DD
NUMBER: 8A500-0
REV:

This document contains confidential proprietary information of DEC. This information shall not be disclosed to persons outside the employ of DEC, except by DEC personnel so authorized by DEC, and only for use by such other persons in the design, production or manufacture of products for DEC. Copyright © Digital Equipment Corporation.

DIGITAL EQUIPMENT CORPORATION
MAYNARD, MASSACHUSETTS

ENGINEERING SPECIFICATION

DATE 4/22/75

TITLE 8A400 and 500 FIELD INSTALLATION ACCEPTANCE PROCEDURE

REVISIONS

REV	DESCRIPTION	CHG NO	ORIG	DATE	APPD BY	DATE

ENG	John Kirk	APPD	<i>Bill East</i>	SIZE	CODE	NUMBER	REV
				A	SP	8A400-0-1	

ENGINEERING SPECIFICATION

digital

CONTINUATION SHEET

TITLE 8A400 and 500 FIELD INSTALLATION ACCEPTANCE PROCEDURE

I. General

Installation of the basic 8A400 or 500 computer requires no special tools or equipment. Normal hand tools are all that are required.

II. Unpacking

Unpack and inspect the equipment using the procedure provided in the Operator's Handbook.

III. Inspection

After removing the equipment packing material, inspect the equipment.

1. Inspect the external surface of the chassis for surface, bezel, switch, and light damage.
2. Internally inspect the 8A enclosure and console for damage, loose nuts, bolts, screws, etc.
3. Inventory all hardware against shipping list.
- Inventory all software against software list, if ordered.
5. Inventory all prints against shipping list, if ordered.

IV. Installation Procedure

Install the equipment using the following procedure:

1. Turn off the power switch of the Limited Function Console.

WARNING

DO NOT TOUCH THE COMPUTER AFTER PLUGGING IT
IN UNTIL IT IS CHECKED FOR THE PROPER GROUNDING.

	SIZE	CODE	NUMBER	REV
	A	SP	8A400-0-1	

TITLE 8A400 and 500 FIELD INSTALLATION ACCEPTANCE PROCEDURE

2. Insure that all power is received from the same source.
3. Plug in the power cord.
4. Before touching the computer, check frame to ground to insure that no AC voltage is present.
5. Unplug power cord.
6. Turn on Power ON/OFF switch and set regulator circuit breaker to the "ON" position. (Behind the Limited Function Console.)
7. Repeat Steps 3 and 4.
8. Power should now be applied to the 8A; fans should be running, and the power light on the Limited Function Console should be "ON".

If none of the above occur, remove the Limited Function panel and check the Master/Slave switch located below the ON/OFF switch on the Limited Function Board.

9. The Run light should not be on. If it is, switch Power Off via the ON/OFF switch.

Remove the M8315 CPU module and set switches as indicated below. Then insert CPU in the first slot in the OMNIBUS™ and turn power back on. The Run light should remain off.

Sl-1 thru Sl-6 set to "OFF" position.
Sl-7 and Sl-8 set to "ON" position.

10. Check modules to insure they are located in their proper position in the OMNIBUS™. Refer to the Operator's Handbook.
11. Check the operation of the Programmer's Console.

SIZE A	CODE SP	NUMBER 8A400-0-1	REV
-----------	------------	---------------------	-----

TITLE 8A400 and 500 FIELD INSTALLATION ACCEPTANCE PROCEDURE

12. Manually load, deposit and examine to insure core memory modules are associated with the correct memory fields. If not, turn the unit off and reconfigure the memory modules to the correct fields.

V. Acceptance Procedure

Perform the Acceptance Tests referred to in Table A. If abnormal indications are encountered, refer to the diagnostic listings for error descriptions. Refer to the Operator's Handbook and the diagnostic listings for instructions on loading diagnostics.

Equipment Required

1. 8A400 or 500 with 8-32K of core memory.
2. Programmer's Console (KC8A and DKC8A).
3. Paper tape input device.
4. Diagnostics and listings.

NOTE: If Programmer's Console and paper tape input device are not available as part of the system being installed, they must be provided by the customer in good working order.

TABLE A

Acceptance of 8K or Greater 8A400 or 500

Program Name	MAINDEC #	Accept Time
PDP8A Central Processor Test	08-DJJK8A	20 minutes
2-32K Random Exerciser	08-DJEXB	20 minutes
MM8AA or MM8AB	Refer to Acceptance Procedure for MM8AA and MM8AB.	

SIZE A	CODE SP	NUMBER 8A400-0-1	REV
-----------	------------	---------------------	-----

ENGINEERING SPECIFICATION



CONTINUATION SHEET

TITLE 8A400 and 500 FIELD INSTALLATION ACCEPTANCE PROCEDURE

DKC8A Option One Refer to Acceptance Procedure for DKC8A.

KM8A Option Two Refer to Acceptance Procedure for KM8A.

SIZE	CODE	NUMBER	REV
A	SP	8A400-0-1	

DIGITAL EQUIPMENT CORPORATION MAYNARD, MASSACHUSETTS PARTS LIST				QUANTITY / VARIATION													
MADE BY Paul Gardner		CHECKED <i>[Signature]</i>		SECTION		8A500-BM	8A500-BN	8A500-BP	8A500-BR	8A500-CM	8A500-CN	8A500-CP	8A500-CR	8A500-EM	8A500-EN	8A500-EP	8A500-ER
DATE 5/8/75		DATE 5/9/75		ISSUED SECT.													
ENG <i>[Signature]</i>		PROD <i>[Signature]</i>															
DATE 5/9/75		DATE 5/9/75															
ITEM NO.	DWG NO. / PART NO.	DESCRIPTION															
1	D-UA-H9300-BA-0	CHASSIS ASSY, H9300 (115V, 60 Hz Core)		1	0	1	0	1	0	1	0	1	0	1	0	1	0
2	D-UA-H9300-BB-0	CHASSIS ASSY, H9300 (230V, 50 Hz CORE)		0	1	0	1	0	1	0	1	0	1	0	1	0	1
3	E-UA-MM8-AA-0	MEMORY, 8K CORE		1	1	0	0	1	1	0	0	1	1	0	0		
4	E-UA-MM8-AB-0	MEMORY, 16K CORE		0	0	1	1	0	0	1	1	0	0	1	1		
5	A-PL-KM8-AA-0	8A INTERNAL OPTION #2		1	1	1	1	1	1	1	1	1	0	0	0	0	
6	A-PL-KM8-AB-0	KM8-AA w/o BOOTSTRAP ROMS		0	0	0	0	0	0	0	0	0	0	0	0	0	
7	A-PL-KM8-E-0	MEMORY EXT. & TIME SHARE CONTROL		0	0	0	0	0	0	0	0	1	1	1	1		
8	A-PL-DKC8-AA-0	8A INTERNAL OPTION #1		0	0	0	0	1	1	1	1	1	0	0	0	0	
9	E-UA-KC8-AA-0	PROGRAMMERS' CONSOLE		0	0	0	0	0	0	0	0	0	0	0	0	0	
10	C-PS-3612308-05-0	NAMEPLATE, 8A500		1	1	1	1	1	1	1	1	1	1	1	1	1	
11	A-SP-3700170-0-0	PKG. INST., INNER CARTON		1	1	1	1	1	1	1	1	1	1	1	1	1	
12	A-SP-3700172-0-0	PKG. INST., OUTER CARTON		.05	.05	.05	.05	.05	.05	.05	.05	.05	.05	.05	.05	.05	
13	A-PL-8A500-0-2	SHIPPING LIST, 8A500		1	1	1	1	1	1	1	1	1	1	1	1	1	
TITLE 8A500				ASSY NO. B-DD-8A500-0	SIZE A	CODE PL	NUMBER 8A500-0-0				REV.	ECO NO.					
SHEET 1 OF 2				DIST.													

DIGITAL EQUIPMENT CORPORATION MAYNARD, MASSACHUSETTS PARTS LIST				QUANTITY / VARIATION													
MADE BY Paul Gardner		CHECKED <i>[Signature]</i>		SECTION		8A500-HM	8A500-HN	8A500-HP	8A500-HR	8A500-LM	8A500-LN	8A500-LP	8A500-LR				
DATE 5/8/75		DATE 5/9/75		ISSUED SECT.													
ENG <i>[Signature]</i>		PROD <i>[Signature]</i>															
DATE 5/9/75		DATE 5/9/75															
ITEM NO.	DWG NO. / PART NO.	DESCRIPTION															
1	D-UA-H9300-BA-0	CHASSIS ASSY, H9300 (115V, 60 Hz CORE)		1	0	1	0	1	0	1	0						
2	D-UA-H9300-BB-0	CHASSIS ASSY, H9300 (230V, 50 Hz CORE)		0	1	0	1	0	1	0	1						
3	E-UA-MM8-AA-0	MEMORY, 8K CORE		1	1	0	0	1	1	0	0						
4	E-UA-MM8-AB-0	MEMORY, 16K CORE		0	0	1	1	0	0	1	1						
5	A-PL-KM8-AA-0	8A INTERNAL OPTION #2		0	0	0	0	0	0	0	0						
6	A-PL-KM8-AB-0	KM8-AA w/o BOOTSTRAP ROMS		0	0	0	0	1	1	1	1						
7	A-PL-KM8-E-0	MEMORY EXT. & TIME SHARE CONTROL		1	1	1	1	0	0	0	0						
8	A-PL-DKC8-AA-0	8A INTERNAL OPTION #1		1	1	1	1	1	1	1	1						
9	E-UA-KC8-AA-0	PROGRAMMER'S CONSOLE		0	0	0	0	1	1	1	1						
10	C-PS-3612308-05-0	NAMEPLATE, 8A500		1	1	1	1	1	1	1	1						
11	A-SP-3700170-0-0	PKG. INST., INNER CARTON		1	1	1	1	1	1	1	1						
12	A-SP-3700172-0-0	PKG. INST., OUTER CARTON		.05	.05	.05	.05	.05	.05	.05	.05						
13	A-PL-8A500-0-2	SHIPPING LIST, 8A500		1	1	1	1	1	1	1	1						
TITLE 8A500				ASSY NO. B-DD-8A500-0	SIZE A	CODE PL	NUMBER 8A500-0-0				REV.	ECO NO.					
SHEET 2 OF 2				DIST.													

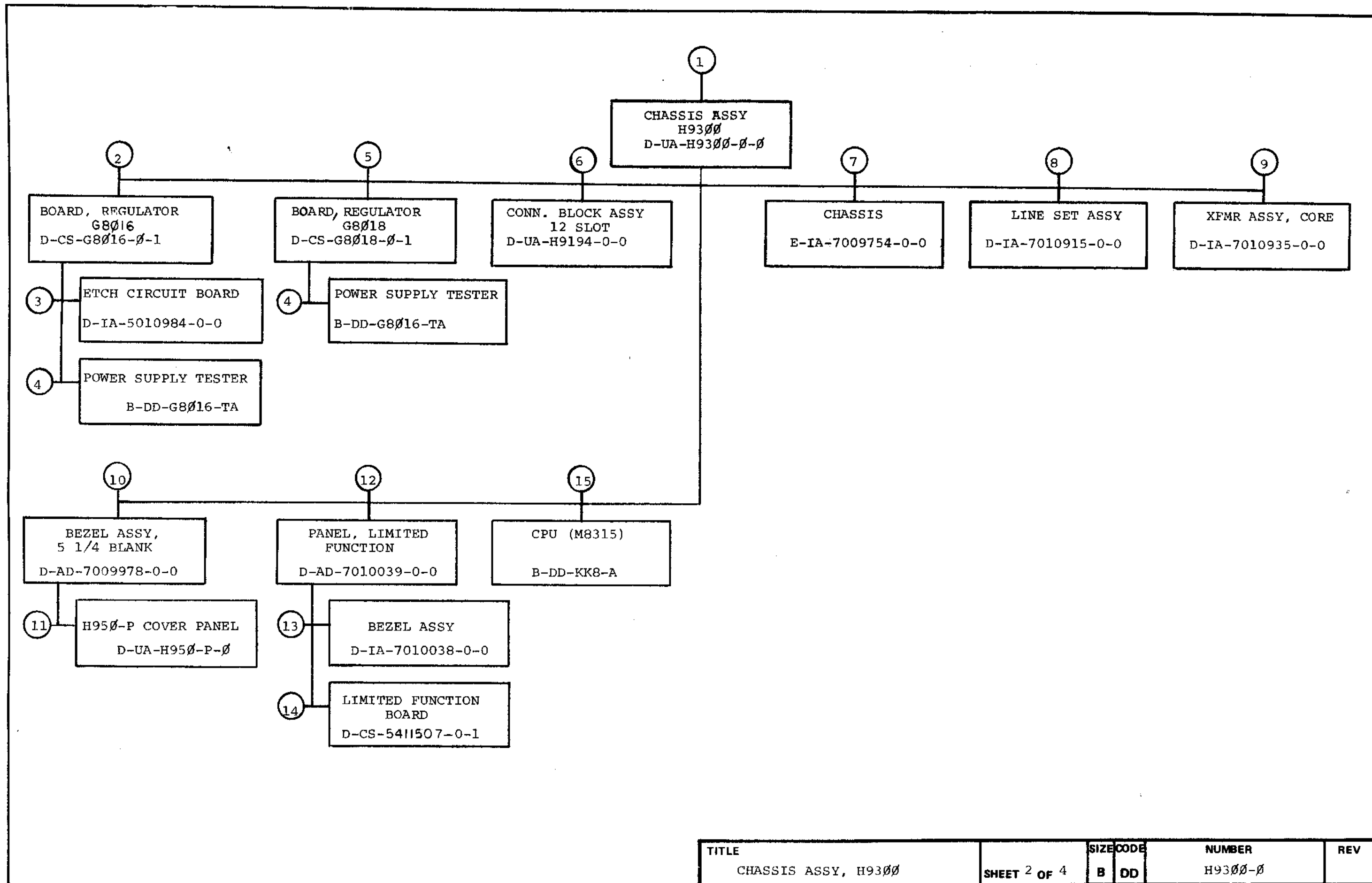

TITLE	SHEET	OF	SIZE	CODE	NUMBER	REV
CHASSIS ASSY, H9300	2	4	B	DD	H9300-0	

CUSTOMER PRINT SET		MECHANICAL					CUSTOMER PRINT SET								
	MFG. SET	FIND NO.	DRAWING NO.	REV	NO OF SHT	DESCRIPTION	OPTION NO./FILE DATE		MFG. SET	FIND NO.	DRAWING NO.	REV	NO OF SHT	DESCRIPTION	OPTION NO./FILE DATE
		8	D-AD-7010915-0-0		1	LINE SET ASSY									
			C-IA-7411983-0-0		1	PLATE, LINE SET									
			A-DC-7412193-0-0		1	DECAL									
		9	D-IA-7010935-0-0		1	XFMR ASSY, CORE									
		10	D-AD-7009978-0-0		1	5 1/4 BLANK BEZEL ASSY									
			C-IA-7411987-0-0		1	BRACKET, BEZEL									
		11	D-UA-H950-P-0		1	H950-P COVER PANEL									
			A-PL-H950-P-0		1	H950-P COVER PANEL									
			D-SC-1209226-0-0		1	5 1/4 SNAP ON BEZEL									
			C-SC-1209176-0-0		1	INLAY									
		12	D-AD-7010039-0-0		1	PANEL, LIMITED FUNCTION									
			C-IA-7413487-0-0		1	BRACKET, MODULE RETAINING									
		13	D-IA-7010038-0-0		1	BEZEL ASSY									
			D-PS-1209226-0-0		1	5 1/4 SNAP ON BEZEL									
			D-MD-7411692-0-0		1	INLAY REWORK									
			B-MD-7411744-0-0		1	WINDOW									
			D-MD-7411945-0-0		1	FRAME									

CUSTOMER PRINT SET CODES
X = PRINT OF DOCUMENT INCLUDED IN PRINT SET
C = INCLUDES ALL PRINTS INDICATED ON DOCUMENT
S = CONFIDENTIAL AUTHORIZED SIGNATURE REQUIRED

TITLE
CHASSIS ASSY, H9300

SHEET 4 OF 4 B DD NUMBER H9300-0 REV

"THIS DRAWING AND SPECIFICATIONS HEREIN ARE THE PROPERTY OF DIGITAL EQUIPMENT CORPORATION AND SHALL NOT BE REPRODUCED OR COPIED OR USED IN WHOLE OR IN PART AS THE BASIS FOR THE MANUFACTURE OR SALE OF ITEMS WITHOUT WRITTEN PERMISSION. COPYRIGHT © 1974 DIGITAL EQUIPMENT CORPORATION"

0-0-0026H 2

ASSEMBLY INSTRUCTIONS

- 1 OPERATIONS TO BE PERFORMED PER HARDWARE STANDARDS SP-7885099-0 AND/OR DEC WORKMANSHIP STANDARDS.
- 2 ATTACH FOAM TAPE (ITEM #34) TO CHASSIS (ITEM #4) AS SHOWN IN VIEW A-A.
- 3 INSTALL FAN HARNESS (ITEM #8) INTO CHASSIS AS SHOWN IN DETAIL "A".
- 4 ATTACH FILTER RETAINERS (ITEM #6) TO THE TWO FAN (ITEM #5) WITH #8-32 X .62 FLAT HEAD SCREW (ITEM #22) AND THE APPROPRIATE MOUNTING HARDWARE (SEE NOTES #1 & 2) FOUR PLACES EACH FAN.
- 5 PLUG FAN HARNESS CONNECTORS J1 & J2 (SEE DETAIL "A") ON TO THE FAN TERMINALS.
- 6 ATTACH FANS TO CHASSIS WITH #8-32 X .62 FLAT HEAD SCREWS (ITEM #22) AND THE APPROPRIATE MOUNTING HARDWARE (SEE NOTE #1) TWO PLACES EACH FAN.
- 7 REWORK FIVE CARD GUIDES (ITEM #13) AS SHOWN ON DETAIL "E".
- 8 INSTALL FULL LENGTH CARD GUIDES (ITEM #13) AND REWORK CARD GUIDES AS SHOWN (10 PLACES).
- 9 INSTALL THE 1/4 TURN RECEPTACLES (ITEM #32) ON THE TWO TABS ON THE BOTTOM OF THE CHASSIS.
- 10 ATTACH THE H9194 CONNECTOR BLOCK ASSEMBLY (ITEM #3) TO THE REAR OF THE CHASSIS WITH #8-32 X .25 PAN HEAD SCREWS (ITEM #24) AND #8 INTERNAL TOOTH LOCK WASHERS (ITEM #25) TEN PLACES.
- 11 PLUG P1 OF THE FAN HARNESS (4 PIN CONNECTOR) INTO J18 OF THE H9194 (SEE DETAIL "B", SHEET 2)
- 12 ATTACH THE LINE SET (ITEM #9, 10, 11 OR 12) TO THE REAR OF THE CHASSIS WITH TWO #8-32 X .25 LG PAN HEAD SCREWS (ITEM #26) AND TWO #8 EXTERNAL TOOTH LOCKWASHERS (ITEM #27) AS SHOWN.
- 13 PLUG P1 (6 PIN CONNECTOR) OF THE LINE SET INTO J15 OF THE H9194 (SEE DETAIL "B").
- 14 PLUG ONE END OF THE 16 CONDUCTOR CABLE (ITEM #19) INTO J14 OF THE H9194 AS SHOWN.
- 15 SET THE TRANSFORMER ASSEMBLY (ITEM #17 OR 18) IN THE CHASSIS AND FASTEN THE GREEN WIRE TO THE CHASSIS WITH ONE #4-40 X .38 SCREW (ITEM #35) TWO #4 INTERNAL TOOTH LOCK WASHERS (ITEM #38) ONE FLAT WASHER (ITEM #23) AND ONE #4-40 KEP NUT (ITEM #15) AS SHOWN IN DETAIL "C".
- 16 PLACE THE TRANSFORMER ASSEMBLY IN POSITION (THE 16 CONDUCTOR CABLE SHOULD BE ROUTED UNDERNEATH THE TRANSFORMER) AND ATTACH TO THE CHASSIS WITH FOUR #10-32 X .50 PAN HEAD SCREWS (ITEM #30) AND #10 INTERNAL TOOTH LOCK WASHERS (ITEM #31) AS SHOWN.
- 17 PLUG P1 OF TRANSFORMER ASSEMBLY (12 PIN CONNECTOR) INTO EITHER J16 (115V) OR J17 (230V) OF THE H9194 (SEE DETAIL "B").
- 18 CONNECT THE THREE LARGE WIRES ON THE TRANSFORMER ASSEMBLY TO THE TABS TB1, TB2 AND TB3 (SEE DETAIL #8) ON THE H9194. THE BLU/BLK WIRE IS ALWAYS CONNECTED TO THE CENTER TAB (TB2).
- 19 PLUG P1 OF THE TRANSFORMER ASSEMBLY (6 PIN CONNECTOR) INTO J19 OF THE H9194 (SEE DETAIL "B").
- 20 PLUG THE 88D18 REGULATOR BOARD (ITEM #2) INTO THE H9194 AS SHOWN, AND SECURE IN PLACE WITH THE TWO ATTACHED 1/4 TURN FASTENERS.
- 21 ATTACH THE LATCH MOLDINGS (ITEM #14) TO THE CHASSIS WITH #10-32 X .75 FLAT HEAD SCREWS (ITEM #29) AND SPEED NUTS (ITEM #28).
- 22 PLUG THE OTHER END OF THE 16 CONDUCTOR CABLE INTO J1 OF THE LIMITED FUNCTION PANEL (ITEM #21) SEE DETAIL "C".
- 23 ATTACH THE LIMITED FUNCTION PANEL TO THE CHASSIS.
- 24 PLUG THE K8-A CPU (ITEM #33) INTO SLOT #1.
- 25 ATTACH THE BLANK BEZEL ASSEMBLY (ITEM #20) TO THE CHASSIS.
- 26 SLIDE FILTERS (ITEM #7) INTO FILTER RETAINERS.

D
C
B
A

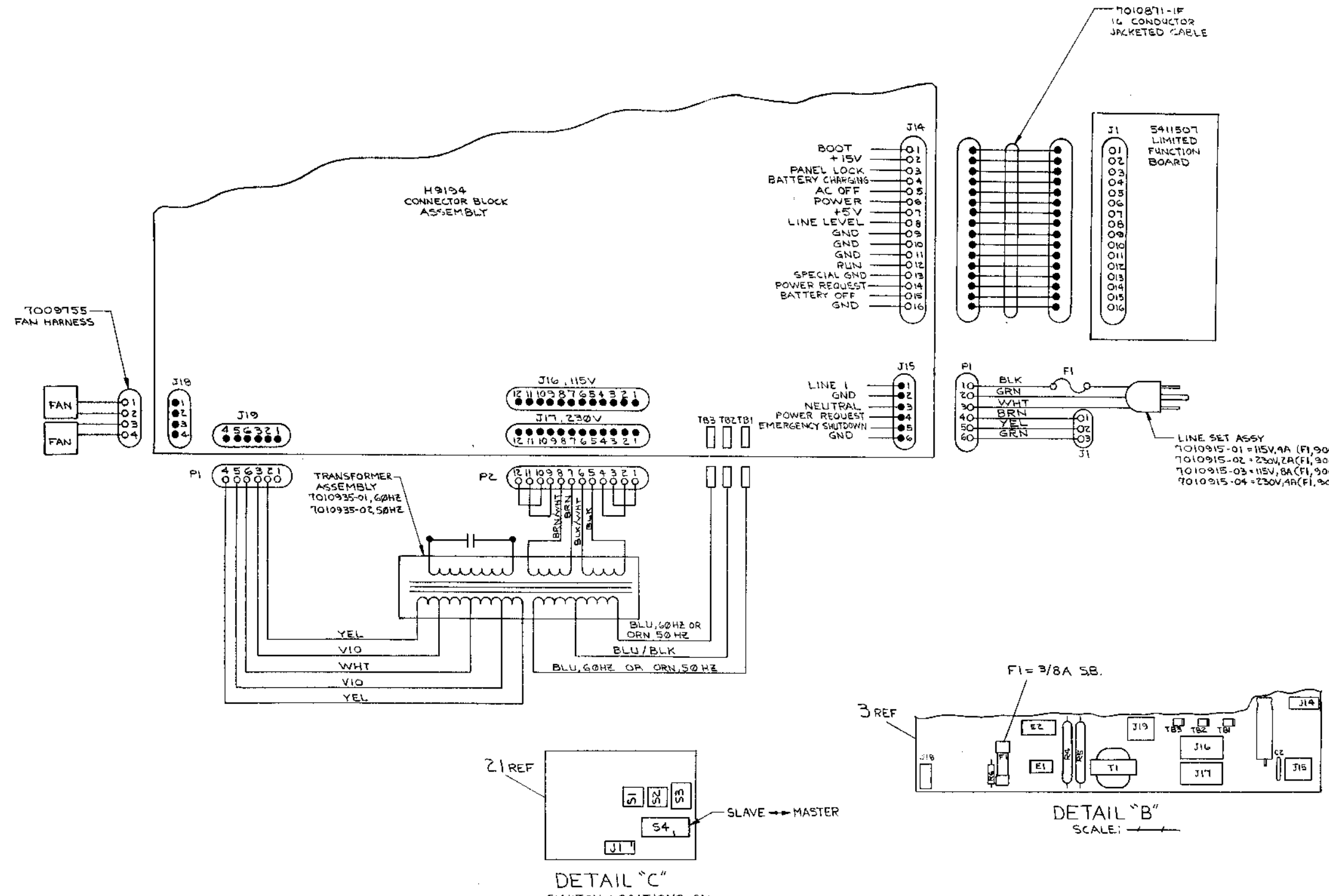

REVISIONS		
CHK	CHANGE NO.	REV.

TITLE	CHASSIS ASSY, H9300	SIZE CODE	D UA	NUMBER	H9300-0-0	REV.	
SCALE		SHEET	2	OF	3	DIST.	

THIS DRAWING AND SPECIFICATIONS HEREIN ARE THE PROPERTY OF DIGITAL EQUIPMENT CORPORATION AND SHALL NOT BE REPRODUCED OR COPIED OR USED IN WHOLE OR IN PART AS THE BASIS FOR THE MANUFACTURE OR SALE OF ITEMS WITHOUT WRITTEN PERMISSION. COPYRIGHT © 1975 DIGITAL EQUIPMENT CORPORATION

MODULE ASSIGNMENTS AND POWER REQUIREMENTS

OPTION	DESCRIPTION	BOARD SIZE	NO. SLOTS USED	ASSIGNED SLOT NO.	CURRENT		
					+5V	+15V	-15V
CMB-F	CARD RDR CONT.	QUAD	1	4 - 12	.55A	---	---
CRB-F	CARD RDR CONT.	↑	↑	4 - 12	.55A	---	---
DBB-EA	INTERPROC. BUFFER	↓	↓	2 - 12	.80A	---	.03A
DKB-EC	RTC, CRYSTAL	↓	↓	2 - 12	.34A	---	---
OKB-EP	RTC, PROG.	QUAD	2	2 - 12	1.43A	---	.07A
OKCB-A	OPTION #1	HEX	1	2 - 3	2.0A	.06A	1.0A
DPB-EA, -EB	MODEM INTERFACE	QUAD	2	2 - 12	1.80A	.05A	.11A
DRB-EA	DIGITAL I/O	QUAD	1	2 - 12	2.25A	---	---
KAB-E	POSITIVE I/O	QUAD	1	4 - 12	1.40A	---	---
KCB-AA, -AB	PROG. CONSOLE	PNL. MT.	0	N.A.	2.5A	---	---
KDB-E	DATA BREAK	QUAD	1	4 - 12	1.2A	---	---
KGB-EA	REDUNDANCY CHECK	QUAD	1	4 - 12	.94A	---	---
KKB-A	C.P.U.	HEX	1	1	5.0A	---	.04A
KLB-JA	ASYNC. DATA CONT.	QUAD	1	2 - 12	1.1A	.05A	.10A
KLB-M	MODEM CONTROL	QUAD	1	2 - 12	.40A	.04A	.04A
KMB-A	OPTION #2	HEX	1	2 - 3	2.0A	---	.10A
KMB-E	MEM. EXT. & T.S. CONT.	QUAD	1	4 - 12	1.0A	---	---
LEB-XX	LINE PRINTER CONT.	QUAD	1	2 - 12	.35A	---	---
LSB-F	LINE PRINTER CONT.	QUAD	1	2 - 12	.40A	---	---
MMB-AA	8K CORE, OPERATING	HEX	2	4 - 8	2.5A	---	---
MMB-AB	8K CORE, STANDBY	HEX	2	4 - 8	2.5A	---	---
MMB-AC	16K CORE, OPERATING	HEX	2	4 - 8	2.5A	---	---
MMB-AD	16K CORE, STANDBY	HEX	2	4 - 8	2.5A	---	---
MRB-AA	1K ROM	QUAD	1	2 - 12	2.0A	---	---
MRB-AB	2K ROM	↑	↑	2 - 12	3.0A	---	---
MRB-AC	3K ROM	↓	↓	2 - 12	4.0A	---	---
MRB-AD	4K ROM	↓	↓	2 - 12	5.0A	---	---
MRB-AB	1K PROM	↓	↓	2 - 12	3.0A	---	.35A
MSB-AA	1K RAM	↓	↓	4 - 12	1.4A	---	---
MSB-AB	2K RAM	↓	↓	4 - 12	2.1A	---	---
MSB-AC	3K RAM	↓	↓	4 - 12	2.8A	---	---
MSB-AD	4K RAM	↓	↓	4 - 12	3.5A	---	---
PCB-E, PRB-E	RDR/PUNCH CONTROL	↓	↓	4 - 12	.04A	---	.05A
RXB-E	RXB1 CONTROL	↓	↓	4 - 8	1.25A	---	---
RXB-EA	RXB5 CONTROL	↓	↓	4 - 12	3.10A	---	---
TAB-AA	TAB0 CONTROL	↓	↓	2 - 12	2.80A	---	---
TMB-EA, -FA	TUI0 CONTROL	↓	↓	4 - 12	4.10A	---	---
VCB-E	DISPLAY CONTROL	↓	↓	2 - 12	.31A	---	---
VTB-E	DISPLAY CONTROL	↓	↓	4 - 12	3.70A	.09A	.13A
XYB-E	PLOTTER CONTROL	QUAD	1	4 - 12	.42A	.01A	.03A

AVAILABLE CURRENT - H9300-AA, AB $\frac{+5V}{20A}$ $\frac{+15V}{2A}$ $\frac{-15V}{2A}$
 - H9300-BA, BB $\frac{+5V}{25A}$ $\frac{+15V}{2A}$ $\frac{-15V}{2A}$

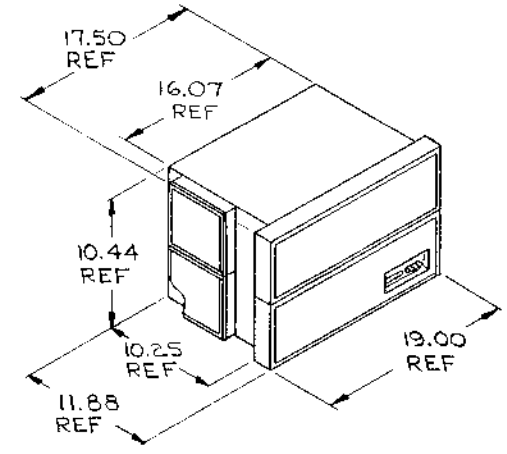

MAX. UNIT WEIGHT = 55 LB.

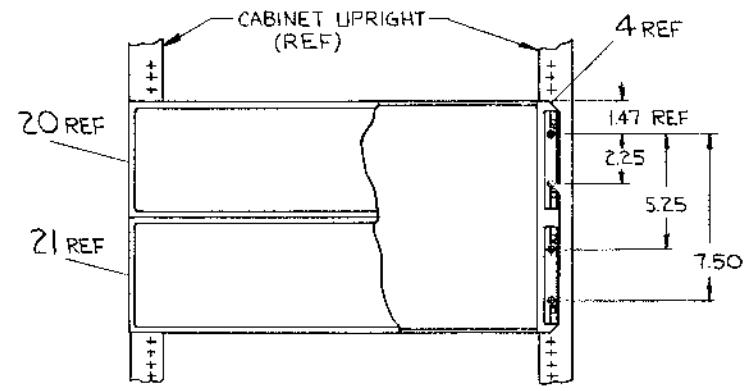

DETAIL "D" SCALE: 1:1

MOUNTING INSTRUCTIONS

1. SEE DETAIL "D" FOR MTG DIM.
2. THE DIM FROM CENTER LINE OF RIGHT CAB UPRIGHT MOUNTING HOLE TO LEFT CAB UPRIGHT MOUNTING HOLE CENTER LINE IS 18.31.
3. REMOVE THE BLANK BEZEL ASSY.
4. REMOVE THE LIMITED FUNCTION PANEL AND DISCONNECT THE CABLE FROM THE LIMITED FUNCTION BD.
5. REMOVE THE LATCH MOULDING (4 PLACES).
6. REMOVE THE SPEED NUT, AND INSTALL ON CABINET POST. 8 PLACES PER MOUNTING DIMENSIONS.
7. IT MAY BE NECESSARY TO REMOVE THE FILTER RETAINER AND THE FILTER IN ORDER TO MOUNT THE BOX IN A CABINET.
8. WITH THE BOX IN PLACE, IN THE CABINET, REPLACE THE LATCH MOULDING AND SPACERS SO AS TO SECURE THE BOX TO THE CABINET.
9. PLUG THE CABLE INTO THE LIMITED FUNCTION BD AND REPLACE LIMITED FUNCTION PANEL.
10. REPLACE THE BLANK BEZEL ASSY; REINSTALL THE FILTER RETAINER AND THE FILTER.

NOTES:

3. TO CREATE A 115V 50 HZ CDRE VARIATION USE THE H9300-BB REPLACE THE LINE SET (ITEM #2) WITH A 115V 30HZ 4A LINE SET (DEC P/N 0-AD-7010915-05) AND PLUG P2 (12 PIN CONN) OF THE TRANSFORMER ASSEMBLY INTO J16 (115V) OF THE H9194.
4. ALL H9300 POWER SUPPLY DC OUTPUTS ARE PROVIDED TO DRIVE LOGIC INTERNAL TO THE BASIC MACHINE ENCLOSURE. DIGITAL WILL NOT BE RESPONSIBLE FOR THE PERFORMANCE OF THE H9300 IF ANY DC POWER IS TAKEN OUTSIDE THE MACHINE.
5. ENVIRONMENTAL CONDITIONS FOR H9300 ARE SPECIFIED IN DEC STD 102 CLASS "C" ENVIRONMENT.
6. THIS ITEM (NAMEPLATE) IS SHOWN FOR REFERENCE ONLY. IT WILL BE ADDED ON A HIGHER LEVEL ASSEMBLY.

REVISIONS		
CHK	CHANGE NO.	REV

TITLE	CHASSIS ASSY, H9300	SIZE/COOR	D UA	NUMBER	H9300-0-0	REV.	
SCALE		SHEET	3	OF	3	DIST.	

THIS DRAWING AND SPECIFICATIONS, HEREIN, ARE THE PROPERTY OF DIGITAL EQUIPMENT CORPORATION AND SHALL NOT BE REPRODUCED OR COPIED OR USED IN WHOLE OR IN PART AS THE BASIS FOR THE MANUFACTURE OR SALE OF ITEMS WITHOUT WRITTEN PERMISSION. COPYRIGHT © 1975, DIGITAL EQUIPMENT CORPORATION.

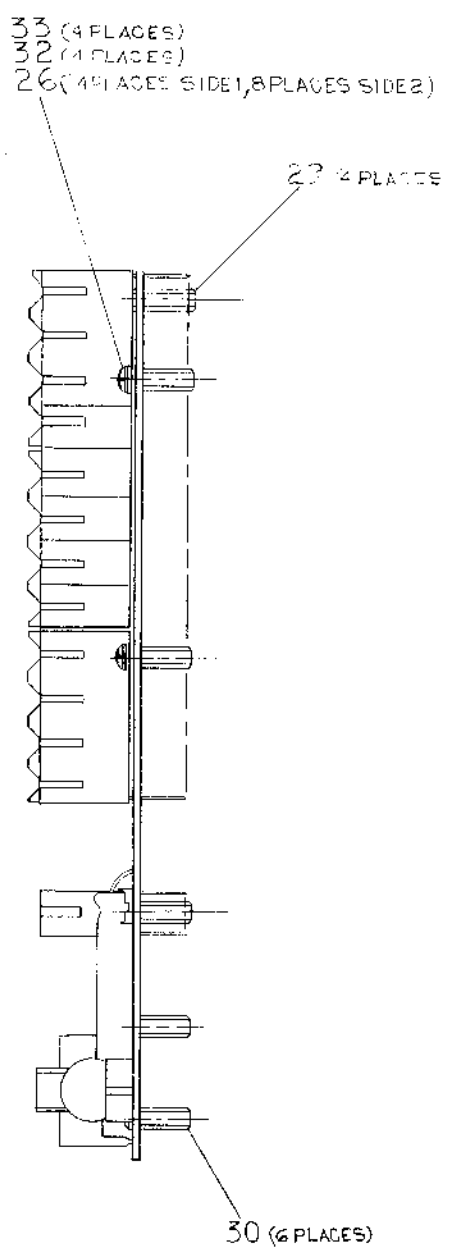
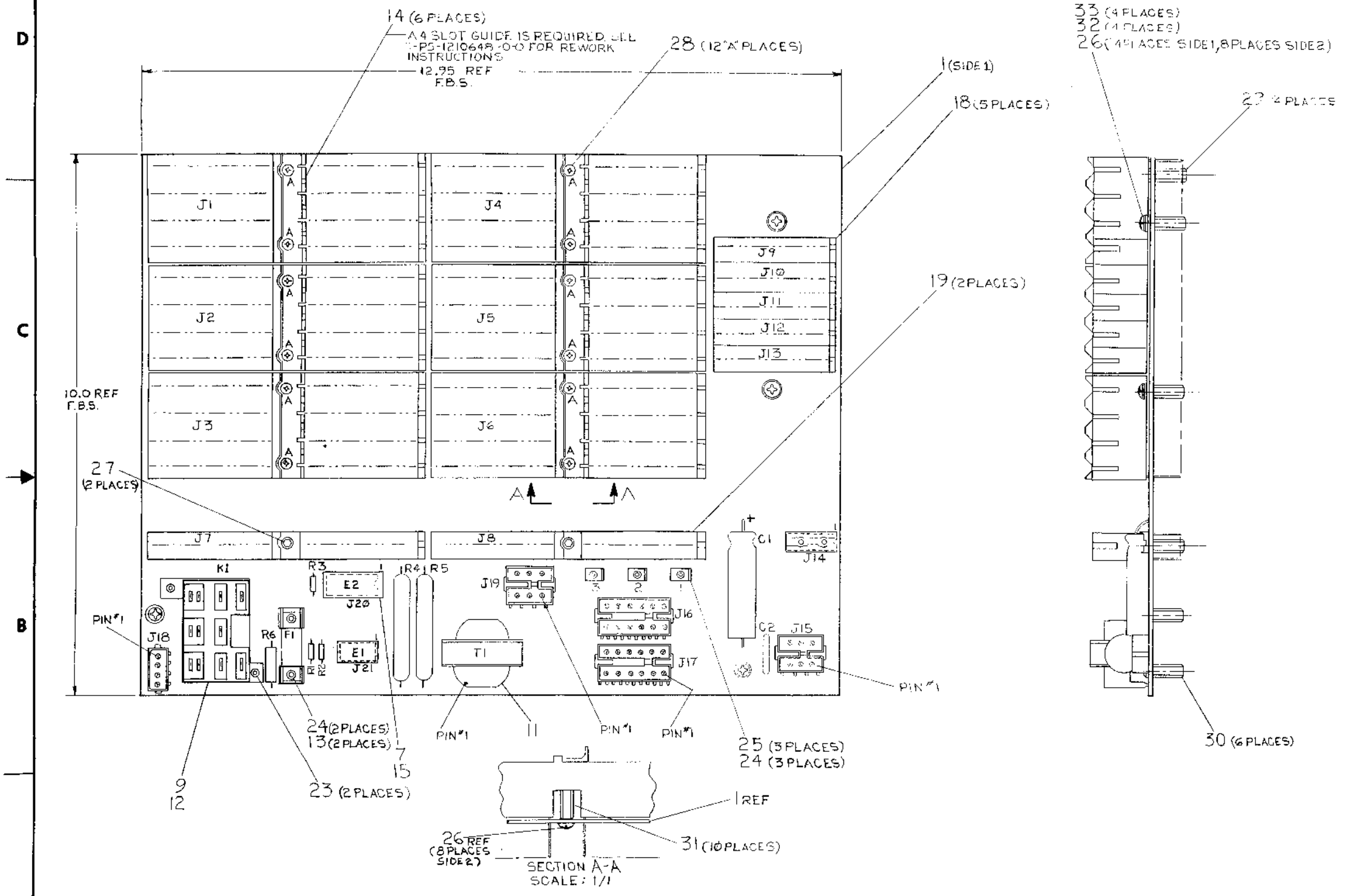

REF	DESCRIPTION	DWG./PART NO.	ITEM NO.
1	CONN, PC, 4 PIN	1211342-04	22
2	CONN, PC, 6 PIN	1211342-06	21
2	CONN, PC, 12 PIN	1211342-12	20
2	CONN BLK, 72 PIN SLTD	1211425	19
5	CONN BLK, 36 PIN SLTD	1211029	18
6	CONN BLK, 288 PIN SLTD	1210258	17
1	SOCKET, IC, 14 PIN	1211813-01	16
2	SOCKET, IC, 16 PIN	1211813-02	15
6	CARD GUIDE, CENTER	1210698	14
2	CLIP, FUSE	9007203	13
1	SOCKET, RELAY	1210684	12
1	TRANSFORMER	1211646	11
1	FUSE, 3/8 A, S.B.	9007207	10
1	RELAY, 3 POLE, 6V, 10AMP	1210683-01	9
1	QUAD CORE DRIVER	1511102	8
1	DIODE ARRAY	C-1A-7010866-0-0	7
1	RES, 10 Ω, 2W, 10%	1300172	6
2	RES, 20 Ω, 10W, 1%	1305416	5
3	RES, 2.2K 1/4W, 5%	1300417	4
1	CAP, .02μ, 1000V, DUAL DISC	1010767	3
1	CAP, 930 μf, 50V	1010509-00	2
1	ETCHED CIRCUIT BOARD	5011505	1

REF	DESCRIPTION	DWG./PART NO.	ITEM NO.
UNLESS OTHERWISE SPECIFIED DIMENSIONS ARE IN INCHES			
ANGLES		NOMINAL DIMENSION RANGE INCHES	
10°-30°	CLASS OF ACCURACY	OVER 0 TO 0.2	OVER 0.2 TO 0.4
	(CHECK DNE)	OVER 0.4 TO 0.6	OVER 0.6 TO 1.0
SURFACE QUALITY	IN	OVER 1.0 TO 1.2	OVER 1.2 TO 40.0
		OVER 12.0 TO 40.0	OVER 40.0 TO 80.0
QUANTITY & VARIATION	MEDIUM	±.004	±.008
	PREFERRED	±.012	±.016
		±.025	±.04
		±.063	±.1

REV.	CHANGE NO.	REV.
C	0001	
B		
A		

THIRD ANGLE PROJECTION	DRN. <i>[Signature]</i>	FIRST USED ON	digital
REMOVE BURRS AND BREAK SHARP CORNERS	CHK'D. <i>[Signature]</i>	H9300	
DO NOT SCALE DWG	ENGR. <i>[Signature]</i>	TITLE	CONNECTOR BLOCK ASSY
	PROJ. ENG. <i>[Signature]</i>		
	PROD. <i>[Signature]</i>		
MATERIAL	NEXT HIGHER ASSY.	SIZE CODE	NUMBER
FINISH	B-00-H9194-0	DAD	H9194-0-0
	SCALE 1/1		
	SHEET 1 OF 1	DIST.	

THIS DRAWING AND SPECIFICATIONS, HEREIN, ARE THE PROPERTY OF DIGITAL EQUIPMENT CORPORATION AND SHALL NOT BE REPRODUCED OR COPIED OR USED IN WHOLE OR IN PART AS THE BASIS FOR THE MANUFACTURE OR SALE OF ITEMS WITHOUT WRITTEN PERMISSION. COPYRIGHT © 1975 DIGITAL EQUIPMENT CORPORATION

PIN	A1	A2	B1	B2	C1	C2	D1	D2	E1	E2
A	A01 = +5V ALL OTHERS = TP	+5V	B02, B03 = BATTERY EMPTY, ALL OTHERS = TP	+5V	C01 = +5V ALL OTHERS = TP	+5V	D02, D03 = PANEL LOCK, ALL OTHERS = TP	+15V	TEST POINT	+20V
B	TEST POINT	-15V	B02, B03 = AC LOW, ALL OTHERS = TP	-15V	TEST POINT	-15V	TEST POINT	-15V	TEST POINT	UNUSED
C	GROUND	GROUND	GROUND	GROUND	GROUND	GROUND	GROUND	GROUND	GROUND	GROUND
D	MA0 L	EMA0 L	MA4 L	INT STROBE H	TP PAUSE L	TP1 H	MA8 L	IR0 L	TEST POINT	UNUSED
E	MA1 L	EMA1 L	MA5 L	BREAK IN PROG L	C0 L	TP2 H	MA9 L	IR1 L	TEST POINT	+20V
F	GROUND	GROUND	GROUND	GROUND	GROUND	GROUND	GROUND	GROUND	GROUND	GROUND
H	MA2 L	EMA2 L	MA6 L	MA, MS, LOAD CONT L	C1 L	TP3 H	MA10 L	IR2 L	TEST POINT	MEMORY REFRESH
J	MA3 L	MEM START L	MA7 L	OVERFLOW L	C2 L	TP4 H	MA11 L	F L	TEST POINT	MEMORY REFRESH
K	MD0 L	MDDIR L	MD4 L	BREAK DATA CONT L	BUS STROBE H	TS1 L	MD8 L	D L	TEST POINT	+20V
L	MD1 L	SOURCE H	MD5 L	BREAK CYCLE L	INTERNAL I/O L	TS2 L	MD9 L	E L	TEST POINT	UNUSED
M	MD2 L	STROBE H	MD6 L	LOAD ADD ENABLE L	NDT LAST XFER L	TS3 L	MD10 L	USE MODE L	TEST POINT	-5V
N	GROUND	GROUND	GROUND	GROUND	GROUND	GROUND	GROUND	GROUND	GROUND	GROUND
P	MD3 L	INHIBIT H	MD7 L	INT IN PROG H	INT REQUEST L	TS4 L	MD11 L	F SET L	TEST POINT	+20V
R	DATA 0 L	RETURN H	DATA 4 L	INTS STALL L	INITIALIZE H	LINK DATA L	DATA 8 L	PULSE LAH	TEST POINT	UNUSED
S	DATA 1 L	WRITE H	DATA 5 L	RES	SKIP L	LINKLOAD L	DATA 9 L	STOP L	UNUSED	UNUSED
T	GROUND	GROUND	GROUND	GROUND	GROUND	GROUND	GROUND	GROUND	JUMPER	GROUND
U	DATA 2 L	RDM ADDRESS L	DATA 6 L	RUN L	CPMA DISABLE L	IND 1 L	DATA 10 L	KEY CONTROL L	UNUSED	UNUSED
V	DATA 3 L	LINK L	DATA 7 L	POWER OK H	MS, IR DISABLE L	IND 2 L	DATA 11 L	SW	UNUSED	UNUSED

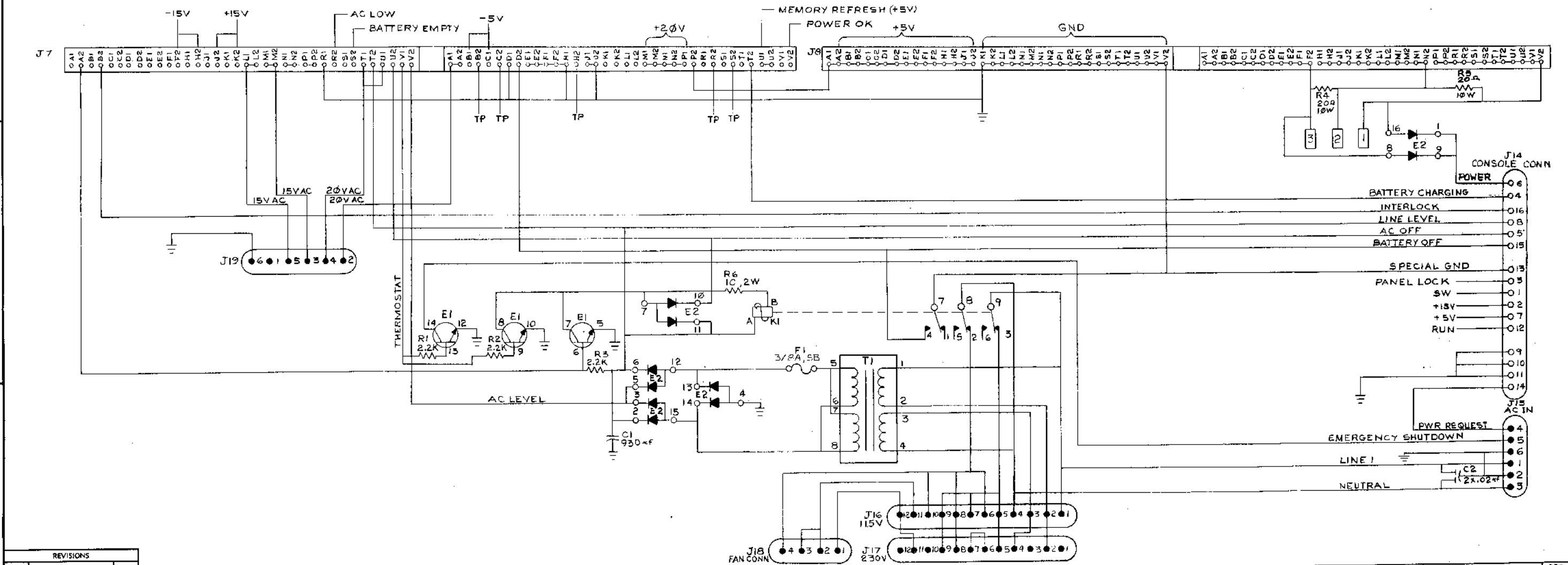

REVISIONS		
CHK	CHANGE NO.	REV.

TITLE	CONN BLOCK ASSY	SIZE CODE	D CS	NUMBER	H9194-0-1	REV.	C
SCALE	1:1	SHEET	2	OF	2	DIST.	

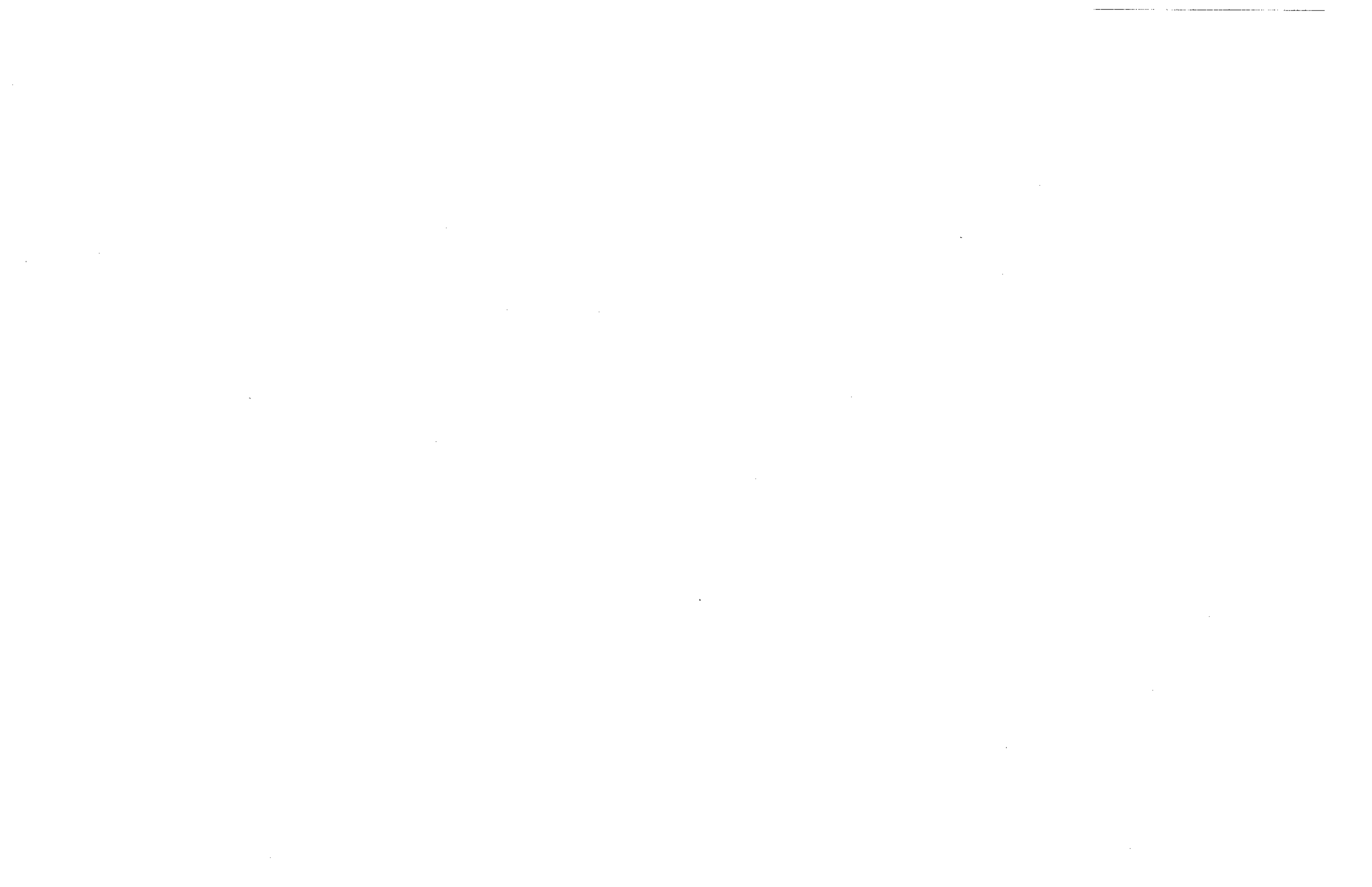

THIS DRAWING AND SPECIFICATIONS HEREIN ARE THE PROPERTY OF DIGITAL EQUIPMENT CORPORATION AND SHALL NOT BE REPRODUCED OR COPIED OR USED IN WHOLE OR IN PART AS THE BASIS FOR THE MANUFACTURE OR SALE OF ITEMS WITHOUT WRITTEN PERMISSION.
 COPYRIGHT © 1975 DIGITAL EQUIPMENT CORPORATION

NOTES:

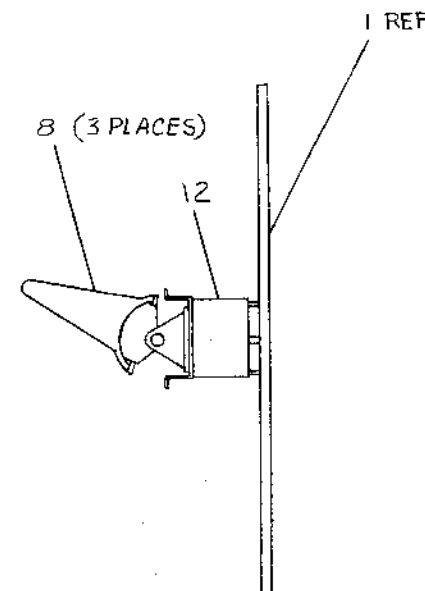
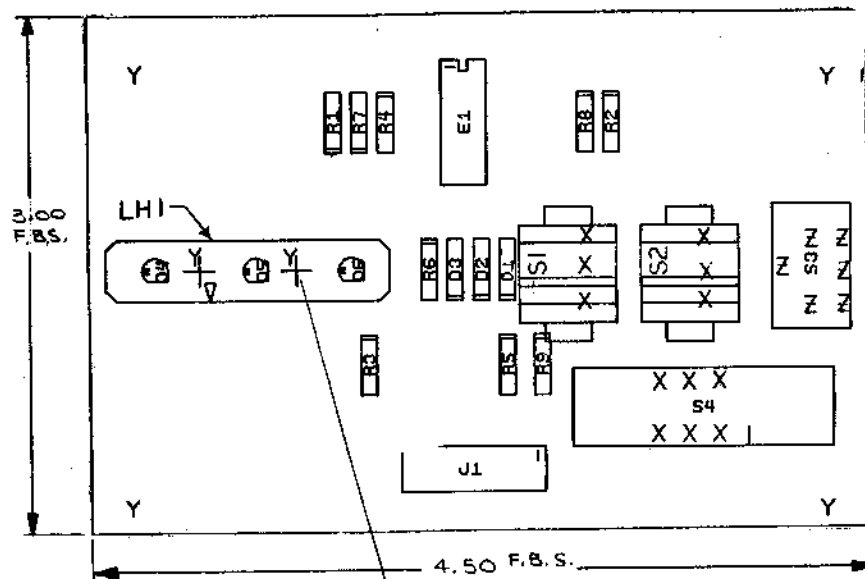
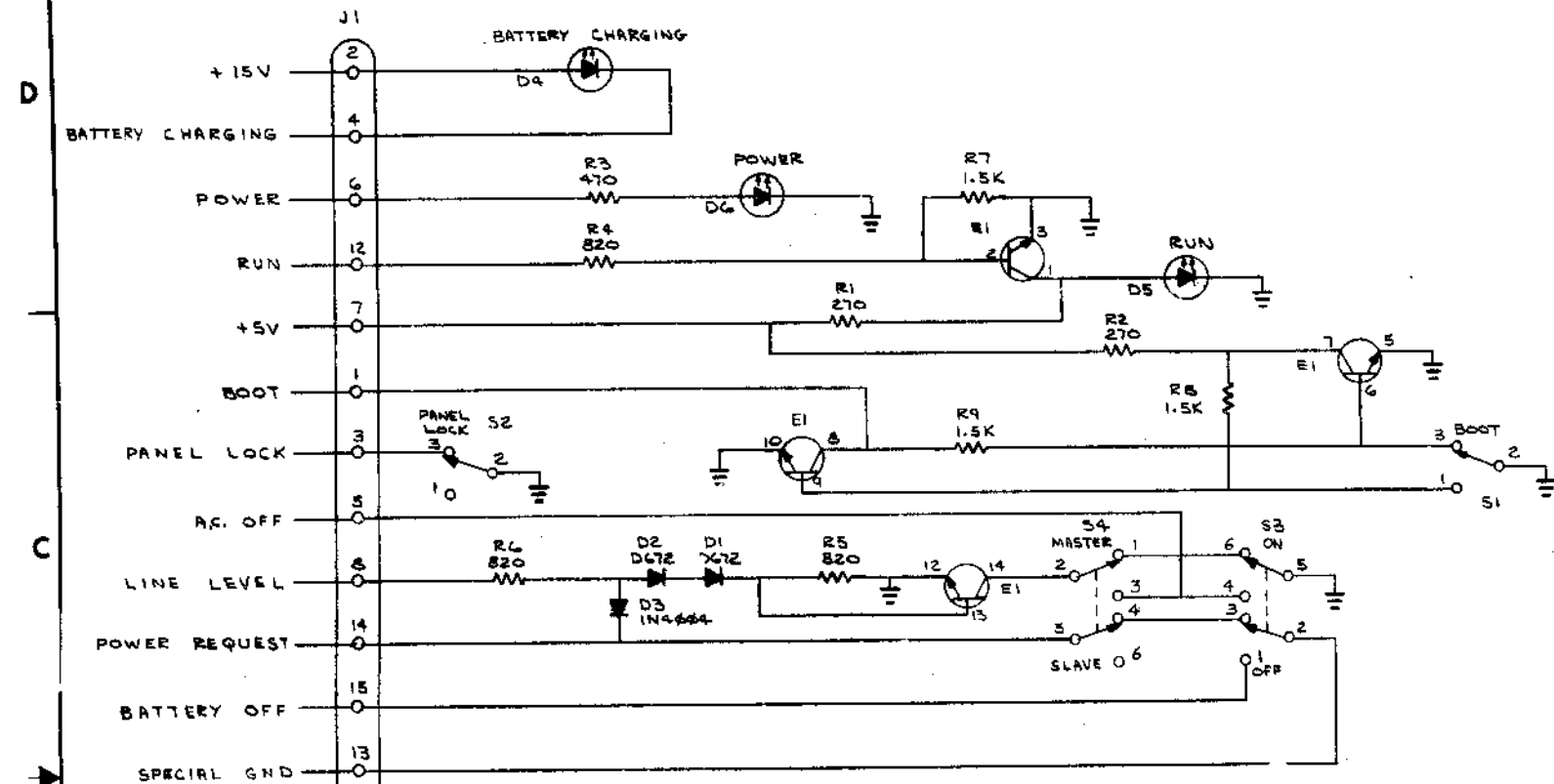

IC TYPE	GND	+5V
GND AND 5V ARE USUALLY PIN 7 AND 14 RESPECTIVELY EXCEPTONS ARE STATED ABOVE		
IC PIN LOCATIONS		

REF	DESCRIPTION	QTY	REF. DESIGNATION	DESCRIPTION	PART NO.	ITEM NO.
	X-Y COORDINATE HOLE LOCATION		K-00-5411507-0-4			1
	ASSY/DRILLING HOLE LAYOUT		D-AH-5411507-0-5			2
	MODULE ECO HISTORY		B-MH-5411507-0-6			3
1	ETCHED CIRCUIT BOARD		5011506			4
2	DIODE, D672		110 5275			5
1	D3		110 5796			6
3	D4, D5, D6		1110 324			7
3	KNOB, DARK GRAY (#47)		1210786-01			8
2	S1, S2		1210830			9
1	S4		1210919			10
1	LHI		1210940-02			11
1	S3		1212010			12
1	R3		1300316			13
3	R7, R8, R9		1300391			14
3	R4, R5, R6		1301775			15
2	R1, R2		1301972			16
1	E1		1511102-00			17
1	J1		1211813-00			18
2	SCR, SLOTTED PAN HD, SELF TRM		9008230-01			19

FIRST USED ON OPTION MODEL
H9300

ORIGINATED	CHANGE NO.	REV.	DATE	BY	DATE	BY	DATE	BY	DATE	BY

DEC NO.	EIA NO.	DEC NO.	EIA NO.

SCALE	SHEET	OF
	1	1

TITLE	NUMBER	REV.
LIMITED FUNCTION BOARD	D-CS 5411507-0-1	*

D-CS 5411507-0-1

"THIS DRAWING AND SPECIFICATIONS HEREIN ARE THE PROPERTY OF DIGITAL EQUIPMENT CORPORATION AND SHALL NOT BE REPRODUCED OR COPIED OR USED IN WHOLE OR IN PART AS THE BASIS FOR THE MANUFACTURE OR SALE OF ITEMS WITHOUT WRITTEN PERMISSION. COPYRIGHT © 1974, DIGITAL EQUIPMENT CORPORATION"

WIRE TABLE				
PART NO.	FROM	TO	TERMINATION	WIRE LENGTH
91-07380-22	TB1	D1	SOLDER AT D1 END. SOLDER AT TB1 END	5.00
91-07380-22	TB3	D2	SOLDER AT D2 END. TAB AT TB3 END	5.00
91-07380-00	TB2	TB4	SOLDER AT TB2 END SOLDER AT TB4 END	7.00
91-07380-00	+ TERMINAL OF C1	TB9 HOLE	SOLDER WIRE AT HOLE END TB9. SOLDERLESS CONNECTOR AT C1 END 90-07926	2.50
91-07380-00	- TERMINAL OF C1	TB10 HOLE	SOLDER WIRE AT HOLE END TB10 SOLDERLESS CONNECTOR AT C1 END 90-07926	1.25
91-07380-00	TB7	TOP TERMINAL OF CBI	SOLDER AT TB7 END. SOLDERLESS CONNECTOR AT CBI END 90-07926	7.00
91-07380-00	TB8	BOTTOM TERMINAL OF CBI	SOLDER AT TB8 END. SOLDERLESS CONNECTOR AT CBI END 90-07926	11.25
91-07350-22	S1	SPLIT LUG	SOLDER AT SPLIT LUG END	4.00
	S1	SPLIT LUG	SOLDER AT S1 END	4.00

QTY	REF	DESIGNATION	DESCRIPTION	PART NO	ITEM
1	R30		RES. 100 1/2W NTC	1311760	53
1	R67		RES. 2.7 1/2W 10%	1309444	54
2	Q7, Q12		TRANS. DEC 2N3715	1503068	55
1	Q2		TRANS. 2N3762	1509649-01	56
16	Q1, Q3, Q4, Q5, Q9, Q10, Q13, Q15, Q17, Q19, Q20, Q21, Q22, Q23, Q24, Q25		TRANS. DEC A05	1510705	57
1	R59		RES. 56K, 1/4W, 5%	1301874	58
4	Q8, Q14, Q16, Q18		TRANS. DEC A55	1510708	59
1	Q9		DIODE SCR C32AX135	1510928	60
2	Q6, Q11		TRANS. 2N5893	1511647	61
2	Q26, Q27		TRANS. D44H8	1510707-01	62
1	T1		TRANSFORMER	1611758	63
1	L1		CHOKE	1611759	64
1	E1		I.C. DEC 72741	1910298	65
1			BRACKET REG. B.D.	7411478	66
2			SCREW 4-40 x .50 PH	9006013-1	67
4			SCREW 6-32 x .25 PH	9006020-1	68
2			SCREW 6-32 x .31 PH	9006021-1	69
3			SCREW 6-32 x .75 PH	9006026-1	70
2			KEPNUT 4-40	9006557	71
7			WASHER #6 INTERNAL	9006633	72
9			WASHER #6 FLAT	9006656	73
2			WASHER #4 FLAT	9006702	74
8			SPLIT LUGS	9006736	75
2	TB5, TB8		TAB FAST-ON (OFF SET)	9007112	76
1			TRANSI PAD #10134	9007200	77
8			SCREW 6-32 x .56 PH	9007793-1	78
REF			G8016 REG. BOARD SPEC	G8016-0-8	79
4			SOLDERLESS CONNECTOR	9007928	80
11			KEPNUT 8-32	9008185	81
A/R			WIRE #12 AWG	9107380-00	82
A/R			WIRE #12 AWG	9107380-22	83
A/R	W3		BUS WIRE #22 AWG (SEE NOTE #10)	9107560-01	84
A/R	W1, W2		REEL JUMPER (SEE NOTE #11)	9107560	85
1			SHIELD BATTERY	7411693-0-0	86
3			SPACER #6 .38 LG.	9006801	87
2	TB5, TB6		EYELET	9009000	88
8	TB1, TB2, TB3, TB4, TB7, TB8, TB9, TB10		EYELET GS4-3	9007836	89
A/R			WIRE #22 AWG	9107350-22	90
2			WASHER #8 INTERNAL	9006634	91
A/R			THERMO COMPOUND	9008268	92
2			SCREW 10-32 x .31	9004030-01	93
2			WASHER #10 INTERNAL	9006635	94
1	C17		CAP .47UF 25V 20% CER.	1010219	95
					96
1			DECAL	A-DC-7413109-0-0	97
REF			FINAL INSP. PROC. FOR G8016	A-SP-G8016-0-9	98
REF			POWER SUPPLY TESTER	B-D-D-G8016-TA	99
REF			PACKAGING INSTRUCTION	A-SP-3700171-0-100	100

REVISIONS		
CHK	CHANGE NO.	REV

THIS DRAWING AND SPECIFICATIONS HEREIN ARE THE PROPERTY OF DIGITAL EQUIPMENT CORPORATION AND SHALL NOT BE REPRODUCED OR COPIED OR USED IN WHOLE OR IN PART AS THE BASIS FOR THE MANUFACTURE OR SALE OF ITEMS WITHOUT WRITTEN PERMISSION. COPYRIGHT © 1974 DIGITAL EQUIPMENT CORPORATION

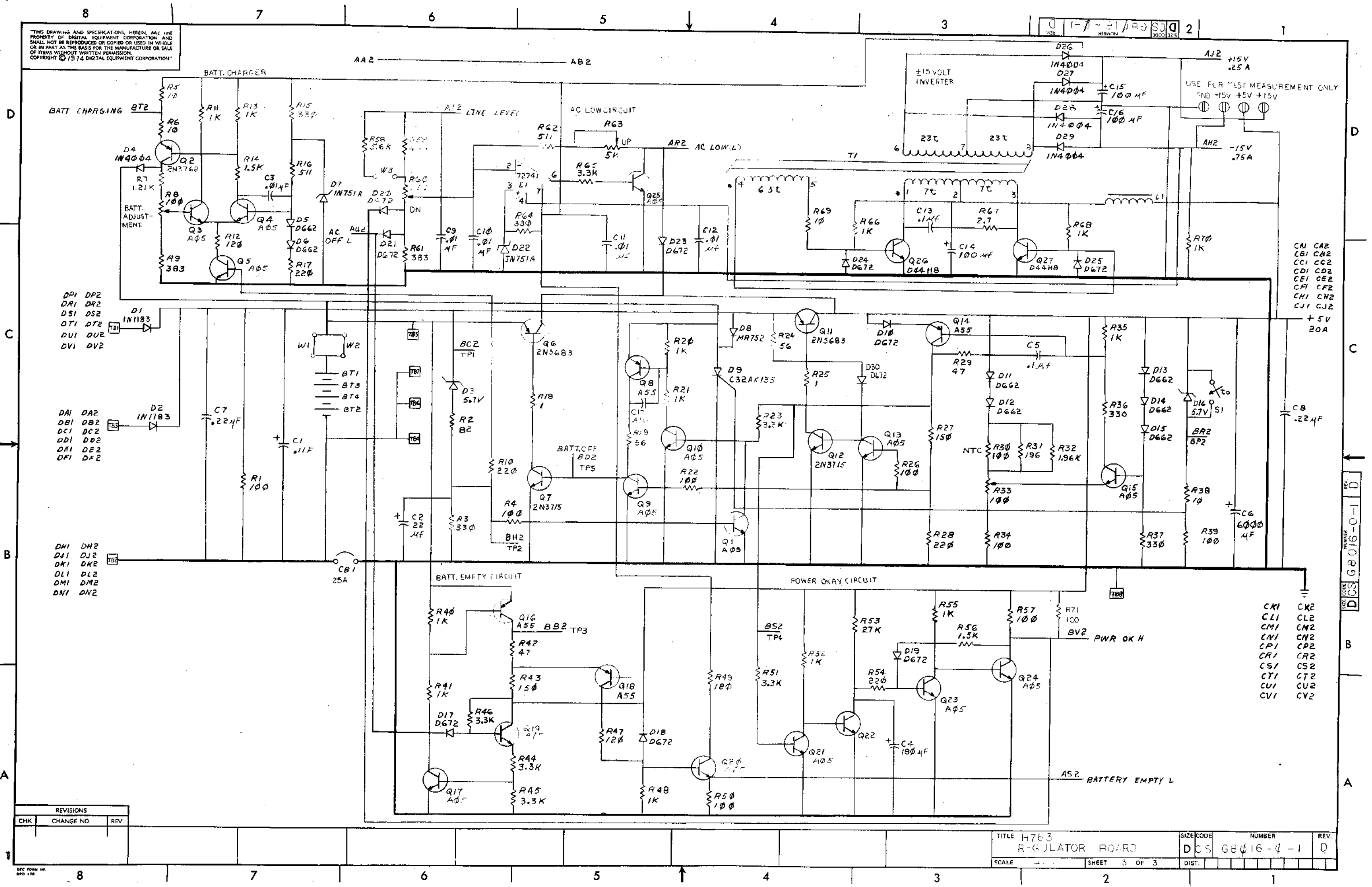

DP1 DP2
DR1 DR2
DS1 DS2
DT1 DT2
DU1 DU2
DV1 DV2

DA1 DA2
DB1 DB2
DC1 DC2
DD1 DD2
DE1 DE2
DF1 DF2

DH1 DH2
DJ1 DJ2
DK1 DK2
DL1 DL2
DM1 DM2
DN1 DN2

CA1 CA2
CB1 CB2
CC1 CC2
CD1 CD2
CE1 CE2
CF1 CF2
CH1 CH2
CJ1 CJ2

CK1 CK2
CL1 CL2
CM1 CM2
CN1 CN2
CP1 CP2
CR1 CR2
CS1 CS2
CT1 CT2
CU1 CU2
CV1 CV2

REVISIONS		
CHK	CHANGE NO.	REV.

TITLE	H763 R-REGULATOR BOARD	SIZE CODE	DCS	NUMBER	68016-4-1	REV.	D
SCALE		SHEET	3 OF 3	DIST.			

DATE LOCKED DCS 68016-0-1 D

THIS DRAWING AND SPECIFICATIONS HEREIN ARE THE PROPERTY OF DIGITAL EQUIPMENT CORPORATION AND SHALL NOT BE REPRODUCED OR COPIED OR USED IN WHOLE OR IN PART AS THE BASIS FOR THE MANUFACTURE OR SALE OF ITEMS WITHOUT WRITTEN PERMISSION. COPYRIGHT © 1976 DIGITAL EQUIPMENT CORPORATION

D
C
B
A

6		SCREW 6-32 X .56	9007793-1	81
1		KEPNUT 6-32	9006563	83
11		KEPNUT 6-32	9008185	84
13		WASHER #6 INTERNAL	9006683	85
1		WASHER #8 INTERNAL	9006634	86
				87
13		WASHER #6 FLAT	9006656	88
1		WASHER #8 FLAT NYLON(WHT)	9006713-00	89
8		FUSE CLIPS	9007203	90
1	F1	FUSE 4A	9007219	91
3	F2, F3, F4	FUSE 2.5A	9008387	92
13	TB1-TB13	EYELET 654-3	9007836	93
8		EYELET	9009000	94
A/R	W1	WIRE JUMPER	9009185	95
A/R		WIRE #22 AWG	9107350-28	96
A/R		WIRE #12 AWG (BLK)	9107380-00	97
A/R		WIRE #12 AWG (RED)	9107380-22	98
				99
A/R		WIRE BUSS #18 AWG	9107560-05	101
2		BRACKET	1210428	102
1	CB1	CIRCUIT BREAKER	1211673	103
1	S1	THERMOSTAT	1211682	104
1		HEAT SINK T-05 (TRANS MOUNTED)	1212322	105
1		HEAT SINK (BRIDGE RECT) 695-18	1210907	106
1		CLAMP CAP	7413208	107
1		BRACKET REG BOARD	7413741	108
2		LUGS SPLIT	9006735	109
11		CONN SODERLESS	9007926-01	110
2		CONN SODERLESS	9007928	111
A/R		COMPOUND THERMO	9008268	112
4	C5, C10	WASHER #6 NYLON	9006707	113
12	D6, D17, D20, D21, D23 D24, D28 - D32, D22	DIODE 0672	1105275	114
A/R		WIRE .30 AWG. GREEN	9105740-05	115
1		DECAL	A-DC-7913498-0-0	116

7	R1, R20, R40, R44, R55, R57, R60	RES 1K 1/4W 5%	1300265	38
1	R45	RES 1.5K 1/4W 5%	1300391	39
1	R27	RES 1.5K 1/4W 5%	1300394	40
2	R36, R41	RES 3.3K 1/4W 5%	1300449	41
1	R38	RES 4.7K 1/4W 5%	1300447	42
1	R16	RES 10 1/4W 5%	1301317	43
2	R42, R47	RES 280 1/4W 5%	1301424	44
1	R46	RES 200 2W 5%	1301494	45
1	R52	RES 511 1/4W 1%	1302411	46
1	R26	RES 56 1/4W 5%	1302502	47
1	R3	RES 56 2W 5%	1302836	48
1	R12	RES 100 1/2W 1%	1302858	49
4	R21, R23, R24, R25	RES 1.21K 1/4W 1%	1302871	50
1	R9	RES 196 1/4W 1%	1302956	51
3	R32, R25, R50	RES 464 1/4W 1%	1303097	52
1	R18	RES 470 2W 5%	1303062	53
1	R57	RES 12.1K 1/4W 1%	1302313	54
1	R2	RES 1.5W 10%	1303365	55
1	R10	RES 1.96K 1/4W 1%	1304833	56
3	R27, R38, R39	RES 15K 1/4W 5%	1300496	57
1	R31	RES 2.2K 1/4W 5%	1300417	58
1	R48	RES 383 1/4W 1%	1305125	59
1	R23	RES 619 1/4W 1%	1305126	60
2	R11, R22	RES 100 3/4W 10%	1309143-04	61
1	R49	RES 500 3/4W 10%	1309143-06	62
1	R53	RES 5K 3/4W 10%	1309143-09	63
1	R58	RES 14.7K 1/4W 1%	1302941	64
1	R20	RES .14 5W 1%	1310189	65
1	R8	RES 100 1/2W, NTC	1311760	66
1	R4	IC DEC 7474	1905547	67
1	R3	IC DEC 74121	1910230	68
2	R2, R5	IC DEC 72741	1910798	69
1	R1	IC DEC 723	1910415	70
3	Q4, Q12, Q20	TRANS DEC 6534B	1503409-01	71
1	Q6	TRANS DEC 2N3791	1509581	72
1	Q2	TRANS MJE 3035	1510555	73
1	Q8	TRANS MJE 2955	1510556	74
2	D3, D12	TRANS CBPA K135 SCE	1510928	75
1	Q1	TRANS 2N5683	1511647	76
13	Q3, Q5, Q7, Q9, Q10, Q11, Q13-Q19	TRANS DEC 6531A	1509338	77
7		SCREW 6-32 X .85	9006020-1	78
6		SCREW 6-32 X .91	9006021-1	79
1		SCREW 8-32 X .75	9006081-1	80

QTY	REF	DESIGNATION	DESCRIPTION	PART NO	ITEM NO
REGULATOR BOARD					
8A CORE					
D CS 68218-0-1					
SHEET 2 OF 4					

REVISIONS		
CHK	CHANGE NO.	REV

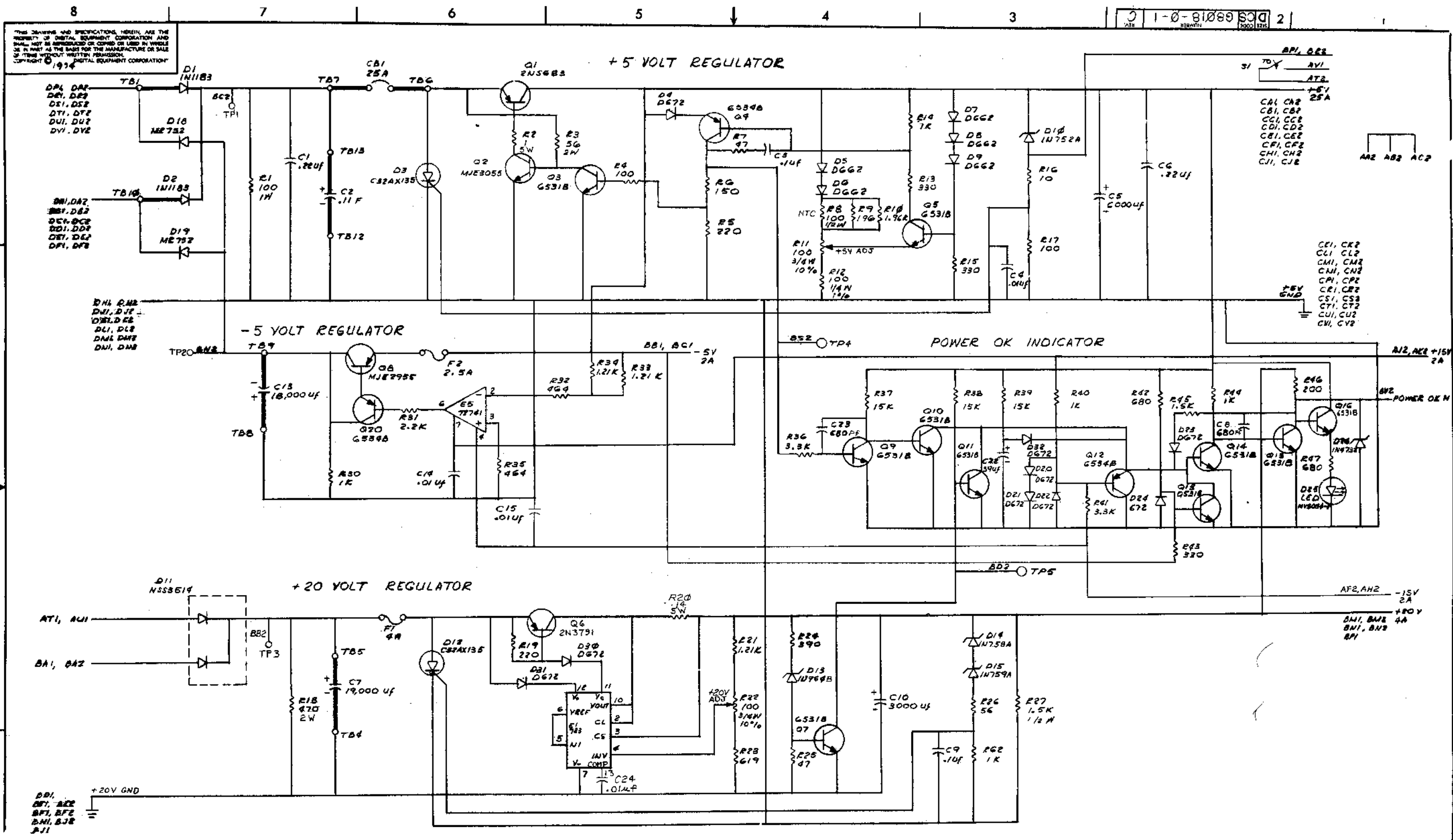

REVISIONS			TITLE		SIZE CODE	NUMBER	REV.
CHK	CHANGE NO.	REV.	REGULATOR BOARD		DCS 68018-0-1	4A	6
			8A CORE				
			SCALE	SHEET 3 OF 4	DIST.		

THIS DRAWING AND SPECIFICATIONS HEREIN ARE THE PROPERTY OF DIGITAL EQUIPMENT CORPORATION AND SHALL NOT BE REPRODUCED OR COPIED OR USED IN WHOLE OR IN PART AS THE BASIS FOR THE MANUFACTURE OR SALE OF ITEMS WITHOUT WRITTEN PERMISSION. COPYRIGHT © 1974 DIGITAL EQUIPMENT CORPORATION

1-0-81080-0-1 C

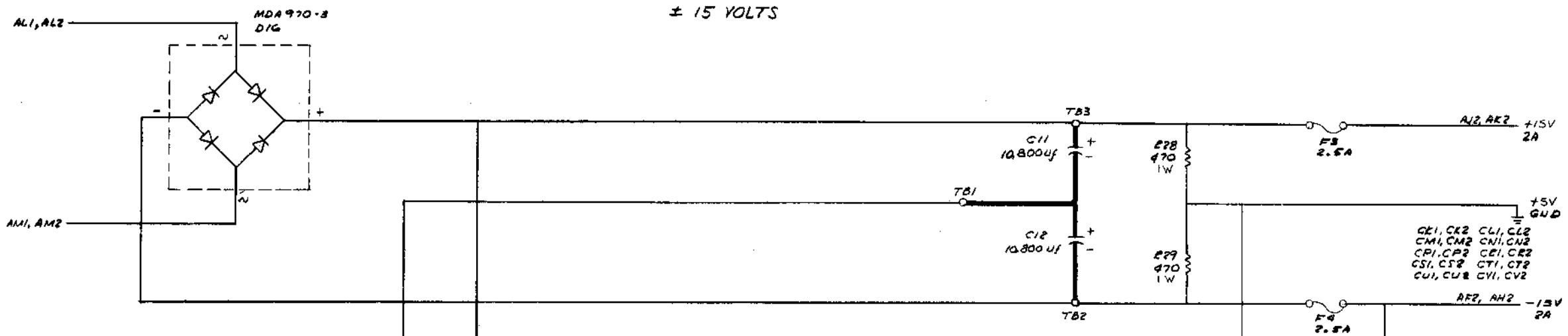

AC LOW INDICATOR

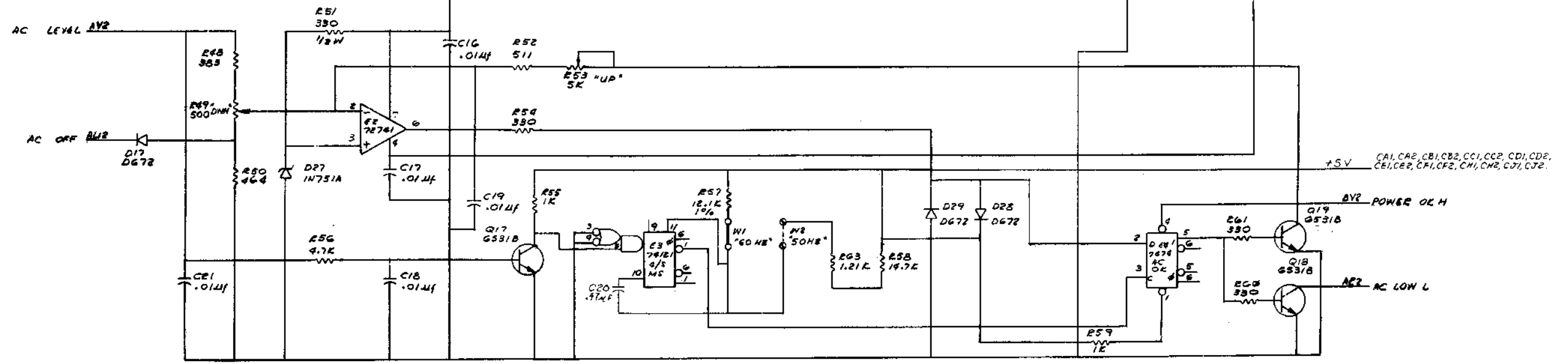

REVISIONS		
CHK	CHANGE NO.	REV.

TITLE	REGULATOR BOARD	SIZE CODE	NUMBER	REV.
	8A CORE	DCS	68018-0-1	C
SCALE	SHEET	4	OF	4

DCS 68018-0-1 C

CUSTOMER PRINT SET		ELECTRICAL					CUSTOMER PRINT SET		MECHANICAL					
MP-KK8-A	MFG. SET	FIND NO.	DRAWING NO.	REV	NO OF SHT	DESCRIPTION	OPTION NO./FILE DATE	MFG. SET	FIND NO.	DRAWING NO.	REV	NO OF SHT	DESCRIPTION	OPTION NO./FILE DATE
X		2	D-CS-M8315-Ø-1	#	10	HEX OMNIBUS CPU			1	A-PL-KK8-A-Ø	*	1	KK8-A PARTS LIST	
			K-CO-M8315-0-4	#	1	X-Y COORDINATE HOLE LOCATION								
			D-AH-M8315-Ø-5	#	1	ASSY HOLE DRAWING								
			B-MH-M8315-Ø-6	#	1	MODULE HISTORY								
X			K-RL-M8315-Ø-8	#	2	ROM PATTERN SPEC ROM H								
X			K-RL-M8315-Ø-9	#	2	ROM PATTERN SPEC ROM E								
X			K-RL-M8315-Ø-10	#	2	ROM PATTERN SPEC ROM D								
X			K-RL-M8315-Ø-11	#	2	ROM PATTERN SPEC ROM C								
X			K-RL-M8315-Ø-12	#	2	ROM PATTERN SPEC ROM B								
X			K-RL-M8315-Ø-13	#	2	ROM PATTERN SPEC ROM A								
X			K-RL-M8315-Ø-14	#	2	ROM PATTERN SPEC ROM J								
X			K-RL-M8315-Ø-15	#	9	ROM PATTERN SPEC ROM F								
X			D-FD-M8315-Ø-16	#	1	FLOW DIAGRAM M8315 INDEX								
X			D-FD-M8315-Ø-17	#	1	FLOW DIAGRAM M8315 FC1								
X			D-FD-M8315-Ø-18	#	1	FLOW DIAGRAM M8315 FC2								
X			D-FD-M8315-Ø-19	#	1	FLOW DIAGRAM M8315 FC3								
X			D-FD-M8315-Ø-20	#	1	FLOW DIAGRAM M8315 FC4								
X			D-FD-M8315-Ø-21	#	1	FLOW DIAGRAM M8315 FC5								
X			D-FD-M8315-Ø-22	#	1	FLOW DIAGRAM M8315 FC6								
X			D-FD-M8315-Ø-23	#	1	FLOW DIAGRAM M8315 FC7								
X			D-FD-M8315-Ø-24	#	1	FLOW DIAGRAM M8315 FC8								
X			D-FD-M8315-Ø-25	#	1	FLOW DIAGRAM M8315 FC9								
X			D-FD-M8315-Ø-26	#	1	FLOW DIAGRAM M8315 FC1Ø								
X			D-FD-M8315-Ø-27	#	2	FLOW DIAGRAM M8315 BUS TIMING								
X		3	D-CS-M8318-Ø-1	#	2	OMNIBUS DIODE CLAMPS								
			K-CO-M8318-Ø-4	#	1	X-Y COORDINATE HOLE LOCATION								
			D-AH-M8318-Ø-5	#	1	ASSY HOLE DRAWING								
			B-MH-M8318-Ø-6	#	1	MODULE HISTORY								

CUSTOMER PRINT SET CODES
X = PRINT OF DOCUMENT INCLUDED IN PRINT SET
C = INCLUDES ALL PRINTS INDICATED ON DOCUMENT
S = CONFIDENTIAL AUTHORIZED SIGNATURE REQUIRED

TITLE: HEX OMNIBUS CPU
SHEET 2 OF 2
SIZE CODE: B DD
NUMBER: KK8-A
REV:

DIGITAL EQUIPMENT CORPORATION MAYNARD, MASSACHUSETTS					QUANTITY / VARIATION															
PARTS LIST					KK8-A	1	1	1	1	1	1	1	1	1	1	1	1	1	1	1
MADE BY PAUL GARDNER		CHECKED <i>S. R. Huts</i>		SECTION																
DATE 11/25/74		DATE 12-20-74																		
ENG <i>John M. G.</i>		PROD <i>John M. G.</i>		ISSUED SECT.																
DATE 12/30/74		DATE 12-20-74																		
ITEM NO.	DWG NO. / PART NO.	DESCRIPTION																		
1	D-CS-M8315-Ø-1	HEX OMNIBUS CPU			1															
2	D-CS-M8318-Ø-1	OMNIBUS DIODE CLAMPS			1															
TITLE				ASSY NO.	SIZE	CODE	NUMBER			REV.	ECO NO.									
KK8-A PARTS LIST					A	PL	KK8-A-Ø													
SHEET 1 OF 1					DIST.															

"THIS DRAWING AND SPECIFICATIONS, HEREIN, ARE THE PROPERTY OF DIGITAL EQUIPMENT CORPORATION AND SHALL NOT BE REPRODUCED OR COPIED OR USED IN WHOLE OR IN PART AS THE BASIS FOR THE MANUFACTURE OR SALE OF ITEMS WITHOUT WRITTEN PERMISSION.
 COPYRIGHT © 1974 DIGITAL EQUIPMENT CORPORATION"

NOTES:
 1. ALL UNLABELED DIODES ARE DEC TYPE D664
 2. +3V, +3VA AND +3VB CONNECTION ON SHEET # B
 3. FOR ETCH CUTS REFER TO DRAWING # 1-1
 4. PEEK CUTS

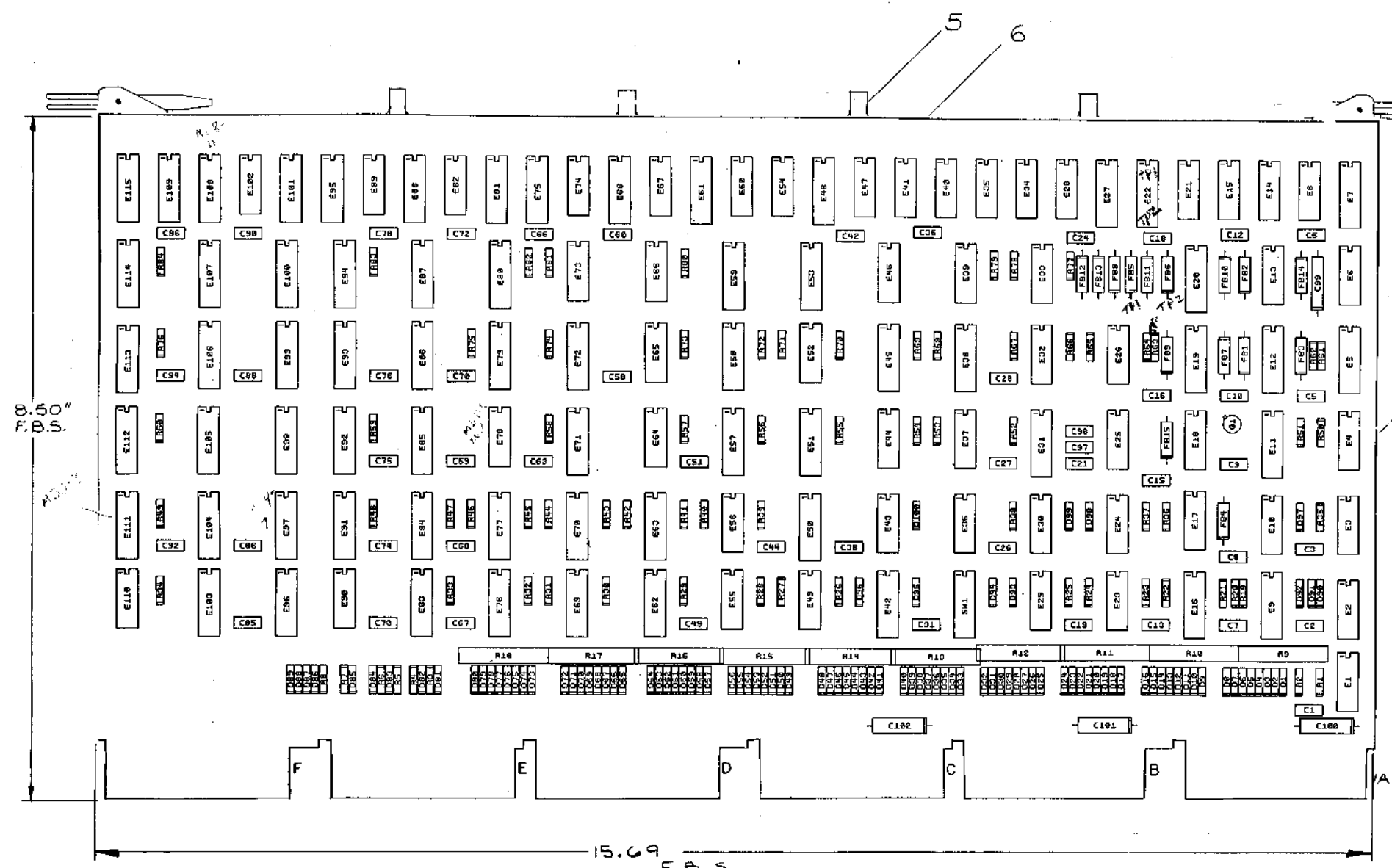

IC 74157	8	16
74S158	8	16
74163	8	16
74S175	8	16
74S194	8	16
380	1	8
8097	8	16
8235	8	16
8234	8	16
8271	8	16
8T10	8	16
256 BIT ROM	8	16
IC TYPE	GND	+5V

GND. CONNECTION—PINS C, F, N, T ON CONNECTORS

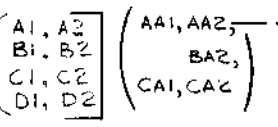

FOR ALL G.B. μ f & .01 μ f CAPS

GND AND 5V ARE USUALLY PIN 7 AND 14 RESPECTIVELY EXCEPTIONS ARE STATED ABOVE
 IC PIN LOCATIONS

1024 BIT ROM	8	16
7442	8	16
7483	12	5
74120	8	16
74123	8	16
74S139	8	16
74151	8	16
74153	8	16
IC TYPE	GND	+5V

REF	DESIGNATION	DESCRIPTION	PART NO.	ITEM NO.
REF	X-Y COORDINATE HOLE LOCATION		K-CO-M8315-0-1	1
REF	ASSY/DRILLING HOLE LAYOUT		D-AH-M8315-0-5	2
REF	MODULE ECO HISTORY		B-MH-8315-0-6	3
1	ETCHED CIRCUIT BOARD		5010932	4
1	HEX BOARD HANDLE ASSY		1210717-2	5
12	EYELETS		9006732	6
3	C100 THRU C102	CAP 6.8uf 35V 10%	1005306	7
2	C97, C98	CAP .047uf 16V DISC	1009678	8
1	C99	CAP 15uf 20V 10%	1004812	9
48	C1 THRU C3, C5 THRU C10, C12, C13, C15, C16, C18, C19, C21, C24, C26, C27, C28, C31, C36, C38, C42, C44, C49, C51, C56, C60, C63, C66 THRU C70, C72 THRU C76, C78, C85, C86, C88, C90, C92, C94, C96	CAP .01uf 100V DISC	1001610-01	10
8	D86 THRU D92, D97	DIODE D662	1100113	11
92	D1 THRU D85, D93 THRU D96, D98 THRU D100	DIODE D664	1100114	12
1	SW1	DIP SWITCH PACKAGE	1211164-04	13
11	R2, R5, R6, R8, R19, R36, R62 THRU R66	RES 390 1/4W 5%	1300309	14
12	R1, R3, R4, R7, R20, R21, R23 THRU R26, R35, R37	RES 470 1/4W 5%	1300316	15
45	R22, R27, R29 THRU R34, R39 THRU R49, R52, R53, R55 THRU R60, R67 THRU R84	RES 1K 1/4W 5%	1300385	16
1	R28	RES 3.3K 1/4W 5%	1300439	17
1	R61	RES 22K 1/4W 5%	1301808	18
2	R50, R51	RES 27 1/4W 5%	1301522	19
5	R9, R10, R13, R14, R18	RES PACK 390 OHM	1312114-00	20
5	R11, R12, R15, R16, R17	RES PACK 470 OHM	1312114-01	21
2	R39, R54	RES 150 1/4W 5%	1300250	22
1	D1	TRANSISTOR DEC 3009B	1503100	23
15	FB1 THRU FB15	FERRITE BEAD CHOKER	1611257-01	24
1	E2	20 MHZ X'TAL OSC	1811860-00	25
6	E1, E10, E17, E26, E29, E48	IC DEC 74500	1910532	26
1	E33	IC DEC 7402	1909004	27
4	E3, E23, E25, E40, E56, E78, E82, E89	IC DEC 74504	1910534	28
3	E47, E85, E74	IC DEC 7408	1910155	29
3	E24, E64, E90	IC DEC 74S10	1910538	30
2	E13, E28	IC DEC 74S11	1910537	31
1	E60	IC DEC 7412	1909955	32
3	E44, E49, E52	IC DEC 7417	1909929	33
2	E110, E102	IC DEC 74H21	1909058	34
1	E54	IC DEC 7430	1905578	35
3	E41, E43, E66	IC DEC 7432	1911521	36
1	E14	IC DEC 7437	1910091	37
2	E16, E32	IC DEC 74S40	1910541	38
1	E71	IC DEC 7442	1910046	39
2	E4, E6	IC DEC 74S51	1911712	40
4	E8, E15, E21, E34	IC DEC 74S74	1910544	41
3	E85, E101, E113	IC DEC 7483	1909932	42
3	E19, E22, E27	IC DEC 74120	1911314	43
1	E7	IC DEC 74123	1910436	44
2	E20, E58	IC DEC 74S139	1911676	45
2	E48, E59	IC DEC 74151	1909936	46
1	E45	IC DEC 74153	1909937	47

FIRST USED ON OPTION MODEL		PARTS LIST	
PDP 8 A		ETCH BOARD REV. E	
DRN. DATE	10/29/74	DATE	11/17/74
CHKD. DATE	11/17/74	DATE	11/17/74
ENG. DATE	11/17/74	DATE	11/17/74
PROJ. ENG. DATE	11/17/74	DATE	11/17/74
PROD. DATE	11/17/74	DATE	11/17/74
NEXT HIGHER ASSY		A-FL-KK3-A-0	
SCALE	1 OF 10	SCALE	1 OF 10
SHEET	1 OF 10	SHEET	1 OF 10
DEC NO.	EIA NO.	DEC NO.	EIA NO.
SEMICONDUCTOR CONVERSION CHART			
TITLE		HEX OMNIBUS CPU	
SIZE CODE	D CS	NUMBER	M8315-0-1
REV.	D	REV.	D

"THIS DRAWING AND SPECIFICATIONS, HEREIN, ARE THE PROPERTY OF DIGITAL EQUIPMENT CORPORATION AND SHALL NOT BE REPRODUCED OR COPIED OR USED IN WHOLE OR IN PART AS THE BASIS FOR THE MANUFACTURE OR SALE OF ITEMS WITHOUT WRITTEN PERMISSION. COPYRIGHT © 1974, DIGITAL EQUIPMENT CORPORATION"

1-0 210000 2

1	E51	IC DEC 74157	1910855	48	
7	E68, E79, E88, E95, E107, E109, E115	IC DEC 74S158	1910549	49	
3	E75, E93, E94	IC DEC 74163	1911713	50	
2	E5, E42	IC DEC 74S175	1910957	51	
8	E9, E11, E12, E16, E61, E99, E100, E114	IC DEC 74S194	1910552	52	
1	E36	IC DEC 380	1909485	53	
2	E67, E73	IC DEC 8093	1910837	54	
4	E77, E84, E104, E105	IC DEC 8097	1911527	55	
3	E80, E86, E98	IC DEC 8234	1911315	56	
3	E81, E87, E92	IC DEC 8235	1909935	57	
1	E31	IC DEC 8271	1909615	58	
5	E30, E35, E37, E39, E55	IC DEC 8881	1909705	59	
11	E50, E62, E83, E91, E96, E97, E103, E106, E108, E111, E112	IC DEC 8T10	1911711	60	
1	E69	256 BIT ROM (A)	23078A1	61	
1	E57	256 BIT ROM (B)	23077A1	62	
1	E70	256 BIT ROM (C)	23078A1	63	
1	E72	256 BIT ROM (D)	23075A1	64	
1	E76	256 BIT ROM (E)	23074A1	65	
1	E63	256 BIT ROM (H)	23073A1	66	
1	E38	256 BIT ROM (J)	23079A1	67	
1	E53	1024 BIT ROM (F)	23080A2	68	
6		WIRE	30AWG GREEN	9105740-58	69

SWITCH SELECTION CHART
(FOR AUTO RESTART LOCATION)

SWI-	1	FIELD 7
	2	4000
	3	2000
	4	1000
	5	400
	6	200
	7	OFF (DISABLES AUTO RESTART)

ONLY ONE SWITCH MAY BE CLOSED AT A TIME

8. CLOSED FOR NORMAL OPERATION; OPEN ONLY FOR SERVICE TO TIMING GENERATOR (TG TEST)

COMPONENT SUBSTITUTION CHART

PART CALLED FOR			SUBSTITUTE PART		
QTY	PART NO	DESC	QTY	PART NO	DESC
1	1909485	IC 380	1	1910392	5380
			1	1909971	6380
			1	1910390	7380
			1	1911469	8440

REVISIONS		
CHK	CHANGE NO.	REV.

TITLE	HEX OMNIBUS CPU	SIZE CODE	D CS	NUMBER	M8315-0-1	REV.	D
SCALE	1/1	SHEET	2	OF 10			

REV. D
M8315-0-1
DCS M8315-0-1

THIS DRAWING AND SPECIFICATIONS HEREIN ARE THE PROPERTY OF DIGITAL EQUIPMENT CORPORATION AND SHALL NOT BE REPRODUCED OR COPIED OR USED IN WHOLE OR IN PART AS THE BASIS FOR THE MANUFACTURE OR SALE OF ITEMS WITHOUT WRITTEN PERMISSION.
 COPYRIGHT © 1974 DIGITAL EQUIPMENT CORPORATION

1-0-5188M SC D 2

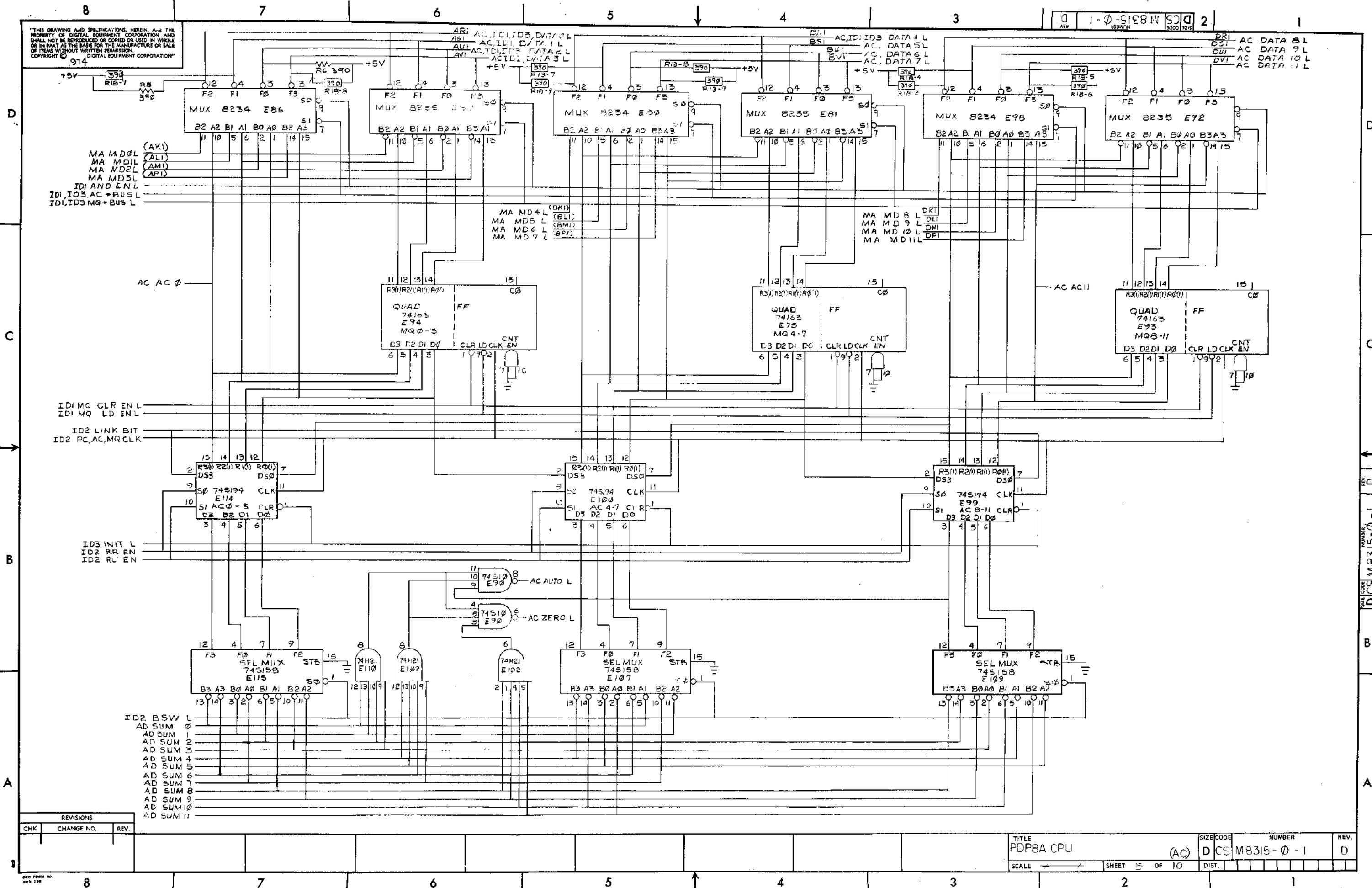

REVISIONS		
CHK	CHANGE NO.	REV.

TITLE: PDP8A CPU
 SIZE CODE: (AQ) DCS M8315-0-1
 NUMBER: 1
 REV: D
 SHEET 3 OF 10

"THIS DRAWING AND SPECIFICATIONS, HEREIN, ARE THE PROPERTY OF DIGITAL EQUIPMENT CORPORATION AND SHALL NOT BE REPRODUCED OR COPIED OR USED IN WHOLE OR IN PART AS THE BASIS FOR THE MANUFACTURE OR SALE OF ITEMS WITHOUT WRITTEN PERMISSION. COPYRIGHT © 1974 DIGITAL EQUIPMENT CORPORATION"

1-0-510RW 000 2

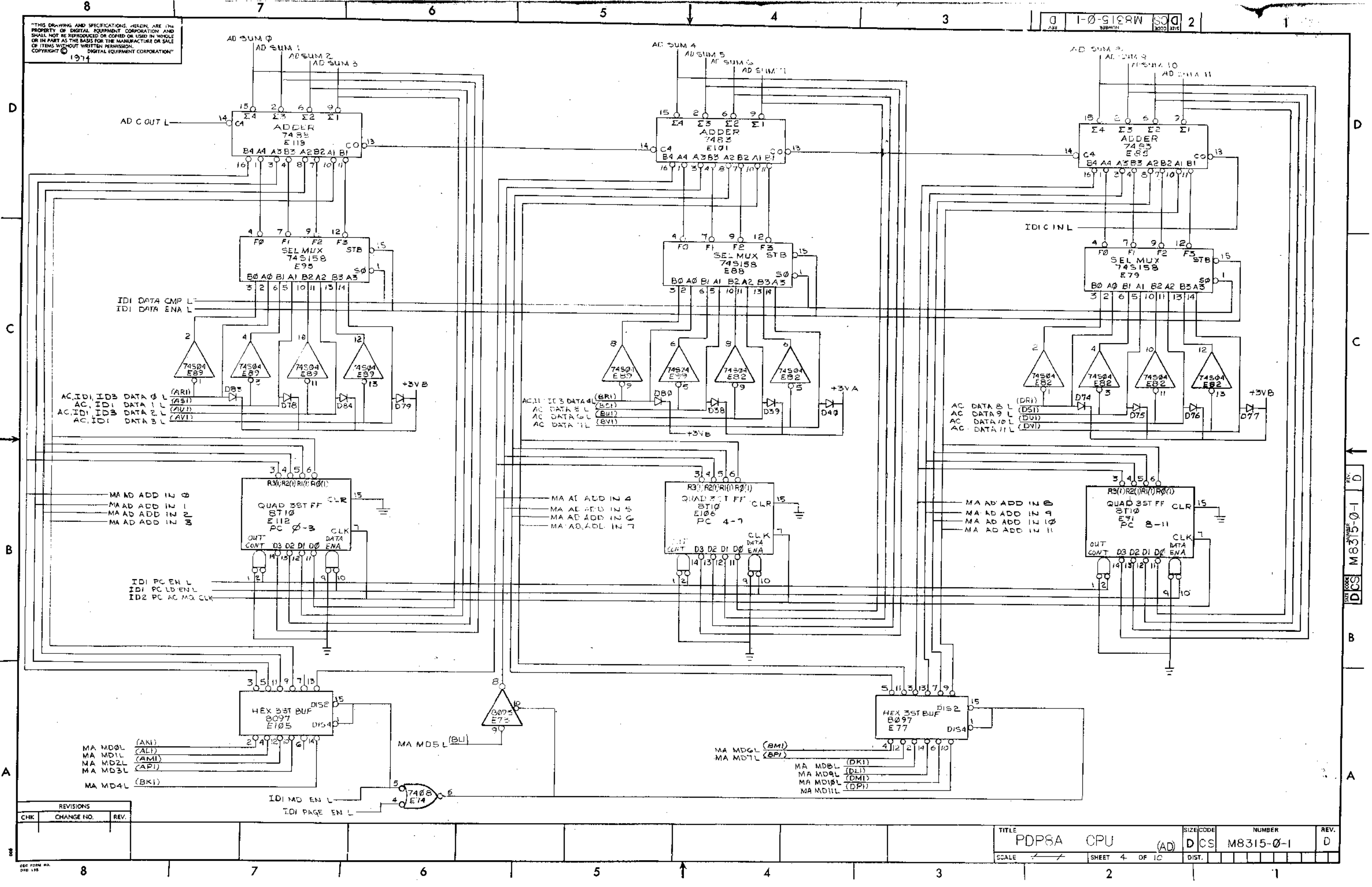

REVISIONS		
CHK	CHANGE NO.	REV.

TITLE	PDP5A CPU (AD)	SIZE CODE	DCS	NUMBER	M8315-0-1	REV.	D
SCALE		SHEET	4	OF 10			

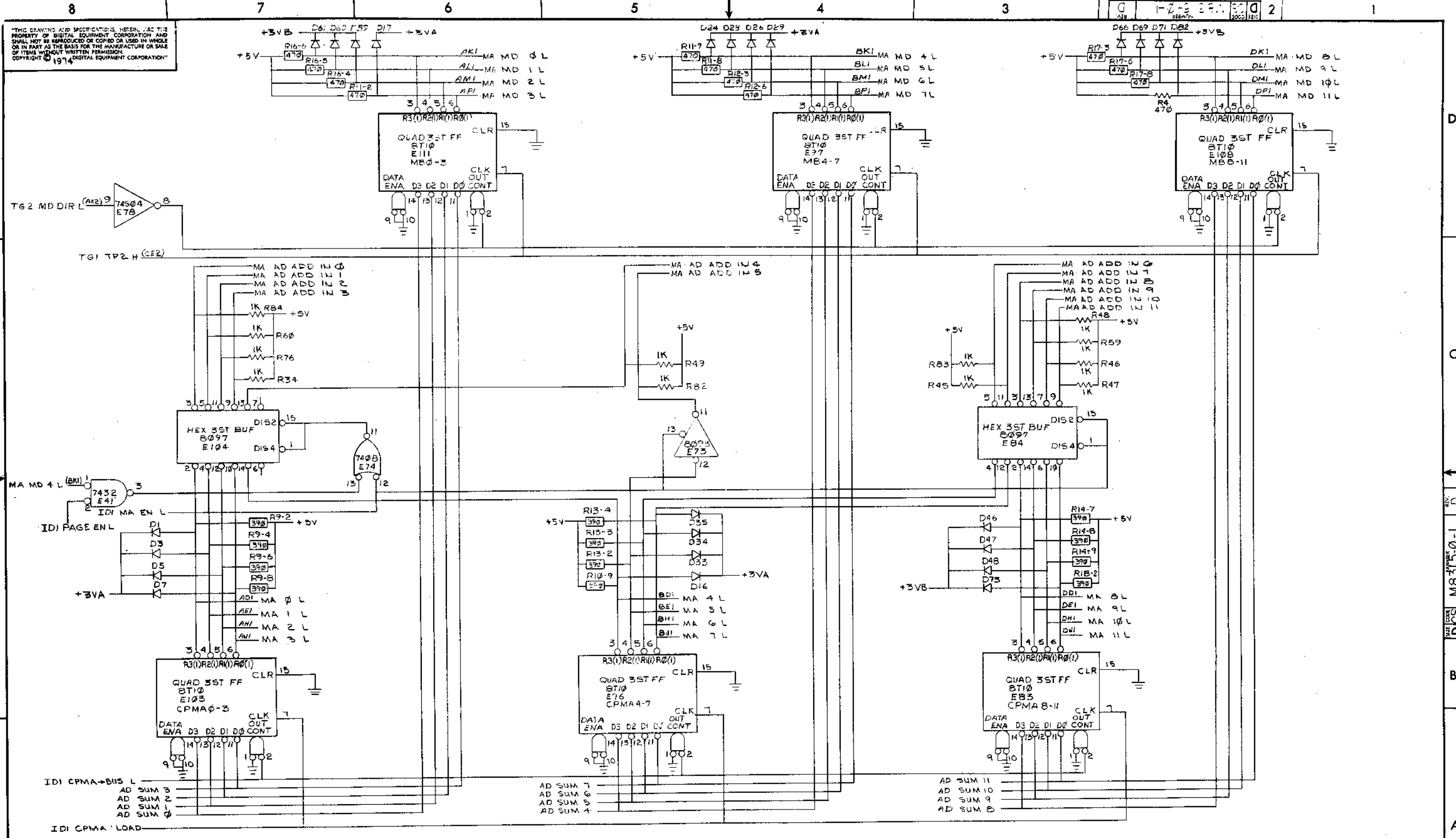

THIS DRAWING AND SPECIFICATIONS HEREIN ARE THE PROPERTY OF DIGITAL EQUIPMENT CORPORATION AND SHALL NOT BE REPRODUCED OR COPIED OR USED IN WHOLE OR IN PART AS THE BASIS FOR THE MANUFACTURE OR SALE OF ITEMS WITHOUT WRITTEN PERMISSION. COPYRIGHT © 1974

REVISIONS		
CHK	CHANGE NO.	REV.

TITLE	PDP8A CPU (MA)	SIZE CODE	D CS	NUMBER	M8315-0-1	REV.	D
SCALE	1/1	SHEET	5	OF 10			

THIS DRAWING AND SPECIFICATIONS HEREIN ARE THE PROPERTY OF DIGITAL EQUIPMENT CORPORATION AND SHALL NOT BE REPRODUCED OR COPIED OR USED IN WHOLE OR IN PART AS THE BASIS FOR THE MANUFACTURE OR SALE OF ITEMS WITHOUT WRITTEN PERMISSION. COPYRIGHT © 1974

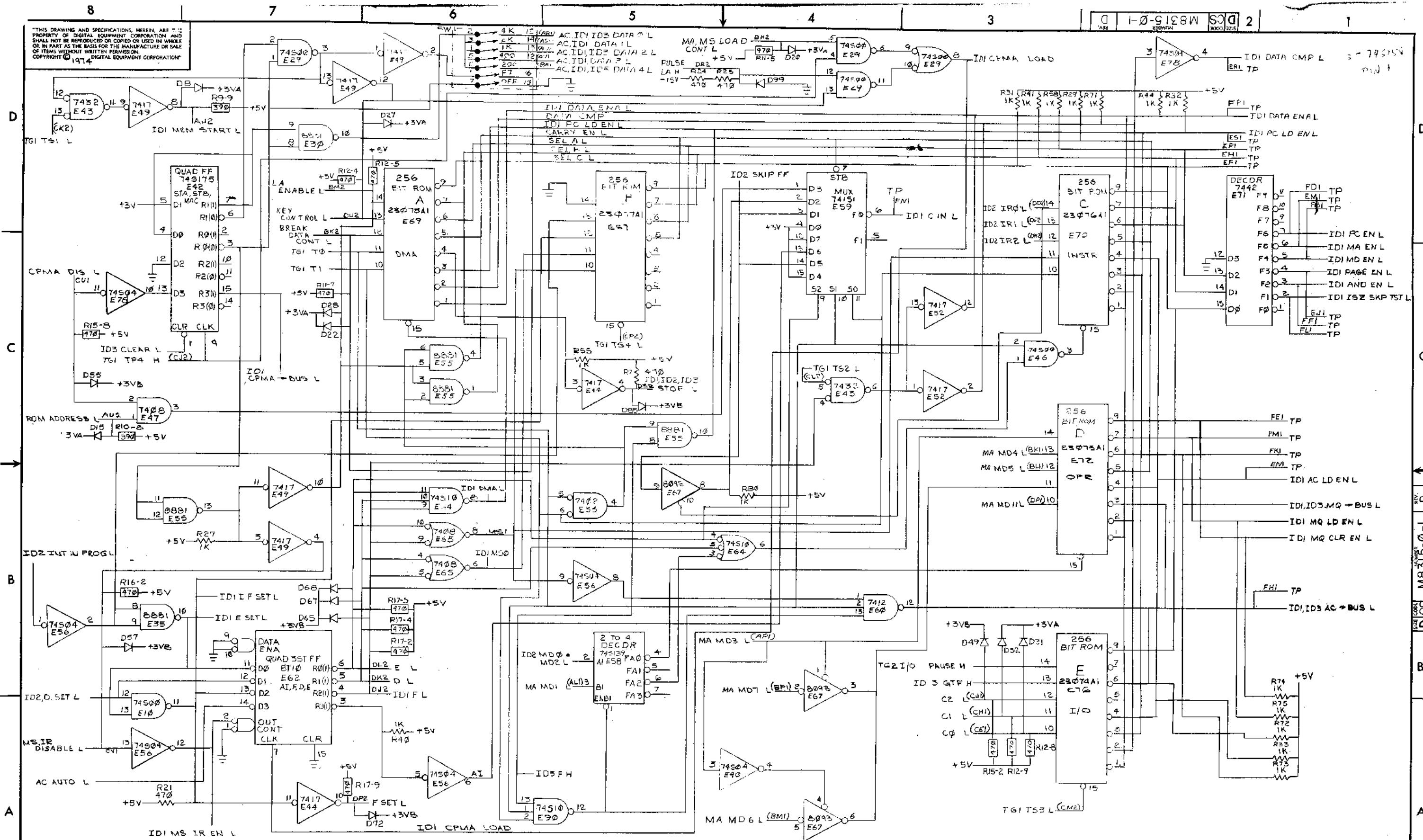

REVISIONS table with columns for CHK, CHANGE NO., and REV.

Metadata table containing TITLE (PDP8A CPU (ID1)), SIZE CODE (D CS), NUMBER (M8315-0-1), and REV. (D).

"THIS DRAWING AND SPECIFICATIONS, HEREIN, ARE THE PROPERTY OF DIGITAL EQUIPMENT CORPORATION AND SHALL NOT BE REPRODUCED OR COPIED OR USED IN WHOLE OR IN PART AS THE BASIS FOR THE MANUFACTURE OR SALE OF ITEMS WITHOUT WRITTEN PERMISSION. COPYRIGHT © 1974 DIGITAL EQUIPMENT CORPORATION"

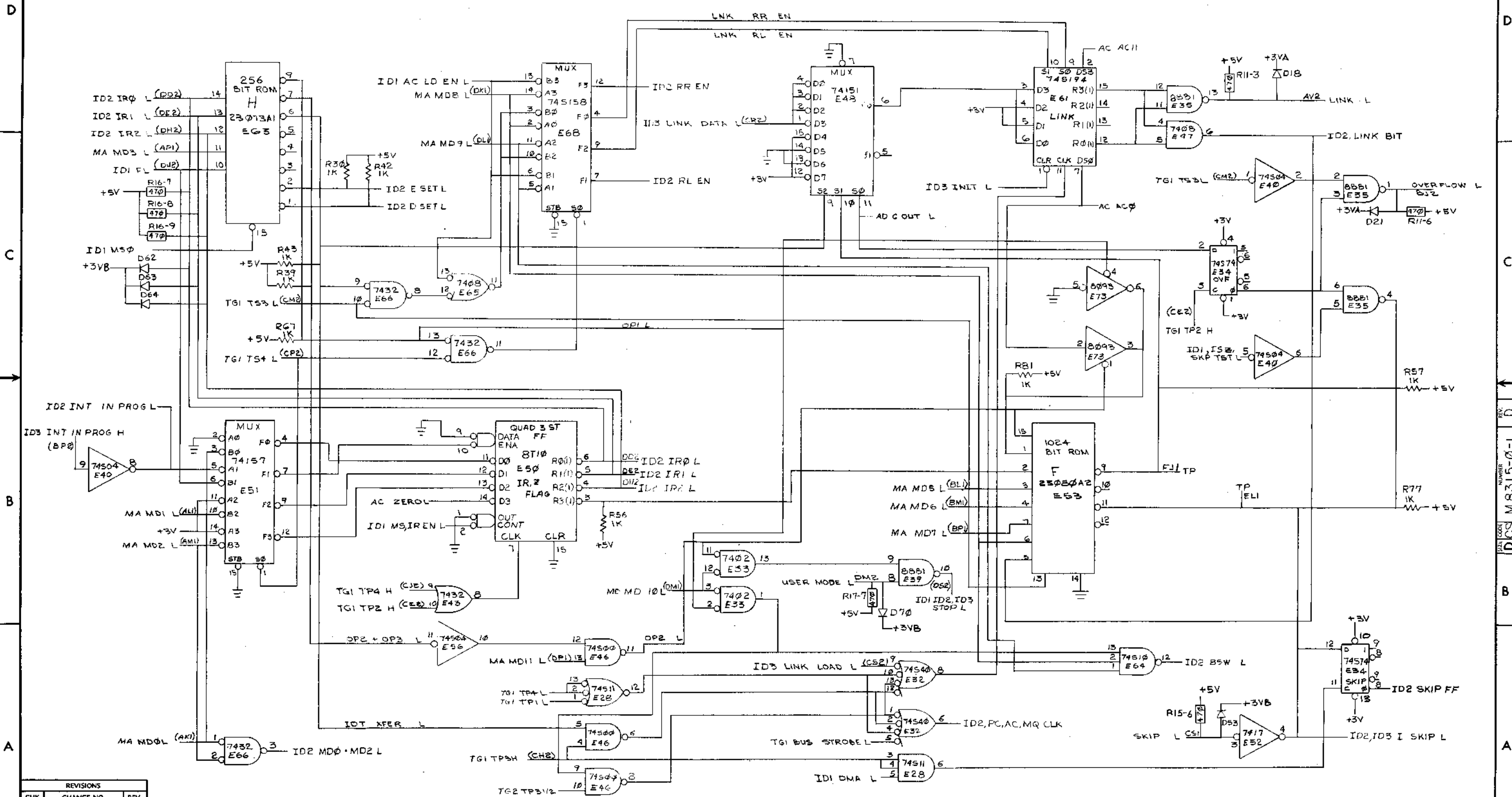

REVISIONS		
CHK	CHANGE NO.	REV.

TITLE	PDP8A CPU (102)	SIZE CODE	D CS	NUMBER	M8315-0-1	REV.	D
SCALE	1:1	SHEET	7	OF 10	DIST.		

"THIS DRAWING AND SPECIFICATIONS, HEREIN, ARE THE PROPERTY OF DIGITAL EQUIPMENT CORPORATION AND SHALL NOT BE REPRODUCED OR COPIED OR USED IN WHOLE OR IN PART AS THE BASIS FOR THE MANUFACTURE OR SALE OF ITEMS WITHOUT WRITTEN PERMISSION. DIGITAL EQUIPMENT CORPORATION. COPYRIGHT © 1974."

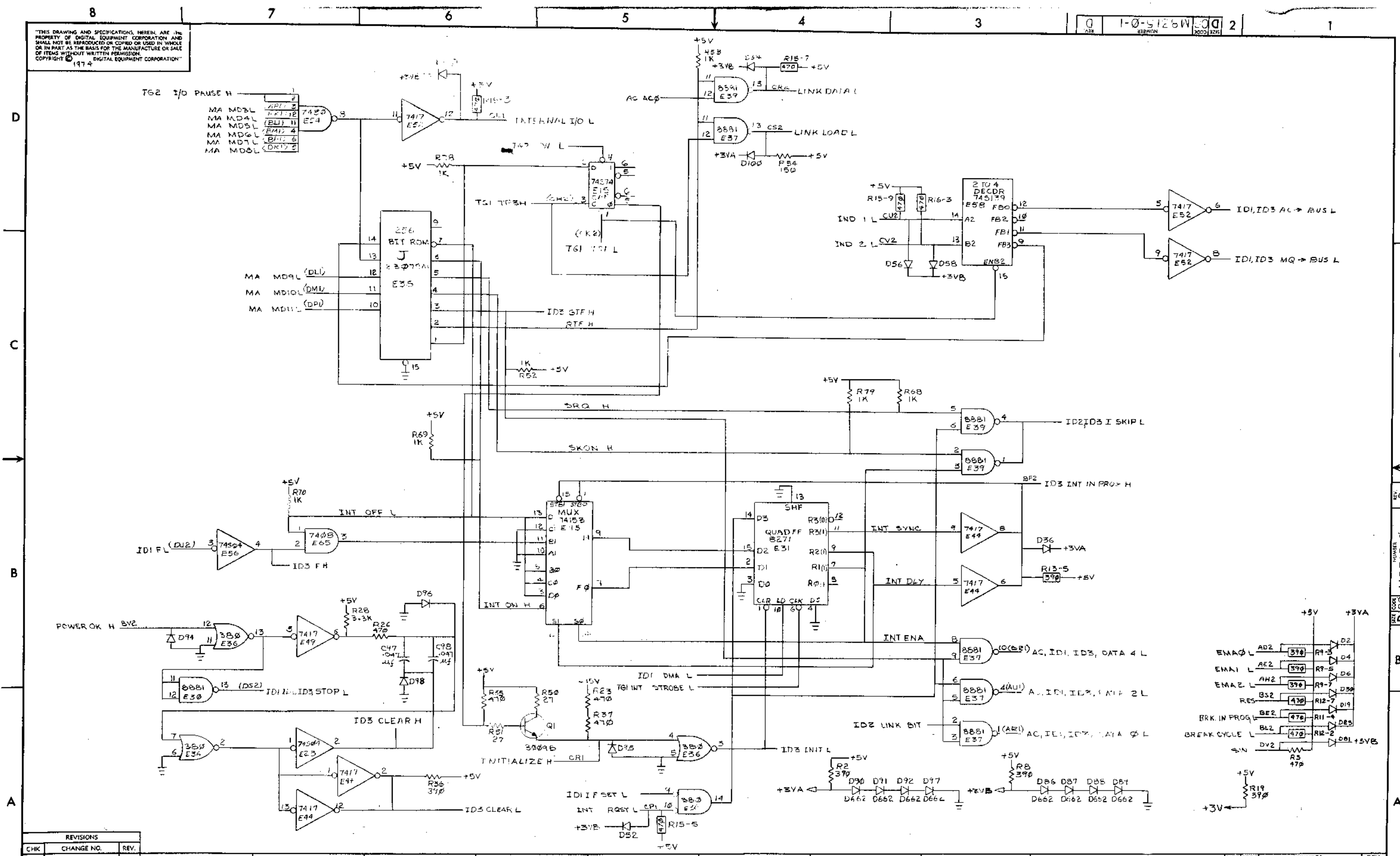

REVISIONS		
CHK	CHANGE NO.	REV.

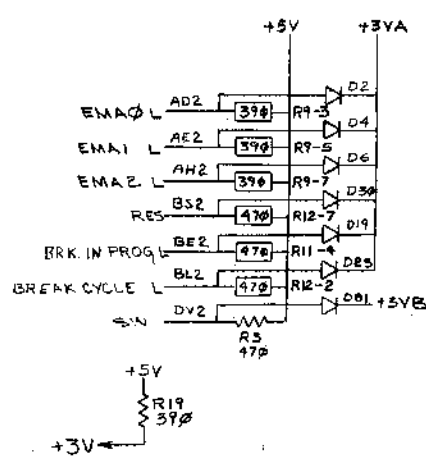

REV. D
NUMBER M8315-0-1
DICE

THIS DRAWING AND SPECIFICATIONS HEREIN ARE THE PROPERTY OF DIGITAL EQUIPMENT CORPORATION AND SHALL NOT BE REPRODUCED OR COPIED OR USED IN WHOLE OR IN PART AS THE BASIS FOR THE MANUFACTURE OR SALE OF ITEMS WITHOUT WRITTEN PERMISSION. DIGITAL EQUIPMENT CORPORATION COPYRIGHT © 1974

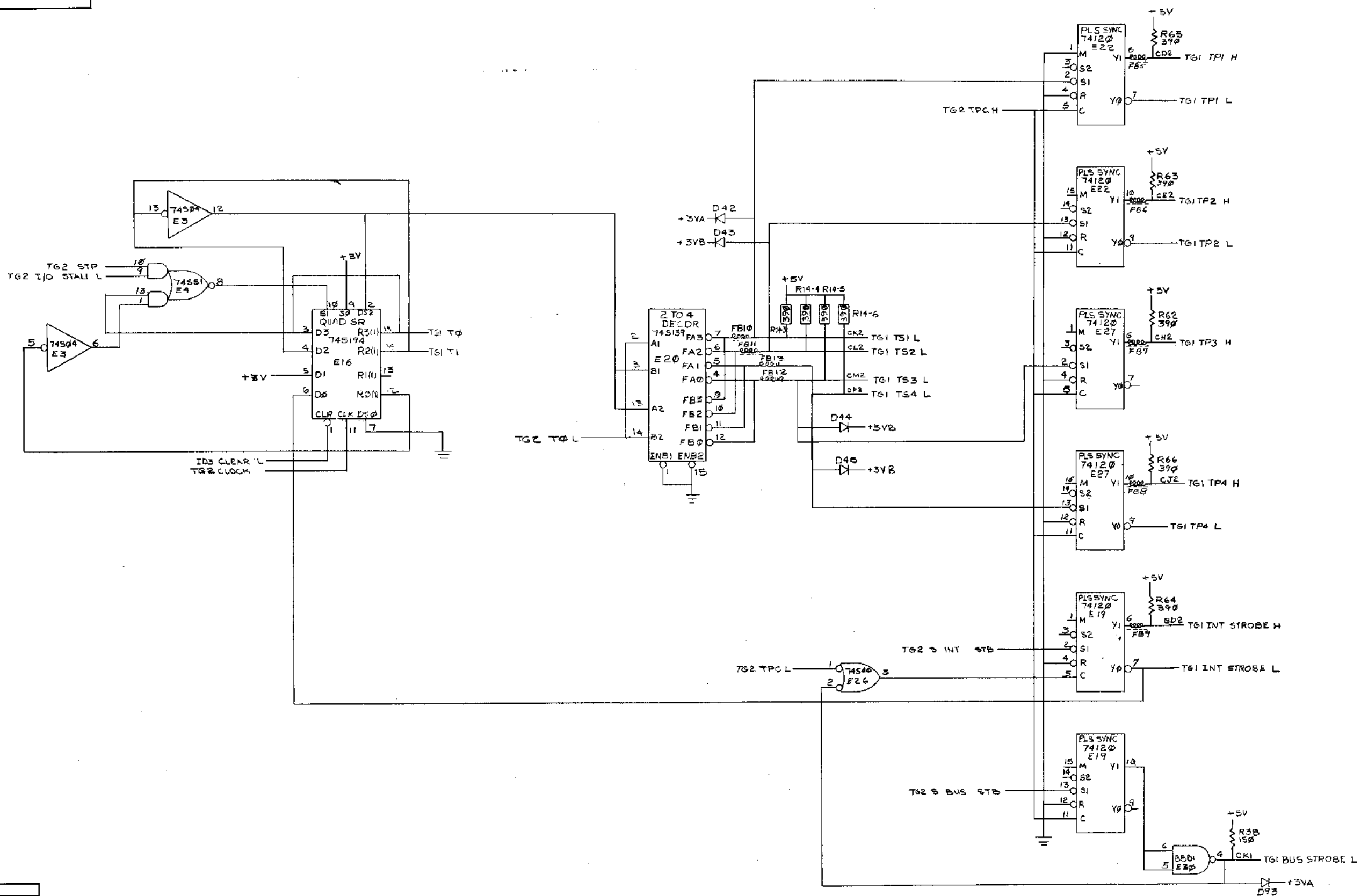

REVISIONS		
CHK	CHANGE NO.	REV.

TITLE	PDP8A CPU (TGD)	SIZE CODE	D CS	NUMBER	M8315-0-1	REV.	D
SCALE	1:1	SHEET	9	OF 10	DIST.		

ALL DRAWINGS AND SPECIFICATIONS HEREIN ARE THE PROPERTY OF DIGITAL EQUIPMENT CORPORATION AND SHALL NOT BE REPRODUCED OR COPIED OR USED IN WHOLE OR IN PART AS THE BASIS FOR THE MANUFACTURE OR SALE OF ITEMS WITHOUT WRITTEN PERMISSION. COPYRIGHT © 1974 DIGITAL EQUIPMENT CORPORATION

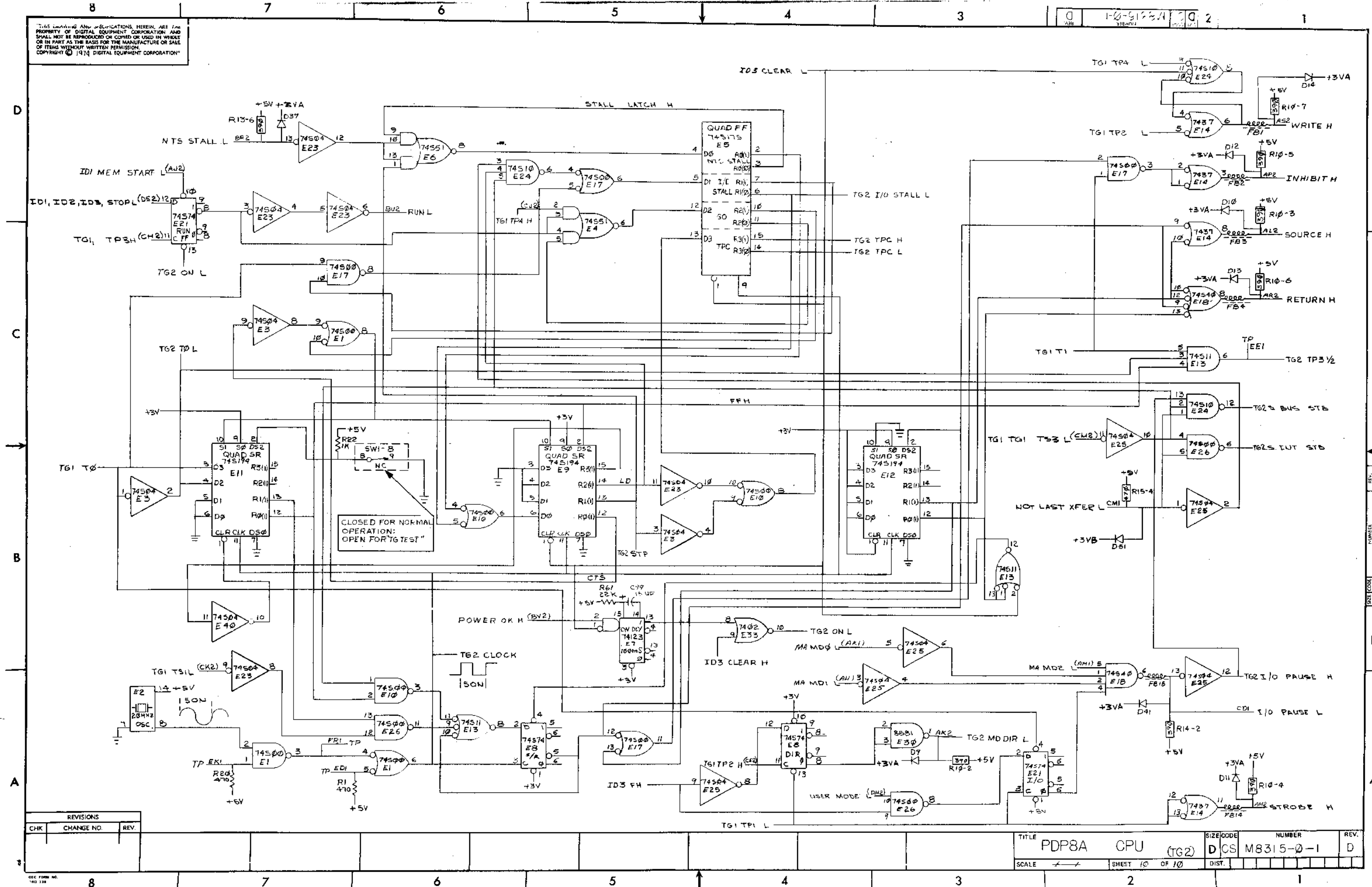

REVISIONS		
CHK	CHANGE NO.	REV.

TITLE	PDP8A CPU (TG2)	SIZE CODE	D CS	NUMBER	M8315-0-1	REV.	D
SCALE	1:1	SHEET	10	OF	10	DIST.	

SIZE CODE NUMBER DCS M8315-0-1 REV. D

This drawing and specifications, herein, are the property of Digital Equipment Corporation and shall not be reproduced or copied or used in whole or in part as the basis for the manufacture or sale of items without written permission. COPYRIGHT © 1974

DIGITAL EQUIPMENT CORPORATION

FIRST USED ON OPTION MODEL	QTY.	DESCRIPTION	PART NO.	ITEM NO.
PDP8-A				
PARTS LIST				
DRN.	DATE	digital EQUIPMENT CORPORATION MAYNARD, MASSACHUSETTS TITLE ROM PATTERN SPEC (ROM H)		
CHK'D.	DATE			
ENG.	DATE			
PROJ. ENG.	DATE			
PROD.	DATE			
NEXT HIGHER ASSEMBLY		SIZE CODE	NUMBER	REV.
B - DD - PDP8 - A		K RL	M8315-Ø-8	
SCALE		DIST.		
SHEET 1 OF 2				

REVISIONS	CHANGE NO.	REV.
CHK		



DEC PART NUMB: 21-071A1
 ORIGINATOR: LOUIS KLOTZ
 DATE OF ORIGIN: 6/27/74

digital EQUIPMENT CORPORATION

DECIMAL LOC	OCTAL LOC	BINARY DATA	OCTAL DATA
0	00	10100011	243
1	01	00000000	000
2	02	01100011	143
3	03	00000000	000
4	04	11000011	303
5	05	00000000	000
6	06	11000011	303
7	07	00000000	000
8	10	11100010	342
9	11	11100011	343
10	12	11100011	343
11	13	11100011	343
12	14	11100010	342
13	15	11100001	341
14	16	11100001	341
15	17	11100001	341
16	20	11100010	342
17	21	11100001	341
18	22	11100001	341
19	23	11100001	341
20	24	11100010	342
21	25	11100001	341
22	26	11100001	341
23	27	11100001	341
24	30	11100010	342
25	31	11100001	341
26	32	11100001	341
27	33	11100001	341
28	34	11100010	342
29	35	11100001	341
30	36	11100001	341
31	37	11100001	341

This drawing and specifications, herein, are the property of Digital Equipment Corporation and shall not be reproduced or copied or used in whole or in part as the basis for the manufacture or sale of items without written permission. COPYRIGHT © 1974

DIGITAL EQUIPMENT CORPORATION

REV. 2 | SIZE CODE KRL | NUMBER M8315-Ø-9

FIRST USED ON OPTION MODEL	QTY.	DESCRIPTION	PART NO.	ITEM NO.
PDP8-A				
PARTS LIST				
DRN. <i>George Drayton</i>	DATE 7/23/74	<div style="text-align: center;">  <p>digital EQUIPMENT CORPORATION MAYNARD, MASSACHUSETTS</p> </div>		
CHK'D. <i>[Signature]</i>	DATE 7/23/74			
ENG. <i>[Signature]</i>	DATE 7/23/74			
PROJ. ENG. <i>[Signature]</i>	DATE 7/23/74			
PROD. <i>[Signature]</i>	DATE 7/23/74			
NEXT HIGHER ASSEMBLY		TITLE ROM PATTERN SPEC (ROM E)		
B-DD-PDP8-A				
SCALE	---	SIZE CODE	NUMBER	REV.
SHEET	1 OF 2	KRL	M8315-Ø-9	
		DIST.		

REV.	
CHANGE NO.	
CHK	

K-RL-MB315-0-9

KOB PATTERN SPEC

PAGE 2 OF 2

DEC PART NUMBER: 23-07441
ORIGINATOR: SOUTS 6601Z
DATE OF ORIGIN: 6/27/74

digital EQUIPMENT CORPORATION

DECIMAL LOC	OCTAL LOC	BINARY DATA	OCTAL DATA
0	00	10101111	257
1	01	10101111	257
2	02	10101111	257
3	03	10101111	257
4	04	10101111	257
5	05	10101111	257
6	06	10101111	257
7	07	10101111	257
8	10	00000000	000
9	11	00000000	000
10	12	00000000	000
11	13	00000000	000
12	14	00000000	000
13	15	00000000	000
14	16	00000000	000
15	17	00000000	000
16	20	10101000	250
17	21	10101000	250
18	22	00101000	050
19	23	00101000	050
20	24	10100100	244
21	25	10000100	204
22	26	10000111	207
23	27	10000100	204
24	30	00000000	000
25	31	00000000	000
26	32	00000000	000
27	33	00000000	000
28	34	00000000	000
29	35	00000000	000
30	36	00000000	000
31	37	10100100	244

K-RL-MB315-0-9

4

3

REV. NUMBER SIZE CODE K RL M8315-Ø-1Ø

2

1

This drawing and specifications, herein, are the property of Digital Equipment Corporation and shall not be reproduced or copied or used in whole or in part as the basis for the manufacture or sale of items without written permission. COPYRIGHT ©1974

DIGITAL EQUIPMENT CORPORATION

B



A

FIRST USED ON OPTION MODEL	QTY.	DESCRIPTION	PART NO.	ITEM NO.
PDP8 -A				
PARTS LIST				
DRN <i>George Drayton</i>	DATE 7/23/74	digital EQUIPMENT CORPORATION MAYNARD, MASSACHUSETTS TITLE ROM PATTERN SPEC (ROM.D) SIZE CODE NUMBER REV. K RL M8315-Ø-1Ø		
CHK'D <i>[Signature]</i>	DATE 7/23/74			
ENG <i>[Signature]</i>	DATE 7/16/74			
PROJ. ENG. <i>[Signature]</i>	DATE 7/16/74			
PROD. <i>[Signature]</i>	DATE 7/16/74			
NEXT HIGHER ASSEMBLY B-DD-PDP8-A				
SCALE --				
SHEET 1 OF 2		DIST.		

REVISIONS	CHANGE NO.	REV.
CHK		

4

3



2

1

K-RL-M8315-Ø-1Ø

ROM PATTERN SPEC

PAGE 2 OF 2

DEC PART NUMB: 23-075A1
 ORIGINATOR: LOUIS KLOTZ
 DATE OF ORIGIN: 6/19/71

DIGITAL EQUIPMENT CORPORATION

DECIMAL LOC	OCTAL LOC	BINARY DATA	OCTAL DATA
0	00	01010100	124
1	01	11110100	364
2	02	11010100	324
3	03	11110100	364
4	04	01110111	167
5	05	11110100	364
6	06	11110111	367
7	07	11110100	364
8	10	10010100	224
9	11	11110000	360
10	12	11010000	320
11	13	11110000	360
12	14	10110111	267
13	15	11110000	360
14	16	11110000	360
15	17	11110000	360
16	20	11100110	346
17	21	11110110	366
18	22	11100100	344
19	23	11110100	364
20	24	11100110	346
21	25	11110110	366
22	26	11100100	344
23	27	11110100	364
24	30	11100010	342
25	31	11110010	362
26	32	11100000	340
27	33	11110000	360
28	34	11100010	342
29	35	11110010	362
30	36	11100000	340
31	37	11110000	360

4

3

REV. NUMBER SIZE CODE K RL M8315-0-11

2

1

This drawing and specifications, herein, are the property of Digital Equipment Corporation and shall not be reproduced or copied or used in whole or in part as the basis for the manufacture or sale of items without written permission. COPYRIGHT © 1974

DIGITAL EQUIPMENT CORPORATION

B



A

FIRST USED ON OPTION MODEL	QTY.	DESCRIPTION	PART NO.	ITEM NO.
PDP8-A		PARTS LIST		
DRN <i>George Drayton</i>	DATE 7/25/74	digital EQUIPMENT CORPORATION MAYNARD, MASSACHUSETTS TITLE ROM PATTERN SPEC (ROM C)		
CHK'D. <i>[Signature]</i>	DATE 7/27/74			
ENG. <i>[Signature]</i>	DATE 7/26/74			
PROJ. ENG. <i>[Signature]</i>	DATE 7/26/74			
PROD. <i>[Signature]</i>	DATE 7/26/74			
NEXT HIGHER ASSEMBLY				
B-DD-PDPS-A		SIZE CODE	NUMBER	REV.
SCALE <i>1/1</i>		K RL	M8315-0-11	
SHEET 1 OF 2		DIST.		

REV.	
CHANGE NO.	
CHK	

4

3



2

1

K-RL-M8315-0-II

ROM PATTERN SPEC

PAGE 2 OF 2

DEC PART NUMB: 23-076A1
ORIGINATOR: LOUIS KLOTZ
DATE OF ORIGIN: 6/19/74

digital
EQUIPMENT
CORPORATION

DECIMAL LOC	OCTAL LOC	BINARY DATA	OCTAL DATA
0	00	00000000	000
1	01	00000000	000
2	02	00000000	000
3	03	00000000	000
4	04	00000000	000
5	05	00000000	000
6	06	00000000	000
7	07	00000000	000
8	10	00000000	000
9	11	11011011	333
10	12	00101111	057
11	13	00111011	073
12	14	01101111	157
13	15	10101011	253
14	16	00101111	057
15	17	11111111	377
16	20	11111100	374
17	21	11110111	367
18	22	00101111	057
19	23	11111111	377
20	24	00101111	057
21	25	10011111	237
22	26	00101111	057
23	27	11111111	377
24	30	00111111	077
25	31	00110100	064
26	32	00101111	057
27	33	11111111	377
28	34	00111111	077
29	35	01010110	126
30	36	00101111	057
31	37	11111111	377

K-RL-M8315-1-II

This drawing and specifications, herein, are the property of Digital Equipment Corporation and shall not be reproduced or copied or used in whole or in part as the basis for the manufacture or sale of items without written permission. COPYRIGHT © 1974

DIGITAL EQUIPMENT CORPORATION

FIRST USED ON OPTION MODEL	QTY.	DESCRIPTION	PART NO.	ITEM NO.
PDP8-A				
PARTS LIST				
DRN: George Drayton	DATE 7/25/74	 <p>digital EQUIPMENT CORPORATION MAYNARD, MASSACHUSETTS</p>		
CHK'D: [Signature]	DATE [Signature]			
ENG: [Signature]	DATE 8/6/74			
PROD. ENG: [Signature]	DATE 8/6/74			
PROD: [Signature]	DATE 8/6/74			
NEXT HIGHER ASSEMBLY		TITLE		
B-DD-PDP8-A		ROM PATTERN SPEC		
		(ROM B)		
SCALE 1/1	SIZE CODE		NUMBER	REV.
	K RL		M8315-Ø-12	
SHEET 1 OF 2	DIST.			

REVISIONS	REV.
	CHANGE NO.
CHK	

K-RL-M8315-0-12

RUM PATTERN SPEC

PAGE 2 OF 2

DEC PART NUMB: 23-077A1
ORIGINATOR: LOUIS KLUTZ
DATE OF ORIGIN: 6/19/74

digital EQUIPMENT CORPORATION

DECIMAL LOC	OCTAL LOC	BINARY DATA	OCTAL DATA
0	00	01100000	140
1	01	01100000	140
2	02	01100000	140
3	03	11110000	360
4	04	11010000	320
5	05	00110000	060
6	06	11110000	360
7	07	11110000	360
8	10	00000000	000
9	11	00000000	000
10	12	00000000	000
11	13	00000000	000
12	14	11110000	360
13	15	11110000	360
14	16	11110000	360
15	17	11110000	360
16	20	00000000	000
17	21	00000000	000
18	22	00000000	000
19	23	00000000	000
20	24	00000000	000
21	25	00000000	000
22	26	00000000	000
23	27	00000000	000
24	30	00000000	000
25	31	00000000	000
26	32	00000000	000
27	33	00000000	000
28	34	00000000	000
29	35	00000000	000
30	36	00000000	000
31	37	00000000	000

K-RL-M8315-0-12

This drawing and specifications, herein, are the property of Digital Equipment Corporation and shall not be reproduced or copied or used in whole or in part as the basis for the manufacture or sale of items without written permission. COPYRIGHT ©1974

DIGITAL EQUIPMENT CORPORATION

REV. NUMBER SIZE CODE
 2 | K RL M8315-Ø-13

FIRST USED ON OPTION MODEL	QTY.	DESCRIPTION	PART NO.	ITEM NO.
PDP8-A				
PARTS LIST				
DRW. <i>George Drayton</i>	DATE 7/25/74	 digital EQUIPMENT CORPORATION <small>MAYNARD, MASSACHUSETTS</small>		
CHK'D.	DATE			
ENG.	DATE			
PROJ. ENG.	DATE			
PROD.	DATE			
NEXT HIGHER ASSEMBLY		TITLE ROM PATTERN SPEC (ROM A)		
B-DD-PDP8-A				
SCALE	1/1			
SHEET 1 OF 2		SIZE CODE	NUMBER	REV.
		K RL	M8315-Ø-13	
		DIST.		

REVISIONS	REV.
	CHANGE NO.
	CHK

K-RL-M8315-Ø-13

ROW PATTERN SPEC

PAGE 2 OF 2

DEC PART NUMB: 21-078A1
ORIGINATOR: LOUIS KLOTZ
DATE OF ORIGIN: 9-11-74



digital EQUIPMENT CORPORATION

DECIMAL LOC	OCTAL LOC	BINARY DATA	OCTAL DATA
0	00	11111111	377
1	01	01011111	137
2	02	00111111	077
3	03	01011111	137
4	04	11111111	377
5	05	11111111	377
6	06	00111111	077
7	07	11111111	377
8	10	10101011	253
9	11	01111111	177
10	12	11111100	374
11	13	11111111	377
12	14	11111100	374
13	15	01111111	177
14	16	00111111	077
15	17	11111000	370
16	20	11111011	373
17	21	01111111	177
18	22	00111111	077
19	23	11110111	367
20	24	11111011	373
21	25	01111111	177
22	26	11111100	374
23	27	11110111	367
24	30	11111111	377
25	31	11111111	377
26	32	00111100	074
27	33	11111111	377
28	34	11111111	377
29	35	11111111	377
30	36	11111100	374
31	37	11111111	377

K-RL-M8315-Ø-13

This drawing and specifications, herein, are the property of Digital Equipment Corporation and shall not be reproduced or copied or used in whole or in part as the basis for the manufacture or sale of items without written permission. COPYRIGHT © 1974

DIGITAL EQUIPMENT CORPORATION

REV. NUMBER SIZE CODE K RL M8315-Ø-14 2 1

FIRST USED ON OPTION MODEL	QTY.	DESCRIPTION	PART NO.	ITEM NO.
PDP8-A				
PARTS LIST				
DRN.	DATE	<div style="text-align: center;">  <p>digital EQUIPMENT CORPORATION MAYNARD, MASSACHUSETTS</p> </div>		
CHK'D.	DATE			
ENG.	DATE			
PROJ. ENG.	DATE			
PROD.	DATE			
NEXT HIGHER ASSEMBLY		TITLE ROM PATTERN SPEC (ROM J)		
B-DD-PDP8-A				
SCALE	---	SIZE CODE	NUMBER	REV.
		K RL	M8315-Ø-14	
SHEET	1 OF 2	DIST.		

REVISIONS	REV.
	CHANGE NO.
CHK	

K-RL-M8315-Ø-14

RUM PATTERN SPEC

PAGE 2 OF 2

DEC PART NUMB: 21-079A1
ORIGINATOR: LOUIS KLOTZ
DATE OF ORIGIN: 6/19/74

digital EQUIPMENT CORPORATION

DECIMAL LOC	OCTAL LOC	BINARY DATA	OCTAL DATA
0	00	00000000	000
1	01	00000000	000
2	02	00000000	000
3	03	00000000	000
4	04	00000000	000
5	05	00000000	000
6	06	00000000	000
7	07	00000000	000
8	10	01000100	104
9	11	01000100	104
10	12	01000100	104
11	13	01000100	104
12	14	01000100	104
13	15	01000100	104
14	16	01000100	104
15	17	01000100	104
16	20	01000001	101
17	21	01000000	100
18	22	01100010	142
19	23	01000100	104
20	24	01010000	120
21	25	00000000	000
22	26	01100000	140
23	27	00001000	010
24	30	01000000	100
25	31	01000000	100
26	32	01000000	100
27	33	01000000	100
28	34	01000000	100
29	35	01000000	100
30	36	01000000	100
31	37	01000000	100

K-RL-M8315-Ø-14

This drawing and specifications, herein, are the property of Digital Equipment Corporation and shall not be reproduced or copied or used in whole or in part as the basis for the manufacture or sale of items without written permission. COPYRIGHT ©1974

DIGITAL EQUIPMENT CORPORATION

REV. 2 SIZE CODE K RL NUMBER M8315-Ø-15

FIRST USED ON OPTION MODEL	QTY.	DESCRIPTION	PART NO.	ITEM NO.
PDP8 -A				
PARTS LIST				
DRN. George Drayton	DATE 7/25/74	<div style="text-align: center;">  <p>digital EQUIPMENT CORPORATION MAYNARD, MASSACHUSETTS</p> </div>		
CHK'D. Kent G. ...	DATE 7/25/74			
ENG. ...	DATE 7/16/74			
PROJ. ENG. ...	DATE 7/16/74			
PROD. P. ...	DATE 7/16/74			
NEXT HIGHER ASSEMBLY		TITLE ROM PATTERN SPEC (ROM F)		
B-DD-PDP8-A				
SCALE	++			
SHEET 1 OF 9		SIZE CODE K RL	NUMBER M8315-Ø-15	REV.
		DIST.		

REV.	
CHANGE NO.	
CHK	

4

3

2

1

4

3

2

1

K-RL-M8315-Ø-15

ROM PATTERN SPEC

PAGE 2 OF 9

DEC PART NUMB: 080A2
ORIGINATOR: LOUIS KLOTZ
DATE OF ORIGIN: 6/19/74

DECIMAL LOC	OCTAL LOC	BINARY DATA	OCTAL DATA
0	000	1010	12
1	001	0010	02
2	002	1000	10
3	003	0000	00
4	004	1010	12
5	005	0010	02
6	006	1000	10
7	007	0000	00
8	010	1000	10
9	011	0010	02
10	012	1010	12
11	013	0000	00
12	014	1000	10
13	015	0000	00
14	016	1010	12
15	017	0010	02
16	020	1010	12
17	021	0010	02
18	022	1000	10
19	023	0000	00
20	024	1010	12
21	025	0010	02
22	026	1000	10
23	027	0000	00
24	030	1000	10
25	031	0010	02
26	032	1010	12
27	033	0000	00
28	034	1000	10
29	035	0000	00
30	036	1010	12
31	037	0010	02
32	040	1000	10
33	041	0010	02
34	042	1010	12
35	043	0000	00

K-RL-M8315-Ø-15

K-RL-M8315-Ø-15

ROM PATTERN SPEC

PAGE 3 OF 9

DEC PART NUMB: 080A2
ORIGINATOR: LOUIS KLOTZ
DATE OF ORIGIN: 6/19/74

DECIMAL LOC	OCTAL LOC	BINARY DATA	OCTAL DATA
36	044	1000	10
37	045	0000	00
38	046	1010	12
39	047	0010	02
40	050	1000	10
41	051	0010	02
42	052	1010	12
43	053	0000	00
44	054	1000	10
45	055	0000	00
46	056	1010	12
47	057	0010	02
48	060	1000	10
49	061	0010	02
50	062	1010	12
51	063	0000	00
52	064	1000	10
53	065	0000	00
54	066	1010	12
55	067	0010	02
56	070	1000	10
57	071	0010	02
58	072	1010	12
59	073	0000	00
60	074	1000	10
61	075	0000	00
62	076	1010	12
63	077	0010	02
64	100	0000	00
65	101	0000	00
66	102	0000	00
67	103	0000	00
68	104	0000	00
69	105	0000	00
70	106	0000	00
71	107	0000	00

DEC PART NUMB: 08042
 ORIGINATOR: LOUIS KLUTZ
 DATE OF ORIGIN: 6/19/74

DECIMAL LOC	OCTAL LOC	BINARY DATA	OCTAL DATA
72	110	0000	00
73	111	0000	00
74	112	0000	00
75	113	0000	00
76	114	0000	00
77	115	0000	00
78	116	0000	00
79	117	0000	00
80	120	0000	00
81	121	0000	00
82	122	0000	00
83	123	0000	00
84	124	0000	00
85	125	0000	00
86	126	0000	00
87	127	0000	00
88	130	0000	00
89	131	0000	00
90	132	0000	00
91	133	0000	00
92	134	0000	00
93	135	0000	00
94	136	0000	00
95	137	0000	00
96	140	1010	12
97	141	0010	02
98	142	1000	10
99	143	0000	00
100	144	1010	12
101	145	0010	02
102	146	1000	10
103	147	0000	00
104	150	1010	12
105	151	0010	02
106	152	1000	10
107	153	0000	00

DEC PART NUMB: 08042
 ORIGINATOR: LOUIS KLUTZ
 DATE OF ORIGIN: 6/19/74

DECIMAL LOC	OCTAL LOC	BINARY DATA	OCTAL DATA
108	154	1010	12
109	155	0010	02
110	156	1000	10
111	157	0000	00
112	160	1000	10
113	161	0010	02
114	162	1010	12
115	163	0000	00
116	164	1000	10
117	165	0000	00
118	166	1010	12
119	167	0010	02
120	170	1000	10
121	171	0010	02
122	172	1010	12
123	173	0000	00
124	174	1000	10
125	175	0000	00
126	176	1010	12
127	177	0010	02
128	200	0010	02
129	201	0010	02
130	202	0010	02
131	203	1010	12
132	204	1010	12
133	205	1010	12
134	206	1010	12
135	207	1010	12
136	210	0010	02
137	211	0010	02
138	212	0010	02
139	213	0010	02
140	214	1010	12
141	215	1010	12
142	216	1010	12
143	217	1010	12

K-RL-M8315-0-15

ROM PATTERN SPEC

PAGE 6 OF 9

DEC PART NUMB: 080A2
ORIGINATOR: LOUIS KLOTZ
DATE OF ORIGIN: 6/19/74

DECIMAL LOC	OCTAL LOC	BINARY DATA	OCTAL DATA
144	220	0010	02
145	221	1010	12
146	222	0010	02
147	223	1010	12
148	224	1010	12
149	225	0010	02
150	226	1010	12
151	227	0010	02
152	230	0010	02
153	231	1010	12
154	232	0010	02
155	233	1010	12
156	234	1010	12
157	235	0010	02
158	236	1010	12
159	237	0010	02
160	240	0010	02
161	241	0010	02
162	242	0010	02
163	243	0010	02
164	244	1010	12
165	245	1010	12
166	246	1010	12
167	247	1010	12
168	250	0010	02
169	251	0010	02
170	252	0010	02
171	253	0010	02
172	254	1010	12
173	255	1010	12
174	256	1010	12
175	257	1010	12
176	260	0010	02
177	261	1010	12
178	262	0010	02
179	263	1010	12

ANALOG EQUIPMENT CORPORATION

K-RL-M8315-0-

K-RL-M8315-0-15

ROM PATTERN SPEC

PAGE 7 OF 9

DEC PART NUMB: 080A2
ORIGINATOR: LOUIS KLOTZ
DATE OF ORIGIN: 6/19/74

DECIMAL LOC	OCTAL LOC	BINARY DATA	OCTAL DATA
180	264	1010	12
181	265	0010	02
182	266	1010	12
183	267	0010	02
184	270	0010	02
185	271	1010	12
186	272	0010	02
187	273	1010	12
188	274	1010	12
189	275	0010	02
190	276	1010	12
191	277	0010	02
192	300	1010	12
193	301	0010	02
194	302	1010	12
195	303	0010	02
196	304	1010	12
197	305	0010	02
198	306	1010	12
199	307	0010	02
200	310	1010	12
201	311	0010	02
202	312	1010	12
203	313	0010	02
204	314	1010	12
205	315	0010	02
206	316	1010	12
207	317	0010	02
208	320	1010	12
209	321	0010	02
210	322	1010	12
211	323	0010	02
212	324	1010	12
213	325	0010	02
214	326	1010	12
215	327	0010	02

ANALOG EQUIPMENT CORPORATION

K-RL-M8315-Ø-15

ROM PATTERN SPEC

PAGE 8 OF 9

DEC PART NUMB: 080A2
ORIGINATOR: LOUIS KLOTZ
DATE OF ORIGIN: 6/19/74

DECIMAL LOC	OCTAL LOC	BINARY DATA	OCTAL DATA
216	330	1010	12
217	331	0010	02
218	332	1010	12
219	333	0010	02
220	334	1010	12
221	335	0010	02
222	336	1010	12
223	337	0010	02
224	340	1010	12
225	341	0010	02
226	342	1010	12
227	343	0010	02
228	344	1010	12
229	345	0010	02
230	346	1010	12
231	347	0010	02
232	350	1010	12
233	351	0010	02
234	352	1010	12
235	353	0010	02
236	354	1010	12
237	355	0010	02
238	356	1010	12
239	357	0010	02
240	360	1010	12
241	361	0010	02
242	362	1010	12
243	363	0010	02
244	364	1010	12
245	365	0010	02
246	366	1010	12
247	367	0010	02
248	370	1010	12
249	371	0010	02
250	372	1010	12
251	373	0010	02

digital CORPORATION

K-RL-M8315-Ø

K-RL-M8315-Ø-15

ROM PATTERN SPEC

PAGE 9 OF 9

DEC PART NUMB: 080A2
ORIGINATOR: LOUIS KLOTZ
DATE OF ORIGIN: 6/19/74

DECIMAL LOC	OCTAL LOC	BINARY DATA	OCTAL DATA
252	374	1010	12
253	375	0010	02
254	376	1010	12
255	377	0010	02

digital CORPORATION

THIS DRAWING AND SPECIFICATIONS HEREIN ARE THE PROPERTY OF DIGITAL EQUIPMENT CORPORATION AND SHALL NOT BE REPRODUCED OR COPIED OR USED IN WHOLE OR IN PART AS THE BASIS FOR THE MANUFACTURE OR SALE OF ITEMS WITHOUT WRITTEN PERMISSION. COPYRIGHT © 1974 DIGITAL EQUIPMENT CORPORATION

FLOW CHART INDEX

F[^]TS1^vTS2
DATA=@TS1:INDICATOR
TS2:AC
MA=INST.ADD
EMA=IF
MD=INSTRUCTION

OPERATES

I/O XFRS

MEMORY REF OR JUMP

FC2 EXECUTION OF OPERATE

FC3 EXECUTION OF IOT

FC4 EXECUTION OF JMP D OR PAGE

F[^]TS3[^]OPR
DATA=AC^vMQ
MA=INST.ADD
EMA=IF
MD=7XXX

F[^]TS3[^]IOT(PAUSE)
DATA=I/O INFO
MA=INST.ADD
EMA=IF
MD=6XXX

F[^]JMP[^]MD3[^]TS3
MEM REF[^]F[^]TS3^vTS4
DATA=PRIOR@TS4
MA←PAGE ADD
EMA=IF

JUMP DIRECT

DIRECT MEMORY REF

ALL INDIRECT

MS,IR DIS:DMA

D[^]JMP[^]TS4
D[^]JMP
DATA=@TS1:INDICATOR
TS4:PRIOR
MA←OPERAND ADD
EMA←DF^vNEW IF
MD=MB←MD+AT

FC5 EXECUTION OF JMP I OR DEFER

JUMP AND^vTAD

ISZ

DCA^vJMS

MS,IR DIS:DMA

MS,IR DIS:DMA

MS,IR DIS:DMA

FC6 EXECUTE + AND OR TAD

FC7 EXECUTE + ISZ

FC8 EXECUTE + DCA OR JMS

E[^]AND^vTAD[^]TS4
DATA=@TS1:IND
@TS3[^]TAD:AC
@TS3[^]AND:AC^vMD
MA=OPERAND ADD
EMA=DF^vIF
MD=OPERAND

E[^]ISZ[^]TS4
DATA=@TS1:IND
MA=OPERAND ADD
EMA=DF^vIF
MD=MB+MD+1

E[^]DCA^vJMS[^]TS4
DATA=@TS1:IND
@TS2[^]DCA:AC
MA=OPERAND ADD
EMA=IF^vDF
DCA:MD←MB←AC
JMS:MD←MB←PC

FC9 NEXT ADD OR INT

F SET AND OPI ROTATES
SENSE INTERRUPTS
MA←NEW INST ADD
EMA←NEW IF

INTERRUPT

INTERRUPT

MS,IR DIS:DMA

MS,IR DIS:DMA

DMA

FC10 BREAK

DIRECT MEMORY ACC.
ADD TO MEMORY

CPMA DIS

CPMA DIS

MAJOR STATE ENCODING

STATE	MS \emptyset	MSI
F	L	L
D	L	H
E	H	L
BK	H	H

TIME STATE ENCODING

TS	T \emptyset	TI
1	L	L
2	H	L
3	H	H
4	L	H

ROM'S ENABLED

	FETCH	DEFER	EXECUTE	BREAK
TS1	H,J	H,J	J	A, J
TS2	H,J	C, H,J	C, J	A, J
TS3	D,-IF OPR. E,-IF IOT J C,-IF JMP	C, F,H,J	C, F,J	A, F, J
TS4	B, H,J	B, H,J	B, J	A,B, J

NOTES:

THIS IS AN INDEX TO THE 8A FLOW CHARTS. THE FLOW CHART NUMBER THAT APPEARS WITHIN THE SYMBOL $\langle FCX \rangle$ REFERS TO ANOTHER FLOW WHICH DETAILS THE ACTION WHICH IS BRIEFLY DESCRIBED IN THE SYMBOL \square

OPTION FLOW CHARTS WILL USE THE SAME FCX TIME REFERENCE TO SHOW ITS RELATION TO THE CPU

FLows WILL BE NUMBERED AS FOLLOWS:
M8315-FCX CPU FLOW FOR TIME 'X'
MABCD-FCX OPTION FLOW FOR CPU TIME 'X'

THE FOLLOWING IS A LIST OF MAJOR OMNIBUS SIGNALS AND THE FLOW CHARTS MOST PERTINENT TO THEM

BUS SIGNAL	FLOW CHARTS	MOST IMPORTANT LOGIC PRINTS
IR \emptyset -2	FC1	ID2
F, D, E	(FC1, FC4), FC5, FC8	ID1
USER MODE	FC2, FC3	ID2, T62
F SET	FC8	ID1
PULSE LA	FC1 \emptyset	ID1
STOP	FC2, FC1 \emptyset	ID1, ID3, T62
KEY CONTROL	FC1 \emptyset	ID1
SW	SEE M8317 TIMING & FLOW CHARTS	
I/O PAUSE	FC3	T62
C \emptyset -2	FC3	ID1
BUS STB	FC3	ID2, T61
NOT LAST XFER	FC3	T62
INT RQST	FC3	ID3
SKIP	FC7, FC8, FC9	ID2
INITIALIZE	FC3	ID3
CPMA DIS	FC4, FC5, FC9	ID1
MSIR DIS	FC1 \emptyset	ID1
LK LD \emptyset DATA	FC3	ID2, ID3
INDI-2	FC1	ID3
MAMS LD CTRL	FC4, FC9, FC1 \emptyset	ID1
OVERFLOW	FC7	ID2
BK DATA CTRL	FC1 \emptyset	ID1
LA ENABLE	FC1, FC1 \emptyset	ID1
INT IN PROG	FC9	ID2, ID3
RUN	FC2, FC1 \emptyset	T62
PWR OK	FC2, FC1 \emptyset	ID3
MEM START	FC1 \emptyset	ID1, T62

FIRST USED ON OPTION/MODEL		QTY.	DESCRIPTION	PART NO.	ITEM NO.
PDP8A					
DIMENSIONAL TOLERANCE		PARTS LIST			
DIMENSIONS ARE MILLIMETERS UNLESS OTHERWISE SPECIFIED		DRN. <i>G. Kauter</i>	DATE 11-11-74	digital	
		CHKD. <i>[Signature]</i>	DATE 11/30/74		
MILLIMETERS	INCHES	ANGLES	PROJ. ENG. <i>[Signature]</i>	DATE 11/30/74	TITLE
.XX = +0.10	.XX = +.005	40° 30'	PROD. <i>[Signature]</i>	DATE 11/30/74	FLOW DIAGRAM M8315 INDEX
X = ±0.5	X = ±.02				
THIRD ANGLE PROJECTION	REMOVE BURRS AND BREAK SHARP CORNERS SURFACE QUALITY ✓	NEXT HIGHER ASSY.			
MATERIAL	FINISH	SCALE	B-DD-KKBA- \emptyset	SIZE CODE	NUMBER
		SHEET 1 OF 1	D FD	M8315- \emptyset -16	REV.

REV.	CHANGE NO.

THIS DRAWING AND SPECIFICATIONS, HEREIN, ARE THE PROPERTY OF DIGITAL EQUIPMENT CORPORATION AND SHALL NOT BE REPRODUCED OR COPIED OR USED IN WHOLE OR IN PART AS THE BASIS FOR THE MANUFACTURE OR SALE OF ITEMS WITHOUT WRITTEN PERMISSION. COPYRIGHT © 1974 DIGITAL EQUIPMENT CORPORATION

MA+1 IS ENABLED TO THE PC
A MEMORY READ IS STARTED (REFER TO TIMING)
INDICATOR INFORMATION IS PLACED ON THE DATA BUS (REFER TO OPTI) FOR THE PANEL TO DISPLAY

THE PC IS LOADED
THE AC IS GATED THROUGH THE ADDERS TO SEE IF IT EQUALS 0
THE INSTRUCTION WILL APPEAR ON THE MD LINES FROM MEMORY
THE IR GETS LOADED WITH THE OPCODE AND THE Z FLAG IS ADJUSTED

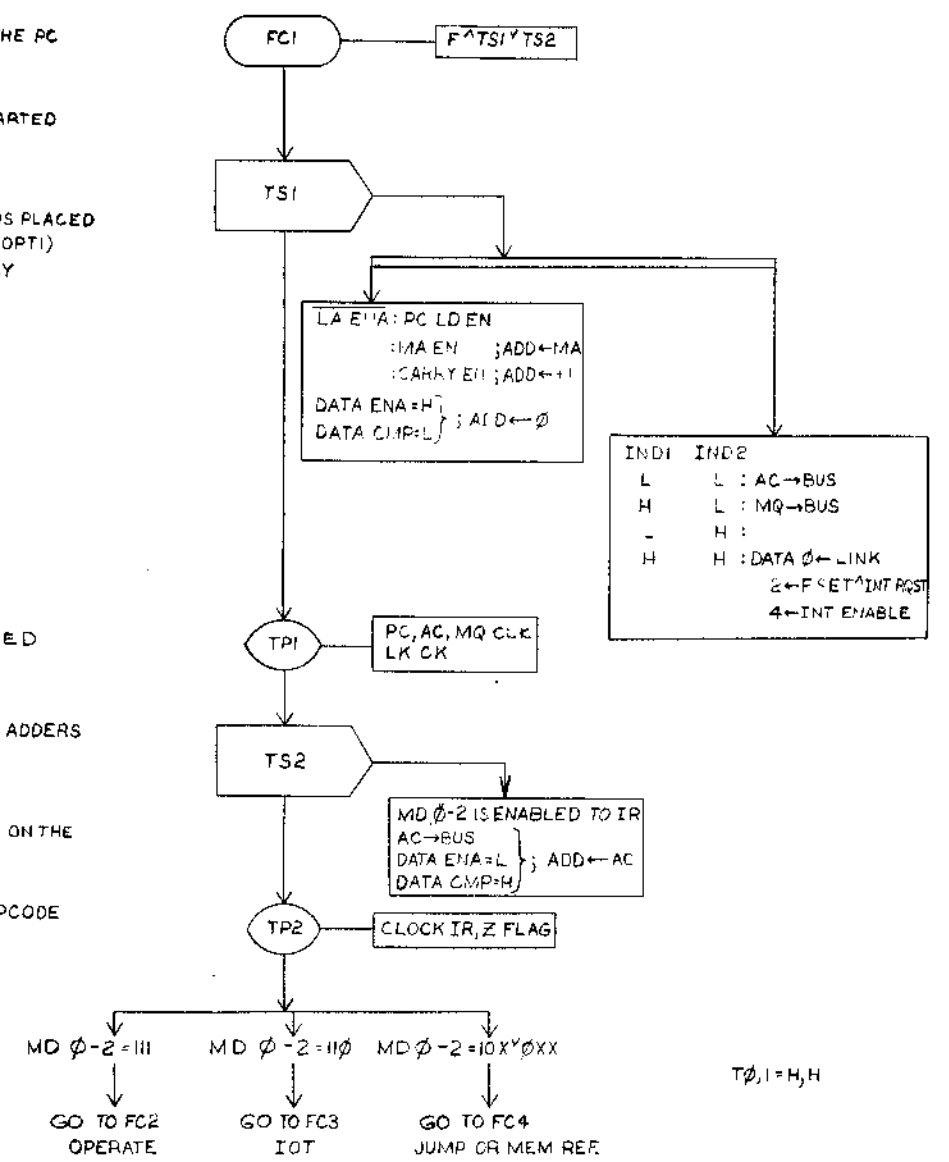

MS 0,1=L,L
T 0,1=L,L

T 0,1=H,L

T 0,1=H,H

THE INSTRUCTION IS DECODED AT THIS POINT AS FOLLOWS:
MD — 0 1 2 3 4 5 6 7 8 9 10 11
AND 0 0 0
TAD 0 0 1
ISZ 0 1 0
DCA 0 1 1
JMS 1 0 0
JMP 1 0 1
IOT 1 1 0
OPR 1 1 1

BITS 3-11
ARE NOT
IMPORTANT AT
THIS TIME

REV.	
CHANGE NO.	
CHK	

FIRST USED ON OPTION/MODEL				QTY.	DESCRIPTION	PART NO.	ITEM NO.
PDP8A							
DIMENSIONAL TOLERANCE				PARTS LIST			
DIMENSIONS ARE MILLIMETERS INCHES UNLESS OTHERWISE SPECIFIED				DRN. 2 Weeks	DATE 11-13-74	digital	
MILLIMETERS INCHES ANGLES				CHK'D	DATE 12/31/74		
XXX ±0.10	JXX ±0.06	±0° 30'		ENG.	DATE 1-21/75		
XX ±0.5	JX ±0.02			PRJ. ENG.	DATE 1-21/75		
X ±0.2	J ±0.1			PROD.	DATE 1-25-75	TITLE	
THIRD ANGLE PROJECTION				NEXT HIGHER ASSY.			
REMOVE BURRS AND BREAK SHARP CORNERS SURFACE QUALITY ✓				MATERIAL			
FINISH				B-DD-KKBA-0			
SCALE				SHEET 1 OF 1			
SIZE CODE				NUMBER			
D F D				M8315-0-17			
REV.							

REV. 2
M8315-0-17

THIS DRAWING AND SPECIFICATIONS HEREIN ARE THE PROPERTY OF DIGITAL EQUIPMENT CORPORATION AND SHALL NOT BE REPRODUCED OR COPIED OR USED IN WHOLE OR IN PART AS THE BASIS FOR THE MANUFACTURE OR SALE OF ITEMS WITHOUT WRITTEN PERMISSION. COPYRIGHT © 1974, DIGITAL EQUIPMENT CORPORATION

THE INSTRUCTION IS DECODED AT THIS POINT AS FOLLOWS
 THE SEQUENCES OF OPERATION ARE LOGICAL NOT CHRONOLOGICAL
 ALL OP2 & OP3 OCCUR AT TP3
 ALL OPI EXCEPT ROTATE LEFT OR RIGHT OCCUR AT TP3
 A SINGLE LEFT OR RIGHT ROTATE OCCURS AT TP4
 A DOUBLE LEFT OR RIGHT ROTATE OCCURS AT TP3 3/2 AND 4 } SEE FLOW CHART 9 F SET

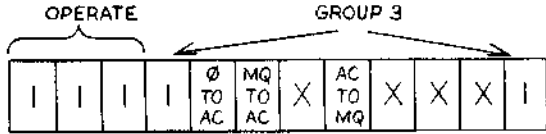

OPERATE GROUP 3

0	0	0	0	0	0	0	0	0	0
0	0	0	0	0	0	0	0	0	0
0	0	0	0	0	0	0	0	0	0
0	0	0	0	0	0	0	0	0	0
0	0	0	0	0	0	0	0	0	0
0	0	0	0	0	0	0	0	0	0
0	0	0	0	0	0	0	0	0	0
0	0	0	0	0	0	0	0	0	0
0	0	0	0	0	0	0	0	0	0
0	0	0	0	0	0	0	0	0	0

NO OPERATION
 AC GOES TO THE MQ AND THE AC IS CLEARED
 MQ "ORED" WITH THE AC GOES TO THE AC
 AC & MQ SWAPS WITH MQ & AC
 THE AC IS CLEARED
 BOTH THE AC AND MQ ARE CLEARED
 THE MQ GOES TO THE AC
 THE MQ GOES TO THE AC AND THE MQ IS CLEARED

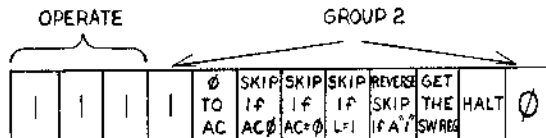

1ST MAKE A SKIP DECISION
 THEN REVERSE THEN DECISION IF BIT 8=1
 THEN CLEAR THE AC IF BIT 4=1
 THEN "OR" THE AC WITH THE SWITCHES IF BIT 9=1
 THEN STOP IF BIT 10=1

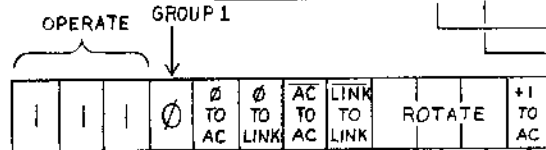

1ST CLEAR THE AC & LINK IF BITS=1
 THEN COMPLEMENT IF BITS=1
 THEN INCREMENT THE L, AC IF BIT 11=1
 THEN ROTATE DEPENDENT UPON 8,9,10 AS FOLLOWS

MD 8 9 10
 H H H NO ROTATE
 H H L SWAP AC & LINK WITH AC & LINK
 H L H ROTATE LEFT ONCE
 H L L ROTATE LEFT TWICE
 L H H ROTATE RIGHT ONCE
 L H L ROTATE RIGHT TWICE
 L L X ILLEGAL

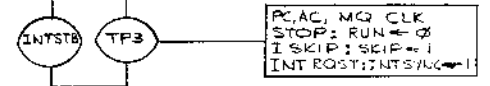
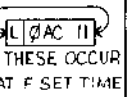

GO TO FC9

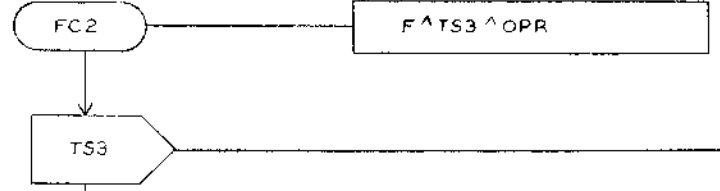

OP3

ENA. ROM D
 MD—4, 5, 7
 (NOP) H H H : DATA ENA; AC → BUS
 (MQL) H H L : DATA CMP; MQ LD EN
 (MQA) H L H : DATA ENA; AC → BUS; MQ → BUS
 (SWP) H L L : DATA ENA; MQ LD EN
 (CLA) L H H : DATA CMP;
 (CLA MQL) L H L : DATA CMP; MQ CLR EN
 (CLA MQA) L L H : DATA ENA; MQ → BUS
 (0 → MQ, AC) L L L : DATA ENA; MQ CLR EN; MQ → BUS

ENA. ROM F
 ADLK = LINK

OP2

ENA. ROM D
 DATA ENA:
 MD4 = 0 : AC → BUS

ENA. ROM F
 I SKIP L = (MD5 ^ AC ^ MD6 ^ ZERO ^ MD7 ^ LINK) ^ MD8
 ADLK = LINK

MD1 ^ UM : STOP
 MD9 : CONSOLE PLACES SWITCH REG ON DATA BUS

OP1

ENA. ROM D : DATA ENA. L
 MD4 = 0 : AC → BUS
 MD6 = 1 : DATA CMP L
 MD11 = 1 : CARRY EN; C IN L = 1

ENA. ROM F
 MD—5, 7
 L L : ADLK = LINK
 L H : LINK
 H L : 0
 H H : 1

MD9 ^ MD8 ^ MD10 : BSW; ADDER 0-5 TO AC 6-11 ADDER 6-11 TO AC 0-5

AC LD EN L : RR EN
 : RL EN
 : LNK RR EN
 : LNK RL EN

EXECUTION OF AN OPERATE				
FIRST USED ON OPTION/MODEL	QTY.	DESCRIPTION	PART NO.	ITEM NO.
POP8A				
DIMENSIONAL TOLERANCE		PARTS LIST		
DIMENSIONS ARE MILLIMETERS UNLESS OTHERWISE SPECIFIED		DRN. <i>D. Vowles</i>	DATE 11-7-74	
MILLIMETERS INCHES ANGLES		CHK'D <i>[Signature]</i>	DATE 12/1/74	
X.XX ±0.10	.XX ±0.05	ENG. <i>[Signature]</i>	DATE 1/1/75	
X.X ±0.5	.X ±0.2	PROJ. ENG. <i>[Signature]</i>	DATE 1/20/75	
THIRD ANGLE PROJECTION REMOVE BURRS AND BREAK SHARP CORNERS SURFACE QUALITY ✓		TITLE		
		FLOW DIAGRAM		
		M8315 FC2		
MATERIAL // FINISH //		SIZE/CODE B-DD-KKSA-0	NUMBER DFD	REV. M8315-Q-18
		SCALE //	SHEET 1 OF 1	

REV.	CHANGE NO.

REV. CONTROL NUMBER DFD M8315-Q-18

THIS DRAWING AND SPECIFICATIONS HEREIN ARE THE PROPERTY OF DIGITAL EQUIPMENT CORPORATION AND SHALL NOT BE REPRODUCED OR COPIED OR USED IN WHOLE OR IN PART AS THE BASIS FOR THE MANUFACTURE OR SALE OF ITEMS WITHOUT WRITTEN PERMISSION. COPYRIGHT © 1974, DIGITAL EQUIPMENT CORPORATION

THE INSTRUCTION AT THIS POINT IS DECODED AS FOLLOWS: ONLY IF *USER MODE IS NEGATED THUS ALLOWING PAUSE TO BE ASSERTED.

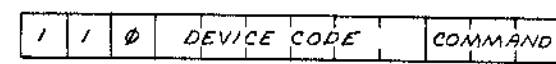

FOR DEVICE CODE 000 THE CPU TAKES CONTROL DEPENDING UPON THE COMMAND AS FOLLOWS:

MD-9	10	11	SKON	ION	IOF	SRQ	*GTF	*RTF	NOP	CAF
0	0	0	SKIP IF INT ON, TURN IT OFF							
0	0	1	TURN INT SYS ON							
0	1	0	TURN INT SYS OFF							
0	1	1	SKIP IF INT RQST							
1	0	0	LINK, INT ON, INT RQST TO AC0,2,4							
1	0	1	AC0 TO LINK, TURN INT SYS ON							
1	1	0	NO OPERATION							
1	1	1	GENERATE INITIALIZE.							

* ALSO SEE OPT 2

OTHER DEVICES SEND OR RECEIVE DATA DEPENDING UPON THE C LINES AS FOLLOWS:

C0	C1	C2	AC-DEV	H H H	THE DEVICE RECEIVES THE AC AT TP3
H	H	L	RELATIVE JUMP	H H L	THE DATA LINES+THE PC GO TO PC AT BUS STB
H	L	H	INPUT OR TO AC	H L H	THE AC'ORED' WITH DATA LINES GOES TO THE AC BUS STB
H	L	L	ABSOLUTE JUMP	H L L	THE DATA LINES GO TO THE PC AT BUS STB
L	H	H	AC-DEV 0-AC	L H H	THE DEVICE RECEIVES THE AC AT TP3 AND THE AC IS CLEARED
L	L	H	INPUT JAM TO AC	L L H	THE DATA LINES GO TO THE AC BUS STB

NOTE ALL I/O XFRS TAKE PLACE OVER THE DATA LINES.

IN REALITY ALL XFRS TAKE PLACE ON THE LEADING EDGE OF BUS STB IN ACCORDANCE WITH THE "C" LINES AT THAT TIME. ASSERTING NOT LAST XFER CAUSES THE CPU TO WAIT FOR A BUS STROBE TO DO THE NEXT XFER. THE CPU WILL NOT ADVANCE TO TS4 UNTIL IT SEES A BUS STROBE WITH NOT LAST XFER NEGATED - THIS IN TURN CAUSES INTERRUPT STROBE.

LINK LOAD SHOULD BE GIVEN IN SYNC WITH BUS STROBE AND CAUSES LINK DATA TO GO TO THE LINK.

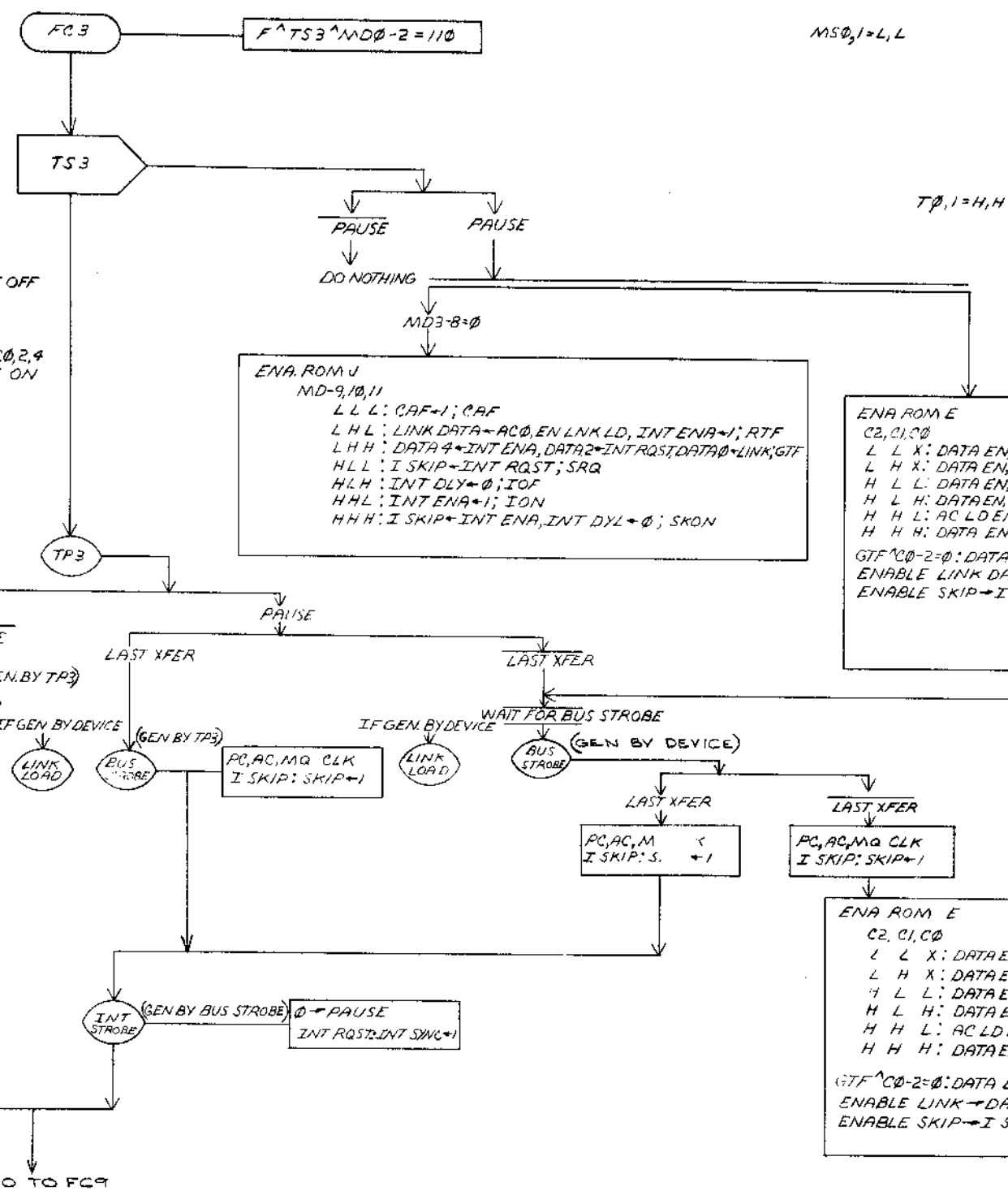

ENA ROM E
C2, C1, C0
L L X: DATA EN, PC LDEN;
L H X: DATA EN, PC LDEN, SEL C;
H L L: DATA EN, AC LDEN;
H L H: DATA EN, AC LDEN, AC-BUS;
H H L: AC LDEN, AC-BUS;
H H H: DATA EN AC LDEN, AC-BUS;
GTF^C0-2=0: DATA EN, AC LDEN;
ENABLE LINK DATA->LINK
ENABLE SKIP->I SKIP

ENA ROM E
C2, C1, C0
L L X: DATA EN, PC LDEN;
L H X: DATA EN, PC LDEN, SEL C;
H L L: DATA EN, AC LDEN;
H L H: DATA EN, AC LDEN, AC-BUS;
H H L: AC LDEN, AC-BUS;
H H H: DATA EN, AC LDEN, AC-BUS;
GTF^C0-2=0: DATA EN, AC LDEN;
ENABLE LINK->DATA
ENABLE SKIP->I SKIP

REV.	CHANGE NO.

EXECUTION OF AN IOT			
FIRST USED ON OPTION/MODEL	QTY.	DESCRIPTION	PART NO.
PDP8A			
PARTS LIST			
DIMENSIONAL TOLERANCE		DRN. <i>S. Charney</i>	DATE 11-6-74
DIMENSIONS ARE MILLIMETERS INCHES		CHK'D <i>[Signature]</i>	DATE 12/3/74
UNLESS OTHERWISE SPECIFIED		ENG. <i>[Signature]</i>	DATE 1-21-75
MILLIMETERS	INCHES	ANGLES	
XXX ±0.10	.XXX ±.005	±0°30'	
XX ±0.5	.XX ±.02		
X ±2	.X ±.1		
THIRD ANGLE PROJECTION	REMOVE BURRS AND BREAK SHARP CORNERS SURFACE QUALITY	PROJ. ENG. <i>[Signature]</i>	DATE 1-21-75
		PROD. <i>[Signature]</i>	DATE 1-21-75
		NEXT HIGHER ASSY.	
		MATERIAL	B-DD-KK8A-0
		FINISH	++
		SCALE	++
		SHEET	OF 1
		DIST.	
TITLE		SIZE CODE	NUMBER
FLOW DIAGRAM M8315 FC3		D F D	M8315-0-19
		REV.	

REV. M8315-0-19

THIS DRAWING AND SPECIFICATIONS, HEREIN, ARE THE PROPERTY OF DIGITAL EQUIPMENT CORPORATION AND SHALL NOT BE REPRODUCED OR COPIED OR USED IN WHOLE OR IN PART AS THE BASIS FOR THE MANUFACTURE OR SALE OF ITEMS WITHOUT WRITTEN PERMISSION. COPYRIGHT © 1977, DIGITAL EQUIPMENT CORPORATION

THE INSTRUCTION IS DECODED AT THIS POINT AS FOLLOWS:

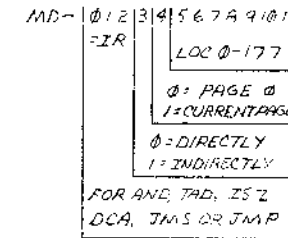

IF A JMP; THE PAGE IS ENABLED TO THE PC
THE PC IS LOADED

FC4
FA JMP DIRECT ^ TS3
FA MEM REF ^ TS3 ^ TS4

MS0,1 = L,L

T0,1 = H,H

MD0-2 = 101 : ENA ROM C
: PAGE EN: ADD ← PAGE
: PC LD EN; P1 ← ADD
: DATA ENA = H; ADD ← 0
: DATA CMP = L; ADD ← 0
: ENA ROM F: DOES NOTHING
: ENA ROM E: DOES NOTHING

INT STB
TP3
PC, AC, MQ CLK; CLK PC
INT RST ^ SET: INT SYNC = 1

TS4

IF JMP DIRECT; GO TO F SET TIME
IF MEM REF; ENABLE PAGE TO MA

IR=011 ^ MD3=0

MD3=1

T0,1 = L,H

IR=011 ^ MD3=0

NO D SET ^ E SET
FROM ROM H;
% F SET TIME

GO TO FC9; JMP DIR

D SET; ROM H
ENA ROM B
PAGE EN: ADD 5-11 ← MDS-11
: MD4: ADD 0-4 ← MA0-4
: MD4: ADD 0-4 ← 0
DATA ENA = H;
DATA CMP = L; ADD ← 0
ADD OUT 0-11 = 001X8; AI ← 1 ENA

E SET; ROM H
ENA ROM B
PAGE EN: ADD 5-11 ← MDS-11
: MD4: ADD 0-4 ← MA0-4
: MD4: ADD 0-4 ← 0
DATA ENA = H;
DATA CMP = L; ADD ← 0
ADD OUT 0-11 = 001X8; AI ← 1 ENA

MA, MS LOAD CONT: CPMA LOAD
D SET : D = 1
E SET : E = 1
PC, AC, MQ CLK
CPMA DIS INH CPMA → BUS

LOAD MA;
TEST BREAK SYSTEM.

MS, IR DIS: DMA; GO TO FC 10

D=1 : GO TO FC5; DEFER
E=1 : IR=00X: GO TO FC6; ANDY TAD DIRECT
IR=010: GO TO FC7; ISZ DIRECT
IR=011: GO TO FC8; DCA DIRECT
IR=100: GO TO FC8; JMS DIRECT

EXECUTION OF A JMP DIRECT OR THE PAGE OPERATION FOR A MEMORY REFERENCE INSTRUCTION				
FIRST USED ON OPTION/MODEL	QTY.	DESCRIPTION	PART NO.	ITEM NO.
PDP8A				
DIMENSIONAL TOLERANCE				
DIMENSIONS ARE MILLIMETERS UNLESS OTHERWISE SPECIFIED				
MILLIMETERS	INCHES	ANGLES		
X,XX = ±0.10 XX = ±0.05 X = ±0.2	.XXX = ±.005 .XX = ±.02 .X = ±.1	±0° 30'		
THIRD ANGLE PROJECTION REMOVE BURRS AND BREAK SHARP CORNERS SURFACE QUALITY				
NEXT HIGHER ASSY.				
MATERIAL				
FINISH				
DRN. DATE 11-13-74		DATE 12-13-74		
CHK'D. DATE 12-13-74		DATE 12-13-74		
ENG. DATE 12-13-74		DATE 12-13-74		
PROJ. ENG. DATE 12-13-74		DATE 12-13-74		
PROD. DATE 12-13-74		DATE 12-13-74		
TITLE			SIZE CODE	NUMBER
FLOW DIAGRAM M8315 FC4			DFD	M8315-0-20
SHEET OF			DIST.	

REV.	CHANGE NO.	DATE

DEC FORM NO. 040 102 C

8 7 6 5 4 3 2 1

REV. M8315-0-20

"THIS DRAWING AND SPECIFICATIONS HEREIN ARE THE PROPERTY OF DIGITAL EQUIPMENT CORPORATION AND SHALL NOT BE REPRODUCED OR COPIED OR USED IN WHOLE OR IN PART AS THE BASIS FOR THE MANUFACTURE OR SALE OF ITEMS WITHOUT WRITTEN PERMISSION. COPYRIGHT © 1974, DIGITAL EQUIPMENT CORPORATION"

D
C
B
A

A MEMORY READ IS STARTED
INDICATOR INFORMATION IS PLACED ON DATA BUS

THE ADDRESS WILL APPEAR ON THE MD LINES
MEMORY DATA+AI GOES TO MEMORY BUFFER (AI= ADDRESS $\phi\phi1\phi-\phi\phi17$)

MEMORY BUFFER IS LOADED AND PLACED ON MD LINES

A MEMORY WRITE IS STARTED
IF JMP; ENABLE MD TO THE PC
IF JMP; LOAD THE PC
IF JMP; GO TO F SET TIME
IF JMP; GO TO E SET
MA+MD (PLACES THE OPERAND ADDRESS IN THE MA) (THE EMA LINES MAY HAVE CHANGED-SEE OPT.1)

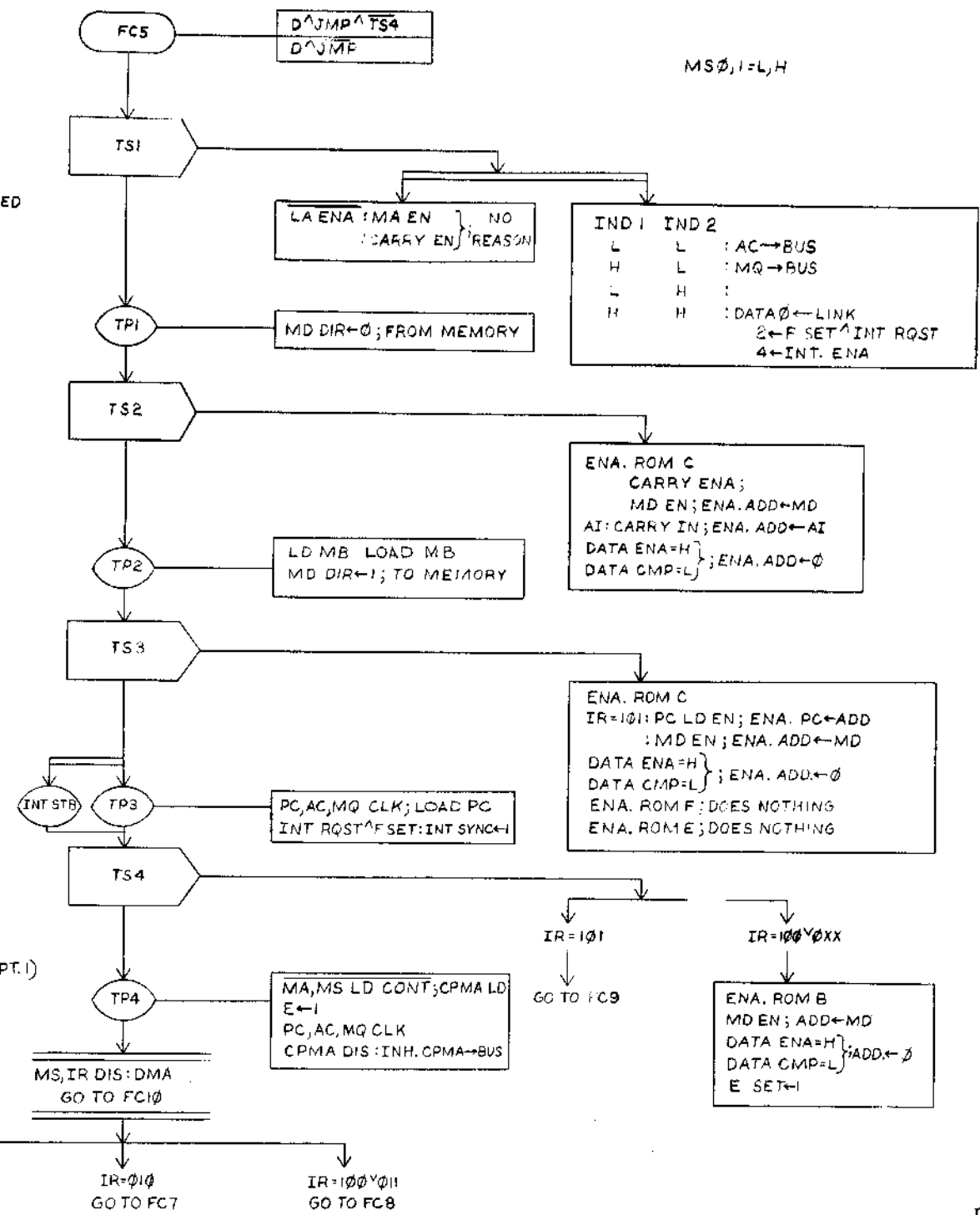

MS ϕ , 1=L,H

T ϕ , 1=L,L

T ϕ , 1=H,L

T ϕ , 1=H,H

T ϕ , 1=L,H

EXECUTION OF A JUMP INDIRECT OR CALCULATING THE INDIRECT ADDRESS FOR AND, TAD, DCA, ISZ OR JMS				
FIRST USED ON OPTION/MODEL	QTY.	DESCRIPTION	PART NO.	ITEM NO.
PDP8A				
PARTS LIST				
DIMENSIONAL TOLERANCE		DRN	DATE	
DIMENSIONS ARE MILLIMETERS UNLESS OTHERWISE SPECIFIED		CHK'D.	DATE	
MILLIMETERS	INCHES	ENG.	DATE	
XXX ±0.10 XX ±0.5 X ±2	.XXX ±0.008 .XX ±0.02 .X ±0.1	PROJ. ENG. PROD.	DATE	
THIRD ANGLE PROJECTION	REMOVE BURRS AND BREAK SHARP CORNERS SURFACE QUALITY	NEXT HIGHER ASSY.	DATE	TITLE
				FLOW DIAGRAM M8315 FC5
	MATERIAL	SIZE CODE	NUMBER	REV.
	FINISH	B-DD-KK8A-0	D FD M8315-0-21	
		SCALE	SHEET OF 1	
			DIST.	

REV. NO. 2
ITEM NO. M8315-0-21

B

A

THIS DRAWING AND SPECIFICATIONS, HEREIN, ARE THE PROPERTY OF DIGITAL EQUIPMENT CORPORATION AND SHALL NOT BE REPRODUCED OR COPIED OR USED IN WHOLE OR IN PART AS THE BASIS FOR THE MANUFACTURE OR SALE OF ITEMS WITHOUT WRITTEN PERMISSION. COPYRIGHT © 1974, DIGITAL EQUIPMENT CORPORATION.

11 100 0 5120 0 020 0 1 2 1

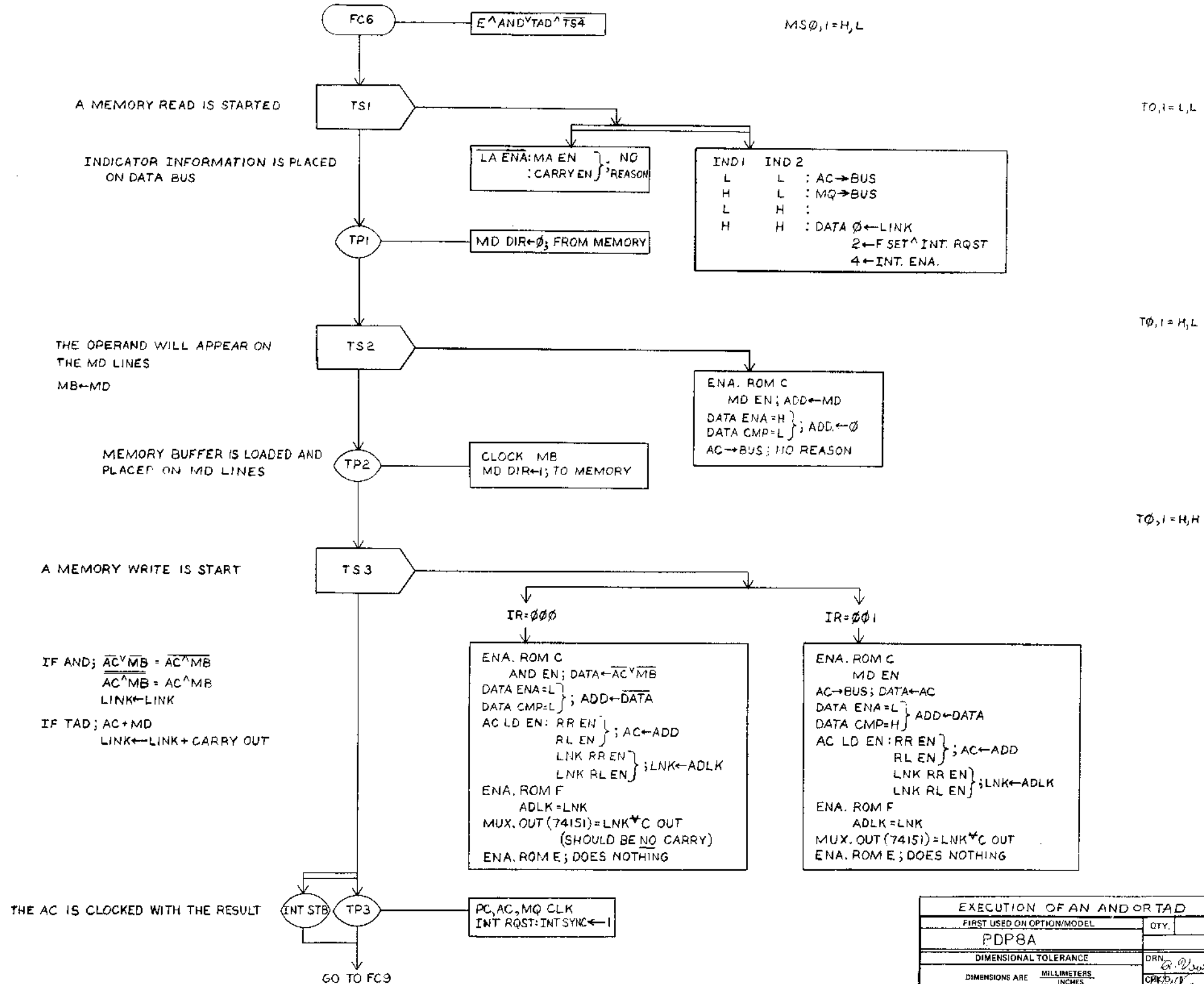

REV.	
CHANGE NO.	
CHK	

DEC FORM NO. 100 100-C

8 7 6 5 4 3 2 1

EXECUTION OF AN AND OR TAD			
FIRST USED OR OPTION/MODEL	QTY.	DESCRIPTION	PART NO. ITEM NO.
PDP8A			
PARTS LIST			
DIMENSIONAL TOLERANCE		DRN	DATE
DIMENSIONS ARE MILLIMETERS UNLESS OTHERWISE SPECIFIED		CHKD	DATE
MILLIMETERS	INCHES	ANGLES	
X,XX = ±0.10	.XXX = ±0.005	10° 30'	
X.X = ±0.5	.XX = ±0.02		
X = ±2	X = ±.1		
THIRD ANGLE PROJECTION	REMOVE BURRS AND BREAK SHARP CORNERS SURFACE QUALITY	ENG	DATE
		PROJ. ENG.	DATE
		PROD.	DATE
		NEXT HIGHER ASSY.	
MATERIAL	FINISH	SIZE/CCODE	NUMBER
		B-DD-KK8A-0	DFD M8315-0-22
		SCALE	REV.
		SHEET 1 OF 1	

REV. NUMBER DFD M8315-0-22



TITLE
FLOW DIAGRAM
M8315 FC6

THIS DRAWING AND SPECIFICATIONS, HEREIN, ARE THE PROPERTY OF DIGITAL EQUIPMENT CORPORATION AND SHALL NOT BE REPRODUCED OR COPIED OR USED IN WHOLE OR IN PART AS THE BASIS FOR THE MANUFACTURE OR SALE OF ITEMS WITHOUT WRITTEN PERMISSION. COPYRIGHT © 1974 DIGITAL EQUIPMENT CORPORATION

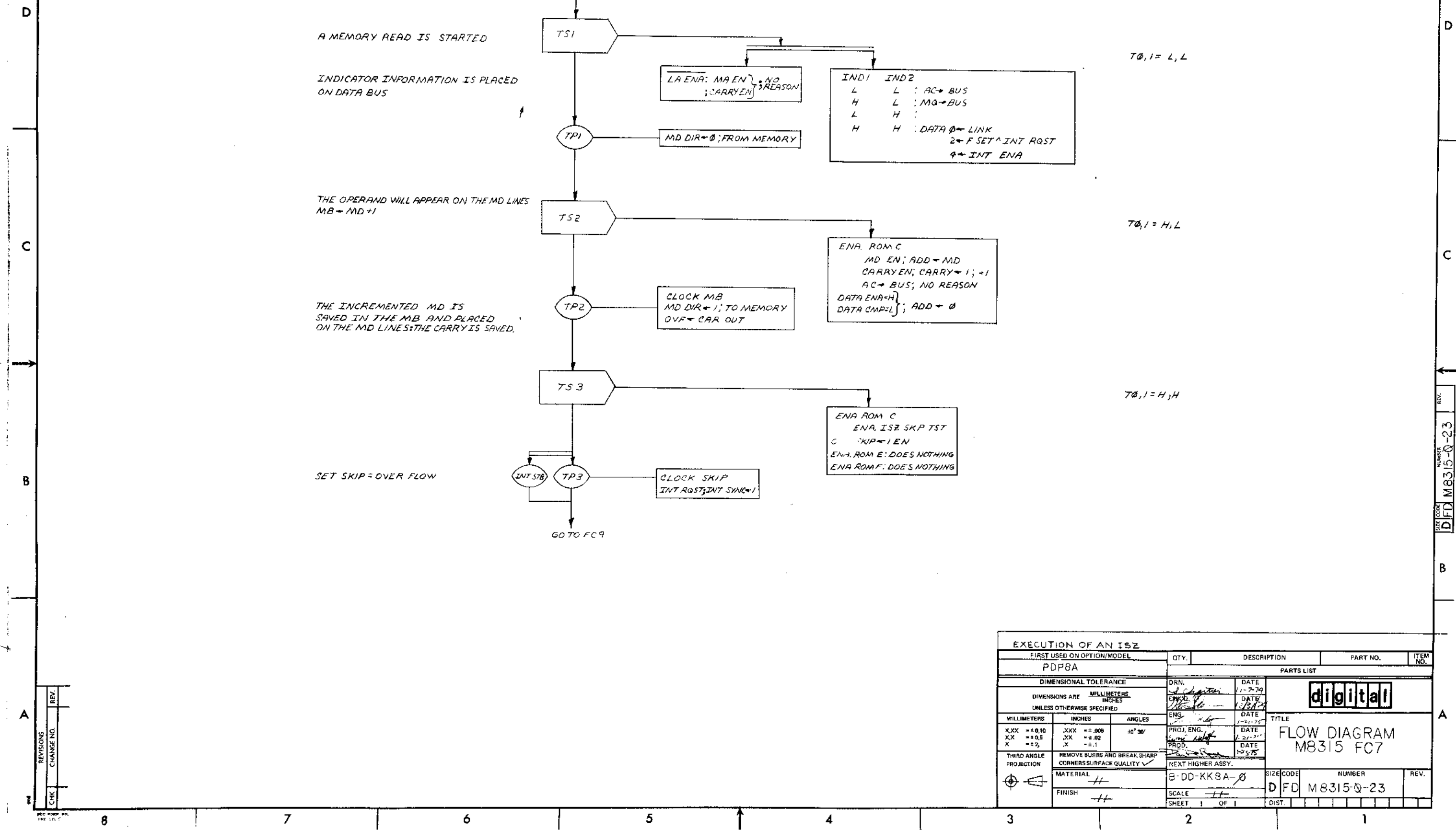

EXECUTION OF AN ISZ				QTY.	DESCRIPTION	PART NO.	ITEM NO.
FIRST USED ON OPTION/MODEL							
PDP8A							
DIMENSIONAL TOLERANCE				PARTS LIST			
DIMENSIONS ARE MILLIMETERS UNLESS OTHERWISE SPECIFIED				DRN.	DATE	digital	
MILLIMETERS INCHES ANGLES				CHKD.	DATE	TITLE	
X, XX = ±0.10	.XXX = ±0.005	30° 30'	ENG.	DATE	FLOW DIAGRAM		
XX = ±0.5	.X = ±0.02		PROJ. ENG.	DATE	M8315 FC7		
X = ±2	.X = ±.1		PROD.	DATE	M8315-Q-23		
THIRD ANGLE PROJECTION	REMOVE BURRS AND BREAK SHARP CORNERS SURFACE QUALITY ✓	NEXT HIGHER ASSY.	SIZE CODE NUMBER REV.				
	MATERIAL //	B-DD-KKSA- \emptyset	D F D M8315-Q-23				
	FINISH //	SCALE //	SHEET 1 OF 1				

REV.	CHANGE NO.

REV. 02-0-918W DFD M8315-Q-23

THIS DRAWING AND SPECIFICATIONS HEREIN ARE THE PROPERTY OF DIGITAL EQUIPMENT CORPORATION AND SHALL NOT BE REPRODUCED OR COPIED OR USED IN WHOLE OR IN PART AS THE BASIS FOR THE MANUFACTURE OR SALE OF ITEMS WITHOUT WRITTEN PERMISSION. COPYRIGHT © 1974, DIGITAL EQUIPMENT CORPORATION.

A MEMORY READ IS STARTED

INDICATOR INFORMATION IS PLACED ON DATA BUS.

THE OPERAND WILL APPEAR ON THE MD LINES

IF DCA; THE AC IS GATED TO THE MB

IF JMS; THE PC + SKIP IS GATED TO THE MB.

MB IS CLOCKED AND PLACED ON MD LINES

A MEMORY WRITE IS STARTED

IF DCA; THE AC GETS CLEARED

IF JMS; THE PC IS UPDATED TO EQUAL THE MA + ROM ADDRESS * CPMA DIS (+1 IS NORMAL)

IF DCA; CLOCK AC TO ZERO IT
IF JMS; CLOCK PC TO GET NEXT INST ADD.

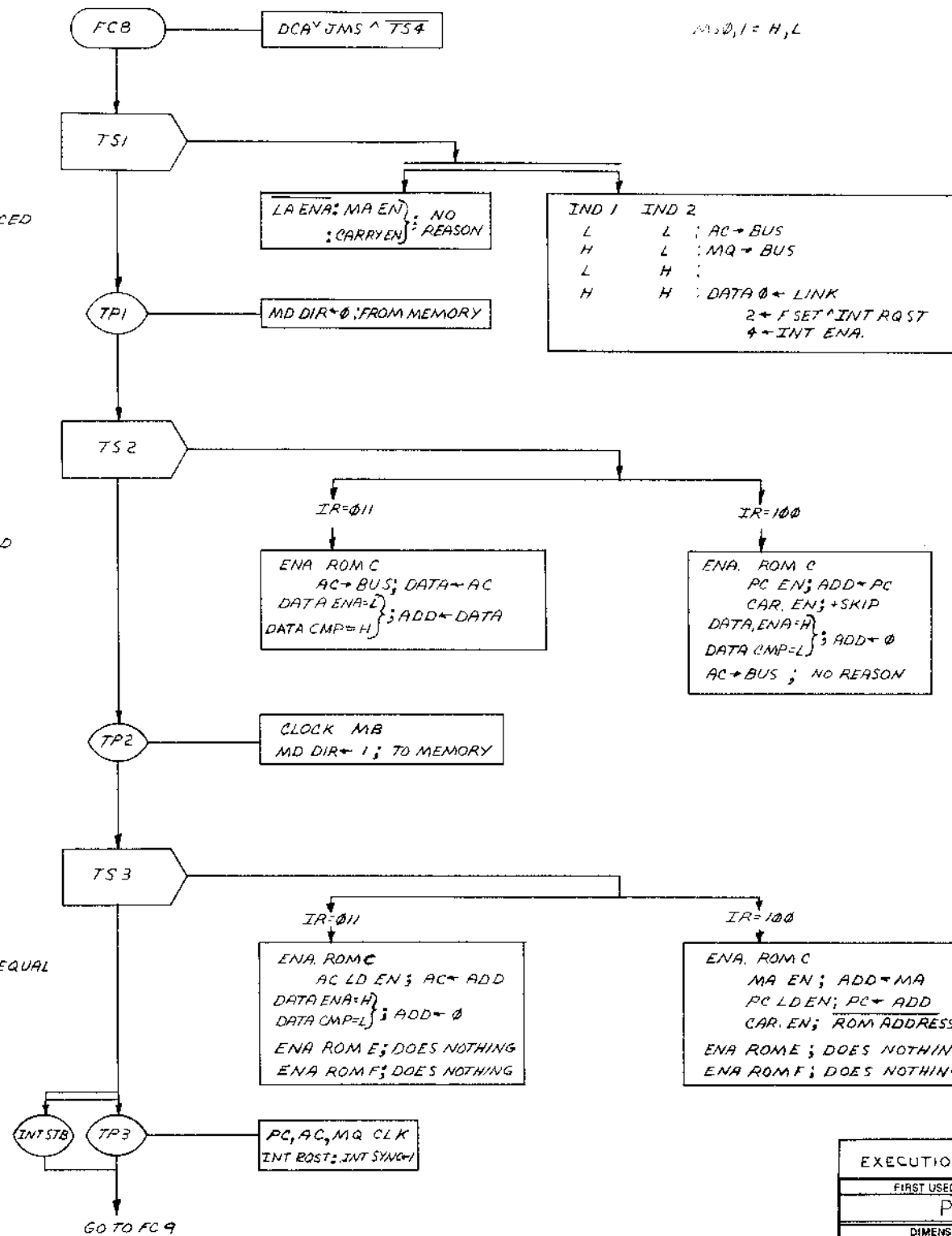

MA, 0, 1 = H, L

T0, 1 = L, L

T0, 1 = H, L

T0, 1 = H, H

EXECUTION OF A DCA OR JMS			
FIRST USED ON OPTION/MODEL	QTY.	DESCRIPTION	PART NO.
PDP8A			
PARTS LIST			
DRAWN	DATE	digital	
CHK'D	DATE		
ENG.	DATE		
PROJ. ENG.	DATE	TITLE	
PROD.	DATE	FLOW DIAGRAM	
		M8315 FC8	
THIRD ANGLE PROJECTION	REMOVE BURRS AND BREAK SHARP CORNERS SURFACE QUALITY	NEXT HIGHER ASSY.	
MATERIAL	B-DD-KK8A-0	SIZE CODE	NUMBER
FINISH		D	FD M8315-0-24
SHEET	1 OF 1	DCT.	

REV.	CHANGE NO.	CHK.

REV. NUMBER DFD M8315-0-24

"THIS DRAWING AND SPECIFICATIONS, HEREIN, ARE THE PROPERTY OF DIGITAL EQUIPMENT CORPORATION AND SHALL NOT BE REPRODUCED OR COPIED OR USED IN WHOLE OR IN PART AS THE BASIS FOR THE MANUFACTURE OR SALE OF ITEMS WITHOUT WRITTEN PERMISSION. COPYRIGHT © 1974, DIGITAL EQUIPMENT CORPORATION"

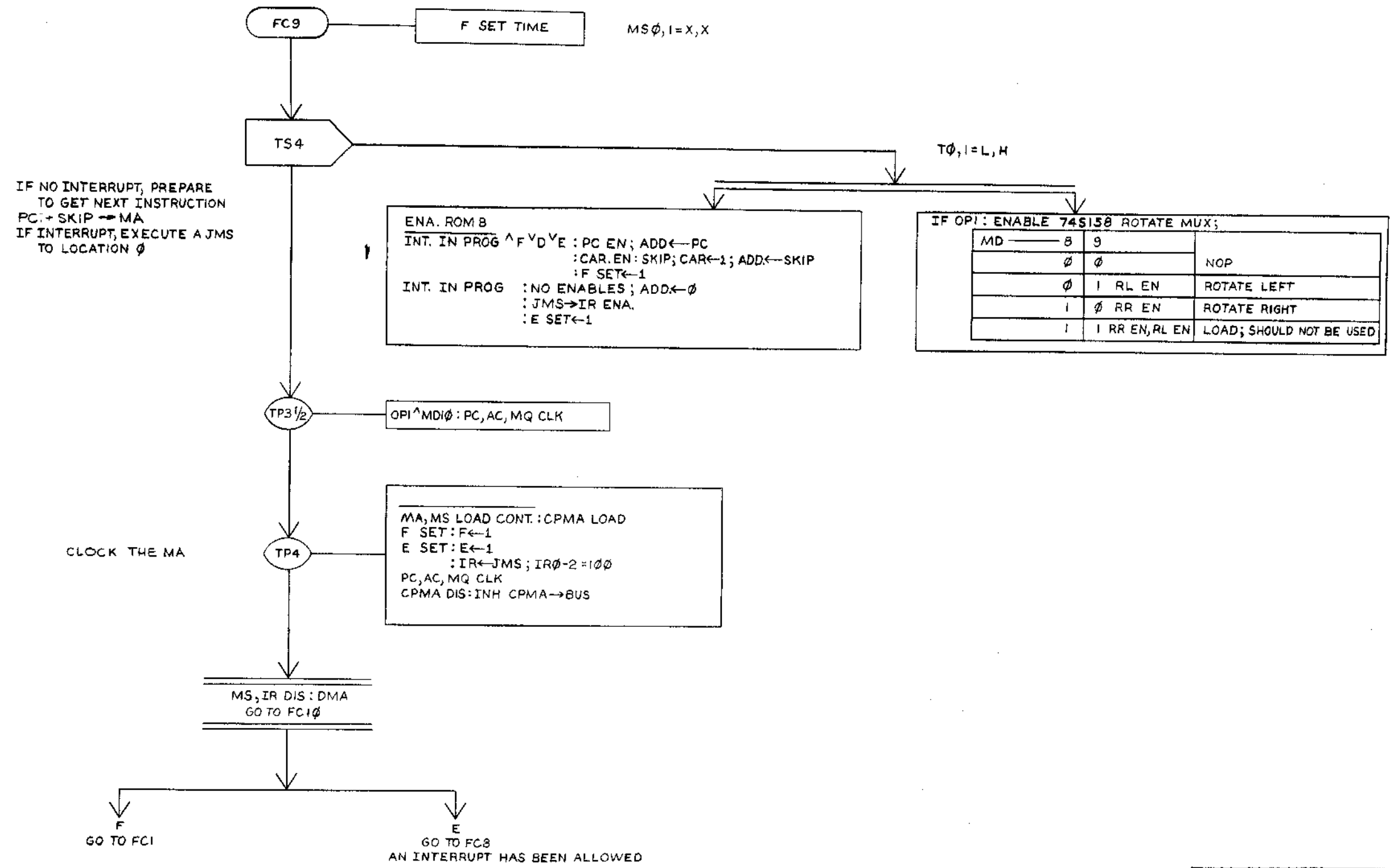

REVISIONS	REV.
CHANGE NO.	
CHK	

GETTING ADDRESS OF NEXT INSTRUCTION, OR ANSWERING INTERRUPT			
FIRST USED ON OPTION/MODEL	QTY.	DESCRIPTION	PART NO. ITEM NO.
PDP8A			
PARTS LIST			
DIMENSIONAL TOLERANCE		DRN	DATE
DIMENSIONS ARE MILLIMETERS		<i>DR Youles</i>	11-6-74
UNLESS OTHERWISE SPECIFIED		CHKD	DATE
		<i>John Shea</i>	12/3/74
		ENG	DATE
		<i>John Shea</i>	1-21-75
		PROJ. ENG.	DATE
		<i>John Shea</i>	1-21-75
		PROD.	DATE
		<i>John Shea</i>	1-21-75
TITLE			
FLOW DIAGRM M8315 FC9			
THIRD ANGLE PROJECTION	REMOVE BURRS AND BREAK SHARP CORNERS SURFACE QUALITY	NEXT HIGHER ASSY.	SIZE CODE
	<input checked="" type="checkbox"/>	B-DD-KK8A-∅	NUMBER
MATERIAL	FINISH	SCALE	D F D
		OF 1	M8315-0-25
		DIST.	

REV. M8315-0-25

THIS DRAWING AND SPECIFICATIONS HEREIN ARE THE PROPERTY OF DIGITAL EQUIPMENT CORPORATION AND SHALL NOT BE REPRODUCED OR COPIED OR USED IN WHOLE OR IN PART AS THE BASIS FOR THE MANUFACTURE OR SALE OF ITEMS WITHOUT WRITTEN PERMISSION. COPYRIGHT © 1974, DIGITAL EQUIPMENT CORPORATION.

THE BREAK CONTROL WORD (LAEN KEY CTRL BK DATA CTRL) IS NORMALLY SET UP AT THE BEGINNING OF THE DATA CYCLE AND REMAINS STABLE FOR THE ENTIRE CYCLE. IT DEFINES OPERATIONS AS FOLLOWS:

LAEN	H H H	H H L	H L H	H L L	L H H	L H L	L L H	L L L
DATA TO MEM	ADD TO MEM	CON DEPOSIT	CON EXAMINE	LOAD ADD	BOOT DEPOSIT	LOAD FIELD 0	LOAD FIELD 1	LOAD FIELD 7
THE CONTENTS OF THE DATA LINES GO TO THE MB	THE CONTENTS OF THE MD LINES PLUS THE CONTENTS OF THE DATA LINES GO TO THE MB	THE CONTENTS OF THE DATA LINES GO TO THE MB	THE CONTENTS OF THE MD LINES GO TO THE MB	THE CONTENTS OF THE MD LINES GO TO THE MB	THE CONTENTS OF THE MD LINES GO TO THE MB	THE CONTENTS OF THE MD LINES GO TO THE MB	THE CONTENTS OF THE MD LINES GO TO THE MB	THE CONTENTS OF THE MD LINES GO TO THE MB
THE MB IS WRITTEN INTO MEMORY	THE MB IS WRITTEN INTO MEMORY	THE MB IS WRITTEN INTO MEMORY	THE MB IS WRITTEN INTO MEMORY	THE MB IS WRITTEN INTO MEMORY	THE MB IS WRITTEN INTO MEMORY	THE MB IS WRITTEN INTO MEMORY	THE MB IS WRITTEN INTO MEMORY	THE MB IS WRITTEN INTO MEMORY
		RUN IS CLEARED	RUN IS CLEARED	THE CONTENTS OF THE DATA LINES GO TO THE PC		CAUTION: AND EN CAUSES THE DATA BUS TO = 7777 THIS DEPENDS UPON THE AC = 0000. THE CONTENTS OF THE DATA LINES GOES TO THE MEMORY EXTENSION CONTROLS IS B.D.F. AT TP3		
		THE PC GOES TO THE MA	THE PC GOES TO THE MA	THE PC GOES TO THE MA	THE PC GOES TO THE MA	AND IF AT TP4	AND IF AT TP4	

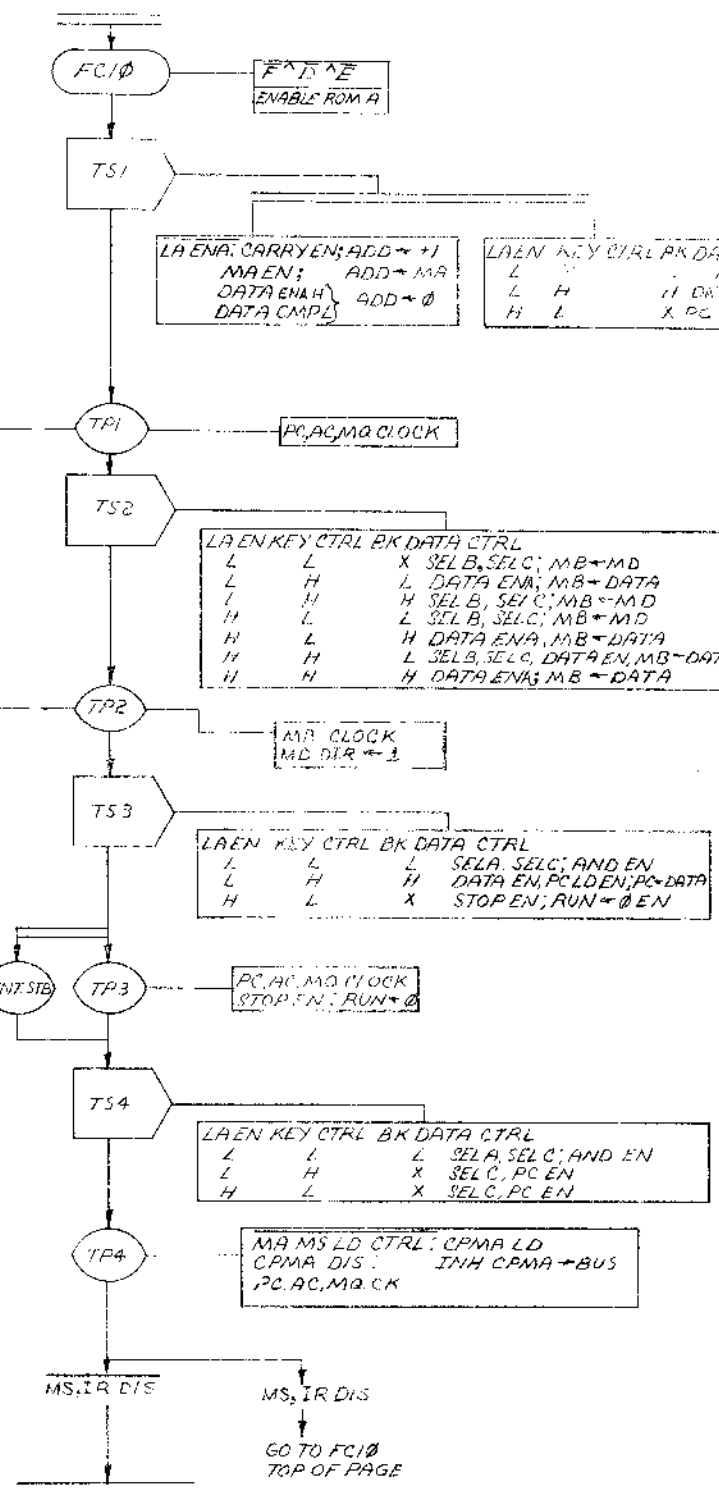

DATA BREAK/CONSOLE OPERATIONS/AUTO RESTART				
FIRST USED ON OPTION/MODEL	QTY.	DESCRIPTION	PART NO.	ITEM NO.
PDP8A				
PARTS LIST				
DIMENSIONAL TOLERANCE		DRN	DATE	
DIMENSIONS ARE MILLIMETERS UNLESS OTHERWISE SPECIFIED		DATE	DATE	
MILLIMETERS	INCHES	ANGLE	DATE	
XXX = ±0.10	XX = ±0.05	XX = ±0.08	XX = ±0.02	
X = ±0.2	X = ±.1	30°/30°		
THRU ANGLE PROJECTION	REMOVE BURRS AND BREAK SHARP CORNERS SURFACE QUALITY	PROJ. ENG.	DATE	
		PROD.	DATE	
		NEXT HIGHER ASSY.		
		MATERIAL	SIZE/CODE	NUMBER
		FINISH	SCALE	REV.

REV.	CHANGE NO.

REV. 1
D E D M 8315-0-26

THIS DRAWING AND SPECIFICATIONS, HEREIN, ARE THE PROPERTY OF DIGITAL EQUIPMENT CORPORATION AND SHALL NOT BE REPRODUCED OR COPIED OR USED IN WHOLE OR IN PART AS THE BASIS FOR THE MANUFACTURE OR SALE OF ITEMS WITHOUT WRITTEN PERMISSION. COPYRIGHT © 1974 DIGITAL EQUIPMENT CORPORATION

(ϕ = 155 x 10 IN NANO SEC'S)

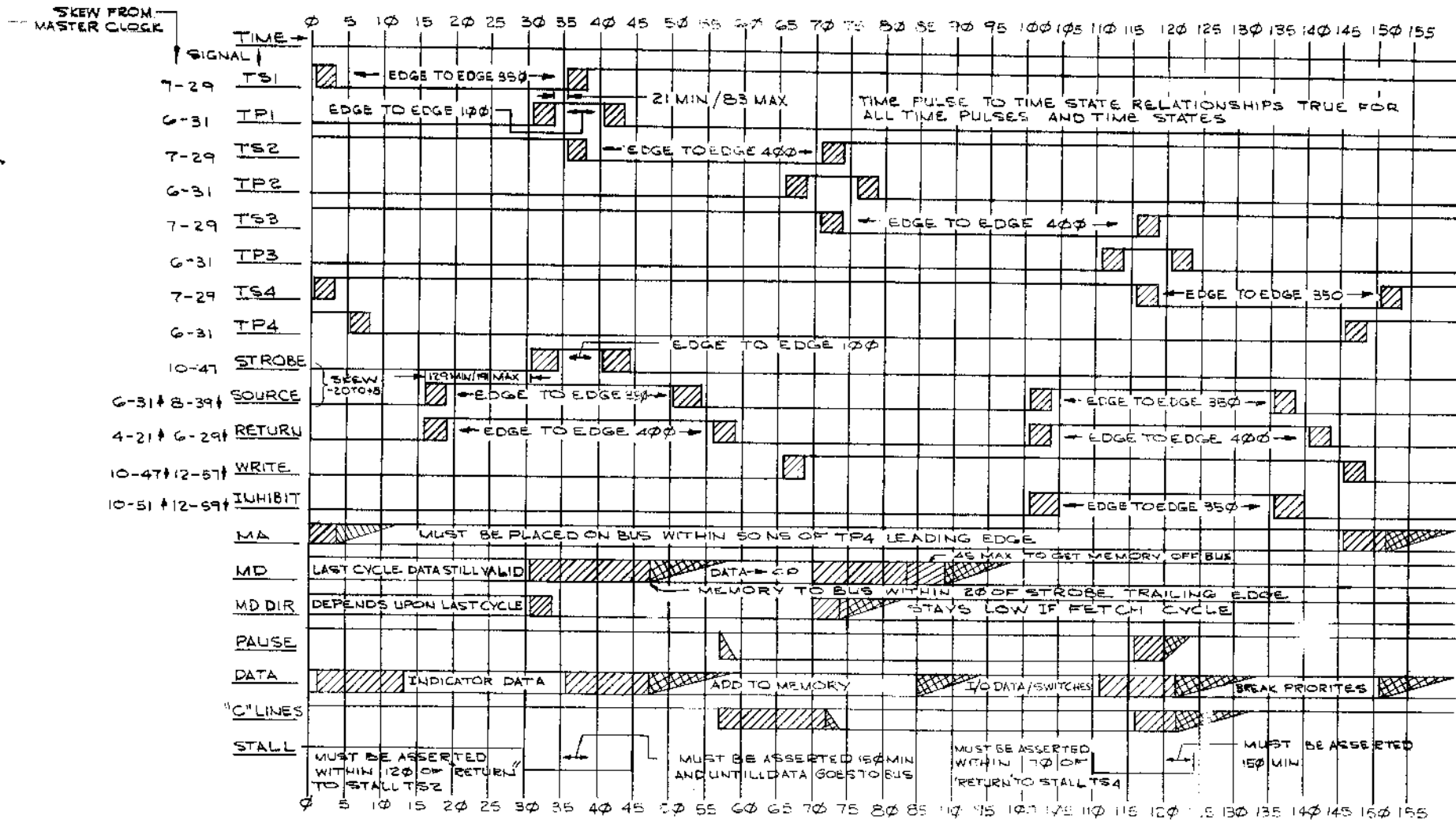

REV.	
CHANGE NO.	
CHK	

8A DATA PATH FUNCTION & TIMING			
FIRST USED ON OPTION/MODEL	QTY.	DESCRIPTION	PART NO.
PDP8A			
PARTS LIST			
DIMENSIONAL TOLERANCE		DATE	DATE
DIMENSIONS ARE MILLIMETERS UNLESS OTHERWISE SPECIFIED		1/22/74	1/25/74
MILLIMETERS	INCHES	ANGLES	
XXX ±0.10	XXX ±.005	30° 30'	
XX ±0.5	XX ±.02		
X ±2	X ±.1		
THIRD ANGLE PROJECTION	REMOVE BURRS AND BREAK SHARP CORNERS SURFACE QUALITY	DATE	DATE
		1/21/74	1/23/75
		TITLE	
		FLOW DIAGRAM MS315 BUS TIMING	
		SIZE CODE	NUMBER
		B-DD-KK8A-0	D.F.D.M8315-0-27
		SCALE	
		SHEET 1 OF 2	

REV. 1
NUMBER
D.F.D.M8315-0-27

"THIS DRAWING AND SPECIFICATIONS, HEREIN, ARE THE PROPERTY OF DIGITAL EQUIPMENT CORPORATION AND SHALL NOT BE REPRODUCED OR COPIED OR USED IN WHOLE OR IN PART AS THE BASIS FOR THE MANUFACTURE OR SALE OF ITEMS WITHOUT WRITTEN PERMISSION. COPYRIGHT © 1975 DIGITAL EQUIPMENT CORPORATION"

NOTES:

1. THE PC, AC AND MQ ARE LOADED BY PC, AC, MQ CLK IF THE LOAD IS ENABLED.
2. ALL FUNCTIONS CONTAINED IN BROKEN LINES ARE ACHIEVED INTERNAL TO IC.
3. THE "PAGE EN" SIGNAL ENABLES MA ϕ -4 AND MDS-11 TO THE INTERNAL REGISTER BUS IF MD4="1".

D
C
B
A

D
C
B
A

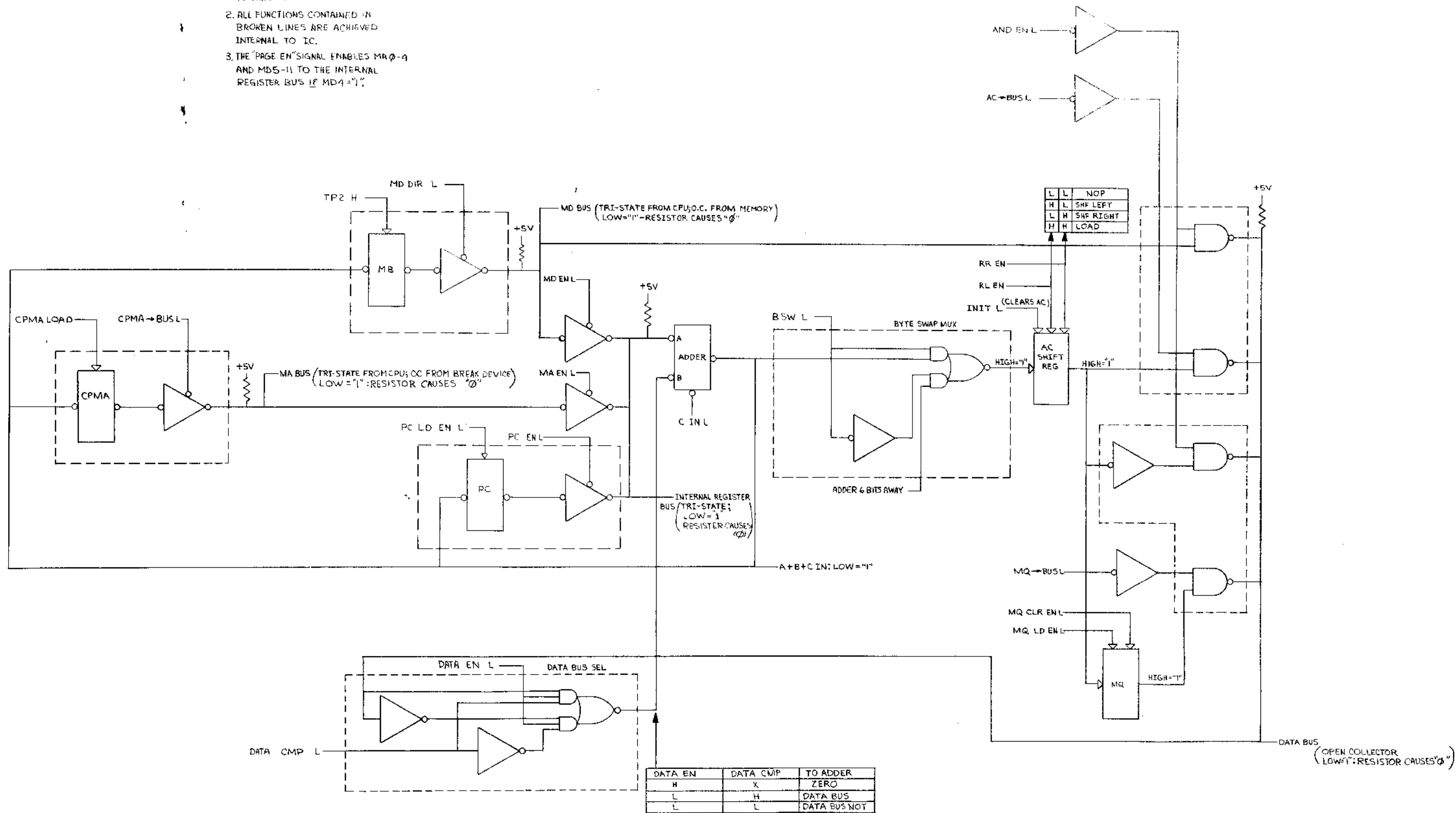

DATA EN	DATA CMP	TO ADDER
H	X	ZERO
L	H	DATA BUS
L	L	DATA BUS NOT

REVISIONS		
CHK	CHANGE NO.	REV.

DATA PATH FUNCTIONS			
TITLE	SIZE CODE	NUMBER	REV.
FLOW DIAGRAM M8315 BUS TIMING	D	FD M8315-0-27	
SCALE	SHEET 2 OF 2	DIST.	

REV. 1
D FD M8315-0-27

THIS DRAWING AND SPECIFICATIONS HEREIN ARE THE PROPERTY OF DIGITAL EQUIPMENT CORPORATION AND SHALL NOT BE REPRODUCED OR COPIED OR USED IN WHOLE OR IN PART AS THE BASIS FOR THE MANUFACTURE OR SALE OF ITEMS WITHOUT WRITTEN PERMISSION. COPYRIGHT © 1977 DIGITAL EQUIPMENT CORPORATION

NOTE:
PINS
AC1, AF1, AN1, AT1
BC1, AF1, AN1, AT1
DC1, AF1, AN1, AT1
DD1, AF1, AN1, AT1
TO GROUND

PIN	DIODE	TO	SIGNAL NAME	PIN	DIODE	TO	SIGNAL NAME	PIN	DIODE	TO	SIGNAL NAME	PIN	DIODE	TO	SIGNAL NAME	
AD2	D150	GND	EMABL	BE1	D145	GND	MA5 L	DJ1	D88	GND	CZ L	DL1	D29	GND	MD9 L	
	D152	+3V			D147	+3V			D87	+3V			D51	+3V		
	D149	GND	MABL	BH2	D143	GND	MA, MS, LOAD CONT L	CK2	D84	GND	TS1 L	DM2	D26	GND	USER MODE H	
AD1	D151	+3V			D142	+3V			D83	+3V			D25	+3V		
	D200	GND	EMAIL	BH1	D141	GND	MA6 L	CK1	D82	GND	BUS STROBE L		D24	GND		
AE2	D189	+3V			D144	+3V			D81	+3V			D23	+3V		
	D198	GND	MAIL	BJ2	D140	GND	OVERFLOW L	CL2	D78	GND	TS2 L	DP2	D22	+3V		
AE1	D197	+3V			D139	+3V			D77	+3V			D21	+3V		
	D195	GND	EMA2L	BJ1	D138	GND	MA7 L	CL1	D80	GND	INTERNAL I/O L	DP1	D22	GND	MD11 L	
AH2	D194	+3V			D137	+3V			D79	+3V			D21	+3V		
	D193	GND	MA2L	BK2	D134	+3V	BREAK DATA CONT L	CM2	D74	GND	TS3 L	DR2	D20	GND	PULSE LA H	
AH1	D196	+3V			D133	+3V			D73	+3V			D19	+3V		
	D190	GND	MEM START L	BK1	D136	GND	MD4 L	CM1	D78	GND	NOT LAST XFER L	DR1	D18	GND	DATA 8 L	
AJ2	D192	+3V			D135	+3V			D75	+3V			D17	+3V		
	D189	GND	MA3L	BL2	D130	GND	BREAK CYCLE	CP2	D70	GND	TS4 L	DS2	D13	GND	STOP L	
AJ1	D191	+3V			D129	+3V			D72	+3V			D16	+3V		
	D188	GND	MD DIR L	BL1	D132	GND	MD5 L	CP1	D69	GND	INT ROST L	DS1	D15	GND	DATA 9 L	
AK2	D187	+3V			D131	+3V			D71	+3V			D14	+3V		
	D186	GND	MD0 L	BM2	D128	GND	LA ENABLE L	CR2	D65	GND	LINK DATA L	DU2	D10	GND	KEY CONTROL L	
AK1	D185	+3V			D127	+3V			D68	+3V			D12	+3V		
	D182	GND	SOURCE H	BM1	D126	GND	MD6 L	CR1	D67	GND	INITIALIZE H	DU1	D9	GND	DATA 10 L	
AL2	D181	+3V			D125	+3V			D66	+3V			D11	+3V		
	D184	GND	MD1 L	BP2	D122	GND	INIT IN PROG H	CS2	D64	GND	LINK LOAD L	DV2	D96	GND	SW	
AL1	D183	+3V			D124	+3V			D62	+3V			D95	+3V		
	D180	GND	STROBE H	BPI	D121	GND	MD7 L	CS1	D63	GND	SKIP L	DV1	D94	GND	DATA 11 L	
AM2	D179	+3V			D123	+3V			D61	+3V			D93	+3V		
AM1	D178	GND	MD2 L	BR2	D117	GND	RES 1 H	CU2	D60	GND	IND 1 L					
	D177	+3V			D120	+3V			D59	+3V						
	D176	GND	INHIBIT H	BR1	D119	GND	DATA 4 L	CU1	D58	GND	CPMA DISABLE L					
AP2	D175	+3V			D118	+3V			D57	+3V						
	D174	GND	MD3 L	BS2	D116	GND	RES 2 H	CV2	D56	GND	IND 2 L					
AP1	D173	+3V			D115	+3V			D55	+3V						
	D169	GND	RETURN H	BS1	D114	GND	DATA 5 L	CV1	D54	GND	MS, IR DISABLE L					
AR2	D172	+3V			D113	+3V			D53	+3V						
	D171	GND	DATA 0 L	BU2	D110	GND	RUN L	DD2	D52	GND	IR0 L					
AR1	D170	+3V			D109	+3V			D50	+3V						
	D168	GND	WRITE H	BU1	D112	GND	DATA 6 L	DD1	D51	GND	MA8 L					
AS2	D167	+3V			D111	+3V			D49	+3V						
	D166	GND	DATA 1 L	BV2	D108	GND	POWER OK H	DE2	D48	GND	IR1 L					
AS1	D165	+3V			D107	+3V			D100	+3V						
	D164	GND	ROM ADDRESS L	BV1	D106	GND	DATA 7 L	DE1	D97	GND	MA9 L					
AU2	D163	+3V			D105	+3V			D98	+3V						
	D162	GND	DATA 2 L	CD2	D156	GND	TP1 H	DH2	D44	GND	IR2 L					
AU1	D161	+3V			D155	+3V			D43	+3V						
	D160	GND	LINK L	CD1	D154	GND	I/O PAUSE L	DH1	D42	GND	MA10 L					
AV2	D159	+3V			D153	+3V			D41	+3V						
	D158	GND	DATA 3 L	CE2	D48	GND	TP2 H	DJ2	D39	GND	F L					
AV1	D157	+3V			D47	+3V			D38	+3V						
	D104	GND	INIT STROBE H	CE1	D46	GND	CB L	DJ1	D37	GND	MA11 L					
BD2	D103	+3V			D45	+3V			D40	+3V						
	D102	GND	MA4 L	CH2	D91	GND	TP3 H	DK2	D36	GND	O L					
BD1	D101	+3V			D90	+3V			D35	+3V						
	D146	GND	BRK IN PROG	CH1	D89	GND	C1 L	DK1	D34	GND	MA8 L					
BE2	D148	+3V			D92	+3V			D33	+3V						
					D86	GND	TP4 H	DL2	D30	GND	E L					
					D85	+3V			D32	+3V						

REVISIONS		
CHK	CHANGE NO.	REV.

TITLE	CMNIBUS DIODE CLAMPS	SIZE CODE	D	NUMBER	CSM8318-0-1	REV.	*
SCALE	1:1	SHEET	2	OF	2	DIST.	

8 7 6 5 4 3 2 1

REV. 1 DCSM8318-0-1

CUSTOMER PRINT SET		ELECTRICAL						CUSTOMER PRINT SET		MECHANICAL							
1		MFG. SET	FIND NO.	DRAWING NO.	REV	NO OF SHT	DESCRIPTION	OPTION NO./FILE DATE	1		MFG. SET	FIND NO.	DRAWING NO.	REV	NO OF SHT	DESCRIPTION	OPTION NO./FILE DATE
X				B-DD-MM8-0	B	2	DRAWING DIRECTORY		X				E-UA-MM8-0-0	B	1	MEMORY SYSTEM ASSY	
X				B-DD-H219-0	A	2	CORE MEMORY STACK ASSY										
X				D-CS-G649-0-1			8K,12 BIT, BASE BOARD ASSY										
X				D-CS-G650-0-1			16K,12 BIT, BASE BOARD ASSY										
X				A-SP-MM8-A-1			FIELD INSTALLATION+ACCEPTANCE PROCEDURE										

CUSTOMER PRINT SET CODES
X = PRINT OF DOCUMENT INCLUDED IN PRINT SET
C = INCLUDES ALL PRINTS INDICATED ON DOCUMENT
S = CONFIDENTIAL AUTHORIZED SIGNATURE REQUIRED

TITLE MEMORY STACK
SHEET 2 OF 2
SIZE CODE B DD
NUMBER MM8-0
REV B

ELECTRICAL					MECHANICAL										
CUSTOMER PRINT SET	MFG. SET	FIND NO.	DRAWING NO.	REV.	NO OF SHT	DESCRIPTION	OPTION NO./FILE DATE	CUSTOMER PRINT SET	MFG. SET	FIND NO.	DRAWING NO.	REV.	NO OF SHT	DESCRIPTION	OPTION NO./FILE DATE
X			B-DD-H219-Ø	A	2	DRAWING DIRECTORY		X			D-UA-H219-Ø-Ø	A	1	CORE MEMORY STACK ASSY	
X			D-CS-5411531-0-1		2	STACK BOARD, CORE MEMORY					D-PS-1211726-0-0		1	STIFFNER BAR, HANDLE	
			E-IA-7010692-0-0		2	CORE PLANE WIRING ASSY					D-PS-1211725-0-0		1	STIFFNER BAR, FINGER	
X			D-CS-5411531-YA-1		3	STACK BOARD CORE MEMORY					B-MD-5511533-0-0		1	STANDOFF ¼ DIA. x .34 LG.	
			E-UA-7010898-0-0		2	CORE PLANE WIRING ASSY					C-MD-5511534-0-0		1	COVER, CORE MEMORY STACK	

CUSTOMER PRINT SET CODES
X = PRINT OF DOCUMENT INCLUDED IN PRINT SET
C = INCLUDES ALL PRINTS INDICATED ON DOCUMENT
S = CONFIDENTIAL AUTHORIZED SIGNATURE REQUIRED

TITLE
MEMORY STACK

SHEET 2 OF 2
SIZE CODE B DD
NUMBER H219-Ø
REV A

"THIS DRAWING AND SPECIFICATIONS HEREIN ARE THE PROPERTY OF DIGITAL EQUIPMENT CORPORATION AND SHALL NOT BE REPRODUCED OR COPIED OR USED IN WHOLE OR IN PART AS THE BASIS FOR THE MANUFACTURE OR SALE OF ITEMS WITHOUT WRITTEN PERMISSION. COPYRIGHT © 1974 DIGITAL EQUIPMENT CORPORATION"

REV. A
D CS 5411531-0-1
NUMBER 2

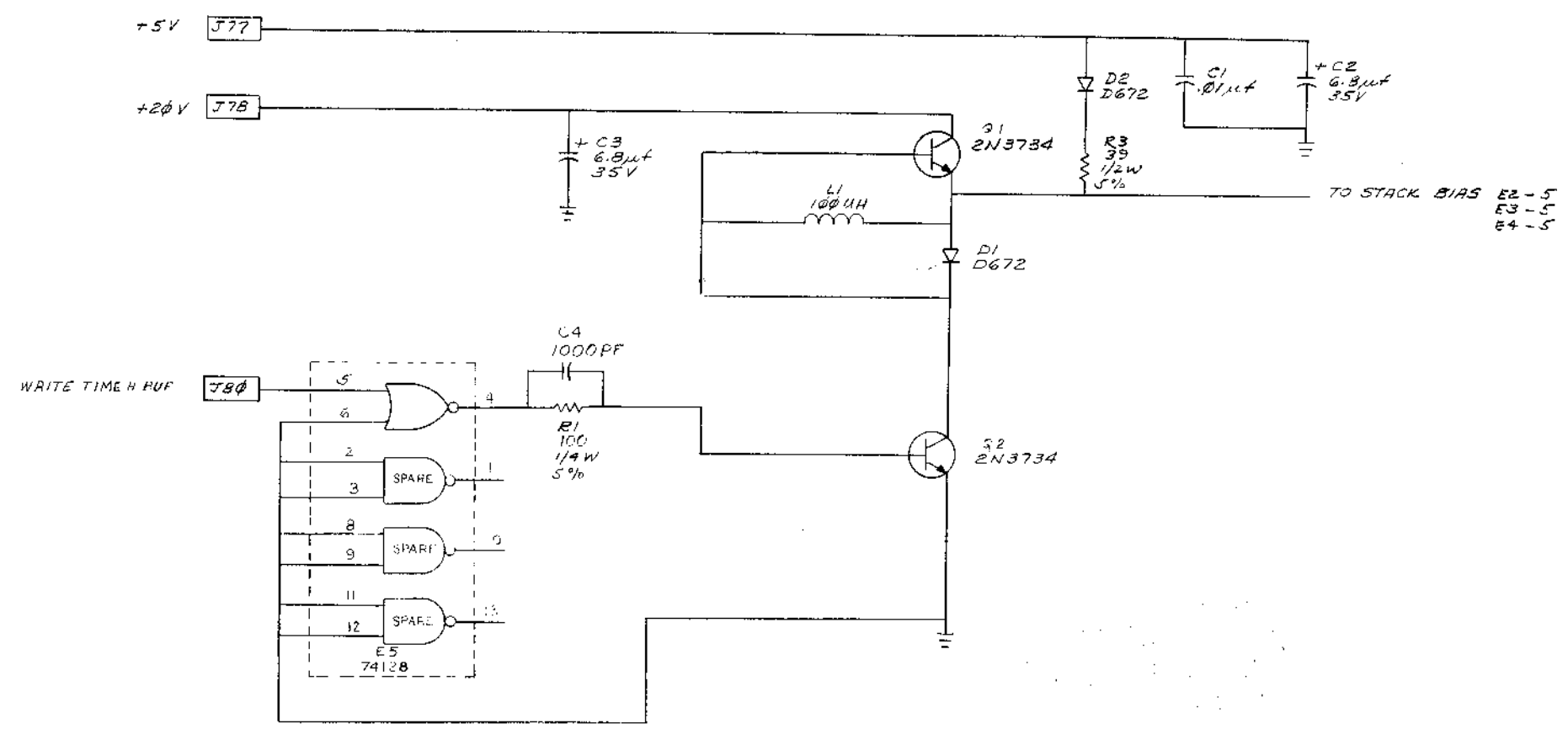

REVISIONS		
CHK	CHANGE NO.	REV.

TITLE CORE MEMORY STACK 8K
 SIZE CODE D CS 5411531-0-1
 NUMBER 2 OF 4
 SHEET 2 OF 4
 SCALE
 DIST.
 REV. A

REV. A
D CS 5411531-0-1
NUMBER

"THIS DRAWING AND SPECIFICATIONS, HEREIN, ARE THE PROPERTY OF DIGITAL EQUIPMENT CORPORATION AND SHALL NOT BE REPRODUCED OR COPIED OR USED IN WHOLE OR IN PART AS THE BASIS FOR THE MANUFACTURE OR SALE OF ITEMS WITHOUT WRITTEN PERMISSION. COPYRIGHT © 1974 DIGITAL EQUIPMENT CORPORATION"

D
C
B
A

D
C
B
A

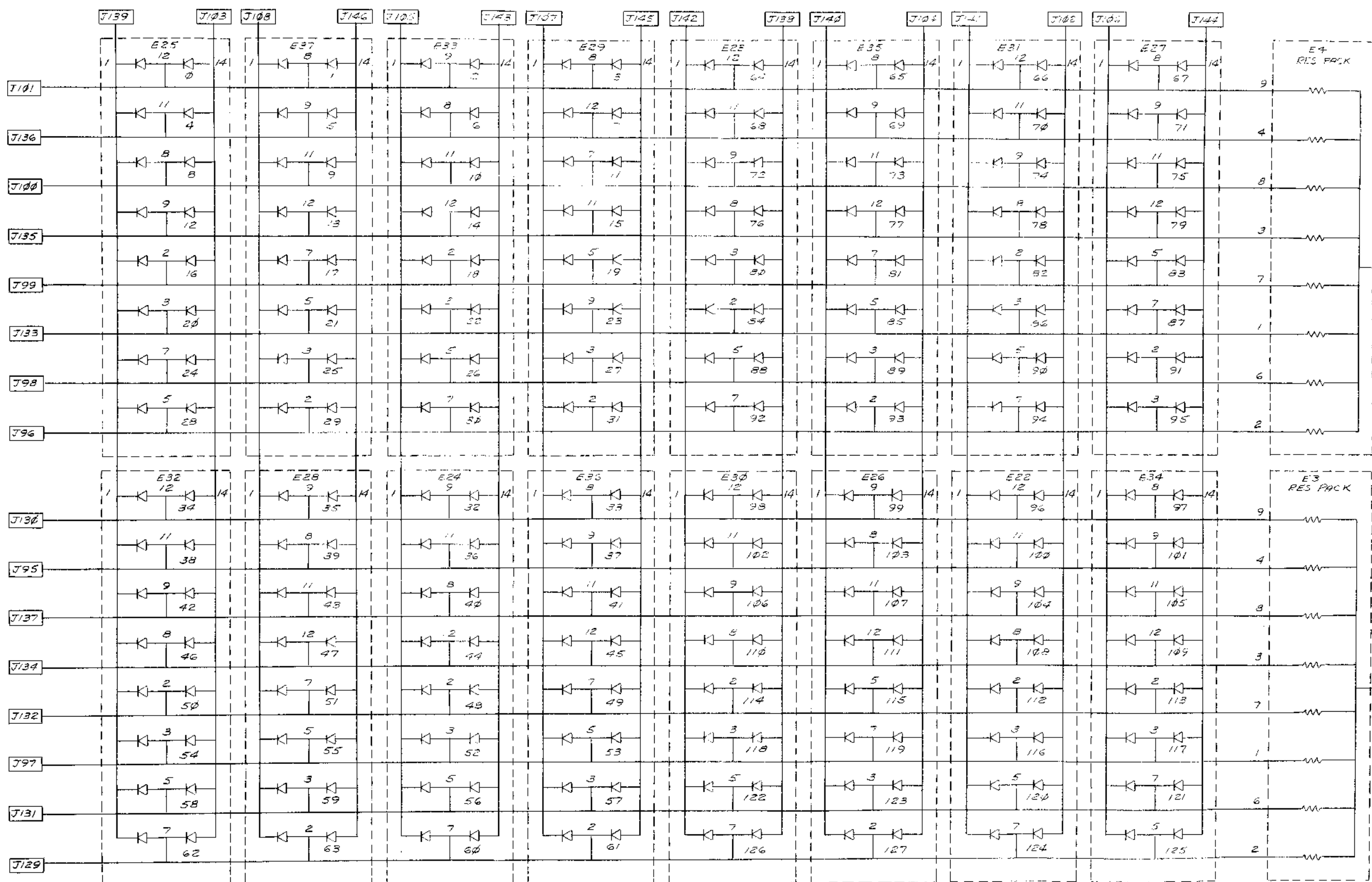

REVISIONS		
CHK	CHANGE NO.	REV.

(X'DRIVE DIMENSION DICDE MATRIX)

TITLE	CORE MEMORY STACK	SIZE CODE	8K	NUMBER	DCS 5411531-0-1	REV.	A
SCALE	---	SHEET	3	OF	7	DIST.	

"THIS DRAWING AND SPECIFICATIONS, HEREIN, ARE THE PROPERTY OF DIGITAL EQUIPMENT CORPORATION AND SHALL NOT BE REPRODUCED OR COPIED OR USED IN WHOLE OR IN PART AS THE BASIS FOR THE MANUFACTURE OR SALE OF ITEMS WITHOUT WRITTEN PERMISSION. COPYRIGHT © 1974 DIGITAL EQUIPMENT CORPORATION"

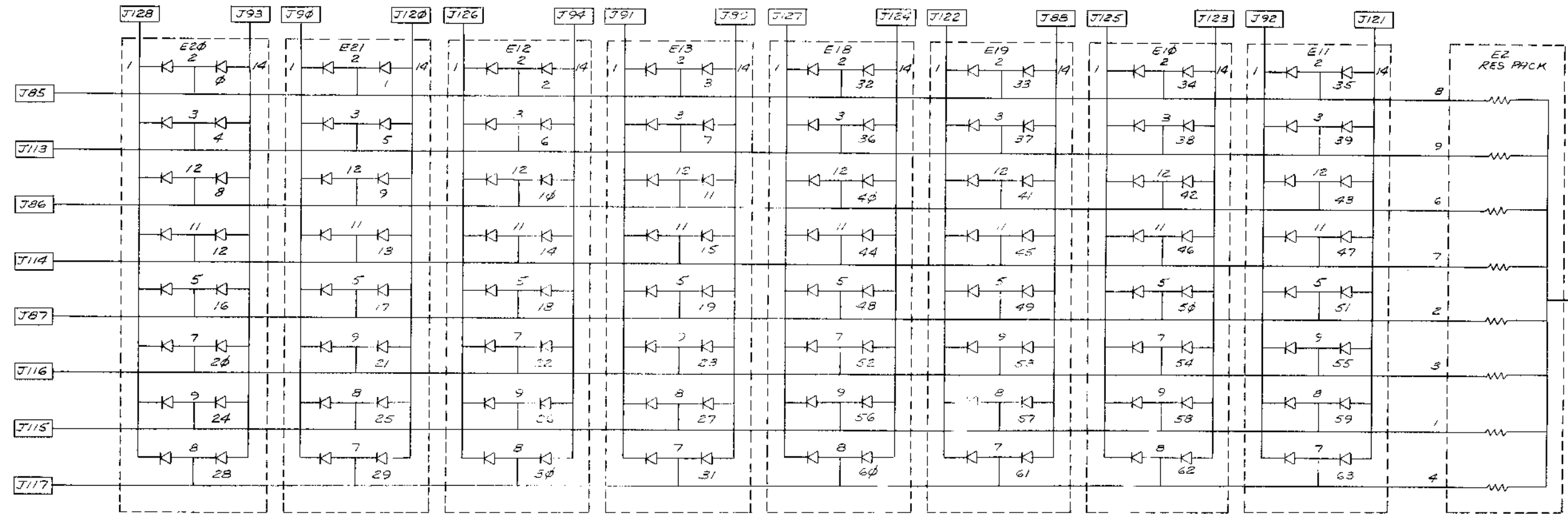

REV. A
DCS 5411531-0-1

REVISIONS		
CHK	CHANGE NO.	REV.

(Y DRIVE DIMENSION CODE MATRIX)

TITLE	CORE MEMORY STACK	SIZE CODE	8K	NUMBER	DCS 5411531-0-1	REV.	A
SCALE	1:1	SHEET	4	OF	4	DIST.	

THIS DRAWING AND SPECIFICATIONS, HEREIN, ARE THE PROPERTY OF DIGITAL EQUIPMENT CORPORATION AND SHALL NOT BE REPRODUCED OR COPIED OR USED IN WHOLE OR IN PART AS THE BASIS FOR THE MANUFACTURE OR SALE OF ITEMS WITHOUT WRITTEN PERMISSION. COPYRIGHT © 1974, DIGITAL EQUIPMENT CORPORATION.

LEGEND	
NUMBER	VARIATION
H219-A	8K x 12 BIT
H219-B	16K x 12 BIT

- NOTES:
- MARK ITEM 3 (STACK BOARD) SIDE 2, DEC 12/84, SERIAL NO. 12/84, (PARTIAL SERIAL NO. 12/84) AND ITEM 13 (WIRING ASSY) USING ITEM 14 (WIRING ASSY).
 - BOND ITEM 3 (STACK BOARD) AND ITEM 4 (WIRING ASSY) TOGETHER, USING ITEM 6 (STAND OFF).
 - SWAGE ITEM 5 (STANDOFF) TO ITEM 3 (STACK BOARD).
 - SWAGE ITEM 5 (STANDOFF) TO ITEM 3 (STACK BOARD).
 - USE ITEM 16 (PROTECTIVE COATING) TO COAT ALL MAGNETIC WIRE TERMINATIONS, AFTER ELECTRICAL TEST.
 - S/I CABLE TO BE BONDED IN PLACE USING ITEM 15 (ADHESIVE), AFTER ELECTRICAL TEST, REF DWG 7010692.
 - BOND THE X AND Y DRIVE LOOP CABLES IN PLACE WHERE NECESSARY, USING ITEM 15 (ADHESIVE).
 - ASSEMBLE ITEMS 1 AND 7 (STIFFENERS) TO ITEM 3 (PC BOARD) USING ITEM 2.
 - ASSEMBLE ITEM 9 (COVER) TO ITEM 6 (STANDOFF) USING ITEMS 10 (SCREWS).
 - APPLY ITEM 11 (NAME PLATE) TO SIDE 2 OF ITEM 3 (PC BOARD) APPROX AS SHOWN.
 - APPLY ITEM 10 (WARRANTY SEAL) TO ITEM 9 (COVER) AS SHOWN.

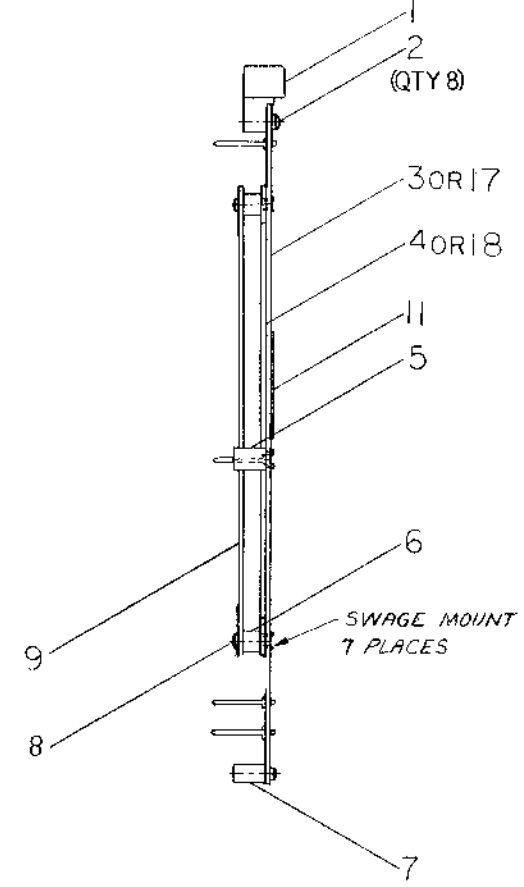
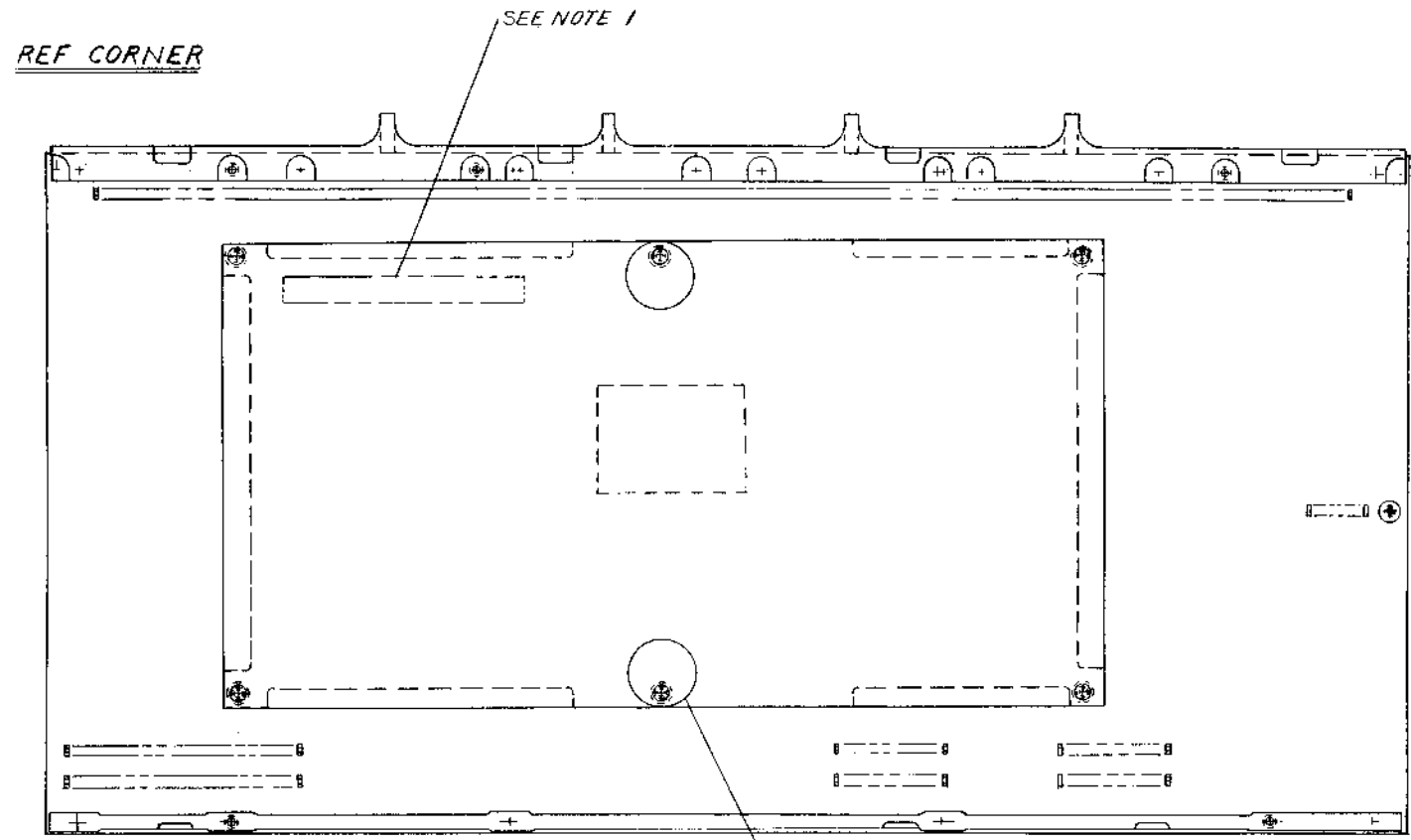
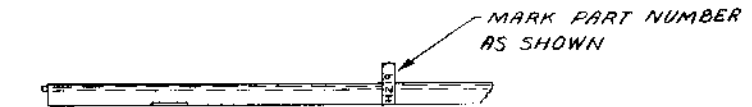

QTY	QTY.	DESCRIPTION	PART NO.	ITEM NO.
1	1	WIRING ASSY CORE PLANE	E-AD-7010898-0-0	18
1	1	STACK BOARD CORE MEMORY	D-CS-5411531-YA-1	17
A/R	A/R	PROTECTIVE COATING	4901083-00	16
A/R	A/R	ADHESIVE (RTV 3140)	4901085-00	15
A/R	A/R	ADHESIVE (RTV 3145)	4901086-00	14
A/R	A/R	EPOXY	4901082-00	13
A/R	A/R	INK, BLACK	4901084-00	12
1	1	NAME PLATE	9009238-00	11
2	2	WARRANTY SEAL		10
1	1	COVER CORE MEMORY STACK	C-MD-5511534-0-0	9
6	6	SCREW, BINDING, PAN/FLANGE 404	9009233-00	8
1	1	STIFFENER, FINGER	D-PS-1211725-0-0	7
6	6	STANDOFF 3/16 DIA x .180 L	9009677-00	6
1	1	STANDOFF 1/4 DIA x .346 L	B-MD-5511533-00	5
1	1	WIRING ASSY, CORE PLANE	E-1A-7010692-0-0	4
1	1	STACK BOARD, CORE MEMORY	D-CS-5411531-0-1	3
8	8	SCREW, PAN, HD, SS, 2-56 x .19	9006000-01	2
1	1	STIFFENER, BAR HANDLED	D-PS-1211726-0-0	1

FIRST USED ON OPTION/MODEL				PARTS LIST			
MMB-AA				DIMENSIONS			
DIMENSIONAL TOLERANCE		UNLESS OTHERWISE SPECIFIED		DATE		DATE	
MILLIMETERS		INCHES		12-4-75		12-26-75	
XXX ±0.10		XXX ±0.05		DATE		DATE	
XX ±0.5		X ±.1		1/10/75		1/10/75	
X ±2		X ±1		DATE		DATE	
THIRD ANGLE PROJECTION		REMOVE BURRS AND BREAK SHARP CORNERS SURFACE QUALITY		NEXT HIGHER ASSY		TITLE	
MATERIAL		FINISH		SCALE		NUMBER	
SEE PARTS LIST		++		MMB-A		DUA 11219-0-0	
SHEET		SHEET		SHEET		SHEET	

REV	CHANGE NO.	DATE	BY	APP.
1	MMB-0002			
2				
3				

REV. A
DUA 11219-0-0
NUMBER

"THIS DRAWING AND SPECIFICATIONS HEREIN ARE THE PROPERTY OF DIGITAL EQUIPMENT CORPORATION AND SHALL NOT BE REPRODUCED OR COPIED OR USED IN WHOLE OR IN PART AS THE BASIS FOR THE MANUFACTURE OR SALE OF ITEMS WITHOUT WRITTEN PERMISSION.
 COPYRIGHT © 1975 DIGITAL EQUIPMENT CORPORATION"

NOTES:

1. OMIT PINS 79, 118, 119.
2. ITEM 5 MUST BE 10-01610-00 NO SUBSTITUTIONS ALLOWED.
3. HEIGHT TOLERANCE MUST BE WATCHED ON ITEM 7 (1000PF) NOT TO EXCEED .312.

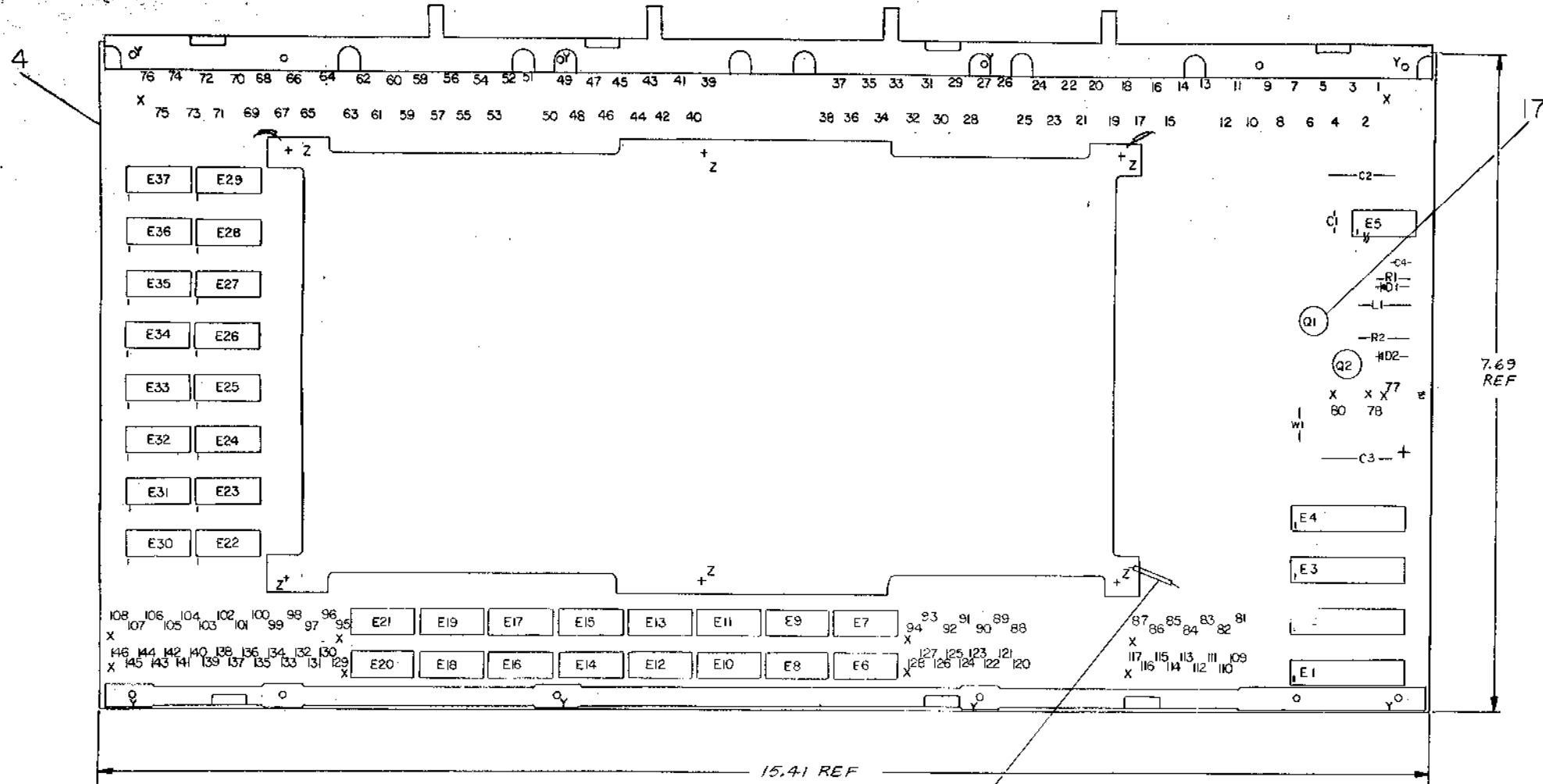

REF	QTY	REF. DESIGNATION	DESCRIPTION	PART NO.	ITEM NO.
REF			X-Y COORDINATE HOLE LOCATION, X-55-541052-1-1		11
REF			ASSY/DRILLING HOLE LAYOUT		12
REF			MODULE ECO HISTORY		13
1		C1	ETCHED CIRCUIT BOARD	5010986-00	14
1		C1	CAP .01UF 100V	1001610-00	15
2		C2, C3	CAP 6.8UF 35V 10% S.TANT	1005306-00	16
1		C4	CAP 1000PF 100V D MICA	1000042-00	17
2		D1, D2	DIODE D672	1105275-00	18
1		R1	RES 100 1/4W 5%	1300229-00	19
1		R2	RES 39 1/2W 5%	1302336-00	20
4		E1-E4	RES PACK	1311742-00	21
2		Q1-Q2	TRANS 2N3734	1510062-00	22
1		L1	INDUCTOR, DD100	1610662-00	23
1		E5	I.C. 74128	1912068-00	24
32		E6-E37	I.C. 2501	1910010-00	25
143		J1-J78, J80-J117, J120-J146	CONTACT MALE (SEE NOTE 1)	1211727-00	26
2			TRANSIPAD	9007201-00	27
1		W1	JUMPER, INSULATED	9009185-00	28
R/A			WIRE, JUMPER	9105740-55	29

IC TYPE	GND	+5V
2501	-	-

GND AND 5V ARE USUALLY PIN 7 AND 14 RESPECTIVELY. EXCEPTIONS ARE STATED ABOVE.

IC PIN LOCATIONS

FIRST USED ON OPTION MODEL: MM8-AB

ETCH BOARD REV. B

DRN	DATE	3/18/75
CHK'D	DATE	3/27/75
ENGR	DATE	4-22-75
PROJ. ENGR	DATE	7-22-75
PRD. ENGR	DATE	8-22-75

digital

TITLE: CORE MEMORY STACK 16K

SIZE CODE: DCS 5411531-YA-1

NUMBER: 1

REV: A

SCALE: 1 OF 4

SHEET 1 OF 4

DIST.:

"THIS DRAWING AND SPECIFICATIONS HEREIN ARE THE PROPERTY OF DIGITAL EQUIPMENT CORPORATION AND SHALL NOT BE REPRODUCED OR COPIED OR USED IN WHOLE OR IN PART AS THE BASIS FOR THE MANUFACTURE OR SALE OF ITEMS WITHOUT WRITTEN PERMISSION. COPYRIGHT © 1975 DIGITAL EQUIPMENT CORPORATION"

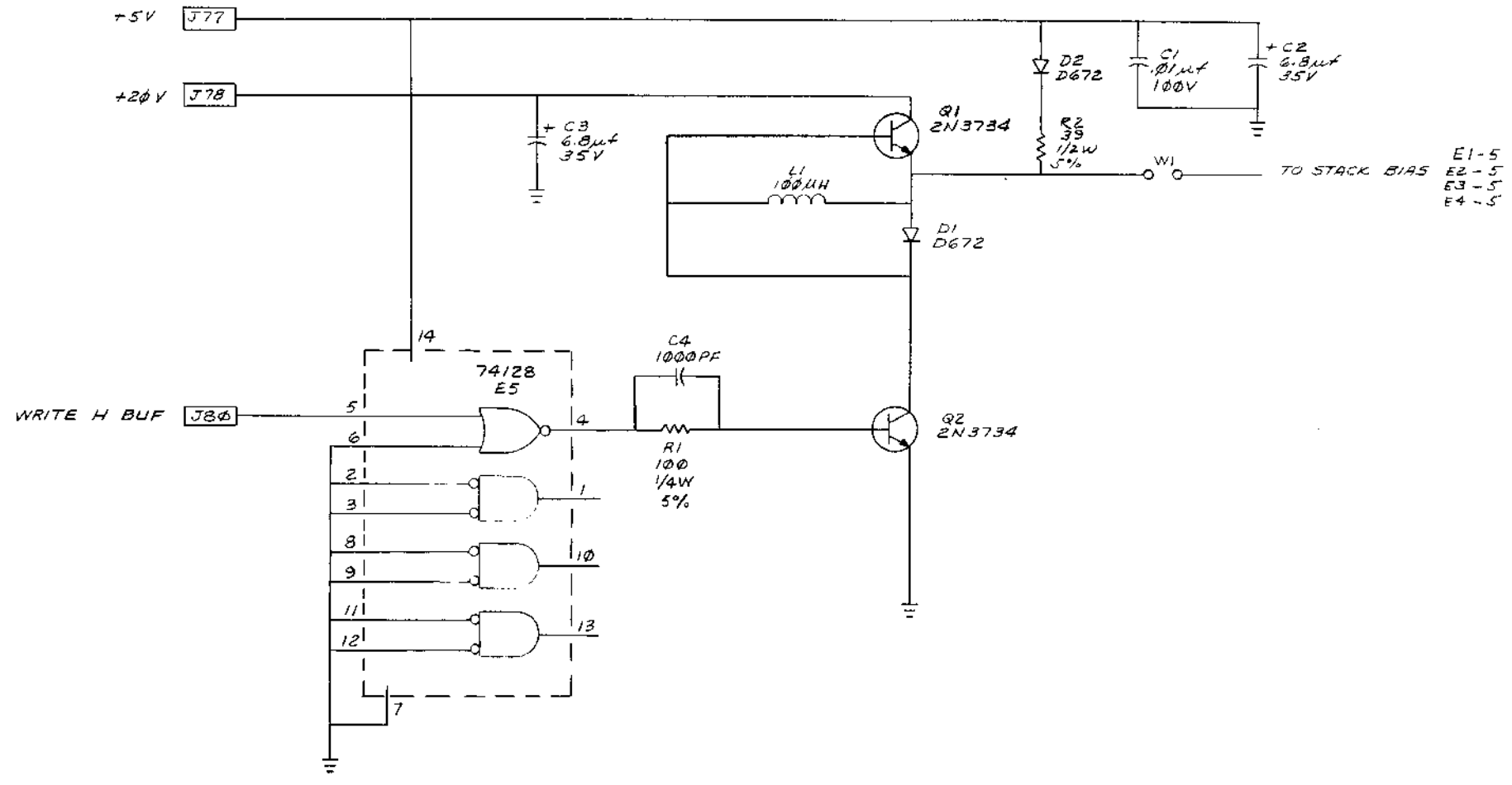

E1-5
E2-5
E3-5
E4-5

REVISIONS		
CHK	CHANGE NO.	REV.

REV. A
DCS 5411531-YA-1

THIS DRAWING AND SPECIFICATIONS HEREIN ARE THE PROPERTY OF DIGITAL EQUIPMENT CORPORATION AND SHALL NOT BE REPRODUCED OR COPIED OR USED IN WHOLE OR IN PART AS THE BASIS FOR THE MANUFACTURE OR SALE OF ITEMS WITHOUT WRITTEN PERMISSION. COPYRIGHT © 1975 DIGITAL EQUIPMENT CORPORATION.

D
C
B
A

D
C
B
A

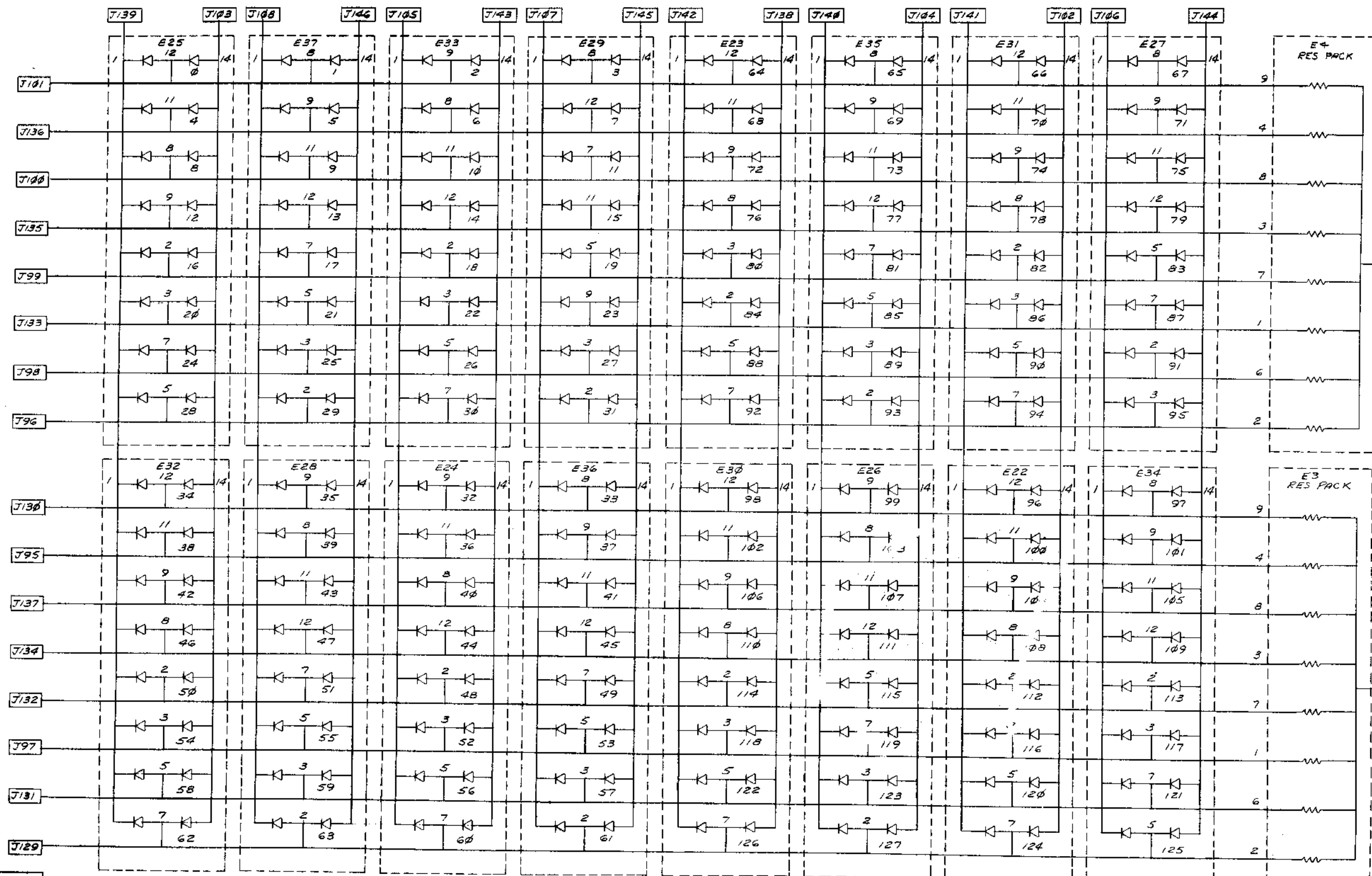

REVISIONS		
CHK	CHANGE NO.	REV.

(“X” DRIVE DIMENSION DIODE MATRIX)

TITLE	CORE MEMORY STACK 16K	SIZE CODE	NUMBER	REV.
SCALE	1/1	SHEET	3 OF 4	DIST.
CS 5411531-YA-1		A		

REV. A
NUMBER 5411531-YA-1
SIZE CODE DCS

THIS DRAWING AND SPECIFICATIONS HEREIN ARE THE PROPERTY OF DIGITAL EQUIPMENT CORPORATION AND SHALL NOT BE REPRODUCED OR COPIED OR USED IN WHOLE OR IN PART AS THE BASIS FOR THE MANUFACTURE OR SALE OF ITEMS WITHOUT WRITTEN PERMISSION. COPYRIGHT © 1975 DIGITAL EQUIPMENT CORPORATION

DCS 5411531-YA-1 2

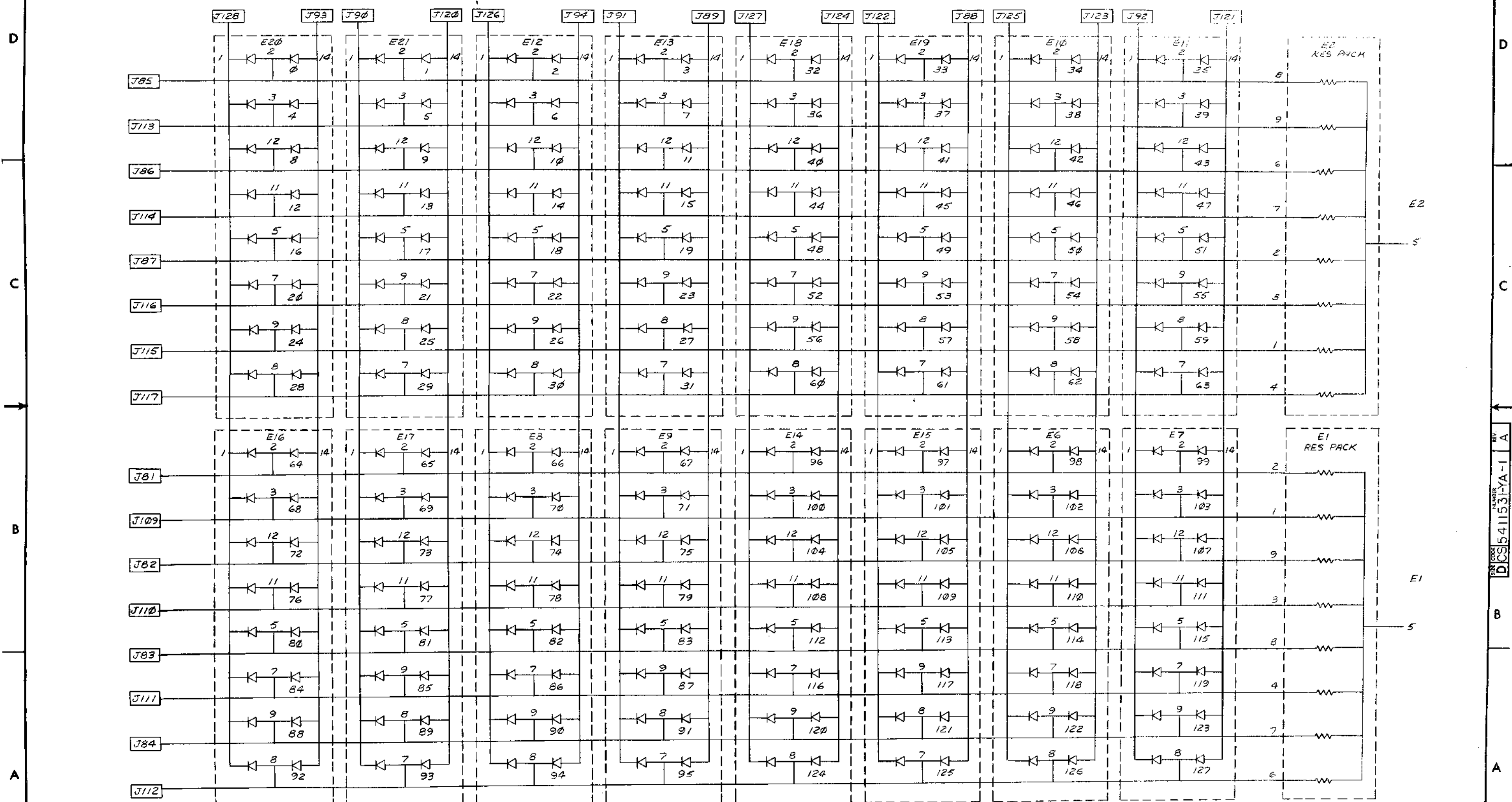

(Y" DRIVE DIMENSION DIODE MATRIX)

REVISIONS		
CHK	CHANGE NO.	REV.

TITLE	CORE MEMORY STACK 16K	SIZE/ CODE	D/CS	NUMBER	5411531-YA-1	REV.	A
SCALE	1/2	SHEET	4	OF	4	DIST.	

REV. A
DCS 5411531-YA-1

THIS DRAWING AND SPECIFICATIONS HEREIN ARE THE PROPERTY OF DIGITAL EQUIPMENT CORPORATION AND SHALL NOT BE REPRODUCED OR COPIED IN WHOLE OR IN PART AS THE BASIS FOR THE MANUFACTURE OR SALE OF ITEMS WITHOUT WRITTEN PERMISSION. COPYRIGHT © 1974, DIGITAL EQUIPMENT CORPORATION.

NOTES:

1. UNLESS OTHERWISE SPECIFIED:
 - a. RESISTORS ARE 1/4W, ±5%
 - b. CAPACITORS ARE 50V
 - c. DIODES ARE D672
2. ALL RECEPTACLES ARE INDICATED WITH J NO'S.
3. C59, C61, C63, C65, C67, C69, C71, C73, C75, C77, C79 & C81 ARE NOT USED.

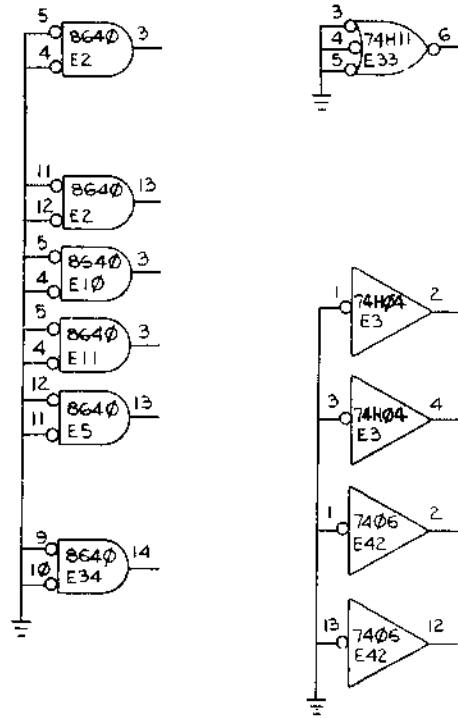
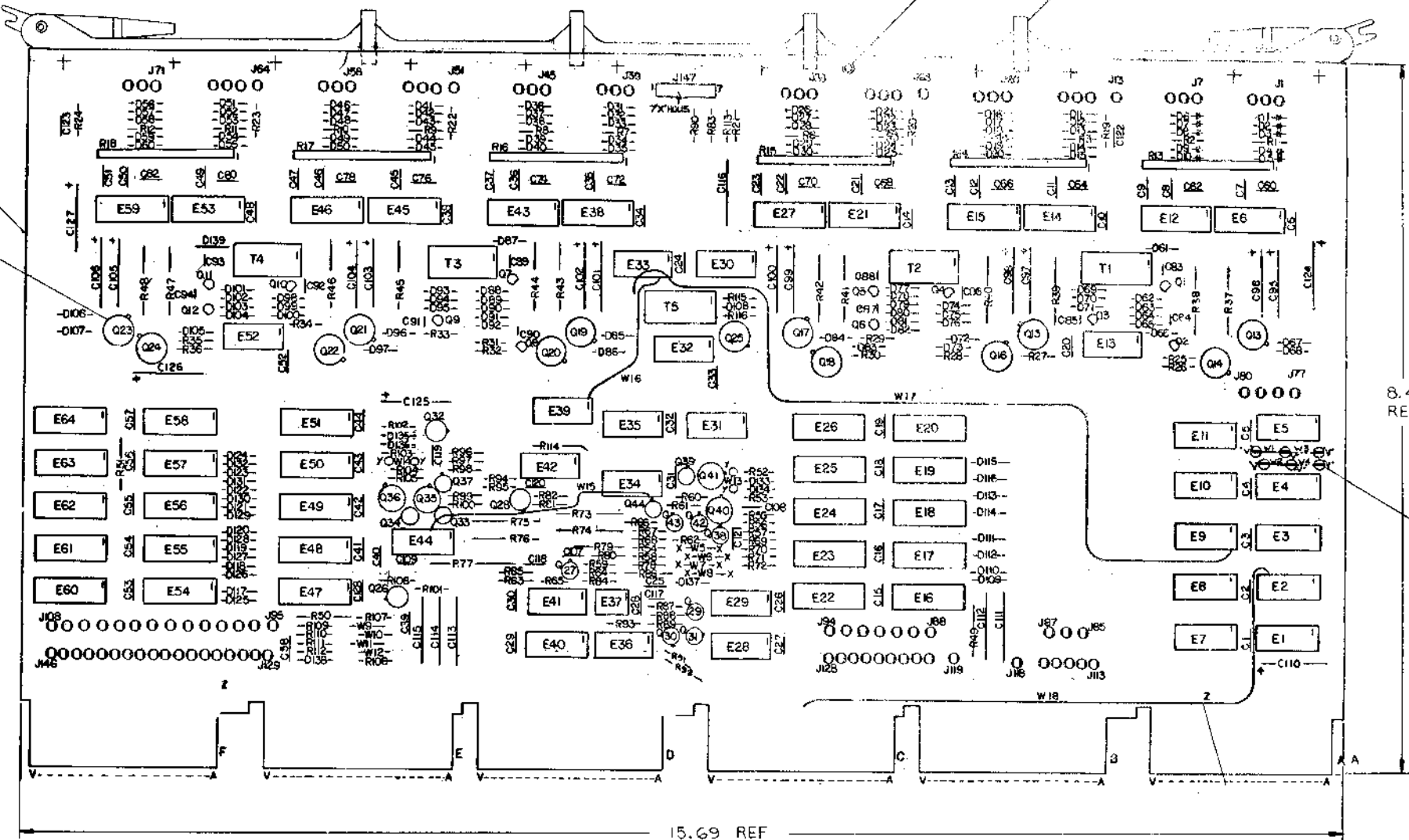

SPARES

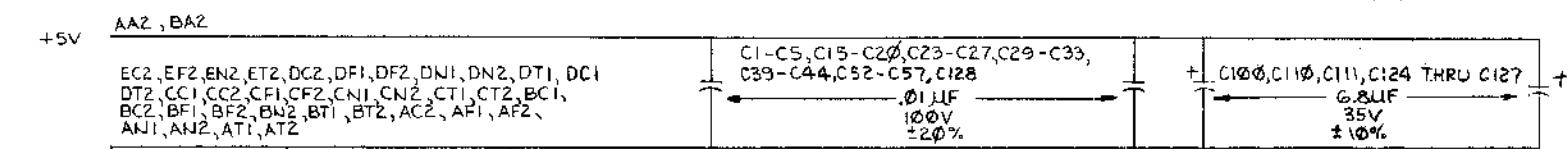

75325		8	9	16
7520	8	9	16	
8640		1	3	
7442		8	16	
741		4	7	
384		1	8	
IC TYPE	-5V	GND	+5V	+20V

GND AND 5V ARE USUALLY PIN 7 AND 14 RESPECTIVELY. EXCEPTIONS ARE STATED ABOVE.

IC PIN LOCATIONS

REV.	CHG.	NO.	REV.	QTY	REF. DESIGNATION	DESCRIPTION	PART NO.	ITEM NO.
FIRST USED ON OPTION MODEL				PDP8-A				
ETCH BOARD REV.				C				
DATE				10/24/74				
CHK'D				S. Stone				
DATE				11/5/74				
END				12/17/74				
PROJ. ENG.				12/17/74				
DATE				12/17/74				
PROD.				12/17/74				
DATE				12/17/74				
NEXT HIGHER ASSY								
SCALE				1 of 12				
SHEET				1				
DEC NO.				EIA NO.				
DEC NO.				EIA NO.				
SCALE				D CS				
SHEET				NUMBER G649-0-1				
SHEET				REV. B				



TITLE 8K, 12 BIT (B1) BASE BOARD

THIS DRAWING AND SPECIFICATIONS HEREIN ARE THE PROPERTY OF DIGITAL EQUIPMENT CORPORATION AND SHALL NOT BE REPRODUCED OR COPIED OR USED IN WHOLE OR IN PART AS THE BASIS FOR THE MANUFACTURE OR SALE OF ITEMS WITHOUT WRITTEN PERMISSION. COPYRIGHT © 1974, DIGITAL EQUIPMENT CORPORATION.

PARTS LIST				
QTY	REF DESIGNATIONS	DESCRIPTION	PART NO	ITEM NO
REF		X-Y COORDINATE HOLE LOCATION	K-CO-G649-0-4	1
REF		ASSY/DRILLING HOLE LAYOUT	D-AH-G649-0-5	2
REF		MODULE ECO HISTORY	B-MH-G649-0-6	3
1		ETCHED CIRCUIT BOARD	5011016	4
1	C119	CAP 47 PF 100V 5% DM	1000011-00	5
12	C60, C62, C64, C66, C68, C70, C72, C74, C76, C78, C80, C82	CAP 100 PF 100V 5% DM	1000016-00	6
1	C108	CAP 56 PF 100V 5% DM	1000012-00	7
1	C109	CAP 2.2 PF 100V 5% DM	1005820-00	8
23	C95-C106, C110-C116, C124-C127	CAP 6.8 μF 35V 10% STANT	1005306-00	9
1	R94	RES 261 1/4W 1%	1302873-00	10
12	C83-C94	CAP 3300 PF 50V 10%	1011740-01	11
1	C117	CAP .022 μF 50V 10%	1011688-00	12
1	R114	RES 1K 1/2W 1%	1300381-00	13
1	D138	DIODE 1N750A 4.7V ZENER	1100124-00	14
127	D1-D136, D139	DIODE D672	1105275-00	15
1	D137	DIODE 1N759A 12V ZENER	1110836-00	16
1		HANDLE, REWORK	7413182-0-0	17
102 (SEE NOTE 2)		RECEPTACLE	1211728-00	18
12	R1-R12	RES 33 1/4W 5%	1300197-00	19
1	R91	RES 100 1/4W 5%	1300229-00	20
1	R77	RES 220 3W 1%	1312123-00	21
3	R49-R51	RES 300 1/2W 5%	1300291-00	22
1	R86	RES 330 1/2W 5%	1300296-00	23
1	R80	RES 1K 1/4W 1%	1303114-00	24
2	R62, R98	RES 3.3K 1/4W 5%	1300439-00	25
4	R52, R53, R102, R103	RES 10K 1/4W 5%	1300479-00	26
1	R97	RES 750 1/4W 1%	1302955-00	27
4	R67, R88, R95, R116	RES 1.2K 1/4W 5%	1301320-00	28
1	R69	RES 31.6K 1/4W 1%	1309416-00	29
1	R65	RES 220 1/4W 5%	1300271-00	30
4	R64, R82, R84, R93	RES 2K 1/4W 1%	1302715-00	31
6	R60, R61, R66, R96, R104, R105	RES 75 1/4W 1%	1303064-00	32
1	R59	RES 1.21K 1/4W 1%	1302871-00	33
2	R83, R90	RES 82K 1/4W 5%	1303219-00	34
1	R58	RES 825 1/4W 1%	1305143-00	35
2	R106, R107	RES 14.7K 1/4W 1%	1302941-00	36
1	R87	RES 5.11K 1/4W 1%	1304854-00	37
12	R25-R36	RES 4.7K 1/4W 5%	1300447-00	38
1	R109	RES 19.6K 1/4W 1%	1309419-00	39
1	R71	RES 137K 1/4W 1%	1305422-00	40
5	R55, R56, R66, R81, R89	RES 562 1/4W 1%	1304693-00	41
4	R54, R57, R99, R100	RES 383 1/4W 1%	1305125-00	42
2	R70, R111	RES 68.1K 1/4W 1%	1305252-00	43
1	R112	RES 121K 1/4W 1%	1305255-00	44
1	R110	RES 34.8K 1/4W 1%	1303156-00	45
2	R63, R85	RES 4.99K 1/4W 1%	1305324-00	46
1	R92	RES 1K 1% THERMISTOR	1310071-00	47
12	R37-R48	RES 22 3W 1% WW	1311738-02	48
6	R13-R18	RES PACK 10/100 CKTS	1311741-00	49

PARTS LIST				
QTY	REF DESIGNATIONS	DESCRIPTION	PART NO	ITEM NO
4	R73-R76	RES 30 3W 1%	1311737-00	50
1	R79	RES 100 1/2W 5%	1300228-00	51
1	R115	RES 180 1/4W 5%	1301322-00	52
1	R113	RES 2.61K 1/4W 1%	1303303-00	53
1	Q26	TRANSISTOR 2N2904A	1301913-00	54
3	Q29-Q31	TRANSISTOR 3009 B	1503100-00	55
4	Q33, Q34, Q38, Q39	TRANSISTOR 6534 B	1503409-01	56
4	Q32, Q37, Q42, Q43	TRANSISTOR 425B	1505321-00	57
12	Q1-Q12	TRANSISTOR 6531 B	1509338-00	58
2	W1, W2	BUS WIRE #22AWG	9107560-01	59
3	Q27, Q28, Q44	TRANSISTOR MXAA55	1510706-00	60
17	Q13-Q25, Q35, Q36, Q40, Q41	TRANSISTOR 2N3725	1510959-00	61
1	T5	TRANSFORMER 1:1	1609996-00	62
4	T1-T4	TRANSFORMER 2:1	1611756-00	63
2	E31, E35	IC 74H40	1905586-00	64
1	E30	IC 74H10	1909057-00	65
2	E4, E33	IC 74H11	1909267-00	66
1	E9	IC 7384	1910393-00	67
1	E39	IC 74H74	1909667-00	68
2	E7, E28, E40	IC 8881	1909705-00	69
1	E3	IC 74H04	1909931-00	70
5	E20, E26, E51, E58, E64	IC 7442	1910046-00	71
1	E44	IC 74121	1910230-00	72
1	E37	IC 741	1910298-00	73
1	E42	IC 7406	1910741-00	74
20	E16-E19, E22-E25, E47-E50, E54-E57, E60-E63	IC 75325	1910960-00	75
10	E1, E2, E5, E8, E10, E11, E29, E34, E36, E41	IC 8640	1911469-00	76
12	E6, E12, E14, E15, E21, E27, E38, E43, E45, E46, E53, E59	IC 7520	1911748-00	77
3	E13, E32, E52	IC 74128	1912068-00	78
6		EYELET (TERMINAL POSTS)	9006735-00	79
8	W5-W12	MACHINE INSERTED JUMPERS	9009185	80
2	W13, W14	INSULATED WIRE #22 AWG	1700035-00	81
1	J147	CONNECTOR PIN	1212104-00	82
12		EYELET	9006732-00	83
6	R19-R24	RES 10K 1/4W 1%	1303312-00	84
52	C1-C6, C9, C10, C13-C20, C23-C34, C37-C44, C47, C48, C51-C58, C118, C120-C123, C128	CAP .01 μF 100V 5%	1001610-00	85
13	C7, C8, C11, C12, C21, C22, C35, C36, C45, C46, C49, C50, C107	CAP .22 μF 50V	1010274-00	86
1	R72	RES 274K 1/4W 1%	1305131-00	87
1	R108	RES 3.16K 1/4W 1%	1303045-00	88
A/R	W15-W18	WIRE #30 AWG SOLID GREEN	9105740-55	89
1	R101	RES 46.4K 1/4W 1%	1303311-00	90
1	R78	RES 5.62K 1/4W 1%	1305128-00	91
18		TRANSIPAD	9007201-00	92
A/R		INSULATION	9107256-10	93

REVISIONS		
CHK	CHANGE NO	REV

TITLE	8K, 12 BIT (B2)	SIZE CODE	D CS	NUMBER	G649-0-1	REV.	B
SCALE	+	SHEET	2 OF 12	DIST.			

"THIS DRAWING AND SPECIFICATIONS HEREIN ARE THE PROPERTY OF DIGITAL EQUIPMENT CORPORATION AND SHALL NOT BE REPRODUCED OR COPIED OR USED IN WHOLE OR IN PART AS THE BASIS FOR THE MANUFACTURE OR SALE OF ITEMS WITHOUT WRITTEN PERMISSION. COPYRIGHT © 1974, DIGITAL EQUIPMENT CORPORATION"

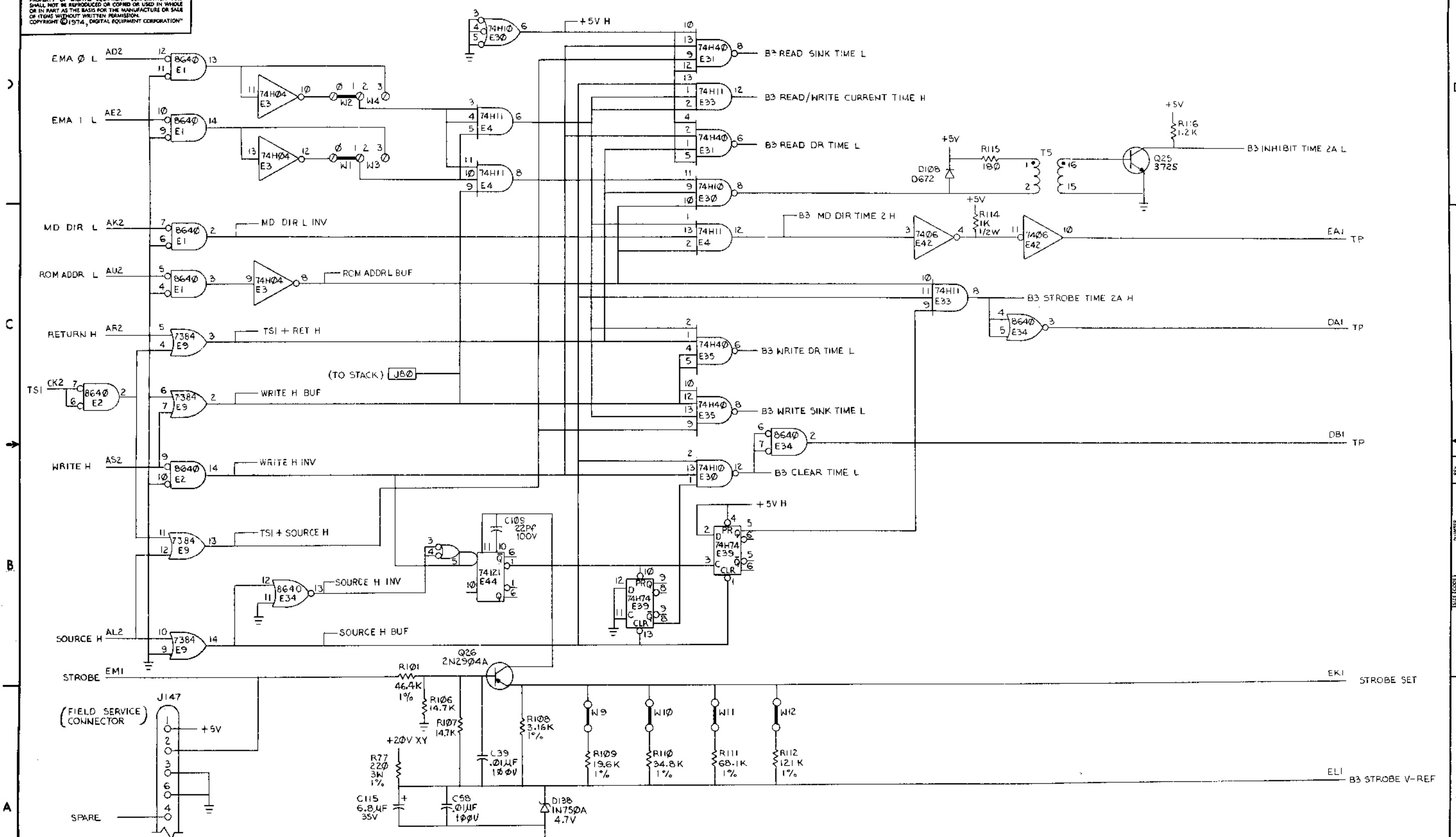

REVISIONS		
CHK	CHANGE NO.	REV.

(MM8-AA TIMING)

TITLE	8K 12 BIT BASE BOARD (B3)	SIZE CODE	D CS	NUMBER	G649-0-1	REV.	B
SCALE	1/1	SHEET	3 OF 12	DIST.			

THIS DRAWING AND SPECIFICATIONS HEREIN ARE THE PROPERTY OF DIGITAL EQUIPMENT CORPORATION AND SHALL NOT BE REPRODUCED OR COPIED OR USED IN WHOLE OR IN PART AS THE BASIS FOR THE MANUFACTURE OR SALE OF ITEMS WITHOUT WRITTEN PERMISSION. COPYRIGHT © 1974, DIGITAL EQUIPMENT CORPORATION.

1-0-6499 DCS 2

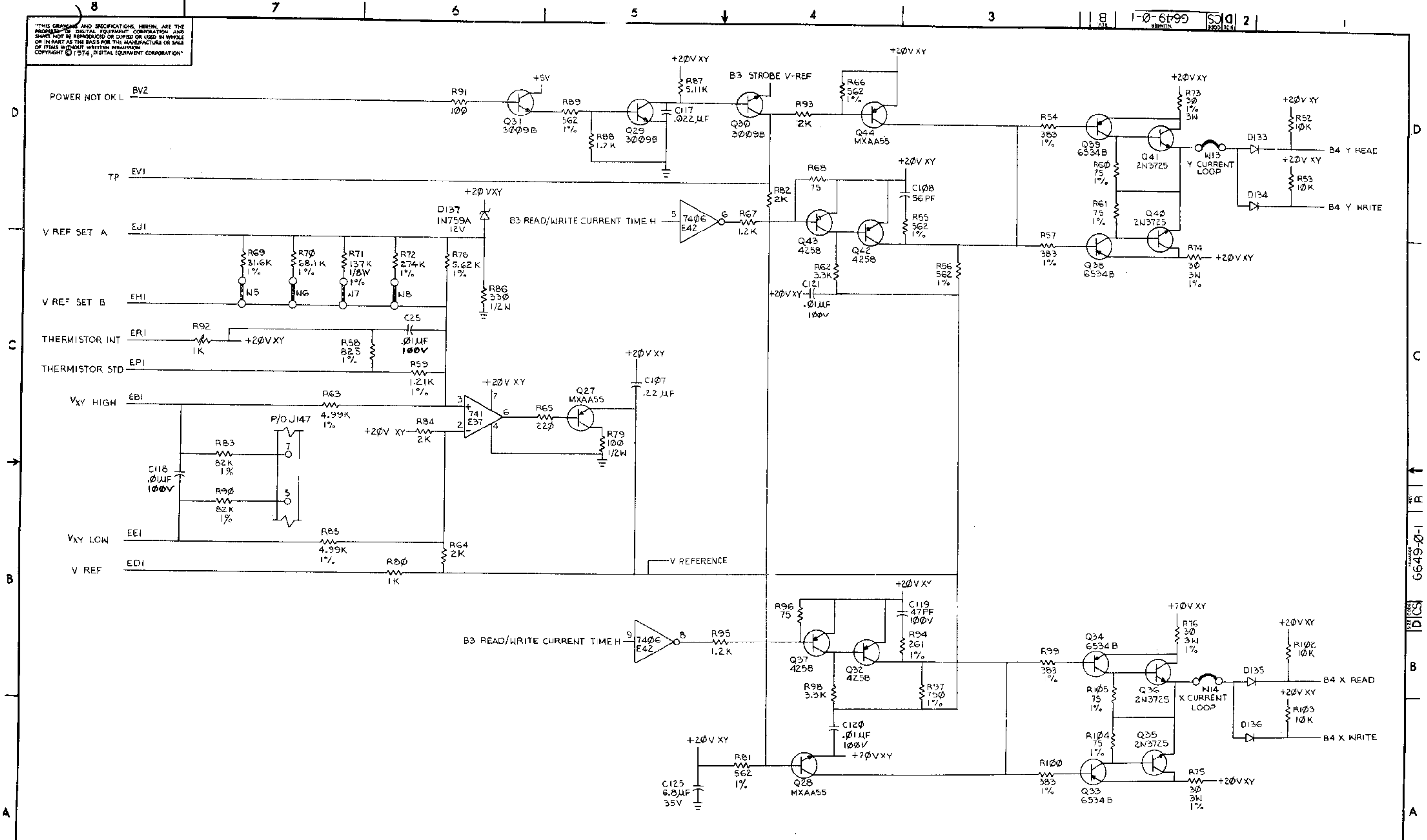

REVISIONS		
CHK	CHANGE NO.	REV.

(CURRENT & CONTROL)
 TITLE 8K, 12 BIT BASE BOARD (B4)
 SIZE CODE DCS NUMBER 6649-0-1 REV. B
 SCALE SHEET 4 OF 12 DIST.

REV. 10/74 6649-0-1

THIS DRAWING AND SPECIFICATIONS HEREIN ARE THE PROPERTY OF DIGITAL EQUIPMENT CORPORATION AND SHALL NOT BE REPRODUCED OR COPIED OR USED IN WHOLE OR IN PART AS THE BASIS FOR THE MANUFACTURE OR SALE OF ITEMS WITHOUT WRITTEN PERMISSION. COPYRIGHT © 1974, DIGITAL EQUIPMENT CORPORATION.

NOTE: ALL 75325 HAVE TYPICAL INTERNAL CONFIGURATION AND PINNING (EXAMPLE: E63)

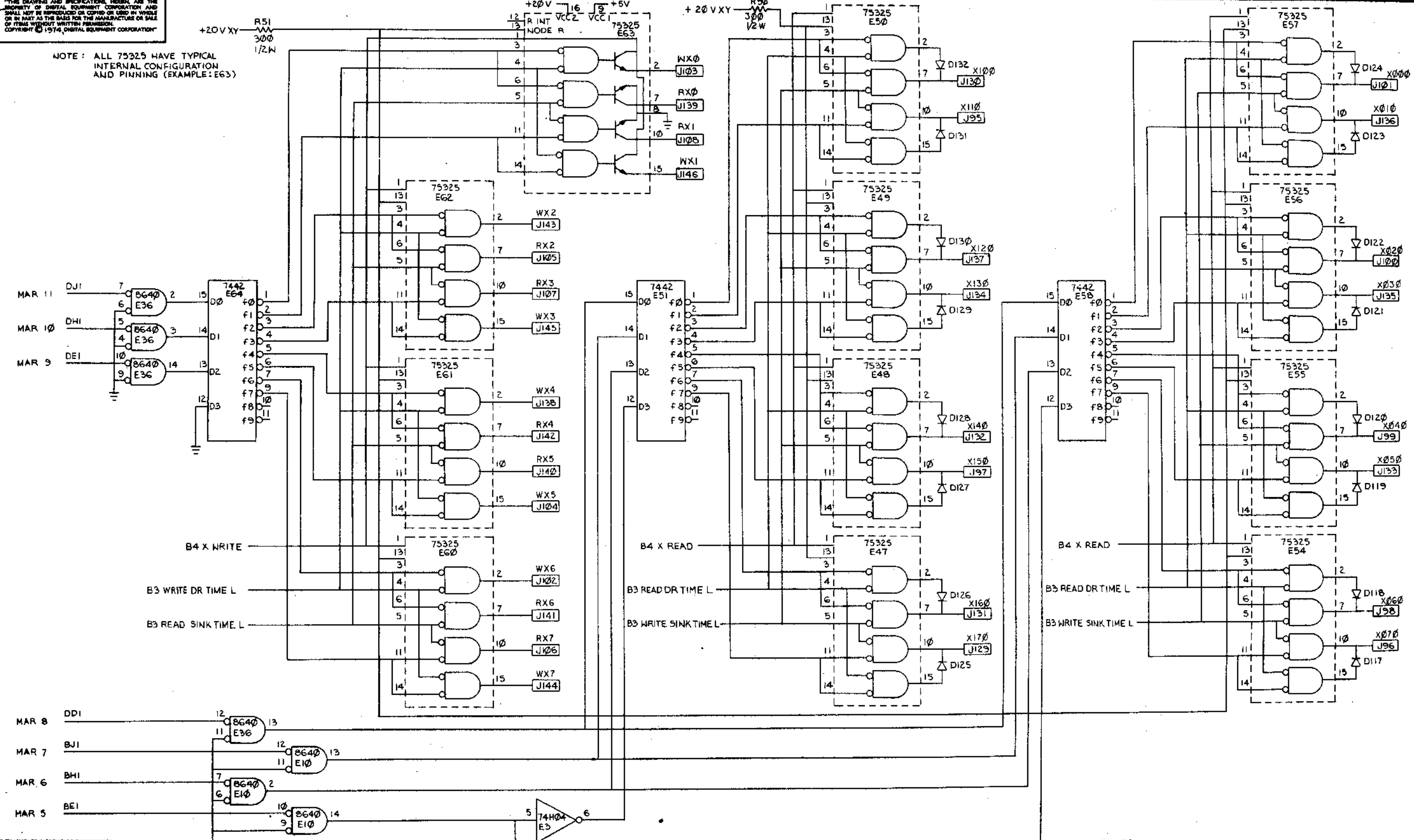

REVISIONS		
CHK	CHANGE NO.	REV.

"THIS DRAWING AND SPECIFICATIONS HEREIN ARE THE PROPERTY OF DIGITAL EQUIPMENT CORPORATION AND SHALL NOT BE REPRODUCED OR COPIED OR USED IN WHOLE OR IN PART AS THE BASIS FOR THE MANUFACTURE OR SALE OF ITEMS WITHOUT WRITTEN PERMISSION. COPYRIGHT © 1974, DIGITAL EQUIPMENT CORPORATION"

8 1-0-6499 2

+20V XY
 R49
 30Ω
 1/2 W
 C112
 6.0μF
 35V

MAR 4 BDI
 MAR 3 AJ1
 MAR 2 AH1

9 10 7 6 5 4
 8640 E5
 8640 E5
 8640 E5

7442 E26
 D0 f0
 D1 f1
 D2 f2
 D3 f3
 f4
 f5
 f6
 f7
 f8
 f9

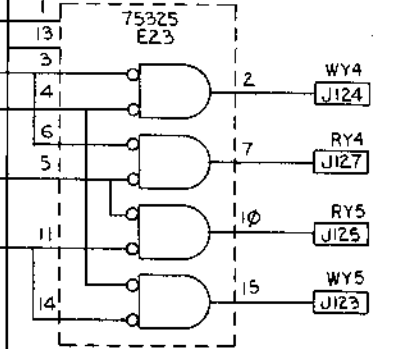
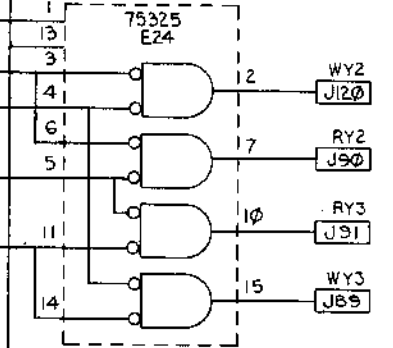
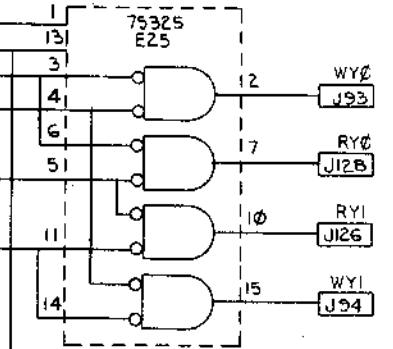

B4 Y WRITE
 B3 WRITE DR TIME L
 B3 READ SINK TIME L

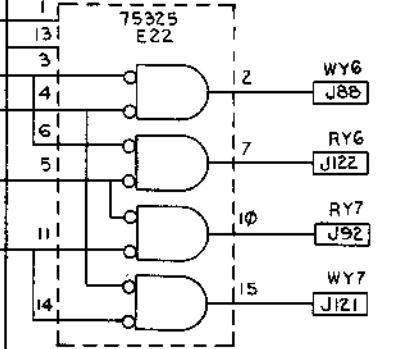

MAR 1 AE1
 MAR 0 AD1
 EMA 2 AH2

12 11 10 9 7 6
 8640 E11
 8640 E11
 8640 E11

7442 E20
 D0 f0
 D1 f1
 D2 f2
 D3 f3
 f4
 f5
 f6
 f7
 f8
 f9

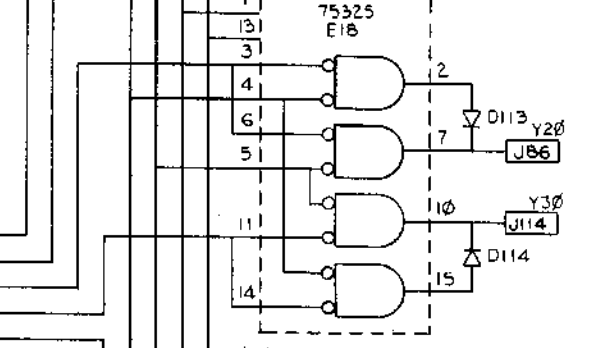
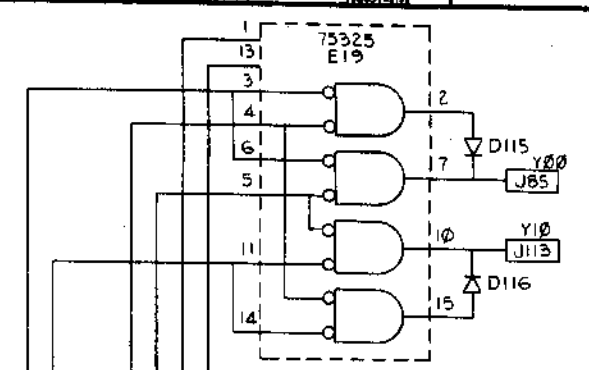

B4 Y READ
 B3 READ DR TIME L
 B3 WRITE SINK TIME L

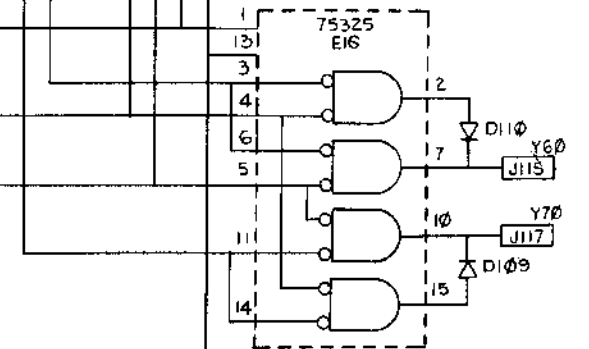

REVISIONS		
CHK	CHANGE NO.	REV.

(Y DRIVE)		TITLE	8K, 2 BIT BASE BOARD (B6)	SIZE CODE	D CS	NUMBER	G649-0-1	REV.	B
SCALE		SHEET	6 OF 12	DIST.					

REV. 10/74 DCS NUMBER 6649-0-1 B

"THIS DRAWING AND SPECIFICATIONS HEREIN ARE THE PROPERTY OF DIGITAL EQUIPMENT CORPORATION AND SHALL NOT BE REPRODUCED OR COPIED OR USED IN WHOLE OR IN PART AS THE BASIS FOR THE MANUFACTURE OR SALE OF ITEMS WITHOUT WRITTEN PERMISSION. COPYRIGHT © 1974, DIGITAL EQUIPMENT CORPORATION"

NOTE:
ALL 7520 HAVE TYPICAL INTERNAL CONFIGURATION AND PINNING (EXAMPLE: E6)

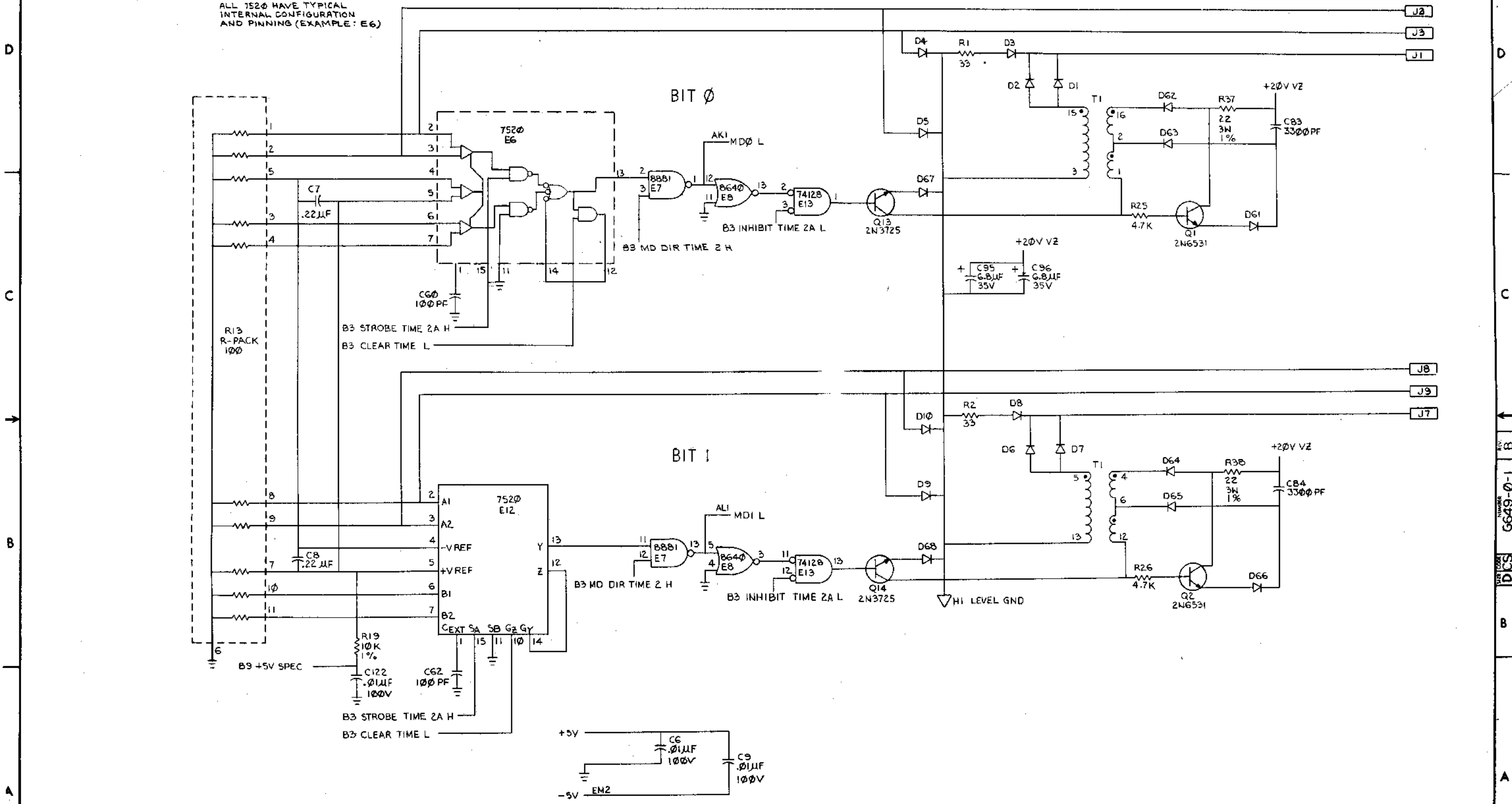

REVISIONS		
CHK	CHANGE NO.	REV.

TITLE 8K 12 BIT BASE BOARD (B7)		SIZE CODE DCS	NUMBER G649-0-1	REV. B
SCALE 1/1	SHEET 7 OF 12	DIST.		

REV. B DCS G649-0-1

"THIS DRAWING AND SPECIFICATIONS HEREIN ARE THE PROPERTY OF DIGITAL EQUIPMENT CORPORATION AND SHALL NOT BE REPRODUCED OR COPIED OR USED IN WHOLE OR IN PART AS THE BASIS FOR THE MANUFACTURE OR SALE OF ITEMS WITHOUT WRITTEN PERMISSION. COPYRIGHT © 1970, DIGITAL EQUIPMENT CORPORATION"

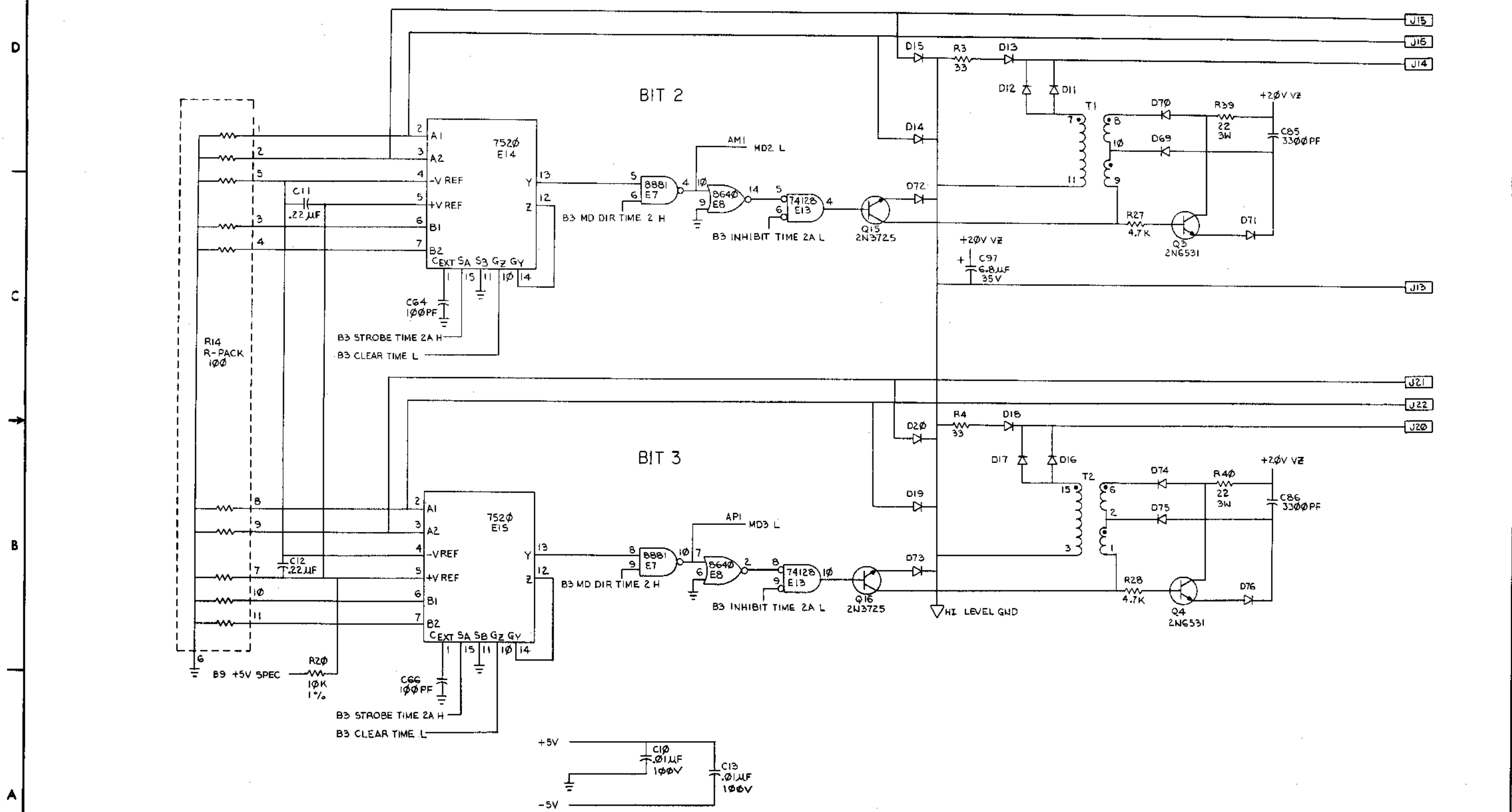

REVISIONS		
CHK	CHANGE NO.	REV.

(SENSE/INHIBIT 2 BITS)		TITLE	8K ₁₂ BIT BASE BOARD (B8)	SIZE CODE	D CS	NUMBER	G649-0-1	REV.	B
SCALE	1	SHEET	8 OF 12	DIST.					

"THE DRAWING AND SPECIFICATIONS HEREIN ARE THE PROPERTY OF DIGITAL EQUIPMENT CORPORATION AND SHALL NOT BE REPRODUCED OR COPIED OR USED IN WHOLE OR IN PART AS THE BASIS FOR THE MANUFACTURE OR SALE OF ITEMS WITHOUT WRITTEN PERMISSION. COPYRIGHT © 1974 DIGITAL EQUIPMENT CORPORATION"

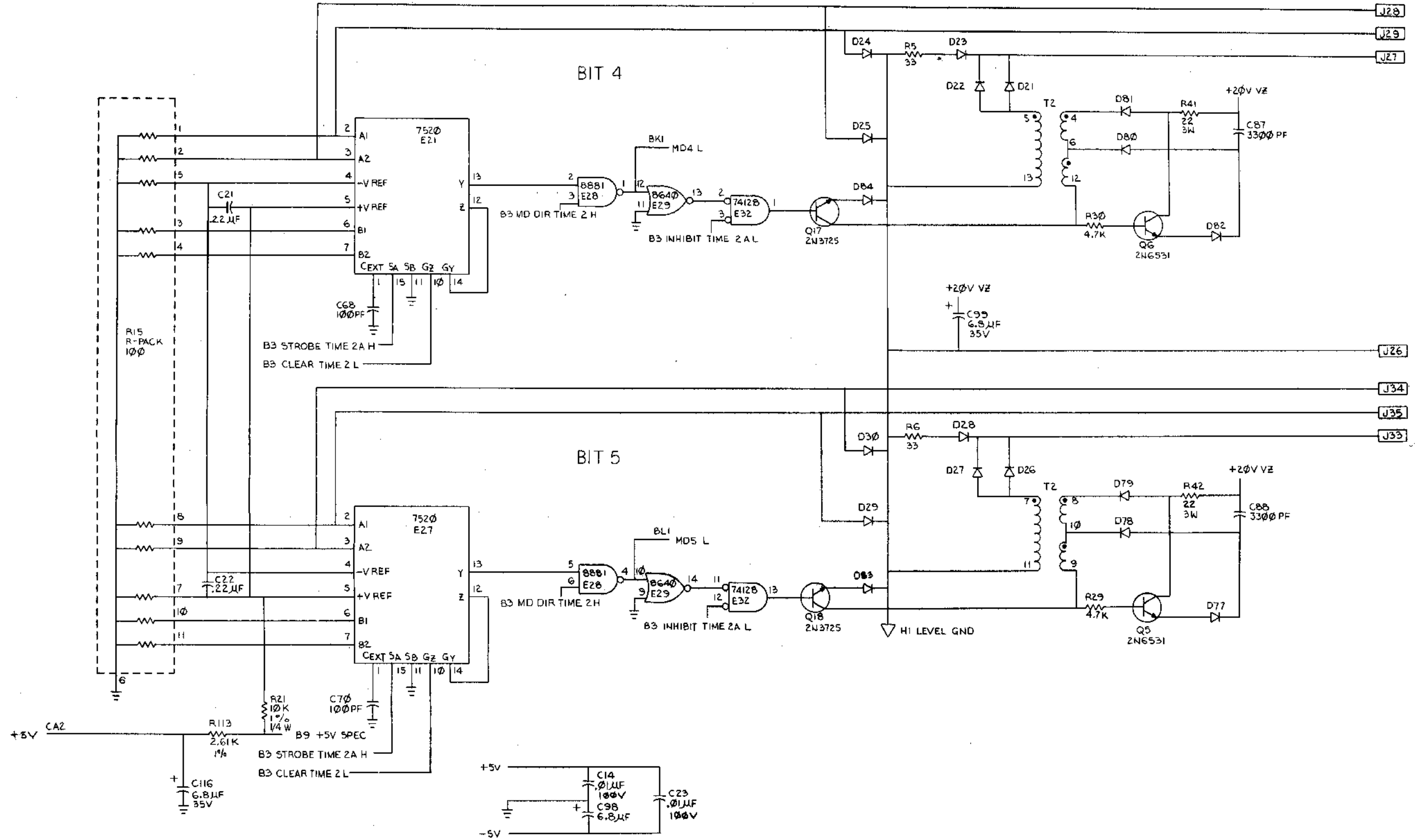

REVISIONS		
CHK	CHANGE NO.	REV.

TITLE		(SENSE/INHIBIT 2 BITS)		SIZE	CODE	NUMBER	REV.
8K 12 BIT		BASE BOARD		D	CS	G649-0-1	B
SCALE	SHEET	9 OF 12		DIST.			

THIS DRAWING AND SPECIFICATIONS HEREIN ARE THE PROPERTY OF DIGITAL EQUIPMENT CORPORATION AND SHALL NOT BE REPRODUCED OR COPIED OR USED IN WHOLE OR IN PART AS THE BASIS FOR THE MANUFACTURE OR SALE OF ITEMS WITHOUT WRITTEN PERMISSION. COPYRIGHT © 1974, DIGITAL EQUIPMENT CORPORATION.

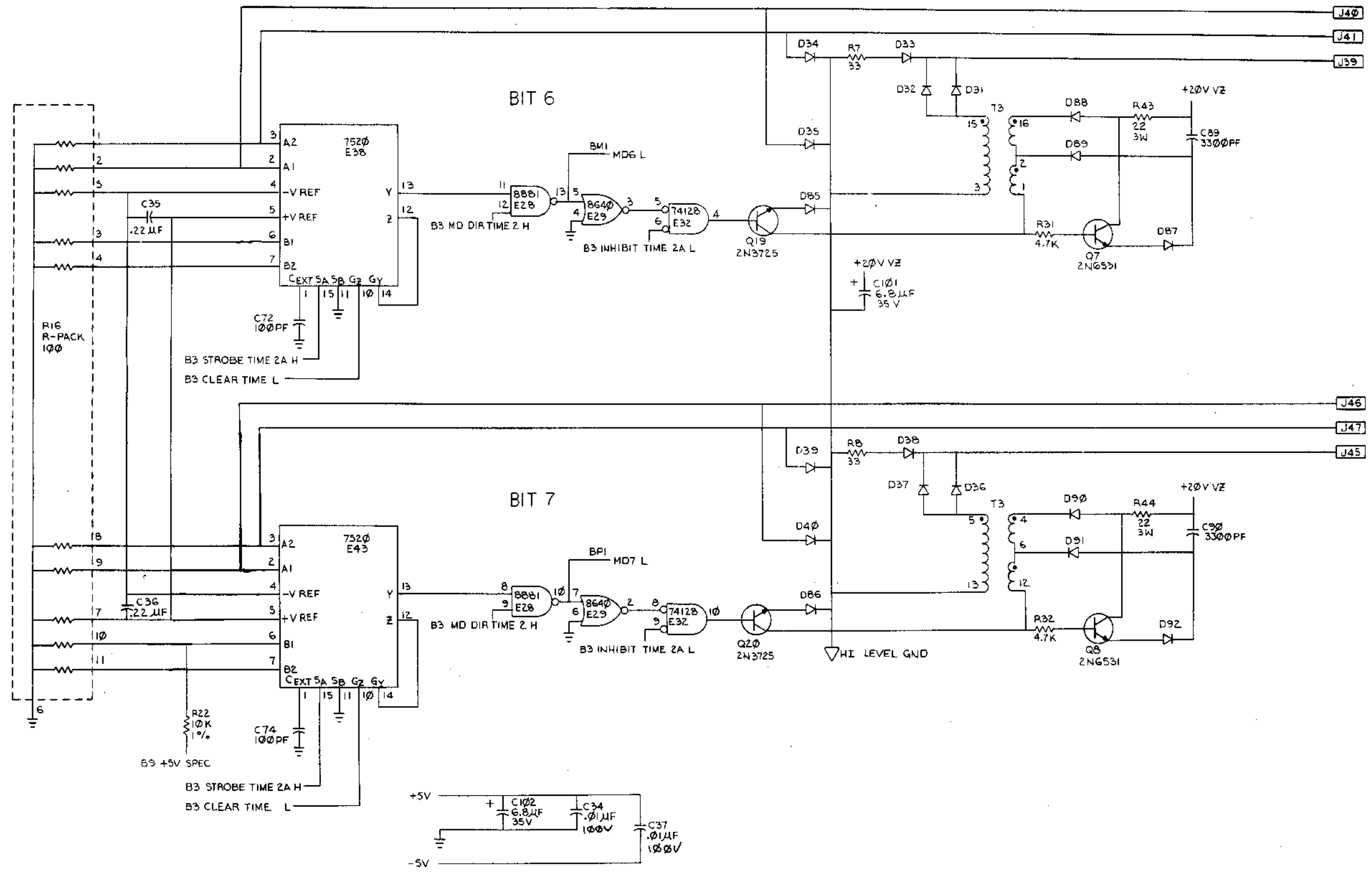

REVISIONS		
CHK	CHANGE NO.	REV.

(SENSE / INHIBIT 2 BITS)		TITLE	SIZE CODE	NUMBER	REV.
8K 12 BIT		8K 12 BIT	D CS	G649-0-1	B
BASE BOARD		SCALE	SHEET	DIST.	
		10 OF 12			

"THIS DRAWING AND SPECIFICATIONS, HEREIN, ARE THE PROPERTY OF DIGITAL EQUIPMENT CORPORATION AND SHALL NOT BE REPRODUCED OR COPIED OR USED IN WHOLE OR IN PART AS THE BASIS FOR THE MANUFACTURE OR SALE OF ITEMS WITHOUT WRITTEN PERMISSION. COPYRIGHT © 1974, DIGITAL EQUIPMENT CORPORATION"

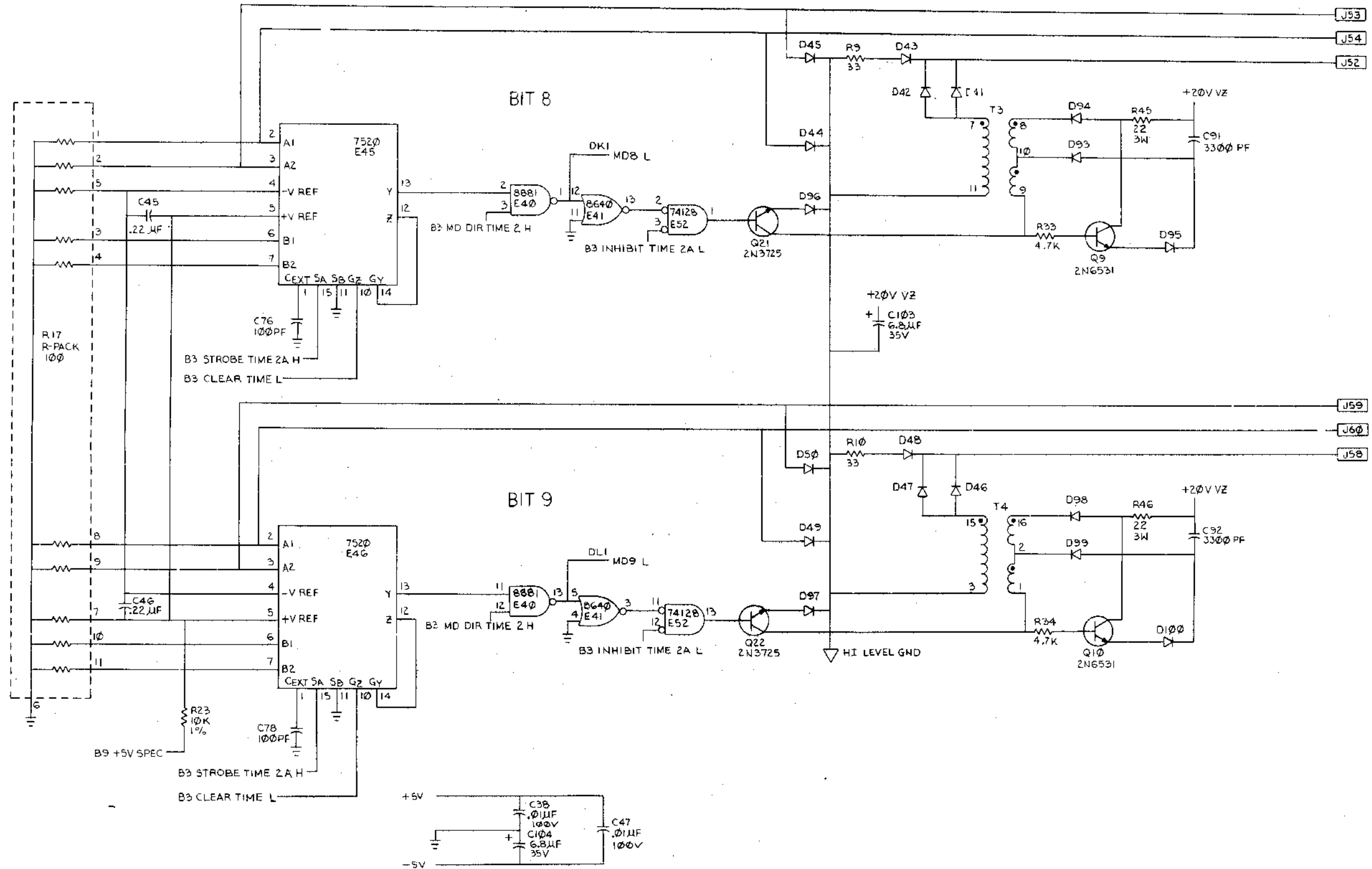

REVISIONS		
CHK	CHANGE NO.	REV.

(SENSE / INHIBIT 2 BITS)		TITLE	8K, 12 BIT BASE BOARD (B11)	SIZE CODE	D CS	NUMBER	G649-0-1	REV.	B
SCALE		SHEET	11 OF 12	DIST.					

"THIS DRAWING AND SPECIFICATIONS HEREIN ARE THE PROPERTY OF DIGITAL EQUIPMENT CORPORATION AND SHALL NOT BE REPRODUCED OR COPIED OR USED IN WHOLE OR IN PART AS THE BASIS FOR THE MANUFACTURE OR SALE OF ITEMS WITHOUT WRITTEN PERMISSION. COPYRIGHT © 1974 DIGITAL EQUIPMENT CORPORATION"

1-0-6499 5012

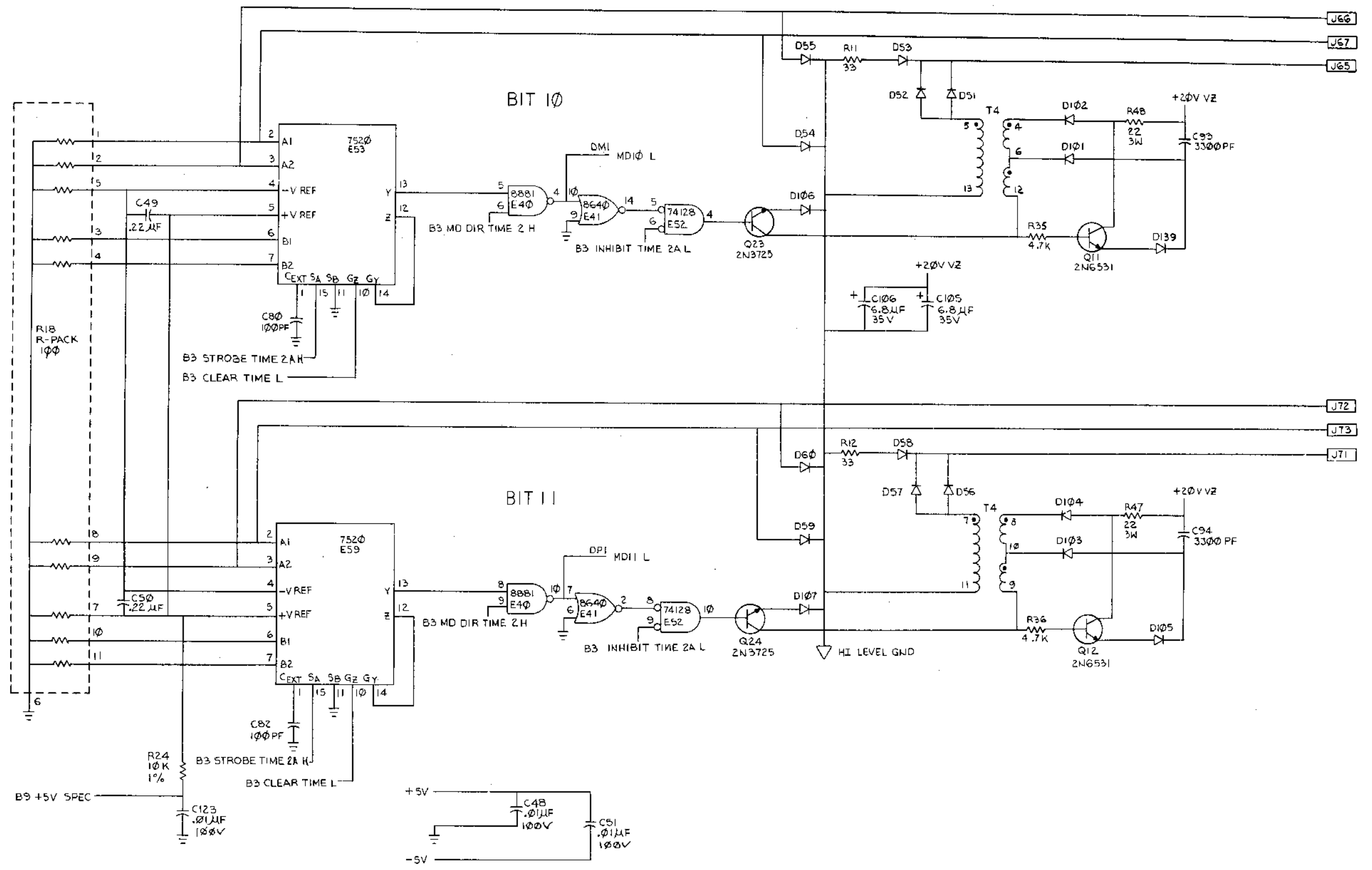

REVISIONS		
CHK	CHANGE NO.	REV.

(SENSE/INHIBIT 2 BITS)		TITLE	8K, 12 BIT BASE BOARD (B12)	SIZE CODE	D CS	NUMBER	G649-0-1	REV.	B
SCALE	1/1	SHEET	12 OF 12	DIST.					

REV. B
 G649-0-1
 DCS

THIS DRAWING AND SPECIFICATIONS HEREIN ARE THE PROPERTY OF DIGITAL EQUIPMENT CORPORATION AND SHALL NOT BE REPRODUCED OR COPIED OR USED IN WHOLE OR IN PART AS THE BASIS FOR THE MANUFACTURE OR SALE OF ITEMS WITHOUT WRITTEN PERMISSION.
 COPYRIGHT © 1975 DIGITAL EQUIPMENT CORPORATION

- NOTES:**
- UNLESS OTHERWISE SPECIFIED:
 - RESISTORS ARE 1/4W, ±5%
 - CAPACITORS ARE 50V
 - DIODES ARE D012
 - ALL RECEPTACLES ARE INDICATED WITH J NOMS.
 - COMP. C68, C104 NOT USED
 - DEFINITION OF MEMORY SELECTION JUMPERS

WITH JUMPERS IN LOCATIONS	MEMORY IS DECODED FOR ADDRESS	MEMORY BANK SELECTED
171	0 TO 16K	1ST 16K
272	16K TO 32K	2ND 16K
373	32K TO 48K	3RD 16K
474	48K TO 64K	4TH 16K

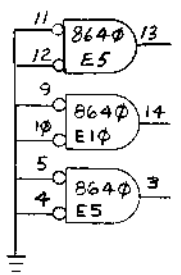

SPARES

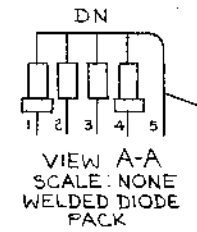
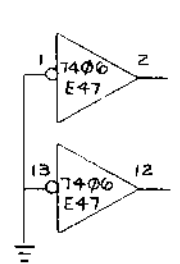

VIEW A-A
SCALE: NONE WELDED DIODE PACK

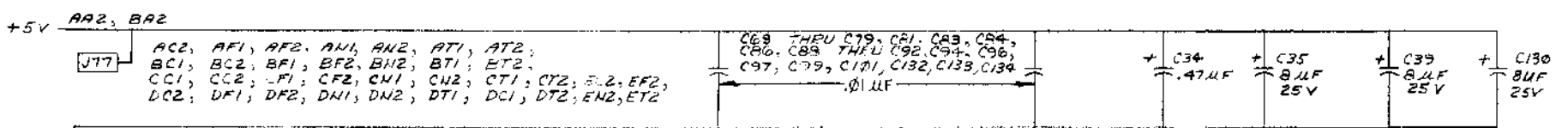
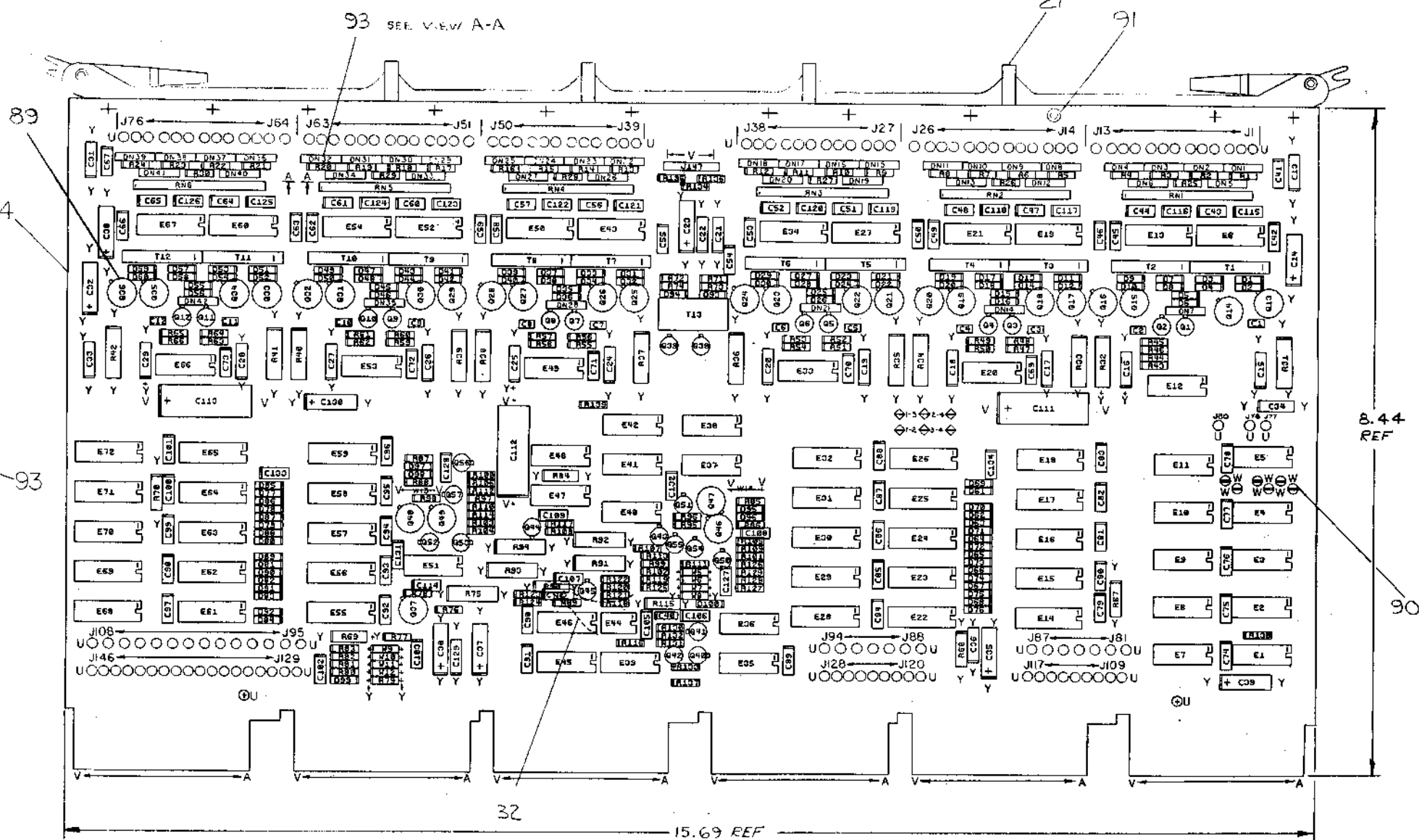

IC TYPE	-5V	GND	+5V	+20V
75325	8	9	16	
7520	8	9	16	
8640	1	8		
7442	8	16		
72741	4	7		
7384	1	8		

GND AND 5V ARE USUALLY PIN 7 AND 14 RESPECTIVELY EXCEPTIONS ARE STATED ABOVE

IC PIN LOCATIONS

REV.	CHANGE NO.	REVISIONS	QTY	REF. DESIGNATION	DESCRIPTION	PART NO.	ITEM NO.

FIRST USED ON OPTION MODEL		PARTS LIST	
MM8-AB	ETCH BOARD REV.	C	

DRW. M. Pinner	DATE 3/11/75	
CHK'D. M. Pinner	DATE 3/12/75	
ENG. J. Pinner	DATE 3/12/75	
PROJ. ENG. J. Pinner	DATE 3/12/75	
PROD. J. Pinner	DATE 3/12/75	
NEXT HIGHER ASSY		
SCALE 1 OF 12		

DEC. NO.	EIA NO.	DEC. NO.	EIA NO.

SEMICONDUCTOR CONVERSION CHART

SIZE CODE	NUMBER	REV.
D CS	6650-0-1	B

TITLE 16K, 12 BIT (B1) BASE BOARD

"THIS DRAWING AND SPECIFICATIONS, HEREIN, ARE THE PROPERTY OF DIGITAL EQUIPMENT CORPORATION AND SHALL NOT BE REPRODUCED OR COPIED OR USED IN WHOLE OR IN PART AS THE BASIS FOR THE MANUFACTURE OR SALE OF ITEMS WITHOUT WRITTEN PERMISSION. COPYRIGHT © 1975 DIGITAL EQUIPMENT CORPORATION"

PARTS LIST

QTY	REF DESIGNATIONS	DESCRIPTION	PART NO.	ITEM NO.
		X-Y COORDINATE HOLE LOCATION	K-CO-6650-0-4	1
		ASSY/DRILLING HOLE LAYOUT	D-AH-6650-0-5	2
		MODULE ECO HISTORY	B-MH-6650-0-6	3
		ETCHED CIRCUIT BOARD	501141B	4
1	C114	CAP 22PF 100V	1005930-00	5
1	C128	CAP 47PF 100V	1000011-00	6
1	C127	CAP 56PF 100V	1000012-00	7
12	C115-C126	CAP 100PF 50V	1000016-00	8
12	C1-C12	CAP 3300PF 50V	1011740-01	9
57	C41, C42, C45, C46, C49, C50, C53, C54, C55, C58, C59, C62, C63, C66, C67, C69-C103, C105-C107, C132, C133, C134	CAP .01UF 50V	1001610-00	10
1	C40	CAP .022UF 50V	1011683-00	11
15	C43, C44, C47, C48, C51, C52, C56, C57, C60, C61, C64, C65, C108, C131, C109	CAP .22UF 50V	1010274-00	12
20	C13, C15-C22, C24-C29, C31, C33, C34, C36, C129	CAP .47UF 50V	1012312-00	13
9	C19, C23, C30, C32, C35, C37, C38, C39, C130	CAP 8UF 25V	1012084-01	14
3	C111-C113	CAP 47UF 30V	1012219-0-0	15
98	D1-D38	DIODE D672	1105275-00	16
1	D99	DIODE IN750A 4.7V ZENER	1100124-00	17
1	D100	DIODE IN759A 12V ZENER	1110836-00	18
42	DN1-DN42	DIODE ASSY	7010318-01	19
143	J1-J78, J80-J117, J120-J146	RECEPTACLE	1211728-00	20
		HANDLE, REWORK	7413182-00	21
1	J147	CONNECTOR 7 PIN	1212104-00	22
1	R30	RES 100 1/2W 5%	1300228-00	23
1	R135	RES 100 1/4W 5%	1300229-00	24
4	R67-R70	RES 300 1/2W 5%	1300291-00	25
1	R115	RES 330 1/2W 5%	1300296-00	26
1	R84	RES 1K 1/2W 1%	1300381-00	27
2	R111, R112	RES 3.3K 1/4W 5%	1300439-00	28
2	R85, R87	RES 10K 1/4W 5%	1300479-00	29
6	R73, R74, R113, R114, R122, R132	RES 1.2K 1/4W 5%	1301320-00	30
2	R71, R72	RES 180 1/4W 5%	1301322-00	31
A/R		WIRE #30 AWG SOLID GREEN	9105740-55	32
5	R116, R117, R118, R121, R138	RES 2K 1/4W 1%	1302715-00	33
1	R119	RES 825 1/4W 1%	1305143-00	34
2	R77, R78	RES 14.7K 1/4W 1%	1302941-00	35
1	R109	RES 1K 1/4W 1%	1303114-00	36
2	R86, R88	RES 348K 1/4W 1%	1305114-00	37
6	R95-R100	RES 75 1/4W 1%	1303064-00	38
1	R82	RES 34.8K 1/4W 1%	1303156-00	39
1	R139	RES 82K 1/4W 5%	1303219-00	40
5	R131, R107, R108, R106, R110	RES 562 1/4W 1%	1304693-00	41
1	R130	RES 5.11K 1/4W 1%	1304854-00	42
4	R101-R104	RES 383 1/4W 1%	1305125-00	43
2	R81, R128	RES 68.1K 1/4W 1%	1305252-00	44
1	R80	RES 121K 1/4W 1%	1305255-00	45
2	R123, R124	RES 4.99K 1/4W 1%	1305324-00	46
1	R83	RES 19.6K 1/4W 1%	1309419-00	47
1	R137	RES 1K THERMISTOR	1310071-00	48
4	R91-R94	RES 30 3W 1%	1311787-00	49

PARTS LIST

QTY	REF DESIGNATIONS	DESCRIPTION	PART NO.	ITEM NO.
12	R31-R42	RES 21 3W 1%	1311738-C1	50
6	RN1-RN6	RES R PACK 1/8W 1%	1311741-00	51
1	R75	RES 220 3W 1%	1312123-00	52
2	R125, R83	RES 1.21K 1/4W 1%	1302871-00	53
3	R126, R134, R135	RES 274K 1/4W 1%	1305131-00	54
1	R127	RES 137K 1/4W 1%	1305422-00	55
1	R129	RES 35.7K 1/4W 1%	1305421-00	56
1	R136	RES 2.61K 1/4W 1%	1303303-00	57
6	R25-R30	RES 10K 1/4W 1%	1303312-00	58
24	R43-R66	RES 4.7K 1/4W 5%	1300447-00	59
1	R76	RES 46.4K 1/4W 1%	1303311-00	60
1	R125	RES 5.62K 1/4W 1%	1305128-00	61
24	R1-R24	RES 33 1/4W 5%	1300197-00	62
28	Q13-Q36, Q46-Q49	TRANSISTOR 2N9725	1510969-00	63
1	Q37	TRANSISTOR 2N2904A	1501913-00	64
5	Q38-Q42	TRANSISTOR 3009B	1503100-00	65
4	Q50-Q53	TRANSISTOR 6534B	1503409-01	66
4	Q54-Q57	TRANSISTOR 4258	1505321-00	67
12	Q1-Q12	TRANSISTOR 6531B	1509338-00	68
3	Q43-Q45	TRANSISTOR M4A55	1510706-00	69
1	T13	TRANSFORMER 1:1	1609996-00	70
12	T1-T12	TRANSFORMER 2:1	1612119-00	71
2	E37, E38	IC 74H40	1905586-00	72
1	E42	IC 74H10	1909057-00	73
2	E4, E41	IC 74H11	1909267-00	74
1	E48	IC 74H74	1909667-00	75
3	E7, E35, E45	IC 8881	1909705-00	76
6	E18, E26, E32, E59, E65, E72	IC 7442	1910046-00	77
1	E51	IC 74121	1910290-00	78
1	E44	IC 72741	1910298-00	79
2	E3, E9	IC 7384	1910393-00	80
1	E47	IC 7406	1910741-00	81
24	E14-E17, E28-E25, E28-E31, E55-E58, E61-E64, E68-E71	IC 75325	1910960-00	82
10	E1, E2, E5, E8, E10, E11, E36, E37, E40, E46	IC 8640	1911469-00	83
12	E6, E13, E19, E21, E27, E34, E43, E50, E56, E54, E60, E67	IC 7520	1911748-00	84
6	E12, E20, E33, E49, E53, E66	IC 74128	1912068-00	85
A/R	W1-W4	BUS WIRE #22 AWG	9107560-01	86
8	W5-W12	MACHINE INSERTED JUMPER	9009185-00	87
A/R	W13, W14	INSULATED WIRE #22 AWG	1700035-00	88
29		TRANSIPAD	9007201-00	89
6		EYELET (TERMINAL POSTS)	9006785-00	90
12		EYELET	9006792-00	91
1	R105	RES 464 1/4W 1%	1303047-00	92
84		DIODE ASSEMBLY SPACER	9107771-00	93
1	R79	RES 3.83K 1/4W 1%	1309413-00	94

REVISIONS		
CHK	CHANGE NO.	REV.

D CS G650-0-1

"THIS DRAWING AND SPECIFICATIONS, HEREIN, ARE THE PROPERTY OF DIGITAL EQUIPMENT CORPORATION AND SHALL NOT BE REPRODUCED OR COPIED OR USED IN WHOLE OR IN PART AS THE BASIS FOR THE MANUFACTURE OR SALE OF ITEMS WITHOUT WRITTEN PERMISSION. COPYRIGHT © 1975 DIGITAL EQUIPMENT CORPORATION"

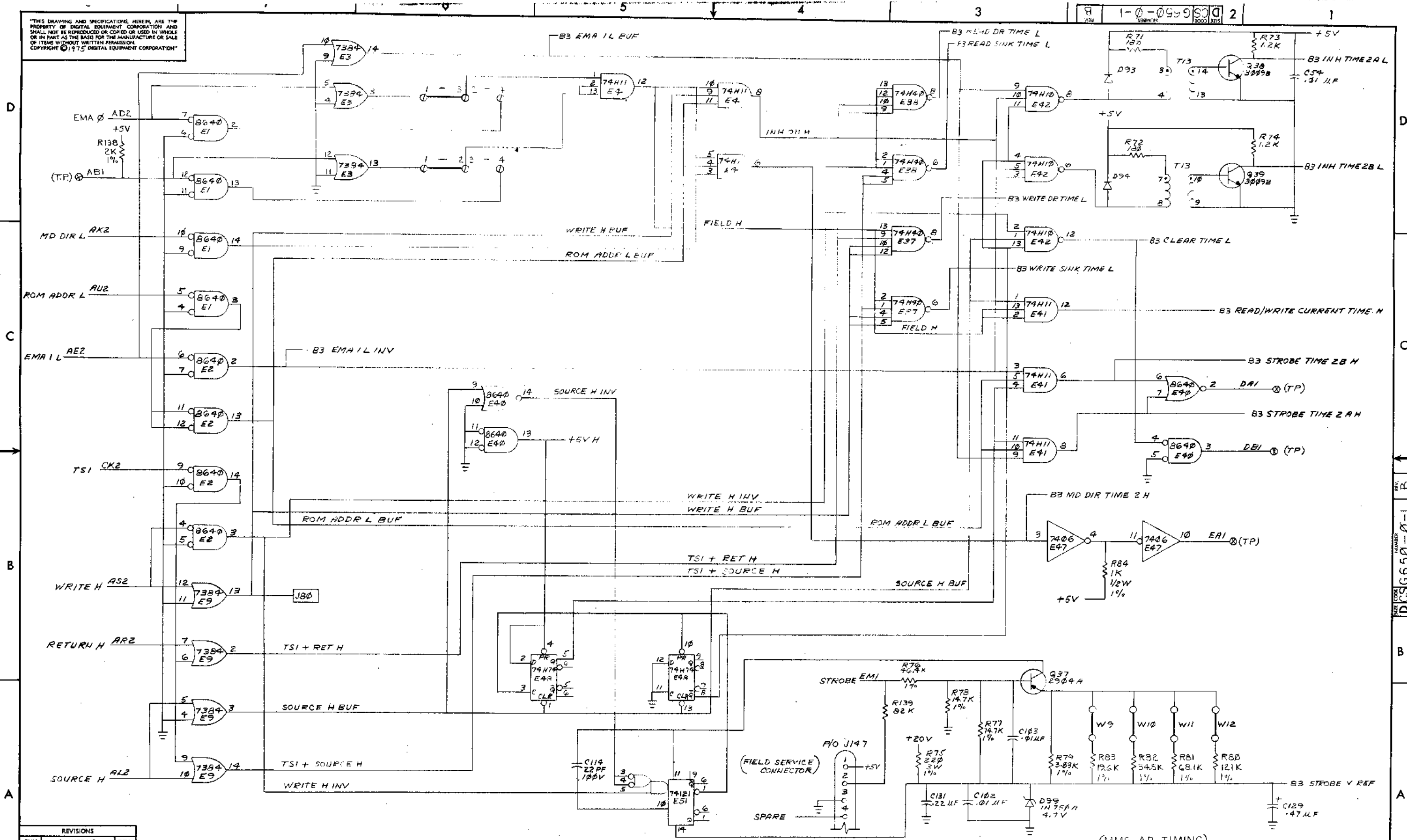

REVISIONS		
CHK	CHANGE NO.	REV.

TITLE 16K, 12 BIT BASE BOARD (B3)		SIZE CODE DCS G650-0-1	NUMBER	REV. B
SCALE	SHEET 3 OF 12	DIST.		

DATE CODE NUMBER DCS G650-0-1 REV. B

"THIS DRAWING AND SPECIFICATIONS HEREIN ARE THE PROPERTY OF DIGITAL EQUIPMENT CORPORATION AND SHALL NOT BE REPRODUCED OR COPIED OR USED IN WHOLE OR IN PART AS THE BASIS FOR THE MANUFACTURE OR SALE OF ITEMS WITHOUT WRITTEN PERMISSION. COPYRIGHT © 1975 DIGITAL EQUIPMENT CORPORATION"

1-0-0999 S3 D 2

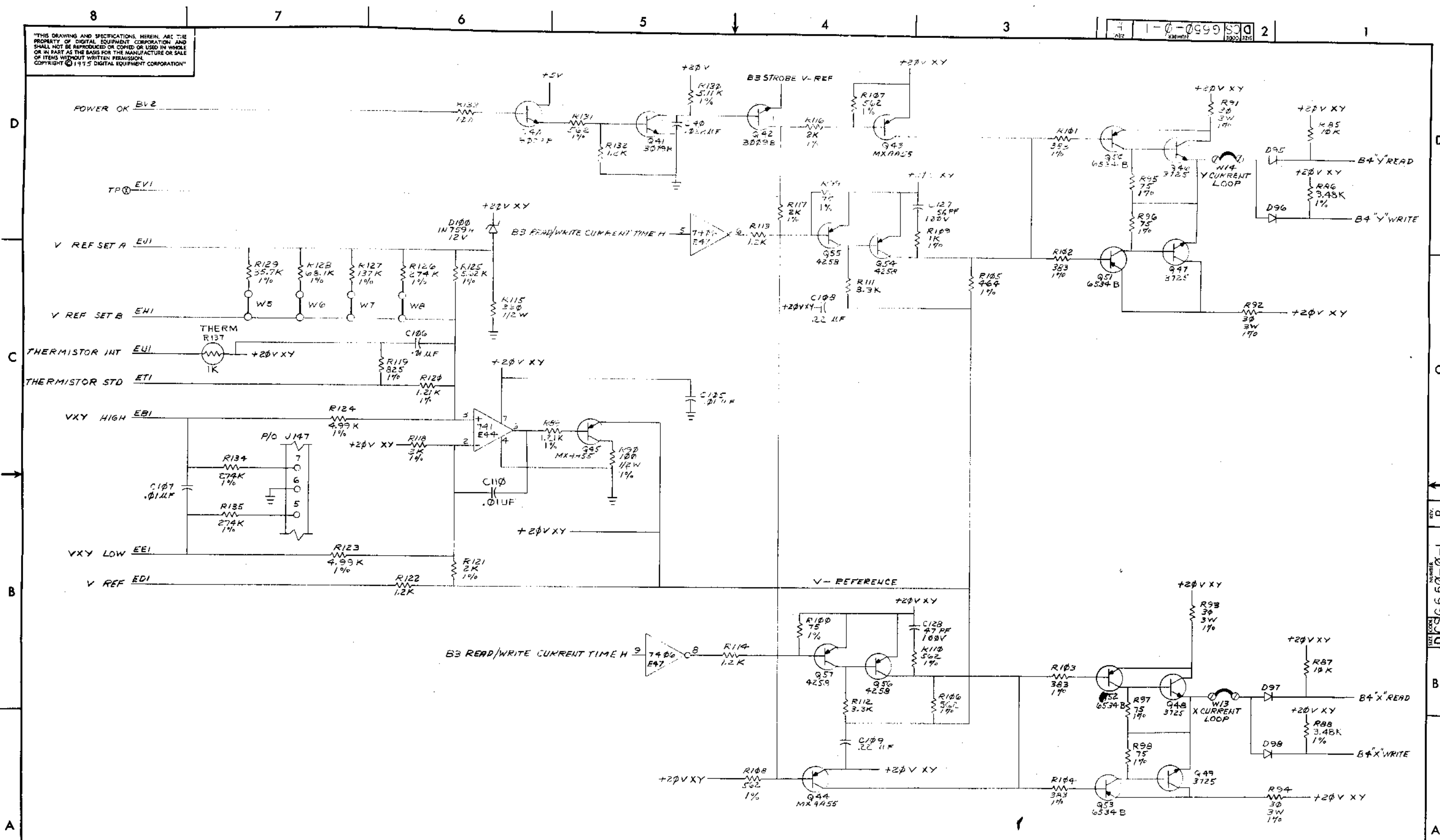

(CURRENT & CONTROL)

REVISIONS		
CHK	CHANGE NO.	REV.

TITLE	16K, 12 BIT BASE BOARD (B4)	SIZE	CODE	NUMBER	REV.
SCALE		SHEET	4	OF 12	
DIST.					

DCS G650-0-1

"THIS DRAWING AND SPECIFICATIONS HEREIN ARE THE PROPERTY OF DIGITAL EQUIPMENT CORPORATION AND SHALL NOT BE REPRODUCED OR COPIED OR USED IN WHOLE OR IN PART AS THE BASIS FOR THE MANUFACTURE OR SALE OF ITEMS WITHOUT WRITTEN PERMISSION. COPYRIGHT © 1975 DIGITAL EQUIPMENT CORPORATION"

NOTE: ALL 75325 HAVE TYPICAL INTERNAL CONFIGURATION AND PINNING (EXAMPLE: E5B)

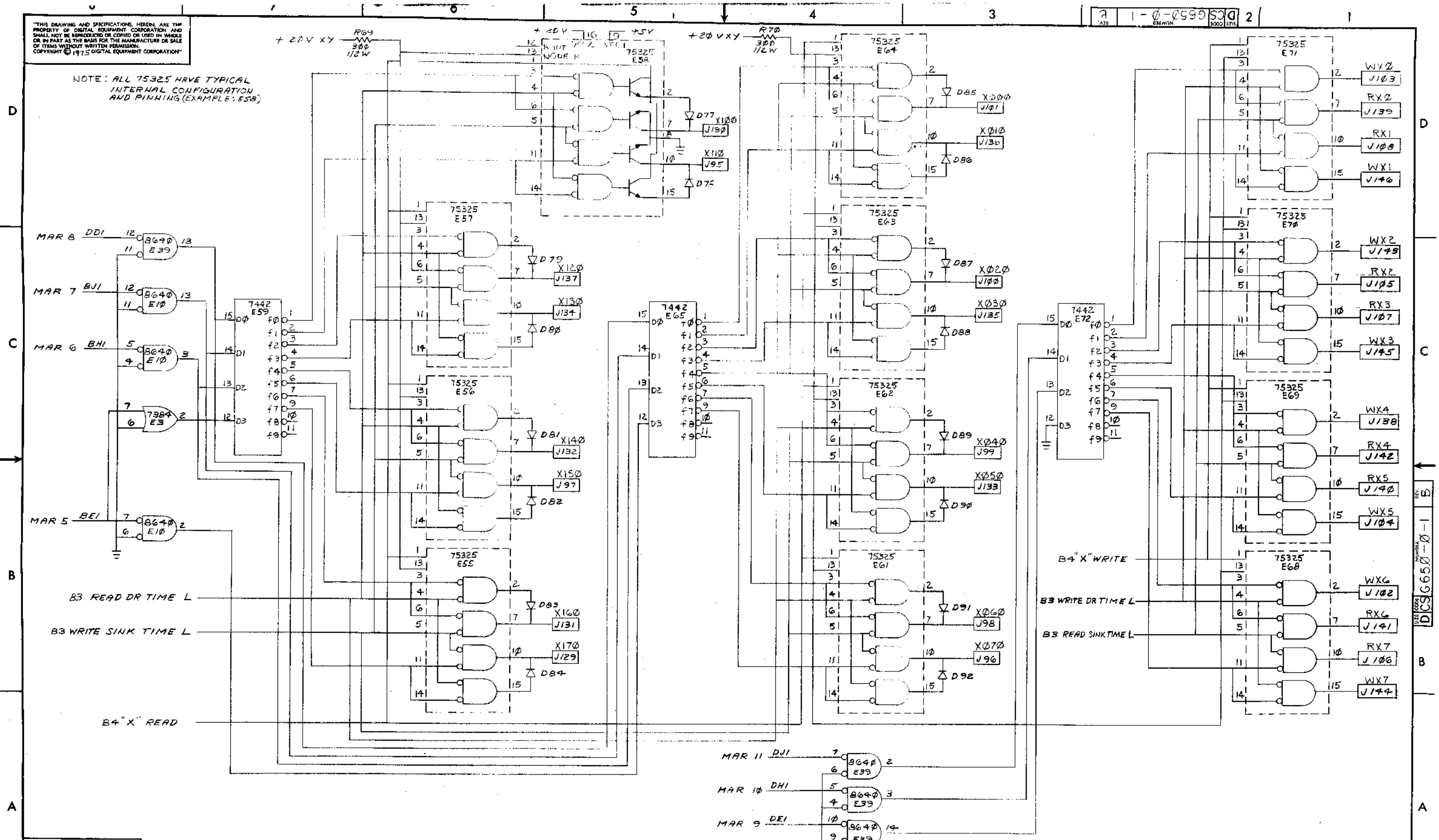

REVISIONS		
CHK	CHANGE NO.	REV.

TITLE		(B5) SIZE CODE	NUMBER	REV.
16K, 12 BIT BASE BOARD		D	CS G650-0-1	B
SCALE	SHEET	OF	DIST.	
	5	12		

THE DRAWING AND SPECIFICATIONS HEREIN, ARE THE PROPERTY OF DIGITAL EQUIPMENT CORPORATION AND SHALL NOT BE REPRODUCED OR COPIED OR USED IN WHOLE OR IN PART AS THE BASIS FOR THE MANUFACTURE OR SALE OF ITEMS WITHOUT WRITTEN PERMISSION. COPYRIGHT © 1965 DIGITAL EQUIPMENT CORPORATION

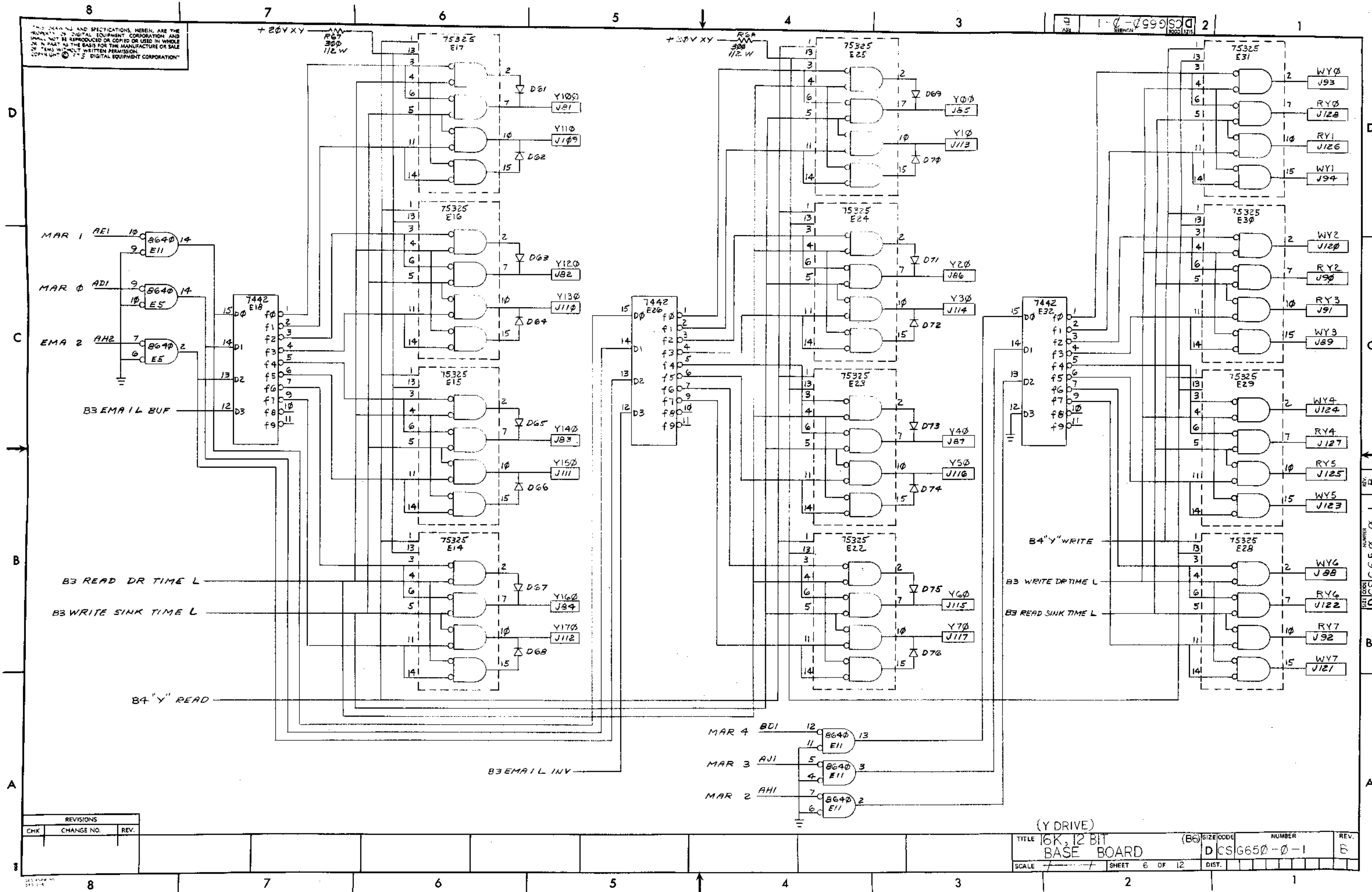

REVISIONS		
CHK	CHANGE NO.	REV.

TITLE 16K, 12 BIT BASE BOARD		(B6) SIZE CODE	NUMBER	REV.
SCALE		SHEET 6 OF 12	D C S G 6 5 0 - 0 - 1	E

"THIS DRAWING AND SPECIFICATIONS HEREIN ARE THE PROPERTY OF DIGITAL EQUIPMENT CORPORATION AND SHALL NOT BE REPRODUCED OR COPIED OR USED IN WHOLE OR IN PART AS THE BASIS FOR THE MANUFACTURE OR SALE OF ITEMS WITHOUT WRITTEN PERMISSION. COPYRIGHT © 1975 DIGITAL EQUIPMENT CORPORATION"

REV. 1 DCS 6650-0-1

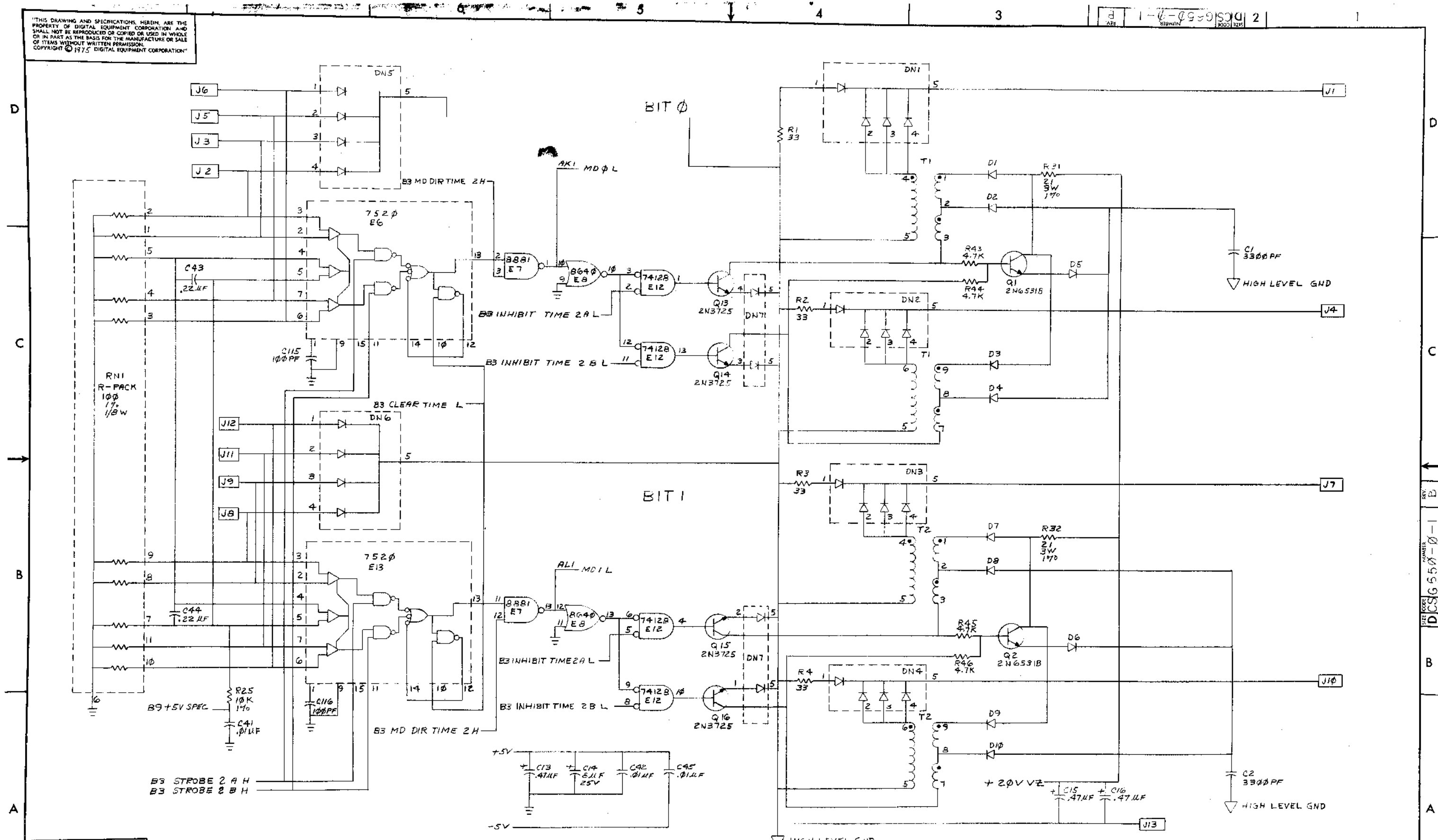

REVISIONS		
CHK	CHANGE NO.	REV.

TITLE 16K, 12 BIT BASE BOARD		B7	SIZE CODE	NUMBER	REV.
SCALE		SHEET 7 OF 12	DIST.	DCS 6650-0-1	15

THIS DRAWING AND SPECIFICATIONS HEREIN ARE THE PROPERTY OF DIGITAL EQUIPMENT CORPORATION AND SHALL NOT BE REPRODUCED OR COPIED OR USED IN WHOLE OR IN PART AS THE BASIS FOR THE MANUFACTURE OR SALE OF ITEMS WITHOUT WRITTEN PERMISSION. COPYRIGHT © 1975 DIGITAL EQUIPMENT CORPORATION

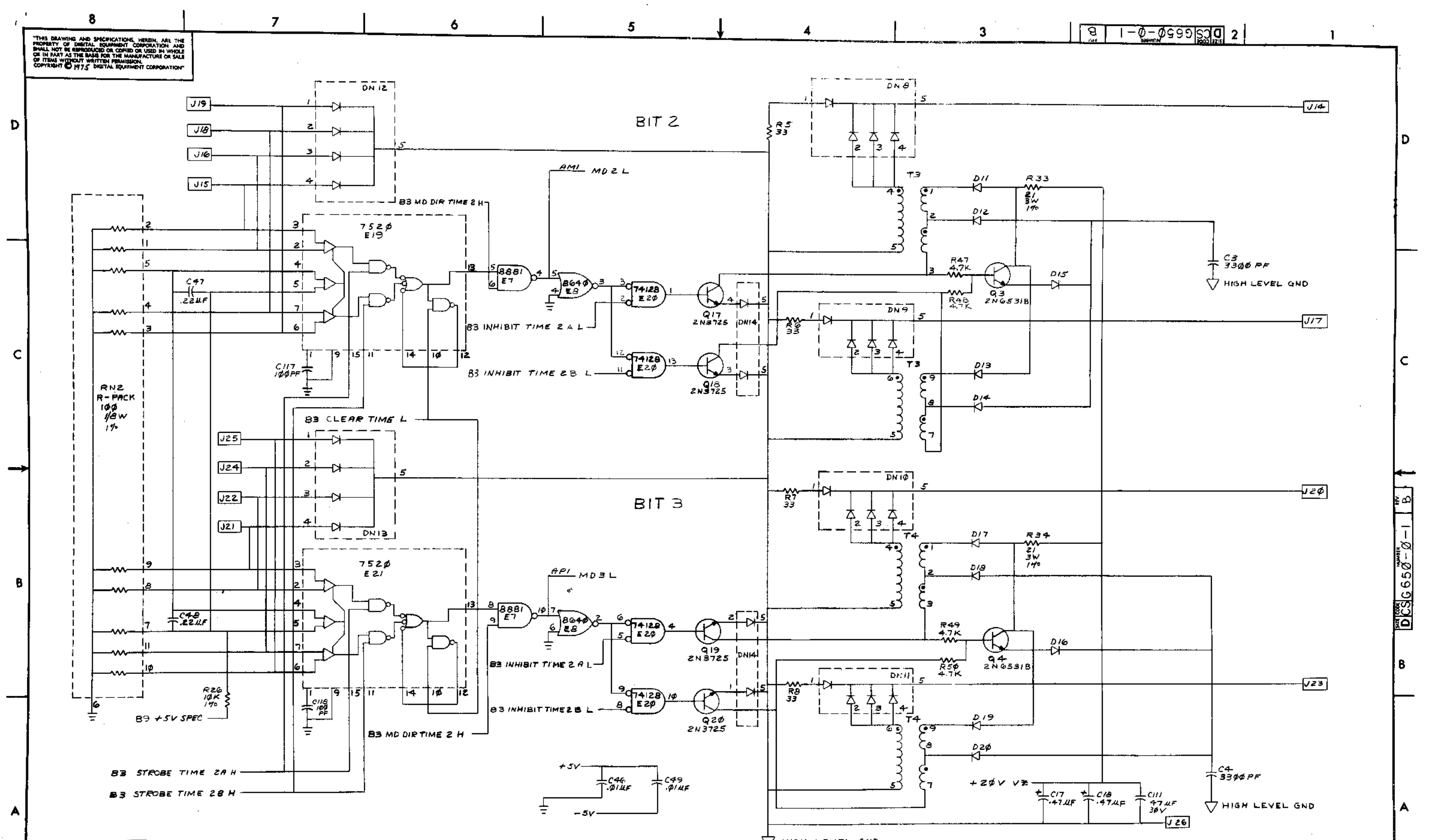

REVISIONS		
CHK	CHANGE NO.	REV.

TITLE 6K, 12 BIT BASE BOARD (BB)		SIZE CODE DCSG650-0-1	NUMBER 8	REV. B
SCALE	SHEET 8 OF 12	DIST.		

DCSG650-0-1 B

THIS DRAWING AND SPECIFICATIONS, WHETHER THE PROPERTY OF THE COMPANY OR INDIVIDUAL, SHALL NOT BE REPRODUCED, COPIED, OR TRANSMITTED IN ANY FORM OR BY ANY MEANS, ELECTRONIC OR MECHANICAL, INCLUDING PHOTOCOPYING, RECORDING, OR BY ANY INFORMATION STORAGE AND RETRIEVAL SYSTEM, WITHOUT THE WRITTEN PERMISSION OF THE COMPANY.

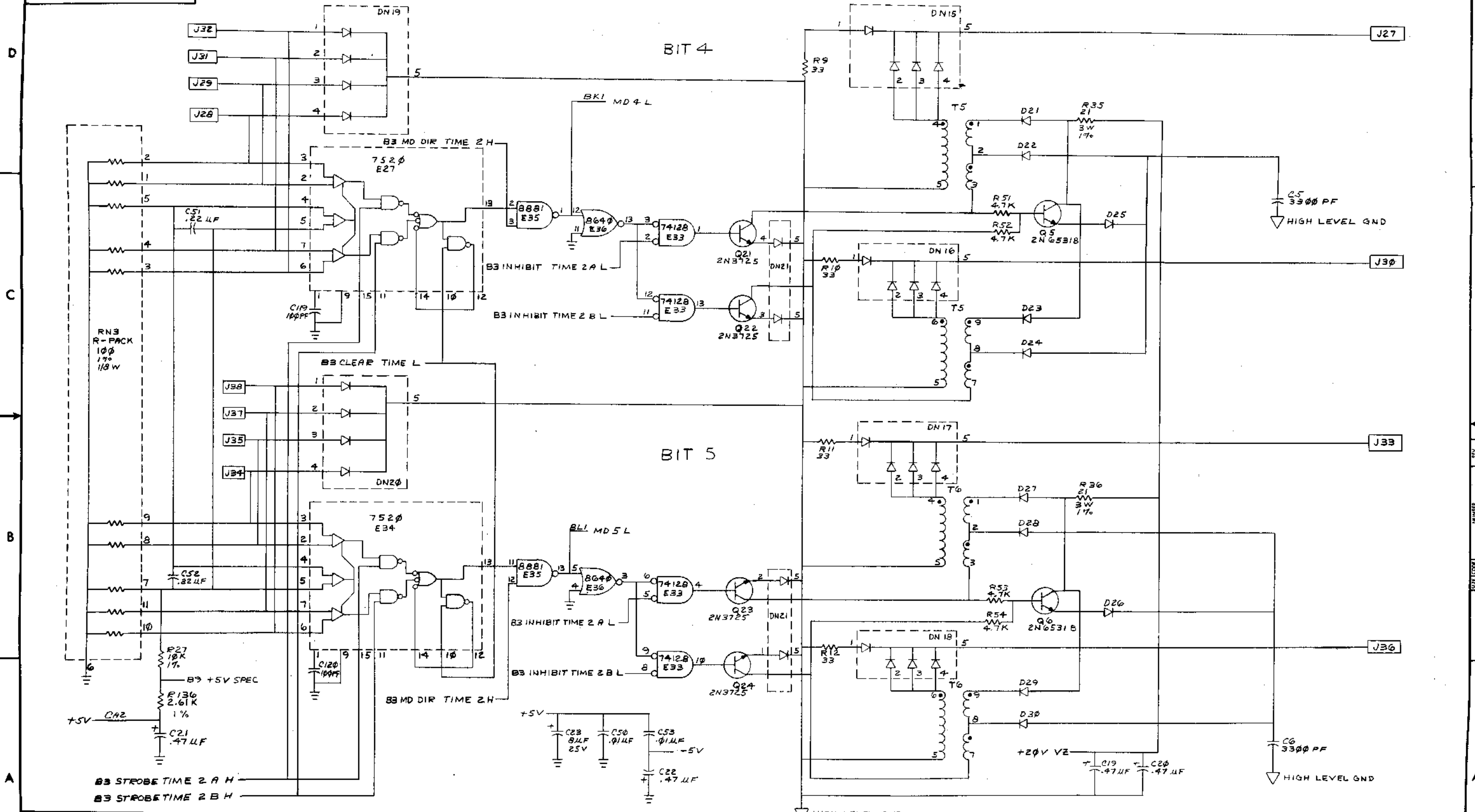

REVISIONS		
CHK	CHANGE NO.	REV.

(SENSE INHIBIT 2BITS)		TITLE	16K, 12 BIT	SIZE/SCALE	(B9)	NUMBER	9 OF 12	REV.	B
		BASE BOARD							

THIS DRAWING AND SPECIFICATIONS HEREIN ARE THE PROPERTY OF DIGITAL EQUIPMENT CORPORATION AND SHALL NOT BE REPRODUCED OR COPIED OR USED IN WHOLE OR IN PART AS THE BASIS FOR THE MANUFACTURE OR SALE OF ITEMS WITHOUT WRITTEN PERMISSION. COPYRIGHT © 1975 DIGITAL EQUIPMENT CORPORATION.

1-0-0999 SCD 2

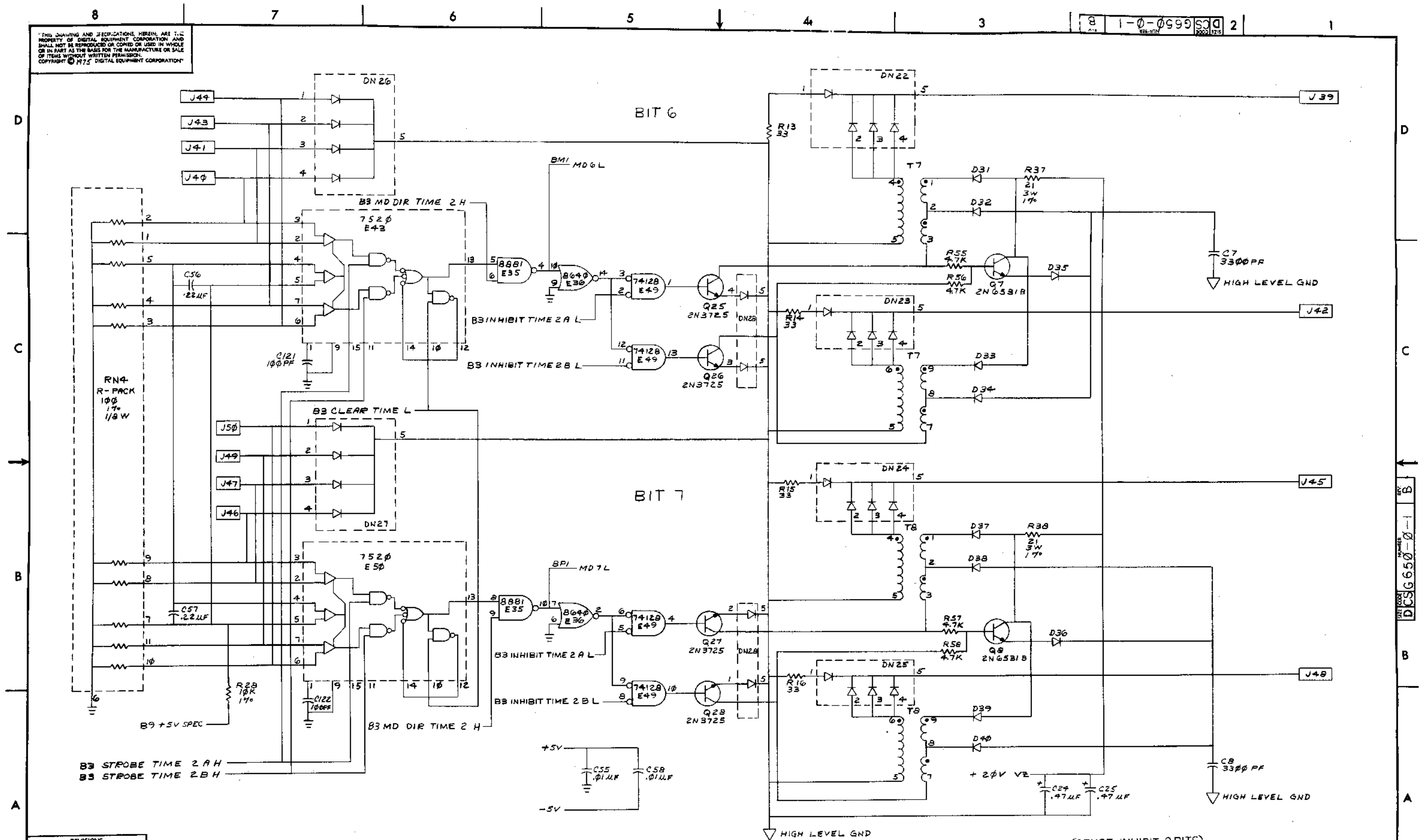

REVISIONS		
CHK	CHANGE NO.	REV.

TITLE		(SENSE INHIBIT 2 BITS)		NUMBER		REV.	
6K.12 BIT BASE BOARD		DCSG650-0-1		B			
SCALE		SHEET 10 OF 12		DIST.			

DCSG650-0-1

THIS DRAWING AND SPECIFICATIONS HEREIN ARE THE PROPERTY OF DIGITAL EQUIPMENT CORPORATION AND SHALL NOT BE REPRODUCED OR COPIED OR USED IN WHOLE OR IN PART AS THE BASIS FOR THE MANUFACTURE OR SALE OF ITEMS WITHOUT WRITTEN PERMISSION. COPYRIGHT © 1975 DIGITAL EQUIPMENT CORPORATION

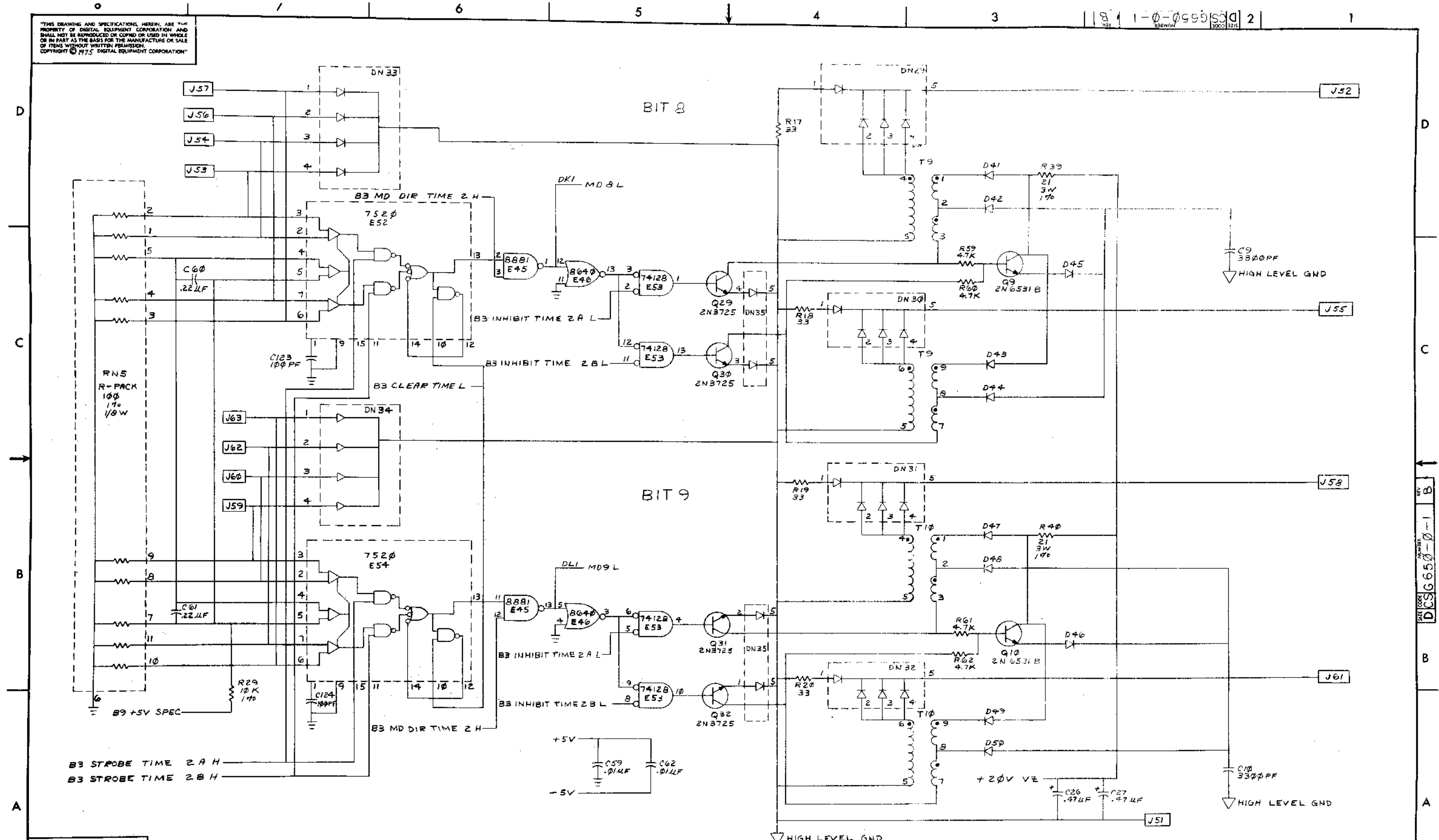

REVISIONS		
CHK	CHANGE NO.	REV.

TITLE 16K, 12 BIT BASE BOARD (SENSE INH. BIT 2 BITS)		SIZE CODE (B11)	NUMBER	REV. B
SCALE	SHEET 11 OF 12	DIST.	DCSG650-0-1	

"THE DRAWING AND SPECIFICATIONS HEREIN ARE THE PROPERTY OF DIGITAL EQUIPMENT CORPORATION AND SHALL NOT BE REPRODUCED OR COPIED OR USED IN WHOLE OR IN PART AS THE BASIS FOR THE MANUFACTURE OR SALE OF ITEMS WITHOUT WRITTEN PERMISSION. COPYRIGHT © 1975 DIGITAL EQUIPMENT CORPORATION"

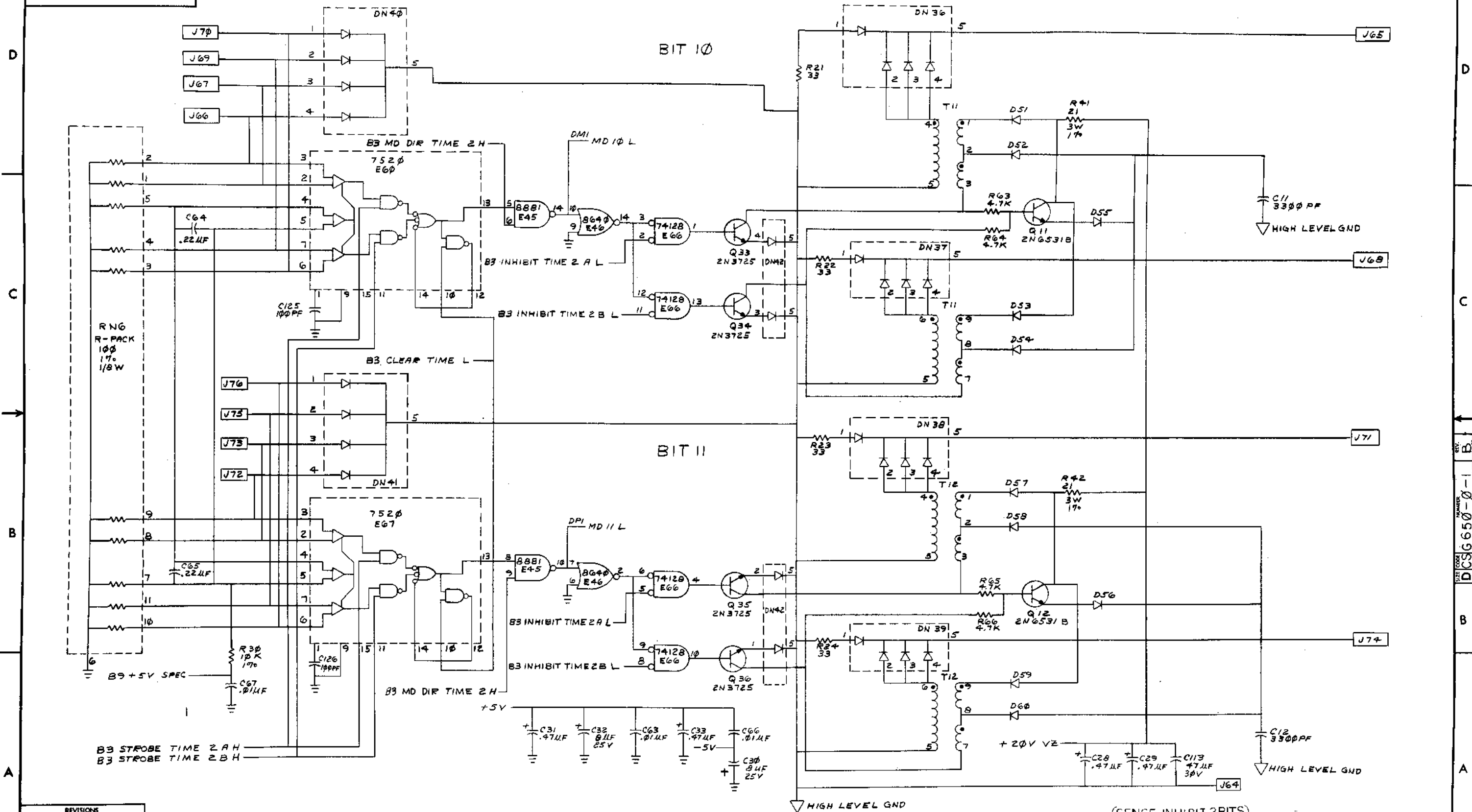

REVISIONS		
CHK	CHANGE NO.	REV.

TITLE 16K, 12 BIT BASE BOARD (B12)		SIZE CODE DCS 6650-0-1	NUMBER	REV B
SCALE 1-1	SHEET 12 OF 12	DIST.		

REV. B
NUMBER DCS 6650-0-1
SIZE CODE

CUSTOMER PRINT SET		ELECTRICAL					CUSTOMER PRINT SET		MECHANICAL						
MP-KMB-A	SET	FIND NO.	DRAWING NO.	REV	NO OF SHT	DESCRIPTION	OPTION NO./FILE DATE	MP-KMB-A	SET	FIND NO.	DRAWING NO.	REV	NO OF SHT	DESCRIPTION	OPTION NO./FILE DATE
X		1	A-SP-KM8-A-1	*	2	FIELD INST. & ACCEPT. PROC.		X		1	A-PL-KM8-A- β	*	1	PARTS LIST	
X			A-PL-KM8-A-2	*	1	SHIPPING LIST									
X			A-PL-KM8-A-3	*	1	SOFTWARE LIST									
X			D-TD-KM8-A-4	*	1	AUTO REST./BOOT START-UP SEQ.									
X			D-TD-KM8-A-5	*	1	BOOTSTRAP TIMING DIAGRAM									
X			D-FD-KM8-A-6	*	2	MEMORY EXT FLOW DIAGRAM									
X			A-SP-KM8-A-7	*	4	ROM PROGRAMMING DIRECTIONS									
			A-SP-KM8-A-8		8	ENG. SPECS									
X		2	D-CS-M8317- β -1	#	7	8A INTERNAL OPTION #2	M8317								
			K-CO-M8317- β -4	#	1	X-Y COORDINATE HOLE LOCATION									
			D-AD-M8317- β -5	#	1	ASSY/DRILLING HOLE LAYOUT									
			B-MH-M8317- β -6	#	1	MODULE HISTORY									
X			K-RL-M8317- β -8	#	2	ROM PATT. SPEC.									
X			K-RL-M8317- β -9	#	9	ROM PATT. SPEC									
X			K-RL-M8317- β -10	#	9	ROM PATT. SPEC									
X			K-RL-M8317- β -11	#	9	ROM PATT. SPEC									

CUSTOMER PRINT SET CODES
X = PRINT OF DOCUMENT INCLUDED IN PRINT SET
C = INCLUDES ALL PRINTS INDICATED ON DOCUMENT
S = CONFIDENTIAL AUTHORIZED SIGNATURE REQUIRED

TITLE: 8A INTERNAL OPTION #2
SHEET 2 OF 2
SIZE CODE: B DD
NUMBER: KM8-A
REV:

This drawing and specifications, herein, are the property of Digital Equipment Corporation and shall not be reproduced or copied or used in whole or in part as the basis for the manufacture or sale of items without written permission.

DIGITAL EQUIPMENT CORPORATION MAYNARD, MASSACHUSETTS						
ENGINEERING SPECIFICATION						DATE 11/19/74
TITLE FIELD INSTALLATION & ACCEPTANCE PROCEDURE FOR KM8-A						
REVISIONS						
REV	DESCRIPTION	CHG NO	ORIG	DATE	APPD BY	DATE

ENG	APPD	SIZE	CODE	NUMBER	REV
ENG <i>Larry Markie</i>	APPD <i>Bob Thie</i>	A	SP	KM8-A-1	

ENGINEERING SPECIFICATION		digital	CONTINUATION SHEET
TITLE FIELD INSTALLATION & ACCEPTANCE PROCEDURE FOR KM8-A			
<p>I GENERAL</p> <p>This procedure defines the performance standards required of the KM8A*, option board #2. This procedure refers to both system and add-on acceptance.</p> <p>NOTE: If KM8A was shipped as part of a PDP-8A system, then proceed to installation procedure.</p> <p>* Memory Extension & Time Share Bootstrap Loaders Power Fail/Auto Restart</p> <p>II INSPECTION</p> <p>After removing the KM8A from the packing material, inspect the module for the following:</p> <ol style="list-style-type: none"> 1. Inventory hardware against shipping list. 2. Inventory software against software list, if ordered. 3. Inventory prints against shipping list, if ordered. 4. Check module for loose or broken components. <p>III INSTALLATION PROCEDURE</p> <p>Install the equipment using the following procedure:</p> <ol style="list-style-type: none"> 1. Set the switches as indicated by the diagnostic write up. <p>NOTE: Refer to Operator's Handbook for switch setting descriptions.</p> <ol style="list-style-type: none"> 2. Insure that the PDP-8A power is removed from the OmnibusTM. 3. Insert the KM8A into the second or third slot of the OmnibusTM. 4. Turn the power back "ON". <p>IV ACCEPTANCE PROCEDURE</p> <p>Perform the acceptance procedure defined in Table A. If abnormal indications are encountered, refer to the diagnostic listing for the type of error. Reference the diagnostic write ups and Operator's Manual for instructions for loading diagnostics.</p>			
		SIZE A	CODE SP
		NUMBER KM8-A-1	REV

ENGINEERING SPECIFICATION

08-11-61

CONTINUATION SHEET

TITLE FIELD INSTALLATION & ACCEPTANCE PROCEDURE FOR KM8-A

IV ACCEPTANCE PROCEDURE (continued)

Equipment required:

1. PDP-8A with 1K min. R/W Memory
2. Paper Tape Input Device
3. Diagnostic and Listings
4. Programmer's Console (KC8-A & DKC8-A)
5. W987 Quad Extender

NOTE: If the programmer's console and paper tape input device are not available as part of the system being used, they must be supplied in good working order by the customer.

TABLE A

Acceptance of KM8A with 4K of R/W Memory

<u>Program Name</u>	<u>Maindec #</u>	<u>Accept Time</u>	<u>Restrictions</u>
KM8A Option Test #2	08-DJKMA-PB	30 min	4K R/W Memory Min

Acceptance of KM8A with Less than 4K R/W Memory

KM8A Option Test #2 Segment #1 (RIM)	08-DJKMA -PM1	10 min	1K R/W memory min
KM8A Option Test #2 Segment #2 (RIM)	08-DJKMA -PM2	10 min	1K R/W Memory Min
KM8A Option Test #2 Segment #4 (RIM)	08-DJKMA -PM4	10 min	1K R/W Memory Min

SIZE	CODE	NUMBER	REV
A	SP	KM8-A-1	

DIGITAL EQUIPMENT CORPORATION MAYNARD, MASSACHUSETTS PARTS LIST					QUANTITY / VARIATION																	
MADE BY Paul Gardner		CHECKED <i>S. R. Berto</i>		SECTION	KMS-AA	KMS-AB																
DATE 11/11/74		DATE 12-20-74																				
ENG <i>Larry Naselle</i>		PROD <i>[Signature]</i>		ISSUED SECT.																		
DATE 12-20-74		DATE 12-20-74																				
ITEM NO.	DWG NO. / PART NO.	DESCRIPTION																				
1	MP-KMS-A	*KMS-A MAINTENANCE PRINT SET			0	0																
2	A-PL-KMS-A-3	*KMS-A SOFTWARE LIST			0	0																
3	DEC8A-HUMAA-A-D	*PDP8A USER'S MANUAL			0	0																
* THIS ITEM IS AN OPTION AND IS TO BE SHIPPED ONLY WHEN PURCHASED AS A SEPARATE ITEM.																						
TITLE				ASSY NO.	SIZE	CODE	NUMBER				REV.	ECO NO.										
SHIPPING LIST, KMS-A					A	PL	KMS-A-2															
				SHEET 1 OF 1	DIST.																	

DIGITAL EQUIPMENT CORPORATION
MAYNARD, MASSACHUSETTS

PARTS LIST

QUANTITY / VARIATION

MADE BY Paul Gardner	CHECKED <i>S. Roberts</i>	SECTION
DATE 11/11/74	DATE 12-20-74	
ENG <i>Larry Naele</i>	PROD <i>[Signature]</i>	ISSUED SECT.
DATE 12-24-74	DATE 12-20-74	

ITEM NO.	DWG NO. / PART NO.	DESCRIPTION	QUANTITY / VARIATION																	
			KMS-AA	KMS-AB																
1	ZF209-RB/KMS-A	4K OPTION #2 SOFTWARE	1	1																
2	ZF210-RB/KMS-A	1K-2K-3K OPTION #2 SOFTWARE	1	1																

TITLE SOFTWARE LIST, KMS-A	ASSY NO.	SIZE CODE A PL	NUMBER KMS-A-3	REV.	ECO NO.
SHEET 1 OF 1		DIST.			

DIGITAL EQUIPMENT CORPORATION MAYNARD, MASSACHUSETTS PARTS LIST				QUANTITY / VARIATION									
MADE BY Paul Gardner		CHECKED <i>S. Roberts</i>		SECTION									
DATE 11/11/74		DATE 12-20-74											
ENG <i>Jimmy Harlin</i>		PROD <i>[Signature]</i>		ISSUED SECT.									
DATE 12-20-74		DATE 12-20-74											
ITEM NO.	DWG NO. / PART NO.	DESCRIPTION		KM8-AA	KM8-AB								
1	D-CS-M8317-Ø-1	8A INTERNAL OPTION #2		1	0								
2	D-CS-M8317-YA-1	8A INT. OPTION #2, W/O BOOTSTRAP ROMS		0	1								
3	A-PL-KM8-A-2	SHIPPING LIST, KM8-A		1	1								
TITLE 8A INTERNAL OPTION #2				ASSY NO. SHEET 1 OF 1		SIZE CODE A PL		NUMBER KM8-A-Ø		REV.		ECO NO.	

THIS DRAWING AND SPECIFICATIONS HEREIN ARE THE PROPERTY OF DIGITAL EQUIPMENT CORPORATION AND SHALL NOT BE REPRODUCED OR COPIED OR USED IN WHOLE OR IN PART AS THE BASIS FOR THE MANUFACTURE OR SALE OF ITEMS WITHOUT WRITTEN PERMISSION. DIGITAL EQUIPMENT CORPORATION © 1974

REV. 1
DITD KM8-A-4

- NOTES:
1. CLOCK ENABLE MAY BE FALSE AT THIS TIME, IF INIT H IS FALSE. CLOCK ENABLE THEN RETURNS HIGH (ASSERTED) WHEN INTN BECOMES TRUE
 2. THE LOGIC WAITS FOR INITIALIZATION TO START OR END BEFORE CONTINUING
 3. THESE FLIP-FLOPS ARE CLEARED AT THE CONCLUSION OF THE AUTO RESTART CYCLE
 4. ACTIVE SETS ON THE NEXT CLOCK PULSE THEN CLEARS AT THE END OF THE CYCLE
 5. GO F/F CLEARS AT THE END OF CYCLE
 6. SEE D-PD-KM8-A FOR DETAILED TIMING DATA AFTER ACTIVE IS SET
 7. THE SWITCHING TIMES FOR AC LOW ARE A FUNCTION OF THE SLEW RATE OF THE CIRCUITS IN THE POWER SUPPLY

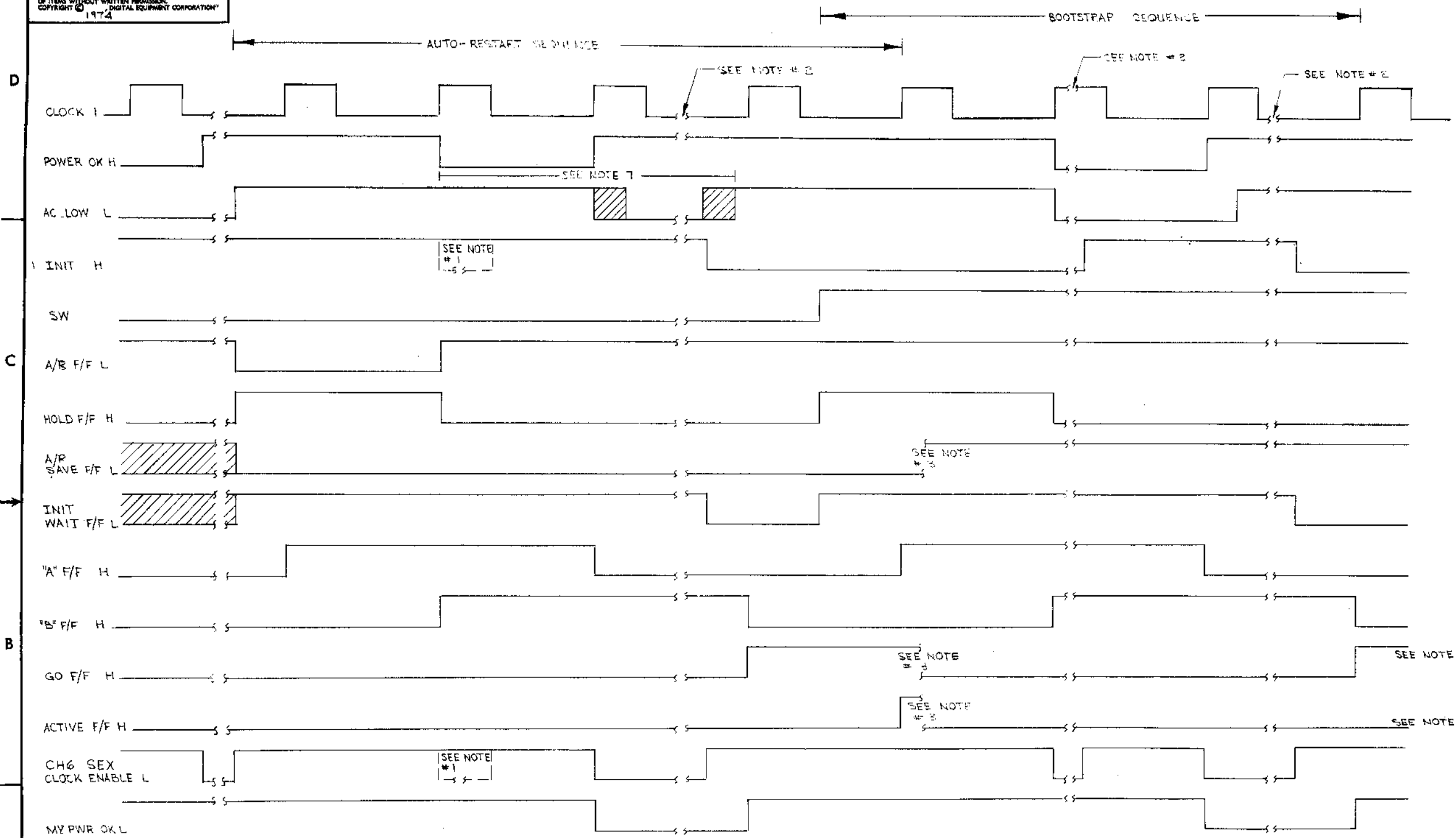

REV.	CHANGE NO.

FIRST USED ON OPTION/MODEL PDP8-A		QTY.	DESCRIPTION	PART NO.	ITEM NO.																																	
DIMENSIONAL TOLERANCE DIMENSIONS ARE UNLESS OTHERWISE SPECIFIED		PARTS LIST																																				
MICROMETERS XXX = ±0.10 XX = ±0.05 X = ±0.02		<table border="1"> <tr> <td>DRWG</td> <td>DATE</td> <td rowspan="4"> </td> </tr> <tr> <td>CHKD.</td> <td>DATE</td> </tr> <tr> <td>ENG.</td> <td>DATE</td> </tr> <tr> <td>PROJ. ENG.</td> <td>DATE</td> </tr> <tr> <td colspan="2">THIRD ANGLE PROJECTION</td> <td>PROD.</td> <td>DATE</td> <td colspan="2">TITLE AUTO RESTART/ BOOTSTRAP START- UP SEQUENCE</td> </tr> <tr> <td colspan="2">REMOVE BURRS AND BREAK SHARP CORNERS SURFACE QUALITY</td> <td colspan="2">NEXT HIGHER ASSY.</td> <td>SIZE CODE</td> <td>NUMBER</td> </tr> <tr> <td colspan="2">MATERIAL</td> <td colspan="2">B-DD-KM8-A</td> <td>DITD</td> <td>KM8-A-4</td> </tr> <tr> <td colspan="2">FINISH</td> <td colspan="2">SCALE</td> <td>SHEET</td> <td>REV.</td> </tr> </table>				DRWG	DATE		CHKD.	DATE	ENG.	DATE	PROJ. ENG.	DATE	THIRD ANGLE PROJECTION		PROD.	DATE	TITLE AUTO RESTART/ BOOTSTRAP START- UP SEQUENCE		REMOVE BURRS AND BREAK SHARP CORNERS SURFACE QUALITY		NEXT HIGHER ASSY.		SIZE CODE	NUMBER	MATERIAL		B-DD-KM8-A		DITD	KM8-A-4	FINISH		SCALE		SHEET	REV.
DRWG	DATE																																					
CHKD.	DATE																																					
ENG.	DATE																																					
PROJ. ENG.	DATE																																					
THIRD ANGLE PROJECTION		PROD.	DATE	TITLE AUTO RESTART/ BOOTSTRAP START- UP SEQUENCE																																		
REMOVE BURRS AND BREAK SHARP CORNERS SURFACE QUALITY		NEXT HIGHER ASSY.		SIZE CODE	NUMBER																																	
MATERIAL		B-DD-KM8-A		DITD	KM8-A-4																																	
FINISH		SCALE		SHEET	REV.																																	
FINISH		SCALE		SHEET	REV.																																	

REV. 1
DITD KM8-A-4

"THIS DRAWING AND SPECIFICATIONS HEREIN ARE THE PROPERTY OF DIGITAL EQUIPMENT CORPORATION AND SHALL NOT BE REPRODUCED OR COPIED OR USED IN WHOLE OR IN PART AS THE BASIS FOR THE MANUFACTURE OR SALE OF ITEMS WITHOUT WRITTEN PERMISSION. COPYRIGHT © 1974, DIGITAL EQUIPMENT CORPORATION"

- NOTES:
- 1 ONE "DEPOSIT" CYCLE IS SHOWN IN DIAGRAM.
 - 2 WHEN "RUN" IS TRUE (LOW) ALL TIMING IS HELD OFF UNTIL THE NEXT CLOCK PULSE AFTER "RUN" GOES FALSE (HIGH).
 - 3 FOR THE "LOAD ADD" CYCLE SIGNALS REMAIN THE SAME AS SHOWN EXCEPT THAT "PULSE LOAD ADD" REPLACES "MEM START" AND "KEY CONTROL" IS NEGATED. FOR "EXT LOAD ADD" KEY CONTROL IS TRUE.
 - 4 MEM START APPEARS HERE ONLY FOR THE "START" FUNCTION. THE EARLIER MEM START IS FOR "DEPOSITS" ONLY.

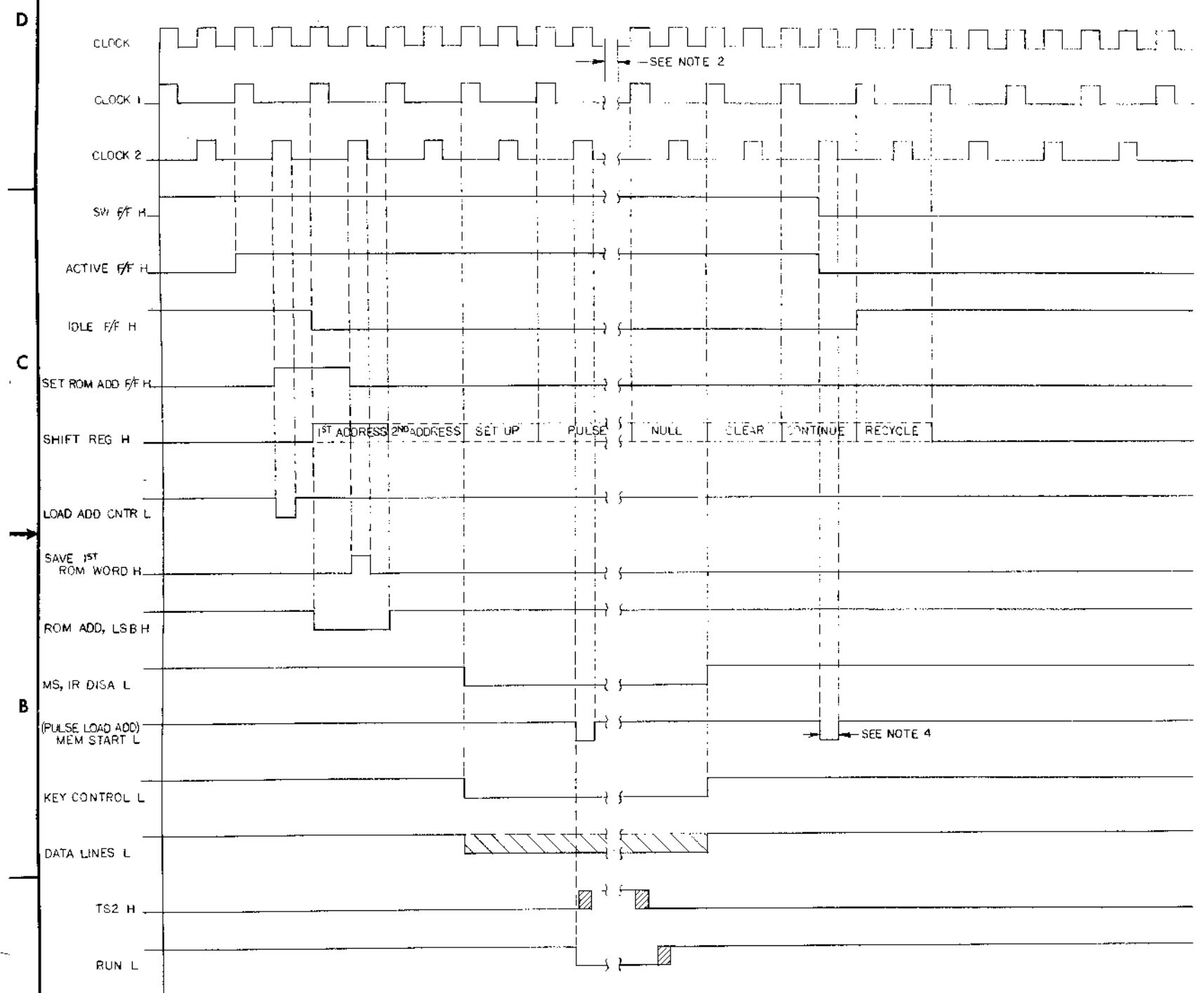

REVISIONS

REV.	CHANGE NO.

FIRST USED ON OPTION/MODEL PDR8-A		QTY.	DESCRIPTION	PART NO.	ITEM NO.
PARTS LIST					
DIMENSIONAL TOLERANCE		DRN. <i>M White</i>	DATE <i>2-21-74</i>		
DIMENSIONS ARE MILLIMETERS INCHES		CHK'D. <i>[Signature]</i>	DATE <i>[Signature]</i>		
UNLESS OTHERWISE SPECIFIED		ENG. <i>[Signature]</i>	DATE <i>1-9-75</i>		
MILLIMETERS	INCHES	PROJ. ENG. <i>[Signature]</i>	DATE <i>8-25</i>		
.XX ± 0.10	.XXX ± 0.05	PROD. <i>[Signature]</i>	DATE <i>1-5</i>	TITLE BOOTSTRAP TIMING DIAGRAM	
.X ± 0.5	.XX ± 0.02	THIRD ANGLE PROJECTION		NEXT HIGHER ASSY.	
X ± 2	.X ± 1	REMOVE BURRS AND BREAK SHARP CORNERS SURFACE QUALITY ✓		SCALE 1:1	
MATERIAL		FINISH		SIZE CODE B-DD-KMB-A	NUMBER D TD KMB-A-5
SHEET 1 OF 1		DIST.		REV.	

REV. NUMBER KMB-A-5

This drawing and specifications, herein, are the property of Digital Equipment Corporation and shall not be reproduced or copied or used in whole or in part as the basis for the manufacture or sale of items without written permission. COPYRIGHT © 1974 DIGITAL EQUIPMENT CORPORATION

9-A-KMB-A-6 2

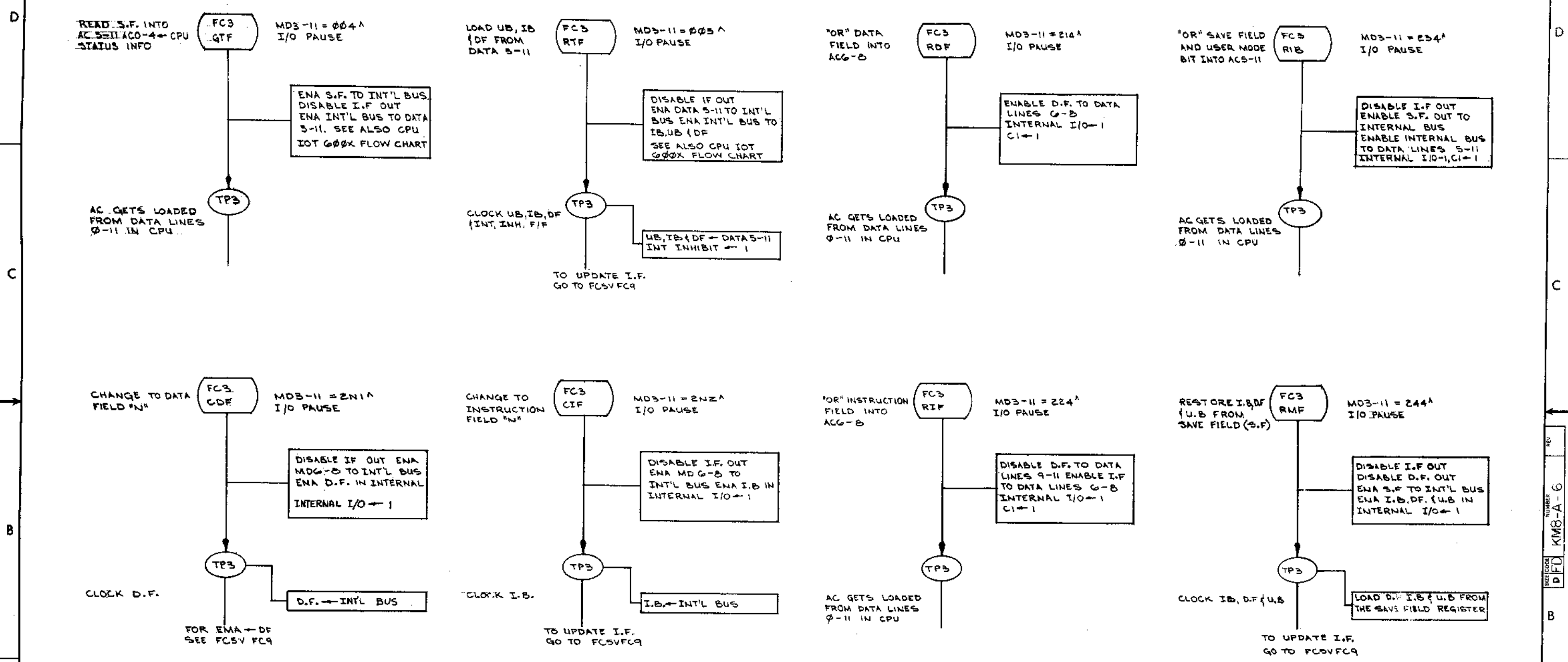

REV	CHANGE NO.

FIRST USED ON OPTION MODEL PDP8A	QTY.	DESCRIPTION	PART NO.	ITEM NO.
PARTS LIST				
UNLESS OTHERWISE SPECIFIED	DRN.	DATE	digital EQUIPMENT CORPORATION MAYNARD, MASSACHUSETTS	
TOLERANCES	CHK'D	DATE	TITLE	
DECIMALS FRACTIONS ANGLES	ENG.	DATE	FLOW CHART FOR	
± .005 ± 1/64 ± 0°30'	PROG'G.	DATE	OPTION BOARD #2	
FINAL SURFACE QUALITY / REMOVE BURRS AND BREAK SHARP CORNERS	PROD.	DATE	M8317	
MATERIAL	NEXT HIGHER ASSY	DATE	SIZE CODE	NUMBER
FINISH	B-DD-KMB-A	SCALE	DFD	KMB-A-6
		SHEET	DIST.	
		1		
		OF 2		

"THIS DRAWING AND SPECIFICATIONS HEREIN ARE THE PROPERTY OF DIGITAL EQUIPMENT CORPORATION AND SHALL NOT BE REPRODUCED OR COPIED OR USED IN WHOLE OR IN PART AS THE BASIS FOR THE MANUFACTURE OR SALE OF ITEMS WITHOUT WRITTEN PERMISSION. DIGITAL EQUIPMENT CORPORATION. COPYRIGHT © 1974"

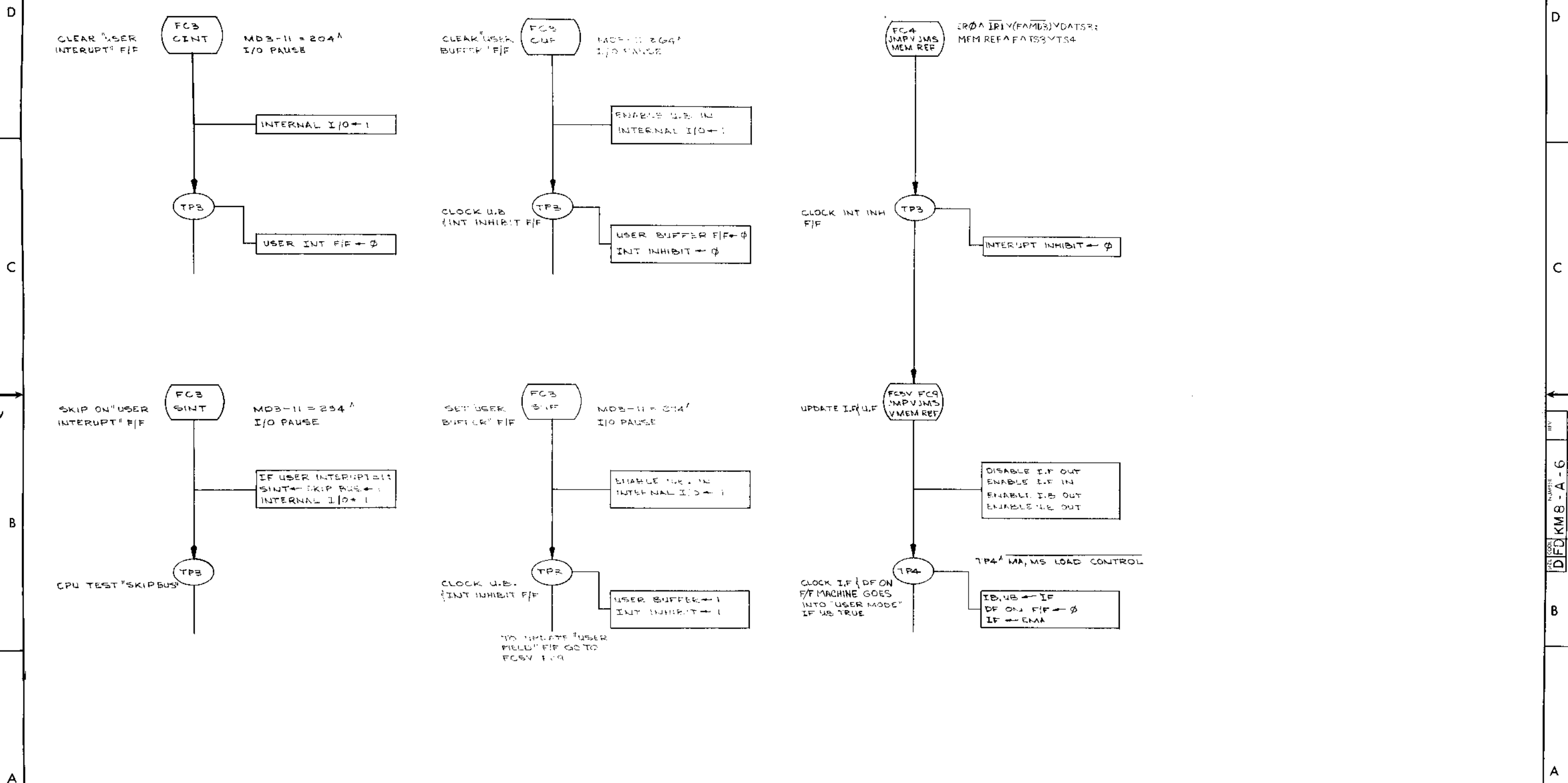

REVISIONS		
CHK	CHANGE NO.	REV

This drawing and specifications, herein, are the property of Digital Equipment Corporation and shall not be reproduced or copied or used in whole or in part as the basis for the manufacture or sale of items without written permission.

DIGITAL EQUIPMENT CORPORATION
MAYNARD, MASSACHUSETTS

ENGINEERING SPECIFICATION

DATE 5/8/74

TITLE ROM PROGRAMMING DIRECTIONS FOR 8A OPTION BOARD #2 KM8-AB (M8317-YA)

REVISIONS

REV	DESCRIPTION	CHG NO	ORIG	DATE	APPD BY	DATE

ENG Larry Narhi	APPD <i>Larry Narhi</i> 12/24/74	SIZE A	CODE SP	NUMBER KM8-A-7	REV
-----------------	----------------------------------	---------------	---------	----------------	-----

ENGINEERING SPECIFICATION

CONTINUATION SHEET

TITLE ROM PROGRAMMING DIRECTIONS FOR 8A OPTION BOARD #2 KM8-AB (M8317-YA)

1. Introduction

This document describes the organization of the two 256 x 4 ROMs, hereafter called ROM #1 and ROM #2, that control and supply data for the Auto-Restart and Bootstrap portions of Option Board #2.

This information is made available to help users program their own ROMs for their specific Auto-Restart and/or Bootstrap program(s).

2. Organization

The two ROMs are connected as follows: the address lines are connected in parallel; i.e., two corresponding address lines of each ROM are connected together, the outputs are arranged in serial fashion forming an 8 bit word, 4 outputs from each ROM. Because 12 bits are required for data/address information, two sequential addresses must be accessed from the ROMs to form a 16 bit word. Where the first 8 bits are temporarily stored in a register, then the next 8 bits are accessed from the ROMs. At this point the control then decides what to do with 12 of the 16 bits. There are four possible actions that can take place at this time:

- a) Load Address
- b) Load Extended Address
- c) Deposit
- d) Start

The remaining 4 bits of the 16 actually tell the control which of the four actions are to take place. So the 16 bit word would look like the word in Figure 1.

	SIZE A	CODE SP	NUMBER KM8-A-7	REV
--	---------------	---------	----------------	-----

ENGINEERING SPECIFICATION

CONTINUATION SHEET

TITLE ROM PROGRAMMING DIRECTIONS FOR 8A OPTION BOARD #2 KM8-AB (M8317-YA)

Figure 1

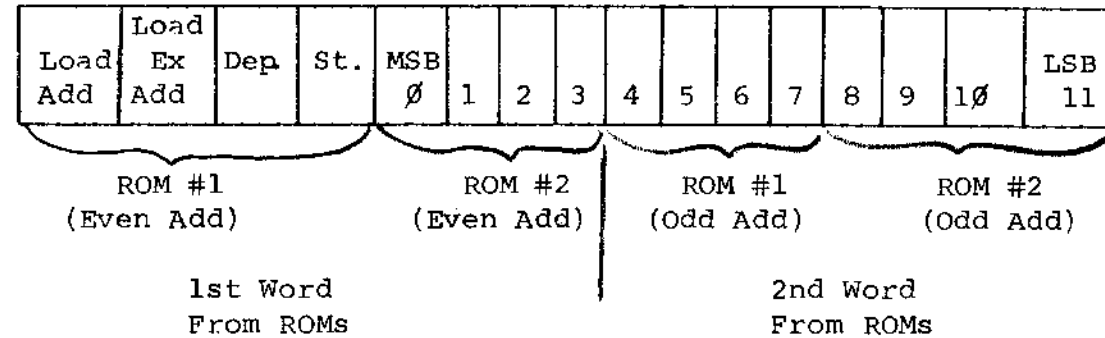

The use of ROMs that have 256 addressable locations allows up to 128 words of ROM storage. These 128 locations may be used for Bootstrap and/or Auto-restart programs. Any Auto-restart or Bootstrap program may be located anywhere in the ROMs so long as the program starts in an even address in the ROM. If it is required that both Bootstrap and Auto-restart programs be accessible at the same time, activated by different signals; of course the Auto-restart program(s) must be located in addresses 0 through 15 in the ROMs. This is due to the addressing limits of the Auto-restart select switches.

3. Auto-Restart/Bootstrap Sequence

The following events should take place when an auto-restart is initiated:

- a) Load a 12 bit address
- b) Load the extended address and start.

The following events should take place when the Bootstrap is initiated:

- a) Load a 12 bit initial address.
- b) Load the extended address.
- c) Deposit 12 bit data words repeating as required by length of program to be deposited.
- d) Load a 12 bit starting address and start.

SIZE A	CODE SP	NUMBER KM8-A-7	REV
-----------	------------	-------------------	-----

ENGINEERING SPECIFICATION

CONTINUATION SHEET

TITLE ROM PROGRAMMING DIRECTIONS FOR 8A OPTION BOARD #2 KM8-AB (M8317-YA)

The decision to do a Bootstrap or an auto-restart is directed by a set of switches on the module. The Bootstrap may be actuated by the transition of the signal AC Low from a logic low to a logic high or by a similar transition of the SW line on the OMNIBUS.

Similarly, an auto-restart may be initiated by the same signals as the Bootstrap. It should be obvious that either the bootstrap or auto-restart should not be activated by the same initializing signal.

4. ROM Programming Examples

Auto-restart example:

- a) Load address 0200
- b) Load field 0, start

Starting at ROM address 004

Bootstrap example:

- a) Load address 0023
- b) Load field 7
- c) Deposit 2000
- d) Deposit 6745
- e) Deposit 0023
- f) Deposit 7650
- h) Deposit 5024
- j) Deposit 5733
- k) Deposit 5031
- l) Load address 0024 and start

Starting at ROM address 124.

SIZE A	CODE SP	NUMBER KM8-A-7	REV
-----------	------------	-------------------	-----



TITLE ROM PROGRAMMING DIRECTIONS FOR 8A OPTION BOARD #2 KM8-AB (M8317-YA)

Auto-Restart example:

Bit Add	ROM #1				ROM #2			
	4	3	2	1	4	3	2	1
4	1	0	0	0	0	0	0	0
5	1	0	0	0	0	0	0	0
6	0	1	0	1	0	0	0	0
7	0	0	0	0	0	0	0	0

Load Address
0200
Load Ext. Add 0
and Start

NOTE: Logic one (1) = +3V

Bootstrap example:

Bit Add	ROM #1				ROM #2			
	4	3	2	1	4	3	2	1
124	1	0	0	0	0	0	0	0
125	0	0	0	1	0	0	1	1
126	0	1	0	0	0	0	0	0
127	0	0	1	1	1	0	0	0
130	0	0	1	0	0	1	0	0
131	0	0	0	0	0	0	0	0
132	0	0	1	0	1	1	0	1
133	1	1	1	0	0	1	0	1
134	0	0	1	0	0	0	0	0
135	0	0	0	1	0	0	1	1
136	0	0	1	0	1	1	1	1
137	1	0	1	0	1	0	0	0
140	0	0	1	0	1	0	1	0
141	0	0	0	1	0	1	0	0
142	0	0	1	0	1	1	0	1
143	1	1	0	1	1	0	1	1
144	0	0	1	0	1	0	1	0
145	0	0	0	1	1	0	0	1
146	1	0	0	1	0	0	0	0
147	0	0	0	1	0	1	0	0

Load Add 0023
Load Ext Add 7
Dep 2000
Dep 6745
Dep 0023
Dep 7650
Dep 5024
Dep 6733
Dep 5031
Load Add 24 & Start

SIZE A	CODE SP	NUMBER KM8-A-7	REV
-----------	------------	-------------------	-----



TITLE ROM PROGRAMMING DIRECTIONS FOR 8A OPTION BOARD #2 KM8-AB (M8317-YA)

5. ROMs

Unprogrammed ROMs should be purchased by the user from Digital Equipment Corporation. The part number for an unprogrammed 256 x 4 ROM is 23-000A8.

SIZE A	CODE SP	NUMBER KM8-A-7	REV
-----------	------------	-------------------	-----

"THIS DRAWING AND SPECIFICATIONS HEREIN, ARE THE PROPERTY OF DIGITAL EQUIPMENT CORPORATION AND SHALL NOT BE REPRODUCED OR COPIED OR USED IN WHOLE OR IN PART AS THE BASIS FOR THE MANUFACTURE OR SALE OF ITEMS WITHOUT WRITTEN PERMISSION.
 COPYRIGHT © 1974 DIGITAL EQUIPMENT CORPORATION"

NOTES:

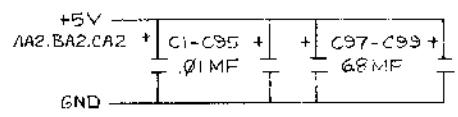
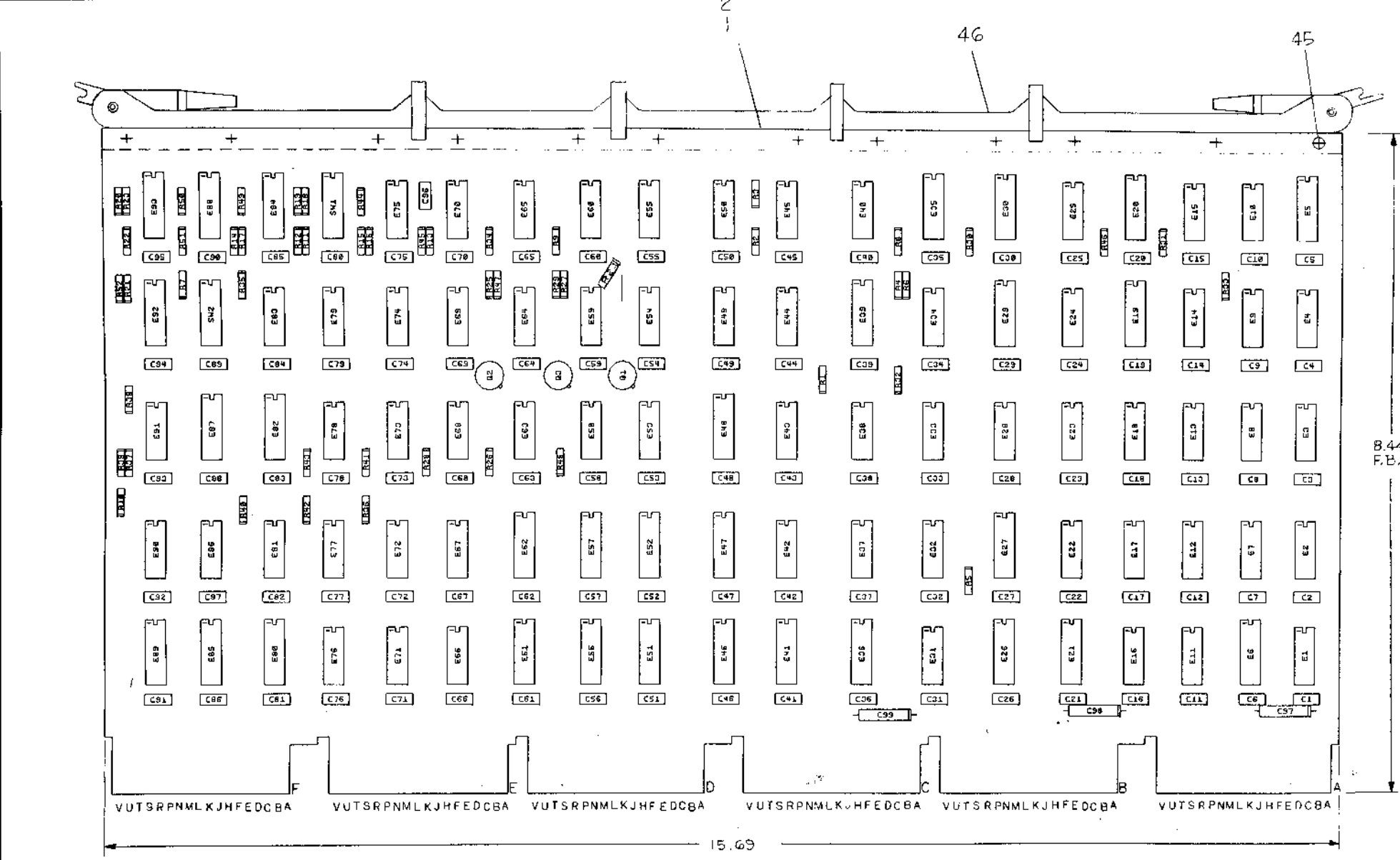

AC1, AC2, AF1, AF2, AN1, AN2, AT1, AT2
 BC1, BC2, BF1, BF2, BN1, BN2, BT1, BT2
 CC1, CC2, CF1, CF2, CN1, CN2, CT1, CT2
 DC1, DC2, DF1, DF2, DN1, DN2, DT1, DT2

IC 7442	8	16
IC 314	1	8
IC 8234	8	16
IC 74173	8	16
IC 74153	8	16
IC 745257	8	16
IC 8837	8	16
IC 7473	11	4
IC 8266	8	16
IC 74175	8	16
IC TYPE	GND	+5V
GND AND 5V ARE USUALLY PIN 7 AND 14 RESPECTIVELY EXCEPTIONS ARE STATED ABOVE		
IC PIN LOCATIONS		

REF	DESCRIPTION	QTY	REF. DESIGNATION	DESCRIPTION	PART NO.	ITEM NO.
REF	X-Y COORDINATE HOLE LOCATION				K-00-M8317-B-4	1
REF	ASSY/DRILLING HOLE LAYOUT				D-AH-M8317-B-5	2
REF	MODULE ECD HISTORY				B-MH-M8317-B-6	3
1	ETCHED CIRCUIT BOARD				5010938	4
1	C96			CAP 5000 PF 100V DISC	1001785	5
95	C1-C95			CAP .01 MF 100V 20%	1001618-01	6
3	C97-C99			CAP 6.8 MF 35V 10%	1005306	7
2	RW1, RW2			DIP SWITCH	1211164-04	8
46	R1-R23, R26, R28-R43, R46, R49-R52, R24			RES. 1K 1/4W 5%	1300365	9
1	R44			RES. 100 OHM 1/4W 5%	1300229	10
4	R25, R27, R47, R48			RES. 27 OHM 1/4W 5%	1301522	11
						12
3	Q1, Q2, Q3			TRANSISTOR MPSA05	1510705	13
6	E9, E8, E3, E5, E7, E8			I.C. 7474	1905547	14
6	E12, E13, E28, E54, E73, E75			I.C. 7460	1905575	15
1	E33			I.C. 7410	1905578	16
2	E18, E48			I.C. 7420	1905577	17
1	E11			I.C. 7430	1905570	18
1	E90			I.C. 7473	1905507	19
3	E14, E32, E69			I.C. 7402	1909004	20
6	E31, E34, E44, E45, E60, E85			I.C. 74511	1910537	21
2	E46, E57			I.C. 745257	1911641	22
1	E8			I.C. 74574	1910544	23
6	E10, E17, E66, E72, E76, E77			I.C. 8881	1909785	24
2	E4, E98			I.C. 7417	1909929	25
2	E84, E92			I.C. 8266	1909934	26
1	E29			I.C. 74153	1909937	27
1	E22			I.C. 74500	1910532	28
2	E83, E91			I.C. 74197	1910035	29
1	E79			I.C. 74164	1910041	30
2	E35, E38			I.C. 7442	1910046	31
3	E25, E71, E74			I.C. 7437	1910091	32
4	E40, E55, E84, E88			I.C. 7408	1910155	33
1	E37			I.C. 314	1909704	34
2	E80, E85			I.C. 74175	1910051	35
1	E24			I.C. 8093	1910037	36
2	E53, E81			I.C. 7427	1910070	37
2	E47, E52			I.C. 8234	1911315	38
6	E19, E20, E30, E48, E51, E56			I.C. 74173	1911330	39
6	E15, E23, E43, E58, E59, E67			I.C. 7404	1909696	40
1	E82	SEE NOTE 2		I.C. M1KP ROM #1 (256 X 4)	23-087A2	41
1	E87	SEE NOTE 2		I.C. M1KP ROM #2 (256 X 4)	23-088A2	42
1	E26			I.C. M1KP ROM #3 (32 X 8)	23-084A1	43
1	E27			I.C. KM1S ROM #1 (256 X 4)	23-086A2	44
12				EYELET, HANDLE	9006732	45
1				HANDLE ASSY	1210711-2	46
4	E1, E2, E3, E7			I.C. 7412	1909955	47
6	E21, E36, E41, E81, E82, E6			I.C. 8037	1911116	48
1	E16			I.C. 74S04	1910534	49
1	E42			I.C. 74S10	1910536	50
4	E82, E87, E88, E93			SOCKET, 16 PIN	1211813	51
1	R45			RES. 220 1/4W 5%	1300271	52

FIRST USED ON OPTION MODEL
KMB-A

PARTS LIST			
ETCH BOARD REV.	DATE	DRN	DATE
D	6-27-74	B. Hedeking	6-27-74
	10-10-74	Bob Kopp	10-10-74
	10-10-74	Sam Harlow	10-10-74
	10-10-74	Sam Harlow	10-10-74
	10-10-74	PROD.	10-10-74

DEC NO.		EIA NO.		DEC NO.		EIA NO.		SCALE NONE		SHEET 1 OF 7	
SEMICONDUCTOR CONVERSION CHART											
TITLE: OPTION BOARD #2											
NUMBER: M8317-0-1											
REV. E											

"THIS DRAWING AND INFORMATION HEREIN ARE THE PROPERTY OF DIGITAL EQUIPMENT CORPORATION AND SHALL NOT BE REPRODUCED OR COPIED OR USED IN WHOLE OR IN PART AS THE BASIS FOR THE MANUFACTURE OR SALE OF ITEMS WITHOUT WRITTEN PERMISSION. COPYRIGHT © 1974, DIGITAL EQUIPMENT CORPORATION"

BOOTSTRAP/AUTO RESTART FUNCTIONAL SWITCH SETTINGS							
DESIRED FUNCTION	ACTIVATING SIGNAL	S1-4	S1-5	S1-6	S1-7	S1-8	S2-1
BOOTSTRAP ENABLED	"BOOT" SW	*	↑	OFF	OFF	ON	N/A
AUTO-RESTART DISABLED	N/A						
BOOTSTRAP ENABLED	"BOOT" SW	*		ON	ON	ON	N/A
AUTO-RESTART ENABLED	"AC LOW"	*		ON	ON	ON	N/A
BOOTSTRAP DISABLED	N/A						
AUTO-RESTART ENABLED	"AC LOW"	*	SPARK	ON	ON	OFF	N/A
BOOTSTRAP ENABLED	"AC LOW"	*	↓	ON	OFF	OFF	N/A
AUTO-RESTART DISABLED	N/A						
BOOTSTRAP ENABLED	"AC LOW" OR "BOOT" SW	*		ON	OFF	ON	N/A
AUTO-RESTART DISABLED	N/A						
TIME SHARE DISABLED	N/A	N/A	N/A	N/A	N/A	N/A	ON
TIME SHARE ENABLED	N/A	N/A	N/A	N/A	N/A	N/A	OFF

AUTO-RESTART SELECT SWITCH SETTINGS			
RESTART ADDRESS	S2-2	S2-3	S2-4
0	OFF	OFF	OFF
2000	OFF	ON	OFF
2000	ON	OFF	OFF
4200	ON	ON	OFF

4. AUTO-RESTART SELECT SWITCHES ARE DEFINED AS FOLLOWS:
- (a) ROM ADDRESS RANGE: 0-16
 - (b) ON = LOGIC 1 OR LOW; OFF = LOGIC 0 OR HIGH
 - (c) ORDER OF SIGNIFICANCE
 - $S_2 2 = 2^3 = 10$
 - $S_2 3 = 2^2 = 4$
 - $S_2 4 = 2^1 = 2$

- NOTES:
- * S1-4 "OFF" - BOOTSTRAP CAN BE ACTIVATED BY "BOOT" SW EITHER IN THE "RUN" OR "STOP" STATE
 - S1-4 "ON" - BOOTSTRAP CAN ONLY BE ACTIVATED BY "BOOT" SW IN THE "RUN" STATE
 - 1. "AC LOW" WILL CAUSE AUTO-RESTART OR BOOTSTRAP, DEPENDING ON SWITCH SETTINGS, TO OCCUR ONLY IN THE "RUN" OR STOPPED STATE
 - S1-6, 7, 8 "OFF" - BOOTSTRAP & AUTO-RESTART DISABLED
 - 2. S2 & E87 ARE NOT ON THE YA VARIATION. ALL OTHER PARTS REMAIN THE SAME

BOOTSTRAP SELECT SWITCH SETTINGS									
PROGRAM	S2-5	S2-6	S2-7	S2-8	S1-1	S1-2	S1-3	ROM ST ADD	MEM ADD START
HI-LO PT RDR	ON	ON	ON	OFF	ON	ON	ON	20	7734
RKBE	ON	OFF	ON	OFF	ON	OFF	ON	124	24
TC00	ON	OFF	OFF	ON	OFF	ON	ON	150	7613
RFB/PF32P	OFF	ON	ON	ON	ON	OFF	OFF	206	7750
TABE	OFF	ON	ON	OFF	ON	OFF	OFF	226	4000

3. BOOTSTRAP SELECT SWITCHES ARE DEFINED AS FOLLOWS:
- (a) ROM ADDRESS RANGE: 0-377
 - (b) ON = LOGIC 0 OR LOW; OFF = LOGIC 1 OR HIGH
 - (c) ORDER OF SIGNIFICANCE
 - $S_2 5 = 2^7 = 200$ (MSB)
 - $S_2 6 = 2^6 = 100$
 - $S_2 7 = 2^5 = 40$
 - $S_2 8 = 2^4 = 20$
 - $S_1 1 = 2^3 = 10$
 - $S_1 2 = 2^2 = 4$
 - $S_1 3 = 2^1 = 2$
- THE LSB OF ADDRESS IS CONTROLLED BY THE BOOTSTRAP/AUTO-RESTART LOGIC

COMPONENT SUBSTITUTION CHART					
PART CALLED FOR			SUBSTITUTE PART		
QTY	PART NO.	DESCRIPTION	QTY	PART NO.	DESCRIPTION
95	1001610-01	OMLFD DISC	95	1001610-02	OMLFD GLASS
3	1510705	MPSA 05	3	1509388	DEC 6531
6	1511330	74173	6	1511711	8T10
1	1509704	314	1	1510391	5314
			1	1509972	6314
			1	1510389	7314
6	1509705	8881	6	1509973	97401

REVISIONS		
CHK	CHANGE NO.	REV.

QTY	REF. DESIGNATION	DESCRIPTION	PART NO.	ITEM NO.

REV. E
 NUMBER M8317-0-1
 DATE CODE DCS

"THIS DRAWING AND SPECIFICATIONS, HEREIN, ARE THE PROPERTY OF DIGITAL EQUIPMENT CORPORATION AND SHALL NOT BE REPRODUCED OR COPIED OR USED IN WHOLE OR IN PART AS THE BASIS FOR THE MANUFACTURE OR SALE OF ITEMS WITHOUT WRITTEN PERMISSION. COPYRIGHT © 1974 DIGITAL EQUIPMENT CORPORATION"

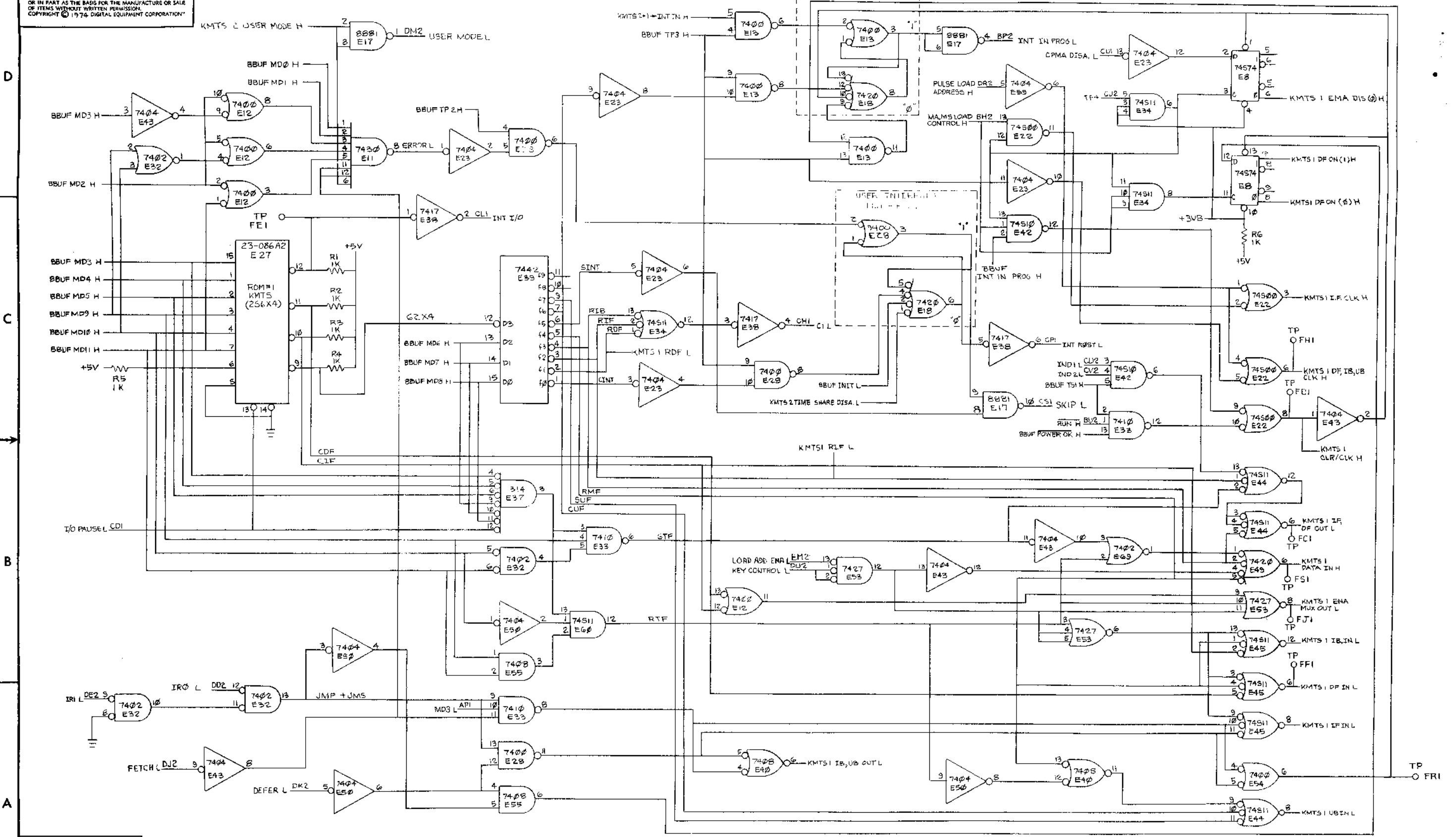

REVISIONS		
CHK	CHANGE NO.	REV.

SIZE CODE DCS
NUMBER M8317-0-1

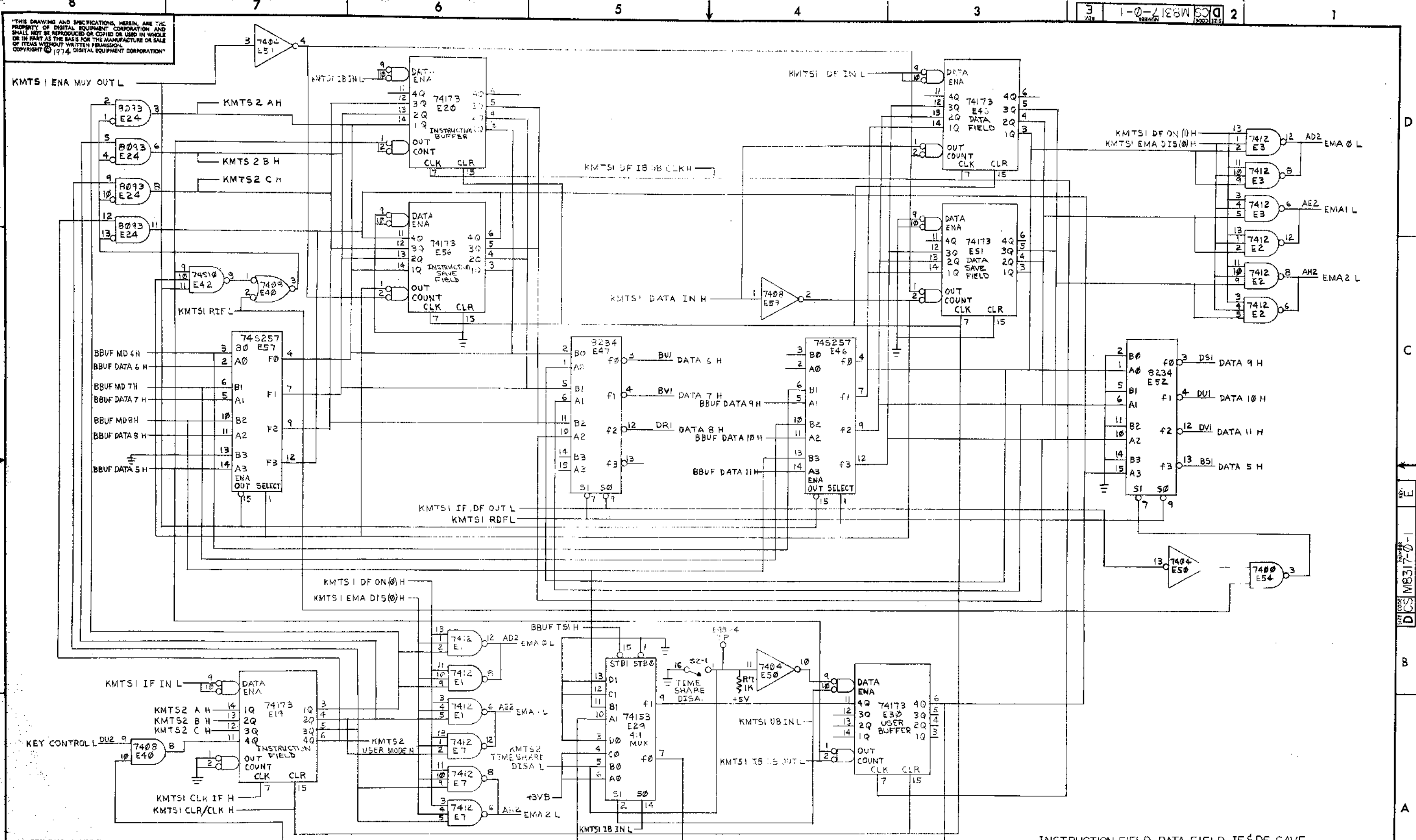

THIS DRAWING AND SPECIFICATIONS, HEREIN, ARE THE PROPERTY OF DIGITAL EQUIPMENT CORPORATION AND SHALL NOT BE REPRODUCED OR COPIED OR USED IN WHOLE OR IN PART AS THE BASIS FOR THE MANUFACTURE OR SALE OF ITEMS WITHOUT WRITTEN PERMISSION. COPYRIGHT © 1974, DIGITAL EQUIPMENT CORPORATION

CHK	CHANGE NO.	REV.

INSTRUCTION FIELD, DATA FIELD, IF & DF SAVE FIELD, INSTRUCTION BUFFER, USER BUFFER		TITLE	SIZE CODE	NUMBER	REV.
OPTION BOARD #2 (KMTS2)		D CS	M8317-0-1	E	
SCALE	NONE	SHEET	4	OF	7
DIST.					

REV. E
NUMBER DCS M8317-0-1

THIS DRAWING AND SPECIFICATIONS HEREIN ARE THE PROPERTY OF DIGITAL EQUIPMENT CORPORATION AND SHALL NOT BE REPRODUCED OR COPIED OR USED IN WHOLE OR IN PART AS THE BASIS FOR THE MANUFACTURE OR SALE OF ITEMS WITHOUT WRITTEN PERMISSION. COPYRIGHT © 1974 DIGITAL EQUIPMENT CORPORATION

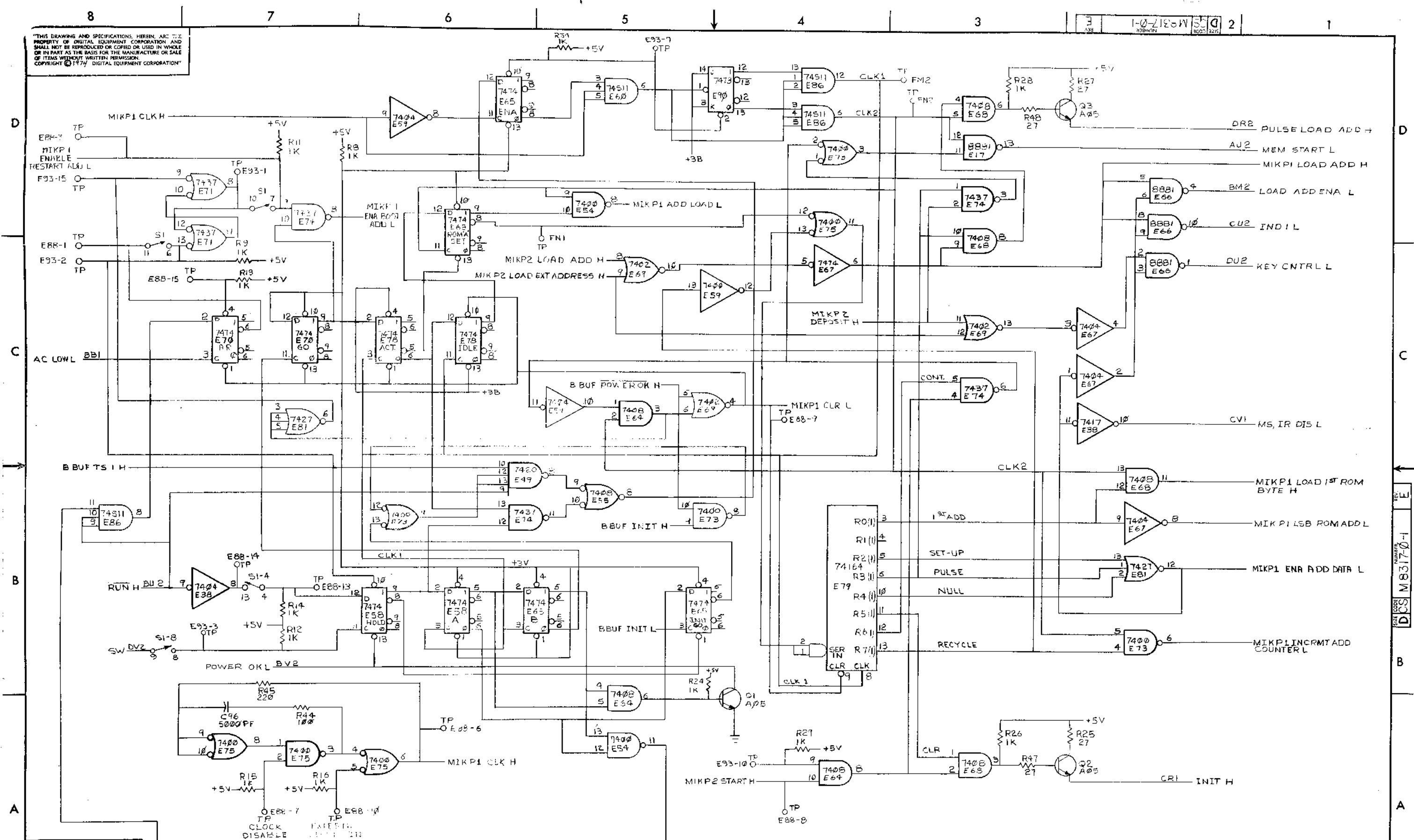

REVISIONS		
CHK	CHANGE NO.	REV.

TITLE		SIZE CODE	NUMBER	REV.
OPTION BOARD # 2		DCS MS	1-0-1	E
SCALE	SHEET	OF	DIST.	
	5	7		

"THIS DRAWING AND SPECIFICATIONS, HEREIN, ARE THE PROPERTY OF DIGITAL EQUIPMENT CORPORATION AND SHALL NOT BE REPRODUCED OR COPIED OR USED IN WHOLE OR IN PART AS THE BASIS FOR THE MANUFACTURE OR SALE OF ITEMS WITHOUT WRITTEN PERMISSION. COPYRIGHT © 1974 DIGITAL EQUIPMENT CORPORATION"

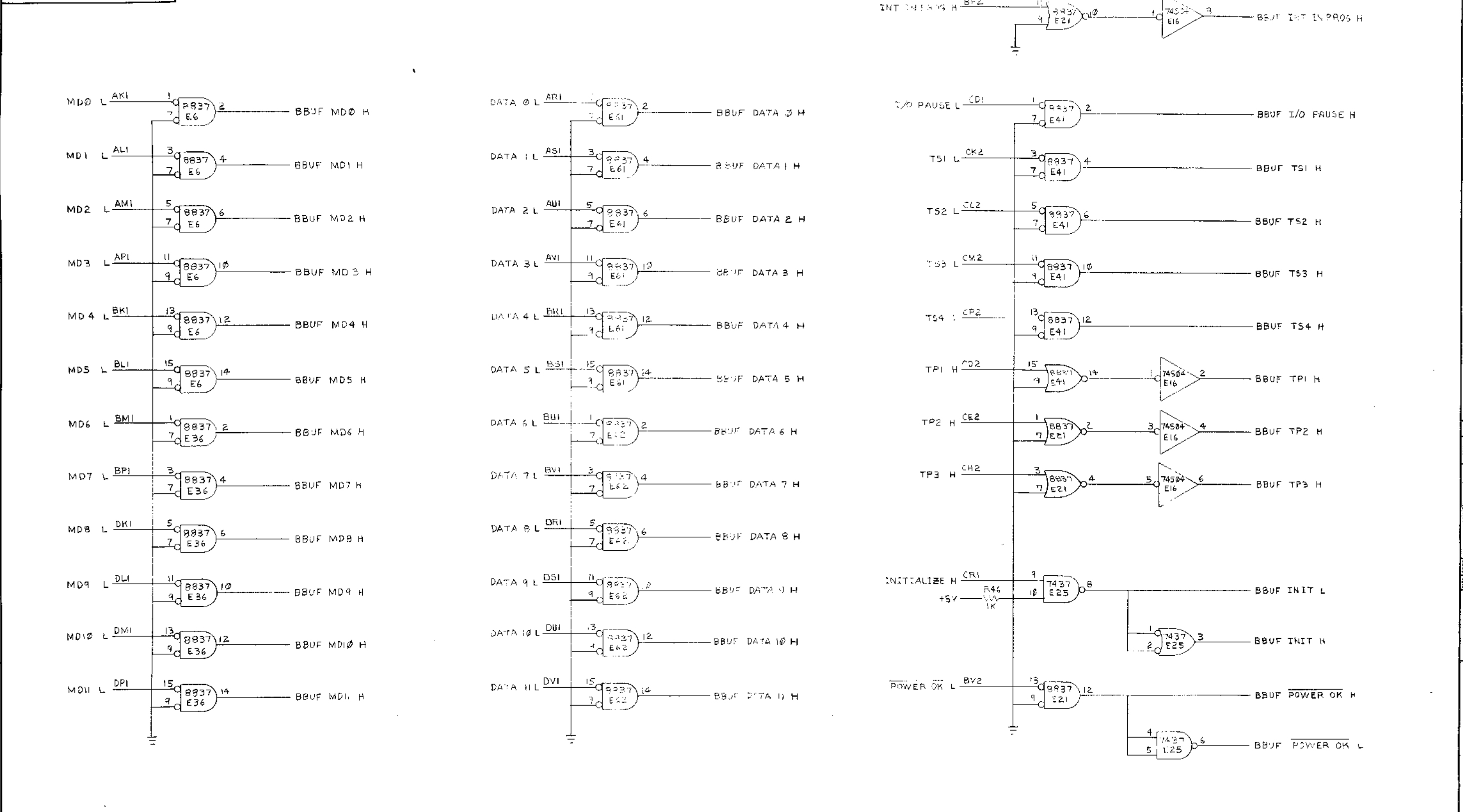

REVISIONS		
CHK	CHANGE NO.	REV.

TITLE		SIZE CODE	NUMBER	REV.
S/A INTERNAL OPTION #2 (BBUF)		DCS	M8317-0-1	E
SCALE	SHEET	OF		
	7	7		

This drawing and specifications, herein, are the property of Digital Equipment Corporation and shall not be reproduced or copied or used in whole or in part as the basis for the manufacture or sale of items without written permission. COPYRIGHT © 1974

DIGITAL EQUIPMENT CORPORATION

SIZE CODE NUMBER
K RL M 8317-0-8

REV.

REVISIONS	REV.	
	CHANGE NO.	
CHK		

FIRST USED ON OPTION MODEL	QTY.	DESCRIPTION	PART NO.	ITEM NO.
PDP8-A				
PARTS LIST				
DRN	DATE	<div style="text-align: center;">  <p>digital EQUIPMENT CORPORATION MAYNARD, MASSACHUSETTS</p> </div>		
CHK'D	DATE			
ENG.	DATE			
PROJ. ENG.	DATE			
PROD.	DATE			
NEXT HIGHER ASSEMBLY		<div style="text-align: center;"> <p>TITLE</p> <p>ROM PATTERN SPEC.</p> </div>		
B-DD-KM8-A				
SCALE				
SHEET 1	OF 2	SIZE CODE	NUMBER	REV.
		K RL	M 8317-0-8	
		DIST.		

DEC PART NUMB: 23-084A1
 ORIGINATOR: LARRY NAPHI
 DATE OF ORIGIN: 6-22-74

DECIMAL LOC	OCTAL LOC	BINARY DATA	OCTAL DATA
0	00	11111111	377
1	01	11111111	377
2	02	11111111	377
3	03	11111111	377
4	04	11111111	377
5	05	11111111	377
6	06	11111111	377
7	07	11111111	377
8	10	11010111	327
9	11	11111111	377
10	12	11111111	377
11	13	11111111	377
12	14	11111111	377
13	15	11111111	377
14	16	11111111	377
15	17	11111111	377
16	20	11111111	377
17	21	11111111	377
18	22	11111111	377
19	23	11111111	377
20	24	11111111	377
21	25	11111111	377
22	26	11111111	377
23	27	11111111	377
24	30	11000111	307
25	31	11111111	377
26	32	11111111	377
27	33	11111111	377
28	34	11111111	377
29	35	11111111	377
30	36	11111111	377
31	37	11111111	377

digital
EQUIPMENT
CORPORATION

This drawing and specifications, herein, are the property of Digital Equipment Corporation and shall not be reproduced or copied or used in whole or in part as the basis for the manufacture or sale of items without written permission. COPYRIGHT © 1974

DIGITAL EQUIPMENT CORPORATION

FIRST USED ON OPTION MODEL	QTY.	DESCRIPTION	PART NO.	ITEM NO.
PDP8 - A				
PARTS LIST				
DRN <i>[Signature]</i>	DATE	<div style="text-align: center;">  <p>digital EQUIPMENT CORPORATION MAYNARD, MASSACHUSETTS</p> </div>		
CHK'D. <i>[Signature]</i>	DATE			
ENG. <i>Larry Harris</i>	DATE 12/20/74			
PROJ. ENG. <i>Larry Harris</i>	DATE 12/20/74			
PROD. <i>[Signature]</i>	DATE 12-20-74			
NEXT HIGHER ASSEMBLY B-DD- KMB-A		TITLE ROM PATTERN SPEC.		
SCALE	SHEET 1 OF 9	SIZE CODE KRL	NUMBER M8317-Ø-9	REV.
		DIST.		

B

A

A

K-RL-M8317-Ø-9

DEC PART NUMB: 21-Ø86A2
ORIGINATOR: LARRY NARHI
DATE OF ORIGIN: 7-12-74

ROM PATTERN SPEC

PAGE 2 OF 9

DECIMAL LOC	OCTAL LOC	BINARY DATA	OCTAL DATA
0	000	1111	17
1	001	1111	17
2	002	1111	17
3	003	1111	17
4	004	1111	17
5	005	1111	17
6	006	1111	17
7	007	1111	17
8	010	1111	17
9	011	1111	17
10	012	1111	17
11	013	1111	17
12	014	1111	17
13	015	1111	17
14	016	1111	17
15	017	1111	17
16	020	1111	17
17	021	1111	17
18	022	1111	17
19	023	1111	17
20	024	1111	17
21	025	1111	17
22	026	1111	17
23	027	1111	17
24	030	1111	17
25	031	1111	17
26	032	1111	17
27	033	1111	17
28	034	1111	17
29	035	1111	17
30	036	1111	17
31	037	1111	17
32	040	1111	17
33	041	1111	17
34	042	1111	17
35	043	1111	17

K-RL-M8317-Ø-9

K-RL-M8317-Ø-9

DEC PART NUMB: 21-Ø86A2
ORIGINATOR: LARRY NARHI
DATE OF ORIGIN: 7-12-74

ROM PATTERN SPEC

PAGE 3 OF 9

DECIMAL LOC	OCTAL LOC	BINARY DATA	OCTAL DATA
36	044	1111	17
37	045	1111	17
38	046	1111	17
39	047	1111	17
40	050	1111	17
41	051	1111	17
42	052	1111	17
43	053	1111	17
44	054	1111	17
45	055	1111	17
46	056	1111	17
47	057	1111	17
48	060	1111	17
49	061	1111	17
50	062	1111	17
51	063	1111	17
52	064	1111	17
53	065	1111	17
54	066	1111	17
55	067	1111	17
56	070	1111	17
57	071	1111	17
58	072	1111	17
59	073	1111	17
60	074	1111	17
61	075	1111	17
62	076	1111	17
63	077	1111	17
64	100	1111	17
65	101	1111	17
66	102	1111	17
67	103	1111	17
68	104	1111	17
69	105	1111	17
70	106	0011	03
71	107	1111	17

K-RL-M8317-Ø-9

K-RL-M8317-Ø-9

DEC PART NUMB: 21-Ø86A2
ORIGINATOR: LARRY NARHI
DATE OF ORIGIN: 7-12-74

ROM PATTERN SPEC

PAGE 4 OF 9

DECIMAL LOC	OCTAL LOC	BINARY DATA	OCTAL DATA
72	110	1111	17
73	111	1111	17
74	112	0101	05
75	113	1111	17
76	114	1111	17
77	115	1111	17
78	116	0001	01
79	117	1111	17
80	120	1111	17
81	121	1111	17
82	122	0110	06
83	123	1111	17
84	124	1111	17
85	125	1111	17
86	126	1111	17
87	127	1111	17
88	130	1111	17
89	131	1111	17
90	132	1111	17
91	133	1111	17
92	134	1111	17
93	135	1111	17
94	136	1111	17
95	137	1111	17
96	140	1111	17
97	141	1111	17
98	142	1111	17
99	143	1111	17
100	144	1111	17
101	145	1111	17
102	146	1111	17
103	147	1111	17
104	150	1111	17
105	151	1111	17
106	152	1111	17
107	153	1111	17

K-RL-M8317-Ø-9

K-RL-M8317-Ø-9

DEC PART NUMB: 21-Ø86A2
ORIGINATOR: LARRY NARHI
DATE OF ORIGIN: 7-12-74

ROM PATTERN SPEC

PAGE 5 OF 9

DECIMAL LOC	OCTAL LOC	BINARY DATA	OCTAL DATA
108	154	1111	17
109	155	1111	17
110	156	1111	17
111	157	1111	17
112	160	1111	17
113	161	1111	17
114	162	1111	17
115	163	1111	17
116	164	1111	17
117	165	1111	17
118	166	1111	17
119	167	1111	17
120	170	1111	17
121	171	1111	17
122	172	1111	17
123	173	1111	17
124	174	1111	17
125	175	1111	17
126	176	1111	17
127	177	1111	17
128	200	1111	17
129	201	1111	17
130	202	1111	17
131	203	1111	17
132	204	1111	17
133	205	1111	17
134	206	1111	17
135	207	1111	17
136	210	1111	17
137	211	1111	17
138	212	1111	17
139	213	1111	17
140	214	1111	17
141	215	1111	17
142	216	1111	17
143	217	1111	17

K-RL-M8317-Ø-9

ROM PATTERN SPEC

PAGE 6 OF 9

DEC PART NUMB: 21-086A2
ORIGINATOR: LARRY NARHI
DATE OF ORIGIN: 7-12-74

DECIMAL LOC	OCTAL LOC	BINARY DATA	OCTAL DATA
144	220	1111	17
145	221	1111	17
146	222	1111	17
147	223	1111	17
148	224	1111	17
149	225	1111	17
150	226	1111	17
151	227	1111	17
152	230	1111	17
153	231	1111	17
154	232	1111	17
155	233	1111	17
156	234	1111	17
157	235	1111	17
158	236	1111	17
159	237	1111	17
160	240	1111	17
161	241	1111	17
162	242	1111	17
163	243	1111	17
164	244	1111	17
165	245	1111	17
166	246	1111	17
167	247	1111	17
168	250	1111	17
169	251	1111	17
170	252	1111	17
171	253	1111	17
172	254	1111	17
173	255	1111	17
174	256	1111	17
175	257	1111	17
176	260	1111	17
177	261	1111	17
178	262	1111	17
179	263	1111	17

K-RL-M8317-Ø-9

K-RL-M8317-Ø-9

ROM PATTERN SPEC

PAGE 7 OF 9

DEC PART NUMB: 21-086A2
ORIGINATOR: LARRY NARHI
DATE OF ORIGIN: 7-12-74

DECIMAL LOC	OCTAL LOC	BINARY DATA	OCTAL DATA
180	264	1111	17
181	265	1111	17
182	266	1111	17
183	267	1111	17
184	270	1111	17
185	271	1111	17
186	272	1111	17
187	273	1111	17
188	274	1111	17
189	275	1111	17
190	276	1111	17
191	277	1111	17
192	300	1111	17
193	301	1111	17
194	302	1111	17
195	303	1111	17
196	304	1111	17
197	305	1111	17
198	306	1111	17
199	307	1111	17
200	310	1111	17
201	311	1111	17
202	312	1111	17
203	313	1111	17
204	314	1111	17
205	315	1111	17
206	316	1111	17
207	317	1111	17
208	320	1111	17
209	321	1111	17
210	322	1111	17
211	323	1111	17
212	324	1111	17
213	325	1111	17
214	326	1111	17
215	327	1111	17

K-RL-M8317-Ø-9

K-RL-M8317-Ø-9

DEC PART NUMB: 23-Ø86A2
ORIGINATOR: LARRY WARHI
DATE OF ORIGIN: 7-12-74

ROM PATTERN SPEC

PAGE 8 OF 9

DECIMAL LOC	OCTAL LOC	BINARY DATA	OCTAL DATA
216	330	1111	17
217	331	1111	17
218	332	1111	17
219	333	1111	17
220	334	1111	17
221	335	1111	17
222	336	1111	17
223	337	1111	17
224	340	1111	17
225	341	1111	17
226	342	1111	17
227	343	1111	17
228	344	1111	17
229	345	1111	17
230	346	1111	17
231	347	1111	17
232	350	1111	17
233	351	1111	17
234	352	1111	17
235	353	1111	17
236	354	1111	17
237	355	1111	17
238	356	1111	17
239	357	1111	17
240	360	1111	17
241	361	1111	17
242	362	1111	17
243	363	1111	17
244	364	1111	17
245	365	1111	17
246	366	1111	17
247	367	1111	17
248	370	1111	17
249	371	1111	17
250	372	1111	17
251	373	1111	17

K-RL-M8317-Ø-9

K-RL-M8317-Ø-9

DEC PART NUMB: 23-Ø86A2
ORIGINATOR: LARRY WARHI
DATE OF ORIGIN: 7-12-74

ROM PATTERN SPEC

PAGE 9 OF 9

DECIMAL LOC	OCTAL LOC	BINARY DATA	OCTAL DATA
252	374	1111	17
253	375	1111	17
254	376	1111	17
255	377	1111	17

This drawing and specifications, herein, are the property of Digital Equipment Corporation and shall not be reproduced or copied or used in whole or in part as the basis for the manufacture or sale of items without written permission. COPYRIGHT © 1974

DIGITAL EQUIPMENT CORPORATION

REVISIONS	REV.
	CHANGE NO.
	CHK

FIRST USED ON OPTION MODEL	QTY.	DESCRIPTION	PART NO.	ITEM NO.
PDP8-A				
PARTS LIST				
DRN. <i>S. Roberts</i>	DATE 12-20-74	 DIGITAL EQUIPMENT CORPORATION MAYNARD, MASSACHUSETTS TITLE ROM PATTERN SPEC		
CHK'D. <i>S. Roberts</i>	DATE 12-20-74			
ENG. <i>Larry Harbin</i>	DATE 12/20/74			
PROJ. ENG. <i>Larry Harbin</i>	DATE 12/20/74			
PROG. <i>[Signature]</i>	DATE 12-20-74			
NEXT HIGHER ASSEMBLY				
B-DD-KMS-A		SIZE CODE	NUMBER	REV.
SCALE		K RL	M8317-0-10	
SHEET	1 OF 9	DIST.		

4

3

2

REV. NUMBER SIZE CODE K RL M8317-0-10

B

B

A

A

4

3

2

1

K-RL-M8317-0-10

RDM PATTERN SPEC

PAGE 2 OF 9

DEC PART NUMB: 23-087A2
ORIGINATOR: LARRY NARHI
DATE OF ORIGIN: 7-16-74

DECIMAL LOC	OCTAL LOC	BINARY DATA	OCTAL DATA
0	000	1000	10
1	001	0000	00
2	002	0101	05
3	003	0000	00
4	004	1000	10
5	005	1000	10
6	006	0101	05
7	007	0000	00
8	010	1000	10
9	011	0000	00
10	012	0101	05
11	013	0000	00
12	014	1000	10
13	015	1000	10
14	016	0101	05
15	017	0000	00
16	020	1000	10
17	021	1101	15
18	022	0100	04
19	023	0000	00
20	024	0010	02
21	025	0000	00
22	026	0010	02
23	027	1111	17
24	030	0010	02
25	031	1101	15
26	032	0010	02
27	033	1101	15
28	034	0010	02
29	035	1111	17
30	036	0010	02
31	037	1110	16
32	040	0010	02
33	041	0000	00
34	042	0010	02
35	043	1110	16

DIGITAL EQUIPMENT CORPORATION

K-RL-M8317-0-10

K-RL-M8317-0-10

RDM PATTERN SPEC

PAGE 3 OF 9

DEC PART NUMB: 23-087A2
ORIGINATOR: LARRY NARHI
DATE OF ORIGIN: 7-16-74

DECIMAL LOC	OCTAL LOC	BINARY DATA	OCTAL DATA
36	044	0010	02
37	045	1111	17
38	046	0010	02
39	047	1111	17
40	050	0010	02
41	051	1111	17
42	052	0010	02
43	053	1110	16
44	054	0010	02
45	055	1110	16
46	056	0010	02
47	057	1110	16
48	060	0010	02
49	061	1111	17
50	062	0010	02
51	063	0001	01
52	064	0010	02
53	065	0001	01
54	066	0010	02
55	067	1110	16
56	070	0010	02
57	071	0001	01
58	072	0010	02
59	073	0100	04
60	074	0000	00
61	075	0000	00
62	076	0010	02
63	077	0100	04
64	100	0010	02
65	101	1111	17
66	102	0010	02
67	103	0000	00
68	104	0010	02
69	105	0001	01
70	106	0010	02
71	107	1111	17

DIGITAL EQUIPMENT CORPORATION

K-RL-M8317-0-10

ROM PATTERN SPEC

PAGE 4 OF 9

DEC PART NUMBER 23-087A2
ORIGINATOR: LARRY NARHI
DATE OF ORIGIN: 7-16-74

DECIMAL LOC	OCTAL LOC	BINARY DATA	OCTAL DATA
72	110	0010	02
73	111	0001	01
74	112	0010	02
75	113	0001	01
76	114	0010	02
77	115	1111	17
78	116	0010	02
79	117	1111	17
80	120	0010	02
81	121	1110	16
82	122	1001	11
83	123	1101	15
84	124	1000	10
85	125	0001	01
86	126	0100	04
87	127	0000	00
88	130	0010	02
89	131	0000	00
90	132	0010	02
91	133	1110	16
92	134	0010	02
93	135	0001	01
94	136	0010	02
95	137	1010	12
96	140	0010	02
97	141	0001	01
98	142	0010	02
99	143	1110	16
100	144	0010	02
101	145	0001	01
102	146	1001	11
103	147	0001	01
104	150	1000	10
105	151	1000	10
106	152	0100	04
107	153	0000	00

digital EQUIPMENT CORPORATION

K-RL-M8317-0-10

K-RL-M8317-0-10

ROM PATTERN SPEC

PAGE 5 OF 9

DEC PART NUMBER 23-087A2
ORIGINATOR: LARRY NARHI
DATE OF ORIGIN: 7-16-74

DECIMAL LOC	OCTAL LOC	BINARY DATA	OCTAL DATA
108	154	0010	02
109	155	1111	17
110	156	0010	02
111	157	1001	11
112	160	0010	02
113	161	1111	17
114	162	0010	02
115	163	1111	17
116	164	0010	02
117	165	1000	10
118	166	0010	02
119	167	1001	11
120	170	0010	02
121	171	1000	10
122	172	0010	02
123	173	1000	10
124	174	0010	02
125	175	1001	11
126	176	1000	10
127	177	1110	16
128	200	0010	02
129	201	0111	07
130	202	0010	02
131	203	0111	07
132	204	1001	11
133	205	1000	10
134	206	1000	10
135	207	1110	16
136	210	0100	04
137	211	0000	00
138	212	0010	02
139	213	1000	10
140	214	0010	02
141	215	1000	10
142	216	0010	02
143	217	1001	11

digital EQUIPMENT CORPORATION

K-RL-M8317- ϕ -1 ϕ

ROM PATTERN SPEC

PAGE 6 OF 9

DEC PART NUMB: 23-087A2
ORIGINATOR: LARRY NARHI
DATE OF ORIGIN: 7-16-74

DECIMAL LOC	OCTAL LOC	BINARY DATA	OCTAL DATA
144	220	0010	02
145	221	1110	16
146	222	0010	02
147	223	1110	16
148	224	1001	11
149	225	1110	16
150	226	1000	10
151	227	0000	00
152	230	0100	04
153	231	0000	00
154	232	0010	02
155	233	1001	11
156	234	0010	02
157	235	1000	10
158	236	0010	02
159	237	1100	14
160	240	0010	02
161	241	1100	14
162	242	0010	02
163	243	1100	14
164	244	0010	02
165	245	1000	10
166	246	0010	02
167	247	1011	13
168	250	0010	02
169	251	1100	14
170	252	0010	02
171	253	1000	10
172	254	0010	02
173	255	1000	10
174	256	0010	02
175	257	1001	11
176	260	0010	02
177	261	1000	10
178	262	0010	02
179	263	1100	14

DIGITAL EQUIPMENT CORPORATION

K-RL-M8317- ϕ -1 ϕ

K-RL-M8317- ϕ -1 ϕ

ROM PATTERN SPEC

PAGE 7 OF 9

DEC PART NUMB: 23-087A2
ORIGINATOR: LARRY NARHI
DATE OF ORIGIN: 7-16-74

DECIMAL LOC	OCTAL LOC	BINARY DATA	OCTAL DATA
180	264	0010	02
181	265	1100	14
182	266	0010	02
183	267	1100	14
184	270	0010	02
185	271	1000	10
186	272	0010	02
187	273	0000	00
188	274	0010	02
189	275	0001	01
190	276	0010	02
191	277	1001	11
192	300	0010	02
193	301	0001	01
194	302	0010	02
195	303	1001	11
196	304	0010	02
197	305	0001	01
198	306	0010	02
199	307	1001	11
200	310	0010	02
201	311	1001	11
202	312	0010	02
203	313	1000	10
204	314	0010	02
205	315	1110	16
206	316	0010	02
207	317	0000	00
208	320	0010	02
209	321	1001	11
210	322	0010	02
211	323	1000	10
212	324	0010	02
213	325	1101	15
214	326	0010	02
215	327	0110	06

DIGITAL EQUIPMENT CORPORATION

K-RL-M8317-Ø-1Ø

ROM PATTERN SPEC

PAGE 8 OF 9

DEC PART NUMB: 23-ØØ7A2
ORIGINATOR: LARRY NARHI
DATE OF ORIGIN: 7-16-74

DECIMAL LOC	OCTAL LOC	BINARY DATA	OCTAL DATA
216	330	0010	02
217	331	1101	15
218	332	1001	11
219	333	0000	00
220	334	0000	00
221	335	0000	00
222	336	0000	00
223	337	0000	00
224	340	0000	00
225	341	0000	00
226	342	0000	00
227	343	0000	00
228	344	0000	00
229	345	0000	00
230	346	0000	00
231	347	0000	00
232	350	0000	00
233	351	0000	00
234	352	0000	00
235	353	0000	00
236	354	0000	00
237	355	0000	00
238	356	0000	00
239	357	0000	00
240	360	0000	00
241	361	0000	00
242	362	0000	00
243	363	0000	00
244	364	0000	00
245	365	0000	00
246	366	0000	00
247	367	0000	00
248	370	0000	00
249	371	0000	00
250	372	0000	00
251	373	0000	00

Digital Equipment Corporation

K-RL-M8317-Ø-1Ø

K-RL-M8317-Ø-1Ø

ROM PATTERN SPEC

PAGE 9 OF 9

DEC PART NUMB: 23-ØØ7A2
ORIGINATOR: LARRY NARHI
DATE OF ORIGIN: 7-16-74

DECIMAL LOC	OCTAL LOC	BINARY DATA	OCTAL DATA
252	374	0000	00
253	375	0000	00
254	376	0000	00
255	377	0000	00

Digital Equipment Corporation

This drawing and specifications, herein, are the property of Digital Equipment Corporation and shall not be reproduced or copied or used in whole or in part as the basis for the manufacture or sale of items without written permission. COPYRIGHT © 1974

DIGITAL EQUIPMENT CORPORATION

REV.	NUMBER	SIZE CODE	2	1
	M8317-0-11	K RL		

FIRST USED ON OPTION MODEL	QTY.	DESCRIPTION	PART NO.	ITEM NO.
PDP8-A				
PARTS LIST				
DRN.	DATE	 digital EQUIPMENT CORPORATION <small>MAYNARD, MASSACHUSETTS</small>		
CHK'D.	DATE			
ENG.	DATE			
PROJ. ENG.	DATE			
PROD.	DATE			
NEXT HIGHER ASSEMBLY		TITLE ROM PATTERN SPEC		
B-DD-KM8-A				
SCALE				
SHEET 1 OF 9		SIZE CODE	NUMBER	REV.
		K RL	M8317-0-11	
		DIST.		

REVISIONS	REV.
	CHANGE NO.
CHK	

K-RL-M8317-Ø-11

ROM PATTERN SPEC

PAGE 2 OF 9

DEC PART NUMB: 23-ØØØA2
ORIGINATOR: LARRY NARHI
DATE OF ORIGIN: 7-16-74

DECIMAL LOC	OCTAL LOC	BINARY DATA	OCTAL DATA
0	000	0000	00
1	001	0000	00
2	002	0000	00
3	003	0000	00
4	004	0000	00
5	005	0000	00
6	006	0000	00
7	007	0000	00
8	010	0100	04
9	011	0000	00
10	012	0000	00
11	013	0000	00
12	014	1000	10
13	015	0000	00
14	016	0000	00
15	017	0000	00
16	020	1111	17
17	021	1111	17
18	022	0000	00
19	023	0000	00
20	024	1100	14
21	025	1100	14
22	026	0001	01
23	027	1110	16
24	030	1110	16
25	031	0110	06
26	032	0010	02
27	033	1111	17
28	034	0100	04
29	035	1110	16
30	036	1010	12
31	037	0000	00
32	040	1100	14
33	041	1001	11
34	042	1010	12
35	043	1110	16

K-RL-M8317-Ø-11

K-RL-M8317-Ø-11

ROM PATTERN SPEC

PAGE 3 OF 9

DEC PART NUMB: 23-ØØØA2
ORIGINATOR: LARRY NARHI
DATE OF ORIGIN: 7-16-74

DECIMAL LOC	OCTAL LOC	BINARY DATA	OCTAL DATA
36	044	0110	06
37	045	0001	01
38	046	0010	02
39	047	0001	01
40	050	0110	06
41	051	1001	11
42	052	0010	02
43	053	0101	05
44	054	0110	06
45	055	1111	17
46	056	0010	02
47	057	0101	05
48	060	0110	06
49	061	0111	07
50	062	1100	14
51	063	1010	12
52	064	1100	14
53	065	1001	11
54	066	1010	12
55	067	1111	17
56	070	1100	14
57	071	1110	16
58	072	1110	16
59	073	0110	06
60	074	1110	16
61	075	0110	06
62	076	1111	17
63	077	1000	10
64	100	1010	12
65	101	1100	14
66	102	1110	16
67	103	0110	06
68	104	1100	14
69	105	1001	11
70	106	1010	12
71	107	0111	07

K-RL-M8317-Ø-11

ROM PATTERN SPEC

PAGE 4 OF 9

DEC PART NUMB: 21-Ø88A2
ORIGINATOR: LARRY NARHI
DATE OF ORIGIN: 7-16-74

DECIMAL LOC	OCTAL LOC	BINARY DATA	OCTAL DATA
72	110	1100	14
73	111	1100	14
74	112	1111	17
75	113	0000	00
76	114	0111	07
77	115	1110	16
78	116	0110	06
79	117	1110	16
80	120	1010	12
81	121	1110	16
82	122	1111	17
83	123	1111	17
84	124	0000	00
85	125	0011	03
86	126	0000	00
87	127	0000	00
88	130	0100	04
89	131	0000	00
90	132	1101	15
91	133	0101	05
92	134	0000	00
93	135	0011	03
94	136	1111	17
95	137	1000	10
96	140	1010	12
97	141	0100	04
98	142	1101	15
99	143	0011	03
100	144	1010	12
101	145	1001	11
102	146	0000	00
103	147	0100	04
104	150	1111	17
105	151	1011	13
106	152	0000	00
107	153	0000	00

K-RL-M8317-Ø-11

K-RL-M8317-Ø-11

ROM PATTERN SPEC

PAGE 5 OF 9

DEC PART NUMB: 21-Ø88A2
ORIGINATOR: LARRY NARHI
DATE OF ORIGIN: 7-16-74

DECIMAL LOC	OCTAL LOC	BINARY DATA	OCTAL DATA
108	154	1101	15
109	155	1100	14
110	156	0010	02
111	157	0010	02
112	160	1101	15
113	161	0110	06
114	162	1101	15
115	163	1001	11
116	164	1010	12
117	165	1110	16
118	166	0010	02
119	167	0011	03
120	170	1010	12
121	171	1101	15
122	172	0001	01
123	173	0000	00
124	174	0000	00
125	175	0000	00
126	176	1111	17
127	177	1100	14
128	200	1111	17
129	201	1111	17
130	202	1111	17
131	203	1111	17
132	204	1111	17
133	205	1011	13
134	206	1111	17
135	207	1000	10
136	210	0000	00
137	211	0000	00
138	212	1111	17
139	213	0000	00
140	214	1101	15
141	215	0011	03
142	216	1101	15
143	217	0010	02

K-RL-M8317-0-11

DEC PART NUMB: 21-08RA2
ORIGINATOR: LARRY NARHI
DATE OF ORIGIN: 7-16-74

ROM PATTERN SPEC

PAGE 6 OF 9

DECIMAL LOC	OCTAL LOC	BINARY DATA	OCTAL DATA
144	220	1010	12
145	221	1010	12
146	222	1011	13
147	223	1010	12
148	224	1111	17
149	225	1000	10
150	226	1000	10
151	227	0000	00
152	230	0000	00
153	231	0000	00
154	232	0010	02
155	233	1111	17
156	234	0010	02
157	235	0110	06
158	236	1101	15
159	237	0100	04
160	240	1101	15
161	241	0110	06
162	242	1101	15
163	243	0011	03
164	244	1010	12
165	245	0100	04
166	246	1110	16
167	247	0100	04
168	250	1101	15
169	251	0010	02
170	252	1111	17
171	253	1000	10
172	254	0110	06
173	255	1001	11
174	256	0111	07
175	257	1110	16
176	260	0010	02
177	261	0101	05
178	262	1101	15
179	263	0100	04

K-RL-M8317-0-11

K-RL-M8317-0-11

DEC PART NUMB: 21-08RA2
ORIGINATOR: LARRY NARHI
DATE OF ORIGIN: 7-16-74

ROM PATTERN SPEC

PAGE 7 OF 9

DECIMAL LOC	OCTAL LOC	BINARY DATA	OCTAL DATA
180	264	1101	15
181	265	0110	06
182	266	1101	15
183	267	0001	01
184	270	1010	12
185	271	1110	16
186	272	1110	16
187	273	0010	02
188	274	1111	17
189	275	1000	10
190	276	0011	03
191	277	1110	16
192	300	1110	16
193	301	0010	02
194	302	0111	07
195	303	1110	16
196	304	1111	17
197	305	0000	00
198	306	0100	04
199	307	1110	16
200	310	0010	02
201	311	1101	15
202	312	1010	12
203	313	1101	15
204	314	1110	16
205	315	0110	06
206	316	1110	16
207	317	0010	02
208	320	0110	06
209	321	1101	15
210	322	1010	12
211	323	0001	01
212	324	1111	17
213	325	1111	17
214	326	0111	07
215	327	1111	17

MASTER DRAWING LIST

MAINTENANCE MANUALS		UNIT VARIATIONS											
		KM8-E											
NO.	TITLE												
KM8-E	MEM EXT & TIME SHARE CONTROL	X											

USED ON OPTIONS											
PDP8-E											
PDP 8/M											

REVISIONS				DRN.	DATE	digital EQUIPMENT CORPORATION <small>MAYNARD, MASSACHUSETTS</small>									
REV.	CHG. NO.	APP'D.		K. GULICK	1/19/71			TITLE	MEM EXT & TIME SHARE CONTROL						
A	00001	R.M.		K. GULICK	1/19/71										
B	KM8E-2	R.M.	6/71	ENG.	DATE	<table border="1" style="width: 100%; border-collapse: collapse;"> <tr> <th>SIZE</th> <th>CODE</th> <th>NUMBER</th> <th>REV.</th> </tr> <tr> <td>A</td> <td>ML</td> <td>KM8-E</td> <td>F</td> </tr> </table>		SIZE	CODE	NUMBER	REV.	A	ML	KM8-E	F
SIZE	CODE	NUMBER	REV.												
A	ML	KM8-E	F												
C	MISC-86	A.V.	7/71	R MADDEN	3/3/71										
D	KM8E-3	<i>one</i>	7/71	PROJ. ENG.	DATE										
E	8E-55	<i>one</i>	1/72	R. VOGELSANG	3/3/71										
F	KM8E-4	<i>one</i>	9/74	PROD.	DATE	<table border="1" style="width: 100%; border-collapse: collapse;"> <tr> <th colspan="2">FIRST USED ON</th> </tr> <tr> <td>A-ML-PDP8/3-0</td> <td></td> </tr> </table>		FIRST USED ON		A-ML-PDP8/3-0					
FIRST USED ON															
A-ML-PDP8/3-0															
				L. SAYLOR	3/3/71										
				SCALE	NONE										
				SHEET	1 OF 2										

PRINT SET					DWG. NO.	REV. LET.	NO. OF SHEETS	TITLE	OPTION NO.	
KM8-E				MFG						
X					E-CS-M837-0-1	#	3	MEM EXT & TIME SHARE CONTROL		
-					A-PL-KM8-E-0	REF	1	MEM EXT & TIME SHARE CONTROL (PL)		
X					A-SP-7665140-0-0		3	KM8E ACCEPTANCE PROCEDURE		
-				X	A-SP-KM8-E-1		4	MEMORY EXTENSION TEST PROCEDURE		
-				X	A-SP-KM8-E-2		2	MEMORY EXTENSION SPECIFICATIONS		
X					A-AL-KM8-E-3			ACCESSORY LIST		
-					LIBKIT-8E-KM8E	REF		PROGRAM LIBRARY KIT		
TITLE					MEM EXT & TIME SHARE CONTROL	SHEET 2 OF 2		SIZE CODE A ML	NUMBER KM8-E	REV. (F)

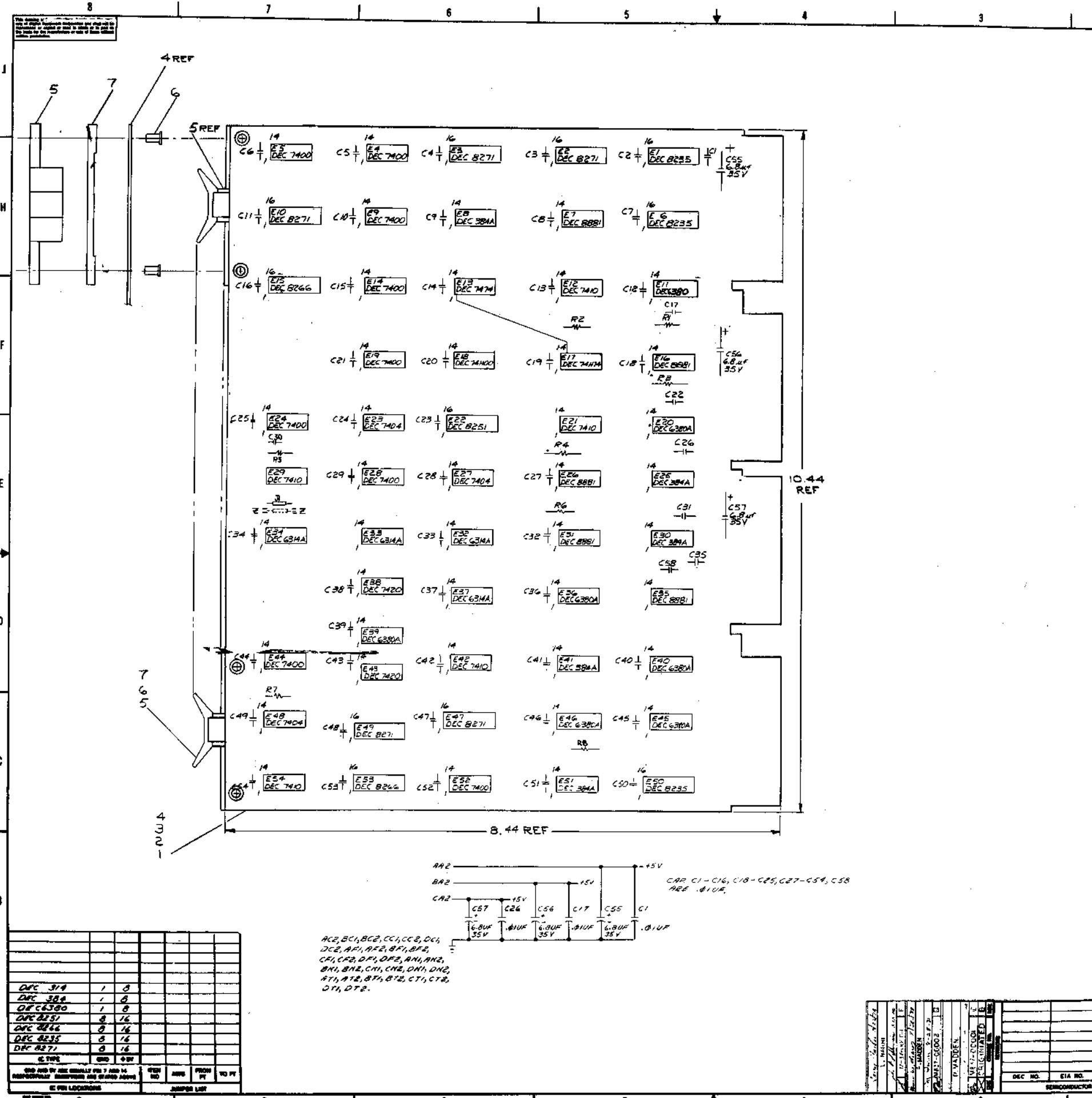

NOTES:
UNLESS OTHERWISE NOTED:
CAPACITORS ARE .01µF 100V 20%
RESISTORS ARE 1/4W 5%

QTY	REF DESIGNATION	DESCRIPTION	PART NO.	REV
1	DIC 314			
1	DIC 388			
1	DIC 6380			
8	DIC 8257			
8	DIC 8266			
8	DIC 8235			
8	DIC 8271			

AC2, BC1, BC2, CC1, CC2, DC1, DC2, AD1, AD2, BA1, BA2, CA1, CA2, DF1, DF2, AN1, AN2, BN1, BN2, CH1, CH2, DN1, DN2, AT1, AT2, BT1, BT2, CT1, CT2, DT1, DT2.

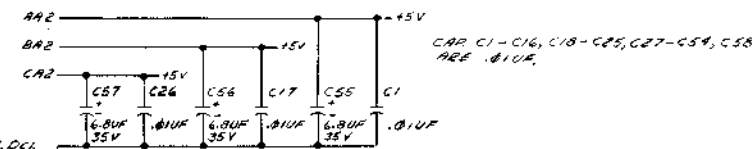

QTY	REF DESIGNATION	DESCRIPTION	PART NO.	REV
7	E14, E20, E36, E37, E40, E45, E46	IC DEC 6380	1909971	25
8	B1-B8	RESISTOR 1/4W 5%	1300365	24
85	C1-C39, C58	CAPACITORS .01µF 100V 20%	1001610	23
3	C55, C56, C57	CAPACITORS 0.1µF 35V 10%	1005306	22
9	E3, E4, E9, E14, E19, E24, E25, E44, E52	IC DEC 7400	1905575	21
5	E16, E22, E31, E35	IC DEC 8281	1909702	20
5	E13, E10, E41, E49	IC DEC 8271	1909675	19
3	E1, E6, E50	IC DEC 8235	1909935	18
2	E15, E23	IC DEC 8266	1909934	17
1	E22	IC DEC 8251	1909594	16
1	E17	IC DEC 7417A	1907667	15
1	E13	IC DEC 7478	1903547	14
2	E18, E43	IC DEC 7400	1905577	13
5	E12, E21, E29, E44, E54	IC DEC 7410	1908576	12
3	E25, E27, E48	IC DEC 7404	1909686	11
1	E18	IC DEC 74100	1909036	10
5	E12, E30, E41, E51	IC DEC 6380A	1909972	9
4	E32, E34, E37	IC DEC 6374A	1909972	8
4		SPACER (CABLE CLAMP)	1909972	7
8		SPACER (CABLE CLAMP)	1909972	6
8		HANDLE FLIP (CHIR-DIPSWITCH)	3000337-06	5
1		ETCHED CIRCUIT BOARD	8007255	4
REF		MODULE HISTORY LIST	BMM-1437-4	3
REF		ASSY/DRILLING HOLE LAYOUT	DAH-1037-2-E	2
REF		K-Y COORDINATE HOLE LOC.	K-CO-1037-2-1	1

ETCH BOARD REV			
DEC NO.	EIA NO.	DEC NO.	EIA NO.
EQUIPMENT CORPORATION			
MEM EXT & TIME SHARE CONTROL			
ECS1M837-0-1			

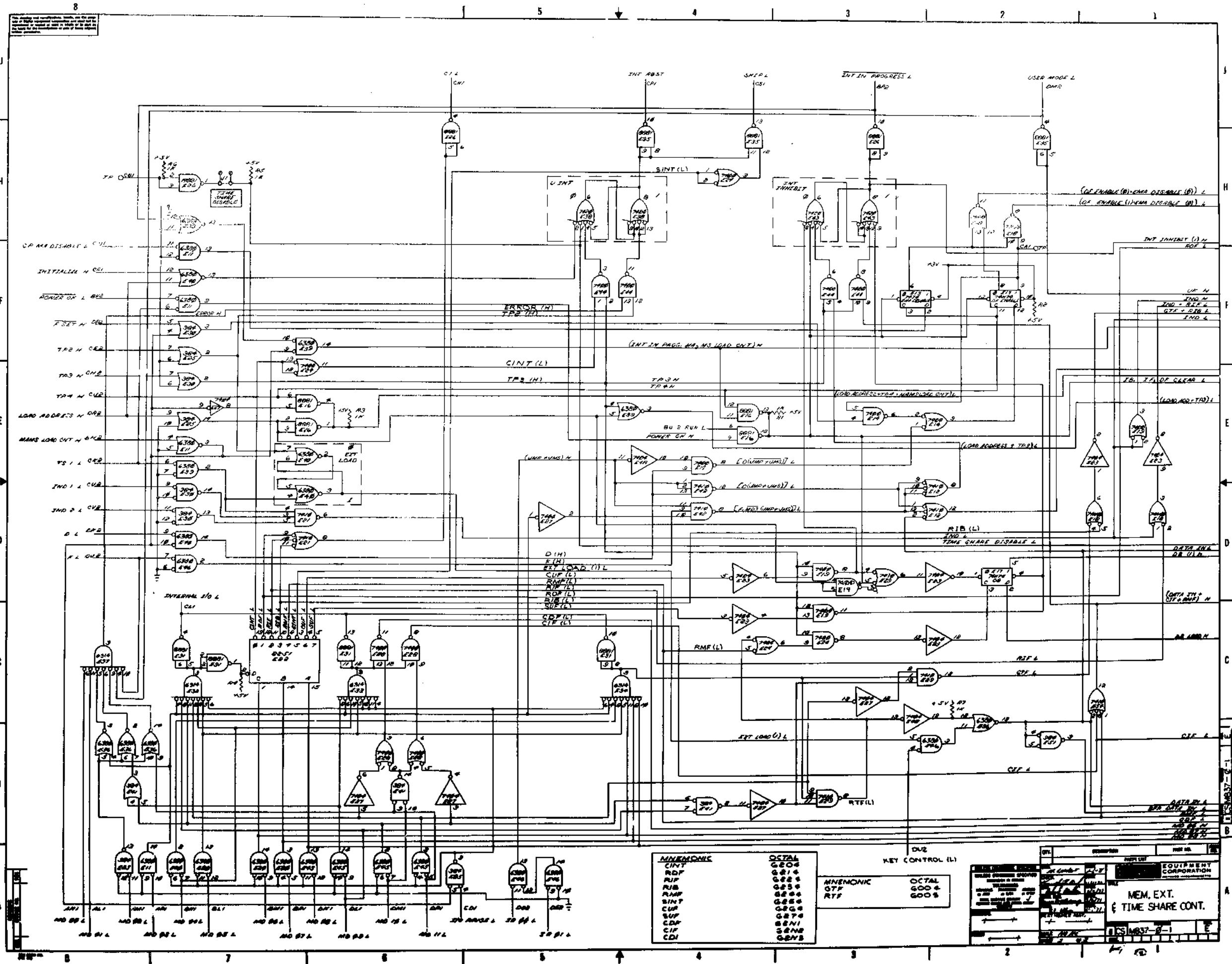

MINEMONIC	OCTAL
CINT	0008
INT	0014
RIP	0024
RIB	0034
RMP	0044
SINT	0054
CUP	0064
SUP	0074
CDP	0084
CIP	0094
CDI	0104

MINEMONIC	OCTAL
RTF	0008

EQUIPMENT CORPORATION	
MEM. EXT. & TIME SHARE CONT.	
CS 1037-8-1	

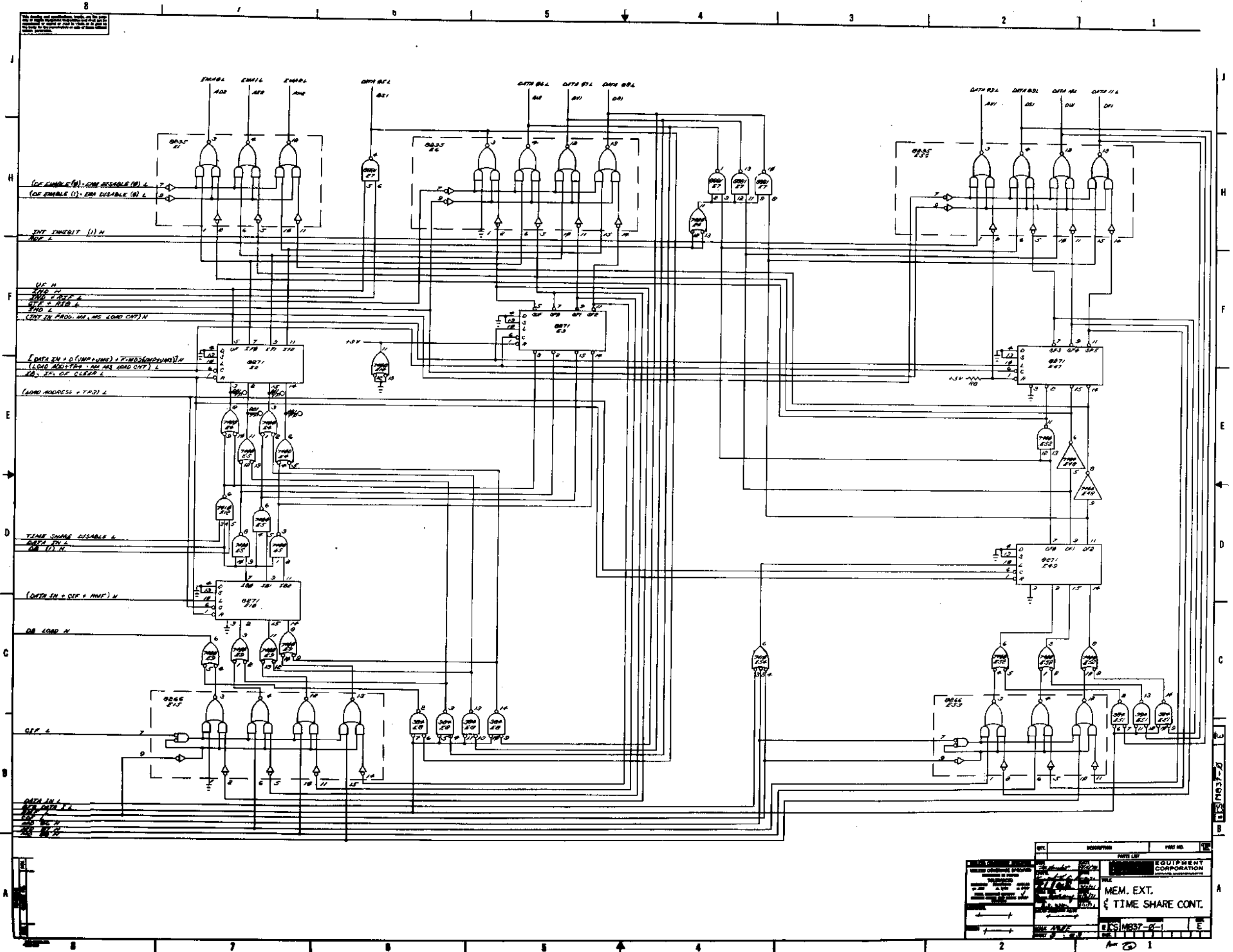

QTY.	DESCRIPTION	PRICE NO.
	MEM. EXT.	
	TIME SHARE CONT.	
	EQUIPMENT CORPORATION	
	CS1037-0-1	

This drawing and specifications, herein, are the property of Digital Equipment Corporation and shall not be reproduced or used in whole or in part as the basis for the manufacture or sale of items without written permission.

**DIGITAL EQUIPMENT CORPORATION
MAYNARD, MASSACHUSETTS**

ENGINEERING SPECIFICATION

DATE 5/26/71

TITLE KM8E ACCEPTANCE PROCEDURE

REVISIONS

REV	DESCRIPTION	CHG NO	ORIG	DATE	APPD BY	DATE

ENG <i>R. E. [Signature]</i>	APPD <i>[Signature]</i>	SIZE A	CODE SP	NUMBER 7665140-0-0	REV
---------------------------------	----------------------------	------------------	------------	-----------------------	-----

ENGINEERING SPECIFICATION

CONTINUATION SHEET

TITLE KM8E ACCEPTANCE PROCEDURE

1.0 SCOPE

1.1 This procedure defines the minimum performance standards required of a KM8E option which is not accepted as an integral part of a PDP8-E, i.e., add-on options.

2.0 SET UP

- 2.1 Inspect the M837 (KM8E) module to insure conformance to "Final Inspection Procedure for Flip-Chip Modules" (A-SP-7665039-0-0) and "Module Rework Standard" (A-SP-7605845-0-0).
- 2.2 Check the M837 (KM8E) module for a legible three character numerical date code.
- 2.3 Check the M837 module to insure the circuit and etch revisions are up to current ECO levels.
- 2.4 A PDP8-E with a minimum of two fields of known good memory must be used to accept the KM8E option.
- 2.5 Make sure the power to the PDP8-E is turned OFF.
- 2.6 Insert the M837 (KM8E) module into the omnibus. Be sure you adhere to the "Recommended Omnibus Assignment List" (A-SP-PDP8-e-0-4).

3.0 ELECTRICAL TEST

- 3.1 Turn on power to the PDP8-E.
- 3.2 Follow the loading procedure for the KM8-E Extended Memory and Time Share Control diagnostic (MAINDEC-8E-D1HA-D).
- 3.3 Run the KM8-E diagnostic following the instructions in the program write-up, this test must run error free for a minimum of 15 minutes.
- 3.4 Follow the loading procedure for Extended Memory Checkerboard (MAINDEC-8E-D1BA).
- 3.5 Run the Extended Memory Checkerboard diagnostic following the instructions in the program write-up. This test must run error free for two (2) minutes.
- 3.6 Follow the loading procedure for the Extended Memory Address Diagnostic (MAINDEC-8E-D1FA).
- 3.7 Run the Extended Memory Address Diagnostic following the instructions in the program write-up. This test must run error free for a minimum of two (2) minutes.

SIZE A	CODE S ⁰	NUMBER 7665140-0-0	REV
------------------	------------------------	-----------------------	-----

TITLE KM8E ACCEPTANCE PROCEDURE

4.0 FAILURE CLASSIFICATION

4.1 Mechanical Failure.

4.1.1 Any M837 (KM8E) module that does not meet the criterion outlined in 2.1, 2.2 and 2.3 will be classified as a failure.

4.1.2 The acceptance supervisor has the option of either waivering the failure (using DEC waiver form 12-1026) or returning the M837 to production for repair.

4.2 Electrical Failure.

4.2.1 Any M837 which while performing 3.3, 3.5 or 3.7 halts, generates error printouts, garble, or runs other than continuous and as specified in the diagnostic write-up will be classified as a failure and returned to production for repair.

SIZE
ACODE
SPNUMBER
7665140-0-0

REV



CUSTOMER PRINT SET		ELECTRICAL					CUSTOMER PRINT SET		MECHANICAL						
MP DKC8-AA	MFG. SET	FIND NO.	DRAWING NO.	REV	NO OF SHT	DESCRIPTION	OPTION NO./FILE DATE	MP DKC8-AA	MFG. SET	FIND NO.	DRAWING NO.	REV	NO OF SHT	DESCRIPTION	OPTION NO./FILE DATE
X		1	A-SP-DKC8-A-1	*	4	FIELD INST. & ACCEPT. PROCEDURE		X		1	A-PL-DKC8-A-0	*	1	PARTS LIST	
X			A-PL-DKC8-A-2	*	1	SHIPPING LIST									
X			A-PL-DKC8-A-3	*	1	SOFTWARE LIST									
			A-SP-DKC8-A-4		11	ENGINEERING SPEC									
X		2	D-CS-M8316-0-1	#	9	8A INTERNAL OPTION #1	M8316								
			K-CO-M8316-0-4	#	1	X-Y COORDINATE HOLE LOCATION									
			D-AH-M8316-0-5	#	1	ASSY HOLE									
			B-MH-M8316-0-6	#	1	MODULE HISTORY									
X			K-RL-M8316-0-8	#	2	ROM PATT. SPEC OPTION #1									
X			K-RL-M8316-0-9	#	2	ROM PATT. SPEC OPTION #1									

CUSTOMER PRINT SET CODES

X = PRINT OF DOCUMENT INCLUDED IN PRINT SET
 C = INCLUDES ALL PRINTS INDICATED ON DOCUMENT
 S = CONFIDENTIAL AUTHORIZED SIGNATURE REQUIRED

TITLE
 8A INTERNAL OPTION #1

SHEET 2 OF 2

SIZE CODE
 B DD

NUMBER
 DKC8 A

REV

This drawing and specifications, herein, are the property of Digital Equipment Corporation and shall not be reproduced or copied or used in whole or in part as the basis for the manufacture or sale of items without written permission.

DIGITAL EQUIPMENT CORPORATION
MAYNARD, MASSACHUSETTS

ENGINEERING SPECIFICATION

DATE 11/19/74

TITLE FIELD INSTALLATION & ACCEPTANCE PROCEDURE FOR DKC8-A

REVISIONS

REV	DESCRIPTION	CHG NO	ORIG	DATE	APPD BY	DATE

ENG <i>J. H. ...</i>	APPD <i>J. C. ...</i>	SIZE A	CODE SP	NUMBER DKC8-A-1	REV
----------------------	-----------------------	---------------	---------	-----------------	-----

ENGINEERING SPECIFICATION

CONTINUATION SHEET

TITLE FIELD INSTALLATION & ACCEPTANCE PROCEDURE FOR DKC8-A

I GENERAL

This procedure defines the performance standard required of the DKC8*, option board #1. This procedure refers to both system acceptance and add-on acceptance.

NOTE: If DKC8 was shipped as part of a PDP-8A system, proceed to installation procedure.

- * Serial Line Unit
- Real Time Clock
- Parallel I/O
- Programmer's Console Logic

II INSPECTION

After removing the DKC8 from the packing material, inspect the module for the following:

1. Inventory hardware against shipping list.
2. Inventory software against software list, if ordered.
3. Inventory prints against shipping list, if ordered.
4. Check hardware for loose or broken components.

III INSTALLATION PROCEDURE

Install the equipment using the following procedure:

1. Set up switches as indicated by the diagnostic write up.

S1-1 thru S1-3	"ON"	9600 baud
S1-4	"ON"	Normally "ON"
S1-5	"ON"	Real Time Clock Enable
S1-6	"ON"	Normally "ON"
S1-7	"ON"	One Stop Bit
S1-8	"OFF"	Disable TTY 20 MA Filter

NOTE: Reference Operator's Handbook for switch setting descriptions.

2. Insert TTY loop back cable (DEC Part #7008517) on DKC8.
3. Insert parallel I/O cable loop back cable (DEC Part # BC08R-1) on DKC8.

SIZE A	CODE SP	NUMBER DKC8-A-1	REV
---------------	---------	-----------------	-----



TITLE FIELD INSTALLATION AND ACCEPTANCE PROCEDURE FOR DKC8-A

III INSTALLATION PROCEDURE (continued)

4. Insert two programmer's console cables on DKC8.
5. Insure that the 8A Power is removed from the Omnibus™.
6. Insert DKC8 into the second or third slot of the Omnibus™.
7. Turn the power back "ON".
8. Check the operation of the programmer's console.

IV ACCEPTANCE PROCEDURE

Perform the acceptance procedure defined in Table A. If abnormal indications are encountered, refer to the diagnostic listing for type of error. Reference the diagnostic write ups and operator's manual for instructions on loading diagnostics.

Equipment Required:

1. PDP-8A with 1K or more R/W Memory
2. Paper Tape Input Device
3. Programmer's Console (KC8-A)
4. Diagnostic and Listings
5. TTY loop Back Cable
6. Parallel I/O Loop Back Cable
7. W987 Quad Extender

NOTE: If the programmer's console and paper tape input device are not available as part of the system being used, they must be supplied in good working order by the customer.

SIZE	CODE	NUMBER	REV
A	SP	DKC8-A-1	

SHEET 3 OF 4



TITLE FIELD INSTALLATION & ACCEPTANCE PROCEDURE FOR DKC8-A

TABLE A

Acceptance of DKC8 with 4K or More R/W Memory

Program Name	Maindec #	Accept Time	Restriction
DKC8-AA Option Test #1	08-DJDKA-PB	30 min	4K R/W Memory

Acceptance of DKC8 with less than 1K of R/W Memory

DKC8-AA Opteion Test #1 Segment #1 (RIM)	08-DJDKA -PM1	10 min	1K R/W Memory
DKC8-AA Option Test #1 Segment #2 (RIM)	08-DJDKA -PM2	10 min	1K R/W Memory
DKC8-AA Option Test #1 Segment #3 (RIM)	08-DJDKA -PM3	10 min	1K R/W Memory
DKC8-AA Option Test #1 Segment #4 (RIM)	08-DJDKA -PM4	10 min	1K R/W Memory

SIZE	CODE	NUMBER	REV
A	SP	DKC8-A-1	

SHEET 4 OF 4

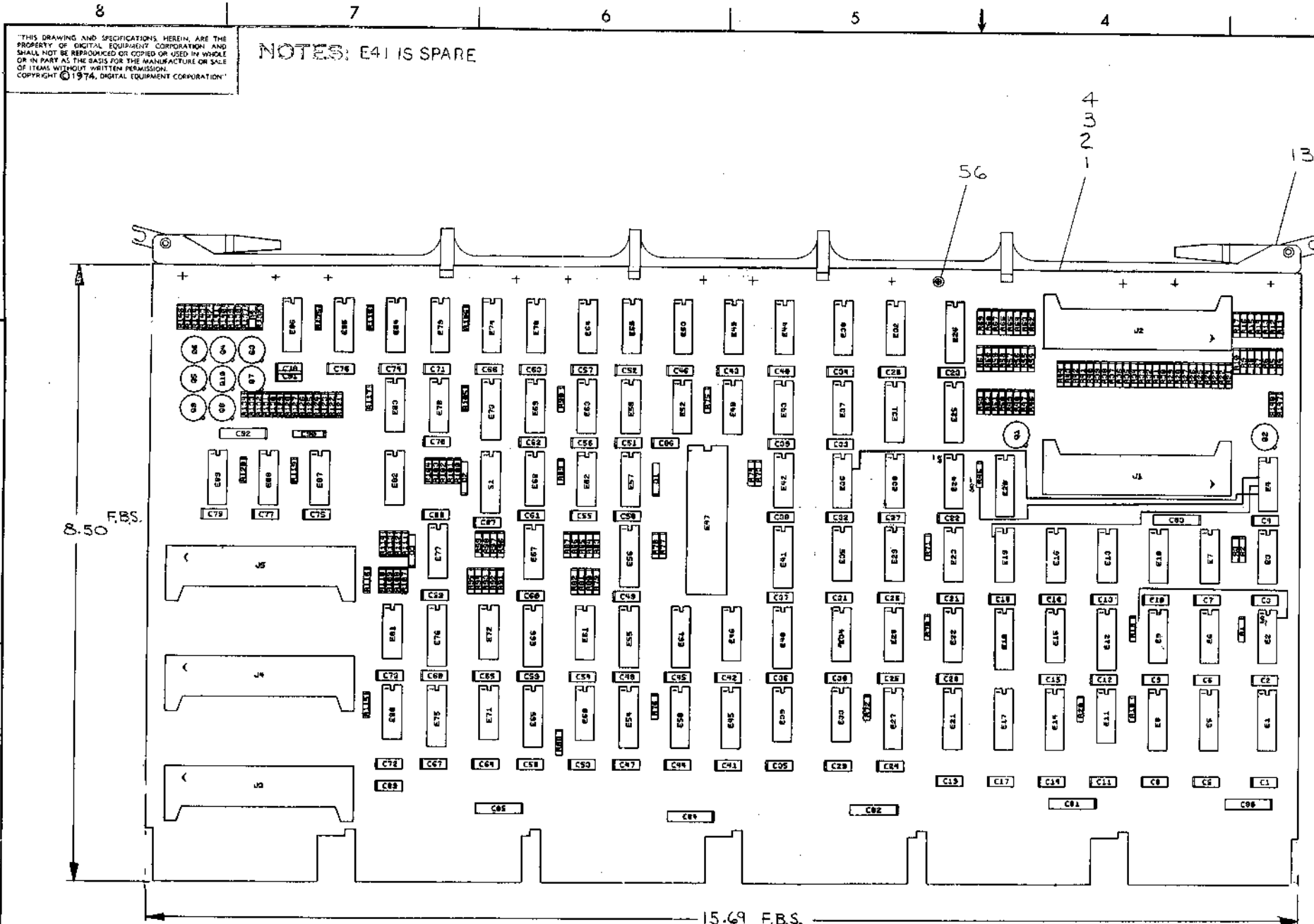

IC PIN LOCATIONS

IC TYPE	GND	+5V	+15V	-15V	-12V
I.C. 1488L	7		14		1
I.C. 1808 (UART)	3	1			2
I.C. 314	1	8			
I.C. 380	1	8			
I.C. 74175	8	16			
I.C. 74174	8	16			
I.C. 74151	8	16			
I.C. 8235	8	16			
I.C. 8234	8	16			
I.C. 7442	8	16			
I.C. 7493	10	5			
I.C. 7492	10	5			
I.C. 7490	10	5			

GND AND 5V ARE USUALLY PIN 7 AND 14 RESPECTIVELY. EXCEPTIONS ARE STATED ABOVE.

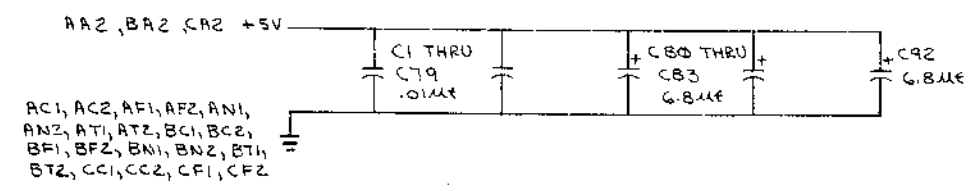

NOTES: E41 IS SPARE

THIS DRAWING AND SPECIFICATIONS HEREIN ARE THE PROPERTY OF DIGITAL EQUIPMENT CORPORATION AND SHALL NOT BE REPRODUCED OR COPIED OR USED IN WHOLE OR IN PART AS THE BASIS FOR THE MANUFACTURE OR SALE OF ITEMS WITHOUT WRITTEN PERMISSION. COPYRIGHT © 1974, DIGITAL EQUIPMENT CORPORATION.

REF	X-Y COORDINATE HOLE LOCATION	K-CO-M8316-0-4	1	
REF	ASSY/DRILLING HOLE LAYOUT	D-AH-M8316-0-5	2	
REF	MODULE ECO HISTORY	B-MH-M8316-0-6	3	
1	ETCHED CIRCUIT BOARD	50'0900	4	
2	C89, C91	CAP. 330pf 100V 5%	1000023	5
82	C1 THRU C79, C86-C88	CAP. .01uF 100V 20%	1001610-01	6
1	C90	CAP. 2.2uF 35V 10%	1002431	7
7	C80 THRU C85, C92	CAP. 6.8uF 35V 10%	1005306	8
1	D4	DIODE D664	1100114	9
3	D1, D2, D3	DIODE IN4742 12V ZENER	1109502	10
5	J1 THRU J5	CONNECTOR (40 PIN)	1209941	11
1	E83	I.C. SOCKET (14 PIN)	1210054	12
1		HANDLE ASSY	1210711-2	13
1	S1	SWITCH PACK (8 POS. D. I.P.)	1211164-04	14
6	E12, E18, E21, E51, E65, E75	I.C. DEC 8837	1911116	15
5	R122 THRU R125, R138	RES. 47 1/4 W 5%	1300202	16
7	R17, R78, R95, R116, R129, R133, R137	RES. 68 1/4 W 5%	1300219	17
13	R22, R24, R26, R28, R30, R34, R36, R38, R40, R42, R44, R147, R32	RES. 680 1/4 W 5%	1301424	18
5	R18, R120, R136, R139, R141	RES. 2.2K 1/4 W 5%	1300417	19
1	R127	RES. 5.6K 1/4 W 5%	1301874	20
1	R131	RES. 6.8K 1/4 W 5%	1301423	21
4	R2, R3, R4, R57	RES. 27 1/4 W 5%	1301522	22
5	Q1, Q2, Q6, Q8, Q9	TRANSISTOR MPS A05	1510705	23
5	Q3, Q4, Q5, Q7, Q10	TRANSISTOR MPS A55	1510706	24
1	E78	CRYSTAL OSCILLATOR, 50688 MHZ	1811660-02	25
7	E13, E29, E88, E42, E48, E49, E53	I.C. DEC 7474	1905547	26
4	E7, E35, E38, E79	I.C. DEC 7400	1905575	27
2	E6, E19	I.C. DEC 7410	1905576	28
1	E23	I.C. DEC 7430	1905578	29
4	E9, E37, E43, E89	I.C. DEC 7402	1909004	30
6	R5, R8, R12, R15, R144, R145	RES. 180 1/4 W 5%	1301322	31
3	E62, E68, E70	I.C. DEC 7492	1909053	32
6	E57, E58, E59, E63, E64, E69	I.C. DEC 7493	1909054	33
1	E2	I.C. DEC 74511	1910537	34
7	E10, E32, E34, E41, E72, E81, E85	I.C. DEC 7404	1909686	35
9	E4, E22, E30, E46, E52, E60, E71, E80, E81	I.C. DEC 88B1	1909705	36
2	E67, E77	I.C. DEC 7416	1909928	37
5	E3, E15, E24, E33, E39	I.C. DEC 7417	1909929	38
3	E8, E21, E54	I.C. DEC 8235	1909935	39
1	E73	I.C. DEC 74151	1909936	40
13	R21, R23, R25, R27, R29, R31, R33, R35, R37, R39, R41, R43, R148	RES 330 1/4 W 5%	1300295	41
2	E16, E74	I.C. DEC 7486	1910011	42
3	E25, E31, E40	I.C. DEC 7442	1910046	43
2	E36, E44	I.C. DEC 7408	1910155	44
1	E82	I.C. DEC 1488L	1910322	45
1	E86	I.C. DEC 1489L	1910323	46
1	E11	I.C. DEC 314	1909704	47
1	E84	I.C. DEC 380	1909485	48
1	E47	I.C. DEC 1802A (UART)	1910459-00	49
1	E55	I.C. DEC 74175	1910651	50
3	E56, E66, E76	I.C. DEC 74174	1910652	51

QTY REF DESIGNATION DESCRIPTION PART NO. ITEM NO.

FIRST USED ON OPTION MODEL PDP8-A

ETCH BOARD REV C

DATE 3-24-74

digital EQUIPMENT CORPORATION

OPTION BD #1

SIZE CODE DCS NUMBER M8316-0-1 REV. D

SCALE NONE

SHEET 1 OF 9

SEMICONDUCTOR CONVERSION CHART

THIS DRAWING AND SPECIFICATIONS HEREIN ARE THE PROPERTY OF DIGITAL EQUIPMENT CORPORATION AND SHALL NOT BE REPRODUCED OR COPIED OR USED IN WHOLE OR IN PART AS THE BASIS FOR THE MANUFACTURE OR SALE OF ITEMS WITHOUT WRITTEN PERMISSION. COPYRIGHT © 1974, DIGITAL EQUIPMENT CORPORATION.

M8316
OPTION #1
SWITCH SETTINGS

SI-1	SI-2	SI-3	BAUD
OFF	OFF	OFF	110
OFF	OFF	ON	150
OFF	ON	OFF	300
OFF	ON	ON	600
ON	OFF	OFF	1200
ON	OFF	ON	2400
ON	ON	OFF	4800
ON	ON	ON	9600

- SI-1 } SLU BAUD RATE
- SI-2 }
- SI-3 } ON = TSI CLEARS DATA AVAIL. F/F
- SI-4 } OFF = DATA AVAIL. OF NOT CLEARED BY TSI
- SI-5 } ON = REAL TIME CLK ENABLE
- } OFF = REAL TIME CLK DISABLE
- SI-6 } TEST SW (ALWAYS ON)
- SI-7 } ON = 1 STOP BIT IN SLU SERIAL CHARACTER
- } OFF = 2 STOP BITS IN SLU SERIAL CHARACTER
- SI-8 } ON = ASR 33/ASR 35 TTY FILTER IN
- } OFF = FILTER OUT (VT05, MODEMS, ETC)

SPARES

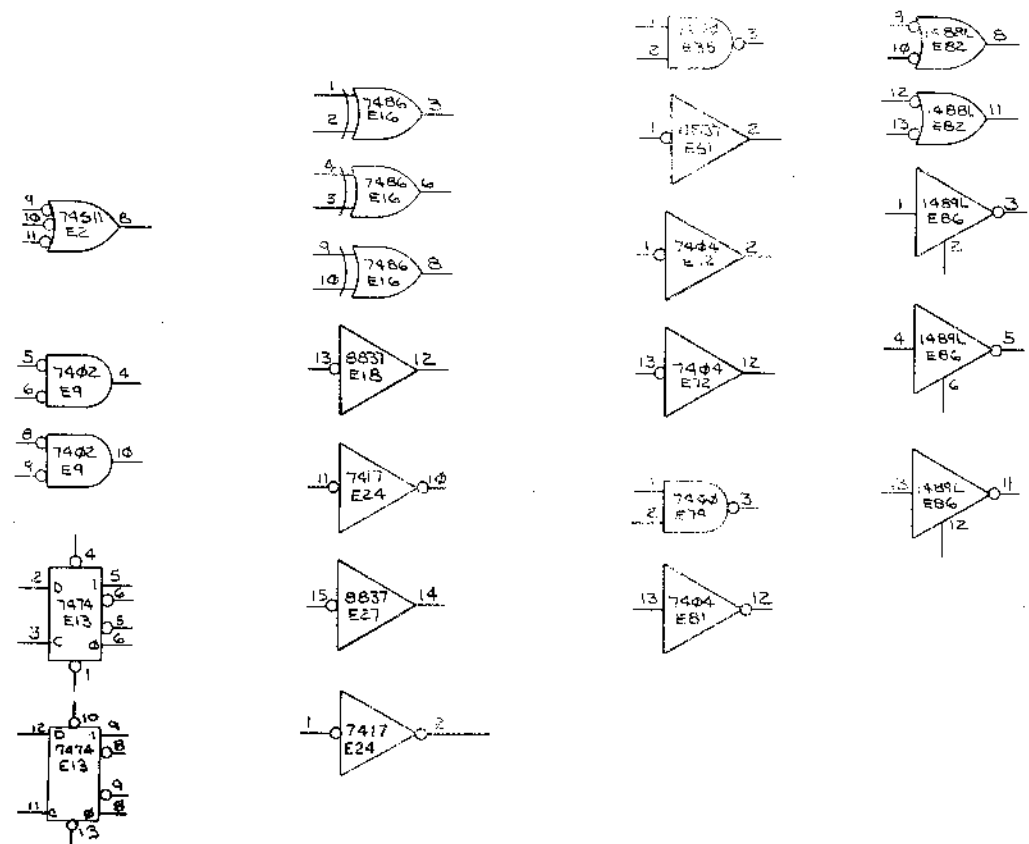

COMPONENT SUBSTITUTION CHART

PART CALLED FOR		SUBSTITUTE PART	
QTY	PART NO. DESC	QTY	DESC
82	10-01610-00 DIF DISC	82	10-01610-00 DIF DISC
1	19-09704 314	1	19-10391 5314
		1	19-09972 6314
		1	19-10389 7314
1	19-04485 380	1	19-10392 5380
		1	19-09971 6380
		1	19-10390 7380
		1	19-11113 11380
9	19-09705 8881	9	19-11767 8840
			19-09973 97401

QTY	REF DESIGNATION	DESCRIPTION	PART NO.	ITEM NO.
1	E28	I.C. DEC 7437	1910091	52
6	E1, E5, E14, E17, E45, E50	I.C. DEC 8234	1911315	53
1	E20	ROM #1, KLDK #1, 32 X 8	23062A1	54
1	E26	ROM #2, KLDK #2, 32 X 8	23063A1	55
12		EYELET GS-4-7	4006732	56
4	R4, R9, R11, R16	RES 390 1/4W 5%	1300309	57
2	R6, R64	RES 470 1/4W 5%	1300316	58
87	R1, R7, R10, R13, R14, R17 THRU R20, R45, R47 THRU R56, R58 THRU R63, R65, THRU R76, R79 THRU R94, R96 THRU R15, R117, R119 THRU R121, R128, R130, R132, R134, R135, R140, R42, R43, R46	RES 1K 1/4W 5%	1300365	59

REVISIONS

CHK	CHANGE NO.	REV

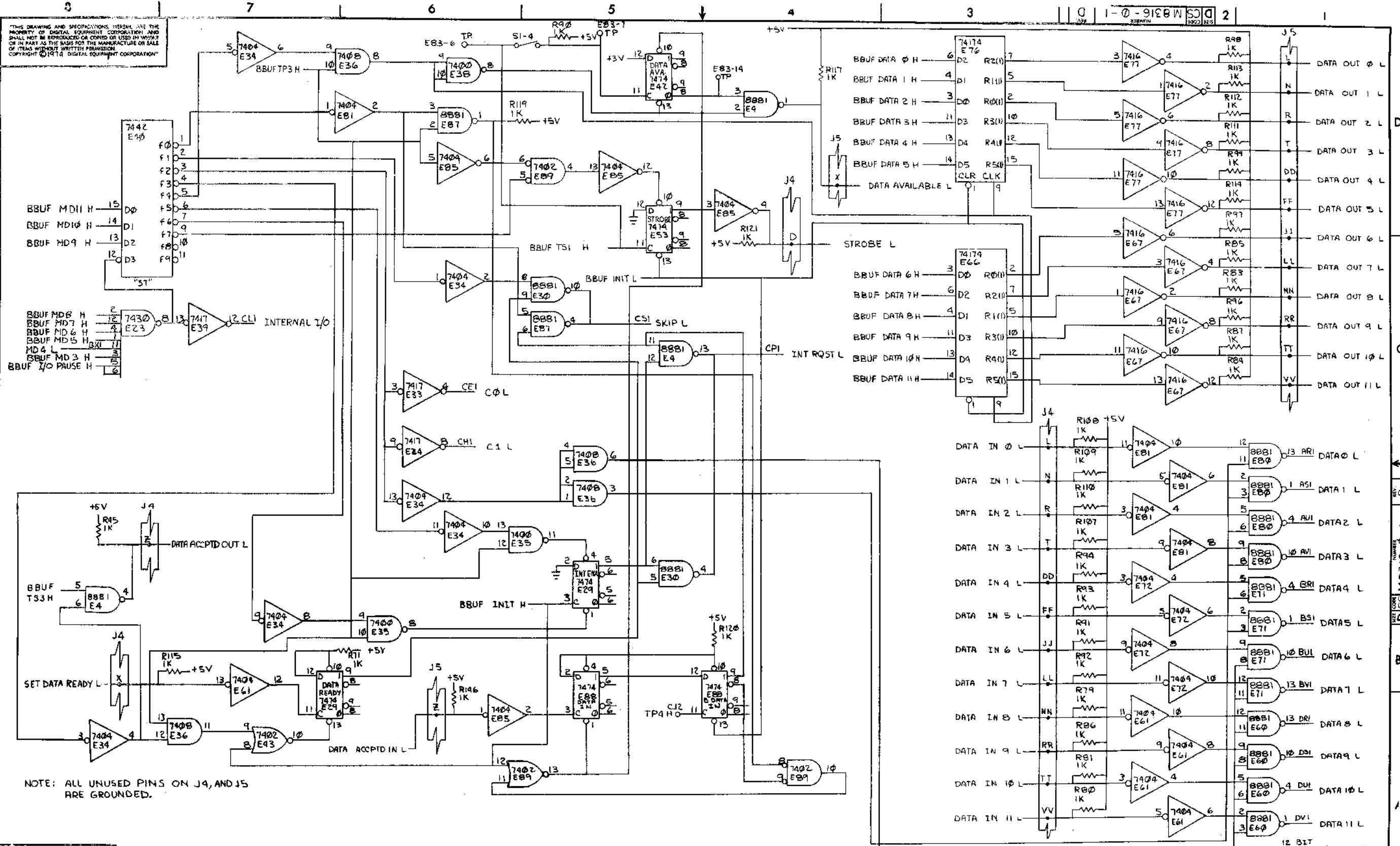

NOTE: ALL UNUSED PINS ON J4, AND J5 ARE GROUNDED.

REVISIONS		
CHK	CHANGE NO.	REV.

TITLE	OPTION BD #1	SIZE CODE	D CS MB316-0-1	NUMBER		REV.	D
SCALE		SHEET	3 OF 9	DIST.			

D CS MB316-0-1

THIS DRAWING AND SPECIFICATIONS, HEREIN, ARE THE PROPERTY OF DIGITAL EQUIPMENT CORPORATION AND SHALL NOT BE REPRODUCED OR COPIED OR USED IN WHOLE OR IN PART AS THE BASIS FOR THE MANUFACTURE OR SALE OF ITEMS WITHOUT WRITTEN PERMISSION. COPYRIGHT © 1974, DIGITAL EQUIPMENT CORPORATION.

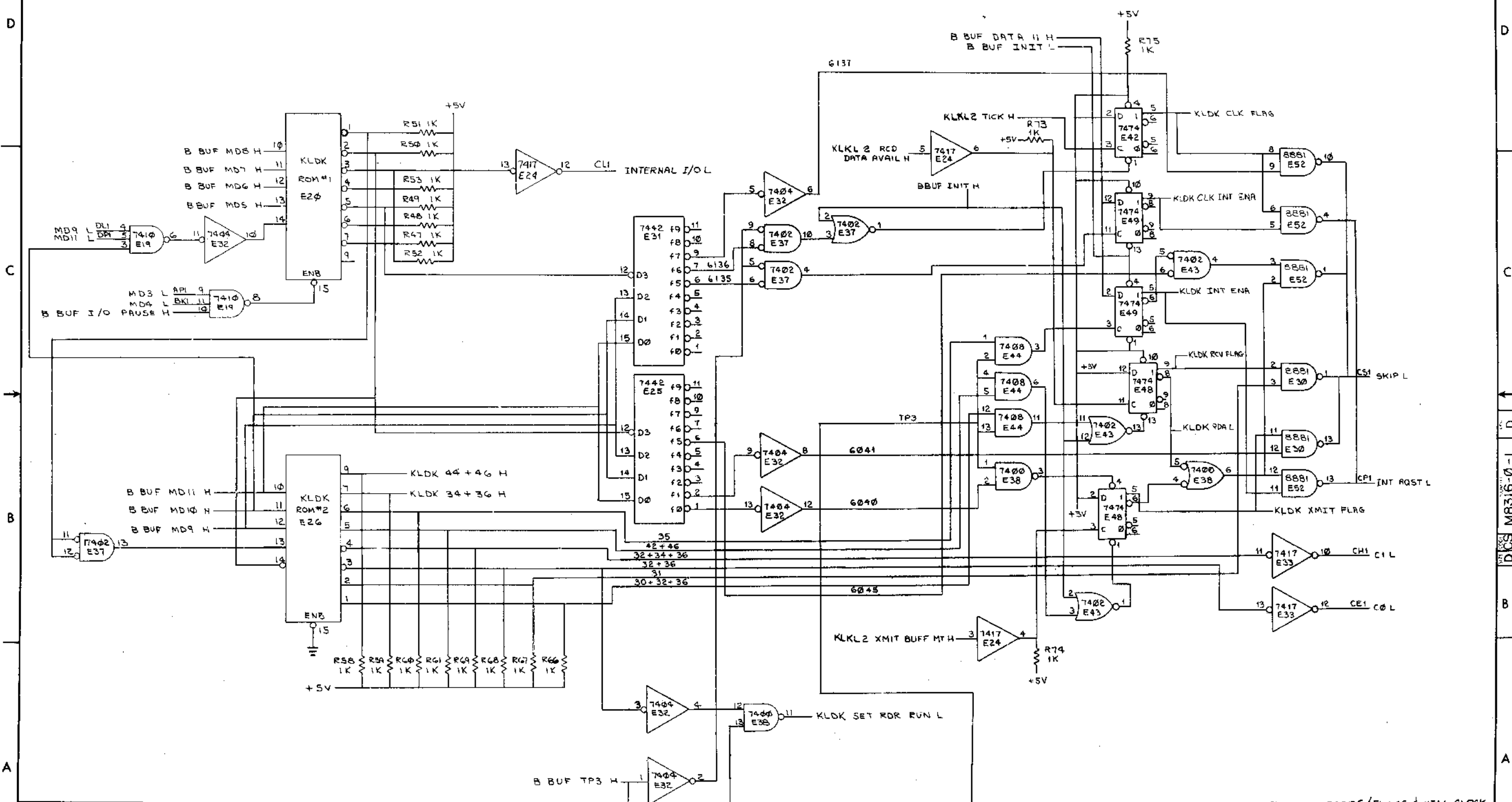

REVISIONS		
CHK	CHANGE NO	REV

TITLE		SIZE CODE	NUMBER	REV.
OPTION BD # 1 (KLDK)		DCS	M8316-0-1	D
SCALE	SHEET	OF	DIST.	
NONE	4	9		

DCS M8316-0-1

"THIS DRAWING AND SPECIFICATIONS HEREIN ARE THE PROPERTY OF DIGITAL EQUIPMENT CORPORATION AND SHALL NOT BE REPRODUCED OR COPIED IN WHOLE OR IN PART AS THE BASIS FOR THE MANUFACTURE OR SALE OF ITEMS WITHOUT WRITTEN PERMISSION. COPYRIGHT © 1974, DIGITAL EQUIPMENT CORPORATION"

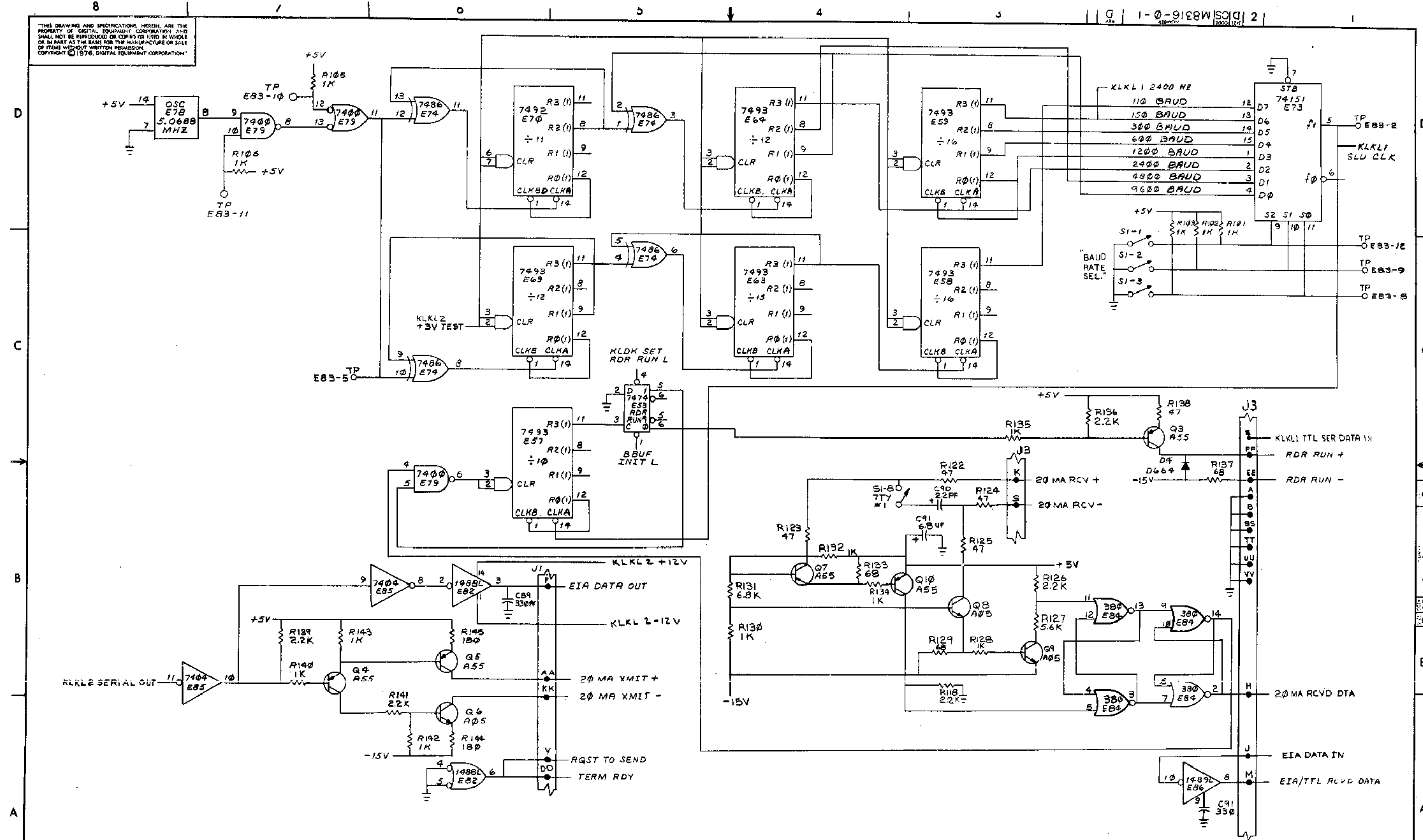

REVISIONS		
CHK	CHANGE NO.	REV.

BAUD RATE GEN & 20 MA. EIA DRIVERS/RECEIVERS		TITLE	SIZE CODE	NUMBER	REV.
		OPTION BD #1 (KLKL1)	D	CS M8316-0-1	D
SCALE	NONE	SHEET	5	OF	9
		DIST.			

DEC FORM NO. 110

THIS DRAWING AND SPECIFICATIONS HEREIN ARE THE PROPERTY OF DIGITAL EQUIPMENT CORPORATION AND SHALL NOT BE REPRODUCED OR COPIED OR USED IN WHOLE OR IN PART AS THE BASIS FOR THE MANUFACTURE OR SALE OF ITEMS WITHOUT WRITTEN PERMISSION. COPYRIGHT © 1974, DIGITAL EQUIPMENT CORPORATION.

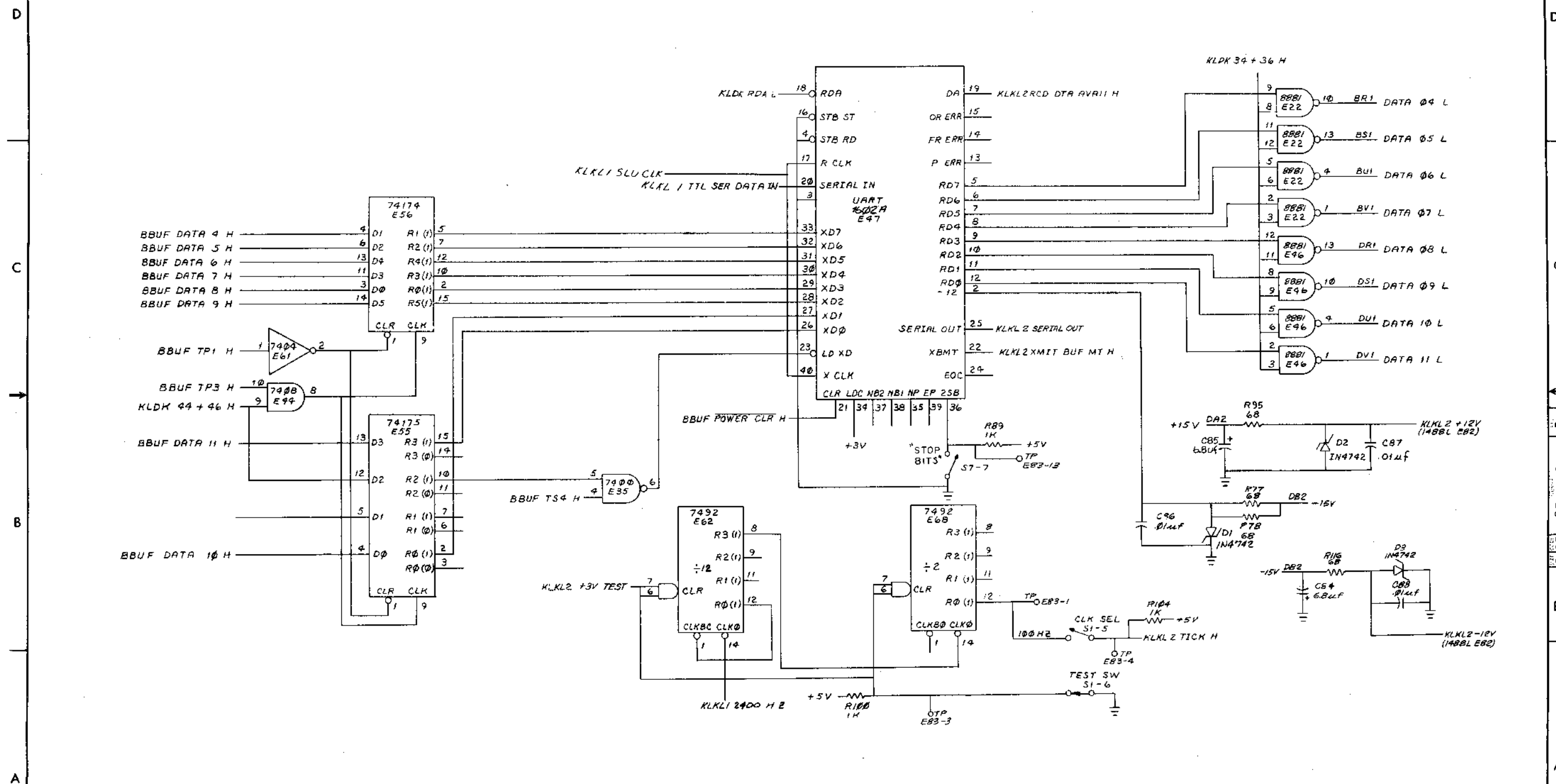

REVISIONS		
CHK	CHANGE NO.	REV.

TITLE	OPTION BD *1 (KLKL 2)	SIZE CODE	DCS	NUMBER	M8316-0-1	REV.	D
SCALE	NONE	SHEET	6	OF	9	DIST.	

"THIS DRAWING AND SPECIFICATIONS HEREON ARE THE PROPERTY OF DIGITAL EQUIPMENT CORPORATION AND SHALL NOT BE REPRODUCED OR COPIED OR USED IN WHOLE OR IN PART AS THE BASIS FOR THE MANUFACTURE OR SALE OF ITEMS WITHOUT WRITTEN PERMISSION. COPYRIGHT © 1974, DIGITAL EQUIPMENT CORPORATION"

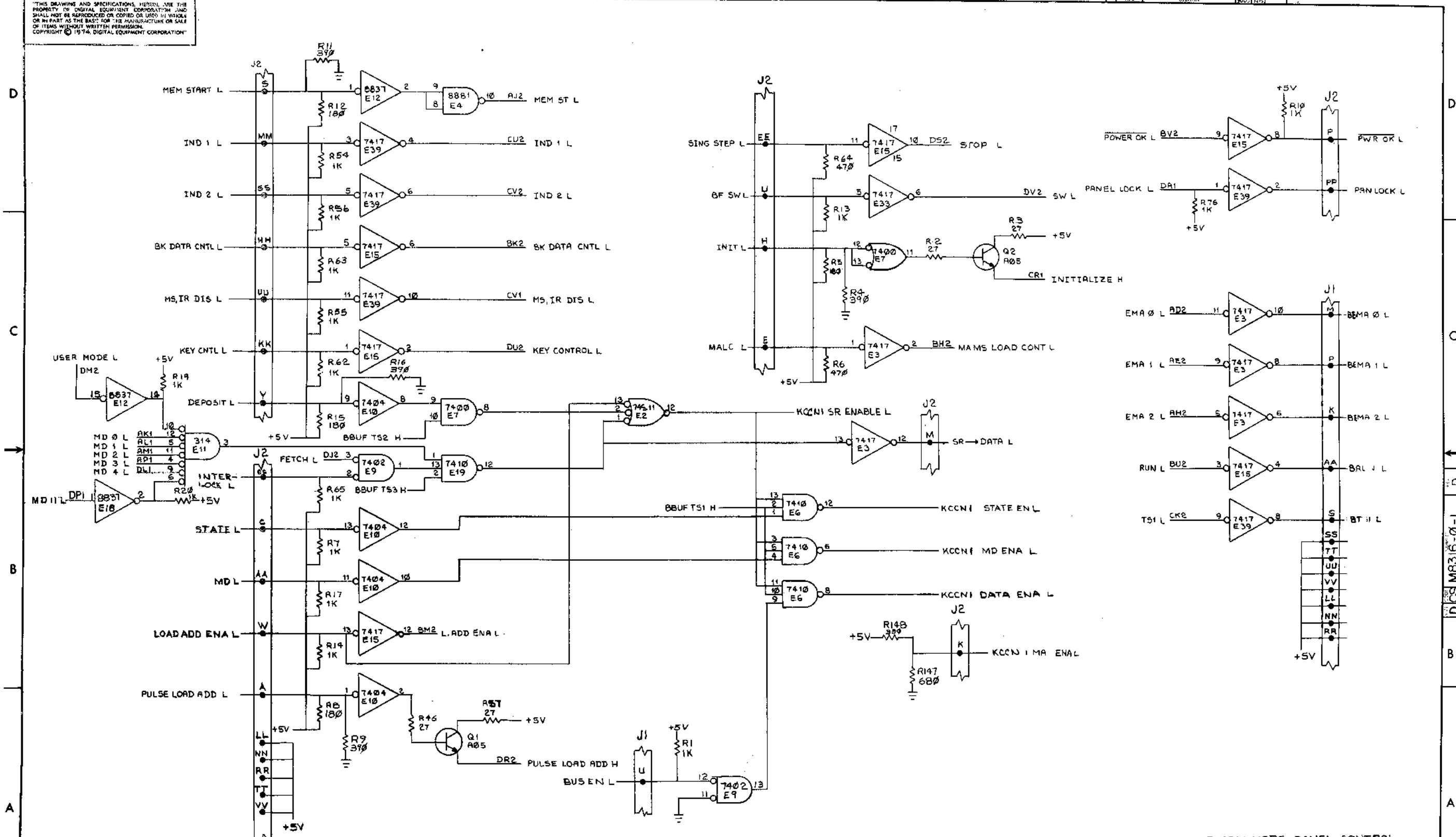

PROGRAMMERS PANEL CONTROL

REVISIONS		
CHK	CHANGE NO.	REV.

"THIS DRAWING AND SPECIFICATIONS, HEREIN, ARE THE PROPERTY OF DIGITAL EQUIPMENT CORPORATION AND SHALL NOT BE REPRODUCED OR COPIED OR USED IN WHOLE OR IN PART AS THE BASIS FOR THE MANUFACTURE OR SALE OF ITEMS WITHOUT WRITTEN PERMISSION. COPYRIGHT © 1974, DIGITAL EQUIPMENT CORPORATION"

DCSM8316-0-1 2

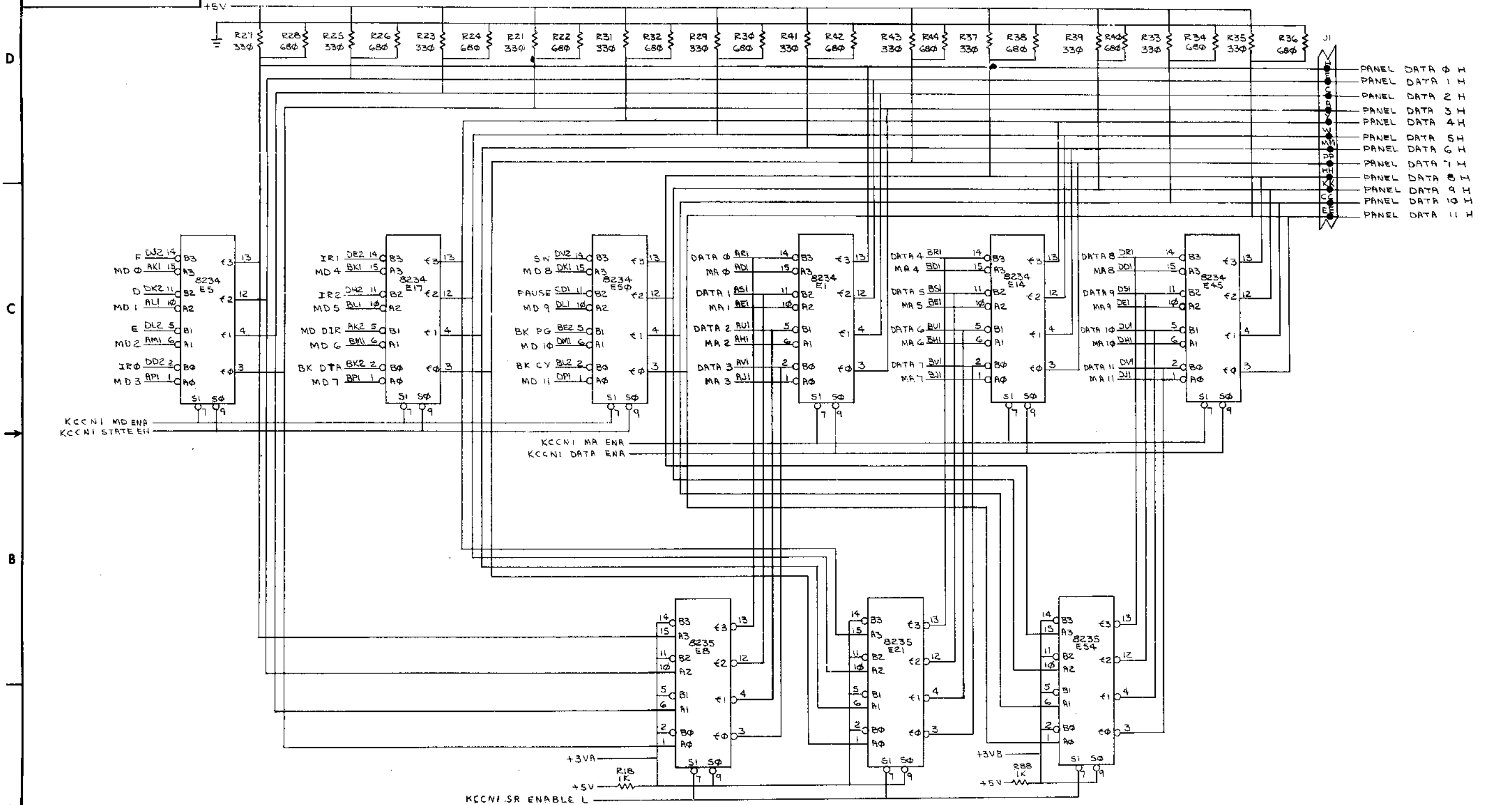

REVISIONS		
CHK	CHANGE NO.	REV.

TITLE		OPTION BOARD #1	SIZE	00B	NUMBER	DCSM8316-0-1	REV.	D
SCALE		1/1	SHEET		8	OF	9	DIST.

DCSM8316-0-1

THIS DRAWING AND SPECIFICATIONS HEREIN ARE THE PROPERTY OF DIGITAL EQUIPMENT CORPORATION AND SHALL NOT BE REPRODUCED OR COPIED OR USED IN WHOLE OR IN PART AS THE BASIS FOR THE MANUFACTURE OR SALE OF ITEMS WITHOUT WRITTEN PERMISSION. COPYRIGHT © 1974 DIGITAL EQUIPMENT CORPORATION

1-2-5185W
MAY 1974
REV. 1

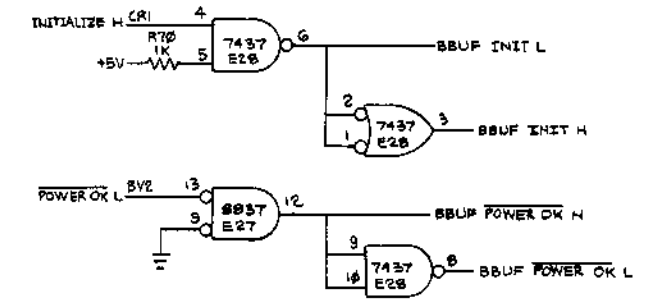
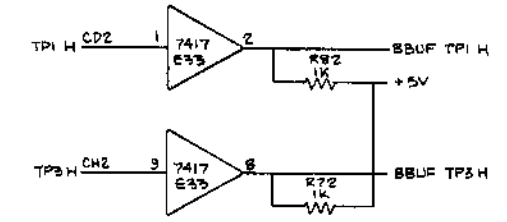
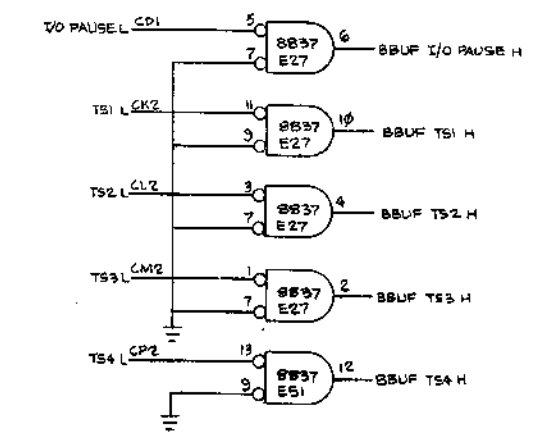
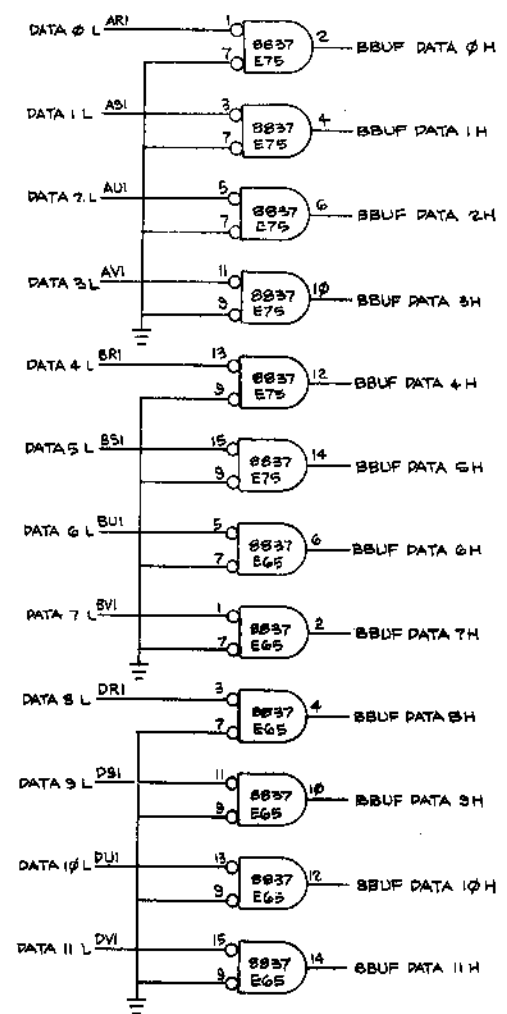
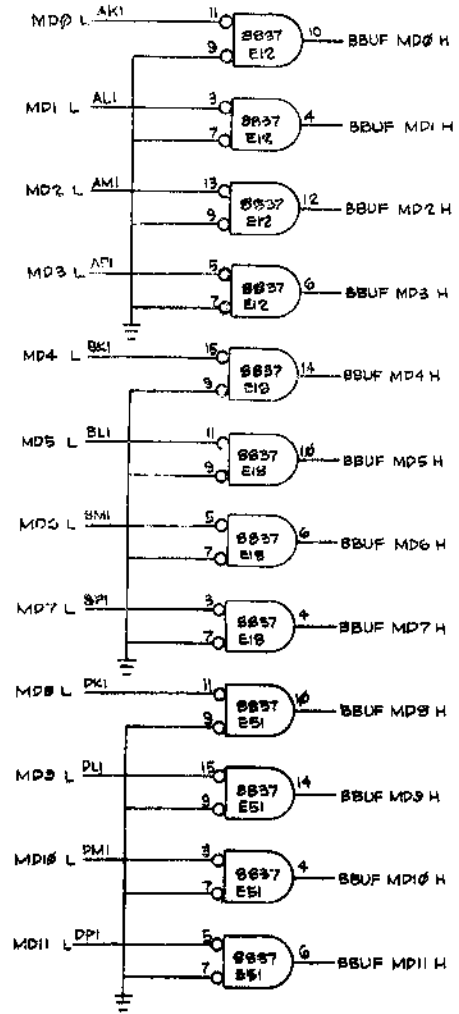

BUS BUFFERS

REVISIONS		
CHK	CHANGE NO.	REV.

TITLE	8/A INTERNAL OPTIONS (BUFF)	SIZE CODE	D CS	NUMBER	M8316-2-1	REV.	D
SCALE	NONE	SHEET	9 OF 9	DIST.			

M3816-2-1

This drawing and specifications, herein, are the property of Digital Equipment Corporation and shall not be reproduced or copied or used in whole or in part as the basis for the manufacture or sale of items without written permission. COPYRIGHT © 1974

DIGITAL EQUIPMENT CORPORATION

SIZE CODE NUMBER
K RL M8316-0-8

REV.

3

4

FIRST USED ON OPTION MODEL	QTY.	DESCRIPTION	PART NO.	ITEM NO.
DKC8 - A				
PARTS LIST				
DRN. <i>J. Green</i>	DATE <i>7/7/74</i>	digital EQUIPMENT CORPORATION MAYNARD, MASSACHUSETTS TITLE ROM PATTERN SPEC OPTION #1 (KLDK ROM #1)		
CHK'D. <i>Blair Green</i>	DATE <i>7/7/74</i>			
ENG. <i>Jimmy Fordin</i>	DATE <i>8/1/74</i>			
PROJ. ENG. <i>Jimmy Fordin</i>	DATE <i>8/1/74</i>			
PROD. <i>Caroline</i>	DATE <i>9/2/74</i>			
NEXT HIGHER ASSEMBLY B-DD-DKC8-A		SIZE CODE K RL	NUMBER M8316-0-8	REV. *
SCALE				
SHEET 1 OF 2		DIST.		

REVISIONS	CHANGE NO.	REV.
	CHK	

4

3

2

1

B

B

A

A

K-RL-M8316-Ø-8

RUM PATTERN SPEC

PAGE 2 OF 2

DEC PART NUMB: 23-062A1
ORIGINATOR: LARRY NARHI
DATE OF ORIGIN: 01-21-74

digital EQUIPMENT CORPORATION

DECIMAL LOC	OCTAL LOC	BINARY DATA	OCTAL DATA
0	00	11111000	370
1	01	11111000	370
2	02	11111000	370
3	03	01011000	130
4	04	10011000	230
5	05	11111000	370
6	06	11111000	370
7	07	11111000	370
8	10	11111000	370
9	11	11111000	370
10	12	11111000	370
11	13	11010000	320
12	14	11111000	370
13	15	11111000	370
14	16	11111000	370
15	17	11111000	370
16	20	11111000	370
17	21	11111000	370
18	22	11111000	370
19	23	01011000	130
20	24	10011000	230
21	25	11111000	370
22	26	11111000	370
23	27	11111000	370
24	30	11001000	310
25	31	11111000	370
26	32	11111000	370
27	33	11010000	320
28	34	11111000	370
29	35	11111000	370
30	36	11111000	370
31	37	11111000	370

K-RL-M8316-Ø-8

This drawing and specifications, herein, are the property of Digital Equipment Corporation and shall not be reproduced or copied or used in whole or in part as the basis for the manufacture or sale of items without written permission. COPYRIGHT © 1974

DIGITAL EQUIPMENT CORPORATION

REV. | 2 | SIZE CODE | KRL | NUMBER | M8316-0-9

FIRST USED ON OPTION MODEL	QTY.	DESCRIPTION	PART NO.	ITEM NO.
DKC8-A				
PARTS LIST				
DRN	<i>Bob Decker</i>	DATE	7/9/74	
CHK'D	<i>Bob Decker</i>	DATE	7/9/74	
ENG	<i>Sally Thibau</i>	DATE	8/1/74	
PROJ. ENG.	<i>Sally Thibau</i>	DATE	8/1/74	
PROD.	<i>Don Dolan</i>	DATE	8/5/74	
NEXT HIGHER ASSEMBLY		B-DD-DKC8-A		
SCALE				
SHEET 1 OF 2				
		SIZE CODE	NUMBER	REV.
		KRL	M8316-0-9	*
		DIST.		

digital EQUIPMENT CORPORATION
MAYNARD, MASSACHUSETTS

TITLE
ROM PATTERN
SPEC OPTION #1
(KLDK ROM #2)

REVISIONS	REV.	
	CHANGE NO.	
CHK		

K RL M8316-Ø-9

DEC PART NUMR: 23-063A1

ORIGINATOR: LARRY NARHI

DATE OF ORIGIN: 01-24-74

ROM PATTERN SPEC

PAGE 2 OF 2

DECIMAL LOC	OCTAL LOC	BINARY DATA	OCTAL DATA
0	00	00110000	060
1	01	00110000	060
2	02	00111000	070
3	03	00110000	060
4	04	00110001	061
5	05	00110000	060
6	06	00111001	071
7	07	00110000	060
8	10	00110000	060
9	11	00110000	060
10	12	00110000	060
11	13	00110000	060
12	14	00110000	060
13	15	00110000	060
14	16	00110000	060
15	17	00110000	060
16	20	00110000	060
17	21	00110000	060
18	22	00110000	060
19	23	00110000	060
20	24	00110000	060
21	25	00110000	060
22	26	00110000	060
23	27	00110000	060
24	30	10110000	260
25	31	01110000	160
26	32	10000000	200
27	33	00110000	060
28	34	00100010	042
29	35	00110100	064
30	36	10000010	202
31	37	00110000	060

K-RL-M8316-Ø-9

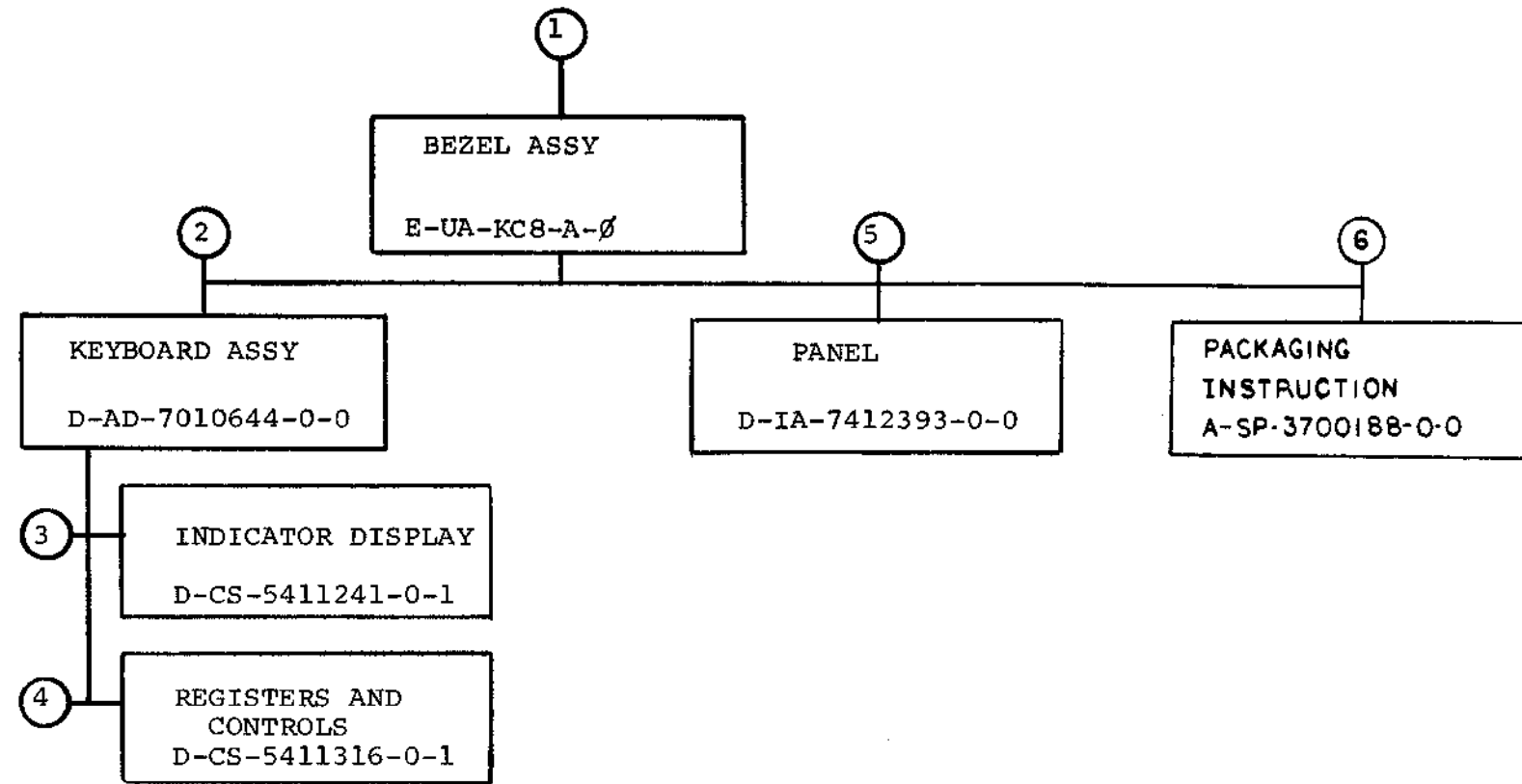

TITLE	SHEET	OF	SIZE	CODE	NUMBER	REV
DRAWING DIRECTORY KC8-A	2	3	B	DD	KC8-A	A

CUSTOMER PRINT SET		ELECTRICAL					CUSTOMER PRINT SET		MECHANICAL						
MP-KC8-A	MFG. SET	FIND NO.	DRAWING NO.	REV	NO OF SHT	DESCRIPTION	OPTION NO./FILE DATE	MP-KC8-A	MFG. SET	FIND NO.	DRAWING NO.	REV	NO OF SHT	DESCRIPTION	OPTION NO./FILE DATE
X		3	D-CS-5411241-0-1	#	3	INDICATOR DISPLAY				1	E-UA-KC8-A-Ø	A	1	BEZEL ASSY	
			K-CO-5411241-0-4	#	1	X-Y COORDINATE HOLE LOCATION					E-MD-7412349-3-0	#	2	BEZEL MACHINED SAND CASTING	
			D-AH-5411241-0-5	#	1	ASSY/DRILLING HOLE LAYOUT					B-MD-7412352-0-0	#	1	CLIP	
			B-MH-5411241-0-6	#	1	MODULE ECO HISTORY					C-IA-7411987-0-0	#	1	BRACKET BEZEL	
											D-MD-7413361-0-0	#	1	COVER PROTECTIVE BEZEL	
								X			A-SP-KC8-A-1	*		FIELD INST. & ACCEPT. PROCEDURE	
X		4	D-CS-5411316-0-1	#	3	REGISTERS AND CONTROL		X			A-PL-KC8-A-2	*	1	SHIPPING LIST	
			K-CO-5411316-0-4	#	1	X-Y COORDINATE HOLE LOCATION									
			D-AH-5411316-0-5	#	1	ASSY/DRILLING HOLE LAYOUT									
			B-MH-5411316-0-6	#	1	MODULE ECO HISTORY		X		2	D-AD-7010644-0-0		1	KEYBOARD ASSY	
										5	D-IA-7412393-0-0	#	1	PANEL	
											C-SS-7412393-1-1	#	1	SILK SCREEN	
											C-SS-7412393-1-2	#	1	SILK SCREEN	
											C-SS-7412393-1-3	#	1	SILK SCREEN	
											C-SS-7412393-2-1	#	1	SILK SCREEN	
											C-SS-74122393-2-2	#	1	SILK SCREEN	
										6	A-SP-3700188-0-0	#	2	PACKAGING INSTRUCTION	
											A-SP-9905703-0-0	#	1	LAMINATED BUILD-UP	
											A-SP-9905704-0-0	#	1	REGULAR SLOTTED CARTON	
											A-SP-9905723-0-0	#	1	REGULAR SLOTTED CARTON	
											A-SP-9905129-0-0	#	1	POLY BAG	

DRB 108

DEC 16 (325)-1062-28-R972

CUSTOMER PRINT SET CODES	X = PRINT OF DOCUMENT INCLUDED IN PRINT SET C = INCLUDES ALL PRINTS INDICATED ON DOCUMENT S = CONFIDENTIAL AUTHORIZED SIGNATURE REQUIRED	TITLE	DRAWING DIRECTORY KC8-A	SIZE	CODE	NUMBER	KC8-A	REV	A
						SHEET 3 OF 3	B DD		

DO NOT SCALE DRAWING

LEGEND	
PCB-A	PROGS CONTROL/BEZEL
PCB-AB	REMOTE PROGS CONTROL/BEZEL

NOTES:
 1 ASSEMBLE ITEM#1 (PANEL) TO ITEM#2 (BEZEL) USING SILASTIC ADHESIVE ITEM#14

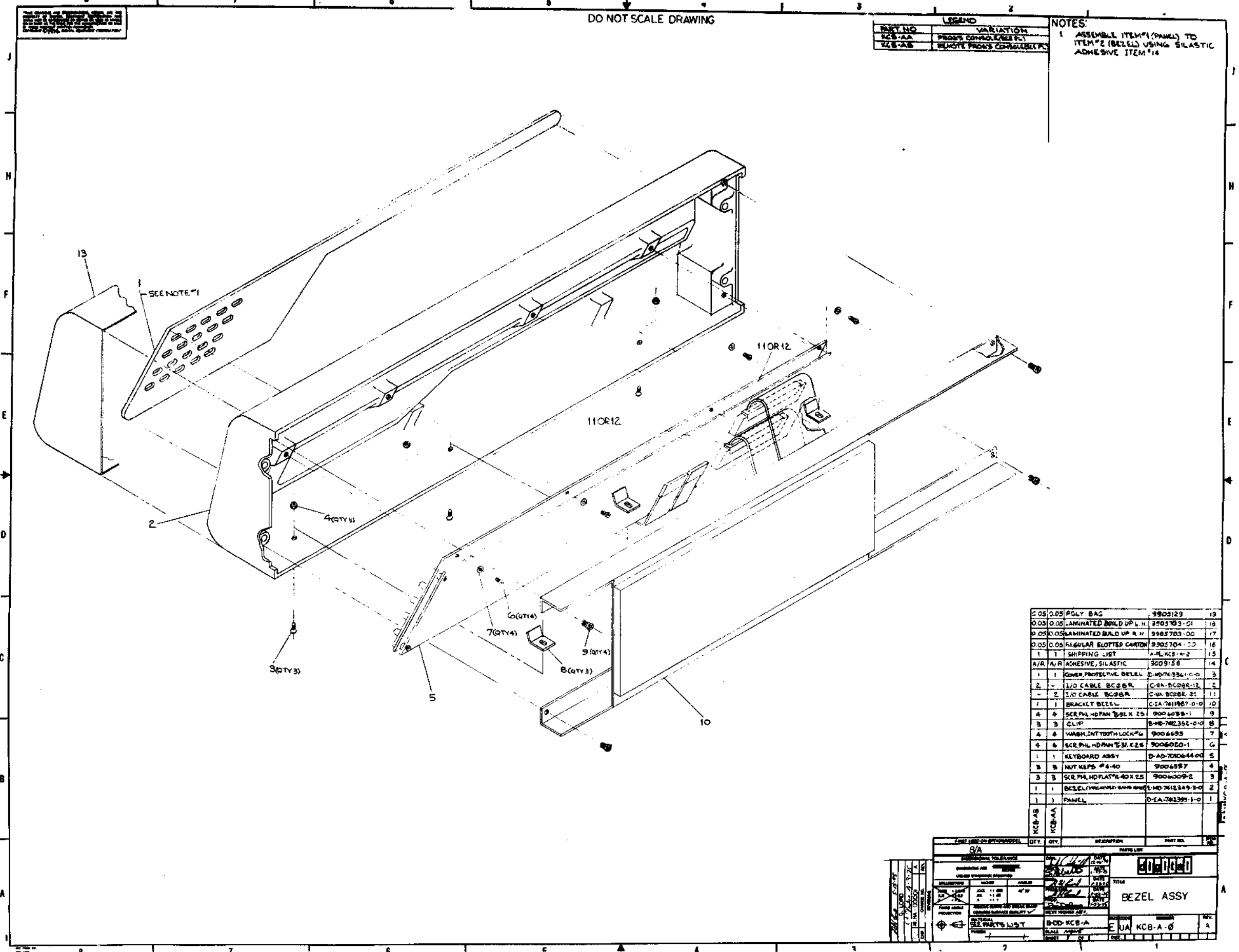

2	05	PGLY BAG	3905123	13
003	005	LAMINATED BUILD UP L.H.	3905703-01	13
005	005	LAMINATED BUILD UP R.H.	3905703-00	17
005	005	REGULAR SLOTTED CARTON	3905704-00	16
1	1	SHIPPING LIST	3905704-02	15
A/R	A/R	ADHESIVE, SILASTIC	9009155	14
1	1	COVER PROTECTIVE BEZEL	D-10-74136-1-0-0	3
2	-	I/O CABLE BC2BR	C-14-50098-12	2
-	2	I/O CABLE BC2BR	C-14-50098-21	11
1	1	BRACKET BEZEL	C-14-7411967-0-0	10
4	4	SCR PHL HD PAN 3/16 X 25	9006020-1	9
3	3	CLIP	B-10-742356-0-0	8
4	4	WASH INT TOOTH LOCK #6	9006693	7
4	4	SCR PHL HD PAN 5/16 X 25	9006020-1	6
1	1	KEYBOARD ASSY	D-10-700644-00	5
3	3	NUT KEPS #4-40	9006597	4
3	3	SCR PHL HD PAN 3/16 X 25	9006020-2	3
1	1	BEZEL (W/KEYBOARD)	D-10-741349-3-0	2
1	1	PANEL	D-14-741399-1-0	1

QTY	QTY	DESCRIPTION	PART NO.						
		R/A							
<table border="1"> <tr> <td>DATE</td> <td>BY</td> <td>TITLE</td> </tr> <tr> <td>10-10-60</td> <td></td> <td>BEZEL ASSY</td> </tr> </table>				DATE	BY	TITLE	10-10-60		BEZEL ASSY
DATE	BY	TITLE							
10-10-60		BEZEL ASSY							
<table border="1"> <tr> <td>REV</td> <td>BY</td> <td>DATE</td> </tr> <tr> <td>1</td> <td>UA</td> <td>10-10-60</td> </tr> </table>				REV	BY	DATE	1	UA	10-10-60
REV	BY	DATE							
1	UA	10-10-60							

"THIS DRAWING AND SPECIFICATIONS, HEREIN, ARE THE PROPERTY OF DIGITAL EQUIPMENT CORPORATION AND SHALL NOT BE REPRODUCED OR COPIED OR USED IN WHOLE OR IN PART AS THE BASIS FOR THE MANUFACTURE OR SALE OF ITEMS WITHOUT WRITTEN PERMISSION. COPYRIGHT © 1974, DIGITAL EQUIPMENT CORPORATION"

DO NOT SCALE DRAWING

NOTES:
 1. INSTALL ITEM #2 (CABLE) AS FOLLOWS.
 PCB-1-J1 TO PCB-2-J3
 PCB-1-J2 TO PCB-2-J4

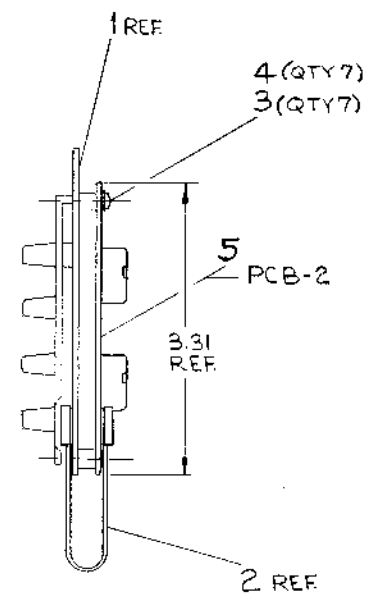
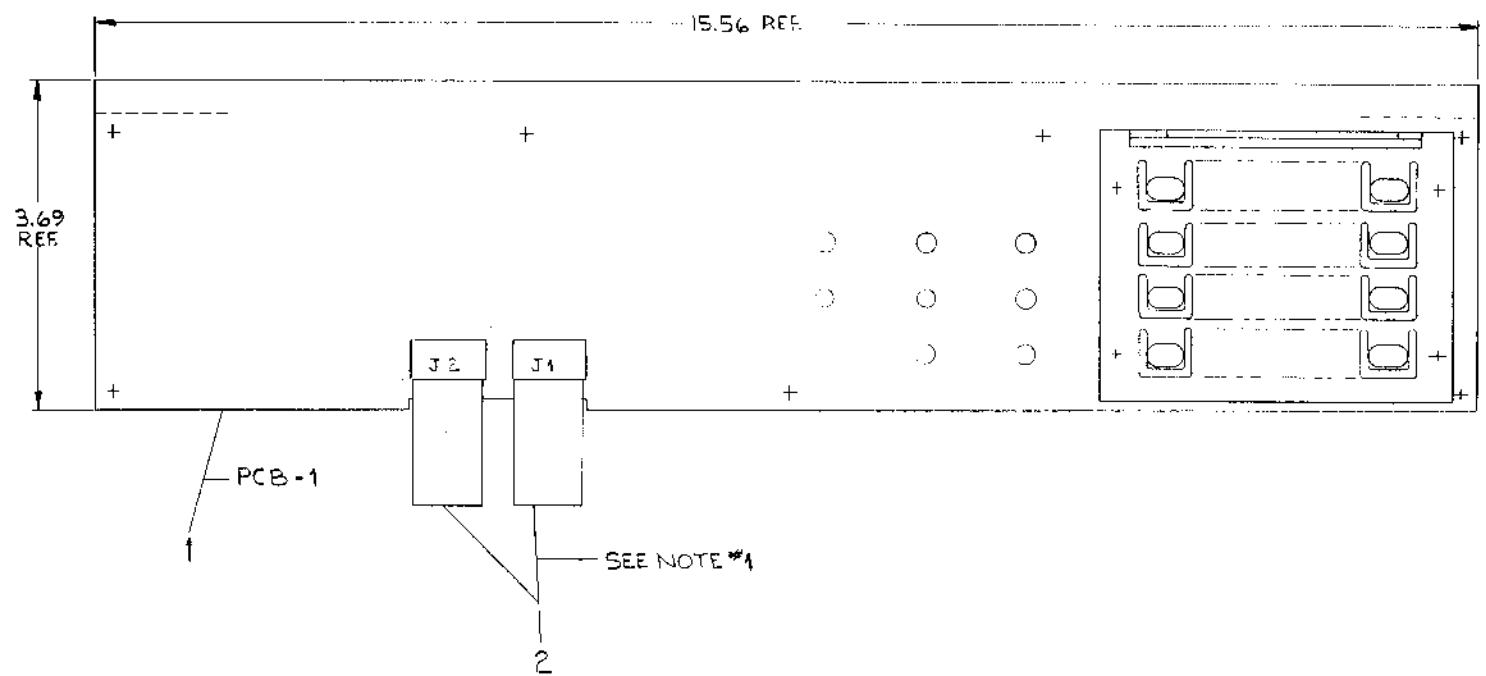

QTY.	DESCRIPTION	PART NO.	ITEM NO.
1	REGISTERS AND CONTROL	D-CS-5411316-0-1	5
7	WASH INT LOCK #4	9006632	4
7	SCR PHL HDPAN #4-40X.25	9008301-1	3
2	CABLE, KEYBOARD	C-1A-7008612-ØD	2
1	INDICATOR DISPLAY	D-CS-5411241-0-1	1

FIRST USED ON OPTION/MODEL 8/A		DATE 12-13-74	
DIMENSIONAL TOLERANCE		DATE 1-23-75	
DIMENSIONS ARE UNLESS OTHERWISE SPECIFIED			
MILLIMETERS	INCHES	ANGLES	
XXX ±0.10 XX ±0.5 X ±2.0	.XXX ±.005 .XX ±.02 X ±.1	10° 30'	
THIRD ANGLE PROJECTION	REMOVE BURRS AND BREAK SHARP CORNERS SURFACE QUALITY ✓	NEXT HIGHER ASSY.	
MATERIAL SEE PART LIST	FINISH	TITLE KEYBOARD ASSY.	
SCALE 1/1		SIZE CODE D AD	NUMBER 7010644-0-0
SHEET 1 OF 1		REV.	

REV.	CHANGE NO.	REVISIONS

985 100-2

D AD 7010644-0-0

THE DRAWING AND SPECIFICATIONS HEREIN ARE THE PROPERTY OF DIGITAL EQUIPMENT CORPORATION AND SHALL NOT BE REPRODUCED OR COPIED OR USED IN WHOLE OR IN PART AS THE BASIS FOR THE MANUFACTURE OR SALE OF ITEMS WITHOUT WRITTEN PERMISSION. COPYRIGHT © 1974 DIGITAL EQUIPMENT CORPORATION

NOTES:
 1 HAND INSERT KEYPAD AFTER WAVE SOLDERING
 2 MOUNT ITEM #37 (INSERTS) IN 7 HOLES, AFTER COMPONENTS HAVE BEEN MOUNTED.

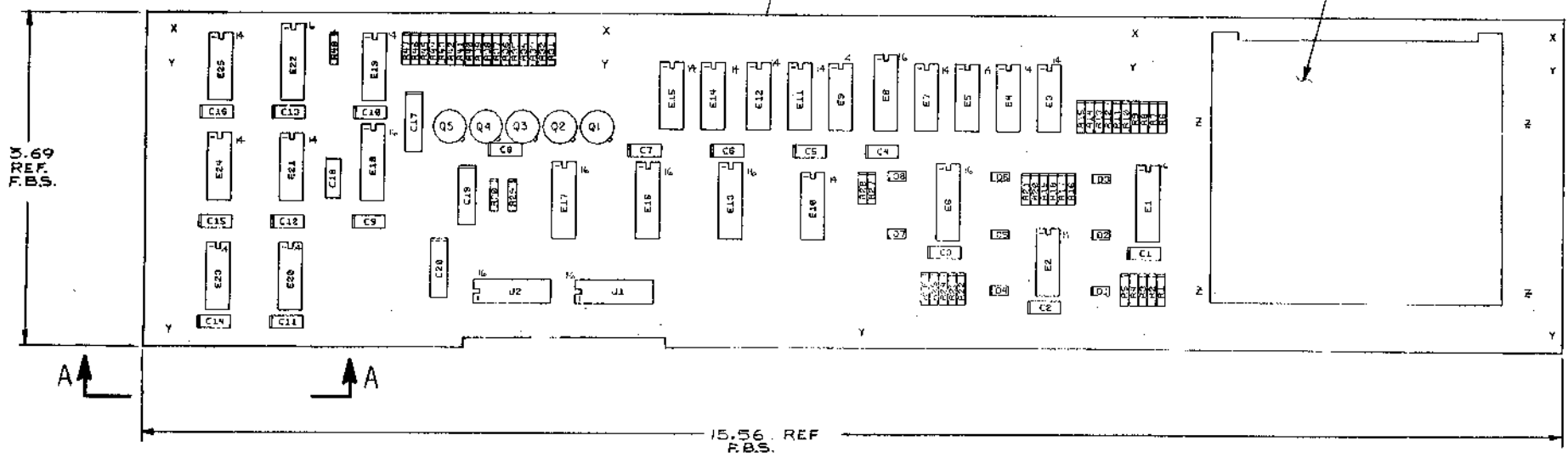
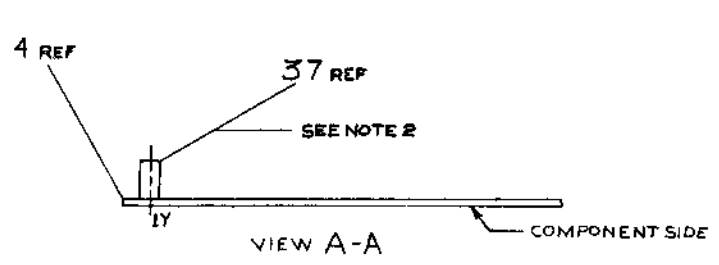

REF	DESCRIPTION	QTY	PART NO.	ITEM NO.
REF	X-Y COORDINATE HOLE LOCATION		K-CO-5411241-B-4	1
REF	ASSY/DRILLING HOLE LAYOUT		D-AH-5411241-B-5	2
REF	MODULE ECO HISTORY		B-MH-5411241-B-6	3
1	ETCHED CIRCUIT BOARD		5011240	4
1	C18 CAPACITOR, 0.2pf, 100V, 5%		1000015	5
16	C1 THRU C16 CAPACITOR, .01uf, 50V, AXIAL		1001810-00	6
1	C17 CAPACITOR, 1.0uf, 35V, 10%		1001776-00	7
2	C19, C20 CAPACITOR, 0.8uf, 35V, 10%		1005306	8
8	D1 THRU D8 LED		1110864	9
9	E3, E5, E7, E9, E11, E12, E14, E15 14 PIN I.C. SOCKET		1211813-03	10
2	J1, J2 16 PIN I.C. SOCKET		1211813-00	11
1	KEYPAD ASSY.		1211856	12
1	R29 RESISTOR, 220, 1/4W, 5%		1300271	13
8	R18 THRU R21, R27, R28 RESISTOR, 330, 1/4W, 5%		1300295	14
5	R32, R35, R38, R41, R44 RESISTOR, 470, 1/4W, 5%		1300316	15
21	R1 THRU R15, R22 THRU R26, R48 RESISTOR, 1K, 1/4W, 5%		1300385	16
1	R40 RESISTOR, 10K, 1/4W, 5%		1300479	17
4	R36, R39, R42, R45 RESISTOR, 10, 1/4W, 5%		1301317	18
1	R30 RESISTOR, 750, 1/4W, 5%		1301481	19
8	R31, R33, R34, R37, R40, R43 RESISTOR, 27, 1/4W, 5%		1301522	20
1	R47 RESISTOR, 6.8K, 1/4W, 5%		1301423	21
5	Q1 THRU Q5 TRANSISTOR, MPS405		1510705	22
1	E23 I.C. DEC 7474		1905547	23
1	E21 I.C. DEC 7420		1905577	24
1	E25 I.C. DEC 7490		1905051	25
1	E24 I.C. DEC 7495		1905955	26
1	E22 I.C. DEC 8251		1905984	27
1	E20 I.C. DEC 7404		1909886	28
1	E19 I.C. DEC 7418		1909828	29
1	E17 I.C. DEC 74145		1910047	30
2	E2, E10 I.C. DEC 7408		1910155	31
1	E18 I.C. DEC 74123		1910436	32
2	E1, E6 I.C. DEC 9318		1910454	33
3	E8, E13, E16 I.C. DEC 7447A		1911295	34
9	E3, E4, E5, E7, E9, E11, E12, E14 E15 7 SEG. DISPLAY		1911291	35
8	WASHER, SHOULDER		9008516	36
7	INSERTS, PC BOARD		9009113-2	37
4	SCREW, PHILIPS 4-40 x 1/2		9006013-1	38
4	NUT, KEP 4-40		9006557	39
2 FT	WIRE #30AWG (GREEN)		9105740-55	40

QTY	REF. DESIGNATION	DESCRIPTION	PART NO.	ITEM NO.

DEC. NO.	EIA NO.	DEC. NO.	EIA NO.
DEC I.C. 8251	8	16	
DEC I.C. 7490	10	5	
DEC I.C. 74145	8	16	
DEC I.C. 7495	8	14	
DEC I.C. 9318	8	16	
DEC I.C. 74123	8	16	
IC TYPE	GND	+5V	

GND AND 5V ARE USUALLY PIN 7 AND 14 RESPECTIVELY EXCEPTIONS ARE STATED ABOVE
 IC PIN LOCATIONS

FIRST USED ON OPTION MODEL
KCBAA

ETCH BOARD REV. B

digital

INDICATOR DISPLAY

D-AD7010644-0-0

SEMICONDUCTOR CONVERSION CHART

SHEET 1 OF 3

"THIS DRAWING AND SPECIFICATIONS HEREIN ARE THE PROPERTY OF DIGITAL EQUIPMENT CORPORATION AND SHALL NOT BE REPRODUCED OR COPIED OR USED IN WHOLE OR IN PART AS THE BASIS FOR THE MANUFACTURE OR SALE OF ITEMS WITHOUT WRITTEN PERMISSION. COPYRIGHT © 1976, DIGITAL EQUIPMENT CORPORATION"

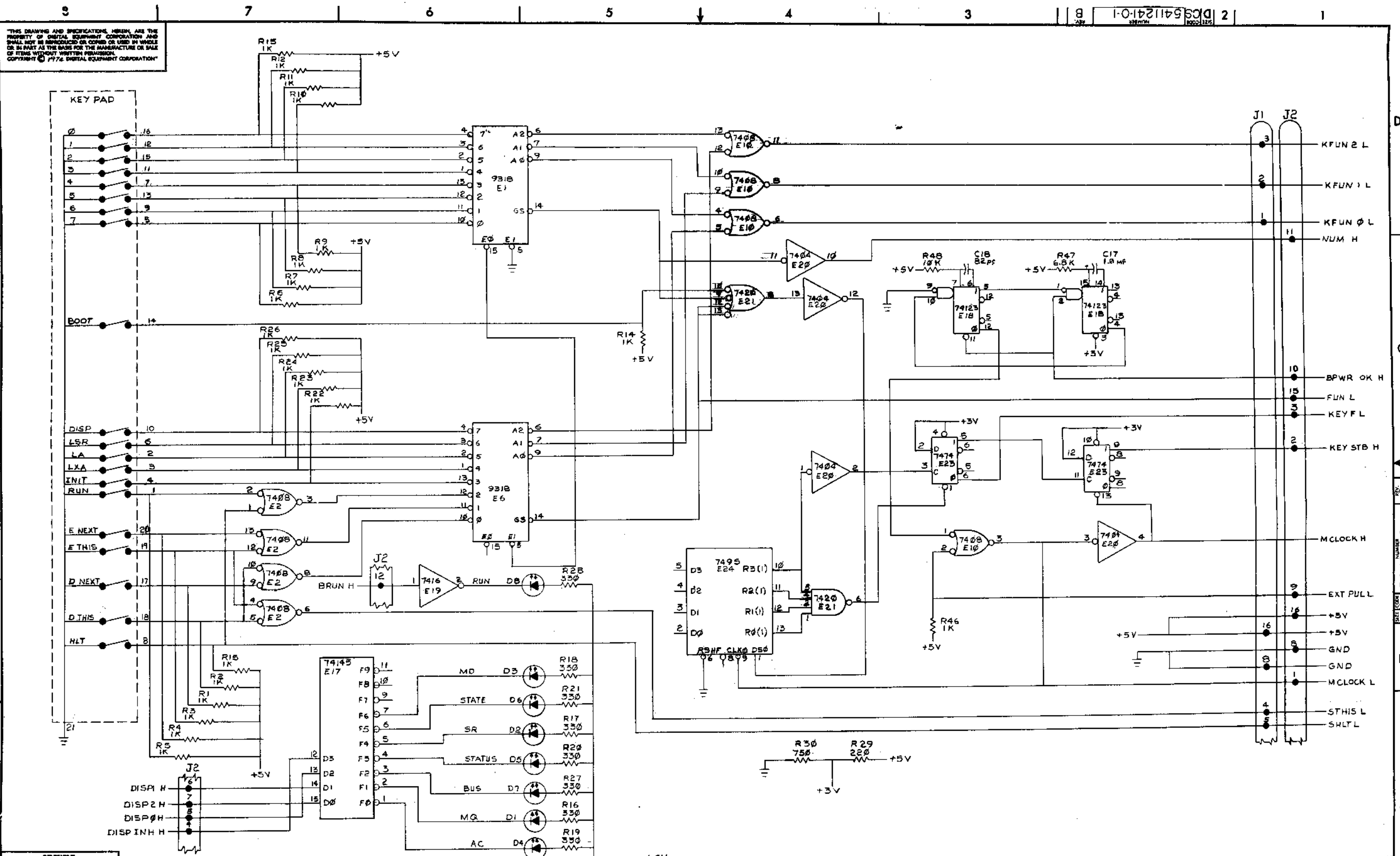

REVISIONS		
CHK	CHANGE NO.	REV.

TITLE	INDICATOR DISPLAY	SIZE/DATE	D CS 5411241-0-1	REV.	B
SCALE	1:1	SHEET	2 OF 3	DIST.	

THIS DRAWING AND SPECIFICATIONS HEREIN ARE THE PROPERTY OF DIGITAL EQUIPMENT CORPORATION AND SHALL NOT BE REPRODUCED OR COPIED OR USED IN WHOLE OR IN PART AS THE BASIS FOR THE MANUFACTURE OR SALE OF ITEMS WITHOUT WRITTEN PERMISSION. COPYRIGHT © 1974, DIGITAL EQUIPMENT CORPORATION.

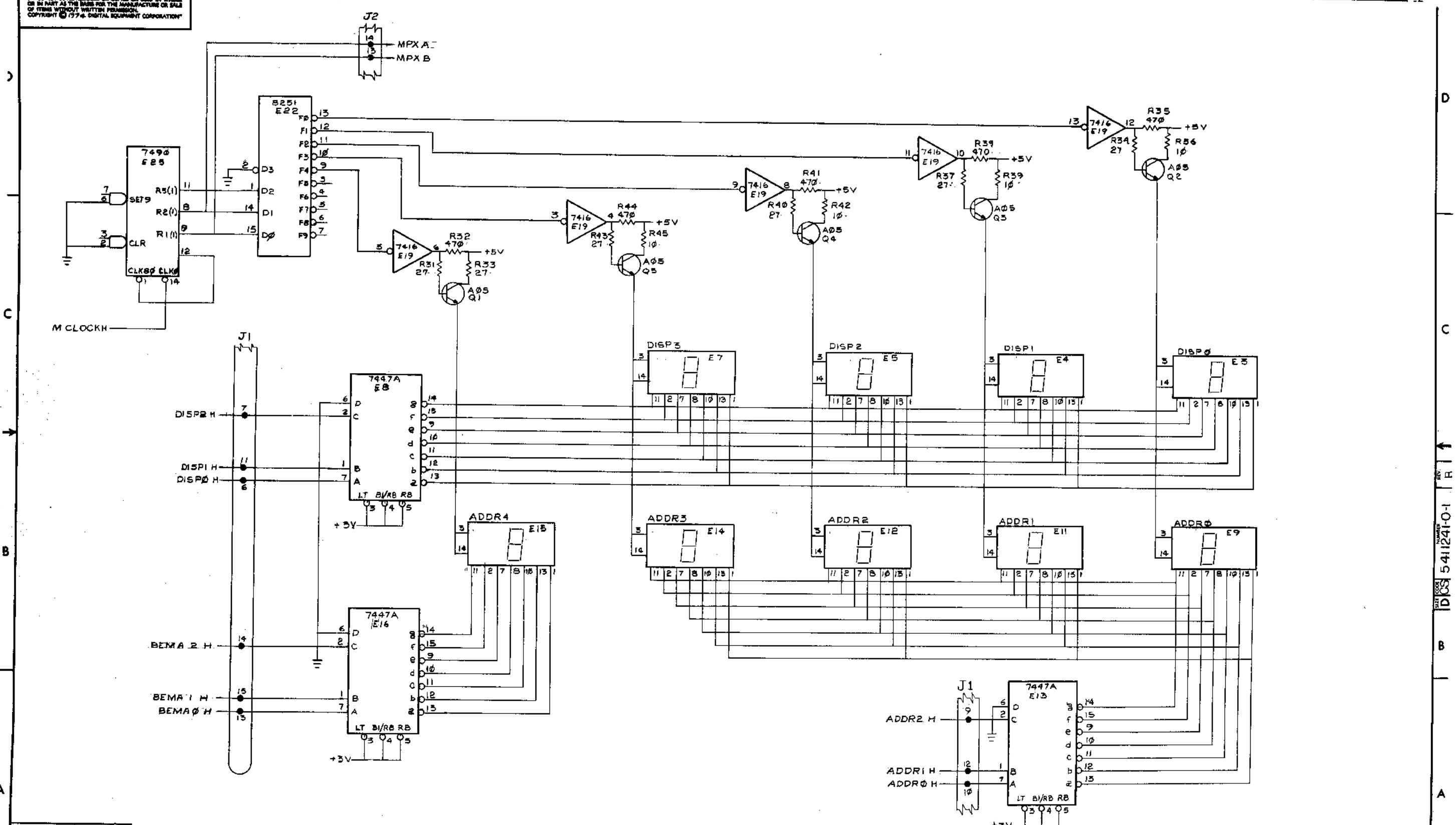

REVISIONS		
CHK	CHANGE NO.	REV.

THIS DRAWING AND SPECIFICATIONS, HEREIN ARE THE PROPERTY OF DIGITAL EQUIPMENT CORPORATION AND SHALL NOT BE REPRODUCED OR COPIED OR USED IN WHOLE OR IN PART AS THE BASIS FOR THE MANUFACTURE OR SALE OF ITEMS WITHOUT WRITTEN PERMISSION. COPYRIGHT © 1975 DIGITAL EQUIPMENT CORPORATION.

NOTES:

J1		J2	
GND	+5V	GND	+5V
B, D, F	16, 11H	R, S, F, J	LL, NH
J, L, N	RL, 10A	L, H, R	RL, TT
E, T, V, X	TT, UU, VV	T, V, X, Z	VV
Z, 1, 2		AL, DL	
DD, FF, JJ		FL, 1	

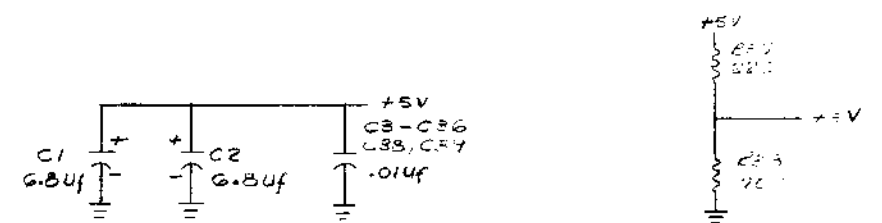
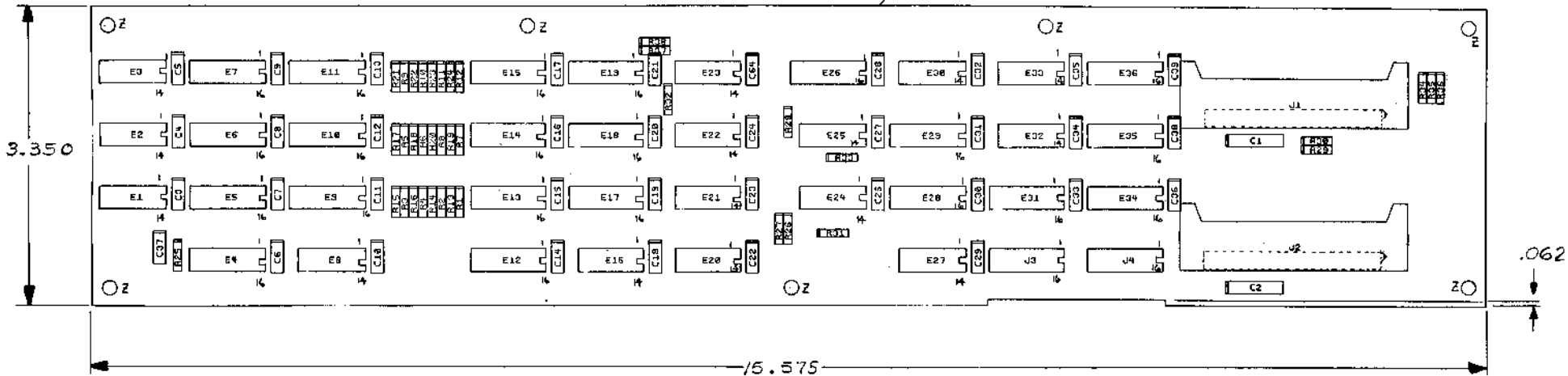

IC TYPE	QTY	REF	DESCRIPTION
I.C DEC 74174	3	16	
I.C DEC 7475	12	5	
I.C DEC 8251	3	16	
I.C DEC 8255	3	16	
I.C DEC 74153	3	16	
I.C DEC 74123	3	16	
I.C DEC 74175	3	16	
I.C DEC 8397	3	16	
IC TYPE		GND	+5V

GND AND 5V ARE USUALLY PIN 7 AND 14 RESPECTIVELY. EXCEPTIONS ARE STATED ABOVE.

IC PIN LOCATIONS

REF	DESIGNATION	DESCRIPTION	PART NO.	QTY	ITEM NO.
REF	X-YCO MOUNTING HOLES (NO. 2)				1
E21	RES 1K 1/4W 5%		1300296		2
E22	RES 220 1/4W 5%		1300271		3
E23	RES 390 1/4W 5%		1300309		4
E24	RES 1K 1/4W 5%		1300266		5
E25	RES 180 1/4W 5%		1301322		6
E26	RES 750 1/4W 5%		1301401		7
E27	RES 6.5K 1/4W 5%		1301423		8
E28	RES 680 1/4W 5%		1301424		9
J1, J2	CONN 40 PIN		1209941		10
J3, J4	SOCKET I.C 16 PIN		1211813-02		11
3FT	WIRE #30 AWG (GRN)		9105740-55		12

FIRST USED ON OPTION MODEL		KCB-AA	
ETCH BOARD REV		B	
PARTS LIST			
DRM	DATE 11/01/75	digital EQUIPMENT CORPORATION	
CHK	DATE 11/16/75	MAINTON, MASSACHUSETTS	
ENG	DATE 11/16/75	TITLE REGISTERS & CONTROL	
PROJ. ENG.	DATE 11/16/75	SIZE CODE DCS	
PROD.	DATE 11/22/75	NUMBER 5411316-0-1	
NEXT HIGHER ASSY		REV. C	
U-AD-7010644-C-0		SCALE	
SEMICONDUCTOR CONVERSION CHART			
SHEET 1 OF 3			

"THIS DRAWING AND SPECIFICATIONS HEREIN ARE THE PROPERTY OF DIGITAL EQUIPMENT CORPORATION AND SHALL NOT BE REPRODUCED OR COPIED OR USED IN WHOLE OR IN PART AS THE BASIS FOR THE MANUFACTURE OR SALE OF ITEMS WITHOUT WRITTEN PERMISSION. COPYRIGHT © 1972 DIGITAL EQUIPMENT CORPORATION"

DCS 5411316-01

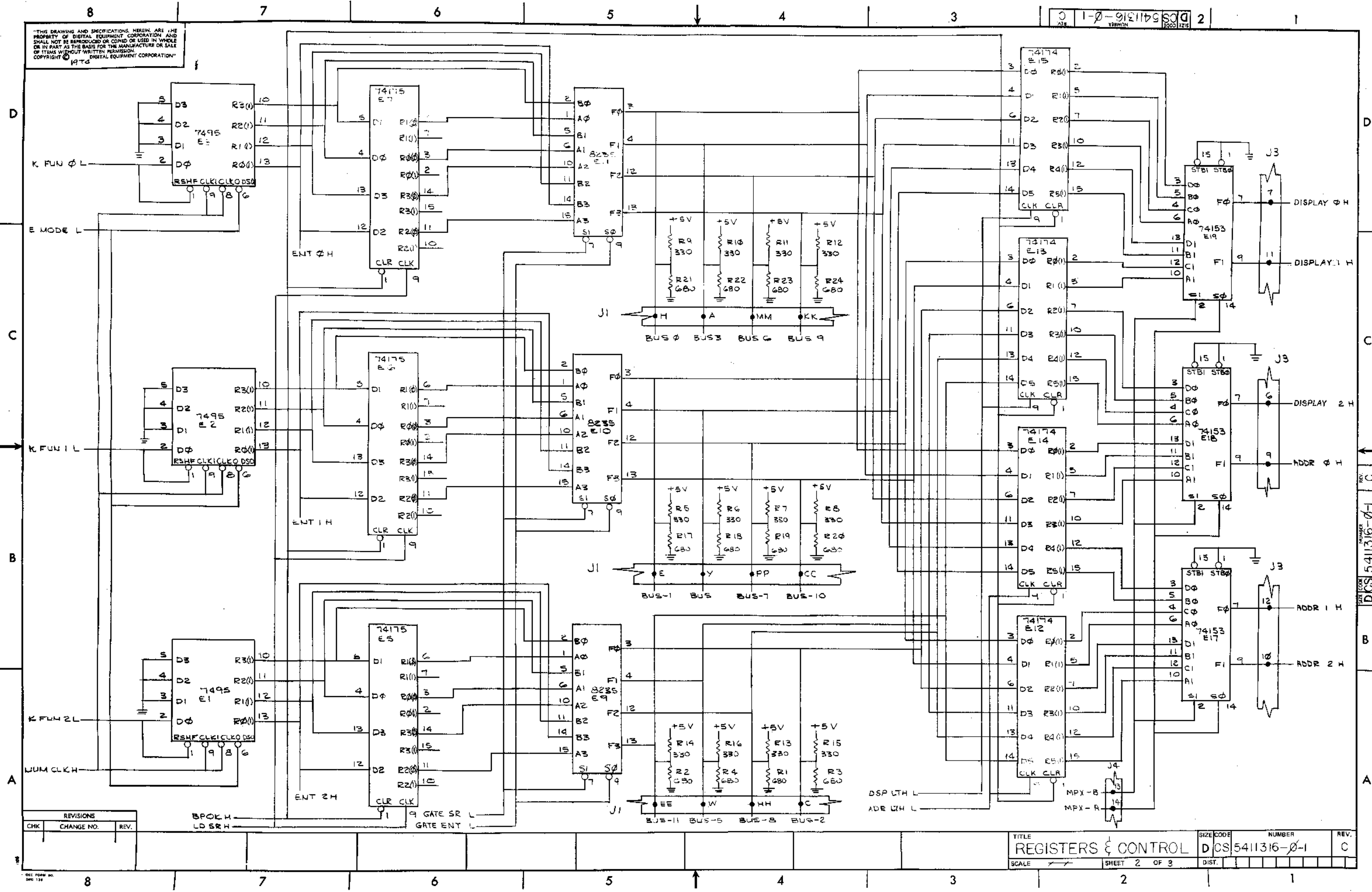

REVISIONS		
CHK	CHANGE NO.	REV.

TITLE: REGISTERS & CONTROL
 NUMBER: DCS 5411316-01
 SHEET 2 OF 3
 SCALE: /

DCS 5411316-01

"THIS DRAWING AND SPECIFICATIONS, HEREIN, ARE THE PROPERTY OF DIGITAL EQUIPMENT CORPORATION AND SHALL NOT BE REPRODUCED OR COPIED OR USED IN WHOLE OR IN PART AS THE BASIS FOR THE MANUFACTURE OR SALE OF ITEMS WITHOUT WRITTEN PERMISSION. COPYRIGHT © 1974 DIGITAL EQUIPMENT CORPORATION"

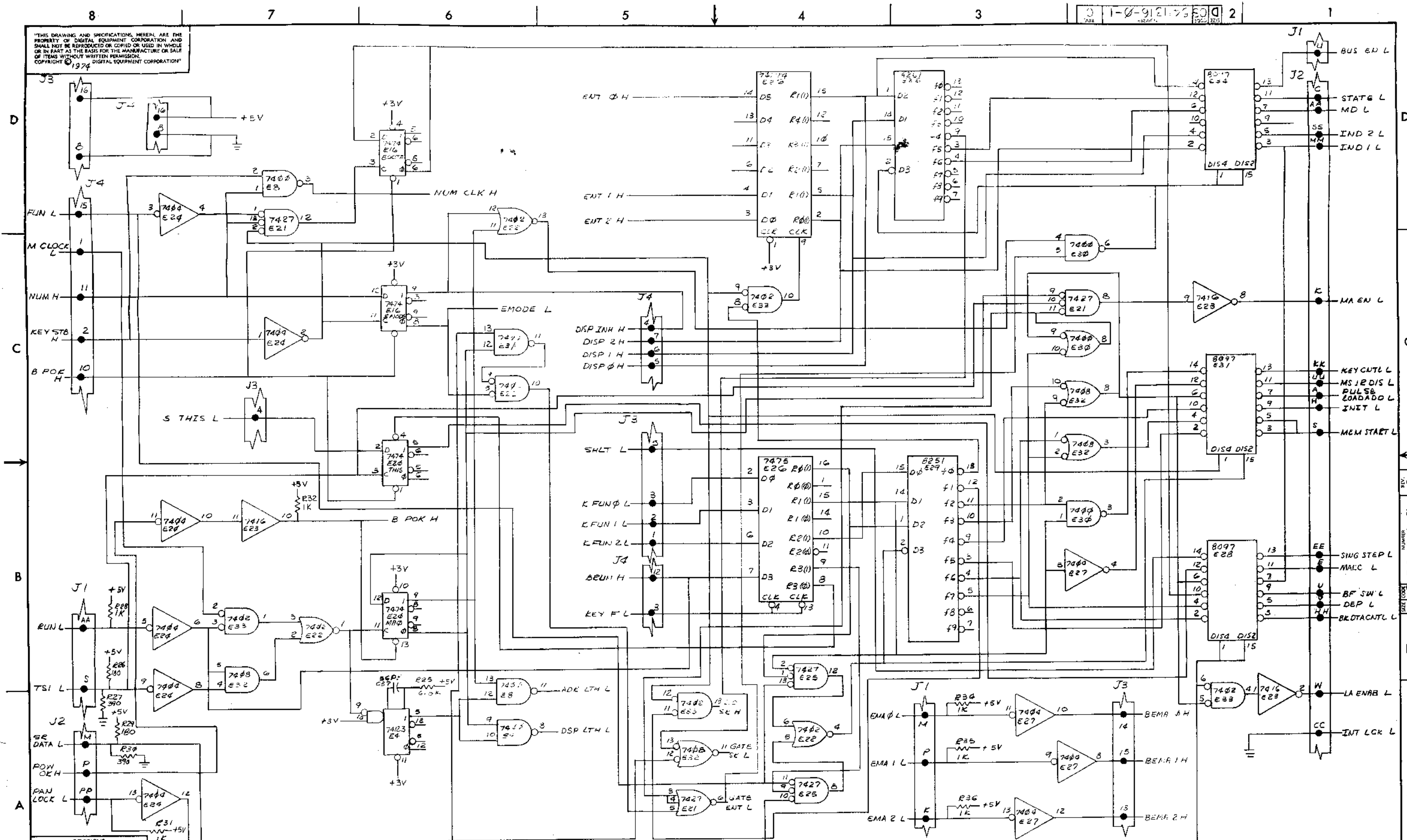

REVISIONS		
CHK	CHANGE NO.	REV.

TITLE	REGISTER & CONTROL	SIZE CODE	DCS 5411316-0-1	NUMBER		REV.	C
SCALE		SHEET	3 OF 3	DIST.			

