

IDENTIFICATION

Product Code: MAINDEC-8/1-D5BB-D  
Product Name: DF32 DISCLESS  
Logic Test, MiniDisc  
Date Created: April 4, 1968  
Maintainer: Diagnostic Group  
Author: J. Hittell

1. ABSTRACT

Discless is a test of the DF32 disc logic and its computer interface. This program does not test the disc, nor associated analog interface circuits.

(The disc is not needed for these routines; if the disc is connected, the disc motor should be turned off. For a complete test of the disc system, use DF32 Disc Data Test.)

2. REQUIREMENTS

2.1 Equipment

- Standard PDP-8/1 Computer
- DF32 Disc Logic
- Light Card (for testing track selector)

2.2 Storage

The program occupies most of memory from address 100 to 3400 and locations 0, 1 and 2.

3. LOADING PROCEDURES

Procedures of normal binary tapes should be followed.

4. STARTING PROCEDURE

For normal operation all switches should be down.

4.1 Starting Address

The starting address for DF32 DISCLESS is 100.

	<u>Special Address</u>
76	Start for abnormal Print Out check
101	Start of Register Test
102	Start of shift, interrupt, error
103	DISC Memory Address Test SR=Address
104	DISC and Computer Extended Address Test SR=Address
105	DISC Data Memory Buffer SR=Data
106	Scope Loop SAD "FF"
107	Scope Loop SAP Pulse
110	Scope Loop ADC "FF"
111	Scope Loop SDP Pulse
112	Scope Loop DEP Pulse

113 Scope Loop TCR "FF"  
 114 Scope Loop IOT 66XX, SR=XX  
 115 Scope Loop Light Box AC 8, 9, 10 and 11=Track

4.2 Program and/or Operator Action

Turn disc motor off

Load Discless into memory

Select EM0 (DISC ZERO) (All other units to off)

Write Inhibit Switches off *Set OPERATE/MAINT switch to MAINT*

Connect Light Card if tracks are to be tested (not necessary for test)

Set the Switch Register to ~~77~~ 100

Load address

Set the SWITCH REGISTER to all zero (down)

Press START

Program will run; if the lightcard is used, lights will light from 0 to 17<sub>8</sub> in sequence and the program will loop upon completion.

5. OPERATING PROCEDURE

5.1 Operational Switch Settings

SW0	UP	Delete Print Out
SW1	UP	Halt After Error
SW2	UP	Sub Test Scope Loop
SW3	UP	Do not Exit Section
SW4	UP	Delete Light Box

There are three basic sections to loop on Interface test, Register test, Shift and Errors test.

When an error is detected and it is necessary to scope it, place SW1 UP to halt on the error, then SW2 UP to loop on it, then SW0 UP to delete printouts.

6. ERRORS

Logic hardware malfunctions detected by the program result in a type out, and a halt if SW2 is UP.

(If the light card is used, operator observance is necessary to detect an error.)

6.1 Error Halts and Description

<u>Address Tag</u>	<u>Function Tested</u>	<u>Good (AC)</u>	<u>Bad (AC)</u>	<u>Corrective Action</u>
603	START KEY CL(TRC)	0000	N/A	A15/B5/B19/B20
611	DSAC, 0 → AC	0000	7777	B18/D22
615	START KEY CL(ADC)	0000	N/A	B16/B5/B19/B18
622	START KEY CL(EMA)	0000	N/A	A21/B5/B19/see 1023
627	START KEY CL(EA)	0000	N/A	A21/B5/B19/see 1023
641	DOES WC BREAK	0000	7777	B29/A13/C15/C16/D22
641	DOES WC BREAK	0000	XXXX	B29/A13
645	DOES CA BREAK	0000	7777	C18 pin K
654	DMAW, 0 → AC	0000	7777	B18
663	DMAR, 0 → AC	0000	7777	B21/D10/D22
670	DMAC NOT SKIP	0000	N/A	B20/B19
676	DMAC, 0 → AC	0000	7777	B21
704	NO DRL STATUS	0000	0004	D20/A13
712	NO NED STATUS	0000	0002	B22/C20/B18/B20/ D18/D19
723	NO FLAG AFTER WRITE	0000	N/A	A19/B22/A15
726	NO FLAG AFTER WRITE	0000	N/A	A19/B22/A15
740	ADDRESS ACCEPT CL(DBR)	0000	0001	A13/B29
740	ADDRESS ACCEPT CL(DBR)	0000	XXXX	A13/B29
744	ADDRESS ACCEPT CL(DBR)	0000	XXXX	A13/B29
1010	NO FLAG AFTER READ	0000	N/A	A19
1013	NO FLAG AFTER READ	0000	N/A	A19
1023	DISC EXT. ADDRESS = 0	0000	XX00	B4/B1/B2/B3
1027	COMPUTER EXT. ADDRESS = 0	0000	0070	CD/23
1027	COMPUTER EXT. ADDRESS = 0	0000	00X0	B27/D20
*1043*	NO SYNC (PSM)	0000	400X	B18/D18/A30
1050	NO PARITY STATUS	0000	0001	A12/B15
1205	SEL ERROR STATUS	0000	N/A	B18/D19/D18/C20
1214	NO WLO (LOWER)	0000	N/A	A17/A12/C20/CHECK WLO SWITCHES
1225	NO WLO (UPPER)	0100	N/A	SAME AS ABOVE
1234	EM3 RAISE NEX	3000	N/A	D18/D19/B18/A30
1243	EM2 RAISE NEX	2000	N/A	D19/B2
1252	EM1 RAISE NEX	1000	N/A	D19/B1
1267	DISC EXT. ADDRESS = SEVEN	3700	0000	CD/23
1267	DISC EXT. ADDRESS = SEVEN	3700	XX00	B1/B2/B3/B4
1303	COMPUTER EXT. ADDRESS	0070	0000	CD/23
1303	COMPUTER EXT. ADDRESS	0070	00X0	D20/B27
1310	SKIP ON NO ERROR (READ)	0000	N/A	B20/C20/A20/B5/B26
**1327	NO INTERRUPT	0000	N/A	D20/B22/A15
1405	SKIP ON DFSE (READ)	0000	N/A	B26/DIODE ON EM SELECT SWITCH
1413	SKIP ON DFSE (WRITE)	0402	N/A	B26/DIODE ON EM SELECT SWITCH
1420	SKIP ON DFSE (WRITE)	0000	N/A	B26/DIODE ON EM SELECT SWITCH
1504	RAISE (NED) STATUS	7002	7000	B22/B18/C20
1522	INTERRUPT ON (NED)	3000	N/A	D20/B22

\*If light card is used (Sync) switch should be off.

\*IF NO LIGHT CARD THEN THE WILL ALWAYS FAIL

\*\* ERROR IN PROGRAM CAUSES THIS 3  
TO ALWAYS FAIL

<u>Address Tag</u>	<u>Function Tested</u>	<u>Good (AC)</u>	<u>Bad (AC)</u>	<u>Corrective Action</u>
1534	CL PAR FF	3000	N/A	A20
1551	WILL (NED) SET (TRC)	7002	N/A	A19/A15/B19/B24
1616	DMA TEST	0000	XXXX	CD22/CD24/B5
1616	DMA BITS 0,1			B6/B12
1616	DMA BITS 2,3			B7/B12
1616	DMA BITS 4,5			B8/B12
1616	DMA BITS 6,7			B9/B13
1616	DMA BITS 8,9			B10/B13
1616	DMA BITS 10,11			B11/B13
1636	EMA TEST			
1636	EMA BIT 1	XX00	XX00	B1/B4
1636	EMA BITS 2,3	XX00	XX00	B2/B4
1636	EMA BITS 4,5	XX00	XX00	B3/B4
1636	EA BITS 6,7,8	XX00	XX00	B27/D20
1663	DMB TEST	XXXX	ALL	B19/A17/A22/B17/A21
		XXXX	0 to 5	B23
		XXXX	6 to 11	B24
1663	DMB BITS 0,1	XXXX	XXXX	A23/B23
1663	DMB BITS 2,3	XXXX	XXXX	A24/B23
1663	DMB BITS 4,5	XXXX	XXXX	A25/B23
1663	DMB BITS 6,7	XXXX	XXXX	A26/B24
1663	DMB BITS 8,9	XXXX	XXXX	A27/B24
1663	DMB BITS 10,11	XXXX	XXXX	A28/B24
2223	SHIFT DMA	1252	2525	A29/B5/B17/A16/A15/ B30
2223	SHIFT DMA	1252	XX52	B6/B7/B8
2223	SHIFT DMA	1252	12XX	B9/B10/B11
2244	SHIFT DMA	6525	XXXX	SAME AS 2223
2261	SHIFT DMA	7252	XXXX	SAME AS 2223
2301	SHIFT DMA	5525	XXXX	SAME AS 2223
2310	SKIP ON (ADC)	N/A	N/A	B16/A17/B15/B18
2341	SHIFT DMB	7777	ALI	A18/A21/A17
2341	SHIFT DMB	7777	XX77	A23/A24/A25/B23
2341	SHIFT DMB	7777	77XX	A26/A27/A28/B24
2430	SHIFT DMB	4000	XXXX	SAME AS 2341
2462	SHIFT DMB	5252	XXXX	SAME AS 2341
2515	SHIFT DMB	2525	XXXX	SAME AS 2341
2617	SHIFT DMA	5777	7777	B14/B15
2632	RAISE (DRL) STATUS	0004	0000	D20/A13
2635	SKIP ON DRL	0004	0004	C20
2641	WILL (DEP) SET (TRC)	N/A	N/A	A19
2653	INTERRUPT ON TRC	N/A	N/A	D20
2675	TRACK COUNTER (EMA)	3702	0000	B16/B19/B23
2675	TRACK COUNTER (EMA)	3702	XX00	B1/B2/B3
2705	TRACK COUNTER (EMA)	0000	XX00	

Light Card Test

NO LIGHTS	A6/A7
2nd & 4th FOUR	A6/A20/A19
1st & 3rd FOUR	A6/A20/A17/A21/ B21/B25
TK 0, 10	A3
TK 1, 11	A3
TK 2, 12	A3
TK 3, 13	A3
TK 4, 14	A2
TK 5, 15	A2
TK 6, 16	A2
TK 7, 17	A2

Printouts created by abnormal switch conditions.

(This test should not be made until program runs in normal.) (Starting Address = 76)

DISK 0 (EM0) SELECTED, EM0 WLO "ON"

LOWER WRITE LOCK "ON"

<u>Address Tag</u>	<u>AC</u>	<u>Function Tested</u>	<u>If No Print Out</u>
1214	0000	WRITE LOCK OFF	A17/A12/C20
1420	0000	SKIP ON NO ERROR	C20

UPPER WRITE LOCK "ON"

1225	0100	WRITE LOCK OFF
1413	0402	SKIP ON NO ERROR

SYNC SWITCH ON LIGHT CARD "ON"

1043	4000	NO SYNC, NO DISC	A30
------	------	------------------	-----

All switches Normal Except

<u>EM OFF</u>	<u>EM1</u>	<u>EM2</u>	<u>EM3</u>	<u>AC</u>	<u>Function Tested</u>	<u>If No Print Out</u>
0712	0712	0712	0712	0002	NO NED STATUS	D19
0744	0744	0744	0744	0001	ADDRESS ACCEPT (0 DBR)	A13/B29
1043	1043	1043	1043	4002	NO SYNC	UNIT SELECTS SW.
1205	1205	1205	1205	1000	SELECT ERROR STATUS	C20/B18
1214	1214	1214	1214	1000	NO WLO	A12/A17/C20
1225	1225	1225	1225	1100	NO WLO	A12/A17/C20
			1234	3002	EM3 RAISE NEX	D19
		1243		2002	EM2 RAISE NEX	D19
	1252			1002	EM1 RAISE NEX	D19
1327	1327	1327	1327	0000	NO INTERRUPT	D20
1413	1413	1413	1413	4406	SKIP ON NO ERROR	C20/A13
1420	1420	1420	1420	0000	SKIP ON NO ERROR	C20/A13/
1551	1551	1551	1551	X006	(NED) SET (TRC)	
2223	2223	2223	2223	2525	SHIFT DMA	B17/D18

<u>EM OFF</u>	<u>EM1</u>	<u>EM2</u>	<u>EM3</u>	<u>AC</u>	<u>Function Tested</u>	<u>If No Print Out</u>
2244	2244	2244	2244	5252	SHIFT DMA	B17/D18
2261	2261	2261	2261	5252	SHIFT DMA	B17/D18
2301	2301	2301	2301	5252	SHIFT DMA	B17/D18
2310	2310	2310	2310	0000	SKIP ON ADC	A17/B18
2430	2430	2430	2430	0000	SHIFT DMB	A17/A21
2462	2462	2462	2462	2525	SHIFT DMB	A17/A21
2617	2617	2617	2617	7777	SHIFT DMB	A17/A21
2632	2632	2632	2632	0000	DRL STATUS	A17/B17/A29
2635	2635	2635	2635	0000	SKIP ON (DRL)	A17/B17/A29
2641	2641	2641	2641	0000	(DEP) SET (TRC)	A19
0622	0622	0622	0622	0100	CL STATUS REQ	

## 6.2 Error Recovery

Press CONTINUE, or restart at 100.

## 7. MISCELLANEOUS

An extra IOT maintenance package has been incorporated in the design of the logic. While this IOT package is not needed for operational use of the disc, it must be in if Discless is to run.

(Coded to 663X)

6631=TAS=TTA      6632=TTB      6634=DBR

*OPERATE/MAINT switch must be set to MAINT for this IOT to work.*

## 8. PROGRAM DESCRIPTION

### 8.1 Discussion

Discless is an incremental test of the DF32 Disc Logic. Starting with basic conditions, such as, "Does START key clear the error and done logic? Can all control flip-flops be set and cleared and can all registers be set and cleared? Will the track counter increment, will all register shift data? Does the Data break work, can we raise an interrupt, check for all status bits, such as write lock out and non-existent disc?" With the use of the light card, test for correct track selection.

There is a chain of flip-flops which must be working if these tests are to pass.

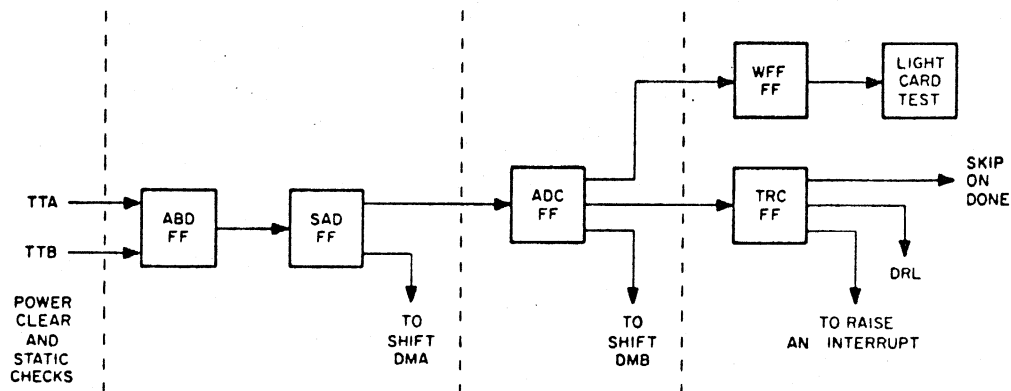

Each disc has  $16_{10}$  tracks, in order to verify the correct track selection a light card indicator is needed. This card is inserted into location A5. With the program running, the lights on the card should rotate from 0 to  $16_{10}$  each pass of the program. (If the light card is not used it will not affect the operation of the test. There is a switch on the card that simulates the photo cell on disc.)

If this test runs and the "abnormal" switch settings on the disc hardware are used to create printouts and the proper one occurs, then any failure that occurs using the DF32 Data Disc Test should be located on the heads, R/W amplifiers, the disc or associated analog circuits.

9. PROGRAM DESCRIPTION

10. LISTING



EXPUNGE  
/MEMORY REFERENCE INSTRUCTIONS  
AND=0000  
TAU=1000  
ISZ=2000  
UCA=3000  
JMS=4000  
JMP=5000  
IOI=6000  
OPR=7000  
/MICROINSTRUCTIONS  
NOP=7020  
CLA=7200  
CLL=7100  
CMA=7040  
CML=7020  
KAR=7010  
KIR=7012  
KAL=7004  
KIL=7006  
IAC=7001  
SMA=7500  
SEA=7440  
SPA=7510  
SNA=7450  
SNL=7420  
SEL=7430  
SKP=7410  
OSK=7404  
HLI=7402  
/COMBINED MICROINSTRUCTIONS  
CIA=7041  
LAS=7604  
SIA=7240  
SIL=7120  
GLK=7204  
/PROGRAM INTERRUPT  
IUN=6001  
IUF=6002  
PUF=6022  
KRB=6012  
/TELETYPE KEYBOARD/READER  
KSF=6031  
KCC=6032  
KRS=6034  
KRB=6036  
/TELETYPE TELEPRINTER/PUNCH  
TSF=6041  
TCF=6042  
TPC=6044  
TLS=6046  
FIXTAB  
PAUSE  
/DIGITAL 8-18-U  
/MESSAGE TYPE-OUT  
/CALL WITH A JMS MESSAGE  
/WITH DATA FOLLOWING  
/RETURN FOLLOWING END OF MESSAGE

3363 0600 PAGE  
 3364 1000  
 3365 3051  
 3366 6600  
 3367 0037  
 3370 7751  
 3371 7750  
 3372 3034  
 3373 3044  
 3374 3024  
 3375 3017  
 3376 3013  
 3377 3000

/CONSTANTS

DMAR=6603  
 TIA=6631  
 TIB=6632  
 MDP=6634  
 DBR=6634  
 DCMA=6601  
 DCEA=6611  
 DSAC=6612  
 UMAW=6605  
 DEAL=6615  
 DEAC=6616  
 DFSE=6621  
 DFSC=6622  
 DMAC=6626  
 XX=7402  
 WC=7750  
 IACW=7751  
 CACW=IACW

/LOAD AND START READ

/CLEAR MAR, PRIIV, DONE FLAG

/CLEAR EXT ADDRESS REGISTERS  
 /CLEAR AC SKIP ON ADC  
 /LOAD AND START WRITE  
 /LOAD EXTENDED ADDRESS  
 /READ EXTENDED ADDRESS  
 /SKIP ON NO ERROR  
 /SKIP ON FLAG  
 /READ DISK ADDRESS  
 /

3400 0000 KA, 0  
 3401 0000 WADD, 0  
 3402 0000 RADD, 0  
 3403 0000 CTC, 0  
 3404 0000 AC, 0 /SAVE AC  
 3405 0000 TKADD, 0  
 3406 0000 ERRDISK, 0  
 3407 0000 ERRTRK, 0  
 3410 0001 NUM, 1  
 3411 0000 CTA, 0  
 3412 0000 CTD, 0  
 3413 0000 WORD1, 0  
 3414 0000 WORD2, 0  
 3415 0000 BA, 0  
 3416 0000 GA, 0  
 3417 0000 BD, 0  
 3420 0000 GD, 0  
 PAGE  
 3600 0000 OUTBUF, 0  
 PAGE  
 4000 2000 INBUF, 0

/IACW-1 FOR WRITE

/IACW-1 FOR READ

/DISK ERROR ADDRESS

/DISK TRACK ERROR ADDRESS

/BAD ADDRESS

/GOOD ADDRESS

/BAD DATA

/GOOD DATA

\*76

/JUMPING OFF FOR ROUTINES

```
/
0076 5124      JMP S82+6      /FOR ABNORMAL TEST
0077 4116      JMS S82        /BS ENTRANCE ADDRESS
0100 5777      JMP BEGIN      /START CR TEST
0101 5776      JMP RTEST     /REGISTER TEST
0102 5775      JMP DYA /SHIFT TEST
0103 5774      JMP SWDMA    /DISC MEMORY ADDRESS
0104 5773      JMP SWEMA    /EXT MEMORY ADDRESS
0105 5772      JMP SWDMB    /DISC MEMORY BUFFER
0106 5771      JMP SA /SAU FF
0107 5770      JMP SB /SAP PLLSE
0110 5767      JMP SC /ADC "FF"
0111 5766      JMP SD /SDP PLLSE
0112 5765      JMP SE /DEP PLLSE
0113 5764      JMP SF /IRC "FF"
0114 5763      JMP SG /IOI 66XX SR = XX
0115 5762      JMP SH /LIGHT BOX SR 8 TO 11 = TRACK
0116 7402      S82,      XX
0117 1161      TAD (NOP
0120 3760      DCA STALL+2
0121 1161      TAD (NOP
0122 3757      DCA S81
0123 5516      JMP I S82
0124 6605      UMAW
0125 6605      UMAW      /CLEARWORD COUNT
0126 5100      JMP 100

/
0157 2620      *
0160 3113
0161 7000
0162 3237
0163 3224
0164 3221
0165 3216
0166 3213
0167 3210
0170 3205
0171 3200
0172 2001
0173 2011
0174 2005
0175 1471
0176 1421
0177 0600
```

```

/COU(00)
*200
0200 0000 MESSAGE, 0
0201 7240 CLA CMA /SET C(AC)=-1
0202 1200 TAD MESSAGE /ADD LOCATION
0203 3010 DCA 10 /AUTO-INDEX REGISTER
0204 1410 TAD I 10 /FETCH FIRST WORD
0205 3210 JCA MSRGHT /SAVE I
0206 1210 TAD MSRGHT
0207 7012 RTR
0210 7012 RTR /ROTATE 0 BITS RIGHT
0211 7012 RTR
0212 4217 JMS TYPECH /TYPE I
0213 1210 TAD MSRGHT /GET DATA AGAIN
0214 4217 JMS TYPECH /TYPE RIGHT HALF
0215 5254 JMP MESSAGE+4 /CONTINUE
0216 0000 MSRGHT, 0 /TEMPORARY STORAGE
0217 0000 TYPECH, 0 /TYPE CHARACTER IN C(AC)0-11
0220 0250 AND MASK77
0221 7450 SNA
0222 5410 JMP I 10 /IS IT END OF MESSAGE?
0223 1251 TAD M40 /YES: EXI
0224 7500 S MA /SUBTRACT 40
0225 5230 JMP .+3 /<40?
0226 1252 TAD C340 /NO
0227 5243 JMP MTP /YES: ADD 300
0230 1253 TAD M3 /10 CODES <40
0231 7440 SZA /SUBTRACT 3
0232 5235 JMP .+3 /IS IT ZERO?
0233 1254 TAD C212 /NO
0234 5243 JMP MTP /YES: CODE 40 IS
0235 1255 TAD M2 /LINE-FEED (212)
0236 7440 SZA /SUBTRACT 2
0237 5242 JMP .+3 /IS IT ZERO?
0240 1256 TAD C215 /NO
0241 5243 JMP MTP /YES: CODE 40 IS
0242 1257 TAD C245 /CARRIAGE-RETURN (215)
0243 6046 MTP, TLS /ADD 200 TO OTHERS >40
0244 6041 TSF /TRANSMIT CHARACTER
0245 5244 JMP .-1 /WAIT FOR FLAG
0246 7200 CLA /NOT SET YES
0247 5617 JMP I TYPECH /SET: CLEAR C(AC)
/RETURN

```

/CONSTANTS

0250	0077	MASK77,	77
0251	7740	M40,	-40
0252	0340	C340,	340
0253	7775	M3, -3	
0254	0212	C212,	212
0255	7776	M2,	-2
0256	0215	C215,	215
0257	0245	C245,	245

0260	7402	SIXTY,	HLT	
0261	7000	NOP		
0262	7000	NOP		/STORE INIT NEXT TIME
0263	7200	CLA		
0264	1660	TAD I	.-4	/ADDRESS OF OPERAND
0265	3267	DCA	.,+2	
0266	5670	JMP I	.,+2	
0267	0000	0		/ADDRESS OF OPERAND
0270	0272	SIXTY+12		/CHANGING REFERENCE (P)
0271	5263	JMP	SIXTY+3	
0272	1667	TAD I	SIXTY+7	/AC (OPERAND)
0273	0377	AND	(0007	
0274	3340	DCA	MASKA	/000X
0275	1667	TAD I	SIXTY+7	/AC (OPERAND)
0276	0370	AND	(0070	
0277	3341	DCA	MASKB	/00X0
0300	1667	TAD I	SIXTY+7	/AC (OPERAND)
0301	0375	AND	(0700	
0302	3342	DCA	MASKC	/0X00
0303	1667	TAD I	SIXTY+7	/AC (OPERAND)
0304	0374	AND	(7000	
0305	3343	DCA	MASKD	/X000
0306	1342	TAD	MASKC	/0X00
0307	7112	RTR	!CLL	
0310	7010	RAR		/0X00 RS3 00X0
0311	1343	TAD	MASKD	/X0X0
0312	7012	RTR		
0313	7010	RAR		
0314	1344	TAD	MASKD+1	/X0X0 RS3 00X0
0315	3342	DCA	MASKC	/TEMP STORAGE
0316	2260	ISZ	SIXTY	/INCREMENT FOR STORAGE
0317	4270	JMS	SIXTY+10	/FIND STORAGE ADDRESS
0320	1342	TAD	MASKC	/0X0X
0321	3667	DCA I	SIXTY+7	/STORE OPERAND AS SPECIFIED
0322	1341	TAD	MASKB	/00X0
0323	7004	RAL		
0324	7006	RTL		/00X0 SL3 00X0
0325	1340	TAD	MASKA	/0X00+000X=00X0
0326	1344	TAD	MASKD+1	/0X0X+6060=6X0X
0327	3343	DCA	MASKD	/TEMP STORAGE
0330	2260	ISZ	SIXTY	/INCREMENT FOR STORAGE
0331	4270	JMS	SIXTY+10	/FIND STORAGE ADDRESS
0332	1343	TAD	MASKD	/0X0X
0333	3667	DCA I	SIXTY+7	/STORE OPERAND AS SPECIFIED
0334	1373	TAD	(SIXTY+12	/HOUSE KEEPING
0335	3270	DCA	SIXTY+10	
0336	2260	ISZ	SIXTY	/INCREMENT FOR RETURN
0337	5660	JMP I	SIXTY	/RETURN
0340	0000	MASKA,	0	
0341	0000	MASKB,	0	
0342	0000	MASKC,	0	
0343	0000	MASKD,	0	
0344	6060		6060	
		PAUSE		
		PAGE		
0373	0272			
0374	7000			
0375	0700			
0376	0070			
0377	0007			

```

/PRINT OUT ROUTINES
/ROUTINE TO PRINT OUT FAILING TEST ADDRESS
/AND CONTENTS OF AC
/XXXX XXXX ---- ADDRESS (AC)

```

0400	7402	ERAUD,	XX	
0401	4777	JMS	IPRINT	
0402	6002	IUF		
0403	4776	JMS	SIXTY	
0404	0400	ERAUD		
0405	0411	.	+4	
0406	0412	.	+4	
0407	4775	JMS	MESSAGE	/ADDRESS
0410	4543	4543		
0411	6060	6060		
0412	6060	6060		
0413	4000	4000		
0414	4776	JMS	SIXTY	
0415	3404	AC		
0416	0422	.	+4	
0417	0423	.	+4	
0420	4775	JMS	MESSAGE	/CONTENTS OF AC
0421	4040	4040		
0422	6060	6060		
0423	6060	6060		
0424	0000	0000		
0425	7604	LAS		
0426	0374	AND	(2002	
0427	7650	SNA:CLA		
0430	5600	JMP	I ERAUD	
0431	1773	TAD	AC	/AC
0432	7402	HLT		
0433	5600	JMP	I ERAUD	

/COMPARISON ERROR PRINT OUT

```

/GDXXXX  BDXXXX
0434  7402  BADCOM,      XX
0435  4777      JMS IPRINT
0436  4776      JMS SIXTY
0437  0434      BADCOM
0440  0444      .+4
0441  0445      .+4
0442  4775      JMS MESSAGE
0443  4543      4543
0444  6060      6060
0445  6060      6060
0446  0000      0000
0447  4776      JMS SIXTY
0450  3420      GD          /GOOD
0451  0463      .+12
0452  0464      .+12
0453  4776      JMS SIXTY
0454  3417      BD          /BAD
0455  0467      .+12
0456  0470      .+12
0457  4775      JMS MESSAGE
0460  4040      4040      /CRLF
0461  0704      0704      /GOOD DATA
0462  4040      4040
0463  6060      6060
0464  6060      6060
0465  4002      4002
0466  0440      0440      /BAD DATA
0467  6060      6060
0470  6060      6060
0471  0000      0000
0472  7604      LAS
0473  0374      AND (2000
0474  7650      SNA:CLA
0475  7410      SKP
0476  7402      HLT
0477  5634      JMP I BADCOM  /EXIT

```



0500	7402	BAUADD,	XX
0501	4777	JMS	IPRINT
0502	4776	JMS	SIXTY
0503	0500	BADADD	
0504	0510	.+4	
0505	0511	.+4	
0506	4775	JMS	MESSAGE
0507	4543	4543	
0510	6060	6060	
0511	6060	6060	
0512	0000	0000	
0513	4776	JMS	SIXTY
0514	3410	GA	
0515	0527	.+12	
0516	0530	.+12	
0517	4776	JMS	SIXTY
0520	3410	BA	
0521	0533	.+12	
0522	0534	.+12	
0523	4775	JMS	MESSAGE
0524	4040	4040	
0525	0701	0701	
0526	4040	4040	
0527	6060	6060	
0530	6060	6060	
0531	4002	4002	
0532	0140	0140	
0533	6060	6060	
0534	6060	6060	
0535	0000	0000	
0536	7604	LAS	
0537	0374	AND	(2000
0540	7650	SNA:CLA	
0541	7410	SKP	
0542	7402	HLT	
0543	5700	JMP	I BADADD

```

0544 0000 PAUSE0
/PDP-8 INTERFACE TEST NO DISC RMX5 3/6/67
/EM0 SHOULD BE SELECTED

0573 3404 PAGE 3
0574 2000
0575 0200
0576 0260
0577 3124

DEFINE SCOPE
<JMS SCOPEA>
DEFINE HALT
<JMS ERADD>
DEFINE NPAGE
<JMP I (.+20087600)>
/FLAG TEST (CLEAR)
BEGIN, DFSC /SKIP ON FLAG
0600 6622 SKP
0601 7410 HALT /FLAG SHOULD HAVE BEEN CLEARED BY START
0602 4777 SCOPE
0603 4776 /DOES 6612 CLEAR THE AC? (DSAC)
CLA CMA /AC SET TO SEVENS
0604 7240 DSAC
0605 6612 NOP
0606 7000 SZA
0607 7440 HALT /HALT BECAUSE AC NOT ZERO
0610 4777 SCOPE
0611 4776 /WAS ADC "FF" CLEARED BY START KEY
DSAC /SKIP ON ADC
0612 6612 SKP
0613 7410 HALT /ADC SET ... START SHOULD CL ADC "FF"
0614 4777 SCOPE
0615 4776 /
/DOES START CLEAR THE DISK EXT ADDRESS
DEAC-2 /READ STATUS REGISTER
0616 6614 AND (3700 /MASK DISC EXT ADDRESS
0617 0375 SZA
0620 7440 HALT /START KEY DID NOT CLEAR EMA
0621 4777 SCOPE
0622 4776 /
/DOES TARI CLEAR THE COMPUTER EXT ADDRESS REGISTER
DEAC-2
0623 6614 AND (0070 /MASK FOR COMPUTER EXT ADDRESS
0624 0374 SZA
0625 7440 HALT /START KEY DID NOT CLEAR EA
0626 4777 SCOPE
0627 4776

```

/DOES DISK BREAK TO RIGHT LOC.

0630	7240	CLA CMA	
0631	3173	DCA WC	
0632	7240	CLA CMA	
0633	3172	DCA IACW	/WRITE ONE WORD
0634	6605	DMAW	
0635	7200	CLA	
0636	1173	TAD WC	
0637	7440	SZA	
0640	4177	HALT	/WORD COUNT NOT CORRECT
0641	7200	CLA	
0642	1172	TAD IACW	
0643	7440	SZA	
0644	4177	HALT	/ADDRESS CONTROL WORD NOT CORRECT
0645	4176	SCOPE	

/IS AC CLEARED BY DMAW?

0640	7240	CLA CMA	
0647	3173	DCA WC	/ONE WORD
0650	7240	CLA CMA	
0651	6605	DMAW	/IOI SHOULD CLEAR AC
0652	1440	SZA	
0653	4177	HALT	/AC NOT CLEARED
0654	4176	SCOPE	

/

/IS AC CLEARED BY DMAR

0655	7240	CLA CMA	
0656	3173	DCA WC	/ONE WORD
0657	7240	CLA CMA	
0660	6603	DMAR	/IOI SHOULD CLEAR AC
0661	7440	SZA	
0662	4177	HALT	/AC NOT CLEARED
0663	4176	SCOPE	

```

/UMAC SHOULD NOT SKIP
0664 6611 DCEA
0665 6620 UMAC
0666 7410 SKP
0667 4777 HALT /UMAC SKIPPED
0670 4776 SCOPE
/
/WILL UMAC CLEAR AC
0671 6601 UCMA /CLEAR UMAC
0672 7240 CLATCMA
0673 6620 UMAC
0674 7440 SZA /MAR TO AC
0675 4777 HALT /AC NOT CLEARED BY USAC
0676 4776 SCOPE
/
/STATUS REGISTER TEST (NO DRL)
0677 6611 DCEA
0700 6610 DEAC /EM0
0701 0371 AND (4 /MASK FOR DRL
0702 7440 SZA
0703 4777 HALT /DRL UP
0704 4776 SCOPE
/
/STATUS REGISTER TEST (NO NEW FF)
0705 6611 DCEA /EM0
0706 6610 DEAC
0707 0370 AND (2
0710 7440 SZA
0711 4777 HALT /WRITE LOOK OUT OR NEW SET
0712 4776 SCOPE
/

```

/  
/CHECK FOR NO FLAG AFTER WRITE  
/ (DMAW) (DFSC)

0/13	7240	CLA CMA	
0/14	3/72	DCA IACW	/MEMORY LOCATION ZERO
0/15	7240	CLA CMA	/AC=7/7/
0/16	3/73	DCA WC	/WORD COUNT=7/7/
0/17	6605	DMAW	/START WRITE ONE WORD
0/20	6622	DFSC	/SKIP ON FLAG
0/21	7410	SKP	
0/22	4/77	HALT	/FLAG UP
0/23	6622	DFSC	/SKIP ON FLAG
0/24	7410	SKP	
0/25	4/77	HALT	/FLAG UP
0/26	4/76	SCOPE	

/  
/WILL ADDRESS ACCEPT CLEAR DATA BREAK REQUEST FF?

0/27	6605	DMAW	/WRITE SET DBR FF
0/30	7200	CLA	
0/31	3/73	DCA WC	
0/32	3/72	DCA IACW	
0/33	6605	DMAW	/SHOULD NOT SET DBR "FF"
0/34	7000	NOP	
0/35	1/73	TAD WC	
0/36	7440	SZA	
0/37	4777	HALT	/WORD COUNT SHOULD BE ZERO
0/40	7200	CLA	
0/41	1/72	TAD IACW	
0/42	7440	SZA	
0/43	4777	HALT	/IACW SHOULD BE ZERO
0/44	4/76	SCOPE	
0/45	5/67	NPAGE	

0/67 1000 PAGE  
 0/70 0002  
 0/71 0004  
 0/72 7751  
 0/73 7750  
 0/74 0070  
 0/75 3700  
 0/76 5242  
 0/77 0400

/DISK MEMORY ADDRESS READ

1000 7240 CLA CMA  
 1001 3777 DCA WC /READ ONE WORD  
 1002 7240 CLA CMA  
 1003 3776 DCA IACW /MEMORY LOCATION ZERO  
 1004 6603 DMAR /START READ ONE WORD  
 1005 0022 DFSC /SKIP ON FLAG  
 1006 7410 SKP  
 1007 4775 HALT /FLAG UP  
 1010 0022 DFSC /SKIP ON FLAG  
 1011 7410 SKP  
 1012 4775 HALT /FLAG UP  
 1013 4774 SCOPE

/STATUS REGISTER CHECK EXTENDED ADDRESS

1014 7200 CLA  
 1015 6610 DEAL  
 1016 7200 CLA /LOAD EXTENDED ADDRESS WITH ZEROS  
 1017 6610 DEAC  
 1020 0373 AND (3700  
 1021 7440 SZA  
 1022 4775 HALT /DISC EXTENDED ADDRESS NOT CLEAR  
 1023 6610 DEAC  
 1024 0372 AND (0070  
 1025 7440 SZA  
 1026 4775 HALT /COMPUTER EXTENDED ADDRESS NOT CLEAR  
 1027 4774 SCOPE

```

/
/DEAC READ DISK EXTENDED ADDRESS
/CHECK FOR NO SYNC MARK
1030 7300 CLA CLL
1031 3771 DCA CID
1032 6616 DEAC
1033 7000 NOP
1034 7500 SMA /SYNC
1035 7410 SKP /NO
1036 5242 JMP .+4 /YES
1037 2771 ISZ CID /LOOP
1040 5232 JMP .-6
1041 7410 SKP /NO SYNC PULSE OR NO DISC SELECTED
1042 4775 HALT /FOUND SYNC PULSE
1043 4774 SCOPE

```

```

/
/PARITY STATUS BIT TEST
1044 6616 DEAC
1045 0370 AND (0001 /MASK FOR PARITY STATUS
1046 7440 SZA
1047 4775 HALT /PARITY STATUS UP
1050 4774 SCOPE

```

```

/
1051 5767 NPAGE

```

```

1167 1200 PAGE
1170 0001
1171 3412
1172 0070
1173 3700
1174 3242
1175 0400
1176 7751
1177 7750

/TEST WRITE LOCK OUT SWITCH OR NO DISC
1200 6602 6602 /READ MODE INHIBIT WRITE LOCK OUT SWITCHES
1201 6616 DEAC
1202 7012 RTR
1203 7430 SZL
1204 4777 HALT /NO DISC NEU SET
1205 4776 SCOPE

/
/CHECK TO SEE IF WRITE LOCK OUT SWITCHES OFF (LOWER)
1206 6604 6604 /WRITE MODE
1207 6616 DEAC /READ STATUS
1210 7000 NOP
1211 7012 RTR /AC10 TO LINK
1212 7430 SZL
1213 4777 HALT /AC1 UP WRITE LOCK OUT SWITCH
1214 4776 SCOPE

/CHECK TO SEE IF WRITE LOCK SWITCH OFF (UPPER)
1215 1377 TAD (3400) /UPPER TRACK
1216 6616 DEAC
1217 6604 DMAW-1 /WRITE MODE
1220 6616 DEAC
1221 7000 NOP
1222 7012 RTR /AC10 TO LINK
1223 7430 SZL
1224 4777 HALT /AC1 UP WRITE LOCK OUT SWITCH
1225 4776 SCOPE

/
/RAISE STATUS BIT AC0/VEX
/EMS SHOULD NOT BE SELECTED
1226 1375 TAD (3000)
1227 6616 DEAC /SELECT DISC/EMS
1230 6616 DEAC /READ STATUS
1231 7000 NOP
1232 7500 SMA
1233 4777 HALT /VEX DID NOT RAISE PSM
1234 4776 SCOPE /DISC 0

```



/EM2 SHOULD NOT BE SELECTED

```
/
1235 1374 TAD (2000 /SELECT EM1
1236 6615 DEAL
1237 6616 DEAC
1240 7000 NOP
1241 7500 SMA
1242 4777 HALT /NEX NOT UP
1243 4776 SCOPE
```

/EM1 SHOULD NOT BE SELECTED

```
/
1244 1373 TAD (1000 /SELECT EM1
1245 6615 DEAL
1246 6616 DEAC
1247 7000 NOP
1250 7500 SMA
1251 4777 HALT /NEX NOT UP
1252 4776 SCOPE
1253 6611 DCEA
```

```

/WILL EXTENDED ADDRESS HOLD SEVENS
1254 7240 CLA:CMA
1255 6615 DEAL
1256 0372 AND (3700 /DISC EXT ADDRESS MASK
1257 3771 DCA BA
1260 1771 TAD BA /STORE BA
1261 7041 CIA
1262 1372 TAD (3700
1263 7650 SNA:CLA /TEST
1264 5267 JMP .+3 /GOOD
1265 1771 TAD BA /BAU
1266 4777 HALT /AC SHOULD =3/00
1267 7000 NOP
1270 7240 CLA:CMA
1271 6615 DEAL
1272 0370 AND (0070 /COMPUTER EXT ADDRESS
1273 3771 DCA BA /STORE
1274 1771 TAD BA
1275 7041 CIA
1276 1370 TAD (0070
1277 7650 SNA:CLA /TEST
1300 5303 JMP .+3 /GOOD
1301 1771 TAD BA /BAU
1302 4777 HALT /AC SHOULD=00/0
1303 4776 SCOPE

/
/SKIP ON NO ERROR CFSE
1304 6611 JCEA
1305 6603 DMAR /READ STATE
1306 6621 DFSE /SKIP ON NO ERROR
1307 4777 HALT /DATA REQUEST LATE, PARITY OR NO DISK SET
1310 4776 SCOPE

```

```

/WILL THE DISK HONOR AN INTERRUPT
1311 4340 JMS CLFLAG
1312 7200 CLA /SET UP FOR INTERRUPT
1313 1367 TAD (10F
1314 3001 DCA 0001
1315 1366 TAD (JMP I 0003
1316 3002 DCA 0002
1317 1365 TAD (.+7
1320 3003 DCA 0003
1321 7240 CLA CMA
1322 3764 DCA WC
1323 6605 DMAW
1324 6001 ION /DID NOT INTERRUPT
1325 7410 SKP
1326 4777 HALT /INTERRUPT UP OR NO DISC
1327 6002 IOF
1330 4776 SCOPE
1331 6611 DCEA
1332 6601 DCMA
1333 7604 LAS
1334 0377 AND (400
1335 7440 SZA /LOOP ON STATIC TEST
1336 5763 JMP BEGIN
1337 5762 NPAGE
/Routine to clear flags
1340 7402 CLFLAG, XX
1341 6601 6601
1342 6002 6002
1343 6022 6022
1344 6042 6042
1345 6012 6012
1346 6072 6072
1347 6502 6502
1350 6032 6032
1351 6762 6762
1352 5740 JMP I CLFLAG
1353 7402 RANDOM, XX
1354 2761 ISZ CID
1355 7200 CLA
1356 1761 TAD CID
1357 5753 JMP I RANDOM

```

1361	3412	PAGE
1362	1400	
1363	0600	
1364	7750	
1365	1326	
1366	5403	
1367	6002	
1370	0070	
1371	3415	
1372	3710	
1373	1000	
1374	2000	
1375	3000	
1376	3242	
1377	0400	

/

/SKIP ON NO ERROR WLO UPPER (READ)

1400	6603	DMAR	/READ STATE
1401	1377	TAD (400)	/UPPER HALF
1402	6615	DEAL	
1403	6621	DFSE	/SKIP ON NO ERROR
1404	4777	HALT	
1405	4776	SCOPE	

/

/SKIP ON NO ERROR (WRITE) WLO (UPPER)

1406	6605	DMAW	/WRITE STATE
1407	1377	TAD (400)	
1410	6615	DEAL	
1411	6621	DFSE	/SKIP ON NO ERROR
1412	4777	HALT	/WIRE LOCK OUT ON
1413	4776	SCOPE	

/

/SKIP ON NO ERROR (WRITE) WLO LOWER

1414	6611	DCEA	/LOWER
1415	6605	DMAW	/WRITE STATE
1416	6621	DFSE	/SKIP ON NO ERROR
1417	4777	HALT	/WRITE LOCK OUT ON
1420	4776	SCOPE	

```

/EXECUTE DMA TEST
1421 7200 RIEST, CLA
1422 6002 IOF
1423 3775 DCA CIA
1424 4774 JMS DMA
1425 7240 CLA:CMA
1426 4774 JMS DMA
1427 4773 JMS RANDOM
1430 4774 JMS DMA
1431 2775 ISZ CIA
1432 5227 JMP .-3
1433 4776 SCOPE

```

```

/EXECUTE EMA TEST
1434 7240 CLA:CMA
1435 6615 DEAL
1436 7000 NOP
1437 7000 NOP
1440 7000 NOP
1441 7200 CLA
1442 3775 DCA CIA
1443 4772 JMS EMA
1444 7240 CLA:CMA
1445 4772 JMS EMA
1446 4773 JMS RANDOM
1447 2775 ISZ CIA
1450 5245 JMP .-3
1451 4776 SCOPE

```

```

/EXECUTE DMB TEST
1452 7200 CLA
1453 6611 DCEA
1454 3775 DCA CIA
1455 4771 JMS DMB
1456 7240 CLA:CMA
1457 4771 JMS DMB
1460 4773 JMS RANDOM
1461 4771 JMS DMB
1462 2775 ISZ CIA
1463 5260 JMP .-3
1464 4776 SCOPE
1465 7604 LAS
1466 0377 AND (400
1467 7440 SZA
1470 5221 JMP RIEST

```

```

/
/RAISE STATUS BIT AC 10
/EMS SHOULD NOT BE SELECTED
1471 7200  OYA,      CLA
1472 1370  TAD (3000
1473 6615  DEAL          /SELECT DISC/EMS/RAISE NEX
1474 6631  TTA          /SET NEU
1475 6616  DEAC
1476 0367  AND (2
1477 1366  TAD (-2
1500 7450  SNA
1501 5304  JMP .+3
1502 6616  DEAC
1503 4777  HALT          /NEX DID NOT RAISE AC 10
1504 7200  CLA
1505 6615  DEAL          /DISC 0
1506 4776  SCOPE

```

```

/FORCE AN INTERRUPT WITH NEU
1507 7200 CLA
1510 1365 TAD (JMP I 0002
1511 3001 DCA 0001
1512 1364 TAD (.+11
1513 3002 DCA 0002
1514 1370 TAD (3000
1515 6615 DEAL /SEL NON EXISTANT DISC
1516 6001 ION
1517 7000 NOP
1520 6002 IOF
1521 4777 HALT /NEU DID NOT RAISE AN INTERRUPT
1522 7200 CLA
1523 4776 SCOPE

/DOES TP1 CLEAR PAR "FF"
1524 6001 DCMA /CLEAR PER
1525 6632 TTB
1526 6632 TTB /TP1 CL PAR
1527 1370 TAD (3000
1530 6615 DEAL /GEN DEP VIA NEU
1531 6631 TTA /SET NEU --- PER IF PAR SET
1532 6621 DFSE /SKIP ON NO ERROR
1533 4777 HALT
1534 4776 SCOPE

/WILL NEU SET DONE (TRC)?
1535 6611 DCEA /CLEAR EXT ADDRESS
1536 6601 DCMA
1537 7240 CLA: CMA
1540 3763 DCA WC
1541 6605 DMAW /SET WORD COUNT OVERFLOW
1542 1370 TAD (3000
1543 6615 DEAL /LOAD EXT ADDRESS - RAISE NEX
1544 6631 TTA /SET NEU GENFRATE DEP
1545 6616 DEAC /READ STATUS
1546 7000 NOP
1547 6622 DFSC /DID NEU SET DONE?
1550 4777 HALT /NJ
1551 4776 SCOPE
1552 5762 NPAGE

```

1562 1600 PAGE  
 1563 7750  
 1564 1523  
 1565 5402  
 1566 7776  
 1567 0002  
 1570 3000  
 1571 1640  
 1572 1620  
 1573 1353  
 1574 1601  
 1575 3411  
 1576 3242  
 1577 0400  
 1600 5777

NPAGE  
 /STATIC ADDRESS REGISTER TEST (DISK MOTOR OFF)  
 /JMS DMA, AC=DATA  
 UMA, XX

1601 7402  
 1602 3776 DCA GA  
 1603 3775 DCA IACW  
 1604 1776 TAD GA  
 1605 6603 6603 /LOAD ADDRESS REG  
 1606 7200 CLA  
 1607 6624 6624 /READ ADDRESS REG  
 1610 3774 DCA BA  
 1611 1774 TAD BA  
 1612 7041 CIA  
 1613 1776 TAD GA  
 1614 7440 SZA  
 1615 4773 JMS BADA00  
 1616 7200 CLA  
 1617 5601 JMP I DMA



```

/STATIC TEST OF EXTENDED ADDRESS REGISTER (DISK MOTOR OFF)
/JMS EMA AC=DATA
1620 7402 EMA, XX
1621 0372 AND (3770)
1622 3776 DCA GA
1623 1776 TAD GA
1624 6615 DEAL /LOAD EXT ADDRESS
1625 7200 CLA
1626 6614 6614 /READ EXT ADDRESS
1627 0372 AND (3770)
1630 3774 DCA BA
1631 1774 TAD BA
1632 7041 CIA
1633 1776 TAD GA
1634 7440 SZA
1635 4773 JMS BADADD
1636 7200 CLA
1637 5620 JMP I EMA

/STATIC DATA REGISTER TEST (DISK MOTOR OFF)
/JMS DMB, AC=DATA
1640 7402 DMB, XX
1641 3771 DCA GD
1642 7240 CLA:CMA
1643 3770 DCA WC
1644 1367 TAD (GD-1)
1645 3775 DCA IACW
1646 6604 6604 /LOAD DMB
1647 7240 CLA:CMA
1650 3770 DCA WC
1651 1376 TAD (BD-1)
1652 3775 DCA IACW
1653 6602 6602 /READ
1654 6634 6634 /RAISE A REQUEST
1655 7200 CLA
1656 1771 TAD GD
1657 7041 CIA
1660 1767 TAD BU
1661 7440 SZA
1662 4766 JMS BADCOM
1663 7200 CLA
1664 5640 JMP I DMB
1766 0434 PAGE
1767 3417
1770 7750
1771 3420
1772 3770
1773 0560
1774 3415
1775 7751
1776 3416
1777 2000

```

```

2000 5215      JMP  .+15          /JMP AROUND SCOPE LOOPS
2001 7200      SWDMB,      CLA
2002 7604      LAS
2003 4777      JMS  DMB
2004 5201      JMP  SWDMB
2005 7200      SWDMA,      CLA
2006 7604      LAS
2007 4776      JMS  DMA
2010 5205      JMP  SWDMA
2011 7200      SWEMA,      CLA
2012 7604      LAS
2013 4775      JMS  EMA
2014 4211      JMS  SWEMA
2015 5774      NPAGE
2174 2200      PAGE
2175 1620
2176 1601
2177 1640

```

```

/INTERFACE USING SPECIAL IOIS
/CAN WE SHIFT DISC MEMORY ADDRESS WITH UMA

```

```

2200 4777      SCOPE
2201 6601      DCMA
2202 6611      6611
2203 4776      JMS  SAD /SET SAD
2204 7200      CLA
2205 1375      TAD  (2525          /DATA TO UMA
2206 6605      DMAW          /LOAD UMA
2207 6632      TTB
2210 6632      TTB          /GEN TP1, CLEAR SAD, SET MAD
2211 4774      JMS  SAP /SHIFT UMA
2212 6620      DMAC          /READ DMAC
2213 3773      DCA BA
2214 1372      TAD  (1252          /WHAT DATA SHOULD BE
2215 7041      CIA
2216 1773      TAD  BA
2217 7650      SNA:CLA /TEST
2220 5223      JMP  .+3
2221 1773      TAD  BA /LOAD AC WITH BA
2222 4771      HALT          /ACI = 2525, ACF = 1252
2223 4777      SCOPE

```

```

/CAN WE SHIFT DMA WITH MAU SET
2224 4776 JMS SAD /SET SAD
2225 7200 CLA
2226 1370 TAD (5252 /DATA TO DMA
2227 6605 DMAW /LOAD DMA AND SET ACH
2230 6632 TTB /GEN TP1, CLEAR SAD SET MAU
2231 6632 TTB
2232 4774 JMS SAP /SHIFT DMA
2233 6626 DMAW /READ DMA
2234 3773 DCA BA /TEMP STORE
2235 1367 TAD (6525 /WHAT DATA SHOULD BE
2236 7041 CIA
2237 1773 TAD BA
2240 7650 SNA:CLA /TEST
2241 5244 JMP .+3
2242 1773 TAD BA /LOAD AC WITH BA
2243 4771 HALT
2244 4777 SCOPE

/
/TO PASS THIS, THE PREVIOUS TEST MUST BE GOOD!!
/SHIFT DMA WITH MAU CLEARED
2245 1360 TAD (7252 /MAU AND ACH SHOULD BE CLEARED
2246 3765 DCA GA
2247 6631 TTA /WITH SAD SET=SAP
2250 6626 DMAW /READ DMA
2251 3773 DCA BA
2252 1773 TAD BA
2253 7041 CIA
2254 1765 TAD GA /SHOULD BE 7252
2255 7650 SNA:CLA /COMPARED
2256 5261 JMP .+3 /GOOD
2257 1773 TAD BA /BAU
2260 4771 HALT /BAU IS IN AC
2261 7604 LAS /SCOPE LOOP SET UP
2262 0364 AND (1000
2263 7640 SZA:CLA
2264 5763 JMP RETURN+1

/
/TO PASS THIS THE PREVIOUS TEST MUST BE GOOD!!
/MAU AND ACH SHOULD BE CLEARED
2265 1362 TAD (5525 /MAU AND ACH SHOULD BE CLEARED
2266 3765 DCA GA
2267 6631 TTA /WITH SAD SET=SAP=SHIFT DMA
2270 6626 DMAW /READ DMA
2271 3773 DCA BA
2272 1773 TAD BA
2273 7041 CIA
2274 1765 TAD GA /SHOULD BE 5525
2275 7650 SNA:CLA /COMPARE
2276 5301 JMP .+3 /GOOD
2277 1773 TAD BA /BAU
2300 4771 HALT /BAU IS IN AC
2301 7604 LAS /SCOPE LOOP SET UP
2302 0364 AND (1000
2303 7640 SZA:CLA
2304 5763 JMP RETURN+1

```

/INTERFACE USING SPECIAL TIMING PULSES  
/SKIP ON ADC PULSE

2305	4761	JMS ADC
2306	6612	DSAC
2307	4771	HALT /ADC NCT SET
2310	4777	SCOPE

/

/SHIFT MEMORY BUFFER/SHIFTS SEVENS

2311	6601	DCMA
2312	6611	DCEA
2313	7240	CLA: CMA
2314	3760	DCA GD
2315	7240	CLA: CMA
2316	3757	DCA WC
2317	1356	TAD (GD=1
2320	3755	DCA IACW
2321	4754	JMS SDP /SHIFT DATA PULSE/LOAD UMB
2322	7240	CLA: CMA
2323	3757	DCA WC
2324	1365	TAD (BD-1
2325	3755	DCA IACW
2326	4753	JMS CLADC
2327	6602	6602 /READ
2330	6634	6634 /RAISE A REQUEST
2331	7200	CLA
2332	1352	TAD (7777
2333	7041	CIA
2334	1756	TAD BU
2335	7650	SNA: CLA
2336	5341	JMP ,+3
2337	1756	TAD BU
2340	4771	HALT /FAILED SHIFTING UMB
2341	4777	SCOPE
2342	5751	NPAGE

PAUSE  
/POP-8 DISCLOSE RMXD - TAPE 4  
PAGE

2351	2400
2352	7777
2353	3030
2354	3024
2355	7751
2356	3417
2357	7750
2360	3420
2361	3017
2362	5525
2363	3253
2364	1000
2365	3416
2366	7252
2367	6525
2370	5252
2371	0400
2372	1252
2373	3415
2374	3013
2375	2525
2376	3000
2377	3242

```

/SHIFT MEMORY BUFFER SHIFT ZERO
2400 6601 DCMA
2401 6611 DCEA
2402 7200 CLA
2403 3777 DCA GD
2404 7240 CLA!CMA
2405 3776 DCA WC
2406 1375 TAD (GD=1
2407 3774 DCA IACW
2410 4773 JMS SDP /SHIFT DATA PULSE/LOAD UMB
2411 7240 CLA!CMA
2412 3776 DCA WC
2413 1372 TAD (BD-1
2414 3774 DCA IACW
2415 4771 JMS CLADC
2416 6602 6602
2417 6634 6634
2420 7200 CLA
2421 1376 TAD (4000 /WHAT DATA SHOULD BE AFTER SHIFT
2422 7041 CIA
2423 1775 TAD BU
2424 7656 SNA!CLA
2425 5236 JMP .+3
2426 1775 TAD BU
2427 4767 HALT /FAILED TEST UMB SHIFT
2430 4766 SCOPE

```

/SHIFT MEMORY BUFFERS (2525) ONE SHIFT

2431	7200	CLA
2432	6601	DCMA
2433	6611	DCEA
2434	1365	TAD (2525)
2435	3777	DCA GD
2436	7240	CLA: CMA
2437	3776	DCA WC
2440	1375	TAD (GD-1)
2441	3774	DCA IACW
2442	4773	JMS SUP
2443	7240	CLA: CMA
2444	3776	DCA WC
2445	1372	TAD (BD-1)
2446	3774	DCA IACW
2447	4771	JMS CLADC
2450	6602	6602
2451	6634	6634
2452	7200	CLA
2453	1364	TAD (5252)
2454	7041	CIA
2455	1775	TAD BU
2456	7650	SNA: CLA
2457	5262	JMP .+3
2460	1775	TAD BU
2461	4767	HALI
2462	4766	SCOPE

/MUP ALSO SET NOW/SHIFT DATA

/READ  
/RAISE A REQUEST

/SHIFT MEMORY BUFFER (2525) 2 SHIFTS

2463	6601	DCMA
2464	6611	DCEA
2465	7200	CLA
2466	1365	TAD (2525
2467	3777	DCA GD
2470	7240	CLA!CMA
2471	3776	DCA WC
2472	1375	TAD (GD-1
2473	3774	DCA IACW
2474	4773	JMS SUP
2475	6631	TTA
2476	7240	CLA!CMA
2477	3776	DCA WC
2500	1372	TAD (BD-1
2501	3774	DCA IACW
2502	4771	JMS CLADC
2503	6602	6602
2504	6634	6634
2505	7200	CLA
2506	1365	TAD (2525
2507	7041	CIA
2510	1775	TAD BD
2511	7650	SNA!CLA
2512	5315	JMP .+3
2513	1775	TAD BD
2514	4767	HALT
2515	4766	SCOPE

/SHIFT DATA MDP ALSO SET  
/EXTRA SHIFT MDP SHOULD BE CLEARED

/READ  
/RAISE A REQUEST

2510 5763 NPAGE  
 2563 2600 PAGE  
 2564 5252  
 2565 2525  
 2566 3242  
 2567 0400  
 2570 4000  
 2571 3030  
 2572 3416  
 2573 3024  
 2574 7151  
 2575 3417  
 2576 7150  
 2577 3420

/  
 /SHIFT DMA WITH ACF ZERO

2600 7200 CLA  
 2601 6605 DMAW /DMA11 TO ZERO  
 2602 4777 JMS SAP /CLEAR ACH  
 2603 7240 CLA:DMA  
 2604 6605 DMAW /LOAD ALL SEVEN  
 2605 4777 JMS SAP /SHIFT DMA  
 2606 6626 DMAC /READ DMAC  
 2607 3776 DCA BA /TEM STORE  
 2610 1375 TAD (5777 /WHAT DATA SHOULD BE  
 2611 7041 CIA  
 2612 1776 TAD BA  
 2613 7650 SNA:CLA /TEST  
 2614 5217 JMP .+3  
 2615 1776 TAD BA  
 2616 4774 HALT  
 2617 4773 SCOPE

/  
 /DATA REQUEST LATE/STATUS AND SKIP TEST  
 S81, SKP

2620 7410  
 2621 5235 JMP .+14 /VALID FOR 855 ONLY  
 2622 6601 DCMA /CL DRL  
 2623 4772 JMS ADC  
 2624 6604 6604 /RAISE A REQUEST  
 2625 6632 TT6 /GENERATE DEP  
 2626 6616 DEAC /READ STATUS  
 2627 0371 AND (4  
 2630 7450 SNA  
 2631 4774 HALT /DATA REQUEST LATE STATUS NOT SET  
 2632 6621 DFSE /SKIP ON NO ERROR  
 2633 7410 SKP  
 2634 4774 HALT /SKIPPED ON DRL  
 2635 4773 SCOPE

/  
 /CHECK GENERATION OF DONE FLAG

2636 4770 JMS TCR /SET DONE FLAG  
 2637 6622 DFSC /SKIP ON FLAG  
 2640 4774 HALT /NO DONE FLAG  
 2641 4773 SCOPE



```

/ FORCE AN INTERRUPT WITH IRC
2642 7200 CLA
2643 1367 TAD (JMP I 0002
2644 3001 DCA 0001
2645 1366 TAD (.+6
2646 3002 DCA 0002
2647 4770 JMS TCR /SET IRC
2650 6001 ION
2651 7000 NOP
2652 4774 HALT /IRC DID NOT RAISE IN INTERRUPT
2653 4773 SCOPE

```

```

/
/ INCREMENT EXTERNAL MEMORY ADDRESS/EMA
2654 6611 DCEA
2655 7200 CLA
2656 1365 TAD (-37
2657 3364 DCA (XX
2660 6615 DEAL /CLEAR EXT ADDRESS
2661 7240 CLA: CMA
2662 4763 JMS DEP /LOAD CMA SET ACH
2663 6601 DCMA /INCREMENT EMA
2664 2364 ISZ (XX /COUNTER
2665 5261 JMP .-4
2666 6616 DEAC /READ EMA
2667 0362 AND (3700
2670 1361 TAD (-3700
2671 7450 SNA /TEST
2672 5275 JMP .+3
2673 6616 DEAC /READ EMA
2674 4774 HALT /AC = 37
2675 4773 SCOPE
2676 7240 CLA: CMA
2677 4763 JMS DEP /LOAD CMA SET ACH
2700 6601 DCMA /INCREMENT EMA
2701 6616 DEAC
2702 0362 AND (3700
2703 7440 SNA
2704 4774 HALT
2705 4773 SCOPE

```

```

/LOOP ON ROUTINE
2/06 4760 JMS CLADC
2/07 7604 LAS
2/10 0374 AND (400 /LOOP ON SHIFT AND STATUS REG TEST
2/11 7640 SZA:CLA
2/12 575/ JMP DYA /SHIFT AND STATUS TEST
/
/
/TEST FOR SKIPPING LIGHT BOX TEST
/
2/13 4760 JMS CLADC
2/14 6611 DCEA
2/15 6601 DCMA
2/16 7604 LAS
2/17 0356 AND (200
2/20 7640 SZA:CLA /SKIP LIGHT BOX
2/21 5755 JMP BEGIN /YES
/
/AUTOMATIC CONTROL FOR LIGHT BOX
2/22 7200 CLA
2/23 6611 DCEA
2/24 1354 TAD (7760 /NUMBER OF TRACKS
2/25 3753 DCA CTA
2/26 3752 DCA KA /TRACK NUMBER
2/27 4751 JMS LGBOX /LIGHT BOX ROUTINE
2/30 2752 ISZ KA
2/31 7200 CLA
2/51 3051 TAD KA
2/52 3400
2/53 3411
2/54 7760
2/55 0600
2/56 0200
2/57 1471
2/60 3030
2/61 4100
2/62 3700
2/63 3044
2/64 7402
2/65 7741
2/66 2653
2/67 5402
2/70 3034
2/71 0004
2/72 3017
2/73 3242
2/74 0400
2/75 5777
2/76 3415
2/77 3013
2/32 1750 /TRACK NUMBER INCREMENTED
2/33 2747 ISZ CIA /DONE
2/34 5327 JMP .-5 /NO
2/35 6611 DCEA /YES
2/36 6601 DCMA /CLEAR DISC
2/37 4746 SCOPE
2/40 4745 JMS CLADC
2/41 5744 JMP BEGIN /GO TO START OF PROGRAM

```

2/44 0600 PAGE  
 2/45 3030  
 2/46 3242  
 2/47 3411  
 2/50 3470

```

/COMMANDS TO BE GENERATED WITH SPECIAL IUTS
/ROUTINE TO SET SEARCH ADDRESS/SAU
3000 7402 SAU, XX
3001 6606 6606 /SET MRS WITH LAD
3002 6632 TTB /SET AEU
3003 6632 TTB /SET ICA
3004 6632 TTB /CL TCA, SET ICB
3005 6632 TTB /SET ICA
3006 6632 TTB /CL TCA, CL TCB, SET MWR
3007 6631 TTA /CL ABL TO SYNC DRS
3010 6632 TTB /DRS=SET WCE
3011 6631 TTA /SET SAU
3012 5600 JMP I SAD /EXIT
/ROUTINE TO SET SHIFT ADDRESS PULSE/SAP
3013 7402 SAP, XX
3014 4200 JMS SAU
3015 6631 TTA /SHIFT DMA
3016 5613 JMP I SAP /EXIT
/ROUTINE FOR SETTING ADDRESS CONFIRMED/ADC
3017 7402 ADC, XX
3020 4200 JMS SAU /SAU AND ABC SHOULD BE SET
3021 6632 TTB
3022 6632 TTB /SET ADC CL SAU
3023 5617 JMP I ADC /EXIT
/ROUTINE TO SHIFT MEMORY BUFFER/SDP
3024 7402 SDP, XX
3025 4217 JMS ADC
3026 6631 TTA /SHIFT DMH
3027 5624 JMP I SDP
/ROUTINE TO CLEAR ADC "FF"
3030 7402 CLADC, XX
3031 6632 TTB
3032 6632 TTB
3033 5630 JMP I CLADC

```

```

/ROUTINE TO SET TRANSFER COMPLETE TCR
3034 7402 TCR, XX
3035 6601 DCMA
3036 7240 CLA: CMA
3037 3777 DCA WC
3040 7240 CLA: CMA
3041 3776 DCA IACW /WRITE ONE WORD WCO SHOULD BE SET
3042 4244 JMS DEP
3043 5634 JMP I TCR
/ROUTINE FOR DATA END PULSE/DEP
3044 7402 DEP, XX
3045 4217 JMS ADC
3046 6632 TTB
3047 6632 TTB /GENERATE TP1
3050 5644 JMP I DEP
/LIGHT BOX USED TO TEST TRACK SELECTION
/SET OR CLEAR "WFF"?
3051 7402 LGBOX, XX
3052 6601 DCMA
3053 3375 DCA (XX /STORE SWITCH
3054 1375 TAD (XX
3055 0374 AND (4 /MASK FOR "WFF"
3056 7450 SNA /SET OR CLEAR
3057 5264 JMP .+5 /CLEAR
3060 4267 JMS KWFF /LOAD DMB, UMA CLEAR WFF
3061 6631 TTA /GEN OPS SET WFF
3062 4311 JMS SIALL
3063 5651 JMP I LGBOX
3064 4267 JMS KWFF /LOAD DMB, UMA AND CLEAR WFF
3065 4311 JMS SIALL
3066 5651 JMP I LGBOX

```

```

/ROUTINE TO CLEAR WFF
3067 7402 KWFF, XX
3070 7200 CLA
3071 1373 TAD (7777 /DATA FOR MB
3072 3772 DCA GD
3073 1371 TAD (GD-1
3074 3776 DCA IACW
3075 1375 TAD (XX /SWITCH REG
3076 7012 RTR
3077 6611 /CL TRACK
3100 6631 6631
3101 6632 6632
3102 4217 JMS AJC
3103 1375 TAD (XX /SWITCH
3104 7104 RAL:CLL
3105 7006 RIL
3106 7006 RTL
3107 6615 DEAL /LOAD EXT ADDRESS
3110 5667 JMP I KWFF /EXIT
3111 7402 STALL, XX
3112 7240 CLA:CMA
3113 1370 TAD (/740
3114 3322 DCA .+6
3115 2323 ISZ .+6
3116 5315 JMP .-1
3117 2322 ISZ .+3
3120 5315 JMP .-3
3121 5711 JMP I STALL
3122 0000 0
3123 0000 0
3124 7402 IPRINI, XX
3125 3767 DCA AC
3126 7604 LAS
3127 0366 AND (4000
3130 7650 SNA:CLA
3131 5337 JMP .+6
3132 1324 TAD IPRINI
3133 1365 TAD (-2
3134 3324 DCA IPRINI
3135 1724 TAD I IPRINI
3136 3324 DCA IPRINI
3137 1767 TAD AC
3140 5724 JMP I IPRINI

```

3165	7776	PAGE
3166	4000	
3167	3404	
3170	7740	
3171	3417	
3172	3420	
3173	7777	
3174	0004	
3175	7402	
3176	7751	
3177	7750	
		/MAINTENANCE SCOPE LOOPS
		/SEARCH ADDRESS
3200	6611	SA, DCEA
3201	4777	JMS SAD
3202	6632	TTB
3203	6632	TTB
3204	5200	JMP .-4
		/SHIFT ADDRESS PULSE
3205	6611	SB, DCEA
3206	4776	JMS SAP
3207	5205	JMP .-2
		/ADDRESS CONFIRMED
3210	6611	SC, DCEA
3211	4775	JMS AUC
3212	5210	JMP .-2
		/SHIFT DATA PULSE
3213	6611	SD, DCEA
3214	4774	JMS SUP
3215	5213	JMP .-2
		/DATA END PULSE
3216	6611	SE, DCEA
3217	4773	JMS DEP
3220	5216	JMP .-2
		/TRANSFER COMPLETE
3221	6611	SF, DCEA
3222	4772	JMS TCR
3223	5221	JMP .-2

```

/MAINTENANCE SCOPE LOOPEX FOR IOTS
/USE SR 8 TO 11 TO SELECT IOT
3224 7000 SG, NOP
3225 7200 CLA
3226 3771 DCA WC
3227 3770 DCA IACW
3230 7604 LAS /IOP SELECTION
3231 0367 AND (0037
3232 1366 TAD (6600
3233 3234 DCA .+1 /GENERATE IOT
3234 7402 XX
3235 7000 NOP /EXECUTE IOT
3236 5225 JMP SG+1 /LOOP
/SCOPE LOOP FOR LIGHT BOX, SR 8-11 EQUAL TRACK
3237 7604 SH, LAS /AC = TRACK
3240 4765 JMS LGBOX
3241 5237 JMP .-2
/SCOPE LOOP SETUP
3242 7402 SCOPEA, XX
3243 7604 LAS
3244 0364 AND (1000
3245 7640 SZA:CLA
3246 5652 JMP I RETURN
3247 1242 TAD SCOPEA
3250 3252 DCA RETURN
3251 5642 JMP I SCOPEA
/
/POINTER FOR SCOPE LOOP
3252 3363 RETURN, (BEGIN
3253 5652 JMP I .-1

```





DISCLESS DF32

